

**Air-Conditioners For Building Application****INDOOR UNIT****CMB-P-V-J****CMB-P-V-JA (MAIN BC CONTROLLER)****CMB-P-V-KB (SUB BC CONTROLLER)****CMB-P-V-KA (MAIN BC CONTROLLER)****INSTALLATION MANUAL**

For safe and correct use, please read this installation manual thoroughly before installing the air-conditioner unit.

**INSTALLATIONSHANDBUCH**

Zum sicheren und ordnungsgemäßen Gebrauch der Klimageräte das Installationshandbuch gründlich durchlesen.

**MANUEL D'INSTALLATION**

Veillez lire le manuel d'installation en entier avant d'installer ce climatiseur pour éviter tout accident et vous assurer d'une utilisation correcte.

**MANUAL DE INSTALACIÓN**

Para un uso seguro y correcto, lea detalladamente este manual de instalación antes de montar la unidad de aire acondicionado.

**MANUALE DI INSTALLAZIONE**

Per un uso sicuro e corretto, leggere attentamente questo manuale di installazione prima di installare il condizionatore d'aria.

**INSTALLATIEHANDLEIDING**

Voor een veilig en juist gebruik moet u deze installatiehandleiding grondig doorlezen voordat u de airconditioner installeert.

**MANUAL DE INSTALAÇÃO**

Para segurança e utilização correctas, leia atentamente este manual de instalação antes de instalar a unidade de ar condicionado.

**ΕΓΧΕΙΡΙΔΙΟ ΟΔΗΓΙΩΝ ΕΓΚΑΤΑΣΤΑΣΗΣ**

Για ασφάλεια και σωστή χρήση, παρακαλείστε διαβάσετε προσεκτικά αυτό το εγχειρίδιο εγκατάστασης πριν αρχίσετε την εγκατάσταση της μονάδας κλιματισμού.

**РУКОВОДСТВО ПО УСТАНОВКЕ**

Для осторожного и правильного использования прибора необходимо тщательно ознакомиться с данным руководством по установке до выполнения установки кондиционера.

**MONTAJ ELKİTABI**

Emniyetli ve doğru biçimde nasıl kullanılacağını öğrenmek için lütfen klima cihazını monte etmeden önce bu elkitabını dikkatle okuyunuz.

**安装手册**

为了安全和正确地使用本空调器，请在安装前仔细阅读本安装手册。

**PŘÍRUČKA K INSTALACI**

V zájmu bezpečného a správného používání si před instalací klimatizační jednotky důkladně pročtěte tuto příručku k instalaci.

**NÁVOD NA INŠTALÁCIU**

Pre bezpečné a správne použitie si pred inštalovaním klimatizačnej jednotky, prosím, starostlivo prečítajte tento návod na inštaláciu.

**TELEPÍTÉSI KÉZIKÖNYV**

A biztonságos és helyes használatához, kérjük, olvassa el alaposan ezt a telepítési kézikönyvet, mielőtt telepítené a légkondicionáló egységet.

**PODRECZNIK INSTALACJI**

W celu bezpiecznego i poprawnego korzystania należy przed zainstalowaniem klimatyzatora dokładnie zapoznać się z niniejszym podręcznikiem instalacji.

**PRIROČNIK ZA NAMESTITEV**

Za varno in pravilno uporabo pred namestitvijo klimatske naprave natančno preberite ta Priročnik za namestitev.

**INSTALLATIONSHANDBOK**

Läs den här installationshandboken noga innan luftkonditioneringsenheten installeras, för säker och korrekt användning.

**PRIRUČNIK ZA UGRADNJU**

Radi sigurne i ispravne uporabe, temeljito pročítajte ovaj priručnik prije ugradnje klimatizacijskog uređaja.

**РЪКОВОДСТВО ЗА МОНТАЖ**

За безопасна и правилна употреба, моля, прочетете внимателно това ръководство преди монтажа на климатизатора.

**MANUAL CU INSTRUCȚIUNI DE INSTALARE**

Pentru o utilizare corectă și sigură, vă rugăm să citiți cu atenție acest manual înainte de a instala unitatea de aer condiționat.

**INSTALLASJONSHÅNDBOK**

For sikker og riktig bruk, skal du lese denne installasjonshåndboken nøye før du installerer klimaanlegget.

GB

D

F

E

I

NL

P

GR

RU

TR

中

CZ

SV

HG

PO

SL

SW

HR

BG

RO

NO

[Fig. 2.2.1]

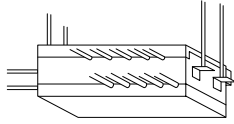

[Fig. 2.3.1]

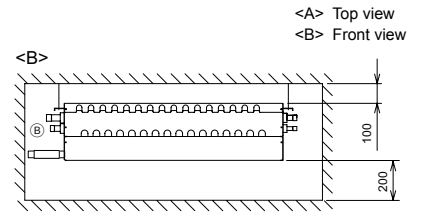
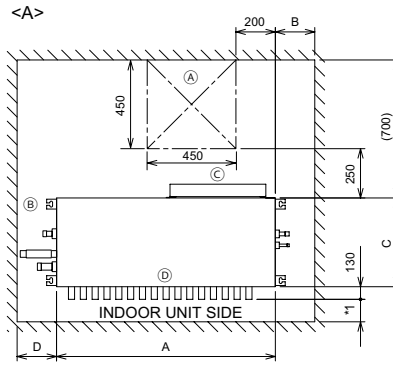

- (A) Inspection hole
- (B) On the side of outdoor unit piping
- (C) Control box
- (D) On the side of indoor unit piping

\*1 Dimensions with which pipe connection can be handled at site

Model name	A	B	C	D
CMB-P104V-J	596	-	429	250
CMB-P106V-J				
CMB-P108V-J				
CMB-P1012V-J	911	250	573	300
CMB-P1016V-J	1135			
CMB-P108V-JA	911			
CMB-P1012V-JA	1135	250	573	300
CMB-P1016V-JA				
CMB-P1016V-KA				
CMB-P104V-KB	596	-	429	250

## 2.4

[Fig. 2.4.1]

### ●Restrictions on piping length

PURY-(E)P200, 250, 300YNW-A, PQRY-P200, 250, 300YLM-A

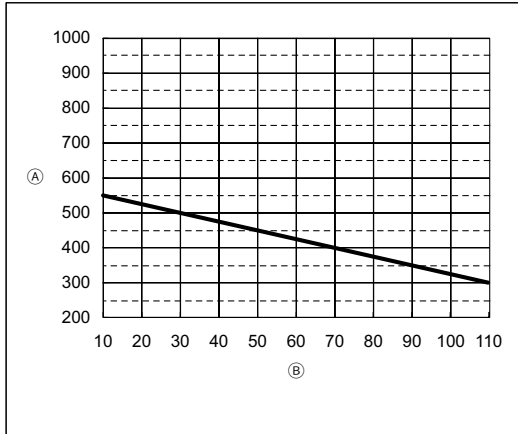

PURY-(E)P350, 400, 450, 500, 550YNW-A

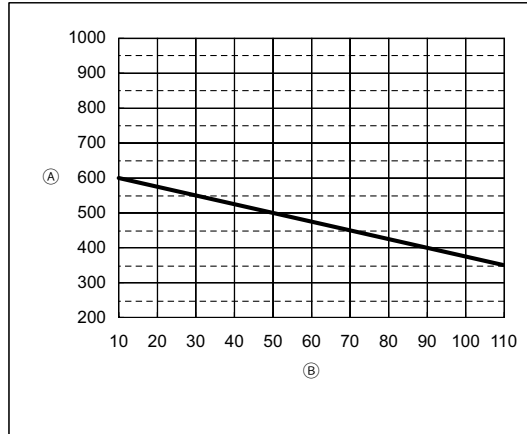

PURY-(E)P400, 450, 500, 550, 600YSNW-A  
PQRY-P350, 400, 450, 500, 550, 600YLM-A  
PQRY-P400, 450, 500, 550, 600, 700, 750, 800, 850, 900YSLM-A

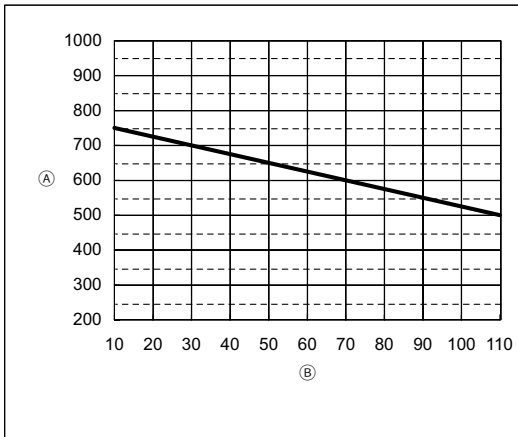

PURY-(E)P650YSNW-A

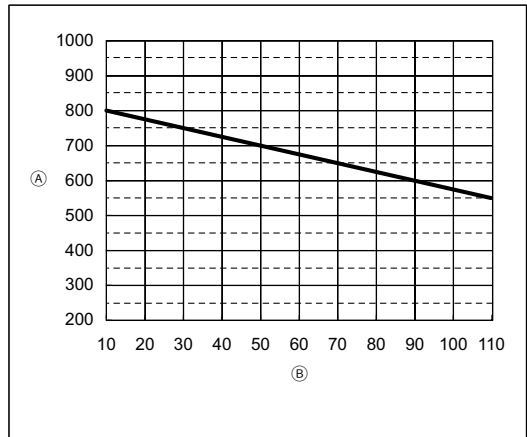

PURY-(E)P700, 750, 800, 850, 900, 950, 1000, 1050, 1100YSNW-A

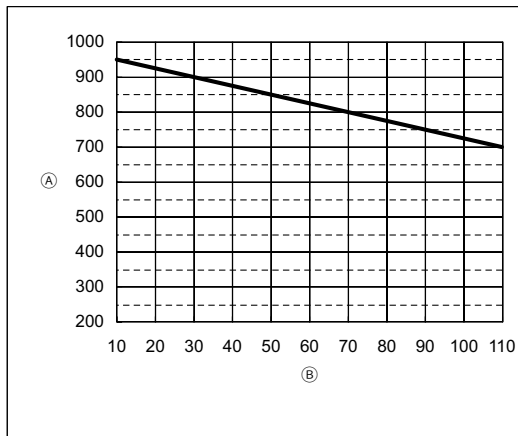

(A) Total piping length (m)    (B) Piping length between outdoor (heat source) unit and main BC controller (m)

[Fig. 3.2.1]

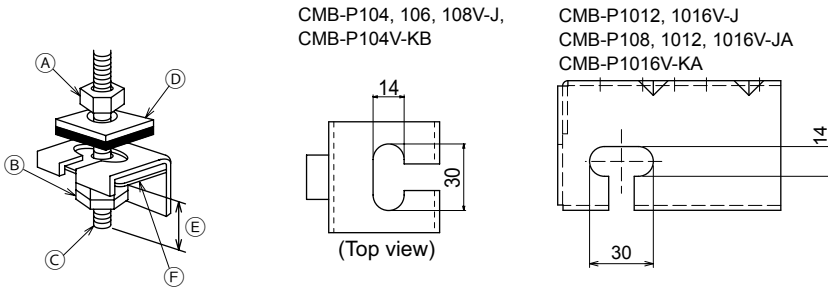

- A Nut (not supplied)
- B Double nut (not supplied)
- C Hanging bolt  $\phi 10$  (M10 screw) (not supplied)
- D Washer (with cushion) (supplied)  
\* Attach the cushion facing down.
- E Minimum 30 mm
- F Washer (without cushion) (supplied)

[Fig. 3.2.2]

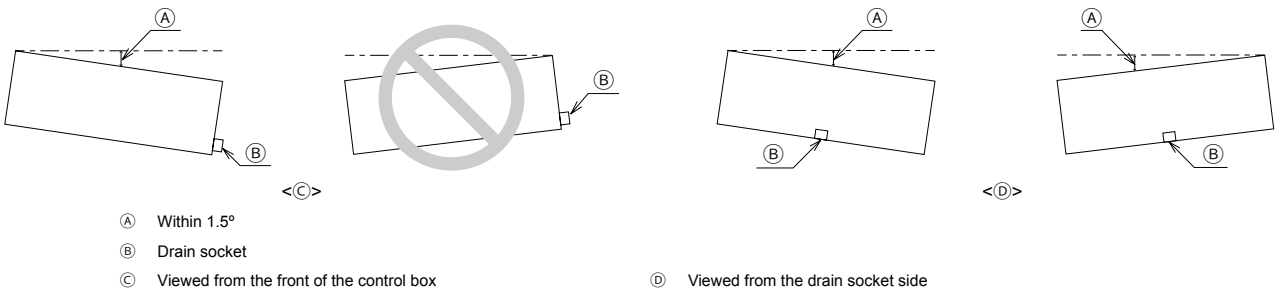

- A Within 1.5°
- B Drain socket
- C Viewed from the front of the control box
- D Viewed from the drain socket side

[Fig. 4.1.1]

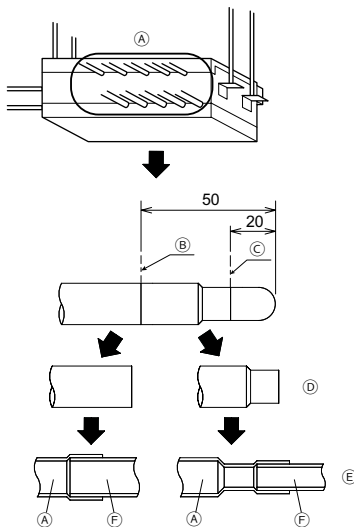

- A Indoor unit connecting port
- B Cutting point :  $\phi 9.52$  (Liquid side) or  $\phi 15.88$  (Gas side)  
(Indoor unit model : above P50)
- C Cutting point :  $\phi 6.35$  (Liquid side) or  $\phi 12.7$  (Gas side)  
(Indoor unit model : P50 or below)
- D Cut the piping at the cutting point
- E Have pipe expansion of indoor unit connecting port
- F Field pipe

**Note:**  
Remove burr after cutting the piping to prevent entering the piping.  
Check that there is no crack at the pipe expansion part.

[Fig. 4.1.2]

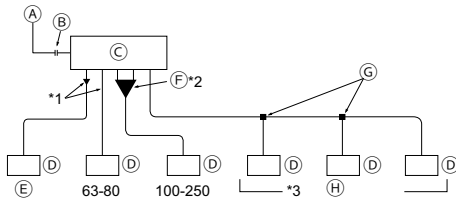

- (A) To outdoor unit (Main BC controller)
- (B) End connection (brazing)
- (C) BC controller (Main BC controller / Sub BC controller)
- (D) Indoor unit
- (E) P50 or below
- (F) Combined piping kit (Model name: CMY-R160-J1)
- (G) Twinning pipe (Model name: CMY-Y102SS-G2, CMY-Y102LS-G2)
- (H) Up to three units for 1 branch hole; total capacity: 80 or below (but same in cooling/heating mode)

**\*1. For connecting 15 to 50 model indoor units**

Have pipe expansion of indoor unit connecting port by cutting the piping at the cutting point which depends on the indoor unit capacity.

**Note:**

**Remove burr after cutting the piping to prevent entering the piping. Check that there is no crack at the pipe expansion part.**

**\*2. To connect a unit with a capacity of 81 or above.**

After combining two branches using an optionally available piping kit (CMY-R160-J1), connect indoor units.

**\*3. Connection of plural indoor units with one connection (or joint pipe)**

- Total capacity of connectable indoor units: 80 or below (250 or below with joint pipe)
- Number of connectable indoor units: Maximum 3 Sets
- Twinning pipe: Use the twinning pipe for CITY MULTI Y Series (CMY-Y102SS-G2, CMY-Y102LS-G2)
- Selection of refrigerant piping  
Select the size according to the total capacity of indoor units to be installed downstream.

Total capacity of indoor units	Liquid line	Gas line
140 or below	ø9.52	ø15.88
141 to 200		ø19.05
201 to 250		ø22.2

## 4.2

[Fig. 4.2.1]

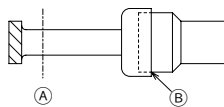

- (A) Cut here
- (B) Remove brazed cap

## 4.3

[Fig. 4.3.1]

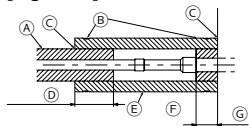

- (A) Insulating material for pipes (not supplied)
- (B) Bind here using band or tape.
- (C) Do not leave any opening.
- (D) Lap margin: more than 40 mm
- (E) Insulating material (not supplied)
- (F) Unit side insulating material
- (G) Minimum 30 mm

[Fig. 4.3.2]

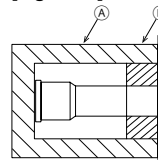

- (A) Insulating material (not supplied)
- (B) Bind here using band or tape.

## 4.4

[Fig. 4.4.1]

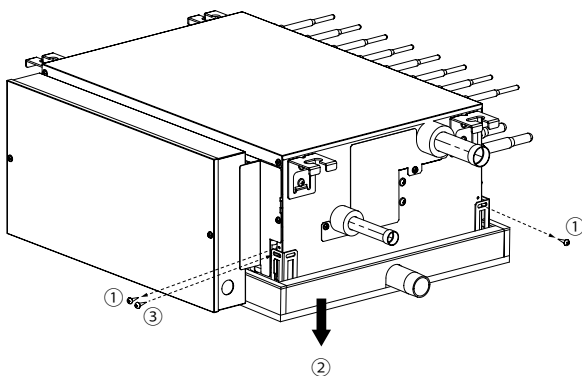

- ① Unscrew the two screws that are holding the side panel on the right side of the control box.
- ② Tilt the drain pan.
- ③ Screw down the screws with the drain pan tilted.

[Fig. 4.4.2]

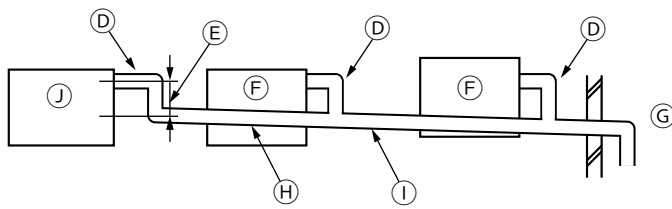
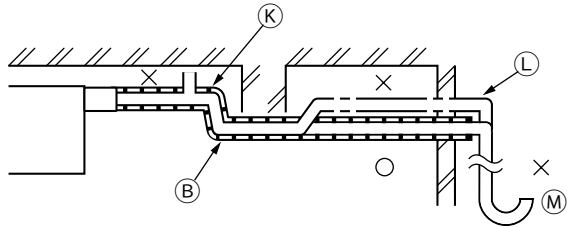
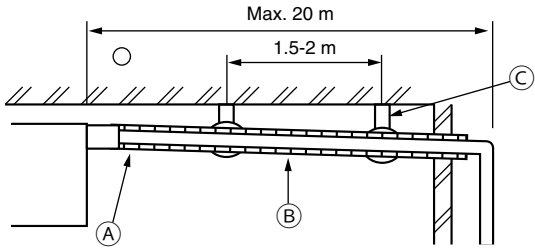

- Correct piping
- × Wrong piping
- (A) Insulation (9 mm or more)
- (B) Downward slope (1/100 or more)
- (C) Support metal
- (K) Air bleeder
- (L) Raised
- (M) Odor trap
- Grouped piping
- (D) O.D. ø32 PVC TUBE
- (E) Make it as large as possible. About 10 cm.
- (F) Indoor unit
- (G) Make the piping size large for grouped piping.
- (H) Downward slope (1/100 or more)
- (I) O.D. ø38 PVC TUBE for grouped piping. (9 mm or more insulation)
- (J) BC controller

[Fig. 4.4.3]

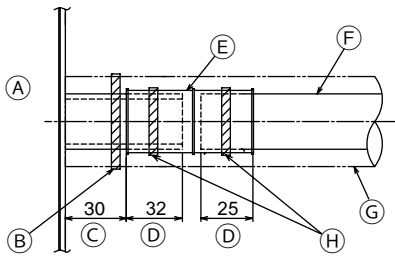

- (A) BC controller
- (B) Tie band (supplied)
- (C) Visible part
- (D) Insertion margin
- (E) Drain hose (supplied)
- (F) Drain pipe (O.D. ø32 PVC TUBE, not supplied)
- (G) Insulating material (not supplied)
- (H) Tie band (supplied)

[Fig. 5.0.1]

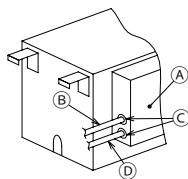

- (A) Control box
- (B) Power source wiring
- (C) ø21 hole (closed rubber bushing)
- (D) Transmission wiring

# Contents

1. Safety precautions.....	7	3. Installing BC controller .....	13
1.1. Before installation and electric work .....	7	3.1. Checking the accessories with BC controller.....	13
1.2. Precautions for devices that use R410A refrigerant .....	8	3.2. Installing BC controllers .....	13
1.3. Before installation .....	8	4. Connecting refrigerant pipes and drain pipes.....	13
1.4. Before installation (relocation) - electrical work .....	8	4.1. Connecting refrigerant pipes.....	13
1.5. Before starting the test run .....	8	4.2. Refrigerant piping work.....	15
2. Selecting an installation site.....	9	4.3. Insulating refrigerant pipes .....	15
2.1. About the product .....	9	4.4. Drain piping work .....	15
2.2. Installation site .....	9	5. Electrical work .....	16
2.3. Securing installation and service space.....	9	6. Setting addresses and operating units .....	16
2.4. Checking the installation site .....	10	7. Test run.....	16

## 1. Safety precautions

### 1.1. Before installation and electric work

- ▶ **Before installing the unit, make sure you read all the “Safety precautions”.**
- ▶ **The “Safety precautions” provide very important points regarding safety. Make sure you follow them.**

#### Symbols used in the text

##### **Warning:**

Describes precautions that should be observed to prevent danger of injury or death to the user.

##### **Caution:**

Describes precautions that should be observed to prevent damage to the unit.

#### Symbols used in the illustrations

 : Indicates an action that must be avoided.

 : Indicates that important instructions must be followed.

 : Indicates a part which must be grounded.

 : Beware of electric shock (This symbol is displayed on the main unit label.) <Color: Yellow>

##### **Warning:**

**Carefully read the labels affixed to the main unit.**

##### **HIGH VOLTAGE WARNING:**

- Control box houses high-voltage parts.
- When opening or closing the front panel of the control box, do not let it come into contact with any of the internal components.
- Before inspecting the inside of the control box, turn off the power, keep the unit off for at least 10 minutes.

##### **Warning:**

- If the supply cord is damaged, it must be replaced by the manufacturer, its service agent or similarly qualified persons in order to avoid a hazard.
- This appliance is not intended for use by persons (including children) with reduced physical, sensory or mental capabilities, or lack of experience and knowledge, unless they have been given supervision or instruction concerning use of the appliance by a person responsible for their safety.
- This appliance is intended to be used by expert or trained users in shops, in light industry and on farms, or for commercial use by lay persons.
- Do not use refrigerant other than the type indicated in the manuals provided with the unit and on the nameplate.
  - Doing so may cause the unit or pipes to burst, or result in explosion or fire during use, during repair, or at the time of disposal of the unit.
  - It may also be in violation of applicable laws.
  - MITSUBISHI ELECTRIC CORPORATION cannot be held responsible for malfunctions or accidents resulting from the use of the wrong type of refrigerant.
- Ask the dealer or an authorized technician to install the air conditioner.
  - Improper installation by the user may result in water leakage, electric shock, or fire.
- Install the unit at a place that can withstand its weight.
  - Failure to do so may cause the unit to fall down, resulting in injuries and damage to the unit.
- Use the specified cables for wiring. Make the connections securely so that the outside force of the cable is not applied to the terminals.
  - Inadequate connection and fastening may generate heat and cause a fire.

- **Prepare for earthquakes and install the unit at the specified place.**
  - Improper installation may cause the unit to fall down and result in injury and damage to the unit.
- **Always use accessories specified by Mitsubishi Electric.**
  - Ask an authorized technician to install the accessories. Improper installation by the user may result in water leakage, electric shock, or fire.
- **Never repair the unit. If the air conditioner must be repaired, consult the dealer.**
  - If the unit is repaired improperly, water leakage, electric shock, or fire may result.
- **Do not touch the refrigerant pipes.**
  - Improper handling may result in injury.
- **When handling this product, always wear protective equipment. EG: Gloves, full arm protection namely boiler suit, and safety glasses.**
  - Improper handling may result in injury.
- **If refrigerant gas leaks during installation work, ventilate the room.**
  - If the refrigerant gas comes into contact with a flame, poisonous gases will be released.
- **Install the air conditioner according to this Installation Manual.**
  - If the unit is installed improperly, water leakage, electric shock, or fire may result.
- **Have all electric work done by a licensed electrician according to “Electric Facility Engineering Standard” and “Interior Wire Regulations” and the instructions given in this manual and always use a dedicated power supply.**
  - If the power source capacity is inadequate or electric work is performed improperly, electric shock and fire may result.
- **Keep the electric parts away from water (washing water etc.).**
  - It might result in electric shock, catching fire or smoke.
- **Securely install the cover of control box.**
  - If the cover is not installed properly, dust or water may enter the outdoor unit and fire or electric shock may result.
- **When installing and moving the air conditioner to another site, do not charge it with a refrigerant different from the refrigerant specified on the unit.**
  - If a different refrigerant or air is mixed with the original refrigerant, the refrigerant cycle may malfunction and the unit may be damaged.
- **If the air conditioner is installed in a small room, measures must be taken to prevent the refrigerant concentration from exceeding the safety limit if the refrigerant should leak.**
  - Consult the dealer regarding the appropriate measures to prevent the safety limit from being exceeded. Should the refrigerant leak and cause the safety limit to be exceeded, hazards due to lack of oxygen in the room could result.
- **When moving and reinstalling the air conditioner, consult the dealer or an authorized technician.**
  - If the air conditioner is installed improperly, water leakage, electric shock, or fire may result.
- **After completing installation work, make sure that refrigerant gas is not leaking.**
  - If the refrigerant gas leaks and is exposed to a fan heater, stove, oven, or other heat source, it may generate noxious gases.
- **Do not reconstruct or change the settings of the protection devices.**
  - If the pressure switch, thermal switch, or other protection device is shorted or operated forcibly, or parts other than those specified by Mitsubishi Electric are used, fire or explosion may result.
- **To dispose of this product, consult your dealer.**
- **The installer and system specialist shall secure safety against leakage according to local regulation or standards.**
  - Choose the appropriate wire size and the switch capacities for the main power supply described in this manual if local regulations are not available.
- **Pay special attention to the place of installation, such as basement, etc. where refrigeration gas can accumulate, since refrigerant is heavier than the air.**
- **Children should be supervised to ensure that they do not play with the appliance.**

## 1.2. Precautions for devices that use R410A refrigerant

### ⚠ Warning:

- **Do not use refrigerant other than the type indicated in the manuals provided with the unit and on the nameplate.**
  - Doing so may cause the unit or pipes to burst, or result in explosion or fire during use, during repair, or at the time of disposal of the unit.
  - It may also be in violation of applicable laws.
  - MITSUBISHI ELECTRIC CORPORATION cannot be held responsible for malfunctions or accidents resulting from the use of the wrong type of refrigerant.

### ⚠ Caution:

- **Do not use existing refrigerant piping.**
  - The old refrigerant and refrigerant oil in the existing piping contains a large amount of chlorine which may cause the refrigerant oil of the new unit to deteriorate.
  - R410A is a high-pressure refrigerant and can cause the existing piping to burst.
- **Use refrigerant piping made of phosphorus deoxidized copper and copper alloy seamless pipes and tubes. In addition, be sure that the inner and outer surfaces of the pipes are clean and free of hazardous sulphur, oxides, dust/dirt, shaving particles, oils, moisture, or any other contaminant.**
  - Contaminants on the inside of the refrigerant piping may cause the refrigerant residual oil to deteriorate.
- **Store the piping to be used during installation indoors and keep both ends of the piping sealed until just before brazing. (Store elbows and other joints in a plastic bag.)**
  - If dust, dirt, or water enters the refrigerant cycle, deterioration of the oil and compressor failure may result.
- **Apply a small amount of ester oil, ether oil, or alkyl benzene to flares. (for indoor unit)**
  - Infiltration of a large amount of mineral oil may cause the refrigerant oil to deteriorate.
- **Use liquid refrigerant to fill the system.**
  - If gas refrigerant is used to fill the system, the composition of the refrigerant in the cylinder will change and performance may drop.
- **Do not use a refrigerant other than R410A.**
  - If another refrigerant (R22, etc.) is mixed with R410A, the chlorine in the refrigerant may cause the refrigerant oil to deteriorate.
- **Use a vacuum pump with a reverse flow check valve.**
  - The vacuum pump oil may flow back into the refrigerant cycle and cause the refrigerant oil to deteriorate.
- **Do not use the following tools that are used with conventional refrigerants. (Gauge manifold, charge hose, gas leak detector, reverse flow check valve, refrigerant charge base, refrigerant recovery equipment)**
  - If the conventional refrigerant and refrigerant oil are mixed in the R410A, the refrigerant may deteriorate.
  - If water is mixed in the R410A, the refrigerant oil may deteriorate.
  - Since R410A does not contain any chlorine, gas leak detectors for conventional refrigerants will not react to it.
- **Do not use a charging cylinder.**
  - Using a charging cylinder may cause the refrigerant to deteriorate.
- **Do not use antioxidant or leak-detection additive.**
- **Be especially careful when managing the tools.**
  - If dust, dirt, or water gets into the refrigerant cycle, the refrigerant may deteriorate.

## 1.3. Before installation

### ⚠ Caution:

- **Do not install the unit where combustible gas may leak.**
  - If the gas leaks and accumulates around the unit, an explosion may result.
- **Do not use the air conditioner where food, pets, plants, precision instruments, or artwork are kept.**
  - The quality of the food, etc. may deteriorate.
- **Do not use the air conditioner in special environments.**
  - Oil, steam, sulfuric smoke, etc. can significantly reduce the performance of the air conditioner or damage its parts.
- **When installing the unit in a hospital, communication station, or similar place, provide sufficient protection against noise.**
  - Inverter equipment, private power generator, high-frequency medical equipment, or radio communication equipment may cause the air conditioner to operate erroneously, or fail to operate. On the other hand, the air conditioner may affect such equipment by creating noise that disturbs medical treatment or image broadcasting.
- **Do not install the unit on or over things that are subject to water damage.**
  - When the room humidity exceeds 80 % or when the drain pipe is clogged, condensation may drip from the indoor unit or BC controller. Perform collective drainage work together with the outdoor unit, as required.
- **Make sure to remove the foamed styrol between the unit and the drain pan.**

## 1.4. Before installation (relocation) - electrical work

### ⚠ Caution:

- **Ground the unit.**
  - Do not connect the ground wire to gas or water pipes, lightning rods, or telephone ground lines. Improper grounding may result in electric shock.
- **Install the power cable so that tension is not applied to the cable.**
  - Tension may cause the cable to break and generate heat and cause a fire.
- **Install a leak circuit breaker, as required.**
  - If a leak circuit breaker is not installed, electric shock may result.
- **Use power line cables of sufficient current carrying capacity and rating.**
  - Cables that are too small may leak, generate heat, and cause a fire.
- **Use only a circuit breaker and fuse of the specified capacity.**
  - A fuse or circuit breaker of a larger capacity, or the use of substitute simple steel or copper wire may result in a general unit failure or fire.
- **Do not wash the air conditioner units.**
  - Washing them may cause an electric shock.
- **Be careful that the installation base is not damaged by long use.**
  - If the damage is left uncorrected, the unit may fall and cause personal injury or property damage.
- **Install the drain piping according to this Installation Manual to ensure proper drainage. Wrap thermal insulation around the pipes to prevent condensation.**
  - Improper drain piping may cause water leakage causing damage to furniture and other possessions.
- **Be very careful about transporting the product.**
  - One person should not carry the product. Its weight is in excess of 20 kg.
  - Some products use PP bands for packaging. Do not use any PP bands as a means of transportation. It is dangerous.
- **Safely dispose of the packing materials.**
  - Packing materials, such as nails and other metal or wooden parts, may cause stabs or other injuries.
  - Tear apart and throw away plastic packaging bags so that children will not play with them. If children play with a plastic bag which has not been torn apart, they face the risk of suffocation.

## 1.5. Before starting the test run

### ⚠ Caution:

- **Turn on the power at least 12 hours before starting operation.**
  - Starting operation immediately after turning on the main power switch can result in irreversible damage to internal parts. Keep the power switch turned on during the operational season.
- **Do not touch the switches with wet fingers.**
  - Touching a switch with wet fingers can result in an electric shock.
- **Do not touch the refrigerant pipes during and immediately after operation.**
  - During and immediately after operation, the refrigerant pipes may be hot or cold, depending on the condition of the refrigerant flowing through the refrigerant piping, compressor, and other refrigerant cycle parts. Your hands may suffer burns or frostbite if you touch the refrigerant pipes.
- **Do not operate the air conditioner with the panels and guards removed.**
  - Rotating, hot, or high-voltage parts can cause injuries.
- **Do not turn off the power immediately after stopping operation.**
  - Always wait at least 5 minutes before turning off the power. Otherwise, drainage water leakage or mechanical failure of sensitive parts may occur.



## 2. Selecting an installation site

### 2.1. About the product

#### ⚠ Warning:

- Do not use refrigerant other than the type indicated in the manuals provided with the unit and on the nameplate.
  - Doing so may cause the unit or pipes to burst, or result in explosion or fire during use, during repair, or at the time of disposal of the unit.
  - It may also be in violation of applicable laws.
  - MITSUBISHI ELECTRIC CORPORATION cannot be held responsible for malfunctions or accidents resulting from the use of the wrong type of refrigerant.
- This unit uses R410A-type refrigerant.
- Piping for systems using R410A may be different from that for systems using conventional refrigerant because the design pressure in systems using R410A is higher. Refer to the Data Book for more information.
- Some of the tools and equipment used for installation with systems that use other types of refrigerant cannot be used with the systems using R410A. Refer to the Data Book for more information.
- Do not use the existing piping, as it contains chlorine, which is found in conventional refrigerating machine oil and refrigerant. This chlorine will deteriorate the refrigerant machine oil in the new equipment. The existing piping must not be used as the design pressure in systems using R410A is higher than that in the systems using other types of refrigerant and the existing pipes may burst.

### 2.2. Installation site

- Install the unit in a place not exposed to rain. The BC controller is designed to be installed indoors.
- Install the unit with adequate space around it for servicing.
- Do not install the unit in a place that would result in the piping length restrictions being exceeded.
- Install the unit in a place not exposed to direct radiant heat from other heat sources.
- Do not install the unit in any oily steamy place or near any machine that generates high frequencies. Doing so may cause a risk of fire, erroneous operation or dew drop.
- Allow enough space and access to ensure water piping, refrigerant piping and electrical wiring can be easily connected.
- Avoid places exposed to the generation, inflow, accumulation or leakage of flammable and sulfuric gases.
- Ensure a downward gradient of at least 1/100 for drain piping.
- Properly install the unit on a stable, load-bearing surface.
- Do not install the unit in a place subject to a large amount of steam. Using the unit in a humid environment may cause condensation during a cooling operation.
- If the inside of the ceiling on which the unit is installed becomes hot and humid, operating the unit for a long time in such environment may cause condensation. However, it poses no problem because condensation water will flow into a drain pan. Though an area where condensation occurred may be colored in white, it does not affect normal operation of the unit.
- Make sure that condensation water of the unit does not come into contact with surrounding wirings.

#### 1. For hanging from the ceiling [Fig. 2.2.1] (P.2)

- Provide an inspection hole 450 mm square in the ceiling surface as shown in [Fig. 2.3.1] (P.2).
- Install the unit in a suitable location (such as in the ceiling of a corridor or in the bathroom etc) away from places regularly occupied. Avoid installing in the center of a room.
- Ensure a pull out strength of at least 60 kg per bolt for hanging bolts.
- Be sure to install the BC controller horizontally.
- Install the unit in a location where the noise from the BC controller will not directly be heard.
- Install the unit in a location where the noise from the unit will not be a problem. (Install indoor unit and BC controller at least 5 m away from each other when installed in a space with low background noise, e.g., hotel rooms). Sound pressure level is as follows.

Sound pressure level [dB] <A scale>

BC Controller model name	CMB-P104V-J	CMB-P106V-J	CMB-P108V-J	CMB-P1012V-J	CMB-P1016V-J	CMB-P108V-JA	CMB-P1012V-JA	CMB-P1016V-JA	CMB-P1016V-KA	CMB-P104V-KB
	Maximum value during normal operation or defrost operation									
(E)P200	49	53	55	49						
(E)P250	49	53	55	49						
(E)P300	49	53	55	49						
(E)P350	53	55	55	53						
(E)P400	-	56	55	-						
(E)P450	-	56	55	-						
(E)P500	-	56	55	-						
(E)P550	-	56	55	-						
(E)P600	-	56	55	-						
(E)P650	-	56	55	-						
(E)P700	-	56	55	-						
(E)P750	-	56	55	-						
(E)P800	-	56	55	-						
(E)P850	-	56	55	-						
(E)P900	-	56	55	-						
(E)P950	-	-	55	-						
(E)P1000	-	-	55	-						
(E)P1050	-	-	55	-						
(E)P1100	-	-	55	-						

\*1. The sound pressure level values were obtained in an anechoic room.

Actual sound pressure level is usually greater than that measured in an anechoic room due to the ambient noise and deflection sound.

\*2. The sound pressure level values were obtained at the location below 1.5 m from the unit.

\*3. The solenoid valve switching sound is 56 dB regardless of the unit model.

#### ⚠ Warning:

Be sure to install the unit in a place that can sustain the entire weight. If there is a lack of strength, it may cause the unit to fall down, resulting in an injury.

#### ⚠ Caution:

Be sure to install the unit horizontally.

### 2.3. Securing installation and service space

#### 1. For hanging from the ceiling

(This is a reference view showing the least installation space.)

[Fig. 2.3.1] (P.2)

- <A> Top view
- <B> Front view
- (A) Inspection hole
- (B) On the side of outdoor unit piping
- (C) Control box
- (D) On the side of indoor unit piping

\*1 Dimensions with which pipe connection can be handled at site

Model name	A	B	C	D
CMB-P104V-J	596	-	429	250
CMB-P106V-J				
CMB-P108V-J				
CMB-P1012V-J	1135	250	573	300
CMB-P1016V-J				
CMB-P108V-JA				
CMB-P1012V-JA	1135	250	573	300
CMB-P1016V-JA				
CMB-P1016V-KA	596	-	429	250
CMB-P104V-KB				

## 2.4. Checking the installation site

Check that the difference of elevation between indoor and outdoor units and the length of refrigerant piping are within the following limitations.

### 1. CMB-P104, 106, 108, 1012, 1016V-J (In the case the outdoor unit is 14-hp (P350 model) or below, and 16 or fewer ports are used.) CMB-P108, 1012, 1016V-JA, CMB-P1016V-KA (When no Sub BC controller is connected)

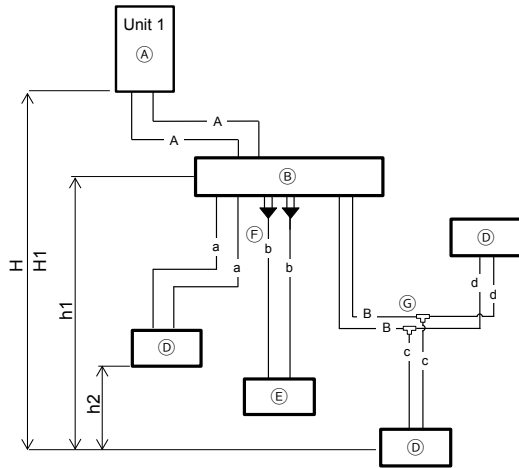

- (A) Outdoor unit (Heat source unit)
- (B) BC controller (Main)
- (C) BC controller (Sub)
- (D) Indoor unit (Total capacity of downstream indoor unit: 15 to 80)
- (E) Indoor unit (Total capacity of downstream indoor unit: 100 to 250)
- (F) Twinning pipe (Model name: CMY-R160-J1)
- (G) 2-Branch Joint Pipe

#### Notes:

- \*1 Refer to "Restrictions on piping length" on P. 3.
- \*2 Refer to the graph "Distance between main BC controller and farthest indoor unit (direct connection)". (However, when P200 or P250 model of indoor unit is connected, the maximum allowable distance between BC controller and farthest indoor unit is 40 m.)
- \*3 The values in the parentheses show the maximum piping length to be followed when the connection capacity of the indoor unit is 200 or above.
- \*4 In the system to which indoor units of the P200 model or above are connected, neither a branch joint nor a branch header may be used.
- \*5 Do not connect the P200 or P250 models of indoor units and other models of indoor units at the same port.
- \*6 In the system to which indoor units of the P100 through P140 models are connected, merge the two ports before connecting them. (Set DIP SW4-6 on the BC controller to ON.)
- \*7 It is possible to connect the P100 through P140 models of indoor units to a single port. (Set DIP SW4-6 to OFF.) Note that the cooling capacity will somewhat decrease. (The factory setting for DIP SW4-6 is OFF.) When connecting only PEFY-P50/63/71/80VMHS2-E units, set the dipswitches SW4-1 and SW4-6 on the BC controller to ON.
- \*8 Indoor units that are connected to the same branch joint cannot be simultaneously operated in different operation modes.
- \*9 When connecting PEFY-P50/63/71/80VMHS2-E units to two ports, use a Joint Pipe Kit CMY-R160-J1.

#### Distance between main BC controller and farthest indoor unit (direct connection)

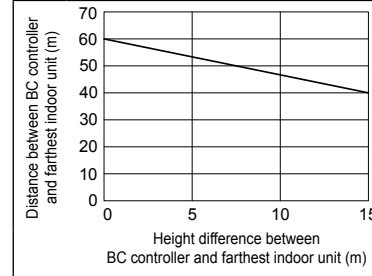

#### \*10 For connecting 15 to 50 model indoor units

Have pipe expansion of indoor unit connecting port by cutting the piping at the cutting point which depends on the indoor unit capacity.

(Unit: m)

Item		Piping portion	Allowable value	
Length	Total piping length	"A+B+a+b+c+d"	Not to exceed the maximum refrigerant piping length *1	
	Longest piping length	"A+B+c"	165 or less (Equivalent length of 190 or less)	
	Between outdoor (heat source) unit and BC controller	"A"	110 or less	
	Between indoor units and BC controller	"a" or "b" or "B+c" or "B+d"	60 or less *2	
Difference of height	Between indoor and outdoor (heat source) units	Above outdoor (heat source) unit	"H"	50 or less
		Below outdoor (heat source) unit	"H1"	40 or less
	Between indoor units and BC controller	"h1"	15 or less (10 or less *3)	
	Between indoor units	"h2"	30 or less (20 or less *3)	

2. CMB-P108, 1012, 1016V-JA, CMB-P1016V-KA (When a Sub BC controller is connected)

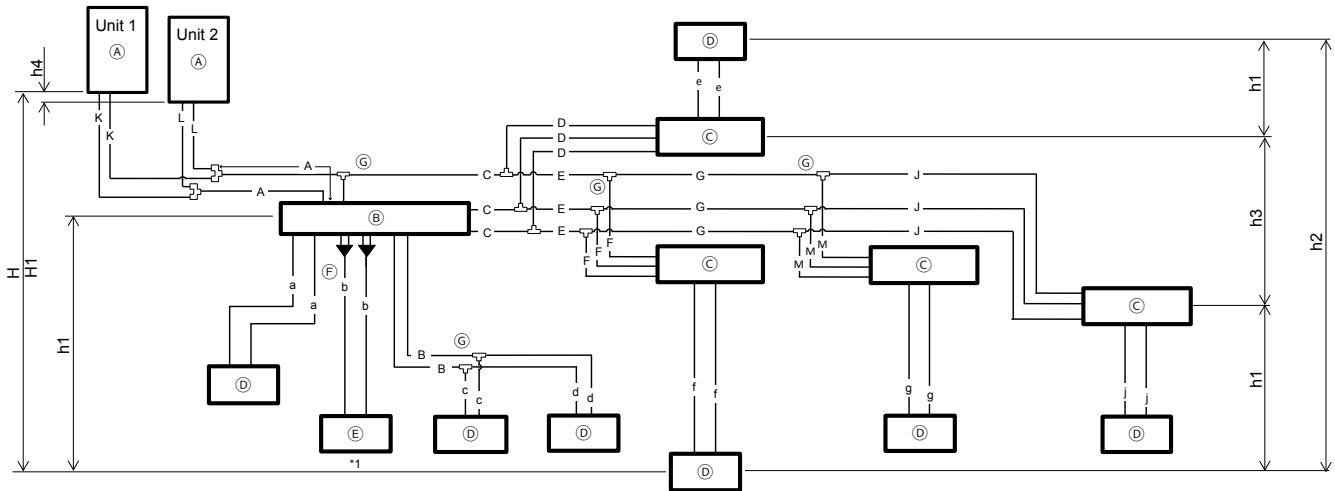

(Unit: m)

Item		Piping portion	Allowable value	
Length	Total piping length	"K+L+A+B+C +D+E+F+G+J +M+a+b+c+d +e+f+g+j"	Not to exceed the maximum refrigerant piping length *1	
	Longest piping length	"K(L)+A+C +E+G+J+j"	165 or less (Equivalent length of 190 or less)	
	Between outdoor (heat source) unit and Main BC controller	"K(L)+A"	110 or less	
	Direct connection between indoor units and (Main or Sub) BC controller	"a" or "b" or "B+c" or "B+d" or "e" or "f" or "g" or "j"	60 or less *2	
	Between indoor units and Main BC controller via Sub BC controller	"C+D+e" or "C+E+F+f" or "C+E+G+M+g" or "C+E+G+J+j"	90 or less *3	
Difference of height	Between indoor and outdoor (heat source) units	Above outdoor (heat source) unit	H	50 or less
		Below outdoor (heat source) unit	H1	40 or less
	Between BC controller (Both Main and Sub) and indoor unit	h1	15 or less (10 or less *4)	
	Between indoor units	h2	30 or less (20 or less *4)	
	Between BC controller (Both Main and Sub) and Sub BC controller	h3	15 or less	
	Between outdoor (heat source) units	h4	0.1 or less	

- (A) Outdoor unit (Heat source unit)
- (B) BC controller (Main)
- (C) BC controller (Sub)
- (D) Indoor unit (Total capacity of downstream indoor unit: 15 to 80)
- (E) Indoor unit (Total capacity of downstream indoor unit: 100 to 250)
- (F) Twinning pipe (Model name: CMY-R160-J1)
- (G) 2-Branch Joint Pipe

Notes:

- \*1 Refer to "Restrictions on piping length" on P. 3.
- \*2 Refer to Fig. 1. (However, when P200 or P250 model of indoor unit is connected, the maximum allowable distance between BC controller and farthest indoor unit is 40 m.)
- \*3 When the piping length or the height difference exceeds the restriction specified in Fig. 1, connect a sub BC controller to the system. The restriction for a system with a sub BC controller is shown in Fig. 2. When a given system configuration falls within the shaded area in Fig. 2, increase the size of the high-pressure pipe and the liquid pipe between the main and sub BC controller by one size. When using P32, P40, P50, P100, or P125 model of indoor units, increase the size of the liquid branch pipe between the sub BC controller and indoor unit by one size. When using P140 or larger model of indoor units, the restriction shown in Fig. 1 cannot be exceeded.
- \*4 The values in the parentheses show the maximum piping length to be followed when the connection capacity of the indoor unit is 200 or above.
- \*5 In the system to which indoor units of the P200 model or above are connected, neither a branch joint nor a branch header may be used.
- \*6 Do not connect the P200 or P250 models of indoor units and other models of indoor units at the same port.
- \*7 In the system to which indoor units of the P100 through P140 models are connected, merge the two ports before connecting them. (Set DIP SW4-6 on the BC controller to ON.)
- \*8 It is possible to connect the P100 through P140 models of indoor units to a single port. (Set DIP SW4-6 to OFF.) Note that the cooling capacity will somewhat decrease. (The factory setting for DIP SW4-6 is OFF.) When connecting only PEFY-P50/63/71/80VMHS2-E units, set the dipswitches SW4-1 and SW4-6 on the BC controller to ON.
- \*9 Indoor units that are connected to the same branch joint cannot be simultaneously operated in different operation modes.
- \*10 When connecting PEFY-P50/63/71/80VMHS2-E units to two ports, use a Joint Pipe Kit CMY-R160-J1.
- \*11 The maximum total capacity of indoor units that can be connected to each Sub BC controller is P350.
- \*12 Sub BC controller cannot be used at (B).
- \*13 For connecting 15 to 50 model indoor units  
Have pipe expansion of indoor unit connecting port by cutting the piping at the cutting point which depends on the indoor unit capacity.
- \*14 Up to 11 Sub BC controllers can be connected.

**Piping length and height between indoor unit and BC controller**

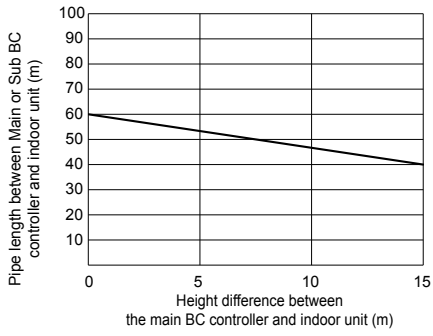

Fig. 1

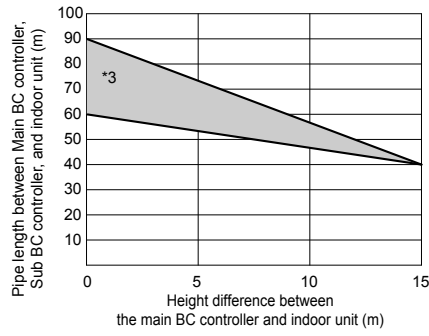
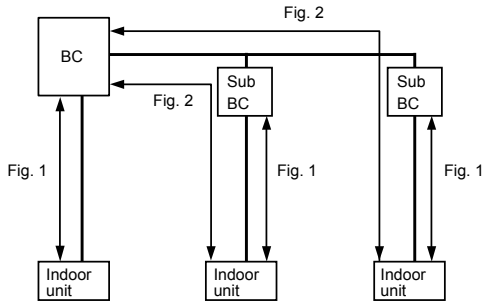

Fig. 2



**\*3** When the piping length or the height difference exceeds the restriction specified in Fig. 1, connect a sub BC controller to the system. The restriction for a system with a sub BC controller is shown in Fig. 2. When a given system configuration falls within the shaded area in Fig. 2, increase the size of the high-pressure pipe and the liquid pipe between the main and sub BC controller by one size. When using P32, P40, P50, P100, or P125 model of indoor units, increase the size of the liquid branch pipe between the sub BC controller and indoor unit by one size. When using P140 or larger model of indoor units, the restriction shown in Fig. 1 cannot be exceeded.

### 3. Installing BC controller

#### 3.1. Checking the accessories with BC controller

The following items are supplied with each BC controller.

	Item	Model name			
		CMB-P104V-J P106V-J P108V-J P1012V-J P1016V-J	CMB-P108V-JA P1012V-JA P1016V-JA	CMB-P1016V-KA	CMB-P104V-KB
		Qty			
①	Drain hose	1	1	1	1
②	Tie band	3	3	3	3
③	Washer for construction	2 kinds (4 each)	2 kinds (4 each)	2 kinds (4 each)	2 kinds (4 each)

#### 3.2. Installing BC controllers

##### Installing hanging bolts

Install locally procured hanging bolts (threaded rod) following the procedure given in the figure. The hanging bolt size is ø10 (M10 screw). To hang the unit, use a lifting machine to lift and pass it through the hanging bolts.

[Fig. 3.2.1] (P.4)

- Ⓐ Nut (not supplied)
- Ⓑ Double nut (not supplied)
- Ⓒ Hanging bolt ø10 (M10 screw) (not supplied)
- Ⓓ Washer (with cushion) (supplied)  
\* Attach the cushion facing down.
- Ⓔ Minimum 30 mm
- Ⓕ Washer (without cushion) (supplied)

- ▶ Be sure to install the BC controller horizontally, using a level. If the controller is installed at an angle, drain water may leak out. If the controller is slanted, loosen the fixing nuts on the hanging brackets to adjust its position.
- ▶ Provide a downward pitch of 1.5° or below to the BC controller.
- ▶ Do not place the BC controller directly on the floor because the drain pan needs to be installed in a tilted position.

[Fig. 3.2.2] (P.4)

- Ⓐ Within 1.5°
- Ⓑ Drain socket
- Ⓒ Viewed from the front of the control box

**Caution:**  
Be sure to install the unit horizontally.

### 4. Connecting refrigerant pipes and drain pipes

#### 4.1. Connecting refrigerant pipes

- Connect the liquid and gas pipes of each indoor unit to the same (correct) end connection numbers as indicated on the indoor unit connection section of each BC controller. If connected to wrong end connection numbers, there will be no normal operation.
- List indoor unit model names in the name plate on the BC controller control box (for identification purposes), and BC controller end connection numbers and address numbers in the name plate on the indoor unit side.
- If the number of ports is greater than the number of indoor units to be connected, use any ports.  
Seal unused end connections using cover caps just as they were capped when shipped from the factory. Not replacing on end cap will lead to refrigerant leak-age.
- When using CMY-Y102S-G2, CMY-Y102L-G2, CMY-Y202S-G2, CMY-R201S-G, CMY-R202S-G, CMY-R203S-G, CMY-R204S-G, or CMY-R205S-G, connect it horizontally.
- Be sure to have pipe expansion of indoor unit connecting port by cutting the piping at the cutting point which depends on the indoor unit capacity.
- Restriction on installing the 2-Branch Joint Pipe CMY-R101/102S-G on the low-pressure piping

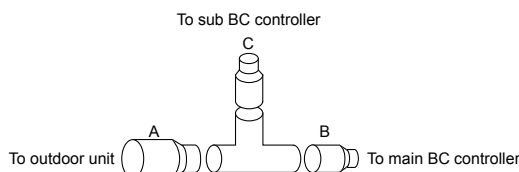

- Regarding the 2-Branch Joint Pipe on the low-pressure piping, A and B must be installed horizontally, and C must be installed upward higher than the horizontal plane of A and B.

- Restriction on installing the 2-Branch Joint Pipe CMY-R201/202/203/204/205S-G on the high-pressure piping, low-pressure piping, and liquid piping.

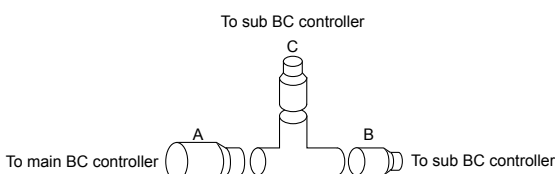

- Regarding the 2-Branch Joint Pipe on the high-pressure/low-pressure/liquid piping, A and B must be installed horizontally, and C must be installed upward higher than the horizontal plane of A and B.

##### Note:

Remove burr after cutting the piping to prevent entering the piping. Check that there is no crack at the pipe expansion part.

[Fig. 4.1.1] (P.4)

- Ⓐ Indoor unit connecting port
  - Ⓑ Cutting point : ø9.52 (Liquid side) or ø15.88 (Gas side)  
(Indoor unit model : above P50)
  - Ⓒ Cutting point : ø6.35 (Liquid side) or ø12.7 (Gas side)  
(Indoor unit model : P50 or below)
  - Ⓓ Cut the piping at the cutting point
  - Ⓔ Have pipe expansion of indoor unit connecting port
  - Ⓕ Field pipe
- Be sure to use non-oxidative brazing where necessary. If you do not use non-oxidative brazing, it may clog the pipes.  
While under a nitrogen purge, braze the indoor unit connecting port before brazing the outdoor unit connecting port of BC controller.  
When brazing the indoor unit connecting port, supply a nitrogen gas into the outdoor unit connecting port of BC controller.  
When brazing the outdoor unit connecting port of BC controller, supply a nitrogen gas into the pipe between the outdoor unit and BC controller.
  - After completing pipe connection, support the pipes to ensure that load is not imparted to the BC controller's end connections (particularly to the gas pipes of indoor units).

**Warning :**  
When installing and moving the unit, do not charge it with refrigerant other than the refrigerant (R410A) specified on the unit.  
- Mixing of a different refrigerant, air, etc. may cause the refrigerant cycle to malfunction and result in severe damage.

**Caution:**

- Use refrigerant piping made of phosphorus deoxidized copper and copper alloy seamless pipes and tubes. In addition, be sure that the inner and outer surfaces of the pipes are clean and free of hazardous sulphur, oxides, dust/dirt, shaving particles, oils, moisture, or any other contaminant.
  - R410A is a high-pressure refrigerant and can cause the existing piping to burst.
- Store the piping to be used during installation indoors and keep both ends of the piping sealed until just before brazing. (Store elbows and other joints in a plastic bag.)
  - If dust, dirt, or water enters the refrigerant cycle, deterioration of the oil and compressor failure may result.
- Apply a small amount of ester oil, ether oil, or alkyl benzene to flares. (for indoor unit)
  - Infiltration of a large amount of mineral oil may cause the refrigerant oil to deteriorate.
- Do not vent R410A into the atmosphere.

## 1. Size of BC controller's end connection piping

Available connection (✓ mark : available)						
Model name	(MAIN)BC CONTROLLER	CMB-P104V-J CMB-P106V-J CMB-P108V-J CMB-P1012V-J CMB-P1016V-J	CMB-P108V-JA CMB-P1012V-JA CMB-P1016V-JA	CMB-P1016V-KA	CMB-P108V-JA CMB-P1012V-JA CMB-P1016V-JA	CMB-P1016V-KA
	SUB BC CONTROLLER	No available	No available	No available	CMB-P104V-KB (Qty. 1 to 11)	CMB-P104V-KB (Qty. 1 to 11)
Outdoor unit Capacity	(E)P200 - 350	✓	✓	✓	✓	✓
	(E)P351 - 900		✓	✓	✓	✓
	(E)P901 - 1100			✓		✓

BC controller / Main BC controller			
Unit model	High pressure side*1	Low pressure side*1	
Outdoor (Heat source) unit side	PURY-(E)P200 PQRY-P200	ø15.88 (Brazing)	ø19.05 (Brazing)
	PURY-(E)P250 PQRY-P250	ø19.05 (Brazing)	ø22.2 (Brazing)
	PURY-(E)P300 PQRY-P300		
	PURY-(E)P350	ø22.2 (Brazing)	ø28.58 (Brazing)
	PQRY-P350		
	PURY-(E)P400 PQRY-P400		
	PURY-(E)P450 PQRY-P450	ø22.2*2 (Brazing)	ø34.93 (Brazing)
	PURY-(E)P550 PQRY-P550		
	PURY-(E)P600 PQRY-P600	ø28.58 (Brazing)	ø41.28 (Brazing)
	PURY-(E)P650		
	PURY-(E)P700 PQRY-P700		
	PURY-(E)P750 PQRY-P750		
	PURY-(E)P800 PQRY-P800		
	PURY-(E)P850 PQRY-P850		
	PURY-(E)P900 PQRY-P900		
	PURY-(E)P950		
PURY-(E)P1000	ø34.93 (Brazing)		
PURY-(E)P1050 PQRY-P1050			
PURY-(E)P1100			

Sub BC controller			
Total capacity of indoor units	High pressure (gas) side *2	Low pressure (gas) side *2	Liquid side *2
200 or less	ø15.88 (Brazing)	ø19.05 (Brazing)	ø9.52 (Brazing)
201 - 300	ø19.05 (Brazing)	ø22.2 (Brazing)	
301 - 350		ø22.2 (Brazing)	ø28.58 (Brazing)
351 - 400			
401 - 600			
601 - 650	ø28.58 (Brazing)	ø34.93 (Brazing)	ø15.88 (Brazing)
651 - 800			
801 - 1000			
1001 -	ø34.93 (Brazing)	ø41.28 (Brazing)	ø19.05 (Brazing)

\*1. The maximum total capacity of indoor units that can be connected to each Sub BC controller is P350.

\*2. Use separately sold parts if the pipe diameter is not appropriate.

- \*1. Use separately sold parts if the pipe diameter is not appropriate.  
 \*2. If the length of high-pressure pipe A exceeds 65 m (213 ft), use the ø28.58 (ø1-1/8) pipes for all pipes after 65 m (213 ft).

### [Fig. 4.1.2] (P.5)

- Ⓐ To outdoor unit (Main BC controller)
- Ⓑ End connection (brazing)
- Ⓒ BC controller (Main BC controller / Sub BC controller)
- Ⓓ Indoor unit
- Ⓔ P50 or below
- Ⓕ Combined piping kit (Model name: CMY-R160-J1)
- Ⓖ Twinning pipe (Model name: CMY-Y102SS-G2, CMY-Y102LS-G2)
- Ⓗ Up to three units for 1 branch hole; total capacity: 80 or below (but same in cooling/heating mode)

The size of BC controller's branch piping is for 63 to 140 type indoor units. Therefore, if you want to connect indoor units other than the above, connect piping following the procedures below.

#### \*1. For connecting 15 to 50 model indoor units

Have pipe expansion of indoor unit connecting port by cutting the piping at the cutting point which depends on the indoor unit capacity.

#### Note:

Remove burr after cutting the piping to prevent entering the piping.  
 Check that there is no crack at the pipe expansion part.

#### \*2. To connect a unit with a capacity of 81 or above.

After combining two branches using an optionally available piping kit (CMY-R160-J1), connect indoor units.

#### \*3. Connection of plural indoor units with one connection (or joint pipe)

- Total capacity of connectable indoor units: 80 or below (250 or below with joint pipe)
- Number of connectable indoor units: Maximum 3 Sets
- Twinning pipe: Use the twinning pipe for CITY MULTI Y Series (CMY-Y102SS-G2, CMY-Y102LS-G2)
- Selection of refrigerant piping  
 Select the size according to the total capacity of indoor units to be installed downstream.

Total capacity of indoor units	Liquid line	Gas line
140 or below	ø9.52	ø15.88
141 to 200		ø19.05
201 to 250		ø22.2

#### Note:

Be sure to use non-oxidative brazing.

## 4.2. Refrigerant piping work

After connecting the refrigerant pipes of all indoor and outdoor units with the outdoor units' stop valves remained fully closed, evacuate vacuum from the outdoor units' stop valve service ports.

After completing the above, open the outdoor units' stop valves. This connects the refrigerant circuit (between outdoor and BC controller) completely. How to handle stop valves is described on each outdoor unit.

### Notes:

- After pipe connection, be sure to check that there is no gas leakage, using a leak detector or soap-and-water solution.
- Before brazing the refrigerant piping, always wrap the piping on the main body, and the thermal insulation piping, with damp cloths to prevent heat shrinkage and burning the thermal insulation tubing. Take care to ensure that the flame does not come into contact with the main body itself.
- Do not use leak-detection additives.

### ⚠ Warning:

Do not mix anything other than the specified refrigerant (R410A) into the refrigerating cycle when installing or moving. Mixing air may cause the refrigerating cycle to reach abnormally high temperature, resulting in burst pipes.

### ⚠ Caution:

Cut the tip of the outdoor unit piping, remove the gas, and then remove the brazed cap.

#### [Fig. 4.2.1] (P.5)

- Ⓐ Cut here
- Ⓑ Remove brazed cap

## 4.3. Insulating refrigerant pipes

Be sure to add insulation work to refrigerant piping by covering high-pressure pipe and low-pressure pipe separately with enough thickness heat-resistant polyethylene, so that no gap is observed in the joint between indoor unit and insulating material, and insulating materials themselves. When insulation work is insufficient, there is a possibility of condensation drip, etc. Pay special attention to insulation work in the ceiling plenum.

#### [Fig. 4.3.1] (P.5)

- Ⓐ Insulating material for pipes (not supplied)
- Ⓑ Bind here using band or tape.
- Ⓒ Do not leave any opening.
- Ⓓ Lap margin: more than 40 mm
- Ⓔ Insulating material (not supplied)
- Ⓕ Unit side insulating material
- Ⓖ Minimum 30 mm

- Insulation materials for the pipes to be added on site must meet the following specifications:

Outdoor unit	High-pressure pipe: 10 mm or more
-BC controller	Low-pressure pipe: 20 mm or more
BC controller	Pipe size 6.35 to 25.4 mm: 10 mm or more
-indoor unit	Pipe size 28.58 to 41.28 mm: 15 mm or more
Temperature resistance	100°C or above

- Installation of pipes in a high-temperature high-humidity environment, such as the top floor of a building, may require the use of insulation materials thicker than the ones specified in the chart above.
- When certain specifications presented by the client must be met, ensure that they also meet the specifications on the chart above.
- The brazed connections must be covered with the insulations, its cutting surface upward and fastened with the bands.
- Insulate the pipe that protrudes from the BC controller if the pipe is not going to be connected to other pipes.

#### [Fig. 4.3.2] (P.5)

- Ⓐ Insulating material (not supplied)
- Ⓑ Bind here using band or tape.

## 4.4. Drain piping work

### 1. Drain piping work

- Tilt the drain pan so that the water will flow toward the drain socket.

#### [Fig. 4.4.1] (P.5)

- ① Unscrew the two screws that are holding the side panel on the right side of the control box.
- ② Tilt the drain pan.
- ③ Screw down the screws with the drain pan tilted.

- Ensure that the drain piping is downward (pitch of more than 1/100) to the outdoor (discharge) side. Do not provide any trap or irregularity on the way.
- Ensure that any cross-wise drain piping is less than 20 m (excluding the difference of elevation). If the drain piping is long, provide metal braces to prevent it from waving. Never provide any air vent pipe. Otherwise drain may be ejected.
- Use a hard vinyl chloride pipe VP-25 (with an external diameter of 32 mm) for drain piping.
- Ensure that collected pipes are 10 cm lower than the unit body's drain port.
- Do not provide any odor trap at the drain discharge port.
- Put the end of the drain piping in a position where no odor is generated.
- Do not put the end of the drain piping in any drain where ionic gases are generated.

#### [Fig. 4.4.2] (P.6)

- Correct piping
- × Wrong piping
- Ⓐ Insulation (9 mm or more)
- Ⓑ Downward slope (1/100 or more)
- Ⓒ Support metal
- Ⓚ Air bleeder
- Ⓛ Raised
- Ⓜ Odor trap
- Grouped piping
- Ⓧ O.D. ø32 PVC TUBE
- Ⓨ Make it as large as possible. About 10 cm.
- Ⓩ Indoor unit
- ⓓ Make the piping size large for grouped piping.
- ⓔ Downward slope (1/100 or more)
- ⓕ O.D. ø38 PVC TUBE for grouped piping. (9 mm or more insulation)
- ⓖ BC controller

1. Insert the drain hose (accessory) into the drain port (insertion margin: 32 mm). (The drain hose must not be bent more than 45° to prevent the hose from breaking or clogging.) (Attach the hose with glue, and fix it with the band (small, supplied).)
2. Attach the drain pipe (O.D. ø32 PVC TUBE PV-25, not supplied). (Attach the pipe with glue, and fix it with the band (small, supplied).)
3. Perform insulation work on the drain pipe (O.D. ø32 PVC TUBE PV-25) and on the socket (including elbow).
4. Check the drainage.
5. Attach the insulating material, and fix it with the band (large, supplied) to insulate the drain port.

#### [Fig. 4.4.3] (P.6)

- Ⓐ BC controller
- Ⓑ Tie band (supplied)
- Ⓒ Visible part
- Ⓓ Insertion margin
- Ⓔ Drain hose (supplied)
- Ⓕ Drain pipe (O.D. ø32 PVC TUBE, not supplied)
- Ⓖ Insulating material (not supplied)
- Ⓗ Tie band (supplied)

### 2. Discharge test

After completing drain piping work, open the BC controller panel, and test drain discharge using a small amount of water. Also, check to see that there is no water leakage from the connections.

### 3. Insulating drain pipes

Provide sufficient insulation to the drain pipes just as for refrigerant pipes.

### ⚠ Caution:

Be sure to provide drain piping with heat insulation in order to prevent excess condensation. Without drain piping, water may leak from the unit causing damage to your property.

## 5. Electrical work

- ▶ Consult all related regulations and power companies beforehand.

### Warning:

Electrical work should be handled by qualified electrical engineers in accordance with all related regulations and attached instruction manuals. Special circuits should also be used. If there is a lack of power capacity or a deficiency in electrical work, it may cause a risk of electric shock or fire.

#### ▶ Connect all wires securely.

- Fix power source wiring to control box by using buffer bushing for tensile force (PG connection or the like).

#### [Fig. 5.0.1] (P.6)

- (A) Control box
- (B) Power source wiring
- (C)  $\varnothing 21$  hole (closed rubber bushing)
- (D) Transmission wiring

- ▶ Never connect the power cable to the terminal board for control cables. (Otherwise it may be broken.)

- ▶ Be sure to wire between the control wire terminal boards for indoor unit, outdoor unit and BC controller.

Use non-polarized 2-wire as transmission cables.

Use 2-core shielding cables (CVVS, CPEVS) of more than 1.25 mm<sup>2</sup> in diameter as transmission cables.

The switch capacity of the main power to BC controllers and the wire size are as follows:

## 6. Setting addresses and operating units

The address switch of each BC controller is set to "000" when shipped from the factory.

- Set the address switch to 1 + the address of the outdoor (heat source) unit.

## 7. Test run

**Before commencing a test run please check the following:**

- ▶ After installing, piping and wiring the indoor units and BC controllers, check to see again that there is no refrigerant leakage and no slack on power and control cables.
- ▶ Use a 500 V megger to check that there is an insulation resistance of more than 1.0 M $\Omega$  between the power terminal block and the ground. If it is less than 1.0 M $\Omega$ , do not operate the unit.

Switch (A)		Molded case circuit breaker	Earth leakage breaker	Wire size
Capacity	Fuse			
16	16	20 A	20 A 30 mA 0.1 s or less	1.5 mm <sup>2</sup>

- For other detailed information, refer to the outdoor unit installation manual.
- Power supply cords of appliances shall not be lighter than design 245 IEC 53 or 227 IEC 53.
- A switch with at least 3 mm contact separation in each pole shall be provided by the Air conditioner installation.

### Caution:

Do not use anything other than the correct capacity fuse and breaker. Using fuse, conductor or copper wire with too large capacity may cause a risk of malfunction or fire.

Ensure that the outdoor units are put to the ground. Do not connect the earth cable to any gas pipe, water pipe, lightning rod or telephone earth cable. Incomplete grounding may cause a risk of electric shock.

- ▶ The BC controller address should generally be set to 1 + the address of the outdoor (heat source) unit. However, if this would result in it having the same address as another outdoor unit, set the address between 51 and 100, making sure that it is different from the address of other BC controllers.
- Please refer to the outdoor (heat source) unit installation manual.

### Caution:

Never measure the insulation resistance of the terminal block for any control cables.