

Air-cooled Chilling Unit

**e-series**

**DATA BOOK**

MODEL

**EAHV-P1500YBL(-H)(-N)(-BS)**

**EAHV-P1800YBL(-H)(-N)(-BS)**

**EACV-P1500YBL(-N)(-BS)**

**EACV-P1800YBL(-N)(-BS)**

# CONTENTS

---

## EAHV-P-YBL(-H)(-N), EACV-P-YBL(-N)

1. Product Specifications .....	2
1-1. Specifications.....	2
1-2. External Dimensions.....	8
1-3. Center of Gravity.....	15
1-4. Electrical Wiring Diagrams.....	16
1-5. Optional parts .....	21
2. Product Data .....	26
2-1. Capacity tables .....	26
2-2. Sound pressure levels .....	47
2-3. Vibration levels .....	50
2-4. Salt Protection Specifications .....	51
3. Installation.....	52
3-1. Selecting the Installation Site.....	52
3-2. Unit Installation .....	55
4. System Design.....	57
4-1. Water Pipe Installation .....	57
5. Wiring Design.....	64
5-1. System Configurations.....	64
5-2. Electrical Wiring Installation .....	88
6. Controller .....	91
6-1. PAR-W31MAA specifications .....	91

# 1. Product Specifications

## 1-1. Specifications

Model		EAHV-P1500YBL(-N)(-BS)	
Power source		3-phase 4-wire 380-400-415V 50/60Hz	
Cooling capacity *1		kW	150.00
		kcal/h	129,000
		BTU/h	511,800
	Power input	kW	45.10
	EER		3.33
	IPLV *6		6.55
Cooling capacity(EN14511) *2	Water flow rate	m <sup>3</sup> /h	25.8
		kW	148.58
		kcal/h	127,779
		BTU/h	506,955
	Power input	kW	46.52
	EER		3.19
	Eurovent efficiency class		A
	ESEER *7		4.74
Heating capacity *3	SEER		4.62
	Water flow rate	m <sup>3</sup> /h	25.8
		kW	150.00
		kcal/h	129,000
		BTU/h	511,800
	Power input	kW	44.59
Heating capacity(EN14511) *4	COP		3.36
	Water flow rate	m <sup>3</sup> /h	25.8
		kW	151.42
		kcal/h	130,221
		BTU/h	516,645
	Power input	kW	46.01
Current input	COP		3.29
	Eurovent efficiency class		A
	SCOP (Reversible) Low/Medium		3.24/2.85
	Water flow rate	m <sup>3</sup> /h	25.8
Water pressure drop *1	Cooling current 380-400-415V *1	A	77-73-70
	Heating current 380-400-415V *3	A	76-72-69
	Maximum current	A	111
		kPa	114
Temp range	Cooling	°C	Outlet water 5~30 *8
		°F	Outlet water 41~86 *8
	Heating	°C	Outlet water 30~55 *8
		°F	Outlet water 86~131 *8
	Outdoor	°C	-15~43 *8
		°F	5~109.4 *8
Circulating water volume range		m <sup>3</sup> /h	12.9~34.0
Sound pressure level (measured in anechoic room) at 1m *1		dB (A)	66
Sound power level (measured in anechoic room) *1		dB (A)	84
Diameter of water pipe (Standard piping)	Inlet	mm (in)	65A (2 1/2B) housing type joint
	Outlet	mm (in)	65A (2 1/2B) housing type joint
Diameter of water pipe (Inside header piping)	Inlet	mm (in)	150A (6B) housing type joint
	Outlet	mm (in)	150A (6B) housing type joint
External finish		Polyester powder coating steel plate	
External dimension H × W × D		mm	2350 × 3400 × 1080
Net weight	Standard piping	kg (lbs)	1310 (2888)
	Inside header piping	kg (lbs)	1326 (2923)
Design pressure	R410A	MPa	4.15
	Water	MPa	1.0
Heat exchanger	Water side	Stainless steel plate and copper brazing	
	Air side	Plate fin and copper tube	
Compressor	Type	Inverter scroll hermetic compressor	
	Maker	MITSUBISHI ELECTRIC CORPORATION	
	Starting method	Inverter	
	Quantity	4	
	Motor output	kW	11.7 × 4
	Lubricant	MEL32	
Fan	Air flow rate	m <sup>3</sup> /min	265 × 4
		L/s	4417 × 4
		cfm	9357 × 4
	Type, Quantity	Propeller fan × 4	
	Starting method	Inverter	
	Motor output	kW	0.92 × 4
Protection	High pressure protection	High pres.Sensor & High pres.Switch at 4.15MPa (601psi)	
	Inverter circuit	Over-heat protection, Over current protection	
	Compressor	Over-heat protection	
Refrigerant	Type × charge	R410A × 15(kg) × 4 *5	
	Control	LEV	

Notes:	Unit converter
*1 Under normal cooling conditions at outdoor temp 35°CDB/24°CWB(95°FDB/75.2°FWB) outlet water temp 7°C(44.6°F) inlet water temp 12°C(53.6°F). Pump input is not included in cooling capacity and power input.	kcal/h = kW × 860
*2 Under normal cooling conditions at outdoor temp 35°CDB/24°CWB(95°FDB/75.2°FWB) outlet water temp 7°C(44.6°F) inlet water temp 12°C(53.6°F). Pump input is included in cooling capacity and power input based on EN14511.	BTU/h = kW × 3,412
*3 Under normal heating conditions at outdoor temp 7°CDB/6°CWB(44.6°FDB/42.8°FWB) outlet water temp 45°C(113°F) inlet water temp 40°C(104°F). Pump input is not included in heating capacity and power input.	lbs = kg/0.4536
*4 Under normal heating conditions at outdoor temp 7°CDB/6°CWB(44.6°FDB/42.8°FWB) outlet water temp 45°C(113°F) inlet water temp 40°C(104°F). Pump input is included in heating capacity and power input based on EN14511.	cfm = m <sup>3</sup> /min × 35.31
*5 Amount of factory-charged refrigerant is 3(kg) × 4. Please add the refrigerant at the field.	
*6 IPLV is calculated in accordance with AHRI 550-590.	
*7 ESEER is calculated in accordance with EUROVENT conditions.	
*Please don't use the steel material for the water piping.	
*Please always make water circulate, or pull the circulation water out completely when not in use.	
*Please do not use groundwater or well water in direct.	
*The water circuit must be closed circuit.	
*Due to continuous improvement, the above specifications may be subject to change without notice.	
*This model doesn't equip with a pump.	
*8 Please refer to 2-1-6. Operation temperature range.	

EAHV-P-YBL(-H)(-N), EACV-P-YBL(-N)

# 1. Product Specifications

Model		EAHV-P1800YBL(-N)(-BS)	
Power source		3-phase 4-wire 380-400-415V 50/60Hz	
Cooling capacity *1		kW	180.00
		kcal/h	154,800
		BTU/h	614,160
	Power input	kW	59.01
	EER		3.05
	IPLV *6		6.33
Cooling capacity(EN14511) *2	Water flow rate	m <sup>3</sup> /h	31.0
		kW	177.76
		kcal/h	152,874
		BTU/h	606,517
	Power input	kW	61.25
	EER		2.90
Heating capacity *3	Eurovent efficiency class		B
	ESEER *7		4.45
	SEER		4.58
	Water flow rate	m <sup>3</sup> /h	31.0
		kW	180.00
		kcal/h	154,800
Heating capacity(EN14511) *4		BTU/h	614,160
	Power input	kW	55.68
	COP		3.23
	Water flow rate	m <sup>3</sup> /h	31.0
		kW	182.24
		kcal/h	156,726
Current input		BTU/h	621,803
	Power input	kW	57.92
	COP		3.15
	Eurovent efficiency class		B
Water pressure drop *1	SCOP (Reversible) Low/Medium		3.24/2.85
	Water flow rate	m <sup>3</sup> /h	31.0
	Cooling current 380-400-415V *1	A	77-73-70
	Heating current 380-400-415V *3	A	76-72-69
Temp range	Maximum current	A	111
	Cooling	°C	Outlet water 5~30 *8
		°F	Outlet water 41~86 *8
	Heating	°C	Outlet water 30~55 *8
		°F	Outlet water 86~131 *8
	Outdoor	°C	-15~43 *8
Circulating water volume range		°F	5~109.4 *8
		m <sup>3</sup> /h	12.9~34.0
Sound pressure level (measured in anechoic room) at 1m *1		dB (A)	68
Sound power level (measured in anechoic room) *1		dB (A)	86
Diameter of water pipe (Standard piping)	Inlet	mm (in)	65A (2 1/2B) housing type joint
	Outlet	mm (in)	65A (2 1/2B) housing type joint
Diameter of water pipe (Inside header piping)	Inlet	mm (in)	150A (6B) housing type joint
	Outlet	mm (in)	150A (6B) housing type joint
External finish			Polyester powder coating steel plate
External dimension H × W × D		mm	2350 × 3400 × 1080
Net weight	Standard piping	kg (lbs)	1310 (2888)
	Inside header piping	kg (lbs)	1326 (2923)
Design pressure	R410A	MPa	4.15
	Water	MPa	1.0
Heat exchanger	Water side		Stainless steel plate and copper brazing
	Air side		Plate fin and copper tube
Compressor	Type		Inverter scroll hermetic compressor
	Maker		MITSUBISHI ELECTRIC CORPORATION
	Starting method		Inverter
	Quantity		4
	Motor output	kW	11.7 × 4
	Lubricant		MEL32
Fan	Air flow rate	m <sup>3</sup> /min	265 × 4
		L/s	4417 × 4
		cfm	9357 × 4
	Type, Quantity		Propeller fan × 4
	Starting method		Inverter
	Motor output	kW	0.92 × 4
Protection	High pressure protection		High pres.Sensor & High pres.Switch at 4.15MPa (601psi)
	Inverter circuit		Over-heat protection, Over current protection
	Compressor		Over-heat protection
Refrigerant	Type × charge		R410A × 15(kg) × 4 *5
	Control		LEV

## Notes:

- \*1 Under normal cooling conditions at outdoor temp 35°CDB/24°CWB(95°FDB/75.2°FWB) outlet water temp 7°C(44.6°F) inlet water temp 12°C(53.6°F). Pump input is not included in cooling capacity and power input.
- \*2 Under normal cooling conditions at outdoor temp 35°CDB/24°CWB(95°FDB/75.2°FWB) outlet water temp 7°C(44.6°F) inlet water temp 12°C(53.6°F). Pump input is included in cooling capacity and power input based on EN14511.
- \*3 Under normal heating conditions at outdoor temp 7°CDB/6°CWB(44.6°FDB/42.8°FWB) outlet water temp 45°C(113°F) inlet water temp 40°C(104°F). Pump input is not included in heating capacity and power input.
- \*4 Under normal heating conditions at outdoor temp 7°CDB/6°CWB(44.6°FDB/42.8°FWB) outlet water temp 45°C(113°F) inlet water temp 40°C(104°F). Pump input is included in heating capacity and power input based on EN14511.
- \*5 Amount of factory-charged refrigerant is 3(kg) × 4. Please add the refrigerant at the field.
- \*6 IPLV is calculated in accordance with AHR1 550-590.
- \*7 ESEER is calculated in accordance with EUROVENT conditions.
- \*Please don't use the steel material for the water piping.
- \*Please always make water circulate, or pull the circulation water out completely when not in use.
- \*Please do not use groundwater or well water in direct.
- \*The water circuit must be closed circuit.
- \*Due to continuous improvement, the above specifications may be subject to change without notice.
- \*This model doesn't equip with a pump.
- \*8 Please refer to 2-1-6. Operation temperature range.

Unit converter	
kcal/h	= kW × 860
BTU/h	= kW × 3,412
lbs	= kg/0.4536
cfm	= m <sup>3</sup> /min × 35.31



# 1. Product Specifications

EAHV-P-YBL(-H)(-N), EACV-P-YBL(-N)

Model		EAHV-P1500YBL-H(-N)(-BS)	
Power source		3-phase 4-wire 380-400-415V 50/60Hz	
Heating capacity *1		kW	150.00
		kcal/h	129,000
		BTU/h	511,800
	Power input	kW	44.59
	COP		3.36
Heating capacity(EN14511) *2		kW	151.42
		kcal/h	130,221
		BTU/h	516,645
	Power input	kW	46.01
	COP		3.29
	Eurovent efficiency class		A
	SCOP (Heating only) Low/Medium		3.20/2.83
Water flow rate		m <sup>3</sup> /h	25.8
Current input	Heating current 380-400-415V *1	A	76-72-69
	Maximum current	A	111
Water pressure drop *1		kPa	114
Temp range	Heating	°C	Outlet water 30~55 *4
		°F	Outlet water 86~131 *4
	Outdoor	°C	-15~43 *4
		°F	5~109.4 *4
Circulating water volume range		m <sup>3</sup> /h	12.9~34.0
Sound pressure level (measured in anechoic room) at 1m *1		dB (A)	66
Sound power level (measured in anechoic room) *1		dB (A)	84
Diameter of water pipe (Standard piping)	Inlet	mm (in)	65A (2 1/2B) housing type joint
	Outlet	mm (in)	65A (2 1/2B) housing type joint
Diameter of water pipe (Inside header piping)	Inlet	mm (in)	150A (6B) housing type joint
	Outlet	mm (in)	150A (6B) housing type joint
External finish		Polyester powder coating steel plate	
External dimension H × W × D		mm	2350 × 3400 × 1080
Net weight	Standard piping	kg (lbs)	1310 (2888)
	Inside header piping	kg (lbs)	1326 (2923)
Design pressure	R410A	MPa	4.15
	Water	MPa	1.0
Heat exchanger	Water side	Stainless steel plate and copper brazing	
	Air side	Plate fin and copper tube	
Compressor	Type	Inverter scroll hermetic compressor	
	Maker	MITSUBISHI ELECTRIC CORPORATION	
	Starting method	Inverter	
	Quantity	4	
	Motor output	kW	11.7 × 4
	Lubricant	MEL32	
Fan	Air flow rate	m <sup>3</sup> /min	265 × 4
		L/s	4417 × 4
		cfm	9357 × 4
	Type, Quantity	Propeller fan × 4	
	Starting method	Inverter	
	Motor output	kW	0.92 × 4
Protection	High pressure protection	High pres. Sensor & High pres. Switch at 4.15MPa (601psi)	
	Inverter circuit	Over-heat protection, Over current protection	
	Compressor	Over-heat protection	
Refrigerant	Type × charge	R410A × 15(kg) × 4 *3	
	Control	LEV	

Notes:	Unit converter
*1 Under normal heating conditions at outdoor temp 7°CDB/6°CWB(44.6°FDB/42.8°FWB) outlet water temp 45°C(113°F) inlet water temp 40°C(104°F). Pump input is not included in heating capacity and power input.	kcal/h = kW × 860
*2 Under normal heating conditions at outdoor temp 7°CDB/6°CWB(44.6°FDB/42.8°FWB) outlet water temp 45°C(113°F) inlet water temp 40°C(104°F). Pump input is included in heating capacity and power input based on EN14511.	BTU/h = kW × 3,412
*3 Amount of factory-charged refrigerant is 3(kg) × 4. Please add the refrigerant at the field.	lbs = kg/0.4536
*Please don't use the steel material for the water piping.	cfm = m <sup>3</sup> /min × 35.31
*Please always make water circulate, or pull the circulation water out completely when not in use.	
*Please do not use groundwater or well water in direct.	
*The water circuit must be closed circuit.	
*Due to continuous improvement, the above specifications may be subject to change without notice.	
*This model doesn't equip with a pump.	
*4 Please refer to 2-1-6. Operation temperature range.	

# 1. Product Specifications

Model			EAHV-P1800YBL-H(-N)(-BS)
Power source			3-phase 4-wire 380-400-415V 50/60Hz
Heating capacity *1		kW	180.00
		kcal/h	154,800
		BTU/h	614,160
	Power input	kW	55.68
	COP		3.23
	Water flow rate	m <sup>3</sup> /h	31.0
Heating capacity(EN14511) *2		kW	182.24
		kcal/h	156,726
		BTU/h	621,803
	Power input	kW	57.92
	COP		3.15
	Eurovent efficiency class		B
	SCOP (Heating only) Low/Medium		3.20/2.83
	Water flow rate	m <sup>3</sup> /h	31.0
Current input	Heating current 380-400-415V *1	A	76-72-69
	Maximum current	A	111
Water pressure drop *1		kPa	164
Temp range	Heating	°C	Outlet water 30~55 *4
		°F	Outlet water 86~131 *4
	Outdoor	°C	-15~43 *4
		°F	5~109.4 *4
Circulating water volume range		m <sup>3</sup> /h	12.9~34.0
Sound pressure level (measured in anechoic room) at 1m *1		dB (A)	68
Sound power level (measured in anechoic room) *1		dB (A)	86
Diameter of water pipe (Standard piping)	Inlet	mm (in)	65A (2 1/2B) housing type joint
	Outlet	mm (in)	65A (2 1/2B) housing type joint
Diameter of water pipe (Inside header piping)	Inlet	mm (in)	150A (6B) housing type joint
	Outlet	mm (in)	150A (6B) housing type joint
External finish			Polyester powder coating steel plate
External dimension H × W × D		mm	2350 × 3400 × 1080
Net weight	Standard piping	kg (lbs)	1310 (2888)
	Inside header piping	kg (lbs)	1326 (2923)
Design pressure	R410A	MPa	4.15
	Water	MPa	1.0
Heat exchanger	Water side		Stainless steel plate and copper brazing
	Air side		Plate fin and copper tube
Compressor	Type		Inverter scroll hermetic compressor
	Maker		MITSUBISHI ELECTRIC CORPORATION
	Starting method		Inverter
	Quantity		4
	Motor output	kW	11.7 × 4
	Lubricant		MEL32
Fan	Air flow rate	m <sup>3</sup> /min	265 × 4
		L/s	4417 × 4
		cfm	9357 × 4
	Type, Quantity		Propeller fan × 4
	Starting method		Inverter
	Motor output	kW	0.92 × 4
Protection	High pressure protection		High pres.Sensor & High pres.Switch at 4.15MPa (601psi)
	Inverter circuit		Over-heat protection, Over current protection
	Compressor		Over-heat protection
Refrigerant	Type × charge		R410A × 15(kg) × 4 *3
	Control		LEV

Notes:	Unit converter
*1 Under normal heating conditions at outdoor temp 7°CDB/6°CWB(44.6°FDB/42.8°FWB) outlet water temp 45°C(113°F) inlet water temp 40°C(104°F). Pump input is not included in heating capacity and power input.	kcal/h = kW × 860
*2 Under normal heating conditions at outdoor temp 7°CDB/6°CWB(44.6°FDB/42.8°FWB) outlet water temp 45°C(113°F) inlet water temp 40°C(104°F). Pump input is included in heating capacity and power input based on EN14511.	BTU/h = kW × 3,412
*3 Amount of factory-charged refrigerant is 3(kg) × 4. Please add the refrigerant at the field.	lbs = kg/0.4536
*Please don't use the steel material for the water piping.	cfm = m <sup>3</sup> /min × 35.31
*Please always make water circulate, or pull the circulation water out completely when not in use.	
*Please do not use groundwater or well water in direct.	
*The water circuit must be closed circuit.	
*Due to continuous improvement, the above specifications may be subject to change without notice.	
*This model doesn't equip with a pump.	
*4 Please refer to 2-1-6. Operation temperature range.	

# 1. Product Specifications

EAHV-P-YBL(-H)(-N), EACV-P-YBL(-N)

Model		EACV-P1500YBL(-N)(-BS)		
Power source		3-phase 4-wire 380-400-415V 50/60Hz		
Cooling capacity *1	kW	150.00		
		kcal/h		129,000
		BTU/h		511,800
	Power input	kW	45.10	
	EER		3.33	
	IPLV *4		6.55	
	Water flow rate	m <sup>3</sup> /h	25.8	
Cooling capacity(EN14511) *2	kW	148.58		
		kcal/h		127,779
		BTU/h		506,955
	Power input	kW	46.52	
	EER		3.19	
	Eurovent efficiency class		A	
	ESEER *5		4.74	
	SEER		4.62	
Water flow rate	m <sup>3</sup> /h	25.8		
Current input	Cooling current 380-400-415V *1	A	77-73-70	
	Maximum current	A	111	
Water pressure drop *1		kPa	114	
Temp range	Cooling	°C	Outlet water 5~30 *6	
		°F	Outlet water 41~86 *6	
	Outdoor	°C	-15~43 *6	
		°F	5~109.4 *6	
Circulating water volume range		m <sup>3</sup> /h	12.9~34.0	
Sound pressure level (measured in anechoic room) at 1m *1		dB (A)	66	
Sound power level (measured in anechoic room) *1		dB (A)	84	
Diameter of water pipe (Standard piping)	Inlet	mm (in)	65A (2 1/2B) housing type joint	
	Outlet	mm (in)	65A (2 1/2B) housing type joint	
Diameter of water pipe (Inside header piping)	Inlet	mm (in)	150A (6B) housing type joint	
	Outlet	mm (in)	150A (6B) housing type joint	
External finish		Polyester powder coating steel plate		
External dimension H × W × D		mm	2350 × 3400 × 1080	
Net weight	Standard piping	kg (lbs)	1240 (2734)	
	Inside header piping	kg (lbs)	1256 (2769)	
Design pressure	R410A	MPa	4.15	
	Water	MPa	1.0	
Heat exchanger	Water side	Stainless steel plate and copper brazing		
	Air side	Plate fin and copper tube		
Compressor	Type	Inverter scroll hermetic compressor		
	Maker	MITSUBISHI ELECTRIC CORPORATION		
	Starting method	Inverter		
	Quantity	4		
	Motor output	kW	11.7 × 4	
	Lubricant	MEL32		
Fan	Air flow rate	m <sup>3</sup> /min	265 × 4	
		L/s	4417 × 4	
		cfm	9357 × 4	
	Type, Quantity	Propeller fan × 4		
	Starting method	Inverter		
	Motor output	kW	0.92 × 4	
Protection	High pressure protection	High pres.Sensor & High pres.Switch at 4.15MPa (601psi)		
	Inverter circuit	Over-heat protection, Over current protection		
	Compressor	Over-heat protection		
Refrigerant	Type × charge	R410A × 15(kg) × 4 *3		
	Control	LEV		

Notes:	Unit converter
*1 Under normal cooling conditions at outdoor temp 35°CDB/24°CWB(95°FDB/75.2°FWB) outlet water temp 7°C(44.6°F) inlet water temp 12°C(53.6°F). Pump input is not included in cooling capacity and power input.	kcal/h = kW × 860
*2 Under normal cooling conditions at outdoor temp 35°CDB/24°CWB(95°FDB/75.2°FWB) outlet water temp 7°C(44.6°F) inlet water temp 12°C(53.6°F). Pump input is included in cooling capacity and power input based on EN14511.	BTU/h = kW × 3,412
*3 Amount of factory-charged refrigerant is 3(kg) × 4. Please add the refrigerant at the field.	lbs = kg/0.4536
*4 IPLV is calculated in accordance with AHRI 550-590.	cfm = m <sup>3</sup> /min × 35.31
*5 ESEER is calculated in accordance with EUROVENT conditions.	
*Please don't use the steel material for the water piping.	
*Please always make water circulate, or pull the circulation water out completely when not in use.	
*Please do not use groundwater or well water in direct.	
*The water circuit must be closed circuit.	
*Due to continuous improvement, the above specifications may be subject to change without notice.	
*This model doesn't equip with a pump.	
*6 Please refer to 2-1-6. Operation temperature range.	

# 1. Product Specifications

Model		EACV-P1800YBL(-N)(-BS)		
Power source		3-phase 4-wire 380-400-415V 50/60Hz		
Cooling capacity *1	kW	180.00		
		kcal/h		154,800
		BTU/h		614,160
	Power input	kW	59.01	
	EER		3.05	
	IPLV *4		6.33	
Water flow rate	m <sup>3</sup> /h	31.0		
Cooling capacity(EN14511) *2	kW	177.76		
		kcal/h		152,874
		BTU/h		606,517
	Power input	kW	61.25	
	EER		2.90	
	Eurovent efficiency class		B	
	ESEER *5		4.45	
	SEER		4.58	
Water flow rate	m <sup>3</sup> /h	31.0		
Current input	Cooling current 380-400-415V *1	A	77-73-70	
	Maximum current	A	111	
Water pressure drop *1		kPa	164	
Temp range	Cooling	°C	Outlet water 5~30 *6	
		°F	Outlet water 41~86 *6	
	Outdoor	°C	-15~43 *6	
		°F	5~109.4 *6	
Circulating water volume range		m <sup>3</sup> /h	12.9~34.0	
Sound pressure level (measured in anechoic room) at 1m *1		dB (A)	68	
Sound power level (measured in anechoic room) *1		dB (A)	86	
Diameter of water pipe (Standard piping)	Inlet	mm (in)	65A (2 1/2B) housing type joint	
	Outlet	mm (in)	65A (2 1/2B) housing type joint	
Diameter of water pipe (Inside header piping)	Inlet	mm (in)	150A (6B) housing type joint	
	Outlet	mm (in)	150A (6B) housing type joint	
External finish	Polyester powder coating steel plate			
External dimension H × W × D		mm	2350 × 3400 × 1080	
Net weight	Standard piping	kg (lbs)	1240 (2734)	
	Inside header piping	kg (lbs)	1256 (2769)	
Design pressure	R410A	MPa	4.15	
	Water	MPa	1.0	
Heat exchanger	Water side	Stainless steel plate and copper brazing		
	Air side	Plate fin and copper tube		
Compressor	Type	Inverter scroll hermetic compressor		
	Maker	MITSUBISHI ELECTRIC CORPORATION		
	Starting method	Inverter		
	Quantity	4		
	Motor output	kW	11.7 × 4	
	Lubricant	MEL32		
Fan	Air flow rate	m <sup>3</sup> /min	265 × 4	
		L/s	4417 × 4	
		cfm	9357 × 4	
	Type, Quantity	Propeller fan × 4		
	Starting method	Inverter		
Motor output	kW	0.92 × 4		
Protection	High pressure protection	High pres.Sensor & High pres.Switch at 4.15MPa (601psi)		
	Inverter circuit	Over-heat protection, Over current protection		
	Compressor	Over-heat protection		
Refrigerant	Type × charge	R410A × 15(kg) × 4 *3		
	Control	LEV		

Notes:	Unit converter
*1 Under normal cooling conditions at outdoor temp 35°CDB/24°CWB(95°FDB/75.2°FWB) outlet water temp 7°C(44.6°F) inlet water temp 12°C(53.6°F). Pump input is not included in cooling capacity and power input.	kcal/h = kW × 860
*2 Under normal cooling conditions at outdoor temp 35°CDB/24°CWB(95°FDB/75.2°FWB) outlet water temp 7°C(44.6°F) inlet water temp 12°C(53.6°F). Pump input is included in cooling capacity and power input based on EN14511.	BTU/h = kW × 3,412
*3 Amount of factory-charged refrigerant is 3(kg) × 4. Please add the refrigerant at the field.	lbs = kg/0.4536
*4 IPLV is calculated in accordance with AHRI 550-590.	cfm = m <sup>3</sup> /min × 35.31
*5 ESEER is calculated in accordance with EUROVENT conditions.	
*Please don't use the steel material for the water piping.	
*Please always make water circulate, or pull the circulation water out completely when not in use.	
*Please do not use groundwater or well water in direct.	
*The water circuit must be closed circuit.	
*Due to continuous improvement, the above specifications may be subject to change without notice.	
*This model doesn't equip with a pump.	
*6 Please refer to 2-1-6. Operation temperature range.	

# 1. Product Specifications

## 1-2. External Dimensions

EAHV-P1500, 1800YBL(-H)(-BS)  
EACV-P1500, 1800YBL(-BS)

Unit: mm

EAHV-P-YBL(-H)(-N), EACV-P-YBL(-N)

### <STANDARD PIPING TYPE>

#### INSTALLATION ON FOUNDATION

1. SECURELY FIX THE UNIT WITH BOLTS TO KEEP THE UNIT FROM FALLING DOWN DURING EARTHQUAKES.
2. INSTALL THE UNIT ON A FOUNDATION MADE OF CONCRETE OR IRON.
3. NOISE AND VIBRATIONS FROM THE UNIT MAY BE TRANSMITTED THROUGH THE FLOOR AND WALLS. PROVIDE ADEQUATE PROTECTION AGAINST NOISE AND VIBRATION.
4. ANCHOR BOLTS SHOULD BE PREPARED ON SITE.
5. WHEN BUILDING THE FOUNDATION, TAKE THE FLOOR STRENGTH, AND PIPING AND WIRING ROUTES INTO CONSIDERATION.

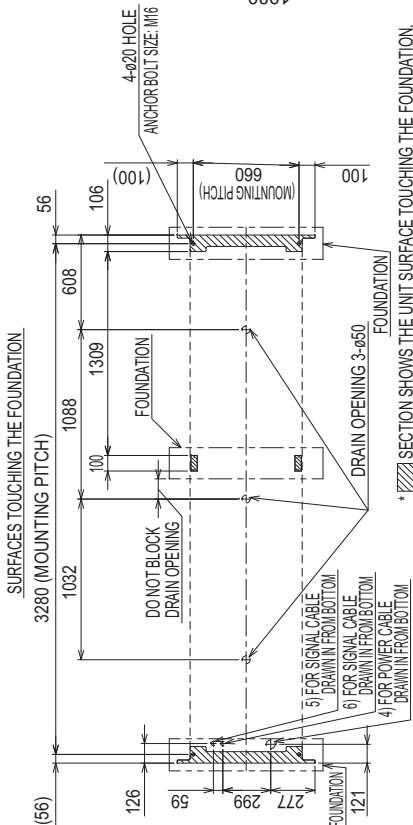

\* SECTION SHOWS THE UNIT SURFACE TOUCHING THE FOUNDATION.

#### SERVICE SPACES AROUND THE UNIT

1. WHEN INSTALLING THE UNIT, BE SURE TO LEAVE A SERVICE SPACE FOR MAINTENANCE AND INSPECTION AROUND THE UNIT.
2. ENSURE THAT THERE ARE NOT ANY WALLS OR OTHER OBJECTS AROUND THE UNIT THAT PREVENT THE UNIT FROM DRAWING IN AIR.

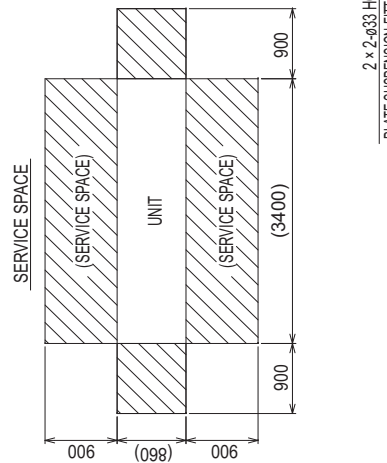

2 x 2-φ33 HOLE  
PLATE SUSPENSION FITTINGS (40)  
(78)

- NOTE 1. CONNECT COOL (HOT) WATER PIPES WHILE MAKING SURE OF CONNECTING THE INLETS AND OUTLETS CORRECTLY.
- NOTE 2. INTRUSION OF FOREIGN MATERIALS INTO THE HEAT EXCHANGER MAY CAUSE PERFORMANCE DEGRADATION OR FREEZING. BE SURE TO INSTALL CLEANABLE STRAINER (20 MESH MIN.) TO THE INLET OF COOL (HOT) WATER PIPES.
- NOTE 3. FOR HOW TO DRAW IN POWER CABLES OR CONNECT COOL (HOT) WATER PIPES, REFER TO THE SEPARATE DOCUMENT.
- NOTE 4. THE HOUSING TYPE JOINTS FOR CONNECTING A COOL (HOT) WATER INLET AND OUTLET SHOULD BE PREPARED ON SITE.

NO.	NAME	DESCRIPTION
1)	COOL (HOT) WATER INLET	2 1/2" B HOUSING TYPE JOINT ATTACHED (x 1)
2)	COOL (HOT) WATER OUTLET	2 1/2" B HOUSING TYPE JOINT ATTACHED (x 1)
3)	DRAIN OPENING	R1 1/2" EXTERNAL THREAD
4)	POWER CABLE INLET	φ66 x 1
5)	SIGNAL CABLE INLET (LOW CURRENT CABLE)	φ34
6)	SIGNAL CABLE INLET (HIGH CURRENT CABLE)	φ34

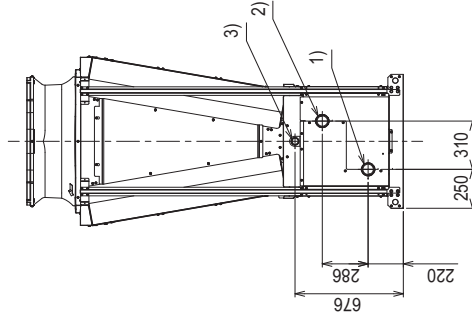
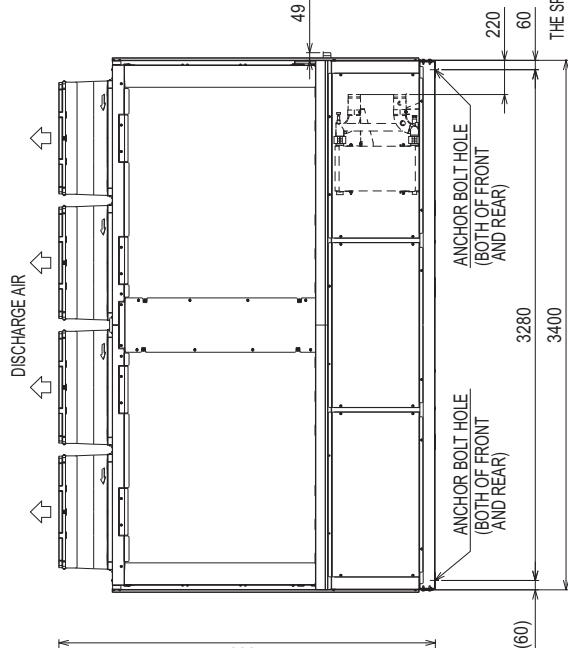
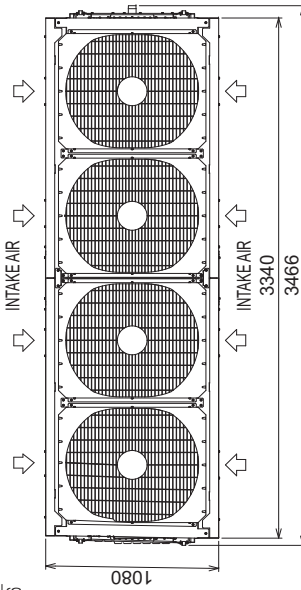

THE SPECIFICATION OF THE PRODUCT IS FOR THE IMPROVEMENT A PREVIOUS NOTICE AND MIGHT CHANGE.

# 1. Product Specifications

EAHV-P1500, 1800YBL(-H)(-BS)  
EACV-P1500, 1800YBL(-BS)

Unit: mm

## <CONNECTED MODULES>

- NOTE 1. CONNECT COOL (HOT) WATER PIPES WHILE MAKING SURE OF CONNECTING THE INLETS AND OUTLETS CORRECTLY.
- NOTE 2. INTRODUCTION OF FOREIGN MATERIALS INTO THE HEAT EXCHANGER MAY CAUSE PERFORMANCE DEGRADATION OR FREEZING. BE SURE TO INSTALL CLEANABLE STRAINER (20 MESH MIN) TO THE INLET OF COOL (HOT) WATER PIPES.
- NOTE 3. FOR HOW TO DRAW IN POWER CABLES OR CONNECT COOL (HOT) WATER PIPES, REFER TO THE SEPARATE DOCUMENT.
- NOTE 4. THE HOUSING TYPE JOINTS FOR CONNECTING A COOL (HOT) WATER INLET AND OUTLET SHOULD BE PREPARED ON SITE.
- NOTE 5. THE VALUES OF A TO C IN THE FIGURE ARE AS FOLLOWS.

MODULE COUNT	A	B	C
	(HANGING HOLE COUNT)	(FOUNDATION HOLE COUNT)	(FOUNDATION HOLE COUNT)
1 MODULE	1080	1	1
2 MODULES	2210	2	2
3 MODULES	3340	3	3
4 MODULES	4470	4	4
5 MODULES	5600	5	5
6 MODULES	6730	6	6
7 MODULES	7860	7	7
8 MODULES	8990	8	8
9 MODULES	10120	9	9
10 MODULES	11250	10	10
11 MODULES	12380	11	11
12 MODULES	13510	12	12

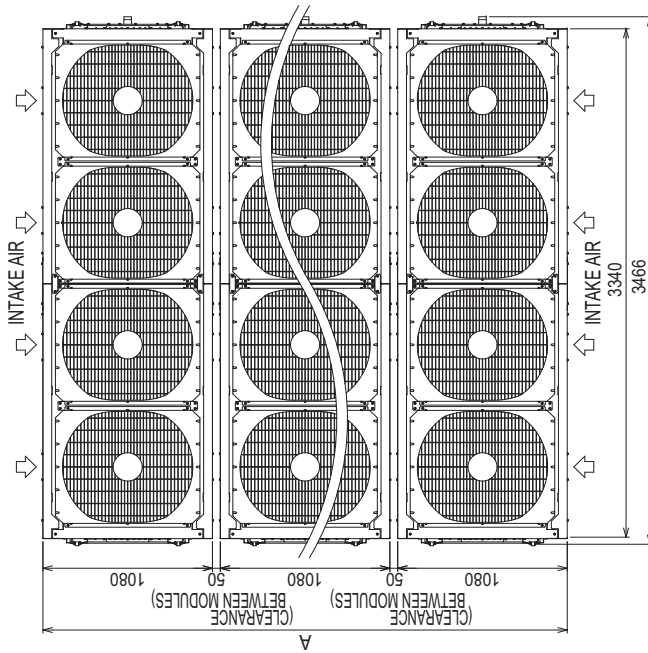

NO.	NAME	DESCRIPTION
1)	COOL (HOT) WATER INLET	2 1/2B HOUSING TYPE JOINT ATTACHED
2)	COOL (HOT) WATER OUTLET	2 1/2B HOUSING TYPE JOINT ATTACHED
3)	DRAIN OPENING	R1 1/2 EXTERNAL THREAD
4)	POWER CABLE INLET	ø66 x 1
5)	SIGNAL CABLE INLET (LOW CURRENT CABLE)	ø34
6)	SIGNAL CABLE INLET (HIGH CURRENT CABLE)	ø34

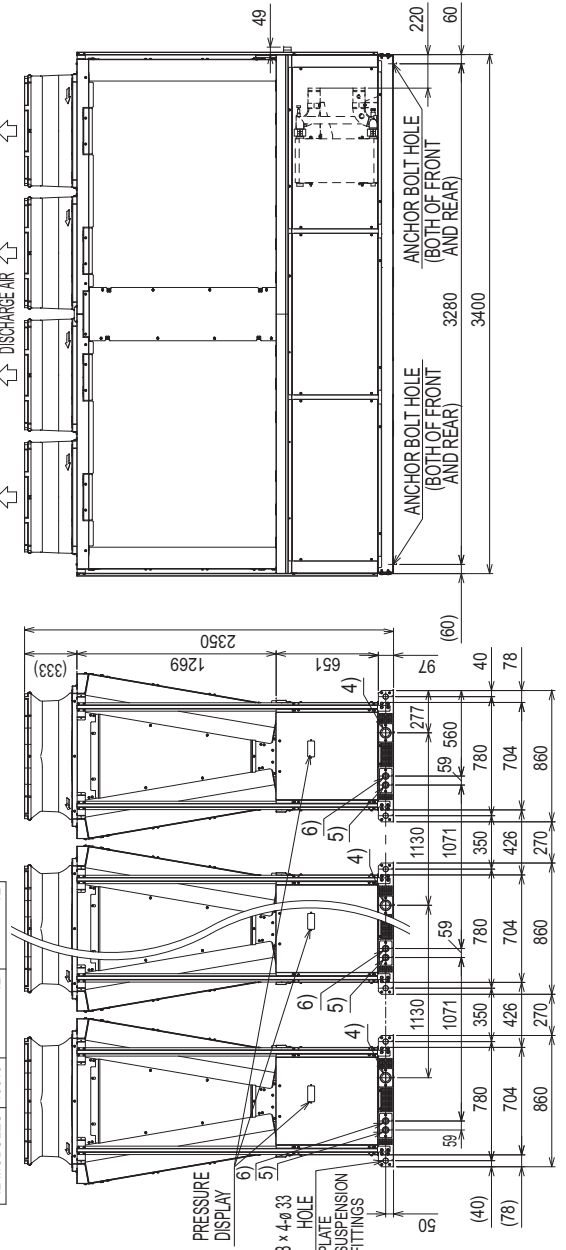

THE SPECIFICATION OF THE PRODUCTS FOR THE IMPROVEMENT A PREVIOUS NOTICE AND MIGHT CHANGE.

EAHV-P-YBL(-H)(-N), EACV-P-YBL(-N)

# 1. Product Specifications

EAHV-P1500, 1800YBL(-H)(-BS)  
EACV-P1500, 1800YBL(-BS)

Unit: mm

EAHV-P-YBL(-H)(-N), EACV-P-YBL(-N)

**SERVICE SPACES AROUND THE UNIT**

1. WHEN INSTALLING THE UNIT, BE SURE TO LEAVE A SERVICE SPACE FOR MAINTENANCE AND INSPECTION AROUND THE UNIT.
2. ENSURE THAT THERE ARE NOT ANY WALLS OR OTHER OBJECTS AROUND THE UNIT THAT PREVENT THE UNIT FROM DRAWING IN AIR.

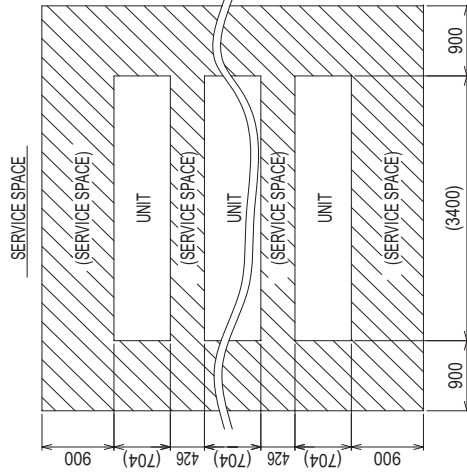

**FOUNDATION CONSTRUCTION**

1. THE FOUNDATION SHOULD BE MADE OF CONCRETE OR STEEL CAPABLE OF BEARING THE OPERATING MASS OF THE UNIT. THE FOUNDATION SHOULD ALLOW FOR WIRING.
2. A CONCRETE FOUNDATION REQUIRES ITS TOP FACE TO BE LEVEL AND FINISHED WITH MORTAR.
3. ANCHOR BOLTS SHOULD BE PREPARED ON SITE.

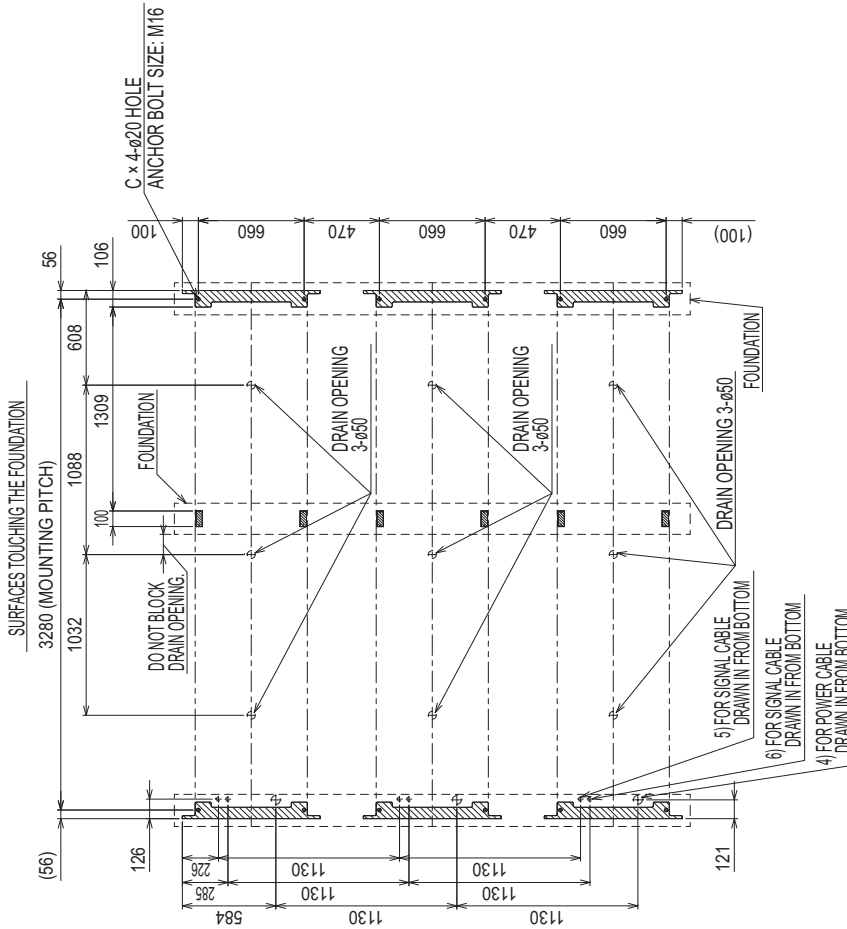

\* SECTION SHOWS THE UNIT SURFACE TOUCHING THE FOUNDATION

THE SPECIFICATION OF THE PRODUCT IS FOR THE IMPROVEMENT A PREVIOUS NOTICE AND MIGHT CHANGE.



# 1. Product Specifications

EAHV-P1500, 1800YBL(-H)-N(-BS)  
EACV-P1500, 1800YBL-N(-BS)

Unit: mm

## <INSIDE HEADER PIPING TYPE>

- NOTE 1. CONNECT COOL (HOT) WATER PIPES WHILE MAKING SURE OF CONNECTING THE INLETS AND OUTLETS CORRECTLY.
- NOTE 2. INTRUSION OF FOREIGN MATERIALS INTO THE HEAT EXCHANGER MAY CAUSE PERFORMANCE DEGRADATION OR FREEZING. BE SURE TO INSTALL CLEANABLE STRAINER (20 MESH MIN.) TO THE INLET OF COOL (HOT) WATER PIPES.
- NOTE 3. FOR HOW TO DRAW IN POWER CABLES OR CONNECT COOL (HOT) WATER PIPES, REFER TO THE SEPARATE DOCUMENT.
- NOTE 4. THE HOUSING JOINTS FOR CONNECTING A COOL (HOT) WATER INLET AND OUTLET SHOULD BE PREPARED ON SITE.
- NOTE 5. COOL (HOT) WATER PIPING CONNECTED TO THE PIPING PORT ON THE OPPOSITE SIDE AND OPPOSITE SIDE ARE THE PIPING CLOSING LID AND THE SIDE PANEL PLEASE INSTALL.
- NOTE 6. CONNECTING PART PIPING AND CONNECTING PART BETWEEN MODULES HOUSING JOINTS, COUPLING JOINTS FITTING, PIPE CLOSING LID. SIDE PANEL ARE INCLUDED SHOULD BE PREPARED ON SITE.

NO.	NAME	DESCRIPTION
1)	COOL (HOT) WATER INLET	6B HOUSING TYPE JOINT ATTACHED (x 1)
2)	COOL (HOT) WATER OUTLET	6B HOUSING TYPE JOINT ATTACHED (x 1)
3)	DRAIN OPENING	R1 1/2 EXTERNAL THREAD
4)	POWER CABLE INLET	ø66 x 1
5)	SIGNAL CABLE INLET (LOW CURRENT CABLE)	ø34
6)	SIGNAL CABLE INLET (HIGH CURRENT CABLE)	ø34

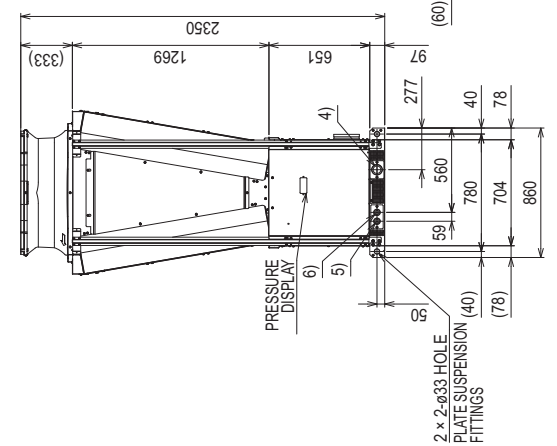
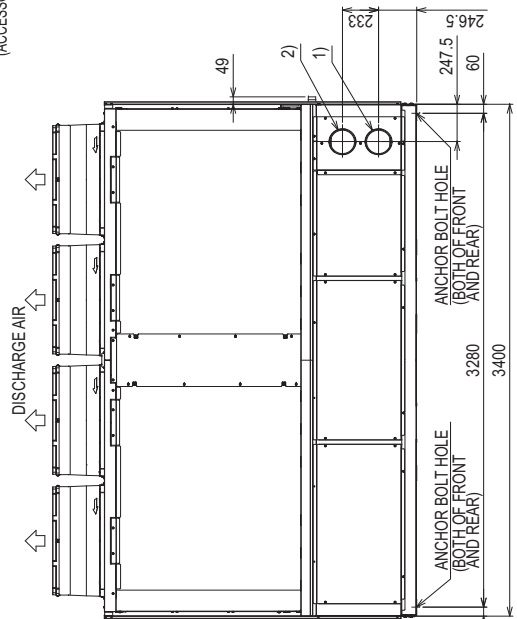
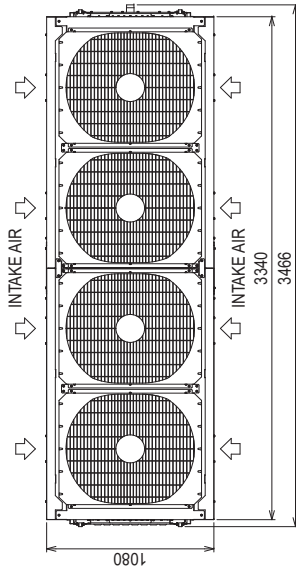

## A (INSIDE HEADER CONNECTION DIAGRAM)

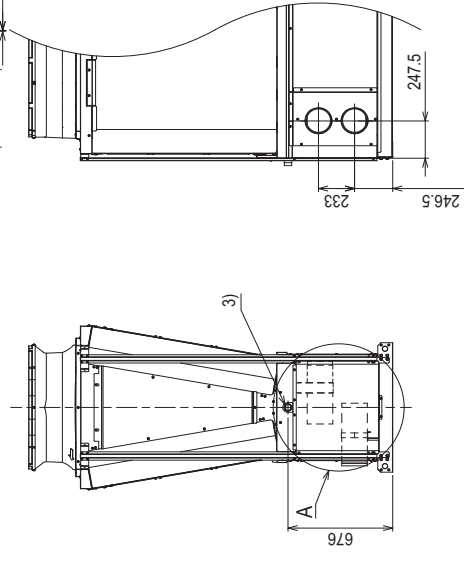
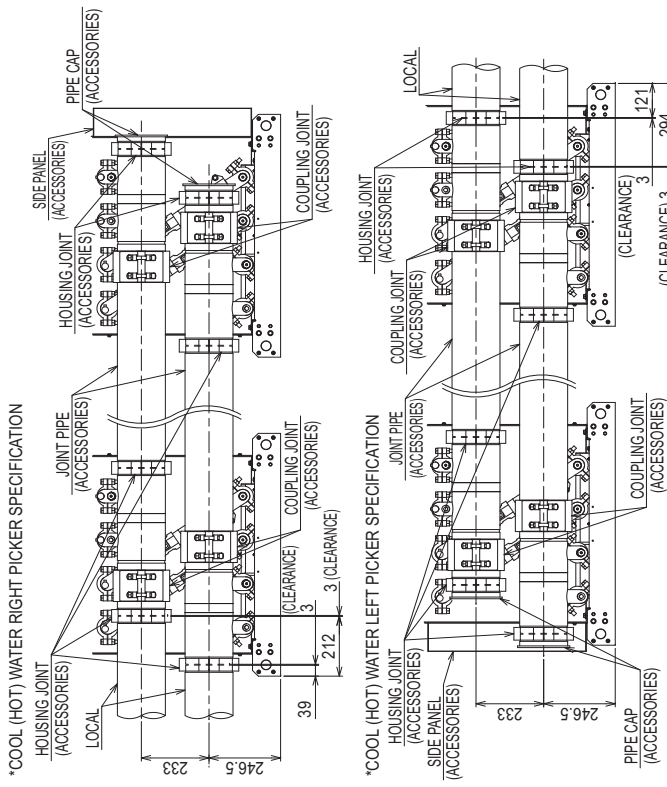

THE SPECIFICATION OF THE PRODUCT IS FOR THE IMPROVEMENT  
A PREVIOUS NOTICE AND MIGHT CHANGE.

EAHV-P-YBL(-H)-(-N), EACV-P-YBL(-N)



# 1. Product Specifications

EAHV-P1500, 1800YBL(-H)-N(-BS)  
EACV-P1500, 1800YBL-N(-BS)

Unit: mm

EAHV-P-YBL(-H)(-N), EACV-P-YBL(-N)

## <INSIDE HEADER PIPING TYPE>

### INSTALLATION ON FOUNDATION

1. SECURELY FIX THE UNIT WITH BOLTS TO KEEP THE UNIT FROM FALLING DOWN DURING EARTHQUAKES.
2. INSTALL THE UNIT ON A FOUNDATION MADE OF CONCRETE OR IRON.
3. NOISE AND VIBRATIONS FROM THE UNIT MAY BE TRANSMITTED THROUGH THE FLOOR AND WALLS. PROVIDE ADEQUATE PROTECTION AGAINST NOISE AND VIBRATION.
4. ANCHOR BOLTS SHOULD BE PREPARED ON SITE.
5. WHEN BUILDING THE FOUNDATION, TAKE THE FLOOR STRENGTH, AND PIPING AND WIRING ROUTES INTO CONSIDERATION.

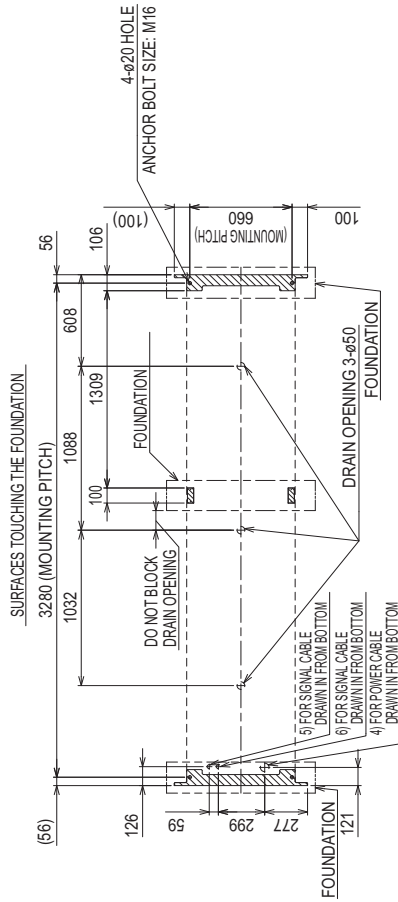

### SERVICE SPACES AROUND THE UNIT

1. WHEN INSTALLING THE UNIT, BE SURE TO LEAVE A SERVICE SPACE FOR MAINTENANCE AND INSPECTION AROUND THE UNIT.
2. ENSURE THAT THERE ARE NOT ANY WALLS OR OTHER OBJECTS AROUND THE UNIT THAT PREVENT THE UNIT FROM DRAWING IN AIR.

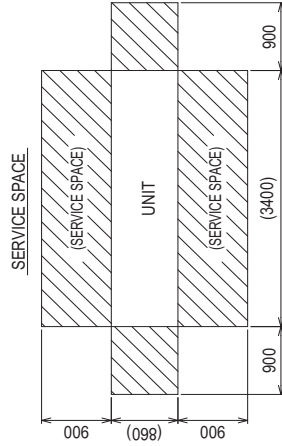

THE SPECIFICATION OF THE PRODUCT IS FOR THE IMPROVEMENT  
A PREVIOUS NOTICE AND MIGHT CHANGE.

# 1. Product Specifications

EAHV-P1500, 1800YBL(-H)-N(-BS)  
EACV-P1500, 1800YBL-N(-BS)

Unit: mm

## <CONNECTED MODULES>

- NOTE 1. CONNECT COOL (HOT) WATER PIPES WHILE MAKING SURE OF CONNECTING THE INLETS AND OUTLETS CORRECTLY.
- NOTE 2. INTRUSION OF FOREIGN MATERIALS INTO THE HEAT EXCHANGER MAY CAUSE PERFORMANCE DEGRADATION OR FREEZING.  
BE SURE TO INSTALL CLEANABLE STRAINER (20 MESH MIN.) TO THE INLET OF COOL (HOT) WATER PIPES.
- NOTE 3. FOR HOW TO DRAW IN POWER CABLES OR CONNECT COOL (HOT) WATER PIPES, REFER TO THE SEPARATE DOCUMENT.
- NOTE 4. THE HOUSING JOINTS FOR CONNECTING A COOL (HOT) WATER INLET AND OUTLET SHOULD BE PREPARED ON SITE.
- NOTE 5. COOL (HOT) WATER PIPING CONNECTED TO THE PIPING PORT ON THE OPPOSITE SIDE AND OPPOSITE SIDE ARE THE PIPING CLOSING LID AND THE SIDE PANEL. PLEASE INSTALL.
- NOTE 6. CONNECTING PART PIPING AND CONNECTING PART BETWEEN MODULES HOUSING JOINTS, COUPLING JOINTS FITTING, PIPE CLOSING LID, SIDE PANEL ARE INCLUDED SHOULD BE PREPARED ON SITE.
- NOTE 7. THE VALUES OF A, B AND C IN THE FIGURE ARE AS FOLLOWS.

MODULE COUNT	A (HANGING HOLE COUNT)	B (HANGING HOLE COUNT)	C (FOUNDATION HOLE COUNT)
1 MODULE	1080	1	1
2 MODULES	2210	2	2
3 MODULES	3340	3	3
4 MODULES	4470	4	4
5 MODULES	5600	5	5
6 MODULES	6730	6	6
7 MODULES	7860	7	7
8 MODULES	8990	8	8
9 MODULES	10120	9	9
10 MODULES	11250	10	10
11 MODULES	12380	11	11
12 MODULES	13510	12	12

NO.	NAME	DESCRIPTION
1)	COOL (HOT) WATER INLET	6B HOUSING TYPE JOINT ATTACHED
2)	COOL (HOT) WATER OUTLET	6B HOUSING TYPE JOINT ATTACHED
3)	DRAIN OPENING	R1½ EXTERNAL THREAD
4)	POWER CABLE INLET	ø66 x 1
5)	SIGNAL CABLE INLET (LOW CURRENT CABLE)	ø34
6)	SIGNAL CABLE INLET (HIGH CURRENT CABLE)	ø34

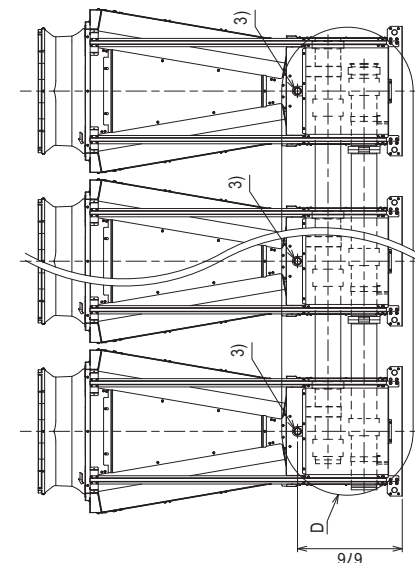
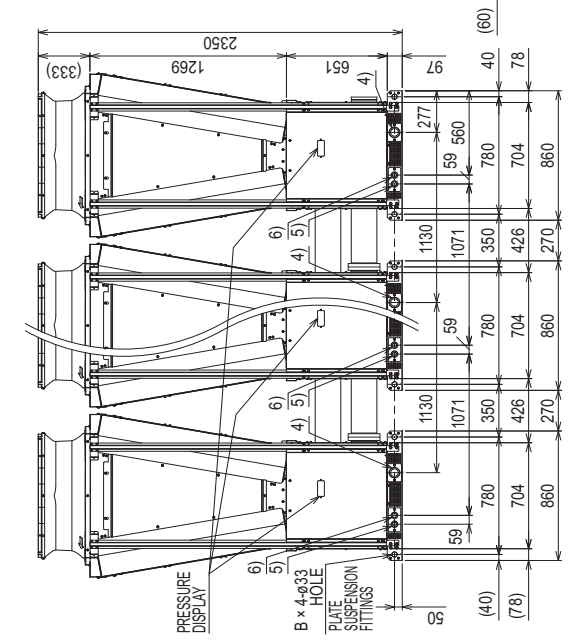
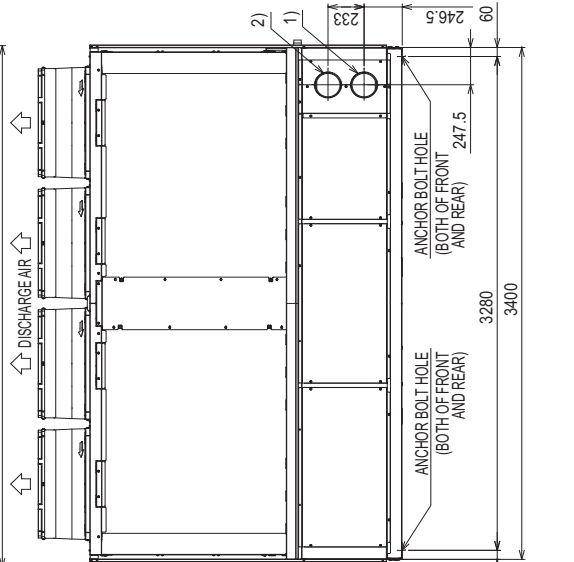
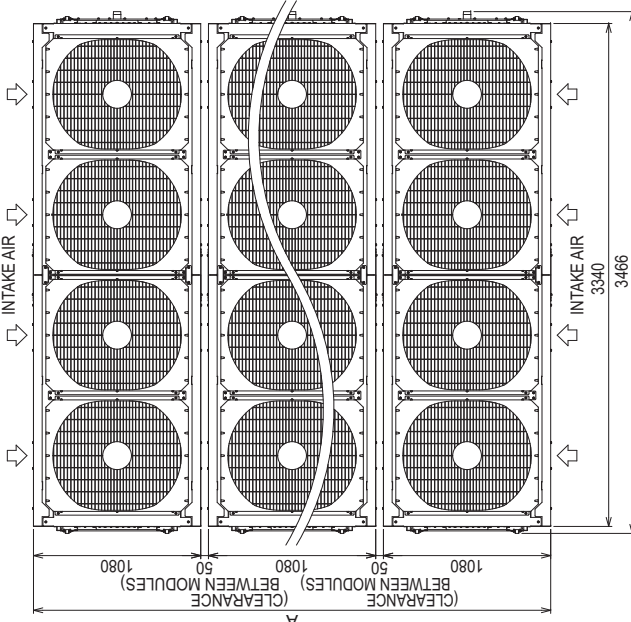

THE SPECIFICATION OF THE PRODUCT IS FOR THE IMPROVEMENT A PREVIOUS NOTICE AND MIGHT CHANGE.

EAHV-P-YBL(-H)-(-N), EACV-P-YBL(-N)

# 1. Product Specifications

EAHV-P-YBL(-H)(-N), EACV-P-YBL(-N)

EAHV-P1500, 1800YBL(-H)-N(-BS)  
EACV-P1500, 1800YBL-N(-BS)

Unit: mm

## <CONNECTED MODULES>

D (INSIDE HEADER CONNECTION DIAGRAM)

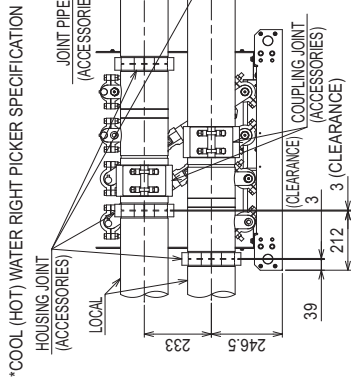

\*COOL (HOT) WATER LEFT PICKER SPECIFICATION

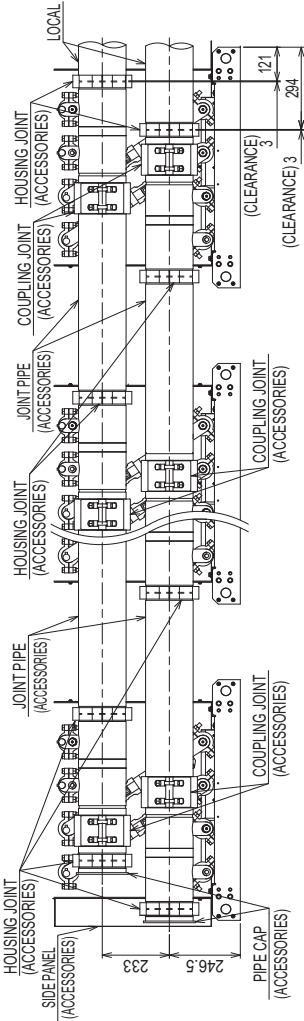

### SERVICE SPACES AROUND THE UNIT

1. WHEN INSTALLING THE UNIT, BE SURE TO LEAVE A SERVICE SPACE FOR MAINTENANCE AND INSPECTION AROUND THE UNIT.
2. ENSURE THAT THERE ARE NOT ANY WALLS OR OTHER OBJECTS AROUND THE UNIT THAT PREVENT THE UNIT FROM DRAWING IN AIR.

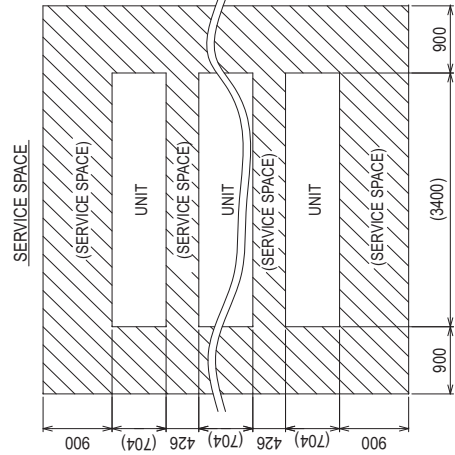

### FOUNDATION CONSTRUCTION

1. THE FOUNDATION SHOULD BE MADE OF CONCRETE OR STEEL CAPABLE OF BEARING THE OPERATING MASS OF THE UNIT.
2. THE FOUNDATION SHOULD ALLOW FOR WIRING.
3. A CONCRETE FOUNDATION REQUIRES ITS TOP FACE TO BE LEVEL AND FINISHED WITH MORTAR.
4. ANCHOR BOLTS SHOULD BE PREPARED ON SITE.

SURFACES TOUCHING THE FOUNDATION

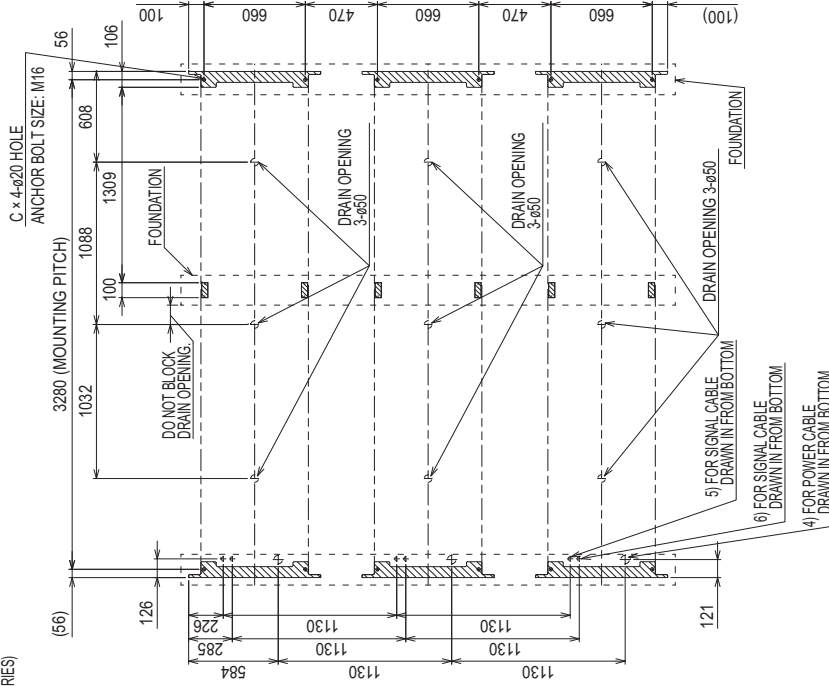

\* SECTION SHOWS THE UNIT SURFACE TOUCHING THE FOUNDATION.

THE SPECIFICATION OF THE PRODUCT IS FOR THE IMPROVEMENT A PREVIOUS NOTICE AND MIGHT CHANGE.

# 1. Product Specifications

## 1-3. Center of Gravity

Standard piping type

Unit: mm

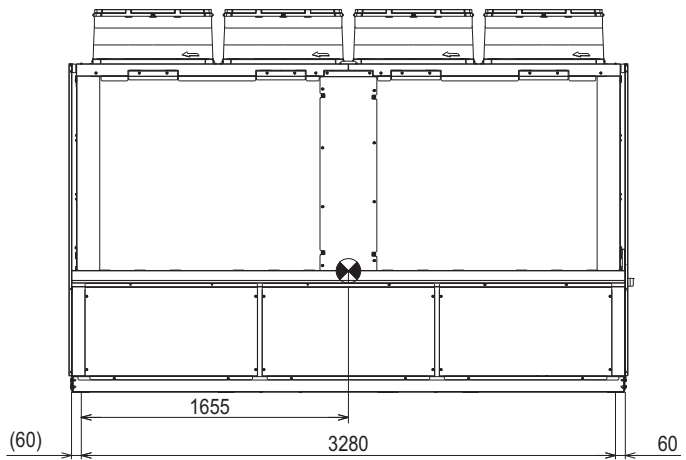
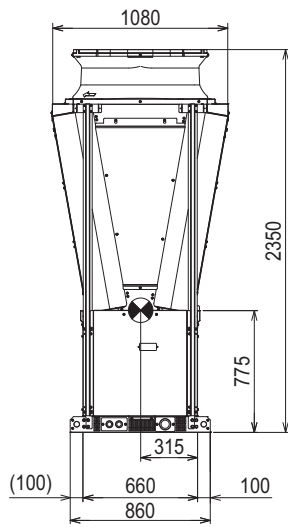

<Service side>

<Right side>

Inside header piping type

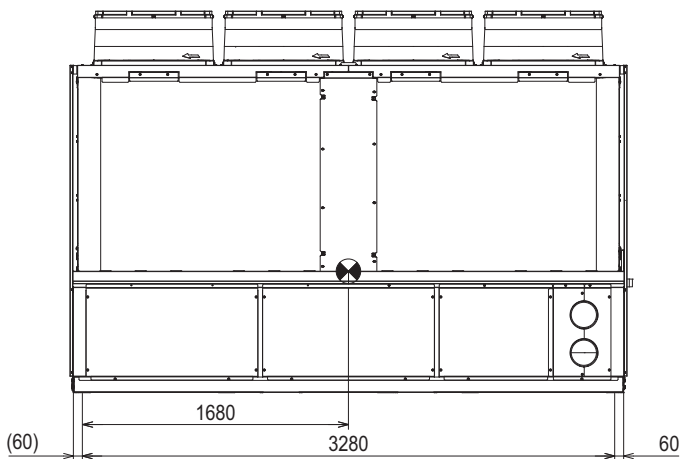
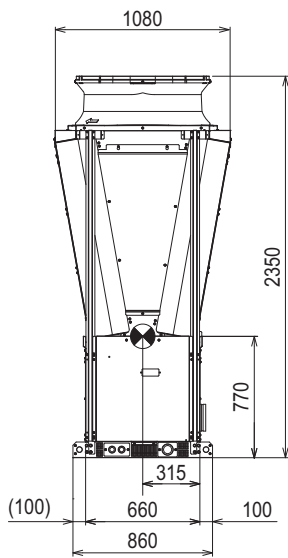

<Service side>

<Right side>

# 1. Product Specifications

## 1-4. Electrical Wiring Diagrams

EAHV-P1500, 1800YB  
EACV-P1500, 1800YB

EAHV-P-YBL(-H)(-N), EACV-P-YBL(-N)

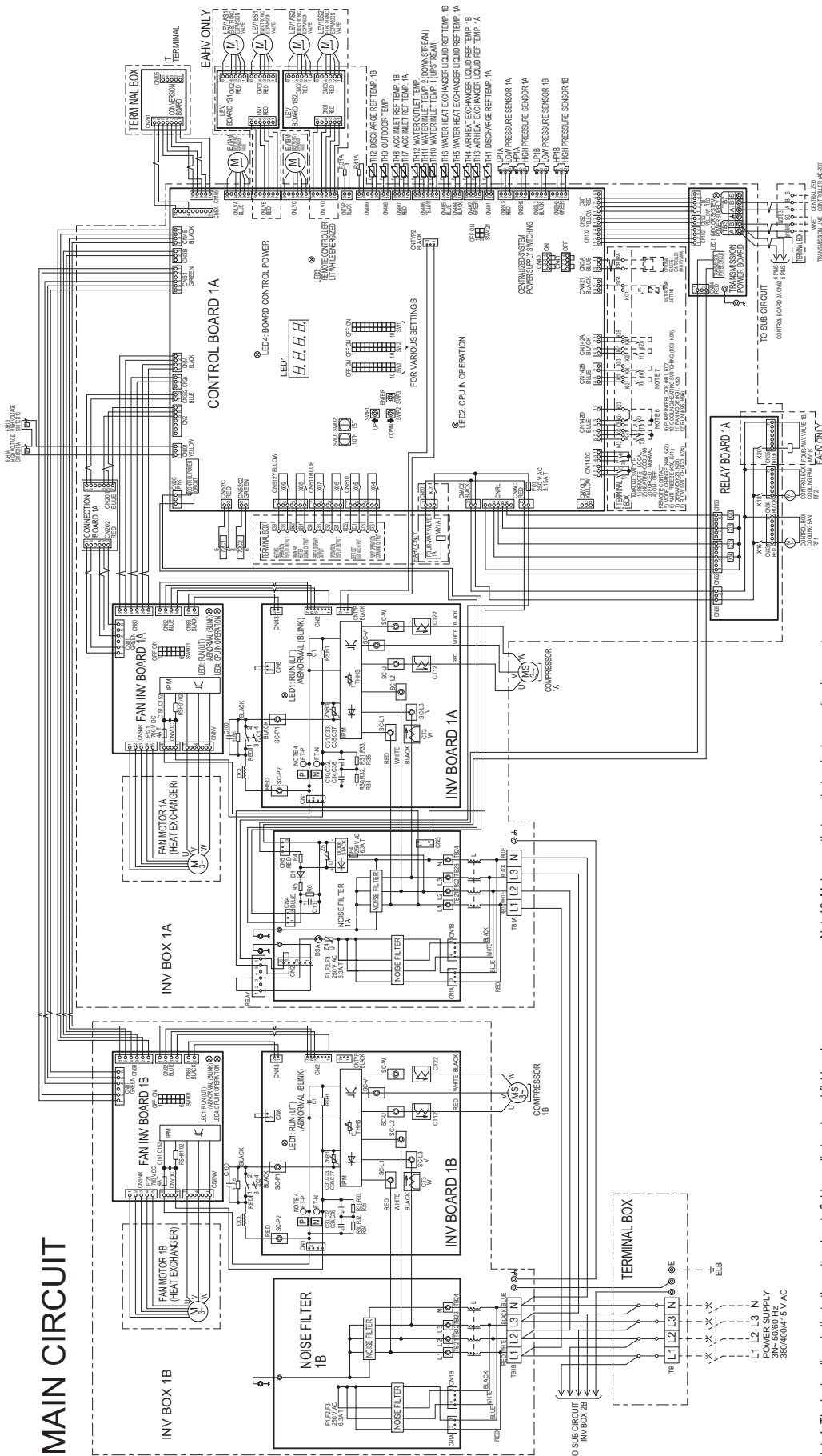

### MAIN CIRCUIT

- Note1. The broken lines indicate the optional parts field-supplied parts, and field work.
- Note2. Dashed lines indicate control box.
- Note3. For modules in the same unit, provide daisy-chain wiring between M1, M2 and SG.
- Note4. The control box has many parts charged with high voltage in it. Before inspecting the inside of the control box, be sure to turn off the power supply and leave it alone for at least 10 minutes and then confirm that the voltage between the tab terminal (FT-P and FT-N) declined sufficiently (to 20 V DC or less).
- Note5. Faston terminals have a locking function.  
Press the tab in the middle of the terminals to remove them.  
Check that the terminals are securely locked in place after insertion.
- Note6. Remove the short circuit wire between the terminals K23 and K24 to connect a flow switch.
- Note7. Be sure to connect the wires from terminals K01 and K02 to the interlock contact on the pump.
- Note8. A short-circuit may cause abnormal stop or malfunctions.  
Operation signals can be received from through the No-voltage contact.
- Note9. Use a 4~20mA signal output device with insulation.  
Feedig 30mA or more current may damage the circuit board.
- Note10. Make sure that on site terminal connection is correct.  
With wrong connection, operation error may occur.
- Note11. Leave a space of at least 5 cm between the low voltage external wiring (No-voltage contact input and remote controller wiring) and wiring of 100V or greater.  
Do not place them in the same conduit tube or cable tray as this will damage the circuit board.
- Note12. When cable tray is used for the control cable wiring, use a separate cable tray for the following wiring.  
Using the same cable tray may cause malfunctions and damage to the unit.  
(a) Optional remote controller wiring  
(b) No-voltage contact input wiring  
(c) No-voltage contact output wiring  
(d) Analog input wiring
- Note13. Use a contact that takes 12VDC 1mA for No-voltage contact input.  
When the power voltage is 380V-400V-415V, No-voltage contact output will be 220VAC-230VAC-240VAC.  
The current range must be between 10mA and 1A.
- The specification of the product is for the improvement a previous notice and might change.

# 1. Product Specifications

EAHV-P1500, 1800YB  
EACV-P1500, 1800YB

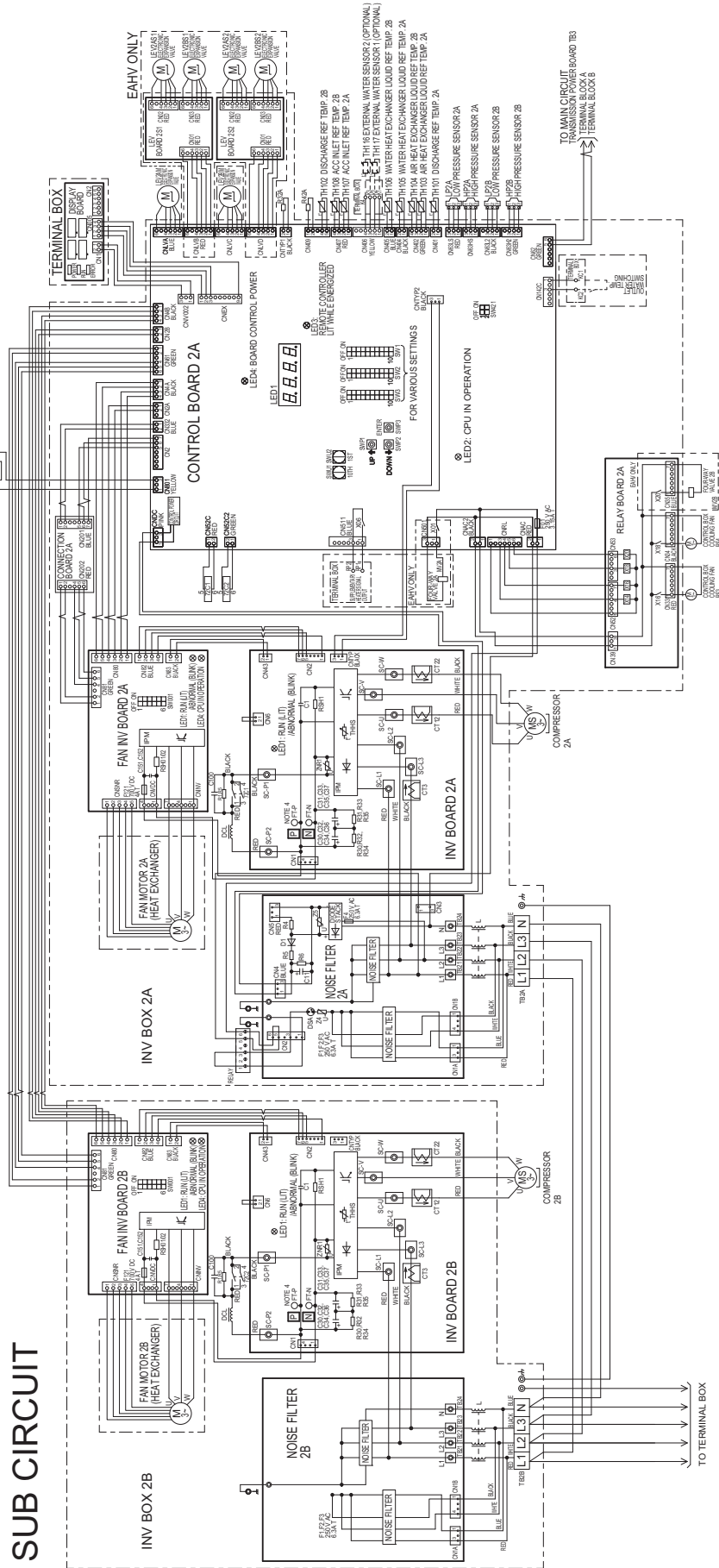

SUB CIRCUIT

The specification of the product is for the improvement a previous notice and might change.

EAHV-P-YBL(-H)(-N), EACV-P-YBL(-N)



# 1. Product Specifications

When using a local controller, refer to the table below for the types of input/output signals that are available and the operations that correspond to the signals.

## External Input/Output

Input type	Dry contact	ON (Close)	OFF (Open)	Terminal block
(a)UNIT OPERATION	Run/Stop	The unit will go into operation when the water temperature drops below the preset temperature.	The unit will stop except when the unit is in the Anti-Freeze mode.	K95-K96
(b)MODE CHANGE *EAHV-P****YBL EAHV-P****YBL-H	Heating ECO/Heating	Heating ECO mode (EAHV-P****YBL: When "COOLING/HEATING SWITCHING" contact (item (i) below) is ON, this mode is enabled.)	Heating mode (EAHV-P****YBL: When "COOLING/ HEATING SWITCHING" contact (item (i) below) is ON, this mode is enabled.)	K40-K42
(c)FAN MODE	Forced/ Normal	When the outdoor temperature is 5°C or less, the fan will remain in operation after the compressor has stopped.	The fan will stop when the compressor stops.	K91-K92
(d)ANTI FREEZE *EAHV-P****YBL EAHV-P****YBL-H	On/Off	The unit will operate in the Anti-Freeze mode (with the target temperature 30°C) when the contact status of (a) "UNIT OPERATION" is "Stop" or the ON/OFF button on the remote controller is turned off. (EAHV-P****YBL: When "COOLING/HEATING SWITCHING" contact (item (i) below) is ON, this mode is enabled.)	The unit will operate according to the status of the "UNIT OPERATION" contact (item (a) above) or the ON/OFF command from the remote controller.	K40-K41
(e)FLOW SWITCH	Normal/Error	The unit is allowed to operate.	The unit will not operate.	K23-K24
(f)PUMP INTERLOCK	Normal/Error	The unit is allowed to operate.	The unit will not operate.	K01-K02
(g)PEAK-DEMAND CONTROL	On/Off	The unit will operate at or below the maximum capacity level that was set for the Peak-demand control setting.	The unit will operate at or below the maximum capacity.	K23-K25
(h)OUTLET WATER TEMP SWITCHING	2nd/1st	Setting temp 2 (Refer to page 80 Settings table)	Setting temp 1 (Refer to page 80 Settings table)	KC1-KC2
(i)COOLING/HEATING SWITCHING *EAHV-P****YBL	Heating/ Cooling	Heating mode	Cooling mode	K93-K94
Analog				Terminal block
Input type		Action		
(j)WATER TEMP SETTING/ CAPACITY CONTROL SIGNAL	Water temperature or capacity control signal can be set by using the external analog input to the CN421 on the MAIN circuit board. One analog input type can be selected from the following types: 4-20 mA, 1-5 V, 0-10 V, or 2-10 V. *Use a 4-20 mA signal output device with insulation.			SG1(+)-KG1(-)
(k)EXTERNAL WATER SENSOR 1 (optional)	For simultaneous operating group			K1-K2
(l)EXTERNAL WATER SENSOR 2 (optional)	For identical water system group			K3-K4
Output type	Contact type	Conditions in which the contact closes (turns on)	Conditions in which the contact opens (turns off)	Terminal block
(m)ERROR INDICATOR	Close/Open	The unit has made an abnormal stop.	During normal operation	K33-K34
(n)OPERATION INDICATOR	Close/Open	The "UNIT OPERATION" contact (item (a) above) or the ON/OFF button on the remote controller is ON.	The "UNIT OPERATION" contact (item (a) above) or the ON/OFF button on the remote controller is OFF.	K31-K32
(o)PUMP OPERATION COMMAND	Close/Open	The pump will operate according to the status of the "UNIT OPERATION" contact or the ON/OFF button on the remote controller button.	Under all conditions other than the ones listed on the left	K75-K76
(p)SUPPLEMENTARY HEATER SIGNAL	Close/Open	Water and outdoor temperature has dropped below a setting water temperature and a set outdoor temperature.	Water temperature is at or above a set water temperature +2°C or the outdoor temperature is at or above a set outdoor temperature +2°C.	RP1-RP2
(q)DEFROST SIGNAL	Close/Open	The unit is in defrost mode.	The unit is not in defrost mode.	KD1-KD2
(r)DRAIN PAN HEATER SIGNAL	Close/Open	Outdoor temperature has dropped below a set outdoor temperature.	Outdoor temperature is at or above a set outdoor temperature +2°C.	KB1-KB2
(s)HEATING OPERATION DISPLAY	Close/Open	The unit is in heating mode.	The unit is in cooling mode.	K38-K39
RC/M-NET	REMOTE CONTROLLER	PAR-W31MAA		RA-RB
	Centralized controller	AE-200		A-B
	M-NET			M1-M2

EAHV-P-YBL(-H)(-N), EACV-P-YBL(-N)

# 1. Product Specifications

**Input and output correspondence table**

		Terminal block	ON	OFF	System leader unit	Group leader unit	SUB unit
No-voltage contact input	Run	K95-K96	Run	Stop	○	-	-
	Fan mode	K91-K92	Forced	Normal	○	-	-
	Cooling/Heating switching	K93-K94	Heating	Cooling	○	-	-
	Pump interlock	K01-K02	Normal	Error	○	○	○*
	Anti freeze	K40-K41	ON	OFF	○	-	-
	Flow switch	K23-K24	Normal	Error	○	○	○*
	Outlet water temp. switching	KC1-KC2	2nd	1st	○	-	-
	Demand	K23-K25	ON	OFF	○	-	-
	Mode change	K40-K42	Heating ECO	Heating	○	-	-
Analog input	Water temp. setting / Capacity control signal	SG1(+)-KG1(-)	4-20mA,0-10,2-10V,1-5V		○	-	-
	External water sensor 1 (Option)	K1-K2	For simultaneous operating group		○	○	-
	External water sensor 2 (Option)	K3-K4	For identical water system group		○	-	-
No-voltage contact output	Supplementary heater signal output	RP1-RP2	During the low outdoor and water temperature is ON.		○	○	○
	Defrost signal output	KD1-KD2	During the defrosting operation is ON.		○	○	○
	Heating operation display	K38-K39	Heating	Cooling	○	○	○
	Operation display output	K31-K32	During the operation command reception is ON.		○	○	○
	Error display output	K33-K34	While abnormally stop is ON.		○	○	○
	Pump operation command output	K75-K76	ON is when the pump is required.		○	○	○*
	Drain pan heater signal output	KB1-KB2	During the low outdoor temperature is ON.		○	○	○
RC	Remote controller	RA-RB	PAR-W31MAA		○	-	-
	Centralized controller	A-B	AE-200		○	-	-

○: Input and output signal is enable.

-: Invalid

\*Invalid when the one pump system



# 1. Product Specifications

## External signal interface

EAHV-P-YBL(-H)(-N), EACV-P-YBL(-N)

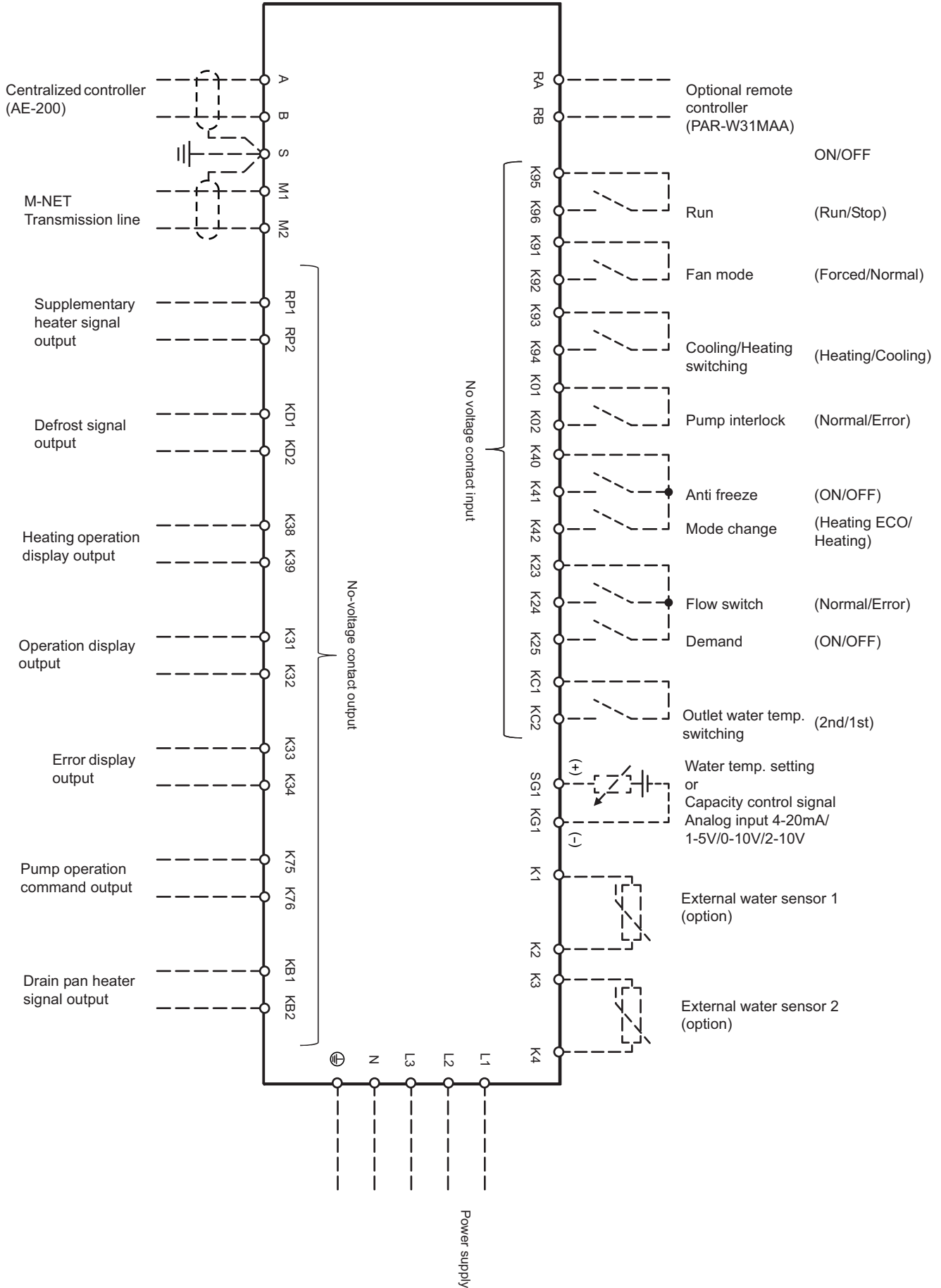

# 1. Product Specifications

## 1-5. Optional parts

### 1-5-1. Piping Kit DT-01HK (Only for Inside header (-N))

Refer to Installation/Instructions Manual.

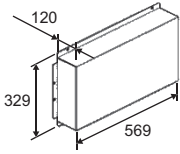
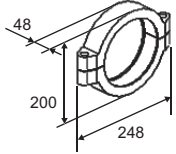
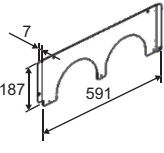
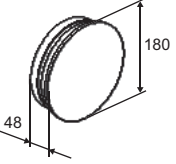
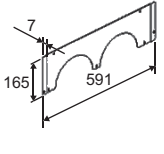
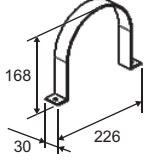
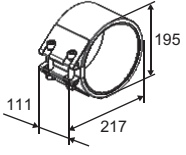
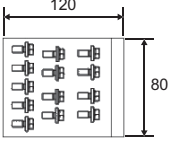
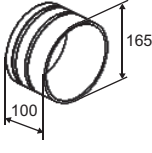
No.	Parts name	Size and shape	Quantity	No.	Parts name	Size and shape	Quantity
1	SIDE PANEL		1	6	VICTAULIC JOINT		4
2	PANEL BL		1	7	PIPE CAP		2
3	PANEL BR		1	8	SADDLE		1
4	STRAUB JOINT		2	9	BOLT M5		1
5	JOINT PIPE (SHORT)		2				

### 1-5-2. Connection Piping Kit DT-02HK (Only for Inside header (-N))

Refer to Installation/Instructions Manual.

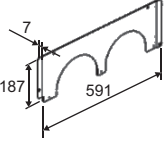
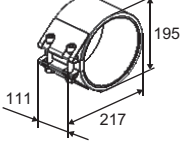
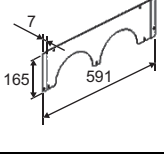
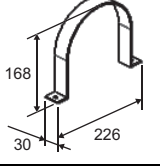
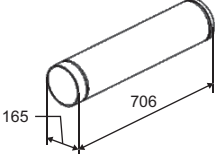
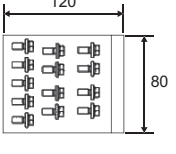
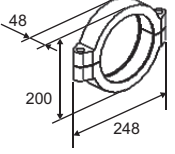
No.	Parts name	Size and shape	Quantity	No.	Parts name	Size and shape	Quantity
1	PANEL BL		2	5	STRAUB JOINT		2
2	PANEL BR		2	6	SADDLE		2
3	JOINT PIPE (LONG)		2	7	BOLT M5		1
4	VICTAULIC JOINT		2				

# 1. Product Specifications

## 1-5-3. Fin Guard DT-150FG

### Parts list

<p>(1) <b>FIN GUARD</b></p> <p>4 pcs.</p>		<p>(2) <b>PLATE</b></p> <p>28 pcs.</p>		<p>(7) <b>SCREWS</b></p> <p>32 pcs.</p>	
<p>(3) <b>FRAME 1</b></p> <p>2 pcs.</p>	<p>(4) <b>FRAME 2</b></p> <p>2 pcs.</p>	<p>(5) <b>FRAME 3</b></p> <p>2 pcs.</p>	<p>(6) <b>FRAME 4</b></p> <p>2 pcs.</p>		

EAHV-P-YBL(-H)(-N), EACV-P-YBL(-N)

# 1. Product Specifications

## Installing the fin guard

(1) Attach four types of frames to each position.

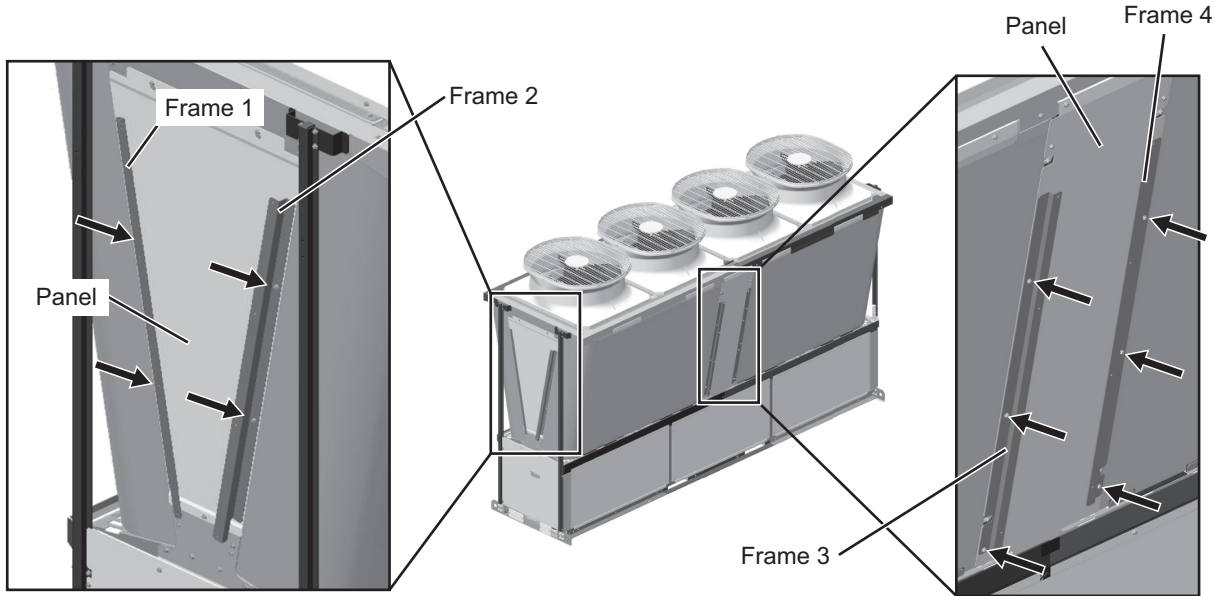

Screw down Frames 1 and 2 on the panel with M5 screws at the four positions indicated with arrows in the figure.  
 \* Screw down Frames 1 and 2 in the same way on the other side.

Screw down Frames 3 and 4 on the panel with M5 screws at the six positions indicated with arrows in the figure.  
 \* Screw down Frames 3 and 4 in the same way on the other side.

(2) Attach the fin guards to four sides.  
 (3) Attach the plates according to the figure below.

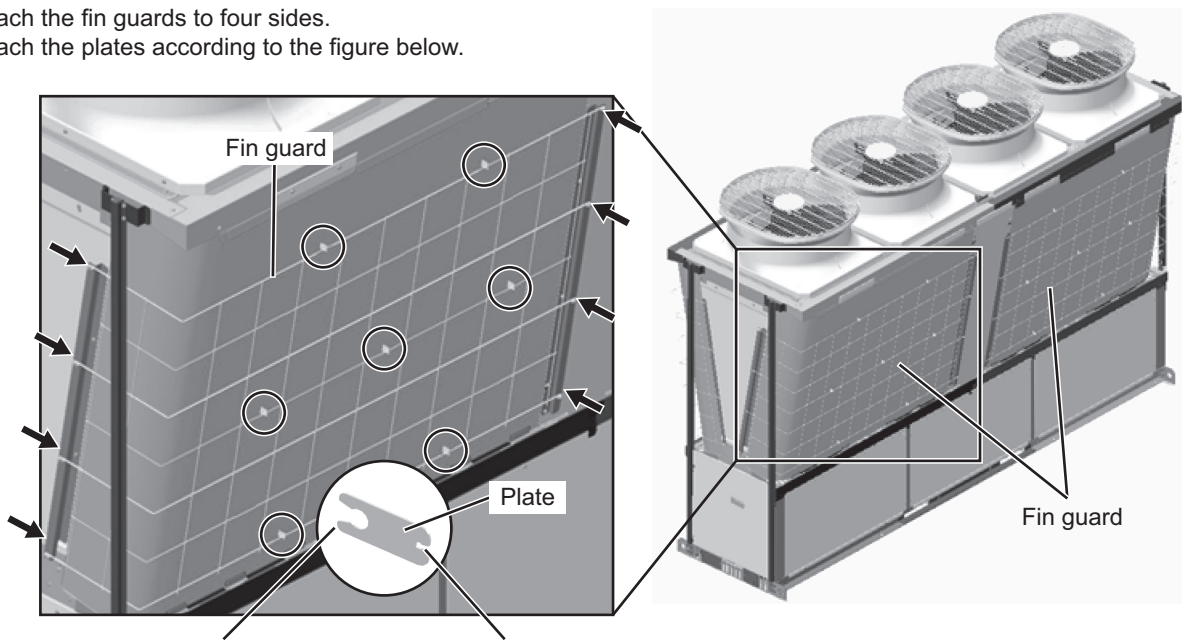

Fix on the pipe for air-heat exchanger.      Fix on the frame of fin guard.

Fix the fin guards at the positions indicated with arrows in the figure with the supplied M5 screws. (Eight screws are used to fix each fin guard.)

Attach the plates at the positions indicated with circles. (Seven plates are used for each fin guard.)

• In the case of two units

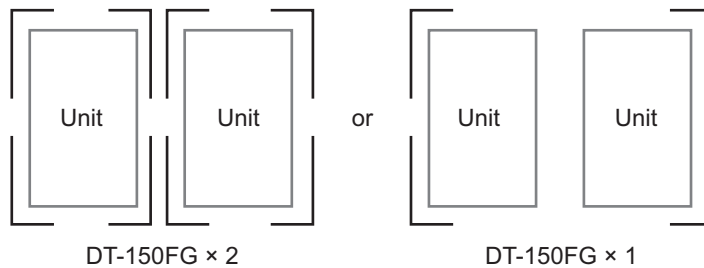

## 1. Product Specifications

### 1-5-4. Remote controller PAR-W31MAA

Refer to 6-1. PAR-W31MAA specifications.

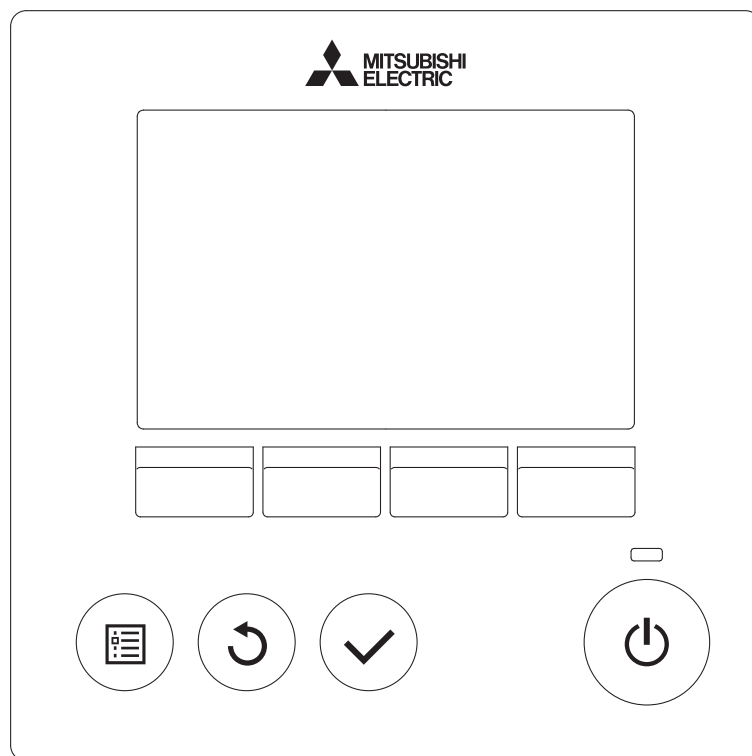

EAHV-P-YBL(-H)(-N), EACV-P-YBL(-N)

# 1. Product Specifications

## 1-5-5. External water temperature sensor TW-TH16

- Required parts for installing a external water temperature sensor
  - External water temperature sensor
  - Cable for connecting between the sensor and the unit\*
  - Cable terminal for connecting to the sensor and the unit terminal block\* (Terminals for M4 screws × 4)\*

\* A) and B) are field-supplied.

### Cable specifications

Size	2-core, 1.25 mm <sup>2</sup> or larger
Type	CVVS or CPEVS
Maximum length	20 m

### 2. Installing a external water temperature sensor

As shown in the figures below, install the sensor at the merged part of water pipes or the load-side tank. The sensor can be installed in either the vertical or the horizontal position. When installing the sensor in the horizontal position, make sure to place the cable-access-hole side down.

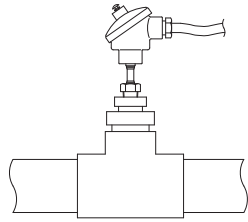

Vertical installation

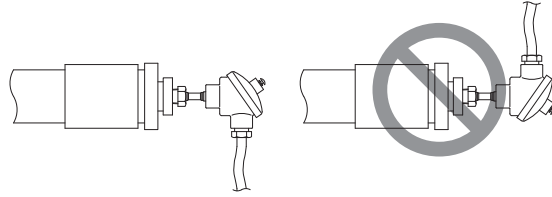

Horizontal installation

### 3. Wiring for a external water temperature sensor

As shown in the figures below, connect the cable to the external water temperature sensor and the terminal block in the unit control box.

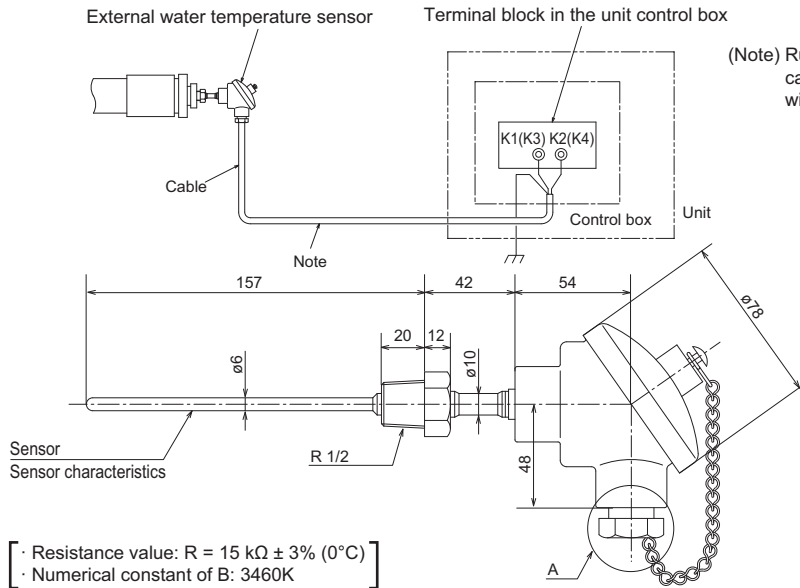

(Note) Run the sensor wiring at least 5 cm away from any wire that carries a voltage of 100 V or more, and do not put the sensor wiring in the same conduit tube with it.

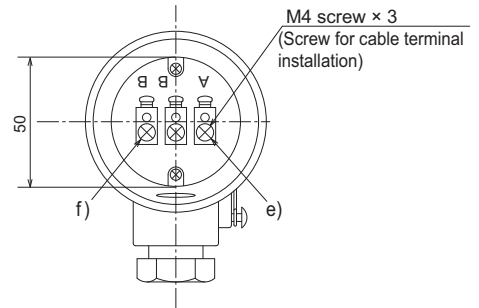

Terminal block on the sensor

On the unit side, connect the sensor cable to the terminals K1 and K2 (or K3 and K4) in the terminal block in the unit control box. Connect the shielded cable to the ground terminal.

On the sensor side, as shown in the figure at right, run the cable through d), c), and b), attach the field-supplied terminals for M4 screws to the cable, and then connect the terminals to the screws e) and f) (terminal A and B).

Cut the shielded cable and leave it unconnected.

(On the unit side, the shielded cable should be connected to the ground terminal already.)

Tighten the tightening screw d), and caulk the gap between the tightening screw d) and cable a) to prevent water leakage.

\*1 In a multiple module connection system, install the temperature sensor where the cold/hot water from each module is sufficiently mixed to provide a representative temperature.

\*2 The temperature sensor must be installed on a pipe between the outlet of the unit and the entrance to the load-side system.

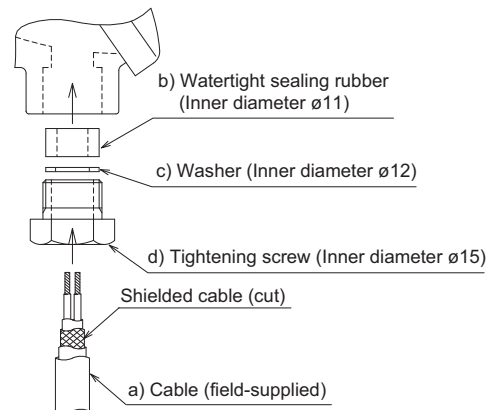

Enlarged view of area A: Cable installation

## 2. Product Data

### 2-1. Capacity tables

#### 2-1-1. Correction by temperature

[Cold/hot water outlet/inlet temperature difference 5°C]

EAHV-P1500YB  
EACV-P1500YB

■ Cooling Capacity [Water]

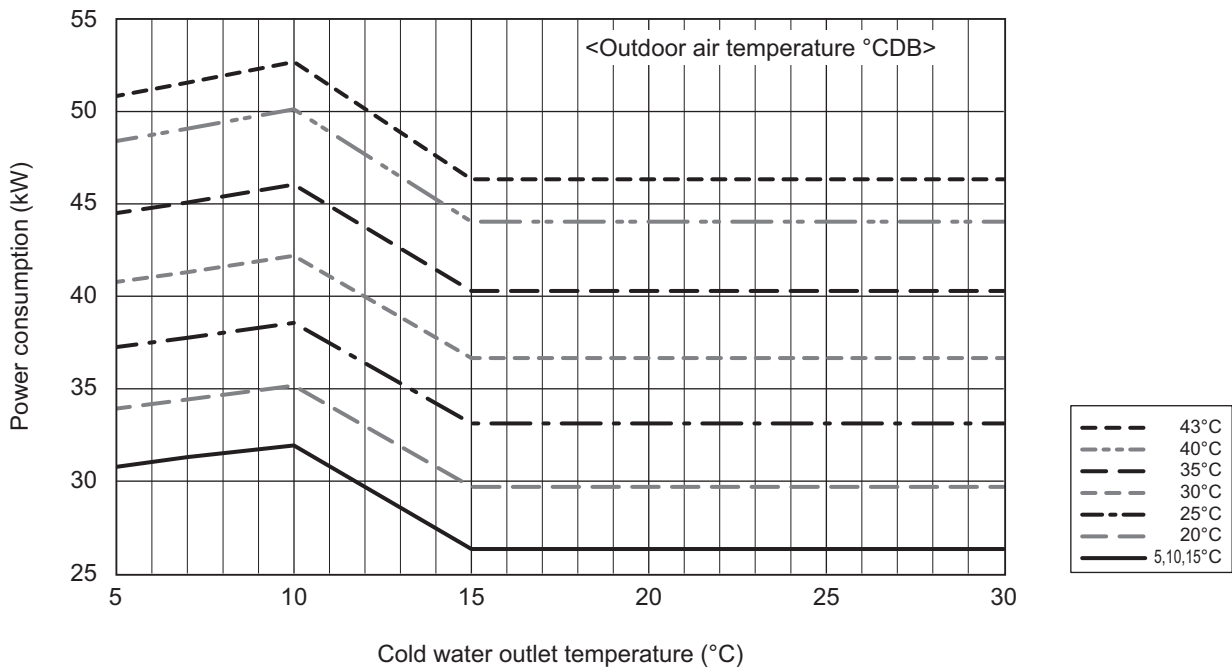
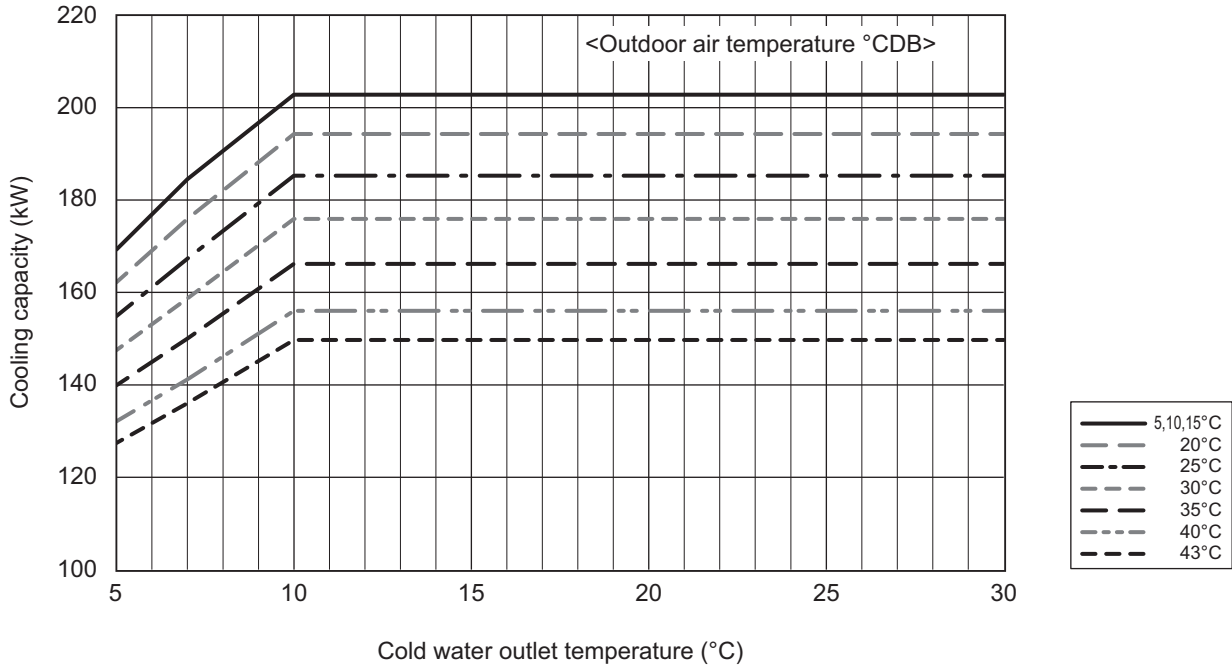

## 2. Product Data

[Cold/hot water outlet/inlet temperature difference 5°C]

EAHV-P1500YB

■ Heating Capacity

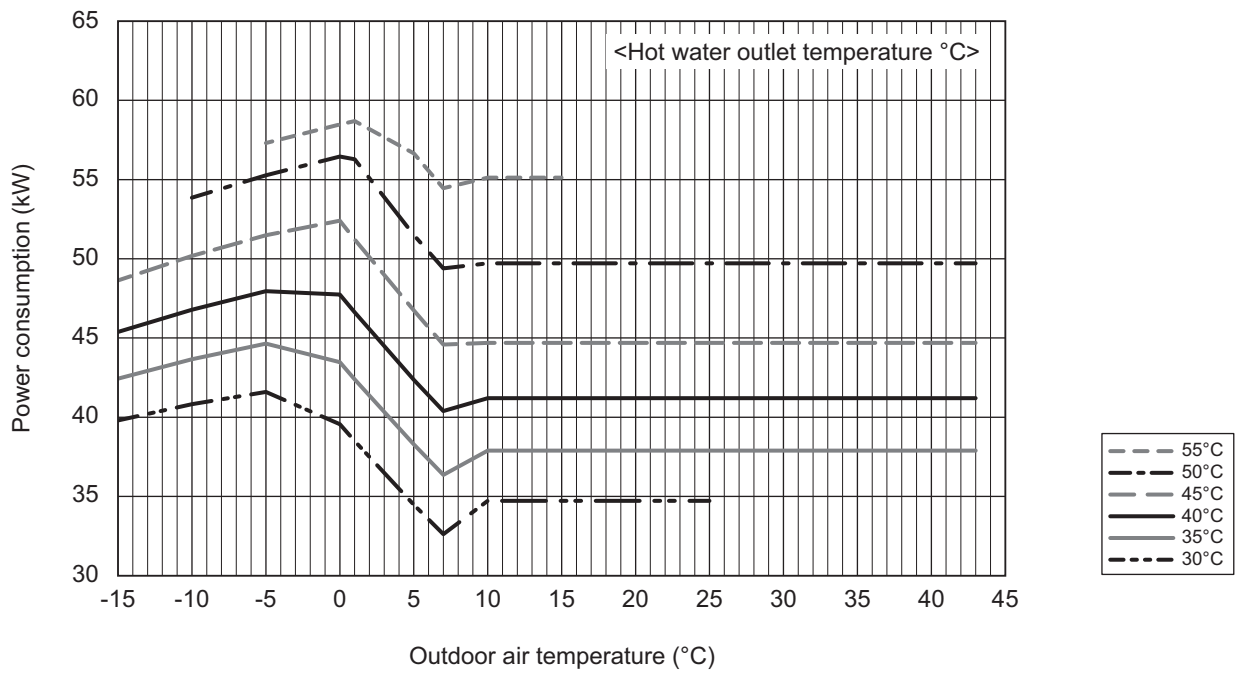
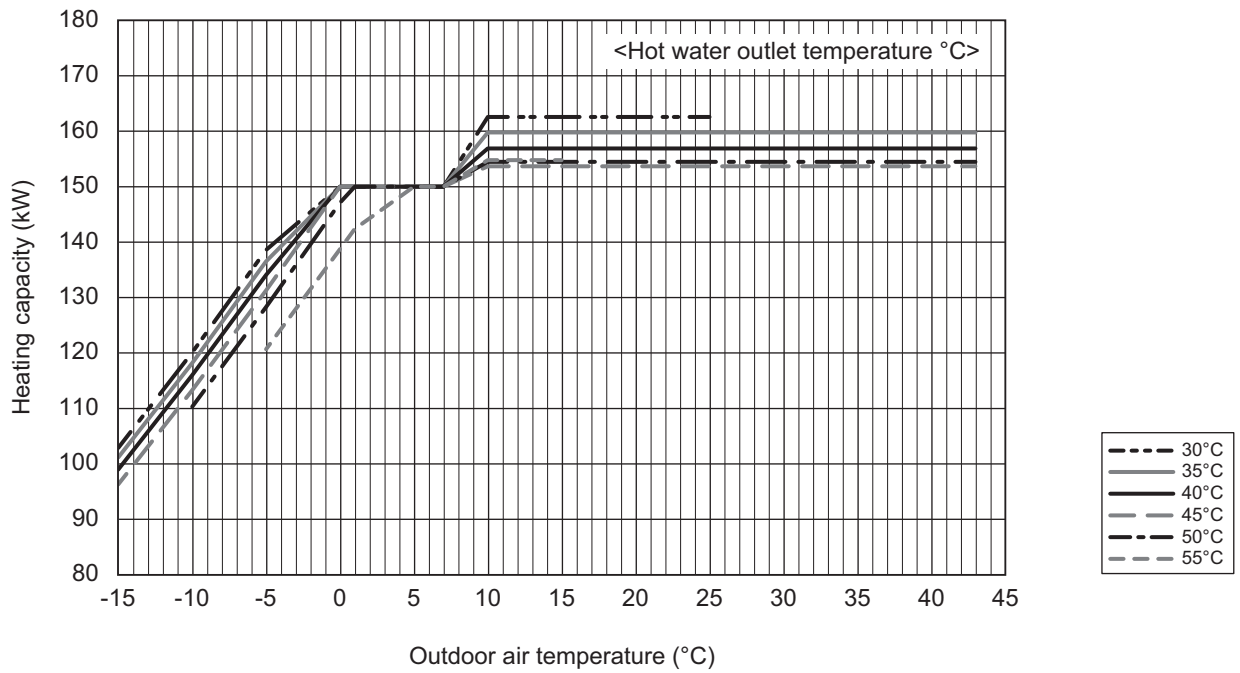



## 2. Product Data

[Cold/hot water outlet/inlet temperature difference 5°C]

EAHV-P1800YB  
EACV-P1800YB

■ Cooling Capacity [Water]

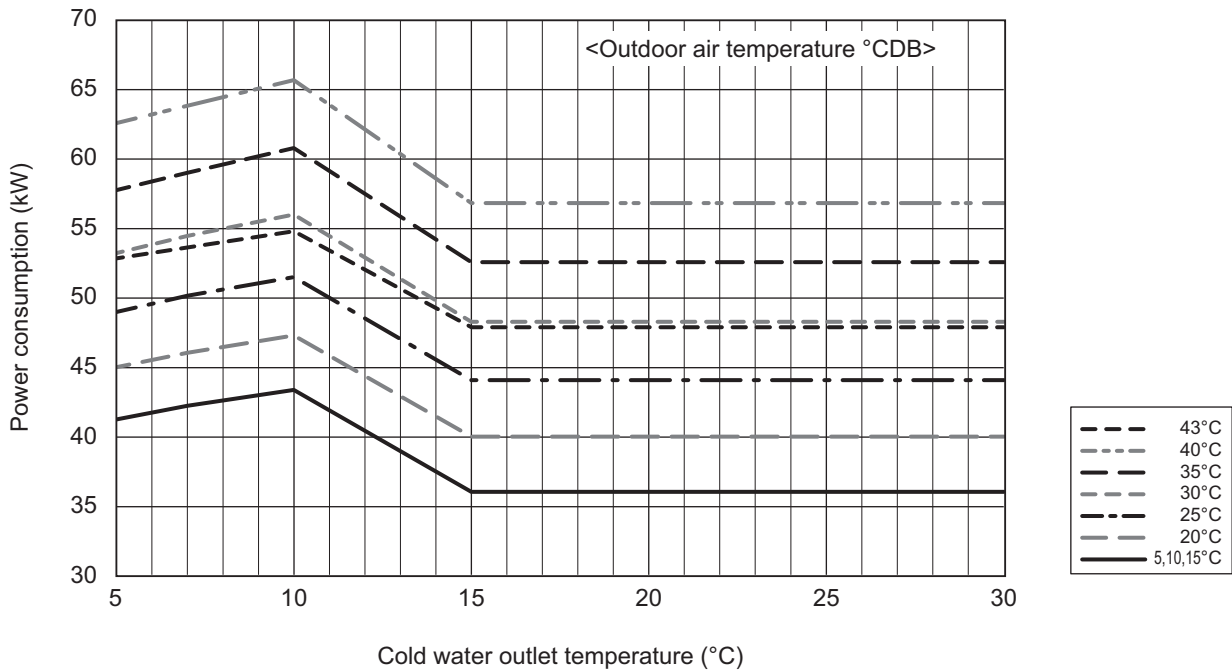
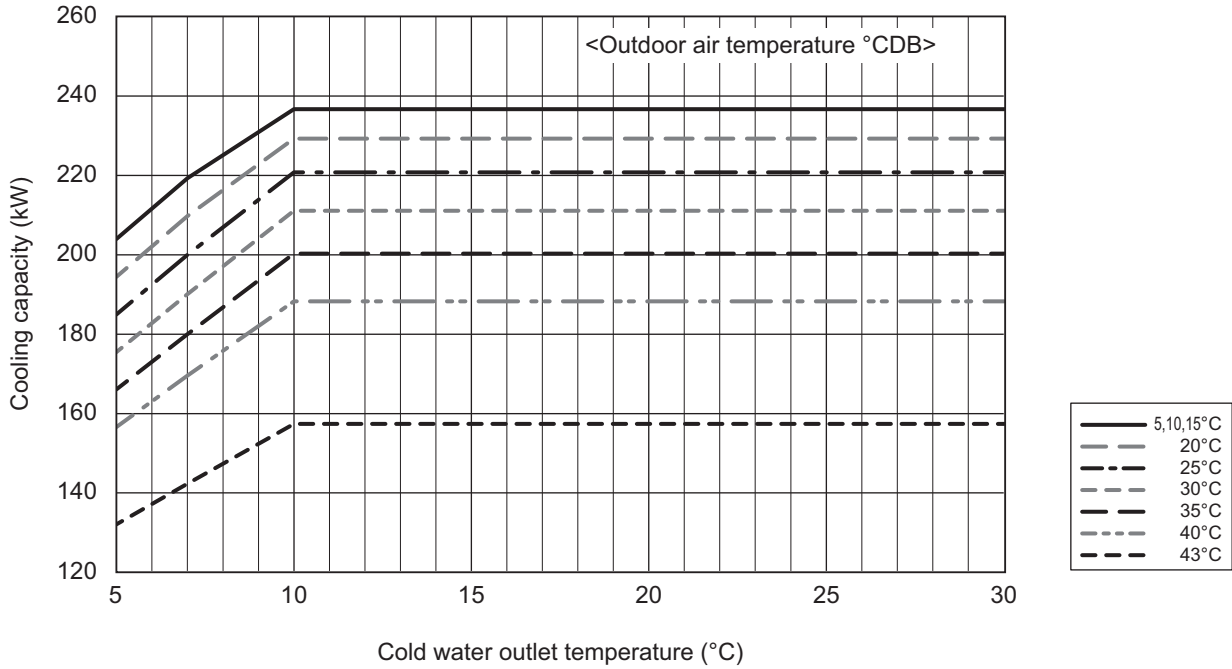

## 2. Product Data

[Cold/hot water outlet/inlet temperature difference 5°C]

EAHV-P1800YB

■ Heating Capacity

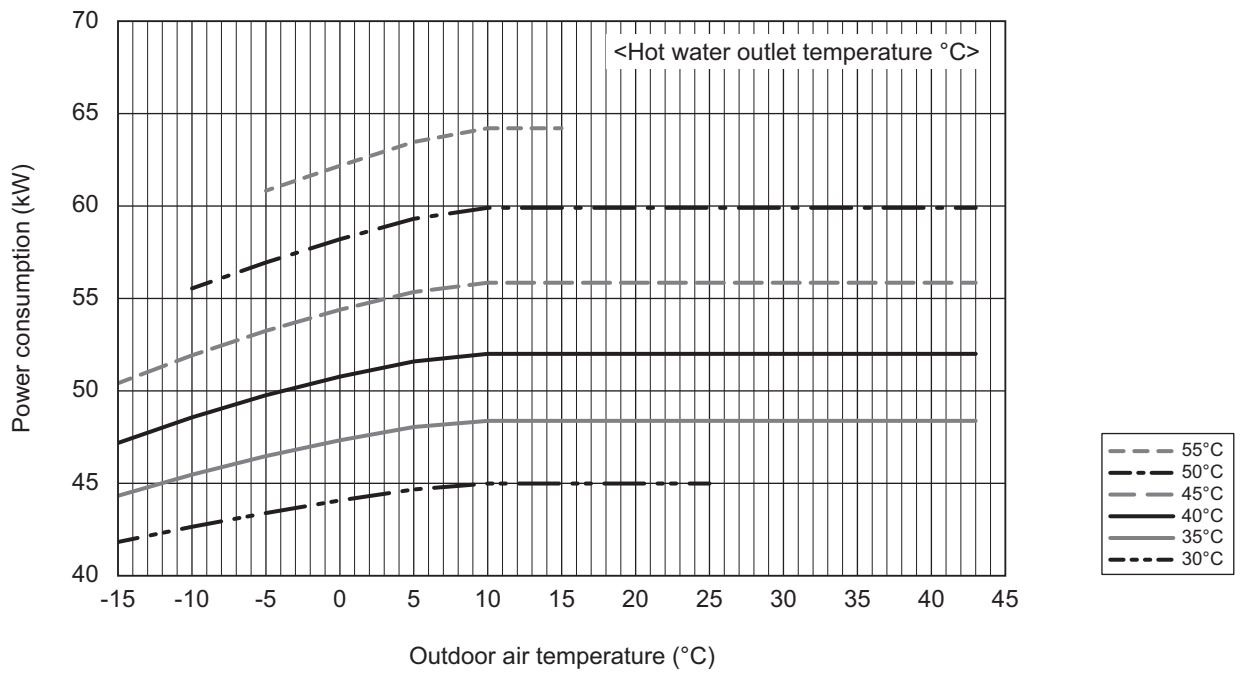
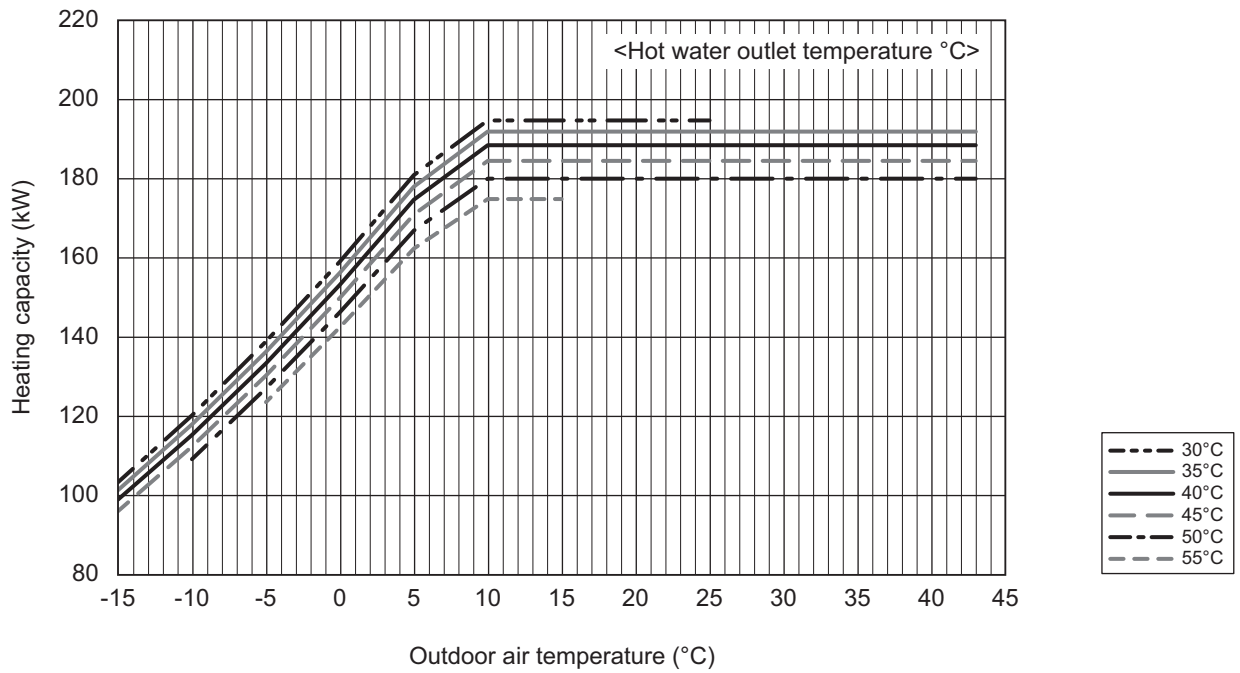

## 2. Product Data

[Cold/hot water outlet/inlet temperature difference 7°C]

EAHV-P1500YB  
EACV-P1500YB

■ Cooling Capacity [Water]

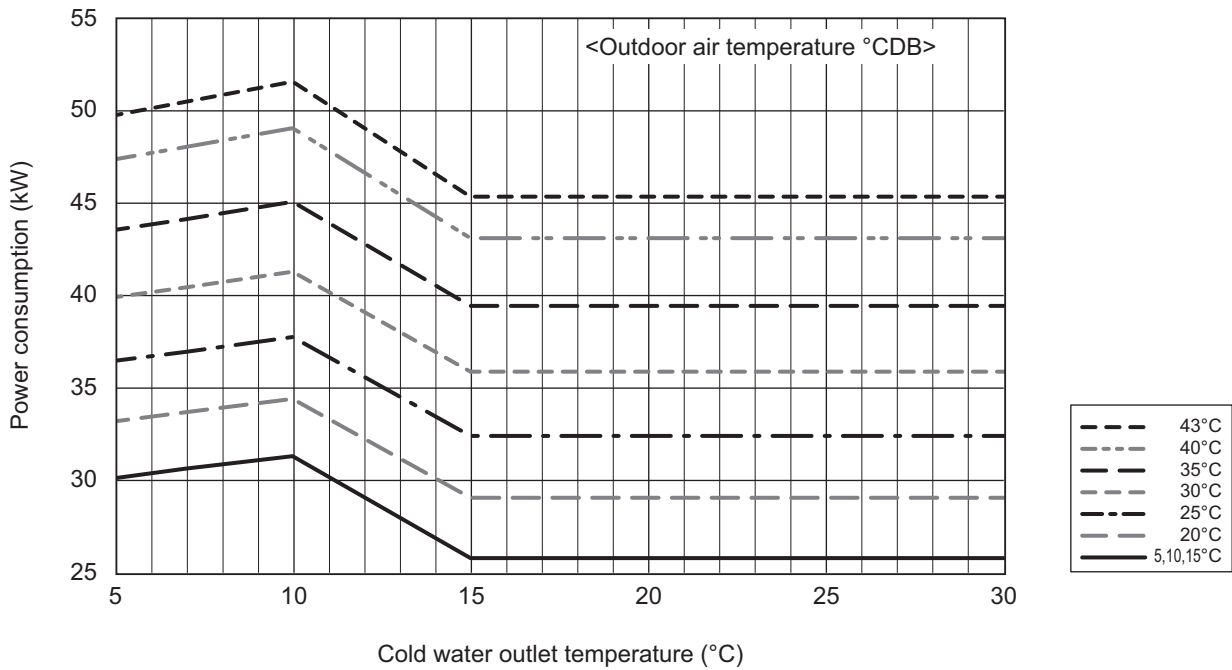
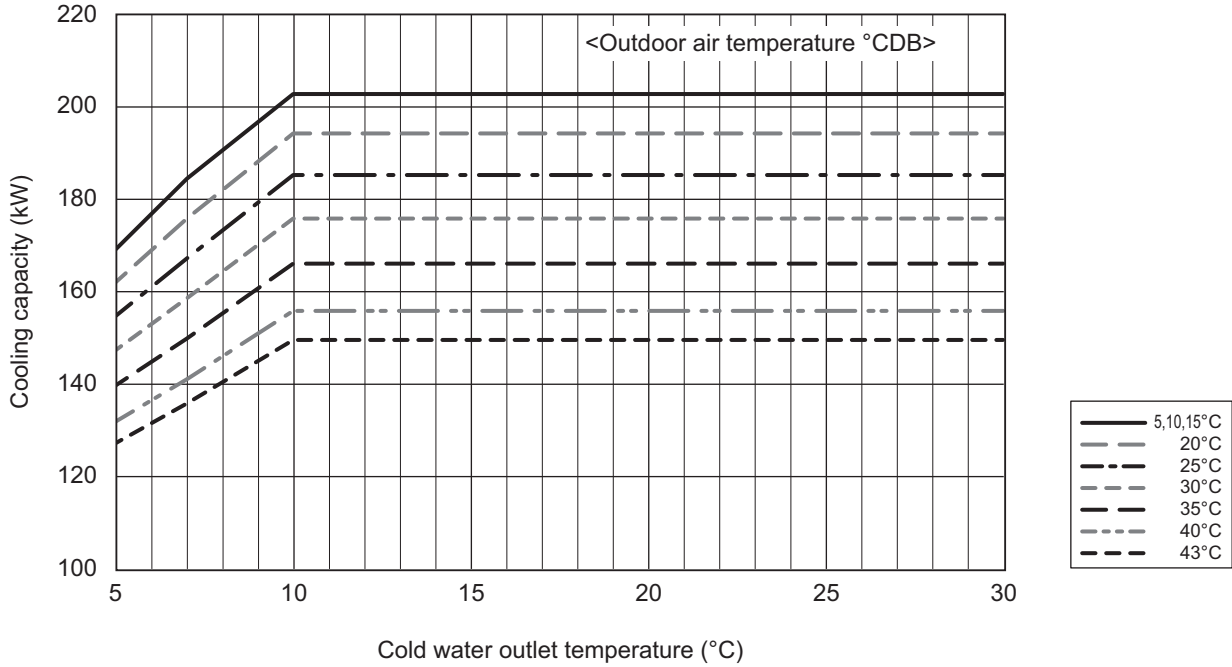

## 2. Product Data

[Cold/hot water outlet/inlet temperature difference 7°C]

EAHV-P1500YB

■ Heating Capacity

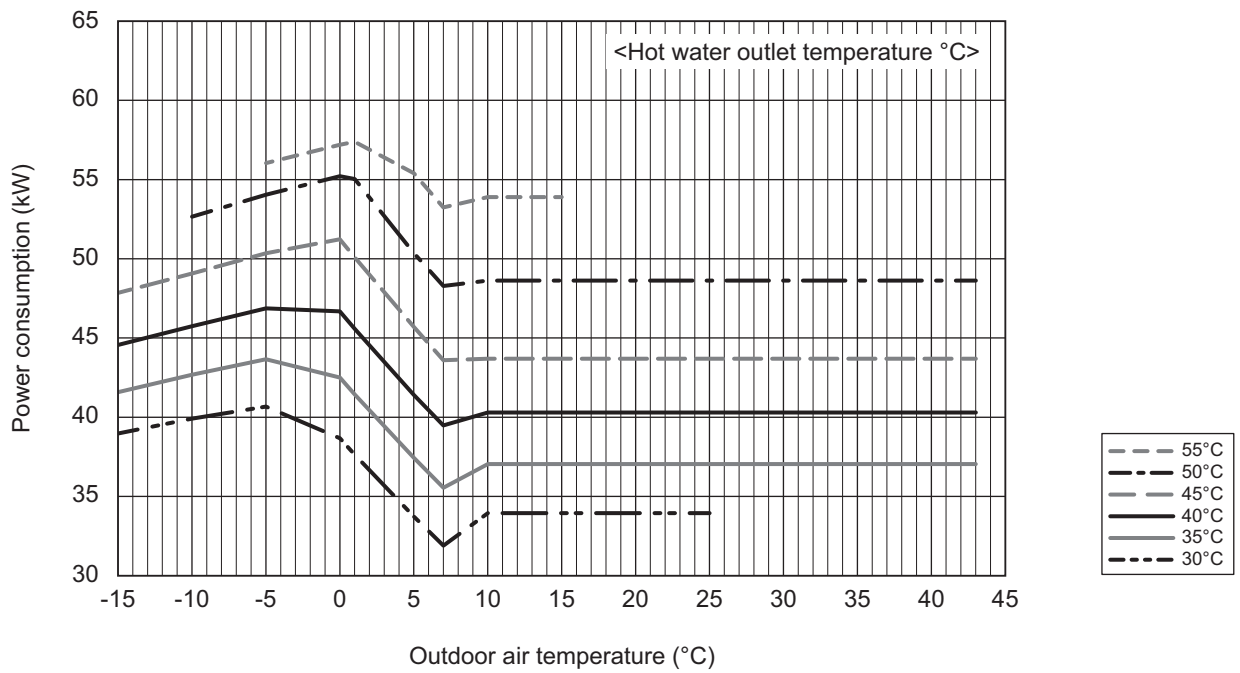
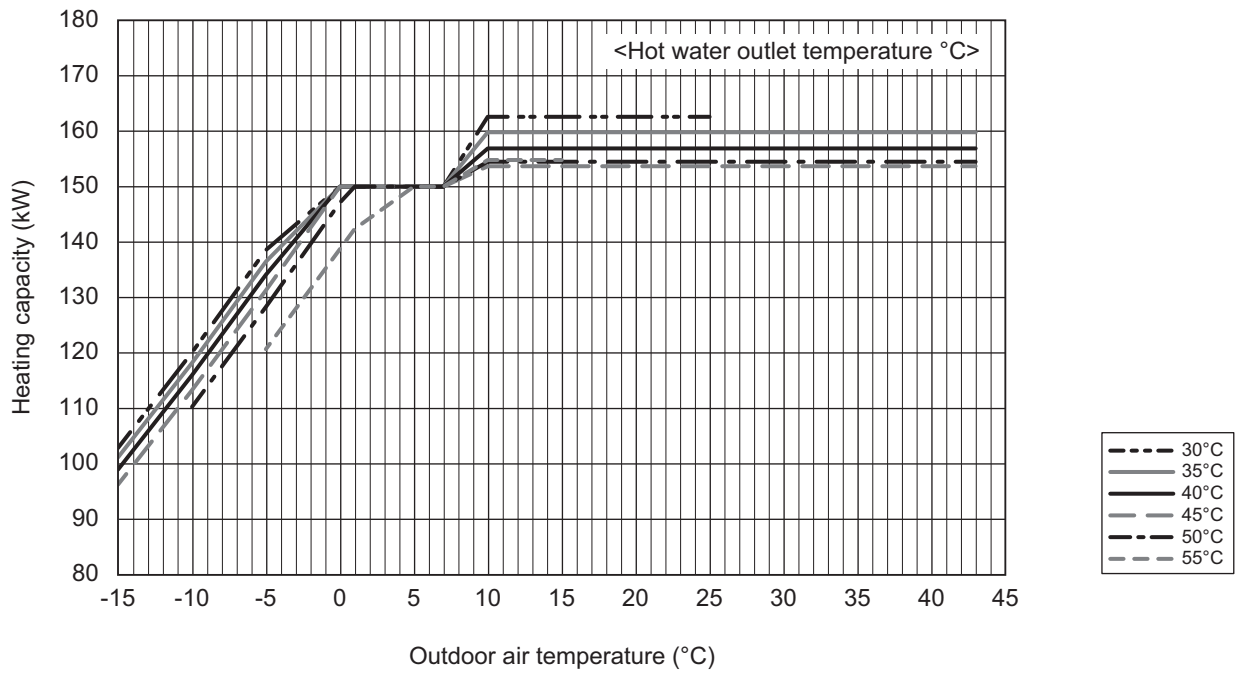

## 2. Product Data

[Cold/hot water outlet/inlet temperature difference 7°C]

EAHV-P1800YB  
EACV-P1800YB

■ Cooling Capacity [Water]

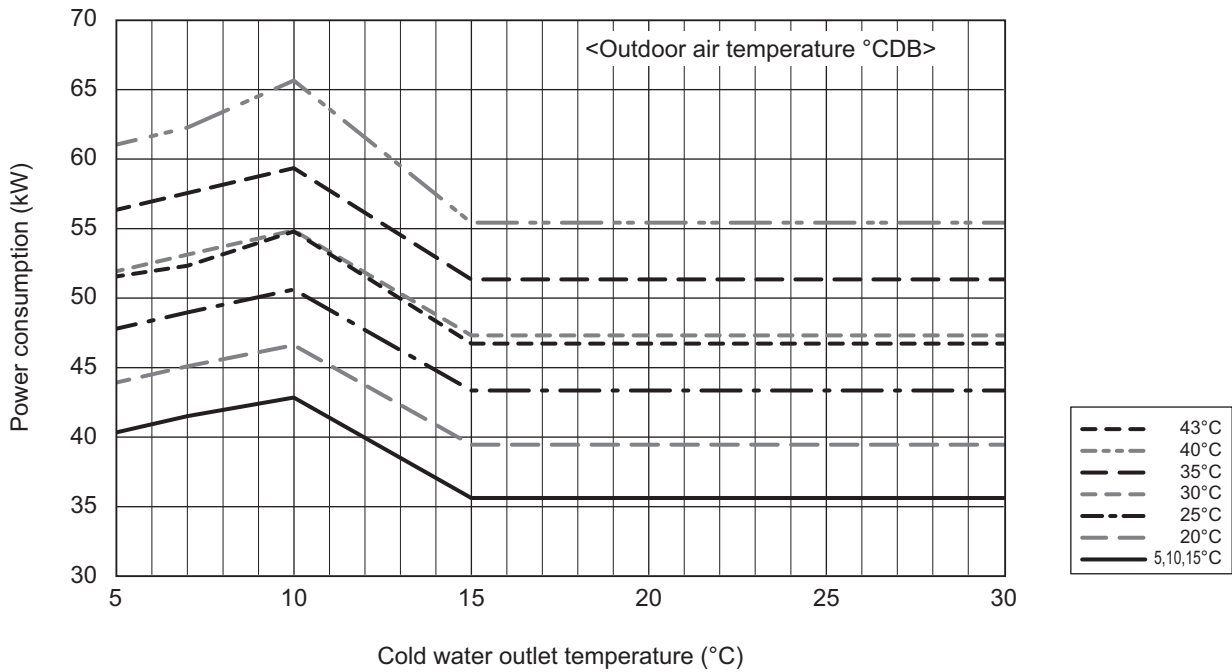
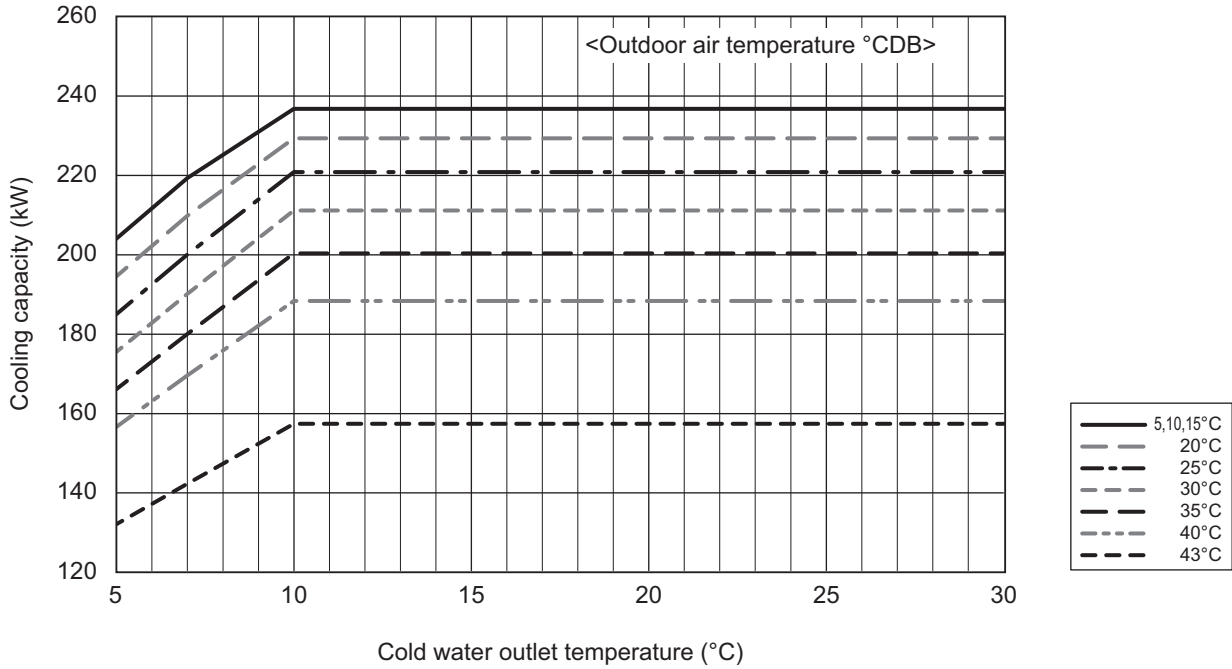

## 2. Product Data

[Cold/hot water outlet/inlet temperature difference 7°C]

EAHV-P1800YB

■ Heating Capacity

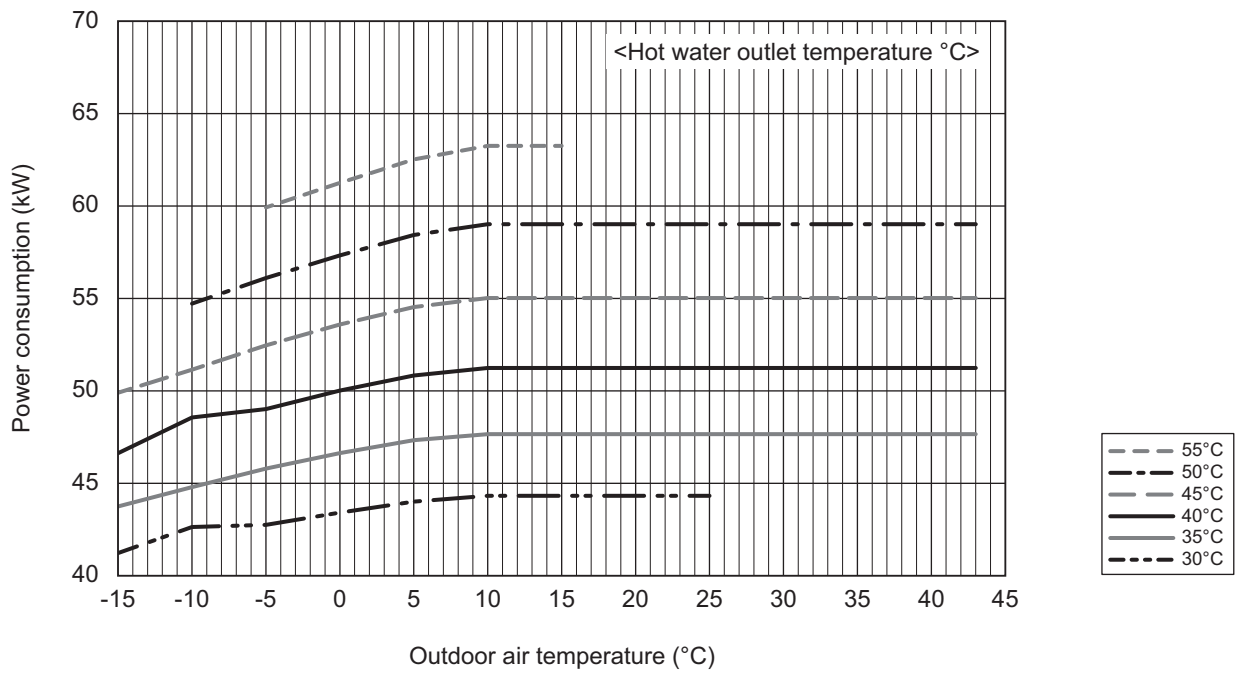
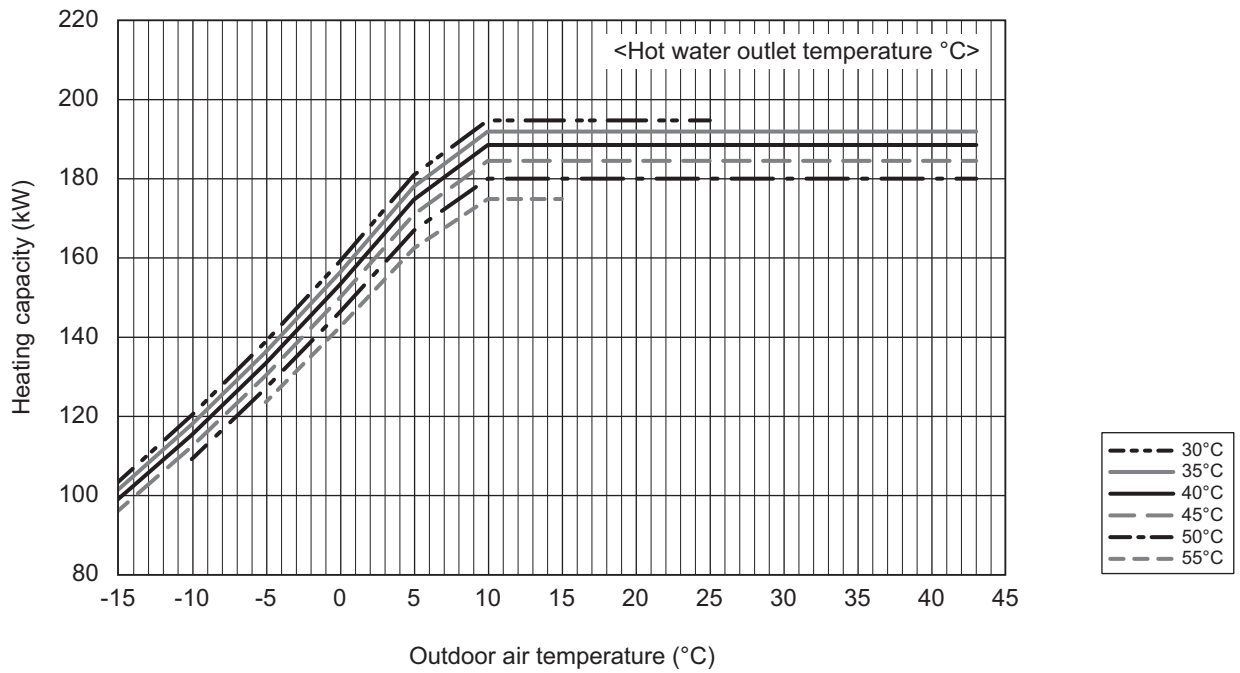

## 2. Product Data

Cooling capacity: Cold water outlet/inlet temperature difference 5°C

### Capacity change mode: Capacity priority

MODEL			EAHV-P1500YB, EACV-P1500YB												
Cold water outlet temperature	Outdoor air temperature °CDB		-15	-10	-5	0	5	10	15	20	25	30	35	40	43
			5	Cooling capacity	kW	169.3	169.3	169.3	169.3	169.3	169.3	169.3	162.2	154.9	147.5
Power consumption	kW	30.83		30.83	30.83	30.83	30.83	30.83	30.83	33.97	37.30	40.82	44.53	48.42	50.85
Cold water flow rate	m <sup>3</sup> /h	29.1		29.1	29.1	29.1	29.1	29.1	29.1	27.9	26.6	25.4	24.1	22.7	21.9
Water pressure loss	kPa	145		145	145	145	145	145	145	133	121	111	100	89	83
7	Cooling capacity	kW	184.5	184.5	184.5	184.5	184.5	184.5	184.5	175.9	167.3	158.7	150.0	141.2	136.0
	Power consumption	kW	31.35	31.35	31.35	31.35	31.35	31.35	31.35	34.47	37.80	41.34	45.10	49.09	51.58
	Cold water flow rate	m <sup>3</sup> /h	31.7	31.7	31.7	31.7	31.7	31.7	31.7	30.3	28.8	27.3	25.8	24.3	23.4
	Water pressure loss	kPa	171	171	171	171	171	171	171	156	142	128	114	102	95
10	Cooling capacity	kW	202.8	202.8	202.8	202.8	202.8	202.8	202.8	194.3	185.3	175.9	166.2	156.0	149.7
	Power consumption	kW	31.98	31.98	31.98	31.98	31.98	31.98	31.98	35.21	38.60	42.22	46.07	50.14	52.69
	Cold water flow rate	m <sup>3</sup> /h	34.0	34.0	34.0	34.0	34.0	34.0	34.0	33.4	31.9	30.3	28.6	26.8	25.7
	Water pressure loss	kPa	196	196	196	196	196	196	196	189	173	156	140	123	114
15	Cooling capacity	kW	202.8	202.8	202.8	202.8	202.8	202.8	202.8	194.3	185.3	175.9	166.2	156.0	149.7
	Power consumption	kW	26.39	26.39	26.39	26.39	26.39	26.39	26.39	29.75	33.17	36.70	40.32	44.06	46.35
	Cold water flow rate	m <sup>3</sup> /h	34.0	34.0	34.0	34.0	34.0	34.0	34.0	33.4	31.9	30.3	28.6	26.8	25.7
	Water pressure loss	kPa	196	196	196	196	196	196	196	189	173	156	140	123	114
20	Cooling capacity	kW	-	202.8	202.8	202.8	202.8	202.8	202.8	194.3	185.3	175.9	166.2	156.0	149.7
	Power consumption	kW	-	26.39	26.39	26.39	26.39	26.39	26.39	29.75	33.17	36.70	40.32	44.06	46.35
	Cold water flow rate	m <sup>3</sup> /h	-	34.0	34.0	34.0	34.0	34.0	34.0	33.4	31.9	30.3	28.6	26.8	25.7
	Water pressure loss	kPa	-	196	196	196	196	196	196	189	173	156	140	123	114
25	Cooling capacity	kW	-	202.8	202.8	202.8	202.8	202.8	202.8	194.3	185.3	175.9	166.2	156.0	149.7
	Power consumption	kW	-	26.39	26.39	26.39	26.39	26.39	26.39	29.75	33.17	36.70	40.32	44.06	46.35
	Cold water flow rate	m <sup>3</sup> /h	-	34.0	34.0	34.0	34.0	34.0	34.0	33.4	31.9	30.3	28.6	26.8	25.7
	Water pressure loss	kPa	-	196	196	196	196	196	196	189	173	156	140	123	114
30	Cooling capacity	kW	-	202.8	202.8	202.8	202.8	202.8	202.8	194.3	185.3	175.9	166.2	156.0	149.7
	Power consumption	kW	-	26.39	26.39	26.39	26.39	26.39	26.39	29.75	33.17	36.70	40.32	44.06	46.35
	Cold water flow rate	m <sup>3</sup> /h	-	34.0	34.0	34.0	34.0	34.0	34.0	33.4	31.9	30.3	28.6	26.8	25.7
	Water pressure loss	kPa	-	196	196	196	196	196	196	189	173	156	140	123	114

\* Pump is not included.

\* Hatching area shows outlet/inlet temperature difference over 5°C.

### Capacity change mode: Capacity priority

MODEL			EAHV-P1800YB, EACV-P1800YB												
Cold water outlet temperature	Outdoor air temperature °CDB		-15	-10	-5	0	5	10	15	20	25	30	35	40	43
			5	Cooling capacity	kW	204.0	204.0	204.0	204.0	204.0	204.0	204.0	194.5	185.0	175.5
Power consumption	kW	41.27		41.27	41.27	41.27	41.27	41.27	41.27	45.03	49.00	53.24	57.77	62.59	52.86
Cold water flow rate	m <sup>3</sup> /h	34.0		34.0	34.0	34.0	34.0	34.0	34.0	33.5	31.8	30.2	28.6	26.9	22.7
Water pressure loss	kPa	196		196	196	196	196	196	196	190	172	155	140	124	89
7	Cooling capacity	kW	219.3	219.3	219.3	219.3	219.3	219.3	219.3	209.8	200.0	190.1	180.0	169.6	142.3
	Power consumption	kW	42.25	42.25	42.25	42.25	42.25	42.25	42.25	46.06	50.17	54.47	59.01	63.84	53.64
	Cold water flow rate	m <sup>3</sup> /h	34.0	34.0	34.0	34.0	34.0	34.0	34.0	34.0	34.0	32.7	31.0	29.2	24.5
	Water pressure loss	kPa	196	196	196	196	196	196	196	196	196	182	164	146	103
10	Cooling capacity	kW	236.7	236.7	236.7	236.7	236.7	236.7	236.7	229.3	220.8	211.1	200.3	188.3	157.4
	Power consumption	kW	43.39	43.39	43.39	43.39	43.39	43.39	43.39	47.31	51.51	56.01	60.79	65.68	54.81
	Cold water flow rate	m <sup>3</sup> /h	34.0	34.0	34.0	34.0	34.0	34.0	34.0	34.0	34.0	34.0	34.0	32.4	27.1
	Water pressure loss	kPa	196	196	196	196	196	196	196	196	196	196	196	178	126
15	Cooling capacity	kW	236.7	236.7	236.7	236.7	236.7	236.7	236.7	229.3	220.8	211.1	200.3	188.3	157.4
	Power consumption	kW	36.06	36.06	36.06	36.06	36.06	36.06	36.06	40.03	44.10	48.29	52.59	56.83	47.91
	Cold water flow rate	m <sup>3</sup> /h	34.0	34.0	34.0	34.0	34.0	34.0	34.0	34.0	34.0	34.0	34.0	32.4	27.1
	Water pressure loss	kPa	196	196	196	196	196	196	196	196	196	196	196	178	126
20	Cooling capacity	kW	-	236.7	236.7	236.7	236.7	236.7	236.7	229.3	220.8	211.1	200.3	188.3	157.4
	Power consumption	kW	-	36.06	36.06	36.06	36.06	36.06	36.06	40.03	44.10	48.29	52.59	56.83	47.91
	Cold water flow rate	m <sup>3</sup> /h	-	34.0	34.0	34.0	34.0	34.0	34.0	34.0	34.0	34.0	34.0	32.4	27.1
	Water pressure loss	kPa	-	196	196	196	196	196	196	196	196	196	196	178	126
25	Cooling capacity	kW	-	236.7	236.7	236.7	236.7	236.7	236.7	229.3	220.8	211.1	200.3	188.3	157.4
	Power consumption	kW	-	36.06	36.06	36.06	36.06	36.06	36.06	40.03	44.10	48.29	52.59	56.83	47.91
	Cold water flow rate	m <sup>3</sup> /h	-	34.0	34.0	34.0	34.0	34.0	34.0	34.0	34.0	34.0	34.0	32.4	27.1
	Water pressure loss	kPa	-	196	196	196	196	196	196	196	196	196	196	178	126
30	Cooling capacity	kW	-	236.7	236.7	236.7	236.7	236.7	236.7	229.3	220.8	211.1	200.3	188.3	157.4
	Power consumption	kW	-	36.06	36.06	36.06	36.06	36.06	36.06	40.03	44.10	48.29	52.59	56.83	47.91
	Cold water flow rate	m <sup>3</sup> /h	-	34.0	34.0	34.0	34.0	34.0	34.0	34.0	34.0	34.0	34.0	32.4	27.1
	Water pressure loss	kPa	-	196	196	196	196	196	196	196	196	196	196	178	126

\* Pump is not included.

\* Hatching area shows outlet/inlet temperature difference over 5°C.

## 2. Product Data

Cooling capacity: Cold water outlet/inlet temperature difference 7°C

### Capacity change mode: Capacity priority

MODEL		EAHV-P1500YB, EACV-P1500YB												
Cold water outlet temperature	Outdoor air temperature °CDB	-15	-10	-5	0	5	10	15	20	25	30	35	40	43
		5	Cooling capacity	kW	169.3	169.3	169.3	169.3	169.3	169.3	162.2	154.9	147.5	139.9
Power consumption	kW		30.17	30.17	30.17	30.17	30.17	30.17	33.24	36.50	39.94	43.57	47.38	49.76
Cold water flow rate	m <sup>3</sup> /h		20.8	20.8	20.8	20.8	20.8	20.8	19.9	19.0	18.1	17.2	16.2	15.7
Water pressure loss	kPa		75	75	75	75	75	75	69	63	58	52	47	44
7	Cooling capacity	kW	184.5	184.5	184.5	184.5	184.5	184.5	175.9	167.3	158.7	150.0	141.2	136.0
	Power consumption	kW	30.68	30.68	30.68	30.68	30.68	30.68	33.73	36.99	40.46	44.14	48.04	50.48
	Cold water flow rate	m <sup>3</sup> /h	22.7	22.7	22.7	22.7	22.7	22.7	21.6	20.6	19.5	18.4	17.3	16.7
	Water pressure loss	kPa	89	89	89	89	89	89	81	74	66	59	53	49
10	Cooling capacity	kW	202.8	202.8	202.8	202.8	202.8	202.8	194.3	185.3	175.9	166.2	156.0	149.7
	Power consumption	kW	31.35	31.35	31.35	31.35	31.35	31.35	34.45	37.78	41.31	45.08	49.06	51.56
	Cold water flow rate	m <sup>3</sup> /h	24.9	24.9	24.9	24.9	24.9	24.9	23.9	22.8	21.6	20.4	19.2	18.4
	Water pressure loss	kPa	107	107	107	107	107	107	99	90	81	73	65	59
15	Cooling capacity	kW	202.8	202.8	202.8	202.8	202.8	202.8	194.3	185.3	175.9	166.2	156.0	149.7
	Power consumption	kW	25.86	25.86	25.86	25.86	25.86	25.86	29.11	32.45	35.91	39.46	43.12	45.36
	Cold water flow rate	m <sup>3</sup> /h	24.9	24.9	24.9	24.9	24.9	24.9	23.9	22.8	21.6	20.4	19.2	18.4
	Water pressure loss	kPa	107	107	107	107	107	107	99	90	81	73	65	59
20	Cooling capacity	kW	-	202.8	202.8	202.8	202.8	202.8	194.3	185.3	175.9	166.2	156.0	149.7
	Power consumption	kW	-	25.86	25.86	25.86	25.86	25.86	29.11	32.45	35.91	39.46	43.12	45.36
	Cold water flow rate	m <sup>3</sup> /h	-	24.9	24.9	24.9	24.9	24.9	23.9	22.8	21.6	20.4	19.2	18.4
	Water pressure loss	kPa	-	107	107	107	107	107	99	90	81	73	65	59
25	Cooling capacity	kW	-	202.8	202.8	202.8	202.8	202.8	194.3	185.3	175.9	166.2	156.0	149.7
	Power consumption	kW	-	25.86	25.86	25.86	25.86	25.86	29.11	32.45	35.91	39.46	43.12	45.36
	Cold water flow rate	m <sup>3</sup> /h	-	24.9	24.9	24.9	24.9	24.9	23.9	22.8	21.6	20.4	19.2	18.4
	Water pressure loss	kPa	-	107	107	107	107	107	99	90	81	73	65	59
30	Cooling capacity	kW	-	202.8	202.8	202.8	202.8	202.8	194.3	185.3	175.9	166.2	156.0	149.7
	Power consumption	kW	-	25.86	25.86	25.86	25.86	25.86	29.11	32.45	35.91	39.46	43.12	45.36
	Cold water flow rate	m <sup>3</sup> /h	-	24.9	24.9	24.9	24.9	24.9	23.9	22.8	21.6	20.4	19.2	18.4
	Water pressure loss	kPa	-	107	107	107	107	107	99	90	81	73	65	59

\* Pump is not included.

### Capacity change mode: Capacity priority

MODEL		EAHV-P1800YB, EACV-P1800YB												
Cold water outlet temperature	Outdoor air temperature °CDB	-15	-10	-5	0	5	10	15	20	25	30	35	40	43
		5	Cooling capacity	kW	204.0	204.0	204.0	204.0	204.0	204.0	194.5	185.0	175.5	166.1
Power consumption	kW		40.35	40.35	40.35	40.35	40.35	40.35	43.94	47.81	51.95	56.37	61.07	51.58
Cold water flow rate	m <sup>3</sup> /h		25.1	25.1	25.1	25.1	25.1	25.1	23.9	22.7	21.6	20.4	19.2	16.2
Water pressure loss	kPa		108	108	108	108	108	108	99	89	81	73	65	47
7	Cooling capacity	kW	219.3	219.3	219.3	219.3	219.3	219.3	209.8	200.0	190.1	180.0	169.6	142.3
	Power consumption	kW	41.52	41.52	41.52	41.52	41.52	41.52	45.11	48.99	53.14	57.58	62.29	52.34
	Cold water flow rate	m <sup>3</sup> /h	26.9	26.9	26.9	26.9	26.9	26.9	25.8	24.6	23.4	22.1	20.8	17.5
	Water pressure loss	kPa	124	124	124	124	124	124	114	104	95	85	75	54
10	Cooling capacity	kW	236.7	236.7	236.7	236.7	236.7	236.7	229.3	220.8	211.1	200.3	188.3	157.4
	Power consumption	kW	42.86	42.86	42.86	42.86	42.86	42.86	46.63	50.64	54.89	59.37	65.68	54.81
	Cold water flow rate	m <sup>3</sup> /h	29.1	29.1	29.1	29.1	29.1	29.1	28.2	27.1	25.9	24.6	23.4	21.1
	Water pressure loss	kPa	145	145	145	145	145	145	136	126	115	104	92	65
15	Cooling capacity	kW	236.7	236.7	236.7	236.7	236.7	236.7	229.3	220.8	211.1	200.3	188.3	157.4
	Power consumption	kW	35.63	35.63	35.63	35.63	35.63	35.63	39.46	43.36	47.33	51.36	55.45	46.74
	Cold water flow rate	m <sup>3</sup> /h	29.1	29.1	29.1	29.1	29.1	29.1	28.2	27.1	25.9	24.6	23.1	19.3
	Water pressure loss	kPa	145	145	145	145	145	145	136	126	115	104	92	65
20	Cooling capacity	kW	-	236.7	236.7	236.7	236.7	236.7	229.3	220.8	211.1	200.3	188.3	157.4
	Power consumption	kW	-	35.63	35.63	35.63	35.63	35.63	39.46	43.36	47.33	51.36	55.45	46.74
	Cold water flow rate	m <sup>3</sup> /h	-	29.1	29.1	29.1	29.1	29.1	28.2	27.1	25.9	24.6	23.1	19.3
	Water pressure loss	kPa	-	145	145	145	145	145	136	126	115	104	92	65
25	Cooling capacity	kW	-	236.7	236.7	236.7	236.7	236.7	229.3	220.8	211.1	200.3	188.3	157.4
	Power consumption	kW	-	35.63	35.63	35.63	35.63	35.63	39.46	43.36	47.33	51.36	55.45	46.74
	Cold water flow rate	m <sup>3</sup> /h	-	29.1	29.1	29.1	29.1	29.1	28.2	27.1	25.9	24.6	23.1	19.3
	Water pressure loss	kPa	-	145	145	145	145	145	136	126	115	104	92	65
30	Cooling capacity	kW	-	236.7	236.7	236.7	236.7	236.7	229.3	220.8	211.1	200.3	188.3	157.4
	Power consumption	kW	-	35.63	35.63	35.63	35.63	35.63	39.46	43.36	47.33	51.36	55.45	46.74
	Cold water flow rate	m <sup>3</sup> /h	-	29.1	29.1	29.1	29.1	29.1	28.2	27.1	25.9	24.6	23.1	19.3
	Water pressure loss	kPa	-	145	145	145	145	145	136	126	115	104	92	65

\* Pump is not included.



## 2. Product Data

Heating capacity: Hot water outlet/inlet temperature difference 5°C

### Capacity change mode: Capacity priority

MODEL		EAHV-P1500YB													
Hot water outlet temperature	Outdoor air temperature °CDB	-15	-10	-5	0	5	10	15	20	25	30	35	40	43	
30	Heating capacity	kW	102.9	120.1	138.6	150.0	150.0	162.6	162.6	162.6	162.6	-	-	-	-
	Power consumption	kW	39.80	40.82	41.60	39.56	34.49	34.72	34.72	34.72	34.72	-	-	-	-
	Hot water flow rate	m <sup>3</sup> /h	17.7	20.7	23.8	25.8	25.8	28.0	28.0	28.0	28.0	-	-	-	-
	Water pressure loss	kPa	55	75	98	114	114	134	134	134	134	-	-	-	-
35	Heating capacity	kW	101.2	118.2	136.5	150.0	150.0	159.8	159.8	159.8	159.8	159.8	159.8	159.8	159.8
	Power consumption	kW	42.43	43.66	44.65	43.48	38.29	37.89	37.89	37.89	37.89	37.89	37.89	37.89	37.89
	Hot water flow rate	m <sup>3</sup> /h	17.4	20.3	23.5	25.8	25.8	27.5	27.5	27.5	27.5	27.5	27.5	27.5	27.5
	Water pressure loss	kPa	53	72	95	114	114	130	130	130	130	130	130	130	130
40	Heating capacity	kW	99.0	116.0	134.1	150.0	150.0	156.9	156.9	156.9	156.9	156.9	156.9	156.9	156.9
	Power consumption	kW	45.38	46.78	47.95	47.74	42.36	41.21	41.21	41.21	41.21	41.21	41.21	41.21	41.21
	Hot water flow rate	m <sup>3</sup> /h	17	20	23.1	25.8	25.8	27	27	27	27	27	27	27	27
	Water pressure loss	kPa	51	70	92	114	114	125	125	125	125	125	125	125	125
45	Heating capacity	kW	96.3	113.3	131.3	150.0	150.0	153.7	153.7	153.7	153.7	153.7	153.7	153.7	153.7
	Power consumption	kW	48.64	50.18	51.49	52.41	46.75	44.69	44.69	44.69	44.69	44.69	44.69	44.69	44.69
	Hot water flow rate	m <sup>3</sup> /h	16.6	19.5	22.6	25.8	25.8	26.4	26.4	26.4	26.4	26.4	26.4	26.4	26.4
	Water pressure loss	kPa	49	66	88	114	114	120	120	120	120	120	120	120	120
50	Heating capacity	kW	-	110.3	128.3	147.1	150.0	154.5	154.5	154.5	154.5	154.5	154.5	154.5	154.5
	Power consumption	kW	-	53.86	55.27	56.46	51.50	49.72	49.72	49.72	49.72	49.72	49.72	49.72	49.72
	Hot water flow rate	m <sup>3</sup> /h	-	19.0	22.1	25.3	25.8	26.6	26.6	26.6	26.6	26.6	26.6	26.6	26.6
	Water pressure loss	kPa	-	63	85	110	114	121	121	121	121	121	121	121	121
55	Heating capacity	kW	-	-	120.7	138.7	150.0	154.8	154.8	-	-	-	-	-	-
	Power consumption	kW	-	-	57.31	58.48	56.66	55.12	55.12	-	-	-	-	-	-
	Hot water flow rate	m <sup>3</sup> /h	-	-	20.8	23.9	25.8	26.6	26.6	-	-	-	-	-	-
	Water pressure loss	kPa	-	-	75	99	114	121	121	-	-	-	-	-	-

\* Pump is not included.

\* This table shows the capacity when the relative humidity is 85%.

\* The performance is the value not including the defrost correction.

### Capacity change mode: Capacity priority

MODEL		EAHV-P1800YB													
Hot water outlet temperature	Outdoor air temperature °CDB	-15	-10	-5	0	5	10	15	20	25	30	35	40	43	
30	Heating capacity	kW	103.4	120.3	138.9	159.1	180.9	194.7	194.7	194.7	194.7	-	-	-	-
	Power consumption	kW	41.82	42.64	43.39	44.07	44.67	44.99	44.99	44.99	44.99	-	-	-	-
	Hot water flow rate	m <sup>3</sup> /h	17.8	20.7	23.9	27.4	31.1	33.5	33.5	33.5	33.5	-	-	-	-
	Water pressure loss	kPa	56	75	99	129	165	190	190	190	190	-	-	-	-
35	Heating capacity	kW	101.4	118	136.3	156.3	178	191.9	191.9	191.9	191.9	191.9	191.9	191.9	191.9
	Power consumption	kW	44.32	45.47	46.47	47.33	48.04	48.38	48.38	48.38	48.38	48.38	48.38	48.38	48.38
	Hot water flow rate	m <sup>3</sup> /h	17.4	20.3	23.4	26.9	30.6	33.0	33.0	33.0	33.0	33.0	33.0	33.0	33.0
	Water pressure loss	kPa	53	72	95	124	160	185	185	185	185	185	185	185	185
40	Heating capacity	kW	99.0	115.3	133.4	153.2	174.7	188.5	188.5	188.5	188.5	188.5	188.5	188.5	188.5
	Power consumption	kW	47.18	48.56	49.76	50.77	51.59	52.00	52.00	52.00	52.00	52.00	52.00	52.00	52.00
	Hot water flow rate	m <sup>3</sup> /h	17.0	19.8	22.9	26.4	30.0	32.4	32.4	32.4	32.4	32.4	32.4	32.4	32.4
	Water pressure loss	kPa	51	68	91	120	153	178	178	178	178	178	178	178	178
45	Heating capacity	kW	96.1	112.4	130.3	149.9	171.0	184.5	184.5	184.5	184.5	184.5	184.5	184.5	184.5
	Power consumption	kW	50.41	51.92	53.25	54.39	55.35	55.85	55.85	55.85	55.85	55.85	55.85	55.85	55.85
	Hot water flow rate	m <sup>3</sup> /h	16.5	19.3	22.4	25.8	29.4	31.7	31.7	31.7	31.7	31.7	31.7	31.7	31.7
	Water pressure loss	kPa	48	65	87	114	148	171	171	171	171	171	171	171	171
50	Heating capacity	kW	-	109.2	127.1	146.3	166.9	180	180	180	180	180	180	180	180
	Power consumption	kW	-	55.54	56.94	58.20	59.31	59.90	59.90	59.90	59.90	59.90	59.90	59.90	59.90
	Hot water flow rate	m <sup>3</sup> /h	-	18.8	21.9	25.2	28.7	31.0	31.0	31.0	31.0	31.0	31.0	31.0	31.0
	Water pressure loss	kPa	-	62	83	109	141	164	164	164	164	164	164	164	164
55	Heating capacity	kW	-	-	123.6	142.5	162.4	174.9	174.9	-	-	-	-	-	-
	Power consumption	kW	-	-	60.82	62.17	63.46	64.20	64.20	-	-	-	-	-	-
	Hot water flow rate	m <sup>3</sup> /h	-	-	21.3	24.5	27.9	30.1	30.1	-	-	-	-	-	-
	Water pressure loss	kPa	-	-	79	103	133	154	154	-	-	-	-	-	-

\* Pump is not included.

\* This table shows the capacity when the relative humidity is 85%.

\* The performance is the value not including the defrost correction.

## 2. Product Data

Heating capacity: Hot water outlet/inlet temperature difference 7°C

### Capacity change mode: Capacity priority

MODEL			EAHV-P1500YB												
Hot water outlet temperature	Outdoor air temperature °CDB		-15	-10	-5	0	5	10	15	20	25	30	35	40	43
30	Heating capacity	kW	102.9	120.1	138.6	150.0	150.0	162.6	162.6	162.6	162.6	-	-	-	-
	Power consumption	kW	38.98	39.91	40.68	38.68	33.73	33.95	33.95	33.95	33.95	-	-	-	-
	Hot water flow rate	m <sup>3</sup> /h	12.9	14.8	17.0	18.4	18.4	20.0	20.0	20.0	20.0	-	-	-	-
	Water pressure loss	kPa	30	39	51	59	59	70	70	70	70	-	-	-	-
35	Heating capacity	kW	101.2	118.2	136.5	150.0	150.0	159.8	159.8	159.8	159.8	159.8	159.8	159.8	159.8
	Power consumption	kW	41.59	42.69	43.66	42.51	37.44	37.05	37.05	37.05	37.05	37.05	37.05	37.05	37.05
	Hot water flow rate	m <sup>3</sup> /h	12.9	14.5	16.8	18.4	18.4	19.6	19.6	19.6	19.6	19.6	19.6	19.6	19.6
	Water pressure loss	kPa	30	38	50	59	59	67	67	67	67	67	67	67	67
40	Heating capacity	kW	99.0	116.0	134.1	150.0	150.0	156.9	156.9	156.9	156.9	156.9	156.9	156.9	156.9
	Power consumption	kW	44.57	45.75	46.88	46.68	41.42	40.30	40.30	40.30	40.30	40.30	40.30	40.30	40.30
	Hot water flow rate	m <sup>3</sup> /h	12.9	14.3	16.5	18.4	18.4	19.3	19.3	19.3	19.3	19.3	19.3	19.3	19.3
	Water pressure loss	kPa	30	37	48	59	59	65	65	65	65	65	65	65	65
45	Heating capacity	kW	96.3	113.3	131.3	150.0	150.0	153.7	153.7	153.7	153.7	153.7	153.7	153.7	153.7
	Power consumption	kW	47.85	49.07	50.35	51.24	45.71	43.70	43.70	43.70	43.70	43.70	43.70	43.70	43.70
	Hot water flow rate	m <sup>3</sup> /h	12.9	13.9	16.1	18.4	18.4	18.9	18.9	18.9	18.9	18.9	18.9	18.9	18.9
	Water pressure loss	kPa	30	35	46	59	59	63	63	63	63	63	63	63	63
50	Heating capacity	kW	-	110.3	128.3	147.1	150.0	154.5	154.5	154.5	154.5	154.5	154.5	154.5	154.5
	Power consumption	kW	-	52.66	54.04	55.21	50.36	48.62	48.62	48.62	48.62	48.62	48.62	48.62	48.62
	Hot water flow rate	m <sup>3</sup> /h	-	13.6	15.8	18.1	18.4	19	19	19	19	19	19	19	19
	Water pressure loss	kPa	-	33	44	58	59	63	63	63	63	63	63	63	63
55	Heating capacity	kW	-	-	120.7	138.7	150.0	154.8	154.8	-	-	-	-	-	-
	Power consumption	kW	-	-	56.04	57.19	55.40	53.89	53.89	-	-	-	-	-	-
	Hot water flow rate	m <sup>3</sup> /h	-	-	14.8	17	18.4	19	19	-	-	-	-	-	-
	Water pressure loss	kPa	-	-	39	51	59	63	63	-	-	-	-	-	-

\* Pump is not included.

\* Hatching area shows outlet/inlet temperature difference under 7°C.

\* This table shows the capacity when the relative humidity is 85%.

\* The performance is the value not including the defrost correction.

### Capacity change mode: Capacity priority

MODEL			EAHV-P1800YB												
Hot water outlet temperature	Outdoor air temperature °CDB		-15	-10	-5	0	5	10	15	20	25	30	35	40	43
30	Heating capacity	kW	103.4	120.3	138.9	159.1	180.9	194.7	194.7	194.7	194.7	-	-	-	-
	Power consumption	kW	41.23	42.64	42.75	43.42	44.01	44.32	44.32	44.32	44.32	-	-	-	-
	Hot water flow rate	m <sup>3</sup> /h	12.9	20.7	17.1	19.5	22.2	23.9	23.9	23.9	23.9	-	-	-	-
	Water pressure loss	kPa	30	75	52	66	85	99	99	99	99	-	-	-	-
35	Heating capacity	kW	101.4	118	136.3	156.3	178	191.9	191.9	191.9	191.9	191.9	191.9	191.9	191.9
	Power consumption	kW	43.75	44.80	45.79	46.63	47.33	47.66	47.66	47.66	47.66	47.66	47.66	47.66	47.66
	Hot water flow rate	m <sup>3</sup> /h	12.9	14.5	16.7	19.2	21.9	23.6	23.6	23.6	23.6	23.6	23.6	23.6	23.6
	Water pressure loss	kPa	30	38	49	65	83	96	96	96	96	96	96	96	96
40	Heating capacity	kW	99.0	115.3	133.4	153.2	174.7	188.5	188.5	188.5	188.5	188.5	188.5	188.5	188.5
	Power consumption	kW	46.63	48.56	49.02	50.02	50.83	51.24	51.24	51.24	51.24	51.24	51.24	51.24	51.24
	Hot water flow rate	m <sup>3</sup> /h	12.9	19.8	16.4	18.8	21.5	23.2	23.2	23.2	23.2	23.2	23.2	23.2	23.2
	Water pressure loss	kPa	30	68	48	62	80	93	93	93	93	93	93	93	93
45	Heating capacity	kW	96.1	112.4	130.3	149.9	171.0	184.5	184.5	184.5	184.5	184.5	184.5	184.5	184.5
	Power consumption	kW	49.90	51.15	52.46	53.59	54.53	55.02	55.02	55.02	55.02	55.02	55.02	55.02	55.02
	Hot water flow rate	m <sup>3</sup> /h	12.9	13.8	16	18.4	21	22.7	22.7	22.7	22.7	22.7	22.7	22.7	22.7
	Water pressure loss	kPa	30	34	45	59	77	89	89	89	89	89	89	89	89
50	Heating capacity	kW	-	109.2	127.1	146.3	166.9	180	180	180	180	180	180	180	180
	Power consumption	kW	-	54.72	56.10	57.33	58.43	59.02	59.02	59.02	59.02	59.02	59.02	59.02	59.02
	Hot water flow rate	m <sup>3</sup> /h	-	13.4	15.6	18	20.5	22.1	22.1	22.1	22.1	22.1	22.1	22.1	22.1
	Water pressure loss	kPa	-	32	43	57	73	85	85	85	85	85	85	85	85
55	Heating capacity	kW	-	-	123.6	142.5	162.4	174.9	174.9	-	-	-	-	-	-
	Power consumption	kW	-	-	59.92	61.25	62.52	63.25	63.25	-	-	-	-	-	-
	Hot water flow rate	m <sup>3</sup> /h	-	-	15.2	17.5	20	21.5	21.5	-	-	-	-	-	-
	Water pressure loss	kPa	-	-	41	54	70	80	80	-	-	-	-	-	-

\* Pump is not included.

\* Hatching area shows outlet/inlet temperature difference under 7°C.

\* This table shows the capacity when the relative humidity is 85%.

\* The performance is the value not including the defrost correction.

## 2. Product Data

### 2-1-2. Capacity table

EER for cooling [Water]

EAHV-P1500YB, EACV-P1500YB

Water flow rate 25.8 m<sup>3</sup>/h

EAHV-P-YBL(-H)(-N), EACV-P-YBL(-N)

Capacity	Air temp (°CD.B)	Outlet water temp (°C)						
		5	7	10	15	20	25	30
175kW (117%)	-15	-	6.41	7.68	-	-	-	-
	-10	-	6.41	7.68	9.31	9.31	9.31	9.31
	-5	-	6.41	7.68	9.31	9.31	9.31	9.31
	0	-	6.41	7.68	9.31	9.31	9.31	9.31
	5	-	6.41	7.68	9.31	9.31	9.31	9.31
	10	-	6.41	7.68	9.31	9.31	9.31	9.31
	15	-	6.41	7.68	9.31	9.31	9.31	9.31
	20	-	5.19	6.27	7.35	7.35	7.35	7.35
	25	-	-	5.16	5.93	5.93	5.93	5.93
	30	-	-	4.23	4.85	4.85	4.85	4.85
	35	-	-	-	-	-	-	-
40	-	-	-	-	-	-	-	
43	-	-	-	-	-	-	-	
150kW (100%)	-15	6.45	7.27	8.42	-	-	-	-
	-10	6.45	7.27	8.42	10.16	10.16	10.16	10.16
	-5	6.45	7.27	8.42	10.16	10.16	10.16	10.16
	0	6.45	7.28	8.43	10.16	10.16	10.16	10.16
	5	6.45	7.28	8.43	10.16	10.16	10.16	10.16
	10	6.45	7.28	8.43	10.16	10.16	10.16	10.16
	15	6.45	7.28	8.43	10.16	10.16	10.16	10.16
	20	5.29	5.97	6.88	8.01	8.01	8.01	8.01
	25	4.34	4.92	5.67	6.43	6.43	6.43	6.43
	30	-	4.06	4.72	5.27	5.27	5.27	5.27
	35	-	3.33	3.93	4.36	4.36	4.36	4.36
40	-	-	3.24	3.62	3.62	3.62	3.62	
43	-	-	-	-	-	-	-	
125kW (83%)	-15	7.19	7.88	8.98	-	-	-	-
	-10	7.19	7.88	8.98	10.78	10.78	10.78	10.78
	-5	7.19	7.88	8.98	10.78	10.78	10.78	10.78
	0	7.19	7.88	8.98	10.78	10.78	10.78	10.78
	5	7.19	7.88	8.98	10.78	10.78	10.78	10.78
	10	7.19	7.88	8.98	10.78	10.78	10.78	10.78
	15	7.19	7.88	8.98	10.78	10.78	10.78	10.78
	20	5.94	6.47	7.32	8.49	8.49	8.49	8.49
	25	4.93	5.37	6.04	6.81	6.81	6.81	6.81
	30	4.12	4.48	5.02	5.55	5.55	5.55	5.55
	35	3.45	3.76	4.21	4.60	4.60	4.60	4.60
40	2.87	3.15	3.55	3.85	3.85	3.85	3.85	
43	2.55	2.82	3.20	3.48	3.48	3.48	3.48	
100kW (67%)	-15	7.57	8.19	9.26	-	-	-	-
	-10	7.57	8.19	9.26	11.10	11.10	11.10	11.10
	-5	7.57	8.19	9.26	11.10	11.10	11.10	11.10
	0	7.57	8.19	9.26	11.10	11.10	11.10	11.10
	5	7.57	8.19	9.26	11.10	11.10	11.10	11.10
	10	7.57	8.19	9.26	11.10	11.10	11.10	11.10
	15	7.57	8.19	9.26	11.10	11.10	11.10	11.10
	20	6.26	6.74	7.56	8.76	8.76	8.76	8.76
	25	5.21	5.58	6.21	7.01	7.01	7.01	7.01
	30	4.35	4.66	5.16	5.69	5.69	5.69	5.69
	35	3.67	3.91	4.31	4.68	4.68	4.68	4.68
40	3.10	3.31	3.63	3.91	3.91	3.91	3.91	
43	2.80	2.99	3.28	3.53	3.53	3.53	3.53	
75kW (50%)	-15	7.62	8.21	9.25	-	-	-	-
	-10	7.62	8.21	9.25	11.09	11.09	11.09	11.09
	-5	7.62	8.21	9.25	11.09	11.09	11.09	11.09
	0	7.62	8.21	9.25	11.09	11.09	11.09	11.09
	5	7.62	8.21	9.25	11.09	11.09	11.09	11.09
	10	7.62	8.21	9.25	11.09	11.09	11.09	11.09
	15	7.62	8.21	9.25	11.09	11.09	11.09	11.09
	20	6.30	6.77	7.56	8.77	8.77	8.77	8.77
	25	5.23	5.60	6.21	7.02	7.02	7.02	7.02
	30	4.37	4.65	5.14	5.68	5.68	5.68	5.68
	35	3.66	3.89	4.26	4.65	4.65	4.65	4.65
40	3.09	3.26	3.56	3.84	3.84	3.84	3.84	
43	2.79	2.95	3.21	3.45	3.45	3.45	3.45	
50kW (33%)	-15	7.34	7.91	8.90	-	-	-	-
	-10	7.34	7.91	8.90	10.64	10.64	10.64	10.64
	-5	7.34	7.91	8.90	10.64	10.64	10.64	10.64
	0	7.34	7.91	8.90	10.64	10.64	10.64	10.64
	5	7.34	7.91	8.90	10.64	10.64	10.64	10.64
	10	7.34	7.91	8.90	10.64	10.64	10.64	10.64
	15	7.34	7.91	8.90	10.64	10.64	10.64	10.64
	20	6.08	6.54	7.28	8.42	8.42	8.42	8.42
	25	5.05	5.41	6.00	6.77	6.77	6.77	6.77
	30	4.20	4.49	4.97	5.50	5.50	5.50	5.50
	35	3.51	3.74	4.11	4.50	4.50	4.50	4.50
40	2.94	3.12	3.42	3.70	3.70	3.70	3.70	
43	2.64	2.80	3.06	3.30	3.30	3.30	3.30	

## 2. Product Data

### EER for cooling [Water]

EAHV-P1800YB, EACV-P1800YB

Water flow rate 31.0 m<sup>3</sup>/h

Capacity	Air temp (°CD.B)	Outlet water temp (°C)						
		5	7	10	15	20	25	30
210kW (117%)	-15	-	5.43	6.37	-	-	-	-
	-10	-	5.43	6.37	7.83	7.83	7.83	7.83
	-5	-	5.43	6.37	7.83	7.83	7.83	7.83
	0	-	5.43	6.37	7.83	7.83	7.83	7.83
	5	-	5.43	6.37	7.83	7.83	7.83	7.83
	10	-	5.43	6.37	7.83	7.83	7.83	7.83
	15	-	5.43	6.37	7.83	7.83	7.83	7.83
	20	-	-	5.30	6.34	6.34	6.34	6.34
	25	-	-	4.47	5.26	5.26	5.26	5.26
	30	-	-	3.80	4.41	4.41	4.41	4.41
	35	-	-	-	-	-	-	-
40	-	-	-	-	-	-	-	
43	-	-	-	-	-	-	-	
180kW (100%)	-15	5.36	6.12	7.23	-	-	-	-
	-10	5.36	6.12	7.23	9.01	9.01	9.01	9.01
	-5	5.36	6.12	7.23	9.01	9.01	9.01	9.01
	0	5.36	6.12	7.23	9.01	9.01	9.01	9.01
	5	5.36	6.12	7.23	9.01	9.01	9.01	9.01
	10	5.36	6.12	7.23	9.01	9.01	9.01	9.01
	15	5.36	6.12	7.23	9.01	9.01	9.01	9.01
	20	4.56	5.11	5.94	7.18	7.18	7.18	7.18
	25	3.85	4.29	4.94	5.86	5.86	5.86	5.86
	30	-	3.62	4.15	4.86	4.86	4.86	4.86
	35	-	3.05	3.51	4.07	4.07	4.07	4.07
40	-	-	2.95	3.41	3.41	3.41	3.41	
43	-	-	-	-	-	-	-	
150kW (83%)	-15	6.02	6.88	8.07	-	-	-	-
	-10	6.02	6.88	8.07	10.19	10.19	10.19	10.19
	-5	6.02	6.88	8.07	10.19	10.19	10.19	10.19
	0	6.02	6.88	8.07	10.19	10.19	10.19	10.19
	5	6.02	6.88	8.07	10.19	10.19	10.19	10.19
	10	6.02	6.88	8.07	10.19	10.19	10.19	10.19
	15	6.02	6.88	8.07	10.19	10.19	10.19	10.19
	20	5.10	5.70	6.59	8.02	8.02	8.02	8.02
	25	4.33	4.76	5.44	6.46	6.46	6.46	6.46
	30	3.66	4.00	4.55	5.31	5.31	5.31	5.31
	35	3.08	3.38	3.83	4.43	4.43	4.43	4.43
40	2.58	2.86	3.24	3.73	3.73	3.73	3.73	
43	-	-	2.94	3.35	3.35	3.35	3.35	
120kW (67%)	-15	6.79	7.62	8.81	-	-	-	-
	-10	6.79	7.62	8.81	11.21	11.21	11.21	11.21
	-5	6.79	7.62	8.81	11.21	11.21	11.21	11.21
	0	6.79	7.62	8.81	11.21	11.21	11.21	11.21
	5	6.79	7.62	8.81	11.21	11.21	11.21	11.21
	10	6.79	7.62	8.81	11.21	11.21	11.21	11.21
	15	6.79	7.62	8.81	11.21	11.21	11.21	11.21
	20	5.68	6.27	7.17	8.73	8.73	8.73	8.73
	25	4.78	5.20	5.89	6.96	6.96	6.96	6.96
	30	4.03	4.35	4.89	5.66	5.66	5.66	5.66
	35	3.41	3.66	4.09	4.68	4.68	4.68	4.68
40	2.88	3.11	3.46	3.93	3.93	3.93	3.93	
43	2.60	2.82	3.14	3.54	3.54	3.54	3.54	
90kW (50%)	-15	7.53	8.21	9.31	-	-	-	-
	-10	7.53	8.21	9.31	11.83	11.83	11.83	11.83
	-5	7.53	8.21	9.31	11.83	11.83	11.83	11.83
	0	7.53	8.21	9.31	11.83	11.83	11.83	11.83
	5	7.53	8.21	9.31	11.83	11.83	11.83	11.83
	10	7.53	8.21	9.31	11.83	11.83	11.83	11.83
	15	7.53	8.21	9.31	11.83	11.83	11.83	11.83
	20	6.18	6.72	7.56	9.16	9.16	9.16	9.16
	25	5.12	5.53	6.19	7.25	7.25	7.25	7.25
	30	4.28	4.59	5.10	5.85	5.85	5.85	5.85
	35	3.59	3.83	4.24	4.79	4.79	4.79	4.79
40	3.03	3.22	3.55	3.99	3.99	3.99	3.99	
43	2.74	2.91	3.20	3.58	3.58	3.58	3.58	
60kW (33%)	-15	7.80	8.29	9.21	-	-	-	-
	-10	7.80	8.29	9.21	11.39	11.39	11.39	11.39
	-5	7.80	8.29	9.21	11.39	11.39	11.39	11.39
	0	7.80	8.29	9.21	11.39	11.39	11.39	11.39
	5	7.80	8.29	9.21	11.39	11.39	11.39	11.39
	10	7.80	8.29	9.21	11.39	11.39	11.39	11.39
	15	7.80	8.29	9.21	11.39	11.39	11.39	11.39
	20	6.36	6.78	7.50	8.92	8.92	8.92	8.92
	25	5.22	5.57	6.15	7.10	7.10	7.10	7.10
	30	4.32	4.60	5.08	5.75	5.75	5.75	5.75
	35	3.58	3.82	4.20	4.70	4.70	4.70	4.70
40	2.99	3.18	3.49	3.90	3.90	3.90	3.90	
43	2.70	2.86	3.12	3.49	3.49	3.49	3.49	

## 2. Product Data

COP for heating

EAHV-P1500YB

Water flow rate 25.8 m<sup>3</sup>/h

Capacity	Air temp (°CDB)	Outlet water temp (°C)					
		30	35	40	45	50	55
175kW (117%)	-15	-	-	-	-	-	-
	-10	-	-	-	-	-	-
	-5	-	-	-	-	-	-
	0	-	-	-	-	-	-
	5	-	-	-	-	-	-
	7	-	-	-	-	-	-
	10	-	-	-	-	-	-
	15	-	-	-	-	-	-
	20	-	-	-	-	-	-
	25	-	-	-	-	-	-
	30	-	-	-	-	-	-
	35	-	-	-	-	-	-
	40	-	-	-	-	-	-
43	-	-	-	-	-	-	
150kW (100%)	-15	-	-	-	-	-	-
	-10	-	-	-	-	-	-
	-5	-	-	-	-	-	-
	0	3.79	3.45	3.14	2.86	-	-
	5	4.34	3.91	3.54	3.20	2.91	2.64
	7	4.59	4.12	3.71	3.36	3.03	2.75
	10	5.03	4.49	4.01	3.60	3.24	2.92
	15	5.81	5.12	4.52	4.00	3.55	3.15
	20	6.63	5.77	5.03	4.38	3.82	-
	25	7.41	6.38	5.49	4.71	4.04	-
	30	-	6.92	5.88	4.99	4.22	-
	35	-	7.36	6.20	5.21	4.36	-
	40	-	7.70	6.43	5.36	4.46	-
43	-	7.85	6.52	5.42	4.49	-	
125kW (83%)	-15	-	-	-	-	-	-
	-10	-	-	-	-	-	-
	-5	3.37	3.07	2.79	2.54	2.31	-
	0	3.84	3.47	3.14	2.85	2.59	2.36
	5	4.37	3.91	3.52	3.17	2.87	2.60
	7	4.60	4.11	3.67	3.30	2.97	2.69
	10	5.06	4.48	3.98	3.55	3.18	2.85
	15	5.73	5.02	4.40	3.88	3.42	3.03
	20	6.39	5.53	4.80	4.17	3.63	-
	25	6.99	5.98	5.13	4.41	3.80	-
	30	-	6.36	5.40	4.60	3.93	-
	35	-	6.65	5.60	4.74	4.02	-
	40	-	6.84	5.71	4.81	4.07	-
43	-	6.91	5.74	4.83	4.08	-	
100kW (67%)	-15	2.63	2.39	-	-	-	-
	-10	3.03	2.74	2.48	2.25	2.03	-
	-5	3.39	3.07	2.78	2.52	2.29	2.08
	0	3.82	3.43	3.09	2.80	2.54	2.31
	5	4.30	3.83	3.42	3.07	2.76	2.49
	7	4.51	4.00	3.56	3.17	2.84	2.55
	10	4.95	4.35	3.84	3.41	3.03	2.71
	15	5.48	4.77	4.17	3.65	3.21	2.84
	20	5.98	5.15	4.45	3.86	3.36	-
	25	6.42	5.46	4.67	4.03	3.48	-
	30	-	5.69	4.83	4.14	3.57	-
	35	-	5.85	4.92	4.20	3.61	-
	40	-	5.92	4.95	4.21	3.62	-
43	-	5.93	4.93	4.19	3.61	-	
75kW (50%)	-15	2.72	2.46	2.21	1.97	-	-
	-10	2.98	2.71	2.45	2.21	1.99	-
	-5	3.30	2.98	2.69	2.44	2.21	2.00
	0	3.67	3.29	2.95	2.65	2.39	2.16
	5	4.08	3.62	3.21	2.86	2.55	2.28
	7	4.26	3.75	3.32	2.94	2.61	2.33
	10	4.64	4.07	3.57	3.15	2.79	2.47
	15	5.04	4.37	3.81	3.32	2.92	2.57
	20	5.38	4.62	3.98	3.46	3.02	-
	25	5.67	4.80	4.11	3.55	3.09	-
	30	-	4.92	4.18	3.59	3.13	-
	35	-	4.97	4.18	3.59	3.13	-
	40	-	4.95	4.13	3.54	3.09	-
43	-	4.91	4.08	3.49	3.06	-	
50kW (33%)	-15	2.47	2.25	2.04	1.85	-	-
	-10	2.69	2.44	2.21	2.01	1.82	-
	-5	2.97	2.67	2.40	2.17	1.96	1.78
	0	3.27	2.92	2.60	2.33	2.09	1.88
	5	3.59	3.17	2.80	2.48	2.19	1.95
	7	3.72	3.27	2.87	2.53	2.23	1.97
	10	4.05	3.56	3.12	2.74	2.42	2.13
	15	4.31	3.75	3.27	2.85	2.50	2.20
	20	4.53	3.89	3.36	2.92	2.56	-
	25	4.70	3.98	3.41	2.95	2.58	-
	30	-	4.00	3.39	2.92	2.56	-
	35	-	3.97	3.32	2.86	2.52	-
	40	-	3.63	3.22	2.76	2.44	-
43	-	3.63	3.14	2.69	2.38	-	

## 2. Product Data

### COP for heating

EAHV-P1800YB

Water flow rate 31.0 m<sup>3</sup>/h

Capacity	Air temp (°CDB)	Outlet water temp (°C)					
		30	35	40	45	50	55
210kW (117%)	-15	-	-	-	-	-	-
	-10	-	-	-	-	-	-
	-5	-	-	-	-	-	-
	0	-	-	-	-	-	-
	5	-	-	-	-	-	-
	7	-	-	-	-	-	-
	10	-	-	-	-	-	-
	15	-	-	-	-	-	-
	20	-	-	-	-	-	-
	25	-	-	-	-	-	-
	30	-	-	-	-	-	-
	35	-	-	-	-	-	-
	40	-	-	-	-	-	-
43	-	-	-	-	-	-	
180kW (100%)	-15	-	-	-	-	-	-
	-10	-	-	-	-	-	-
	-5	-	-	-	-	-	-
	0	-	-	-	-	-	-
	5	4.05	-	-	-	-	-
	7	4.25	3.88	3.54	3.23	-	-
	10	4.58	4.16	3.78	3.44	3.12	2.83
	15	5.24	4.71	4.23	3.80	3.41	3.06
	20	5.95	5.29	4.69	4.15	3.67	-
	25	6.65	5.85	5.12	4.47	3.89	-
	30	-	6.37	5.51	4.75	4.07	-
	35	-	6.81	5.84	4.98	4.21	-
	40	-	7.15	6.10	5.15	4.31	-
43	-	7.32	6.21	5.22	4.35	-	
150kW (83%)	-15	-	-	-	-	-	-
	-10	-	-	-	-	-	-
	-5	-	-	-	-	-	-
	0	3.60	3.29	3.01	-	-	-
	5	4.05	3.68	3.35	3.05	2.78	2.54
	7	4.25	3.85	3.49	3.17	2.91	2.63
	10	4.58	4.12	3.72	3.36	3.04	2.76
	15	5.16	4.60	4.10	3.66	3.27	2.93
	20	5.73	5.06	4.47	3.94	3.48	-
	25	6.26	5.49	4.79	4.18	3.64	-
	30	-	5.85	5.07	4.37	3.77	-
	35	-	6.13	5.27	4.52	3.86	-
	40	-	6.34	5.41	4.61	3.92	-
43	-	6.42	5.47	4.65	3.93	-	
120kW (67%)	-15	-	-	-	-	-	-
	-10	2.82	-	-	-	-	-
	-5	3.17	2.89	2.65	2.42	2.21	2.02
	0	3.54	3.22	2.94	2.68	2.45	2.25
	5	3.97	3.59	3.25	2.95	2.68	2.45
	7	4.16	3.74	3.37	3.05	2.77	2.51
	10	4.44	3.97	3.56	3.20	2.89	2.61
	15	4.89	4.35	3.86	3.44	3.06	2.73
	20	5.32	4.68	4.12	3.64	3.21	-
	25	5.69	4.97	4.35	3.80	3.32	-
	30	-	5.19	4.51	3.92	3.40	-
	35	-	5.35	4.61	3.99	3.45	-
	40	-	5.44	4.67	4.02	3.47	-
43	-	5.46	4.67	4.02	3.46	-	
90kW (50%)	-15	2.53	2.30	2.09	1.89	-	-
	-10	2.78	2.54	2.31	2.10	1.91	-
	-5	3.06	2.79	2.54	2.32	2.12	1.94
	0	3.39	3.08	2.79	2.54	2.31	2.11
	5	3.75	3.37	3.04	2.75	2.49	2.25
	7	3.89	3.49	3.14	2.83	2.55	2.30
	10	4.10	3.66	3.28	2.94	2.63	2.37
	15	4.42	3.92	3.48	3.10	2.75	2.45
	20	4.70	4.14	3.65	3.22	2.85	-
	25	4.92	4.30	3.77	3.31	2.91	-
	30	-	4.41	3.84	3.36	2.95	-
	35	-	4.47	3.87	3.38	2.96	-
	40	-	4.47	3.85	3.35	2.95	-
43	-	4.46	3.82	3.32	2.93	-	
60kW (33%)	-15	2.32	2.13	1.94	1.76	-	-
	-10	2.52	2.30	2.10	1.92	1.75	-
	-5	2.75	2.51	2.29	2.09	1.90	1.74
	0	3.00	2.73	2.47	2.24	2.04	1.85
	5	3.25	2.93	2.65	2.39	2.15	1.94
	7	3.34	3.01	2.71	2.44	2.19	1.97
	10	3.46	3.12	2.80	2.50	2.24	2.01
	15	3.65	3.26	2.91	2.60	2.32	2.07
	20	3.81	3.38	2.99	2.66	2.36	-
	25	3.93	3.45	3.03	2.68	2.39	-
	30	-	3.47	3.04	2.68	2.39	-
	35	-	3.46	3.00	2.65	2.36	-
	40	-	3.42	2.94	2.58	2.32	-
43	-	3.38	2.89	2.54	2.28	-	

## 2. Product Data

### 2-1-3. Correction by relative humidity

#### [EAHV]

#### ■ Heating capacity correction diagram (relative humidity correction diagram)

The heating capacity changes depending on the relative humidity.

When the relative humidity is other than RH=85%, correct the capacity based on the following graph.

[Example] When the outdoor air temperature = 0°C and relative humidity RH=50%  
 Heating capacity in performance diagram × 0.926 <Correction value> = Heating capacity after correction

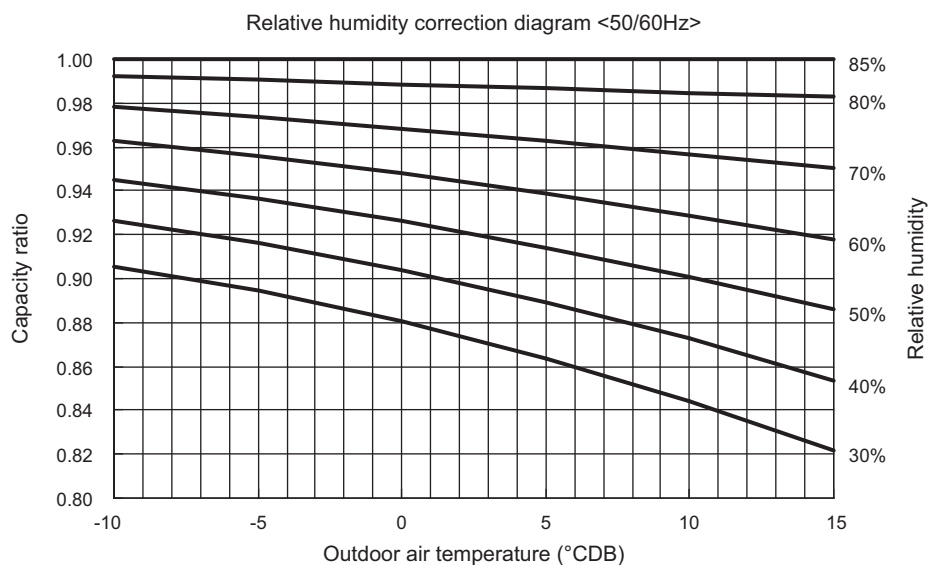

#### ■ Heating capacity reduction factor by frosting (reference)

Outdoor air temperature (DB)	-7°C	-5°C	-3°C	0°C	3°C	5°C	7°C
Heating capacity reduction factor	0.87	0.87	0.86	0.84	0.87	0.98	1.00

\* In the actual setup status, there are factors (weather, outside wind, relative humidity, etc.) other than outdoor air temperature, so consider the above factors as references.

## 2. Product Data

### 2-1-4. Correction by water flow rate

EAHV-P1500YB  
EACV-P1500YB

#### ■ Cooling

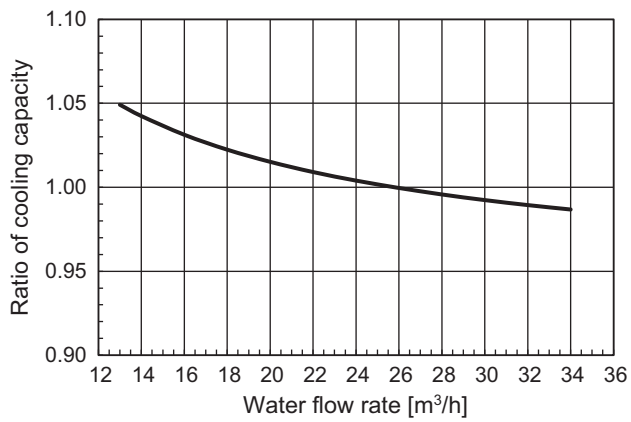

\*Conditions  
Outdoor temperature 35°C  
Outlet water temperature 7°C

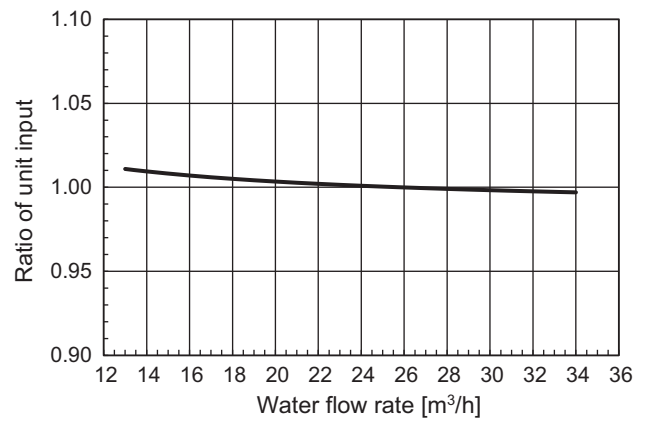

\*Conditions  
Outdoor temperature 35°C  
Outlet water temperature 7°C

#### ■ Heating

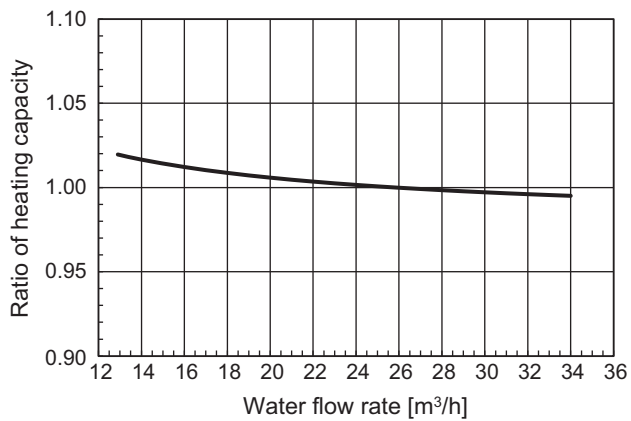

\*Conditions  
Outdoor temperature 7°C  
Outlet water temperature 45°C

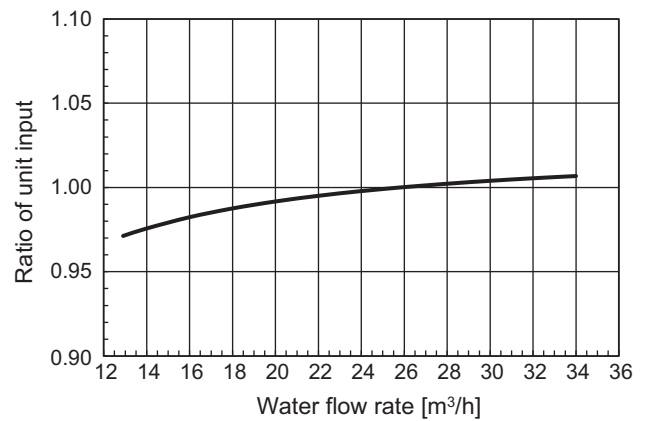

\*Conditions  
Outdoor temperature 7°C  
Outlet water temperature 45°C



## 2. Product Data

EAHV-P1800YB  
EACV-P1800YB

### ■ Cooling

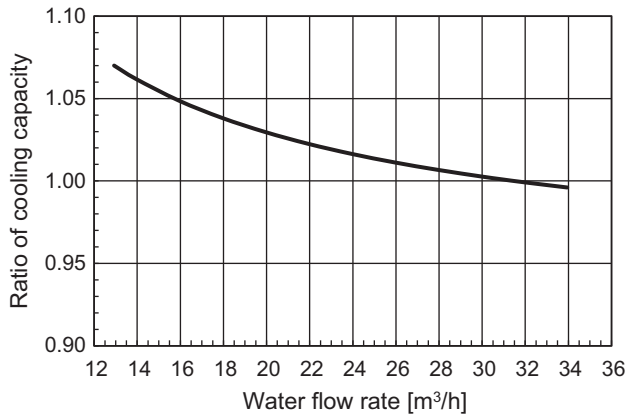

\*Conditions  
Outdoor temperature 35°C  
Outlet water temperature 7°C

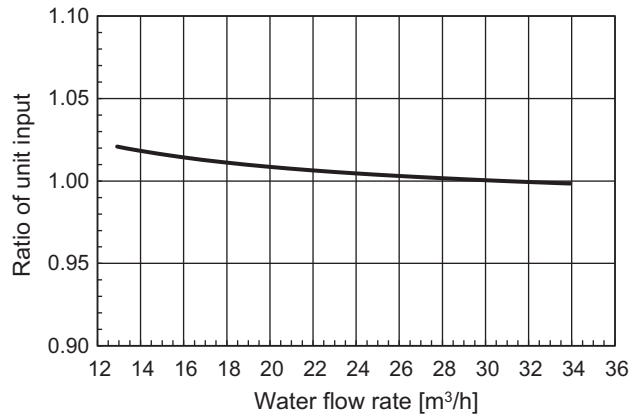

\*Conditions  
Outdoor temperature 35°C  
Outlet water temperature 7°C

### ■ Heating

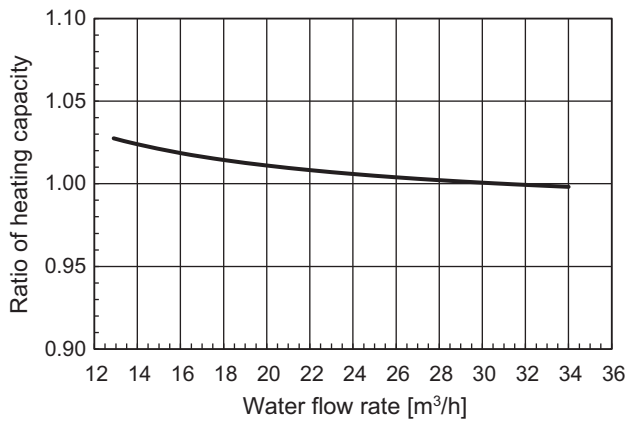

\*Conditions  
Outdoor temperature 7°C  
Outlet water temperature 45°C

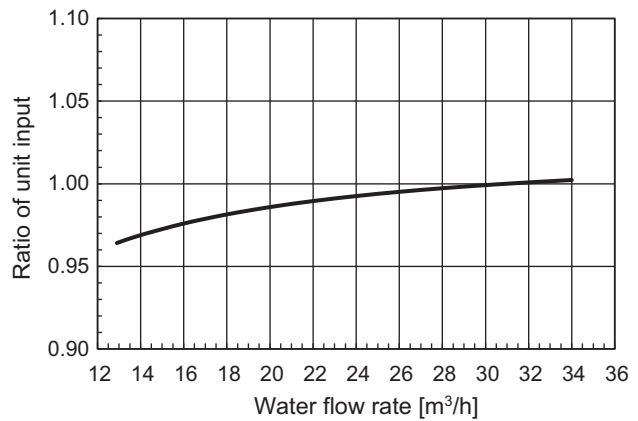

\*Conditions  
Outdoor temperature 7°C  
Outlet water temperature 45°C

## 2. Product Data

### 2-1-5. Water pressure drop

EAHV-P1500, 1800YB  
EACV-P1500, 1800YB  
[Water]

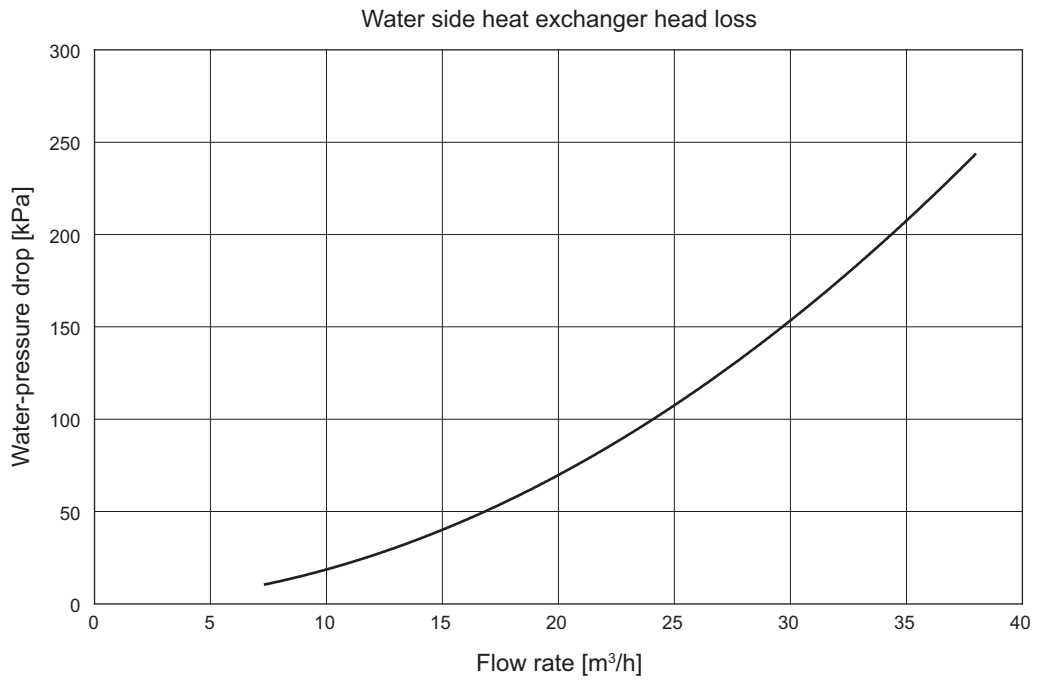

EAHV-P-YBL(-H)(-N), EACV-P-YBL(-N)

## 2. Product Data

### 2-1-6. Operation temperature range

EAHV-P1500, 1800YBL(-N)(-BS)

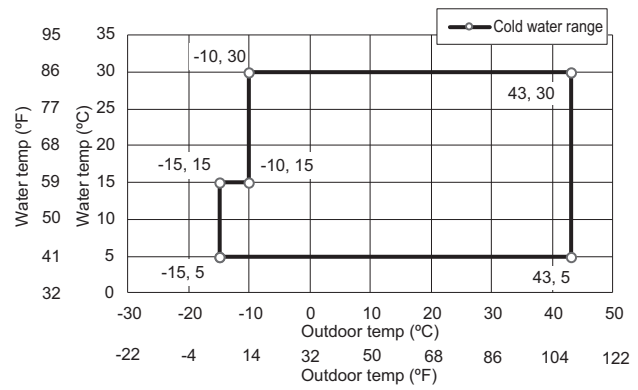
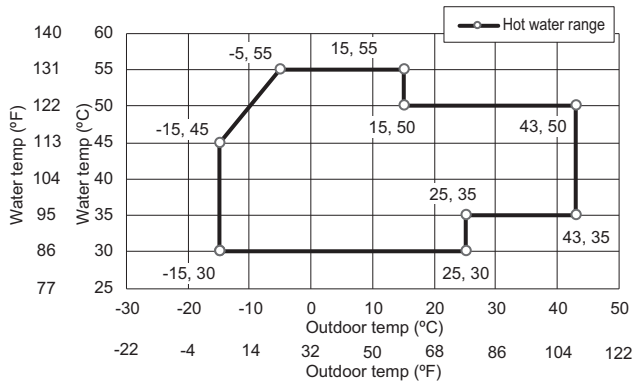

EAHV-P1500, 1800YBL-H(-N)(-BS)

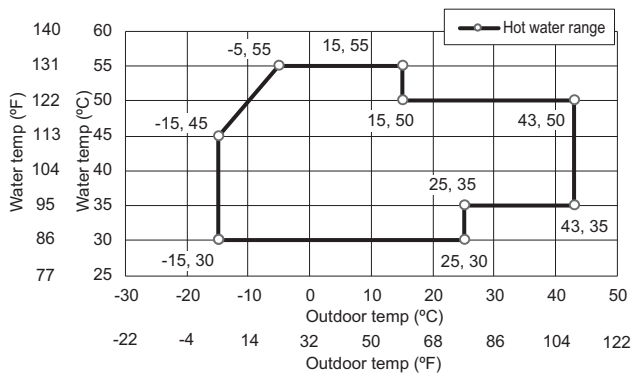

EACV-P1500, 1800YBL(-N)(-BS)

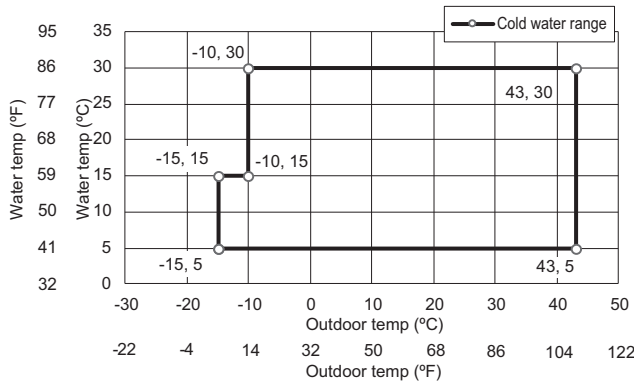

## 2. Product Data

### 2-2. Sound pressure levels

Measurement condition  
 EAHV-P1500, 1800YB  
 EACV-P1500, 1800YB

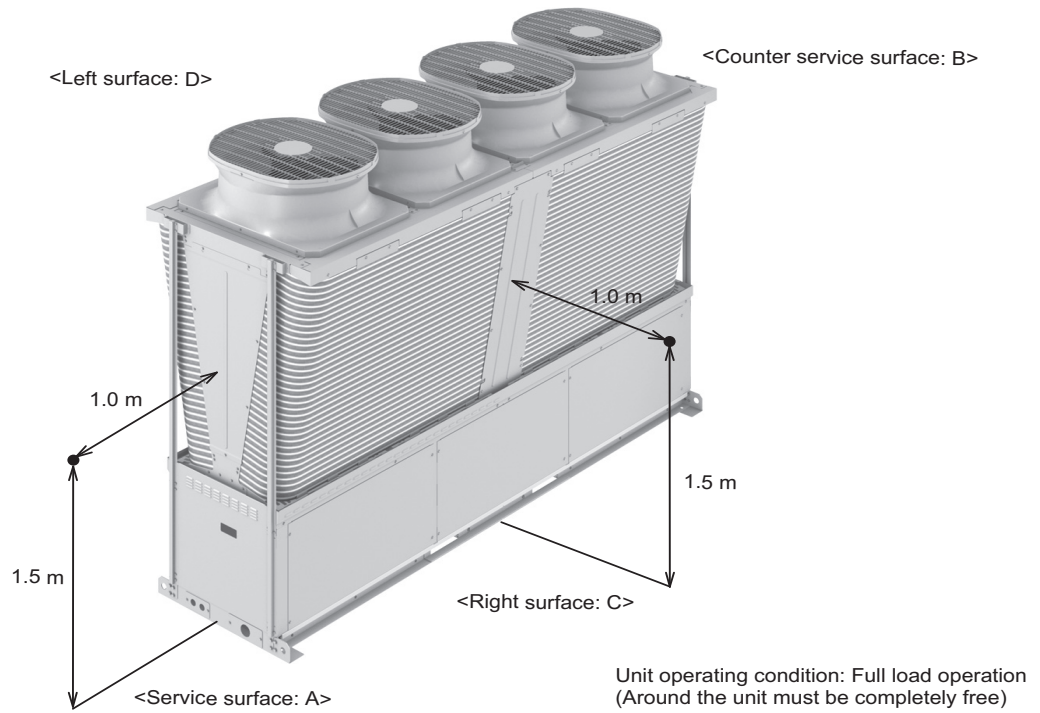

#### Sound pressure level

The following values are the planned value.

Sound pressure level dB <A> (anechoic room level)		
Measurement location	EAHV-P1500YB EACV-P1500YB	EAHV-P1800YB EACV-P1800YB
Service surface: A	66	68
Counter service surface: B	66	67
Right surface: C	68	71
Left surface: D	70	70

\* The above values are obtained by converting the values measured in location with less echo sound to the anechoic room level.  
 The values could be larger than those values if the operating conditions are different or the measuring location is affected by echo sound.  
 (It could be roughly 4 dB to 6 dB higher though it depends on the installation conditions.)  
 Regarding the installation, consider the effect of echo sound, implement soundproof treatment as necessary.

## 2. Product Data

EAHV-P1500YB  
EACV-P1500YB

EAHV-P-YBL(-H)(-N), EACV-P-YBL(-N)

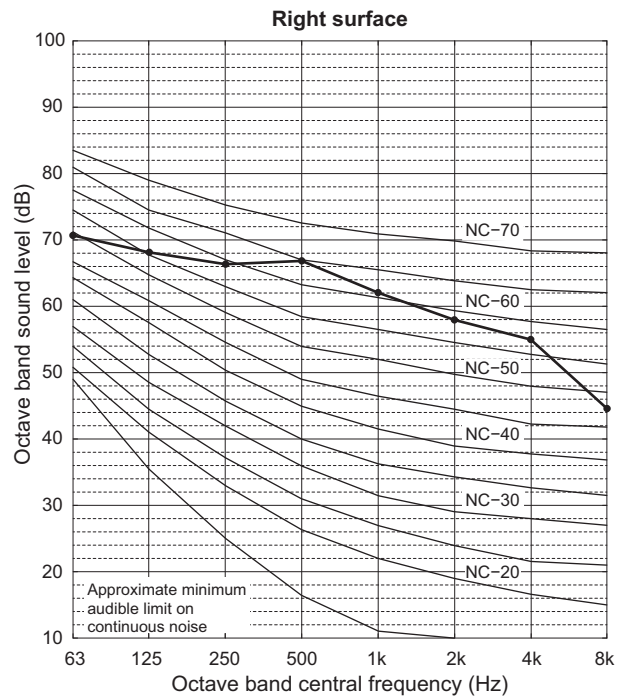
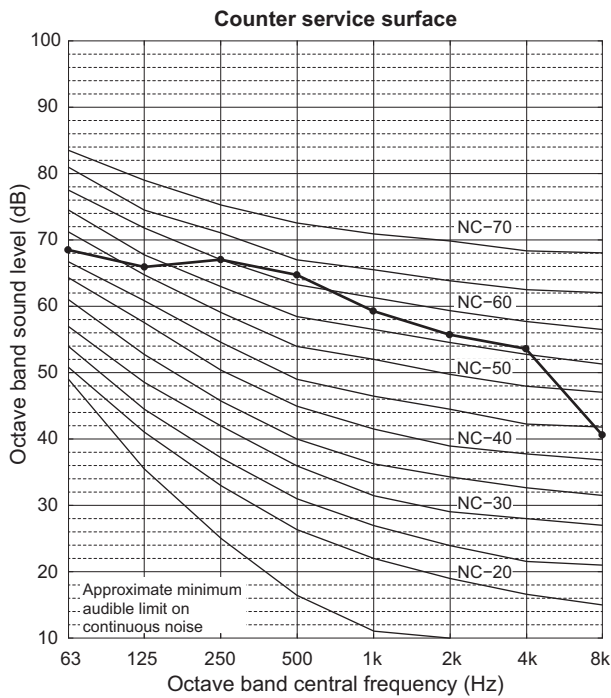
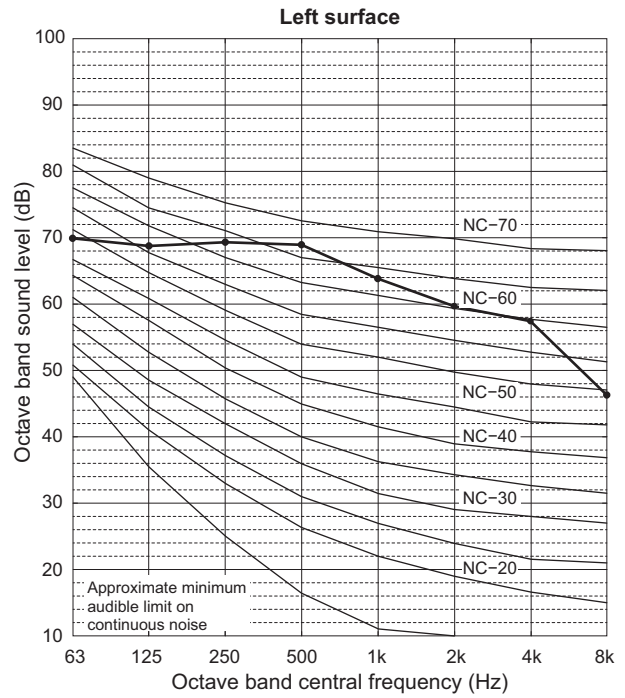
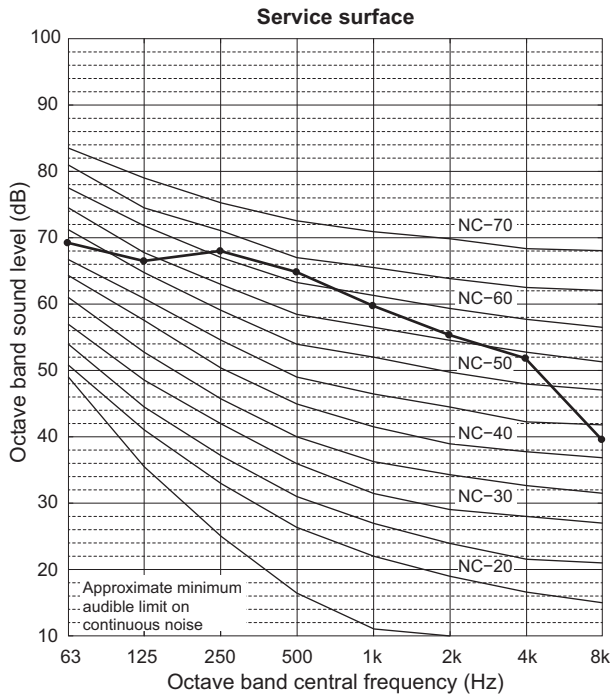

## 2. Product Data

EAHV-P1800YB  
EACV-P1800YB

EAHV-P-YBL(-H)(-N), EACV-P-YBL(-N)

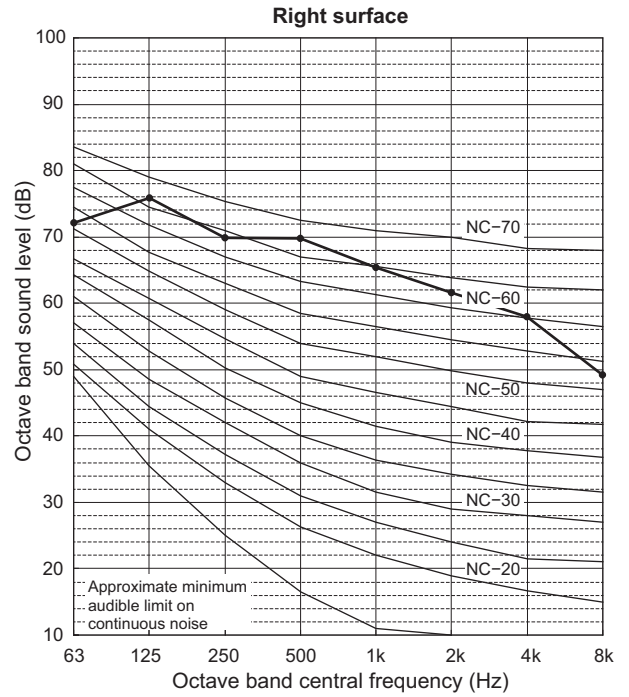
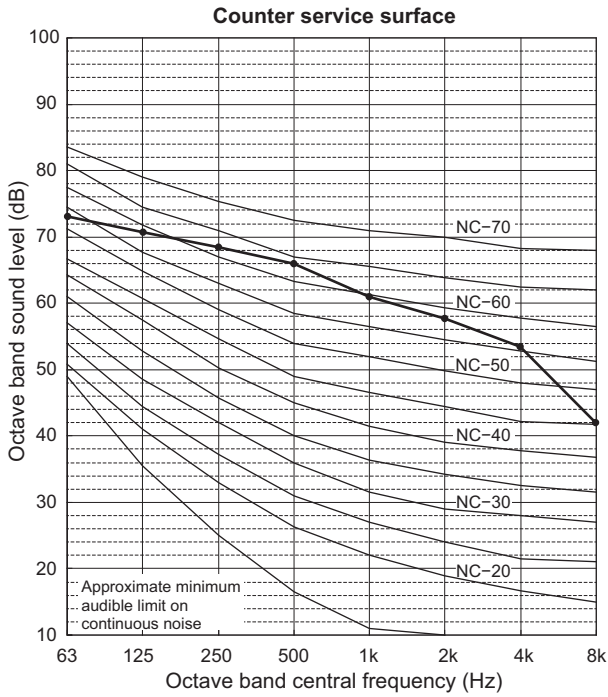
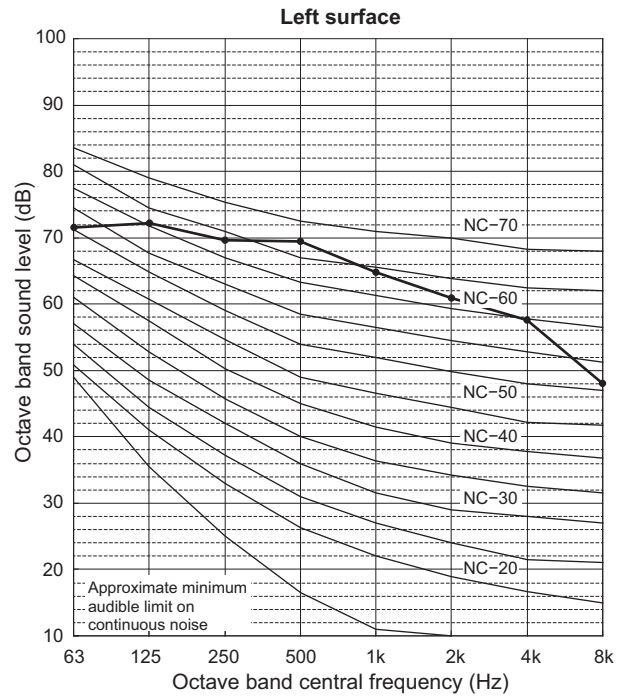
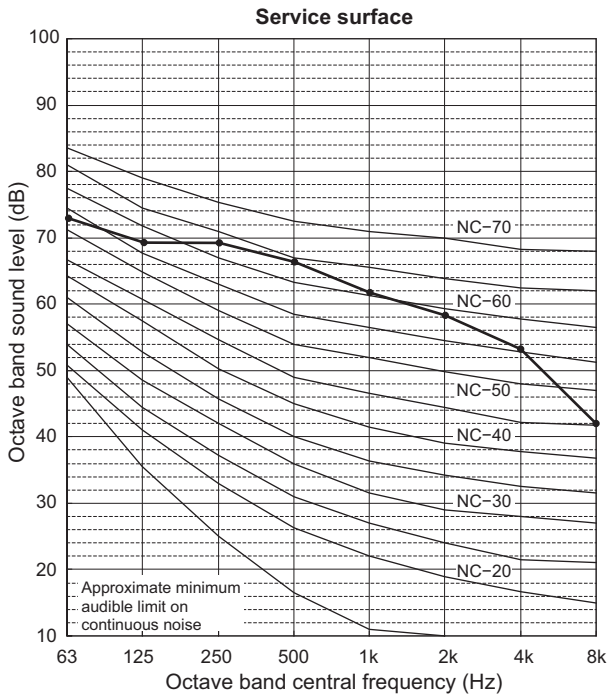

## 2. Product Data

### 2-3. Vibration levels

EAHV-P1500, 1800YB  
EACV-P1500, 1800YB

EAHV-P-YBL(-H)(-N), EACV-P-YBL(-N)

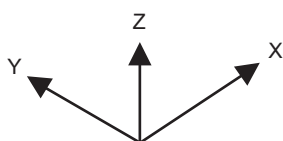
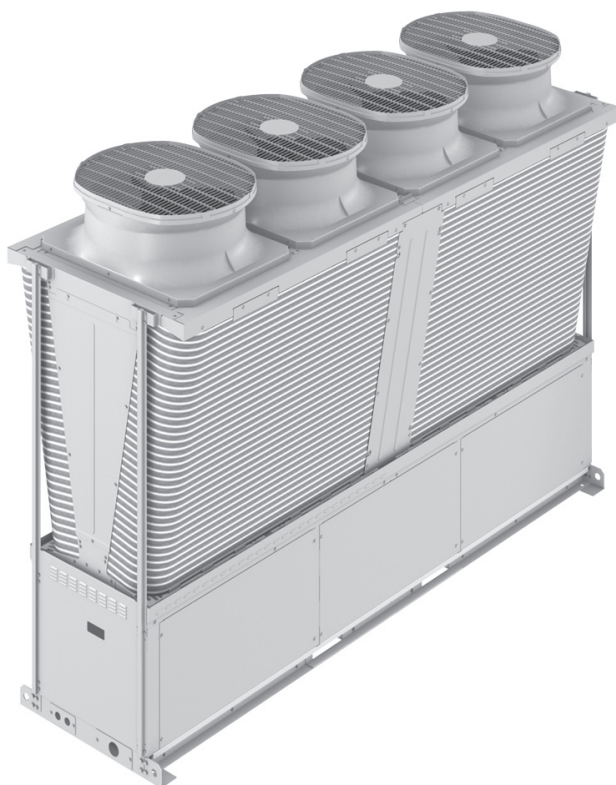

unit:  $\mu\text{m}$  (one side amplitude effective value)

	X	Y	Z
A	24	14	24
B	48	64	50
C	26	100	26
D	8	18	26

\* The above values are the planned value.

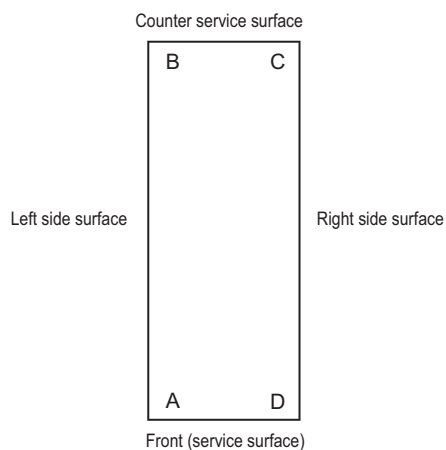

#### Note

1. Unit operation condition
  - Full load operation
2. Unit installation conditions
  - Directly placed on the surface plate in the test room in the Works

## 2. Product Data

### 2-4. Salt Protection Specifications

No.	Name	Base material	EAHV/EACV		Surface treatment	Treatment thickness	
			standard	salt damage protection		External	Internal
1	Fan guard Bell mouth	Polypropylene resin	●	●	-	-	-
2	Panel	Alloyed galvanized sheet	●		Polyester resin coating	30 μm or more	30 μm or more
				●	Polyester resin coating	70 μm or more	70 μm or more
3	Fan	Polypropylene resin	●	●	-	-	-
4	Motor	Unsaturated polyester resin	●	●	-	-	-
5	Motor support	Galvanized sheet	●	●	-	-	-
6	Heat exchanger (Only fin)	Aluminum plate	●	●	Cellulose series and urethane series resin coating	1 μm or more	-
7	Bottom frame (Including drain pan)	Alloyed galvanized sheet	●	●	Polyester resin coating	70 μm or more	70 μm or more
8	Compressor	Carbon steel	●	●	Epoxy resin coating	13 μm or more	13 μm or more
9	Pillar	Alloyed galvanized sheet	●		Polyester resin coating	30 μm or more	30 μm or more
				●	Polyester resin coating	70 μm or more	70 μm or more
10	Water-side heat exchanger (Including water piping)	Stainless steel	●	●	-	-	-
11	Electrical parts box	Galvanized sheet	●	●	-	-	-
12	Printed circuit board	Composite material <CEM-3>	●	●	Polyurethane coating	20 μm or more	20 μm or more
13	Terminal box	Galvanized sheet	●	●	-	-	-
14	Receiver	Carbon steel	●		Phenolic modified alkyd resin dip	30 μm or more	-
				●	Epoxy resin and polyurethane resin coating	70 μm or more	-
15	Accumulator	Carbon steel	●		Phenolic modified alkyd resin dip	30 μm or more	-
				●	Epoxy resin and polyurethane resin coating	70 μm or more	-
16	Saddle (Water piping)	Stainless steel	●	●	-	-	-
17	Fin guard (Option)	Iron wires	●	●	Polyethylene resin coating	300 μm or more	300 μm or more
18	Screw	Stainless steel, Carbon steel	●	●	Zinc-nickel alloy plating + Geomet filming (only carbon steel screw)	-	-

#### Application Guide

	Distance from sea		
	300 m	500 m	1 km
Direct sea breeze			
Facing inland sea	BS	STD	
Facing ocean		BS	
Island location		BS	
Indirect sea breeze			
Facing inland sea	BS	STD	
Facing ocean		BS	
Island location		BS	

#### Caution;

- 1 Set the outdoor unit to the place with rare direct sea breeze.
- 2 Don't attach a sunshade. A rain will clean the attached salt.
- 3 Set the outdoor unit horizontally. The water should not keep in the unit.
- 4 Please wash the outdoor unit periodically.
- 5 Repair the scratch on the panel as soon as possible.
- 6 Inspect periodically. Paint or change parts if necessary.



### 3. Installation

#### 3-1. Selecting the Installation Site

##### 3-1-1. Installation Conditions

**Select the installation site in consultation with the client.**

Select a site to install the unit that meets the following conditions:

- The unit will not be subject to heat from other heat sources.
- The noise from the unit will not be a problem.
- The unit will not be exposed to strong winds.
- Water from the unit can be drained properly.
- Enough space for installation and service as shown in 3-1. Selecting the Installation Site.
- There is a possibility of injuring with the fin of the heat exchanger, so abide by following contents.

- 1) Limit the access of the general public to the location where they can touch the product.
- 2) Take a measure so the general public cannot easily access the location where they can touch the product.
- 3) When installing in a location where the general public can touch the product, install the optional fin guard.

Option Parts: DT-150FG

When two units are joined

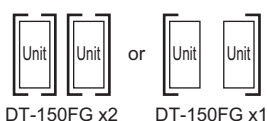

##### 1. Protection against winds

- Pay attention to the wind direction and installation location to ensure that the air heat exchanger is not directly exposed to strong winds.
- If unable to avoid strong winds, install wind breaking hoods or walls, etc.

##### 2. Cold Climate Installation

Observe the following when installing the units in areas where snow or strong winds prevail.

- Avoid direct exposure to rain, winds, and snow.
- If the unit is installed in the direct line of rain, winds, or snow, install snow hoods. Use a snow net or snow fence as necessary to protect the unit.
- Install the unit on a base approximately twice as high as the expected snowfall.
- If the unit of heating mode is continuously operated for a long time with the outdoor temperature below the freezing point, install a heater at the drain pan of the unit to prevent freezing of drain.

##### 3. Weight

		Net weight (kg)	Operating weight (kg)
EAHV	Standard piping	1310	1337
	Inside header piping	1326	1394
EACV	Standard piping	1240	1267
	Inside header piping	1256	1324

\* Weight of the optional parts: DT-01HK (29 kg), DT-02HK (42 kg), DT-150FG (13 kg)

### 3. Installation

#### 3-1-2. Installation Space Requirement

##### 1. Single unit installation

(1) Required space

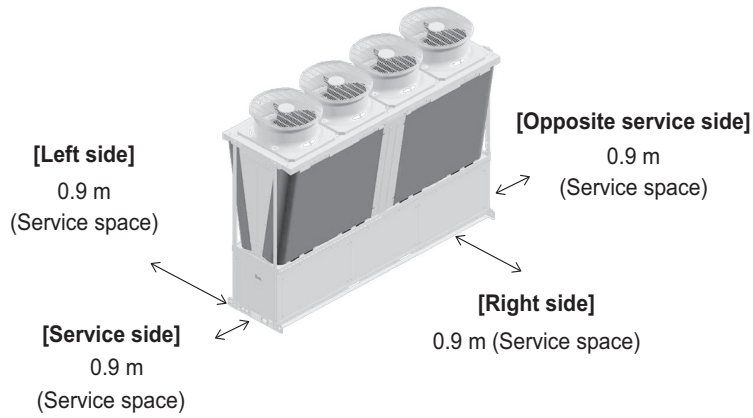

(2) If entire surrounding area enclosed by walls (but vent holes installed at bottom of wall)

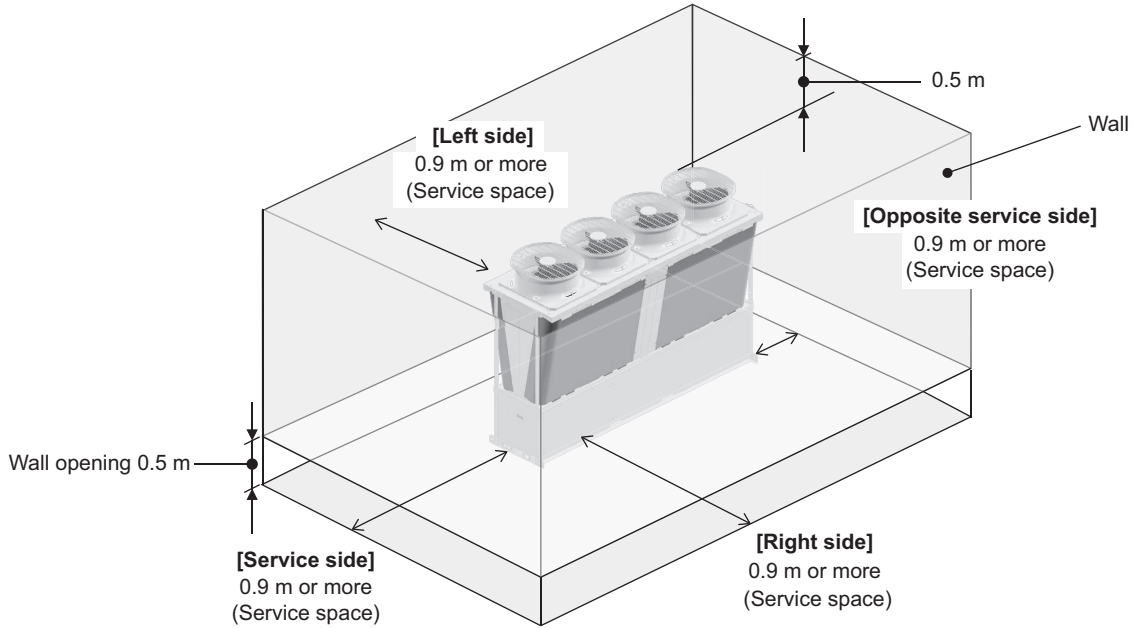

\*Wall height 2.9 m (unit height (2.4 m + 0.5 m))

\*Vent holes: 0.5 m from floor

\*Even if installed as shown in this figure, a short cycle may occur due to the influence of wind.

### 3. Installation

#### 2. Multiple unit installation

##### (1) Required space

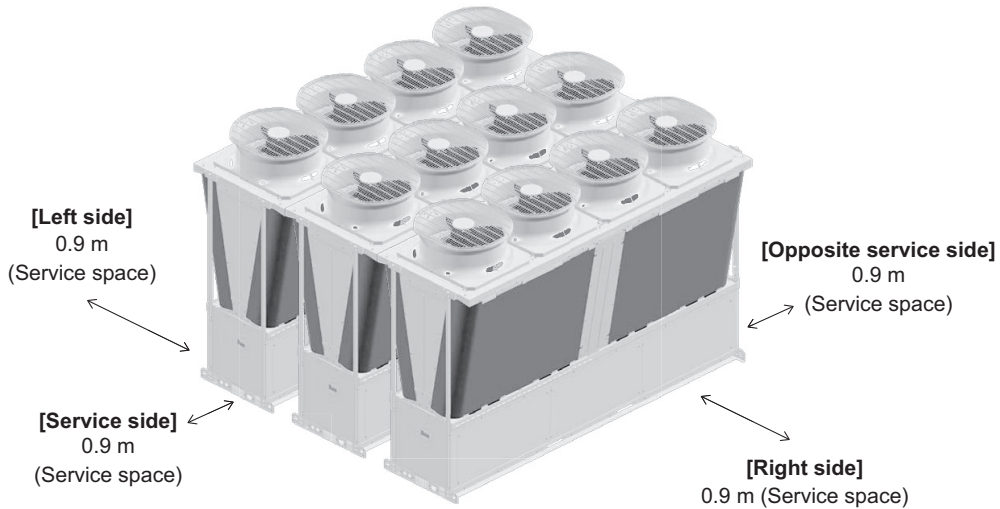

##### (2) If entire surrounding area enclosed by walls (but vent holes installed at bottom of wall)

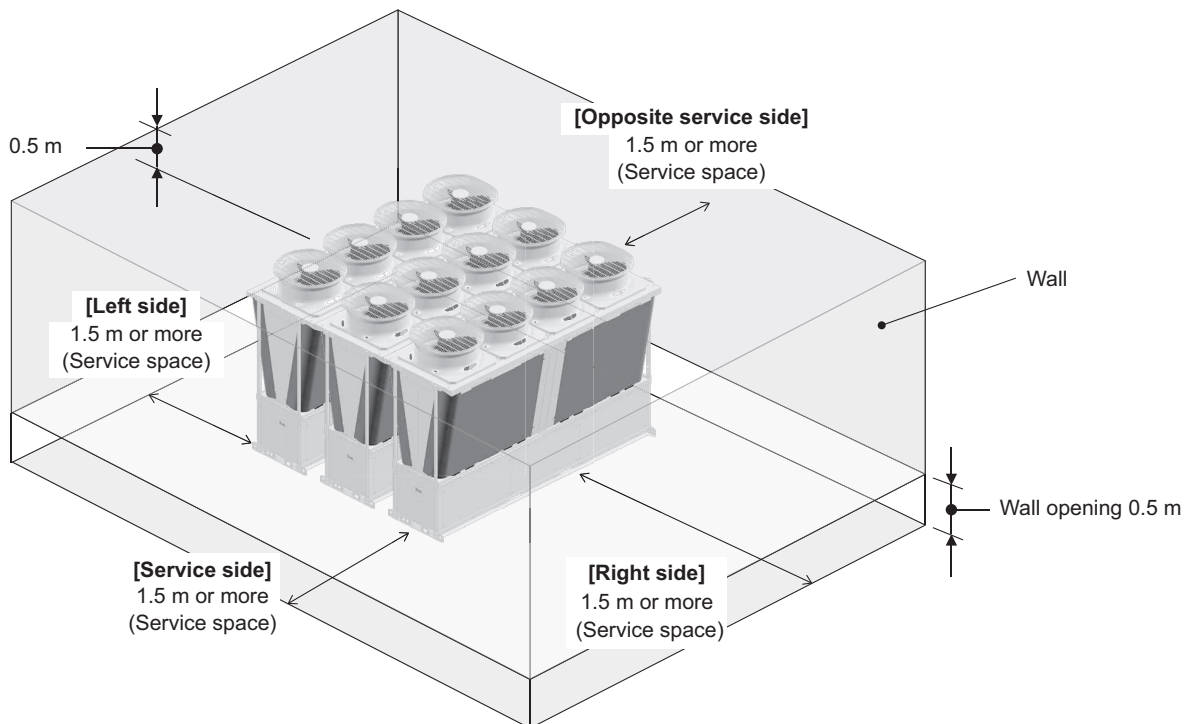

\*Wall height 2.9 m (unit height (2.4 m + 0.5 m))

\*Vent holes: 0.5 m from floor

\*Even if installed as shown in this figure, a short cycle may occur due to the influence of wind.

## 3. Installation

### 3-2. Unit Installation

Units should be installed only by personnel certified by Mitsubishi Electric.

#### 3-2-1. Product suspension method

- If transporting the product suspended, use the two suspension sections at the front and rear.
- Always feed rope through the four suspension sections so that the unit is not subjected to shocks.
- Use two ropes that are 10 m or longer. (Use four ropes that are 5 m or longer.)
- Use suspension equipment that is capable of supporting the weight of the product.
- Always suspend the product in four sections. (do not suspend the product two sections as this is dangerous)
- Use the appropriate protective pads to ensure that the rope does not rub against the outer panel.
- Refer to the center of gravity position shown in 1-3. Center of Gravity, and suspend the unit while taking care to prevent a deviated center of gravity.

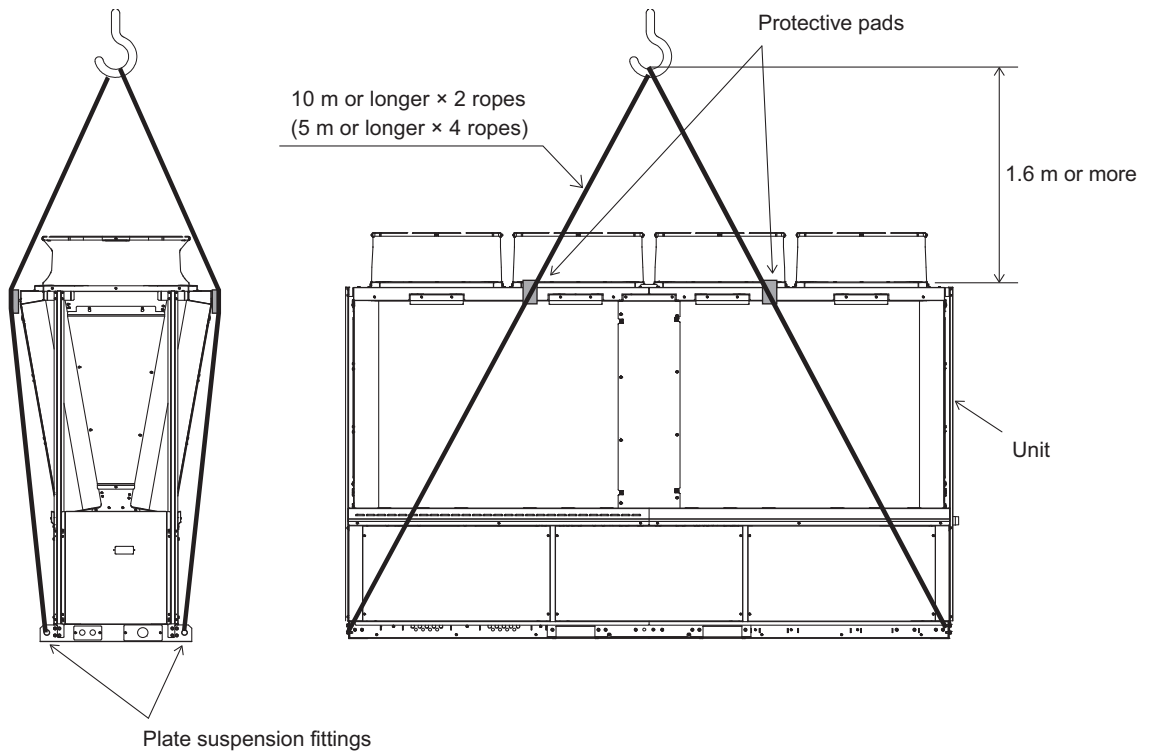

#### **Warning:**

- Lift the unit by placing the slings at designated locations. Support the unit securely at four points to keep it from slipping and sliding. If the unit is not properly supported, it may fall and cause personal injury.

### 3. Installation

#### 3-2-2. Installation on foundation

- Securely fix the unit with bolts to keep the unit from falling down during earthquakes.
- Install the unit on a foundation made of concrete or iron.
- Noise and vibrations from the unit may be transmitted through the floor and walls. Provide adequate protection against noise and vibration.

#### ⚠ Warning:

- Be sure to install the unit on a surface strong enough to withstand its weight to keep the unit from falling down and causing injury.
- Provide adequate protection against earthquakes. Improper installation may cause the unit to fall down, resulting in personal injury.

When building the foundation, take the floor strength, and piping and wiring routes into consideration.

Bolt size	Number
M16	4

Unit: mm

[Enlarged view]

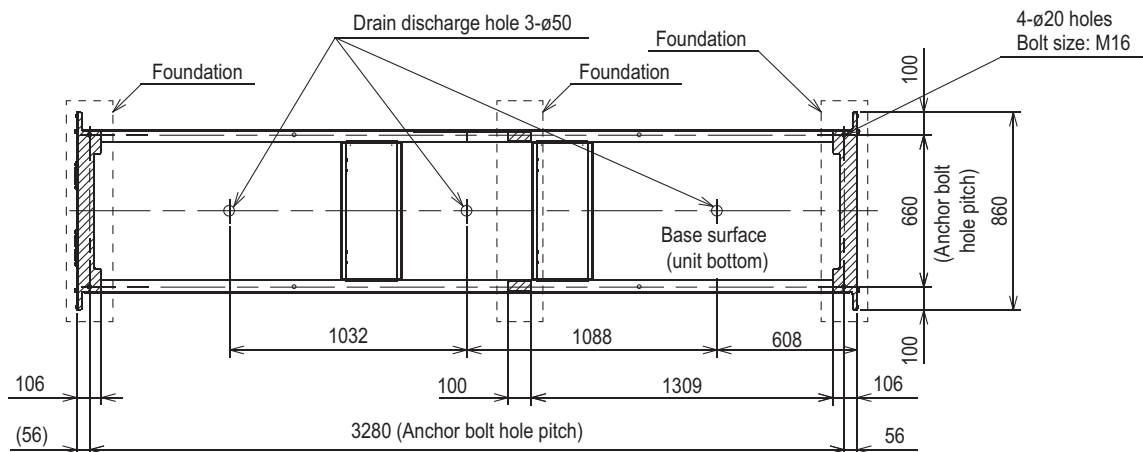
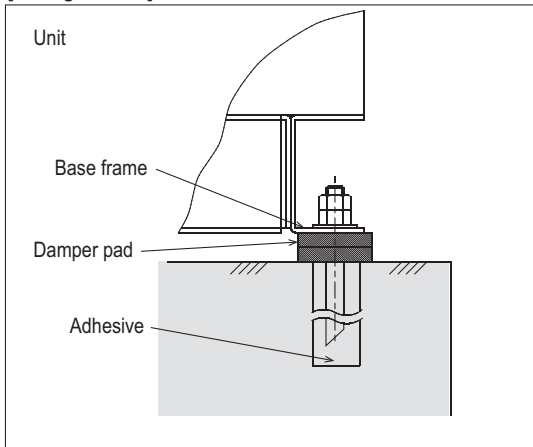

\* show mounting surface.

EAHV-P-YBL(-H)(-N), EACV-P-YBL(-N)

## 4. System Design

### 4-1. Water Pipe Installation

#### 4-1-1. Schematic Piping Diagram and Piping System Components

Water circuit

**Please build the water circuit so that it is a closed system.**

Do not use water directly for showers or other applications.

Do not allow other heat source water to mix with the water circuit.

Build a water circuit as inlet water temperature fluctuation is within 5°C/10 minutes.

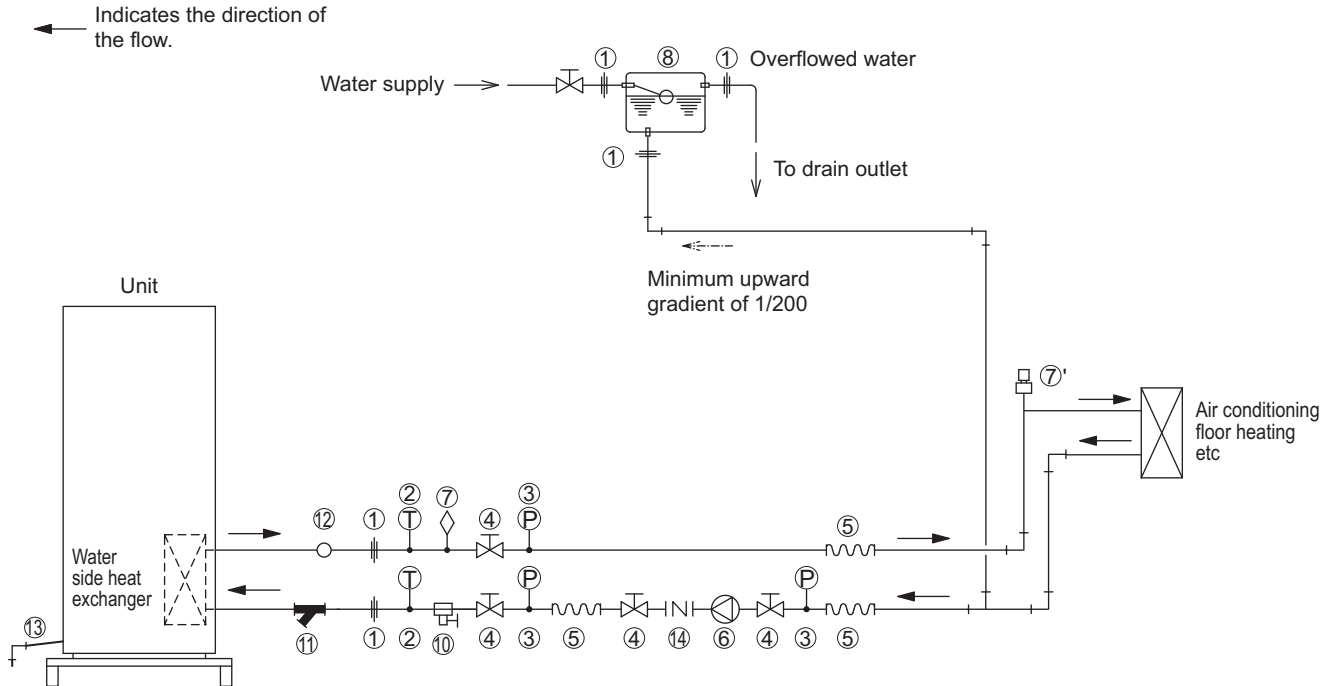

① Union joints/flange joints	Required to allow for a replacement of equipment.
② Thermometer	Required to check the performance and monitor the operation of the units.
③ Water pressure gauge	Recommended for checking the operation status.
④ Valve	Required to allow for a replacement or cleaning of the flow adjuster.
⑤ Flexible joint	Recommended to prevent the noise and vibration from the pump from being transmitted.
⑥ Pump	Use a pump that is large enough to compensate for the total water pressure loss and supply sufficient water to the unit.
⑦ Air vent valve	Install air venting valves to the places where air can accumulate. Automatic air vent valves (such as ⑦') are effective.
⑧ Expansion tank	Install an expansion tank to accommodate expanded water and to supply water.
⑨ Water pipe	Use pipes that allow for easy air purging, and provide adequate insulation.
⑩ Drain valve	Install drain valves so that water can be drained for servicing.
⑪ Strainer	Install a strainer near the unit to keep foreign materials from entering the water-side head exchanger.
⑫ Flow switch	Required to protect the unit.
⑬ Drain pipe	Install the drain pipe with a downward inclination of between 1/100 and 1/200. To prevent drain water from freezing in winter, install the drain pipe as steep an angle as practically possible and minimize the straight line. For cold climate installation, take an appropriate measure (e.g., drain heater) to prevent the drain water from freezing.
⑭ Check valve	Required to prevent the backward flow.

## 4. System Design

### 4-1-2. Standard piping type

EAHV-P-YBL(-H)(-N), EACV-P-YBL(-N)

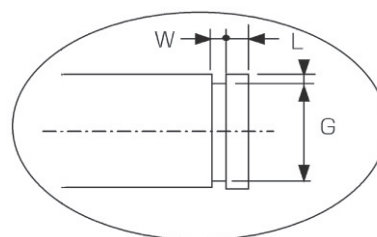
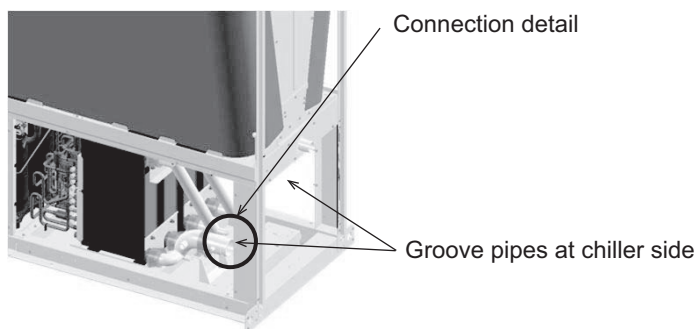
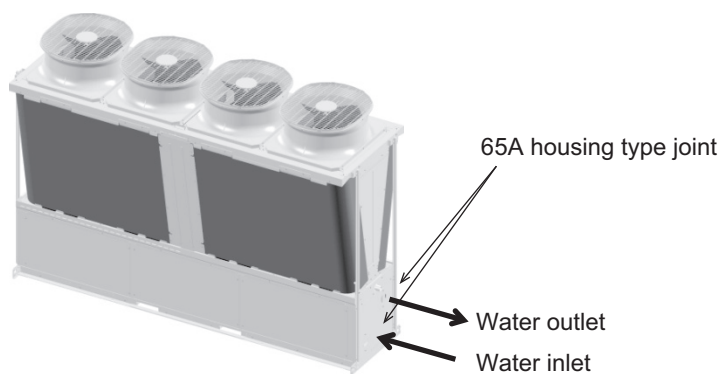

The dimension of the groove pipe at the chiller side

Victaulic standard groove specifications

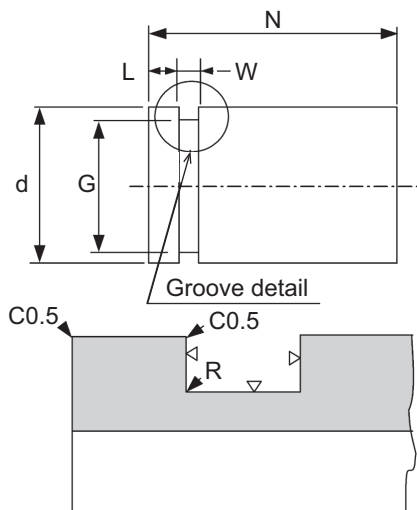

(Unit: mm)

	Pipe size
	2-1/2B (65A)
d	ø76.1
G	ø72.2 <sup>+0</sup> <sub>-0.4</sub>
W	8.7 <sup>+0</sup> <sub>-0.7</sub>
L	15.88 <sup>+0</sup> <sub>-0.7</sub>
N	50
R	1.0

4-1-3. Inside header piping type

EAHV-P-YBL(-H)(-N), EACV-P-YBL(-N)

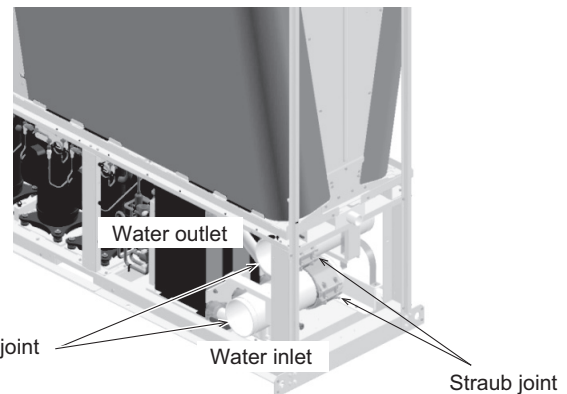
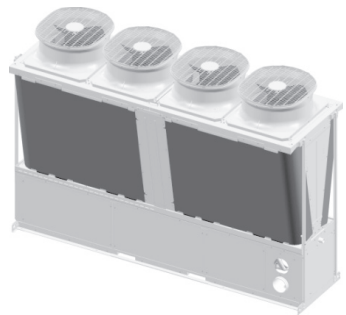

150A housing type joint

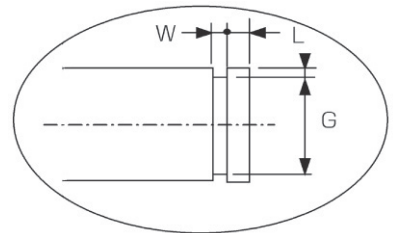
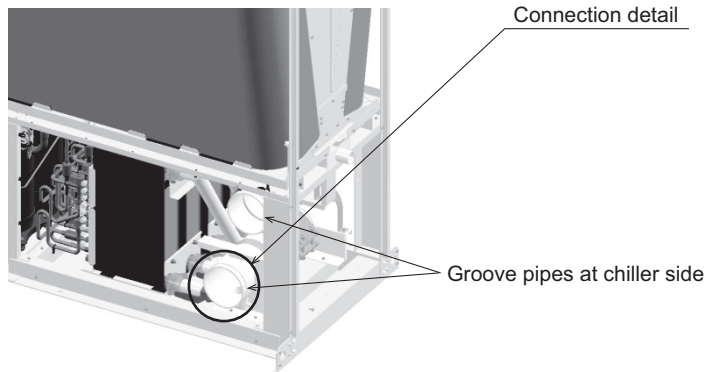

The dimension of the groove pipe at the chiller side

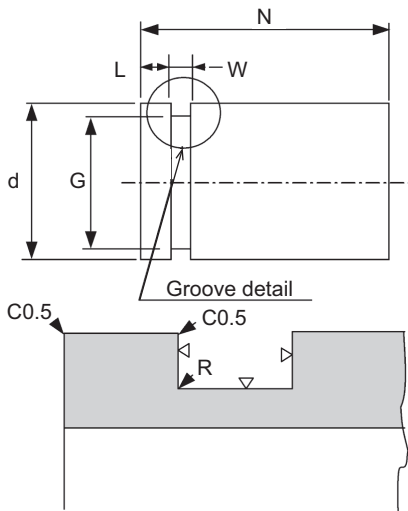

(Unit: mm)

	Pipe size
	6B (150A)
d	ø165.1
G	ø160.8
W	8.7 <sup>+0.7</sup> / <sub>-0</sub>
L	15.9 <sup>+0.7</sup> / <sub>-0</sub>
N	50.0
R	1.0

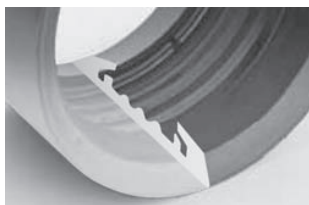

The seal rubber has a lip construction to improve water stopping performance.

Adjust the Straub position to that the marking on both sides is visible.

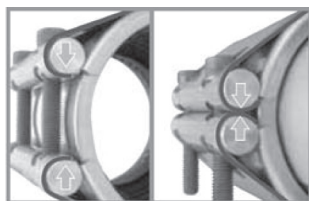
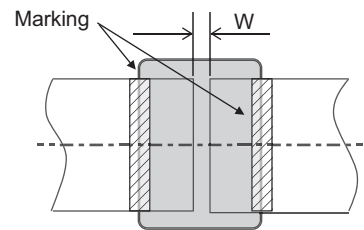

The bolts need only be tightened until the casing is sealed (metal touches). Consequently, the procedure can be carried out accurately by anyone to the same level, regardless of worker proficiency or the type of pipe.

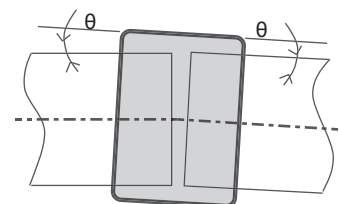

- Allowable tolerance for gaps and tilting  
 Pipe gap tolerance [W]: 0 to 25 mm  
 Allowable pipe tilt angle [θ]: ±2°



## 4. System Design

### 4-1-4. Notes on pipe corrosion

#### Water processing and water quality control

Poor-quality circulating water can cause the water-side heat exchanger to scale up or corrode, reducing heat-exchange performance. Properly control the quality of the circulating water.

- Removing foreign objects and impurities in the pipes

During installation, keep foreign objects, such as welding and sealant fragments and rust, out of the pipes.

- Water Quality Control

- (1) Poor-quality water can corrode or scale up the heat exchanger. Regular water treatment is recommended.

Water circulation systems using open heat storage tanks are particularly prone to corrosion.

When using an open heat storage tank, install a water-to-water heat exchanger, and use a closed-loop circuit.

If a water supply tank is installed, keep contact with air to a minimum, and keep the level of dissolved oxygen in the water no higher than 1 mg/ℓ.

- (2) Water quality standard

Items		Lower mid-range temperature water system Water Temp. ≤ 60°C		Higher mid-range temperature water system Water Temp. > 60°C		Tendency	
		Recirculating water	Make-up water	Recirculating water	Make-up water	Corrosive	Scale-forming
Standard items	pH (25 °C)	7.0 ~ 8.0	7.0 ~ 8.0	7.0 ~ 8.0	7.0 ~ 8.0	○	○
	Electric conductivity (mS/m) (25 °C) (μs/cm) (25 °C)	30 or less [300 or less]	30 or less [300 or less]	30 or less [300 or less]	30 or less [300 or less]	○	○
	Chloride ion (mg Cl/ℓ)	50 or less	50 or less	30 or less	30 or less	○	
	Sulfate ion (mg SO <sub>4</sub> <sup>2-</sup> /ℓ)	50 or less	50 or less	30 or less	30 or less	○	
	Acid consumption (pH4.8) (mg CaCO <sub>3</sub> /ℓ)	50 or less	50 or less	50 or less	50 or less		○
	Total hardness (mg CaCO <sub>3</sub> /ℓ)	70 or less	70 or less	70 or less	70 or less		○
	Calcium hardness (mg CaCO <sub>3</sub> /ℓ)	50 or less	50 or less	50 or less	50 or less		○
	Ionic silica (mg SiO <sub>2</sub> /ℓ)	30 or less	30 or less	30 or less	30 or less		○
Reference items	Iron (mg Fe/ℓ)	1.0 or less	0.3 or less	1.0 or less	0.3 or less	○	○
	Copper (mg Cu/ℓ)	1.0 or less	1.0 or less	1.0 or less	1.0 or less	○	
	Sulfide ion (mg S <sup>2-</sup> /ℓ)	Not to be detected	Not to be detected	Not to be detected	Not to be detected	○	
	Ammonium ion (mg NH <sub>4</sub> <sup>+</sup> /ℓ)	0.3 or less	0.1 or less	0.1 or less	0.1 or less	○	
	Residual chlorine (mg Cl/ℓ)	0.25 or less	0.3 or less	0.1 or less	0.3 or less	○	
	Free carbon dioxide (mg CO <sub>2</sub> /ℓ)	0.4 or less	4.0 or less	0.4 or less	4.0 or less	○	
Ryzner stability index	-	-	-	-	○	○	

Reference: Guideline of Water Quality for Refrigeration and Air Conditioning Equipment. (JRA GL02E-1994)

- (3) Please consult with a water quality control specialist about water quality control methods and water quality calculations before using anti-corrosive solutions for water quality management.

- (4) When replacing an air conditioner (including when only the heat exchanger is replaced), first analyze the water quality and check for possible corrosion.

Corrosion can occur in water systems in which there has been no signs of corrosion. If the water quality level has dropped, adjust the water quality before replacing the unit.

- (5) Suspended solids in the water

Sand, pebbles, suspended solids, and corrosion products in water can damage the heating surface of the heat exchanger and cause corrosion. Install a good quality strainer (20 mesh or better) at the inlet of the unit to filter out suspended solids.

#### Removing foreign substances from the water system

Consider installing a settlement tank or a bypass strainer to remove foreign substances from the water system.

Select a strainer capable of handling two to three percent of the circulating water. The figure below shows a sample system with a bypass strainer.

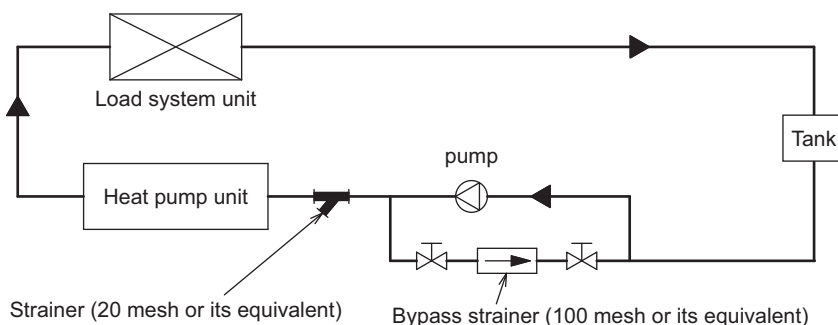

## 4. System Design

### (6) Connecting pipes made from different materials

If different types of metals are placed in direct contact with each other, the contact surface will corrode.

Install an insulating material between pipes that are made of different materials to keep them out of direct contact with each other.

### (7) Piping material

Use hot water output piping material that can withstand heat of 60°C or more. Use hot water input piping material that can withstand the maximum input water temperature. All piping must be made of SUS or similar material to withstand corrosion.

## 4-1-5. Installing the Strainer and Flow Switch

### 1. Installing the strainer

Install a strainer on the inlet pipe near the unit to filter out suspended solids and prevent clogging or corrosion of the heat exchanger.

Install a strainer in a way that allows for easy access for cleaning, and instruct the user to clean it regularly.

Operating the units with a clogged strainer may cause the units to make an abnormal stop. Select a location to install a strainer, taking into consideration the installation angle, insulation thickness, and maintenance space.

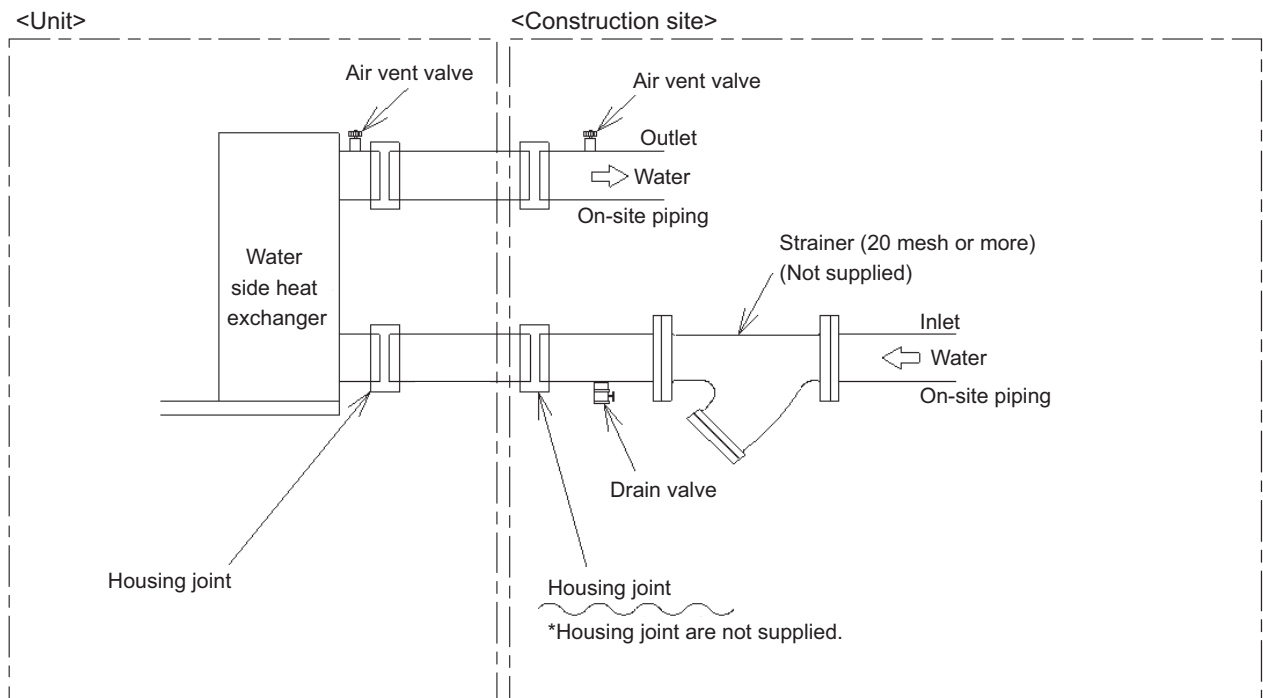

### 2. Installing a flow switch

Install a flow switch that meets the following specifications on the water pipe.

Connect the flow switch to the flow switch contact on the unit.

Minimum flow rate = 12.9 m<sup>3</sup>/h (215 L/min)

Unit usage range (water flow rate): 12.9 - 34.0 m<sup>3</sup>/h

## 4. System Design

### 4-1-6. Ensuring enough water in the water circuit

#### 1. Required amount of water

If the amount of water in the water circuit (circulating water circuit) is insufficient, the unit operation hours may become shorter or the amount of water temperature change to be controlled may become extremely large.

Also, the defrost operation during the heating mode may not function properly. Refer to the table below for the minimum amount of water required in the circuit.

If the water pipe is too short to keep enough amount of water, install a cushion tank in the water pipe to ensure enough amount of water.

Model	Minimum amount of water (ℓ)
EAHV-P1500, 1800YBL	1450
EACV-P1500, 1800YBL	800

#### 2. Calculating the required amount of water in the water circuit

The required amount of water in the water circuit can be obtained from the following formula.

(Required amount of water in the water circuit) = (Amount of water that can be held in the water pipe) + (Amount of water that can be held in the heat source unit) + (Amount of water that can be held in the load-side unit)

#### The amount of water that can be held per meter of the water pipe (ℓ/m)

Pipe size					
2 1/2B (65A)	3B (80A)	4B (100A)	5B (125A)	6B (150A)	8B (200A)
3.77	5.16	8.87	13.23	18.91	32.44

#### The amount of water that can be held in the heat source unit (ℓ)

Standard	Inside header piping type
27	68

#### 3. Inlet/Outlet pipe connection size and material

The table below shows the inlet/outlet pipe connection size.

#### Inlet/Outlet pipe connection size

Piping type	Inlet pipe connection	Outlet pipe connection
Standard	65A housing type joint (Field-supplied Victaulic joint)	65A housing type joint (Field-supplied Victaulic joint)
Inside header piping type	150A housing type joint (Field-supplied Victaulic joint)	150A housing type joint (Field-supplied Victaulic joint)

## 4. System Design

### 4-1-7. Water Piping Size and Location

#### 1. Standard piping type

Unit: mm

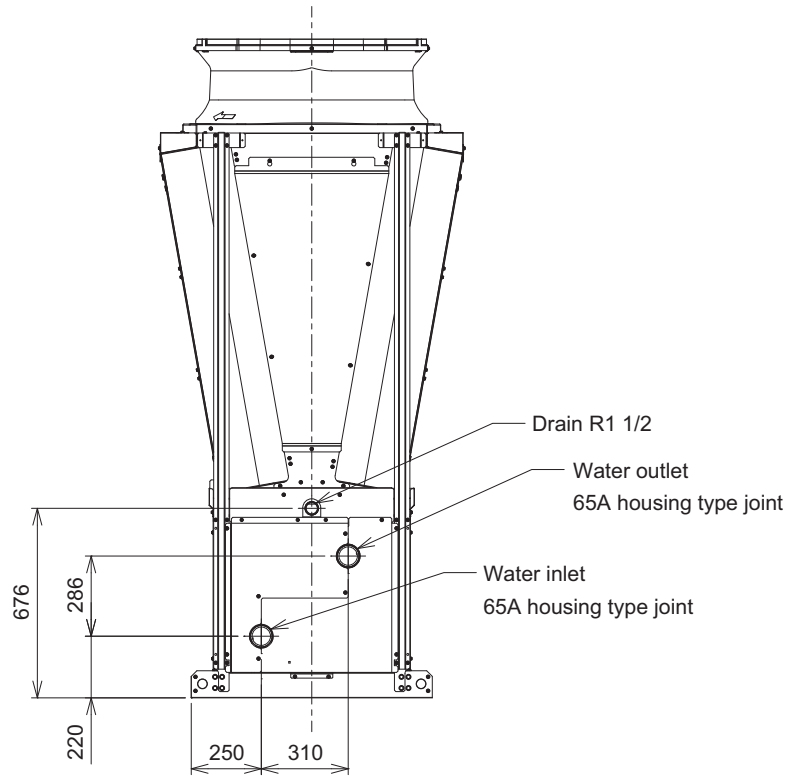

#### 2. Inside header piping type

Unit: mm

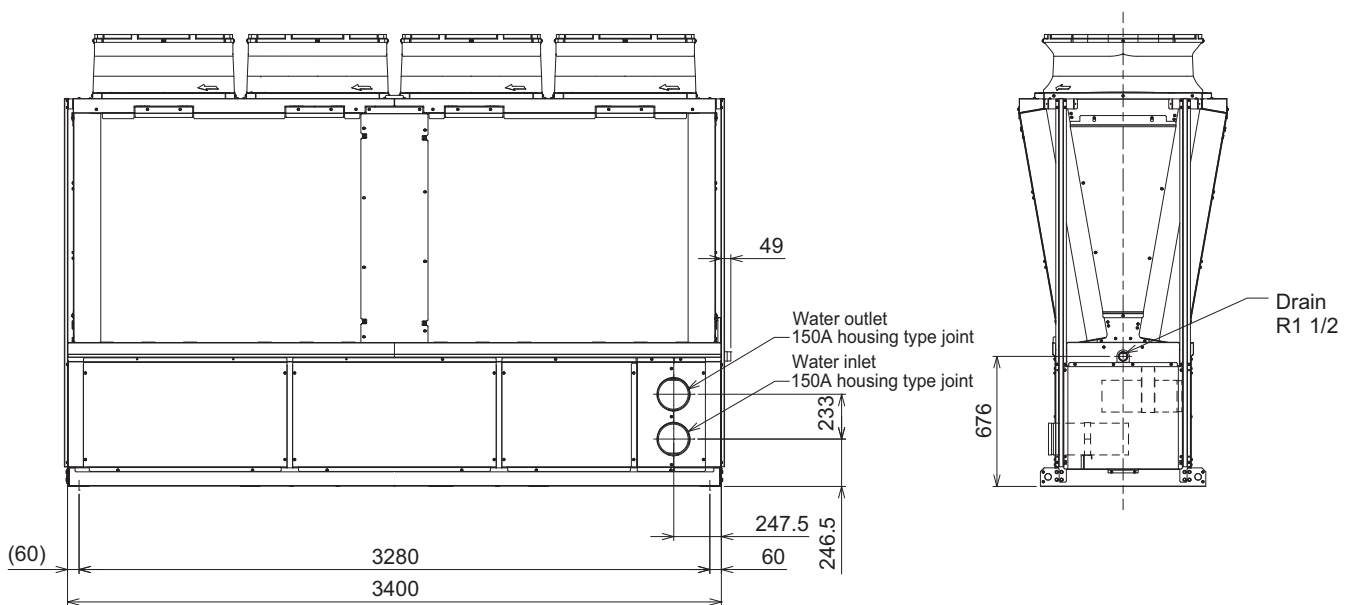

## 5. Wiring Design

### 5-1. System Configurations

The system must be configured only by personnel certified by Mitsubishi Electric.

#### 5-1-1. Schematic Diagrams of Individual and Multiple Module Connection Systems

##### (1) Individual system

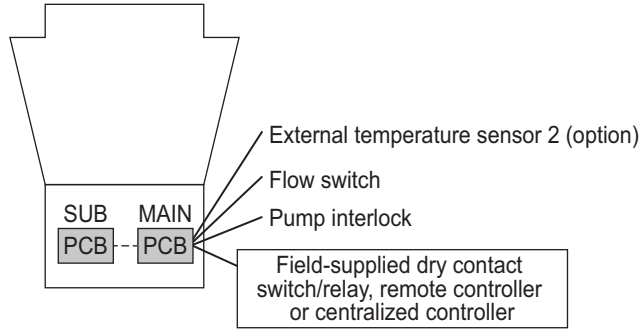

Refer to the sections "Switch Types and the Factory Settings" and "Configuring the settings" for further details.

##### (2) Multiple module connection system (Max.24 modules)

System leader unit	The unit controls the identical water system group.
Group leader unit	The unit transmits the command from the system leader unit to the sub unit.
Sub unit	The unit is other than leader unit.

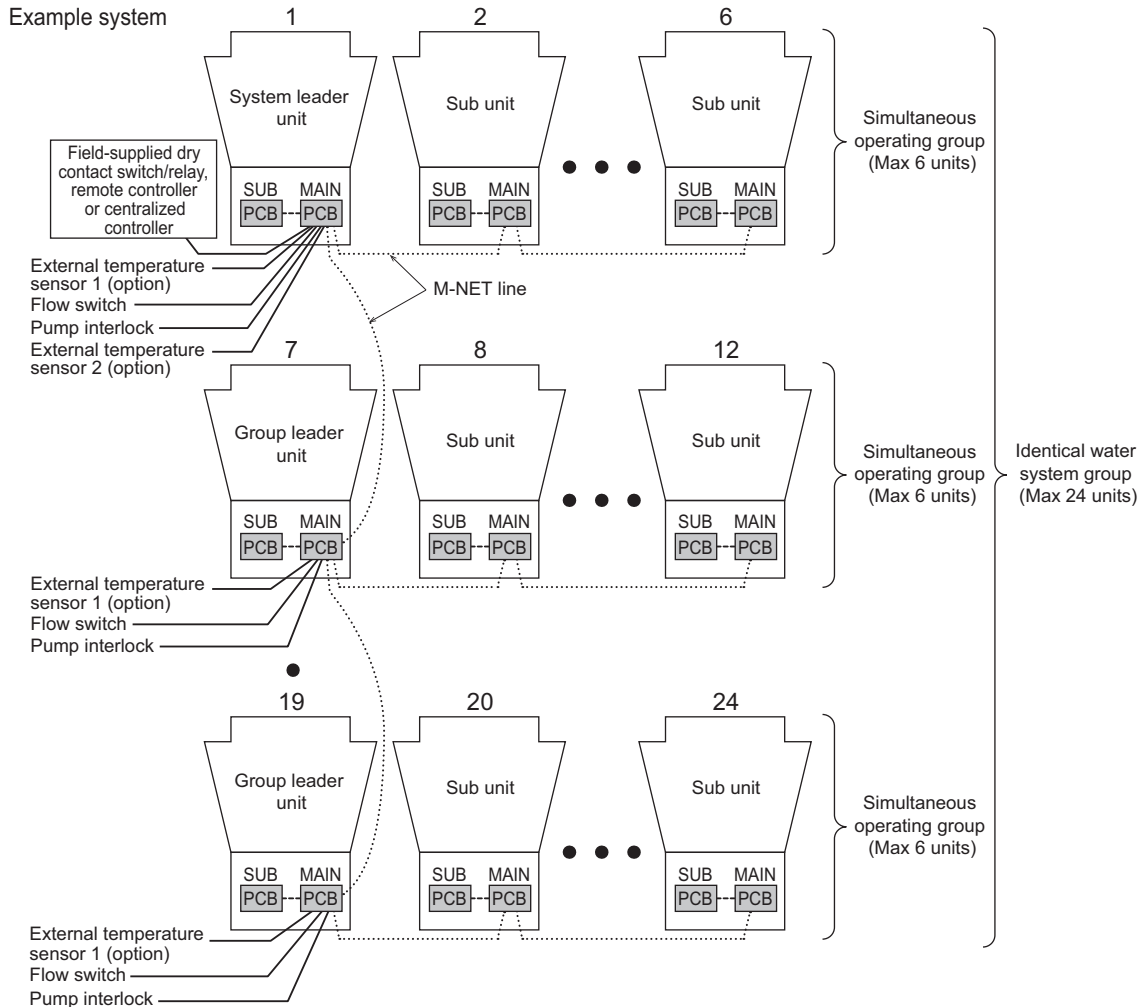

Refer to the sections "Switch Types and the Factory Settings" and "Configuring the settings" for further details.

### 5-1-2. Switch Types and the Factory Settings

(1) Switch names and functions

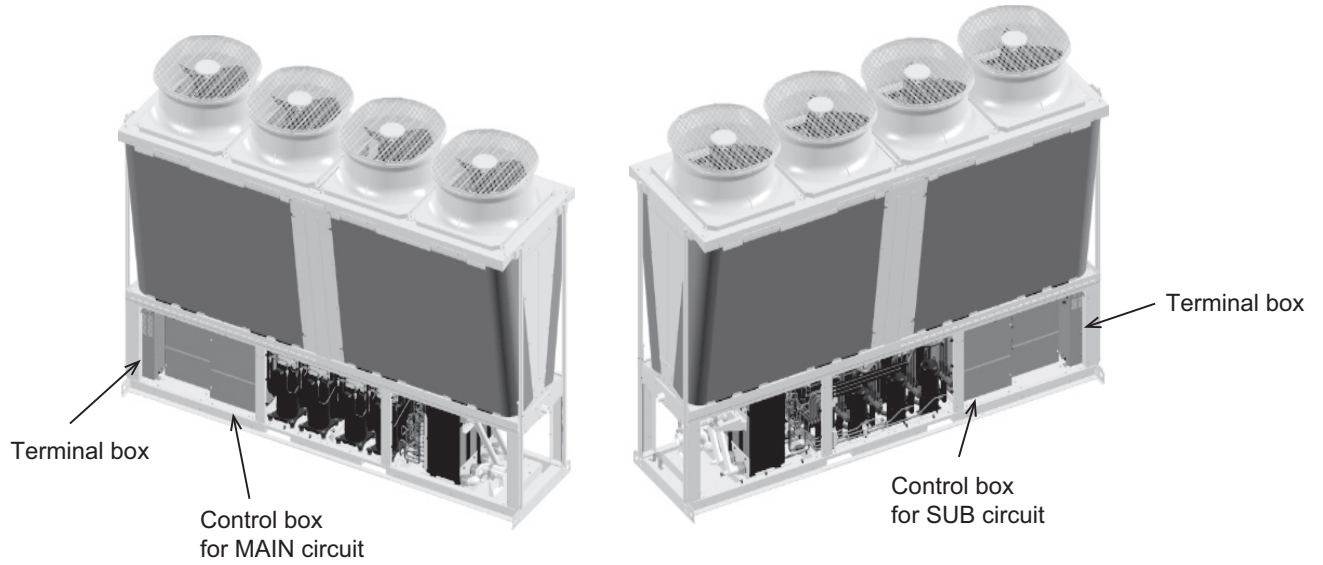

There are three main ways to set the settings as follows:

- 1) Dip switches (SW1 - SW3, SW421)
- 2) Dip switches used in combination with the push switches
- 3) Rotary switches

See below for how these switches are used to set certain items.

## 5. Wiring Design

### Different types of switches on the PCB

[Control board]

[Enlarged the operation area 1]

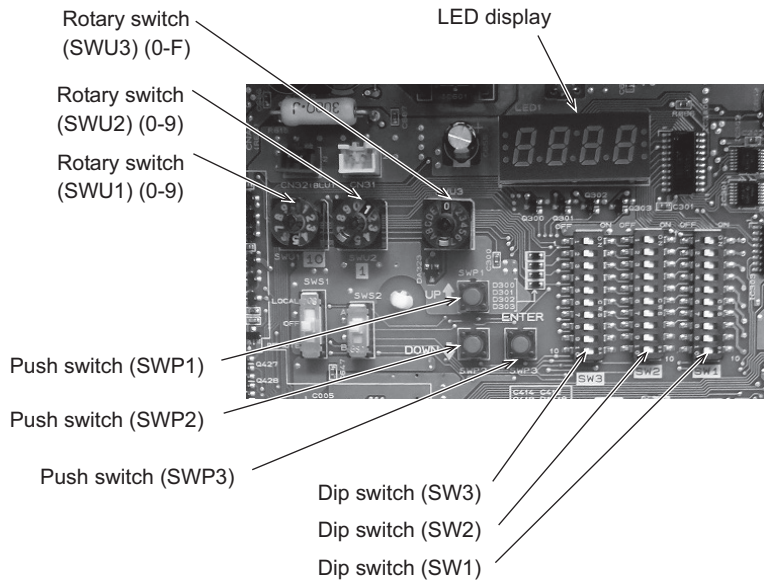
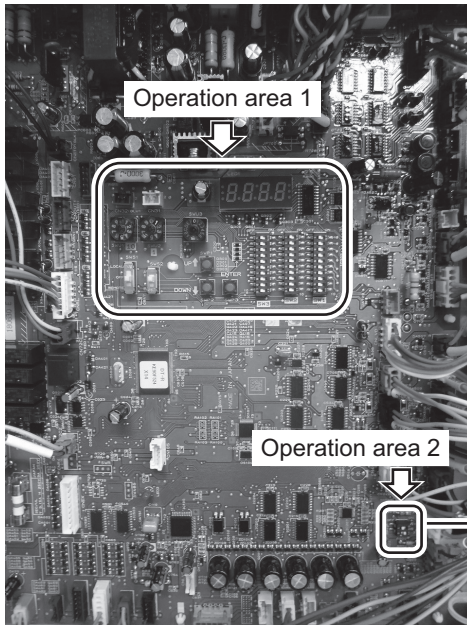

[Enlarged the operation area 2]

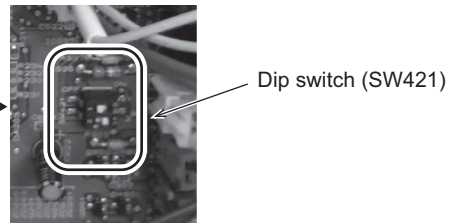

			Initial Setting	
			MAIN circuit	SUB circuit
Rotary switch	SWU1	Sets the 10's digit of the unit address.	"0"	"5"
	SWU2	Sets the 1's digit of the unit address.	"1"	"1"
	SWU3	Use for switching the setting.	"0"	"0"
Push switch	SWP1	Use for increasing the setting value.	-	-
	SWP2	Use for decreasing the setting value.	-	-
	SWP3	Use for changing and deciding the setting value.	-	-
Dip switch	SW1-3	Select a setting which is decided with a combination of switch numbers.	-	-
	SW421	Analog input type setting (Refer to Page 82 and 83)	-	(Unused)

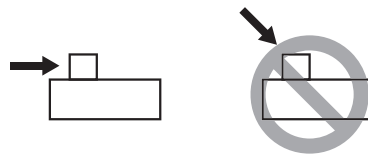
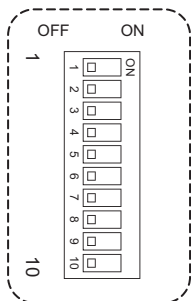

Slide the dip switches:  
do not push down the switches.

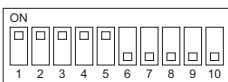

The figure at left shows that the switches 1 through 5 are set to ON and 6 through 10 are set to OFF.

## 5. Wiring Design

(2) Factory Switch Settings (Dip switch settings table)

SW	Function	Usage	Factory setting		OFF setting	ON setting	System leader unit	Group leader unit	SUB module	Setting timing	
			MAIN circuit	SUB circuit							
SW1	1	Settings change or view the settings	These switches are used for setting change with push switch SWP 1, 2 and 3.	OFF	OFF	The 7-segment LED display is changed.	Depends on the setting	Depends on the setting	Depends on the setting	Depends on the setting	
	2										
	3										
	4										
	5										
	6										
	7										
	8										
	9										
	10										
SW2	1	Model setting	-	-	Leave the setting as it is.		-	-	-	At a reset	
	2	System setting	Set the duties to each unit.	OFF	-	2 / 3		Required	Required	Required	At a reset
	3					System leader unit : ON ON Group leader unit : ON OFF Sub unit : OFF OFF					
	4	Water-temperature control 1 (option)	Selects either the external water temperature sensor or the built-in sensor to be used to control water temperature. (Simultaneous operating group)	OFF	-	Built-in sensor on the unit	External water temperature sensor 1	Required	Required	Required	At a reset
	5	Water-temperature control 2 (option)	Selects target temperature correction control. (Identical water system group)	OFF	-	OFF	ON (External water sensor 2 is required.)	Required	Fixed OFF	Fixed OFF	At a reset
	6	Multiple unit control	Selects optimum control of number of operating units.	OFF	-	Ineffective	Effective	Required	Fixed OFF	Fixed OFF	At a reset
	7	Analog input setting	Allows or disallows the analog signals from a remote location.	OFF	-	Disallows the external analog signals.	Allows the external analog signals.	Required	Fixed OFF	Fixed OFF	At a reset
	8	Analog input signal switching	Selects either the water temperature or the capacity control ratio. (Effective only when SW2-7 is set to ON.)	OFF	-	Water temperature	Capacity control ratio	Required	Fixed OFF	Fixed OFF	At a reset
	9	BMS setting *		OFF	-	No input from BMS	Input from BMS	Required	Fixed OFF	Fixed OFF	At a reset
	10	Model setting		OFF	OFF	Leave the setting as it is.		Fixed OFF	Fixed OFF	Fixed OFF	Any time
SW3	1	Analog input type setting	Selects analog input 4-20mA/0-10V/1-5V/2-10V. (Effective only when SW2-7 is set to ON and SW3-4 is set to OFF.)	OFF	-	1 / 2		Required	Fixed OFF	Fixed OFF	Any time
	2					4-20mA: OFF OFF 1-5V: ON OFF 0-10V: OFF ON 2-10V: ON ON					
	3	Model setting		OFF	OFF	Leave the setting as it is.		Fixed OFF	Fixed OFF	Fixed OFF	Any time
	4										
	5										
	6										
	7	Auto restart after power failure	Enables or disables the automatic restoration of operation after power failure (in the same mode as the unit was in before a power failure).	ON	ON	An alarm will be issued when power is restored after a power outage. The alarm will be reset when the power is turned off and then turned back on.	Automatically restores operation after power failure.	Required	Required	Required	Any time
	8										
	10	Model setting		OFF	OFF	Leave the setting as it is.		Fixed OFF	Fixed OFF	Fixed OFF	Any time

"-" in the table indicates that the function in the corresponding row will be disabled regardless of the actual switch setting. The factory setting for these items is OFF.

\* Connection to a BMS requires an installation of Procon A1M (Modbus interface), which is available from MITSUBISHI ELECTRIC UK. Use a BMS with insulation

SW2-7	SW2-8	SW2-9	Input from BMS
ON	OFF	ON	Target temperature
ON	ON	ON	Capacity
OFF	OFF	ON	Outdoor temperature



5-1-3. Configuring the Settings

The settings must be set only by a qualified personnel.

1. System configuration

(1) Set the dip switches.

Switch settings on the MAIN circuit

Set the dip switches (labeled A in the figure at right) that correspond to the items below, according to the local system.

- Water temperature control based on the external water temperature reading
- Analog signals from a remote location

Refer to "Dip switch settings table" for further details.

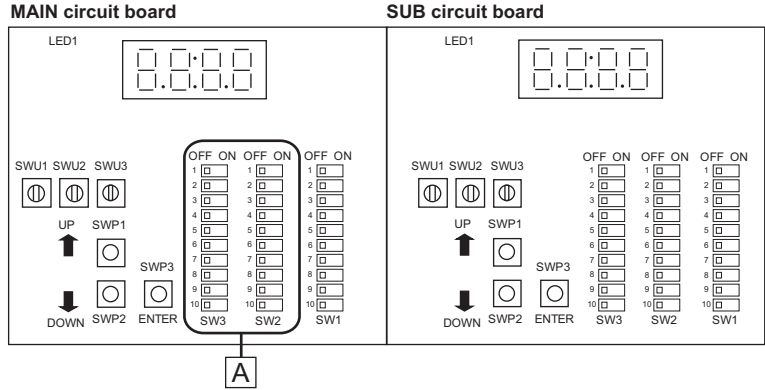

(2) Set the rotary switches. (Address setting)

Example of address setting

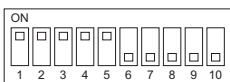
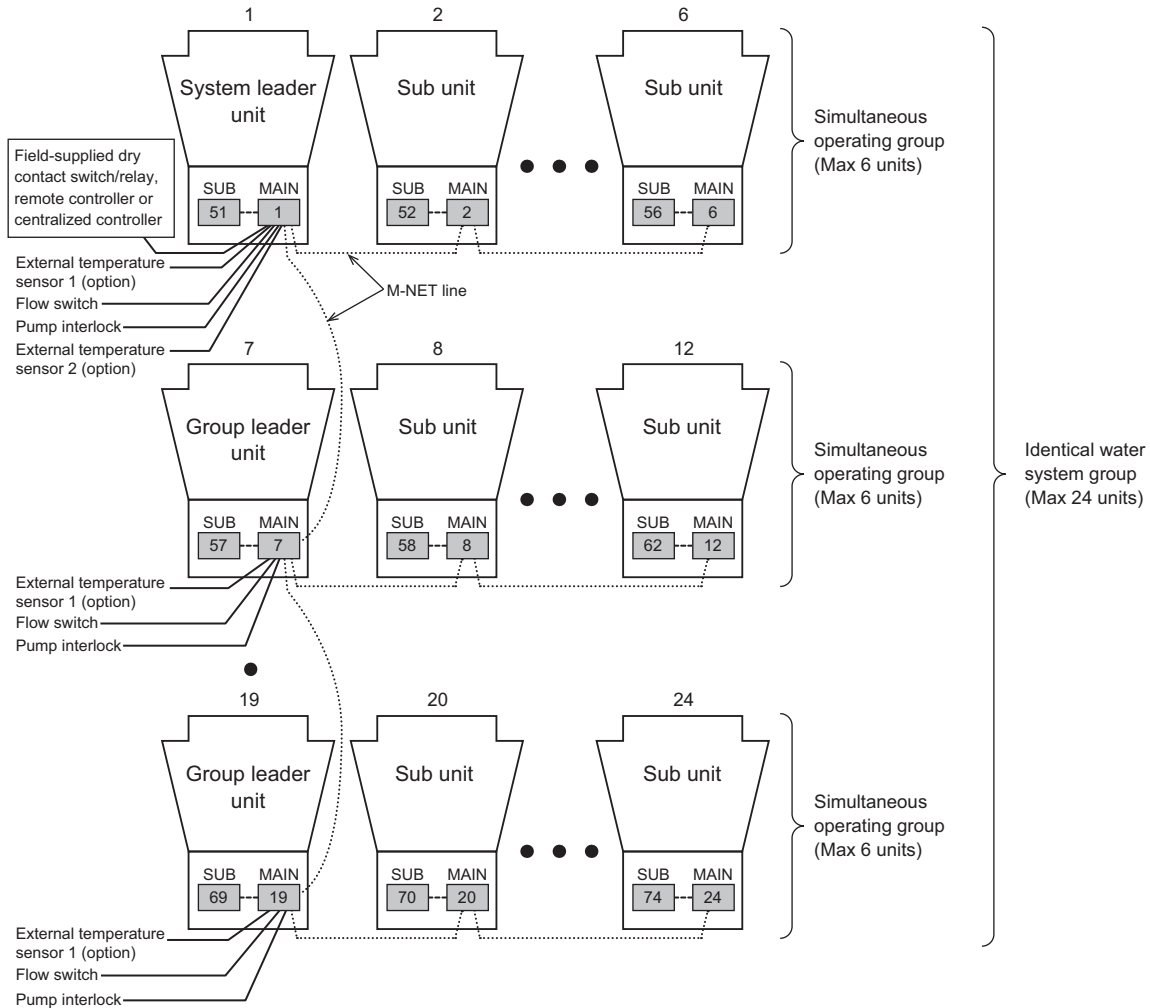

The figure at left shows that the switches 1 through 5 are set to ON and 6 through 10 are set to OFF.

EAHV-P-YBL(-H)(-N), EACV-P-YBL(-N)

## 5. Wiring Design

### Setting the switches on the system leader unit

Make sure the address of the MAIN circuit on the main module is set to "1" (labeled A in the figure at right) and that the address of the SUB circuit on the main module is set to "51" (labeled B in the figure at right).

The address of each SUB circuit should equal the sum of the MAIN circuit address on the same module and 50.

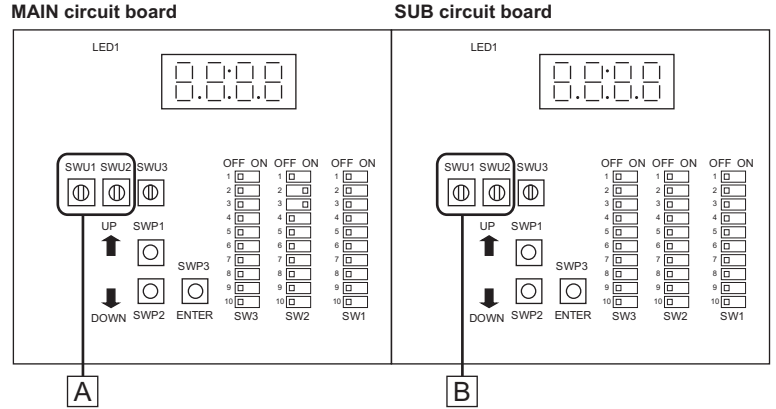

### Setting the switches on the group leader unit and the sub unit

#### MAIN circuit

(1) Set the MAIN circuit addresses with the rotary switches. (labeled A in the figure). Set the 10's digit with SWU1, and set the 1's digit with SWU2. Assign sequential addresses to the MAIN circuit on all sub modules starting with 2.

#### SUB circuit

(2) Set the SUB circuit addresses with the rotary switches (labeled B in the figure). Set the 10's digit with SWU1, and set the 1's digit with SWU2. Assign sequential addresses to the SUB circuit on all sub modules starting with 52.

### (3) Set the M-NET power supply.

When connecting a system leader unit and a group leader unit to a multiple units connection system, the connector connected to CN41 on the MAIN circuit board (Address 1) must be disconnected and then connected to CN40.

\*Leave the connector connected to CN41 when using an AE-200 as the centralized controller.

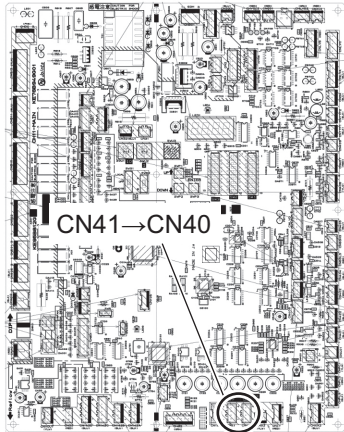

Address 1	All addresses other than Address 1
Move the connector from CN41 to CN40.	Leave the connector connected to CN41.

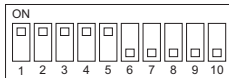

The figure at left shows that the switches 1 through 5 are set to ON and 6 through 10 are set to OFF.

## 5. Wiring Design

### Selector switch settings

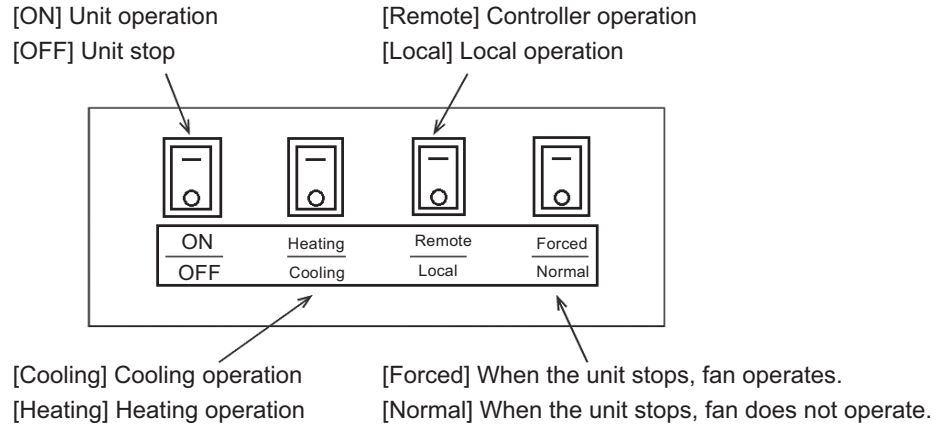

### ⚠ CAUTION

- Do not open the terminal cover, when selector switches are operated.

### Display

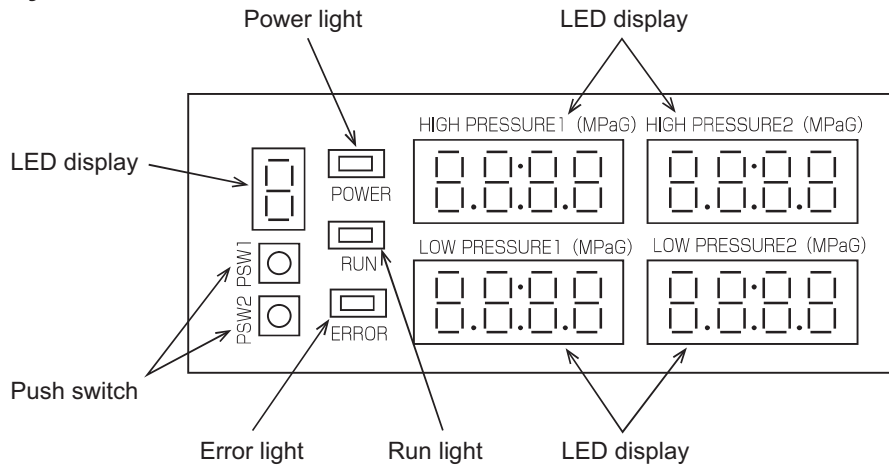

### The positions of the selector switch and the display

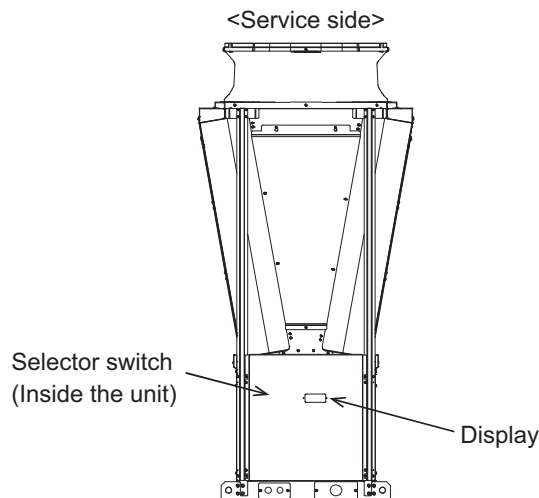

## 5. Wiring Design

### Priority order of the water-temperature-setting-input-signal sources

Water temperature can be controlled by using the signals from the four types of input sources listed below. The setting for the item with higher priority will override the settings for the items with lower priorities. The water temperature will be controlled according to the temperature setting in the "Target water temperature" column that corresponds to a specific combination of the settings for the four items.

No-voltage contact input K93-K94 ON: Heating (EAHV-P\*\*\*\*YB, EAHV-P\*\*\*\*YB-H)

Priority 1	Priority 2	Priority 3	Priority 4			Target water temperature	
No-voltage contact input K40-K41	Analog input or BMS (SW 2-9: ON)	No-voltage contact input K40-K42	Remote controller PAR-W31MAA Input from centralized controller AE-200 or BMS (*3)				
Anti-freeze		Mode change	No remote controller	Manual setting	Schedule setting		
ON	Ineffective	Ineffective	-	Ineffective	Ineffective	30°C	
OFF	SW2-7: ON	Ineffective	-	Ineffective	Ineffective	Temperature setting for the analog signal input	
	SW2-7: OFF	ON (Heating ECO)	-	Ineffective	Ineffective	Heating ECO	
		OFF (Heating)	When no RC is used	-	-	-	Heating
			-	-	Anti-freeze	-	30°C
			-	-	Heating ECO	-	Heating ECO
			-	-	Heating	-	Heating
			-	-	Cooling (*1)	-	Cooling
-	-	-	-	When schedule has been set (*2)	Target water temp is controlled according to the setting on the remote controller.		

\*1: This mode is disabled in EAHV-P\*\*\*\*YB-H.

\*2: EAHV-P\*\*\*\*YB can also set Cooling.

\*3: AE-200 and BMS cannot both be simultaneously connected. Only connect one or the other.

No-voltage contact input K93-K94 OFF: Cooling (EAHV-P\*\*\*\*YB, EACV-P\*\*\*\*YB)

\* When the operation mode is Cooling, K40-K41 (Anti-freeze) and K40-K42 (Mode change) are disabled.

Priority 1	Priority 2			Target water temperature
Analog input	Remote controller PAR-W31MAA Input from centralized controller AE-200 or BMS (*3)			
	No remote controller	Manual setting	Schedule setting	
SW2-7: ON	-	Ineffective	Ineffective	Temperature setting for the analog signal input
SW2-7: OFF	When no RC is used	-	-	Cooling
	-	Anti freeze (*1)	-	30°C
	-	Heating ECO (*1)	-	Heating ECO
	-	Heating (*1)	-	Heating
	-	Cooling	-	Cooling
	-	-	-	When schedule has been set (*2)

\*1: This mode is disabled in EACV-P\*\*\*\*YB.

\*2: EAHV-P\*\*\*\*YB can also set Heating or Heating ECO.

\*3: AE-200 and BMS cannot both be simultaneously connected. Only connect one or the other.

### Priority order of the operation signal sources

	No-voltage contact	Remote controller PAR-W31MAA	Input from centralized controller AE-200 or BMS
Unit operation (Run/Stop)	The last setting has priority.		
Operation mode	Cooling *1	The last setting has priority.	
	Heating *1	The last setting has priority.	
	Heating ECO *1*2	The last setting has priority.	
	Anti-freeze *2	The last setting has priority.	
Fan mode (The contact ON has priority.)	OFF	The last setting has priority.	
	ON	Ineffective	

\*1: When the Anti-freeze contact is ON during heating operation, the setting change is ineffective.

\*2: Changing by contact is effective during heating operation.

### 2. Making the settings

Use the LED display and the three push switches (SWP1 (↑), SWP2 (↓), and SWP3 (Enter)) to change the current settings on the circuit board and to monitor various monitored values.

#### (1) Setting procedures

Take the following steps to set the push switches SWP1 through SWP3. These switches must be set after the dip switch SW1 has been set.

1)

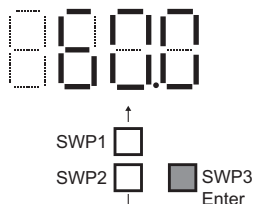

Normally a value of setting item appears on the display.



Press SWP3 (Enter) to enable the configuration changes.

2)

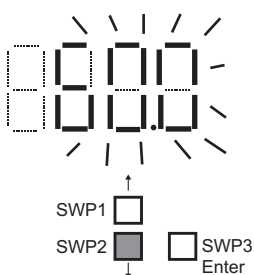

The current setting value will blink.



The left figure shows that the current setting value is "60.0."

To decrease this value to 58.0, for example, press SWP2 (↓).

Press SWP1 (↑) to increase the value.

3)

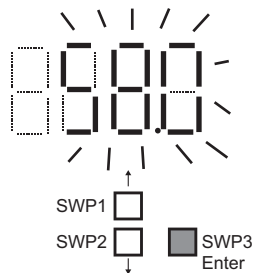

When the desired value is displayed (58.0 in the example at left), press SWP3 (Enter).



The displayed value will stop blinking and stay lit.

A lit LED indicates that the new setting has been saved.



















\* Pressing SWP1 (↑) or SWP2 (↓) will change the blinking setting value, but the change will not be saved until SWP3 (Enter) is pressed.

Press and hold SWP1 (↑) or SWP2 (↓) for one second or longer to fast forward through the numbers.

## 5. Wiring Design

### (2) Table of settings items

Set the dip switch SW1 as shown in the table below to set the value for the items in the "Setting item" column.

No.	Rotary switch (SWU3)	Dip switch setting (SW1) *1	Setting Item	Default	Need or non-need to set the setting *4						Notes
					System		Group		Sub		
					M	S	M	S	M	S	
1	1		Setting temp 1 (Cooling mode) *2	7°C	○	—	—	—	—	—	Range 5-30°C
2	1		Setting temp 2 (Cooling mode) *2	7°C	○	—	—	—	—	—	Range 5-30°C
3	1		Setting temp 1 (Heating mode) *3	45°C	○	—	—	—	—	—	Range 30-55°C
4	1		Setting temp 2 (Heating mode) *3	45°C	○	—	—	—	—	—	Range 30-55°C
5	1		Setting water temp A at Heating ECO mode *3	55°C	○	—	—	—	—	—	Range 30-55°C
6	1		Setting outdoor temp A at Heating ECO mode *3	0°C	○	—	—	—	—	—	Range -30-50°C
7	1		Setting water temp B at Heating ECO mode *3	35°C	○	—	—	—	—	—	Range 30-55°C
8	1		Setting outdoor temp B at Heating ECO mode *3	25°C	○	—	—	—	—	—	Range -30-50°C
9	1		Setting water temp C at Heating ECO mode *3	45°C	○	—	—	—	—	—	Range 30-55°C
10	1		Setting outdoor temp C at Heating ECO mode *3	15°C	○	—	—	—	—	—	Range -30-50°C
11	1		Select a heating curve *3	1	○	—	—	—	—	—	0: 2-point system, 1: curve
12	1		Peak-demand control signal input source	0	○	—	—	—	—	—	0: Dry contact 1: PAR-W31MAA 2: AE-200
13	1		Maximum peak-demand capacity	100%	○	—	—	—	—	—	Range 60-100%
14	1		Preset temp. A (Cooling)	5°C	○	—	—	—	—	—	Range 5-30°C
15	1		Preset temp. B (Cooling)	30°C	○	—	—	—	—	—	Range 5-30°C
16	1		Preset temp. A (Heating)	30°C	○	—	—	—	—	—	Range 30-55°C
17	1		Preset temp. B (Heating)	55°C	○	—	—	—	—	—	Range 30-55°C
18	1		Supplementary heater operation water temp *3	40°C	○	—	○	—	○	—	Range 0-55°C

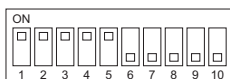

The figure at left shows that the switches 1 through 5 are set to ON and 6 through 10 are set to OFF.

## 5. Wiring Design

EAHV-P-YBL(-H)(-N), EACV-P-YBL(-N)

No.	Rotary switch (SWU3)	Dip switch setting (SW1) *1	Setting Item	Default	Need or non-need to set the setting *4						Notes
					System		Group		Sub		
					M	S	M	S	M	S	
19	1		Supplementary heater operation outdoor temp *3	-10°C	○	—	○	—	○	—	Range -30-50°C
20	1		Drain pan heater operation outdoor temp	0°C	○	—	○	—	○	—	Range -40-20°C
21	1		Thermo differential 1 (Cooling mode) *2	3°C	○	—	○	—	○	—	Range 0.2-5°C
22	1		Thermo differential 2 (Cooling mode) *2	2°C	○	—	○	—	○	—	Range 0.2-5°C
23	1		Thermo differential 1 (Heating mode) *3	3°C	○	—	○	—	○	—	Range 0.2-5°C
24	1		Thermo differential 2 (Heating mode) *3	2°C	○	—	○	—	○	—	Range 0.2-5°C
25	1		Year setting	-	○	—	—	—	—	—	
26	1		Month/Date setting	-	○	—	—	—	—	—	
27	1		Current time	-	○	—	—	—	—	—	

\*1: Do not apply undue force when changing the Dip switch settings as this may cause malfunctions.

\*2: They are enabled during the cooling. (EAHV-P\*\*\*\*YB, EACV-P\*\*\*\*YB)

\*3: They are enabled during the heating. (EAHV-P\*\*\*\*YB, EAHV-P\*\*\*\*YB-H)

\*4: System: System leader unit

Group: Group leader unit

Sub: Sub unit

M: MAIN circuit

S: SUB circuit

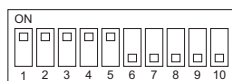

The figure at left shows that the switches 1 through 5 are set to ON and 6 through 10 are set to OFF.

## 5. Wiring Design

### 3. Setting procedures

#### (1) System setting

<1>Making the settings for the initial start-up process

##### (A) Single unit

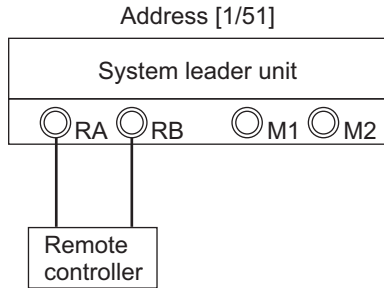

##### Setting address 1

- 1) Turn off the power.
- 2) System leader unit (Address 1 SW2-2, 2-3: ON)
- 3) Turn the power back on.
  - Address 1 → LED display [EEEE]
  - Address 51 → LED display [9999]
- 4) SWU3: Press and hold F and ENTER for 5 seconds. (Initializes the system)
  - Address 1 → LED display [9999]
  - Address 51 → LED display [9999]
- 5) Start-up process complete
  - Address 1 → LED display [\_\_|\_\_]
  - Address 51 → LED display [\_\_|\_\_]
- 6) SWU3: 0

\*No settings are required for address 51.

##### (B) One system leader unit and two sub units (1 group, 3 units in the group)

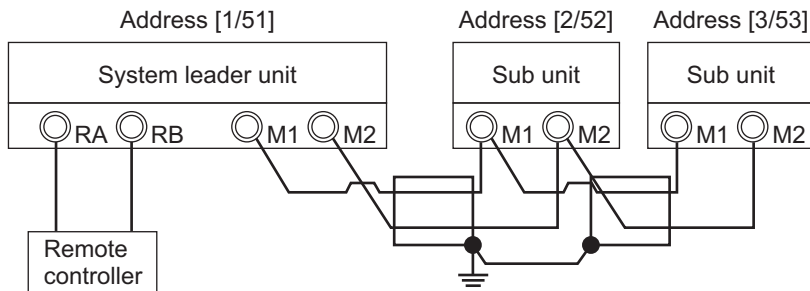

##### Setting address 1

- 1) Turn off the power.
- 2) System leader unit (Address 1 SW2-2, 2-3: ON)
- 3) Turn the power back on.
  - Address 1 → LED display [EEEE]
  - Address 51 → LED display [9999]
- 4) Setting the number of units for the group
  - SWU3: 1
  - SW1: 1, 2, 3, 4, 8, 10 ON
  - Press ENTER once.
  - ↓
  - Address 1 → LED display [1]
  - ↓
  - Press UP twice.
  - ↓
  - Address 1 → LED display [3]
  - ↓
  - Press ENTER once.
  - SW1 OFF
- 5) SWU3: Press and hold F and ENTER for 5 seconds. (Initializes the system)
  - Address 1 → LED display [9999]
  - Address 51 → LED display [9999]
- 6) Start-up process complete
  - Address 1 → LED display [\_\_|\_\_]
  - Address 51 → LED display [\_\_|\_\_]
- 7) SWU3: 0

\*No settings are required for any address other than for address 1.

\*The default setting for the number of units in a group is 1.  
The maximum number of units per group is 6.



(C) System leader unit and group leader unit (3 groups, 1 unit in each group)

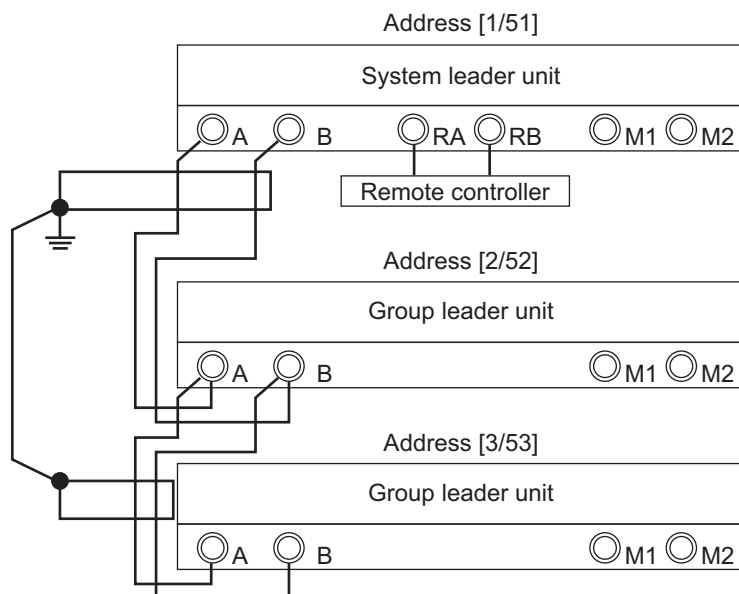

(1) Setting address 1

- 1) Turn off the power.
- 2) System leader unit (Address 1 SW2-2, 2-3: ON)
- 3) Turn the power back on.

Address 1 → LED display [EEEE]

Address 51 → LED display [9999]

4) Setting the number of units for each group

\*The default setting for the number of units in a group is 1.

5) Setting the number of groups

SWU3: 1

Press ENTER once.

SW1: 5, 8, 10 ON

↓

Address 1 → LED display [1]

↓

Press UP twice.

↓

Address 1 → LED display [3]

↓

Press ENTER once.

SW1 OFF

\*The default setting for the number of units in a group is 1.

The maximum number of groups is 24.

(2) Setting address 2

- 6) Turn off the power.
- 7) Group leader unit (SW2-2: ON)
- 8) Turn the power back on.

Address 2 → LED display [EEEE]

Address 52 → LED display [9999]

9) Setting the number of units for each group

\*The default setting for the number of units in a group is 1.

10) SWU3: Press and hold F and ENTER for 5 seconds.

(Initializes the system)

Address 2 → LED display [9999]

Address 52 → LED display [9999]

Start-up process complete

Address 2 → LED display [9999]

Address 52 → LED display [\_\_\_\_|\_|]

\*Address 3 (Group leader unit) is set in the same way as above.)

(3) Setting address 1 (second time)

11) SWU3: Press and hold F and ENTER for 5 seconds.

(Initializes the system. System leader unit initialized last)

Address 1 → LED display [9999]

Address 51 → LED display [9999]

Start-up process complete

Address 1 → LED display [\_\_\_\_|\_|]

Address 51 → LED display [\_\_\_\_|\_|]

12) SWU3: 0

(D) System leader unit, Group leader unit and Sub unit (2 groups, 3 units in each group)

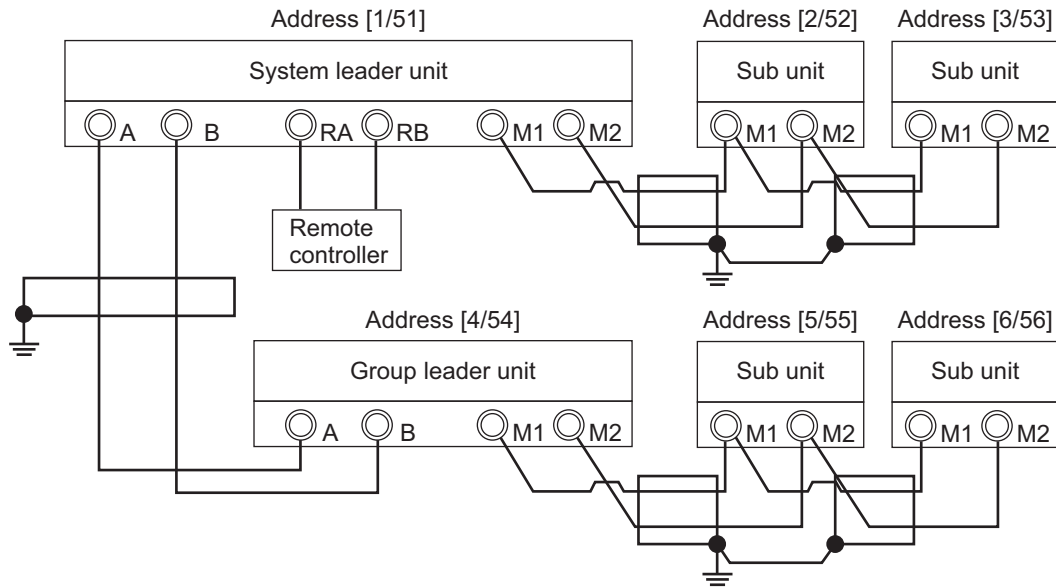

- (1) Setting address 1
  - 1) Turn off the power.
  - 2) System leader unit (Address 1 SW2-2, 2-3: ON)
  - 3) Turn the power back on.

Address 1 → LED display [EEEE]  
 Address 51 → LED display [9999]

- 4) Setting the number of units for each group

SWU3: 1  
 Press ENTER once.  
 SW1: 1, 2, 3, 4, 8, 10 ON

↓  
 Address 1 → LED display [1]

↓  
 Press UP twice.

↓  
 Address 1 → LED display [3]

↓  
 Press ENTER once.  
 SW1 OFF

\*The default setting for the number of units in a group is 1.  
 The maximum number of units per group is 6.

- 5) Setting the number of groups

SWU3: 1  
 Press ENTER once.  
 SW1: 5, 8, 10 ON

↓  
 Address 1 → LED display [1]

↓  
 Press UP twice.

↓  
 Address 1 → LED display [2]

↓  
 Press ENTER once.  
 SW1 OFF

\*The default setting for the number of units in a group is 1.  
 The maximum number of units per group is 24.

- (2) Setting address 4
  - 6) Turn off the power.
  - 7) Group leader unit (SW2-2: ON)
  - 8) Turn the power back on.

Address 4 → LED display [EEEE]  
 Address 54 → LED display [9999]

- 9) Setting the number of units for each group

SWU3: 1  
 Press ENTER once.  
 SW1: 1, 2, 3, 4, 8, 10 ON

↓  
 Address 4 → LED display [1]

↓  
 Press UP twice.

↓  
 Address 4 → LED display [3]

↓  
 Press ENTER once.  
 SW1 OFF

\*No group number settings are required for address 4 (Group leader unit).

- 10) SWU3: Press and hold F and ENTER for 5 seconds.  
 (Initializes the system)

Address 4 → LED display [9999]  
 Address 54 → LED display [9999]

Start-up process complete

Address 4 → LED display [9999]  
 Address 54 → LED display [\_\_|\_|]

- (3) Setting address 1 (second time)

- 11) SWU3: Press and hold F and ENTER for 5 seconds.  
 (Initializes the system. System leader unit initialized last)

Address 1 → LED display [9999]  
 Address 51 → LED display [9999]

Start-up process complete

Address 1 → LED display [\_\_|\_|]  
 Address 51 → LED display [\_\_|\_|]

- 12) SWU3: 0

\*No settings are required for any address other than for addresses 1 and 4.

## 5. Wiring Design

### <2>Multiple unit control

By setting SW2-6 to ON for address 1, optimum control of number of operating units will be performed.  
All units will simultaneously operate when SW2-6 is set to OFF.

(A) System leader unit, group leader unit, and sub unit

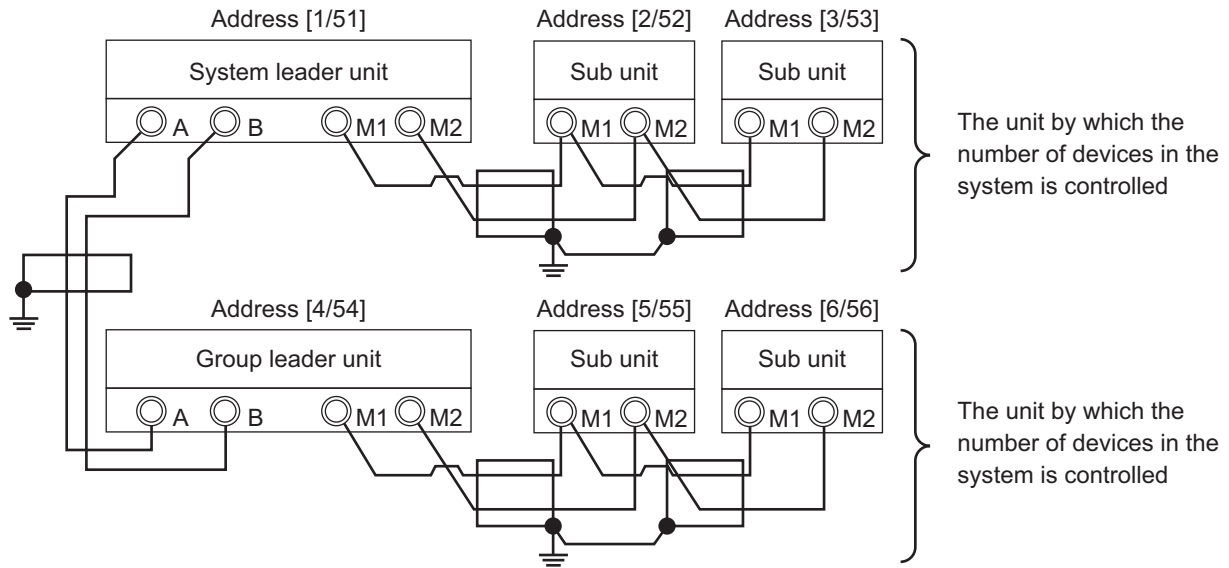

(B) System leader unit and group leader unit

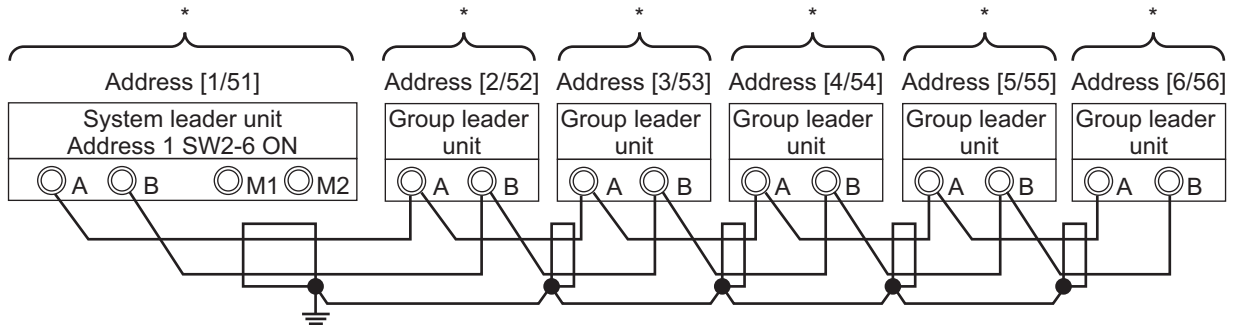

\*The unit by which the number of devices in the system is controlled

## 5. Wiring Design

<3>Example of system configuration  
Optimum control of number of operating units

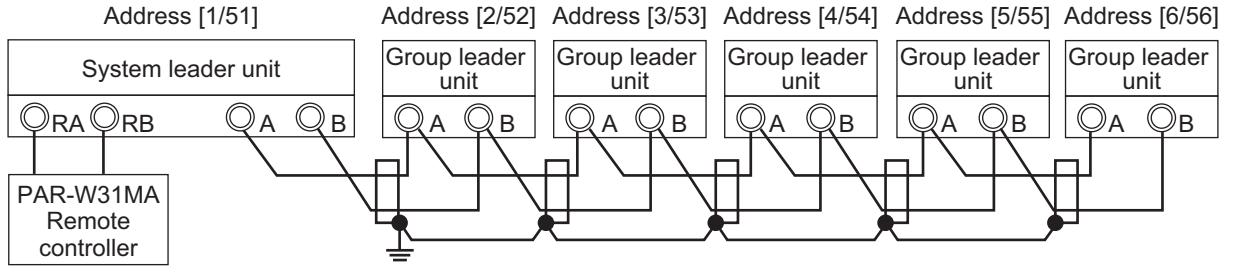

Settings table

Setting item	SWU3	DIP SW	SW1	Setting timing	System leader unit		Simultaneous operation Group leader unit		Simultaneous operation Group leader unit		Simultaneous operation Group leader unit		Simultaneous operation Group leader unit			
					1		2		3		4		5		6	
					MAIN	SUB	MAIN	SUB	MAIN	SUB	MAIN	SUB	MAIN	SUB	MAIN	SUB
M-NET address	-	-	-	At a reset	1	51	2	52	3	53	4	54	5	55	6	56
M-NET power supply	-	-	-	-	CN40	CN41	CN41	CN41	CN41	CN41	CN41	CN41	CN41	CN41	CN41	CN41
System settings	-	2-2	-	At a reset	ON	-	ON	-	ON	-	ON	-	ON	-	ON	-
	-	2-3	-	At a reset	ON	-	OFF	-	OFF	-	OFF	-	OFF	-	OFF	-
Number of groups	1	-	ON 1 2 3 4 5 6 7 8 9 10	At a reset	6	-	1	-	1	-	1	-	1	-	1	-
Number of units per group	1	-	ON 1 2 3 4 5 6 7 8 9 10	At a reset	1	-	1	-	1	-	1	-	1	-	1	-
Multiple unit control	-	2-6	ON 1 2 3 4 5 6 7 8 9 10	At a reset	ON	-	OFF	-	OFF	-	OFF	-	OFF	-	OFF	-
Remote controller address setting	1	-	ON 1 2 3 4 5 6 7 8 9 10	At a reset	1	-	2	-	2	-	2	-	2	-	2	-

\*The shaded cells indicate the settings that requires changes from the default settings.

\*Some settings require the following after the settings were changed: A power reset, or setting SWU3 to F, and pressing and holding ENTER for 5 seconds.

\*When using an AE-200 as the centralized controller, leave the M-NET power supply connector as it is.

<4>Setting the pump system

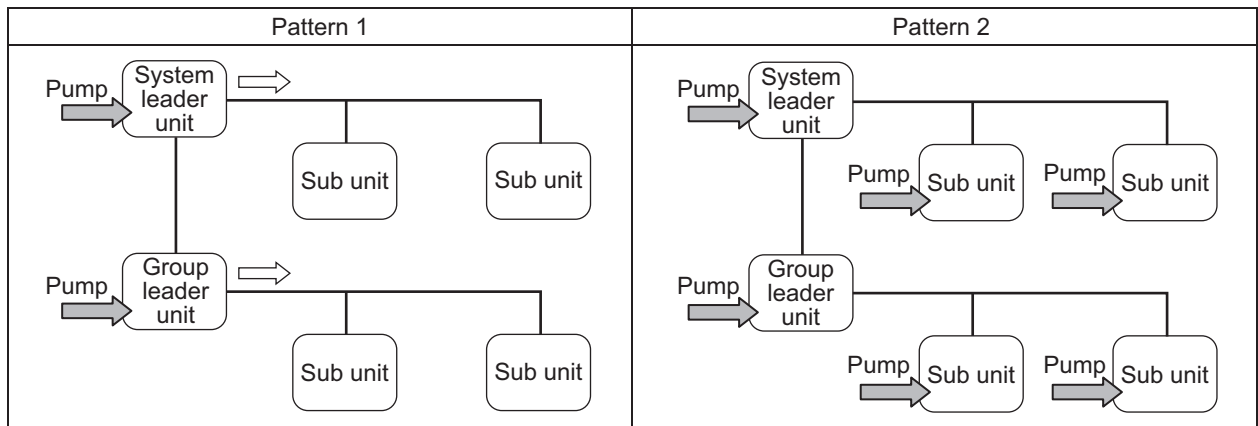

Setting item	SWU3	DIPSW	SW1	Factory setting		Note
				MAIN	SUB	
Pump setting	1	-	ON 1 2 3 4 5 6 7 8 9 10	0	-	0: Pattern 1, 1: Pattern 2

\*Pump settings must be made on the MAIN circuit on all units.



The figure at left shows that the switches 1 through 5 are set to ON and 6 through 10 are set to OFF.

## 5. Wiring Design

### (2) Water-temperature setting

Different water temperature settings can be set for different modes.











Set the dip switches on the circuit board as follows to make the settings for the items described in this section.

Press the push switch SWP3 to enable the configuration changes.

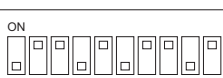
Press the push switches SWP1 (↑) or SWP2 (↓) to increase or decrease the value.

When the desired value is displayed, press SWP3 to save the setting value.

Settings table

No.	Rotary switch (SWU3)	Dip switch setting (SW1)	Setting Item	Initial value	Unit	Setting			Setting change from an optional remote controller (PAR-W31MAA) *1
						Increments	Lower limit	Upper limit	
1	1		Setting temp 1 (Cooling mode) *2	7	°C	0.1°C	5	30	Possible *2
2	1		Setting temp 2 (Cooling mode) *3	7	°C	0.1°C	5	30	Possible *3
3	1		Setting temp 1 (Heating mode) *2	45	°C	0.1°C	30	55	Possible *2
4	1		Setting temp 2 (Heating mode) *3	45	°C	0.1°C	30	55	Possible *3
5	1		Setting water temp A at Heating ECO mode	55	°C	0.1°C	30	55	Not possible
6	1		Setting outdoor temp A at Heating ECO mode	0	°C	0.1°C	-30	50	Not possible
7	1		Setting water temp B at Heating ECO mode	35	°C	0.1°C	30	55	Not possible
8	1		Setting outdoor temp B at Heating ECO mode	25	°C	0.1°C	-30	50	Not possible
9	1		Setting water temp C at Heating ECO mode	45	°C	0.1°C	30	55	Not possible
10	1		Setting outdoor temp C at Heating ECO mode	15	°C	0.1°C	-30	50	Not possible
11	1		Select a heating curve	1	-	0: 2-point system, 1: curve			Not possible

\*1 Temperature setting increments: 0.5°C

\*2 No-voltage contact KC1-KC2: OFF

\*3 No-voltage contact KC1-KC2: ON

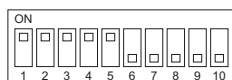

The figure at left shows that the switches 1 through 5 are set to ON and 6 through 10 are set to OFF.

## 5. Wiring Design

### Heating ECO (2-point system)

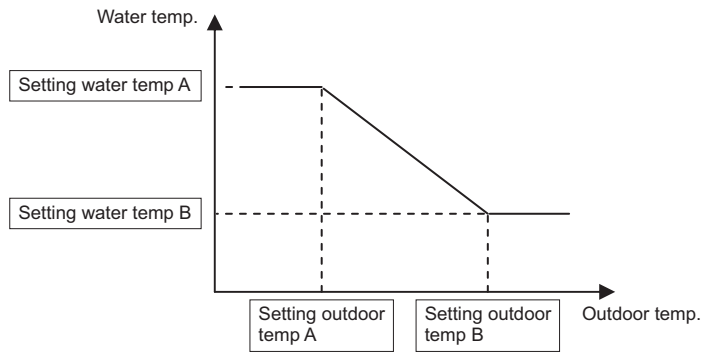

\*Setting temp C cannot be used.

When the outdoor temp A and B are set to the same value.

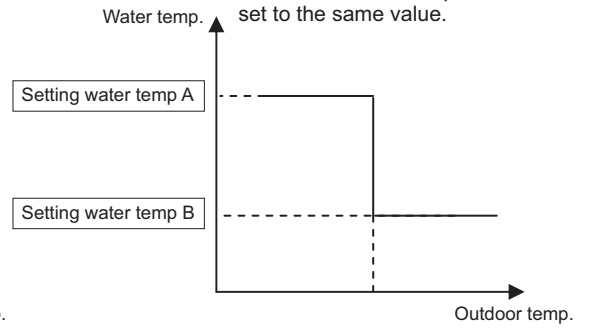

### Heating ECO (Curve)

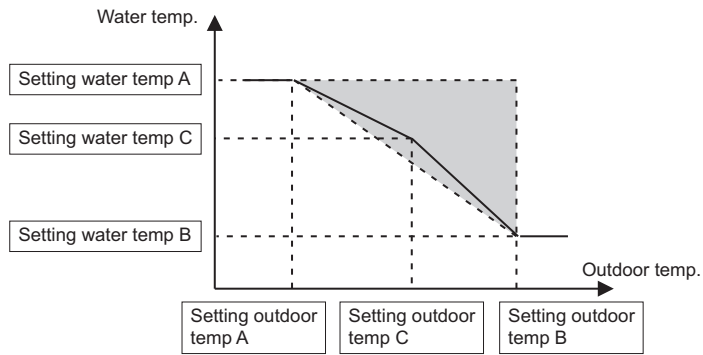

\*Always use a value for setting C that is between setting value A and setting value B.

## 5. Wiring Design

### (3) Peak-demand control operation

Peak-demand control is a function used to control the power consumptions of the units.

The compressor's maximum operating frequency will be controlled according to the peak-demand control signal.

Set the dip switches on the circuit board as follows to make the settings for the items described in this section.

Press the push switch SWP3 to enable the configuration changes.

Press the push switches SWP1 (↑) or SWP2 (↓) to increase or decrease the value.

When the desired value is displayed, press SWP3 to save the setting value.

Settings table

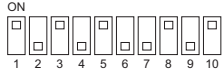
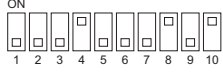
No.	Rotary switch (SWU3)	Dip switch setting (SW1)	Setting Item	Initial value	Unit	Setting			Setting change from an optional remote controller (PAR-W31MAA)
						Increments	Lower limit	Upper limit	
1	1		Peak-demand control signal input source	0	-	1	0	2	Not possible
2	1		Maximum peak-demand capacity	100	%	1%	60	100	Not possible

### (4) Remote water temperature or capacity control ratio setting input signal type

When SW2-7 is ON, SW2-8 is OFF and SW2-9 is OFF external analog signals can be used to set the water temperatures.

When SW2-7 and SW2-8 are ON, external analog signals can be used to set the capacity control ratio.

Analog input type can be selected from the following four types:

4-20 mA

0-10 V

1-5 V

2-10 V

Select SW3-1 and SW3-2 to set the type of analog input signal from a remote location.

Set the dip switches on the circuit board as follows to change the settings.

	SW421-1	SW421-2	SW3-1	SW3-2
4-20 mA	ON	ON	OFF	OFF
1-5 V	OFF	ON	ON	OFF
0-10 V	OFF	OFF	OFF	ON
2-10 V	OFF	OFF	ON	ON

\* Incorrectly setting SW421 may cause damage to the circuit board.

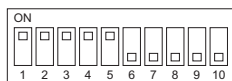

The figure at left shows that the switches 1 through 5 are set to ON and 6 through 10 are set to OFF.

## 5. Wiring Design

### (5) Setting the water temperature using analog signal input

When dip switch SW2-7 is set to ON (Enable external input), SW2-8 is set to OFF and SW2-9 is set to OFF, the target water temperature varies with the preset temperatures A and B and the type of analog input signal.





Set the dip switches on the circuit board as follows to make the settings for the items described in this section.

Press the push switch SWP3 to enable the configuration changes.



Press the push switches SWP1 (↑) or SWP2 (↓) to increase or decrease the value.

When the desired value is displayed, press SWP3 to save the setting value.

Settings table

No.	Rotary switch (SWU3)	Dip switch setting (SW1)	Setting Item	Initial value	Unit	Setting			Setting change from an optional remote controller (PAR-W31MAA)
						Increments	Lower limit	Upper limit	
1	1		Preset temp. A (Cooling)	5	°C	1°C	5	30	Not possible
2	1		Preset temp. B (Cooling)	30	°C	1°C	5	30	Not possible
3	1		Preset temp. A (Heating)	30	°C	1°C	30	55	Not possible
4	1		Preset temp. B (Heating)	55	°C	1°C	30	55	Not possible

\* Due to the resistance of the wire that is connected to the analog input, the preset temperature may not properly be sent. If this is the case, check the current value of the analog input, and adjust the output value of the connected signal output device. Refer to the table below for how to display the value of the analog input.

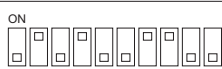
No.	Rotary switch (SWU3)	Dip switch setting (SW1)	Monitorable items	Unit
1	0		Current value (4-20 mA)	mA
2	0		5V voltage value (1-5 V)	V
3	0		10V voltage value (0-10 V or 2-10 V)	V

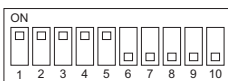

The figure at left shows that the switches 1 through 5 are set to ON and 6 through 10 are set to OFF.

◆ When the water temperature setting input signal type is 4-20 mA

- External analog input signal of 6 mA: Preset temp. A
- External analog input signal of 18 mA: Preset temp. B
- External analog input signal of between 6 and 18 mA: the preset temperature will be linearly interpolated.

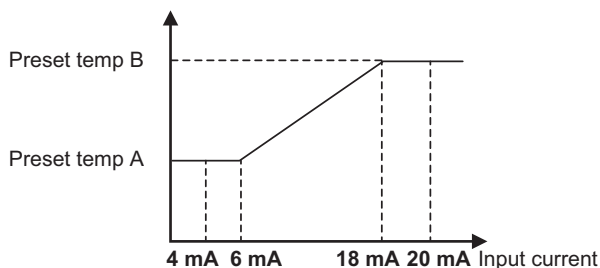



## 5. Wiring Design

- When the water temperature setting input signal type is 0-10 V
  - External analog input signal of 1 V: Preset temp. A
  - External analog input signal of 9 V: Preset temp. B
  - External analog input signal of between 1 and 9 V: the preset temperature will be linearly interpolated.

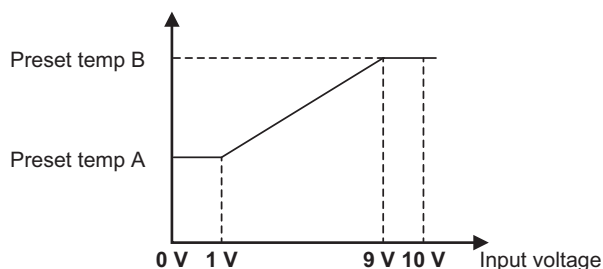

- When the water temperature setting input signal type is 1-5 V
  - External analog input signal of 1.5 V: Preset temp. A
  - External analog input signal of 4.5 V: Preset temp. B
  - External analog input signal of between 1.5 and 4.5 V: the preset temperature will be linearly interpolated.

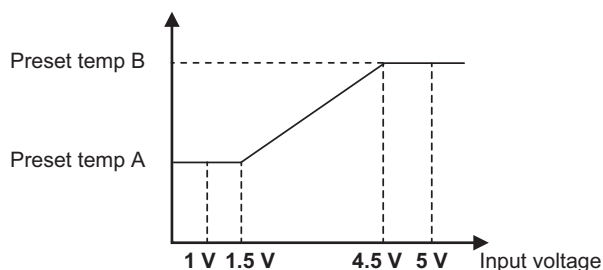

- When the water temperature setting input signal type is 2-10 V
  - External analog input signal of 3 V: Preset temp. A
  - External analog input signal of 9 V: Preset temp. B
  - External analog input signal of between 3 and 9 V: the preset temperature will be linearly interpolated.

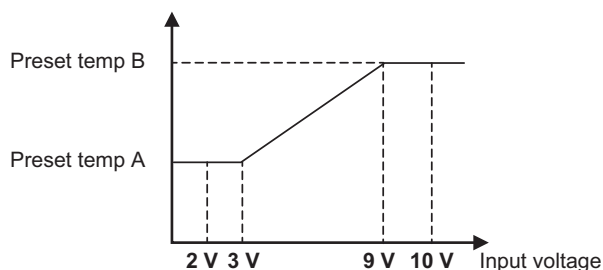

### (6) Setting the capacity control ratio using analog signal input

When dip switch SW2-7 is set to ON (Enable external input), SW2-8 is set to ON and SW2-9 is set to OFF, the capacity control ratio varies with the type of analog input signal.

- When the water temperature setting input signal type is 4-20 mA
  - External analog input signal of 6 mA: 0%
  - External analog input signal of 18 mA: 100%
  - External analog input signal of between 6 and 18 mA: the percent will be linearly interpolated.

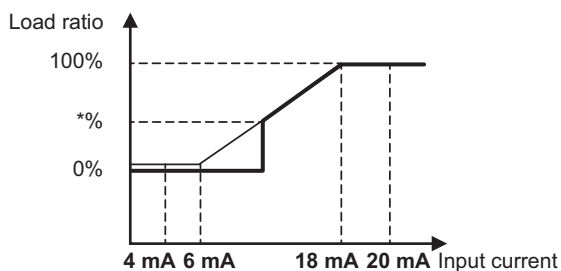

## 5. Wiring Design

- When the water temperature setting input signal type is 0-10 V

- External analog input signal of 1 V: 0%
- External analog input signal of 9 V: 100%
- External analog input signal of between 1 and 9 V: the percent will be linearly interpolated.

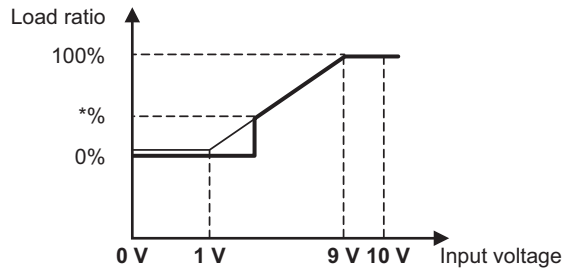

- When the water temperature setting input signal type is 1-5 V

- External analog input signal of 1.5 V: 0%
- External analog input signal of 4.5 V: 100%
- External analog input signal of between 1.5 and 4.5 V: the percent will be linearly interpolated.

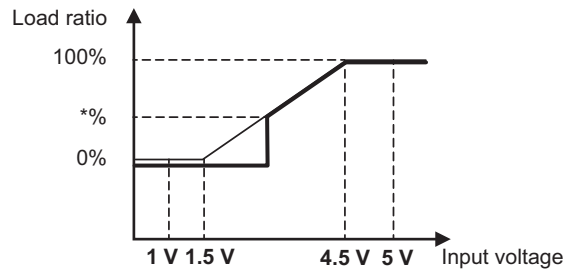

- When the water temperature setting input signal type is 2-10 V

- External analog input signal of 3 V: 0%
- External analog input signal of 9 V: 100%
- External analog input signal of between 3 and 9 V: the percent will be linearly interpolated.

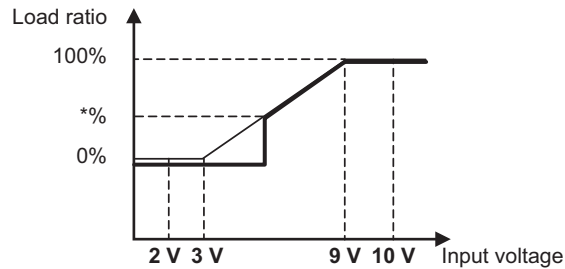

\*%: When the compressor frequency drops below the lowest frequency, the compressor stops.  
The frequency value that causes the compressor to stop varies depending on the outside temperature and water temperature.

## 5. Wiring Design

### (7) Setting the supplementary heater signal output conditions

A temperature at which the signal output to operate supplementary heaters can be selected.

#### Supplementary heater signal output conditions

The operation command signal is ON and at least one of the following two conditions is met.

- [1] Water-temperature control option (SW2-4) is set to OFF, the inlet water temperature drops below a set water temperature, and the outdoor temperature drops below a set outdoor temperature.
- [2] Water-temperature control option (SW2-4) is set to ON, the external water temperature sensor reading (TH117) drops below a set water temperature, and the outdoor temperature drops below a set outdoor temperature.

The supplementary heater signal is output from RP1-RP2.

#### Supplementary heater signal output stop conditions

The operation command signal is OFF or at least one of the following two conditions is met.

- [1] The inlet water temperature is at or above a set water temperature +2°C or the outdoor temperature is at or above a set outdoor temperature +2°C.
- [2] External water temperature sensor reading (TH117) is at or above a set water temperature +2°C.

Set the dip switches on the circuit board as follows to make the settings for the items described in this section.

Press the push switch SWP3 to enable the configuration changes.

Press the push switches SWP1 (↑) or SWP2 (↓) to increase or decrease the value.

When the desired value is displayed, press SWP3 to save the setting value.

Settings table

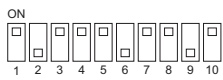
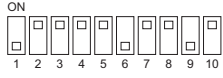
No.	Rotary switch (SWU3)	Dip switch setting (SW1)	Setting Item	Initial value	Unit	Setting			Setting change from an optional remote controller (PAR-W31MAA)
						Increments	Lower limit	Upper limit	
1	1		Supplementary heater operation water temp	40	°C	0.1°C	0	55	Not possible
2	1		Supplementary heater operation outdoor temp	-10		0.1°C	-30	50	Not possible

### (8) Setting the drain pan heater signal output condition

A temperature at which the signal output to operate drain pan heaters can be selected.

#### Drain pan heater signal output condition

The following condition is met.

- ♦The outdoor temperature drops below a set outdoor temperature.

The drain pan signal is output from KB1-KB2.

#### Drain pan heater signal output stop condition

The following condition is met.

- ♦The outdoor temperature is at or above a set outdoor temperature +2°C.

Set the dip switches on the circuit board as follows to make the settings for the items described in this section.

Press the push switch SWP3 to enable the configuration changes.

Press the push switches SWP1 (↑) or SWP2 (↓) to increase or decrease the value.

When the desired value is displayed, press SWP3 to save the setting value.

Settings table

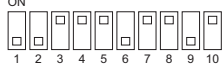
No.	Rotary switch (SWU3)	Dip switch setting (SW1)	Setting Item	Initial value	Unit	Setting			Setting change from an optional remote controller (PAR-W31MAA)
						Increments	Lower limit	Upper limit	
1	1		Drain pan heater operation outdoor temp	0	°C	1°C	-40	20	Not possible

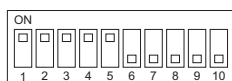

The figure at left shows that the switches 1 through 5 are set to ON and 6 through 10 are set to OFF.

## 5. Wiring Design

### (9) External temperature sensor control

An optional External temperature sensor (TW-TH16) is required.

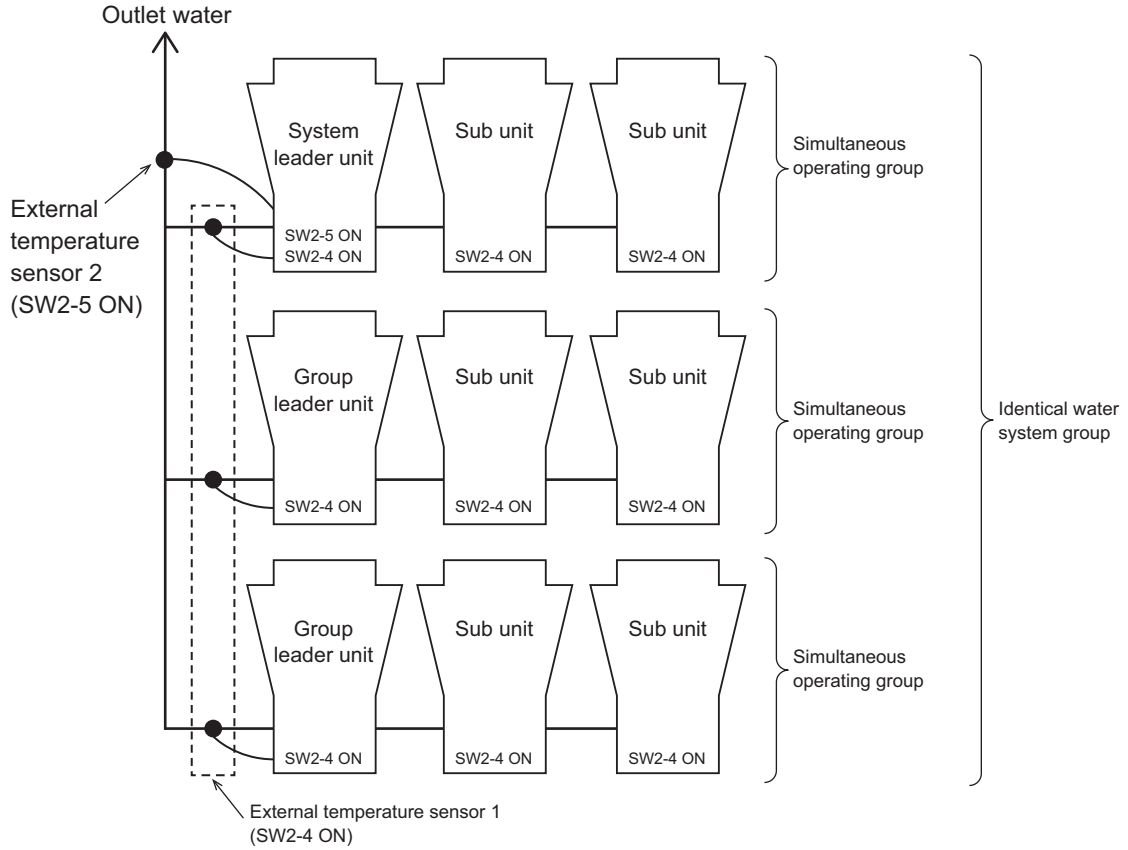

#### External temperature sensor 1

Used to control the water temperature of simultaneous operating group.

#### External temperature sensor 2

The water outlet temperature of each unit in the identical water system group is corrected to bring the water temperature at the merged section of the outlet water pipes toward the target temperature.

## 5. Wiring Design

### 5-2. Electrical Wiring Installation

#### 5-2-1. Main Power Supply Wiring and Switch Capacity

Schematic Drawing of Wiring (Example)

- <A> Switch (with current breaking capability)
- <B> Current leakage breaker
- <C> unit

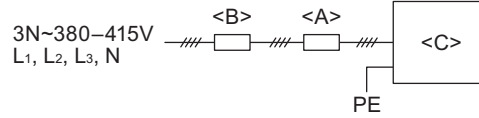

Main power supply wire size, switch capacities, and system impedance

Model	Minimum wire thickness (mm <sup>2</sup> )			Current leakage breaker	Local switch (A)		No-fuse breaker (A)	Max. Permissible System Impedance
	Main cable	Branch	Ground		Capacity	Fuse		
EAHV/EACV-P1500, 1800YB	35	-	35	160 A 200 mA 0.1 sec. or less	150	150	160	0.07 Ω

- 1) Use a dedicated power supply for each unit. Ensure that each unit is wired individually.
- 2) When installing wiring, consider ambient conditions (e.g., temperature).
- 3) The wire size is the minimum value for metal conduit wiring. If voltage drop is a problem, use a wire that is one size thicker. Make sure the power-supply voltage does not drop more than 5%.
- 4) Specific wiring requirements should adhere to the wiring regulations of the region.
- 5) Power supply cords of appliances shall not be lighter than polychloroprene sheathed flexible cord (design 60245 IEC57).
- 6) A switch with at least 3 mm contact separation in each pole shall be provided by the Air Conditioner installer.
- 7) Do not install a phase advancing capacitor on the motor. Doing so may damage the capacitor and result in fire.

#### ⚠ WARNING

- ♦ Be sure to use specified wires and ensure no external force is imparted to terminal connections. Loose connections may cause overheating and fire.
- ♦ Be sure to use the appropriate type of overcurrent protection switch. Note that overcurrent may include direct current.

#### ⚠ CAUTION

- ♦ Some installation sites may require an installation of an earth leakage breaker for the inverter. If no earth leakage breaker is installed, there is a danger of electric shock.
- ♦ Only use properly rated breakers and fuses. Using a fuse or wire of the wrong capacity may cause malfunction or fire.

#### Note

- ♦ This device is intended for the connection to a power supply system with a maximum permissible system impedance shown in the above table at the interface point (power service box) of the user's supply.
- ♦ Ensure that this device is connected only to a power supply system that fulfills the requirements above. If necessary, consult the public power supply company for the system impedance at the interface point.
- ♦ This equipment complies with IEC 61000-3-12 provided that the short-circuit power  $S_{sc}$  is greater than or equal to  $S_{sc} (*2)$  at the interface point between the user's supply and the public system. It is the responsibility of the installer or user of the equipment to ensure, in consultation with the distribution network operator if necessary, that the equipment is connected only to a supply with a short-circuit power  $S_{sc}$  greater than or equal to  $S_{sc} (*2)$ .

$S_{sc}(*2)$

S <sub>sc</sub> (MVA)
9.57

Control cable specifications

Remote controller cable	Size	0.3 mm <sup>2</sup> (Max. 200 m total)
	Recommended cable types	2-core sheathed cable
M-NET cable between units *1	Size	Min. 1.25 mm <sup>2</sup> (Max. 120 m total)
	Recommended cable types	Shielded cable CVVS, CPEVS or MVVS
External input wire size		Min. 0.3 mm <sup>2</sup>
External output wire size		1.25 mm <sup>2</sup>

\*1 Use a CVVS or CPEVS cable (Max. total length of 200 m) if there is a source of electrical interference nearby (e.g., factory) or the total length of control wiring exceeds 120 m.

## 5. Wiring Design

### 5-2-2. Cable Connections

#### 1. Schematic Diagram of a Unit and Terminal Block Arrangement

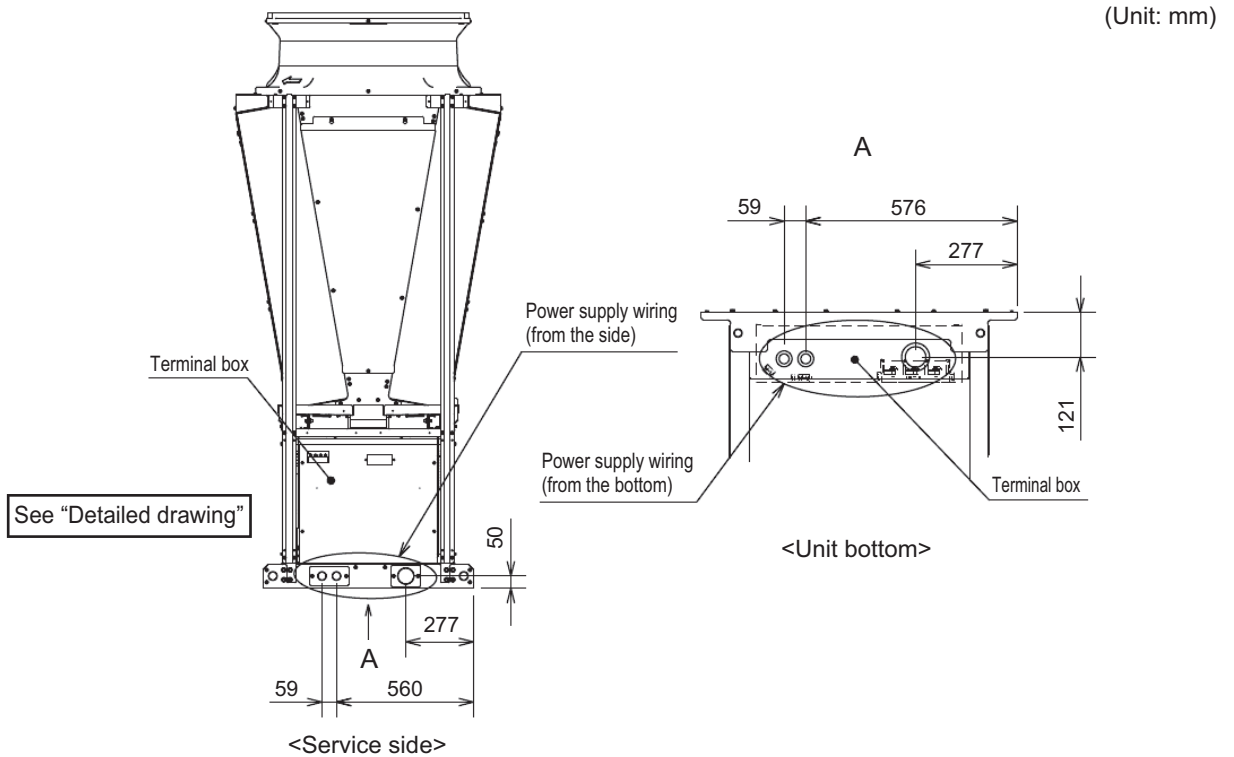

Detailed drawing

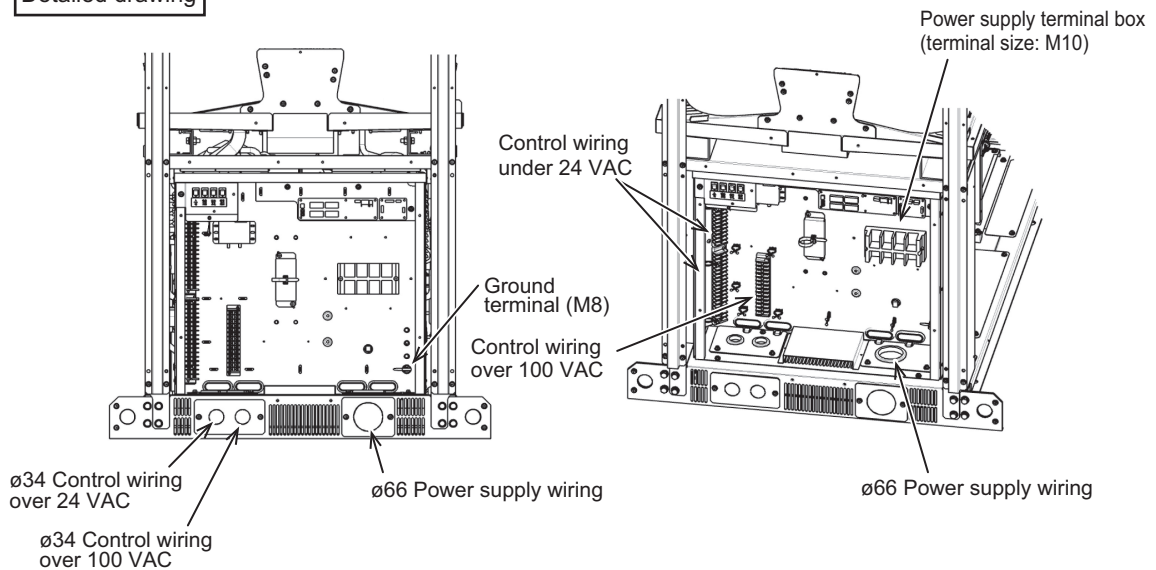

- (1) Remove the front terminal box cover.
- (2) Wire the power supply and control wires. The terminal box is covered with a bush.  
Cut the bush before connecting wires to the terminal box.
- (3) Fasten the power supply wires by the cable strap.
- (4) Secure the cable conduit, and then waterproof the area around the pipe with silicon, etc.
- (5) Reattach the terminal box cover.

## 5. Wiring Design

### 2. Precautions when fastening screws

- \* Faulty contacts due to loose screws may cause overheating and fire.
- \* Using the circuit board while it is damaged may cause overheating and fire.

<1> Screw fastening torque

Power supply terminal block, M8 screw: **10 to 13.5 N·m**

Use the following methods to check that the screws have been fastened.

1) Check that the spring washer is in a parallel position.

- \* If the screw is biting into the washer, simply fastening the screw to the specified torque cannot determine whether it has been installed properly.

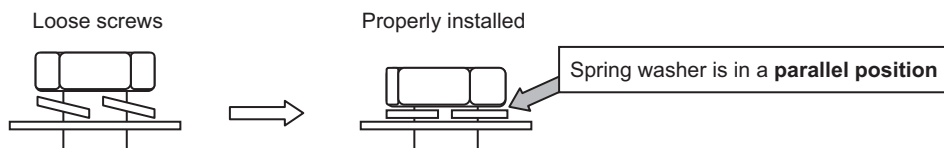

2) Check that the wiring does not move at the screw terminal.

<2> Take extra care not to ruin the screw thread due to fastening the screw at an angle.

- \* To prevent fastening the screw at an angle, install the round terminals so they are back to back.

<3> After fastening the screw, use a permanent marker to tick off the screw head, washer and terminal.

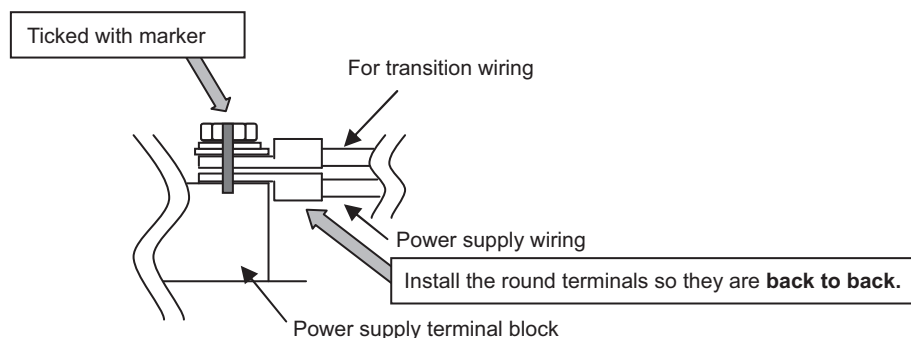

### 3. Installing the conduit tube

- Always use a conduit to run the power supply wiring.
- Select the conduit size based on the hole.
- The cable conduits must be prepared locally.
- Do not store the 24VDC or less low-voltage circuit and 100VAC or higher main circuit and control circuit cables in the same multi-core cable, or bundle them together.
- Attach cable conduits securely to the foundation, etc. to ensure that excessive loads are not applied to the power supply terminal box.
- Seal the area around the cable conduit connection to ensure that no water penetrates the cable conduit connection port.

## 6. Controller

### 6-1. PAR-W31MAA specifications

Item	Description	Operations	Display
ON/OFF	Runs and stops the operation of a group of units	○	○
Operation mode switching	Switches between Heating/Heating ECO/Anti-freeze/Cooling * Available operation modes vary depending on the unit to be connected. * Switching limit setting can be made via a remote controller.	○	○
Water temperature setting	Temperature can be set within the ranges below. (in increments of 0.5°C or 0.5°F)  Heating           30°C ~ 55°C Heating ECO    30°C ~ 55°C Anti-freeze      30°C Cooling          5°C ~ 30°C * The settable range varies depending on the unit to be connected.	○	○
Water temperature display	-20°C ~ 90°C (in increments of 0.5°C or 0.5°F) * The settable range varies depending on the unit to be connected.	×	○
Permit/Prohibit local operation	Individually prohibits operations of each local remote control function: ON/OFF, Operation modes, water temperature setting, Circulating water replacement warning reset. * Upper level controller may not be connected depending on the unit to be connected.	×	○
Weekly scheduler	ON/OFF/Water temperature setting can be done up to 6 times one day in the week. (in increments of a minute)	○	○
Error	When an error is currently occurring on a unit, the afflicted unit and the error code are displayed.	×	○
Self check (Error history)	Searches the latest error history by pressing the CHECK button twice.	○	○
LANGUAGE setting	The language on the dot matrix LCD can be changed. (11 languages) English/French/German/Swedish/Spanish/Italian/Danish/Dutch/Finnish/Norwegian/Portuguese	○	○
Operation locking function	Remote controller operation can be locked or unlocked. • All-switch locking • Locking except ON/OFF switch	○	○







**for a greener tomorrow**

Eco Changes is the Mitsubishi Electric Group's environmental statement, and expresses the Group's stance on environmental management. Through a wide range of businesses, we are helping contribute to the realization of a sustainable society.

**⚠ Warning**

- Do not use refrigerant other than the type indicated in the manuals provided with the unit and on the nameplate.
  - Doing so may cause the unit or pipes to burst, or result in explosion or fire during use, repair, or at the time of disposal of the unit.
  - It may also be in violation of applicable laws.
  - MITSUBISHI ELECTRIC CORPORATION cannot be held responsible for malfunctions or accidents resulting from the use of the wrong type of refrigerant.
- Our chilling units contain a fluorinated greenhouse gas, R410A.

**MITSUBISHI ELECTRIC CORPORATION**

[www.MitsubishiElectric.com](http://www.MitsubishiElectric.com)