

**e-series  
Air-cooled Chilling Unit**

**EAHV/EACV**

**Installation/Operation Manual**

**EAHV-P1500YB(L)(-H)(-N)(-BS)  
EAHV-P1800YB(L)(-H)(-N)(-BS)  
EACV-P1500YB(L)(-N)(-BS)  
EACV-P1800YB(L)(-N)(-BS)**

**CONTENTS**

Safety Precautions.....	2
1. Selecting the Installation Site.....	7
2. Unit Installation .....	10
3. Water Pipe Installation.....	13
4. Electrical Wiring Installation.....	23
5. System Configurations.....	35
6. Troubleshooting .....	62
7. Operating the Unit.....	69
8. Main Specifications.....	77
9. Maintenance .....	82

**Thoroughly read this manual prior to use.**



**Save this manual for future reference.**

**Some of the items in this manual may not apply to made-to-order units.**

**Make sure that this manual is passed on to the end users.**

# Safety Precautions

- Thoroughly read the following safety precautions prior to use.
- Observe these precautions carefully to ensure safety.

 <b>WARNING</b>	Indicates a risk of death or serious injury
 <b>CAUTION</b>	Indicates a risk of injury or structural damage
 <b>IMPORTANT</b>	Indicates a risk of damage to the unit or other components in the system

**All electric work must be performed by personnel certified by Mitsubishi Electric.**

## General

### **WARNING**

**Do not use refrigerant other than the type indicated in the manuals provided with the unit and on the nameplate.**

- Doing so may cause the unit or pipes to burst, or result in explosion or fire during use, during repair, or at the time of disposal of the unit.
- It may also be in violation of applicable laws.
- MITSUBISHI ELECTRIC CORPORATION cannot be held responsible for malfunctions or accidents resulting from the use of the wrong type of refrigerant.

**Do not install the unit in a place where large amounts of oil, steam, organic solvents, or corrosive gases, such as sulfuric gas, are present or where acidic/alkaline solutions or sprays containing sulfur are used frequently.**

These substances can compromise the performance of the unit or cause certain components of the unit to corrode, which can result in refrigerant leakage, water leakage, injury, electric shock, malfunctions, smoke, or fire.

**Do not try to defeat the safety features of the unit or make unauthorized setting changes.**

Forcing the unit to operate the unit by defeating the safety features of the devices such as the pressure switch or the temperature switch, making unauthorized changes to the switch settings, or using accessories other than the ones recommended by Mitsubishi Electric may result in smoke, fire, or explosion.

To reduce the risk of fire or explosion, do not use volatile or flammable substances as a heat carrier.

To reduce the risk of burns or electric shock, do not touch exposed pipes and wires.

To reduce the risk of shorting, current leakage, electric shock, malfunctions, smoke, or fire, do not splash water on electric parts.

To reduce the risk of electric shock, malfunctions, smoke or fire, do not operate the switches/buttons or touch other electrical parts with wet hands.

To reduce the risk of electric shock and injury from the fan or other rotating parts, stop the operation and turn off the main power before cleaning, maintaining, or inspecting the unit.

To reduce the risk of burns or frost bites, do not touch the refrigerant pipes or refrigerant circuit components with bare hands during and immediately after operation.

Before cleaning the unit, switch off the power. (Unplug the unit, if it is plugged in.)

To reduce the risk of injury, keep children away while installing, inspecting, or repairing the unit.

Children should be supervised to ensure that they do not play with the appliance.

This appliance is not intended for use by persons (including children) with reduced physical, sensory or mental capabilities, or lack of experience and knowledge, unless they have been given supervision or instruction concerning use of the appliance by a person responsible for their safety.

**Keep the space well ventilated. Refrigerant can displace air and cause oxygen starvation.**

If leaked refrigerant comes in contact with a heat source, toxic gas may be generated.

**Always replace a fuse with one with the correct current rating.**

The use of improperly rated fuses or a substitution of fuses with steel or copper wire may result in fire or explosion.

**If any abnormality (e.g., burning smell) is noticed, stop the operation, turn off the power switch, and consult your dealer.**

Continuing the operation may result in electric shock, malfunctions, or fire.

**Properly install all required covers and panels on the terminal box and control box to keep moisture and dust out.**

Dust accumulation and water may result in electric shock, smoke, or fire.

**Consult an authorized agency for the proper disposal of the unit.**

Refrigerant oil and refrigerant that may be left in the unit pose a risk of fire, explosion, or environmental pollution.

**Avoid frequent switching between Cooling and Heating modes.**

Too frequent switching of operation modes may cause the unit to make an abnormal stop. Before switching the operation mode from Heating to Cooling, make sure the water temperature is 35°C or below. Before switching the operation mode from Cooling to Heating, make sure the water temperature is 15°C or above. Before switching the operation mode between Cooling and Heating, leave the unit stopped for approximately 15 minutes.

## CAUTION

To reduce the risk of fire or explosion, do not place flammable materials or use flammable sprays around the unit.

Do not operate the unit without panels and safety guards properly installed.

To reduce the risk of injury, do not sit, stand, or place objects on the unit.

**Do not connect the makeup water pipe directly to the potable water pipe. Use a cistern tank between them.**

Connecting these pipes directly may cause the water in the unit to migrate into the potable water and cause health problems.

To reduce the risk of adverse effects on plants and animals, do not place them where they are directly exposed to discharge air from the unit.

**Do not install the unit on or over things that are vulnerable to water damage.**

Condensation may drip from the unit.

The model of heat pump unit described in this manual is not intended for use to preserve food, animals, plants, precision instruments, or art work.

To reduce the risk of injury, do not touch the heat exchanger fins or sharp edges of components with bare hands.

**Do not place a container filled with water on the unit.**

If water spills on the unit, it may result in shorting, current leakage, electric shock, malfunction, smoke, or fire.

**Always wear protective gears when touching electrical components on the unit.**

Several minutes after the power is switched off, residual voltage may still cause electric shock.

To reduce the risk of injury, do not insert fingers or foreign objects into air inlet/outlet grills.

To reduce the risk of injury, wear protective gear when working on the unit.

**Do not release refrigerant into the atmosphere. Collect and reuse the refrigerant, or have it properly disposed of by an authorized agency.**

Refrigerant poses environmental hazards if released into the air.

**To prevent environmental pollution, dispose of brine in the unit and cleaning solutions according to the local regulations.**

It is punishable by law not to dispose of them according to the applicable laws.

**The water heated by the heat pump is not suitable for use as drinking water or for cooking.**

It may cause health problems or degrade food.

**In areas where temperature drops to freezing during the periods of non-use, blow the water out of the pipes or fill the pipes with anti-freeze solution.**

Not doing so may cause the water to freeze, resulting in burst pipes and damage to the unit or the furnishings.

In areas where temperature drops to freezing, use an anti-freeze circuit and leave the main power turned on to prevent the water in the water circuit from freezing and damaging the unit or causing water leakage and resultant damage to the furnishings.

**Use clean tap water.**

The use of acidic or alkaline water or water high in chlorine may corrode the unit or the pipes, causing water leakage and resultant damage to the furnishings.

**In areas where temperature can drop low enough to cause the water in the pipes to freeze, operate the unit often enough to prevent the water from freezing.**

Frozen water in the water circuit may cause the water to freeze, resulting in burst pipes and damage to the unit or the furnishings.

**Periodically inspect and clean the water circuit.**

Dirty water circuit may compromise the unit's performance or corrodes the unit or cause water leakage and resultant damage to the furnishings.

**Ensure that the flow rate of the feed-water is within the permitted range.**

If the flow rate exceeds the permitted range, the unit may become damaged due to corrosion. Furniture may become wet due to water leaks.

## Transportation

### WARNING

**Lift the unit by placing the slings at designated locations. Support the outdoor unit securely at four points to keep it from slipping and sliding.**

If the unit is not properly supported, it may fall and cause personal injury.

### CAUTION

To reduce the risk of injury, do not carry the product by the PP bands that are used on some packages.

To reduce the risk of injury, products weighing 20 kg or more should be carried by two or more people.

## Installation

### WARNING

**Do not install the unit where there is a risk of leaking flammable gas.**

If flammable gas accumulates around the unit, it may ignite and cause a fire or explosion.

**Properly dispose of the packing materials.**

Plastic bags pose suffocation hazard to children.

**The unit should be installed only by personnel certified by Mitsubishi Electric according to the instructions detailed in the Installation/Operation Manual.**

Improper installation may result in refrigerant leakage, water leakage, injury, electric shock, or fire.

**Periodically check the installation base for damage.**

If the unit is left on a damaged base, it may fall and cause injury.

**Remove packing materials from the unit before operating the unit. Note that some accessories may be taped to the unit. Properly install all accessories that are required.**

Failing to remove the packing materials or failing to install required accessories may result in refrigerant leakage, oxygen starvation, smoke, or fire.

Consult your dealer and take appropriate measures to safeguard against refrigerant leakage and resultant oxygen starvation. An installation of a refrigerant gas detector is recommended.

Any additional parts must be installed by qualified personnel. Only use the parts specified by Mitsubishi Electric.

Take appropriate safety measures against wind gusts and earthquakes to prevent the unit from toppling over and causing injury.

**Be sure to install the unit horizontally, using a level.**

If the unit is installed at an angle, it may fall and cause injury or cause water leakage.

The unit should be installed on a surface that is strong enough to support its weight.

**As an anti-freeze, use ethylene glycol or propylene glycol diluted to the specified concentration.**

The use of other types of anti-freeze solution may cause corrosion and resultant water leakage. The use of flammable anti-freeze may cause fire or explosion.

### CAUTION

**Do not install the unit on or over things that are vulnerable to water damage.**

When the indoor humidity exceeds 80% or if the drain water outlet becomes clogged, condensation may drip from the indoor unit onto the ceiling or floor.

**All drainage work should be performed by the dealer or qualified personnel according to the instructions detailed in the Installation Manual.**

Improper drainage work may cause rain water or drain water to enter the buildings and damage the furnishings.

## Pipe installation

### WARNING

To prevent explosion, do not heat the unit with refrigerant gas in the refrigerant circuit.

**Check for refrigerant leakage at the completion of installation.**

If leaked refrigerant comes in contact with a heat source, toxic gas may be generated.

### CAUTION

**Check that no substance other than the specified refrigerant (R410A) is present in the refrigerant circuit.**

Infiltration of other substances may cause the pressure to rise abnormally high and cause the pipes to explode.

To keep the ceiling and floor from getting wet due to condensation, properly insulate the pipes.

**Piping work should be performed by the dealer or qualified personnel according to the instructions detailed in the Installation Manual.**

Improper piping work may cause water leakage and damage the furnishings.

To keep the ceiling and floor from getting wet due to condensation, properly insulate the pipes.

## Electrical wiring

To reduce the risk of wire breakage, overheating, smoke, and fire, keep undue force from being applied to the wires.

**Properly secure the cables in place and provide adequate slack in the cables so as not to stress the terminals.**

Improperly connected cables may break, overheat, and cause smoke or fire.

To reduce the risk of injury or electric shock, switch off the main power before performing electrical work.

**All electric work must be performed by a qualified electrician according to the local regulations, standards, and the instructions detailed in the Installation Manual.**

Capacity shortage to the power supply circuit or improper installation may result in malfunction, electric shock, smoke, or fire.

To reduce the risk of electric shock, smoke, or fire, install an inverter circuit breaker on the power supply to each unit.

**Use properly rated breakers and fuses (inverter breaker, Local Switch <Switch + Type-B fuse>, or no-fuse breaker).**

The use of improperly rated breakers may result in malfunctions or fire.

To reduce the risk of current leakage, overheating, smoke, or fire, use properly rated cables with adequate current carrying capacity.

**Keep the unsheathed part of cables inside the terminal block.**

If unsheathed part of the cables come in contact with each other, electric shock, smoke, or fire may result.

**Proper grounding must be provided by a licensed electrician. Do not connect the grounding wire to a gas pipe, water pipe, lightning rod, or telephone wire.**

Improper grounding may result in electric shock, smoke, fire, or malfunction due to electrical noise interference.

**⚠ CAUTION**

To reduce the risk of current leakage, wire breakage, smoke, or fire, keep the wiring out of contact with the refrigerant pipes and other parts, especially sharp edges.

To reduce the risk of electric shock, shorting, or malfunctions, keep wire pieces and sheath shavings out of the terminal block.

## Transportation and repairs

**⚠ WARNING**

**The unit should be moved, disassembled, or repaired only by qualified personnel. Do not alter or modify the unit.**

Improper repair or unauthorized modifications may result in refrigerant leakage, water leakage, injury, electric shock, or fire.

**After disassembling the unit or making repairs, replace all components as they were.**

Failing to replace all components may result in injury, electric shock, or fire.

If the supply cord is damaged, it must be replaced by the manufacturer, its service agent or similarly qualified persons in order to avoid a hazard.

**⚠ CAUTION**

To reduce the risk of shorting, electric shock, fire, or malfunction, do not touch the circuit board with tools or with your hands, and do not allow dust to accumulate on the circuit board.

## IMPORTANT

To avoid damage to the unit, use appropriate tools to install, inspect, or repair the unit.

To reduce the risk of malfunction, turn on the power at least 12 hours before starting operation, and leave the power turned on throughout the operating season.

**Recover all refrigerant from the unit.**

It is punishable by law to release refrigerant into the atmosphere.

**Do not unnecessarily change the switch settings or touch other parts in the refrigerant circuit.**

Doing so may change the operation mode or damage the unit.

To reduce the risk of malfunctions, use the unit within its operating range.

**Do not switch on or off the main power in a cycle of shorter than 10 minutes.**

Short-cycling the compressor may damage the compressor.

To maintain optimum performance and reduce the risk of malfunction, keep the air pathway clear.

To reduce the risk of both the breaker on the product side and the upstream breaker from tripping and causing problems, split the power supply system or provide protection coordination between the earth leakage breaker and no-fuse breaker.

**When servicing the refrigerant, open and close the check joint using two spanners, as there is the risk of refrigerant leaking due to damaged piping.**



**Please build the water circuit so that it is a closed system.**

Do not use water directly for showers or other applications. Do not allow other heat source water to mix with the water circuit.

**To ensure proper operation of the unit, periodically check for proper concentration of anti-freeze.**

Inadequate concentration of anti-freeze may compromise the performance of the unit or cause the unit to abnormally stop.

**Take appropriate measures against electrical noise interference when installing the air conditioners in hospitals or facilities with radio communication capabilities.**

Inverter, high-frequency medical, or wireless communication equipment as well as power generators may cause the air conditioning system to malfunction. Air conditioning system may also adversely affect the operation of these types of equipment by creating electrical noise.

**Check the water system, using a relevant manual as a reference.**

Using the system that does not meet the standards (including water quality and water flow rate) may cause the water pipes to corrode.

To reduce the risk of power capacity shortage, always use a dedicated power supply circuit.

Have a backup system, if failure of the unit has a potential for causing significant problems or damages.

This appliance is intended to be used by expert or trained users in shops, in light industry and on farms, or for commercial use by lay persons.

**This appliance is Electromagnetic Compatibility Directive Class A. When it uses at residential environment, it may cause electromagnetic interference. User may be asked to prepare the properly way.**

Other products installed in the same environment have the risk of malfunction.

# 1. Selecting the Installation Site

## [1] Installation Conditions

Select the installation site in consultation with the client.

Select a site to install the unit that meets the following conditions:

- The unit will not be subject to heat from other heat sources.
- A site does not cause a trouble by the noise from the unit.
- The unit will not be exposed to strong winds.
- Water from the unit can be drained properly.
- The space requirements (specified on pages 7 through 9) are met.
- There is a possibility of injuring with the fin of the heat exchanger, so abide by following contents.

- ① Limit the access of the general public to the location where they can touch the product.
- ② Take a measure so the general public cannot easily access the location where they can touch the product.
- ③ When installing in a location where the general public can touch the product, install the optional fin guard.

Option Parts: DT-150FG

When two units are joined

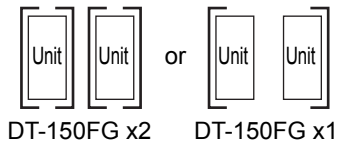

### <1> Protection against winds

- Pay attention to the wind direction and installation location to ensure that the air heat exchanger is not directly exposed to strong winds.
- If unable to avoid strong winds, install wind breaking hoods or walls, etc.

### <2> Cold Climate Installation

Observe the following when installing the units in areas where snow or strong winds prevail.

- Avoid direct exposure to rain, winds, and snow.
- If the unit is installed in the direct line of rain, winds, or snow, install snow hoods. Use a snow net or snow fence as necessary to protect the unit.
- Install the unit on a base approximately twice as high as the expected snowfall.
- If the unit of heating mode is continuously operated for a long time with the outdoor temperature below the freezing point, install a heater at the drain pan of the unit to prevent freezing of drain.

### <3> Weight

		Net weight (kg)	Operating weight (kg)
EAHV	Standard piping	1310	1337
	Inside header piping	1326	1394
EACV	Standard piping	1240	1267
	Inside header piping	1256	1324

\* Weight of the optional parts: DT-01HK (29 kg), DT-02HK (42 kg), DT-150FG (13 kg)

## [2] Installation Space Requirement

### <1> Single unit installation

(1) Required space

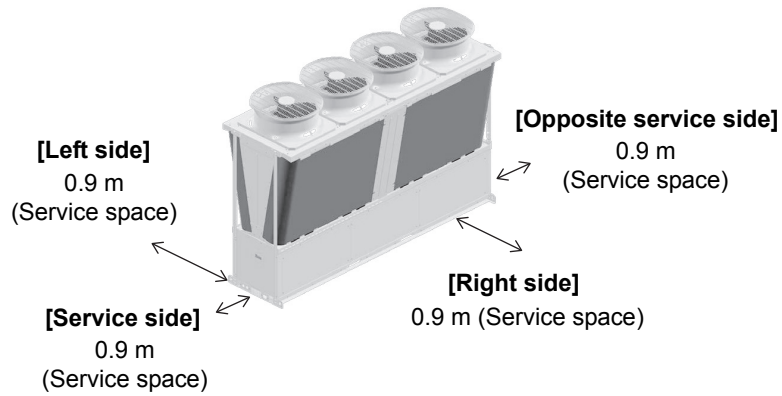

(2) If entire surrounding area enclosed by walls (but vent holes installed at bottom of wall)

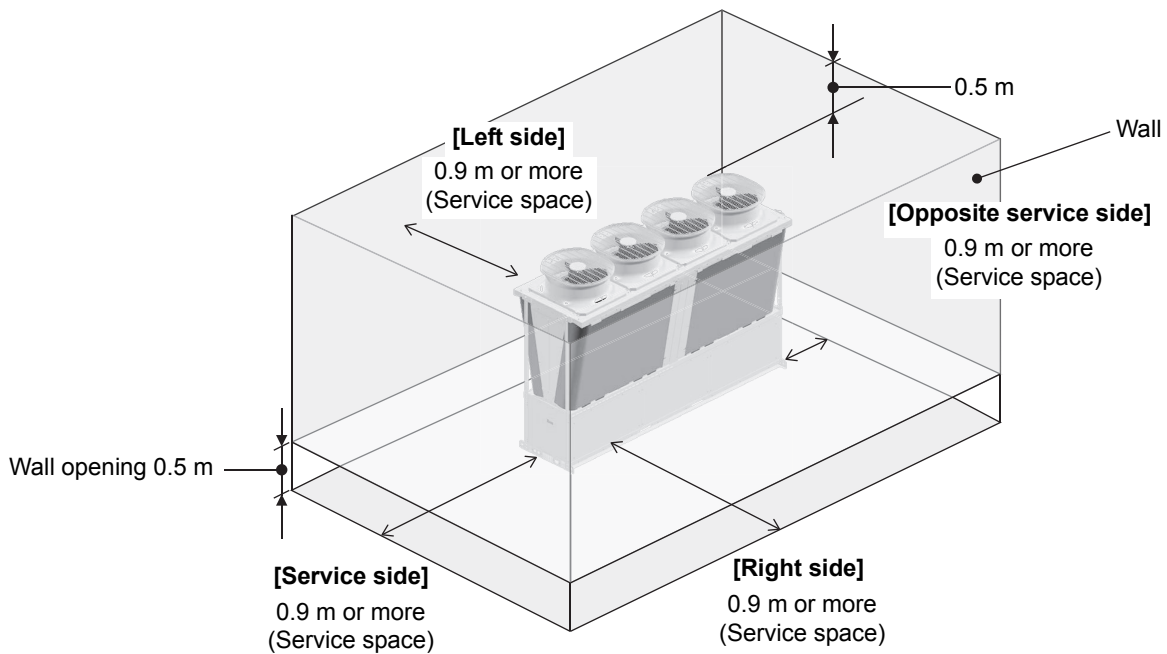

\*Wall height 2.9 m (unit height (2.4 m + 0.5 m))

\*Vent holes: 0.5 m from floor

\*Even if installed as shown in this figure, a short cycle may occur due to the influence of wind.



## <2> Multiple unit installation

### (1) Required space

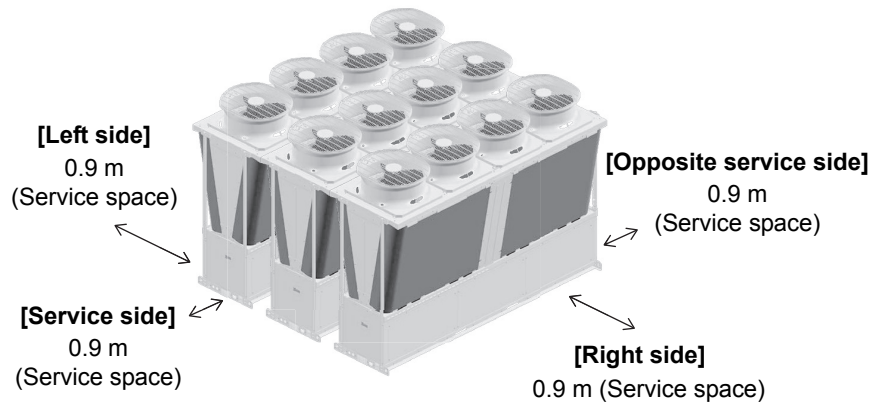

### (2) If entire surrounding area enclosed by walls (but vent holes installed at bottom of wall)

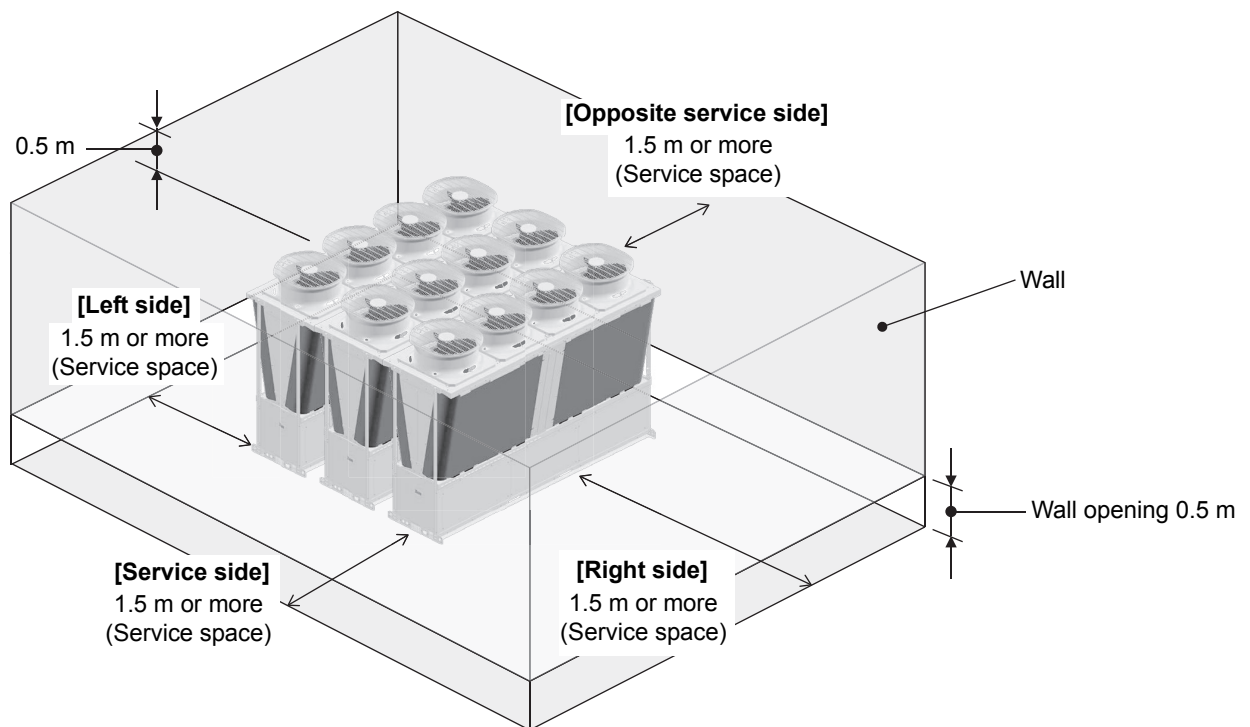

\*Wall height 2.9 m (unit height (2.4 m + 0.5 m))

\*Vent holes: 0.5 m from floor

\*Even if installed as shown in this figure, a short cycle may occur due to the influence of wind.

## 2. Unit Installation

Units should be installed only by personnel certified by Mitsubishi Electric.

### [1] Product suspension method

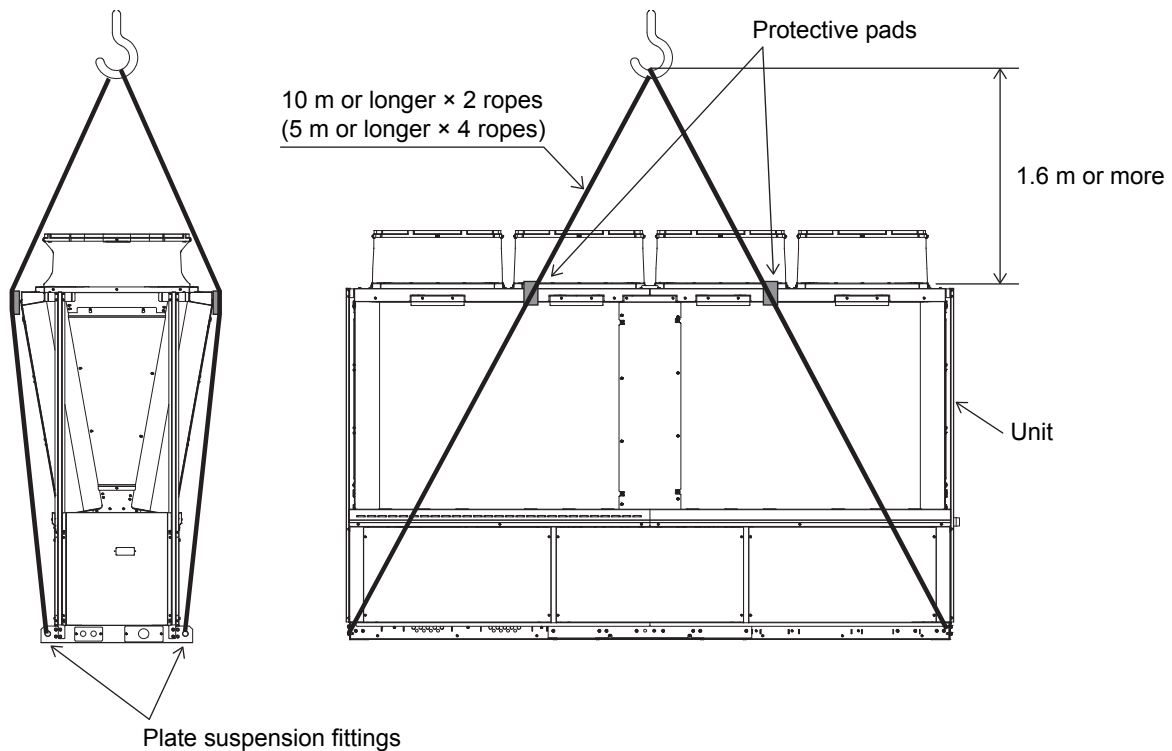

- If transporting the product suspended, use the two suspension sections at the front and rear.
- Always feed rope through the four suspension sections so that the unit is not subjected to shocks.
- Use two ropes that are 10 m or longer. (Use four ropes that are 5 m or longer.)
- Use suspension equipment that is capable of supporting the weight of the product.
- Always suspend the product in four sections. (do not suspend the product two sections as this is dangerous)
- Use the appropriate protective pads to ensure that the rope does not rub against the outer panel.
- Refer to the center of gravity position shown in [2], and suspend the unit while taking care to prevent a deviated center of gravity.

#### **Warning:**

- **Lift the unit by placing the slings at designated locations. Support the unit securely at four points to keep it from slipping and sliding. If the unit is not properly supported, it may fall and cause personal injury.**

## [2] Center of gravity position

The center of gravity position is shown with the  mark.

Standard piping type

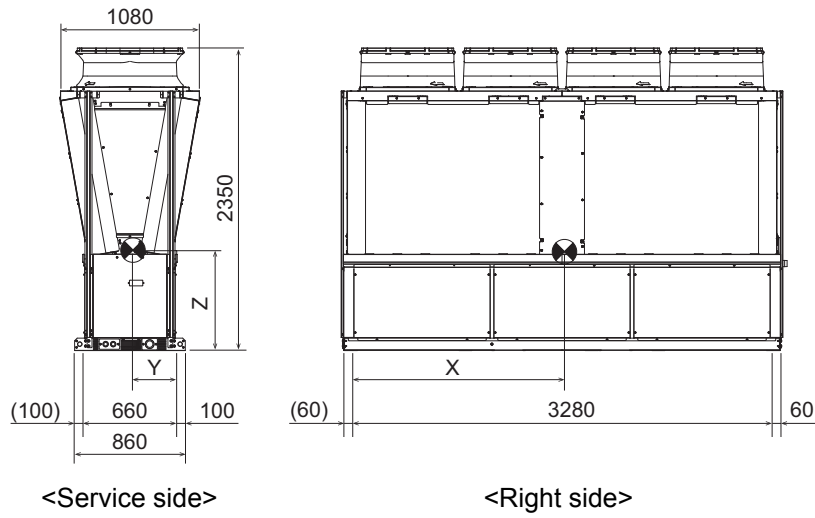

Inside header piping type

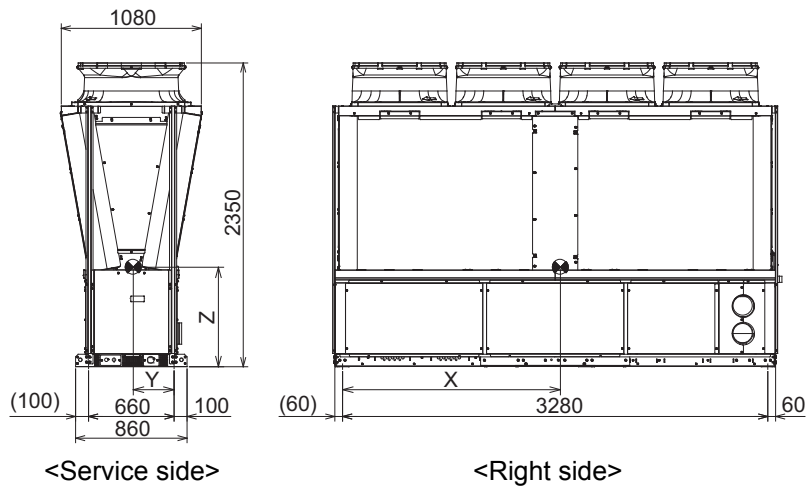

(Unit: m)

Specification	X	Y	Z
Standard piping type	1655	315	775
Inside header piping type	1680	315	770

### [3] Installation on foundation

- Securely fix the unit with bolts to keep the unit from falling down during earthquakes.
- Install the unit on a foundation made of concrete or iron.
- Noise and vibrations from the unit may be transmitted through the floor and walls. Provide adequate protection against noise and vibration.

**Warning:**

- Be sure to install the unit on a surface strong enough to withstand its weight to keep the unit from falling down and causing injury.
- Provide adequate protection against earthquakes. Improper installation may cause the unit to fall down, resulting in personal injury.

When building the foundation, take the floor strength, and piping and wiring routes into consideration.

Bolt size	Number
M16	4

[Enlarged view]

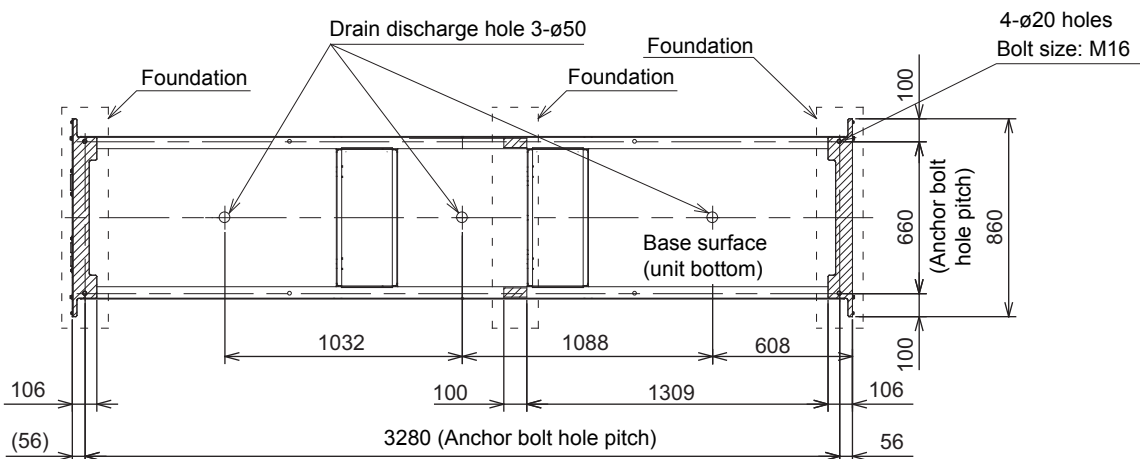
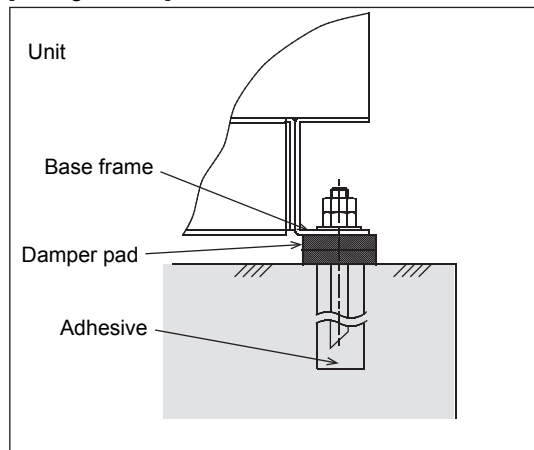

\*  show mounting surface.



[2] Standard piping type

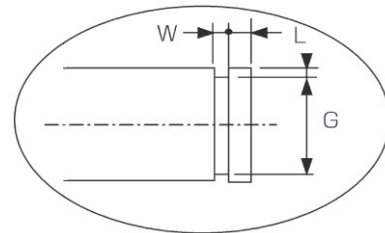
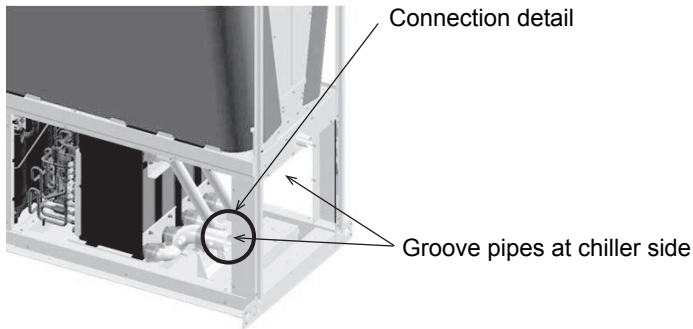
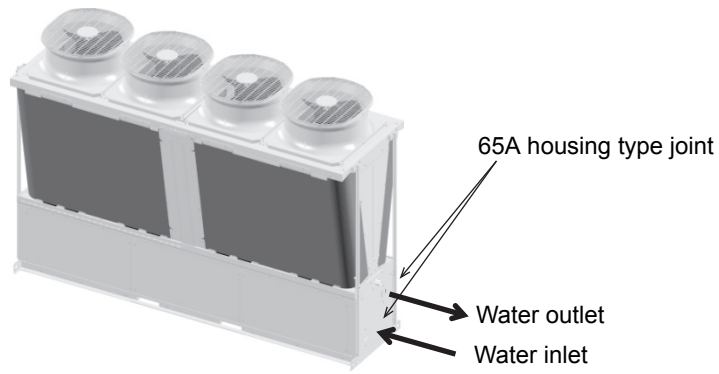

The dimension of the groove pipe at the chiller side

Victaulic standard groove specifications

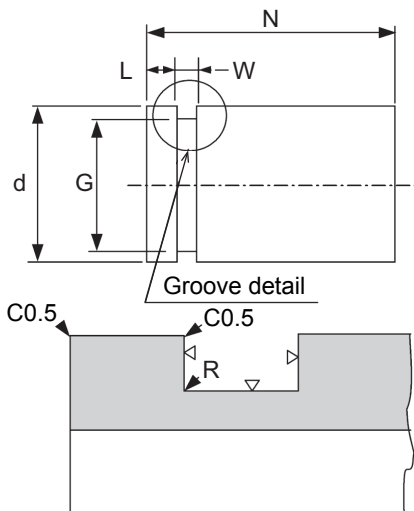

(Unit: mm)

	Pipe size
	2-1/2B (65A)
d	ø76.1
G	ø72.2 <sup>+0</sup> <sub>-0.4</sub>
W	8.7 <sup>+0</sup> <sub>-0.7</sub>
L	15.88 <sup>+0</sup> <sub>-0.7</sub>
N	50
R	1.0

[3] Inside header piping type

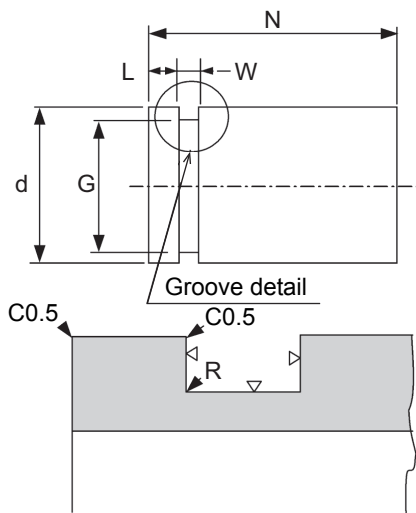
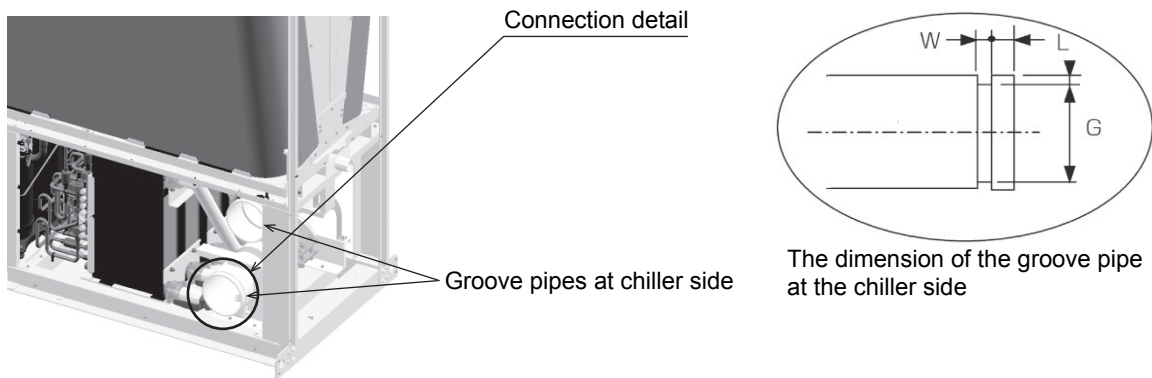
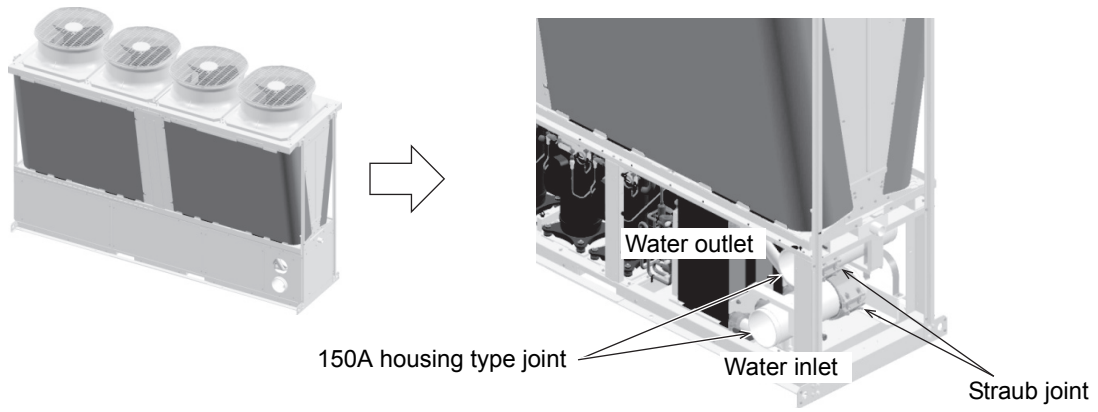

(Unit: mm)

	Pipe size
	6B (150A)
d	ø165.1
G	ø160.8
W	8.7 <sup>+0.7</sup> <sub>-0</sub>
L	15.9 <sup>+0.7</sup> <sub>-0</sub>
N	50.0
R	1.0

## Installing the straub joint

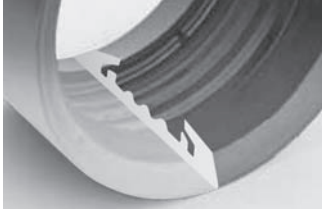

The seal rubber has a lip construction to improve water stopping performance.

Adjust the Straub position to that the marking on both sides is visible.

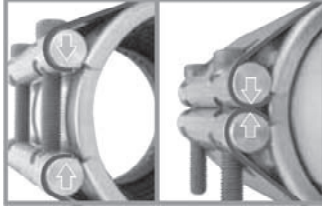

The bolts need only be tightened until the casing is sealed (metal touches). Consequently, the procedure can be carried out accurately by anyone to the same level, regardless of worker proficiency or the type of pipe.

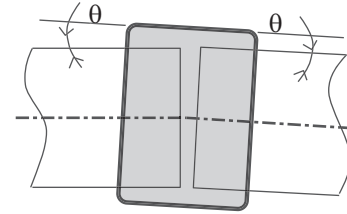
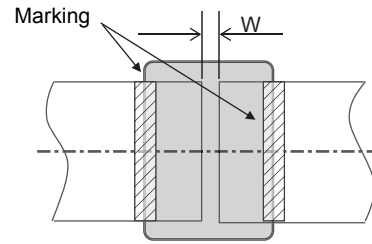

- Allowable tolerance for gaps and tilting  
Pipe gap tolerance [W]: 0 to 25 mm  
Allowable pipe tilt angle [ $\theta$ ]:  $\pm 2^\circ$



## [4] Notes on Pipe Corrosion

### Water treatment and water quality control

Poor-quality circulating water can cause the water-side heat exchanger to scale up or corrode, reducing heat-exchange performance. Properly control the quality of the circulating water.

- Removing foreign objects and impurities in the pipes  
During installation, keep foreign objects, such as welding and sealant fragments and rust, out of the pipes.
- Water Quality Control
  - (1) Poor-quality water can corrode or scale up the heat exchanger. Regular water treatment is recommended.  
Water circulation systems using open heat storage tanks are particularly prone to corrosion.  
When using an open heat storage tank, install a water-to-water heat exchanger, and use a closed-loop circuit.  
If a water supply tank is installed, keep contact with air to a minimum, and keep the level of dissolved oxygen in the water no higher than 1 mg/ℓ.

### (2) Water quality standard

Items		Lower mid-range temperature water system		Higher mid-range temperature water system		Tendency	
		Water Temp. ≤ 60°C		Water Temp. > 60°C		Corrosive	Scale-forming
		Recirculating water	Make-up water	Recirculating water	Make-up water		
Standard items	pH (25°C)	7.0 ~ 8.0	7.0 ~ 8.0	7.0 ~ 8.0	7.0 ~ 8.0	○	○
	Electric conductivity (mS/m) (25°C)	30 or less	30 or less	30 or less	30 or less	○	○
	(μs/cm) (25°C)	[300 or less]	[300 or less]	[300 or less]	[300 or less]		
	Chloride ion (mg Cl <sup>-</sup> /ℓ)	50 or less	50 or less	30 or less	30 or less	○	
	Sulfate ion (mg SO <sub>4</sub> <sup>2-</sup> /ℓ)	50 or less	50 or less	30 or less	30 or less	○	
	Acid consumption (pH4.8) (mg CaCO <sub>3</sub> /ℓ)	50 or less	50 or less	50 or less	50 or less		○
	Total hardness (mg CaCO <sub>3</sub> /ℓ)	70 or less	70 or less	70 or less	70 or less		○
	Calcium hardness (mg CaCO <sub>3</sub> /ℓ)	50 or less	50 or less	50 or less	50 or less		○
Ionic silica (mg SiO <sub>2</sub> /ℓ)	30 or less	30 or less	30 or less	30 or less		○	
Reference items	Iron (mg Fe/ℓ)	1.0 or less	0.3 or less	1.0 or less	0.3 or less	○	○
	Copper (mg Cu/ℓ)	1.0 or less	1.0 or less	1.0 or less	1.0 or less	○	
	Sulfide ion (mg S <sup>2-</sup> /ℓ)	Not to be detected	Not to be detected	Not to be detected	Not to be detected	○	
	Ammonium ion (mg NH <sub>4</sub> <sup>+</sup> /ℓ)	0.3 or less	0.1 or less	0.1 or less	0.1 or less	○	
	Residual chlorine (mg Cl/ℓ)	0.25 or less	0.3 or less	0.1 or less	0.3 or less	○	
	Free carbon dioxide (mg CO <sub>2</sub> /ℓ)	0.4 or less	4.0 or less	0.4 or less	4.0 or less	○	
	Ryzner stability index	—	—	—	—	○	○

Reference: Guideline of Water Quality for Refrigeration and Air Conditioning Equipment. (JRA GL02E-1994)

- (3) Please consult with a water quality control specialist about water quality control methods and water quality calculations before using anti-corrosive solutions for water quality management.
- (4) When replacing an air conditioner (including when only the heat exchanger is replaced), first analyze the water quality and check for possible corrosion.  
Corrosion can occur in water systems in which there has been no signs of corrosion. If the water quality level has dropped, adjust the water quality before replacing the unit.

### (5) Suspended solids in the water

Sand, pebbles, suspended solids, and corrosion products in water can damage the heating surface of the heat exchanger and cause corrosion. Install a good quality strainer (20 mesh or more) at the inlet of the unit to filter out suspended solids.

#### Removing foreign substances from the water system

Consider installing a settlement tank or a bypass strainer to remove foreign substances from the water system. Select a strainer capable of handling two to three percent of the circulating water. The figure below shows a sample system with a bypass strainer.

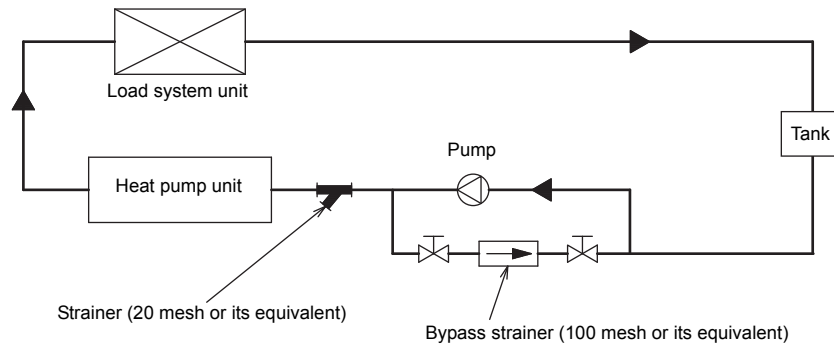

### (6) Connecting pipes made from different materials

If different types of metals are placed in direct contact with each other, the contact surface will corrode. Install an insulating material between pipes that are made of different materials to keep them out of direct contact with each other.

### (7) Piping material

Use hot water output piping material that can withstand heat of 60°C or more. Use hot water input piping material that can withstand the maximum input water temperature. All piping must be made of SUS or similar material to withstand corrosion.

## [5] Installing the Strainer and Flow Switch

### <1> Installing the strainer

Install a strainer on the inlet pipe near the unit to filter out suspended solids and prevent clogging or corrosion of the heat exchanger.

Install a strainer in a way that allows for easy access for cleaning, and instruct the user to clean it regularly.

Operating the units with a clogged strainer may cause the units to make an abnormal stop.

Select a location to install a strainer, taking into consideration the installation angle, insulation thickness, and maintenance space.

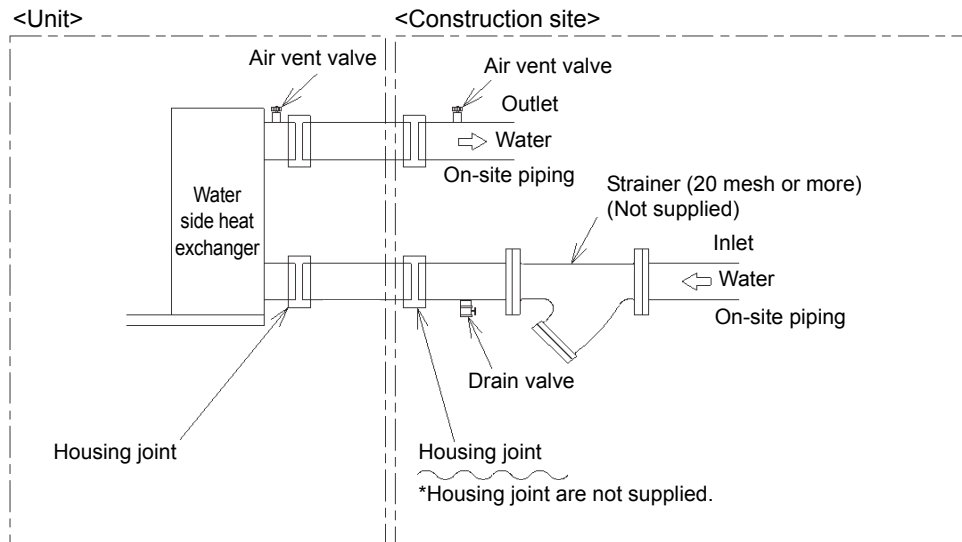

### <2> Installing a flow switch

Install a flow switch that meets the following specifications on the water pipe.

Connect the flow switch to the flow switch contact on the unit.

Minimum flow rate= 12.9 m<sup>3</sup>/h (215 L/min)

Unit usage range (water flow rate): 12.9 - 34.0 m<sup>3</sup>/h

## [6] Installing the external water temperature sensor

### <1> Parts that are required to install an external water temperature sensor

- (1) External water temperature sensor
  - (2) Wiring to connect the sensor and the unit\*
  - (3) Wiring terminals to connect the wiring to the sensor and the terminal block on the unit  
(Four for M4 screws)\*
- \*Items (1) and (2) are field supplied.

### Wire specifications

Wire size	2-core cable Min. 1.25 mm <sup>2</sup>
Type	CVVS or CPEVS
Maximum length	20 m

### <2> Installing the external water temperature sensor

- Install the external water temperature sensor where the water pipes merge or on the load-side tank as shown in the figure at right.
- Install horizontally or vertically on top of the pipe.
- When installing horizontally, make sure the wire faces down.

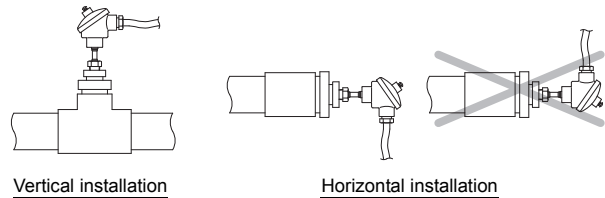

### <3> Wiring the external water temperature sensor

Connect the external temperature sensor wiring to the terminal block in the control box on the unit as shown in the figure below.

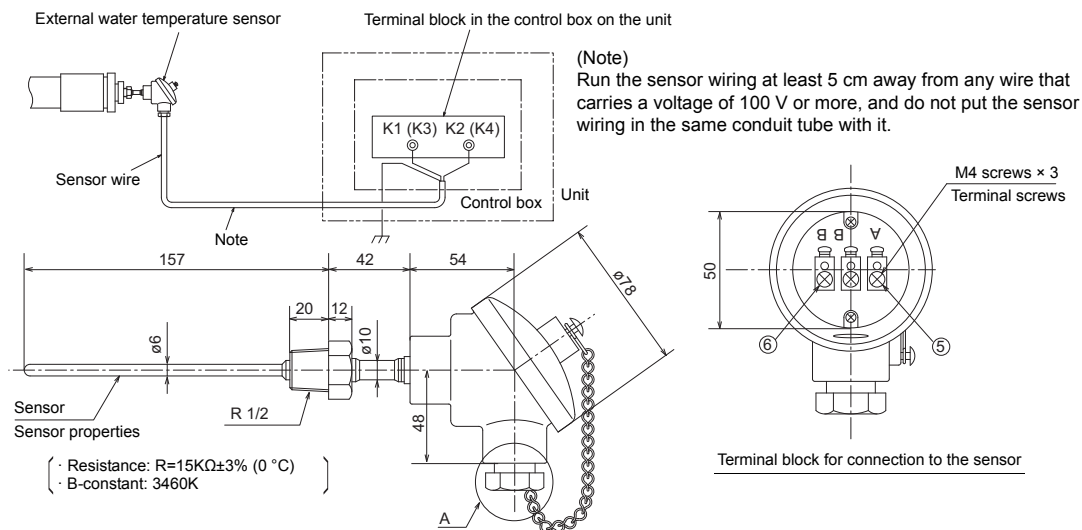

Connect the sensor wiring to terminals K1 and K2 (or K3 and K4) of the terminal block in the control box on the unit.

Connect the shield to the earth terminal.

Thread the wire to the external water temperature sensor through parts ② through ④ as shown in the figure at right. Attach M4 terminals (field-supplied) to the wires, and connect them to ⑤ and ⑥ (terminals A and B).

Cut the shield wire. Do not connect it to the terminal. (Connect the shield on the unit side to the ground terminal.)

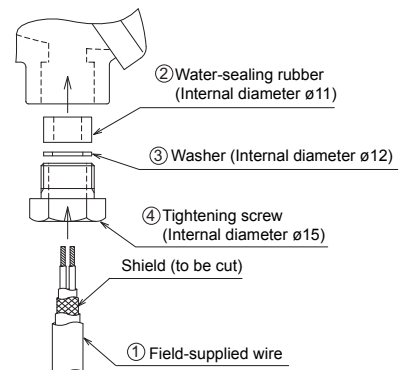

Detailed view of the area labeled "A" in the figure above

After the wire is connected, securely tighten the tightening screw ④, and then caulk the gap between the wire ① and the tightening screw to keep water from entering.

\*1 In a multiple module connection system, install the temperature sensor where the cold/hot water from each module is sufficiently mixed to provide a representative temperature.

\*2 The temperature sensor must be installed on a pipe between the outlet of the unit and the entrance to the load-side system.

## [7] Ensuring enough water in the water circuit

### <1> Required amount of water

If the amount of water in the water circuit (circulating water circuit) is insufficient, the unit operation hours may become shorter or the amount of water temperature change to be controlled may become extremely large. Also, the defrost operation during the heating mode may not function properly. Refer to the table below for the minimum amount of water required in the circuit. If the water pipe is too short to keep enough amount of water, install a cushion tank in the water pipe to ensure enough amount of water.

Model	Minimum amount of water (ℓ)
EAHV-P1500/1800YB(-H)	1450
EACV-P1500/1800YB	800

### <2> Calculating the required amount of water in the water circuit

The required amount of water in the water circuit can be obtained from the following formula.

(Required amount of water in the water circuit) = (Amount of water that can be held in the water pipe) + (Amount of water that can be held in the heat source unit) + (Amount of water that can be held in the load-side unit)

#### The amount of water that can be held per meter of the water pipe (ℓ/m)

Pipe size					
2 1/2B (65A)	3B (80A)	4B (100A)	5B (125A)	6B (150A)	8B (200A)
3.77	5.16	8.87	13.23	18.91	32.44

#### The amount of water that can be held in the heat source unit (ℓ)

Standard	Inside header piping type
27	68

### <3> Inlet/Outlet pipe connection size and material

The table below shows the inlet/outlet pipe connection size.

#### Inlet/Outlet pipe connection size

Piping type	Inlet pipe connection	Outlet pipe connection
Standard	65A housing type joint (Field-supplied Victaulic joint)	65A housing type joint (Field-supplied Victaulic joint)
Inside header piping type	150A housing type joint (Field-supplied Victaulic joint)	150A housing type joint (Field-supplied Victaulic joint)

## [8] Water Piping Size and Location

### <1> Standard piping type

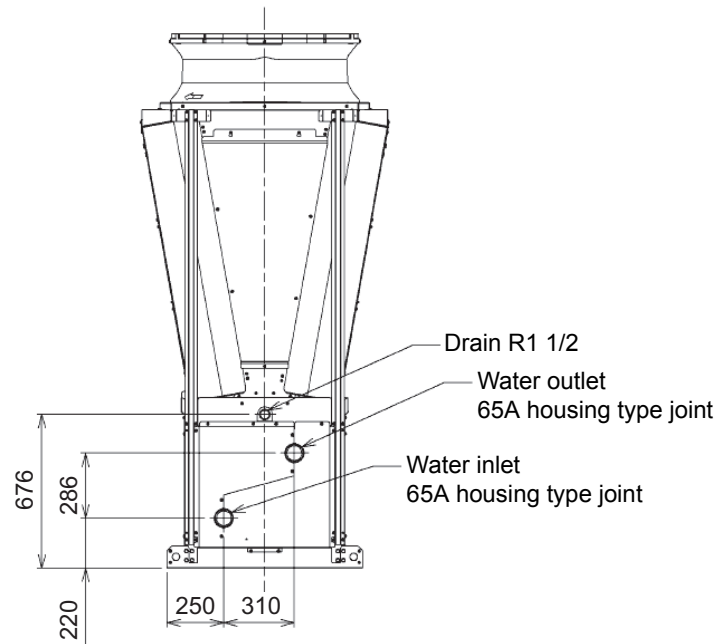

### <2> Inside header piping type

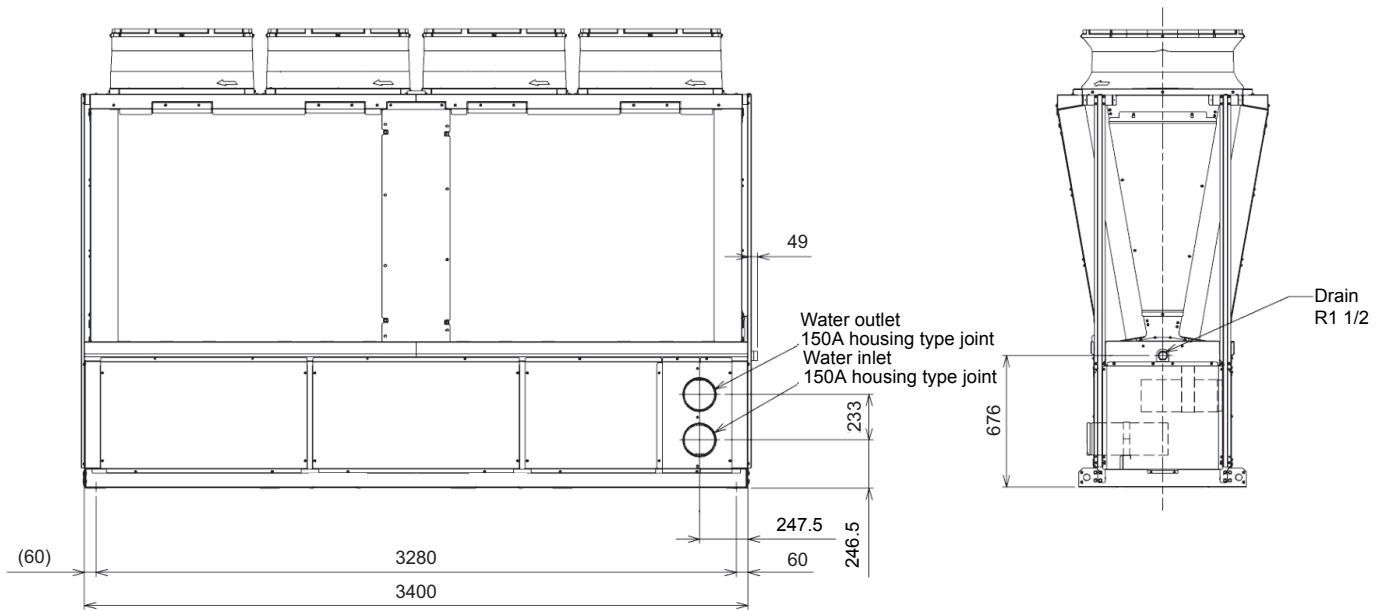

# 4. Electrical Wiring Installation

## [1] Main Power Supply Wiring and Switch Capacity

### Schematic Drawing of Wiring (Example)

(A): Switch (with current breaking capability)

(B): Current leakage breaker

(C): Unit

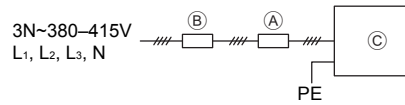

### Main power supply wire size, switch capacities, and system impedance

Model	Minimum wire size (mm <sup>2</sup> )			Current leakage breaker	Local switch (A)		No-fuse breaker (A)	Max. Permissive System Impedance
	Main cable	Branch	Ground		Capacity	Fuse		
EACV/EAHV-P1500/1800YB	35	-	35	160 A 200 mA 0.1 sec. or less	150	150	160	0.07 Ω

1. Use a dedicated power supply for each unit. Ensure that each unit is wired individually.
2. When installing wiring, consider ambient conditions (e.g., temperature).
3. The wire size is the minimum value for metal conduit wiring. If voltage drop is a problem, use a wire that is one size thicker.  
Make sure the power-supply voltage does not drop more than 5%.
4. Specific wiring requirements should adhere to the wiring regulations of the region.
5. Power supply cords of appliances shall not be lighter than polychloroprene sheathed flexible cord (design 60245 IEC57).
6. A switch with at least 3 mm contact separation in each pole shall be provided by the Air Conditioner installer.
7. Do not install a phase advancing capacitor on the motor. Doing so may damage the capacitor and result in fire.

### ⚠ Warning:

- Be sure to use specified wires and ensure no external force is imparted to terminal connections. Loose connections may cause overheating and fire.
- Be sure to use the appropriate type of overcurrent protection switch. Note that overcurrent may include direct current.

### ⚠ Caution:

- Some installation sites may require an installation of an earth leakage breaker for the inverter. If no earth leakage breaker is installed, there is a danger of electric shock.
- Only use properly rated breakers and fuses. Using a fuse or wire of the wrong capacity may cause malfunction or fire.

### Note:

- This device is intended for the connection to a power supply system with a maximum permissible system impedance shown in the above table at the interface point (power service box) of the user's supply.
- Ensure that this device is connected only to a power supply system that fulfills the requirements above. If necessary, consult the public power supply company for the system impedance at the interface point.
- This equipment complies with IEC 61000-3-12 provided that the short-circuit power  $S_{SC}$  is greater than or equal to  $S_{SC} (*2)$  at the interface point between the user's supply and the public system. It is the responsibility of the installer or user of the equipment to ensure, in consultation with the distribution network operator if necessary, that the equipment is connected only to a supply with a short-circuit power  $S_{SC}$  greater than or equal to  $S_{SC} (*2)$ .

$S_{SC} (*2)$

$S_{SC}$ (MVA)
9.57

### Control cable specifications

Remote controller cable	Size	0.3 mm <sup>2</sup> (Max. 200 m total)
	Recommended cable types	2-core sheathed cable
M-NET cable between units	Size	Min. 1.25 mm <sup>2</sup> (Max. 120 m total)
	Recommended cable types	Shielded cable CVVS, CPEVS or MVVS
External input wire size		Min. 0.3 mm <sup>2</sup>
External output wire size		1.25 mm <sup>2</sup>

\*1 Use a CVVS or CPEVS cable (Max. total length of 200 m) if there is a source of electrical interference nearby (e.g., factory) or the total length of control wiring exceeds 120 m.

## [2] Cable Connections

### <1> Schematic Diagram of a Unit and Terminal Block Arrangement

<Unit: mm>

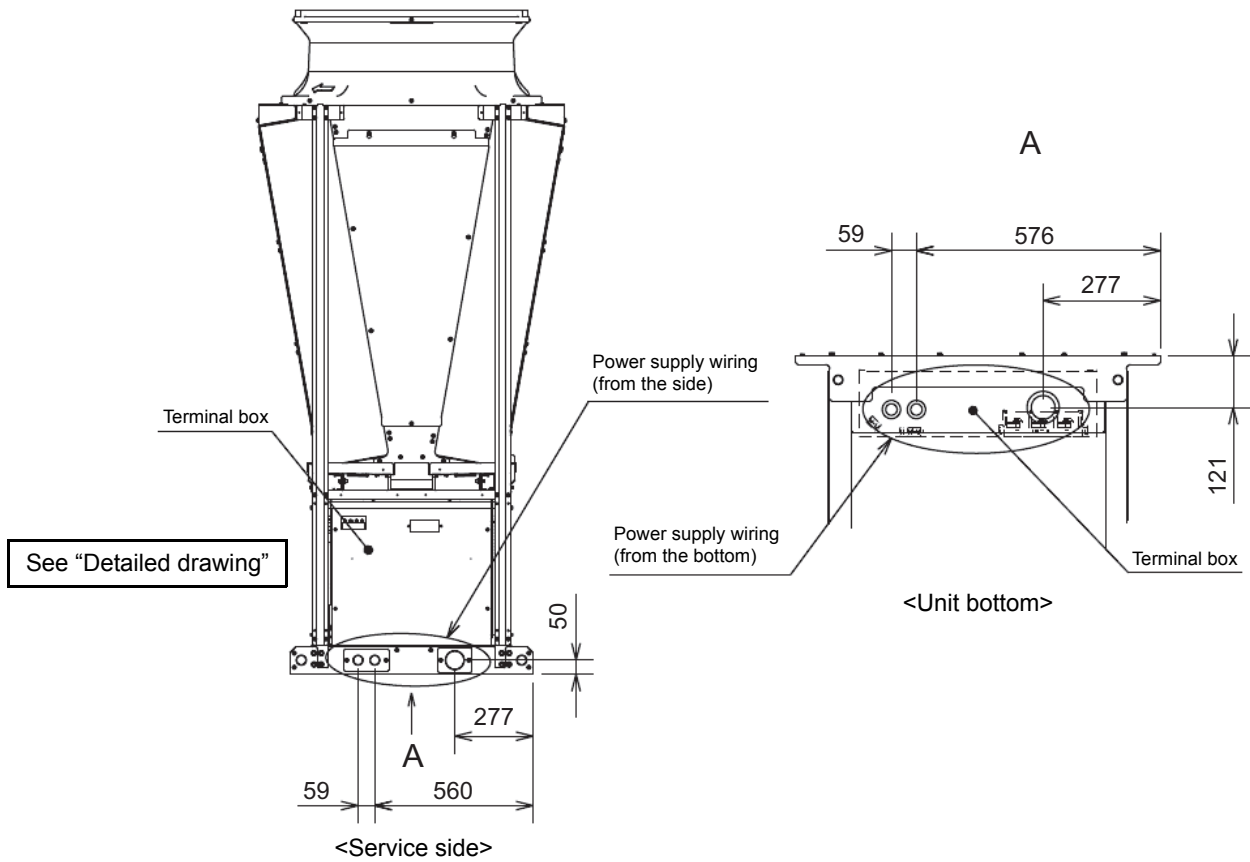

Detailed drawing

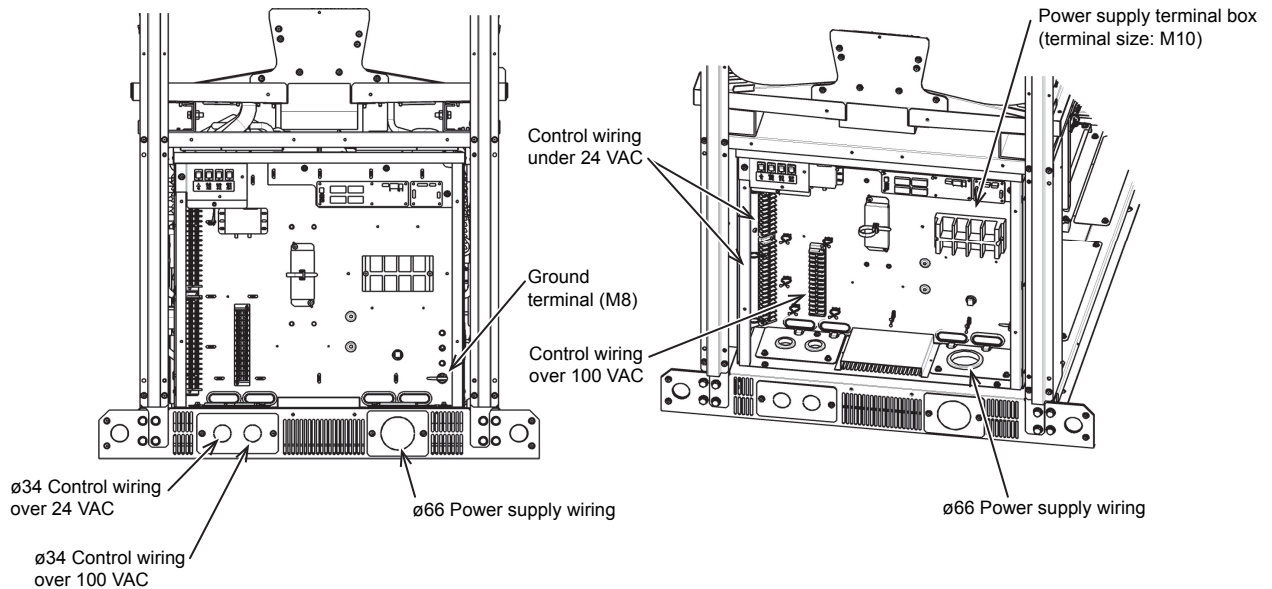

- (1) Remove the front terminal box cover.
- (2) Wire the power supply and control wires. The terminal box is covered with a bush. Cut the bush before connecting wires to the terminal box.
- (3) Fasten the power supply wires by the cable strap.
- (4) Secure the cable conduit, and then waterproof the area around the pipe with silicon, etc.
- (5) Reattach the terminal box cover.



## <2> Precautions when fastening screws

- \* Faulty contacts due to loose screws may cause overheating and fire.
- \* Using the circuit board while it is damaged may cause overheating and fire.

### ① Screw fastening torque

Power supply terminal block, M8 screw: 10 to 13.5 N·m

Use the following methods to check that the screws have been fastened.

#### 1. Check that the spring washer is in a parallel position.

- \* If the screw is biting into the washer, simply fastening the screw to the specified torque cannot determine whether it has been installed properly.

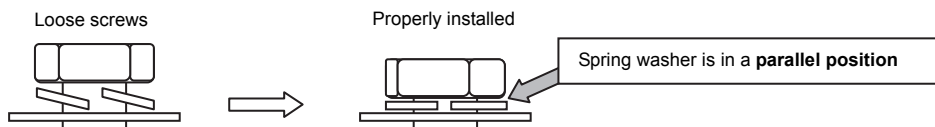

#### 2. Check that the wiring does not move at the screw terminal.

- ② Take extra care not to ruin the screw thread due to fastening the screw at an angle.
  - \* To prevent fastening the screw at an angle, install the round terminals so they are back to back.
- ③ After fastening the screw, use a permanent marker to tick off the screw head, washer and terminal.

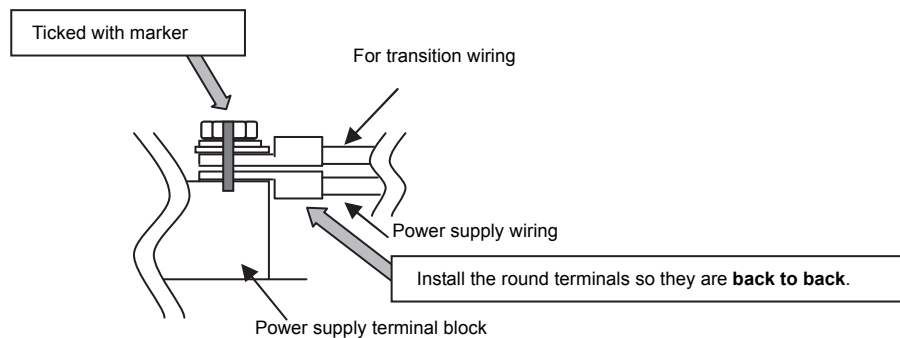

## <3> Installing the conduit tube

- Always use a conduit to run the power supply wiring.
- Select the conduit size based on the hole.
- The cable conduits must be prepared locally.
- Do not store the 24VDC or less low-voltage circuit and 100VAC or higher main circuit and control circuit cables in the same multi-core cable, or bundle them together.
- Attach cable conduits securely to the foundation, etc. to ensure that excessive loads are not applied to the power supply terminal box.
- Seal the area around the cable conduit connection to ensure that no water penetrates the cable conduit connection port.

**EAHV-P1500, 1800YB(L)-(H)-(N)-(BS)/EACV-P1500, 1800YB(L)-(N)-(BS)  
ELECTRICAL WIRING DIAGRAM**

**MAIN CIRCUIT**

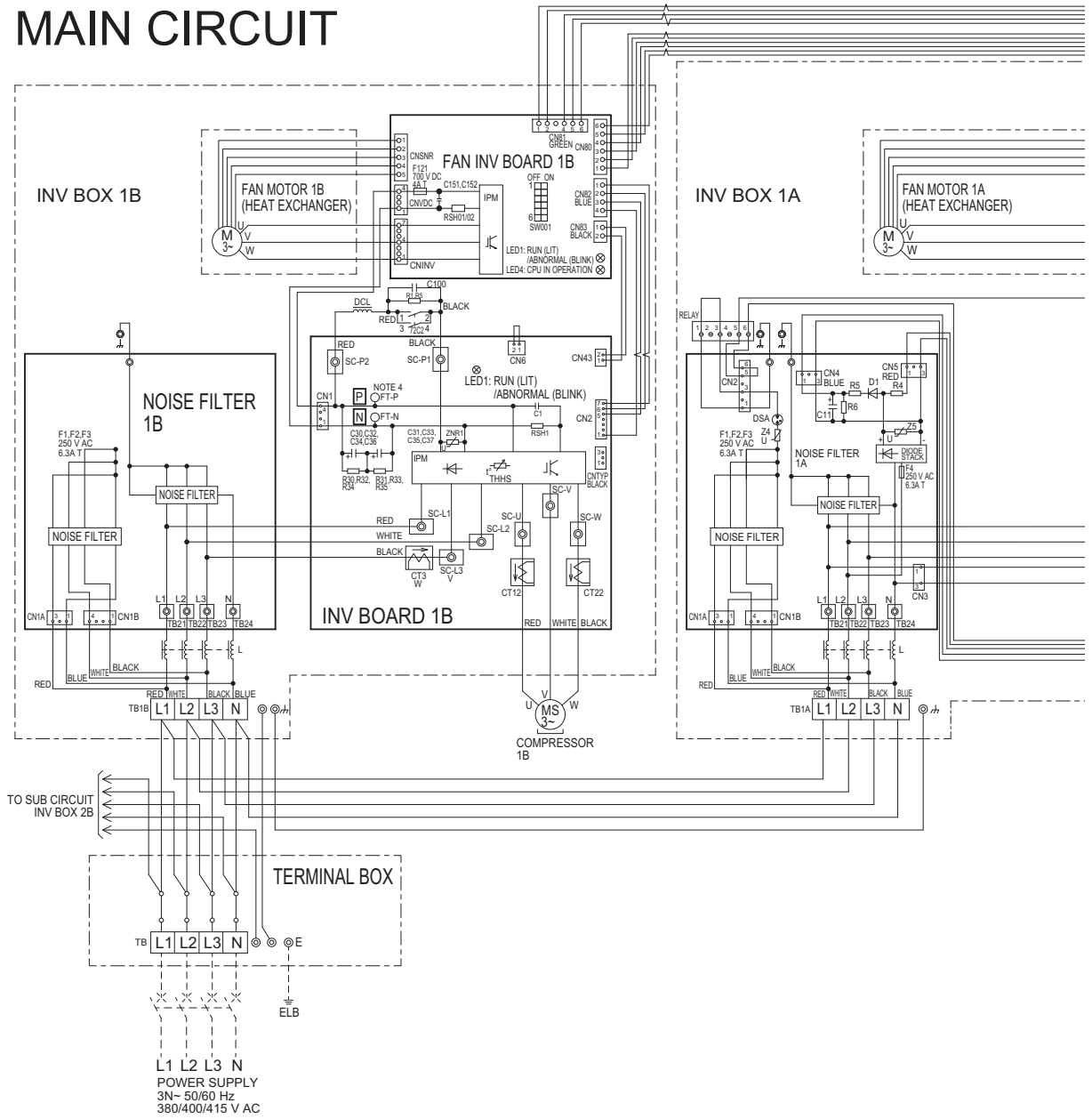

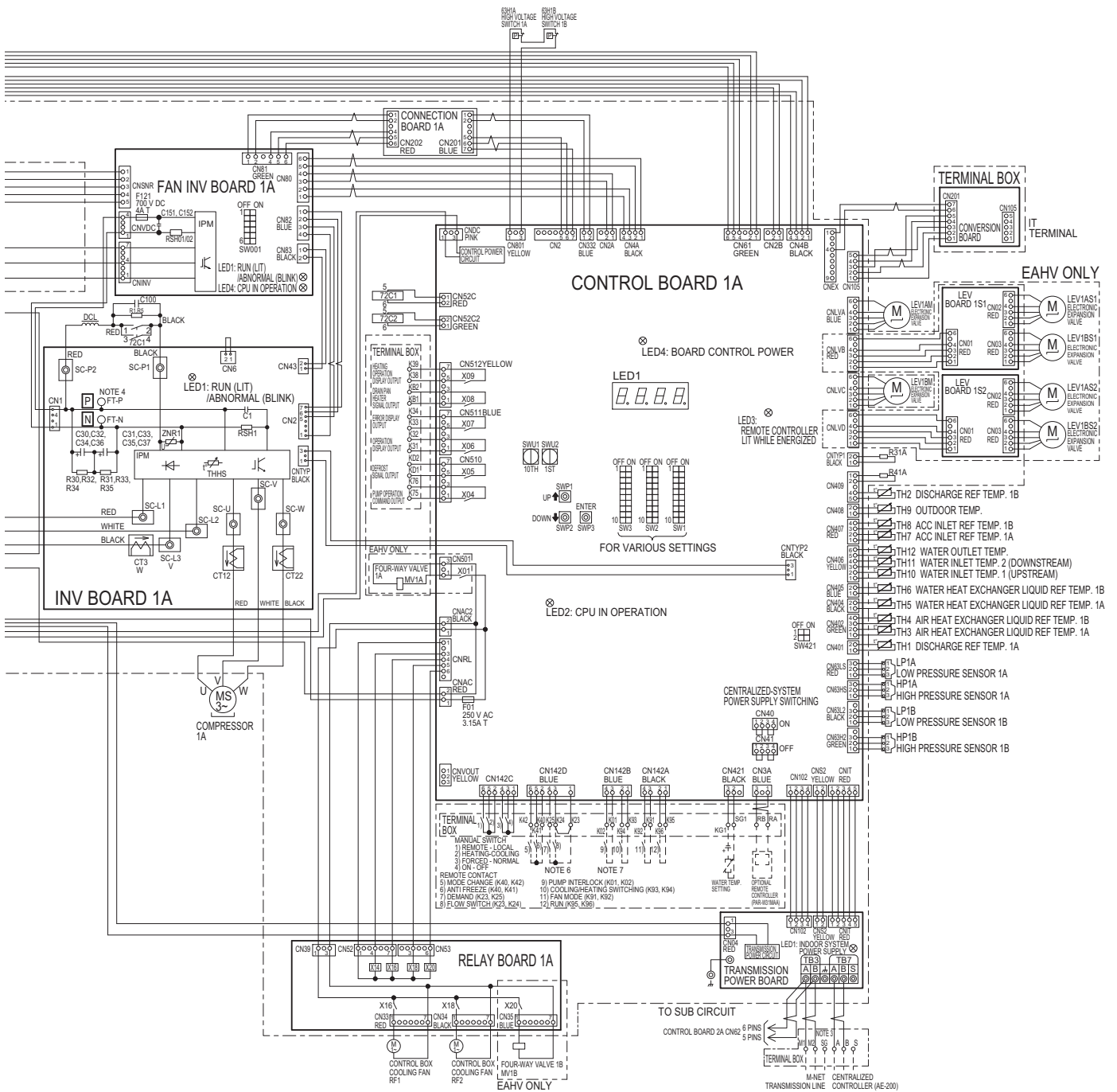

The specification of the product is for the improvement a previous notice and might change.

- 
- Note1. The broken lines indicate the optional parts, field-supplied parts, and field work.
- Note2. Dashed lines indicate control box.
- Note3. For modules in the same unit, provide daisy-chain wiring between M1, M2 and SG.
- Note4. The control box has many parts charged with high voltage in it.  
Before inspecting the inside of the control box, be sure to turn off the power supply and leave it alone for at least 10 minutes and then confirm that the voltage between the tab terminal (FT-P and FT-N) declined sufficiently (to 20 V DC or less).
- Note5. Faston terminals have a locking function.  
Press the tab in the middle of the terminals to remove them.  
Check that the terminals are securely locked in place after insertion.
- Note6. Remove the short circuit wire between the terminals K23 and K24 to connect a flow switch.
- Note7. Be sure to connect the wires from terminals K01 and K02 to the interlock contact on the pump.  
A short-circuit may cause abnormal stop or malfunctions.
- Note8. Operation signals can be received from through the No-voltage contact.
- Note9. Use a 4-20mA signal output device with insulation.  
Feeding 30mA or more current may damage the circuit board.
- Note10. Make sure that on site terminal connection is correct.  
With wrong connection, operation error may occur.
- Note11. Leave a space of at least 5 cm between the low voltage external wiring (No-voltage contact input and remote controller wiring) and wiring of 100V or greater.  
Do not place them in the same conduit tube or cable as this will damage the circuit board.
- Note12. When cable is used for the control cable wiring, use a separate cable for the following wiring.  
Using the same cable may cause malfunctions and damage to the unit.
- (a) Optional remote controller wiring
  - (b) No-voltage contact input wiring
  - (c) No-voltage contact output wiring
  - (d) Analog input wiring
- Note13. Use a contact that takes 12VDC 1mA for No-voltage contact input.  
When the power voltage is 380V-400V-415V, No-voltage contact output will be 220VAC-230VAC-240VAC. The current range must be between 10mA and 1A.



# SUB CIRCUIT

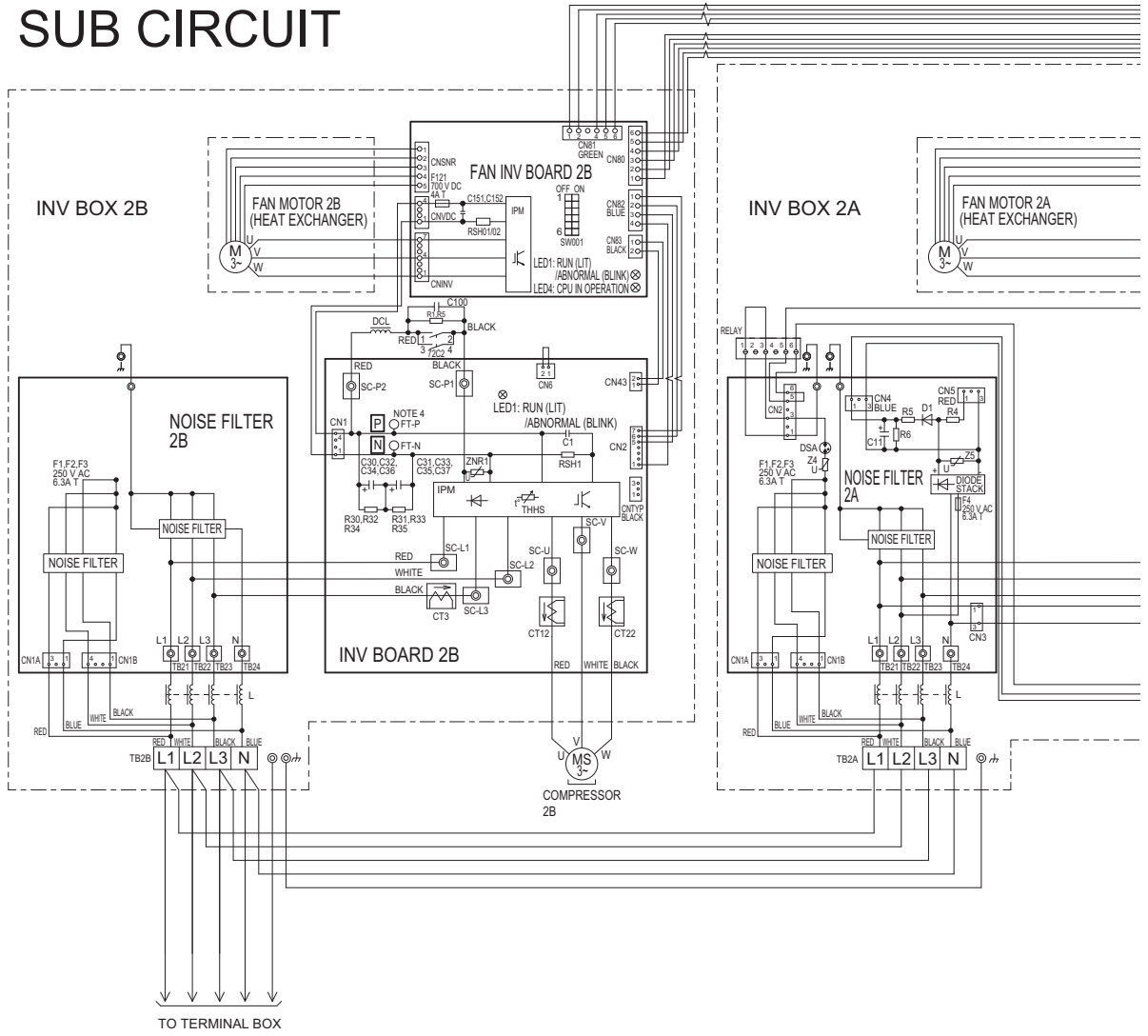

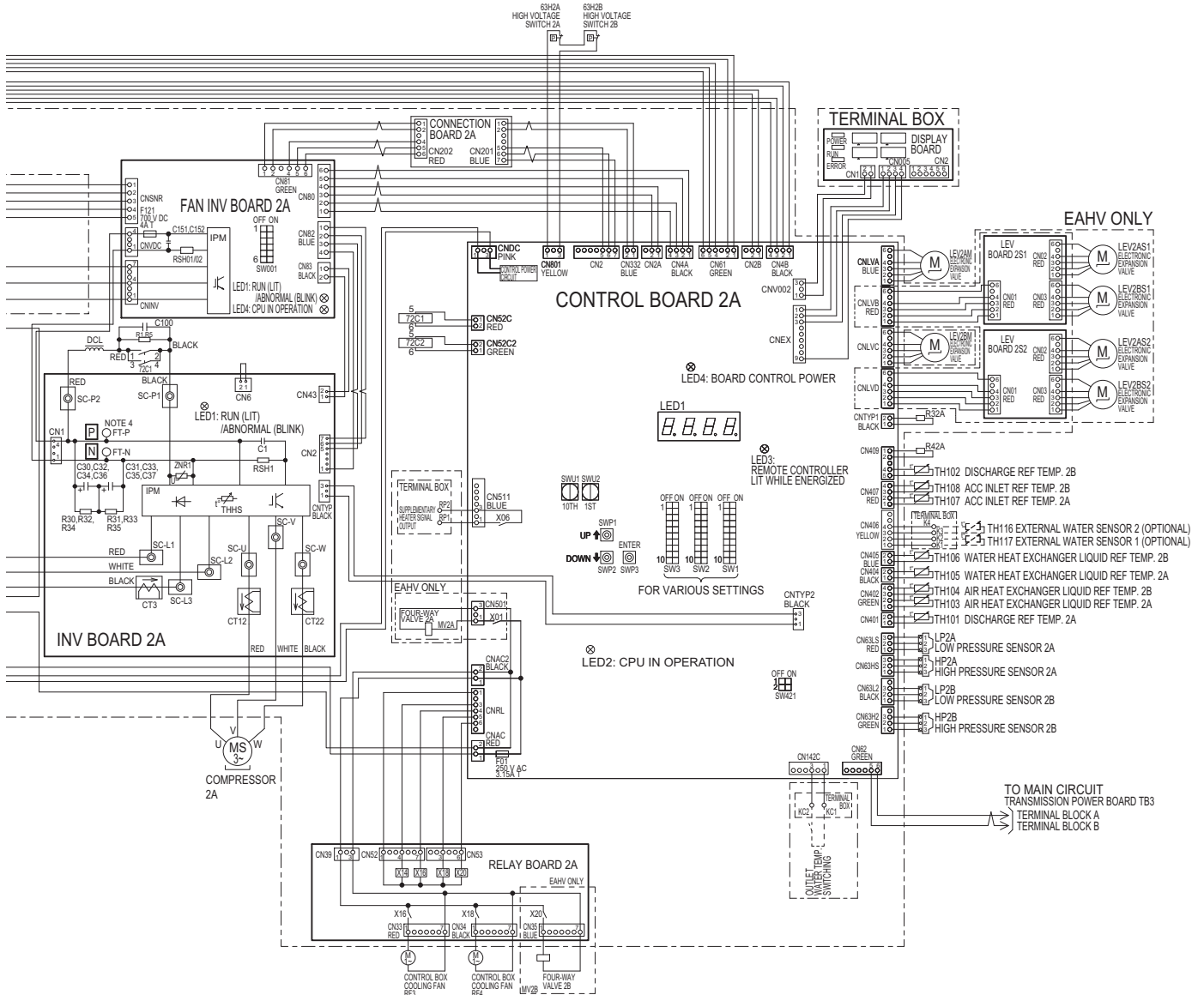

The specification of the product is for the improvement a previous notice and might change.

When using a local controller, refer to the table below for the types of input/output signals that are available and the operations that correspond to the signals.

### External Input/Output

Input type	Dry contact		ON (Close)	OFF (Open)	Terminal block
	(a) UNIT OPERATION	Run/Stop	The unit will go into operation when the water temperature drops below the preset temperature.	The unit will stop except when the unit is in the Anti-Freeze mode.	K95-K96
(b) MODE CHANGE * EAHV-P****YB EAHV-P****YB-H	Heating ECO/Heating	Heating ECO mode (EAHV-P****YB: When "COOLING/HEATING SWITCHING" contact (item (i) below) is ON, this mode is enabled.)	Heating mode (EAHV-P****YB: When "COOLING/HEATING SWITCHING" contact (item (i) below) is ON, this mode is enabled.)	K40-K42	
(c) FAN MODE	Forced/ Normal	When the outdoor temperature is 5°C or less, the fan will remain in operation after the compressor has stopped.	The fan will stop when the compressor stops.	K91-K92	
(d) ANTI FREEZE * EAHV-P****YB EAHV-P****YB-H	On/Off	The unit will operate in the Anti-Freeze mode (with the target temperature 30°C) when the contact status of (a) "UNIT OPERATION" is "Stop" or the ON/OFF button on the remote controller is turned off. (EAHV-P****YB: When "COOLING/HEATING SWITCHING" contact (item (i) below) is ON, this mode is enabled.)	The unit will operate according to the status of the "UNIT OPERATION" contact (item (a) above) or the ON/OFF command from the remote controller.	K40-K41	
(e) FLOW SWITCH	Normal/Error	The unit is allowed to operate.	The unit will not operate.	K23-K24	
(f) PUMP INTERLOCK	Normal/Error	The unit is allowed to operate.	The unit will not operate.	K01-K02	
(g) PEAK-DEMAND CONTROL	On/Off	The unit will operate at or below the maximum capacity level that was set for the Peak-demand control setting.	The unit will operate at or below the maximum capacity.	K23-K25	
(h) OUTLET WATER TEMP SWITCHING	2nd/1st	Setting temp 2 (Refer to page 52 Settings table)	Setting temp 1 (Refer to page 52 Settings table)	KC1-KC2	
(i) COOLING/HEATING SWITCHING * EAHV-P****YB	Heating/ Cooling	Heating mode	Cooling mode	K93-K94	
<b>Analog</b>					<b>Terminal block</b>
<b>Input type</b>		<b>Action</b>			
(j) WATER TEMP SETTING/ CAPACITY CONTROL SIGNAL		Water temperature or capacity control signal can be set by using the external analog input to the CN421 on the MAIN circuit board. One analog input type can be selected from the following types: 4-20 mA, 1-5 V, 0-10 V, or 2-10 V. * Use a 4-20 mA signal output device with insulation.			SG1(+)-KG1(-)
(k) EXTERNAL WATER SENSOR 1 (option)		For simultaneous operating group			K1-K2
(l) EXTERNAL WATER SENSOR 2 (option)		For identical water system group			K3-K4
Output type	Contact type		Conditions in which the contact closes (turns on)	Conditions in which the contact opens (turns off)	Terminal block
	(m) ERROR INDICATOR	Close/Open	The unit has made an abnormal stop.	During normal operation	K33-K34
(n) OPERATION INDICATOR	Close/Open	The "UNIT OPERATION" contact (item (a) above) or the ON/OFF button on the remote controller is ON.	The "UNIT OPERATION" contact (item (a) above) or the ON/OFF button on the remote controller is OFF.	K31-K32	
(o) PUMP OPERATION COMMAND	Close/Open	The pump will operate according to the status of the "UNIT OPERATION" contact or the ON/OFF button on the remote controller button.	Under all conditions other than the ones listed on the left	K75-K76	
(p) SUPPLEMENTARY HEATER SIGNAL	Close/Open	Water and outdoor temperature has dropped below a setting water temperature and a set outdoor temperature.	Water temperature is at or above a set water temperature +2°C or the outdoor temperature is at or above a set outdoor temperature +2°C.	RP1-RP2	
(q) DEFROST SIGNAL	Close/Open	The unit is in defrost mode.	The unit is not in defrost mode.	KD1-KD2	
(r) DRAIN PAN HEATER SIGNAL	Close/Open	Outdoor temperature has dropped below a set outdoor temperature.	Outdoor temperature is at or above a set outdoor temperature +2°C.	KB1-KB2	
(s) HEATING OPERATION DISPLAY	Close/Open	The unit is in heating mode.	The unit is in cooling mode.	K38-K39	
RC/M-NET	REMOTE CONTROLLER	PAR-W31MAA			RA-RB
	Centralized controller	AE-200			A-B
	M-NET				M1-M2



## Input and output correspondence table

		Terminal block	ON	OFF	System leader unit	Group leader unit	SUB unit
No-voltage contact input	Run	K95-K96	Run	Stop	○	—	—
	Fan mode	K91-K92	Forced	Normal	○	—	—
	Cooling/Heating switching	K93-K94	Heating	Cooling	○	—	—
	Pump interlock	K01-K02	Normal	Error	○	○	○*
	Anti freeze	K40-K41	ON	OFF	○	—	—
	Flow switch	K23-K24	Normal	Error	○	○	○*
	Outlet water temp. switching	KC1-KC2	2nd	1st	○	—	—
	Demand	K23-K25	ON	OFF	○	—	—
	Mode change	K40-K42	Heating ECO	Heating	○	—	—
Analog input	Water temp. setting / Capacity control signal	SG1(+)-KG1(-)	4-20mA,0-10,2-10V,1-5V		○	—	—
	External water sensor 1 (Option)	K1-K2	For simultaneous operating group		○	○	—
	External water sensor 2 (Option)	K3-K4	For identical water system group		○	—	—
No-voltage contact output	Supplementary heater signal output	RP1-RP2	During the low outdoor and water temperature is ON.		○	○	○
	Defrost signal output	KD1-KD2	During the defrosting operation is ON.		○	○	○
	Heating operation display	K38-K39	Heating	Cooling	○	○	○
	Operation display output	K31-K32	During the operation command reception is ON.		○	○	○
	Error display output	K33-K34	While abnormally stop is ON.		○	○	○
	Pump operation command output	K75-K76	ON is when the pump is required.		○	○	○*
	Drain pan heater signal output	KB1-KB2	During the low outdoor temperature is ON.		○	○	○
RC	Remote controller	RA-RB	PAR-W31MAA		○	—	—
	Centralized controller	A-B	AE-200		○	—	—

○: Input and output signal is enabled.

—: Invalid

\* Invalid when the one pump system

# External signal interface

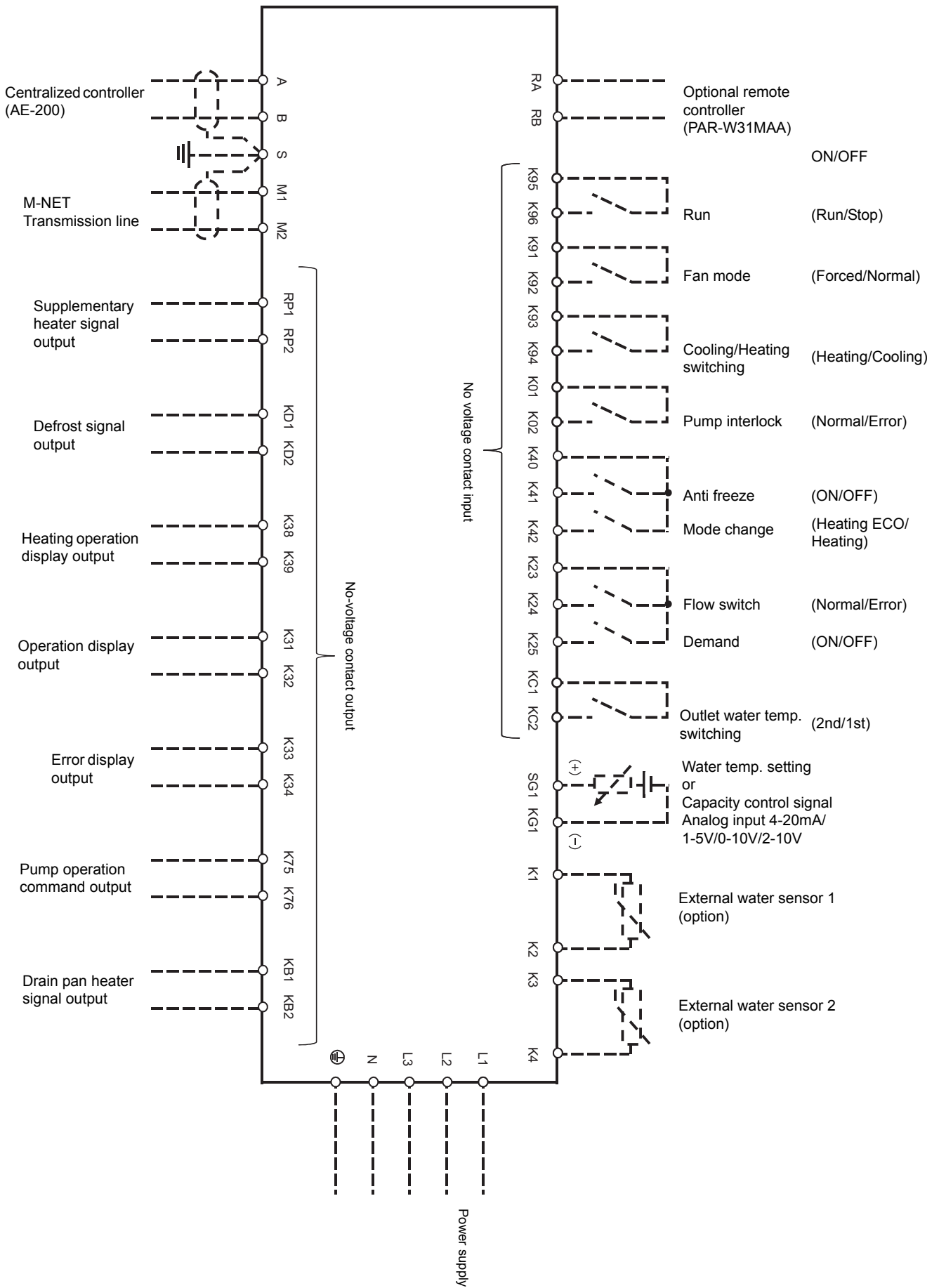

# 5. System Configurations

The system must be configured only by personnel certified by Mitsubishi Electric.

## [1] Schematic Diagrams of Individual and Multiple Units Connection Systems

### (1) Individual system

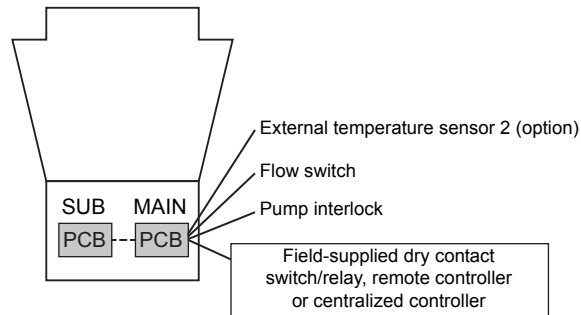

Refer to the sections "Switch Types and the Factory Settings" on the next page and "Configuring the Settings" (page 39) for further details.

### (2) Multiple units connection system (Max 24 units)

System leader unit	The unit controls the identical water system group.
Group leader unit	The unit transmits the command from the system leader unit to the sub unit.
Sub unit	The unit is other than leader unit.

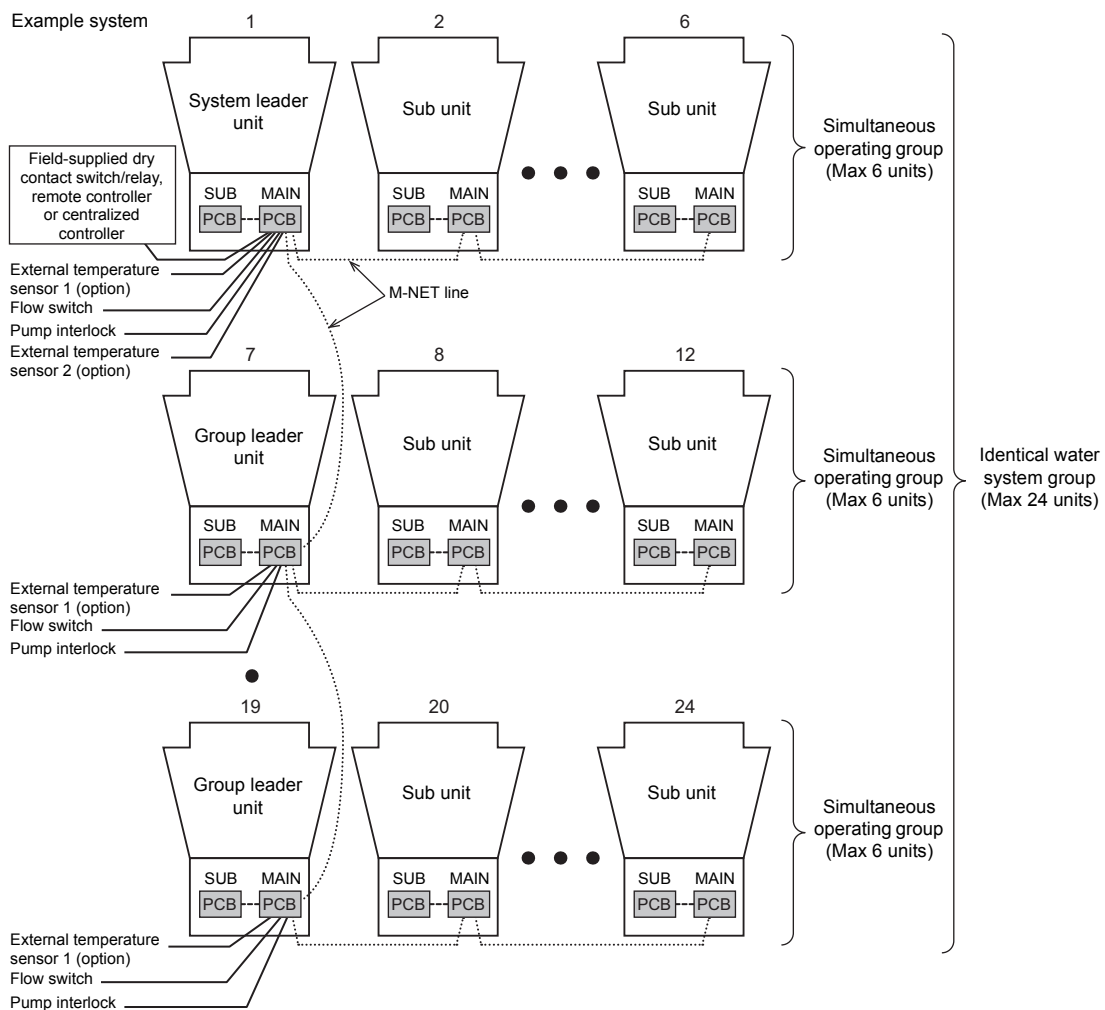

Refer to the sections "Switch Types and the Factory Settings" on the next page and "Configuring the Settings" (page 39) for further details.

## [2] Switch Types and the Factory Settings

### (1) Switch names and functions

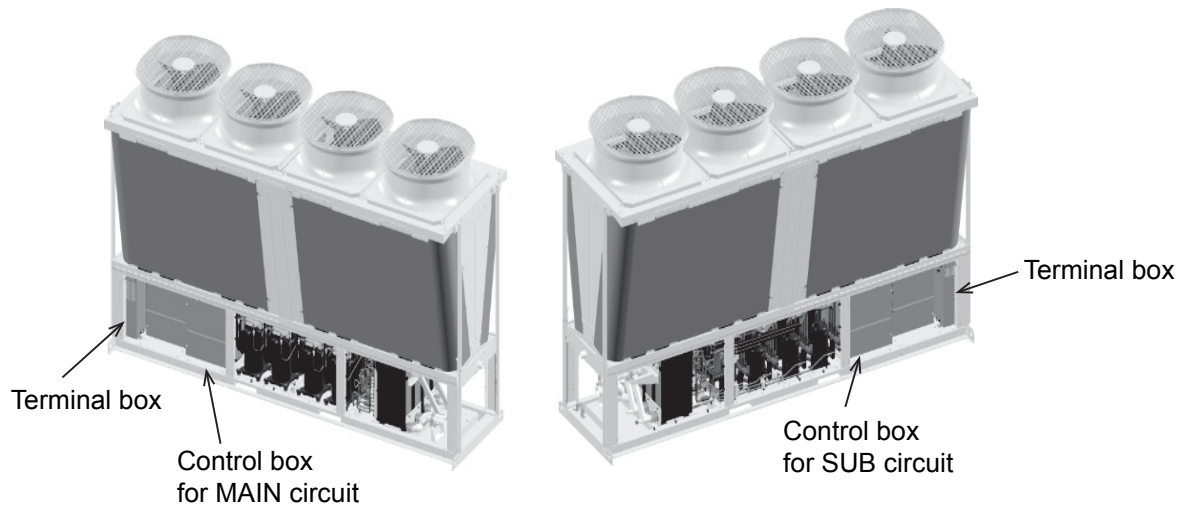

There are three main ways to set the settings as follows:

- ① Dip switches (SW1 - SW3, SW421)
- ② Dip switches used in combination with the push switches
- ③ Rotary switches

See below for how these switches are used to set certain items.

# Different types of switches on the PCB

[Control board]

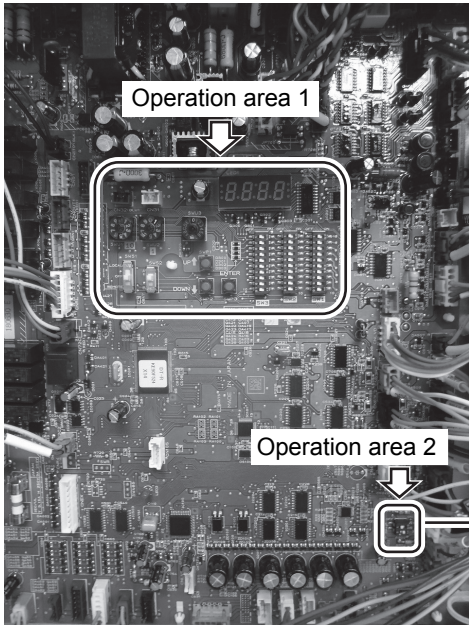

[Enlarged the operation area 1]

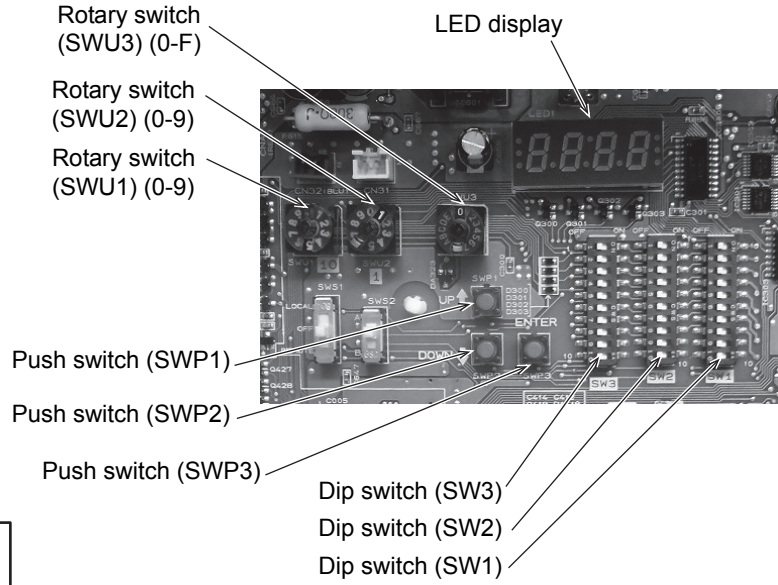

[Enlarged the operation area 2]

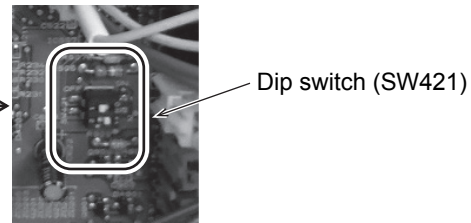

			Initial Setting	
			MAIN circuit	SUB circuit
Rotary switch	SWU1	Sets the 10's digit of the unit address.	"0"	"5"
	SWU2	Sets the 1's digit of the unit address.	"1"	"1"
	SWU3	Use for switching the setting.	"0"	"0"
Push switch	SWP1	Use for increasing the setting value.	-	-
	SWP2	Use for decreasing the setting value.	-	-
	SWP3	Use for changing and deciding the setting value.	-	-
Dip switch	SW1-3	Select a setting witch is decided with a combination of switch numbers.	-	-
	SW421	Analog input type setting (Refer to Page 54)	-	(Unused)

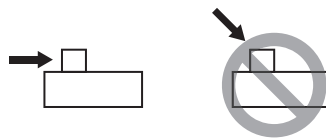
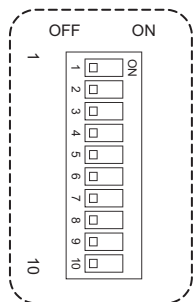

Slide the dip switches:  
do not push down the switches.

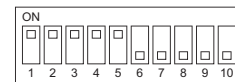

Example: on the upper figure.  
1 to 5 are "ON" and 6 to 10 are "OFF".

## (2) Factory Switch Settings (Dip switch settings table)

SW	Function	Usage	Factory setting		OFF setting	ON setting	System leader unit	Group leader unit	SUB unit	Setting timing	
			MAIN circuit	SUB circuit							
SW1	1	Settings change or view the settings	These switches are used for setting change with push switch SWP 1, 2 and 3.	OFF	OFF	The 7-segment LED display is changed.	Depends on the setting	Depends on the setting	Depends on the setting	Depends on the setting	
	2										
	3										
	4										
	5										
	6										
	7										
	8										
	9										
	10										
SW2	1	Model setting	-	-	Leave the setting as it is.		-	-	-	At a reset	
	2	System setting	Set the duties to each unit.	OFF	-	System leader unit: ON ON Group leader unit : ON OFF Sub unit : OFF OFF	Required	Required	Required	At a reset	
	3										
	4	Water-temperature control 1 (option)	Selects either the external water temperature sensor or the built-in sensor to be used to control water temperature. (Simultaneous operating group)	OFF	-	Built-in sensor on the unit	External water temperature sensor 1	Required	Required	Required	At a reset
	5	Water-temperature control 2 (option)	Selects target temperature correction control. (Identical water system group)	OFF	-	OFF	ON (External water sensor 2 is required.)	Required	Fixed OFF	Fixed OFF	At a reset
	6	Multiple unit control	Selects optimum control of number of operating units.	OFF	-	Ineffective	Effective	Required	Fixed OFF	Fixed OFF	At a reset
	7	Analog input setting	Allows or disallows the analog signals from a remote location.	OFF	-	Disallows the external analog signals.	Allows the external analog signals.	Required	Fixed OFF	Fixed OFF	At a reset
	8	Analog input signal switching	Selects either the water temperature or the capacity control ratio. (Effective only when SW2-7 is set to ON.)	OFF	-	Water temperature	Capacity control ratio	Required	Fixed OFF	Fixed OFF	At a reset
	9	BMS setting *		OFF	-	No input from BMS	Input from BMS	Required	Fixed OFF	Fixed OFF	At a reset
	10	Model setting		OFF	OFF	Leave the setting as it is.		Fixed OFF	Fixed OFF	Fixed OFF	Any time
SW3	1	Analog input type setting	Selects analog input 4-20mA/0-10V/1-5V/2-10V. (Effective only when SW2-7 is set to ON and SW3-4 is set to OFF.)	OFF	-	1 / 2 4-20mA : OFF OFF 1-5V : ON OFF 0-10V : OFF ON 2-10V : ON ON	Required	Fixed OFF	Fixed OFF	Any time	
	2										
	3	Model setting		OFF	OFF	Leave the setting as it is.	Fixed OFF	Fixed OFF	Fixed OFF	Any time	
	4										
	5										
	6										
	7										
	8										
	9	Auto restart after power failure	Enables or disables the automatic restoration of operation after power failure (in the same mode as the unit was in before a power failure).	ON	ON	An alarm will be issued when power is restored after a power outage. The alarm will be reset when the power is turned off and then turned back on.	Automatically restores operation after power failure.	Required	Required	Required	Any time
	10	Model setting		OFF	OFF	Leave the setting as it is.		Fixed OFF	Fixed OFF	Fixed OFF	Any time

"-" in the table indicates that the function in the corresponding row will be disabled regardless of the actual switch setting. The factory setting for these items is OFF.

\* Connection to a BMS requires an installation of Procon A1M (Modbus interface), which is available from MITSUBISHI ELECTRIC UK. Use a BMS with insulation.

SW2-7	SW2-8	SW2-9	Input from BMS
ON	OFF	ON	Target temperature
ON	ON	ON	Capacity
OFF	OFF	ON	Outdoor temperature

## [3] Configuring the Settings

The settings must be set only by a qualified personnel.

### <1> System configuration

#### (1) Set the dip switches.

##### Switch settings on the MAIN circuit

Set the dip switches (labeled A in the figure at right) that correspond to the items below, according to the local system.

- Water temperature control based on the external water temperature reading
- Analog signals from a remote location

Refer to "Dip switch settings table" (page 38) for further details.

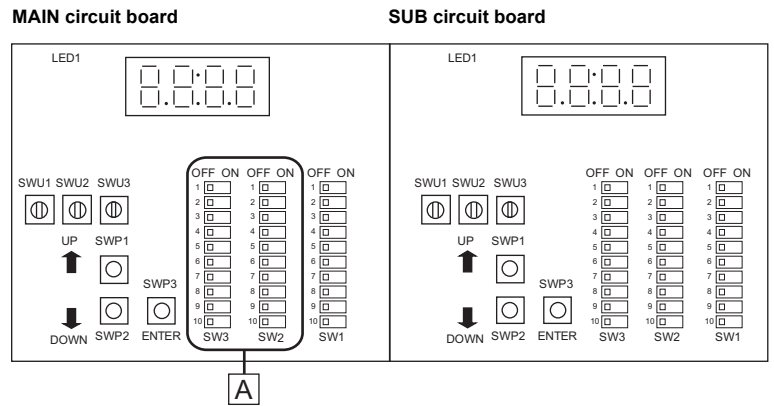

#### (2) Set the rotary switches. (Address setting)

##### Example of address setting

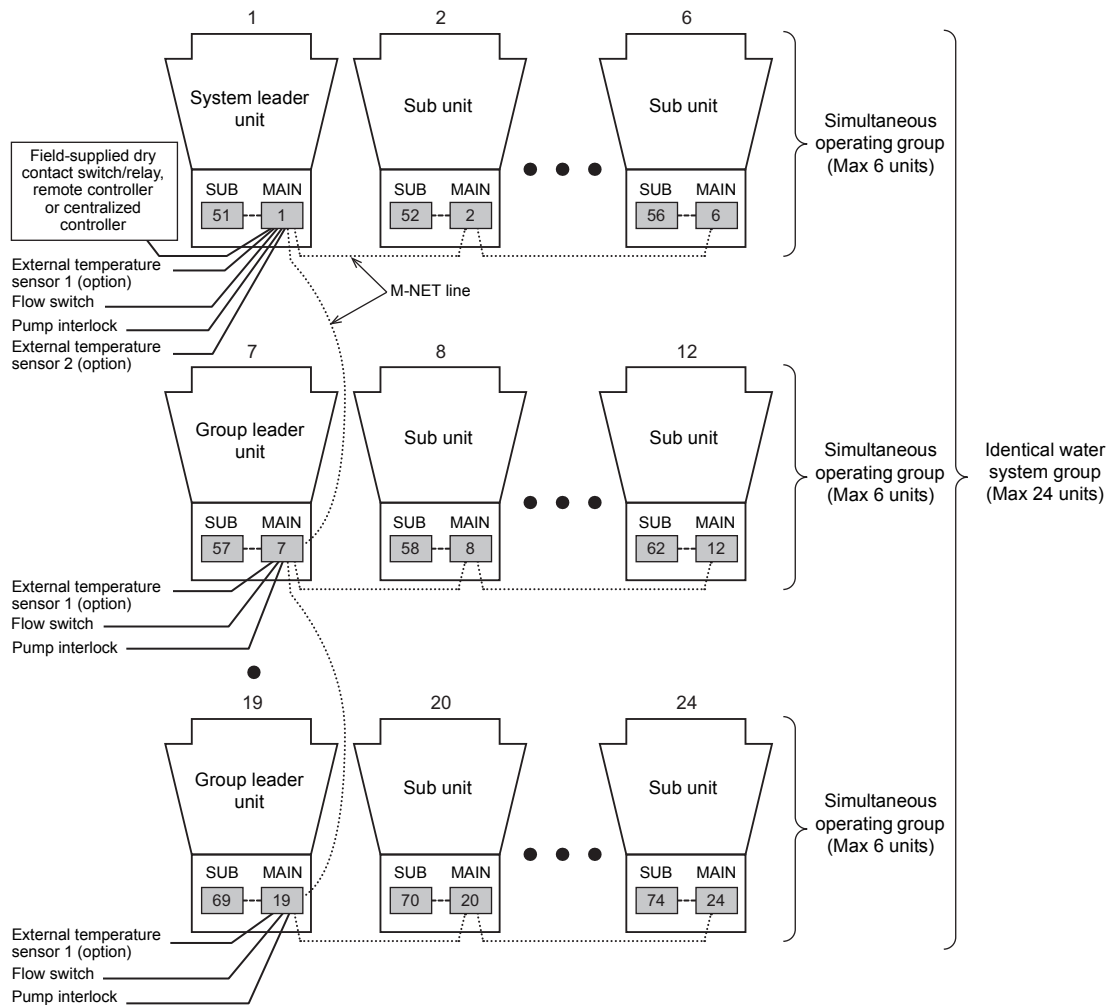

## Setting the switches on the system leader unit

Make sure the address of the MAIN circuit on the main module is set to "1" (labeled A in the figure at right) and that the address of the SUB circuit on the main module is set to "51" (labeled B in the figure at right).

The address of each SUB circuit should equal the sum of the MAIN circuit address on the same module and 50.

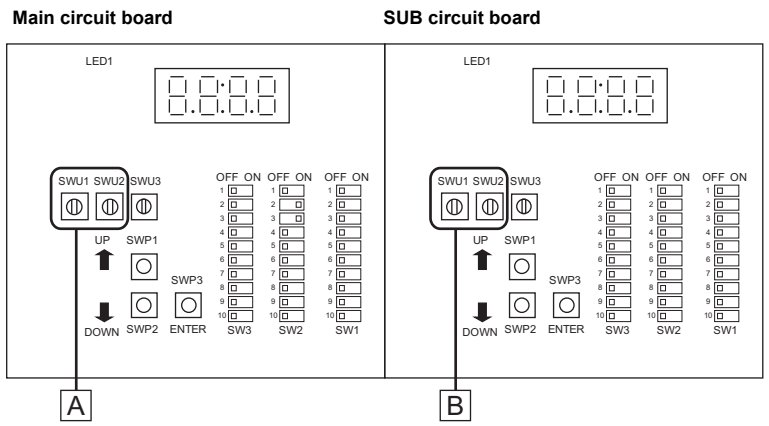

## Setting the switches on the group leader unit and the sub unit

### MAIN circuit

(1) Set the MAIN circuit addresses with the rotary switches. (labeled A in the figure). Set the 10's digit with SWU1, and set the 1's digit with SWU2. Assign sequential addresses to the MAIN circuit on all sub modules starting with 2.

### SUB circuit

(2) Set the SUB circuit addresses with the rotary switches (labeled B in the figure). Set the 10's digit with SWU1, and set the 1's digit with SWU2. Assign sequential addresses to the SUB circuit on all sub modules starting with 52.

## (3) Set the M-NET power supply.

When connecting a system leader unit and a group leader unit to a multiple units connection system, the connector connected to CN41 on the MAIN circuit board (Address 1) must be disconnected and then connected to CN40.

\*Leave the connector connected to CN41 when using an AE-200 as the centralized controller.

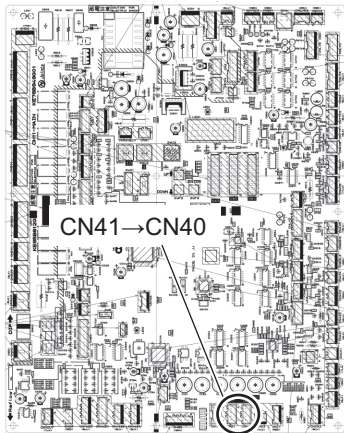

Address 1	All addresses other than Address 1
Move the connector from CN41 to CN40.	Leave the connector connected to CN41.
<p>Diagram showing a vertical connector strip labeled CN41 on the left and a larger connector strip labeled CN40 on the right. A U-shaped connector is shown being moved from CN41 to CN40.</p>	<p>Diagram showing a vertical connector strip labeled CN41 on the left and a larger connector strip labeled CN40 on the right. A U-shaped connector is shown connected to CN41.</p>



## Selector switch settings

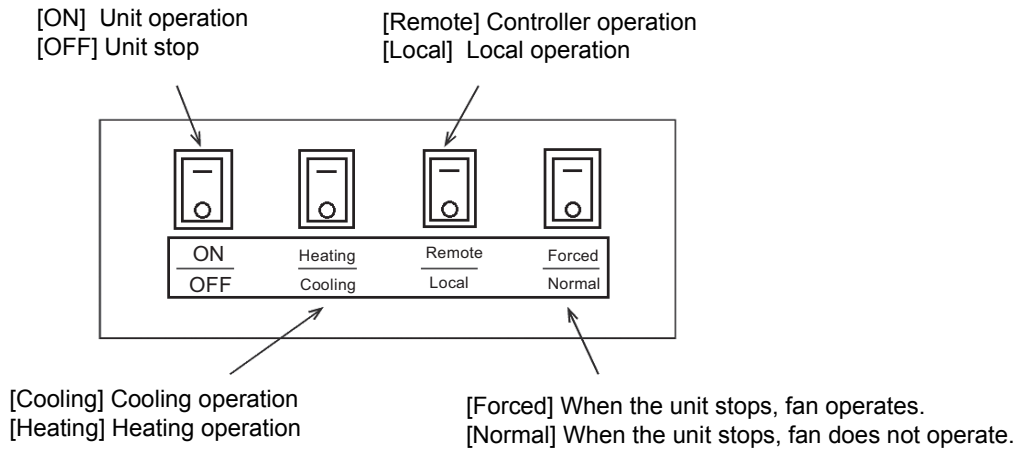

## ⚠ CAUTION

- Do not open the terminal cover, when selector switches are operated.

## Display

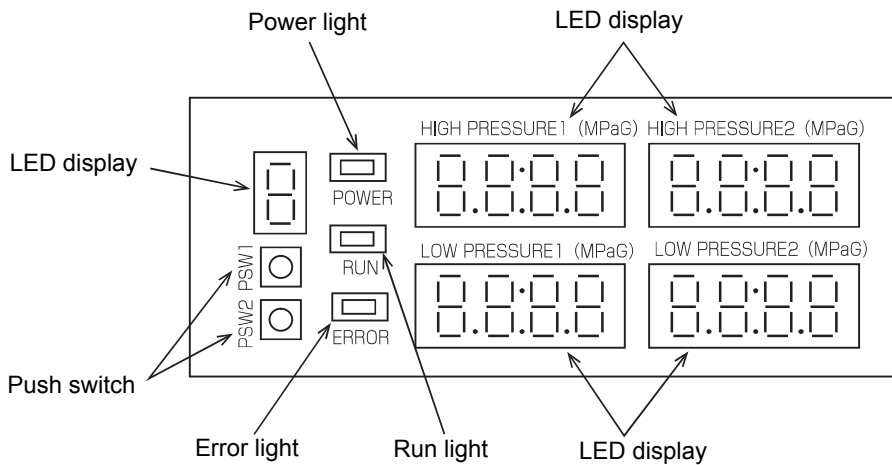

## The positions of the selector switch and the display

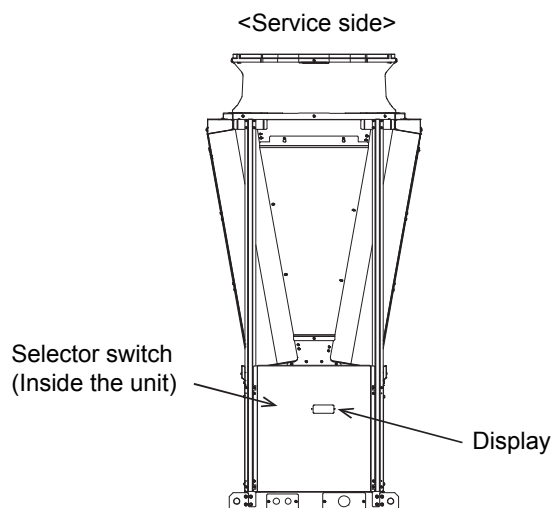

## Priority order of the water-temperature-setting-input-signal sources

Water temperature can be controlled by using the signals from the four types of input sources listed below. The setting for the item with higher priority will override the settings for the items with lower priorities. The water temperature will be controlled according to the temperature setting in the "Target water temperature" column that corresponds to a specific combination of the settings for the four items.

### No-voltage contact input K93-K94 ON: Heating (EAHV-P\*\*\*\*YB, EAHV-P\*\*\*\*YB-H)

Priority 1	Priority 2	Priority 3	Priority 4			Target water temperature	
No-voltage contact input K40-K41	Analog input or BMS (SW 2-9: ON)	No-voltage contact input K40-K42	Remote controller PAR-W31MAA Input from centralized controller AE-200 or BMS (*3)				
Anti-freeze			Mode change	No remote controller	Manual setting	Schedule setting	
ON	Ineffective	Ineffective	-	Ineffective	Ineffective	30°C	
OFF	SW2-7: ON	Ineffective	-	Ineffective	Ineffective	Temperature setting for the analog signal input	
	SW2-7: OFF	Ineffective	-	Ineffective	Ineffective	Heating or Heating ECO	
		ON (Heating ECO)	-	Ineffective	Ineffective	Heating ECO	
		OFF (Heating)	When no RC is used	-	-	-	Heating
			-	-	Anti-freeze	-	30°C
			-	-	Heating ECO	-	Heating ECO
			-	-	Heating	-	Heating
			-	-	Cooling (*1)	-	Cooling
-	-	-	-	When schedule has been set (*2)	Target water temp is controlled according to the setting on the remote controller.		

\*1 This mode is disabled in EAHV-P\*\*\*\*YB-H.

\*2 EAHV-P\*\*\*\*YB can also set Cooling.

\*3 AE-200 and BMS cannot both be simultaneously connected. Only connect one or the other.

### No-voltage contact input K93-K94 OFF: Cooling (EAHV-P\*\*\*\*YB, EACV-P\*\*\*\*YB)

\* When the operation mode is Cooling, K40-K41 (Anti-freeze) and K40-K42 (Mode change) are disabled.

Priority 1	Priority 2			Target water temperature
Analog input	Remote controller PAR-W31MAA Input from centralized controller AE-200 or BMS (*3)			
	No remote controller	Manual setting	Schedule setting	
SW2-7: ON	-	Ineffective	Ineffective	Temperature setting for the analog signal input
SW2-7: OFF	-	Ineffective (Cooling)	Ineffective (Cooling)	Cooling
	When no RC is used	-	-	Cooling
	-	Anti freeze (*1)	-	30°C
	-	Heating ECO (*1)	-	Heating ECO
	-	Heating (*1)	-	Heating
	-	Cooling	-	Cooling
	-	-	-	When schedule has been set (*2)

\*1 This mode is disabled in EACV-P\*\*\*\*YB.

\*2 EAHV-P\*\*\*\*YB can also set Heating or Heating ECO.

\*3 AE-200 and BMS cannot both be simultaneously connected. Only connect one or the other.

## Priority order of the operation signal sources

		No-voltage contact	Remote controller PAR-W31MAA	Input from centralized controller AE-200 or BMS
Unit operation (Run/Stop)		The last setting has priority.		
Operation mode	Cooling *1	The last setting has priority.		
	Heating *1	The last setting has priority.		
	Heating ECO *1*2	The last setting has priority.		
	Anti-freeze *2	The last setting has priority.		
Fan mode (The contact ON has priority.)		OFF	The last setting has priority.	
		ON	Ineffective	

\*1 When the Anti-freeze contact is ON during heating operation, the setting change is ineffective.

\*2 Changing by contact is effective during heating operation.

## <2> Making the settings

Use the LED display and the three push switches (SWP1 (↑), SWP2 (↓), and SWP3 (Enter)) to change the current settings on the circuit board and to monitor various monitored values.

### (1) Setting procedures

Take the following steps to set the push switches SWP1 through SWP3. These switches must be set after the dip switch SW1 has been set.

①

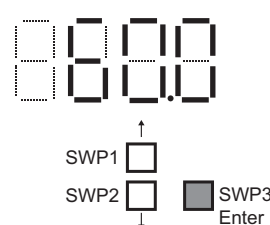

Normally a value of setting item appears on the display.

↓

Press SWP3 (Enter) to enable the configuration changes.

②

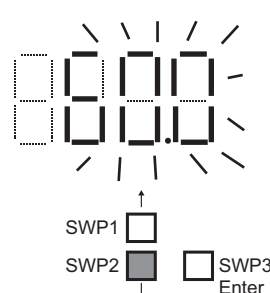

The current setting value will blink.

↓

The left figure shows that the current setting value is "60.0."  
To decrease this value to 58.0, for example, press SWP2 (↓).  
Press SWP1 (↑) to increase the value.

③

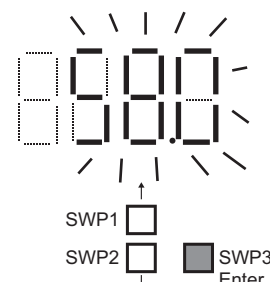

When the desired value is displayed (58.0 in the example at left), press SWP3 (Enter).

↓

The displayed value will stop blinking and stay lit.  
A lit LED indicates that the new setting has been saved.

\* Pressing SWP1 (↑) or SWP2 (↓) will change the blinking setting value, but the change will not be saved until SWP3 (Enter) is pressed.  
Press and hold SWP1 (↑) or SWP2 (↓) for one second or longer to fast forward through the numbers.

## (2) Table of settings items

Set rotary switch SWU3 and dip switch SW1 as shown in the table below to set the value for the items in the "Setting item" column.

No.	Rotary switch (SWU3)	Dip switch setting (SW1) *1	Setting Item	Default	Need or non-need to set the setting *4						Notes
					System		Group		Sub		
					M	S	M	S	M	S	
1	1		Setting temp 1 (Cooling mode) *2	7°C	○	—	—	—	—	—	Range 5–30°C
2	1		Setting temp 2 (Cooling mode) *2	7°C	○	—	—	—	—	—	Range 5–30°C
3	1		Setting temp 1 (Heating mode) *3	45°C	○	—	—	—	—	—	Range 30–55°C
4	1		Setting temp 2 (Heating mode) *3	45°C	○	—	—	—	—	—	Range 30–55°C
5	1		Setting water temp A at Heating ECO mode *3	55°C	○	—	—	—	—	—	Range 30–55°C
6	1		Setting outdoor temp A at Heating ECO mode *3	0°C	○	—	—	—	—	—	Range -30–50°C
7	1		Setting water temp B at Heating ECO mode *3	35°C	○	—	—	—	—	—	Range 30–55°C
8	1		Setting outdoor temp B at Heating ECO mode *3	25°C	○	—	—	—	—	—	Range -30–50°C
9	1		Setting water temp C at Heating ECO mode *3	45°C	○	—	—	—	—	—	Range 30–55°C
10	1		Setting outdoor temp C at Heating ECO mode *3	15°C	○	—	—	—	—	—	Range -30–50°C
11	1		Select a heating curve *3	1	○	—	—	—	—	—	0: 2-point system, 1: curve
12	1		Peak-demand control signal input source	0	○	—	—	—	—	—	0: Dry contact 1: PAR-W31MAA 2: AE-200
13	1		Maximum peak-demand capacity	100%	○	—	—	—	—	—	Range 60-100%
14	1		Preset temp. A (Cooling)	5°C	○	—	—	—	—	—	Range 5–30°C
15	1		Preset temp. B (Cooling)	30°C	○	—	—	—	—	—	Range 5–30°C
16	1		Preset temp. A (Heating)	30°C	○	—	—	—	—	—	Range 30–55°C
17	1		Preset temp. B (Heating)	55°C	○	—	—	—	—	—	Range 30–55°C
18	1		Supplementary heater operation water temp *3	40°C	○	—	○	—	○	—	Range 0–55°C

No.	Rotary switch (SWU3)	Dip switch setting (SW1) *1	Setting Item	Default	Need or non-need to set the setting *4						Notes
					System		Group		Sub		
					M	S	M	S	M	S	
19	1		Supplementary heater operation outdoor temp *3	-10°C	○	—	○	—	○	—	Range -30~50°C
20	1		Drain pan heater operation outdoor temp	0°C	○	—	○	—	○	—	Range -40~20°C
21	1		Thermo differential 1 (Cooling mode) *2	3°C	○	—	○	—	○	—	Range 0.2~5°C
22	1		Thermo differential 2 (Cooling mode) *2	2°C	○	—	○	—	○	—	Range 0.2~5°C
23	1		Thermo differential 1 (Heating mode) *3	3°C	○	—	○	—	○	—	Range 0.2~5°C
24	1		Thermo differential 2 (Heating mode) *3	2°C	○	—	○	—	○	—	Range 0.2~5°C
25	1		Year setting	-	○	—	—	—	—	—	
26	1		Month/Date setting	-	○	—	—	—	—	—	
27	1		Current time	-	○	—	—	—	—	—	

\*1: Do not apply undue force when changing the Dip switch settings as this may cause malfunctions.

\*2: They are enabled during the cooling. (EAHV-P\*\*\*\*YB, EACV-P\*\*\*\*YB)

\*3: They are enabled during the heating. (EAHV-P\*\*\*\*YB, EAHV-P\*\*\*\*YB-H)

\*4: System: System leader unit

Group: Group leader unit

Sub: Sub unit

M: MAIN circuit

S: SUB circuit

## <3> Setting procedures

### (1) System setting

#### 1. Making the settings for the initial start-up process

(A) Single unit

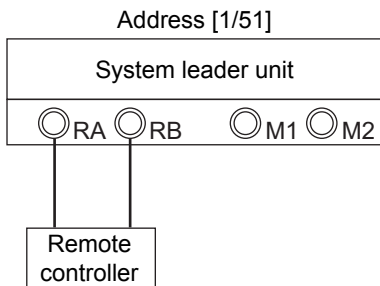

Setting address 1

- 1) Turn off the power.
- 2) System leader unit (Address 1 SW2-2, 2-3: ON)
- 3) Turn the power back on.
  - Address 1 → LED display [EEEE]
  - Address 51 → LED display [9999]
- 4) SWU3: Press and hold F and ENTER for 5 seconds. (Initializes the system)
  - Address 1 → LED display [9999]
  - Address 51 → LED display [9999]
- 5) Start-up process complete
  - Address 1 → LED display [\_\_|\_|]
  - Address 51 → LED display [\_\_|\_|]
- 6) SWU3: 0

\*No settings are required for address 51.

(B) One system leader unit and two sub units (1 group, 3 units in the group)

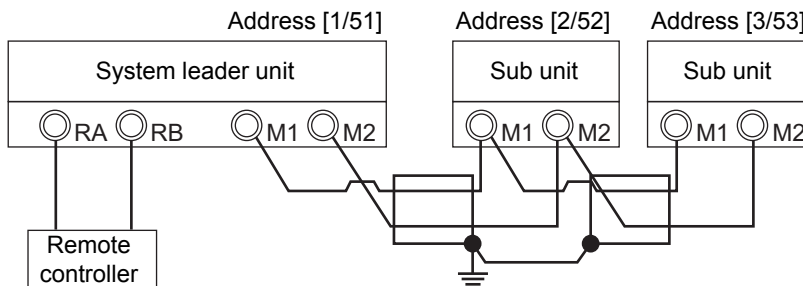

Setting address 1

- 1) Turn off the power.
- 2) System leader unit (Address 1 SW2-2, 2-3: ON)
- 3) Turn the power back on.
  - Address 1 → LED display [EEEE]
  - Address 51 → LED display [9999]
- 4) Setting the number of units for the group
  - SWU3: 1
  - SW1: 1, 2, 3, 4, 8, 10 ON
  - Press ENTER once.
  - ↓
  - Address 1 → LED display [1]
  - ↓
  - Press UP twice.
  - ↓
  - Address 1 → LED display [3]
  - ↓
  - Press ENTER once.
  - SW1 OFF
- 5) SWU3: Press and hold F and ENTER for 5 seconds. (Initializes the system)
  - Address 1 → LED display [9999]
  - Address 51 → LED display [9999]
- 6) Start-up process complete
  - Address 1 → LED display [\_\_|\_|]
  - Address 51 → LED display [\_\_|\_|]
- 7) SWU3: 0

\*No settings are required for any address other than for address 1.

\*The default setting for the number of units in a group is 1.  
The maximum number of units per group is 6.

(C) System leader unit and group leader unit (3 groups, 1 unit in each group)

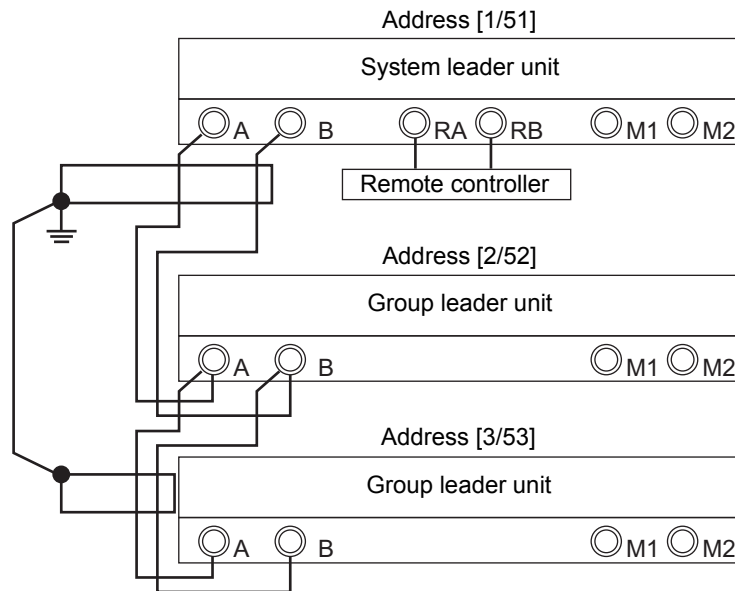

① Setting address 1

- 1) Turn off the power.
- 2) System leader unit (Address 1 SW2-2, 2-3: ON)
- 3) Turn the power back on.  
 Address 1 → LED display [EEEE]  
 Address 51 → LED display [9999]
- 4) Setting the number of units for each group  
 \*The default setting for the number of units in a group is 1.
- 5) Setting the number of groups  
 SWU3: 1  
 Press ENTER once.  
 SW1: 5, 8, 10 ON  
 ↓  
 Address 1 → LED display [1]  
 ↓  
 Press UP twice.  
 ↓  
 Address 1 → LED display [3]  
 ↓  
 Press ENTER once.  
 SW1 OFF  
 \*The default setting for the number of units in a group is 1.  
 The maximum number of groups is 24.

② Setting address 2

- 6) Turn off the power.
- 7) Group leader unit (SW2-2: ON)
- 8) Turn the power back on.  
 Address 2 → LED display [EEEE]  
 Address 52 → LED display [9999]
- 9) Setting the number of units for each group  
 \*The default setting for the number of units in a group is 1.
- 10) SWU3: Press and hold F and ENTER for 5 seconds.  
 (Initializes the system)  
 Address 2 → LED display [9999]  
 Address 52 → LED display [9999]  
 Start-up process complete  
 Address 2 → LED display [9999]  
 Address 52 → LED display [\_\_|\_|]  
 \*Address 3 (Group leader unit) is set in the same way as above.)

③ Setting address 1 (second time)

- 11) SWU3: Press and hold F and ENTER for 5 seconds.  
 (Initializes the system. System leader unit initialized last)  
 Address 1 → LED display [9999]  
 Address 51 → LED display [9999]  
 Start-up process complete  
 Address 1 → LED display [\_\_|\_|]  
 Address 51 → LED display [\_\_|\_|]
- 12) SWU3: 0



(D) System leader unit, Group leader unit and Sub unit (2 groups, 3 units in each group)

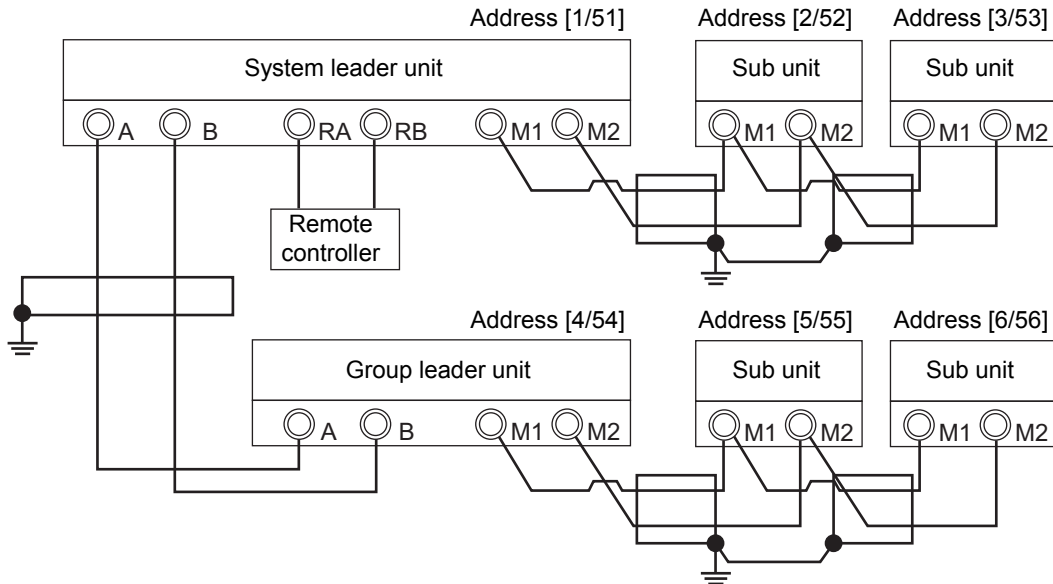

① Setting address 1

- 1) Turn off the power.
- 2) System leader unit (Address 1 SW2-2, 2-3: ON)
- 3) Turn the power back on.  
Address 1 → LED display [EEEE]  
Address 51 → LED display [9999]

4) Setting the number of units for each group

- SWU3: 1  
Press ENTER once.  
SW1: 1, 2, 3, 4, 8, 10 ON  
↓  
Address 1 → LED display [1]  
↓  
Press UP twice.  
↓  
Address 1 → LED display [3]  
↓  
Press ENTER once.  
SW1 OFF

\*The default setting for the number of units in a group is 1.  
The maximum number of units per group is 6.

5) Setting the number of groups

- SWU3: 1  
Press ENTER once.  
SW1: 5, 8, 10 ON  
↓  
Address 1 → LED display [1]  
↓  
Press UP twice.  
↓  
Address 1 → LED display [2]  
↓  
Press ENTER once.  
SW1 OFF

\*The default setting for the number of units in a group is 1.  
The maximum number of units per group is 24.

② Setting address 4

- 6) Turn off the power.
- 7) Group leader unit (SW2-2: ON)
- 8) Turn the power back on.  
Address 4 → LED display [EEEE]  
Address 54 → LED display [9999]

9) Setting the number of units for each group

- SWU3: 1  
Press ENTER once.  
SW1: 1, 2, 3, 4, 8, 10 ON  
↓  
Address 4 → LED display [1]  
↓  
Press UP twice.  
↓  
Address 4 → LED display [3]  
↓  
Press ENTER once.  
SW1 OFF

\*No group number settings are required for address 4 (Group leader unit).

10) SWU3: Press and hold F and ENTER for 5 seconds.

- (Initializes the system)  
Address 4 → LED display [9999]  
Address 54 → LED display [9999]  
Start-up process complete  
Address 4 → LED display [9999]  
Address 54 → LED display [\_\_\_\_|\_|]

③ Setting address 1 (second time)

- 11) SWU3: Press and hold F and ENTER for 5 seconds.  
(Initializes the system. System leader unit initialized last)  
Address 1 → LED display [9999]  
Address 51 → LED display [9999]

Start-up process complete  
Address 1 → LED display [\_\_\_\_|\_|]  
Address 51 → LED display [\_\_\_\_|\_|]

12) SWU3: 0

\*No settings are required for any address other than for addresses 1 and 4.

## 2. Multiple unit control

By setting SW2-6 to ON for address 1, optimum control of number of operating units will be performed.  
All units will simultaneously operate when SW2-6 is set to OFF.

(A) System leader unit, group leader unit, and sub unit

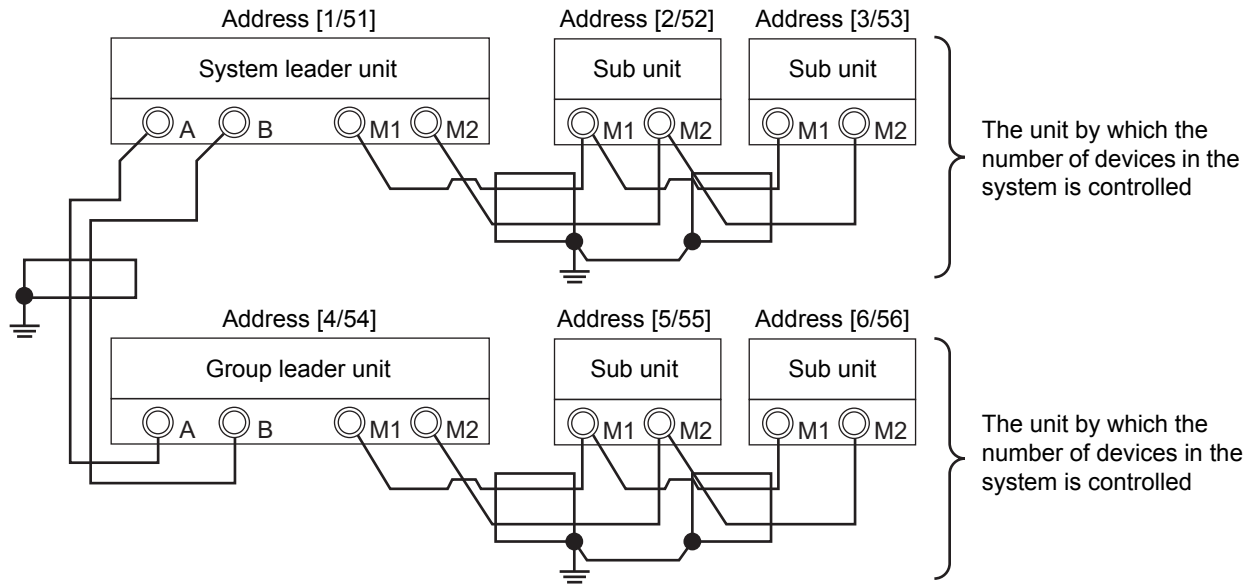

(B) System leader unit and group leader unit

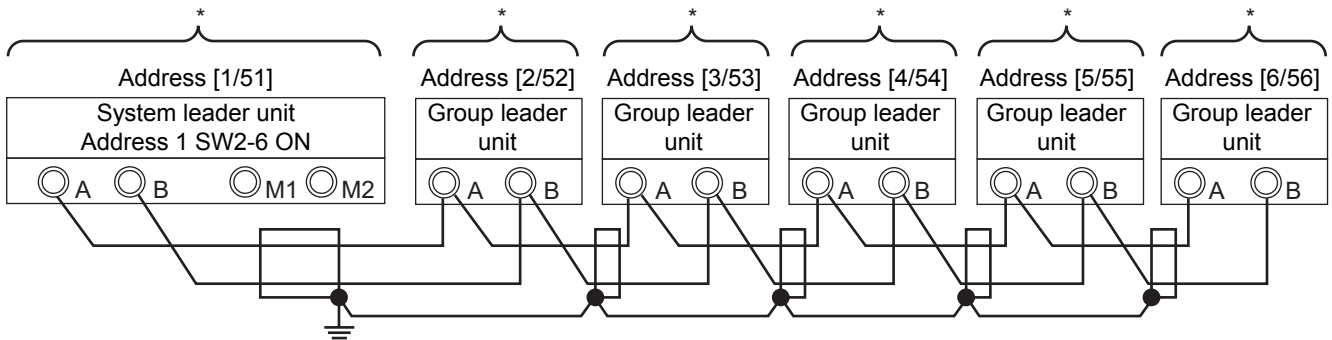

\*The unit by which the number of devices in the system is controlled

### 3. Example of system configuration

Optimum control of number of operating units

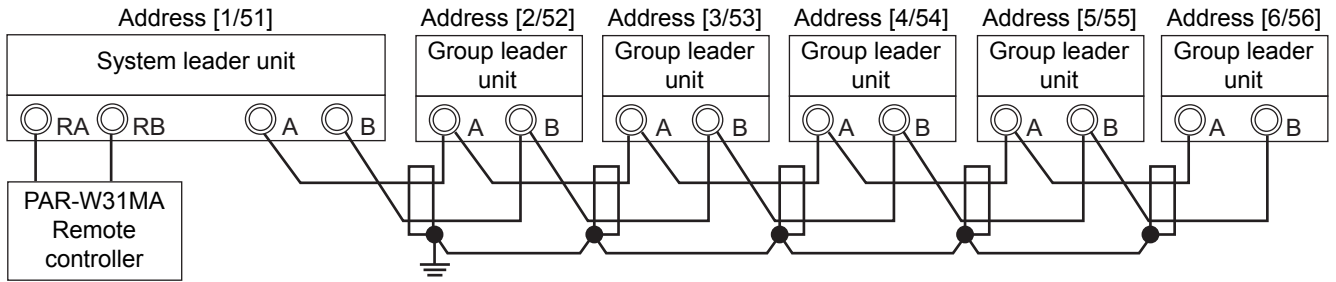

Setting item	SWU3	DIP SW	SW1	Setting timing	System leader unit		Simultaneous operation Group leader unit		Simultaneous operation Group leader unit		Simultaneous operation Group leader unit		Simultaneous operation Group leader unit			
					1		2		3		4		5		6	
					MAIN	SUB	MAIN	SUB	MAIN	SUB	MAIN	SUB	MAIN	SUB	MAIN	SUB
M-NET address	-	-	-	At a reset	1	51	2	52	3	53	4	54	5	55	6	56
M-NET power supply	-	-	-	-	CN40	CN41	CN41	CN41	CN41	CN41	CN41	CN41	CN41	CN41	CN41	CN41
System settings	-	2-2	-	At a reset	ON	-	ON	-	ON	-	ON	-	ON	-	ON	-
	-	2-3	-	At a reset	ON	-	OFF	-	OFF	-	OFF	-	OFF	-	OFF	-
Number of groups	1	-	ON 1 2 3 4 5 6 7 8 9 10	At a reset	6	-	1	-	1	-	1	-	1	-	1	-
Number of units per group	1	-	ON 1 2 3 4 5 6 7 8 9 10	At a reset	1	-	1	-	1	-	1	-	1	-	1	-
Multiple unit control	-	2-6	ON 1 2 3 4 5 6 7 8 9 10	At a reset	ON	-	OFF	-	OFF	-	OFF	-	OFF	-	OFF	-
Remote controller address setting	1	-	ON 1 2 3 4 5 6 7 8 9 10	At a reset	1	-	2	-	2	-	2	-	2	-	2	-

\*The shaded cells indicate the settings that requires changes from the default settings.

\*Some settings require the following after the settings were changed: A power reset, or setting SWU3 to F, and pressing and holding ENTER for 5 seconds.

\*When using an AE-200 as the centralized controller, leave the M-NET power supply connector as it is.

### 4. Setting the pump system

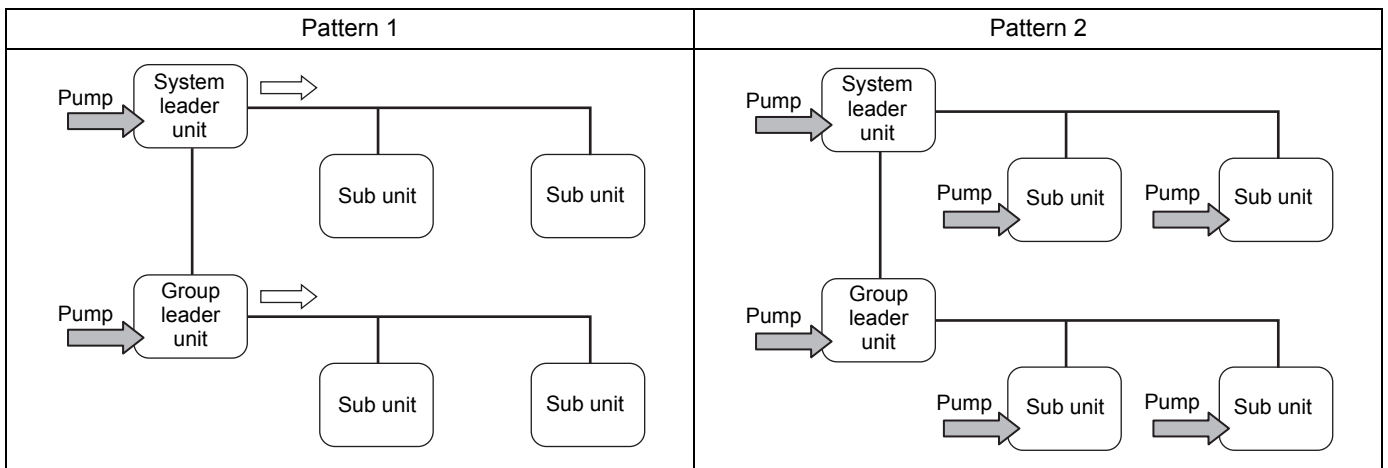

Setting item	SWU3	DIPSW	SW1	Factory setting		Note
				MAIN	SUB	
Pump setting	1	-	ON 1 2 3 4 5 6 7 8 9 10	0	-	0: Pattern 1, 1: Pattern 2

\*Pump settings must be made on the MAIN circuit on all units.

## (2) Water-temperature setting

Different water temperature settings can be set for different modes.









Set the dip switches on the circuit board as follows to make the settings for the items described in this section.

Press the push switch SWP3 to enable the configuration changes.

Press the push switches SWP1 (↑) or SWP2 (↓) to increase or decrease the value.

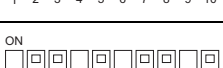
When the desired value is displayed, press SWP3 to save the setting value.

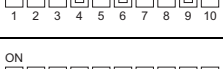
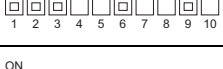
### Settings table

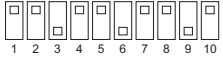
No.	Rotary switch (SWU3)	Dip switch setting (SW1)	Setting Item	Initial value	Unit	Setting			Setting change from an optional remote controller (PAR-W31MAA) *1
						Increments	Lower limit	Upper limit	
1	1		Setting temp 1 (Cooling mode) *2	7	°C	0.1°C	5	30	Possible
2	1		Setting temp 2 (Cooling mode) *3	7	°C	0.1°C	5	30	Possible
3	1		Setting temp 1 (Heating mode) *2	45	°C	0.1°C	30	55	Possible
4	1		Setting temp 2 (Heating mode) *3	45	°C	0.1°C	30	55	Possible
5	1		Setting water temp A at Heating ECO mode	55	°C	0.1°C	30	55	Not possible
6	1		Setting outdoor temp A at Heating ECO mode	0	°C	0.1°C	-30	50	Not possible
7	1		Setting water temp B at Heating ECO mode	35	°C	0.1°C	30	55	Not possible
8	1		Setting outdoor temp B at Heating ECO mode	25	°C	0.1°C	-30	50	Not possible
9	1		Setting water temp C at Heating ECO mode	45	°C	0.1°C	30	55	Not possible
10	1		Setting outdoor temp C at Heating ECO mode	15	°C	0.1°C	-30	50	Not possible
11	1		Select a heating curve	1	-	0: 2-point system, 1: curve			Not possible

\*1 Temperature setting increments: 0.5°C

\*2 No-voltage contact KC1-KC2: OFF

\*3 No-voltage contact KC1-KC2: ON

### Heating ECO (2-point system)

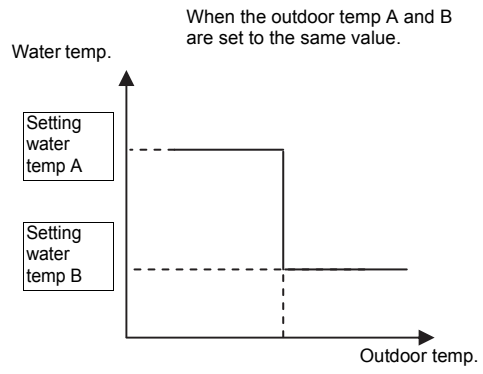
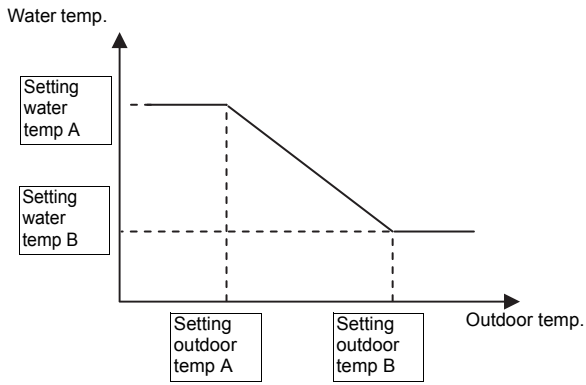

\* Setting temp C cannot be used.

### Heating ECO (Curve)

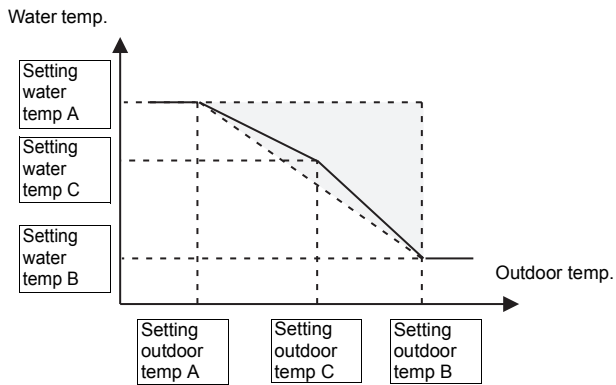

\* Always use a value for setting C that is between setting value A and setting value B.

### (3) Peak-demand control operation

Peak-demand control is a function used to control the power consumptions of the units.

The compressor's maximum operating frequency will be controlled according to the peak-demand control signal.

Set the dip switches on the circuit board as follows to make the settings for the items described in this section.

Press the push switch SWP3 to enable the configuration changes.

Press the push switches SWP1 (↑) or SWP2 (↓) to increase or decrease the value.

When the desired value is displayed, press SWP3 to save the setting value.

#### Settings table

No.	Rotary switch (SWU3)	Dip switch setting (SW1)	Setting Item	Initial value	Unit	Setting			Setting change from an optional remote controller (PAR-W31MAA)
						Increments	Lower limit	Upper limit	
1	1		Peak-demand control signal input source	0	-	1	0	2	Not possible
2	1		Maximum peak-demand capacity	100	%	1%	60	100	Not possible

### (4) Remote water temperature or capacity control ratio setting input signal type

When SW2-7 is ON, SW2-8 is OFF, and SW2-9 is OFF, external analog signals can be used to set the water temperatures.

When SW2-7 and SW2-8 are ON, external analog signals can be used to set the capacity control ratio.

Analog input type can be selected from the following four types:

- 4-20 mA
- 1-5 V
- 0-10 V
- 2-10 V

Select SW3-1 and SW3-2 to set the type of analog input signal from a remote location.

Set the dip switches on the circuit board as follows to change the settings.

	SW421-1	SW421-2	SW3-1	SW3-2
4-20 mA	ON	ON	OFF	OFF
1-5 V	OFF	ON	ON	OFF
0-10 V	OFF	OFF	OFF	ON
2-10 V	OFF	OFF	ON	ON

\* Incorrectly setting SW421 may cause damage to the circuit board.

## (5) Setting the water temperature using analog signal input

When dip switch SW2-7 is set to ON (Enable external input), SW2-8 is set to OFF, and SW2-9 is set to OFF, the target water temperature varies with the preset temperatures A and B and the type of analog input signal.

Set the dip switches on the circuit board as follows to make the settings for the items described in this section.

Press the push switch SWP3 to enable the configuration changes.

Press the push switches SWP1 (↑) or SWP2 (↓) to increase or decrease the value.

When the desired value is displayed, press SWP3 to save the setting value.

### Settings table

No.	Rotary switch (SWU3)	Dip switch setting (SW1)	Setting Item	Initial value	Unit	Setting			Setting change from an optional remote controller (PAR-W31MAA)
						Increments	Lower limit	Upper limit	
1	1		Preset temp. A (Cooling)	5	°C	1°C	5	30	Not possible
2	1		Preset temp. B (Cooling)	30	°C	1°C	5	30	Not possible
3	1		Preset temp. A (Heating)	30	°C	1°C	30	55	Not possible
4	1		Preset temp. B (Heating)	55	°C	1°C	30	55	Not possible

\* Due to the resistance of the wire that is connected to the analog input, the preset temperature may not properly be sent. If this is the case, check the current value of the analog input, and adjust the output value of the connected signal output device. Refer to the table below for how to display the value of the analog input.

No.	Rotary switch (SWU3)	Dip switch setting (SW1)	Monitorable items	Unit
1	0		Current value (4-20 mA)	mA
2	0		5V voltage value (1-5 V)	V
3	0		10V voltage value (0-10 V or 2-10 V)	V

- When the water temperature setting input signal type is 4-20 mA
  - External analog input signal of 6 mA: Preset temp. A
  - External analog input signal of 18 mA: Preset temp. B
  - External analog input signal of between 6 and 18 mA: the preset temperature will be linearly interpolated.

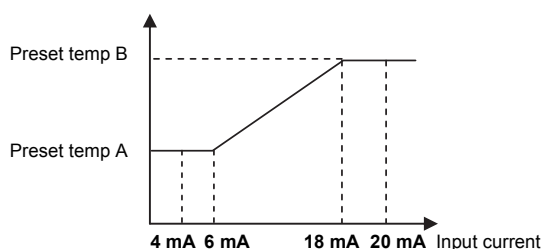

- When the water temperature setting input signal type is 0-10 V

- External analog input signal of 1 V: Preset temp. A
- External analog input signal of 9 V: Preset temp. B
- External analog input signal of between 1 and 9 V: the preset temperature will be linearly interpolated.

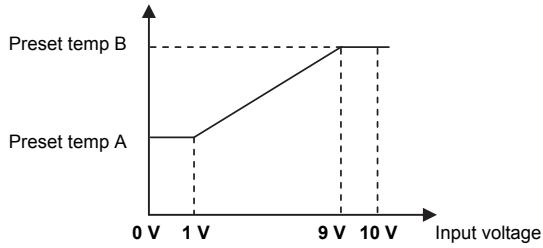

- When the water temperature setting input signal type is 1-5 V

- External analog input signal of 1.5 V: Preset temp. A
- External analog input signal of 4.5 V: Preset temp. B
- External analog input signal of between 1.5 and 4.5 V: the preset temperature will be linearly interpolated.

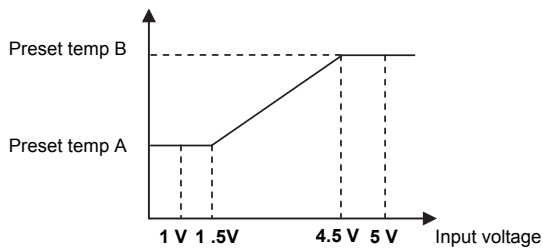

- When the water temperature setting input signal type is 2-10 V

- External analog input signal of 3 V: Preset temp. A
- External analog input signal of 9 V: Preset temp. B
- External analog input signal of between 3 and 9 V: the preset temperature will be linearly interpolated.

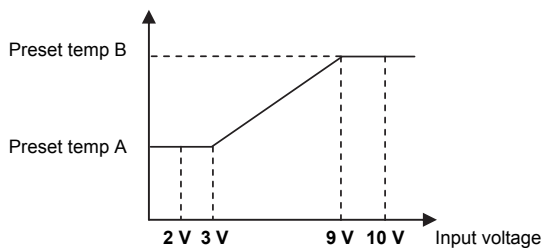



## (6) Setting the capacity control ratio using analog signal input

When dip switch SW2-7 is set to ON (Enable external input), SW2-8 is set to ON, and SW2-9 is set to OFF, the capacity control ratio varies with the type of analog input signal.

- When the water temperature setting input signal type is 4-20 mA
  - External analog input signal of 6 mA: 0%
  - External analog input signal of 18 mA: 100%
  - External analog input signal of between 6 and 18 mA: the percent will be linearly interpolated.

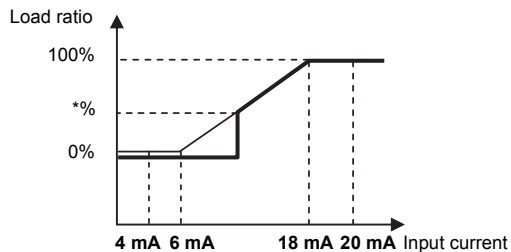

- When the water temperature setting input signal type is 0-10 V
  - External analog input signal of 1 V: 0%
  - External analog input signal of 9 V: 100%
  - External analog input signal of between 1 and 9 V: the percent will be linearly interpolated.

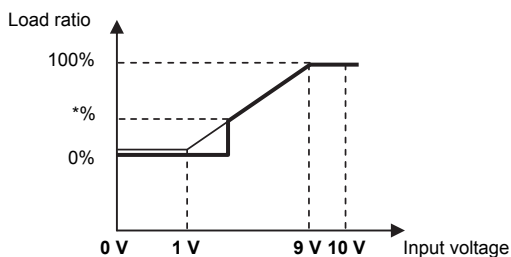

- When the water temperature setting input signal type is 1-5 V
  - External analog input signal of 1.5 V: 0%
  - External analog input signal of 4.5 V: 100%
  - External analog input signal of between 1.5 and 4.5 V: the percent will be linearly interpolated.

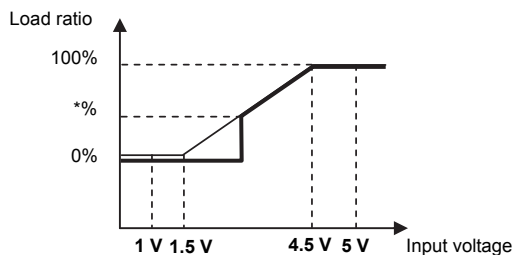

---

- When the water temperature setting input signal type is 2-10 V

- External analog input signal of 3 V: 0%
- External analog input signal of 9 V: 100%
- External analog input signal of between 3 and 9 V: the percent will be linearly interpolated.

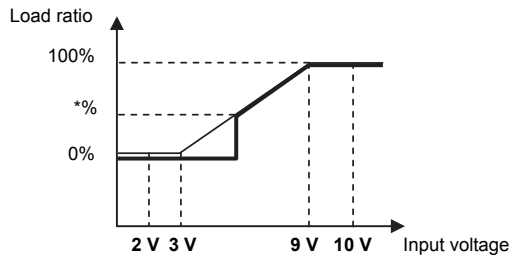

\*%: When the compressor frequency drops below the lowest frequency, the compressor stops.  
The frequency value that causes the compressor to stop varies depending on the outside temperature and water temperature.

## (7) Setting the supplementary heater signal output conditions

A temperature at which the signal output to operate supplementary heaters can be selected.

### Supplementary heater signal output conditions

The operation command signal is ON and at least one of the following two conditions is met.

- 1 Water-temperature control option (SW2-4) is set to OFF, the inlet water temperature drops below a set water temperature, and the outdoor temperature drops below a set outdoor temperature.
- 2 Water-temperature control option (SW2-4) is set to ON, the external water temperature sensor reading (TH117) drops below a set water temperature, and the outdoor temperature drops below a set outdoor temperature.

The supplementary heater signal is output from RP1-RP2.

### Supplementary heater signal output stop conditions

The operation command signal is OFF or at least one of the following two conditions is met.

- 1 The inlet water temperature is at or above a set water temperature +2°C or the outdoor temperature is at or above a set outdoor temperature +2°C.
- 2 External water temperature sensor reading (TH117) is at or above a set water temperature +2°C.

Set the dip switches on the circuit board as follows to make the settings for the items described in this section.

Press the push switch SWP3 to enable the configuration changes.

Press the push switches SWP1 (↑) or SWP2 (↓) to increase or decrease the value.

When the desired value is displayed, press SWP3 to save the setting value.

### Settings table

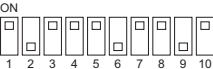
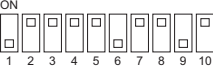
No.	Rotary switch (SWU3)	Dip switch setting (SW1)	Setting Item	Initial value	Unit	Setting			Setting change from an optional remote controller (PAR-W31MAA)
						Increments	Lower limit	Upper limit	
1	1		Supplementary heater operation water temp	40	°C	0.1°C	0	55	Not possible
2	1		Supplementary heater operation outdoor temp	-10		0.1°C	-30	50	Not possible

## (8) Setting the drain pan heater signal output condition

A temperature at which the signal output to operate drain pan heaters can be selected.

### Drain pan heater signal output condition

The following condition is met.

The outdoor temperature drops below a set outdoor temperature.

The drain pan signal is output from KB1-KB2.

### Drain pan heater signal output stop condition

The following condition is met.

The outdoor temperature is at or above a set outdoor temperature +2°C.

Set the dip switches on the circuit board as follows to make the settings for the items described in this section.

Press the push switch SWP3 to enable the configuration changes.

Press the push switches SWP1 (↑) or SWP2 (↓) to increase or decrease the value.

When the desired value is displayed, press SWP3 to save the setting value.

### Settings table

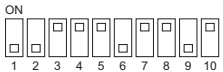
No.	Rotary switch (SWU3)	Dip switch setting (SW1)	Setting Item	Initial value	Unit	Setting			Setting change from an optional remote controller (PAR-W31MAA)
						Increments	Lower limit	Upper limit	
1	1		Drain pan heater operation outdoor temp	0	°C	1°C	-40	20	Not possible

## (9) External temperature sensor control

An optional External temperature sensor (TW-TH16) is required.

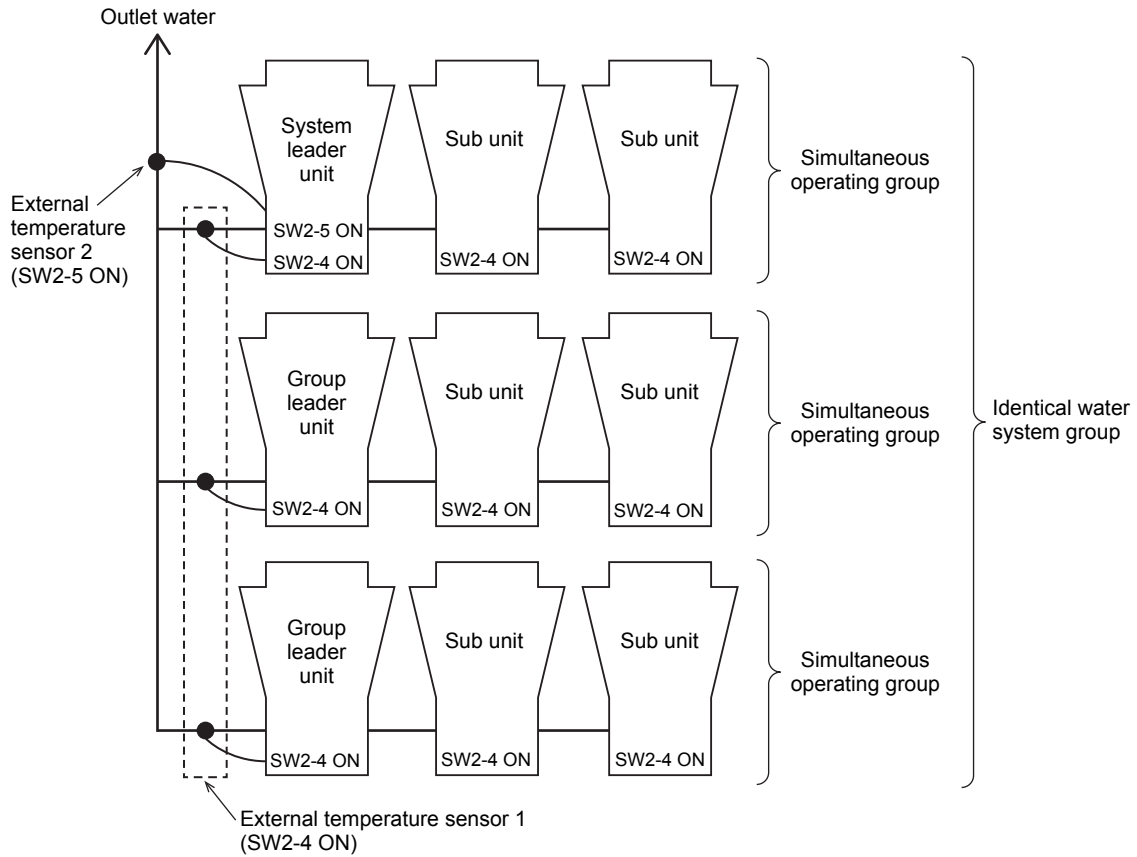

### External temperature sensor 1

Used to control the water temperature of simultaneous operating group.

### External temperature sensor 2

The water outlet temperature of each unit in the identical water system group is corrected to bring the water temperature at the merged section of the outlet water pipes toward the target temperature.

# 6. Troubleshooting

Troubleshooting must be performed only by personnel certified by Mitsubishi Electric.

## [1] Diagnosing Problems for which No Error Codes Are Available

If a problem occurs, please check the following. If a protection device has tripped and brought the unit to stop, resolve the cause of the error before resuming operation.

Resuming operation without removing the causes of an error may damage the unit and its components.

Problem	Check item		Cause	Solution
The unit does not operate.	The fuse in the control box is not blown.	The power lamp on the circuit board is not lit.	The main power is not turned on.	Switch on the power.
		The power lamp on the circuit board is lit.	The pump interlock circuit is not connected. The flow switch wiring is not connected.	Connect the pump interlock circuit wiring to the system. Connect the flow switch wiring to the system.
	The fuse in the control box is blown.	Measure the circuit resistance and the earth resistance.	Short-circuited circuit or ground fault	Resolve the cause, and replace the fuse.
	Automatic Start/Stop thermistor has tripped.	Water temperature is high. (Cooling)	The setting for the automatic Start/Stop thermistor is too high.	Change the setting for the automatic Start/Stop thermistor.
		Water temperature is low. (Heating)	The setting for the automatic Start/Stop thermistor is too low.	Change the setting for the automatic Start/Stop thermistor.
The unit is in operation, but the water does not heat up. (Heating)	Water temperature is low.	The water inlet/outlet temperature differential is normal.	The water-heating load is too high.	Install more units.
			Low refrigerant charge due to a leak.	Perform a leakage test, repair the leaks, evacuate the system, and charge the refrigerant circuit with refrigerant.
		The water inlet/outlet temperature differential is small.	LEV fault in the main circuit	Replace the LEV in the main circuit.
	Compressor failure		Replace the compressor.	
	High pressure is too high, or low pressure is too low.		Operate the units within the specified pressure range.	
	Water temperature is high.	-	Water flow shortage	Increase the water flow rate.
		-	Problem with the external devices	Repair the devices.
The unit is in operation, but the water does not heat up. (Cooling)	Water temperature is low.	-	Water flow shortage	Increase the water flow rate.
			Problem with the external devices	Repair the devices.
	Water temperature is high.	The water inlet/outlet temperature differential is normal.	The water-cooling load is too high.	Install more units.
			Low refrigerant charge due to a leak.	Perform a leakage test, repair the leaks, evacuate the system, and charge the refrigerant circuit with refrigerant.
		The water inlet/outlet temperature differential is small.	LEV fault in the main circuit	Replace the LEV in the main circuit.
			Compressor failure	Replace the compressor.
			High pressure is too high, or low pressure is too low.	Operate the units within the specified pressure range.

## [2] Diagnosing Problems Using Error Codes

If a problem occurs, please check the following before calling for service.

(1) Check the error code against the table below.

(2) Check for possible causes of problems listed in the "Cause" column that correspond to the error code.

(3) If the error codes that appear on the display are not listed in the table below, or no problems were found with the items listed in the "Cause" column, please consult your dealer or servicer.

### Diagnosing Problems Using Error Codes

Error code *1	Error type		Cause (Installation/Setting error)	Cause (Parts problems)	Error reset *2	
					Operation SW	
					Selector switch	Remote controller
4 106	Power supply fault *3		Power supply fault occurred when the operation switch is switched on.	-	○	○
2503	Water supply cutoff (Flow switch has been triggered.)		The water flow rate dropped below the flow switch threshold. Water supply cutoff	<ul style="list-style-type: none"> <li>Open-circuited flow switch</li> <li>Broken flow switch wiring</li> </ul>	×	×
2501	Water supply cutoff (detection by sensor) 101, 201: Upper side 102, 202: Lower side 203: Inlet/outlet of unit		No water Water supply cutoff	<ul style="list-style-type: none"> <li>Inlet water thermistor fault</li> <li>Outlet water thermistor fault</li> </ul>	×	×
1302 1303	High pressure fault 101: MAIN circuit 102: SUB circuit		No water Water supply cutoff	<ul style="list-style-type: none"> <li>Linear expansion valve fault</li> <li>High-pressure sensor fault</li> </ul>	○	○
1176	Discharge SH fault 101: MAIN circuit 102: SUB circuit		-	<ul style="list-style-type: none"> <li>Low-pressure sensor fault</li> <li>ACC inlet refrigerant temperature thermistor fault</li> <li>High-pressure sensor fault</li> <li>Discharge refrigerant temperature thermistor fault</li> <li>Linear expansion valve fault</li> </ul>	○	○
1301	Low pressure fault 101: MAIN circuit 102: SUB circuit		The outdoor temperature was below the operating range.	<ul style="list-style-type: none"> <li>Low-pressure sensor fault</li> <li>ACC inlet refrigerant temperature thermistor fault</li> <li>Linear expansion valve fault</li> <li>Refrigerant deficiency (refrigerant gas leak)</li> </ul>	○	○
1189	ACC inlet SH fault 101: MAIN circuit 102: SUB circuit		-	<ul style="list-style-type: none"> <li>ACC inlet refrigerant temperature thermistor fault</li> <li>Linear expansion valve fault</li> <li>Low-pressure sensor fault</li> </ul>	○	○
5 109	Thermistor fault	Outdoor temperature (TH9)	-	Broken or shorted thermistor wiring	○	○
5 110		Inlet water temperature (TH10)	-	Broken or shorted thermistor wiring	○	○
5 111		Inlet water temperature (TH11)	-	Broken or shorted thermistor wiring	○	○
5 112		Outlet water temperature (TH12)	-	Broken or shorted thermistor wiring	○	○
5 107 5 108		ACC inlet refrigerant temperature (TH7, 8/TH107, 108)	-	Broken or shorted thermistor wiring	○	○
5 103 5 104		Air heat exchanger refrigerant temperature (TH3, 103/TH4, 104)	-	Broken or shorted thermistor wiring	○	○
5 105 5 106		Water heat exchanger refrigerant temperature (TH5, 105/TH6, 106)	-	Broken or shorted thermistor wiring	○	○
5 101 5 102		Discharge refrigerant temperature (TH1, 101/TH2, 102) 101: Sensor error 102: Installation error	-	Broken or shorted thermistor wiring	○	○
5 116		External water sensor 2 fault (TH116)	-	Broken or shorted thermistor wiring	○	○
5 117		External water sensor 1 fault (TH117)	-	Broken or shorted thermistor wiring	○	○
5201	High-pressure sensor fault/high-pressure fault 101: MAIN circuit 102: SUB circuit		-	Broken or shorted pressure sensor wiring	○	○
5202	Low-pressure sensor fault/low-pressure fault 101: MAIN circuit 102: SUB circuit		-	Broken or shorted pressure sensor wiring	○	○
7 102	Connection count error		-	Setting of connection count fault	×	×
7 113	Model setting error 1		Dip switches on the PCB were set incorrectly during maintenance.	-	○	○
7 117	Model setting error 2		-	CNTYP1 resistor fault (connected to the Main control board)	○	○
4 115	Power supply frequency fault		Power supply frequency is a frequency other than 50 Hz or 60 Hz.	-	○	○
4 102	Open phase		There is an open phase.	<ul style="list-style-type: none"> <li>Circuit board fault</li> </ul>	×	×
4 103	Reversed phase error		Reversed phase	<ul style="list-style-type: none"> <li>Wiring fault</li> </ul>	×	×

Error code *1	Error type		Cause (Installation/Setting error)	Cause (Parts problems)	Error reset *2	
					Operation SW	
					Selector switch	Remote controller
1102	Discharge temperature fault (A discharge refrigerant temperature of 120°C or above is detected momentarily while the compressor is in operation.) 101: MAIN circuit 102: SUB circuit		No water Abrupt change in water temperature (5K/min. or greater) Pump failure	<ul style="list-style-type: none"> <li>High-pressure sensor fault</li> <li>Linear expansion valve fault</li> <li>Refrigerant deficiency (refrigerant gas leak)</li> </ul>	○	○
1138	Hot water abnormal rise		Drop in water flow or water supply cutoff Water temperature rise	-	○	○
1503	Cold water abnormal drop *4		Drop in water flow or water supply cutoff Water temperature drop	-	×	×
1510	Gas leak fault		-	<ul style="list-style-type: none"> <li>High pressure sensor fault</li> <li>Refrigerant deficiency (refrigerant gas leak)</li> </ul>	○	○
1512	Low evaporation temperature fault 101: MAIN circuit 102: SUB circuit		Drop in water flow Water temperature drop	-	×	×
426*	Cooling fan fault		-	<ul style="list-style-type: none"> <li>Cooling fan fault</li> </ul>	○	○
4122	Fan interlock fault		Disconnection of wiring	<ul style="list-style-type: none"> <li>Fan motor fault</li> <li>FANCONT board fault</li> </ul>	○	○
425* (101)	Inverter error	IPM error	-	<ul style="list-style-type: none"> <li>INV board, Fan INV board fault</li> <li>Ground fault of the compressor</li> <li>Coil problem</li> <li>IPM error (loose terminal screws, cracked due to swelling)</li> <li>Items listed under "Heatsink overheat protection" below</li> </ul>	○	○
425* (102)		ACCT overcurrent	-	<ul style="list-style-type: none"> <li>INV board fault</li> <li>Ground fault of the compressor</li> <li>Coil problem</li> </ul>	○	○
425* (103)		DCCT overcurrent	-	<ul style="list-style-type: none"> <li>IPM error (loose terminal screws, cracked due to swelling)</li> </ul>	○	○
425* (107)		Overcurrent relay trip (effective value) (During operation)	-		○	○
425* (105)		Overcurrent relay trip (momentary value) (During operation)	-		○	○
425* (104)		Short-circuited IPM/ground fault (During operation)	-	<ul style="list-style-type: none"> <li>INV board, Fan INV board fault</li> <li>Ground fault of the compressor</li> <li>IPM error (loose terminal screws, cracked due to swelling)</li> </ul>	○	○
425* (105)		Overcurrent error due to a short-circuited (During operation)	Inter-phase voltage drop	<ul style="list-style-type: none"> <li>INV board, Fan INV board fault</li> <li>Ground fault of the compressor</li> <li>Shorted output wiring</li> </ul>	○	○
422* (108)		Voltage related problems during operation	Bus voltage drop protection	Momentary power failure/power failure Power supply voltage drop	<ul style="list-style-type: none"> <li>INV board fault</li> <li>72C fault</li> <li>R1, R5 fault</li> </ul>	○
422* (109)	Bus voltage rise protection		Incorrect power supply voltage	<ul style="list-style-type: none"> <li>INV board fault</li> </ul>	○	○
422* (110)	VDC error		Power supply voltage rise or drop	<ul style="list-style-type: none"> <li>PCB fault</li> <li>R1, R5 fault</li> <li>INV board fault</li> <li>72C fault</li> </ul>	○	○
422* (111)	Logic error		Malfunction due to external noise interference <ul style="list-style-type: none"> <li>Faulty grounding</li> <li>Improper transmission and external wiring installation (Shielded cable is not used.)</li> <li>Low-voltage signal wire and high-voltage wire are in contact. (Placing the signal wire and power wire in the same conduit)</li> </ul>	<ul style="list-style-type: none"> <li>INV board, Fan INV board fault</li> </ul>	○	○
422* (111)	Inverter bus voltage fault		Power supply voltage drop	<ul style="list-style-type: none"> <li>MAIN board fault</li> <li>Power supply voltage drop</li> </ul>	○	○
423* (125)		Heatsink fault (Heatsink overheat protection)	Power supply voltage drop Clogged heatsink cooling air passage	<ul style="list-style-type: none"> <li>Cooling fan fault</li> <li>INV board fault</li> <li>IPM error (loose terminal screws, cracked due to swelling)</li> </ul>	○	○



Error code *1	Error type		Cause (Installation/Setting error)	Cause (Parts problems)	Error reset *2	
					Operation SW	
					Selector switch	Remote controller
424*	Inverter error	Overload protection	Clogged heatsink cooling air passage Power supply voltage drop	• Cooling fan fault • Current sensor fault • INV circuit fault • Compressor fault	○	○
530* (115)		ACCT sensor fault	-	• INV board fault • Ground fault of the compressor and IPM error	○	○
530* (116)		DCCT sensor	-	• INV board fault • Ground fault of the compressor and IPM error	○	○
530* (117)		ACCT sensor/circuit fault	-	• INV board fault	○	○
530* (118)		DCCT sensor/circuit fault	-	• INV board fault	○	○
530* (119)		Open-circuited IPM/loose ACCT sensor	-	• ACCT sensor fault • Broken compressor wiring • INV circuit fault (IPM error etc.)	○	○
530* (120)		Faulty wiring	-	• INV board fault	○	○
530* (132)	Position error in startup	-	• INV board fault	○	○	
530* (133)	Position error in operation	-	• INV board fault	○	○	
530* (134)	Position error before operation	-	• INV board fault	○	○	
5114 (0*)	Inverter error	THHS sensor/circuit fault	-	• INV board fault	○	○
0403 (0*)		Serial communication error	-	• Communication error between control board and INV board, Fan INV board (noise interference, broken wiring)	○	○
6831	Remote controller error (incl. remote controller wiring fault)	Remote controller signal reception error 1	Remote controller cable is not connected. Broken wiring	• Broken remote controller wiring • Main control board communication circuit fault	—	—
6832		Remote controller signal transmission error	Communication error due to external noise interference	• Main control board communication circuit fault	—	—
6834		Remote controller signal reception error 2	Communication error due to external noise interference	• Main control board communication circuit fault	—	—
6833		Remote controller over current	Remote controller cable short circuit Remote controller malfunction	• Broken remote controller wiring	—	—
4126	Analog input error (Control board (MAIN) CN421)		Analog input type fault (SW3-1, SW3-2)	• Broken or open analog signal output device wiring (CN421)	—	—
6600	Communication error between the main and sub units Communication error between the MAIN and SUB circuits		-	-	—	—
6600	Transmission line power supply PCB fault Communication error between the main and sub units (Simple multiple unit control mode)		Communication error due to external noise interference	• Broken wiring to the transmission power supply circuit board (between the main and sub units) • Transmission power supply PCB communication circuit fault	—	—
6602 6603 6606 6607 6608					—	—
7100	Capacity code error		Other capacity units in a group	• Group setting fault	—	—

\*1: If an error occurs, error codes shown above will appear in the 4-digit digital display on the PCB and the remote controller.

\*2: Definition of symbols in the "Error reset" column.

- : Errors that can be reset if the remote reset setting on the unit is set to "Enable" (factory setting)  
Errors that cannot be reset if the remote reset setting on the unit is set to "Disable"
- ×: Errors that cannot be reset
- : Errors that will be automatically cancelled once its cause is removed

\*3: Power failure will be detected as an error only when the "Automatic recovery after power failure" setting on the unit is set to "Disable."  
(The default setting for the "Automatic recovery after power failure" setting is "Enable.")

\*4: Before resetting this error, remove its causes. Resuming operation without removing the causes of heat exchanger freeze up will cause heat exchanger damage.

\*5: "\*" shows types of components. (0/1: COMP for MAIN circuit, 2: COMP for SUB circuit, 5: FAN for MAIN circuit, 6: FAN for SUB circuit)

## Abnormal stop condition table

Error code	Error type	Preliminary error code	One side circuit can be operated	Another unit can be operated in the group
1102	Discharge temperature fault	1202	○	⊙
1138	Hot water abnormal rise	-	×	⊙
1176	Discharge SH fault	1276	○	⊙
1189	ACC inlet SH fault	1289	○	⊙
1301	Low pressure fault	1401	○	⊙
1302 1303	High pressure fault	1402	○	⊙
1503	Cold water abnormal drop	-	×	⊙
1510	Gas leak fault	-	×	⊙
1512	Low evaporation temperature fault	1612 or none	×	⊙
2503	Water supply cutoff (Flow switch)	-	×	×*1
2501	Water supply cutoff (Sensor)	-	×	⊙
4102	Open phase	4152 or none	×	⊙
4103	Reversed phase error	-	×	⊙
4106	Power supply fault	-	×	⊙
4115	Power supply frequency fault	-	×	⊙
4122	Fan interlock fault	4172	×	⊙
4126	Analog input error	-	—	—
422*	Inverter bus voltage fault	432*	COMP: ○ / FAN: ×	⊙
423*	Inverter overheat protection fault	433*	○	⊙
424*	Inverter overload protection	434*	COMP: ○ / FAN: ×	⊙
425*	IPM error (inclusive)/overcurrent relay	435*	COMP: ○ / FAN: ×	⊙
426*	Cooling fan fault	-	○	⊙
5101	Discharge refrigerant temp. (TH1, 101)	1201	×	⊙
5102	Discharge refrigerant temp. (TH2, 102)	1202	×	⊙
5103	Air heat exchanger refrigerant temp. (TH3, 103)	-	×	⊙
5104	Air heat exchanger refrigerant temp. (TH4, 104)	-	×	⊙
5105	Water heat exchanger refrigerant temp. (TH5, 105)	-	×	⊙
5106	Water heat exchanger refrigerant temp. (TH6, 106)	-	×	⊙
5107	ACC inlet refrigerant temperature (TH7, 8)	-	×	⊙
5108	ACC inlet refrigerant temp. (TH107, 108)	-	×	⊙
5109	Outdoor temperature (TH9)	-	×	⊙
5110	Inlet water temperature (TH10)	-	×	⊙
5111	Inlet water temperature (TH11)	-	×	⊙
5112	Outlet water temperature	-	×	⊙
5114	THHS sensor/Circuit fault	1214	○	⊙
5116	External water sensor 2 fault (TH116)	-	×	⊙
5117	External water sensor 1 fault (TH117)	-	×	⊙
5201	High pressure sensor fault	-	×	⊙
5202	Low pressure sensor fault	-	×	⊙
530*	ACCT sensor fault/Circuit fault	430*	COMP: ○ / FAN: ×	⊙
0403	Serial communication error	430*	COMP: ○ / FAN: ×	⊙
6500	Communication error between the MAIN and SUB units	-	×*2	⊙
6600	Communication error between the MAIN and SUB units	-	×	⊙
6602	Communication error between the MAIN and SUB units	-	×	⊙
6603	Communication error between the MAIN and SUB units	-	×	⊙
6606	Communication error between the MAIN and SUB units	-	×	⊙
6607	Communication error between the MAIN and SUB units	-	×	⊙
6608	Communication error between the MAIN and SUB units	-	×	⊙
6831	Remote controller signal reception error 1	-	—	—
6832	Remote controller signal transmission error	-	—	—
6834	Remote controller signal reception error 2	-	—	—
6833	Remote controller over current	-	×	⊙
7100	Capacity code error	-	×	×
7102	Connection count error	-	×	⊙
7113 7117	Model setting error	-	×	⊙

○: One side circuit can be operated.

⊙: Another module can be operated.

×: Operation impossible

—: Not abnormal stop

- 
- \*1: Case of the one pump system
  - \*2: Case of the communication error between the MAIN and SUB circuits
  - \*3: "\*" shows types of components. (0/1: COMP A, 2: COMP B, 5: FAN A, 6: FAN B)

---

### **[3] Calling for Service**

If the problem cannot be solved by following the instructions provided in the table on the previous pages, please contact your dealer or servicer along with the types of information listed below.

#### **(1) Model name**

The model name is a string that starts with "EAHV" or "EACV" and is found on the lower part of the unit.

#### **(2) Serial number**

Example: 75W00001

#### **(3) Error code**

#### **(4) Nature of the problem in detail**

Example: The unit stops approximately one minute after it was started.

---

# 7. Operating the Unit

---

## [1] Initial Operation

1. Make sure the Run/Stop switch that controls the unit on the local control panel is switched off.
2. Switch on the main power.
3. Leave the main power switched on for at least 12 hours before turning on the Run/Stop switch that controls the unit on the on-site control panel to warm up the compressor.
4. Switch on the Run/Stop switch that controls the unit on the on-site control panel.

## [2] Daily Operation

### To start an operation

Switch on the Run/Stop switch that controls the unit on the local control panel, or press the ON/OFF button on the remote controller. (\*1)

#### Note

The unit described in this manual features a circuit that protects the compressor from short-cycling. Once the compressor stops, it will not start up again for up to 12 minutes. If the unit does not start when the ON/OFF switch is turned on, leave the switch turned on for 12 minutes. The unit will automatically start up within 12 minutes.

### To stop an operation

Switch off the Run/Stop switch that controls the unit on the on-site control panel, or press the ON/OFF button on the remote controller. (\*1)

\*1 Refer to the following pages for how to use the remote controller.

## IMPORTANT

- Keep the main power turned on throughout the operating season, in which the unit is stopped for three days or shorter (e.g., during the night and on weekends).
- Unless in areas where the outdoor temperature drops to freezing, switch off the main power when the unit will not be operated for four days or longer. (Switch off the water circulating pump if the pump is connected to a separate circuit.)
- When resuming operation after the main power has been turned off for a full day or longer, follow the steps under "Initial Operation".
- If the main power was turned off for six days or longer, make sure that the clock on the unit is correct.

### [3] Using the Unit in Sub-freezing

**In areas where temperature drops to freezing during the periods of non-use, blow the water out of the pipes or fill the pipes with anti-freeze solution.**

Not doing so may cause the water to freeze, resulting in burst pipes and damage to the unit or the furnishings.

**In areas where temperature can drop low enough to cause the water in the pipes to freeze, operate the unit often enough to prevent the water from freezing.**

Frozen water in the water circuit may cause the water to freeze, resulting in burst pipes and damage to the unit or the furnishings.

In areas where temperature drops to freezing, use an anti-freeze circuit and leave the main power turned on to prevent the water in the water circuit from freezing and damaging the unit or causing water leakage and resultant damage to the furnishings.

- In areas where the air around the unit drops below freezing, leave the main switch turned on even when the unit will not be operated for four days or longer. Leave the switch on the water circulation pump turned on if the pump is connected to a separate circuit.
- If the unit is left turned off for a while (e.g., overnight) when the temperature around the unit drops below freezing, the water in the water circuit will freeze and damage the pipes and the heat exchanger.
- The recommended electric circuit has an anti-freeze circuit. For this circuit to function, the main power must be turned on.
- If the water circulation pump is connected differently from the recommended way, make sure the circuit has some type of anti-freeze function\*.  
(\* A function that automatically operates the water circulation pump to prevent the water in the circuit from freezing when the water temperature drops.)

## [4] Using the Remote Controller (PAR-W31MAA)

### <1> Power ON/OFF

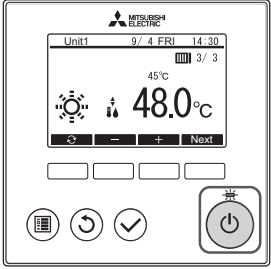
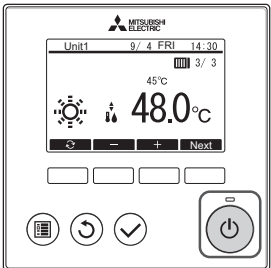
During operation		<p>Press the [ON/OFF] button.</p> <p>The ON/OFF lamp will light up in green, and the operation will start.</p>
During stoppage		<p>Pressing the [ON/OFF] button brings up a confirmation screen. When it appears, press the [F3] button.</p> <p>The ON/OFF lamp will come off, and the operation will stop.</p>

### <2> Operation mode and set temperature settings

#### Operation mode setting

Button operation

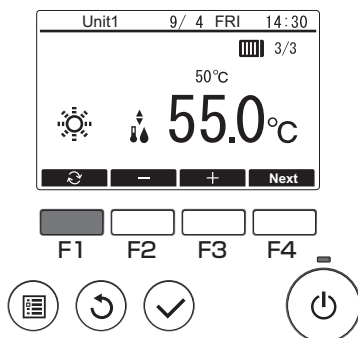

Press the [F1] button to go through the operation modes in the order of "Heating, Anti-Freeze, Cooling and Heating-ECO."  
Select the desired operation mode.

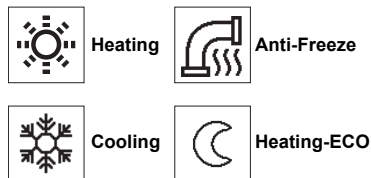

#### Set temperature setting

Button operation

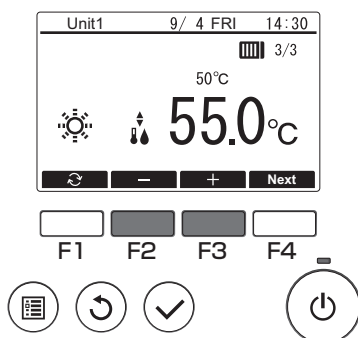

Press the [F2] button to decrease the set temperature, and press the [F3] button to increase.

## <3> Using Weekly timer

### Function description

Following settings can be used to change the operating schedule according to the day of the week.

- Set the schedule for ON/OFF, operation mode and set temperature for each day of the week.

Button operation

1

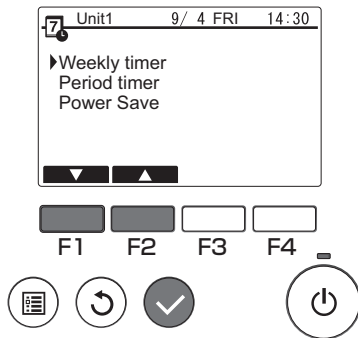

Select "Weekly timer" from the Schedule menu, and press the [Select] button.

2

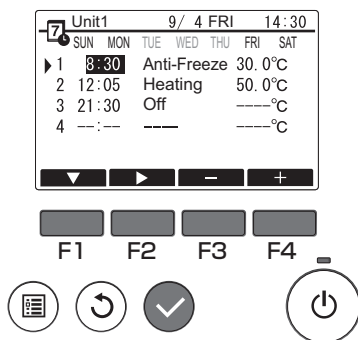

The Weekly timer screen will be displayed.

To check the operation settings:

Press the [F1] or [F2] button to check the settings from Monday to Sunday. The [F4] button displays the following page.

To change the operation settings:

Press the [F1] or [F2] button to select a day and then press the [F3] button to confirm the day to be set. (Multiple days can be selected.)

After selecting the desired day, press the [Select] button.

3

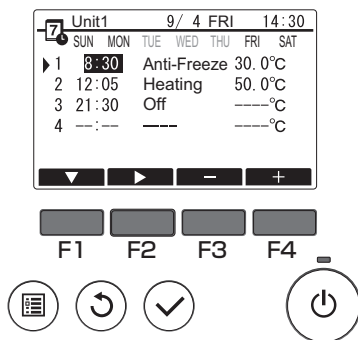

The pattern setting screen will be displayed.

Press the [F1] button to select a pattern.

Press the [F2] button to select the item you want to change.

Press the [F3] or [F4] button to switch to the desired setting.

Time	Set in 5-minute increments. * Hold down the button to change the value continuously.
Operation mode, Off	The options available vary depending on the connected unit. * If you select an operation mode other than Off, the connected unit will operate.
Set temperature	You can change the set temperature (in 0.5°C increments).

Weekly timer operation is disabled in the following situations:

- When Schedule is disabled
- On days when the period timer is also enabled

Weekly timer operation may not be executed depending on the system configuration.

#### Navigating through the screens

- To save the settings ..... [Select] button
- To return to the Main display ..... [Menu] button
- To return to the previous screen ..... [Return] button



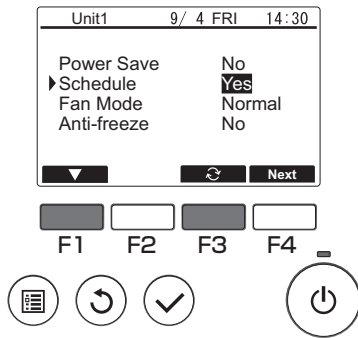

In the Operation setting screen, press the [F1] button to move the cursor to "Schedule".  
Press the [F3] button to select "Yes".

## <4> Using Period timer

### Function description

Following settings can be made to change the specified period and daily operating schedule.

- Set the schedule for ON/OFF, operation mode and set temperature.

\* If the periods specified in 1 and 2 overlap, only the period specified in 1 will be implemented.

Button operation

1

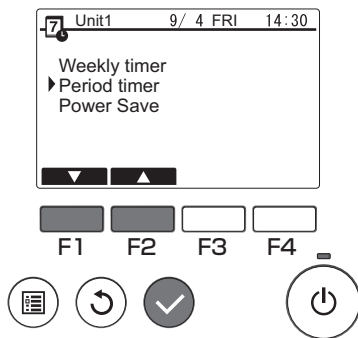

Select "Period timer" from the Schedule menu, and press the [Select] button.

2

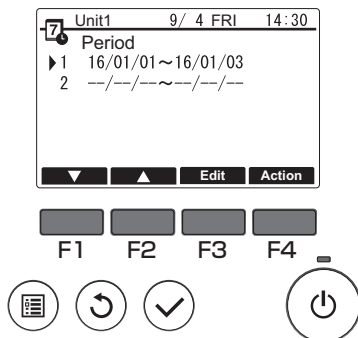

The suitable periods for the period timer will be displayed.

To set the period:

Press the [F1] or [F2] button to select the specified date and then press the [F3] button. ... Move to 3.

To set the operation:

Press the [F1] or [F2] button to select the specified date and then press the [F4] button. ... Move to 4.

3

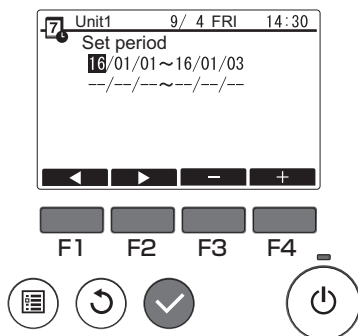

The period setting screen will be displayed.

Press the [F1] or [F2] button to move to the item you want to change.

Press the [F3] or [F4] button to change the start date and end date for the period timer and then press the [Select] button to update the setting.

# 4

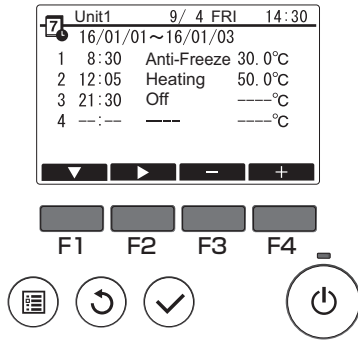

The pattern setting screen will be displayed.

\* Refer to the section on Weekly timer for details on using the pattern setting screen.

Weekly timer operation will be disabled in the following situations:

- When Schedule is disabled

When Schedule is disabled with the centralized controller or the connected unit, Schedule settings cannot be made with the remote controller.

After switching to the desired setting, press the [Select] button. A setting confirmation screen will appear.

### Navigating through the screens

- To save the settings ..... [Select] button
- To return to the Main display ..... [Menu] button
- To return to the previous screen ..... [Return] button

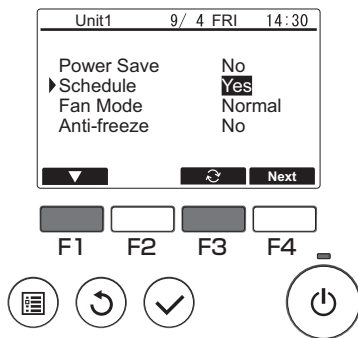

In the Operation setting screen, press the [F1] button to move the cursor to "Schedule".

Press the [F3] button to select "Yes".

## <5> Using power save

### Function description

Power Save is a function that regulates the compressor rotation count either daily or according to a specified period and according to a preset time interval or regulated capacity. Use this function when you want to inhibit electric power use.

A typical scenario where Power Save can be used to inhibit the power consumption for water heating would be periods of particularly heavy operating loads for air conditioning and other equipment, such as periods when large numbers of people check in at a hotel or similar accommodation facility.

Button operation

1

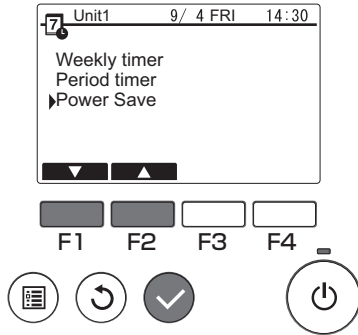

From the Main menu, select "Schedule" > "Power Save" and press the [Select] button.

2

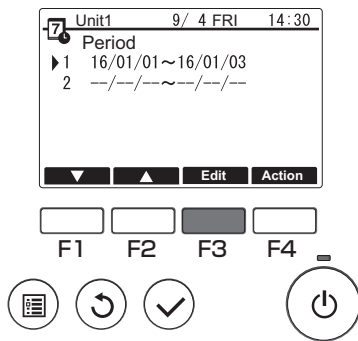

Press the [F3] button to proceed to the settings screen. You can set 2 types of pattern, as necessary.

\* If the periods specified in 1 and 2 overlap, only period specified in 1 will be implemented.

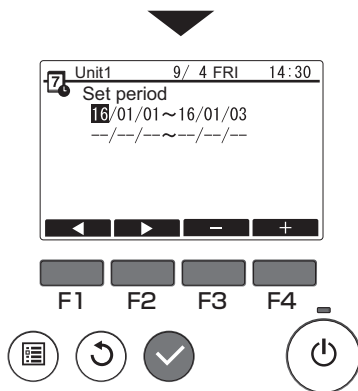

Press the [F1] to [F4] buttons to set the period and then press the [Select] button.

3

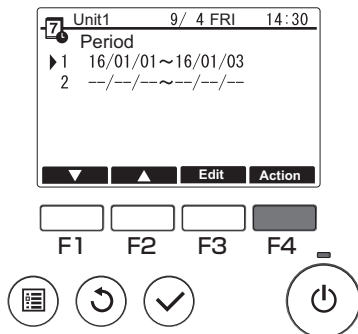

The Power Save screen will be displayed. Press the [F4] button.

# 4

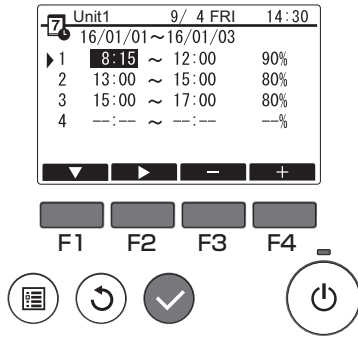

Press the [F1] to [F4] buttons to set the Power Save start time, end time and control value.

# 5

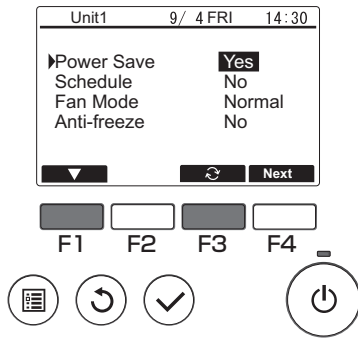

In the Operation setting screen, press the [F1] button to move the cursor to Power Save.

Press the [F3] button to select "Yes".

## <6> Fan mode

### Function description

Spins the fan even when the compressor is stopped to prevent snow buildup on the fan when it snows in regions where there is relatively little snow cover.

Normal: The fan also stops when the compressor is stopped.

Snow: The fan continues to operate even when the compressor is stopped.

Button operation

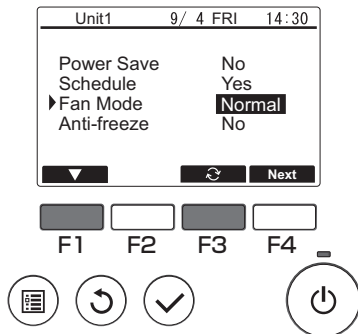

Select "Fan Mode" from the menu, and press the [F3] button to select "Snow".

# 8. Main Specifications

## [1] Model name

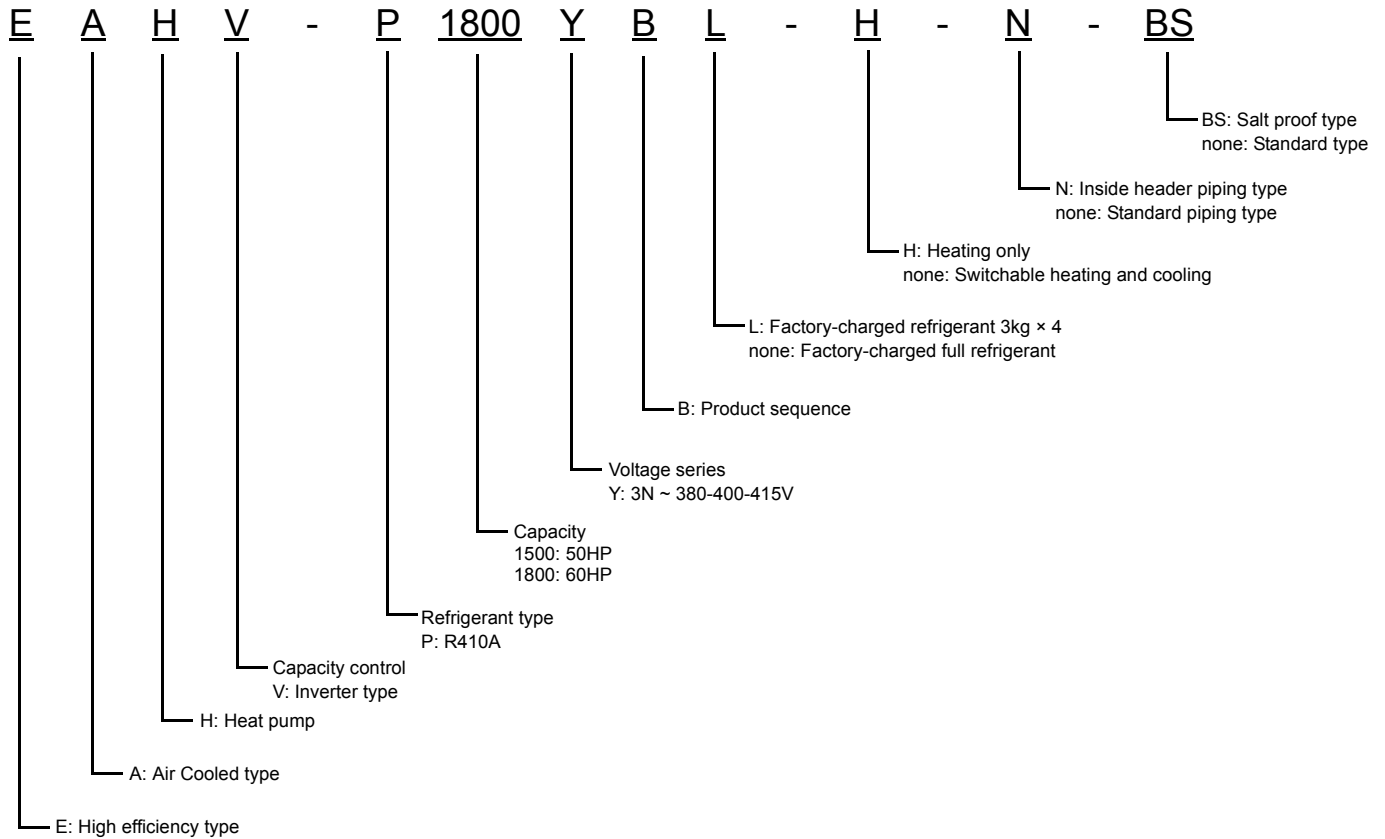
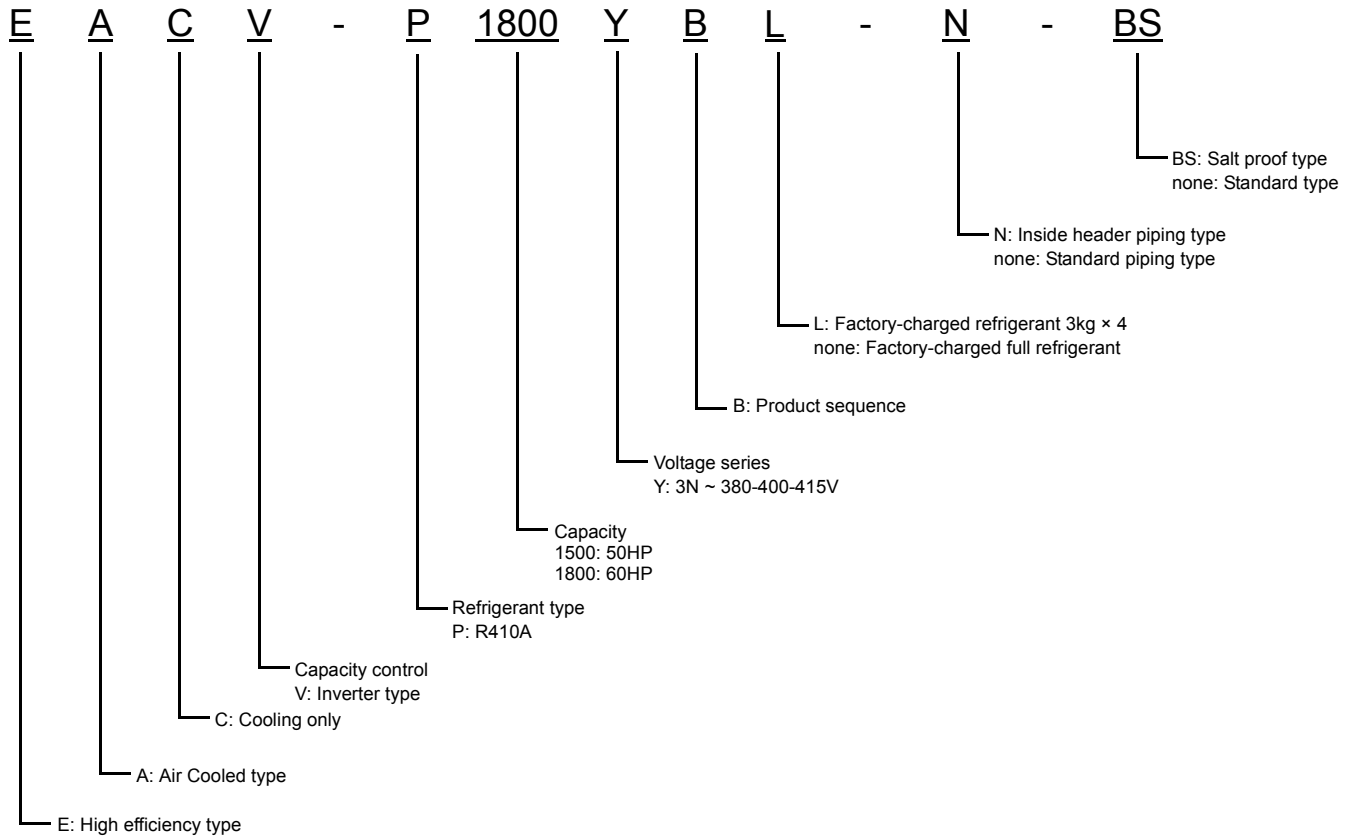

## [2] Specifications

Model		EAHV-P1500YB(L)(-H)(-N)(-BS) EACV-P1500YB(L)(-N)(-BS)	EAHV-P1800YB(L)(-H)(-N)(-BS) EACV-P1800YB(L)(-N)(-BS)	
Power source		3-phase 4-wire 380-400-415V 50/60Hz		
Cooling capacity <sup>*1</sup> <Except for EAHV-P****YB(L)(-H)(-N)(-BS)>		kW	150.00	
		kcal/h	129,000	
		BTU/h	511,800	
	Power input	kW	45.10	
	EER		3.33	
	IPLV <sup>*6</sup>		6.55	
Water flow rate	m <sup>3</sup> /h	25.8	31.0	
Cooling capacity(EN14511) <sup>*2</sup> <Except for EAHV-P****YB(L)(-H)(-N)(-BS)>		kW	148.58	
		kcal/h	127,779	
		BTU/h	506,955	
	Power input	kW	46.52	
	EER		3.19	
	Eurovent efficiency class		A	
	ESEER <sup>*7</sup>		4.74	
	SEER		4.76	
Water flow rate	m <sup>3</sup> /h	25.8	31.0	
Heating capacity <sup>*3</sup> <Except for EACV-P****YB(L)(-N)(-BS)>		kW	150.00	
		kcal/h	129,000	
		BTU/h	511,800	
	Power input	kW	44.59	
	COP		3.36	
	Water flow rate	m <sup>3</sup> /h	25.8	31.0
Heating capacity (EN14511) <sup>*4</sup> <Except for EACV-P****YB(L)(-N)(-BS)>		kW	151.42	
		kcal/h	130,221	
		BTU/h	516,645	
	Power input	kW	46.01	
	COP		3.29	
	Eurovent efficiency class		A	
	SCOP (Heating only) Low/Medium		3.20 / 2.83	
	SCOP (Reversible) Low/Medium		3.24 / 2.85	
Water flow rate	m <sup>3</sup> /h	25.8	31.0	
Current input	Cooling current 380-400-415V <sup>*1</sup>	A	77 - 73 - 70	
	Heating current 380-400-415V <sup>*3</sup>	A	76 - 72 - 69	
	Maximum current	A	111	
Water pressure drop <sup>*1</sup>	kPa	114	164	
Temp range	Cooling	°C	Outlet water 5~30 <sup>*8</sup>	
		°F	Outlet water 41~86 <sup>*8</sup>	
	Heating	°C	Outlet water 30~55 <sup>*8</sup>	
		°F	Outlet water 86~131 <sup>*8</sup>	
	Outdoor	°C	-15~43 <sup>*8</sup>	
		°F	5~109.4 <sup>*8</sup>	
Circulating water volume range	m <sup>3</sup> /h	12.9~34.0		
Sound pressure level (measured in anechoic room) at 1m <sup>*1</sup>	dB (A)	66	68	
Sound power level (measured in anechoic room) <sup>*1</sup>	dB (A)	84	86	
Diameter of water pipe (Standard piping)	Inlet	mm (in)	65A (2 1/2B) housing type joint	
	Outlet	mm (in)	65A (2 1/2B) housing type joint	
Diameter of water pipe (Inside header piping)	Inlet	mm (in)	150A (6B) housing type joint	
	Outlet	mm (in)	150A (6B) housing type joint	
External finish		Polyester powder coating steel plate		
External dimensions H x W x D	mm	2350 x 3400 x 1080		
Net weight	Standard piping	kg (lbs)	EAHV: 1310 (2888)/EACV: 1240 (2734)	
	Inside header piping	kg (lbs)	EAHV: 1326 (2923)/EACV: 1256 (2769)	
Design pressure	R410A	MPa	4.15	
	Water	MPa	1.0	
Heat exchanger	Water side	Stainless steel plate and copper brazing		
	Air side	Plate fin and copper tube		
Compressor	Type	Inverter scroll hermetic compressor		
	Maker	MITSUBISHI ELECTRIC CORPORATION		
	Starting method	Inverter		
	Quantity	4		
	Motor output	kW	11.7 x 4	
	Lubricant	MEL32		
Fan	Air flow rate	m <sup>3</sup> /min	265 x 4	
		L/s	4417 x 4	
		cfm	9357 x 4	
	Type, Quantity	Propeller fan x 4		
	Starting method	Inverter		
	Motor output	kW	0.92 x 4	
Protection	High pressure protection	High pres.Sensor & High pres.Switch at 4.15MPa (601psi)		
	Inverter circuit	Over-heat protection, Over current protection		
	Compressor	Over-heat protection		
Refrigerant	Type x charge	R410A x 15(kg) x 4 <sup>*5</sup>		
	Control	LEV		

- \*1 Under normal cooling conditions at outdoor temp 35°CDB/24°CWB (95°FDB/75.2°FWB) outlet water temp 7°C (44.6°F) inlet water temp 12°C (53.6°F). Pump input is not included in cooling capacity and power input.
  - \*2 Under normal cooling conditions at outdoor temp 35°CDB/24°CWB (95°FDB/75.2°FWB) outlet water temp 7°C (44.6°F) inlet water temp 12°C (53.6°F). Pump input is included in cooling capacity and power input based on EN14511.
  - \*3 Under normal heating conditions at outdoor temp 7°CDB/6°CWB (44.6°FDB/42.8°FWB) outlet water temp 45°C (113°F) inlet water temp 40°C (104°F). Pump input is not included in heating capacity and power input.
  - \*4 Under normal heating conditions at outdoor temp 7°CDB/6°CWB (44.6°FDB/42.8°FWB) outlet water temp 45°C (113°F) inlet water temp 40°C (104°F). Pump input is included in heating capacity and power input based on EN14511.
  - \*5 Amount of factory-charged refrigerant is 3(kg) x 4 when the model name has "L". Please add the refrigerant at the field.
  - \*6 IPLV is calculated in accordance with AHRI 550-590.
  - \*7 ESEER is calculated in accordance with EUROVENT conditions.
- Please do not use the steel material for the water piping.
  - Please always make water circulate, or pull the circulation water out completely when not in use.
  - Please do not use groundwater or well water in direct.
  - The water circuit must be closed circuit.
  - Due to continuous improvement, the above specifications may be subject to change without notice.
  - This model does not equip with a pump.

\*8

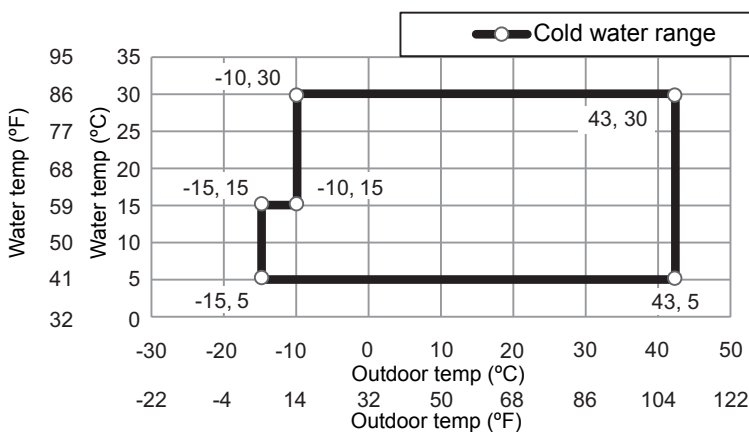
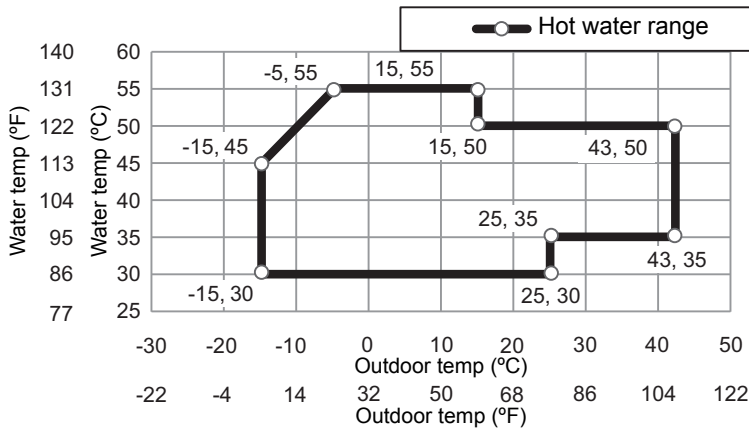



Unit converter

kcal/h = kW x 860

BTU/h = kW x 3,412

lbs = kg/0.4536

cfm = m<sup>3</sup>/min x 35.31

**MITSUBISHI ELECTRIC**

**AIR-COOLED CHILLING UNIT**

**MODEL EAHV-P1500YBL <G>**

---

REFRIGERANT  
R410A (GWP:2088)  
WEIGHT 15.0kg×4  
CO<sub>2</sub> EQUIVALENT 125.3t

---

LEGAL REFRIGERATION TON 16.8RT (4.20RT×4)

ALLOWABLE HP 4.15MPa (41.5bar)  
PRESSURE(Ps) LP 2.21MPa (22.1bar)

---

WEIGHT 1310kg  
IP CODE IP24

---

YEAR OF MANUFACTURE

---



SERIAL No.

OPERATION	COOLING			HEATING		
	380	400	415	380	400	415
RATED VOLTAGE 3N~ V	380	400	415	380	400	415
FREQUENCY Hz	50/60			50/60		
CAPACITY	kW			151.42		
	kcal/h			130221		
	Btu/h			516645		
RATED INPUT kW	46.52			46.01		
EER/COP	3.19			3.29		
RATED CURRENT A	77	73	70	76	72	69
MAX CURRENT A	111			111		
RATED CONDITION						
OUTLET WATER TEMP. °C	7			45		
INLET WATER TEMP. °C	12			40		
OUTDOOR DB/WB. °C	35/24			7/6		

EER/COP and capacity according to EN14511

Contains fluorinated greenhouse gases.

MANUFACTURER:  
MITSUBISHI ELECTRIC CORPORATION  
AIR-CONDITIONING & REFRIGERATION SYSTEMS WORKS  
5-66, TEBIRA, 6-CHOME, WAKAYAMA CITY, JAPAN  
MADE IN JAPAN

**MITSUBISHI ELECTRIC**

**AIR-COOLED CHILLING UNIT**

**MODEL EAHV-P1800YBL <G>**

---

REFRIGERANT  
R410A (GWP:2088)  
WEIGHT 15kg×4  
CO<sub>2</sub> EQUIVALENT 125.3t

---

LEGAL REFRIGERATION TON 19.8RT (4.95RT×4)

ALLOWABLE HP 4.15MPa (41.5bar)  
PRESSURE(Ps) LP 2.21MPa (22.1bar)

---

WEIGHT 1310kg  
IP CODE IP24

---

YEAR OF MANUFACTURE

---

SERIAL No.

OPERATION	COOLING			HEATING		
	380	400	415	380	400	415
RATED VOLTAGE 3N~ V	380	400	415	380	400	415
FREQUENCY Hz	50/60			50/60		
CAPACITY	kW			182.24		
	kcal/h			156726		
	Btu/h			621803		
RATED INPUT kW	61.25			57.92		
EER/COP	2.90			3.15		
RATED CURRENT A	100	95	92	94	90	87
MAX CURRENT A	111			111		
RATED CONDITION						
OUTLET WATER TEMP. °C	7			45		
INLET WATER TEMP. °C	12			40		
OUTDOOR DB/WB. °C	35/24			7/6		

EER/COP and capacity according to EN14511

Contains fluorinated greenhouse gases.

MANUFACTURER:  
MITSUBISHI ELECTRIC CORPORATION  
AIR-CONDITIONING & REFRIGERATION SYSTEMS WORKS  
5-66, TEBIRA, 6-CHOME, WAKAYAMA CITY, JAPAN  
MADE IN JAPAN



### [3] Technical documentation of fan

TECHNICAL DOCUMENTATION

TECHNICAL DOCUMENTATION & PRODUCT INFORMATION

PRODUCT MODEL	EAHV-P1500YB(L)(-H)(-N)(-BS), EACV-P1500YB(L)(-N)(-BS) EAHV-P1800YB(L)(-H)(-N)(-BS), EACV-P1800YB(L)(-N)(-BS)
---------------	--

Requirements		Information
(1)	Overall efficiency (%)	39.29
(2)	Measurement category	A
(3)	Efficiency category	STATIC
(4)	Efficiency grade (N)	40
(5)	VSD	The VSD is integrated within the fan
(6)	Year of manufacture	2018
(7)	Manufacturer	MITSUBISHI ELECTRIC CORPORATION HEAD OFFICE: TOKYO BUILDING 2-7-3, MARUNOUCHI, CHIYODA-KU, TOKYO 100-8310, JAPAN AUTHORIZED REPRESENTATIVE IN EU: MITSUBISHI ELECTRIC EUROPE B.V. HARMAN HOUSE, 1GEORGE STREET, UXBRIDGE, MIDDLESEX UB8 1QQ, U.K. COMMERCIAL REGISTRATION NO.33279602
(8)	Model number	EAHV-P1500YB(L)(-H)(-N)(-BS), EACV-P1500YB(L)(-N)(-BS) EAHV-P1800YB(L)(-H)(-N)(-BS), EACV-P1800YB(L)(-N)(-BS)
(9)	Motor power input (kW)	0.60
	Flow rate (m <sup>3</sup> /s)	3.49
	Pressure (Pa)	68.36
(10)	Rotations per minute	751
(11)	Specific ratio	1.0
(12)	Information relevant for facilitating disassembly, recycling or disposal at end-of-life	Your product should be disposed of separately from household waste in line with local laws and regulations. When this product reaches its end of life, dispose of it at your local waste collection point/recycling centre. The separate collection and recycling of your product at the time of disposal will help conserve natural resources and ensure that it is recycled in a manner that protects human health and the environment. For more information for WEEE recyclers please contact us at <a href="http://www.mitsubishielectric.eu/contact_us_form">http://www.mitsubishielectric.eu/contact_us_form</a>
(13)	Information relevant to minimise impact on the environment and ensure optimal life expectancy as regards installation, use and maintenance of the fan	In addition to daily checks (eg cleaning of filters), periodic maintenance and checks by a skilled technician are required to ensure that the unit is maintained in a good condition for a long period of time, and that it may be used with confidence.
(14)	Description of additional items used when determining the fan energy efficiency	-

# 9. Maintenance

## [1] Operation status check

Operate the unit for at least 30 minutes until the operation is stabilized before checking the operation status.  
Refer to the table in [2].

### <1> Voltage

Ensure that the power-supply voltage is normal.

- Ensure that the terminal voltage is within the range between -5% and +5% of the rated voltage at the rated frequency.

### <2> Current

Ensure that the operation current <total current of the fan and compressor system> is normal.

Operation current varies with outside temperature, cold-water temperature, and operation conditions. Approximate normal values at 400 V are summarized in the table below.

Model	Cooling	Heating
EACV-P1500YB	73 A	72 A
EAHV-P1500YB(-H)		
EACV-P1800YB	95 A	90 A
EAHV-P1800YB(-H)		

\*1 Under normal cooling conditions at outdoor temperature 35°CDB/24°CWB (95°FDB/75.2°FWB)

Outlet water temperature 7°C (44.6°F)

Inlet water temperature 12°C (53.6°F)

\*2 Under normal heating conditions at outdoor temperature 7°CDB/6°CWB (44.6°FDB/42.8°FWB)

Outlet water temperature 45°C (113°F)

Inlet water temperature 40°C (104°F)

### <3> Pressure

Approximate normal high and low pressures are summarized in the table below.

Pressure varies with operation status and conditions.

Pressure	Operation pressure
High pressure <MPa>	1.5 – 3.8
Low pressure <MPa>	0.2 – 1.4

<4> Water temperature

Ensure that the inlet/outlet cold/hot water temperatures match the set temperatures.

When a standard piping type is shared by two or more modules, make sure that the temperatures at the inlet/outlet of each module are approximately equal.

- \* Ensure that the water-flows are well-balanced. Adjust the flows with valves.
- \* Note that the water temperature may abnormally rise from heat generation from the pump if the pump is operated alone for a long time with the unit operation command being set to OFF (operation stop).

<<Standard piping: opposite side of the maintenance access>>

<<Built-in piping: left side>>

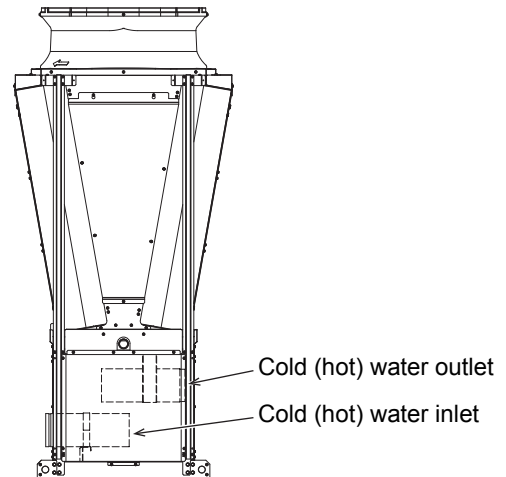
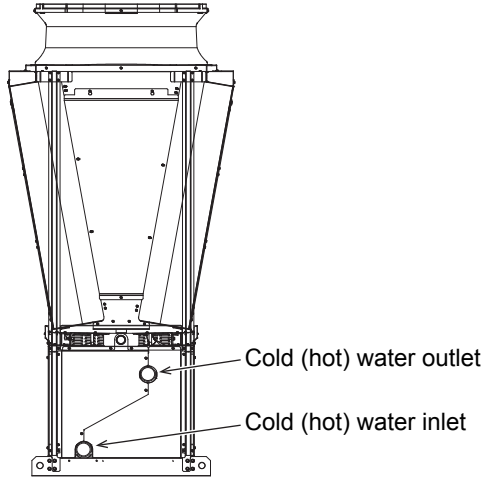

<5> Others

- Check for abnormal operation noise or vibration.
- Ensure that air-side heat exchanger inlet is not clogged with dirt or dead leaves.
- Ensure that the top of the unit is clear of snow.
- Ensure that the drainage of machine compartment is not clogged.

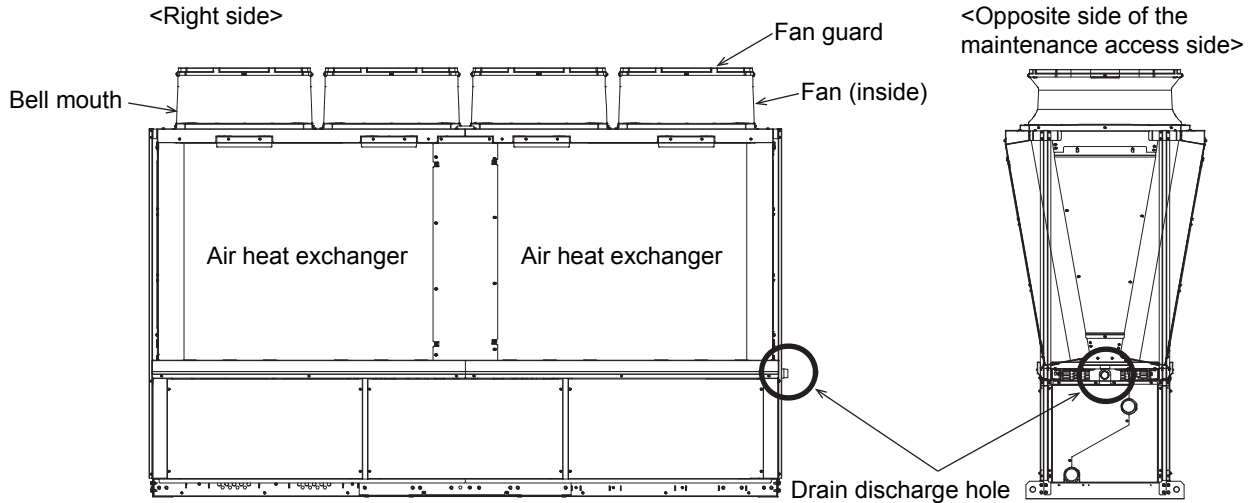

<Top view (ceiling side)>

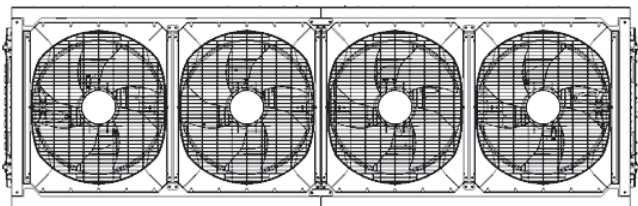

## [2] Guidelines for Maintenance and Inspection of Major Parts of Air-cooled Air-conditioners and Air-cooled Heat Pumps

The table below shows regular inspection items, schedule, and parts replacement criteria under normal use condition. The "Inspection schedule" column under the "Preventive maintenance" column indicates the regular inspection schedule, and the "Maintenance schedule" column indicates an estimation of the time when the parts need to be cleaned or adjusted or when old parts need to be replaced or repaired. The cleaning/adjustment schedule is provided in order to take proper measure to protect the parts from deterioration or performance drop, and the estimated operating time or use period when each part goes into the wear-out failure period is provided so that replacement of the parts can be made at the right timing after the inspection.

Component parts	Parts name		Regular inspection				Preventive maintenance				
	Parts name	Target		Inspection item	Inspection method/tools	Judgement criteria <Reference>	Models			Maintenance item	
		In-door	Out-door				For buildings	For equipment	For stores		
Refrigerant circuit	Compressor		○	○	<ul style="list-style-type: none"> <li>• Sound or vibration at startup, during operation and at stoppage of the compressor</li> <li>• Insulation resistance</li> <li>• Terminals and wiring</li> </ul>	Visual, auditory, and tactile check 500V megahertz Screwdriver, visual check	<ul style="list-style-type: none"> <li>• Free from abnormal noise and vibration</li> <li>• The insulation resistance is 1MΩ or greater.</li> <li>• Free from loose terminals and wiring contacts</li> </ul>	○	○	○	<ul style="list-style-type: none"> <li>• If abnormal, replace the compressor.</li> <li>• If the insulation resistance is 1MΩ or less, replace the compressor.</li> <li>• Retighten the terminals, and rewire the wiring.</li> </ul>
	Electronic expansion valve		○	○	<ul style="list-style-type: none"> <li>• Operation</li> <li>• Operating sound by turning ON or OFF the unit (pressure check)</li> </ul>	Tactile check Auditory and tactile check	<ul style="list-style-type: none"> <li>• Refrigerant circulation is confirmed.</li> <li>• Operating sound is heard and temperature change is confirmed.</li> </ul>	○	○	○	<ul style="list-style-type: none"> <li>• Replace the electronic expansion valve if it is stuck.</li> </ul>
	Refrigerant system	Inner piping	○	○	<ul style="list-style-type: none"> <li>• Sympathetic vibration, contact, and corrosion of the inner piping</li> <li>• Sympathetic vibration and contact of the capillary tube</li> </ul>	Visual check Visual check	<ul style="list-style-type: none"> <li>• Free from abnormal sympathetic vibration, sound, and corrosion</li> <li>• Free from abnormal sympathetic vibration and contact wear</li> </ul>	○	○	○	<ul style="list-style-type: none"> <li>• If the pipes are severely corroded, replace or repair the pipe.</li> <li>• If the pipes are severely worn out, replace or repair the pipe.</li> </ul>
		Solenoid valve, 4-way valve	○	○	<ul style="list-style-type: none"> <li>• Operation and insulation performance of the solenoid valve and the 4-way valve</li> <li>• Corrosion and abnormal sound</li> </ul>	500V megahertz Visual and auditory check	<ul style="list-style-type: none"> <li>• The insulation resistance is 1MΩ or greater.</li> <li>• Free from abnormal noise and corrosion</li> </ul>	○	○	○	<ul style="list-style-type: none"> <li>• If the insulation resistance is 1MΩ or less, replace the valve.</li> </ul>
		Container	○	○	<ul style="list-style-type: none"> <li>• Corrosion of the accumulator or the oil separator</li> </ul>	Visual check	<ul style="list-style-type: none"> <li>• Free from corrosion</li> </ul>	○	○	○	<ul style="list-style-type: none"> <li>• If there is corrosion, paint the surface.</li> </ul>
	Protection device (security parts)	High-voltage circuit breaker	○	○	<ul style="list-style-type: none"> <li>• Operating pressure, refrigerant leak, and insulation resistance</li> </ul>	Pressure gauge etc.	<ul style="list-style-type: none"> <li>• The high-voltage circuit breaker operates at the set value.</li> <li>• The measured value is within the range specified by the regulation.</li> </ul>	○	○	○	<ul style="list-style-type: none"> <li>• Replace the parts regularly.</li> </ul>
		Fusible plug	○	○	<ul style="list-style-type: none"> <li>• Appearance (swollen soluble metal)</li> </ul>	Visual check	<ul style="list-style-type: none"> <li>• The soluble metal is at the normal position.</li> </ul>	○	○	○	
	Heat exchanger		○	○	<ul style="list-style-type: none"> <li>• Clogging and damage</li> <li>• Refrigerant leak</li> </ul>	Visual check Refrigerant leak detector	<ul style="list-style-type: none"> <li>• Free from clogging and damage</li> <li>• Free from leakage</li> </ul>	○	○	○	<ul style="list-style-type: none"> <li>• Clean the air inlet if clogged.</li> <li>• If the refrigerant leak is detected, repair or replace the heat exchanger</li> </ul>
Electrical parts	Fan motor		○	○	<ul style="list-style-type: none"> <li>• Abnormal sound</li> <li>• Insulation resistance</li> </ul>	Auditory check 500V megahertz	<ul style="list-style-type: none"> <li>• Free from abnormal noise</li> <li>• The insulation resistance is 1MΩ or greater.</li> </ul>	○	○	○	<ul style="list-style-type: none"> <li>• If the bearing sound is loud, replace the bearing.</li> <li>• If the insulation erodes, replace the motor.</li> </ul>
	Drain pump		○	○	<ul style="list-style-type: none"> <li>• Drainage and dirt</li> <li>• Insulation resistance</li> </ul>	Visual check 500V megahertz	<ul style="list-style-type: none"> <li>• Free from abnormal drainage and abnormal dirt</li> <li>• The insulation resistance is 1MΩ or greater.</li> </ul>	○	○	○	<ul style="list-style-type: none"> <li>• If it does not drain properly, replace the drain pump.</li> </ul>
	Float switch		○	○	<ul style="list-style-type: none"> <li>• Operation</li> </ul>	Tester	<ul style="list-style-type: none"> <li>• Normal ON-OFF operation</li> </ul>	○	○	○	<ul style="list-style-type: none"> <li>• If abnormal, replace the float switch</li> </ul>
	Auto louver motor		○	○	<ul style="list-style-type: none"> <li>• Insulation resistance and abnormal sound</li> </ul>	500V megahertz, auditory check	<ul style="list-style-type: none"> <li>• The insulation resistance is 1MΩ or greater. Free from abnormal sound</li> </ul>	○	○	○	<ul style="list-style-type: none"> <li>• If the insulation resistance is 1MΩ or less, replace the motor or the heater.</li> </ul>
	Anti-freezing/anti-dew condensation heater		○	○	<ul style="list-style-type: none"> <li>• Insulation resistance and appearance</li> </ul>	500V megahertz, visual check	<ul style="list-style-type: none"> <li>• The insulation resistance is 1MΩ or greater. Free from abnormality</li> </ul>	○	○	○	
	Cooling fan		○	○	<ul style="list-style-type: none"> <li>• Insulation resistance and abnormal sound</li> </ul>	500V megahertz, auditory check	<ul style="list-style-type: none"> <li>• The insulation resistance is 1MΩ or greater. Free from abnormal sound</li> </ul>	○	○	○	<ul style="list-style-type: none"> <li>• Replace the cooling fan if the fan is stuck.</li> </ul>
	Switch (including FFB and ELB)	Electromagnetic switch Overcurrent relay Auxiliary relay	○	○	<ul style="list-style-type: none"> <li>• Operation and appearance</li> <li>• Contact points</li> </ul>	Visual check	<ul style="list-style-type: none"> <li>• Free from deformation</li> <li>• Normal operation and free from deformation</li> <li>• Free from deformation and discoloration</li> </ul>	○	○	○	<ul style="list-style-type: none"> <li>• Replace the switches in case of malfunction, deformation, or discoloration.</li> </ul>
			○	○	<ul style="list-style-type: none"> <li>• Whether the crankcase heater is powered during compressor stop</li> <li>• Insulation resistance of the crankcase heater</li> </ul>	Tester 500V megahertz	<ul style="list-style-type: none"> <li>• The crankcase heater is powered during compressor stop, and is heated up.</li> <li>• The insulation resistance is 1MΩ or greater.</li> </ul>	○	○	○	<ul style="list-style-type: none"> <li>• Rewire the electric wiring.</li> <li>• If the insulation resistance is 1MΩ or less, replace the crankcase heater.</li> </ul>
	Fuse		○	○	<ul style="list-style-type: none"> <li>• Appearance</li> </ul>	Visual check	<ul style="list-style-type: none"> <li>• Free from deformation and discoloration</li> </ul>	○	○	○	<ul style="list-style-type: none"> <li>• Replace the fuse if the fuse is blown.</li> </ul>
Electronic parts	Control box (including inverter)		○	○	<ul style="list-style-type: none"> <li>• Insulation resistance or the circuit</li> <li>• Dust of the circuit board</li> <li>• Terminals and connectors</li> <li>• Appearance of the electrolytic capacitor</li> </ul>	500V megahertz Visual check Screwdriver, visual check Visual check	<ul style="list-style-type: none"> <li>• The insulation resistance is 1MΩ or greater.</li> <li>• Free from accumulation of dust</li> <li>• All connectors are properly connected.</li> <li>• Free from liquid leak and deformation</li> </ul>	○	○	○	<ul style="list-style-type: none"> <li>• If tainted with a large amount of dust, clean with a brush.</li> <li>• Replace the circuit board in case of malfunction.</li> <li>• Retighten the terminals, and reconnect the connectors.</li> <li>• Replace the electrolytic capacitor in case of liquid leak.</li> </ul>
	Smoothing capacitor		○	○	<ul style="list-style-type: none"> <li>• Capacitance and insulation resistance</li> </ul>	Electrostatic meter, 500V megahertz	<ul style="list-style-type: none"> <li>• At or over the specified value</li> </ul>	○	○	○	<ul style="list-style-type: none"> <li>• Replace the capacitor regularly.</li> </ul>
	Electric parts box (including circuit board)		○	○	<ul style="list-style-type: none"> <li>• Insulation resistance of the circuit and appearance of the capacitor</li> <li>• Terminals and connectors</li> <li>• Self-diagnosis mode and appearance</li> </ul>	Visual check Visual check	<ul style="list-style-type: none"> <li>• The insulation resistance is 1MΩ or greater.</li> <li>• All connectors are properly connected.</li> <li>• No error display appears.</li> </ul>	○	○	○	<ul style="list-style-type: none"> <li>• Retighten the terminals, and reconnect the connectors.</li> <li>• Replace the circuit board in case of liquid leak.</li> </ul>
	Pressure sensor, thermistor		○	○	<ul style="list-style-type: none"> <li>• Open, short-circuit, and appearance</li> </ul>	Tester, visual check	<ul style="list-style-type: none"> <li>• Within the specified value, and free from discoloration</li> </ul>	○	○	○	<ul style="list-style-type: none"> <li>• If the wire is disconnected or short-circuit, replace the pressure sensor or the thermistor.</li> </ul>
	SW power source		○	○	<ul style="list-style-type: none"> <li>• Output voltage</li> </ul>	Tester	<ul style="list-style-type: none"> <li>• Within the specified output voltage range</li> </ul>	○	○	○	<ul style="list-style-type: none"> <li>• Replace the SW if the voltage is abnormal.</li> </ul>
			○	○							
Electro-mechanical parts	Filter		○	○	<ul style="list-style-type: none"> <li>• Dirt or tear</li> </ul>	Visual check	<ul style="list-style-type: none"> <li>• The filter material is seen through.</li> <li>• Free from tear and deformation</li> </ul>	○	○	○	<ul style="list-style-type: none"> <li>• Wash the filter with water if it is dirty.</li> <li>• Replace the filter if it is torn.</li> </ul>
	Fan casing		○	○	<ul style="list-style-type: none"> <li>• Vibration and balance</li> <li>• Dust accumulation and appearance</li> </ul>	Visual check Visual check	<ul style="list-style-type: none"> <li>• Free from abnormal vibration</li> <li>• Free from rust and deformation</li> </ul>	○	○	○	<ul style="list-style-type: none"> <li>• Replace the fan if it vibrates abnormally or the fan is out of balance.</li> <li>• If tainted with a large amount of dust, clean with brush, or wash the fan with water.</li> </ul>
	Inlet/outlet grille		○	○	<ul style="list-style-type: none"> <li>• Dirt or damage</li> <li>• Operation of the outlet grille louver</li> </ul>	Visual check	<ul style="list-style-type: none"> <li>• Free from damage and deformation</li> </ul>	○	○	○	<ul style="list-style-type: none"> <li>• Repair or replace the inlet/outlet grille in case of deformation or damage.</li> <li>• Replace the bearing or the motor in case of malfunction.</li> </ul>
Structural parts	Decorative part (design part)		○	○	<ul style="list-style-type: none"> <li>• Dirt and damage</li> </ul>	Visual check	<ul style="list-style-type: none"> <li>• Free from dirt, damage, and deformation</li> </ul>	○	○	○	<ul style="list-style-type: none"> <li>• Wash the panel with neutral detergent, and paint the surface.</li> </ul>
	Frame, bottom plate		○	○	<ul style="list-style-type: none"> <li>• Rust and insulation material</li> <li>• Flaked coating</li> </ul>	Visual check	<ul style="list-style-type: none"> <li>• Free from rust and damaged insulation</li> </ul>	○	○	○	<ul style="list-style-type: none"> <li>• Repair the frame or the bottom plate if the insulation material is torn.</li> <li>• Paint the surface.</li> </ul>
	Guard panel		○	○	<ul style="list-style-type: none"> <li>• Flaked coating</li> </ul>	Visual check	<ul style="list-style-type: none"> <li>• Free from rust</li> </ul>	○	○	○	<ul style="list-style-type: none"> <li>• Paint the surface.</li> </ul>
	Anti-vibration rubber		○	○	<ul style="list-style-type: none"> <li>• Erode or harden of the rubber</li> </ul>	Visual and auditory check	<ul style="list-style-type: none"> <li>• The anti-vibrate function operates properly.</li> </ul>	○	○	○	<ul style="list-style-type: none"> <li>• Replace the anti-vibration rubber if it erodes or hardens.</li> </ul>
Optional parts	Remote controller switch		○	○	<ul style="list-style-type: none"> <li>• Controllability</li> </ul>	Visual check	<ul style="list-style-type: none"> <li>• The display obeys the operation command.</li> </ul>	○	○	○	<ul style="list-style-type: none"> <li>• Replace the remote controller switch if the display does not obey the operation command or wrong display appears.</li> </ul>
	Moisture humidifier		○	○	<ul style="list-style-type: none"> <li>• Humidification condition and moisture supply</li> <li>• Nozzle</li> <li>• Scale and insulation resistance</li> </ul>	Visual check 500V megahertz	<ul style="list-style-type: none"> <li>• Moisture is generated according to the specifications.</li> <li>• The insulation resistance is 1MΩ or greater.</li> </ul>	○	○	○	<ul style="list-style-type: none"> <li>• Check the vapor pressure.</li> <li>• Clean the nozzle if clogged.</li> </ul>
	Electric heater		○	○	<ul style="list-style-type: none"> <li>• Heat generation part and damage on safe device</li> <li>• Insulation material</li> </ul>	Visual check 500V megahertz	<ul style="list-style-type: none"> <li>• Free from damage and deformation</li> <li>• The insulation resistance is 1MΩ or greater.</li> </ul>	○	○	○	<ul style="list-style-type: none"> <li>• Replace the heater if damaged or deformed.</li> </ul>

Note1) Unexpected failure is a sudden and unpredictable failure that occurs randomly before the parts or the device reaches its lifespan. It is difficult to take the technical measures, and at the moment where only the measures based on statistics can be taken.

Note2) The elapsed year shown in the column marked with \* is the estimated period of time under the condition the equipment used 10 hours per day and for 2500 hours per year without frequent start and stop. The years vary depending on the operating condition. Confirm the details whenever conclude the maintenance contract.

Note3) shows the estimated year of initial wear-out happen and increase of failure rate year by year.

Remark of semiotics

- : Inspection schedule
- : Cleaning or adjustment schedule of the parts based on the inspection result
- ▲ : Replacement or repair of the parts in case of error after inspection
- ◆ : Regular replacement (consumable parts)

Inspection schedule		Maintenance schedule		Preventive maintenance															Remarks				
Yearly	Others	Inspection schedule	Hour of use	Period of use	Elapsed year*																		
					1	2	3	4	5	6	7	8	9	10	11	12	13	14		15			
●		Before cooling operation season	20,000Hr																				
●			20,000Hr										▲										
			20,000Hr																				
●			25,000Hr																				Consumable parts
			15,000Hr																				Consumable parts
●				5 years																			Parts to be cleaned Dirt caused by being exposed to the air
●		Before cooling operation season	20,000Hr																				
●			20,000Hr																				
●			20,000Hr																				
●			25,000Hr																				
●				8 years																			Consumable parts
●				10 years																			Consumable parts
●		Before cooling operation season	25,000Hr																				
			10 years																				Consumable parts
●			25,000Hr																				
●			5 years																				
●			10 years																				
●	Weekly			5 years																			Consumable parts
●	Before cooling operation season	Outdoor	10 years	13 years																			
●			8 years	5 years																			
●	Before cooling operation season		8 years																			Parts to be cleaned	
●			10 years																				
●	Before cooling operation season		25,000Hr																				
●	Before heating operation season		5 years																			Parts to be cleaned	
●			8 years																				





---

This product is designed and intended for use in the residential,  
commercial and light-industrial environment.

The product at hand is  
based on the following  
EU regulations:

- Low Voltage Directive 2014/35/EU
- Electromagnetic Compatibility Directive  
2014/30/EU
- Pressure Equipment Directive 2014/68/EU
- Machinery Directive 2006/42/EC

Please be sure to put the contact address/telephone number on  
this manual before handing it to the customer.

## **MITSUBISHI ELECTRIC CORPORATION**

**HEAD OFFICE:** TOKYO BLDG., 2-7-3, MARUNOUCHI, CHIYODA-KU, TOKYO 100-8310, JAPAN

**Authorized representative in EU:** MITSUBISHI ELECTRIC EUROPE B.V.

HARMAN HOUSE, 1 GEORGE STREET, UXBRIDGE, MIDDLESEX UB8 1QQ, U.K.