Procon

MICRO M2M-SMS-A/08

FOR INSTALLERS

INSTALLATION AND OPERATION MANUAL Version 1.02

For safe and correct use, please read this installation manual thoroughly before installing the MICRO M2M-SMS-A/08.

mitsubishi
MITSUBISHI ELECTRIC

Preface

Safety warnings

Caution:

Do not expose to rain or moisture.

Screened Signal Cables:

Use only screened cables for connecting peripherals to any Procon Micro M2M device to reduce the possibility of interference with radio communications services. Using screened cables ensures that you maintain the appropriate EMC classification for the intended environment.

CE Notice:

This product has been determined to be in compliance with 2004/108/EC (EMC Directive) and amendments of the European Union.

European Union, Class A:

Class A products are intended for use in non-residential/non-domestic environments. Class A products may also be utilised in residential/domestic environments but may cause interference and require the user to take adequate corrective measures.

This is a Class A product. In a domestic environment this product may cause radio frequency interference in which case the user may be required to take adequate measures.

A "Declaration of Conformity" in accordance with the preceding directives and standards has been made and is available on request.

If this equipment does cause interference with radio communications services, which can be determined by turning the equipment off and on, you are encouraged to try to correct the interference by one or more of the following measures:

- Reorient the receiving antenna.
- Relocate the Procon Micro M2M with respect to the receiver.
- Move the Procon Micro M2M away from the receiver.

If necessary, consult a Procon Micro M2M technical support representative or an experienced radio/television or EMC technician for additional suggestions.

Disclaimer

Warranty:

All products manufactured on behalf of Mitsubishi Electric UK are warranted against defective materials for a period of three years from the date of delivery to the original purchaser.

Warning:

Mitsubishi Electric UK assumes no liability for damages consequent to the user of this product. We reserve the right to change this manual at any time without notice. The information furnished by us is believed to be accurate and reliable. However, no responsibility is assumed by us for its use, nor for any infringements of patents or other rights of third parties resulting from its use.

Contents

Preface	2
Safety warnings	2
1. Safety precautions	9
2. Overview	10
3. Size and weight	11
4. Getting Started	12
4.1. Unpacking	12
4.2. Before Switching On	12
4.3. SIM Card	12
4.3.1. Pay As You Go (PAYG) SIM card	12
4.3.2. Contract SIM card	12
5. Installation	13
5.1. Selecting an Installation Site	13
5.2. Installation	13
5.2.1. Physical unit installation	13
5.2.2. Fitting a SIM card	13
5.2.3. Power supply	13
5.2.4. Modbus wiring	14
5.3. Initial Power On	14
5.4. Status Indicators	14
6. Functions – Monitor and Control	15
6.1. SMS Command Detail	15
6.1.1. Adding a phone number to the Micro M2M	15
6.1.2. Registering air conditioning units	15
6.1.3. Registered units	16
6.1.4. Status of units connected	17
6.1.5. Setting a maximum temperature alarm	18
6.1.6. Checking the maximum temperature alarm	18
6.1.7. Removing a phone number	18
6.1.8. Registered numbers	18
6.1.9. Setting the air conditioning units	19
6.1.10. Help	19
6.1.11. Factory reset	20
6.1.12. SMS reset	20
6.1.13. Fault reset	20
6.2. Autonomously generated SMS responses	20
6.3. Backup and Rotate Feature	21
7. Applicable Air Conditioning Models	23
8. Important Notes	24
9. Trouble Shooting	25

1

[Fig. 1]
Included Items

A



B



A 1 x MICRO M2M-SMS-A08

B 1 x A1M

C 1 x Aerial

C



2

[Fig. 2]
Outside of Unit

- A Aerial Connection
- B Power LED
- C Signal strength LED
- D Modbus Read LED
- E Modbus Write LED

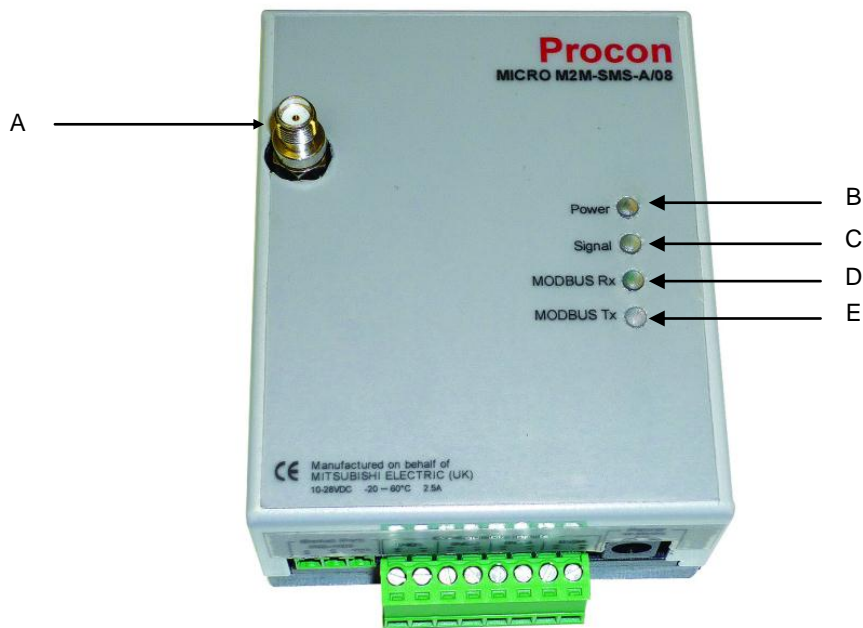

3

[Fig. 3]
Inside of Units

- A SIM card holder
- B Aerial connection
- C Power input 12-28V DC
- D Reset button
- E RS-485 Modbus connector



Note: The following terminals and buttons are not used for this product

- Sync button
- Configurable inputs IN01, IN02, IN03 and IN04
- Digital outputs DO01 and DO02
- Auxiliary power
- USB terminal

4

[Fig. 4]
Wiring Diagram

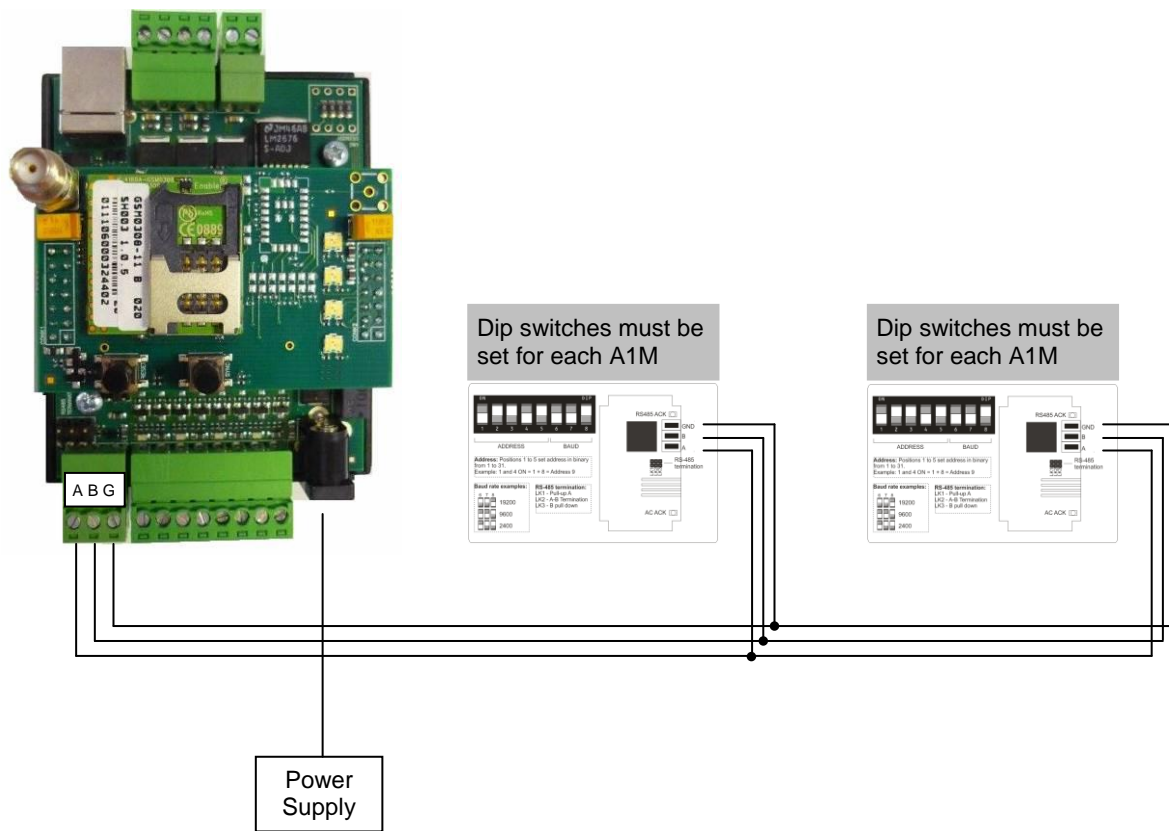

Notes:

- GND must be connected
- Screened cable must be used
- For communication over RS-485 all 3 connections are needed. These are labelled A, B and GND
- The RS-485 cable must be a screened data cable. Mains flex or other unscreened cable must not be used
- The cable screen must be connected to GND at one end only
- RS-485 has polarised data connections. It is crucial that all 'A's are connected together, all 'B's are connected together and all 'GND's are connected together
- The RS-485 cable must be a daisy-chained network. T-junctions (e.g. star network) are not permitted
- Please see Procon A1M Installation and Operation manual for more details

Quick Set Up

Step 1:

A SIM Card must be purchased (any provider). Check for mobile phone coverage.

Step 2:

A 10 to 28VDC 0.5-2.5amp power supply must be purchased (Recommendation, RS components: 458-935 (UK plug top) or equivalent)

Step 3:

Connect the Modbus network between the Micro M2M and the A1M(s).

Important notes:

- ***A must be connect to A, B to B and GND to GND***
- ***Screened cable must be used***
- ***Each A1M must be addressed***

Step 4:

Open the front cover and install the SIM Card (see page 14 for more detail). Make note of the SIM's phone number.

Step 5:

Close the front cover and switch ON the power supply.

Step 6:

Add your phone number to the Micro M2M by sending **[PIN] ADD**.

- The PIN is the last 4 digits of the Micro M2M serial number
- If the serial number of the Micro M2M is SN322987 the PIN is 2987 so 2987 ADD
- The serial number can be found on the top board adjacent to the modem or on the bottom of the base

Step 7:

Register the number of indoor units (number of A1M(s)) by sending e.g. **REGISTER 1** to register 1 unit.

Step 8:

You can now send for instance:

- **STATUS** to read the Status of all indoor units
- **SET 1 ON HEAT 21** to set unit 1 to ON, HEAT, 21°C

1. Safety precautions

- **Before installing the unit, make sure you read all the “Safety precautions”**
- **The “Safety precautions” provide very important points regarding safety. Make sure you follow them**

Symbols used in the text

Warning:

Describes precautions that should be observed to prevent danger of injury or death to the user.

Caution:

Describes precautions that should be observed to prevent damage to the unit.

-  **Warning:**
Carefully read the labels affixed to the main unit

Warning:

- **Ask the dealer or an authorised technician to install the unit**
 - Improper installation by the user may result in water leakage, electric shock, or fire
- **Use the specified cables for wiring. Make the connections securely so that any outside forces acting on the cables are not applied to the terminals**
 - Inadequate connection and fastening may generate heat and cause a fire
- **Never repair the unit. If the controller must be repaired, consult the dealer**
 - If the unit is repaired improperly, electric shock, or fire may result
- **When handling this product, always wear protective equipment. EG: Gloves, full arm protection and safety glasses**
 - Improper handling may result in injury
- **Have all electric work done by a licensed electrician according to "Electric Facility Engineering Standard", "Interior Wire Regulations" and the instructions given in this manual and always use a special circuit**
 - If the power source capacity is inadequate or electric work is performed improperly, electric shock and fire may result
- **Keep the electric parts away from any water - washing water etc...**
 - Contact may result in electric shock, fire or smoke
- **Do not reconstruct or change the settings of the protection devices**
 - If the protection device is shorted or operated forcibly, or parts other than those specified by Mitsubishi Electric are used, fire or explosion may result
- **To dispose of this product, consult your dealer**

Caution:

- **Ground the unit**
 - Do not connect the ground wire to gas or water pipes, lightning rods, or telephone ground lines. Improper grounding may result in electric shock
- **Install the power cable so that tension is not applied to the cable**
 - Tension may cause the cable to break and generate heat which may, in turn, cause fire
- **Install a leak circuit breaker, as required**
 - If a leak circuit breaker is not installed, electric shock may result
- **Use power line cables of sufficient current carrying capacity and rating**
 - Cables that are too small may leak, generate heat, and cause a fire
- **Use only a circuit breaker and fuse of the specified capacity**
 - A fuse or circuit breaker of a larger capacity or a steel or copper wire may result in a general unit failure or fire
- **Be careful that the installation base is not damaged**
 - If the damage is left uncorrected, the unit may fall and cause personal injury or property damage
- **Safely dispose of the packing materials**
 - Packing materials, such as nails and other metal or wooden parts, may cause stabs or other injuries
 - Tear apart and throw away plastic packaging bags so that children will not play with them - If children play with a plastic bag which has not been torn apart, they face the risk of suffocation

2. Overview

The Micro M2M is designed to work with splits systems. The interface can monitor and control up to 8 splits systems. The Micro M2M cannot be connected to the M2M server but can be monitored and controlled using text messages (SMS).

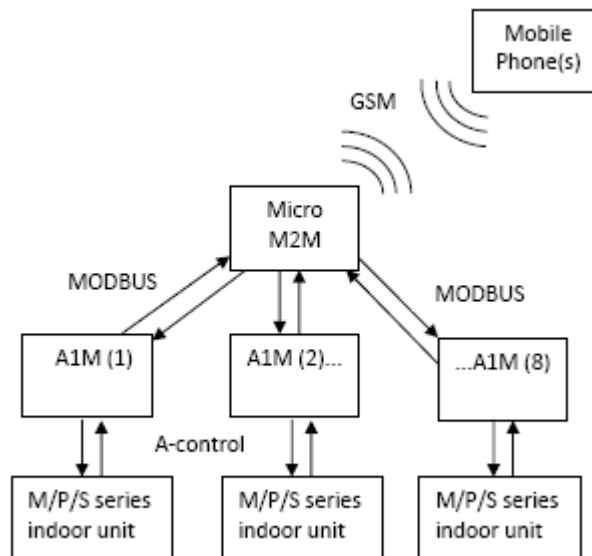

The panel will be fed with a 12-28VDC power supply (not supplied)

The unit is supplied with accessories to interface with the Air Conditioning indoor unit:

- 1 A1M Modbus interface which connects the Micro M2M to M/S and P series indoor units via CN105/CN92. See page 23 for more detail.

Figure 1 shows the items included with the MICRO M2M-SMS-A/08

Figure 2 shows the outside of the unit.

Figure 3 shows the inside of the unit.

Figure 4 shows the wiring diagram of the unit.

3. Size and weight

The panel details are:

- Height 105mm
- Width 70mm
- Depth 51mm
- Weight 250g

4. Getting Started

4.1. Unpacking

The Procon Micro M2M is supplied with the following components:

- Procon MICRO-M2M-SMS A/08 unit
- External magmount antenna with 2m, SMA terminated coaxial cable
- Procon A1M. (Modbus converter for connecting to split systems)
- This installation and operation manual

Please contact your supplier if any of these components are missing.

4.2. Before Switching On

Please carefully read the Installation section 5. Before switching the unit on, please check all connections are secure.

The unit does not come with a power supply. The unit requires a 12-28V DC 2.5A power supply (12V DC 0.5A is suitable)

The unit does not come with a SIM card. Please refer to the fitting a SIM card section in Installation, section 5.2.2.

4.3. SIM Card

The Procon Micro M2M unit is provided with a GSM modem, which works in conjunction with a suitable PAY AS YOU GO SIM card (**not provided**) to provide a wireless connection to the service providers SMS server allowing monitor and control of the Micro M2M via a standard mobile phone text message.

Please purchase a suitable SIM card with SMS enabled from any network provider prior to installation.

To install the SIM card follow the instructions in Installation, section 5.2.2.

4.3.1. Pay As You Go (PAYG) SIM card

If purchasing a pay as you go SIM card, the SIM will have to be topped up with credit to allow the system to communicate via SMS. The cost of a standard text varies between providers. The Procon Micro M2M will allow users to monitor how many SMS text messages have been sent.

The Procon Micro M2M will send an SMS every 28 days to keep the PAYG SIM card activated.

4.3.2. Contract SIM card

If purchasing a contract SIM card, the system will only use SMS texts to communicate. The cost of a standard text varies between providers. The Procon Micro M2M will allow users to monitor how many SMS text messages have been sent.

5. Installation

5.1. Selecting an Installation Site

- Avoid locations in direct sunlight
- Avoid locations exposed to steam or oil vapour
- Avoid locations where combustible gas may leak, settle or be generated
- Avoid installation near machines emitting high-frequency waves
- Avoid places where acidic solutions are frequently handled
- Avoid places where sulphur-based or other sprays are frequently used
- Avoid areas of high humidity
- Install inside the building
- Install near the connected indoor units

5.2. Installation

5.2.1. Physical unit installation

The Procon Micro M2M has DIN Rail mounts on the bottom of the unit. Please secure the Procon Micro M2M before powering the unit on.

5.2.2. Fitting a SIM card

Before using Procon Micro M2M, a valid SIM card with credit added may be installed. This SIM card can be either a Pay As You Go SIM or a monthly contract SIM card. To do this:

- Ensure the power to the unit is switched off
- Remove the cover by pressing the plastic holders either side of the unit
- Remove the cover by lifting upwards
- Locate the SIM card holder which is located on the electronic circuit board, raised from the main PCB board
- Slide the SIM card into the SIM holder with the contacts facing down
- Reassemble the case and clip back into place

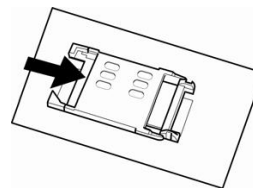

5.2.3. Power supply

⚠ Warning:

Electrical work should be done by qualified electrical engineers / electrician in accordance with "Engineering Standards for Electrical Installation" and supplied installation manuals. Dedicated circuits should also be used. If the power circuit lacks capacity or has an installation failure, it may cause a risk of electric shock or fire.

The Procon Micro M2M does not come with a power supply. Please purchase a power supply with the following specifications and attach the plug to the Procon Micro M2M power in.

- 12-28V DC 2.5A (12V DC 0.5A is sufficient)
- Recommendation, RS components: 459-954 (EU plug top) or equivalent.

⚠ Caution:

Do not use anything other than the correct capacity breaker and fuse. Using fuse, wire or copper wire with too large capacity may cause a risk of malfunction or fire.

- Be sure to take power from the special branch circuit
- Install the unit to prevent any of the control circuit cables coming into direct contact with power cables
- Ensure that there is no slack on all wire connections
- Never connect the power cable to leads for the transmission cables. This will damage the transmission cables

5.2.4. Modbus wiring

⚠ Caution:

All notes below should be carefully followed to ensure the Modbus network communicates correctly.

- GND must be connected. Screened cable must be used
- For communication over RS-485 all 3 connections are needed. These are labelled A, B and GND
- The RS-485 cable must be a screened data cable. Mains flex or other unscreened cable must not be used. The cable screen should be connected to GND at one end only
- RS-485 has polarised data connections. It is crucial that all 'A's are connected together, all 'B's are connected together and all 'GND's are connected together
- The RS-485 cable must be daisy-chained in a bus network. T-junctions (e.g. star network wiring) are not permitted
- Please see Procon A1M Installation and Operation manual for more details

5.3. Initial Power On

Once all above has been carried out, apply power to the unit. The power indicator on the front panel will light up to indicate that it has started.

When power is first applied Micro M2M will attempt to connect to the SMS network. Once successful the unit can be commissioned (see section 6).

5.4. Status Indicators

The status indicators have the following functions:

Indicator	Description
Power	On constantly – Micro M2M is powered up. Off – there is no power to Micro M2M
Signal	On constantly – there is sufficient GSM signal strength to make a connection Off– there is insufficient GSM signal strength Flashing – the modem is resetting
MODBUS Rx	Blinks when the Micro M2M receives signal from the A1M
MODBUS Tx	Blinks when the Micro M2M sends signal from the A1M

6. Functions – Monitor and Control

6.1. SMS Command Detail

The Procon Micro M2M communicates via SMS text messages. When a text is sent to the Micro M2M it will in most cases respond with a text to the registered number. To verify that SMS are intended for a particular Micro M2M, messages must come from a recognised number.

Below is a list of SMS commands. Commissioning of the Micro M2M can be carried out with these commands. Please note for the system to work, a SIM card with credit needs to be installed, the power to all units needs to be on (including air conditioning units) and all cables connected. The commissioning engineer also requires an SMS enabled phone or access to an SMS web server on the internet.

Below the messages are described presuming the ADD command has been issued and the phone number has been stored in the Micro M2M memory. At the end of every SMS from the Micro M2M will be a count noting the total number of SMS sent. This value will count from 1-999 at which point it will stop until the SMS RESET command is issued.

Please note that the bulleted point under each section is the command.

6.1.1. Adding a phone number to the Micro M2M

– [PIN] ADD

Example

○ 1234 ADD

This adds the sender's phone number into the Micro M2M's memory. In this case the PIN is the last four digits of the serial number (SN) of the Micro M2M unit. The SN number is a 6 digit number and can be found on the top board adjacent to the modem or on the bottom of the base.

There are 8 slots available allowing up to 8 numbers to be stored. If all slots are already occupied the following response will be generated:

```
ERROR ADDRESS BOOK FULL
```

```
SMS:[SMS count value]
```

6.1.2. Registering air conditioning units

– REGISTER [number of A1M units (0-8)] [unit 1 name (up to 14 characters)], [unit 2 name (up to 14 characters)], ... , [unit 8 name (up to 14 characters)]

Examples

○ REGISTER 3
○ REGISTER 2 SERVERROOM RECEPTION
○ REGISTER 4 SERVERROOM SERVERRM2 RECEPTION OFFICE
○ REGISTER 0

This sets the number of A1M units the Micro M2M will communicate with. Choosing 0 will prevent the M2M from communicating with any A1M units. If the register command is issued again with one or more A1Ms selected the M2M will communicate with the required number of A1M units. The A1Ms can be renamed if desired (defaults 1 ... 8).

The names are restricted by the following conditions;

- Can be up to 14 characters long
- Must start with a letter
- Can include numbers
- Must not contain spaces
- Must be separated by spaces
- Must only include letters and numbers

This command is used to add as well as remove A1M units (This SMS will not need to be sent if the Micro M2M is connected to only 1 A1M). If names are too long or are identical the following SMS will be sent:

NAMES TOO LONG OR INVALID: 14 CHARACTERS MAX CANNOT CONTAIN SPACES MUST START WITH A LETTER CAN CONTAIN NUMBERS AND MUST BE SEPARATED BY SPACES

SMS:[SMS count value]

6.1.3. Registered units

- **UNITS**

Example

o UNITS

This requests the number of A1M units registered to the Micro M2M, it will respond to the sender with:

```
[number of A1M units (0-8)] A1M UNITS REGISTERED  
[A1M unit 1 name]  
...  
[A1M unit 8 name]
```

SMS:[SMS count value]

Examples

```
3 UNITS REGISTERED  
SERVERROOM  
SERVERRM2  
RECEPTION
```

SMS:6

```
4 UNITS REGISTERED  
1  
2  
3  
4
```

SMS:4

6.1.4. Status of units connected

- **STATUS**

Example

- o STATUS

This requests the status of all connected A1M units. Micro M2M will respond as described below with a separate SMS for each individual A1M.

- **STATUS [A1M unit name]**

Examples

- o STATUS 1
- o STATUS RECEPTION

Requests the status of a single A1M unit.

The Micro M2M will reply to the sender with the status details for the requested A1M with 1 of 2 messages depending on whether or not a fault has been detected:

If the system is operating correctly the following SMS will be sent:

```
STATUS [A1M unit name]:OK
A1M COMMS:OK
DRIVE:[value (ON/OFF) ]
TEMP:[value]
SETPOINT:[value]
MODE:[value (Heat... Cool etc)]
FAN:[value (Low...High etc)]

SMS:[SMS count value]
```

Example

```
STATUS SERVERROOM21:OK
A1M COMMS:OK
DRIVE:OFF
ROOM TEMP:22
TEMP SETPOINT:20
MODE:AUTO
FAN:HIGH

SMS:2
```

If a fault has been detected the following status message will be generated:

```
STATUS [A1M unit name] : [OK/code (fault type)]
A1M COMMS: [value(OK/FAULT)]
PLEASE CALL 0870 3000300 FOR ASSISTANCE

SMS [SMS count value]
```

Example

```
STATUS STAFF ROOM :6999 COMMUNICATIONS FAULT
A1M COMMS: OK
PLEASE CALL 0870 3000300 FOR ASSISTANCE

SMS:4
```

6.1.5. Setting a maximum temperature alarm

- **MAXTEMP** [value]

Example

- o MAXTEMP 28

This command sets the maximum room temperature threshold. If the room temperature reaches this value Micro M2M will send a room temperature warning SMS to all contacts as detailed in section 6.2. Autonomously generated SMS responses. If the maximum temperature is reached when using with the BACKUP command, the Micro M2M will start all available units to bring the temperature back down to set point.

Please note: all units will remain on until the next changeover cycle.

6.1.6. Checking the maximum temperature alarm

- **MAXTEMP**

This requests the maximum room temperature value. The Micro M2M will reply to the sender with the following SMS:

```
MAXIMUM TEMPERATURE THRESHOLD:[value]
```

```
SMS:[SMS count value]
```

6.1.7. Removing a phone number

- **REMOVE**

Example

- o REMOVE

This removes the sender's number from the Micro M2M's address book. Note, to remove all numbers from one mobile phone you must carry out a factory reset.

6.1.8. Registered numbers

- **NUMBERS**

Example

- o NUMBERS

When Micro M2M receives this message it will respond to the sender with an SMS detailing the phone numbers it currently has stored:

```
STORED NUMBERS  
[number (country code + phone number)]
```

```
SMS:[SMS count value]
```

Example

```
STORED NUMBERS  
447929388696  
447959455788
```

SMS:17

6.1.9. Setting the air conditioning units

- **SET** [A1M unit name] [command 1] ... [command 5]

Examples

- o SET ON
- o SET 3 HEAT
- o SET RECEPTION ON HEAT 22 HIGH
- o SET HEAT 25

The Set command will adjust the settings of a split system connected to a specified A1M unit. If the unit name is omitted from the SMS, Micro M2M will assume that unit 1 is being referred to. Each SMS can contain one request for each setting giving a total of up to 5 commands in a single SMS. The possible values for each setting are as follows:

DRIVE: ON OFF
MODE: HEAT COOL FAN AUTO
TEMP: 19 to 29
FAN: LOW MID1 MID2 HIGH

Micro M2M will then respond after a small delay (approximately 30 seconds) when the changes have been implemented, with a status SMS as detailed above showing the new settings or fault status if the split air-conditioning/A1M unit is currently in fault.

6.1.10. Help

- **HELP**

Example

- o HELP

When Micro M2M receives this SMS it responds to the sender with one of the following SMS depending on whether their phone number is stored in the Micro M2M's memory. If the number is not recognised the following SMS will be sent detailing how to add the user's number (SN number is the serial number of the M2M):

TO ADD YOUR NUMBER TO THE LIST OF CONTACTS PLEASE REPLY WITH:
[PIN] ADD
WHERE [PIN] IS THE LAST 4 DIGITS OF THE SN NUMBER.

SMS:[SMS count value]

If the number is recognised then the following SMS will be sent detailing the commands that can be issued:

Commands:
REGISTER [0-8] [names]
UNITS
STATUS [name]
MAXTEMP [value]
MAXTEMP
REMOVE
NUMBERS
SET [name] [values]
FACTORYRESET
SMSRESET

SMS:[SMS count value]

6.1.11. Factory reset

- **FACTORYRESET**

Example

- o FACTORYRESET

This SMS causes the Micro M2M to reset to its factory settings. All numbers will be erased from its address book and it will be configured to communicate with a single A1M unit.

6.1.12. SMS reset

- **SMSRESET**

Example

- o SMSRESET

This resets to zero the SMS count that is displayed at the bottom of every SMS from Micro M2M. This should be performed after credit has been added to a Pay As You Go SIM.

6.1.13. Fault reset

- **FAULTRESET**

Example

- o FAULTRESET

See section 6.2.

6.2. *Autonomously generated SMS responses*

- When an SMS is received with the correct PIN but the command is not recognised or the command is recognised but the number is unknown (and the PIN has not been provided) the Micro M2M will respond by sending the relevant HELP SMS as detailed above to the number it received the SMS from.
- If a split air-conditioning unit develops a fault the STATUS SMS will be sent after 30 seconds to all the stored phone numbers.
- If the status of a fault changes or a unit returns to normal operation a status SMS will be sent.
- If an A1M unit fails to communicate with an air-conditioning unit or Micro M2M fails to communicate with an A1M converter for more than 30 seconds, the STATUS SMS will be sent indicating the type of communications failure to all the stored phone numbers.
- For instances of a repeated fault occurring in a split unit the following sequence of SMS will be generated:
 - o on 1st fault sends SMS,
 - o If upon the 2nd instance of the fault there has been less than 5 other warnings and less than 6 hours has elapsed it sends 'Fault Repeating' SMS and further SMS for this fault code are inhibited.
 - o This is possible for up to 5 different fault codes, if there are more than this number of intermittent faults, all instances of the additional faults will generate an SMS.

User sends a 'Faults Reset' SMS to return to normal.

Example

- FAULTSRESET

- When the inlet temperature on any split air-conditioning unit exceeds the high temperature set point (default 27°C) for more than 30 seconds Micro M2M will send the following warning SMS detailing any units over the set point:

```
*WARNING* MAX TEMP SETPOINT DETECTED BY FOLLOWING UNIT(S):  
[unit name] IS CURRENTLY [value]
```

```
SMS:[SMS count value]
```

Example

```
*WARNING* MAX TEMP SETPOINT DETECTED BY FOLLOWING UNIT(S):  
RECEPTION IS AT 27  
SERVERROOM IS AT 27
```

```
SMS:30
```

This warning will also be inhibited if multiple temperature warnings occur, in a similar manner to fault SMS.

- Upon powering up and initialising the Micro M2M will send the following SMS to all contacts, this can be used to warn of power failures.

```
MICRO M2M IS NOW ONLINE
```

```
SMS:[SMS count value]
```

- Once every 28 days Micro M2M will send a status SMS to all stored numbers to ensure that Pay As You Go type SIMs do not expire from lack of use.

6.3. Backup and Rotate Feature

Micro M2M can handle Backup and Rotate functionality for 2 to 8 indoor units. On a periodic basis, typically every week, the operational units can be cycled to share the cooling load.

A jumper must be attached on to IN01 + and – to ensure the back up and rotate feature is enabled. After this has been done ensure the power is cycled from OFF to ON.

If any failure of any unit is detected, or if the high temperature is exceeded by any unit, all units are brought into operation. An SMS will be sent to indicate that all units have been turned on. All units will remain on until the next changeover cycle.

This command allows the Backup and Rotate feature to be set up and toggled on and off:

- **BACKUP [ON|OFF] ([Number of units running] [Days between rotations] [Setpoint] [Error response])**

Examples

- BACKUP ON 3 7 18 NEXT

-
- BACKUP OFF
 - BACKUP ON

As the Micro M2M is not aware of the real time, the daily timer will be started upon power-up. If power fails to the Micro M2M, the Backup and Rotate timer will be restarted, and the cycle will start from the beginning.

Backup and Rotate feature will be ready and configured for use based upon input. Backup and Rotate can be toggled remotely via SMS.

The status request is also available for the backup function

– **BACKUP**

Example

- BACKUP

Micro M2M will respond with the following SMS detailing the current configuration of the backup and rotate feature: ON/OFF status, number of units on, days between rotation, temperature set point and whether all units come on in the event of an error or the next available unit.

```
BACKUP AND ROTATE: [ON/OFF]
NUMBER OF UNITS:[value]
DAYS BETWEEN ROTATION:[value]
TEMP SETPOINT: [value]
ERROR RESPONSE:[ALL/NEXT]
SMS:[SMS count value]
```

Example

```
BACKUP AND ROTATE: ON
NUMBER OF UNITS: 3
DAYS BETWEEN ROTATION: 1
TEMP SETPOINT: 20
ERROR RESPONSE: NEXT
SMS:24
```

7. Applicable Air Conditioning Models

Below is a list of Air Conditioning models that can be connected to this unit:

- M series product range (includes MXZ but excluding MSZ-HC Classic models)
- Mr Slim product range (includes S series) *

Please note that:

- **An A1M is required for each split indoor unit**
- **The Micro M2M is not compatible with MSZ-HC Classic models**
- **The unit will only work if the split has a CN92 / CN105 terminal on the indoor unit PCB**
- **Units older than 2006 do not have this terminal, thus will not work**
- *** It is not recommended to use twin / triple / quad combinations.**
 - o If these are used, please install 1 x A1M per SYSTEM on the master indoor unit.
 - o The rotation then acts as a rotate by system rather than rotate by indoor unit.
 - o Please note that NO faults will be received from the slave units.
- **The Micro M2M does not work with City Multi units**

8. Important Notes

- Ensure there is sufficient GSM signal at the site of the Micro M2M
- The Modbus network must be connected A to A, B to B, GND to GND
- Screened cable must be used on the Modbus network
- The Modbus network must be daisy chained and not in a star network
- Each A1M must be addressed
- 1 A1M unit is required per indoor unit (or one per system on the master if using twins / triples / quads)
- **The Micro M2M does not come with a power supply**
- **The Micro M2M does not come with a SIM card**
- Pay As You Go or contract SIM cards are suitable. The SIM card has to have credit on it to work
- If the SIM runs out of credit, no messages will be sent
- Make note of the SIMs phone number
- Only registered mobile phone numbers can monitor and control units attached to a Micro M2M
- 8 units (A1Ms) can be registered with a Micro M2M
- The Micro M2M will send a text message to all registered users every 28 days to keep SIM cards valid
- **The Micro M2M only works with split units**
- The split units must have CN92 / CN105 connection. This connection is only on units produced on or after 2006
- The Micro M2M will not work with City Multi (e.g. PFD)
- When using the backup command, all units will be forced in to cooling mode
- If BACKUP command is used, but a unit(s) is/are in fault or OFF, then healthy units will continue to run even when the rotate function is operational
- If BACKUP command is used, ensure a jumper on IN01 is installed
- **For critical systems Mitsubishi Electric suggest that a back up system is used. Mitsubishi Electric can not be held liable in the unlikely event the product does not operate correctly**

9. Trouble Shooting

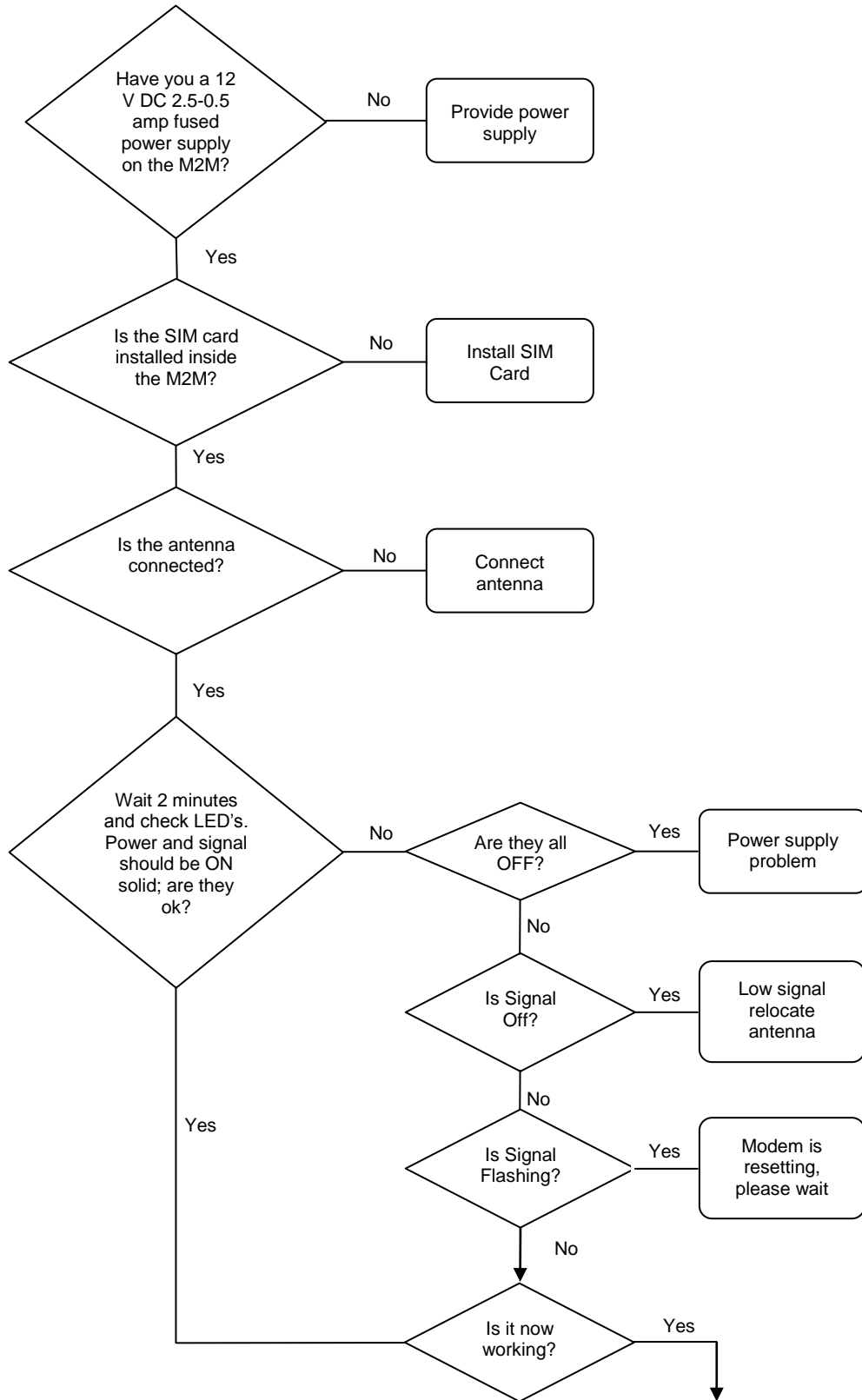

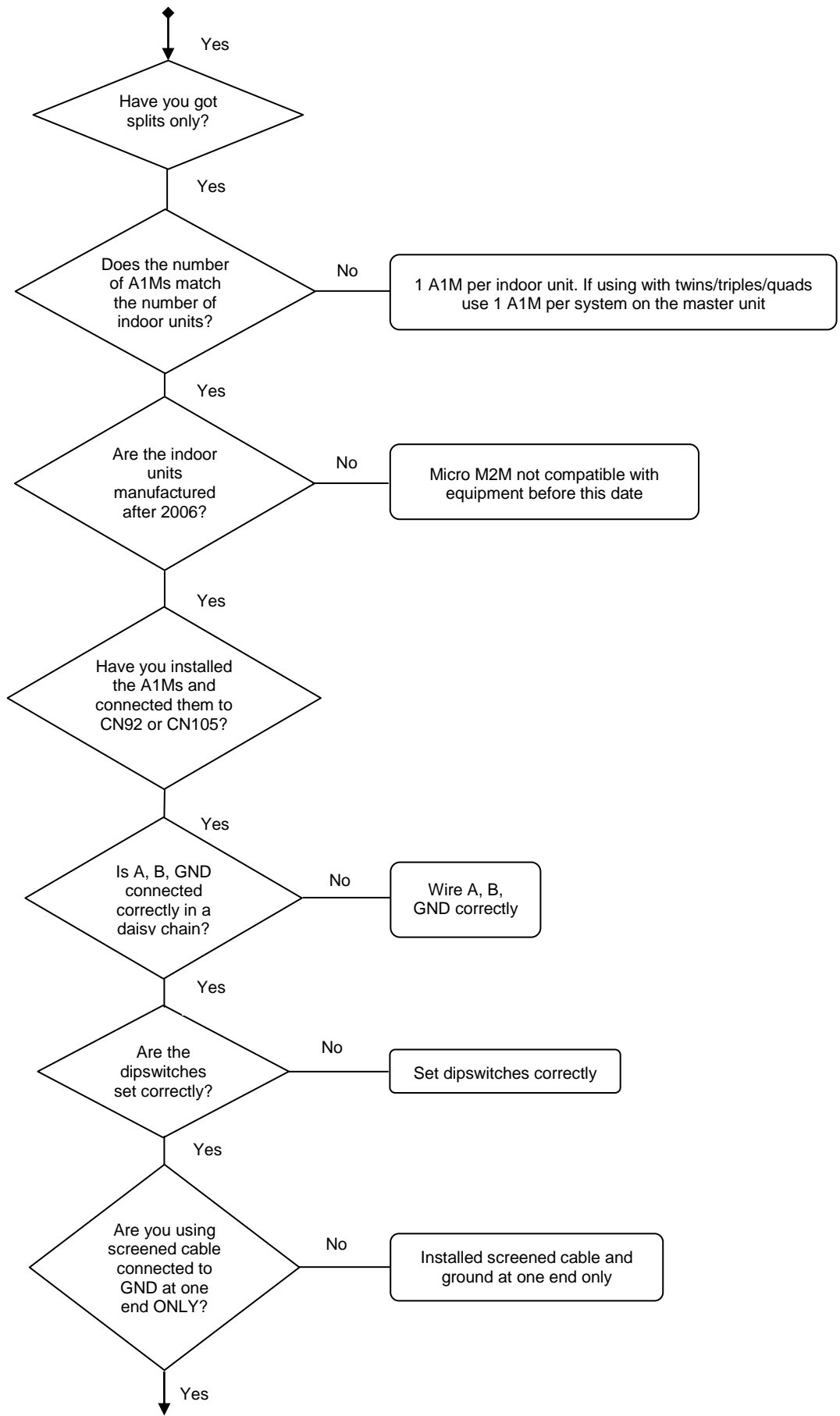

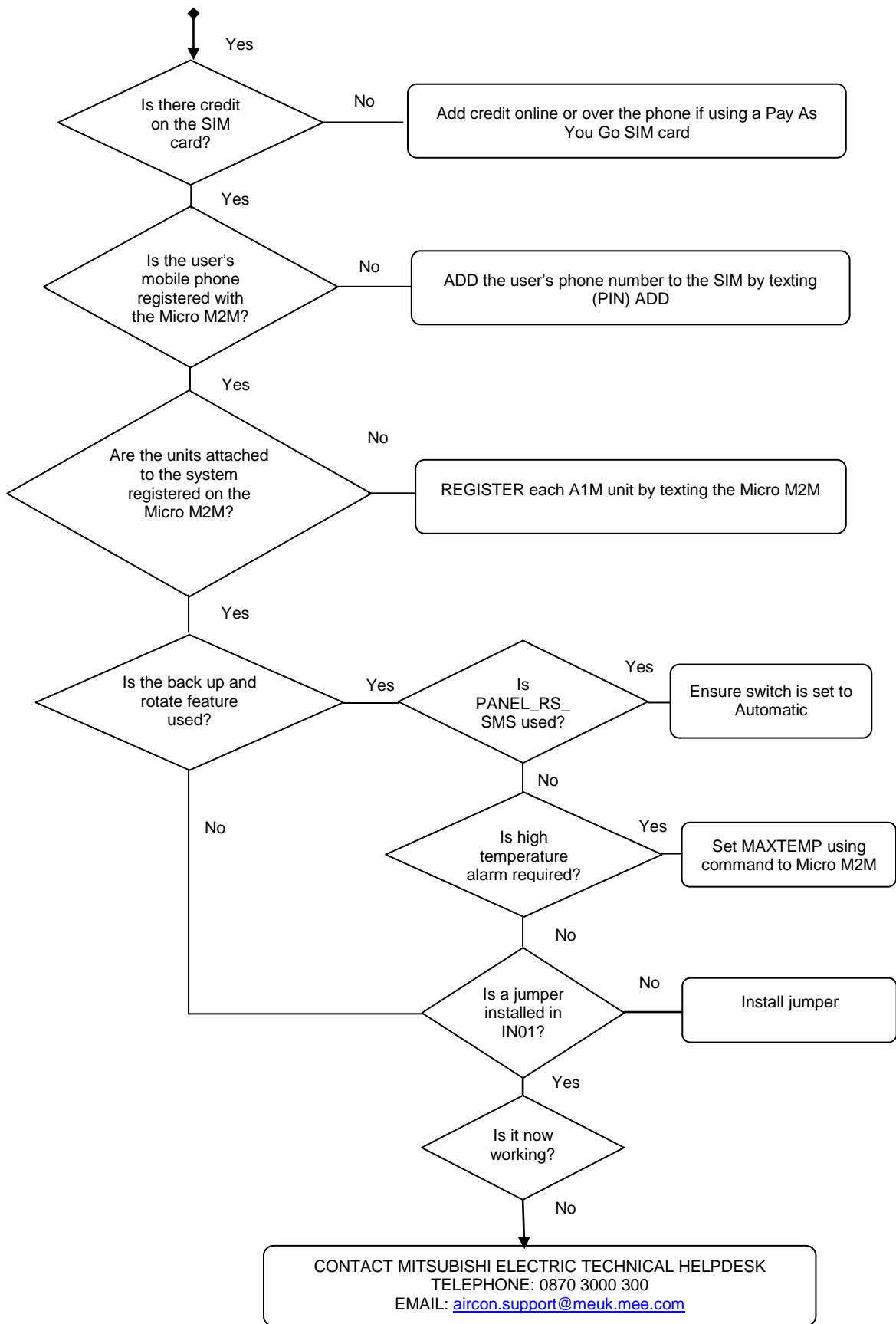

This product is designed and intended for use in the residential, commercial and light-industrial environment.

The product at hand is based on the following EU regulations:

- Low Voltage Directive 73/23/EEC
- Electromagnetic Compatibility Directive 89/336/EEC

Please be sure to put the contact address/telephone number on this manual before handing it to the customer.

mitsubishi electric uk

MITSUBISHI ELECTRIC UK, TRAVELLERS LANE, HATFIELD HERTFORDSHIRE, AL10 8XB