

PARTS CATALOG

Series PLA Ceiling Cassettes R32/R410A

Indoor unit

[Model Name]	[Service Ref.]
PLA-M35EA	PLA-M35EA.UK
PLA-M50EA	PLA-M50EA.UK
PLA-M60EA	PLA-M60EA.UK
PLA-M71EA	PLA-M71EA.UK
PLA-M100EA	PLA-M100EA.UK
PLA-M125EA	PLA-M125EA.UK
PLA-M140EA	PLA-M140EA.UK

Grille model

[Model Name]	[Service Ref.]	
PLP-6EA	PLP-6EA	PLP-6EAR1
PLP-6EAE	PLP-6EAE	PLP-6EAER1
PLP-6EAL	PLP-6EAL	PLP-6EALR1
PLP-6EALE	PLP-6EALE	PLP-6EALER1
PLP-6EAJ	PLP-6EAJ	
PLP-6EAJE	PLP-6EAJE	
PLP-6EALM	PLP-6EALM	
PLP-6EALME	PLP-6EALME	

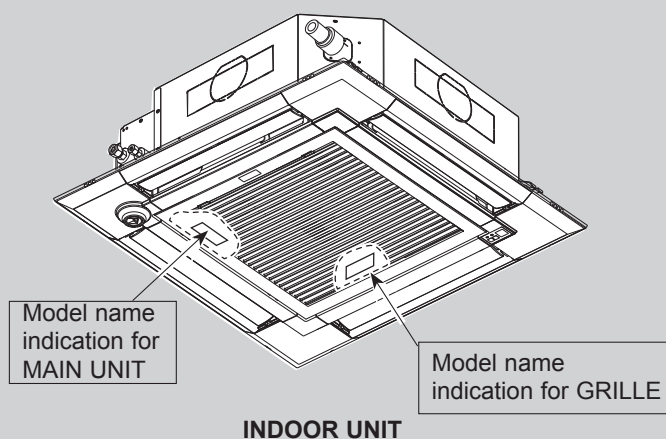

CONTENTS

- | | |
|------------------------------|---|
| 1. SERVICE PARTS LIST | 2 |
| 2. OPTIONAL PARTS LIST | 6 |

SERVICE MANUAL (OCH697)

1

SERVICE PARTS LIST

GRILLE PARTS

[Service Ref.]

PLP-6EA	PLP-6EAR1	(Standard)
PLP-6EAL	PLP-6EALR1	(Standard with signal receiver)
PLP-6EAE	PLP-6EAER1	(Standard with i-see Sensor)
PLP-6EALE	PLP-6EALER1	(Standard with signal receiver and i-see Sensor)
PLP-6EAJ		(Elevation)
PLP-6EAJE		(Elevation with i-see Sensor)
PLP-6EALM		(Standard with signal receiver and wireless remote controller)
PLP-6EALME		(Standard with signal receiver, i-see Sensor, and wireless remote controller)

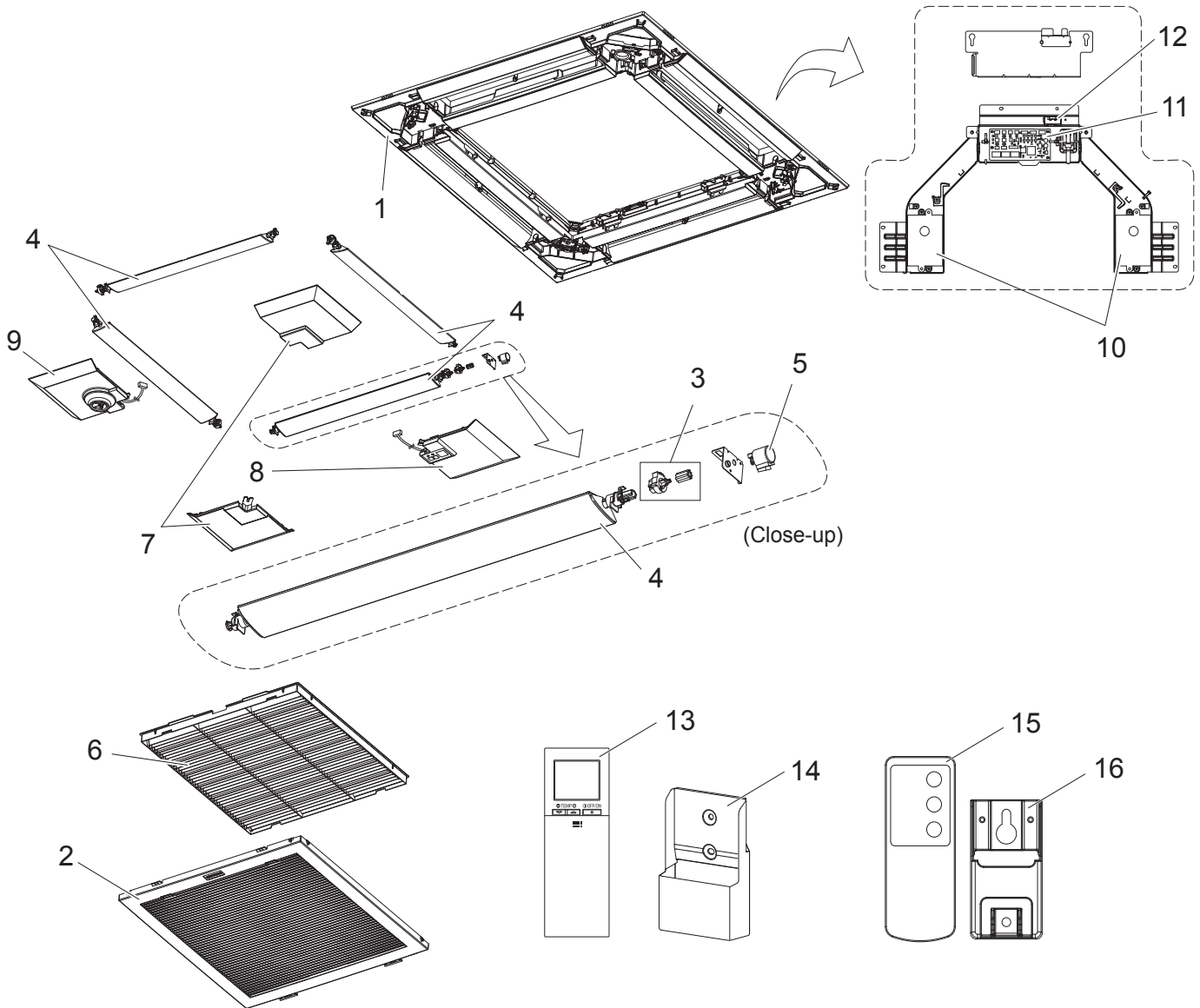

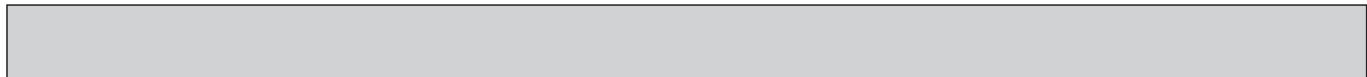

No.	Part No.	Part Name	Specification	Q'ty/unit										Wiring Diagram Symbol			
				PLP-6EA	PLP-6EAR1	PLP-6EAL	PLP-6EALR1	PLP-6EAE	PLP-6EAER1	PLP-6EALE	PLP-6EALER1	PLP-6EAJ	PLP-6EAJE		PLP-6EALM	PLP-6EALME	
1	E17 D72 003	AIR OUTLET GRILLE		1		1		1		1							
	E17 F85 003	AIR OUTLET GRILLE			1		1		1		1	1	1	1	1		
2	E17 D72 010	INTAKE GRILLE		1		1		1		1							
	E17 F85 010	INTAKE GRILLE			1		1		1		1			1	1		
	E17 F91 010	INTAKE GRILLE									1	1					
3	E17 D72 031	GEAR (VANE&S/M)		4		4		4		4							
	E17 F85 031	GEAR (VANE&S/M)			4		4		4		4	4	4	4	4	4	
4	E17 D72 037	AUTO VANE&VANE BUSH		4		4		4		4							
	E17 F85 037	AUTO VANE&VANE BUSH			4		4		4		4	4	4	4	4	4	
5	E17 103 303	VANE MOTOR		4	4	4	4	4	4	4	4	4	4	4	4	4	MV
6	E17 D72 100	AIR FILTER		1		1		1		1							
	E17 F85 100	AIR FILTER			1		1		1		1	1	1	1	1		
7	E17 D72 975	CORNER PANEL		4		3		3		2							
	E17 F85 975	CORNER PANEL			4		3		3		2	3	2	3	2		
8	E17 D73 975	CORNER PANEL (Signal receiver)				1				1							
	E17 F88 975	CORNER PANEL (Signal receiver)					1			1	1	1	1	1	1		
9	E17 D74 975	CORNER PANEL (i-see Sensor)						1		1							
	E17 F86 975	CORNER PANEL (i-see Sensor)							1		1		1		1		
10	E17 F91 471	MOTOR BOX										2	2				
11	E17 F91 447	CONTROLLER BOARD										1	1				
12	E17 F91 316	LIMIT SWITCH										1	1				
13	E17 F89 426	WIRELESS REMOTE CONTROLLER	PAR-SL100A-E												1	1	
14	E17 D44 083	HOLDER	for PAR-SL100A-E												1	1	
15	E17 F91 426	WIRELESS REMOTE CONTROLLER	for Elevation panel									1	1				
16	E17 F91 083	HOLDER	for Elevation panel									1	1				

STRUCTURAL AND FUNCTIONAL PARTS

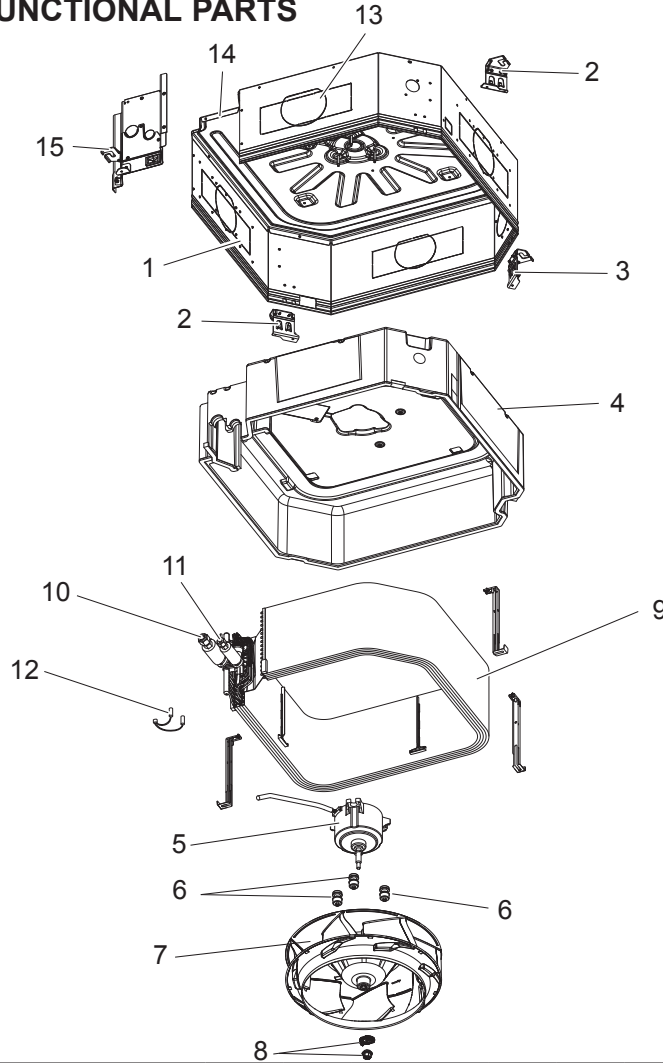

No.	Part No.	Part Name	Specification	Q'ty/unit						Wiring Diagram Symbol	
				PLA-M-EA.UK							
				35	50	60	71	100	125	140	
1	S70 0B7 688	DRUM 2 ASSY		1	1	1	1				
	S70 0B8 688	DRUM 2 ASSY						1	1	1	
2	S70 EA2 130	LEG PUMP		2	2	2	2	2	2	2	
3	S70 EA1 130	LEG FA		1	1	1	1	1	1	1	
4	S70 0B4 659	INNER COVER ASSY-S		1	1	1	1				
	S70 0B5 659	INNER COVER ASSY-L						1	1	1	
5	S70 0B4 762	FAN MOTOR	(DC)-S	1	1	1	1				MF
	S70 0B5 762	FAN MOTOR	(DC)-M					1	1	1	MF
6	S70 0B1 105	MOTOR MOUNT		3	3	3	3	3	3	3	
7	S70 0B4 114	TURBO FAN		1	1	1	1	1	1	1	
8	S70 11B 097	WASHER / NUT		1	1	1	1	1	1	1	
9	S70 B29 480	HEAT EXCHANGER		1	1						
	S70 B30 480	HEAT EXCHANGER				1					
	S70 B28 480	HEAT EXCHANGER					1				
	S70 B26 480	HEAT EXCHANGER						1			
	S70 B27 480	HEAT EXCHANGER							1	1	
10	S70 0B2 097	FLARE NUT	1/2"	1	1						
	S70 0B5 097	FLARE NUT	5/8"			1	1	1	1	1	
11	S70 0B3 097	FLARE NUT	1/4"	1	1						
	S70 0B4 097	FLARE NUT	3/8"			1	1	1	1	1	
12	S70 0B4 202	THERMISTOR		1	1	1	1	1	1	1	TH2/TH5
13	S70 0B5 688	DRUM 1 ASSY		1	1	1	1				
	S70 0B6 688	DRUM 1 ASSY						1	1	1	
14	S70 0B2 687	BASE		1	1	1	1	1	1	1	
15	S70 EA3 130	LEG PIPE		1	1	1	1	1	1	1	

FUNCTIONAL AND ELECTRICAL PARTS

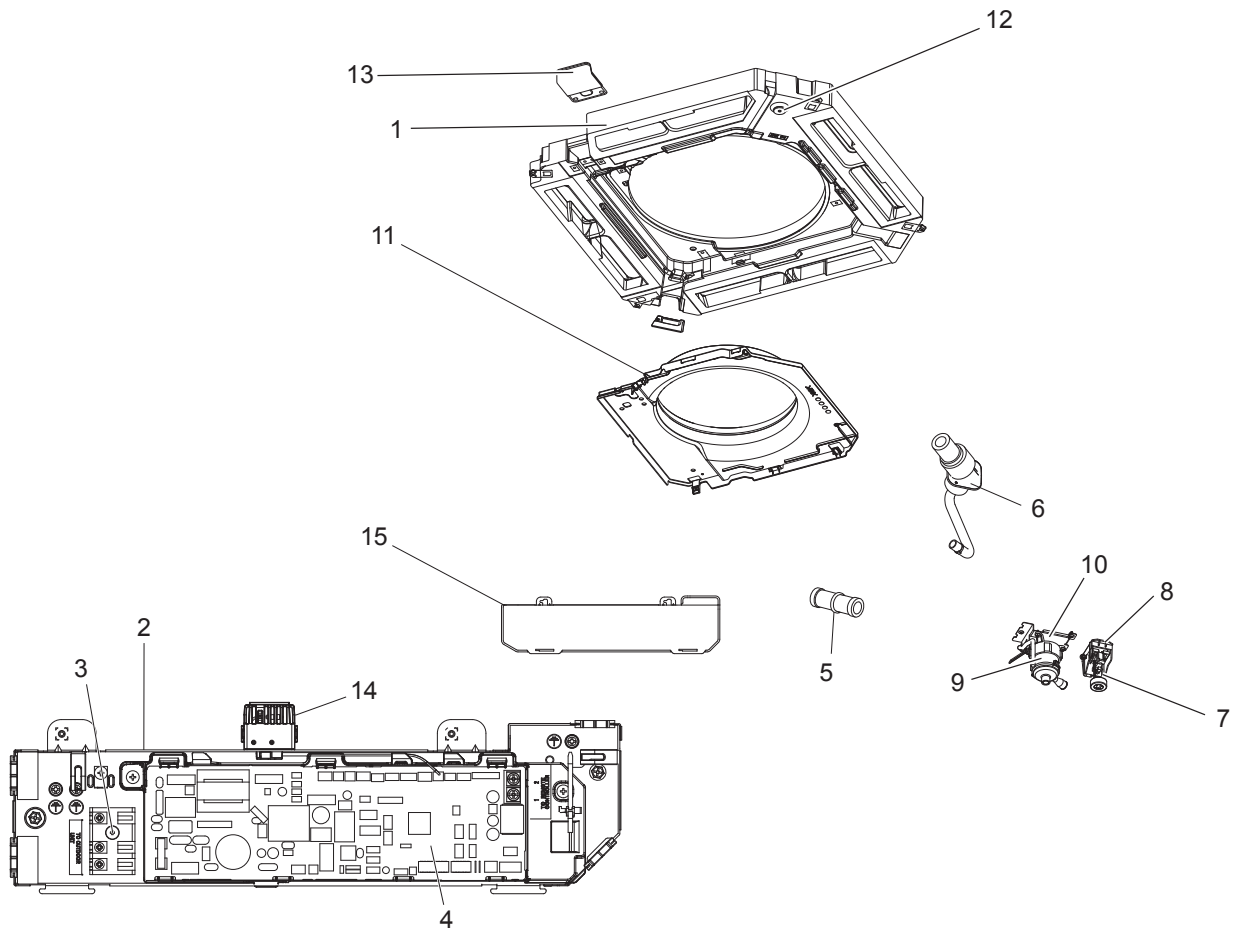

No.	Part No.	Part Name	Specification	Q'ty/unit						Remarks (Drawing No.)	Wiring Diagram Symbol	
				PLA-M-EA.UK								
				35	50	60	71	100	125			140
1	S70 0B4 529	DRAIN PAN		1	1	1	1	1	1	1		
2	S70 0B7 501	ELECTRICAL CONTROL BOX		1	1	1	1	1	1	1		
3	S70 K03 716	TERMINAL BLOCK	3P(S1,S2,S3)	1	1	1	1	1	1	1		TB4
4	S70 B40 310	INDOOR CONTROLLER BOARD		1	1	1	1	1	1	1		I.B
5	S70 29H 523	DRAIN SOCKET		1	1	1	1	1	1	1		
6	S70 0B2 527	DRAIN HOSE ASSY EA		1	1	1	1	1	1	1		
7	S70 0B2 266	FLOAT SWITCH		1	1	1	1	1	1	1		FS
8	S70 0B2 533	FLOAT SWITCH BASE		1	1	1	1	1	1	1		
9	S70 0B2 355	DRAIN PUMP	220-240 V	1	1	1	1	1	1	1		DP
10	S70 0B3 533	DRAIN PUMP BASE		1	1	1	1	1	1	1		
11	S70 0B3 502	BELLMOUTH-S		1	1	1	1					
	S70 0B4 502	BELLMOUTH-L						1	1	1		
12	S70 A41 524	DRAIN PLUG		1	1	1	1	1	1	1		
13	S70 EA1 663	WIRE COVER		1	1	1	1	1	1	1		
14	S70 0B3 202	ROOM TEMP. THERMISTOR	220XAP	1	1	1	1	1	1	1		TH1
15	-	CONT COVER		1	1	1	1	1	1	1	(BK02Y559G05)	

2

OPTIONAL PARTS

Parts name	Parts No.
SPACE PANEL	PAC-SJ65AS-E
AIR OUTLET SHUTTER PLATE	PAC-SJ37SP-E
WIRED REMOTE CONTROLLER (MA REMOTE CONTROLLER)	PAR-33MAA
WIRED REMOTE CONTROLLER (SIMPLE MA REMOTE CONTROLLER)	PAC-YT52CRA
WIRELESS REMOTE CONTROLLER	PAR-SL100A-E
POWER SUPPLY TERMINAL KIT	PAC-SJ39HR-E
HIGH EFFICIENCY FILTER ELEMENT	PAC-SH59KF-E
MULTI-FUNCTIONAL CASEMENT	PAC-SJ41TM-E
FLANGE FOR FRESH AIR INTAKE	PAC-SH65OF-E
SYSTEM CONTROL INTERFACE	MAC-333IF
MA & CONTACT TERMINAL INTERFACE	MAC-397IF-E
REMOTE SENSOR	PAC-SE41TS-E
Wi-Fi INTERFACE	MAC-557IF-E
REMOTE ON/OFF ADAPTER	PAC-SE55RA-E
REMOTE OPERATION ADAPTER	PAC-SF40RM-E
CONNECTOR CABLE FOR REMOTE DISPLAY	PAC-SA88HA-E
GRILLE (i-see Sensor)	PLP-6EAE, PLP-6EAER1
GRILLE (i-see Sensor with signal receiver)	PLP-6EAE, PLP-6EALER1
GRILLE (i-see Sensor with receiver and wireless remote controller)	PLP-6EALME
GRILLE (Standard)	PLP-6EA, PLP-6EAR1
GRILLE (Standard with signal receiver)	PLP-6EAL, PLP-6EALR1
GRILLE (Standard with receiver and wireless remote controller)	PLP-6EALM
GRILLE (Automatic filter elevation without i-see Sensor)	PLP-6EAJ
GRILLE (Automatic filter elevation with i-see Sensor)	PLP-6EAJE
i-SEE SENSOR CORNER PANEL	PAC-SE1ME-E
SIGNAL RECEIVER CORNER PANEL	PAR-SE9FA-E

MITSUBISHI ELECTRIC CORPORATION

HEAD OFFICE : TOKYO BUILDING, 2-7-3, MARUNOUCHI, CHIYODA-KU, TOKYO 100-8310, JAPAN