

# TECHNICAL & SERVICE MANUAL

## Series PKFY Wall Mounted

Indoor unit

[Model Name]

[Service Ref.]

PKFY-WL10VLM-E      PKFY-WL10VLM-E.TH

PKFY-WL15VLM-E      PKFY-WL15VLM-E.TH

PKFY-WL20VLM-E      PKFY-WL20VLM-E.TH

PKFY-WL25VLM-E      PKFY-WL25VLM-E.TH

PKFY-WL32VLM-E      PKFY-WL32VLM-E.TH

PKFY-WL40VLM-E      PKFY-WL40VLM-E.TH

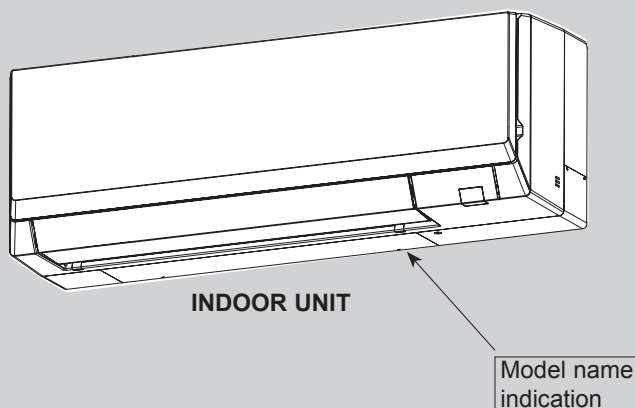

### CONTENTS

|                                    |    |
|------------------------------------|----|
| 1. SAFETY PRECAUTION.....          | 2  |
| 2. PARTS NAMES AND FUNCTIONS.....  | 3  |
| 3. SPECIFICATION .....             | 11 |
| 4. NOISE CRITERION CURVES.....     | 14 |
| 5. OUTLINES AND DIMENSIONS.....    | 16 |
| 6. WIRING DIAGRAM .....            | 18 |
| 7. REFRIGERANT SYSTEM DIAGRAM..... | 19 |
| 8. TROUBLESHOOTING .....           | 19 |
| 9. DISASSEMBLY PROCEDURE .....     | 26 |

**PARTS CATALOG (OCB711)**

# CITY MULTI

## Read before installation and performing electrical work

- Thoroughly read the following safety precautions prior to installation.
- Observe these safety precautions for your safety.
- This equipment may have adverse effects on the equipment on the same power supply system.
- Contact the local power authority before connecting to the system.

### Symbol explanations

#### WARNING

This symbol indicates that failure to follow the instructions exactly as stated poses the risk of serious injury or death.

#### CAUTION

This symbol indicates that failure to follow the instructions exactly as stated poses the risk of serious injury or damage to the unit.



Indicates an action that must be avoided.



Indicates important instructions.



Indicates a parts that requires grounding.



Indicates that caution must be taken with rotating parts. (This symbol is on the main unit label.) <Color: Yellow>



Indicates that the parts that are marked with this symbol pose a risk of electric shock. (This symbol is on the main unit label.) <Color: Yellow>

#### WARNING

Carefully read the labels affixed to the main unit.

#### WARNING

##### •Do not use refrigerant other than the type indicated in the manuals provided with the unit and on the nameplate.

- Doing so may cause the unit or pipes to burst, or result in explosion or fire during use, during repair, or at the time of disposal of the unit.

It may also be in violation of applicable laws.

MITSUBISHI ELECTRIC CORPORATION cannot be held responsible for malfunctions or accidents resulting from the use of the wrong type of refrigerant.

##### •Ask your dealer or a qualified technician to install the unit.

- Improper installation by the user may result in water leakage, electric shock, or fire.

##### •Properly install the unit on a surface that can withstand its weight.

- Unit installed on an unstable surface may fall and cause injury.

##### •Only use specified cables. Securely connect each cable so that the terminals do not carry the weight of the cable.

- Improperly connected cables may produce heat and start a fire.

##### •Take appropriate safety measures against wind gusts and earthquakes to prevent the unit from toppling over.

- Improper installation may cause the unit to topple over and cause injury or damage to the unit.

##### •Only use accessories (i.e., air cleaners, humidifiers, electric heaters) recommended by Mitsubishi Electric.

##### •Do not make any modifications or alterations to the unit.

Consult your dealer for repair.

- Improper repair may result in water leakage, electric shock, or fire.

##### •Do not touch the heat exchanger fins with bare hands.

- The fins are sharp and pose a risk of cuts.

##### •Properly install the unit according to the instructions in the Installation Manual.

- Improper installation may result in water leakage, electric shock, or fire.

##### •Have all electrical work performed by an authorized electrician according to the local regulations and the instructions in this manual. Use a dedicated circuit.

- Insufficient power supply capacity or improper installation of the unit may result in malfunctions of the unit, electric shock, or fire.

##### •Keep electrical parts away from water.

- Wet electrical parts pose a risk of electric shock, smoke, or fire.

##### •Securely attach the control box cover.

- If the cover is not installed properly, dust or water may infiltrate and pose a risk of electric shock, smoke, or fire.

##### •Only use the type of refrigerant that is indicated on the unit when installing or relocating the unit.

- Infiltration of any other types of refrigerant or air into the unit may adversely affect the refrigerant cycle and may cause the pipes to burst or explode.

##### •Consult your dealer or a qualified technician when moving or reinstalling the unit.

- Improper installation may result in water leakage, electric shock, or fire.

##### •After completing the service work, check for a refrigerant leak.

- If leaked refrigerant is exposed to a heat source, such as a fan heater, stove, or electric grill, toxic gases will be generated.

##### •Do not try to defeat the safety features of the unit.

- Forced operation of the pressure switch or the temperature switch by defeating the safety features for these devices, or the use of accessories other than the ones that are recommended by Mitsubishi Electric may result in smoke, fire, or explosion.

##### •Consult your dealer for proper disposal method.

##### •Do not use a leak detection additive.

### Precautions for handling units for use with water

#### CAUTION

##### •Do not use the existing water piping.

- Store the piping materials indoors, and keep both ends of the pipes sealed until immediately before installation. Keep the joints wrapped in plastic bags. If dust or dirt enters the water circuit, it may damage the heat exchanger and cause water leakage.

##### •Only use water.

- Only use clean water as a refrigerant. The use of water outside the specification may damage the refrigerant circuit.

##### •Install the unit so that external force is not applied to the water pipes.

# 2

# PARTS NAMES AND FUNCTIONS

## 2-1. Indoor unit

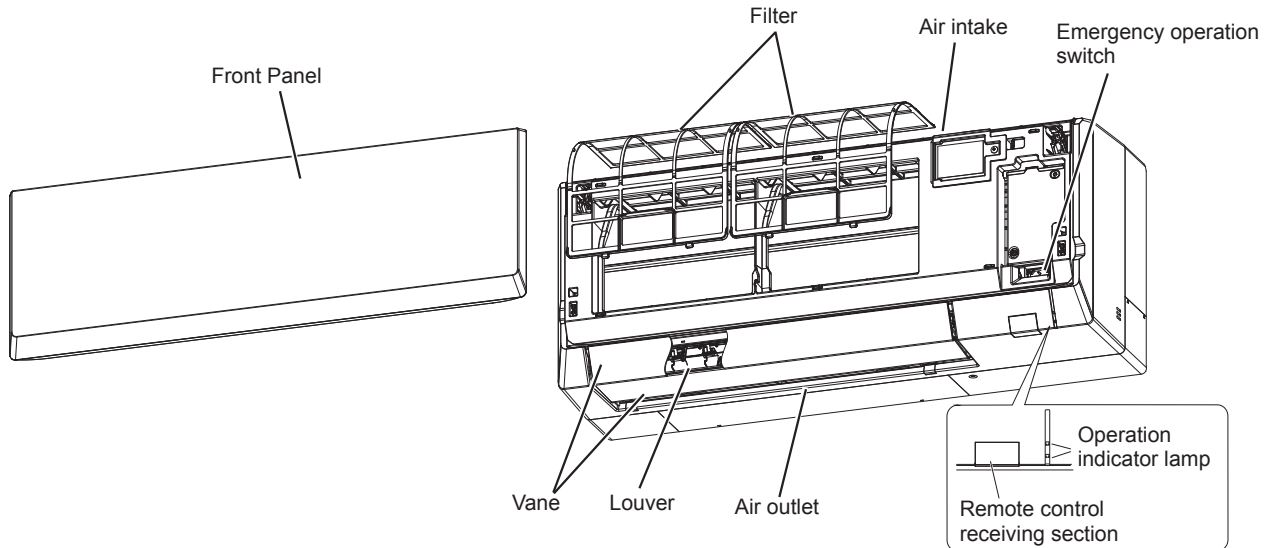

## 2-2. Wired Remote Controller <PAR-40MAA>

### Wired remote controller function

The functions which can be used are restricted according to each model.

○ : Supported ✕ : Unsupported

|               | Function                                   | PAR-40MAA        |            |
|---------------|--|------------------|------------|
|               |  | Slim             | CITY MULTI |
| Body          | Product size H × W × D (mm)                | 120 × 120 × 14.5 |            |
|               | LCD  | Full Dot LCD     |            |
|               | Backlight                                  | ○                |            |
| Energy saving | Energy saving operation schedule           | ○                | ✕          |
|               | Automatic return to the preset temperature | ○                |            |
| Restriction   | Setting the temperature range restriction  | ○                |            |
| Function*     | Operation lock function                    | ○                |            |
|               | Weekly timer                               | ○                |            |
|               | ON/OFF timer                               | ○                |            |
|               | High Power                                 | ○                | ✕          |
|               | Manual vane angle                          | ○                |            |

\*Some functions may not be available depending on model types.

## Controller interface

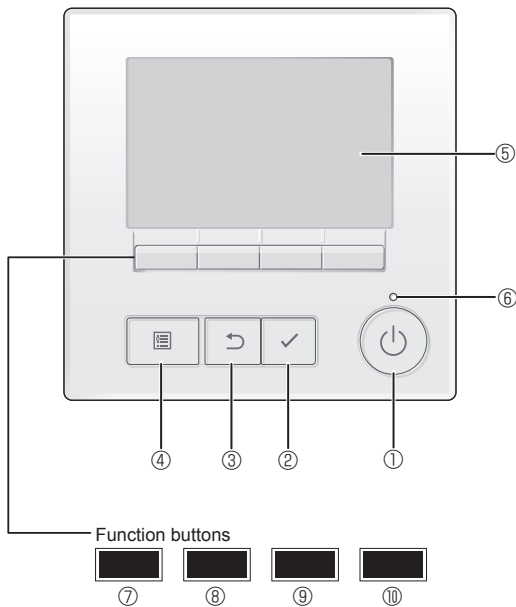

### ① [ON/OFF] button

Press to turn ON/OFF the indoor unit.

### ② [SELECT] button

Press to save the setting.

### ③ [RETURN] button

Press to return to the previous screen.

### ④ [MENU] button

Press to bring up the Main menu.

### ⑤ Backlit LCD

Operation settings will appear.

When the backlight is off, pressing any button turns the backlight on and it will stay lit for a certain period of time depending on the screen.

When the backlight is off, pressing any button turns the backlight on and does not perform its function. (except for the [ON/OFF] button)

The functions of the function buttons change depending on the screen.

Refer to the button function guide that appears at the bottom of the LCD for the functions they serve on a given screen.

When the system is centrally controlled, the button function guide that corresponds to the locked button will not appear.

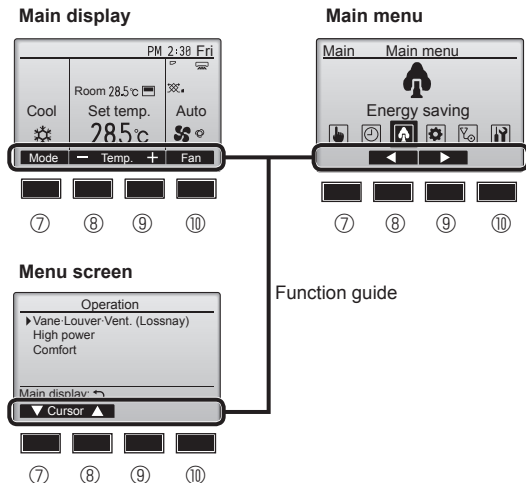

### ⑥ ON/OFF lamp

This lamp lights up in green while the unit is in operation. It blinks while the remote controller is starting up or when there is an error.

### ⑦ Function button [F1]

Main display: Press to change the operation mode.

Menu screen: The button function varies with the screen.

### ⑧ Function button [F2]

Main display: Press to decrease temperature.

Main menu: Press to move the cursor left.

Menu screen: The button function varies with the screen.

### ⑨ Function button [F3]

Main display: Press to increase temperature.

Main menu: Press to move the cursor right.

Menu screen: The button function varies with the screen.

### ⑩ Function button [F4]

Main display: Press to change the fan speed.

Menu screen: The button function varies with the screen.

## Display

The main display can be displayed in two different modes: "Full" and "Basic". The factory setting is "Full". To switch to the "Basic" mode, change the setting on the Main display setting. (Refer to operation manual included with remote controller.)

### <Full mode>

\* All icons are displayed for explanation.

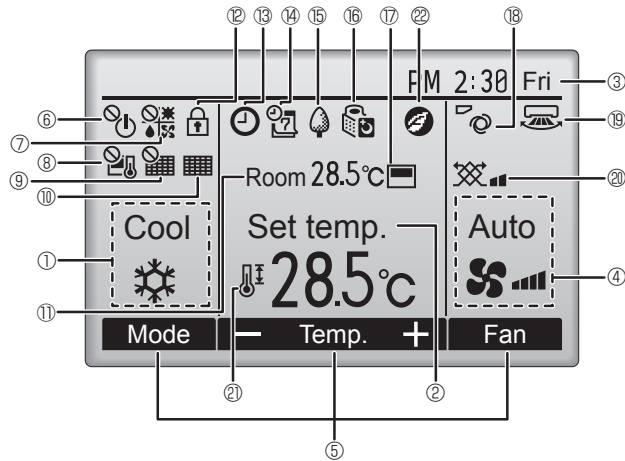

### <Basic mode>

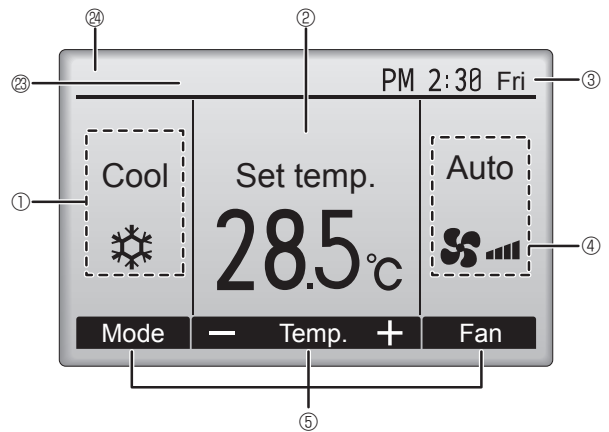

#### ① Operation mode

#### ② Preset temperature

#### ③ Clock

Current time appears here.

#### ④ Fan speed

#### ⑤ Button function guide

Functions of the corresponding buttons appear here.



Appears when the ON/OFF operation is centrally controlled.



Appears when the operation mode is centrally controlled.



Appears when the preset temperature is centrally controlled.



Appears when the filter reset function is centrally controlled.



Indicates when filter needs maintenance.

#### ⑪ Room temperature

Current room temperature appears here.



Appears when the buttons are locked.



Appears when the On/Off timer, Night setback, or Auto-off timer function is enabled.



appears when the timer is disabled by the centralized control system.



Appears when the Weekly timer is enabled.



Appears while the units are operated in the energy-save mode. (Will not appear on some models of indoor units)



Appears while the outdoor units are operated in the silent mode. (This indication is not available for CITY MULTI models.)



Appears when the built-in thermistor on the remote controller is activated to monitor the room temperature (⑪).



appears when the thermistor on the indoor unit is activated to monitor the room temperature.



Indicates the vane setting.



Indicates the louver setting.



Indicates the ventilation setting.



Appears when the preset temperature range is restricted.



Appears when an energy-saving operation is performed using a "3D i-See sensor" function. (not available)

#### ⑳ Centrally controlled

Appears for a certain period of time when a centrally-controlled item is operated.

#### ㉔ Preliminary error display

An error code appears during the preliminary error.

Most settings (except ON/OFF, mode, fan speed, temperature) can be made from the Main menu. (Refer to Page 10.)

## Menu structure

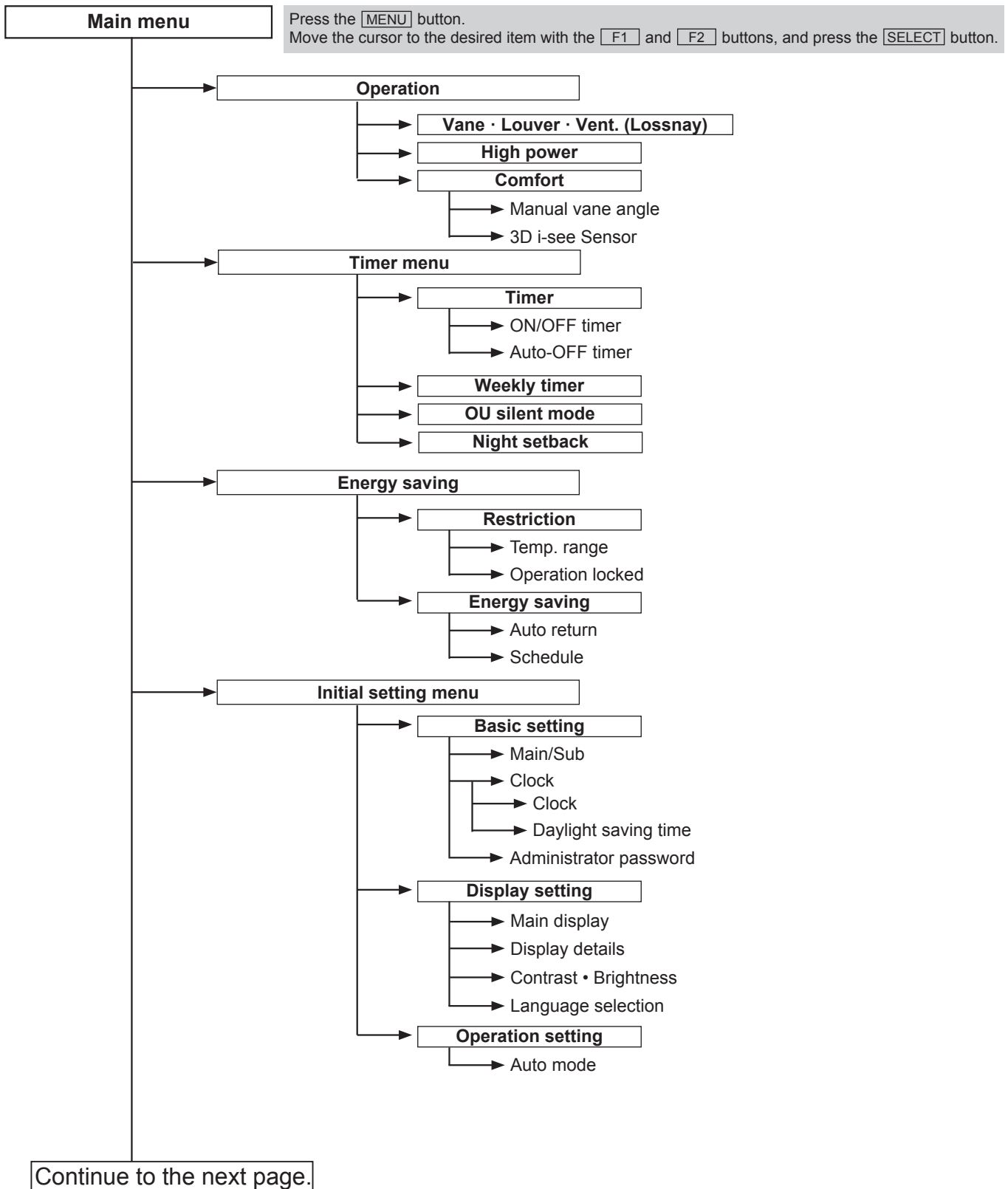

Not all functions are available on all models of indoor units.

Continue from the previous page.

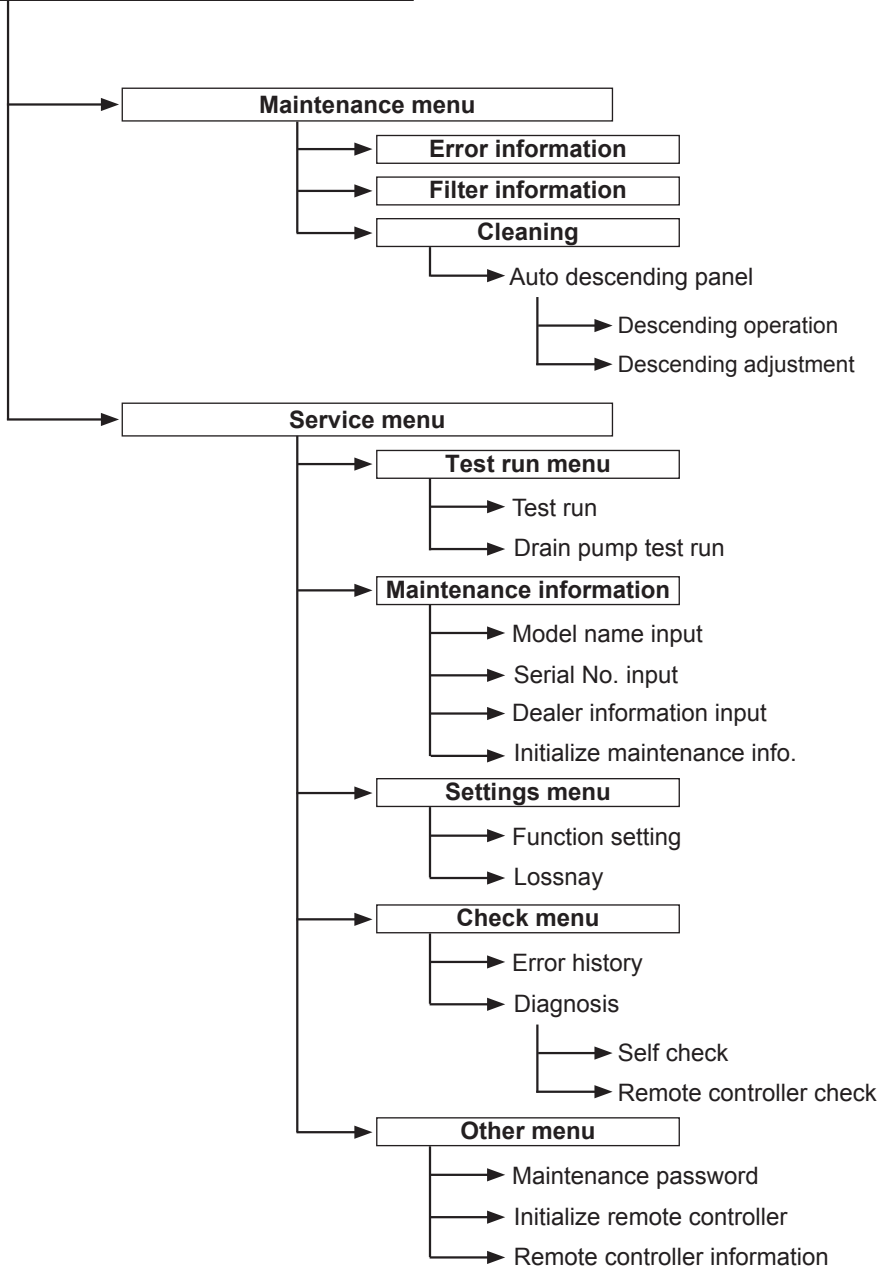

Not all functions are available on all models of indoor units.

## Main menu list

| Main menu     | Setting and display items       |                   | Setting details   |
|---------------|---------------------------------|-------------------|---|
| Operation     | Vane · Louver · Vent. (Lossnay) |                   | <b>Use to set the vane angle.</b> <ul style="list-style-type: none"> <li>• Select a desired vane setting from 5 different settings.</li> </ul> <b>Use to turn ON/OFF the louver.</b> <ul style="list-style-type: none"> <li>• Select a desired setting from "ON" and "OFF."</li> </ul> <b>Use to set the amount of ventilation.</b> <ul style="list-style-type: none"> <li>• Select a desired setting from "Off," "Low," and "High."</li> </ul> |
|               | High power                      |                   | <b>Use to reach the comfortable room temperature quickly.</b> <ul style="list-style-type: none"> <li>• Units can be operated in the High-power mode for up to 30 minutes.</li> </ul>  |
|               | Comfort                         | Manual vane angle | Use to fix each vane angle.   |
|               |                                 | 3D i-see Sensor   | <b>Use to set the following functions for 3D i-see Sensor.</b> <ul style="list-style-type: none"> <li>• Air distribution</li> <li>• Energy saving option</li> <li>• Seasonal airflow</li> </ul>   |
| Timer         | Timer                           | ON/OFF timer *1   | <b>Use to set the operation ON/OFF times.</b> <ul style="list-style-type: none"> <li>• Time can be set in 5-minute increments.</li> </ul>   |
|               |                                 | Auto-Off timer    | <b>Use to set the Auto-Off time.</b> <ul style="list-style-type: none"> <li>• Time can be set to a value from 30 to 240 in 10-minute increments.</li> </ul>   |
|               | Weekly timer *1, *2             |                   | <b>Use to set the weekly operation ON/OFF times.</b> <ul style="list-style-type: none"> <li>• Up to 8 operation patterns can be set for each day. (Not valid when the ON/OFF timer is enabled.)</li> </ul>  |
|               | OU silent mode *1               |                   | <b>Use to set the time periods in which priority is given to quiet operation of outdoor units over temperature control. Set the Start/Stop times for each day of the week.</b> <ul style="list-style-type: none"> <li>• Select the desired silent level from "Normal," "Middle," and "Quiet."</li> </ul>  |
|               | Night setback *1                |                   | <b>Use to make Night setback settings.</b> <ul style="list-style-type: none"> <li>• Select "Yes" to enable the setting, and "No" to disable the setting. The temperature range and the start/stop times can be set.</li> </ul>  |
| Energy saving | Restriction                     | Temp. range *2    | <b>Use to restrict the preset temperature range.</b> <ul style="list-style-type: none"> <li>• Different temperature ranges can be set for different operation modes.</li> </ul>   |
|               |                                 | Operation lock    | <b>Use to lock selected functions.</b> <ul style="list-style-type: none"> <li>• The locked functions cannot be operated.</li> </ul>   |
|               | Energy saving                   | Auto return *2    | <b>Use to get the units to operate at the preset temperature after performing energy saving operation for a specified time period.</b> <ul style="list-style-type: none"> <li>• Time can be set to a value from 30 and 120 in 10-minute increments. (This function will not be valid when the preset temperature ranges are restricted.)</li> </ul>   |
|               |                                 | Schedule *1       | <b>Set the start/stop times to operate the units in the energy saving mode for each day of the week, and set the energy saving rate.</b> <ul style="list-style-type: none"> <li>• Up to 4 energy saving operation patterns can be set for each day.</li> <li>• Time can be set in 5-minute increments.</li> <li>• Energy saving rate can be set to a value from 0% or 50 to 90% in 10% increments.</li> </ul>                                   |

\*1 Clock setting is required.

\*2 1°C (33.8°F) increments.





| Main menu                     | Setting and display items |  | Setting details  |
|-------------------------------|---------------------------|--|--|
| Initial setting               | Basic setting             | Main/Sub   | When connecting 2 remote controllers, one of them needs to be designated as a sub controller.  |
|                               |                           | Clock  | Use to set the current time.   |
|                               |                           | Daylight saving time   | Set the daylight saving time.  |
|                               |                           | Administrator password   | The administrator password is required to make the settings for the following items.<br><ul style="list-style-type: none"> <li>• Timer setting</li> <li>• Energy saving setting</li> <li>• Weekly timer setting</li> <li>• Restriction setting</li> <li>• Outdoor unit silent mode setting</li> <li>• Night set back</li> </ul>  |
|                               | Display setting           | Main display   | Use to switch between "Full" and "Basic" modes for the Main display.<br><ul style="list-style-type: none"> <li>• The initial setting is "Full."</li> </ul>   |
|                               |                           | Black and white inversion setting  | Use to invert the colors of the display, turning white background to black and black characters to white.  |
|                               |                           | Display details  | Make the settings for the remote controller related items as necessary.<br><b>Clock:</b> The initial settings are "Yes" and "24h" format.<br><b>Temperature:</b> Set either Celsius (°C) or Fahrenheit (°F).<br><b>Room temp. :</b> Set Show or Hide.<br><b>Auto mode:</b> Set the Auto mode display or Only Auto display.   |
|                               |                           | Contrast • Brightness  | Use to adjust screen contrast and brightness.  |
|                               | Language selection        | Use to select the desired language.  |  |
| Operation setting             | Auto mode                 | Whether or not to use the Auto mode can be selected by using the button. This setting is valid only when indoor units with the Auto mode function are connected. |  |
| Maintenance                   | Error information         |  | Use to check error information when an error occurs.<br><ul style="list-style-type: none"> <li>• Check code, error source, refrigerant address, unit model, manufacturing number, contact information (dealer's phone number) can be displayed.</li> </ul> (The unit model, manufacturing number, and contact information need to be registered in advance to be displayed.) |
|                               | Filter information        |  | Use to check the filter status.<br><ul style="list-style-type: none"> <li>• The filter sign can be reset.</li> </ul>   |
|                               | Cleaning                  | Auto descending panel  | Use to lift and lower the auto descending panel (Optional parts).  |
| Service                       | Test run                  |  | Select "Test run" from the Service menu to bring up the Test run menu.<br><ul style="list-style-type: none"> <li>• Test run</li> <li>• Drain pump test run</li> </ul>  |
|                               | Input maintenance         |  | Select "Input maintenance Info." from the Service menu to bring up the Maintenance information screen.<br>The following settings can be made from the Maintenance Information screen.<br><ul style="list-style-type: none"> <li>• Model name input</li> <li>• Serial No. input</li> <li>• Dealer information input</li> <li>• Initialize maintenance info.</li> </ul>        |
|                               | Settings                  | Function setting   | Make the settings for the indoor unit functions via the remote controller as necessary.  |
|                               |                           | LOSSNAY setting  | This setting is required only when the operation of CITY MULTI units is interlocked with LOSSNAY units.  |
|                               | Check                     | Error history  | Display the error history and execute "delete error history".  |
|                               |                           | Diagnosis  | <b>Self check:</b> Error history of each unit can be checked via the remote controller.<br><b>Remote controller check:</b> When the remote controller does not work properly, use the remote controller checking function to troubleshoot the problem.   |
|                               | Other                     | Maintenance password   | Use to change the maintenance password.  |
|                               |                           | Initialize remote controller   | Use to initialize the remote controller to the factory shipment status.  |
| Remote controller information |                           | Use to display the remote controller model name, software version, and serial number.  |  |

## 2-3. Wireless remote controller

### Controller interface

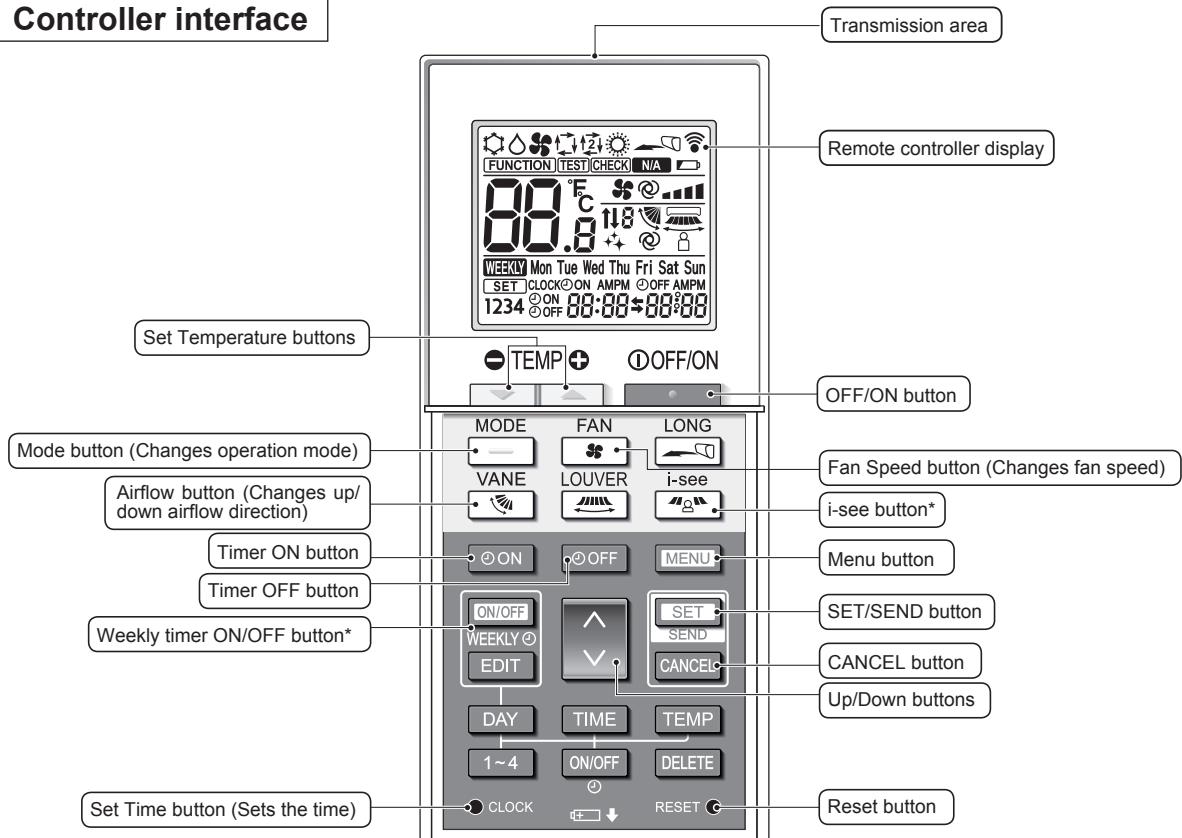

#### Note:

\* This button is enabled or disabled depending on the model of the indoor unit.

### Display

#### Operation mode

- Cool
- Dry
- Fan
- Auto (single set point)
- Heat
- Auto\* (dual set point)

\* The initial setting is necessary.

#### Temperature setting

The units of temperature can be changed. For details, refer to the Installation Manual.

#### Vane setting

Step 1 Step 2 Step 3 Step 4 Step 5 Swing Auto



#### Not available

Appears when a non-supported function is selected.

#### Battery replacement indicator

Appears when the remaining battery power is low.

#### Fan speed setting

Auto



#### 3D i-see sensor (Air distribution)

Default Direct Indirect



When Direct or Indirect is selected, the vane setting is set to "Auto".

## 3-1. SPECIFICATIONS

| Model  |  | PKFY-WL10VLM-E  | PKFY-WL15VLM-E             | PKFY-WL20VLM-E  | PKFY-WL25VLM-E   |                 |      |
|--|--|---|----------------------------|-----------------|--|-----------------|------|
| Power source   |  | 1-phase 220-240 V 50 Hz, 1-phase 220 V 60 Hz  |                            |                 |  |                 |      |
| Cooling capacity<br>(Nominal)  | *1                                       | kW  | 1.2                        | 1.7             | 2.2  | 2.8             |      |
|  | *1                                       | kcal/h  | 1000                       | 1500            | 1900   | 2400            |      |
|  | *1                                       | BTU/h   | 4100                       | 5800            | 7500   | 9600            |      |
|  |  | Power input   | kW                         | 0.02            | 0.02   | 0.03            | 0.04 |
|  |  | Current input   | A                          | 0.20            | 0.20   | 0.25            | 0.35 |
| Heating capacity<br>(Nominal)  | *2                                       | kW  | 1.4                        | 1.9             | 2.5  | 3.2             |      |
|  | *2                                       | kcal/h  | 1200                       | 1600            | 2200   | 2800            |      |
|  | *2                                       | BTU/h   | 4800                       | 6500            | 8500   | 10900           |      |
|  |  | Power input   | kW                         | 0.01            | 0.01   | 0.02            | 0.03 |
|  |  | Current input   | A                          | 0.15            | 0.15   | 0.20            | 0.30 |
| External finish(Munsell No.)   |  | Plastic (0.7PB 9.2/0.4)   |                            |                 |  |                 |      |
| External dimension H x W x D   |  | mm  | 299 × 773 × 238            |                 |  |                 |      |
|  |  | in  | 11-25/32 x 30-7/16 x 9-3/8 |                 |  |                 |      |
| Net weight   | kg (lb)                                  | 11(25)  |                            |                 |  |                 |      |
| Heat exchanger   |  | Cross fin (Aluminum fin and copper tube)  |                            |                 |  |                 |      |
| Fan  | Type x Quantity                          |   | Line flow fan x 1          |                 |  |                 |      |
|  | External static press                    | Pa (mmH2O)  | 0(0)                       |                 |  |                 |      |
|  | Motor type                               |   | DC motor                   |                 |  |                 |      |
|  | Motor output                             | kW  | 0.03                       |                 |  |                 |      |
|  | Driving mechanism                        |   | Direct driven              |                 |  |                 |      |
|  | Airflow rate<br>(Low-Mid2<br>-Mid1-High) | m <sup>3</sup> /min   | 3.3-3.8-4.1-4.5            | 3.3-3.8-4.3-4.9 | 4.0-5.0-6.0-7.0  | 4.0-5.4-7.0-8.4 |      |
|  |  | L/s   | 55-63-68-75                | 55-63-72-82     | 67-83-100-117  | 67-90-117-140   |      |
| cfm  |  | 117-134-145-159   | 117-134-152-173            | 141-177-212-247 | 141-191-247-297  |                 |      |
| Sound pressure level<br>(Low-Mid2-Mid1-High)<br>(measured in anechoic room)  | dB <A>                                   | 22-26-28-30   | 22-26-29-32                | 22-28-33-36     | 22-30-36-41  |                 |      |
| Insulation material  |  | Polyethylene sheet  |                            |                 |  |                 |      |
| Connectable outdoor unit   |  | HYBRID CITY MULTI/CMB-WM-V-AA, CMB-WM-V-AB/CMH-WM-V-A   |                            |                 |  |                 |      |
| Air filter   |  | PP Honeycomb  |                            |                 |  |                 |      |
| Protection device  |  | Fuse  |                            |                 |  |                 |      |
| Connection size  | Water Inlet                              | in  | Rc3/4 screw                |                 |  |                 |      |
|  | Water outlet                             | in  | Rc3/4 screw                |                 |  |                 |      |
| Field drain pipe size  | mm (in)                                  | I.D.16 (5/8)  |                            |                 |  |                 |      |
| Standard attachment  |  | Installation Manual, Instruction Book   |                            |                 |  |                 |      |
| Optional parts   | DRAIN PUMP KIT                           |   | PAC-SK01DM-E               |                 |  |                 |      |
|  | VALVE KIT                                |   | PAC-SK04VK-E               |                 |  |                 |      |
| Remark   |  | Details on foundation work, duct work, insulation work, electrical wiring, power source switch, and other items shall be referred to the Installation Manual.<br>Due to continuing improvement, above specifications may be subject to change without notice. |                            |                 |  |                 |      |
| Notes:   |  |   |                            |                 | Unit converter   |                 |      |
| *1.Nominal cooling conditions (subject to JIS B8615-1)<br>Indoor: 27°C.D.B./19°C.W.B. (81°F.D.B./66°F.W.B.), Outdoor: 35°C.D.B. (95°F.D.B.)<br>Pipe length: 7.5 m (24-9/16 ft), Level difference: 0 m (0 ft) |  |   |                            |                 | kcal/h = kW × 860<br>Btu/h = kW × 3,412<br>cfm = m <sup>3</sup> /min × 35.31<br>lb = kg/0.4536 |                 |      |
| *2.Nominal heating conditions (subject to JIS B8615-1)<br>Indoor: 20°C.D.B. (68°F.D.B.), Outdoor: 7°C.D.B./6°C.W.B. (45°F.D.B./43°F.W.B.)<br>Pipe length: 7.5 m (24-9/16 ft), Level difference: 0 m (0 ft)   |  |   |                            |                 | Note: Above specification data is subject to rounding variation.                               |                 |      |

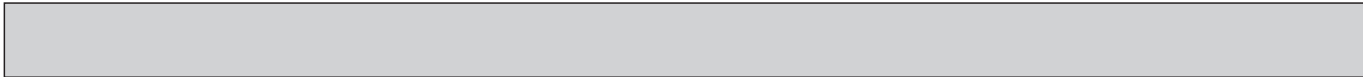

| Model  |                                      |            | PKFY-WL32VLM-E  | PKFY-WL40VLM-E    |  |
|--|--------------------------------------|------------|---|-------------------|--|
| Power source   |                                      |            | 1-phase 220-240 V 50 Hz, 1-phase 220 V 60 Hz  |                   |  |
| Cooling capacity<br>(Nominal)  | *1                                   | kW         | 3.6   | 4.5               |  |
|  | *1                                   | kcal/h     | 3100  | 3900              |  |
|  | *1                                   | BTU/h      | 12300   | 15400             |  |
|  | Power input                          | kW         | 0.04  | 0.05              |  |
|  | Current input                        | A          | 0.35  | 0.45              |  |
| Heating capacity<br>(Nominal)  | *2                                   | kW         | 4.0   | 5.0               |  |
|  | *2                                   | kcal/h     | 3400  | 4300              |  |
|  | *2                                   | BTU/h      | 13600   | 17100             |  |
|  | Power input                          | kW         | 0.03  | 0.04              |  |
|  | Current input                        | A          | 0.30  | 0.40              |  |
| External finish(Munsell No.)   |                                      |            | Plastic (0.7PB 9.2/0.4)   |                   |  |
| External dimension H x W x D   |                                      | mm         | 299 x 898 x 238   |                   |  |
|  |                                      | in         | 11-25/32 x 35-3/8 x 9-3/8   |                   |  |
| Net weight   |                                      | kg (lb)    | 13(29)  |                   |  |
| Heat exchanger   |                                      |            | Cross fin (Aluminum fin and copper tube)  |                   |  |
| Fan  | Type x Quantity                      |            | Line flow fan x 1   |                   |  |
|  | External static press                | Pa (mmH2O) | 0(0)  |                   |  |
|  |                                      | Motor type | DC motor  |                   |  |
|  | Motor output                         | kW         | 0.03  |                   |  |
|  | Driving mechanism                    |            | Direct driven   |                   |  |
|  | Airflow rate<br>(Low-Mid2-Mid1-High) | m³/min     | 6.3-7.6-9.0-10.4  | 6.4-8.2-10.0-11.9 |  |
|  |                                      | L/s        | 105-127-150-173   | 107-137-167-198   |  |
|  |                                      | cfm        | 222-268-318-367   | 226-290-353-420   |  |
| Sound pressure level<br>(Low-Mid2-Mid1-High)<br>(measured in anechoic room)  |                                      | dB <A>     | 29-34-38-41   | 30-36-41-45       |  |
| Insulation material  |                                      |            | Polyethylene sheet  |                   |  |
| Connectable outdoor unit   |                                      |            | HYBRID CITY MULTI/CMB-WM-V-AA, CMB-WM-V-AB/CMH-WM-V-A   |                   |  |
| Air filter   |                                      |            | PP Honeycomb  |                   |  |
| Protection device  |                                      |            | Fuse  |                   |  |
| Connection size  | Water Inlet                          | in         | Rc3/4 screw   |                   |  |
|  | Water outlet                         | in         | Rc3/4 screw   |                   |  |
| Field drain pipe size  |                                      | mm (in)    | I.D.16 (5/8)  |                   |  |
| Standard attachment  |                                      |            | Installation Manual, Instruction Book   |                   |  |
| Optional parts   | DRAIN PUMP KIT                       |            | PAC-SK01DM-E  |                   |  |
| Remark   |                                      |            | Details on foundation work, duct work, insulation work, electrical wiring, power source switch, and other items shall be referred to the Installation Manual.<br>Due to continuing improvement, above specifications may be subject to change without notice. |                   |  |
| Notes:<br>*1.Nominal cooling conditions (subject to JIS B8615-1)<br>Indoor: 27°C.D.B./19°C.W.B. (81°F.D.B./66°F.W.B.), Outdoor: 35°C.D.B. (95°F.D.B.)<br>Pipe length: 7.5 m (24-9/16 ft), Level difference: 0 m (0 ft)<br>*2.Nominal heating conditions (subject to JIS B8615-1)<br>Indoor: 20°C.D.B. (68°F.D.B.), Outdoor: 7°C.D.B./6°C.W.B. (45°F.D.B./43°F.W.B.)<br>Pipe length: 7.5 m (24-9/16 ft), Level difference: 0 m (0 ft) |                                      |            |   |                   |  |

### 3-2. ELECTRICAL PARTS SPECIFICATIONS

| Service ref.<br>Parts name                   | Symbol | PKFY-WL10VLM-E.TH<br>PKFY-WL15VLM-E.TH<br>PKFY-WL20VLM-E.TH<br>PKFY-WL25VLM-E.TH      | PKFY-WL32VLM-E.TH<br>PKFY-WL40VLM-E.TH |
|--|--------|---|--|
| Room temperature detection thermistor        | TH21   | Resistance 0°C /15kΩ, 10°C /9.6kΩ, 20°C /6.3kΩ, 25°C /5.4kΩ, 30°C /4.3kΩ, 40°C /3.0kΩ |  |
| Pipe temperature detection thermistor/liquid | TH22   | Resistance 0°C /15kΩ, 10°C /9.6kΩ, 20°C /6.3kΩ, 25°C /5.4kΩ, 30°C /4.3kΩ, 40°C /3.0kΩ |  |
| Pipe temperature detection thermistor/gas    | TH23   | Resistance 0°C /15kΩ, 10°C /9.6kΩ, 20°C /6.3kΩ, 25°C /5.4kΩ, 30°C /4.3kΩ, 40°C /3.0kΩ |  |
| Fuse (Indoor controller board)               | FUSE   | T3.15AL250V   |  |
| Fan motor (with thermal fuse)                | MF     | 8 X 30W / RC0J30-QD   |  |
| Vane motor (Upper)                           | MV1    | MSFBC20 DC12V   |  |
| Vane motor (Lower)                           | MV2    | NSEK302 DC12V   |  |
| Power supply terminal block                  | TB2    | (L, N, ⊕) Rated to 250V 20A *   |  |
| Transmission terminal block                  | TB5    | (M1, M2, S) Rated to 250V 20A *   |  |
| MA-Remote controller terminal block          | TB15   | (1, 2) Rated to 250V 10A *  |  |

\* Refer to WIRING DIAGRAM for the supplied voltage.

### 3-3. SOUND PRESSURE LEVEL

PKFY-WL-VLM-E

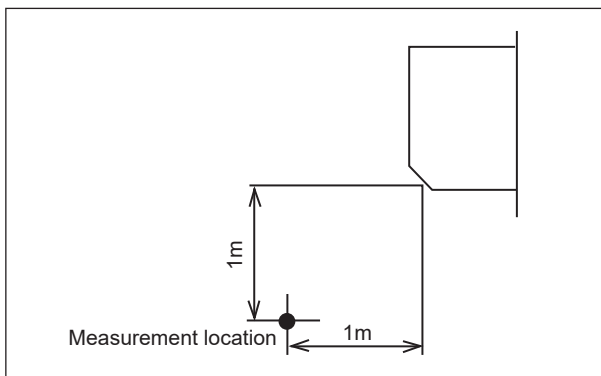

\* Measured in anechoic room.

Sound pressure level at anechoic room : Low-Middle2-Middle1-High

| Service Ref.      | Sound pressure level dB (A) |
|-------------------|-----------------------------|
| PKFY-WL10VLM-E.TH | 22-26-28-30                 |
| PKFY-WL15VLM-E.TH | 22-26-29-32                 |
| PKFY-WL20VLM-E.TH | 22-28-33-36                 |
| PKFY-WL25VLM-E.TH | 22-30-36-41                 |
| PKFY-WL32VLM-E.TH | 29-34-38-41                 |
| PKFY-WL40VLM-E.TH | 30-36-41-45                 |

NOISE CRITERION CURVES

PKFY-WL10VLM-E.TH

| FAN     | SPL(dB) | LINE |
|---------|---------|------|
| High    | 30      | ○—○  |
| Medium1 | 28      | ●—●  |
| Medium2 | 26      | □—□  |
| Low     | 22      | ■—■  |

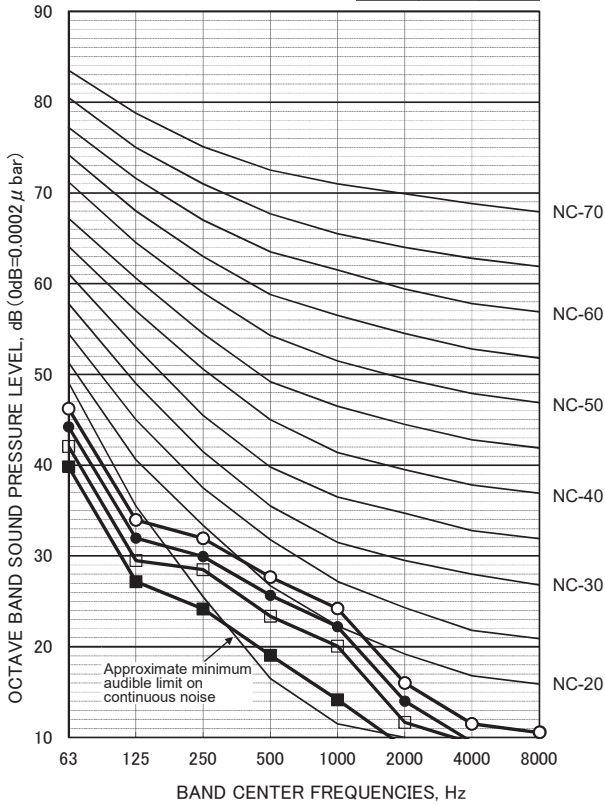

PKFY-WL15VLM-E.TH

| FAN     | SPL(dB) | LINE |
|---------|---------|------|
| High    | 32      | ○—○  |
| Medium1 | 29      | ●—●  |
| Medium2 | 26      | □—□  |
| Low     | 22      | ■—■  |

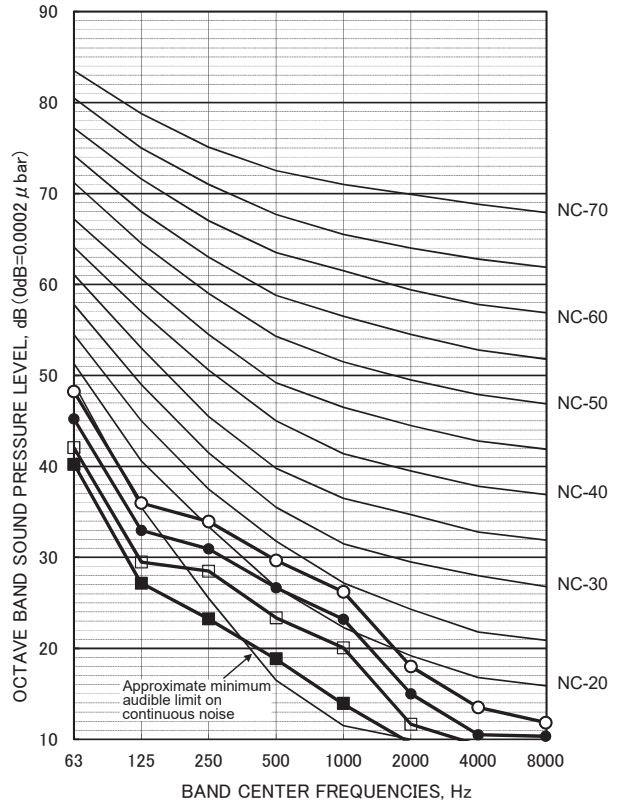

PKFY-WL20VLM-E.TH

| FAN     | SPL(dB) | LINE |
|---------|---------|------|
| High    | 36      | ○—○  |
| Medium1 | 33      | ●—●  |
| Medium2 | 28      | □—□  |
| Low     | 22      | ■—■  |

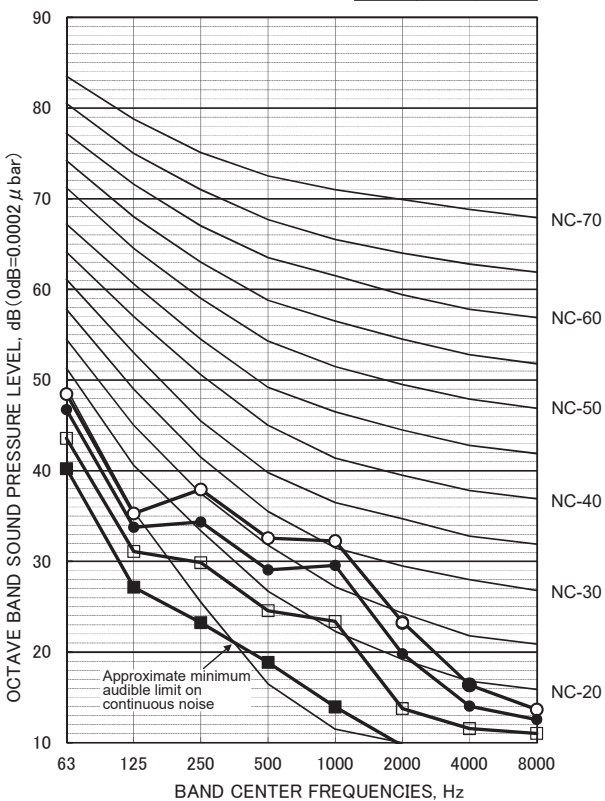

PKFY-WL25VLM-E.TH

| FAN     | SPL(dB) | LINE |
|---------|---------|------|
| High    | 41      | ○—○  |
| Medium1 | 36      | ●—●  |
| Medium2 | 30      | □—□  |
| Low     | 22      | ■—■  |

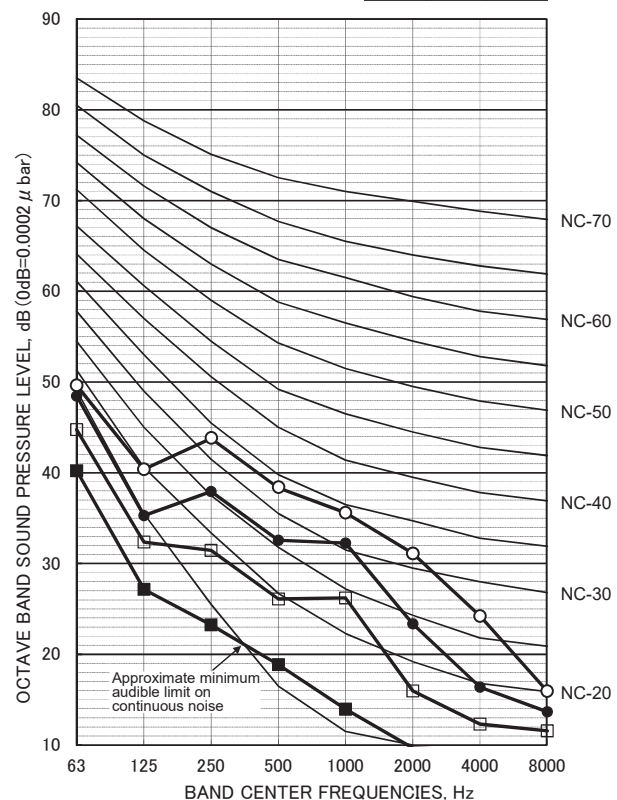

**PKFY-WL32VLM-E.TH**

| FAN     | SPL(dB) | LINE |
|---------|---------|------|
| High    | 41      | ○—○  |
| Medium1 | 38      | ●—●  |
| Medium2 | 34      | □—□  |
| Low     | 29      | ■—■  |

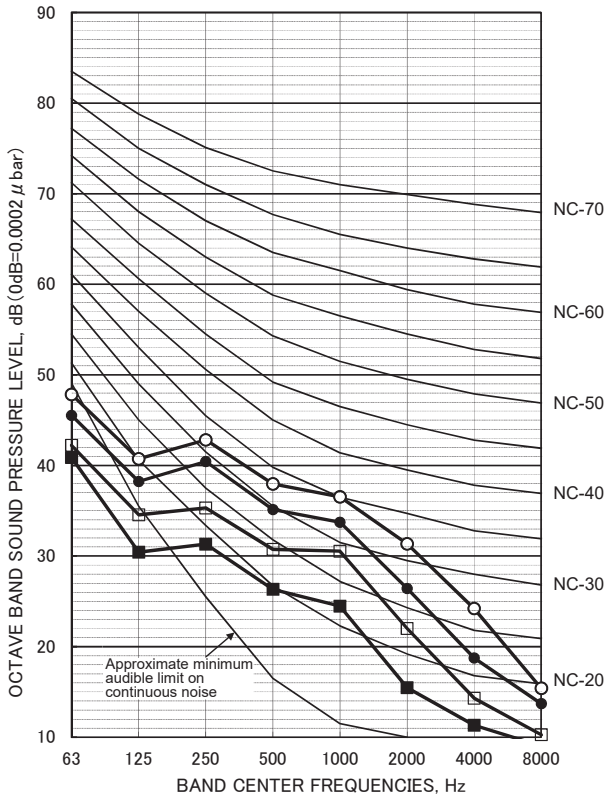

**PKFY-WL40VLM-E.TH**

| FAN     | SPL(dB) | LINE |
|---------|---------|------|
| High    | 45      | ○—○  |
| Medium1 | 41      | ●—●  |
| Medium2 | 36      | □—□  |
| Low     | 30      | ■—■  |

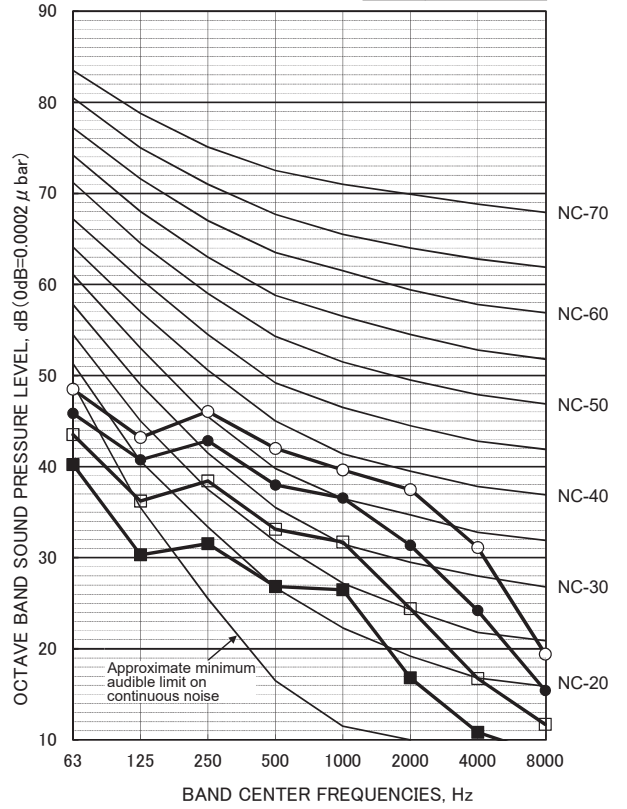







PKFY-WL10VLM-E.TH  
 PKFY-WL20VLM-E.TH  
 PKFY-WL32VLM-E.TH

PKFY-WL15VLM-E.TH  
 PKFY-WL25VLM-E.TH  
 PKFY-WL40VLM-E.TH

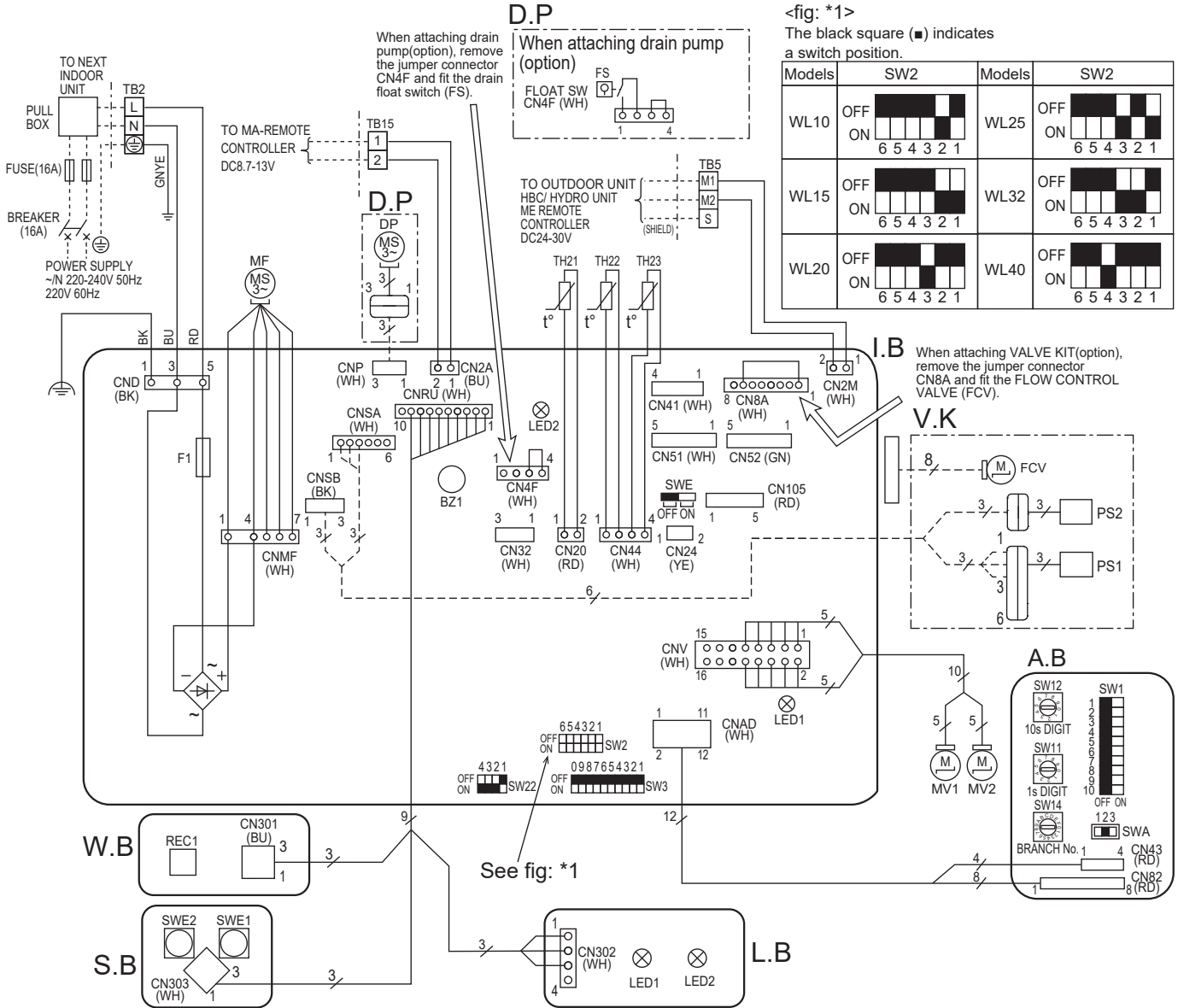

<fig: \*1>  
 The black square (■) indicates a switch position.

| Models | SW2                   | Models | SW2                   |
|--------|-----------------------|--------|-----------------------|
| WL10   | OFF ON<br>6 5 4 3 2 1 | WL25   | OFF ON<br>6 5 4 3 2 1 |
| WL15   | OFF ON<br>6 5 4 3 2 1 | WL32   | OFF ON<br>6 5 4 3 2 1 |
| WL20   | OFF ON<br>6 5 4 3 2 1 | WL40   | OFF ON<br>6 5 4 3 2 1 |

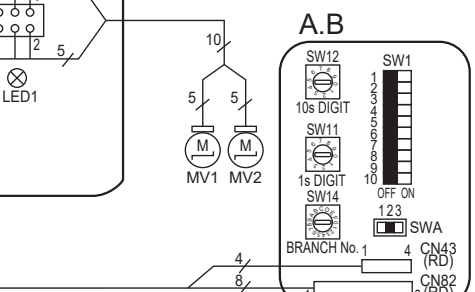
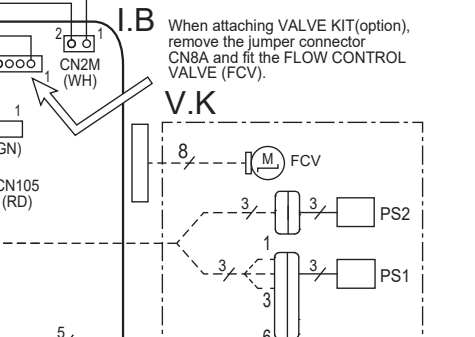

| SYMBOL | NAME                                | SYMBOL | NAME  |
|--------|-------------------------------------|--------|---|
| I.B    | INDOOR CONTROLLER BOARD             | TH21   | THERMISTOR ROOM TEMP. DETECTION (0°C/15kΩ, 25°C/5.4kΩ)                |
| CN32   | CONNECTOR REMOTE SWITCH             | TH22   | THERMISTOR PIPE TEMP. DETECTION / INLET WATER (0°C/15kΩ, 25°C/5.4kΩ)  |
| CN51   | CENTRALLY CONTROL                   | TH23   | THERMISTOR PIPE TEMP. DETECTION / OUTLET WATER (0°C/15kΩ, 25°C/5.4kΩ) |
| CN52   | REMOTE INDICATION                   | A.B    | ADDRESS BOARD   |
| CN105  | IT TERMINAL                         | SW1    | SWITCH MODE SELECTION   |
| BZ1    | BUZZER                              | SW11   | SWITCH ADDRESS SETTING 1s DIGIT                                       |
| F1     | FUSE (T3.15A/250V)                  | SW12   | SWITCH ADDRESS SETTING 10s DIGIT                                      |
| LED1   | POWER SUPPLY (I.B)                  | SW14   | SWITCH BRANCH No.   |
| LED2   | POWER SUPPLY (MA-REMOTE CONTROLLER) | S.B    | SWITCH BOARD  |
| SW2    | SWITCH CAPACITY CODE                | SWE1   | SWITCH EMERGENCY OPERATION(HEAT)                                      |
| SW3    | SWITCH MODE SELECTION               | SWE2   | SWITCH EMERGENCY OPERATION(COOL)                                      |
| SW22   | SWITCH PAIR NO. SETTING             | W.B    | PCB FOR WIRELESS REMOTE CONTROLLER                                    |
| SWE    | SWITCH FAN-DRAIN PUMP (TEST MODE)   | REC1   | RECEIVING UNIT  |
| MF     | FAN MOTOR                           | I.B    | LED BOARD   |
| MV1    | VANE MOTOR (UPPER)                  | LED1   | LED(OPERATING INDICATOR:GREEN)  |
| MV2    | VANE MOTOR (LOWER)                  | LED2   | LED(STANDBY FOR HEATING : ORANGE )                                    |
| TB2    | TERMINAL POWER SUPPLY               | D.P    | DRAIN PUMP KIT (OPTION)   |
| TB5    | TERMINAL TRANSMISSION               | FS     | DRAIN FLOAT SWITCH  |
| TB15   | TERMINAL MA-REMOTE CONTROLLER       | DP     | DRAIN PUMP  |
| V.K    | VALVE KIT (OPTION)                  |        |   |
| FCV    | FLOW CONTROL VALVE                  |        |   |
| PS1    | PRESSURE SENSOR 1 (INLET WATER)     |        |   |
| PS2    | PRESSURE SENSOR 2 (OUTLET WATER)    |        |   |

- NOTES:
- At servicing for outdoor unit, always follow the wiring diagram of outdoor unit.
  - In case of using MA-Remote controller, please connect to TB15. (Remote controller wire is non-polar.)
  - In case of using M-NET, please connect to TB5. (Transmission line is non-polar.)
  - Symbol [S] of TB5 is the shield wire connection.
  - Symbols used in wiring diagram above are, [ ] : terminal block, [ ] : connector.
  - The setting of the SW2 dip switches differs in the capacity. For the detail, refer to the fig : \*1.

LED on indoor controller board for service

| Symbol | Meaning                               | Function   |
|--------|---------------------------------------|--|
| LED1   | Main power supply                     | Main power supply (Indoor unit:220-240V)<br>Power on → lamp is lit |
| LED2   | Power supply for MA-Remote controller | Power supply for MA-Remote controller<br>on → lamp is lit          |

# 7

# REFRIGERANT SYSTEM DIAGRAM

PKFY-WL10VLM-E.TH  
 PKFY-WL20VLM-E.TH  
 PKFY-WL32VLM-E.TH

PKFY-WL15VLM-E.TH  
 PKFY-WL25VLM-E.TH  
 PKFY-WL40VLM-E.TH

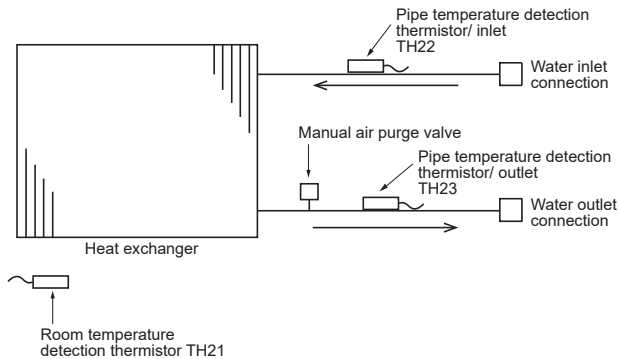

Unit: in

| Item         | Model | PKFY-WL10/15/20/25/32/40VLM-E |
|--------------|-------|-------------------------------|
| Water inlet  |       | Rc3/4 screw                   |
| Water outlet |       | Rc3/4 screw                   |

# 8

# TROUBLESHOOTING

## 8-1. HOW TO CHECK THE PARTS

PKFY-WL10VLM-E.TH  
 PKFY-WL20VLM-E.TH  
 PKFY-WL32VLM-E.TH

PKFY-WL15VLM-E.TH  
 PKFY-WL25VLM-E.TH  
 PKFY-WL40VLM-E.TH

| Parts name  | Check points  |                      |                                       |               |                                       |                     |                     |                     |                     |                   |                       |                 |           |   |               |                  |           |
|---|---|----------------------|---------------------------------------|---------------|---------------------------------------|---------------------|---------------------|---------------------|---------------------|-------------------|-----------------------|-----------------|-----------|---|---------------|------------------|-----------|
| Room temperature detection thermistor (TH21)<br>Pipe temperature detection thermistor/liquid (TH22)<br>Pipe temperature detection thermistor/gas (TH23) | Disconnect the connector then measure the resistance with a tester.<br>(At the ambient temperature 10 to 30°C)<br><table border="1" style="margin-left: 20px;"> <tr> <td style="text-align: center;">Normal</td> <td rowspan="2" style="vertical-align: middle;">Refer to "8-1-1. Thermistor".</td> </tr> <tr> <td style="text-align: center;">4.3 to 9.6 kΩ</td> </tr> </table>  | Normal               | Refer to "8-1-1. Thermistor".         | 4.3 to 9.6 kΩ |                                       |                     |                     |                     |                     |                   |                       |                 |           |   |               |                  |           |
| Normal  | Refer to "8-1-1. Thermistor".   |                      |                                       |               |                                       |                     |                     |                     |                     |                   |                       |                 |           |   |               |                  |           |
| 4.3 to 9.6 kΩ   |   |                      |                                       |               |                                       |                     |                     |                     |                     |                   |                       |                 |           |   |               |                  |           |
| Vane motor (MV1)<br>  | Measure the resistance between the terminals with a tester. (At the ambient temperature 25°C)<br><table border="1" style="margin-left: 20px;"> <tr> <th colspan="4" style="text-align: center;">Normal</th> </tr> <tr> <td style="text-align: center;">⑩-⑨<br/>Red-Sky Blue</td> <td style="text-align: center;">⑩-⑧<br/>Red-Sky Blue</td> <td style="text-align: center;">⑩-⑦<br/>Red-Sky Blue</td> <td style="text-align: center;">⑩-⑥<br/>Red-Sky Blue</td> </tr> <tr> <td colspan="4" style="text-align: center;">300 Ω ±7%</td> </tr> </table>   | Normal               |                                       |               |                                       | ⑩-⑨<br>Red-Sky Blue | ⑩-⑧<br>Red-Sky Blue | ⑩-⑦<br>Red-Sky Blue | ⑩-⑥<br>Red-Sky Blue | 300 Ω ±7%         |                       |                 |           |   |               |                  |           |
| Normal  |   |                      |                                       |               |                                       |                     |                     |                     |                     |                   |                       |                 |           |   |               |                  |           |
| ⑩-⑨<br>Red-Sky Blue   | ⑩-⑧<br>Red-Sky Blue   | ⑩-⑦<br>Red-Sky Blue  | ⑩-⑥<br>Red-Sky Blue                   |               |                                       |                     |                     |                     |                     |                   |                       |                 |           |   |               |                  |           |
| 300 Ω ±7%   |   |                      |                                       |               |                                       |                     |                     |                     |                     |                   |                       |                 |           |   |               |                  |           |
| Vane motor (Lower (MV2))<br>  | Measure the resistance between the terminals with a tester. (At the ambient temperature 25°C)<br><table border="1" style="margin-left: 20px;"> <tr> <th colspan="4" style="text-align: center;">Normal</th> </tr> <tr> <td style="text-align: center;">⑤-④<br/>Red-Sky Blue</td> <td style="text-align: center;">⑤-③<br/>Red-Sky Blue</td> <td style="text-align: center;">⑤-②<br/>Red-Sky Blue</td> <td style="text-align: center;">⑤-①<br/>Red-Sky Blue</td> </tr> <tr> <td colspan="4" style="text-align: center;">300 ±26.3 Ω</td> </tr> </table>   | Normal               |                                       |               |                                       | ⑤-④<br>Red-Sky Blue | ⑤-③<br>Red-Sky Blue | ⑤-②<br>Red-Sky Blue | ⑤-①<br>Red-Sky Blue | 300 ±26.3 Ω       |                       |                 |           |   |               |                  |           |
| Normal  |   |                      |                                       |               |                                       |                     |                     |                     |                     |                   |                       |                 |           |   |               |                  |           |
| ⑤-④<br>Red-Sky Blue   | ⑤-③<br>Red-Sky Blue   | ⑤-②<br>Red-Sky Blue  | ⑤-①<br>Red-Sky Blue                   |               |                                       |                     |                     |                     |                     |                   |                       |                 |           |   |               |                  |           |
| 300 ±26.3 Ω   |   |                      |                                       |               |                                       |                     |                     |                     |                     |                   |                       |                 |           |   |               |                  |           |
| Fan motor (MF)  | Refer to "8-1-3. DC Fan motor (fan motor/indoor controller board)   |                      |                                       |               |                                       |                     |                     |                     |                     |                   |                       |                 |           |   |               |                  |           |
| Flow control valve (FCV)<br>  | Disconnect the connector then measure the resistance between terminals with a tester.<br>Refer to the next page for details.<br><table border="1" style="margin-left: 20px;"> <tr> <th colspan="4" style="text-align: center;">Normal</th> <th rowspan="2" style="text-align: center;">Abnormal</th> </tr> <tr> <td style="text-align: center;">1-5<br/>Yellow-Blue</td> <td style="text-align: center;">2-5<br/>Orange-Blue</td> <td style="text-align: center;">3-5<br/>Red-Blue</td> <td style="text-align: center;">4-5<br/>Green-Blue</td> </tr> <tr> <td colspan="4" style="text-align: center;">55 Ω ±5.6 Ω (at 25°C)</td> <td style="text-align: center;">Open or short</td> </tr> </table>   | Normal               |                                       |               |                                       | Abnormal            | 1-5<br>Yellow-Blue  | 2-5<br>Orange-Blue  | 3-5<br>Red-Blue     | 4-5<br>Green-Blue | 55 Ω ±5.6 Ω (at 25°C) |                 |           |   | Open or short |                  |           |
| Normal  |   |                      |                                       | Abnormal      |                                       |                     |                     |                     |                     |                   |                       |                 |           |   |               |                  |           |
| 1-5<br>Yellow-Blue  | 2-5<br>Orange-Blue  | 3-5<br>Red-Blue      | 4-5<br>Green-Blue                     |               |                                       |                     |                     |                     |                     |                   |                       |                 |           |   |               |                  |           |
| 55 Ω ±5.6 Ω (at 25°C)   |   |                      |                                       | Open or short |                                       |                     |                     |                     |                     |                   |                       |                 |           |   |               |                  |           |
| Drain pump (DP)<br>   | ① Check if the drain float switch works properly.<br>② Check if the drain pump works and drains water properly in cooling operation.<br>③ If no water drains, confirm that the check code 2502 will not be displayed 10 minutes after the operation starts.<br>Note: The drain pump for this model is driven by the internal DC motor, so it is not possible to measure the resistance between the terminals.<br>Normal<br>Red-Black: Input 13 V DC → The pump motor starts to rotate.  |                      |                                       |               |                                       |                     |                     |                     |                     |                   |                       |                 |           |   |               |                  |           |
| Drain float switch (FS)<br>   | Measure the resistance between the terminals with a tester.<br><table border="1" style="margin-left: 20px;"> <tr> <th>State of moving part</th> <th>Normal</th> <th>Abnormal</th> <th>Drain float switch connector terminal</th> </tr> <tr> <td style="text-align: center;">UP</td> <td style="text-align: center;">Short</td> <td style="text-align: center;">Other than short</td> <td style="text-align: center;">①(+)-②(-)</td> </tr> <tr> <td style="text-align: center;">DOWN</td> <td style="text-align: center;">Open</td> <td style="text-align: center;">Other than open</td> <td style="text-align: center;">①(+)-②(-)</td> </tr> <tr> <td style="text-align: center;">-</td> <td style="text-align: center;">Short</td> <td style="text-align: center;">Other than short</td> <td style="text-align: center;">③(+)-④(-)</td> </tr> </table> | State of moving part | Normal                                | Abnormal      | Drain float switch connector terminal | UP                  | Short               | Other than short    | ①(+)-②(-)           | DOWN              | Open                  | Other than open | ①(+)-②(-) | - | Short         | Other than short | ③(+)-④(-) |
| State of moving part  | Normal  | Abnormal             | Drain float switch connector terminal |               |                                       |                     |                     |                     |                     |                   |                       |                 |           |   |               |                  |           |
| UP  | Short   | Other than short     | ①(+)-②(-)                             |               |                                       |                     |                     |                     |                     |                   |                       |                 |           |   |               |                  |           |
| DOWN  | Open  | Other than open      | ①(+)-②(-)                             |               |                                       |                     |                     |                     |                     |                   |                       |                 |           |   |               |                  |           |
| -   | Short   | Other than short     | ③(+)-④(-)                             |               |                                       |                     |                     |                     |                     |                   |                       |                 |           |   |               |                  |           |

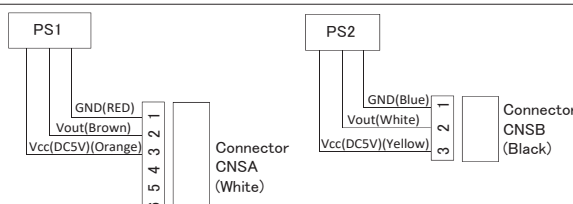
| Parts name                       | Check points   |
|----------------------------------|--|
| Pressure sensor (Optional parts) | <ul style="list-style-type: none"> <li>Pressure sensor (inner water) PS1</li> <li>Pressure sensor (outlet water) PS2</li> </ul> <ol style="list-style-type: none"> <li>Check that the pressure sensor is connected.</li> <li>Check the pressure sensor wiring for breakage.</li> </ol> <p>Pressure 0-1.0 MPa [145 psi] Vout 0.5-4.5 V<br/> 0.392 V / 0.098 MPa [14 psi]<br/> Pressure [MPa] = 0.25 × Vout [V] - 0.125<br/> Pressure [psi] = (0.25 × Vout [V] - 0.125) × 145</p>  |

### 8-1-1. Thermistor

<Thermistor characteristic graph>

Thermistor for lower temperature

Room temperature detection thermistor (TH21)  
Pipe temperature detection thermistor/liquid (TH22)  
Pipe temperature detection thermistor/gas (TH23)

Thermistor  $R_0=15\text{ k}\Omega \pm 3\%$   
Fixed number of  $B=3480 \pm 2\%$

$$R_t = 15 \exp \left\{ 3480 \left( \frac{1}{273+t} - \frac{1}{273} \right) \right\}$$

|      |        |
|------|--------|
| 0°C  | 15 kΩ  |
| 10°C | 9.6 kΩ |
| 20°C | 6.3 kΩ |
| 25°C | 5.4 kΩ |
| 30°C | 4.3 kΩ |
| 40°C | 3.0 kΩ |

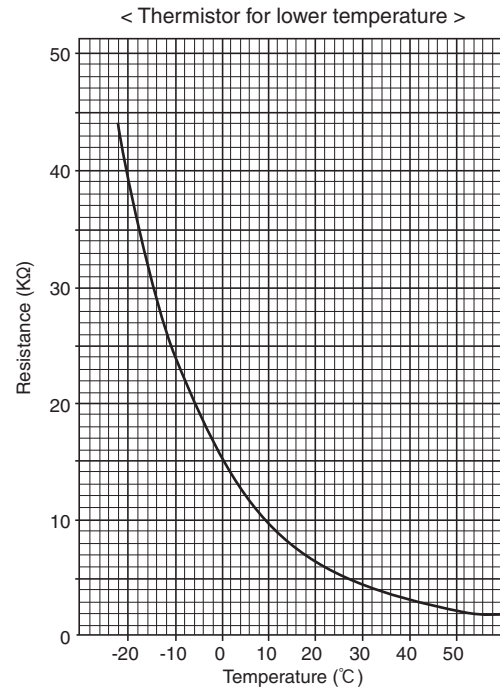

### 8-1-2. Flow control valve (FCV)

#### ① Summary of flow control valve (FCV) operation

- The FCV is operated by a stepping motor, which operates by receiving a pulse signal from the indoor control board.
- The FCV position changes in response to the pulse signal.

#### Indoor control board and FCV connection

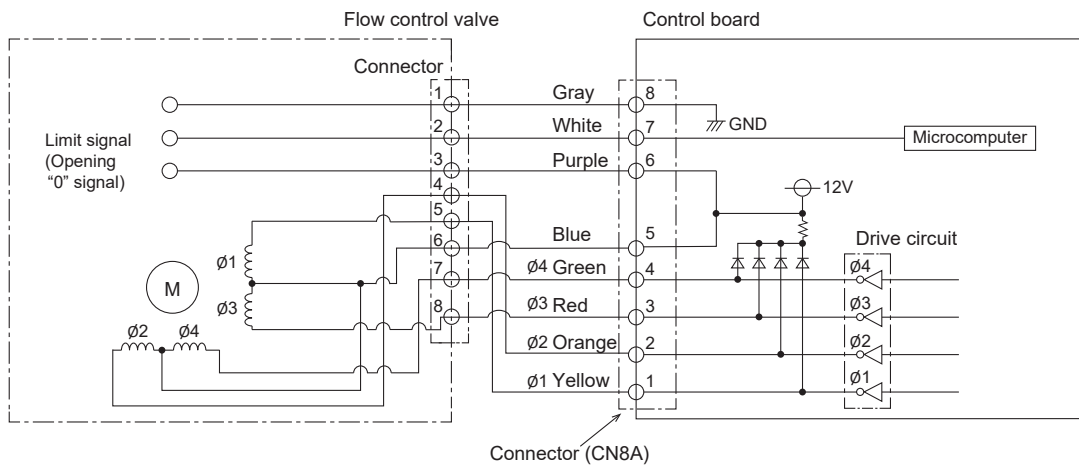

#### Pulse signal output and valve operation

| Output (phase) number | Output status |     |     |     |
|-----------------------|---------------|-----|-----|-----|
|                       | 1             | 2   | 3   | 4   |
| φ1                    | OFF           | ON  | ON  | OFF |
| φ2                    | ON            | ON  | OFF | OFF |
| φ3                    | ON            | OFF | OFF | ON  |
| φ4                    | OFF           | OFF | ON  | ON  |

The output pulse changes in the following order:  
When the valve closes 1 -> 2 -> 3 -> 4 -> 1  
When the valve opens 4 -> 3 -> 2 -> 1 -> 4

② FCV operation

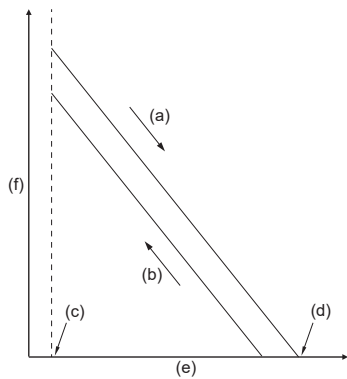

- (a) Close
- (b) Open
- (c) Fully open valve (85 pulses)
- (d) Fully close valve (770 pulses)
- (e) No. of pulses
- (f) Valve opening degree

8-1-3. DC Fan motor (fan motor/indoor controller board)

Check method of indoor fan motor (fan motor/indoor controller board)

① Notes

- High voltage is applied to the connector (CNMF) for the fan motor. Pay attention to the service.
- Do not pull out the connector (CNMF) for the motor with the power supply on.  
(It causes trouble of the indoor controller board and fan motor.)

② Self check

Conditions : The indoor fan cannot rotate.

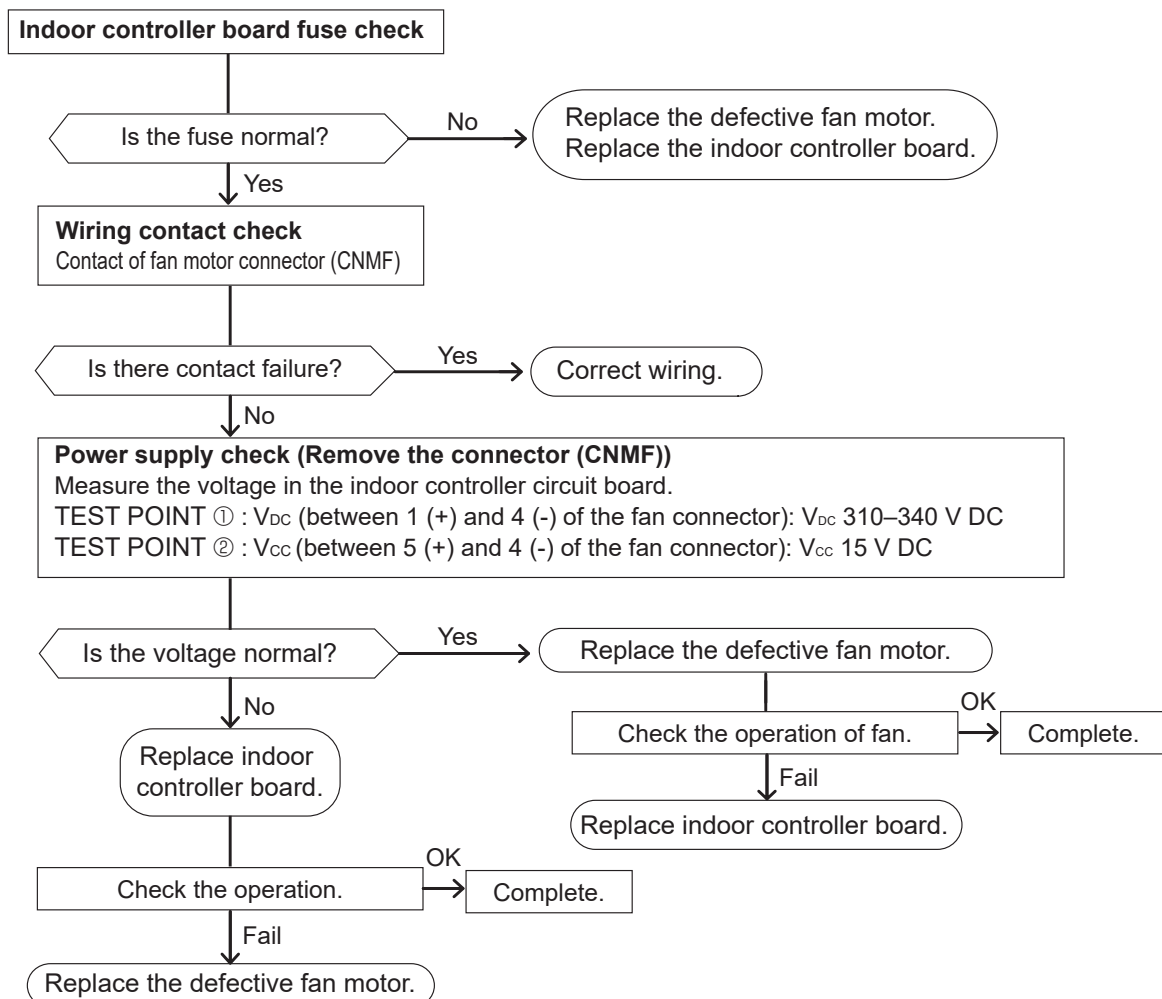

## 8-2. FUNCTION OF DIP SWITCH

PKFY-WL10VLM-E.TH  
 PKFY-WL20VLM-E.TH  
 PKFY-WL32VLM-E.TH

PKFY-WL15VLM-E.TH  
 PKFY-WL25VLM-E.TH  
 PKFY-WL40VLM-E.TH

The black square (■) indicates a switch position.









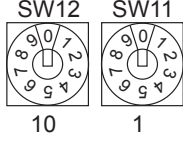
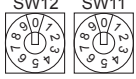
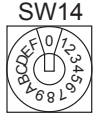

| Switch                       | Pole   | Function   | Operation by switch  |                                     | Effective timing | Remarks   |     |      |  |  |  |  |  |  |  |  |  |  |  |  |  |      |  |      |  |  |  |  |  |      |  |  |  |  |  |  |  |  |  |  |  |  |  |  |  |  |  |  |  |  |  |      |  |  |  |  |  |  |  |  |  |  |  |  |  |  |  |  |  |  |  |  |  |      |  |  |  |  |  |  |  |  |  |  |  |  |  |  |  |  |  |  |  |  |  |      |  |  |  |  |  |  |  |  |  |  |  |  |  |  |  |  |  |  |  |  |  |      |  |  |  |  |  |  |  |  |  |  |  |  |  |  |  |  |  |  |  |  |  |                        |   |
|------------------------------|--|--|--|-------------------------------------|------------------|---|-----|------|--|--|--|--|--|--|--|--|--|--|--|--|--|------|--|------|--|--|--|--|--|------|--|--|--|--|--|--|--|--|--|--|--|--|--|--|--|--|--|--|--|--|--|------|--|--|--|--|--|--|--|--|--|--|--|--|--|--|--|--|--|--|--|--|--|------|--|--|--|--|--|--|--|--|--|--|--|--|--|--|--|--|--|--|--|--|--|------|--|--|--|--|--|--|--|--|--|--|--|--|--|--|--|--|--|--|--|--|--|------|--|--|--|--|--|--|--|--|--|--|--|--|--|--|--|--|--|--|--|--|--|------------------------|---|
|                              |  |  | ON   | OFF                                 |                  |   |     |      |  |  |  |  |  |  |  |  |  |  |  |  |  |      |  |      |  |  |  |  |  |      |  |  |  |  |  |  |  |  |  |  |  |  |  |  |  |  |  |  |  |  |  |      |  |  |  |  |  |  |  |  |  |  |  |  |  |  |  |  |  |  |  |  |  |      |  |  |  |  |  |  |  |  |  |  |  |  |  |  |  |  |  |  |  |  |  |      |  |  |  |  |  |  |  |  |  |  |  |  |  |  |  |  |  |  |  |  |  |      |  |  |  |  |  |  |  |  |  |  |  |  |  |  |  |  |  |  |  |  |  |                        |   |
| SW1<br>Mode Selection        | 1  | Thermistor <Intake temperature detection> position   | Built-in remote controller   | Indoor unit                         | Under suspension | <div style="border: 1px solid black; padding: 5px; margin-bottom: 5px;">Address board</div> <Initial setting><br>ON <table border="1" style="display: inline-table; vertical-align: middle;"><tr><td> </td><td> </td><td> </td><td> </td><td> </td><td> </td><td> </td><td> </td><td> </td><td> </td></tr></table><br>OFF <table border="1" style="display: inline-table; vertical-align: middle;"><tr><td> </td><td> </td><td> </td><td> </td><td> </td><td> </td><td> </td><td> </td><td> </td><td> </td></tr></table><br>1 2 3 4 5 6 7 8 9 10          |     |      |  |  |  |  |  |  |  |  |  |  |  |  |  |      |  |      |  |  |  |  |  |      |  |  |  |  |  |  |  |  |  |  |  |  |  |  |  |  |  |  |  |  |  |      |  |  |  |  |  |  |  |  |  |  |  |  |  |  |  |  |  |  |  |  |  |      |  |  |  |  |  |  |  |  |  |  |  |  |  |  |  |  |  |  |  |  |  |      |  |  |  |  |  |  |  |  |  |  |  |  |  |  |  |  |  |  |  |  |  |      |  |  |  |  |  |  |  |  |  |  |  |  |  |  |  |  |  |  |  |  |  |                        |   |
|                              |  |  |  |                                     |                  |   |     |      |  |  |  |  |  |  |  |  |  |  |  |  |  |      |  |      |  |  |  |  |  |      |  |  |  |  |  |  |  |  |  |  |  |  |  |  |  |  |  |  |  |  |  |      |  |  |  |  |  |  |  |  |  |  |  |  |  |  |  |  |  |  |  |  |  |      |  |  |  |  |  |  |  |  |  |  |  |  |  |  |  |  |  |  |  |  |  |      |  |  |  |  |  |  |  |  |  |  |  |  |  |  |  |  |  |  |  |  |  |      |  |  |  |  |  |  |  |  |  |  |  |  |  |  |  |  |  |  |  |  |  |                        |   |
|                              |  |  |  |                                     |                  |   |     |      |  |  |  |  |  |  |  |  |  |  |  |  |  |      |  |      |  |  |  |  |  |      |  |  |  |  |  |  |  |  |  |  |  |  |  |  |  |  |  |  |  |  |  |      |  |  |  |  |  |  |  |  |  |  |  |  |  |  |  |  |  |  |  |  |  |      |  |  |  |  |  |  |  |  |  |  |  |  |  |  |  |  |  |  |  |  |  |      |  |  |  |  |  |  |  |  |  |  |  |  |  |  |  |  |  |  |  |  |  |      |  |  |  |  |  |  |  |  |  |  |  |  |  |  |  |  |  |  |  |  |  |                        |   |
|                              | 2  | Filter clogging  | Provided   | Not provided                        |                  |   |     |      |  |  |  |  |  |  |  |  |  |  |  |  |  |      |  |      |  |  |  |  |  |      |  |  |  |  |  |  |  |  |  |  |  |  |  |  |  |  |  |  |  |  |  |      |  |  |  |  |  |  |  |  |  |  |  |  |  |  |  |  |  |  |  |  |  |      |  |  |  |  |  |  |  |  |  |  |  |  |  |  |  |  |  |  |  |  |  |      |  |  |  |  |  |  |  |  |  |  |  |  |  |  |  |  |  |  |  |  |  |      |  |  |  |  |  |  |  |  |  |  |  |  |  |  |  |  |  |  |  |  |  |                        |   |
|                              | 3  | Filter sign indication   | 2,500 hr   | 100 hr                              |                  |   |     |      |  |  |  |  |  |  |  |  |  |  |  |  |  |      |  |      |  |  |  |  |  |      |  |  |  |  |  |  |  |  |  |  |  |  |  |  |  |  |  |  |  |  |  |      |  |  |  |  |  |  |  |  |  |  |  |  |  |  |  |  |  |  |  |  |  |      |  |  |  |  |  |  |  |  |  |  |  |  |  |  |  |  |  |  |  |  |  |      |  |  |  |  |  |  |  |  |  |  |  |  |  |  |  |  |  |  |  |  |  |      |  |  |  |  |  |  |  |  |  |  |  |  |  |  |  |  |  |  |  |  |  |                        |   |
|                              | 4  | Air intake*1   | Not effective  | Not effective                       |                  |   |     |      |  |  |  |  |  |  |  |  |  |  |  |  |  |      |  |      |  |  |  |  |  |      |  |  |  |  |  |  |  |  |  |  |  |  |  |  |  |  |  |  |  |  |  |      |  |  |  |  |  |  |  |  |  |  |  |  |  |  |  |  |  |  |  |  |  |      |  |  |  |  |  |  |  |  |  |  |  |  |  |  |  |  |  |  |  |  |  |      |  |  |  |  |  |  |  |  |  |  |  |  |  |  |  |  |  |  |  |  |  |      |  |  |  |  |  |  |  |  |  |  |  |  |  |  |  |  |  |  |  |  |  |                        |   |
|                              | 5  | Remote indication switching  | Thermo-ON signal indication  | Fan output indication               |                  |   |     |      |  |  |  |  |  |  |  |  |  |  |  |  |  |      |  |      |  |  |  |  |  |      |  |  |  |  |  |  |  |  |  |  |  |  |  |  |  |  |  |  |  |  |  |      |  |  |  |  |  |  |  |  |  |  |  |  |  |  |  |  |  |  |  |  |  |      |  |  |  |  |  |  |  |  |  |  |  |  |  |  |  |  |  |  |  |  |  |      |  |  |  |  |  |  |  |  |  |  |  |  |  |  |  |  |  |  |  |  |  |      |  |  |  |  |  |  |  |  |  |  |  |  |  |  |  |  |  |  |  |  |  |                        |   |
|                              | 6  | Humidifier control   | Fan operation at Heating mode  | Thermo-ON operation at heating mode |                  |   |     |      |  |  |  |  |  |  |  |  |  |  |  |  |  |      |  |      |  |  |  |  |  |      |  |  |  |  |  |  |  |  |  |  |  |  |  |  |  |  |  |  |  |  |  |      |  |  |  |  |  |  |  |  |  |  |  |  |  |  |  |  |  |  |  |  |  |      |  |  |  |  |  |  |  |  |  |  |  |  |  |  |  |  |  |  |  |  |  |      |  |  |  |  |  |  |  |  |  |  |  |  |  |  |  |  |  |  |  |  |  |      |  |  |  |  |  |  |  |  |  |  |  |  |  |  |  |  |  |  |  |  |  |                        |   |
|                              | 7  | Air flow set in case of heat thermo-OFF  | Low*2  | Extra low*2                         |                  |   |     |      |  |  |  |  |  |  |  |  |  |  |  |  |  |      |  |      |  |  |  |  |  |      |  |  |  |  |  |  |  |  |  |  |  |  |  |  |  |  |  |  |  |  |  |      |  |  |  |  |  |  |  |  |  |  |  |  |  |  |  |  |  |  |  |  |  |      |  |  |  |  |  |  |  |  |  |  |  |  |  |  |  |  |  |  |  |  |  |      |  |  |  |  |  |  |  |  |  |  |  |  |  |  |  |  |  |  |  |  |  |      |  |  |  |  |  |  |  |  |  |  |  |  |  |  |  |  |  |  |  |  |  |                        |   |
|                              | 8  |  | Setting air flow*1   | Depends on SW1-7                    |                  |   |     |      |  |  |  |  |  |  |  |  |  |  |  |  |  |      |  |      |  |  |  |  |  |      |  |  |  |  |  |  |  |  |  |  |  |  |  |  |  |  |  |  |  |  |  |      |  |  |  |  |  |  |  |  |  |  |  |  |  |  |  |  |  |  |  |  |  |      |  |  |  |  |  |  |  |  |  |  |  |  |  |  |  |  |  |  |  |  |  |      |  |  |  |  |  |  |  |  |  |  |  |  |  |  |  |  |  |  |  |  |  |      |  |  |  |  |  |  |  |  |  |  |  |  |  |  |  |  |  |  |  |  |  |                        |   |
| 9                            | Auto restart function  | Effective  | Not effective  |                                     |                  |   |     |      |  |  |  |  |  |  |  |  |  |  |  |  |  |      |  |      |  |  |  |  |  |      |  |  |  |  |  |  |  |  |  |  |  |  |  |  |  |  |  |  |  |  |  |      |  |  |  |  |  |  |  |  |  |  |  |  |  |  |  |  |  |  |  |  |  |      |  |  |  |  |  |  |  |  |  |  |  |  |  |  |  |  |  |  |  |  |  |      |  |  |  |  |  |  |  |  |  |  |  |  |  |  |  |  |  |  |  |  |  |      |  |  |  |  |  |  |  |  |  |  |  |  |  |  |  |  |  |  |  |  |  |                        |   |
| 10                           | Power ON/OFF   | Effective  | Not effective  |                                     |                  |   |     |      |  |  |  |  |  |  |  |  |  |  |  |  |  |      |  |      |  |  |  |  |  |      |  |  |  |  |  |  |  |  |  |  |  |  |  |  |  |  |  |  |  |  |  |      |  |  |  |  |  |  |  |  |  |  |  |  |  |  |  |  |  |  |  |  |  |      |  |  |  |  |  |  |  |  |  |  |  |  |  |  |  |  |  |  |  |  |  |      |  |  |  |  |  |  |  |  |  |  |  |  |  |  |  |  |  |  |  |  |  |      |  |  |  |  |  |  |  |  |  |  |  |  |  |  |  |  |  |  |  |  |  |                        |   |
| SW2<br>Capacity code setting | 1-4  | <table border="1" style="width: 100%; text-align: center;"> <thead> <tr> <th>Models</th> <th>SW2</th> <th>Models</th> <th>SW2</th> </tr> </thead> <tbody> <tr> <td>WL10</td> <td>OFF <table border="1" style="display: inline-table; vertical-align: middle;"><tr><td> </td><td> </td><td> </td><td> </td><td> </td><td> </td><td> </td><td> </td><td> </td><td> </td></tr></table><br/>ON <table border="1" style="display: inline-table; vertical-align: middle;"><tr><td> </td><td> </td><td> </td><td> </td><td> </td><td> </td><td> </td><td> </td><td> </td><td> </td></tr></table><br/>6 5 4 3 2 1</td> <td>WL25</td> <td>OFF <table border="1" style="display: inline-table; vertical-align: middle;"><tr><td> </td><td> </td><td> </td><td> </td><td> </td><td> </td><td> </td><td> </td><td> </td><td> </td></tr></table><br/>ON <table border="1" style="display: inline-table; vertical-align: middle;"><tr><td> </td><td> </td><td> </td><td> </td><td> </td><td> </td><td> </td><td> </td><td> </td><td> </td></tr></table><br/>6 5 4 3 2 1</td> </tr> <tr> <td>WL15</td> <td>OFF <table border="1" style="display: inline-table; vertical-align: middle;"><tr><td> </td><td> </td><td> </td><td> </td><td> </td><td> </td><td> </td><td> </td><td> </td><td> </td></tr></table><br/>ON <table border="1" style="display: inline-table; vertical-align: middle;"><tr><td> </td><td> </td><td> </td><td> </td><td> </td><td> </td><td> </td><td> </td><td> </td><td> </td></tr></table><br/>6 5 4 3 2 1</td> <td>WL32</td> <td>OFF <table border="1" style="display: inline-table; vertical-align: middle;"><tr><td> </td><td> </td><td> </td><td> </td><td> </td><td> </td><td> </td><td> </td><td> </td><td> </td></tr></table><br/>ON <table border="1" style="display: inline-table; vertical-align: middle;"><tr><td> </td><td> </td><td> </td><td> </td><td> </td><td> </td><td> </td><td> </td><td> </td><td> </td></tr></table><br/>6 5 4 3 2 1</td> </tr> <tr> <td>WL20</td> <td>OFF <table border="1" style="display: inline-table; vertical-align: middle;"><tr><td> </td><td> </td><td> </td><td> </td><td> </td><td> </td><td> </td><td> </td><td> </td><td> </td></tr></table><br/>ON <table border="1" style="display: inline-table; vertical-align: middle;"><tr><td> </td><td> </td><td> </td><td> </td><td> </td><td> </td><td> </td><td> </td><td> </td><td> </td></tr></table><br/>6 5 4 3 2 1</td> <td>WL40</td> <td>OFF <table border="1" style="display: inline-table; vertical-align: middle;"><tr><td> </td><td> </td><td> </td><td> </td><td> </td><td> </td><td> </td><td> </td><td> </td><td> </td></tr></table><br/>ON <table border="1" style="display: inline-table; vertical-align: middle;"><tr><td> </td><td> </td><td> </td><td> </td><td> </td><td> </td><td> </td><td> </td><td> </td><td> </td></tr></table><br/>6 5 4 3 2 1</td> </tr> </tbody> </table> |  | Models                              | SW2              | Models  | SW2 | WL10 | OFF <table border="1" style="display: inline-table; vertical-align: middle;"><tr><td> </td><td> </td><td> </td><td> </td><td> </td><td> </td><td> </td><td> </td><td> </td><td> </td></tr></table><br>ON <table border="1" style="display: inline-table; vertical-align: middle;"><tr><td> </td><td> </td><td> </td><td> </td><td> </td><td> </td><td> </td><td> </td><td> </td><td> </td></tr></table><br>6 5 4 3 2 1 |  |  |  |  |  |  |  |  |  |  |  |  |      |  |      |  |  |  |  |  | WL25 | OFF <table border="1" style="display: inline-table; vertical-align: middle;"><tr><td> </td><td> </td><td> </td><td> </td><td> </td><td> </td><td> </td><td> </td><td> </td><td> </td></tr></table><br>ON <table border="1" style="display: inline-table; vertical-align: middle;"><tr><td> </td><td> </td><td> </td><td> </td><td> </td><td> </td><td> </td><td> </td><td> </td><td> </td></tr></table><br>6 5 4 3 2 1 |  |  |  |  |  |  |  |  |  |  |  |  |  |  |  |  |  |  |  |  | WL15 | OFF <table border="1" style="display: inline-table; vertical-align: middle;"><tr><td> </td><td> </td><td> </td><td> </td><td> </td><td> </td><td> </td><td> </td><td> </td><td> </td></tr></table><br>ON <table border="1" style="display: inline-table; vertical-align: middle;"><tr><td> </td><td> </td><td> </td><td> </td><td> </td><td> </td><td> </td><td> </td><td> </td><td> </td></tr></table><br>6 5 4 3 2 1 |  |  |  |  |  |  |  |  |  |  |  |  |  |  |  |  |  |  |  |  | WL32 | OFF <table border="1" style="display: inline-table; vertical-align: middle;"><tr><td> </td><td> </td><td> </td><td> </td><td> </td><td> </td><td> </td><td> </td><td> </td><td> </td></tr></table><br>ON <table border="1" style="display: inline-table; vertical-align: middle;"><tr><td> </td><td> </td><td> </td><td> </td><td> </td><td> </td><td> </td><td> </td><td> </td><td> </td></tr></table><br>6 5 4 3 2 1 |  |  |  |  |  |  |  |  |  |  |  |  |  |  |  |  |  |  |  |  | WL20 | OFF <table border="1" style="display: inline-table; vertical-align: middle;"><tr><td> </td><td> </td><td> </td><td> </td><td> </td><td> </td><td> </td><td> </td><td> </td><td> </td></tr></table><br>ON <table border="1" style="display: inline-table; vertical-align: middle;"><tr><td> </td><td> </td><td> </td><td> </td><td> </td><td> </td><td> </td><td> </td><td> </td><td> </td></tr></table><br>6 5 4 3 2 1 |  |  |  |  |  |  |  |  |  |  |  |  |  |  |  |  |  |  |  |  | WL40 | OFF <table border="1" style="display: inline-table; vertical-align: middle;"><tr><td> </td><td> </td><td> </td><td> </td><td> </td><td> </td><td> </td><td> </td><td> </td><td> </td></tr></table><br>ON <table border="1" style="display: inline-table; vertical-align: middle;"><tr><td> </td><td> </td><td> </td><td> </td><td> </td><td> </td><td> </td><td> </td><td> </td><td> </td></tr></table><br>6 5 4 3 2 1 |  |  |  |  |  |  |  |  |  |  |  |  |  |  |  |  |  |  |  |  | Before power supply ON | <div style="border: 1px solid black; padding: 5px; margin-bottom: 5px;">Indoor controller board</div> <Initial setting><br>Set for each capacity. |
|                              |  | Models   | SW2  | Models                              | SW2              |   |     |      |  |  |  |  |  |  |  |  |  |  |  |  |  |      |  |      |  |  |  |  |  |      |  |  |  |  |  |  |  |  |  |  |  |  |  |  |  |  |  |  |  |  |  |      |  |  |  |  |  |  |  |  |  |  |  |  |  |  |  |  |  |  |  |  |  |      |  |  |  |  |  |  |  |  |  |  |  |  |  |  |  |  |  |  |  |  |  |      |  |  |  |  |  |  |  |  |  |  |  |  |  |  |  |  |  |  |  |  |  |      |  |  |  |  |  |  |  |  |  |  |  |  |  |  |  |  |  |  |  |  |  |                        |   |
|                              |  | WL10   | OFF <table border="1" style="display: inline-table; vertical-align: middle;"><tr><td> </td><td> </td><td> </td><td> </td><td> </td><td> </td><td> </td><td> </td><td> </td><td> </td></tr></table><br>ON <table border="1" style="display: inline-table; vertical-align: middle;"><tr><td> </td><td> </td><td> </td><td> </td><td> </td><td> </td><td> </td><td> </td><td> </td><td> </td></tr></table><br>6 5 4 3 2 1 |                                     |                  |   |     |      |  |  |  |  |  |  |  |  |  |  |  |  |  |      |  | WL25 | OFF <table border="1" style="display: inline-table; vertical-align: middle;"><tr><td> </td><td> </td><td> </td><td> </td><td> </td><td> </td><td> </td><td> </td><td> </td><td> </td></tr></table><br>ON <table border="1" style="display: inline-table; vertical-align: middle;"><tr><td> </td><td> </td><td> </td><td> </td><td> </td><td> </td><td> </td><td> </td><td> </td><td> </td></tr></table><br>6 5 4 3 2 1 |  |  |  |  |      |  |  |  |  |  |  |  |  |  |  |  |  |  |  |  |  |  |  |  |  |  |      |  |  |  |  |  |  |  |  |  |  |  |  |  |  |  |  |  |  |  |  |  |      |  |  |  |  |  |  |  |  |  |  |  |  |  |  |  |  |  |  |  |  |  |      |  |  |  |  |  |  |  |  |  |  |  |  |  |  |  |  |  |  |  |  |  |      |  |  |  |  |  |  |  |  |  |  |  |  |  |  |  |  |  |  |  |  |  |                        |   |
|                              |  |  |  |                                     |                  |   |     |      |  |  |  |  |  |  |  |  |  |  |  |  |  |      |  |      |  |  |  |  |  |      |  |  |  |  |  |  |  |  |  |  |  |  |  |  |  |  |  |  |  |  |  |      |  |  |  |  |  |  |  |  |  |  |  |  |  |  |  |  |  |  |  |  |  |      |  |  |  |  |  |  |  |  |  |  |  |  |  |  |  |  |  |  |  |  |  |      |  |  |  |  |  |  |  |  |  |  |  |  |  |  |  |  |  |  |  |  |  |      |  |  |  |  |  |  |  |  |  |  |  |  |  |  |  |  |  |  |  |  |  |                        |   |
|                              |  |  |  |                                     |                  |   |     |      |  |  |  |  |  |  |  |  |  |  |  |  |  |      |  |      |  |  |  |  |  |      |  |  |  |  |  |  |  |  |  |  |  |  |  |  |  |  |  |  |  |  |  |      |  |  |  |  |  |  |  |  |  |  |  |  |  |  |  |  |  |  |  |  |  |      |  |  |  |  |  |  |  |  |  |  |  |  |  |  |  |  |  |  |  |  |  |      |  |  |  |  |  |  |  |  |  |  |  |  |  |  |  |  |  |  |  |  |  |      |  |  |  |  |  |  |  |  |  |  |  |  |  |  |  |  |  |  |  |  |  |                        |   |
|                              |  |  |  |                                     |                  |   |     |      |  |  |  |  |  |  |  |  |  |  |  |  |  |      |  |      |  |  |  |  |  |      |  |  |  |  |  |  |  |  |  |  |  |  |  |  |  |  |  |  |  |  |  |      |  |  |  |  |  |  |  |  |  |  |  |  |  |  |  |  |  |  |  |  |  |      |  |  |  |  |  |  |  |  |  |  |  |  |  |  |  |  |  |  |  |  |  |      |  |  |  |  |  |  |  |  |  |  |  |  |  |  |  |  |  |  |  |  |  |      |  |  |  |  |  |  |  |  |  |  |  |  |  |  |  |  |  |  |  |  |  |                        |   |
|                              |  |  |  |                                     |                  |   |     |      |  |  |  |  |  |  |  |  |  |  |  |  |  |      |  |      |  |  |  |  |  |      |  |  |  |  |  |  |  |  |  |  |  |  |  |  |  |  |  |  |  |  |  |      |  |  |  |  |  |  |  |  |  |  |  |  |  |  |  |  |  |  |  |  |  |      |  |  |  |  |  |  |  |  |  |  |  |  |  |  |  |  |  |  |  |  |  |      |  |  |  |  |  |  |  |  |  |  |  |  |  |  |  |  |  |  |  |  |  |      |  |  |  |  |  |  |  |  |  |  |  |  |  |  |  |  |  |  |  |  |  |                        |   |
| WL15                         | OFF <table border="1" style="display: inline-table; vertical-align: middle;"><tr><td> </td><td> </td><td> </td><td> </td><td> </td><td> </td><td> </td><td> </td><td> </td><td> </td></tr></table><br>ON <table border="1" style="display: inline-table; vertical-align: middle;"><tr><td> </td><td> </td><td> </td><td> </td><td> </td><td> </td><td> </td><td> </td><td> </td><td> </td></tr></table><br>6 5 4 3 2 1 |  |  |                                     |                  |   |     |      |  |  |  |  |  |  |  |  |  |  |  |  |  | WL32 | OFF <table border="1" style="display: inline-table; vertical-align: middle;"><tr><td> </td><td> </td><td> </td><td> </td><td> </td><td> </td><td> </td><td> </td><td> </td><td> </td></tr></table><br>ON <table border="1" style="display: inline-table; vertical-align: middle;"><tr><td> </td><td> </td><td> </td><td> </td><td> </td><td> </td><td> </td><td> </td><td> </td><td> </td></tr></table><br>6 5 4 3 2 1 |      |  |  |  |  |  |      |  |  |  |  |  |  |  |  |  |  |  |  |  |  |  |  |  |  |  |  |  |      |  |  |  |  |  |  |  |  |  |  |  |  |  |  |  |  |  |  |  |  |  |      |  |  |  |  |  |  |  |  |  |  |  |  |  |  |  |  |  |  |  |  |  |      |  |  |  |  |  |  |  |  |  |  |  |  |  |  |  |  |  |  |  |  |  |      |  |  |  |  |  |  |  |  |  |  |  |  |  |  |  |  |  |  |  |  |  |                        |   |
|                              |  |  |  |                                     |                  |   |     |      |  |  |  |  |  |  |  |  |  |  |  |  |  |      |  |      |  |  |  |  |  |      |  |  |  |  |  |  |  |  |  |  |  |  |  |  |  |  |  |  |  |  |  |      |  |  |  |  |  |  |  |  |  |  |  |  |  |  |  |  |  |  |  |  |  |      |  |  |  |  |  |  |  |  |  |  |  |  |  |  |  |  |  |  |  |  |  |      |  |  |  |  |  |  |  |  |  |  |  |  |  |  |  |  |  |  |  |  |  |      |  |  |  |  |  |  |  |  |  |  |  |  |  |  |  |  |  |  |  |  |  |                        |   |
|                              |  |  |  |                                     |                  |   |     |      |  |  |  |  |  |  |  |  |  |  |  |  |  |      |  |      |  |  |  |  |  |      |  |  |  |  |  |  |  |  |  |  |  |  |  |  |  |  |  |  |  |  |  |      |  |  |  |  |  |  |  |  |  |  |  |  |  |  |  |  |  |  |  |  |  |      |  |  |  |  |  |  |  |  |  |  |  |  |  |  |  |  |  |  |  |  |  |      |  |  |  |  |  |  |  |  |  |  |  |  |  |  |  |  |  |  |  |  |  |      |  |  |  |  |  |  |  |  |  |  |  |  |  |  |  |  |  |  |  |  |  |                        |   |
|                              |  |  |  |                                     |                  |   |     |      |  |  |  |  |  |  |  |  |  |  |  |  |  |      |  |      |  |  |  |  |  |      |  |  |  |  |  |  |  |  |  |  |  |  |  |  |  |  |  |  |  |  |  |      |  |  |  |  |  |  |  |  |  |  |  |  |  |  |  |  |  |  |  |  |  |      |  |  |  |  |  |  |  |  |  |  |  |  |  |  |  |  |  |  |  |  |  |      |  |  |  |  |  |  |  |  |  |  |  |  |  |  |  |  |  |  |  |  |  |      |  |  |  |  |  |  |  |  |  |  |  |  |  |  |  |  |  |  |  |  |  |                        |   |
|                              |  |  |  |                                     |                  |   |     |      |  |  |  |  |  |  |  |  |  |  |  |  |  |      |  |      |  |  |  |  |  |      |  |  |  |  |  |  |  |  |  |  |  |  |  |  |  |  |  |  |  |  |  |      |  |  |  |  |  |  |  |  |  |  |  |  |  |  |  |  |  |  |  |  |  |      |  |  |  |  |  |  |  |  |  |  |  |  |  |  |  |  |  |  |  |  |  |      |  |  |  |  |  |  |  |  |  |  |  |  |  |  |  |  |  |  |  |  |  |      |  |  |  |  |  |  |  |  |  |  |  |  |  |  |  |  |  |  |  |  |  |                        |   |
| WL20                         | OFF <table border="1" style="display: inline-table; vertical-align: middle;"><tr><td> </td><td> </td><td> </td><td> </td><td> </td><td> </td><td> </td><td> </td><td> </td><td> </td></tr></table><br>ON <table border="1" style="display: inline-table; vertical-align: middle;"><tr><td> </td><td> </td><td> </td><td> </td><td> </td><td> </td><td> </td><td> </td><td> </td><td> </td></tr></table><br>6 5 4 3 2 1 |  |  |                                     |                  |   |     |      |  |  |  |  |  |  |  |  |  |  |  |  |  | WL40 | OFF <table border="1" style="display: inline-table; vertical-align: middle;"><tr><td> </td><td> </td><td> </td><td> </td><td> </td><td> </td><td> </td><td> </td><td> </td><td> </td></tr></table><br>ON <table border="1" style="display: inline-table; vertical-align: middle;"><tr><td> </td><td> </td><td> </td><td> </td><td> </td><td> </td><td> </td><td> </td><td> </td><td> </td></tr></table><br>6 5 4 3 2 1 |      |  |  |  |  |  |      |  |  |  |  |  |  |  |  |  |  |  |  |  |  |  |  |  |  |  |  |  |      |  |  |  |  |  |  |  |  |  |  |  |  |  |  |  |  |  |  |  |  |  |      |  |  |  |  |  |  |  |  |  |  |  |  |  |  |  |  |  |  |  |  |  |      |  |  |  |  |  |  |  |  |  |  |  |  |  |  |  |  |  |  |  |  |  |      |  |  |  |  |  |  |  |  |  |  |  |  |  |  |  |  |  |  |  |  |  |                        |   |
|                              |  |  |  |                                     |                  |   |     |      |  |  |  |  |  |  |  |  |  |  |  |  |  |      |  |      |  |  |  |  |  |      |  |  |  |  |  |  |  |  |  |  |  |  |  |  |  |  |  |  |  |  |  |      |  |  |  |  |  |  |  |  |  |  |  |  |  |  |  |  |  |  |  |  |  |      |  |  |  |  |  |  |  |  |  |  |  |  |  |  |  |  |  |  |  |  |  |      |  |  |  |  |  |  |  |  |  |  |  |  |  |  |  |  |  |  |  |  |  |      |  |  |  |  |  |  |  |  |  |  |  |  |  |  |  |  |  |  |  |  |  |                        |   |
|                              |  |  |  |                                     |                  |   |     |      |  |  |  |  |  |  |  |  |  |  |  |  |  |      |  |      |  |  |  |  |  |      |  |  |  |  |  |  |  |  |  |  |  |  |  |  |  |  |  |  |  |  |  |      |  |  |  |  |  |  |  |  |  |  |  |  |  |  |  |  |  |  |  |  |  |      |  |  |  |  |  |  |  |  |  |  |  |  |  |  |  |  |  |  |  |  |  |      |  |  |  |  |  |  |  |  |  |  |  |  |  |  |  |  |  |  |  |  |  |      |  |  |  |  |  |  |  |  |  |  |  |  |  |  |  |  |  |  |  |  |  |                        |   |
|                              |  |  |  |                                     |                  |   |     |      |  |  |  |  |  |  |  |  |  |  |  |  |  |      |  |      |  |  |  |  |  |      |  |  |  |  |  |  |  |  |  |  |  |  |  |  |  |  |  |  |  |  |  |      |  |  |  |  |  |  |  |  |  |  |  |  |  |  |  |  |  |  |  |  |  |      |  |  |  |  |  |  |  |  |  |  |  |  |  |  |  |  |  |  |  |  |  |      |  |  |  |  |  |  |  |  |  |  |  |  |  |  |  |  |  |  |  |  |  |      |  |  |  |  |  |  |  |  |  |  |  |  |  |  |  |  |  |  |  |  |  |                        |   |
|                              |  |  |  |                                     |                  |   |     |      |  |  |  |  |  |  |  |  |  |  |  |  |  |      |  |      |  |  |  |  |  |      |  |  |  |  |  |  |  |  |  |  |  |  |  |  |  |  |  |  |  |  |  |      |  |  |  |  |  |  |  |  |  |  |  |  |  |  |  |  |  |  |  |  |  |      |  |  |  |  |  |  |  |  |  |  |  |  |  |  |  |  |  |  |  |  |  |      |  |  |  |  |  |  |  |  |  |  |  |  |  |  |  |  |  |  |  |  |  |      |  |  |  |  |  |  |  |  |  |  |  |  |  |  |  |  |  |  |  |  |  |                        |   |
| SW3<br>Function Selection    | 1  | Heat pump/Cool only  | Cooling only   | Heat pump                           | Under suspension | <div style="border: 1px solid black; padding: 5px; margin-bottom: 5px;">Indoor controller board</div> <Initial setting><br>ON <table border="1" style="display: inline-table; vertical-align: middle;"><tr><td> </td><td> </td><td> </td><td> </td><td> </td><td> </td><td> </td><td> </td><td> </td><td> </td></tr></table><br>OFF <table border="1" style="display: inline-table; vertical-align: middle;"><tr><td> </td><td> </td><td> </td><td> </td><td> </td><td> </td><td> </td><td> </td><td> </td><td> </td></tr></table><br>1 2 3 4 5 6 7 8 9 0 |     |      |  |  |  |  |  |  |  |  |  |  |  |  |  |      |  |      |  |  |  |  |  |      |  |  |  |  |  |  |  |  |  |  |  |  |  |  |  |  |  |  |  |  |  |      |  |  |  |  |  |  |  |  |  |  |  |  |  |  |  |  |  |  |  |  |  |      |  |  |  |  |  |  |  |  |  |  |  |  |  |  |  |  |  |  |  |  |  |      |  |  |  |  |  |  |  |  |  |  |  |  |  |  |  |  |  |  |  |  |  |      |  |  |  |  |  |  |  |  |  |  |  |  |  |  |  |  |  |  |  |  |  |                        |   |
|                              |  |  |  |                                     |                  |   |     |      |  |  |  |  |  |  |  |  |  |  |  |  |  |      |  |      |  |  |  |  |  |      |  |  |  |  |  |  |  |  |  |  |  |  |  |  |  |  |  |  |  |  |  |      |  |  |  |  |  |  |  |  |  |  |  |  |  |  |  |  |  |  |  |  |  |      |  |  |  |  |  |  |  |  |  |  |  |  |  |  |  |  |  |  |  |  |  |      |  |  |  |  |  |  |  |  |  |  |  |  |  |  |  |  |  |  |  |  |  |      |  |  |  |  |  |  |  |  |  |  |  |  |  |  |  |  |  |  |  |  |  |                        |   |
|                              |  |  |  |                                     |                  |   |     |      |  |  |  |  |  |  |  |  |  |  |  |  |  |      |  |      |  |  |  |  |  |      |  |  |  |  |  |  |  |  |  |  |  |  |  |  |  |  |  |  |  |  |  |      |  |  |  |  |  |  |  |  |  |  |  |  |  |  |  |  |  |  |  |  |  |      |  |  |  |  |  |  |  |  |  |  |  |  |  |  |  |  |  |  |  |  |  |      |  |  |  |  |  |  |  |  |  |  |  |  |  |  |  |  |  |  |  |  |  |      |  |  |  |  |  |  |  |  |  |  |  |  |  |  |  |  |  |  |  |  |  |                        |   |
|                              | 2  | —  | —  | —                                   |                  |   |     |      |  |  |  |  |  |  |  |  |  |  |  |  |  |      |  |      |  |  |  |  |  |      |  |  |  |  |  |  |  |  |  |  |  |  |  |  |  |  |  |  |  |  |  |      |  |  |  |  |  |  |  |  |  |  |  |  |  |  |  |  |  |  |  |  |  |      |  |  |  |  |  |  |  |  |  |  |  |  |  |  |  |  |  |  |  |  |  |      |  |  |  |  |  |  |  |  |  |  |  |  |  |  |  |  |  |  |  |  |  |      |  |  |  |  |  |  |  |  |  |  |  |  |  |  |  |  |  |  |  |  |  |                        |   |
|                              | 3  | —  | —  | —                                   |                  |   |     |      |  |  |  |  |  |  |  |  |  |  |  |  |  |      |  |      |  |  |  |  |  |      |  |  |  |  |  |  |  |  |  |  |  |  |  |  |  |  |  |  |  |  |  |      |  |  |  |  |  |  |  |  |  |  |  |  |  |  |  |  |  |  |  |  |  |      |  |  |  |  |  |  |  |  |  |  |  |  |  |  |  |  |  |  |  |  |  |      |  |  |  |  |  |  |  |  |  |  |  |  |  |  |  |  |  |  |  |  |  |      |  |  |  |  |  |  |  |  |  |  |  |  |  |  |  |  |  |  |  |  |  |                        |   |
|                              | 4  | —  | —  | —                                   |                  |   |     |      |  |  |  |  |  |  |  |  |  |  |  |  |  |      |  |      |  |  |  |  |  |      |  |  |  |  |  |  |  |  |  |  |  |  |  |  |  |  |  |  |  |  |  |      |  |  |  |  |  |  |  |  |  |  |  |  |  |  |  |  |  |  |  |  |  |      |  |  |  |  |  |  |  |  |  |  |  |  |  |  |  |  |  |  |  |  |  |      |  |  |  |  |  |  |  |  |  |  |  |  |  |  |  |  |  |  |  |  |  |      |  |  |  |  |  |  |  |  |  |  |  |  |  |  |  |  |  |  |  |  |  |                        |   |
|                              | 5  | —  | —  | —                                   |                  |   |     |      |  |  |  |  |  |  |  |  |  |  |  |  |  |      |  |      |  |  |  |  |  |      |  |  |  |  |  |  |  |  |  |  |  |  |  |  |  |  |  |  |  |  |  |      |  |  |  |  |  |  |  |  |  |  |  |  |  |  |  |  |  |  |  |  |  |      |  |  |  |  |  |  |  |  |  |  |  |  |  |  |  |  |  |  |  |  |  |      |  |  |  |  |  |  |  |  |  |  |  |  |  |  |  |  |  |  |  |  |  |      |  |  |  |  |  |  |  |  |  |  |  |  |  |  |  |  |  |  |  |  |  |                        |   |
|                              | 6  | —  | —  | —                                   |                  |   |     |      |  |  |  |  |  |  |  |  |  |  |  |  |  |      |  |      |  |  |  |  |  |      |  |  |  |  |  |  |  |  |  |  |  |  |  |  |  |  |  |  |  |  |  |      |  |  |  |  |  |  |  |  |  |  |  |  |  |  |  |  |  |  |  |  |  |      |  |  |  |  |  |  |  |  |  |  |  |  |  |  |  |  |  |  |  |  |  |      |  |  |  |  |  |  |  |  |  |  |  |  |  |  |  |  |  |  |  |  |  |      |  |  |  |  |  |  |  |  |  |  |  |  |  |  |  |  |  |  |  |  |  |                        |   |
|                              | 7  | —  | —  | —                                   |                  |   |     |      |  |  |  |  |  |  |  |  |  |  |  |  |  |      |  |      |  |  |  |  |  |      |  |  |  |  |  |  |  |  |  |  |  |  |  |  |  |  |  |  |  |  |  |      |  |  |  |  |  |  |  |  |  |  |  |  |  |  |  |  |  |  |  |  |  |      |  |  |  |  |  |  |  |  |  |  |  |  |  |  |  |  |  |  |  |  |  |      |  |  |  |  |  |  |  |  |  |  |  |  |  |  |  |  |  |  |  |  |  |      |  |  |  |  |  |  |  |  |  |  |  |  |  |  |  |  |  |  |  |  |  |                        |   |
|                              | 8  | Heating 4 degree up  | Not effective  | Effective                           |                  |   |     |      |  |  |  |  |  |  |  |  |  |  |  |  |  |      |  |      |  |  |  |  |  |      |  |  |  |  |  |  |  |  |  |  |  |  |  |  |  |  |  |  |  |  |  |      |  |  |  |  |  |  |  |  |  |  |  |  |  |  |  |  |  |  |  |  |  |      |  |  |  |  |  |  |  |  |  |  |  |  |  |  |  |  |  |  |  |  |  |      |  |  |  |  |  |  |  |  |  |  |  |  |  |  |  |  |  |  |  |  |  |      |  |  |  |  |  |  |  |  |  |  |  |  |  |  |  |  |  |  |  |  |  |                        |   |
| 9                            | —  | —  | —  |                                     |                  |   |     |      |  |  |  |  |  |  |  |  |  |  |  |  |  |      |  |      |  |  |  |  |  |      |  |  |  |  |  |  |  |  |  |  |  |  |  |  |  |  |  |  |  |  |  |      |  |  |  |  |  |  |  |  |  |  |  |  |  |  |  |  |  |  |  |  |  |      |  |  |  |  |  |  |  |  |  |  |  |  |  |  |  |  |  |  |  |  |  |      |  |  |  |  |  |  |  |  |  |  |  |  |  |  |  |  |  |  |  |  |  |      |  |  |  |  |  |  |  |  |  |  |  |  |  |  |  |  |  |  |  |  |  |                        |   |
| 10                           | —  | —  | —  |                                     |                  |   |     |      |  |  |  |  |  |  |  |  |  |  |  |  |  |      |  |      |  |  |  |  |  |      |  |  |  |  |  |  |  |  |  |  |  |  |  |  |  |  |  |  |  |  |  |      |  |  |  |  |  |  |  |  |  |  |  |  |  |  |  |  |  |  |  |  |  |      |  |  |  |  |  |  |  |  |  |  |  |  |  |  |  |  |  |  |  |  |  |      |  |  |  |  |  |  |  |  |  |  |  |  |  |  |  |  |  |  |  |  |  |      |  |  |  |  |  |  |  |  |  |  |  |  |  |  |  |  |  |  |  |  |  |                        |   |

<Table A>

|       |       |                  |
|-------|-------|------------------|
| SW1-7 | SW1-8 |                  |
| OFF   | OFF   | Extra low        |
| ON    | OFF   | Low              |
| OFF   | ON    | Setting air flow |
| ON    | ON    | stop             |

Continue to the next page

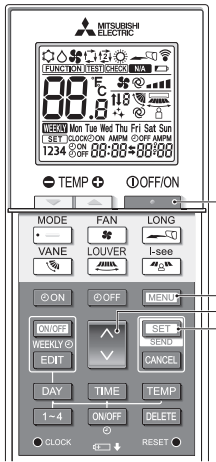
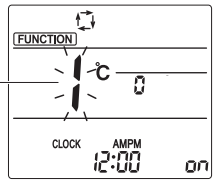
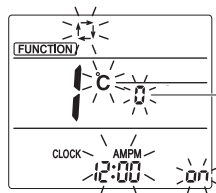
The black square (■) indicates a switch position.

| Switch  | Pole                                   | Function  | Effective timing       | Remarks  |                |     |                               |  |   |   |   |   |   |   |   |  |                         |  |   |  |                  |  |  |  |        |        |    |    |   |                 |     |    |   |   |    |     |   |   |     |     |     |   |                               |  |
|---|--|---|------------------------|--|----------------|-----|-------------------------------|--|---|---|---|---|---|---|---|--|-------------------------|--|---|--|------------------|--|--|--|--------|--------|----|----|---|-----------------|-----|----|---|---|----|-----|---|---|-----|-----|-----|---|-------------------------------|--|
| SWA<br>(Fan speed)  | 1~3                                    |  <p>Fan speed can be changed depending on SWA setting.</p> <table border="1" data-bbox="614 392 1029 459"> <tr> <td></td> <td>Setting</td> </tr> <tr> <td>PKFY-WL**VLM-E</td> <td>2</td> </tr> </table>  |                        | Setting  | PKFY-WL**VLM-E | 2   | Under operation or suspension | <div style="border: 1px solid black; padding: 2px; text-align: center;">Address board</div> <p>&lt;Initial setting&gt;<br/>It follows as the left table.</p> |   |   |   |   |   |   |   |  |                         |  |   |  |                  |  |  |  |        |        |    |    |   |                 |     |    |   |   |    |     |   |   |     |     |     |   |                               |  |
|   | Setting                                |   |                        |  |                |     |                               |  |   |   |   |   |   |   |   |  |                         |  |   |  |                  |  |  |  |        |        |    |    |   |                 |     |    |   |   |    |     |   |   |     |     |     |   |                               |  |
| PKFY-WL**VLM-E  | 2                                      |   |                        |  |                |     |                               |  |   |   |   |   |   |   |   |  |                         |  |   |  |                  |  |  |  |        |        |    |    |   |                 |     |    |   |   |    |     |   |   |     |     |     |   |                               |  |
| SW11<br>1s digit address setting<br><br>SW12<br>10s digit address setting | Rotary switch                          |  <p>Address setting should be done when M-NET remote controller is being used.</p>   | Before power supply ON | <div style="border: 1px solid black; padding: 2px; text-align: center;">Address board</div> <p>&lt;Initial setting&gt;</p>  |                |     |                               |  |   |   |   |   |   |   |   |  |                         |  |   |  |                  |  |  |  |        |        |    |    |   |                 |     |    |   |   |    |     |   |   |     |     |     |   |                               |  |
| SW14<br>Connection No. setting  | Rotary switch                          |  <p>This is the switch to be used when the indoor unit is operated with R2 series outdoor unit as a set.</p>   |                        | <div style="border: 1px solid black; padding: 2px; text-align: center;">Address board</div> <p>&lt;Initial setting&gt;</p>  |                |     |                               |  |   |   |   |   |   |   |   |  |                         |  |   |  |                  |  |  |  |        |        |    |    |   |                 |     |    |   |   |    |     |   |   |     |     |     |   |                               |  |
| SW22<br>Function selection  | Jumper                                 | <table border="1" data-bbox="391 952 1013 1097"> <thead> <tr> <th></th> <th>Function</th> <th>ON</th> <th>OFF</th> </tr> </thead> <tbody> <tr> <td>1</td> <td>—</td> <td>—</td> <td>—</td> </tr> <tr> <td>2</td> <td>—</td> <td>—</td> <td>—</td> </tr> <tr> <td>3</td> <td>Pair No. of wireless remote controller</td> <td colspan="2" rowspan="2">Depends on SW22-3, 22-4</td> </tr> <tr> <td>4</td> <td>Pair No. of wireless remote controller</td> </tr> </tbody> </table> <ul style="list-style-type: none"> <li>To operate each indoor unit by each remote controller when installed 2 indoor units or more are near, Pair No. setting is necessary. <ul style="list-style-type: none"> <li>Pair No. setting is available with the 4 patterns (Setting patterns A to D).</li> </ul> </li> <li>You may not set it when operating it by one remote controller. Setting for indoor unit.</li> </ul> <p>Wireless remote controller pair number:</p> <ul style="list-style-type: none"> <li>Setting operation (Fig. 1 ㉑)</li> </ul> <ol style="list-style-type: none"> <li>Press the  button ① to stop the air conditioner.</li> <li>Press the  button ②.</li> <li>Check that function No."1" is displayed, and then press the  button ③. The Screen display setting screen will be displayed. (Fig. 2.)</li> </ol> <ul style="list-style-type: none"> <li>Pair No. changing operation (Fig. 2 ㉒)</li> </ul> <ol style="list-style-type: none"> <li>Press the  button ④.</li> <li>Each time the  button ④ is pressed, the pair No.0~3 changes.</li> <li>Press the  button ③ to check the setting.</li> <li>Press the  button ②.</li> </ol> <table border="1" data-bbox="391 1579 1005 1758"> <thead> <tr> <th rowspan="2">Indoor unit SW22</th> <th colspan="2">Pair No. of wireless remote controller</th> <th rowspan="2"></th> </tr> <tr> <th>SW22-3</th> <th>SW22-4</th> </tr> </thead> <tbody> <tr> <td>ON</td> <td>ON</td> <td>0</td> <td>Initial setting</td> </tr> <tr> <td>OFF</td> <td>ON</td> <td>1</td> <td>—</td> </tr> <tr> <td>ON</td> <td>OFF</td> <td>2</td> <td>—</td> </tr> <tr> <td>OFF</td> <td>OFF</td> <td>3~9</td> <td>—</td> </tr> </tbody> </table> |                        | Function   | ON             | OFF | 1                             | —  | — | — | 2 | — | — | — | 3 | Pair No. of wireless remote controller | Depends on SW22-3, 22-4 |  | 4 | Pair No. of wireless remote controller | Indoor unit SW22 | Pair No. of wireless remote controller |  |  | SW22-3 | SW22-4 | ON | ON | 0 | Initial setting | OFF | ON | 1 | — | ON | OFF | 2 | — | OFF | OFF | 3~9 | — | Under operation or suspension | <p>&lt;Initial setting&gt;</p>  <p>① ② ③ ④</p>  <p>Fig. 1</p>  <p>Fig. 2</p> |
|   | Function                               | ON  | OFF                    |  |                |     |                               |  |   |   |   |   |   |   |   |  |                         |  |   |  |                  |  |  |  |        |        |    |    |   |                 |     |    |   |   |    |     |   |   |     |     |     |   |                               |  |
| 1   | —                                      | —   | —                      |  |                |     |                               |  |   |   |   |   |   |   |   |  |                         |  |   |  |                  |  |  |  |        |        |    |    |   |                 |     |    |   |   |    |     |   |   |     |     |     |   |                               |  |
| 2   | —                                      | —   | —                      |  |                |     |                               |  |   |   |   |   |   |   |   |  |                         |  |   |  |                  |  |  |  |        |        |    |    |   |                 |     |    |   |   |    |     |   |   |     |     |     |   |                               |  |
| 3   | Pair No. of wireless remote controller | Depends on SW22-3, 22-4   |                        |  |                |     |                               |  |   |   |   |   |   |   |   |  |                         |  |   |  |                  |  |  |  |        |        |    |    |   |                 |     |    |   |   |    |     |   |   |     |     |     |   |                               |  |
| 4   | Pair No. of wireless remote controller |   |                        |  |                |     |                               |  |   |   |   |   |   |   |   |  |                         |  |   |  |                  |  |  |  |        |        |    |    |   |                 |     |    |   |   |    |     |   |   |     |     |     |   |                               |  |
| Indoor unit SW22  | Pair No. of wireless remote controller |   |                        |  |                |     |                               |  |   |   |   |   |   |   |   |  |                         |  |   |  |                  |  |  |  |        |        |    |    |   |                 |     |    |   |   |    |     |   |   |     |     |     |   |                               |  |
|   | SW22-3                                 | SW22-4  |                        |  |                |     |                               |  |   |   |   |   |   |   |   |  |                         |  |   |  |                  |  |  |  |        |        |    |    |   |                 |     |    |   |   |    |     |   |   |     |     |     |   |                               |  |
| ON  | ON                                     | 0   | Initial setting        |  |                |     |                               |  |   |   |   |   |   |   |   |  |                         |  |   |  |                  |  |  |  |        |        |    |    |   |                 |     |    |   |   |    |     |   |   |     |     |     |   |                               |  |
| OFF   | ON                                     | 1   | —                      |  |                |     |                               |  |   |   |   |   |   |   |   |  |                         |  |   |  |                  |  |  |  |        |        |    |    |   |                 |     |    |   |   |    |     |   |   |     |     |     |   |                               |  |
| ON  | OFF                                    | 2   | —                      |  |                |     |                               |  |   |   |   |   |   |   |   |  |                         |  |   |  |                  |  |  |  |        |        |    |    |   |                 |     |    |   |   |    |     |   |   |     |     |     |   |                               |  |
| OFF   | OFF                                    | 3~9   | —                      |  |                |     |                               |  |   |   |   |   |   |   |   |  |                         |  |   |  |                  |  |  |  |        |        |    |    |   |                 |     |    |   |   |    |     |   |   |     |     |     |   |                               |  |
| SWE<br>Test run for Drain pump  | Connector                              | <p>Drain pump and fan are activated simultaneously after the connector SWE is set to ON and turn on the power.</p>  <p>The connector SWE is set to OFF after test run.</p>   | Under operation        | <p>&lt;Initial setting&gt;</p>    |                |     |                               |  |   |   |   |   |   |   |   |  |                         |  |   |  |                  |  |  |  |        |        |    |    |   |                 |     |    |   |   |    |     |   |   |     |     |     |   |                               |  |

## 8-3. TEST POINT DIAGRAM

### 8-3-1. Indoor controller board (I.B)

PKFY-WL10VLM-E.TH

PKFY-WL20VLM-E.TH

PKFY-WL32VLM-E.TH

PKFY-WL15VLM-E.TH

PKFY-WL25VLM-E.TH

PKFY-WL40VLM-E.TH

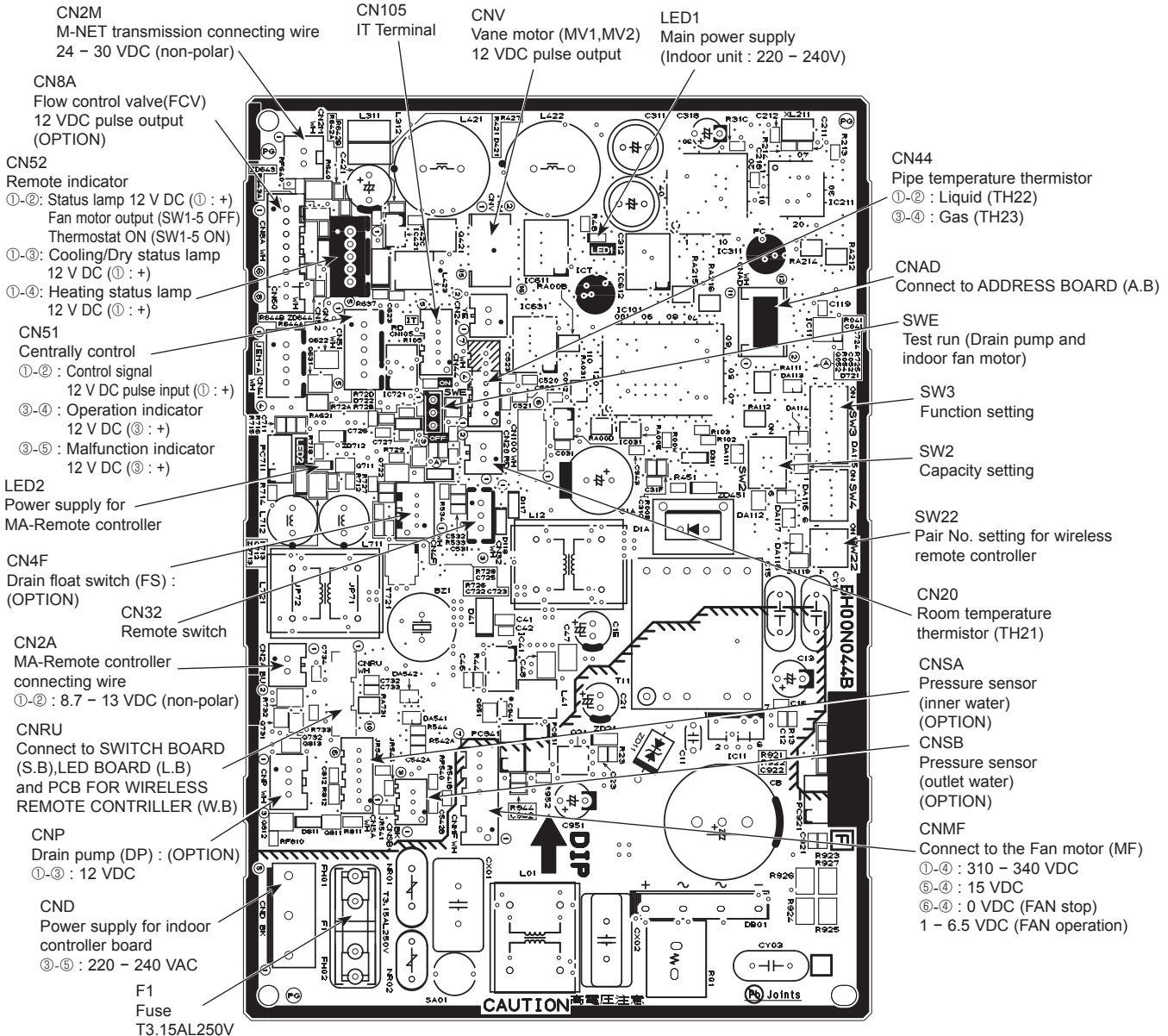

Note: The voltage range of 12 V DC in this page is between 11.5 to 13.7 V DC.



### 8-3-2. PCB FOR WIRELESS REMOTE CONTROLLER (W.B), SWITCH BOARD (S.B) and LED BOARD (L.B)

PKFY-WL10VLM-E.TH  
 PKFY-WL20VLM-E.TH  
 PKFY-WL32VLM-E.TH

PKFY-WL15VLM-E.TH  
 PKFY-WL25VLM-E.TH  
 PKFY-WL40VLM-E.TH

PCB FOR WIRELESS REMOTE CONTROLLER (W.B)

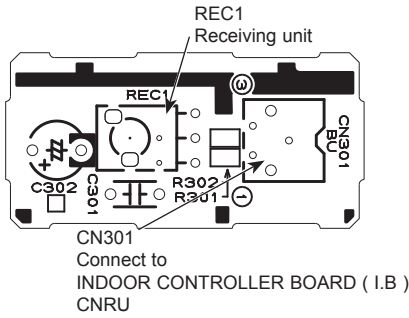

SWITCH BOARD (S.B)

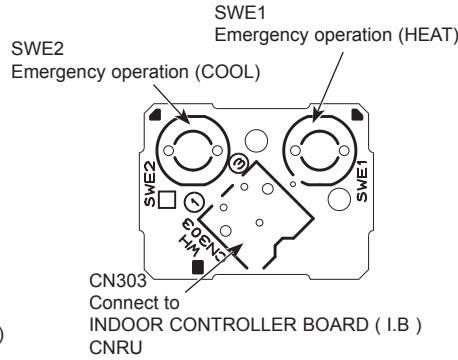

LED BOARD (L.B)

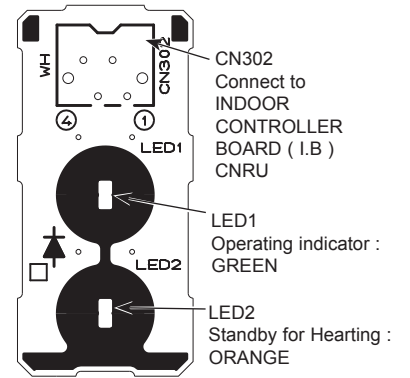

### 8-3-3. Address board (A.B)

PKFY-WL10VLM-E.TH  
 PKFY-WL20VLM-E.TH  
 PKFY-WL32VLM-E.TH

PKFY-WL15VLM-E.TH  
 PKFY-WL25VLM-E.TH  
 PKFY-WL40VLM-E.TH

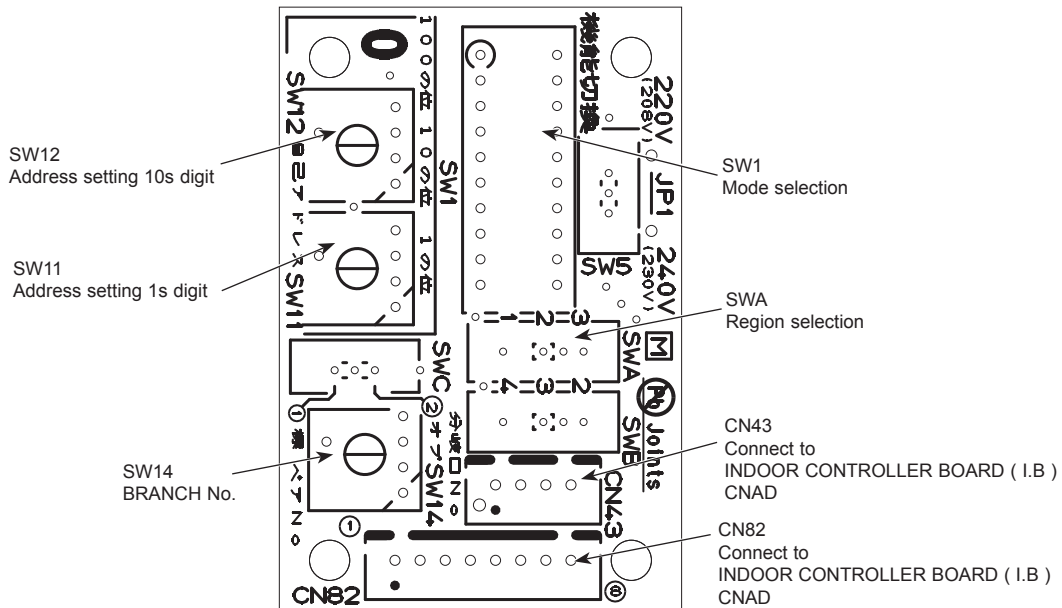

PKFY-WL10VLM-E.TH  
 PKFY-WL20VLM-E.TH  
 PKFY-WL32VLM-E.TH

PKFY-WL15VLM-E.TH  
 PKFY-WL25VLM-E.TH  
 PKFY-WL40VLM-E.TH

NOTE: Turn OFF the power supply before assembly.

Be careful when removing heavy parts.

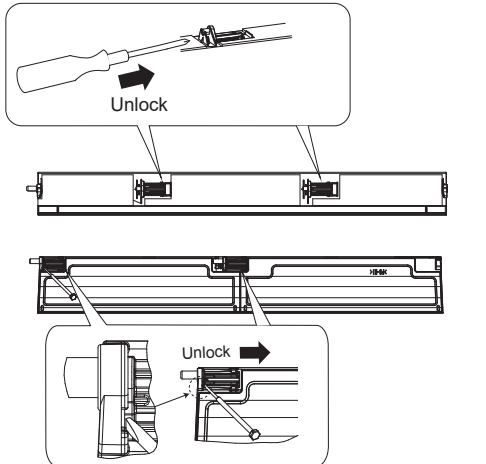
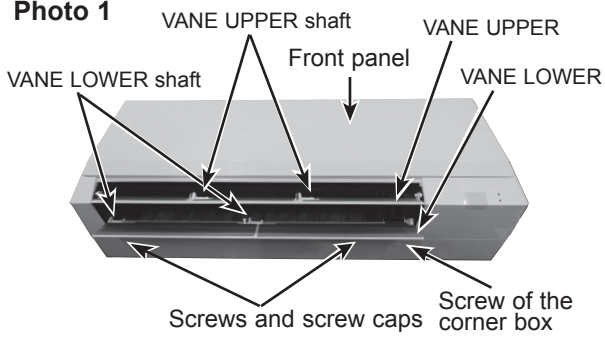
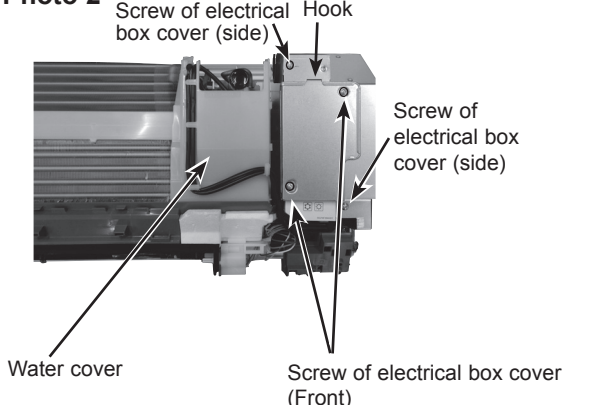
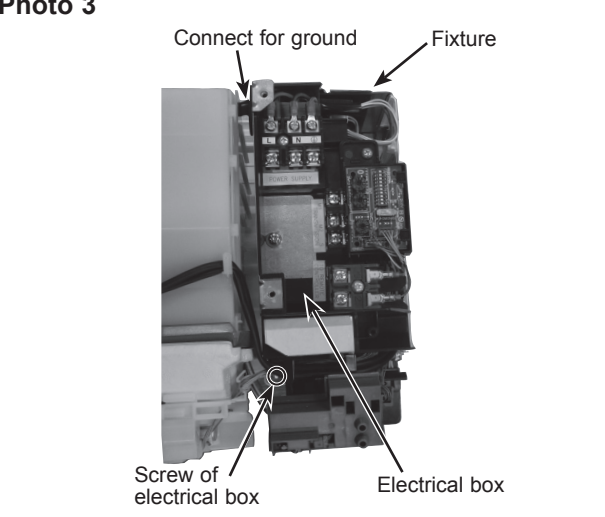
| OPERATION PROCEDURE  | PHOTOS/FIGURES  |
|--|---|
| <p><b>1. REMOVING THE PANEL</b></p> <p>(1) Insert the screwdriver to the hole at VANE LOWER shaft and slide the VANE LOWER shaft (2 places each). Push VANE UPPER shaft with the screwdriver.</p> <p>(2) Pull the VANE LOWER and VANE UPPER from unit.</p> <p>(3) Remove 2 screw caps of the front panel. Remove 2 screws. (See Photo 1)</p> <p>(4) Hold the lower part of both ends of the front panel and pull it slightly toward you, and then remove the front panel by pushing it upward.</p> <p>(5) Remove the screw of the corner box. (See Photo 1)<br/>       Remove the corner box.</p> <div data-bbox="172 869 691 1444" style="border: 1px solid black; padding: 5px; margin-top: 10px;"> <p>Unlock the stopper and remove the horizontal vanes using following tool like a screwdriver.</p>  </div> | <p><b>Photo 1</b></p>  <p><b>Photo 2</b></p>  |
| <p><b>2. REMOVING THE ELECTRICAL BOX</b></p> <p>(1) Remove the panel and the corner box. (Refer procedure to 1)</p> <p>(2) Remove the front and side electrical box covers (each 2 screw).</p> <p>(3) Remove the transmission wiring of TB5, the power supply wiring of TB2 and the wiring of MA-remote controller (TB15).</p> <p>(4) Disconnect the connectors on the indoor controller board.</p> <p>(5) Disconnect the connector for ground wire.</p> <p>(6) Remove the screw on lower side of the electrical box. (See Photo 3)</p> <p>(7) Push up the upper fixture catch to remove the box, then remove it from the box fixture.</p>   | <p><b>Photo 3</b></p>   |

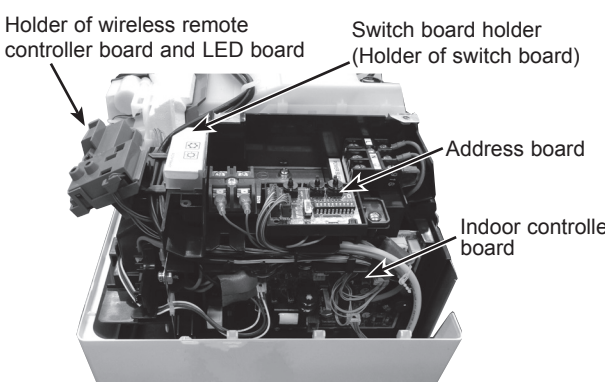
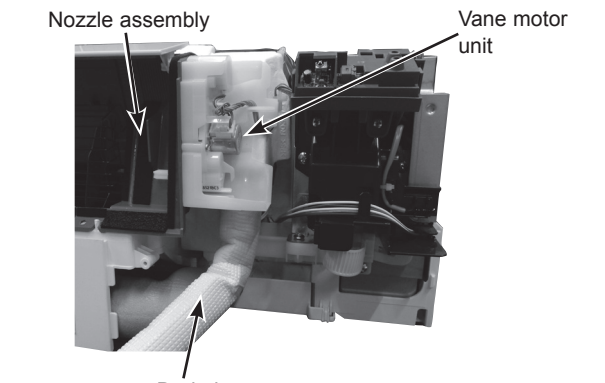
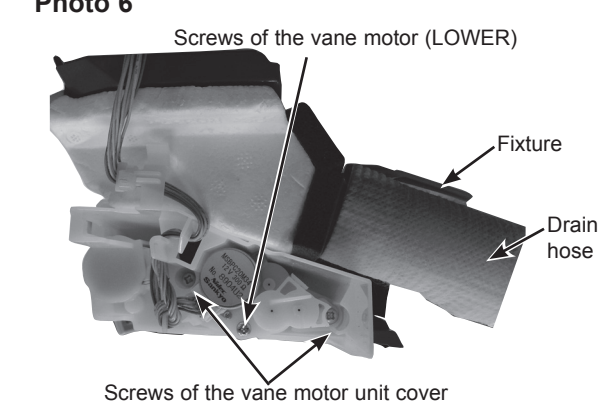
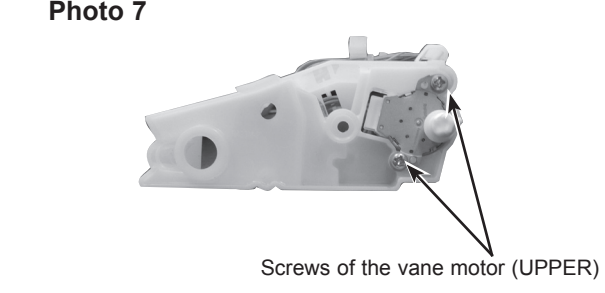

| OPERATION PROCEDURE   | PHOTOS/FIGURES  |
|---|---|
| <p><b>3. REMOVING THE ADDRESS BOARD, THE INDOOR CONTROLLER BOARD, THE WIRELESS CONTROLLER BOARD, LED BOARD</b></p> <ol style="list-style-type: none"><li>(1) Remove the panel and the corner box. (Refer to procedure 1)</li><li>(2) Remove the front and side electrical box covers (each 2 screw).</li><li>(3) Disconnect the connectors of address board.</li><li>(4) Disconnect the connectors on the indoor controller board. (See Photo 4)</li><li>(5) Remove the switch board holder and open the cover.</li><li>(6) Pull out the indoor controller board toward you then remove the indoor controller board and switch board. (See Photo 4)</li><li>(7) Remove the holder of wireless remote controller board and LED board.</li><li>(8) Disconnect the connector of wireless remote controller board and LED board.</li><li>(9) Remove the wireless remote controller board and LED board from the holder.</li></ol> | <p><b>Photo 4</b></p>  <p>Holder of wireless remote controller board and LED board      Switch board holder (Holder of switch board)</p> <p>Address board</p> <p>Indoor controller board</p> <p><b>Photo 5</b> (see the bottom)</p>  <p>Nozzle assembly      Vane motor unit</p> <p>Drain hose</p> |
| <p><b>4. REMOVING THE NOZZLE ASSEMBLY (with VANE and VANE MOTOR) AND DRAIN HOSE</b></p> <ol style="list-style-type: none"><li>(1) Remove the panel and corner box. (Refer to procedure 1)</li><li>(2) Remove the electrical box covers. (Refer to procedure 2)</li><li>(3) Disconnect the vane motor connector (CNV) on the indoor controller board.</li><li>(4) Push fixture and pull out the drain hose from the nozzle assembly, and remove nozzle assembly. (See Photo 6)</li></ol>   | <p><b>Photo 6</b></p>  <p>Screws of the vane motor (LOWER)</p> <p>Fixture</p> <p>Drain hose</p> <p>Screws of the vane motor unit cover</p>  |
| <p><b>5. REMOVING THE VANE MOTOR</b></p> <ol style="list-style-type: none"><li>(1) Remove the nozzle assembly. (Refer to procedure 4)</li><li>(2) Remove 2 screws of the vane motor unit cover, and pull out the vane motor unit.</li><li>(3) Remove screw of the vane motor (LOWER).</li><li>(4) Remove the vane motor (LOWER) from the vane motor unit cover.</li><li>(5) Disconnect the connector (white) from the vane motor. (LOWER)</li><li>(6) Remove 2 screw of the vane motor (UPPER).</li><li>(7) Remove the vane motor (UPPER) from the vane motor unit cover.</li><li>(8) Disconnect the connector (blue) from the vane motor (UPPER).</li></ol>  | <p><b>Photo 7</b></p>  <p>Screws of the vane motor (UPPER)</p>  |

## OPERATION PROCEDURE

### 6. REMOVING THE INDOOR FAN MOTOR AND THE LINE FLOW FAN

- (1) Remove the panel and the corner box. (Refer to procedure 1)
- (2) Remove the electrical box (Refer to procedure 2) and the nozzle assembly (Refer to procedure 4).
- (3) Remove the water cover. (See Photo 2)
- (4) Loosen the screw fixing the line flow fan. (See Photo 9)
- (5) Remove 3 screws fixing the motor bed. (See Photo 8)
- (6) Remove the motor bed together with fan motor and motor band.
- (7) Release the 2 hooks of the motor band. Remove the motor band. Pull out the indoor fan motor.
- (8) Remove 2 screws fixing the left side of the heat exchanger. (See Photo 10)
- (9) Lift the heat exchanger, and pull out the line flow fan to the lower-left.

Note: When attaching the line flow fan, screw the line flow fan so 4mm gap is provided between the right end of the line flow fan and the right wall of the air passage of the box. (See Photo 9)

## PHOTOS/FIGURES

Photo 8

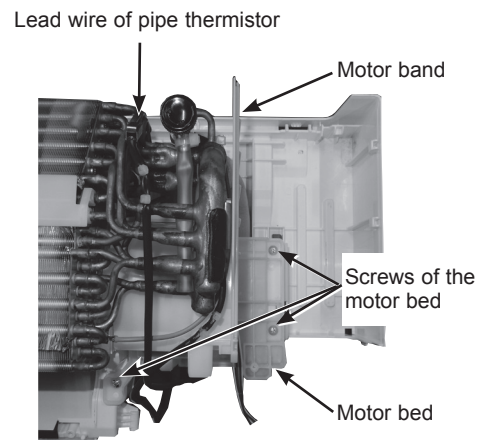

Photo 9

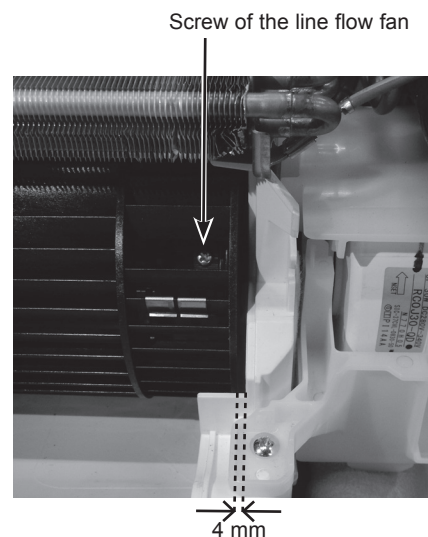
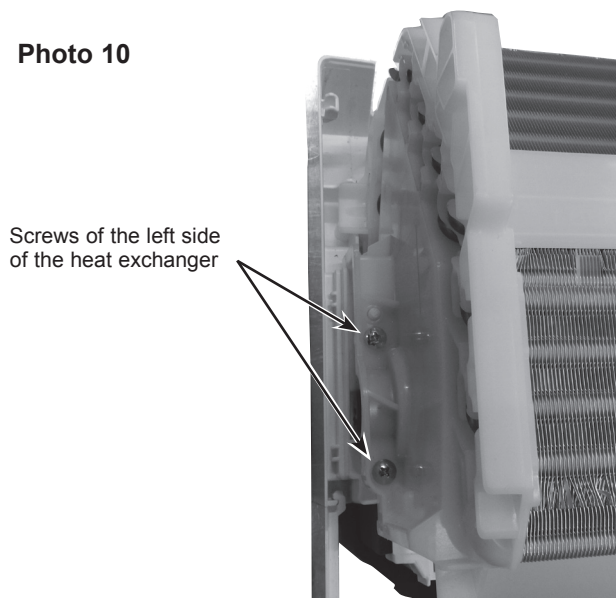

Photo 10



### 7. REMOVING PIPE THERMISTOR AND AIR PURGE VALVE

- (1) Remove the panel and the corner box. (Refer to procedure 1)
- (2) Remove the electrical box covers. (Refer to procedure 2)
- (3) Remove the water cover. (See Photo 2)
- (4) Remove the inlet pipe thermistor and outlet pipe thermistor.
- (5) Disconnect the connector (CN44) on the indoor controller board. (TH22 and TH23/CN44)
- (6) Remove the air purge valve

Photo 11

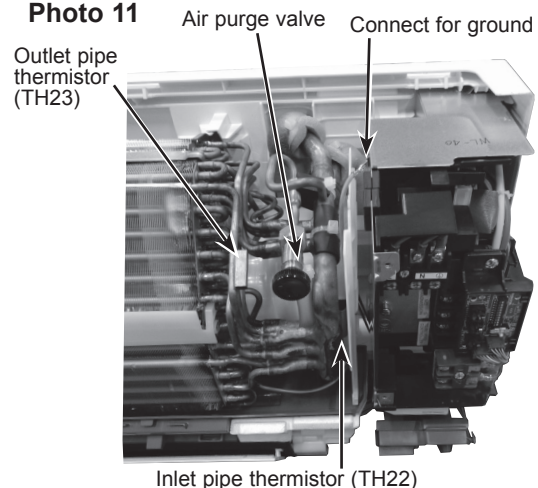

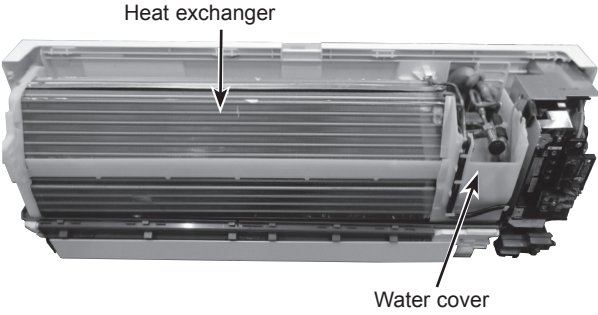
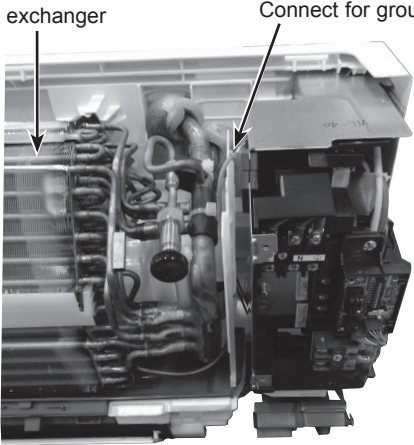
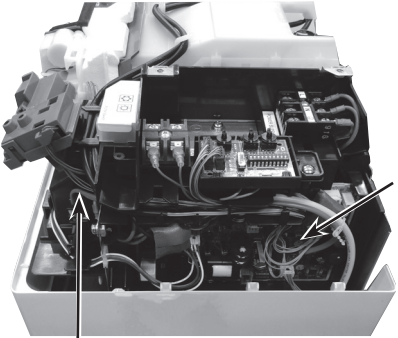

| OPERATION PROCEDURE  | PHOTOS/FIGURES   |
|--|--|
| <p><b>8. REMOVING THE HEAT EXCHANGER</b></p> <ol style="list-style-type: none"><li>(1) Remove the panel and the corner box (Refer to procedure 1).</li><li>(2) Remove the electrical box (Refer to procedure 3) and the nozzle assembly (Refer to procedure 4).</li><li>(3) Remove the water cover.</li><li>(4) Remove the pipe thermistors. (Refer to procedure 7).</li><li>(5) Disconnect the connector (CN60) on the indoor controller board.</li><li>(6) Remove the motor bed together with fan motor and motor band (Refer to procedure 6).</li><li>(7) Remove 2 screws fixing the left side of the heat exchanger. (See Photo 10)</li><li>(8) Remove the heat exchanger.</li></ol> | <p><b>Photo 12</b></p>  <p>Heat exchanger</p> <p>Water cover</p> <p><b>Photo 13</b></p>  <p>Heat exchanger</p> <p>Connect for ground</p> |
| <p><b>9. REMOVING THE ROOM TEMPERATURE THERMISTOR</b></p> <ol style="list-style-type: none"><li>(1) Remove the panel and corner box. (Refer to procedure 1)</li><li>(2) Remove the electrical box covers. (Refer to procedure 2)</li><li>(3) Remove the room temperature thermistor.</li><li>(4) Disconnect the connector (CN20) on the indoor controller board.</li></ol>   | <p><b>Photo 14</b></p>  <p>Indoor controller board</p> <p>Room temp. thermistor (TH21)</p>   |

# CITY MULTI

**mitsubishi** **ELECTRIC CORPORATION**

HEAD OFFICE : TOKYO BUILDING, 2-7-3, MARUNOUCHI, CHIYODA-KU TOKYO 100-8310, JAPAN

---