

AIR CONDITIONING SYSTEMS

# CITY MULTI



## DATA BOOK

MODEL

---

**CMB-M-V-J1(-TR)**

**CMB-M-V-JA1(-TR)**



**CMB-P-V-KA1(-TR)**

**CMB-M-V-KB1(-TR)**



**CMB-M-V-J1(-TR), CMB-M-V-JA1(-TR), CMB-P-V-KA1(-TR), CMB-M-V-KB1(-TR)**

1. SPECIFICATIONS .....	2
2. EXTERNAL DIMENSIONS .....	13
3. ELECTRICAL WIRING DIAGRAMS .....	18
4. SOUND LEVELS .....	27
4-1. Sound levels in cooling mode .....	27
4-2. Sound levels in heating mode .....	28
4-3. Sound levels in defrost mode .....	29
5. ELECTRICAL CHARACTERISTICS .....	30
6. OPTIONAL PARTS .....	31
6-1. JOINT and REDUCER .....	31
6-2. JOINT KIT "CMY-R160-J1" FOR BC CONTROLLER .....	36
7. INSTALLATION .....	37
7-1. Installing BC controllers .....	37
8. SYSTEM DESIGN .....	38
8-1. Compatibility .....	38
8-2. System examples .....	39

# 1. SPECIFICATIONS

BC controller

BC controller

Model			<b>CMB-M104V-J1 (-TR)</b>		
Number of branch			4		
Power source			1-phase 220-230-240 V		
			50Hz	60Hz	
Power input	Cooling	kW	0.067/0.076/0.085	0.054/0.061/0.067	
	Heating	kW	0.030/0.034/0.038	0.024/0.027/0.030	
Current input	Cooling	A	0.31/0.34/0.36	0.25/0.27/0.28	
	Heating	A	0.14/0.15/0.16	0.11/0.12/0.13	
External finish			Galvanized steel plate (Lower part drain pan: Pre-coated galvanized sheets + powder coating)		
Connectable outdoor/heat source unit capacity			P200 to P350/M200 to M300		
Indoor unit capacity connectable to 1 branch			*14 Model P/M80 or smaller (Use optional joint pipe combining 2 branches when the total unit capacity exceeds P/M81.)		
External dimension H x W x D		mm	250 x 596 x 476		
		in.	9-7/8 x 23-1/2 x 18-3/4		
Refrigerant piping diameter	To outdoor/heat source unit	Connectable unit capacity		High press. Pipe	Low press. Pipe
		mm (in.) O.D.	P200/M200	15.88 (5/8) Brazed	19.05 (3/4) Brazed
		mm (in.) O.D.	P250/P300	19.05 (3/4) Brazed	22.2 (7/8) Brazed
		*15 mm (in.) O.D.	P350	19.05 (3/4) Brazed or 22.2 (7/8) Brazed	28.58 (1-1/8) Brazed
	mm (in.) O.D.	M250/M300	15.88 (5/8) Brazed	22.2 (7/8) Brazed	
	To indoor unit	Liquid pipe		Gas pipe	
mm (in.) O.D.	Indoor unit Model 50 or smaller 6.35 (1/4) Brazed bigger than 50 9.52 (3/8) Brazed		Indoor unit Model 50 or smaller 12.7 (1/2) Brazed bigger than 50 15.88 (5/8) Brazed (19.05 (3/4), 22.2 (7/8) with optional joint pipe used.)		
Field drain pipe size		mm (in.)	O.D. 32 (1-1/4)		
Net weight		kg (lbs)	26 (58)		
Sound power level (measured in anechoic room)	Rated operation	dB <A>	59		
	Defrost	dB <A>	71		
Sound pressure level (measured in anechoic room)	Rated operation	dB <A>	40		
	*16 Defrost	dB <A>	53		
Accessories			Drain Connection pipe, Washer, Tie band		
Remarks					

- Notes:
- 1.Installation/foundation work, electrical connection work, insulation work, power source switch, and other items shall be referred to the Installation Manual.
  - 2.The equipment is for R410A or R32 refrigerant.
  - 3.Install this product in a location where noise (refrigerant noise) emitted by the unit will not disturb the neighbors. (For use in quiet environments with low background noise, position the BC CONTROLLER at least 5m away from any indoor units.)
  - 4.Sound pressure/power level differs depending on the connected outdoor/heat source unit capacity or operation condition. The sound pressure/power level at the rated operation is the value of the cooling mode.
  - 5.The sound pressure/power level values were obtained in an anechoic room. Actual sound pressure level is usually greater than that measured in anechoic room due to ambient noise and deflection sound.
  - 6.The sound pressure level values were obtained at the location below 1.5m from the unit.
  - 7.The solenoid valve switching sound is 56 dB (sound pressure level) regardless of the unit model.
  - 8.Indoor units P/M100, P/M125, P/M140 can be connected to 1 branch. (In this case, cooling capacity decrease a little.)
  - 9.Refrigerant piping diameter for connection of plural indoor units with 1 branch shall be referred to the Installation Manual.
  - 10.This unit is not designed for outside installations.
  - 11.When blazing the pipes, be sure to blaze, after covering a wet cloth to the insulation pipes of the units in order to prevent it from burning and shrinking by heat.
  - 12.The ambient relative humidity of the BC controller needs to be kept below 80%.
  - 13.R32 is flammable, and certain restrictions apply to the installation of units. When installing new units, moving the existing units, or changing the layout of the room, ensure that installation restrictions are observed. For detail, refer to the section in the DATA BOOK on installation restrictions.
  - 14.Indoor unit capacity connectable to 1 branch is changed depending on the indoor unit type and connection method. Please refer to the Installation Manual for more information.
  - 15.For the refrigerant pipe size, refer to Installation Manual of outdoor units/heat source units.
  - 16.The sound pressure level measured by the conventional method in JIS for reference purpose.

Model			CMB-M106V-J1 (-TR)		
Number of branch			6		
Power source			1-phase 220-230-240 V		
			50Hz	60Hz	
Power input	Cooling	kW	0.097/0.110/0.123		0.078/0.088/0.097
	Heating	kW	0.045/0.051/0.057		0.036/0.041/0.045
Current input	Cooling	A	0.45/0.48/0.52		0.36/0.39/0.41
	Heating	A	0.21/0.23/0.24		0.17/0.18/0.19
External finish			Galvanized steel plate (Lower part drain pan: Pre-coated galvanized sheets + powder coating)		
Connectable outdoor/heat source unit capacity			P200 to P350/M200 to M300		
Indoor unit capacity connectable to 1 branch *14			Model P/M80 or smaller (Use optional joint pipe combining 2 branches when the total unit capacity exceeds P/M81.)		
External dimension H x W x D		mm	250 x 596 x 476		
		in.	9-7/8 x 23-1/2 x 18-3/4		
Refrigerant piping diameter	To outdoor/heat source unit	Connectable unit capacity		High press. Pipe	Low press. Pipe
		mm (in.) O.D.	P200/M200	15.88 (5/8) Brazed	19.05 (3/4) Brazed
		mm (in.) O.D.	P250/P300	19.05 (3/4) Brazed	22.2 (7/8) Brazed
		mm (in.) O.D.	P350	19.05 (3/4) Brazed or 22.2 (7/8) Brazed	28.58 (1-1/8) Brazed
	mm (in.) O.D.	M250/M300	15.88 (5/8) Brazed	22.2 (7/8) Brazed	
	To indoor unit		Liquid pipe		Gas pipe
		mm (in.) O.D.	Indoor unit Model 50 or smaller 6.35 (1/4) Brazed bigger than 50 9.52 (3/8) Brazed	Indoor unit Model 50 or smaller 12.7 (1/2) Brazed bigger than 50 15.88 (5/8) Brazed (19.05 (3/4), 22.2 (7/8) with optional joint pipe used.)	
Field drain pipe size		mm (in.)	O.D. 32 (1-1/4)		
Net weight		kg (lbs)	29 (64)		
Sound power level (measured in anechoic room)	Rated operation	dB <A>	59		
	Defrost	dB <A>	71		
Sound pressure level (measured in anechoic room) *16	Rated operation	dB <A>	40		
	Defrost	dB <A>	53		
Accessories			Drain Connection pipe, Washer, Tie band		
Remarks					

Notes:

- 1.Installation/foundation work, electrical connection work, insulation work, power source switch, and other items shall be referred to the Installation Manual.
- 2.The equipment is for R410A or R32 refrigerant.
- 3.Install this product in a location where noise (refrigerant noise) emitted by the unit will not disturb the neighbors. (For use in quiet environments with low background noise, position the BC CONTROLLER at least 5m away from any indoor units.)
- 4.Sound pressure/power level differs depending on the connected outdoor/heat source unit capacity or operation condition. The sound pressure/power level at the rated operation is the value of the cooling mode.
- 5.The sound pressure/power level values were obtained in an anechoic room. Actual sound pressure level is usually greater than that measured in anechoic room due to ambient noise and deflection sound.
- 6.The sound pressure level values were obtained at the location below 1.5m from the unit.
- 7.The solenoid valve switching sound is 56 dB (sound pressure level) regardless of the unit model.
- 8.Indoor units P/M100, P/M125, P/M140 can be connected to 1 branch. (In this case, cooling capacity decrease a little.)
- 9.Refrigerant piping diameter for connection of plural indoor units with 1 branch shall be referred to the Installation Manual.
- 10.This unit is not designed for outside installations.
- 11.When blazing the pipes, be sure to blaze, after covering a wet cloth to the insulation pipes of the units in order to prevent it from burning and shrinking by heat.
- 12.The ambient relative humidity of the BC controller needs to be kept below 80%.
- 13.R32 is flammable, and certain restrictions apply to the installation of units. When installing new units, moving the existing units, or changing the layout of the room, ensure that installation restrictions are observed. For detail, refer to the section in the DATA BOOK on installation restrictions.
- 14.Indoor unit capacity connectable to 1 branch is changed depending on the indoor unit type and connection method. Please refer to the Installation Manual for more information.
- 15.For the refrigerant pipe size, refer to Installation Manual of outdoor units/heat source units.
- 16.The sound pressure level measured by the conventional method in JIS for reference purpose.

# 1. SPECIFICATIONS

BC controller

BC controller

Model			CMB-M108V-J1 (-TR)		
Number of branch			8		
Power source			1-phase 220-230-240 V		
			50Hz	60Hz	
Power input	Cooling	kW	0.127/0.144/0.161	0.102/0.115/0.127	
	Heating	kW	0.060/0.068/0.076	0.048/0.054/0.060	
Current input	Cooling	A	0.58/0.63/0.68	0.47/0.50/0.53	
	Heating	A	0.28/0.30/0.32	0.22/0.24/0.25	
External finish			Galvanized steel plate (Lower part drain pan: Pre-coated galvanized sheets + powder coating)		
Connectable outdoor/heat source unit capacity			P200 to P350/M200 to M300		
Indoor unit capacity connectable to 1 branch			*14 Model P/M80 or smaller (Use optional joint pipe combining 2 branches when the total unit capacity exceeds P/M81.)		
External dimension H x W x D		mm	250 x 596 x 476		
		in.	9-7/8 x 23-1/2 x 18-3/4		
Refrigerant piping diameter	To outdoor/heat source unit	Connectable unit capacity		High press. Pipe	Low press. Pipe
		mm (in.) O.D.	P200/M200	15.88 (5/8) Brazed	19.05 (3/4) Brazed
		mm (in.) O.D.	P250/P300	19.05 (3/4) Brazed	22.2 (7/8) Brazed
		*15 mm (in.) O.D.	P350	19.05 (3/4) Brazed or 22.2 (7/8) Brazed	28.58 (1-1/8) Brazed
	mm (in.) O.D.	M250/M300	15.88 (5/8) Brazed	22.2 (7/8) Brazed	
	To indoor unit	Liquid pipe		Gas pipe	
mm (in.) O.D.		Indoor unit Model 50 or smaller 6.35 (1/4) Brazed bigger than 50 9.52 (3/8) Brazed	Indoor unit Model 50 or smaller 12.7 (1/2) Brazed bigger than 50 15.88 (5/8) Brazed (19.05 (3/4), 22.2 (7/8) with optional joint pipe used.)		
Field drain pipe size		mm (in.)	O.D. 32 (1-1/4)		
Net weight		kg (lbs)	33 (73)		
Sound power level (measured in anechoic room)	Rated operation	dB <A>	59		
	Defrost	dB <A>	71		
Sound pressure level (measured in anechoic room)	Rated operation	dB <A>	40		
	*16 Defrost	dB <A>	53		
Accessories			Drain Connection pipe, Washer, Tie band		
Remarks					

**Notes:**

1. Installation/foundation work, electrical connection work, insulation work, power source switch, and other items shall be referred to the Installation Manual.
2. The equipment is for R410A or R32 refrigerant.
3. Install this product in a location where noise (refrigerant noise) emitted by the unit will not disturb the neighbors. (For use in quiet environments with low background noise, position the BC CONTROLLER at least 5m away from any indoor units.)
4. Sound pressure/power level differs depending on the connected outdoor/heat source unit capacity or operation condition. The sound pressure/power level at the rated operation is the value of the cooling mode.
5. The sound pressure/power level values were obtained in an anechoic room. Actual sound pressure level is usually greater than that measured in anechoic room due to ambient noise and deflection sound.
6. The sound pressure level values were obtained at the location below 1.5m from the unit.
7. The solenoid valve switching sound is 56 dB (sound pressure level) regardless of the unit model.
8. Indoor units P/M100, P/M125, P/M140 can be connected to 1 branch. (In this case, cooling capacity decrease a little.)
9. Refrigerant piping diameter for connection of plural indoor units with 1 branch shall be referred to the Installation Manual.
10. This unit is not designed for outside installations.
11. When blazing the pipes, be sure to blaze, after covering a wet cloth to the insulation pipes of the units in order to prevent it from burning and shrinking by heat.
12. The ambient relative humidity of the BC controller needs to be kept below 80%.
13. R32 is flammable, and certain restrictions apply to the installation of units. When installing new units, moving the existing units, or changing the layout of the room, ensure that installation restrictions are observed. For detail, refer to the section in the DATA BOOK on installation restrictions.
14. Indoor unit capacity connectable to 1 branch is changed depending on the indoor unit type and connection method. Please refer to the Installation Manual for more information.
15. For the refrigerant pipe size, refer to Installation Manual of outdoor units/heat source units.
16. The sound pressure level measured by the conventional method in JIS for reference purpose.

# 1. SPECIFICATIONS

Model			<b>CMB-M1012V-J1 (-TR)</b>		
Number of branch			12		
Power source			1-phase 220-230-240 V		
			50Hz	60Hz	
Power input	Cooling	kW	0.186/0.211/0.236		0.150/0.168/0.186
	Heating	kW	0.090/0.102/0.114		0.072/0.081/0.090
Current input	Cooling	A	0.85/0.92/0.99		0.69/0.74/0.78
	Heating	A	0.42/0.44/0.48		0.33/0.36/0.38
External finish			Galvanized steel plate (Lower part drain pan: Pre-coated galvanized sheets + powder coating)		
Connectable outdoor/heat source unit capacity			P200 to P350/M200 to M300		
Indoor unit capacity connectable to 1 branch *14			Model P/M80 or smaller (Use optional joint pipe combining 2 branches when the total unit capacity exceeds P/M81.)		
External dimension H x W x D			mm	252 x 911 x 622	
			in.	9-15/16 x 35-7/8 x 24-1/2	
Refrigerant piping diameter	To outdoor/heat source unit	Connectable unit capacity		High press. Pipe	Low press. Pipe
		mm (in.) O.D.	P200/M200	15.88 (5/8) Brazed	19.05 (3/4) Brazed
		mm (in.) O.D.	P250/P300	19.05 (3/4) Brazed	22.2 (7/8) Brazed
		*15 mm (in.) O.D.	P350	19.05 (3/4) Brazed or 22.2 (7/8) Brazed	28.58 (1-1/8) Brazed
	mm (in.) O.D.	M250/M300	15.88 (5/8) Brazed	22.2 (7/8) Brazed	
	To indoor unit		Liquid pipe		Gas pipe
		Indoor unit Model 50 or smaller 6.35 (1/4) Brazed bigger than 50 9.52 (3/8) Brazed		Indoor unit Model 50 or smaller 12.7 (1/2) Brazed bigger than 50 15.88 (5/8) Brazed (19.05 (3/4), 22.2 (7/8) with optional joint pipe used.)	
Field drain pipe size			mm (in.)	O.D. 32 (1-1/4)	
Net weight			kg (lbs)	49 (109)	
Sound power level (measured in anechoic room)	Rated operation	dB <A>	59		
	Defrost	dB <A>	71		
Sound pressure level (measured in anechoic room) *16	Rated operation	dB <A>	40		
	Defrost	dB <A>	53		
Accessories			Drain Connection pipe, Washer, Tie band		
Remarks					

**Notes:**

1. Installation/foundation work, electrical connection work, insulation work, power source switch, and other items shall be referred to the Installation Manual.
2. The equipment is for R410A or R32 refrigerant.
3. Install this product in a location where noise (refrigerant noise) emitted by the unit will not disturb the neighbors. (For use in quiet environments with low background noise, position the BC CONTROLLER at least 5m away from any indoor units.)
4. Sound pressure/power level differs depending on the connected outdoor/heat source unit capacity or operation condition. The sound pressure/power level at the rated operation is the value of the cooling mode.
5. The sound pressure/power level values were obtained in an anechoic room. Actual sound pressure level is usually greater than that measured in anechoic room due to ambient noise and deflection sound.
6. The sound pressure level values were obtained at the location below 1.5m from the unit.
7. The solenoid valve switching sound is 56 dB (sound pressure level) regardless of the unit model.
8. Indoor units P/M100, P/M125, P/M140 can be connected to 1 branch. (In this case, cooling capacity decrease a little.)
9. Refrigerant piping diameter for connection of plural indoor units with 1 branch shall be referred to the Installation Manual.
10. This unit is not designed for outside installations.
11. When blazing the pipes, be sure to blaze, after covering a wet cloth to the insulation pipes of the units in order to prevent it from burning and shrinking by heat.
12. The ambient relative humidity of the BC controller needs to be kept below 80%.
13. R32 is flammable, and certain restrictions apply to the installation of units. When installing new units, moving the existing units, or changing the layout of the room, ensure that installation restrictions are observed. For detail, refer to the section in the DATA BOOK on installation restrictions.
14. Indoor unit capacity connectable to 1 branch is changed depending on the indoor unit type and connection method. Please refer to the Installation Manual for more information.
15. For the refrigerant pipe size, refer to Installation Manual of outdoor units/heat source units.
16. The sound pressure level measured by the conventional method in JIS for reference purpose.

# 1. SPECIFICATIONS

BC controller

BC controller

Model			<b>CMB-M1016V-J1 (-TR)</b>		
Number of branch			16		
Power source			1-phase 220-230-240 V		
			50Hz	60Hz	
Power input	Cooling	kW	0.246/0.279/0.312		0.198/0.222/0.246
	Heating	kW	0.119/0.135/0.151		0.096/0.108/0.119
Current input	Cooling	A	1.12/1.22/1.30		0.90/0.97/1.03
	Heating	A	0.55/0.59/0.63		0.44/0.47/0.50
External finish			Galvanized steel plate (Lower part drain pan: Pre-coated galvanized sheets + powder coating)		
Connectable outdoor/heat source unit capacity			P200 to P350/M200 to M300		
Indoor unit capacity connectable to 1 branch			*14 Model P/M80 or smaller (Use optional joint pipe combining 2 branches when the total unit capacity exceeds P/M81.)		
External dimension H x W x D		mm	252 x 1,135 x 622		
		in.	9-15/16 x 44-11/16 x 24-1/2		
Refrigerant piping diameter	To outdoor/heat source unit	Connectable unit capacity		High press. Pipe	Low press. Pipe
		mm (in.) O.D.	P200/M200	15.88 (5/8) Brazed	19.05 (3/4) Brazed
		mm (in.) O.D.	P250/P300	19.05 (3/4) Brazed	22.2 (7/8) Brazed
		*15 mm (in.) O.D.	P350	19.05 (3/4) Brazed or 22.2 (7/8) Brazed	28.58 (1-1/8) Brazed
	mm (in.) O.D.	M250/M300	15.88 (5/8) Brazed	22.2 (7/8) Brazed	
	To indoor unit	Liquid pipe			Gas pipe
mm (in.) O.D.		Indoor unit Model 50 or smaller 6.35 (1/4) Brazed bigger than 50 9.52 (3/8) Brazed		Indoor unit Model 50 or smaller 12.7 (1/2) Brazed bigger than 50 15.88 (5/8) Brazed (19.05 (3/4), 22.2 (7/8) with optional joint pipe used.)	
Field drain pipe size		mm (in.)	O.D. 32 (1-1/4)		
Net weight		kg (lbs)	59 (131)		
Sound power level (measured in anechoic room)	Rated operation	dB <A>	59		
	Defrost	dB <A>	71		
Sound pressure level (measured in anechoic room)	Rated operation	dB <A>	40		
	*16 Defrost	dB <A>	53		
Accessories			Drain Connection pipe, Washer, Tie band		
Remarks					

**Notes:**

- 1.Installation/foundation work, electrical connection work, insulation work, power source switch, and other items shall be referred to the Installation Manual.
- 2.The equipment is for R410A or R32 refrigerant.
- 3.Install this product in a location where noise (refrigerant noise) emitted by the unit will not disturb the neighbors. (For use in quiet environments with low background noise, position the BC CONTROLLER at least 5m away from any indoor units.)
- 4.Sound pressure/power level differs depending on the connected outdoor/heat source unit capacity or operation condition. The sound pressure/power level at the rated operation is the value of the cooling mode.
- 5.The sound pressure/power level values were obtained in an anechoic room. Actual sound pressure level is usually greater than that measured in anechoic room due to ambient noise and deflection sound.
- 6.The sound pressure level values were obtained at the location below 1.5m from the unit.
- 7.The solenoid valve switching sound is 56 dB (sound pressure level) regardless of the unit model.
- 8.Indoor units P/M100, P/M125, P/M140 can be connected to 1 branch. (In this case, cooling capacity decrease a little.)
- 9.Refrigerant piping diameter for connection of plural indoor units with 1 branch shall be referred to the Installation Manual.
- 10.This unit is not designed for outside installations.
- 11.When blazing the pipes, be sure to blaze, after covering a wet cloth to the insulation pipes of the units in order to prevent it from burning and shrinking by heat.
- 12.The ambient relative humidity of the BC controller needs to be kept below 80%.
- 13.R32 is flammable, and certain restrictions apply to the installation of units. When installing new units, moving the existing units, or changing the layout of the room, ensure that installation restrictions are observed. For detail, refer to the section in the DATA BOOK on installation restrictions.
- 14.Indoor unit capacity connectable to 1 branch is changed depending on the indoor unit type and connection method. Please refer to the Installation Manual for more information.
- 15.For the refrigerant pipe size, refer to Installation Manual of outdoor units/heat source units.
- 16.The sound pressure level measured by the conventional method in JIS for reference purpose.

Model		<b>CMB-M108V-JA1 (-TR)</b>				
Number of branch		8				
Power source		1-phase 220-230-240 V				
Power input	Cooling	kW	50Hz	60Hz		
			0.127/0.144/0.161	0.102/0.115/0.127		
Current input	Heating	kW	0.060/0.068/0.076		0.048/0.054/0.060	
			Cooling	A	0.58/0.63/0.68	
External finish	Heating	A			0.28/0.30/0.32	
			Galvanized steel plate (Lower part drain pan: Pre-coated galvanized sheets + powder coating)			
Connectable outdoor/heat source unit capacity		P200 to P900/M200 to M300				
Indoor unit capacity connectable to 1 branch		*14	Model P/M80 or smaller (Use optional joint pipe combining 2 branches when the total unit capacity exceeds P/M81.)			
External dimension H x W x D		mm	252 x 911 x 622			
		in.	9-15/16 x 35-7/8 x 24-1/2			
Refrigerant piping diameter	To outdoor/heat source unit	Connectable unit capacity		High press. pipe	Low press. pipe	
		mm (in.) O.D.	P200/M200	15.88 (5/8) Brazed	19.05 (3/4) Brazed	
		mm (in.) O.D.	P250/P300	19.05 (3/4) Brazed	22.2 (7/8) Brazed	
		*15 mm (in.) O.D.	P350	19.05 (3/4) Brazed or 22.2 (7/8) Brazed	28.58 (1-1/8) Brazed	
		mm (in.) O.D.	P400 to P500	22.2 (7/8) Brazed	28.58 (1-1/8) Brazed	
		*15 mm (in.) O.D.	P550	22.2 (7/8) Brazed or 28.58 (1-1/8) Brazed	28.58 (1-1/8) Brazed	
		*15 mm (in.) O.D.	P600	22.2 (7/8) Brazed or 28.58 (1-1/8) Brazed	28.58 (1-1/8) Brazed or 34.93 (1-3/8) Brazed	
		mm (in.) O.D.	P650	28.58 (1-1/8) Brazed	28.58 (1-1/8) Brazed	
		mm (in.) O.D.	P700 to P800	28.58 (1-1/8) Brazed	34.93 (1-3/8) Brazed	
		mm (in.) O.D.	P850 to P900	28.58 (1-1/8) Brazed	41.28 (1-5/8) Brazed	
	mm (in.) O.D.	M250/M300	15.88 (5/8) Brazed	22.2 (7/8) Brazed		
	To indoor unit	Liquid pipe		Gas pipe		
		mm (in.) O.D.	Indoor unit Model 50 or smaller 6.35 (1/4) Brazed bigger than 50 9.52 (3/8) Brazed	Indoor unit Model 50 or smaller 12.7 (1/2) Brazed bigger than 50 15.88 (5/8) Brazed (19.05 (3/4), 22.2 (7/8) with optional joint pipe used.)		
	To other BC controller	Total down-stream Indoor unit capacity		High press. pipe	Liquid pipe	Low press. pipe
		mm (in.) O.D.	to P200/M200	15.88 (5/8) Brazed	9.52 (3/8) Brazed	19.05 (3/4) Brazed
		mm (in.) O.D.	P201 to P300	19.05 (3/4) Brazed	9.52 (3/8) Brazed	22.2 (7/8) Brazed
		mm (in.) O.D.	P301 to P350	19.05 (3/4) Brazed	12.7 (1/2) Brazed	28.58 (1-1/8) Brazed
		mm (in.) O.D.	P351 to P400	22.2 (7/8) Brazed	12.7 (1/2) Brazed	28.58 (1-1/8) Brazed
		mm (in.) O.D.	P401 to P600	22.2 (7/8) Brazed	15.88 (5/8) Brazed	28.58 (1-1/8) Brazed
		mm (in.) O.D.	P601 to P650	28.58 (1-1/8) Brazed	15.88 (5/8) Brazed	28.58 (1-1/8) Brazed
mm (in.) O.D.		P651 to P800	28.58 (1-1/8) Brazed	19.05 (3/4) Brazed	34.93 (1-3/8) Brazed	
mm (in.) O.D.		P801 to P1000	28.58 (1-1/8) Brazed	19.05 (3/4) Brazed	41.28 (1-5/8) Brazed	
mm (in.) O.D.		P1001 or above	34.93 (1-3/8) Brazed	19.05 (3/4) Brazed	41.28 (1-5/8) Brazed	
mm (in.) O.D.		M201 to M300	15.88 (5/8) Brazed	9.52 (3/8) Brazed	22.2 (7/8) Brazed	
mm (in.) O.D.		M301 to M350	15.88 (5/8) Brazed	12.7 (1/2) Brazed	28.58 (1-1/8) Brazed	
mm (in.) O.D.		M351 to M400	19.05 (3/4) Brazed	12.7 (1/2) Brazed	28.58 (1-1/8) Brazed	
mm (in.) O.D.	M401 to M450	19.05 (3/4) Brazed	15.88 (5/8) Brazed	28.58 (1-1/8) Brazed		
Field drain pipe size		mm (in.)	O.D. 32 (1-1/4)			
Net weight		kg (lbs)	48 (106)			
Sound power level (measured in anechoic room)	Rated operation	dB <A>	68			
	Defrost	dB <A>	74			
Sound pressure level (measured in anechoic room)	Rated operation	dB <A>	50			
	*16 Defrost	dB <A>	56			
Accessories		Drain Connection pipe, Washer, Tie band				
Remarks						

- Notes:
- 1.Installation/foundation work, electrical connection work, insulation work, power source switch, and other items shall be referred to the Installation Manual.
  - 2.The equipment is for R410A or R32 refrigerant.
  - 3.Install this product in a location where noise (refrigerant noise) emitted by the unit will not disturb the neighbors.  
(For use in quiet environments with low background noise, position the BC CONTROLLER at least 5m away from any indoor units.)
  - 4.Sound pressure/power level differs depending on the connected outdoor/heat source unit capacity or operation condition.  
The sound pressure/power level at the rated operation is the value of the cooling mode.
  - 5.The sound pressure/power level values were obtained in an anechoic room. Actual sound pressure level is usually greater than that measured in anechoic room due to ambient noise and deflection sound.
  - 6.The sound pressure level values were obtained at the location below 1.5m from the unit.
  - 7.The solenoid valve switching sound is 56 dB (sound pressure level) regardless of the unit model.
  - 8.Indoor units P/M100, P/M125, P/M140 can be connected to 1 branch. (In this case, cooling capacity decrease a little.)
  - 9.Refrigerant piping diameter for connection of plural indoor units with 1 branch shall be referred to the Installation Manual.
  - 10.This unit is not designed for outside installations.
  - 11.When blazing the pipes, be sure to blaze, after covering a wet cloth to the insulation pipes of the units in order to prevent it from burning and shrinking by heat.
  - 12.The ambient relative humidity of the BC controller needs to be kept below 80%.
  - 13.R32 is flammable, and certain restrictions apply to the installation of units.  
When installing new units, moving the existing units, or changing the layout of the room, ensure that installation restrictions are observed.  
For detail, refer to the section in the DATA BOOK on installation restrictions.
  - 14.Indoor unit capacity connectable to 1 branch is changed depending on the indoor unit type and connection method. Please refer to the Installation Manual for more information.
  - 15.For the refrigerant pipe size, refer to Installation Manual of outdoor units/heat source units.
  - 16.The sound pressure level measured by the conventional method in JIS for reference purpose.



Model			<b>CMB-M1012V-JA1 (-TR)</b>				
Number of branch			12				
Power source			1-phase 220-230-240 V				
Power input	Cooling	kW	50Hz		60Hz		
			0.186/0.211/0.236		0.150/0.168/0.186		
Current input	Heating	kW	50Hz		60Hz		
			0.090/0.102/0.114		0.072/0.081/0.090		
External finish	Cooling	A	50Hz		60Hz		
			0.85/0.92/0.99		0.69/0.74/0.78		
Connectable outdoor/heat source unit capacity	Heating	A	50Hz		60Hz		
			0.42/0.44/0.48		0.33/0.36/0.38		
External finish			Galvanized steel plate (Lower part drain pan: Pre-coated galvanized sheets + powder coating)				
Indoor unit capacity connectable to 1 branch			*14 P200 to P900/M200 to M300 Model P/M80 or smaller (Use optional joint pipe combining 2 branches when the total unit capacity exceeds P/M81.)				
External dimension H x W x D			mm 252 x 1,135 x 622 in. 9-15/16 x 44-11/16 x 24-1/2				
Refrigerant piping diameter	To outdoor/heat source unit	mm (in.) O.D.	Connectable unit capacity		High press. pipe	Low press. pipe	
			P200/M200	15.88 (5/8) Brazed	19.05 (3/4) Brazed		
		*15	mm (in.) O.D.	P250/P300	19.05 (3/4) Brazed		
				P350	19.05 (3/4) Brazed or 22.2 (7/8) Brazed		
		*15	mm (in.) O.D.	P400 to P500	22.2 (7/8) Brazed		
				P550	22.2 (7/8) Brazed or 28.58 (1-1/8) Brazed		
		*15	mm (in.) O.D.	P600	22.2 (7/8) Brazed or 28.58 (1-1/8) Brazed		
				P650	28.58 (1-1/8) Brazed		
				P700 to P800	28.58 (1-1/8) Brazed		
				P850 to P900	28.58 (1-1/8) Brazed		
	To indoor unit	mm (in.) O.D.	Liquid pipe		Gas pipe		
			Indoor unit Model 50 or smaller 6.35 (1/4) Brazed bigger than 50 9.52 (3/8) Brazed		Indoor unit Model 50 or smaller 12.7 (1/2) Brazed bigger than 50 15.88 (5/8) Brazed (19.05 (3/4), 22.2 (7/8) with optional joint pipe used.)		
		To other BC controller	mm (in.) O.D.	Total down-stream Indoor unit capacity	High press. pipe	Liquid pipe	Low press. pipe
				to P200/M200	15.88 (5/8) Brazed	9.52 (3/8) Brazed	19.05 (3/4) Brazed
			mm (in.) O.D.	P201 to P300	19.05 (3/4) Brazed	9.52 (3/8) Brazed	22.2 (7/8) Brazed
				P301 to P350	19.05 (3/4) Brazed	12.7 (1/2) Brazed	28.58 (1-1/8) Brazed
			mm (in.) O.D.	P351 to P400	22.2 (7/8) Brazed	12.7 (1/2) Brazed	28.58 (1-1/8) Brazed
				P401 to P600	22.2 (7/8) Brazed	15.88 (5/8) Brazed	28.58 (1-1/8) Brazed
			mm (in.) O.D.	P601 to P650	28.58 (1-1/8) Brazed	15.88 (5/8) Brazed	28.58 (1-1/8) Brazed
				P651 to P800	28.58 (1-1/8) Brazed	19.05 (3/4) Brazed	34.93 (1-3/8) Brazed
mm (in.) O.D.	P801 to P1000		28.58 (1-1/8) Brazed	19.05 (3/4) Brazed	41.28 (1-5/8) Brazed		
	P1001 or above		34.93 (1-3/8) Brazed	19.05 (3/4) Brazed	41.28 (1-5/8) Brazed		
mm (in.) O.D.	M201 to M300	15.88 (5/8) Brazed	9.52 (3/8) Brazed	22.2 (7/8) Brazed			
	M301 to M350	15.88 (5/8) Brazed	12.7 (1/2) Brazed	28.58 (1-1/8) Brazed			
	M351 to M400	19.05 (3/4) Brazed	12.7 (1/2) Brazed	28.58 (1-1/8) Brazed			
	M401 to M450	19.05 (3/4) Brazed	15.88 (5/8) Brazed	28.58 (1-1/8) Brazed			
Field drain pipe size			mm (in.) O.D. 32 (1-1/4)				
Net weight			kg (lbs) 60 (133)				
Sound power level (measured in anechoic room)	Rated operation	dB <A>	68				
	Defrost	dB <A>	74				
Sound pressure level (measured in anechoic room)	Rated operation	dB <A>	50				
	*16 Defrost	dB <A>	56				
Accessories			Drain Connection pipe, Washer, Tie band				
Remarks							

- Notes:
- 1.Installation/foundation work, electrical connection work, insulation work, power source switch, and other items shall be referred to the Installation Manual.
  - 2.The equipment is for R410A or R32 refrigerant.
  - 3.Install this product in a location where noise (refrigerant noise) emitted by the unit will not disturb the neighbors. (For use in quiet environments with low background noise, position the BC CONTROLLER at least 5m away from any indoor units.)
  - 4.Sound pressure/power level differs depending on the connected outdoor/heat source unit capacity or operation condition. The sound pressure/power level at the rated operation is the value of the cooling mode.
  - 5.The sound pressure/power level values were obtained in an anechoic room. Actual sound pressure level is usually greater than that measured in anechoic room due to ambient noise and deflection sound.
  - 6.The sound pressure level values were obtained at the location below 1.5m from the unit.
  - 7.The solenoid valve switching sound is 56 dB (sound pressure level) regardless of the unit model.
  - 8.Indoor units P/M100, P/M125, P/M140 can be connected to 1 branch. (In this case, cooling capacity decrease a little.)
  - 9.Refrigerant piping diameter for connection of plural indoor units with 1 branch shall be referred to the Installation Manual.
  - 10.This unit is not designed for outside installations.
  - 11.When blazing the pipes, be sure to blaze, after covering a wet cloth to the insulation pipes of the units in order to prevent it from burning and shrinking by heat.
  - 12.The ambient relative humidity of the BC controller needs to be kept below 80%.
  - 13.R32 is flammable, and certain restrictions apply to the installation of units. When installing new units, moving the existing units, or changing the layout of the room, ensure that installation restrictions are observed. For detail, refer to the section in the DATA BOOK on installation restrictions.
  - 14.Indoor unit capacity connectable to 1 branch is changed depending on the indoor unit type and connection method. Please refer to the Installation Manual for more information.
  - 15.For the refrigerant pipe size, refer to Installation Manual of outdoor units/heat source units.
  - 16.The sound pressure level measured by the conventional method in JIS for reference purpose.

# 1. SPECIFICATIONS

Model		<b>CMB-M1016V-JA1 (-TR)</b>					
Number of branch		16					
Power source		1-phase 220-230-240 V					
		50Hz		60Hz			
Power input	Cooling	kW	0.246/0.279/0.312	0.198/0.222/0.246			
	Heating	kW	0.119/0.135/0.151	0.096/0.108/0.119			
Current input	Cooling	A	1.12/1.22/1.30	0.90/0.97/1.03			
	Heating	A	0.55/0.59/0.63	0.44/0.47/0.50			
External finish		Galvanized steel plate (Lower part drain pan: Pre-coated galvanized sheets + powder coating)					
Connectable outdoor/heat source unit capacity		P200 to P900/M200 to M300					
Indoor unit capacity connectable to 1 branch		*14 Model P/M80 or smaller (Use optional joint pipe combining 2 branches when the total unit capacity exceeds P/M81.)					
External dimension H x W x D		mm	252 x 1,135 x 622				
		in.	9-15/16 x 44-11/16 x 24-1/2				
Refrigerant piping diameter	To outdoor/heat source unit	Connectable unit capacity		High press. pipe	Low press. pipe		
		mm (in.) O.D.	P200/M200	15.88 (5/8) Brazed	19.05 (3/4) Brazed		
		mm (in.) O.D.	P250/P300	19.05 (3/4) Brazed	22.2 (7/8) Brazed		
		*15	mm (in.) O.D.	P350	19.05 (3/4) Brazed or 22.2 (7/8) Brazed	28.58 (1-1/8) Brazed	
			mm (in.) O.D.	P400 to P500	22.2 (7/8) Brazed	28.58 (1-1/8) Brazed	
			mm (in.) O.D.	P550	22.2 (7/8) Brazed or 28.58 (1-1/8) Brazed	28.58 (1-1/8) Brazed	
		*15	mm (in.) O.D.	P600	22.2 (7/8) Brazed or 28.58 (1-1/8) Brazed	28.58 (1-1/8) Brazed or 34.93 (1-3/8) Brazed	
			mm (in.) O.D.	P650	28.58 (1-1/8) Brazed	28.58 (1-1/8) Brazed	
			mm (in.) O.D.	P700 to P800	28.58 (1-1/8) Brazed	34.93 (1-3/8) Brazed	
		mm (in.) O.D.	P850 to P900	28.58 (1-1/8) Brazed	41.28 (1-5/8) Brazed		
		mm (in.) O.D.	M250/M300	15.88 (5/8) Brazed	22.2 (7/8) Brazed		
		To indoor unit	mm (in.) O.D.	Liquid pipe		Gas pipe	
				Indoor unit Model 50 or smaller 6.35 (1/4) Brazed bigger than 50 9.52 (3/8) Brazed		Indoor unit Model 50 or smaller 12.7 (1/2) Brazed bigger than 50 15.88 (5/8) Brazed (19.05 (3/4), 22.2 (7/8) with optional joint pipe used.)	
		To other BC controller	Total down-stream Indoor unit capacity		High press. pipe	Liquid pipe	Low press. pipe
			mm (in.) O.D.	to P200/M200	15.88 (5/8) Brazed	9.52 (3/8) Brazed	19.05 (3/4) Brazed
	mm (in.) O.D.		P201 to P300	19.05 (3/4) Brazed	9.52 (3/8) Brazed	22.2 (7/8) Brazed	
	mm (in.) O.D.		P301 to P350	19.05 (3/4) Brazed	12.7 (1/2) Brazed	28.58 (1-1/8) Brazed	
	mm (in.) O.D.		P351 to P400	22.2 (7/8) Brazed	12.7 (1/2) Brazed	28.58 (1-1/8) Brazed	
	mm (in.) O.D.		P401 to P600	22.2 (7/8) Brazed	15.88 (5/8) Brazed	28.58 (1-1/8) Brazed	
	mm (in.) O.D.		P601 to P650	28.58 (1-1/8) Brazed	15.88 (5/8) Brazed	28.58 (1-1/8) Brazed	
	mm (in.) O.D.		P651 to P800	28.58 (1-1/8) Brazed	19.05 (3/4) Brazed	34.93 (1-3/8) Brazed	
	mm (in.) O.D.		P801 to P1000	28.58 (1-1/8) Brazed	19.05 (3/4) Brazed	41.28 (1-5/8) Brazed	
	mm (in.) O.D.		P1001 or above	34.93 (1-3/8) Brazed	19.05 (3/4) Brazed	41.28 (1-5/8) Brazed	
	mm (in.) O.D.		M201 to M300	15.88 (5/8) Brazed	9.52 (3/8) Brazed	22.2 (7/8) Brazed	
	mm (in.) O.D.		M301 to M350	15.88 (5/8) Brazed	12.7 (1/2) Brazed	28.58 (1-1/8) Brazed	
	mm (in.) O.D.	M351 to M400	19.05 (3/4) Brazed	12.7 (1/2) Brazed	28.58 (1-1/8) Brazed		
	mm (in.) O.D.	M401 to M450	19.05 (3/4) Brazed	15.88 (5/8) Brazed	28.58 (1-1/8) Brazed		
Field drain pipe size		mm (in.)	O.D. 32 (1-1/4)				
Net weight		kg (lbs)	68 (150)				
Sound power level (measured in anechoic room)	Rated operation	dB <A>	68				
	Defrost	dB <A>	74				
Sound pressure level (measured in anechoic room)	Rated operation	dB <A>	50				
	*16 Defrost	dB <A>	56				
Accessories		Drain Connection pipe, Washer, Tie band					
Remarks							

**Notes:**

- 1.Installation/foundation work, electrical connection work, insulation work, power source switch, and other items shall be referred to the Installation Manual.
- 2.The equipment is for R410A or R32 refrigerant.
- 3.Install this product in a location where noise (refrigerant noise) emitted by the unit will not disturb the neighbors. (For use in quiet environments with low background noise, position the BC CONTROLLER at least 5m away from any indoor units.)
- 4.Sound pressure/power level differs depending on the connected outdoor/heat source unit capacity or operation condition. The sound pressure/power level at the rated operation is the value of the cooling mode.
- 5.The sound pressure/power level values were obtained in an anechoic room. Actual sound pressure level is usually greater than that measured in anechoic room due to ambient noise and deflection sound.
- 6.The sound pressure level values were obtained at the location below 1.5m from the unit.
- 7.The solenoid valve switching sound is 56 dB (sound pressure level) regardless of the unit model.
- 8.Indoor units P/M100, P/M125, P/M140 can be connected to 1 branch. (In this case, cooling capacity decrease a little.)
- 9.Refrigerant piping diameter for connection of plural indoor units with 1 branch shall be referred to the Installation Manual.
- 10.This unit is not designed for outside installations.
- 11.When blazing the pipes, be sure to blaze, after covering a wet cloth to the insulation pipes of the units in order to prevent it from burning and shrinking by heat.
- 12.The ambient relative humidity of the BC controller needs to be kept below 80%.
- 13.R32 is flammable, and certain restrictions apply to the installation of units. When installing new units, moving the existing units, or changing the layout of the room, ensure that installation restrictions are observed. For detail, refer to the section in the DATA BOOK on installation restrictions.
- 14.Indoor unit capacity connectable to 1 branch is changed depending on the indoor unit type and connection method. Please refer to the Installation Manual for more information.
- 15.For the refrigerant pipe size, refer to Installation Manual of outdoor units/heat source units.
- 16.The sound pressure level measured by the conventional method in JIS for reference purpose.

# 1. SPECIFICATIONS

BC controller

BC controller

Model			<b>CMB-P1016V-KA1 (-TR)</b>			
Number of branch			16			
Power source			1-phase 220-230-240 V			
			50Hz	60Hz		
Power input	Cooling	kW	0.246/0.279/0.312		0.198/0.222/0.246	
	Heating	kW	0.119/0.135/0.151		0.096/0.108/0.119	
Current input	Cooling	A	1.12/1.22/1.30		0.90/0.97/1.03	
	Heating	A	0.55/0.59/0.63		0.44/0.47/0.50	
External finish			Galvanized steel plate (Lower part drain pan: Pre-coated galvanized sheets + powder coating)			
Connectable outdoor/heat source unit capacity			P200 to P1100			
Indoor unit capacity connectable to 1 branch			*13 Model P80 or smaller (Use optional joint pipe combining 2 branches when the total unit capacity exceeds P81.)			
External dimension H x W x D		mm	250 x 1,135 x 622			
		in.	9-7/8 x 44-11/16 x 24-1/2			
Refrigerant piping diameter	To outdoor/heat source unit		Connectable unit capacity	High press. pipe	Low press. Pipe	
	*14	mm (in.) O.D.	P200	15.88 (5/8) Brazed	19.05 (3/4) Brazed	
		mm (in.) O.D.	P250/P300	19.05 (3/4) Brazed	22.2 (7/8) Brazed	
		mm (in.) O.D.	P350	19.05 (3/4) Brazed or 22.2 (7/8) Brazed	28.58 (1-1/8) Brazed	
		mm (in.) O.D.	P400 to P500	22.2 (7/8) Brazed	28.58 (1-1/8) Brazed	
		mm (in.) O.D.	P550	22.2 (7/8) Brazed or 28.58 (1-1/8) Brazed	28.58 (1-1/8) Brazed	
		mm (in.) O.D.	P600	22.2 (7/8) Brazed or 28.58 (1-1/8) Brazed	28.58 (1-1/8) Brazed or 34.93 (1-3/8) Brazed	
		mm (in.) O.D.	P650	28.58 (1-1/8) Brazed	28.58 (1-1/8) Brazed	
		mm (in.) O.D.	P700 to P800	28.58 (1-1/8) Brazed	34.93 (1-3/8) Brazed	
		mm (in.) O.D.	P850 to P1000	28.58 (1-1/8) Brazed	41.28 (1-5/8) Brazed	
		mm (in.) O.D.	P1050 to P1100	34.93 (1-3/8) Brazed	41.28 (1-5/8) Brazed	
	To indoor unit		Liquid pipe		Gas pipe	
		mm (in.) O.D.	Indoor unit Model 50 or smaller 6.35 (1/4) Brazed bigger than 50 9.52 (3/8) Brazed	Indoor unit Model 50 or smaller 12.7 (1/2) Brazed bigger than 50 15.88 (5/8) Brazed (19.05 (3/4), 22.2 (7/8) with optional joint pipe used.)		
	To other BC controller		Total down-stream Indoor unit capacity	High press. pipe	Liquid pipe	Low press. pipe
		mm (in.) O.D.	to P200	15.88 (5/8) Brazed	9.52 (3/8) Brazed	19.05 (3/4) Brazed
		mm (in.) O.D.	P201 to P300	19.05 (3/4) Brazed	9.52 (3/8) Brazed	22.2 (7/8) Brazed
		mm (in.) O.D.	P301 to P350	19.05 (3/4) Brazed	12.7 (1/2) Brazed	28.58 (1-1/8) Brazed
		mm (in.) O.D.	P351 to P400	22.2 (7/8) Brazed	12.7 (1/2) Brazed	28.58 (1-1/8) Brazed
		mm (in.) O.D.	P401 to P600	22.2 (7/8) Brazed	15.88 (5/8) Brazed	28.58 (1-1/8) Brazed
		mm (in.) O.D.	P601 to P650	28.58 (1-1/8) Brazed	15.88 (5/8) Brazed	28.58 (1-1/8) Brazed
	mm (in.) O.D.	P651 to P800	28.58 (1-1/8) Brazed	19.05 (3/4) Brazed	34.93 (1-3/8) Brazed	
	mm (in.) O.D.	P801 to P1000	28.58 (1-1/8) Brazed	19.05 (3/4) Brazed	41.28 (1-5/8) Brazed	
	mm (in.) O.D.	P1001 or above	34.93 (1-3/8) Brazed	19.05 (3/4) Brazed	41.28 (1-5/8) Brazed	
Field drain pipe size		mm (in.)	O.D. 32 (1-1/4)			
Net weight		kg (lbs)	69 (153)			
Sound power level (measured in anechoic room)	Rated operation	dB <A>	66			
	Defrost	dB <A>	73			
Sound pressure level (measured in anechoic room)	Rated operation	dB <A>	48			
	*15 Defrost	dB <A>	55			
Accessories		Drain Connection pipe, Washer, Tie band				
Remarks						

- Notes:
1. Installation/foundation work, electrical connection work, insulation work, power source switch, and other items shall be referred to the Installation Manual.
  2. The equipment is for R410A refrigerant.
  3. Install this product in a location where noise (refrigerant noise) emitted by the unit will not disturb the neighbors. (For use in quiet environments with low background noise, position the BC CONTROLLER at least 5m away from any indoor units.)
  4. Sound pressure/power level differs depending on the connected outdoor/heat source unit capacity or operation condition. The sound pressure/power level at the rated operation is the value of the cooling mode.
  5. The sound pressure/power level values were obtained in an anechoic room. Actual sound pressure level is usually greater than that measured in anechoic room due to ambient noise and deflection sound.
  6. The sound pressure level values were obtained at the location below 1.5m from the unit.
  7. The solenoid valve switching sound is 56 dB (sound pressure level) regardless of the unit model.
  8. Indoor units P100, P125, P140 can be connected to 1 branch. (In this case, cooling capacity decrease a little.)
  9. Refrigerant piping diameter for connection of plural indoor units with 1 branch shall be referred to the Installation Manual.
  10. This unit is not designed for outside installations.
  11. When brazing the pipes, be sure to blaze, after covering a wet cloth to the insulation pipes of the units in order to prevent it from burning and shrinking by heat.
  12. The ambient relative humidity of the BC controller needs to be kept below 80%.
  13. Indoor unit capacity connectable to 1 branch is changed depending on the indoor unit type and connection method. Please refer to the Installation Manual for more information.
  14. For the refrigerant pipe size, refer to Installation Manual of outdoor units/heat source units.
  15. The sound pressure level measured by the conventional method in JIS for reference purpose.

# 1. SPECIFICATIONS

Model			<b>CMB-M104V-KB1 (-TR)</b>				
Number of branch			4				
Power source			1-phase 220-230-240 V				
			50Hz	60Hz			
Power input	Cooling	kW	0.060/0.068/0.076		0.048/0.054/0.060		
	Heating	kW	0.030/0.034/0.038		0.024/0.027/0.030		
Current input	Cooling	A	0.28/0.30/0.32		0.22/0.24/0.25		
	Heating	A	0.14/0.15/0.16		0.11/0.12/0.13		
External finish			Galvanized steel plate (Lower part drain pan: Pre-coated galvanized sheets + powder coating)				
Connectable Main BC controller			CMB-M108/1012/1016V-JA1 (-TR), CMB-P1016V-KA1 (-TR)				
The maximum number of connectable Sub BC controllers			11				
The maximum connectable capacity of indoor units			P/M350 for each				
External dimension H x W x D		mm	250 x 596 x 476				
		in.	9-7/8 x 23-1/2 x 18-3/4				
Refrigerant piping diameter	To outdoor/heat source unit		Connectable unit capacity	High press. pipe	Low press. pipe		
			mm (in.) O.D.	-	-		
	To indoor unit		Liquid pipe		Gas pipe		
			mm (in.) O.D.	Indoor unit Model 50 or smaller 6.35 (1/4) Brazen bigger than 50 9.52 (3/8) Brazen	Indoor unit Model 50 or smaller 12.7 (1/2) Brazen bigger than 50 15.88 (5/8) Brazen (19.05 (3/4), 22.2 (7/8) with optional joint pipe used.)		
	To other BC controller		Total down-stream Indoor unit capacity	High press. pipe	Liquid pipe	Low press. pipe	
			mm (in.) O.D.	to P200/M200	15.88 (5/8) Brazen	9.52 (3/8) Brazen	19.05 (3/4) Brazen
			mm (in.) O.D.	P201 to P300	19.05 (3/4) Brazen	9.52 (3/8) Brazen	22.2 (7/8) Brazen
			mm (in.) O.D.	P301 to P350	19.05 (3/4) Brazen	12.7 (1/2) Brazen	28.58 (1-1/8) Brazen
			mm (in.) O.D.	P351 to P400	22.2 (7/8) Brazen	12.7 (1/2) Brazen	28.58 (1-1/8) Brazen
			mm (in.) O.D.	P401 to P600	22.2 (7/8) Brazen	15.88 (5/8) Brazen	28.58 (1-1/8) Brazen
			mm (in.) O.D.	P601 to P650	28.58 (1-1/8) Brazen	15.88 (5/8) Brazen	28.58 (1-1/8) Brazen
			mm (in.) O.D.	P651 to P800	28.58 (1-1/8) Brazen	19.05 (3/4) Brazen	34.93 (1-3/8) Brazen
			mm (in.) O.D.	P801 to P1000	28.58 (1-1/8) Brazen	19.05 (3/4) Brazen	41.28 (1-5/8) Brazen
			mm (in.) O.D.	P1001 or above	34.93 (1-3/8) Brazen	19.05 (3/4) Brazen	41.28 (1-5/8) Brazen
			mm (in.) O.D.	M201 to M300	15.88 (5/8) Brazen	9.52 (3/8) Brazen	22.2 (7/8) Brazen
		mm (in.) O.D.	M301 to M350	15.88 (5/8) Brazen	12.7 (1/2) Brazen	28.58 (1-1/8) Brazen	
		mm (in.) O.D.	M351 to M400	19.05 (3/4) Brazen	12.7 (1/2) Brazen	28.58 (1-1/8) Brazen	
		mm (in.) O.D.	M401 to M450	19.05 (3/4) Brazen	15.88 (5/8) Brazen	28.58 (1-1/8) Brazen	
Field drain pipe size		mm (in.)	O.D. 32 (1-1/4)				
Net weight		kg (lbs)	23 (51)				
Sound power level (measured in anechoic room)	Rated operation	dB <A>	59				
	Defrost	dB <A>	71				
Sound pressure level (measured in anechoic room)	Rated operation	dB <A>	40				
	*15 Defrost	dB <A>	53				
Accessories			Drain Connection pipe, Washer, Tie band				
Remarks							

- Notes:
- 1.Installation/foundation work, electrical connection work, insulation work, power source switch, and other items shall be referred to the Installation Manual.
  - 2.The equipment is for R410A or R32 refrigerant.
  - 3.Install this product in a location where noise (refrigerant noise) emitted by the unit will not disturb the neighbors.  
(For use in quiet environments with low background noise, position the BC CONTROLLER at least 5m away from any indoor units.)
  - 4.Sound pressure/power level differs depending on the connected outdoor/heat source unit capacity or operation condition.  
The sound pressure/power level at the rated operation is the value of the cooling mode.
  - 5.The sound pressure/power level values were obtained in an anechoic room. Actual sound pressure level is usually greater than that measured in anechoic room due to ambient noise and deflection sound.
  - 6.The sound pressure level values were obtained at the location below 1.5m from the unit.
  - 7.The solenoid valve switching sound is 56 dB (sound pressure level) regardless of the unit model.
  - 8.Indoor units P/M100, P/M125, P/M140 can be connected to 1 branch. (In this case, cooling capacity decrease a little.)
  - 9.Refrigerant piping diameter for connection of plural indoor units with 1 branch shall be referred to the Installation Manual.
  - 10.This unit is not designed for outside installations.
  - 11.When blazing the pipes, be sure to blaze, after covering a wet cloth to the insulation pipes of the units in order to prevent it from burning and shrinking by heat.
  - 12.Can't use singleness. (MAIN BC CONTROLLER is necessary)
  - 13.The ambient relative humidity of the BC controller needs to be kept below 80%.
  - 14.R32 is flammable, and certain restrictions apply to the installation of units.  
When installing new units, moving the existing units, or changing the layout of the room, ensure that installation restrictions are observed.  
For detail, refer to the section in the DATA BOOK on installation restrictions.
  - 15.The sound pressure level measured by the conventional method in JIS for reference purpose.

# 1. SPECIFICATIONS

BC controller

BC controller

Model			CMB-M108V-KB1 (-TR)				
Number of branch			8				
Power source			1-phase 220-230-240 V				
			50Hz	60Hz			
Power input	Cooling	kW	0.119/0.135/0.151		0.096/0.108/0.119		
	Heating	kW	0.060/0.068/0.076		0.048/0.054/0.060		
Current input	Cooling	A	0.55/0.59/0.63		0.44/0.47/0.50		
	Heating	A	0.28/0.30/0.32		0.22/0.24/0.25		
External finish			Galvanized steel plate (Lower part drain pan: Pre-coated galvanized sheets + powder coating)				
Connectable Main BC controller			CMB-M108/1012/1016V-JA1 (-TR), CMB-P1016V-KA1 (-TR)				
The maximum number of connectable Sub BC controllers			11				
The maximum connectable capacity of indoor units			P/M350 for each				
External dimension H x W x D		mm	250 x 596 x 476				
		in.	9-7/8 x 23-1/2 x 18-3/4				
Refrigerant piping diameter	To outdoor/heat source unit		Connectable unit capacity	High press. pipe	Low press. pipe		
			mm (in.) O.D.	-	-		
	To indoor unit		Liquid pipe		Gas pipe		
			mm (in.) O.D.	Indoor unit Model 50 or smaller 6.35 (1/4) Brazed bigger than 50 9.52 (3/8) Brazed	Indoor unit Model 50 or smaller 12.7 (1/2) Brazed bigger than 50 15.88 (5/8) Brazed (19.05 (3/4), 22.2 (7/8) with optional joint pipe used.)		
	To other BC controller		Total down-stream Indoor unit capacity	High press. pipe	Liquid pipe	Low press. pipe	
			mm (in.) O.D.	to P200/M200	15.88 (5/8) Brazed	9.52 (3/8) Brazed	19.05 (3/4) Brazed
			mm (in.) O.D.	P201 to P300	19.05 (3/4) Brazed	9.52 (3/8) Brazed	22.2 (7/8) Brazed
			mm (in.) O.D.	P301 to P350	19.05 (3/4) Brazed	12.7 (1/2) Brazed	28.58 (1-1/8) Brazed
			mm (in.) O.D.	P351 to P400	22.2 (7/8) Brazed	12.7 (1/2) Brazed	28.58 (1-1/8) Brazed
			mm (in.) O.D.	P401 to P600	22.2 (7/8) Brazed	15.88 (5/8) Brazed	28.58 (1-1/8) Brazed
			mm (in.) O.D.	P601 to P650	28.58 (1-1/8) Brazed	15.88 (5/8) Brazed	28.58 (1-1/8) Brazed
			mm (in.) O.D.	P651 to P800	28.58 (1-1/8) Brazed	19.05 (3/4) Brazed	34.93 (1-3/8) Brazed
			mm (in.) O.D.	P801 to P1000	28.58 (1-1/8) Brazed	19.05 (3/4) Brazed	41.28 (1-5/8) Brazed
			mm (in.) O.D.	P1001 or above	34.93 (1-3/8) Brazed	19.05 (3/4) Brazed	41.28 (1-5/8) Brazed
			mm (in.) O.D.	M201 to M300	15.88 (5/8) Brazed	9.52 (3/8) Brazed	22.2 (7/8) Brazed
		mm (in.) O.D.	M301 to M350	15.88 (5/8) Brazed	12.7 (1/2) Brazed	28.58 (1-1/8) Brazed	
		mm (in.) O.D.	M351 to M400	19.05 (3/4) Brazed	12.7 (1/2) Brazed	28.58 (1-1/8) Brazed	
		mm (in.) O.D.	M401 to M450	19.05 (3/4) Brazed	15.88 (5/8) Brazed	28.58 (1-1/8) Brazed	
Field drain pipe size		mm (in.)	O.D. 32 (1-1/4)				
Net weight		kg (lbs)	31 (69)				
Sound power level (measured in anechoic room)	Rated operation	dB <A>	59				
	Defrost	dB <A>	71				
Sound pressure level (measured in anechoic room)	Rated operation	dB <A>	40				
	*15 Defrost	dB <A>	53				
Accessories			Drain Connection pipe, Washer, Tie band				
Remarks							

**Notes:**

1. Installation/foundation work, electrical connection work, insulation work, power source switch, and other items shall be referred to the Installation Manual.
2. The equipment is for R410A or R32 refrigerant.
3. Install this product in a location where noise (refrigerant noise) emitted by the unit will not disturb the neighbors. (For use in quiet environments with low background noise, position the BC CONTROLLER at least 5m away from any indoor units.)
4. Sound pressure/power level differs depending on the connected outdoor/heat source unit capacity or operation condition. The sound pressure/power level at the rated operation is the value of the cooling mode.
5. The sound pressure/power level values were obtained in an anechoic room. Actual sound pressure level is usually greater than that measured in anechoic room due to ambient noise and deflection sound.
6. The sound pressure level values were obtained at the location below 1.5m from the unit.
7. The solenoid valve switching sound is 56 dB (sound pressure level) regardless of the unit model.
8. Indoor units P/M100, P/M125, P/M140 can be connected to 1 branch. (In this case, cooling capacity decrease a little.)
9. Refrigerant piping diameter for connection of plural indoor units with 1 branch shall be referred to the Installation Manual.
10. This unit is not designed for outside installations.
11. When blazing the pipes, be sure to blaze, after covering a wet cloth to the insulation pipes of the units in order to prevent it from burning and shrinking by heat.
12. Can't use singleness. (MAIN BC CONTROLLER is necessary)
13. The ambient relative humidity of the BC controller needs to be kept below 80%.
14. R32 is flammable, and certain restrictions apply to the installation of units.  
When installing new units, moving the existing units, or changing the layout of the room, ensure that installation restrictions are observed.  
For detail, refer to the section in the DATA BOOK on installation restrictions.
15. The sound pressure level measured by the conventional method in JIS for reference purpose.

CMB-M104, 106, 108V-J1(-TR)

Unit: mm

- <Accessories>
- Drain hose I.D.32 ..... 1pc.
  - Tie band ..... 3pcs.
  - Square washer (with cushion) ..... 4pcs.
  - Square washer ..... 4pcs.

- Note 1. Suspension bolt(φ10) and nut(M10) prepare in the field.  
 2. Take notice of service space as shown.  
 (Please give attention not to occupy service space by letting ducts and pipes through.)  
 3. Install this product in a location where noise (refrigerant noise) emitted by the unit will not disturb the neighbors.  
 (For use in quiet environments with low background noise, position the BC CONTROLLER at least 5m away from any indoor units.)  
 4. Refer to the Installation Manual for refrigerant piping diameter size when connecting plural indoor units with 1 branch.  
 5. Refer to the Table-1 for connection pipe of outdoor unit diameter size.  
 6. Refer to the Installation Manual for insulation of connection pipe and drain piping.  
 7. Do not place the BC controller directly on the floor.

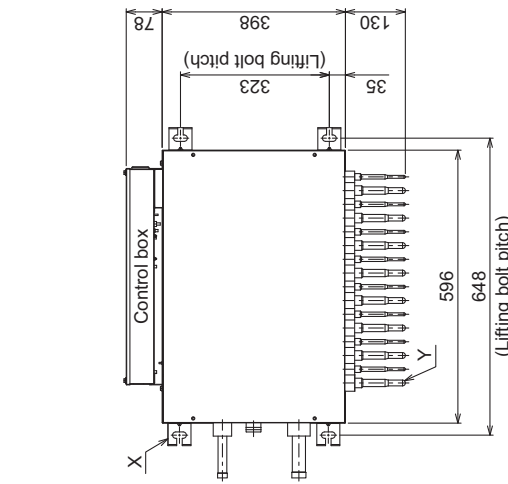
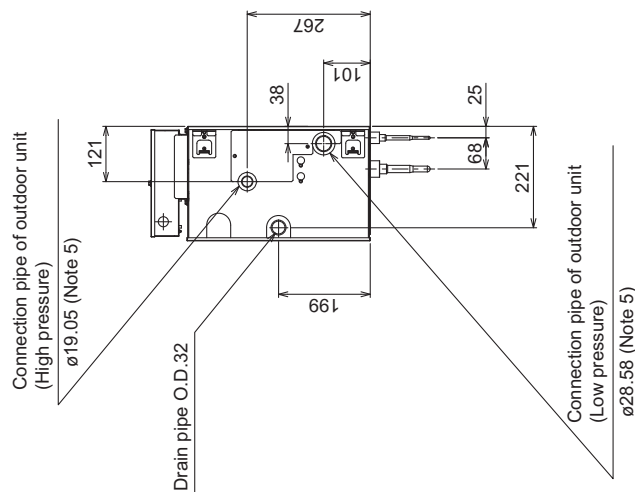
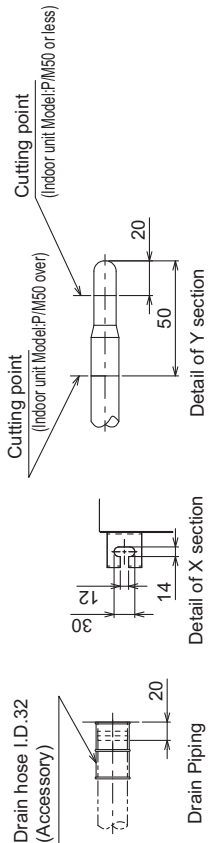
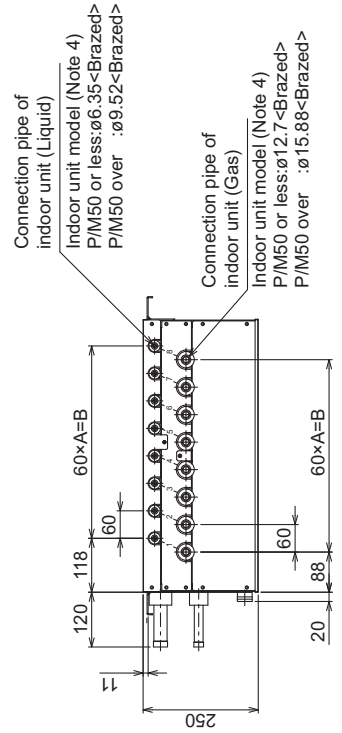
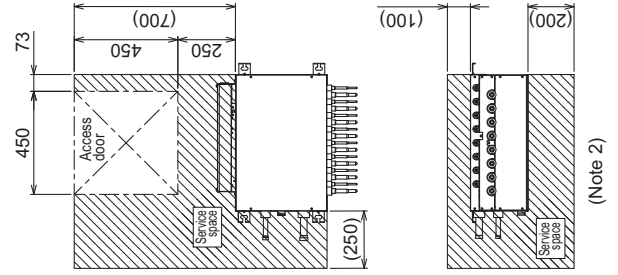

Table-1. To outdoor/heat source unit (Note.5)

Connectable unit capacity	High press. Pipe	Low press. Pipe
P200	ø15.88	ø19.05
P250, P300	ø19.05	ø22.2
P350	ø19.05 or ø22.2	ø28.58
M200	ø15.88	ø19.05
M250, M300	ø15.88	ø22.2

\*For the refrigerant pipe size, refer to Installation Manual of outdoor units/heat source units.



	A	B
CMB-M104V-J1(-TR)	3	180
CMB-M106V-J1(-TR)	5	300
CMB-M108V-J1(-TR)	7	420

CMB-M1012, 1016V-J1(-TR)

- <Accessories>  
 · Drain hose I.D.32 ..... 1pc.  
 · Tie band ..... 3pcs.  
 · Square washer (with cushion) ..... 4pcs.  
 · Square washer ..... 4pcs.

- Note 1. Suspension bolt(φ10) and nut(M10) prepare in the field.  
 2. Take notice of service space as shown.  
 (Please give attention not to occupy service space by letting ducts and pipes through.)  
 3. Install this product in a location where noise (refrigerant noise) emitted by the unit will not disturb the neighbors.  
 (For use in quiet environments with low background noise, position the BC CONTROLLER at least 5m away from any indoor units.)  
 4. Refer to the Installation Manual for refrigerant piping diameter size when connecting plural indoor units with 1 branch.  
 5. Refer to the Table-1 for connection pipe of outdoor unit diameter size.  
 6. Refer to the Installation Manual for insulation of connection pipe and drain piping.  
 7. Do not place the BC controller directly on the floor.

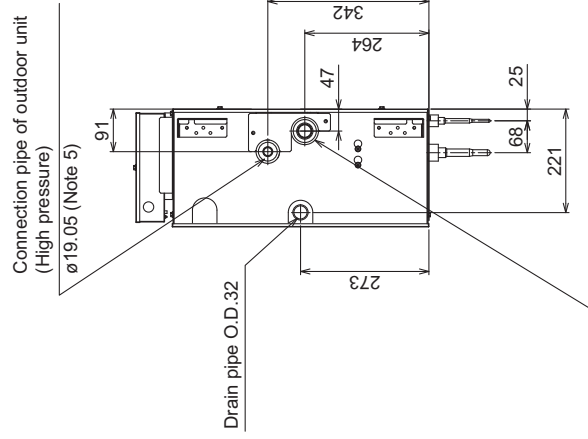
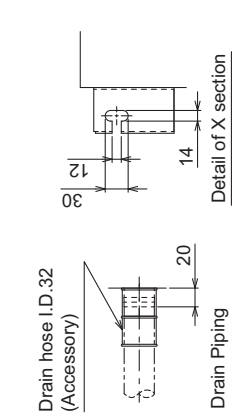
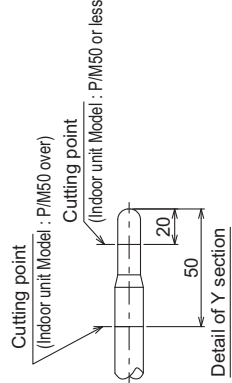
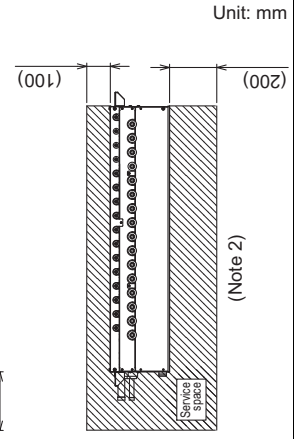
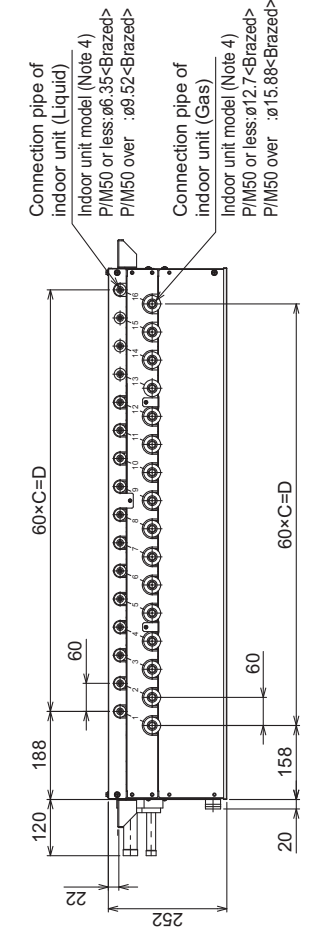
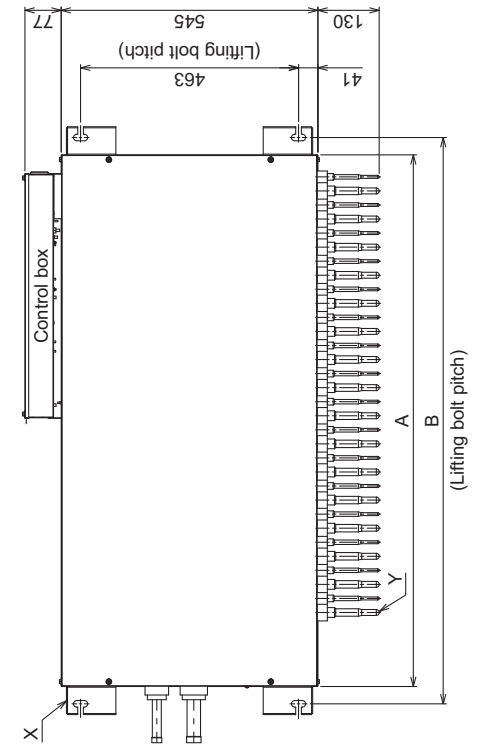

Table-1. To outdoor/heat source unit (Note.5)

Connectable unit capacity	High press. Pipe	Low press. Pipe
P200	φ15.88	φ19.05
P250, P300	φ22.2	φ22.2
P350	φ19.05 or φ22.2	φ28.58
M200	φ15.88	φ19.05
M250, M300	φ15.88	φ22.2

\*For the refrigerant pipe size, refer to Installation Manual of outdoor units/heat source units.



	A	B	C	D	E
CMB-M1012V-J1(-TR)	911	983	11	660	231
CMB-M1016V-J1(-TR)	1135	1207	15	900	343

CMB-M108, 1012, 1016V-JA1(-TR)

Unit: mm

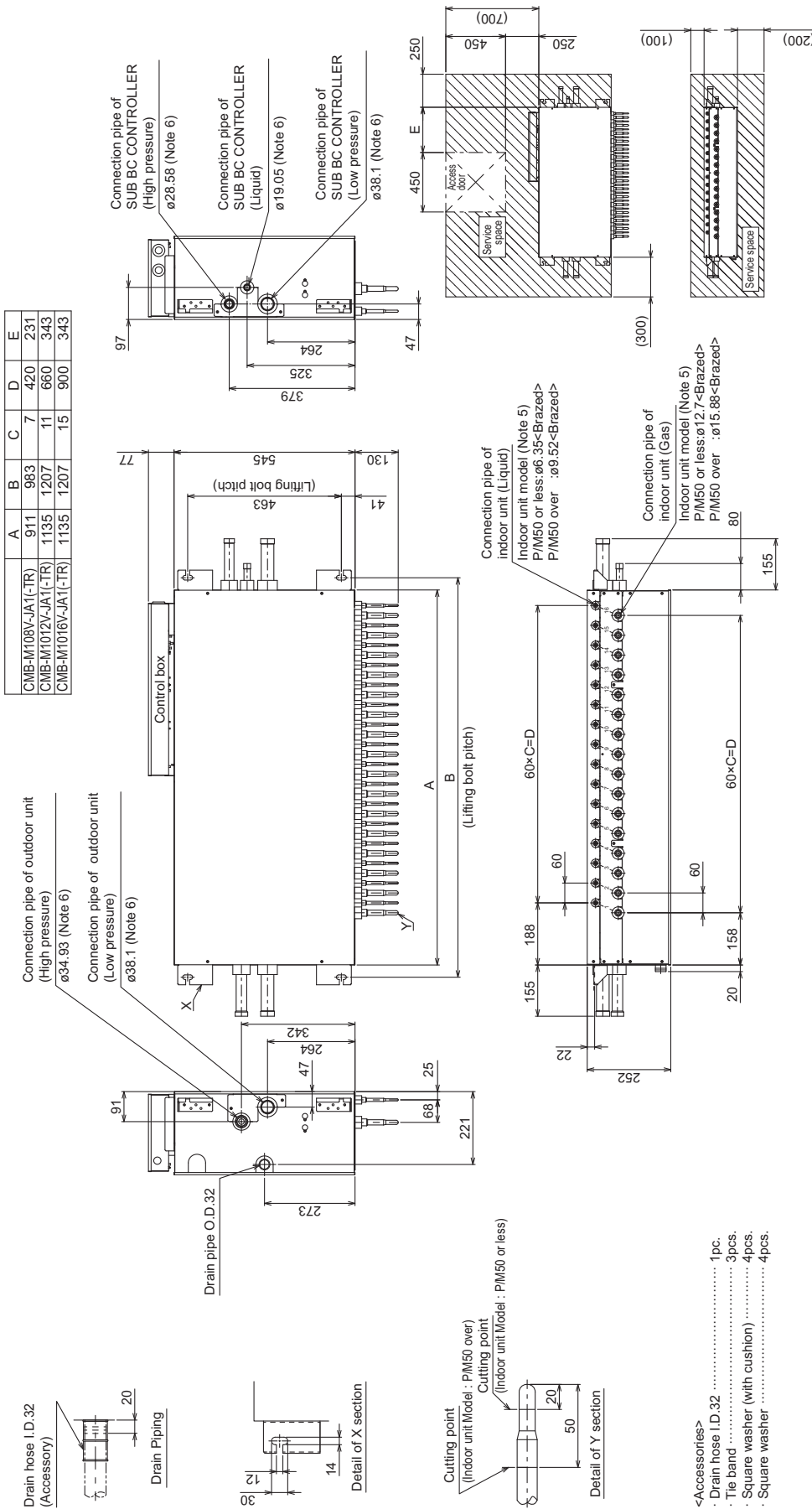

	A	B	C	D	E
CMB-M108V-JA1(-TR)	911	983	7	420	231
CMB-M1012V-JA1(-TR)	1135	1207	11	660	343
CMB-M1016V-JA1(-TR)	1135	1207	15	900	343

Table-2. To other BC controller (Note.6)

Total downstream Indoor unit capacity	High press. Pipe	Liquid Pipe	Low press. Pipe
P200	ø15.88	ø9.52	ø19.05
P201~300	ø19.05	ø9.52	ø22.2
P301~350	ø19.05	ø12.7	ø28.58
P351~400	ø22.2	ø12.7	ø28.58
P401~600	ø22.2	ø15.88	ø28.58
P601~650	ø28.58	ø15.88	ø28.58
P651~800	ø28.58	ø19.05	ø34.93
P801~1000	ø28.58	ø19.05	ø41.28
P1001~M200	ø34.93	ø19.05	ø41.28
M201~300	ø15.88	ø9.52	ø19.05
M301~350	ø15.88	ø9.52	ø22.2
M351~400	ø19.05	ø12.7	ø28.58
M401~450	ø19.05	ø15.88	ø28.58

Table-1. To outdoor/heat source unit (Note.6)

Connectable unit capacity	High press. Pipe	Low press. Pipe
P200, P300	ø15.88	ø19.05
P250, P350	ø19.05 or ø22.2	ø22.2
P400 to P500	ø22.2	ø28.58
P550	ø22.2 or ø28.58	ø28.58
P600	ø22.2 or ø28.58	ø28.58 or ø34.93
P650	ø28.58	ø34.93
P700 to P800	ø28.58	ø34.93
P850, P900	ø28.58	ø41.28
M200	ø15.88	ø19.05
M250, M300	ø15.88	ø22.2

\*For the refrigerant pipe size, refer to Installation Manual of outdoor units/heat source units.

- Note 1. Suspension bolt(ø10) and nut(M10) prepare in the field.
- Note 2. Take notice of service space as shown.  
(Please give attention not to occupy service space by letting ducts and pipes through.)
- Note 3. Please take service space for connection pipe of SUB BC CONTROLLER.  
(Please refer to the Installation Manual of SUB BC CONTROLLER.)
- Note 4. Install this product in a location where noise (refrigerant noise) emitted by the unit will not disturb the neighbors.  
(For use in quiet environments with low background noise, position the BC CONTROLLER at least 5m away from any indoor units.)
- Note 5. Refer to the Installation Manual for refrigerant piping diameter size when connecting plural indoor units with 1 branch.
- Note 6. Refer to the Table-1,2 connection pipe of outdoor unit or SUB BC CONTROLLER diameter size.
- Note 7. Refer to the Installation Manual for insulation of connection pipe and drain piping.
- Note 8. Do not place the BC controller directly on the floor.

- <Accessories>
- Drain hose I.D.32 ..... 1pc.
  - Tie band ..... 3pcs.
  - Square washer (with cushion) ..... 4pcs.
  - Square washer ..... 4pcs.



CMB-P1016V-KA1(-TR)

Unit: mm

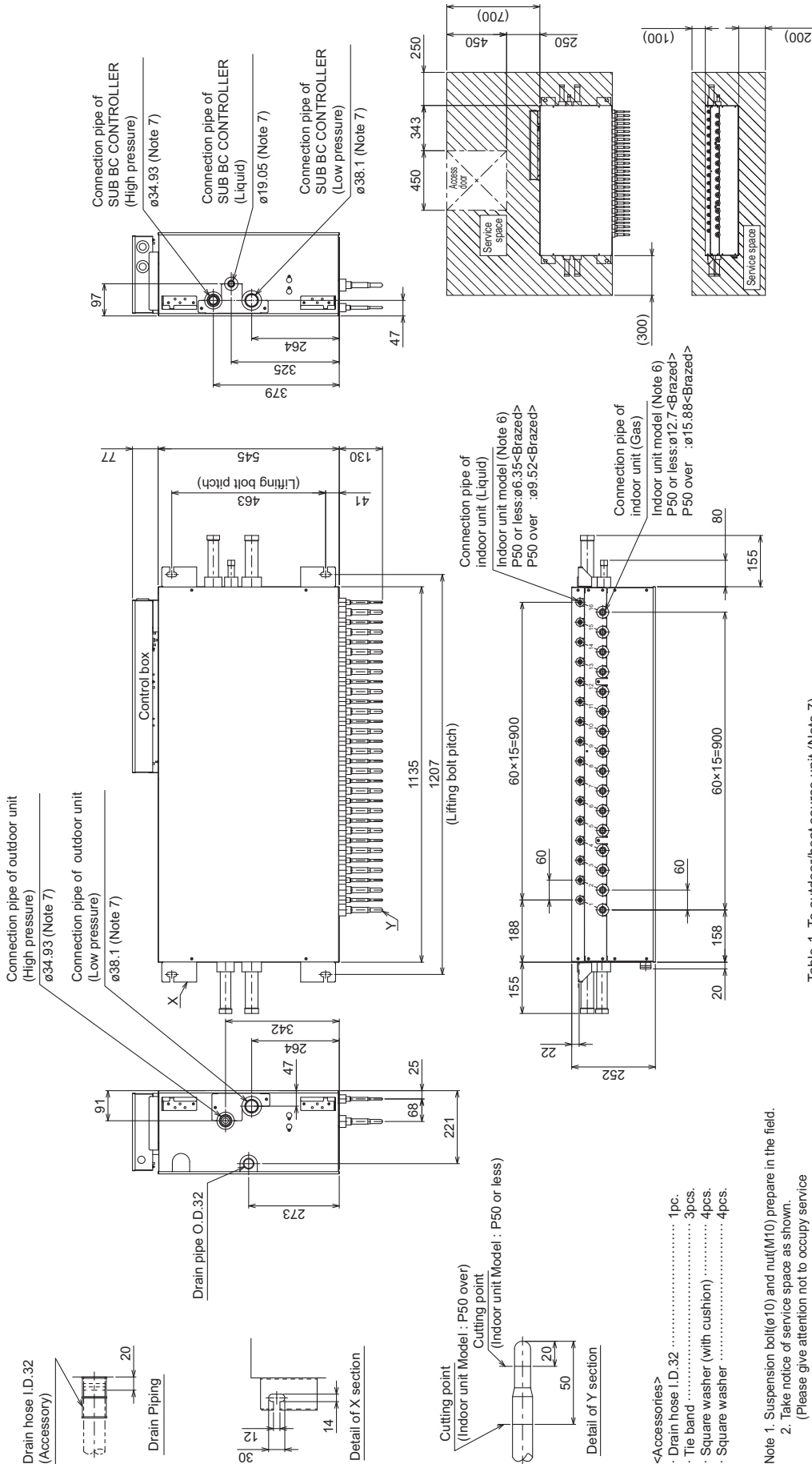

Table-1. To outdoor/heat source unit (Note 7)

Connectable unit capacity	High press. Pipe	Low press. Pipe
P200	ø15.88	ø19.05
P250, P300	ø19.05	ø22.2
P350	ø19.05 or ø22.2	ø28.58
P400 to P500	ø22.2	ø28.58
P550	ø22.2 or ø28.58	ø28.58
P600	ø22.2 or ø28.58	ø28.58 or ø34.93
P650	ø28.58	ø34.93
P700 to P800	ø28.58	ø34.93
P850 to P1000	ø28.58	ø41.28
P1050 to P1100	ø34.93	ø41.28

\*For the refrigerant pipe size, refer to Installation Manual of outdoor units/heat source units.

Table-2. To other BC controller (Note 7)

Total downstream Indoor unit capacity	High press. Pipe	Liquid Pipe	Low press. Pipe
~P200	ø15.88	ø9.52	ø19.05
P201~300	ø19.05	ø9.52	ø22.2
P301~350	ø19.05	ø12.7	ø28.58
P351~400	ø22.2	ø12.7	ø28.58
P401~400	ø22.2	ø15.88	ø28.58
P601~650	ø28.58	ø15.88	ø28.58
P651~800	ø28.58	ø19.05	ø34.93
P801~1000	ø28.58	ø19.05	ø41.28
P1001~	ø34.93	ø19.05	ø41.28

- Note 1. Suspension bolt(ø10) and nut(M10) prepare in the field.  
 2. Take notice of service space as shown.  
 (Please give attention not to occupy service space by letting ducts and pipes through.)  
 3. Please take service space for connection pipe of SUB BC CONTROLLER.  
 4. When using an outdoor unit-38HP(P950) or more, use this product.  
 5. Install this product in a location where noise (refrigerant noise) emitted by the unit will not disturb the neighbors.  
 (For use in quiet environments with low background noise, position the BC CONTROLLER at least 5m away from any indoor units.)  
 6. Refer to the Installation Manual for refrigerant piping diameter size when connecting plural indoor units with 1 branch.  
 7. Refer to the Table-1,2 for connection pipe of outdoor unit or SUB BC CONTROLLER diameter size.  
 8. Refer to the Installation Manual for insulation of connection pipe and drain piping.  
 9. Do not place the BC controller directly on the floor.

- <Accessories>  
 · Drain hose I.D.32 ..... 1pc.  
 · Tie band ..... 3pcs.  
 · Square washer (with cushion) ..... 4pcs.  
 · Square washer ..... 4pcs.

CMB-M104, 108V-KB1(-TR)

Unit: mm

- <Accessories>
- Drain hose I.D.32 ..... 1pc.
  - Tie band ..... 3pcs.
  - Square washer (with cushion) ..... 4pcs.
  - Square washer ..... 4pcs.

- Note 1. Suspension bolt(ø10) and nut(M10) prepare in the field.  
 2. Take notice of service space as shown.  
 (Please give attention not to occupy service space by letting ducts and pipes through.)  
 3. Can't use singleness. (MAIN BC CONTROLLER is necessary.)  
 4. Install this product in a location where noise (refrigerant noise) emitted by the unit will not disturb the neighbors.  
 (For use in quiet environments with low background noise, position the BC CONTROLLER at least 5m away from any indoor units.)  
 5. Refer to the Installation Manual for refrigerant piping diameter size when connecting plural indoor units with 1 branch.  
 6. Refer to the Table-1 for connection pipe of MAIN BC CONTROLLER.  
 7. Refer to the Installation Manual for insulation of connection pipe and drain piping.  
 8. Do not place the BC controller directly on the floor.

Table-1. To other BC controller (Note.6)

Total downstream Indoor unit capacity	High press. Pipe	Liquid Pipe	Low press. Pipe
~P200	ø15.88	ø9.52	ø19.05
P201~300	ø19.05	ø9.52	ø22.2
P301~350	ø19.05	ø12.7	ø28.58
P351~400	ø22.2	ø12.7	ø28.58
P401~600	ø22.2	ø15.88	ø28.58
P601~650	ø28.58	ø15.88	ø28.58
P651~800	ø28.58	ø19.05	ø34.93
P801~1000	ø28.58	ø19.05	ø41.28
P1001~	ø34.93	ø19.05	ø41.28
~M200	ø15.88	ø9.52	ø19.05
M201~300	ø15.88	ø9.52	ø22.2
M301~350	ø15.88	ø12.7	ø28.58
M351~400	ø19.05	ø12.7	ø28.58
M401~450	ø19.05	ø15.88	ø28.58

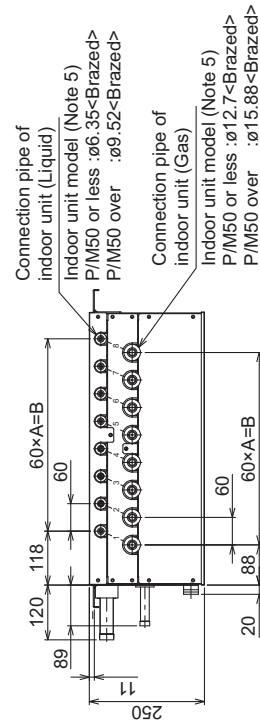
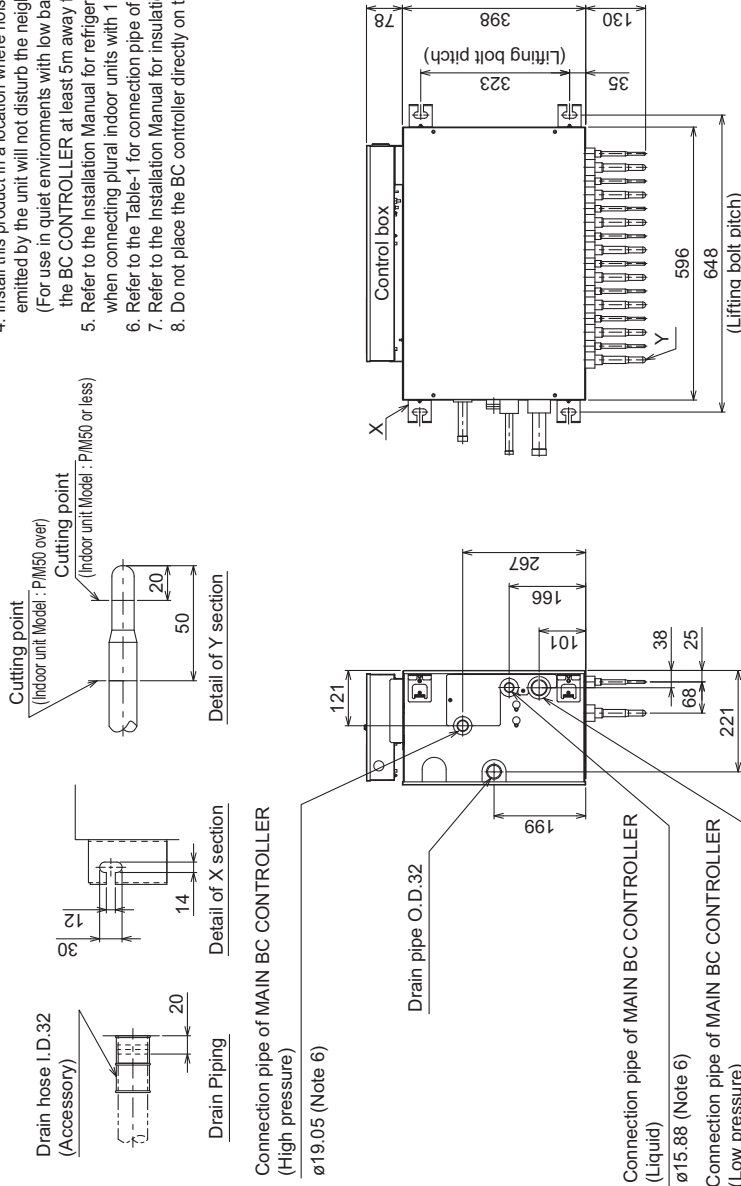

	A	B
CMB-M104V-KB1(-TR)	3	180
CMB-M108V-KB1(-TR)	7	420

CMB-M104V-J1(-TR)

(Symbol explanation)

Symbol	Name
TR	Transformer
TH11,12,15,16	Thermister sensor
LEV1,3	Expansion valve
PS1,3	Pressure sensor
CONT. B	Circuit BC controller terminal block
TB01	Terminal block (for power source)
TB02	Terminal block (for Transmission)
SV1~4A,B,C	Solenoid valve
T1~4	Terminal
F01	Fuse AC250V 6.3A F
Z1	Function setting connector

- Note 1. TB02 is transmission terminal block.  
Never connect power line to it.
2. The initial set values of switch on CONT. B are as follows.  
SW1:0  
SW2:0

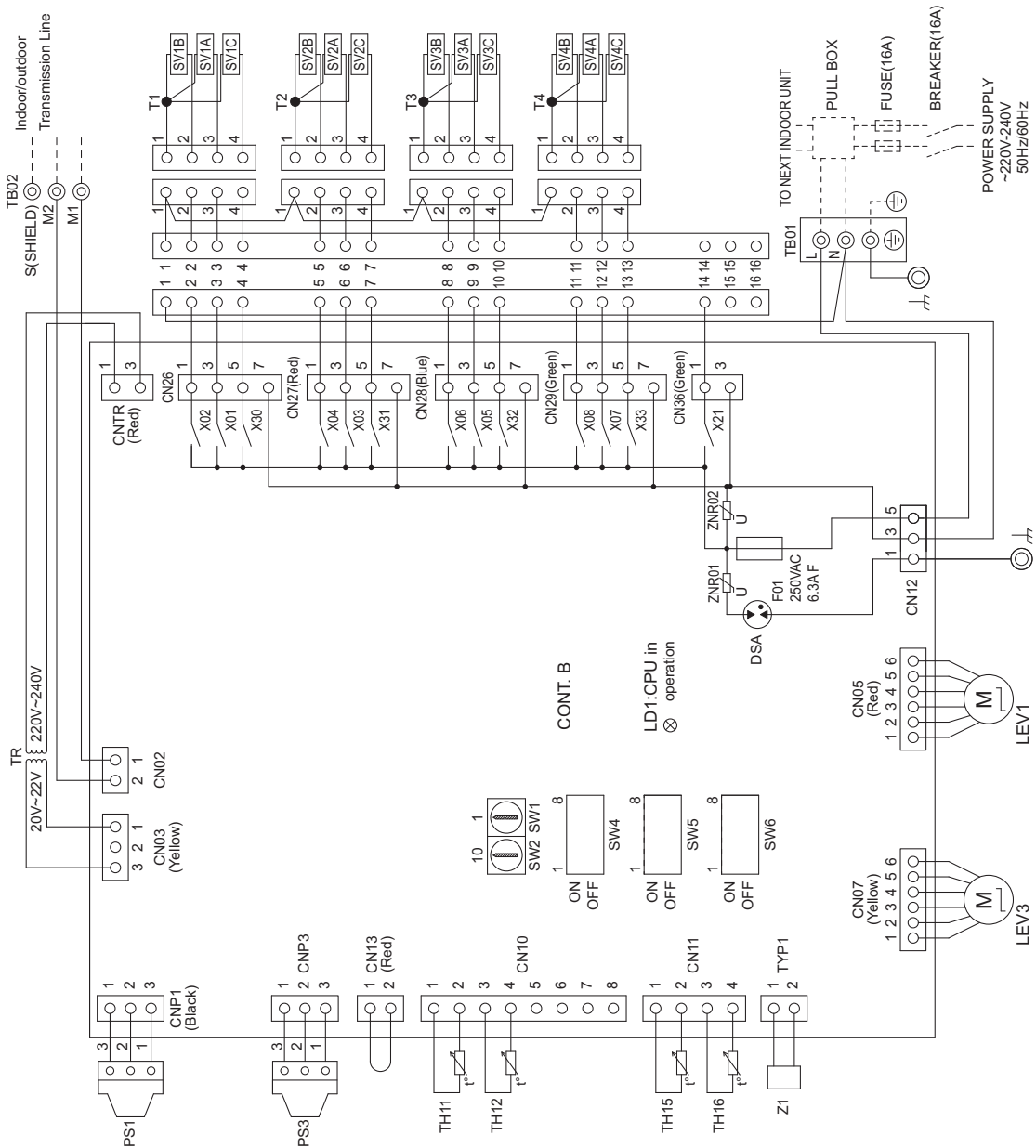

CMB-M106V-J1(-TR)

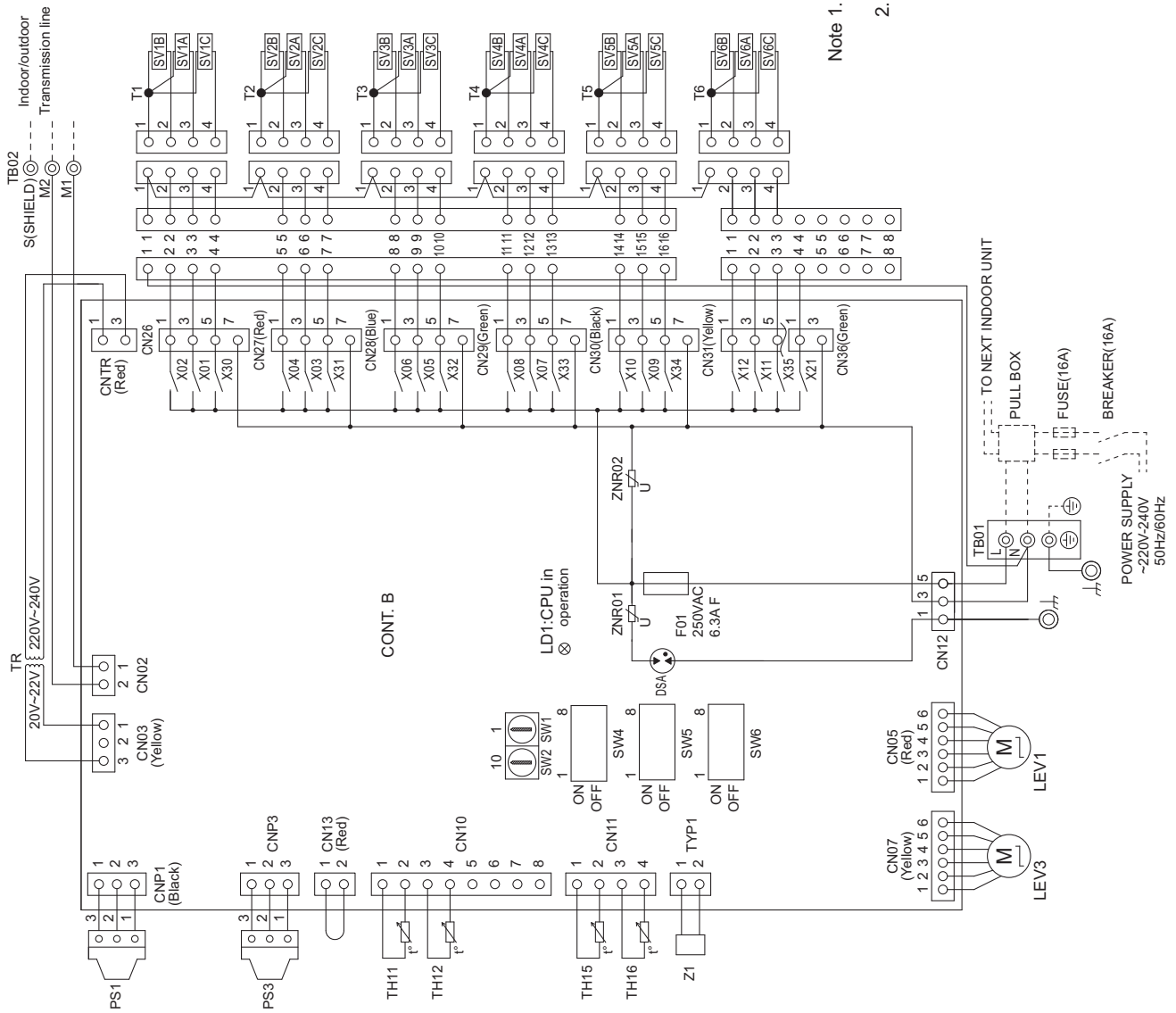

(Symbol explanation)

Symbol	Name
TR	Transformer
TH11,12,15,16	Thermister sensor
LEV1,3	Expansion valve
PS1,3	Pressure sensor
CONT. B	Circuit board BC controller
TB01	Terminal block (for power source)
TB02	Terminal block (for Transmission)
SV1-6A,B,C	Solenoid valve
T1-6	Terminal
F01	Fuse AC250V 6.3A F
Z1	Function setting connector

- Note 1. TB02 is transmission terminal block.  
Never connect power line to it.
2. The initial set values of switch on CONT. B are as follows.  
SW1:0  
SW2:0

CMB-M108V-J1(-TR)

(Symbol explanation)

Symbol	Name
TR	Transformer
TH1,12,15,16	Thermister sensor
LEV1,3	Expansion valve
PS1,3	Pressure sensor
REL. B	Relay
CONT. B	BC controller
TB01	Terminal block (for power source)
TB02	Terminal block (for Transmission)
SV1~8A,B,C	Solenoid valve
T1~8	Terminal
F01	Fuse AC250V 6.3A F
Z1	Function setting connector

- Note 1. TB02 is transmission terminal block.  
Never connect power line to it.
2. The initial set values of switch on CONT. B are as follows.  
SW1:0  
SW2:0

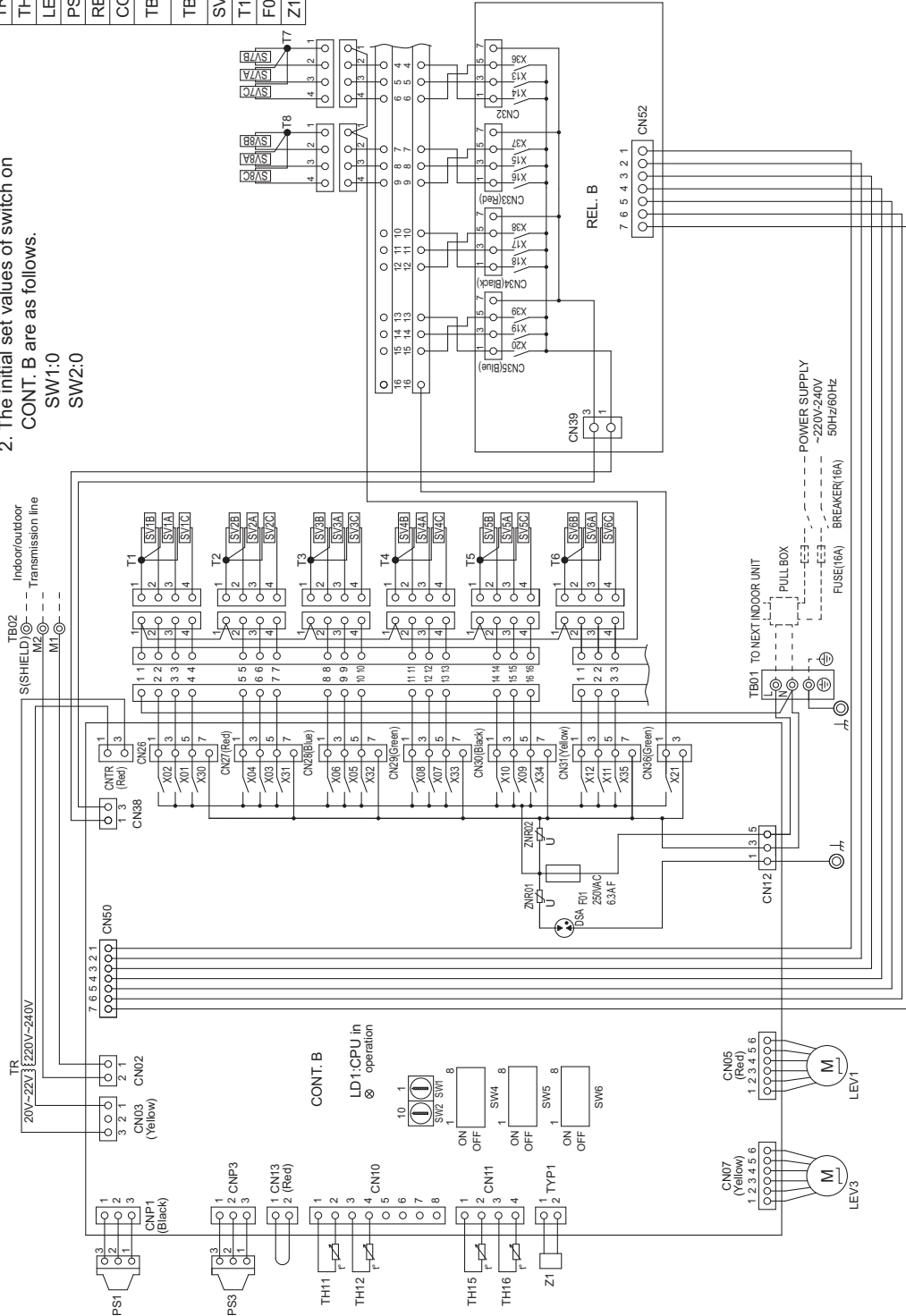

CMB-M1012, 1016V-J1(-TR)

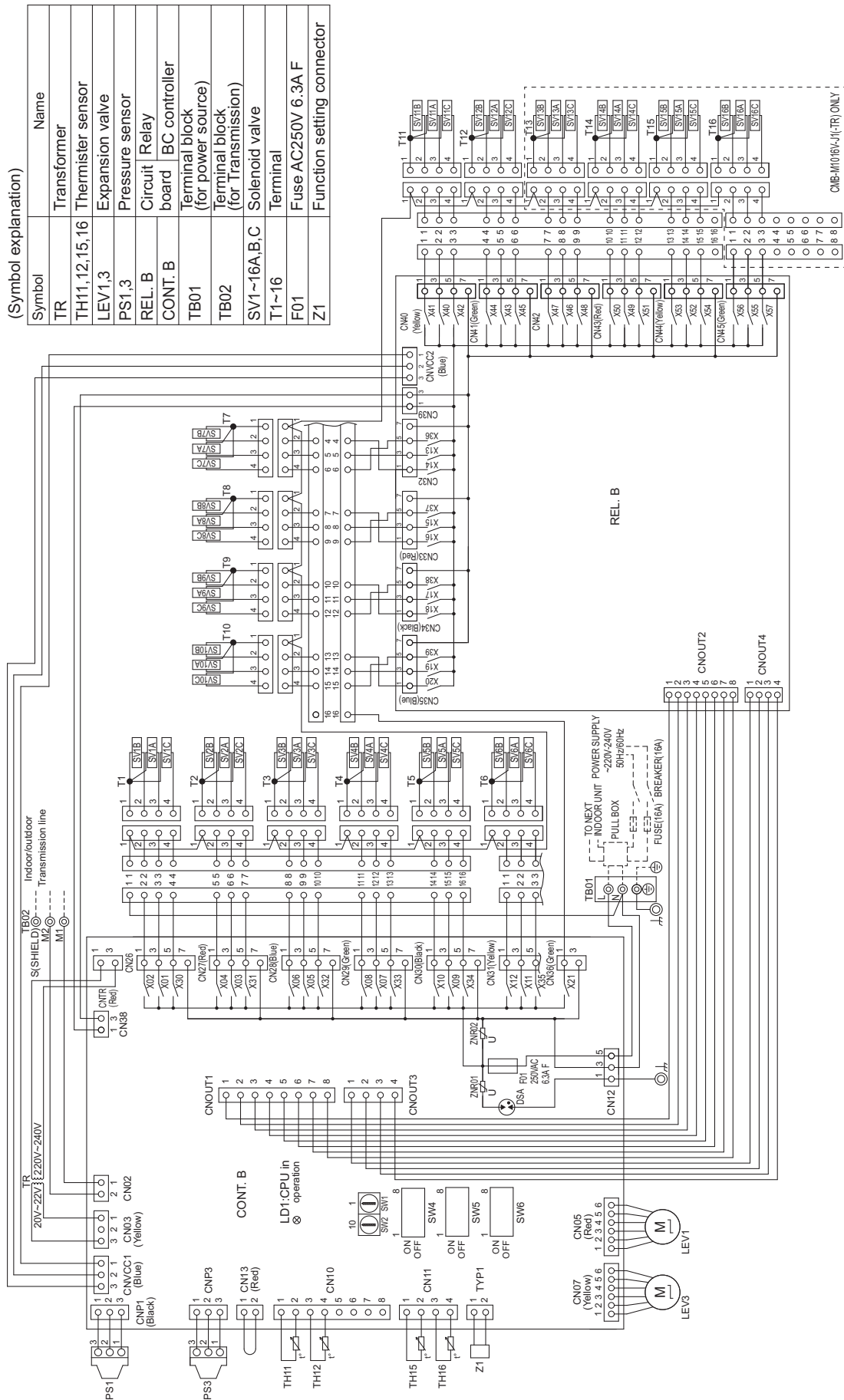

- Note 1. TB02 is transmission terminal block.  
 Never connect power line to it.
2. The initial set values of switch on CONT. B are as follows.  
 SW1:0  
 SW2:0

CMB-M108V-JA1(-TR)

(Symbol explanation)

Symbol	Name
TR	Transformer
TH11, 12, 15, 16	Thermister sensor
LEV1, 3, 4	Expansion valve
PS1, 3	Pressure sensor
REL. B	Circuit Relay
CONT. B	BC controller board
TB01	Terminal block (for power source)
TB02	Terminal block (for Transmission)
SV1~8A,B,C	Solenoid valve
SVM1,SVM1b	Solenoid valve
T1~8	Terminal
F01	Fuse AC250V 6.3A F
Z1	Function setting connector

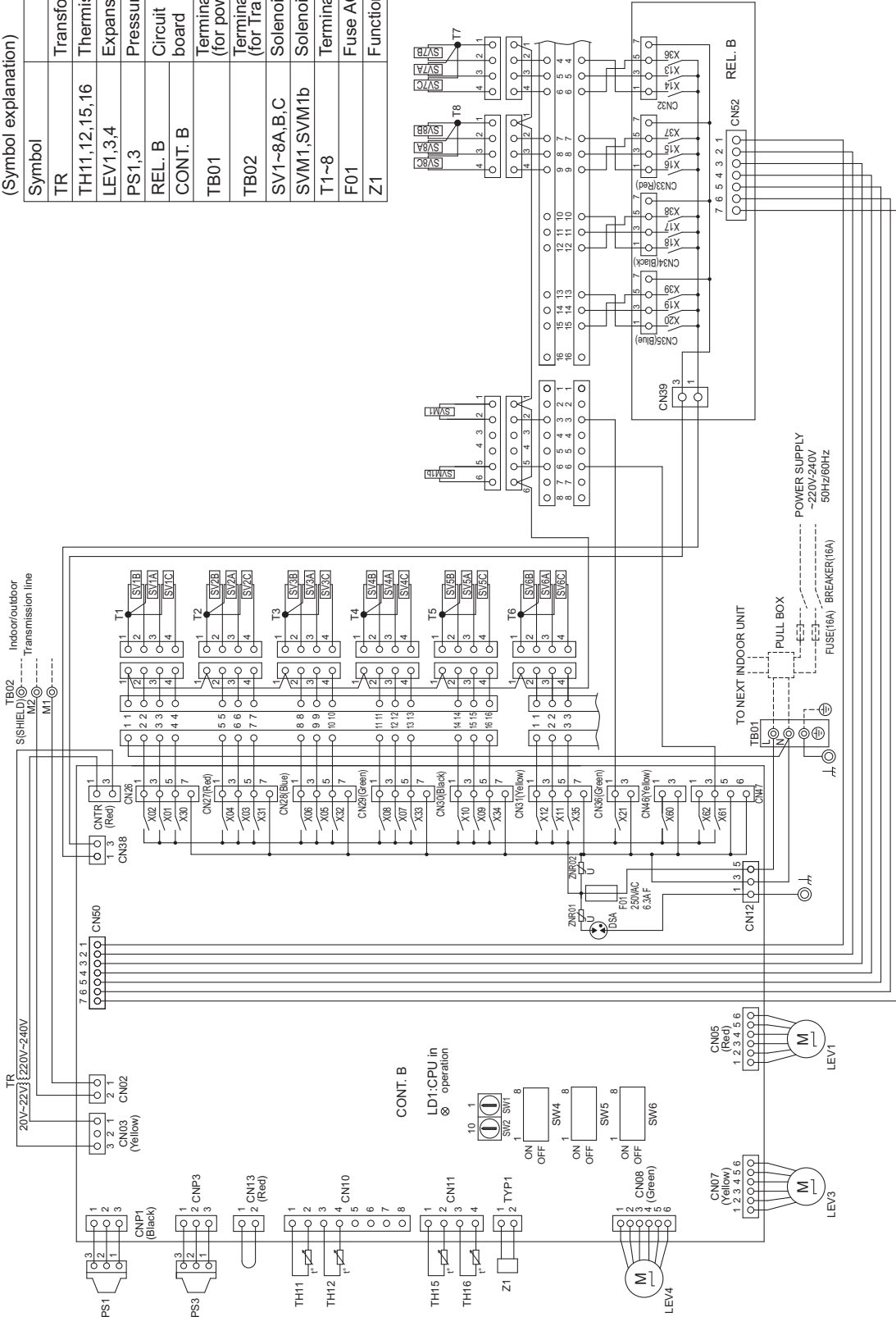

Note 1. TB02 is transmission terminal block.  
 Never connect power line to it.  
 2. The initial set values of switch on CONT. B are as follows.  
 SW1:0  
 SW2:0

CMB-M1012, 1016V-JA1(-TR)

Symbol	Name
TR	Transformer
TH11,12,15,16	Thermister sensor
LEV1,3,4	Expansion valve
PS1,3	Pressure sensor
REL. B	Circuit board
CONT. B	BC controller
TB01	Terminal block (for power source)
TB02	Terminal block (for Transmission)
SV1~16A,B,C	Solenoid valve
SVM1,SVM1b	Solenoid valve
T1~16	Terminal
F01	Fuse AC250V 6.3A F
Z1	Function setting connector

(Symbol explanation)

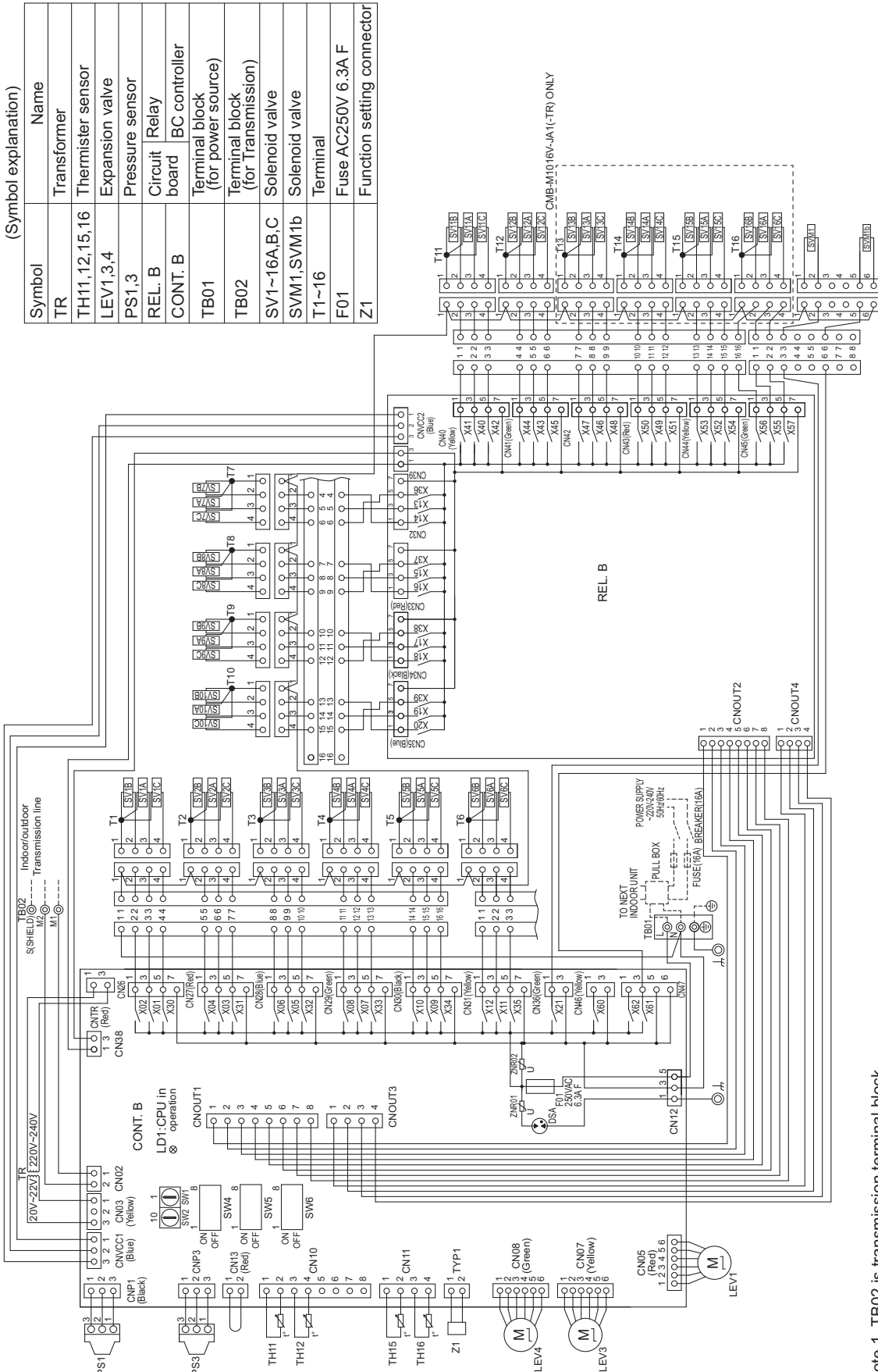

- Note 1. TB02 is transmission terminal block.  
 Never connect power line to it.
2. The initial set values of switch on CONT. B are as follows.  
 SW1:0  
 SW2:0



CMB-P1016V-KA1(-TR)

Symbol	Name
TR	Transformer
TH1,12,15,16	Thermister sensor
LEV1,3,4	Expansion valve
PS1,3	Pressure sensor
REL. B	Circuit Relay board
CONT. B	BC controller
TB01	Terminal block (for power source)
TB02	Terminal block (for Transmission)
SV1~16A,B,C	Solenoid valve
SVM1,1b	Solenoid valve
T1~16	Terminal
F01	Fuse AC250V 6.3A F
Z1	Function setting connector

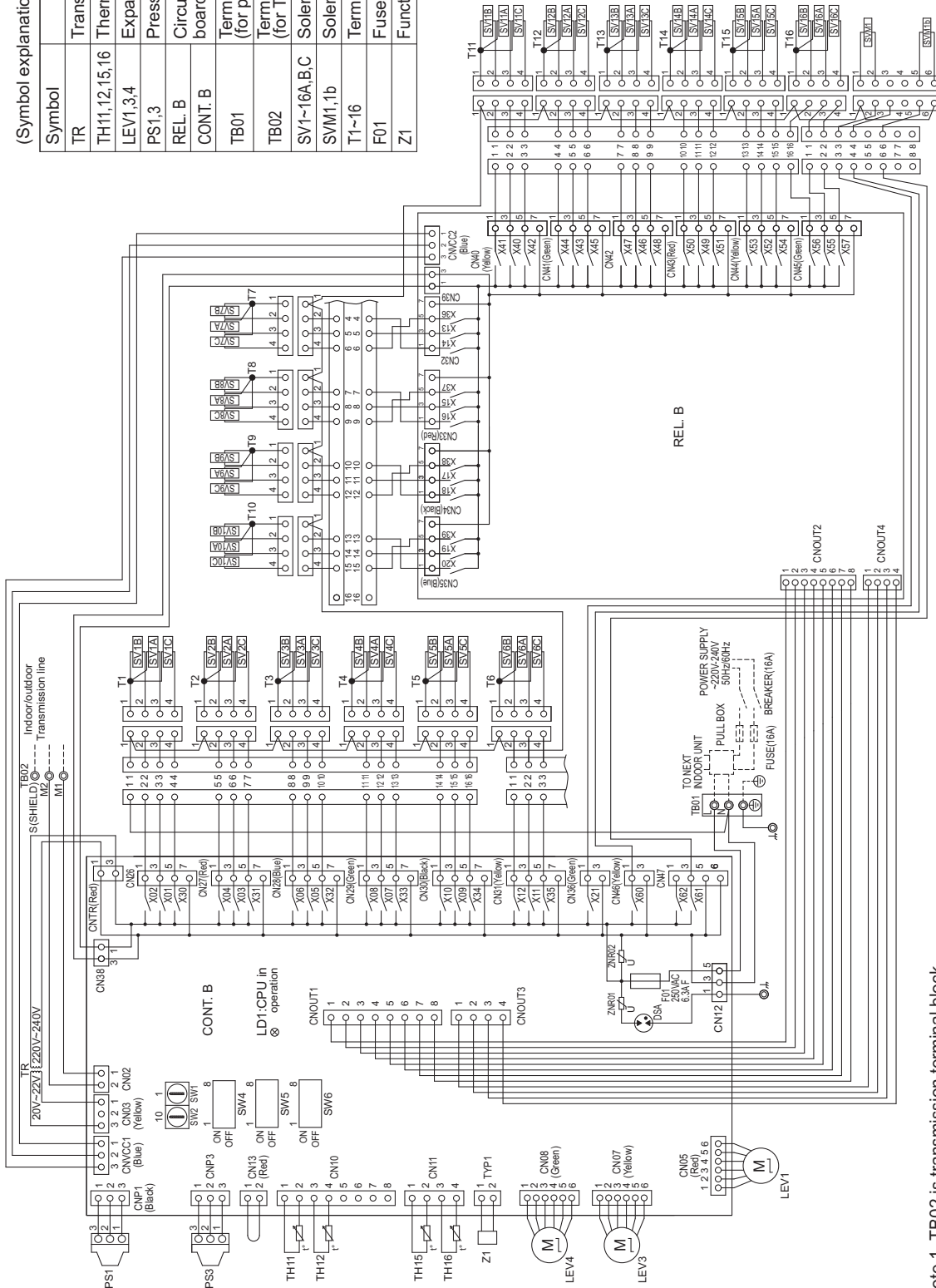

- Note 1. TB02 is transmission terminal block.  
 Never connect power line to it.
2. The initial set values of switch on CONT. B are as follows.  
 SW1:0  
 SW2:0

CMB-M104V-KB1(-TR)

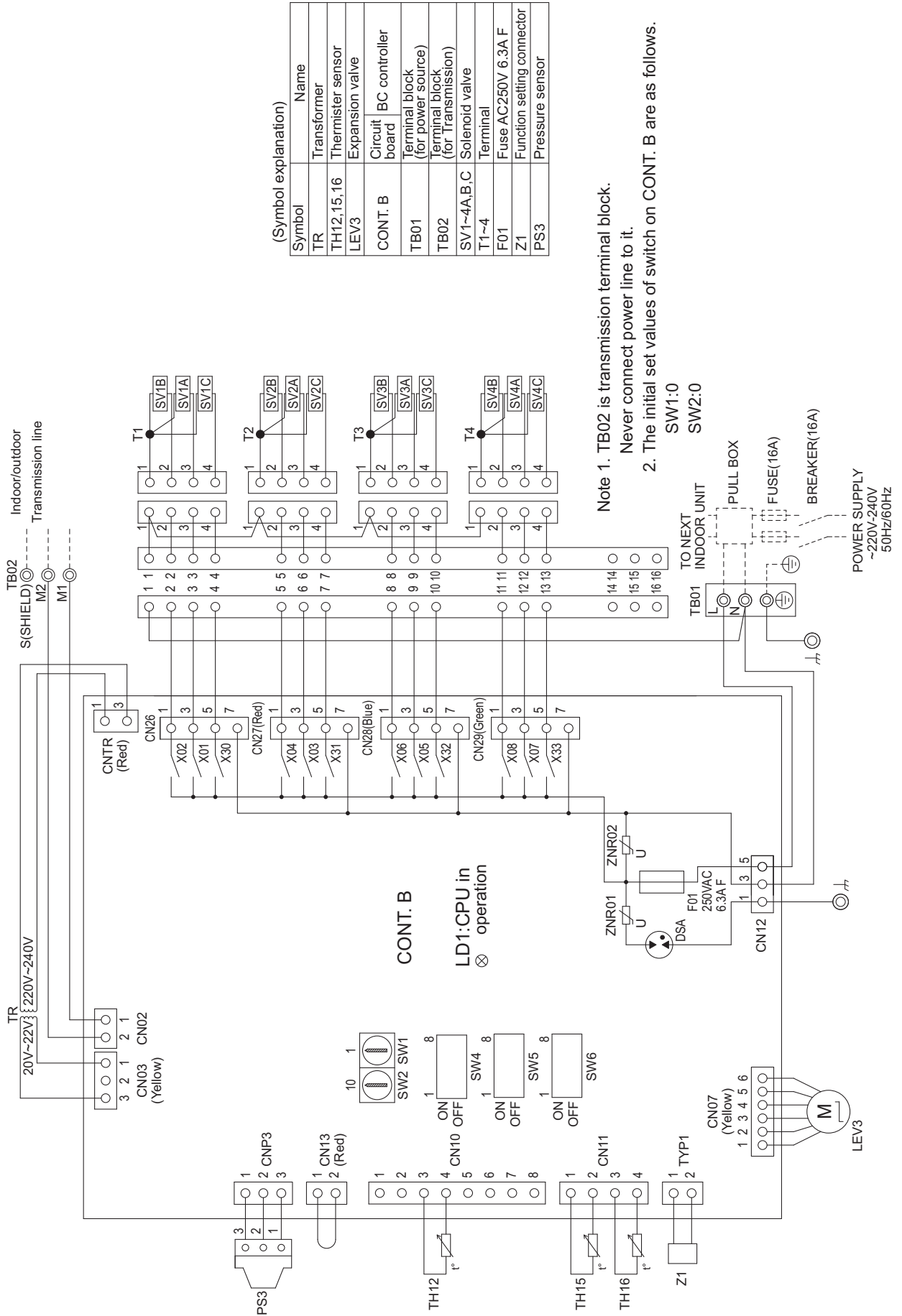

(Symbol explanation)

Symbol	Name
TR	Transformer
TH12,15,16	Thermister sensor
LEV3	Expansion valve
CONT. B	Circuit board
TB01	Terminal block (for power source)
TB02	Terminal block (for Transmission)
SV1~4A,B,C	Solenoid valve
T1~4	Terminal
F01	Fuse AC250V 6.3A F
Z1	Function setting connector
PS3	Pressure sensor

- Note 1. TB02 is transmission terminal block.  
 Never connect power line to it.  
 2. The initial set values of switch on CONT. B are as follows.



4-1. Sound levels in cooling mode

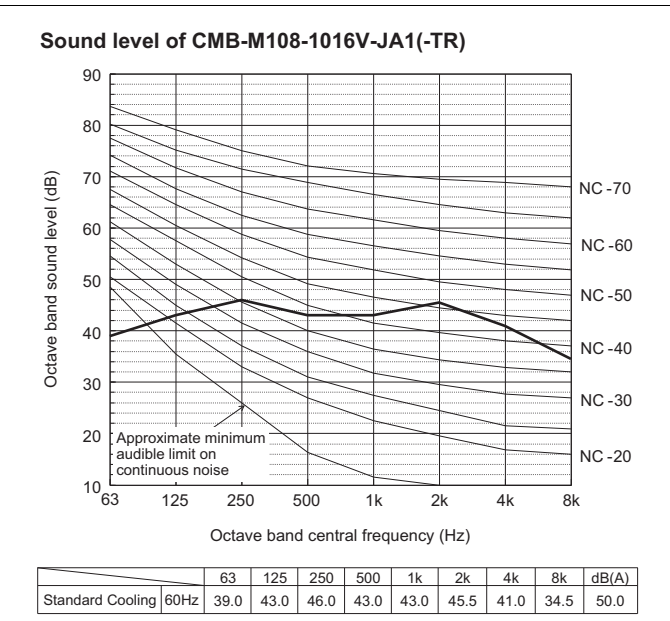
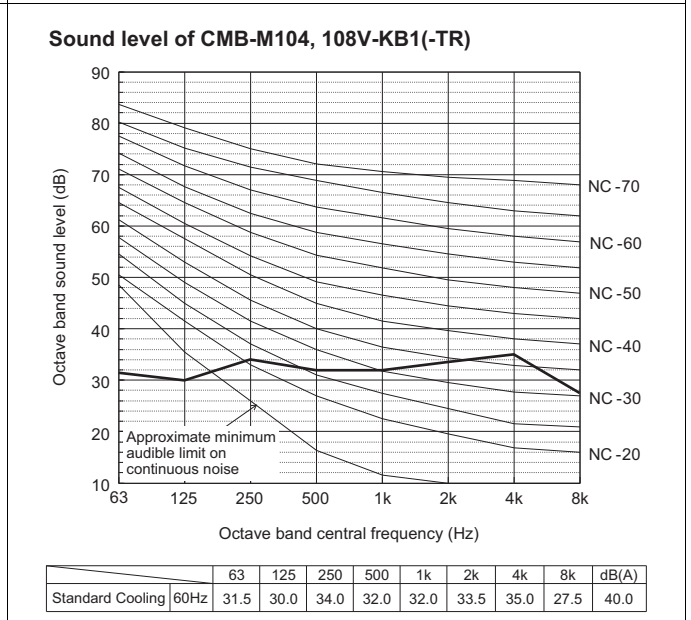
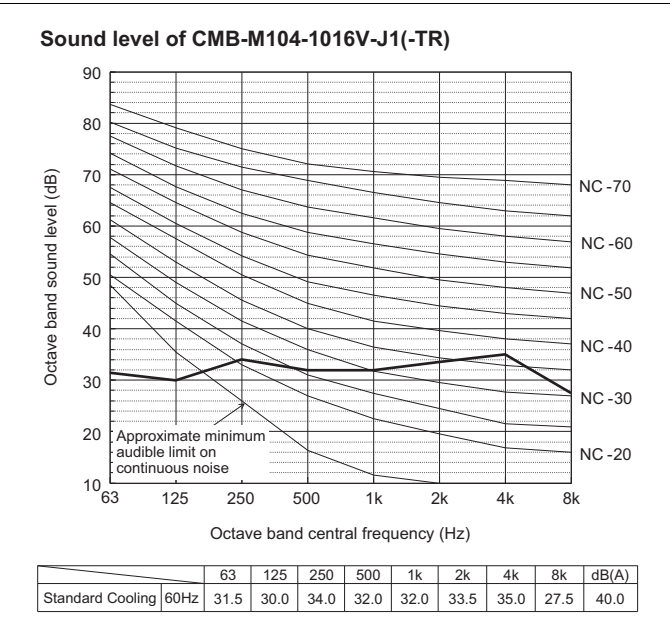
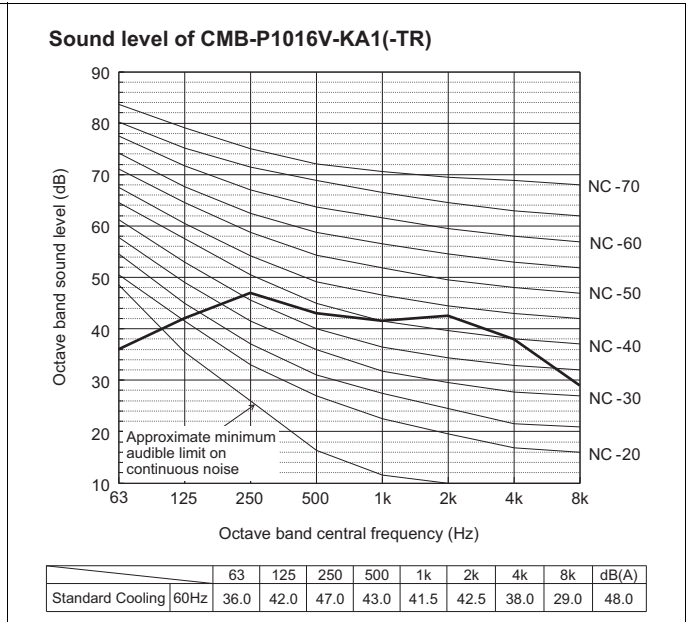
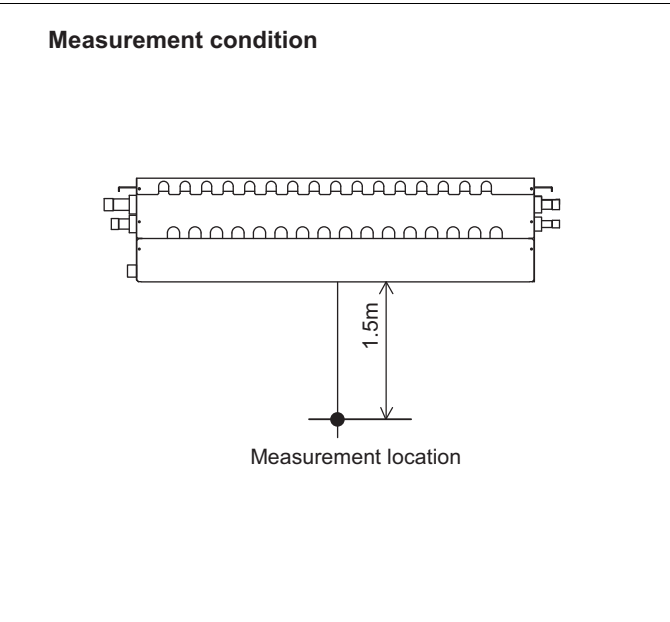

• Depending on the operation conditions, the unit generates noise caused by valve actuation, refrigerant flow, and pressure changes when operating normally. Please consider to avoid location where quietness is required.  
The sound pressure level measured by the conventional method in JIS for reference purpose.

4-2. Sound levels in heating mode

Measurement condition

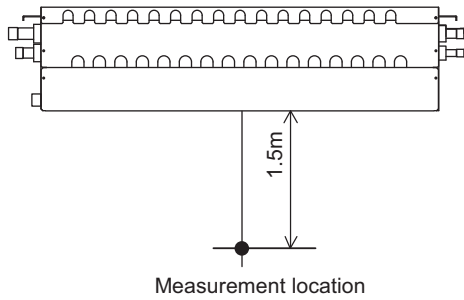

Sound level of CMB-P1016V-KA1(-TR)

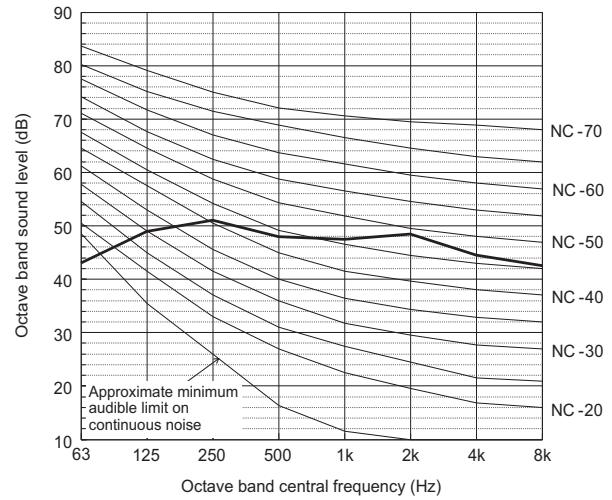

	63	125	250	500	1k	2k	4k	8k	dB(A)
Standard Heating 60Hz	43.0	49.0	51.0	48.0	47.5	48.5	44.5	42.5	54.0

Sound level of CMB-M104-1016V-J1(-TR)

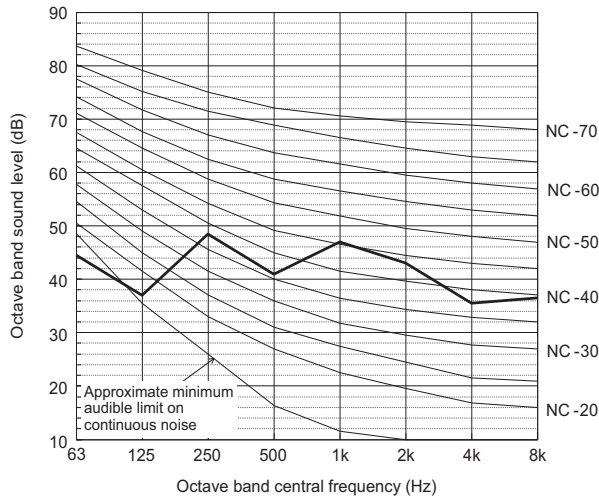

	63	125	250	500	1k	2k	4k	8k	dB(A)
Standard Heating 60Hz	44.5	37.0	48.5	41.0	47.0	43.0	35.5	36.5	50.0

Sound level of CMB-M104, 108V-KB1(-TR)

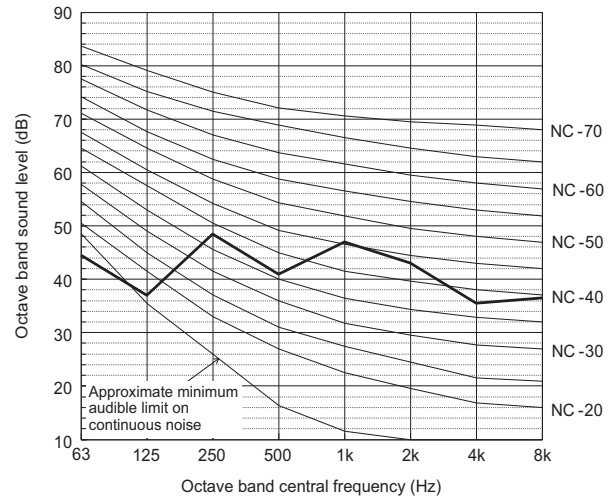

	63	125	250	500	1k	2k	4k	8k	dB(A)
Standard Heating 60Hz	44.5	37.0	48.5	41.0	47.0	43.0	35.5	36.5	50.0

Sound level of CMB-M108-1016V-JA1(-TR)

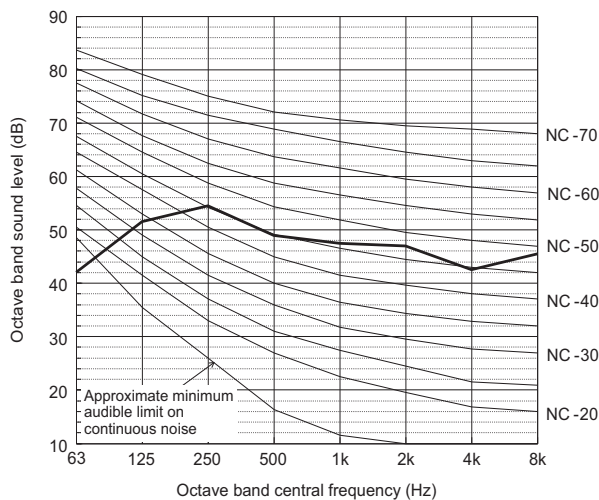

	63	125	250	500	1k	2k	4k	8k	dB(A)
Standard Heating 60Hz	42.0	51.5	54.5	49.0	47.5	47.0	42.5	45.5	54.0

\*Depending on the operation conditions, the unit generates noise caused by valve actuation, refrigerant flow, and pressure changes when operating normally. Please consider to avoid location where quietness is required.  
The sound pressure level measured by the conventional method in JIS for reference purpose.

4-3. Sound levels in defrost mode

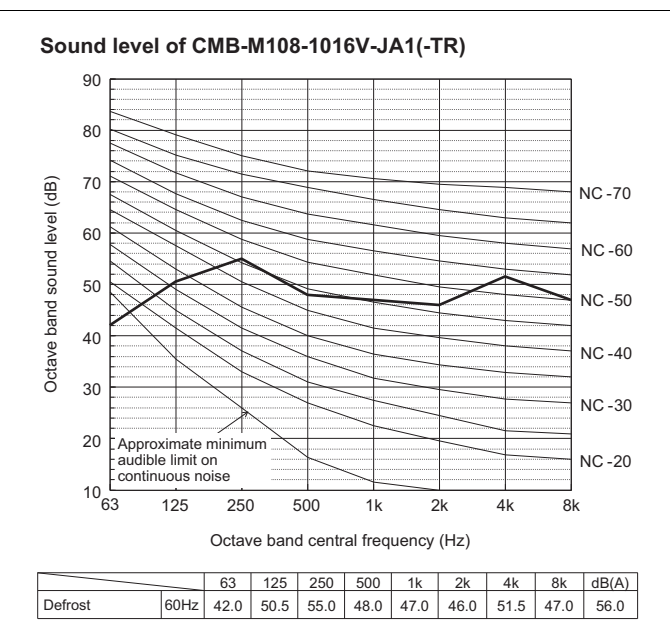
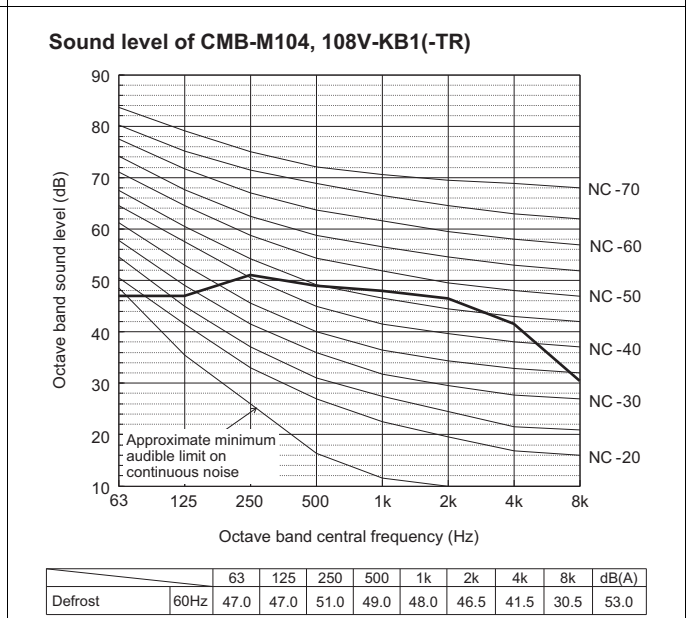
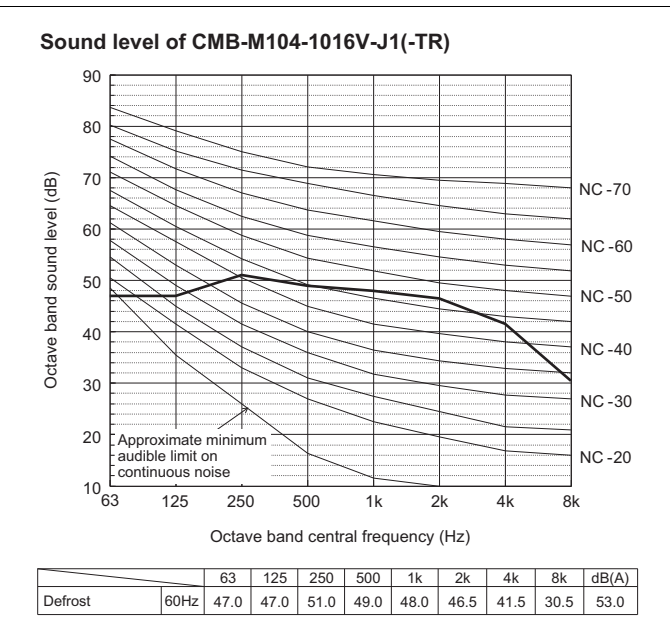
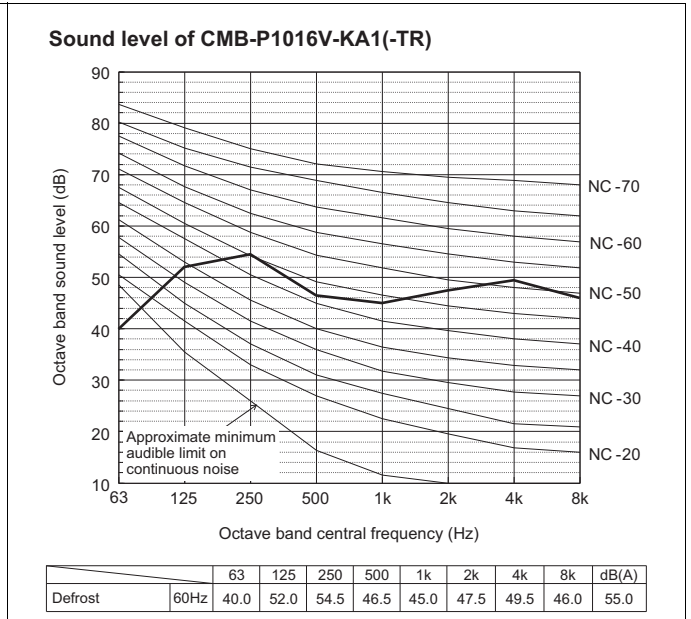
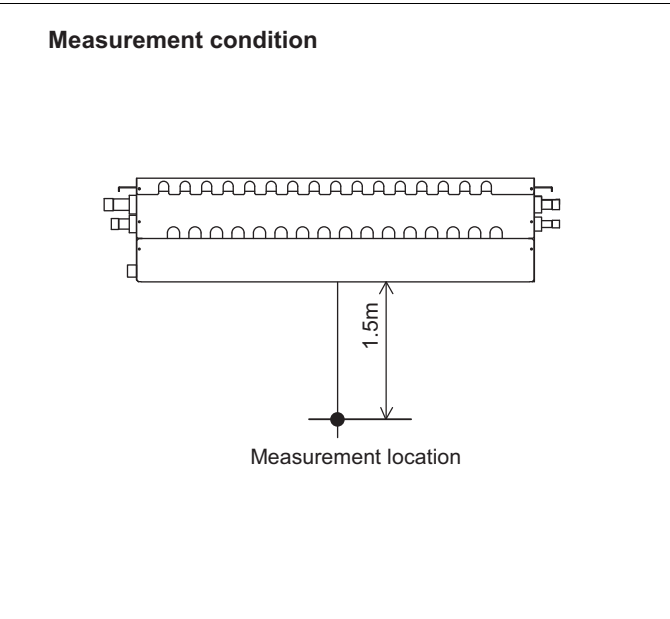

• Depending on the operation conditions, the unit generates noise caused by valve actuation, refrigerant flow, and pressure changes when operating normally. Please consider to avoid location where quietness is required.  
The sound pressure level measured by the conventional method in JIS for reference purpose.

## 5. ELECTRICAL CHARACTERISTICS

BC controller

Symbols: MCA (Max. Circuit Amps), MFA (Max. Fuse Amps), RLA (Rated Load Amps)

BC controller

BC controller	Power supply					RLA(A)
	Hz	Volts	Range±10%	MCA(A)	MFA(A)	
CMB-M104V-J1 (-TR)	50/60	220	Max.: 264V Min.: 198V	0.45	15	0.31
		230				0.34
		240				0.36
CMB-M106V-J1 (-TR)		220		0.65		0.45
		230				0.48
		240				0.52
CMB-M108V-J1 (-TR)		220		0.85		0.58
		230				0.63
		240				0.68
CMB-M1012V-J1 (-TR)		220		1.24		0.85
		230				0.92
		240				0.99
CMB-M1016V-J1 (-TR)		220		1.63		1.12
		230				1.22
		240				1.30
CMB-M108V-JA1 (-TR)	220	0.85	0.58			
	230		0.63			
	240		0.68			
CMB-M1012V-JA1 (-TR)	220	1.24	0.85			
	230		0.92			
	240		0.99			
CMB-M1016V-JA1 (-TR)	220	1.63	1.12			
	230		1.22			
	240		1.30			
CMB-P1016V-KA1 (-TR)	220	1.63	1.12			
	230		1.22			
	240		1.30			
CMB-M104V-KB1 (-TR)	220	0.40	0.28			
	230		0.30			
	240		0.32			
CMB-M108V-KB1 (-TR)	220	0.79	0.55			
	230		0.59			
	240		0.63			

6-1. JOINT and REDUCER

CITY MULTI units can be easily connected by using Joint sets and Reducer sets provided by Mitsubishi Electric. Refer to section "Piping Design" or the Installation Manual that comes with the Joint set or Reducer set for how to install the Joint set or Reducer set.

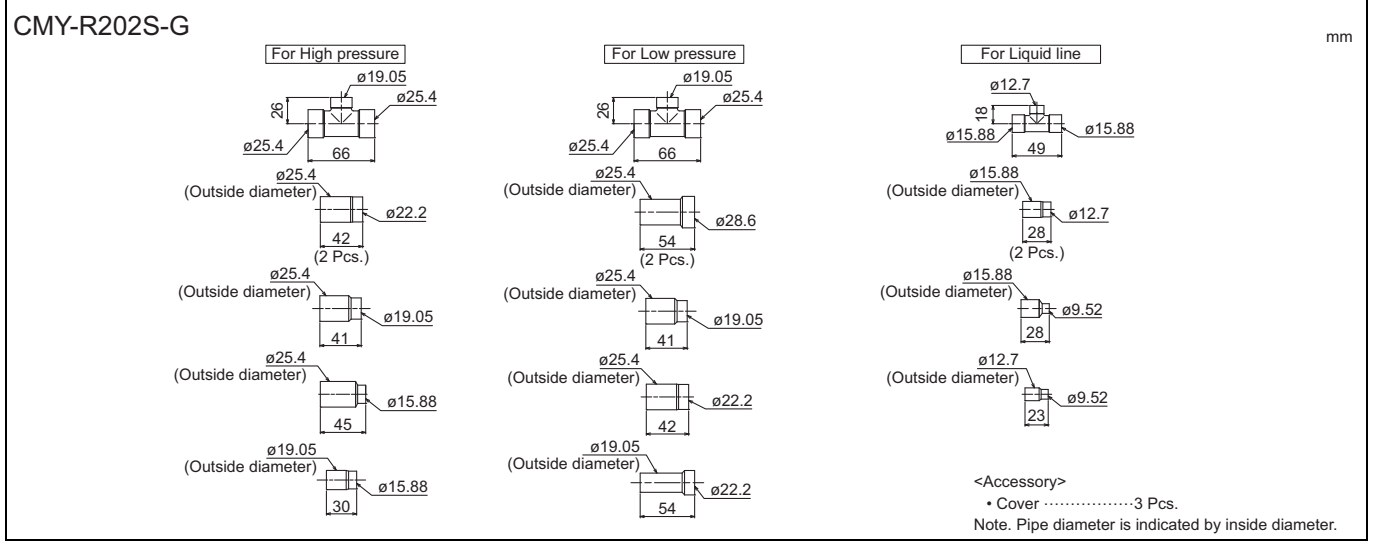
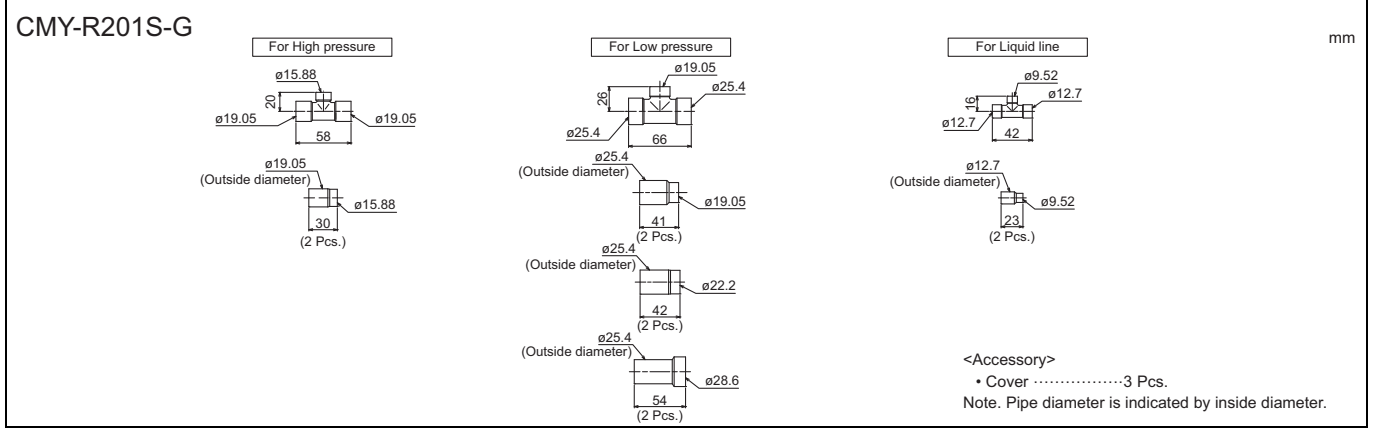
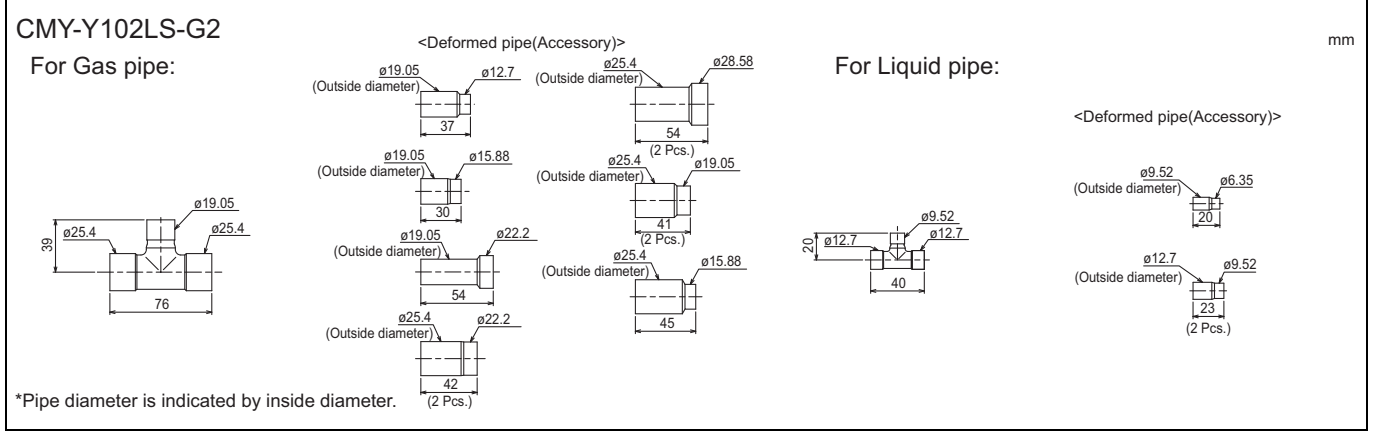
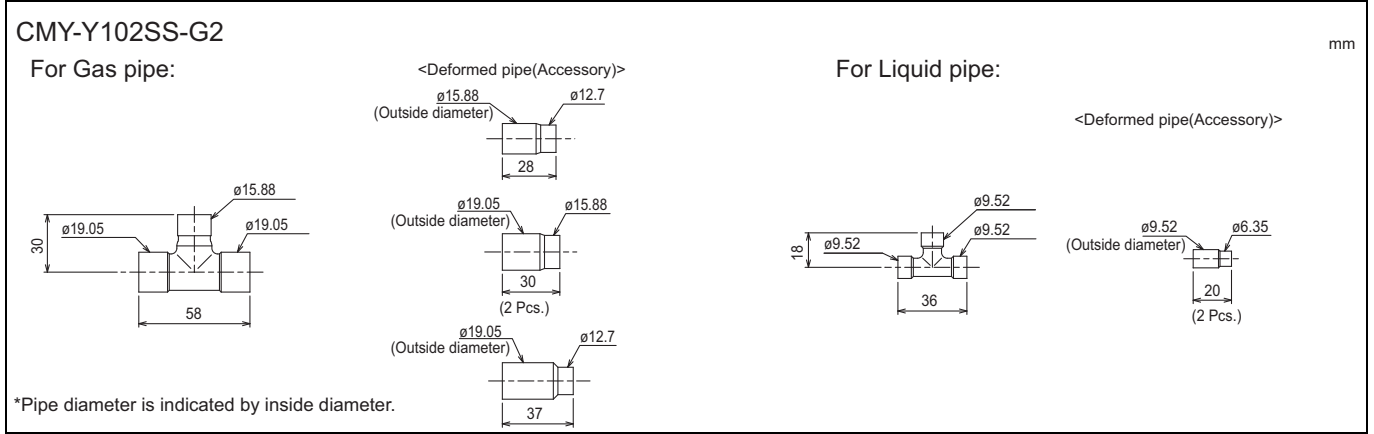



CMY-R203S-G

mm

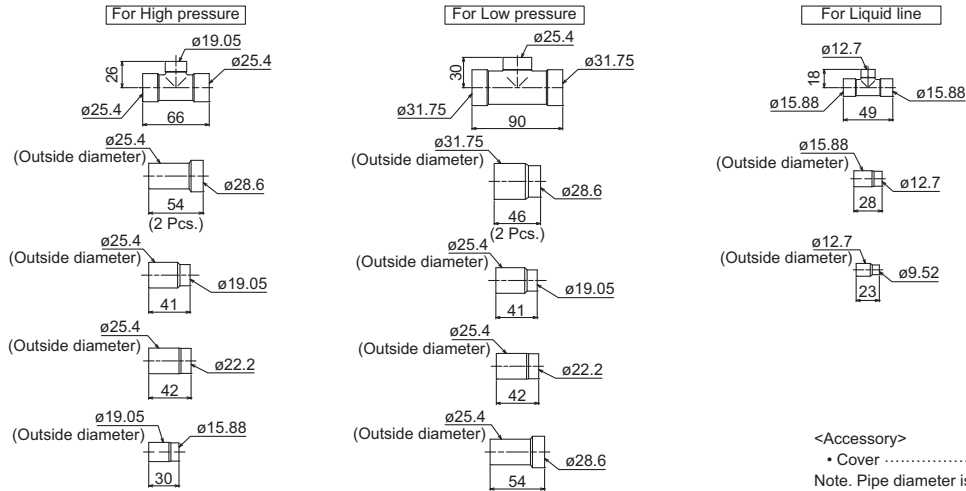

CMY-R204S-G

mm

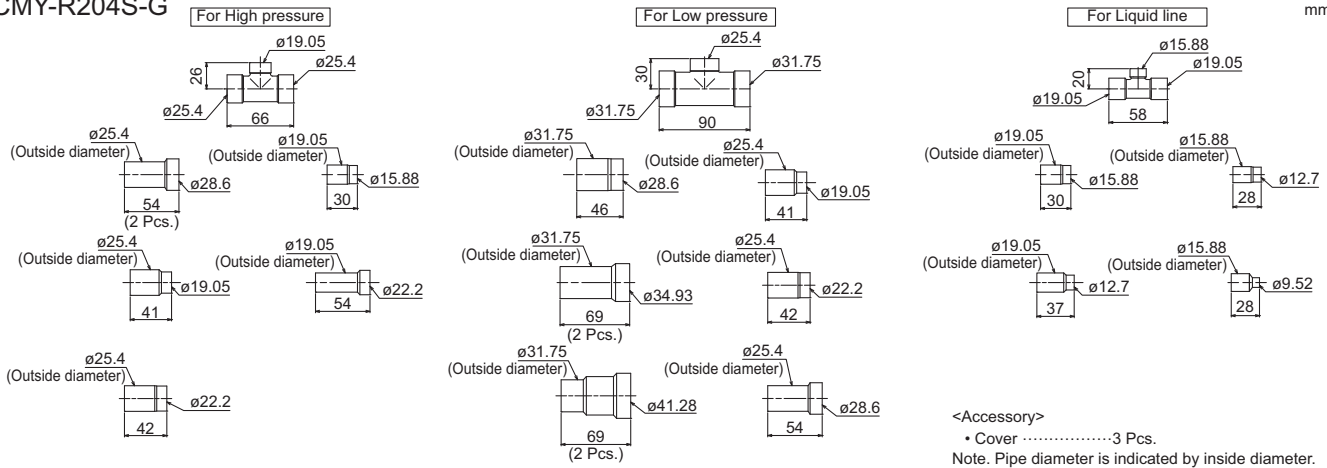

CMY-R205S-G

mm

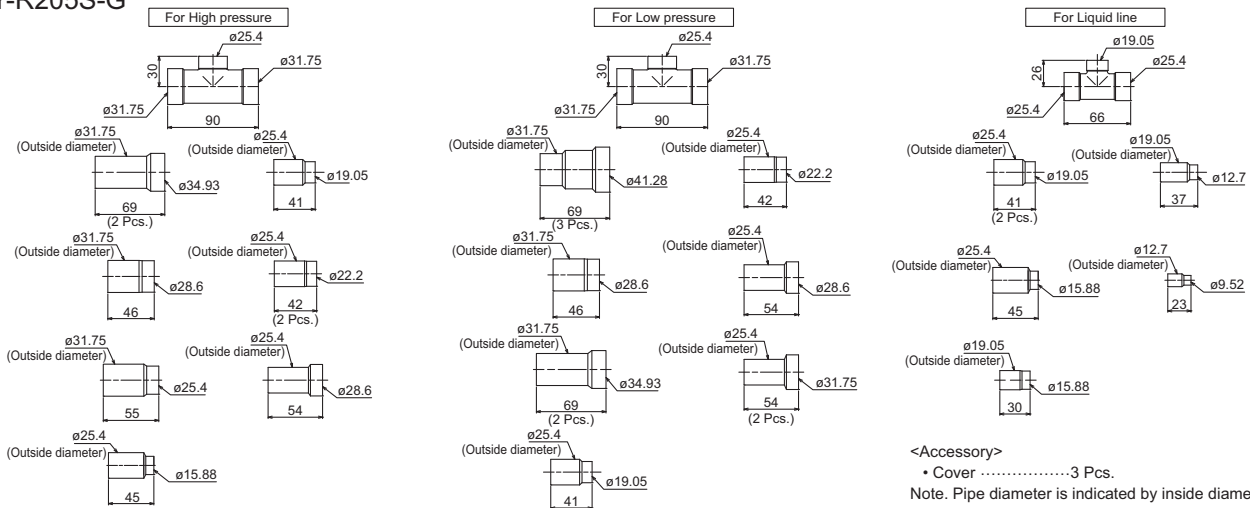

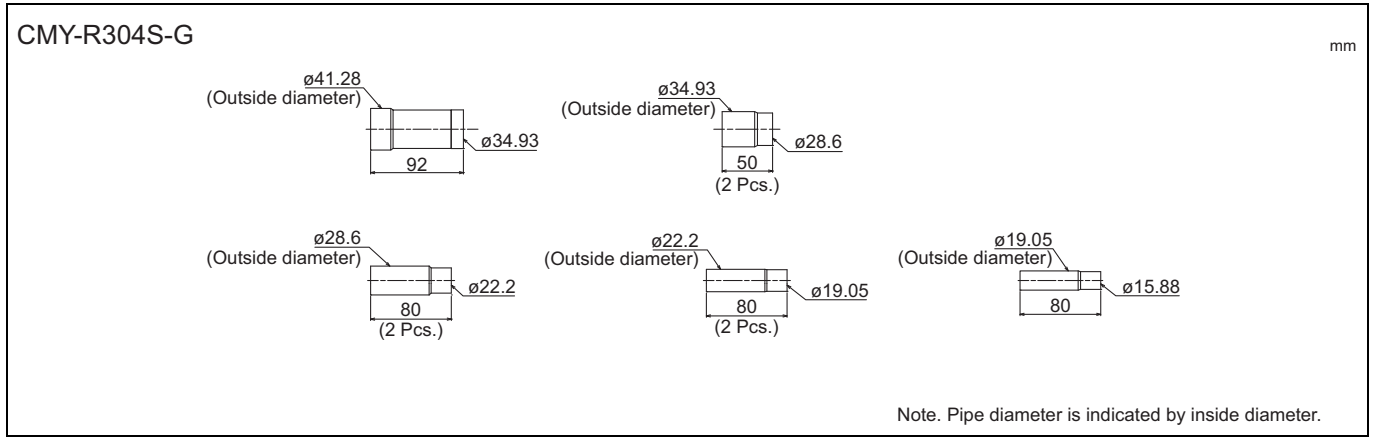
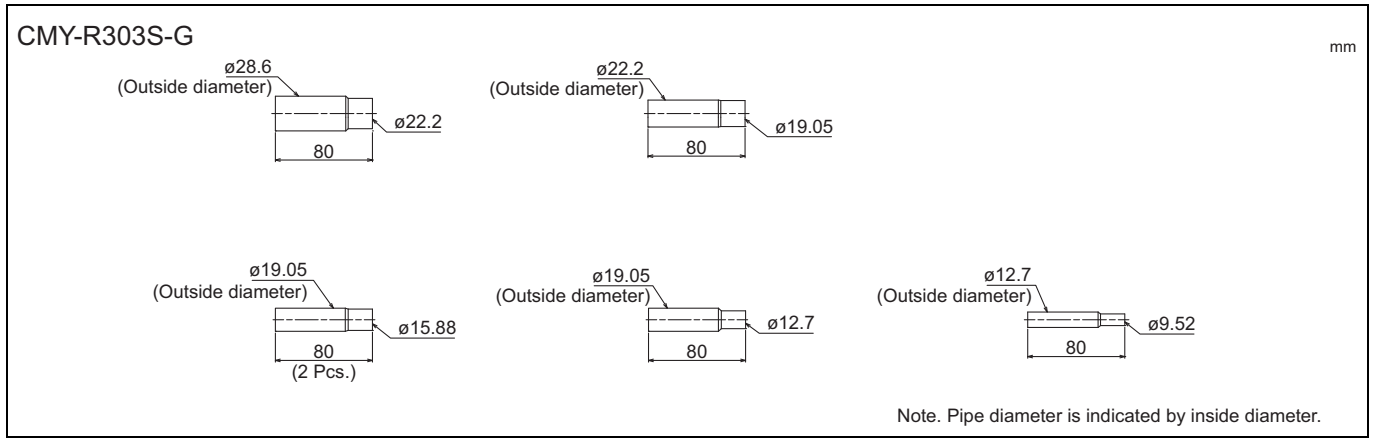
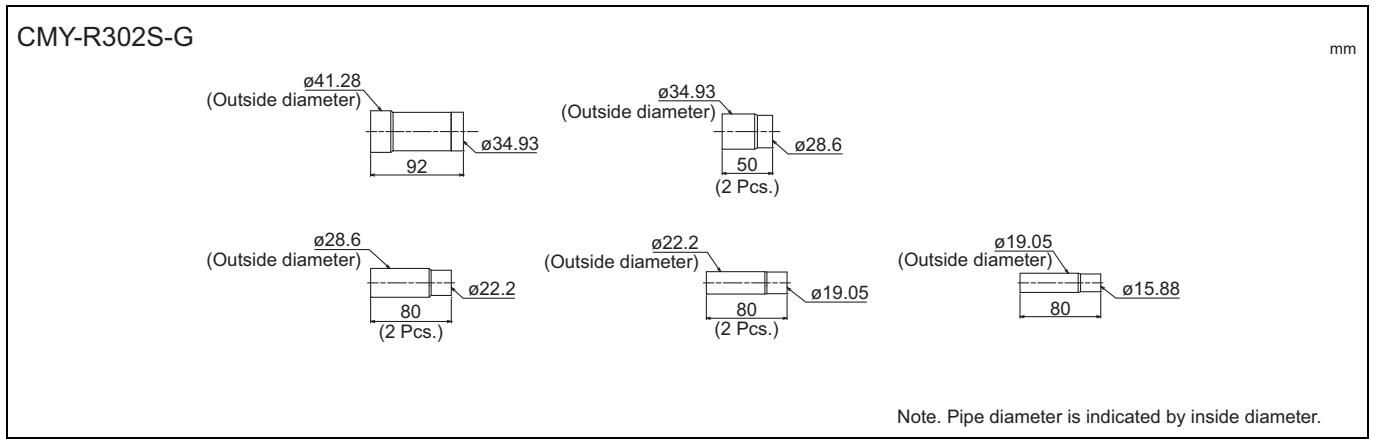
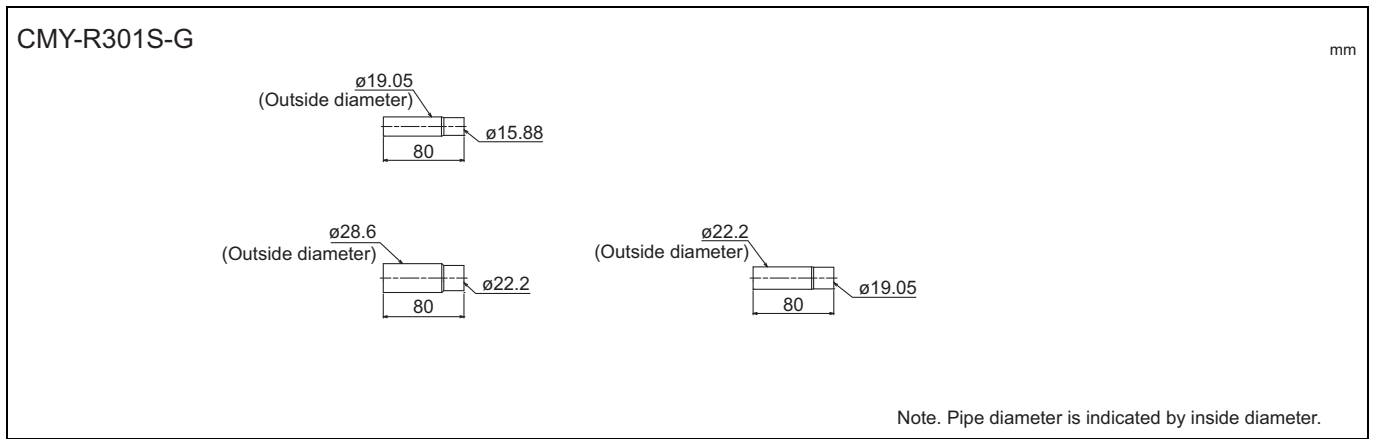

CMY-R305S-G

mm

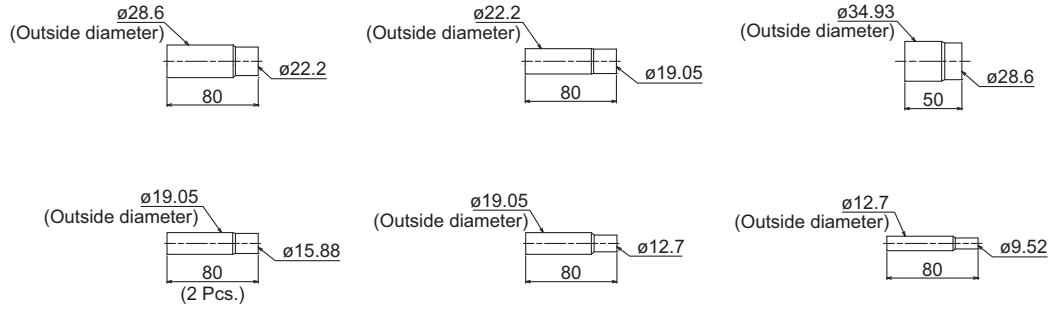

Note. Pipe diameter is indicated by inside diameter.

CMY-R306S-G

mm

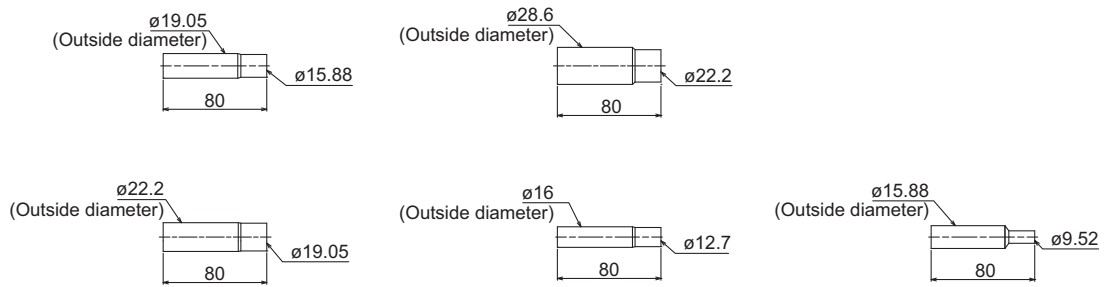

Note. Pipe diameter is indicated by inside diameter.

How to select Joint and Reducer

Outdoor/Heat source unit

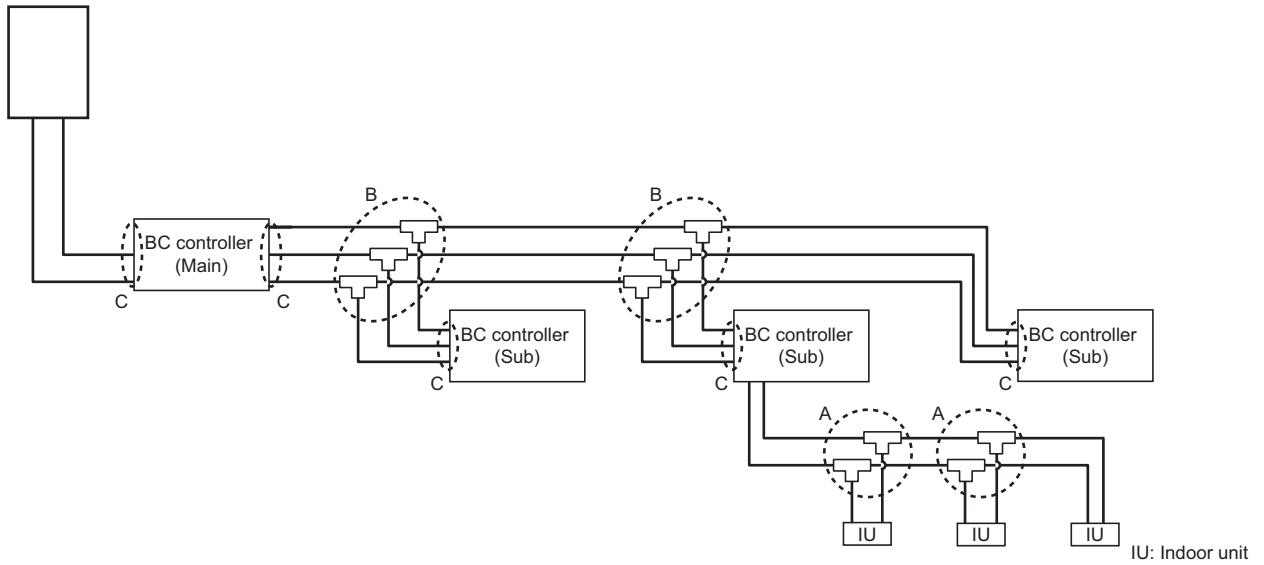

A	Branch joint	Between BC and indoor units	CMY-Y102SS-G2	Total down-stream indoor unit capacity: -P200/-M200
			CMY-Y102LS-G2	Total down-stream indoor unit capacity: P201-P250/-M201-M250
B	Branch joint	Between Main BC and Sub BC	CMY-R201S-G	Total down-stream indoor unit capacity: -P350/-M350
			CMY-R202S-G	Total down-stream indoor unit capacity: P351-P600/-M351-M450
			CMY-R203S-G	Total down-stream indoor unit capacity: P601-P650
			CMY-R204S-G	Total down-stream indoor unit capacity: P651-P1000
			CMY-R205S-G	Total down-stream indoor unit capacity: P1001-
C	Reducer	Between outdoor/heat source units and BC	CMY-R301S-G	For J1 type (Outdoor/Heat source unit capacity: P200-P300/M200-M300)
			CMY-R302S-G	For JA1 type (Outdoor/Heat source unit capacity: P200-P900/M200-M300)
			CMY-R304S-G	For KA1 type (Outdoor/Heat source unit capacity: P200-P1000)
		Between Main BC and Sub BC	CMY-R303S-G	For JA1 type (When using the Sub BC controller)
			CMY-R305S-G	For KA1 type (When using the Sub BC controller)
			CMY-R306S-G	For KB1 type

♦Items "B" is not necessary when J1-type BC controller is used.

### 6-2. JOINT KIT "CMY-R160-J1" FOR BC CONTROLLER

Joint kit "CMY-R160-J1" for BC controller is used to combine 2 ports of the BC controller at a PURY/PQRY system so as to enable down-stream Indoor capacity above P80/M80 as shown in Fig. 1.

The Joint kit include following items:

① Instruction	② Joint pipe (Small)	③ Joint pipe (Large)	④ Cover 1	⑤ Cover 2	⑥ Cover 3	⑦ Band	⑧ Reducer 1	⑨ Reducer 2
This sheet 1pc	1pc	1pc	2pcs	1pc for gas side	1pc for liquid side	8pcs	OD19.05-ID22.2 1pc	OD19.05-ID15.88 1pc

Please prepare the following items in the field. ①Tape for insulation material sealing ②Extension pipe for refrigerant circuit

② Joint pipe (for liquid side)

③ Joint pipe (for gas side)

mm (in.)

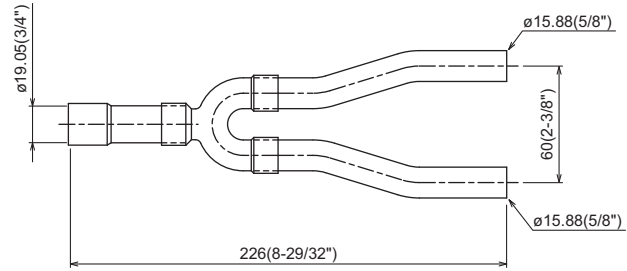
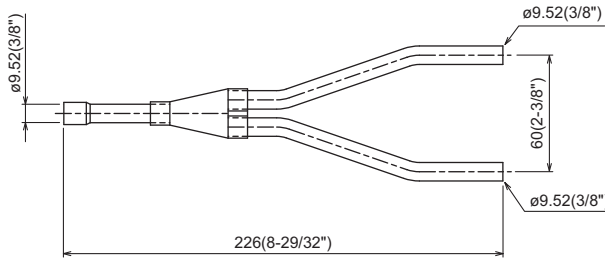

#### 1. Designing CMY-R160-J1 to a PURY/PQRY system

The maximum down-stream Indoor capacity for 1 port of BC controller is P80/M80. When the down-stream Indoor capacity is above P80/M80, Joint kit CMY-R160-J1 is needed to combined 2 ports of BC controller to enlarge the capacity, like Group 2 and 3 in Fig. 1.

Maximum 3 Indoor units are allowed to connect to 1 port of BC controller or 2 combined ports of BC controller using CMY-R160-J1.

When connecting Indoor units to 1 port of BC controller or 2 combined ports of BC controller using CMY-R160-J1 or CMY-Y102SS-G2 is applicable, like Group 1 and 2 in Fig. 1

Caution: Mixed cooling and heating mode at the same time for Indoor units connecting to 1 port or 2 combined ports is not available.

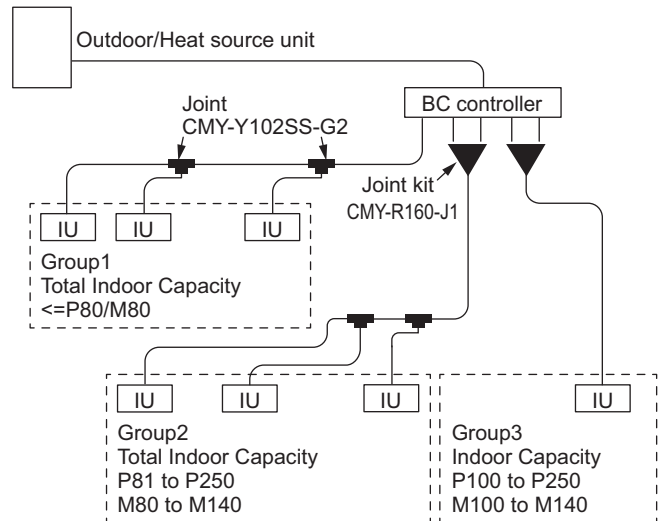

Fig.1. CMY-R160-J1 applying scheme

#### 2. Piping at the installation site

The connection of CMY-R160-J1 to BC controller and pipe leading to Indoor units is referable to Fig. 2. Non-oxidized brazing is necessary. All piping must be careful to avoid foreign material getting inside.

After piping and air-tight testing, insulation work to the Joint and pipe should be done. Details is available at the Installation Manual.

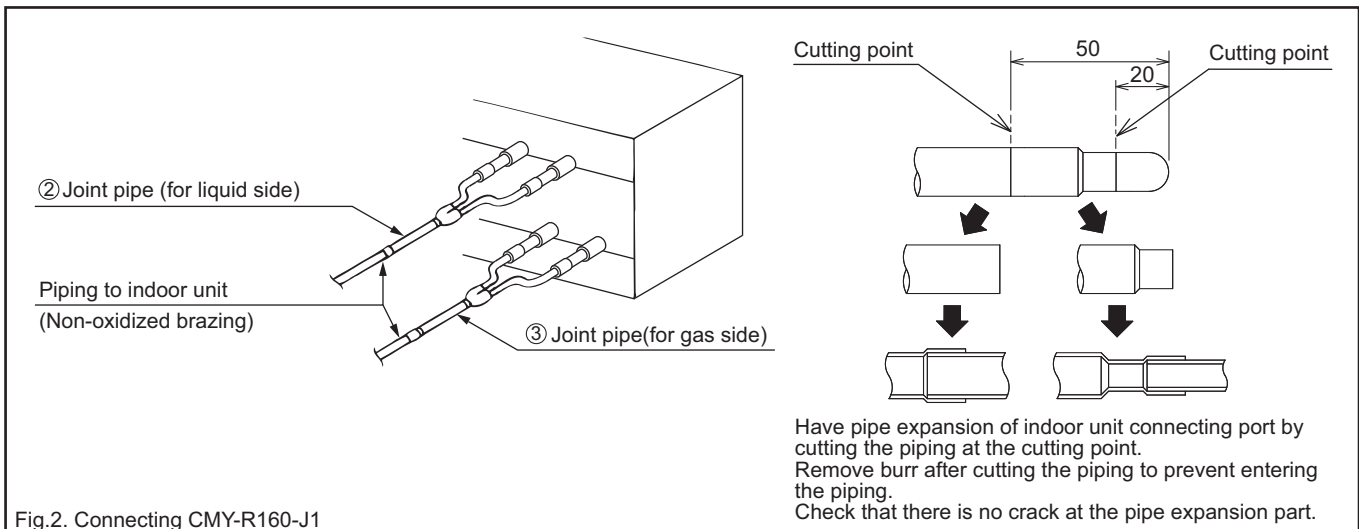

Fig.2. Connecting CMY-R160-J1

### 7-1. Installing BC controllers

#### Installing hanging bolts

Install locally procured hanging bolts (threaded rod) following the procedure given in the figure.

The hanging bolt size is  $\phi 10$  (M10 screw).

To hang the unit, use a lifting machine to lift and pass it through the hanging bolts.

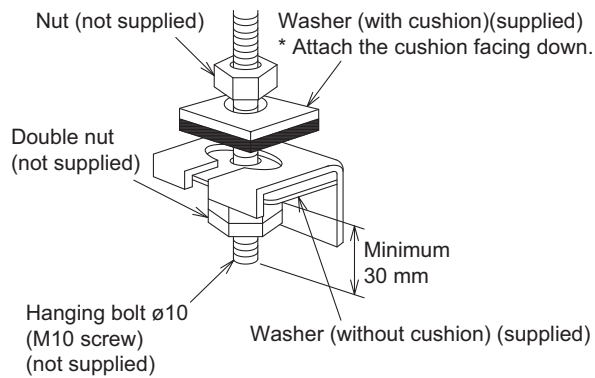

CMB-M104, 106, 108V-J1,  
CMB-M104, 108V-KB1

CMB-M1012, 1016V-J1  
CMB-M108, 1012, 1016V-JA1  
CMB-P1016V-KA1

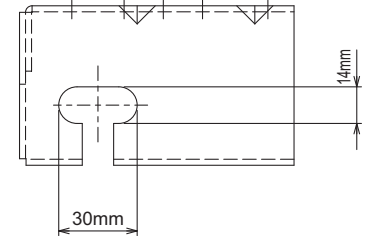
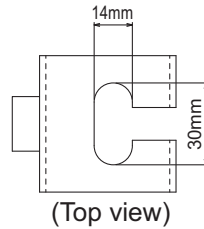

- ▶ Be sure to install the BC controller horizontally, using a level. If the controller is installed at an angle, drain water may leak out. If the controller is slanted, loosen the fixing nuts on the hanging brackets to adjust its position.
- ▶ Provide a downward pitch of  $1.5^\circ$  or below to the BC controller.
- ▶ Do not place the BC controller directly on the floor because the drain pan needs to be installed in a tilted position.

## 8-1. Compatibility

BC controller

Outdoor/Heat source unit	BC controller	Compatibility
PURY-(E)M-YNW	P-J type	Not compatible
PURY-(E)M-YNW	M-J1 type	Compatible
PURY-(E)P-Y(S)NW PURY-(E)P-Y(S)LM S/W Ver. 7.08 or later PQRY-P-Y(S)LM S/W Ver. 6.42 or later PURY-RP-Y(S)JM S/W Ver. 5.58 or later PURY-(E)P-Y(S)JM S/W Ver. 1.42 or later	P-J type	Compatible
PURY-(E)P-Y(S)NW PURY-(E)P-Y(S)LM S/W Ver. 7.08 or later PQRY-P-Y(S)LM S/W Ver. 6.42 or later PURY-RP-Y(S)JM S/W Ver. 5.58 or later PURY-(E)P-Y(S)JM S/W Ver. 1.42 or later	M-J1 type	Compatible

Outdoor/Heat source unit	BC controller		Compatibility
	Main	Sub	
PURY-(E)P-Y(S)NW	P-JA type	M-KB1 type	Compatible
PURY-(E)P-Y(S)LM S/W Ver. 7.08 or later	P-KA type	M-KB1 type	Compatible
PQRY-P-Y(S)LM S/W Ver. 6.42 or later	M-JA1 type	P-KB type	Compatible
PURY-RP-Y(S)JM S/W Ver. 5.58 or later	P-KA1 type	M-KB1 type	Compatible
PURY-(E)P-Y(S)JM S/W Ver. 1.42 or later	P-JA type	P-KB type	Compatible
	P-KA type	P-KB type	Compatible
	P-KA1 type	P-KB type	Compatible
	M-JA1 type	M-KB1 type	Compatible

Outdoor/Heat source unit	BC controller		Compatibility
	Main	Sub	
PURY-(E)M-YNW	P-JA type	M-KB1 type	Not compatible
	P-KA type	M-KB1 type	Not compatible
	M-JA1 type	P-KB type	Not compatible
	P-KA1 type	M-KB1 type	Not compatible
	P-JA type	P-KB type	Not compatible
	P-KA type	P-KB type	Not compatible
	P-KA1 type	P-KB type	Not compatible
	M-JA1 type	M-KB1 type	Compatible

8-2. System examples

Refer to “6-1. JOINT and REDUCER” and “Piping Design of Outdoor/Heat source Units” for joint/reducer selection rules, pipe length restrictions, and pipe diameter.

8-2-1. When M-J1-type BC controller is used

- Note1. No Header usable on PURY system.
- Note2. Indoor unit sized P100-P250/M100-M140 should be connected to BC controller via Y shape joint CMY-R160-J1 ; If the system consists only of PEFY-P50, 63, 71, 80, 100VMHS2-E models of indoor units, connect to the BC controller via Y-shape joint CMY-R160-J1.
- Note3. Indoor unit sized P100-P250/M100-M140 does NOT share BC controller ports with other Indoor units ;
- Note4. As bents cause pressure loss on transportation of refrigerant, fewer bents design is better ; Piping length needs to consider the actual length and equivalent length which bents are counted. Equivalent piping length (m)=Actual piping length+“M” x Number of bent.
- Note5. Set DIP-SW 4-6 to ON of BC controller, in case of connected Indoor unit sized P100-P250/M100-M140 with 2 ports. If the system consists only of PEFY-P50, 63, 71, 80, 100VMHS2-E models of indoor units, set the dipswitches SW4-1 and SW4-6 on the BC controller to ON.
- Note6. It is also possible to connect Indoor unit sized P100-P140/M100-M140 with 1 port (set DIP-SW 4-1 and 4-6 to OFF). PEFY-P50, 63, 71, 80, 100VMHS2-E models of indoor units can be connected to the system using a single port. However, the cooling capacity decreases a little.
- Note7. Do not connect multiple indoor units to the same port when operating each of them in different mode (cooling, heating, stop, and thermo-off). The indoor units connected to the same port must be set to operate in the same mode. Set them in the same group to make them run/stop in the same mode all together. For other options, enable the thermo setting on the remote controller, or set the common thermostat (optional) to run/stop the units in the same mode based on a representative temperature.
- Note8. Indoor capacity is described as its model size. For example, PEFY-P63VML-E, its capacity is P63.
- Note9. Total down-stream Indoor capacity is the summary of the model size of Indoors down-stream. For example, PEFY-P63VML-E + PEFY-P32VML-E: Total Indoor capacity = P63 + P32 = P95.
- Note10. To enable the continuous heating mode, set SW4 (848) to ON.
- Note11. To connect the BC controller to the main pipe, use the reducer.

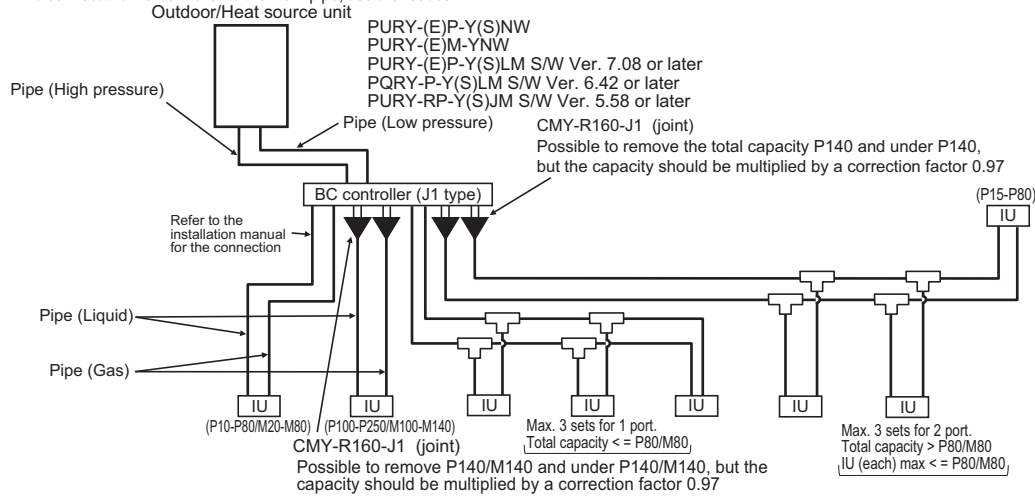
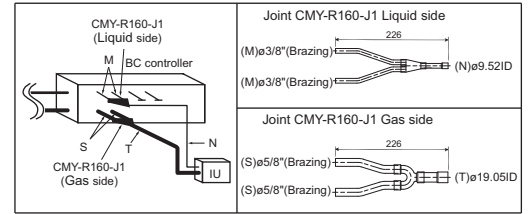

IU: Indoor unit

8-2-2. When P-J-type BC controller is used

- Note1. No Header usable on PURY system.
- Note2. Indoor unit sized P100-P250 should be connected to BC controller via Y shape joint CMY-R160-J1 ;
- Note3. Indoor unit sized P100-P250 does NOT share BC controller ports with other Indoor units ;
- Note4. As bents cause pressure loss on transportation of refrigerant, fewer bents design is better ; Piping length needs to consider the actual length and equivalent length which bents are counted. Equivalent piping length (m)=Actual piping length+“M” x Number of bent.
- Note5. Set DIP-SW 4-6 to ON of BC controller, in case of connected Indoor unit sized P100-P250 with 2 ports.
- Note6. It is also possible to connect Indoor unit sized P100-P140 with 1 port (set DIP-SW 4-6 to OFF). However, the cooling capacity decreases a little.
- Note7. Do not connect multiple indoor units to the same port when operating each of them in different mode (cooling, heating, stop, and thermo-off). The indoor units connected to the same port must be set to operate in the same mode. Set them in the same group to make them run/stop in the same mode all together. For other options, enable the thermo setting on the remote controller, or set the common thermostat (optional) to run/stop the units in the same mode based on a representative temperature.
- Note8. Indoor capacity is described as its model size. For example, PEFY-P63VML-E, its capacity is P63.
- Note9. Total down-stream Indoor capacity is the summary of the model size of Indoors down-stream. For example, PEFY-P63VML-E + PEFY-P32VML-E : Total Indoor capacity = P63 + P32 = P95.
- Note10. To enable the continuous heating mode, set SW4 (848) to ON.

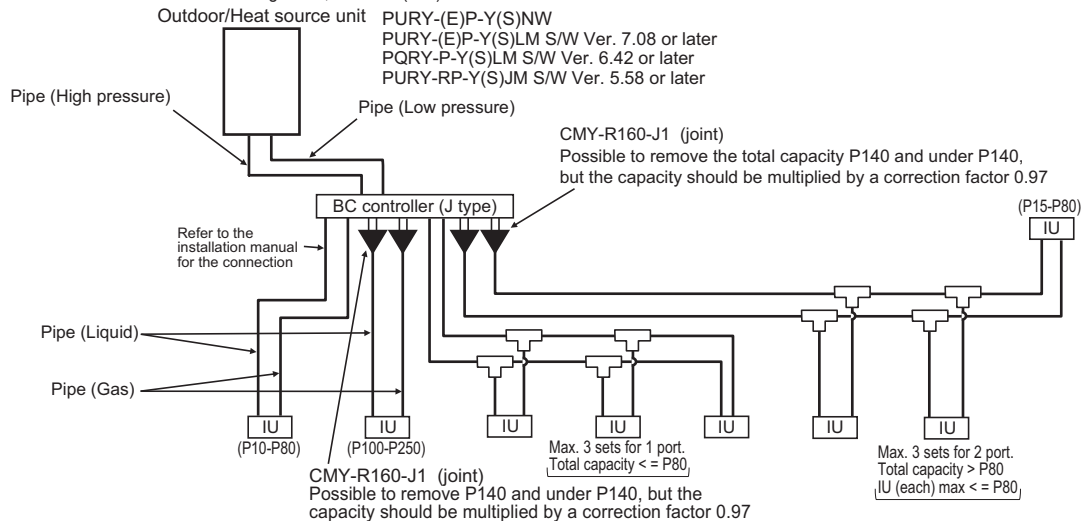
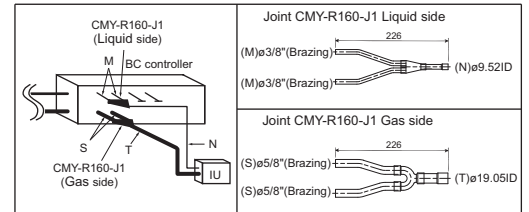

IU: Indoor unit



8-2-3. When M-JA1/P-KA1- and M-KB1/P-KB-type BC controllers are used together

- Note1. No Header usable on PURY system.
- Note2. Indoor unit sized P100-P250/M100-M140 should be connected to BC controller via Y shape joint CMY-R160-J1 ; If the system consists only of PEFY-P50, 63, 71, 80, 100VMHS2-E models of indoor units, connect to the BC controller via Y-shape joint CMY-R160-J1.
- Note3. Indoor unit sized P100-P250/M100-M140 does NOT share BC controller ports with other Indoor units ;
- Note4. As bents cause pressure loss on transportation of refrigerant, fewer bents design is better ; Piping length needs to consider the actual length and equivalent length which bents are counted. Equivalent piping length (m)=Actual piping length+“M” x Number of bent.
- Note5. Set DIP-SW 4-6 to ON of BC controller, in case of connected Indoor unit sized P100-P250/M100-M140 with 2 ports.If the system consists only of PEFY-P50, 63, 71, 80, 100VMHS2-E models of indoor units, set the dipswitches SW4-1 and SW4-6 on the BC controller to ON.
- Note6. It is also possible to connect Indoor unit sized P100-P140/M100-M140 with 1 port (set DIP-SW 4-1 and 4-6 to OFF). PEFY-P50, 63, 71, 80, 100VMHS2-E models of indoor units can be connected to the system using a single port. However, the cooling capacity decreases a little.
- Note7. Do not connect multiple indoor units to the same port when operating each of them in different mode (cooling, heating, stop, and thermo-off). The indoor units connected to the same port must be set to operate in the same mode. Set them in the same group to make them run/stop in the same mode all together. For other options, enable the thermo setting on the remote controller, or set the common thermostat (optional) to run/stop the units in the same mode based on a representative temperature.
- Note8. The maximum total capacity of indoor units that can be connected to each sub BC controller CMB-P-V-KB is 350.
- Note9. Indoor capacity is described as its model size. For example, PEFY-P63VML-E, its capacity is P63.
- Note10. Total down-stream Indoor capacity is the summary of the model size of Indoors down-stream. For example, PEFY-P63VML-E + PEFY-P32VML-E : Total Indoor capacity = P63 + P32 = P95.
- Note11. To enable the continuous heating mode, set SW4 (848) to ON.
- Note12. To connect the BC controller to the main pipe, use the reducer.
- Note13. To connect the sub BC controller to the main BC controller, use the reducer.

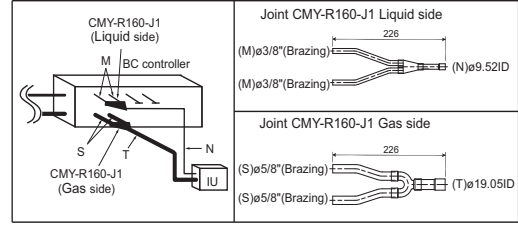

Outdoor/Heat source unit

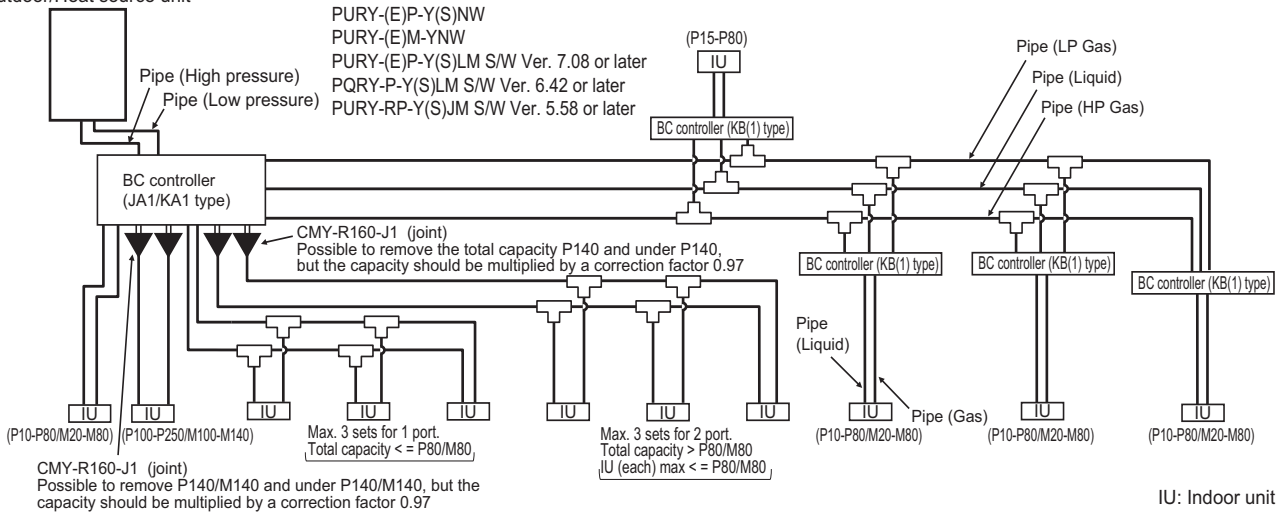

IU: Indoor unit

8-2-4. When P-JA/KA- and M-KB1/P-KB-type BC controllers are used together

- Note1. No Header usable on PURY system.
- Note2. Indoor unit sized P100-P250 should be connected to BC controller via Y shape joint CMY-R160-J1 ; If the system consists only of PEFY-P50, 63, 71, 80, 100VMHS2-E models of indoor units, connect to the BC controller via Y-shape joint CMY-R160-J1.
- Note3. Indoor unit sized P100-P250 does NOT share BC controller ports with other Indoor units ;
- Note4. As bents cause pressure loss on transportation of refrigerant, fewer bents design is better ; Piping length needs to consider the actual length and equivalent length which bents are counted. Equivalent piping length (m)=Actual piping length+“M” x Number of bent.
- Note5. Set DIP-SW 4-6 to ON of BC controller, in case of connected Indoor unit sized P100-P250 with 2 ports. If the system consists only of PEFY-P50, 63, 71, 80, 100VMHS2-E models of indoor units, set the dipswitches SW4-1 and SW4-6 on the BC controller to ON.
- Note6. It is also possible to connect Indoor unit sized P100-P140 with 1 port (set DIP-SW 4-1 and 4-6 to OFF). PEFY-P50, 63, 71, 80, 100VMHS2-E models of indoor units can be connected to the system using a single port. However, the cooling capacity decreases a little.
- Note7. Do not connect multiple indoor units to the same port when operating each of them in different mode (cooling, heating, stop, and thermo-off). The indoor units connected to the same port must be set to operate in the same mode. Set them in the same group to make them run/stop in the same mode all together. For other options, enable the thermo setting on the remote controller, or set the common thermostat (optional) to run/stop the units in the same mode based on a representative temperature.
- Note8. For sub BC controller CMB-P-V-GB1 the connectable indoor unit capacities may sum to equal that of a P350 unit or less. However, if two sub controllers are used the TOTAL sum of connectable units connected to BOTH sub controllers must also not exceed that of a P350 unit. For sub BC controller CMB-P1016V-HB1 the connectable indoor unit capacities may sum to equal that of a P350 unit or less. However, if two sub controllers are used the TOTAL sum of connectable units connected to BOTH sub controllers must also not exceed that of a P450 unit.
- Note9. Indoor capacity is described as its model size. For example, PEFY-P63VML-E, its capacity is P63.
- Note10. Total down-stream Indoor capacity is the summary of the model size of Indoors down-stream. For example, PEFY-P63VML-E + PEFY-P32VML-E : Total Indoor capacity = P63 + P32 = P95.
- Note11. To enable the continuous heating mode, set SW4 (848) to ON.
- Note12. To connect the BC controller to the main pipe, use the reducer.
- Note13. To connect the sub BC controller to the main BC controller, use the reducer.

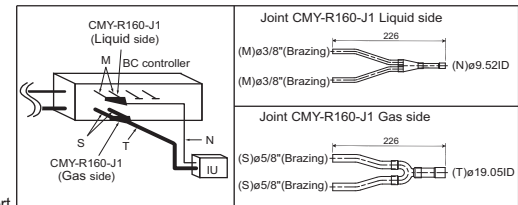

Outdoor/Heat source unit

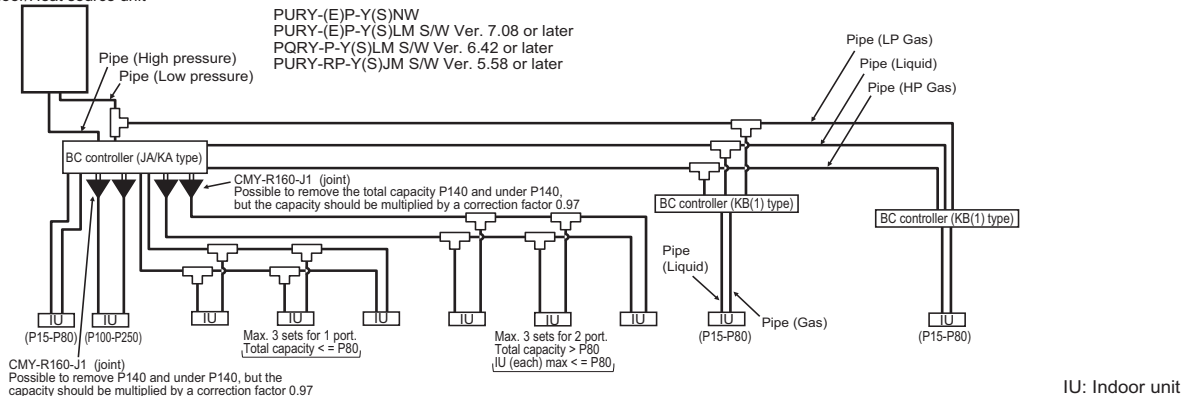

IU: Indoor unit



**for a greener tomorrow**

Eco Changes is the Mitsubishi Electric Group's environmental statement, and expresses the Group's stance on environmental management. Through a wide range of businesses, we are helping contribute to the realization of a sustainable society.

**⚠ Warning**

- Do not use refrigerant other than the type indicated in the manuals provided with the unit and on the nameplate.
  - Doing so may cause the unit or pipes to burst, or result in explosion or fire during use, repair, or at the time of disposal of the unit.
  - It may also be in violation of applicable laws.
  - MITSUBISHI ELECTRIC CORPORATION cannot be held responsible for malfunctions or accidents resulting from the use of the wrong type of refrigerant.
- Our air conditioning equipment and heat pumps contain a fluorinated greenhouse gas, R32 or R410A.

**MITSUBISHI ELECTRIC CORPORATION**

[www.MitsubishiElectric.com](http://www.MitsubishiElectric.com)