



**Mitsubishi Electric Air Conditioner Network System****PI controller****PAC-YG60MCA****Installation/Instruction Manual****Table of Contents**

	Page
1. Safety Precautions .....	1
2. Usage .....	2
3. Parts List.....	2
4. Specifications .....	2
4-1. Device Specifications .....	2
4-2. External Dimensions.....	3
5. Example of System Configuration .....	4
6. Installation .....	5
6-1. Parts Purchased Separately.....	5
6-2. Installation Instructions .....	6
7. Wiring Instructions .....	7
7-1. Terminal Diagram .....	7
7-2. Connecting the Power and M-NET Transmission Lines.....	8
7-3. Connecting the Signal Lines.....	9
(1) Pulse input (non-voltage a-contact)....	9
8. Initial Settings .....	9
9. Dip Switch Functions .....	11
10. LED Display Designations .....	12
10-1. Pulse Input and Error Displays .....	12
10-2. Communication Error Displays .....	12
11. System Operation Test.....	13
12. Precautions for Expansion.....	13

# 1 Safety Precautions

- Thoroughly read the following safety precautions before use.
- Hazards that can occur from incorrect handling are classified by the symbols below:

 Warning	Incorrect handling can result in death, serious injury, etc.
 Caution	Incorrect handling can result in bodily injury and/or structure damage.

- After reading this manual, keep this manual for future reference. When the device is reinstalled or repaired, give this manual to those who provide these services. When the user changes, make sure that the new user receives this manual.

## WARNING

**Only a dealer or qualified technician should install, relocate, reinstall, or repair the device.**  
Improper installation or repair may result in electrical shock or fire.

**Properly install the device on a stable, load-bearing surface.**  
Device installed on an unstable surface may fall and cause injury.

**Only use the specified cables; securely connect each so that the terminals do not bear any cable weight.**  
Improperly connected or short-circuited cables may produce heat and cause a fire.

**Do not make any modifications or alternations to the device.**  
Modifications or improper repair may result in electric shock or fire. Consult your dealer for repair.

**All electrical work should be performed by an authorized electrician according to local regulations and instructions outlined in this manual.**  
Capacity shortage to the power supply circuit or improper installation may result in electrical shock or fire.

**Properly install the device according to the instructions in this Installation/Instruction Manual.**  
Improper installation may result in electric shock or fire.

## CAUTION

**Do not install the device in a location where a flammable gas leak may occur.**  
Gas may leak, collect around the device, ignite, and/or explode.

**Do not install the device in environments where large amounts of oil (including machine), sulfidizing gas, or acidic, alkaline, chemical sprays are present.**  
These types of substances may damage internal parts, cause device performance to be reduced, and cause electrical shock.

**When installing the device in a hospital, communication facilities, etc., provide sufficient protection against frequency noise.**  
Power generators and inverters, high-frequency medical, or radio communication equipment may interfere with the normal operation of this device. Subsequently, the device may also affect medical treatment, image broadcasting, etc., by creating frequency noise.

**Include some slack in the power supply wires.**  
Tension on the wires may cause them to excessively heat up and/or break, resulting in a fire.

**Do not install the device in a location where there is direct sunlight or where the temperature may become greater than 40°C (104°F) or less than 0°C (32°F).**  
If the device is installed in such place, it may result in deformation or malfunctions.

**Do not install the device in a bathroom, kitchen, or any room where steam could form.** Condensation may develop and cause electrical shock and/or the device to malfunction.

**Use standard wires with the proper current capacity** to avoid the possibility of current leak, excessive heat, and/or fire.

**Do not touch the main circuit board; also, make sure that dust does not accumulate on the circuit board.**

**Do not immerse the device in water.**  
Doing so may lead to electric shock or malfunctions.

**The maximum applied voltage for the device is 24 VDC - do not use with an AC power source. (The maximum applied voltage for the M-NET terminal is 30 VDC.)**  
Using the incorrect voltage may result in device failure, ignition, and/or fire.

## Additional Precautions

If the supply cord is damaged, it must be replaced by the manufacturer, its service agent or similarly qualified persons in order to avoid a hazard.

This appliance is not intended for use by persons (including children) with reduced physical, sensory or mental capabilities, or lack of experience and knowledge, unless they have been given supervision or instruction concerning use of the appliance by a person responsible for their safety. Children should be supervised to ensure that they do not play with the appliance.

This appliance is intended to be used by expert or trained users in shops, in light industry and on farms, or for commercial use by lay persons.

## 2 Usage

The PI controller counts pulses from a power meter, gas meter, water meter, and calorimeter. Combining the use of the EB-50GU, AG-150A, GB-50ADA, G(B)-50A and TG-2000A allows for calculating the charges for each unit and performing peak-cut (e.g., demand control) operation.

Meter settings can be set and the meter readings can be monitored from the EB-50GU Web browser, AG-150A LCDs/ Web browser, GB-50ADA Web browser, G-50A Web browser, and TG-2000A, but not from the LCDs on the G-50A.

### ⚠ Caution: Usage Restrictions

- Mitsubishi Electric does not take financial responsibility for damages caused by issues beyond our control or special circumstances (predicable or unpredictable); and secondary or accidental damages, and damages to other objects. We also do not take financial responsibility for opportunities lost as a result of device failure, or electrical power failure at the end-user site.  
Mitsubishi Electric does not take financial responsibility caused by end-users' requests including, but not limited to, device testing, startup, readjustment, and replacement.
- Because the PI controller only counts pulses, accuracy and performance of pulse conversion depend on the meter. Mitsubishi Electric does not take financial responsibility for damages caused by issues beyond our control or special circumstances (predicable or unpredictable); and secondary or accidental damages and damages to other object.
- Depending on each country's laws and regulations, etc., there may be cases these measured charges cannot be used for certificate of transaction.

## 3 Parts List

- The following parts should be included in your shipment:

Number	Part Name	Quantity
1	PI controller	1
2	Installation/instruction manual (this document)	1

\* In addition to the parts listed above, see your local Mitsubishi Electric dealer to purchase the other parts necessary to operate this device (Refer to section 6-1). Furthermore, depending on the application, other Mitsubishi Electric parts may be required. For details, refer to "6. Installation".

## 4 Specifications

### 4-1. Device Specifications

Item	Rating and Specification		
Power Supply	24 VDC±10%: 5 W		
Interface	M-NET communication	17 to 30 VDC (*1)	
	Non-voltage a-contact input	Number of contacts: 4 Pulse signal: a-contact Pulse width: 100 ms to 300 ms (Idle period until next pulse: 100 ms or more) <div style="text-align: center;"> </div> Rated voltage: 24 VDC Rated current: 1 mA or less (*2)	
Environment Conditions	Temperature	Operating temperature range	0 to 40°C [32°F to 104°F]
		Storage temperature range	-20 to 60°C [-4°F to 140°F]
	Humidity	30 to 90%RH (no condensation)	
Dimensions	200 (W) × 120 (H) × 45 (D) mm / 77/8 (W) × 43/4 (H) × 125/32 (D) in		
Weight	0.6 kg / 13/8 lb		
Time Backup During Power Failure	In the event of power failure or shut-off, the internal capacitor will continue to track time for approximately one week. (The internal capacitor takes about 24 hours to fully charge; a replacement battery is not necessary.)		
Installation Environment	Inside the metal control panel (indoors) * Use this product in a hotel, a business office environment or similar environment.		
Sound Pressure Level	The A-weighted sound pressure level is below 70 dB.		

\*1: Supply electric power from a power unit for the transmission line or an outdoor unit. Furthermore, the power consumption factor of the M-NET circuitry of this device is "1/4" (equivalent to one ME Remote Controller).

\*2: Supply electric power from the main unit to the contacts of the meters.

\*3: M3 is the size of the screw on the terminal block (ISO metric screw thread). The number indicates the screw diameter (mm).

## 4-2. External Dimensions

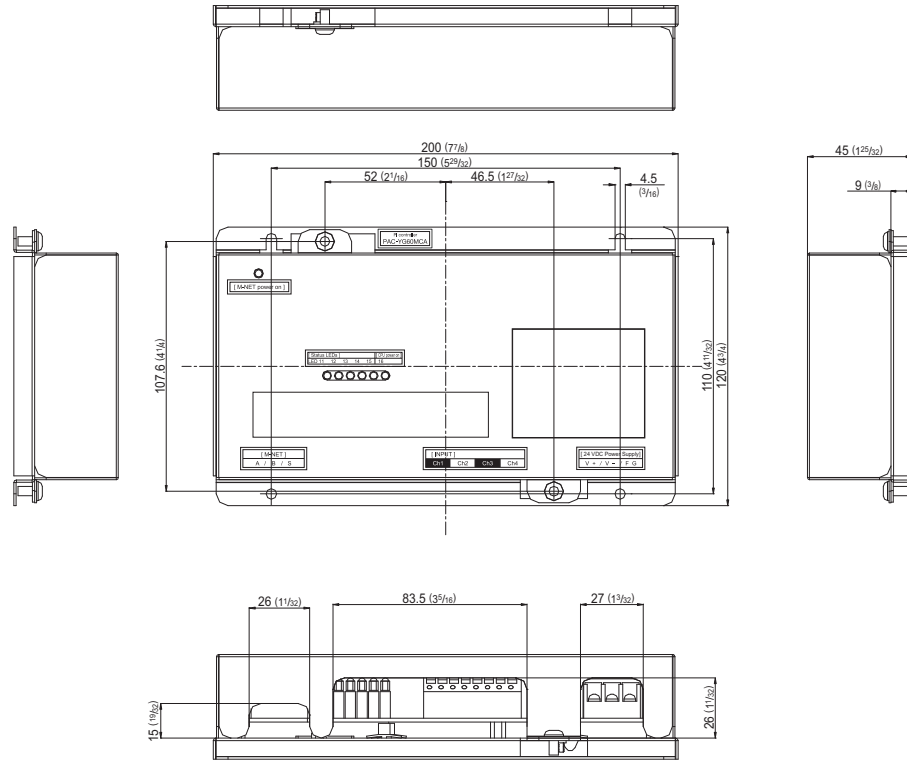

Unit: mm (in)

## 5 Example of System Configuration

### <Restrictions>

For the maximum number of connectable units in cases when this controller is managed by the system controller or TG-2000A, refer to the manual supplied with the system controller or TG-2000A.

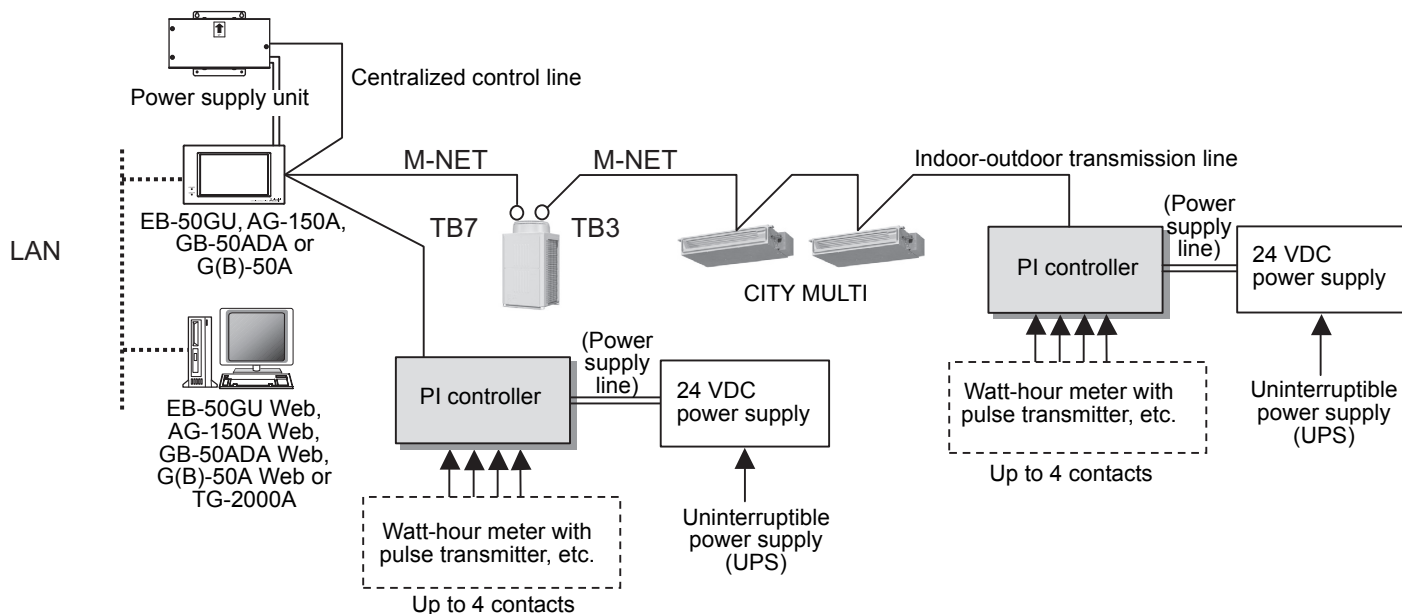

\* This figure omits the power supply line and only shows the transmission line. (The power supply lines to the AG-150A and PI controller are shown.)

### Note:

- For the shield ground of the M-NET centralized control line for central control, use single-point grounding at the power unit for the transmission line. However, when supplying electric power to the M-NET centralized control line from the R410A series outdoor unit without using a power supply unit for the transmission line, use single-point grounding at the TB7 of that outdoor unit. Furthermore, when connecting this device to the M-NET indoor-outdoor transmission line, use grounding at the TB3 for each outdoor unit system.
- Connecting an Uninterruptible power supply (UPS) to the 24 VDC power supply is recommended in order to prevent the loss of pulse data in the event of a power failure. If a UPS cannot be connected, try to make the AC power supply to the 24 VDC power supply as much same as the AC power supply line to the meters.
- This device does not support level meters. To use a level meter, incorporate a Converter circuit externally and convert to pulse input.
- If the M-NET transmission line of this device is connected to an M-NET indoor-outdoor transmission line and the outdoor unit is down because, for example, the power supply is interrupted for servicing or there is a failure, the PI controller cannot be controlled from the system controller.
- Settings for the meters connected to the PI controller can be set and their meter readings can be monitored from the EB-50GU Web browser, AG-150A LCDs/Web browser, GB-50ADA Web browser, G-50A Web browser, and TG-2000A, but not from the LCDs on the G-50A.

## 6 Installation

### 6-1. Parts Purchased Separately

Prepare the following parts to install this device.

Required Part	Specification
Unit fixing screws	M4 screw × 4 (* M4: ISO metric screw thread)
Power supply for this device	Power source: 24 VDC 0.2 A (Minimum loading), SELV circuit, power line with grounding terminal Ripple noise: Lower than 200 mVp-p Compatible specification Authorized or CE marked products Subject to regulations: - IEC60950 (or EN60950) - CISPR22/24 (or EN55022/24) - IEC61000-3-2/3-3 (or EN61000-3-2/3-3) (With enhanced insulation and has a withstand voltage of (3kV 1 minute) between the primary and secondary sides.)
Power line	Use a sheathed vinyl cord or cable. At least 0.75 mm <sup>2</sup> (AWG18)
M-NET transmission line	Type of the cable: Sheathed vinyl cords or cable which comply with the following specifications or equivalent. • CPEV $\Phi$ 1.2 mm to $\Phi$ 1.6 mm • CVVS 1.25 mm <sup>2</sup> to 2 mm <sup>2</sup> (AWG16 to 14) * CPEV: PE insulated PVC jacketed shielded communication cable * CVVS: PVC insulated PVC jacketed shielded control cable PE: Polyethylene PVC: Polyvinyl chloride Power needs to be supplied to the M-NET circuitry of this device. Use an outdoor unit or a separately purchased power supply unit for the transmission line.
Signal lines	Shows the size of the electric wire (copper wire) that is adapted to the terminal block of this device. Electric wire size..... (1) Solid wire: $\Phi$ 0.65 mm (AWG21) - $\Phi$ 1.2 mm (AWG16) (2) Stranded wire: 0.75 mm <sup>2</sup> (AWG18) - 1.25 mm <sup>2</sup> (AWG16) Single strand: At least $\Phi$ 0.18 mm

[Parts to be Purchased Separately]

Name	Model	Application	Remark
Power supply unit	PAC-SC51KUA or PAC-SC50KUA etc.	Power supply to the M-NET transmission line	This is not required when power is to be supplied from an outdoor unit.

[Commercially available parts]

Part	Use	Remark
External 24 VDC power source	Supplies power to the PI controller.	Refer to "Power supply for this device" in "Required Part" above for the capacity of the power supply.

[Recommended Pulse Specifications]

Prepare a measuring instrument that measures the type of pulse signals indicated in table below.

Type	Specification
Output pulse relay method	Semiconductor relay method
Output pulse width	100 ~ 300 ms (100 ms and above) Choose an instrument that outputs non-voltage a-contact point pulse per each pulse output.
Pulse unit	Watt-hour meter: 0.1 kWh/pulse, 1 kWh/pulse recommended Water meter: m <sup>3</sup> /pulse Gas meter: m <sup>3</sup> /pulse Calorimeter: MJ/pulse * Except for the watt-hour meter, select instruments that take measurements in the appropriate pulse unit.

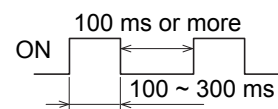

## 6-2. Installation Instructions

The PI controller PAC-YG60MCA does not have a waterproof structure.

Be sure to install the PI controller inside a metal control panel that is located indoors.

Prepare a metal control panel capable of storing this device such as the one shown in the figure. (Install the device in a metal control panel strong enough to withstand a weight of 0.6 kg [1<sup>3</sup>/<sub>8</sub> lb].)

This device can be installed horizontally, or as shown below, vertically. The following diagram also provides a rough estimate of how much space is required around the installation.

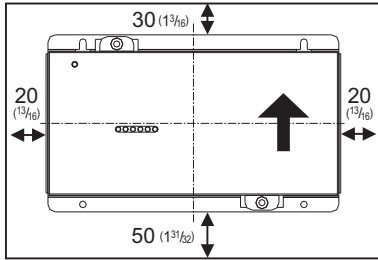

Size of the device: 200 (W) × 120 (H) × 45 (D) mm/  
77/8 (W) × 43/4 (H) × 125/32 (D) in

Unit: mm (in)

Note: The space shown above does not include space for peripherals. Additionally, the amount of space necessary varies according to the functions that are used and the wiring method. Secure enough space appropriate for the type of installation.

- (1) Fix the top of this device to the metal control panel at two points by loosely tightening the screws (M4) that were procured locally. Fix the bottom in place with two screws and then tighten all four of the screws.

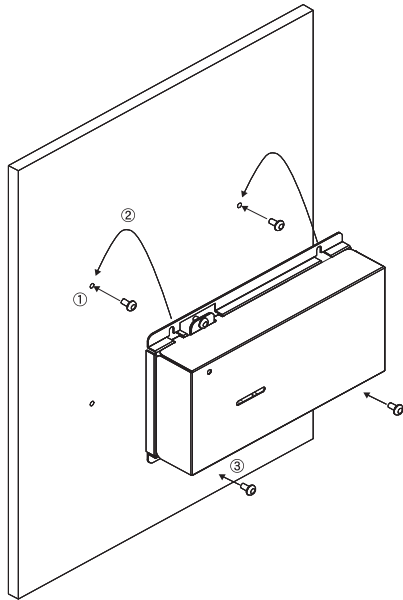

Screw pitch

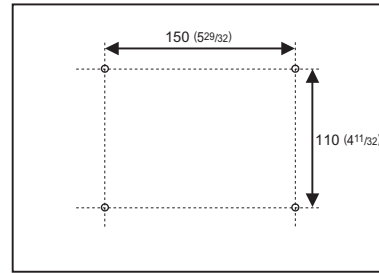

Unit: mm (in)

- (2) To remove the cover, as shown in the figure, remove the two screws for fixing the cover in place and then remove the cover by unhooking the upper hook section from the lower case. To attach the cover, hook the upper hook section on the lower case and then fix the cover in place with the two screws that were removed.

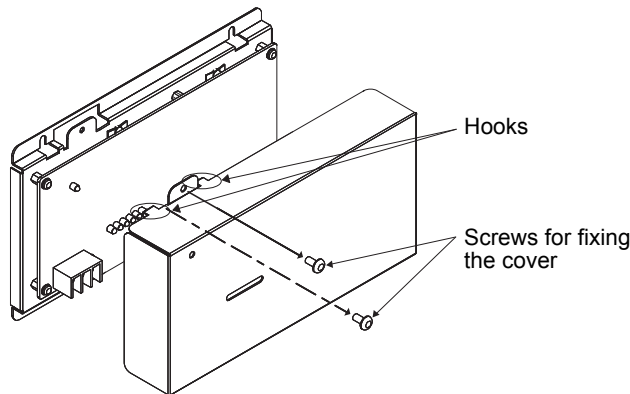

Note: Two hooks are located on the upper section of the cover.

(3) Refer to "7. Wiring Instructions" and connect the wires for the power line, M-NET transmission line, and power line (to the unit to be measured).

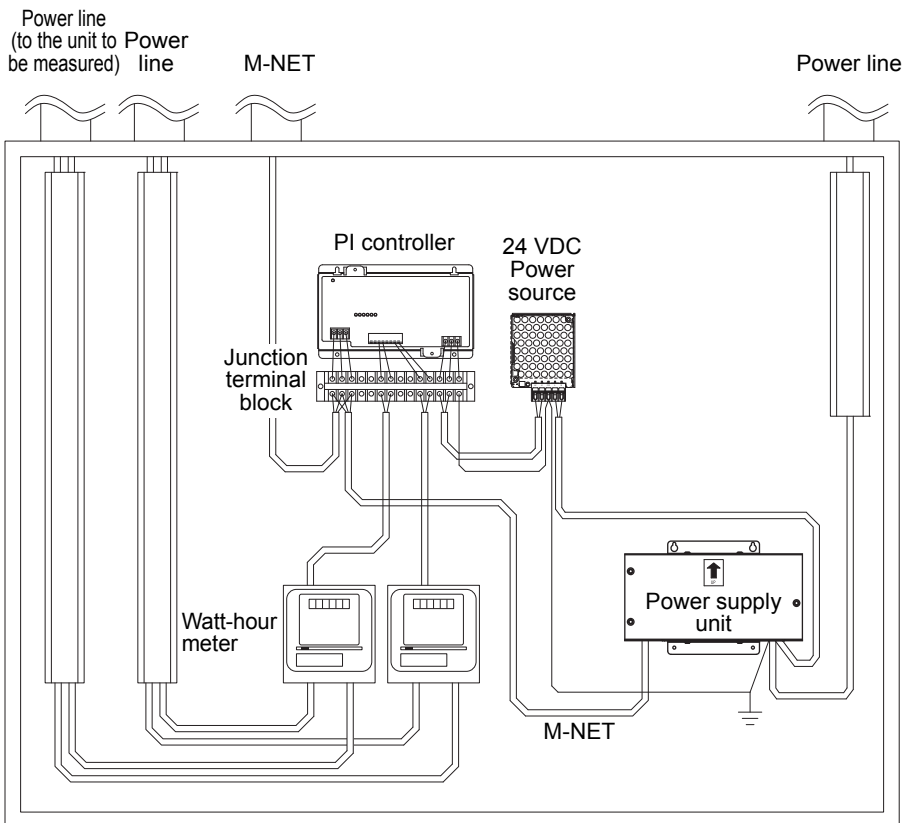

Diagram Image (Installed within a metal control panel)

**Caution:**

- Perform wiring so that the terminal block is not strained. If strained, use a wire guide or junction terminal to alleviate the stress on the terminal block.
- Do not connect the wires directly from the top of the metal control panel to the terminal block. Moisture may enter this device along the wiring and cause electric shock or fire.

**Note:**

- The input signal line should not come into contact with or be installed alongside the M-NET transmission line and power supply line.
- Connecting an Uninterruptible power supply (UPS) to the 24 VDC power supply is recommended in order to prevent the loss of pulse data in the event of a power failure.
- If a UPS cannot be connected, try to make the AC power supply to the 24 VDC power supply as much same as the AC power supply line to the meters.

\* The wiring in the diagram has been simplified.

## 7 Wiring Instructions

### 7-1. Terminal Diagram

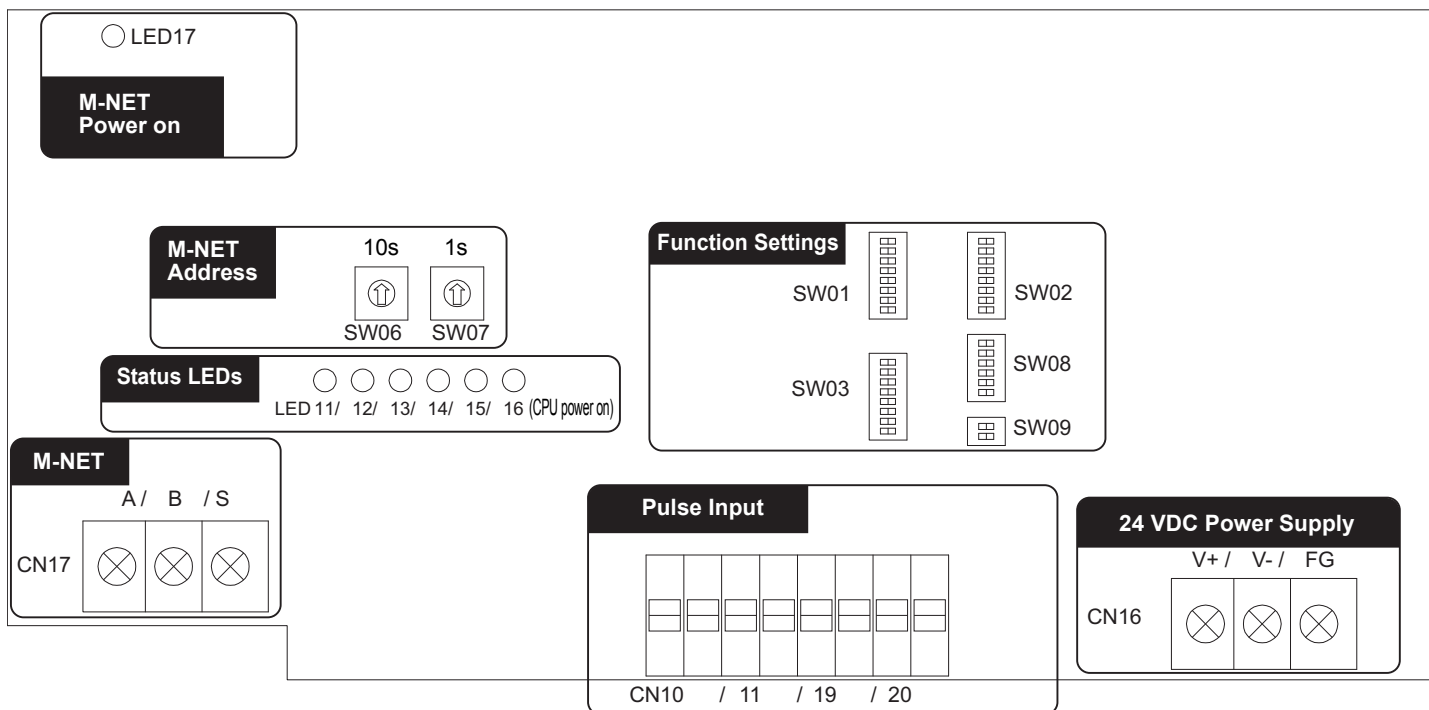



## 7-2. Connecting the Power and M-NET Transmission Lines

Tightening torque for terminal screws: 1 N·m

Connect the M-NET transmission line (either the centralized control line or indoor-outdoor transmission line) to CN17 on the controller.

Connect the power supply line (24 VDC, polarized) to CN16 on the controller.

\* Only the M-NET circuitry of this device receives the power from the M-NET transmission line. The power consumption factor is "1/4" (equivalent to one ME Remote Controller).

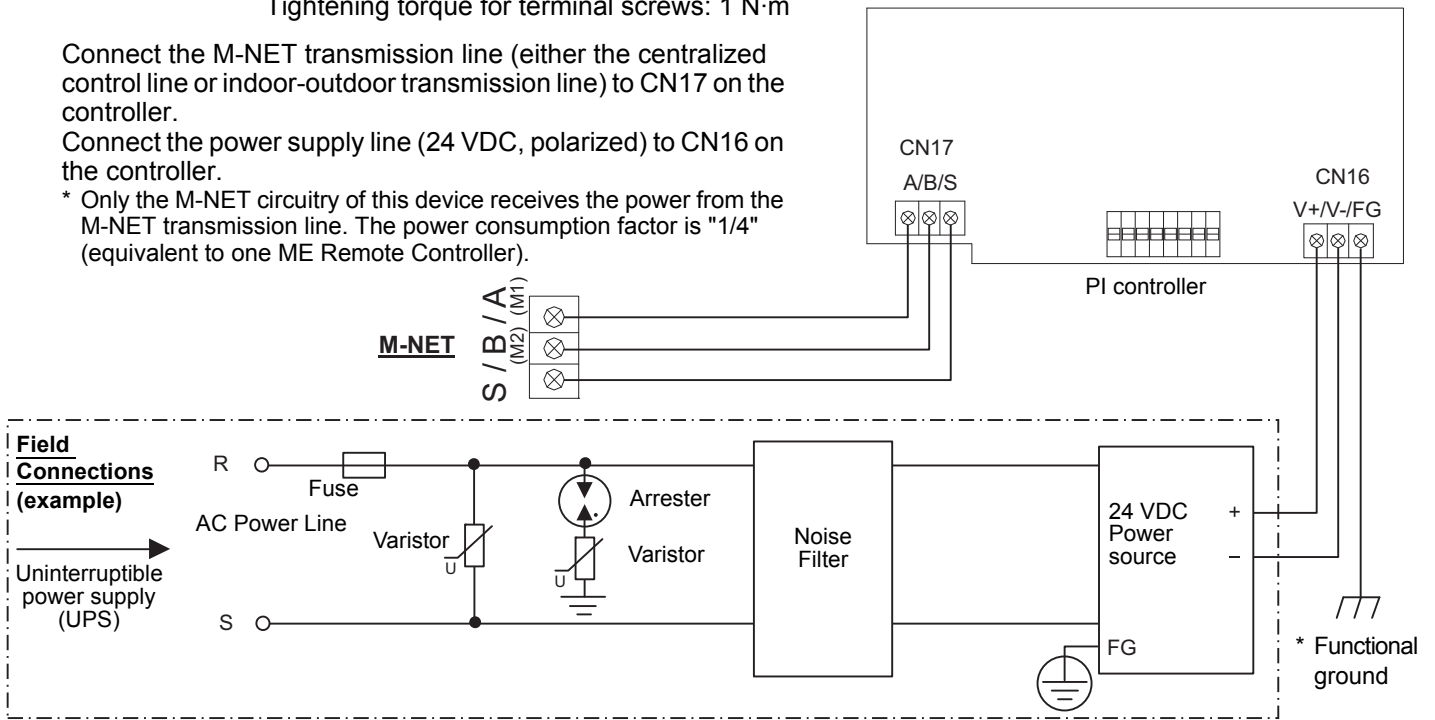

Figure 7-1 Example of Connecting the Power Line and M-NET Transmission Line

### ⚠ Caution:

- Use a power line and M-NET transmission line that satisfy the specifications described in "6-1. Parts Purchased Separately".
- Attach a circuit comprising the following components to the supply primary side of the 24 VDC power supply.
  - (1) Varistor, (2) Arrester, (3) Noise filter, (4) Fuse
- It is important to pay attention to the polarity when connecting to the 24 VDC power supply terminal block. Connecting the positive and negative in the reverse order will cause a failure.
- Fix the power line and M-NET transmission line in place on the outside to ensure that the terminal block is not affected by any external force.
 

Not securely connecting and fixing the wires in place may cause heat generation and fire.
- Make sure that the copper wiring is not short-circuiting the plates (cover, lower case) or neighboring wires.
 

Cover the shielded line of the M-NET transmission line with materials such as vinyl tape and prevent short-circuiting with the plates.

### Note:

- Connecting an Uninterruptible power supply (UPS) is recommended in order to prevent the loss of pulse data in the event of a power failure. If a UPS cannot be connected, try to make the AC power supply to the 24 VDC power supply as much same as the AC power supply line to the meters.
- If the M-NET transmission line of this device is connected to an M-NET indoor-outdoor transmission line and the outdoor unit is down because, for example, the power supply is interrupted for servicing or there is a failure, the PI controller cannot be set and monitored from the system controller.

### 7-3. Connecting the Signal Lines

- Separately procure items such as terminal blocks and cables locally.
- The maximum wire length is 100 m (328 ft). However, since the use of long wires makes the device susceptible to noise, using wires shorter than 10 m (32.8 ft) is recommended.

(1) Pulse input (non-voltage a-contact)

\* To use these, various settings need to be configured. Refer to "8. Initial Settings".

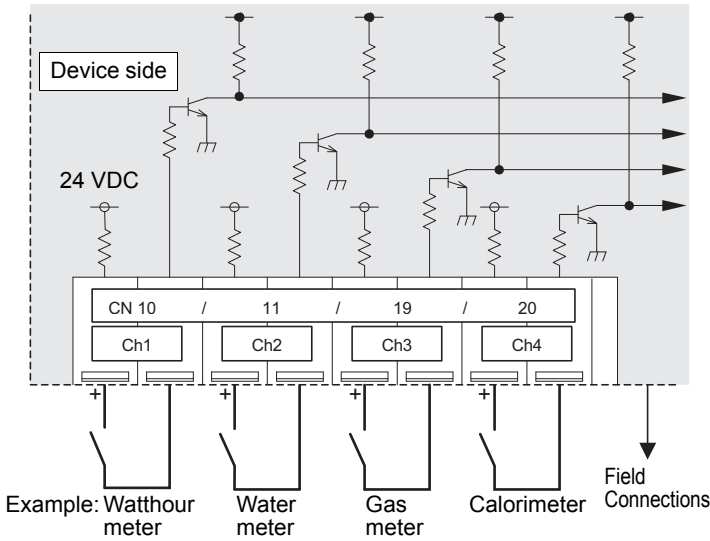
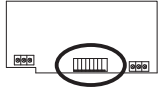

\* A pulse is counted each time a meter's output-pulse contacts turn on.

**Note:**

- The pulse unit (weight) can be added to each of the inputs of channels 1 to 4. For details, refer to "9. Dip Switch Functions".
- This device does not support level meters. To use a level meter, incorporate a Converter circuit externally and convert to pulse input.

**Caution:**

- The polarity of the input terminals is important, so be sure to match the polarity when using contacts that have polarity.
- Select a contact with a minimum applicable load of 1 mA or less.
- Supply 24 VDC 1 mA from the positive terminal to the contacts of the meters.
- The pulse unit of the watt-hour meter being used should be 1 kWh/pulse or less. Note that the apportioning error will increase if a watt-hour meter with large pulse unit is used.
- The input signal line should not come into contact with or be installed alongside the M-NET transmission line and power supply line. Care must also be taken to avoid wiring loops.
- Strip 12±1 mm (15/32 ±1/32 in) of the wire coating and insert firmly into the terminal.
- Make sure that the copper wiring is not short-circuiting the plates (cover, lower case) or neighboring wires.
- Perform wiring so that the terminal block is not strained. If strained, use a wire guide or junction terminal to alleviate the stress on the terminal block.

## 8 Initial Settings

After completing the procedures described in "6. Installation" and "7. Wiring Instructions", set the initial settings in accordance with the procedure described below.

(1) M-NET address settings

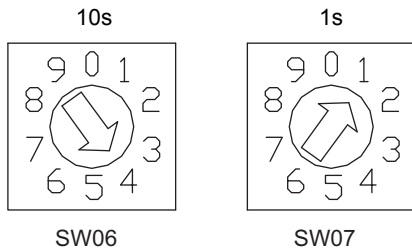

In the case of address "41"

**Note:**

- An address from 01 to 50 can be set.
- Set an address that is not the same as that of another unit.

The address is set to "01" at factory default.

(2) Use the dip switches to select functions.

Select the function required for each input channel to be used.

The switch assignment for each channel is shown below. Configure each of the settings while referring to "9. Dip Switch Functions".

Make sure to set whether to use Input contact for the input channel to ON (SW01-1, 2, 3, 4).

Setting	Operation Switch			
	Ch1	Ch2	Ch3	Ch4
Whether to use Input contact	SW01-1	SW01-2	SW01-3	SW01-4
Pulse unit (weight) value	SW02-1, 2	SW02-3, 4	SW02-5, 6	SW02-7, 8

Note:

- When connecting a system controller (EB-50GU, AG-150A, GB-50ADA, G(B)-50A or TG-2000A), set the pulse unit (weight) value to "SC setting". (Recommended)
- If measuring usage amounts without connecting a system controller, set the pulse unit (weight) value to "× 0.1", "× 1.0", or "× 10" as appropriate.

⚠ Caution:

- Be sure to configure the pulse unit (weight) settings. If these setting are not configured, the charge function and peak cut control will not work normally because correct measurement of usage amounts will not be made.

(3) Turn on the power of this device.

Verify that the LED16 (CPU power on) and LED17 (M-NET power on) are lit.

(4) Set the time.

Set the current time from a system controller (EB-50GU, AG-150A, GB-50ADA, G(B)-50A or TG-2000A).

(5) Set the meter settings so that this device is a target for control from a system controller.

Configure the settings of the system controller. For details, refer to the instruction manual for the system controller.

Setting	Setting with system controller	Setting with TG-2000A
Pulse unit (weight) value	Set the pulse unit (weight) value setting switch (SW02) to the "SC setting", and set the setting with system controller or TG-2000A.	
Measurement unit	Set the volume unit (kWh, m <sup>3</sup> , MJ) with system controller or TG-2000A.	
Charge time zone	–	Set the charge time zone of the rates.
Heat storage device connection	–	Set connection or non-connection of a heat storage device.
Settlement day	–	Set the settlement day.

Note:

- Configure the settings of the TG-2000A connection system from TG-2000A. If these setting are not configured, the charge function and peak cut control will not work normally because correct measurement of usage amounts will not be made.

⚠ Caution:

- Be sure to set the pulse unit (weight) settings from this device or a system controller (EB-50GU, AG-150A, GB-50ADA, G(B)-50A or TG-2000A). If the pulse unit (weight) value has not been set as required, the charge function and peak cut control will not work normally because correct measurement of usage amounts will not be made.

## 9 Dip Switch Functions

SW	Supported Channel	Function	OFF	ON	Remark	
SW01	1	Channel 1	Use of input contact	No	Yes	Set whether to use the Channel 1 input.
	2	Channel 2	Use of input contact	No	Yes	Set whether to use the Channel 2 input.
	3	Channel 3	Use of input contact	No	Yes	Set whether to use the Channel 3 input.
	4	Channel 4	Use of input contact	No	Yes	Set whether to use the Channel 4 input.
	5	Unused				Set to OFF
	6	Unused				Set to OFF
	7	Unused				Set to OFF
	8	Unused				Set to OFF
SW02	1	Channel 1	Pulse unit (weight) value setting: SC setting (*1): × 0.1: × 1: × 10:	SW02-1	SW02-2	Set 1 pulse of the meter connected to channel 1. Unit: [kWh/pulse] [m <sup>3</sup> /pulse] [MJ/pulse]
	2			OFF	OFF	
	3	Channel 2	Pulse unit (weight) value setting: SC setting (*1): × 0.1: × 1: × 10:	SW02-3	SW02-4	Set 1 pulse of the meter connected to channel 2. Unit: [kWh/pulse] [m <sup>3</sup> /pulse] [MJ/pulse]
	4			OFF	OFF	
	5	Channel 3	Pulse unit (weight) value setting: SC setting (*1): × 0.1: × 1: × 10:	SW02-5	SW02-6	Set 1 pulse of the meter connected to channel 3. Unit: [kWh/pulse] [m <sup>3</sup> /pulse] [MJ/pulse]
	6			OFF	OFF	
	7	Channel 4	Pulse unit (weight) value setting: SC setting (*1): × 0.1: × 1: × 10:	SW02-7	SW02-8	Set 1 pulse of the meter connected to channel 4. Unit: [kWh/pulse] [m <sup>3</sup> /pulse] [MJ/pulse]
	8			OFF	OFF	
SW03	1	Unused				Set to OFF
	2	Unused				Set to OFF
	3	Unused				Set to OFF
	4	Unused				Set to OFF
	5	Unused				Set to OFF
	6	Unused				Set to OFF
	7	Unused				Set to OFF
	8	Unused				Set to OFF
SW06	M-NET address		(Address 10s) 0 to 9 (decimal)		An address from 01 to 50 can be set. Set an address that is not the same as that of another unit.	
SW07			(Address 1s) 0 to 9 (decimal)			
SW08	1	Communication error status display (error code display) Temporary mask setting	Change the switch to ON once and then return it to OFF.		Only enabled during communication error status display. * The communication error status display is masked for 10 seconds and the contact input status is displayed.	
	2	Unused			Set to OFF	
	3	Unused			Set to OFF	
	4	Unused			Set to OFF	
	5	Unused			Set to OFF	
	6	Unused			Set to OFF	
SW09	1	Unused			Set to OFF	
	2	Unused			Set to OFF	

Set the dip switches for function selection according to the system to be used.

At factory default, all dip switches are set to OFF and the M-NET address is set to 01.

Be sure to turn off the power before changing switch settings.

\*1: If a system controller (EB-50GU, AG-150A (including the ones connected to expansion controllers), GB-50ADA, G(B)-50A or TG-2000A) is connected, select the "SC setting" (factory default) and set the pulse unit (weight) value settings from a system controller. If set to another setting, this dip switch setting is prioritized even when set from a system controller.

\*2: The pulse unit of the watt-hour meter being used should be 1 kWh/pulse or less. Note that the apportioning error will increase if a watt-hour meter with large pulse unit is used.

## 10 LED Display Designations

The LEDs of this device indicate the pulse input status and error status of this device.

### 10-1.Pulse Input and Error Displays

Display Item		Display LED	Content																		
			Note ● : On, ○ : Off, ✨ : Flashing																		
Power supply status	(1) Power supply to CPU	LED16 (CPU power on)	● : Lights when the CPU is energized. ✨ : Flashes during M-NET communication.																		
	(2) Power supply to M-NET circuit	LED17 (M-NET power on)	● : Lights when the M-NET is energized.																		
Input status	Channels 1 to 4	LED12/13/14/15 (Status display LEDs)	<table border="1"> <thead> <tr> <th>Input Method</th> <th>–</th> <th>Ch1</th> <th>Ch2</th> <th>Ch3</th> <th>Ch4</th> </tr> <tr> <td></td> <td>LED11</td> <td>LED12</td> <td>LED13</td> <td>LED14</td> <td>LED15</td> </tr> </thead> <tbody> <tr> <td>Pulse Input</td> <td>○</td> <td colspan="4">● : Input ○ : No Input</td> </tr> </tbody> </table>	Input Method	–	Ch1	Ch2	Ch3	Ch4		LED11	LED12	LED13	LED14	LED15	Pulse Input	○	● : Input ○ : No Input			
Input Method	–	Ch1	Ch2	Ch3	Ch4																
	LED11	LED12	LED13	LED14	LED15																
Pulse Input	○	● : Input ○ : No Input																			
Communication error status (*1)	(1) 4-digit error code	LED12/13/14/15 (Status display LEDs)	Refer to "10-2. Communication Error Displays".																		

\*1: If a communication error occurs, switch to "Communication Error Displays". Changing SW08-1 from ON to OFF masks the "Communication Error Displays" for 10 seconds so that the input status of channels 1 to 4 can be displayed.

### 10-2.Communication Error Displays

If a communication error occurs, a 4-digit error code will be repeatedly displayed according to the steps shown below. "Communication Error Displays" consist of the following 10 steps. This operation is performed repeatedly to indicate the 4-digit error code for the communication error.

Furthermore, changing SW08-1 from ON to OFF masks the "Communication Error Displays" for 10 seconds so that the input status of channels 1 to 4 can be displayed.

Note ● :On, ○ :Off, ✨ :Flashing

	LED11	LED12	LED13	LED14	LED15	Function	Remark
	Error cord display (Binary number indication)						
Common	$2^3=8$ $2^2=4$ $2^1=2$ $2^0=1$						
STEP1	○	✨	✨	✨	✨	"Communication Error Displays" Starting Point Indication	LEDs 12 to 15 flash 3 times
STEP2	○	○	○	○	○	Blank	Turn Off
STEP3	●	●/○	●/○	●/○	●/○	Error code 1000's digit	Error code 1000's digit indication In the case of 6, ○●●○
STEP4	○	○	○	○	○	Blank	Turn Off
STEP5	●	●/○	●/○	●/○	●/○	Error code 100's digit	Error code 100's digit indication In the case of 6, ○●●○
STEP6	○	○	○	○	○	Blank	Turn Off
STEP7	●	●/○	●/○	●/○	●/○	Error code 10's digit	Error code 10's digit indication In the case of 0, ○○○○
STEP8	○	○	○	○	○	Blank	Turn Off
STEP9	●	●/○	●/○	●/○	●/○	Error code 1's digit	Error code 1's digit indication In the case of 7, ○●●●
STEP10	○	○	○	○	○	Blank	Turn Off

The error codes that are displayed for M-NET communication errors are as shown below.

Error Code	Description of Error
6600	Multiple address error
6601	M-NET polarity unset error
6602	Transmission processor hardware error
6603	Transmission circuit bus-busy error
6606	Communications with transmission processor error
6607	No ACK error
6608	No return of response frame

## 11 System Operation Test

Use the following procedure to confirm operation of the system.

- (1) Configure the settings of this device and the system controllers while referring to "8. Initial Settings".
- (2) Perform an operation from a system controller and confirm whether a connected device can be operated normally.
  - (a) Confirm that signal lines from the meters have been connected correctly.
  - (b) Monitor measurement values using the system controller. (Updating takes approximately one minute.)
  - (c) Input a pulse from a connected meter to the unit.
  - (d) Using the pulse input from step (c), confirm whether the additional meter value is consistent with the monitor value difference from the system controller.
  - (e) Change the monitor value (current value) from the system controller to the meter value, and confirm that this monitor value now matches the meter value.

If there is a problem, check the wiring and settings.

For details on configuring settings, refer to "8. Initial Settings" and "9. Dip Switch Functions".

**Note:**

- Various settings related to the charge operation need to be configured from the TG-2000A prior to starting the charge function operation. Furthermore, in such a case, be sure to perform a charge test run according to the instruction manual for TG-2000A.

**⚠ Caution:**

- Do not turn the power OFF after starting operation. The power rate will not be counted while the power interruption.
- Forcible pulse input must never be carried out after startup.

## 12 Precautions for Expansion

Observe the following matters when expanding the watt-hour meter or meters.

- (1) The power must be turned OFF while expanding the units. The power rate, etc. will not be counted while the power is OFF.
- (2) After expanding the units in the charge system, change the system settings with TG-2000A, check the settings, and test the operation.



This product is designed and intended for use in the residential, commercial and light-industrial environment.

This product at hand is based on the following EU regulations:

- Low Voltage Directive 2014/35/EU
- Electromagnetic Compatibility Directive 2014/30/EU

**NOTE:**

This equipment has been tested and found to comply with the limits for a Class B digital device, pursuant to Part 15 of the FCC Rules. These limits are designed to provide reasonable protection against harmful interference in a residential installation. This equipment generates, uses and can radiate radio frequency energy and, if not installed and used in accordance with the instructions, may cause harmful interference to radio communications.

However, there is no guarantee that interference will not occur in a particular installation.

If this equipment does cause harmful interference to radio or television reception, which can be determined by turning the equipment off and on, the user is encouraged to try to correct the interference by one or more of the following measures:

- Reorient or relocate the receiving antenna.
- Increase the separation between the equipment and receiver.
- Connect the equipment into an outlet on a circuit different from that to which the receiver is connected.
- Consult the dealer or an experienced radio/TV technician for help.

## **MITSUBISHI ELECTRIC CORPORATION**

**HEAD OFFICE:** TOKYO BLDG., 2-7-3, MARUNOUCHI, CHIYODA-KU, TOKYO 100-8310, JAPAN

**MANUFACTURER:** MITSUBISHI ELECTRIC CORPORATION

Air-conditioning & Refrigeration Systems Works  
5-66, Tebira 6 Chome, Wakayama-city, 640-8686, Japan