

**Mitsubishi Electric Air Conditioner Network System**

# AI controller

## PAC-YG63MCA



### Installation/Instruction Manual

## Table of Contents

	Page
1. Safety Precautions .....	1
2. Usage .....	2
3. Parts List.....	2
4. Specifications .....	2
4-1. Device Specifications .....	2
4-2. External Dimensions.....	3
5. Example of System Configuration .....	3
6. Installation .....	4
6-1. Parts Purchased Separately.....	4
6-2. Installation Instructions .....	5
7. Wiring Instructions .....	6
7-1. Terminal Diagram .....	6
7-2. Connecting the Power and M-NET Transmission Lines.....	7
7-3. Connecting the Sensors .....	8
(1) Channel 1 Pt100 Input.....	8
(2) Channel 1 (Channel 2) Analog Input .....	8
7-4. Connecting Alarm Setpoint Outputs ...	9
8. Initial Settings .....	10
9. Dip Switch Functions .....	12
10. LED Display Designations .....	13
10-1. Alarm Setpoint Output and Error Displays .....	13
10-2. Sensor and Communication Error Displays .....	13
11. System Operation Test.....	14

# 1 Safety Precautions

- Thoroughly read the following safety precautions before use.
- Hazards that can occur from incorrect handling are classified by the symbols below:

 Warning	Incorrect handling can result in death, serious injury, etc.
 Caution	Incorrect handling can result in bodily injury and/or structure damage.

- After reading this manual, keep this manual for future reference. When the device is reinstalled or repaired, give this manual to those who provide these services. When the user changes, make sure that the new user receives this manual.

## WARNING

**Only a dealer or qualified technician should install, relocate, reinstall, or repair the device.**  
Improper installation or repair may result in electrical shock or fire.

**Do not make any modifications or alternations to the device.**  
Modifications or improper repair may result in electric shock or fire. Consult your dealer for repair.

**Properly install the device on a stable, load-bearing surface.**  
Device installed on an unstable surface may fall and cause injury.

**All electrical work should be performed by an authorized electrician according to local regulations and instructions outlined in this manual.**  
Capacity shortage to the power supply circuit or improper installation may result in electrical shock or fire.

**Only use the specified cables; securely connect each so that the terminals do not bear any cable weight.**  
Improperly connected or short-circuited cables may produce heat and cause a fire.

**Properly install the device according to the instructions in this Installation/Instruction Manual.**  
Improper installation may result in electric shock or fire.

## CAUTION

**Do not install the device in a location where a flammable gas leak may occur.**  
Gas may leak, collect around the device, ignite, and/or explode.

**Do not install the device in a bathroom, kitchen, or any room where steam could form.** Condensation may develop and cause electrical shock and/or the device to malfunction.

**Do not install the device in environments where large amounts of oil (including machine), sulfidizing gas, or acidic, alkaline, chemical sprays are present.**  
These types of substances may damage internal parts, cause device performance to be reduced, and cause electrical shock.

**Use standard wires with the proper current capacity** to avoid the possibility of current leak, excessive heat, and/or fire.

**Do not touch the main circuit board; also, make sure that dust does not accumulate on the circuit board.**

**When installing the device in a hospital, communication facilities, etc., provide sufficient protection against frequency noise.**  
Power generators and inverters, high-frequency medical, or radio communication equipment may interfere with the normal operation of this device. Subsequently, the device may also affect medical treatment, image broadcasting, etc., by creating frequency noise.

**Include some slack in the power supply wires.**  
Tension on the wires may cause them to excessively heat up and/or break, resulting in a fire.

**Do not immerse the device in water.**  
Doing so may lead to electric shock or malfunctions.

**Do not install the device in a location where there is direct sunlight or where the temperature may become greater than 40°C (104°F) or less than 0°C (32°F).**  
If the device is installed in such place, it may result in deformation or malfunctions.

**The maximum applied voltage for the device is 24 VDC - do not use with an AC power source. (The maximum applied voltage for the M-NET terminal is 30 VDC.)**  
Using the incorrect voltage may result in device failure, ignition, and/or fire.

## Additional Precautions

If the supply cord is damaged, it must be replaced by the manufacturer, its service agent or similarly qualified persons in order to avoid a hazard.

This appliance is intended to be used by expert or trained users in shops, in light industry and on farms, or for commercial use by lay persons.

This appliance is not intended for use by persons (including children) with reduced physical, sensory or mental capabilities, or lack of experience and knowledge, unless they have been given supervision or instruction concerning use of the appliance by a person responsible for their safety.  
Children should be supervised to ensure that they do not play with the appliance.

## 2 Usage

The AI controller measures temperature and humidity; it also has an alarm capability if the measurement data exceeds defined setpoints. Historical measurement data can be displayed via only the EB-50GU Web browser, AG-150A LCD/ Web browser, GB-50ADA Web browser, or G(B)-50A Web browser and TG-2000A. Temperature and humidity cannot be displayed on the G-50A LCD.

Furthermore, an alarm can be output if measurement data exceeds a preset upper or lower limit.

The AI controller also features a function that interlocks M-NET devices for indoor units, etc. set in advance and performs settings such as temperature control and operation/stoppage using measurement data values.

### ⚠ Caution: Usage Restrictions

- Mitsubishi Electric does not take financial responsibility for damages caused by issues beyond our control or special circumstances (predictable or unpredictable); and secondary or accidental damages, and damages to other objects. We also do not take financial responsibility for opportunities lost as a result of device failure, or electrical power failure at the end-user site. Mitsubishi Electric does not take financial responsibility caused by end-users' requests including, but not limited to, device testing, startup, readjustment and replacement.
- Do not use this device in disaster prevention security or "critical to life" applications.

## 3 Parts List

- The following parts should be included in your shipment:

Number	Part Name	Quantity
1	AI controller	1
2	Installation/instruction manual (this document)	1

\* In addition to the parts listed above, see your local Mitsubishi Electric dealer to purchase the other parts necessary to operate this device (Refer to section 6-1). Furthermore, depending on the application, other Mitsubishi Electric parts may be required. For details, refer to "6. Installation".

## 4 Specifications

### 4-1. Device Specifications

Item	Description											
Power Supply	24 VDC±10%: 5 W					Screw terminal block (M3) (*5)						
Interface	M-NET communication		17 to 30 VDC (*1)			Screw terminal block (M3) (*5)						
	Input	Ch	Sensor	Measurement target	Measurement range	Measurement error	External connection method					
		Ch1	Pt100 (3-wire system)	Temperature	-30 to 60°C [-22 to 140°F]	±0.3%FS ±0.1°C (0.18°F) <sup>(*3)</sup> [at 25°C (77°F)]	Screwless terminal block (3 poles)					
								Analog	Temperature/ humidity	(Set by system controller)	±0.5%FS ±0.1°C (0.18°F) <sup>(*3)</sup> ±0.5%FS ±0.1%RH [at 25°C (77°F)]	Screwless terminal block (2 poles)
	Analog	4 to 20 mADC	Temperature/ humidity	(Set by system controller)	±0.5%FS ±0.1°C (0.18°F) <sup>(*3)</sup> ±0.5%FS ±0.1%RH [at 25°C (77°F)]	Screwless terminal block (2 poles)						
1 to 5 VDC	0 to 10 VDC											
Ch2	Analog	4 to 20 mADC	Temperature/ humidity	(Set by system controller)	±0.5%FS ±0.1°C (0.18°F) <sup>(*3)</sup> ±0.5%FS ±0.1%RH [at 25°C (77°F)]	Screwless terminal block (2 poles)						
1 to 5 VDC	0 to 10 VDC											
Output	Upper/lower limit alarm interlock output (non-voltage contact)		Applied load MAX: 24 VDC, 5 W MIN: 5 VDC, 2 mW * AC loads cannot be connected.			Screw terminal block (M3.5) (*5)						
Interlock Function	Interlock M-NET devices according to measurement data values. (*4)											
Environment Conditions	Temperature		Operating temperature range		0 to 40°C [32°F to 104°F]							
	Humidity		Storage temperature range		-20 to 60°C [-4°F to 140°F]							
Dimensions	200 (W) × 120 (H) × 45 (D) mm / 77/8 (W) × 43/4 (H) × 125/32 (D) in											
Weight	0.6 kg / 13/8 lb											
Time Backup During Power Failure	In the event of power failure or shut-off, the internal capacitor will continue to track time for approximately one week. (The internal capacitor takes about 24 hours to fully charge; a replacement battery is not necessary.)											
Installation Environment	Inside the metal control panel (indoors) * Use this product in a hotel, a business office environment or similar environment.											
Sound Pressure Level	The A-weighted sound pressure level is below 70 dB.											

\*1: Supply electric power from a power supply unit for the transmission line or an outdoor unit. Furthermore, the power consumption factor of the M-NET circuitry of this unit is "1/4" (equivalent to one ME Remote Controller).

\*2: Configure the dip switch settings for the analog input method to use while referring to "9. Dip Switch Functions".

\*3: The measurement error for the system includes the measurement error for this unit, sensor, and wiring.  
a%FS (full scale) = a% × ([measurement range's upper limit value] - [lower limit value])

\*4: Settings for the interlock function are performed from the Maintenance Tool. For details, refer to the operation manual for the Maintenance Tool. (Consult the maintenance provider or dealer for how to set the interlock settings.)

\*5: M3 and M3.5 are sizes of the screw on the terminal block (ISO metric screw thread). The number indicates the screw diameter (mm).

## 4-2. External Dimensions

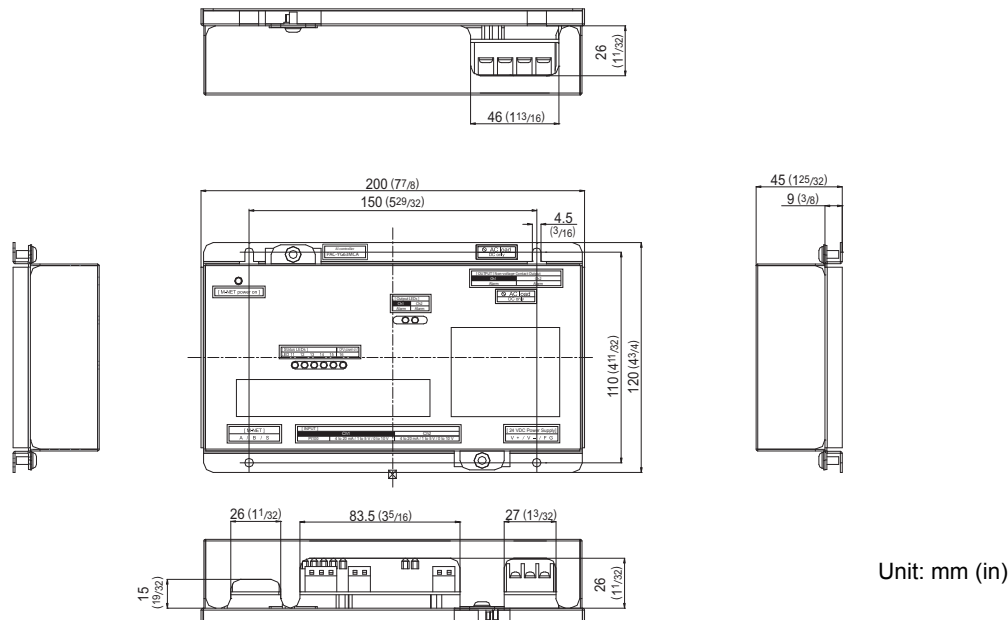

## 5 Example of System Configuration

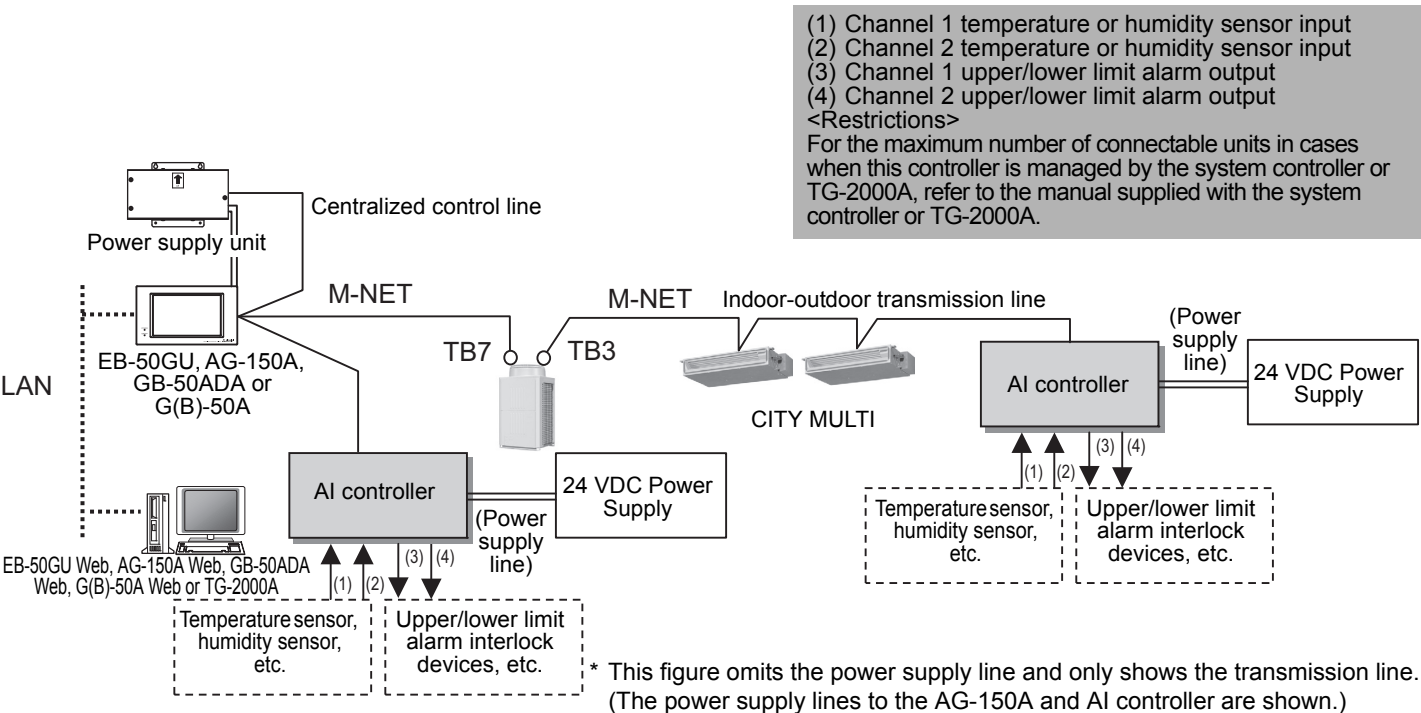

### Note:

- For the shield ground of the M-NET centralized control line, use single-point grounding at the power unit for the transmission line. However, when supplying electric power to the M-NET centralized control line from the R410A series outdoor unit without using a power supply unit for the transmission line, use single-point grounding at the TB7 of that outdoor unit. Furthermore, when connecting the M-NET transmission line of this device to the M-NET indoor-outdoor transmission line, use grounding at the TB3 for each outdoor unit system.
- If the M-NET transmission line of this device is connected to an M-NET indoor-outdoor transmission line and the outdoor unit is down because, for example, the power supply is interrupted for servicing or there is a failure, the AI controller cannot be set and monitored from the system controller.
- The sensor connected to the AI controller can only be set or monitored from EB-50GU Web browser, AG-150A LCD/Web browser, GB-50ADA Web browser, G(B)-50A Web browser and TG-2000A. The sensor cannot be monitored from the G-50A LCD.

## 6 Installation

### 6-1. Parts Purchased Separately

Prepare the following parts to install this device.

Required Part	Specification
Unit fixing screws	M4 screw × 4 (* M4: ISO metric screw thread)
Power supply for this device	Commercially available power source: 24 VDC±10% 0.2 A (Minimum loading), SELV circuit, power line with grounding terminal Ripple noise: Lower than 200 mVp-p Compatible specification Authorized or CE marked products. Subject to regulations: - IEC60950 (or EN60950) - CISPR22/24 (or EN55022/24) - IEC61000-3-2/3-3 (or EN61000-3-2/3-3) (With enhanced insulation and has a withstand voltage of (3kV 1 minute) between the primary and secondary sides.)
Power supply for sensors	A separate power supply for sensors may be required. In the case of 24 VDC voltage, the capacity of the power supply for this unit can be increased so that the power supply can be shared.
Power line	Use a sheathed vinyl cord or cable. At least 0.75 mm <sup>2</sup> (AWG18)
M-NET transmission line	Type of the cable: Sheathed vinyl cords or cable which comply with the following specifications or equivalent. • CPEV $\Phi$ 1.2 mm to $\Phi$ 1.6 mm • CVVS 1.25 mm <sup>2</sup> to 2 mm <sup>2</sup> (AWG 16 to 14) * CPEV: PE insulated PVC jacketed shielded communication cable * CVVS: PVC insulated PVC jacketed shielded control cable PE: Polyethylene PVC: Polyvinyl chloride Power needs to be supplied to the M-NET circuitry of this device. Use an outdoor unit or a separately purchased power supply unit for the transmission line.
Signal lines (Sensor input lines)	Shows the size of the electric wire (copper wire) that is adapted to the terminal block of this device. Refer to the usage and cautionary items of the sensor when performing settings. However, use a line with shielded line. Electric wire size … (1) Solid wire: $\Phi$ 0.65 mm (AWG21) - $\Phi$ 1.2 mm (AWG16) (2) Stranded wire: 0.75 mm <sup>2</sup> (AWG18) - 1.25 mm <sup>2</sup> (AWG16) Single strand: At least $\Phi$ 0.18 mm

[Parts to be Purchased Separately]

Name	Model	Application	Remark
Power supply unit	PAC-SC51KUA or PAC-SC50KUA etc.	Power supply to the M-NET transmission line	This is not required when power is to be supplied from an outdoor unit.

[Commercially available parts]

Part	Use	Remark
External 24 VDC power source	Supplies power to the AI controller.	Refer to "Power supply for this device" and "Power supply for sensors" in "Required Part" above for the capacity of the power supply.
Sensor	Measures temperature and humidity.	Temperature sensor (PAC-SE40TSA) cannot be connected. Use a commercially available temperature sensor and humidity sensor that meet the specifications in "4-1. Device Specifications."

## 6-2. Installation Instructions

The AI controller PAC-YG63MCA does not have a waterproof structure.

Be sure to install the AI controller inside a metal control panel that is located indoors.

Prepare a metal control panel capable of storing this device such as the one shown in the figure. (Install the device in a metal control panel strong enough to withstand a weight of 0.6 kg [1<sup>3</sup>/<sub>8</sub> lb].)

This device can be installed horizontally, or as shown below, vertically. The following diagram also provides a rough estimate of how much space is required around the installation.

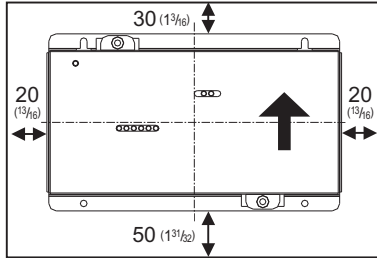

Size of the device: 200 (W) × 120 (H) × 45 (D) mm/  
77<sup>7</sup>/<sub>8</sub> (W) × 43<sup>3</sup>/<sub>4</sub> (H) × 125<sup>5</sup>/<sub>32</sub> (D) in

Unit: mm (in)

**Note:** The space shown above does not include space for peripherals. Additionally, the amount of space necessary varies according to the functions that are used and the wiring method. Secure enough space appropriate for the type of installation.

- (1) Fix the top of this device to the metal control panel at two points by loosely tightening the screws (M4) that were procured locally. Fix the bottom in place with two screws and then tighten all four of the screws.

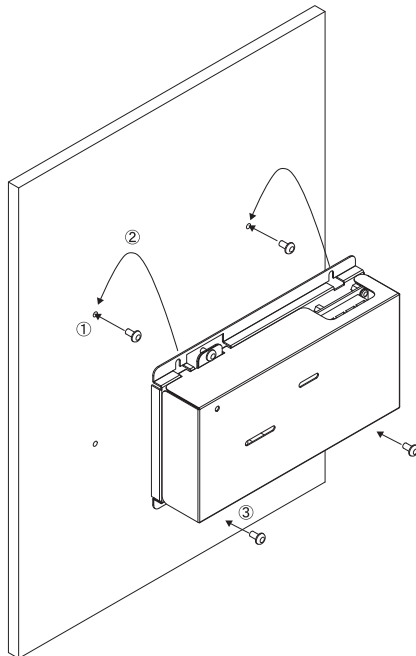

Screw pitch

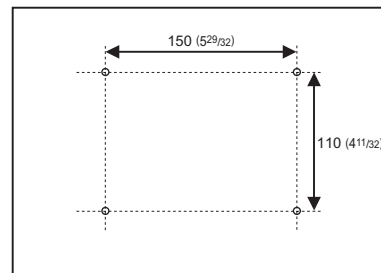

Unit: mm (in)

- (2) To remove the cover, as shown in the figure, remove the two screws for fixing the cover in place and then remove the cover by unhooking the upper hook section from the lower case. To attach the cover, hook the upper hook section on the lower case and then fix the cover in place with the two screws that were removed.

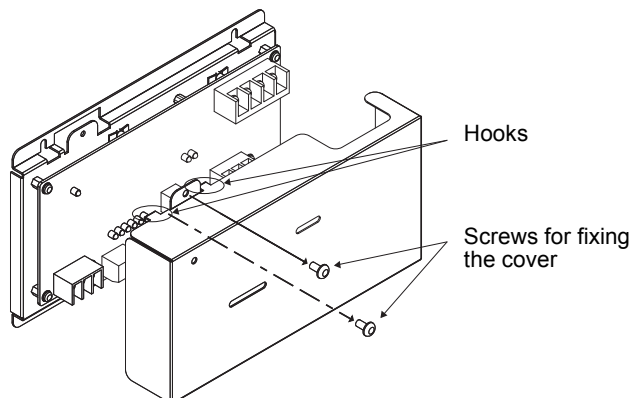

**Note:** Two hooks are located on the upper section of the cover.

(3) Refer to "7. Wiring Instructions" and connect the wires for the power line, M-NET transmission line, output signal lines, and sensor input signal lines.

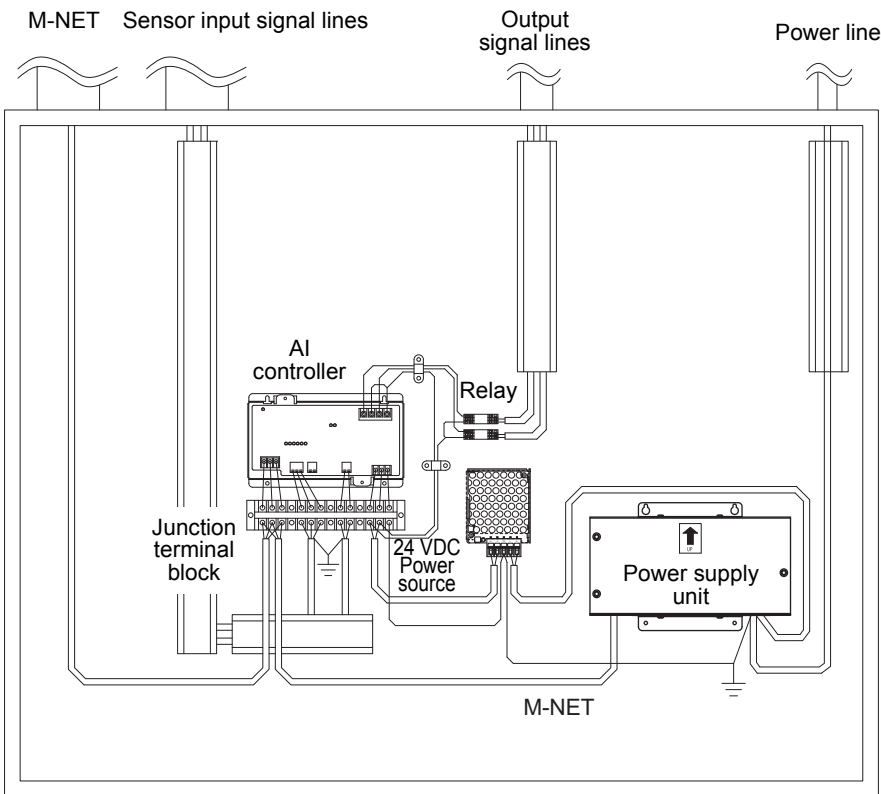

**Note:**

- Do not install the sensor input signal lines parallel to or near the M-NET transmission line or power line. Also avoid loop wiring.
- Be sure to ground this device, Power supply unit and 24 VDC Power source. Measurement accuracy may be affected if devices are not grounded.

**⚠ Caution:**

- Perform wiring so that the terminal block is not strained. If strained, use a wire guide or junction terminal to alleviate the stress on the terminal block.
- Do not connect the wires directly from the top of the metal control panel to the terminal block. Moisture may enter this device along the wiring and cause electric shock or fire.

Diagram Image (Installed within a metal control panel)

\* The wiring in the diagram has been simplified.

## 7 Wiring Instructions

### 7-1. Terminal Diagram

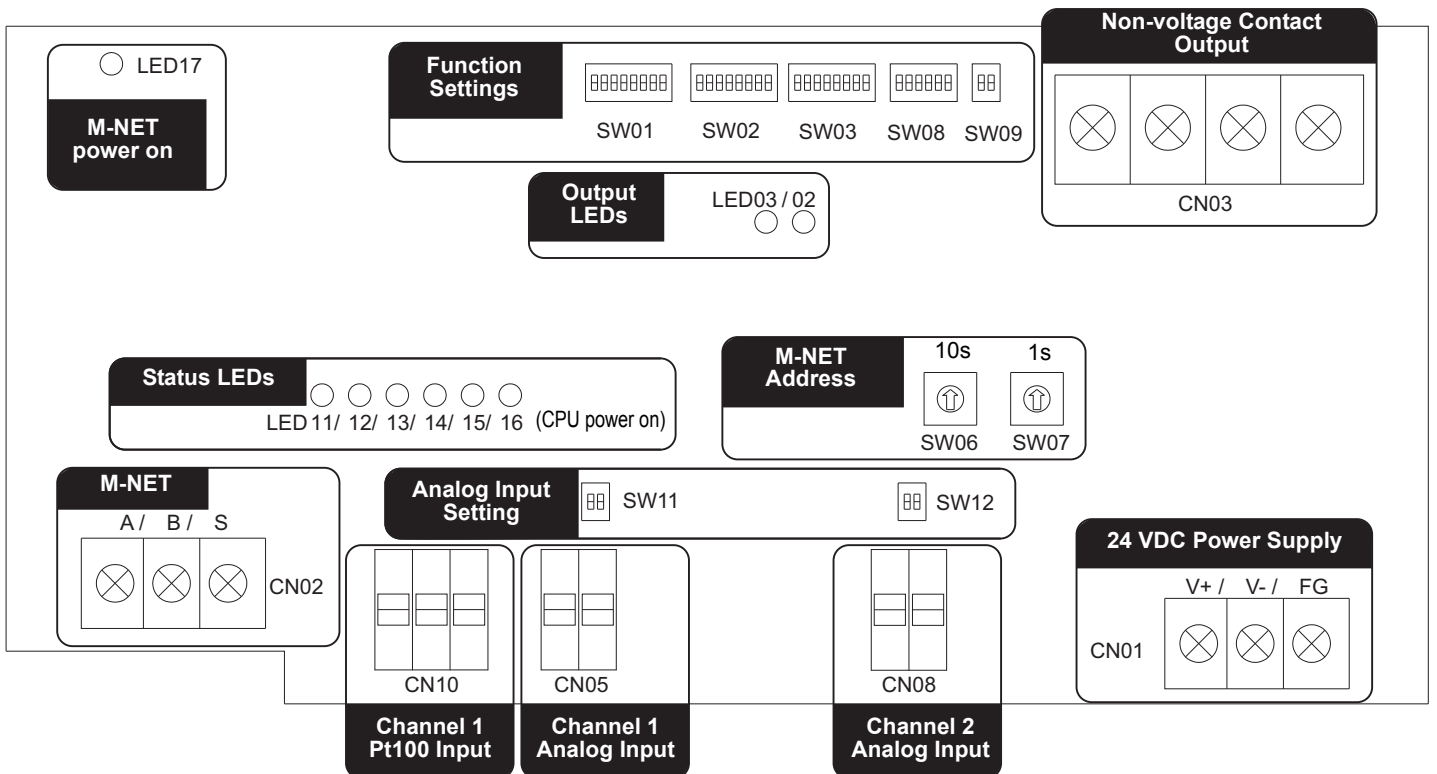

## 7-2. Connecting the Power and M-NET Transmission Lines

Tightening torque for terminal screws: 1 N·m

Connect the M-NET transmission line (either the centralized control line or indoor-outdoor transmission line) to CN02 on the controller.

Connect the power supply line (24 VDC, polarized) to CN01 on the controller.

\* Only the M-NET circuitry of this device receives the power from the M-NET transmission line. The power consumption factor is "1/4" (equivalent to one ME Remote Controller).

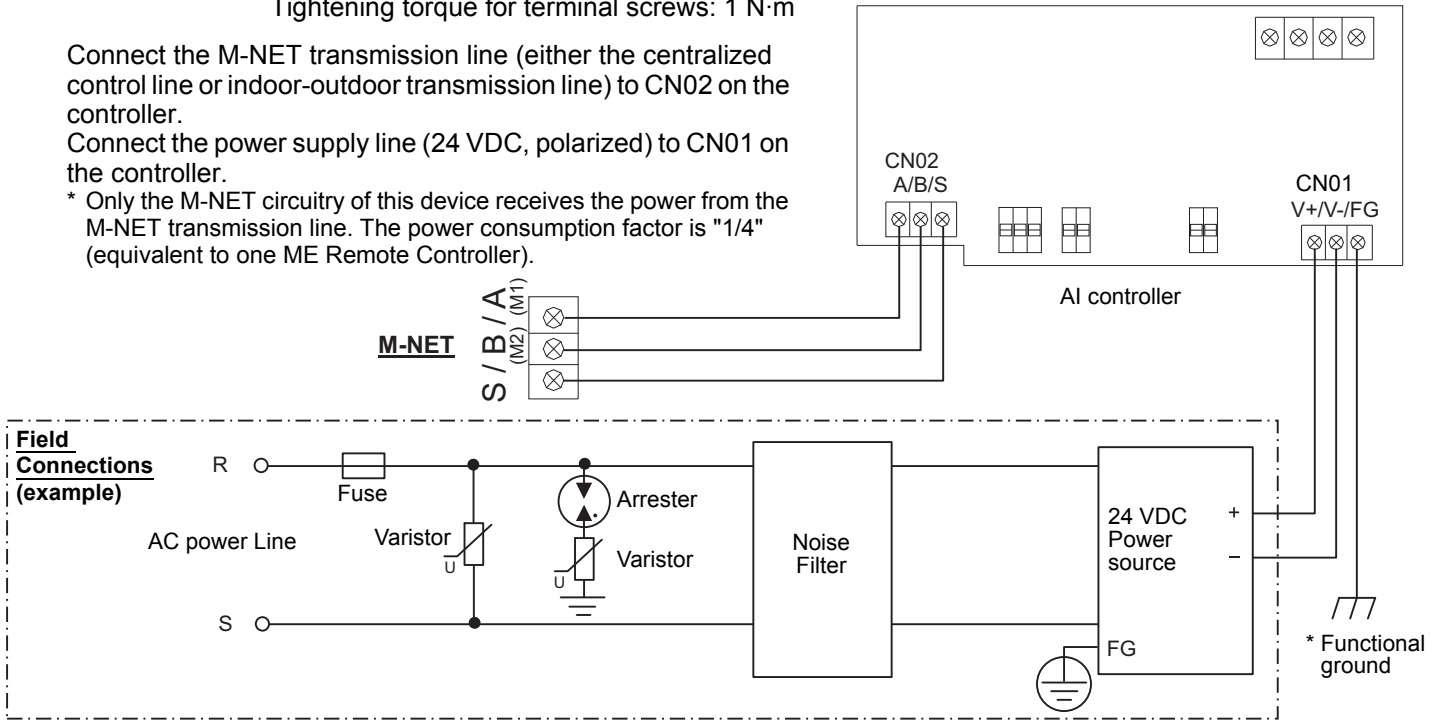

Figure 7-1 Example of Connecting the Power Line and M-NET Transmission Line

### ⚠ Caution:

- Use a power line and M-NET transmission line that satisfy the specifications described in "6-1. Parts Purchased Separately".
- Attach a circuit comprising the following components to the supply primary side of the 24 VDC power supply.  
(1) Varistor, (2) Arrester, (3) Noise filter, (4) Fuse
- It is important to pay attention to the polarity when connecting to the 24 VDC power supply terminal block. Connecting the positive and negative in the reverse order will cause a failure.
- Fix the power line and M-NET transmission line in place on the outside to ensure that the terminal block is not affected by any external force.  
Not securely connecting and fixing the wires in place may cause heat generation and fire.
- Make sure that the copper wiring is not short-circuiting the plates (cover, lower case) or neighboring wires.  
Cover the shielded line of the M-NET transmission line with materials such as vinyl tape and prevent short-circuiting with the plates.

### Note:

- If the M-NET transmission line of this device is connected to an M-NET indoor-outdoor transmission line and the outdoor unit is down because, for example, the power supply is interrupted for servicing or there is a failure, the AI controller cannot be set and monitored from the system controller.
- Be sure to ground this device, Power supply unit and 24 VDC Power source.  
Measurement accuracy may be affected if devices are not grounded.



### 7-3. Connecting the Sensors

- For channel 1, select one of the following four types: Pt100 detection, 4 to 20 mADC, 1 to 5 VDC, or 0 to 10 VDC analog input.
- For channel 2, select one of the following three types: 4 to 20 mADC, 1 to 5 VDC, or 0 to 10 VDC analog input.
- The wire length depends on the specifications of the sensor. However, since the use of long wires makes the device susceptible to noise, using wires shorter than 12 m (39.4 ft) is recommended. Use a shielded line for the sensor line and connect to the FG terminal on this unit or the FG terminal on the metal control panel.

(1) Channel 1 Pt100 Input

To use these, various settings need to be configured. Refer to "8. Initial Settings".

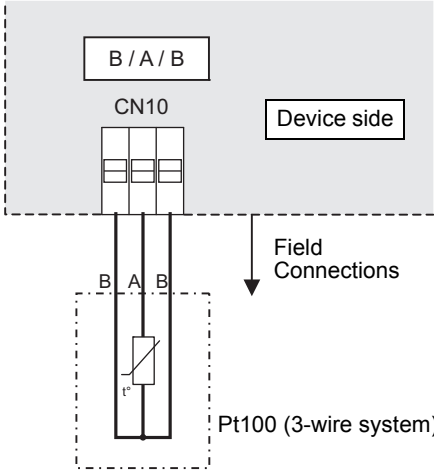

**⚠ Caution:**

- Use a 3-wire system for Pt100.
- A/B polarity is important for Pt100. Be sure to match the polarity when using Pt100.
- Do not install the sensor input line parallel to or near the M-NET transmission line or power line. Also avoid loop wiring. Furthermore, confirm the precautions for the sensor.
- Strip  $12 \pm 1$  mm ( $15/32 \pm 1/32$  in) of the wire coating and insert firmly into the terminal.
- Make sure that the copper wiring is not short-circuiting the plates (cover, lower case) or neighboring wires.
- Perform wiring so that the terminal block is not strained. If strained, use a wire guide or junction terminal to alleviate the stress on the terminal block.

(2) Channel 1 (Channel 2) Analog Input (4 to 20 mADC, 1 to 5 VDC, 0 to 10 VDC)

To use these, various settings need to be configured. Refer to "8. Initial Settings".



(a) When 1 to 5 VDC, 0 to 10 VDC, or 4 to 20 mADC (type for which power is supplied to the sensor) is connected

(b) When 4 to 20 mADC (type for which power is supplied to the signal line) is connected

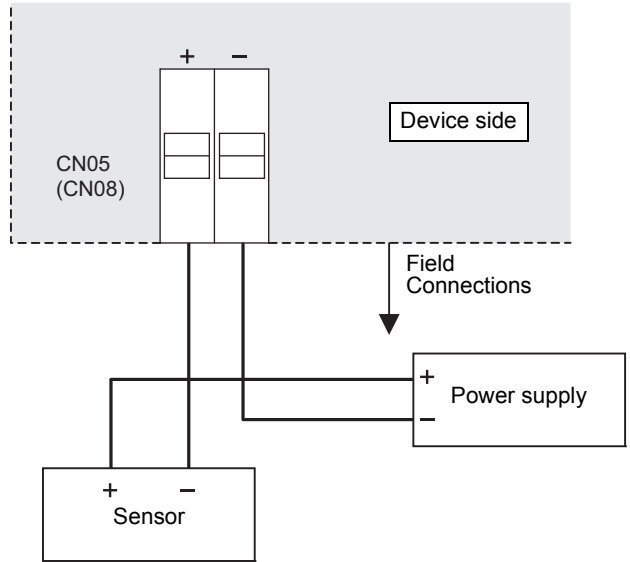
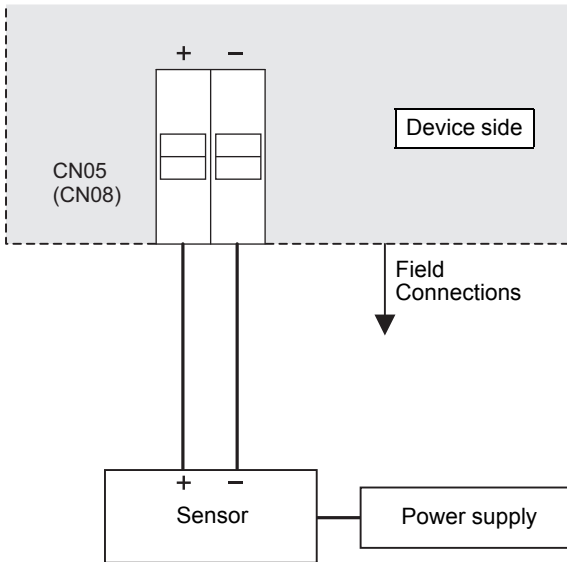

**⚠ Caution:**

- Select a power supply that is suitable for the sensor to be used.
- Do not install the sensor input line parallel to or near the M-NET transmission line or power line. Also avoid loop wiring. Furthermore, confirm the precautions for the sensor.
- Strip  $12 \pm 1$  mm ( $15/32 \pm 1/32$  in) of the wire coating and insert firmly into the terminal.
- Make sure that the copper wiring is not short-circuiting the plates (cover, lower case) or neighboring wires.
- Perform wiring so that the terminal block is not strained. If strained, use a wire guide or junction terminal to alleviate the stress on the terminal block.

### 7-4. Connecting Alarm Setpoint Outputs (Non-voltage Contacts)

The maximum wire length is 100 m. However, since the use of long wires makes the device susceptible to noise, using wires no more than 10 m long is recommended.

To use these, various settings need to be configured. Refer to "8. Initial Settings".

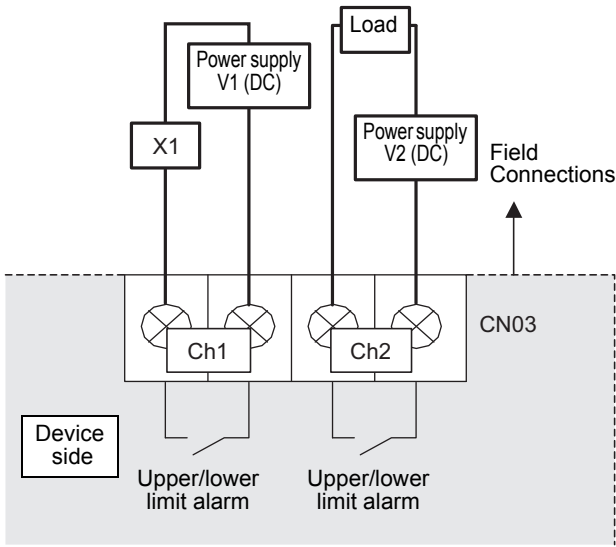
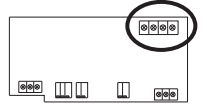

Tightening torque for terminal screws: 1 N·m.

\* The contact of the internal relay is always ON during detection of an upper/lower limit alarm. (Level output)

**⚠ Caution:**

- To use X1 relay, obtain one that satisfies the following specifications.  
 Operating coil  
 [Applied load]  
 MAX: 24 VDC, 5 W (Built-in diode)  
 MIN: 5 VDC, 2 mW (Built-in diode)  
 \*1 AC loads cannot be connected.  
 \*2 Provide a power supply (V1, V2) that matches the load and relay to be used.
- To drive a direct load, use ones within the following.  
 [Applied load]  
 MAX: 24 VDC, 5 W  
 MIN: 5 VDC, 2 mW  
 \* AC loads cannot be connected.
- Make sure that the copper wiring is not short-circuiting the plates (cover, lower case) or neighboring wires.
- Perform wiring so that the terminal block is not strained. If strained, use a wire guide or junction terminal to alleviate the stress on the terminal block.
- Do not connect the wires directly from the top of the metal control panel to the terminal block. Moisture may enter this device along the wiring and cause electric shock or fire.

## 8 Initial Settings

After completing the procedures described in "6. Installation" and "7. Wiring Instructions", set the initial settings in accordance with the procedure described below.

### (1) M-NET address settings

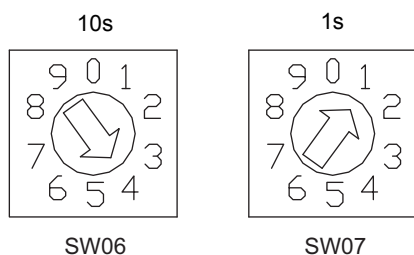

In the case of address "41"

#### Note:

- An address from 01 to 50 can be set.
- Set an address that is not the same as that of another unit.

The address is set to "01" at factory default.

### (2) Use the dip switches to select functions.

Select the function required for each input/output channel to be used.

The switch assignment for each channel is shown below. Configure each of the settings while referring to "9. Dip Switch Functions".

- For channel 1, select one of the following four types: Pt100 detection, 4 to 20 mADC, 1 to 5 VDC, or 0 to 10 VDC analog input.
- For channel 2, select one of the following three types: 4 to 20 mADC, 1 to 5 VDC, or 0 to 10 VDC analog input.

#### (a) When using Pt100 detection (only channel 1 can be used)

Ch	Setting	Setting Switch	Pt100	To not use
Ch1	Pt100 used	(1) SW01-1 (2) SW01-3	ON ON	OFF OFF

#### (b) When using one of the analog inputs (4 to 20 mADC detection, 1 to 5 VDC detection, and 0 to 10 VDC detection)

Ch	Setting	Setting Switch	4 to 20 mADC	1 to 5 VDC	0 to 10 VDC	To not use
Ch1	Setting of sensor to use	(1) SW11-1	ON	OFF	OFF	OFF
		(2) SW11-2	ON	ON	OFF	OFF
		(3) SW01-1	ON	ON	ON	OFF
		(4) SW01-2	OFF	OFF	ON	OFF
		(5) SW01-3	OFF	OFF	OFF	OFF
Ch2	Setting of sensor to use	(1) SW12-1	ON	OFF	OFF	OFF
		(2) SW12-2	ON	ON	OFF	OFF
		(3) SW02-1	ON	ON	ON	OFF
		(4) SW02-2	OFF	OFF	ON	OFF

#### (c) When using upper/lower limit alarm interlock output

Ch	Setting	Setting Switch	To use	To not use
Ch1	Usage of upper/lower limit alarm interlock output	(1) SW01-5	ON	OFF
Ch2	Usage of upper/lower limit alarm interlock output	(1) SW02-5	ON	OFF

#### (d) Measurement data backup interval setting (for servicing)

Ch	Setting	Setting Switch	1 min	2 min	5 min	10 min
Common	Measurement data backup interval setting	(1) SW03-1	OFF	OFF	ON	ON
		(2) SW03-2	OFF	ON	OFF	ON

(3) Turn on the power of this device.

Verify that the LED16 (CPU power on) and LED17 (M-NET power on) are lit.

(4) Set the time.

Set the current time from a system controller (EB-50GU, AG-150A, GB-50ADA, G(B)-50A, TG-2000A) or a Maintenance Tool.

(5) Configure the settings of the system controller.

Configure settings for the system controller such as the type of sensor to use and the measurement range.

The main items that should be set are shown below.

(a) When using Pt100 detection (only channel 1 can be used)

Ch	Setting	Setting with system controller or TG-2000A
Ch1	Measurement category setting	Select temperature/humidity (Be sure to select temperature.)
	Measurement range setting	Set the upper limit and lower limit values (Set a range from -30°C [-22°F] to 60°C [140°F].)
	Measurement correction	Input the measurement temperature correction value (offset value)

(b) When using an analog input (4 to 20 mADC detection, 1 to 5 VDC detection, or 0 to 10VDC detection)

Ch	Setting	Setting with system controller or TG-2000A
Ch1	Measurement category setting	Select the temperature/humidity
	Measurement range setting	Set the upper limit and lower limit values
	Measurement correction	Input the measurement correction value (offset value)
Ch2	Measurement category setting	Select the temperature/humidity
	Measurement range setting	Set the upper limit and lower limit values
	Measurement correction	Input the measurement correction value (offset value)

(c) When using upper/lower limit alarm interlock output

Ch	Setting	Setting with system controller or TG-2000A
Ch1	Upper/lower limit alarm detection value and cancellation value settings	Upper/lower limit alarm detection value and cancellation value settings
Ch2	Upper/lower limit alarm detection value and cancellation value settings	Upper/lower limit alarm detection value and cancellation value settings

(6) Settings for the interlock function are performed from the Maintenance Tool.

Perform settings such as interlock criteria for this device from Maintenance Tool.

For details, refer to the operating manual for the Maintenance Tool.

(Consult the maintenance provider or dealer for how to set the interlock settings.)

## 9 Dip Switch Functions

SW	Supported Channel	Function	OFF	ON	Remark	
SW01	1	Selection of the input to use	No	Yes	Specify whether to use the channel 1 input terminal.	
	2	Selection of the analog input type (1)	4 to 20 mADC/ 1 to 5 VDC detection	0 to 10 VDC detection	Set the type of analog input for channel 1 (1). * This should also be set in accordance with the selection of analog input type (2) (SW11-1 and 2). * The setting of SW01-2 is disabled when SW01-3 is ON.	
	3		–	Pt100 detection		
	4	Channel 1	Unused		Set to OFF	
	5	Selection of upper/lower limit alarm interlock output use	No	Yes	Specify whether to use channel 1 upper/lower limit alarm interlock output.	
	6	Unused			Set to OFF	
	7	Unused			Set to OFF	
	8	Unused			Set to OFF	
SW02	1	Selection of the input to use	No	Yes	Specify whether to use the channel 2 input terminal.	
	2	Selection of the analog input type (1)	4 to 20 mADC/ 1 to 5 VDC detection	0 to 10 VDC detection	Set the type of analog input for channel 2 (1). * This should also be set in accordance with the selection of analog input type (2) (SW12-1 and 2).	
	3		Unused			
	4	Channel 2	Unused		Set to OFF	
	5	Selection of upper/lower limit alarm interlock output use	No	Yes	Specify whether to use channel 2 upper/lower limit alarm interlock output.	
	6	Unused			Set to OFF	
	7	Unused			Set to OFF	
	8	Unused			Set to OFF	
SW03	1	Measurement data backup interval 1-minute interval: (2 hours worth) 2-minute interval: (4 hours worth) 5-minute interval: (10 hours worth) 10-minute interval: (20 hours worth)	SW03-1	SW03-2	Set to back up measurement data to the fixed memory. Excess past data will be erased.	
	2		OFF	OFF		
			OFF	ON		
			ON	OFF		
			ON	ON		
	3	Unused			Set to OFF	
	4	Unused			Set to OFF	
	5	Unused			Set to OFF	
6	Unused			Set to OFF		
7	Unused			Set to OFF		
8	Unused			Set to OFF		
SW06	M-NET address		(Address 10s) 0 to 9 (decimal)		An address from 01 to 50 can be set. Set an address that is not the same as that of another unit.	
SW07			(Address 1s) 0 to 9 (decimal)			
SW08	1	Unused			Set to OFF	
	2	Unused			Set to OFF	
	3	Unused			Set to OFF	
	4	Unused			Set to OFF	
	5	Unused			Set to OFF	
	6	Unused			Set to OFF	
SW09	1	Unused			Set to OFF	
	2	Unused			Set to OFF	
SW11	1	Channel 1	Selection of analog input type (2)	SW11-1	SW11-2	Set the type of analog input for channel 1 (2) *1: This setting is not necessary when SW01-3 is ON.
	2		0 to 10 VDC detection : 1 to 5 VDC detection : Setting not possible : 4 to 20 mADC detection:	OFF OFF ON ON	OFF ON OFF ON	
SW12	1	Channel 2	Selection of analog input type (2)	SW12-1	SW12-2	Set the type of analog input for channel 2 (2)
	2		0 to 10 VDC detection : 1 to 5 VDC detection : Setting not possible : 4 to 20 mADC detection:	OFF OFF ON ON	OFF ON OFF ON	

Set the dip switches for function selection according to the system to be used.

At factory default, the SW01, SW02, SW03, SW08, and SW09 dipswitches are all set to OFF; the SW11 and SW12 dipswitches are both set to ON, and the M-NET address is set to 01.

Be sure to turn off the power before changing switch settings.

## 10 LED Display Designations

The LEDs of this device indicate the upper/lower limit alarm interlock output status and error status of this device.

### 10-1. Alarm Setpoint Output and Error Displays

Display Item		Display LED	Content								
			Note ●:On, ○:Off, ✨:Flashing								
Power supply status	(1) Power supply to CPU	LED16 (CPU power on)	● : Lights when the CPU is energized. ✨ : Flashes during M-NET communication.								
	(2) Power supply to M-NET circuit	LED17 (M-NET power on)	● : Lights when the M-NET is energized.								
Output status	Ch1, 2	(1) Upper/lower limit alarm interlock output status	LED03/02 (Output LEDs)								
			<table border="1"> <thead> <tr> <th rowspan="2">Output Method</th> <th>Ch1</th> <th>Ch2</th> </tr> <tr> <th>LED 03</th> <th>LED 02</th> </tr> </thead> <tbody> <tr> <td>Level Output</td> <td>● : Alarm output ○ : Alarm stop</td> <td>● : Alarm output ○ : Alarm stop</td> </tr> </tbody> </table>	Output Method	Ch1	Ch2	LED 03	LED 02	Level Output	● : Alarm output ○ : Alarm stop	● : Alarm output ○ : Alarm stop
Output Method	Ch1	Ch2									
	LED 03	LED 02									
Level Output	● : Alarm output ○ : Alarm stop	● : Alarm output ○ : Alarm stop									
Error status (*1)	(1) 4-digit error code	LED12/13/14/15 (Status display LEDs)	Refer to "10-2. Sensor and Communication Error Displays".								

\*1: When a sensor error or communication error occurs, the error status is displayed.

### 10-2. Sensor and Communication Error Displays

If a sensor error or communication error occurs, a 4-digit error code will be repeatedly displayed according to the steps shown below.

"Sensor and Communication Error Displays" consist of the following 10 steps. This operation is performed repeatedly to indicate the 4-digit error code for the error.

Note ●:On, ○:Off, ✨:Flashing

	LED11	LED12	LED13	LED14	LED15	Function	Remark
	Common	Error code display (Binary number indication)					
		2 <sup>3</sup> =8	2 <sup>2</sup> =4	2 <sup>1</sup> =2	2 <sup>0</sup> =1		
STEP1	○	✨	✨	✨	✨	"Sensor and Communication Error Displays" Starting Point Indication	LEDs 12 to 15 flash 3 times
STEP2	○	○	○	○	○	Blank	Turn Off
STEP3	●	●/○	●/○	●/○	●/○	Error code 1000's digit	Error code 1000's digit indication In the case of 6, ○●●○
STEP4	○	○	○	○	○	Blank	Turn Off
STEP5	●	●/○	●/○	●/○	●/○	Error code 100's digit	Error code 100's digit indication In the case of 6, ○●●○
STEP6	○	○	○	○	○	Blank	Turn Off
STEP7	●	●/○	●/○	●/○	●/○	Error code 10's digit	Error code 10's digit indication In the case of 0, ○○○○
STEP8	○	○	○	○	○	Blank	Turn Off
STEP9	●	●/○	●/○	●/○	●/○	Error code 1's digit	Error code 1's digit indication In the case of 7, ○●●●
STEP10	○	○	○	○	○	Blank	Turn Off

The error codes that are displayed for M-NET communication errors and sensor errors are as shown below.

Error Code	Description of Error	Error Code	Description of Error
6600	Multiple address error	6607	No ACK error
6601	M-NET polarity unset error	6608	No return of response frame
6602	Transmission processor hardware error	5010	Sensor trouble in Channel 1
6603	Transmission bus-busy error	5020	Sensor trouble in Channel 2
6606	Communications with transmission processor error		

## 11 System Operation Test

Use the following procedure to confirm operation of the system.

- (1) Configure the settings of this device and the system controller while referring to "8. Initial Settings".
- (2) Confirm whether the measurement values of channel 1 and channel 2 are displayed on the system controller properly.
  - \* Depending on the conditions, compare the measurement values with those of, for example, a commercially available portable thermohygrometer.  
If the measurement accuracy of the sensor used results in extreme differences in the measurement values, use the measurement correction value (offset value) input function of the system controller to correct the measurement values.
- (3) When upper/lower limit alarm interlock is to be used, input a value that exceeds the set alarm level and confirm whether the alarm is displayed on the controller. Furthermore, confirm whether the alarm output operation takes place from the contact output at the same time.

If there is a problem, check the wiring and settings.

For details on configuring settings, refer to "8. Initial Settings" and "9. Dip switch functions".

This product is designed and intended for use in the residential, commercial and light-industrial environment.

This product at hand is based on the following EU regulations:

- Low Voltage Directive 2014/35/EU
- Electromagnetic Compatibility Directive 2014/30/EU

**NOTE:**

This equipment has been tested and found to comply with the limits for a Class B digital device, pursuant to Part 15 of the FCC Rules. These limits are designed to provide reasonable protection against harmful interference in a residential installation. This equipment generates, uses and can radiate radio frequency energy and, if not installed and used in accordance with the instructions, may cause harmful interference to radio communications.

However, there is no guarantee that interference will not occur in a particular installation.

If this equipment does cause harmful interference to radio or television reception, which can be determined by turning the equipment off and on, the user is encouraged to try to correct the interference by one or more of the following measures:

- Reorient or relocate the receiving antenna.
- Increase the separation between the equipment and receiver.
- Connect the equipment into an outlet on a circuit different from that to which the receiver is connected.
- Consult the dealer or an experienced radio/TV technician for help.

## **MITSUBISHI ELECTRIC CORPORATION**

**HEAD OFFICE:** TOKYO BLDG., 2-7-3, MARUNOUCHI, CHIYODA-KU, TOKYO 100-8310, JAPAN

**MANUFACTURER:** MITSUBISHI ELECTRIC CORPORATION

Air-conditioning & Refrigeration Systems Works

5-66, Tebira 6 Chome, Wakayama-city, 640-8686, Japan