

GR-Z

9 – 156 kW

DATA BOOK

Air cooled condensers for IT Cooling with axial fans.
Outdoor installation.



The picture of the unit is indicative and may vary depending on the model

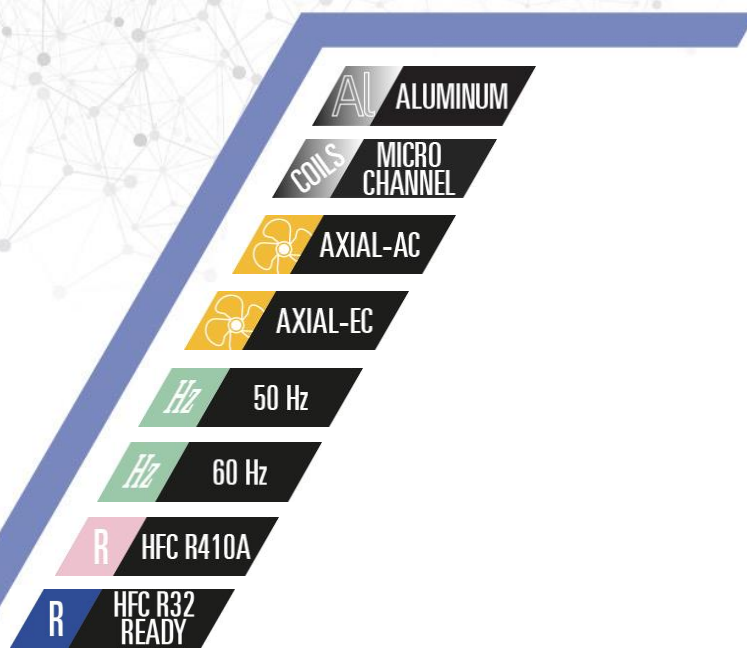

- FULL ALUMINUM FRAME FOR OUTDOOR INSTALLATION
- MICROCHANNEL CONDENSING COIL
- AXIAL FANS WITH AC (GR-Z A) OR EC (GR-Z E) ELECTRIC MOTOR
- 2 SOUND LEVELS
- REFRIGERANT R410A
- 50Hz OR 60Hz POWER SUPPLY
- PREDISPOSITION FOR R32 REFRIGERANT

INDEX

MEHITS CERTIFICATIONS.....	3
GENERAL CHARACTERISTICS	4
PRODUCT FEATURES AND BENEFITS	4
F-GAS DIRECTIVE	4
WORKING LIMITS	4
TRANSPORT AND STORAGE TEMPERATURE.....	4
MODEL IDENTIFICATION.....	5
AVAILABLE SERIES	5
MAIN COMPONENTS.....	8
STANDARDS	9
OPTIONAL ACCESSORIES	9
CORROSION RESISTANCE OF THE COIL	10
TECHNICAL DATA GR-Z A B 50 – 230/1/50.....	11
ACOUSTIC DATA GR-Z A B 50 – 230/1/50	11
TECHNICAL DATA GR-Z A L 50 – 230/1/50	12
ACOUSTIC DATA GR-Z A L 50 – 230/1/50.....	12
AXIAL FANS EQUIPPED WITH EC ELECTRIC MOTORS	13
TECHNICAL DATA GR-Z E B 50 – 230/1/50 - 400/3/50	14
ACOUSTIC DATA GR-Z E B 50 – 230/1/50 - 400/3/50	14
TECHNICAL DATA GR-Z E L 50 – 230/1/50 - 400/3/50.....	15
ACOUSTIC DATA GR-Z E L 50 – 230/1/50 - 400/3/50.....	15
TECHNICAL DATA GR-Z E B 60 – 220/1/60 - 380/3/60	16
ACOUSTIC DATA GR-Z E B 60 – 220/1/60 - 380/3/60	16
TECHNICAL DATA GR-Z E L 60 – 220/1/60 - 380/3/60.....	17
ACOUSTIC DATA GR-Z E L 60 – 220/1/60 - 380/3/60.....	17
TECHNICAL DATA GR-Z E B 60 – 265/1/60 - 460/3/60	18
ACOUSTIC DATA GR-Z E B 60 – 265/1/60 - 460/3/60	18
TECHNICAL DATA GR-Z E L 60 – 265/1/60 - 460/3/60.....	19
ACOUSTIC DATA GR-Z E L 60 – 265/1/60 - 460/3/60.....	19
DIMENSIONS & REFRIGERANT CONNECTIONS.....	20
REFRIGERANT CHARGE	21
RECOMMENDED REFRIGERANT LINES	21
INSTALLATION DIAGRAM	23
RECOMMENDATIONS FOR INSTALLATION.....	24
CONDENSING CONTROL	26
POWER SUPPLY.....	26
ELECTRICAL CONNECTION TO THE INDOOR UNIT	26
MACHINES DRAWINGS.....	27
WIRING DIAGRAMS	36
OPTIONAL ACCESSORIES: 1042 - VERTICAL AIR FLOW DIRECTION.....	44
OPTIONAL ACCESSORIES: 2211 – STOP VALVES	51
OPTIONAL ACCESSORIES: 876 - E-COATING MICROCHANNEL COIL	51
OPTIONAL ACCESSORIES: P101 – ANTI-SEISMIC FIXING KIT.....	52
SHIPMENT: PACKING DIMENSIONS.....	60
SHIPMENT: SHIPPING WEIGHT FOR STANDARD MACHINES.....	61
SHIPMENT: SHIPPING WEIGHT FOR ANTI-SEISMIC MACHINES.....	62

MEHITS CERTIFICATIONS



ISO 9001 CERTIFICATION – MEHITS S.p.A.
Quality Management System



ISO 14001 CERTIFICATION – MEHITS S.p.A.
Environmental Management System



BS OHSAS 18001 CERTIFICATION – MEHITS S.p.A.
Occupational Health and Safety Management System



CE MARKING



RoHS 2011/65/EU



CCC – CQC CERTIFICATION
(People’s Republic of China)



EAC CERTIFICATION
(Russian Federation, Belarus, Kazakhstan)



GENERAL CHARACTERISTICS

Air cooled condenser for IT Cooling with axial fans and horizontal or vertical air flow.
Air flow from coil to fan.
Condensers are supplied with seal charge; the refrigerant charge must be carried out.
Full aluminium frame for outdoor installation.
The constructive solutions allow high application flexibility.
2 series with 12 models each with capacity from 9 to 156kW.
The series has an independent power supply from the indoor unit.
Among the indoor unit and the condenser is necessary the refrigerant connection and electrical connection of the condensing proportional control signal and the alarms.

PRODUCT FEATURES AND BENEFITS

- Suitable for any type of plant;
- Structure entirely in magnesium aluminium alloy;
- Microchannel heat exchanger with low refrigerant content;
- Aluminium structure and heat exchanger that guarantee the absence of electrochemical potentials produced by different materials;
- Reduced dimensions and weight to facilitate handling and installation;
- Independent power supply from the indoor unit;
- Available for 50Hz or 60Hz power supply;
- Models with 1/2/3 fans – horizontal air flow from heat exchanger to fan. On request vertical air flow;
- Models with 4/6 fans - vertical air flow from heat exchanger to fan;
- 2 sound levels and quiet operation particularly suitable for applications in urban areas;
- Electrical panel with line disconnect on the machine;
- Axial fans with AC or EC electric motor;
- High efficiency fans in line with Erp2020;

F-GAS DIRECTIVE

The units highlighted in this publication contain HFC R410A [GWP₁₀₀ 2088] fluorinated greenhouse gases.

WORKING LIMITS

AMBIENT AIR TEMPERATURE

50°C	Maximum ambient air temperature.
-35°C	Minimum ambient air temperature for units equipped EC fans.
-45°C	Minimum ambient air temperature for units equipped AC fans.

POWER SUPPLY

230 V ± 10%	Maximum tolerance of the supply voltage for version with AC motors.
200 V ÷ 277 V	Power supply range for single-phase version with EC motor.
380V ÷ 480 V	Power supply range for three-phases version with EC motor.
50 Hz / 60 Hz	Power frequency for all versions with EC motor.
± 2%	Maximum unbalance between the phases (only for fans with EC motor).

TRANSPORT AND STORAGE TEMPERATURE

During transport and if the machine is not installed at the reception, do not remove the packaging and place the machine in an enclosed, dry and protected from sunlight site at temperatures ranging between -40°C and 60°C in absence of superficial condensation.

MODEL IDENTIFICATION



GR-Z A B 50 015

- GR-Z** **Air cooled condenser for refrigerant R410A**
- A** **Fan electric motor**
 A = with AC electric motor
 E = with EC electric motor
- B** **Sound level**
 B = standard
 L = low noise
- 50** **Power supply frequency**
 50 = 50Hz
 60 = 60Hz
- 015** **Model code** that corresponds to the nominal capacity (kW)

AVAILABLE SERIES



- GR-Z A B 50:** Remote condenser equipped with AC fan
 Standard acoustic version
 Power supply 230/1/50 for all models
- GR-Z A L 50:** Remote condenser equipped with AC fan
 Low noise acoustic version
 Power supply 230/1/50 for all models
- GR-Z E B 50:** Remote condenser equipped with EC fan
 Standard acoustic version
 Power supply 230/1/50 for models 013 and 015
 Power supply 400/3/50 for other models
- GR-Z E L 50:** Remote condenser equipped with EC fan
 Low noise acoustic version
 Power supply 230/1/50 for models 010 and 011
 Power supply 400/3/50 for other models



- GR-Z E B 60:** Remote condenser equipped with EC fan
 Standard acoustic version
 Power supply 220/1/60 for models 013 and 015
 Power supply 380/3/60 for all models
- GR-Z E L 60:** Remote condenser equipped with EC fan
 Low noise acoustic version
 Power supply 220/1/60 for models 010 and 011
 Power supply 380/3/60 for all models
- GR-Z E B 60:** Remote condenser equipped with EC fan
 Standard acoustic version
 Power supply 265/1/60 for models 013 and 015
 Power supply 460/3/60 for all models
- GR-Z E L 60:** Remote condenser equipped with EC fan
 Low noise acoustic version
 Power supply 265/1/60 for models 010 and 011
 Power supply 460/3/60 for all models

MODELS EQUIPPED WITH 1 / 2 / 3 FANS

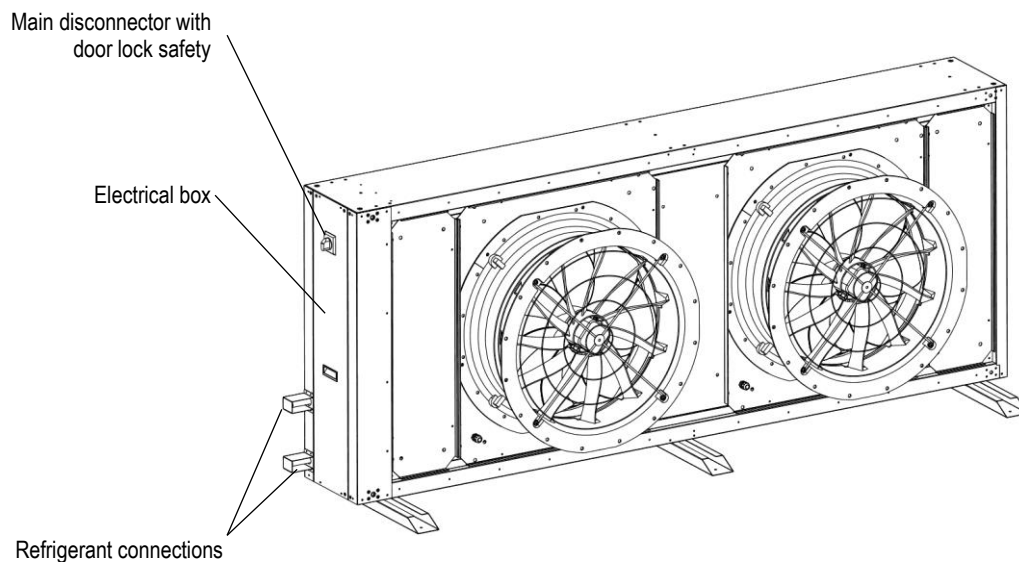

MODELS EQUIPPED WITH 4 / 6 FANS

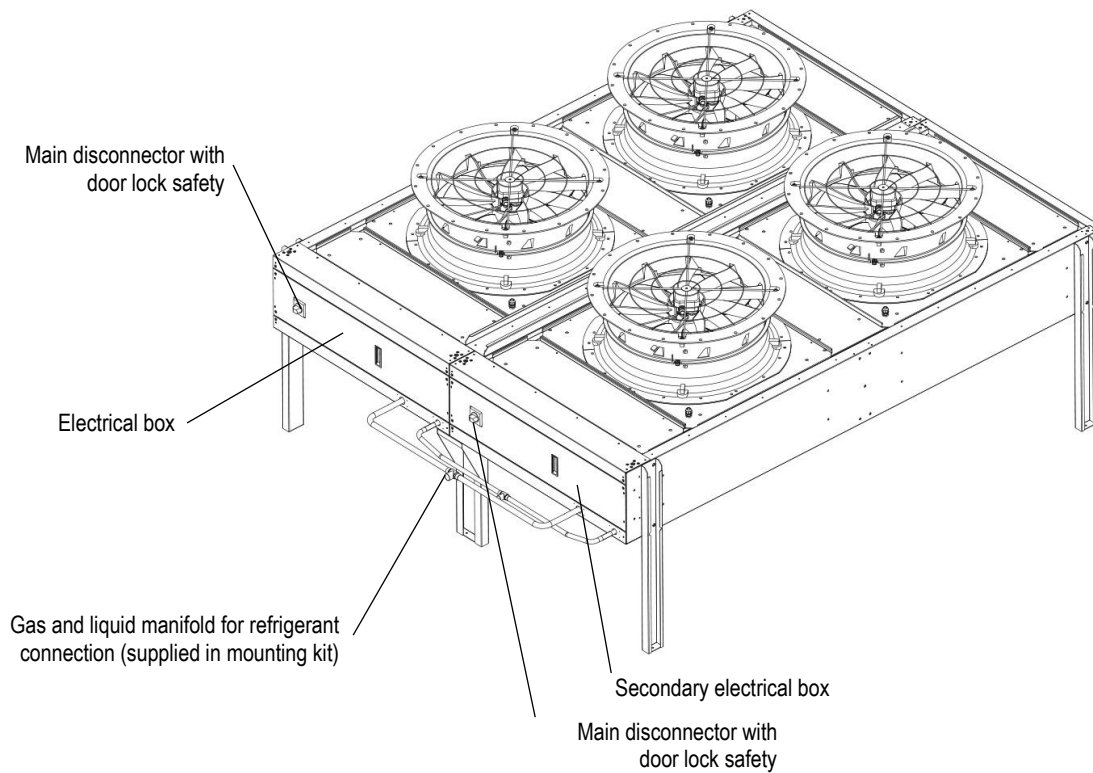

AVAILABLE MODELS

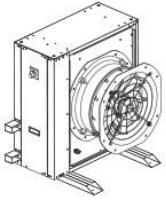

Model
Standard 013 / 015
Low Noise 010 / 011

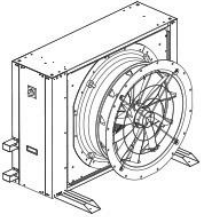

Model
Standard 024 / 027
Low Noise 018 / 021

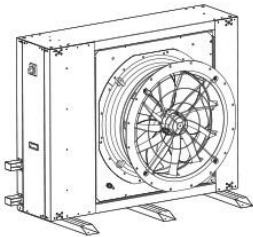

Model
Standard 034
Low Noise 025

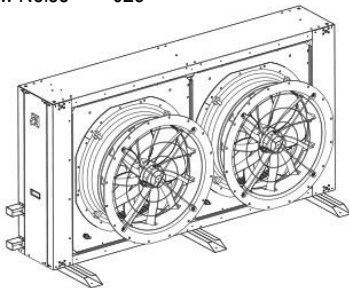

Model
Standard 049 / 055
Low Noise 036 / 043

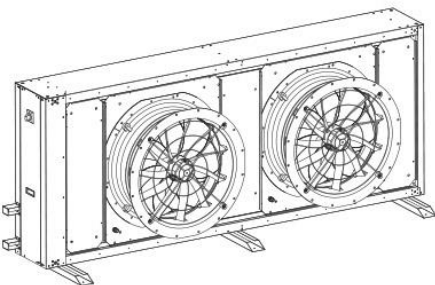

Model
Standard 067
Low Noise 051

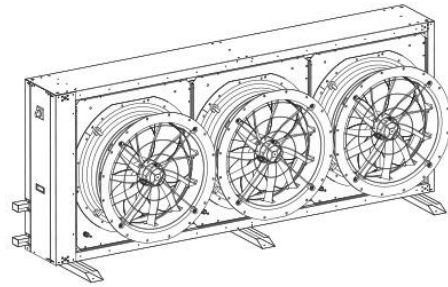

Model
Standard 082
Low Noise 063

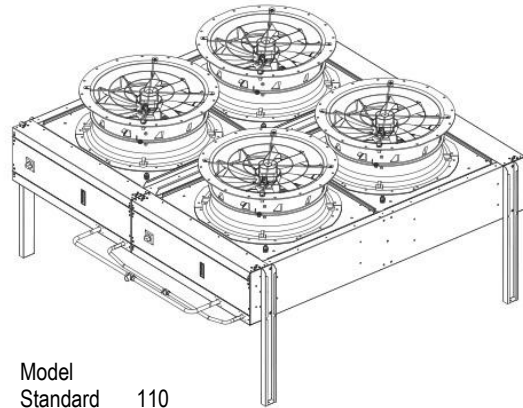

Model
Standard 110
Low Noise 086

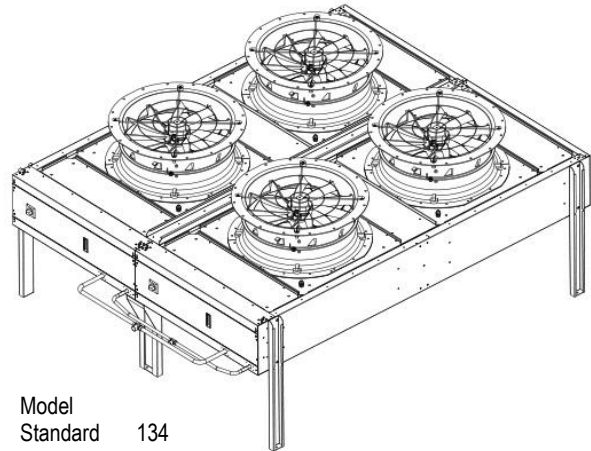

Model
Standard 134
Low Noise 102

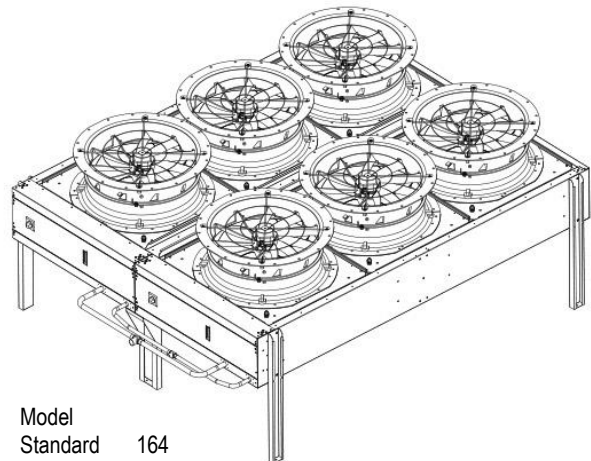

Model
Standard 164
Low Noise 126

MAIN COMPONENTS



FRAMEWORK

- Supporting and anchoring supports, self-supporting structure and panelling made of smooth sheet in PERALLUMAN 5754 H22 cold-rolled aluminium-magnesium alloy.
- Removable lateral panels.
- Lateral compartment for electrical panel with direct access to control and regulation devices.
- Not painted structure.
- Fully recyclable structure at the end of life.

LOW NOISE VERSION

- Dedicated fans and electronics to guarantee low noise levels.
- Sound-proof insulation of lateral panelling.

PERALLUMAN 5754 H22

The aluminum alloy used for the structure of the condenser, as well as offering a high mechanical resistance $R_m 220 \div 270 \text{ N / mm}^2$ and a good surface hardness HB 63, shows its best characteristics in the corrosion resistance according to ISO 12944-2014:

- EXCELLENT for environments classified C1 - C4
- GOOD for environments classified C5.

FAN SECTION

- Axial fans with sickle-shaped blades, fan guard and optimized for low noise levels.
- Maximum air flow and efficiency thanks to:
 - aluminum blades with bionic design
 - air flow conveyor in composite material
 - integrated diffuser with dynamic energy recovery system
- Electric motor with external rotor
- Integrated motor thermal protection - Insulation class F - THC 155°C
- Motor rotation speed control through a 0-10Vdc proportional signal coming from the indoor unit controller
- Protection grid on the fan air supply.
- Dynamic balancing on 2 planes.
- VDE, UL, CCC, EAC, CE approvals.
- IP54 enclosure class.
- Complies with the current ErP directive and ErP 2020 ready.

VERSION WITH AC ELECTRIC MOTOR – series GR-Z A

- Rotation speed control via external electronics

VERSION WITH EC ELECTRIC MOTOR – series GR-Z E

- Rotation speed control with integrated controller

CONDENSING COIL

- Fully-aluminium microchannel condensing coil
- No galvanic corrosion thanks to the use of aluminium Long-Life Alloy 9153.
- Compared to a traditional finned coil the microchannel exchanger offers:
 - Up to 40% reduction in refrigerant pressure drop
 - Up to 30% reduction in air flow pressure drop
 - Up to 50% reduction in refrigerant content
 - Up to 45% increase in heat exchange efficiency
- Fully recyclable coil at the end of life.
- The coil is supplied with seal charge.

REFRIGERANT CIRCUIT

The condenser is supplied with seal charge.

- Service Schrader valve on refrigerant inlet pipe. The valve can be used for the emptying of the sealing charge, the creation of the vacuum and the refrigerant charge operation.
- Welding copper connection on the gas inlet and liquid outlet manifolds.

Models with 4/6 fans:

- Copper manifolds already prepared for the parallel connection of the two condensing coils, supplied in mounting kit.



ELECTRICAL PANEL

The electrical panel is positioned inside the condenser structure; remove the side panel to access.

The electrical panel is suitable for outdoor installation and complies with EN60204-1 standards.

The electrical panel includes:

- IP44 enclosure class – enclosure class of the electrical panel inserted in the structure of the machine and not referred to the panel only.
- Main disconnector with door lock safety.
- Terminal block for electrical connections:
 - power supply - the power supply is independent of the indoor unit.
 - 0-10Vdc signal for fan rotation speed control - to be connected to the indoor unit.
 - alarm signal of the fans and, if present, of the FMC electronic card - to be connected to the indoor unit.

VERSION WITH AC ELECTRIC MOTOR – series GR-Z A

- FMC electronic board for fan rotation speed control. In case of power failure and malfunction, the board sends an alarm signal to the indoor unit (refer to the wiring diagrams)
- Fan supply voltage regulation system managed by the FMC electronic board.

VERSION WITH EC ELECTRIC MOTOR – series GR-Z E

- Direct control of fan rotation speed by 0-10Vdc signal.

Models with 4/6 fans:

There are two electrical panels, each one with the mentioned equipment. The panels are already interconnected and only one is the main panel. The power supply, the control and alarm signals must be connected to the main panel.

STANDARDS

STANDARDS FOR ELECTRIC PANEL AND MACHINE

- EN 60204-1
- 2006/42/EC Machinery Directive
- PED 97/23/EC
- LVD 2006/95/EC
- EMC 2014/30/EC:
 - EN 61000-6-2:2005 “Electromagnetic compatibility – Immunity for industrial environments
 - EN 61000-6-3:2007 “Electromagnetic compatibility – Emission standard for residential, commercial and light industrial environments”

OPTIONAL ACCESSORIES

- 1042** **Vertical air flow direction:** Excluding models with 4/6 fans. Support legs for vertical air flow supplied in assembly kit. The optional is not suitable for installation in seismic areas.
- 876** **E-coating microchannel coil:** Condensing coil with additional E-coating protective treatment.
- 2211** **Stop valves:** Ball valves for refrigerant line - supplied in assembly kit.
- P101** **Anti-seismic fixing kit:** Only for models with 1/2/3 fans Version for installation in seismic areas.
- 9973** **Wooden cage packing:** Excluded models with 4/6 fans. The machines are delivered on wooden pallet, covered with shrink wrap and packaged in wooden cage.

WARNING

The Manufacturer reserves the right to accept the matching of the optional installed on the machine.

CORROSION RESISTANCE OF THE COIL

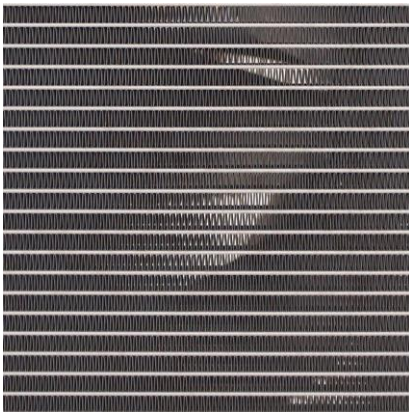

CLASSIFICATION OF INSTALLATION ENVIRONMENTS

For resistance against atmospheric agents, ISO 12944-2014 classifies the environments in different categories of corrosivity as shown in the following table:

CORROSIVITY CATEGORIES		OUTDOOR AREAS	INTERNAL ENVIRONMENT
C1	VERY LOW	--	Heated buildings with a clean atmosphere. (Offices, schools, shops, hotels)
C2	LOW	Atmosphere contaminated to a small extent, mainly rural regions.	Unheated buildings where condensation may occur. (Depots, sports hall)
C3	MEDIUM	Industrial and urban atmosphere with an average contamination level. Inshore areas of low salinity.	Production rooms with high humidity and some air pollution. (food processing plants, laundries, breweries, or dairies)
C4	HIGH	Industrial areas. Inshore areas of medium salinity.	chemical plants, swimming pools, and boat yards
C5 - I	VERY HIGH - INDUSTRIAL	Industrial areas of high humidity and aggressive atmosphere.	Buildings are areas with almost permanent condensation and with high pollution.
C5 - M	VERY HIGH - MARINE	Inshore areas and offshore areas of high salinity.	

SWAAT TEST ON CONDENSING COILS

Tests conducted on the condensing coils of the GR series according to the ASTM G85-A3 - Acidified synthetic seawater test - at 49°C with Ph included between 2,8 and 3,0.

- Long Life Alloy standard coil: **SWAAT test di 2000 ore**
- Long Life Alloy coil with E-coating protection: **SWAAT test di 4000 ore**

Types of application of condensing coils according to ISO 12944-2014:

CORROSIVITY CATEGORIES		CONDENSING COIL TYPE
C1	VERY LOW	Long Life Alloy coil
C2	LOW	Long Life Alloy coil
C3	MEDIUM	Long Life Alloy coil
C4	HIGH	Long Life Alloy coil + E-coating
C5 - I	VERY HIGH - INDUSTRIAL	Long Life Alloy coil + E-coating
C5 - M	VERY HIGH - MARINE	Long Life Alloy coil + E-coating

TECHNICAL DATA GR-Z A B 50 – 230/1/50

Fans with AC electric motors and STANDARD acoustic version

MODEL		013	015	024	027	034	049
REFRIGERANT		R410A	R410A	R410A	R410A	R410A	R410A
POWER SUPPLY	V/ph/Hz	230/1/50	230/1/50	230/1/50	230/1/50	230/1/50	230/1/50
ACOUSTIC VERSION		B	B	B	B	B	B
CAPACITY (1)	kW	12,9	14,4	23,0	25,7	32,0	47,0
AXIAL FANS "AC"	n.	1	1	1	1	1	2
Total air flow	m ³ /h	3910	4600	7098	8350	9550	15555
External static pressure	Pa	0	0	0	0	0	0
Total engaged power	kW	0,26	0,31	0,51	0,60	0,54	0,87
Total absorbed current (SA)	A	1,4	1,7	2,5	2,9	2,9	4,94
Maximum total engaged power (FLI)	kW	0,32	0,38	0,54	0,64	0,64	1,08
Maximum total absorbed current (FLA)	A	1,4	1,7	2,5	2,9	2,9	4,94
NET WEIGHT	kg	30	30	45	45	53	86

MODEL		055	067	082	110	134	164
REFRIGERANT		R410A	R410A	R410A	R410A	R410A	R410A
POWER SUPPLY	V/ph/Hz	230/1/50	230/1/50	230/1/50	230/1/50	230/1/50	230/1/50
ACOUSTIC VERSION		B	B	B	B	B	B
CAPACITY (1)	kW	52,5	63,8	77,8	105,0	128,0	156,0
AXIAL FANS "AC"	n.	2	2	3	4	4	6
Total air flow	m ³ /h	18300	19000	25000	36600	38000	50000
External static pressure	Pa	0	0	0	0	0	0
Total engaged power	kW	1,02	0,99	1,55	2,04	1,98	3,10
Total absorbed current (SA)	A	5,8	5,8	8,7	11,6	11,6	17,4
Maximum total engaged power (FLI)	kW	1,28	1,28	1,92	2,56	2,56	3,84
Maximum total absorbed current (FLA)	A	5,8	5,8	8,7	11,6	11,6	17,4
NET WEIGHT	kg	86	100	120	177	208	248

1. Referred to condensing temperature at 50°C and ambient air temperature at 35°C.

The units highlighted in this publication contain <HFC R410A [GWP₁₀₀ 2088]> fluorinated greenhouse gas

ACOUSTIC DATA GR-Z A B 50 – 230/1/50

Fans with AC electric motors and STANDARD acoustic version

MODEL		013	015	024	027	034	049
REFRIGERANT		R410A	R410A	R410A	R410A	R410A	R410A
POWER SUPPLY	V/ph/Hz	230/1/50	230/1/50	230/1/50	230/1/50	230/1/50	230/1/50
ACOUSTIC VERSION		B	B	B	B	B	B
Sound power level [Lw] ISO 9614-2	dB(A)	65	69	66	70	71	70
Average sound pressure level [Lpm] ISO 3744							
At 1 m	dB(A)	51	54	51	55	56	54
At 5 m	dB(A)	39	43	40	44	45	44
At 10 m	dB(A)	34	38	35	39	40	39

MODEL		055	067	082	110	134	164
REFRIGERANT		R410A	R410A	R410A	R410A	R410A	R410A
POWER SUPPLY	V/ph/Hz	230/1/50	230/1/50	230/1/50	230/1/50	230/1/50	230/1/50
ACOUSTIC VERSION		B	B	B	B	B	B
Sound power level [Lw] ISO 9614-2	dB(A)	73	74	75	76	77	78
Average sound pressure level [Lpm] ISO 3744							
At 1 m	dB(A)	57	58	59	59	59	60
At 5 m	dB(A)	47	48	49	50	50	51
At 10 m	dB(A)	42	42	43	44	45	46

TECHNICAL DATA GR-Z A L 50 – 230/1/50

Fans with AC electric motors and LOW NOISE acoustic version

MODEL		010	011	018	021	025	036
REFRIGERANT		R410A	R410A	R410A	R410A	R410A	R410A
POWER SUPPLY	V/ph/Hz	230/1/50	230/1/50	230/1/50	230/1/50	230/1/50	230/1/50
ACOUSTIC VERSION		L	L	L	L	L	L
CAPACITY (1)	kW	9,41	11,2	16,7	20,0	24,5	34,2
AXIAL FANS "AC"	n.	1	1	1	1	1	2
Total air flow	m ³ /h	2530	3220	4593	5845	6685	10065
External static pressure	Pa	0	0	0	0	0	0
Total engaged power	kW	0,17	0,22	0,33	0,42	0,38	0,56
Total absorbed current (SA)	A	0,9	1,2	1,6	2,03	2,03	3,2
Maximum total engaged power (FLI)	kW	0,21	0,27	0,35	0,45	0,45	0,70
Maximum total absorbed current (FLA)	A	0,9	1,2	1,6	2,03	2,03	3,2
NET WEIGHT	kg	32	32	47	47	56	89

MODEL		043	051	063	086	102	126
REFRIGERANT		R410A	R410A	R410A	R410A	R410A	R410A
POWER SUPPLY	V/ph/Hz	230/1/50	230/1/50	230/1/50	230/1/50	230/1/50	230/1/50
ACOUSTIC VERSION		L	L	L	L	L	L
CAPACITY (1)	kW	40,9	48,6	60,0	81,8	97,1	120,1
AXIAL FANS "AC"	n.	2	2	3	4	4	6
Total air flow	m ³ /h	12810	13300	17500	25620	26600	35000
External static pressure	Pa	0	0	0	0	0	0
Total absorbed current (SA)	kW	0,71	0,69	1,10	1,43	1,40	2,17
Maximum total engaged power (FLI)	A	4,06	4,06	6,09	8,12	8,12	12,2
Maximum total absorbed current (FLA)	kW	0,9	0,9	1,34	1,79	1,79	2,69
Maximum total absorbed current (FLA)	A	4,06	4,06	6,09	8,12	8,12	12,2
NET WEIGHT	kg	89	103	124	184	215	255

1. Referred to condensing temperature at 50°C and ambient air temperature at 35°C.

The units highlighted in this publication contain <HFC R410A [GWP₁₀₀ 2088]> fluorinated greenhouse gas

ACOUSTIC DATA GR-Z A L 50 – 230/1/50

Fans with AC electric motors and LOW NOISE acoustic version

MODEL		010	011	018	021	025	036
REFRIGERANT		R410A	R410A	R410A	R410A	R410A	R410A
POWER SUPPLY	V/ph/Hz	230/1/50	230/1/50	230/1/50	230/1/50	230/1/50	230/1/50
ACOUSTIC VERSION		L	L	L	L	L	L
Sound power level [Lw] ISO 9614-2	dB(A)	56	60	59	62	63	62
Average sound pressure level [Lpm] ISO 3744							
At 1 m	dB(A)	41	45	44	47	48	46
At 5 m	dB(A)	30	34	33	36	37	36
At 10 m	dB(A)	25	29	28	31	32	31

MODEL		043	051	063	086	102	126
REFRIGERANT		R410A	R410A	R410A	R410A	R410A	R410A
POWER SUPPLY	V/ph/Hz	230/1/50	230/1/50	230/1/50	230/1/50	230/1/50	230/1/50
ACOUSTIC VERSION		L	L	L	L	L	L
Sound power level [Lw] ISO 9614-2	dB(A)	66	66	67	69	69	70
Average sound pressure level [Lpm] ISO 3744							
At 1 m	dB(A)	50	50	51	52	51	52
At 5 m	dB(A)	40	40	41	43	42	43
At 10 m	dB(A)	35	34	35	37	37	38

AXIAL FANS EQUIPPED WITH EC ELECTRIC MOTORS



The "EC" axial fans are equipped with a brushless type synchronous motor with integrated electronic commutated system. The motor rotation control is obtained with the EC system (Electronic Commutation) that manages the motor according to the 0÷10V proportional signal coming from the microprocessor control.

- Characteristics of "EC" motors:
- no electromagnetic noise
 - efficiency 83÷86%
 - minimum power input

Characteristics comparison between an "AC" asynchronous electric motor with phase-cut control (voltage controller) and "EC" brushless type synchronous motor.

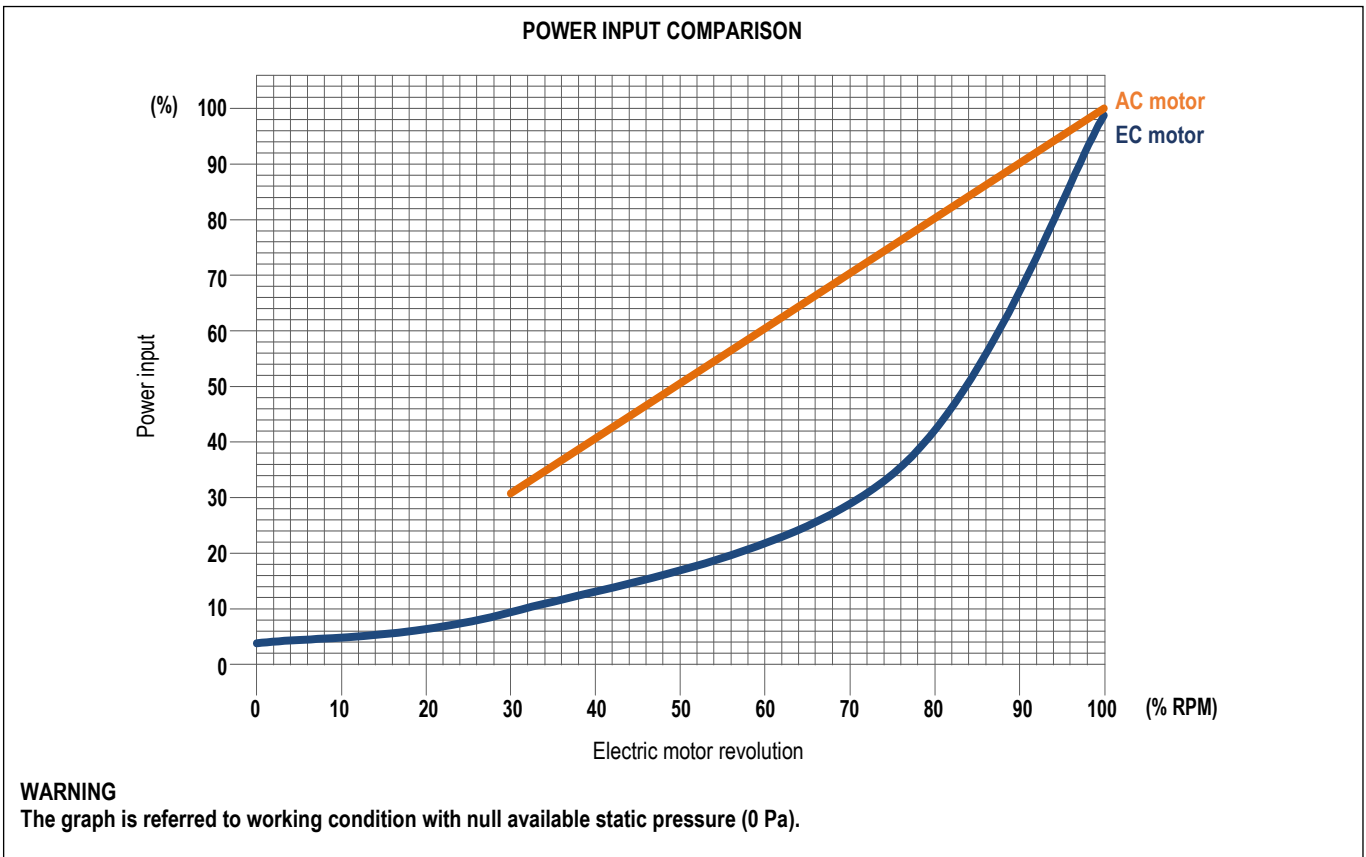

TECHNICAL DATA GR-Z E B 50 – 230/1/50 - 400/3/50

Fans with EC electric motors and STANDARD acoustic version

MODEL		013	015	024	027	034	049
REFRIGERANT		R410A	R410A	R410A	R410A	R410A	R410A
POWER SUPPLY	V/ph/Hz	230/1/50	230/1/50	400/3/50	400/3/50	400/3/50	400/3/50
ACOUSTIC VERSION		B	B	B	B	B	B
CAPACITY (1)	kW	11,4	13,8	23,0	25,7	32,0	47,0
AXIAL FANS "EC"	n.	1	1	1	1	1	2
Total air flow	m ³ /h	3300	4300	7098	8350	9550	15555
External static pressure	Pa	0	0	0	0	0	0
Total engaged power	kW	0,08	0,18	0,23	0,38	0,34	0,45
Total absorbed current (SA)	A	0,91	0,91	1,92	1,92	1,92	3,84
Maximum total engaged power (FLI)	kW	0,21	0,21	1,0	1,0	1,0	2,0
Maximum total absorbed current (FLA)	A	0,91	0,91	1,92	1,92	1,92	3,84
NET WEIGHT	kg	28	28	43	43	50	82

MODEL		055	067	082	110	134	164
REFRIGERANT		R410A	R410A	R410A	R410A	R410A	R410A
POWER SUPPLY	V/ph/Hz	400/3/50	400/3/50	400/3/50	400/3/50	400/3/50	400/3/50
ACOUSTIC VERSION		B	B	B	B	B	B
CAPACITY (1)	kW	52,5	63,8	77,8	105,0	128,0	156,0
AXIAL FANS "EC"	n.	2	2	3	4	4	6
Total air flow	m ³ /h	18300	19000	25000	36600	38000	50000
External static pressure	Pa	0	0	0	0	0	0
Total engaged power	kW	0,65	0,65	0,98	1,3	1,3	1,95
Total absorbed current (SA)	A	3,84	3,84	5,76	7,68	7,68	11,5
Maximum total engaged power (FLI)	kW	2,0	2,0	3,0	4,0	4,0	6,0
Maximum total absorbed current (FLA)	A	3,84	3,84	5,76	7,68	7,68	11,5
NET WEIGHT	kg	82	96	114	169	200	237

1. Referred to condensing temperature at 50°C and ambient air temperature at 35°C.

The units highlighted in this publication contain <HFC R410A [GWP₁₀₀ 2088]> fluorinated greenhouse gas

ACOUSTIC DATA GR-Z E B 50 – 230/1/50 - 400/3/50

Fans with EC electric motors and STANDARD acoustic version

MODEL		013	015	024	027	034	049
REFRIGERANT		R410A	R410A	R410A	R410A	R410A	R410A
POWER SUPPLY	V/ph/Hz	230/1/50	230/1/50	400/3/50	400/3/50	400/3/50	400/3/50
ACOUSTIC VERSION		B	B	B	B	B	B
Sound power level [Lw] ISO 9614-2	dB(A)	58	64	66	70	71	70
Average sound pressure level [Lpm] ISO 3744							
At 1 m	dB(A)	43	49	51	55	56	54
At 5 m	dB(A)	32	38	40	44	45	44
At 10 m	dB(A)	27	33	35	39	40	39

MODEL		055	067	082	110	134	164
REFRIGERANT		R410A	R410A	R410A	R410A	R410A	R410A
POWER SUPPLY	V/ph/Hz	400/3/50	400/3/50	400/3/50	400/3/50	400/3/50	400/3/50
ACOUSTIC VERSION		B	B	B	B	B	B
Sound power level [Lw] ISO 9614-2	dB(A)	73	74	75	76	77	78
Average sound pressure level [Lpm] ISO 3744							
At 1 m	dB(A)	57	58	59	59	59	60
At 5 m	dB(A)	47	48	49	50	50	51
At 10 m	dB(A)	42	42	43	44	45	46

TECHNICAL DATA GR-Z E L 50 – 230/1/50 - 400/3/50

Fans with EC electric motors and STANDARD acoustic version

MODEL		010	011	018	021	025	036
REFRIGERANT		R410A	R410A	R410A	R410A	R410A	R410A
POWER SUPPLY	V/ph/Hz	230/1/50	230/1/50	400/3/50	400/3/50	400/3/50	400/3/50
ACOUSTIC VERSION		L	L	L	L	L	L
CAPACITY (1)	kW	8,3	10,7	16,7	20,0	24,5	34,2
AXIAL FANS "EC"	n.	1	1	1	1	1	2
Total air flow	m ³ /h	2150	3010	4593	5845	6685	10065
External static pressure	Pa	0	0	0	0	0	0
Total engaged power	kW	0,02	0,06	0,06	0,13	0,12	0,12
Total absorbed current (SA)	A	0,91	0,91	1,92	1,92	1,92	3,84
Maximum total engaged power (FLI)	kW	0,21	0,21	1,0	1,0	1,0	2,0
Maximum total absorbed current (FLA)	A	0,91	0,91	1,92	1,92	1,92	3,84
NET WEIGHT	kg	29	29	45	45	53	85

MODEL		043	051	063	086	102	126
REFRIGERANT		R410A	R410A	R410A	R410A	R410A	R410A
POWER SUPPLY	V/ph/Hz	400/3/50	400/3/50	400/3/50	400/3/50	400/3/50	400/3/50
ACOUSTIC VERSION		L	L	L	L	L	L
CAPACITY (1)	kW	40,9	48,6	60,0	81,8	97,1	120,0
AXIAL FANS "EC"	n.	2	2	3	4	4	6
Total air flow	m ³ /h	12810	13300	17500	25620	26600	35000
External static pressure	Pa	0	0	0	0	0	0
Total engaged power	kW	0,22	0,22	0,33	0,45	0,44	0,67
Total absorbed current (SA)	A	3,84	3,84	5,76	7,68	7,68	11,50
Maximum total engaged power (FLI)	kW	2,0	2,0	3,0	4,0	4,0	6,0
Maximum total absorbed current (FLA)	A	3,84	3,84	5,76	7,68	7,68	11,50
NET WEIGHT	kg	85	99	118	176	207	244

1. Referred to condensing temperature at 50°C and ambient air temperature at 35°C.

The units highlighted in this publication contain <HFC R410A [GWP₁₀₀ 2088]> fluorinated greenhouse gas

ACOUSTIC DATA GR-Z E L 50 – 230/1/50 - 400/3/50

Fans with EC electric motors and LOW NOISE acoustic version

MODEL		010	011	018	021	025	036
REFRIGERANT		R410A	R410A	R410A	R410A	R410A	R410A
POWER SUPPLY	V/ph/Hz	230/1/50	230/1/50	400/3/50	400/3/50	400/3/50	400/3/50
ACOUSTIC VERSION		L	L	L	L	L	L
Sound power level [Lw] ISO 9614-2	dB(A)	51	57	59	62	63	62
Average sound pressure level [Lpm] ISO 3744							
At 1 m	dB(A)	36	42	44	47	48	46
At 5 m	dB(A)	25	31	33	36	37	36
At 10 m	dB(A)	20	26	28	31	32	31

MODEL		043	051	063	086	102	126
REFRIGERANT		R410A	R410A	R410A	R410A	R410A	R410A
POWER SUPPLY	V/ph/Hz	400/3/50	400/3/50	400/3/50	400/3/50	400/3/50	400/3/50
ACOUSTIC VERSION		L	L	L	L	L	L
Sound power level [Lw] ISO 9614-2	dB(A)	66	66	67	69	69	70
Average sound pressure level [Lpm] ISO 3744							
At 1 m	dB(A)	50	50	51	52	51	52
At 5 m	dB(A)	40	40	41	43	42	43
At 10 m	dB(A)	35	34	35	37	37	38

TECHNICAL DATA GR-Z E B 60 – 220/1/60 - 380/3/60

Fans with EC electric motors and STANDARD acoustic version

MODEL		013	015	024	027	034	049
REFRIGERANT		R410A	R410A	R410A	R410A	R410A	R410A
POWER SUPPLY	V/ph/Hz	220/1/60	220/1/60	380/3/60	380/3/60	380/3/60	380/3/60
ACOUSTIC VERSION		B	B	B	B	B	B
CAPACITY (1)	kW	11,4	13,8	23,0	25,7	32,0	47,0
AXIAL FANS "EC"	n.	1	1	1	1	1	2
Total air flow	m ³ /h	3300	4300	7098	8350	9550	15555
External static pressure	Pa	0	0	0	0	0	0
Total engaged power	kW	0,08	0,18	0,23	0,38	0,34	0,45
Total absorbed current (SA)	A	0,95	0,95	2	2	2	4
Maximum total engaged power (FLI)	kW	0,21	0,21	1	1	1	2
Maximum total absorbed current (FLA)	A	0,95	0,95	2	2	2	4
NET WEIGHT	kg	28	28	43	43	50	82

MODEL		055	067	082	110	134	164
REFRIGERANT		R410A	R410A	R410A	R410A	R410A	R410A
POWER SUPPLY	V/ph/Hz	380/3/60	380/3/60	380/3/60	380/3/60	380/3/60	380/3/60
ACOUSTIC VERSION		B	B	B	B	B	B
CAPACITY (1)	kW	52,5	63,8	77,8	105,0	128,0	156,0
AXIAL FANS "EC"	n.	2	2	3	4	4	6
Total air flow	m ³ /h	18300	19000	25000	36600	38000	50000
External static pressure	Pa	0	0	0	0	0	0
Total engaged power	kW	0,65	0,65	0,98	1,3	1,3	1,95
Total absorbed current (SA)	A	4	4	6	8	8	12
Maximum total engaged power (FLI)	kW	2	2	3	4	4	6
Maximum total absorbed current (FLA)	A	4	4	6	8	8	12
NET WEIGHT	kg	82	96	114	169	200	237

1. Referred to condensing temperature at 50°C and ambient air temperature at 35°C.

The units highlighted in this publication contain <HFC R410A [GWP₁₀₀ 2088]> fluorinated greenhouse gas

ACOUSTIC DATA GR-Z E B 60 – 220/1/60 - 380/3/60

Fans with EC electric motors and STANDARD acoustic version

MODEL		013	015	024	027	034	049
REFRIGERANT		R410A	R410A	R410A	R410A	R410A	R410A
POWER SUPPLY	V/ph/Hz	220/1/60	220/1/60	380/3/60	380/3/60	380/3/60	380/3/60
ACOUSTIC VERSION		B	B	B	B	B	B
Sound power level [Lw] ISO 9614-2	dB(A)	58	64	66	70	71	70
Average sound pressure level [Lpm] ISO 3744							
At 1 m	dB(A)	43	49	51	55	56	54
At 5 m	dB(A)	32	38	40	44	45	44
At 10 m	dB(A)	27	33	35	39	40	39

MODEL		055	067	082	110	134	164
REFRIGERANT		R410A	R410A	R410A	R410A	R410A	R410A
POWER SUPPLY	V/ph/Hz	380/3/60	380/3/60	380/3/60	380/3/60	380/3/60	380/3/60
ACOUSTIC VERSION		B	B	B	B	B	B
Sound power level [Lw] ISO 9614-2	dB(A)	73	74	75	76	77	78
Average sound pressure level [Lpm] ISO 3744							
At 1 m	dB(A)	57	58	59	59	59	60
At 5 m	dB(A)	47	48	49	50	50	51
At 10 m	dB(A)	42	42	43	44	45	46

TECHNICAL DATA GR-Z E L 60 – 220/1/60 - 380/3/60

Fans with EC electric motors and LOW NOISE acoustic version

MODEL		010	011	018	021	025	036
REFRIGERANT		R410A	R410A	R410A	R410A	R410A	R410A
POWER SUPPLY	V/ph/Hz	220/1/60	220/1/60	380/3/60	380/3/60	380/3/60	380/3/60
ACOUSTIC VERSION		L	L	L	L	L	L
CAPACITY (1)	kW	8,3	10,7	16,7	20,0	24,5	34,2
AXIAL FANS "EC"	n.	1	1	1	1	1	2
Total air flow	m ³ /h	2150	3010	4593	5845	6685	10065
External static pressure	Pa	0	0	0	0	0	0
Total engaged power	kW	0,02	0,06	0,06	0,13	0,12	0,12
Total absorbed current (SA)	A	0,95	0,95	2	2	2	4
Maximum total engaged power (FLI)	kW	0,21	0,21	1	1	1	2
Maximum total absorbed current (FLA)	A	0,95	0,95	2	2	2	4
NET WEIGHT	kg	29	29	45	45	53	85

MODEL		043	051	063	086	102	126
REFRIGERANT		R410A	R410A	R410A	R410A	R410A	R410A
POWER SUPPLY	V/ph/Hz	380/3/60	380/3/60	380/3/60	380/3/60	380/3/60	380/3/60
ACOUSTIC VERSION		L	L	L	L	L	L
CAPACITY (1)	kW	40,9	48,6	60,0	81,8	97,1	120,0
AXIAL FANS "EC"	n.	2	2	3	4	4	6
Total air flow	m ³ /h	12810	13300	17500	25620	26600	35000
External static pressure	Pa	0	0	0	0	0	0
Total engaged power	kW	0,22	0,22	0,33	0,45	0,44	0,67
Total absorbed current (SA)	A	4	4	6	8	8	12
Maximum total engaged power (FLI)	kW	2	2	3	4	4	6
Maximum total absorbed current (FLA)	A	4	4	6	8	8	12
NET WEIGHT	kg	85	99	118	176	207	244

1. Referred to condensing temperature at 50°C and ambient air temperature at 35°C.

The units highlighted in this publication contain <HFC R410A [GWP₁₀₀ 2088]> fluorinated greenhouse gas

ACOUSTIC DATA GR-Z E L 60 – 220/1/60 - 380/3/60

Fans with EC electric motors and LOW NOISE acoustic version

MODEL		010	011	018	021	025	036
REFRIGERANT		R410A	R410A	R410A	R410A	R410A	R410A
POWER SUPPLY	V/ph/Hz	220/1/60	220/1/60	380/3/60	380/3/60	380/3/60	380/3/60
ACOUSTIC VERSION		L	L	L	L	L	L
Sound power level [Lw] ISO 9614-2	dB(A)	51	57	59	62	63	62
Average sound pressure level [Lpm] ISO 3744							
At 1 m	dB(A)	36	42	44	47	48	46
At 5 m	dB(A)	25	31	33	36	37	36
At 10 m	dB(A)	20	26	28	31	32	31

MODEL		043	051	063	086	102	126
REFRIGERANT		R410A	R410A	R410A	R410A	R410A	R410A
POWER SUPPLY	V/ph/Hz	380/3/60	380/3/60	380/3/60	380/3/60	380/3/60	380/3/60
ACOUSTIC VERSION		L	L	L	L	L	L
Sound power level [Lw] ISO 9614-2	dB(A)	66	66	67	69	69	70
Average sound pressure level [Lpm] ISO 3744							
At 1 m	dB(A)	50	50	51	52	51	52
At 5 m	dB(A)	40	40	41	43	42	43
At 10 m	dB(A)	35	34	35	37	37	38

TECHNICAL DATA GR-Z E B 60 – 265/1/60 - 460/3/60

Fans with EC electric motors and STANDARD acoustic version

MODEL		013	015	024	027	034	049
REFRIGERANT		R410A	R410A	R410A	R410A	R410A	R410A
POWER SUPPLY	V/ph/Hz	265/1/60	265/1/60	460/3/60	460/3/60	460/3/60	460/3/60
ACOUSTIC VERSION		B	B	B	B	B	B
CAPACITY (1)	kW	11,4	13,8	23,0	25,7	32,0	47,0
AXIAL FANS "EC"	n.	1	1	1	1	1	2
Total air flow	m ³ /h	3300	4300	7098	8350	9550	15555
External static pressure	Pa	0	0	0	0	0	0
Total engaged power	kW	0,08	0,18	0,23	0,38	0,34	0,45
Total absorbed current (SA)	A	0,79	0,79	1,67	1,67	1,67	3,34
Maximum total engaged power (FLI)	kW	0,21	0,21	1	1	1	2
Maximum total absorbed current (FLA)	A	0,79	0,79	1,67	1,67	1,67	3,34
NET WEIGHT	kg	28	28	43	43	50	82

MODEL		055	067	082	110	134	164
REFRIGERANT		R410A	R410A	R410A	R410A	R410A	R410A
POWER SUPPLY	V/ph/Hz	460/3/60	460/3/60	460/3/60	460/3/60	460/3/60	460/3/60
ACOUSTIC VERSION		B	B	B	B	B	B
CAPACITY (1)	kW	52,5	63,8	77,8	105,0	128,0	156,0
AXIAL FANS "EC"	n.	2	2	3	4	4	6
Total air flow	m ³ /h	18300	19000	25000	36600	38000	50000
External static pressure	Pa	0	0	0	0	0	0
Total engaged power	kW	0,65	0,65	0,98	1,3	1,3	1,95
Total absorbed current (SA)	A	3,34	3,34	5,01	6,68	6,68	10
Maximum total engaged power (FLI)	kW	2	2	3	4	4	6
Maximum total absorbed current (FLA)	A	3,34	3,34	5,01	6,68	6,68	10
NET WEIGHT	kg	82	96	114	169	200	237

1. Referred to condensing temperature at 50°C and ambient air temperature at 35°C.

The units highlighted in this publication contain <HFC R410A [GWP₁₀₀ 2088]> fluorinated greenhouse gas

ACOUSTIC DATA GR-Z E B 60 – 265/1/60 - 460/3/60

Fans with EC electric motors and STANDARD acoustic version

MODEL		013	015	024	027	034	049
REFRIGERANT		R410A	R410A	R410A	R410A	R410A	R410A
POWER SUPPLY	V/ph/Hz	265/1/60	265/1/60	460/3/60	460/3/60	460/3/60	460/3/60
ACOUSTIC VERSION		B	B	B	B	B	B
Sound power level [L _w] ISO 9614-2	dB(A)	58	64	66	70	71	70
Average sound pressure level [L _p m] ISO 3744							
At 1 m	dB(A)	43	49	51	55	56	54
At 5 m	dB(A)	32	38	40	44	45	44
At 10 m	dB(A)	27	33	35	39	40	39

MODEL		055	067	082	110	134	164
REFRIGERANT		R410A	R410A	R410A	R410A	R410A	R410A
POWER SUPPLY	V/ph/Hz	460/3/60	460/3/60	460/3/60	460/3/60	460/3/60	460/3/60
ACOUSTIC VERSION		B	B	B	B	B	B
Sound power level [L _w] ISO 9614-2	dB(A)	73	74	75	76	77	78
Average sound pressure level [L _p m] ISO 3744							
At 1 m	dB(A)	57	58	59	59	59	60
At 5 m	dB(A)	47	48	49	50	50	51
At 10 m	dB(A)	42	42	43	44	45	46

TECHNICAL DATA GR-Z E L 60 – 265/1/60 - 460/3/60

Fans with EC electric motors and LOW NOISE acoustic version

MODEL		010	011	018	021	025	036
REFRIGERANT		R410A	R410A	R410A	R410A	R410A	R410A
POWER SUPPLY	V/ph/Hz	265/1/60	265/1/60	460/3/60	460/3/60	460/3/60	460/3/60
ACOUSTIC VERSION		L	L	L	L	L	L
CAPACITY (1)	kW	8,3	10,7	16,7	20,0	24,5	34,2
AXIAL FANS "EC"	n.	1	1	1	1	1	2
Total air flow	m ³ /h	2150	3010	4593	5845	6685	10065
External static pressure	Pa	0	0	0	0	0	0
Total engaged power	kW	0,02	0,06	0,06	0,13	0,12	0,12
Total absorbed current (SA)	A	0,79	0,79	1,67	1,67	1,67	3,34
Maximum total engaged power (FLI)	kW	0,21	0,21	1	1	1	2
Maximum total absorbed current (FLA)	A	0,79	0,79	1,67	1,67	1,67	3,34
NET WEIGHT	kg	29	29	45	45	53	85

MODEL		043	051	063	086	102	126
REFRIGERANT		R410A	R410A	R410A	R410A	R410A	R410A
POWER SUPPLY	V/ph/Hz	460/3/60	460/3/60	460/3/60	460/3/60	460/3/60	460/3/60
ACOUSTIC VERSION		L	L	L	L	L	L
CAPACITY (1)	kW	40,9	48,6	60,0	81,8	97,1	120,0
AXIAL FANS "EC"	n.	2	2	3	4	4	6
Total air flow	m ³ /h	12810	13300	17500	25620	26600	35000
External static pressure	Pa	0	0	0	0	0	0
Total engaged power	kW	0,22	0,22	0,33	0,45	0,44	0,67
Total absorbed current (SA)	A	3,34	3,34	5,01	6,68	6,68	10
Maximum total engaged power (FLI)	kW	2	2	3	4	4	6
Maximum total absorbed current (FLA)	A	3,34	3,34	5,01	6,68	6,68	10
NET WEIGHT	kg	85	99	118	176	207	244

1. Referred to condensing temperature at 50°C and ambient air temperature at 35°C.

The units highlighted in this publication contain <HFC R410A [GWP₁₀₀ 2088]> fluorinated greenhouse gas

ACOUSTIC DATA GR-Z E L 60 – 265/1/60 - 460/3/60

Fans with EC electric motors and LOW NOISE acoustic version

MODEL		010	011	018	021	025	036
REFRIGERANT		R410A	R410A	R410A	R410A	R410A	R410A
POWER SUPPLY	V/ph/Hz	265/1/60	265/1/60	460/3/60	460/3/60	460/3/60	460/3/60
ACOUSTIC VERSION		L	L	L	L	L	L
Sound power level [Lw] ISO 9614-2	dB(A)	51	57	59	62	63	62
Average sound pressure level [Lpm] ISO 3744							
At 1 m	dB(A)	36	42	44	47	48	46
At 5 m	dB(A)	25	31	33	36	37	36
At 10 m	dB(A)	20	26	28	31	32	31

MODEL		043	051	063	086	102	126
REFRIGERANT		R410A	R410A	R410A	R410A	R410A	R410A
POWER SUPPLY	V/ph/Hz	460/3/60	460/3/60	460/3/60	460/3/60	460/3/60	460/3/60
ACOUSTIC VERSION		L	L	L	L	L	L
Sound power level [Lw] ISO 9614-2	dB(A)	66	66	67	69	69	70
Average sound pressure level [Lpm] ISO 3744							
At 1 m	dB(A)	50	50	51	52	51	52
At 5 m	dB(A)	40	40	41	43	42	43
At 10 m	dB(A)	35	34	35	37	37	38

DIMENSIONS & REFRIGERANT CONNECTIONS

MODEL STANDARD		013	015	024	027	034	049
MODEL LOW NOISE		010	011	018	021	025	036
A - Length	mm	840	840	1220	1220	1430	2110
B - Width	mm	718	718	718	718	718	718
H - Height	mm	900	900	900	900	1100	1100
REFRIGERANT CONNECTIONS							
Liquid - ODS	Ø mm	12	12	16	16	16	18
Gas - ODS	Ø mm	16	16	18	18	18	22

MODEL STANDARD		055	067	082	110	134	164
MODEL LOW NOISE		043	051	063	086	102	126
A - Length	mm	2110	2670	2670	2280	2835	2849
B - Width	mm	718	718	718	2200	2200	2200
H - Height	mm	1100	1100	1100	1168	1168	1168
REFRIGERANT CONNECTIONS							
Liquid - ODS	Ø mm	18	18	22	22 (*)	22 (*)	28 (*)
Gas - ODS	Ø mm	22	22	28	28 (*)	28 (*)	35 (*)

(*) Referred to manifold connection.

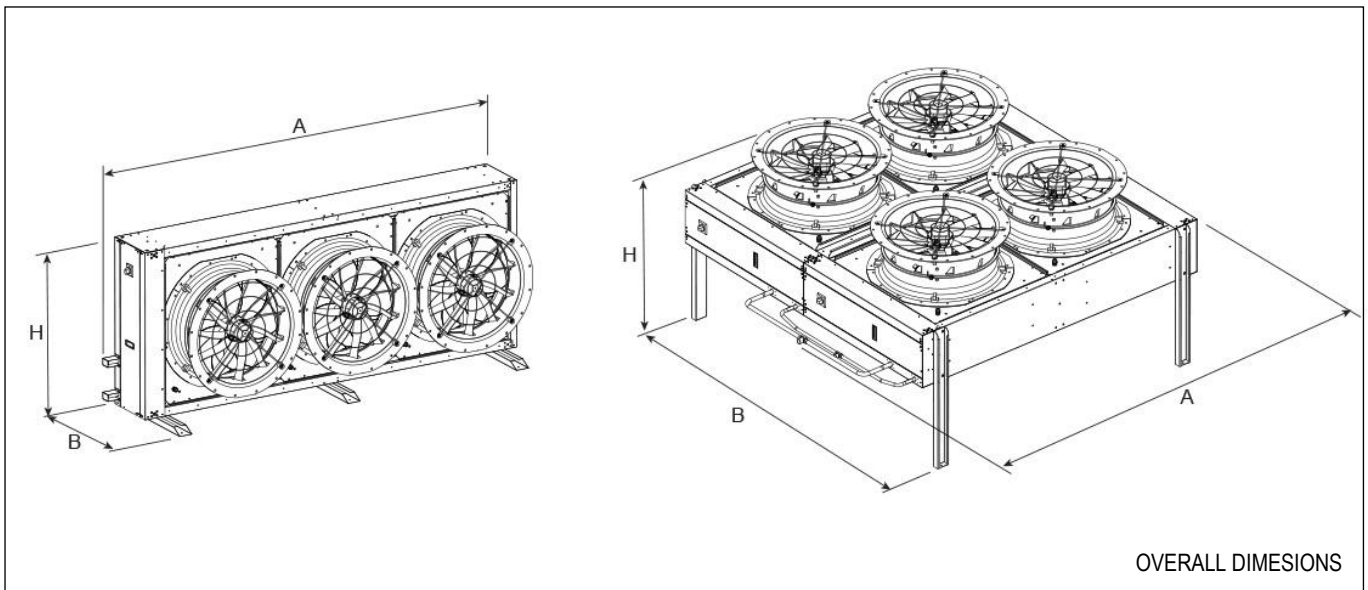

REFRIGERANT CHARGE

The condenser is supplied with seal charge. **Refrigerant must be charged.**

The following table shows the refrigerant charge for the condenser only; the indoor unit, the connections pipes and optional are excluded.

MODEL STANDARD		013	015	024	027	034	049
MODEL LOW NOISE		010	011	018	021	025	036
REFRIGERANT		R410A	R410A	R410A	R410A	R410A	R410A
Refrigerant charge	kg	0,50	0,50	0,85	0,85	1,30	2,07
F Gas - CO ₂ equivalent (R410A)	t	1,044	1,044	1,774	1,774	2,704	4,322

MODEL STANDARD		055	067	082	110	134	164
MODEL LOW NOISE		043	051	063	086	102	126
REFRIGERANT		R410A	R410A	R410A	R410A	R410A	R410A
Refrigerant charge	kg	2,07	2,56	2,56	4,14	5,12	5,12
F Gas - CO ₂ equivalent (R410A)	t	4,322	5,354	5,354	6,844	10,690	10,690

RECOMMENDED REFRIGERANT LINES

Connection to air conditioners series b-NEXT DX, t-NEXT DX and i-NEXT DX

Value referred to "EQUIVALENT LENGHT".

You are kindly requested to always refer to the "INSTALLATION DIAGRAM" to properly select all necessary components

Verify the need to use pressure limiting devices (safety valves) where not already provided for by Directive 2014/68 / EU.

In some cases, the diameter of the refrigerant lines may not correspond with the diameter of the cooling taps.

This is completely normal. It is enough to provide a reduction fitting to adjust the diameter.

ON/OFF COMPRESSORS

Model	Capacity for single circuit [kW]	Line	Nominal Ø [mm]	EQUIVALENT LENGHT [m] FOR ON / OFF COMPRESSORS R410A										
				5	10	15	20	25	30	35	40	45	50	
007 P1 S	7	Gas	12	12 mm										16 mm
		Liquid	12	12 mm										
009 P1 S	9	Gas	12	12 mm					16 mm					
		Liquid	12	12 mm										16 mm
011 P1 S	11	Gas	12	12 mm				16 mm						
		Liquid	12	12 mm					16 mm					
014 P1 S	14	Gas	16	16 mm										
		Liquid	12	12 mm				16 mm						
016 P1 S	16	Gas	16	16 mm										
		Liquid	12	12 mm		16 mm								
020 P1 S	20	Gas	16	16 mm					18 mm					
		Liquid	16	16 mm										
022 P1 S	22	Gas	16	16 mm					18 mm					
		Liquid	16	16 mm										18 mm
026 P1 S	26	Gas	22	22 mm										
		Liquid	16	16 mm					18 mm					
032 P1 S	32	Gas	22	22 mm										
		Liquid	16	16 mm			18 mm				22 mm			
037 P1 S	37	Gas	22	22 mm										
		Liquid	16	16 mm		18 mm			22 mm					
041 P1 S	41	Gas	22	22 mm										
		Liquid	22	22 mm										
045 P1 S	45	Gas	22	22 mm										28 mm
		Liquid	22	22 mm										
039 P2 D	19,5	Gas	16	16 mm					18 mm					
		Liquid	16	16 mm										

Model	Capacity for single circuit [kW]	Line	Nominal Ø [mm]	EQUIVALENT LENGHT [m] FOR ON / OFF COMPRESSORS R410A									
				5	10	15	20	25	30	35	40	45	50
048 P2 D	24	Gas	16	16 mm					18 mm				
		Liquid	16	16 mm						18 mm			
055 P2 D	27,5	Gas	22	22 mm									
		Liquid	16	16 mm					18 mm				
062 P2 D	31	Gas	22	22 mm									
		Liquid	16	16 mm			18 mm				22 mm		
075 P2 D	37,5	Gas	22	22 mm									
		Liquid	22	22 mm									
082 P2 D	41	Gas	22	22 mm									
		Liquid	22	22 mm									
092 P2 D	46	Gas	22	22 mm									28 mm
		Liquid	22	22 mm									
102 P2 D	51	Gas	22	22 mm						28 mm			
		Liquid	22	22 mm									
117 P4 D	58,5	Gas	28	28 mm									
		Liquid	22	22 mm						28 mm			
146 P4 D	73	Gas	28	28 mm									
		Liquid	22	22 mm				28 mm					

For equivalent lengths over 50m, please contact the Manufacturer's Sales Office.

INVERTER COMPRESSORS

Model	Capacity for single circuit [kW]	Line	Nominal Ø [mm]	EQUIVALENT LENGHT [m] FOR INVERTER COMPRESSORS R410A									
				5	10	15	20	25	30	35	40	45	50
012 M1 S	12	Gas	12	12 mm					■				
		Liquid	12	12 mm									
018 M1 S	18	Gas	16	16 mm									
		Liquid	12	12 mm	16 mm								
022 M1 S	22	Gas	16	16 mm						■			
		Liquid	16	16 mm									
030 M1 S	30	Gas	18	18 mm									
		Liquid	16	16 mm					18 mm				
047 M1 S	47	Gas	22	22 mm									
		Liquid	22	22 mm									
042 M2 D	21	Gas	16	16 mm						■			
		Liquid	16	16 mm									
068 M2 D	34	Gas	18	18 mm									
		Liquid	16	16 mm				18 mm					
094 M2 D	47	Gas	22	22 mm									
		Liquid	22	22 mm									
120 M4 D	60	Gas	28	28 mm									
		Liquid	22	22 mm								28 mm	
150 M4 D	75	Gas	28	28 mm									
		Liquid	22	22 mm					28 mm				

■ Equivalent length unreachable.

For equivalent lengths over 50m, please contact the Manufacturer's Sales Office.

INSTALLATION DIAGRAM

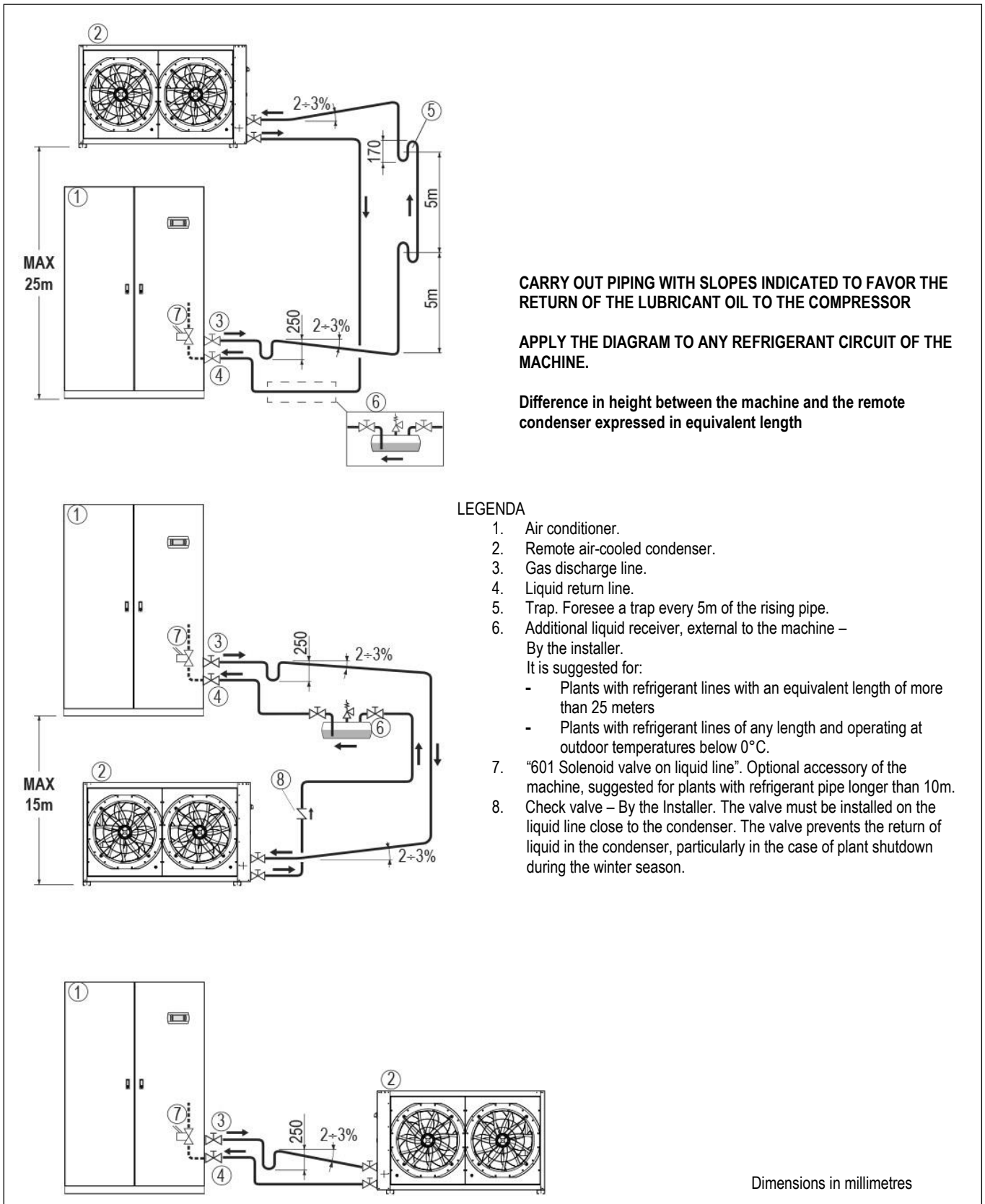

WARNING

It is necessary to provide the refrigerant charge for the connection pipes and for the remote air-cooled condenser. Charge refrigerant in the suitable quantity and lubricant oil in 10% ratio of charged refrigerant. Lubricant oil must be the same type as the charged one as shown on the compressor plate.

RECOMMENDATIONS FOR INSTALLATION

The machine must be placed in an access area only allowed for OPERATORS, MAINTENANCE TECHNICIAN and TECHNICIANS; otherwise it must be surrounded by a fenced perimeter placed at least two meters from the external surfaces of the machine.

Avoid suspended wall or ceiling installations.

CLEARANCE SPACE

Ensure adequate clearance spaces as indicated in below.

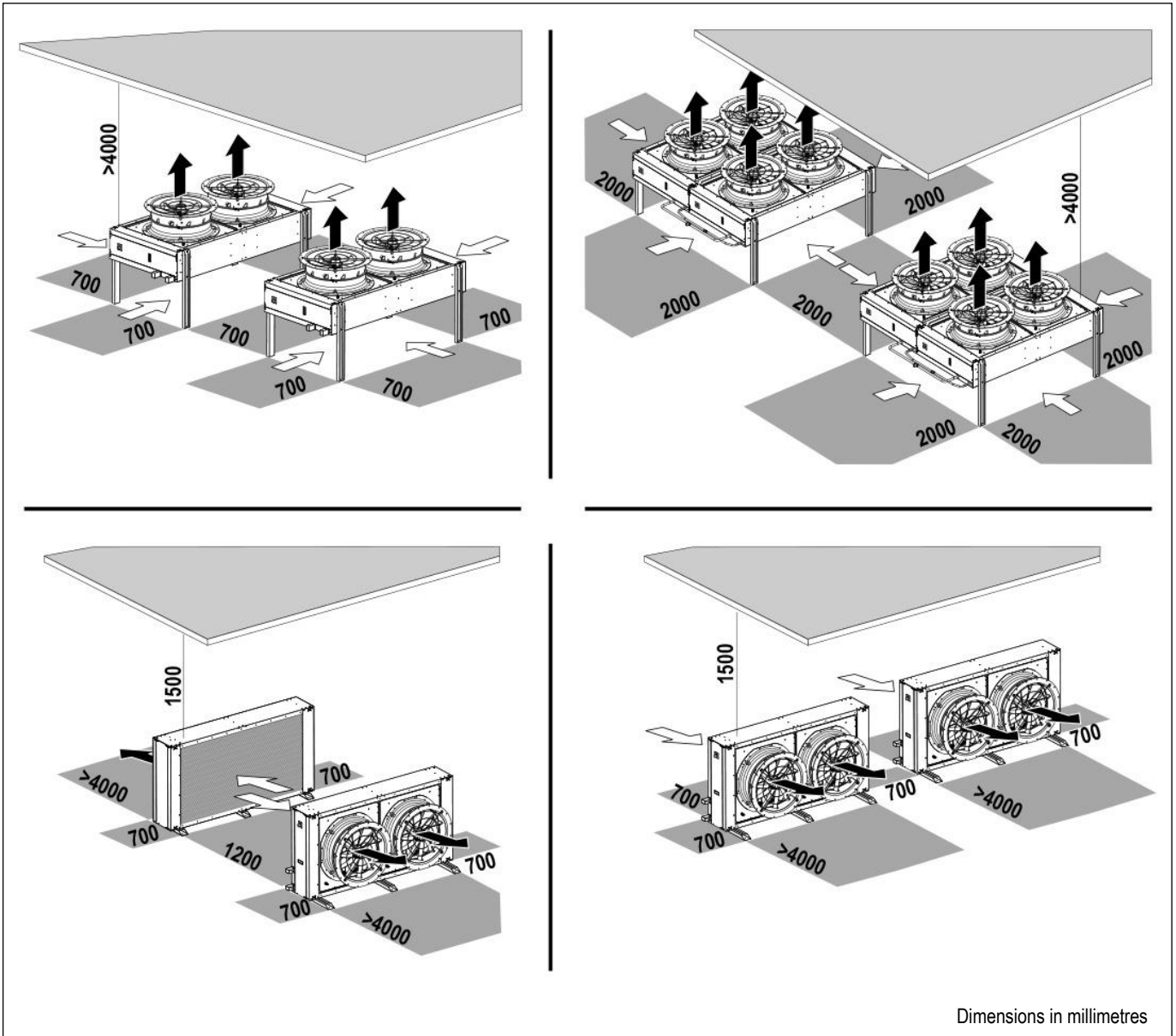

Dimensions in millimetres

OBSTACLES TO AIR CIRCULATION

The air expelled from the machine must be easily dispersed in the environment.

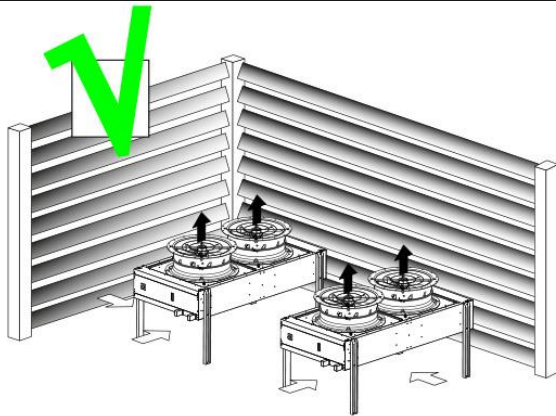

Perimeter structure with grating.
No height limits.

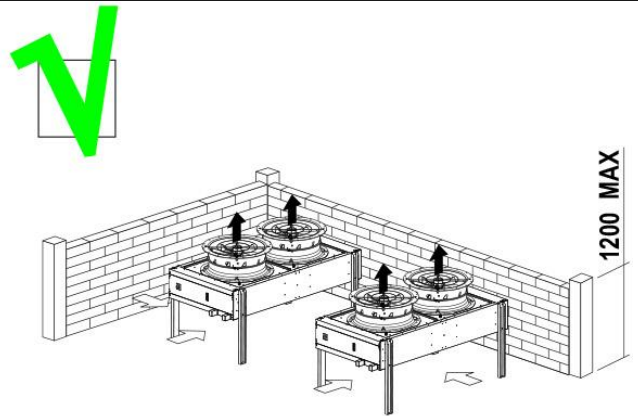

Walling perimeter structure.
Height limit of 1200 mm.

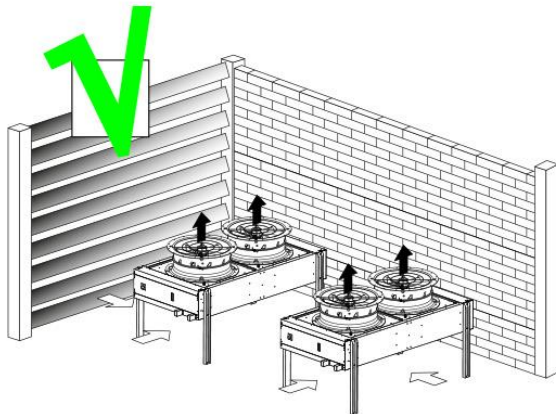

A very high walling structure is permitted but must be present a very wide finned barrier

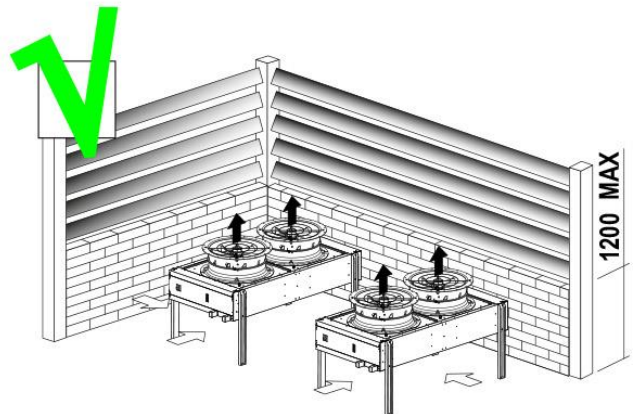

In case of walling perimeter structure with height limit of 1200 mm the grating can overcome the wall.

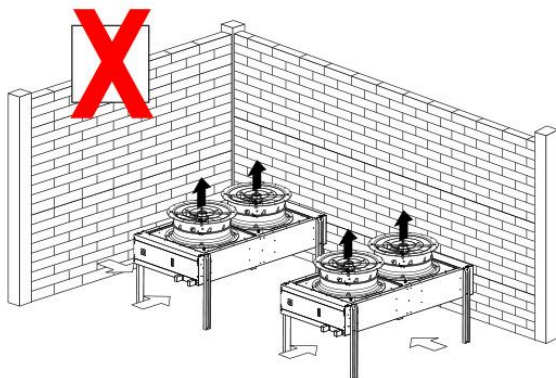

PROHIBITED TO SURROUND THE INSTALLATION WITH A WALL HAVING HEIGHT OVER 1200 mm.

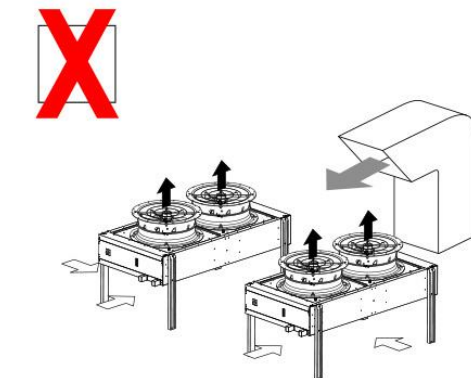

AVOID THE INSTALLATION OF THE MACHINE IN THE DISCHARGE AIR FLOW OF EXTRACTORS.

Dimensions in millimetres



INSTALLATIONS IN ZONES WITH STRONG WINDS

Installation in areas protected by the wind is necessary in order to avoid that dominant winds and air recirculation can interfere with the operation of the fan and the condensation control.

IF IT WAS NOT POSSIBLE TO INSTALL THE CONDENSER IN AN AREA PROTECTED BY THE WIND, WE RECOMMEND INSTALLATION WITH VERTICAL AIR FLOW.

Machines with horizontal air flow

Strong winds (over 50 km/h) generate very high forces on the machine structure. It is therefore necessary to contrast these forces with appropriate anchors to the supporting structures as follows:

WIND CONSTRAINT REACTION

MODEL STANDARD		013	015	024	027	034	049
MODEL LOW NOISE		010	011	018	021	025	036
Traction reaction of the single bolt	N	886,1	886,1	1349,0	1349,0	1612,4	2424,6
Bolt quantity	n.	4	4	4	4	4	6
Bolt Grade Class		8.8	8.8	8.8	8.8	8.8	8.8
Bolt type		M8	M8	M8	M8	M8	M8

MODEL STANDARD		055	067	082	110	134	164
MODEL LOW NOISE		043	051	063	086	102	126
Traction reaction of the single bolt	N	2424,6	3083,4	3085,7	--	--	--
Bolt quantity	n.	6	6	6	--	--	--
Bolt Grade Class		8.8	8.8	8.8	--	--	--
Bolt type		M8	M8	M8	--	--	--

(--) Not available

CONDENSING CONTROL

UNITS WITH AXIAL FANS WITH AC ELECTRIC MOTOR

Units are equipped with an electronic system for continuous variation of the rotation speed of the fan motor according to the 0÷10Vdc proportional signal coming from the internal unit microprocessor control.

In case of power failure and malfunction, the controller sends a digital alarm signal to the indoor unit (refer to the wiring diagrams).

The FMC electronic board manages and controls the supply voltage to the fans to maintain condensation at the values expected by the indoor unit.

UNITS WITH AXIAL FANS WITH EC ELECTRIC MOTOR

The units are equipped with axial fans with directly coupled EC type electric motor, with continuous variation of the rotation speed for condensation pressure control based on a 0-10V proportional signal coming from the indoor unit controller.

POWER SUPPLY

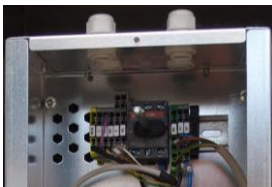

The power supply is independent from the indoor unit.

The supply line must be equipped with all the protections and controls required by current regulations.

If the condenser is powered from the indoor unit, the power line protections are already present.

ELECTRICAL CONNECTION TO THE INDOOR UNIT

The electrical connection with the indoor unit is provided by the installer:

- Cable of the 0-10Vdc signal for the condenser fan speed control.
- Cable for condenser fan alarm signal / FMC card if present
- Possible power supply of the condenser if provided on the indoor unit

MACHINES DRAWINGS

Dimensions in mm

STANDARD MODEL 013 – 015

LOW NOISE MODEL 010 – 011

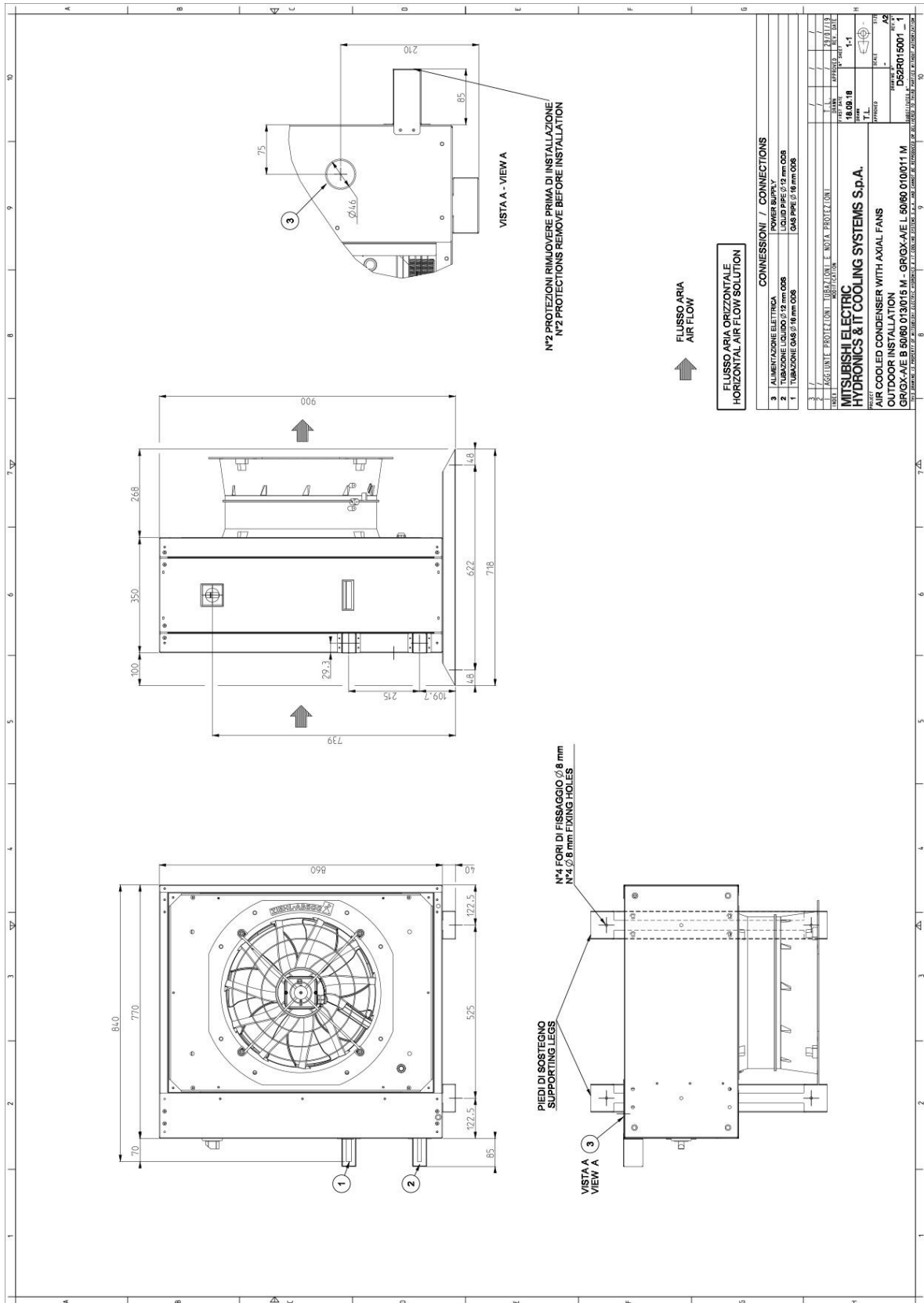

MACHINE DRAWINGS Dimensions in mm

STANDARD MODEL 024 - 027
LOW NOISE MODEL 018 - 021

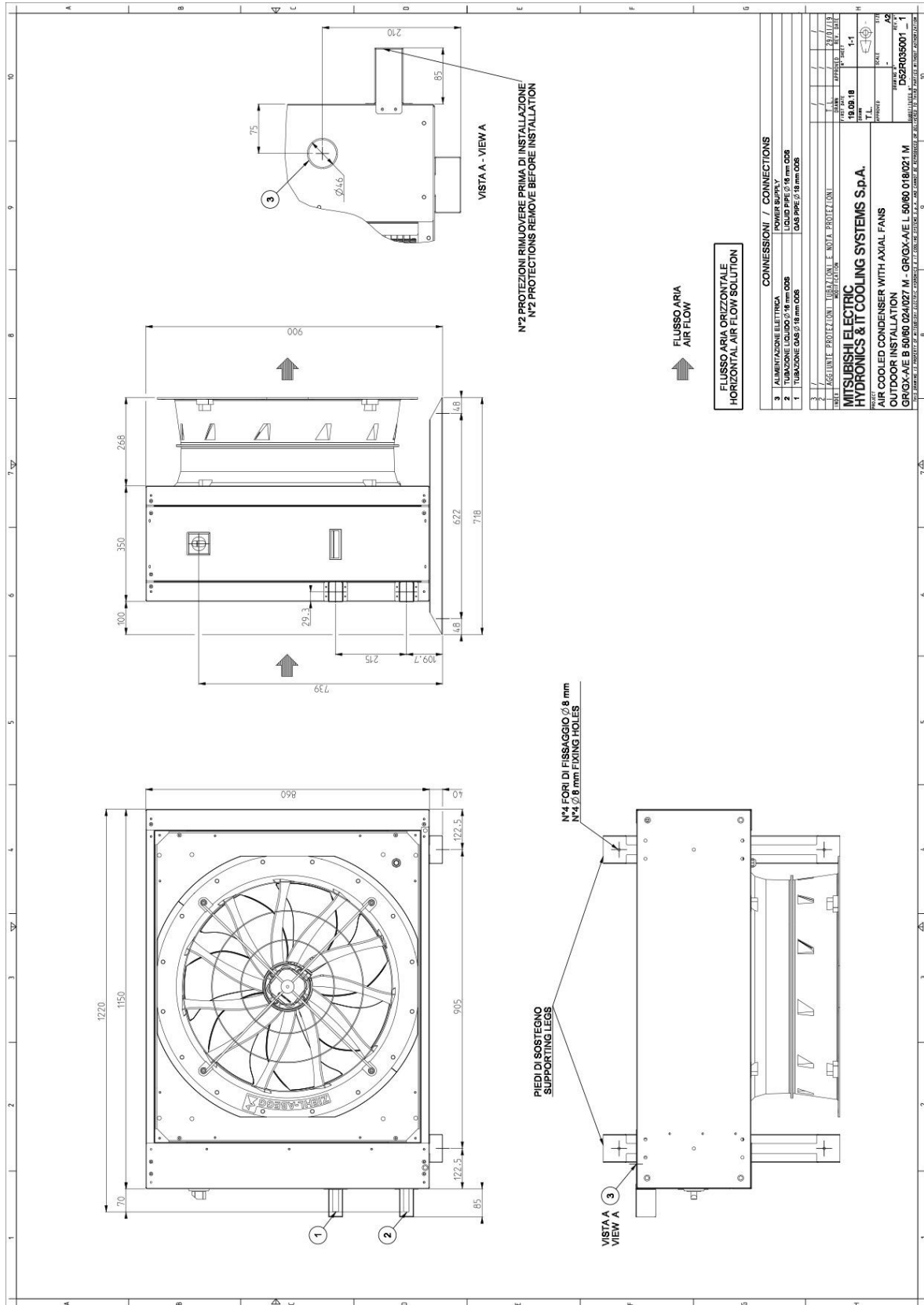

MACHINE DRAWINGS Dimensions in mm

STANDARD MODEL 034
LOW NOISE MODEL 025

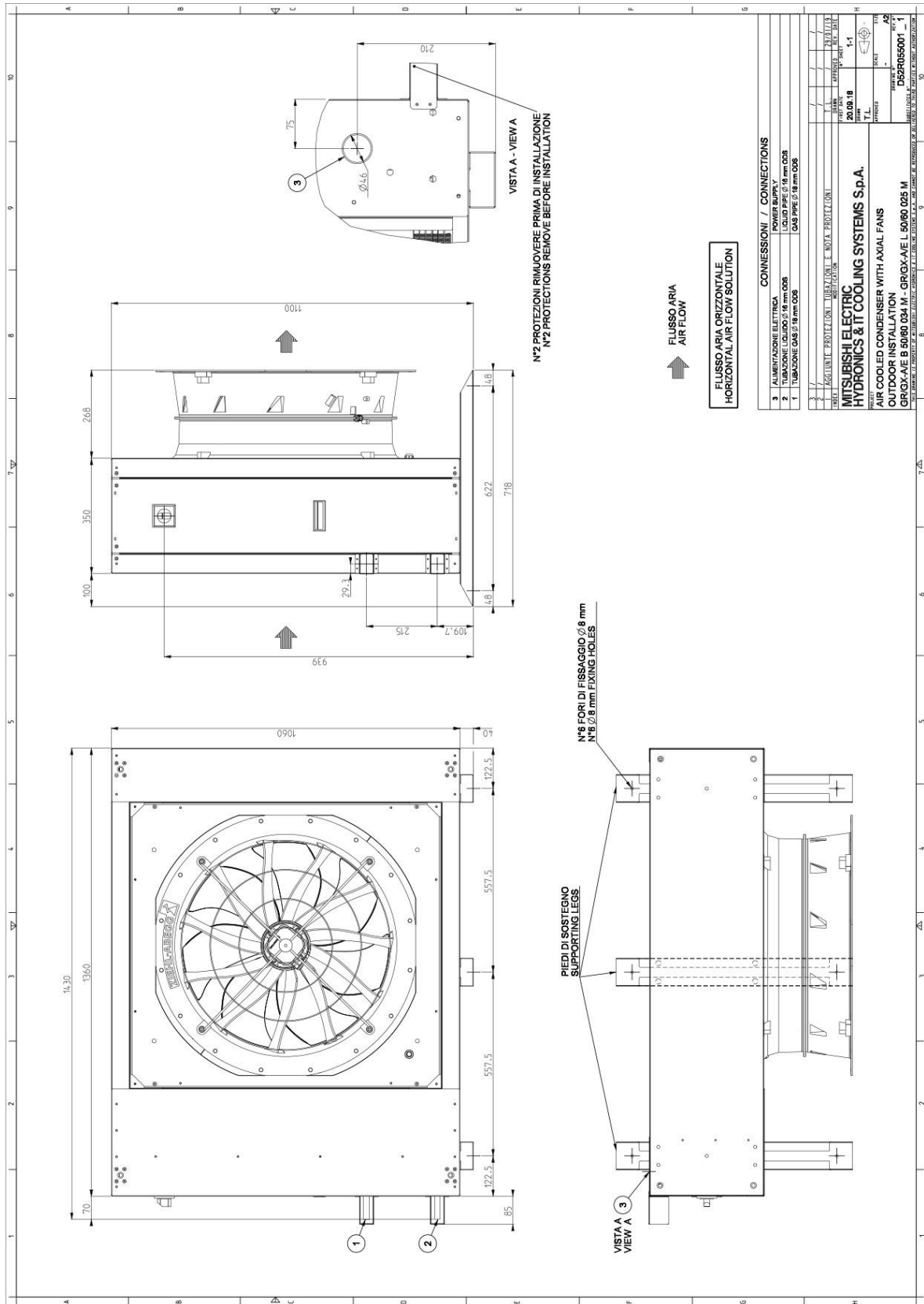

MACHINE DRAWINGS Dimensions in mm

STANDARD MODEL 067
LOW NOISE MODEL 051

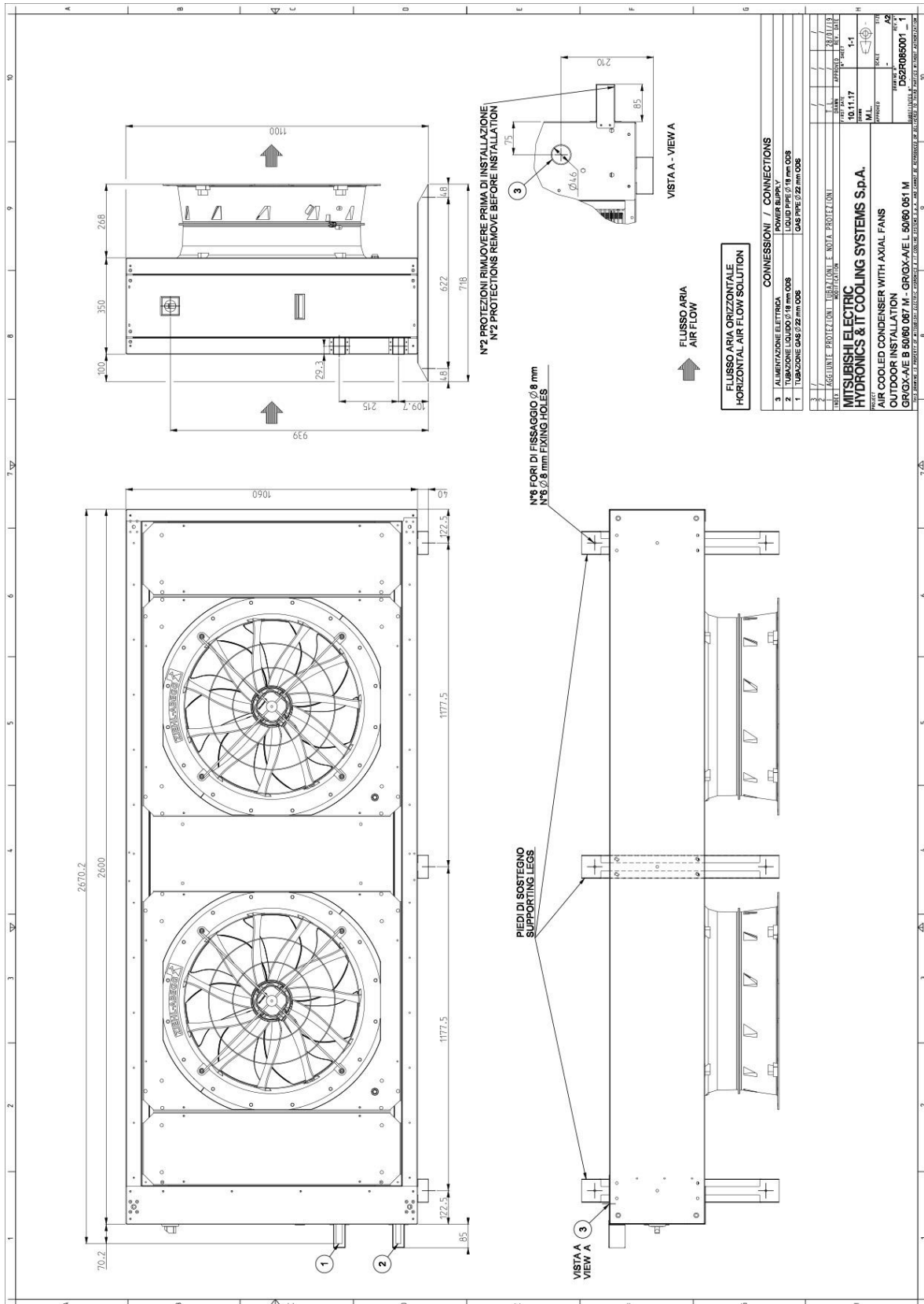

MACHINE DRAWINGS Dimensions in mm

STANDARD MODEL 082
LOW NOISE MODEL 063

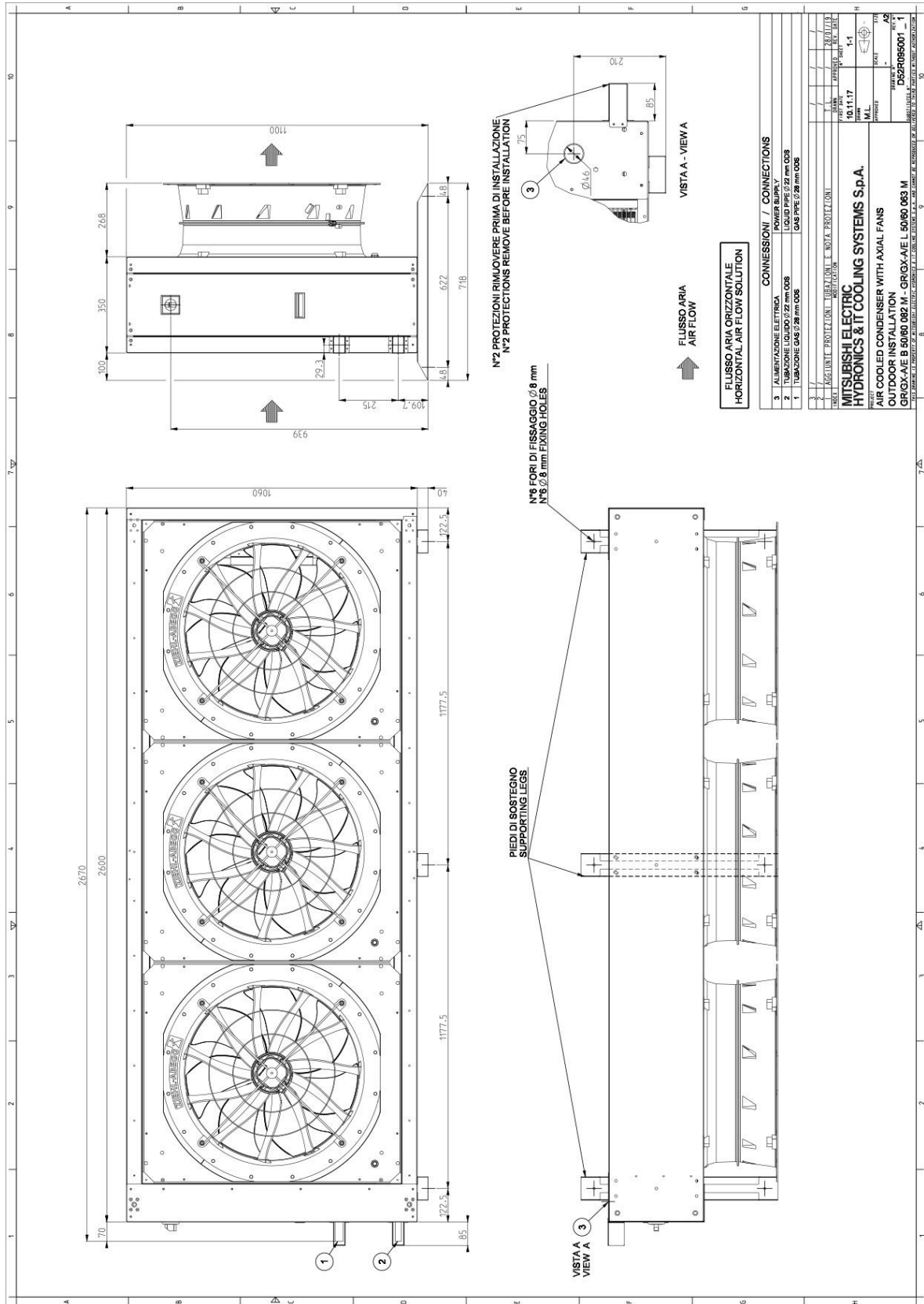

MACHINE DRAWINGS Dimensions in mm

STANDARD MODEL 110
LOW NOISE MODEL 086

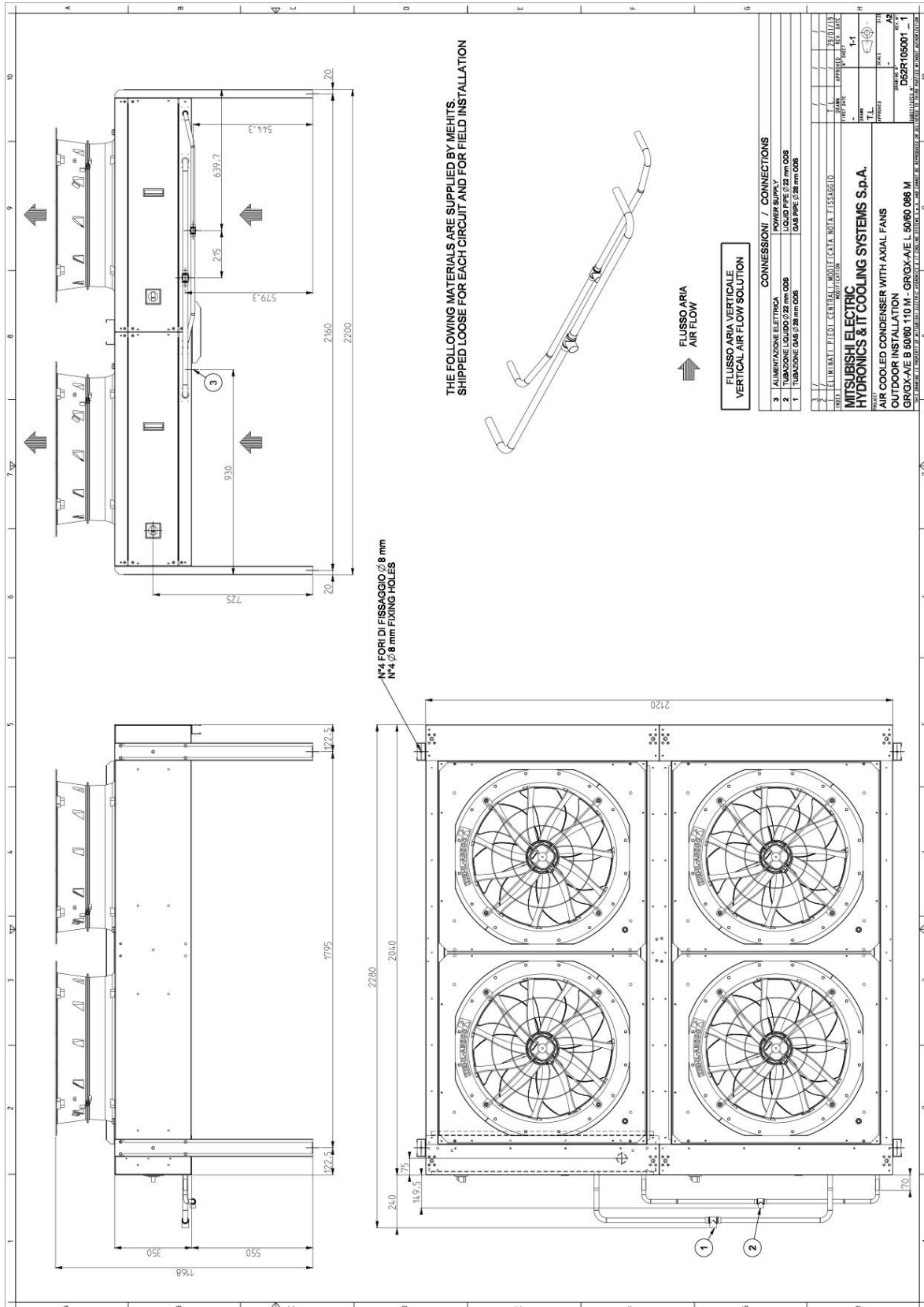

MACHINE DRAWINGS Dimensions in mm

STANDARD MODEL 134
LOW NOISE MODEL 102

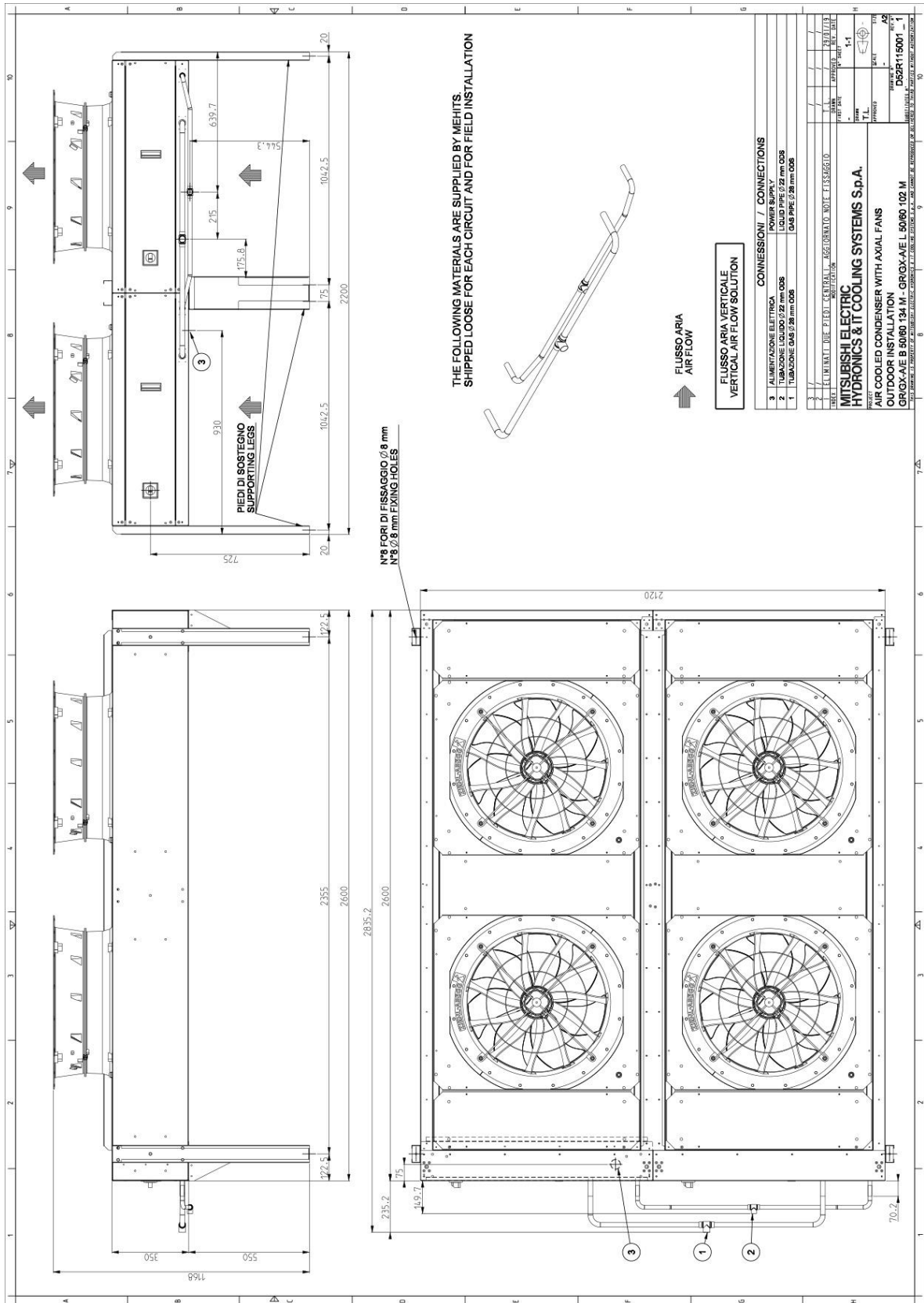

MACHINE DRAWINGS Dimensions in mm

STANDARD MODEL 164
LOW NOISE MODEL 126

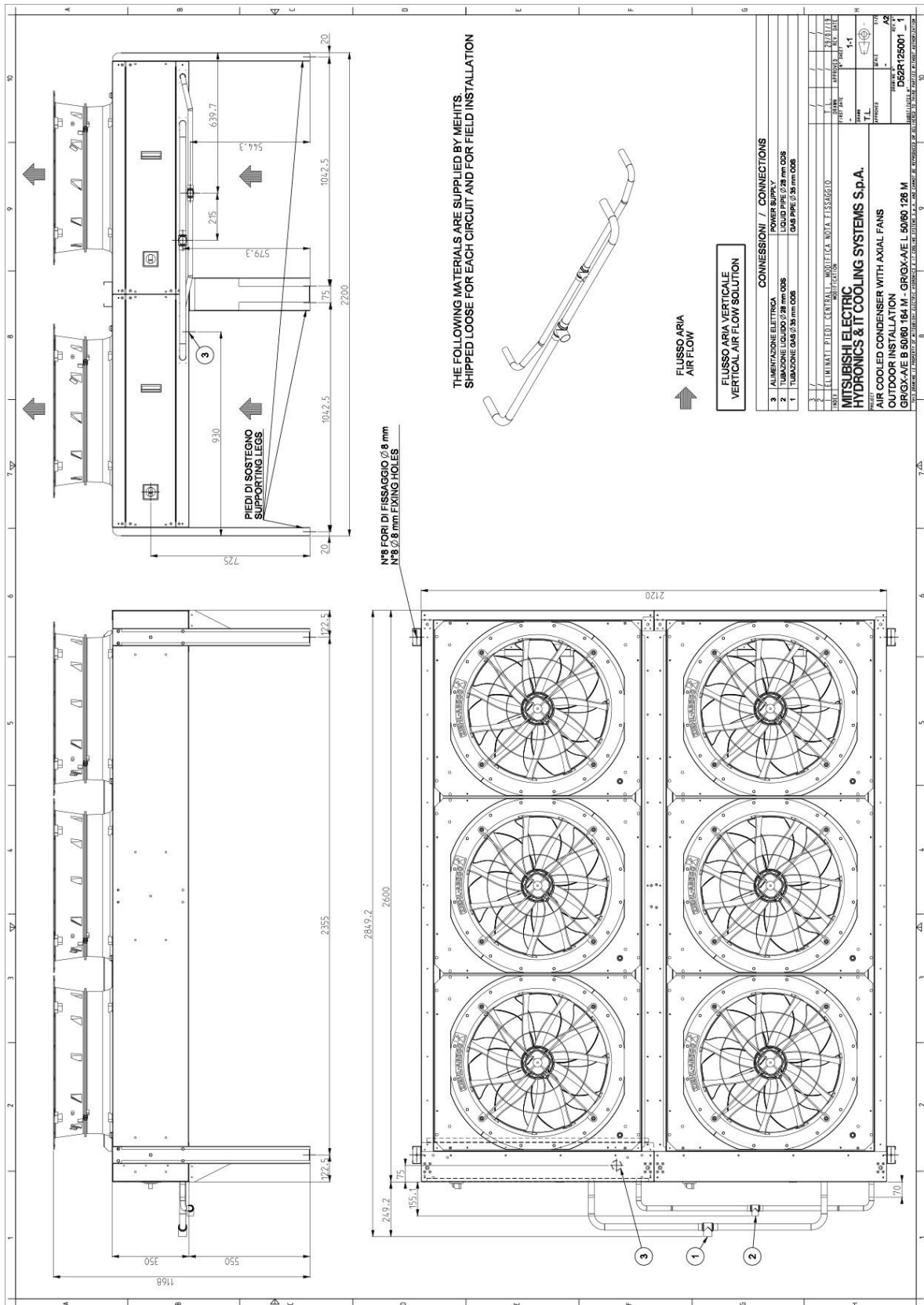

WIRING DIAGRAMS

STANDARD MODEL 013 – 015 – 024 – 027 – 034
 LOW NOISE MODEL 010 – 011 – 018 – 021 – 025

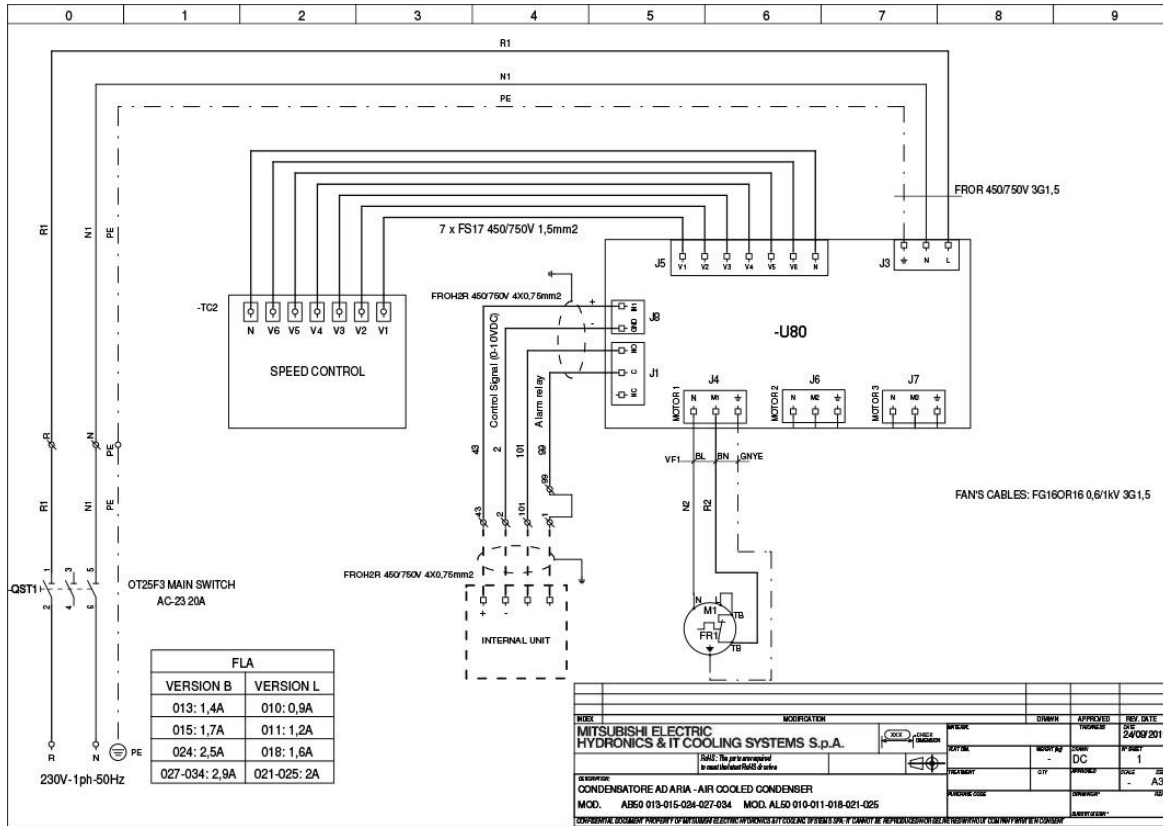

STANDARD MODEL 049 – 055 – 067
 LOW NOISE MODEL 036 – 043 – 051

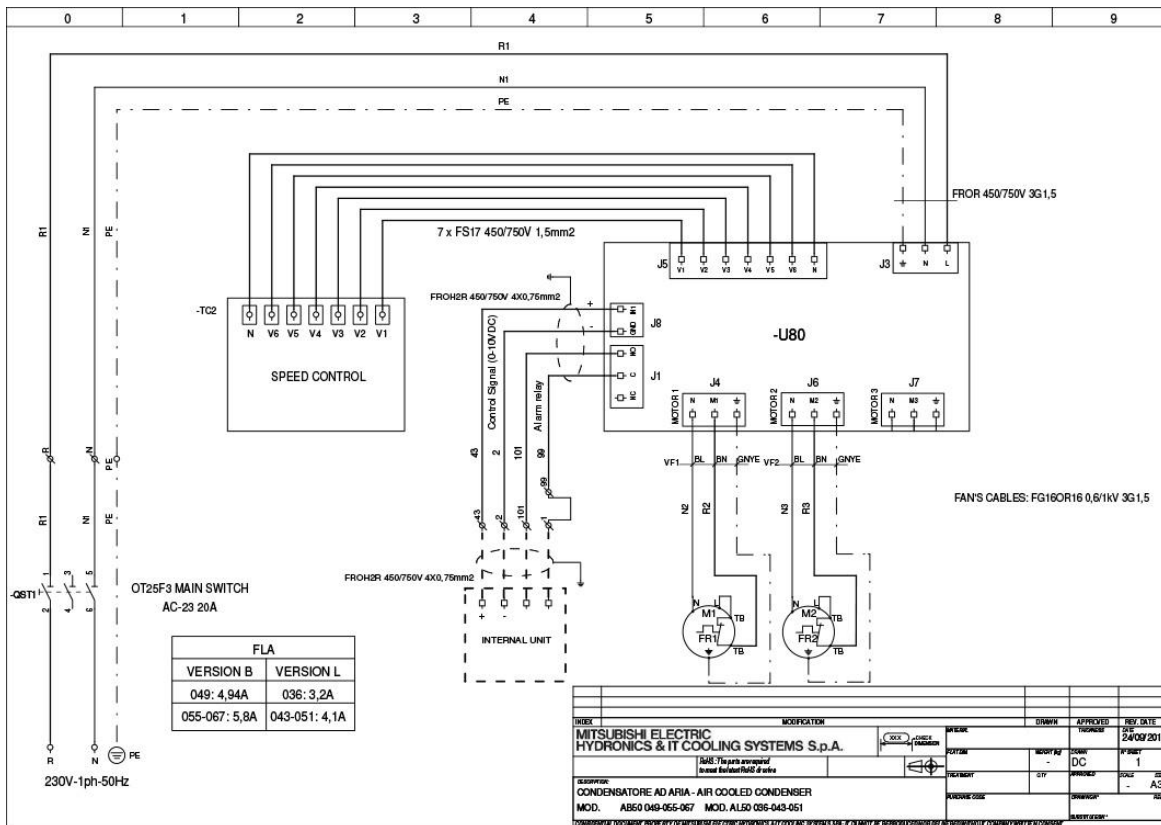

WIRING DIAGRAMS

STANDARD MODEL 082
LOW NOISE MODEL 063

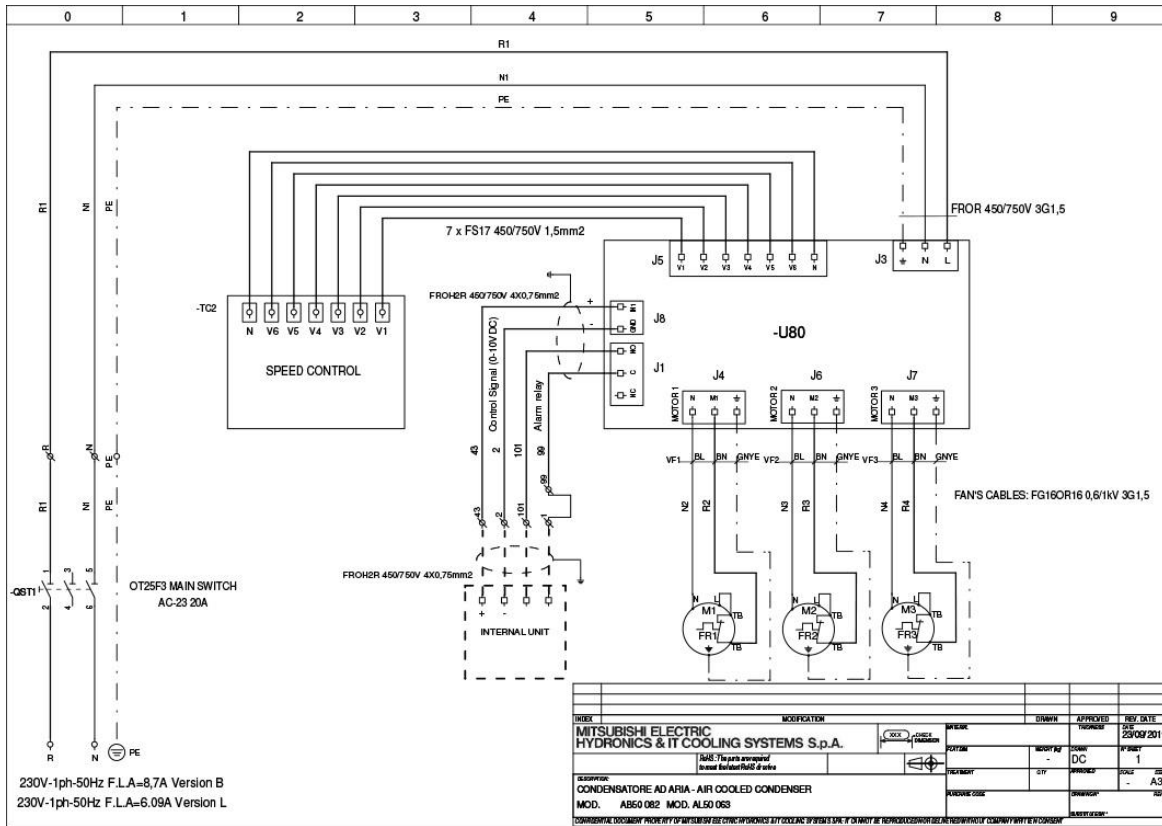

WIRING DIAGRAMS

STANDARD MODEL 110 – 134
 LOW NOISE MODEL 086 – 102

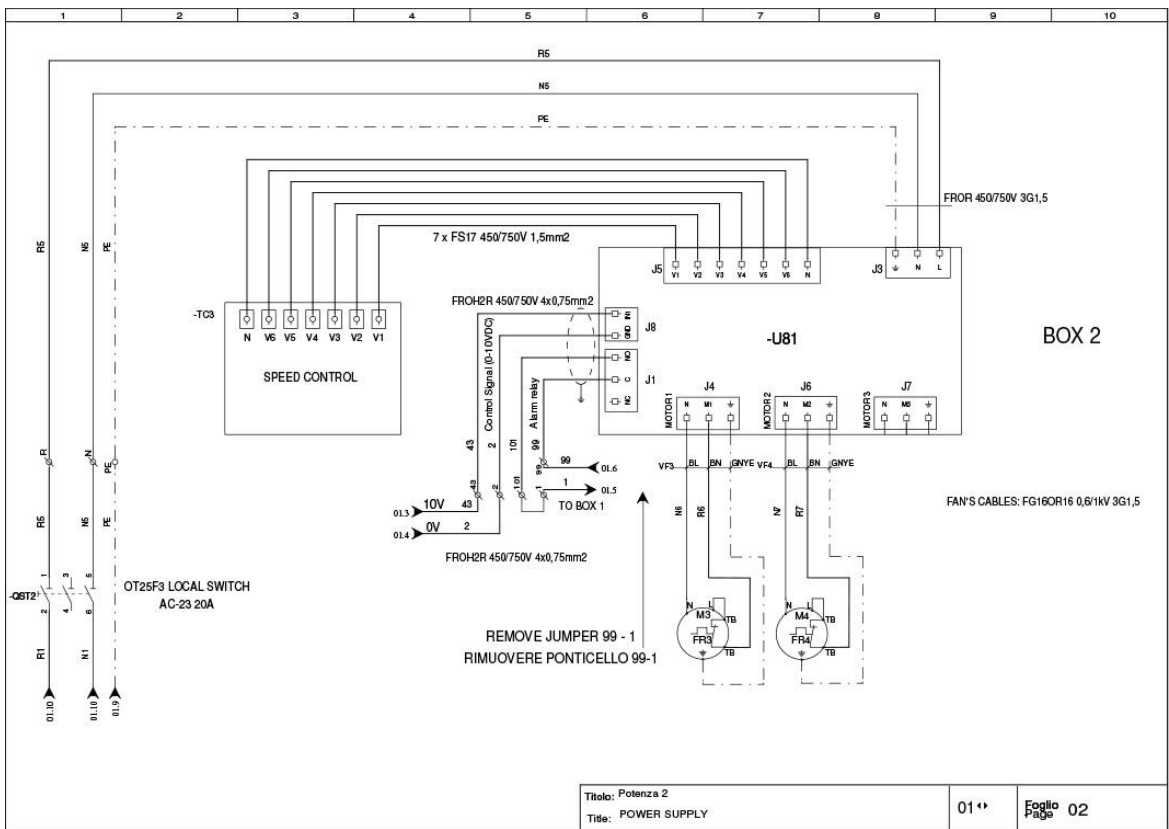
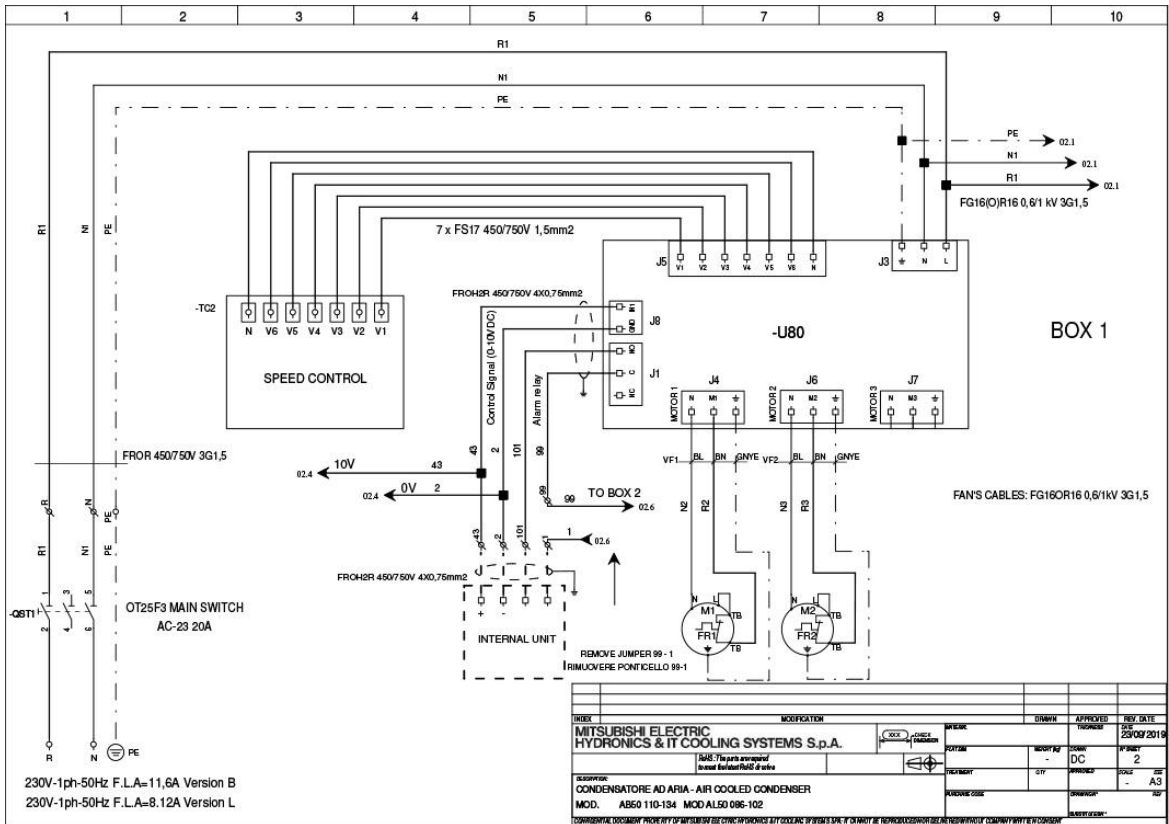

WIRING DIAGRAMS

STANDARD MODEL 164
LOW NOISE MODEL 126

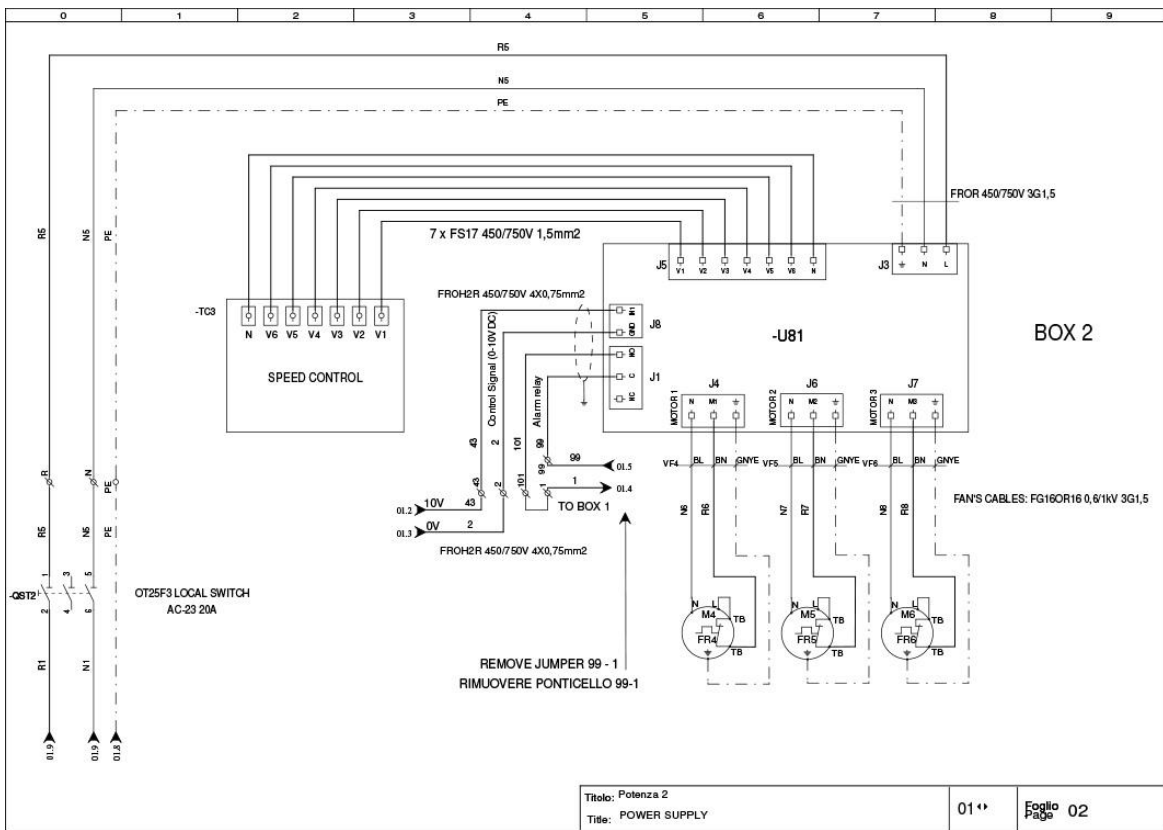
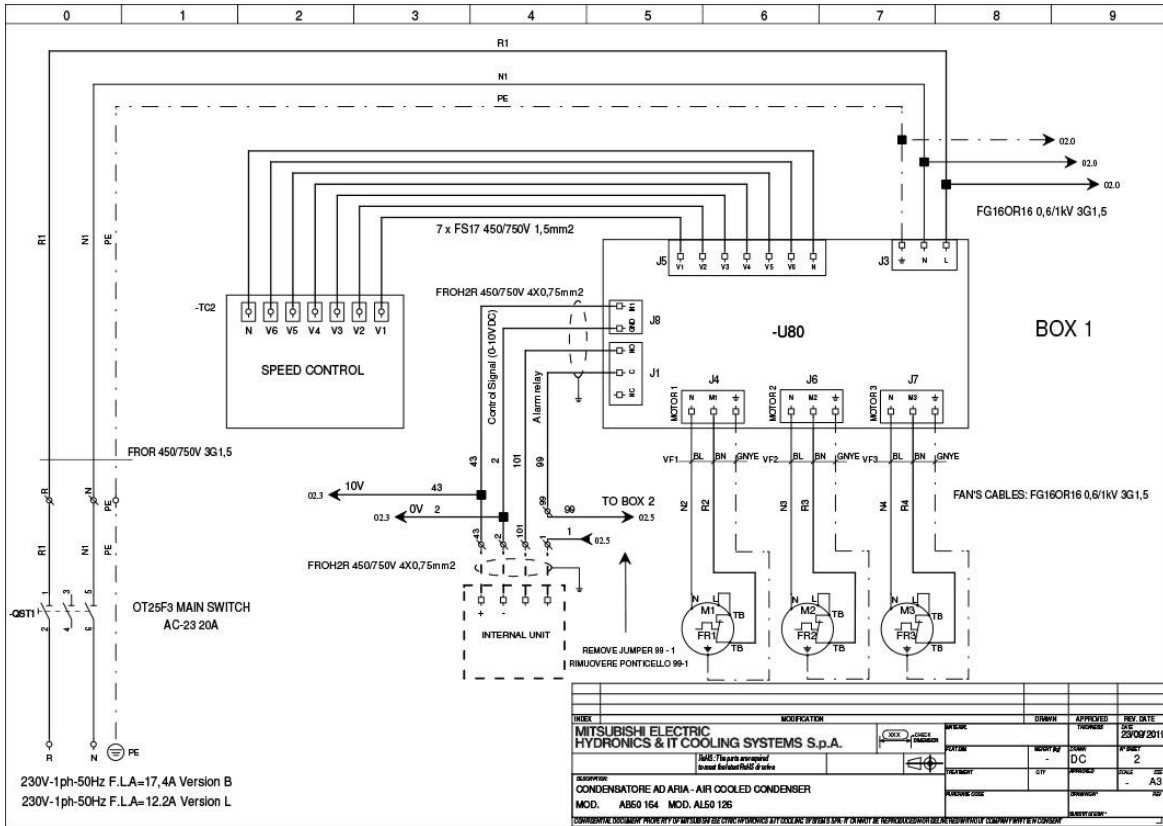

WIRING DIAGRAMS

STANDARD MODEL 013 – 015
LOW NOISE MODEL 010 – 011

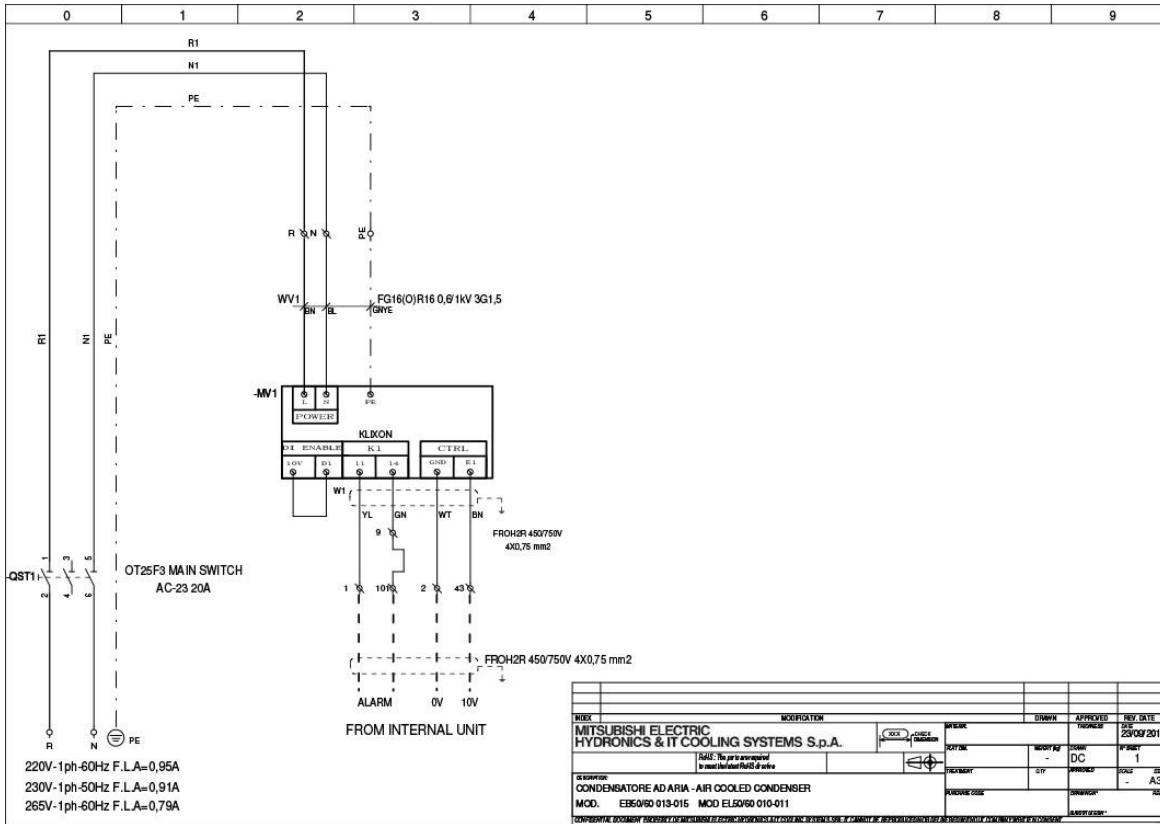

STANDARD MODEL 024 – 027 – 034
LOW NOISE MODEL 018 – 021 – 025

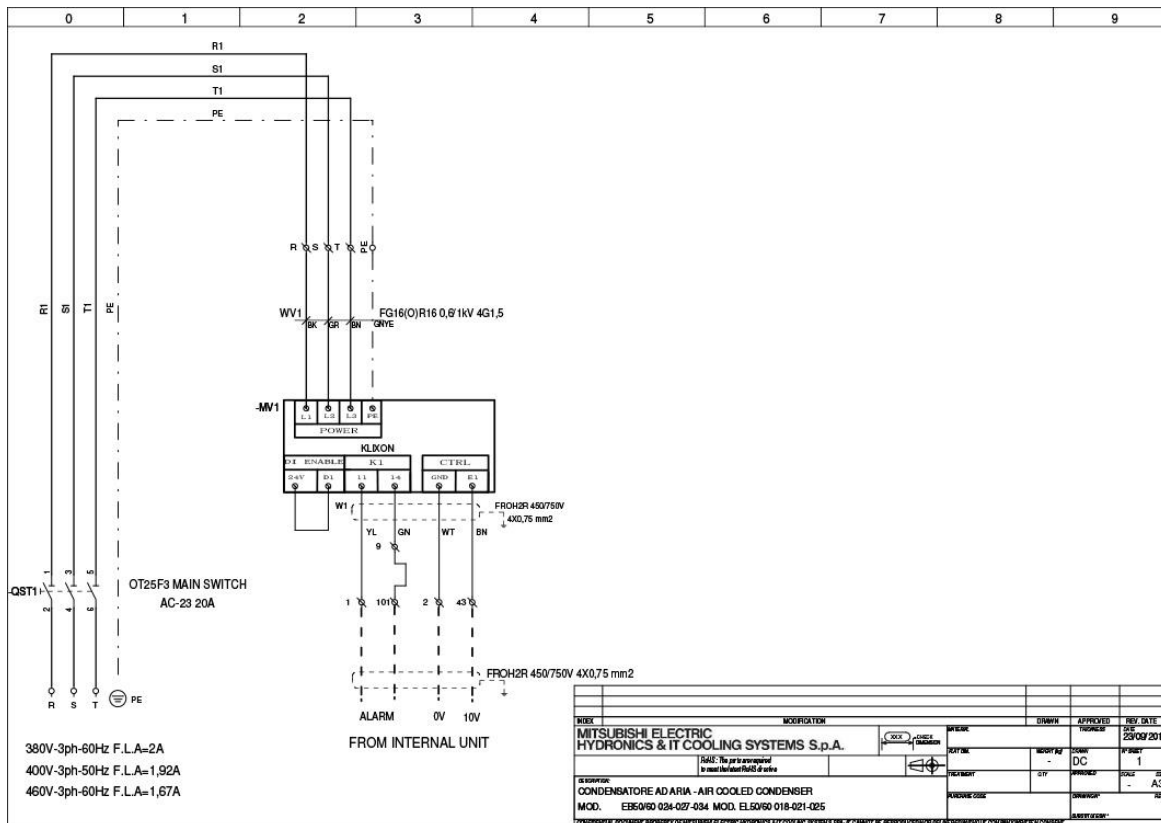

WIRING DIAGRAMS

STANDARD MODEL 049 – 055 – 067
 LOW NOISE MODEL 036 – 043 – 051

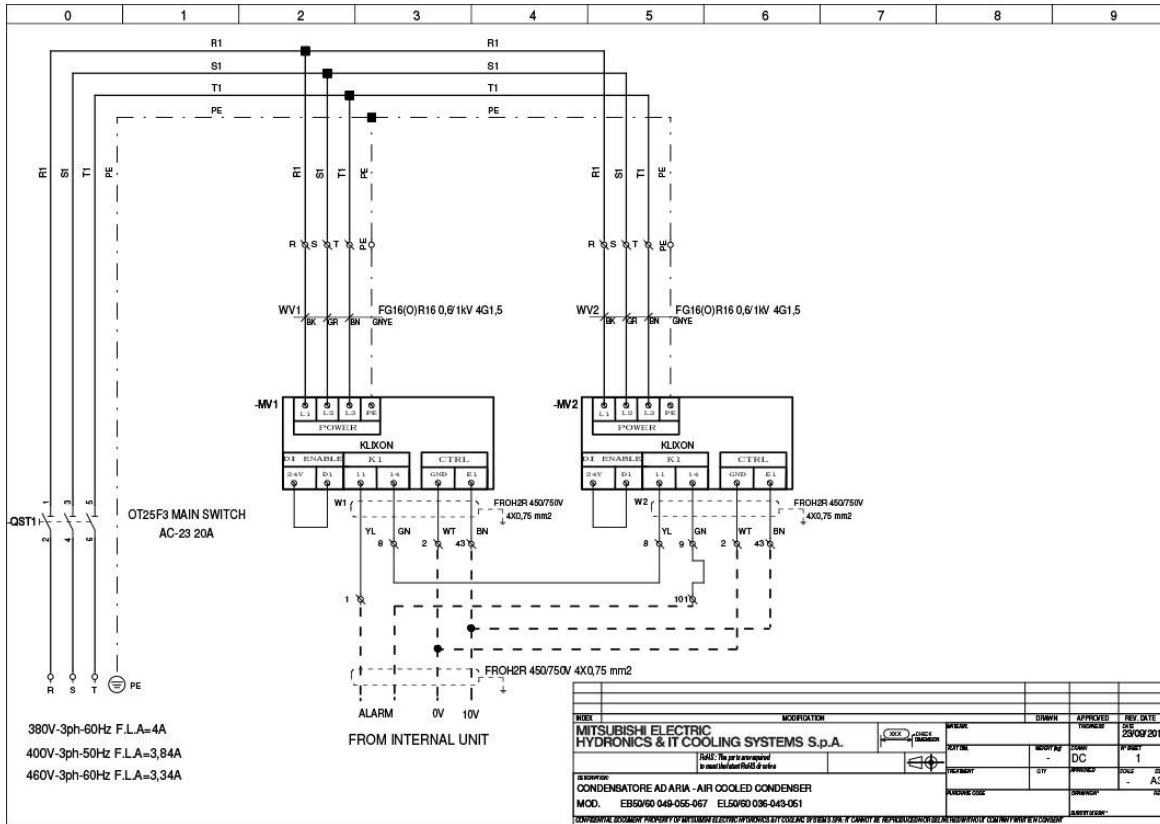

STANDARD MODEL 082
 LOW NOISE MODEL 063

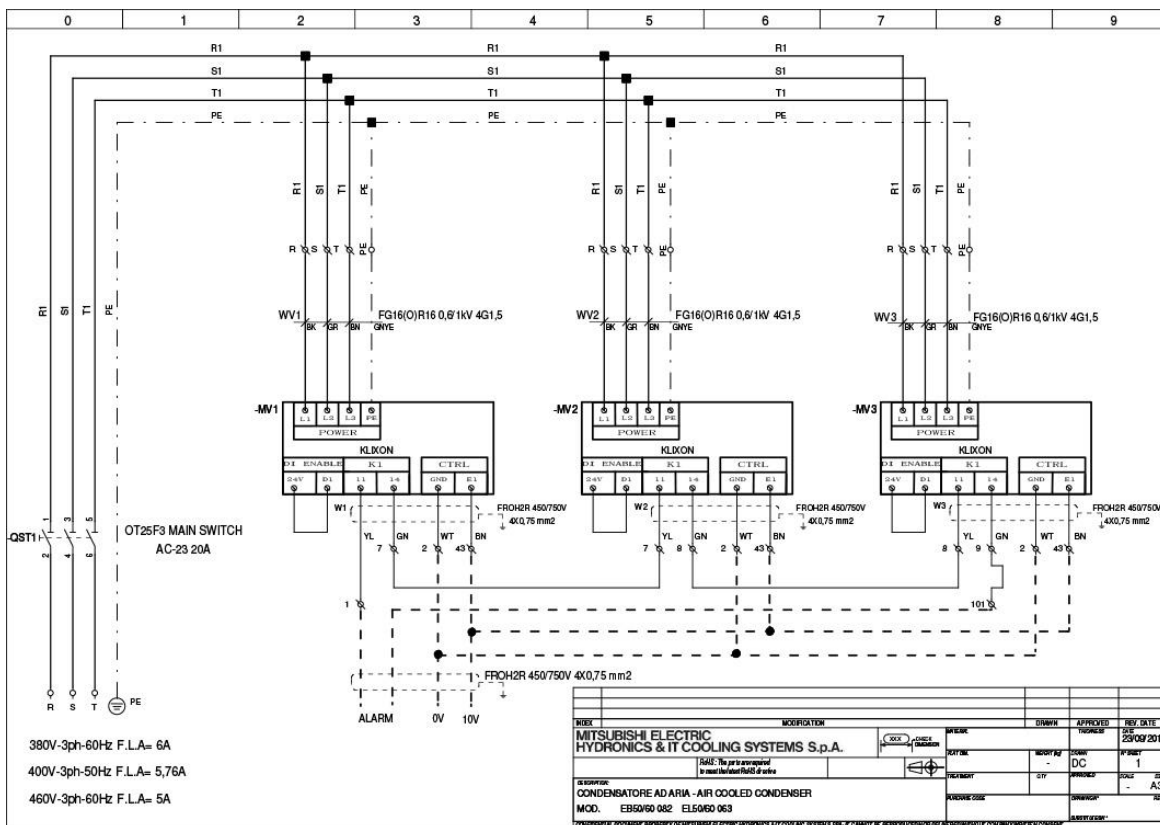

WIRING DIAGRAMS

STANDARD MODEL 110 – 134
LOW NOISE MODEL 086 – 102

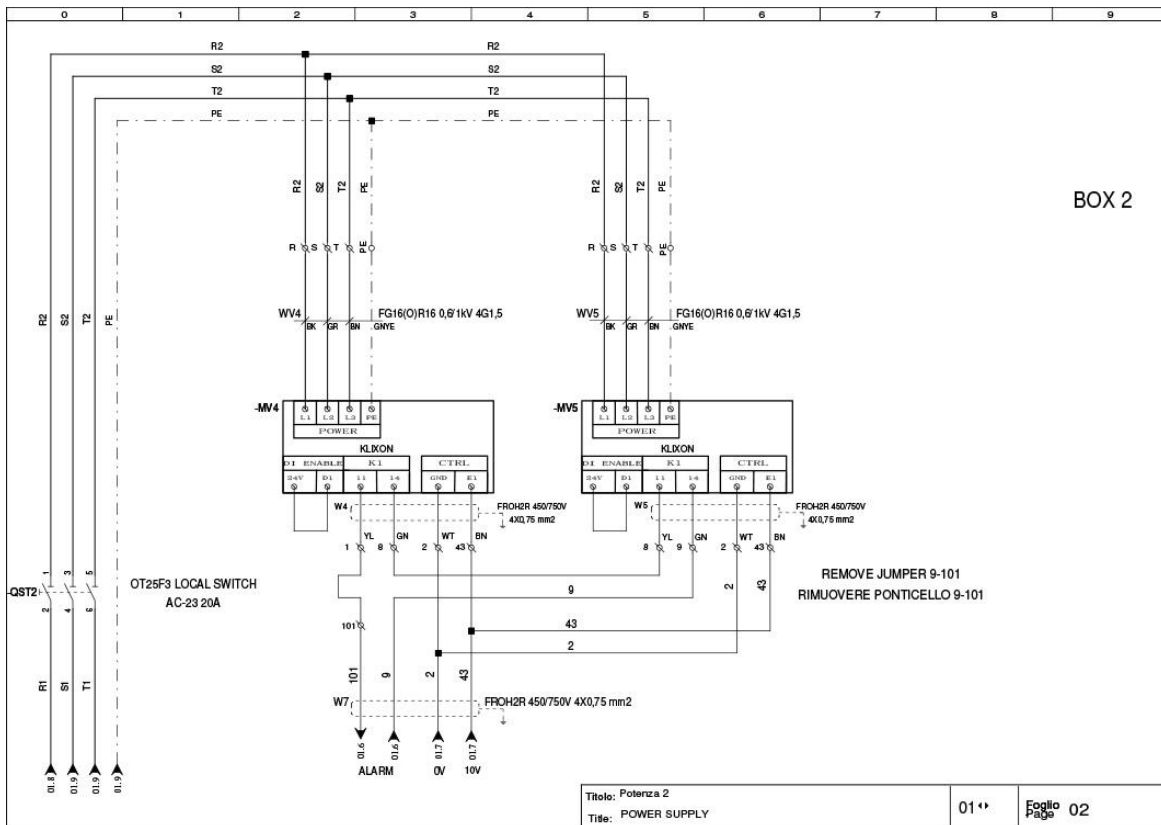
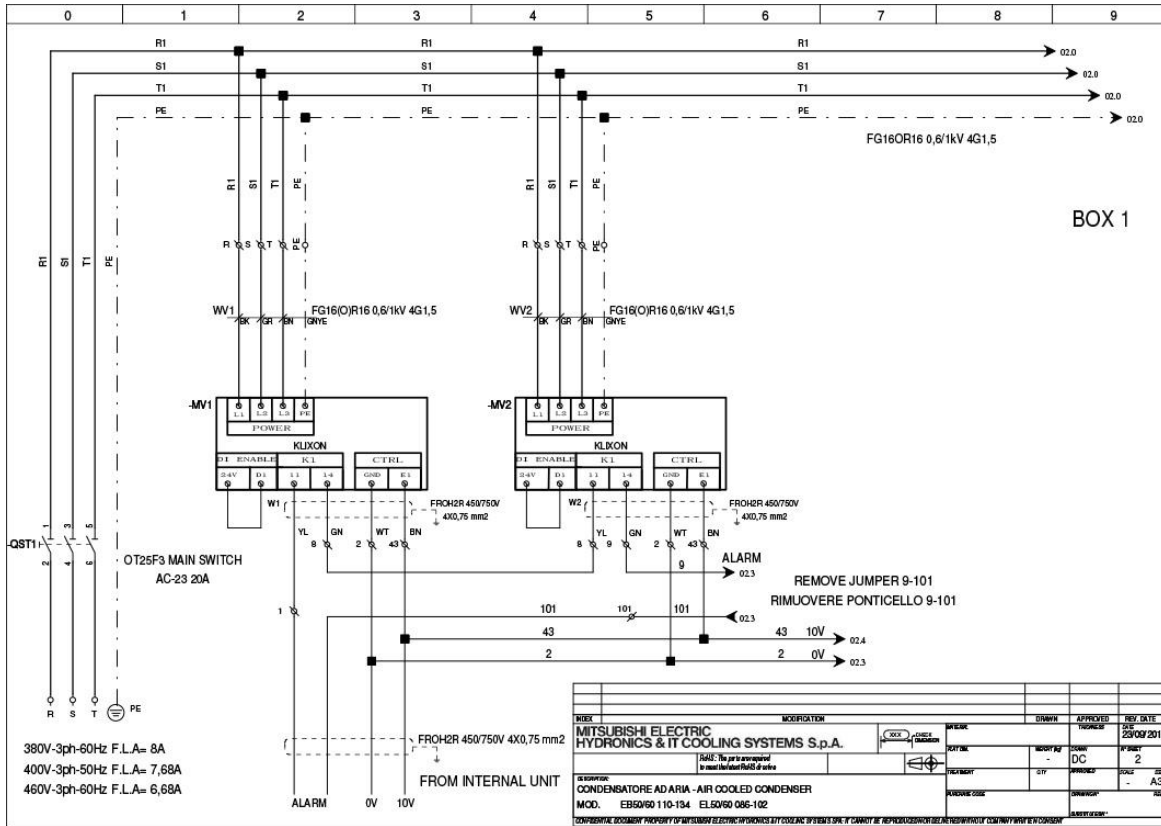

WIRING DIAGRAMS

STANDARD MODEL 164
LOW NOISE MODEL 126

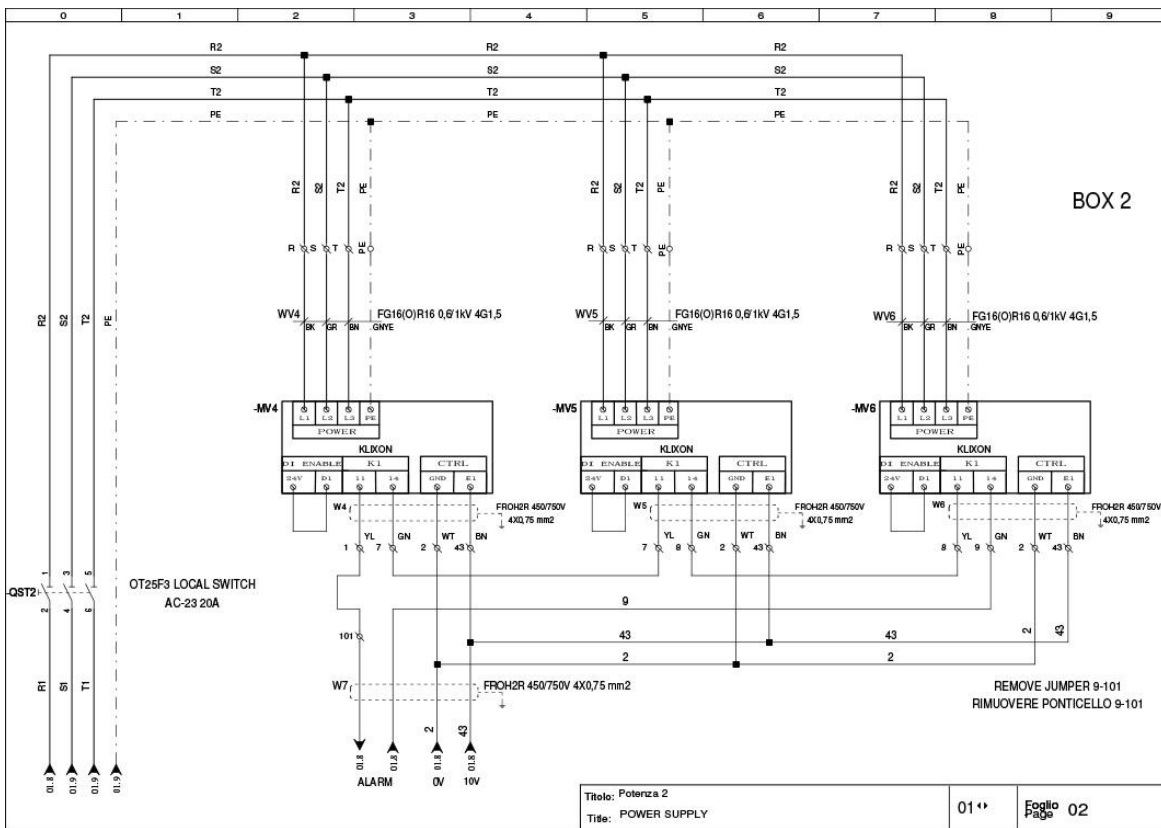
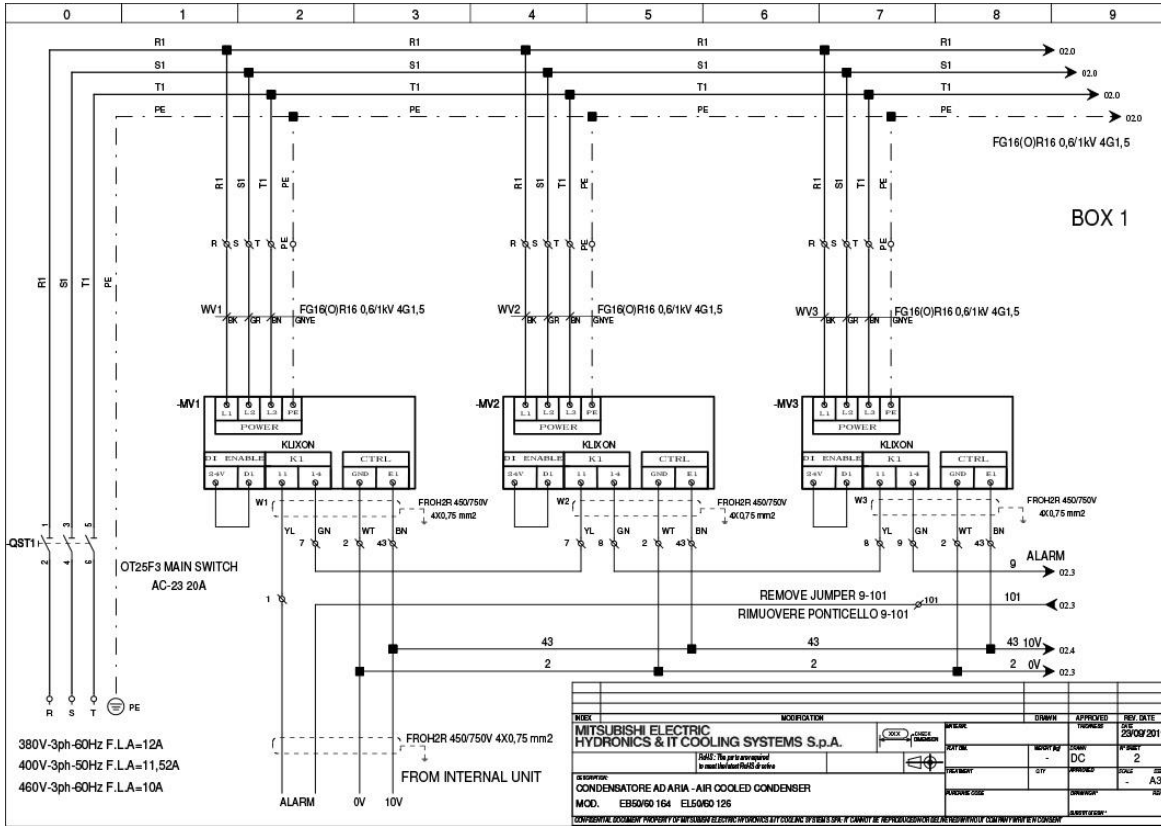

OPTIONAL ACCESSORIES: 1042 - VERTICAL AIR FLOW DIRECTION

The optional is only available for machines equipped with 1/2/3 fans.
 The units can be supplied with supporting legs for vertical airflow.
 The support legs are supplied in mounting kit, with the necessary hardware.
 The installation of the support legs is the responsibility of the Installer.
 Always fix the unit to the floor as intended for the base version.

The vertical air flow version is recommended for installations in windy areas.
 The vertical air flow version is not suitable for installation in seismic areas.

WEIGHT OF THE MACHINES WITH VERTICAL AIR FLOW

Series GR-Z A B 50

MODEL		013	015	024	027	034	049	055	067	082	110	134	164
ACOUSTIC VERSION		B	B	B	B	B	B	B	B	B	B	B	B
NET WEIGHT	kg	33,1	33,1	47,9	47,9	54,7	88,1	88,1	104	123,6	---	---	---

Series GR-Z A L 50

MODEL		010	011	018	021	025	036	043	051	063	086	102	126
ACOUSTIC VERSION		L	L	L	L	L	L	L	L	L	L	L	L
NET WEIGHT	kg	35,1	35,1	49,9	49,9	57,7	91,1	91,1	107	127,6	---	---	---

Series GR-Z E B 50/60

MODEL		013	015	024	027	034	049	055	067	082	110	134	164
ACOUSTIC VERSION		B	B	B	B	B	B	B	B	B	B	B	B
NET WEIGHT	kg	31,1	31,1	45,9	45,9	51,7	84,1	84,1	100	117,6	---	---	---

Series GR-Z E L 50/60

MODEL		010	011	018	021	025	036	043	051	063	086	102	126
ACOUSTIC VERSION		L	L	L	L	L	L	L	L	L	L	L	L
NET WEIGHT	kg	32,1	32,1	47,9	47,9	54,7	87,1	87,1	103	121,6	---	---	---

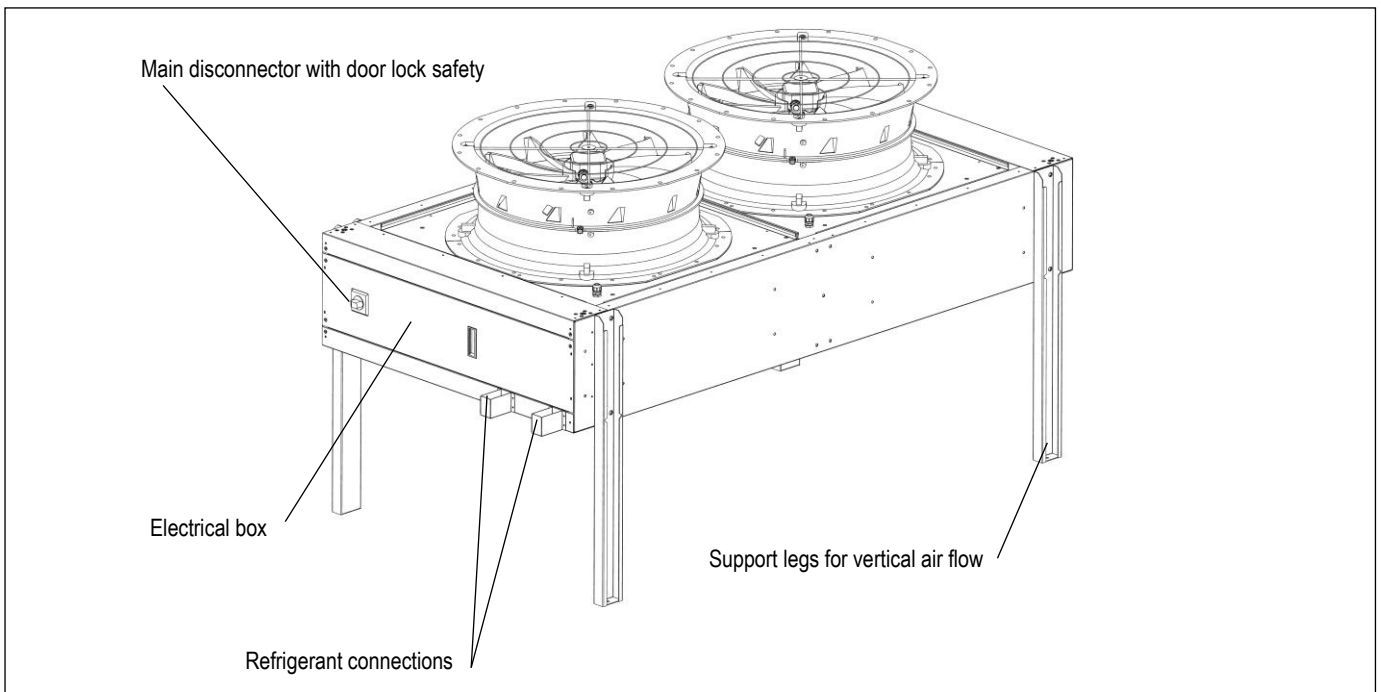

MACHINE DRAWINGS WITH VERTICAL AIR FLOW

Dimensions in mm

STANDARD MODEL 013 – 015
 LOW NOISE MODEL 010 – 011

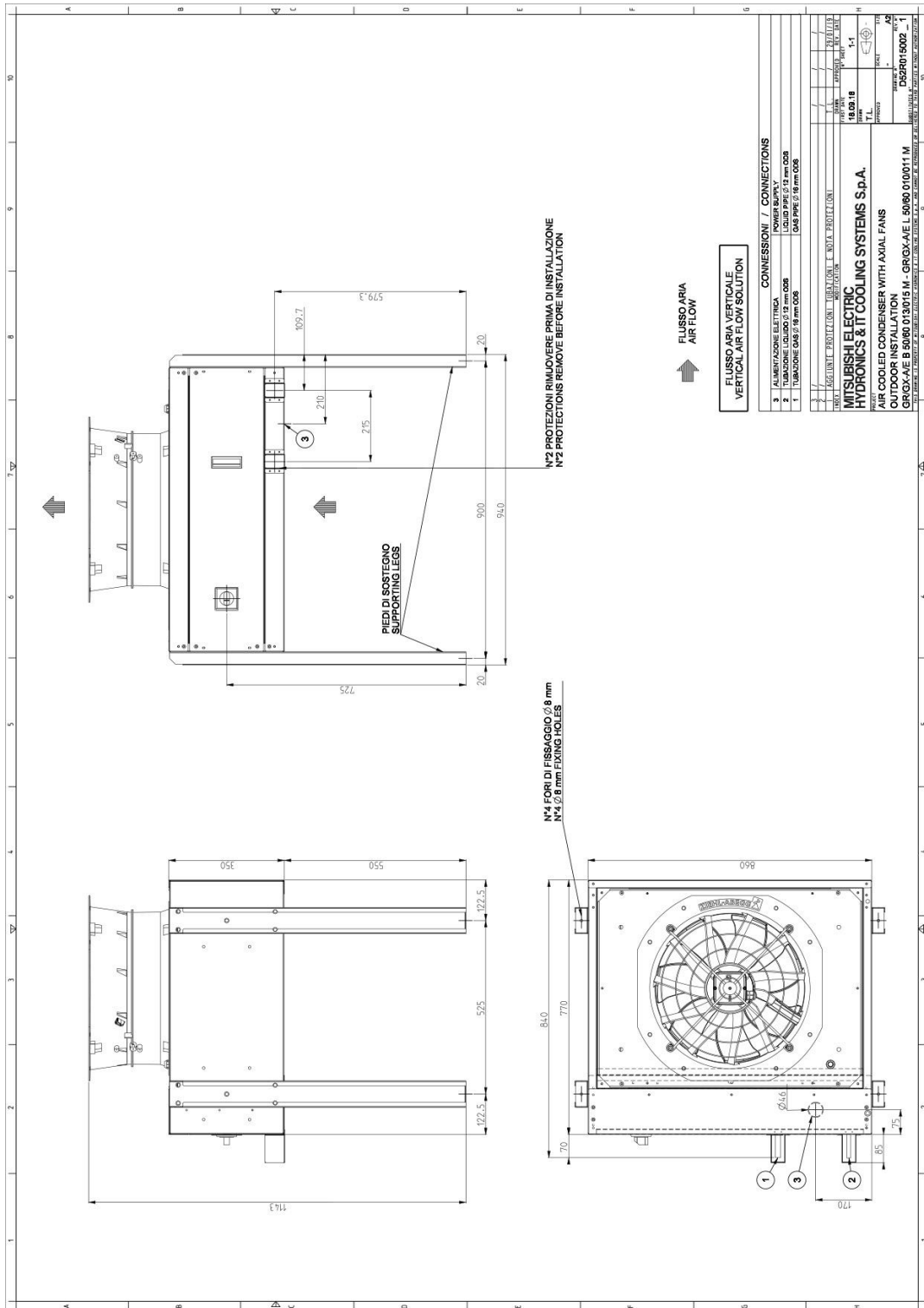

MACHINE DRAWINGS WITH VERTICAL AIR FLOW

Dimensions in mm

STANDARD MODEL 024 – 027
 LOW NOISE MODEL 018 – 021

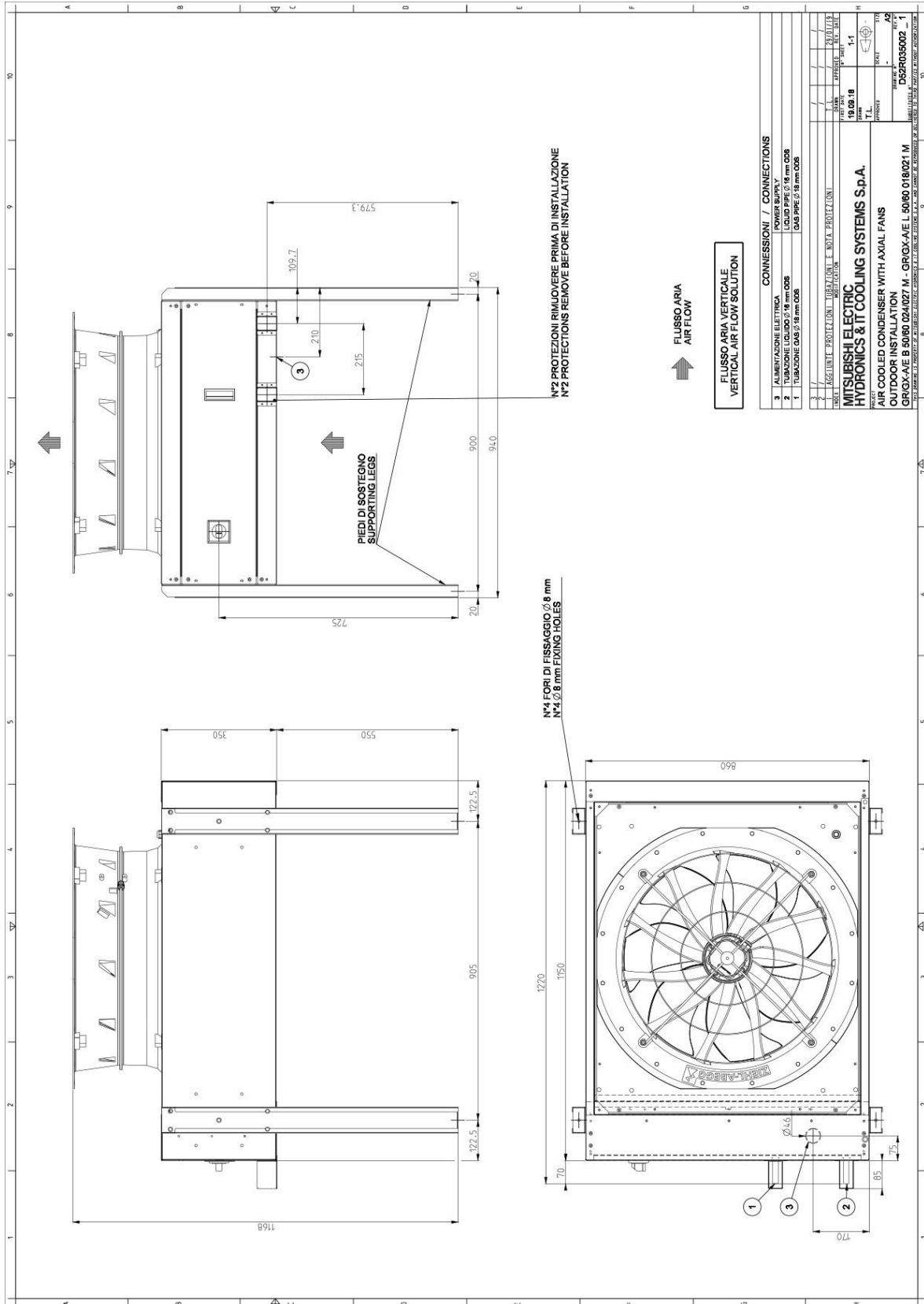

MACHINE DRAWINGS WITH VERTICAL AIR FLOW

Dimensions in mm

STANDARD MODEL 034
LOW NOISE MODEL 025

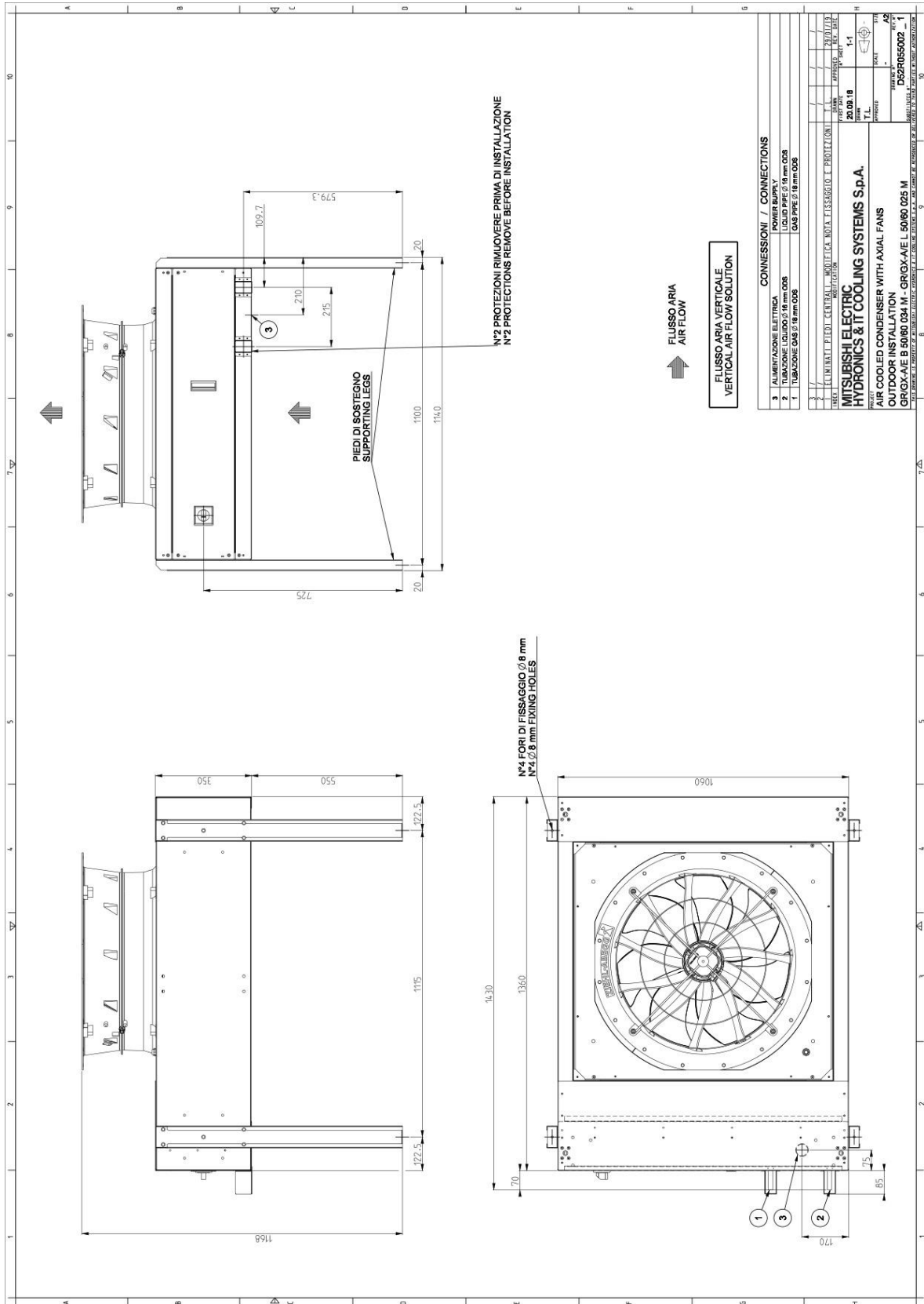

MACHINE DRAWINGS WITH VERTICAL AIR FLOW

Dimensions in mm

STANDARD MODEL 049 – 055

LOW NOISE MODEL 036 – 043

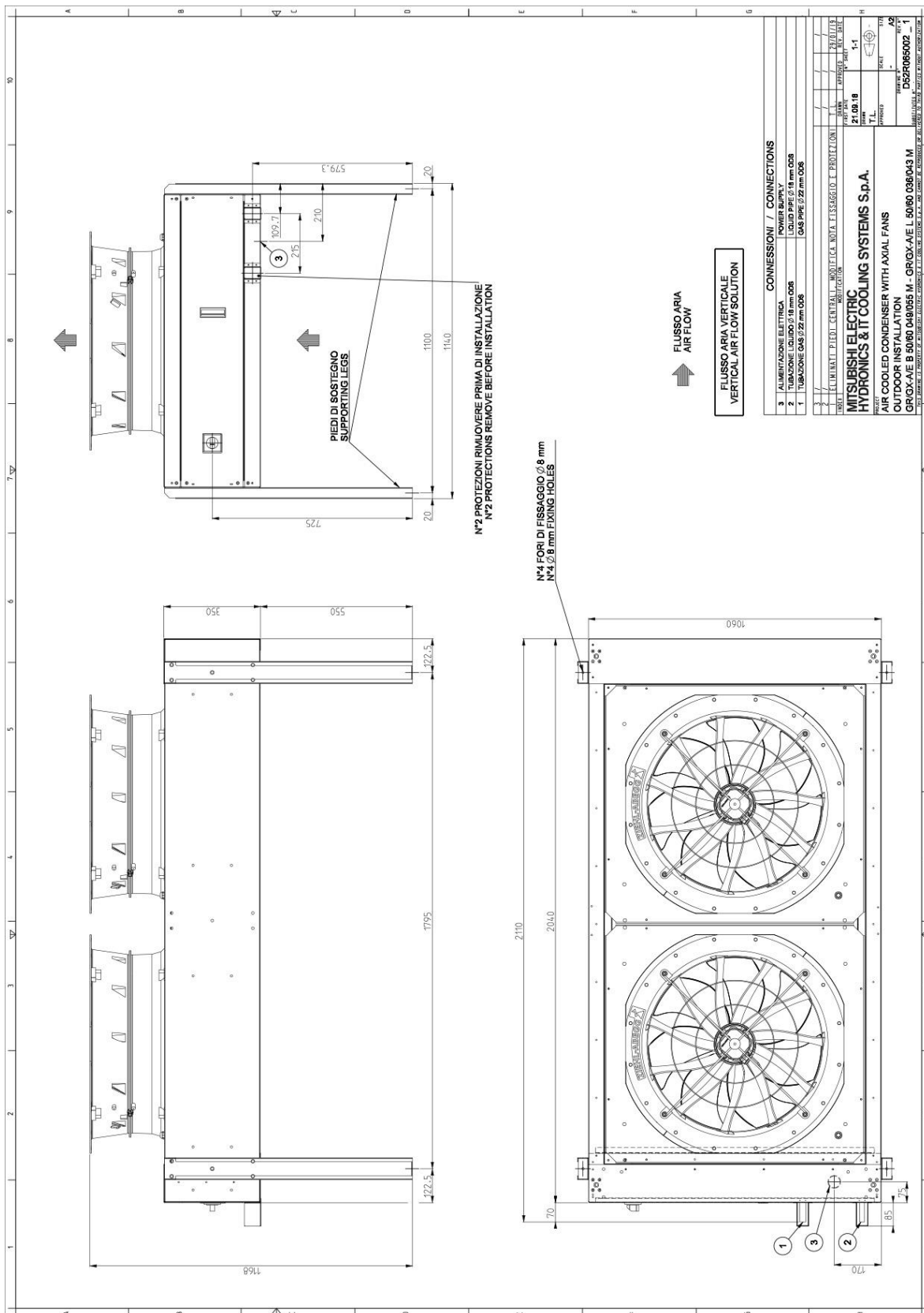

MACHINE DRAWINGS WITH VERTICAL AIR FLOW

Dimensions in mm

STANDARD MODEL 067
LOW NOISE MODEL 051

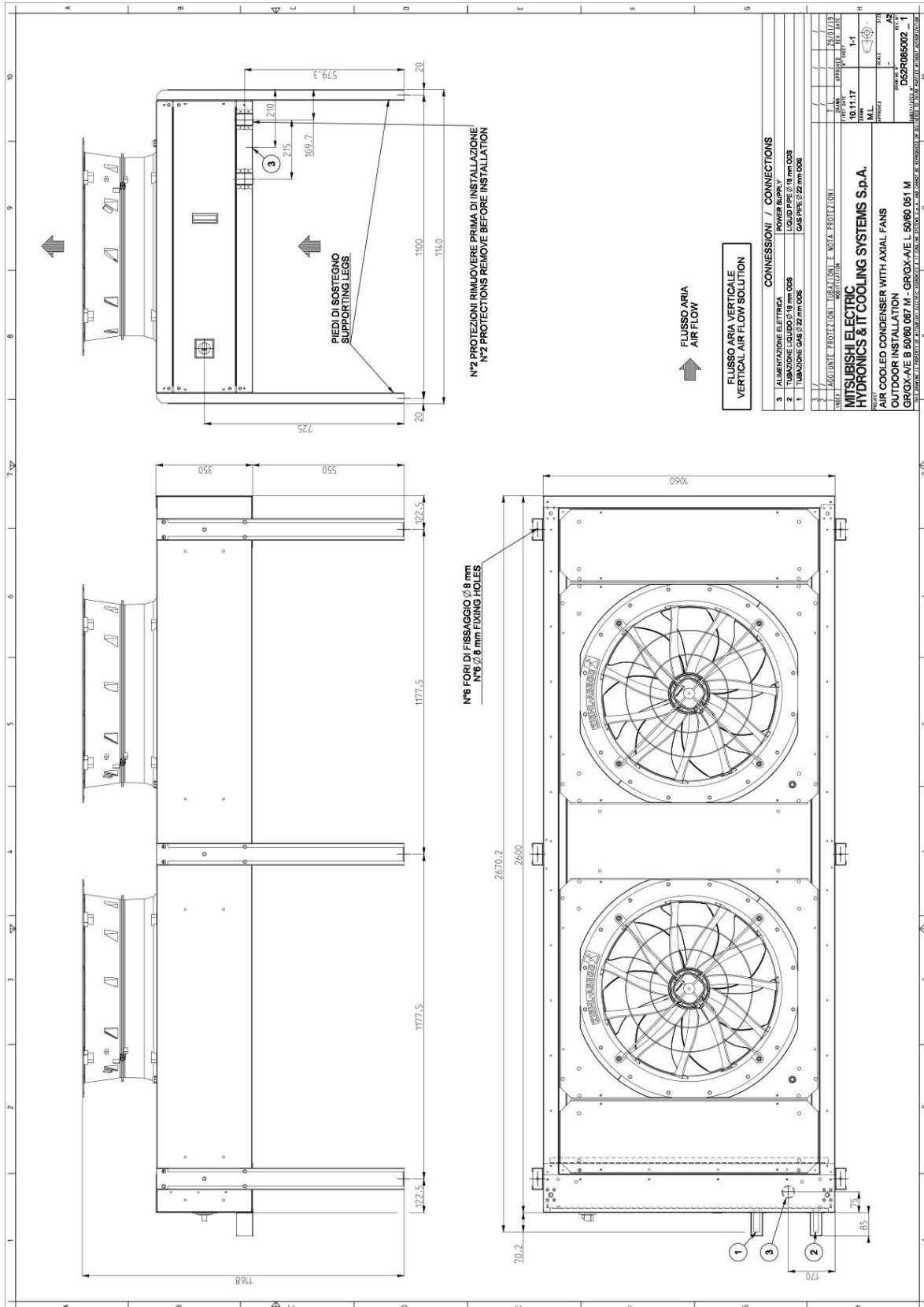

MACHINE DRAWINGS WITH VERTICAL AIR FLOW

Dimensions in mm

STANDARD MODEL 082
 LOW NOISE MODEL 063

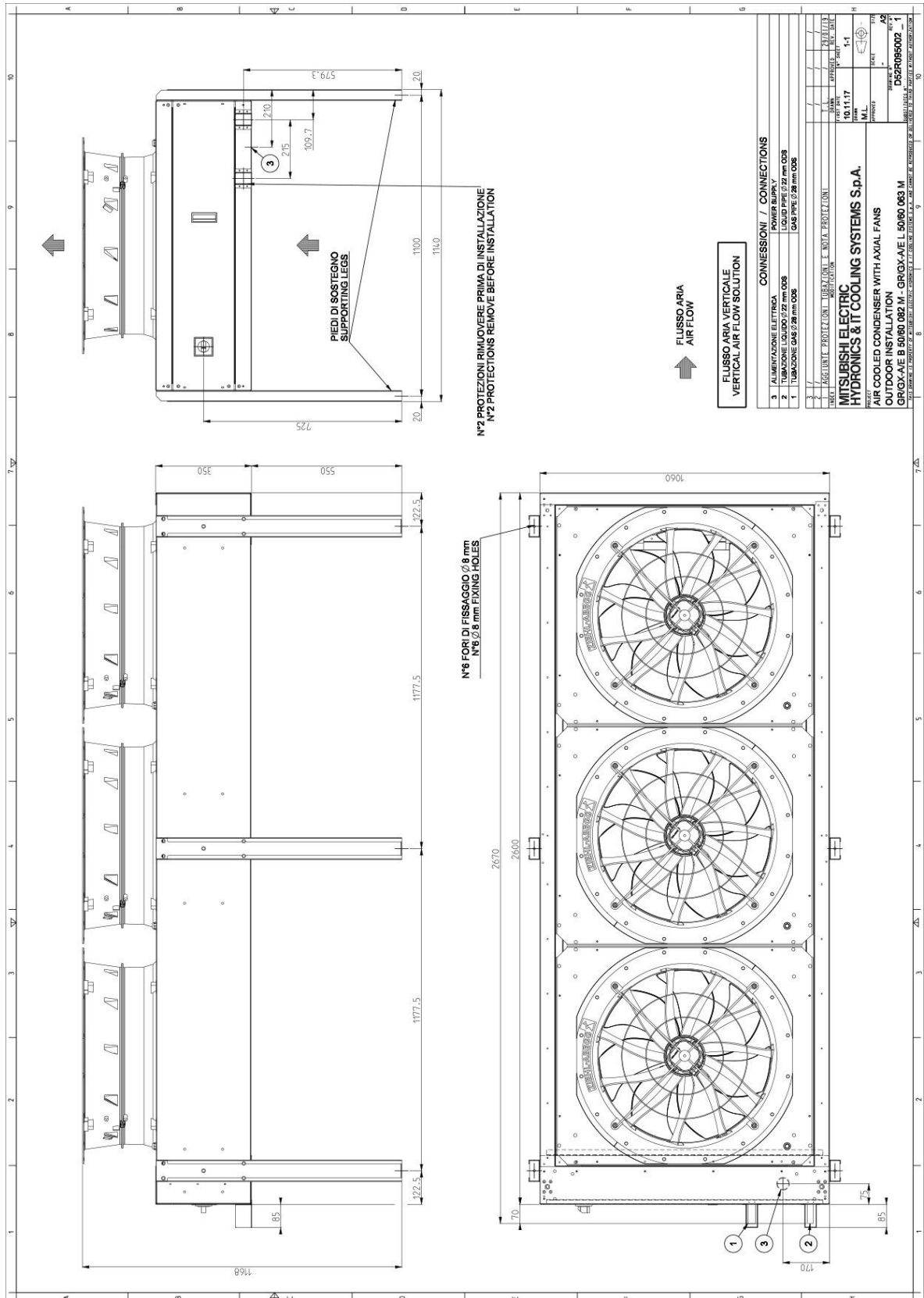

OPTIONAL ACCESSORIES: 2211 – STOP VALVES

Ball valves for refrigerant lone. The valves are supplied in mounting kit.

Connections ODS	Kv Factor	PS	PED.	H	L	Weight
Ø [mm]	[m³/h]	[bar]		[mm]	[mm]	[g]
12	5	45	Art. 3.3	73	121	300
16	14,5	45	Art. 3.3	80	141	410
18	14,5	45	Art. 3.3	80	141	410
22	24	45	Art. 3.3	95,5	175	760
28	40	45	Art. 3.3	101,5	206	1050
35	68	45	Art. 3.3	117	210	1518

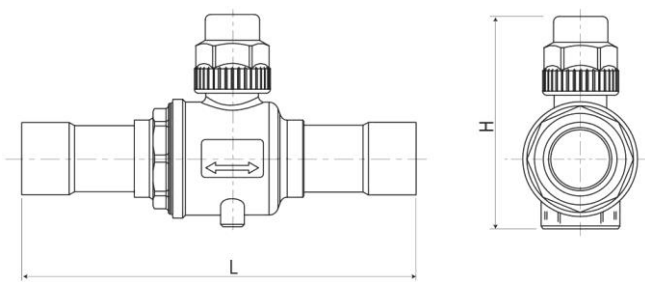

OPTIONAL ACCESSORIES: 876 - E-COATING MICROCHANNEL COIL

E-coating is a process for electrodeposition with epoxy resin. The coating is applied through a complete immersion in a tank, in which the coil behaves like a magnet, attracting the coating on every point of its surface

Advantages of E-coating protective treatment:

- Cathodic deposition which guarantees 100% coating of the exchanger;
- 1-2% exchanger efficiency loss;
- 5-year warranty on C5 class exposure
- High durability, 15 years of protection in C5 environment according to ISO12944;
- Thickness of protective film 0.6 - 1.2 mm;
- Flexible and resistant protective film;
- Colour of the protective film Black;
- Additional protection against UV rays is available on request (Top-Coating);

ELECTRODEPOSITION PROCESS

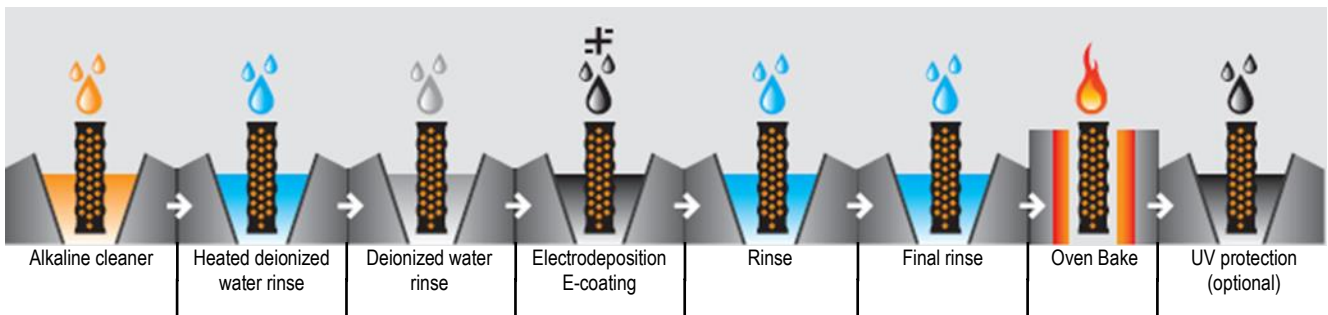

To ensure correct machine operation and the best operating conditions, it is important to keep the exchangers clean and efficient as indicated in the Installation, Use and Maintenance manuals. The E-coating protective treatment does not exclude maintenance and cleaning operations of the exchangers.

OPTIONAL ACCESSORIES: P101 – ANTI-SEISMIC FIXING KIT



For the purposes of resistance against seismic events the condenser have been certified at the highest level of seismic intensity as required by the ICC-ES AC 156 "Acceptance criteria for seismic certification by shake-table testing of nonstructural components -oct. 2010 "by performing dynamic tests on a vibrating table with oscillations on vertical and transversal axes.

As foreseen by the standard, the purpose of the tests followed is to certify non structural components subjected to seismic stresses with a frequency higher than 1.3 Hz (Section 13.2.5 of ASCE 7). The evaluation criterion followed is aimed at providing supporting data for the architectural seismic certification of mechanical, electrical and other parts not considered "structural" that must be permanently connected to an architectural building or component. The integrity of the anchorage of the machine and of the components to the structure must be guaranteed by accepting small subsidence, small fractures and anomalies provided these do not have any impact on the safety of people during the seismic event.

The ICC-ES AC 156 is related to ISO 13033:2013 "Bases For Design Of Structures — Loads, Forces And Other Actions — Seismic Actions On Nonstructural Components For Building Applications".

When installations in seismic zones are planned, the machines must be installed in an appropriate way:

- Avoid installations with vertical air flow
- Pay attention to anchoring to the support structure.

The machine in anti-seismic version is equipped with a reinforced structure already assembled in the factory and must be selected when ordering.

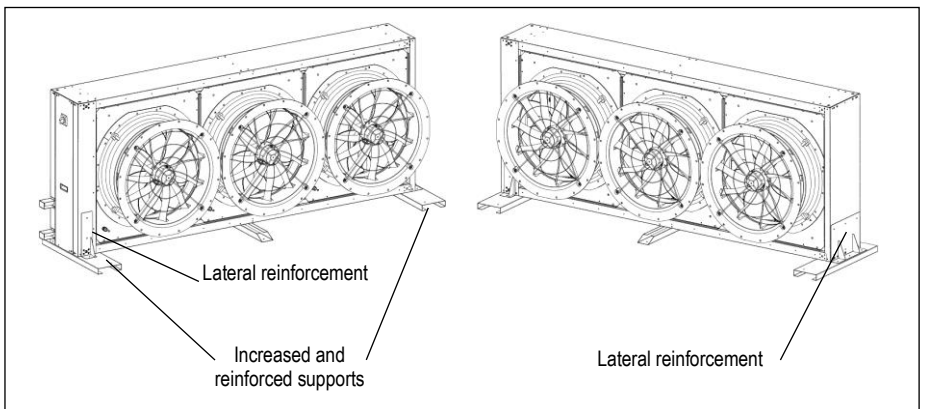

ANTI-SEISMIC CONSTRAINT REACTION

MODEL STANDARD		013	015	024	027	034	049
MODEL LOW NOISE		010	011	018	021	025	036
Traction reaction of the single bolt	N	74,6	74,6	124,9	124,9	121,4	208,3
Bolt quantity	n.	4	4	4	4	4	6
Bolt Grade Class		8.8	8.8	8.8	8.8	8.8	8.8
Bolt type		M8	M8	M8	M8	M8	M8

MODEL STANDARD		055	067	082	110	134	164
MODEL LOW NOISE		043	051	063	086	102	126
Traction reaction of the single bolt	N	208,3	233,5	293,3	--	--	--
Bolt quantity	n.	6	6	6	--	--	--
Bolt Grade Class		8.8	8.8	8.8	--	--	--
Bolt type		M8	M8	M8	--	--	--

(--) Not available

WEIGHT OF MACHINES IN ANTI-SIESMIC VERSION

Serie GR-Z A B 50

MODEL		013	015	024	027	034	049	055	067	082	110	134	164
ACOUSTIC VERSION		B	B	B	B	B	B	B	B	B	B	B	B
NET WEIGHT	kg	40,3	40,3	56	56	66	100	100	114	134	--	--	--

Serie GR-Z A L 50

MODEL		010	011	018	021	025	036	043	051	063	086	102	126
ACOUSTIC VERSION		L	L	L	L	L	L	L	L	L	L	L	L
NET WEIGHT	kg	42,3	42,3	58	58	69	103	103	117	138	--	--	--

Serie GR-Z E B 50/60

MODEL		013	015	024	027	034	049	055	067	082	110	134	164
ACOUSTIC VERSION		B	B	B	B	B	B	B	B	B	B	B	B
NET WEIGHT	kg	38,3	38,3	54	54	63	96	96	110	128	--	--	--

Serie GR-Z E L 50/60

MODEL		010	011	018	021	025	036	043	051	063	086	102	126
ACOUSTIC VERSION		L	L	L	L	L	L	L	L	L	L	L	L
NET WEIGHT	kg	39,3	39,3	56	56	66	99	99	113	132	--	--	--

(--) Not available

REFRIGERANT / ELECTRICAL CONNECTIONS IN SEISMIC AREAS

Avoid rigid connections between the machine and the plant; it is necessary to isolate the machine with a flexible system that allows free movement in case of seismic event.

The refrigerant / electrical connection is at the Installer's charge; the choice of flexible components and installation must follow the instructions of the Designer / Engineer responsible for the plant.

MACHINE DRAWINGS FOR ANTISEISMIC VERSION Dimensions in mm

STANDARD MODEL 013 - 015
LOW NOISE MODEL 010 - 011

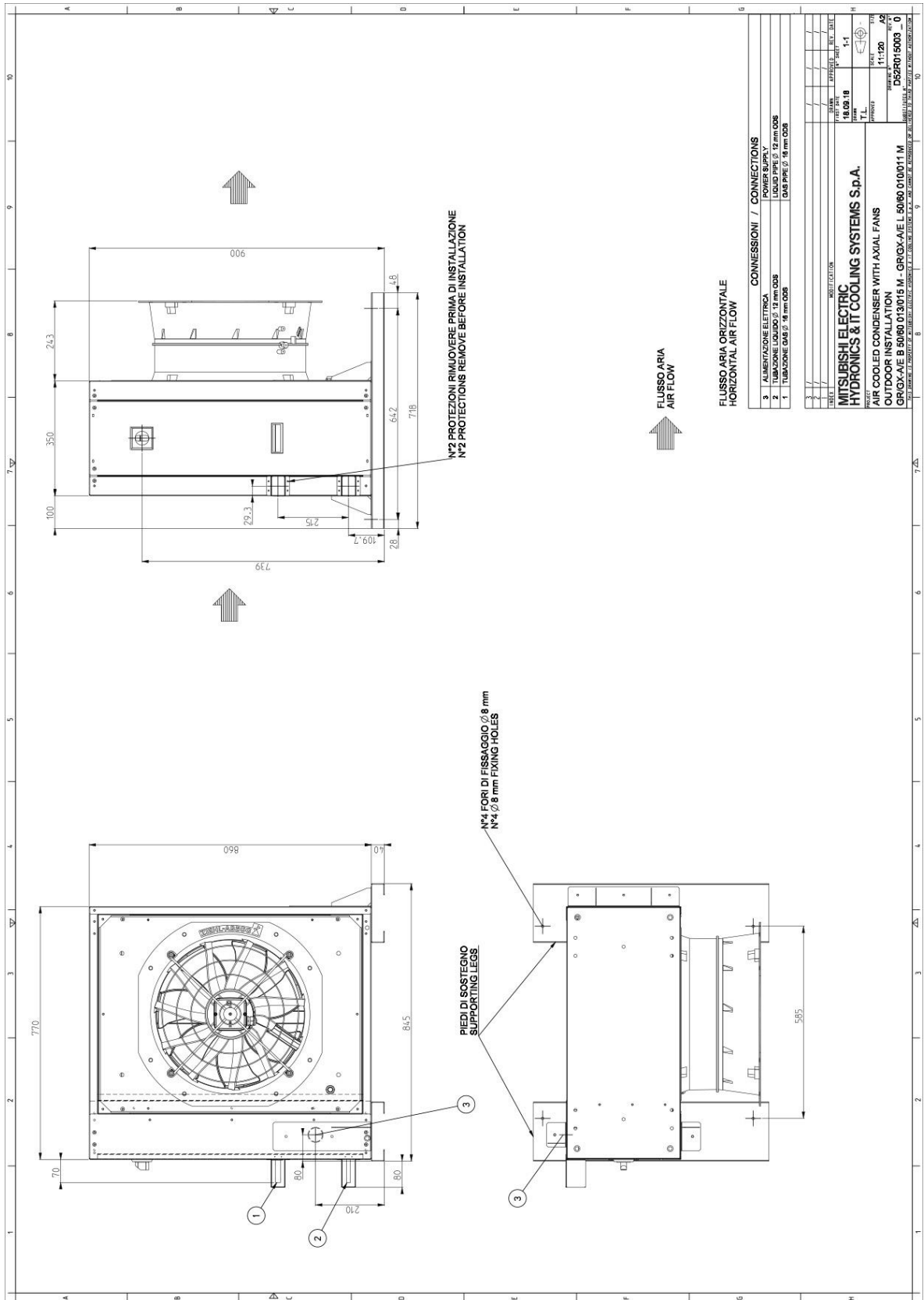

MACHINE DRAWINGS FOR ANTISEISMIC VERSION Dimensions in mm

STANDARD MODEL 024 – 027
LOW NOISE MODEL 018 – 021

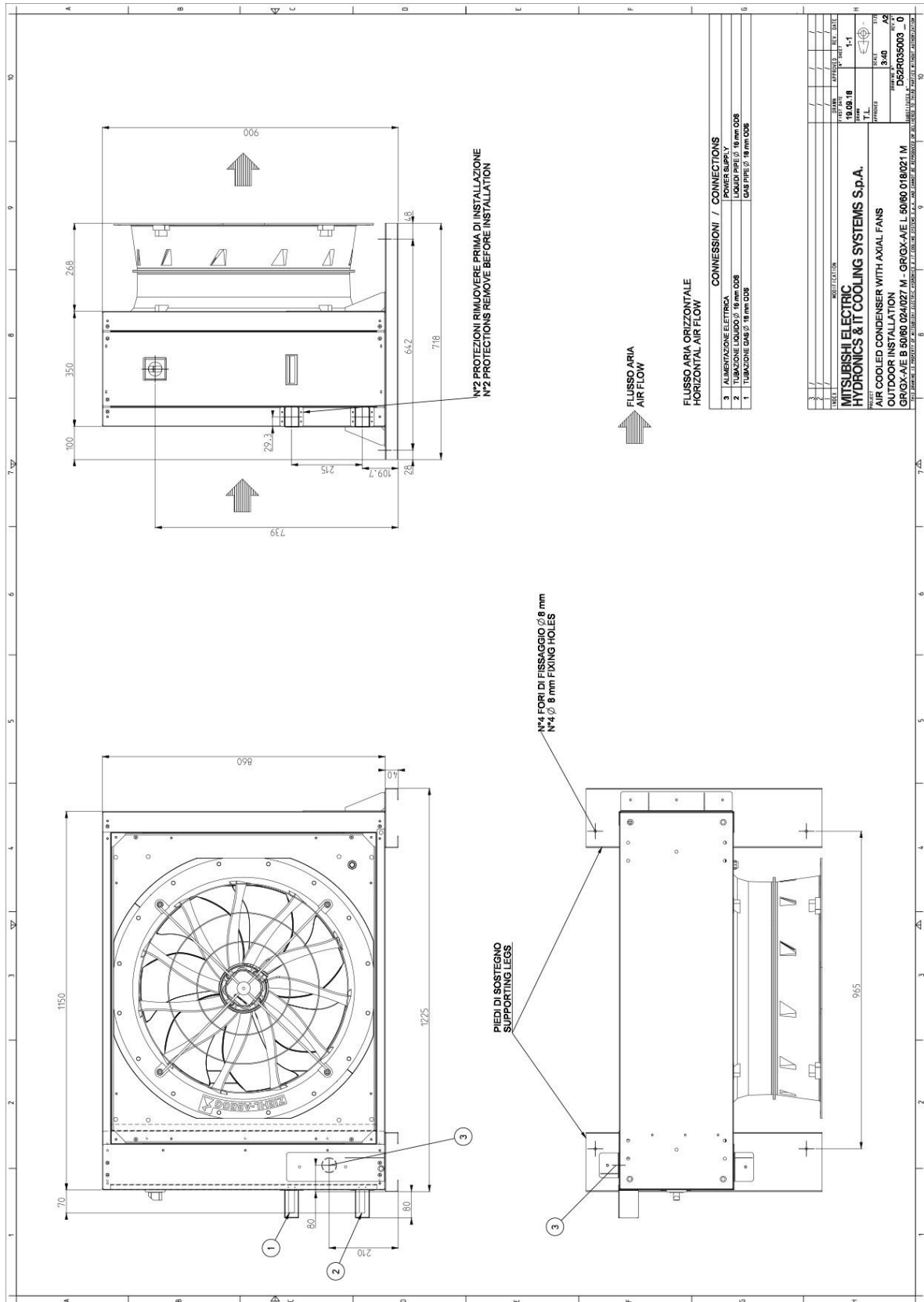

MACHINE DRAWINGS FOR ANTISEISMIC VERSION Dimensions in mm

STANDARD MODEL 034
LOW NOISE MODEL 025

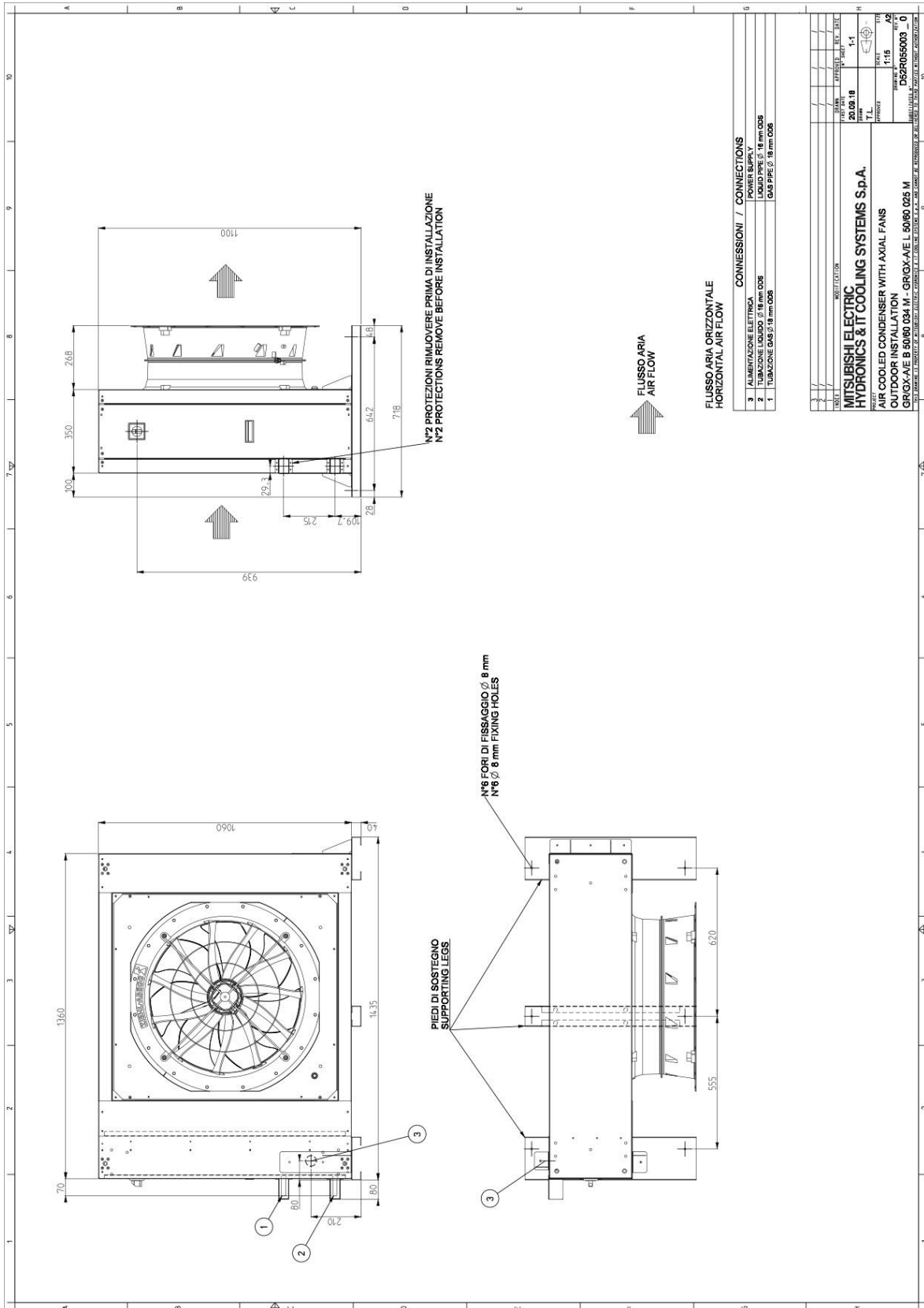

MACHINE DRAWINGS FOR ANTISEISMIC VERSION Dimensions in mm

STANDARD MODEL 049 – 055
LOW NOISE MODEL 036 – 043

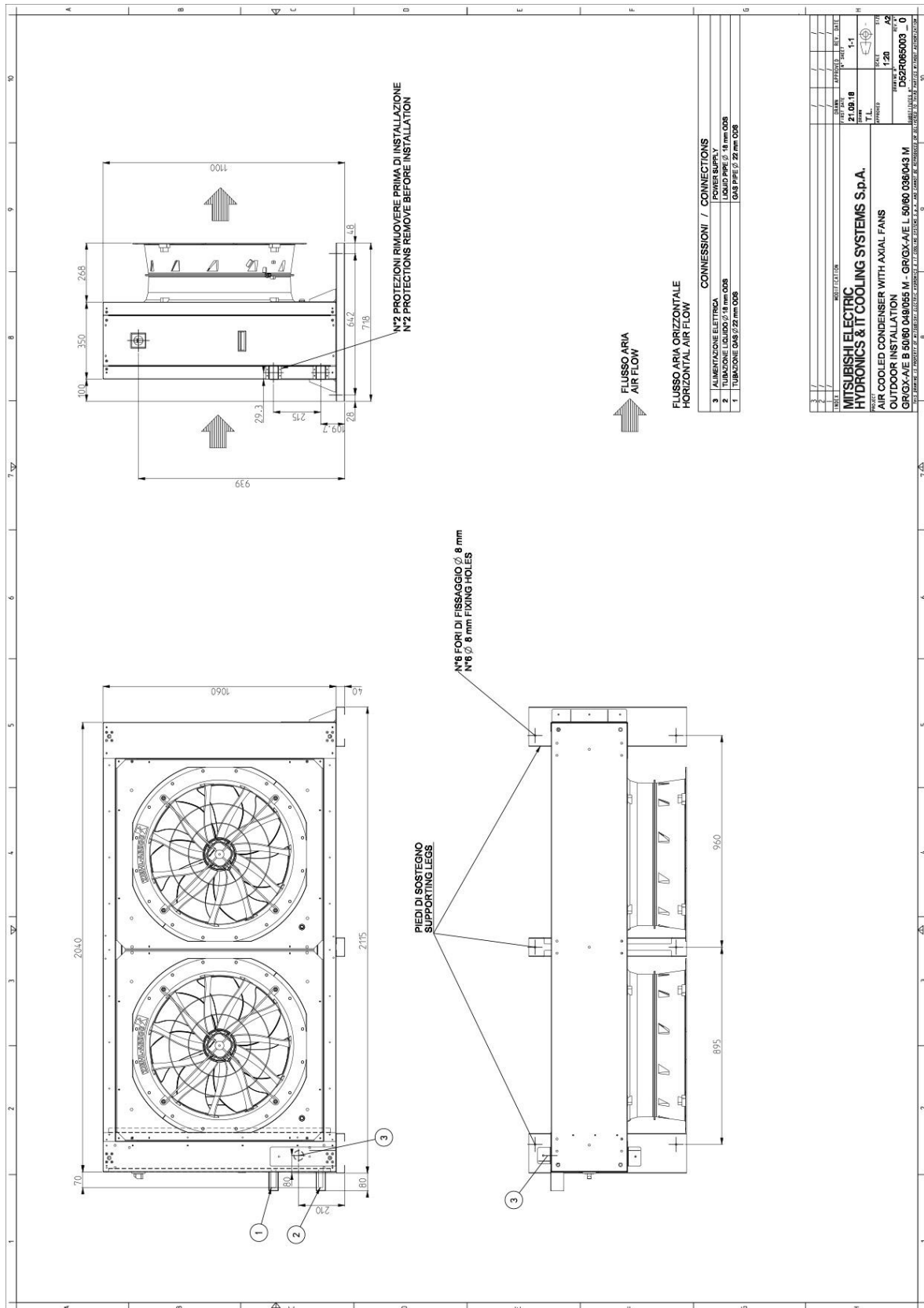

MACHINE DRAWINGS FOR ANTISEISMIC VERSION Dimensions in mm

STANDARD MODEL 067
LOW NOISE MODEL 051

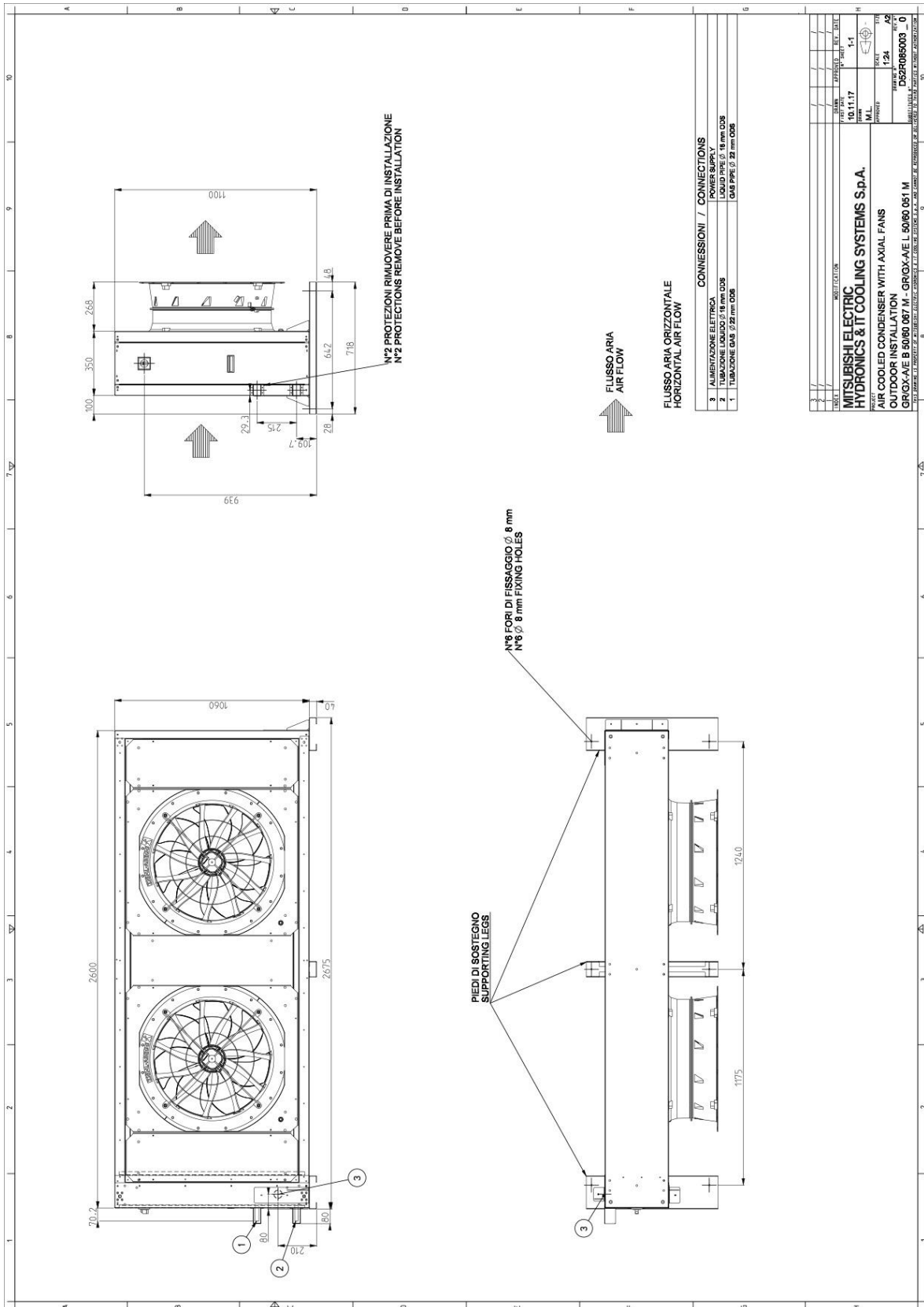

MACHINE DRAWINGS FOR ANTISEISMIC VERSION Dimensions in mm

STANDARD MODEL 082
LOW NOISE MODEL 063

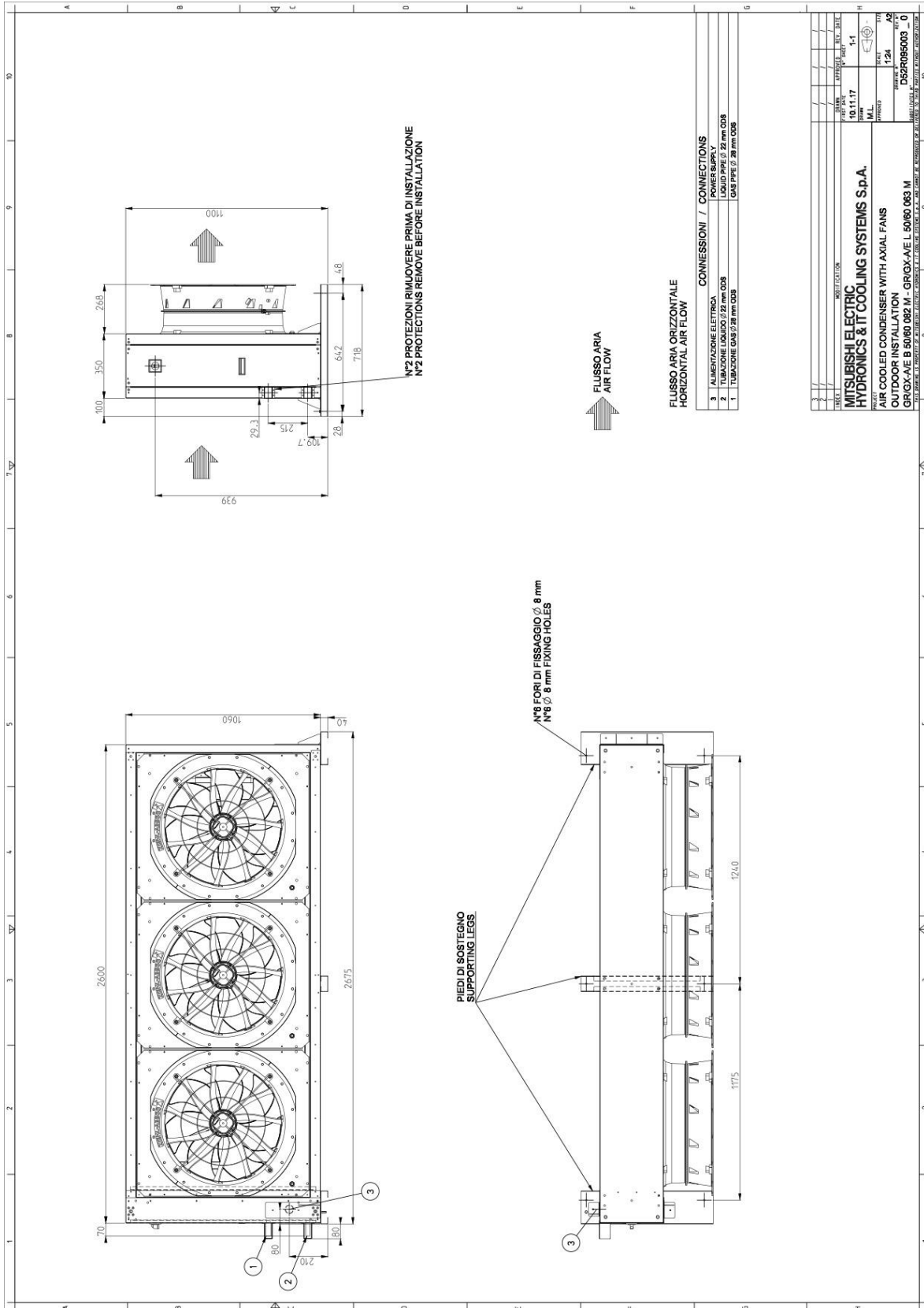

SHIPMENT: PACKING DIMENSIONS

Values referred to basic machine. The presence of some accessories increases the weight of machine.

MODELS WITH 1/2/3 FANS – HORIZONTAL AIR FLOW

The machines are shipped on pallet and covered with shrink wrap.
On request packing on pallet covered with shrink wrap and wooden cage.
When foreseen the wooden cage, stacking on two levels is allowed.

STANDARD PACKING DIMENSIONS

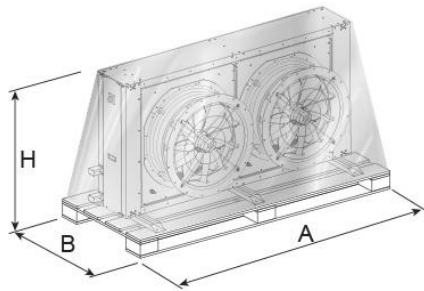

Model STANDARD	Model LOW NOISE	A (mm)	B (mm)	H (mm)
013	010	1050	850	1050
015	011	1050	850	1050
024	018	1400	850	1050
027	021	1400	850	1050
034	025	1650	850	1250
049	036	2300	850	1250
055	043	2300	850	1250
067	051	2850	850	1250
082	063	2850	850	1250

OPTIONAL 9973 - WOODEN CAGE PACKING DIMENSIONS

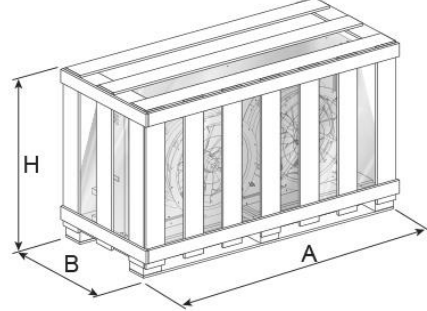

Model STANDARD	Model LOW NOISE	A (mm)	B (mm)	H (mm)
013	010	1100	900	1200
015	011	1100	900	1200
024	018	1450	900	1200
027	021	1450	900	1200
034	025	1700	900	1400
049	036	2350	900	1400
055	043	2350	900	1400
067	051	2900	900	1400
082	063	2900	900	1400

MODELS WITH 4/6 FANS – VERTICAL AIR FLOW

The machines are shipped in vertical position on pallet, covered with shrink wrap and wooden cage.
Stacking not allowed.

STANDARD WOODEN CAGE PACKING DIMENSIONS

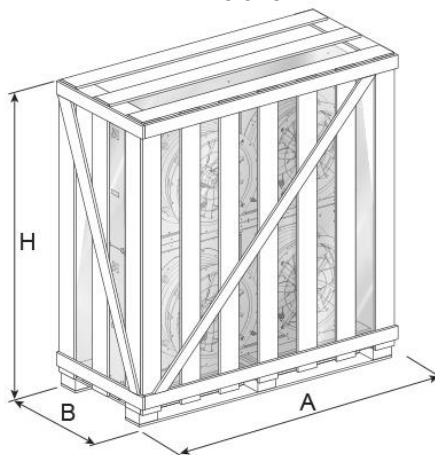

Model STANDARD	Model LOW NOISE	A (mm)	B (mm)	H (mm)
110	086	2350	900	2400
134	102	2950	900	2400
164	126	2950	900	2400

SHIPMENT: SHIPPING WEIGHT FOR STANDARD MACHINES

Series	Voltage	Model											
GR-Z A B 50	230/1/50	013	015	024	027	034	049	055	067	082	110	134	164
PACKING TYPE													
Standard	kg	47	47	66	66	80	123	123	153	173	---	---	---
Wooden cage	kg	61	61	81	81	96	143	143	183	203	283	337	377

Series	Voltage	Model											
GR-Z A L 50	230/1/50	010	011	018	021	025	036	043	051	063	086	102	126
PACKING TYPE													
Standard	kg	49	49	68	68	83	126	126	156	177	---	---	---
Wooden cage	kg	63	63	83	83	99	146	146	186	207	290	344	384

Series	Voltage	Model											
GR-Z E B 50	230/1/50 - 400/3/50	013	015	024	027	034	049	055	067	082	110	134	164
PACKING TYPE													
Standard	kg	45	45	64	64	77	119	119	149	167	---	---	---
Wooden cage	kg	59	59	79	79	93	139	139	179	197	275	329	366

Series	Voltage	Model											
GR-Z E L 50	230/1/50 - 400/3/50	010	011	018	021	025	036	043	051	063	086	102	126
PACKING TYPE													
Standard	kg	46	46	66	66	80	122	122	152	171	---	---	---
Wooden cage	kg	60	60	81	81	96	142	142	182	201	282	336	373

Series	Voltage	Model											
GR-Z E B 60	220/1/60 - 380/3/60 265/1/60 - 460/3/60	013	015	024	027	034	049	055	067	082	110	134	164
PACKING TYPE													
Standard	kg	45	45	64	64	77	119	119	149	167	---	---	---
Wooden cage	kg	59	59	79	79	93	139	139	179	197	275	329	366

Series	Voltage	Model											
GR-Z E L 60	220/1/60 - 380/3/60 265/1/60 - 460/3/60	010	011	018	021	025	036	043	051	063	086	102	126
PACKING TYPE													
Standard	kg	46	46	66	66	80	122	122	152	171	---	---	---
Wooden cage	kg	60	60	81	81	96	142	142	182	201	282	336	373

(--) Not available

SHIPMENT: SHIPPING WEIGHT FOR ANTI-SEISMIC MACHINES

Series	Voltage	Model											
GR-Z A B 50	230/1/50	013	015	024	027	034	049	055	067	082	110	134	164
PACKING TYPE													
Standard	kg	57,3	57,3	77	77	93	137	137	167	187	---	---	---
Wooden cage	kg	71,3	71,3	92	92	109	157	157	197	217	---	---	---

Series	Voltage	Model											
GR-Z A L 50	230/1/50	010	011	018	021	025	036	043	051	063	086	102	126
PACKING TYPE													
Standard	kg	59,3	59,3	79	79	96	140	140	170	191	---	---	---
Wooden cage	kg	73,3	73,3	94	94	112	160	160	200	221	---	---	---

Series	Voltage	Model											
GR-Z E B 50	230/1/50 - 400/3/50	013	015	024	027	034	049	055	067	082	110	134	164
PACKING TYPE													
Standard	kg	55,3	55,3	75	75	90	133	133	163	181	---	---	---
Wooden cage	kg	69,3	69,3	90	90	106	153	153	193	211	---	---	---

Series	Voltage	Model											
GR-Z E L 50	230/1/50 - 400/3/50	010	011	018	021	025	036	043	051	063	086	102	126
PACKING TYPE													
Standard	kg	56,3	56,3	77	77	93	136	136	166	185	---	---	---
Wooden cage	kg	70,3	70,3	92	92	109	156	156	196	215	---	---	---

Series	Voltage	Model											
GR-Z E B 60	220/1/60 - 380/3/60 265/1/60 - 460/3/60	013	015	024	027	034	049	055	067	082	110	134	164
PACKING TYPE													
Standard	kg	55,3	55,3	75	75	90	133	133	163	181	---	---	---
Wooden cage	kg	69,3	69,3	90	90	106	153	153	193	211	---	---	---

Series	Voltage	Model											
GR-Z E L 60	220/1/60 - 380/3/60 265/1/60 - 460/3/60	010	011	018	021	025	036	043	051	063	086	102	126
PACKING TYPE													
Standard	kg	56,3	56,3	77	77	93	136	136	166	185	---	---	---
Wooden cage	kg	70,3	70,3	92	92	109	156	156	196	215	---	---	---

(-) Not available



for a greener tomorrow

Eco-Changes è il motto per l'ambiente del gruppo Mitsubishi Electric ed esprime la posizione dell'azienda relativamente alla gestione ambientale. Attraverso le nostre numerose attività di business diamo un contributo alla realizzazione di una società sostenibile.



MITSUBISHI ELECTRIC HYDRONICS & IT COOLING SYSTEMS S.p.A.

Via Caduti di Cefalonia, 1 - 36061 Bassano del Grappa (VI) Italy
Ph. (+39) 0424 509 500 • Fax (+39) 0424 509 509
www.melcohit.com

©Mitsubishi Electric Hydronics & IT Cooling Systems S.p.A. The Company reserves the right to make any variation in technical specification to the equipment described, or to withdraw or replace products without prior notification or public announcement. Mitsubishi Electric Hydronics & IT Cooling Systems S.p.A. is constantly developing and improving its products. All descriptions, illustrations, drawings and specifications in this publication present only general particulars and shall not part of any contract. All goods are supplied subject to the Company's General Conditions of Sales, a copy of which is available on request. Third-party product and brand names may be trademarks or registered trademarks of their respective owners.