

FLOW TEMP. CONTROLLER 2BR (Cased) PAC-IF033B-E

INSTALLATION MANUAL

FOR INSTALLER

For safe and correct use, read this manual thoroughly before installing the FTC2BR unit.

English

Contents

1. Safety precautions.....	2	6. Before test run.....	22
2. Installing the FTC2BR unit	3	7. Remote controller operation	23
3. System	4	8. Troubleshooting.....	29
4. Electrical work	10	9. Supplementary information	31
5. Dip switch setting	17	Local application factors	32

“FTC2BR” is the abbreviation of “Flow Temperature Controller 2BR”, which is described as “FTC2BR” in this manual. Mitsubishi Electric is not responsible for the failure of locally supplied parts.

1. Safety precautions

- ▶ Before installing the FTC2BR unit, make sure you read all the “Safety precautions”.
- ▶ Please report to your supply authority or obtain their consent before connecting this equipment to the power supply system.

⚠ Warning:
Precautions that must be observed to prevent injuries or death.

⚠ Caution:
Precautions that must be observed to prevent damages to the unit.

- ⚠ Warning:**
- The unit must not be installed by the user. Ask an installer or an authorized technician to install the unit. If the unit is installed improperly, electric shock, or fire may be caused.
 - For installation work, follow the instructions in the Installation Manual and use tools and pipe components specifically made for use with refrigerant specified in the outdoor unit installation manual.
 - The unit must be installed according to the instructions in order to minimize the risk of damages by earthquakes, typhoons, or strong winds. Improperly installed unit may fall down and cause damages or injuries.
 - The unit must be securely installed on a structure that can sustain its weight. If the unit is mounted on an unstable structure, it may fall down and cause damages or injuries.
 - All electric work must be performed by a qualified technician according to local regulations and the instructions given in this manual. The unit must be powered by dedicated power lines and the correct voltage and circuit breakers must be used. Power lines with insufficient capacity or incorrect electrical work may result in electric shock or fire.

After installation, perform the test run to ensure normal operation. Then explain your customer the “Safety Precautions,” use, and maintenance of the unit based on the information in the Operation Manual provided by local application manufacture. Both the Installation Manual and the Operation Manual must be given to the user. These manuals must always be kept by the actual users.
⚡ : Indicates a part which must be grounded.

⚠ Warning:
Carefully read the labels attached to the unit.

- Only the specified cables can be used for wiring. Connections must be made securely without tension on the terminals. If cables are connected or installed improperly, it may result in overheating or fire.
- Terminal block cover panel of the unit must be firmly fixed. If the cover panel is mounted improperly, dust and moisture may enter the unit, and it may cause electric shock or fire.
- Make sure to use accessories authorized by Mitsubishi Electric and ask an installer or an authorized technician to install them. If accessories are improperly installed, it may cause electric shock, or fire.
- Do not remodel the unit. Consult an installer for repairs. If alterations or repairs are not performed correctly, it may cause electric shock or fire.
- The user should never attempt to repair the unit or transfer it to another location. If the unit is installed improperly, it may cause electric shock or fire. If the FTC2BR unit needs to be repaired or moved, ask an installer or an authorized technician.
- During installing a heat pump system, keep water from splashing on the FTC2BR unit.
- When installing sensors and parts, do not expose the terminals.

1.1. Before installation (Environment)

- ⚠ Caution:**
- Do not install the FTC2BR unit in outdoor location as it is designed for indoor installation only. Otherwise electric shock or breakdown may be caused by water drop, wind or dust.
 - Do not use the unit in an unusual environment. If the FTC2BR unit is installed or exposed to steam, volatile oil (including machine oil), or sulfuric gas, or exposed to briny air, the internal parts can be damaged.
 - Do not install the unit where combustible gases may leak, be produced, flow, or accumulate. If combustible gas accumulates around the unit, it may cause fire or explosion.

- When installing the unit in a hospital or in a building where communications equipment are installed, you may need to take measure to noise and electronic interference. Inverters, home appliances, high-frequency medical equipment, and radio communications equipment can cause the FTC2BR unit to malfunction or to breakdown. At the same time, the noise and electric interference from the FTC2BR unit may disturb the proper operation of medical equipment, and communications equipment.

1.2. Before installation or relocation

- ⚠ Caution:**
- Be fully careful when moving the units. Do not hold the packaging bands. Wear protective gloves to unpack and to move it, in order to avoid your hands be injured by parts.

- Be sure to safely dispose of the packaging materials. Packaging materials, such as nails and other metal or wooden parts may cause injuries.
- Do not wash the FTC2BR unit. You may receive an electric shock.

1.3. Before electric work

- ⚠ Caution:**
- Be sure to install a circuit breaker. If it is not installed, there may be a risk to get an electric shock.
 - For the power lines, use standard cables of sufficient capacity. Otherwise, it may cause a short circuit, overheating, or fire.
 - When installing the power lines, do not apply tension to the cables. The cables may be cut or overheated resulting in a fire.

- Make sure to ground the unit. Do not connect the ground wire to gas or water pipes, lightning rods, or telephone grounding lines. If the unit is not properly grounded, there may be a risk to get an electric shock.
- Make sure to use circuit breakers (ground fault interrupter, isolating switch (+B fuse), and molded case circuit breaker) with the specified capacity. If the circuit breaker capacity is larger than the specified capacity, breakdown or fire may result.

1.4. Before starting the test run

- ⚠ Caution:**
- Turn on the main power switch of the outdoor unit more than 12 hours before starting operation. Starting operation immediately after turning on the power switch can severely damage the internal parts. Keep the main power switch turned on during the operation period.
 - Before starting operation, check that all protective parts are correctly installed. Make sure not to get injured by touching high voltage parts.

- Do not touch any switch with wet hands. There may be a risk to get an electric shock.
- After stopping operation, make sure to wait at least 5 minutes before turning off the main power. Otherwise, it may cause breakdown.

1.5. Electric booster and Immersion heaters

- ⚠ Warning:**
- FTC2BR has signal outputs for booster heaters however it can not isolate power to them in the event of overheating. All electrical heaters used on the water circuit must have

- a) A thermostat to prevent overheating
- b) A non-self resetting thermal mechanism to prevent overheating

2. Installing the FTC2BR unit

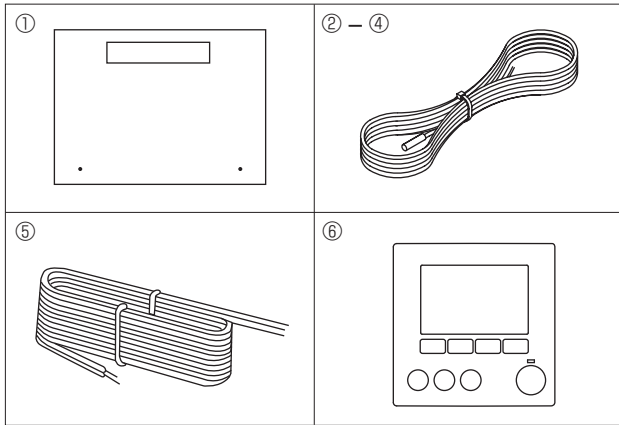

<Fig. 2.1.1>

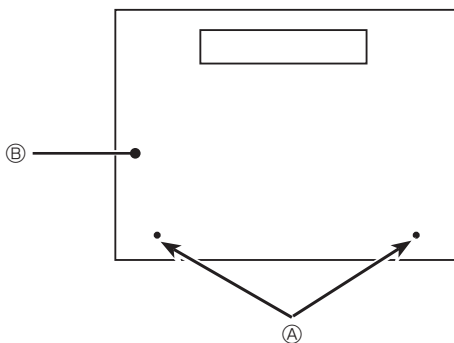

<Fig. 2.3.1>

Top

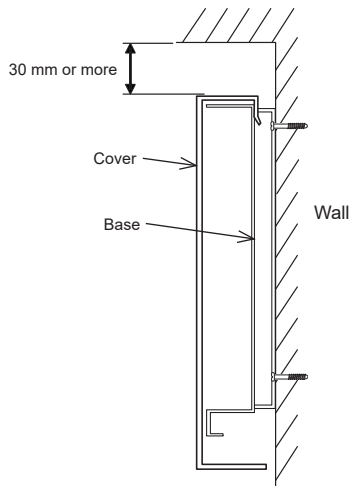

<Fig. 2.3.2>
Service space

2.1. Check the parts (Fig. 2.1.1)

The FTC2BR unit should be supplied with the following parts.

	Part Name	W/D symbol	Q'ty
①	FTC2BR unit	—	1
②	Liquid refrigerant temp. thermistor (Lead wire: 5m/Red, Connector: 3p/Yellow)	TH2	1
③	Flow water temp. and Return water temp. thermistor (Lead wire: 5m/Gray(Flow water temp.), 5m/Black(Return water temp.), Connector: 4p/Red)	THW1/2	1
④	Tank water temp. thermistor (Lead wire: 5m/Gray, Connector: 2p/White)	THW5	1
⑤	Remote controller cable (5m)	—	1
⑥	Remote controller	—	1

2.2. Choosing the FTC2BR unit installation location

- Do not install the FTC2BR unit in outdoor location as it is designed for indoor installation only. (The FTC2BR circuit board and casing are not waterproof.)
- Avoid locations where the unit is exposed to direct sunlight or other sources of heat.
- Select a location where easy wiring access to the power source is available.
- Avoid locations where combustible gases may leak, be produced, flow, or accumulate.
- Select a level location that can bear the weight and vibration of the unit.
- Avoid locations where the unit is exposed to oil, steam, or sulfuric gas.
- Do not install in location that is hot or humid for long periods of time.

2.3. Installing the FTC2BR unit (Fig. 2.3.1, 2.3.2, 2.3.3, 2.3.4)

1. Remove 2 screws (A Screw) from FTC2BR unit and remove the cover. (See Fig. 2.3.1)
2. Install the 4 screws (locally supplied) in the 4 holes (C Hole).
* To prevent the unit from falling off the wall, select the appropriate screws (locally supplied) and secure the base horizontally to the appropriate wall location. (See Fig. 2.3.2)

A Screw

B Cover

C Hole for installation

Weight	2.4 kg + ACCESSORIES 0.8 kg
Allowable ambient temperature	0 to 35°C
Allowable ambient humidity	80% RH or less

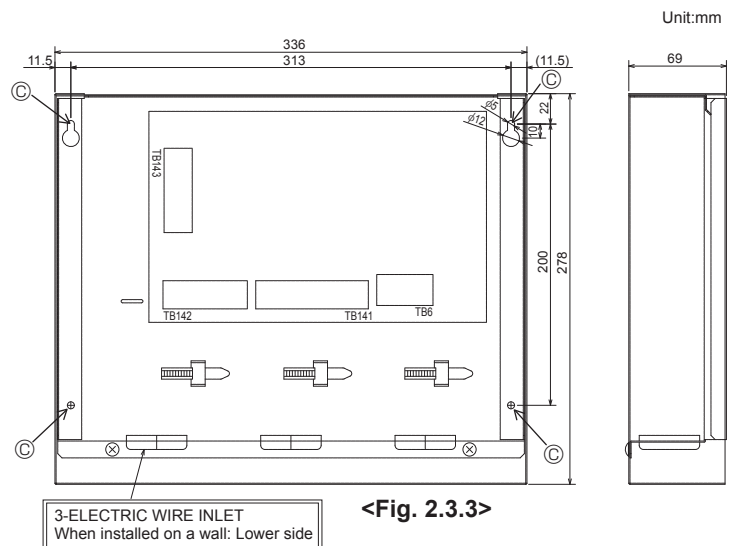

<Fig. 2.3.3>

3-ELECTRIC WIRE INLET
When installed on a wall: Lower side

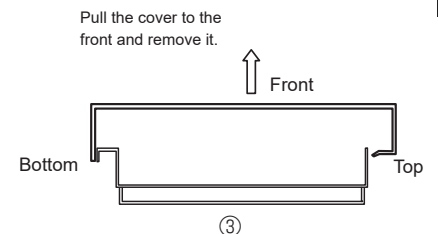
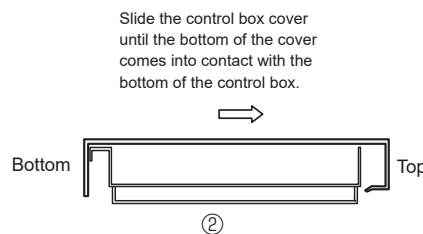
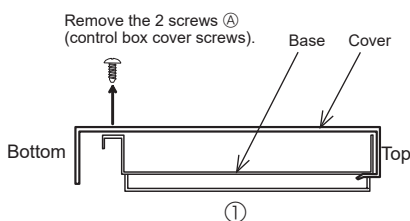

<Fig. 2.3.4>

3. System

The FTC2BR is designed for use with a number of heat pump systems. Please refer to the following table to find the relevant installation information for your system.

3.1. First step (Electrical work)

Mode select	Temp. setting	System diagram	Power supplies	Operation mode input
Remote controller	Remote controller	<p>The diagram shows a shaded box labeled 'FTC2BR' connected to a vertical-striped box labeled 'Outdoor unit'. A remote controller icon is connected to the bottom of the FTC2BR box. A power symbol is connected to the right side of the Outdoor unit box.</p>	Outdoor unit only → 4.1	Remote controller only → 4.2
Local controller (External input: Contact signal)	Remote controller	<p>The diagram shows a shaded box labeled 'FTC2BR' connected to a vertical-striped box labeled 'Outdoor unit'. A remote controller icon is connected to the bottom of the FTC2BR box. A local controller box is connected to the left side of the FTC2BR box. A power symbol is connected to the right side of the Outdoor unit box.</p>	Outdoor unit only → 4.1	Remote controller and external input → 4.2 4.4 4.4.1
Local controller (External input: Contact signal)	Local controller (External input: Analog signal)	<p>The diagram shows a shaded box labeled 'FTC2BR' connected to a vertical-striped box labeled 'Outdoor unit'. A local controller box is connected to the left side of the FTC2BR box. A power symbol is connected to the right side of the Outdoor unit box.</p>	Outdoor unit only → 4.1	External input and analog input → 4.4 4.4.1 4.4.2

3. System

3.2. Second step (Thermistor setting)

Outdoor unit type (Split type / Packaged type)

Domestic hot water tank (DHW tank)

Outdoor unit type	DHW tank	System diagram	Thermistor
Split type	✓ (Present)		TH2: Liquid refrigerant temp. THW1: Flow water temp. THW2: Return water temp. THW5: Tank water temp. → 4.3
	— (Absent)		TH2: Liquid refrigerant temp. THW1: Flow water temp. THW2: Return water temp. → 4.3
Packaged type	✓ (Present)		THW1: Flow water temp. THW2: Return water temp. THW5: Tank water temp. → 4.3
	— (Absent)		THW1: Flow water temp. THW2: Return water temp. → 4.3

3. System

3.3. Third step (Heater setting)

Immersion heater
Booster heater position

Immersion heater	Booster heater position	System diagram	Output signal
— (Absent)	both DHW and Heating		Booster heater only → 4.4 4.4.3 4.5
✓ (Present)	both DHW and Heating		Booster heater and Immersion heater → 4.4 4.4.3 4.5
— (Absent)	Heating only		Booster heater only → 4.4 4.4.3 4.5
✓ (Present)	Heating only		Booster heater and Immersion heater → 4.4 4.4.3 4.5

Note(*):
When the booster heater is positioned for heating only, flow water temp. thermistor (THW1) is not able to detect the outlet water temperature of circulation water during DHW or legionella prevention mode. To determine more accurately if the heater is ON with DHW or legionella prevention mode, THW1 must be placed where it is able to detect the outlet water temperature of circulation water. Therefore the recommended booster heater position is for both DHW and heating.
Although the booster heater is positioned for both DHW and heating, switching ON Dip SW 2-9 deactivates the booster heater during DHW or legionella prevention mode.

3. System

3.4. Fourth step (Water circuit parts installation)

* Make sure to check the followings for your safety when designing a system. These are the minimum requirement for the safe use of FTC2BR unit.

Parts name	Requirement																																		
Booster heater	General	<p>* Consider necessity and capacity of booster heater to meet the following points.</p> <p>(1) Heating capacity and flow water temperature should always be sufficient.</p> <p>(2) System can increase the temperature of the stored water in tank to inhibit legionella bacterium growth.</p>																																	
	Control Power for Contactor	<p>Current: 0.5A Max. , 10mA Min. , Power supply: 230V AC</p> <p>* Use a relay.</p> <p>Connect the surge absorber according to the load at site.</p>																																	
	Separate power for Heater	<p>Install an earth leakage circuit breaker for heater, separate from control power.</p> <p>* When using two booster heaters, booster heater 1 capacity must be less than that of booster heater 2.</p> <p>When using a single booster heater, use booster heater 1.</p> <p>Heater capacity/Breaker/wiring (recommended)</p> <table border="1"> <thead> <tr> <th colspan="5"><1 Phase></th> <th colspan="5"><3 Phase></th> </tr> <tr> <th>Description</th> <th>Power supply</th> <th>Total capacity (BH1 + BH2)</th> <th>Breaker</th> <th>Wiring</th> <th>Description</th> <th>Power supply</th> <th>Total capacity (BH1 + BH2)</th> <th>Breaker</th> <th>Wiring</th> </tr> </thead> <tbody> <tr> <td>Booster heater (Primary circuit)</td> <td>~N 230V 50Hz</td> <td>2 kW (2 kW + 0 kW) 6 kW (2 kW + 4 kW)</td> <td>16 A 32 A</td> <td>2.5 mm² 6.0 mm²</td> <td>Booster heater (Primary circuit)</td> <td>3~ 400V 50Hz</td> <td>9 kW (3 kW + 6 kW)</td> <td>16 A</td> <td>2.5 mm²</td> </tr> </tbody> </table> <p>* When installing a booster heater with the capacity of bigger than shown above, select an appropriate size breaker and cable (diameter) based on the maximum possible electric current.</p>	<1 Phase>					<3 Phase>					Description	Power supply	Total capacity (BH1 + BH2)	Breaker	Wiring	Description	Power supply	Total capacity (BH1 + BH2)	Breaker	Wiring	Booster heater (Primary circuit)	~N 230V 50Hz	2 kW (2 kW + 0 kW) 6 kW (2 kW + 4 kW)	16 A 32 A	2.5 mm ² 6.0 mm ²	Booster heater (Primary circuit)	3~ 400V 50Hz	9 kW (3 kW + 6 kW)	16 A	2.5 mm ²			
	<1 Phase>					<3 Phase>																													
Description	Power supply	Total capacity (BH1 + BH2)	Breaker	Wiring	Description	Power supply	Total capacity (BH1 + BH2)	Breaker	Wiring																										
Booster heater (Primary circuit)	~N 230V 50Hz	2 kW (2 kW + 0 kW) 6 kW (2 kW + 4 kW)	16 A 32 A	2.5 mm ² 6.0 mm ²	Booster heater (Primary circuit)	3~ 400V 50Hz	9 kW (3 kW + 6 kW)	16 A	2.5 mm ²																										
Safety device	<p>(1) Use an overheat protection thermostat (manual reset type) (to detect unusual temperature increase/heating up without water). Protection device operating temperature must be above 80 °C. Protection device should not operate quickly, but water circuit must not boil even when heater(s) overshoot.</p> <p>(Reference value) Thermostat operation temperature used in our Cylinder unit and Hydrobox : 90 °C ± 4 °C</p> <p>(2) Connect a pressure relief valve on the primary circuit side.</p>																																		
Immersion heater	General	<p>* Consider necessity and capacity of immersion heater to meet the following points.</p> <p>(1) Heating capacity and flow water temperature should always be sufficient.</p> <p>(2) System can increase the temperature of the stored water in tank to inhibit legionella bacterium growth.</p>																																	
	Control Power for Contactor	<p>Current: 0.5A Max. , 10mA Min. , Power supply: 230V AC</p> <p>* Use a relay.</p> <p>Connect the surge absorber according to the load at site.</p>																																	
	Separate power for heater	<p>Install an earth leakage circuit breaker for heater, separate from control power.</p> <p>Heater capacity/Breaker/wiring (recommended)</p> <table border="1"> <thead> <tr> <th>Description</th> <th>Power supply</th> <th>Capacity</th> <th>Breaker</th> <th>Wiring</th> </tr> </thead> <tbody> <tr> <td>Immersion heater (DHW tank)</td> <td>~N 230V 50Hz</td> <td>3 kW</td> <td>16 A</td> <td>2.5 mm²</td> </tr> </tbody> </table> <p>* When installing an immersion heater with the capacity of bigger than shown above, select an appropriate size breaker and cable (diameter) based on the maximum possible electric current.</p>	Description	Power supply	Capacity	Breaker	Wiring	Immersion heater (DHW tank)	~N 230V 50Hz	3 kW	16 A	2.5 mm ²																							
	Description	Power supply	Capacity	Breaker	Wiring																														
Immersion heater (DHW tank)	~N 230V 50Hz	3 kW	16 A	2.5 mm ²																															
Safety device	<p>(1) Install the enclosed thermistor THW5 on the DHW tank. (Microcomputer detecting temperature for protection: 80 °C)</p> <p>(2) Use a built-in direct cut-off thermostat (manual reset type). Protection device operating temperature must be above 80 °C. Protection device should not operate quickly, but water circuit must not boil even when a heater overshoots.</p> <p>(Reference value) Thermostat operation temperature used in our Cylinder unit : 85 °C ± 5°C</p> <p>(3) Connect a pressure relief valve on the sanitary water side.</p>																																		
Water circulation pump	<p>Connect a pump via relay.</p> <p>Current: 0.5A Max. , 10mA Min.</p> <p>Power supply: 230V AC</p> <p>Connect the surge absorber according to the load at site.</p> <p>Adjust the pump speed so that the flow rate in the primary circuit is appropriate for the outdoor unit installed see the table and figures below.</p> <table border="1"> <thead> <tr> <th></th> <th>Outdoor heat pump unit</th> <th>Water flow rate range [L/min]</th> </tr> </thead> <tbody> <tr> <td rowspan="5">Packaged model</td> <td>PUZ-WM50</td> <td>6.5 - 14.3</td> </tr> <tr> <td>PUZ-WM60</td> <td>8.6 - 17.2</td> </tr> <tr> <td>PUZ-WM85</td> <td>10.8 - 25.8</td> </tr> <tr> <td>PUZ-WM112</td> <td>14.4 - 32.1</td> </tr> <tr> <td>PUZ-HWM140</td> <td>17.9 - 40.1</td> </tr> <tr> <td rowspan="9">Split model</td> <td>PUHZ-SW75</td> <td>10.2 - 22.9</td> </tr> <tr> <td>PUHZ-SW100</td> <td>14.4 - 32.1</td> </tr> <tr> <td>PUHZ-SW120</td> <td>20.1 - 45.9</td> </tr> <tr> <td>PUHZ-SW160</td> <td>23.0 - 63.1</td> </tr> <tr> <td>PUHZ-SW200</td> <td>28.7 - 71.7</td> </tr> <tr> <td>PUHZ-SHW80</td> <td>10.2 - 22.9</td> </tr> <tr> <td>PUHZ-SHW112</td> <td>14.4 - 32.1</td> </tr> <tr> <td>PUHZ-SHW140</td> <td>17.9 - 40.1</td> </tr> <tr> <td>PUHZ-SHW230</td> <td>28.7 - 65.9</td> </tr> </tbody> </table> <p>* The water velocity in pipes should be kept within certain limits of material to avoid erosion corrosion and excessive noise generation. (e.g. Copper pipe: 1.5m/s)</p>			Outdoor heat pump unit	Water flow rate range [L/min]	Packaged model	PUZ-WM50	6.5 - 14.3	PUZ-WM60	8.6 - 17.2	PUZ-WM85	10.8 - 25.8	PUZ-WM112	14.4 - 32.1	PUZ-HWM140	17.9 - 40.1	Split model	PUHZ-SW75	10.2 - 22.9	PUHZ-SW100	14.4 - 32.1	PUHZ-SW120	20.1 - 45.9	PUHZ-SW160	23.0 - 63.1	PUHZ-SW200	28.7 - 71.7	PUHZ-SHW80	10.2 - 22.9	PUHZ-SHW112	14.4 - 32.1	PUHZ-SHW140	17.9 - 40.1	PUHZ-SHW230	28.7 - 65.9
	Outdoor heat pump unit	Water flow rate range [L/min]																																	
Packaged model	PUZ-WM50	6.5 - 14.3																																	
	PUZ-WM60	8.6 - 17.2																																	
	PUZ-WM85	10.8 - 25.8																																	
	PUZ-WM112	14.4 - 32.1																																	
	PUZ-HWM140	17.9 - 40.1																																	
Split model	PUHZ-SW75	10.2 - 22.9																																	
	PUHZ-SW100	14.4 - 32.1																																	
	PUHZ-SW120	20.1 - 45.9																																	
	PUHZ-SW160	23.0 - 63.1																																	
	PUHZ-SW200	28.7 - 71.7																																	
	PUHZ-SHW80	10.2 - 22.9																																	
	PUHZ-SHW112	14.4 - 32.1																																	
	PUHZ-SHW140	17.9 - 40.1																																	
	PUHZ-SHW230	28.7 - 65.9																																	

3. System

Parts name	Requirement
3-way valve	Connect a 3-way valve via relay. Current: 0.5A Max. , 10mA Min. Power supply: 230V AC Connect the surge absorber according to the load at site.
Flow switch	It is required to protect system from the effects of insufficient flow.
Flow sensor	It is required to detect an error in flow rate. (The operation is validated with SIKA VVX20.)
Strainer /Magnetic filter (water circuit)	Provide it as required to protect parts from damages caused by iron particles/water/contamination (e.g. the position before pump and return part from emitters).
Pressure relief valve (Primary circuit side) (Sanitary water side)	It is required to protect system from reaching high pressure. Select the operating pressure depending on water pressure in the circuit in normal use. * Follow the national regulations.
Expansion Vessel (Primary circuit side) Expansion Vessel (Sanitary water side)	When the water circuit is closed, select the expansion vessel according to water quantity of the water circuit. * Follow the national regulations.
Limits of TOTAL electric current when connecting field supply parts	(Power supply from outdoor unit) TOTAL current requirement MUST be $\leq 3A$ (otherwise, the fuse on the outdoor unit PCB will blow).

4. Electrical work

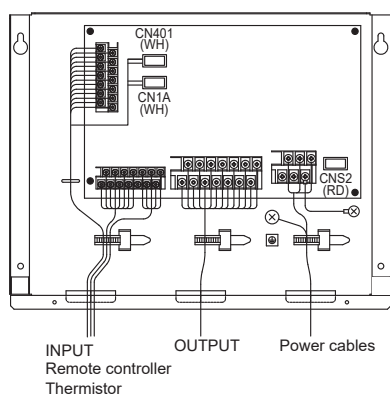

<Fig. 4.1.1>
Wiring for FTC2BR

<1 phase>

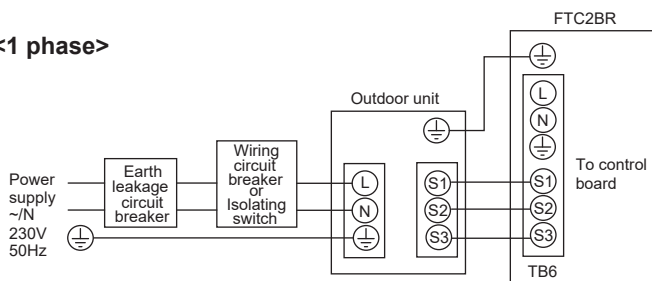

<3 phase>

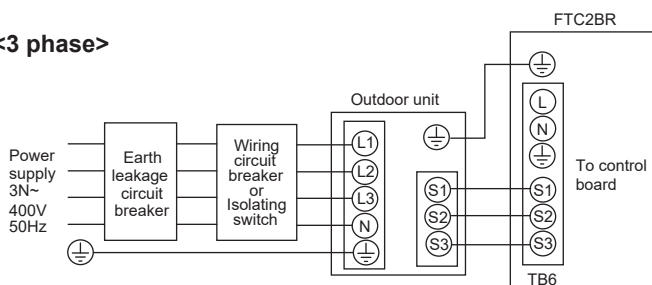

<Fig. 4.1.2>
Electrical connections 1 phase/3 phase

Wiring No. x size (mm ²)	FTC2BR - Outdoor unit	*2	3 × 1.5 (polar)
	FTC2BR - Outdoor unit earth	*2	1 × Min. 1.5
Circuit rating	FTC2BR - Outdoor unit S1 - S2	*3	230V AC
	FTC2BR - Outdoor unit S2 - S3	*3	24V DC

4.1. Electrical connection

All electrical work should be carried out by a suitably qualified technician. Failure to comply with this could lead to electrocution, fire, and death. It will also invalidate product warranty. All wiring should be according to national wiring regulations.

Connections should be made to the terminals indicated in the following figures depending on the phase.

When the wires are wired to adjacent terminals use ring terminals and insulate the wires.

Notes:

- Do not run the low voltage cables through a slot that the high voltage cables go through.
- Do not bundle power cables together with other cables.
- Bundle cables as Fig. 4.1.1 by using clamps.

Option 1: FTC2BR powered via outdoor unit

- *1 If the installed earth leakage circuit breaker does not have an over-current protection function, install a breaker with that function along the same power line.
- *2 Affix label A that is included with the manuals near each wiring diagram for FTC2BR and outdoor units.

Note:

In accordance with IEE regulations the circuit breaker/isolating switch located on the outdoor unit should be installed with lockable devices (health and safety).

- *1. A breaker with at least 3.0 mm contact separation in each pole shall be provided. Use earth leakage breaker (NV). The breaker shall be provided to ensure disconnection of all active phase conductors of the supply.

- *2. Max. 45 m
If 2.5 mm² used, Max. 50 m
If 2.5 mm² used and S3 separated, Max. 80 m

- *3. The values given in the table above are not always measured against the ground value.

Notes:

- Wiring size must comply with the applicable local and national codes.
- FTC2BR/outdoor unit connecting cords shall not be lighter than polychloroprene sheathed flexible cord. (Design 60245 IEC 57)
- Install an earth longer than other cables.

3. System

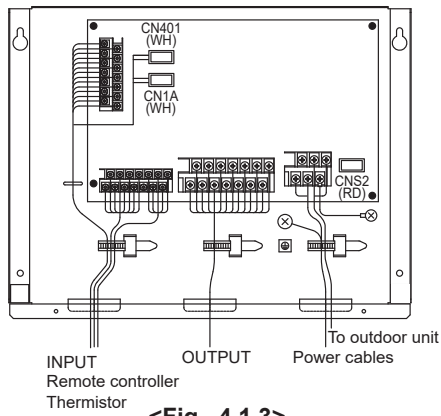

<Fig. 4.1.3>
Wiring for FTC2BR

<1 phase>

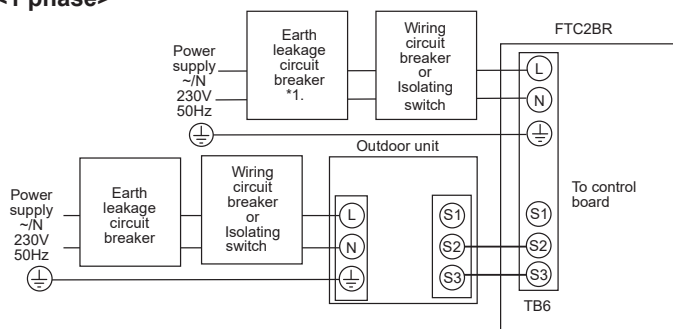

<3 phase>

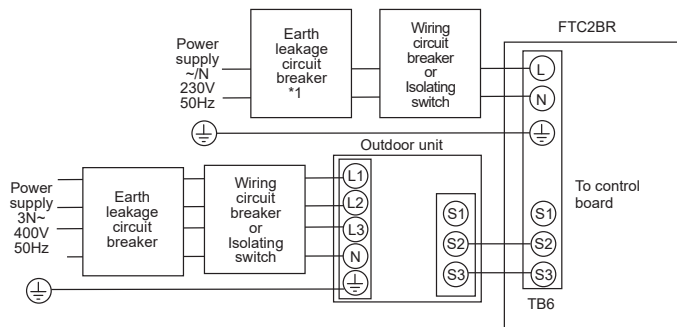

<Fig. 4.1.4>
Electrical connections 1 phase/3 phase

Option 2: FTC2BR powered by independent source

If FTC2BR and outdoor units have separate power supplies, the following requirements MUST be carried out.

- Remove the short circuited connector CNS2.
 - Turn on the outdoor unit before the FTC2BR.
 - Outdoor unit DIP switch settings changed to SW8-3 ON.
 - Power by independent source is not available for particular models of outdoor unit model.
- For more detail, refer to the connecting outdoor unit installation manual.

Notes:

1. Do not run the low voltage cables through a slot that the high voltage cables go through.
2. Do not bundle power cables together with other cables.
3. Bundle cables as Fig. 4.1.3 by using clamps.

- *1. A breaker with at least 3.0 mm contact separation in each pole shall be provided. Use earth leakage breaker (NV). The breaker shall be provided to ensure disconnection of all active phase conductors of the supply.
- *2. Max. 45 m
If 2.5 mm² used, Max. 50 m
If 2.5 mm² used and S3 separated, Max. 80 m
- *3. The values given in the table above are not always measured against the ground value.

Notes:

1. Wiring size must comply with the applicable local and national codes.
2. FTC2BR/outdoor unit connecting cords shall not be lighter than polychloroprene sheathed flexible cord. (Design 60245 IEC 57)
FTC2BR unit power supply cords shall not be lighter than polychloroprene sheathed flexible cord. (Design 60227 IEC 53)
3. Install an earth longer than other cables.

FTC2BR power supply		~N 230 V 50 Hz
FTC2BR input capacity		16A
Wiring Wiring No. x size(mm ²)	FTC2BR - power supply	2×Min. 1.5
	FTC2BR - power supply earth	1×Min. 1.5
	FTC2BR - Outdoor unit *2	2×Min. 0.3
	FTC2BR - Outdoor unit earth	—
Circuit rating	FTC2BR L-N *3	230V AC
	FTC2BR - Outdoor unit S1 - S2 *3	—
	FTC2BR - Outdoor unit S2 - S3 *3	24V DC

4. Electrical work

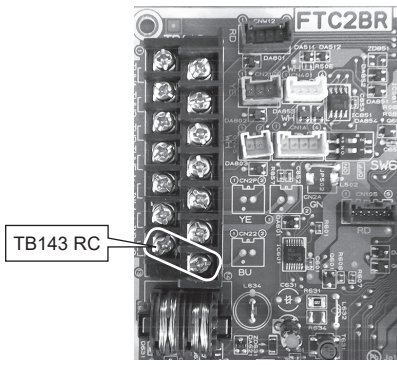

<Fig. 4.2.1>

4.2. Connecting the remote controller

4.2.1. Connect the remote controller cable to FTC2BR

Connect the remote controller cable to 13 and 14 on the terminal block (TB143) on the FTC2BR controller. <Fig. 4.2.1>

Wiring wire No. × size (mm²): 2 × 0.3 (non polar)

The 5 m wire is attached as an accessory. Max. 500 m

Wiring size must comply with the applicable local and national codes.

Circuit rating: 12V DC

Circuit rating is NOT always against the ground.

Notes:

Wiring for remote controller cable shall be (5 cm or more) apart from power source wiring so that it is not influenced by electric noise from power source wiring. (Do not insert remote controller cable and power source wiring in the same conduit.) (Refer to Fig. 4.1.1)

When wiring to TB143, use the ring type terminals and insulate them from the cables of adjoining terminals.

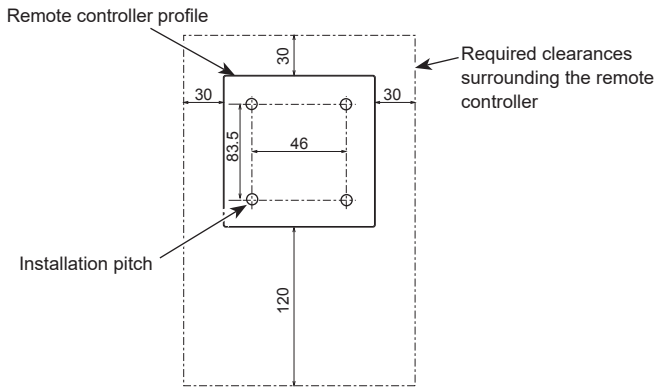

<Fig. 4.2.2>

4.2.2. Installing the remote controller

1. The remote controller can be installed either in the switch box or directly on the wall. Perform the installation properly according to the method.

(1) Secure clearances shown in <Fig. 4.2.2> regardless of whether installing the remote controller either directly on the wall or in the switch box.

(2) Prepare the following items in the field.

- Double switch box
- Thin metal conduit
- Locknut and bushing
- Cable cover
- Wall plug

2. Drill an installation hole in the wall.

■ Installation using a switch box

- Drill a hole in the wall for the switch box, and install the switch box in the hole.
- Fit the conduit tube into the switch box.

■ Direct wall installation

- Drill a cable access hole and thread the remote controller cable through it.

⚠ Caution:

To prevent entry of dew, water, and insects, seal the gap between the cable and the hole through which the cable is threaded with putty. Otherwise, electric shock, fire, or failure may result.

3. Have the remote controller ready.

Remove the back cover from the remote controller.

4. Connect the remote controller cable to the terminal block on the back cover.

Modify the remote controller cable as shown in <Fig. 4.2.5>, and thread the cable from behind the back cover.

Completely thread the cable to the front so that the unsheathed part of the cable cannot be seen behind the back cover.

Connect the remote controller cable to the terminal block on the back cover.

■ Direct wall installation

- Seal the gap between the cable and the hole through which the cable is threaded.

⚠ Caution

To prevent electric shock or failure, keep the sheath ends or any other foreign objects out of the terminal block.

Do not use ring terminals to connect the wires to the terminal block on the back cover. The terminals will come in contact with the control board and the cosmetic cover, which will result in failure.

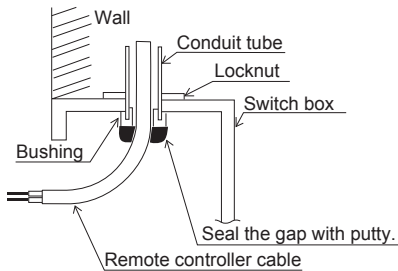

<Fig. 4.2.3>

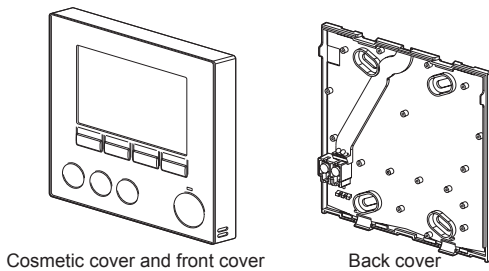

<Fig. 4.2.4>

Completely thread the unsheathed portion to the front.

The 2 inner wires must not be seen on the back.

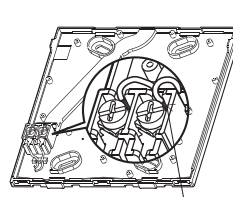
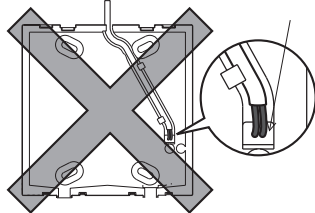
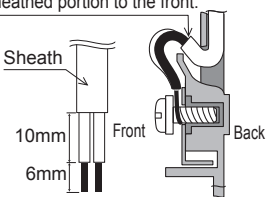

Connect the 2 inner wires to the terminal block (non polarized).

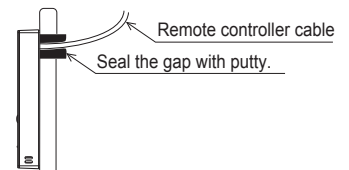

Thread the cable from behind the remote controller.

<Fig. 4.2.5>

4. Electrical work

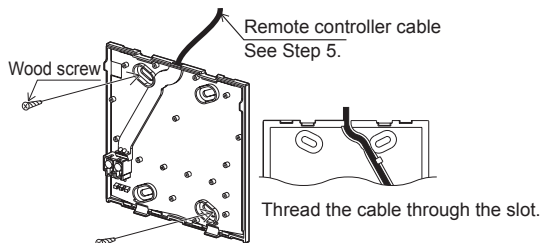
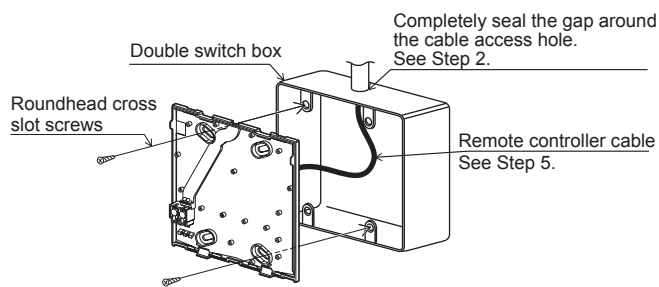

<Fig. 4.2.6>

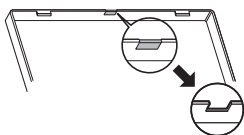

<Fig. 4.2.7>

Securely plug the connector into the jack.

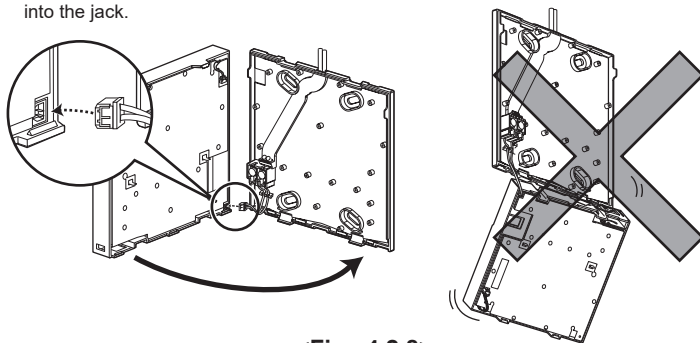

<Fig. 4.2.8>

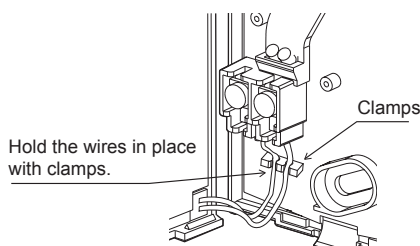

<Fig. 4.2.9>

5. Install the back cover.

- Installation using a switch box
 - When installing the back cover in the switch box, secure at least two corners of the switch box with screws.

■ Direct wall installation

- Thread the cable through the slot provided.
- When mounting the back cover on the wall, secure at least two corners of the remote controller with screws.
- To prevent the back cover from lifting, use top-left bottom-right corners of the remote controller (viewed from the front) to secure the back cover to the wall with wall plugs or the like.

⚠ **Caution:**

To avoid causing deformation or cracks to the remote controller, do not overtighten the screws and make an additional installation hole(s).

6. Cut out the cable access hole.

■ Direct wall installation

- Cut out the knockout hole (indicated with grey in <Fig. 4.2.7>) in the cosmetic cover by knife or nipper.
- Thread the remote controller cable from the slot behind the back cover through this access hole.

7. Plug the lead wire cable into the front cover.

Plug the lead wire cable coming from the back cover into the front cover.

⚠ **Caution:**

To avoid failures, do not remove the controller board protective sheet and the controller board from the front cover.

After the cable is plugged into the front cover, do not hang the front cover as shown in <Fig. 4.2.8>. Otherwise, the remote controller cable could sever, which could cause malfunction to the remote controller.

8. Fit the lead wires into the clamps.

⚠ **Caution:**

Hold the wires in place with clamps to prevent excessive strain from being applied on the terminal block and causing cable breakage.

4. Electrical work

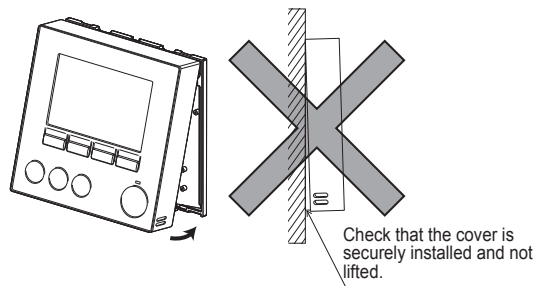

<Fig. 4.2.10>

Seal the gap between the cable and the access hole with putty.
Use a cable cover.

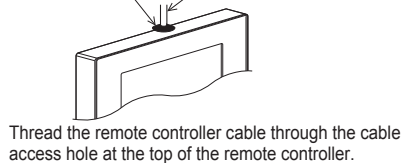

<Fig. 4.2.11>

9. Fit the front cover and the cosmetic cover onto the back cover.

The front cover assembly (fitted with the cosmetic cover at factory shipment) has two tabs on top. Hook the tabs onto the back cover and snap the front cover onto the back cover into place. Check that the cover is securely installed.

⚠ Caution:

When the front cover is correctly attached to the back cover a click is heard. If the cover is not clicked into place it may fall off.

- Direct wall installation (when routing the remote controller cable along the wall surface)
 - Thread the remote controller cable through the cable access hole at the top of the remote controller.
 - Seal the gap between the cable and the access hole with putty.
 - Use a cable cover.

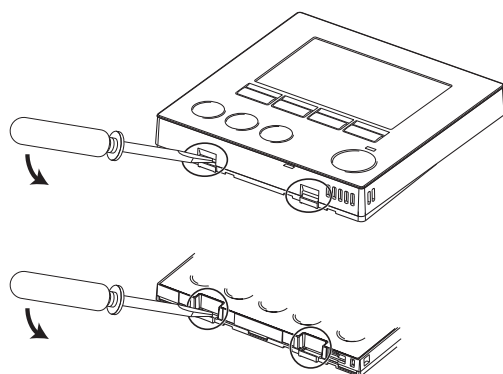

<Fig. 4.2.12>

● Disassembling the front cover and the cosmetic cover

(1) Remove the cosmetic cover.

Insert a flat head screwdriver into either of two open slots at the bottom of the remote controller and move the screwdriver handle downward as shown. The engagement of the tabs will be released. Then pull the cosmetic cover toward the front to remove the cosmetic cover.

(2) Remove the front cover.

Insert a flat head screwdriver into either of two open slots at the bottom of the remote controller. The subsequent procedure is the same as that of the cosmetic cover.

⚠ Caution:

Use a 5 mm- flat head screwdriver. Do not turn the screwdriver forcibly while placing the blade in the slots. Doing so could break the covers.

4. Electrical work

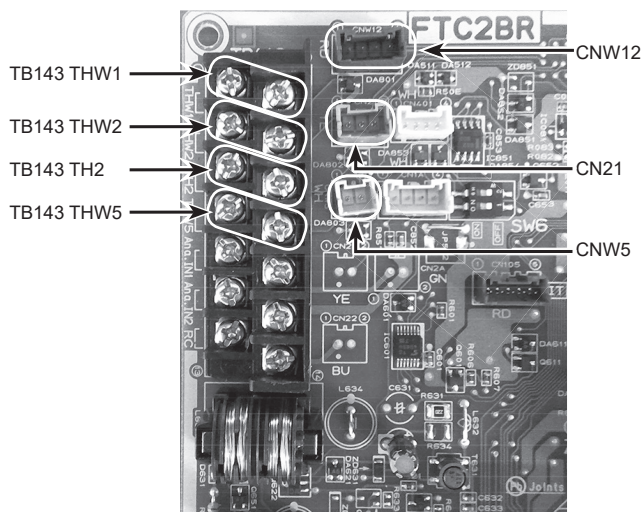

<Fig. 4.3.1>

4.3. Connecting the thermistor cables

Connect the thermistor for the FTC2BR controller.

4.3.1. Connecting the refrigerant pipe temp. thermistor (TH2) cable

Connect the TH2 cable to the CN21 connector on FTC2BR.

For split Outdoor unit : Connect TH2.

For packaged Outdoor unit : It is NOT necessary to connect TH2.

When the TH2 cable is too long, connect to TH2 terminal (TB143.5-6) after cut them to the appropriate length or bundle the excess cable outside the FTC2BR unit. Do not bind the wires in the FTC2BR unit.

<Thermistor position>

Place TH2 on **refrigerant** piping (**liquid** side).

It is recommended to protect the thermistor with heat insulating materials so as not to be affected by ambient temperature.

Note: Be sure to place TH2 where it correctly detects refrigerant piping temp. (liquid side).
Because;

- (1) TH2 is required to detect heating subcool correctly.
- (2) Refrigerant temperature of water-to-refrigerant heat exchanger also needs to be detected for protection purpose.

4.3.2. Connecting the flow water temp. thermistor (THW1) cable and the return water temp. thermistor (THW2) cable

The THW1 and the THW2 cables share a connector, and the connector connects to CNW12 connector on FTC2BR.

When the THW1 and THW2 cable are too long, connect to THW1 and THW2 terminal (TB143.1-2 and 3-4) after cut them to the appropriate length or bundle the excess cable outside the FTC2BR unit. Do not bind the wires in the FTC2BR unit.

<Thermistor position>

Place THW1 on **water** piping (water **outlet** side) after booster heater, and THW2 on the water **inlet** side.

It is recommended to protect the thermistor with heat insulating materials so as not to be affected by ambient temperature.

Note: Be sure to attach THW1 where it correctly detects Flow temp. (water outlet side).

4.3.3. Connecting the actual DHW tank thermistor (THW5) cable

Connect the THW5 cable to the CNW5 connector on FTC2BR if the DHW tank is available.

When the THW5 cable is too long, connect to THW5 terminal (TB143.7-8) after cut them to the appropriate length or bundle the excess cable outside the FTC2BR unit. Do not bind the wires in the FTC2BR unit.

<Thermistor position>

Place THW5 on the position where tank water temperature can be detected correctly.

It is recommended to position the thermistor at the mid height of the DHW tank (to control DHW heating with this sensor).

It is recommended to protect the thermistor with heat insulating materials so as not to be affected by ambient temperature.

Especially for double (insulated) tank, thermistor should be attached to the inner side (to detect the water temperature).

Note:

Connect the terminals by using the ring terminals and also insulate the cables of adjoining terminals when wiring to TB143.

⚠ Caution:

Do not route the thermistor cables together with power cables.

The sensor part of the thermistor should be installed where user can not access.

(It should be separated, by supplementary insulation, from areas the user can access.)

4. Electrical work

4.3.4. Thermistor position and necessity

<Thermistor position and necessity>

Outdoor unit type	DHW tank	TH2	THW1	THW2	THW5
Split	Present	✓	✓	✓	✓
	Absent	✓	✓	✓	—
Packaged	Present	—	✓	✓	✓
	Absent	—	✓	✓	—

✓: Necessary. Connect the thermistor.

—: Not necessary. The thermistor is not required, do not connect.

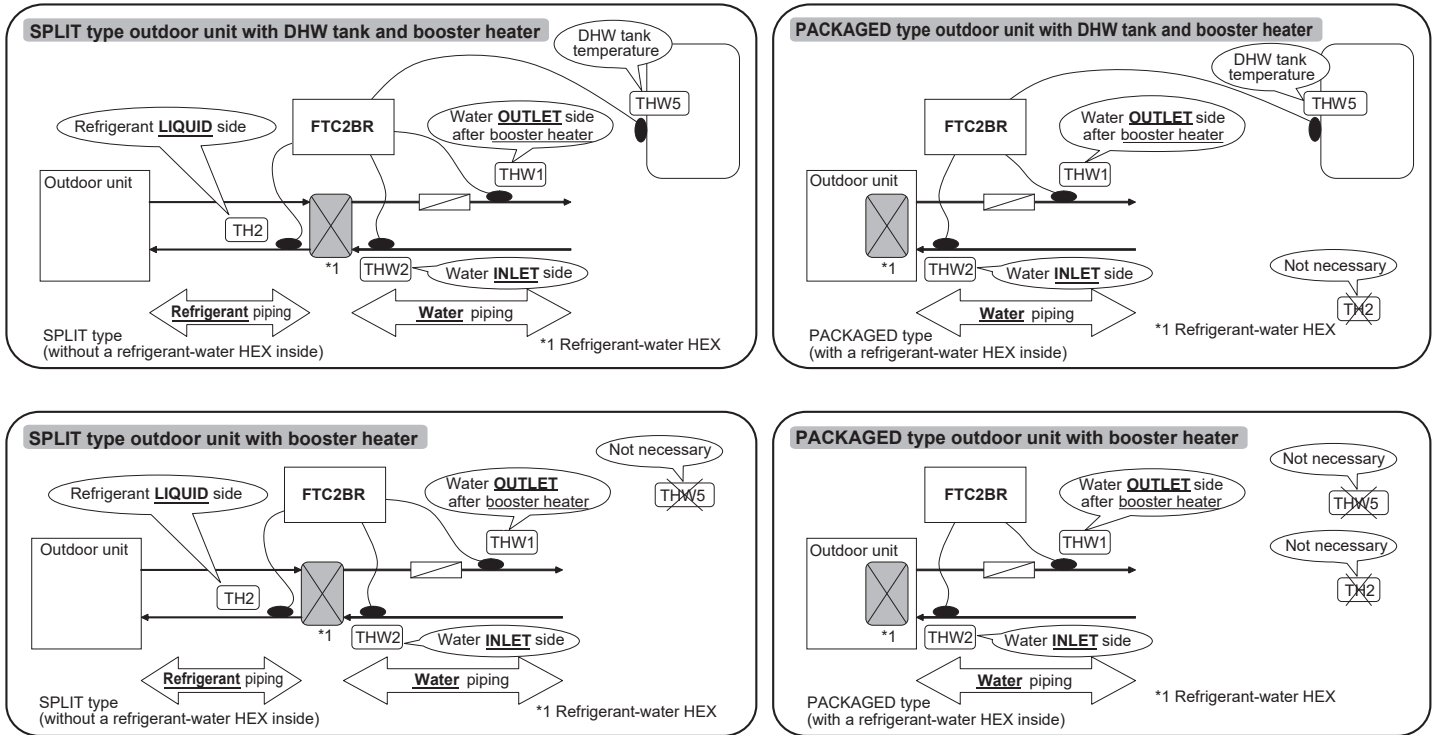

<Fig. 4.3.2>

4. Electrical work

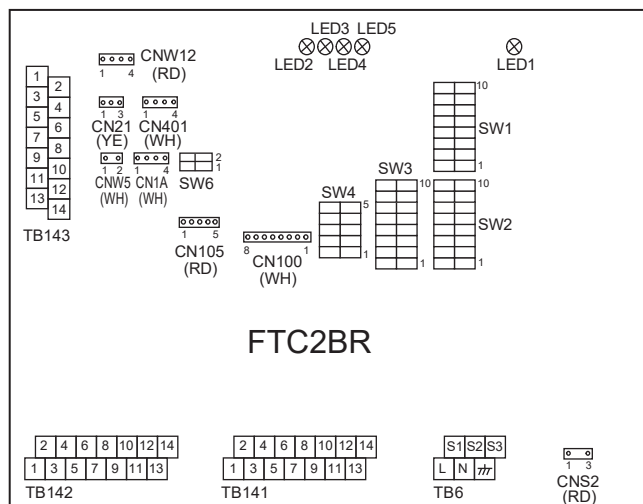

<Fig. 4.4.1>

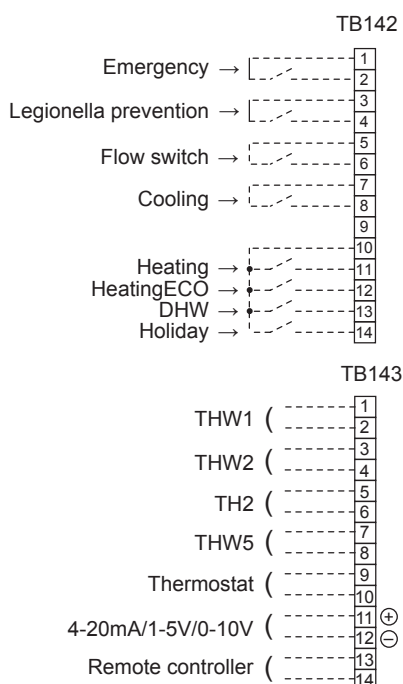

4-20mA / 1-5V / 0-10V setting

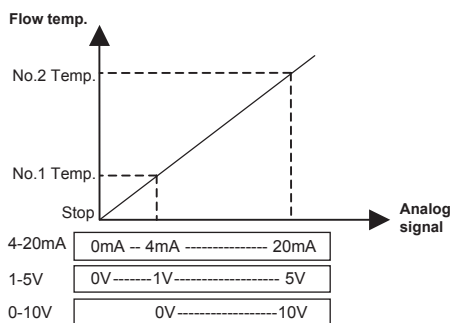

4.4. Connecting external inputs/outputs

FTC2BR can be operated by following external input.

When the wires are wired to adjacent terminals use ring terminals and insulate the wires.

4.4.1. External inputs (Contact signal)

Name	Terminal block	Item	OFF(Open)	ON(Short)
IN1	TB142 1-2	Emergency operation input	Standard operation	Emergency operation
IN2	TB142 3-4	Legionella prevention mode input *1	OFF	Legionella prevention mode
IN3	TB142 5-6	Flow switch input	Refer to SW3-6 in <5.1. Dip switch function>	
IN4	TB142 7-8	Cooling mode input	OFF	Cooling mode
IN5	TB142 10-11	Heating mode input	OFF	Heating mode
IN6	TB142 10-12	Heating ECO mode input *2	OFF	Heating ECO mode
IN7	TB142 10-13	DHW mode input *3	OFF	DHW mode
IN8	TB142 10-14	Holiday mode input	OFF	Holiday mode
Ana.IN1	TB143 9-10	Room thermostat input	Refer to SW3-4 in <5.1. Dip switch function>	

*1 Input signal: Pulse

Pulse specifications: ON (short)

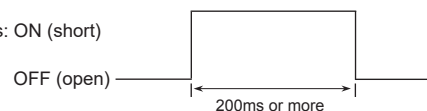

*2 Heating ECO mode sets the set temperature depending on the outdoor temperature.

*3 When SW1-1 and SW1-2 are OFF, the mode is switched into auto DHW mode.

Input signal: Pulse

Pulse specifications: ON (short)

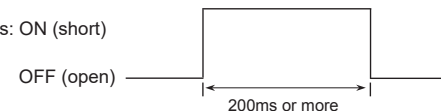

When SW1-1 or SW1-2, or both are ON, the mode is switched into DHW mode.

4.4.2. External inputs (Analog signal) 4-20mA / 1-5V / 0-10V

Connect the transmission cables to No.11 and 12 on the terminal block (TB143).

No.11 on the terminal block (TB143) : Plus side

No.12 on the terminal block (TB143) : Minus side (Reference side)

Wiring specification and field supply parts

Item	Name	Model and specifications
External inputs function	External inputs wire	Use sheathed vinyl coated cord or cable. Max. 10 m Wire type: CV, CVS or equivalent Wire size: Stranded wire 0.5 mm ² to 1.25 mm ² Solid wire: ϕ 0.65 mm to ϕ 1.2 mm
	Switch	Non-voltage "a" contact signals Remote switch: minimum applicable load 12V DC, 1mA

4.4.3. External inputs (Pressure sensor / Flow sensor)

Item	Connector	Description
Pressure sensor (option)	CN401	Pressure sensor is necessary for SUZ-SWM outdoor unit. Turn Dip SW 4-1 to ON. * Refer to the manual of PAC-PS01-E for details.
Flow sensor (option)	CN1A *1	Flow sensor is necessary for PUZ-(H)WM outdoor unit. Turn Dip SW 4-2 to ON. * Refer to the manual of PAC-FS01-E for details.

*1 Do not connect flow sensor of CN1A to CNW12.

4. Electrical work

4.4.4. Outputs

Name	Terminal block	Item	OFF	ON	Signal / Current	Max. total current
OUT1	TB141 1-2	Water circulation pump output	OFF	ON	230V AC 0.5A Max. 10mA Min. (Relay)	3 A
OUT2	TB141 3-4	Booster heater 1 output	OFF	ON	230V AC 0.5A Max. 10mA Min. (Relay)	
OUT3	TB141 5-6	Booster heater 2 output	OFF	ON	230V AC 0.5A Max. 10mA Min. (Relay)	
OUT4	TB141 7-8	Immersion heater output	OFF	ON	230V AC 0.5A Max. 10mA Min. (Relay)	
OUT5	TB141 9-10	3-way valve output	Heating	DHW	230V AC 0.5A Max. 10mA Min. (Relay)	
OUT6	TB141 11-12	Defrost output	Normal	Defrost	230V AC 0.5A Max. 10mA Min.	
OUT7	TB141 13-14	Error output	Normal	Error	230V AC 0.5A Max. 10mA Min.	

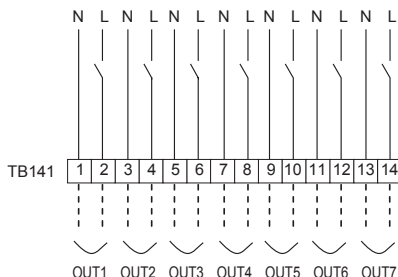

Wiring specification and field supply parts

Item	Name	Model and specifications
External outputs function	External outputs wire	Use sheathed vinyl coated cord or cable. Max. 50 m Wire type: CV, CVS or equivalent Wire size: Stranded wire 0.5 mm ² to 1.25 mm ² Solid wire: ø0.65 mm to ø1.2 mm

Note:

- Do not drive the pump directly, heater and valve by these output signals.
- Connect the surge absorber according to the load at site.

<Wiring for booster heater with a built-in direct cut-off thermostat>

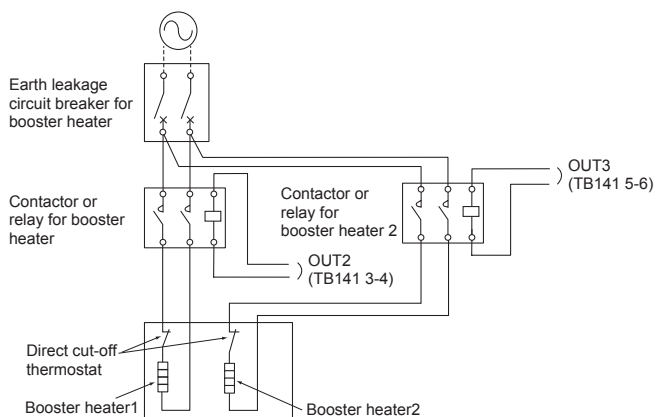

<Fig. 4.5.1>

<Wiring for booster heater with a built-in indirect cut-off thermostat>

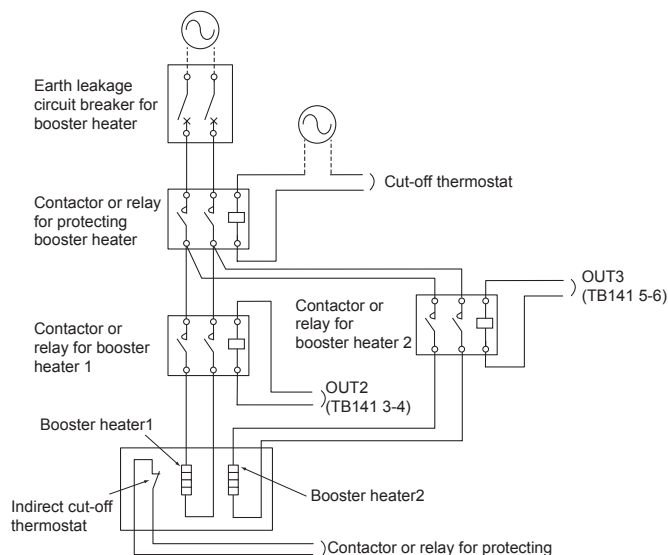

<Fig. 4.5.2>

4.5. Wiring for heater

<Care to be taken when connecting a booster heater(s)>

When the connected booster heater(s) has a built-in direct cut-off thermostat, perform wiring according to Fig. 4.5.1.

When the connected booster heater(s) has a built-in indirect cut-off thermostat, perform wiring according to Fig. 4.5.2.

<Care to be taken when connecting an immersion heater>

The initial setting assumes that the connected immersion heater has a built-in direct cut-off thermostat. <Fig. 4.5.3>

<Wiring for immersion heater with a built-in direct cut-off thermostat>

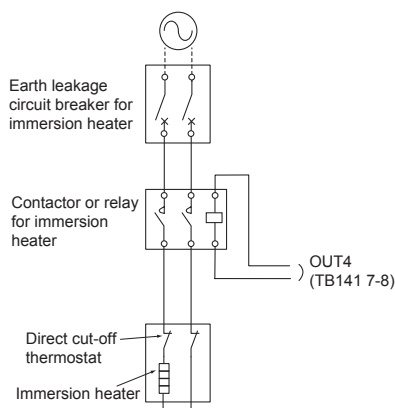

<Fig. 4.5.3>

5. Dip switch setting

5.1. Dip switch functions

Located on the FTC2BR printed circuit board are 5 sets of small white switches known as Dip switches. The Dip switch number is printed on the circuit board next to the relevant switches. The word ON is printed on the circuit board and on the Dip switch block itself. To move the switch you will need to use a pin or the corner of a thin metal ruler or similar.

Dip switch settings are listed below.

Make sure to turn off both indoor unit and outdoor unit power supplies before changing the switch settings.

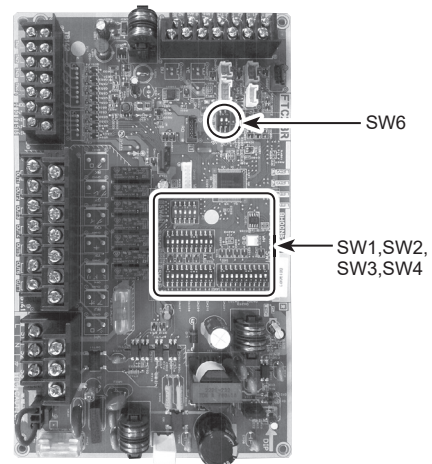

Dip switch		Function	OFF		ON		Default setting	
SW1	SW1-1	System setting	SW1-1	SW1-2	ON/OFF input	Change mode input	Change temp. input	OFF
			OFF	OFF	Remote controller	Remote controller	Remote controller	
			ON	OFF	External input		Remote controller	
			OFF	ON	Analog input (4-20mA/1-5V)	External input	Analog input (4-20mA/1-5V)	
		ON	ON	External input		Analog input (0-10V)	OFF	
	SW1-2							
	SW1-3	DHW tank	WITH DHW tank			WITHOUT DHW tank		OFF
	SW1-4	Immersion heater	WITHOUT Immersion heater			WITH Immersion heater		OFF
	SW1-5	Booster heater function	For Heating and DHW			For Heating only or WITHOUT Booster heater		OFF
	SW1-6	Outdoor unit type	Split type			Packaged type		OFF
SW1-7	Cooling mode function	Inactive			Active		OFF	
SW1-8	Automatic change over mode function (Heating mode ↔ DHW mode)	Active			Inactive		OFF	
SW1-9	Automatic change over mode function (Cooling mode ↔ DHW mode)	Active			Inactive		OFF	
SW1-10	Heat pump maximum outlet water temp.	55°C			60°C		ON*1	
SW2	SW2-1	DHW temperature drop	10deg			20deg		OFF
	SW2-2	Operation in DHW mode	Eco			Nomal		OFF
	SW2-3	Economy setting for water circulation pump	Inactive			Active		OFF
	SW2-4	Legionella prevention mode setting	SW2-4	SW2-5	Operation		ON	
			OFF	OFF	Activate every "1 times" DHW operations.			
			ON	OFF	Activate every "15 times" DHW operations.			
			OFF	ON	Activate every "150 times" DHW operations.			
		ON	ON	Activate by IN2.		OFF		
	SW2-5							
	SW2-6	Legionella prevention hot water temp.	60°C			65°C		OFF
SW2-7	Immersion heater usage in DHW mode	Used			Not used		OFF	
SW2-8	Booster heater usage in Heating mode	Used			Not used		OFF	
SW2-9	Booster heater usage in DHW mode	Used			Not used		OFF	
SW2-10	Heater delay timer in DHW mode	15min			30min		OFF	
SW3	SW3-1	3-way valve control during defrost in Heating mode	OFF (Heating circuit)			ON (DHW circuit)		OFF
	SW3-2	Water circulation pump manual operation	OFF			ON		OFF
	SW3-3	3-way valve manual operation	OFF			ON		OFF
	SW3-4	Room thermostat input (Ana,IN1) logic change	Operation stop at thermostat short			Operation stop at thermostat open		OFF
	SW3-5	Comp. OFF for mode change (DHW ↔ Heating)	Inactive			Active		OFF
	SW3-6	Flow switch input (IN3) logic change	Failure detection at flow switch short			Failure detection at flow switch open		OFF
	SW3-7	Emergency mode (Heater only operation)	Normal			Emergency mode (Heater only operation) (To be activated only when powered ON)		OFF*2
	SW3-8	Freeze protection function	Active			Inactive		OFF
	SW3-9	Thermo differential during comp. cycling (ON/OFF) prevention operation	Target temp. ±3deg			Target temp. ±5deg		OFF
	SW3-10	—	—			—		OFF
SW4	SW4-1	Pressure sensor	WITHOUT Pressure sensor			WITH Pressure sensor		OFF
	SW4-2	Flow sensor	WITHOUT Flow sensor			WITH Flow sensor		OFF
	SW4-3	—	—			—		OFF
	SW4-4	—	—			—		OFF
	SW4-5	—	—			—		OFF
SW6	SW6-1	Analog input setting	SW6-1	SW6-2	Operation		OFF	
			OFF	OFF	0-10V or Not used			
			ON	OFF	—			
			OFF	ON	1-5V			
		ON	ON	4-20mA		OFF		

Note: *1. When the FTC2BR is connected with an outdoor unit of which maximum outlet water temperature is 55°C, Dip SW1-10 must be changed to OFF.

*2. If emergency mode is no longer required, return the switch to OFF position.

5. Dip switch setting

5.2. Outdoor unit setting

Set Dip SW 1-6 to set the outdoor unit type.

Dip SW 1-6	Setting	Note
OFF	Split type	Necessary to connect TH2
ON	Packaged type	Not necessary to connect TH2

Pressure sensor (option) is necessary for SUZ-SWM outdoor unit.

Dip SW 4-1	Setting
OFF	WITHOUT Pressure sensor
ON	WITH Pressure sensor

Flow sensor (option) is necessary for PUZ-(H)WM outdoor unit.

Dip SW 4-2	Setting
OFF	WITHOUT Flow sensor
ON	WITH Flow sensor

5.3. Functions setting

Set Dip SW 1-3 to set whether the system has a DHW tank.

Dip SW 1-3	Setting	Note
OFF	WITH DHW tank	Necessary to connect THW5
ON	WITHOUT DHW tank	Not necessary to connect THW5

When Dip SW 1-3 is ON, DHW and legionella prevention mode is not available.

Set Dip SW 1-4 to set whether the system has an immersion heater.

Dip SW 1-4	Setting
OFF	WITHOUT immersion heater
ON	WITH immersion heater

Set Dip SW 1-5 to set the booster heater function.

Dip SW 1-5	Setting
OFF	For heating and DHW
ON	For heating only or WITHOUT booster heater

<Summary of Function setting>

Dip SW 1-3 (DHW tank)	Dip SW 1-4 (Immersion heater)	Dip SW 1-5 (BH function)	System diagram
OFF (WITH DHW tank)	OFF (WITHOUT immersion heater)	OFF (For heating and DHW)	
OFF (WITH DHW tank)	ON (WITH immersion heater)	OFF (For heating and DHW)	
OFF (WITH DHW tank)	OFF (WITHOUT immersion heater)	ON (For heating only)	
OFF (WITH DHW tank)	ON (WITH immersion heater)	ON (For heating only)	
ON (WITHOUT DHW tank)	—	—	

5. Dip switch setting

5.4. Operation setting

5.4.1. Operation mode setting

Operation mode	Description
Heating mode	Space heating through heat emitters
Heating ECO mode	Space heating incorporating outdoor temperature compensation through heat emitters
Cooling mode	Space cooling through heat emitters
DHW mode	Domestic hot water heating mode for showers, sinks, etc
Legionella prevention mode	A function on systems with tanks to prevent the growth of legionella bacterium
Holiday mode	Space heating for unused time (Different target temperature from above-mentioned heating mode is settable.)

Set Dip-SW1-1/1-2/6-1/6-2 to set switching ON/OFF, changing over operation mode and target temperature setting.

ON/OFF input	Change mode input	Change temp. input	SW1-1	SW1-2	SW6-1	SW6-2
Remote controller	Remote controller or External input (non-voltage contact)	Remote controller	OFF	OFF	OFF	OFF
External input (non-voltage contact)	External input (non-voltage contact)	Remote controller	ON	OFF	OFF	OFF
Analog input (1-5V) *1	External input (non-voltage contact)	Analog input (1-5V)	OFF	ON	OFF	ON
Analog input (4-20mA) *2	External input (non-voltage contact)	Analog input (4-20mA)	OFF	ON	ON	ON
External input (non-voltage contact)	External input (non-voltage contact)	Analog input (0-10V)	ON	ON	OFF	OFF

*1 1-5V ... OFF: 0-0.5V

*2 4-20mA ... OFF: 0-2mA

Set Dip SW 1-7 to set activate or deactivate cooling mode.

Dip SW 1-7	Setting
OFF	Inactive
ON	Active

When Dip SW 1-7 is OFF, cooling mode is not available.

Set Dip SW 1-8 to set activate or deactivate automatic change over mode (DHW ↔ Heating).

Dip SW 1-8	Setting
OFF	Active
ON	Inactive

Set Dip SW 1-9 to set activate or deactivate automatic change over mode (DHW ↔ Cooling).

Dip SW 1-9	Setting
OFF	Active
ON	Inactive

Automatic change over mode

<SW1-1 OFF/SW1-2 OFF>

Mode	System operation
Heating	SW1-8 OFF Heating and DHW mode (Automatic change over mode)
	SW1-8 ON Heating mode only
Heating ECO	SW1-8 OFF Heating ECO and DHW mode (Automatic change over mode)
	SW1-8 ON Heating ECO mode only
Cooling	SW1-9 OFF Cooling and DHW mode (Automatic change over mode)
	SW1-9 ON Cooling mode only
DHW	DHW (Domestic hot water) mode only
Holiday	Holiday mode only

<SW1-1 ON/SW1-2 OFF or SW1-1 OFF/SW1-2 ON or SW1-1 ON/SW1-2 ON>

Mode	System operation
Heating	SW1-8 OFF Heating mode only *1
	SW1-8 ON Heating mode only
Heating ECO	SW1-8 OFF Heating ECO mode only *1
	SW1-8 ON Heating ECO mode only
Cooling	SW1-9 OFF Cooling mode only *1
	SW1-9 ON Cooling mode only
DHW	DHW (Domestic hot water) mode only *1
Holiday	Holiday mode only

*1 Automatic change over mode is available only when SW1-1/1-2 is set ON/OFF and the FTC2BR receives external signals for Heating (or Heating ECO or Cooling) and DHW at the same time from the local controller.

Automatic change over mode is NOT available when SW1-1/1-2 are set OFF/ON or ON/ON.

5. Dip switch setting

The priority order of external signals is DHW>Heating>Heating ECO>Holiday>Cooling. However, the priority order might be changed if you put DHW, Heating or Heating ECO or Holiday and Cooling signals at the same time.

When automatic change over mode is selected DHW always has priority over space heating.

System example

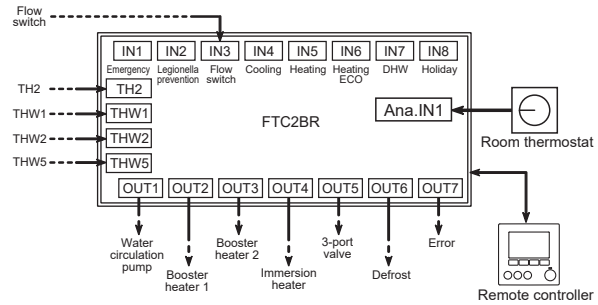
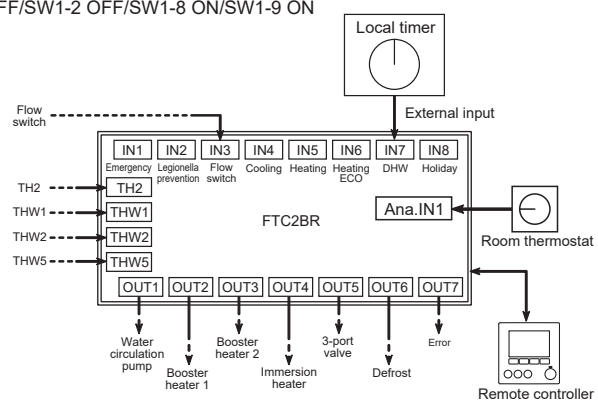
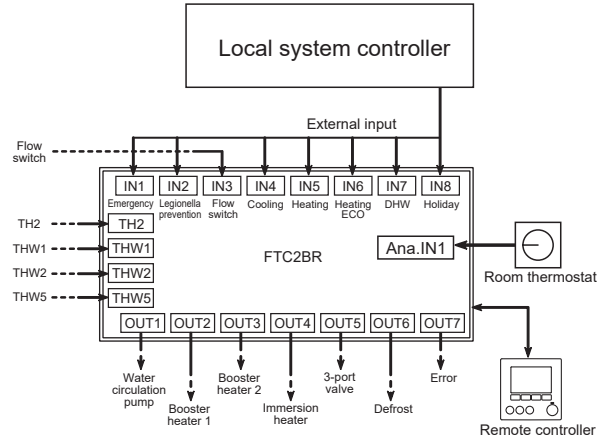
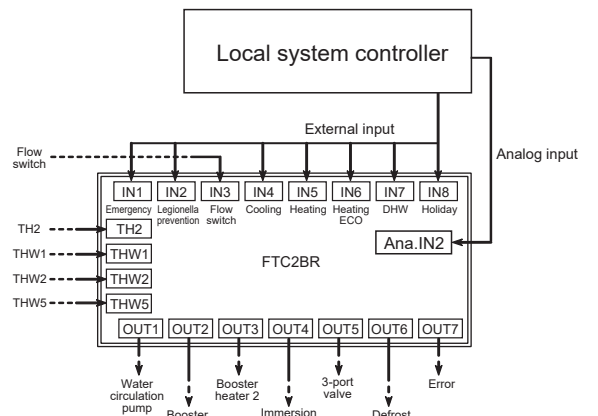
<p>Example 1: <u>Only our remote controller is used for system control. No local system controller exists.</u> Target temperature for each mode and Heating or Heating ECO or Cooling mode are set with remote controller. Automatic change over mode is selected (SW1-8 or SW1-9 must be switched to OFF). The system will automatically change from Heating or Heating ECO or Cooling to DHW mode and back dependent on the DHW tank temperature.</p>	<p>SW1-1 OFF/SW1-2 OFF/SW1-8 OFF/SW1-9 OFF or SW1-1 OFF/SW1-2 OFF/SW1-8 OFF/SW1-9 ON or SW1-1 OFF/SW1-2 OFF/SW1-8 ON/SW1-9 OFF</p> 
<p>Example 2: <u>A local timer and our remote controller are used for system control.</u> Target temperature for each mode and Heating or Heating ECO or Cooling mode are set with remote controller. A local timer is used rather than automatic change over mode (SW1-8 and SW1-9 must be switched to ON). The system runs in Heating or Heating ECO or Cooling until a signal is received from the local timer (the signal received from local timer must be longer than 200 ms). The system then switches to DHW mode. Once DHW mode is satisfied the system automatically reverts to Heating or Heating ECO or Cooling.</p>	<p>SW1-1 OFF/SW1-2 OFF/SW1-8 ON/SW1-9 ON</p> 
<p>Example 3: <u>A Local controller and our remote controller are used for system control.</u> Target temperatures for each mode are set with remote controller. A local controller is used to select the running mode. Automatic change over mode is available when SW1-8 and SW1-9 is OFF and the FTC2BR receives external signals for Heating or Heating ECO or Cooling, and DHW at the same time from the local controller. Automatic change over mode is not available when SW1-8 and SW1-9 is ON.</p> <p><IMPORTANT NOTE> In this system, the operation mode must be switched by a local controller which can output separate signals for each operation mode. (This can be realised by using a schedule timer and relays.)</p>	<p>SW1-1 ON/SW1-2 OFF/SW1-8 OFF/SW1-9 OFF or SW1-1 ON/SW1-2 OFF/SW1-8 ON/SW1-9 ON</p> 
<p>Example 4: <u>Only a Local controller is used for system control.</u> The system operates in the same way as Example 3 except that the target temperatures for each mode must also be inputted via the analogue signal from the local controller. (SW1-8 and SW1-9 must be switched to ON)</p> <p><IMPORTANT NOTE> In this system, the operation mode must be switched by a local controller which can output separate signals for each operation mode. In addition, the target temperature in each operation mode must be sent by analog signal from the local controller.</p>	<p>SW1-1 OFF/SW1-2 ON/SW1-8 ON/SW1-9 ON or SW1-1 ON/SW1-2 ON/SW1-8 ON/SW1-9 ON</p> 

en

5. Dip switch setting

5.4.2. DHW mode setting

Set Dip SW 2-1 to set DHW max. temperature drop (Difference in temperature between DHW max. temperature (Desired temperature of stored hot water) and the temperature at which DHW mode restarts).

Dip SW 2-1	Setting
OFF	10 deg
ON	20 deg

Set Dip SW 2-2 to operation in DHW mode.

Dip SW 2-2	Setting
OFF	Eco
ON	Normal

DHW mode can run in either 'Normal' or 'Eco' mode. Normal mode will heat the water in the DHW tank more quickly using the full power of the heat pump. Eco mode takes a little longer to heat the water in the DHW tank but the energy used is reduced. This is because heat pump operation is restricted using signals from the FTC2BR based on measured DHW tank temperature.

Set Dip SW 2-7 to set immersion heater usage in DHW mode.

Dip SW 2-7	Setting
OFF	Used
ON	Not used

Set Dip SW 2-9 to set booster heater usage in DHW mode.

Dip SW 2-9	Setting
OFF	Used
ON	Not used

5.4.3. Legionella prevention mode setting

Set Dip SW 2-4 and 2-5 to set how often the Legionella prevention operation is activated.

SW 2-4	SW 2-5	Setting
OFF	OFF	Activate every "1 times" DHW operations.
ON	OFF	Activate every "15 times" DHW operations.
OFF	ON	Activate every "150 times" DHW operations.
ON	ON	Activate by IN2.

Set Dip SW 2-6 to set Legionella prevention hot water (Desired temperature of stored hot water).

Dip SW 2-6	Setting
OFF	60°C
ON	65°C

The 65°C setting can not be selected when there is no heater in the DHW circuit, Dip SW settings is as follows;
SW1-4 OFF and SW1-5 ON, SW1-4 OFF and SW1-5 OFF and SW2-9 ON. And when the heat pump max. outlet water temperature is 55°C (SW1-10 OFF), legionella prevention mode is not available.

5.5. Manual operation

When the system is installed, the whole circuit must be filled with water. At this stage, water circulation pump and 3-way valve shall be operated individually.

Water circulation pump operates according to Dip SW 3-2 setting.

Dip SW 3-2	Operation
OFF	Water circulation pump is OFF.
ON	Water circulation pump is ON. (It is switched OFF after 60 minutes consecutive operation.)

3-way valve operates according to Dip SW 3-3 setting.

Dip SW 3-3	Operation
OFF	3-way valve is OFF.
ON	3-way valve is ON. (It is switched OFF after 60 minutes consecutive operation.)

* NOTE

Even if you forget to reset the Dip SW settings above, the normal operation mode can be recovered automatically in **60 minutes**.

5.4.4. Heating / Heating ECO / Cooling / Holiday mode setting

Set Dip SW 2-3 to set economy setting for water circulation pump in Heating and Heating ECO and Cooling mode.

Dip SW 2-3	Setting
OFF	Inactive
ON	Active

When the setting is inactive, the water circuit pump is always ON. When the setting is active, the water circulation pump stops 5 min after the heat pump has stopped, then starts operating again after 3-minutes stop. After 1 minute, the water circulation pump stops again. Then water circulation pump repeats 3-min OFF → 1-min ON → 3-min OFF.

Set Dip SW 2-8 to set booster heater usage in Heating and Heating ECO and Holiday mode.

Dip SW 2-8	Setting
OFF	Used
ON	Not used

Set Dip SW 3-1 to set 3-way valve control during defrost in Heating and Heating ECO and Holiday mode.

Dip SW 3-1	Setting
OFF	OFF (Heating circuit)
ON	ON (DHW circuit)

5.4.5. Other setting

Set Dip SW 3-4 to set the room thermostat input (Ana.IN1) logic.

Dip SW 3-4	Setting
OFF	Comp. OFF at thermostat short
ON	Comp. OFF at thermostat open

Set Dip SW 3-6 to set the flow switch input (IN3) logic.

Dip SW 3-6	Setting
OFF	Failure detection at short
ON	Failure detection at open

5.6. Emergency mode

The emergency mode is available when a failure on the outdoor unit of the heat pump or a communication error occurs.

This mode uses booster heater or immersion heater as a heat source and automatically controls between the DHW mode and the heating mode. When the system is not incorporated with heater, the emergency mode is not available.

Emergency mode can be started by following two ways.

1) Dip switch

Before starting the emergency mode, turn off the outdoor unit and FTC2BR, and then turn Dip SW3-7 to ON. Then, turn on FTC2BR to start the emergency mode. FTC2BR can be power-supplied by the outdoor unit.

If emergency mode is no longer required, please turn off both outdoor and indoor unit power supply before returning Dip SW3-7 to OFF position.

2) External input (IN1)

If you switch external input (IN1) to ON, emergency mode will start.

If emergency mode is no longer required, you can resume to normal operation with switching external input (IN1) to OFF (TB142 1-2 open).

Please turn off both outdoor and indoor unit power supply before switching external input (IN1) to OFF.

6. Before test run

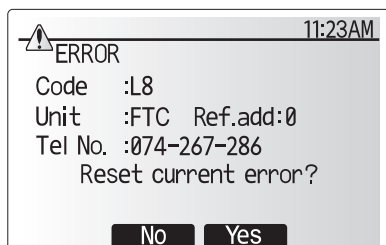
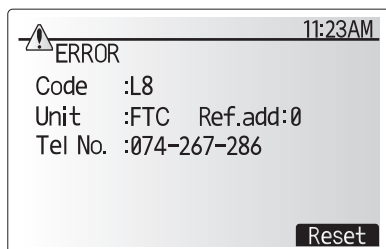

6.1. Check

After completing installation and the wiring and piping of the local application and outdoor units, check for refrigerant leakage, looseness in the power supply or control wiring, wrong polarity, and power cable is securely connected.

Use a 500-volt megohmmeter to check that the resistance between the power supply terminals and ground is at least 1.0MΩ.

Warning:
Do not use the system if the insulation resistance is less than 1.0MΩ.

Caution:
Do not carry out this test on the control wiring (low voltage circuit) terminals.

6.2. Self-check

When an error occurs when power is applied or during operation

- Indication of error details

The code, unit, address, and telephone number are displayed.

The telephone number is displayed if registered.

- Resetting the error

Press the F4 (RESET) button, and the F3 (Yes) button to reset the current error.

Code	LED4	LED5	Error	Action
L3	Light up	Light up	Circulation water temperature overheat protection	Flow rate may be reduced check for; • Water leakage • Strainer blockage • Water circulation pump function (Error code may display during filling of primary circuit, complete filling and reset error code.)
L4	Blink	Blink	DHW tank water temperature overheat protection	Check the immersion heater and it's contactor.
L5	Blink	Light down	Thermistor (Return water temp.) (THW2)	Check resistance across the thermistor.
L6	Light up	Blink	Circulation water freeze protection	See Action for L3.
L8	Light down	Light up	Heating operation error	Re-attach any thermistors that have become dislodged.
L9	Light up	Light down	Low primary circuit flow rate detected by flow switch (flow switch)	See Action for L3. If the flow switch itself does not work, replace it. Caution: The pump valves may be hot, please take care.
LA	Light down	Light down	Pressure sensor failure	Check pressure sensor cable for damage or loose connections.
LB	Light down	Light down	High pressure protection	• Flow rate of the heating circuit may be reduced. Check water circuit. • Plate heat exchanger may be clogged. Check the plate heat exchanger. • Outdoor unit failure. Refer to outdoor unit service manual.
LF	Light down	Light down	Flow sensor failure	Check flow sensor cable for damage or loose connections.
P1	Blink	Light down	Thermistor (Flow water temp.) (THW1) failure	Check resistance across the thermistor.
P2	Light down	Blink	Thermistor (Ref. liquid temp.) (TH2) failure	Check resistance across the thermistor.
P6	Blink	Light up	Anti-freeze protection of plate heat exchanger	See Action for L3. Check for correct amount of refrigerant.
P9	Blink	Light down	Thermistor (Tank water temp.) (THW5) failure	Check resistance across the thermistor.
E0, E3, E4, E5	—	—	Communication failure between remote controller and FTC2BR	Check connection cable for damage or loose connections.
E1, E2	—	—	Remote controller board error	Replace remote controller.
E6 - EF	—	—	Communication failure between FTC2BR and outdoor unit	Check that the outdoor unit has not been turned off. Check connection cable for damage or loose connections. Refer to outdoor unit service manual.
EE	—	—	Combination error between FTC2BR and outdoor unit	Check combination of FTC2BR and outdoor unit.
U*, F*	—	—	Outdoor unit failure	Refer to outdoor unit service manual.

Note: For the system using a local controller (External input: Contact signal), you cannot cancel an error with the remote controller.

When all of the IN4 to IN8 inputs are not received, the error will be cancelled.

For description of each LED (LED1 to 3) provided on the FTC2BR, refer to the following table.

LED 1 (Power for microcomputer)	Indicates whether control power is supplied. Make sure that this LED is always lit.
LED 2 (Power for remote controller)	Indicates whether power is supplied to the remote controller. This LED lights only in the case of the FTC2BR unit which is connected to the outdoor unit refrigerant address "0".
LED 3 (Communication between FTC2BR and outdoor unit)	Indicates state of communication between the FTC2BR and outdoor unit. Make sure that this LED is always blinking.

7. Remote controller operation

Remote Controller

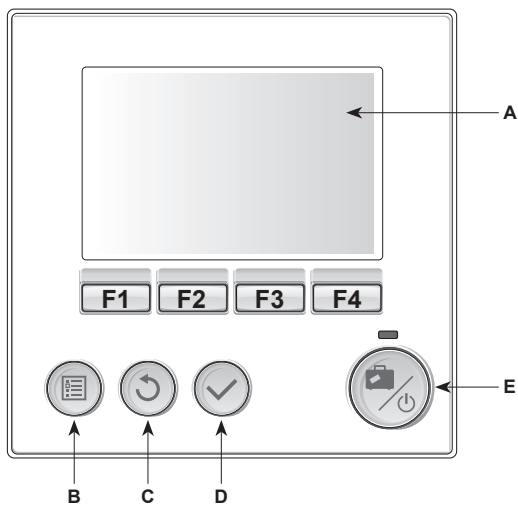

<Remote controller parts>

Letter	Name	Function
A	Screen	Screen in which all information is displayed
B	Menu	Access to system settings for initial set up and modifications.
C	Back	Return to previous menu.
D	Confirm	Used to select or save. (Enter key)
E	Power/Holiday	If system is switched off pressing once will turn system on. Pressing again when system is switched on will enable Holiday Mode. Holding the button down for 3 secs will turn the system off. (*1)
F1-4	Function keys	Used to scroll through menu and adjust settings. Function is determined by the menu screen visible on screen A.

*1

When the system is switched off or the power supply is disconnected, the water circuit protection functions will NOT operate. Please beware that without these safety functions enabled the water circuit may potentially become exposed to damage.

<Main screen icons>

No.	Item	Icon	Description
1	Operation prohibition		ON/OFF
			Mode
			Set temperature
2	Operation lock		Displayed when the buttons are locked.
3	Holiday mode		Displayed when 'Holiday mode' activated.
4	Heat pump status		Displayed when 'Heat pump' is running.
			Displayed when defrosting.
5	Restriction for preset temperature range		Displayed when the preset temperature range is not restricted.
			Displayed when the preset temperature range is restricted.
6	Operation mode		DHW
			Heating
			Heating ECO
			Cooling
7	Current temperature		Current water temperature
8	Target temperature		Target flow temperature

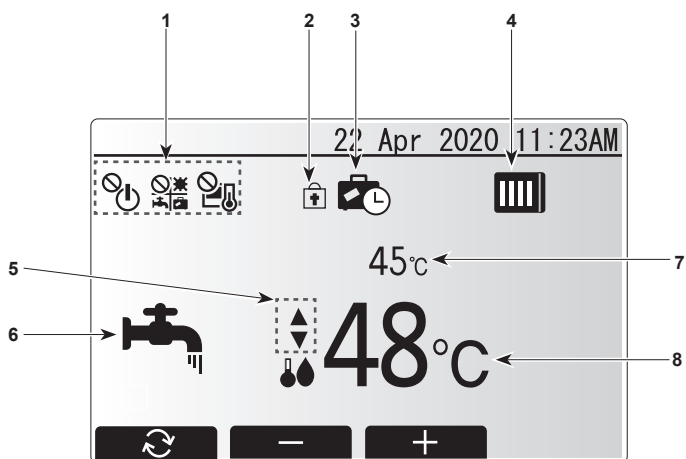

7. Remote controller operation

<Remote controller menu tree>

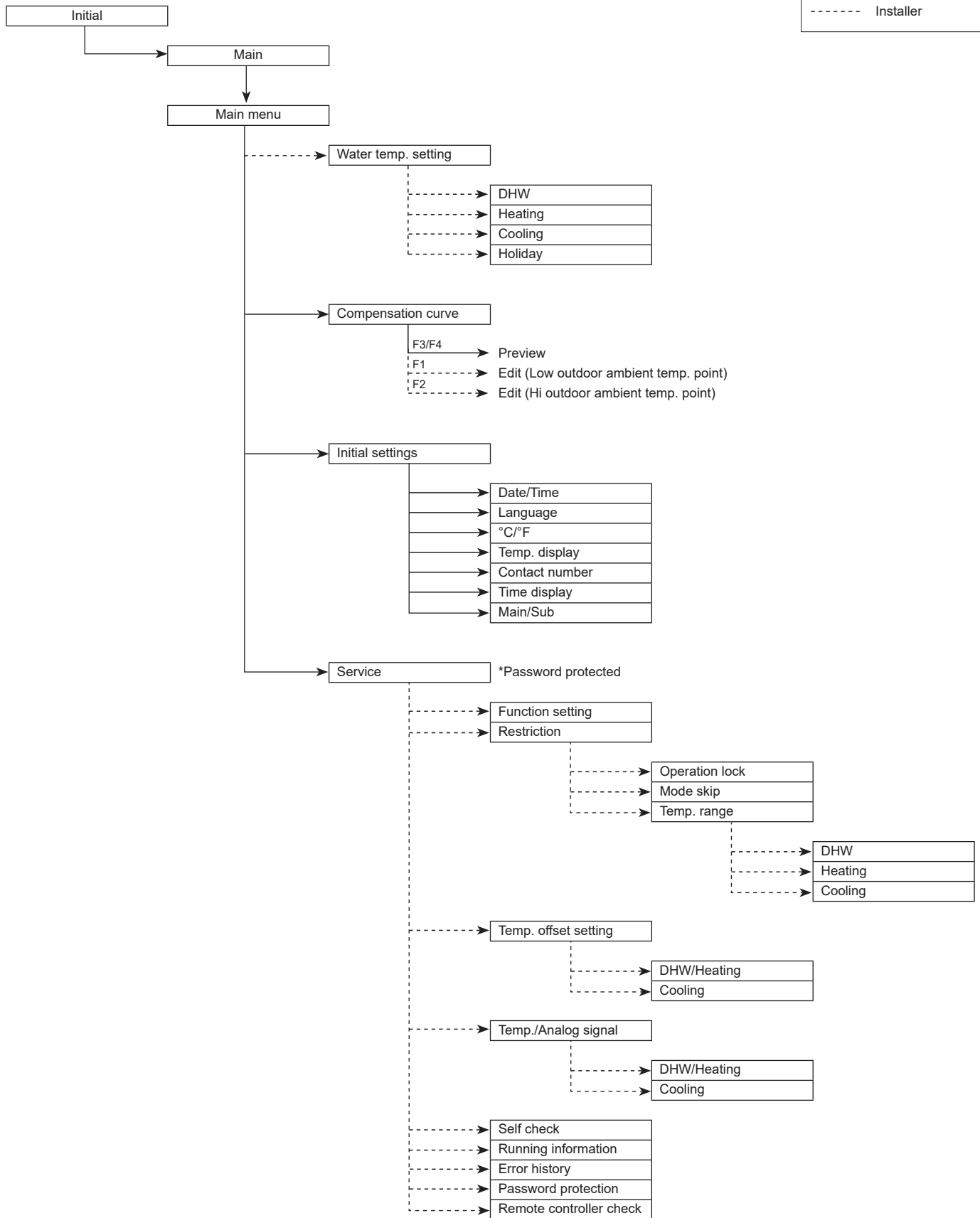
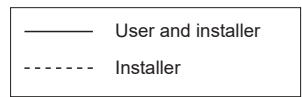

en

7. Remote controller operation

■ Setting the remote controller

After the power has been connected to the outdoor unit and FTC2BR unit, the initial system settings can be entered via the remote controller.

1. Check all breakers and other safety devices are correctly installed and turn on power to the system.
2. When the remote controller switched on for the first time, the screen automatically goes to Initial settings menu, language setting screen and date/time setting screen in order.
3. Remote controller will automatically start up. Wait approximately 6 min whilst the control menus load.
4. When the controller is ready a blank screen with a line running across the top will be displayed.
5. Press button E (Power) (refer to page 23) to turn on the system. Before turning on the system, perform initial settings as instructed below.

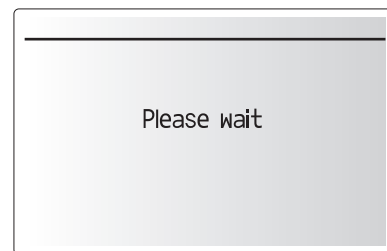

■ Main menu

The main menu can be accessed by pressing the MENU button. To reduce the risk of untrained end users altering the settings accidentally there are two access levels to the settings; and the service section menu is password protected.

User Level – Short press

If the MENU button is pressed once for a short time the settings will be displayed but without the edit function. This will enable the user to view current settings but **NOT** change the parameters.

Installer Level – Long press

If the MENU button is pressed down for 3 secs the main settings will be displayed with all functionality available.

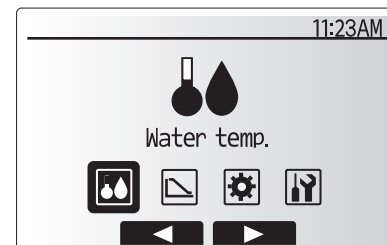

The following items can be viewed and/or edited (dependent on access level).

- Water temp. setting (Installer level)
- Compensation curve
- Initial settings
- Service (Password protected)

Use the F2 and F3 buttons to move between the icons. The highlighted icon will appear as a larger version in the centre of the screen. Press CONFIRM to select and edit the highlighted mode.

Icon	Description
	Water temp.
	Compensation curve
	Initial settings
	Service

■ Initial settings

From the Initial settings menu the installer can set the following.

- Date/Time
- Language
- °C/°F
- Temp. display
- Contact number
- Time display
- Main/Sub

1. Use buttons F1 and F2 to move scroll through the menu list. When the title is highlighted press CONFIRM to edit.
2. Use function buttons appropriate to edit each setting then press CONFIRM to save the setting.

Note: For Main/Sub setting, select “Main” (Initial setting). Do not change the setting to “Sub”, it is not available with FTC2BR.

■ Water temp. setting

Set the initial value of the set water temperature for following modes.

- DHW mode
- Heating mode
- Cooling mode
- Holiday mode

The set water temperature is changeable in main screen during operation.

■ Compensation curve

During late spring and summer usually the demand for space heating is reduced. To prevent the heat pump from producing excessive flow temperatures for the primary circuit the compensation curve mode can be used to maximise efficiency and reduce running costs. The compensation curve is used to restrict the flow temperature of the primary space heating circuit dependent on the outdoor ambient temperature. The FTC2BR uses information from both an outdoor ambient temperature sensor and a temperature sensor on the primary circuit supply to ensure the heat pump is not producing excessive flow temperatures if the weather conditions do not require it.

Preview:

You can check the target water temperature in compensation curve. Select outdoor ambient temp. with F3 and F4 buttons.

Edit (Installer level):

Pressing F1 or F2 will cause the relevant edit screen to be displayed.

Press F1 to edit the flow temperature of Lo outdoor ambient temperature point.

Press F2 to edit the flow temperature of Hi outdoor ambient temperature point.

See the following for more detailed explanation of editing.

In the parameter edit screen the flow temperature and outdoor ambient temperature for the compensation curve graph can be set and altered for the 2 extremes of Lo and Hi.

1. Press F1 and F2 to change the flow temperature (y-axis of compensation curve).
2. Pressing F1 will lower the desired flow temperature for the set outdoor ambient temperature.
3. Pressing F2 will raise the desired flow temperature for the set outdoor ambient temperature.
4. Press F3 and F4 to change the outdoor ambient temperature (x-axis of compensation curve).
5. Pressing F3 will lower the outdoor ambient temperature for the set flow temperature.
6. Pressing F4 will raise the outdoor ambient temperature for the set flow temperature.

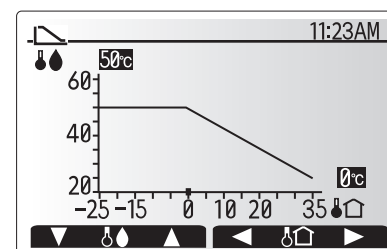
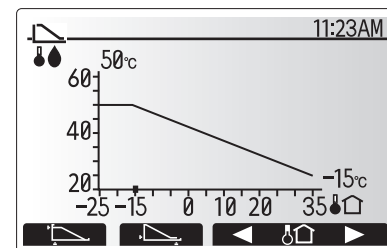

en

7. Remote controller operation

■ Holiday mode

From the main menu screen press button E, the holiday mode activation screen will be displayed. Be careful not to hold down button E for too long as this will turn off the controller and system.

Once the holiday mode activation screen is displayed you can select the duration that you would like holiday mode to run for.

- Use buttons F2, F3 and F4 to input the date which you would like holiday mode to activate or deactivate for space heating.

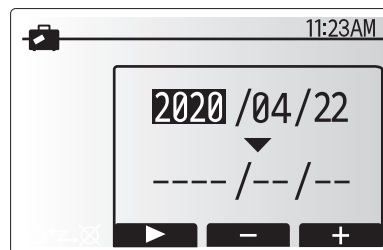

Holiday Mode activation screen

■ Service Menu

The service menu provides functions for use by installer or service engineer. It is NOT intended the home owner alters settings within this menu. It is for this reason password protection is required to prevent unauthorised access to the service settings.

1. From the main setting menu use F2 and F3 to highlight the service icon then press CONFIRM.
2. You will be prompted to enter a password. **THE FACTORY DEFAULT PASSWORD IS "0000"**.
3. Press CONFIRM.

The service menu is navigated using the F1 and F2 buttons to scroll through the functions. The menu is split across two screens and is comprised of the following functions;

1. Function setting
2. Restriction
3. Temp. offset setting
4. Temp./Analog setting
5. Self check
6. Running information
7. Error history
8. Password protection
9. Remote controller check

Note: Many functions can not be set whilst the indoor unit is running. The installer should turn OFF the unit before trying to set these functions. If the installer attempts to change the settings whilst the unit is running the remote controller will display a reminder message prompting the installer to stop operation before continuing. By selecting "Yes" the unit will cease operation.

■ Service

Function settings

Function setting allows the setting of auto recovery after power failure only.

1. Ensure the Ref. address and unit number are displayed to the right.
2. Press CONFIRM.
3. Use F3 and F4 to highlight either 1/2/3 (see below).
4. Press CONFIRM.

Note: Changes can ONLY be made to Mode 1.

Mode 1 Setting number meanings

- 1 - Power failure automatic recovery NOT available
- 2 - Power failure automatic recovery AVAILABLE (Approx. 4-minute delay after power is restored.)
- 3 - No function

Restriction

<Operation lock>

Restrict the operation of switching ON/OFF, changing the operation mode and the set temperature with remote controller. Select a option from "none", "Mode & Temp" and "All", then press CONFIRM. The meanings of the options are as indicated below.

none: No restriction

Mode & Temp: Restrict changing the operation mode and the set temperature

All: Restrict switching ON/OFF, changing the operation mode and the set temperature

Note: Holiday mode button is available regardless of the operation lock setting.

<Mode skip>

Set the usage of each operation mode using remote controller. Tick the modes that will be used. You cannot select a mode that is without tick mark.

<Temp. range>

Restrict the range of set temperature that is made using remote controller. Select the mode you wish to set, set the lower limit and higher limit of set temperature, then press CONFIRM.

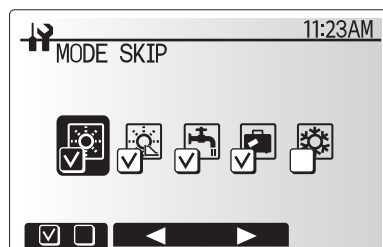
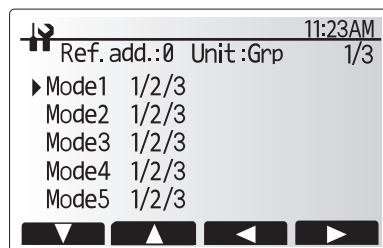
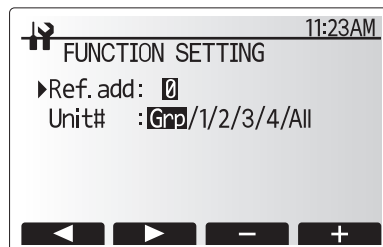

7. Remote controller operation

Temp. offset setting

This setting is to adjust the difference between the actual temperature and the temperature sensed by the thermistor (THW1 or THW5) which tends to be lower due to heat leakage or something.

To set offset of DHW mode, select "DHW/Heating".

Note: Offset setting is not available in Heating mode of FTC2BR.

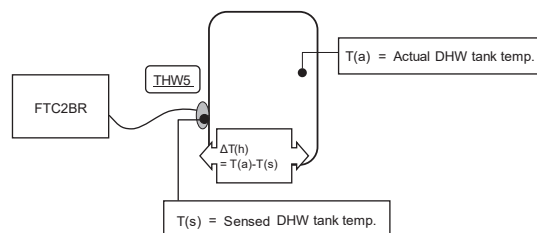

TEMP OFFSET HEATING
(temperature offset setting for Domestic Hot Water)

To set offset of Cooling mode, select "Cooling".

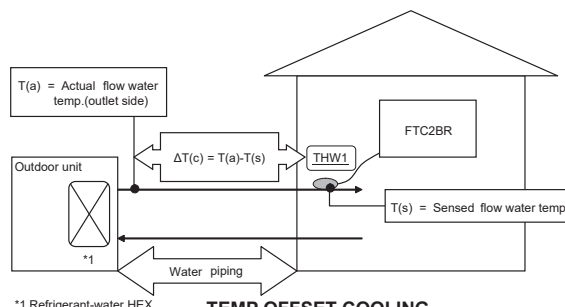

TEMP OFFSET COOLING
(temperature offset setting for Cooling)

Temp./Analog signal

Set following 2 parameters to assign the target temperature value to analog signal figures.

1. Select "DHW/Heating" for the settings of DHW mode, Heating mode and Holiday mode, select "Cooling" for the settings of Cooling mode.
 2. "Lower" shows the target temp. of 4mA/1V/0V signal, "Upper" shows target temp. of 20mA/5V/10V signal (Refer to the right chart).
- Set upper and lower, press CONFIRM.

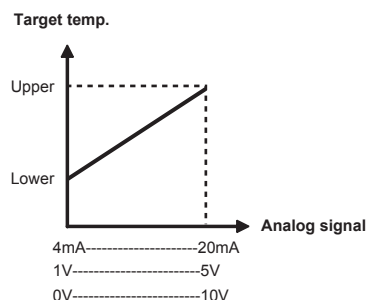

Self check

Error history of each unit can be checked via the remote controller.

1. With the F1 or F2 button, enter the refrigerant address, and press the SELECT button.
2. Error code and attribute will appear. "-" will appear if no error history is available.
3. To delete error history, press the F4 button on the screen that shows the error history.
4. A confirmation screen will appear asking if you want to delete the error history.

Running information

This function shows current temperature and other data of main component parts of both the indoor and outdoor units.

1. Press F2 and F3 buttons to set the Ref. address.
2. Use the function buttons (F1-F4) to enter index code for the component to be viewed. (See the service manual for component index codes.)
3. Press CONFIRM.

Error history

Error history allows the service engineer to view previous error codes, the unit address and the date on which they occurred. Up to 16 Error codes can be stored in the history the most recent Error event is displayed at the top of the list.

To delete an Error history item; from Error history screen press F4 button (Rubbish bin icon), then press F3 button (Yes).

Password protection

Password protection is available to prevent unauthorised access to the service menu by untrained persons.

1. When password input screen is displayed use buttons F1 and F2 to move left and right between the four digits, F3 to lower the selected digit by 1, and F4 to increase the selected digit by 1.
2. When you have input your password press CONFIRM.
3. The password verify screen is displayed.
4. To verify your new password press button F3.
5. Your password is now set and the completion screen is displayed.

Remote controller check

When the remote controller does not work properly, use the remote controller checking function to troubleshoot the problem.

1. Press F3 to start the remote controller check and see the check results.
2. The remote controller check results are displayed.
 - OK: No problems are found with the remote controller. Check other parts for problems.
 - E3: There is noise on the transmission line, or the indoor unit or another remote controller is faulty. Check the transmission line and the other remote controllers.
 - NG (ALL0, ALL1): Send-recv circuit fault. Remote controller needs replacing.
 - ERC: The number of data errors is the discrepancy between the number of bits in the data transmitted from the remote controller and that of the data that was actually transmitted over the transmission line. If data errors are found, check the transmission line for external noise interference.
3. If the F3 is pressed after the remote controller check results are displayed, remote controller check will end, and the remote controller will automatically reboot itself.

Note:

Check the remote controller display and see if anything is displayed (including lines). Nothing will appear on the remote controller display if the correct voltage (8.5-12 VDC) is not supplied to the remote controller. If this is the case, check the remote controller wiring and FTC2BR units.

7. Remote controller operation

Should settings be changed from default please enter new setting in 'Field Setting' column. This will ease resetting in the future should the system use change or the circuit board need to be replaced.

Commissioning/Field settings record sheet

Remote controller screen			Parameters		Default setting	Field setting	Notes			
Main	DHW max. temp.		20 - 60°C		50°C					
	Heating mode		20 - 60°C		45°C					
	Cooling mode		5 - 25°C		15°C					
	Holiday mode		Active/Non active/Set time		—					
Menu	Water temp. setting	DHW		20 - 60°C		50°C				
		Heating		20 - 60°C		45°C				
		Cooling		5 - 25°C		15°C				
		Holiday		20 - 45°C		35°C				
	Compensation curve	Low outdoor ambient temp. point	Outdoor ambient temp.		-15 - 34°C		-15°C			
			Target flow temp.		20 - 60°C		50°C			
		Hi outdoor ambient temp. point	Outdoor ambient temp.		-14 - 35°C		35°C			
			Target flow temp.		20 - 60°C		25°C			
	Initial settings	Language		ENG/GER/SP/IT/FR/SW/JP		ENG				
		°C/°F		1°C/1°F		1°C				
		Temp. display		ON/OFF		OFF				
		Time display		hh:mm/hh:mm AMPM/AMPM hh:mm		hh:mm				
	Service	Restriction	Operation lock		none/Mode&Temp/All		none			
			Mode skip	DHW		Used/Not used (Skipped)		Used		
				Heating		Used/Not used (Skipped)		Used		
				Heating Eco		Used/Not used (Skipped)		Used		
				Cooling		Used/Not used (Skipped)		Used		
				Holiday		Used/Not used (Skipped)		Used		
		Temp. range	DHW	20 - 60°C		20 - 60°C				
Heating			20 - 60°C		20 - 60°C					
Cooling			5 - 25°C		5 - 25°C					
Temp. offset setting		DHW/Heating		-15 - 15°C		0°C				
		Cooling		-15 - 15°C		0°C				
Temp./Analog signal		DHW/Heating	Target temp. of low signal point -20 - 90°C		20°C					
			Target temp. of hi signal point -20 - 90°C		60°C					
	Cooling	Target temp. of low signal point -20 - 90°C		5°C						
		Target temp. of hi signal point -20 - 90°C		25°C						

8. Troubleshooting

<Troubleshooting by inferior phenomena>

No.	Fault symptom	Possible cause	Explanation - Solution
1	Remote controller display is blank.	<ol style="list-style-type: none"> There is no power supply to remote controller. Power is supplied to remote controller, however, the display on the remote controller does not appear. 	<ol style="list-style-type: none"> Check LED2 on FTC2BR. <ol style="list-style-type: none"> When LED2 is lit. Check for damage or contact failure of the remote controller wiring. When LED2 is blinking. Refer to No. 5 below. When LED2 is not lit. Refer to No. 4 below. Check the following: <ul style="list-style-type: none"> Disconnection between the remote controller cable and the FTC2BR control board Failure of the remote controller if "Please Wait" is not displayed Refer to No. 2 below if "Please Wait" is displayed.
2	"Please Wait" remains displayed on the remote controller.	<ol style="list-style-type: none"> "Please Wait" is displayed for up to 6 minutes. Communication failure between the remote controller and FTC2BR Communication failure between FTC2BR and outdoor unit 	<ol style="list-style-type: none"> Normal operation 3. Go to "Remote controller check" pressing BACK button for 5 seconds (Refer to page 27). If "OK" is displayed, conduct the procedures below. <ul style="list-style-type: none"> Check the wiring connections on the outdoor unit control board and the FTC2BR control board. (Ensure S1 and S2 are not cross-wired and S3 is securely wired with no damage.) Replace the outdoor unit and/or the FTC2BR control board. If the messages other than "OK" is displayed, see "Remote controller check" on page 27.
3	The main screen appears with a press of the "ON" button, but disappears in a second.	The remote controller operations do not work for a whilst after the settings are changed in the service menu. This is because the system takes time to apply the changes.	<p>Normal operation</p> <p>The indoor unit is applying updated settings made in the service menu. Normal operation will start shortly.</p>
4	LED2 on FTC2BR is off.	When LED1 on FTC2BR is also off. <FTC2BR powered via outdoor unit.>	<ol style="list-style-type: none"> Check the voltage across the terminals L and N or L3 and N on the outdoor power board. <ul style="list-style-type: none"> When the voltage is not 220 to 240V AC, check wiring of the outdoor unit and of the breaker. When the voltage is at 220 to 240V AC, go to "2." below. Check the voltage across the outdoor unit terminals S1 and S2. <ul style="list-style-type: none"> When the voltage is not 220 to 240V AC, check the fuse on the outdoor control board and check for faulty wiring. When the voltage is 220 to 240V AC, go to "3." below. Check the voltage across the indoor unit terminals S1 and S2. <ul style="list-style-type: none"> When the voltage is not 220 to 240V AC, check FTC2BR - outdoor unit wiring for faults. When the voltage is 220 to 240V AC, go to "4." below. Check the FTC2BR control board. <ul style="list-style-type: none"> Check the fuse on FTC2BR control board. Check for faulty wiring. If no problem found with the wiring, the FTC2BR control board is faulty.
		<FTC2BR powered on independent source>	<ol style="list-style-type: none"> Check the voltage across the L and N terminals on the indoor power supply terminal block. <ul style="list-style-type: none"> When the voltage is not 220 to 240V AC, check for faulty wiring to power supply. When the voltage is 220 to 240V AC, go to 2. below. Check the FTC2BR control board. <ul style="list-style-type: none"> Check the fuse on FTC2BR control board. Check for faulty wiring. If no problem found with the wiring, the FTC2BR control is faulty.
		When LED1 on FTC2BR is lit. Incorrect setting of refrigerant address for outdoor unit (None of the refrigerant address is set to "0".)	<p>Recheck the refrigerant address setting on the outdoor unit.</p> <p>Set the refrigerant address to "0". (Set refrigerant address using Dip switch on outdoor controller circuit board.)</p>
5	LED2 on FTC2BR is blinking.	When LED1 is also blinking on FTC2BR. Faulty wiring between FTC2BR and outdoor unit	Check for faulty wiring between FTC2BR and outdoor unit.
		When LED1 on FTC2BR is lit.	<ol style="list-style-type: none"> Check for faulty wiring in remote controller. The number of indoor units that can be wired to a single outdoor unit is one. Additional indoor units must be wired individually to a single outdoor unit. 3. Remove remote controller wires and check LED2 on FTC2BR. <ul style="list-style-type: none"> If LED2 is blinking, check for short circuits in the remote controller wiring. If LED2 is lit, wire the remote controller again and: <ul style="list-style-type: none"> - if LED2 is blinking, the remote controller is faulty; - if LED2 is lit, faulty wiring of the remote controller has been corrected.
6	No water at hot tap.	<ol style="list-style-type: none"> Cold main off. Strainer blocked. 	<ol style="list-style-type: none"> Check and open stop cock. Isolate water supply and clean strainer.
7	Cold water at tap.	<ol style="list-style-type: none"> Hot water run out. Heat pump not working. Booster heater cut-out tripped. The earth leakage circuit breaker for booster heater breaker (ECB1) tripped. Immersion heater cut-out tripped. Immersion heater breaker (ECB2) tripped. 3-way valve fault 	<ol style="list-style-type: none"> Ensure DHW mode is operating and wait for DHW tank to re-heat. Check heat pump – consult outdoor unit service manual. Check booster heater thermostat and press reset button if safe. If the heater has been operated with no water inside it may have failed, so please replace it with a new one. Check the cause and reset if safe. Check immersion heater thermostat and press reset button, located on immersion heater boss, if safe. If the heater has been operated with no water inside it may have failed, so please replace it with a new one. Check the cause and reset if safe. Check plumbing/wiring to 3-way valve.

8. Troubleshooting

No.	Fault symptom	Possible cause	Explanation - Solution
8	Water heating takes longer.	<ol style="list-style-type: none"> Heat pump not working. Booster heater cut-out tripped. Booster heater breaker tripped. Immersion heater cut-out has been triggered. Immersion heater breaker tripped. 	<ol style="list-style-type: none"> Check heat pump – consult outdoor unit service manual. Check booster heater thermostat and press reset button if safe. If the heater has been operated with no water inside it may have failed, so please replace it with a new one. Check the cause and reset if safe. Check immersion heater thermostat and press reset button located on immersion heater boss, if safe. If the heater kept running with no water inside, this may have resulted in failure, so replace it with a new one. Check the cause and reset if safe.
9	Temperature of DHW tank water dropped.	<p>When DHW operation is not running, the DHW tank emits heat and the water temperature decreases to a certain level. If water in the DHW tank is reheated frequently because of a significant drop in water temperature, check for the following.</p> <ol style="list-style-type: none"> Water leakage in the pipes that connect to the DHW tank Insulation material coming loose or off. 3-way valve failure 	<ol style="list-style-type: none"> Take the following measures. <ul style="list-style-type: none"> Retighten the nuts holding the pipes onto the DHW tank. Replace seal materials. Replace the pipes. Fix insulation. Check plumbing/wiring to 3-way valve.
10	Hot or warm water from cold tap.	Heat of hot water pipe is transferred to cold water pipe.	Insulate/re-route pipework.
11	Water leakage	<ol style="list-style-type: none"> Poorly sealed connections of water circuit components Water circuit components reaching the end of life 	<ol style="list-style-type: none"> Tighten connections as required. Replace them as necessary.
12	Heating system does not reach the set temperature.	<ol style="list-style-type: none"> The temperature sensor does not detect the water temperature accurately. Heat pump not working. Booster heater cut-out tripped. Booster heater breaker tripped. Incorrectly sized heat emitter. 3-way valve failure 	<ol style="list-style-type: none"> Check if the temperature sensor is affected by ambient temperature (except water temperature). Check heat pump – consult outdoor unit service manual. Check booster heater thermostat and press reset button if safe. If the heater has been operated with no water inside it may have failed, so please replace it with a new one. Check the cause of the trip and reset if safe. Check the heat emitter surface area is adequate. Increase size if necessary. Check plumbing/wiring to 3-way valve.
13	The room temperature rises during DHW operation.	3-way valve failure	Check the 3-way valve.
14	Water discharges from pressure relief valve. (Primary circuit)	<ol style="list-style-type: none"> If continual – pressure relief valve may be damaged. If intermittent – expansion vessel charge may have reduced/bladder perished. 	<ol style="list-style-type: none"> Turn the handle on the pressure relief valve to check for foreign objects in it. If the problem is not still solved, replace the pressure relief valve with a new one. Check pressure in expansion vessel. Recharge to 1 bar if necessary. If bladder perished replace expansion vessel with a new one.
15	Water discharges from pressure relief valve (Sanitary circuit)	<ol style="list-style-type: none"> If continual – pressure reducing valve not working. If continual – pressure relief valve seat may be damaged. If intermittent – expansion vessel charge may have reduced/bladder perished. DHW tank may have subjected to backflow. 	<ol style="list-style-type: none"> Check function of pressure reducing valve and replace if necessary. Turn the handle on the pressure relief valve to check for foreign objects inside. If the problem is not still solved, replace the pressure relief valve. Check gas-side pressure in expansion vessel. Recharge to correct precharge pressure if necessary. If bladder perished replace expansion vessel with a new one with appropriate pre-charge. Check pressure in DHW tank. If pressure in DHW tank is similar to that in incoming mains, cold water supply that merges with incoming mains water supply could flow back to DHW tank. Investigate source of back-feed and rectify error in pipework/fitting configuration. Adjust pressure in cold supply.
16	Noisy water circulation pump	Air in water circulation pump.	Use manual and automatic air vents to remove air from system. Top up water if necessary to achieve 1 bar on primary circuit.
17	Noise during hot water draw off typically worse in the morning.	<ol style="list-style-type: none"> Loose airing cupboard pipework. Heaters switching on/off. 	<ol style="list-style-type: none"> Install extra pipe fastening clips. Normal operation no action necessary.
18	Mechanical noise heard coming from the indoor unit.	<ol style="list-style-type: none"> Heaters switching on/off. 3-way valve changing position between DHW and heating mode. 	Normal operation no action necessary.
19	Water circulation pump runs for a short time unexpectedly .	Water circulation pump jam prevention mechanism (routine) to inhibit the build-up of scale.	Normal operation no action necessary.
20	Milky/Cloudy water (Sanitary circuit)	Oxygenated water	Water from any pressurised system will release oxygen bubbles when water is running. The bubbles will settle out.
21	FTC2BR that was running in the heating mode before power failure is running in the DHW mode after power recovery.	FTC2BR is designed to run in an operation mode with a higher priority (i.e. DHW mode in this case) at power recovery.	<ul style="list-style-type: none"> Normal operation After the DHW max. operation time has elapsed or the DHW max. temperature has been reached, the DHW mode switches to the other mode (ex. Heating mode).
22	The cooling system does not cool down to the set temperature.	When the water in the circulation circuit is unduly hot, Cooling mode starts with a delay for the protection of the outdoor unit.	Normal operation

9. Supplementary information

9.1 Refrigerant collecting (pumpdown) for split model systems only

When operating pumpdown, do not enter the signals IN1/IN2/IN4/IN5/IN6/IN7/IN8 for external inputs (refer to 4.4.1). And if the system is set in Dip-SW1-1/1-2 is OFF/ON or ON/ON, pumpdown operation cannot be started. Set Dip-SW1-1/1-2 to OFF/OFF or ON/OFF. For more details, refer to "Refrigerant collection" in the outdoor unit installation manual or service manual.

Local application factors

- * This FTC2BR is designed to connect ecodan inverter outdoor unit of MITSUBISHI ELECTRIC to local systems. Please check the following when designing the local system.
- * MITSUBISHI ELECTRIC does not take any responsibility for the local system design.

Heat exchanger

(1) Withstanding pressure

Designed pressure of outdoor unit is 4.15 MPa. Following must be satisfied for burst pressure of connecting application.

Burst pressure: More than 12.45 MPa (3 times more than designed pressure)

(2) Performance

Secure the heat exchanger capacity which meets the following conditions. If the conditions are not met, it may result in malfunction caused by the protection operation or the outdoor unit may be turned off due to the operation of protection system.

- In case of hot water supply, condense temperature is less than 58 °C in max. frequency operation with the outside temperature 7 °C D.B./6 °C W.B.

(3) Heat exchanger internal capacity

Heat exchanger internal capacity must be within the capacity range shown below. If the heat exchanger below the minimum capacity is connected, it may result in the back flow of liquid or the failure of the compressor.

If the heat exchanger above the maximum capacity is connected, it may result in the deficiency in performance due to lack of refrigerant or overheating of the compressor.

Outdoor unit	PUHZ-SW	75	100	—	120	160	200
	PUHZ-SHW	80	112	140	—	230	—
Maximum capacity [cm ³]		2130	3000	3750	4200	6000	7500
Minimum capacity [cm ³]		710	1000	1250	1400	2000	2500

(4) Contamination maintenance

1. Wash the inside of heat exchanger to keep it clean. Be sure to RINSE not to leave flux. Do not use chlorine detergent when washing.
2. Be sure that the amount of contamination per unit cubic content of heat transfer pipe is less than the following amount.

Example) In case of ϕ 9.52 mm

Residual water: 0.6 mg/m, Residual oil: 0.5 mg/m, Solid foreign object: 1.8 mg/m

Thermistor position

Refer to 4.3.

Notes

- Install the hydraulic filter at the water inlet pipework.
- Inlet water temperature of heat exchanger should be within the range 5 °C - 55 °C.
- Water quality should be to European Directive 98/83 EC standards
 - pH value of 6.5 - 8
 - Calcium \leq 100 mg/L
 - Chlorine \leq 100 mg/L
 - Iron/Manganese \leq 0.5 mg/L
- Refrigerant pipe diameter from outdoor unit to refrigerant-water HEX (Only for SPLIT type)
Use the pipe with same diameter size as the refrigerant pipe connection diameter of outdoor unit. (Refer to outdoor unit installation manual.)
- Ensure that there is sufficient anti-freeze chemical in the water circuit. It is recommended to use 7 : 4 anti-freeze to water ratio.
- The water velocity in pipes should be kept within certain limits of material to avoid erosion, corrosion and excessive noise generation.
Be aware, and take care of , that local velocities in small pipes, bends and similar obstructions can exceed the values above.
e.g.) Copper: 1.5 m/s

⚠ Warning:

- **Always use water that meets the above quality requirements. Using water that does not meet these standards may result in damage to the system pipework and heating components.**
- **Never use anything other than water as a medium. It may cause a fire or an explosion.**
- **Do not use heated water that is produced by the air to water heat pump directly for drinking or cooking. There is a risk to damage your health. There is also a risk that installing the water heat exchanger may corrode if the necessary water quality for air to water heat pump system cannot be maintained. If you wish to use the heated water from the heated pump for these purposes, take measure such as to the second heat exchanger within the water piping system.**

R32 Refrigerant

1. Introduction and Notice

MITSUBISHI ELECTRIC does NOT take any responsibility on the failure (including outdoor unit) caused by local indoor unit and system design.

Important Notice (Fire safety)

R32 is flammable refrigerant, and the fire safety warranty for the whole system (including outdoor unit) must be done by your side. Conformity of regulations and laws must be confirmed on the system by your side. As a reference, the following section 7.3 and 7.4 describe outlines of IEC 60335 2-40 (Edition 6.0). However, if you follow this standard, make sure to read the original IEC 60335. Also satisfying the following descriptions does NOT mean the guarantee of safety or the conformity with IEC 60335 2-40 (Edition 6.0).

Other requirements

- Requirements for marking (e.g. flame symbol) and information in the manual shall be satisfied.
- Requirements for constructions (e.g. location of the refrigerant detection sensor) shall be satisfied.

2. Additional Requirements for using R32 Refrigerant

(a) Flow sensor (Outdoor unit: PUZ-(H)WM**)

Flow sensor (option) is necessary for PUZ-(H)WM outdoor unit. Refer to the manual of PAC-FS01-E for details.

(b) Pressure relief valve (Outdoor unit: PUZ-(H)WM**)

Do not attach the pressure relief valve to the space heating (cooling) circuit of local indoor unit.

R32 Packaged model (PUZ-(H)WM**)

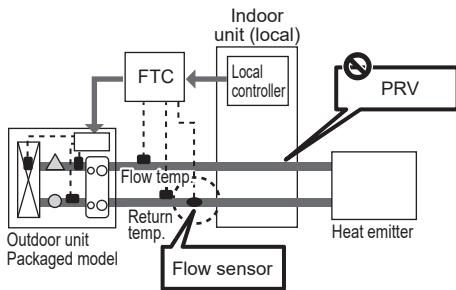

EC DECLARATION OF CONFORMITY
EG-KONFORMITÄTSEKTLÄRUNG
DECLARATION DE CONFORMITÉ CE
EG-KONFORMITEITSVERKLARING
DECLARACIÓN DE CONFORMIDAD CE
DICHIARAZIONE DI CONFORMITÀ CE
ΔΗΛΩΣΗ ΠΙΣΤΟΤΗΤΑΣ ΕΚ

DECLARAÇÃO DE CONFORMIDADE CE
EU-OVERENSSTEMMELSESEKTLÆRING
EG-DEKLARATION OM ØVERENSSTÅMELSE
EC UYGUNLUK BEYANI
ДЕКЛАРАЦИЯ СООТВЕТСТВИЯ НОРМАМ ЕС
ДЕКЛАРАЦІЯ ВІДПОВІДНОСТІ НОРМАМ ЄС
ЕС ДЕКЛАРАЦІЯ ЗА СЪОТВЕТСТВИЕ

DEKLARACJA ZGODNOŚCI WE
CE-ERKLÆRING OM SAMSVAR
EY-VAATIMUSTENMUKAISUUSVAKUUTUS
ES PROHLÁŠENÍ O SHODĚ
VYHLÁSENIE O ZHODE ES
EK MEGFELELŐSÉGI NYILATKOZAT
IZJAVA O SKLADNOSTI ES

DECLARAȚIE DE CONFORMITATE CE
EŪ VASTAVUSDEKLARATSIOON
EK ATBILSTĪBAS DEKLARĀCIJA
EB ATITIKTIES DEKLARACIJA
EC IZJAVA O SUKLADNOSTI
EZ IZJAVA O USAGLAŠENOSTI

mitsubishi electric corporation
Tokyo Building, 2-7-3, Marunouchi, Chiyoda-Ku, Tokyo 100-8310, Japan

hereby declares under its sole responsibility that the heating system components described below for use in residential, commercial and light-industrial environments:
erklärt hiermit auf seine alleinige Verantwortung, dass die unten beschriebenen Zubehöriteile für das Heizungs-System zur Benutzung im häuslichen, kommerziellen und leicht-industriellen Umfeld:
déclare par la présente et sous son entière responsabilité que les composants du système de chauffage décrits ci-dessous pour l'utilisation dans des environnements résidentiels, commerciaux et d'industrie légère :
verklaart hierbij als enige verantwoordelijke dat de componenten van het verwarmingsstroom die hieronder worden beschreven, bedoeld zijn voor gebruik in woonomgevingen en in commerciële en licht industriële omgevingen:
declara por la presente bajo su responsabilidad exclusiva que los componentes del sistema de calefacción descritos a continuación para su uso en zonas residenciales, comerciales y para la industria ligera:
con la presente dichiara, sotto la sua esclusiva responsabilità, che i componenti dell'impianto di riscaldamento descritto di seguito, destinato all'uso in ambienti residenziali, commerciali e industriali:
διά του παρόντος δηλώνει υπό αποκλειστική ευθύνη της ότι τα εξαρτήματα του συστήματος θέρμανσης που περιγράφονται παρακάτω για χρήση σε κατοικημένες, εμπορικές και ελαφριές βιομηχανικές περιοχές.
através da presente declara sob sua única responsabilidade que os componentes do sistema de aquecimento abaixo descritos para uso residencial, comercial e de indústria ligeira:
erklærer hermed under eneansvar, at de herunder beskrevne komponenter til opvarmning til brug i privat boligbyggeri, erhvervsområder og inden for let industri:
intyggar härmed att uppvärmningssystemkomponenterna som beskrivs nedan är för användning i bostäder, kommersiella miljöer och lätt industri:
aşağıda anlatılan ısıtma sistemi bileşenlerinin konutlarda, ticari ve hafif sanayi ortamlarında kullanımına yönelik olduğunu tamamen kendi sorumluluğunda beyan eder:
настоящим заявляет и берет на себя исключительную ответственность за то, что кондиционеры и тепловые насосы, описанные ниже и предназначенные для эксплуатации в жилых помещениях, торговых залах и на предприятиях легкой промышленности:
заявляє виключно під власну відповідальність, що компоненти системи опалення, описані нижче, призначені для використання в побутовому, комерційному та наближеному до промислового середовищах.
с настоящото декларира на своя отговорност, че описаните по-долу компоненти за отоплителна система са годни за експлоатация в жилищна, търговска и лекопромишлена среда:
niniejszym oświadczam na swoją wyłączną odpowiedzialność, że klimatyzatory i pompy ciepła opisane poniżej, są przeznaczone do zastosowań w środowisku mieszkalnym, handlowym i lekkim przemysłowym:
erklærer hermed som sitt ansvar, ene og alene, at komponentene i varmesystemet som beskrives nedenfor og som er beregnet for bruk i bolig-, forretnings- og lettindustri miljøer:
vakuumtaa täten asiasta yksin vastuussa, että alla kuvatut lämmitysjärjestelmän osat, jotka on tarkoitettu käytettäväksi asuin-, toimisto- ja kevyen teollisuuden ympäristöissä:
tímto na vlastní odpovědnost prohlašuje, že níže popsané klimatizační jednotky a tepelná čerpadla pro použití v obytných prostředích, komerčních prostředích a prostředích lehkého průmyslu:
týmto vyhlasuje na vlastnú zodpovednosť, že komponenty vykurovacieho systému opísané nižšie pre použitie v obytných, komerčných a ľahkých priemyselných oblastiach:
ezennel kizárólagos felelősséggel kijelenti, hogy az alábbiakban leírt, lakó-, kereskedelmi és könnyűipari környezetben használható fűtőrendszer alkatrészei:
s tem izrecno izjavljamo, da so spodaj opisane komponente ogrevalnega sistema za uporabo v stanovanjskih, poslovnih in lahkoindustrijskih okoljih:
Prin prezentul document, compania declară pe propria răspundere că piesele sistemului de încălzire descrise mai jos sunt potrivite pentru utilizarea în medii rezidențiale, comerciale și ușor industriale:
Kinnitab oma ainuvastutusele, et allpool kirjeldatud küttesüsteemi komponendid on mõeldud kasutamiseks elu-, kaubandus- ja kergetööstuskeskkonnas:
ar šo piltībā atbild par to, ka tālāk aprakstītie apsildes sistēmas komponenti, kas izmantojami dzīvojamās, komerciālās un vieglās industriālās vidēs:
prisiimdamas visą atsakomybę pareiškia, kad žemiau aprašyti šildymo sistemos komponentai skirti naudoti gyvenamojoje, komercinėje ir lengvosios pramonės aplinkose:
ovime izjavljuje pod isključivo svojom odgovornošću da dolje opisane komponente sustava za grijanje za upotrebu u stambenim, komercijalnim i lakooindustrijskim okruženjima:
ovim izjavljujemo pod svojom isključivom odgovornošću da su opisane komponente sistema grejanja za upotrebu u stambenim, poslovnim i lakim industrijskim okruženjima:

MITSUBISHI ELECTRIC, PAC-IF033B-E

Note: Its serial number is on the nameplate of the product.
Hinweis: Die Seriennummer befindet sich auf dem Kennschild des Produkts.
Remarque : Le numéro de série de l'appareil se trouve sur la plaque du produit.
Opmerking: het serienummer staat op het naamplaatje van het product.
Nota: El número de serie se encuentra en la placa que contiene el nombre del producto.
Nota: il numero di serie si trova sulla targhetta del prodotto.
Σημείωση: Ο σειριακός του αριθμός βρίσκεται στην πινακίδα ονόματος του προϊόντος.
Nota: o número de série encontra-se na placa que contém o nome do produto.
Bemærk: Seriennummeret står på produktets fabriksskilt.
Obs: Serienumret finns på produktens namnplåt.
Not: Seri numarası ürünün isim plakasında yer alır.
Примечание: серийный номер указан на паспортное табличке изделия.
Примітка. Серійний номер вказано на паспортній таблиці виробу.
Забелешка: Серийният му номер е на табелката на продукта.

Uwaga: Numer seryjny znajduje się na tabliczce znamionowej produktu.
Merk: Seriennummeret befinner seg på navneplaten til produktet.
Huomautus: Sarjanumero on merkitty laitteen arvokilpeeseen.
Poznámka: Příslušné sériové číslo se nachází na štítku produktu.
Poznámka: Výrobné číslo sa nachádza na typovom štítku výrobku.
Megjegyzés: A sorozatszám a termék adattábláján található.
Opomba: serijska številka je zapisana na tipski ploščici enote.
Notă: Numărul de serie este specificat pe plăcuța indicatoare a produsului.
Märkus. Seerianumber asub toote andmesidil.
Piezīme. Sērijas numurs ir norādīts uz ierīces datu plāksnītes.
Pastaba. Sērijas numeris nurodytas gaminio vardinį duomenų lentelėje.
Napomena: serijski broj nalazi se na natpisnoj pločici proizvoda.
Napomena: Serijski broj nalazi se na nazivnoj pločici proizvoda.

Directives
Richtlijnen
Directives
Directives
Directives
Directives
Direttive
Οδηγίες

Directivas
Direktiver
Direktiv
Direktifler
Директивы
Директиви
Директиви

Dyrektwy
Direktiver
Direktivit
Směrnice
Smernice
Írányelvek
Direktive

Directive
Direktiivid
Direktivas
Direktivos
Direktive
Direktive

2014/35/EU: Low Voltage
2014/30/EU: Electromagnetic Compatibility
2011/65/EU, (EU) 2015/863 and (EU) 2017/2102: RoHS Directive

Issued
JAPAN

1 Dec. 2019

Katsuo YABUTA
Senior Manager, Quality Assurance Department

Please be sure to put the contact address/telephone number on
this manual before handing it to the customer.