

PARTS CATALOG

[Model Name]

PAC-IF011B-E
PAC-IF012B-E
PAC-IF021B-E
PAC-IF031B-E
PAC-IF032B-E
PAC-IF033B-E
PAC-IF013B-E
PAC-SIF013B-E

Revision:

- Some descriptions have been modified in REVISED EDITION-F.

OCB427 REVISED EDITION-E is void.

CONTENTS

1. SERVICE PARTS LIST	2
------------------------------------	----------

1

SERVICE PARTS LIST

PAC-IF011B-E
PAC-IF021B-E
PAC-IF032B-E

PAC-IF012B-E
PAC-IF031B-E
PAC-IF033B-E

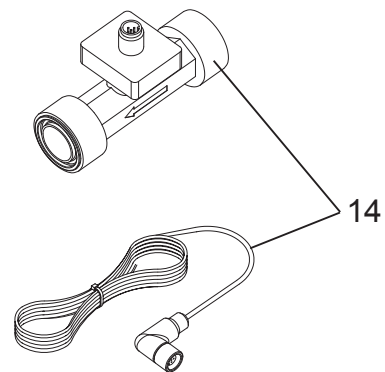
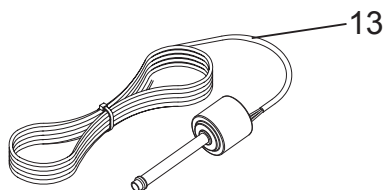
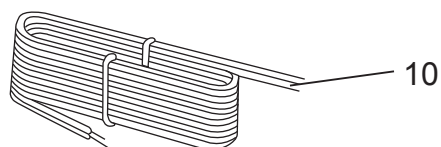
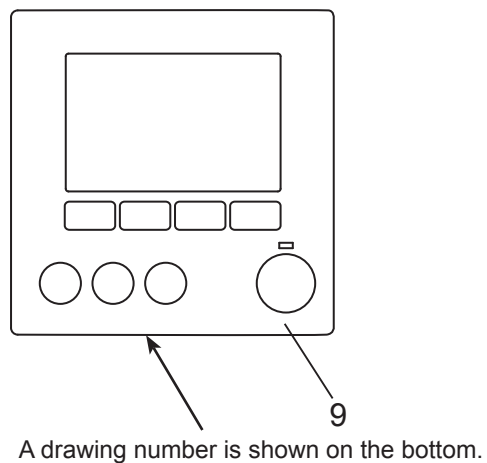
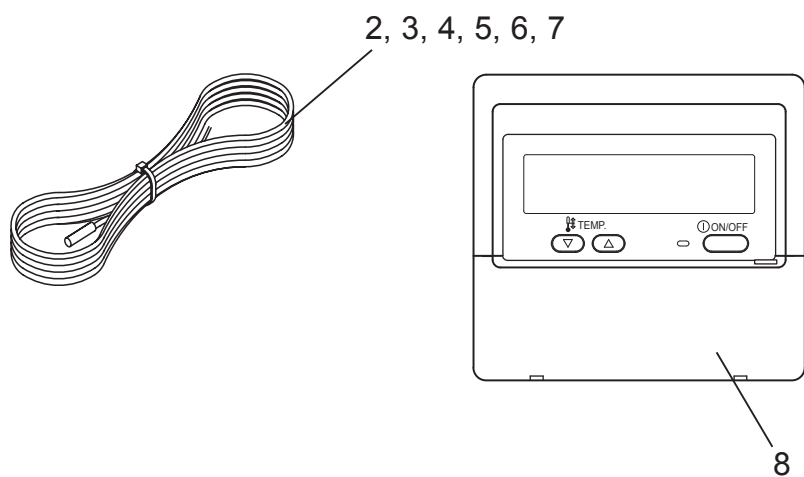
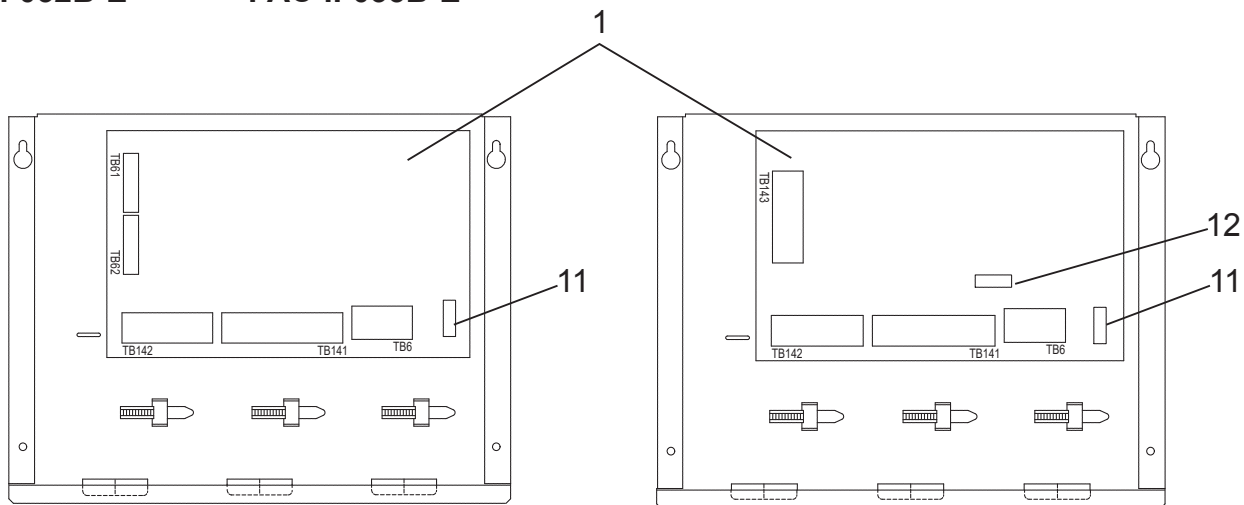

1. The part quantity below indicates the required number of pieces per unit.
2. The circled No. indicates that the part is not shown in the figure.

No.	Parts No.	Parts Name	PAC-IF011B-E	PAC-IF012B-E	PAC-IF021B-E	PAC-IF031B-E	PAC-IF032B-E	PAC-IF033B-E	Wiring Diagram Symbol	Remarks [Drawing No.]
1	T7W E68 310	INTERFACE BOARD	1						Interface controller	
1	T7W E91 310	INTERFACE BOARD		1					Interface controller	
1	R01 V18 310	INTERFACE BOARD			1				FTC	
1	T7W E92 310	INTERFACE BOARD				1			FTC2	
1	T7W F02 310	INTERFACE BOARD					1		FTC2B	
1	T7W F25 310	INTERFACE BOARD						1	FTC2BR	
2	R01 H80 202	THERMISTOR	1	1	1	1			TH1, TH2, TH5	5 m, SHEATH: GRAY
3	T7W E55 202	THERMISTOR	1	1	1	1				5 m, SHEATH: BLACK
4	T7W E62 202	THERMISTOR		1		1				5 m, SHEATH: RED
5	T7W E63 202	THERMISTOR					1	1	TH2	5 m, CONNECTOR: YELLOW
6	T7W E64 202	THERMISTOR					1	1	THW1, THW2	5 m, CONNECTOR: RED
7	T7W E65 202	THERMISTOR					1	1	THW5	5 m, CONNECTOR: WHITE
8	—	REMOTE CONTROLLER			1					PAR-W21MAA
8	R01 E00 713	REMOTE CONTROLLER				1				
9	T7W E18 713	REMOTE CONTROLLER					1	1		
10	R01 E10 305	REMOCON CABLE 5M			1	1	1	1		5 m, FOR REMOTE CONTROLLER
11	R01 E11 239	FUSE 3.15 A 250 V	1	1	1	1	1	1	F1	3.15 A 250 V
12	R01 E14 239	FUSE 6.3 A 250 V						1	F2	6.3 A 250 V
13	—	PRESSURE SENSOR						1	CN401	1.9 m, PAC-PS01-E (Optional part)
14	—	FLOW SENSOR						1	CN1A	5 m, PAC-FS01-E (Optional part)

PAC-IF013B-E

PAC-SIF013B-E

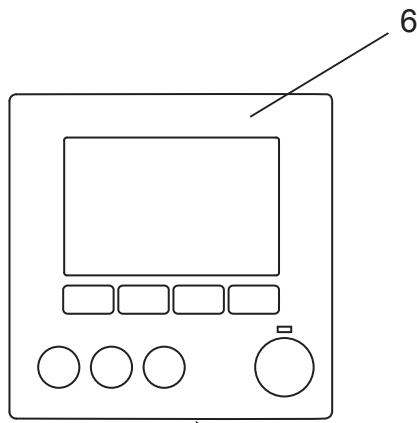
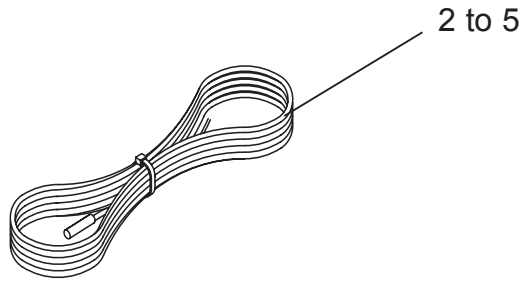
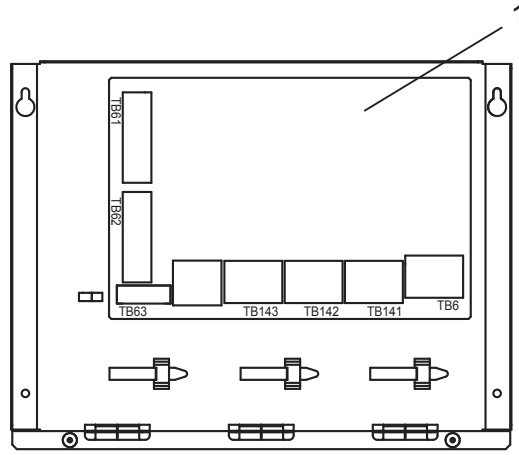

A drawing number is shown on the bottom.

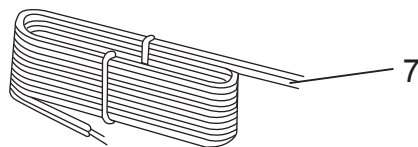

1. The part quantity below indicates the required number of pieces per unit.
2. The circled No. indicates that the part is not shown in the figure.

No.	Parts No.	Parts Name	PAC-IF013B-E	PAC-SIF013B-E	Wiring Diagram Symbol	Remarks [Drawing No.]
1	T7W F14 310	INTERFACE BOARD	1	1	Interface controller	
2	R01 H80 202	THERMISTOR	1	1	TH1, TH2, TH5, TH11	5 m, SHEATH: GRAY
3	T7W E55 202	THERMISTOR	1	1		5 m, SHEATH: BLACK
4	T7W E62 202	THERMISTOR	1	1		5 m, SHEATH: RED
5	T7W E76 202	THERMISTOR	1	1		5 m, SHEATH: BLUE
6	T7W E20 713	REMOTE CONTROLLER	1			[BH00J360B01]
7	R01 E10 305	REMOCON CABLE 5M	1			5 m, FOR REMOTE CONTROLLER
8	R01 E17 239	FUSE 3.15A 250V	1	1	F1	3.15 A 250 V

MITSUBISHI ELECTRIC CORPORATION

HEAD OFFICE: TOKYO BUILDING, 2-7-3, MARUNOUCHI, CHIYODA-KU, TOKYO 100-8310, JAPAN

©Copyright 2007 MITSUBISHI ELECTRIC CORPORATION
Issued: Mar. 2020 No. OCB427 REVISED EDITION-F
Issued: Mar. 2019 No. OCB427 REVISED EDITION-E
Issued: Jul. 2015 No. OCB427 REVISED EDITION-D
Issued: Sep. 2013 No. OCB427 REVISED EDITION-C
Issued: Apr. 2009 No. OCB427 REVISED EDITION-B PDF 7
Issued: Apr. 2008 No. OCB427 REVISED EDITION-A PDF 8
Published: Oct. 2007 No. OCB427 PDF 8
Made in Japan

Specifications are subject to change without notice.