

Lossnay Quick Reference Guide 2010

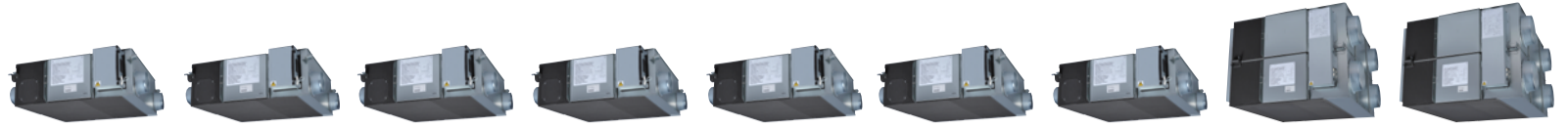

MODEL REFERENCE		COMMERCIAL LGH-15RX5-E	COMMERCIAL LGH-25RX5-E	COMMERCIAL LGH-35RX5-E	COMMERCIAL LGH-50RX5-E	COMMERCIAL LGH-65RX5-E	COMMERCIAL LGH-80RX5-E	COMMERCIAL LGH-100RX5-E	COMMERCIAL LGH-150RX5-E	COMMERCIAL LGH-200RX5-E	
ELECTRICAL POWER SUPPLY		220-240V, 50Hz	220-240V, 50Hz	220-240V, 50Hz	220-240V, 50Hz	220-240V, 50Hz	220-240V, 50Hz	220-240V, 50Hz	220-240V, 50Hz	220-240V, 50Hz	
STARTING CURRENT (A)		0.8	0.9	2.4	3.0	4.4	3.8	4.6	7.3	11.9	
RUNNING CURRENT (A)	Extra Low	0.15	0.18	0.30	0.40	0.60	0.65	0.90	-	-	
	Low	0.25	0.27	0.51	0.85	1.20	1.45	1.70	2.90	3.40	
	High	0.38	0.48	0.74	1.00	1.50	1.60	2.10	3.20	4.20	
	Extra High	0.46	0.55	0.92	1.25	1.80	1.75	2.40	3.50	4.80	
INPUT POWER (W)	Extra Low	35	42	69	95	140	145	200	-	-	
	Low	59	62	116	190	265	340	380	680	785	
	High	90	114	169	228	322	370	475	740	980	
	Extra High	110	129	212	286	380	415	535	830	1100	
AIRFLOW (m³/h)	Extra Low	70	105	115	180	265	355	415	-	-	
	Low	110	155	210	390	520	700	755	1300	1580	
	High / Extra High	150	250	350	500	650	800	1000	1500	2000	
AIRFLOW (l/s)	Extra Low	19	29	32	50	74	99	115	-	-	
	Low	31	43	58	108	144	194	210	361	439	
	High / Extra High	42	69	97	139	181	222	278	417	556	
EXTERNAL STATIC PRESSURE (Pa)	Extra Low	14	9	9	10	8	20	18	-	-	
	Low	40	25	30	60	50	95	60	100	65	
	High	70	60	80	90	80	120	110	135	105	
	Extra High	105	85	160	155	120	150	170	175	165	
NOISE (dBA)	Lossnay	Extra Low	18	19	18	19	22	22	22	-	-
		Low	23.5	21.5	23	28	31.5	31	32.5	35	34
		High	27	26	29.5	32	33	33	35	37.5	38
		Extra High	28	27	32	34	34.5	34.5	37	39	40
	Bypass	Extra Low	19	19	18	19	22.5	22	22	-	-
		Low	24	22	24	29	30.5	32	33	37	35
		High	28	26.5	30.5	32.5	33.5	34	36	39	39
		Extra High	29	27.5	32.5	35	35	35.5	38	40.5	41
TEMPERATURE EXCHANGE EFFICIENCY (%)	Extra Low	85.5	83.5	88	86	86	87.5	87	-	-	
	Low	84	81.5	85	81	80	80.5	83	81	83	
	High	82	79	80	78	77	79	80	80	80	
	Extra High	82	79	80	78	77	79	80	80	80	
ENTHALPY EXCHANGE EFFICIENCY (%)	Heating	Extra Low	81	77.5	81.5	78	78	79.5	80	-	-
		Low	77.5	74	76.5	71	70.5	72.5	74	72.5	73.5
		High / Extra High	75	69.5	71.5	69	68.5	71	72.5	72	72.5
	Cooling	Extra Low	81	76	81	77	77	79.5	79	-	-
		Low	76.5	72.5	75.5	68	68.5	71.5	73	71.5	72
		High / Extra High	73	68	71	66.5	66	70	71	70.5	71
WEIGHT (kg)		20	20	29	32	40	53	59	105	118	
DIMENSIONS (mm)	Width	735	735	874	1016	954	1004	1231	1004	1231	
	Depth	780	780	888	888	908	1144	1144	1144	1144	
	Height	273	273	315	315	386	399	399	798	798	
DUCT SIZE (mm)		100	150	150	200	200	250	250	(S.A.R.A)250 (O.A.EA)270x700	(S.A.R.A)250 (O.A.EA)270x700	
STANDARD FILTER*1		EU-G3	EU-G3	EU-G3	EU-G3	EU-G3	EU-G3	EU-G3	EU-G3	EU-G3	
FUSE RATING (BS88) - HRC (A)		6	6	6	6	6	6	6	10	16	
MAINS CABLE NO. CORES		3	3	3	3	3	3	3	3	3	

Notes: Running Current, Input Power and Recovery Efficiency are based on the above airflow rate, power supply 240V, 50Hz. Extra High and High mode available via dip switch setting. Extra Low mode not available on sizes 150 and 200. Noise measured at 1.5m under the centre of panel. *1: EU-F7 filter available as optional parts.

CIBSE RECOMMENDED FRESH AIR RATES (36m³/h/person or 10l/s/person)

Number of people in Office	4.2	6.9	9.7	13.9	18.1	22.2	27.8	41.7	55.6	
Area of Office (m²)	16	27	37	53	69	85	107	160	214	
Recovery Heat Energy (kW)	Heating	1.2	1.9	2.7	3.7	4.8	6.2	7.9	11.7	15.8
	Cooling	0.5	0.8	1.2	1.6	2.1	2.8	3.5	5.2	7.0
Recovery Heat Energy (W/m²)	Heating	77	69	73	71	70	72	74	73	74
	Cooling	34	31	33	31	31	32	33	33	33

Calculation Conditions Winter = Outdoor air: DB 2.5 degC, RH 50% Indoor air: DB 21 degC, RH 50% Summer = Outdoor air: DB 27 degC, RH 50% Indoor air: DB 21 degC, RH 50% Hi fan speed, above airflow. m³/h = metres cubed per hour, l/s = litres per second.

Lossnay Installation Example

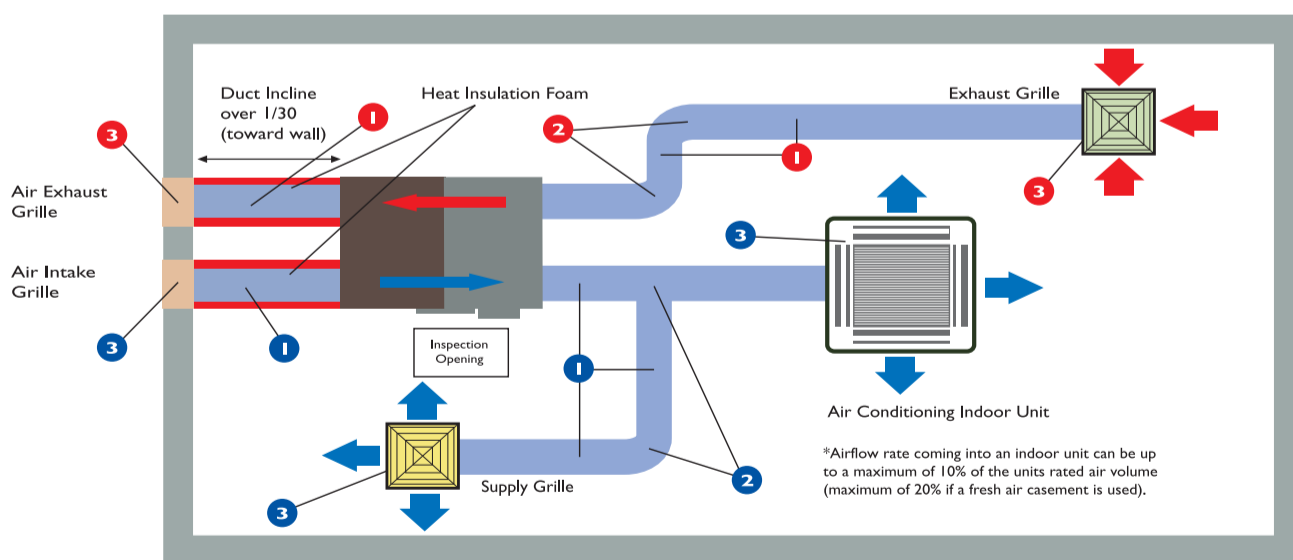

Step	How to calculate ductwork / air volume for supply duct run	Example
1	Required airflow → A (draw line A)	950 [m³/h]
2	Add together static pressure losses for the following. Static pressure loss from straight duct length Static pressure loss at curved sections Static pressure loss of related parts → B (draw line B)	1 20 [Pa] 2 40 [Pa] 3 35 [Pa] Total 95 [Pa]
3	Draw curve C (Estimated static pressure loss curve) which passes the intersection point between line A and line B	-
4	The intersection point between curve C and Hi fan characteristic curve shows the actual Hi fan airflow → D	992 [m³/h]
5	The intersection point between curve C and Low fan characteristic curve shows the actual Low fan airflow → E	857 [m³/h]
6	Three intersection points between three exchange efficiency curves and line D show the actual efficiency at Hi fan speed	78% - 72% - 67%
7	Three intersection points between three exchange efficiency curves and line D show the actual efficiency at Low fan speed	82% - 74% - 69%

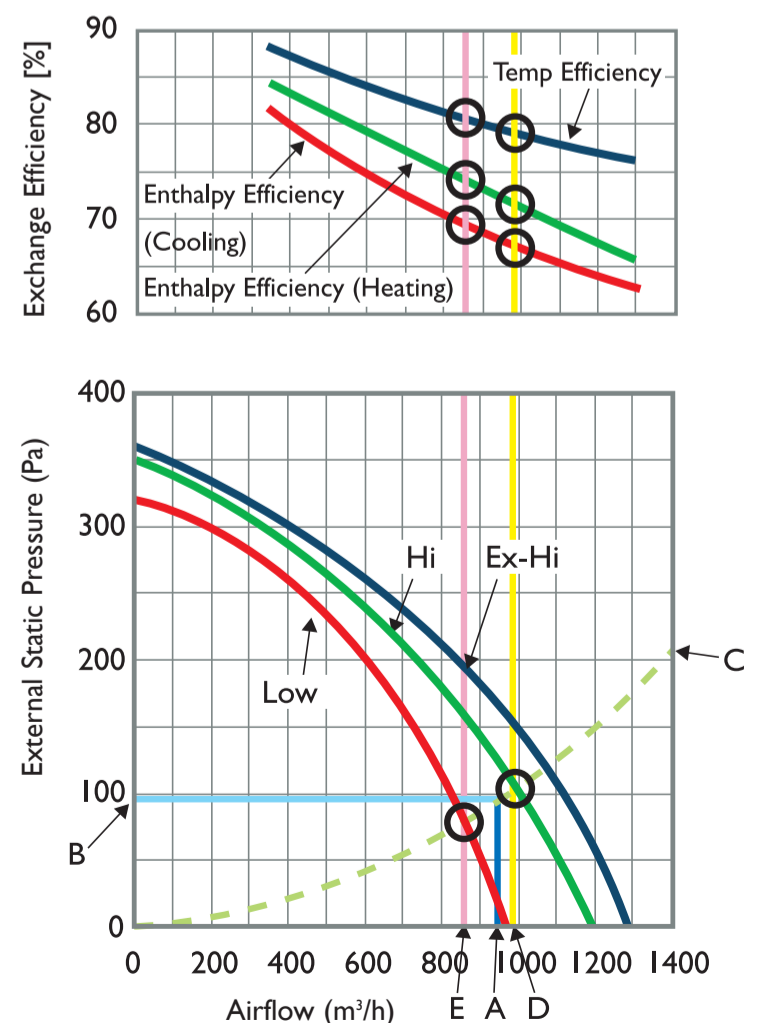

Lossnay Quick Reference Guide 2010

Fan Characteristic Curves

LGH-15RX5-E

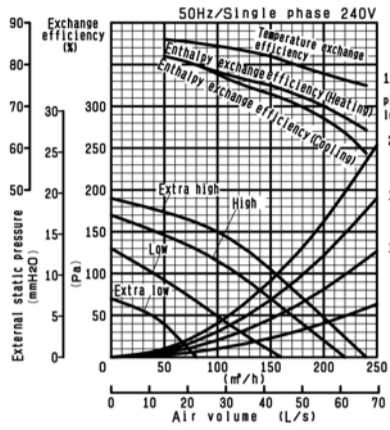

LGH-25RX5-E

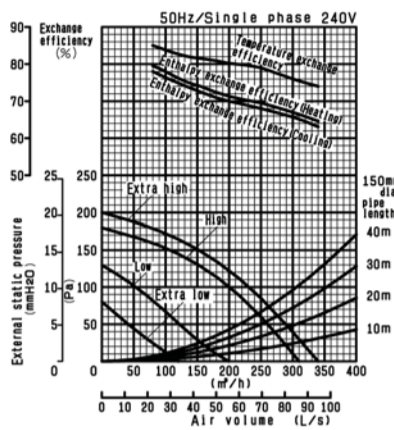

LGH-35RX5-E

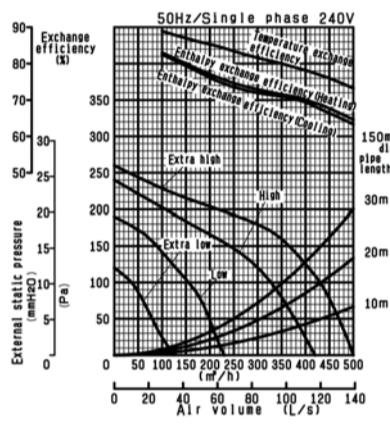

LGH-50RX5-E

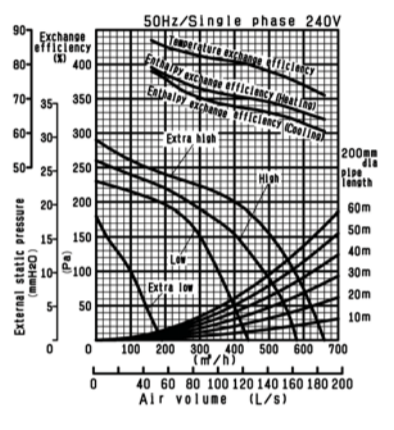

LGH-65RX5-E

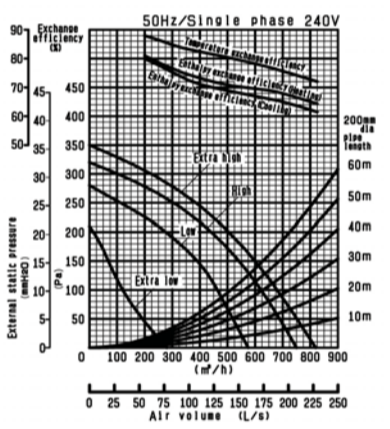

LGH-80RX5-E

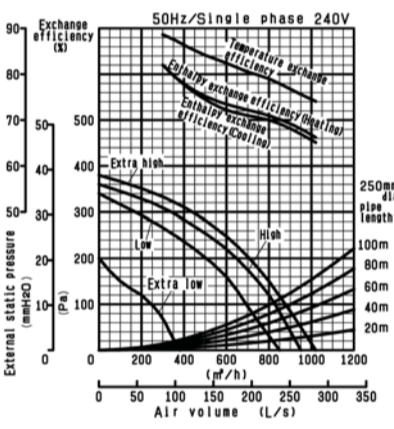

LGH-100RX5-E

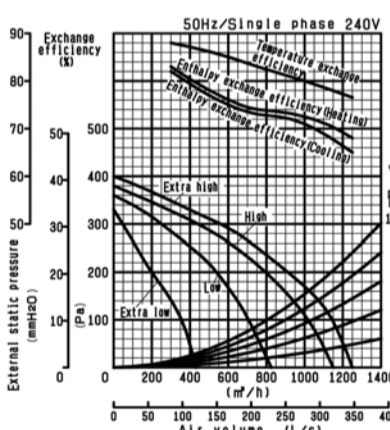

LGH-150RX5-E

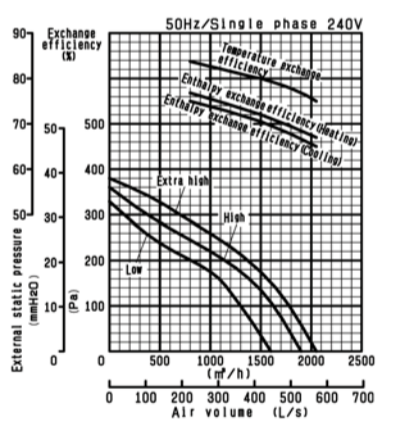

LGH-200RX5-E

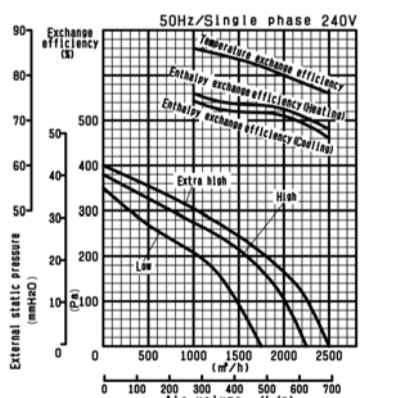

Wiring Diagrams

LGH-15-100RX5-E

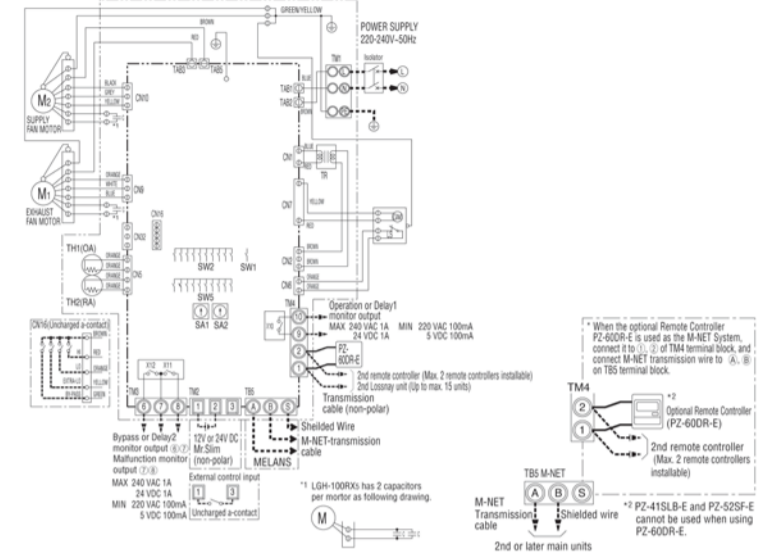

LGH-150-200RX5-E

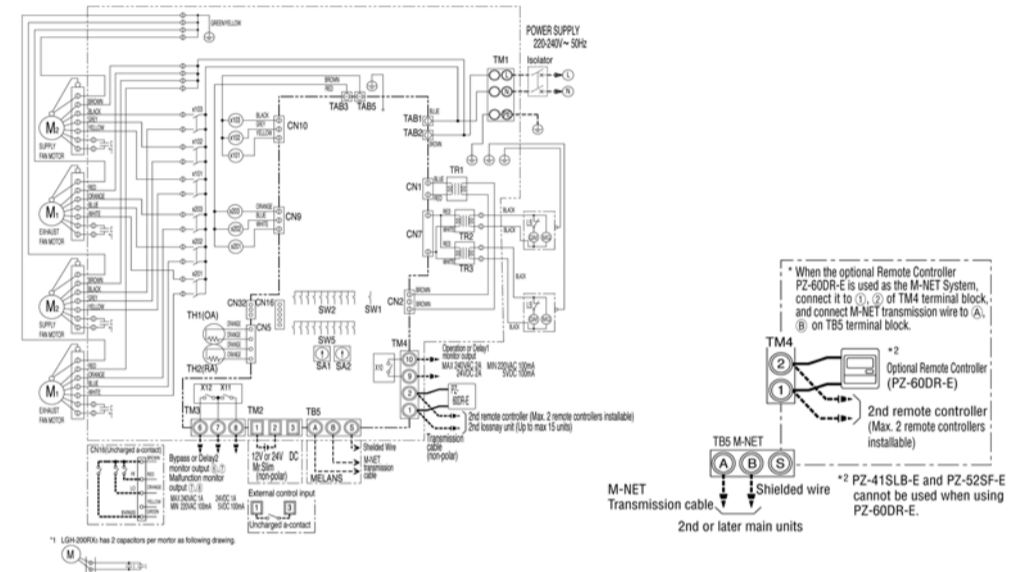

Schematics

LGH-15-100RX5-E

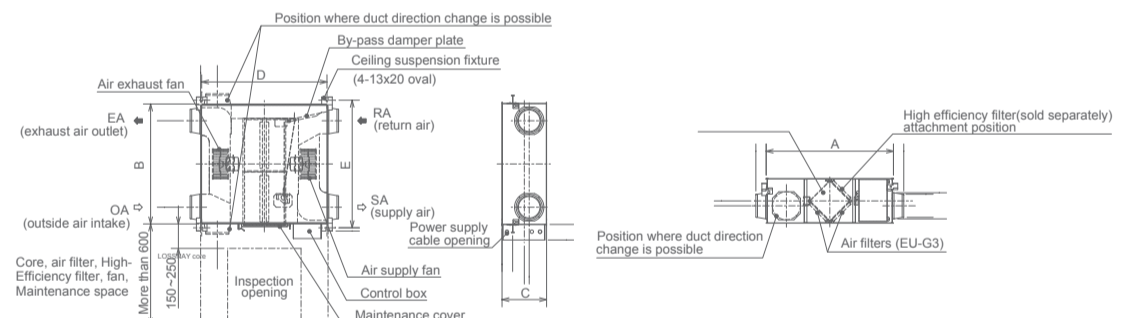

MODEL REFERENCE	DIMENSIONS			CEILING SUSPENSION FIXTURE PITCH		NOMINAL DIAMETER
	A	B	C	D	E	
LGH-15RX5-E	780		273	768	782	ø100
LGH-25RX5-E	780		273	768	782	ø150
LGH-35RX5-E	888		315	875	921	ø150
LGH-50RX5-E	888		315	875	1063	ø200
LGH-65RX5-E	908		386	895	1001	ø200
LGH-80RX5-E	1144		399	1010	1036	ø250
LGH-100RX5-E	1144		399	1010	1263	ø250

LGH-150-200RX5-E

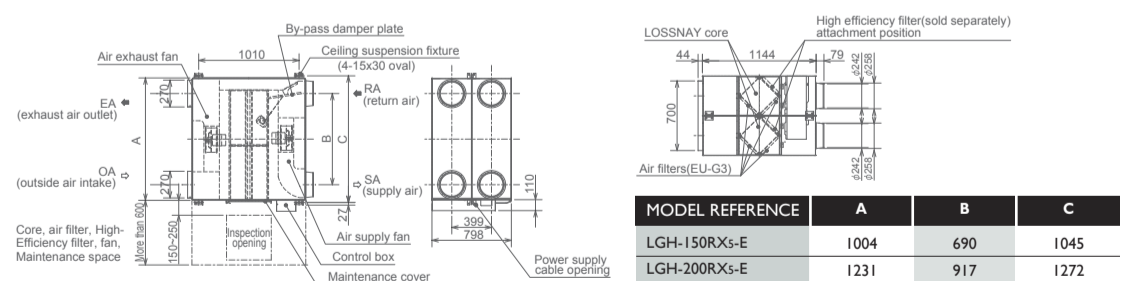

MODEL REFERENCE	DIMENSIONS		
	A	B	C
LGH-150RX5-E	1004	690	1045
LGH-200RX5-E	1231	917	1272

Lossnay Core

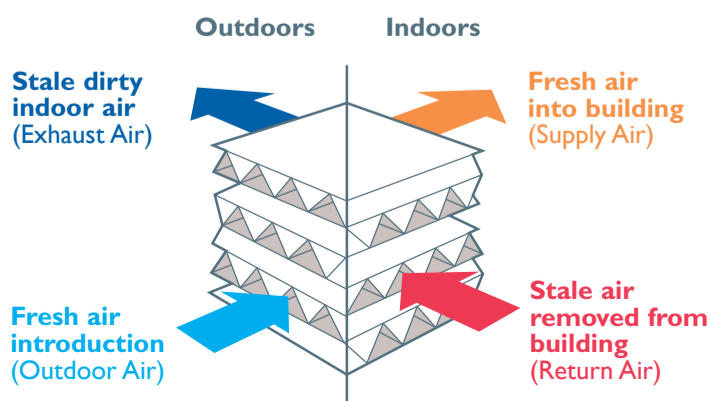

General Enquiries **01707 282880**
 Post Sales Technical Support / Spares & Warranty **0870 3000 300**
 email: airconditioning@meuk.mee.com web: www.mitsubishielectric.co.uk/aircon

UNITED KINGDOM Mitsubishi Electric Europe Air Conditioning Systems Division
 Travellers Lane, Hatfield, Hertfordshire, AL10 8XB, England. General enquiries Tel: 01707 282880 Fax: 01707 278674

IRELAND Mitsubishi Electric Europe
 Westgate Business Park, Ballymount, Dublin 24, Ireland. Tel: Dublin (01) 419 8800 Fax: Dublin (01) 419 8890 International code: (003531)

Country of origin: United Kingdom - Japan - Thailand - Malaysia. © Mitsubishi Electric Europe 2010. Mitsubishi and Mitsubishi Electric are trademarks of Mitsubishi Electric Europe B.V. The company reserves the right to make any variation in technical specification to the equipment described or to withdraw or replace products without prior notification or public announcement. Mitsubishi Electric is constantly developing and improving its products. All descriptions, illustrations, drawings and specifications in this publication present only general particulars and shall not form part of any contract. All goods are supplied subject to the Company's General Conditions of Sale, a copy of which is available on request. Third-party product and brand names may be trademarks or registered trademarks of their respective owners.