

SERVICE MANUAL

R32

<Outdoor unit>

[Model Name]

PUZ-HWM140VHA

PUZ-HWM140YHA

[Service Ref.]

PUZ-HWM140VHA

PUZ-HWM140YHA

Notes:

- This manual describes service data of outdoor unit only.

Revision:

- Added connectable indoor units in REVISED EDITION-A.

OCH748 is void.

Salt proof model

PUZ-HWM140VHA-BS

PUZ-HWM140YHA-BS

PUZ-HWM140VHA-BS

PUZ-HWM140YHA-BS

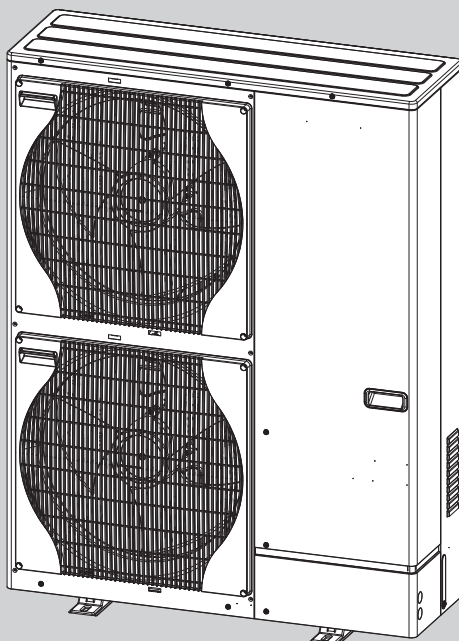





CONTENTS

1. REFERENCE MANUAL.....	2
2. SAFETY PRECAUTION.....	3
3. SPECIFICATIONS.....	10
4. DATA	13
5. OUTLINES AND DIMENSIONS.....	14
6. WIRING DIAGRAM.....	15
7. WIRING SPECIFICATIONS	17
8. REFRIGERANT SYSTEM DIAGRAM	18
9. TROUBLESHOOTING	19
10. DISASSEMBLY PROCEDURE.....	68

PARTS CATALOG (OCB748)

Models		Power inverter	
Type		Package	
Refrigerant		Heat pump	
Refrigerant		R32	
Type	Model name	PUZ-HWM140VHA(-BS)	PUZ-HWM140YHA(-BS)
Cylinder unit	EHPT20X-MED	x	x
	EHPT20X-VM6D	x	x
	EHPT20X-YM9D	x	x
	EHPT20X-YM9ED	x	x
	EHPT20X-TM9D	x	x
	EHPT20X-MHEDW	x	x
	ERPT20X-MD	x	x
	ERPT20X-VM2D	x	x
	ERPT20X-VM6D	x	x
	EHPT30X-MED	x	x
	EHPT30X-YM9ED	x	x
	ERPT30X-VM2ED	x	x
	EHPT20X-YM9E	x	x
	EHPT20X-TM9E	x	x
	EHPT20X-MEHEW	x	x
	EHPT30X-YM9EE	x	x
	ERPT20X-VM2E	x	x
	ERPT20X-VM6E	x	x
	ERPT20X-YM9E	x	x
	ERPT30X-VM2EE	x	x
	ERPT30X-VM6EE	x	x
ERPT30X-YM9EE	x	x	
Hydrobox	EHPX-MED	x	x
	EHPX-VM2D	x	x
	EHPX-VM6D	x	x
	EHPX-YM9D	x	x
	EHPX-YM9ED	x	x
	ERPX-ME	x	x
	ERPX-VM2E	x	x
	ERPX-VM6E	x	x
ERPX-YM9E	x	x	

MEANINGS OF SYMBOLS DISPLAYED ON THE UNIT

	WARNING (Risk of fire)	This mark is for R32 refrigerant only. Refrigerant type is written on nameplate of heat pump unit. In case that refrigerant type is R32, this unit uses a flammable refrigerant. If refrigerant leaks and comes in contact with fire or heating part, it will create harmful gas and there is risk of fire.
	Read the OPERATION MANUAL carefully before operation.	
	Service personnel are required to carefully read the OPERATION MANUAL and INSTALLATION MANUAL before operation.	
	Further information is available in the OPERATION MANUAL, INSTALLATION MANUAL, and the like.	

2-1. ALWAYS OBSERVE FOR SAFETY

Before obtaining access to terminal, all supply circuits must be disconnected.

2-2. CAUTIONS RELATED TO NEW REFRIGERANT

Cautions for units utilizing refrigerant R32

Preparations before the repair service

- Prepare the proper tools.
- Prepare the proper protectors.
- Provide adequate ventilation.
- After stopping the operation of the air to water heat pump unit, turn off the power-supply breaker.
- Discharge the condenser before the work involving the electric parts.

Use a vacuum pump with a reverse flow check valve.

Vacuum pump oil may flow back into refrigerant cycle and that can cause deterioration of refrigerant oil, etc.

Use the following tools specifically designed for use with R32 refrigerant.

The following tools are necessary to use R32 refrigerant.

Tools for R32	
Gauge manifold	Flare tool
Charge hose	Size adjustment gauge
Gas leak detector	Vacuum pump adaptor
Torque wrench	Electronic refrigerant charging scale

Do not use refrigerant other than R32.

If other refrigerant (R22, etc.) is used, chlorine in refrigerant can cause deterioration of refrigerant oil, etc.

Preparations during the repair service

- Do not perform the work involving the electric parts with wet hands.
- Do not pour water into the electric parts.
- Do not touch the refrigerant.
- Do not touch the hot or cold areas in the refrigerating cycle.
- When the repair or the inspection of the circuit needs to be done without turning off the power, exercise great caution not to touch the live parts.

Handle tools with care.

If dirt, dust or moisture enters into refrigerant cycle, that can cause deterioration of refrigerant oil or malfunction of compressor.

Use the specified refrigerant only.**Never use any refrigerant other than that specified.**

Doing so may cause a burst, an explosion, or fire when the unit is being used, serviced, or disposed of.

Correct refrigerant is specified in the manuals and on the spec labels provided with our products.

We will not be held responsible for mechanical failure, system malfunction, unit breakdown or accidents caused by failure to follow the instructions.

Ventilate the room if refrigerant leaks during operation. If refrigerant comes into contact with a flame, poisonous gases will be released.

[1] Warning for service

- (1) Do not alter the unit.
- (2) For installation and relocation work, follow the instructions in the Installation Manual and use tools and pipe components specifically made for use with refrigerant specified in the outdoor unit installation manual.
- (3) Ask a dealer or an authorized technician to install, relocate and repair the unit.
For appliances not accessible to the general public.
- (4) Refrigerant pipes connection shall be accessible for maintenance purposes.
- (5) If the heat pump unit is installed in a small room or closed room, measures must be taken to prevent the refrigerant concentration in the room from exceeding the safety limit in the event of refrigerant leakage. Should the refrigerant leak and cause the concentration limit to be exceeded, hazards due to lack of oxygen in the room may result.
- (6) Keep gas-burning appliances, electric heaters, and other fire sources (ignition sources) away from the location where installation, repair, and other work will be performed.
If refrigerant comes into contact with a flame, poisonous gases will be released.
- (7) When installing or relocating, or servicing the heat pump unit, use only the specified refrigerant (R32) to charge the refrigerant lines.
Do not mix it with any other refrigerant and do not allow air to remain in the lines.
If air is mixed with the refrigerant, then it can be the cause of abnormal high pressure in the refrigerant line, and may result in an explosion and other hazards.
- (8) After installation has been completed, check for refrigerant leaks. If refrigerant leaks into the room and comes into contact with the flame of a heater or portable cooking range, poisonous gases will be released.
- (9) Do not use low temperature solder alloy in the case of brazing the refrigerant pipes.
- (10) When performing brazing work, be sure to ventilate the room sufficiently or work outside. Make sure that there are no hazardous or flammable materials nearby.
When performing the work in a closed room, small room, or similar location, make sure that there are no refrigerant leaks before performing the work.
If refrigerant leaks and accumulates, it may ignite or poisonous gases may be released.
- (11) Do not install the unit in places where refrigerant may build-up or places with poor ventilation such as a semi-basement: Refrigerant is heavier than air, and inclined to fall away from the leak source.
- (12) The appliance shall be stored in a room without continuously operating ignition sources (for example: open flames, an operating gas appliance or an operating electric heater).
- (13) Do not pierce or burn.
- (14) Do not use means to accelerate the defrosting process or to clean, other than those recommended by the manufacturer.
- (15) Be aware that refrigerants may not contain an odour.
- (16) Pipe-work shall be protected from physical damage.
- (17) Compliance with national gas regulations shall be observed.
- (18) Keep any required ventilation openings clear of obstruction.
- (19) Servicing shall be performed only as recommended by the manufacturer.
- (20) The appliance shall be stored in a well-ventilated area where the room size corresponds to the room area as specified for operation.
- (21) Maintenance, service and repair operations shall be performed by authorized technician with required qualification.
- (22) Be sure to have appropriate ventilation in order to prevent ignition. Furthermore, be sure to carry out fire prevention measures that there are no dangerous or flammable objects in the surrounding area.

[2] Cautions for service

- (1) Perform service after recovering the refrigerant left in unit completely.
- (2) Do not release refrigerant in the air.
- (3) After completing service, charge the cycle with specified amount of refrigerant.
- (4) When performing service, install a filter drier simultaneously.
Be sure to use a filter drier for new refrigerant.

[3] Refrigerant charge

When charging directly from cylinder

R32 is a single refrigerant and its composition does not change. Therefore, both liquid charging and gas charging are possible. Liquid charging of refrigerant all at once from the low pressure side may cause the compressor malfunction. Accordingly, make sure that charging is gradual.

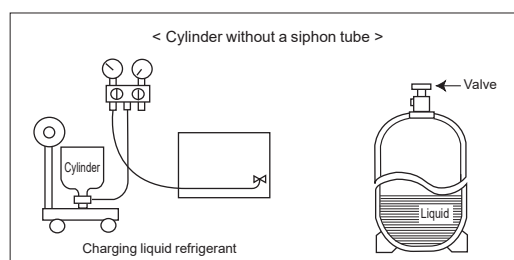
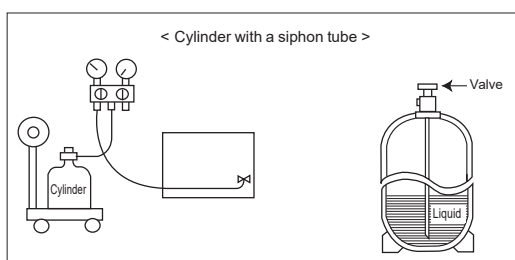

[4] Cautions for unit using R32 refrigerant

Pay careful attention to the following points.

(1) Information on servicing

(1-1) Checks on the Area

Prior to beginning work on systems containing flammable refrigerants, safety checks are necessary to ensure that the risk of ignition is minimized.

For repair to the refrigerating systems, (1-3) to (1-7) shall be completed prior to conducting work on the systems.

(1-2) Work Procedure

Work shall be undertaken under a controlled procedure so as to minimize the risk of a flammable gas or vapor being present while the work is being performed.

(1-3) General Work Area

All maintenance staff and others working in the local area shall be instructed on the nature of work being carried out.

Work in confined spaces shall be avoided. The area around the workspace shall be sectioned off. Ensure that the conditions within the area have been made safe by control of flammable material.

(1-4) Checking for Presence of Refrigerant

The area shall be checked with an appropriate refrigerant detector prior to and during work, to ensure the technician is aware of potentially toxic or flammable atmospheres. Ensure that the leak detection equipment being used is suitable for use with all applicable refrigerants, i.e. non-sparking, adequately sealed or intrinsically safe.

(1-5) Presence of Fire Extinguisher

If any hot work is to be conducted on the refrigeration equipment or any associated parts, appropriate fire extinguishing equipment shall be available to hand.

Have a dry powder or CO2 fire extinguisher adjacent to the charging area.

(1-6) No Ignition Sources

No person carrying out work in relation to a refrigeration system which involves exposing any pipe work shall use any sources of ignition in such a manner that it may lead to the risk of fire or explosion. All possible ignition sources, including cigarette smoking, should be kept sufficiently far away from the site of installation, repairing, removing and disposal, during which refrigerant can possibly be released to the surrounding space. Prior to work taking place, the area around the equipment is to be surveyed to make sure that there are no flammable hazards or ignition risks. "No Smoking" signs shall be displayed.

(1-7) Ventilated Area

Ensure that the area is in the open or that it is adequately ventilated before breaking into the system or conducting any hot work. A degree of ventilation shall continue during the period that the work is carried out. The ventilation should safely disperse any released refrigerant and preferably expel it externally into the atmosphere.

(1-8) Checks on the Refrigeration Equipment

Where electrical components are being changed, they shall be fit for the purpose and to the correct specification. At all times the manufacturer's maintenance and service guidelines shall be followed. If in doubt, consult the manufacturer's technical department for assistance.

The following checks shall be applied to installations using flammable refrigerants:

- The charge size is in accordance with the room size within which the refrigerant containing parts are installed.
- The ventilation machinery and outlets are operating adequately and are not obstructed.
- Marking to the equipment continues to be visible and legible. Markings and signs that are illegible shall be corrected.
- Refrigeration pipe or components are installed in a position where they are unlikely to be exposed to any substance which may corrode refrigerant containing components, unless the components are constructed of materials which are inherently resistant to being corroded or are suitably protected against being corroded.

(1-9) Checks on Electrical Devices

Repair and maintenance to electrical components shall include initial safety checks and component inspection procedures. If a fault exists that could compromise safety, then no electrical supply shall be connected to the circuit until it is satisfactorily dealt with. If the fault cannot be corrected immediately but it is necessary to continue operation, an adequate temporary solution shall be used. This shall be reported to the owner of the equipment so all parties are advised. Initial safety checks shall include that:

- capacitors are discharged: this shall be done in a safe manner to avoid possibility of sparking;
- no live electrical components and wiring are exposed while charging, recovering or purging the system;
- there is continuity of earth bonding

(2) Repairs to Sealed Components

(2-1) During repairs to sealed components, all electrical supplies shall be disconnected from the equipment being worked upon prior to any removal of sealed covers, etc. If it is absolutely necessary to have an electrical supply to equipment during servicing, then a permanently operating form of leak detection shall be located at the most critical point to warn of a potentially hazardous situation.

(2-2) Particular attention shall be paid to the following to ensure that by working on electrical components, the casing is not altered in such a way that the level of protection is affected. This shall include damage to cables, excessive number of connections, terminals not made to original specification, damage to seals, incorrect fitting of glands, etc.

Ensure that the apparatus is mounted securely.

Ensure that seals or sealing materials have not degraded to the point that they no longer serve the purpose of preventing the ingress of flammable atmospheres.

Replacement parts shall be in accordance with the manufacturer's specifications.

(3) Repair to intrinsically Safe Components

Do not apply any permanent inductive or capacitance loads to the circuit without ensuring that this will not exceed the permissible voltage and current permitted for the equipment in use.

Intrinsically safe components are the only types that can be worked on while live in the presence of a flammable atmosphere. The test apparatus shall be at the correct rating.

Replace components only with parts specified by the manufacturer. Other parts may result in the ignition of refrigerant in the atmosphere from a leak.

(4) Cabling

Check that cabling will not be subject to wear, corrosion, excessive pressure, vibration, sharp edges or any other adverse environmental effects. The check shall also take into account the effects of aging or continual vibration from sources such as compressors or pumps.

(5) Detection of Flammable Refrigerants

Under no circumstances shall potential sources of ignition be used in the searching for or detection of refrigerant leaks.

A halide torch (or any other detector using a naked flame) shall not be used.

(6) Leak Detection Methods

Electronic leak detectors may be used to detect refrigerant leaks but, in the case of flammable refrigerants, the sensitivity may not be adequate, or may need re-calibration. (Detection equipment shall be calibrated in a refrigerant-free area.)

Ensure that the detector is not a potential source of ignition and is suitable for the refrigerant used. Leak detection equipment shall be set at a percentage of the LFL of the refrigerant and shall be calibrated to the refrigerant employed, and the appropriate percentage of gas (25% maximum) is confirmed.

Leak detection fluids are suitable for use with most refrigerants but the use of detergents containing chlorine shall be avoided as the chlorine may react with the refrigerant and corrode the copper pipe-work.

If a leak is suspected, all naked flames shall be removed/extinguished.

If a leakage of refrigerant is found which requires brazing, all of the refrigerant shall be recovered from the system, or isolated (by means of shut off valves) in a part of the system remote from the leak. For appliances containing flammable refrigerants, oxygen free nitrogen (OFN) shall then be purged through the system both before and during the brazing process.

(7) Removal and Evacuation

When breaking into the refrigerant circuit to make repairs – or for any other purpose conventional procedures shall be used. However, for flammable refrigerants it is important that best practice is followed since flammability is a consideration. The following procedure shall be adhered to:

- remove refrigerant
- purge the circuit with inert gas
- evacuate
- purge again with inert gas
- open the circuit by cutting or brazing.

The refrigerant charge shall be recovered into the correct recovery cylinders. For appliances containing flammable refrigerants, the system shall be “flushed” with OFN to render the unit safe. This process may need to be repeated several times.

Compressed air or oxygen shall not be used for purging refrigerant systems.

For appliances containing flammable refrigerants, flushing shall be achieved by breaking the vacuum in the system with OFN and continuing to fill until the working pressure is achieved, then venting to atmosphere, and finally pulling down to a vacuum. This process shall be repeated until no refrigerant is within the system. When the final OFN charge is used, the system shall be vented down to atmospheric pressure to enable work to take place. This operation is absolutely vital if brazing operations on the pipe-work are to take place.

Ensure that the outlet for the vacuum pump is not close to any ignition sources and that ventilation is available.

(8) Charging Procedures

In addition to conventional charging procedures, the following requirements shall be followed:

- Ensure that contamination of different refrigerants does not occur when using charging equipment. Hoses or lines shall be as short as possible to minimize the amount of refrigerant contained in them.
- Cylinders shall be kept upright.
- Ensure that the refrigeration system is earthed prior to charging the system with refrigerant.
- Label the system when charging is complete (if not already).
- Extreme care shall be taken not to overfill the refrigeration system.

Prior to recharging the system, it shall be pressure-tested with the appropriate purging gas. The system shall be leak-tested on completion of charging but prior to commissioning. A follow up leak test shall be carried out prior to leaving the site.

(9) Decommissioning

Before carrying out this procedure, it is essential that the technician is completely familiar with the equipment and all its detail. It is recommended good practice that all refrigerants are recovered safely. Prior to the task being carried out, an oil and refrigerant sample shall be taken in case analysis is required prior to re-use of reclaimed refrigerant. It is essential that electrical power is available before the task is commenced.

a) Become familiar with the equipment and its operation.

Continued to the next page

- b) Isolate system electrically.
- c) Before attempting the procedure, ensure that:
 - mechanical handling equipment is available, if required, for handling refrigerant cylinders;
 - all personal protective equipment is available and being used correctly;
 - the recovery process is supervised at all times by a competent person;
 - recovery equipment and cylinders conform to the appropriate standards.
- d) If a vacuum is not possible, make a manifold so that refrigerant can be removed from various parts of the system.
- e) Make sure that cylinder is situated on the scales before recovery takes place.
- f) Start the recovery machine and operate in accordance with manufacturer's instructions.
- g) Do not overfill cylinders. (No more than 80 % volume liquid charge).
- h) Do not exceed the maximum working pressure of the cylinder, even temporarily.
- i) When the cylinders have been filled correctly and the process completed, make sure that the cylinders and the equipment are removed from site promptly and all isolation valves on the equipment are closed off.
- j) Recovered refrigerant shall not be charged into another refrigeration system unless it has been cleaned and checked.

(10) Labelling

Equipment shall be labelled stating that it has been de-commissioned and emptied of refrigerant. The label shall be dated and signed. For appliances containing flammable refrigerants, ensure that there are labels on the equipment stating the equipment contains flammable refrigerant.

(11) Recovery

When removing refrigerant from a system, either for servicing or decommissioning, it is recommended good practice that all refrigerants are removed safely. When transferring refrigerant into cylinders, ensure that only appropriate refrigerant recovery cylinders are employed. Ensure that the correct number of cylinders for holding the total system charge are available. All cylinders to be used are designated for the recovered refrigerant and labelled for that refrigerant (i.e. special cylinders for the recovery of refrigerant). Cylinders shall be complete with pressure-relief valve and associated shut-off valves in good working order. Empty recovery cylinders are evacuated and, if possible, cooled before recovery occurs.

The recovery equipment shall be in good working order with a set of instructions concerning the equipment that is at hand and shall be suitable for the recovery of all appropriate refrigerants including, when applicable, flammable refrigerants. In addition, a set of calibrated weighing scales shall be available and in good working order. Hoses shall be complete with leak-free disconnect couplings and in good condition. Before using the recovery machine, check that it is in satisfactory working order, has been properly maintained and that any associated electrical components are sealed to prevent ignition in the event of a refrigerant release. Consult manufacturer if in doubt.

The recovered refrigerant shall be returned to the refrigerant supplier in the correct recovery cylinder, and the relevant waste transfer note arranged. Do not mix refrigerants in recovery units and especially not in cylinders. If compressors or compressor oils are to be removed, ensure that they have been evacuated to an acceptable level to make certain that flammable refrigerant does not remain within the lubricant. The evacuation process shall be carried out prior to returning the compressor to the suppliers. Only electric heating to the compressor body shall be employed to accelerate this process. When oil is drained from a system, it shall be carried out safely.

(12) Parts inspection

Parts	Check every	Possible failures
Pressure relief valve (3 bar) Temperature and pressure relief valve	1 year (pushing the lever manually)	PRV would be fixed and expansion vessel would burst

[5] Service tools

Use the below service tools as exclusive tools for R32 refrigerant.

No.	Tool name	Specifications
①	Gauge manifold	<ul style="list-style-type: none"> · Only for R32 · Use the existing fitting specifications. (UNF1/2) · Use high-tension side pressure of 5.3 MPa·G or over.
②	Charge hose	<ul style="list-style-type: none"> · Only for R32 · Use pressure performance of 5.09 MPa·G or over.
③	Electronic weighing scale	—
④	Gas leak detector	· Use the detector for R134a, R407C, R410a or R32.
⑤	Adaptor for reverse flow check	· Attach on vacuum pump.
⑥	Refrigerant charge base	—
⑦	Refrigerant cylinder	<ul style="list-style-type: none"> · Only for R32 · Cylinder with syphon
⑧	Refrigerant recovery equipment	—

2-3. PRECAUTIONS WHEN REUSING EXISTING R22/R410a REFRIGERANT TOOLS

Cautions for refrigerant piping work

Tools for R32 (The following table shows whether conventional tools can be used or not.)

Tools and materials	Use	R32 tools	Can R22 tools be used?	Can R407C tools be used?	Can R410a tools be used?
Gauge manifold	Air purge, refrigerant charge and operation check	Tool exclusive for R32	×	×	○
Charge hose	charge and operation check	Tool exclusive for R32	×	×	○
Gas leak detector	Gas leak check	Tool for HFC refrigerant	×	○	○
Refrigerant recovery equipment	Refrigerant recovery	Tool exclusive for R32	×	×	○
Refrigerant cylinder	Refrigerant charge	Tool exclusive for R32	×	×	×
Safety charger	Prevent compressor malfunction when charging refrigerant by spraying liquid refrigerant	Tool exclusive for R32	×	×	○
Charge valve	Prevent gas from blowing out when detaching charge hose	Tool exclusive for R32	×	×	○
Vacuum pump	Vacuum drying and air purge	Tools for other refrigerants can be used if equipped with adapter for reverse flow check	△(Usable if equipped with adapter for reverse flow)	△(Usable if equipped with adapter for reverse flow)	△(Usable if equipped with adapter for reverse flow)
Welder and nitrogen gas cylinder	Weld the pipes	Tools for other refrigerants can be used	○	○	○
Refrigerant charging scale	Refrigerant charge	Tools for other refrigerants can be used	○	○	○
Vacuum gauge or thermistor vacuum gauge and vacuum valve	Check the degree of vacuum. (Vacuum valve prevents back flow of oil and refrigerant to thermistor vacuum gauge)	Tools for other refrigerants can be used	○	○	○
Charging cylinder	Refrigerant charge	Tool exclusive for R32	×	—	×

×: Prepare a new tool. (Use the new tool as the tool exclusive for R32.)

△: Tools for other refrigerants can be used under certain conditions.

○: Tools for other refrigerants can be used.

2-4. PRECAUTIONS FOR SALT PROOF TYPE "-BS" MODEL

Although "-BS" model has been designed to be resistant to salt damage, observe the following precautions to maintain the performance of the unit.

1. Avoid installing the unit in a location where it will be exposed directly to seawater or sea breeze.
2. If the cover panel may become covered with salt, be sure to install the unit in a location where the salt will be washed away by rainwater. (If a sunshade is installed, rainwater may not clean the panel.)
3. To ensure that water does not collect in the base of the outdoor unit, make sure that the base is level, not at angle. Water collecting in the base of the outdoor unit could cause rust.
4. If the unit is installed in a coastal area, clean the unit with water regularly to remove any salt build-up.
5. If the unit is damaged during installation or maintenance, be sure to repair it.
6. Be sure to check the condition of the unit regularly.
7. Be sure to install the unit in a location with good drainage.

2-5. Choosing the outdoor unit installation location

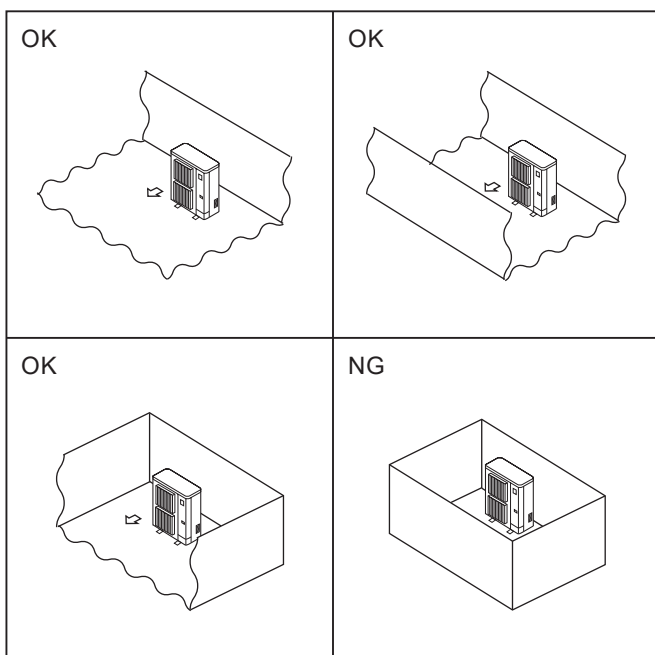

R32 is heavier than air—as well as other refrigerants—so tends to accumulate at the base (in the vicinity of the floor). If R32 accumulates around base, it may reach a flammable concentration in case room is small. To avoid ignition, maintaining a safe work environment is required by ensuring appropriate ventilation. If a refrigerant leak is confirmed in a room or an area where there is insufficient ventilation, refrain from using of flames until the work environment can be improved by ensuring appropriate ventilation.

Install outdoor units in a place where at least one of the four sides is open, and in a sufficiently large space without depressions.

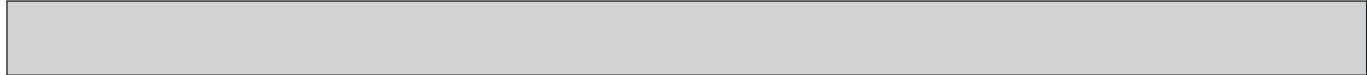

2-6. Minimum installation area

If you unavoidably install a unit in a space where all four sides are blocked or there are depressions, confirm that one of these situations (A, B or C) is satisfied.

Note: These countermeasures are for keeping safety not for specification guarantee.

A) Secure sufficient installation space (minimum installation area A_{min}).

Install in a space with an installation area of A_{min} or more, corresponding to refrigerant amount M (factory-charged refrigerant + locally added refrigerant).

M [kg]	A_{min} [m ²]
1.0	12
1.5	17
2.0	23
2.5	28
3.0	34
3.5	39
4.0	45
4.5	50
5.0	56
5.5	62
6.0	67
6.5	73
7.0	78
7.5	84

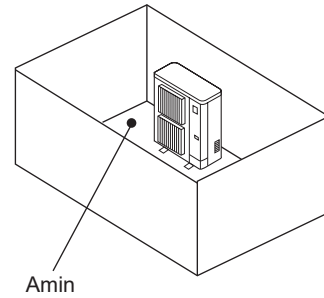

B) Install in a space with a depression height of ≤ 0.125 [m].

Height from the bottom of
0.125 [m] or less

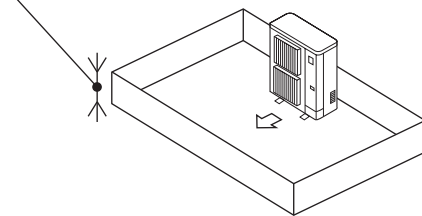

Height from the bottom of
0.125 [m] or less

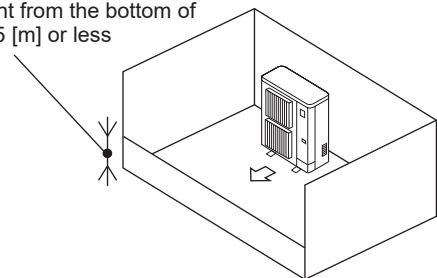

C) Create an appropriate ventilation open area.

Make sure that the width of the open area is 0.9 [m] or more and the height of the open area is 0.15 [m] or more. However, the height from the bottom of the installation space to the bottom edge of the open area should be 0.125 [m] or less.

Open area should be 75% or more opening.

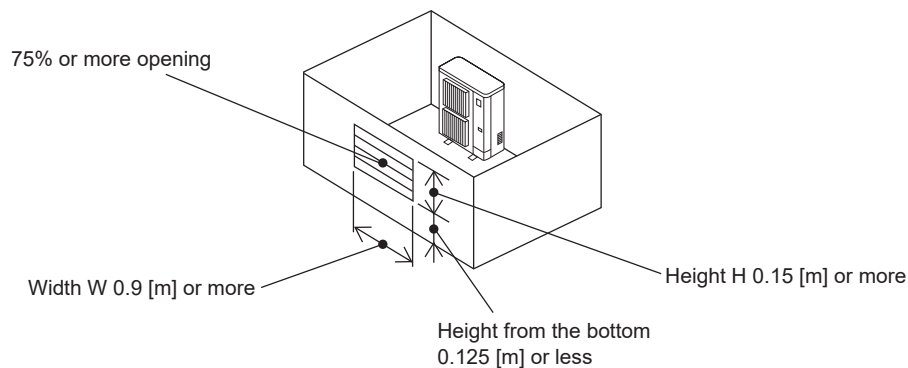

3-1. SPECIFICATIONS

PUZ-HWM140VHA

PUZ-HWM140VHA-BS

Power supply (Phase, Voltage, Frequency)		1 ϕ , 230 V, 50 Hz	
Nominal water flow rate (Heating mode)		L/min	40.1
Heating (A7/W35)	Capacity	kW	14.00
	COP		4.46
	Power input	kW	3.14
Heating (A2/W35)	Capacity	kW	14.00
	COP		3.15
	Power input	kW	4.45
Pressure difference (water circuit)		kPa	9
Heating pump input (based on EN14511)		kW	0.02
Nominal water flow rate (Cooling mode)		L/min	34.1
Cooling (A35/W7)	Capacity	kW	11.90
	EER (COP)		3.00
	Power input	kW	3.97
Cooling (A35/W18)	Capacity	kW	11.10
	EER (COP)		4.10
	Power input	kW	2.71
Pressure difference (water circuit)		kPa	7
Cooling pump input (based on EN14511)		kW	0.02

Note: "COP" and "Power input" in the above table are values that contains the "pump input (based on EN 14511)".

Outdoor unit specifications			
Service ref.		PUZ-HWM140VHA PUZ-HWM140VHA-BS	
Running current	Heating (A7/W35)	A	13.8
	Cooling (A35/W7)	A	16.8
Power factor	Heating (A7/W35)	%	97
	Cooling (A35/W7)	%	97
Max. current		A	35.0
Breaker size		A	40
Outer casing		Galvanized plate	
External finish		Munsell 3Y 7.8/1.1	
Refrigerant control		Linear expansion valve	
Compressor		Hermetic scroll	
	Model	AVB36FJDMT	
	Motor output	kW	2.5
	Start type	Inverter	
	Protection devices	HP switch Discharge thermo Comp. surface thermo Overcurrent detection	
	Oil (Model)	L	1.4 (FW68S)
Crankcase heater		W	-
Heat exchanger	Air	Plate fin coil	
	Water	Plate heat exchanger	
Fan	Fan (drive) × No.	Propeller fan × 2	
	Fan motor output	kW	0.074 × 2
	Airflow	m ³ /min	100
(CFM)		(3,530)	
Defrost method		Reverse cycle ^{*1}	
Noise level (SPL)	Heating	dB	53 ^{*2*}
	Cooling	dB	53 ^{*2}
Dimensions	Width	mm (in)	1020 (40-3/16)
	Depth	mm (in)	330 +30 ^{*4} (13+1-3/16)
	Height	mm (in)	1350 (53-1/8)
Weight		kg (lb)	132 (291)
Refrigerant		R32	
	Quantity	kg (lb)	3.3 (7.3)
Guaranteed operating range (Outdoor)	Heating	°C	-28 ⁽⁵⁾ to +21
	Cooling	°C	+10 to +46
Outlet water temp. (Max in heat, Min in cool)	Heating	°C	+60
	Cooling	°C	+5
Nominal return water temperature range	Heating	°C	+9 ⁽⁶⁾ to +59
	Cooling	°C	+8 to +28
Water flow rate range		L/min	17.9 to 40.1 ¹⁷

Nominal operating condition	
Heating (A7/W35)	
Outside air temperature (Dry-bulb)	+ 7°C
Outside air temperature (Wet-bulb)	+ 6°C
Water temperature (inlet/outlet)	+30/+35°C
Heating (A2/W35)	
Outside air temperature (Dry-bulb)	+ 2°C
Outside air temperature (Wet-bulb)	+ 1°C
Water temperature (inlet/outlet)	-/+35°C
Cooling (A35/W7)	
Outside air temperature (Dry-bulb)	+35°C
Outside air temperature (Wet-bulb)	+ 24°C
Water temperature (inlet/outlet)	+12/+7°C
Cooling (A35/W18)	
Outside air temperature (Dry-bulb)	+35°C
Outside air temperature (Wet-bulb)	+ 24°C
Water temperature (inlet/outlet)	+23/+18°C

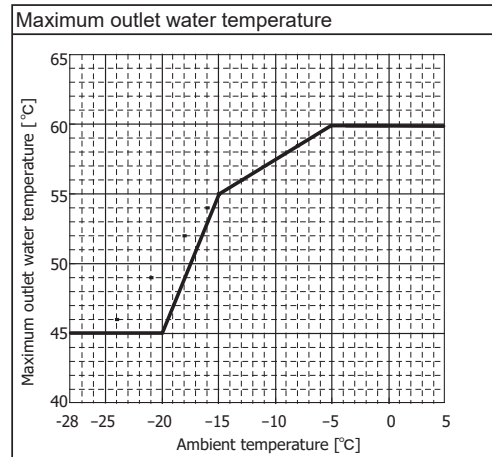
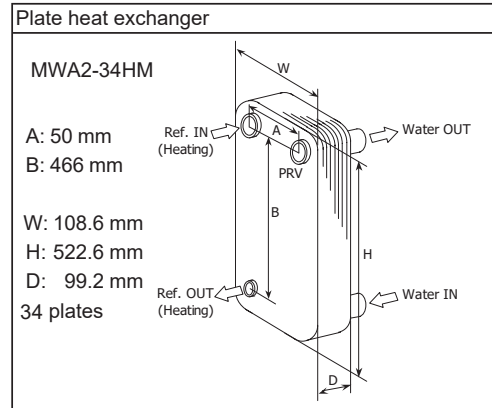

*1 Hot gas with 4-way valve

*2 at distance of 1 m from outdoor unit

*3 A weighted sound power level in accordance with ISO9614-1 for EN14511 testing is 67 dBA.

*4 grille

*5 Lower limit of use is -5°C for EN14511 testing purposes.

*6 Lowest entering temperature is 12°C for EN14511 testing purposes.

*7 For details of the minute return water temperature at each water flow rate, refer to "3-2. AVAILABLE RANGE (WATER FLOW RATE, RETURN WATER TEMP.)".

PUZ-HWM140YHA

PUZ-HWM140YHA-BS

Power supply (Phase, Voltage, Frequency)		3 φ, 400 V, 50 Hz	
Nominal water flow rate (Heating mode)		L/min	40.1
Heating (A7/W35)	Capacity	kW	14.00
	COP		4.46
	Power input	kW	3.14
Heating (A2/W35)	Capacity	kW	14.00
	COP		3.15
	Power input	kW	4.45
Pressure difference (water circuit)		kPa	9
Heating pump input (based on EN14511)		kW	0.02
Nominal water flow rate (Cooling mode)		L/min	34.1
Cooling (A35/W7)	Capacity	kW	11.90
	EER (COP)		3.00
	Power input	kW	3.97
Cooling (A35/W18)	Capacity	kW	11.10
	EER (COP)		4.10
	Power input	kW	2.71
Pressure difference (water circuit)		kPa	7
Cooling pump input (based on EN14511)		kW	0.02

Note: "COP" and "Power input" in the above table are values that contains the "pump input (based on EN 14511)".

Outdoor unit specifications			
Service ref.		PUZ-HWM140YHA PUZ-HWM140YHA-BS	
Running current	Heating (A7/W35)	A	4.5
	Cooling (A35/W7)	A	5.5
Power factor	Heating (A7/W35)	%	95
	Cooling (A35/W7)	%	95
Max. current	A		13.0
Breaker size	A		16
Outer casing		Galvanized plate	
External finish		Munsell 3Y 7.8/1.1	
Refrigerant control		Linear expansion valve	
Compressor		Hermetic scroll	
Model		AVB36FJCMT	
Motor output	kW	2.8	
Start type		Inverter	
Protection devices		HP switch Discharge thermo Comp. surface thermo Overcurrent detection	
Oil (Model)	L	1.4 (FW68S)	
Crankcase heater	W	-	
Heat exchanger	Air	Plate fin coil	
	Water	Plate heat exchanger	
Fan	Fan(drive)×No.	Propeller fan × 2	
	Fan motor output	kW	0.074 × 2
	Airflow	m ³ /min	100
(CFM)		(3,530)	
Defrost method		Reverse cycle ^{*1}	
Noise level (SPL)	Heating	dB	53 ^{*2*}
	Cooling	dB	53 ^{*2}
Dimensions	Width	mm (in)	1020 (40-3/16)
	Depth	mm (in)	330 +30 ^{*4} (13+1-3/16)
	Height	mm (in)	1350 (53-1/8)
Weight	kg (lb)	143 (315.3)	
Refrigerant		R32	
Quantity		kg (lb)	3.3 (7.3)
Guaranteed operating range (Outdoor)	Heating	°C	-28 ⁽⁵⁾ to +21
	Cooling	°C	+10 to +46
Outlet water temp. (Max in heat, Min in cool)	Heating	°C	+60
	Cooling	°C	+5
Nominal return water temperature range	Heating	°C	+9 ⁽⁶⁾ to +59
	Cooling	°C	+8 to +28
Water flow rate range	L/min	17.9 to 40.1 ⁷	

Nominal operating condition	
Heating (A7/W35)	
Outside air temperature (Dry-bulb)	+ 7°C
Outside air temperature (Wet-bulb)	+ 6°C
Water temperature (inlet/outlet)	+30/+35°C
Heating (A2/W35)	
Outside air temperature (Dry-bulb)	+ 2°C
Outside air temperature (Wet-bulb)	+ 1°C
Water temperature (inlet/outlet)	-/+35°C
Cooling (A35/W7)	
Outside air temperature (Dry-bulb)	+35°C
Outside air temperature (Wet-bulb)	+ 24°C
Water temperature (inlet/outlet)	+12/+7°C
Cooling (A35/W18)	
Outside air temperature (Dry-bulb)	+35°C
Outside air temperature (Wet-bulb)	+ 24°C
Water temperature (inlet/outlet)	+23/+18°C

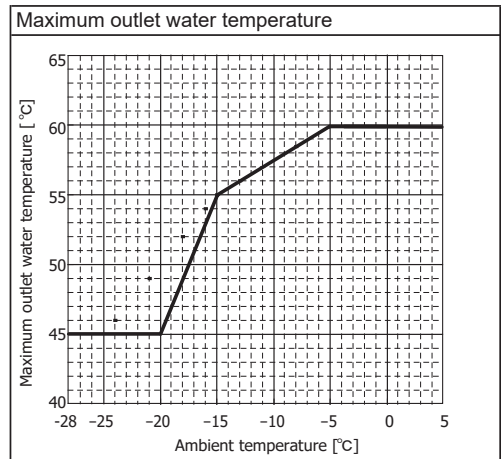
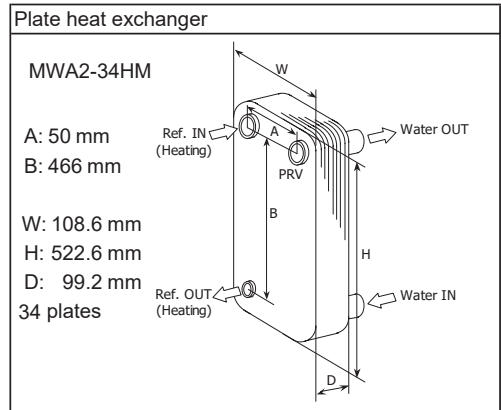

*1 Hot gas with 4-way valve
 *2 at distance of 1 m from outdoor unit
 *3 A weighted sound power level in accordance with ISO9614-1 for EN14511 testing is 67 dBA.
 *4 grille
 *5 Lower limit of use is -5°C for EN14511 testing purposes.
 *6 Lowest entering temperature is 12°C for EN14511 testing purposes.
 *7 For details of the minute return water temperature at each water flow rate, refer to "3-2. AVAILABLE RANGE (WATER FLOW RATE, RETURN WATER TEMP.)".



3-2. AVAILABLE RANGE (WATER FLOW RATE, RETURN WATER TEMP.)

- Notes: • If the value of water flow rate and return water temp. become lower than the available range, it could cause damage to the parts of unit.
- Be sure to avoid the unavailable range during defrosting. Otherwise, the outdoor unit is insufficiently defrosted and/or the heat exchanger of the indoor unit may freeze.

<Heating>

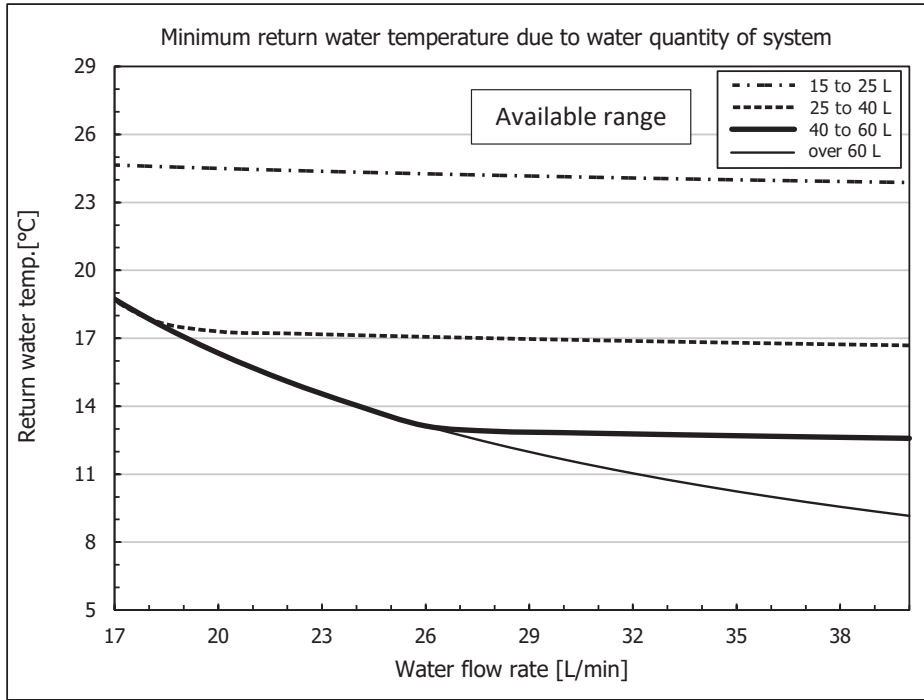

<Cooling>

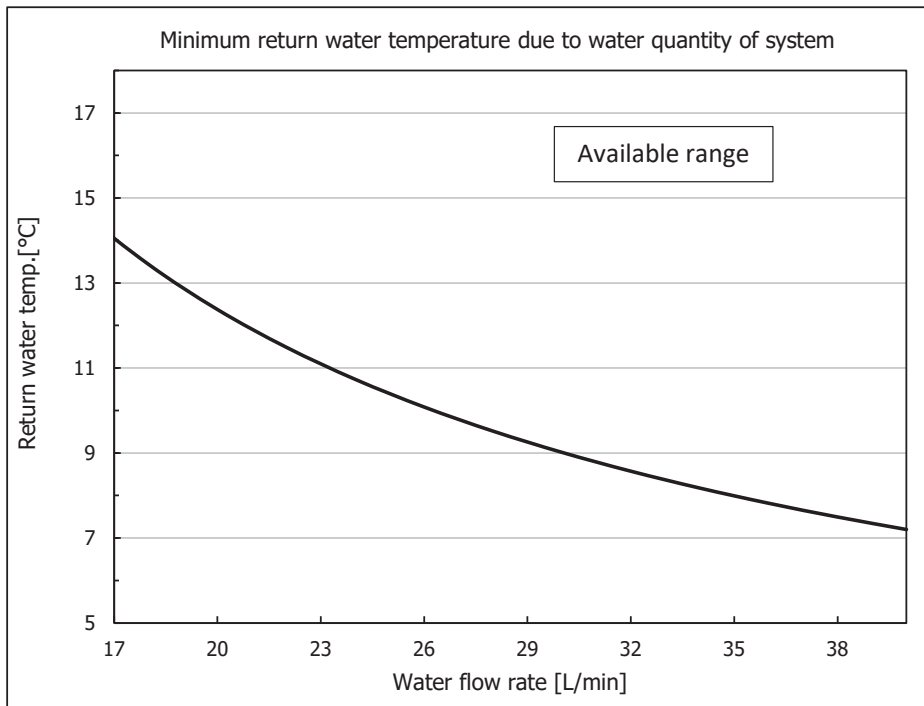

4-1. NOISE CRITERION CURVES

PUZ-HWM140VHA(-BS)
PUZ-HWM140YHA(-BS)

MODE	SPL(dB)	LINE
COOLING	53	○—○
HEATING	53	●—●

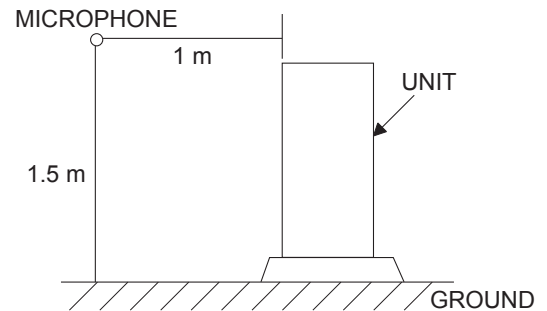
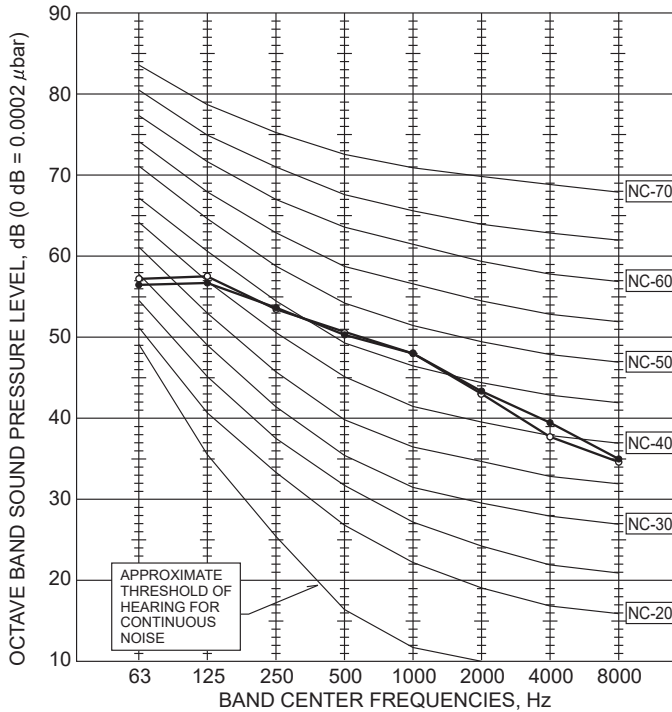

4-2. STANDARD OPERATION DATA

Mode			Cooling (A35/W7)	Heating (A7/W35)
Total	Capacity	W	11,900	14,000
	Input	kW	3.97	3.14
Electrical circuit	Outdoor unit		PUZ-HWM140VHA/ PUZ-HWM140YHA	
	Phase, Hz		1 / 3, 50	
	Voltage	V	230 / 400	
	Current	A	16.8 / 5.5	13.8 / 4.5
Refrigerant circuit	Discharge pressure	MPa	2.83	2.2
	Suction pressure	MPa	0.86	0.69
	Discharge temperature	°C	84	71
	Condensing temperature	°C	47	37
	Suction temperature	°C	8	1
Water conditions	Flow volume	L/min	34.1	40.1
	Outlet water temperature	°C	7	35
Outdoor conditions	Intake air temperature	D.B. °C	35	7
		W.B. °C	24	6

The unit of pressure has been changed to MPa based on international SI system.
The conversion factor is: 1 (MPa) = 10.2 (kgf/cm²)

PUZ-HWM140VHA(-BS)

PUZ-HWM140YHA(-BS)

Unit: mm

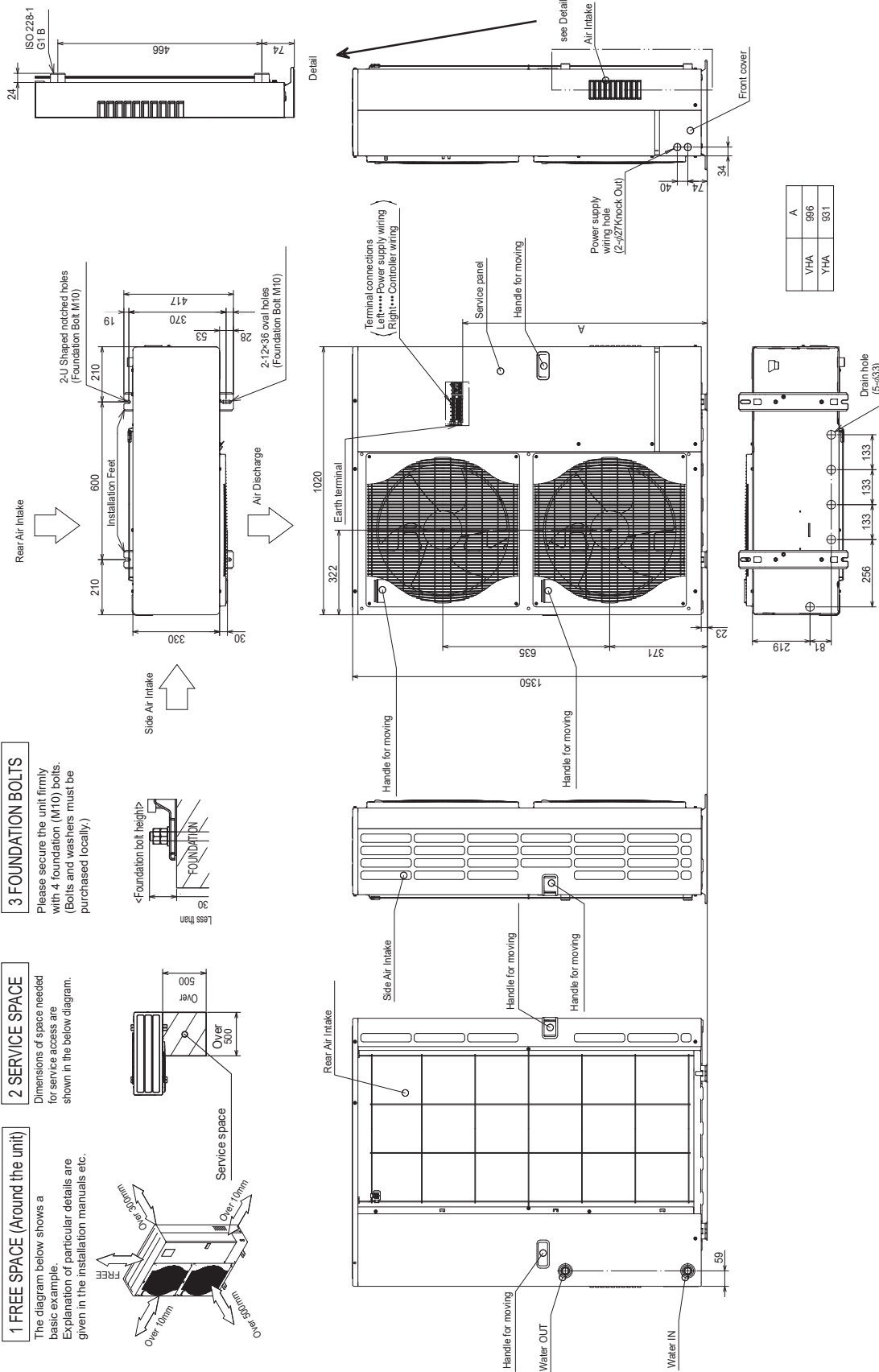

3 FOUNDATION BOLTS
Please secure the unit firmly with 4 foundation (M10) bolts. (Bolts and washers must be purchased locally.)

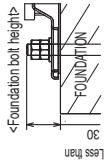

2 SERVICE SPACE
Dimensions of space needed for service access are shown in the below diagram.

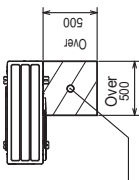

1 FREE SPACE (Around the unit)
The diagram below shows a basic example. Explanation of particular details are given in the installation manuals etc.

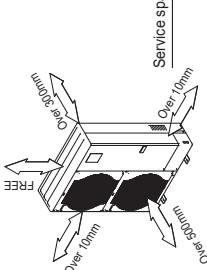

PUZ-HWM140VHA(-BS)

SYMBOL	NAME	SYMBOL	NAME
TB1	Terminal Block (Power Supply)	CY1, CY2	Capacitor
TB2	Terminal Block (Indoor/Outdoor)	P. B.	Power Circuit Board
MC	Motor for Compressor	N. F.	Noise Filter Circuit Board
MF1, MF2	Fan Motor	C. B.	Controller Circuit Board
21S4	Solenoid Valve Coil (4-Way Valve)	SW1	Switch (Manual Defrost, Defect History Record Reset, Function Switch)
63H	High Pressure Switch	SW4	Switch (Function Switch)
63HS	Pressure Sensor	SW5	Switch (Function Switch)
TH3	Thermistor (Liquid)	SW6	Switch (Function Switch, Model Select)
TH4	Thermistor (Discharge)	SW7	Switch (Function Switch)
TH6	Thermistor (2-Phase pipe)	SW8	Switch (Function Switch)
TH7	Thermistor (Ambient)	SW9	Switch (Function Switch)
TH8	Thermistor (Heat Sink)	SV1/CH	Connector (Connection for Option)
TH32	Thermistor (Suction)	SV3/SS	Connector (Connection for Option)
TH33	Thermistor (Comp. Surface)	CNDM	Connector (Connection for Option)
TH34	Thermistor (Plate Hex Liquid)	F1, F2	Fuse (T10AL250V)
LEV-A, LEV-B, LEV-C	Linear Expansion Valve	F3, F4	Fuse (T6.3AL250V)
DCL1, DCL2, DCL3	Reactor		

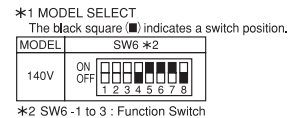
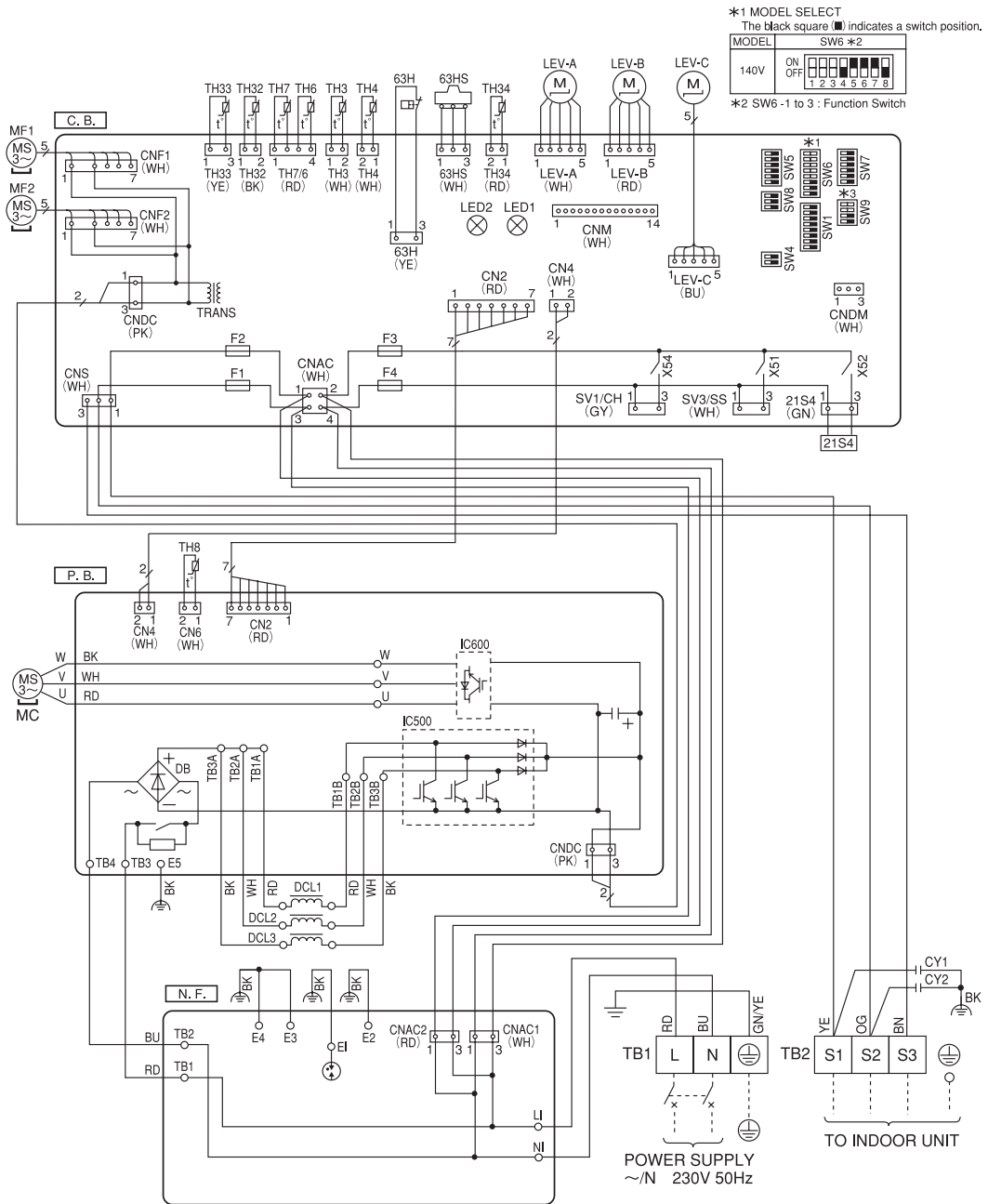

*3 Ambient temp. of ZUBADAN Flash Injection becomes effective.
The black square (■) indicates a switch position.

Ambient temp.	SW9-3, 9-4 *4	Ambient temp.	SW9-3, 9-4 *4	Ambient temp.	SW9-3, 9-4 *4	Ambient temp.	SW9-3, 9-4 *4
3°C or less (Default setting)	ON OFF 1 2 3 4	0°C or less	ON OFF 1 2 3 4	-3°C or less	ON OFF 1 2 3 4	-6°C or less	ON OFF 1 2 3 4

*4 SW9 -1 to 2 : Function Switch

PUZ-HWM140YHA(-BS)

SYMBOL	NAME	SYMBOL	NAME
TB1	Terminal Block (Power Supply)	RS	Rush Current Protect Resistor
TB2	Terminal Block (Indoor/Outdoor)	P. B.	Power Circuit Board
MC	Motor for Compressor	N. F.	Noise Filter Circuit Board
MF1, MF2	Fan Motor	CONV. B.	Converter Circuit Board
21S4	Solenoid Valve Coil (4-Way Valve)	C. B.	Controller Circuit Board
63H	High Pressure Switch	SW1	Switch (Manual Defrost, Defect History Record Reset, Function Switch)
63HS	Pressure Sensor	SW4	Switch (Function Switch)
TH3	Thermistor (Liquid)	SW5	Switch (Function Switch)
TH4	Thermistor (Discharge)	SW6	Switch (Function Switch, Model Select)
TH6	Thermistor (2-Phase pipe)	SW7	Switch (Function Switch)
TH7	Thermistor (Ambient)	SW8	Switch (Function Switch)
TH8	Thermistor (Heat Sink)	SW9	Switch (Function Switch)
TH32	Thermistor (Suction)	CNDM	Connector (Connection for Option)
TH33	Thermistor (Comp. Surface)	SV1/CH	Connector (Connection for Option)
TH34	Thermistor (Plate Hex Liquid)	SV3/SS	Connector (Connection for Option)
LEV-A, LEV-B, LEV-C	Linear Expansion Valve	F1, F2	Fuse (T10AL250V)
ACL1, ACL2, ACL3, ACL4	Reactor	F3, F4	Fuse (T6.3AL250V)
CY1, CY2	Capacitor		
CK	Capacitor		

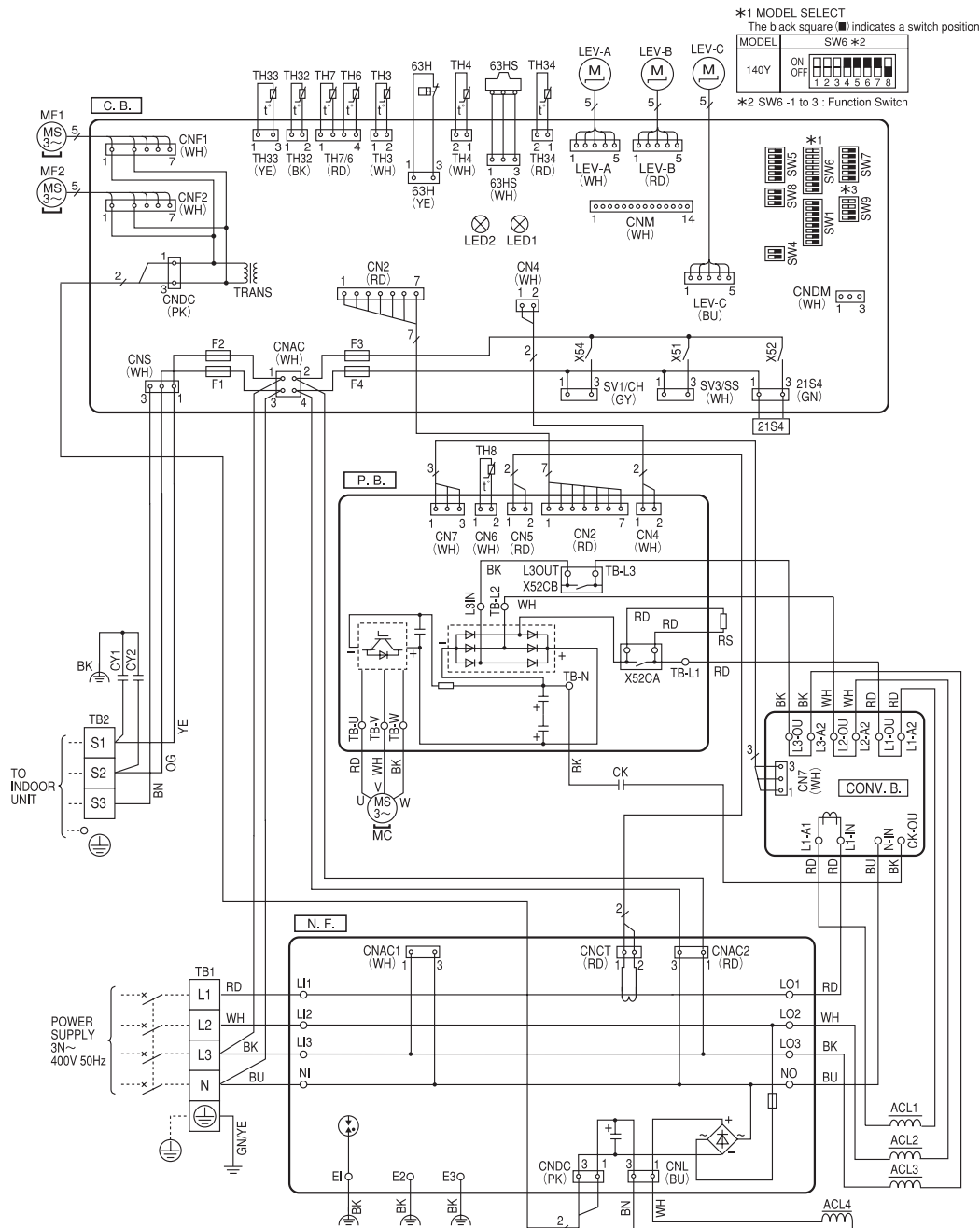

*1 MODEL SELECT
The black square (■) indicates a switch position.

*2 SW6 -1 to 3 : Function Switch

*3 Ambient temp. of ZUBADAN Flash Injection becomes effective.
The black square (■) indicates a switch position.

Ambient temp.	SW9-3, 9-4 *4	Ambient temp.	SW9-3, 9-4 *4	Ambient temp.	SW9-3, 9-4 *4	Ambient temp.	SW9-3, 9-4 *4
3°C or less (Default setting)	ON OFF ■■■ 1 2 3 4	0°C or less	ON OFF ■■■ 1 2 3 4	-3°C or less	ON OFF ■■■ 1 2 3 4	-6°C or less	ON OFF ■■■ 1 2 3 4

*4 SW9 -1 to 2 : Function Switch

FIELD ELECTRICAL WIRING (power wiring specifications)

Outdoor model name		HWM140V	HWM140Y
Outdoor unit power supply		~/N (single), 50 Hz, 230 V	3N~ (3 ph 4-wires), 50 Hz, 400 V
Outdoor unit input capacity Main switch (Breaker) *1		40 A	16 A
Wiring Wire No. x size (mm ²)	Outdoor unit power supply	3 x Min. 6	5 x Min. 1.5
	Indoor unit-Outdoor unit *2	3 x 1.5 (Polar)	3 x 1.5 (Polar)
	Indoor unit-Outdoor unit earth *2	1 x Min. 1.5	1 x Min. 1.5
	Remote controller-Indoor unit *3	2 x 0.3 (Non-polar)	2 x 0.3 (Non-polar)
Circuit rating	Outdoor unit L-N (single) *4	230 VAC	230 VAC
	Outdoor unit L1-N, L2-N, L3-N (3 phase) *4	230 VAC	230 VAC
	Indoor unit-Outdoor unit S1-S2 *4	24 VDC	24 VDC
	Indoor unit-Outdoor unit S2-S3 *4	12 VDC	12 VDC

*1. A breaker with at least 3.0 mm contact separation in each poles shall be provided. Use earth leakage breaker (NV).

Make sure that the current leakage breaker is one compatible with higher harmonics.

Always use a current leakage breaker that is compatible with higher harmonics as this unit is equipped with an inverter.

The use of an inadequate breaker can cause the incorrect operation of inverter.

*2. Max. 45 m

If 2.5 mm² used, Max. 50 m

If 2.5 mm² used and S3 separated, Max. 80 m

*3. The 10 m wire is attached in the remote controller accessory.

*4. The figures are NOT always against the ground.

S3 terminal has 24 VDC against S2 terminal. However between S3 and S1, these terminals are NOT electrically insulated by the transformer or other device.

⚠ Caution: Be sure to install N-line. Without N-line, it could cause damage to the unit.

Notes: 1. In multi-phase appliances, the colour of the neutral conductor of the supply cord, if any, shall be blue.

2. Wiring size must comply with the applicable local and national codes.

3. Power supply cables and the cables between Controller and Outdoor unit shall not be lighter than polychloroprene sheathed flexible cables. (Design 60245 IEC 57)

4. Be sure to connect the cables between Controller and Outdoor unit directly to the units (no intermediate connections are allowed).

Intermediate connections may result in communication errors. If water enters at the intermediate connection point, it may cause insufficient insulation to ground or a poor electrical contact.

(If an intermediate connection is necessary, be sure to take measures to prevent water from entering the cables.)

5. Install an earth line longer than power cables.

6. Do not construct a system with a power supply that is turned ON and OFF frequently.

7. Use self-extinguishing distribution cables for power supply wiring.

8. Properly route wiring so as not to contact the sheet metal edge or a screw tip.

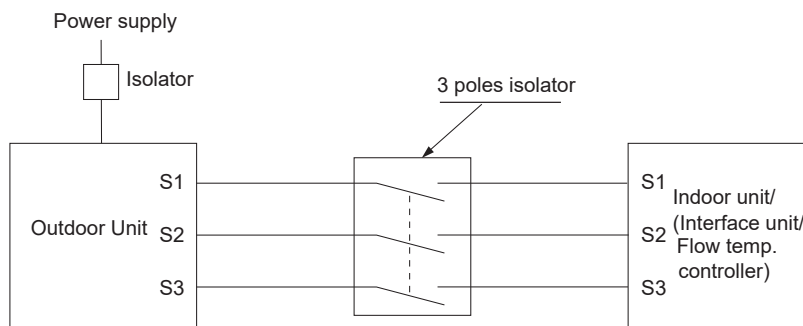

⚠ Warning:

In the case of A-control wiring, there is high voltage potential on the S3 terminal caused by electrical circuit design that has no electrical insulation between power line and communication signal line. Therefore, please turn off the main power supply when servicing. And do not touch the S1, S2, S3 terminals when the power is energized. If isolator should be used between indoor unit and outdoor unit, please use 3-pole type.

Never splice the power cable or the indoor-outdoor connection cable, otherwise it may result in a smoke, a fire or communication failure.

PUZ-HWM140VHA(-BS)

PUZ-HWM140YHA(-BS)

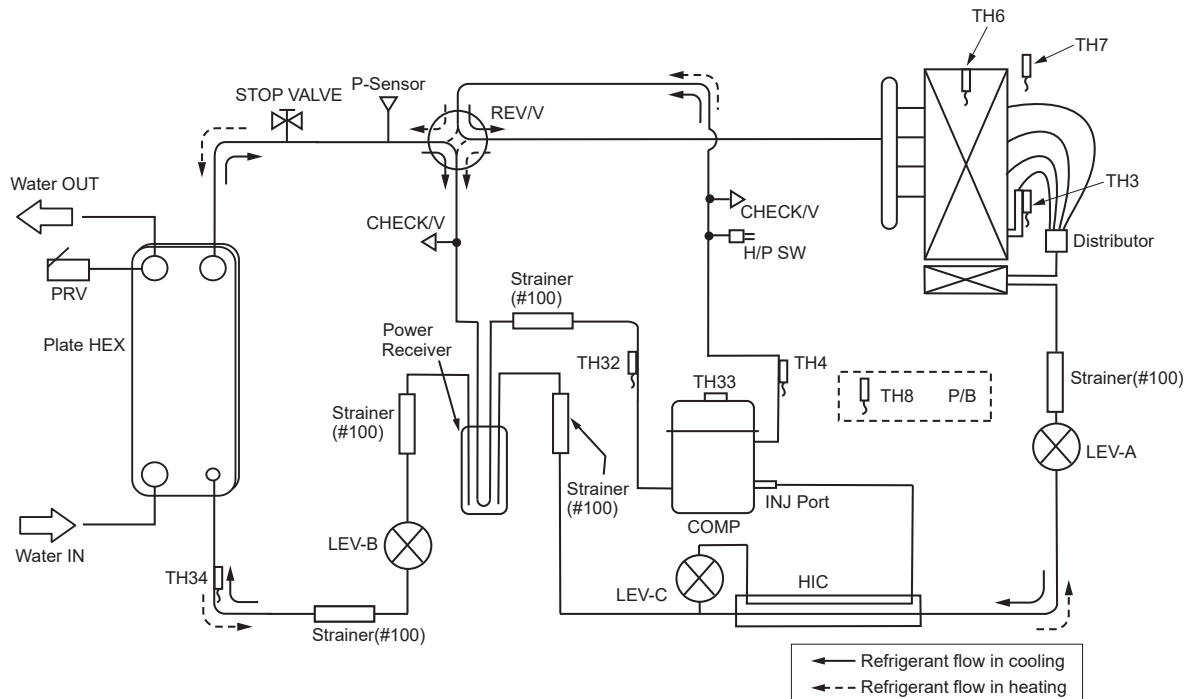

Symbol	Part name	Detail
COMP	Compressor	DC inverter scroll compressor (Mitsubishi Electric Corporation)
H/P SW	High pressure switch (63H)	For protection (OFF: 4.15MPa)
Plate HEX	Plate Heat Exchanger	MWA2-34HM (Mitsubishi Electric Corporation)
REV/V	Reversing (4-way) valve (21S4)	Change the refrigerant circuit (Heating / Cooling) and for Defrosting
STOP VALVE	Stop valve	For refrigerant charge
CHECK/V	Check valve	High pressure / Low pressure
P-Sensor	Pressure sensor (63HS)	For calculation of the saturation temperature from refrigerant pressure
P/B	Power board	Inverter power board
LEV-A	Linear expansion valve -A	Heating: Secondary LEV Cooling: Primary LEV
LEV-B	Linear expansion valve -B	Heating: Primary LEV Cooling: Secondary LEV
LEV-C	Linear expansion valve -C	For HIC (heating only)
TH32	Suction temperature thermistor	For LEV control
TH3	Liquid temperature thermistor	Heating: Evaporating temperature Cooling: Sub cool liquid temperature
TH4	Discharge temperature thermistor	For LEV control and for compressor protection
TH6	2-Phase pipe thermistor	Heating: Evaporating temperature Cooling: Condensing temperature
TH34	Plate HEX liquid temperature thermistor	Heating: Sub cool liquid temperature Cooling: Evaporating temperature
TH7	Ambient temperature thermistor	For fan control and for compressor frequency control
TH8	Heatsink temperature thermistor	For power board protection
TH33	Comp. surface temperature thermistor	For compressor protection
Power Receiver	Power Receiver	For accumulation of refrigerant
HIC	Heat interchange circuit	For high heating capacity

9-1. TROUBLESHOOTING

<Check code displayed by self-diagnosis and actions to be taken for service (summary)>

Present and past check codes are logged, and they can be displayed on the control board of outdoor unit. Actions to be taken for service, which depends on whether or not the trouble is reoccurring in the field, are summarized in the table below. Check the contents below before investigating details.

Unit conditions at service	Check code	Actions to be taken for service (summary)
The trouble is reoccurring.	Displayed	Judge what is wrong and take a corrective action according to "9-3. SELF-DIAGNOSIS ACTION TABLE".
	Not displayed	Conduct troubleshooting and ascertain the cause of the trouble.
The trouble is not reoccurring.	Logged	① Consider the temporary defects such as the work of protection devices in the refrigerant circuit including compressor, poor connection of wiring, noise, etc. Re-check the symptom, and check the installation environment, refrigerant amount, weather when the trouble occurred, matters related to wiring, etc. ② Reset check code logs and restart the unit after finishing service. ③ There is no abnormality in electrical component, controller board, etc.
	Not logged	① Re-check the abnormal symptom. ② Conduct troubleshooting and ascertain the cause of the trouble. ③ Continue to operate unit for the time being if the cause is not ascertained. ④ There is no abnormality concerning of parts such as electrical component, controller board, etc.

9-2. CHECKPOINT UNDER TEST RUN

Before test run

- After installation of outdoor units, piping work and electric wiring work, re-check that there is no water leakage, loosened connections and incorrect polarity.
- Measure impedance between the ground and the power supply terminal block (L, N) on the outdoor unit by 500 V Megger and check that it is 1.0 MΩ or over.
- Turn on power supply 12 hours before test run in order to protect compressor.
- Make sure to read operation manual before test run. (Especially items to secure safety.)

9-3. SELF-DIAGNOSIS ACTION TABLE

<Abnormalities detected when the power is turned on>

Check Code	Abnormal point and detection method	Cause	Judgment and action
None	—	① No voltage is supplied to terminal block (TB1) of outdoor unit. a) Power supply breaker is turned off. b) Contact failure or disconnection of power supply terminal c) Open phase (L, L2 or N phase) ② Electric power is not charged to power supply terminal of outdoor power circuit board. a) Contact failure of power supply terminal b) Open phase on the outdoor power circuit board ③ Electric power is not supplied to outdoor controller circuit board. a) Disconnection of connector (CNDC) ④ Disconnection of reactor (DCL or ACL) ⑤ Disconnection of outdoor noise filter circuit board or parts failure in outdoor noise filter circuit board ⑥ Defective outdoor power circuit board ⑦ Defective outdoor controller circuit board	① Check following items. a) Power supply breaker b) Connection of power supply terminal block (TB1) c) Connection of power supply terminal block (TB1) ② Check following items. a) Connection of power supply terminal block (TB1) b) Connection of terminal on outdoor power circuit board ③ Check connection of the connector (CNDC) on the outdoor controller circuit board. Check connection of the connector and CNDC on the outdoor power circuit board (V)/ noise filter circuit board (Y). ④ Check connection of reactor. (DCL or ACL) ⑤ a) Check connection of outdoor noise filter circuit board. b) Replace outdoor noise filter circuit board. ⑥ Replace outdoor power circuit board. ⑦ Replace outdoor controller circuit board (When items above are checked but the units cannot be repaired.)
F5 (5201)	63H connector open Abnormal if 63H connector circuit is open for 3 minutes continuously from being switched on. 63H: High pressure switch	① Disconnection or contact failure of 63H connector on outdoor controller circuit board ② Disconnection or contact failure of 63H ③ 63H is working due to defective parts. ④ Defective outdoor controller circuit board	① Check connection of 63H connector on outdoor controller circuit board. Refer to "9-7. TEST POINT DIAGRAM". ② Check the 63H side of connecting wire. ③ Check for continuity of 63H. Replace high pressure switch if it is defective. ④ Replace outdoor controller circuit board.



Check Code	Abnormal point and detection method	Cause	Judgment and action
EA (6844)	<p>Miswiring of Interface unit/Flow temp. controller-outdoor unit connecting wire</p> <p>1. Outdoor controller circuit board can automatically check the number of connected Interface unit/Flow temp. controller. Abnormal if the number cannot be checked automatically due to miswiring of Interface unit/Flow temp. controller-outdoor unit connecting wire and etc. after power is turned on for 4 minutes.</p> <p>2. Abnormal if outdoor controller circuit board recognizes excessive number of Interface unit/Flow temp. controller.</p>	<p>① Contact failure or miswiring of Interface unit/Flow temp. controller-outdoor unit connecting wire</p> <p>② Diameter or length of Interface unit/Flow temp. controller-outdoor unit connecting wire is out of specified capacity.</p> <p>③ Excessive number of Interface unit/Flow temp. controller is connected to 1 outdoor unit. (2 units or more)</p> <p>④ Defective transmitting receiving circuit of outdoor controller circuit board</p> <p>⑤ Defective transmitting receiving circuit of Interface/Flow temp. controller board</p> <p>⑥ Noise has entered into power supply or Interface/Flow temp. controller-outdoor unit connecting wire.</p>	<p>① Check disconnection, looseness or polarity of Interface unit/Flow temp. controller-outdoor unit connecting wire of Interface unit/Flow temp. controller and outdoor units.</p> <p>② Check diameter and length of Interface unit/Flow temp. controller-outdoor unit connecting wire. Total wiring length: 80 m (Including wiring connecting each Interface unit/Flow temp. controller unit and between Interface unit/Flow temp. controller and outdoor unit) Also check if the connection order of flat cable is S1, S2, S3.</p> <p>③ Check the number of Interface unit/Flow temp. controller that is connected to 1 outdoor unit. (If EA is detected.)</p> <p>④-⑤ Turn the power off once, and on again to check. Replace outdoor controller circuit board or Interface/Flow temp. controller board if abnormality occurs again.</p> <p>⑥ Check transmission path, and remove the cause.</p> <p>Note: The descriptions above, ①-⑥, are for EA, Eb and EC.</p>
Eb (6845)	<p>Miswiring of Interface unit/Flow temp. controller-outdoor unit connecting wire (reverse wiring or disconnection)</p> <p>Outdoor controller circuit board can automatically set the unit number of Interface unit/Flow temp. controller.</p> <p>Abnormal if the Interface unit/Flow temp. controller number cannot be set within 4 minutes after power on because of miswiring (reverse wiring or disconnection) of Interface unit/Flow temp. controller-outdoor unit connecting wire.</p>	<p>① Contact failure or miswiring of Interface unit/Flow temp. controller-outdoor unit connecting wire</p> <p>② Diameter or length of Interface unit/Flow temp. controller-outdoor unit connecting wire is out of specified capacity.</p> <p>④ Defective transmitting receiving circuit of outdoor controller circuit board</p> <p>⑤ Defective transmitting receiving circuit of Interface/Flow temp. controller board</p> <p>⑥ Noise has entered into power supply or Interface unit/Flow temp. controller-outdoor unit connecting wire.</p>	<p>⑥ Check transmission path, and remove the cause.</p> <p>Note: The descriptions above, ①-⑥, are for EA, Eb and EC.</p>
EC (6846)	<p>Startup time over</p> <p>The unit cannot finish startup process within 4 minutes after power on.</p>	<p>① Contact failure of Interface unit /Flow temp. controller-outdoor unit connecting wire</p> <p>② Diameter or length of Interface unit/Flow temp. controller-outdoor unit connecting wire is out of specified capacity.</p> <p>⑥ Noise has entered into power supply or Interface unit/Flow temp. controller-outdoor unit connecting wire.</p>	
EE (7130)	<p>Incorrect connection</p> <p>The outdoor unit does not receive the signals of I/F or FTC.</p>	<p>① A device other than Interface unit or Flow temp. controller unit is connected to the unit.</p>	<p>① Connect I/F or FTC to the unit.</p>

<Abnormalities detected while unit is operating>

Check Code	Abnormal point and detection method	Cause	Judgment and action
U1 (1302)	<p>High pressure (High pressure switch 63H operated) Abnormal if high pressure switch 63H operated (*) during compressor operation. *4.15 MPa</p> <p>63H: High pressure switch</p>	<p>① Decreased water flow ② Clogged filter of water pipe ③ Dirt of plate heat exchanger ④ Locked water pump ⑤ Malfunction of water pump ⑥ Clogged or broken pipe ⑦ Locked outdoor fan motor ⑧ Malfunction of outdoor fan motor ⑨ Short cycle of outdoor unit ⑩ Dirt of outdoor heat exchanger ⑪ Decreased airflow caused by defective inspection of outside temperature thermistor (It detects lower temperature than actual temperature.) ⑫ Disconnection or contact failure of connector (63H) on outdoor controller board ⑬ Disconnection or contact failure of 63H connection ⑭ Defective outdoor controller board ⑮ Defective operation of linear expansion valve ⑯ Malfunction of fan driving circuit</p>	<p>①–⑤ Check water circuit and repair the defect.</p> <p>⑥ Check piping and repair the defect. ⑦–⑩ Check outdoor unit and repair the defect.</p> <p>⑪ Check the detected temperature of outside temperature thermistor on LED display. (SW2: Refer to "9-8. OUTDOOR UNIT OPERATION MONITOR FUNCTION".)</p> <p>⑫ – ⑭ Turn the power off and check F5 is displayed when the power is turned on again. When F5 is displayed, refer to "Judgment and action" for F5.</p> <p>⑮ Check linear expansion valve. Refer to "9-6. HOW TO CHECK THE COMPONENTS". ⑯ Replace outdoor controller board.</p>
U2 (TH4: 1102) (TH33: 1103)	<p>High discharge temperature Abnormal if discharge temperature thermistor (TH4) exceeds 125°C or 110°C continuously for 5 minutes. Abnormal if during defrosting discharge temperature thermistor (TH4) exceeds 110°C continuously for 30 minutes.</p> <p>High comp. surface temperature Abnormal if comp. surface temperature (TH33) exceeds 125°C or 110°C continuously for 5 minutes. In the case of high comp. surface temperature error, compressor does not restart unless the thermistor (TH33) becomes less than 95°C.</p>	<p>① Overheated compressor operation caused by insufficient refrigerant ② Defective thermistor ③ Defective outdoor controller board ④ Defective operation of linear expansion valve ⑤ In the case of the unit does not restart: Detection temp. of thermistor (TH33) ≥ 95°C</p>	<p>① Check intake super heat. Check leakage of refrigerant. Charge additional refrigerant. ②③ Turn the power off and check if U3 is displayed when the power is turned ON again. When U3 is displayed, refer to "Judgment and action" for U3. ④ Check linear expansion valve. Refer to "9-6. HOW TO CHECK THE COMPONENTS".</p>
U3 (TH4: 5104) (TH33: 5132)	<p>Open/short circuit of discharge temperature thermistor (TH4)/comp. surface thermistor (TH33) Abnormal if open (3°C or less) or short (217°C or more) is detected during compressor operation. (Open (3°C or less) detection is inoperative for 10 minutes of compressor starting process and for 10 minutes after or during defrosting.)</p>	<p>① Disconnection or contact failure of connector (TH4/TH33) on the outdoor controller circuit board ② Defective thermistor ③ Defective outdoor controller circuit board</p>	<p>① Check connection of connector (TH4/TH33) on the outdoor controller circuit board. Check the lead wire for thermistor (TH4/TH33). Refer to "9-7. TEST POINT DIAGRAM". ② Check resistance value of thermistor (TH4/TH33) or temperature on LED display. (Thermistor/TH4/TH32: Refer to "9-6. HOW TO CHECK THE COMPONENTS".) (SW2: Refer to "9-8. OUTDOOR UNIT OPERATION MONITOR FUNCTION".) ③ Replace outdoor controller board.</p>



Check Code	Abnormal point and detection method	Cause	Judgment and action																														
U4 (TH3:5105) (TH6:5107) (TH7:5106) (TH8:5110) (TH32:5105) (TH34:5105)	Open/short of outdoor unit thermistors (TH3, TH32, TH34, TH6, TH7, and TH8) Abnormal if open or short is detected during compressor operation. Open detection of thermistors TH3, TH32 and TH6 is not detected for 10 seconds to 10 minutes after compressor starting and 10 minutes after and during defrosting. Note: Check which unit has abnormality in its thermistor by switching the mode of SW2. (PAC-SK52ST) (Refer to "9-8. OUTDOOR UNIT OPERATION MONITOR FUNCTION".) Note: HWM140VHA Heat sink thermistor (TH8) is in the power module.	① Disconnection or contact failure of connectors (Outdoor controller circuit board: TH3, TH32, TH34, TH6/TH7) (Outdoor power circuit board: CN6) ② Defective thermistor ③ Defective outdoor controller circuit board	① Check connection of connector (TH3, TH32, TH34, TH6/TH7) on the outdoor controller circuit board. Check connection of connector (CN6) on the outdoor power circuit board. Check the lead wire for thermistor (TH3, TH32, TH34, TH6, TH7, TH8). Refer to "9-7. TEST POINT DIAGRAM". ② Check resistance value of thermistor (TH3, TH32, TH34, TH6, TH7, TH8) or check temperature on LED display. (Thermistor/TH3, TH32, TH34, TH6, TH7, TH8: Refer to "9-6. HOW TO CHECK THE COMPONENTS".) (SW2: Refer to "9-8. OUTDOOR UNIT OPERATION MONITOR FUNCTION".) ③ Replace outdoor controller circuit board.																														
	<table border="1" style="width:100%; border-collapse: collapse;"> <thead> <tr> <th colspan="2">Thermistors</th> <th rowspan="2">Open detection</th> <th rowspan="2">Short detection</th> </tr> <tr> <th>Symbol</th> <th>Name</th> </tr> </thead> <tbody> <tr> <td>TH3</td> <td>Thermistor <Liquid></td> <td>-40°C or below</td> <td>90°C or above</td> </tr> <tr> <td>TH32</td> <td>Thermistor <Suction></td> <td>-40°C or below</td> <td>90°C or above</td> </tr> <tr> <td>TH34</td> <td>Thermistor <Plate HEX liquid></td> <td>-40°C or below</td> <td>90°C or above</td> </tr> <tr> <td>TH6</td> <td>Thermistor <2-phase pipe></td> <td>-40°C or below</td> <td>90°C or above</td> </tr> <tr> <td>TH7</td> <td>Thermistor <Ambient></td> <td>-40°C or below</td> <td>90°C or above</td> </tr> <tr> <td>TH8</td> <td>Thermistor <Heat sink></td> <td>-35°C or below</td> <td>102°C or above</td> </tr> </tbody> </table>				Thermistors		Open detection	Short detection	Symbol	Name	TH3	Thermistor <Liquid>	-40°C or below	90°C or above	TH32	Thermistor <Suction>	-40°C or below	90°C or above	TH34	Thermistor <Plate HEX liquid>	-40°C or below	90°C or above	TH6	Thermistor <2-phase pipe>	-40°C or below	90°C or above	TH7	Thermistor <Ambient>	-40°C or below	90°C or above	TH8	Thermistor <Heat sink>	-35°C or below
Thermistors		Open detection	Short detection																														
Symbol	Name																																
TH3	Thermistor <Liquid>	-40°C or below	90°C or above																														
TH32	Thermistor <Suction>	-40°C or below	90°C or above																														
TH34	Thermistor <Plate HEX liquid>	-40°C or below	90°C or above																														
TH6	Thermistor <2-phase pipe>	-40°C or below	90°C or above																														
TH7	Thermistor <Ambient>	-40°C or below	90°C or above																														
TH8	Thermistor <Heat sink>	-35°C or below	102°C or above																														
U5 (4230)	Temperature of heat sink Abnormal if heat sink thermistor (TH8) detects temperature indicated below. HWM140VHA..... 76°C HWM140YHA..... 95°C	① The outdoor fan motor is locked. ② Failure of outdoor fan motor ③ Airflow path is clogged. ④ Ambient temperature is high. ⑤ Defective thermistor ⑥ Defective input circuit of outdoor power circuit board ⑦ Failure of outdoor fan drive circuit	①② Check outdoor fan. ③ Check airflow path for cooling. ④ Check if there is something which causes temperature rise around outdoor unit. (Upper limit of ambient temperature is 46°C.) Turn off power, and on again to check if U5 is displayed within 30 minutes. If U4 is displayed instead of U5, refer to check code U4. ⑤ Check resistance value of thermistor (TH8) or temperature by microprocessor. (Thermistor/TH8: Refer to "9-6. HOW TO CHECK THE COMPONENTS".) (SW2: Refer to "9-8. OUTDOOR UNIT OPERATION MONITOR FUNCTION".) ⑥ Replace outdoor power circuit board. ⑦ Replace outdoor controller circuit board.																														
U6 (4250)	Power module Check abnormality by driving power module in case overcurrent is detected. (UF or UP error condition)	① Defective outdoor power circuit board ② Decrease of power supply voltage ③ Looseness, disconnection or reverse of compressor wiring connection ④ Defective compressor	① Replace outdoor power circuit board. ② Check facility of power supply. ③ Correct the wiring (U-V-W phase) to compressor. Refer to "9-7. TEST POINT DIAGRAM" (Outdoor power circuit board). ④ Check compressor referring to "9-5. HOW TO CHECK THE PARTS".																														
U7 (1502)	Too low superheat due to low discharge temperature Abnormal if discharge superheat is continuously detected -15°C or less for 3 minutes even though linear expansion valve has minimum open pulse after compressor starts operating for 10 minutes.	① Disconnection or loose connection of discharge temperature thermistor (TH4) ② Defective holder of discharge temperature thermistor ③ Disconnection or loose connection of linear expansion valve's coil ④ Disconnection or loose connection of linear expansion valve's connector ⑤ Defective linear expansion valve	①② Check the installation conditions of discharge temperature thermistor (TH4). ③ Check the coil of linear expansion valve. Refer to "9-6. HOW TO CHECK THE COMPONENTS". ④ Check the connection or contact of LEV-A and LEV-B on outdoor controller circuit board. ⑤ Check linear expansion valve. Refer to "9-5. HOW TO CHECK THE PARTS".																														
U8 (4400)	Outdoor fan motor Abnormal if rotational frequency of the fan motor is not detected during DC fan motor operation. Fan motor rotational frequency is abnormal if; • 100 rpm or below detected continuously for 15 seconds at 20°C or more outside air temperature • 50 rpm or below or 1500 rpm or more detected continuously for 1 minute.	① Failure in the operation of the DC fan motor ② Failure in the outdoor circuit controller board	① Check or replace the DC fan motor. ② Check the voltage of the outdoor circuit controller board during operation. ③ Replace the outdoor circuit controller board. (When the failure is still indicated even after performing the remedy ① above.)																														



Check Code	Abnormal points and detection method	Case	Judgment and action	
U9	Detailed codes	To find out the detail history (latest) about U9 error, turn ON SW2-1, 2-2 and 2-6. Refer to "9-9. FUNCTION OF SWITCHES, CONNECTORS AND JUMPERS".		
	01	Overvoltage error • Increase in DC bus voltage to HWM140V: 430 V HWM140Y: 760 V	① Abnormal increase in power source voltage ② Disconnection of compressor wiring ③ Defective outdoor power circuit board ④ Compressor has a ground fault.	① Check the field facility for the power supply. ② Correct the wiring (U·V·W phase) to compressor. Refer to "9-7. TEST POINT DIAGRAM" (Outdoor power circuit board). ③ Replace outdoor power circuit board. ④ Check compressor for electrical insulation. Replace compressor.
	02	Undervoltage error • Instantaneous decrease in DC bus voltage to HWM140V: 200 V HWM140Y: 400 V	① Decrease in power source voltage, instantaneous stop ② Defective converter drive circuit in outdoor power circuit board (HWM140V) ③ Defective 52C drive circuit in outdoor power circuit board ④ Disconnection or loose connection of rush current protect resistor RS (HWM140Y) ⑤ Disconnection or loose connection of CN2 on the outdoor power circuit board /controller circuit board (HWM140V) ⑥ Power circuit failure on DC supply for 15 VDC output on outdoor controller circuit board (HWM140V)	① Check the field facility for the power supply. ② Replace outdoor power circuit board. (HWM140V) ③ Replace outdoor power circuit board. ④ Check RS wiring. (HWM140Y) ⑤ Check CN2 wiring. (HWM140V) ⑥ Replace outdoor controller circuit board. (HWM140V)
	04	Input current sensor error/ L1-phase open error • Decrease in input current through outdoor unit to 0.1 A only if operation frequency is more than or equal to 40 Hz or compressor current is more than or equal to 6 A.	① L1-phase open (HWM140Y) ② Disconnection or loose connection between TB1 and outdoor noise filter circuit board (HWM140Y) ③ Disconnection or loose connection of CN5 on the outdoor power circuit board/CNCT on the outdoor noise filter board (HWM140Y) ④ Defective ACCT (AC current trans) on the outdoor noise filter circuit board (HWM140Y) ⑤ Defective input current detection circuit in outdoor power circuit board ⑥ Defective outdoor controller circuit board	① Check the field facility for the power supply. (HWM140Y) ② Check the wiring between TB1 and outdoor noise filter circuit board. (HWM140Y) ③ Check CN5/CNCT wiring. (HWM140Y) ④ Replace outdoor noise filter circuit board. (HWM140Y) ⑤ Replace outdoor power circuit board. ⑥ Replace outdoor controller circuit board.
	08	Abnormal power synchronous signal • No input of power synchronous signal to power circuit board • Power synchronous signal of 44 Hz or less, or 65 Hz or more is detected on power circuit board.	① Distortion of power source voltage, noise superimposition ② Disconnection or loose connection of earth wiring ③ Disconnection or loose connection of CN2 on the outdoor power circuit board/controller circuit board ④ Defective power synchronous signal circuit in outdoor controller circuit board ⑤ Defective power synchronous signal circuit in outdoor power circuit board	① Check the field facility for the power supply. ② Check earth wiring. ③ Check CN2 wiring. ④ Replace outdoor controller circuit board. ⑤ Replace outdoor power circuit board.
10	PFC error (Overvoltage/ Undervoltage/Overcurrent) • PFC detected any of the following: a) Increase in DC bus voltage to 460V b) Decrease in PFC control voltage to 12 VDC or lower c) Increase in input current to 74 A peak	① Abnormal increase in power source voltage ② Decrease in power source voltage, instantaneous stop ③ Disconnection of compressor wiring ④ Misconnection of reactor (DCL) ⑤ Defective outdoor power circuit board ⑥ Defective Reactor(DCL) ⑦ Disconnection or loose connection of CN2 on the outdoor power circuit board/controller circuit board	①② Check the field facility for the power supply. ③ Correct the wiring (U.V.W phase) to compressor. Refer to "9-7. TEST POINT DIAGRAM". ④ Correct the wiring of reactor (DCL). ⑤ Replace outdoor power circuit board. ⑥ Replace Reactor (DCL). ⑦ Check CN2 wiring.	

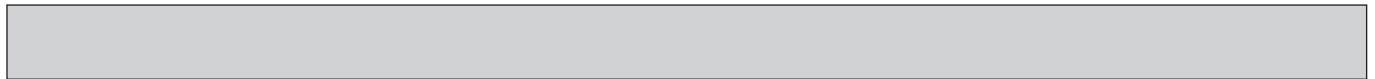

Check Code	Abnormal point and detection method	Cause	Judgment and action
Ud (1504)	Overheat protection Abnormal if outdoor pipe thermistor (TH3) detects 70°C or more or condensing temperature of pressure sensor (63HS) detects 70°C or more during compressor operation.	<ul style="list-style-type: none"> ① Defective outdoor fan (fan motor) or short cycle of outdoor unit during cooling operation ② Defective outdoor pipe thermistor (TH3) ③ Defective outdoor controller board ④ Defective pressure sensor 	<ul style="list-style-type: none"> ① Check outdoor unit air passage. ②③ Turn the power off and on again to check the check code. If U4 is displayed, follow the U4 processing direction. ④ Check pressure by microprocessor. (Pressure sensor/ 63HS) (SW2: Refer to "9-8. OUTDOOR UNIT OPERATION MONITOR FUNCTION".)
UF (4100)	Compressor overcurrent interruption (When compressor locked) Abnormal if overcurrent of DC bus or compressor is detected within 30 seconds after compressor starts operating.	<ul style="list-style-type: none"> ① Decrease of power supply voltage ② Looseness, disconnection or reverse of compressor wiring connection ③ Defective compressor ④ Defective outdoor power board ⑤ Decreased water flow ⑥ Clogged filter of water pipe ⑦ Clogged plate heat exchanger ⑧ Locked water pump ⑨ Malfunction of water pump 	<ul style="list-style-type: none"> ① Check facility of power supply. ② Correct the wiring (U·V·W phase) to compressor. Refer to "9-7. TEST POINT DIAGRAM" (Outdoor power circuit board). ③ Check compressor. Refer to "9-5. HOW TO CHECK THE PARTS" ④ Replace outdoor power circuit board. ⑤–⑨ Check water circuit and repair the defect.
UH (5300)	Current sensor error or input current error ·Abnormal if current sensor detects –1.0 A to 1.0 A during compressor operation. (This error is ignored during test run.) ·Abnormal if 40 A of input current is detected or 39 A or more of input current is detected for 10 seconds continuously. (HWM140V only)	<ul style="list-style-type: none"> ① Disconnection of compressor wiring ② Defective circuit of current sensor on outdoor power circuit board ③ Decrease of power supply voltage ④ Leakage or shortage of refrigerant 	<ul style="list-style-type: none"> ① Correct the wiring (U·V·W phase) to compressor. Refer to "9-7. TEST POINT DIAGRAM" (Outdoor power circuit board). ② Replace outdoor power circuit board. ③ Check the facility of power supply. ④ Check leakage of refrigerant.
UP (4210)	Compressor overcurrent interruption Abnormal if overcurrent DC bus or compressor is detected after compressor starts operating for 30 seconds.	<ul style="list-style-type: none"> ① Decrease of power supply voltage ② Looseness, disconnection or reverse of compressor wiring connection ③ Defective fan of outdoor units ④ Short cycle of indoor/outdoor units ⑤ Defective input circuit of outdoor controller board ⑥ Defective compressor ⑦ Decreased water flow ⑧ Clogged filter of water pipe ⑨ Clogged plate heat exchanger □ Locked water pump ┆ Malfunction of water pump 	<ul style="list-style-type: none"> ① Check facility of power supply. ② Correct the wiring (U·V·W phase) to compressor. Refer to "9-7. TEST POINT DIAGRAM" (Outdoor power circuit board). ③ Check outdoor fan. ④ Solve short cycle. ⑤ Replace outdoor controller circuit board. ⑥ Check compressor. Refer to "9-5. HOW TO CHECK THE PARTS". <p>Note: Before the replacement of the outdoor controller circuit board, disconnect the wiring to compressor from the outdoor power circuit board and check the output voltage among phases, U, V, W, during test run. No defect on board if voltage among phases (U-V, V-W and W-U) is same. Make sure to perform the voltage check with same performing frequency.</p> <ul style="list-style-type: none"> ⑦–┆ Check water circuit and repair the defect.
E0 or E4 (6831 or 6834)	Remote controller transmission error (E0)/signal receiving error (E4) ① Abnormal if main or sub remote controller cannot receive any transmission normally from Interface unit/Flow temp. controller of refrigerant address "0" for 3 minutes. (Check code: E0) ② Abnormal if sub-remote controller could not receive any signal for 2 minutes. (Check code: E0) ① Abnormal if Interface/Flow temp. controller board cannot receive any data normally from remote controller board or from other Interface/Flow temp. controller board for 3 minutes. (Check code: E4) ② Interface/Flow temp. controller board cannot receive any signal from remote controller for 2 minutes. (Check code: E4)	<ul style="list-style-type: none"> ① Contact failure at transmission wire of remote controller ② All remote controllers are set as "sub" remote controller. In this case, E0 is displayed on remote controller, and E4 is displayed at LED (LED1, LED2) on the outdoor controller circuit board. ③ Miswiring of remote controller ④ Defective transmitting receiving circuit of remote controller ⑤ Noise has entered into the transmission wire of remote controller. 	<ul style="list-style-type: none"> ① Check disconnection or looseness of Interface unit/Flow temp. controller unit or transmission wire of remote controller. ② Set one of the remote controllers "main" if there is no problem with the action above. ③ Check wiring of remote controller. <ul style="list-style-type: none"> • Total wiring length: max. 500 m (Do not use cable with 3 or more cores.) • The number of connecting remote controller (Refer to the indoor unit's Installation Manual.) <p>If the cause of trouble is not in ①–③ above,</p> <ul style="list-style-type: none"> ④ Diagnose remote controllers. <ul style="list-style-type: none"> a) When "OK" is displayed, remote controllers have no problem. Turn the power off, and on again to check. If abnormality occurs again, replace Interface/Flow temp. controller board. b) When "NG" is displayed, replace remote controller. c) When "E3" or "00–66" is displayed, noise may be causing abnormality.

Check Code	Abnormal point and detection method	Cause	Judgment and action
E1 or E2 (6201 or 6202)	Remote controller control board ① Abnormal if data cannot be read normally from the nonvolatile memory of the remote controller control board. (Check code: E1) ② Abnormal if the clock function of remote controller cannot be operated normally. (Check code: E2)	① Defective remote controller	① Replace remote controller.
E3 or E5 (6832 or 6833)	Remote controller transmission error (E3)/signal receiving error (E5) ① Abnormal if remote controller could not find blank of transmission path for 6 seconds and could not transmit. (Check code: E3) ② When remote controller receives the transmitted data same time and compares these data. Abnormal if the data is judged to be different for 30 continuous times. (Check code: E3) ① Abnormal if Interface/Flow temp. controller board could not find blank of transmission path. (Check code: E5) ② When Interface/Flow temp. controller receives the transmitted data same time and compares these data. Abnormal if the data is judged to be different for 30 continuous times. (Check code: E5)	① Refer to the indoor unit's Installation Manual for remote controller connection. ② Defective transmitting receiving circuit of remote controller ③ Defective transmitting receiving circuit of Interface/Flow temp. controller board ④ Noise has entered into transmission wire of remote controller.	① Refer to the indoor unit's Installation Manual for remote controller connection. ②-④ Diagnose remote controller. a) When "OK" is displayed, remote controllers have no problem. Turn the power off, and on again to check. When becoming abnormal again, replace indoor controller board. b) When "NG" is displayed, replace remote controller. c) When "E3" or "00-66" is displayed, noise may be causing abnormality.
E8 (6840)	Indoor/outdoor unit communication error (Signal receiving error) (Outdoor unit) (1) Abnormal if outdoor controller circuit board could not receive anything normally for 3 minutes.	① Contact failure of indoor/outdoor unit connecting wire ② Defective communication circuit of outdoor controller circuit board ③ Defective communication circuit of indoor controller board ④ Noise has entered into indoor/outdoor unit connecting wire.	① Check disconnection or looseness of indoor/outdoor unit connecting wire of Interface unit/Flow temp. controller or outdoor unit. ②-④ Turn the power off, and on again to check. Replace indoor controller board or outdoor controller circuit board if abnormality is displayed again.
E9 (6841)	Indoor/outdoor unit communication error (Transmitting error) (Outdoor unit) (1) Abnormal if "0" receiving is detected 30 times continuously though outdoor controller circuit board has transmitted "1". (2) Abnormal if outdoor controller circuit board could not find blank of transmission path for 3 minutes.	① Indoor/outdoor unit connecting wire has contact failure. ② Defective communication circuit of outdoor controller circuit board ③ Noise has entered power supply. ④ Noise has entered indoor/outdoor unit connecting wire.	① Check disconnection or looseness of indoor/outdoor unit connecting wire. ②-④ Turn the power off, and on again to check. Replace outdoor controller circuit board if abnormality is displayed again.
EF (6607 or 6608)	Non defined check code This code is displayed when non defined check code is received.	① Noise has entered transmission wire of remote controller. ② Noise has entered indoor/outdoor unit connecting wire.	①② Turn the power off, and on again to check. Replace indoor/outdoor controller circuit board if abnormality is displayed again.
Ed (0403)	Serial communication error Abnormal if serial communication between outdoor controller circuit board and outdoor power circuit board is defective.	① Wire disconnection or contact failure of connector CN2 between the outdoor controller circuit board and the outdoor power circuit board ② Wire disconnection or contact failure of connector CN4 between the outdoor controller circuit board and the outdoor power circuit board ③ Defective communication circuit of outdoor power circuit board ④ Defective communication circuit of outdoor controller circuit board for outdoor power circuit board	①② Check connection of each connector CN2 and CN4 between the outdoor controller circuit board and the outdoor power circuit board. ③ Replace outdoor power circuit board. ④ Replace outdoor controller circuit board.

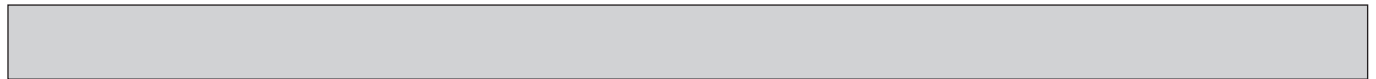





Check Code	Abnormal point and detection method	Cause	Judgment and action
P6 (1503)	Freezing/overheating protection is working (1) Freezing protection Plate HEX Liquid temperature (TH34) or refrigerant saturation temperature is 10 seconds smaller than the threshold. The threshold is dynamically calculated by inner operation using the operating time of the compressor and the water temperature.	(1) Freezing protection <Cooling mode> ① Reduced water flow · Clogged filter · Leakage of water ② Low temperature · Low-load · Inlet water is too cold. ③ Defective water pump ④ Defective outdoor fan control ⑤ Leakage or shortage of refrigerant ⑥ Defective refrigerant circuit (clogs) ⑦ Malfunction of linear expansion valve <Heating mode> ① Reduced water flow · Clogged filter · Leakage of water ② Low temperature · Low-load · Inlet water is cold. ③ Defective water pump ④ Leakage or shortage of refrigerant ⑤ Malfunction of linear expansion valve	(1) Freezing protection <Cooling mode> ①② Check water piping. ③ Check water pump. ④ Check outdoor fan motor. ⑤-⑦ Check operating condition of refrigerant circuit. ⑦ Check linear expansion valve. <Heating mode> ①② Check water piping. ③ Check water pump. ④ Correct to proper amount of refrigerant. ⑤ Check linear expansion valve. Refer to "9-6. HOW TO CHECK THE COMPONENTS".
P8 (1110)	Pipe temperature Abnormal if the following conditions are detected for continuously 3 minutes after compressor starts operating for 10 minutes. 1. Cooling mode TH6-TH7 $\leq 2^{\circ}\text{C}$ and TH3-TH7 $\leq 4^{\circ}\text{C}$ or TH6-TH3 $< 0^{\circ}\text{C}$ and THW2 (Indoor)-TH34 $\leq 0^{\circ}\text{C}$ 2. Heating mode T63HS-THW2 (Indoor) $\leq 2^{\circ}\text{C}$ and TH6-THW2 (Indoor) $\leq 1^{\circ}\text{C}$ and TH7-TH3 $\leq 1^{\circ}\text{C}$ T63HS: Condensing temperature of pressure sensor (63HS) Thermistor TH3: Liquid temperature TH34: Plate HEX Liquid temperature TH7: Ambient temperature THW2(Indoor): Return water temp from indoor unit thermistor	① Leakage or shortage of refrigerant ② Malfunction of linear expansion valve ③ Refrigerant circuit is clogged with foreign objects. Note: Clogging occurs in the parts which become below freezing point when water enters in refrigerant circuit. ④ Disconnection of thermistor holder	① Check intake superheat. Check leakage of refrigerant. ② Check linear expansion valve. ③ After recovering refrigerant, remove water from entire refrigerant circuit under vacuum more than 1 hour. ④ Check temperature display on outdoor controller circuit board. Temperature display is indicated by setting SW2 of outdoor controller circuit board. Check the holder of thermistor.
UE (1509)	Abnormal pressure of pressure sensor (63HS) Abnormal if pressure sensor (63HS) detects 0.1 MPa or less. Detection is inoperative for 3 minutes after compressor starting and 3 minutes after and during defrosting.	① Disconnection or contact failure of connector (63HS) on the outdoor controller circuit board ② Defective pressure sensor ③ Defective outdoor controller circuit board	① Check connection of connector (63HS) on the outdoor controller circuit board. Check breaking of the lead wire for thermistor (63HS). ② Check pressure by microprocessor. (Pressure sensor/ 63HS) (SW2: Refer to "9-8. OUTDOOR UNIT OPERATION MONITOR FUNCTION".) ③ Replace outdoor controller board.
PE	Inlet water temperature Abnormal if the following conditions are detected for continuously 10 seconds. 1. Cooling mode During compressor operation THW2 (Indoor) $< 3^{\circ}\text{C}$ 2. Heating mode (exclude defrosting) During compressor operation THW2 (Indoor) $< -10^{\circ}\text{C}$ 3. Defrosting mode During compressor operation THW2 (Indoor) $< 0^{\circ}\text{C}$ Thermistor THW2 (Indoor): Return water temp from Indoor unit thermistor	① Reduced water flow · Clogged filter · Leak of water ② Low temperature · Low-load · Low temperature inlet water ③ Defective water pump ④ Leakage or shortage of refrigerant	①② Check water piping. ③ Check water pump. ④ Check intake superheat. Check leakage of refrigerant.

9-4. TROUBLESHOOTING OF PROBLEMS

Phenomena	Factor	Countermeasure
1. Remote controller display does not work.	<p>① 12 VDC is not supplied to remote controller.</p> <p>② 12–15 VDC is supplied to remote controller, however, no display is indicated.</p> <ul style="list-style-type: none"> • "Please Wait" is not displayed. • "Please Wait" is displayed. 	<p>① Check LED2 on indoor controller board.</p> <p>(1) When LED2 is lit: Check the remote controller wiring for breaking or contact failure.</p> <p>(2) When LED2 is blinking: Check short circuit of remote controller wiring.</p> <p>(3) When LED2 is not lit: Refer to No.3 below.</p> <p>② Check the following.</p> <ul style="list-style-type: none"> • Failure of remote controller if "Please Wait" is not displayed • Refer to No.2 below if "Please Wait" is displayed.
2. "Please Wait" display is remained on the remote controller.	<p>① At longest 2 minutes after the power supply "Please Wait" is displayed to start up.</p> <p>② Communication error between the remote controller and indoor unit</p> <p>③ Communication error between the indoor and outdoor unit</p> <p>④ Outdoor unit protection device connector is open.</p>	<p>① Normal operation</p> <p>② Self-diagnosis of remote controller</p> <p>③ "Please Wait" is displayed for 6 minutes at most in the case of indoor/outdoor unit communication error. Check LED3 on indoor controller board.</p> <p>(1) When LED3 is not blinking. Check indoor/outdoor connecting wire for miswiring. (Converse wiring of S1 and S2, or break of S3 wiring.)</p> <p>(2) When LED3 is blinking. Indoor/outdoor connecting wire is normal.</p> <p>④ Check LED display on outdoor controller circuit board. Refer to "9-6.TEST POINT DIAGRAM". Check protection device connector (63L and 63H) for contact failure.</p>
3. When pressing the remote controller operation switch, the OPERATION display is appeared but it will be turned off soon.	① After cancelling to select function from the remote controller, the remote controller operation switch will not be accepted for approx. 30 seconds.	① Normal operation
4. Remote controller display works normally and the unit performs cooling operation, however, the capacity cannot be fully obtained.	<p>① Refrigerant shortage</p> <p>② Filter clogging</p>	<p>① If refrigerant leaks, discharge temperature rises and LEV opening increases. Inspect leakage by checking the temperature and opening. Check pipe connections for gas leakage.</p> <p>② Clean the filter of water piping.</p>
5. Remote controller display works normally and the unit performs heating operation, however, the capacity cannot be fully obtained.	<p>① Linear expansion valve fault Opening cannot be adjusted well due to linear expansion valve fault.</p> <p>② Refrigerant shortage</p> <p>③ Lack of insulation for refrigerant piping</p> <p>④ Filter clogging</p> <p>⑤ Bypass circuit of outdoor unit fault</p>	<p>① Discharge temperature and indoor heat exchanger temperature does not rise. Inspect the failure by checking discharging pressure. Replace linear expansion valve.</p> <p>② If refrigerant leaks, discharge temperature rises and LEV opening increases. Inspect leakage by checking the temperature and opening. Check pipe connections for gas leakage.</p> <p>③ Check the insulation.</p> <p>④ Clean the filter of water piping.</p> <p>⑤ Check refrigerant system during operation.</p>
6. ① For 3 minutes after temperature adjuster turns off, the compressor will not start operating even if temperature adjuster is turned on. ② For 3 minutes after temperature adjuster turns on, the compressor will not stop operating even if temperature adjuster is turned off. (Compressor stops operating immediately when turning off by the remote controller.)	①② Normal operation (For protection of compressor)	①② Normal operation
7. The compressor does not work after breaker switched on.	<p>① Normal operation (For protection of compressor) The unit might not run, in order to protect the compressor, when the following two conditions holds:</p> <ol style="list-style-type: none"> 1.The unit was not supplied power for a while, e.g. at the first use of the unit; 2. Ambient and compressor surface are below freezing temperature. It may last up to 12 hours until the unit runs. 	① Start operating after 12 hours of power-on.



Phenomena	Countermeasure
A flowing water sound or occasional hissing sound is heard.	<ul style="list-style-type: none"> These sounds can be heard when refrigerant and/or water is (are) flowing in the indoor unit or refrigerant pipe, or when the refrigerant and/or water is (are) chugging.
Water does not heat or cool well.	<ul style="list-style-type: none"> Clean the filter of water piping. (Flow is reduced when the filter is dirty or clogged.) Check the temperature adjustment and adjust the set temperature. Make sure that there is plenty of space around the outdoor unit.
Water is dripping or vapour is emitted from the outdoor unit.	<ul style="list-style-type: none"> During cooling mode, water may form and drip from the cool pipes and joints. During heating mode, water may form and drip from the heat exchanger of outdoor unit. During defrosting mode, water on the heat exchanger of outdoor unit evaporates and water vapour may be emitted.
The operation indicator does not appear in the remote controller display.	<ul style="list-style-type: none"> Turn on the power switch. "●" will appear in the remote controller display*.
"  appears in the remote controller display.*	<ul style="list-style-type: none"> During external signal control, " appears in the remote controller display and FTC operation cannot be started or stopped using the remote controller.
When restarting the outdoor unit soon after stopping it, it does not operate even though the ON/OFF button is pressed.*	<ul style="list-style-type: none"> Wait approximately 3 minutes. (Operation has stopped to protect the outdoor unit.)
FTC operates without the ON/OFF button being pressed.*	<ul style="list-style-type: none"> Is the on timer set? Press the ON/OFF button to stop operation. Is the FTC connected to a external signal? Consult the concerned people who control the FTC. Does " appear in the remote controller display? Consult the concerned people who control the FTC. Has the auto recovery feature from power failures been set? Press the ON/OFF button to stop operation.
FTC stops without the ON/OFF button being pressed.*	<ul style="list-style-type: none"> Is the off timer set? Press the ON/OFF button to restart operation. Is the FTC connected to a central remote controller? Consult the concerned people who control the FTC. Does " appear in the remote controller display? Consult the concerned people who control the FTC.
Remote controller timer operation cannot be set.*	<ul style="list-style-type: none"> Are timer settings invalid? If the timer can be set, (WEEKLY), (SIMPLE), or (AUTO OFF) appears in the remote controller display.
"Please Wait" appears in the remote controller display.	<ul style="list-style-type: none"> The initial settings are being performed. Wait approximately 3 minutes. If the remote controller is not only for FTC, change it.
A check code appears in the remote controller display.	<ul style="list-style-type: none"> The protection devices have operated to protect the FTC and outdoor unit. Do not attempt to repair this equipment by yourself. Turn off the power switch immediately and consult your dealer. Be sure to provide the dealer with the model name and information that appeared in the remote controller display.

*PAC-IF011B-E only

- If the unit cannot be operated properly after test run, refer to the following table to find the cause.

Symptom		Cause
Wired remote controller	LED 1, 2 (PCB in outdoor unit)	
Please Wait	For about 2 minutes after power-on	After LED 1, 2 are lit, LED 2 is turned off, then only LED 1 is lit. (Correct operation)
Please Wait → Check code	Subsequent to about 2 minutes after power-on	Only LED 1 is lit. → LED 1, 2 blink.
		Only LED 1 is lit. → LED 1 blinks twice, LED 2 blinks once.
Display messages do not appear even when operation switch is turned ON (operation lamp does not light up).		<ul style="list-style-type: none"> For about 2 minutes following power-on, operation of the remote controller is not possible due to system startup. (Correct operation) Connector for the outdoor unit's protection device is not connected. Reverse or open phase wiring for the outdoor unit's power terminal block (L1, L2, L3) Incorrect wiring between FTC and outdoor (incorrect polarity of S1, S2, S3) Remote controller wire short

Note: Operation is not possible for about 30 seconds after cancellation of function selection. (Correct operation)

For description of each LED (LED1, 2, 3) provided on the FTC, refer to the following table.

LED1 (power for microprocessor)	Indicates whether control power is supplied. Make sure that this LED is always lit.
LED2 (power for remote controller)	Indicates whether power is supplied to the remote controller. This LED lights only in the case of the FTC which is connected to the outdoor unit refrigerant addresses "0".
LED3 (communication between FTC and outdoor units)	Indicates state of communication between the FTC and outdoor units. Make sure that this LED is always blinking.

Symptoms: "Please Wait" is kept being displayed on the remote controller.





Diagnosis flow	Cause	Inspection method and troubleshooting
<pre> graph TD Start[Check the display time of "Please Wait" after turning on the main power.] --> D1{How long is "Please Wait" kept being displayed on the remote controller?} D1 -- "6 minutes or more" --> Step1[Check the LED display of the outdoor controller circuit board.] D1 -- "2 to 6 minutes" --> D2{Are any check codes displayed on the remote controller?} D1 -- "2 minutes or less" --> End1[Normal. The startup diagnosis will be over in around 2 minutes.] D2 -- YES --> Step1 D2 -- NO --> Cause1[Defective indoor controller board Defective remote controller] Step1 --> D3{Are any check codes displayed on the LED?} D3 -- YES --> Cause2[Miswiring of indoor/outdoor connecting wire Breaking of indoor/outdoor connecting wire (S3) Defective indoor controller board Defective outdoor controller circuit board] D3 -- NO --> Cause1 </pre>	<ul style="list-style-type: none"> • "Please Wait" will be displayed during the startup diagnosis after turning on the main power. • Miswiring of indoor/outdoor connecting wire • Breaking of indoor/outdoor connecting wire (S3) • Defective indoor controller board • Defective outdoor controller circuit board • Defective indoor controller board • Defective remote controller 	<ul style="list-style-type: none"> • Normal. The startup diagnosis will be over in around 2 minutes. • Refer to "Self-diagnosis action table" in order to solve the trouble. • In the case of communication errors, the display of remote controller may not match the LED display of the outdoor unit.

Symptoms: Nothing is displayed on the remote controller. ①

LED display of the indoor controller board
 LED1: ○
 LED2: ○
 LED3: ○



Diagnosis flow	Cause	Inspection method and troubleshooting
<pre> graph TD A[Check the voltage between S1 and S2 on the terminal block of the indoor unit which is used to connect the indoor unit and the outdoor unit.] --> B{198 to 264 VAC?} B -- NO --> C[Check the voltage among L(L3) and N on the terminal block (TB1) of the outdoor power circuit board.] B -- YES --> D[] C --> E{198 to 264 VAC?} E -- NO --> F[] E -- YES --> G[Check the voltage between S1 and S2 on the terminal block (TB1) of the outdoor unit which is used to connect the indoor unit and the outdoor unit.] G --> H{198 to 264 VAC?} H -- NO --> I[] H -- YES --> J[] D --> J I --> F F --> Cause1[• Troubles concerning power supply] I --> Cause2[• Bad wiring of the outdoor controller board • The fuses on the outdoor controller circuit board are blown.] J --> Cause3[• Bad wiring of the outdoor controller board • The fuses on the outdoor controller circuit board are blown.] D --> Cause4[• The fuses on the indoor controller circuit board are blown. • Defective indoor controller board] </pre> <p>The flowchart starts with a rectangular box: "Check the voltage between S1 and S2 on the terminal block of the indoor unit which is used to connect the indoor unit and the outdoor unit." This leads to a diamond decision: "198 to 264 VAC?". If "NO", it goes to a rectangular box: "Check the voltage among L(L3) and N on the terminal block (TB1) of the outdoor power circuit board." This leads to another diamond: "198 to 264 VAC?". If "NO", it points to the first cause. If "YES", it goes to a rectangular box: "Check the voltage between S1 and S2 on the terminal block (TB1) of the outdoor unit which is used to connect the indoor unit and the outdoor unit." This leads to a third diamond: "198 to 264 VAC?". If "NO", it points to the second cause. If "YES", it points to the third cause. The "YES" path from the first diamond also points to the fourth cause.</p>	<ul style="list-style-type: none"> • Troubles concerning power supply • Bad wiring of the outdoor controller board • The fuses on the outdoor controller circuit board are blown. • Bad wiring of the outdoor controller board • The fuses on the outdoor controller circuit board are blown. • The fuses on the indoor controller circuit board are blown. • Defective indoor controller board 	<ul style="list-style-type: none"> • Check the power wiring to the outdoor unit. • Check the breaker. • Check the wiring of the outdoor unit. • Check if the wiring is bad. Check if the fuses are blown. The fuses on the outdoor controller circuit board will be blown when the indoor /outdoor connecting wire short-circuits. • Check if miswiring, breaking or poor contact is causing this problem. Indoor/outdoor connecting wire is polarized 3-core type. Connect the indoor unit and the outdoor unit by wiring each pair of S1, S2 and S3 on the both side of indoor/outdoor terminal blocks. • Check if the fuses are blown. • Replace the indoor controller board.

Symptoms: Nothing is displayed on the remote controller. ②

LED display of the indoor controller board
 LED1: 
 LED2: 
 LED3:  or 

Diagnosis flow	Cause	Inspection method and troubleshooting
<p>Check the voltage between S1 and S2 on the terminal block of the indoor unit which is used to connect the indoor unit and the outdoor unit.</p> <p>198 to 264 VAC?</p> <p>NO → Check the looseness or disconnection of the indoor/outdoor connecting wire.</p> <p>YES → Check the status of the indoor controller board LED3 display.</p> <p>Not lighting. → Check the looseness or disconnection of the indoor/outdoor connecting wire.</p> <p>Blinking. → Are there looseness or disconnection of the indoor/outdoor connecting wire?</p> <p>NO → Check the refrigerant address of the outdoor unit. (SW1-3 to 1-6)</p> <p>NO → Is the refrigerant address "0"?</p> <p>YES → Check the LED display of the outdoor unit after turning on the main power again.</p> <p>NO → Is anything displayed?</p> <p>YES → Is "EA" or "Eb" displayed?</p> <p>NO → Is "E8" displayed?</p> <p>YES → Can the unit be restarted?</p> <p>NO → Can all the indoor unit be operated?</p> <p>YES → Check the voltage between S2 and S3 on the terminal block of the outdoor unit.</p> <p>NO → 17 to 28 VDC?</p> <p>YES →</p>	<ul style="list-style-type: none"> • Breaking or poor contact of the indoor/outdoor connecting wire • Normal Only the unit which has the refrigerant address "0" supplies power to the remote controller • Defective outdoor controller circuit board • Defective outdoor controller circuit board • Defective indoor controller board • Influence of electromagnetic noise • Defective outdoor power circuit board • Defective indoor power board 	<ul style="list-style-type: none"> • Fix the breaking or poor contact of the indoor/outdoor connecting wire. • Set the refrigerant address to "0". In the case of the multiple outdoor units control, recheck the refrigerant address again. • Replace the outdoor controller circuit board. • Replace the outdoor controller circuit board. • Replace the indoor controller board of the indoor unit which does not operate. • Not abnormal. There may be the influence of electromagnetic noise. Check the transmission wire and get rid of the causes. • Replace the outdoor power circuit board. • Replace the indoor power board.

Symptoms: Nothing is displayed on the remote controller. ③

LED display of the indoor controller board
 LED1: 
 LED2:  or 
 LED3: —

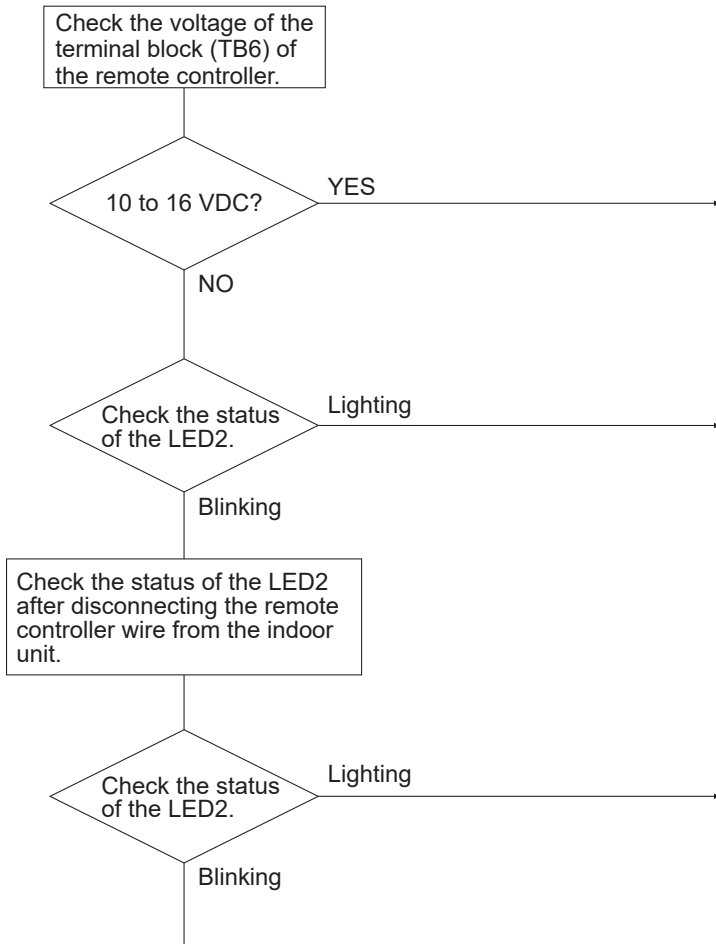
Diagnosis flow	Cause	Inspection method and troubleshooting
 <pre> graph TD A[Check the voltage of the terminal block (TB6) of the remote controller.] --> B{10 to 16 VDC?} B -- YES --> C[Defective remote controller] B -- NO --> D{Check the status of the LED2.} D -- Lighting --> E[Breaking or poor contact of the remote controller wire] D -- Blinking --> F[Check the status of the LED2 after disconnecting the remote controller wire from the indoor unit.] F --> G{Check the status of the LED2.} G -- Lighting --> H[The remote controller wire short-circuits] G -- Blinking --> I[Defective indoor controller board] </pre>	<ul style="list-style-type: none"> • Defective remote controller • Breaking or poor contact of the remote controller wire • The remote controller wire short-circuits • Defective indoor controller board 	<ul style="list-style-type: none"> • Replace the remote controller. • Check if there is breaking or poor contact of the remote controller wire. Check the voltage of the remote controller wire. If it is not between 10 and 16 VDC, the indoor controller board must be defective. • Check if the remote controller wire is short-circuited. • Replace the indoor controller board.

9-5. HOW TO CHECK THE PARTS

PUZ-HWM140VHA(-BS)

PUZ-HWM140YHA(-BS)

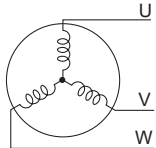
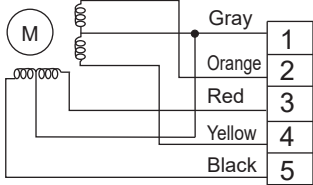
Parts name	Checkpoints														
TH3: Liquid pipe temp. TH4: Discharge temp. TH6: 2-phase pipe temp. TH7: Ambient temp. TH8: Heat sink temp. TH32: Suction pipe temp. TH34: Plate Hex liquid pipe temp.	Disconnect the connector then measure the resistance with a multimeter. (At the ambient temperature of 10 to 30°C) <table border="1" style="margin-top: 10px;"> <thead> <tr> <th></th> <th>Normal</th> <th>Abnormal</th> </tr> </thead> <tbody> <tr> <td>TH4 TH33</td> <td>160 to 410 kΩ</td> <td rowspan="3">Open or short</td> </tr> <tr> <td>TH3 TH6 TH7 TH34</td> <td>4.3 to 9.6 kΩ</td> </tr> <tr> <td>TH8</td> <td>39 to 105 kΩ</td> </tr> </tbody> </table>		Normal	Abnormal	TH4 TH33	160 to 410 kΩ	Open or short	TH3 TH6 TH7 TH34	4.3 to 9.6 kΩ	TH8	39 to 105 kΩ				
	Normal	Abnormal													
TH4 TH33	160 to 410 kΩ	Open or short													
TH3 TH6 TH7 TH34	4.3 to 9.6 kΩ														
TH8	39 to 105 kΩ														
Fan motor (MF1)	Refer to the next page.														
Solenoid valve coil <4-way valve> (21S4)	Measure the resistance between the terminals with a multimeter. (At the ambient temperature of 20°C) <table border="1" style="margin-top: 10px;"> <thead> <tr> <th>Normal</th> <th>Abnormal</th> </tr> </thead> <tbody> <tr> <td>1725 ± 172.5 Ω</td> <td>Open or short</td> </tr> </tbody> </table>	Normal	Abnormal	1725 ± 172.5 Ω	Open or short										
Normal	Abnormal														
1725 ± 172.5 Ω	Open or short														
Compressor (MC) 	Measure the resistance between the terminals with a multimeter. (Winding temperature 20°C) <table border="1" style="margin-top: 10px;"> <thead> <tr> <th colspan="2">Normal</th> <th>Abnormal</th> </tr> </thead> <tbody> <tr> <td>HWM140V</td> <td>HWM140Y</td> <td rowspan="2">Open or short</td> </tr> <tr> <td>0.188 Ω</td> <td>0.302 Ω</td> </tr> </tbody> </table>	Normal		Abnormal	HWM140V	HWM140Y	Open or short	0.188 Ω	0.302 Ω						
Normal		Abnormal													
HWM140V	HWM140Y	Open or short													
0.188 Ω	0.302 Ω														
Linear expansion valve (LEV-A) (LEV-B) (LEV-C) 	Disconnect the connector then measure the resistance with a multimeter. (Winding temperature 20°C) <table border="1" style="margin-top: 10px;"> <thead> <tr> <th colspan="4">Normal</th> <th>Abnormal</th> </tr> </thead> <tbody> <tr> <td>Gray - Black</td> <td>Gray - Red</td> <td>Gray - Yellow</td> <td>Gray - Orange</td> <td rowspan="2">Open or short</td> </tr> <tr> <td colspan="4" style="text-align: center;">46 ± 3 Ω</td> </tr> </tbody> </table>	Normal				Abnormal	Gray - Black	Gray - Red	Gray - Yellow	Gray - Orange	Open or short	46 ± 3 Ω			
Normal				Abnormal											
Gray - Black	Gray - Red	Gray - Yellow	Gray - Orange	Open or short											
46 ± 3 Ω															

Check method of DC fan motor (fan motor/outdoor multi controller circuit board)

- ① Notes
 - High voltage is applied to the connector (CNF1, 2) for the fan motor. Pay attention to the service.
 - Do not pull out the connector (CNF1, 2) for the motor with the power supply on.
(It may damage the outdoor controller circuit board and fan motor.)
- ② Self check
Symptom: The outdoor fan cannot rotate.

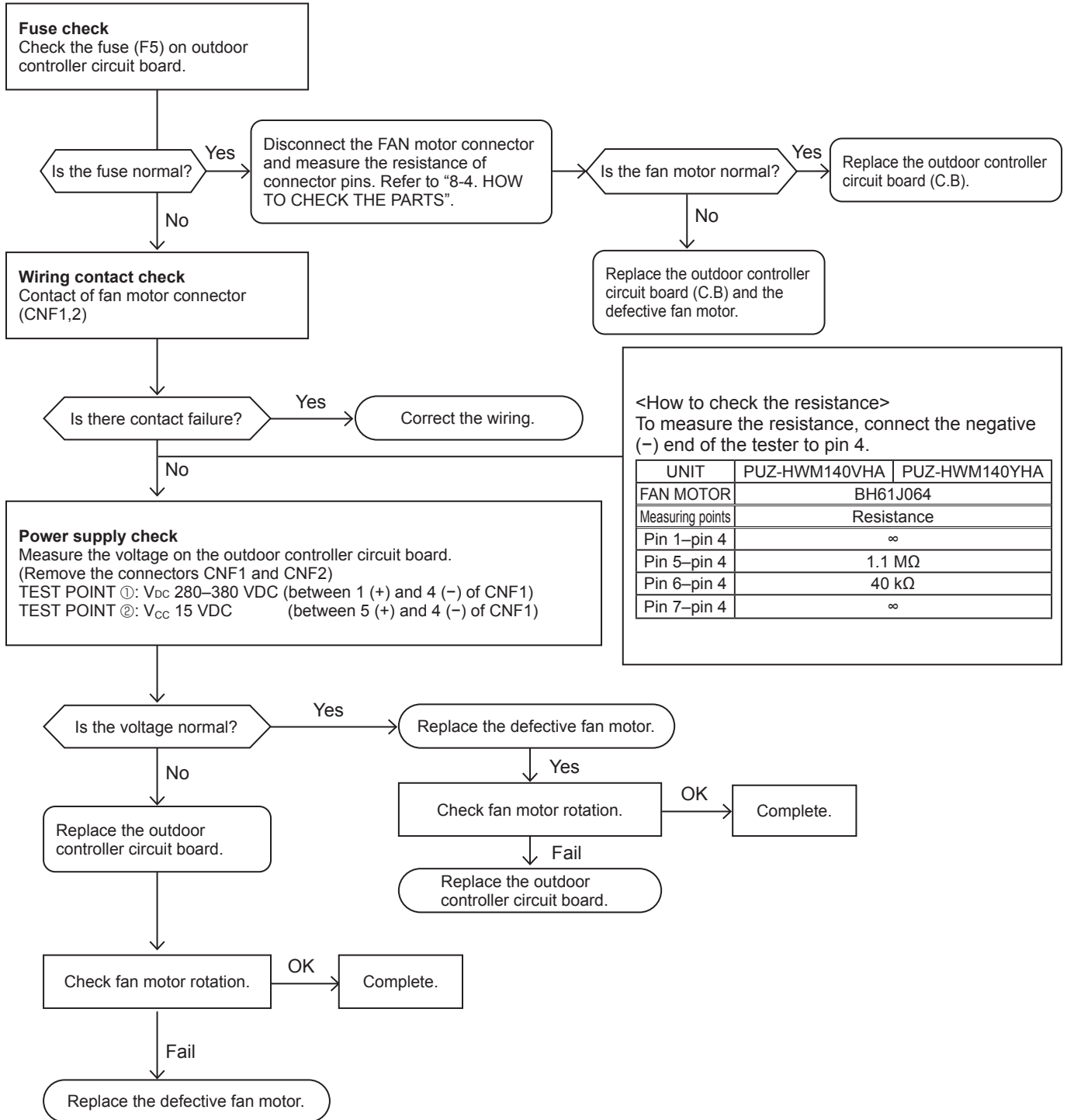

9-6. HOW TO CHECK THE COMPONENTS

9-6-1. Thermistor feature chart

Low temperature thermistors

- Thermistor <Liquid> (TH3)
- Thermistor <2-phase pipe> (TH6)
- Thermistor <Ambient> (TH7)
- Thermistor <Suction> (TH32)
- Thermistor <Plate Hex liquid> (TH34)

Thermistor R0 = 15 kΩ ± 3%

B constant = 3480 ± 2%

$$R_t = 15 \exp\left\{3480 \left(\frac{1}{273+t} - \frac{1}{273} \right)\right\}$$

0°C	15 kΩ	30°C	4.3 kΩ
10°C	9.6 kΩ	40°C	3.0 kΩ
20°C	6.3 kΩ		
25°C	5.2 kΩ		

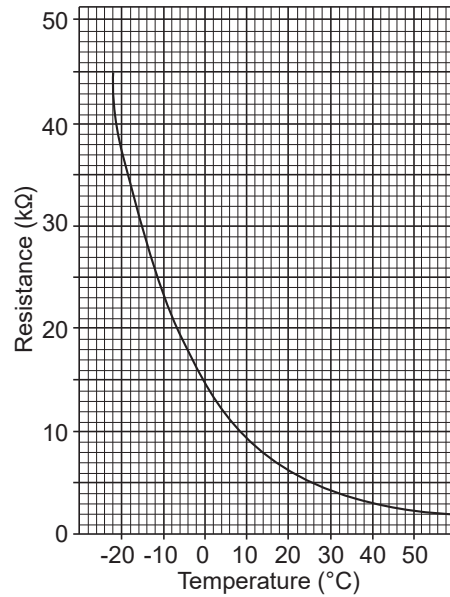

Medium temperature thermistor

- Thermistor <Heat sink> (TH8)

Thermistor R50 = 17 kΩ ± 2%

B constant = 4150 ± 3%

$$R_t = 17 \exp\left\{4150 \left(\frac{1}{273+t} - \frac{1}{323} \right)\right\}$$

0°C	180 kΩ
25°C	50 kΩ
50°C	17 kΩ
70°C	8 kΩ
90°C	4 kΩ

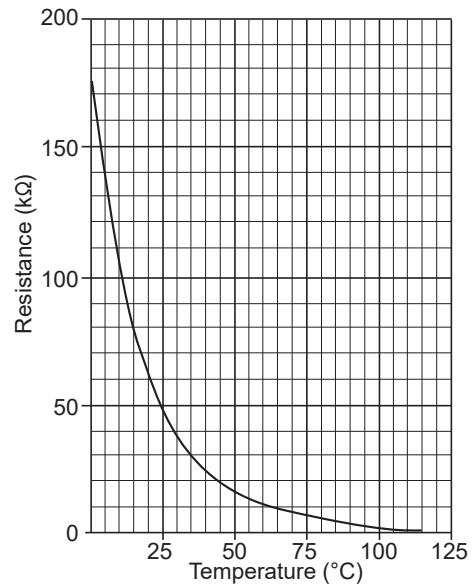

High temperature thermistors

- Thermistor <Discharge> (TH4)
- Thermistor <Comp. surface> (TH33)

Thermistor R120 = 7.465 kΩ ± 2%

B constant = 4057 ± 2%

$$R_t = 7.465 \exp\left\{4057 \left(\frac{1}{273+t} - \frac{1}{393} \right)\right\}$$

20°C	250 kΩ	70°C	34 kΩ
30°C	160 kΩ	80°C	24 kΩ
40°C	104 kΩ	90°C	17.5 kΩ
50°C	70 kΩ	100°C	13.0 kΩ
60°C	48 kΩ	110°C	9.8 kΩ

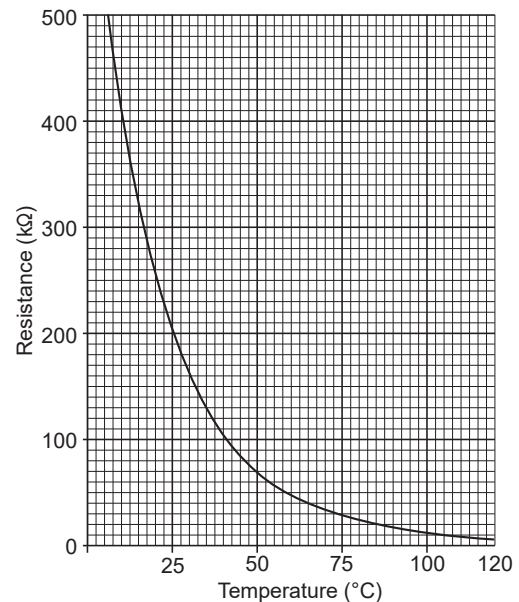

9-6-2. High pressure sensor

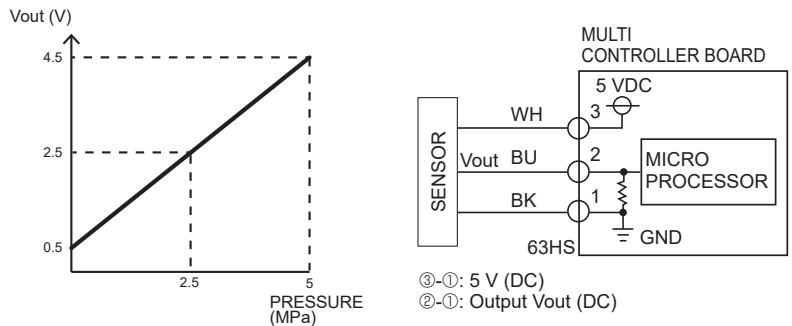

9-6-3. Linear expansion valve

(1) Operation summary of the linear expansion valve

- Linear expansion valve opens/closes through stepping motor after receiving the pulse signal from the outdoor controller board.
- Valve position can be changed in proportion to the number of pulse signal.

<Connection between the outdoor controller board and the linear expansion valve>

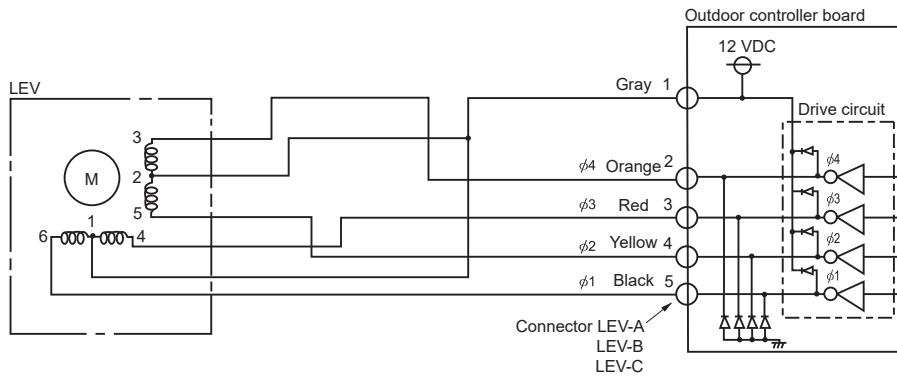

<Output pulse signal and the valve operation>

Output (Phase)	Output							
	1	2	3	4	5	6	7	8
φ1	ON	ON	OFF	OFF	OFF	OFF	OFF	ON
φ2	OFF	ON	ON	ON	OFF	OFF	OFF	OFF
φ3	OFF	OFF	OFF	ON	ON	ON	OFF	OFF
φ4	OFF	OFF	OFF	OFF	OFF	ON	ON	ON

The output pulse shifts in below order.

Opening a valve : 8 → 7 → 6 → 5 → 4 → 3 → 2 → 1 → 8

Closing a valve : 1 → 2 → 3 → 4 → 5 → 6 → 7 → 8 → 1

- When linear expansion valve operation stops, all output phases become OFF.

(2) Linear expansion valve operation

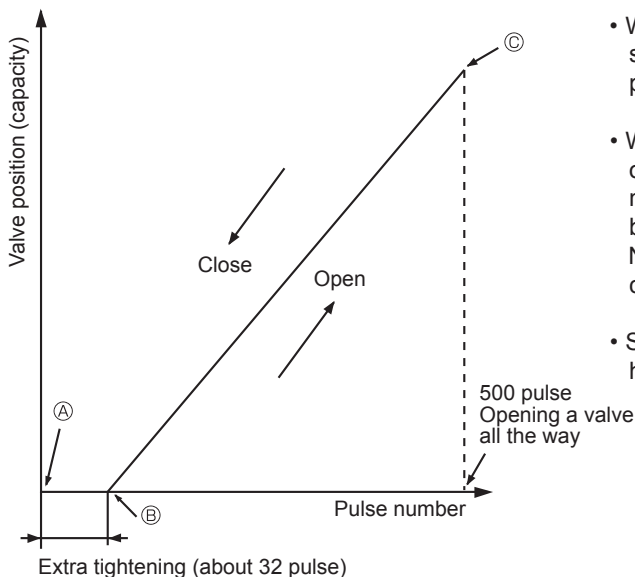

- When the power is turned on, 700 pulse closing valve signal will be sent till it goes to ① point in order to define the valve position. (The pulse signal is being sent for about 20 seconds.)
- When the valve moves smoothly, there is no sound or vibration occurring from the linear expansion valve: however, when the pulse number moves from ② to ① or when the valve is locked, sound can be heard. No sound is heard when the pulse number moves from ② to ① in case coil is burnt out or motor is locked by open-phase.
- Sound can be detected by placing the ear against the screw driver handle while putting the screw driver to the linear expansion valve.

(3) How to attach and detach the coil of linear expansion valve

<Composition>

Linear expansion valve is separable into the main body and the coil as shown in the diagram below.

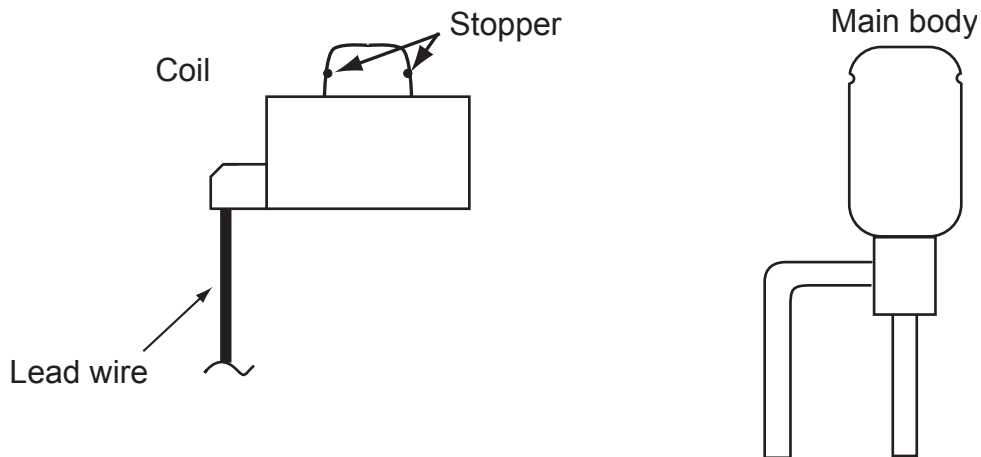

<How to detach the coil>

Hold the lower part of the main body (shown as A) firmly so that the main body does not move and detach the coil by pulling it upward.

Be sure to detach the coil holding main body firmly. Otherwise pipes can bend due to stress.

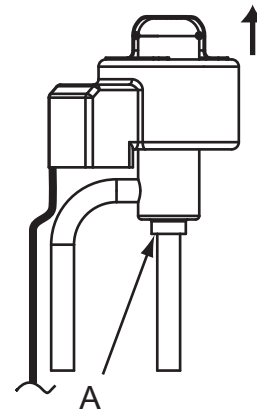

<How to attach the coil>

Hold the lower part of the main body (shown as A) firmly so that the main body does not move and attach the coil by inserting it downward into the main body. Then securely attach the coil stopper to main body. (At this time, be careful that stress is not added to lead wire and main body is not wound by lead wire.) If the stopper is not firmly attached to main body, coil may be detached from the main body and that can cause defective operation of linear expansion valve.

To prevent piping stress, be sure to attach the coil holding the main body of linear expansion valve firmly. Otherwise pipe may break.

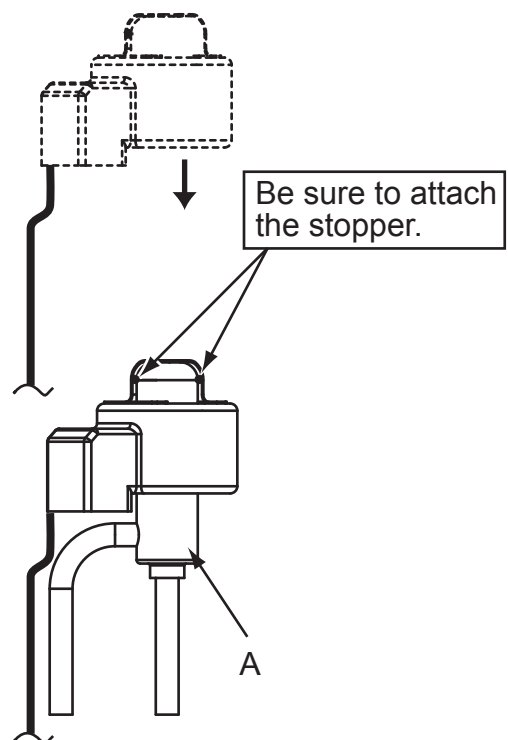

9-7. TEST POINT DIAGRAM

Outdoor controller circuit board PUZ-HWM140VHA(-BS)

PUZ-HWM140YHA(-BS)

<CAUTION> TEST POINT ① is high voltage.

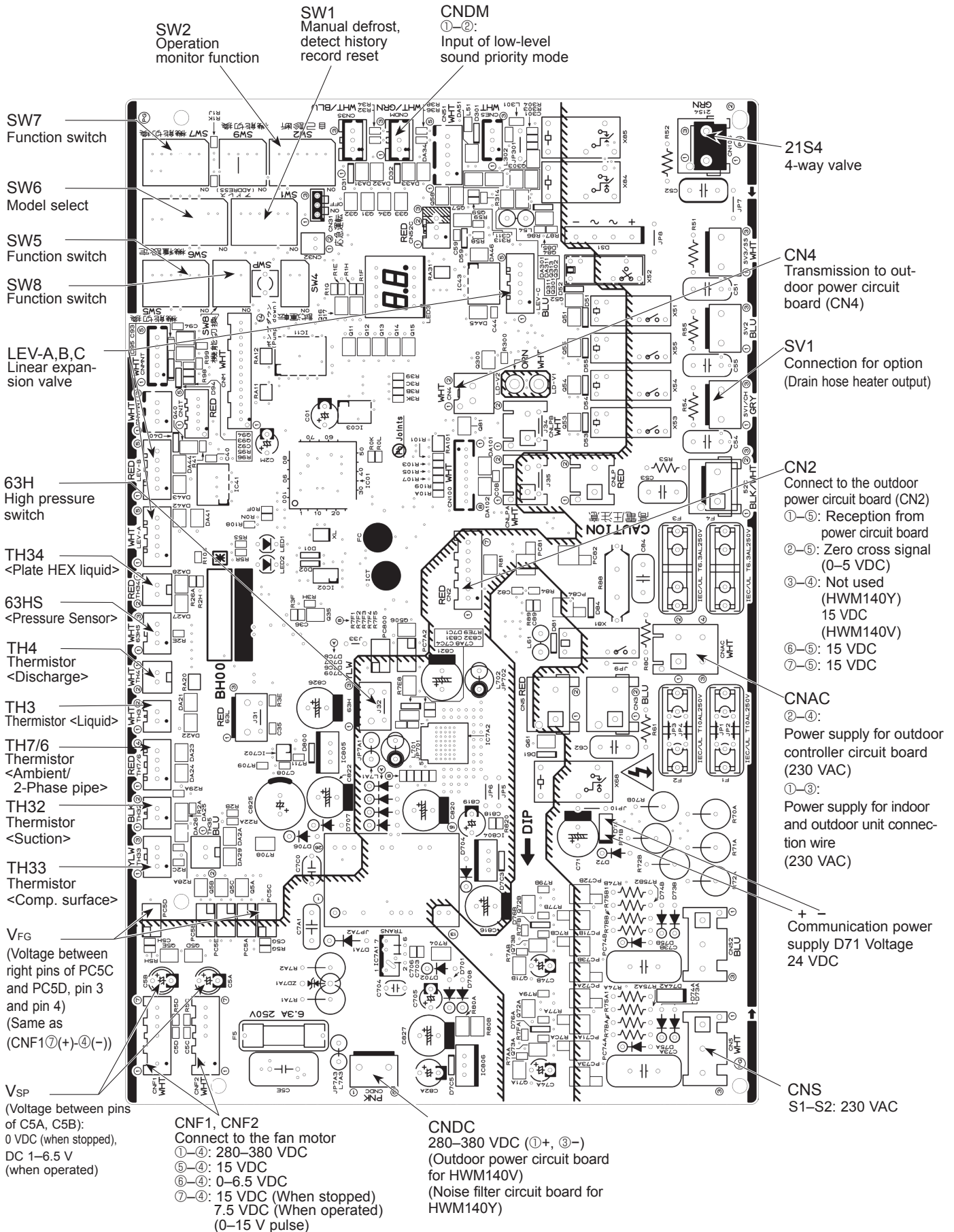

**Outdoor noise filter circuit board
PUZ-HWM140VHA(-BS)**

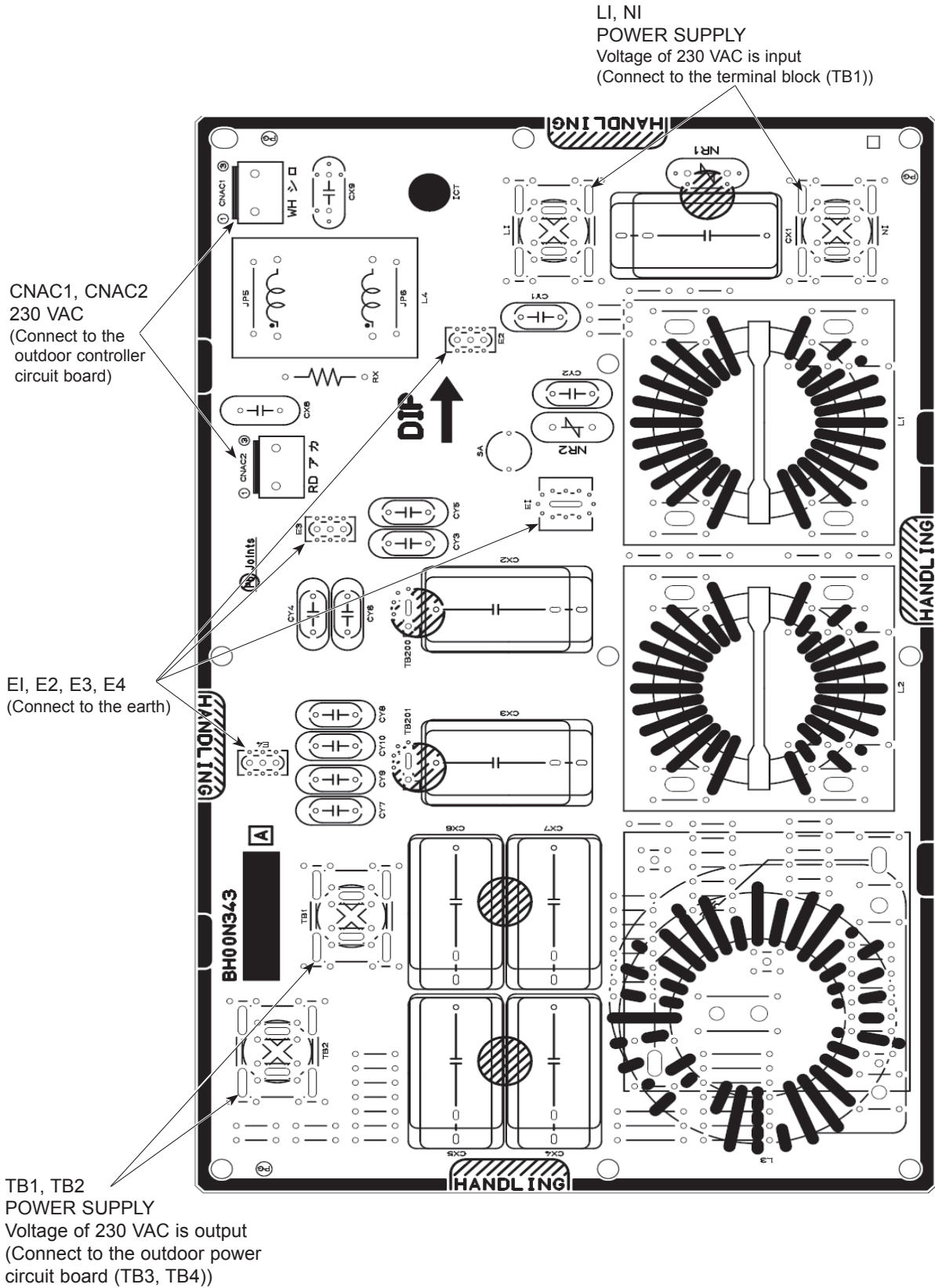

Outdoor noise filter circuit board PUZ-HWM140YHA(-BS)

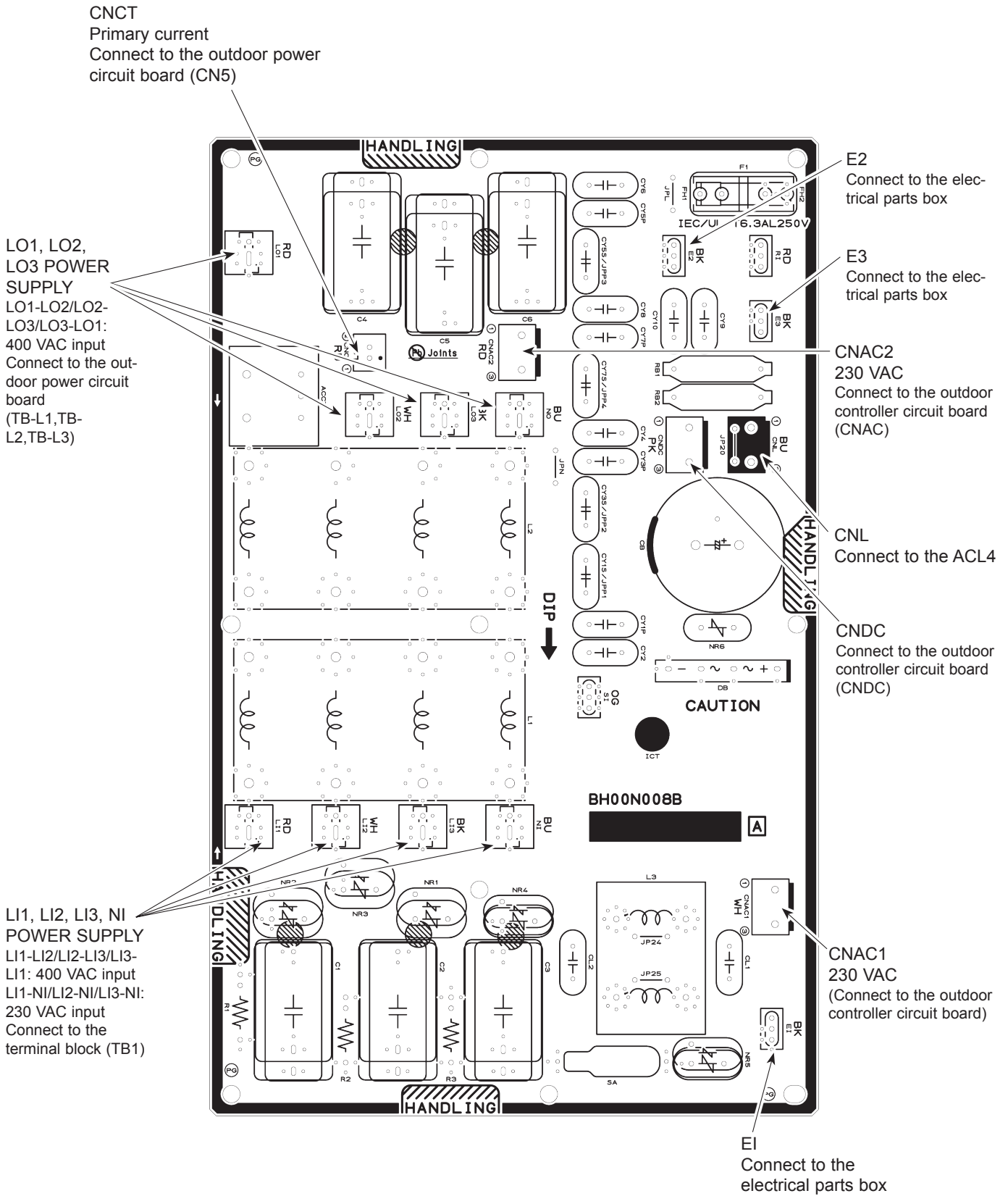

Outdoor power circuit board PUZ-HWM140VHA(-BS)

Brief Check of POWER MODULE

If they are short-circuited, it means that they are broken.
Measure the resistance in the following points (connectors, etc.).

1. Check of POWER MODULE

① Check of DIODE circuit

R - P1, **S** - P1, **R** - N1, **S** - N1

② Check of PFC circuit

P2 - L1, **P2** - L2, **P2** - L3, **N2** - L1, **N2** - L2, **N2** - L3

③ Check of INVERTER circuit

P3 - U, **P3** - V, **P3** - W, **N3** - U, **N3** - V, **N3** - W

Note: The marks **R**, **S**, **L1**, **L2**, **L3**, **P1**, **P2**, **P3**,
N1, **N2**, **N3**, **U**, **V** and **W**
shown in the diagram are not actually printed on the board.

TB3, TB4
POWER SUPPLY
Voltage of 230 VAC is input
(Connect to the outdoor noise filter board (TB1, TB2))

E5
Connect to the earth

TB1A, TB2A, TB3A,
TB1B, TB2B, TB3B
Connect to DCL

CNDC
280-380 VDC
(①+, ②-)
Connect to the
outdoor control-
ler circuit board
(CNDC)

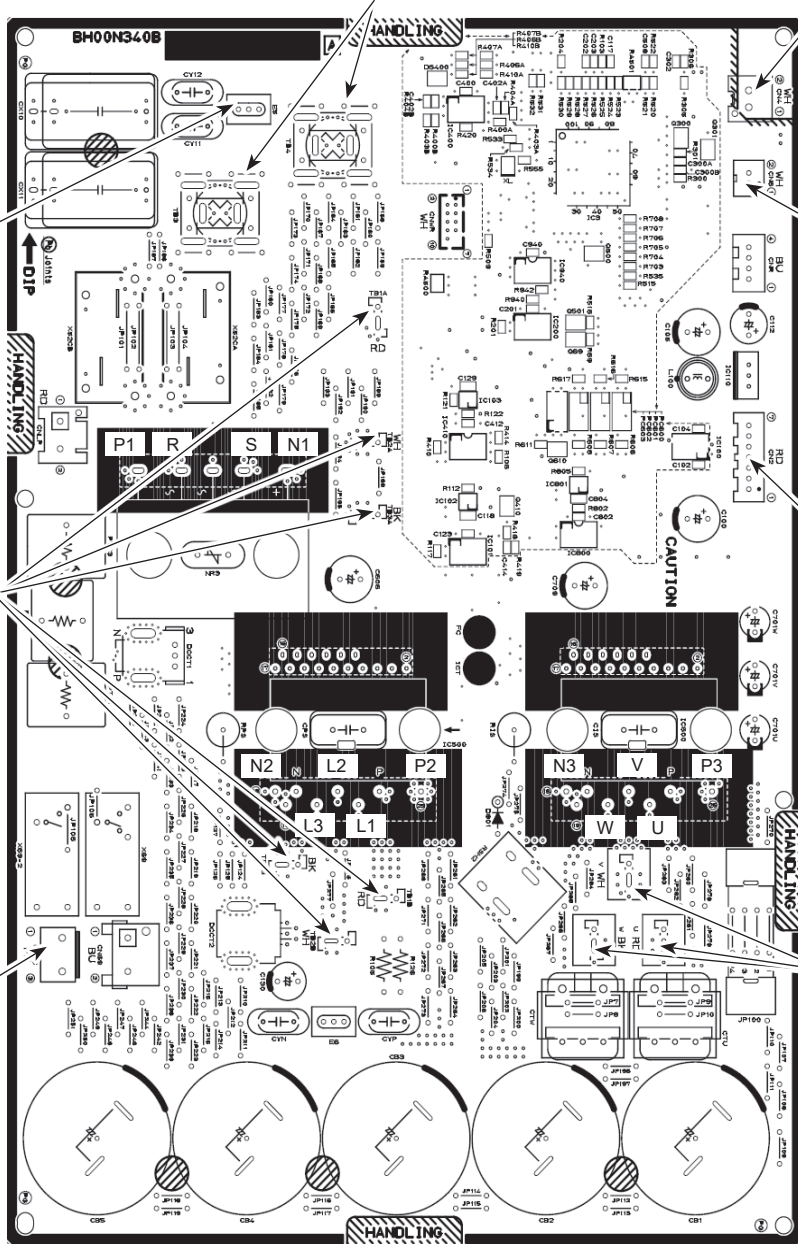

CN4
Connect to the outdoor
controller circuit board (CN4)

CN6
Thermistor

CN2
Connect to the outdoor
controller circuit board (CN2)
①-⑤: Transmitting signal to
outdoor controller circuit
board (0-5 VDC)
②-⑤: Zero cross signal
(0-5 VDC)
③-④: 15 VDC
⑥-⑤: 15 VDC
⑦-⑤: 15 VDC

TB-U, TB-V, TB-W
Connect to the compressor (MC)
Voltage among phases:
10-270 VAC

Outdoor power circuit board PUZ-HWM140YHA(-BS)

Brief Check of POWER MODULE

If they are short-circuited, it means that they are broken.
Measure the resistance in the following points (connectors, etc.).

1. Check of POWER MODULE

①. Check of DIODE circuit

L1-P1, **L2**-P1, **L3**-P1, **L1**-N1, **L2**-N1, **L3**-N1

②. Check of INVERTER circuit

P2-U, **P2**-V, **P2**-W, **N2**-U, **N2**-V, **N2**-W

Note: The marks, **L1**, **L2**, **L3**, **N1**, **N2**, **P1**, **P2**, **U**, **V** and **W** shown in the diagram are not actually printed on the board.

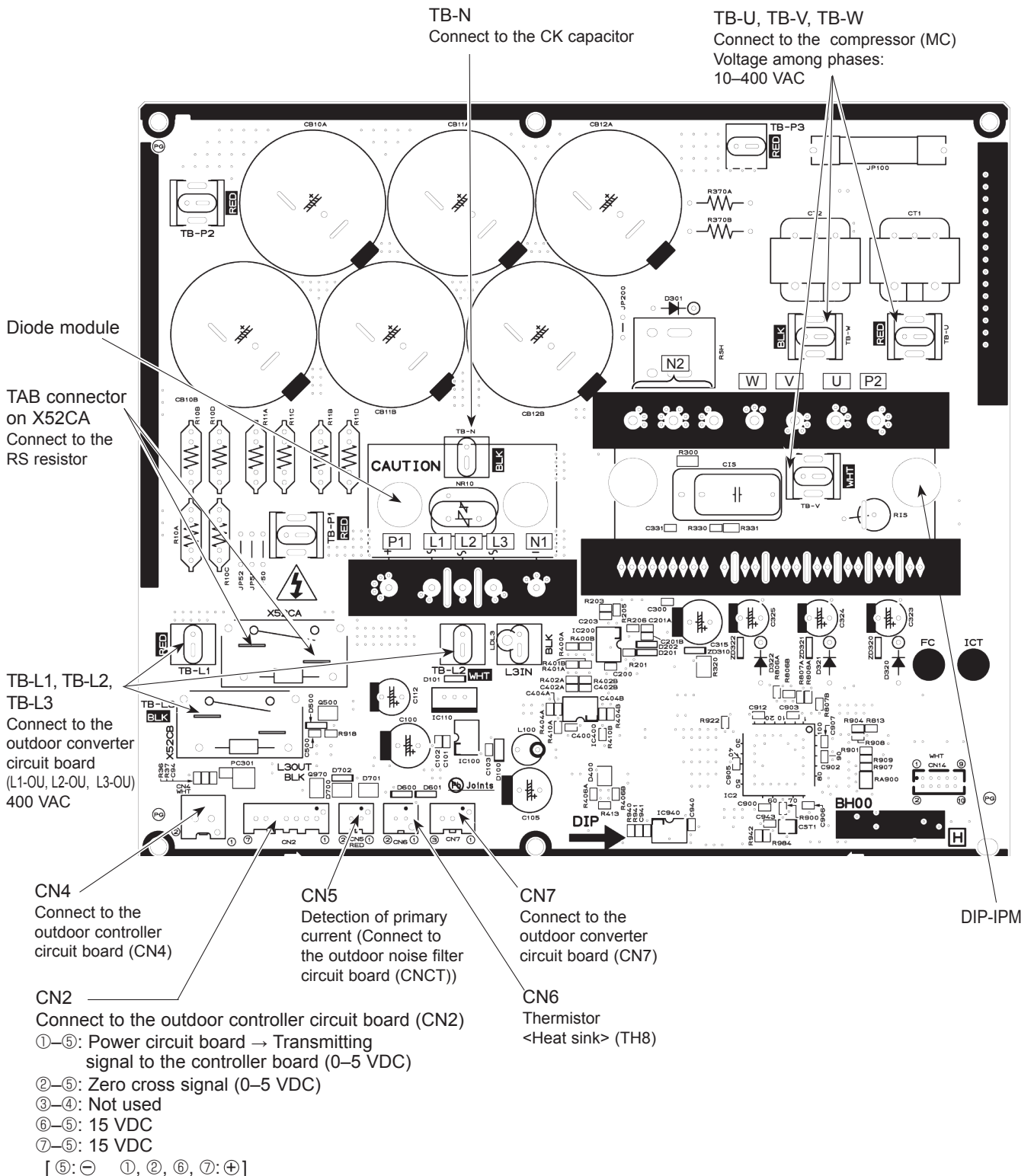

Outdoor converter circuit board PUZ-HWM140YHA(-BS)

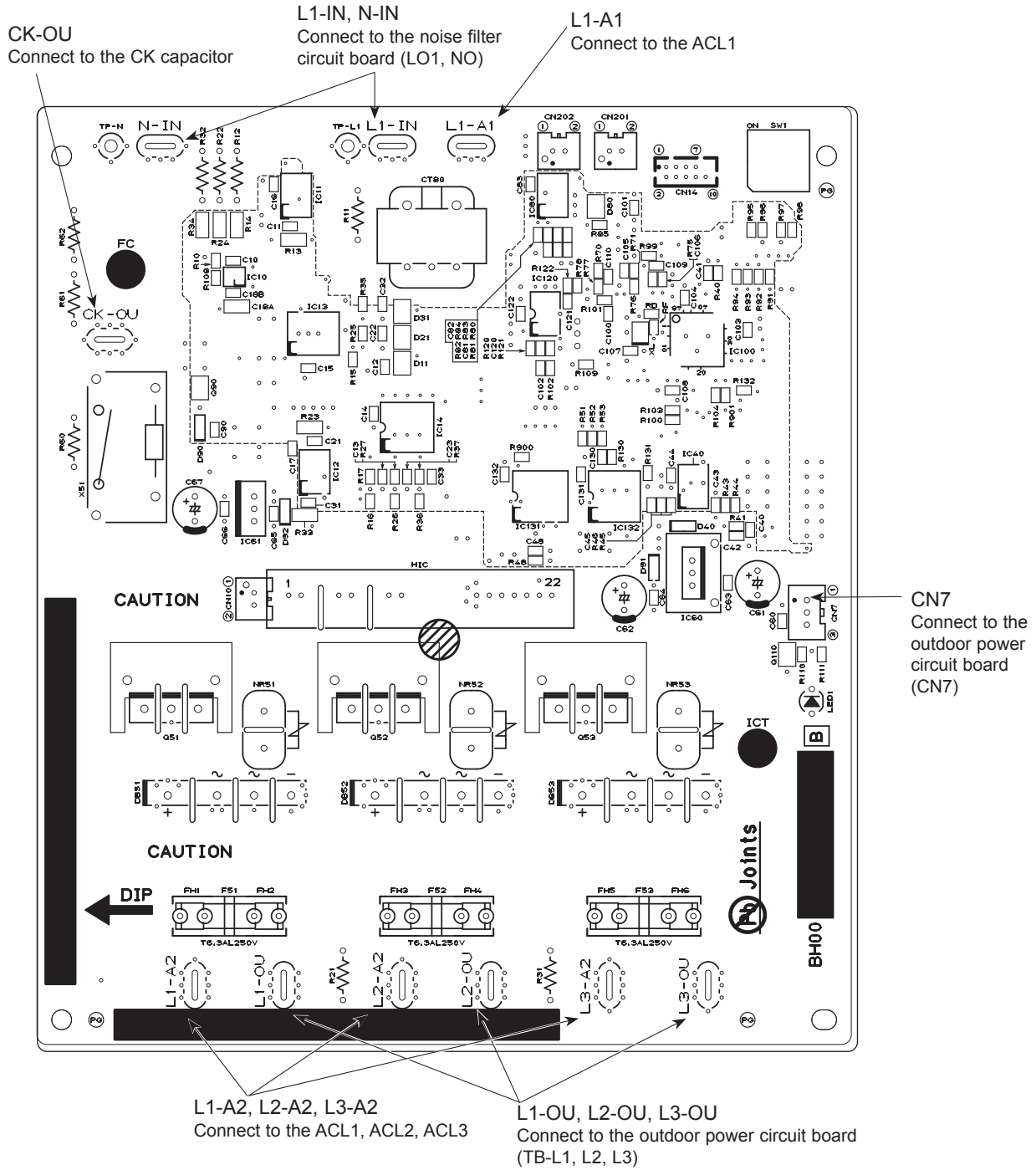



Indication		Error			Detailed reference page
Outdoor controller board LED1 (Green)	LED2 (Red)	Contents	Check code*	Inspection method	
3 blinking	1 blinking	Abnormality of discharging temperature (TH4) and Comp. surface temperature (TH33)	U2	①Check if stop valves are open. ②Check if connectors (TH4, LEV-A, and LEV-B) on outdoor controller board are not disconnected.	P.22
		Abnormality of superheat due to low discharge temperature	U7		③Check if unit is filled with specified amount of refrigerant. ④Measure resistance values among terminals on indoor valve and outdoor linear expansion valve using a multimeter.
	2 blinking	Abnormal high pressure (High pressure switch 63H operated.)	U1	①Check if indoor/outdoor units have a short cycle on their air ducts. ②Check if connector (63H) (63L) on outdoor controller board is not disconnected. ③Check if heat exchanger and filter is not dirty. ④Measure resistance values among terminals on linear expansion valve using a multimeter.	P.22
	3 blinking	Abnormality of outdoor fan motor rotational speed	U8	①Check the outdoor fan motor. ②Check if connector (TH3) (63HS) on outdoor controller board is disconnected.	P.23
		Protection from overheat operation (TH3)	Ud		P.25
	4 blinking	Compressor overcurrent breaking(Startup locked)	UF	①Check if connecting wire of indoor unit or remote controller is connected correctly. ②Check if noise entered into transmission wire of remote controller. ③Re-check error by turning off power, and on again.	P.25
		Compressor overcurrent breaking	UP		P.25
		Abnormality of current sensor (P.B.)	UH		P.25
		Abnormality of power module	U6		P.23
	5 blinking	Open/short of outdoor thermistors (TH4, TH33)	U3	①Check if connectors (TH3, TH32, TH4, TH33 and TH7/6) on outdoor controller board and connector (CN6) on outdoor power board are not disconnected. ②Measure resistance value of outdoor thermistors.	P.22
		Open/short of outdoor thermistors (TH3, TH32, TH6, TH7 and TH8)	U4		P.23
	6 blinking	Abnormality of heat sink temperature	U5	①Check if indoor/outdoor units have a short cycle on their air ducts. ②Measure resistance value of outdoor thermistor (TH8).	P.23
	7 blinking	Abnormality of voltage	U9	①Check looseness, disconnection, and converse connection of compressor wiring. ②Measure resistance value among terminals on compressor using a multimeter. ③Check if power supply voltage decreases.	P.24
4 blinking	1 blinking	Abnormality of room temperature thermistor (TH1)	P1	①Check if connectors on indoor controller board are not disconnected. ②Measure resistance value of indoor thermistors.	**
		Abnormality of pipe temperature thermistor /Liquid (TH2)	P2		**
		Abnormality of tank temperature thermistor	P9		**
	4 blinking	Abnormality of pipe temperature	P8	①Check if indoor thermistors(TH2 and TH5) are not disconnected from holder. ②Check if stop valve is open. ③Check converse connection of extension pipe. (on plural units connection) ④Check if indoor/outdoor connecting wire is connected correctly. (on plural units connection)	P.27

* Check code displayed on remote controller
 ** Refer to service manual for indoor unit.



<Outdoor unit operation monitor function>

[When optional part 'A-Control Service Tool (PAC-SK52ST)' is connected to outdoor controller board (CNM)]

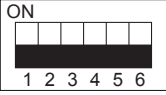
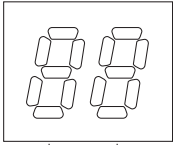

Digital indicator LED1 displays 2 digit number or code to inform operation condition and the meaning of check code by controlling DIP SW2 on "A-Control Service Tool".

Operation indicator SW2: Indicator change of self-diagnosis

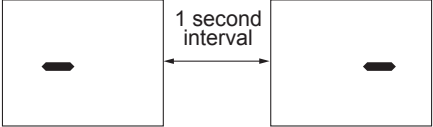
The black square (■) indicates a switch position.

SW2 setting	Display detail	Explanation for display	Unit																																																																	
	<p><Digital indicator LED1 working details> (Be sure that 1 to 6 in the SW2 are set to OFF.)</p> <p>(1) Display when the power supply ON When the power supply ON, blinking displays by turns. Wait for 4 minutes at the longest.</p> <p>(2) When the display lights (Normal operation)</p> <p>① Operation mode display</p> <div style="display: flex; justify-content: space-around; align-items: center;"> <div style="text-align: center;">  <p>(Lighting)</p> </div> <div style="text-align: center;">  <p>(Initial setting)</p> </div> </div> <div style="display: flex; justify-content: space-around; margin-top: 20px;"> <div style="width: 45%;"> <p>The tens digit: Operation mode</p> <table border="1" style="width:100%; border-collapse: collapse;"> <thead> <tr> <th>Display</th> <th>Operation Model</th> </tr> </thead> <tbody> <tr><td>O</td><td>OFF / FAN</td></tr> <tr><td>C</td><td>COOLING / DRY</td></tr> <tr><td>H</td><td>HEATING</td></tr> <tr><td>d</td><td>DEFROSTING</td></tr> </tbody> </table> <p>② Display during error postponement Postponement code is displayed when compressor stops due to the work of protection device. Postponement code is displayed while error is being postponed.</p> </div> <div style="width: 45%;"> <p>The ones digit: Relay output</p> <table border="1" style="width:100%; border-collapse: collapse;"> <thead> <tr> <th>Display</th> <th>Warming-up Compressor</th> <th>Compressor</th> <th>4-way valve</th> <th>Solenoid valve</th> </tr> </thead> <tbody> <tr><td>0</td><td>—</td><td>—</td><td>—</td><td>—</td></tr> <tr><td>1</td><td>—</td><td>—</td><td>—</td><td>ON</td></tr> <tr><td>2</td><td>—</td><td>—</td><td>ON</td><td>—</td></tr> <tr><td>3</td><td>—</td><td>—</td><td>ON</td><td>ON</td></tr> <tr><td>4</td><td>—</td><td>ON</td><td>—</td><td>—</td></tr> <tr><td>5</td><td>—</td><td>ON</td><td>—</td><td>ON</td></tr> <tr><td>6</td><td>—</td><td>ON</td><td>ON</td><td>—</td></tr> <tr><td>7</td><td>—</td><td>ON</td><td>ON</td><td>ON</td></tr> <tr><td>8</td><td>ON</td><td>—</td><td>—</td><td>—</td></tr> <tr><td>A</td><td>ON</td><td>—</td><td>ON</td><td>—</td></tr> </tbody> </table> </div> </div>	Display	Operation Model	O	OFF / FAN	C	COOLING / DRY	H	HEATING	d	DEFROSTING	Display	Warming-up Compressor	Compressor	4-way valve	Solenoid valve	0	—	—	—	—	1	—	—	—	ON	2	—	—	ON	—	3	—	—	ON	ON	4	—	ON	—	—	5	—	ON	—	ON	6	—	ON	ON	—	7	—	ON	ON	ON	8	ON	—	—	—	A	ON	—	ON	—		
Display	Operation Model																																																																			
O	OFF / FAN																																																																			
C	COOLING / DRY																																																																			
H	HEATING																																																																			
d	DEFROSTING																																																																			
Display	Warming-up Compressor	Compressor	4-way valve	Solenoid valve																																																																
0	—	—	—	—																																																																
1	—	—	—	ON																																																																
2	—	—	ON	—																																																																
3	—	—	ON	ON																																																																
4	—	ON	—	—																																																																
5	—	ON	—	ON																																																																
6	—	ON	ON	—																																																																
7	—	ON	ON	ON																																																																
8	ON	—	—	—																																																																
A	ON	—	ON	—																																																																
	<p>(3) When the display blinks Inspection code is displayed when compressor stops due to the work of protection devices.</p> <table border="1" style="width:100%; border-collapse: collapse;"> <thead> <tr> <th>Display</th> <th>Contents to be inspected (During operation)</th> </tr> </thead> <tbody> <tr><td>U1</td><td>Abnormal high pressure (63H operated)</td></tr> <tr><td>U2</td><td>Abnormal high discharge temperature, high comp. surface temperature, shortage of refrigerant</td></tr> <tr><td>U3</td><td>Open/short of outdoor unit thermistors (TH4, TH33)</td></tr> <tr><td>U4</td><td>Open/short of outdoor unit thermistors (TH3, TH6, TH7, TH8 and TH34)</td></tr> <tr><td>U5</td><td>Abnormal temperature of heat sink</td></tr> <tr><td>U6</td><td>Abnormality of power module</td></tr> <tr><td>U7</td><td>Abnormality of superheat due to low discharge temperature</td></tr> <tr><td>U8</td><td>Abnormality in outdoor fan motor</td></tr> <tr><td>Ud</td><td>Overheat protection</td></tr> <tr><td>UF</td><td>Compressor overcurrent interruption (When Comp. locked)</td></tr> <tr><td>UH</td><td>Current sensor error</td></tr> <tr><td>UL</td><td>Abnormal low pressure (63L operated)</td></tr> <tr><td>UP</td><td>Compressor overcurrent interruption</td></tr> <tr><td>P1-P8</td><td>Abnormality of indoor units</td></tr> </tbody> </table>	Display	Contents to be inspected (During operation)	U1	Abnormal high pressure (63H operated)	U2	Abnormal high discharge temperature, high comp. surface temperature, shortage of refrigerant	U3	Open/short of outdoor unit thermistors (TH4, TH33)	U4	Open/short of outdoor unit thermistors (TH3, TH6, TH7, TH8 and TH34)	U5	Abnormal temperature of heat sink	U6	Abnormality of power module	U7	Abnormality of superheat due to low discharge temperature	U8	Abnormality in outdoor fan motor	Ud	Overheat protection	UF	Compressor overcurrent interruption (When Comp. locked)	UH	Current sensor error	UL	Abnormal low pressure (63L operated)	UP	Compressor overcurrent interruption	P1-P8	Abnormality of indoor units																																					
Display	Contents to be inspected (During operation)																																																																			
U1	Abnormal high pressure (63H operated)																																																																			
U2	Abnormal high discharge temperature, high comp. surface temperature, shortage of refrigerant																																																																			
U3	Open/short of outdoor unit thermistors (TH4, TH33)																																																																			
U4	Open/short of outdoor unit thermistors (TH3, TH6, TH7, TH8 and TH34)																																																																			
U5	Abnormal temperature of heat sink																																																																			
U6	Abnormality of power module																																																																			
U7	Abnormality of superheat due to low discharge temperature																																																																			
U8	Abnormality in outdoor fan motor																																																																			
Ud	Overheat protection																																																																			
UF	Compressor overcurrent interruption (When Comp. locked)																																																																			
UH	Current sensor error																																																																			
UL	Abnormal low pressure (63L operated)																																																																			
UP	Compressor overcurrent interruption																																																																			
P1-P8	Abnormality of indoor units																																																																			
	<table border="1" style="width:100%; border-collapse: collapse;"> <thead> <tr> <th>Display</th> <th>Inspection unit</th> </tr> </thead> <tbody> <tr><td>0</td><td>Outdoor unit</td></tr> <tr><td>1</td><td>Indoor unit 1</td></tr> <tr><td>2</td><td>Indoor unit 2</td></tr> </tbody> </table>	Display	Inspection unit	0	Outdoor unit	1	Indoor unit 1	2	Indoor unit 2																																																											
Display	Inspection unit																																																																			
0	Outdoor unit																																																																			
1	Indoor unit 1																																																																			
2	Indoor unit 2																																																																			
	<table border="1" style="width:100%; border-collapse: collapse;"> <thead> <tr> <th>Display</th> <th>Contents to be inspected (When power is turned on)</th> </tr> </thead> <tbody> <tr><td>F3</td><td>63L connector(red) is open.</td></tr> <tr><td>F5</td><td>63H connector(yellow) is open.</td></tr> <tr><td>F9</td><td>2 connectors(63H/63L) are open.</td></tr> <tr><td>E8</td><td>Indoor/outdoor communication error (Signal receiving error) (Outdoor unit)</td></tr> <tr><td>E9</td><td>Indoor/outdoor communication error (Transmitting error) (Outdoor unit)</td></tr> <tr><td>EA</td><td>Miswiring of indoor/outdoor unit connecting wire, excessive number of indoor units (4 units or more)</td></tr> <tr><td>Eb</td><td>Miswiring of indoor/outdoor unit connecting wire(reverse wiring or disconnection)</td></tr> <tr><td>EC</td><td>Startup time over</td></tr> <tr><td>EE</td><td>Incorrect connection</td></tr> <tr><td>E0-E7</td><td>Communication error except for outdoor unit</td></tr> </tbody> </table>	Display	Contents to be inspected (When power is turned on)	F3	63L connector(red) is open.	F5	63H connector(yellow) is open.	F9	2 connectors(63H/63L) are open.	E8	Indoor/outdoor communication error (Signal receiving error) (Outdoor unit)	E9	Indoor/outdoor communication error (Transmitting error) (Outdoor unit)	EA	Miswiring of indoor/outdoor unit connecting wire, excessive number of indoor units (4 units or more)	Eb	Miswiring of indoor/outdoor unit connecting wire(reverse wiring or disconnection)	EC	Startup time over	EE	Incorrect connection	E0-E7	Communication error except for outdoor unit																																													
Display	Contents to be inspected (When power is turned on)																																																																			
F3	63L connector(red) is open.																																																																			
F5	63H connector(yellow) is open.																																																																			
F9	2 connectors(63H/63L) are open.																																																																			
E8	Indoor/outdoor communication error (Signal receiving error) (Outdoor unit)																																																																			
E9	Indoor/outdoor communication error (Transmitting error) (Outdoor unit)																																																																			
EA	Miswiring of indoor/outdoor unit connecting wire, excessive number of indoor units (4 units or more)																																																																			
Eb	Miswiring of indoor/outdoor unit connecting wire(reverse wiring or disconnection)																																																																			
EC	Startup time over																																																																			
EE	Incorrect connection																																																																			
E0-E7	Communication error except for outdoor unit																																																																			

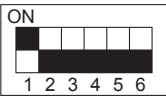
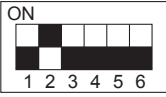
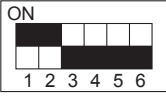
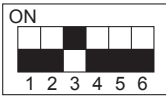
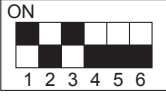
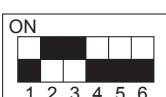
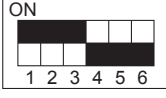
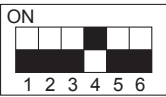
The black square (■) indicates a switch position.

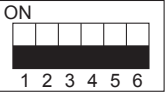
SW2 setting	Display detail	Explanation for display	Unit
	Pipe temperature/Liquid (TH3) -40 to 90	-40 to 90 (When the coil thermistor detects 0°C or below, “-” and temperature are displayed by turns.) (Example) When -10°C; <div style="text-align: center;"> 0.5 s 0.5 s 2 s -□ → 10 → □□ ↑—————↓—————↓ </div>	°C
	Discharge temperature (TH4) -20 to 217	-20 to 217 (When the discharge thermistor detects 100°C or more, hundreds digit, tens digit and ones digit are displayed by turns.) (Example) When 105°C; <div style="text-align: center;"> 0.5 s 0.5 s 2 s □1 → 05 → □□ ↑—————↓—————↓ </div>	°C
	Output step of outdoor FAN 0 to 16	0 to 16	Step
	The number of ON/OFF times of compressor 0 to 9999	0 to 9999 (When the number of times is 100 or more, hundreds digit, tens digit and ones digit are displayed by turns.) (Example) When 42500 times (425 × 100 times); <div style="text-align: center;"> 0.5 s 0.5 s 2 s □4 → 25 → □□ ↑—————↓—————↓ </div>	100 times
	Compressor integrating operation times 0 to 9999	0 to 9999 (When it is 100 hours or more, hundreds digit, tens digit and ones digit are displayed by turns.) (Example) When 2450 hours (245 × 10 hours); <div style="text-align: center;"> 0.5 s 0.5 s 2 s □2 → 45 → □□ ↑—————↓—————↓ </div>	10 hours
	Compressor operating current 0 to 50	0 to 50 Note: Value after the decimal point will be truncated.	A
	Compressor operating frequency 0 to 255	0 to 255 (When it is 100 Hz or more, hundreds digit, tens digit and ones digit are displayed by turns.) (Example) When 125 Hz; <div style="text-align: center;"> 0.5 s 0.5 s 2 s □1 → 05 → □□ ↑—————↓—————↓ </div>	Hz
	Primary LEV opening pulse 0 to 500 Heating: LEV-B Cooling: LEV-A	0 to 500 (When it is 100 pulse or more, hundreds digit, tens digit and ones digit are displayed by turns.) (Example) When 150 pulse; <div style="text-align: center;"> 0.5 s 0.5 s 2 s □1 → 50 → □□ ↑—————↓—————↓ </div>	Pulse
	Error postponement code history (1) of outdoor unit	Postponement code display Blinking: During postponement Lighting: Cancellation of postponement “00” is displayed in the case of no postponement.	Code display
	Operation mode on error occurring	Operation mode of when operation stops due to error is displayed by setting SW2 like below. (SW2) 	Code display



The black square (■) indicates a switch position.

SW2 setting	Display detail	Explanation for display	Unit				
	Pipe temperature/Liquid (TH3) on error occurring -40 to 90	-40 to 90 (When the coil thermistor detects 0°C or below, “-” and temperature are displayed by turns.) (Example) When -15°C; <div style="text-align: center;"> 0.5 s 0.5 s 2 s -□ → 15 → □□ ↑—————↓ </div>	°C				
	Discharge temperature (TH4) on error occurring -20 to 217	-20 to 217 (When the temperature is 100°C or more, the hundreds digit, tens digit and ones digit are displayed by turns.) (Example) When 130°C; <div style="text-align: center;"> 0.5 s 0.5 s 2 s □1 → 30 → □□ ↑—————↓ </div>	°C				
	Compressor operating current on error occurring 0 to 50	0 to 50	A				
	Error history (1) (latest) Alternate display of abnormal unit number and code	When no error history, “0” and “-” are displayed by turns.	Code display				
	Error history (2) Alternate display of error unit number and code	When no error history, “0” and “-” are displayed by turns.	Code display				
	Thermo ON time 0 to 999	0 to 999 (When it is 100 minutes or more, the hundreds digit, tens digit and ones digit are displayed by turns.) (Example) When 245 minutes; <div style="text-align: center;"> 0.5 s 0.5 s 2 s □2 → 45 → □□ ↑—————↓ </div>	Minute				
	Test run elapsed time 0 to 120	0 to 120 (When it is 100 minutes or more, the hundreds digit, tens digit and ones digit are displayed by turns.) (Example) When 105 minutes; <div style="text-align: center;"> 0.5 s 0.5 s 2 s □1 → 50 → □□ ↑—————↓ </div>	Minute				
	The number of connected indoor units 0 to 4	0 to 4 (The number of connected indoor units is displayed.)	Unit				
	Capacity setting display	Displayed as an outdoor capacity code. <table border="1" style="margin-left: auto; margin-right: auto;"> <tr> <td>Model</td> <td>Code</td> </tr> <tr> <td>PUZ-HWM140</td> <td>25</td> </tr> </table>	Model	Code	PUZ-HWM140	25	Code display
Model	Code						
PUZ-HWM140	25						

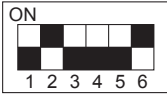
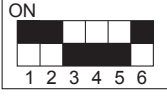
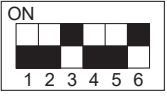
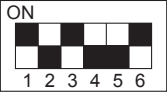
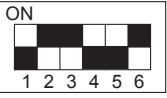
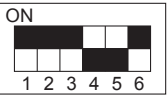
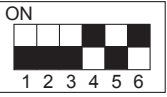
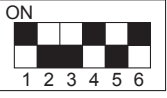

The black square (■) indicates a switch position.

SW2 setting	Display detail	Explanation for display	Unit										
	Outdoor unit setting information	<ul style="list-style-type: none"> The tens digit (Total display for applied setting) <table border="1"> <thead> <tr> <th>Setting details</th> <th>Display details</th> </tr> </thead> <tbody> <tr> <td>H·P / Cooling only</td> <td>0: H·P 1: Cooling only</td> </tr> <tr> <td>Single phase / 3 phase</td> <td>0: Single phase 2: 3 phase</td> </tr> </tbody> </table> The ones digit <table border="1"> <thead> <tr> <th>Setting details</th> <th>Display details</th> </tr> </thead> <tbody> <tr> <td>Defrosting switch</td> <td>0: Normal 1: For high humidity</td> </tr> </tbody> </table> <p>(Example) When heat pump, 3 phase and defrosting (normal) are set up, "20" is displayed.</p>	Setting details	Display details	H·P / Cooling only	0: H·P 1: Cooling only	Single phase / 3 phase	0: Single phase 2: 3 phase	Setting details	Display details	Defrosting switch	0: Normal 1: For high humidity	Code display
Setting details	Display details												
H·P / Cooling only	0: H·P 1: Cooling only												
Single phase / 3 phase	0: Single phase 2: 3 phase												
Setting details	Display details												
Defrosting switch	0: Normal 1: For high humidity												
	Plate HEX liquid pipe temperature (TH34) -40 to 90	-40 to 90 (When the temperature is 0°C or less, "-" and temperature are displayed by turns.)	°C										
	Condensing temperature (T63HS) -39 to 88	-39 to 88 (When the temperature is 0°C or less, "-" and temperature are displayed by turns.)	°C										
	Return water temperature 0 to 100	0 to 100	°C										
	Flow water temperature 0 to 100	0 to 100	°C										
	2-phase pipe temperature thermistor (TH6) -40 to 90	-40 to 90 (When the temperature is 0°C or less, "-" and temperature are displayed by turns.)	°C										
	Ambient temperature (TH7) -40 to 90	-40 to 90 (When the temperature is 0°C or less, "-" and temperature are displayed by turns.)	°C										
	Outdoor heat sink temperature (TH8) -40 to 200	-40 to 200 (When the temperature is 0°C or less, "-" and temperature are displayed by turns.) (When the thermistor detects 100°C or more, hundreds digit, tens digit and ones digit are displayed by turns.)	°C										
	Discharge superheat SHd 0 to 255 [Cooling = TH4 or TH33*-TH6 Heating = TH4 or TH33*-T63HS] *Choose higher one	0 to 255 (When the temperature is 100°C or more, hundreds digit, tens digit and ones digit are displayed by turns.)	°C										
	Number of defrost cycles 0 to FFFE	0 to FFFE (in hexadecimal notation) (When more than FF in hex (255 in decimal), the number is displayed in order of 16 ³ 's and 16 ² 's, and 16 ¹ 's and 16 ⁰ 's places. (Example) When 5000 cycles; <table style="margin-left: auto; margin-right: auto;"> <tr> <td style="text-align: center;">0.5 s</td> <td style="text-align: center;">0.5 s</td> <td style="text-align: center;">2 s</td> </tr> <tr> <td style="text-align: center;">□9</td> <td style="text-align: center;">→ C4</td> <td style="text-align: center;">→ □□</td> </tr> <tr> <td style="text-align: center;">↑</td> <td></td> <td style="text-align: center;">↓</td> </tr> </table>	0.5 s	0.5 s	2 s	□9	→ C4	→ □□	↑		↓	2 cycles	
0.5 s	0.5 s	2 s											
□9	→ C4	→ □□											
↑		↓											
	Input current of outdoor unit	0 to 500 (When it is 100 or more, hundreds digit, tens digit and ones digit are displayed by turns.)	0.1 A										

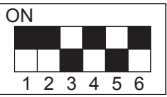

The black square (■) indicates a switch position.

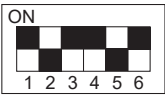
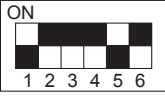
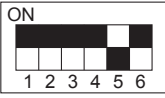
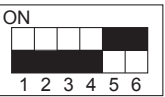
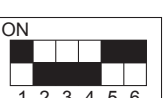
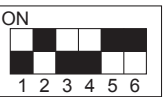
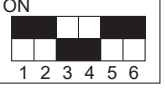
SW2 setting	Display detail	Explanation for display	Unit															
	Secondary LEV opening pulse 0 to 500 Heating: LEV-A Cooling: LEV-B	0 to 500 (When it is 100 pulse or more, hundreds digit, tens digit and ones digit are displayed by turns.)	Pulse															
	U9 error detail history (latest)	<table border="1" data-bbox="842 409 1393 658"> <thead> <tr> <th>Description</th> <th>Display</th> </tr> </thead> <tbody> <tr> <td>Normal</td> <td>00</td> </tr> <tr> <td>Overvoltage error</td> <td>01</td> </tr> <tr> <td>Undervoltage error</td> <td>02</td> </tr> <tr> <td>Input current sensor error</td> <td rowspan="2">04</td> </tr> <tr> <td>L1-phase open error</td> </tr> <tr> <td>Abnormal power synchronous signal</td> <td>08</td> </tr> <tr> <td>PFC error (Overvoltage/Undervoltage/Overcurrent)</td> <td>10</td> </tr> </tbody> </table> <p>Display examples for multiple errors: Overvoltage (01) + Undervoltage (02) = 03 Undervoltage (02) + Power-sync signal error (08) = 0 A L1 phase open error (04) + PFC error (10) = 14</p>	Description	Display	Normal	00	Overvoltage error	01	Undervoltage error	02	Input current sensor error	04	L1-phase open error	Abnormal power synchronous signal	08	PFC error (Overvoltage/Undervoltage/Overcurrent)	10	Code display
Description	Display																	
Normal	00																	
Overvoltage error	01																	
Undervoltage error	02																	
Input current sensor error	04																	
L1-phase open error																		
Abnormal power synchronous signal	08																	
PFC error (Overvoltage/Undervoltage/Overcurrent)	10																	
	DC bus voltage 100 to 1023	100 to 1023 (When it is 100 V or more, hundreds digit, tens digit and ones digit are displayed by turns.)	V															
	Communication demand capacity 0 to 255	0 to 255 When the communication demand is not set, "100" is displayed.	%															
	Error postponement code history (2) of outdoor unit	Postponement code display Blinking: During postponement Lighting: Cancellation of postponement "00" is displayed in the case of no postponement.	Code display															
	Error postponement code history (3) of outdoor unit	Postponement code display Blinking: During postponement Lighting: Cancellation of postponement "00" is displayed in the case of no postponement.	Code display															
	Error history (3) (Oldest) Alternate display of abnormal unit number and code	When no error history, "0" and "- -" are displayed by turns.	Code display															
	Error thermistor display [When there is no error thermistor, "-" is displayed.]	3: Liquid pipe temperature (TH3), Suction pipe temperature (TH32) 4: Discharge pipe temperature (TH4) 6: 2-phase pipe temperature (TH6) 7: Ambient temperature (TH7) 8: Heat sink temperature (TH8) 33: Comp. surface temperature (TH33) 34: Plate HEX liquid pipe thermistor (TH34)	Code display															
	Operation frequency on error occurring 0 to 255	0 to 255 (When it is 100 Hz or more, hundreds digit, tens digit and ones digit are displayed by turns.) (Example) When 125 Hz; <div style="text-align: center;"> 0.5 s 0.5 s 2 s □1 → 25 → □□ ↑ </div>	Hz															
	Fan step on error occurring 0 to 16	0 to 16	Step															

The black square (■) indicates a switch position.



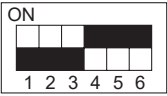
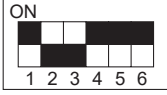

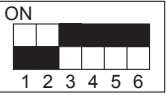
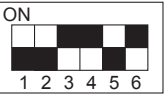

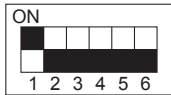
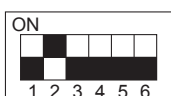

SW2 setting	Display detail	Explanation for display	Unit
	Return water temperature on error occurring 0 to 100	0 to 100	°C
	Plate HEX liquid pipe thermistor (TH34) on error occurring -40 to 90	-40 to 90 (When the temperature is 0°C or less, “-” and temperature are displayed by turns.) 0.5 s 0.5 s 2 s -□ → 15 → □□	°C
	Pressure saturation temperature (T63HS) on error occurring -39 to 88	-39 to 88 (When the temperature is 0°C or less, “-” and temperature are displayed by turns.) (Example) When -15°C; 0.5 s 0.5 s 2 s -□ → 15 → □□	°C
	2-phase pipe temperature thermistor (TH6) -40 to 90	-40 to 90 (When the temperature is 0°C or less, “-” and temperature are displayed by turns.) (Example) When -15°C; 0.5 s 0.5 s 2 s -□ → 15 → □□	°C
	Ambient temperature (TH7) on error occurring -40 to 90	-40 to 90 (When the temperature is 0°C or less, “-” and temperature are displayed by turns.) (Example) When -15°C; 0.5 s 0.5 s 2 s -□ → 15 → □□	°C
	Outdoor heat sink temperature (TH8) on error occurring -40 to 200	-40 to 200 (When the temperature is 0°C or less, “-” and temperature are displayed by turns.) (When the temperature is 100°C or more, hundreds digit, tens digit and ones digit are displayed by turns.)	°C
	Discharge superheat on error occurring SHd 0 to 255 [Cooling = TH4 or TH33*-TH6 Heating = TH4 or TH33*-T63HS] *Choose higher one	0 to 255 (When the temperature is 100°C or more, hundreds digit, tens digit and ones digit are displayed by turns.) (Example) When 150°C; 0.5 s 0.5 s 2 s □1 → 50 → □□	°C
	Sub cool on error occurring SC 0 to 255 [Cooling = TH6-TH3 Heating = T63HS-TH34]	0 to 255 (When the temperature is 100°C or more, hundreds digit, tens digit and ones digit are displayed by turns.) (Example) When 115°C; 0.5 s 0.5 s 2 s □1 → 15 → □□	°C
	Thermo-on time until error stops 0 to 999	0 to 999 (When it is 100 minutes or more, hundreds digit, tens digit and ones digit are displayed by turns.) (Example) When 415 minutes; 0.5 s 0.5 s 2 s □4 → 15 → □□	Minute

The black square (■) indicates a switch position.

SW2 setting	Display detail	Explanation for display	Unit																
	Comp. surface temperature (TH33) -52 to 221	<p>-52 to 221 (When the temperature is 0°C or less, "-" and temperature are displayed by turns.) (When the discharge thermistor detects 100°C or more, hundreds digit, tens digit, and ones digit are displayed by turns.) (Example) When 105;</p> <p style="text-align: center;">0.5 s 0.5 s 2 s 1 → 05 → </p>	Code display																
	Controlling status of compressor operating frequency	<p>The following code will be a help to know the operating status of unit.</p> <ul style="list-style-type: none"> The tens digit <table border="1" style="width: 100%;"> <thead> <tr> <th>Display</th> <th>Compressor operating frequency control</th> </tr> </thead> <tbody> <tr> <td>1</td> <td>Primary current control</td> </tr> <tr> <td>2</td> <td>Secondary current control</td> </tr> </tbody> </table> <ul style="list-style-type: none"> The ones digit (In this digit, the total number of activated control is displayed.) <table border="1" style="width: 100%;"> <thead> <tr> <th>Display</th> <th>Compressor operating frequency control</th> </tr> </thead> <tbody> <tr> <td>1</td> <td>Preventive control for excessive temperature rise of discharge temperature</td> </tr> <tr> <td>2</td> <td>Preventive control for excessive temperature rise of condensing temperature</td> </tr> <tr> <td>4</td> <td>Frosting preventing control</td> </tr> <tr> <td>8</td> <td>Preventive control for excessive temperature rise of radiator panel</td> </tr> </tbody> </table> <p>(Example) The following controls are activated.</p> <ul style="list-style-type: none"> Primary current control Preventive control for excessive temperature rise of condensing temperature Preventive control for excessive temperature rise of heat sink <div style="text-align: right;"> <p>LED</p>  </div>	Display	Compressor operating frequency control	1	Primary current control	2	Secondary current control	Display	Compressor operating frequency control	1	Preventive control for excessive temperature rise of discharge temperature	2	Preventive control for excessive temperature rise of condensing temperature	4	Frosting preventing control	8	Preventive control for excessive temperature rise of radiator panel	Code display
Display	Compressor operating frequency control																		
1	Primary current control																		
2	Secondary current control																		
Display	Compressor operating frequency control																		
1	Preventive control for excessive temperature rise of discharge temperature																		
2	Preventive control for excessive temperature rise of condensing temperature																		
4	Frosting preventing control																		
8	Preventive control for excessive temperature rise of radiator panel																		
	Outdoor suction pipe temperature (TH32) -39 to 88	<p>-39 to 88 (When the temperature is 0°C or less, "-" and temperature are displayed by turns.) (Example) When -15°C;</p> <p style="text-align: center;">0.5 s 0.5 s 2 s - → 15 → </p>	°C																
	LEV-C opening pulse 0 to 500	<p>0 to 500 (When it is 100 pulse or more, hundreds digit are displayed by turns.)</p>	Pulse																

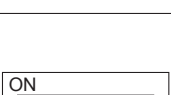
<Service check mode:SW7-2 ON Backup data>



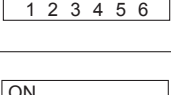



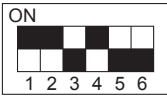
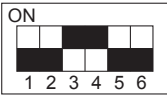
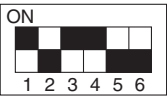
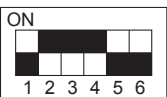
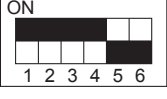
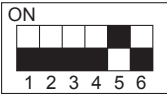
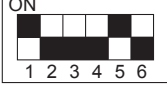
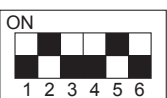



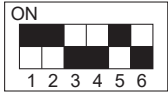

The black square (■) indicates a switch position.

SW2 setting	Display detail	Explanation for display	Unit
	The primary current when the last error occurred 0 to 50	0 to 50	A
	The DC bus voltage when the last error occurred 100 to 1023	100 to 1023 (When it is 100 or more, hundreds digit, tens digit and ones digit are displayed by turns.)	V
	The suction pipe temperature (TH32) when the last error occurred -39 to 88	-39 to 88 (When it is 0 or less, “-” and numbers are displayed by turns.)	°C
	The comp. surface temperature (TH33) when the last error occurred -20 to 217	-20 to 217 (When it is 0 or less, “-” and numbers are displayed by turns.) (When it is 100 or more, hundreds digit, tens digit and ones digit are displayed by turns.)	°C
	The LEV-B opening pulse when the last error occurred 0 to 500	0 to 500 (When it is 100 or more, hundreds digit, tens digit and ones digit are displayed by turns.)	Pulse
	The LEV-C opening pulse when the last error occurred 0 to 500	0 to 500 (When it is 100 or more, hundreds digit, tens digit and ones digit are displayed by turns.)	Pulse
	The operation mode when the second-to-last error occurred	This setting shows the operation mode when the second-to-last error occurred as well as the default setting (Refer to the following). (SW2) 	Mode
	The operating frequency when the second-to-last error occurred 0 to 255	0 to 255 (When it is 100 or more, hundreds digit, tens digit and ones digit are displayed by turns.)	Hz
	The compressor current when the second-to-last error occurred 0 to 50	0 to 50	A
	The primary current when the second-to-last error occurred 0 to 500	0 to 500 (When it is 100 or more, hundreds digit, tens digit and ones digit are displayed by turns.)	0.1 A
	The DC bus voltage when the second-to-last error occurred 100 to 1023	100 to 1023 (When it is 100 or more, hundreds digit, tens digit and ones digit are displayed by turns.)	V

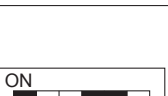
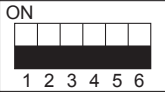
The black square (■) indicates a switch position.

SW2 setting	Display detail	Explanation for display	Unit
	The fan step when the second-to-last error occurred 0 to 16	0 to 16	Step
	The return water temperature (THW2) when the second-to-last error occurred 0 to 60	0 to 60	°C
	The plate HEX liquid pipe temperature (TH34) when the second-to-last error occurred (The average temperature when 2 or more indoor units are connected) -39 to 88	-39 to 88 Plate HEX liquid pipe temperature (TH34) $\Sigma(\text{TH34(N)})/n$ (When it is 0 or less, “-” and numbers are displayed by turns.)	°C
	The plate HEX pipe temperature/Cond./Eva. (T63HS) when the second-to-last error occurred (The average temperature when 2 or more indoor units are connected) -39 to 88	-39 to 88 Plate HEX pipe temperature/Cond./Eva. (T63HS) $\Sigma(\text{T63HS(N)})/n$ (When it is 0 or less, “-” and numbers are displayed by turns.)	°C
	The discharge temperature (TH4) when the second-to-last error occurred -20 to 217	-20 to 217 (When it is 0 or less, “-” and numbers are displayed by turns.) (When it is 100 or more, hundreds digit, tens digit and ones digit are displayed by turns.)	°C
	The outdoor liquid pipe temperature (TH3) when the second-to-last error occurred -39 to 88	-39 to 88 (When it is 0 or less, “-” and numbers are displayed by turns.)	°C
	The outdoor 2-phase pipe temperature (TH6) when the second-to-last error occurred -39 to 88	-39 to 88 (When it is 0 or less, “-” and numbers are displayed by turns.)	°C
	The ambient temperature (TH7) when the second-to-last error occurred -39 to 88	-39 to 88 (When it is 0 or less, “-” and numbers are displayed by turns.)	°C

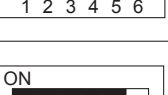

The black square (■) indicates a switch position.

SW2 setting	Display detail	Explanation for display	Unit
	The heat sink temperature (TH8) when the second-to-last error occurred -40 to 200	-40 to 200 (When it is 0 or less, “-” and numbers are displayed by turns.) (When it is 100 or more, hundreds digit, tens digit and ones digit are displayed by turns.)	°C
	The suction pipe temperature (TH32) when the second-to-last error occurred -39 to 88	-39 to 88 (When it is 0 or less, “-” and numbers are displayed by turns.)	°C
	The Comp. surface temperature (TH33) when the second-to-last error occurred -20 to 217	-20 to 217 (When it is 0 or less, “-” and numbers are displayed by turns.) (When it is 100 or more, hundreds digit, tens digit and ones digit are displayed by turns.)	°C
	The LEV-A opening pulse when the second-to-last error occurred 0 to 500	0 to 500 (When it is 100 or more, hundreds digit, tens digit and ones digit are displayed by turns.)	Pulse
	The LEV-B opening pulse when the second-to-last error occurred 0 to 500	0 to 500 (When it is 100 or more, hundreds digit, tens digit and ones digit are displayed by turns.)	Pulse
	The LEV-C opening pulse when the second-to-last error occurred 0 to 500	0 to 500 (When it is 100 or more, hundreds digit, tens digit and ones digit are displayed by turns.)	Pulse
	The operation mode when the third-to-last error occurred	This setting shows the operation mode when the third-to-last error occurred as well as the default setting (Refer to the following). (SW2) 	Mode
	The operating frequency when the third-to-last error occurred 0 to 255	0 to 255 (When it is 100 or more, hundreds digit, tens digit and ones digit are displayed by turns.)	Hz
	The compressor current when the third-to-last error occurred 0 to 50	0 to 50	A
	The primary current when the third-to-last error occurred 0 to 500	0 to 500 (When it is 100 or more, hundreds digit, tens digit and ones digit are displayed by turns.)	0.1 A
	The DC bus voltage when the third-to-last error occurred 100 to 1023	100 to 1023 (When it is 100 or more, hundreds digit, tens digit and ones digit are displayed by turns.)	V
	The fan step when the third-to-last error occurred 0 to 16	0 to 16	Step
	The return water temperature (THW2) when the third-to-last error occurred 0 to 60	0 to 60	°C

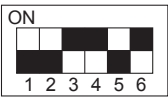
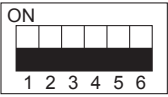
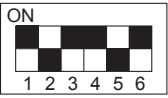
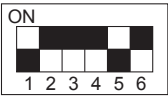
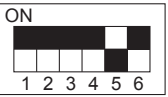
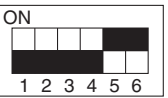
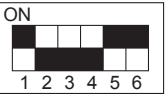
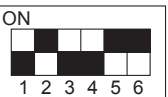
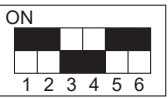
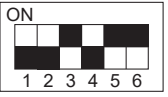

The black square (■) indicates a switch position.

SW2 setting	Display detail	Explanation for display	Unit
	The plate HEX liquid pipe temperature (TH2) when the third-to-last error occurred -39 to 88	-39 to 88 Plate HEX liquid pipe temperature (TH34) $\Sigma(\text{TH34(N)})/n$ (When it is 0 or less, “-” and numbers are displayed by turns.)	°C
	The plate HEX pipe temperature/Cond./Eva. (T63HS) when the third-to-last error occurred -39 to 88	-39 to 88 Plate HEX pipe temperature/Cond./Eva. (T63HS) $\Sigma(\text{T63HS(N)})/n$ (When it is 0 or less, “-” and numbers are displayed by turns.)	°C
	The discharge temperature (TH4) when the third-to-last error occurred -20 to 217	-20 to 217 (When it is 0 or less, “-” and numbers are displayed by turns.) (When it is 100 or more, hundreds digit and ones digit are displayed by turns.)	°C
	The outdoor liquid pipe temperature (TH3) when the third-to-last error occurred -39 to 88	-39 to 88 (When it is 0 or less, “-” and numbers are displayed by turns.)	°C
	The outdoor 2-phase pipe temperature (TH6) when the third-to-last error occurred -39 to 88	-39 to 88 (When it is 0 or less, “-” and numbers are displayed by turns.)	°C
	The ambient temperature (TH7) when the third-to-last error occurred -39 to 88	-39 to 88 (When it is 0 or less, “-” and numbers are displayed by turns.)	°C
	The heat sink temperature (TH8) when the third-to-last error occurred -40 to 200	-40 to 200 (When it is 0 or less, “-” and numbers are displayed by turns.) (When it is 100 or more, hundreds digit, tens digit and ones digit are displayed by turns.)	°C
	The suction pipe temperature (TH32) when the third-to-last error occurred -39 to 88	-39 to 88 (When it is 0 or less, “-” and numbers are displayed by turns.)	°C
	The Comp. surface temperature (TH33) when the third-to-last error occurred -20 to 217	-20 to 217 (When it is 0 or less, “-” and numbers are displayed by turns.) (When it is 100 or more, hundreds digit, tens digit and ones digit are displayed by turns.)	°C
	The LEV-A opening pulse when the third-to-last error occurred 0 to 500	0 to 500 (When it is 100 or more, hundreds digit, tens digit and ones digit are displayed by turns.)	Pulse
	The LEV-B opening pulse when the third-to-last error occurred 0 to 500	0 to 500 (When it is 100 or more, hundreds digit, tens digit and ones digit are displayed by turns.)	Pulse
	The LEV-C opening pulse when the third-to-last error occurred 0 to 500	0 to 500 (When it is 100 or more, hundreds digit, tens digit and ones digit are displayed by turns.)	Pulse

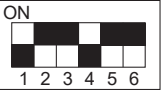
The black square (■) indicates a switch position.

SW2 setting	Display detail	Explanation for display	Unit
	The operation mode when the fourth-to-last error occurred	This setting shows the operation mode when the fourth-to-last error occurred as well as the default setting (Please refer to the following). (SW2) 	Mode
	The operating frequency when the fourth-to-last error occurred 0 to 255	0 to 255 (When it is 100 or more, hundreds digit, tens digit and ones digit are displayed by turns.)	Hz
	The compressor current when the fourth-to-last error occurred 0 to 50	0 to 50	A
	The primary current when the fourth-to-last error occurred 0 to 500	0 to 500 (When it is 100 or more, hundreds digit, tens digit and ones digit are displayed by turns.)	0.1 A
	The DC bus voltage when the fourth-to-last error occurred 100 to 1023	100 to 1023 (When it is 100 or more, hundreds digit, tens digit and ones digit are displayed by turns.)	V
	The fan step when the fourth-to-last error occurred 0 to 16	0 to 16	Step
	The return water temperature (THW2) when the fourth-to-last error occurred 0 to 60	0 to 60	°C
	The plate HEX liquid pipe temperature (TH34) when the fourth-to-last error occurred -39 to 88	-39 to 88 Plate HEX liquid pipe temperature (TH34) $\Sigma(\text{TH34(N)})/n$ (When it is 0 or less, “-” and numbers are displayed by turns.)	°C
	The plate HEX pipe temperature/Cond./Eva. (T63HS) when the fourth-to-last error occurred -39 to 88	-39 to 88 Plate HEX pipe temperature/Cond./Eva. (T63HS) $\Sigma(\text{T63HS(N)})/n$ (When it is 0 or less, “-” and numbers are displayed by turns.)	°C
	The discharge temperature (TH4) when the fourth-to-last error occurred -20 to 217	-20 to 217 (When it is 0 or less, “-” and numbers are displayed by turns.) (When it is 100 or more, hundreds digit, tens digit and ones digit are displayed by turns.)	°C
	The outdoor liquid pipe temperature (TH3) when the fourth-to-last error occurred	-39 to 88 (When it is 0 or less, “-” and numbers are displayed by turns.)	°C

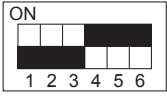
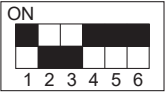
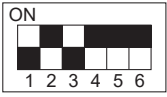
The black square (■) indicates a switch position.

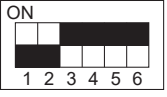
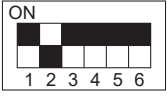
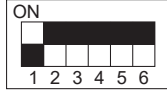
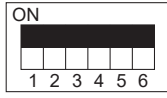
SW2 setting	Display detail	Explanation for display	Unit
	The outdoor 2-phase pipe temperature (TH6) when the fourth-to-last error occurred -39 to 88	-39 to 88 (When it is 0 or less, “-” and numbers are displayed by turns.)	°C
	The ambient temperature (TH7) when the fourth-to-last error occurred -39 to 88	-39 to 88 (When it is 0 or less, “-” and numbers are displayed by turns.)	°C
	The heat sink temperature (TH8) when the fourth-to-last error occurred -40 to 200	-40 to 200 (When it is 0 or less, “-” and numbers are displayed by turns.) (When it is 100 or more, hundreds digit, tens digit and ones digit are displayed by turns.)	°C
	The suction pipe temperature (TH32) when the fourth-to-last error occurred -39 to 88	-39 to 88 (When it is 0 or less, “-” and numbers are displayed by turns.)	°C
	The Comp. surface temperature (TH33) when the fourth-to-last error occurred -20 to 217	-20 to 217 (When it is 0 or less, “-” and numbers are displayed by turns.) (When it is 100 or more, hundreds digit, tens digit and ones digit are displayed by turns.)	°C
	The LEV-A opening pulse when the fourth-to-last error occurred 0 to 500	0 to 500 (When it is 100 or more, hundreds digit, tens digit and ones digit are displayed by turns.)	Pulse
	The LEV-B opening pulse when the fourth-to-last error occurred 0 to 500	0 to 500 (When it is 100 or more, hundreds digit, tens digit and ones digit are displayed by turns.)	Pulse
	The LEV-C opening pulse when the fourth-to-last error occurred 0 to 500	0 to 500 (When it is 100 or more, hundreds digit, tens digit and ones digit are displayed by turns.)	Pulse
	The LEV-A opening pulse when the last error occurred 0 to 500	0 to 500 (When it is 100 or more, hundreds digit, tens digit and ones digit are displayed by turns.)	Pulse

9-9. FUNCTION OF SWITCHES PUZ-HWM140VHA(-BS)

PUZ-HWM140YHA(-BS)

The black square (■) indicates a switch position.

Type of Switch	Switch	No.	Function	Action by the switch operation		Effective timing														
				ON	OFF															
DIP switch	SW1	1	Manual defrost *1	Start	Normal	When compressor is working in heat operation *1														
		2	Abnormal history clear	Clear	Normal	OFF or operating														
		3	Refrigerant address setting				When power supply ON													
		4																		
		5																		
		6																		
	SW4	1	No function	–	–	–														
		2	No function	–	–	–														
	SW8	1	No function	–	–	–														
		2	No function	–	–	–														
		3	Separate indoor/outdoor unit power supplies	Used	Not used	When power supply ON														
	SW5	1	No function	–	–	–														
		2	Power failure automatic recovery *2	Auto recovery	No auto recovery	When power supply ON														
		3, 4	No function	–	–	–														
		5	Capacity operation	Passive mode	Active mode	When power supply ON														
	SW7*3	1	Mode select *4	Demand function	Low noise mode	When power supply ON														
			Service check function*5	Backup data	Normal	Always														
		3	No function	–	–	–														
		4	No function	–	–	–														
		5	No function	–	–	–														
		6	Defrost setting	For high humidity	Normal	Always														
		6	Defrost setting	For high humidity	Normal	Always														
	SW9	1	No function	–	–	–														
		2	No function	–	–	–														
		3, 4	Starting Ambient temp. of blink injection	Ambient temp. of ZUBADAN blink injection becomes effective. <table border="1"> <thead> <tr> <th>SW9-3</th> <th>SW9-4</th> <th>Ambient temp.</th> </tr> </thead> <tbody> <tr> <td>OFF</td> <td>OFF</td> <td>≤ 3°C (Initial setting)</td> </tr> <tr> <td>OFF</td> <td>ON</td> <td>≤ 0°C</td> </tr> <tr> <td>ON</td> <td>OFF</td> <td>≤ -3°C</td> </tr> <tr> <td>ON</td> <td>ON</td> <td>≤ -6°C</td> </tr> </tbody> </table>		SW9-3	SW9-4	Ambient temp.	OFF	OFF	≤ 3°C (Initial setting)	OFF	ON	≤ 0°C	ON	OFF	≤ -3°C	ON	ON	≤ -6°C
	SW9-3	SW9-4	Ambient temp.																	
	OFF	OFF	≤ 3°C (Initial setting)																	
	OFF	ON	≤ 0°C																	
	ON	OFF	≤ -3°C																	
ON	ON	≤ -6°C																		
SW6	1	Model select	MODEL SW6 *6		Always															
	2		140V ON OFF																	
	3		140V ON OFF																	
	4		140V ON OFF																	
	5		140V ON OFF																	
	6		140V ON OFF																	
	7		140V ON OFF																	
	8		140V ON OFF																	

*1 Manual defrost should be done as follows.

① Change the DIP SW1-1 on the outdoor controller board from OFF to ON.

② Manual defrost will start by the above operation ① if these conditions written below are satisfied.

- Heat mode setting
- 10 minutes have passed since compressor started operating or previous manual defrost finished.
- Pipe temperature is less than or equal to 8°C.

Manual defrost will finish if certain conditions are satisfied.

Manual defrost can be done if above conditions are satisfied when DIP SW1-1 is changed from OFF to ON.

After DIP SW1-1 is changed from OFF to ON, there is no problem if DIP SW1-1 is left ON or changed to OFF again.

This depends on the service conditions.

*2 "Power failure automatic recovery" can be set by either remote controller or this DIP SW. If one of them is set to ON, "Auto recovery" activates. Please set "Auto recovery" basically by remote controller because all units do not have DIP SW. Please refer to the indoor unit installation manual.

*3 Please do not use SW7-2, 4, 5, 6 usually. Trouble might be caused by the usage condition.

*4 SW7-1 is setting change over of Demand. It is effective only in the case of external input. (Local wiring is necessary. Refer to the next page: Special function.)

*5 This function displays the backup data when errors occurred. (Last 4 data at the maximum)

*6 SW6-1 to 3: Function Switch

SPECIAL FUNCTION

9.9.1. Low noise mode (on-site modification) (Fig. 9-9-1)

1. Using the CNDM connector (Option)

By performing the following modification, operation noise of the outdoor unit can be reduced.

The low noise mode will be activated when a commercially available timer or the contact input of an ON/OFF switch is added to the CNDM connector (option) on the control board of the outdoor unit.

- The ability varies according to the outdoor temperature and conditions, etc.

- ① Complete the circuit as shown when using the external input adapter (PAC-SC36NA-E). (Option)
- ② SW7-1 (Outdoor unit control board): OFF
- ③ SW1 ON: Low noise mode
SW1 OFF: Normal operation

2. Using remote controller

Refer to the indoor unit installation manual.

9.9.2. Demand function (on-site modification) (Fig. 9-9-2)

By performing the following modification, energy consumption can be reduced to 0–100% of the normal consumption.

The demand function will be activated when a commercially available timer or the contact input of an ON/OFF switch is added to the CNDM connector (option) on the control board of the outdoor unit.

- ① Complete the circuit as shown when using the external input adapter (PAC-SC36NA-E). (Option)
- ② By setting SW7-1 on the control board of the outdoor unit, the energy consumption (compared to the normal consumption) can be limited as shown below.

	SW7-1	SW2	SW3	Energy consumption
Demand function	ON	OFF	OFF	100%
		ON	OFF	75%
		ON	ON	50%
		OFF	ON	0% (Stop)

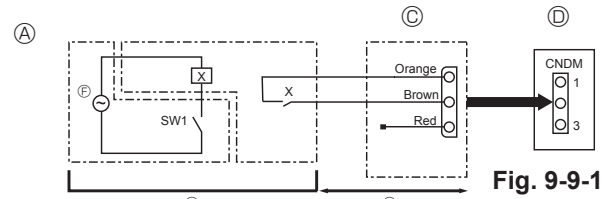

Fig. 9-9-1

- Ⓐ Circuit diagram example (low noise mode)
- Ⓑ On-site arrangement
- Ⓒ External input adapter (PAC-SC36NA-E)
- Ⓓ Outdoor unit control board
- Ⓔ Max. 10 m
- Ⓕ Power supply for relay
- X: Relay

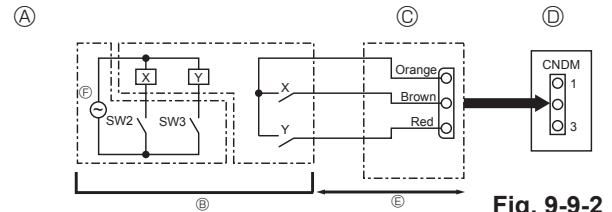

Fig. 9-9-2

- Ⓐ Circuit diagram example (Demand function)
- Ⓑ On-site arrangement
- Ⓒ External input adapter (PAC-SC36NA-E)
- Ⓓ Outdoor unit control board
- Ⓔ Max. 10 m
- Ⓕ Power supply for relay
- X, Y: Relay

9-10. Request code list

Certain indoor/outdoor combinations do not have the request code function; therefore, no request codes are displayed. Refer to indoor unit service manual for how to use the controllers and request codes for indoor unit.

Request code	Request content	Description (Display range)	Unit	Remarks
0	Operation state	Refer to 9-10-1. Detail Contents in Request Code.	—	
1	Compressor-Operating current (rms)	0 to 50	A	
2	Compressor-Accumulated operating time	0 to 9999	10 hours	
3	Compressor-Number of operation times	0 to 9999	100 times	
4	Discharge temperature (TH4)	3 to 217	°C	
5	Outdoor unit -Liquid pipe 1 temperature (TH3)	-40 to 90	°C	
6	Water inlet temperature (TH32)	-40 to 101	°C	
7	Outdoor unit-Plate HEX pipe temperature (TH6)	-39 to 88	°C	
8	Outdoor unit-Suction pipe temperature (TH33)	-39 to 88	°C	
9	Outdoor unit-Ambient temperature (TH7)	-39 to 88	°C	
10	Outdoor unit-Heatsink temperature (TH8)	-40 to 200	°C	
11				
12	Discharge superheat (SHd)	0 to 255	°C	
13	Sub-cool (SC)	0 to 130	°C	
14	Condensing temperature (T63HS)	-39 to 88	°C	
15				
16	Compressor-Operating frequency	0 to 255	Hz	
17	Compressor-Target operating frequency	0 to 255	Hz	
18	Outdoor unit-Fan output step	0 to 16	Step	
19	Outdoor unit-Fan 1 speed (Only for air conditioners with DC fan motor)	0 to 9999	rpm	
20	Outdoor unit-Fan 2 speed (Only for air conditioners with DC fan motor)	0 to 9999	rpm	"0" is displayed if the air conditioner is a single-fan type.
21	Requested capacity step (Q STEP)	0 to 7	Step	
22	LEV (A) opening	0 to 500	Pulses	
23	LEV (B) opening	0 to 500	Pulses	
24	LEV (C) opening	0 to 500	Pulses	
25	Primary current	0 to 50	A	
26	DC bus voltage	100 to 1023	V	
27				
28				
29				
30				
31				
32				
33				
34				
35				
36				
37				
38				
39				
40				
41				
42				
43				
44				
45				
46				
47				
48	Thermostat ON operating time	0 to 999	Minutes	
49				



Request code	Request content	Description (Display range)	Unit	Remarks
50				
51	Outdoor unit-Control state	Refer to 9-10-1.Detail Contents in Request Code.	—	
52	Compressor-Frequency control state	Refer to 9-10-1.Detail Contents in Request Code.	—	
53	Outdoor unit-Fan control state	Refer to 9-10-1.Detail Contents in Request Code.	—	
54	Actuator output state	Refer to 9-10-1.Detail Contents in Request Code.	—	
55	Error content (U9)	Refer to 9-10-1.Detail Contents in Request Code.	—	
56				
57				
58				
59				
60				
61				
62				
63				
64				
65				
66				
67				
68				
69				
70	Outdoor unit-Capacity setting display	Refer to 9-10-1.Detail Contents in Request Code.	—	
71	Outdoor unit-Setting information	Refer to 9-10-1.Detail Contents in Request Code.	—	
72				
73				
74				
75				
76				
77				
78				
79				
80				
81				
82				
83				
84				
85				
86				
87				
88				
89				
90	Outdoor unit-Microprocessor version information	Examples) Ver 5.01 → "0501"	Ver	
91	Outdoor unit-Microprocessor version information (sub No.)	Auxiliary information (displayed after version information) Examples) Ver 5.01 A000 → "A000"	—	
92				
93				
94				
95				
96				
97				
98				
99				
100	Outdoor unit - Error postponement history 1 (latest)	Displays postponement code. (" - - " is displayed if no postponement code is present)	Code	
101	Outdoor unit - Error postponement history 2 (previous)	Displays postponement code. (" - - " is displayed if no postponement code is present)	Code	
102	Outdoor unit - Error postponement history 3 (last but one)	Displays postponement code. (" - - " is displayed if no postponement code is present)	Code	



Request code	Request content	Description (Display range)	Unit	Remarks
103	Error history 1 (latest)	Displays error history. (" --" is displayed if no history is present.)	Code	
104	Error history 2 (second to last)	Displays error history. (" --" is displayed if no history is present.)	Code	
105	Error history 3 (third to last)	Displays error history. (" --" is displayed if no history is present.)	Code	
106	Abnormal thermistor display (TH3/TH6/TH7/TH8/TH32)	3: TH3/TH32 6: TH6 7: TH7 8: TH8 0: No thermistor error	Sensor number	
107	Operation mode when the last error occurred	Displayed in the same way as request code "0".	—	
108	Compressor-Operating current when the last error occurred	0 to 50	A	
109	Compressor-Accumulated operating time when the last error occurred	0 to 9999	10 hours	
110	Compressor-Number of operation times when the last error occurred	0 to 9999	100 times	
111	Discharge temperature when the last error occurred	-20 to 217	°C	
112	Outdoor unit -Liquid pipe 1 temperature (TH3) when the last error occurred	-40 to 90	°C	
113	Water inlet temperature (TH32) when the last error occurred	-40 to 101	°C	
114	Plate HEX liquid pipe temperature (TH6) when the last error occurred	-39 to 88	°C	
115	Outdoor unit-Suction pipe temperature (TH33)	-39 to 88	°C	
116	Outdoor unit-Ambient temperature (TH7) when the last error occurred	-39 to 88	°C	
117	Outdoor unit-Heatsink temperature (TH8) when the last error occurred	-40 to 200	°C	
118	Discharge superheat (SHd) when the last error occurred	0 to 255	°C	
119	Sub-cool (SC) when the last error occurred	0 to 130	°C	
120	Compressor-Operating frequency when the last error occurred	0 to 255	Hz	
121	Outdoor unit when the last error occurred • Fan output step	0 to 16	Step	
122	Outdoor unit when the last error occurred • Fan 1 speed (Only for air conditioners with DC fan)	0 to 9999	rpm	
123	Outdoor unit when the last error occurred • Fan 2 speed (Only for air conditioners with DC fan)	0 to 9999	rpm	"0" is displayed if the air conditioner is a single-fan type.
124				
125	LEV (A) opening pulse when the last error occurred	0 to 500	Pulses	
126	LEV (B) opening pulse when the last error occurred	0 to 500	Pulses	
127	LEV (C) opening pulse when the last error occurred	0 to 500	Pulses	
128				
129	Condensing temperature (T63HS) when the last error occurred	-39 to 88	°C	
130	Thermostat ON time until operation stops due to error	0 to 999	Minutes	

9-10-1. Detail Contents in Request Code

[Operation state] (Request code: "0")

Data display

□ □ C 4

Relay output state
Operation mode

Operation mode

Display	Operation mode
0	STOP • FAN
C	COOLING • DRY
H	HEATING
d	DEFROSTING

Relay output state

Display	Power currently supplied to compressor	Compressor	4-way valve	Solenoid valve
0	–	–	–	–
1				ON
2			ON	
3			ON	ON
4		ON		
5		ON		ON
6		ON	ON	
7		ON	ON	ON
8	ON			
A	ON		ON	

[Outdoor unit – Control state] (Request code: "51")

Data display	State
0 0 0 0	Normal
0 0 0 1	Preparing for heat operation
0 0 0 2	Defrost

[Compressor – Frequency control state] (Request code: "52")

Data display

0 0 * *

Frequency control state ②
Frequency control state ①

Frequency control state ①

Display	Current limit control
0	No current limit
1	Primary current limit control is ON.
2	Secondary current limit control is ON.

Frequency control state ②

Display	Discharge temperature overheat prevention	Condensation temperature overheat prevention	Anti-freeze protection control	Heatsink temperature overheat prevention
0				
1	Controlled			
2		Controlled		
3	Controlled	Controlled		
4			Controlled	
5	Controlled		Controlled	
6		Controlled	Controlled	
7	Controlled	Controlled	Controlled	
8				Controlled
9	Controlled			Controlled
A		Controlled		Controlled
b	Controlled	Controlled		Controlled
C			Controlled	Controlled
d	Controlled		Controlled	Controlled
E		Controlled	Controlled	Controlled
F	Controlled	Controlled	Controlled	Controlled

[Fan control state] (Request code: "53")

Data display

0 0 * *

Fan step correction value by heatsink temperature overheat prevention control
Fan step correction value by cool condensation temperature overheat prevention control

Display	Correction value
– (minus)	–1
0	0
1	+1
2	+2

[Actuator output state] (Request code: "54")

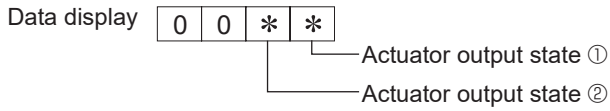

Actuator output state ①

Display	SV1	4-way valve	Compressor	Compressor is warming up
0				
1	ON			
2		ON		
3	ON	ON		
4			ON	
5	ON		ON	
6		ON	ON	
7	ON	ON	ON	
8				ON
9	ON			ON
A		ON		ON
b	ON	ON		ON
C			ON	ON
d	ON		ON	ON
E		ON	ON	ON
F	ON	ON	ON	ON

Actuator output state ②

Display	52C	SV2	SS
0			
1	ON		
2		ON	
3	ON	ON	
4			ON
5	ON		ON
6		ON	ON
7	ON	ON	ON

[Error content (U9)] (Request code: "55")

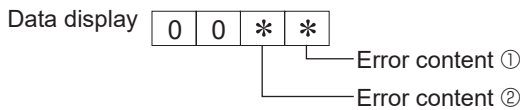

Error content ①

●: Detected

Display	Overvoltage error	Undervoltage error	L1-phase open error	Power synchronizing signal error
0				
1	●			
2		●		
3	●	●		
4			●	
5	●		●	
6		●	●	
7	●	●	●	
8				●
9	●			●
A		●		●
b	●	●		●
C			●	●
d	●		●	●
E		●	●	●
F	●	●	●	●

Error content ②

●: Detected

Display	Converter Fo error	PAM error
0		
1	●	
2		●
3	●	●

[Outdoor unit – Capacity setting display] (Request code: "70")

Data display	Capacity
9	35
10	50
11	60
14	71
20	100
25	125
28	140
40	200
50	250

[Outdoor unit – Setting information] (Request code: "71")

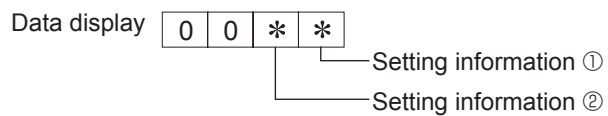

Setting information ①

Display	Defrost mode
0	Standard
1	For high humidity

Setting information ②

Display	Single-/ 3-phase	Heat pump/ cooling only
0	Single-phase	Heat pump
1		Cooling only
2	3-phase	Heat pump
3		Cooling only

PUZ-HWM140VHA(-BS)

PUZ-HWM140YHA(-BS)

→ : Indicates the visible parts in the photos/figures.

NOTE: Turn OFF the power supply before disassembly.

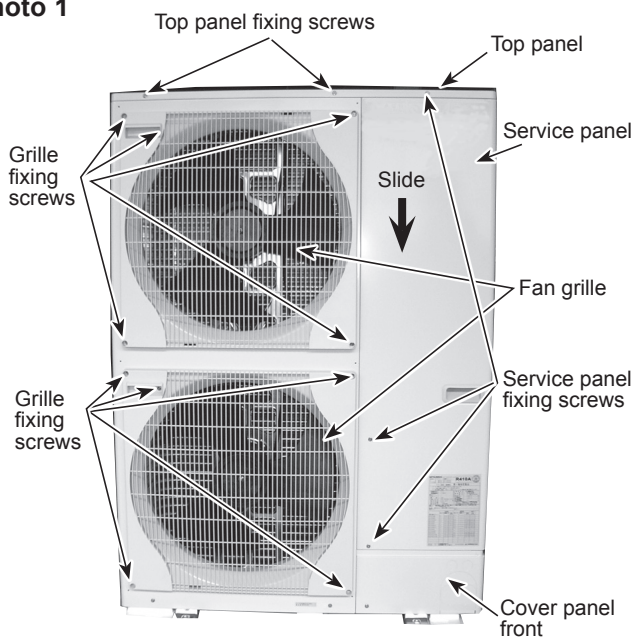
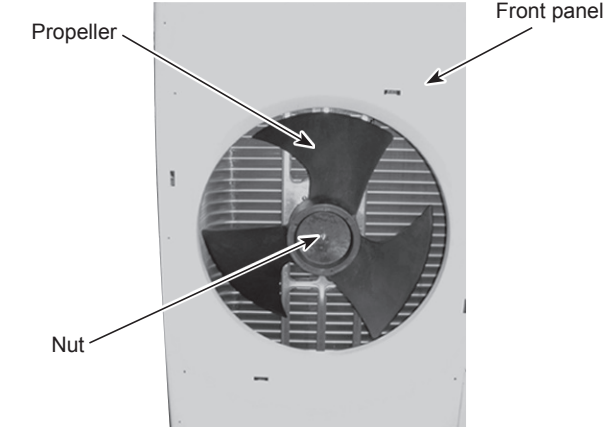
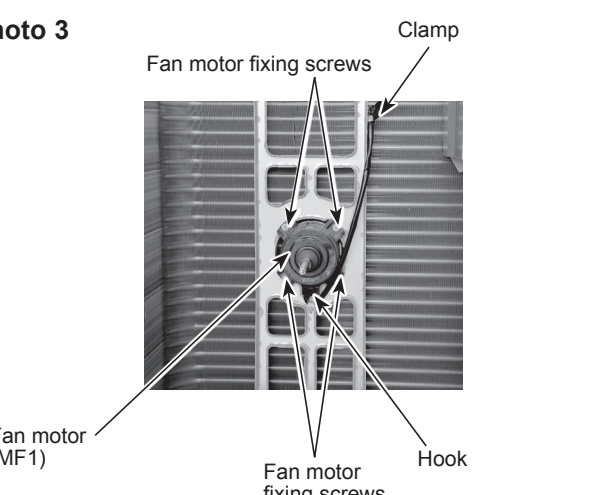
OPERATING PROCEDURE	PHOTOS/FIGURES
<p>1. Removing the service panel and top panel</p> <p>(1) Remove 3 service panel fixing screws (5 × 12) and slide the hook on the right downward to remove the service panel.</p> <p>(2) Remove screws (2 for front, 3 for rear/5 × 12) of the top panel and remove it.</p>	<p>Photo 1</p> 
<p>2. Removing the fan motor (MF1, MF2)</p> <p>(1) Remove the service panel. (Refer to procedure 1)</p> <p>(2) Remove the top panel. (Refer to procedure 1)</p> <p>(3) Remove the screws (2 for front/5 x 12) of the cover panel front and remove it. (See Photo1)</p> <p>(4) Remove the screws (4 for front/5 x 12, 2 for front/4 x 10) of the front panel and remove it.</p> <p>(5) Disconnect the connectors, CNF1 and CNF2 on controller circuit board in electrical parts box.</p> <p>(6) Loosen the clamp for the lead wire on motor support and separator.</p> <p>(7) Remove a nut (for right handed screw of M6) to detach the propeller. (See Photo 2)</p> <p>(8) Remove 4 fan motor fixing screws (5 × 20) to detach the fan motor. (See Photo 3)</p> <p>Note: When attaching the fan motor, make sure to route the cable through the hook below the fan motor and fix firmly with the clamp.</p>	<p>Photo 2</p>  <p>Photo 3</p> 

OPERATING PROCEDURE

3. Removing the electrical parts box

- (1) Remove the service panel. (Refer to procedure 1)
- (2) Remove the top panel. (Refer to procedure 1)
- (3) Disconnect the indoor/outdoor connecting wire and power supply wire from terminal block.
- (4) Disconnect the connectors of CNF1, CNF2, 63HS, LEV-A, LEV-B and LEV-C on the controller circuit board.
 - <Symbols on the board>
 - CNF1, CNF2: Fan motor
 - 63HS: Pressure Sensor
 - LEV-A, LEV-B, LEV-C: LEV-A, LEV-B, LEV-C
 Remove the lead wires of LEV and 63HS from clamp. Disconnect the pipe-side connections of the following parts.
 - Thermistor <Liquid>(TH3)
 - Thermistor <Discharge>(TH4)
 - Thermistor <2-Phase pipe>(TH6)
 - Thermistor <Ambient>(TH7)
 - Thermistor <Suction> (TH32)
 - Thermistor <Comp. surface> (TH33)
 - Thermistor <Plate HEX liquid> (TH34)
 - High pressure switch (63H)
 - 4-way valve coil (21S4)
- (5) Disengage the terminal cover from the hook to remove it.
- (6) Remove the fixing screws of the 4-way valve to disconnect the compressor lead wire.
- (7) Remove the sensor holder from the rear guard on back of the unit.
- (8) Remove 2 electrical parts box fixing screws (4 × 10) and detach the electrical parts box by pulling it upward. The electrical parts box is fixed with 2 hooks on the left and 1 hook on the right.

Photo 5 (PUZ-HWM140V)

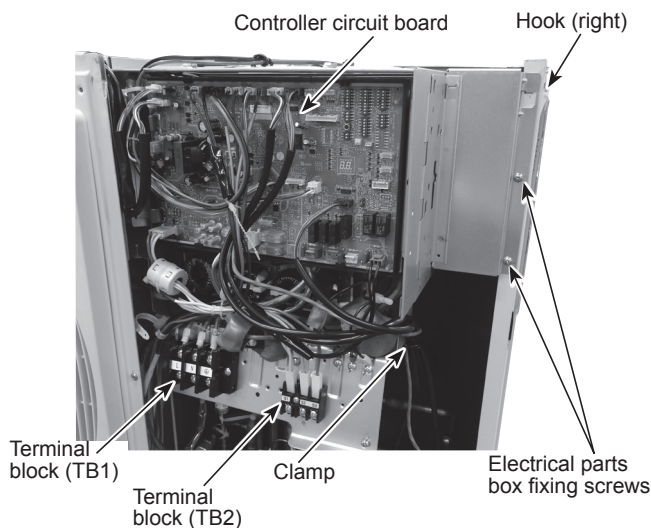

PHOTOS/FIGURES

Photo 4 (PUZ-HWM140Y)

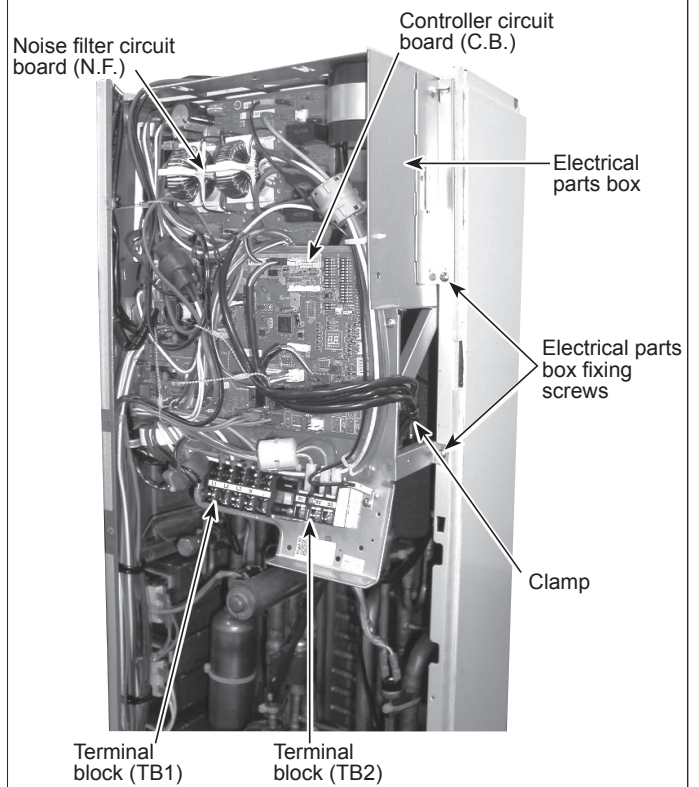

Photo 6

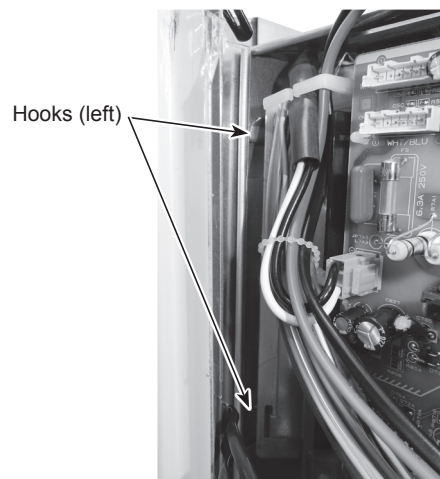
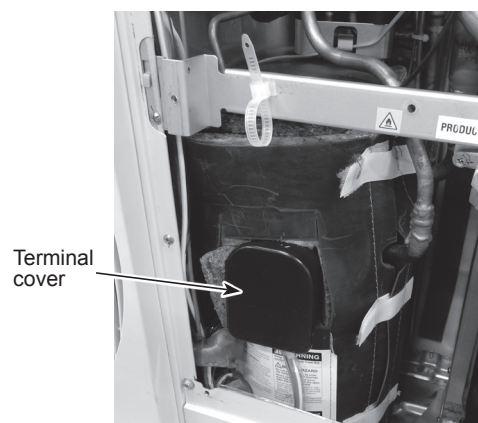

Photo 7



OPERATING PROCEDURE

4. Disassembling the electrical parts box (PUZ-HWM140Y)

- (1) Disconnect all the connectors on the controller circuit board.
- (2) Remove the 3 screws, screw ①, ② and ③, that fix the plate equipped with the outdoor controller circuit board, and the electrical parts box, screw ① from the front and the screw ② and ③ from the bottom of the electrical parts box. (See Photo 8 and 9)
- (3) Slide the plate in the direction of the arrow A and remove it. (See Photo 8)
- (4) Remove the lead wires from the clamp on the bottom of the electrical parts box. (See Photo 10)
- (5) Remove the 3 screws, screw ④ and ⑤, that fix the bottom side of the electrical parts box and remove the bottom side plate by sliding in the direction of the arrow B. (See Photo 10 and 11)
- (6) Remove the noise filter circuit board. (See Photo 12)
- (7) Remove the screw ⑥ and ⑦, and remove the plate that equips the converter circuit board. (See Photo 9)
- (8) Remove the converter circuit board from the plate. (See Photo 11)

Note: When reassembling the electrical parts box, make sure the wirings are correct.

PHOTOS/FIGURES

Photo 8

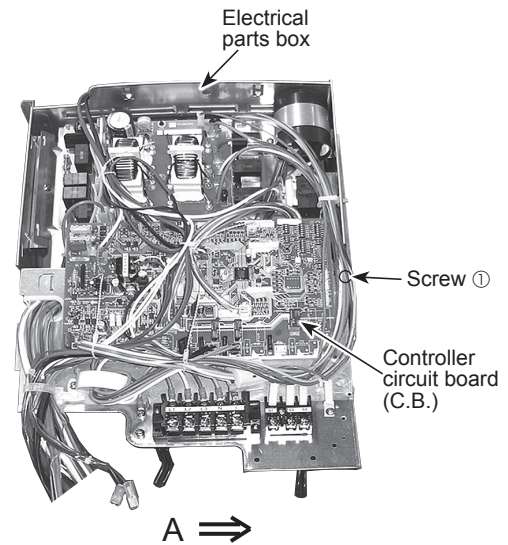

Photo 9

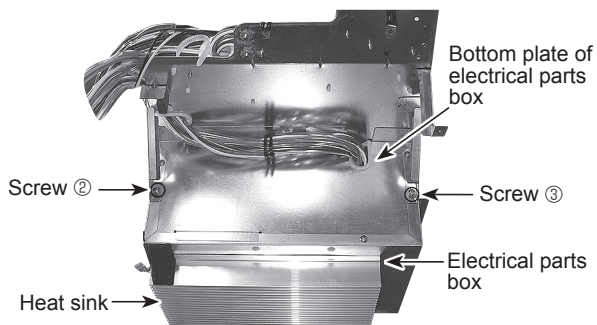

Photo 10

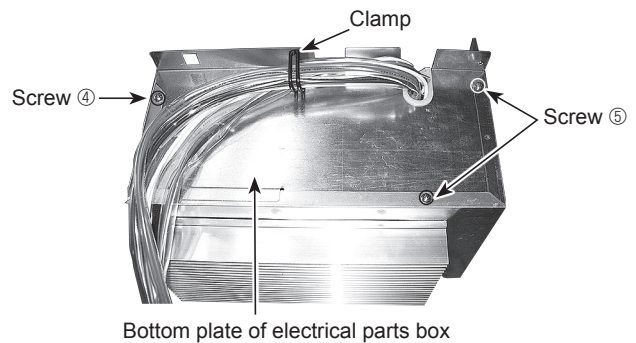

Photo 11

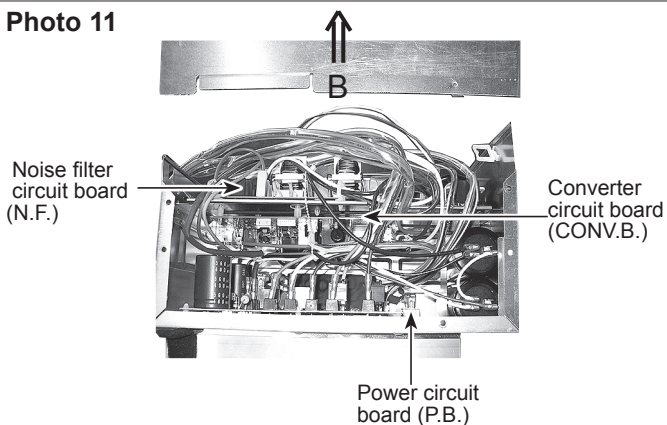
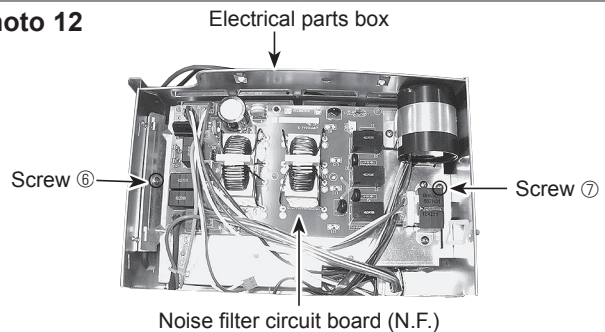

Photo 12



OPERATING PROCEDURE

5. Removing the thermistor <Plate HEX liquid> (TH34) and thermistor <Ambient> (TH7)

- (1) Remove the service panel. (Refer to procedure 1)
- (2) Remove the top panel. (Refer to procedure 1)
- (3) Disconnect the connectors, TH7/34 (red) on the controller circuit board in the electrical parts box.
- (4) Loosen the 2 wire clamps on top of the electrical parts box.
- (5) Loosen the fastener of the electrical parts box to disconnect the lead wire.
- (6) Pull out the thermistor <Plate HEX liquid> (TH34) and thermistor <Ambient> (TH7) from the sensor holder.

Note: In the case of replacing thermistor <Plate HEX liquid> (TH34) or thermistor <Ambient> (TH7), replace it together.

Photo 14

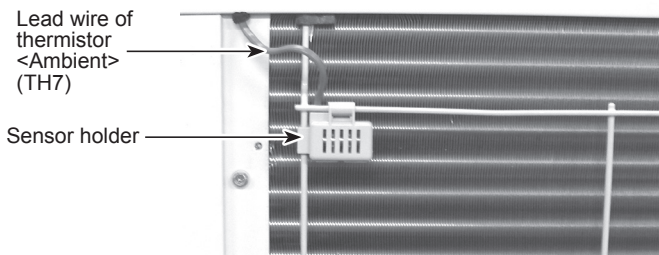

6. Removing the thermistor <Discharge> (TH4) and thermistor <Comp. surface> (TH33)

- (1) Remove the service panel. (Refer to procedure 1)
- (2) Disconnect the white connector for TH3 and black connector for TH32 on the controller circuit board in the electrical parts box.
- (3) Disconnect the lead wire from the cable strap on the left of the electrical parts box.
- (4) Loosen the wire clamps of the separator to disconnect the lead wire.
- (5) Pull out the thermistor <Discharge> (TH4) from the sensor holder.

[Removing the thermistor <Comp. surface> (TH33)]

- (5) Pull out the thermistor <Comp. surface> (TH33) from the holder of the compressor shell.

PHOTOS/FIGURES

Photo 13

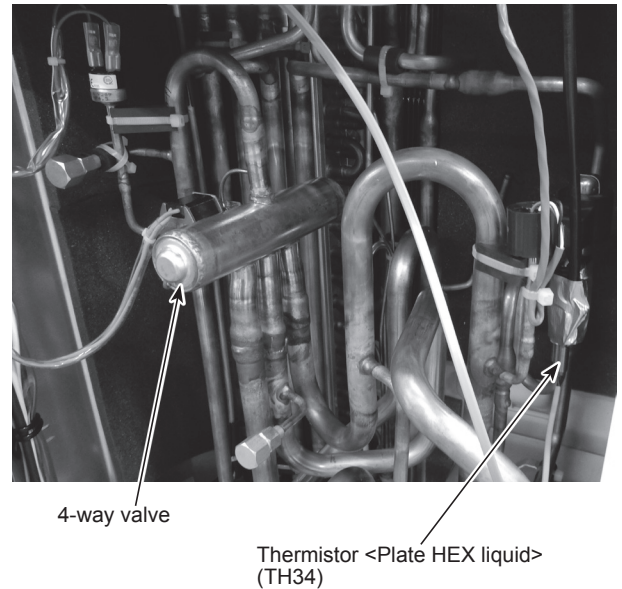
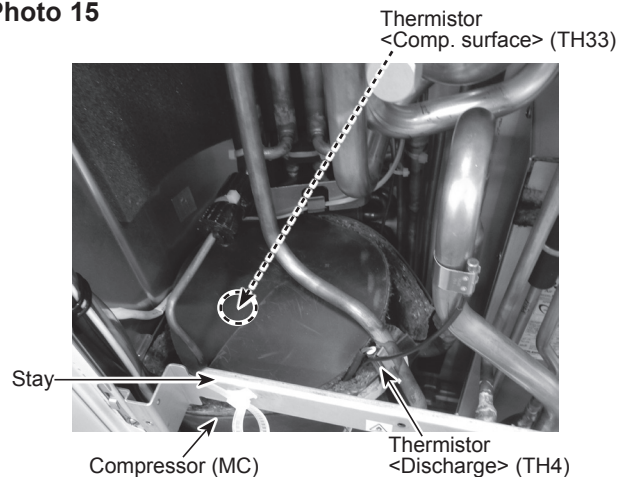

Photo 15



7. Removing the thermistor <Liquid> (TH3) and thermistor <Suction> (TH32)

- (1) Remove the service panel. (Refer to procedure 1)
- (2) Disconnect the white connector for TH3 and black connector for TH32 on the controller circuit board in the electrical parts box.
- (3) Disconnect the lead wire from the cable strap on the left of the electrical parts box.
- (4) Loosen the wire clamps of the separator to disconnect the lead wire.
- (5) Pull out the thermistor <Liquid> (TH3), <Suction> (TH32) from the sensor clip.

Photo 16

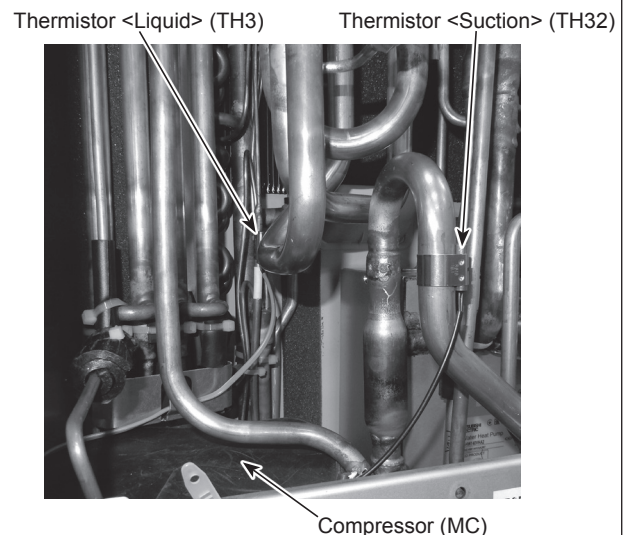

Note1: When removing the parts for refrigerant circuit, take out the refrigerant soon after removing the service panel.

Note2: Recover refrigerant without spreading it in the air.

Note3: When installing the 4-way valve, the LEV, the pressure switch (63H) and the high pressure switch (63HS), cover it with a wet cloth to prevent it from heating (120°C or more for the 4-way valve and the LEV/ 100°C or more for 63H and 63HS), then braze the pipes so that the inside of pipes are not oxidized.

Note4: A rubber cap is attached to the sealing part of refrigerant. The rubber cap needs to be detached when recovering refrigerant. Do not lose the rubber cap and attach the rubber cap again after charging refrigerant.

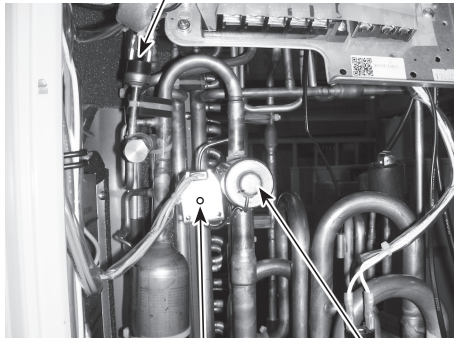
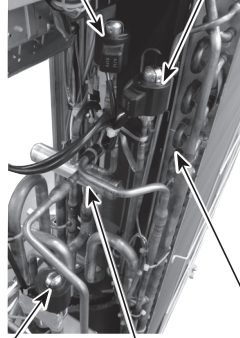
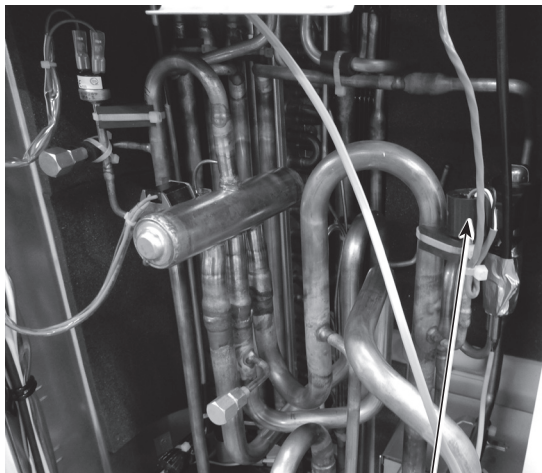
OPERATING PROCEDURE	PHOTOS/FIGURES
<p>8. Removing the 4-way valve coil (21S4), and LEV coil (LEV-A, LEV-B, LEV-C)</p> <p>(1) Remove the service panel. (Refer to procedure 1)</p> <p>[Removing the 4-way valve coil] (See Photo 17)</p> <p>(2) Disconnect the green connector for 21S4 on the controller circuit board in the electrical parts box.</p> <p>(3) Release the lead wire from the cable strap of the electrical parts box.</p> <p>(4) Loosen the wire clamps of the separator to disconnect the lead wire.</p> <p>(5) Remove the 4-way valve coil by sliding the coil towards you.</p> <p>(6) Remove the 4-way valve coil fixing screw (M4 × 6).</p> <p>[Removing the LEV coil] (See Photo 18)</p> <p>(2) Remove the LEV coil by sliding the coil upward.</p> <p>(3) Loosen the clamp for lead wire on the electrical parts box.</p> <p>(4) Disconnect the connectors, LEV-A (white), LEV-B (red) and LEV-C (blue) on the controller circuit board in the electrical parts box.</p>	<p>Photo 17</p> <p>Pressure switch (63H)</p>  <p>4-way valve coil fixing screw</p> <p>4-way valve</p>
<p>9. Removing the 4-way valve</p> <p>(1) Remove the electrical parts box. (Refer to procedure 4)</p> <p>(2) Remove 3 valve bed fixing screws (4 × 10), 2 valve and fixing screws (5 × 16) then remove the valve bed.</p> <p>(3) Remove cover panel (front) fixing screws (2 for front/5 × 12) to remove the cover panel (front).</p> <p>(4) Remove the water pipe.</p> <p>(5) Remove 5 right side panel (R) fixing screws (5 × 12) (4: rear of the unit/1: right side base) and remove the side panel (R).</p> <p>(6) Recover refrigerant.</p> <p>(7) Remove the welded part of 4-way valve.</p>	<p>Photo 18</p> <p>LEV (LEV-A) LEV (LEV-C)</p>  <p>LEV (LEV-B) 4-way valve Heat exchanger</p>
<p>10. Removing the LEV</p> <p>(1) Remove the electrical parts box. (Refer to procedure 4)</p> <p>(2) Remove 3 valve bed fixing screws (4 × 10), 2 valve and fixing screws (5 × 16) then remove the valve bed.</p> <p>(3) Remove cover panel (front) fixing screws (2 for front/5 × 12) to remove the cover panel (front).</p> <p>(4) Remove the water pipe.</p> <p>(5) Remove 5 right side panel (R) fixing screws (5 × 12) (4: rear of the unit/1: right side base) and remove the side panel (R).</p> <p>(6) Remove the LEV coil.</p> <p>(7) Recover refrigerant.</p> <p>(8) Remove the welded part of LEV.</p>	<p>Photo 19</p>  <p>High pressure sensor (63HS)</p>
<p>11. Removing the pressure switch (63H) (See Photo 17) and the low pressure switch (63L)</p> <p>(1) Remove the electrical parts box. (Refer to procedure 4)</p> <p>(2) Remove 3 valve bed fixing screws (4 × 10), 2 valve and fixing screws (5 × 16) then remove the valve bed.</p> <p>(3) Remove cover panel (front) fixing screws (2 for front/5 × 12) to remove the cover panel (front).</p> <p>(4) Remove 5 right side panel (R) fixing screws (5 × 12) (4: rear of the unit/1: right side base) and remove the side panel (R).</p> <p>(5) Recover refrigerant.</p> <p>(6) Remove the welded part of high pressure switch and low pressure switch.</p>	
<p>12. Removing high pressure sensor (63HS) (See Photo 19)</p> <p>(1) Remove the electrical parts box. (Refer to procedure 4)</p> <p>(2) Remove 3 valve bed fixing screws (4 × 10), 2 valve and fixing screws (5 × 16) then remove the valve bed.</p> <p>(3) Remove cover panel (front) fixing screws (2 for front/5 × 12) to remove the cover panel (front).</p> <p>(4) Remove the water pipe.</p> <p>(5) Remove 5 right side panel (R) fixing screws (5 × 12) (4: rear of the unit/1: right side base) and remove the side panel (R).</p> <p>(6) Recover refrigerant.</p> <p>(7) Remove the welded part of high pressure sensor.</p>	

OPERATING PROCEDURE

13. Removing the plate heat exchanger

- (1) Remove the electrical parts box. (Refer to procedure 4)
- (2) Remove 3 valve bed fixing screws (4 × 10), 2 valve and fixing screws (5 × 16) then remove the valve bed.
- (3) Remove cover panel (front) fixing screws (2 for front/5 × 12) to remove the cover panel (front).
- (4) Remove the water pipe.
- (5) Remove 5 right side panel (R) fixing screws (5 × 12) (4:rear of the unit/1: right side base) and remove the side panel (R).
- (6) Recover the refrigerant.
- (7) Remove 2 welded pipes of plate heat exchanger inlet and outlet.
- (8) Remove 3 plate heat exchanger fixing screws (4 × 10), then remove the plate heat exchanger.

Note 1: Recover refrigerant without letting it out in the air.

Note 2: Before removing the thermistor <Inlet water> (TH32), recover water in the plate heat exchanger

PHOTOS/FIGURES

Photo 20

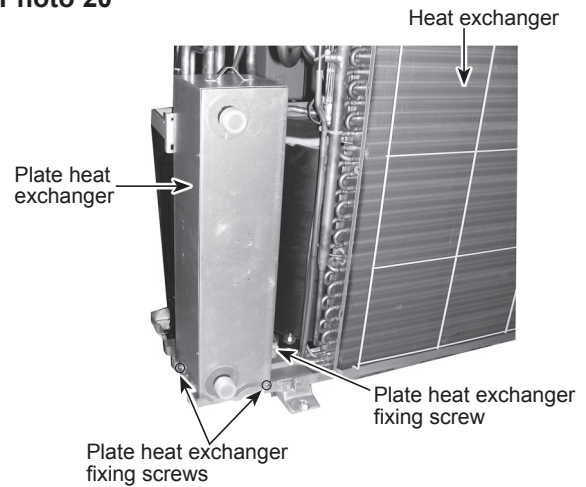

14. Removing the reactors (ACL1, ACL2, ACL3) (PUZ-HWM140Y)

- (1) Remove the service panel. (Refer to procedure 1)
- (2) Remove the top panel. (Refer to procedure 1)
- (3) Remove the 6 screws, that fix the front panel and remove the front panel.
- (4) Remove the 2 screws, screw ⑧ and ⑨ (both 4 × 10), that fix the separator, screw ⑧ from the stay and screw ⑨ from the bottom of the separator, and tilt the separator to the side of the fan motor slightly. (See Photo 21)
- (5) Remove the 4-way valve.
- (6) Disconnect the lead wires from the reactor and remove the 4 screws, screw ⑩, that fix the reactor to remove the reactor. (See Photo 22 and 23)

Note 1: The reactor is very heavy (4 kg)! Be careful when handling it.

Note 2: The reactors can be removed if the 4-way valve is not removed.

Photo 22

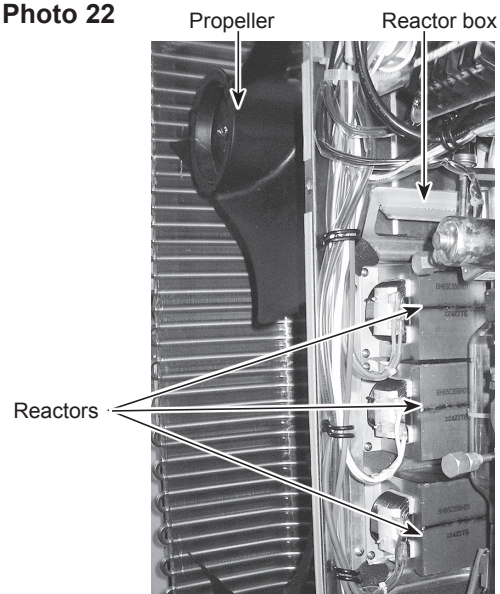

Photo 21

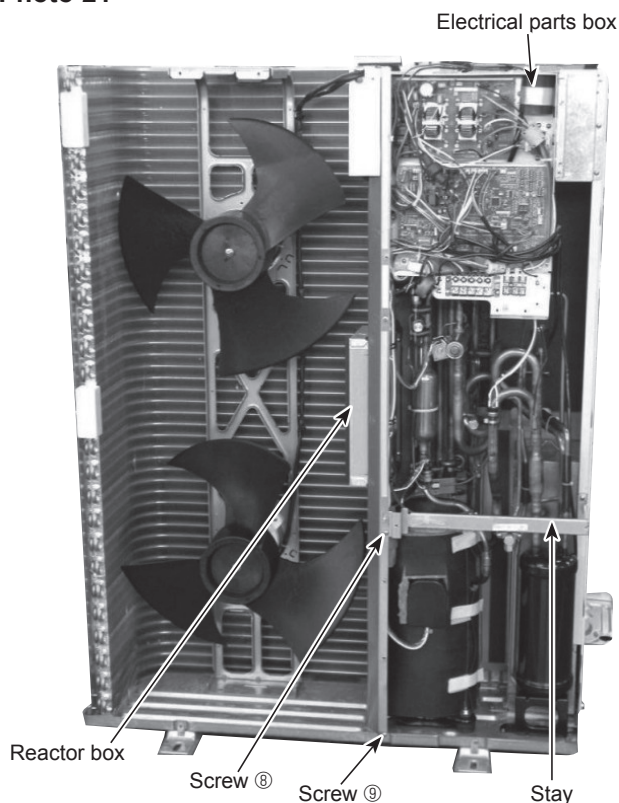
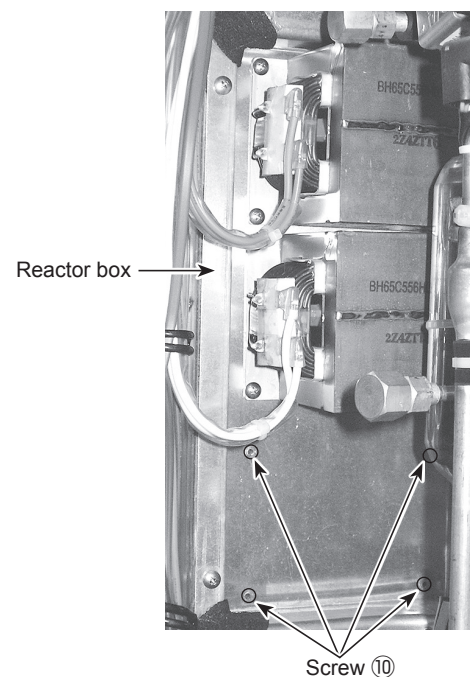
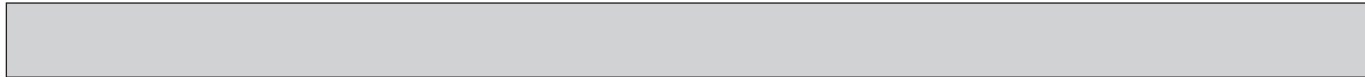

Photo 23





OPERATING PROCEDURE

- 15. Removing the compressor (MC)**
- (1) Remove the service panel. (Refer to procedure 1)
 - (2) Remove the top panel. (Refer to procedure 1)
 - (3) Remove the electrical parts box. (See Photo 4, 5)
 - (4) Remove 3 valve bed fixing screws (4 × 10), 2 valve and fixing screws (5 × 16) then remove the stay.
 - (5) Remove cover panel (front) fixing screws (2 for front/5 × 12) to remove the cover panel (front).
 - (6) Remove 5 right side panel (R) fixing screws (5 × 12) (4:rear of the unit/1: right side base) and remove the side panel (R).
 - (7) Remove the front panel.
 - (8) Remove 3 separator fixing screws (4 × 10) and remove the separator.
 - (9) Remove the soundproof cover for compressor.
 - (10) Remove the terminal cover and remove the compressor lead wire.
 - (11) Recover refrigerant.
 - (12) Remove the welded pipe of compressor inlet and outlet then remove the compressor.
 - (13) Remove the 3 points of the compressor fixing nut using a spanner or a adjustable wrench.

Note: Recover refrigerant without spreading it in the air.

16. Removing the power receiver

- (1) Remove the service panel. (Refer to procedure 1)
- (2) Remove the top panel. (Refer to procedure 1)
- (3) Remove the electrical parts box. (See Photo 4, 5)
- (4) Remove 3 valve bed fixing screws (4 × 10), 2 valve and fixing screws (5 × 16) then remove the stay.
- (5) Remove cover panel (front) fixing screws (2 for front/5 × 12) to remove the cover panel (front).
- (6) Remove 5 right side panel (R) fixing screws (5 × 12) (4:rear of the unit/1: right side base) and remove the side panel (R).
- (7) Recover refrigerant.
- (8) Remove 4 welded pipes of power receiver inlet and outlet.
- (9) Remove 2 receiver leg fixing screws (4 × 10).

Note: Recover refrigerant without spreading it in the air.

17. Removing the pressure relief valve

- (1) Remove the service panel. (Refer to procedure 1)
- (2) Remove the valve bed. (Refer to procedure 12(2))
- (3) Remove the quick fastener which fixes the plate heat exchanger and the PRV. (See Photo 26)
- (4) Pull the PRV to remove it. (See Photo 26)
- (5) Remove the O-ring. (See Photo 27)

Note 1: Make sure that the operation stops before removing.

Note 2: When replacing the O-ring if necessary, use the O-ring and grease which are used in Cylinder unit (e.g. EHST20C series) .

PHOTOS/FIGURES

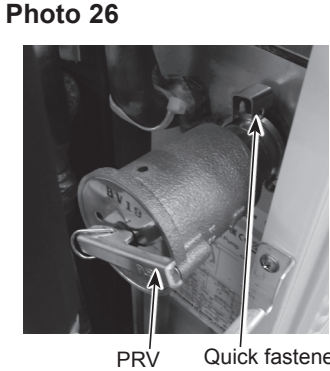
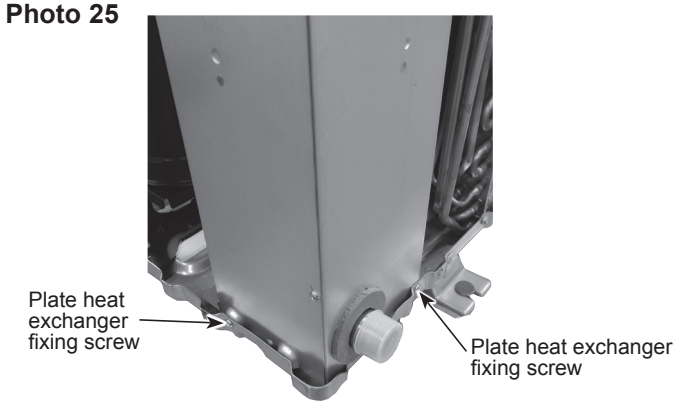
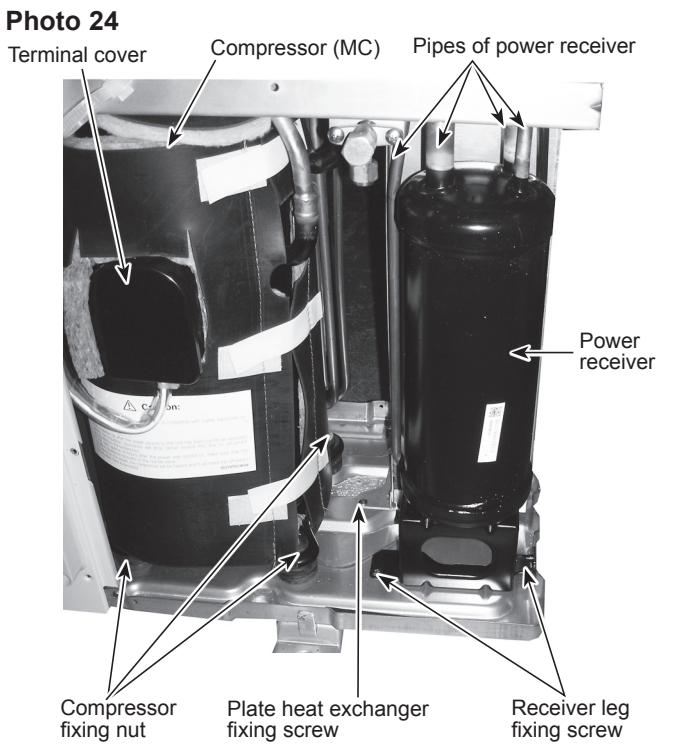

MITSUBISHI ELECTRIC CORPORATION

HEAD OFFICE: TOKYO BUILDING, 2-7-3, MARUNOUCHI, CHIYODA-KU, TOKYO 100-8310, JAPAN