

Air-Conditioners Indispensable Optional Parts BRANCH BOX

PAC-MK53BCB PAC-MK33BCB

ONLY FOR R410A OUTDOOR UNIT**ONLY FOR INDOOR USE****HFC
utilized****R410A**

INSTALLATION MANUAL

For safe and correct use, please read this installation manual thoroughly before installing the air-conditioner unit.

FOR INSTALLER

INSTALLATIONSHANDBUCH

Zum sicheren und ordnungsgemäßen Gebrauch der Klimaanlage das Installationshandbuch gründlich durchlesen.

FÜR INSTALLATEURE

MANUEL D'INSTALLATION

Veillez lire le manuel d'installation en entier avant d'installer ce climatiseur pour éviter tout accident et vous assurer d'une utilisation correcte.

POUR L'INSTALLATEUR

INSTALLATIEHANDLEIDING

Voor een veilig en juist gebruik moet u deze installatiehandleiding grondig doorlezen voordat u de airconditioner installeert.

VOOR DE INSTALLATEUR

MANUAL DE INSTALACIÓN

Para un uso seguro y correcto, lea detalladamente este manual de instalación antes de montar la unidad de aire acondicionado.

PARA EL INSTALADOR

MANUALE DI INSTALLAZIONE

Per un uso sicuro e corretto, leggere attentamente questo manuale di installazione prima di installare il condizionatore d'aria.

PER L'INSTALLATORE

ΕΓΧΕΙΡΙΔΙΟ ΟΔΗΓΙΩΝ ΕΓΚΑΤΑΣΤΑΣΗΣ

Για ασφάλεια και σωστή χρήση, παρακαλείστε διαβάσετε προσεκτικά αυτό το εγχειρίδιο εγκατάστασης πριν αρχίσετε την εγκατάσταση της μονάδας κλιματισμού.

ΓΙΑ ΑΥΤΟΝ ΠΟΥ ΚΑΝΕΙ ΤΗΝ ΕΓΚΑΤΑΣΤΑΣΗ

MANUAL DE INSTALAÇÃO

Para segurança e utilização correctas, leia atentamente este manual de instalação antes de instalar a unidade de ar condicionado.

PARA O INSTALADOR

INSTALLATIONSMANUAL

Læs venligst denne installationsmanual grundigt, før De installerer airconditionanlægget, af hensyn til sikker og korrekt anvendelse.

TIL INSTALLATØREN

INSTALLATIONSMANUAL

Läs denna installationsmanual noga för säkert och korrekt bruk innan luftkonditioneringen installeras.

FÖR INSTALLATÖREN

MONTAJ ELKİTABI

Emniyetli ve doğru biçimde nasıl kullanılacağını öğrenmek için lütfen klima cihazını monte etmeden önce bu elkitabını dikkatle okuyunuz.

MONTÖR İÇİN

РУКОВОДСТВО ПО УСТАНОВКЕ

Для осторожного и правильного использования прибора необходимо тщательно ознакомиться с данным руководством по установке до выполнения установки кондиционера.

ДЛЯ УСТАНОВИТЕЛЯ

INSTALLASJONSHÅNDBOK

For å sikre trygg og riktig bruk, vennligst les denne installasjonshåndboken grundig før du installerer klimaanlægget.

FOR MONTØR

INSTRUKCJA MONTAŻU

Aby zapewnić bezpieczne i prawidłowe korzystanie z urządzenia, przed montażem klimatyzatora należy dokładnie zapoznać się z instrukcją montażu.

DLA INSTALATORA

English

Deutsch

Français

Nederlands

Español

Italiano

Ελληνικά

Português

Dansk

Svenska

Türkçe

Русский

Norsk

Polski

Contents

1. Safety precautions	2	6. Mounting the Branch Box	7
2. Selecting a location for installation	2	7. Installing refrigerant piping	7
3. Confirming supplied accessories	3	8. Electrical work	9
4. Dimensions and required servicing space of Branch Box	3	9. Test run	14
5. Refrigerant piping	6		

This installation manual is only for the branch box installation. In installing the indoor units and outdoor units, refer to the installation manual attached to each unit.

1. Safety precautions

- ▶ Before installing the unit, make sure you read all the “Safety precautions”.
- ▶ Please report to or take consent by the supply authority before connection to the system.
- ▶ PAC-MK•BC series are designed as professional equipment. When installing the unit in a regular house, install the optional Reactor Box (PAC-RB01BC) for harmonic suppression.
- ▶ When receiving electricity from the outdoor unit, applicable standards for the outdoor unit may not be satisfied depending on the indoor unit used.

⚠ Warning:

Describes precautions that must be observed to prevent danger of injury or death to the user.

⚠ Warning:

- The unit must not be installed by the user.
- Ask a dealer or an authorized technician to install the unit.
- For installation work, follow the instructions in the Installation Manual and use tools and pipe components specifically made for use with refrigerant specified in the outdoor unit installation manual.
- The unit must be installed according to the instructions in order to minimize the risk of damage from earthquakes, typhoons, or strong winds. An incorrectly installed unit may fall down and cause damage or injuries.
- The unit must be securely installed on a structure that can sustain its weight.
- If the air conditioner is installed in a small room, measures must be taken to prevent the refrigerant concentration in the room from exceeding the safety limit in the event of refrigerant leakage. Should the refrigerant leak and cause the concentration limit to be exceeded, hazards due to lack of oxygen in the room may result.
- Ventilate the room if refrigerant leaks during operation. If refrigerant comes into contact with a flame, poisonous gases will be released.
- All electric work must be performed by a qualified technician according to local regulations and the instructions given in this manual.
- Use only specified cables for wiring.
- The terminal block cover panel of the unit must be firmly attached.
- Use only accessories authorized by Mitsubishi Electric and ask a dealer or an authorized technician to install them.
- The user should never attempt to repair the unit or transfer it to another location.
- After installation has been completed, check for refrigerant leaks. If refrigerant leaks into the room and comes into contact with the flame of a heater or portable cooking range, poisonous gases will be released.
- Be sure to connect the power supply cords and the connecting wires for the indoor units, outdoor units, and branch boxes directly to the units (no intermediate connections). Intermediate connections can lead to communication errors if water enters the cords or wires and causes insufficient insulation to ground or a poor electrical contact at the intermediate connection point. (If an intermediate connection is necessary, be sure to take measures to prevent water from entering the cords and wires.)

⚠ Caution:

Describes precautions that must be observed to prevent damage to the unit.

After installation work has been completed, explain the “Safety Precautions,” use, and maintenance of the unit to the customer according to the information in the Operation Manual and perform the test run to ensure normal operation. Both the Installation Manual and Operation Manual must be given to the user for keeping. These manuals must be passed on to subsequent users.

⚡ : Indicates a part which must be grounded.

⚠ Warning:

Carefully read the labels affixed to the main unit.

⚠ Caution:

- Make sure that the refrigerant pipes are well insulated to prevent condensation. Incomplete insulation may cause condensation on the surface of pipes, wetting of the ceiling, floor and other important properties.
- Do not use the unit in an unusual environment. If the air conditioner is installed in areas exposed to steam, volatile oil (including machine oil), or sulfuric gas, areas exposed to high salt content such as the seaside, the performance can be significantly reduced and the internal parts can be damaged.
- Do not install the unit where combustible gases may leak, be produced, flow, or accumulate. If combustible gas accumulates around the unit, fire or explosion may result.
- When installing the unit in a hospital or communications office, be prepared for noise and electronic interference. Inverters, home appliances, high-frequency medical equipment, and radio communications equipment can cause the air conditioner to malfunction or breakdown. The air conditioner may also affect medical equipment, disturbing medical care, and communications equipment, harming the screen display quality.
- Thermal insulation of the refrigerant pipe is necessary to prevent condensation. If the refrigerant pipe is not properly insulated, condensation will be formed.
- Place thermal insulation on the pipes to prevent condensation. If the drain-pipe is installed incorrectly, water leakage and damage to the ceiling, floor, furniture, or other possessions may result.
- Do not clean the air conditioner unit with water. Electric shock may result.
- Tighten all flare nuts to specification using a torque wrench. If tightened too much, the flare nut can break after an extended period.
- Be sure to install circuit breakers, if not installed, electric shock may result.
- For the power lines, use standard cables of sufficient capacity. Otherwise, a short circuit, overheating, or fire may result.
- When installing the power lines, do not apply tension to the cables. If the connections are loosened, the cables can snap or break and overheating or fire may result.
- Do not connect the ground wire to gas or water pipes, lighting rods, or telephone grounding lines. If the unit is not properly grounded, electric shock may result.

2. Selecting a location for installation

* The branch box is only for indoor use.

Please attach the special optional cover (PAC-AK350CVR-E) to install the branch box in the outdoors.

- Ensure that the branch box is installed in a location which facilitates servicing and maintenance. (ensure that the required maintenance hole or service space is available).

- Ensure that the branch box is installed above the ceiling of corridor, bath room, etc., where persons are not regularly there. Do not install near bed rooms, living rooms, etc. The sound of refrigerant flowing through the piping may sometimes be audible. Also, do not install where maintenance cannot be carried out.
- Ensure that it is located where noise in operation will not be a problem. After power is supplied or after an operation stop for a while, a small clicking noise may be heard from the inside of the branch box. The electronic expansion valve is opening and closing. The unit is not faulty.

- Determine the route of refrigerant piping, and electrical wiring beforehand.
- Ensure that the location of the installation is such that the length of refrigerant piping is within the specified limits.

• Do not install in location that is hot or humid for long periods of time.

* Ensure that the unit is installed in a location able to support its weight.

⚠ Warning:

Ensure that the unit is installed firmly in a location able to support its weight. If the installation is of insufficient strength the unit may fall, resulting in injury.

3. Confirming supplied accessories

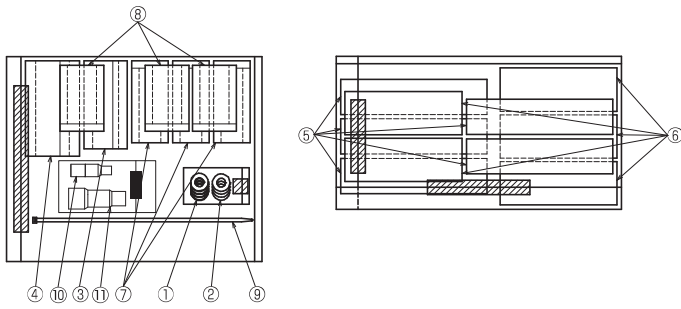

Fig. 3-1

3.1. Check the Branch Box accessories and parts

No.	Accessory name	Q'ty		Remarks
		PAC-MK33BCB	PAC-MK53BCB	
①	Washer (with insulation)	4	4	
②	Washer	4	4	
③	Pipe cover (Liquid)	1	1	To outdoor unit
④	Pipe cover (Gas)	1	1	To outdoor unit
⑤	Pipe cover (Liquid)	3	5	To indoor units
⑥	Pipe cover (Gas)	3	5	To indoor units
⑦	Joint cover (Liquid)	1	3	
⑧	Joint cover (Gas)	1	3	
⑨	Band	16	24	
⑩	Joint Pipe (Liquid)	1	1	
⑪	Joint Pipe (Gas)	1	1	

4. Dimensions and required servicing space of Branch Box

Optional different-diameter (deformed) joints

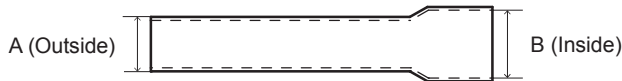

Fig. 4-1

Model name	Connected pipes diameter	Outside Diameter A	Inside Diameter B
	mm	mm	mm
PAC-SG78RJB-E	ø9.52 → ø12.7	ø9.52	ø12.7
PAC-SG79RJB-E	ø12.7 → ø9.52	ø12.7	ø9.52
PAC-SG80RJB-E	ø12.7 → ø15.88	ø12.7	ø15.88
PAC-SG77RJB-E	ø6.35 → ø9.52	ø6.35	ø9.52
PAC-SG76RJB-E	ø9.52 → ø15.88	ø9.52	ø15.88
PAC-SJ72RJB-E	ø15.88 → ø19.05	ø15.88	ø19.05

- * Please connect 2 indoor units or more with 1 system.
- * Up to 2 branch boxes may be connected to 1 outdoor unit.
- * Suspension bolt : W3/8 (M10)
- * Refrigerant pipe brazed connection

* The piping connection size differs according to the type and capacity of indoor units. Match the piping connection size for indoor unit and branch box. If the piping connection size of branch box does not match the piping connection size of indoor unit, use optional different-diameter (deformed) joints to the branch box side. (Connect deformed joint directly to the branch box side.)

■ PAC-MK53BCB (5-branches type)

(mm)

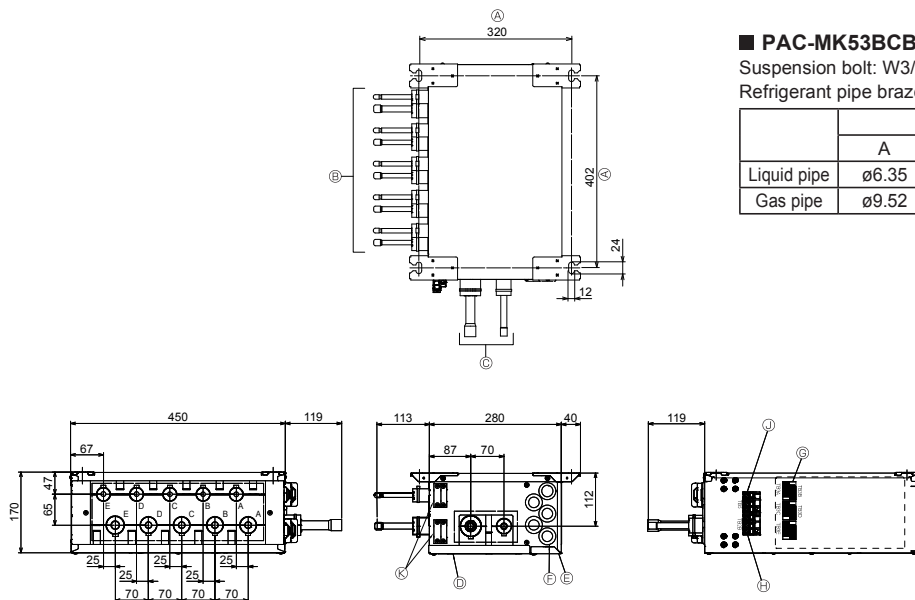

Fig. 4-2

- Ⓐ Suspension bolt pitch
- Ⓑ To indoor unit
- Ⓒ To outdoor unit
- Ⓓ Service panel
- Ⓔ Electric cover
- Ⓕ Rubber bush
- Ⓖ Terminal block (to indoor unit on control board)
- Ⓗ Terminal block (to outdoor unit)
- Ⓙ Terminal block (for communication cable)
- Ⓚ Cable clamp

■ PAC-MK53BCB (Fig.4-2)

Suspension bolt: W3/8 (M10)

Refrigerant pipe brazed connection

mm

	To indoor unit					To outdoor unit
	A	B	C	D	E	
Liquid pipe	ø6.35	ø6.35	ø6.35	ø6.35	ø6.35	ø9.52
Gas pipe	ø9.52	ø9.52	ø9.52	ø9.52	ø12.7	ø15.88

4. Dimensions and required servicing space of Branch Box

■ PAC-MK33BCB (3-branches type)

(mm)

■ PAC-MK33BCB (Fig.4-3)

Suspension bolt: W3/8 (M10)

Refrigerant pipe brazed connection

	To indoor unit			To outdoor unit
	A	B	C	
Liquid pipe	ø6.35	ø6.35	ø6.35	ø9.52
Gas pipe	ø9.52	ø9.52	ø9.52	ø15.88

mm

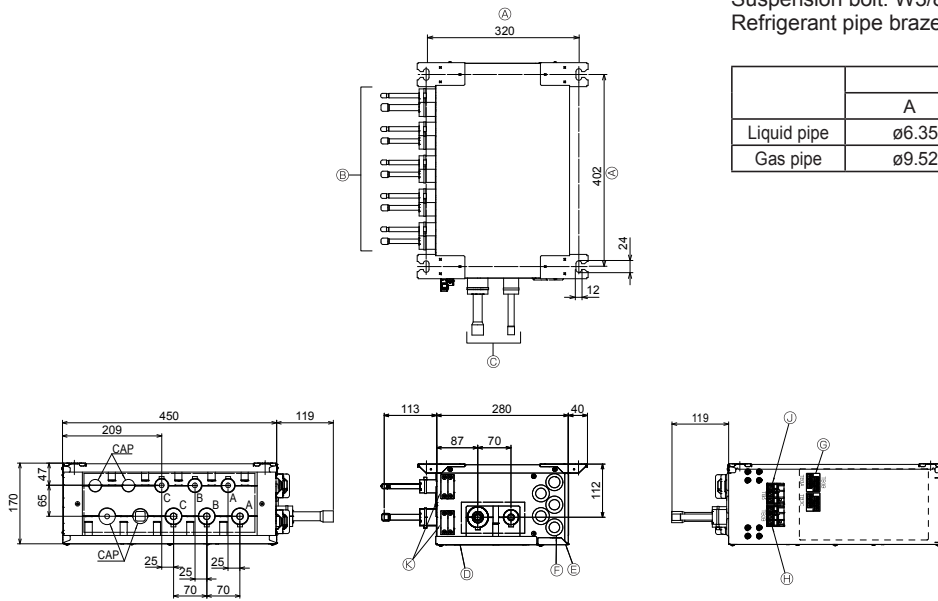

Fig. 4-3

4.1. The direction of the piping can be changed.
(Fig. 4-4)

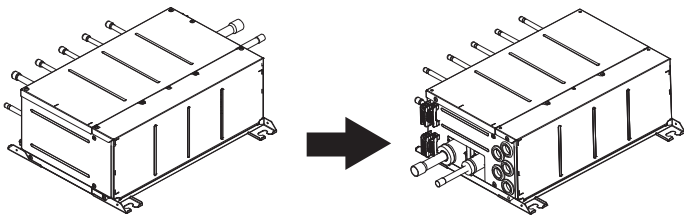

Fig. 4-4

① Remove the screws in each part.

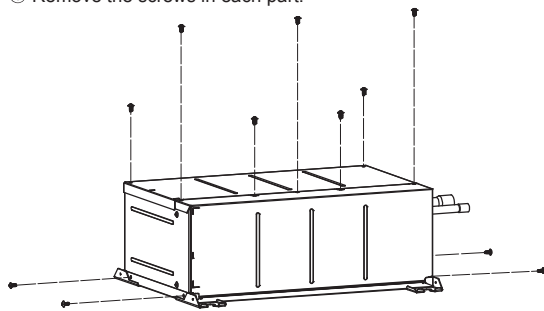

Fig. 4-5

4.2. Piping direction change work procedures
(Fig. 4-5 ①~⑧)

4. Dimensions and required servicing space of Branch Box

② Remove the electric cover, service panel, and top panel.

- Ⓐ Electric cover
- Ⓑ Service panel
- Ⓒ Top panel

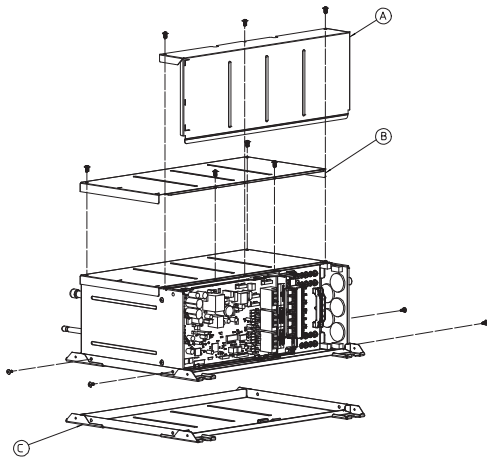

③ Install the top panel on the opposite surface.

- Ⓒ Top panel

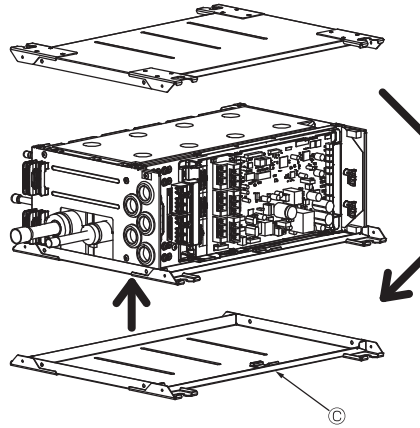

④ Fasten the screws in each part.

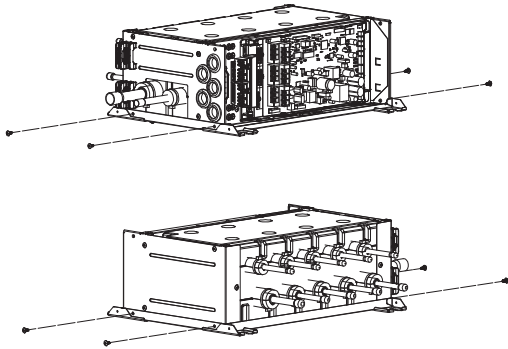

⑤ Install the service panel on the opposite surface.

- Ⓑ Service panel

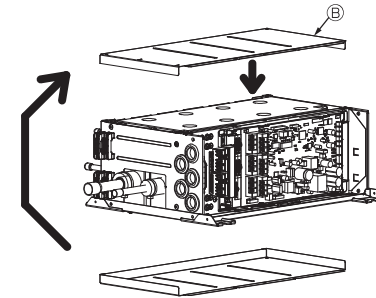

⑥ Fasten the screws in each part.

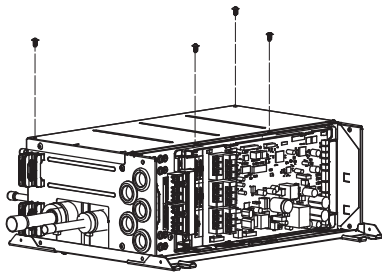

⑦ Install the electric cover on the opposite surface.

- Ⓐ Electric cover

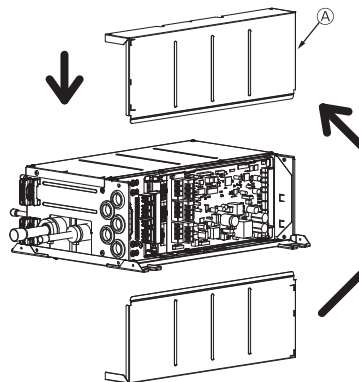

⑧ Fasten the screws in each part.

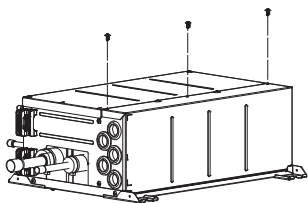

Fig. 4-5

4. Dimensions and required servicing space of Branch Box

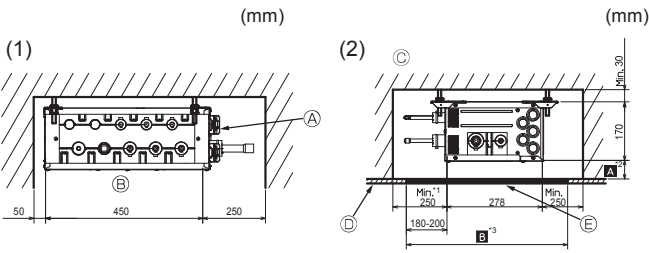

Fig. 4-6

Fig. 4-7

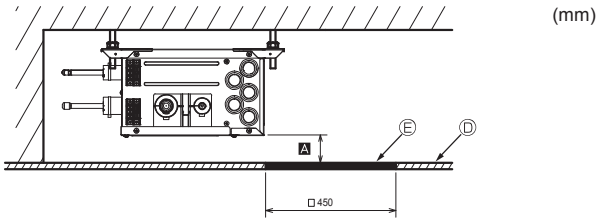

Fig. 4-8

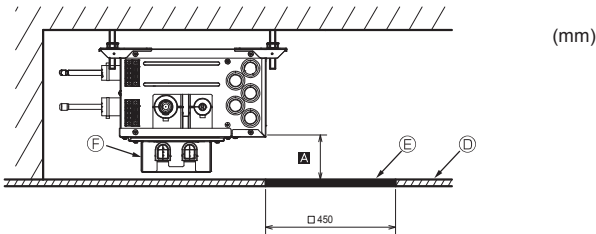

Fig. 4-9

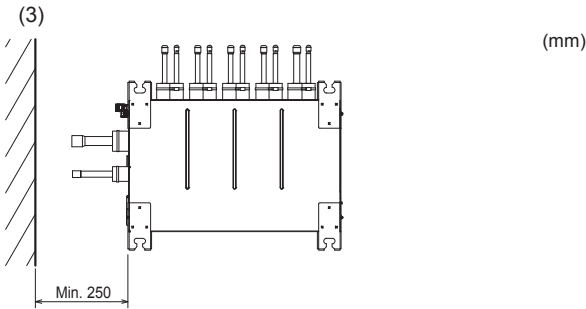

Fig. 4-10

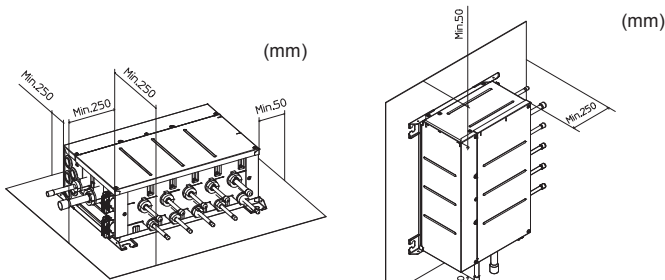

Fig. 4-11

Fig. 4-12

4.3. Space required for installation and servicing

I. The space when installing with the suspension bolts.

- (1) Front View (Fig. 4-6)
 - Ⓐ Branch box
 - Ⓑ On the side of piping
- (2) Side View (Fig. 4-7, Fig. 4-8, Fig. 4-9)
 - Ⓒ For indoor installations
 - Ⓓ Ceiling board
 - Ⓔ Maintenance hole
 - Ⓕ Reactor Box (Optional parts)

*1: Minimum 350 mm is required for 90° bends in refrigerant piping.

*2: **A** is "Min. 200 mm" <recommendation>.

In the case of less than 200 mm (for example **A** is 100 mm), the exchange work of Branch box from a maintenance hole becomes difficult (Only exchange work of a PCB, linear expansion valve coils and sensors are possible). To install the optional Reactor Box, set **A** to Min. 270 mm <recommendation> (Fig. 4-9).

*3: **B** is "□ 600 mm" <recommendation>.

In the case of "□ 450 mm", prepare a maintenance hole at a PCB side (as it is shown in Fig. 4-8, Fig. 4-9), and "Min. 300 mm" is needed as distance **A**. In the case of less than 300 mm (for example **A** is 100 mm), the exchange work of Branch box, linear expansion valve coils and sensors from a maintenance hole becomes difficult (Only exchange work of a PCB is possible).

- (3) Top View (Fig. 4-10)

II. The space when installing on the floor. (Fig. 4-11)

III. The space when installing on a wall. (Fig. 4-12)

⚠ Warning:

The installation direction is limited when installing on a wall. (Fig. 4-13)

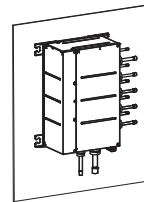

Correct installation direction

When installing the unit on the wall, install the piping connected to the outdoor unit facing down. Other ways are not acceptable.



When installing on the wall, do not place the device in the manner shown below. Doing so may cause electric shock or fire.

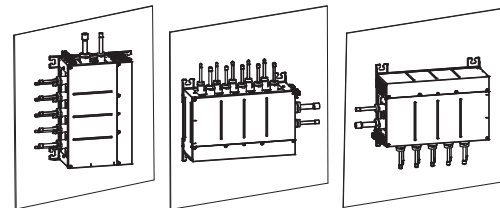

Fig. 4-13

5. Refrigerant piping

* Always follow the specifications written in the installation manual of the outdoor unit. Exceeding these requirements may cause reduced performance of the equipment, and malfunctions.

6. Mounting the Branch Box

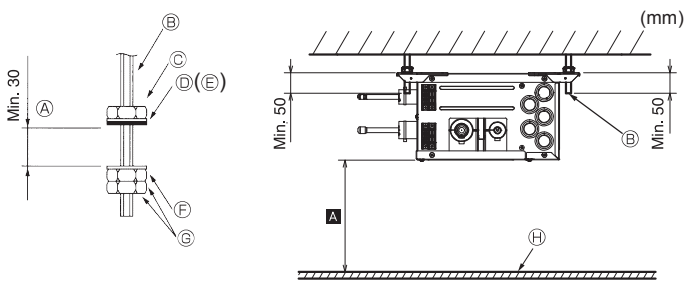

Fig. 6-1

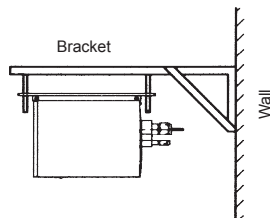

Fig. 6-2

* Purchase an appropriate bracket locally if the unit is to be mounted on a wall.

- (1) Install the suspension bolts (procure locally) at the specified pitch (Fig. 4-2, 4-3).
- (2) Fit the washers (①, ②) and nuts (procure locally) to the suspension bolts. (Fig. 6-1)
- (3) Hang the unit on the suspension bolts.
- (4) Fully tighten the nuts (check ceiling height).
- (5) Use a level to adjust the branch box to the horizontal.

- Ⓐ When unit is hung and nuts tightened
- Ⓑ Suspension bolt
- Ⓒ Nut (procure locally)
- Ⓓ Washer (with cushion) ①
- Ⓔ Ensure that cushion faces downwards
- Ⓕ Washer (without cushion) ②
- Ⓖ Nut (procure locally)
- Ⓗ Ceiling board

7. Installing refrigerant piping

⚠ CAUTION

- Use refrigerant piping made of phosphorus deoxidized copper and copper alloy seamless pipes and tubes. In addition, be sure that the inner and outer surfaces of the pipes are clean and free of hazardous sulphur, oxides, dust/dirt, shaving particles, oils, moisture, or any other contaminant.
 - R410A is a high-pressure refrigerant and can cause the existing piping to burst.
- Store the piping to be used during installation indoors and keep both ends of the piping sealed until just before brazing. (Store elbows and other joints in a plastic bag.)
 - If dust, dirt, or water enters the refrigerant cycle, deterioration of the oil and compressor failure may result.

NOTE

- After pipe connection, be sure to check that there is no gas leakage, using a leak detector or soap-and-water solution.
- Before brazing the refrigerant piping, always wrap the piping on the main body, and the thermal insulation piping, with wet towels to prevent heat shrinkage and burning the thermal insulation tubing. Take care to ensure that the flame does not come into contact with the main body itself. (Fig.7-1)
- Do not use leak-detection additives.

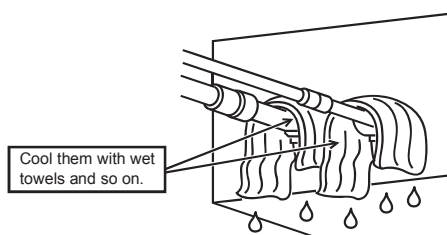
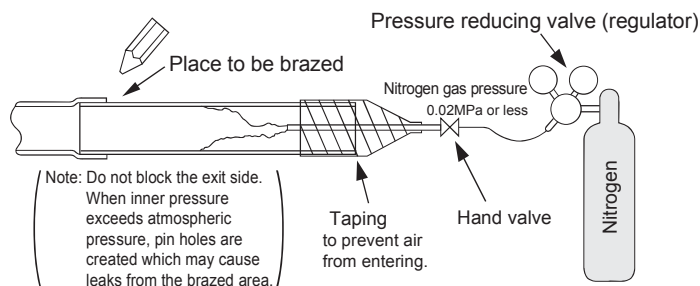

Fig. 7-1



Be sure to use the pressure reducing valve.
Be sure to use nitrogen gas. (Do not use oxygen, carbon dioxide, or CFC gas.)

Fig. 7-2

- ▶ Connect the liquid and gas pipes of each indoor unit to the same end connection numbers as indicated on the indoor unit flare connection section of each Branch Box.
- ▶ When connecting indoor units, make sure to connect refrigerant pipes and connection wires to the appropriate connection ports marked with matching alphabets. (Ex. A, B, C, D, E) If connected to wrong end connection numbers, it doesn't work normally.

Note:

- ▶ Be sure to mark all the local refrigerant piping (liquid pipes, gas pipes, etc.) for each indoor unit designating clearly which room it belongs in. (Ex. A, B, C, D, E)
- ▶ List indoor unit model names in the name plate of Branch Box (for identification purposes).

- Conduct sufficient anti-condensation and insulation work to prevent water dripping from the refrigerant piping. (liquid pipe/gas pipe)
- Increase insulation depending on the environment where the refrigerant piping is installed, or condensation may occur on the surface of the insulation material. (Insulation material Heat-resistant temperature: 120 °C, Thickness: 15 mm or more)
 - * When the refrigerant piping is used in locations subject to high temperature and humidity such as in the attic, further addition of insulation may be required.
- Insulate the liquid and gas pipes of the branch box by attaching the heat-resistant polyethylene foam tightly around them. (Fig. 7-6) Otherwise, a burn during pipe connection work or water leakage due to condensation on pipes may result.
- ▶ When using commercially available refrigerant piping, ensure that both liquid and gas piping are wrapped with commercially available thermal insulation materials (insulation materials at least 12 mm thick and able to withstand temperatures in excess of 100 °C).
- ▶ Refer to the installation manual of the outdoor unit when creating a vacuum and opening or closing valves.

When connecting piping by brazing, be sure to use nitrogen-substituted non-oxidation brazing. Do not use commercial antioxidants which may cause pipe corrosion and degradation of refrigerant oil. Use non-oxidation brazing, or the compressor may be damaged. (Fig. 7-2)

- *1 Properly ventilate during brazing work. Before brazing in a closed room or a small room, make sure that there is no refrigerant leakage. Buildup of leaked refrigerant poses toxicity and combustion issues.
- *2 Keep ignition sources, such as gas burning appliances and electrical heater, etc., away from where the air conditioner is being installed or repaired.
- *3 Use good quality brazing filler metal.
- *4 When using flux, pay attention to the following points.
 - After brazing, completely remove flux. If the chlorine contained in the flux remaining in the pipe, the refrigerator oil is degraded and it becomes contamination.

7. Installing refrigerant piping

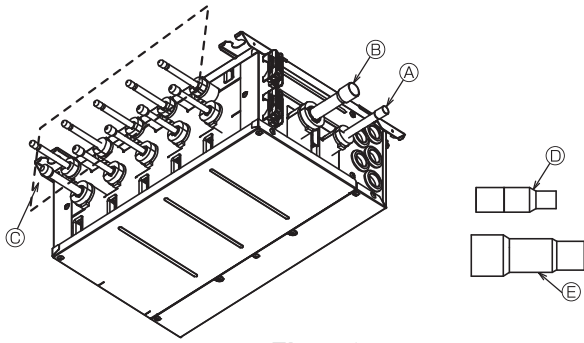

Fig. 7-3

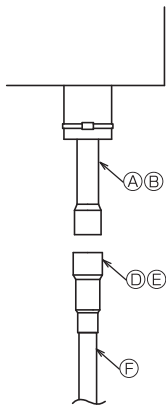

Fig. 7-4



Fig. 7-5

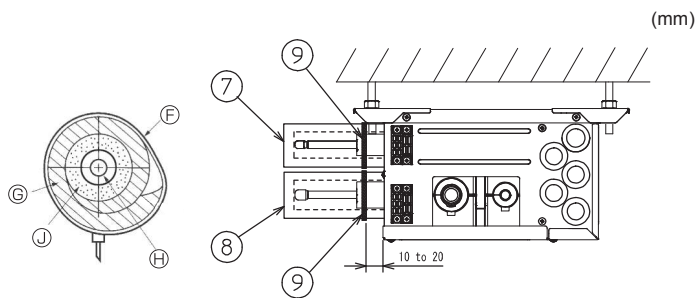

Fig. 7-6

Fig. 7-7

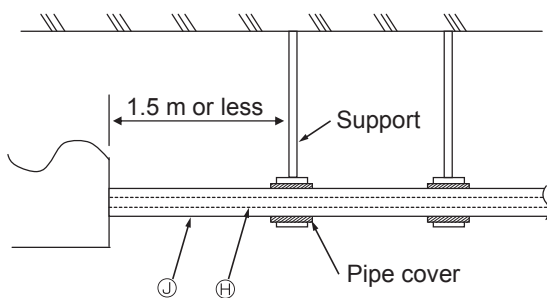

Fig. 7-8

- (1) Remove the rubber caps from the outdoor unit side connection pipe (A) and (B).
- (2) After brazing (C) to the liquid pipe side and (E) to the gas pipe of the refrigerant pipe connected to the outdoor unit side, braze the branch box to connect. (Fig. 7-3, 7-4)
When installing the unit on a wall, do not braze the joint pipe to the unit first. Doing so will make filling the gap with filler metal difficult, resulting in a refrigerant leak when brazing the refrigerant pipe.
- (3) When brazing in succession, conduct the next brazing once the welded section has cooled down to room temperature. Failure to do so will cause the insulation material or the unit to melt causing condensation.
Remove the copper cap of (C), and braze the refrigerant piping connected to the indoor unit. (Fig. 7-3)
- (4) When the indoor unit is not connected, do not remove the copper cap of (C), or refrigerant leaks.
- (5) After cutting piping or unsoldering brazed piping or copper caps, ensure to clean away any foreign object (i.e., brazing material, cutting chips) so as to prevent entry of any foreign object into the piping. Failure to do so may cause malfunction of the outdoor compressor, and the like. (Fig. 7-5)
 - Ⓐ To outdoor unit connection pipe. (Liquid)
 - Ⓑ To outdoor unit connection pipe. (Gas)
 - Ⓒ To indoor unit connection pipes
 - Ⓓ Joint pipe (Liquid) (3.1 Accessories No. ⑩)
 - Ⓔ Joint pipe (Gas) (3.1 Accessories No. ⑪)

Note:

Optional joint pipes are to some indoor units.
Please refer to the installation manual of outdoor unit and indoor unit for details.

- (6) Press the pipe covers (3) and (5) on the liquid piping against the unit and wrap to hold in place. (Fig. 7-6)
- (7) Press the pipe covers (4) and (6) on the gas piping against the unit and wrap to hold in place. (Fig. 7-6)
- (8) Apply the supplied bands (9) at a position 10 - 20 mm from each end of the pipe covers (3, 4, 5, 6). (Fig. 7-7)
- (9) If the indoor unit is not connected, fit the supplied pipe covers (with caps, (7) and (8)) to the branch box refrigerant piping connections against the unit to prevent condensation dripping from the pipes. (Fig. 7-7)
- (10) Clamp the pipe covers ((7) & (8)) in place with the supplied bands (9). (Fig. 7-7)
 - Ⓕ Band (3.1 Accessories No. ⑨)
 - Ⓖ Pipe covers (3.1 Accessories No. ③, ④, ⑤, ⑥)
 - Ⓗ Refrigerant piping
 - Ⓖ Thermal insulation for refrigerant piping

► Refrigerant charge:

Refer to the installation manual of the outdoor unit.
Use only R410A refrigerant (use of other refrigerants may cause troubles).

⚠ Caution:

To avoid excessive strain on the branch box, support the piping with one or more support(s) 1.5 m or less from the branch box.

Refer to Fig. 7-8 as an example.

- Ⓗ Refrigerant piping
- Ⓖ Thermal insulation for refrigerant piping

8. Electrical work

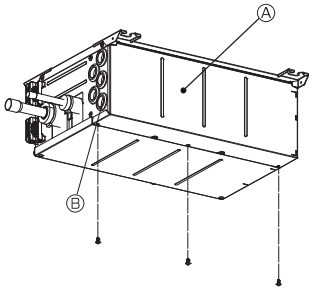

Fig. 8-1

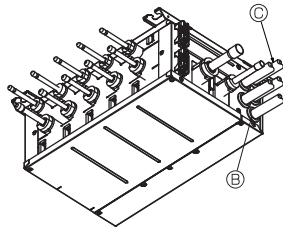

Fig. 8-2

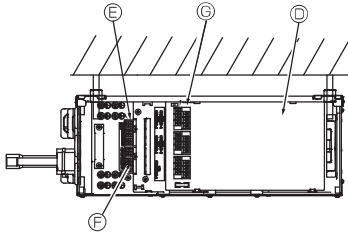

Fig. 8-3

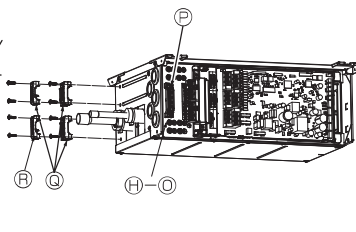

Fig. 8-4

- (A) Electric cover
- (B) Rubber bush
- (C) Wiring
- (D) Controller board
- (E) Terminal block: TB5
- (F) Terminal block: TB2B
- (G) Terminal block: TB3A-TB3E
<To indoor unit>
- (H) Earth Terminal <power supply>

- (J) Earth Terminal <For TB3A>
- (K) Earth Terminal <For TB3B>
- (L) Earth Terminal <For TB3D>
- (M) Earth Terminal <For TB3C>
- (N) Earth Terminal <For TB3E>
- (O) Earth Terminal <To other branch box>
- (P) Cable clamp <For TB2B>
- (Q) Cable clamp <For TB3A-TB3E>
- (R) Cable clamp <For TB5>

► Cautions for electrical work.

⚠ Warning:

- Always use dedicated circuits with breakers, and at the rated voltage. Power supply circuits with insufficient capacity, and bad workmanship during installation, may result in electric shock or fire.

⚠ Caution:

- Be sure to establish an earth. Do not earth the unit to a utility pipe, arrester, or telephone earth.
- Incomplete earth may cause electrical shock. A high surge current from lightning or other sources may cause damage to the air conditioner.
- Use the specified electrical wiring and ensure that it is connected properly, and that it is not under tension.
- Failure to follow these requirements may result in broken wiring, heating, or fire.
- Before turning Branch Box on, be sure to set the switches.
- When power is separately supplied to the branch box and the outdoor unit, turn on the branch box first.
- Wiring connecting branch box and outdoor unit, and branch box and indoor units, functions as both power supply and signal cable. Connect this wiring in accordance with the terminal block numbers to ensure correct polarity.

► Connect refrigerant pipes and electrical wiring to the appropriate ports marked with matching alphabets (Ex. A, B, C, D, E) on this unit. Incorrect wiring will interfere with the correct operation of the unit.

- Always fix each ground wire separately with a ground screw.
- To prevent that wiring installed in the ceiling is chewed by rats etc., it should be installed in wiring conduit.
 - (1) Remove the electric cover. (Fig. 8-1)
 - (2) Pass the wiring into the branch box each wire in place with a wiring clamp.
 - (3) Firmly connect each wire to the appropriate terminal block. (Fig. 8-8)
 - (4) Set dip sw. (Refer to 8.3)
 - (5) Replace the electric cover.

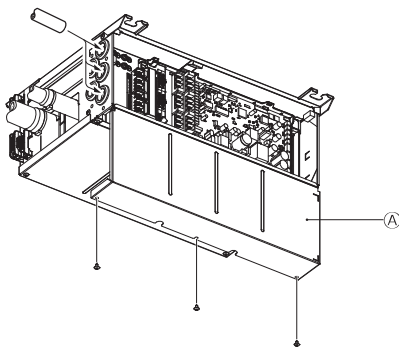

Fig. 8-5

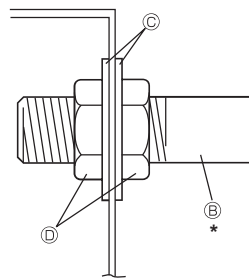

Fig. 8-6

8.1. When using wiring conduit (Fig. 8-5, 8-6, 8-7)

Replace the electric cover when the wiring conduit has been fixed in place.

- (A) Electric cover
- (B) Wiring conduit
- (C) Washer
- (D) Nut

Wiring conduit of up to 1" OD may be used.

- (1) When using 1" OD wiring conduit, remove the bush and fix to the branch box. Remove the electric cover while fixing to the branch box.
- (2) When using wiring conduit of 3/4" OD or smaller, notch the bush and insert the wiring conduit approximately 100 mm into the branch box.
 - * Replace the electric cover when the wiring conduit has been fixed in place.

⚠ Caution:

To avoid excessive strain on the branch box, support the wiring conduit (B) with one or more support(s) 1.5 m or less from the branch box. Refer to Fig. 8-7 as an example.

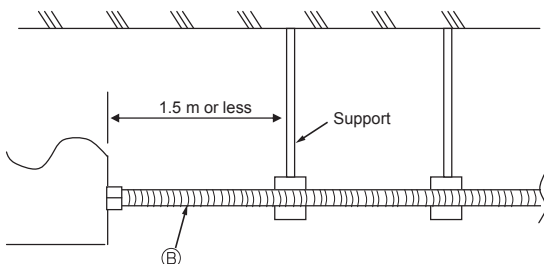
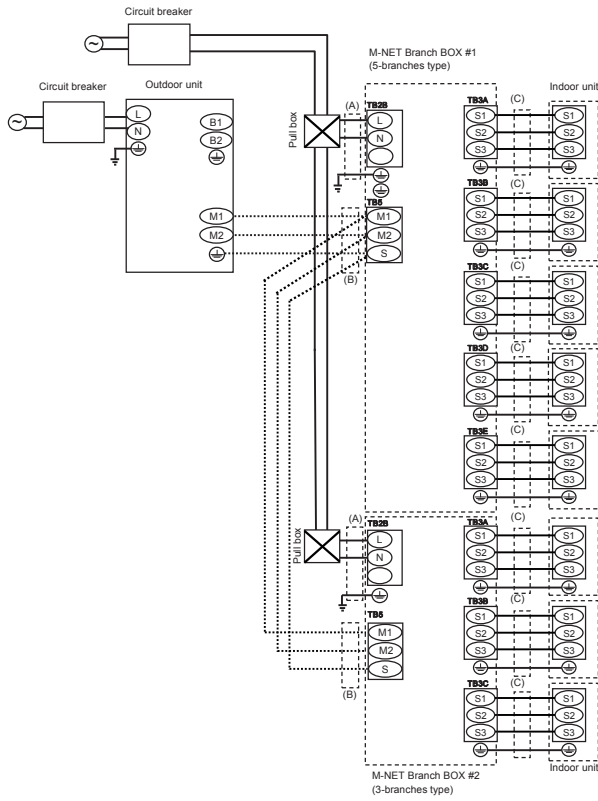

Fig. 8-7

8. Electrical work

■ Supply power (1-phase) separately to branch box and outdoor unit



■ Supply power (1-phase) separately to branch box and outdoor unit

When installing the unit in a regular house. (Refer to Note ③)

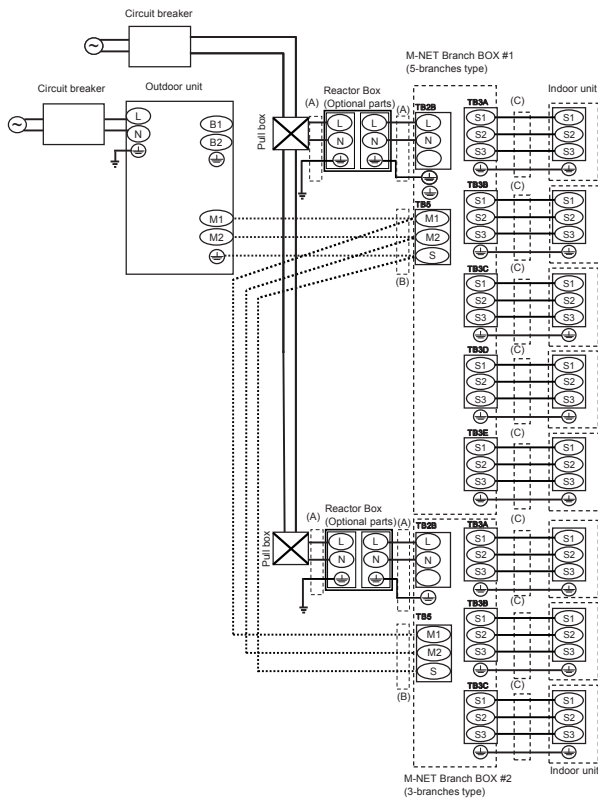

8.2. External wiring procedure (Fig. 8-8)

■ Power supply (1-phase) from Outdoor unit

* Refer to installation manual of the outdoor unit

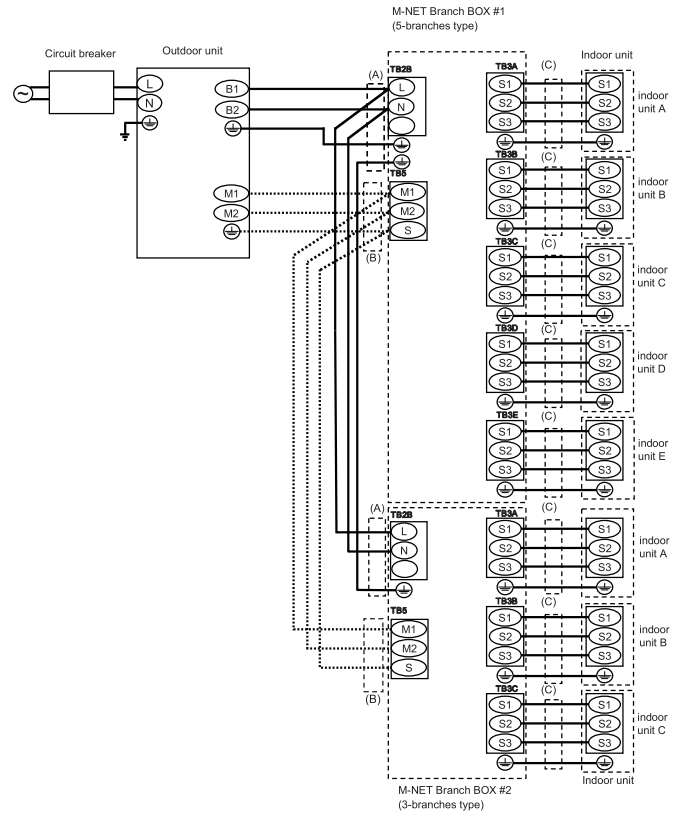

■ Power supply (3-phase) from Outdoor unit

When installing the unit in a regular house. (Refer to Note ⑧)

* Refer to installation manual of the outdoor unit

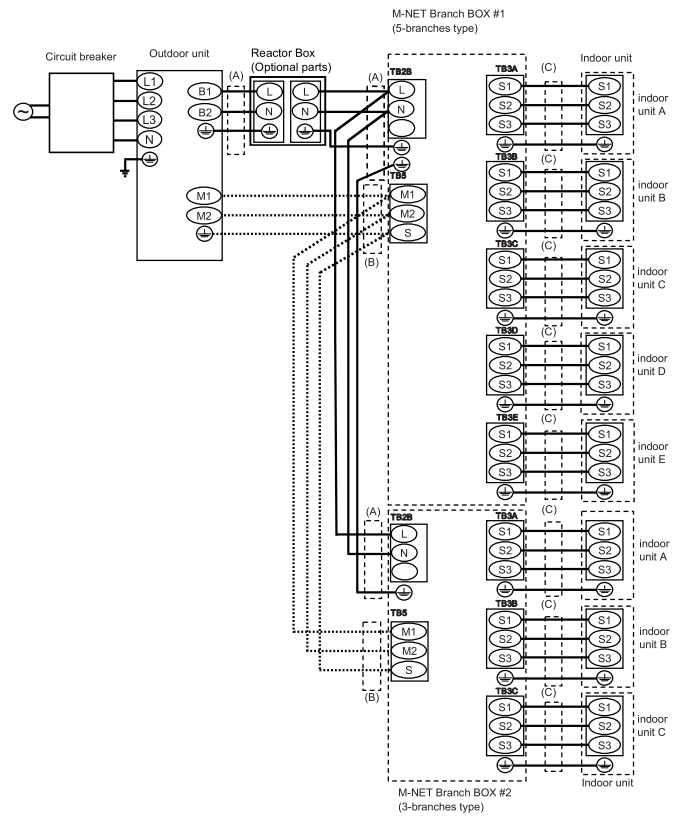

Fig. 8-8

8. Electrical work

Note:

- ① Connect wiring in accordance with the terminal block names to ensure correct polarity.
- ② As for lines (C), S1 and S2 are for connecting the power source. And S2 and S3 are for signals. S2 is common cable for the power source and signal.

Wire diameter		
(A) Main power line/ Earth line	(B) M-NET cable shielding wire CVVS, CPEVS or MVVS	(C) Signal line/ Earth line
3-core 2.5 mm ²	2-core 1.25 mm ² Less than 200 m	4-core 1.5 mm ² Less than 25 m

- ③ When using twisted wire for the wiring, the use of round terminal is required.
- ④ Wiring size must comply with the applicable local and national code.
- ⑤ Power supply cords and indoor unit/branch box/outdoor unit connecting cords shall not be lighter than polychloroprene sheathed flexible cord. (Design 60245 IEC 57)
- ⑥ Install an earth line longer than power cables.
- ⑦ Do not bundle the M-NET cable with the connection cable and power supply cable.
It may cause erroneous operation.
- ⑧ Reactor BOX (Optional parts)
When the product is used for a purpose other than as professional equipment, the Reactor BOX may be necessary.

Outdoor unit	Branch box power supply method	
	Power supply from outdoor unit	Separate power supply
1-phase power supply	Unnecessary	Necessary
3-phase power supply	Necessary	Necessary

⑨ Recommended Connection Method

When connecting one indoor unit to the branch box, connect it to TB3A. When connecting 2 indoor units, connect them to TB3A and TB3B. When connecting 3 indoor units, connect them to TB3A, TB3B, and TB3C. Connect indoor units in the order of A→B→C→D→E.

■ Power supply wiring (Supply power separately to branch box and outdoor unit)

- Install an earth line longer than other cables.
- Power supply cords of appliance shall not be lighter than design 60245 IEC 57 or 60227 IEC 57, 60245 IEC 53 or 60227 IEC 53.
- A switch with at least 3 mm, 1/8 inch contact separation in each pole shall be provided by the air conditioner installation.

[Fig. 8-10]

- Ⓐ Ground-fault interrupter
- Ⓑ Local switch/Wiring breaker
- Ⓒ Branch Box
- Ⓓ Pull box
- Ⓔ M-NET CONTROL INDOOR UNIT

⚠ Warning:

Never splice the cable, otherwise it may result in a smoke, a fire or communication failure.

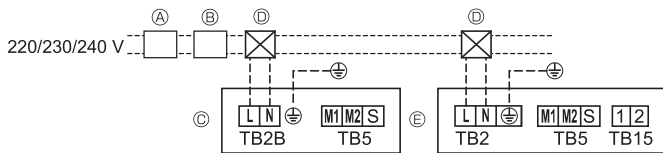

Fig. 8-10

8. Electrical work

Total operating current of the indoor unit	Minimum wire thickness (mm ²)			Capacity (A)	Fuse (A)	Breaker for wiring (NFB)	Ground-fault interrupter *1
	Main cable	Branch	Ground				
F0 = 16A or less *2	1.5	1.5	1.5	16	16	20	20A current sensitivity *3
F0 = 25A or less *2	2.5	2.5	2.5	25	25	30	30A current sensitivity *3
F0 = 32A or less *2	4.0	4.0	4.0	32	32	40	40A current sensitivity *3

Apply to IEC61000-3-3 about max. permissive system impedance.

*1 The Ground-fault interrupter should support inverter circuit.

The Ground-fault interrupter should combine using of local switch or wiring breaker.

*2 Take the larger of F1 or F2 as the value for F0.

F1 = Total operating maximum current of the indoor units × 1.2

F2 = (V1/C)

Connect to Branch box (PAC-MK•BC(B))

Indoor unit	V1	V2
Type 1 SEZ-KD•VAQ(L), SEZ-M•DA(L), PCA-RP•KAQ, PCA-M•KA, SLZ-KF•VA, SLZ-M•FA, PLA-RP•BA, PLA-RP•EA	19.8	2.4
Type 2 PEAD-RP•JAQ(L), PEAD-M•JA(L)	26.9	
Type 3 MLZ-KA•VA	9.9	
Type 4 MSZ-FH•VE, MSZ-GF•VE, MSZ-SF•VE, MSZ-EF•VE, MSZ-SF•VA, MSZ-AP•VF	6.8	
Type 5 MFZ-KJ•VE2, MSZ-LN•VG, MSZ-AP•VG, MLZ-KP•VF	7.4	
Type 6 Branch box (PAC-MK•BC(B))	5.1	
Type 7 ecodan C generation*5	5.1	

*This value may increase due to a locally connected actuator.

C : Multiple of tripping current at tripping time 0.01s

Please pick up "C" from the tripping characteristic of the breaker.

Condition: Branch Box × 2 + SEZ-M•DA × 5, C=8 (refer to right sample chart)

$$F2 = 5.1 \times 2/8 + 19.8 \times 5/8 = 13.65$$

*3 Current sensitivity is calculated using the following formula.

$$G1 = V2 + V3 \times (\text{Wire length[km]})$$

G1	Current sensitivity
30 or less	30 mA 0.1sec or less
100 or less	100 mA 0.1sec or less

Wire thickness (mm ²)	V3
1.5	48
2.5	56
4.0	66

When connecting 3 units of the PLA-RP series respectively to the Branch Box 1.5mm² using 20m of wiring and connecting the Branch Box and PEFY-VMA to a single breaker using wiring totaling 100m in length;

$$G1 = 2.4 \times 3 + 3 + 1.6 + 48 \times 0.02 \times 3 + 56 \times 0.1 = 20.28$$

→ 30 mA Current sensitivity

*5 When the ecodan is connected, the master controller (G-50A etc.) cannot be connected.

⚠ Warning:

In case of A-control wiring, there is high voltage potential on the S3 terminal caused by electrical circuit design that has no electrical insulation between power line and communication signal line. Therefore, please turn off the main power supply when servicing. And do not touch the S1, S2, S3 terminals when the power is energized. If isolator should be used between outdoor unit and branch box and branch box, please use 2-pole or 3-pole type, as shown in the following figures.

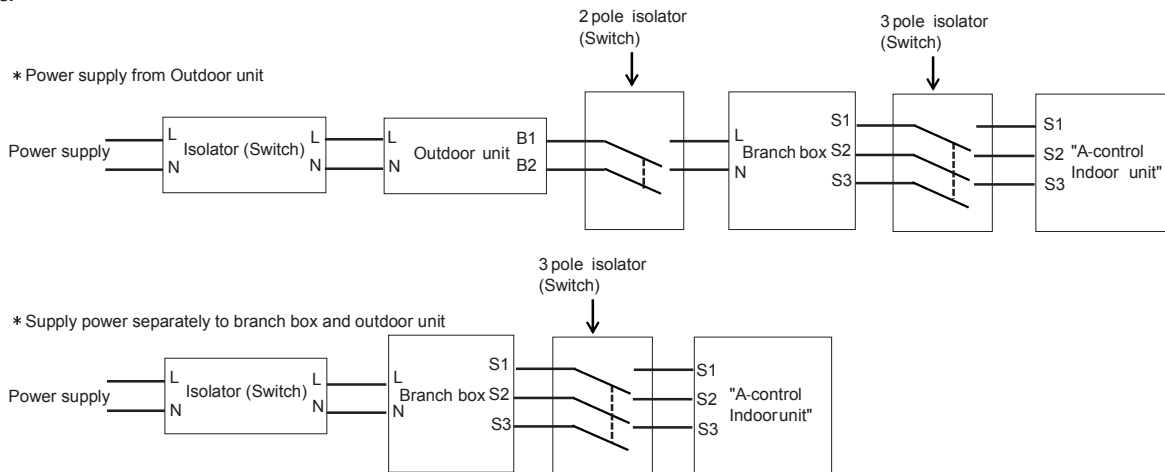

▶ As for types not listed in the left-side table for indoor units connected to the branch box, refer to the attached sheet, "Criteria for selecting breaker when branch box is fed from separate power source".
 ▶ As to coefficient (V1, V2) of the LEV kit connected indoor unit and City Multi indoor unit, refer to the outdoor unit INSTALLATION MANUAL.

Sample chart

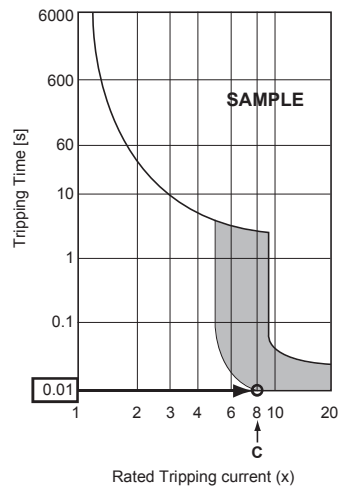

⚠ Caution:

After using the isolator, be sure to turn off and on the main power supply to reset the system. Otherwise, the outdoor unit may not be able to detect the branch box(es) or indoor units.

8. Electrical work

8.3. Switch setting

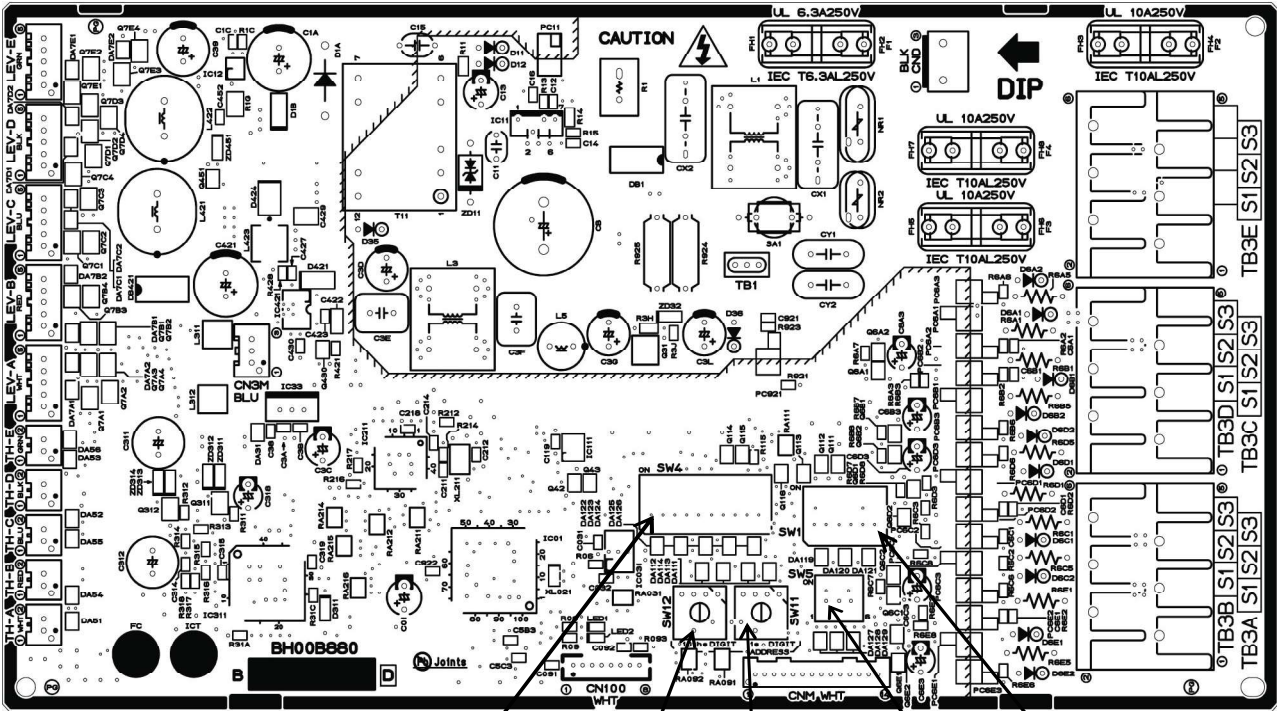

SW4 Model selection
 SW12 Address setting TENS DIGIT
 SW11 Address setting ONES DIGIT
 SW5 Indoor unit setting
 SW1 Indoor unit connections

Dip switch setting (Effective only before turning on the power)

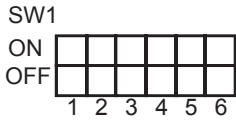

(Example)
 • When the indoor units are connected to Indoor unit A and C, turn SW1-1 and SW1-3 to on.

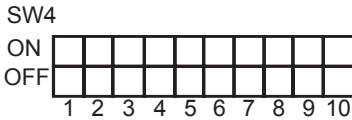

(Example)
 • When the indoor unit is cooling only system, turn SW4-5 to on.

SW1	Indoor unit	SW1	
		OFF	ON
1	Indoor unit A	Not connected	Connected
2	Indoor unit B	Not connected	Connected
3	Indoor unit C	Not connected	Connected
4	Indoor unit D	Not connected	Connected
5	Indoor unit E	Not connected	Connected
6	Not used		

SW4-5	SW4-5	
	OFF	ON
	Cooling & Heating system	Cooling only system

When connecting the Cylinder or the Hydro box unit to the unit in the house, connect the air to air system indoor unit connected in the bedrooms to A to C ports and make the following switch settings below.

Also, after referring to the outdoor unit installation manual, add refrigerant. Port A to C are available for setting for up to a maximum of 3 rooms.

SW5		SW5	
		OFF	ON
4	Port A	Other	Bedroom
5	Port B	Other	Bedroom
6	Port C	Other	Bedroom

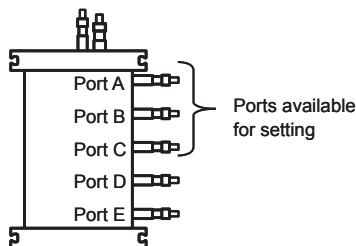

Address switch (Effective only before turning on the power)

Actual indoor unit address varies in different systems. Refer to the installation manual for the outdoor unit for details on how to make the address setting. Each address is set with a combination of the settings for the tens digit and ones digit.

- (Example)
- When setting the address to "3", set the ones digit to 3, and the tens digit to 0.
 - When setting the address to "25", set the ones digit to 5, and the tens digit to 2.

- (Example)
- When setting the address of the branch BOX to "3", an address is assigned to each indoor unit starting with Unit A as shown below no matter if each indoor unit is connected. (SW1-1~5 ON)

Indoor Unit A	Address 3
Indoor Unit B	Address 4
Indoor Unit C	Address 5
Indoor Unit D	Address 6
Indoor Unit E	Address 7
 - When the address is set to "25" and also 3 indoor units (Unit A, Unit C, and Unit E) are connected. (SW1-1, 1-3, 1-5 ON)

Indoor Unit A	Address 25
Indoor Unit C	Address 26
Indoor Unit E	Address 27

9. Test run

- Refer to the "Test run" section of the installation manual of the indoor units and outdoor unit.
- When the branch box and outdoor power source are separate, turn on the power of the branch box first, and then turn on the outdoor unit power.

• After power is supplied or after an operation stop for a while, a small clicking noise may be heard from the inside of the branch box. The electronic expansion valve is opening and closing. The unit is not faulty.

- Be sure to perform the test run in cooling mode for each indoor unit. Make sure each indoor unit operates properly following the installation manual attached to the unit.
- If you perform the test run for all indoor units at once, you cannot detect any erroneous connection, if any, of the refrigerant pipes and the indoor/outdoor unit connecting wires.
- To check for improper wiring, perform the test run for each indoor unit individually.

⚠ Caution:

- Use the remote controller to operate the indoor unit.
- The following symptoms are not malfunctions.

Symptom	Cause	Indoor unit LED display *
Indoor unit does not operate even if set to cooling (heating) operation	The cooling (heating) operation cannot be operated when the heating (cooling) operation of another indoor unit is operating.	Stand by (For Multi System)
Indoor unit fan stops during heating operation	The fan stops during defrosting operation.	-
	Fan stops when the refrigerant collecting mode ** is activated.	Stand by (For Multi System)

* See the operation manual of indoor units for details.

** This mode is activated for approximately 1 minute to help avoid an insufficient supply of refrigerant during heating operation when refrigerant is stored in an indoor unit that has been turned off or thermo-off.

This product is designed and intended for use in the residential,
commercial and light-industrial environment.

Importer:

Mitsubishi Electric Europe B.V.
Capronilaan 46, 1119 NS, Schiphol Rijk, The Netherlands

French Branch
25, Boulevard des Bouvets, 92741 Nanterre Cedex, France

German Branch
Mitsubishi-Electric-Platz 1, 40882 Ratingen, Germany

Belgian Branch
Autobaan 2, 8210 Loppem, Belgium

Irish Branch
Westgate Business Park, Ballymount, Dublin 24, Ireland

Italian Branch
Centro Direzionale Colleoni, Palazzo Sirio-Ingresso 1 Viale Colleoni 7, 20864 Agrate Brianza
(MB), Italy

Norwegian Branch
Gneisveien 2D, 1914 Ytre Enebakk, Norway

Portuguese Branch
Avda. do Forte, 10, 2799-514, Carnaxide, Lisbon, Portugal

Spanish Branch
Carretera de Rubi 76-80 - Apdo. 420 08173 Sant Cugat del Valles (Barcelona), Spain

Scandinavian Branch
Hammarbacken 14, P.O. Box 750 SE-19127, Sollentuna, Sweden

UK Branch
Travellers Lane, Hatfield, Herts., AL10 8XB, England, U.K.

Polish Branch
Krakowska 50, PL-32-083 Balice, Poland

MITSUBISHI ELECTRIC TURKEY ELEKTRİK ÜRÜNLERİ A.Ş.
Şerifali Mah. Kale Sok. No: 41 34775 Ümraniye, İstanbul / Turkey

MITSUBISHI ELECTRIC (RUSSIA) LLC
115114, Russia, Moscow, Letnikovskaya street 2, bld.1, 5th

Please be sure to put the contact address/telephone number on
this manual before handing it to the customer.