

MODEL	LGH-50RVS-E	SIGN	
-------	-------------	------	--

Heat exchange system	Heat recovery ventilating system				
Heat exchanger material	Plastic counter flow heat exchanger				
Cladding	Galvanized steel sheet				
Motor	EC motor				
Filter	Non-woven fabrics filter (ISO 16890 Coarse 50%)				
Surrounding air condition	0°C to 40 °C, 80% or less Dew point of the ambient air shall be lower than 11°C in winter(e.g. 20°C 56%RH or less)				
Return air condition	The absolute humidity of RA shall be lower than 0.0139kg/kg(DA) in winter and the relative humidity of RA shall be lower than 90%RH through the year. *Examples of the absolute humidity 0.0139kg/kg(DA) are 20.7°C 90%RH, 25°C 70%, 30°C 50% etc.				
Supply fan operation under low outdoor temperature	0°C to -5°C : Intermittent operation 10 min OFF, 30 min ON -5°C or less : Sensing operation 55 min OFF, 5 min ON * Exhaust fan speed changes to 100%(Factory setting) during supply fan stoping at 0 to 5°C, or all condition at less than -5°C.				
Weight	55kg (67kg with maximum drain water)				
Electrical power supply	220-240V/50Hz, 220V/60Hz				
Fan speed	100%	75%	50%	25%	Test condition ISO 16494 Temp. exchange efficiency is winter condition
Input power [W]	190	110	60	25	
Air volume [m <sup>3</sup> /h]	500	375	250	125	
[L/s]	139	104	69	35	
Specific fan power [W/(L/s)]	1.37	1.06	0.86	0.72	
External static pressure [Pa]	150	84	38	9	
Temp. exchange efficiency [%]	87.0	89.0	91.0	93.0	
Noise [dB]	33.0	27.0	22.0	18.0	
Exhaust air transfer ratio [%]	5				
Insulation resistance	10MΩ or more				
Dielectric strength	AC 1000V 1 minute				
Maximum current [A]	2.20				
Inrush current [A]	6.1A @10ms, 3.6A@100ms				

#### ■ Characteristic curve

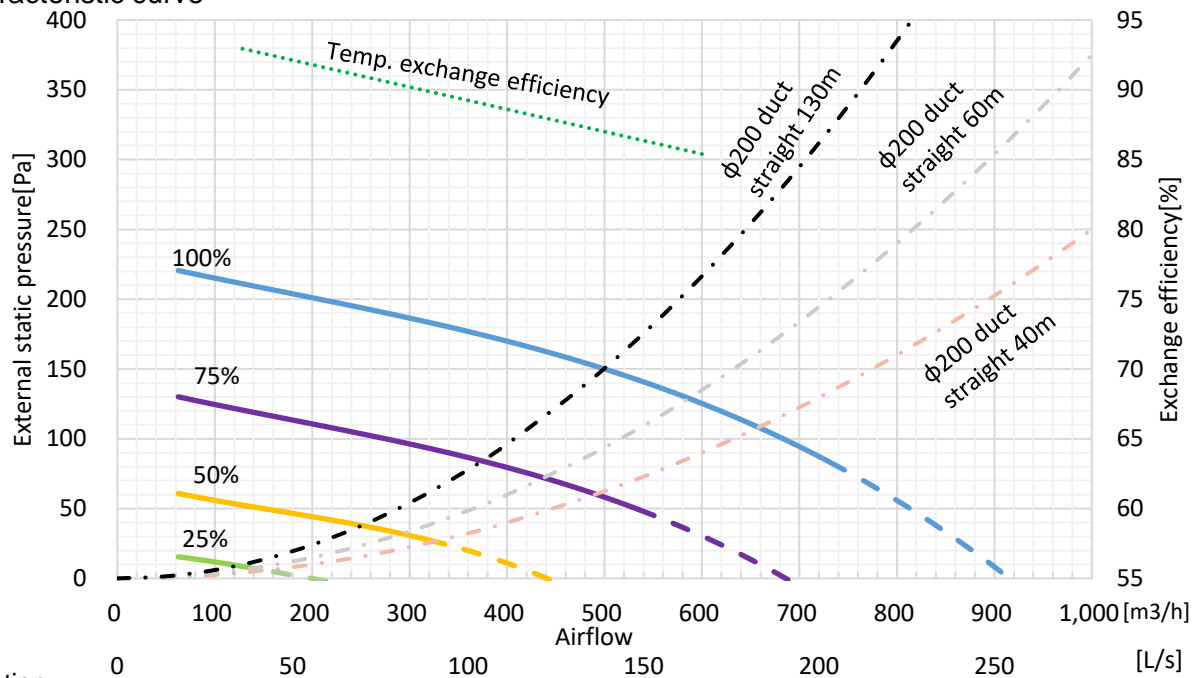

#### ■ Attention

- The input power, the efficiency and the noise are based on the rating air volume, and 230V/50Hz. Temperature exchange efficiency (%) is measured at indoor DB 20°C/ WB 15°C and outdoor DB 5°C/ WB 3°C.  
When the indoor humidity is low and condensation in the heat exchanger does not occur, the exchange efficiency may be decreased in winter.  
Noise (A-weighted sound pressure level) is measured 1.5m off from the center of the unit in an anechoic chamber.
- Heat recovery ventilation mode starts automatically while detecting OA temperature lower than 8°C, even Bypass mode is selected. Remote controller continues to display "Bypass ventilation" in this case.
- Booster fan is not allowed to install after fans of the unit. It may cause preventing the drain water from coming out.
- It is prohibited to use the unit where salt, sulphur or hot spring steam damage is expected.
- Do not use with acid, alkalis, organic solvent, oil mist, paint, or harmful gas as pesticide, corrosive gas, etc.
- In cold area or strong wind area, outdoor air may enter the unit because of the pressure difference or external wind even when the unit stops. It is recommended to install an electrically damper to block outdoor air in such cases.
- Avoid to install air inlets and outlets where insects are likely to gather like a place near interior or exterior lights. They could be intrude inside the unit and affect choking of the drain pipe. In that case, select hoods or louvers which have repellent net.
- When using this unit in the area where the outdoor temperature often becomes lower than 0°C, a pre-heater is recommended to install in OA duct. In that case, the pre-heater shall be possible to control heater outlet air temperature.

※Specifications may be subject to change without notice.

SPECIFICATIONS	DATE	TYPE	CEILING RECESSED LOSSNAY
	13-May-21	MODEL	LGH-50RVS-E
MITSUBISHI ELECTRIC CORPORATION	NUMBER	N20HHGU0015C	1/4

## ■ Outline drawings

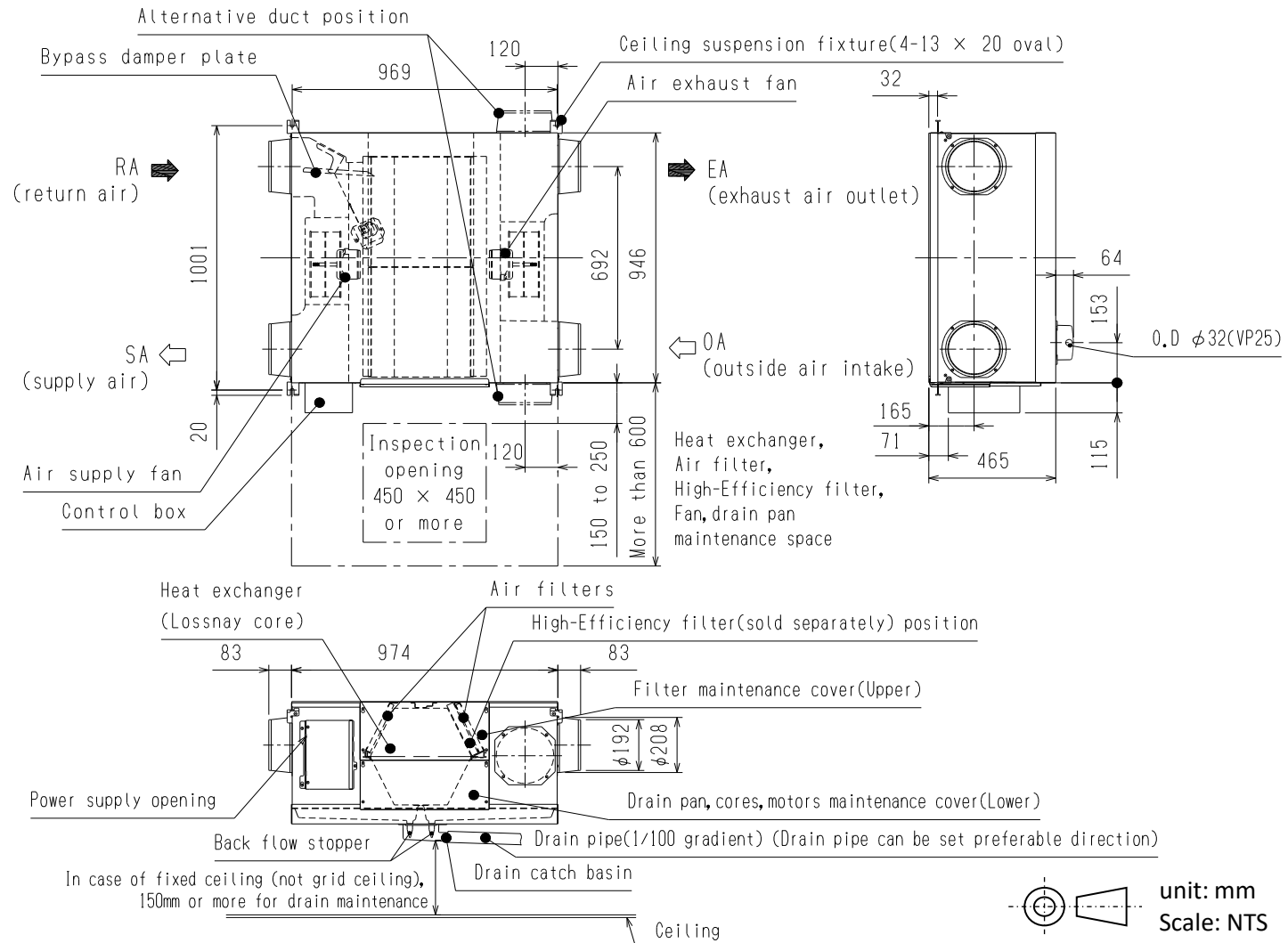

## ■ Caution for installation

1. Do not modify the unit as it may cause malfunction.
2. Do not install the unit upside-down nor vertically.
3. Install the anchor bolts to ensure the product's weight or earthquake load. Correctly rated wire/chain may also be used.
4. The unit shall be installed level within  $\pm 0.5^\circ$ .
5. Leave sufficient space and make inspection opening (450 × 450mm or more) for the filter and Lossnay core removal side for maintenance purpose.
6. Take care in locating air inlet to prevent intake of dirty air or disgusting smell from exhaust gas of factory, air from rubbish disposal, etc.
7. Take care as below to prevent from condensation.
  - ① The outdoor side (OA, EA) and SA ducts must be heat-insulated in order to prevent from condensation.
  - ② If the ambient temperature around the Lossnay unit is close to outdoor condition, it is recommended to insulate RA duct and additional insulation foam on the unit surface.
  - ③ Condensation may occur on the Lossnay unit surface, because of the outdoor air condition or humidity condition above the ceiling. A supplemental insulation foam for the unit surface is necessary in that case.
8. Do not install this product in a place where it is exposed to ultraviolet light. UV may be damage covering insulation.
9. Outdoor air may enter the Lossnay owing to the pressure difference between indoor and outdoor or external winds even when the product is not operated. It is recommended to install an electrically operated damper to block the outdoor air.
10. Install louvers or covers for OA inlet & EA outlet to prevent rainwater from entering the Lossnay unit. The outdoor side duct (OA and EA) shall decline by 1/30 or more downward to outdoor.
11. Make sure to install with all accessorized parts for drain work and decline 1/100 for drain pipe.
12. Do not put positive pressure on the drain pipe from drain backstream side. It may cause drain over flow from the unit.
13. When RA duct is not installed and RA is suctioned directly from the unit surrounding space, a repellent net is necessary for the RA inlet to prevent large size dust or something from intruding into the unit.
14. Take precautions when using the product in a quiet location.
15. If an external drain pump is necessary, it shall be installed with the responsibility of the installer. Error detection and indicator function is mandatory.
16. When RA comes from a space which have strong odor like aromatic or detergent in wash room or shower room, the SA location is recommended not to arrange directly over the human living space.
17. When replacing to Lossnay RVS series from other models, take care of control box location, maintenance space and the duct connecting place.

※Specifications may be subject to change without notice.

OUTLINE DRAWINGS	DATE	TYPE	CEILING RECESSED LOSSNAY	
	13-May-21	MODEL	LGH-50RVS-E	
MITSUBISHI ELECTRIC CORPORATION		NUMBER	N20HHGU0015C	2/4

## ■ Wiring diagrams

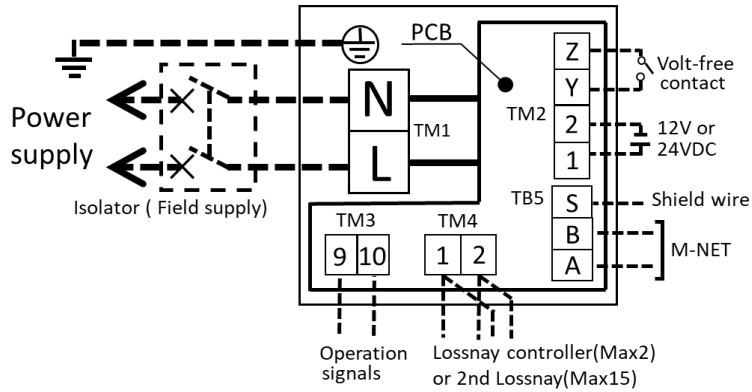

Dotted lines are field work

## ■ Caution for electrical work

1. Make sure to ground and install an all-pole electrical leakage isolator securely.
2. Select proper circuit breaker according to the electrical current on the 1st page.
3. Perform electrical installation to meet appropriate regulations and standards.
4. Always use double insulated cable for the transmission cables.
5. Wiring work must be performed by qualified professionals.
6. All supply circuits must be disconnected before obtaining access to the terminal devices.
7. When only Lossnay units are used in M-NET, power supply unit is required to connect to centralised controller. Number of power supply units or the transmission boosters should correspond with the connected Lossnay units.
8. In the case of installing a duct heater interlocked with Lossnay, be sure to observe the following:
  - ① Choose a OA pre-heater which can control the heater outlet air temperature even both the air flow is maximum and minimum, and set Lossnay inlet air temperature from 2 to 13°C. Otherwise it could fall the supply fan into intermittent operation.
  - ② Select a duct heater in compliance with local and national laws, ordinances, and standards. Select a duct heater that is tested by a certification body.
  - ③ Always select a heater that is equipped with a non-self-resetting safety device.
  - ④ Do not directly supply power from the Lossnay unit to the duct heater. Doing so could cause fire.
  - ⑤ Install a circuit breaker for the duct heater in compliance with all applicable laws, ordinances, and standards.
  - ⑥ Install the duct heater separated from the product by a distance of 2 m or more.
  - ⑦ Ensure that the duct heater and Lossnay are wired and that the Lossnay function settings have been configured, and then always check operation by trial operation.
9. With this product, the wiring installation method will vary according to the design of the system. Refer to the installation manual for more detail.

※Specifications may be subject to change without notice.

WIRING DIAGRAMS	DATE	TYPE MODEL	CEILING RECESSED LOSSNAY	
	13-May-21		LGH-50RVS-E	
MITSUBISHI ELECTRIC CORPORATION		NUMBER	N20HHGU0015C	3/4

■ Maintenance and lifetime

Remove all dust and dirt on air filters and Lossnay cores at regular intervals to prevent from a deterioration in the Lossnay function.

Refer to each model's operation instructions for the suggested maintenance period and methods.

General indication of lifetime of the main parts is as below. Time below is unrelated to guaranteed period for service. And parts exchange period varies with usage condition.

- Lossnay cores : Around 10 years with maintenance at stated periods.
- Air Filters : Around 5 years with maintenance at stated periods
- High efficiency filters : 3,000 hours
- Motor : 30,000 hours
- Circuit board : 25,000 hours
- Backflow stopper : Around 10 years with maintenance at stated periods.

■ Other notes

Refer to each model's operation instructions for the suggested maintenance period and methods. General indication of lifetime of the main parts is as below. Time below is unrelated to guaranteed period for service. And parts exchange period varies with usage condition.

Measurements by pitot tube on site could be as much 20% difference from JIS test room conditions. If the measuring point is close to sources of turbulence like bends, contractions and dampers etc., it is difficult to measure air volume correctly. A straight duct length more than 10D (D=duct diameter) from the source of turbulence is recommended for correct measurement. On-site measurement should therefore be measured in accordance with BSRIA guideline (Commissioning Air Systems. Application procedures for buildings AG3/89.3(2001)).

※Specifications may be subject to change without notice.

<b>SAFTY NOTES</b>	DATE	TYPE MODEL	CEILING RECESSED LOSSNAY	
	13-May-21		LGH-50RVS-E	
<b>MITSUBISHI ELECTRIC CORPORATION</b>		NUMBER	<b>N20HHGU0015C</b>	4/4