

PARTS CATALOG

**<Outdoor unit>
[Model Name]**

PUMY-P112VKM5
 PUMY-P125VKM5
 PUMY-P140VKM5
 PUMY-P112VKM5-ET
 PUMY-P125VKM5-ET
 PUMY-P140VKM5-ET
 PUMY-P112VKM5-ER
 PUMY-P125VKM5-ER
 PUMY-P140VKM5-ER

[Service Ref.]

PUMY-P112VKM5
PUMY-P125VKM5
PUMY-P140VKM5
PUMY-P112VKM5-ET
PUMY-P125VKM5-ET
PUMY-P140VKM5-ET
PUMY-P112VKM5-ER
PUMY-P125VKM5-ER
PUMY-P140VKM5-ER

Salt proof model

PUMY-P112VKM5-BS
 PUMY-P125VKM5-BS
 PUMY-P140VKM5-BS
 PUMY-P112VKM5-ETBS
 PUMY-P125VKM5-ETBS
 PUMY-P140VKM5-ETBS
 PUMY-P112VKM5-ERBS
 PUMY-P125VKM5-ERBS
 PUMY-P140VKM5-ERBS

PUMY-P112VKM5-BS
PUMY-P125VKM5-BS
PUMY-P140VKM5-BS
PUMY-P112VKM5-ETBS
PUMY-P125VKM5-ETBS
PUMY-P140VKM5-ETBS
PUMY-P112VKM5-ERBS
PUMY-P125VKM5-ERBS
PUMY-P140VKM5-ERBS

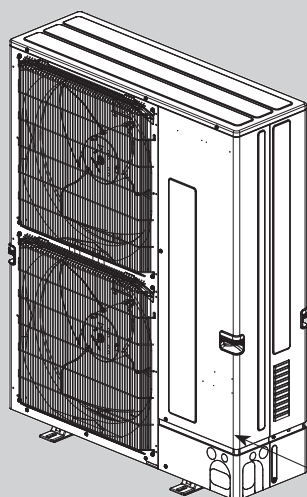

Model name
indication

OUTDOOR UNIT

CONTENTS

- | | |
|----------------------------|---|
| 1. SERVICE PARTS LIST..... | 2 |
| 2. OPTIONAL PARTS..... | 6 |

SERVICE MANUAL (OCH740/OCH741)

CITY MULTI

1-1. STRUCTURAL PARTS

PUMY-P112VKM5
 PUMY-P112VKM5-ET
 PUMY-P112VKM5-ER
 PUMY-P112VKM5-BS
 PUMY-P112VKM5-ETBS
 PUMY-P112VKM5-ERBS

PUMY-P125VKM5
 PUMY-P125VKM5-ET
 PUMY-P125VKM5-ER
 PUMY-P125VKM5-BS
 PUMY-P125VKM5-ETBS
 PUMY-P125VKM5-ERBS

PUMY-P140VKM5
 PUMY-P140VKM5-ET
 PUMY-P140VKM5-ER
 PUMY-P140VKM5-BS
 PUMY-P140VKM5-ETBS
 PUMY-P140VKM5-ERBS

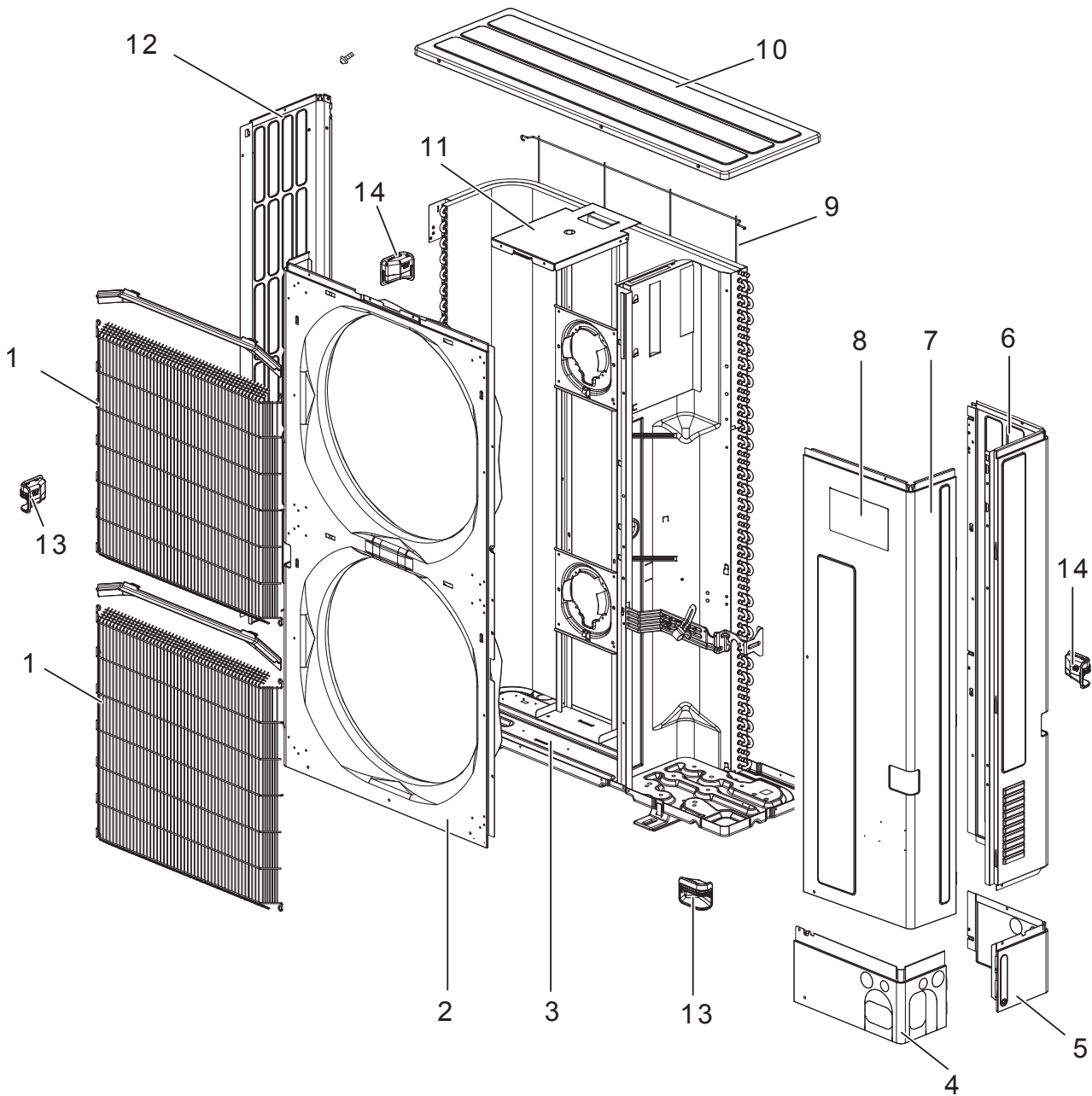

1. The part quantity below indicates the required number of pieces per unit.
2. The circled No. indicates that the part is not shown in the figure.

No.	Parts No.	Parts Name	PUMY-P112VKM5																Remarks			
			PUMY-P112VKM5	PUMY-P125VKM5	PUMY-P140VKM5	PUMY-P112VKM5-ET	PUMY-P125VKM5-ET	PUMY-P140VKM5-ET	PUMY-P112VKM5-ER	PUMY-P125VKM5-ER	PUMY-P140VKM5-ER	PUMY-P112VKM5-BS	PUMY-P125VKM5-BS	PUMY-P140VKM5-BS	PUMY-P112VKM5-ETBS	PUMY-P125VKM5-ETBS	PUMY-P140VKM5-ETBS	PUMY-P112VKM5-ERBS		PUMY-P125VKM5-ERBS	PUMY-P140VKM5-ERBS	
1	T 7 W E 1 3 6 9 1	WIRE GRILLE	2	2	2	2	2	2	2	2	2	2	2	2	2	2	2	2	2	2	2	
2	R 0 1 E 2 3 6 6 8	FRONT PANEL	1	1	1	1	1	1	1	1	1	1	1	1	1	1	1	1	1	1	1	
3	R 0 1 E 5 3 6 8 6	BASE ASSY	1	1	1	1	1	1	1	1	1	1	1	1	1	1	1	1	1	1	1	
4	R 0 1 E 4 1 6 5 8	COVER PANEL(FRONT)	1	1	1	1	1	1	1	1	1	1	1	1	1	1	1	1	1	1	1	
5	R 0 1 E 4 2 6 5 8	COVER PANEL(REAR)	1	1	1	1	1	1	1	1	1	1	1	1	1	1	1	1	1	1	1	
6	R 0 1 E 7 4 6 6 1	SIDE PANEL(R)	1	1	1	1	1	1	1	1	1	1	1	1	1	1	1	1	1	1	1	
7	T 7 W E 2 5 6 6 8	SERVICE PANEL	1	1	1	1	1	1	1	1	1	1	1	1	1	1	1	1	1	1	1	
8	T 7 W A 1 1 0 0 5	BRAND LABEL (ME_CM)	1	1	1	1	1	1	1	1	1	1	1	1	1	1	1	1	1	1	1	CITY MULTI
9	R 0 1 E 1 0 6 9 8	REAR GUARD	1	1	1	1	1	1	1	1	1	1	1	1	1	1	1	1	1	1	1	
10	R 0 1 E 3 6 6 4 1	TOP PANEL	1	1	1	1	1	1	1	1	1	1	1	1	1	1	1	1	1	1	1	
11	R 0 1 E 5 9 1 3 0	MOTOR SUPPORT	1	1	1	1	1	1	1	1	1	1	1	1	1	1	1	1	1	1	1	
12	R 0 1 E 3 0 6 6 2	SIDE PANEL(L)	1	1	1	1	1	1	1	1	1	1	1	1	1	1	1	1	1	1	1	
13	R 0 1 E 0 5 6 5 5	HANDLE(FRONT)	2	2	2	2	2	2	2	2	2	2	2	2	2	2	2	2	2	2	2	
14	R 0 1 E 0 6 6 5 5	HANDLE(REAR)	2	2	2	2	2	2	2	2	2	2	2	2	2	2	2	2	2	2	2	

1-2. FUNCTIONAL PARTS

PUMY-P112VKM5
 PUMY-P112VKM5-ET
 PUMY-P112VKM5-ER
 PUMY-P112VKM5-BS
 PUMY-P112VKM5-ETBS
 PUMY-P112VKM5-ERBS

PUMY-P125VKM5
 PUMY-P125VKM5-ET
 PUMY-P125VKM5-ER
 PUMY-P125VKM5-BS
 PUMY-P125VKM5-ETBS
 PUMY-P125VKM5-ERBS

PUMY-P140VKM5
 PUMY-P140VKM5-ET
 PUMY-P140VKM5-ER
 PUMY-P140VKM5-BS
 PUMY-P140VKM5-ETBS
 PUMY-P140VKM5-ERBS

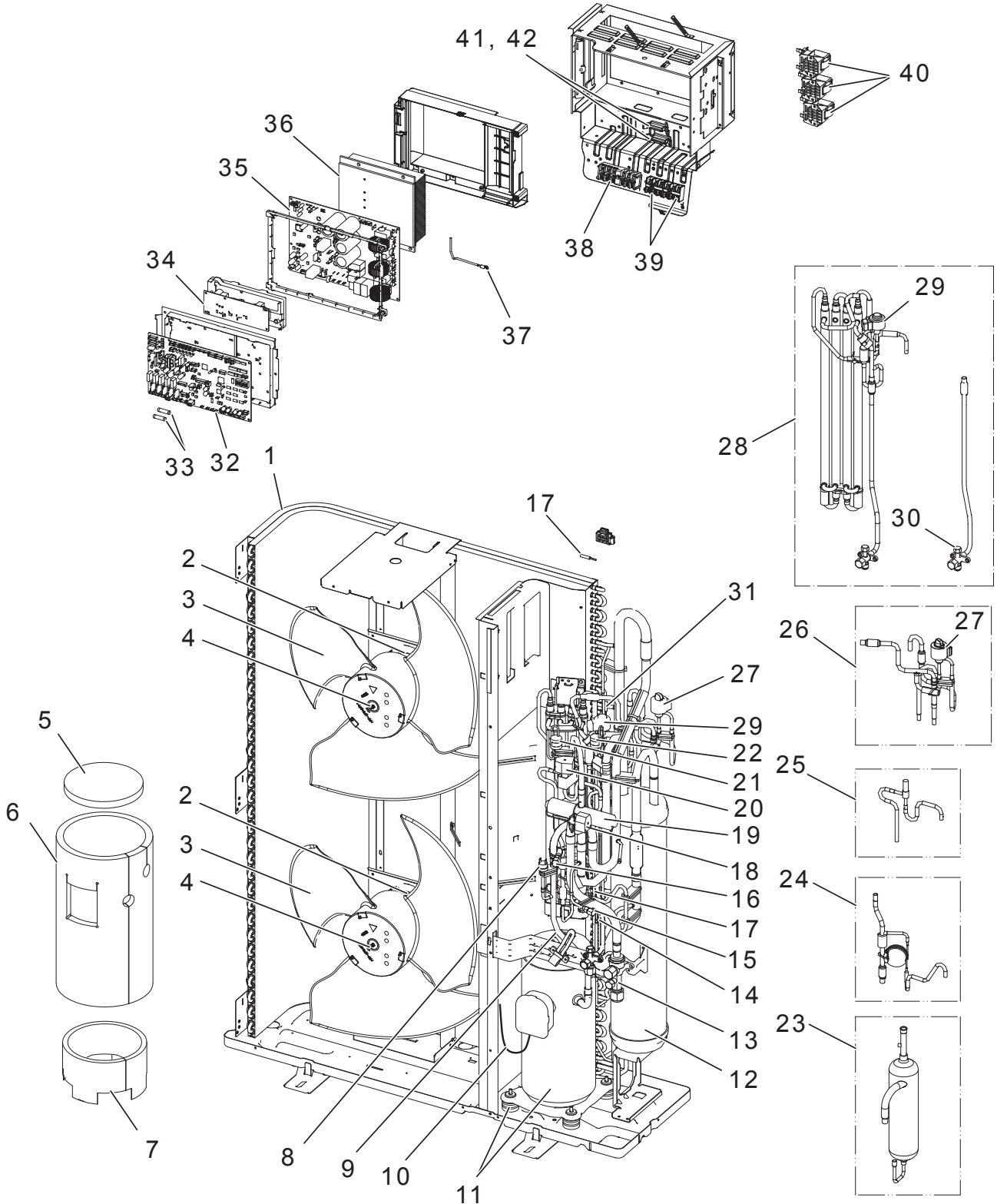

1. The part quantity below indicates the required number of pieces per unit.
2. The circled No. indicates that the part is not shown in the figure.

No.	Parts No.	Parts Name	PUMY-P112VKM5	PUMY-P125VKM5	PUMY-P140VKM5	PUMY-P112VKM5-ET	PUMY-P125VKM5-ET	PUMY-P140VKM5-ET	PUMY-P112VKM5-ER	PUMY-P125VKM5-ER	PUMY-P140VKM5-ER	PUMY-P112VKM5-BS	PUMY-P125VKM5-BS	PUMY-P140VKM5-BS	PUMY-P112VKM5-ETBS	PUMY-P125VKM5-ETBS	PUMY-P140VKM5-ETBS	PUMY-P112VKM5-ERBS	PUMY-P125VKM5-ERBS	PUMY-P140VKM5-ERBS	Wiring Diagram Symbol	Remarks	
			1	1	1	1	1	1	1	1	1	1	1	1	1	1	1	1	1	1			1
1	R01 R65 408	HEAT EXCHANGER	1	1	1	1	1	1	1	1	1	1	1	1	1	1	1	1	1	1			
2	R01 E83 221	FAN MOTOR	2	2	2	2	2	2	2	2	2	2	2	2	2	2	2	2	2	2	2	MF1, MF2	
3	R01 E16 115	PROPELLER FAN/D550	2	2	2	2	2	2	2	2	2	2	2	2	2	2	2	2	2	2	2		
4	R01 E16 097	CAP NUT (MEC) M6	2	2	2	2	2	2	2	2	2	2	2	2	2	2	2	2	2	2	2		
5	R01 A57 602	COMP FELT (TOP)	1	1	1	1	1	1	1	1	1	1	1	1	1	1	1	1	1	1	1		
6	T7W B07 602	COMP FELT-B/ANB33	1	1	1				1	1	1	1	1	1				1	1	1			
6	T7W B08 602	COMP FELT-B/ANB33(ET				1	1	1							1	1	1						
7	R01 U00 602	COMP FELT-U/ANB	1	1	1	1	1	1	1	1	1	1	1	1	1	1	1	1	1	1	1		
8	R01 H06 208	HIGH PRESSURE SWITCH	1	1	1	1	1	1	1	1	1	1	1	1	1	1	1	1	1	1	1	63H	
9	R01 E36 201	THERMISTOR (SHELL)	1	1	1	1	1	1	1	1	1	1	1	1	1	1	1	1	1	1	1	TH4 (Compressor)	
10	R01 C11 510	LEAD ASSY COMP	1	1	1	1	1	1	1	1	1	1	1	1	1	1	1	1	1	1	1		
11	T97 477 077	COMPRESSOR	1	1	1	1	1	1	1	1	1	1	1	1	1	1	1	1	1	1	1	MC	ANB33FNHMT Includes RUBBER MOUNT
12	R01 E84 440	ACCUMULATOR	1	1	1	1	1	1	1	1	1	1	1	1	1	1	1	1	1	1	1		
13	R01 E16 411	BALL VALVE 5/8F	1	1	1	1	1	1	1	1	1	1	1	1	1	1	1	1	1	1	1		Includes STRAINER
14	R01 M30 202	THERMISTOR	1	1	1	1	1	1	1	1	1	1	1	1	1	1	1	1	1	1	1	TH2	
15	R01 E29 413	CHARGE PLUG/LB54	1	1	1	1	1	1	1	1	1	1	1	1	1	1	1	1	1	1	1		
16	R01 E24 413	CHARGE PLUG/LB90	1	1	1	1	1	1	1	1	1	1	1	1	1	1	1	1	1	1	1		
17	R01 M31 202	THERMISTOR W	1	1	1	1	1	1	1	1	1	1	1	1	1	1	1	1	1	1	1	TH6 (Suction Pipe) TH7 (Ambient)	Combined Port
18	T7W E89 242	SOLENOID COIL (21S4)	1	1	1	1	1	1	1	1	1	1	1	1	1	1	1	1	1	1	1	21S4	Includes SCREW
19	R01 E39 403	4WAY VALVE	1	1	1	1	1	1	1	1	1	1	1	1	1	1	1	1	1	1	1	21S4	
20	T7W H02 242	SOLENOID COIL (SV)	1	1	1	1	1	1	1	1	1	1	1	1	1	1	1	1	1	1	1	SV1	Includes SCREW
21	R01 E14 208	H.P.SENSOR	1	1	1	1	1	1	1	1	1	1	1	1	1	1	1	1	1	1	1	63HS	
22	R01 E04 209	LOW PRESSURE SENSOR	1	1	1	1	1	1	1	1	1	1	1	1	1	1	1	1	1	1	1	63LS	
23	R01 E16 490	OIL SEPARATOR	1	1	1	1	1	1	1	1	1	1	1	1	1	1	1	1	1	1	1		
24	R01 E02 426	CT ASSY	1	1	1	1	1	1	1	1	1	1	1	1	1	1	1	1	1	1	1		
25	R01 E19 428	SV1 ASSY	1	1	1	1	1	1	1	1	1	1	1	1	1	1	1	1	1	1	1	SV1	
26	R01 R27 401	LEV ASSY-A	1	1	1	1	1	1	1	1	1	1	1	1	1	1	1	1	1	1	1	LEV-A	Includes RESTRICTOR VALVE
27	R01 HR1 242	COIL (LEV)/XAP-5P WH	1	1	1	1	1	1	1	1	1	1	1	1	1	1	1	1	1	1	1	LEV-A	
28	R01 R28 401	LEV ASSY HIC	1	1	1	1	1	1	1	1	1	1	1	1	1	1	1	1	1	1	1	LEV-B	
29	R01 H58 242	COIL (LEV)/XAP-5P RED	1	1	1	1	1	1	1	1	1	1	1	1	1	1	1	1	1	1	1	LEV-B	
30	R01 E36 410	STOP VALVE ASSY-3/8F	1	1	1	1	1	1	1	1	1	1	1	1	1	1	1	1	1	1	1		
31	R01 H87 202	THERMISTOR	1	1	1	1	1	1	1	1	1	1	1	1	1	1	1	1	1	1	1	TH3	
32	R01 M04 350	CONTROLLER BOARD	1	1	1	1	1	1	1	1	1	1	1	1	1	1	1	1	1	1	1	MULTI.B.	
33	R01 E14 239	FUSE 6.3A 250V	2	2	2	2	2	2	2	2	2	2	2	2	2	2	2	2	2	2	2	F1, F2	
34	R01 E07 311	M-NET POWER BOARD	1	1	1	1	1	1	1	1	1	1	1	1	1	1	1	1	1	1	1	M-NET P.B.	
35	R01 M05 353	POWER BOARD	1	1	1	1	1	1	1	1	1	1	1	1	1	1	1	1	1	1	1	P.B.	
36	R01 A22 371	HEAT SINK	1	1	1	1	1	1	1	1	1	1	1	1	1	1	1	1	1	1	1		Includes SCREWS
37	R01 M13 202	THERMISTOR(HS)	1	1	1	1	1	1	1	1	1	1	1	1	1	1	1	1	1	1	1	TH8	
38	T7W P03 246	T.B./LNE+B1.B2	1	1	1	1	1	1	1	1	1	1	1	1	1	1	1	1	1	1	1	TB1	
39	R01 E27 246	T.B./M1.M2.S	2	2	2	2	2	2	2	2	2	2	2	2	2	2	2	2	2	2	2	TB3, TB7	
40	R01 E56 259	REACTOR	3	3	3	3	3	3	3	3	3	3	3	3	3	3	3	3	3	3	3	DCL	
41	R01 E20 239	FUSE 20A 250V	2	2	2	2	2	2	2	2	2	2	2	2	2	2	2	2	2	2	2	FUSE1, FUSE2	
42	R01 30L 241	FUSE HOLDER	2	2	2	2	2	2	2	2	2	2	2	2	2	2	2	2	2	2	2		

2-1. FOR OUTDOOR UNIT

Parts name	Parts No.
DRAIN SOCKET	PAC-SG61DS-E
AIR OUTLET GUIDE*1	PAC-SH96SG-E
AIR GUIDE*1	PAC-SH95AG-E
DRAIN PAN	PAC-SH97DP-E
2 BRANCH PIPE (Joint)	CMY-Y62-G-E
4 BRANCH PIPE (Joint)	CMY-Y64-G-E
8 BRANCH PIPE (Joint)	CMY-Y68-G-E
2-BRANCH PIPE (Joint) (In the case of using 2-branch boxes)*2	MSDD-50AR-E (flare)
	MSDD-50BR-E (brazing)
JOINT PIPE (Unit→Extension pipe)	PAC-SG73RJ-E (ø9.52 → ø12.7)
	PAC-SG75RJ-E (ø15.88 → ø19.05)
BASE HEATER	PAC-SJ20BH-E
CONNECTION KIT	PAC-LV11M-J
BRANCH BOX	PAC-MK34BC (Flare)
	PAC-MK54BC (Flare)
INSULATION KIT	PAC-INS01-E
FAN MOTOR (For high outdoor static pressure use)	PAC-SJ71FM-E

*1 Need 2 pieces.

*2 Select a joint according to the connection method.

2-2. FOR BRANCH BOX

Parts name	Parts No.
BRANCH BOX OUTER COVER (for outdoor installation)	PAC-AK350CVR-E
REACTOR BOX	PAC-RB01BC

DIFFERENT-DIAMETER JOINT

Different-diameter joint (optional parts) (Fig.2-1)

Model name	Connected pipes diameter	Diameter A	Diameter B
	mm	mm	mm
PAC-493PI	ø6.35 → ø9.52	ø6.35	ø9.52
MAC-A454JP-E	ø9.52 → ø12.7	ø9.52	ø12.7
PAC-SG76RJ-E	ø9.52 → ø15.88	ø9.52	ø15.88
MAC-A455JP-E	ø12.7 → ø9.52	ø12.7	ø9.52
MAC-A456JP-E	ø12.7 → ø15.88	ø12.7	ø15.88

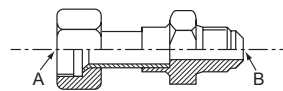

Fig.2-1

Conversion formula

1/4 inch	ø6.35 mm
3/8 inch	ø9.52 mm
1/2 inch	ø12.7 mm
5/8 inch	ø15.88 mm
3/4 inch	ø19.05 mm

MITSUBISHI ELECTRIC CORPORATION

HEAD OFFICE: TOKYO BUILDING, 2-7-3, MARUNOUCHI, CHIYODA-KU, TOKYO 100-8310, JAPAN