

AIR CONDITIONING SYSTEMS

CITY MULTI



DATA BOOK

MODEL

PUMY-P112-140VKM5 (-BS)

PUMY-P112-140YKM4 (-BS)



PUMY-P112-140YKME4 (-BS)

PUMY-P200YKM2 (-BS)

PUMY-P250-300YBM (-BS)



Line-up of Outdoor Units of R410A CITY MULTI

Heat Pump S Series



PUMY-P112VKM5(-BS)
 PUMY-P125VKM5(-BS)
 PUMY-P140VKM5(-BS)

PUMY-P112YKM(E)4(-BS)
 PUMY-P125YKM(E)4(-BS)
 PUMY-P140YKM(E)4(-BS)
 PUMY-P200YKM2(-BS)

4.5, 5, 6, 8HP

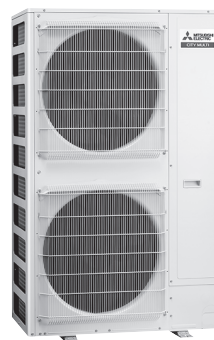

PUMY-P250YBM(-BS)
 PUMY-P300YBM(-BS)

10, 12HP

PUMY-P-VKM5, PUMY-P-YKM(E)4, PUMY-P-YKM2, PUMY-P-YBM

1. SPECIFICATIONS	2
2. EXTERNAL DIMENSIONS	7
3. CENTER OF GRAVITY	11
4. ELECTRICAL WIRING DIAGRAMS	14
5. SOUND LEVELS	19
6. OPERATION TEMPERATURE RANGE	21
7. CAPACITY TABLES	22
7-1. Selection of Cooling/Heating Units	22
7-2. Correction by temperature	28
7-3. Correction by total indoor	34
7-4. Correction by refrigerant piping length	37
7-5. Correction at frost and defrost	38
8. OPTIONAL PARTS	39
8-1. JOINT	39
8-2. HEADER	40
8-3. BRANCH BOX	41
9. ELECTRICAL WORK	42
9-1. General cautions	42
9-2. Power supply for Outdoor unit	43
9-3. Power cable specifications	44
9-4. Power supply examples	50
10.M-NET CONTROL	53
10-1.Transmission cable length limitation	53
10-2.Transmission cable specifications	55
10-3.System configuration restrictions	56
10-4.Address setting	60
11.PIPING DESIGN	70
11-1.R410A Piping material	70
11-2.Piping Design	71
11-3.Refrigerant charging calculation	92
12.OUTDOOR INSTALLATION	93
12-1.Requirement on installation site	93
12-2.Spacing	95
12-3.Piping direction	97

1. SPECIFICATIONS

S-Series

PUMY-P-VKM5, YKM(E)4, YKM2, YBM

Model		PUMY-P112VKM5(-BS)	PUMY-P125VKM5(-BS)	PUMY-P140VKM5(-BS)		
Power source		1-phase 220-230-240 V, 50 Hz; 1-phase 220-230 V, 60 Hz				
Cooling capacity (Nominal)	kW*1	12.5	14.0	15.5		
	kcal/h*1	10,750	12,040	13,330		
	Btu/h*1	42,650	47,768	52,886		
	Power input kW	2.79	3.46	4.52		
	Current input A	12.87-12.32-11.80, 12.87-12.32	15.97-15.27-14.64, 15.97-15.27	20.86-19.95-19.12, 20.86-19.95		
	COP	kW/kW	4.48	4.05	3.43	
Temp. range of cooling	Indoor temp.	W.B. 15 to 24°C				
	Outdoor temp.	D.B. -5 to 52°C *3, *4				
Heating capacity (Nominal)	kW*2	14.0	16.0	18.0		
	kcal/h*2	12,040	13,760	15,480		
	Btu/h*2	47,768	54,592	61,416		
	Power input kW	3.04	3.74	4.47		
	Current input A	14.03-13.42-12.86, 14.03-13.42	17.26-16.51-15.82, 17.26-16.51	20.63-19.73-18.91, 20.63-19.73		
	COP	kW/kW	4.61	4.28	4.03	
Temp. range of heating	Indoor temp.	D.B. 15 to 27°C				
	Outdoor temp.	W.B. -20 to 15°C				
Indoor unit connectable	Total capacity 50 to 130% of outdoor unit capacity					
	Model/Quantity	CITY MULTI	P10 - P140 / 9	P10 - P140 / 10	P10 - P140 / 12	
		Branch box*6	P15 - P100 / 8	P15 - P100 / 8	P15 - P100 / 8	
	Mixed system	Branch box 1unit*6	CITY MULTI	P15 - P140 / 5	P15 - P140 / 5	P15 - P140 / 5
		Branch box 2unit*6	CITY MULTI	P15 - P140 / 3 or 2*5	P15 - P140 / 3	P15 - P140 / 3
	Branch box	P15 - P100 / 7 or 8*5	P15 - P100 / 8	P15 - P100 / 8		
Sound pressure level (SPL) (measured in anechoic room)	dB <A>		49/51	50/52	51/53	
Sound power level (PWL) (measured in anechoic room)	dB <A>		69/71	70/72	71/73	
Refrigerant piping diameter	Liquid pipe	mm (inch) 9.52 (3/8)				
	Gas pipe	mm (inch) 15.88 (5/8)				
FAN *2	Type × Quantity		Propeller Fan x 2			
	Airflow rate	m³/min	110			
		L/s	1,833			
		cfm	3,884			
	Control, Driving mechanism		DC control			
	Motor output	kW 0.074+0.074				
External static press.	0					
Compressor	Type × Quantity		Scroll hermetic compressor x 1			
	Manufacture		Mitsubishi Electric Corporation			
	Starting method		Inverter			
	Capacity control	%	Cooling 26 to 100 Heating 20 to 100	Cooling 24 to 100 Heating 18 to 100	Cooling 21 to 100 Heating 17 to 100	
	Motor output	kW 2.9				
	Case heater	kW 0				
Lubricant	FV50S (2.3liter)					
External finish		Galvanized Steel Sheet Munsell No. 3Y 7.8/1.1				
External dimension H × W × D	mm	1,338×1,050×330(+40)				
	inch	52-11/16 × 41-11/32 × 13(+1-9/16)				
Protection devices	High pressure protection		High pressure Switch			
	Inverter circuit (COMP./FAN)		Overcurrent detection, Overheat detection(Heat sink thermistor)			
	Compressor		Compressor thermistor, Overcurrent detection			
	Fan motor		Overheating, Voltage protection, Overcurrent detection			
Refrigerant	Type × original charge		R410A 4.8 kg			
	Control		Linear expansion valve			
Net weight	kg (lb)		123 (271)			
Heat exchanger		Cross Fin and Copper tube				
HIC circuit (HIC: Heat Inter-Changer)		Double pipe heat exchanger				
Defrosting method		Reversed refrigerant circuit				
Standard attachment	Document		Installation Manual			
	Accessory		Grounded lead wire ×1			
Optional parts		Joint: CMY-Y62-G-E, Header: CMY-Y64/68-G-E, Branch box: PAC-MK34/54BC				
Remarks	*1 Nominal cooling conditions		*2 Nominal heating conditions		Unit converter kcal/h = kW × 860 Btu/h = kW × 3,412 cfm = m³/min × 35.31 lb = kg/0.4536 Above specification data is subject to rounding variation.	
	Indoor : 27°C D.B./19°C W.B. [81°F D.B./66°F W.B.]		20°C D.B. [68°F D.B.]			
	Outdoor : 35°C D.B. [95°F D.B.]		7°C DB/6°C W.B. [45°F D.B./43°F W.B.]			
	Pipe length : 7.5 m [24-9/16 ft]		7.5 m [24-9/16 ft]			
	Level difference : 0 m [0 ft]		0 m [0 ft]			
	*3 10 to 52°C D.B. [50 to 126°F D.B.], when connecting following models: PKFY-P10/15/20/25/32VLM, PFFY-P20/25/32VLEM, PFFY-P20/25/32VLRM(M), PFFY-P20/25/32VKM, PFFY-P20/25/32VCM, PFFY-P25/32/40VMA3; and M series, S series, and P series type indoor unit.					
	*4 -15 to 52°C D.B. [50 to 126°F D.B.], when using an optional air protect guide [PAC-SH95AG-E]. However, this condition does not apply to the indoor unit listed in *3.					
	*5 When connecting 7 indoor units via branch box, connectable CITY MULTI indoor units are 3; connecting 8 indoor units via branch box, connectable CITY MULTI indoor units are 2.					
	*6 At least two indoor unit must be connected when using branch box.					
	Notes : 1. Nominal conditions *1, *2 are subject to ISO 15042. 2. Due to continuing improvement, above specifications may be subject to change without notice.					

1. SPECIFICATIONS

Model		PUMY-P112YKM4(-BS)	PUMY-P125YKM4(-BS)	PUMY-P140YKM4(-BS)	
Power source		3-phase 380-400-415 V, 50 Hz; 3-phase 380 V, 60 Hz			
Cooling capacity (Nominal)	kW *1	12.5	14.0	15.5	
		kcal/h *1	10,750	12,040	13,330
		Btu/h *1	42,650	47,768	52,886
	Power input	kW	2.79	3.46	4.52
	Current input	A	4.99-4.74-4.57, 4.99	5.84-5.55-5.35, 5.84	7.23-6.87-6.62, 7.23
COP	kW/kW	4.48	4.05	3.43	
	Indoor temp.	W.B.	15 to 24°C		
Temp. range of cooling	Outdoor temp.	D.B.	-5 to 52°C *3, *4		
	Heating capacity (Nominal)	kW *2	14.0	16.0	18.0
kcal/h *2			12,040	13,760	15,480
Btu/h *2			47,768	54,592	61,416
Power input		kW	3.04	3.74	4.47
Current input		A	5.43-5.16-4.98, 5.43	6.31-6.00-5.78, 6.31	7.15-6.79-6.55, 7.15
COP	kW/kW	4.61	4.28	4.03	
	Indoor temp.	D.B.	15 to 27°C		
Temp. range of heating	Outdoor temp.	W.B.	-20 to 15°C		
	Indoor unit connectable	Total capacity	50 to 130% of outdoor unit capacity		
Model/Quantity		CITY MULTI	P10 - P140 / 9	P10 - P140 / 10	P10 - P140 / 12
	Branch box*6		P15 - P100 / 8	P15 - P100 / 8	P15 - P100 / 8
	Mixed system	Branch box 1unit*6	CITY MULTI	P15 - P140 / 5	P15 - P140 / 5
		Branch box	P15 - P100 / 5	P15 - P100 / 5	P15 - P100 / 5
		Branch box 2unit*6	CITY MULTI	P15 - P140 / 3 or 2*5	P15 - P140 / 3
Branch box	P15 - P100 / 7 or 8*5	P15 - P100 / 8	P15 - P100 / 8		
Sound pressure level (SPL) (measured in anechoic room)	dB <A>	49/51	50/52	51/53	
Sound power level (PWL) (measured in anechoic room)	dB <A>	69/71	70/72	71/73	
Refrigerant piping diameter	Liquid pipe	mm (inch)	9.52 (3/8)		
	Gas pipe	mm (inch)	15.88 (5/8)		
FAN *2	Type x Quantity		Propeller Fan x 2		
	Airflow rate	m ³ /min	110		
		L/s	1,833		
		cfm	3,884		
	Control, Driving mechanism		DC control		
	Motor output	kW	0.074+0.074		
External static press.		0			
Compressor	Type x Quantity		Scroll hermetic compressor x 1		
	Manufacture		Mitsubishi Electric Corporation		
	Starting method		Inverter		
	Capacity control	%	Cooling 26 to 100 Heating 20 to 100	Cooling 24 to 100 Heating 18 to 100	Cooling 21 to 100 Heating 17 to 100
		Motor output	kW	2.9	3.5
	Case heater	kW	0		
	Lubricant		FV50S(2.3liter)		
External finish		Galvanized Steel Sheet Munsell No. 3Y 7.8/1.1			
External dimension H x W x D	mm	1338 x 1050 x 330(+40)			
	inch	52-11/16 x 41-11/32 x 13 (+1-9/16)			
Protection devices	High pressure protection		High pressure Switch		
	Inverter circuit (COMP./FAN)		Overcurrent detection, Overheat detection(Heat sink thermistor)		
	Compressor		Compressor thermistor, Over current detection		
	Fan motor		Overheating, Voltage protection, Over current detection		
Refrigerant	Type x original charge		R410A 4.8 kg		
	Control		Linear expansion valve		
Net weight	kg (lb)	125 (276)			
Heat exchanger		Cross Fin and Copper tube			
HIC circuit (HIC: Heat Inter-Changer)		Double pipe heat exchanger			
Defrosting method		Reversed refrigerant circuit			
Standard attachment	Document	Installation Manual			
	Accessory	Grounded lead wire x1			
Optional parts		Joint: CMY-Y62-G-E, Header: CMY-Y64/68-G-E, Branch box: PAC-MK34/54BC			
Remarks	*1 Nominal cooling conditions		*2 Nominal heating conditions		
	Indoor: 27°C D.B./19°C W.B. [81°F D.B./66°F W.B.]		20°C D.B. [68°F D.B.]		
	Outdoor: 35°C D.B. [95°F D.B.]		7°C DB/6°C W.B. [45°F D.B./43°F W.B.]		
	Pipe length: 7.5 m [24-9/16 ft]		7.5 m [24-9/16 ft]		
	Level difference: 0 m [0 ft]		0 m [0 ft]		
	*3 10 to 52:D.B. [50 to 126_F D.B.], when connecting following models: PKFY-P10/15/20/25/32VLM, PFFY-P20/25/32VLEM, PFFY-P20/25/32VLRM(M), PFFY-P20/25/32VKM, PFFY-P20/25/32VCM, PEFY-P25/32/40VMA3; and M series, S series, and P series type indoor unit.				
	*4 -15 to 52:D.B. [50 to 126_F D.B.], when using an optional air protect guide [PAC-SH95AG-E]. However, this condition does not apply to the indoor unit listed in *3.				
	*5 When connecting 7 indoor units via branch box, connectable CITY MULTI indoor units are 3; connecting 8 indoor units via branch box, connectable CITY MULTI indoor units are 2.				
	*6 At least two indoor unit must be connected when using branch box.				
	Notes: 1. Nominal conditions *1, *2 are subject to ISO 15042. 2. Due to continuing improvement, above specifications may be subject to change without notice.				
			Unit converter		
			kcal/h = kW x 860 Btu/h = kW x 3,412 cfm = m ³ /min x 35.31 lb = kg/0.4536		
			Above specification data is subject to rounding variation.		

1. SPECIFICATIONS

S-Series

PUMY-P-VKM5, YKM(E)4, YKM2, YBM

Model		PUMY-P112YKME4(-BS)	PUMY-P125YKME4(-BS)	PUMY-P140YKME4(-BS)	
Power source		3-phase 380-400-415 V, 50 Hz			
Cooling capacity (Nominal)	kW*1	12.5	14.0	15.5	
	kcal/h*1	10,750	12,040	13,330	
	Btu/h*1	42,650	47,768	52,886	
	Power input kW	2.79	3.46	4.52	
	Current input A	4.99-4.74-4.57	5.84-5.55-5.35	7.23-6.87-6.62	
COP	kW/kW	4.48	4.05	3.43	
Temp. range of cooling	Indoor temp.	W.B. 15 to 24°C			
	Outdoor temp.	D.B. -5 to 52°C *3, *4			
Heating capacity (Nominal)	kW*2	14.0	16.0	18.0	
	kcal/h*2	12,040	13,760	15,480	
	Btu/h*2	47,768	54,592	61,416	
	Power input kW	3.04	3.74	4.47	
	Current input A	5.43-5.16-4.98	6.31-6.00-5.78	7.15-6.79-6.55	
COP	kW/kW	4.61	4.28	4.03	
Temp. range of heating	Indoor temp.	D.B. 15 to 27°C			
	Outdoor temp.	W.B. -20 to 15°C			
Indoor unit connectable	Total capacity	50 to 130% of outdoor unit capacity			
	Model/Quantity	CITY MULTI	P10 - P140 / 9	P10 - P140 / 10	P10 - P140 / 12
		Branch box*6	P15 - P100 / 8	P15 - P100 / 8	P15 - P100 / 8
	Mixed system	Branch box 1unit*6	CITY MULTI	P15 - P140 / 5	P15 - P140 / 5
		Branch box	P15 - P100 / 5	P15 - P100 / 5	P15 - P100 / 5
Branch box 2unit*6		CITY MULTI	P15 - P140 / 3 or 2*5	P15 - P140 / 3	
Branch box	P15 - P100 / 7 or 8*5	P15 - P100 / 8	P15 - P100 / 8		
Sound pressure level (SPL) (measured in anechoic room)	dB <A>	49/51	50/52	51/53	
Sound power level (PWL) (measured in anechoic room)	dB <A>	69/71	70/72	71/73	
Refrigerant piping diameter	Liquid pipe mm (inch)	9.52 (3/8)			
	Gas pipe mm (inch)	15.88 (5/8)			
FAN *2	Type × Quantity	Propeller Fan x 2			
	Airflow rate	m³/min	110		
		L/s	1,833		
		cfm	3,884		
	Control, Driving mechanism	DC control			
	Motor output kW	0.074+0.074			
External static press.	0				
Compressor	Type × Quantity	Scroll hermetic compressor x 1			
	Manufacture	Mitsubishi Electric Corporation			
	Starting method	Inverter			
	Capacity control	%	Cooling 26 to 100 Heating 20 to 100	Cooling 24 to 100 Heating 18 to 100	Cooling 21 to 100 Heating 17 to 100
		Motor output kW	2.9	3.5	3.9
	Case heater kW	0			
	Lubricant	FV50S (2.3liter)			
External finish	Galvanized Steel Sheet Munsell No. 3Y 7.8/1.1				
External dimension H × W × D	mm	1,338×1,050×330(+40)			
	inch	52-11/16 × 41-11/32 × 13(+1-9/16)			
Protection devices	High pressure protection	High pressure Switch			
	Inverter circuit (COMP./FAN)	Overcurrent detection, Overheat detection(Heat sink thermistor)			
	Compressor	Compressor thermistor, Overcurrent detection			
	Fan motor	Overheating, Voltage protection, Overcurrent detection			
Refrigerant	Type × original charge	R410A 4.8kg			
	Control	Linear expansion valve			
Net weight	kg (lb)	136 (300)			
Heat exchanger	Cross Fin and Copper tube				
HIC circuit (HIC: Heat Inter-Changer)	Double pipe heat exchanger				
Defrosting method	Reversed refrigerant circuit				
Standard attachment	Document	Installation Manual			
	Accessory	Grounded lead wire ×1			
Optional parts	Joint: CMY-Y62-G-E, Header: CMY-Y64/68-G-E, Branch box: PAC-MK34/54BC				
Remarks	*1 Nominal cooling conditions	*2 Nominal heating conditions		Unit converter	
	Indoor: 27°C D.B./19°C W.B. [81°F D.B./66°F W.B.] Outdoor: 35°C D.B. [95°F D.B.] Pipe length: 7.5 m [24-9/16 ft] Level difference: 0 m [0 ft]	20°C D.B. [68°F D.B.] 7°C DB/6°C W.B. [45°F D.B./43°F W.B.] 7.5 m [24-9/16 ft] 0 m [0 ft]			
*3 10 to 52°C D.B. [50 to 126°F D.B.], when connecting following models: PKFY-P10/15/20/25/32VLM, PFFY-P20/25/32VLEM, PFFY-P20/25/32VLRM(M), PFFY-P20/25/32VKM, PFFY-P20/25/32VCM, PEFY-P25/32/40VMA3; and M series, S series, and P series type indoor unit.				kcal/h = kW × 860 Btu/h = kW × 3,412 cfm = m³/min × 35.31 lb = kg/0.4536	
*4 -15 to 52°C D.B. [50 to 126°F D.B.], when using an optional air protect guide [PAC-SH95AG-E]. However, this condition does not apply to the indoor unit listed in *3.					
*5 When connecting 7 indoor units via branch box, connectable CITY MULTI indoor units are 3; connecting 8 indoor units via branch box, connectable CITY MULTI indoor units are 2.				Above specification data is subject to rounding variation.	
*6 At least two indoor unit must be connected when using branch box.					
Notes: 1. Nominal conditions *1, *2 are subject to ISO 15042. 2. Due to continuing improvement, above specifications may be subject to change without notice.					

1. SPECIFICATIONS

S-Series

Model			PUMY-P200YKM2, PUMY-P200YKM2-BS	
Power source			3-phase 380-400-415 V, 50 Hz	
Cooling capacity (Nominal)	kW ^{*1}		22.4	
	kcal/h ^{*1}		19,300	
	Btu/h ^{*1}		76,400	
	Power input	kW	6.05	
	Current input	A	9.88- 9.39- 9.05	
Temp. range of cooling	Indoor temp.	W.B.	15 to 24°C	
	Outdoor temp.	D.B.	-5 to 52°C ^{*3,*4}	
Heating capacity (Nominal)	kW ^{*2}		25.0	
	kcal/h ^{*2}		21,500	
	Btu/h ^{*2}		85,300	
	Power input	kW	5.84	
	Current input	A	9.54- 9.06- 8.74	
Temp. range of heating	Indoor temp.	D.B.	15 to 27°C	
	Outdoor temp.	W.B.	-20 to 15°C ^{*3,*4}	
Indoor unit connectable	Total capacity		50 to 130% of outdoor unit capacity	
	Model/Quantity Mixed system	CITY MULTI		P10-P200/12
		Branch box		kW type: P15-P100/8
		Branch box 1 unit	CITY MULTI	P10-P200/5
			Branch box	kW type: P15-P100/5
		Branch box 2 units	CITY MULTI	P10-P200/3
Branch box			kW type: P15-P100/8	
Sound pressure level (SPL) (measured in anechoic room)			dB <A> 56/61	
Power pressure level (PWL) (measured in anechoic room)			dB <A> 75/80	
Refrigerant piping diameter	Liquid pipe	mm (inch)	9.52 (3/8) ^{*5}	
	Gas pipe	mm (inch)	19.05 (3/4)	
FAN	Type × Quantity		Propeller Fan × 2	
	Airflow rate	m ³ /min	139/141	
		L/s	2,317/2,350	
		cfm	4,909/4,979	
	Control, Driving mechanism		DC control	
	Motor output	kW	0.20 + 0.20	
	External static pressure		0	
Compressor	Type × Quantity		Scroll hermetic compressor × 1	
	Manufacturer		Siam Compressor Industry Co., Ltd.	
	Starting method		Inverter	
	Capacity control	%	Cooling 25 to 100 Heating 17 to 100	
	Motor output	kW	5.3	
	Case heater	kW	0	
	Lubricant		FVC68D (2.3litter)	
External finish			Galvanized Steel Sheet Munsell No. 3Y 7.8/1.1	
External dimension HxWxD	mm		1,338×1,050×330(+40)	
	inch		52-11/16 × 41-11/32 × 13(+1-10/16)	
Protection devices	High pressure protection		High pressure Switch	
	Inverter circuit (COMP./FAN)		Overcurrent detection, Overheat detection(Heat sink thermistor)	
	Compressor		Compressor thermistor, Over current detection	
	Fan motor		Overheating, Voltage protection	
Refrigerant	Type × original charge		R410A 7.3 kg	
	Control		Linear Expansion Valve	
Net weight	kg (lb)		141 (311)	
Heat exchanger			Cross Fin and Copper tube	
HIC circuit (HIC: Heat Inter-Changer)			Double pipe heat exchanger	
Defrosting method			Reversed refrigerant circuit	
Standard attachment	Document		Installation Manual	
	Accessory		Grounded lead wire ×1	
Optional parts			Joint: CMY-Y62-G-E Header: CMY-Y64/68-G-E	
^{*1} Nominal cooling conditions Indoor : 27°C D.B./19°C W.B. [81°F D.B./66°F W.B.] Outdoor : 35°C D.B. [95°F D.B.] Pipe length : 7.5 m [24-9/16 ft] Level difference : 0 m [0 ft]			Unit converter kcal/h = kW × 860 Btu/h = kW × 3,412 cfm = m ³ /min × 35.31 lb = kg/0.4536	
^{*2} Nominal heating conditions 20°C D.B. [68°F D.B.] 7°C DB/6°C W.B. [45°F D.B./43°F W.B.] 7.5 m [24-9/16 ft] 0 m [0 ft]				
^{*3} 10 to 52°C, when connecting following models: PKFY-P10/15/20/25/32VLM, PFFY-P20/25/32VLEM, PFFY-P20/25/32VLRM(M), PFFY-P20/25/32VKM, PFFY-P20/25/32VCM, PEFY-P40/63VMA3-E and M series, S series, and P series type indoor unit. ^{*4} -15 to 52°C, when using an optional air protect guide [PAC-SH95AG-E]. However, this condition does not apply to the indoor unit listed in ^{*3} . ^{*5} Liquid pipe diameter: 12.7 mm, when further piping length is longer than 60 m. Note: 1. Nominal conditions ^{*1} , ^{*2} are subject to ISO 15042. 2. Due to continuing improvement, above specifications may be subject to change without notice.				

1. SPECIFICATIONS

S-Series

PUMY-P-VKM5, YKM(E)4, YKM2, YBM

Model		PUMY-P250YBM (-BS)		PUMY-P300YBM (-BS)		
Power source		3-phase, 380-400-415V, 50Hz				
Cooling capacity (Nominal)	kW *1	28.0		33.5		
		kcal/h *1	24,100		28,800	
			Btu/h *1	95,500		114,300
	Power input	kW		8.21		10.12
	Current input	A	13.35 - 12.68 - 12.22		16.36 - 15.54 - 14.98	
EER	kW/kW	3.41		3.31		
Temp. range of cooling	Indoor temp.	W.B.	15 to 24°C			
	Outdoor temp.	D.B.	-5 to 52°C *3,*4			
Heating capacity (Nominal)	kW *2	31.5		37.5		
		kcal/h *2	27,100		32,200	
			Btu/h *2	107,500		128,000
	Power input	kW		7.41		9.12
	Current input	A	12.11 - 11.51 - 11.09		14.74 - 14.01 - 13.50	
COP	kW/kW	4.25		4.11		
Temp. range of heating	Indoor temp.	D.B.	15 to 27°C			
	Outdoor temp.	W.B.	-20 to 15°C			
Indoor unit connectable	Total capacity		50 to 130% of outdoor unit capacity			
	Model/Max Quantity	CITY MULTI	P10 - P250/ 30			
			Branch box	kW type: P15 - P50/ 12		
		Branch box 1 unit	CITY MULTI	P10-P250/ 25		P10-P250/ 25
			Branch box	kW type: P15-P50/ 5		kW type: P15-P50/ 5
			Total (Quantity)	30		30
		Branch box 2 units	CITY MULTI	P10-P250/ 23		P10-P250/ 23
			Branch box	kW type: P15-P50/ 10		kW type: P15-P50/ 10
			Total (Quantity)	30		30
		Branch box 3 units	CITY MULTI	P10-P250/ 22		P10-P250/ 22
Branch box			kW type: P15-P50/ 12		kW type: P15-P50/ 12	
Total (Quantity)	30		30			
Sound pressure level (SPL) (measured in anechoic room)	dB <A>	55 / 61		57 / 62		
Power pressure level (PWL) (measured in anechoic room)	dB <A>	73 / 79		75 / 79		
Refrigerant piping diameter	Liquid pipe	mm (inch)	ø9.52 (3/8) *5		ø12.7 (1/2)	
	Gas pipe	mm (inch)	ø22.4 (7/8)		ø25.4 (1)	
FAN	Type × Quantity		Propeller Fan × 2			
	Airflow rate	m³/min	165/183		165/183	
		L/s	2750/3050		2750/3050	
		cfm	5826/6462		5826/6462	
	Control, Driving mechanism		DC control			
	Motor output	kW	0.375 × 2			
External static pressure		0Pa / 30Pa *6				
Compressor	Type × Quantity		Scroll hermetic compressor × 1			
	Manufacturer		Siam Compressor Industry Co., Ltd.			
	Starting method		Inverter			
	Motor output	kW	5.7		6.9	
	Case heater	kW	-			
Lubricant		FVC68D (3.0 liter)				
External finish		Galvanized Steel Sheet Munsell No. 3Y 7.8/1.1				
External dimension HxWxD		mm	1,662 × 1,050 × 460(+45)			
		inch	65-7/16 × 41-11/32 × 187/64 (+ 1-49/64)			
Protection devices	High pressure protection		High pressure Switch			
	Inverter circuit (COMP./FAN)		Overcurrent detection, Overheat detection (Heat sink thermistor)			
	Compressor		Compressor thermistor, Overcurrent detection			
	Fan motor		Overheating, Voltage protection			
Refrigerant	Type × original charge		R410A 9.3 kg			
	Control		Linear Expansion Valve			
Net weight	kg (lb) [-BS kg (lbs)]	196 (432) [198 (437)]				
Heat exchanger		Cross Fin and Copper tube				
HIC circuit (HIC: Heat Inter-Changer)		Double pipe heat exchanger				
Defrosting method		Reversed refrigerant circuit				
Standard attachment	Document		Installation Manual			
	Accessory		Grounded lead wire ×1	Joint pipe×1 set, Grounding lead wire ×1		
Optional parts		Joint: CMY-Y62-G-E Header: CMY-Y64/68-G-E				
*1. Nominal cooling conditions (subject to ISO 15042) Indoor: 27°CDB./19°CWB. [81°FDB./66°FWB.], Outdoor: 35°CDB. [95°FDB.], Pipe length: 7.5 m [24-9/16 ft.], Level difference: 0 m [0 ft.]					Unit converter kcal/h = kW × 860 Btu/h = kW × 3,412 cfm = m3/min × 35.31 lb = kg/0.4536 Above specification data is subject to rounding variation.	
*2. Nominal heating conditions (subject to ISO 15042) Indoor: 20°CDB. [68°FDB.], Outdoor: 7°CDB./6°CWB. [45°FDB./43°FWB.], Pipe length: 7.5 m [24-9/16 ft.], Level difference: 0 m [0 ft.]						
*3. 10 to 52°C, when connecting following models: PKFY-P10/15/20/25/32VLM, PFFY-P20/25/32VKM, PFFY-P20/25/32VCM, PFFY-P20/25/32VLEM, PEFY-P63/71/80VMA3-E; and M series type indoor unit.						
*4. -15 to 52°C, when using an optional air protect guide [PAC-SK21AG-E]. However, this condition does not apply to the indoor unit listed in *3.						
*5. Liquid pipe diameter: 12.7mm, when further piping length is longer than 90m, and when PEFY-P200 or P250 is connected.						
*6. It is possible to set the External static pressure to 30 Pa by Dip Switch.						
Notes: · Nominal conditions *1, *2 are subject to ISO15042 · Due to continuing improvement, above specifications may be subject to change without notice.						

PUMY-P250, 300YBM(-BS)

Unit: mm

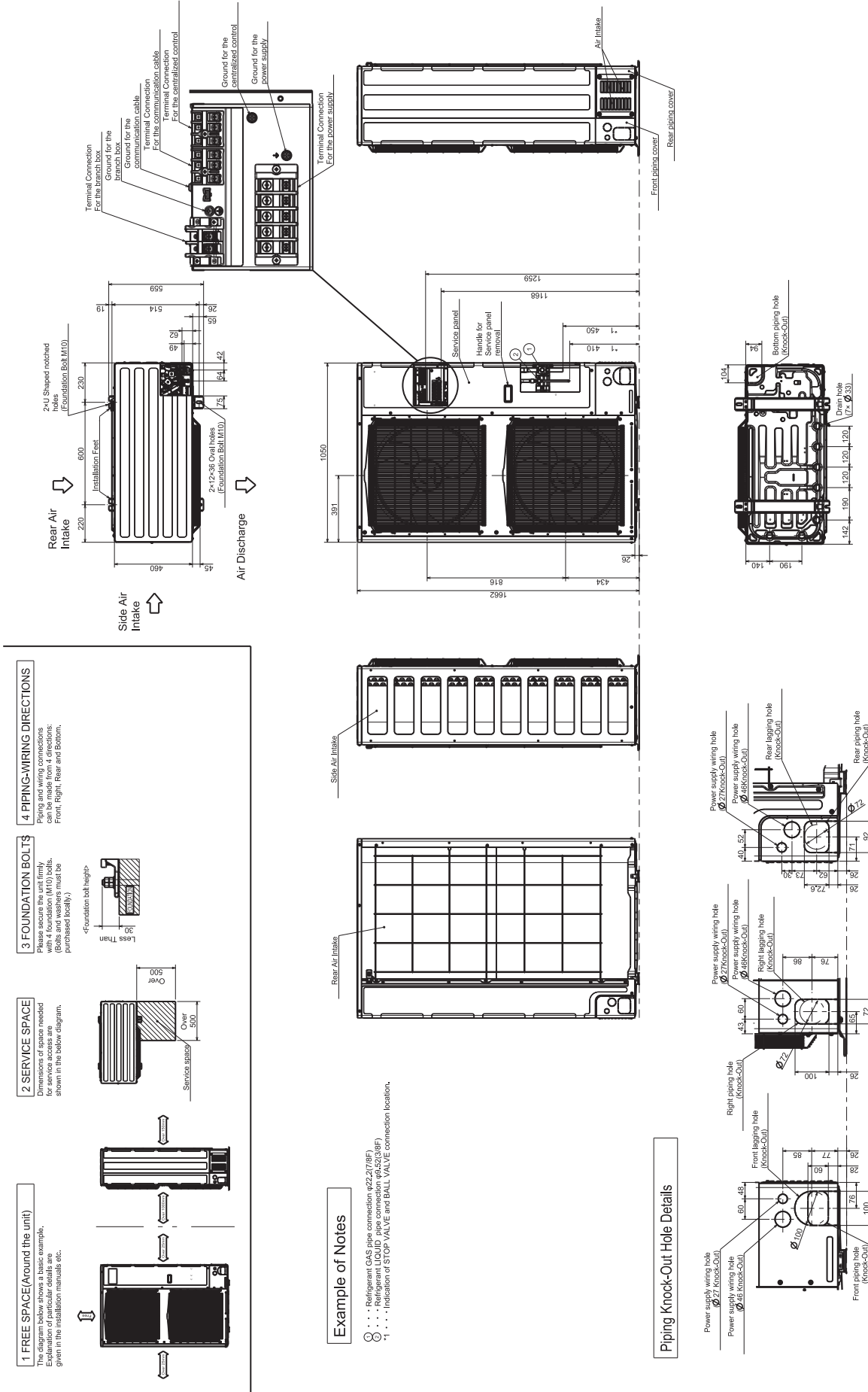

PUMY-P112, 125, 140VKM5(-BS)
PUMY-P112, 125, 140YKM4(-BS)
PUMY-P112, 125, 140YKME4(-BS)

Unit: mm

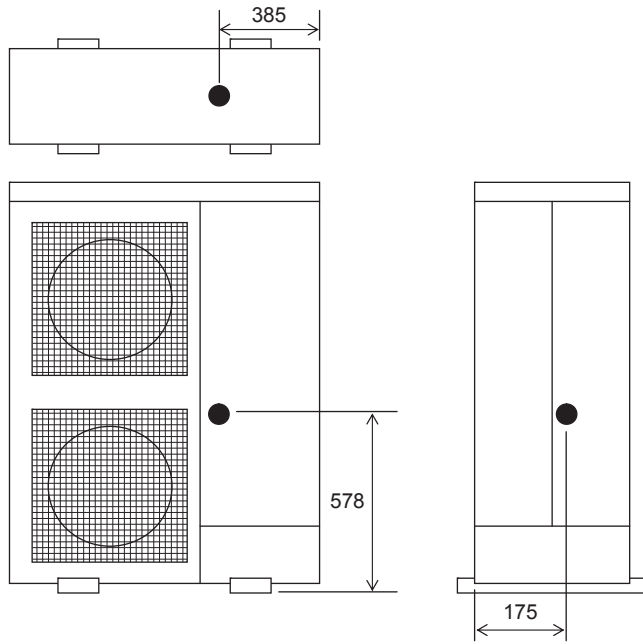

PUMY-P-VKM5, YKM(E)4, YKM2, YBM

PUMY-P-VKM5, YKM(E)4, YKM2, YBM

PUMY-P200YKM2(-BS)

Unit: mm

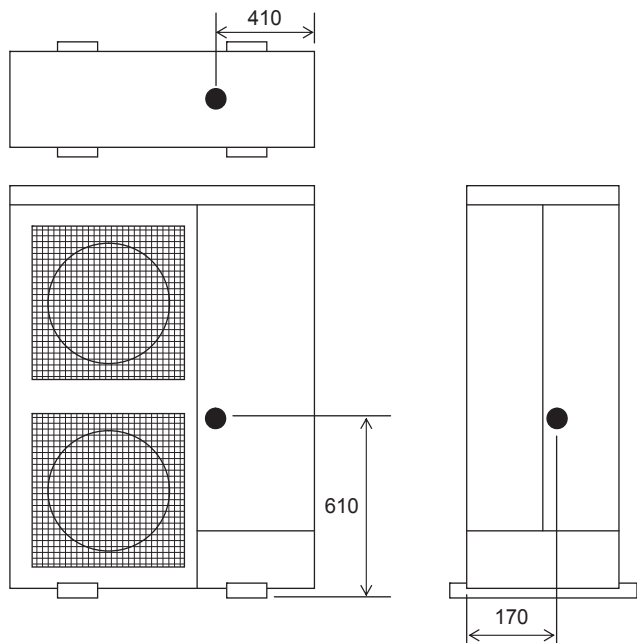

PUMY-P250, 300YBM(-BS)

Unit: mm

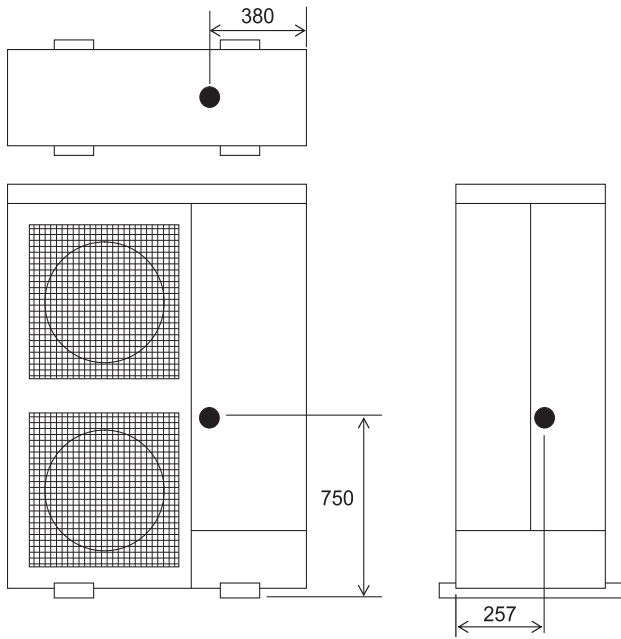

PUMY-P-VKM5, YKM(E)4, YKM2, YBM

PUMY-P-VKM5, YKM(E)4, YKM2, YBM

PUMY-P112, 125, 140VKM5(-BS)

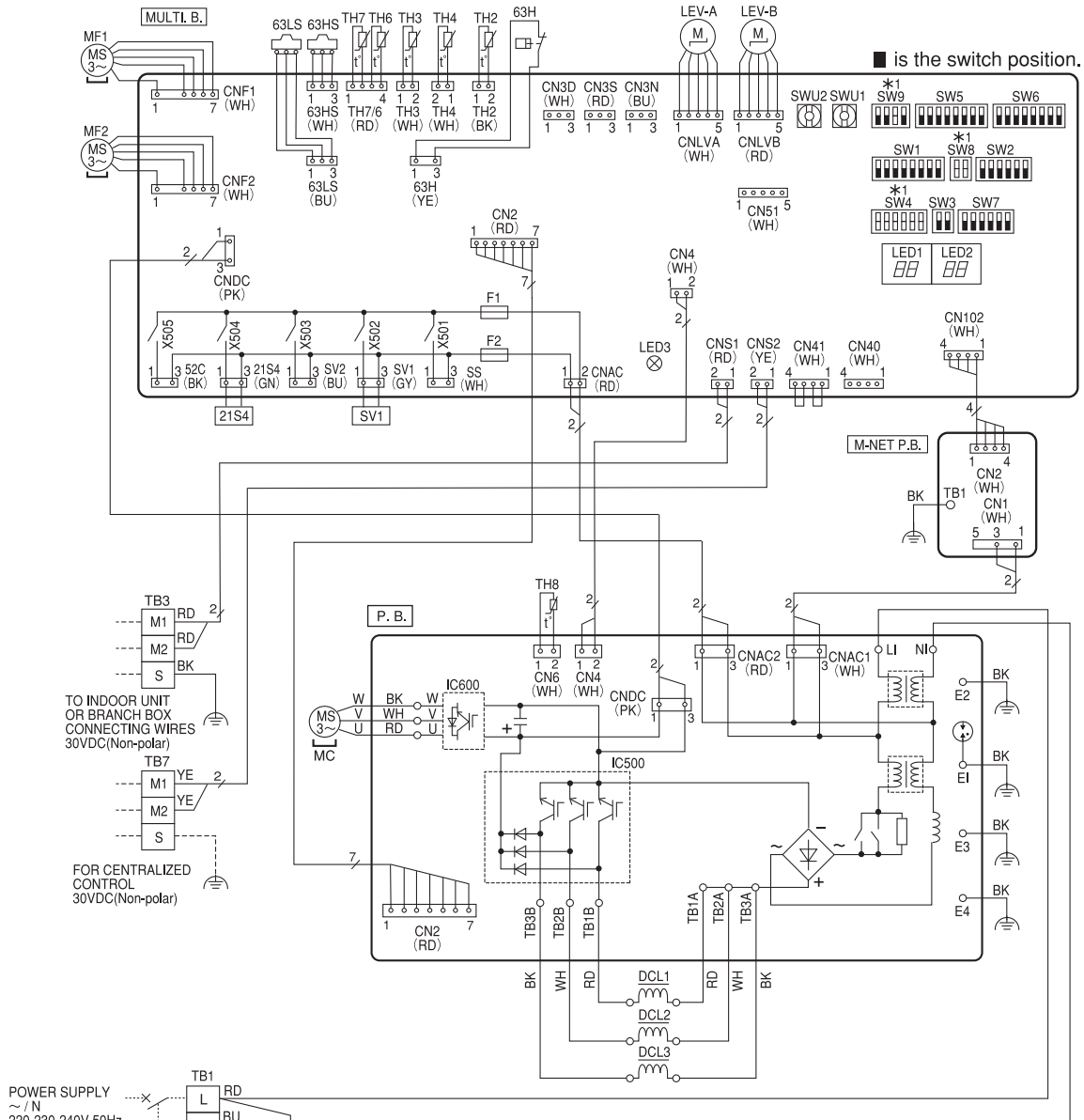

■ is the switch position.

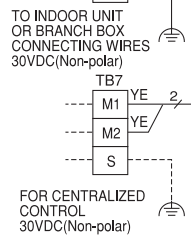

***1 MODEL SELECTION**
The black square (■) indicates a switch position.

MODEL	SW4	SW8	SW9
PUMY-P112VKM5	ON OFF 1 2 3 4 5 6	ON OFF 1 2	ON OFF 1 2 3 4
PUMY-P125VKM5	ON OFF 1 2 3 4 5 6	ON OFF 1 2	ON OFF 1 2 3 4
PUMY-P140VKM5	ON OFF 1 2 3 4 5 6	ON OFF 1 2	ON OFF 1 2 3 4

SYMBOL	NAME	SYMBOL	NAME	SYMBOL	NAME
TB1	Terminal Block (Power Supply)	TH8	Thermistor (Heat Sink)	SW6	Switch (Function Selection)
TB3	Terminal Block (Indoor/Outdoor, Branch Box/Outdoor Transmission Line)	LEV-A, LEV-B	Linear Expansion Valve	SW7	Switch (Function Selection)
TB7	Terminal Block (Centralized Control Transmission Line)	DCL1, DCL2, DCL3	Reactor	SW8	Switch (Model Selection)
FUSE1, FUSE2	Fuse (T20AL250V)	P.B.	Power Circuit Board	SW9	Switch (Function/Model Selection)
MC	Motor for Compressor	U/V/W	Connection Terminal (U/V/W-Phase)	SWU1	Switch (Unit Address Selection, ones digit)
MF1, MF2	Fan Motor	LI	Connection Terminal (L-Phase)	SWU2	Switch (Unit Address Selection, tens digit)
21S4	Solenoid Valve Coil (4-Way Valve)	NI	Connection Terminal (N-Phase)	SS	Connector (Connection for Option)
63H	High Pressure Switch	TB1A, TB2A, TB3A	Connection Terminal (Reactor)	CN3D	Connector (Connection for Option)
63HS	High Pressure Sensor	TB1B, TB2B, TB3B	Connection Terminal (Reactor)	CN3S	Connector (Connection for Option)
63LS	Low Pressure Sensor	IC500	Converter	CN3N	Connector (Connection for Option)
SV1	Solenoid Valve Coil (Bypass Valve)	IC600	Inverter	CN51	Connector (Connection for Option)
TH2	Thermistor (HIC Pipe)	E1, E2, E3, E4	Connection Terminal (Electrical Parts Box)	LED1, LED2	LED (Operation Inspection Display)
TH3	Thermistor (Outdoor Liquid Pipe)	MULTI.B.	Multi Controller Circuit Board	LED3	LED (Power Supply to Main Microcomputer)
TH4	Thermistor (Compressor)	SW1	Switch (Display Selection)	F1, F2	Fuse (T6.3AL250V)
TH6	Thermistor (Suction Pipe)	SW2	Switch (Function Selection)	X501~X505	Relay
TH7	Thermistor (Ambient)	SW3	Switch (Test Run)	M-NET P.B.	M-NET Power Circuit Board
		SW4	Switch (Model Selection)	TB1	Connection Terminal (Electrical Parts Box)
		SW5	Switch (Function Selection)		

PUMY-P112, 125, 140YKM4(-BS)

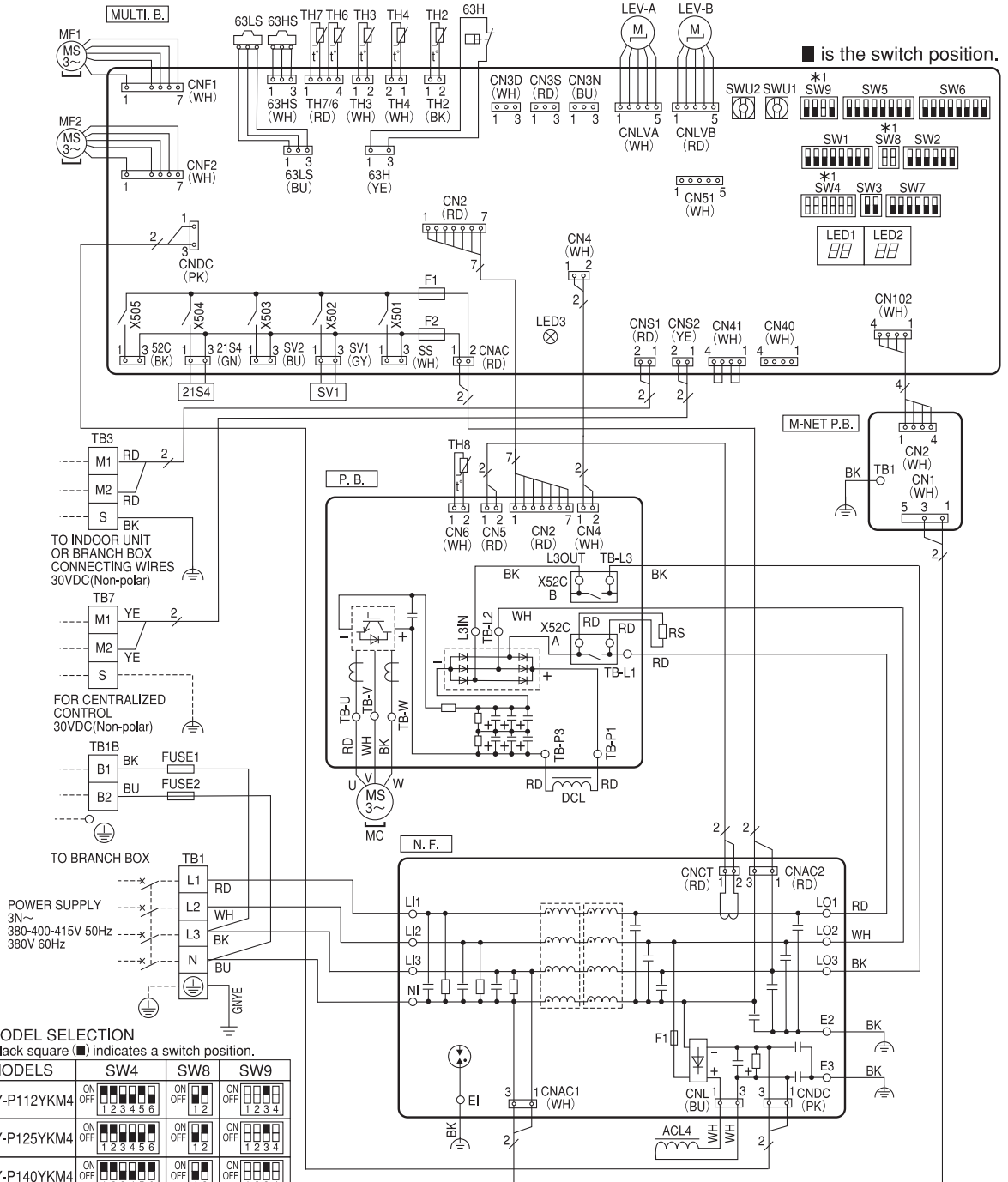

*1 MODEL SELECTION
The black square (■) indicates a switch position.

MODELS	SW4	SW8	SW9
PUMY-P112YKM4	ON OFF [Diagram]	ON OFF [Diagram]	ON OFF [Diagram]
PUMY-P125YKM4	ON OFF [Diagram]	ON OFF [Diagram]	ON OFF [Diagram]
PUMY-P140YKM4	ON OFF [Diagram]	ON OFF [Diagram]	ON OFF [Diagram]

SYMBOL	NAME	SYMBOL	NAME	SYMBOL	NAME
TB1	Terminal Block (Power Supply)	RS	Rush Current Protect Resistor	SW6	Switch (Function Selection)
TB1B	Terminal Block (Branch Box)	LEV-A,LEV-B	Linear Expansion Valve	SW7	Switch (Function Selection)
TB3	Terminal Block (Indoor/Outdoor, Branch Box/Outdoor Transmission Line)	ACL4	Reactor	SW8	Switch (Model Selection)
TB7	Terminal Block (Centralized Control Transmission Line)	DCL	Reactor	SW9	Switch (Function/Model Selection)
FUSE1,FUSE2	Fuse (T20AL250V)	P.B.	Power Circuit Board	SWU1	Switch (Unit Address Selection, ones digit)
MC	Motor for Compressor	TB-U/W/V	Connection Terminal (U/W/V-Phase)	SWU2	Switch (Unit Address Selection, tens digit)
MF1,MF2	Fan Motor	TB-L1/L2/L3	Connection Terminal (L1/L2/L3-Power Supply)	CNS1	Connector (Indoor/Outdoor, Branch Box/Outdoor Transmission Line)
21S4	Solenoid Valve Coil (4-Way Valve)	TB-P1/P3	Connection Terminal (Reactor)	CNS2	Connector (Centralized Control Transmission Line)
63H	High Pressure Switch	X52CA/B	52C Relay	SS	Connector (Connection for Option)
63HS	High Pressure Sensor	N.F.	Noise Filter Circuit Board	CN3D	Connector (Connection for Option)
63LS	Low Pressure Sensor	LO1/LO2/LO3	Connection Terminal (L1/L2/L3-Power Supply)	CN3S	Connector (Connection for Option)
SV1	Solenoid Valve Coil (Bypass Valve)	L1/L2/L3/N1	Connection Terminal (L1/L2/L3/N-Power Supply)	CN3N	Connector (Connection for Option)
TH2	Thermistor (H/C Pipe)	E1,E2,E3	Connection Terminal (Electrical Parts Box)	CN51	Connector (Connection for Option)
TH3	Thermistor (Outdoor Liquid Pipe)	F1	Fuse (T6.3AL250V)	CN51	Connector (Connection for Option)
TH4	Thermistor (Compressor)	MULTI.B.	Multi Controller Circuit Board	LED1,LED2	LED (Operation Inspection Display)
TH6	Thermistor (Suction Pipe)	SW1	Switch (Display Selection)	LED3	LED (Power Supply to Main Microcomputer)
TH7	Thermistor (Ambient)	SW2	Switch (Function Selection)	F1,F2	Fuse (T6.3AL250V)
TH8	Thermistor (Heat Sink)	SW3	Switch (Test Run)	X501~505	Relay
		SW4	Switch (Model Selection)	M-NET P.B.	M-NET Power Circuit Board
		SW5	Switch (Function Selection)	TB1	Connection Terminal (Electrical Parts Box)

PUMY-P112, 125, 140YKME4(-BS)

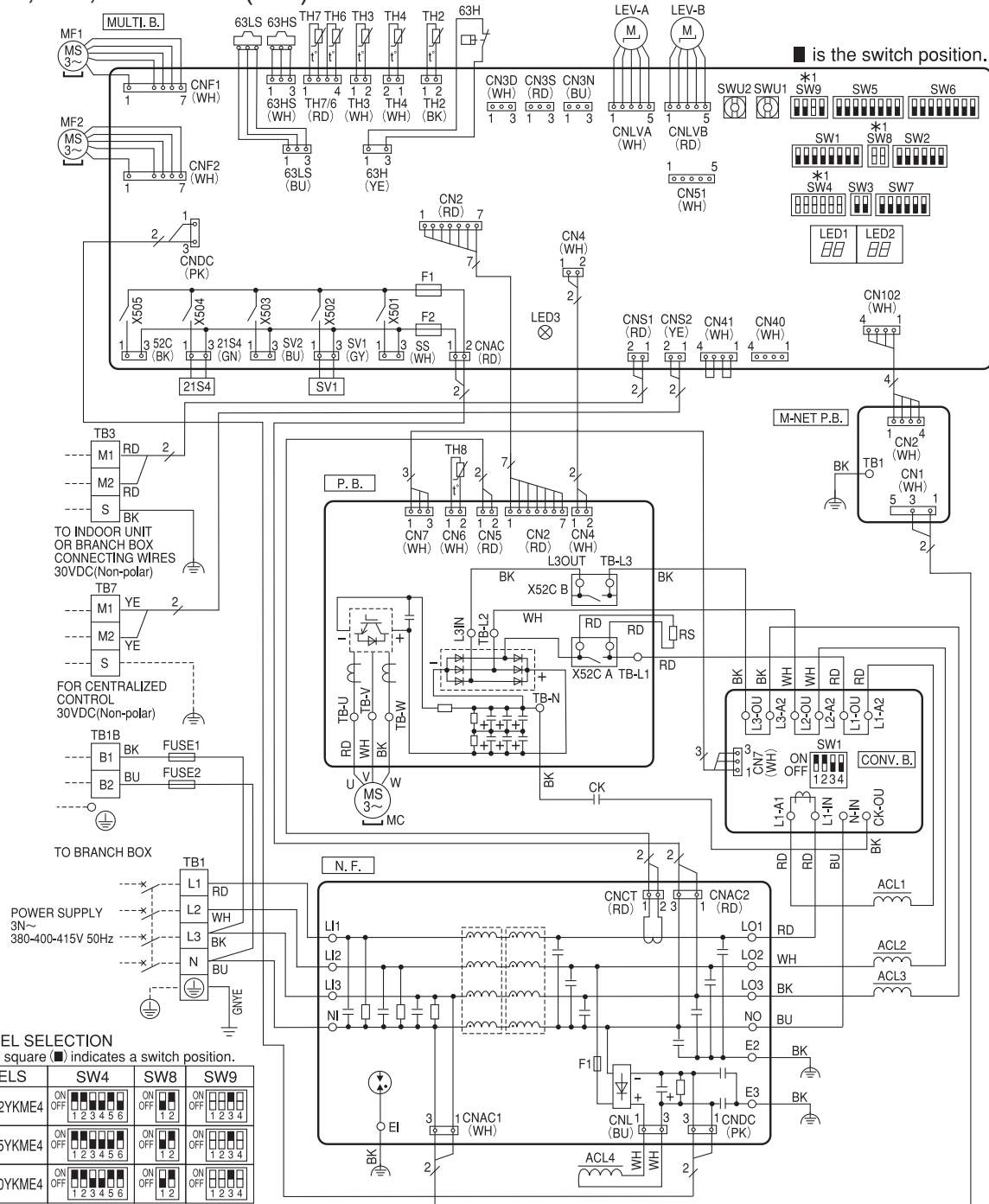

***1 MODEL SELECTION**
The black square (■) indicates a switch position.

MODELS	SW4	SW8	SW9
PUMY-P112YKME4	ON OFF 1 2 3 4 5 6	ON OFF 1 2	ON OFF 1 2 3 4
PUMY-P125YKME4	ON OFF 1 2 3 4 5 6	ON OFF 1 2	ON OFF 1 2 3 4
PUMY-P140YKME4	ON OFF 1 2 3 4 5 6	ON OFF 1 2	ON OFF 1 2 3 4

SYMBOL	NAME	SYMBOL	NAME	SYMBOL	NAME
TB1	Terminal Block (Power Supply)	ACL1,ACL2,ACL3,ACL4	Reactor	SW4	Switch (Model Selection)
TB1B	Terminal Block (Branch Box)	P.B.	Power Circuit Board	SW5	Switch (Function Selection)
TB3	Terminal Block (Indoor/Outdoor, Branch Box/Outdoor Transmission Line)	TB-U/V/W	Connection Terminal (U/V/W-Phase)	SW6	Switch (Function Selection)
TB7	Terminal Block (Centralized Control Transmission Line)	TB-L1/L2/L3	Connection Terminal (L1/L2/L3-Power Supply)	SW7	Switch (Function Selection)
FUSE1,FUSE2	Fuse (T20AL250V)	TB-N	Connection Terminal	SW8	Switch (Model Selection)
MC	Motor for Compressor	X52CA/B	52C Relay	SW9	Switch (Function/Model Selection)
MF1, MF2	Fan Motor	CONV.B.	Converter Circuit Board	SWU1	Switch (Unit Address Selection, ones digit)
21S4	Solenoid Valve Coil (4-Way Valve)	SW1	Switch (Model Selection)	SWU2	Switch (Unit Address Selection, tens digit)
63H	High Pressure Switch	L1-A1/IN	Connection Terminal (L1-Power Supply)	CNS1	Connector (Indoor/Outdoor, Branch Box/Outdoor Transmission Line)
63HS	High Pressure Sensor	L1-A2/OU	Connection Terminal (L1-Power Supply)	CNS2	Connector (Centralized Control Transmission Line)
63LS	Low Pressure Sensor	L2-A2/OU	Connection Terminal (L2-Power Supply)	SS	Connector (Connection for Option)
SV1	Solenoid Valve Coil (Bypass Valve)	L3-A2/OU	Connection Terminal (L3-Power Supply)	CN3D	Connector (Connection for Option)
TH2	Thermistor (H/C Pipe)	N-IN	Connection Terminal	CN3S	Connector (Connection for Option)
TH3	Thermistor (Outdoor Liquid Pipe)	CK-OU	Connection Terminal	CN3N	Connector (Connection for Option)
TH4	Thermistor (Compressor)	N.F.	Noise Filter Circuit Board	CN51	Connector (Connection for Option)
TH6	Thermistor (Suction Pipe)	L01/L02/L03/NO	Connection Terminal (L1/L2/L3/N-Power Supply)	LED1,LED2	LED (Operation Inspection Display)
TH7	Thermistor (Ambient)	L1/L2/L3/NI	Connection Terminal (L1/L2/L3/N-Power Supply)	LED3	LED (Power Supply to Main Microcomputer)
TH8	Thermistor (Heat Sink)	E1,E2,E3	Connection Terminal (Electrical Parts Box)	F1, F2	Fuse (T6.3AL250V)
RS	Rush Current Protect Resistor	F1	Fuse (T6.3AL250V)	X501~505	Relay
CK	Capacitor	MULTI.B.	Multi Controller Circuit Board	M-NET P.B.	M-NET Power Circuit Board
LEV-A,LEV-B	Linear Expansion Valve	SW1	Switch (Display Selection)	TB1	Connection Terminal (Electrical Parts Box)
		SW2	Switch (Function Selection)		
		SW3	Switch (Test Run)		

PUMY-P-VKM5, YKM(E)4, YKM2, YBM

PUMY-P200YKM2(-BS)

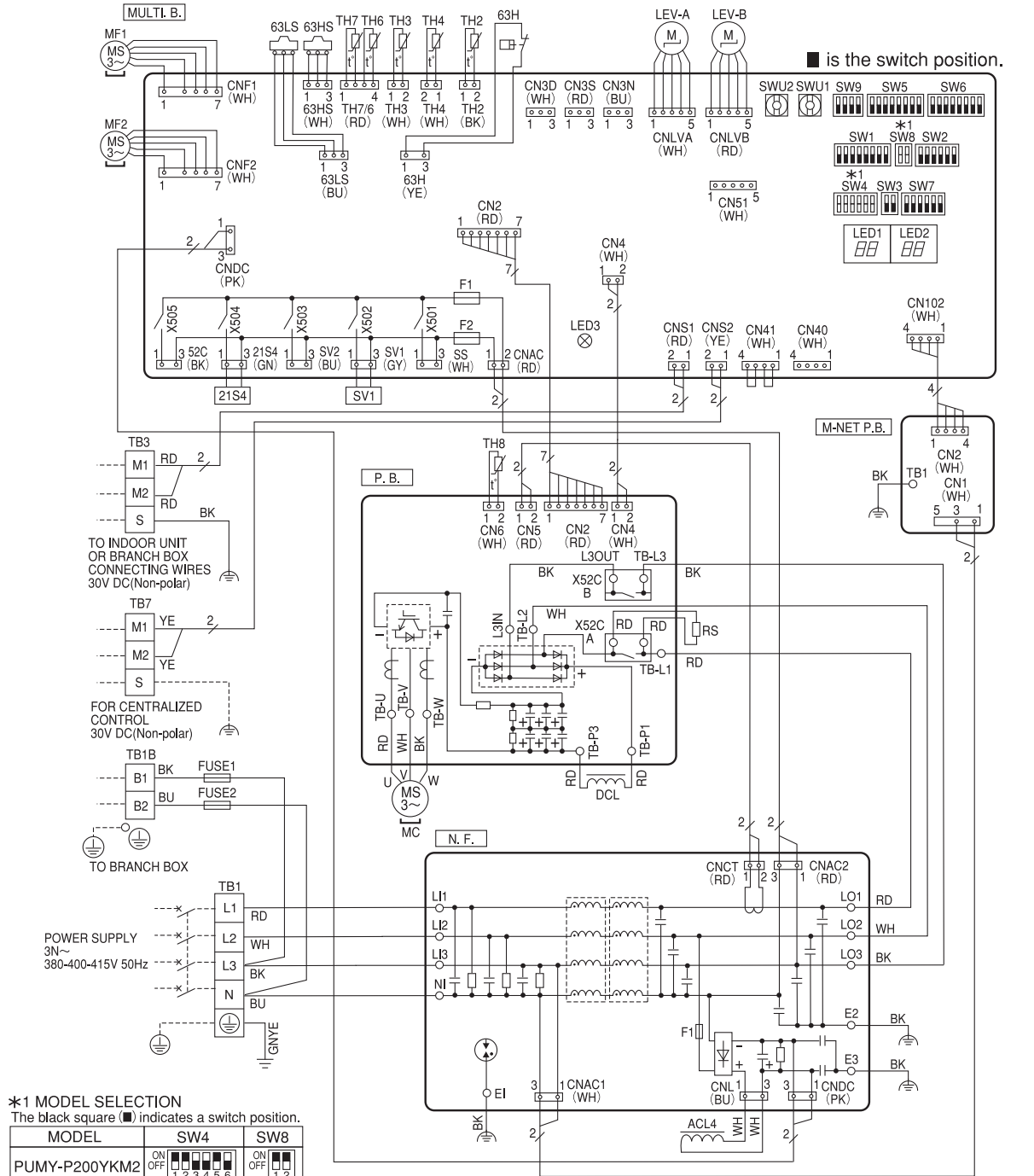

SYMBOL	NAME	SYMBOL	NAME	SYMBOL	NAME
TB1	Terminal Block (Power Supply)	RS	Rush Current Protect Resistor	SW6	Switch (Function Selection)
TB1B	Terminal Block (Branch Box)	LEV-A, LEV-B	Linear Expansion Valve	SW7	Switch (Function Selection)
TB3	Terminal Block (Indoor/Outdoor, Branch Box/Outdoor Transmission Line)	ACL4	Reactor	SW8	Switch (Model Selection)
TB7	Terminal Block (Centralized Control Transmission Line)	DCL	Reactor	SW9	Switch (Function/Model Selection)
FUSE1, FUSE2	Fuse (T20AL250V)	P.B.	Power Circuit Board	SWU1	Switch (Unit Address Selection, ones digit)
MC	Motor for Compressor	TB-L1/L2/L3	Connection Terminal (L1/L2/L3-Power Supply)	SWU2	Switch (Unit Address Selection, tens digit)
MF1, MF2	Fan Motor	TB-V/W	Connection Terminal (U/V/W-Phase)	CNS1	Connector (Indoor/Outdoor, Branch Box/Outdoor Transmission Line)
21S4	Solenoid Valve Coil (4-Way Valve)	X52CA/B	52C Relay	CNS2	Connector (Centralized Control Transmission Line)
63H	High Pressure Switch	N.F.	Noise Filter Circuit Board	SS	Connector (Connection For Option)
63HS	High Pressure Sensor	LO1/LO2/LO3	Connection Terminal (L1/L2/L3-Power Supply)	CN3D	Connector (Connection For Option)
63LS	Low Pressure Sensor	L1/L2/L3/N1	Connection Terminal (L1/L2/L3/N-Power Supply)	CN3S	Connector (Connection For Option)
SV1	Solenoid Valve Coil (Bypass Valve)	E1/E2/E3	Connection Terminal (Electrical Parts Box)	CN3N	Connector (Connection For Option)
TH2	Thermistor (HIC Pipe)	F1	Fuse (T6.3AL250V)	CN51	Connector (Connection For Option)
TH3	Thermistor (Outdoor Liquid Pipe)	MULTI.B.	Multi Controller Circuit Board	LED1, LED2	LED (Operation Inspection Display)
TH4	Thermistor (Compressor)	SW1	Switch (Display Selection)	LED3	LED (Power Supply to Main Microcomputer)
TH6	Thermistor (Suction Pipe)	SW2	Switch (Function Selection)	F1, F2	Fuse (T6.3AL250V)
TH7	Thermistor (Ambient)	SW3	Switch (Test Run)	X501~505	Relay
TH8	Thermistor (Heat Sink)	SW4	Switch (Model Selection)	M-NET P.B.	M-NET Power Circuit Board
		SW5	Switch (Function Selection)	TB1	Connection Terminal (Electrical Parts Box)

PUMY-P250, 300YBM(-BS)

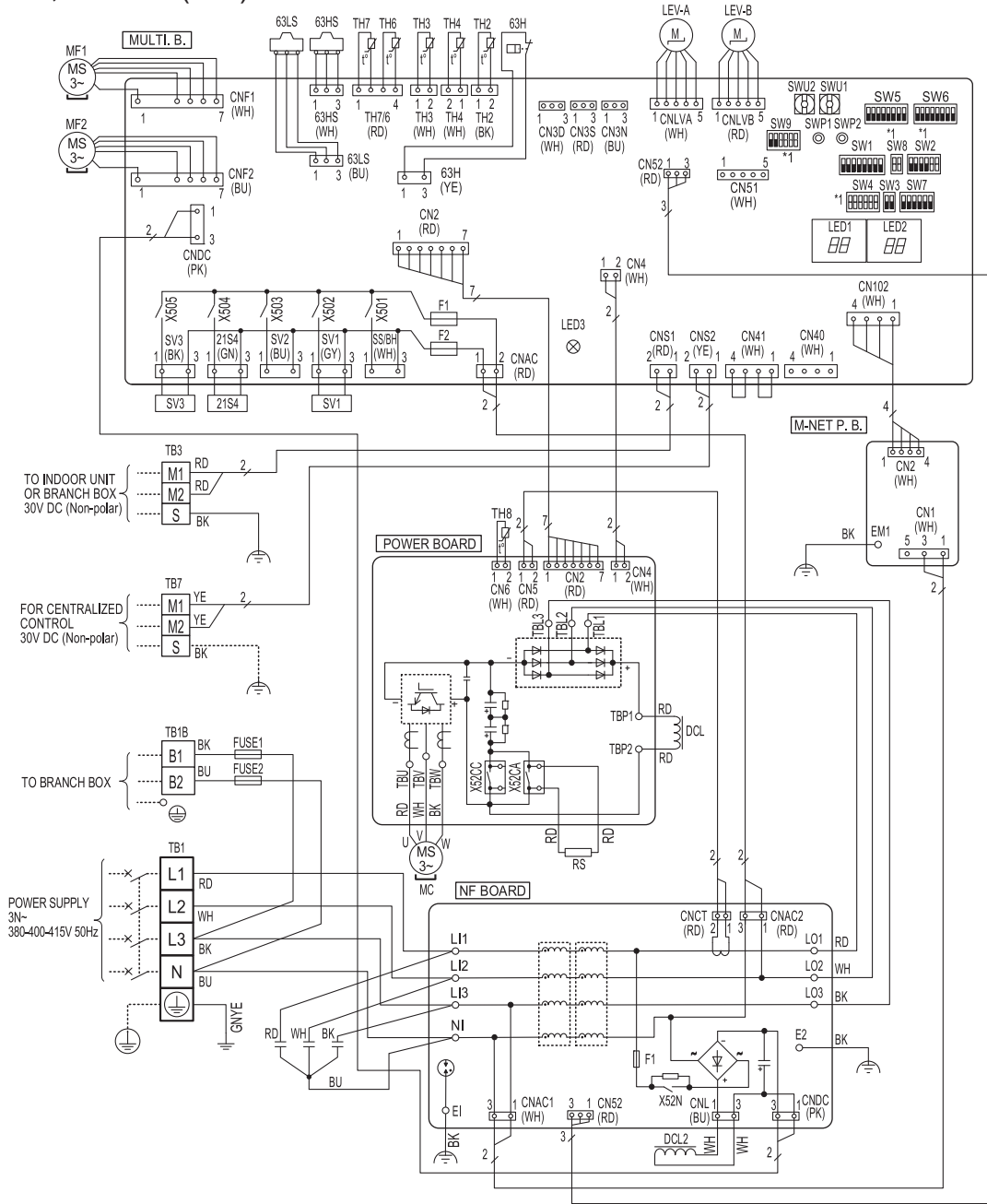

*1 MODEL SELECT
The black square (■) indicates a switch position.

MODELS	SW2	SW4	SW8	SW9
PUMY-P250YBM	ON OFF ■ 5 6	ON OFF ■ 1 2 3 4 5 6	ON OFF ■ 1 2	ON OFF ■ 3 4 5 6
PUMY-P300YBM	ON OFF ■ 5 6	ON OFF ■ 1 2 3 4 5 6	ON OFF ■ 1 2	ON OFF ■ 3 4 5 6

[LEGEND]

SYMBOL	NAME	SYMBOL	NAME	SYMBOL	NAME
TB1	Terminal Block <Power Supply>	RS	Rush Current Protect Resistor	SW5	Switch <Function Selection>
TB1B	Terminal Block <Branch Box>	LEV-A, LEV-B	Linear Expansion Valve	SW6	Switch <Function Selection>
TB3	Terminal Block <Branch Box/Outdoor Transmission Line>	DCL	Reactor	SW7	Switch <Function Selection>
TB7	Terminal Block <Centralized Control Transmission Line>	DCL2	Reactor	SW8	Switch <Function Selection>
FUSE1, FUSE2	Fuse <T20AL250V>	POWER BOARD	Power Circuit Board	SW9	Switch <Function/Model Selection>
MC	Motor for Compressor	TB1, TB2, TB3	Connection Terminal <L1/L2/L3-Power Supply>	SWP1	Switch <Function Selection>
MF1, MF2	Fan Motor	TBP1, TBP2	Connection Terminal <Reactor>	SWP2	Switch <Display Selection>
63H	High Pressure Switch	TBU, TBV, TBW	Connection Terminal <U/V/W-Phase>	SWU1	Switch <Unit Address Selection, ones digit>
63HS	High Pressure Sensor	X52CA, X52CC	Relay with Connection Terminal	SWU2	Switch <Unit Address Selection, tens digit>
63LS	Low Pressure Sensor	NF BOARD	Noise Filter Circuit Board	SS/BH	Connector <Connection for Option>
SV1	Solenoid Valve Coil <Bypass Valve>	LI1, LI2, LI3, NI	Connection Terminal <L1/L2/L3-N-Power Supply>	CN3D	Connector <Connection for Option>
SV3	Solenoid Valve Coil <Oil return Valve>	LO1, LO2, LO3	Connection Terminal <L1/L2/L3-Power Supply>	CN3S	Connector <Connection for Option>
21S4	Solenoid Valve Coil <4-Way Valve>	EI, E2	Connection Terminal <Electrical Parts Box>	CN3N	Connector <Connection for Option>
TH2	Thermistor <H/C Pipe>	F1	Fuse <T10AL250V>	CN51	Connector <Connection for Option>
TH3	Thermistor <Outdoor Liquid Pipe>	MULTLB.	Multi Controller Circuit Board	LED1, LED2	LED <Operation Inspection Display>
TH4	Thermistor <Compressor>	SW1	Switch <Display Selection>	LED3	LED <Power Supply to Main Microcomputer>
TH6	Thermistor <Suction Pipe>	SW2	Switch <Function/Model Selection>	F1, F2	Fuse <T6.3AL250V>
TH7	Thermistor <Ambient>	SW3	Switch <Test Run>	M-NET P.B.	M-NET Power Circuit Board
TH8	Thermistor <Heat Sink>	SW4	Switch <Model Selection>	EMI	Connection Terminal <Electrical Parts Box>

PUMY-P-VKM5, YKM(E)4, YKM2, YBM

Measurement condition
PUMY-P112, 125, 140VKM5(-BS)
PUMY-P112, 125, 140YKM4(-BS)
PUMY-P112, 125, 140YKME4(-BS)

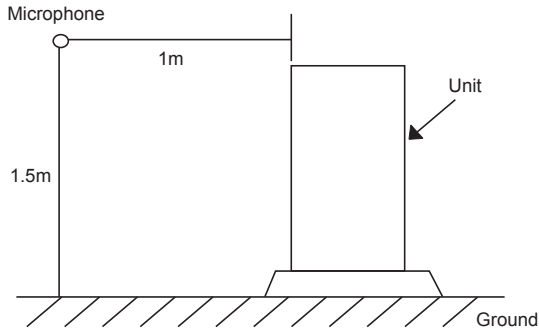

Sound level of PUMY-P140VKM5/PUMY-P140YKM(E)4

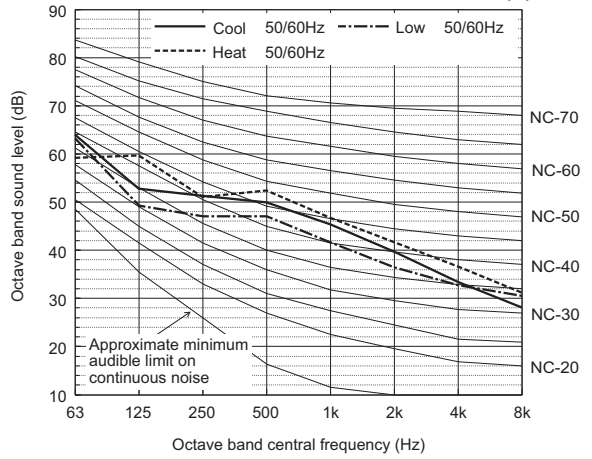

		63	125	250	500	1k	2k	4k	8k	dB(A)
Standard Cooling	50/60Hz	64.0	52.8	51.3	50.0	45.4	39.7	33.5	28.2	51.0
Standard Heating	50/60Hz	59.2	59.7	51.1	52.4	46.8	41.7	36.7	31.2	53.0
Low noise mode	50/60Hz	63.2	49.2	47.0	47.1	41.6	36.5	32.8	30.6	48.0

When Low noise mode is set, the A/C system's capacity is limited. The system could return to normal operation from Low noise mode automatically in the case that the operation condition is severe.

Sound level of PUMY-P112VKM5/PUMY-P112YKM(E)4

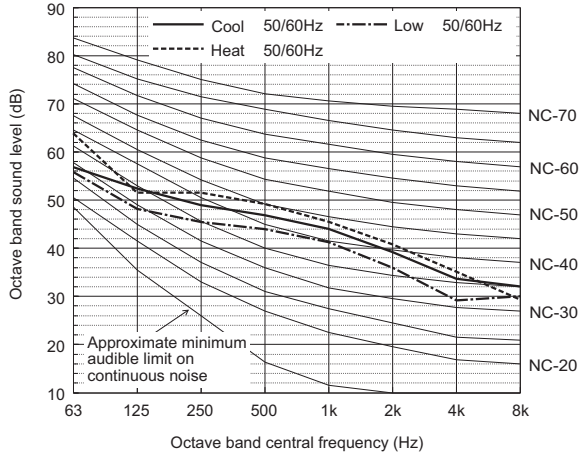

		63	125	250	500	1k	2k	4k	8k	dB(A)
Standard Cooling	50/60Hz	56.9	52.4	49.0	46.9	44.0	39.2	33.7	32.1	49.0
Standard Heating	50/60Hz	63.9	51.6	51.6	49.2	45.5	40.8	35.1	29.3	51.0
Low noise mode	50/60Hz	55.8	48.1	45.5	44.0	41.2	36.0	29.2	30.0	46.0

When Low noise mode is set, the A/C system's capacity is limited. The system could return to normal operation from Low noise mode automatically in the case that the operation condition is severe.

Sound level of PUMY-P125VKM5/PUMY-P125YKM(E)4

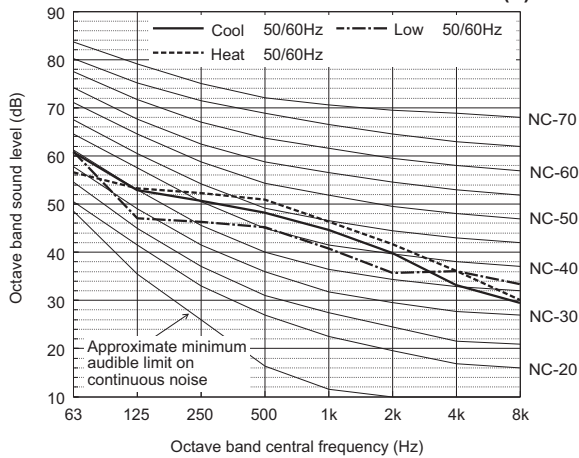

		63	125	250	500	1k	2k	4k	8k	dB(A)
Standard Cooling	50/60Hz	60.8	52.8	50.6	48.2	44.7	39.9	33.2	29.5	50.0
Standard Heating	50/60Hz	56.6	53.3	52.2	50.9	46.4	41.7	36.2	30.1	52.0
Low noise mode	50/60Hz	60.9	47.1	46.3	45.2	40.7	35.7	36.1	33.4	47.0

When Low noise mode is set, the A/C system's capacity is limited. The system could return to normal operation from Low noise mode automatically in the case that the operation condition is severe.

PUMY-P-VKM5, YKM(E)4, YKM2, YBM

Measurement condition
 PUMY-P200YKM2(-BS)
 PUMY-P250YBM(-BS)
 PUMY-P300YBM(-BS)

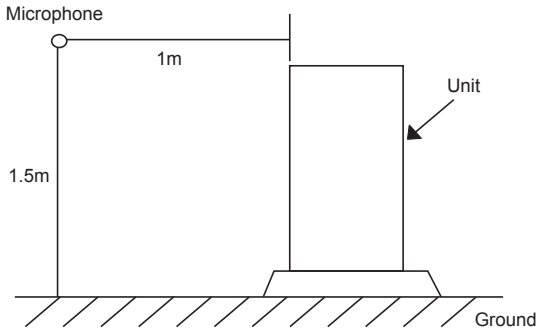

Sound level of PUMY-P250YBM

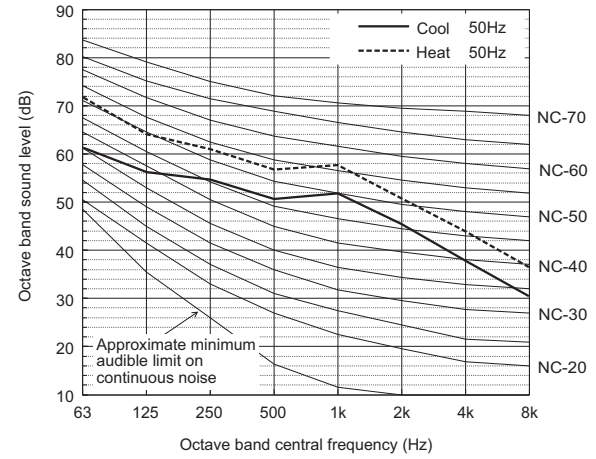

		63	125	250	500	1k	2k	4k	8k	dB(A)
Standard Cooling	50 Hz	61.3	56.2	54.7	50.7	51.8	45.5	37.8	30.4	55.0
Standard Heating	50 Hz	71.8	64.1	61.0	56.8	57.7	50.8	43.9	36.5	61.0

When Low noise mode is set, the A/C system's capacity is limited. The system could return to normal operation from Low noise mode automatically in the case that the operation condition is severe.

Sound level of PUMY-P200YKM2

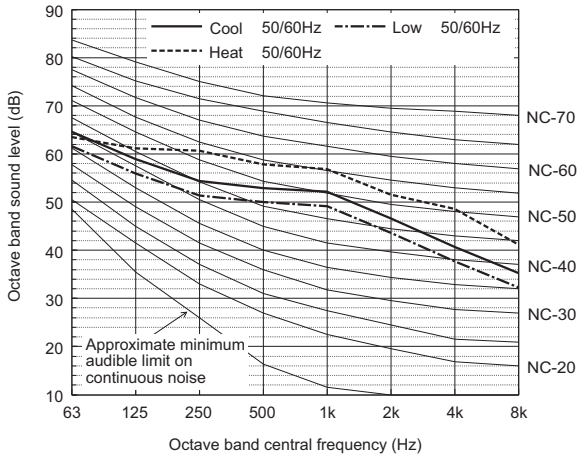

		63	125	250	500	1k	2k	4k	8k	dB(A)
Standard Cooling	50/60Hz	64.6	58.9	54.4	53.0	52.1	46.6	40.7	35.3	56.0
Standard Heating	50/60Hz	63.4	61.2	60.7	57.8	56.9	51.6	48.6	41.1	61.0
Low noise mode	50/60Hz	61.6	55.9	51.4	50.0	49.1	43.6	37.7	32.3	53.0

When Low noise mode is set, the A/C system's capacity is limited. The system could return to normal operation from Low noise mode automatically in the case that the operation condition is severe.

Sound level of PUMY-P300YBM

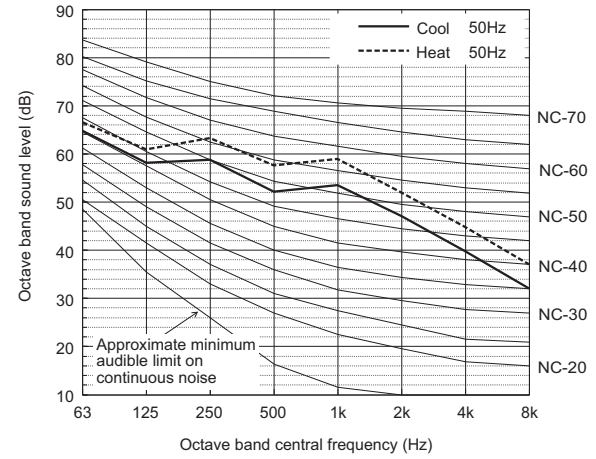

		63	125	250	500	1k	2k	4k	8k	dB(A)
Standard Cooling	50 Hz	64.7	58.1	58.7	52.1	53.5	47.0	39.7	32.0	57.0
Standard Heating	50 Hz	66.5	60.9	63.2	57.5	58.9	51.9	44.8	37.0	62.0

When Low noise mode is set, the A/C system's capacity is limited. The system could return to normal operation from Low noise mode automatically in the case that the operation condition is severe.

• Cooling

PUMY-P-VKM5/YKM4/YKME4
PUMY-P-YKM2
PUMY-P-YBM

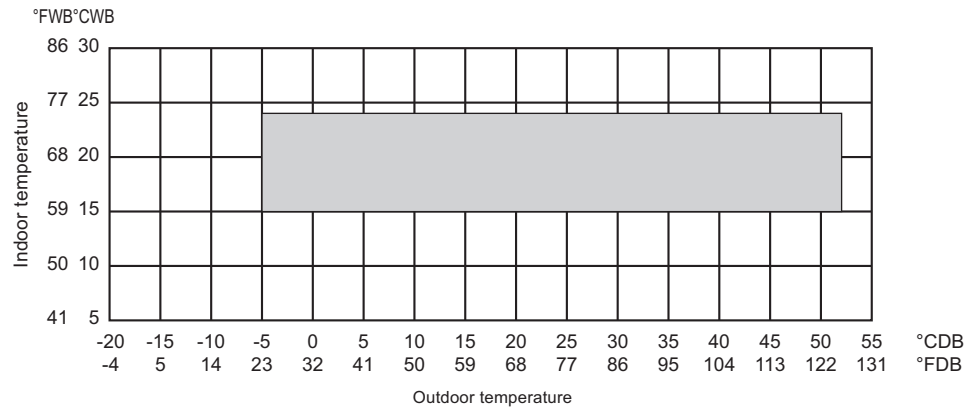

* [PUMY-P-VKM5/YKM4/YKME4]

10 to 52°CDB (50 to 126°FDB), when connecting following models: PKFY-P10/15/20/25/32VLM, PFFY-P20/25/32VLEM, PFFY-P20/25/32VLRM(M), PFFY-P20/25/32VKM, PFFY-P20/25/32VCM, PEFY-P25/32/40VMA3; and M-Series, S-Series, and P-Series type indoor unit.

[PUMY-P-YKM2]

10 to 52°CDB (50 to 126°FDB), when connecting following models: PKFY-P10/15/20/25/32VLM, PFFY-P20/25/32VLEM, PFFY-P20/25/32VLRM(M), PFFY-P20/25/32VKM, PFFY-P20/25/32VCM, PEFY-P40/63VMA3; and M-Series, S-Series, and P-Series type indoor unit.

[PUMY-P-YBM]

10 to 52°CDB (50 to 126°FDB), when connecting following models: PKFY-P10/15/20/25/32VLM, PFFY-P20/25/32VKM, PFFY-P20/25/32VCM, PFFY-P20/25/32VLEM, PEFY-P63/71/80VMA3-E; and M-Series type indoor unit.

• Heating

PUMY-P-VKM5/YKM4/YKME4
PUMY-P-YKM2
PUMY-P-YBM

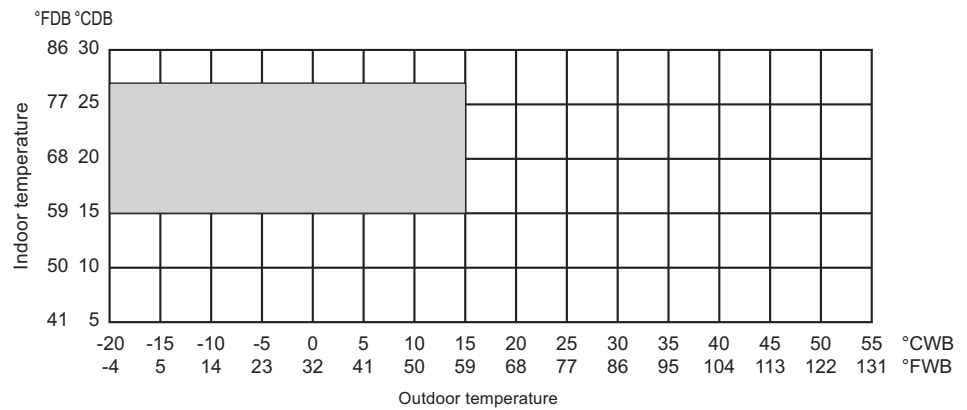

7-1. Selection of Cooling/Heating Units

How to determine the capacity when less than or equal 100% indoor model size units are connected in total:

The purpose of this flow chart is to select the indoor and outdoor units. For other purposes, this flow chart is intended only for reference.

PUMY-P-VKM5, YKM(E)4, YKM2, YBM

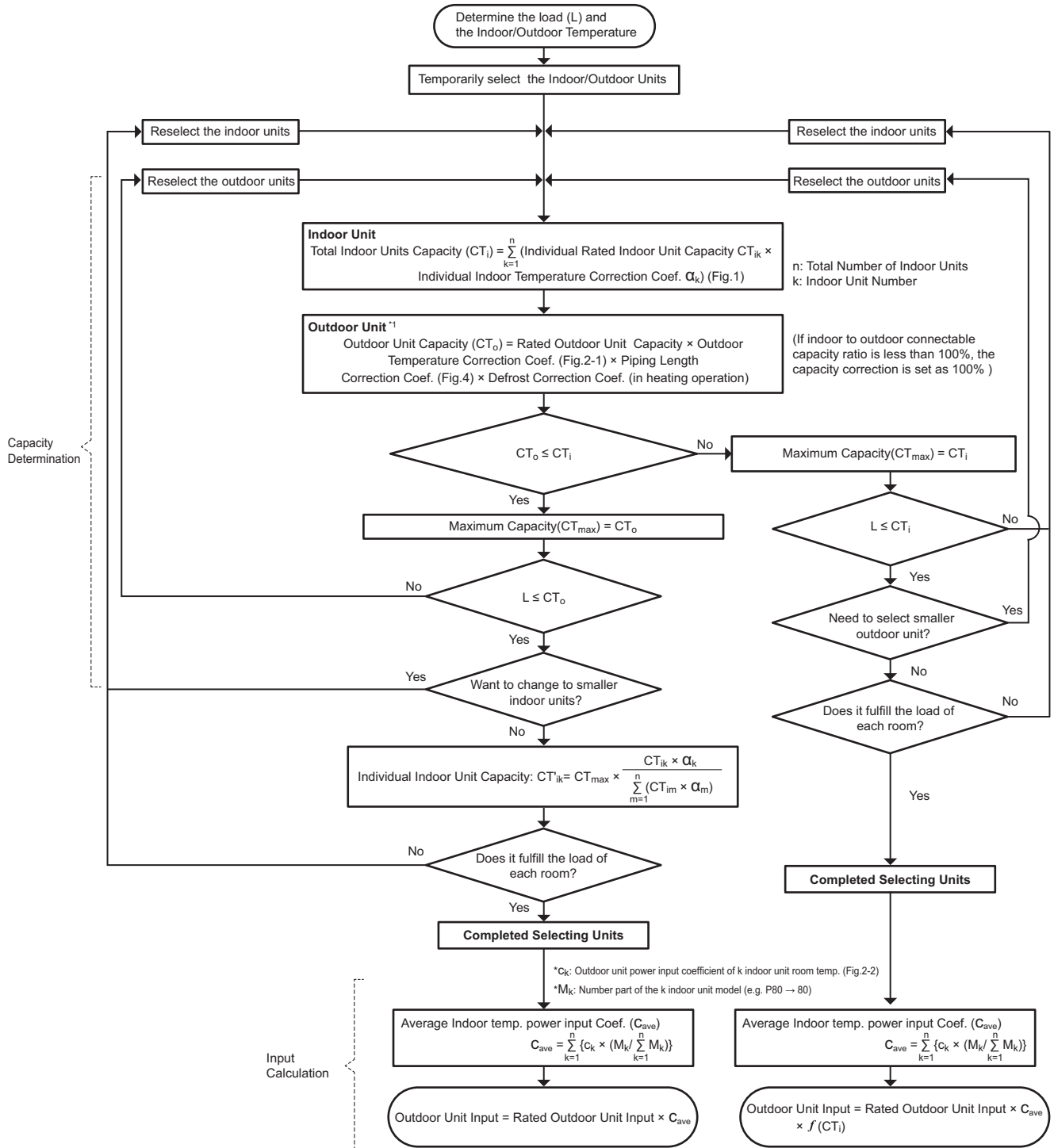

f(x) is the approximate correction function when less than or equal 100% model size units are input as connected. (Refer to "7-3 Correction by total indoor")

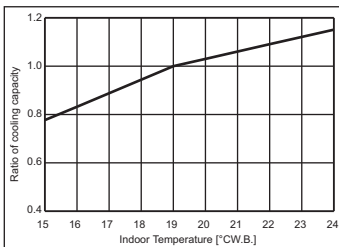

Fig.1 Indoor unit temperature correction *1

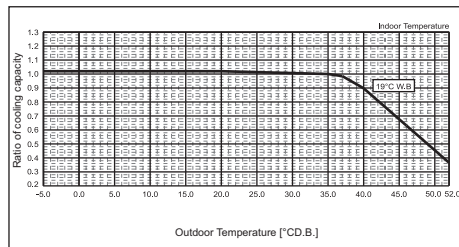

Fig.2-1 Outdoor unit temperature correction (capacity) *1

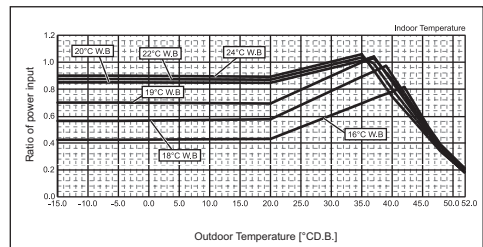
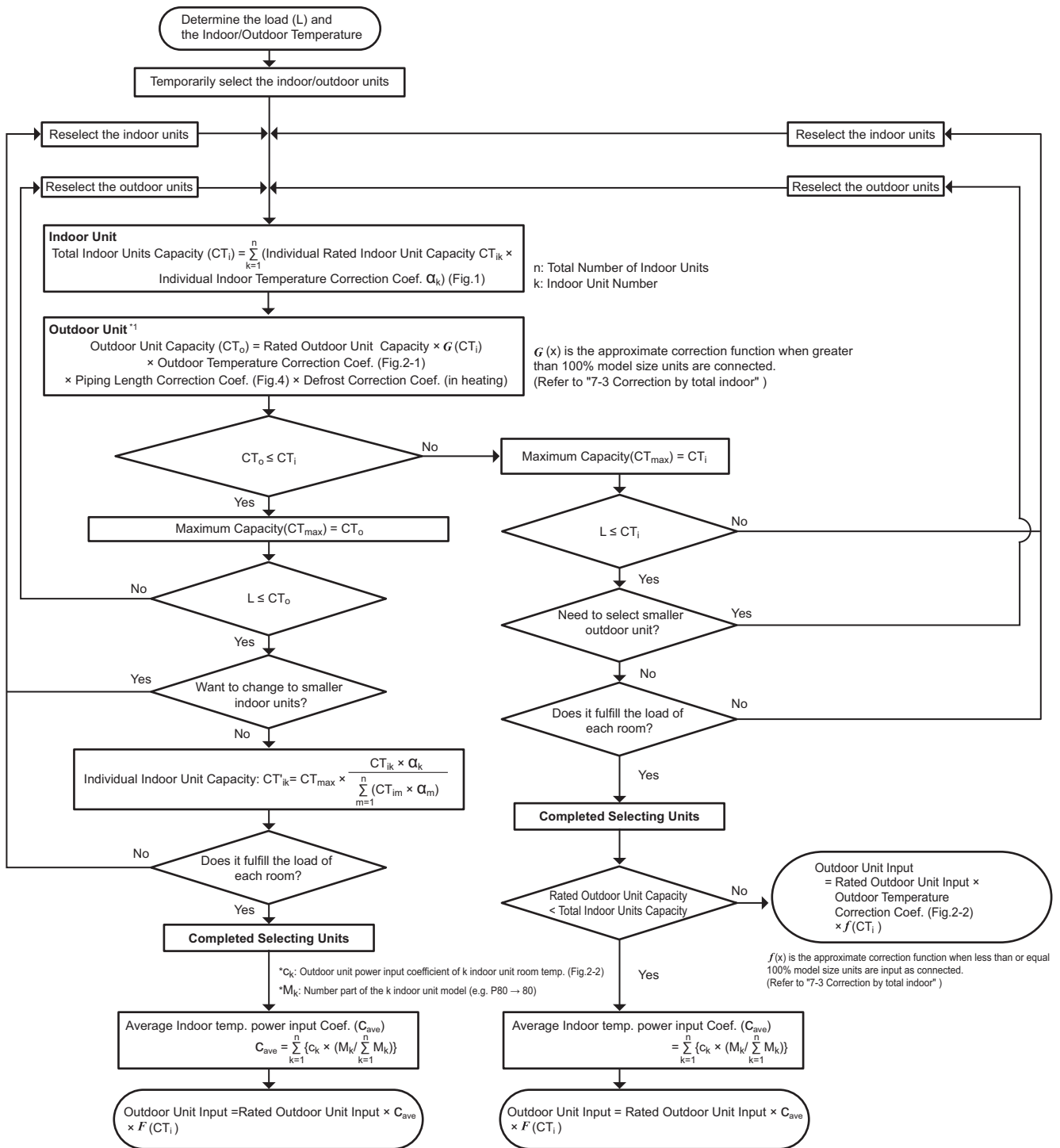

Fig.2-2 Outdoor unit temperature correction (power input) *1

*1 This figure shows the characteristic of PUMY-P112/125/140VKM5 (-BS) and PUMY-P112/125/140YKM4 (-BS).

How to determine the capacity when greater than 100% indoor model size units are connected in total:

The purpose of this flow chart is to select the indoor and outdoor units. For other purposes, this flow chart is intended only for reference.



F (x) is the approximate correction function when greater than 100% model size units are input as connected. (Refer to "7-3 Correction by total indoor")

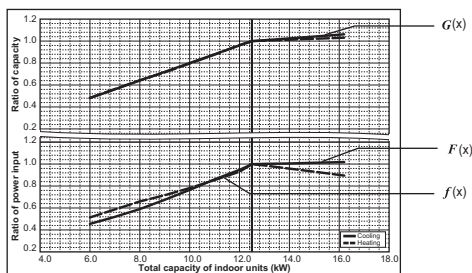

Fig.3 Correction by total indoor *1

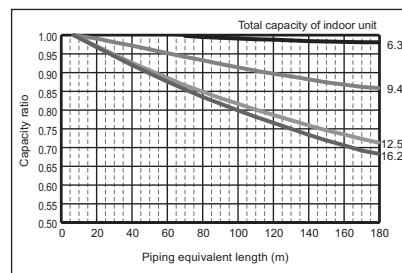

Fig.4 Correction of refrigerant piping length *1

*1 This figure shows the characteristic of PUMY-P112VKM5 (-BS) and PUMY-P112YKM4 (-BS).

<Cooling>

Design Condition	
Outdoor Design Dry Bulb Temperature	40.5°C
Total Cooling Load	8.5 kW
Room1	
Indoor Design Dry Bulb Temperature	27°C
Indoor Design Wet Bulb Temperature	20°C
Cooling Load	4.0 kW
Room2	
Indoor Design Dry Bulb Temperature	32°C
Indoor Design Wet Bulb Temperature	22°C
Cooling Load	4.5 kW
<Other>	
Indoor/Outdoor Equivalent Piping Length	60 m

1. Cooling Calculation

(1) Temporary Selection of Indoor Units

Room1	PEFY-P40	4.5 kW (Rated)
Room2	PEFY-P50	5.6 kW (Rated)

(2) Total Indoor Units Capacity

$P40 + P50 = P90$

(3) Selection of Outdoor Unit

The P112 outdoor unit is selected as total indoor units capacity is P90

PUMY-P112	12.5 kW
-----------	---------

(4) Total Indoor Units Capacity Correction Calculation

Room1	Indoor Design Wet Bulb Temperature Correction (20°C)	1.03 (Refer to Figure 1)
Room2	Indoor Design Wet Bulb Temperature Correction (22°C)	1.09 (Refer to Figure 1)

Total Indoor Units Capacity (CT_i)

$$CT_i = \sum (\text{Indoor Unit Rating} \times \text{Indoor Design Temperature Correction})$$

$$= 4.5 \times 1.03 + 5.6 \times 1.09$$

$$= 10.7 \text{ kW}$$

(5) Outdoor Unit Correction Calculation

Outdoor Design Dry Bulb Temperature Correction (40.5°C)	0.88 (Refer to Figure 2)
Piping Length Correction (60 m)	0.94 (Refer to Figure 3)
Total Outdoor Unit Capacity (CT _o)	
$CT_o = \text{Outdoor Rating} \times \text{Outdoor Design Temperature Correction} \times \text{Piping Length Correction}$	
$= 12.5 \times 0.88 \times 0.94$	
$= 10.3 \text{ kW}$	

(6) Determination of Maximum System Capacity

Comparison of Capacity between Total Indoor Units Capacity (CT_i) and Total Outdoor Unit Capacity (CT_o)

$CT_i = 10.7 > CT_o = 10.3$, thus, select CT_o.

$CT_{max} = CT_o = 10.3 \text{ kW}$

(7) Comparison with Essential Load

Against the essential load 8.5 kW, the maximum system capacity is 10.3 kW: Proper outdoor units have been selected.

(8) Calculation of Maximum Indoor Unit Capacity of Each Room

$CT_{max} = CT_o$, thus, calculate by the calculation below

Room1

$$\text{Maximum Capacity} \times \text{Room1 Capacity after the Temperature Correction} / (\text{Room1,2 Total Capacity after the Temperature Correction})$$

$$= 10.3 \times (4.5 \times 1.03) / (4.5 \times 1.03 + 5.6 \times 1.09)$$

$$= 4.4 \text{ kW} \quad \text{OK: fulfills the load 4.0 kW}$$

Room2

$$\text{Maximum Capacity} \times \text{Room2 Capacity after the Temperature Correction} / (\text{Room1,2 Total Capacity after the Temperature Correction})$$

$$= 10.3 \times (5.6 \times 1.09) / (4.5 \times 1.03 + 5.6 \times 1.09)$$

$$= 5.9 \text{ kW} \quad \text{OK: fulfills the load 4.5 kW}$$

Note: If $CT_{max} = CT_i$, please refer to the <Heating> section to calculate the Maximum Indoor Unit Capacity of Each Room.

Go on to the heating trial calculation since the selected units fulfill the cooling loads of Room 1, 2.

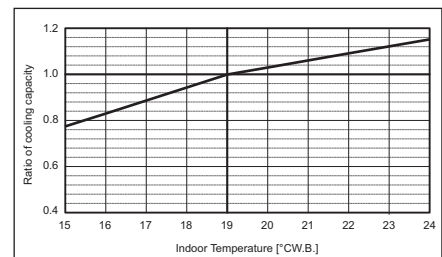

Figure 1 Indoor unit temperature correction
To be used to correct indoor unit only

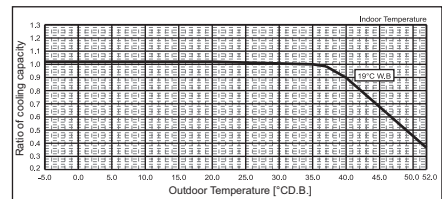

Figure 2 Outdoor unit temperature correction
To be used to correct outdoor unit only

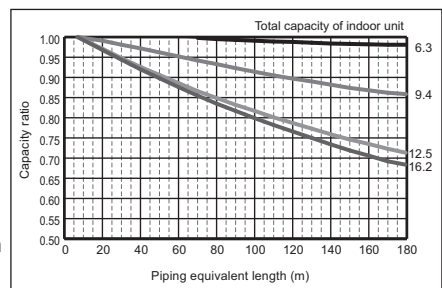

Figure 3 Correction of refrigerant piping length

<Heating>

Design Condition	
Outdoor Design Wet Bulb Temperature	2°C
Total Heating Load	10.3 kW
Room1	
Indoor Design Dry Bulb Temperature	21°C
Heating Load	4.8 kW
Room2	
Indoor Design Dry Bulb Temperature	23°C
Heating Load	5.5 kW
<Other>	
Indoor/Outdoor Equivalent Piping Length	90 m

2. Heating Calculation

(1) Temporary Selection of Indoor Units

Room1	PEFY-P40	5.0 kW (Rated)
Room2	PEFY-P50	6.3 kW (Rated)

(2) Total Indoor Units Capacity

P40 + P50 = P90

(3) Selection of Outdoor Unit

The P112 outdoor unit is selected as total indoor units capacity is P90
 PUMY-P112 **14.0 kW**

(4) Total Indoor Units Capacity Correction Calculation

Room1	Indoor Design Dry Bulb Temperature Correction (21°C)	0.96 (Refer to Figure 4)
Room2	Indoor Design Dry Bulb Temperature Correction (23°C)	0.88 (Refer to Figure 4)

Total Indoor Units Capacity (CT_i)

$$CT_i = \sum (\text{Indoor Unit Rating} \times \text{Indoor Design Temperature Correction})$$

$$= 5.0 \times 0.96 + 6.3 \times 0.88$$

$$= 10.3 \text{ kW}$$

(5) Outdoor Unit Correction Calculation

Outdoor Design Wet Bulb Temperature Correction (2°C)	1.0 (Refer to Figure 5)
Piping Length Correction (90 m)	0.95 (Refer to Figure 6)
Defrost Correction	0.89 (Refer to Table 1)

Total Outdoor Unit Capacity (CT_o)

$$CT_o = \text{Outdoor Unit Rating} \times \text{Outdoor Design Temperature Correction} \times \text{Piping Length Correction} \times \text{Defrost Correction}$$

$$= 14.0 \times 1.0 \times 0.95 \times 0.89$$

$$= 11.8 \text{ kW}$$

(6) Determination of Maximum System Capacity

Comparison of Capacity between Total Indoor Units Capacity (CT_i) and Total Outdoor Unit Capacity (CT_o)

CT_i = 10.3 < CT_o = 11.8, thus, select CT_i.
 CT_{max} = CT_i = 10.3 kW

(7) Comparison with Essential Load

Against the essential load 10.3 kW, the maximum system capacity is 10.3 kW: Proper indoor units have been selected.

(8) Calculation of Maximum Indoor Unit Capacity of Each Room

CT_{max} = CT_i, thus, calculate by the calculation below

Room1	Indoor Unit Rating × Indoor Design Temperature Correction	= 5.0 × 0.96	OK: fulfills the load 4.8 kW
		= 4.8 kW	

Room2	Indoor Unit Rating × Indoor Design Temperature Correction	= 6.3 × 0.88	OK: fulfills the load 5.5 kW
		= 5.5 kW	

Note: If CT_{max} = CT_o, please refer to the <Cooling> section to calculate the Maximum Indoor Unit Capacity of Each Room.
 Completed selecting units since the selected units fulfill the heating loads of Room 1, 2.

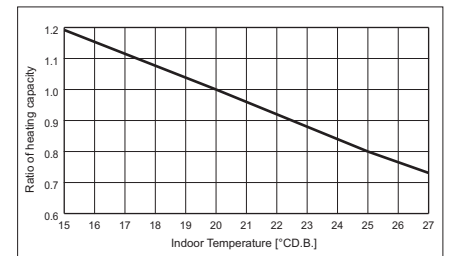

Figure 4 Indoor unit temperature correction
 To be used to correct indoor unit only

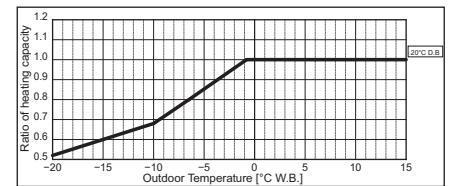

Figure 5 Outdoor unit temperature correction
 To be used to correct outdoor unit only

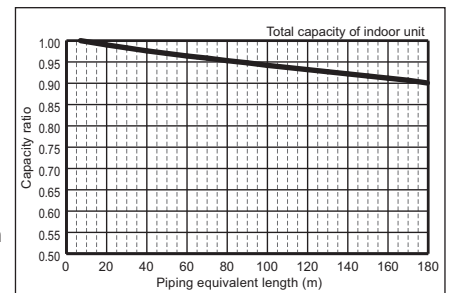

Figure 6 Correction of refrigerant piping length

Table 1 Table of correction factor at frost and defrost

Outdoor inlet air temp. °C W.B.	6	4	2	0	-2	-4	-6	-8	-10	-15	-20
PUMY-P112,125,140VKM5	1.0	0.98	0.89	0.88	0.89	0.90	0.95	0.95	0.95	0.95	0.95
PUMY-P112,125,140YKME4	1.0	0.98	0.89	0.88	0.89	0.90	0.95	0.95	0.95	0.95	0.95

3. Power input of outdoor unit

<Cooling>

(1) Rated power input of outdoor unit **2.79 kW****(2) Calculation of the average indoor temperature power input coefficient**

Coefficient of the outdoor unit for indoor unit 1 (Outdoor temp. 40.5 °CD.B., Indoor temp. 20 °CW.B.)

0.82

Coefficient of the outdoor unit for indoor unit 2 (Outdoor temp. 40.5 °CD.B., Indoor temp. 22 °CW.B.)

0.76

$$\text{Average indoor temp. power input coefficient } (C_{ave}) = \sum_{k=1}^n \{c_k \times (M_k / \sum_{k=1}^n M_k)\}$$

n: Total number of the indoor units

k: Number of the indoor unit

c_k: Outdoor unit power input coefficient of k indoor unit room temp.M_k: Number part of the k indoor unit model (e.g. P80 → 80)

$$= 0.82 \times 40 / (40 + 50) + 0.76 \times 50 / (40 + 50)$$

$$= 0.79$$

(3) No need to consider Coefficient of the partial load f(CT_i) -**(4) Outdoor power input (PI_o)**Maximum System Capacity (CT_{max}) = Total Outdoor unit Capacity (CT_o), so use the following formula

$$PI_o = \text{Outdoor unit Cooling Rated Power Input} \times C_{ave}$$

$$= 2.79 \times 0.79$$

$$= 2.20 \text{ kW}$$

<Heating>

(1) Rated power input of outdoor unit **3.04 kW****(2) Calculation of the average indoor temperature power input coefficient**Coefficient of the outdoor unit for indoor unit 1 (Outdoor temp. 2 °CW.B., Indoor temp. 21 °CD.B.)
1.12Coefficient of the outdoor unit for indoor unit 2 (Outdoor temp. 2 °CW.B., Indoor temp. 22 °CD.B.)
1.0

$$\text{Average indoor temp. power input coefficient } (C_{ave}) = \sum_{k=1}^n \{c_k \times (M_k / \sum_{k=1}^n M_k)\}$$

n: Total number of the indoor units

k: Number of the indoor unit

c_k: Outdoor unit power input coefficient of k indoor unit room temp.M_k: Number part of the k indoor unit model (e.g. P80 → 80)

$$= 1.12 \times 40 / (40 + 50) + 1.0 \times 50 / (40 + 50)$$

$$= 1.05$$

(3) Coefficient of the partial load $f(CT_i)$ **0.89****(4) Outdoor power input (PI_o)**Maximum System Capacity (CT_{max}) = Total Indoor unit Capacity (CT_i), so use the following formula

$$PI_o = \text{Outdoor unit Heating Rated Power Input} \times C_{ave} \times f(CT_i)$$

$$= 3.04 \times 1.05 \times 0.89$$

$$= 2.84 \text{ kW}$$

7-2. Correction by temperature

CITY MULTI could have varied capacity at different designing temperature. Using the nominal cooling/heating capacity value and the ratio below, the capacity can be observed at various temperature.

<Cooling>

PUMY-		P112VKM5	P125VKM5	P140VKM5
Nominal Cooling Capacity	kW	12.5	14.0	15.5
	BTU/h	42,650	47,768	52,886
Input	kW	2.79	3.46	4.52

PUMY-		P112YKM(E)4	P125YKM(E)4	P140YKM(E)4
Nominal Cooling Capacity	kW	12.5	14.0	15.5
	BTU/h	42,650	47,768	52,886
Input	kW	2.79	3.46	4.52

Indoor unit temperature correction

To be used to correct indoor unit capacity only

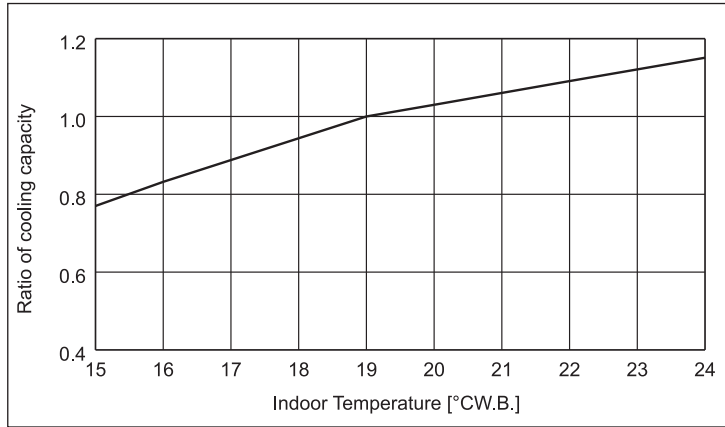

Outdoor unit temperature correction

To be used to correct outdoor unit only

Outdoor unit capacity is NOT affected by the indoor temperature.

Outdoor unit power input is affected by the indoor and outdoor temperatures. Please consult the sales office for details.

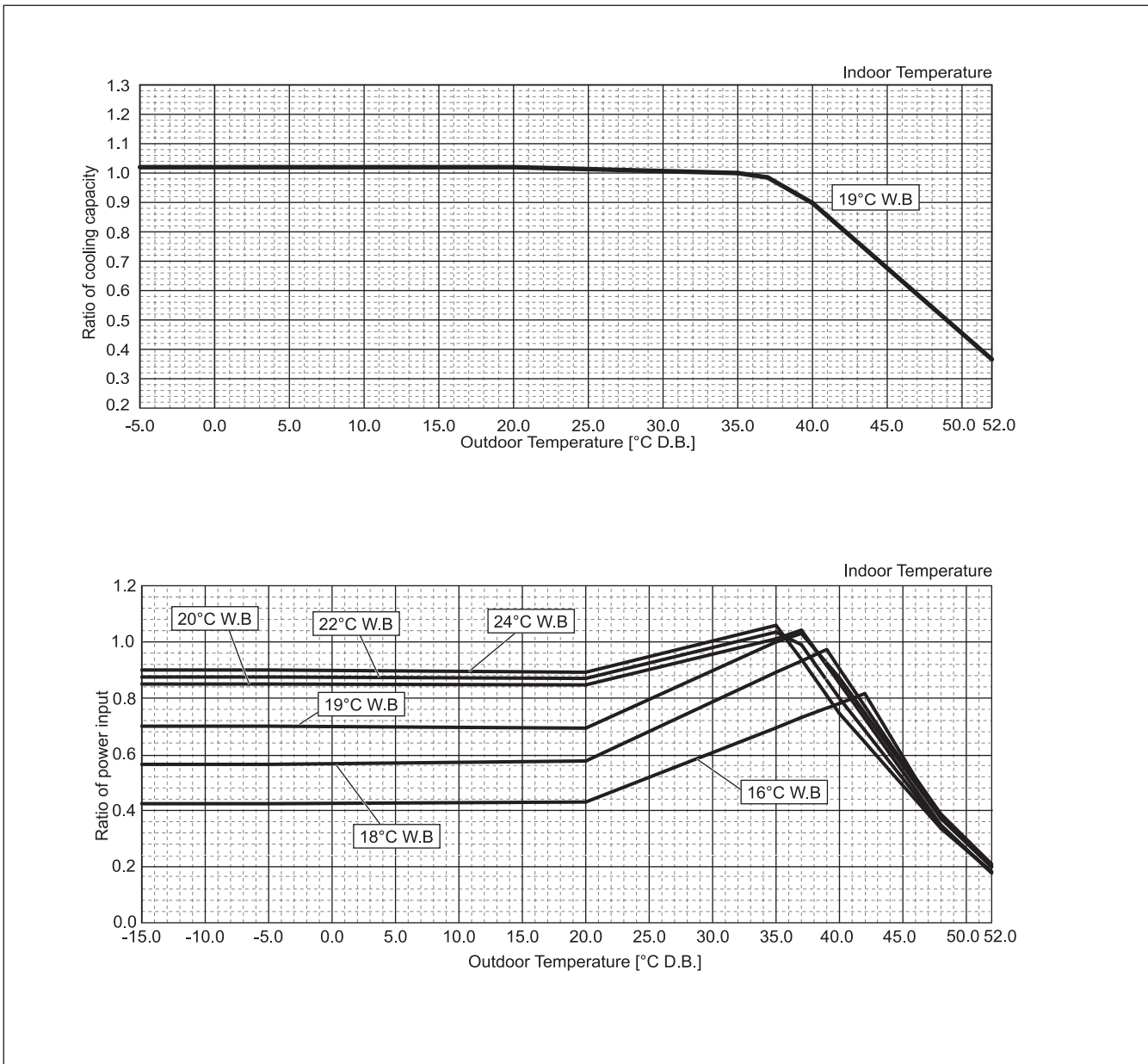

PUMY-P-VKM5, YKM(E)4, YKM2, YBM

<Heating>

PUMY-		P112VKM5	P125VKM5	P140VKM5
Nominal Heating Capacity	kW	14.0	16.0	18.0
	BTU/h	47,768	54,592	61,416
Input	kW	3.04	3.74	4.47

PUMY-		P112YKM(E)4	P125YKM(E)4	P140YKM(E)4
Nominal Heating Capacity	kW	14.0	16.0	18.0
	BTU/h	47,768	54,592	61,416
Input	kW	3.04	3.74	4.47

Indoor unit temperature correction

To be used to correct indoor unit capacity only

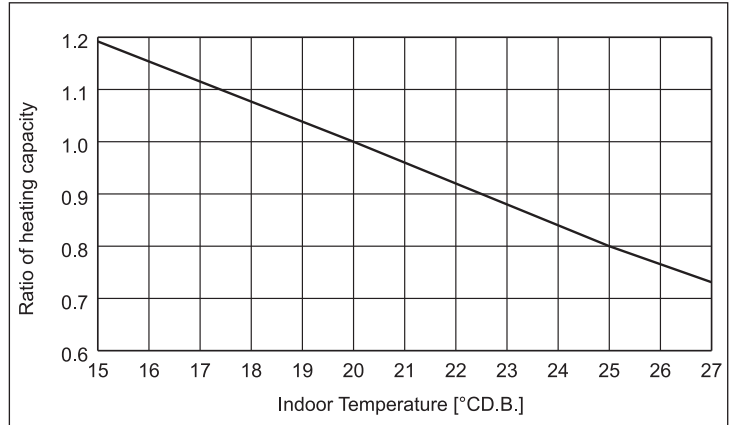

Outdoor unit temperature correction

To be used to correct outdoor unit only

Outdoor unit capacity is NOT affected by the indoor temperature.

Outdoor unit power input is affected by the indoor and outdoor temperatures. Please consult the sales office for details.

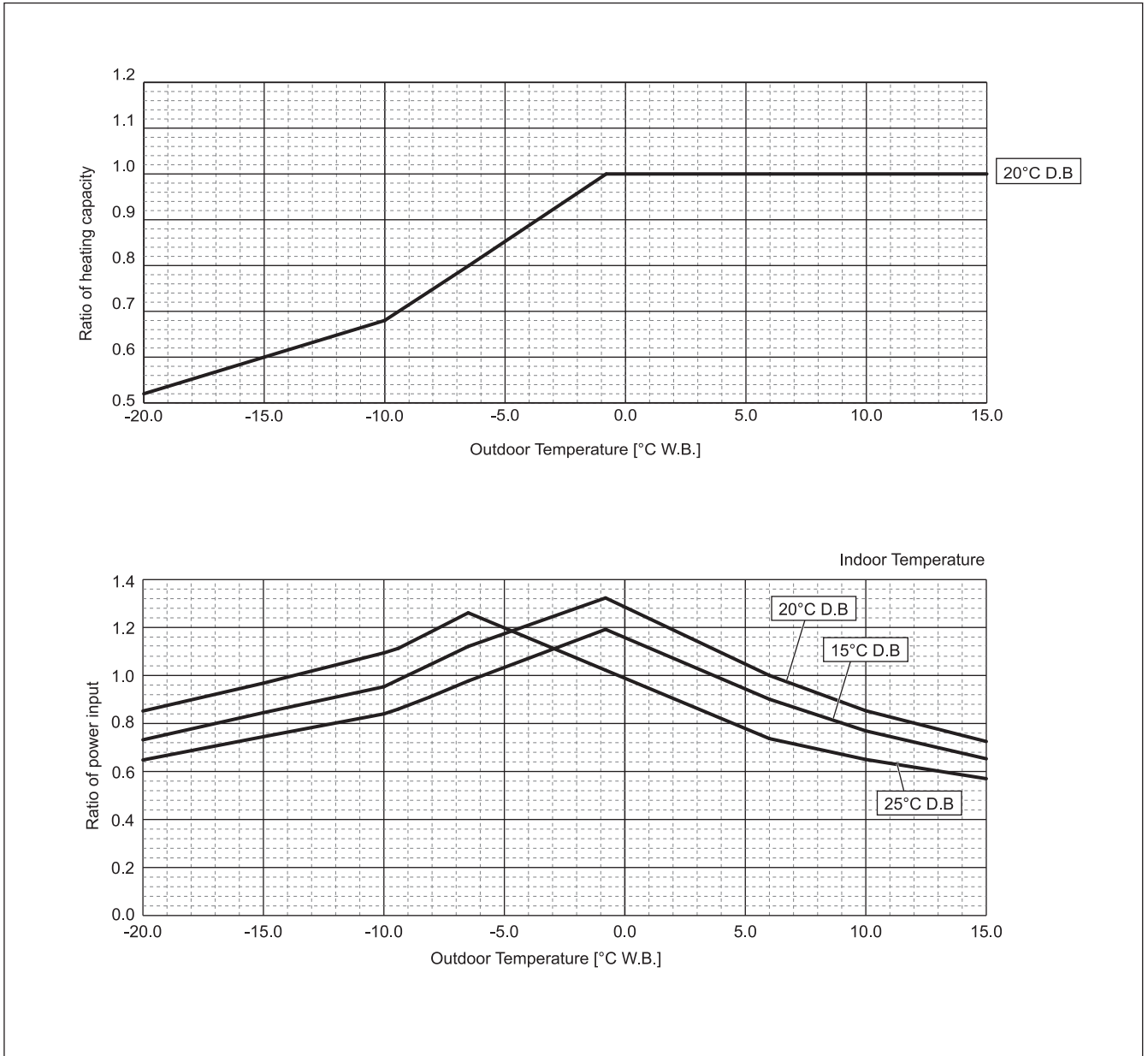

PUMY-P-VKM5, YKM(E)4, YKM2, YBM

<Cooling>

PUMY-		P200YKM2
Nominal Cooling Capacity	kW	22.4
	BTU/h	76,400
Input	kW	6.05

Indoor unit temperature correction

To be used to correct indoor unit capacity only

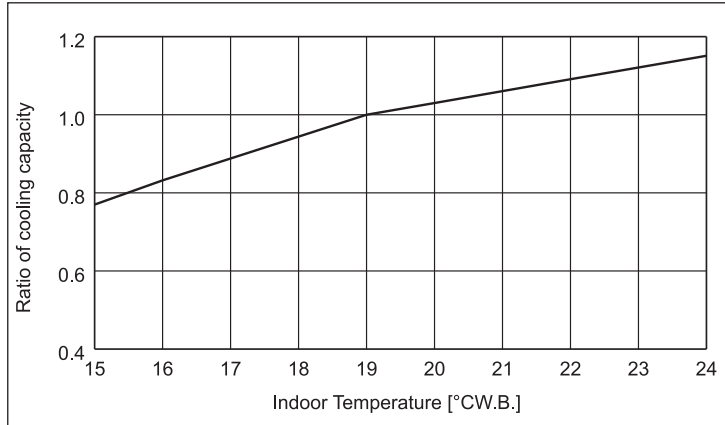

Outdoor unit temperature correction

To be used to correct outdoor unit only

Outdoor unit capacity is NOT affected by the indoor temperature.

Outdoor unit power input is affected by the indoor and outdoor temperatures. Please consult the sales office for details.

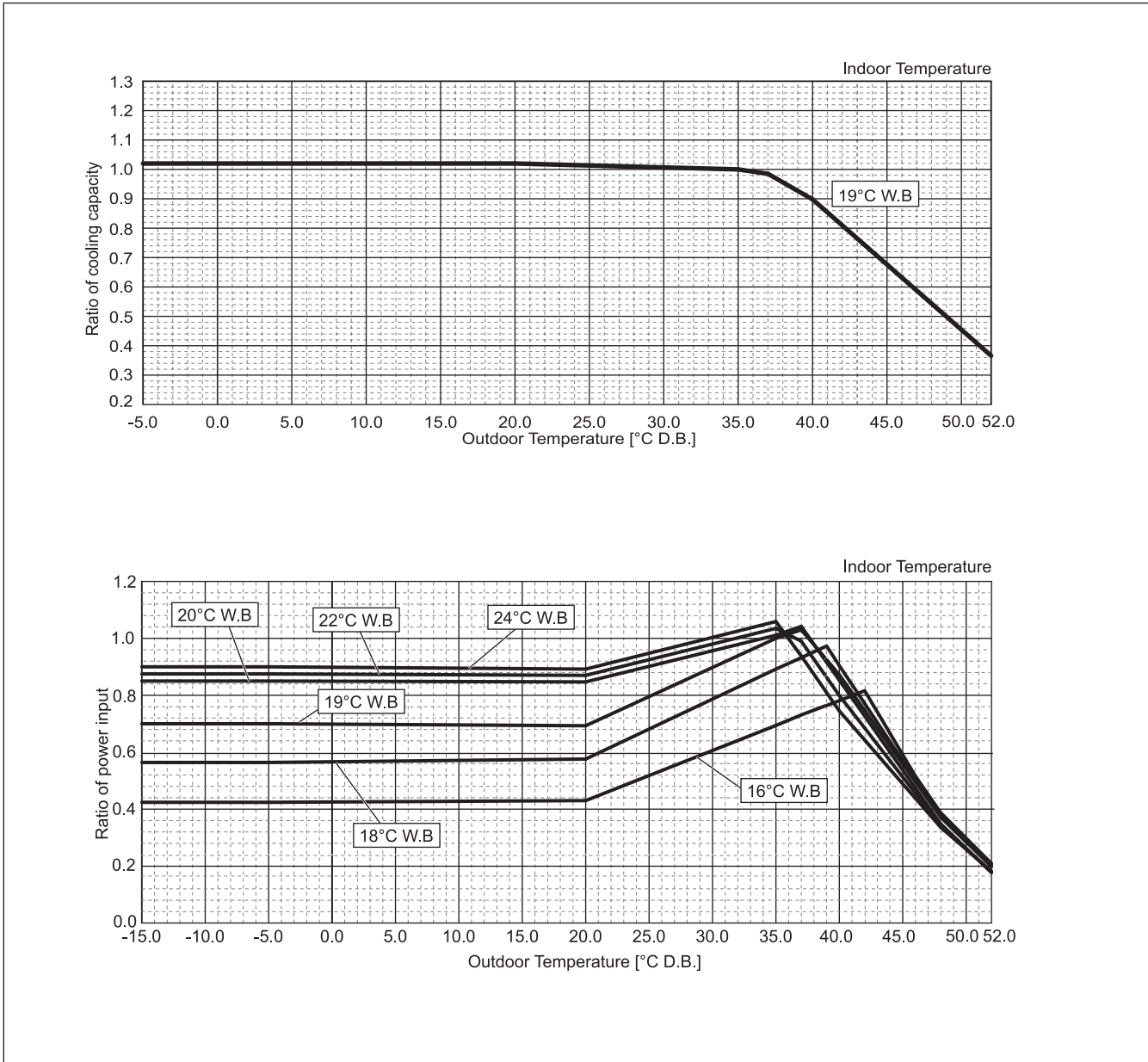

PUMY-P-VKM5, YKM(E)4, YKM2, YBM

<Heating>

PUMY-		P200YKM2
Nominal Heating Capacity	kW	25.0
	BTU/h	85,300
Input	kW	5.84

Indoor unit temperature correction

To be used to correct indoor unit capacity only

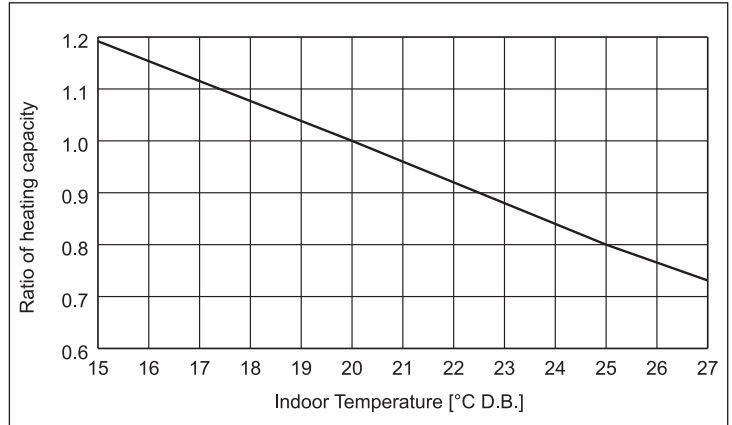

Outdoor unit temperature correction

To be used to correct outdoor unit only

Outdoor unit capacity is NOT affected by the indoor temperature.

Outdoor unit power input is affected by the indoor and outdoor temperatures. Please consult the sales office for details.

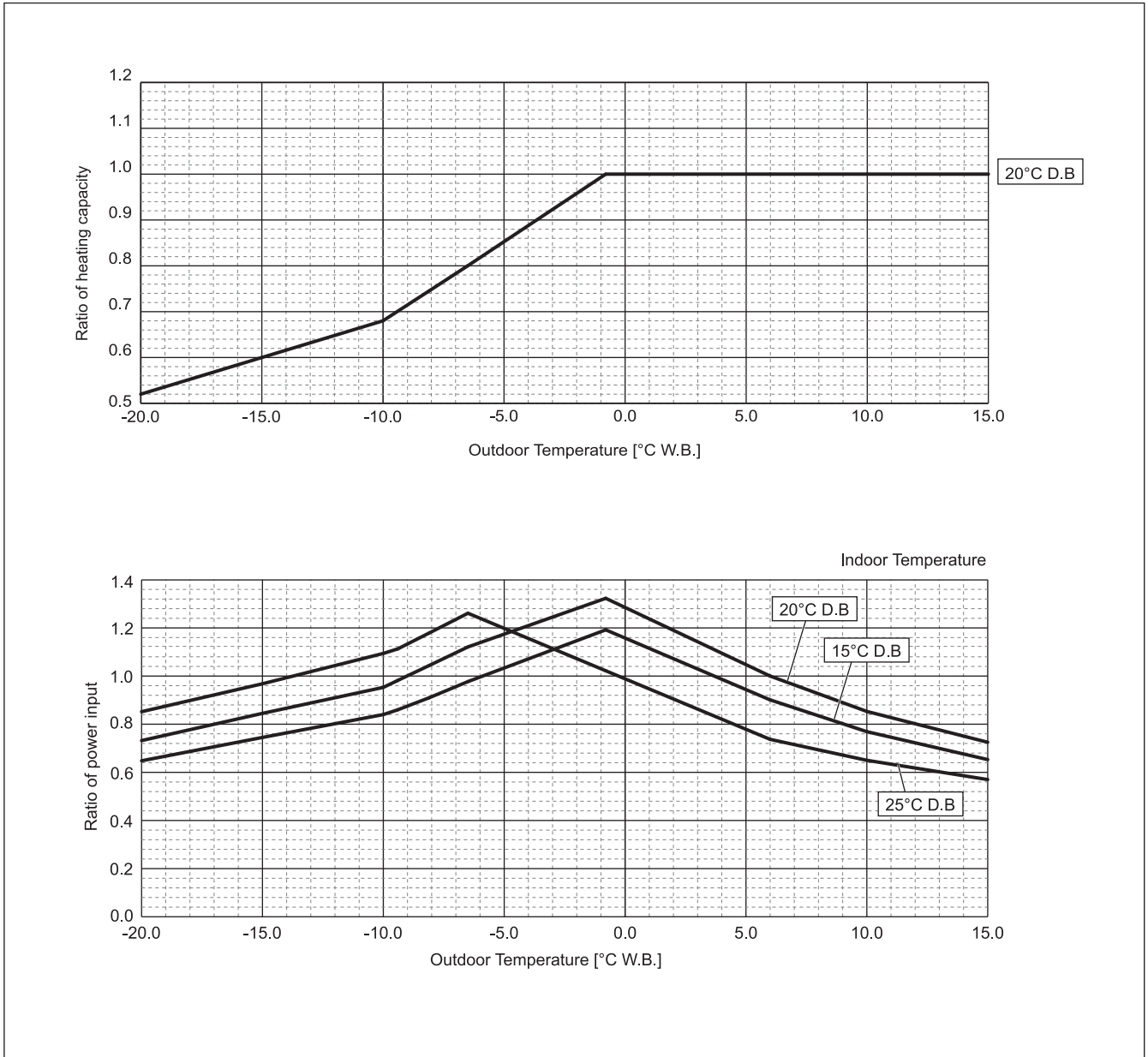

PUMY-P-VKM15, YKM(E)4, YKM2, YBM

<Cooling>

PUMY-		P250YBM	P300YBM
Nominal Cooling Capacity	kW	28.0	33.5
	BTU/h	95,500	114,300
Input	kW	8.21	10.12

Indoor unit temperature correction

To be used to correct indoor unit capacity only

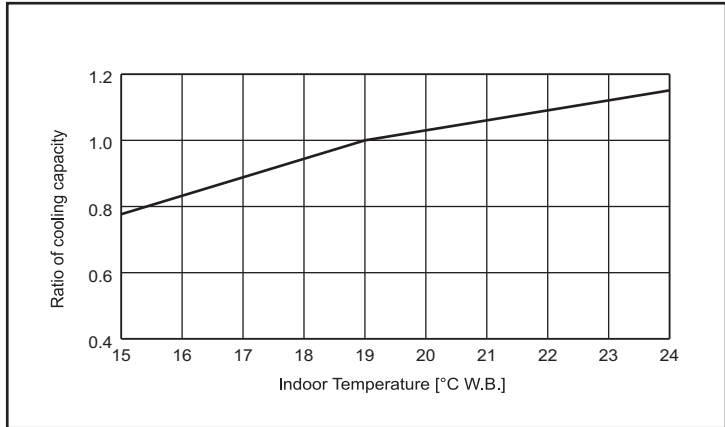

Outdoor unit temperature correction

To be used to correct outdoor unit only

Outdoor unit capacity is NOT affected by the indoor temperature.

Outdoor unit power input is affected by the indoor and outdoor temperatures. Please consult the sales office for details.

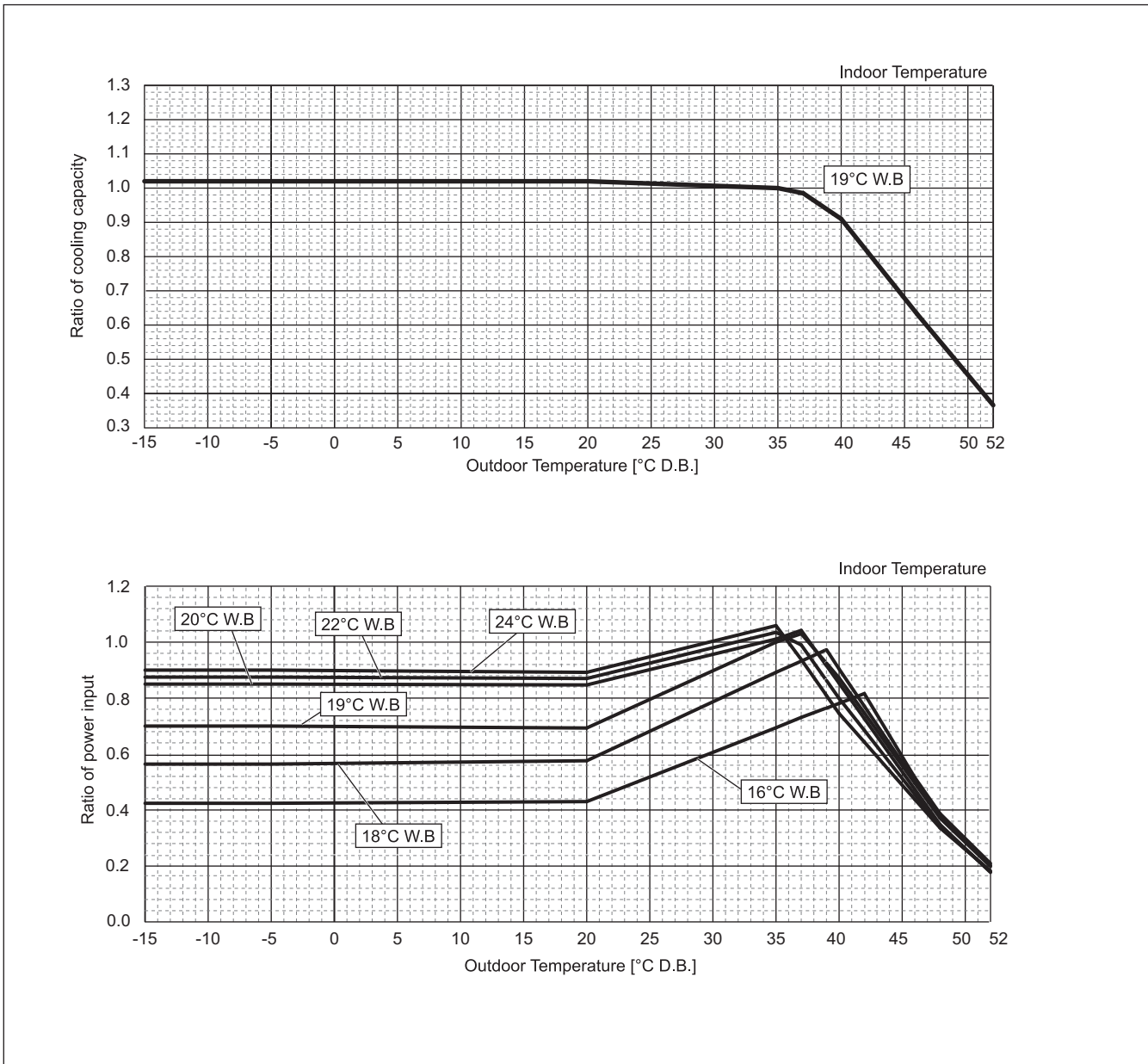

PUMY-P-VKM5, YKM(E)4, YKM2, YBM

<Heating>

PUMY-		P250YBM	P300YBM
Nominal Heating Capacity	kW	31.5	37.5
	BTU/h	107,500	128,000
Input	kW	7.41	9.12

Indoor unit temperature correction

To be used to correct indoor unit capacity only

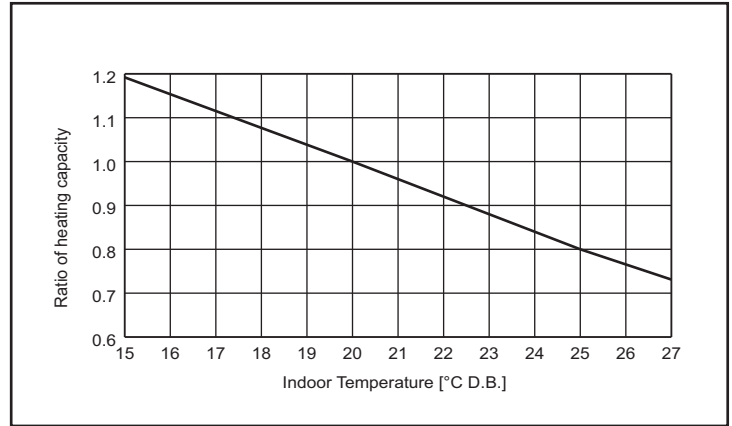

Outdoor unit temperature correction

To be used to correct outdoor unit only

Outdoor unit capacity is NOT affected by the indoor temperature.

Outdoor unit power input is affected by the indoor and outdoor temperatures. Please consult the sales office for details.

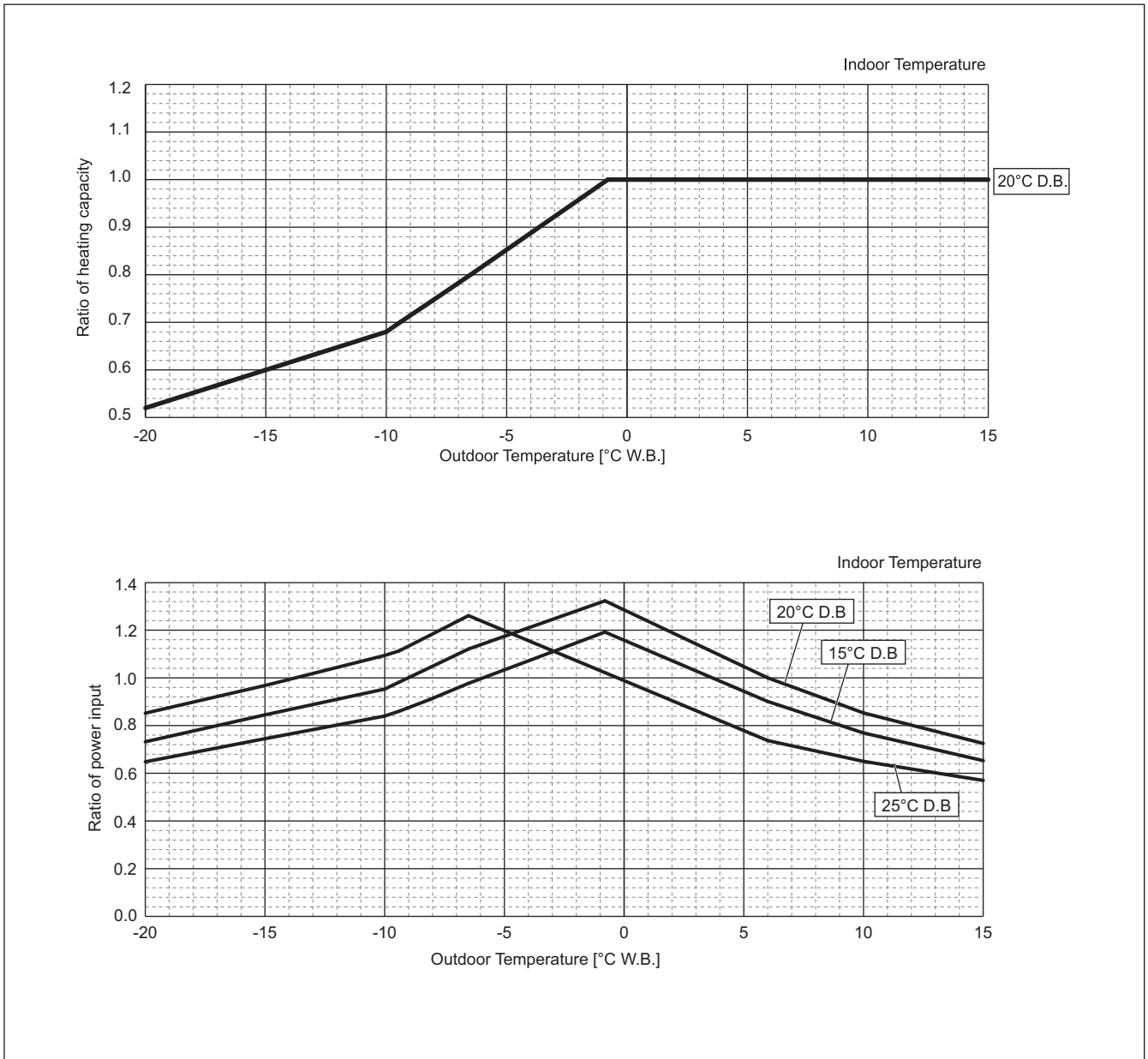

PUMY-P-VKM5, YKM(E)4, YKM2, YBM

7-3. Correction by total indoor

CITY MULTI system has different capacities and inputs when many combinations of indoor units with different total capacities are connected. Using following tables, the maximum capacity can be found to ensure the system is installed with enough capacity for a particular application.

PUMY-P-VKM5, YKM(E)4, YKM2, YBM

PUMY-P112VKM5/YKM(E)4		
Nominal Cooling Capacity	kW	12.5
	BTU/h	42,650
Input	kW	2.79

PUMY-P112VKM5/YKM(E)4		
Nominal Heating Capacity	kW	14.0
	BTU/h	47,768
Input	kW	3.04

PUMY-P112VKM5/YKM(E)4

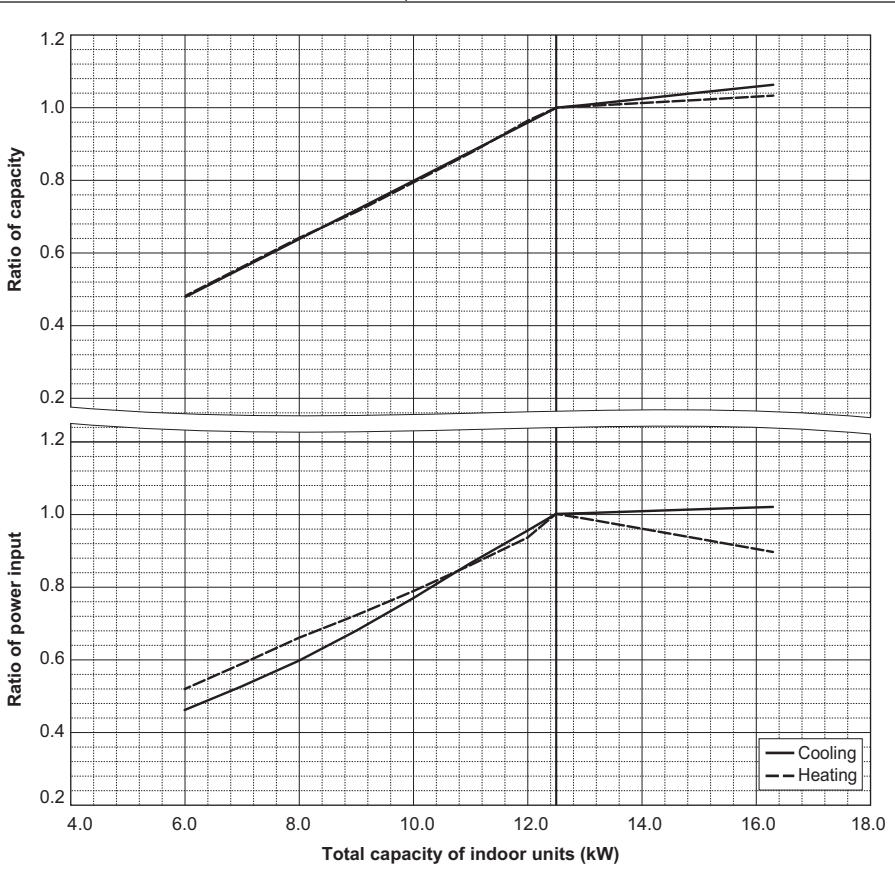

PUMY-P125VKM5/YKM(E)4		
Nominal Cooling Capacity	kW	14.0
	BTU/h	47,768
Input	kW	3.46

PUMY-P125VKM5/YKM(E)4		
Nominal Heating Capacity	kW	16.0
	BTU/h	54,592
Input	kW	3.74

PUMY-P125VKM5/YKM(E)4

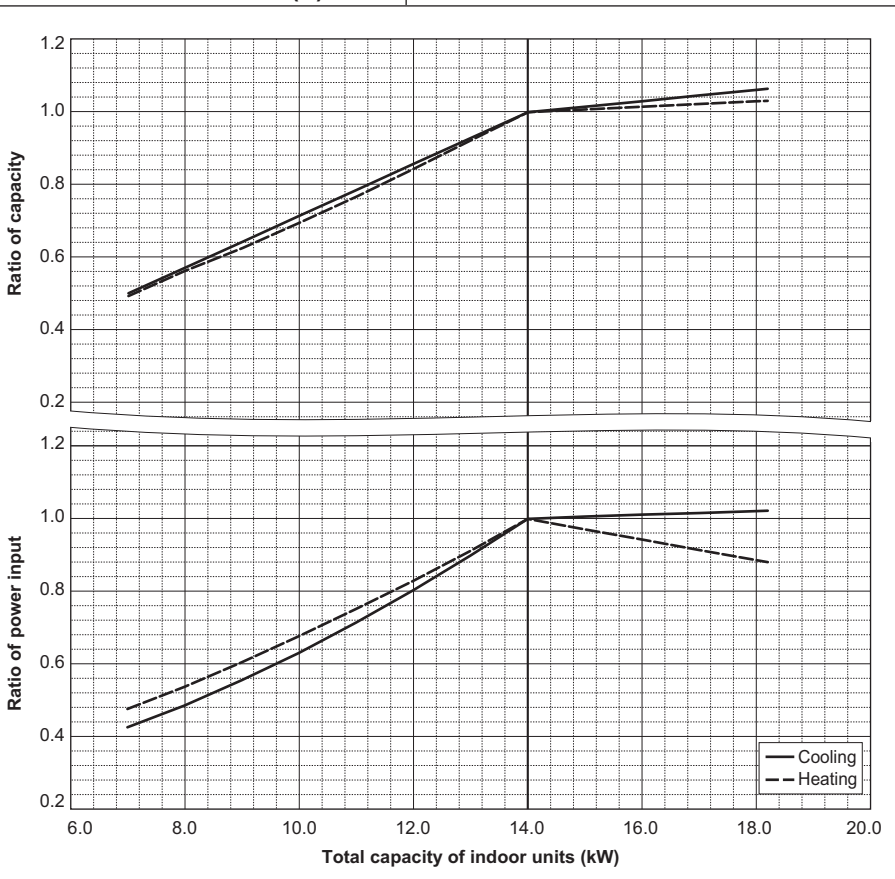

PUMY-P140VKM5/YKM(E)4		
Nominal Cooling Capacity	kW	15.5
	BTU/h	52,886
Input	kW	4.52

PUMY-P140VKM5/YKM(E)4		
Nominal Heating Capacity	kW	18.0
	BTU/h	61,416
Input	kW	4.47

PUMY-P140VKM5/YKM(E)4

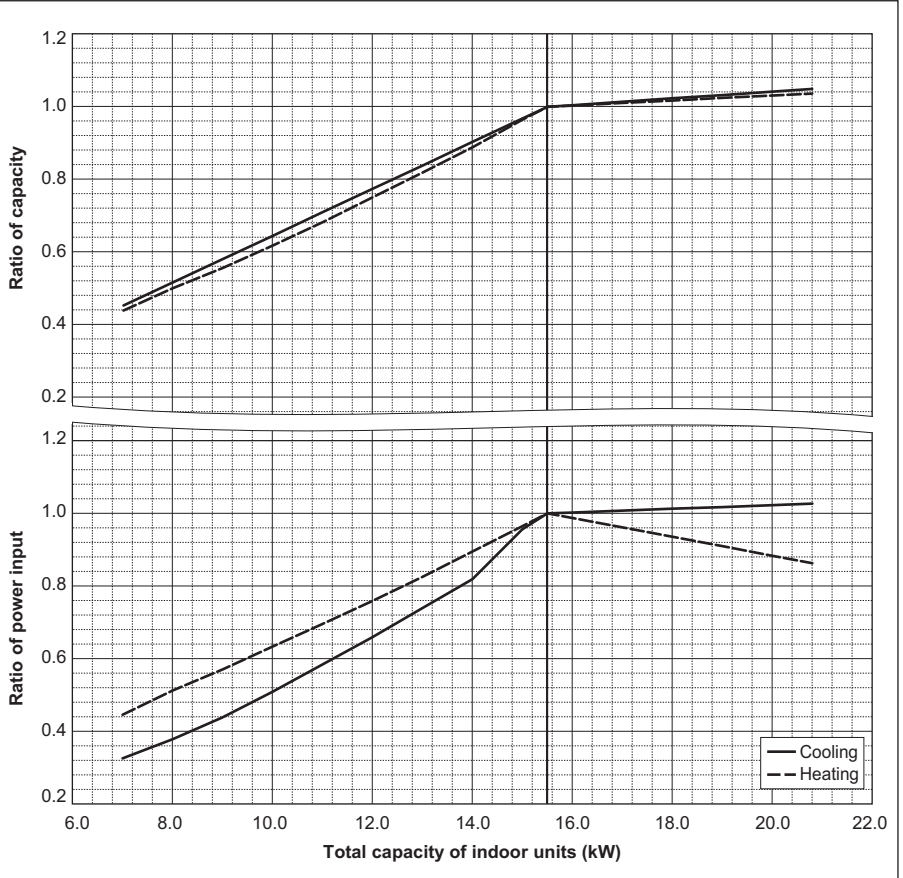

PUMY-P200YKM2		
Nominal Cooling Capacity	kW	22.4
	BTU/h	76,400
Input	kW	6.05

PUMY-P200YKM2		
Nominal Heating Capacity	kW	25.0
	BTU/h	85,300
Input	kW	5.84

PUMY-P200YKM2

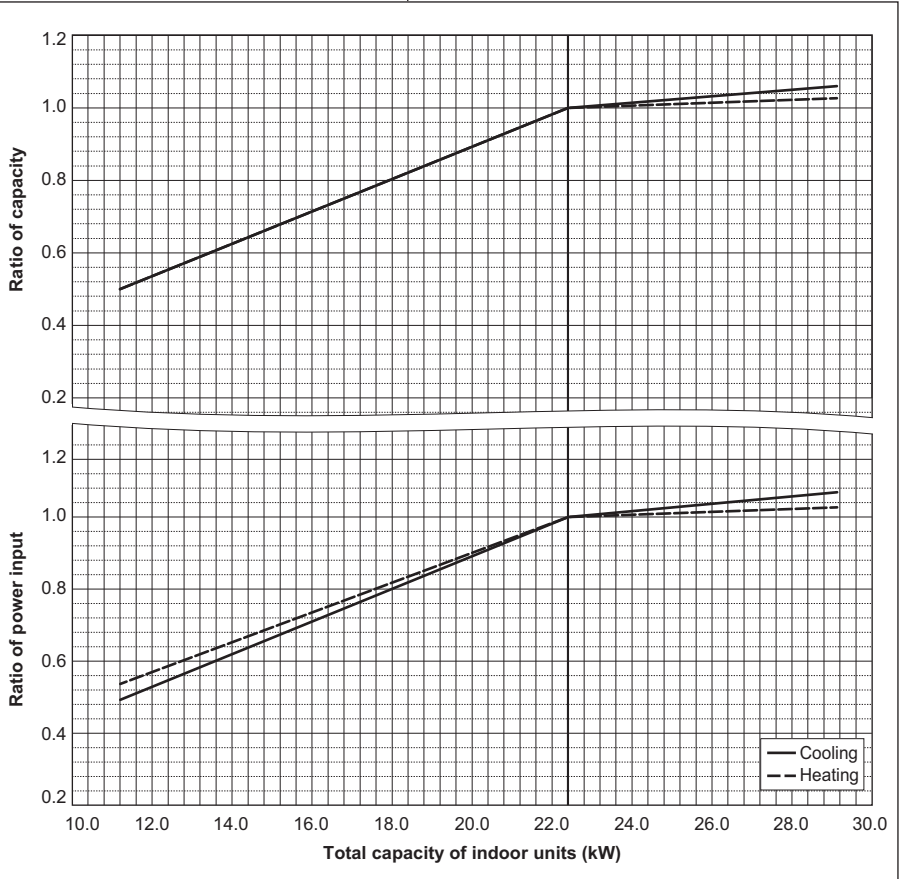

PUMY-P-VKM5, YKM(E)4, YKM2, YBM

PUMY-P250YBM (-BS)		
Nominal Cooling Capacity	kW	28.0
	BTU/h	95,500
Input	kW	8.21

PUMY-P250YBM (-BS)		
Nominal Heating Capacity	kW	31.5
	BTU/h	107,500
Input	kW	7.41

PUMY-P250YBM (-BS)

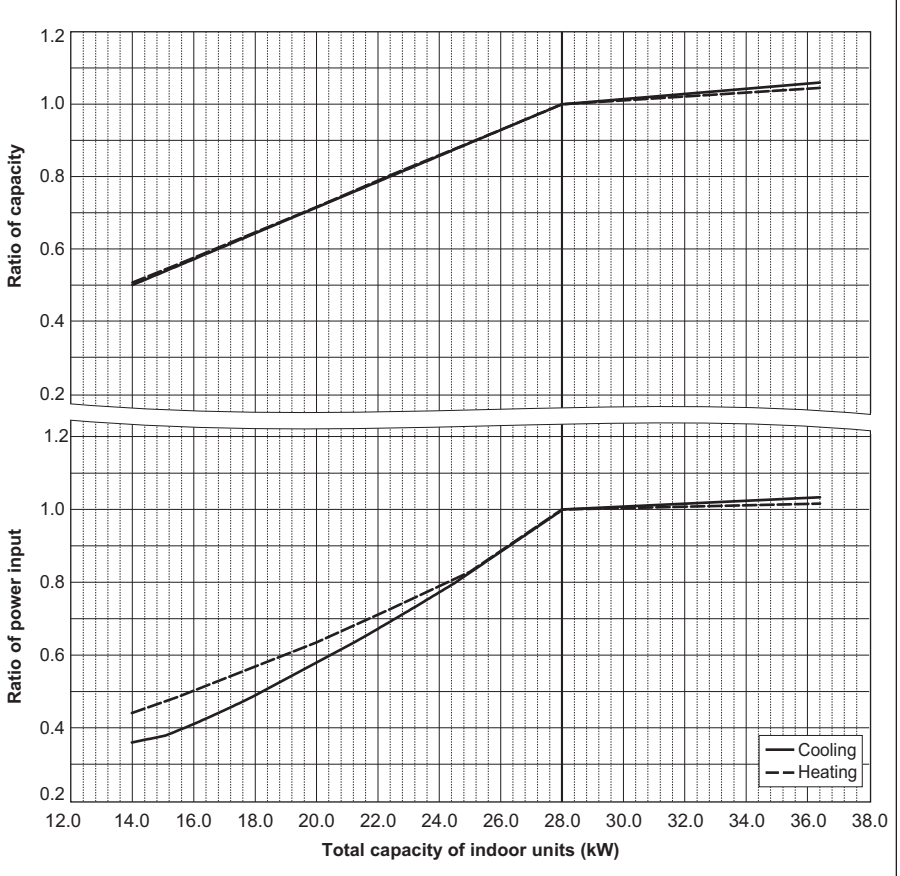

PUMY-P300YBM (-BS)		
Nominal Cooling Capacity	kW	33.5
	BTU/h	114,300
Input	kW	10.12

PUMY-P300YBM (-BS)		
Nominal Heating Capacity	kW	37.5
	BTU/h	128,000
Input	kW	9.12

PUMY-P300YBM (-BS)

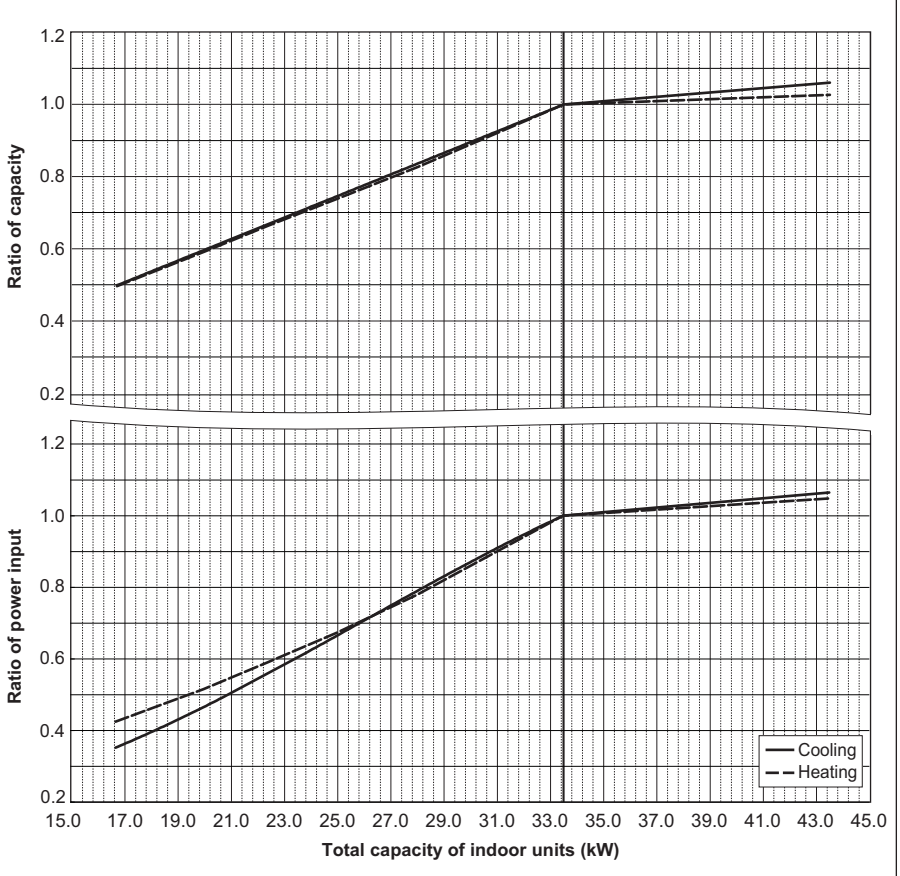

7-4. Correction by refrigerant piping length

CITY MULTI systems can have extended piping lengths if certain limitations are followed, but cooling/heating capacity could be reduced. Using following correction factor by equivalent piping length shown at 7-4-1 and 7-4-2, capacity can be found. 7-4-3 shows how to obtain the equivalent piping length.

7-4-1. Cooling capacity correction

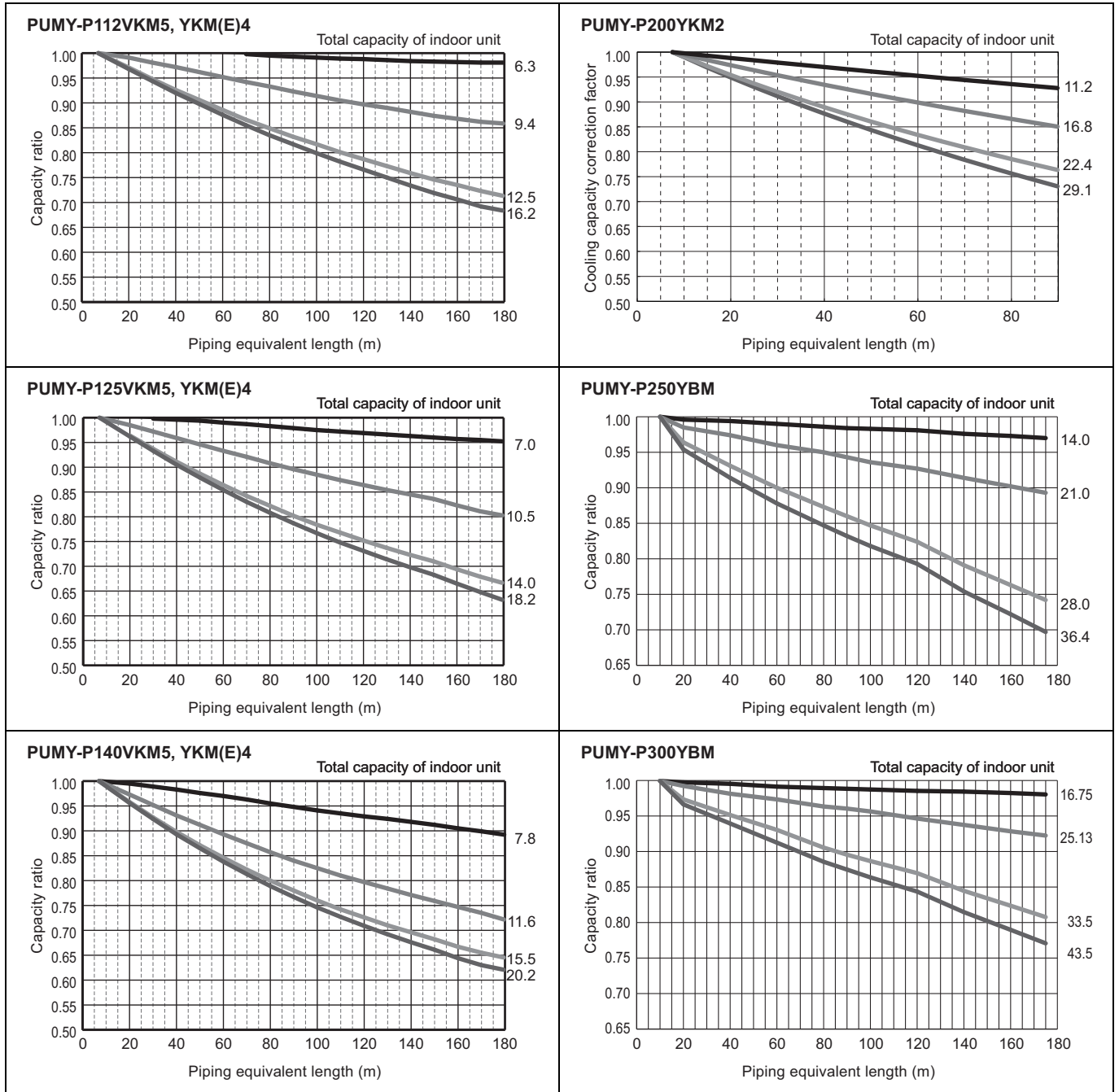

7-4-2. Heating capacity correction

PUMY-P-VKM5, YKM(E)4, YKM2, YBM

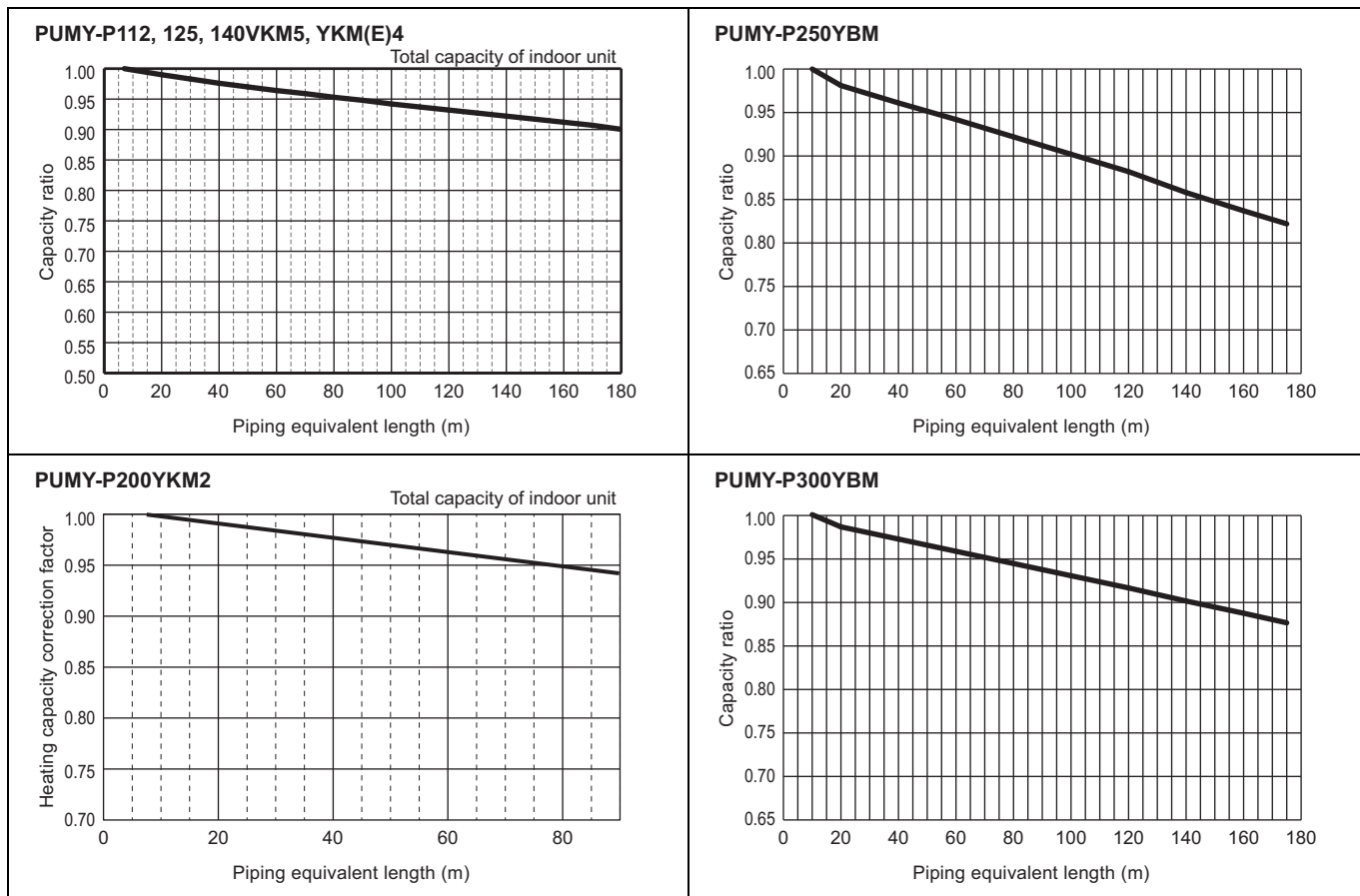

7-4-3. How to obtain the equivalent piping length

$$\text{Equivalent length} = (\text{Actual piping length to the farthest indoor unit}) + (0.30 \times \text{number of bends on the piping}) \text{ m}$$

7-5. Correction at frost and defrost

Due to frost at the outdoor heat exchanger and the automatic defrosting operation, the heating capacity of the outdoor unit should be considered by multiplying the correction factor which shown in the table below.

Table of correction factor at frosting and defrosting

Outdoor inlet air temp. °C W.B.	6	4	2	0	-2	-4	-6	-8	-10	-15	-20
Outdoor inlet air temp. °F W.B.	43	39	36	32	28	25	21	18	14	-5	-4
PUMY-P112,125,140VKM5	1.0	0.98	0.89	0.88	0.89	0.90	0.95	0.95	0.95	0.95	0.95
PUMY-P112,125,140YKM(E)4	1.0	0.98	0.89	0.88	0.89	0.90	0.95	0.95	0.95	0.95	0.95
PUMY-P200YKM2	1.0	0.98	0.89	0.88	0.89	0.90	0.95	0.95	0.95	0.95	0.95
PUMY-P250, 300YBM	1.0	0.98	0.89	0.88	0.89	0.90	0.95	0.95	0.95	0.95	0.95

8-1. JOINT

CITY MULTI units can be easily connected by using Joint sets and Header sets provided by Mitsubishi Electric. Refer to section "Piping Design" or the Installation Manual that comes with the Joint set for how to install the Joint set.

CMY-Y62-G-E Unit: mm

1. Specification

	Items	Details
Main	Number of ports	2 ports
	Number of branch joints	One for each liquid and gas pipe
	Pipe material	Phosphorus deoxidized copper C1220T-OL (JIS H3300)
Accessory	Insulation material	Foamed polyethylene (one for each liquid and gas pipe)
	Reducer	10 reducers of 7 types (Refer to the external drawing for details.)

2. External drawing

For liquid pipe:

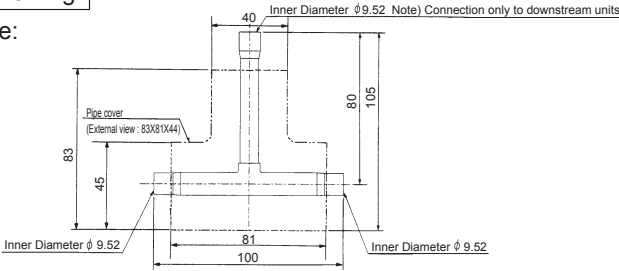

Reducer (Accessory):

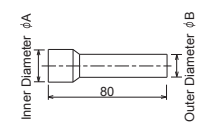

A (Inner Diameter)	B (Outer Diameter)	Number of reducers
φ 12.7	φ 9.52	2
φ 19.05	φ 15.88	1
φ 22.22	φ 19.05	1

For gas pipe:

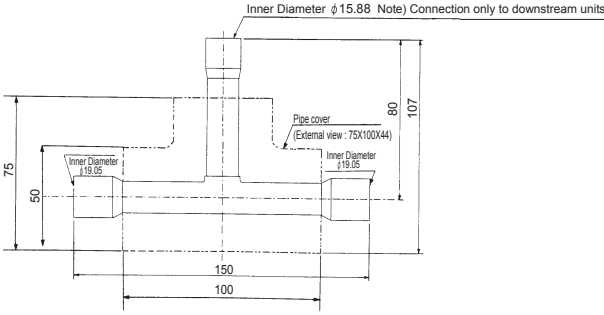
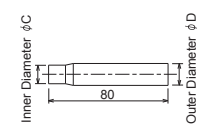
C (Inner Diameter)	D (Outer Diameter)	Number of reducers
φ 6.35	φ 9.52	2
φ 12.7	φ 15.88	1
φ 12.7	φ 19.05	1
φ 15.88	φ 19.05	2

8-2. HEADER

CITY MULTI units can be easily connected by using Joint sets and Header sets provided by Mitsubishi Electric. Refer to section "Piping Design" or the Installation Manual that comes with the Header set for how to install the Header set.

PUMY-P-VKM5, YKM(E)4, YKM2, YBM

CMY-Y64-G-E

Unit: mm

1. Specification

	Items	Details
Main	Number of ports	3 ~ 4 ports
	Number of branch joints	One for each liquid and gas pipe
	Pipe material	Phosphorus deoxidized copper C1220T-OL (JIS H3300)
Accessory	Insulation material	Foamed polyethylene
	Reducer	7 reducers of 5 types
	Cap	2 caps of 2 different types for each liquid and gas pipe 4 caps in total

2. External drawing

For liquid pipe:

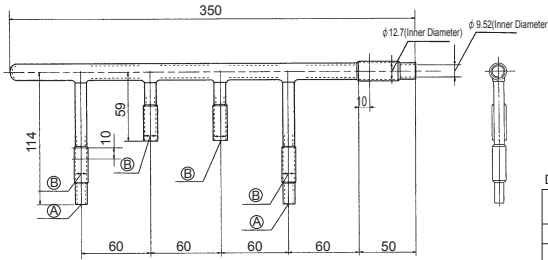

Dimension table

Symbol	Inner Diameter (mm)
A	φ 6.35
B	φ 9.52

Reducer (Accessory):

A (Inner Diameter)	B (Outer Diameter)	Number of reducers
φ 19.05	φ 15.88	1
φ 15.88	φ 12.7	2
φ 9.52	φ 6.35	2

For gas pipe:

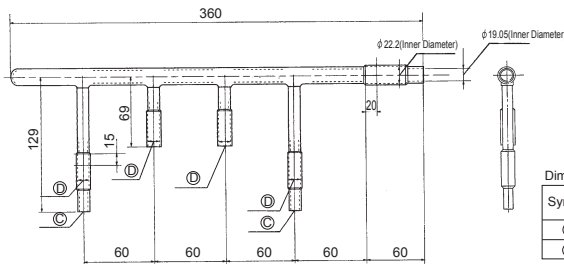

Dimension table

Symbol	Inner Diameter (mm)
C	φ 12.7
D	φ 15.88

C (Inner Diameter)	D (Outer Diameter)	Number of reducers
φ 15.88	φ 19.05	1
φ 9.52	φ 12.7	1

CMY-Y68-G-E

Unit: mm

1. Specification

	Items	Details
Main	Number of ports	5 ~ 8 ports
	Number of branch joints	One for each liquid and gas pipe
	Pipe material	Phosphorus deoxidized copper C1220T-OL (JIS H3300)
Accessory	Insulation material	Foamed polyethylene
	Reducer	3 reducers of 3 types
	Cap	3 caps for each liquid and gas pipe 6 in total

2. External drawing

For liquid pipe:

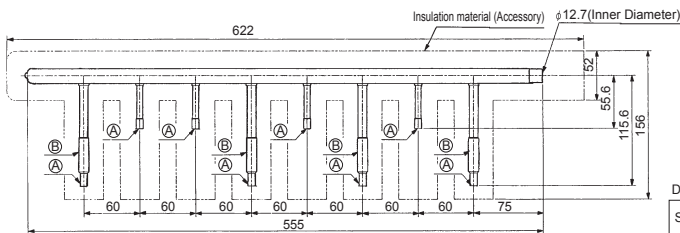

Dimension table

Symbol	Inner Diameter (mm)
A	φ 6.35
B	φ 9.52

Reducer (Accessory):

A (Inner Diameter)	B (Outer Diameter)	Number of reducers
φ 19.05	φ 15.88	1
φ 12.7	φ 9.52	1

For gas pipe:

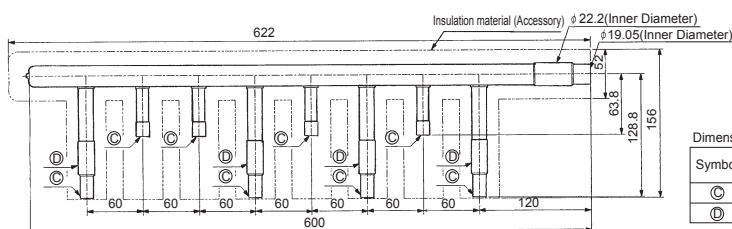

Dimension table

Symbol	Inner Diameter (mm)
C	φ 12.7
D	φ 15.88

C (Inner Diameter)	D (Outer Diameter)	Number of reducers
φ 15.88	φ 19.05	1

8-3. BRANCH BOX

PUMY-P112/125/140VKM5, PUMY-P112/125/140YKM(E)4 and PUMY-P200YKM2 units can be connected to M, S, P series indoor units and PUMY-P250/300 YBM units can be connected only to M series indoor units easily by using Branch box provided by Mitsubishi Electric. Refer to section "Piping Design" or the Installation Manual that comes with the Branch box for how to install the Branch box.

(1) PAC-MK34/54BC

These can connect to PUMY-P112/125/140VKM5, PUMY-P112/125/140YKM(E)4, PUMY-P200YKM2 and PUMY-P250/300YBM.

PAC-MK34BC mm

1. Specification

Model Name				PAC-MK34BC	
Connectable number of indoor units				Maximum 3	
Power supply (from outdoor unit)				Single phase, 220/230/240V, 50Hz, Single phase, 220V, 60Hz	
Input				kW 0.003	
Running current				A 0.05 (Max. 6)	
External finish				Galvanized sheets	
Dimensions	Width	mm		450	
	Depth	mm		280	
	Height	mm		170	
Weight				kg 6.7	
Piping connection (Flare)	Branch (indoor side)	Liquid	mm ø6.35 × 3 (A,B,C)		
		Gas	mm ø9.52 × 3 (A,B,C)		
	Main (outdoor side)	Liquid	mm ø9.52		
		Gas	mm ø15.88		

* The piping connection size differs according to the type and capacity of outdoor/indoor units. Match the piping connection size of branch box with outdoor/indoor unit. If the piping connection size of branch box does not match the piping connection size of outdoor/indoor unit, use optional different-diameter (deformed) joints to the branch box side. (Connect deformed joint directly to the branch box side.)

2. External drawing

SUSPENSION BOLT : W3/8(M10)

REFRIGERANT PIPE BRAZED CONNECTION

	A	B	C		TO OUTDOOR UNIT
LIQUID PIPE	ø6.35	ø6.35	ø6.35		ø9.52
GAS PIPE	ø9.52	ø9.52	ø9.52		ø15.88

PAC-MK54BC mm

1. Specification

Model Name				PAC-MK54BC	
Connectable number of indoor units				Maximum 5	
Power supply (from outdoor unit)				Single phase, 220/230/240V, 50Hz, Single phase, 220V, 60Hz	
Input				kW 0.003	
Running current				A 0.05 (Max. 6)	
External finish				Galvanized sheets	
Dimensions	Width	mm		450	
	Depth	mm		280	
	Height	mm		170	
Weight				kg 7.4	
Piping connection (Flare)	Branch (indoor side)*	Liquid	mm ø6.35 × 5 (A,B,C)		
		Gas	mm ø9.52 × 4 (A,B,C,D), ø12.7 × 1 (E)		
	Main (outdoor side)	Liquid	mm ø9.52		
		Gas	mm ø15.88		

* The piping connection size differs according to the type and capacity of outdoor/indoor units. Match the piping connection size of branch box with outdoor/indoor unit. If the piping connection size of branch box does not match the piping connection size of outdoor/indoor unit, use optional different-diameter (deformed) joints to the branch box side. (Connect deformed joint directly to the branch box side.)

2. External drawing

SUSPENSION BOLT : W3/8(M10)

REFRIGERANT PIPE BRAZED CONNECTION

	A	B	C	D	E	TO OUTDOOR UNIT
LIQUID PIPE	ø6.35	ø6.35	ø6.35	ø6.35	ø6.35	ø9.52
GAS PIPE	ø9.52	ø9.52	ø9.52	ø9.52	ø12.7	ø15.88

9-1. General cautions

- ① Follow ordinance of your governmental organization for technical standard related to electrical equipment, wiring regulations, and guidance of each electric power company.
- ② Wiring for control (hereinafter referred to as transmission cable) shall be (50mm[1-5/8in.] or more) apart from power source wiring so that it is not influenced by electric noise from power source wiring. (Do not insert transmission cable and power source wire in the same conduit.)
- ③ Be sure to provide designated grounding work to outdoor unit.
- ④ Give some allowance to wiring for electrical part box of indoor and outdoor units, because the box is sometimes removed at the time of service work.
- ⑤ Never connect 380~415V(220~240V) power source to terminal block of transmission cable. If connected, electrical parts will be damaged.
- ⑥ Use 2-core shield cable for transmission cable. If transmission cables of different systems are wired with the same multiple-core cable, the resultant poor transmitting and receiving will cause erroneous operations.
- ⑦ When extending the transmission line, make sure to extend the shield cable as well.

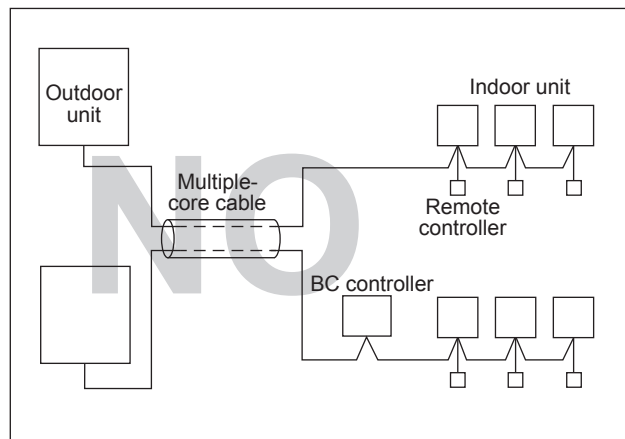
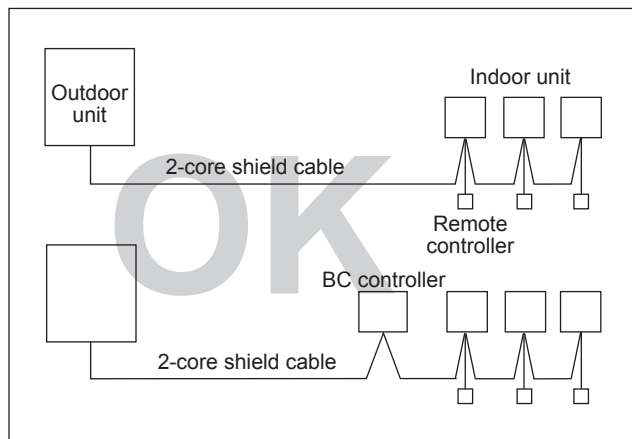

9-2. Power supply for Outdoor unit

9-2-1. Electrical characteristics of Outdoor unit at cooling mode

Symbols: MCA Max Circuit Amps

RLA (Rated Load Amps), SC (Starting Current)

PUMY-P-VKM	Units			Power supply	Compressor		FAN	RLA (A)
	Hz	Volts	Voltage Range	MCA (A)	Output (kW)	SC (A)	Output (kW)	
PUMY-P112VKM5	50	220	Max.: 264V Min.: 198V	29.5	2.9	14	0.074+0.074	12.87/12.32/11.80
PUMY-P125VKM5		230		29.5	3.5	14	0.074+0.074	15.97/15.27/14.64
PUMY-P140VKM5		240		29.5	3.9	14	0.074+0.074	20.86/19.95/19.12

PUMY-P-VKM	Units			Power supply	Compressor		FAN	RLA (A)
	Hz	Volts	Voltage Range	MCA (A)	Output (kW)	SC (A)	Output (kW)	
PUMY-P112VKM5	60	220	Max.: 253V Min.: 198V	29.5	2.9	14	0.074+0.074	12.87/12.32
PUMY-P125VKM5		230		29.5	3.5	14	0.074+0.074	15.97/15.27
PUMY-P140VKM5				29.5	3.9	14	0.074+0.074	20.86/19.95

PUMY-P-YKM	Units			Power supply	Compressor		FAN	RLA (A)
	Hz	Volts	Voltage Range	MCA (A)	Output (kW)	SC (A)	Output (kW)	
PUMY-P112YKM4	50	380 400 415	Max.: 456V Min.: 342V	13.0	2.9	7	0.074+0.074	4.99/4.74/4.57
PUMY-P125YKM4				13.0	3.5	7	0.074+0.074	5.84/5.55/5.35
PUMY-P140YKM4				13.0	3.9	7	0.074+0.074	7.23/6.87/6.62
PUMY-P200YKM2				19.0	5.3	7	0.20+0.20	9.88/9.39/9.05

PUMY-P-YBM	Units			Power supply	Compressor		FAN	RLA (A)
	Hz	Volts	Voltage Range	MCA (A)	Output (kW)	SC (A)	Output (kW)	
PUMY-P250YBM	50	380	Max.: 456V Min.: 342V	28.24	5.7	7	0.375+0.375	13.35/12.68/12.22
PUMY-P300YBM		400 415		31.74	6.9	7	0.375+0.375	16.36/15.54/14.98

PUMY-P-YKM	Units			Power supply	Compressor		FAN	RLA (A)
	Hz	Volts	Voltage Range	MCA (A)	Output (kW)	SC (A)	Output (kW)	
PUMY-P112YKM4	60	380	Max.: 418V Min.: 342V	13.0	2.9	7	0.074+0.074	4.99
PUMY-P125YKM4				13.0	3.5	7	0.074+0.074	5.84
PUMY-P140YKM4				13.0	3.9	7	0.074+0.074	7.23

PUMY-P-YKME	Units			Power supply	Compressor		FAN	RLA (A)
	Hz	Volts	Voltage Range	MCA (A)	Output (kW)	SC (A)	Output (kW)	
PUMY-P112YKME4	50	380	Max.: 456V Min.: 342V	13.0	2.9	7	0.074+0.074	4.99/4.74/4.57
PUMY-P125YKME4		400		13.0	3.5	7	0.074+0.074	5.84/5.55/5.35
PUMY-P140YKME4		415		13.0	3.9	7	0.074+0.074	7.23/6.87/6.62

9-3. Power cable specifications

Thickness of wire for main power supply, capacities of the switch and system impedance

■ PUMY-P-VKM5/PUMY-P-YKM4/PUMY-P-YKME4

<Outdoor unit> When power is supplied to outdoor unit and branch box separately

	Model	Minimum wire thickness (mm ²)			Ground-fault interrupter *1	Local switch (A)		Breaker for wiring (A) (Non-fuse breaker)	Max. Permissible System Impedance
		Main cable	Ground			Capacity	Fuse		
Outdoor unit	PUMY-P112VKM5	6.0	6.0		32A 30mA 0.1sec. or less	32	32	32	-
	PUMY-P125VKM5	6.0	6.0		32A 30mA 0.1sec. or less	32	32	32	-
	PUMY-P140VKM5	6.0	6.0		32A 30mA 0.1sec. or less	32	32	32	-
	PUMY-P112YKM4	1.5	1.5		16A 30mA 0.1sec. or less	16	16	16	-
	PUMY-P125YKM4	1.5	1.5		16A 30mA 0.1sec. or less	16	16	16	-
	PUMY-P140YKM4	1.5	1.5		16A 30mA 0.1sec. or less	16	16	16	-
	PUMY-P112YKME4	1.5	1.5		16A 30mA 0.1sec. or less	16	16	16	-
	PUMY-P125YKME4	1.5	1.5		16A 30mA 0.1sec. or less	16	16	16	-

<Outdoor unit> When power is supplied to branch box from the outdoor unit

	Model	Minimum wire thickness (mm ²)			Ground-fault interrupter *1	Local switch (A)		Breaker for wiring (A) (Non-fuse breaker)	Max. Permissible System Impedance
		Main cable	Ground			Capacity	Fuse		
Outdoor unit	PUMY-P112VKM5	6.0	6.0		40A 30mA 0.1sec. or less	40	40	40	-
	PUMY-P125VKM5	6.0	6.0		40A 30mA 0.1sec. or less	40	40	40	-
	PUMY-P140VKM5	6.0	6.0		40A 30mA 0.1sec. or less	40	40	40	-
	PUMY-P112YKM4	2.5	2.5		32A 30mA 0.1sec. or less	20	20	20	-
	PUMY-P125YKM4	2.5	2.5		32A 30mA 0.1sec. or less	20	20	20	-
	PUMY-P140YKM4	2.5	2.5		32A 30mA 0.1sec. or less	20	20	20	-
	PUMY-P112YKME4	2.5	2.5		32A 30mA 0.1sec. or less	20	20	20	-
	PUMY-P125YKME4	2.5	2.5		32A 30mA 0.1sec. or less	20	20	20	-
	PUMY-P140YKME4	2.5	2.5		32A 30mA 0.1sec. or less	20	20	20	-

<Indoor units> When power is supplied to indoor unit and outdoor unit separately

	Model	Minimum wire thickness (mm ²)			Ground-fault interrupter *1	Local switch (A)		Breaker for wiring (A) (Non-fuse breaker)	Max. Permissible System Impedance
		Main cable	Branch	Ground		Capacity	Fuse		
Total operating current of the indoor unit	F0 = 16A or less *2	1.5	1.5	1.5	20A current sensitivity *4	16	16	20	-
	F0 = 25A or less *2	2.5	2.5	2.5	30A current sensitivity *4	25	25	30	-
	F0 = 32A or less *2	4.0	4.0	4.0	40A current sensitivity *4	32	32	40	-

*1 The Ground-fault interrupter should support Inverter circuit.
The Ground-fault interrupter should combine using of local switch or wiring breaker.

*2 Please take the larger of F1 or F2 as the value for F0.
F1 = Total operating maximum current of the indoor units × 1.2
F2 = {V1 × (Quantity of Type1)/C} + {V1 × (Quantity of Type2)/C} + {V1 × (Quantity of Type3)/C} + ... + {V1 × (Quantity of Type16)/C}

Connect to Branch box (PAC-MK-BC(B))

Indoor unit		V1	V2
Type1	PEAD-RP-JA(L)Q, PEAD-M-JA(L), PEY-(S)P-JA	26.9	2.4
Type2	SEZ-KD-VAQ(L), SEZ-M-DA(L), PCA-RP-KAQ, PCA-M-KA, PLA-RP-BA, PLA-RP-EA, SLZ-KF-VA2, SLZ-M-FA, PLY-(S)P-BA, SEZ-KH-VALT, PCY-(S)P-KA, PLA-M-EA	19.8	
Type3	MLZ-KA-VA, MLZ-KP-VF	9.9	
Type4	MFZ-KJ-VE2, MSXY-FJ-VE, MSZ-LN-VG, MSZ-AP-VG(D), MSZ-AP-VF, MSZ-EF-VG-E2, MSZ-EF-VGK-E1, MSZ-AP-VGK, MFZ-KT-VG, MSZ-LN-VG2	7.4	
Type5	MSZ-FH-VE, MSZ-SF-VE, MSZ-EF-VE, MSZ-SF-VA, MSZ-GF-VE, MSZ-GE-VA, MSZ-EF-VA, MSY-GE-VA, MSY-EF-VA, MSZ-FH-VA, MSY-GH-VA, MSZ-FK-VA, MSZ-GC-NA, MSZ-EF-VG-E1	6.8	
Type6	Branch box (PAC-MK-BC)		3.0
Type7	ecodan (Cylinder unit, Hydrobox)	5.1	5.0 *3

*3 This value may increase due to a locally connected actuator.

Connect to Connection kit (PAC-LV11M-J)

Indoor unit		V1	V2
Type8	MFZ-KJ-VE2, MSZ-LN-VG, MSZ-AP-VG(D), MSZ-AP-VF, MSZ-EF-VG-E2, MSZ-EF-VGK-E1, MSZ-AP-VGK, MFZ-KT-VG, MSZ-LN-VG2	7.4	2.4
Type9	MSZ-GE-VA(D), MSZ-SF-VA, MSZ-SF-VE, MSZ-EF-VE, MSZ-FH-VE, MSY-GE-VA, MSY-GH-VA, MSZ-EF-VG-E1	6.8	
Type10	Connection kit (PAC-LV11M-J)	3.5	

Connect to City Multi

Indoor unit		V1	V2
Type11	PEFY-P-VMA(L)-E(2), PEFY-P-VMA3-E	38.0	1.6
Type12	PEFY-VMHS-E-F, PEFY-P10-140VMHS-E	26.8	1.6
Type13	PMFY-VBM-E, PLFY-VBM-E, PLFY-VEM-E, PLFY-VFM-E1, PEFY-VMS1(L)-E, PCFY-VKM-E, PKFY-VHM-E, PKFY-VKM-E, PFFY-VKM-E2, PFFY-VLRMM-E, PLFY-EP-VEM-E, PMFY-P-VFM-D, PKFY-VLM-E, PFFY-VCM-E	19.8	2.4
Type14	PEFY-P-VMA(L)-E3, PEFY-M-VMA(L)-A	18.6	3.0
Type15	PKFY-VBM-E	3.5	2.4
Type16	PLFY-VLMD-E, PEFY-VMR-E-L/R, PFFY-VLEM-E, PFFY-VLRM-E, PWFY-VM-E1(2)-AU, PEFY-P-VMH-E-F, GUF-RD(H)4	0.0	0.0

C: Multiple of tripping current at tripping time 0.01s
Please pick up "C" from the tripping characteristic of the breaker.

<Example of "F2" calculation>

Condition PEFY-VMS × 4 + PEFY-VMA × 1, C = 8 (refer to right sample chart)

$$F2 = 19.8 \times 4/8 + 38 \times 1/8$$

$$= 14.65$$

→16 A breaker (Tripping current = 8 × 16 A at 0.01s)

Sample chart

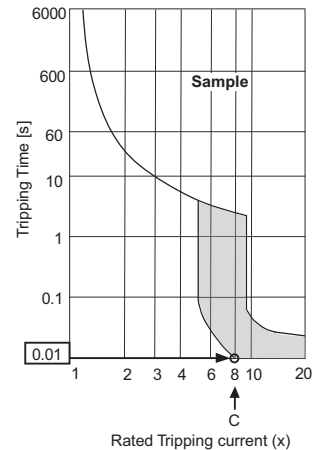

*4 Current sensitivity is calculated using the following formula.

$$G1 = V2 \times (\text{Quantity of Type1}) + V2 \times (\text{Quantity of Type2}) + V2 \times (\text{Quantity of Type3}) + \dots + V2 \times (\text{Quantity of Type16}) + V3 \times (\text{Wire length [km]})$$

G1	Current sensitivity
30 or less	30 mA 0.1sec or less
100 or less	100 mA 0.1sec or less

Wire thickness	V3
1.5 mm ²	48
2.5 mm ²	56
4.0 mm ²	66

1. Bear in mind ambient conditions (ambient temperature, direct sunlight, rain water, etc.) when proceeding with the wiring and connections.
2. The wire size is the minimum value for metal conduit wiring. The power cord size should be 1 rank thicker consideration of voltage drops. Make sure the power-supply voltage does not drop more than 10%.
3. Specific wiring requirements should adhere to the wiring regulations of the region.
4. Power supply cords of parts of appliances for outdoor use shall not be lighter than polychloroprene sheathed flexible cord (design 60245 IEC57). For example, use wiring such as YZW.
5. Install an earth line longer than power cables.

⚠ WARNING

- ◆ Be sure to use specified wires for connections and ensure no external force is imparted to terminal connections. If connections are not fixed firmly, heating or fire may result.
- ◆ Be sure to use the appropriate type of overcurrent protection switch. Note that generated overcurrent may include some amount of direct current.

⚠ CAUTION

- ◆ The breakers for current leakage should support Inverter circuit. (e.g. Mitsubishi Electric's NV-S-Series or equivalent). If no earth leakage breaker is installed, it may cause an electric shock.
- ◆ Breakers for current leakage should combine using of switch.
- ◆ Do not use anything other than a breaker with the correct capacity. Using a breaker of too large capacity may cause malfunction or fire.
- ◆ If a large electric current flows due to malfunction or faulty wiring, earth-leakage breakers on the unit side and on the upstream side of the power supply system may both operate. Depending on the importance of the system, separate the power supply system or take protective coordination of breakers.

Note

- ◆ This device is intended for the connection to a power supply system with a maximum permissible system impedance shown in the above table at the interface point (power service box) of the user's supply.
- ◆ The user must ensure that this device is connected only to a power supply system which fulfils the requirement above. If necessary, the user can ask the public power supply company for the system impedance at the interface point.

Thickness of wire for main power supply, capacities of the switch and system impedance

<Outdoor unit> <When power is supplied to outdoor unit and branch box separately>

	Model	Minimum wire thickness (mm ²)			Ground-fault interrupter *1	Local switch (A)		Breaker for wiring (A) (Non-fuse breaker)	Max. Permissible System Impedance
		Main cable	Branch	Ground		Capacity	Fuse		
Outdoor unit	PUMY-P200YKM2	2.5		2.5	25A 30mA 0.1sec. or less	25	25	25	-

<Outdoor unit> <When power is supplied to branch box from the outdoor unit>

	Model	Minimum wire thickness (mm ²)			Ground-fault interrupter *1	Local switch (A)		Breaker for wiring (A) (Non-fuse breaker)	Max. Permissible System Impedance
		Main cable	Branch	Ground		Capacity	Fuse		
Outdoor unit	PUMY-P200YKM2	4.0		4.0	32A 30mA 0.1sec. or less	32	32	32	-

<Indoor units> <When power is supplied to indoor unit and outdoor unit separately>

	Model	Minimum wire thickness (mm ²)			Ground-fault interrupter *1	Local switch (A)		Breaker for wiring (A) (Non-fuse breaker)	Max. Permissible System Impedance
		Main cable	Branch	Ground		Capacity	Fuse		
Total operating current of the indoor unit	F0 = 16A or less *2	1.5	1.5	1.5	20A current sensitivity *3	16	16	20	-
	F0 = 25A or less *2	2.5	2.5	2.5	30A current sensitivity *3	25	25	30	-
	F0 = 32A or less *2	4.0	4.0	4.0	40A current sensitivity *3	32	32	40	-

*1 The Ground-fault interrupter should support Inverter circuit.

The Ground-fault interrupter should combine using of local switch or wiring breaker.

*2 Please take the larger of F1 or F2 as the value for F0.

F1 = Total operating maximum current of the indoor units × 1.2

F2 = {V1 × (Quantity of Type1)/C} + {V1 × (Quantity of Type2)/C} + {V1 × (Quantity of Type3)/C} + ... + {V1 × (Quantity of Type16)/C}

Connect to Branch box (PAC-MK-BC)

Indoor unit		V1	V2
Type1	SEZ-KD-VAQ(L), SEZ-M-DA(L), PCA-RP-KAQ, PCA-M-KA, SLZ-KF-VA, SLZ-M-FA, PLA-RP-EA, PLA-M-EA	19.8	2.4
Type2	PEAD-RP-JAQ(L), PEAD-M-JA(L)	26.9	
Type3	MLZ-KA-VA, MLZ-KP-VF	9.9	
Type4	MSZ-FH-VE, MSZ-GF-VE, MSZ-SF-VE, MSZ-EF-VE, MSZ-SF-VA, MSZ-EF-VG-E1	6.8	
Type5	MFZ-KJ-VE2, MSZ-LN-VG, MSZ-AP-VG, MSZ-AP-VF, MSZ-EF-VG-E2, MSZ-EF-VGK-E1, MSZ-AP-VGK, MFZ-KT-VG, MSZ-LN-VG2	7.4	
Type6	Branch box	5.1	

Connect to Connection kit (PAC-LV11M)

Indoor unit		V1	V2
Type7	MSZ-EF-VE, MSZ-SF-VA, MSZ-SF-VE, MSZ-FH-VE, MSZ-EF-VG-E1	6.8	2.4
Type8	MFZ-KJ-VE2, MSZ-LN-VG, MSZ-AP-VG, MSZ-AP-VF, MSZ-EF-VG-E2, MSZ-EF-VGK-E1, MSZ-AP-VGK, MFZ-KT-VG, MSZ-LN-VG2	7.4	
Type9	Connection kit (PAC-LV11M)	3.5	

Connect to CITY MULTI

Indoor unit		V1	V2
Type10	PEFY-P-VMA(L)-E(2), PEFY-P-VMA3-E	38.0	1.6
Type11	PEFY-VMHS-E-F, PEFY-P40-140VMHS-E	26.8	1.6
Type12	PMFY-P-VBM-E, PLFY-P-VBM-E, PEFY-P-VMS1-E, PCFY-P-VKM-E, PKFY-P-VKM-E, PLFY-P-VEM-E, PLFY-EP-VEM-E, PLFY-P-VFM-E, PFFY-VKM-E2, PFFY-VLRMM-E, PKFY-VLM-E, PFFY-VCM-E, PLFY-M-VEM-E	19.8	2.4
Type13	PEFY-VMA(L)-E3, PEFY-M-VMA(L)-A	18.6	3.0
Type14	PEFY-P200VMHS-E	13.8	4.8
Type15		-	-
Type16	PLFY-P-VLMD-E, PEFY-P-VMR-E-L/R, PEFY-P-VMH-E-F, PFFY-P-VLEM-E, GUF-RD(H)4, PFFY-VLRM-E	0.0	0.0

C: Multiple of tripping current at tripping time 0.01s

Please pick up "C" from the tripping characteristic of the breaker.

<Example of "F2" calculation>

*Condition PLFY-P-VBM-E × 4 + PEFY-VMA-E × 1, C = 8 (refer to right sample chart)

$$F2 = 19.8 \times 4/8 + 38 \times 1/8$$

$$= 14.65$$

→16 A breaker (Tripping current = 8 × 16 A at 0.01s)

*3 Current sensitivity is calculated using the following formula.

$$G1 = V2 \times (\text{Quantity of Type1}) + V2 \times (\text{Quantity of Type2}) + V2 \times (\text{Quantity of Type3}) + \dots + V2 \times (\text{Quantity of Type16}) + V3 \times (\text{Wire length [km]})$$

G1	Current sensitivity
30 or less	30 mA 0.1sec or less
100 or less	100 mA 0.1sec or less

Wire thickness	V3
1.5 mm ²	48
2.5 mm ²	56
4.0 mm ²	66

Sample chart

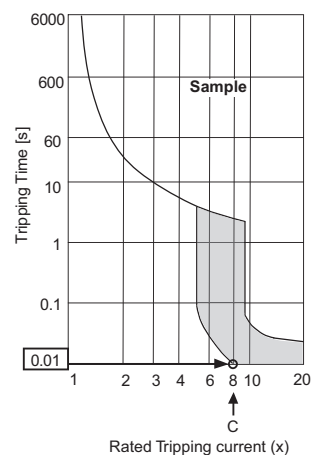

PUMY-P-VKM5, YKM(E)4, YKM2, YBM

1. Bear in mind ambient conditions (ambient temperature, direct sunlight, rain water, etc.) when proceeding with the wiring and connections.
2. The wire size is the minimum value for metal conduit wiring. The power cord size should be 1 rank thicker consideration of voltage drops. Make sure the power-supply voltage does not drop more than 10%.
3. Specific wiring requirements should adhere to the wiring regulations of the region.
4. Power supply cords of parts of appliances for outdoor use shall not be lighter than polychloroprene sheathed flexible cord (design 60245 IEC57). For example, use wiring such as YZW.
5. Install an earth line longer than power cables.

⚠ WARNING

- ◆ Be sure to use specified wires for connections and ensure no external force is imparted to terminal connections. If connections are not fixed firmly, heating or fire may result.
- ◆ Be sure to use the appropriate type of overcurrent protection switch. Note that generated overcurrent may include some amount of direct current.

⚠ CAUTION

- ◆ The breakers for current leakage should support Inverter circuit. (e.g. Mitsubishi Electric's NV-S-Series or equivalent). If no earth leakage breaker is installed, it may cause an electric shock.
- ◆ Breakers for current leakage should combine using of switch.
- ◆ Do not use anything other than a breaker with the correct capacity. Using a breaker of too large capacity may cause malfunction or fire.
- ◆ If a large electric current flows due to malfunction or faulty wiring, earth-leakage breakers on the unit side and on the upstream side of the power supply system may both operate. Depending on the importance of the system, separate the power supply system or take protective coordination of breakers.

Note

- ◆ This device is intended for the connection to a power supply system with a maximum permissible system impedance shown in the above table at the interface point (power service box) of the user's supply.
- ◆ The user must ensure that this device is connected only to a power supply system which fulfils the requirement above. If necessary, the user can ask the public power supply company for the system impedance at the interface point.

Thickness of wire for main power supply, capacities of the switch and system impedance

■ PUMY-P-YBM

<Outdoor unit> When power is supplied to outdoor unit and branch box separately

	Model	Minimum wire thickness (mm ²)		Ground-fault interrupter *1	Local switch (A)		Breaker for wiring (A) (Non-fuse breaker)	Max. Permissible System Impedance
		Main cable	Ground		Capacity	Fuse		
Outdoor unit	PUMY-P250YBM	4.0	4.0	32A 30mA 0.1sec. or less	32	32	32	-
	PUMY-P300YBM	6.0	6.0	40A 30mA 0.1sec. or less	40	40	40	-

<Outdoor unit> When power is supplied to branch box from the outdoor unit

	Model	Minimum wire thickness (mm ²)		Ground-fault interrupter *1	Local switch (A)		Breaker for wiring (A) (Non-fuse breaker)	Max. Permissible System Impedance
		Main cable	Ground		Capacity	Fuse		
Outdoor unit	PUMY-P250YBM	6.0	6.0	40A 30mA 0.1sec. or less	40	40	40	-
	PUMY-P300YBM	6.0	6.0	40A 30mA 0.1sec. or less	40	40	40	-

*1 A breaker with at least 3.0 mm contact separation in each poles shall be provided. Use non-fuse breaker (NF) or earth leakage breaker (NV).

<Outdoor unit> When power is supplied to indoor unit and outdoor unit separately

	Model	Minimum wire thickness (mm ²)			Ground-fault interrupter *1	Local switch (A)		Breaker for wiring (NFB)
		Main cable	Branch	Ground		Capacity	Fuse	
Total operating current of the indoor unit	F0 = 16A or less *2	1.5	1.5	1.5	20A current sensitivity *3	16	16	20
	F0 = 25A or less *2	2.5	2.5	2.5	30A current sensitivity *3	25	25	30
	F0 = 32A or less *2	4.0	4.0	4.0	40A current sensitivity *3	32	32	40

Apply to IEC61000-3-3 about max. permissible system impedance.

*1 The Ground-fault interrupter should support Inverter circuit.

The Ground-fault interrupter should combine using of local switch or wiring breaker.

*2 Please take the larger of F1 or F2 as the value for F0.

F1 = Total operating maximum current of the indoor units × 1.2

F2 = {V1 × (Quantity of Type1)/C} + {V1 × (Quantity of Type2)/C} + {V1 × (Quantity of Type3)/C} + ... + {V1 × (Quantity of Type14)/C}

Connect to Branch box (PAC-MK-BC)

Indoor unit		V1	V2
Type1	MSZ-AP-VG, MSZ-EF-VG-E2/ER2/ET2, MSZ-EF-VGK-E1/ER1/ET1, MSZ-AP-VGK, MFZ-KT-VG, MSZ-LN-VG2	7.4	2.4
Type2	MSZ-FH-VE2	6.8	
Type3	Branch box (PAC-MK-BC)	5.1	3.0

Connect to Connection kit (PAC-LV11M)

Indoor unit		V1	V2
Type4	MSZ-AP-VG, MSZ-EF-VG-E2/ER2/ET2, MSZ-EF-VGK-E1/ER1/ET1, MSZ-AP-VGK, MFZ-KT-VG, MSZ-LN-VG2	7.4	2.4
Type5	MSZ-FH-VE2	6.8	
Type6	Connection kit (PAC-LV11M)	3.5	

Connect to CITY MULTI

Indoor unit		V1	V2
Type7	PEFY-P-VMA3-E, PEFY-P-VMA(L)-E1	38.0	1.6
Type8	PEFY-P-VMHS-E-F, PEFY-P40-140VMHS-E	26.8	
Type9	PEFY-M-VMA(2)(L)-A, PEFY-P-VMA(L)-E3	18.6	3.0
Type10	PMFY-P-VBM-E, PLFY-EP-VEM-E, PLFY-P-VFM-E, PEFY-P-VMS1(L)-E, PCFY-P-VKM-E, PKFY-P-VKM-E, PEFY-P-VCM-E, PKFY-P-VLM-E/ET, PLFY-M-VEM-E/ET, PLFY-P-VEM-E	19.8	2.4
Type11	PLFY-P-VEM-PA	17.1	
Type12	PLFY-P-VLMD-E, PEFY-P-VMR-E-L/R, PEFY-P-VKM-E2, PEFY-P-VLEM-E, GUF-RD(H)4, PEFY-P-VMH-E/E2	0	0
Type13	PEFY-P200/250VMHS-E	13.8	4.8
Type14	PEFY-P-VMX(L)-E(1)	38.0	2.4

C: Multiple of tripping current at tripping time 0.01s

Please pick up "C" from the tripping characteristic of the breaker.

<Example of "F2" calculation>

*Condition PLFY-VBM × 4 + PEFY-VMA × 1, C = 8 (refer to right sample chart)

F2 = 19.8 × 4/8 + 38 × 1/8

= 14.65

→ 16 A breaker (Tripping current = 8 × 16 A at 0.01s)

*3 Current sensitivity is calculated using the following formula.

G1 = V2 × (Quantity of Type1) + V2 × (Quantity of Type2) + V2 × (Quantity of Type3) + ... + V2 × (Quantity of Type14) + V3 × (Wire length [km])

G1	Current sensitivity
30 or less	30 mA 0.1sec or less
100 or less	100 mA 0.1sec or less

Wire thickness	V3
1.5 mm ²	48
2.5 mm ²	56
4.0 mm ²	66

Sample chart

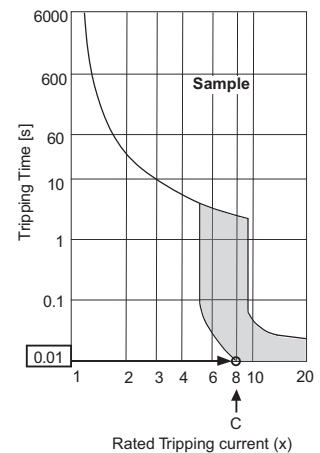

PUMY-P-VKM5, YKM(E)4, YKM2, YBM

1. Bear in mind ambient conditions (ambient temperature, direct sunlight, rain water, etc.) when proceeding with the wiring and connections.
2. The wire size is the minimum value for metal conduit wiring. The power cord size should be 1 rank thicker consideration of voltage drops. Make sure the power-supply voltage does not drop more than 10%.
3. Specific wiring requirements should adhere to the wiring regulations of the region.
4. Power supply cords of parts of appliances for outdoor use shall not be lighter than polychloroprene sheathed flexible cord (design 60245 IEC57). For example, use wiring such as YZW.
5. Install an earth line longer than power cables.

⚠ WARNING

- ◆ Be sure to use specified wires for connections and ensure no external force is imparted to terminal connections. If connections are not fixed firmly, heating or fire may result.
- ◆ Be sure to use the appropriate type of overcurrent protection switch. Note that generated overcurrent may include some amount of direct current.

⚠ CAUTION

- ◆ The breakers for current leakage should support Inverter circuit. (e.g. Mitsubishi Electric's NV-S-Series or equivalent). If no earth leakage breaker is installed, it may cause an electric shock.
- ◆ Breakers for current leakage should combine using of switch.
- ◆ Do not use anything other than a breaker with the correct capacity. Using a breaker of too large capacity may cause malfunction or fire.
- ◆ If a large electric current flows due to malfunction or faulty wiring, earth-leakage breakers on the unit side and on the upstream side of the power supply system may both operate. Depending on the importance of the system, separate the power supply system or take protective coordination of breakers.

Note

- ◆ This device is intended for the connection to a power supply system with a maximum permissible system impedance shown in the above table at the interface point (power service box) of the user's supply.
- ◆ The user must ensure that this device is connected only to a power supply system which fulfils the requirement above. If necessary, the user can ask the public power supply company for the system impedance at the interface point.

9-4. Power supply examples

The local standards and/or regulations is applicable at a higher priority.

9-4-1. PUMY-P112, 125, 140VKM5

PUMY-P-VKM5, YKM(E)4, YKM2, YBM

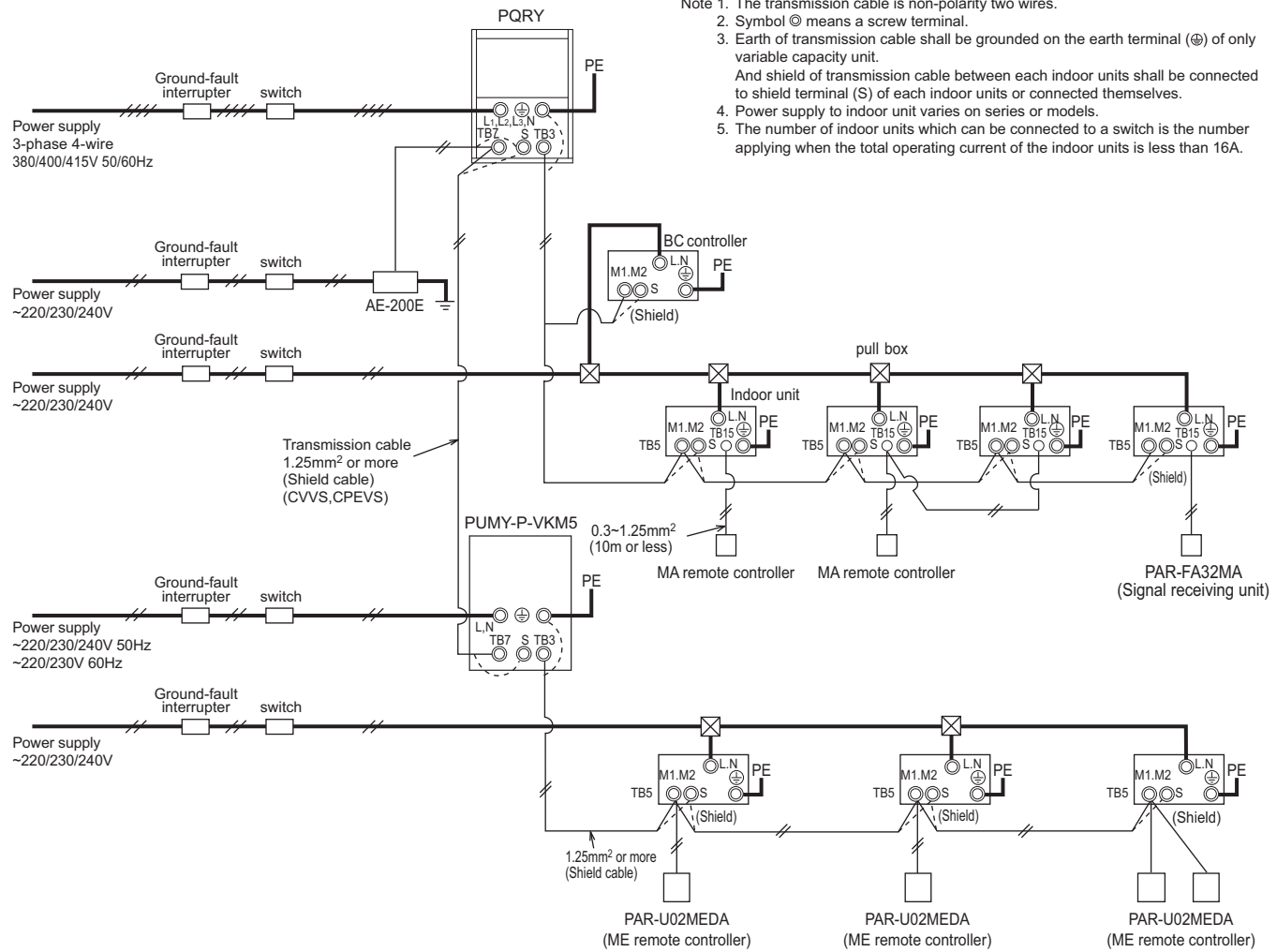

- Note 1. The transmission cable is non-polarity two wires.
- Note 2. Symbol © means a screw terminal.
- Note 3. Earth of transmission cable shall be grounded on the earth terminal (⊕) of only variable capacity unit.
And shield of transmission cable between each indoor units shall be connected to shield terminal (S) of each indoor units or connected themselves.
- Note 4. Power supply to indoor unit varies on series or models.
- Note 5. The number of indoor units which can be connected to a switch is the number applying when the total operating current of the indoor units is less than 16A.

The local standards and/or regulations is applicable at a higher priority.

9-4-2. PUMY-P112, 125, 140YKM(E)4
PUMY-P200YKM2

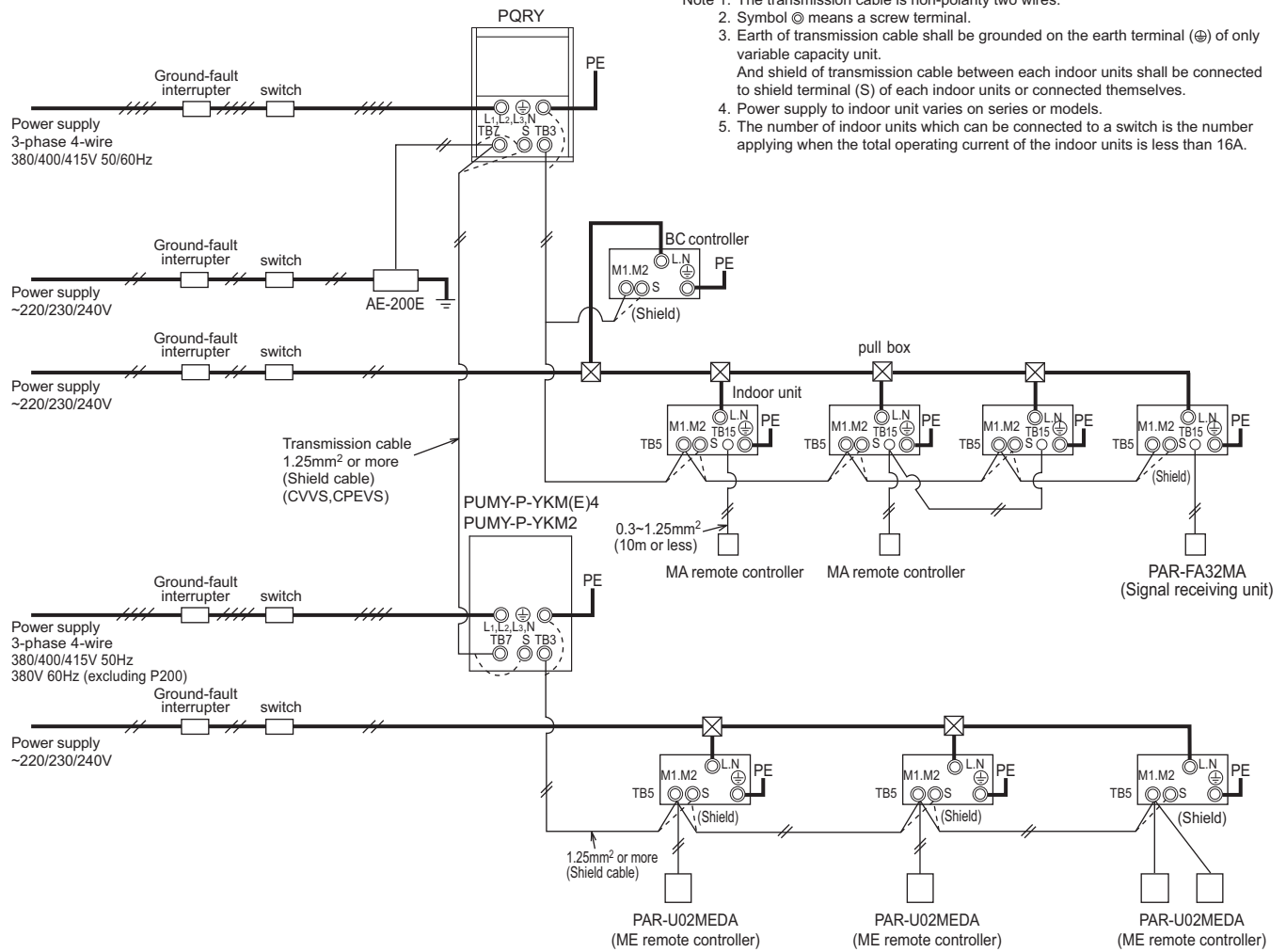

The local standards and/or regulations is applicable at a higher priority.

9-4-3. PUMY-P250, 300YBM

PUMY-P-VKM5, YKM(E)4, YKM2, YBM

- Note 1. The transmission cable is non-polarity two wires.
- 2. Symbol ⊙ means a screw terminal.
- 3. Earth of transmission cable shall be grounded on the earth terminal (⊕) of only variable capacity unit.
And shield of transmission cable between each indoor units shall be connected to shield terminal (S) of each indoor units or connected themselves.
- 4. Power supply to indoor unit varies on series or models.
- 5. The number of indoor units which can be connected to a switch is the number applying when the total operating current of the indoor units is less than 16A.

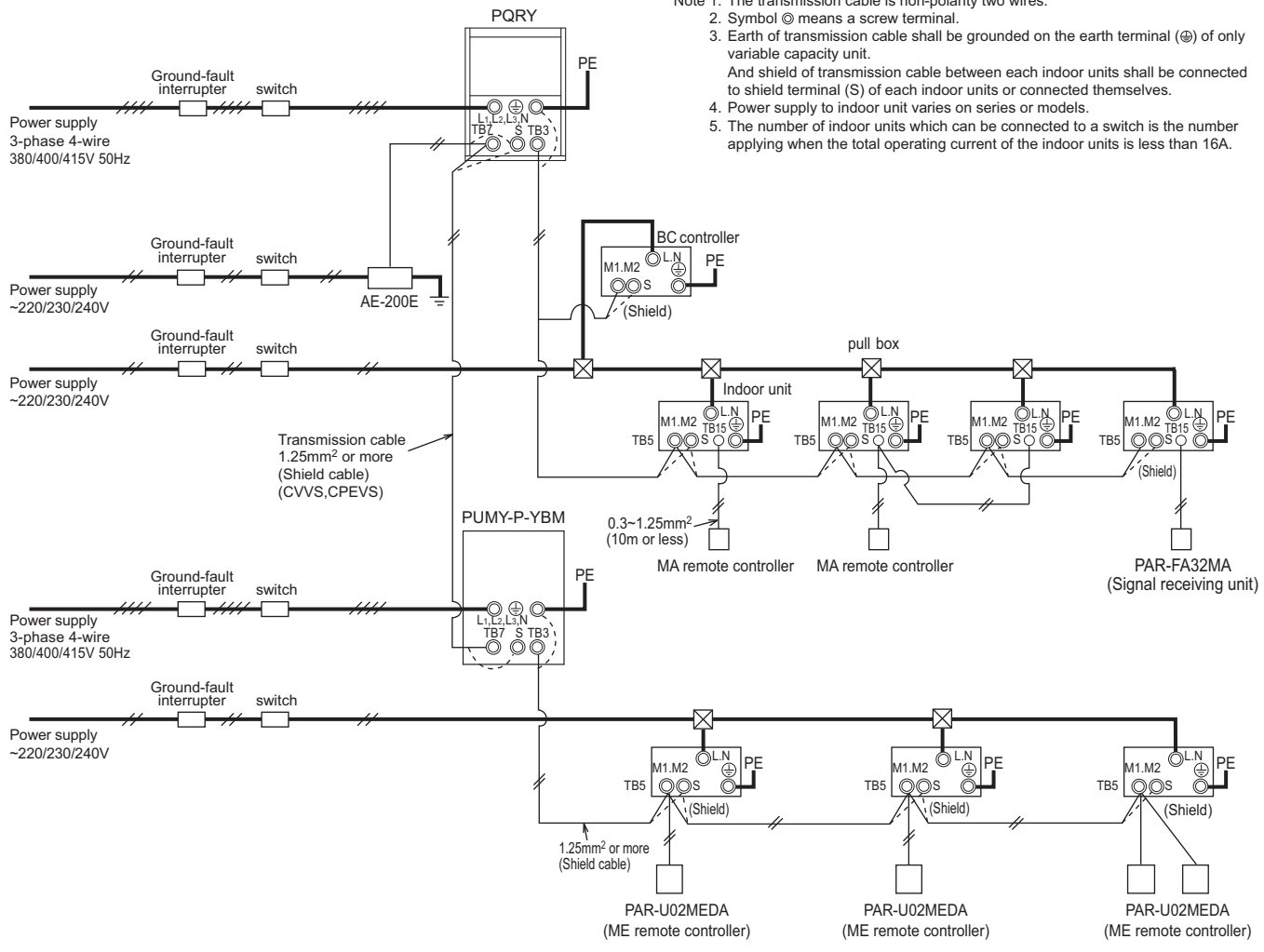

10-1. Transmission cable length limitation

10-1-1. Using MA Remote controller

Long transmission cable causes voltage down, therefore, the length limitation should be obeyed to secure proper transmission.

Max. length via Outdoor (M-NET cable)	$L_1+L_2+L_3, L_1+L_2+L_4+L_5, L_3+L_4+L_5$	$\leq 500\text{m}[1640\text{ft}]$	1.25mm ² [AWG16] or thicker
Max. length to Outdoor (M-NET cable)	L_1, L_3, L_2+L_4, L_5	$\leq 200\text{m}[656\text{ft}]$	1.25mm ² [AWG16] or thicker
Max. length from MA to Indoor for each group	$a_1+a_2, a_1+a_2+a_3+a_4$	$\leq 200\text{m}[656\text{ft}]$	0.3-1.25mm ² [AWG22-16]
24VDC to AG-150A	n	$\leq 50\text{m}[164\text{ft.}]$	0.75-2.0 mm ² [AWG18-14]

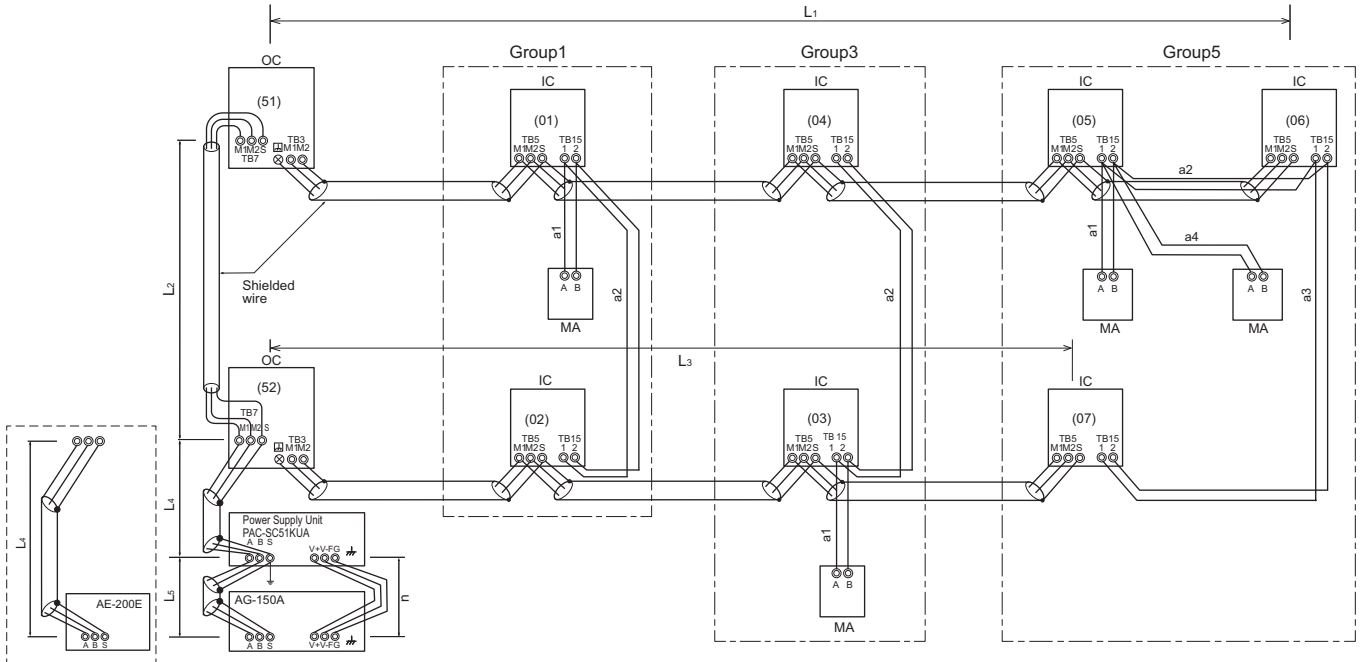

OC: Outdoor unit; IC: Indoor unit; MA: MA remote controller

10-1-2. Using ME Remote controller

Long transmission cable causes voltage down, therefore, the length limitation should be obeyed to secure proper transmission.

Max. length via Outdoor (M-NET cable)	$L_1+L_2+L_3+L_4, L_1+L_2+L_6+L_7, L_1+L_2+L_3+L_5, L_3+L_4+L_6+L_7, L_3+L_5+L_6+L_7, L_4+L_5$	$\leq 500\text{m}[1640\text{ft}]$	1.25mm ² [AWG16] or thicker
Max. length to Outdoor (M-NET cable)	$L_1, L_3+L_4, L_2+L_6, L_7, L_3+L_5$	$\leq 200\text{m}[656\text{ft}]$	1.25mm ² [AWG16] or thicker
Max. length from ME to Indoor	e_1, e_2, e_3, e_4	$\leq 10\text{m}[32\text{ft}] *1$	0.3-1.25mm ² [AWG22-16] *1
24VDC to AG-150A	n	$\leq 50\text{m}[164\text{ft.}]$	0.75-2.0 mm ² [AWG18-14]

*1. If the length from ME to Indoor exceed 10m, use 1.25 mm²[AWG16] shielded cable, but the total length should be counted into Max. length via Outdoor.

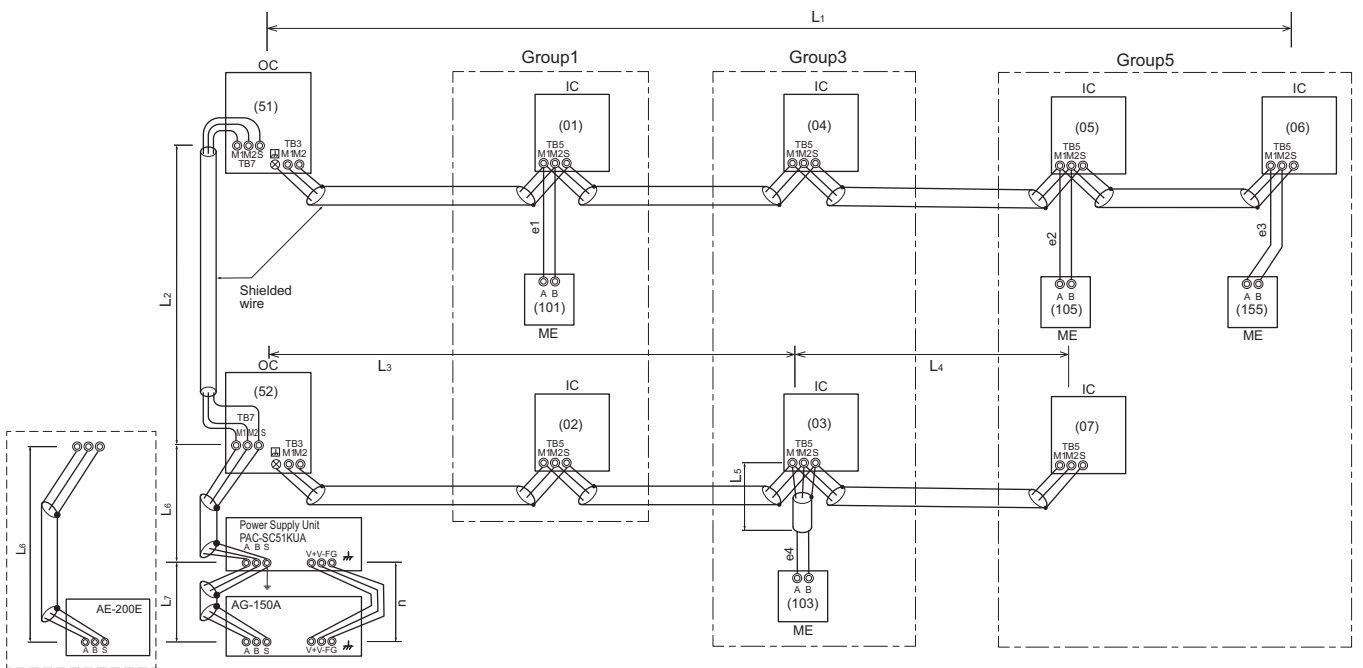

OC: Outdoor unit; IC: Indoor unit; ME: ME remote controller

10-1-3. Using a Branch Box

Long transmission cable causes voltage down, therefore, the length limitation should be obeyed to secure proper transmission.

Max length via outdoor units (M-NET cable):	$L_1 + L_2 + L_3 + L_4 + L_5$	$\leq 500\text{m}[1640\text{ft}]$	1.25mm ² [AWG16] or thicker
Max transmission cable length (M-NET cable):	$L_1 + L_2, L_3 + L_4, L_5$	$\leq 200\text{m}[656\text{ft}]$	1.25mm ² [AWG16] or thicker

<Example of Transmission Cable Wiring: When Using a Branch Box>

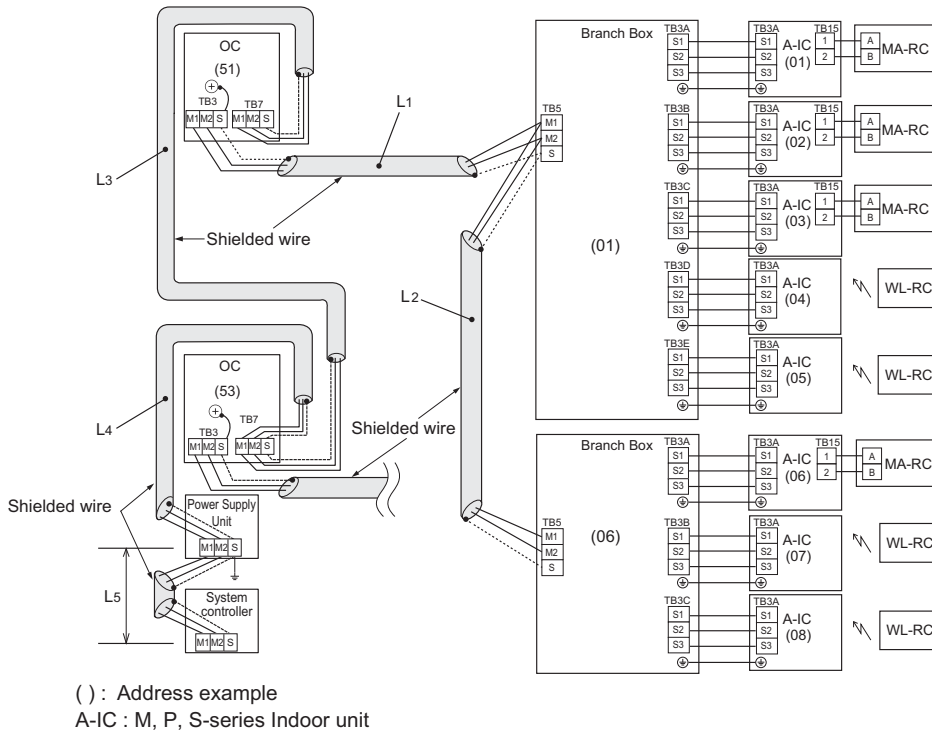

10-1-4. Mixing system

Long transmission cable causes voltage down, therefore, the length limitation should be obeyed to secure proper transmission.

Max length via outdoor units:	$L_1 + L_2 + L_3 + L_4 + L_5 + L_6 + L_7$	$\leq 500\text{m}[1640\text{ft}]$	1.25mm ² [AWG16] or thicker
Max transmission cable length:	$L_1 + L_2 + L_3 + L_4, L_5 + L_6, L_7$	$\leq 200\text{m}[656\text{ft}]$	1.25mm ² [AWG16] or thicker

<Example of Transmission Cable Wiring: Mixing system>

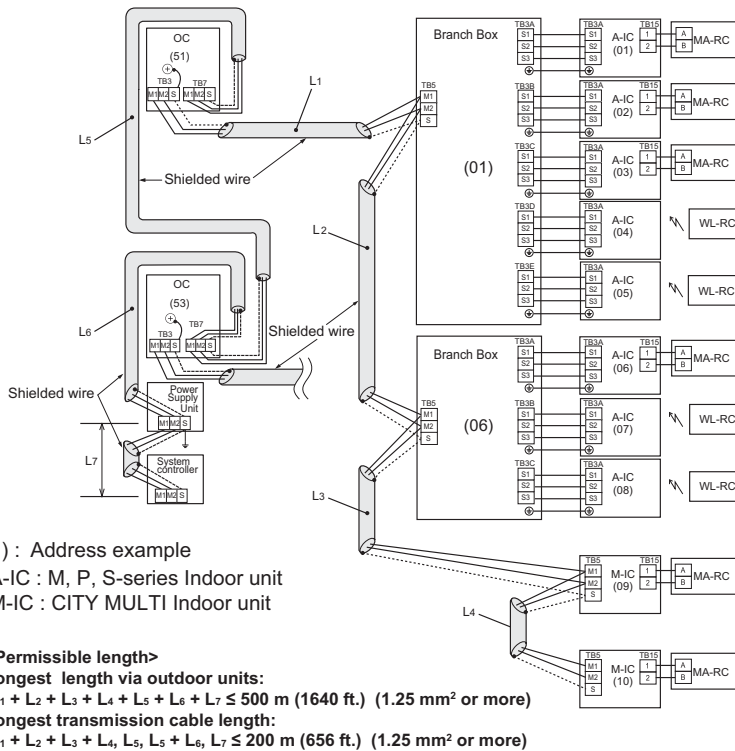

PUMY-P-VKM5, YKM(E)4, YKM2, YBM

10-2. Transmission cable specifications

	Transmission cables (Li)	M-NET remote controller cables (ei)	MA Remote controller cables (ai)
Type of cable	Shielding wire (2-core) CVVS, CPEVS or MVVS	Sheathed 2-core cable (unshielded) CVV	
Cable size	More than 1.25 mm ² [AWG16]	0.3 ~ 1.25 mm ² [AWG22~16]	0.3 ~ 1.25 mm ² [AWG22 ~16]*1
Remarks	Max length: within 200 m	When 10 m [32ft] is exceeded, use cables with the same specification as transmission cables.	Max length: 200 m [656ft]

*1 To wire PAR-CT01MA, PAR-4XMAA ("X" represents 0 or later), and Simple MA remote controller, use a wire with a diameter of 0.3 mm² [AWG22].

CVVS, MVVS: PVC insulated PVC sheathed shielded control cable
CPEVS: PE insulated PVC sheathed shielded communication cable
CVV: PVC insulated PVC sheathed control cable

10-3. System configuration restrictions

10-3-1. Common restrictions for the CITY MULTI system

For each Outdoor/Heat source unit, the maximum connectable quantity of Indoor unit is specified at its Specifications table.

- A) 1 Group of Indoor units can have 1-16 Indoor units;
 *OA processing unit GUF-RD(H) is considered as Indoor unit.
- B) Maximum 2 remote controllers for 1 group;
 *MA/ME remote controllers cannot be present together in 1group.
 *When a PAR-CT01MA or PAR-4XMAA ("X" represents 0 or later) is connected to a group, no other MA remote controllers can be connected to the same group.
- C) 1 Lossnay unit can interlock maximum 16 Indoor units; 1 Indoor unit can interlock only 1 Lossnay unit.
- D) Maximum 3 System controllers are connectable when connecting to TB3 of the Outdoor/Heat source unit.
- E) A maximum of 6 system controller are connectable to TB3 and TB7 of Outdoor/Heat source unit.
- F) 4 System controllers or more are connectable when connecting to TB7 of the Outdoor/Heat source unit, if the transmission power is supplied by the power supply unit PAC-SC51KUA.
 *System controller connected as described in D) would have a risk that the failure of connected Outdoor/Heat source unit would stop power supply to the System controller.

10-3-2. Ensuring proper communication power and the number of connected units for M-NET

In order to ensure proper communication among Outdoor/Heat source unit, Indoor unit, Lossnay, OA processing unit GUF-RD(H), and Controllers, the transmission power situation for the M-NET should be observed. In some cases, Transmission booster should be used. Taking the power consumption of Indoor unit as 1, the equivalent power consumption or supply of others are listed at Table 1 and Table 2.

Both the transmission line for centralized controller and indoor-outdoor transmission line must meet the conditions listed below. (Both conditions a) and b) must be met.)

a) [Total equivalent power consumption] ≤ [The equivalent power supply]

b) [Total equivalent number of units (Table 1)] ≤ [40]

Table 1 The equivalent power consumption and the equivalent number of units

Category	Model	The equivalent power consumption	The equivalent number of units
CITY MULTI indoor unit OA unit CITY MULTI connection kit Air handling unit controller	Except for the models indicated by *2 PEFY-AF2500, 3000, 4000, 5000, 6000MH GUF-50, 100 PAC-LV11M-J PAC-AH125, 140, 250, 500M-J	1	1
CITY MULTI indoor unit *2	PDFY-P100VM-E-RE	2	2
BC controller	CMB	2	1
PWFY *1	P100VM-E-BU	6	1
	P200VM-E1-AU P200VM-E2-AU	5	1
	(E)P100VM-E1-AU (E)P100VM-E2-AU P140VM-E1-AU P140VM-E2-AU	1	1
PFAV	P250, 300, 500, 600VM-E(-F)	1	1
	P750, 900VM-E(-F)	2	2
PFV, PEV	P200, 250, 400, 500YM-A	1	1
MA remote controller/Lossnay	PAR-CT01MA PAR-21MA PAR-31, 32, 33MA PAR-40, 41MA PAC-YT52CRA PAR-FA32MA LGH PZ-60, 61, 62DR-E PZ-43SMF-E	0	0
ME remote controller	PAR-U02MEDA	0.5	1
	PZ-52SF	0.25	1
System controller	AE-200E AE-50E EW-50E LM-AP	0	0
	AG-150A EB-50GU-J PAC-IF01AHC-J	0.5	1
	AT-50B	1.5	5
	PAC-YG60MCA PAC-YG66DCA PAC-YG63MCA	0.25	1
ON/OFF controller	PAC-YT40ANRA	1	1
MN converter	CMS-MNG-E	2	1
Outdoor/Heat source unit	TB7 power consumption	0	0
System control interface	MAC-333IF-E	0	0
A-M converter	PAC-SF83MA-E		

*1 PWFY cannot be connected to PUMY model.

Table 2 The equivalent power supply

Category	Model	The equivalent power supply		
Transmission Booster	PAC-SF46EPA-G	25 *1		
Power supply unit	PAC-SC51KUA	5		
Expansion controller	PAC-YG50ECA	6		
BM ADAPTER	BAC-HD150	6		
System controller	AE-200E/AE-50E	0.75		
	EW-50E	1.5		
	LM-AP	0		
Outdoor/Heat source unit		TB3 and TB7 total	TB7 only	TB3 only
	Outdoor unit except S-Series and TKA *2	32 *1	6	32 *1-equivalent power supplied to TB7
	S-Series outdoor unit	12 *1	0	12 *1
	TKA outdoor unit	32 *1	- *3	32 *1

*1 When one or more indoor units listed below is connected, subtract 3 from the equivalent power supply.

Table 3

Category	Model
Indoor unit	Sized P200/P250
	PEFY-AF4000/5000/6000MH, PFFY-P400/500YM-E, PFFY-P400/500YMH-C
	PFFY-P300/600YM-E-F, PFFY-P300/600YM-C-F, PDFY-P100VM-E-RE
Air handling unit controller	PAC-AH250/500M-J
PFAV	PFAV-P500/600/750/900VM-E(-F)
PFV	PFV-P400/500YM-A
PEV	PEV-P400/500YM-A

*2 If PAC-SC51KUA is used to supply power at TB7 side, no power supply need from Outdoor/Heat source unit at TB7, Connector TB3 itself will therefore have 32.

*3 Do not supply power to TB7 from TKA outdoor units.

Use PAC-SC51KUA or PAC-SF46EPA-G when connecting an M-NET device to TB7.

With the equivalent power consumption values and the equivalent number of units in Table 1 and Table 2, PAC-SF46EPA-G can be designed into the air-conditioner system to ensure proper system communication according to (A), (B), (C).

- (A) Firstly, count from TB3 at TB3 side the total equivalent number of units of Indoor units, OA processing units, ME remote controller, and System controllers. If the total equivalent number of units reaches 40, a PAC-SF46EPA-G should be set.
- (B) Secondly, count from TB7 side to TB3 side the total transmission power consumption. If the total equivalent power supply reaches 32, a PAC-SF46EPA-G should be set. Yet, if a PAC-SC51KUA or another controller with a built-in power supply, such as PAC-YG50ECA, is used to supply power at TB7 side, count from TB3 side only.
- (C) Thirdly, count from TB7 at TB7 side the total transmission power consumption, If the total equivalent power supply for only TB7 reaches 6, a PAC-SF46EPA-G should be set. Also, count from TB7 at TB7 side the total equivalent number of units of System controllers, and so on. If the total equivalent number of units reaches 40, a PAC-SF46EPA-G should be set.

* The equivalent power supply of S-Series outdoor unit is 12.

* When one or more indoor units listed in Table 3 is connected, subtract 3 from the equivalent power supply.

■ System example

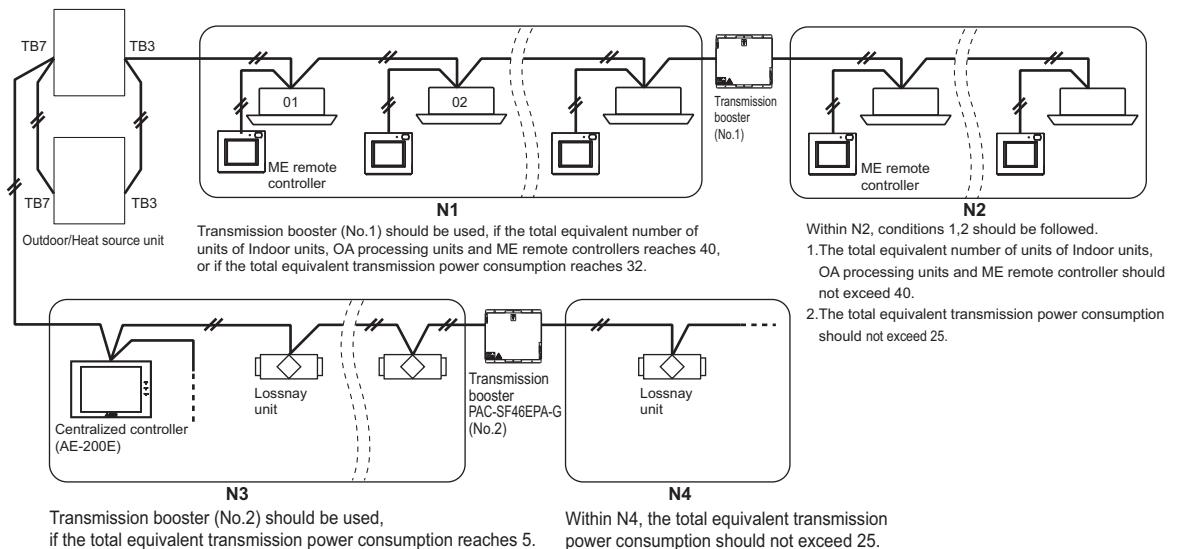

PUMY-P-VKM5, YKM(E)4, YKM2, YBM

10-3-3. Ensuring proper power supply to System controller

The power to System controller (excluding AE-200E, AE-50E, EW-50E, BAC-HD150, LM-AP) is supplied via M-NET transmission line. M-NET transmission line at TB7 side is called Centralized control transmission line while one at TB3 side is called Indoor-Outdoor/Heat source transmission line. There are 3 ways to supply power to the System controller.

- A) Connecting to TB3 of the Outdoor/Heat source unit and receiving power from the Outdoor/Heat source unit.
 - B) Connecting to TB7 of the Outdoor/Heat source unit and receiving power from the Outdoor/Heat source unit. (Not applicable to the PUMY model)
 - C) Connecting to TB7 of the Outdoor/Heat source unit but receiving power from power supply unit PAC-SC51KUA.
- * System controllers (AE-200E, AE-50E, EW-50E, BAC-HD150, LM-AP) have a built-in function to supply power to the M-NET transmission lines, so no power needs to be supplied to the M-NET transmission lines from the Outdoor/Heat source units or from PAC-SC51KUA.

10-3-3-A. When connecting to TB3 of the Outdoor/Heat source unit and receiving power from the Outdoor/Heat source unit.

Maximum 3 System controllers can be connected to TB3. If there is more than 1 Outdoor/Heat source unit, it is necessary to replace power supply switch connector CN41 with CN40 on one Outdoor/Heat source unit.

Fig. 10-3-3-A

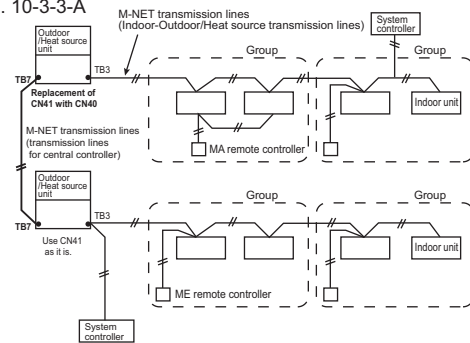

10-3-3-B. When connecting to TB7 of the Outdoor/Heat source unit and receiving power from the Outdoor/Heat source unit. (Not applicable to the PUMY model)

A maximum of 6 system controller are connectable to TB3 and TB7 of Outdoor/Heat source unit. (Not applicable to the PUMY model) It is necessary to replace power supply switch connector CN41 with CN40 on one Outdoor/Heat source unit.

Fig. 10-3-3-B

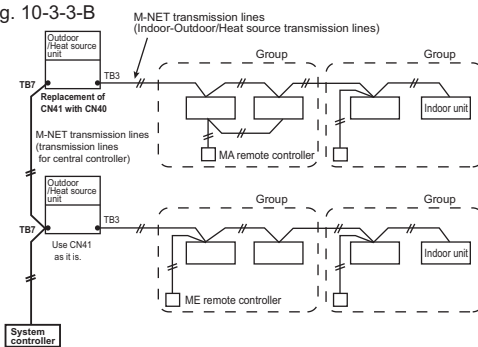

10-3-3-C. When connecting to TB7 of the Outdoor/Heat source unit but receiving power from PAC-SC51KUA.

When using PAC-SC51KUA to supply transmission power, the power supply connector CN41 on the Outdoor/Heat source units should be kept as it is. It is also a factory setting. 1 PAC-SC51KUA supports maximum 1 AG-150A or 1 EB-50GU-J unit due to the limited power 24VDC at its TB3. However, 1 PAC-SC51KUA supplies transmission power at its TB2 equal to 5 Indoor units, which is referable at Table 2. If System controller, ON/OFF controller connected to TB7 consume transmission power more than 5 (Indoor units), Transmission booster PAC-SF46EPA-G is needed. PAC-SF46EPA-G supplies transmission power equal to 25 Indoor units.

Fig. 10-3-3-C

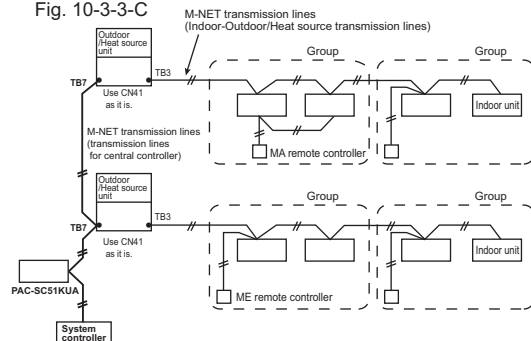

CAUTION

- How to connect system controllers (AE-200E, AE-50E, EW-50E, BAC-HD150, LM-AP) to a given system
- System controllers (AE-200E, AE-50E, EW-50E, BAC-HD150, LM-AP) have a built-in function to supply power to the M-NET transmission lines, so no power needs to be supplied to the M-NET transmission lines from the Outdoor/Heat source units or from PAC-SC51KUA. Leave the power supply connector on the Outdoor/Heat source unit connected to CN41 as it is. Refer to 10-3-2 for information about the power-supply capacity of each system controller (EW-50E, BAC-HD150, LM-AP) to the low-level system controllers.

Fig. 10-3-3-D

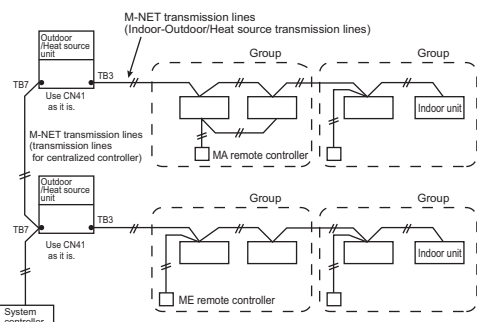

10-3-4. Power supply to LM-AP

1-phase 220-240VAC power supply is needed.

The power supply unit PAC-SC51KUA is not necessary when connecting only the LM-AP. Yet, make sure to change the power supply changeover connector CN41 to CN40 on the LM-AP.

10-3-5. Power supply to expansion controller

1-phase 100-240VAC power supply is needed.

The power supply unit PAC-SC51KUA is not necessary.

The expansion controller supplies power through TB3, which equals 6 indoor units. (refer to Table 2)

10-3-6. Power supply to BM ADAPTER

1-phase 100-240VAC power supply is needed.

The power supply unit PAC-SC51KUA is not necessary when only BM ADAPTER is connected.

Yet, make sure to move the power jumper from CN41 to CN40 on the BM ADAPTER.

10-3-7. Power supply to AE-200E/AE-50E/EW-50E

1-phase 100-240VAC power supply is needed.

The power supply unit PAC-SC51KUA is not necessary when connecting only the AE-200E/AE-50E/EW-50E.

PUMY-P-VKM5, YKM(E)4, YKM2, YBM

10-4. Address setting

10-4-1. Switch operation

In order to constitute CITY MULTI in a complete system, switch operation for setting the unit address No. and connection No. is required.

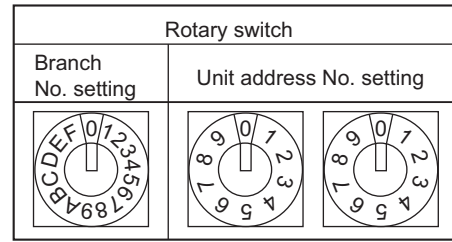

① Address No. of outdoor unit, indoor unit and remote controller.

The address No. is set at the address setting board.

In the case of R2 system, it is necessary to set the same No. at the branch No. switch of indoor unit as that of the BC controller connected. (When connecting two or more branches, use the lowest branch No.)

② Caution for switch operations

- Be sure to shut off power source before switch setting. If operated with power source on, switch can not operate properly.
- No units with identical unit address shall exist in one whole air conditioner system. If set erroneously, the system can not operate.

③ MA remote controller

- When connecting only one remote controller to one group, it is always the main remote controller. When connecting two remote controllers to one group, set one remote controller as the main remote controller and the other as the sub remote controller.
- The factory setting is "Main".

PAR-4XMAA ("X" represents 0 or later), PAR-CT01MA
 The MA remote controller does not have the switches listed above.
 Refer to the installation manual for the function setting.

PAC-YT52CRA

Setting the dip switches

There are switches on the back of the top case. Remote controller Main/Sub and other function settings are performed using these switches. Ordinarily, only change the Main/Sub setting of SW1.
 (The factory settings are ON for SW1, 2, and 3 and OFF for SW4.)

SW No.	SW contents Main	ON	OFF	Comment
1	Remote controller Main/Sub setting	Main	Sub	Set one of the two remote controllers at one group to "ON".
2	Temperature display units setting	Celsius	Fahrenheit	When the temperature is displayed in [Fahrenheit], set to "OFF".
3	Cooling/heating display in AUTO mode	Yes	No	When you do not want to display "Cooling" and "Heating" in the AUTO mode, set to "OFF".
4	Indoor temperature display	Yes	No	When you want to display the indoor temperature, set to "ON".

10-4-2. Rule of setting address

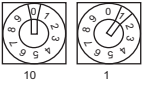
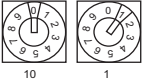
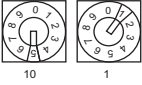
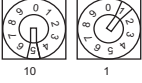
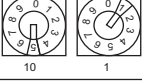
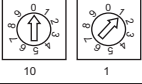
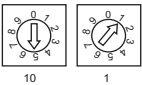
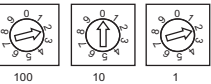
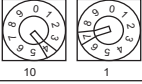
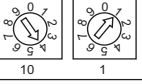
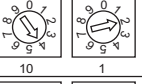
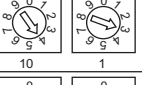
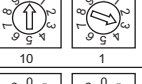
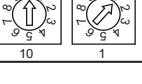
Unit	Address setting	Example	Note														
Indoor unit	01 ~ 50		Use the most recent address within the same group of indoor units. Make the indoor units address connected to the BC controller (Sub) larger than the indoor units address connected to the BC controller (Main). If applicable, set the sub BC controllers in an PURY/PQRY system in the following order: (1) Indoor unit to be connected to the BC controller (Main) (2) Indoor unit to be connected to the BC controller (No.1 Sub) (3) Indoor unit to be connected to the BC controller (No.2 Sub) Set the address so that (1)<(2)<(3)														
Branch Box	01 ~ 50		Use a number within the range 01~ 50, but it should not make the highest address of connected A-IC exceed 50. • Specify whether indoor units are connected to each port (A, B, C, D, and E). <table border="1" data-bbox="898 591 1177 645"> <tr> <td>SW1</td> <td>1</td> <td>2</td> <td>3</td> <td>4</td> <td>5</td> <td>(6)</td> </tr> <tr> <td>Port</td> <td>A</td> <td>B</td> <td>C</td> <td>D</td> <td>E</td> <td>not use</td> </tr> </table> indoor units are connected ON indoor units are not connected OFF	SW1	1	2	3	4	5	(6)	Port	A	B	C	D	E	not use
SW1	1	2	3	4	5	(6)											
Port	A	B	C	D	E	not use											
Outdoor unit	51 ~ 99, 100		The smallest address of indoor unit in same refrigerant system + 50 * The address automatically becomes "100" if it is set as "01~ 50"														
BC controller (Main)	52 ~ 99, 100		The address of outdoor unit + 1 * Please reset another address between 51 and 99 when two addresses overlap. * The address automatically becomes "100" if it is set as "01~ 50"														
BC controller (Sub)	53 ~ 99, 100		Lowest address within the indoor units connected to the BC controller (Sub) plus 50.														
Local remote controller	ME Remote controller (Main)	101 ~ 150	1 Fixed 	The smallest address of indoor unit in the group + 100 * The place of "100" is fixed to "1"													
	ME Remote controller (Sub)	151 ~ 199, 200	1 Fixed 	The address of main remote controller + 50 * The address automatically becomes "200" if it is set as "00"													
System controller	ON/OFF remote controller	201 ~ 250		The smallest group No. to be managed + 200 * The smallest group No. to be managed is changeable.													
	AE-200E/AE-50E AG-150A EB-50GU-J EW-50E AT-50B	000, 201 ~ 250	0 0 0 100 10 1	* AT-50B cannot be set to "000".													
	PAC-YG50ECA	000, 201 ~ 250	0 0 0 100 10 1	* Settings are made on the initial screen of AG-150A.													
	BAC-HD150	000, 201 ~ 250	0 0 0 100 10 1	* Settings are made with setting tool of BM ADAPTER.													
	LMAP04-E	201 ~ 250	2 Fixed 														
PI, AI, DIDO	PAC-YG60MCA	01 ~ 50															
	PAC-YG63MCA	01 ~ 50															
	PAC-YG66DCA	01 ~ 50															
Lossnay, OA processing unit	01 ~ 50		After setting the addresses of all the indoor units, assign an arbitrary address.														
PAC-IF01AHC	201 ~ 250	2 Fixed 															

PUMY-P-VKM5, YKM(E)4, YKM2, YBM

10-4-3. System example

Factory setting

Original switch setting of the outdoors, indoors, controllers, LM-AP and BM ADAPTER at shipment is as follows.

- Outdoor unit : Address: 00, CN41: ON (Jumper), DipSW2-1: OFF
- Indoor unit : Address: 00
- ME Remote controller : Address: 101
- LM-AP : Address: 247, CN41: ON (Jumper), DipSW1-2: OFF
- BM ADAPTER : Address: 000, CN41: ON (Jumper)
- AE-200E/AE-50E/EW-50E : Address: 000, CN21: ON (Jumper)

10-4-3-1. Basic (No address setting)

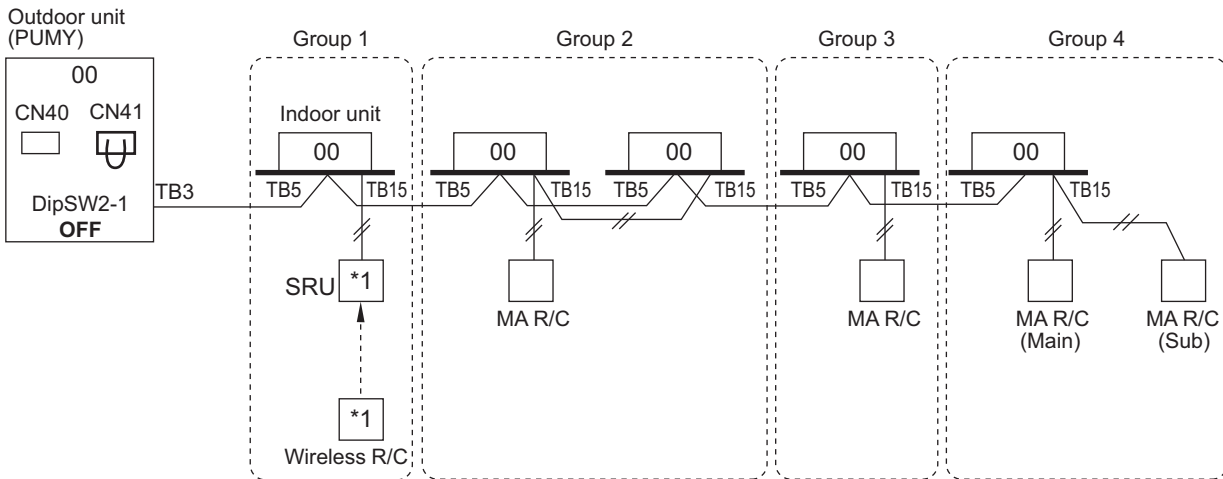

*1 For wireless R/C and Signal receiver unit(SBU), channel 1, 2 and 3 are selectable and should be set same channel.

10-4-3-2. Basic, Sub/main ME remote controller

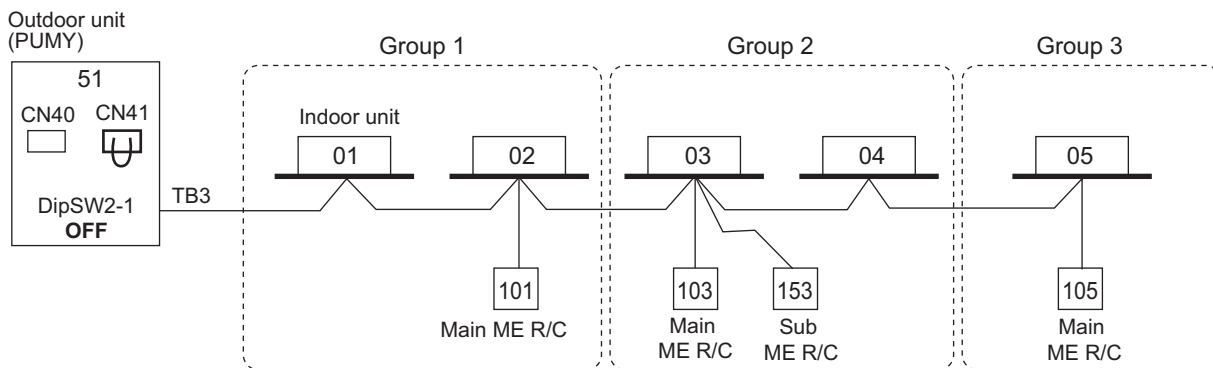

10-4-3-3. Grouping in different refrigerant system

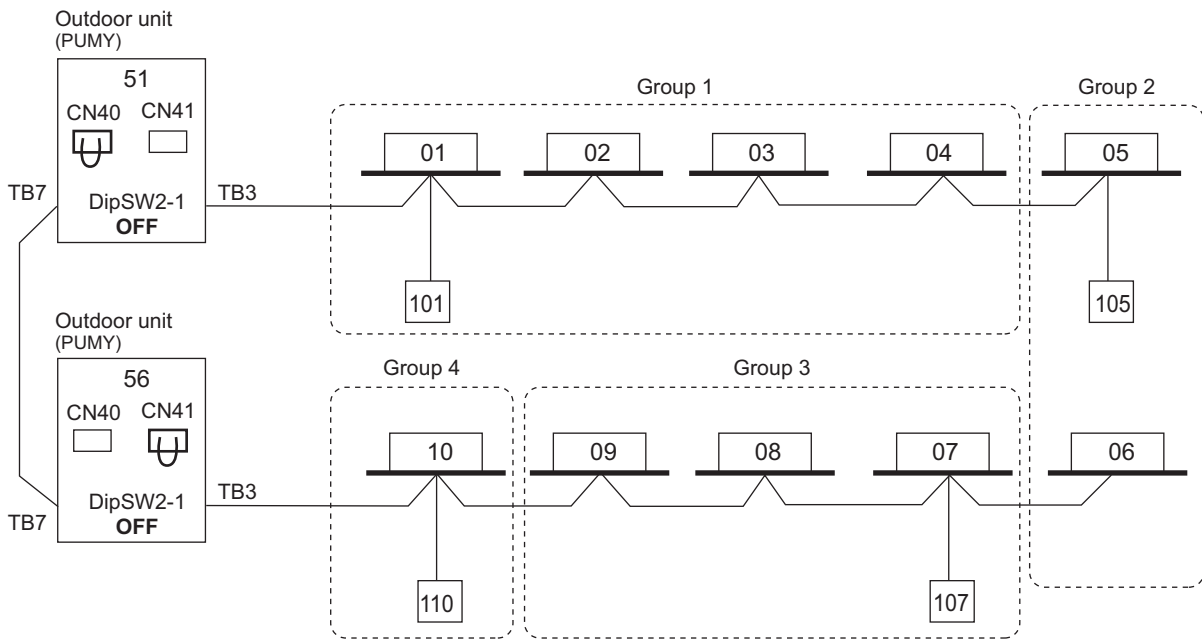

NOTE

- It is necessary to change the connector to CN40 on the outdoor unit (Heat source unit) control board (only one outdoor unit (Heat source unit)) when the group is set between other refrigerant systems.
- It is necessary to set on the remote controller by manual when group sets on the different refrigerant system. Please refer to remote controller installation manual.

10-4-3-4. 2 Outdoor unit, AG-150A, AE-200E, MA

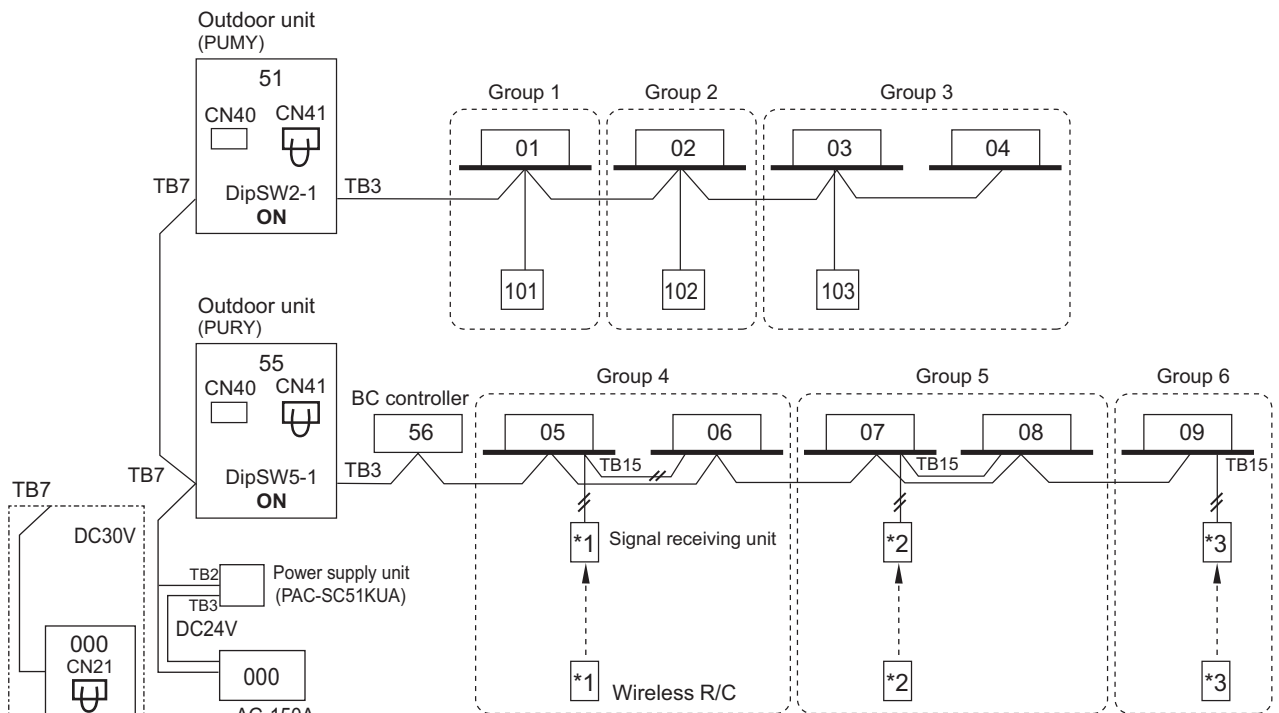

* For wireless R/C and Signal receiver unit(SBU), channel 1, 2 and 3 are selectable and should be set same channel.

PUMY-P-VKM5, YKM(E)4, YKM2, YBM

10-4-3-5. TG-2000A(*1)+AE-200E/AE-50E/EW-50E

AE-200E can control max. 50 indoor units;
 TG-2000A can control max. 40 of AE-200E/AE-50E/EW-50E;*2
 TG-2000A can control max. 2000 indoor units.

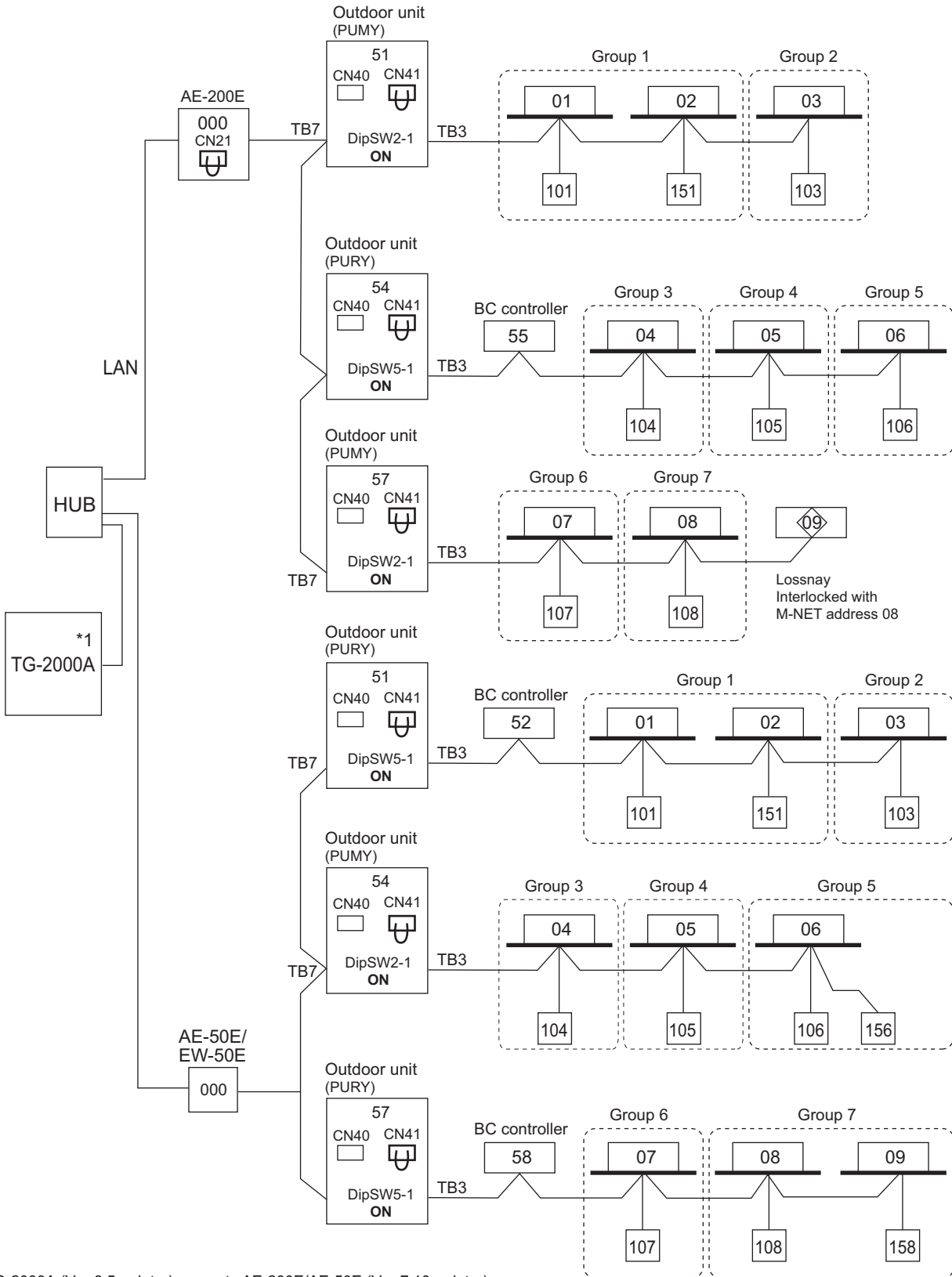

*1 TG-2000A (Ver.6.5 or later) supports AE-200E/AE-50E (Ver.7.10 or later).
 TG-2000A (Ver.6.60 or later) supports EW-50E.

*2 When AE-200E connected with AE-50E/EW-50E is connected, the number of AE-50E/EW-50E will be the maximum controllable number.
 TG-2000A can control up to 40 AE-200E/AE-50E/EW-50E or AE-200E without AE-50E/EW-50E connection.

10-4-3-6. AE-200E + AE-50E/EW-50E
 AE-200E can control max. 200 indoor units/via AE-50E/EW-50E.

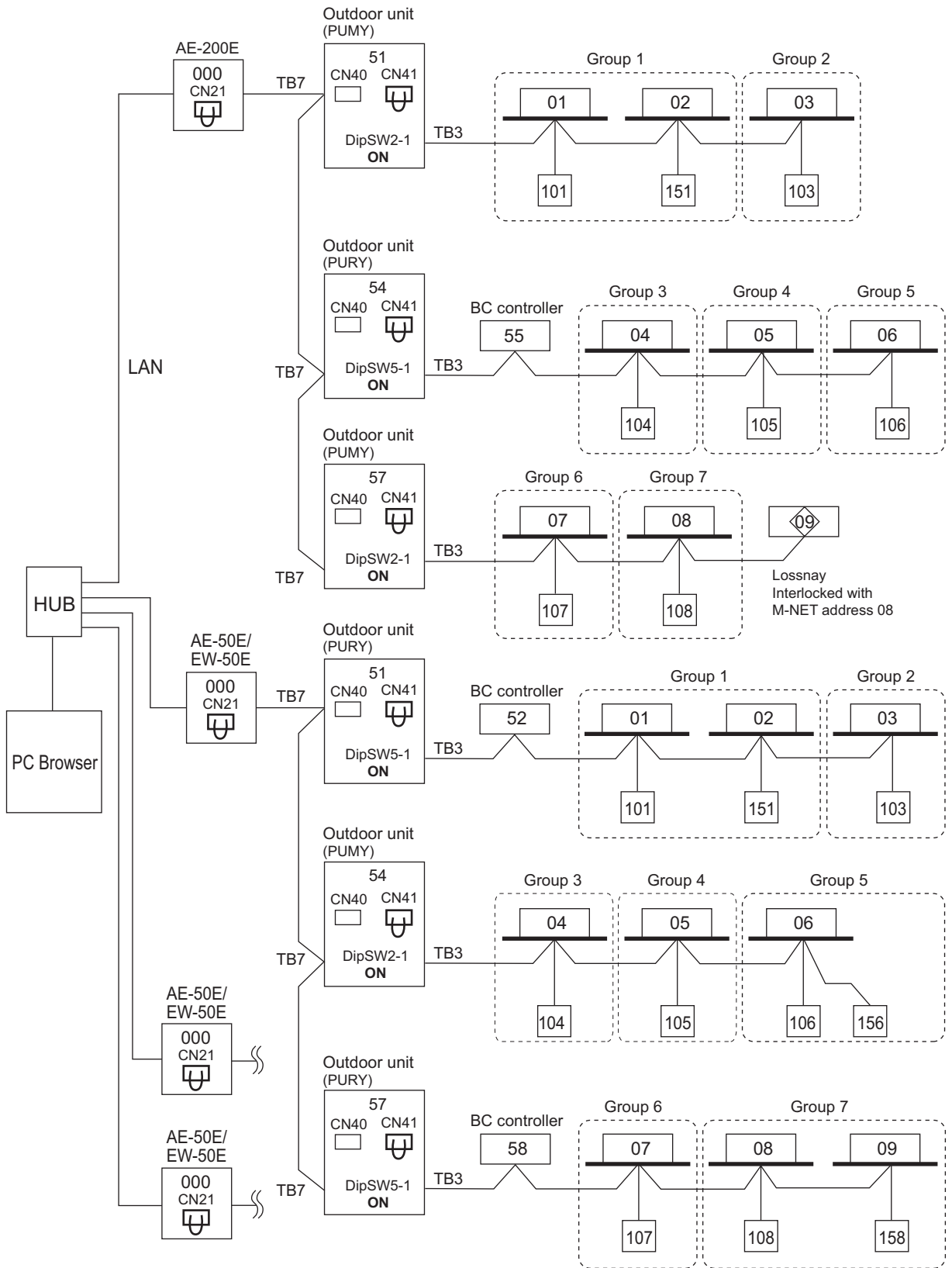

PUMY-P-VKM5, YKM(E)4, YKM2, YBM

PUMY-P-VKM5, YKM(E)4, YKM2, YBM

10-4-3-7. LM-AP

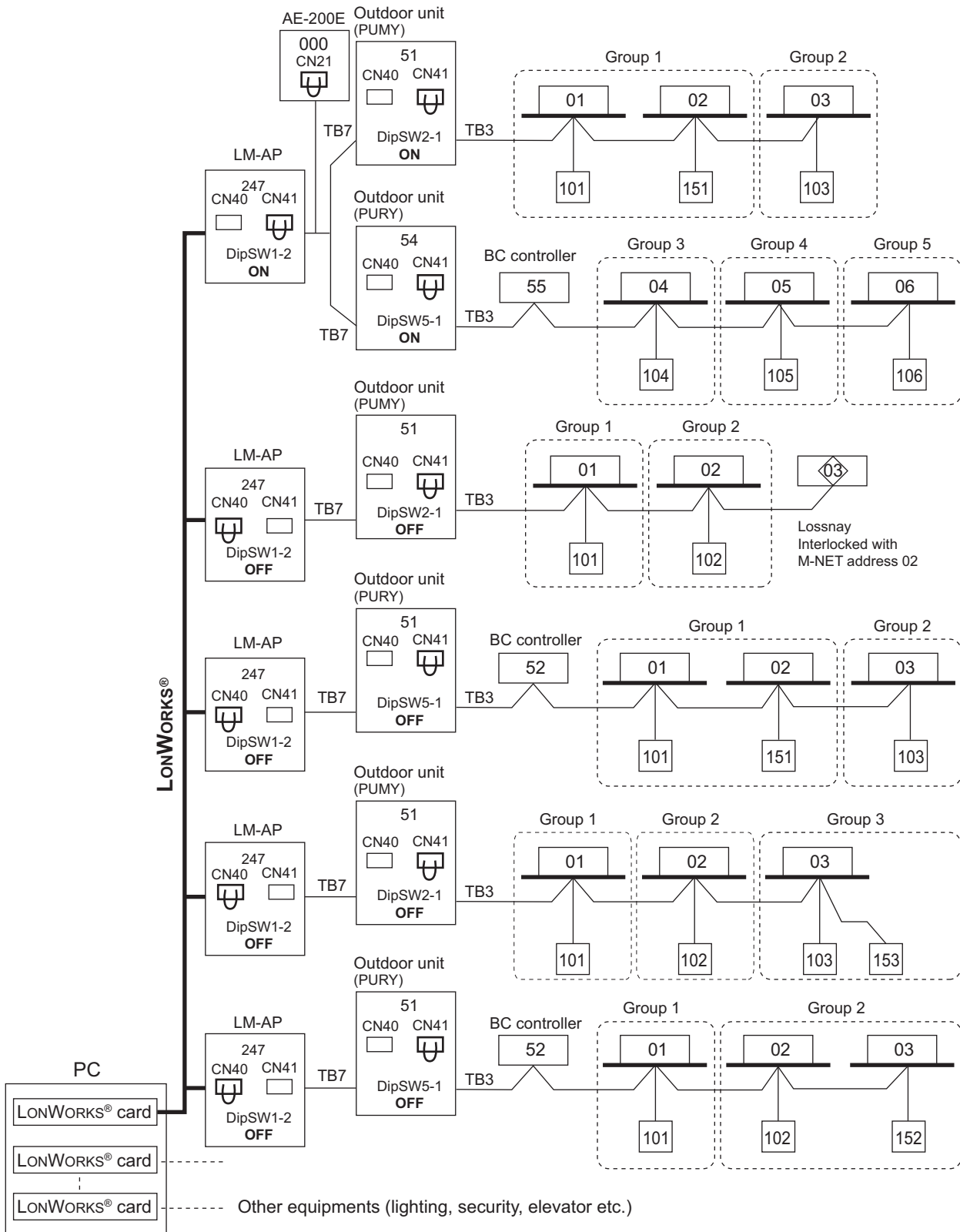

NOTE

- LM-AP can control 50 indoor units.
- It is necessary to turn on the DipSW1-2 on the LM-AP control board and the DipSW2-1 on the outdoor unit (heat source unit) control board with centralized controller (Power supply unit).
- It is necessary to change the connector to CN40 on the LM-AP control board without centralized controllers (Power supply unit).

10-4-3-8. BM ADAPTER

BM ADAPTER can transmit for max. 50 indoor units;
 Change Jumper from CN41 to CN40 to activate power supply to BM ADAPTER itself for those BM ADAPTER connected without the power supply unit.

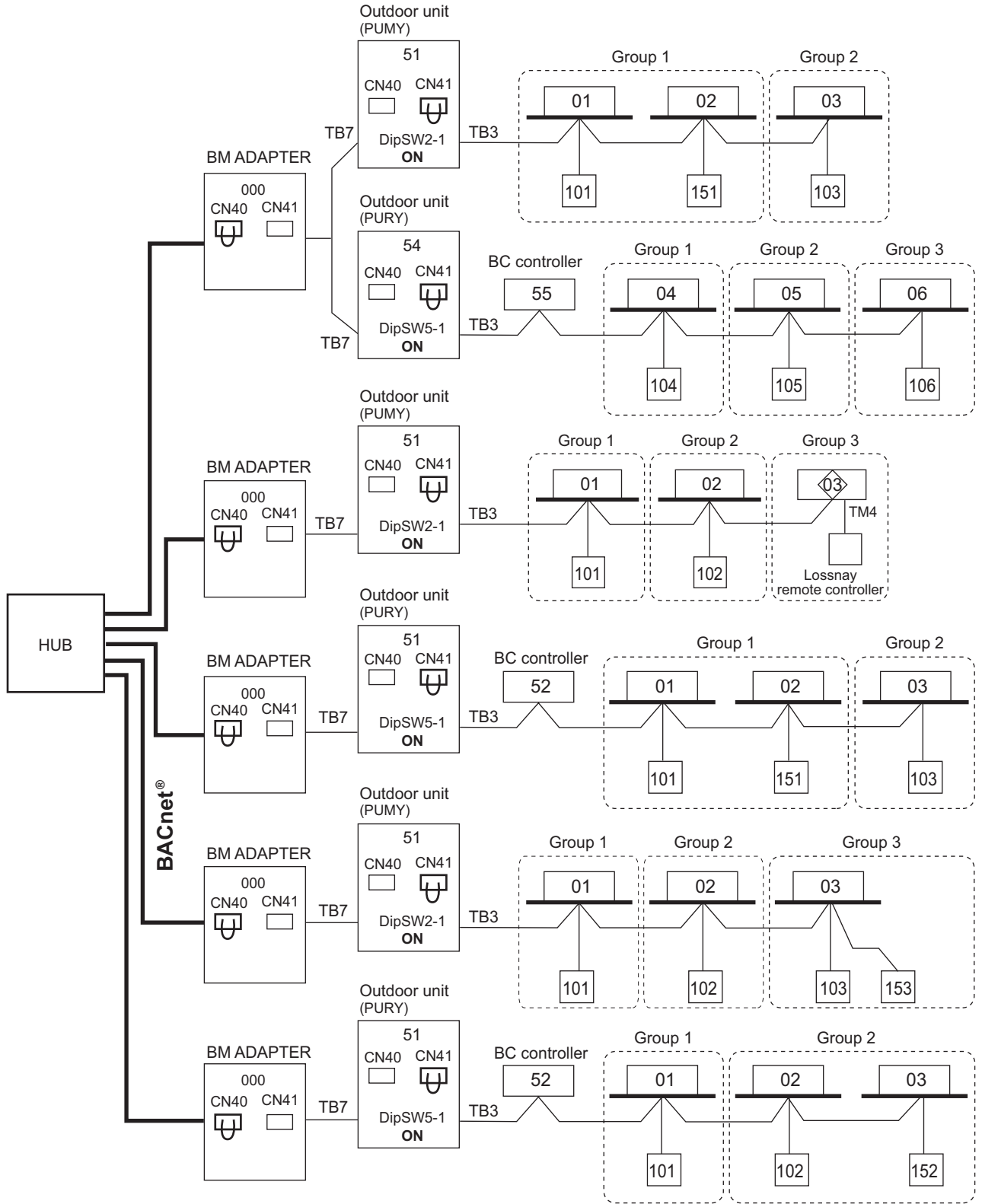

PUMY-P-VKM5, YKM(E)4, YKM2, YBM

PUMY-P-VKM5, YKM(E)4, YKM2, YBM

10-4-3-9. BM ADAPTER+PAC-YG50ECA (Expansion controller)

BM ADAPTER(*1) can transmit for max. 150 indoor units/via expansion controllers (PAC-YG50ECA).
 When the dual-set-point function is used, no expansion controllers can be connected, and only up to 50 units can be controlled from each BAC-HD150.

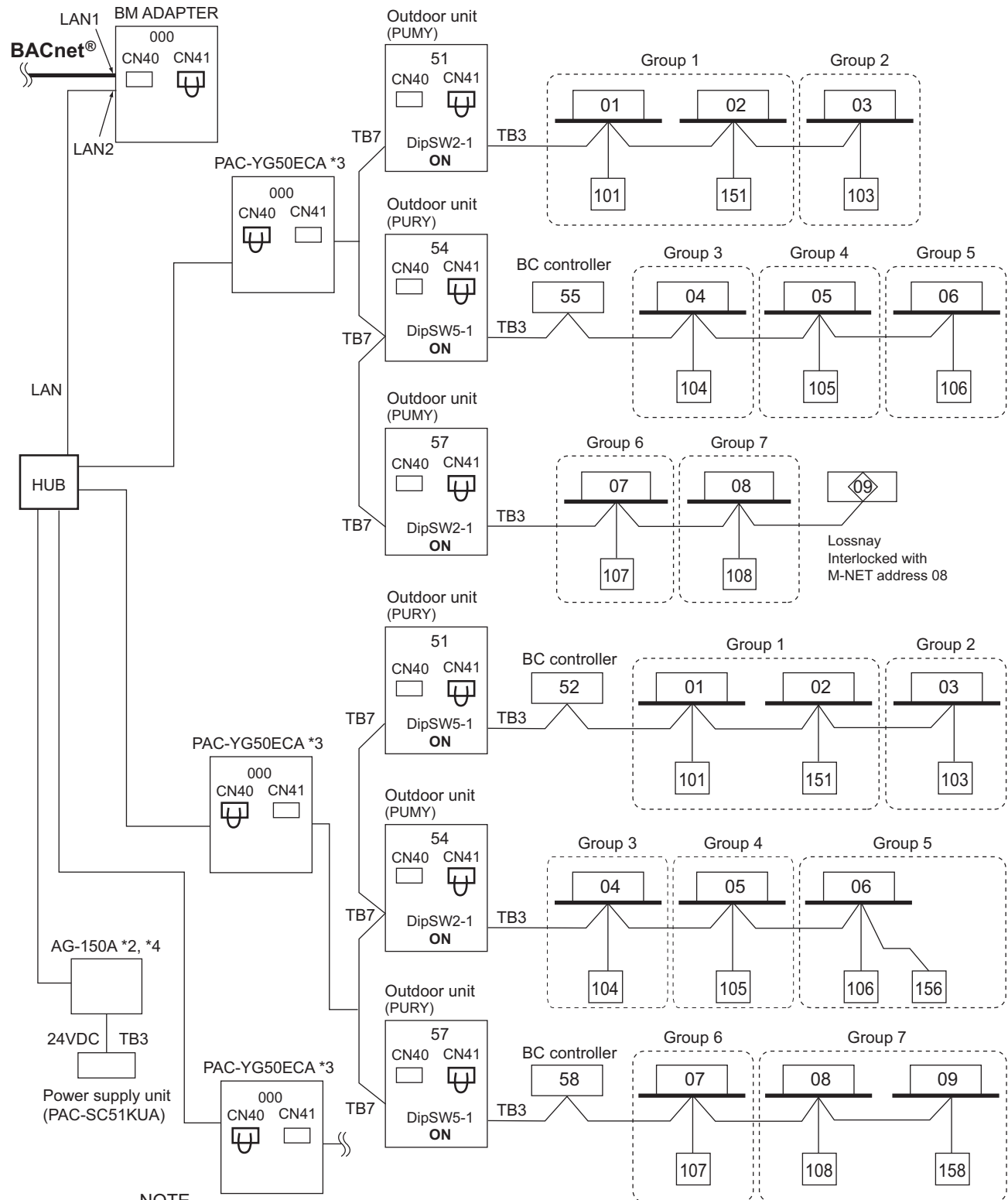

- NOTE**
- It is not necessary to connect the M-NET transmission line to the TB3 on BM ADAPTER. Leave the power jumper of BM ADAPTER connected to CN41.
 - *1 BM ADAPTER (Ver.2.00 or later) supports the expansion controller.
 - *2 AG-150A (Ver.2.30 or later) supports the BM ADAPTER.
 - *3 PAC-YG50ECA (Ver.1.30 or later) supports the BM ADAPTER.
 - *4 Consult your dealer for restrictions when connecting both AG-150A and BM ADAPTER to PAC-YG50ECA.

10-4-3-10. BM ADAPTER+AE-200E/AE-50E/EW-50E
 BM ADAPTER can transmit for max. 50 indoor units.
 One BM ADAPTER is required for one AE-200E/AE-50E/EW-50E.

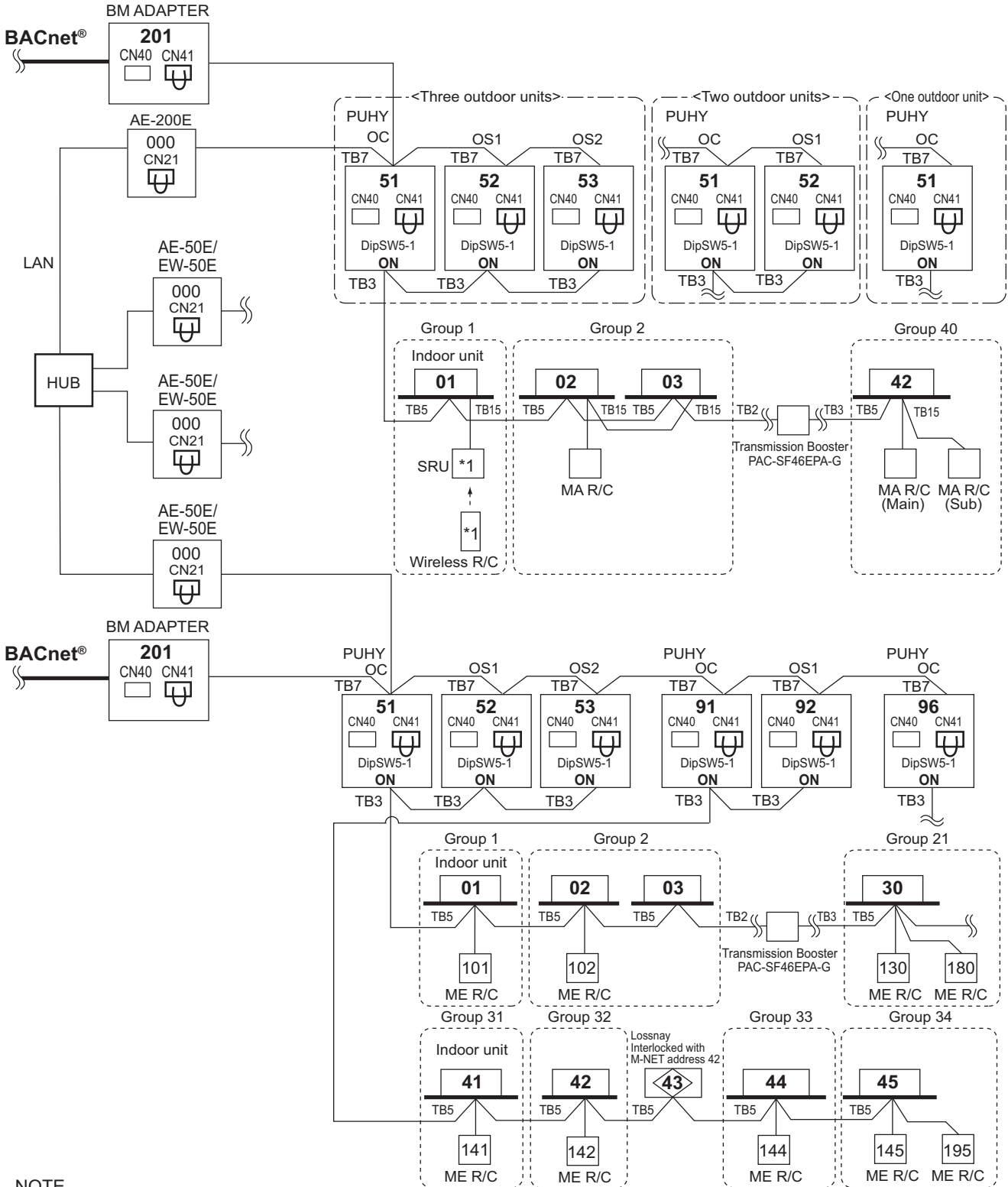

NOTE

- It is not necessary to connect the M-NET transmission line to the TB3 on BM ADAPTER. Leave the power jumper of BM ADAPTER connected to CN41.
- *1 For Wireless R/C and Signal receiver unit (SRU), channel 1, 2 and 3 are selectable and should be set to same channel.
- *2 Consult your dealer for restrictions when connecting both AE-200E/AE-50E/EW-50E and BM ADAPTER.
- *3 When a PAR-CT01MA or PAR-3X MA-Series (X indicates 1, 2...) is connected to a group, no other MA remote controllers can be connected to the same group.
- *4 In a system that uses AE-200E and/or AE-50E/EW-50E, each BM-ADAPTER must be connected to the M-NET line.

11-1. R410A Piping material

Refrigerant pipe for CITY MULTI shall be made of phosphorus deoxidized copper, and has two types.

A. Type-O: Soft copper pipe (annealed copper pipe), can be easily bent with human's hand.

B. Type-1/2H pipe: Hard copper pipe (Straight pipe), being stronger than Type-O pipe of the same radical thickness.

The maximum operation pressure of R410A air conditioner is 4.30 MPa [623psi]. The refrigerant piping should ensure the safety under the maximum operation pressure. MITSUBISHI ELECTRIC recommends pipe size as Table1, or You shall follow the local industrial standard. Pipes of radical thickness 0.7mm or less shall not be used.

Table 1. Copper pipe size and radial thickness for R410A CITY MULTI.

Size (mm)	Size (inch)	Radial thickness (mm)	Radial thickness (mil)	Pipe type
ø6.35	ø1/4"	0.8	[32]	Type-O
ø9.52	ø3/8"	0.8	[32]	Type-O
ø12.7	ø1/2"	0.8	[32]	Type-O
ø15.88	ø5/8"	1.0	[40]	Type-O
ø19.05	ø3/4"	1.2	[48]	Type-O
ø19.05	ø3/4"	1.0	[40]	Type-1/2H or H
ø22.2	ø7/8"	1.0	[40]	Type-1/2H or H
ø25.4	ø1"	1.0	[40]	Type-1/2H or H
ø28.58	ø1-1/8"	1.0	[40]	Type-1/2H or H
ø31.75	ø1-1/4"	1.1	[44]	Type-1/2H or H
ø34.93	ø1-3/8"	1.2	[48]	Type-1/2H or H
ø41.28	ø1-5/8"	1.4	[56]	Type-1/2H or H

* For pipe sized ø19.05 (3/4") for R410A air conditioner, choice of pipe type is up to you.

* The figures in the radial thickness column are based on the Japanese standards and provided only as a reference. Use pipes that meet the local standards.

Flare

Due to the relative higher operation pressure of R410A compared to R22, the flare connection should follow dimensions mentioned below so as to achieve enough the air-tightness.

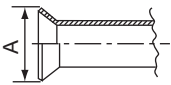
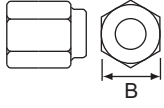
Flare pipe	Pipe size	A (For R410A)	(mm[in.])	Flare nut	Pipe size	B (For R410A)	(mm[in.])
	ø6.35 [1/4"]	9.1			ø6.35 [1/4"]	17.0	
	ø9.52 [3/8"]	13.2			ø9.52 [3/8"]	22.0	
	ø12.70 [1/2"]	16.6			ø12.70 [1/2"]	26.0	
	ø15.88 [5/8"]	19.7			ø15.88 [5/8"]	29.0	
	ø19.05 [3/4"]	24.0			ø19.05 [3/4"]	36.0	

11-2. Piping Design

11-2-1. Use of the existing refrigerant piping

⚠ WARNING

Before operating the compressor, make sure the refrigerant pipes are properly installed.

• Operating the compressor without the refrigerant pipes properly being connected and with the stop (ball) valve open, the compressor may suck in air, raising the pressure inside the refrigerant cycle abnormally high and resulting in pipe bursting and personal injury.

- Adequately insulate the liquid and gas refrigerant pipes to keep condensation from dripping.
- Provide additional insulation on the refrigerant pipes as necessary to keep condensation from forming on the insulation surface. (Insulating material ··· Heat-resistance temperature: 120°C; Thickness: 15 mm or greater)
 - * Installation of the unit in high-temperature high-humidity conditions, such as in the ceiling of the top floor, may require additional insulation.
- Insulate refrigerant pipes with heat-resistant polyethylene foam and without leaving any gap between indoor unit and insulating material or between insulating materials. (Exposed pipes may cause condensation and pose burn hazard.)
- Keep the piping length within the limits, and charge the required amount of refrigerant (R410A).
 - * Before charging refrigerant, evacuate the extended piping and the indoor units, and charge refrigerant through the stop valve (applicable when the unit is stopped). When charging refrigerant through the check valve on the suction side, use a safety charger to prevent liquid refrigerant from being inhaled (applicable when the unit is operated).
 - * When charging refrigerant, record the amount of refrigerant charged in the relevant section of the maintenance manual (attached to the product).
- **Determine the reusability of the existing piping, using the flowchart below.**
- **If the diameter of the existing piping differs from the standard diameter, check the reusability of the piping and restrictive conditions for reuse.**

Cautionary notes on reusing the existing piping

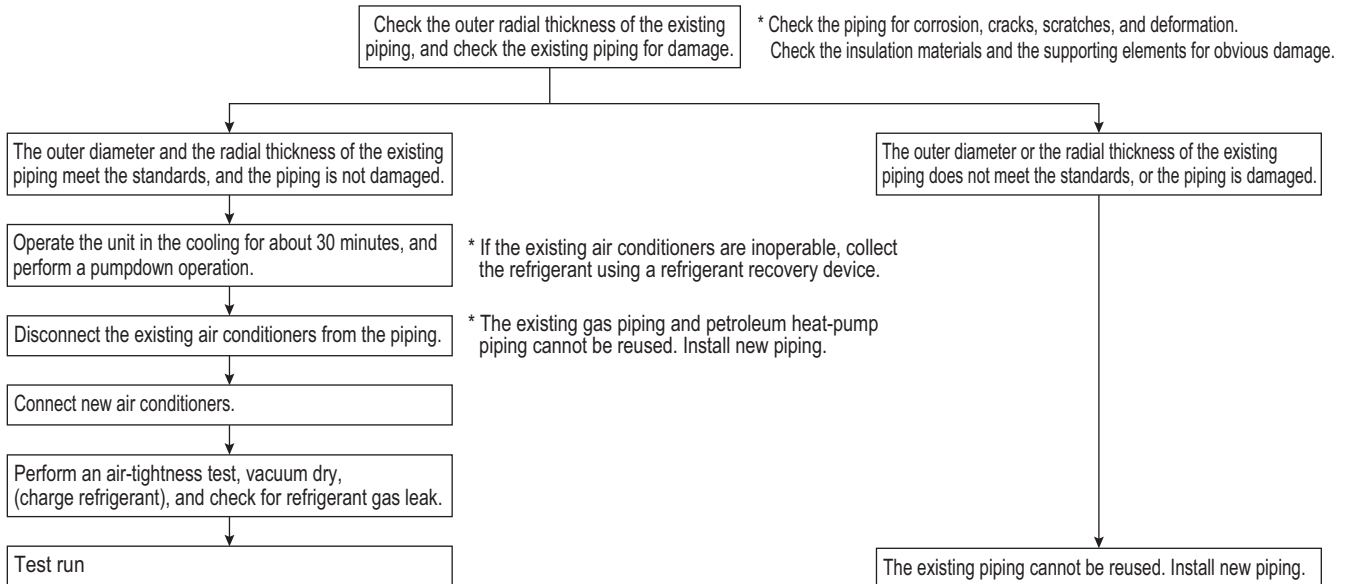

Connecting non-standard diameter pipes

• The following restrictions apply when using pipes with a diameter different from the standard recommended size.

Usability of pipes with non-standard diameters

• Main pipe size

	Outside diameter(mm)	Radial thickness	P112	P125	P140	P200	P250	P300
Gas pipe	ø12.7	t 0.8	NA	NA	NA	NA	NA	NA
	ø15.88	t 1.0	A	A	A	NA	NA	NA
	ø19.05	t 1.0 Type-O	C	C	C	C	NA	NA
		t 1.2 Type-O or t1.0 Type-1/2H or H	B	B	B	A		
	ø22.2	t 1.0	NA	NA	NA	B	A	E
	ø25.4	t 1.0	NA	NA	NA	NA	B	A
ø28.58 or greater	t 1.0 or greater	NA	NA	NA	NA	NA	NA	
Liquid pipe	ø9.52	t 0.8	A	A	A	A	A	NA
	ø12.7	t 0.8	D	D	D	D	D	A
	ø15.88	t 1.0	D	D	D	D	D	D
	ø19.05 or greater	t 1.0 or greater	NA	NA	NA	NA	NA	NA

A: Standard piping
 B: Usable (with no loss of performance)
 C: Usable (with loss of performance),
 Set the SW6-1 from OFF to ON.
 D: Usable (Restrictions on refrigerant charge apply.)
 E: Usable (with loss of performance)
 NA: Unusable

• Size of the piping after branching and up to indoor units

	Outside diameter(mm)	Radial thickness	P10	P15	P20	P25	P32	P40	P50	P63	P71	P80	P100	P125	P140	P200	P250	
Gas pipe	ø12.7	t 0.8	A	A	A	A	A	A	A	E	E	E	E	E	E	NA	NA	
	ø15.88	t 1.0	NA	NA	NA	NA	NA	B	B	A	A	A	A	A	A	NA	NA	
	ø19.05	t 1.0 Type-O	NA	NA	NA	NA	NA	NA	NA	NA	NA	C	C	C	C	C	NA	
		t 1.2 Type-O or t1.0 Type-1/2H or H	NA	NA	NA	NA	NA	NA	NA	NA	NA	B	B	B	B	A	NA	
	ø22.2	t 1.0	NA	NA	NA	NA	NA	NA	NA	NA	NA	NA	NA	NA	NA	NA	B	A
	ø25.4	t 1.0	NA	NA	NA	NA	NA	NA	NA	NA	NA	NA	NA	NA	NA	NA	NA	B
ø28.58	t 1.0	NA	NA	NA	NA	NA	NA	NA	NA	NA	NA	NA	NA	NA	NA	NA	NA	
Liquid pipe	ø6.35	t 0.8	A	A	A	A	A	A	A	15 m or less	NA	NA	NA	NA	NA	NA	NA	
	ø9.52	t 0.8	D	D	D	D	D	D	D	A	A	A	A	A	A	A	A	
	ø12.7	t 0.8	NA	NA	NA	NA	NA	NA	NA	D	D	D	D	D	D	D	D	
	ø15.88	t 1.0	NA	NA	NA	NA	NA	NA	NA	NA	NA	NA	NA	NA	NA	NA	NA	
ø19.05 or greater	t 1.0	NA	NA	NA	NA	NA	NA	NA	NA	NA	NA	NA	NA	NA	NA	NA		

Pipe diameter and radial thickness Note: For pipes with a diameter of ø22.2 and up, use 1/2-H or H-material.

Outside diameter (mm)	ø6.35	ø9.52	ø12.7	ø15.88	ø19.05	ø22.2	ø25.4	ø28.58
Radial thickness (mm)	0.8	0.8	0.8	1.0	1.0	1.0	1.0	1.0

Restrictions on extending piping/Amount of refrigerant to be charged (REPLACE units)

When reusing the existing piping, calculate the amount of refrigerant to be charged using the formula below. The existing piping is usable if the result of the calculation below is less than 10 kg. If the calculation result is at or above 10 kg, use new piping.

When reusing the existing piping, charge the amount of refrigerant required for the piping and for the indoor units.

• Calculating the amount of refrigerant to be charged based on pipe size and length

$$\begin{matrix} \text{Total length of } \phi 15.88 \\ \text{liquid pipes} \times 0.20 \\ (m) \times 0.20 \text{ (kg/m)} \end{matrix} + \begin{matrix} \text{Total length of } \phi 12.7 \\ \text{liquid pipes} \times 0.092 \\ (m) \times 0.092 \text{ (kg/m)} \end{matrix} + \begin{matrix} \text{Total length of } \phi 9.52 \\ \text{liquid pipes} \times 0.05 \\ (m) \times 0.05 \text{ (kg/m)} \end{matrix} + \begin{matrix} \text{Total length of } \phi 6.35 \\ \text{liquid pipes} \times 0.019 \\ (m) \times 0.019 \text{ (kg/m)} \end{matrix} = \begin{matrix} \text{Amount of additional refrigerant} \\ \text{to be charged (REPLACE units)} \\ \text{(kg)} \end{matrix}$$

• Calculating the amount of refrigerant to be charged based on indoor unit capacity

PUMY-P112-140

Total capacity index of the connected indoor units	Amount of refrigerant to be charged
– 8.0kW	1.5kg
8.1kW – 16.0kW	2.5kg
16.1kW –	3.0kg

PUMY-P200

Total capacity index of the connected indoor units	Amount of refrigerant to be charged
– 16.0kW	2.5kg
16.1kW – 25.0kW	3.0kg
25.1kW –	3.5kg

PUMY-P250/300

Total capacity index of the connected indoor units	Amount of refrigerant to be charged
– 16.0kW	2.5kg
16.1kW – 27.0kW	3.0kg
27.1kW – 31.0kW	3.5kg
31.1kW – 34.0kW	4.0kg

Total capacity index of the connected indoor units	Amount of refrigerant to be charged
34.1kW – 36.5kW	4.5kg
36.6kW – 39.0kW	5.0kg
39.1kW – 41.0kW	5.5kg
41.1kW –	6.1kg

11-2-2. PUMY-P112, 125, 140VKM5/YKM(E)4 Piping

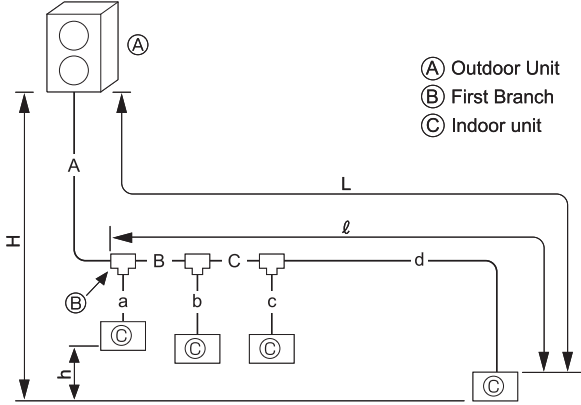
<p>Line-Branch Method Connection Examples (Connecting to 4 Indoor Units)</p>		 <p> (A) Outdoor Unit (B) First Branch (C) Indoor unit </p>																						
<p>Permissible Length</p>	<p>Total Piping Length</p>	<p>$A+B+C+a+b+c+d \leq 300 \text{ m}$</p>																						
	<p>Farthest Piping Length (L)</p>	<p>$A+B+C+d \leq 150 \text{ m}$</p>																						
	<p>Farthest Piping Length After First Branch (ℓ)</p>	<p>$B+C+d \leq 30 \text{ m}$</p>																						
<p>Permissible High/Low Difference</p>	<p>High/Low Difference in Indoor/Outdoor Section (H)</p>	<p>$H \leq 50 \text{ m}$ (In the case of outdoor unit is set higher than indoor unit) $H \leq 40 \text{ m}$ (In the case of outdoor unit is set lower than indoor unit) $H \leq 30 \text{ m}$ (In the case of outdoor unit is set lower than indoor unit and PKFY-P10/15/20/25/32VLM, PFFY-P*VKM, PFFY-P*VCM, PFFY-P*VL* type of indoor units are included)</p>																						
	<p>High/Low Difference in Indoor/Indoor Section (h)</p>	<p>$h \leq 15 \text{ m}$</p>																						
<p>■ Selecting the Refrigerant Branch Kit</p>		<p>Use an optional branch piping kit (CMY-Y62-G-E).</p>																						
<p>■ Select Each Section of Refrigerant Piping</p> <p>(1) Section From Outdoor Unit to First Branch (A)</p> <p>(2) Sections From Branch to Indoor Unit (a, b, c, d)</p> <p>(3) Section From Branch to Branch (B, C)</p> <p>Each Section of Piping</p> <p>Select the size from the table to the right.</p>		<p>(1) Refrigerant Piping Diameter In Section From Outdoor Unit to First Branch (Outdoor Unit Piping Diameter)</p>	<p>(2) Refrigerant Piping Diameter In Section From Branch to Indoor Unit (Indoor Unit Piping Diameter)</p>																					
		<table border="1"> <thead> <tr> <th>Model</th> <th colspan="2">Piping Diameter (mm)</th> </tr> </thead> <tbody> <tr> <td rowspan="2">PUMY-P112 PUMY-P125 PUMY-P140</td> <td>Liquid Pipe</td> <td>ø9.52</td> </tr> <tr> <td>Gas Pipe</td> <td>ø15.88</td> </tr> </tbody> </table>	Model	Piping Diameter (mm)		PUMY-P112 PUMY-P125 PUMY-P140	Liquid Pipe	ø9.52	Gas Pipe	ø15.88	<table border="1"> <thead> <tr> <th>Model</th> <th colspan="2">Piping Diameter (mm)</th> </tr> </thead> <tbody> <tr> <td rowspan="2">- 50</td> <td>Liquid Pipe</td> <td>ø6.35</td> </tr> <tr> <td>Gas Pipe</td> <td>ø12.7</td> </tr> <tr> <td rowspan="2">63 - 140</td> <td>Liquid Pipe</td> <td>ø9.52</td> </tr> <tr> <td>Gas Pipe</td> <td>ø15.88</td> </tr> </tbody> </table>	Model	Piping Diameter (mm)		- 50	Liquid Pipe	ø6.35	Gas Pipe	ø12.7	63 - 140	Liquid Pipe	ø9.52	Gas Pipe	ø15.88
Model	Piping Diameter (mm)																							
PUMY-P112 PUMY-P125 PUMY-P140	Liquid Pipe	ø9.52																						
	Gas Pipe	ø15.88																						
Model	Piping Diameter (mm)																							
- 50	Liquid Pipe	ø6.35																						
	Gas Pipe	ø12.7																						
63 - 140	Liquid Pipe	ø9.52																						
	Gas Pipe	ø15.88																						
		<p>(3) Refrigerant Piping Diameter In Section From Branch to Branch</p> <table border="1"> <thead> <tr> <th>Liquid Line (mm)</th> <th>Gas Line (mm)</th> </tr> </thead> <tbody> <tr> <td>ø9.52</td> <td>ø15.88</td> </tr> </tbody> </table>	Liquid Line (mm)	Gas Line (mm)	ø9.52	ø15.88	<p>Note: When connecting the CONNECTION KIT (PAC-LV11M-J) and an M-series indoor unit, refer to the installation manual for the CONNECTION KIT when selecting the pipe size and piping length.</p>																	
Liquid Line (mm)	Gas Line (mm)																							
ø9.52	ø15.88																							
<p>■ Additional refrigerant charge</p>		<p>Refer to "11-3. Refrigerant charging calculation"</p>																						

PUMY-P-VKM5, YKM(E)4, YKM2, YBM

Header-Branch Method
Connection Examples
(Connecting to 4 Indoor Units)

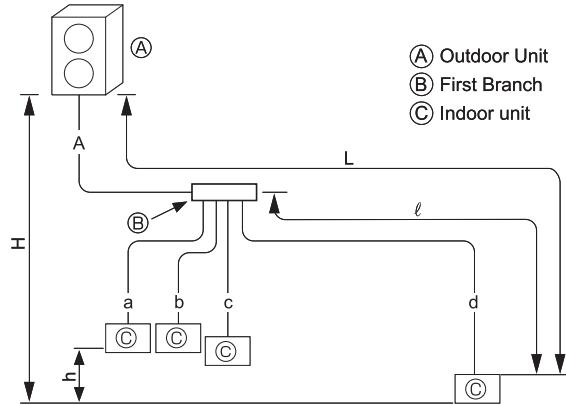

Permissible Length	Total Piping Length	$A+a+b+c+d \leq 300 \text{ m}$																								
	Farthest Piping Length (L)	$A+d \leq 150 \text{ m}$																								
	Farthest Piping Length After First Branch (l)	$d \leq 30 \text{ m}$																								
Permissible High/Low Difference	High/Low Difference in Indoor/Outdoor Section (H)	$H \leq 50 \text{ m}$ (In the case of outdoor unit is set higher than indoor unit) $H \leq 40 \text{ m}$ (In the case of outdoor unit is set lower than indoor unit) $H \leq 30 \text{ m}$ (In the case of outdoor unit is set lower than indoor unit and PKFY-P10/15/20/25/32VLM, PFFY-P*VKM, PFFY-P*VCM, PFFY-P*VL* type of indoor units are included)																								
	High/Low Difference in Indoor/Indoor Section (h)	$h \leq 15 \text{ m}$																								
■ Selecting the Refrigerant Branch Kit		Please select branching kit, which is sold separately, from the table below. (The kit comprises sets for use with liquid pipes and for use with gas pipes.)																								
		<table border="1"> <tr> <th>Branch header (4 branches)</th> <th>Branch header (8 branches)</th> </tr> <tr> <td>CMY-Y64-G-E</td> <td>CMY-Y68-G-E</td> </tr> </table>	Branch header (4 branches)	Branch header (8 branches)	CMY-Y64-G-E	CMY-Y68-G-E																				
Branch header (4 branches)	Branch header (8 branches)																									
CMY-Y64-G-E	CMY-Y68-G-E																									
■ Select Each Section of Refrigerant Piping (1) Section From Outdoor Unit to First Branch (A) (2) Sections From Branch to Indoor Unit (a, b, c, d) Select the size from the table to the right.		(1) Refrigerant Piping Diameter In Section From Outdoor Unit to First Branch (Outdoor Unit Piping Diameter)	(2) Refrigerant Piping Diameter In Section From Branch to Indoor Unit (Indoor Unit Piping Diameter)																							
		<table border="1"> <thead> <tr> <th>Model</th> <th colspan="2">Piping Diameter (mm)</th> </tr> </thead> <tbody> <tr> <td>PUMY-P112</td> <td>Liquid Pipe</td> <td>ø9.52</td> </tr> <tr> <td>PUMY-P125</td> <td rowspan="2">Gas Pipe</td> <td rowspan="2">ø15.88</td> </tr> <tr> <td>PUMY-P140</td> </tr> </tbody> </table>	Model	Piping Diameter (mm)		PUMY-P112	Liquid Pipe	ø9.52	PUMY-P125	Gas Pipe	ø15.88	PUMY-P140	<table border="1"> <thead> <tr> <th>Model</th> <th colspan="2">Piping Diameter (mm)</th> </tr> </thead> <tbody> <tr> <td rowspan="2">- 50</td> <td>Liquid Pipe</td> <td>ø6.35</td> </tr> <tr> <td>Gas Pipe</td> <td>ø12.7</td> </tr> <tr> <td rowspan="2">63 - 140</td> <td>Liquid Pipe</td> <td>ø9.52</td> </tr> <tr> <td>Gas Pipe</td> <td>ø15.88</td> </tr> </tbody> </table>	Model	Piping Diameter (mm)		- 50	Liquid Pipe	ø6.35	Gas Pipe	ø12.7	63 - 140	Liquid Pipe	ø9.52	Gas Pipe	ø15.88
Model	Piping Diameter (mm)																									
PUMY-P112	Liquid Pipe	ø9.52																								
PUMY-P125	Gas Pipe	ø15.88																								
PUMY-P140																										
Model	Piping Diameter (mm)																									
- 50	Liquid Pipe	ø6.35																								
	Gas Pipe	ø12.7																								
63 - 140	Liquid Pipe	ø9.52																								
	Gas Pipe	ø15.88																								
		Note: When connecting the CONNECTION KIT (PAC-LV11M-J) and an M-series indoor unit, refer to the installation manual for the CONNECTION KIT when selecting the pipe size and piping length.																								
■ Additional refrigerant charge		Refer to "11-3. Refrigerant charging calculation".																								

Method of Combined Branching of Lines and Headers
Connection Examples
 (Connecting to 5 Indoor Units)

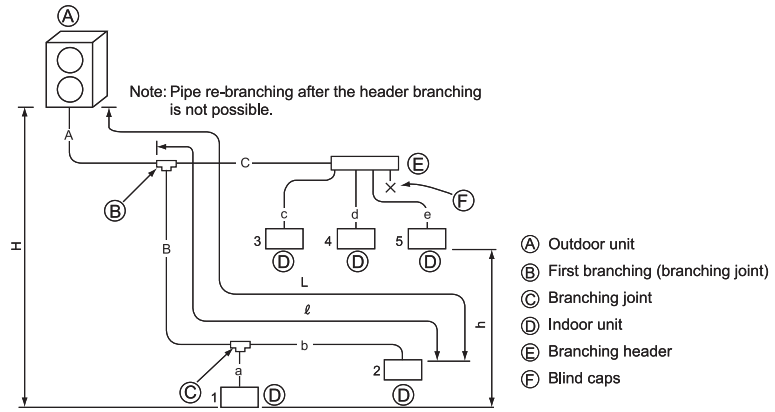

Permissible Length	Total Piping Length	$A+B+C+a+b+c+d+e \leq 300 \text{ m}$																			
	Farthest Piping Length (L)	$A+B+b \leq 150 \text{ m}$																			
	Farthest Piping Length After First Branch (l)	$B+b \leq 30 \text{ m}$																			
Permissible High/Low Difference	High/Low Difference in Indoor/Outdoor Section (H)	$H \leq 50 \text{ m}$ (In the case of outdoor unit is set higher than indoor unit) $H \leq 40 \text{ m}$ (In the case of outdoor unit is set lower than indoor unit) $H \leq 30 \text{ m}$ (In the case of outdoor unit is set lower than indoor unit and PKFY-P10/15/20/25/32VLM, PFFY-P*VKM, PFFY-P*VCM, PFFY-P*VL* type of indoor units are included)																			
	High/Low Difference in Indoor/Indoor Section (h)	$h \leq 15 \text{ m}$																			
■ Selecting the Refrigerant Branch Kit		Please select branching kit, which is sold separately, from the table below. (The kit comprises sets for use with liquid pipes and for use with gas pipes.)																			
		Branch Joint	Branch Header (4 branches)	Branch Header (8 branches)																	
		CMY-Y62-G-E	CMY-Y64-G-E	CMY-Y68-G-E																	
■ Select Each Section of Refrigerant Piping (1) Section From Outdoor Unit to First Branch (A) (2) Sections From Branch to Indoor Unit (a, b, c, d, e) (3) Section From Branch to Branch (B, C)		(1) Refrigerant Piping Diameter In Section From Outdoor Unit to First Branch (Outdoor Unit Piping Diameter) <table border="1"> <thead> <tr> <th>Model</th> <th>Piping Diameter (mm)</th> </tr> </thead> <tbody> <tr> <td>PUMY-P112</td> <td>Liquid Pipe $\phi 9.52$</td> </tr> <tr> <td>PUMY-P125</td> <td rowspan="2">Gas Pipe $\phi 15.88$</td> </tr> <tr> <td>PUMY-P140</td> </tr> </tbody> </table>			Model	Piping Diameter (mm)	PUMY-P112	Liquid Pipe $\phi 9.52$	PUMY-P125	Gas Pipe $\phi 15.88$	PUMY-P140										
Model	Piping Diameter (mm)																				
PUMY-P112	Liquid Pipe $\phi 9.52$																				
PUMY-P125	Gas Pipe $\phi 15.88$																				
PUMY-P140																					
(2) Refrigerant Piping Diameter In Section From Branch to Indoor Unit (Indoor Unit Piping Diameter) <table border="1"> <thead> <tr> <th>Model number</th> <th colspan="2">Piping Diameter (mm)</th> </tr> </thead> <tbody> <tr> <td rowspan="2">- 50</td> <td>Liquid Pipe</td> <td>$\phi 6.35$</td> </tr> <tr> <td>Gas Pipe</td> <td>$\phi 12.7$</td> </tr> <tr> <td rowspan="2">63 - 140</td> <td>Liquid Pipe</td> <td>$\phi 9.52$</td> </tr> <tr> <td>Gas Pipe</td> <td>$\phi 15.88$</td> </tr> </tbody> </table>		Model number	Piping Diameter (mm)		- 50	Liquid Pipe	$\phi 6.35$	Gas Pipe	$\phi 12.7$	63 - 140	Liquid Pipe	$\phi 9.52$	Gas Pipe	$\phi 15.88$	(3) Refrigerant Piping Diameter In Section From Branch to Branch <table border="1"> <thead> <tr> <th>Liquid Pipe (mm)</th> <th>Gas Pipe (mm)</th> </tr> </thead> <tbody> <tr> <td>$\phi 9.52$</td> <td>$\phi 15.88$</td> </tr> </tbody> </table>			Liquid Pipe (mm)	Gas Pipe (mm)	$\phi 9.52$	$\phi 15.88$
Model number	Piping Diameter (mm)																				
- 50	Liquid Pipe	$\phi 6.35$																			
	Gas Pipe	$\phi 12.7$																			
63 - 140	Liquid Pipe	$\phi 9.52$																			
	Gas Pipe	$\phi 15.88$																			
Liquid Pipe (mm)	Gas Pipe (mm)																				
$\phi 9.52$	$\phi 15.88$																				
Select the size from the table to the right.		Note: When connecting the CONNECTION KIT (PAC-LV11M-J) and an M-series indoor unit, refer to the installation manual for the CONNECTION KIT when selecting the pipe size and piping length.																			
■ Additional refrigerant charge		Refer to "11-3. Refrigerant charging calculation".																			

PUMY-P-VKM5, YKM(E)4, YKM2, YBM

11-2-3. PUMY-P200YKM2 Piping

<p>Line-Branch Method Connection Examples (Connecting to 4 Indoor Units)</p>																																												
Permissible Length	Total Piping Length	$A+B+C+a+b+c+d \leq 150 \text{ m}$																																										
	Farthest Piping Length (L)	$A+B+C+d \leq 80 \text{ m}$																																										
	Farthest Piping Length After First Branch (ℓ)	$B+C+d \leq 30 \text{ m}$																																										
Permissible High/Low Difference	High/Low Difference in Indoor/Outdoor Section (H)	$H \leq 50 \text{ m}$ (In the case of outdoor unit is set higher than indoor unit)																																										
	High/Low Difference in Indoor/Indoor Section (h)	$h \leq 15 \text{ m}$																																										
<p>■ Selecting the Refrigerant Branch Kit</p>		<p>Use an optional branch piping kit (CMY-Y62-G-E).</p>																																										
<p>■ Select Each Section of Refrigerant Piping</p> <p>(1) Section From Outdoor Unit to First Branch (A)</p> <p>(2) Sections From Branch to Indoor Unit (a,b,c,d)</p> <p>(3) Section From Branch to Branch (B,C)</p> <p>Select the size from the table to the right.</p>		<p>(1) Refrigerant Piping Diameter In Section From Outdoor Unit to First Branch (Outdoor Unit Piping Diameter)</p> <table border="1"> <thead> <tr> <th rowspan="2">Model</th> <th colspan="2">Piping Diameter (mm)</th> </tr> <tr> <th>Liquid pipe</th> <th>Gas pipe</th> </tr> </thead> <tbody> <tr> <td>$L \leq 60\text{m}$</td> <td>$\phi 9.52$</td> <td rowspan="2">$\phi 19.05$</td> </tr> <tr> <td>$L > 60\text{m}$</td> <td>$\phi 12.7$</td> </tr> </tbody> </table> <p>(2) Refrigerant Piping Diameter In Section From Branch to Indoor Unit (Indoor Unit Piping Diameter)</p> <table border="1"> <thead> <tr> <th rowspan="2">Model number</th> <th colspan="2">Piping Diameter (mm)</th> </tr> <tr> <th>Liquid Pipe</th> <th>Gas Pipe</th> </tr> </thead> <tbody> <tr> <td rowspan="2">- 50</td> <td>$\phi 6.35$</td> <td rowspan="2">$\phi 12.7$</td> </tr> <tr> <td>$\phi 9.52$</td> </tr> <tr> <td rowspan="2">63 - 140</td> <td>$\phi 9.52$</td> <td rowspan="2">$\phi 15.88$</td> </tr> <tr> <td>$\phi 15.88$</td> </tr> <tr> <td rowspan="2">200</td> <td>$\phi 9.52$</td> <td rowspan="2">$\phi 19.05$</td> </tr> <tr> <td>$\phi 19.05$</td> </tr> </tbody> </table> <p>(3) Refrigerant Piping Diameter In Section From Branch to Branch</p> <table border="1"> <thead> <tr> <th rowspan="2">Total downstream capacity of indoor units</th> <th colspan="2">Liquid pipe (mm)</th> <th rowspan="2">Gas pipe (mm)</th> </tr> <tr> <th>$L \leq 60 \text{ m}$</th> <th>$L > 60 \text{ m}$</th> </tr> </thead> <tbody> <tr> <td rowspan="2">- 16.0 kW</td> <td>$\phi 9.52$</td> <td rowspan="2">$\phi 15.88$</td> </tr> <tr> <td>$\phi 12.7$</td> </tr> <tr> <td rowspan="2">16.1 - 29.1 kW</td> <td>$\phi 9.52$</td> <td rowspan="2">$\phi 19.05$</td> </tr> <tr> <td>$\phi 12.7$</td> </tr> </tbody> </table>		Model	Piping Diameter (mm)		Liquid pipe	Gas pipe	$L \leq 60\text{m}$	$\phi 9.52$	$\phi 19.05$	$L > 60\text{m}$	$\phi 12.7$	Model number	Piping Diameter (mm)		Liquid Pipe	Gas Pipe	- 50	$\phi 6.35$	$\phi 12.7$	$\phi 9.52$	63 - 140	$\phi 9.52$	$\phi 15.88$	$\phi 15.88$	200	$\phi 9.52$	$\phi 19.05$	$\phi 19.05$	Total downstream capacity of indoor units	Liquid pipe (mm)		Gas pipe (mm)	$L \leq 60 \text{ m}$	$L > 60 \text{ m}$	- 16.0 kW	$\phi 9.52$	$\phi 15.88$	$\phi 12.7$	16.1 - 29.1 kW	$\phi 9.52$	$\phi 19.05$	$\phi 12.7$
Model	Piping Diameter (mm)																																											
	Liquid pipe	Gas pipe																																										
$L \leq 60\text{m}$	$\phi 9.52$	$\phi 19.05$																																										
$L > 60\text{m}$	$\phi 12.7$																																											
Model number	Piping Diameter (mm)																																											
	Liquid Pipe	Gas Pipe																																										
- 50	$\phi 6.35$	$\phi 12.7$																																										
	$\phi 9.52$																																											
63 - 140	$\phi 9.52$	$\phi 15.88$																																										
	$\phi 15.88$																																											
200	$\phi 9.52$	$\phi 19.05$																																										
	$\phi 19.05$																																											
Total downstream capacity of indoor units	Liquid pipe (mm)		Gas pipe (mm)																																									
	$L \leq 60 \text{ m}$	$L > 60 \text{ m}$																																										
- 16.0 kW	$\phi 9.52$	$\phi 15.88$																																										
	$\phi 12.7$																																											
16.1 - 29.1 kW	$\phi 9.52$	$\phi 19.05$																																										
	$\phi 12.7$																																											
<p>■ Additional refrigerant charge</p>		<p>Refer to "11-3. Refrigerant charging calculation"</p>																																										

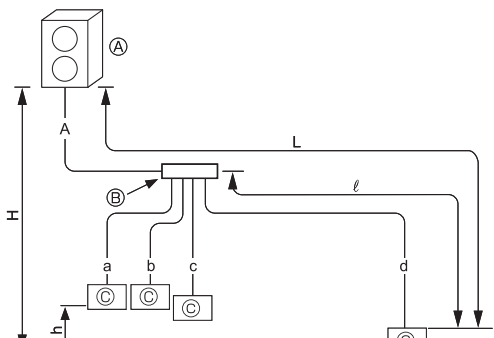
<p>Header-Branch Method Connection Examples (Connecting to 4 Indoor Units)</p>		 <p> A Outdoor Unit B First Branch C Indoor unit </p>																													
<p>Permissible Length</p>	<p>Total Piping Length</p>	<p>$A+a+b+c+d \leq 150$ m</p>																													
	<p>Farthest Piping Length (L)</p>	<p>$A+d \leq 80$ m</p>																													
	<p>Farthest Piping Length After First Branch (ℓ)</p>	<p>$d \leq 30$ m</p>																													
<p>Permissible High/Low Difference</p>	<p>High/Low Difference in Indoor/Outdoor Section (H)</p>	<p>$H \leq 50$ m (In the case of outdoor unit is set higher than indoor unit) $H \leq 40$ m (In the case of outdoor unit is set lower than indoor unit)</p>																													
	<p>High/Low Difference in Indoor/Indoor Section (h)</p>	<p>$h \leq 15$ m</p>																													
<p>■ Selecting the Refrigerant Branch Kit</p>		<p>Please select branching kit, which is sold separately, from the table below. (The kit comprises sets for use with liquid pipes and for use with gas pipes.)</p>																													
<table border="1" style="width: 100%; border-collapse: collapse;"> <tr> <td style="width: 50%; text-align: center;">Branch header (4 branches)</td> <td style="width: 50%; text-align: center;">Branch header (8 branches)</td> </tr> <tr> <td style="text-align: center;">CMY-Y64-G-E</td> <td style="text-align: center;">CMY-Y68-G-E</td> </tr> </table>		Branch header (4 branches)	Branch header (8 branches)	CMY-Y64-G-E	CMY-Y68-G-E																										
Branch header (4 branches)	Branch header (8 branches)																														
CMY-Y64-G-E	CMY-Y68-G-E																														
<p>■ Select Each Section of Refrigerant Piping</p> <p>(1) Section From Outdoor Unit to First Branch (A) } Each Section of Piping (2) Sections From Branch to Indoor Unit (a,b,c,d) }</p> <p>Select the size from the table to the right.</p>	<p>(1) Refrigerant Piping Diameter In Section From Outdoor Unit to First Branch (Outdoor Unit Piping Diameter)</p> <table border="1" style="width: 100%; border-collapse: collapse;"> <thead> <tr> <th rowspan="2">Model</th> <th colspan="2">Piping Diameter (mm)</th> </tr> <tr> <th>Liquid pipe</th> <th>Gas pipe</th> </tr> </thead> <tbody> <tr> <td>$L \leq 60$m</td> <td>$\phi 9.52$</td> <td rowspan="2">$\phi 19.05$</td> </tr> <tr> <td>$L > 60$m</td> <td>$\phi 12.7$</td> </tr> </tbody> </table> <p>Note: When connecting the CONNECTION KIT (PAC-LV11M-J) and an M-series indoor unit, refer to the installation manual for the CONNECTION KIT when selecting the pipe size and piping length.</p>		Model	Piping Diameter (mm)		Liquid pipe	Gas pipe	$L \leq 60$ m	$\phi 9.52$	$\phi 19.05$	$L > 60$ m	$\phi 12.7$	<p>(2) Refrigerant Piping Diameter In Section From Branch to Indoor Unit (Indoor Unit Piping Diameter)</p> <table border="1" style="width: 100%; border-collapse: collapse;"> <thead> <tr> <th>Model number</th> <th colspan="2">Piping Diameter (mm)</th> </tr> </thead> <tbody> <tr> <td rowspan="2">- 50</td> <td>Liquid Pipe</td> <td>$\phi 6.35$</td> </tr> <tr> <td>Gas Pipe</td> <td>$\phi 12.7$</td> </tr> <tr> <td rowspan="2">63 - 140</td> <td>Liquid Pipe</td> <td>$\phi 9.52$</td> </tr> <tr> <td>Gas Pipe</td> <td>$\phi 15.88$</td> </tr> <tr> <td rowspan="2">200</td> <td>Liquid Pipe</td> <td>$\phi 9.52$</td> </tr> <tr> <td>Gas Pipe</td> <td>$\phi 19.05$</td> </tr> </tbody> </table>	Model number	Piping Diameter (mm)		- 50	Liquid Pipe	$\phi 6.35$	Gas Pipe	$\phi 12.7$	63 - 140	Liquid Pipe	$\phi 9.52$	Gas Pipe	$\phi 15.88$	200	Liquid Pipe	$\phi 9.52$	Gas Pipe	$\phi 19.05$
	Model	Piping Diameter (mm)																													
Liquid pipe		Gas pipe																													
$L \leq 60$ m	$\phi 9.52$	$\phi 19.05$																													
$L > 60$ m	$\phi 12.7$																														
Model number	Piping Diameter (mm)																														
- 50	Liquid Pipe	$\phi 6.35$																													
	Gas Pipe	$\phi 12.7$																													
63 - 140	Liquid Pipe	$\phi 9.52$																													
	Gas Pipe	$\phi 15.88$																													
200	Liquid Pipe	$\phi 9.52$																													
	Gas Pipe	$\phi 19.05$																													
<p>■ Additional refrigerant charge</p>		<p>Refer to "11-3. Refrigerant charging calculation".</p>																													

Method of Combined Branching of Lines and Headers
Connection Examples
 (Connecting to 5 Indoor Units)

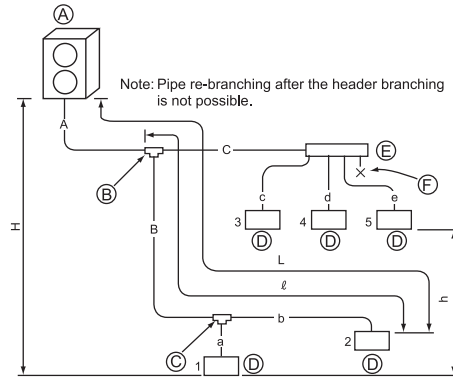

- (A) Outdoor unit
- (B) First branching (branching joint)
- (C) Branching joint
- (D) Indoor unit
- (E) Branching header
- (F) Blind caps

Permissible Length	Total Piping Length	$A+B+C+a+b+c+d+e \leq 150$ m
	Farthest Piping Length (L)	$A+B+b \leq 80$ m
	Farthest Piping Length After First Branch (ℓ)	$B+b \leq 30$ m
Permissible High/Low Difference	High/Low Difference in Indoor/Outdoor Section (H)	$H \leq 50$ m (In the case of outdoor unit is set higher than indoor unit) $H \leq 40$ m (In the case of outdoor unit is set lower than indoor unit)
	High/Low Difference in Indoor/Indoor Section (h)	$h \leq 15$ m

■ **Selecting the Refrigerant Branch Kit**

Please select branching kit, which is sold separately, from the table below.
 (The kit comprises sets for use with liquid pipes and for use with gas pipes.)

Branch Joint	Branch header (4 branches)	Branch header (8 branches)
CMY-Y62-G-E	CMY-Y64-G-E	CMY-Y68-G-E

■ **Select Each Section of Refrigerant Piping**

(1) Section From Outdoor Unit to First Branch (A)
 (2) Sections From Branch to Indoor Unit (a,b,c,d,e)
 (3) Section From Branch to Branch (B,C)

Each Section of Piping

Select the size from the table to the right.

(1) Refrigerant Piping Diameter In Section From Outdoor Unit to First Branch (Outdoor Unit Piping Diameter)	(2) Refrigerant Piping Diameter In Section From Branch to Indoor Unit (Indoor Unit Piping Diameter)																														
<table border="1"> <thead> <tr> <th rowspan="2"></th> <th colspan="2">Piping Diameter (mm)</th> </tr> <tr> <th>Liquid pipe</th> <th>Gas pipe</th> </tr> </thead> <tbody> <tr> <td>$L \leq 60$m</td> <td>$\phi 9.52$</td> <td rowspan="2">$\phi 19.05$</td> </tr> <tr> <td>$L > 60$m</td> <td>$\phi 12.7$</td> </tr> </tbody> </table>		Piping Diameter (mm)		Liquid pipe	Gas pipe	$L \leq 60$ m	$\phi 9.52$	$\phi 19.05$	$L > 60$ m	$\phi 12.7$	<table border="1"> <thead> <tr> <th rowspan="2">Model number</th> <th colspan="2">Piping Diameter (mm)</th> </tr> <tr> <th>Liquid Pipe</th> <th>Gas Pipe</th> </tr> </thead> <tbody> <tr> <td rowspan="2">- 50</td> <td>$\phi 6.35$</td> <td>$\phi 12.7$</td> </tr> <tr> <td>$\phi 9.52$</td> <td>$\phi 15.88$</td> </tr> <tr> <td rowspan="2">63 - 140</td> <td>$\phi 9.52$</td> <td>$\phi 15.88$</td> </tr> <tr> <td>$\phi 9.52$</td> <td>$\phi 19.05$</td> </tr> <tr> <td rowspan="2">200</td> <td>$\phi 9.52$</td> <td>$\phi 19.05$</td> </tr> <tr> <td>$\phi 9.52$</td> <td>$\phi 19.05$</td> </tr> </tbody> </table>	Model number	Piping Diameter (mm)		Liquid Pipe	Gas Pipe	- 50	$\phi 6.35$	$\phi 12.7$	$\phi 9.52$	$\phi 15.88$	63 - 140	$\phi 9.52$	$\phi 15.88$	$\phi 9.52$	$\phi 19.05$	200	$\phi 9.52$	$\phi 19.05$	$\phi 9.52$	$\phi 19.05$
		Piping Diameter (mm)																													
	Liquid pipe	Gas pipe																													
$L \leq 60$ m	$\phi 9.52$	$\phi 19.05$																													
$L > 60$ m	$\phi 12.7$																														
Model number	Piping Diameter (mm)																														
	Liquid Pipe	Gas Pipe																													
- 50	$\phi 6.35$	$\phi 12.7$																													
	$\phi 9.52$	$\phi 15.88$																													
63 - 140	$\phi 9.52$	$\phi 15.88$																													
	$\phi 9.52$	$\phi 19.05$																													
200	$\phi 9.52$	$\phi 19.05$																													
	$\phi 9.52$	$\phi 19.05$																													
(3) Refrigerant Piping Diameter In Section From Branch to Branch																															
<table border="1"> <thead> <tr> <th rowspan="2">Total downstream capacity of indoor units</th> <th colspan="2">Liquid pipe (mm)</th> <th rowspan="2">Gas pipe (mm)</th> </tr> <tr> <th>$L \leq 60$ m</th> <th>$L > 60$ m</th> </tr> </thead> <tbody> <tr> <td rowspan="2">- 16.0 kW</td> <td>$\phi 9.52$</td> <td rowspan="2">$\phi 15.88$</td> </tr> <tr> <td>$\phi 12.7$</td> </tr> <tr> <td rowspan="2">16.1 - 29.1 kW</td> <td>$\phi 9.52$</td> <td rowspan="2">$\phi 19.05$</td> </tr> <tr> <td>$\phi 12.7$</td> </tr> </tbody> </table>	Total downstream capacity of indoor units	Liquid pipe (mm)		Gas pipe (mm)	$L \leq 60$ m	$L > 60$ m	- 16.0 kW	$\phi 9.52$	$\phi 15.88$	$\phi 12.7$	16.1 - 29.1 kW	$\phi 9.52$	$\phi 19.05$	$\phi 12.7$																	
Total downstream capacity of indoor units		Liquid pipe (mm)			Gas pipe (mm)																										
	$L \leq 60$ m	$L > 60$ m																													
- 16.0 kW	$\phi 9.52$	$\phi 15.88$																													
	$\phi 12.7$																														
16.1 - 29.1 kW	$\phi 9.52$	$\phi 19.05$																													
	$\phi 12.7$																														
Note: When connecting the CONNECTION KIT (PAC-LV11M-J) and an M-series indoor unit, refer to the installation manual for the CONNECTION KIT when selecting the pipe size and piping length.																															

■ **Additional refrigerant charge**

Refer to "11-3. Refrigerant charging calculation".

11-2-4. PUMY-P250, 300YBM Piping

<p>Line-Branch Method Connection Examples (Connecting to 5 Indoor Units)</p>																																																																								
Permissible Length	Total Piping Length	$A+B+C+D+a+b+c+d+e \leq 310$ m																																																																						
	Farthest Piping Length (L)	$A+B+C+D+e \leq 150$ m																																																																						
	Farthest Piping Length After First Branch (ℓ)	$B+C+D+e \leq 30$ m																																																																						
Permissible High/Low Difference	High/Low Difference in Indoor/Outdoor Section (H)	$H \leq 50$ m (In the case of outdoor unit is set higher than indoor unit)																																																																						
	High/Low Difference in Indoor/Indoor Section (h)	$h \leq 15$ m																																																																						
	High/Low Difference in Indoor/Outdoor Section	$H \leq 40$ m (In the case of outdoor unit is set lower than indoor unit)																																																																						
<p>■ Selecting the Refrigerant Branch Kit</p>		<p>Use an optional branch piping kit (CMY-Y62-G-E).</p>																																																																						
<p>■ Select Each Section of Refrigerant Piping</p> <p>(1) Section From Outdoor Unit to First Branch (A) (2) Sections From Branch to Indoor Unit (a,b,c,d,e) (3) Section From Branch to Branch (B,C,D)</p> <p>Each Section of Piping</p> <p>Select the size from the table to the right.</p>		<p>(1) Refrigerant Piping Diameter In Section From Outdoor Unit to First Branch (Outdoor Unit Piping Diameter) (mm)</p> <table border="1"> <thead> <tr> <th>Model</th> <th></th> <th>Liquid pipe</th> <th>Gas pipe</th> </tr> </thead> <tbody> <tr> <td rowspan="2">P250</td> <td>$L \leq 90$ m</td> <td>$\phi 9.52^*$</td> <td>$\phi 22.2$</td> </tr> <tr> <td>$L > 90$ m</td> <td>$\phi 12.7$</td> <td>$\phi 22.2$</td> </tr> <tr> <td>P300</td> <td>All</td> <td>$\phi 12.7$</td> <td>$\phi 25.4$</td> </tr> </tbody> </table> <p>(2) Refrigerant Piping Diameter In Section From Branch to Indoor Unit (Indoor Unit Piping Diameter) (mm)</p> <table border="1"> <thead> <tr> <th>Model number</th> <th>Liquid pipe</th> <th>Gas pipe</th> </tr> </thead> <tbody> <tr> <td>10 - 50</td> <td>$\phi 6.35$</td> <td>$\phi 12.7$</td> </tr> <tr> <td>63 - 140</td> <td>$\phi 9.52$</td> <td>$\phi 15.88$</td> </tr> <tr> <td>200</td> <td>$\phi 9.52$</td> <td>$\phi 19.05$</td> </tr> <tr> <td>250</td> <td>$\phi 9.52$</td> <td>$\phi 22.2$</td> </tr> </tbody> </table> <p>(3) Refrigerant Piping Diameter In Section From Branch to Branch (B, C, D) (mm)</p> <table border="1"> <thead> <tr> <th>Total down-stream capacity of indoor units</th> <th>Model</th> <th>Liquid Pipe</th> <th>Gas Pipe</th> </tr> </thead> <tbody> <tr> <td rowspan="3">- 16.0 kW</td> <td rowspan="2">P250</td> <td>$L \leq 90$ m</td> <td>$\phi 9.52^*$</td> </tr> <tr> <td>$L > 90$ m</td> <td>$\phi 12.7$</td> </tr> <tr> <td>P300</td> <td>All</td> <td>$\phi 12.7$</td> </tr> <tr> <td rowspan="3">16.1 - 22.4 kW</td> <td rowspan="2">P250</td> <td>$L \leq 90$ m</td> <td>$\phi 9.52^*$</td> </tr> <tr> <td>$L > 90$ m</td> <td>$\phi 12.7$</td> </tr> <tr> <td>P300</td> <td>All</td> <td>$\phi 12.7$</td> </tr> <tr> <td rowspan="3">22.5 - 36.4 kW</td> <td rowspan="2">P250</td> <td>$L \leq 90$ m</td> <td>$\phi 9.52^*$</td> </tr> <tr> <td>$L > 90$ m</td> <td>$\phi 12.7$</td> </tr> <tr> <td>P300</td> <td>All</td> <td>$\phi 12.7$</td> </tr> <tr> <td>36.5 kW -</td> <td>P300</td> <td>All</td> <td>$\phi 12.7$</td> </tr> <tr> <td></td> <td></td> <td>$\phi 25.4$</td> <td></td> </tr> </tbody> </table> <p>L: The farthest piping length from the outdoor unit to an indoor unit. * $\phi 12.7$ when connecting the indoor unit for PEFY-P200 or P250. Note: When connecting the CONNECTION KIT (PAC-LV11M-J) and an M-series indoor unit, refer to the installation manual for the CONNECTION KIT when selecting the pipe size and piping length.</p>		Model		Liquid pipe	Gas pipe	P250	$L \leq 90$ m	$\phi 9.52^*$	$\phi 22.2$	$L > 90$ m	$\phi 12.7$	$\phi 22.2$	P300	All	$\phi 12.7$	$\phi 25.4$	Model number	Liquid pipe	Gas pipe	10 - 50	$\phi 6.35$	$\phi 12.7$	63 - 140	$\phi 9.52$	$\phi 15.88$	200	$\phi 9.52$	$\phi 19.05$	250	$\phi 9.52$	$\phi 22.2$	Total down-stream capacity of indoor units	Model	Liquid Pipe	Gas Pipe	- 16.0 kW	P250	$L \leq 90$ m	$\phi 9.52^*$	$L > 90$ m	$\phi 12.7$	P300	All	$\phi 12.7$	16.1 - 22.4 kW	P250	$L \leq 90$ m	$\phi 9.52^*$	$L > 90$ m	$\phi 12.7$	P300	All	$\phi 12.7$	22.5 - 36.4 kW	P250	$L \leq 90$ m	$\phi 9.52^*$	$L > 90$ m	$\phi 12.7$	P300	All	$\phi 12.7$	36.5 kW -	P300	All	$\phi 12.7$			$\phi 25.4$	
Model		Liquid pipe	Gas pipe																																																																					
P250	$L \leq 90$ m	$\phi 9.52^*$	$\phi 22.2$																																																																					
	$L > 90$ m	$\phi 12.7$	$\phi 22.2$																																																																					
P300	All	$\phi 12.7$	$\phi 25.4$																																																																					
Model number	Liquid pipe	Gas pipe																																																																						
10 - 50	$\phi 6.35$	$\phi 12.7$																																																																						
63 - 140	$\phi 9.52$	$\phi 15.88$																																																																						
200	$\phi 9.52$	$\phi 19.05$																																																																						
250	$\phi 9.52$	$\phi 22.2$																																																																						
Total down-stream capacity of indoor units	Model	Liquid Pipe	Gas Pipe																																																																					
- 16.0 kW	P250	$L \leq 90$ m	$\phi 9.52^*$																																																																					
		$L > 90$ m	$\phi 12.7$																																																																					
	P300	All	$\phi 12.7$																																																																					
16.1 - 22.4 kW	P250	$L \leq 90$ m	$\phi 9.52^*$																																																																					
		$L > 90$ m	$\phi 12.7$																																																																					
	P300	All	$\phi 12.7$																																																																					
22.5 - 36.4 kW	P250	$L \leq 90$ m	$\phi 9.52^*$																																																																					
		$L > 90$ m	$\phi 12.7$																																																																					
	P300	All	$\phi 12.7$																																																																					
36.5 kW -	P300	All	$\phi 12.7$																																																																					
		$\phi 25.4$																																																																						
<p>■ Additional refrigerant charge</p>		<p>Refer to "11-3. Refrigerant charging calculation"</p>																																																																						

PUMY-P-VKM5, YKM(E)4, YKM2, YBM

<p>Header-Branch Method Connection Examples (Connecting to 6 Indoor Units)</p>																																				
Permissible Length	Total Piping Length	$A+a+b+c+d+e+f \leq 310$ m																																		
	Farthest Piping Length (L)	$A+f \leq 150$ m																																		
	Farthest Piping Length After First Branch (l)	$f \leq 30$ m																																		
Permissible High/Low Difference	High/Low Difference in Indoor/Outdoor Section (H)	$H \leq 50$ m (In the case of outdoor unit is set higher than indoor unit)																																		
	High/Low Difference in Indoor/Outdoor Section	$H \leq 40$ m (In the case of outdoor unit is set lower than indoor unit)																																		
	High/Low Difference in Indoor/Indoor Section (h)	$h \leq 15$ m																																		
<p>■ Selecting the Refrigerant Branch Kit</p>		<p>Please select branching kit, which is sold separately, from the table below. (The kit comprises sets for use with liquid pipes and for use with gas pipes.)</p> <table border="1"> <tr> <td>Branch header (4 branches)</td> <td>Branch header (8 branches)</td> </tr> <tr> <td>CMY-Y64-G-E</td> <td>CMY-Y68-G-E</td> </tr> </table>		Branch header (4 branches)	Branch header (8 branches)	CMY-Y64-G-E	CMY-Y68-G-E																													
Branch header (4 branches)	Branch header (8 branches)																																			
CMY-Y64-G-E	CMY-Y68-G-E																																			
<p>■ Select Each Section of Refrigerant Piping</p> <p>(1) Section From Outdoor Unit to First Branch (A) } Each Section of Piping (2) Sections From Branch to Indoor Unit (a,b,c,d,e,f)</p> <p>Select the size from the table to the right.</p>		<p>(1) Refrigerant Piping Diameter In Section From Outdoor Unit to First Branch (Outdoor Unit Piping Diameter)</p> <table border="1"> <thead> <tr> <th rowspan="2">Model</th> <th colspan="2">A (mm)</th> </tr> <tr> <th>Liquid pipe</th> <th>Gas pipe</th> </tr> </thead> <tbody> <tr> <td rowspan="2">P250</td> <td>$L \leq 90$ m</td> <td>$\phi 9.52^*$</td> <td>$\phi 22.2$</td> </tr> <tr> <td>$L > 90$ m</td> <td>$\phi 12.7$</td> <td>$\phi 22.2$</td> </tr> <tr> <td>P300</td> <td>All</td> <td>$\phi 12.7$</td> <td>$\phi 25.4$</td> </tr> </tbody> </table> <p>(2) Refrigerant Piping Diameter In Section From Branch to Indoor Unit (Indoor Unit Piping Diameter)</p> <table border="1"> <thead> <tr> <th rowspan="2">Model number</th> <th colspan="2">a, b, c, d, e, f (mm)</th> </tr> <tr> <th>Liquid pipe</th> <th>Gas pipe</th> </tr> </thead> <tbody> <tr> <td>10 - 50</td> <td>$\phi 6.35$</td> <td>$\phi 12.7$</td> </tr> <tr> <td>63 - 140</td> <td>$\phi 9.52$</td> <td>$\phi 15.88$</td> </tr> <tr> <td>200</td> <td>$\phi 9.52$</td> <td>$\phi 19.05$</td> </tr> <tr> <td>250</td> <td>$\phi 9.52$</td> <td>$\phi 22.2$</td> </tr> </tbody> </table> <p>L: The farthest piping length from the outdoor unit to an indoor unit. * $\phi 12.7$ when connecting the indoor unit for PEFY-P200 or P250. Note: When connecting the CONNECTION KIT (PAC-LV11M-J) and an M-series indoor unit, refer to the installation manual for the CONNECTION KIT when selecting the pipe size and piping length.</p>		Model	A (mm)		Liquid pipe	Gas pipe	P250	$L \leq 90$ m	$\phi 9.52^*$	$\phi 22.2$	$L > 90$ m	$\phi 12.7$	$\phi 22.2$	P300	All	$\phi 12.7$	$\phi 25.4$	Model number	a, b, c, d, e, f (mm)		Liquid pipe	Gas pipe	10 - 50	$\phi 6.35$	$\phi 12.7$	63 - 140	$\phi 9.52$	$\phi 15.88$	200	$\phi 9.52$	$\phi 19.05$	250	$\phi 9.52$	$\phi 22.2$
Model	A (mm)																																			
	Liquid pipe	Gas pipe																																		
P250	$L \leq 90$ m	$\phi 9.52^*$	$\phi 22.2$																																	
	$L > 90$ m	$\phi 12.7$	$\phi 22.2$																																	
P300	All	$\phi 12.7$	$\phi 25.4$																																	
Model number	a, b, c, d, e, f (mm)																																			
	Liquid pipe	Gas pipe																																		
10 - 50	$\phi 6.35$	$\phi 12.7$																																		
63 - 140	$\phi 9.52$	$\phi 15.88$																																		
200	$\phi 9.52$	$\phi 19.05$																																		
250	$\phi 9.52$	$\phi 22.2$																																		
<p>■ Additional refrigerant charge</p>		<p>Refer to "11-3. Refrigerant charging calculation"</p>																																		

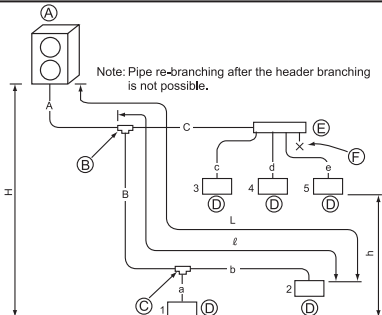
<p>Method of Combined Branching of Lines and Headers Connection Examples (Connecting to 5 Indoor Units)</p>		 <p> (A) Outdoor unit (B) First branching (branching joint) (C) Branching joint (D) Indoor unit (E) Branching header (F) Blind caps </p>																																																																							
Permissible Length	Total Piping Length	$A+B+C+a+b+c+d+e \leq 310\text{m}$																																																																							
	Farthest Piping Length (L)	$A+B+b \leq 150\text{m}$																																																																							
	Farthest Piping Length After First Branch (l)	$B+b \leq 30\text{m}$																																																																							
Permissible High/Low Difference	High/Low Difference in Indoor/Outdoor Section (H)	$H \leq 50\text{ m}$ (In the case of outdoor unit is set higher than indoor unit) $H \leq 40\text{ m}$ (In the case of outdoor unit is set lower than indoor unit)																																																																							
	High/Low Difference in Indoor/Indoor Section (h)	$h \leq 15\text{ m}$																																																																							
<p>■ Selecting the Refrigerant Branch Kit</p>		Please select branching kit, which is sold separately, from the table below. (The kit comprises sets for use with liquid pipes and for use with gas pipes.)																																																																							
		Branch Joint	Branch header (4 branches)	Branch header (8 branches)																																																																					
		CMY-Y62-G-E	CMY-Y64-G-E	CMY-Y68-G-E																																																																					
<p>■ Select Each Section of Refrigerant Piping</p> <p>(1) Section From Outdoor Unit to First Branch (A) (2) Sections From Branch to Indoor Unit (a,b,c,d,e) (3) Section From Branch to Branch (B,C)</p> <p>Each Section of Piping</p> <p>Select the size from the table to the right.</p>		<p>(1) Refrigerant Piping Diameter In Section From Outdoor Unit to First Branch (Outdoor Unit Piping Diameter) (mm)</p> <table border="1" data-bbox="587 996 1037 1120"> <thead> <tr> <th rowspan="2">Model</th> <th colspan="2">Liquid pipe</th> <th>Gas pipe</th> </tr> <tr> <th>L ≤ 90 m</th> <th>L > 90 m</th> <th></th> </tr> </thead> <tbody> <tr> <td rowspan="2">P250</td> <td>ø9.52*</td> <td>ø12.7</td> <td>ø22.2</td> </tr> <tr> <td colspan="2">All</td> <td>ø25.4</td> </tr> </tbody> </table> <p>(2) Refrigerant Piping Diameter In Section From Branch to Indoor Unit (Indoor Unit Piping Diameter) (mm)</p> <table border="1" data-bbox="1050 996 1508 1142"> <thead> <tr> <th rowspan="2">Model number</th> <th colspan="2">Liquid pipe</th> <th>Gas pipe</th> </tr> <tr> <th>a, b, c, d, e</th> <th></th> <th></th> </tr> </thead> <tbody> <tr> <td>10 – 50</td> <td>ø6.35</td> <td>ø12.7</td> <td></td> </tr> <tr> <td>63 – 140</td> <td>ø9.52</td> <td>ø15.88</td> <td></td> </tr> <tr> <td>200</td> <td>ø9.52</td> <td>ø19.05</td> <td></td> </tr> <tr> <td>250</td> <td>ø9.52</td> <td>ø22.2</td> <td></td> </tr> </tbody> </table> <p>(3) Refrigerant Piping Diameter In Section From Branch to Branch (B, C, D) (mm)</p> <table border="1" data-bbox="587 1220 1252 1590"> <thead> <tr> <th rowspan="2">Total downstream capacity of indoor units</th> <th rowspan="2">Model</th> <th colspan="2">Liquid pipe</th> <th rowspan="2">Gas pipe</th> </tr> <tr> <th>L ≤ 90 m</th> <th>L > 90m</th> </tr> </thead> <tbody> <tr> <td rowspan="2">– 16.0kW</td> <td rowspan="2">P250</td> <td>ø9.52*</td> <td>ø12.7</td> <td rowspan="2">ø15.88</td> </tr> <tr> <td colspan="2">All</td> </tr> <tr> <td rowspan="2">16.1 – 22.4 kW</td> <td rowspan="2">P250</td> <td>ø9.52*</td> <td>ø12.7</td> <td rowspan="2">ø19.05</td> </tr> <tr> <td colspan="2">All</td> </tr> <tr> <td rowspan="2">22.5 – 36.4 kW</td> <td rowspan="2">P250</td> <td>ø9.52*</td> <td>ø12.7</td> <td rowspan="2">ø22.2</td> </tr> <tr> <td colspan="2">All</td> </tr> <tr> <td>36.5 kW –</td> <td>P300</td> <td colspan="2">All</td> <td>ø25.4</td> </tr> </tbody> </table> <p>L: The farthest piping length from the outdoor unit to an indoor unit. * ø12.7 when connecting the indoor unit for PEFY-P200 or P250. Note: When connecting the CONNECTION KIT (PAC-LV11M-J) and an M-series indoor unit, refer to the installation manual for the CONNECTION KIT when selecting the pipe size and piping length.</p>		Model	Liquid pipe		Gas pipe	L ≤ 90 m	L > 90 m		P250	ø9.52*	ø12.7	ø22.2	All		ø25.4	Model number	Liquid pipe		Gas pipe	a, b, c, d, e			10 – 50	ø6.35	ø12.7		63 – 140	ø9.52	ø15.88		200	ø9.52	ø19.05		250	ø9.52	ø22.2		Total downstream capacity of indoor units	Model	Liquid pipe		Gas pipe	L ≤ 90 m	L > 90m	– 16.0kW	P250	ø9.52*	ø12.7	ø15.88	All		16.1 – 22.4 kW	P250	ø9.52*	ø12.7	ø19.05	All		22.5 – 36.4 kW	P250	ø9.52*	ø12.7	ø22.2	All		36.5 kW –	P300	All		ø25.4
Model	Liquid pipe		Gas pipe																																																																						
	L ≤ 90 m	L > 90 m																																																																							
P250	ø9.52*	ø12.7	ø22.2																																																																						
	All		ø25.4																																																																						
Model number	Liquid pipe		Gas pipe																																																																						
	a, b, c, d, e																																																																								
10 – 50	ø6.35	ø12.7																																																																							
63 – 140	ø9.52	ø15.88																																																																							
200	ø9.52	ø19.05																																																																							
250	ø9.52	ø22.2																																																																							
Total downstream capacity of indoor units	Model	Liquid pipe		Gas pipe																																																																					
		L ≤ 90 m	L > 90m																																																																						
– 16.0kW	P250	ø9.52*	ø12.7	ø15.88																																																																					
		All																																																																							
16.1 – 22.4 kW	P250	ø9.52*	ø12.7	ø19.05																																																																					
		All																																																																							
22.5 – 36.4 kW	P250	ø9.52*	ø12.7	ø22.2																																																																					
		All																																																																							
36.5 kW –	P300	All		ø25.4																																																																					
<p>■ Additional refrigerant charge</p>		Refer to “11-3. Refrigerant charging calculation”																																																																							

PUMY-P-VKM5, YKM(E)4, YKM2, YBM

11-2-5. PUMY-P112, 125, 140VKM5/YKM(E)4 (WHEN USING BRANCH BOX)

Branch box Method
 Connection Examples
 (Connecting to 8 Indoor Units)

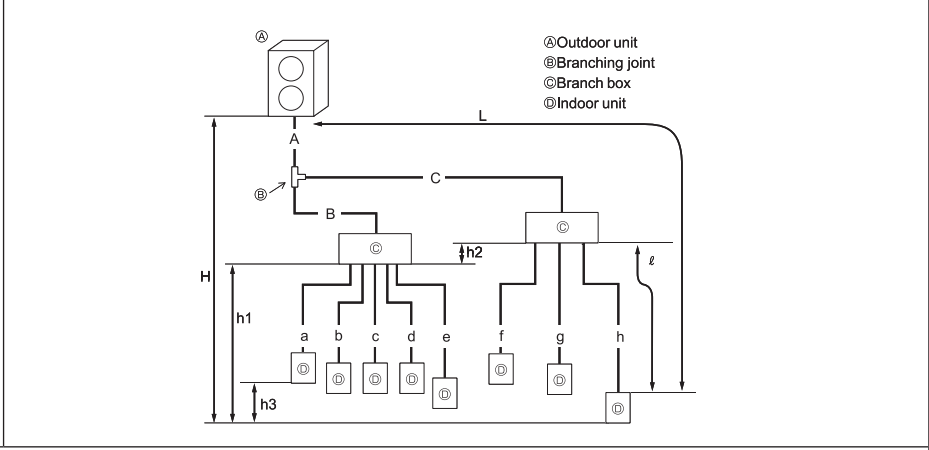

Permissible length (One-way)	Total piping length	$A + B + C + a + b + c + d + e + f + g + h \leq 150 \text{ m}$
	Farthest piping length (L)	$A + C + h \leq 80 \text{ m}$
	Piping length between outdoor unit and branch boxes	$A + B + C \leq 55 \text{ m}$
	Farthest piping length after branch box (l)	$l \leq 25 \text{ m}$
	Total piping length between branch boxes and indoor units	$a + b + c + d + e + f + g + h \leq 95 \text{ m}$
Permissible height difference (One-way)	In indoor/outdoor section (H)*1	$H \leq 50 \text{ m}$ (In the case of that outdoor unit is set higher than indoor unit) $H \leq 40 \text{ m}$ (In the case of that outdoor unit is set lower than indoor unit)
	In branch box/indoor unit section (h1)	$h1 + h2 \leq 15 \text{ m}$
	In each branch unit (h2)	$h2 \leq 15 \text{ m}$
	In each indoor unit (h3)	$h3 \leq 12 \text{ m}$
Number of bends		≤ 15

*1 Branch box should be placed within the level between the outdoor unit and indoor units.

■ Select Each Section of Refrigerant Piping

(1) Section From Outdoor Unit to Branch box (A, B, C)
 (2) Sections From Branch box to Indoor Unit (a to h)

Each Section of Piping

Select the size from the table to the right.

(1) Refrigerant Piping Diameter In Section From Outdoor Unit to Branch box (Outdoor Unit Piping Diameter)

Model	Piping Diameter (mm)	
PUMY-P112	Liquid Line	ø9.52
PUMY-P125		
PUMY-P140	Gas Line	ø15.88

(2) Refrigerant Piping Diameter In Section From Branch box to Indoor Unit (Indoor Unit Piping Diameter)

Indoor unit series	Model number	A Liquid pipe (mm)	B Gas pipe (mm)
M series or S series	15 - 42	ø6.35	ø9.52
	50	ø6.35	ø12.7
	60	ø6.35	ø15.88
	71	ø9.52	ø15.88
P series	35,50	ø6.35	ø12.7
	60 - 100	ø9.52	ø15.88

■ Additional refrigerant charge Refer to "11-3. Refrigerant charging calculation".

Mixed Method
Connection Examples
(Connecting to 1 Branch box)

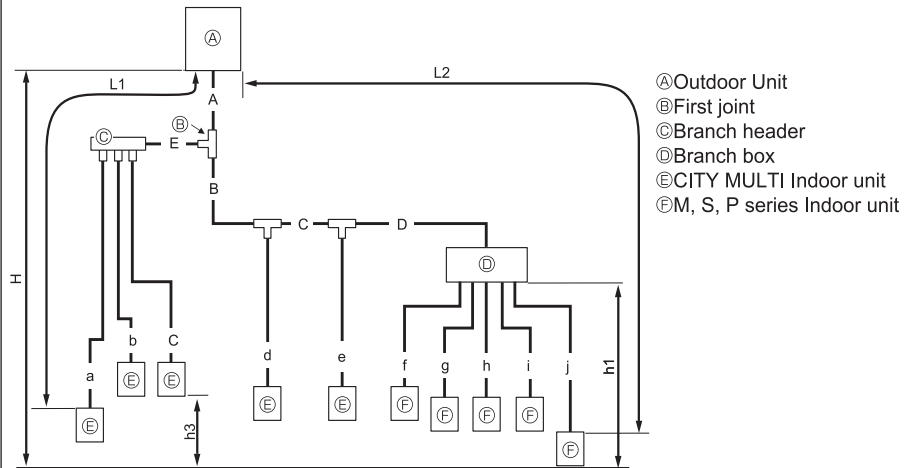

Permissible length (One-way)	Total piping length	$A+B+C+D+E+a+b+c+d+e+f+g+h+i+j \leq 300 \text{ m}^2$
	Farthest piping length (L1)	$A+E+a$ or $A+B+C+e \leq 85 \text{ m}$
	Farthest piping length. Via Branch box (L2)	$A+B+C+D+j \leq 80 \text{ m}$
	Piping length between outdoor unit and branch box	$A+B+C+D \leq 55 \text{ m}$
	Farthest piping length from the first joint	$B+C+D$ or $B+C+e \leq 30 \text{ m}$
	Farthest piping length after branch box	$j \leq 25 \text{ m}$
	Total piping length between branch boxes and indoor units	$f+g+h+i+j \leq 95 \text{ m}$
Permissible height difference (One-way)	In indoor/outdoor section (H) ^{*1}	$H \leq 50 \text{ m}$ (In the case of outdoor unit is set higher than indoor unit) $H \leq 40 \text{ m}$ (In the case of outdoor unit is set lower than indoor unit)
	In branch box/indoor unit section (h1)	$h1 \leq 15 \text{ m}$
	In each indoor unit (h3)	$h3 \leq 12 \text{ m}$
Number of bends		≤ 15

*1 Branch box should be placed within the level between the outdoor unit and indoor units.

*2 When a cylinder unit or hydrobox is connected, the maximum piping length is 150 m.

■ **Selecting the Refrigerant Branch Kit**

Please select branching kit, which is sold separately, from the table below. (The kit comprises sets for use with liquid pipes and for use with gas pipes.)

Branch header (4 branches)	Branch header (8 branches)
CMY-Y64-G-E	CMY-Y68-G-E

■ **Select Each Section of Refrigerant Piping**

- (1) Section From Outdoor Unit to Branch box or Branch header (A to E)
 - (2) Sections From Branch box or Branch header to Indoor Unit (a to j)
- } Each Section of Piping

Select the size from the table to the right.

(1) Refrigerant Piping Diameter In Section From Outdoor Unit to Branch box or Branch header (Outdoor Unit Piping Diameter)

Model	Piping Diameter (mm)	
PUMY-P112 PUMY-P125 PUMY-P140	Liquid Line	ø9.52
	Gas Line	ø15.88

(2) Refrigerant Piping Diameter In Section From Branch box or Branch header to Indoor Unit (Indoor Unit Piping Diameter)

Indoor unit series	Model number	A Liquid pipe (mm)	B Gas pipe (mm)
CITY MULTI	10 – 50	ø6.35	ø12.7
	63 – 140	ø9.52	ø15.88
M series or S series	15 – 42	ø6.35	ø9.52
	50	ø6.35	ø12.7
	60	ø6.35	ø15.88
P series	71	ø9.52	ø15.88
	35,50	ø6.35	ø12.7
	60 – 100	ø9.52	ø15.88

Note:

When connecting the CONNECTION KIT (PAC-LV11M-J) and an M-series indoor unit, refer to the installation manual for the CONNECTION KIT when selecting the pipe size and piping length.

■ **Additional refrigerant charge**

Refer to "11-3. Refrigerant charging calculation".

Mixed Method
Connection Examples
(Connecting to 2 Branch boxes)

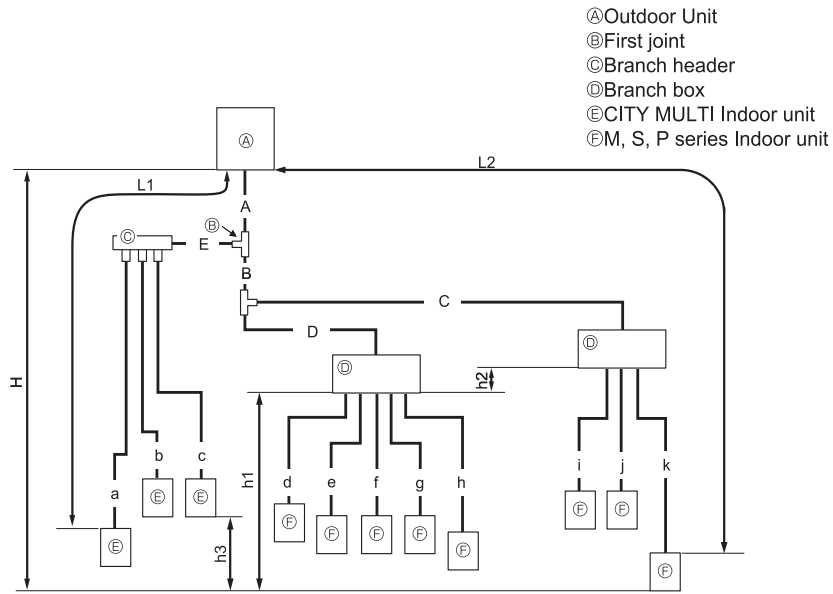

Permissible length (One-way)	Total piping length	$A+B+C+D+E+a+b+c+d+e+f+g+h+i+j+k \leq 240 \text{ m}^{*2}$
	Farthest piping length (L1)	$A+E+a \leq 85 \text{ m}$
	Farthest piping length. Via Branch box (L2)	$A+B+C+k \leq 80 \text{ m}$
	Piping length between outdoor unit and branch boxes	$A+B+C+D \leq 55 \text{ m}$
	Farthest piping length from the first joint	$B+C \text{ or } E+a \leq 30 \text{ m}$
	Farthest piping length after branch box	$k \leq 25 \text{ m}$
	Farthest branch box form outdoor unit	$A+B+C \leq 55 \text{ m}$
Permissible height difference (One-way)	Total piping length between branch boxes and indoor units	$d+e+f+g+h+i+j+k \leq 95 \text{ m}$
	In indoor/outdoor section (H) ^{*1}	$H \leq 50 \text{ m}$ (In the case of outdoor unit is set higher than indoor unit) $H \leq 40 \text{ m}$ (In the case of outdoor unit is set lower than indoor unit)
	In branch box/indoor unit section (h1)	$h1+h2 \leq 15 \text{ m}$
	In each branch unit (h2)	$h2 \leq 15 \text{ m}$
	In each indoor unit (h3)	$h3 \leq 12 \text{ m}$
Number of bends	≤ 15	

^{*1} Branch box should be placed within the level between the outdoor unit and indoor units.

^{*2} When a cylinder unit or hydrobox is connected, the maximum piping length is 150 m.

■ **Selecting the Refrigerant Branch Kit**

Please select branching kit, which is sold separately, from the table below.
(The kit comprises sets for use with liquid pipes and for use with gas pipes.)

Branch header (4 branches)	Branch header (8 branches)
CMY-Y64-G-E	CMY-Y68-G-E

■ **Select Each Section of Refrigerant Piping**

- (1) Section From Outdoor Unit to Branch box or Branch header (A to E)
 - (2) Sections From Branch box or Branch header to Indoor Unit (a to k)
- } Each Section of Piping

Select the size from the table to the right.

(1) Refrigerant Piping Diameter In Section From Outdoor Unit to Branch box or Branch header (Out-door Unit Piping Diameter)

Model	Piping Diameter (mm)	
PUMY-P112 PUMY-P125 PUMY-P140	Liquid Line	ø9.52
	Gas Line	ø15.88

(2) Refrigerant Piping Diameter In Section From Branch box or Branch header to Indoor Unit (Indoor Unit Piping Diameter)

Indoor unit series	Model number	A Liquid pipe (mm)	B Gas pipe (mm)
CITY MULTI	10 – 50	ø6.35	ø12.7
	63 – 140	ø9.52	ø15.88
M series or S series	15 – 42	ø6.35	ø9.52
	50	ø6.35	ø12.7
	60	ø6.35	ø15.88
P series	71	ø9.52	ø15.88
	35, 50	ø6.35	ø12.7
	60 – 100	ø9.52	ø15.88

Note:

When connecting the CONNECTION KIT (PAC-LV11M-J) and an M-series indoor unit, refer to the installation manual for the CONNECTION KIT when selecting the pipe size and piping length.

■ **Additional refrigerant charge**

Refer to "11-3. Refrigerant charging calculation".

11-2-6. PUMY-P200YKM2 Piping (WHEN USING BRANCH BOX)

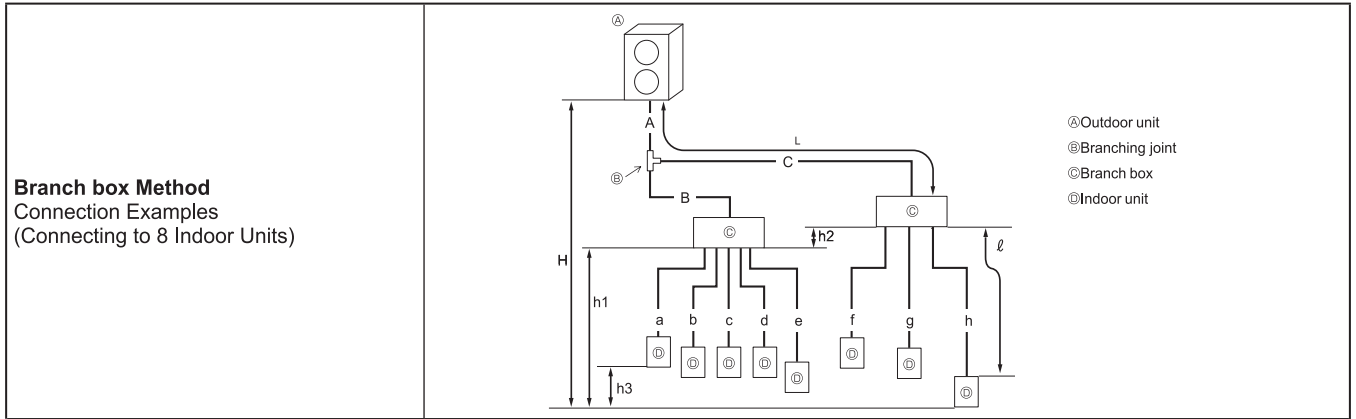

Branch box Method
Connection Examples
(Connecting to 8 Indoor Units)

- Ⓐ Outdoor unit
- Ⓑ Branching joint
- Ⓒ Branch box
- Ⓓ Indoor unit

Permissible length (One-way)	Total piping length	$A + B + C + a + b + c + d + e + f + g + h \leq 150 \text{ m}$
	Farthest piping length (L)	$A + C + h \leq 80 \text{ m}$
	Piping length between outdoor unit and branch boxes	$A + B + C \leq 55 \text{ m}$
	Farthest piping length after branch box (ℓ)	$\ell \leq 25 \text{ m}$
	Total piping length between branch boxes and indoor units	$a + b + c + d + e + f + g + h \leq 95 \text{ m}$
Permissible height difference (One-way)	In indoor/outdoor section (H)*1	$H \leq 50 \text{ m}$ (In the case of that outdoor unit is set higher than indoor unit) $H \leq 40 \text{ m}$ (In the case of that outdoor unit is set lower than indoor unit)
	In branch box/indoor unit section (h1)	$h1 + h2 \leq 15 \text{ m}$
	In each branch unit (h2)	$h2 \leq 15 \text{ m}$
	In each indoor unit (h3)	$h3 \leq 12 \text{ m}$
Number of bends		≤ 15

*1 Branch box should be placed within the level between the outdoor unit and indoor units.

■ Select Each Section of Refrigerant Piping

(1) Section From Outdoor Unit to Branch box (A, B, C)

(2) Sections From Branch box to Indoor Unit (a to h)

Each Section of Piping

Select the size from the table to the right.

(1) Refrigerant Piping Diameter In Section From Outdoor Unit to First Branch (Outdoor Unit Piping Diameter) A, C

	Piping Diameter (mm)		Total downstream capacity of indoor units	Liquid pipe (mm)		Gas pipe (mm)
	Liquid pipe	Gas pipe		L ≤ 20m	L > 20m	
L ≤ 20m	ø9.52	ø19.05	- 16.0kW	ø9.52	ø15.88	
L > 20m	ø12.7					
16.1 - 29.1kW				L ≤ 20m	ø9.52	ø19.05
				L > 20m	ø12.7	
				L > 20m	ø12.7	

L: The farthest piping length from the outdoor unit to an indoor unit.

(2) Refrigerant Piping Diameter In Section From Branch box to Indoor Unit (Indoor Unit Piping Diameter)

Indoor unit series	Model number	Liquid pipe (mm)	B Gas pipe (mm)
M series or S series	- 42	ø6.35 mm	ø9.52 mm
	50	ø6.35 mm	ø12.7 mm
	60	ø6.35 mm	ø15.88 mm
	71-	ø9.52 mm	ø15.88 mm
P series	- 50	ø6.35 mm	ø12.77 mm
	60 -	ø9.52 mm	ø15.88 mm

■ Additional refrigerant charge

Refer to "11-3. Refrigerant charging calculation".

PUMY-P-VKM5, YKM(E)4, YKM2, YBM

Mixed Method
Connection Examples
(Connecting to 1 Branch box)

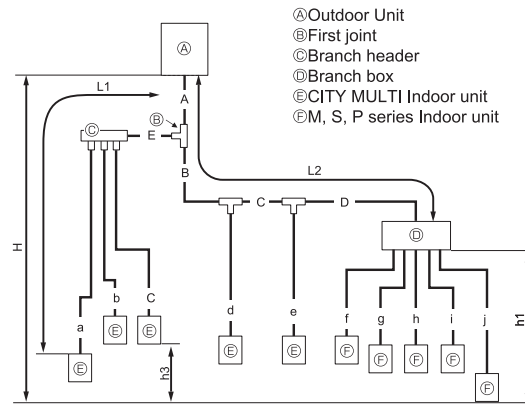

Permissible length (One-way)	Total piping length	$A+B+C+D+E+a+b+c+d+e+f+g+h+i+j \leq 150$ m
	Farthest piping length (L1)	$A+E+a$ or $A+B+C+e \leq 80$ m
	Farthest piping length. Via Branch box	$A+B+C+D+j \leq 80$ m
	Piping length between outdoor unit and branch box	$A+B+C+D \leq 55$ m
	Farthest piping length from the first joint	$B+C+D$ or $B+C+e \leq 30$ m
	Farthest piping length after branch box	$j \leq 25$ m
	Total piping length between branch boxes and indoor units	$f+g+h+i+j \leq 95$ m
Permissible height difference (One-way)	In indoor/outdoor section (H)*1	$H \leq 50$ m (In the case of outdoor unit is set higher than indoor unit) $H \leq 40$ m (In the case of outdoor unit is set lower than indoor unit)
	In branch box/indoor unit section (h1)	$h1 \leq 15$ m
	In each indoor unit (h3)	$h3 \leq 12$ m
Number of bends		≤ 15

*1 Branch box should be placed within the level between the outdoor unit and indoor units.

■ **Selecting the Refrigerant Branch Kit**

Please select branching kit, which is sold separately, from the table below. (The kit comprises sets for use with liquid pipes and for use with gas pipes.)

Branch header (4 branches)	Branch header (8 branches)
CMY-Y64-G-E	CMY-Y68-G-E

■ **Select Each Section of Refrigerant Piping**

- (1) Section From Outdoor Unit to Branch box or Branch header (A to E)
 - (2) Sections From Branch box or Branch header to Indoor Unit (a to j)
- Each Section of Piping

Select the size from the table to the right.

(1) Refrigerant Piping Diameter In Section From Outdoor Unit to Branch box or Branch header (Outdoor Unit Piping Diameter)

A	Piping Diameter (mm)	
	Liquid pipe	Gas pipe
	$L1 \leq 60$ m and $L2 \leq 20$ m	$\phi 9.52$
$L1 > 60$ m or $L2 > 20$ m	$\phi 12.7$	$\phi 19.05$

Total down-stream capacity of indoor units	Liquid pipe (mm)		Gas pipe (mm)
	$L1 \leq 60$ m or $L2 \leq 20$ m	$\phi 9.52$	
- 16.0kW	$L1 > 60$ m or $L2 > 20$ m	$\phi 12.7$	$\phi 15.88$
	$L1 \leq 60$ m or $L2 \leq 20$ m	$\phi 9.52$	
16.1 - 29.1kW	$L1 > 60$ m or $L2 > 20$ m	$\phi 12.7$	$\phi 19.05$
	$L1 \leq 60$ m or $L2 \leq 20$ m	$\phi 9.52$	

L1: The farthest piping length from the outdoor unit to an indoor unit.
L2: The farthest piping length for the main pipes from the outdoor unit to the branch box.

(2) Refrigerant Piping Diameter In Section From Branch box or Branch header to Indoor Unit (Indoor Unit Piping Diameter)

Indoor unit series	Model number	Liquid pipe (mm)	Gas pipe (mm)
CITY MULTI	- 50	$\phi 6.35$ mm	$\phi 12.7$ mm
	63 - 140	$\phi 9.52$ mm	$\phi 15.88$ mm
	200 -	$\phi 9.52$ mm	$\phi 19.05$ mm
M series or S series	- 42	$\phi 6.35$ mm	$\phi 9.52$ mm
	50	$\phi 6.35$ mm	$\phi 12.7$ mm
	60	$\phi 6.35$ mm	$\phi 15.88$ mm
	71 -	$\phi 9.52$ mm	$\phi 15.88$ mm
P series	- 50	$\phi 6.35$ mm	$\phi 12.7$ mm
	60 -	$\phi 9.52$ mm	$\phi 15.88$ mm

Note:
When connecting the CONNECTION KIT (PAC-LV11M-J) and an M-series indoor unit, refer to the installation manual for the CONNECTION KIT when selecting the pipe size and piping length.

■ **Additional refrigerant charge**

Refer to "11-3. Refrigerant charging calculation".

Mixed Method
Connection Examples
(Connecting to 2 Branch boxes)

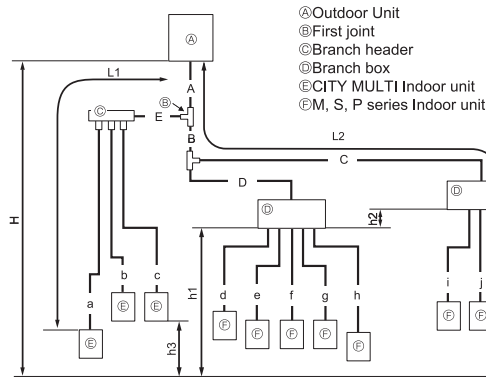

Permissible length (One-way)	Total piping length	$A+B+C+D+E+a+b+c+d+e+f+g+h+i+j+k \leq 150$ m
	Farthest piping length (L1)	$A+E+a \leq 80$ m
	Farthest piping length. Via Branch box	$A+B+C+k \leq 80$ m
	Piping length between outdoor unit and branch boxes	$A+B+C+D \leq 55$ m
	Farthest piping length from the first joint	$B+C$ or $E+a \leq 30$ m
	Farthest piping length after branch box	$k \leq 25$ m
	Farthest branch box from outdoor unit	$A+B+C \leq 55$ m
Permissible height difference (One-way)	Total piping length between branch boxes and indoor units	$d+e+f+g+h+i+j+k \leq 95$ m
	In indoor/outdoor section (H)*1	$H \leq 50$ m (In the case of outdoor unit is set higher than indoor unit) $H \leq 40$ m (In the case of outdoor unit is set lower than indoor unit)
	In branch box/indoor unit section (h1)	$h1+h2 \leq 15$ m
	In each branch unit (h2)	$h2 \leq 15$ m
Number of bends	In each indoor unit (h3)	$h3 \leq 12$ m
		≤ 15

*1 Branch box should be placed within the level between the outdoor unit and indoor units.

■ **Selecting the Refrigerant Branch Kit**

Please select branching kit, which is sold separately, from the table below. (The kit comprises sets for use with liquid pipes and for use with gas pipes.)

Branch header (4 branches)	Branch header (8 branches)
CMY-Y64-G-E	CMY-Y68-G-E

■ **Select Each Section of Refrigerant Piping**

- (1) Section From Outdoor Unit to Branch box or Branch header (A to E)
 - (2) Sections From Branch box or Branch header to Indoor Unit (a to k)
- } Each Section of Piping

Select the size from the table to the right.

(1) Refrigerant Piping Diameter In Section From Outdoor Unit to Branch box or Branch header (Outdoor Unit Piping Diameter)

A	Piping Diameter (mm)	
	Liquid pipe	Gas pipe
	$L1 \leq 60$ m and $L2 \leq 20$ m	$\phi 9.52$
$L1 > 60$ m or $L2 > 20$ m	$\phi 12.7$	

B to E	Total down-stream capacity of indoor units	Liquid pipe (mm)		Gas pipe (mm)
		$L1 \leq 60$ m or $L2 \leq 20$ m	$\phi 9.52$	
- 16.0kW		$L1 > 60$ m or $L2 > 20$ m	$\phi 12.7$	
		$L1 \leq 60$ m or $L2 \leq 20$ m	$\phi 9.52$	$\phi 19.05$
16.1 – 29.1kW		$L1 > 60$ m or $L2 > 20$ m	$\phi 12.7$	

L1: The farthest piping length from the outdoor unit to an indoor unit.
L2: The farthest piping length for the main pipes from the outdoor unit to the branch box.

(2) Refrigerant Piping Diameter In Section From Branch box or Branch header to Indoor Unit (Indoor Unit Piping Diameter)

Indoor unit series	Model number	Liquid pipe (mm)	Gas pipe (mm)
CITY MULTI	- 50	$\phi 6.35$ mm	$\phi 12.7$ mm
	63 – 140	$\phi 9.52$ mm	$\phi 15.88$ mm
	200 –	$\phi 9.52$ mm	$\phi 19.05$ mm
M series or S series	- 42	$\phi 6.35$ mm	$\phi 9.52$ mm
	50	$\phi 6.35$ mm	$\phi 12.7$ mm
	60	$\phi 6.35$ mm	$\phi 15.88$ mm
	71 –	$\phi 9.52$ mm	$\phi 15.88$ mm
P series	- 50	$\phi 6.35$ mm	$\phi 12.7$ mm
	60 –	$\phi 9.52$ mm	$\phi 15.88$ mm

Note:
When connecting the CONNECTION KIT (PAC-LV11M-J) and an M-series indoor unit, refer to the installation manual for the CONNECTION KIT when selecting the pipe size and piping length.

■ **Additional refrigerant charge**

Refer to "11-3. Refrigerant charging calculation".

PUMY-P-VKM5, YKM(E)4, YKM2, YBM

11-2-7. PUMY-P250, 300YBM Piping (WHEN USING BRANCH BOX)

Branch box Method
 Connection Examples
 (Connecting to 12 Indoor Units)

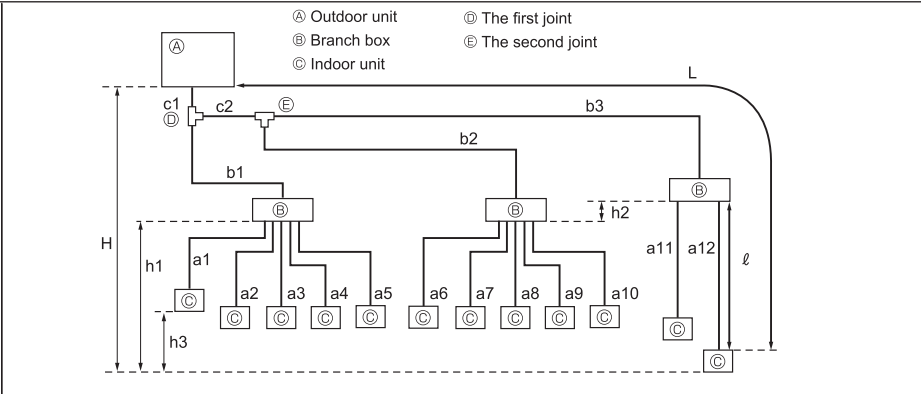

Permissible length (one-way)	Total piping length	$c1 + c2 + b1 + b2 + b3 + a1 + a2 + a3 + a4 + a5 + a6 + a7 + a8 + a9 + a10 + a11 + a12 \leq 240$ m
	Farthest piping length (L)	$c1 + c2 + b3 + a12 \leq 80$ m
	Piping length between outdoor unit and branch boxes	$c1 + c2 + b1 + b2 + b3 \leq 95$ m
	Farthest branch box from the first joint	$c2 + b3 \leq 30$ m
	Farthest piping length after branch box (ℓ)	$a12 \leq 25$ m
	Total piping length between branch boxes and indoor units	$a1 + a2 + a3 + a4 + a5 + a6 + a7 + a8 + a9 + a10 + a11 + a12 \leq 145$ m
Permissible height difference (one-way)	In indoor/outdoor section (H) *1	$H \leq 50$ m (In the case of outdoor unit is set higher than indoor unit) $H \leq 40$ m (In the case of outdoor unit is set lower than indoor unit)
	In branch box/indoor unit section	$h1 + h2 \leq 15$ m
	In each branch unit (h2)	$h2 \leq 15$ m
	In each indoor unit (h3)	$h3 \leq 12$ m
Number of bends	$ c1 + b1 + a1 , c1 + b1 + a2 , c1 + b1 + a3 , c1 + b1 + a4 , c1 + b1 + a5 , c1 + c2 + b2 + a6 , c1 + c2 + b2 + a7 , c1 + c2 + b2 + a8 , c1 + c2 + b2 + a9 , c1 + c2 + b2 + a10 , c1 + c2 + b3 + a11 , c1 + c2 + b3 + a12 \leq 23$	

*1 Branch box should be placed within the level between the outdoor unit and indoor units.

Select Each Section of Refrigerant Piping

(1) Section From Outdoor Unit to Branch box or Branch header (b1 to b3 and c1, c2)

(2) Sections From Branch box to Indoor Unit (a1 to a12)

Each Section of Piping

Select the size from the table to the right.

1) Refrigerant Piping Diameter In Section From Outdoor Unit to Branch box or Branch header (Outdoor Unit Piping Diameter) (mm)

Model	c1, c2	
	Liquid pipe	Gas pipe
P250	ø9.52	ø22.2
P300	ø12.7	ø25.4

b1 to b3 (mm)

Total down-stream capacity of indoor units	Model	Liquid pipe	Gas pipe
- 16.0kW	P250	ø9.52	ø15.88
	P300	ø12.7	
16.1 kW – 22.4 kW	P250	ø9.52	ø19.05
	P300	ø12.7	
22.5 kW –	P250	ø9.52	ø22.2
	P300	ø12.7	

(2) Refrigerant Piping Diameter In Section From Branch box to Indoor Unit (Indoor Unit Piping Diameter) (mm)

Indoor unit series	Model number	Liquid pipe	Gas pipe
M series	15 – 42	ø6.35	ø9.52
	50	ø6.35	ø12.7

Additional refrigerant charge Refer to "11-3. Refrigerant charging calculation"

Mixed Method
Connection Examples
(Connecting to 1 Branch box)

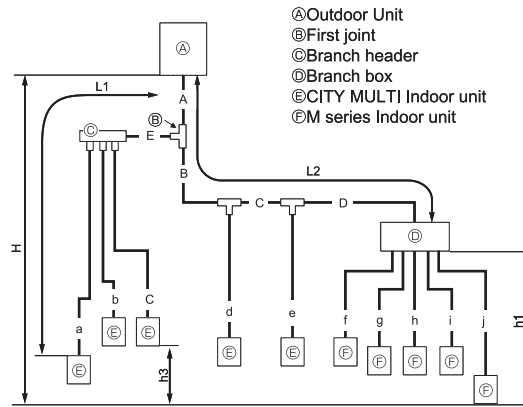

Permissible length (One-way)	Total piping length	$A+B+C+D+E+a+b+c+d+e+f+g+h+i+j \leq 310 \text{ m}$
	Farthest piping length (L1)	$A+E+a \text{ or } A+B+C+e \leq 85 \text{ m}$
	Farthest piping length, Via Branch box	$A+B+C+D+j \leq 80 \text{ m}$
	Piping length between outdoor unit and branch box	$A+B+C+D \leq 80 \text{ m}$
	Farthest piping length from the first joint	$B+C+D \text{ or } B+C+e \leq 30 \text{ m}$
	Farthest piping length after branch box	$j \leq 25 \text{ m}$
Permissible height difference (One-way)	Total piping length between branch boxes and indoor units	$f+g+h+i+j \leq 145 \text{ m}$
	In indoor/outdoor section (H)*1	$H \leq 50 \text{ m}$ (In the case of outdoor unit is set higher than indoor unit) $H \leq 40 \text{ m}$ (In the case of outdoor unit is set lower than indoor unit)
	In branch box/indoor unit section (h1)	$h1 \leq 15 \text{ m}$
Number of bends	In each indoor unit (h3)	$h3 \leq 12 \text{ m}$
		≤ 23

*1 Branch box should be placed within the level between the outdoor unit and indoor units.

■ **Selecting the Refrigerant Branch Kit**

Please select branching kit, which is sold separately, from the table below. (The kit comprises sets for use with liquid pipes and for use with gas pipes.)

Branch joint	Branch header (4 branches)	Branch header (8 branches)
CMY-Y62-G-E	CMY-Y64-G-E	CMY-Y68-G-E

■ **Select Each Section of Refrigerant Piping**

- (1) Section From Outdoor Unit to Branch box or Branch header (A to E)
 - (2) Sections From Branch box or Branch header to Indoor Unit (a to j)
- } Each Section of Piping

Select the size from the table to the right.

(1) Refrigerant Piping Diameter In Section From Outdoor Unit to Branch box or Branch header (Outdoor Unit Piping Diameter)

Model	A (mm)	
	Liquid pipe	Gas pipe
P250	$\phi 9.52^*$	$\phi 22.2$
P300	$\phi 12.7$	$\phi 25.4$

B to E (mm)

Total down-stream capacity of indoor units	Model	Liquid pipe	Gas pipe
- 16.0kW	P250	$\phi 9.52^*$	$\phi 15.88$
	P300	$\phi 12.7$	
16.1 kW - 22.4 kW	P250	$\phi 9.52^*$	$\phi 19.05$
	P300	$\phi 12.7$	
22.5 kW - 36.4 kW	P250	$\phi 9.52^*$	$\phi 22.2$
	P300	$\phi 12.7$	
36.5 kW -	P300	$\phi 12.7$	$\phi 25.4$

* $\phi 12.7$ when connecting the indoor unit for PEFY-P200 or P250.

(2) Refrigerant Piping Diameter In Section From Branch box or Branch header to Indoor Unit (Indoor Unit Piping Diameter)

Indoor unit series	Model number	Liquid pipe	Gas pipe
CITY MULTI	10 - 50	$\phi 6.35$	$\phi 12.7$
	63 - 140	$\phi 9.52$	$\phi 15.88$
	200	$\phi 9.52$	$\phi 19.05$
	250	$\phi 9.52$	$\phi 22.2$
M series	15 - 42	$\phi 6.35$	$\phi 9.52$
	50	$\phi 6.35$	$\phi 12.7$

Note:

When connecting the CONNECTION KIT (PAC-LV11M-J) and an M-series indoor unit, refer to the installation manual for the CONNECTION KIT when selecting the pipe size and piping length.

■ **Additional refrigerant charge**

Refer to "11-3. Refrigerant charging calculation"

Mixed Method
Connection Examples
(Connecting to 2 Branch boxes)

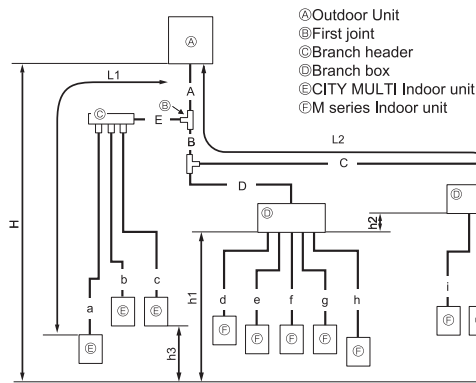

Permissible length (One-way)	Total piping length	$A+B+C+D+E+a+b+c+d+e+f+g+h+i+j+k \leq 310 \text{ m}$
	Farthest piping length (L1)	$A+E+a \leq 85 \text{ m}$
	Farthest piping length. Via Branch box	$A+B+C+k \leq 80 \text{ m}$
	Piping length between outdoor unit and branch boxes	$A+B+C+D \leq 95 \text{ m}$
	Farthest piping length from the first joint	$B+C \text{ or } E+a \leq 30 \text{ m}$
	Farthest piping length after branch box	$k \leq 25 \text{ m}$
	Total piping length between branch boxes and indoor units	$d+e+f+g+h+i+j+k \leq 145 \text{ m}$
Permissible height difference (One-way)	In indoor/outdoor section (H)*1	$H \leq 50 \text{ m}$ (In the case of outdoor unit is set higher than indoor unit) $H \leq 40 \text{ m}$ (In the case of outdoor unit is set lower than indoor unit)
	In branch box/indoor unit section (h1)	$h1+h2 \leq 15 \text{ m}$
	In each branch unit (h2)	$h2 \leq 15 \text{ m}$
	In each indoor unit (h3)	$h3 \leq 12 \text{ m}$
Number of bends		≤ 23

*1 Branch box should be placed within the level between the outdoor unit and indoor units.

■ **Selecting the Refrigerant Branch Kit**

Please select branching kit, which is sold separately, from the table below.
(The kit comprises sets for use with liquid pipes and for use with gas pipes.)

Branch joint	Branch header (4 branches)	Branch header (8 branches)
CMY-Y62-G-E	CMY-Y64-G-E	CMY-Y68-G-E

■ **Select Each Section of Refrigerant Piping**

- (1) Section From Outdoor Unit to Branch box or Branch header (A to E)
 - (2) Sections From Branch box or Branch header to Indoor Unit (a to k)
- } Each Section of Piping

Select the size from the table to the right.

(1) Refrigerant Piping Diameter In Section From Outdoor Unit to Branch box or Branch header (Outdoor Unit Piping Diameter)

Model	A (mm)	
	Liquid pipe	Gas pipe
P250	$\phi 9.52^*$	$\phi 22.2$
P300	$\phi 12.7$	$\phi 25.4$

Total down-stream capacity of indoor units	B to E (mm)		
	Model	Liquid pipe	Gas pipe
- 16.0kW	P250	$\phi 9.52^*$	$\phi 15.88$
	P300	$\phi 12.7$	
16.1 kW - 22.4 kW	P250	$\phi 9.52^*$	$\phi 19.05$
	P300	$\phi 12.7$	
22.5 kW - 36.4 kW	P250	$\phi 9.52^*$	$\phi 22.2$
	P300	$\phi 12.7$	
36.5 kW -	P300	$\phi 12.7$	$\phi 25.4$

* $\phi 12.7$ when connecting the indoor unit for PEFY-P200 or P250.

(2) Refrigerant Piping Diameter In Section From Branch box or Branch header to Indoor Unit (Indoor Unit Piping Diameter) (mm)

Indoor unit series	Model number	Liquid pipe	Gas pipe
CITY MULTI	10 - 50	$\phi 6.35$	$\phi 12.7$
	63 - 140	$\phi 9.52$	$\phi 15.88$
	200	$\phi 9.52$	$\phi 19.05$
	250	$\phi 9.52$	$\phi 22.2$
M series	15 - 42	$\phi 6.35$	$\phi 9.52$
	50	$\phi 6.35$	$\phi 12.7$

Note:

When connecting the CONNECTION KIT (PAC-LV11M-J) and an M-series indoor unit, refer to the installation manual for the CONNECTION KIT when selecting the pipe size and piping length.

■ **Additional refrigerant charge**

Refer to "11-3. Refrigerant charging calculation"

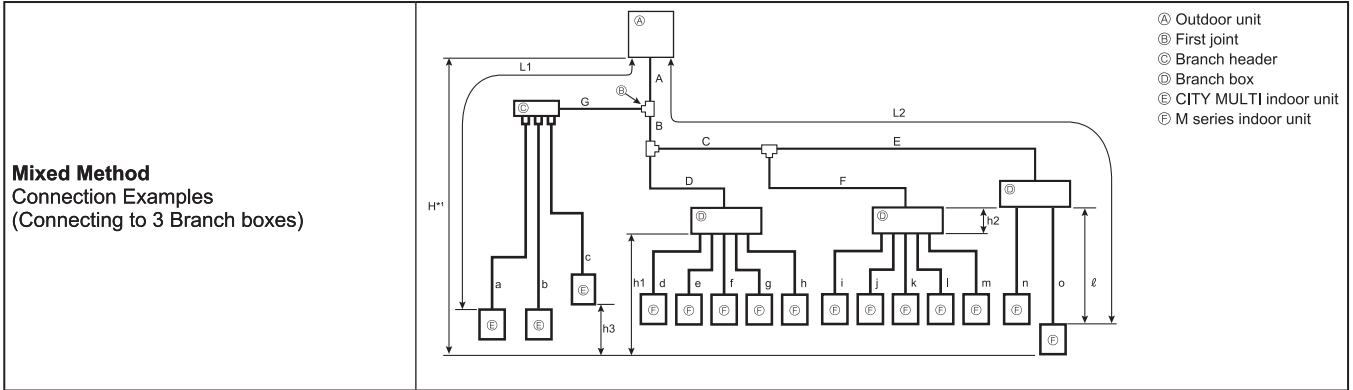

Permissible length (One-way)	Total piping length	$A + G + B + C + D + F + E + a + b + c + d + e + f + g + h + i + j + k + l + m + n + o \leq 310 \text{ m}$
	Farthest piping length (L1)	$A + G + a \leq 85 \text{ m}$
	Farthest piping length via branch box (L2)	$A + B + C + E + o \leq 80 \text{ m}$
	Piping length between outdoor unit and branch boxes	$A + B + C + D + F + E \leq 95 \text{ m}$
	Farthest piping length from the first joint	$B + C + E \text{ or } G + a \leq 30 \text{ m}$
	Farthest piping length after branch box (ℓ)	$o \leq 25 \text{ m}$
	Total piping length between branch boxes and indoor units	$d + e + f + g + h + i + j + k + l + m + n + o \leq 145 \text{ m}$
Permissible height difference (One-way)	In indoor/outdoor section (H)*1	$H \leq 50 \text{ m}$ (In the case of outdoor unit is set higher than indoor unit) $H \leq 40 \text{ m}$ (In the case of outdoor unit is set lower than indoor unit)
	In branch box/indoor unit section	$h1 + h2 \leq 15 \text{ m}$
	In each branch unit (h2)	$h2 \leq 15 \text{ m}$
	In each indoor unit (h3)	$h3 \leq 12 \text{ m}$
Number of bends		≤ 23

*1 Branch box should be placed within the level between the outdoor unit and indoor units.

■ **Selecting the Refrigerant Branch Kit**

Please select branching kit, which is sold separately, from the table below. (The kit comprises sets for use with liquid pipes and for use with gas pipes.)

Branch joint	Branch header (4 branches)	Branch header (8 branches)
CMY-Y62-G-E	CMY-Y64-G-E	CMY-Y68-G-E

■ **Select Each Section of Refrigerant Piping**

- (1) Section From Outdoor Unit to Branch box or Branch header (A to G)
 - (2) Sections From Branch box or Branch header to Indoor Unit (a to o)
- } Each Section of Piping

Select the size from the table to the right.

(1) Refrigerant Piping Diameter In Section From Outdoor Unit to Branch box or Branch header (Outdoor Unit Piping Diameter)

A (mm)

Model	Liquid pipe	Gas pipe
P250	ø9.52*	ø22.2
P300	ø12.7	ø25.4

B to G (mm)

Total down-stream capacity of indoor units	Model	Liquid pipe	Gas pipe
- 16.0kW	P250	ø9.52*	ø15.88
	P300	ø12.7	
16.1 kW - 22.4 kW	P250	ø9.52*	ø19.05
	P300	ø12.7	
22.5 kW - 36.4 kW	P250	ø9.52*	ø22.2
	P300	ø12.7	
36.5 kW -	P300	ø12.7	ø25.4

* ø12.7 when connecting the indoor unit for PEFY-P200 or P250.

(2) Refrigerant Piping Diameter In Section From Branch box or Branch header to Indoor Unit (Indoor Unit Piping Diameter)

Indoor unit series	Model number	Liquid pipe	Gas pipe
CITY MULTI	10 - 50	ø6.35	ø12.7
	63 - 140	ø9.52	ø15.88
	200	ø9.52	ø19.05
	250	ø9.52	ø22.2
M series	15 - 42	ø6.35	ø9.52
	50	ø6.35	ø12.7

Note:
When connecting the CONNECTION KIT (PAC-LV11M-J) and an M-series indoor unit, refer to the installation manual for the CONNECTION KIT when selecting the pipe size and piping length.

■ **Additional refrigerant charge**

Refer to "11-3. Refrigerant charging calculation".

PUMY-P-VKM5, YKM(E)4, YKM2, YBM

11-3. Refrigerant charging calculation

Additional refrigerant charge

Refrigerant for the extended piping is not included in the outdoor unit when the unit is shipped from the factory. Therefore, charge each refrigerant piping system with additional refrigerant at the installation site. In addition, in order to carry out service, enter the size and length of each liquid pipe and additional refrigerant charge amounts in the spaces provided on the "Refrigerant amount" plate on the outdoor unit.

Calculation of additional refrigerant charge

- Calculate the additional charge using the liquid pipe size and length of the extended piping and total capacity of connected indoor units.
- Calculate the additional refrigerant charge using the procedure below, and charge with the additional refrigerant.
- For amounts less than 0.1 kg, round up the calculated additional refrigerant charge.
(For example, if the calculated charge is 6.01 kg, round up the charge to 6.1 kg.)

PUMY-P112, 125, 140

• Calculation of additional refrigerant charge

Pipe size Liquid pipe ø6.35	+	Pipe size Liquid pipe ø9.52	+	Total capacity of connected indoor units	Amount for the indoor units
(m) x 19.0 (g/m)		(m) x 50.0 (g/m)		- 8.0kW	1.5kg
				8.1 - 16.0kW	2.5kg
				16.1kW -	3.0kg

PUMY-P200

• Calculation of additional refrigerant charge

Pipe size Liquid pipe ø6.35	+	Pipe size Liquid pipe ø9.52	+	Pipe size Liquid pipe ø12.7	+	Total capacity of connected indoor units	Amount for the indoor units
(m) x 19.0 (g/m)		(m) x 50.0 (g/m)		(m) x 92.0 (g/m)		- 16.0kW	2.5kg
						16.1 - 25.0kW	3.0kg
						25.1kW -	3.5kg

* When connecting 4 PEFY-P-VMA3 indoor units, use 3.5kg regardless of the amount indicated in the preceding table according to the total capacity.

PUMY-P250/300

• Calculation of additional refrigerant charge

Pipe size Liquid pipe ø6.35	+	Pipe size Liquid pipe ø9.52	+	Pipe size Liquid pipe ø12.7	+	Total capacity of connected indoor units	Amount for the indoor units
(m) x 19.0 (g/m)		(m) x 50.0 (g/m)		(m) x 92.0 (g/m)		- 16.0kW	2.5kg
						16.1kW - 27.0kW	3.0kg
						27.1kW - 31.0kW	3.5kg
						31.1kW - 34.0kW	4.0kg
						34.1kW - 36.5kW	4.5kg
						36.6kW - 39.0kW	5.0kg
						39.1kW - 41.0kW	5.5kg
						41.1kW -	6.1kg

Example of refrigerant charge

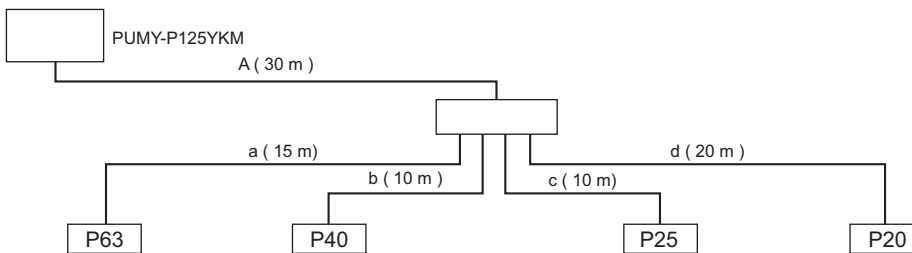

<Example>

Outdoor model: P125

Indoor 1: P63 (7.1kW) A: ø9.52 30 m a: ø9.52 15 m
 2: P40 (4.5kW) b: ø6.35 10 m
 3: P25 (2.8kW) c: ø6.35 10 m
 4: P20 (2.2kW) d: ø6.35 20 m

<Calculation example>

Additional refrigerant charge

$$40 \times \frac{19.0}{1000} + 45 \times \frac{50.0}{1000} + 3.0 = 6.1\text{kg (rounded up)}$$

The total length of each liquid line is as follows:

$$\text{ø9.52: } A + a = 30 + 15 = 45 \text{ m}$$

$$\text{ø6.35: } b + c + d = 10 + 10 + 20 = 40 \text{ m}$$

The total capacity of connected indoor unit is as follows:

$$7.1 + 4.5 + 2.8 + 2.2 = 16.6$$

■ Maximum refrigerant charge

There is a limit to the amount of refrigerant that can be charged into a unit.

Regardless of the amount yielded by the formula above, observe the maximum refrigerant charge in the table below.

For P250/300, the amount of additional refrigerant which is calculated from the total capacity of indoor units and the combination of extended pipes must not be over 22.8 kg.

Total index of the outdoor units		P112VKM5	P125VKM5	P140VKM5	P112YKM(E)4	P125YKM(E)4	P140YKM(E)4	P200YKM2	P250YBM	P300YBM
Maximum refrigerant charge	Factory charge	kg	4.8	4.8	4.8	4.8	4.8	7.3	9.3	9.3
	Charged on site	kg	13.8	13.8	13.8	13.8	13.8	13.1	22.8	22.8
	Total for system	kg	18.6	18.6	18.6	18.6	18.6	20.4	32.1	32.1

12-1. Requirement on installation site

12-1-1. General caution

- A. Avoid locations exposed to direct sunlight or other sources of heat.
- B. Select a location from which noise emitted by the unit will not inconvenience the neighbors.
- C. Select a location permitting easy wiring and pipe access to the power source and indoor unit.
- D. Avoid locations where combustible gases may leak, be produced, flow, or accumulate.
- E. Note that water may drain from the unit during operation.
- F. Select a level location that can bear the weight and vibration of the unit.
- G. Avoid locations where the unit can be covered by snow. In areas where heavy snow fall is anticipated, special precautions such as raising the installation location or installing a hood on the air intake must be taken to prevent the snow from blocking the air intake or blowing directly against it. This can reduce the airflow and a malfunction may result.
- H. Avoid locations exposed to oil, steam, or sulfuric gas.
- I. Use the transportation handles of the outdoor unit to transport the unit. If the unit is carried from the bottom, hands or fingers may be pinched.

12-1-2. Installation at windy location.

When installing the outdoor unit on a rooftop or other location unprotected from the wind, situate the air outlet of the unit so that it is not directly exposed to strong winds. Strong wind entering the air outlet may impede the normal airflow and a malfunction may result.

The following shows two examples of precautions against strong winds.

- ① Install an optional air protect guide if the unit is installed in a location where strong winds from a typhoon, etc. may directly enter the air outlet. (Fig. 12-1-2a, c)
 - Ⓐ Air protect guide
- ② Position the unit so that the air outlet blows perpendicularly to the seasonal wind direction, if possible. (Fig. 12-1-2b, d)
 - Ⓑ Wind direction

■PUMY-P112, 125, 140VKM5/YKM(E)4
PUMY-P200YKM2

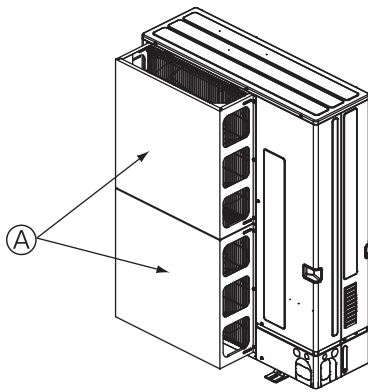

Fig. 12-1-2a

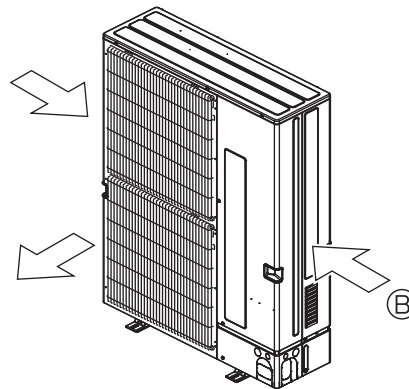

Fig. 12-1-2b

■PUMY-P250, 300YBM

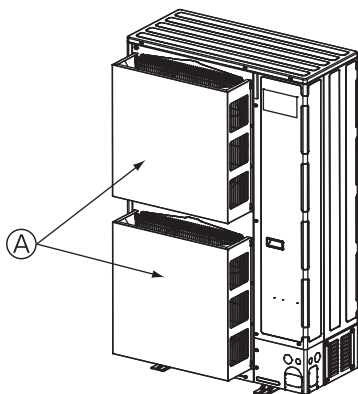

Fig. 12-1-2c

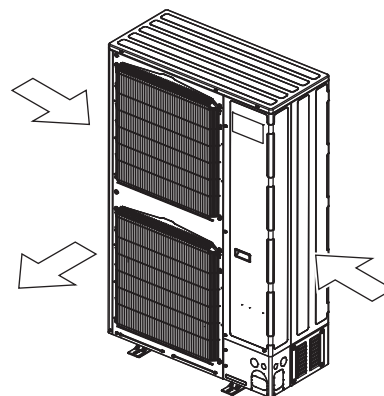

Fig. 12-1-2d

12-1-3. Foundation

A. Be sure to install the unit in a sturdy, level surface to prevent rattling noises during operation.
(see Fig. 12-1-3a)

B. Foundation specifications are as follows.

mm [in.]			
Thickness of concrete	Weight-bearing capacity	Foundation bolt	Bolt length
120 [4-3/4"]	320 kg [706lbs]	M10 [3/8"]	70 [2-25/32"]

C. Make sure that the length of the foundation bolt is within 30 mm [1-3/16"] of the bottom surface of the base.

D. Secure the base of the unit firmly with four-M10 [3/8"] foundation bolts in sturdy locations.

⚠ Warning:

- A. The foundation base should be strong enough to support the outdoor unit, otherwise, it may fall down and cause damage or injuries.
- B. The unit must be installed according to the instructions in order to minimize the risk of damage from earthquakes, typhoons, or strong winds.

■ PUMY-P-VKM5/YKM(E)4, PUMY-P-YKM2

■ PUMY-P250, 300YBM

(mm)

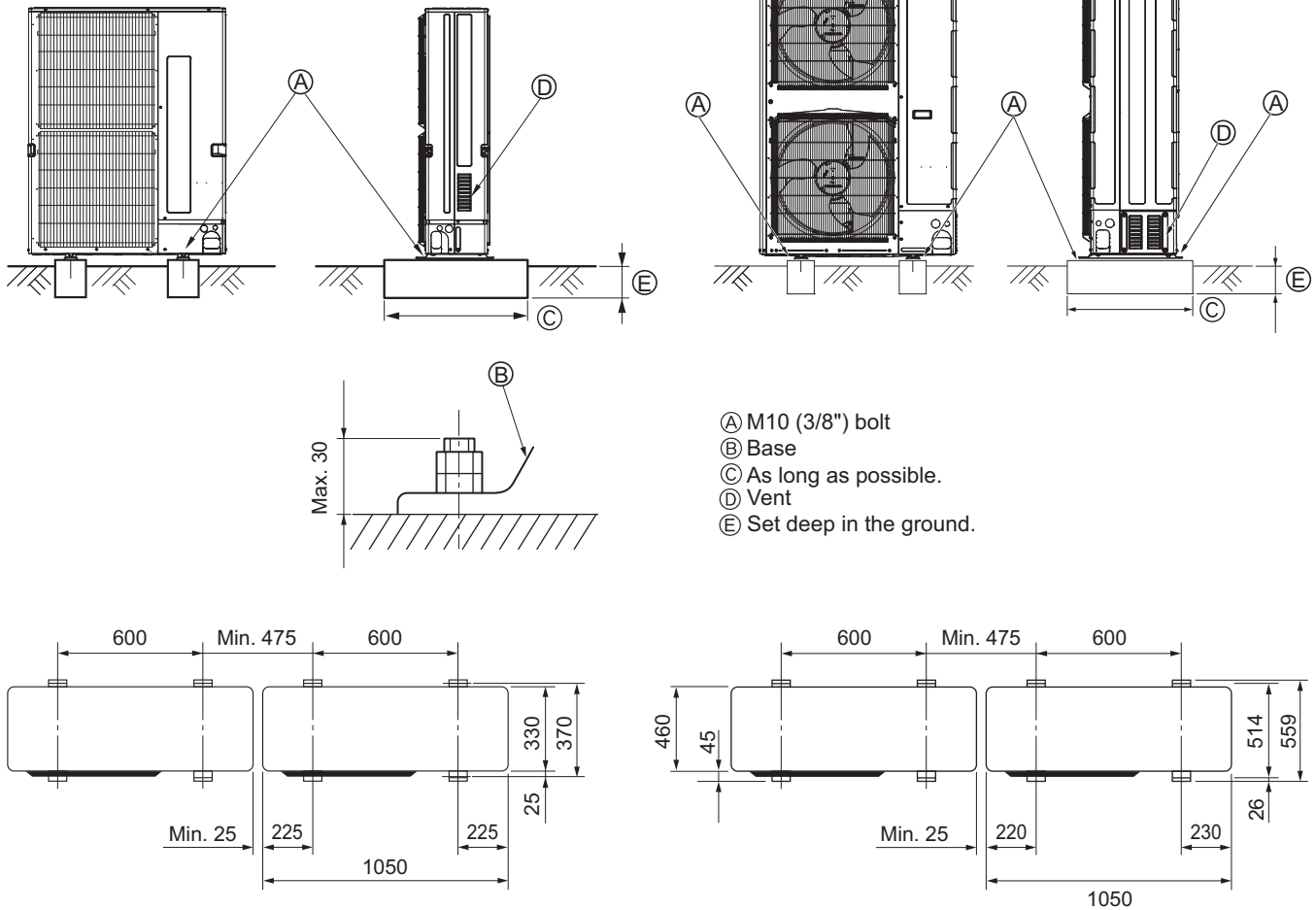

Fig. 12-1-3a

PUMY-P-VKM5, YKM(E)4, YKM2, YBM

12-2. Spacing

12-2-1. PUMY-P112, 125, 140VKM5/YKM(E)4
PUMY-P200YKM2

(mm)

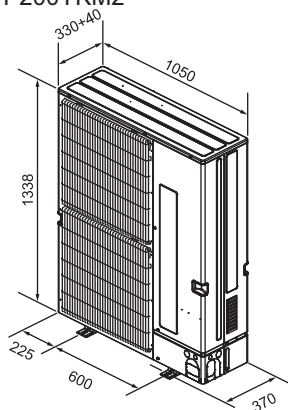

Fig. 12-2-1

12-2-1-1. Spacing individual PUMY-P-VKM5/YKM4(2)/YKME4

Follow Fig. 12-2-2~7 to space individual PUMY-P-VKM5/
YKM4(2)/YKME4 at the installation site.

mm[in.]

12-2-1-2. Spacing grouped PUMY-P-VKM5/YKM4(2)/YKME4

Follow Fig. 4-2-8~13 to space grouped PUMY-P-VKM5/
YKM4(2)/YKME4 at the installation site. Leave 25 mm space or
more between PUMY-P-VKM5/YKM4(2)/YKME4 units.

PUMY-P-VKM5, YKM(E)4, YKM2, YBM

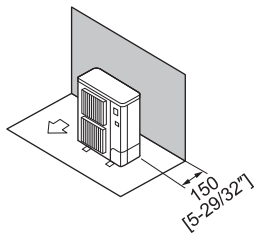

Fig. 12-2-2
Obstacles at rear only

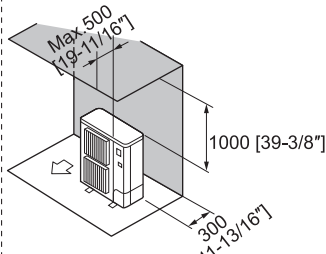

Fig. 12-2-3
Obstacles at rear and above only

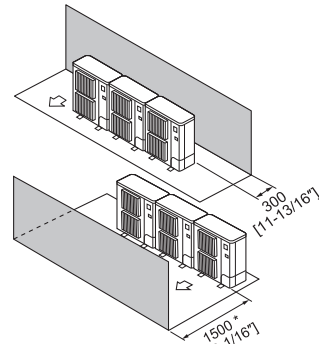

Fig. 12-2-8
Obstacles at rear or front only

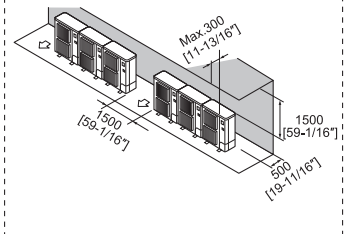

Fig. 12-2-9
Obstacles at rear and above only

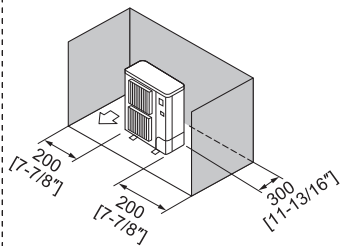

Fig. 12-2-4
Obstacles at rear and sides only

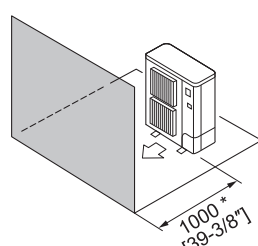

Fig. 12-2-5
Obstacles at front only

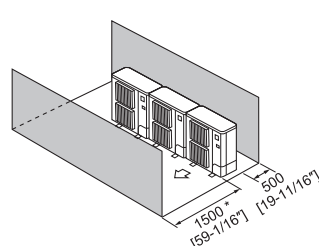

Fig. 12-2-10
Obstacles at front and rear only

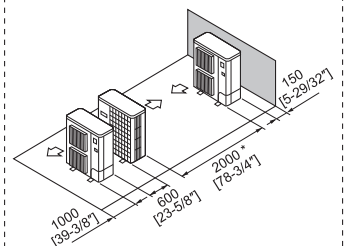
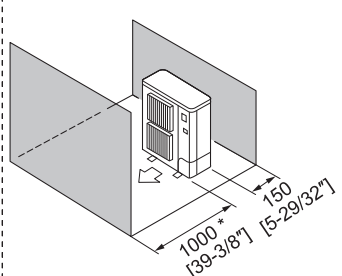
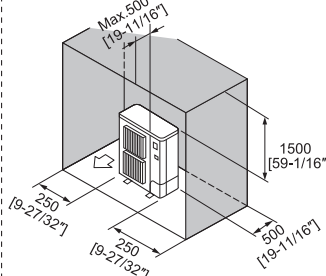

Fig. 12-2-11
Parallel individuals arrangement



* Using an optional air outlet guide, the clearance \geq 500 mm [19-11/16"].

Fig. 12-2-6
Obstacles at front and rear only



* NO upward airflow outlet guide.

Fig. 12-2-7
Obstacles at rear, sides and above only

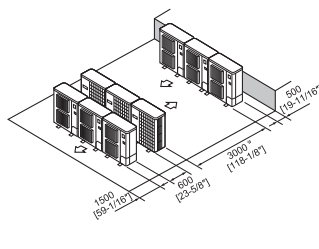

* Using an optional air outlet guide for upward airflow, the clearance \geq 1500 mm [59-11/16"].

Fig. 12-2-12
Parallel groups arrangement

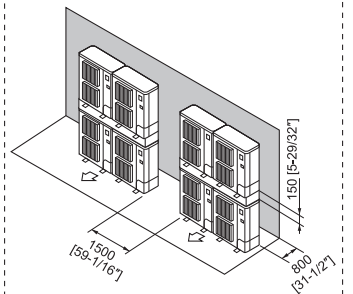

* Stacked layer \leq 2 units;
* Side-by-side stacked groups \leq 2 groups;

Fig. 12-2-13
Stacked groups arrangement

12-2-14. PUMY-P250, 300YBM

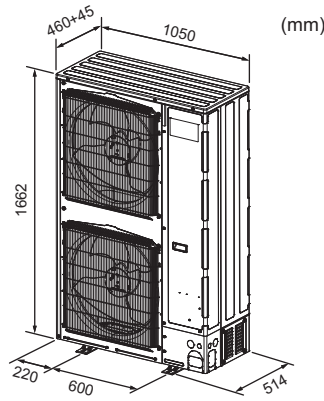

Fig. 12-2-1

12-2-14-1. Spacing individual PUMY-P-YBM

Follow Fig. 12-2-15~20 to space individual PUMY-P-YBM at the installation site.

12-2-14-2. Spacing grouped PUMY-P-YBM

Follow Fig. 4-2-21~26 to space grouped PUMY-P-YBM at the installation site. Leave 25 mm space or more between PUMY-P-YBM units.

PUMY-P-VKM5, YKM(E)4, YKM2, YBM

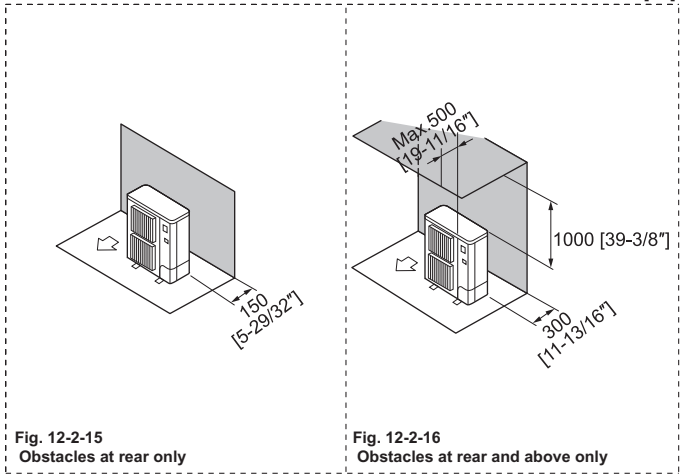

Fig. 12-2-15
Obstacles at rear only

Fig. 12-2-16
Obstacles at rear and above only

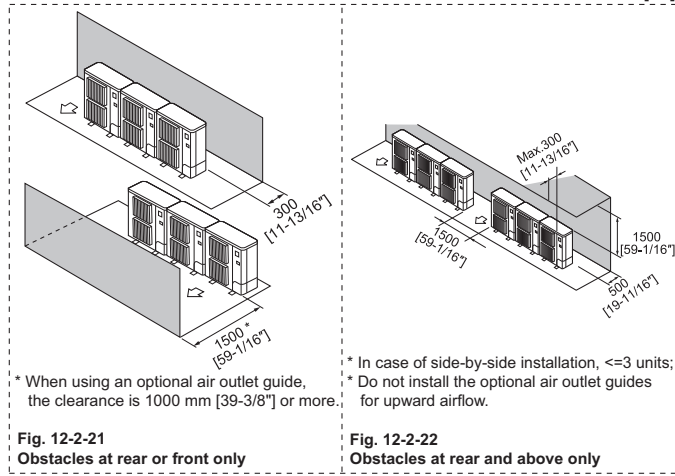

Fig. 12-2-21
Obstacles at rear or front only

Fig. 12-2-22
Obstacles at rear and above only

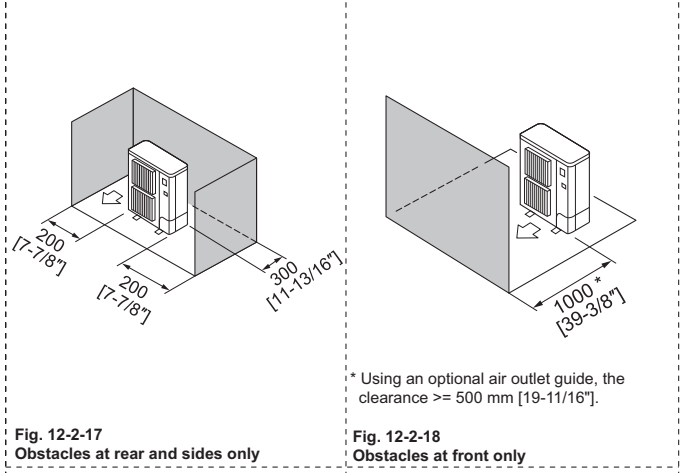

Fig. 12-2-17
Obstacles at rear and sides only

Fig. 12-2-18
Obstacles at front only

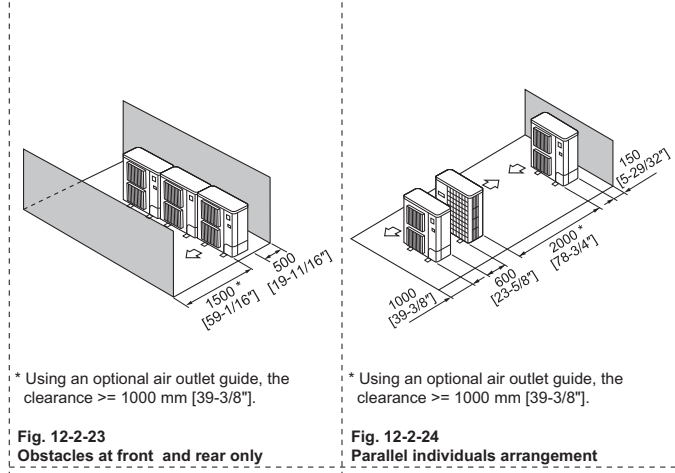

Fig. 12-2-23
Obstacles at front and rear only

Fig. 12-2-24
Parallel individuals arrangement

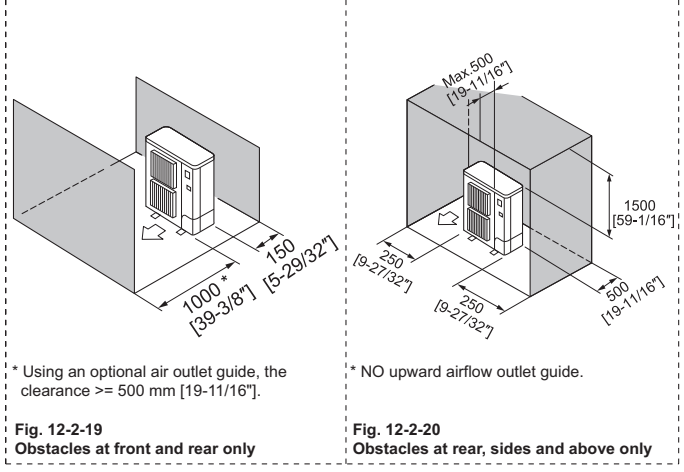

Fig. 12-2-19
Obstacles at front and rear only

Fig. 12-2-20
Obstacles at rear, sides and above only

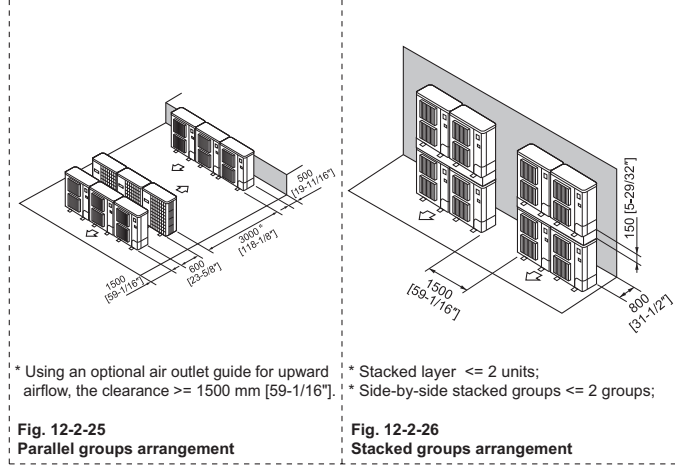

Fig. 12-2-25
Parallel groups arrangement

Fig. 12-2-26
Stacked groups arrangement

* Using an optional air outlet guide, the clearance \geq 500 mm [19-11/16"].

* NO upward airflow outlet guide.

* Using an optional air outlet guide for upward airflow, the clearance \geq 1500 mm [59-1/16"].

* Stacked layer \leq 2 units;
* Side-by-side stacked groups \leq 2 groups;

12-3. Piping direction

PUMY-P112, 125, 140VKM5/YKM(E)4
PUMY-P200YKM2

PUMY-P250, 300YBM

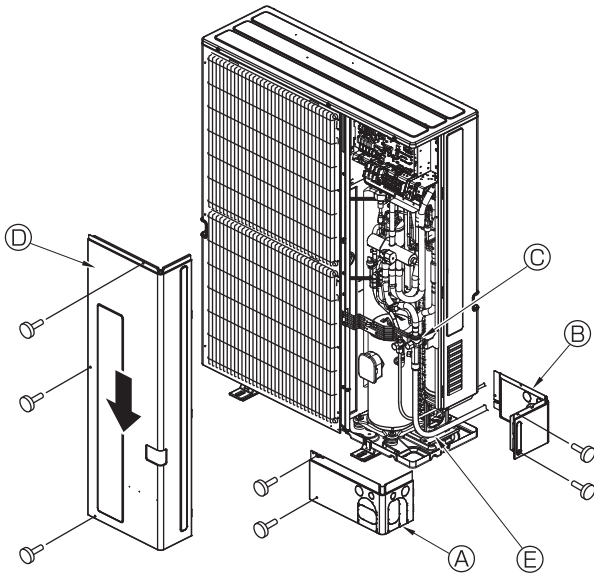

- (A) Front piping cover
- (B) Piping cover
- (C) Stop valve
- (D) Service panel
- (E) Bend radius : 100 mm - 150 mm

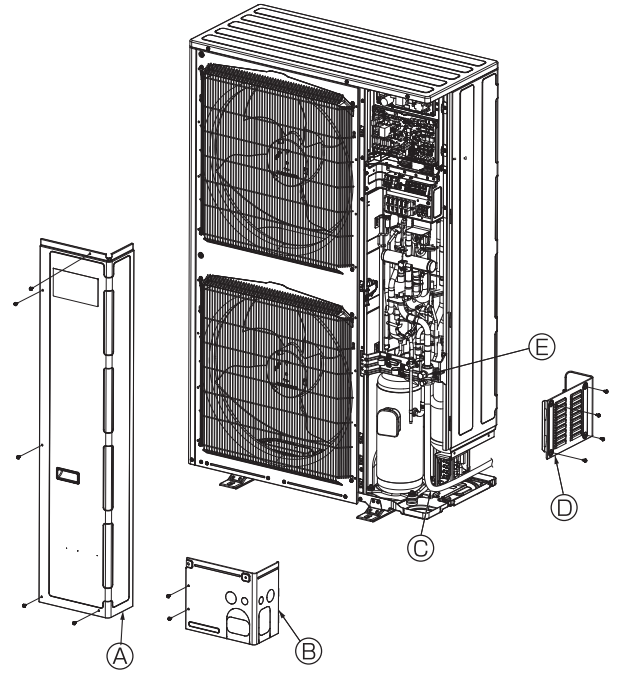

- (A) Service panel
- (B) Front piping cover
- (C) Bend radius : 100 mm or more
- (D) Rear piping cover
- (E) Stop (Ball) valve

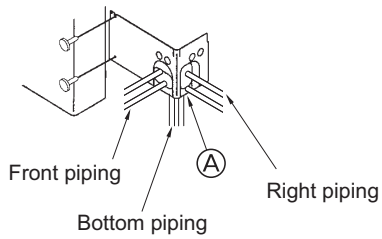

⚠ Warning

- Do not use refrigerant other than the type indicated in the manuals provided with the unit and on the nameplate.
 - Doing so may cause the unit or pipes to burst, or result in explosion or fire during use, repair, or at the time of disposal of the unit.
 - It may also be in violation of applicable laws.
 - MITSUBISHI ELECTRIC CORPORATION cannot be held responsible for malfunctions or accidents resulting from the use of the wrong type of refrigerant.
- Our air conditioning equipment and heat pumps contain a fluorinated greenhouse gas, R410A.

MITSUBISHI ELECTRIC CORPORATION

www.MitsubishiElectric.com