



Lossnay CO₂ Sensor Built-In Type **PZ-70CSB-E**

Installation and Instruction Manual

This CO₂ sensor optimizes the amount of airflow in accordance with the CO₂ concentration within the room, and thus reduces the fresh air load.

- This manual must be read both fully and carefully before commencing installation procedures; furthermore, the subsequent installation must be performed correctly and safely in accordance with the instructions given.
- After installation, ensure that this manual is given to the customer.

1. Safety Precautions

	WARNING	Incorrect handling could cause serious injury or death.
--	----------------	---

- **Never modify or repair by yourself.**
If the product is modified or inappropriately repaired, electric shock, fire, etc. could result. Contact your dealer for repair.
- **Do not move or reinstall the product by yourself.**
If it is installed improperly, electric shock, fire, etc. could result. Contact your dealer or technical representative.
- **Use the specified cables for wiring and connect them securely. Hold the cables so as not to apply external force of the cables to the connector.**
Improper connection could result in heat generation or fire.
- **All electrical work must be performed by a licensed technician, according to local regulations and the instructions given in this Installation manual.**
- **Ensure that installation work is done correctly following this Installation manual.**
If it is installed improperly, electric shock, fire, etc. could result.
- **Close the control cover after installation.**
- **Do not install the product in a place where flammable gases may leak.**
If gas should leak or accumulate around the product, fire or explosion could result.
- **Do not use the product in special environments.**
The product could be damaged if it is used in locations subject to large quantities of oil (including machine oil), steam, or sulfide gas.
- **Do not install the unit in a place where the temperature rises above 40 °C (104°F), where large amounts of oil, steam, organic solvents, or corrosive gases, such as sulfuric gas, are present, or where acidic/alkaline solutions or sprays are used frequently.**
These substances can compromise the performance of the unit or cause certain components of the unit to corrode, which can result in electric shock, malfunctions, smoke, or fire.

	CAUTION	Incorrect handling could cause injury or damage to property or household effects.
--	----------------	---

- **Wire so that it does not receive any tension.**
Tension could cause wire breakage, heating or fire.
- **Put on gloves during installation.**
Failure to do so could cause injury.

2. External Dimensions, Included Accessories, and Specifications

■ Included accessories

Please confirm that the following accessory parts are included in the box.

1. CO₂ sensor unit: x 1
2. Cross-slot truss head small screws 4x8: x 2
3. Safety caution for installation: x 1
4. Cord clip: x 1

■ External dimensions

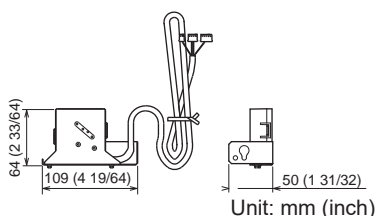

■ Specifications

Rated power supply voltage: 5 VDC (Supplied from the Lossnay)

Power consumption: 2 W or less.

Usage environment: 0 °C to 40 °C (32 °F to 104 °F), 90 % RH or less. (No Cigarette Smoke or Sulfur and with no dew condensation)

Measurement accuracy: $\pm (70 + 5\%$ of measurement value) ppm

Detection range: 300 to 2000 ppm

Weight: 0.14 kg (0.31 lb)

* 1: In the range of 0 °C (32 °F) or less, CO₂ Sensor may not detect the correct CO₂ Concentration.

* 2: Measures the CO₂ concentration around the location where the CO₂ sensor is installed. In addition, the measurement accuracy may vary depending on the usage environment, installation conditions, etc. but this is not a malfunction.

3. Installation Method

* Refer to the Operation Instructions and Installation instructions of Lossnay unit.

* Figures show the installation method of LGH-RVS series.

3.1 Before installation

- (1) Remove the Lossnay unit control box cover.

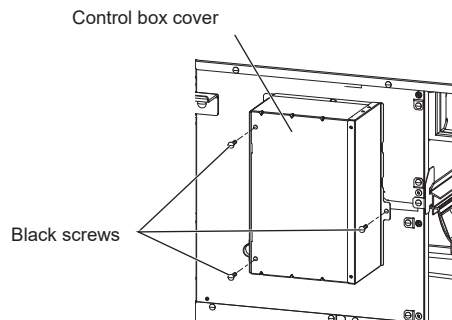

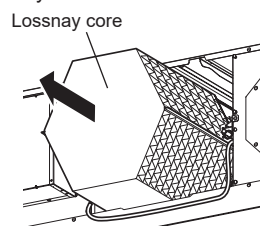

- (2) Remove the Lossnay cores.



- (3) Check that the installation screw hole positioning plate is affixed in the ventilation path (RA).

3.2 CO₂ sensor installation

- (1) Temporarily tighten the installation screw (included) at the position indicated by  on the installation positioning plate. After hooking CO₂ sensor key hole on the temporary screw, align  on the plate with the screw holes and fully tighten the two screws to secure.
 - Hole positions are approximate. If you cannot see the hole positions, remove the installation screw hole positioning plate.
 - Depending on the Lossnay model and installation conditions, the figure below may be inverted. Additionally, please be aware that the CO₂ sensor installation location may differ depending on the Lossnay model.

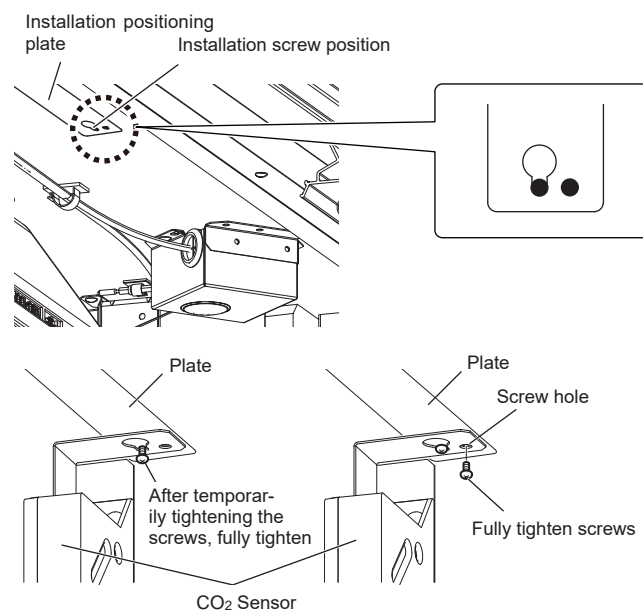

Note:

- Ensure that the CO₂ sensor is installed in alignment with the position indicated by the plate. Installing this in the wrong position may prevent correct operation. Furthermore, this may result in damage to the sensor, or a shortened service life.
- Do not use an electric screwdriver.
- Screw tightening torque: $1.42 \pm 0.25 \text{ N} \cdot \text{m}$
- Do not disassemble the CO₂ sensor (sensor section) resin case.
- Do not use any screws other than the included screws.

(2) Pass the CO₂ sensor cable through the Lossnay unit communication cables hole.

- If the inlet is covered by a packing, wind the packing onto CO₂ sensor cable also. After winding the packing, return the packing to its original position.

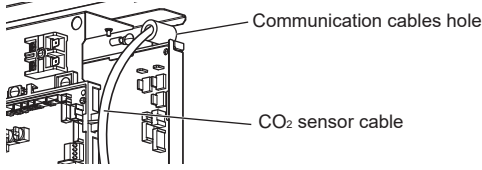

Note:

- Return the packing so that it does not come off the Lossnay unit.

(3) Affix the included cord clip to the Lossnay unit, and secure the CO₂ sensor cable.

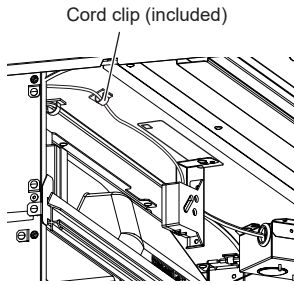

Note:

- Be careful not to exert force on the CO₂ sensor.
- Ensure this is fixed in a position that will not interfere with removal or attachment of the Lossnay cores and air filters.
- Do not secure the CO₂ sensor cable to the cord clip that was originally affixed to the Lossnay unit. (Doing so may wire to incorrect operation or damage)

4. Wiring Diagram

- A qualified electrical technician is to carry out connection work.
- Once installation work is complete, confirm again that wiring is as per the wiring diagram, and that no parts or screws remain unused.
- Do not disconnect connectors that are already connected.

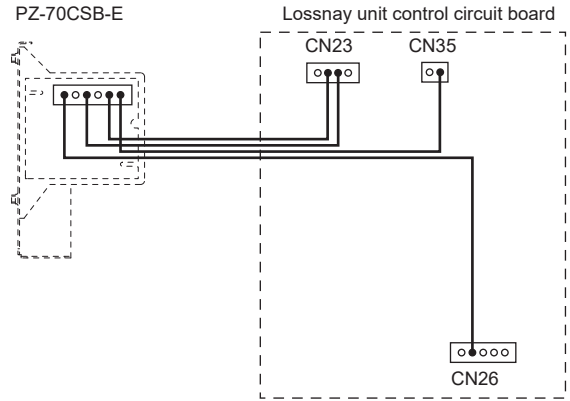

4.1 CO₂ sensor connector connection

- Pull the CO₂ sensor cable into the Lossnay unit circuit box. (In order to protect the edge, pass through the packing included with the Lossnay unit board)
- Connect the yellow and white wires to CN23; the blue wire to CN26, and the red wire to CN35 on the Lossnay unit board.

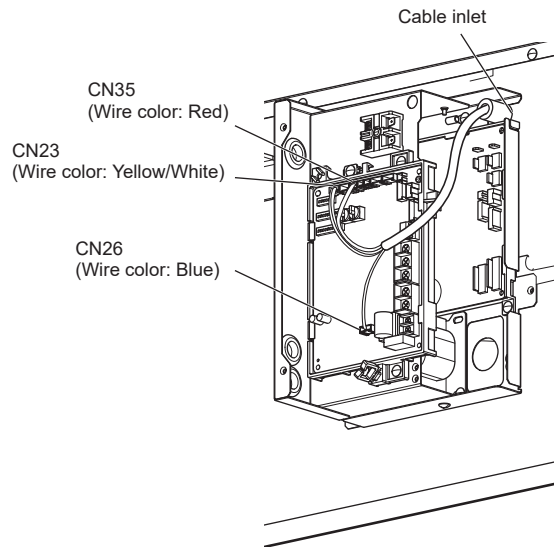

Note:

- Ensure that connectors are fully inserted so that they do not come loose.
- Do not subject the connector to force.
- Refer to the wiring diagram for the connection location of each connector.
- Connect CN26 to the white connector. Do not connect to the red or green connectors. (This will result in damage to the circuit board or CO₂ sensor)

4.2 Collecting excess cable

- (1) Collect excess cable using the cord clip included with the Lossnay unit.

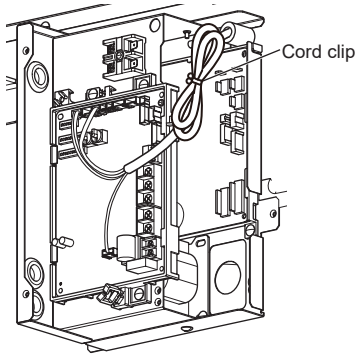

Note:

- Do not contact the CO₂ sensor cable to PCB and the power cable.

- (2) Reinstall Lossnay cores, filters, covers etc. according to the Lossnay unit instruction book.

Note:

- Ensure the cable is not pinched in the control box.

■ When using external bypass switching on this product

- While referring to the figure below, cut the wire of the CO₂ sensor cable, and connect the remote controller adapter (PAC-SA88HA-E or PAC-725AD (sold separately)).

Note:

- Ensure that a qualified electrical technician carries out cutting and connecting of the wires.
- Ensure that unused wires (orange, green) are properly insulated.
- The product could be damaged if the wires are connected incorrectly.
- For details, refer to the Lossnay unit Installation Instructions.

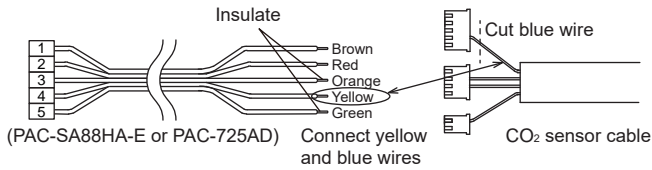

5. Precautions

Airflow function (unbalanced supply and exhaust air flow setting) is not available during the Lossnay unit fan speed is controlled by CO₂ sensor.

- CO₂ concentrations will differ depending on the usage environment and product installation conditions, therefore the value measured by the CO₂ sensor may differ from the actual CO₂ concentration within the room. Additionally, for approximately 15 minutes after start-up, the measured values may differ significantly from the actual CO₂ concentration within the room.
- The automatic calibration function recognizes the lowest CO₂ concentrations, such as at night or when there are fewer people coming and going, as the standard value (corresponding to normal outside CO₂ concentrations) and corrects these correspondingly, therefore the CO₂ concentrations detected by the CO₂ sensor and the actual CO₂ concentration within the room may differ. Therefore, if this product is used in locations in which the outside CO₂ concentration is normally higher than the standard value (such as near a major highway), or in an interior environment with higher-than-normal CO₂ concentrations, then there may be a significant discrepancy between the actual CO₂ concentrations and the detected concentrations. In these cases, use this product after configuring concentration correction settings (Section 6.5) of the sensor output using the remote controller (PZ-62DR-E).
- This CO₂ sensor does not support automatic start/stop control.
- This CO₂ sensor is intended for use in normal interior environments, and may not be able to correctly detect CO₂ concentrations if used in rooms with extreme levels of dust, etc.
- Sudden changes in temperature or humidity may adversely impact the detection accuracy of the CO₂ sensor, causing the sensor to be unable to correctly detect the CO₂ concentration within the room.
- This product cannot be used in rooms in which cigarette smoke is present.
- This product should not be used as a safety device to detect or prevent poisonous gases that could cause hypoxia or carbon monoxide poisoning, or flammable gases.
- This product cannot be used in hot spring areas or other areas with high levels of sulfur dioxide. Doing so may lead to deterioration of the CO₂ sensor.
- During night purge operation, auto fan speed by the CO₂ sensor will not be possible.

6. Settings

To use the CO₂ sensor for auto fan speed, configuration of settings on the remote controller (PZ-62DR-E) or the Lossnay circuit board dip switch is required. Additionally, when using group control for multiple Lossnay units, configuration of address settings is required in order to configure different function settings between Lossnay units. For how to configure the settings, refer to the Installation Instructions for the Lossnay unit used and the remote controller.

* Group control and settings from Section 6.4 onward can only be set when using the PZ-62DR-E.

6.1 Main unit settings

When using a single CO₂ sensor to group-control multiple Lossnay units, connect the Main Lossnay unit (Lossnay unit with the youngest address in the group) to the CO₂ sensor.

* If not connecting a PZ-62DR-E, group control will not be available.

6.2 CO₂ sensor setting

In order to use the CO₂ sensor for auto fan speed, set either the Lossnay unit dip switch or the remote controller function settings to "Connected to PZ-70CSB-E." Configuring these settings enables to use auto fan speed using the CO₂ sensor.

- If using a single CO₂ sensor for group control of multiple Lossnay units, keep "CO₂ sensor or BMS setting" for other than the Main Lossnay unit at factory setting.
- When using group control for multiple Lossnay units, if connecting a CO₂ sensor to each Lossnay unit, keep "CO₂ sensor or BMS setting" in all Lossnay units to "PZ-70CSB-E connection," and set "Input priority setting" to "Individual control priority."
- If using a remote controller, configure **6.4. CO₂ sensor setting - maximum side and minimum side**.

6.3 Auto fan speed setting without Lossnay or M-NET centralized remote controller

If not connecting remote controllers or M-NET centralized controllers to the Lossnay unit, set the "Auto fan speed setting without Lossnay or M-NET centralized remote controller" dip switch to ON.

6.4 CO₂ sensor setting - maximum side and minimum side

The upper and lower limit of CO₂ concentration are selectable.

The Lossnay unit controls its fan speed according to the set upper and the lower limit. Refer to the example on below.

Configure the settings from the remote controller CO₂ control screen function settings. For how to configure the setting, refer to the Installation Instructions for the remote controller.

* Upper limit available setting range: 600 (lower limit + 300) to 2000 ppm (increments of 50 ppm)

* Lower limit available setting range: 300 to (upper limit - 300) ppm (increments of 50 ppm)

* This automatically controls the amount of airflow with the set CO₂ concentration as standard, however given that CO₂ concentration detection will differ depending on the usage environment and product installation conditions, the value may exceed upper limit depending on the usage environment .

* If not using a remote controller, automatic airflow control will be carried out at the factory default setting.

* Factory default setting: Upper limit 1000 ppm, lower limit 450 ppm

<Example>

Auto fan speed with the following limits:

CO₂ upper limit: 1000 ppm

CO₂ lower limit: 450 ppm

(Factory setting)

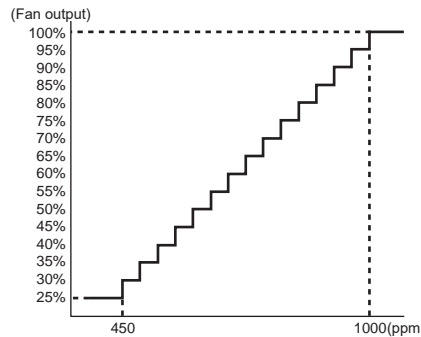

* Fan output is switched in 16 steps for each CO₂ concentration equally divided between 450 ppm (CO₂ lower limit) and 1000 ppm (CO₂ upper limit).

6.5 CO₂ sensor correction

The CO₂ sensor recognizes the lowest CO₂ concentration over the previous week as the standard value (corresponding to normal outside CO₂ concentrations), and carries out calibration. The standard value for calibration is 400 ppm, however if this product is used in locations in which the outside CO₂ concentration is normally higher than the standard value (such as near a major highway), or in an interior environment with higher-than-normal CO₂ concentrations, then there may be a significant discrepancy between the actual CO₂ concentrations and the detected concentrations.

Therefore, configure the concentration correction function for CO₂ sensor output.

For how to configure the setting, refer to "CO₂ sensor correction" in the Installation Instructions for the Lossnay unit.

6.6 CO₂ concentration display setting

When using a remote controller, the CO₂ concentration can be displayed on the applicable Lossnay remote controller screen.

- To set the CO₂ concentration display, refer to the remote controller Installation Manual, and set "Display details setting > Sensor value" to "Yes."
- When displaying the CO₂ concentration, the supply air temperature cannot be displayed at the same time.
- The CO₂ concentration display value may differ from the actual CO₂ concentration within the room. This product cannot be used as a measurement device.
- For approximately 15 minutes after turning the power on, or when changing **6.2 CO₂ sensor setting**, the CO₂ sensor will be in warm-up operation. During warm-up operation, the remote controller CO₂ concentration display will show "---ppm."
- For approximately 15 minutes after starting operation, The CO₂ concentration display value may greatly differ from the actual CO₂ concentration within the room.
- The CO₂ concentration display range is 400 to 2000 ppm. If the concentration exceeds 2000 ppm, "2000 ppm" will be displayed, and if less than 400 ppm, "LO ppm" will be displayed. Additionally, the concentration is displayed in increments of 50 ppm from 400 to 1000 ppm, and increments of 100 ppm from 1000 to 2000 ppm.

6.7 CO₂ concentration correction

The CO₂ sensor detects CO₂ concentration at the RA path in the Lossnay unit and CO₂ concentration within the room varies. Thus, the CO₂ concentration values displayed on the remote controller may differ from CO₂ concentration values detected by environment measuring instruments. If there is a gap between the CO₂ concentration values displayed on the remote controller and the environment measuring instrument, the display can be corrected by the remote controller function setting "CO₂ concentration correction."

7. Trial Operation

Trial operation with the remote controller

Press the ON/OFF button on the Lossnay remote controller, press the **F2** button, and confirm that the remote controller responds in the following order. Confirm that the CO₂ concentration is displayed on the screen. (When CO₂ concentration display is set to "Available")

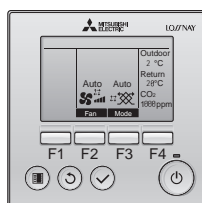

* The airflow scale next to the "Auto" fan speed icon automatically changes according to the fan speed switched by the CO₂ sensor.

- Setting the fan speed to "Auto" will start automatic fan speed control using the CO₂ sensor.
- In order to detect the CO₂ concentration in the room at the start of operation with the "Auto" fan speed, sensing operation is performed at fan speed 4 for about 15 minutes. After sensing is completed, the fan speed is automatically switched according to the CO₂ concentration. The remote controller displays the fan speed on a scale of 1 to 4. For the 16 steps fan speed by the automatic fan speed control:
 - During 25 to 45% fan speed operation, it displays the fan speed on a scale of 1.
 - During 50 to 70% fan speed operation, it displays the fan speed on a scale of 1 and 2.
 - During 75 to 95% fan speed operation, it displays the fan speed on a scale of 1 to 3.
 - During 100% fan speed operation, it displays the airflow on a scale of 1 to 4.
- If a "5501" error is displayed on the remote controller, this may indicate an error in either the CO₂ sensor connection method or the settings method. Check the installation method and wiring diagram, and reinstall.
- For approximately 15 minutes after turning the power on, or when changing **6.2 CO₂ sensor setting**, the CO₂ sensor will be in warm-up operation. During warm-up operation, the Lossnay unit operates at fan speed 4, and the remote controller displays "--- ppm" on the screen regardless of the CO₂ concentration.
- If the CO₂ concentration display does not change for a long period of time, there may be incorrect wiring or broken wiring.

After trial operation, check if there is any abnormality displayed on the remote controller or on the centralized controller, or if the abnormality display LED on the Lossnay unit control board is blinking.

If there is an abnormality displayed, check the installation method and wiring diagram, and reinstall.



Manual Download

Go to the website below to download manuals, select model name, then choose language.



<http://www.mitsubishielectric.com/ldg/ibim/>

MITSUBISHI ELECTRIC CORPORATION

TOKYO BLDG. , 2-7-3, MARUNOUCHI, CHIYODA-KU, TOKYO 100-8310, JAPAN