

PARTS CATALOG

[Model Name]

EHPT17X-VM2D	EHST20D-MED	ERST17D-VM2BD
EHPT17X-VM6D	EHST20D-TM9D	ERST17D-VM2D
EHPT17X-YM9D	EHST20D-VM2D	ERST17D-VM6BD
EHPT20X-MED	EHST20D-VM6D	ERST17D-VM6D
EHPT20X-MHEDW	EHST20D-YM9D	ERST17D-YM9BD
EHPT20X-TM9D	EHST20D-YM9ED	ERST20C-VM2D
EHPT20X-VM6D	EHST30C-MED	ERST20C-VM6D
EHPT20X-YM9D	EHST30C-TM9ED	ERST20C-YM9D
EHPT20X-YM9ED	EHST30C-VM6ED	ERST20D-VM2D
EHPT30X-MED	EHST30C-YM9ED	ERST20D-VM6D
EHPT30X-YM9ED	EHST30D-MED	ERST20D-YM9D
EHST17D-VM2D	EHST30D-TM9ED	ERST30C-VM2ED
EHST17D-YM9D	EHST30D-VM6ED	ERST30C-VM6ED
EHST20C-MED	EHST30D-YM9ED	ERST30C-YM9ED
EHST20C-TM9D	ERPT17X-VM2D	ERST30D-VM2ED
EHST20C-VM2D	ERPT20X-MD	ERST30D-VM6ED
EHST20C-VM6D	ERPT20X-VM2D	ERST30D-YM9ED
EHST20C-YM9D	ERPT20X-VM6D	
EHST20C-YM9ED	ERPT30X-VM2ED	

Revision:

• ERST17D-VM2BD.UK,
ERST17D-VM6BD.UK and
ERST17D-YM9BD.UK
have been added in
REVISED-EDITION-D.

OCB714C is void.

[Service Ref.]

Refer to page 2.

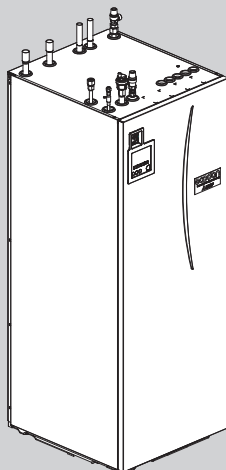
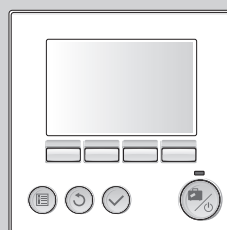
CYLINDER UNIT

**MAIN REMOTE
CONTROLLER**
CONTENTS

1. SERVICE PARTS LIST 4
2. OPTIONAL PARTS 63

SERVICE MANUAL (OCH714)

[Service Ref.]

EHPT17X-VM2D.UK
EHPT17X-VM2DR1.UK
EHPT17X-VM6D.UK
EHPT17X-VM6DR1.UK
EHPT17X-YM9D.UK
EHPT17X-YM9DR1.UK
EHPT20X-MED.UK
EHPT20X-MEDR1.UK
EHPT20X-MHEDW.UK
EHPT20X-MHEDWR1.UK
EHPT20X-TM9D.UK
EHPT20X-TM9DR1.UK
EHPT20X-VM6D.UK
EHPT20X-VM6DR1.UK
EHPT20X-YM9D.UK
EHPT20X-YM9DR1.UK
EHPT20X-YM9ED.UK
EHPT20X-YM9EDR1.UK
EHPT30X-MED.UK
EHPT30X-MEDR1.UK
EHPT30X-YM9ED.UK
EHPT30X-YM9EDR1.UK
EHST17D-VM2D.UK
EHST17D-VM2DR1.UK
EHST17D-YM9DR1.UK
EHST20C-MED.UK
EHST20C-MEDR1.UK
EHST20C-TM9D.UK
EHST20C-TM9DR1.UK
EHST20C-VM2D.UK
EHST20C-VM2DR1.UK
EHST20C-VM6D.UK
EHST20C-VM6DR1.UK
EHST20C-YM9D.UK
EHST20C-YM9DR1.UK
EHST20C-YM9ED.UK
EHST20C-YM9EDR1.UK
EHST20D-MED.UK
EHST20D-MEDR1.UK
EHST20D-TM9D.UK
EHST20D-TM9DR1.UK
EHST20D-VM2D.UK

EHST20D-VM2DR1.UK
EHST20D-VM6D.UK
EHST20D-VM6DR1.UK
EHST20D-YM9D.UK
EHST20D-YM9DR1.UK
EHST20D-YM9ED.UK
EHST20D-YM9EDR1.UK
EHST30C-MED.UK
EHST30C-MEDR1.UK
EHST30C-TM9ED.UK
EHST30C-TM9EDR1.UK
EHST30C-VM6ED.UK
EHST30C-VM6EDR1.UK
EHST30C-YM9ED.UK
EHST30C-YM9EDR1.UK
EHST30D-MED.UK
EHST30D-MEDR1.UK
EHST30D-TM9ED.UK
EHST30D-TM9EDR1.UK
EHST30D-VM6ED.UK
EHST30D-VM6EDR1.UK
EHST30D-YM9ED.UK
EHST30D-YM9EDR1.UK
ERPT17X-VM2D.UK
ERPT17X-VM2DR1.UK
ERPT20X-MD.UK
ERPT20X-MDR1.UK
ERPT20X-VM2D.UK
ERPT20X-VM2DR1.UK
ERPT20X-VM6D.UK
ERPT20X-VM6DR1.UK
ERPT30X-VM2ED.UK
ERPT30X-VM2EDR1.UK
ERPT30X-VM6EDR1.UK
ERST17D-VM2BD.UK
ERST17D-VM2D.UK
ERST17D-VM2DR1.UK
ERST17D-VM6BD.UK
ERST17D-VM6DR1.UK
ERST17D-YM9BD.UK
ERST20C-VM2D.UK
ERST20C-VM2DR1.UK

ERST20C-VM6DR1.UK
ERST20C-YM9DR1.UK
ERST20D-VM2D.UK
ERST20D-VM2DR1.UK
ERST20D-VM6DR1.UK
ERST20D-YM9DR1.UK
ERST30C-VM2ED.UK
ERST30C-VM2EDR1.UK
ERST30C-VM6EDR1.UK
ERST30C-YM9EDR1.UK
ERST30D-VM2ED.UK
ERST30D-VM2EDR1.UK
ERST30D-VM6EDR1.UK
ERST30D-YM9EDR1.UK

This page is intentionally left blank.

1

SERVICE PARTS LIST

EHST17D-VM2D.UK
ERST17D-VM2D.UK
EHST17D-VM2DR1.UK

ERST17D-VM2DR1.UK
EHST17D-YM9DR1.UK
ERST17D-VM6DR1.UK

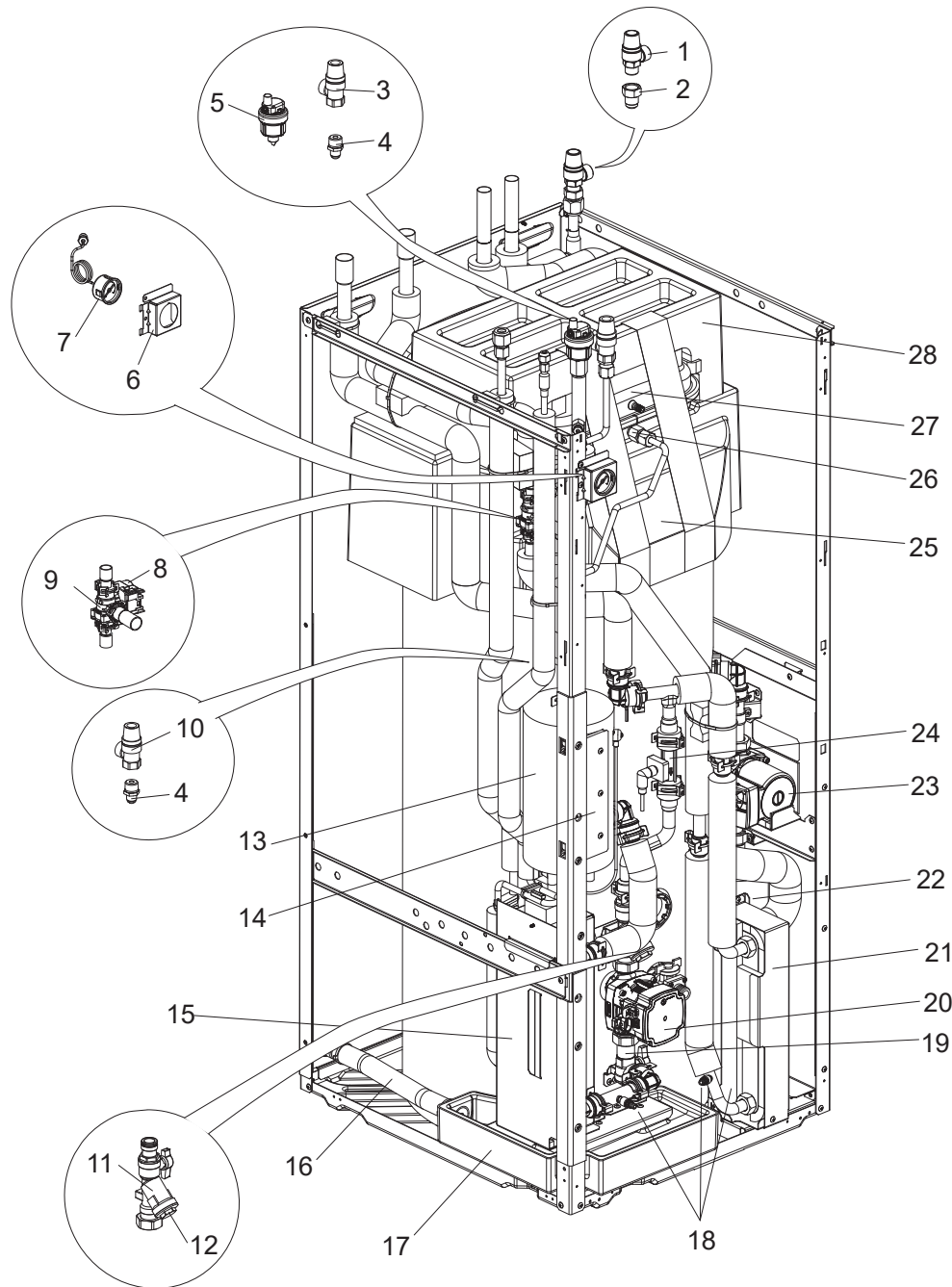

1. The part quantity below indicates the required number of pieces per unit.
2. The circled No. indicates that the part is not shown in the figure

No.	Parts No.	Parts name	EHST17D-VM2D.UK	ERST17D-VM2D.UK	EHST17D-VM2DR1.UK	EHST17D-VM9DR1.UK	ERST17D-VM2DR1.UK	ERST17D-VM6DR1.UK	Wiring Diagram Symbol	Remarks [Drawing No.]
1	S70 C30 404	PRESSURE RELIEF VALVE	1	1	1	1	1	1		10 bar/ FOR SANITARY SIDE
2	S70 C70 096	FLARE JOINT	1	1	1	1	1	1		5/8F-R1/2
3	S70 C21 404	PRESSURE RELIEF VALVE	1	1	1	1	1	1		3 bar
4	S70 C60 096	FLARE JOINT	1	1	2	2	2	2		3/8F-R1/2
5	S70 C18 150	AIR VENT (AUTOMATIC)	1	1	1	1	1	1		
6	S70 C80 206	MANOMETER STAY	1	1	1	1	1	1		
7	S70 C20 205	MANOMETER	1	1	1	1	1	1		
8	S70 C34 406	3WAY VALVE	1	1	1	1	1	1		Small
9	S70 C34 406	3WAY VALVE (MOTOR)	1	1	1	1	1	1		Small
10	S70 C40 404	PRESSURE RELIEF VALVE			1	1	1	1		5 bar
11	S70 C20 452	STRAINER VALVE	1	1	1	1	1	1		
12	S70 C28 460	STRAINER PACKING	1	1	1	1	1	1		
13	S70 C42 441	BOOSTER HEATER	1	1	1		1		BH1	1 ø 230 V 2 kW
13	S70 C43 441	BOOSTER HEATER						1	BH1, BH2	1 ø 230 V 6 kW
13	S70 C44 441	BOOSTER HEATER				1			BH1, BH2	3 ø 400 V 9 kW
14	—	BOOSTER HEATER STAY	1	1	1		1	1		[RK00L196G01]
14	—	BOOSTER HEATER STAY				1				[RK00B922G01]
15	S70 C51 408	WATER COIL ASSY (2HP)	1	1	1	1	1	1		REFRIGERANT/ WATER
16	S70 C10 527	DRAIN HOSE		1			1	1		
17	S70 C20 529	DRAIN PAN ASSY		1			1	1		
18	S70 C10 358	DRAIN COCK/AIR VENT (WATER CAP ASSY 320)	3	3	3	3	3	3		FOR PRIMARY/ SANITARY CIRCUIT
19	S70 C60 356	PUMP VALVE	1	1	1	1	1	1		
20	S70 C11 355	WATER PUMP	1		1	1			UPM3	
20	S70 C13 355	WATER PUMP		1			1	1	UPM3K	FOR PRIMARY CIRCUIT
21	S70 C90 408	WATER COIL ASSY (W)	1	1	1	1	1	1		WATER/ WATER
22	S70 C60 357	SCALE TRAP	1	1	1	1	1	1		
23	S70 C05 355	WATER PUMP	1	1	1	1	1	1	UPSO	FOR SANITARY CIRCUIT
24	S70 C74 266	FLOW SENSOR (body & Cable)	1	1	1	1	1	1		
25	—	TANK CUSHION TOP	1	1	1	1	1	1		[RK25A422G02]
26	S70 C50 096	FLARE JOINT	1	1	1	1	1	1		3/8F-G3/8
27	S70 C15 402	EXPANSION VESSEL	1	1	1	1	1	1		12 L
28	—	EXPANSION VESSEL CUSHION	1	1	1	1	1	1		[RK25A423G01]
29	S70 C69 202	THERMISTOR (FLOW WATER TEMP & RETURN WATER TEMP)	1	1	1	1	1	1		
30	S70 C55 460	GASKET 1"	4	4	4	4	4	4		
31	S70 C66 460	GASKET 3/4"	7	7	7	7	7	7		
32	S70 C77 460	GASKET 3/8"	1	1	1	1	1	1		
33	S70 C88 460	GASKET 1/4"	1	1	1	1	1	1		
34	S70 C23 460	O-RING	18	18	18	18	18	18		BLACK
35	S70 C01 800	GREASE	1*	1*	1*	1*	1*	1*		FOR QUICK CONNECTION
36	S70 C10 465	FASTENER	18	18	18	18	18	18		FOR QUICK CONNECTION
37	S70 C45 097	ADJUST BOLT	4	4	4	4	4	4		ACCESSORY
38	S70 C26 460	O-RING	2	2	2	2	2	2		BLACK/ FOR FLOW SENSOR
39	S70 C30 460	O-RING	4	4	4	4	4	4		BLACK/ FOR 3WAY VALVE/TANK
40	S70 C20 465	FASTENER	2	2	2	2	2	2		FOR FLOW SENSOR
41	S70 C40 465	FASTENER	4	4	4	4	4	4		FOR 3WAY VALVE/TANK

Do not reuse the O-ring or strainer packing that was once removed, but be sure to replace with a new one.
 * Apply grease appropriately on the O-ring for the quick connection in the unit.

ERST17D-VM2BD.UK

ERST17D-VM6BD.UK

ERST17D-YM9BD.UK

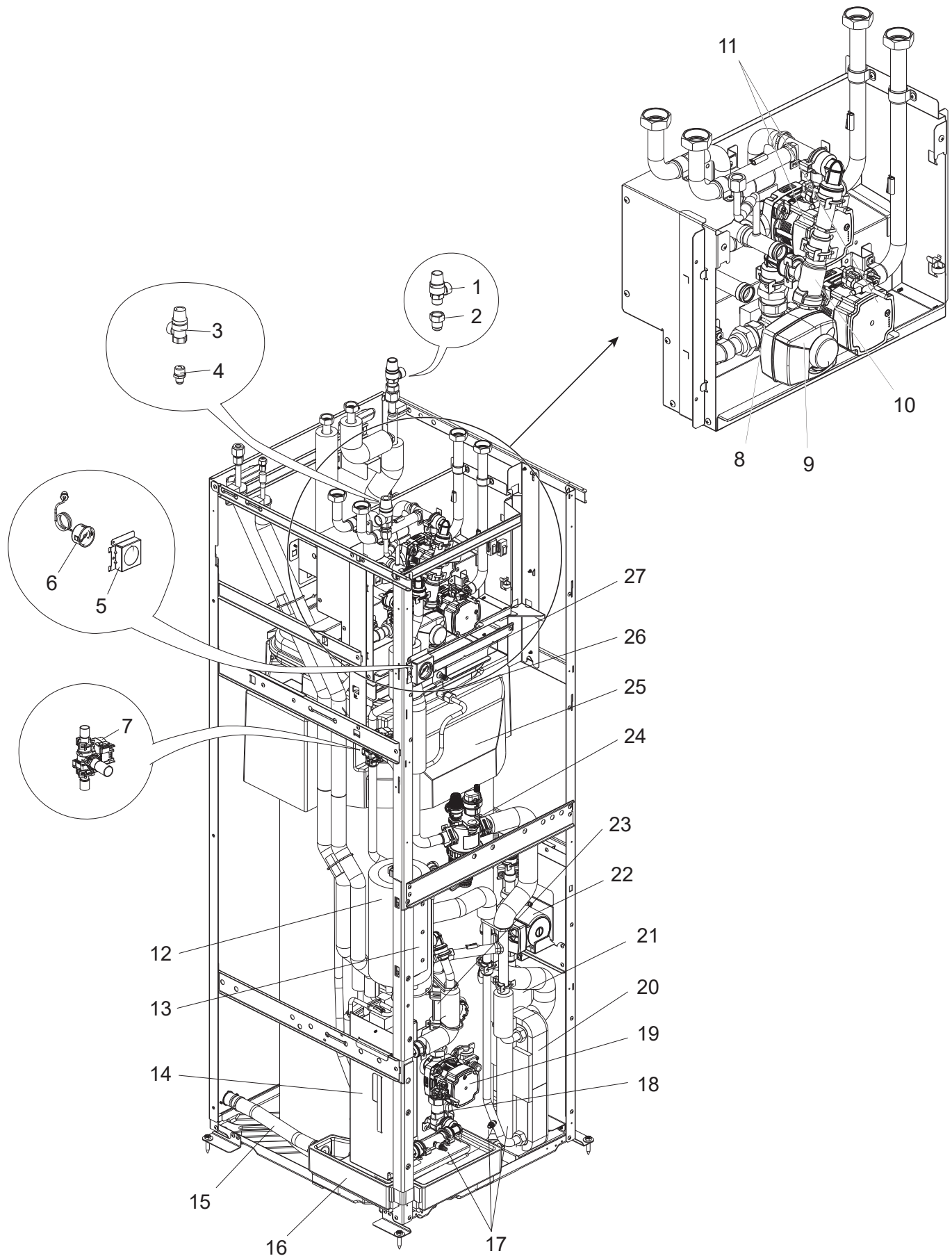

1. The part quantity below indicates the required number of pieces per unit.
2. The circled No. indicates that the part is not shown in the figure

No.	Parts No.	Parts name	ERST17D-VM2BD.UK	ERST17D-VM6BD.UK	ERST17D-VM9BD.UK	Wiring Diagram Symbol	Remarks [Drawing No.]
1	S70 C30 404	PRESSURE RELIEF VALVE	1	1	1		10 bar/ FOR SANITARY SIDE
2	S70 C70 096	FLARE JOINT	1	1	1		5/8F-R1/2
3	S70 C21 404	PRESSURE RELIEF VALVE	1	1	1		3 bar
4	S70 C60 096	FLARE JOINT	2	2	2		3/8F-R1/2
5	S70 C80 206	MANOMETER STAY	1	1	1		
6	S70 C20 205	MANOMETER	1	1	1		
7	S70 C34 406	3WAY VALVE/3WAY VALVE MOTOR	1	1	1		Small
8	S70 C10 206	MIXING VALVE BODY	1	1	1		
9	S70 C10 762	MIXING VALVE MOTOR	1	1	1		
10	S70 C10 500	MAGNETIC FILTER	1	1	1		
11	S70 T19 355	WATER PUMP	2	2	2	UPM3K AUTO 15-70	
12	S70 C42 441	BOOSTER HEATER	1			BH1	1 ø 230 V 2 kW
13	S70 C43 441	BOOSTER HEATER		1		BH1, BH2	1 ø 230 V 6 kW
13	S70 C44 441	BOOSTER HEATER			1	BH1, BH2	3 ø 400 V 9 kW
13	—	BOOSTER HEATER STAY	1	1			[RK00L196G01]
14	—	BOOSTER HEATER STAY			1		[RK00B922G01]
14	S70 C11 408	WATER COIL ASSY (2HP)	1	1	1		REFRIGERANT/ WATER
15	S70 C10 527	DRAIN HOSE	1	1	1		
16	S70 C20 529	DRAIN PAN ASSY	1	1	1		
17	S70 C10 358	DRAIN COCK/AIR VENT (WATER CAP ASSY 320)	3	3	3		FOR PRIMARY/ SANITARY CIRCUIT
18	S70 C60 356	PUMP VALVE	1	1	1		
19	S70 C13 355	WATER PUMP	1	1	1	UPM3K	FOR PRIMARY CIRCUIT
20	S70 C90 408	WATER COIL ASSY (W)	1	1	1		WATER/WATER
21	S70 C60 357	SCALE TRAP	1	1	1		
22	S70 C05 355	WATER PUMP	1	1	1	UPSO	FOR SANITARY CIRCUIT
23	S70 C74 266	FLOW SENSOR (body & Cable)	1	1	1		
24	S70 C01 570	MULTI FUNCTION GROUP	1	1	1		
25	—	TANK CUSHION TOP	1	1	1		[RK25A422G02]
26	S70 C50 096	FLARE JOINT	1	1	1		3/8F-G3/8
27	S70 C15 402	EXPANSION VESSEL	1	1	1		12 L
(28)	S70 C69 202	THERMISTOR (FLOW WATER TEMP & RETURN WATER TEMP)	1	1	1		
(29)	S70 C71 202	THERMISTOR 8P	1	1	1		
(30)	S70 C55 460	GASKET 1"	10	10	10		
(31)	S70 C66 460	GASKET 3/4"	7	7	7		
(32)	S70 C77 460	GASKET 3/8"	1	1	1		
(33)	S70 C88 460	GASKET 1/4"	1	1	1		
(34)	S70 C23 460	O-RING	22	22	22		BLACK
(35)	S70 C01 800	GREASE	1	1	1		FOR QUICK CONNECTION
(36)	S70 C10 465	FASTENER	22	22	22		FOR QUICK CONNECTION
(37)	S70 C45 097	ADJUST BOLT	4	4	4		ACCESSORY
(38)	S70 C26 460	O-RING	4	4	4		BLACK/ FOR FLOW SENSOR
(39)	S70 C30 460	O-RING	4	4	4		FOR 3WAY VALVE/TANK
(40)	S70 C20 465	FASTENER	4	4	4		FOR FLOW SENSOR
(41)	S70 C40 465	FASTENER	4	4	4		FOR 3WAY VALVE/TANK

Do not reuse the O-ring or strainer packing that was once removed, but be sure to replace with a new one.
 * Apply grease appropriately on the O-ring for the quick connection in the unit.

**EHST20D-MED.UK
EHST20D-YM9D.UK
ERST20D-VM2D.UK**

**EHST20D-VM2D.UK
EHST20D-YM9ED.UK**

**EHST20D-VM6D.UK
EHST20D-TM9D.UK**

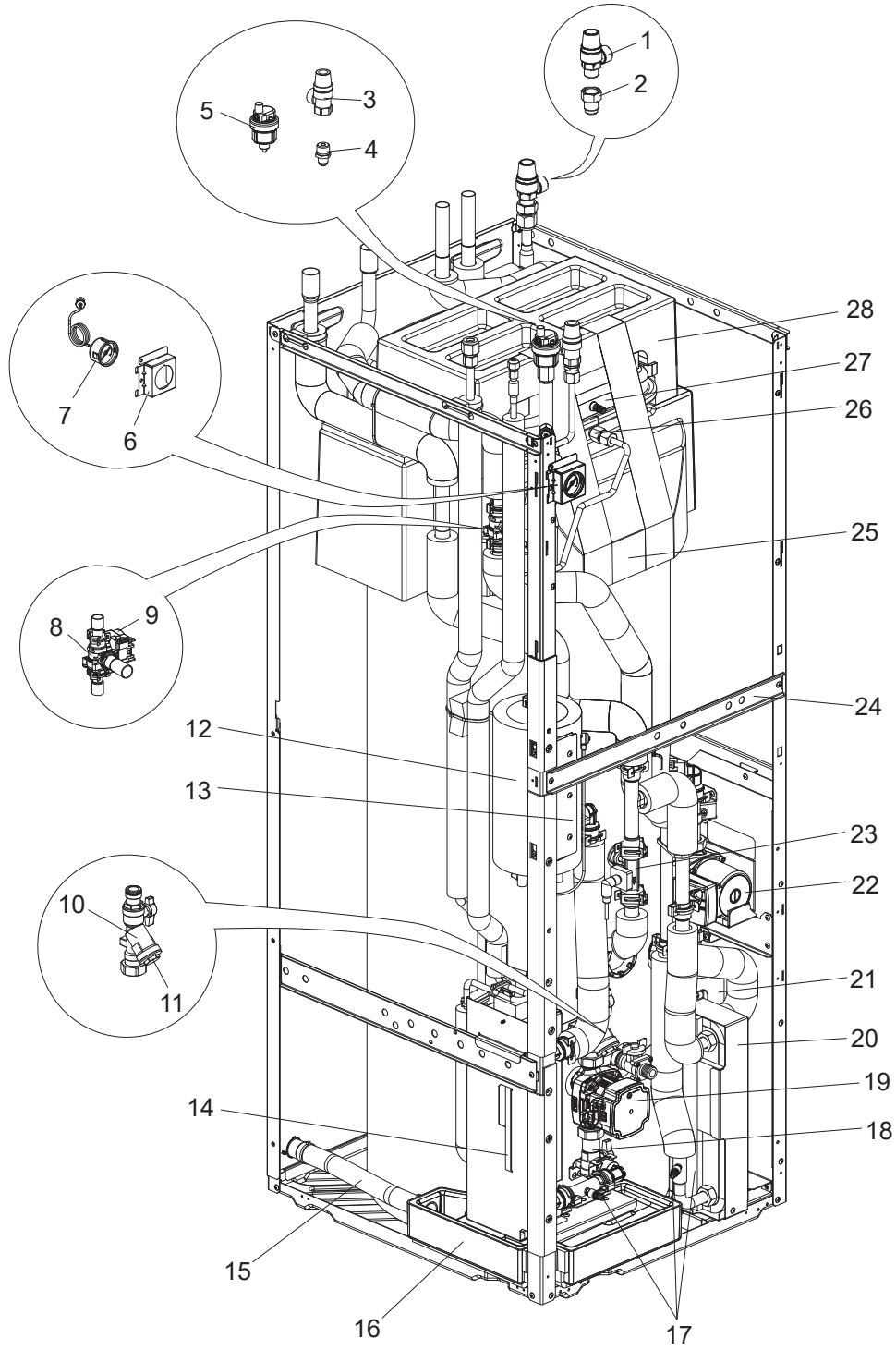

1. The part quantity below indicates the required number of pieces per unit.
2. The circled No. indicates that the part is not shown in the figure.

No.	Parts No.	Parts name	EHST20D-MED.UK	EHST20D-VM2D.UK	EHST20D-VM6D.UK	EHST20D-VM9D.UK	EHST20D-YM9ED.UK	EHST20D-TM9D.UK	ERST20D-VM2D.UK	Wiring Diagram Symbol	Remarks [Drawing No.]
1	S70 C30 404	PRESSURE RELIEF VALVE	1	1	1	1	1	1	1		10 bar/ FOR SANITARY SIDE
2	S70 C70 096	FLARE JOINT	1	1	1	1	1	1	1		5/8F-R1/2
3	S70 C21 404	PRESSURE RELIEF VALVE	1	1	1	1	1	1	1		3 bar
4	S70 C60 096	FLARE JOINT	1	1	1	1	1	1	1		3/8F-R1/2
5	S70 C18 150	AIR VENT (AUTOMATIC)	1	1	1	1	1	1	1		
6	S70 C80 206	MANOMETER STAY	1	1	1	1	1	1	1		
7	S70 C20 205	MANOMETER	1	1	1	1	1	1	1		
8	S70 C34 406	3WAY VALVE	1	1	1	1	1	1	1		Small
9	S70 C34 406	3WAY VALVE (MOTOR)	1	1	1	1	1	1	1		Small
10	S70 C20 452	STRAINER VALVE	1	1	1	1	1	1	1		
11	S70 C28 460	STRAINER PACKING	1	1	1	1	1	1	1		
12	S70 C41 441	BOOSTER HEATER	1								0 kW
12	S70 C42 441	BOOSTER HEATER		1					1	BH1	1 ø 230 V 2 kW
12	S70 C43 441	BOOSTER HEATER			1					BH1, BH2	1 ø 230 V 6 kW
12	S70 C44 441	BOOSTER HEATER				1	1			BH1, BH2	3 ø 400 V 9 kW
12	S70 C45 441	BOOSTER HEATER						1		BH1, BH2	3 ø 230 V 9 kW
13	—	BOOSTER HEATER STAY	1	1	1				1		[RK00L196G01]
13	—	BOOSTER HEATER STAY 9 kW				1	1	1			[RK00B922G01]
14	S70 C61 408	WATER COIL ASSY (2HP)	1	1	1	1	1	1	1		REFRIGERANT/ WATER
15	S70 C10 527	DRAIN HOSE							1		
16	S70 C20 529	DRAIN PAN ASSY							1		
17	S70 C10 358	DRAIN COCK/AIR VENT (WATER CAP ASSY 320)	3	3	3	3	3	3	3		FOR PRIMARY/ SANITARY CIRCUIT
18	S70 C60 356	PUMP VALVE	1	1	1	1	1	1	1		
19	S70 C11 355	WATER PUMP	1	1	1	1	1	1		UPM3	
19	S70 C13 355	WATER PUMP							1	UPM3K	FOR PRIMARY CIRCUIT
20	S70 C90 408	WATER COIL ASSY (W)	1	1	1	1	1	1	1		WATER/ WATER
21	S70 C60 357	SCALE TRAP	1	1	1	1	1	1	1		
22	S70 C05 355	WATER PUMP	1	1	1	1	1	1	1	UPSO	FOR SANITARY CIRCUIT
23	S70 C74 266	FLOW SENSOR (body & Cable)	1	1	1	1	1	1	1		
24	—	DIV FRAME H	1	1	1	1	1	1	1		[BK02N520G03]
25	—	TANK CUSHION TOP	1	1	1	1	1	1	1		[RK25A422G02]
26	S70 C50 096	FLARE JOINT		1	1	1		1	1		3/8F-G3/8
27	S70 C15 402	EXPANSION VESSEL		1	1	1		1	1		12 L
28	—	EXPANSION VESSEL CUSHION	1	1	1	1	1	1	1		[RK25A423G01]
29	S70 C69 202	THERMISTOR (FLOW WATER TEMP & RETURN WATER TEMP)	1	1	1	1	1	1	1		
30	S70 C55 460	GASKET 1"	4	4	4	4	4	4	4		
31	S70 C66 460	GASKET 3/4"	7	7	7	7	7	7	7		
32	S70 C77 460	GASKET 3/8"		1	1	1		1	1		
33	S70 C88 460	GASKET 1/4"	1	1	1	1	1	1	1		
34	S70 C23 460	O-RING	17	17	17	17	17	17	17		BLACK
35	S70 C01 800	GREASE	1*	1*	1*	1*	1*	1*	1*		FOR QUICK CONNECTION
36	S70 C10 465	FASTENER	17	17	17	17	17	17	17		FOR QUICK CONNECTION
37	S70 C45 097	ADJUST BOLT	4	4	4	4	4	4	4		ACCESSORY
38	S70 C26 460	O-RING	2	2	2	2	2	2	2		BLACK/ FOR FLOW SENSOR
39	S70 C30 460	O-RING	4	4	4	4	4	4	4		BLACK/ FOR 3WAY VALVE/TANK
40	S70 C20 465	FASTENER	2	2	2	2	2	2	2		FOR FLOW SENSOR
41	S70 C40 465	FASTENER	4	4	4	4	4	4	4		FOR 3WAY VALVE/TANK

Do not reuse the O-ring or strainer packing that was once removed, but be sure to replace with a new one.

* Apply grease appropriately on the O-ring for the quick connection in the unit.

EHST20D-MEDR1.UK
EHST20D-YM9DR1.UK
ERST20D-VM2DR1.UK

EHST20D-VM2DR1.UK
EHST20D-YM9EDR1.UK
ERST20D-VM6DR1.UK

EHST20D-VM6DR1.UK
EHST20D-TM9DR1.UK
ERST20D-YM9DR1.UK

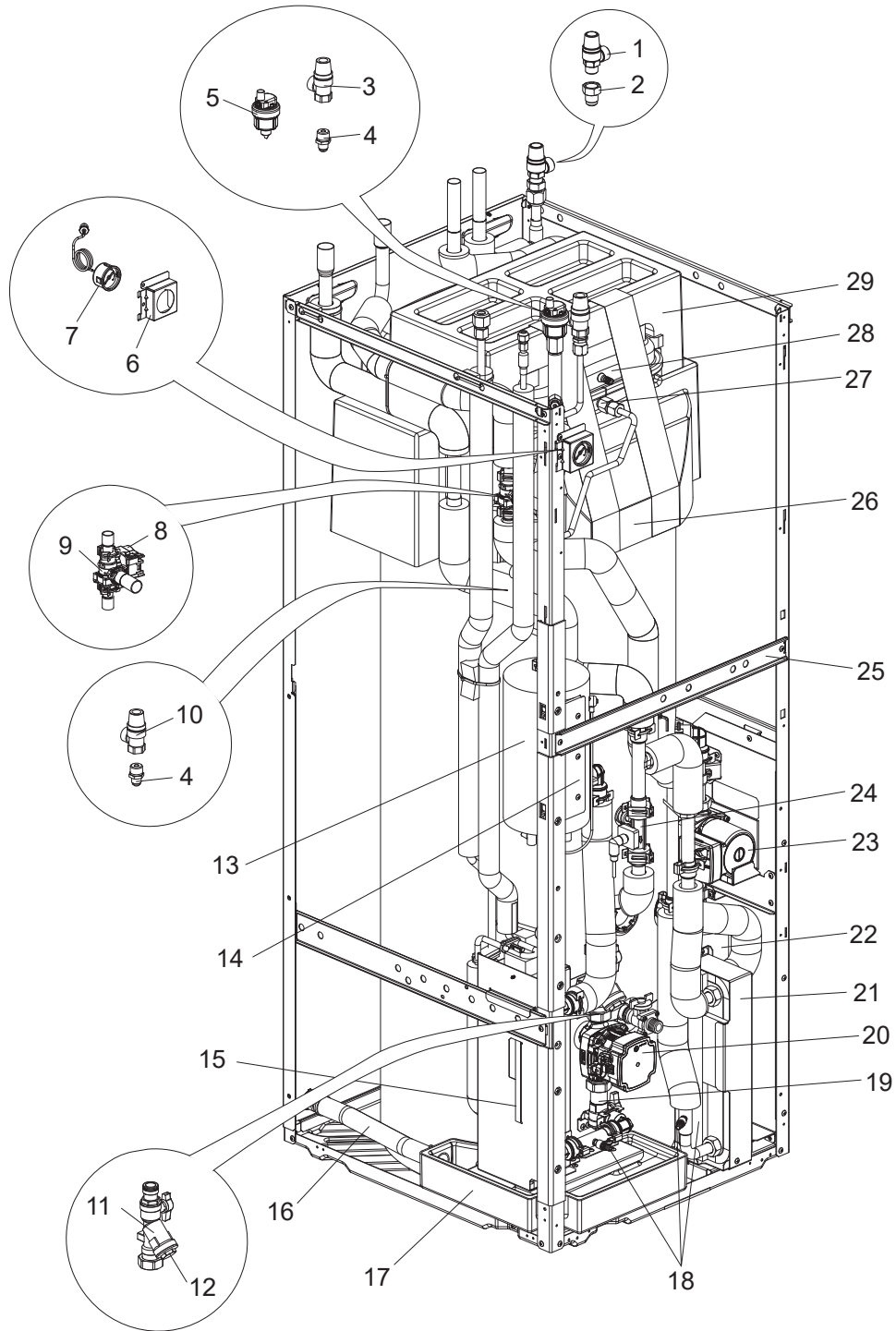

1. The part quantity below indicates the required number of pieces per unit.
2. The circled No. indicates that the part is not shown in the figure.

No.	Parts No.	Parts name	EHST20D-MEDR1.UK	EHST20D-VM2DR1.UK	EHST20D-VM6DR1.UK	EHST20D-VM9DR1.UK	EHST20D-VM9EDR1.UK	EHST20D-TM9DR1.UK	ERST20D-VM2DR1.UK	ERST20D-VM6DR1.UK	ERST20D-VM9DR1.UK	Wiring Diagram Symbol	Remarks [Drawing No.]
			1	1	1	1	1	1	1	1	1		
1	S70 C30 404	PRESSURE RELIEF VALVE	1	1	1	1	1	1	1	1	1		10 bar/ FOR SANITARY SIDE
2	S70 C70 096	FLARE JOINT	1	1	1	1	1	1	1	1	1		5/8F-R1/2
3	S70 C21 404	PRESSURE RELIEF VALVE	1	1	1	1	1	1	1	1	1		3 bar
4	S70 C60 096	FLARE JOINT	1	2	2	2	1	2	2	2	2		3/8F-R1/2
5	S70 C18 150	AIR VENT (AUTOMATIC)	1	1	1	1	1	1	1	1	1		
6	S70 C80 206	MANOMETER STAY	1	1	1	1	1	1	1	1	1		
7	S70 C20 205	MANOMETER	1	1	1	1	1	1	1	1	1		
8	S70 C34 406	3WAY VALVE	1	1	1	1	1	1	1	1	1		Small
9	S70 C34 406	3WAY VALVE (MOTOR)	1	1	1	1	1	1	1	1	1		Small
10	S70 C40 404	PRESSURE RELIEF VALVE		1	1	1			1	1	1		5 bar
11	S70 C20 452	STRAINER VALVE	1	1	1	1	1	1	1	1	1		
12	S70 C28 460	STRAINER PACKING	1	1	1	1	1	1	1	1	1		
13	S70 C41 441	BOOSTER HEATER	1										0 kW
13	S70 C42 441	BOOSTER HEATER		1						1		BH1	1 ø 230 V 2 kW
13	S70 C43 441	BOOSTER HEATER			1						1	BH1, BH2	1 ø 230 V 6 kW
13	S70 C44 441	BOOSTER HEATER				1	1					BH1, BH2	3 ø 400 V 9 kW
13	S70 C45 441	BOOSTER HEATER						1				BH1, BH2	3 ø 230 V 9 kW
14	—	BOOSTER HEATER STAY	1	1	1				1	1			[RK00L196G01]
14	—	BOOSTER HEATER STAY 9 kW				1	1	1			1		[RK00B922G01]
15	S70 C61 408	WATER COIL ASSY (2HP)	1	1	1	1	1	1	1	1	1		REFRIGERANT/ WATER
16	S70 C10 527	DRAIN HOSE							1	1	1		
17	S70 C20 529	DRAIN PAN ASSY							1	1	1		
18	S70 C10 358	DRAIN COCK/AIR VENT (WATER CAP ASSY 320)	3	3	3	3	3	3	3	3	3		FOR PRIMARY/ SANITARY CIRCUIT
19	S70 C60 356	PUMP VALVE	1	1	1	1	1	1	1	1	1		
20	S70 C11 355	WATER PUMP	1	1	1	1	1	1				UPM3	
20	S70 C13 355	WATER PUMP							1	1	1	UPM3K	FOR PRIMARY CIRCUIT
21	S70 C90 408	WATER COIL ASSY (W)	1	1	1	1	1	1	1	1	1		WATER/ WATER
22	S70 C60 357	SCALE TRAP	1	1	1	1	1	1	1	1	1		
23	S70 C05 355	WATER PUMP	1	1	1	1	1	1	1	1	1	UPSO	FOR SANITARY CIRCUIT
24	S70 C74 266	FLOW SENSOR (body & Cable)	1	1	1	1	1	1	1	1	1		
25	—	DIV FRAME H	1	1	1	1	1	1	1	1	1		[BK02N520G03]
26	—	TANK CUSHION TOP	1	1	1	1	1	1	1	1	1		[RK25A422G02]
27	S70 C50 096	FLARE JOINT		1	1	1			1	1	1		3/8F-G3/8
28	S70 C15 402	EXPANSION VESSEL		1	1	1			1	1	1		12 L
29	—	EXPANSION VESSEL CUSHION		1	1	1			1	1	1		[RK25A423G01]
30	S70 C69 202	THERMISTOR (FLOW WATER TEMP & RETURN WATER TEMP)	1	1	1	1	1	1	1	1	1		
31	S70 C55 460	GASKET 1"	4	4	4	4	4	4	4	4	4		
32	S70 C66 460	GASKET 3/4"	7	7	7	7	7	7	7	7	7		
33	S70 C77 460	GASKET 3/8"		1	1	1			1	1	1		
34	S70 C88 460	GASKET 1/4"	1	1	1	1	1	1	1	1	1		
35	S70 C23 460	O-RING	17	17	17	17	17	17	17	17	17		BLACK
36	S70 C01 800	GREASE	1*	1*	1*	1*	1*	1*	1*	1*	1*		FOR QUICK CONNECTION
37	S70 C10 465	FASTENER	17	17	17	17	17	17	17	17	17		FOR QUICK CONNECTION
38	S70 C45 097	ADJUST BOLT	4	4	4	4	4	4	4	4	4		ACCESSORY
39	S70 C26 460	O-RING	2	2	2	2	2	2	2	2	2		BLACK/ FOR FLOW SENSOR
40	S70 C30 460	O-RING	4	4	4	4	4	4	4	4	4		BLACK/ FOR 3WAY VALVE/TANK
41	S70 C20 465	FASTENER	2	2	2	2	2	2	2	2	2		FOR FLOW SENSOR
42	S70 C40 465	FASTENER	4	4	4	4	4	4	4	4	4		FOR 3WAY VALVE/TANK

Do not reuse the O-ring or strainer packing that was once removed, but be sure to replace with a new one.

* Apply grease appropriately on the O-ring for the quick connection in the unit.

EHST30D-MED.UK
EHST30D-TM9ED.UK

EHST30D-VM6ED.UK
ERST30D-VM2ED.UK

EHST30D-YM9ED.UK

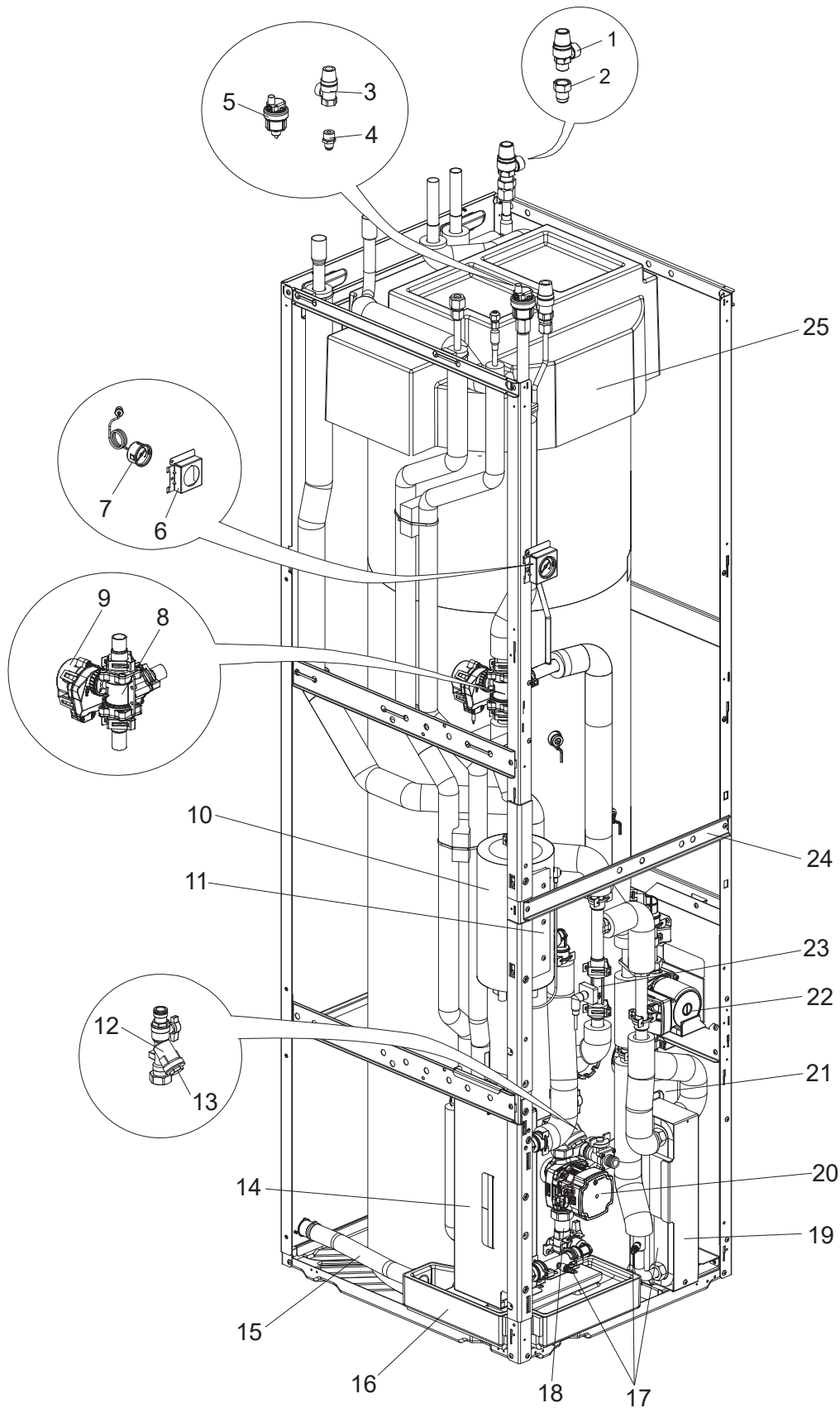

1. The part quantity below indicates the required number of pieces per unit.
2. The circled No. indicates that the part is not shown in the figure.

No.	Parts No.	Parts name						Wiring Diagram Symbol	Remarks [Drawing No.]
			EHST30D-MED.UK	EHST30D-VM6ED.UK	EHST30D-YM9ED.UK	EHST30D-TM9ED.UK	ERST30D-VM2ED.UK		
1	S70 C30 404	PRESSURE RELIEF VALVE	1	1	1	1	1		10 bar/ FOR SANITARY SIDE
2	S70 C70 096	FLARE JOINT	1	1	1	1	1		5/8F-R1/2
3	S70 C21 404	PRESSURE RELIEF VALVE	1	1	1	1	1		3 bar
4	S70 C60 096	FLARE JOINT	1	1	1	1	1		3/8F-R1/2
5	S70 C18 150	AIR VENT (AUTOMATIC)	1	1	1	1	1		
6	S70 C80 206	MANOMETER STAY	1	1	1	1	1		
7	S70 C20 205	MANOMETER	1	1	1	1	1		
8	S70 C45 762	3WAY VALVE	1	1	1	1	1		Large
9	S70 C45 762	3WAY VALVE (MOTOR)	1	1	1	1	1		Large
10	S70 C41 441	BOOSTER HEATER	1						0 kW
10	S70 C42 441	BOOSTER HEATER					1	BH1	1 ø 230 V 2 kW
10	S70 C43 441	BOOSTER HEATER		1				BH1, BH2	1 ø 230 V 6 kW
10	S70 C44 441	BOOSTER HEATER			1			BH1, BH2	3 ø 400 V 9 kW
10	S70 C45 441	BOOSTER HEATER				1		BH1, BH2	3 ø 230 V 9 kW
11	—	BOOSTER HEATER STAY	1	1			1		[RK00L196G01]
11	—	BOOSTER HEATER STAY 9kW			1	1			[RK00B922G01]
12	S70 C20 452	STRAINER VALVE	1	1	1	1	1		
13	S70 C28 460	STRAINER PACKING	1	1	1	1	1		
14	S70 C71 408	WATER COIL ASSY (2HP)	1	1	1	1	1		REFRIGERANT/ WATER
15	S70 C10 527	DRAIN HOSE					1		
16	S70 C20 529	DRAIN PAN ASSY					1		
17	S70 C10 358	DRAIN COCK/AIR VENT (WATER CAP ASSY 320)	3	3	3	3	3		FOR PRIMARY/ SANITARY CIRCUIT
18	S70 C60 356	PUMP VALVE	1	1	1	1	1		
19	S70 C85 408	WATER COIL ASSY (W)	1	1	1	1	1		WATER/ WATER
20	S70 C11 355	WATER PUMP	1	1	1	1		UPM3	FOR PRIMARY CIRCUIT
20	S70 C13 355	WATER PUMP					1	UPM3K	
21	S70 C60 357	SCALE TRAP	1	1	1	1	1		
22	S70 C05 355	WATER PUMP	1	1	1	1	1	UPSO	FOR SANITARY CIRCUIT
23	S70 C74 266	FLOW SENSOR (body & Cable)	1	1	1	1	1		
24	—	DIV FRAME H	1	1	1	1	1		[BK02N520G03]
25	—	TANK CUSHION TOP	1	1	1	1	1		[RK25A412G02]
(26)	S70 C69 202	THERMISTOR (FLOW WATER TEMP & RETURN WATER TEMP)	1	1	1	1	1		
(27)	S70 C55 460	GASKET 1"	4	4	4	4	4		
(28)	S70 C66 460	GASKET 3/4"	7	7	7	7	7		
(29)	S70 C88 460	GASKET 1/4"	1	1	1	1	1		
(30)	S70 C23 460	O-RING	18	18	18	18	18		BLACK
(31)	S70 C01 800	GREASE	1*	1*	1*	1*	1*		FOR QUICK CONNECTION
(32)	S70 C10 465	FASTENER	18	18	18	18	18		FOR QUICK CONNECTION
(33)	S70 C45 097	ADJUST BOLT	4	4	4	4	4		ACCESSORY
(34)	S70 C26 460	O-RING	5	5	5	5	5		BLACK/ FOR FLOW SENSOR/3WAY VALVE
(35)	S70 C30 460	O-RING	1	1	1	1	1		BLACK/ FOR TANK
(36)	S70 C20 465	FASTENER	5	5	5	5	5		FOR FLOW SENSOR/ 3WAY VALVE
(37)	S70 C40 465	FASTENER	1	1	1	1	1		FOR TANK

Do not reuse the O-ring or strainer packing that was once removed, but be sure to replace with a new one.

* Apply grease appropriately on the O-ring for the quick connection in the unit.

EHST30D-MEDR1.UK
EHST30D-TM9EDR1.UK
ERST30D-YM9EDR1.UK

EHST30D-VM6EDR1.UK
ERST30D-VM2EDR1.UK

EHST30D-YM9EDR1.UK
ERST30D-VM6EDR1.UK

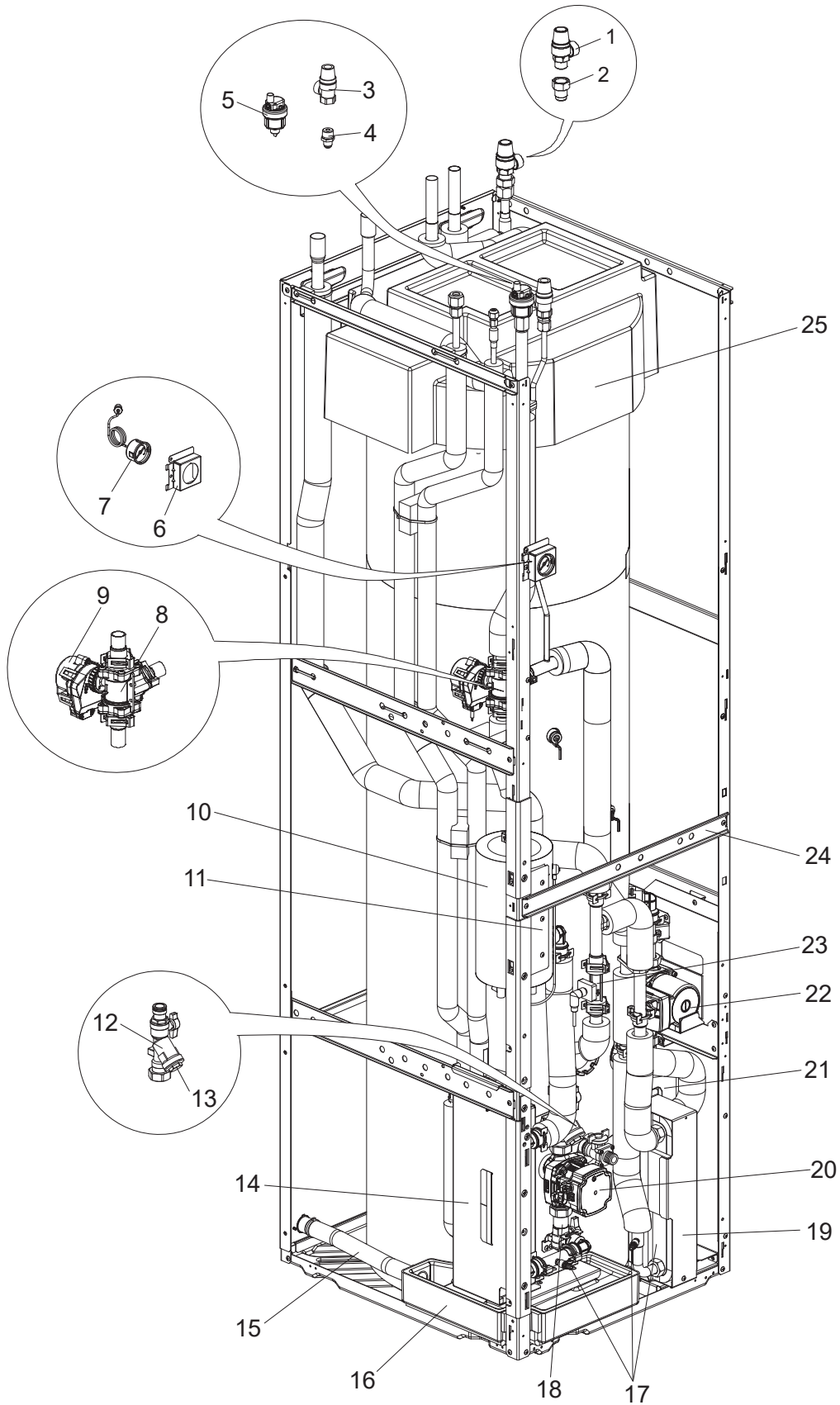

1. The part quantity below indicates the required number of pieces per unit.
2. The circled No. indicates that the part is not shown in the figure.

No.	Parts No.	Parts name								Wiring Diagram Symbol	Remarks [Drawing No.]
			EHST30D-MEDR1.UK	EHST30D-VM6EDR1.UK	EHST30D-YM9EDR1.UK	EHST30D-TM9EDR1.UK	ERST30D-VM2EDR1.UK	ERST30D-VM6EDR1.UK	ERST30D-YM9EDR1.UK		
1	S70 C30 404	PRESSURE RELIEF VALVE	1	1	1	1	1	1	1		10 bar/ FOR SANITARY SIDE
2	S70 C70 096	FLARE JOINT	1	1	1	1	1	1	1		5/8F-R1/2
3	S70 C21 404	PRESSURE RELIEF VALVE	1	1	1	1	1	1	1		3 bar
4	S70 C60 096	FLARE JOINT	1	1	1	1	1	1	1		3/8F-R1/2
5	S70 C18 150	AIR VENT (AUTOMATIC)	1	1	1	1	1	1	1		
6	S70 C80 206	MANOMETER STAY	1	1	1	1	1	1	1		
7	S70 C20 205	MANOMETER	1	1	1	1	1	1	1		
8	S70 C45 762	3WAY VALVE	1	1	1	1	1	1	1		Large
9	S70 C45 762	3WAY VALVE (MOTOR)	1	1	1	1	1	1	1		Large
10	S70 C41 441	BOOSTER HEATER	1								0 kW
10	S70 C42 441	BOOSTER HEATER					1			BH1	1 ø 230 V 2 kW
10	S70 C43 441	BOOSTER HEATER		1				1		BH1, BH2	1 ø 230 V 6 kW
10	S70 C44 441	BOOSTER HEATER			1				1	BH1, BH2	3 ø 400 V 9 kW
10	S70 C45 441	BOOSTER HEATER				1				BH1, BH2	3 ø 230 V 9 kW
11	—	BOOSTER HEATER STAY	1	1			1	1			[RK00L196G01]
11	—	BOOSTER HEATER STAY 9kW			1	1			1		[RK00B922G01]
12	S70 C20 452	STRAINER VALVE	1	1	1	1	1	1	1		
13	S70 C28 460	STRAINER PACKING	1	1	1	1	1	1	1		
14	S70 C71 408	WATER COIL ASSY (2HP)	1	1	1	1	1	1	1		REFRIGERANT/ WATER
15	S70 C10 527	DRAIN HOSE					1	1	1		
16	S70 C20 529	DRAIN PAN ASSY					1	1	1		
17	S70 C10 358	DRAIN COCK/AIR VENT (WATER CAP ASSY 320)	3	3	3	3	3	3	3		FOR PRIMARY/ SANITARY CIRCUIT
18	S70 C60 356	PUMP VALVE	1	1	1	1	1	1	1		
19	S70 C85 408	WATER COIL ASSY (W)	1	1	1	1	1	1	1		WATER/ WATER
20	S70 C11 355	WATER PUMP	1	1	1	1				UPM3	FOR PRIMARY CIRCUIT
20	S70 C13 355	WATER PUMP					1	1	1	UPM3K	
21	S70 C60 357	SCALE TRAP	1	1	1	1	1	1	1		
22	S70 C05 355	WATER PUMP	1	1	1	1	1	1	1	UPSO	FOR SANITARY CIRCUIT
23	S70 C74 266	FLOW SENSOR (body & Cable)	1	1	1	1	1	1	1		
24	—	DIV FRAME H	1	1	1	1	1	1	1		[BK02N520G03]
25	—	TANK CUSHION TOP	1	1	1	1	1	1	1		[RK25A412G01]
26	S70 C69 202	THERMISTOR (FLOW WATER TEMP & RETURN WATER TEMP)	1	1	1	1	1	1	1		
27	S70 C55 460	GASKET 1"	4	4	4	4	4	4	4		
28	S70 C66 460	GASKET 3/4"	7	7	7	7	7	7	7		
29	S70 C88 460	GASKET 1/4"	1	1	1	1	1	1	1		
30	S70 C23 460	O-RING	18	18	18	18	18	18	18		BLACK
31	S70 C01 800	GREASE	1*	1*	1*	1*	1*	1*	1*		FOR QUICK CONNECTION
32	S70 C10 465	FASTENER	18	18	18	18	18	18	18		FOR QUICK CONNECTION
33	S70 C45 097	ADJUST BOLT	4	4	4	4	4	4	4		ACCESSORY
34	S70 C26 460	O-RING	5	5	5	5	5	5	5		BLACK/ FOR FLOW SENSOR/3WAY VALVE
35	S70 C30 460	O-RING	1	1	1	1	1	1	1		BLACK/ FOR TANK
36	S70 C20 465	FASTENER	5	5	5	5	5	5	5		FOR FLOW SENSOR/ 3WAY VALVE
37	S70 C40 465	FASTENER	1	1	1	1	1	1	1		FOR TANK

Do not reuse the O-ring or strainer packing that was once removed, but be sure to replace with a new one.
 * Apply grease appropriately on the O-ring for the quick connection in the unit.

EHST20C-MED.UK
EHST20C-YM9D.UK
ERST20C-VM2D.UK

EHST20C-VM2D.UK
EHST20C-YM9ED.UK

EHST20C-VM6D.UK
EHST20C-TM9D.UK

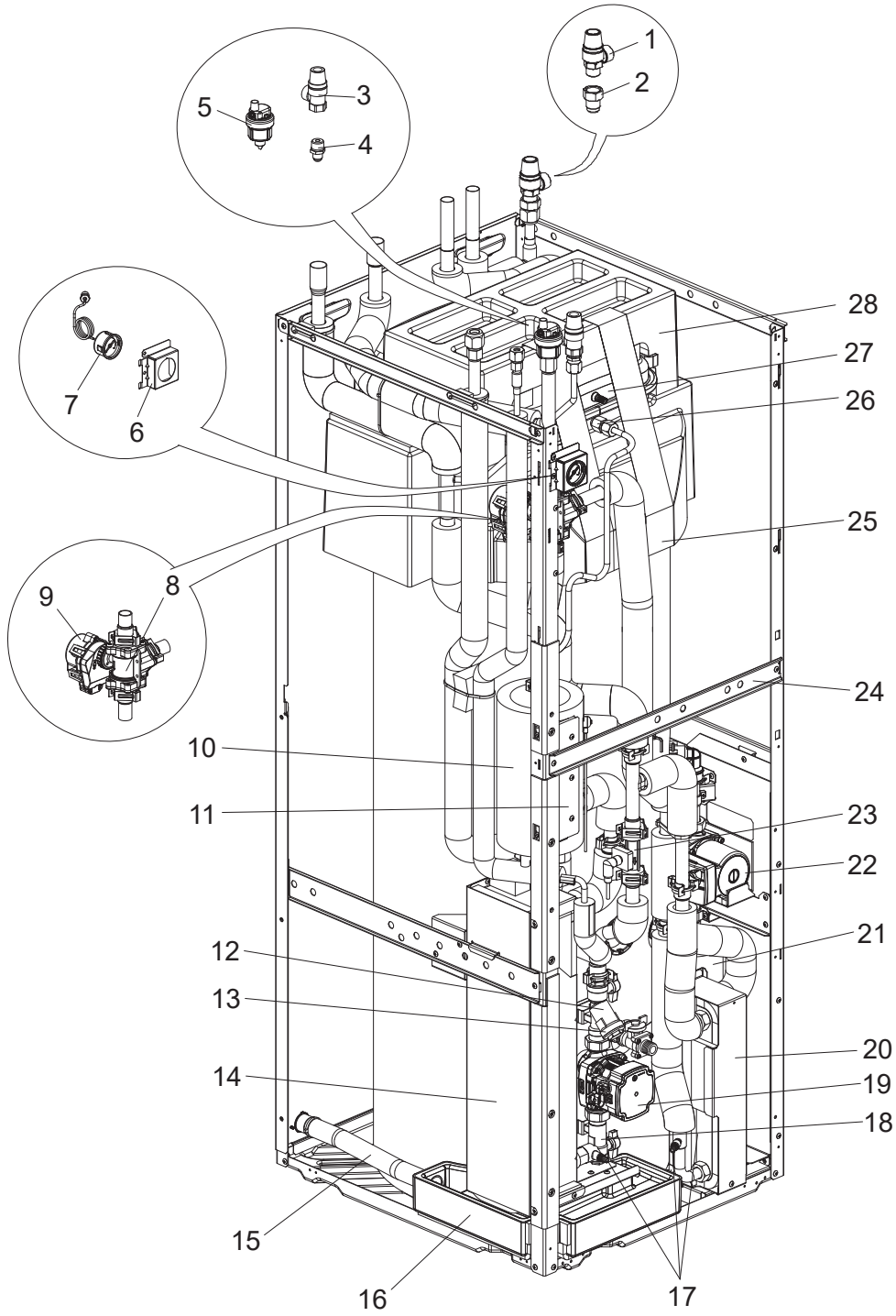

1. The part quantity below indicates the required number of pieces per unit.
2. The circled No. indicates that the part is not shown in the figure.

No.	Parts No.	Parts name	EHST20C-MED.UK	EHST20C-VM2D.UK	EHST20C-VM6D.UK	EHST20C-YM9D.UK	EHST20C-YM9ED.UK	EHST20C-TM9D.UK	ERST20C-VM2D.UK	Wiring Diagram Symbol	Remarks [Drawing No.]
1	S70 C30 404	PRESSURE RELIEF VALVE	1	1	1	1	1	1	1		10 bar/ FOR SANITARY SIDE
2	S70 C70 096	FLARE JOINT	1	1	1	1	1	1	1		5/8F-R1/2
3	S70 C21 404	PRESSURE RELIEF VALVE	1	1	1	1	1	1	1		3 bar
4	S70 C60 096	FLARE JOINT	1	1	1	1	1	1	1		3/8F-R1/2
5	S70 C18 150	AIR VENT (AUTOMATIC)	1	1	1	1	1	1	1		
6	S70 C80 206	MANOMETER STAY	1	1	1	1	1	1	1		
7	S70 C20 205	MANOMETER	1	1	1	1	1	1	1		
8	S70 C45 762	3WAY VALVE	1	1	1	1	1	1	1		Large
9	S70 C45 762	3WAY VALVE (MOTOR)	1	1	1	1	1	1	1		Large
10	S70 C41 441	BOOSTER HEATER	1								0 kW
10	S70 C42 441	BOOSTER HEATER		1					1	BH1	1 ø 230 V 2 kW
10	S70 C43 441	BOOSTER HEATER			1					BH1, BH2	1 ø 230 V 6 kW
10	S70 C44 441	BOOSTER HEATER				1	1			BH1, BH2	3 ø 400 V 9 kW
10	S70 C45 441	BOOSTER HEATER						1		BH1, BH2	3 ø 230 V 9 kW
11	—	BOOSTER HEATER STAY	1	1	1				1		[RK00L196G01]
11	—	BOOSTER HEATER STAY 9 kW				1	1	1			[RK00B922G01]
12	S70 C20 452	STRAINER VALVE	1	1	1	1	1	1	1		
13	S70 C28 460	STRAINER PACKING	1	1	1	1	1	1	1		
14	S70 C81 408	WATER COIL ASSY (5HP)	1	1	1	1	1	1	1		REFRIGERANT/ WATER
15	S70 C10 527	DRAIN HOSE							1		
16	S70 C20 529	DRAIN PAN ASSY							1		
17	S70 C10 358	DRAIN COCK/AIR VENT (WATER CAP ASSY 320)	3	3	3	3	3	3	3		FOR PRIMARY/ SANITARY CIRCUIT
18	S70 C20 356	PUMP VALVE	1	1	1	1	1	1	1		
19	S70 C11 355	WATER PUMP	1	1	1	1	1	1		UPM3	FOR PRIMARY CIRCUIT
19	S70 C13 355	WATER PUMP							1	UPM3K	
20	S70 C85 408	WATER COIL ASSY (W)	1	1	1	1	1	1	1		WATER/ WATER
21	S70 C60 357	SCALE TRAP	1	1	1	1	1	1	1		
22	S70 C05 355	WATER PUMP	1	1	1	1	1	1	1	UPSO	FOR SANITARY CIRCUIT
23	S70 C74 266	FLOW SENSOR (body & Cable)	1	1	1	1	1	1	1		
24	—	DIV FRAME H	1	1	1	1	1	1	1		[BK02N520G03]
25	—	TANK CUSHION TOP	1	1	1	1	1	1	1		[RK25A422G02]
26	S70 C50 096	FLARE JOINT		1	1	1		1	1		3/8F-G3/8
27	S70 C15 402	EXPANSION VESSEL		1	1	1		1	1		12 L
28	—	EXPANSION VESSEL CUSHION	1	1	1	1	1	1	1		[RK25A423G01]
29	S70 C69 202	THERMISTOR (FLOW WATER TEMP & RETURN WATER TEMP)	1	1	1	1	1	1	1		
30	S70 C55 460	GASKET 1"	4	4	4	4	4	4	4		
31	S70 C66 460	GASKET 3/4"	7	7	7	7	7	7	7		
32	S70 C77 460	GASKET 3/8"		1	1	1		1	1		
33	S70 C88 460	GASKET 1/4"	1	1	1	1	1	1	1		
34	S70 C23 460	O-RING	13	13	13	13	13	13	13		BLACK
35	S70 C01 800	GREASE	1*	1*	1*	1*	1*	1*	1*		FOR QUICK CONNECTION
36	S70 C10 465	FASTENER	13	13	13	13	13	13	17		FOR QUICK CONNECTION
37	S70 C45 097	ADJUST BOLT	4	4	4	4	4	4	4		ACCESSORY
38	S70 C26 460	O-RING	5	5	5	5	5	5	5		BLACK/ FOR FLOW SENSOR/3WAY VALVE
39	S70 C30 460	O-RING	1	1	1	1	1	1	1		BLACK/ FOR TANK
40	S70 C20 465	FASTENER	5	5	5	5	5	5	5		FOR FLOW SENSOR/ 3WAY VALVE
41	S70 C40 465	FASTENER	1	1	1	1	1	1	1		FOR TANK

Do not reuse the O-ring or strainer packing that was once removed, but be sure to replace with a new one.

* Apply grease appropriately on the O-ring for the quick connection in the unit.

EHST20C-MEDR1.UK
EHST20C-YM9DR1.UK
ERST20C-VM2DR1.UK

EHST20C-VM2DR1.UK
EHST20C-YM9EDR1.UK
ERST20C-VM6DR1.UK

EHST20C-VM6DR1.UK
EHST20C-TM9DR1.UK
ERST20C-YM9DR1.UK

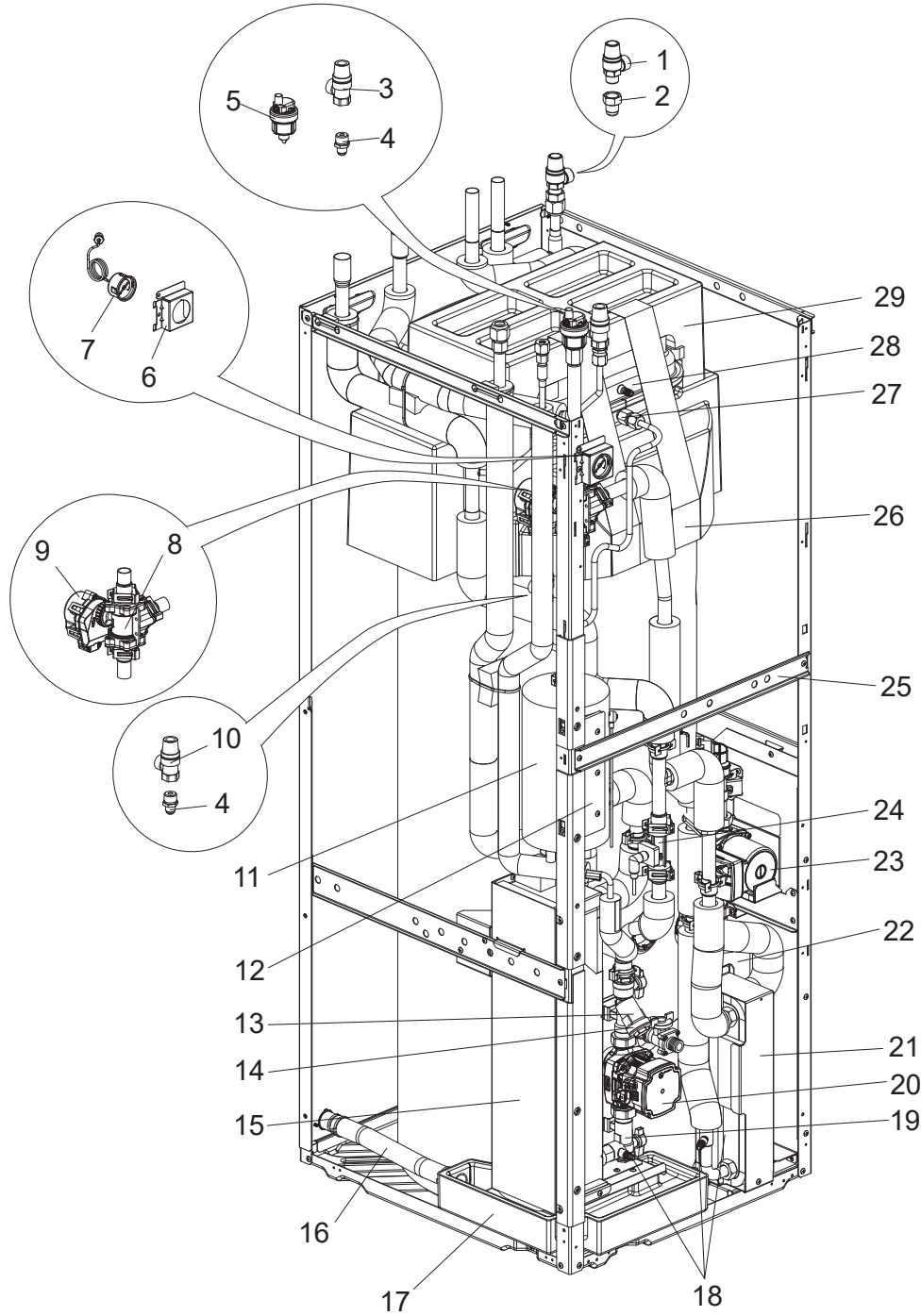

1. The part quantity below indicates the required number of pieces per unit.
2. The circled No. indicates that the part is not shown in the figure.

No.	Parts No.	Parts name	EHST20C-MEDR1.UK	EHST20C-VM2DR1.UK	EHST20C-VM6DR1.UK	EHST20C-VM9DR1.UK	EHST20C-VM9EDR1.UK	EHST20C-TM9DR1.UK	ERST20C-VM2DR1.UK	ERST20C-VM6DR1.UK	ERST20C-VM9DR1.UK	Wiring Diagram Symbol	Remarks [Drawing No.]
1	S70 C30 404	PRESSURE RELIEF VALVE	1	1	1	1	1	1	1	1	1		10 bar/ FOR SANITARY SIDE
2	S70 C70 096	FLARE JOINT	1	1	1	1	1	1	1	1	1		5/8F-R1/2
3	S70 C21 404	PRESSURE RELIEF VALVE	1	1	1	1	1	1	1	1	1		3 bar
4	S70 C60 096	FLARE JOINT	1	2	2	2	1	2	2	2	2		3/8F-R1/2
5	S70 C18 150	AIR VENT (AUTOMATIC)	1	1	1	1	1	1	1	1	1		
6	S70 C80 206	MANOMETER STAY	1	1	1	1	1	1	1	1	1		
7	S70 C20 205	MANOMETER	1	1	1	1	1	1	1	1	1		
8	S70 C45 762	3WAY VALVE	1	1	1	1	1	1	1	1	1		Large
9	S70 C45 762	3WAY VALVE (MOTOR)	1	1	1	1	1	1	1	1	1		Large
10	S70 C40 404	PRESSURE RELIEF VALVE		1	1	1		1	1	1	1		5 bar
11	S70 C41 441	BOOSTER HEATER	1										0 kW
11	S70 C42 441	BOOSTER HEATER		1					1			BH1	1 ø 230 V 2 kW
11	S70 C43 441	BOOSTER HEATER			1					1		BH1, BH2	1 ø 230 V 6 kW
11	S70 C44 441	BOOSTER HEATER				1	1				1	BH1, BH2	3 ø 400 V 9 kW
11	S70 C45 441	BOOSTER HEATER						1				BH1, BH2	3 ø 230 V 9 kW
12	—	BOOSTER HEATER STAY	1	1	1				1	1			[RK00L196G01]
12	—	BOOSTER HEATER STAY 9 kW				1	1	1			1		[RK00B922G01]
13	S70 C20 452	STRAINER VALVE	1	1	1	1	1	1	1	1	1		
14	S70 C28 460	STRAINER PACKING	1	1	1	1	1	1	1	1	1		
15	S70 C81 408	WATER COIL ASSY (5HP)	1	1	1	1	1	1	1	1	1		REFRIGERANT/ WATER
16	S70 C10 527	DRAIN HOSE							1	1	1		
17	S70 C20 529	DRAIN PAN ASSY							1	1	1		
18	S70 C10 358	DRAIN COCK/AIR VENT (WATER CAP ASSY 320)	3	3	3	3	3	3	3	3	3		FOR PRIMARY/ SANITARY CIRCUIT
19	S70 C20 356	PUMP VALVE	1	1	1	1	1	1	1	1	1		
20	S70 C11 355	WATER PUMP	1	1	1	1	1	1				UPM3	FOR PRIMARY CIRCUIT
20	S70 C13 355	WATER PUMP							1	1	1	UPM3K	
21	S70 C85 408	WATER COIL ASSY (W)	1	1	1	1	1	1	1	1	1		WATER/ WATER
22	S70 C60 357	SCALE TRAP	1	1	1	1	1	1	1	1	1		
23	S70 C05 355	WATER PUMP	1	1	1	1	1	1	1	1	1	UPSO	FOR SANITARY CIRCUIT
24	S70 C74 266	FLOW SENSOR (body & Cable)	1	1	1	1	1	1	1	1	1		
25	—	DIV FRAME H	1	1	1	1	1	1	1	1	1		[BK02N520G03]
26	—	TANK CUSHION TOP	1	1	1	1	1	1	1	1	1		[RK25A422G02]
27	S70 C50 096	FLARE JOINT		1	1	1		1	1	1	1		3/8F-G3/8
28	S70 C15 402	EXPANSION VESSEL		1	1	1		1	1	1	1		12 L
29	—	EXPANSION VESSEL CUSHION		1	1	1		1	1	1	1		[RK25A423G01]
30	S70 C69 202	THERMISTOR (FLOW WATER TEMP & RETURN WATER TEMP)	1	1	1	1	1	1	1	1	1		
31	S70 C55 460	GASKET 1"	4	4	4	4	4	4	4	4	4		
32	S70 C66 460	GASKET 3/4"	7	7	7	7	7	7	7	7	7		
33	S70 C77 460	GASKET 3/8"		1	1	1		1	1	1	1		
34	S70 C88 460	GASKET 1/4"	1	1	1	1	1	1	1	1	1		
35	S70 C23 460	O-RING	13	13	13	13	13	13	13	13	13		BLACK
36	S70 C01 800	GREASE	1*	1*	1*	1*	1*	1*	1*	1*	1*		FOR QUICK CONNECTION
37	S70 C10 465	FASTENER	13	13	13	13	13	13	13	13	13		FOR QUICK CONNECTION
38	S70 C45 097	ADJUST BOLT	4	4	4	4	4	4	4	4	4		ACCESSORY
39	S70 C26 460	O-RING	5	5	5	5	5	5	5	5	5		BLACK/ FOR FLOW SENSOR/3WAY VALVE
40	S70 C30 460	O-RING	1	1	1	1	1	1	1	1	1		BLACK/ FOR TANK
41	S70 C20 465	FASTENER	5	5	5	5	5	5	5	5	5		FOR FLOW SENSOR/ 3WAY VALVE
42	S70 C40 465	FASTENER	1	1	1	1	1	1	1	1	1		FOR TANK

Do not reuse the O-ring or strainer packing that was once removed, but be sure to replace with a new one.
 * Apply grease appropriately on the O-ring for the quick connection in the unit.

EHST30C-MED.UK
EHST30C-TM9ED.UK

EHST30C-VM6ED.UK
ERST30C-VM2ED.UK

EHST30C-YM9ED.UK

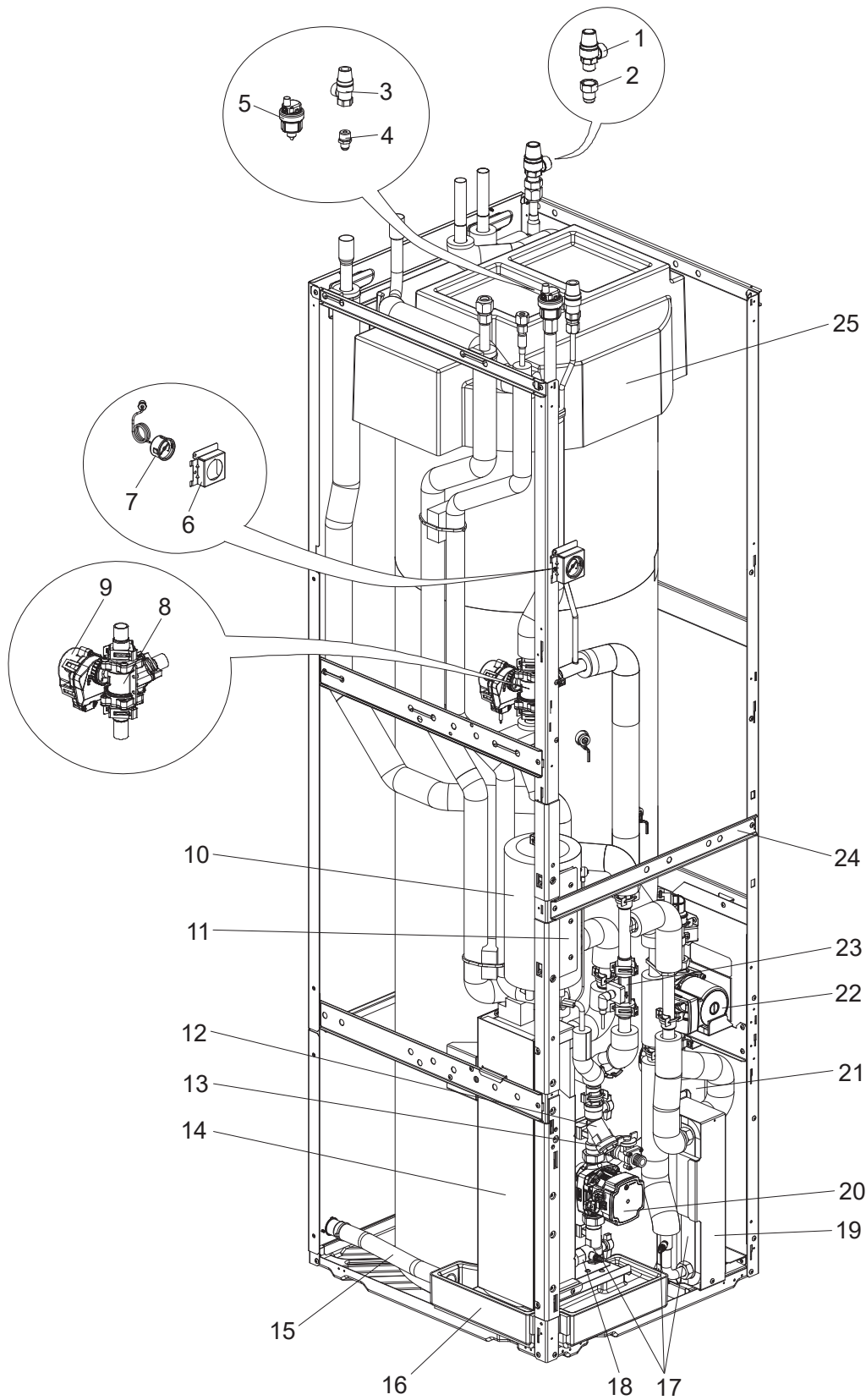

1. The part quantity below indicates the required number of pieces per unit.
2. The circled No. indicates that the part is not shown in the figure.

No.	Parts No.	Parts name						Wiring Diagram Symbol	Remarks [Drawing No.]
			EHST30C-MED.UK	EHST30C-VM6ED.UK	EHST30C-YM9ED.UK	EHST30C-TM9ED.UK	ERST30C-VM2ED.UK		
1	S70 C30 404	PRESSURE RELIEF VALVE	1	1	1	1	1		10 bar/ FOR SANITARY SIDE
2	S70 C70 096	FLARE JOINT	1	1	1	1	1		5/8F-R1/2
3	S70 C21 404	PRESSURE RELIEF VALVE	1	1	1	1	1		3 bar
4	S70 C60 096	FLARE JOINT	1	1	1	1	1		3/8F-R1/2
5	S70 C18 150	AIR VENT (AUTOMATIC)	1	1	1	1	1		
6	S70 C80 206	MANOMETER STAY	1	1	1	1	1		
7	S70 C20 205	MANOMETER	1	1	1	1	1		
8	S70 C45 762	3WAY VALVE	1	1	1	1	1		Large
9	S70 C45 762	3WAY VALVE (MOTOR)	1	1	1	1	1		Large
10	S70 C41 441	BOOSTER HEATER	1						0 kW
10	S70 C42 441	BOOSTER HEATER					1	BH1	1 ø 230 V 2 kW
10	S70 C43 441	BOOSTER HEATER		1				BH1, BH2	1 ø 230 V 6 kW
10	S70 C44 441	BOOSTER HEATER			1			BH1, BH2	3 ø 400 V 9 kW
10	S70 C45 441	BOOSTER HEATER				1		BH1, BH2	3 ø 230 V 9 kW
11	—	BOOSTER HEATER STAY	1	1			1		[RK00L196G01]
11	—	BOOSTER HEATER STAY 9kW			1	1			[RK00B922G01]
12	S70 C20 452	STRAINER VALVE	1	1	1	1	1		
13	S70 C28 460	STRAINER PACKING	1	1	1	1	1		
14	S70 C91 408	WATER COIL ASSY (5HP)	1	1	1	1	1		REFRIGERANT/ WATER
15	S70 C10 527	DRAIN HOSE					1		
16	S70 C20 529	DRAIN PAN ASSY					1		
17	S70 C10 358	DRAIN COCK/AIR VENT (WATER CAP ASSY 320)	3	3	3	3	3		
18	S70 C20 356	PUMP VALVE	1	1	1	1	1		
19	S70 C85 408	WATER COIL ASSY (W)	1	1	1	1	1		WATER/ WATER
20	S70 C11 355	WATER PUMP	1	1	1	1		UPM3	FOR PRIMARY CIRCUIT
20	S70 C13 355	WATER PUMP					1	UPM3K	
21	S70 C60 357	SCALE TRAP	1	1	1	1	1		
22	S70 C05 355	WATER PUMP	1	1	1	1	1	UPSO	FOR SANITARY CIRCUIT
23	S70 C74 266	FLOW SENSOR (body & Cable)	1	1	1	1	1		
24	—	DIV FRAME H	1	1	1	1	1		[BK02N520G03]
25	—	TANK CUSHION TOP	1	1	1	1	1		[RK25A412G02]
26	S70 C69 202	THERMISTOR(FLOW WATER TEMP & RETURN WATER TEMP)	1	1	1	1	1		
27	S70 C55 460	GASKET 1"	4	4	4	4	4		
28	S70 C66 460	GASKET 3/4"	7	7	7	7	7		
29	S70 C88 460	GASKET 1/4"	1	1	1	1	1		
30	S70 C23 460	O-RING	13	13	13	13	13		BLACK
31	S70 C01 800	GREASE	1*	1*	1*	1*	1*		FOR QUICK CONNECTION
32	S70 C10 465	FASTENER	13	13	13	13	13		FOR QUICK CONNECTION
33	S70 C45 097	ADJUST BOLT	4	4	4	4	4		ACCESSORY
34	S70 C26 460	O-RING	5	5	5	5	5		BLACK/ FOR FLOW SENSOR/ 3WAY VALVE
35	S70 C30 460	O-RING	1	1	1	1	1		BLACK/ FOR TANK
36	S70 C20 465	FASTENER	5	5	5	5	5		FOR FLOW SENSOR/ 3WAY VALVE
37	S70 C40 465	FASTENER	1	1	1	1	1		FOR TANK

Do not reuse the O-ring or strainer packing that was once removed, but be sure to replace with a new one.

* Apply grease appropriately on the O-ring for the quick connection in the unit.

EHST30C-MEDR1.UK
EHST30C-TM9EDR1.UK
ERST30C-YM9EDR1.UK

EHST30C-VM6EDR1.UK
ERST30C-VM2EDR1.UK

EHST30C-YM9EDR1.UK
ERST30C-VM6EDR1.UK

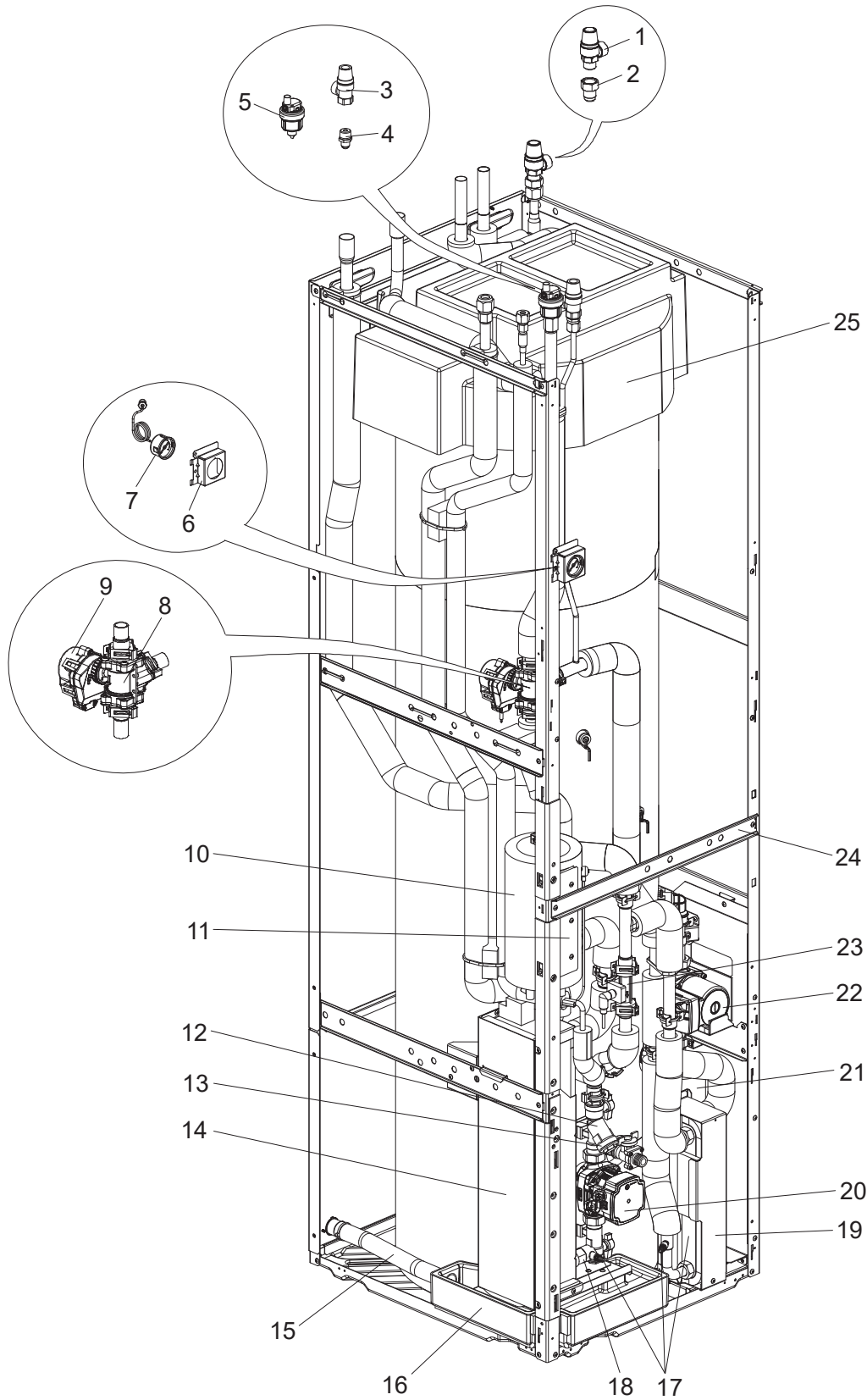

1. The part quantity below indicates the required number of pieces per unit.
2. The circled No. indicates that the part is not shown in the figure.

No.	Parts No.	Parts name								Wiring Diagram Symbol	Remarks [Drawing No.]
			EHST30C-MEDR1.UK	EHST30C-VM6EDR1.UK	EHST30C-YM9EDR1.UK	EHST30C-TM9EDR1.UK	ERST30C-VM2EDR1.UK	ERST30C-VM6EDR1.UK	ERST30C-YM9EDR1.UK		
1	S70 C30 404	PRESSURE RELIEF VALVE	1	1	1	1	1	1	1		10 bar/ FOR SANITARY SIDE
2	S70 C70 096	FLARE JOINT	1	1	1	1	1	1	1		5/8F-R1/2
3	S70 C21 404	PRESSURE RELIEF VALVE	1	1	1	1	1	1	1		3 bar
4	S70 C60 096	FLARE JOINT	1	1	1	1	1	1	1		3/8F-R1/2
5	S70 C18 150	AIR VENT (AUTOMATIC)	1	1	1	1	1	1	1		
6	S70 C80 206	MANOMETER STAY	1	1	1	1	1	1	1		
7	S70 C20 205	MANOMETER	1	1	1	1	1	1	1		
8	S70 C45 762	3WAY VALVE	1	1	1	1	1	1	1		Large
9	S70 C45 762	3WAY VALVE (MOTOR)	1	1	1	1	1	1	1		Large
10	S70 C41 441	BOOSTER HEATER	1								0 kW
10	S70 C42 441	BOOSTER HEATER					1			BH1	1 ø 230 V 2 kW
10	S70 C43 441	BOOSTER HEATER		1					1	BH1, BH2	1 ø 230 V 6 kW
10	S70 C44 441	BOOSTER HEATER			1				1	BH1, BH2	3 ø 400 V 9 kW
10	S70 C45 441	BOOSTER HEATER				1				BH1, BH2	3 ø 230 V 9 kW
11	—	BOOSTER HEATER STAY	1	1			1	1			[RK00L196G01]
11	—	BOOSTER HEATER STAY 9kW			1	1			1		[RK00B922G01]
12	S70 C20 452	STRAINER VALVE	1	1	1	1	1	1	1		
13	S70 C28 460	STRAINER PACKING	1	1	1	1	1	1	1		
14	S70 C91 408	WATER COIL ASSY (5HP)	1	1	1	1	1	1	1		REFRIGERANT/ WATER
15	S70 C10 527	DRAIN HOSE					1	1	1		
16	S70 C20 529	DRAIN PAN ASSY					1	1	1		
17	S70 C10 358	DRAIN COCK/AIR VENT (WATER CAP ASSY 320)	3	3	3	3	3	3	3		
18	S70 C20 356	PUMP VALVE	1	1	1	1	1	1	1		
19	S70 C85 408	WATER COIL ASSY (W)	1	1	1	1	1	1	1		WATER/ WATER
20	S70 C11 355	WATER PUMP	1	1	1	1				UPM3	FOR PRIMARY CIRCUIT
20	S70 C13 355	WATER PUMP					1	1	1	UPM3K	
21	S70 C60 357	SCALE TRAP	1	1	1	1	1	1	1		
22	S70 C05 355	WATER PUMP	1	1	1	1	1	1	1	UPSO	FOR SANITARY CIRCUIT
23	S70 C74 266	FLOW SENSOR (body & Cable)	1	1	1	1	1	1	1		
24	—	DIV FRAME H	1	1	1	1	1	1	1		[BK02N520G03]
25	—	TANK CUSHION TOP	1	1	1	1	1	1	1		[RK25A412G02]
26	S70 C69 202	THERMISTOR(FLOW WATER TEMP & RETURN WATER TEMP)	1	1	1	1	1	1	1		
27	S70 C55 460	GASKET 1"	4	4	4	4	4	4	4		
28	S70 C66 460	GASKET 3/4"	7	7	7	7	7	7	7		
29	S70 C88 460	GASKET 1/4"	1	1	1	1	1	1	1		
30	S70 C23 460	O-RING	13	13	13	13	13	13	13		BLACK
31	S70 C01 800	GREASE	1*	1*	1*	1*	1*	1*	1*		FOR QUICK CONNECTION
32	S70 C10 465	FASTENER	13	13	13	13	13	13	13		FOR QUICK CONNECTION
33	S70 C45 097	ADJUST BOLT	4	4	4	4	4	4	4		ACCESSORY
34	S70 C26 460	O-RING	5	5	5	5	5	5	5		BLACK/ FOR FLOW SENSOR/3WAY VALVE
35	S70 C30 460	O-RING	1	1	1	1	1	1	1		BLACK/ FOR TANK
36	S70 C20 465	FASTENER	5	5	5	5	5	5	5		FOR FLOW SENSOR/ 3WAY VALVE
37	S70 C40 465	FASTENER	1	1	1	1	1	1	1		FOR TANK

Do not reuse the O-ring or strainer packing that was once removed, but be sure to replace with a new one.

* Apply grease appropriately on the O-ring for the quick connection in the unit.

EHPT17X-VM2D.UK
ERPT17X-VM2D.UK

EHPT17X-VM6D.UK

EHPT17X-YM9D.UK

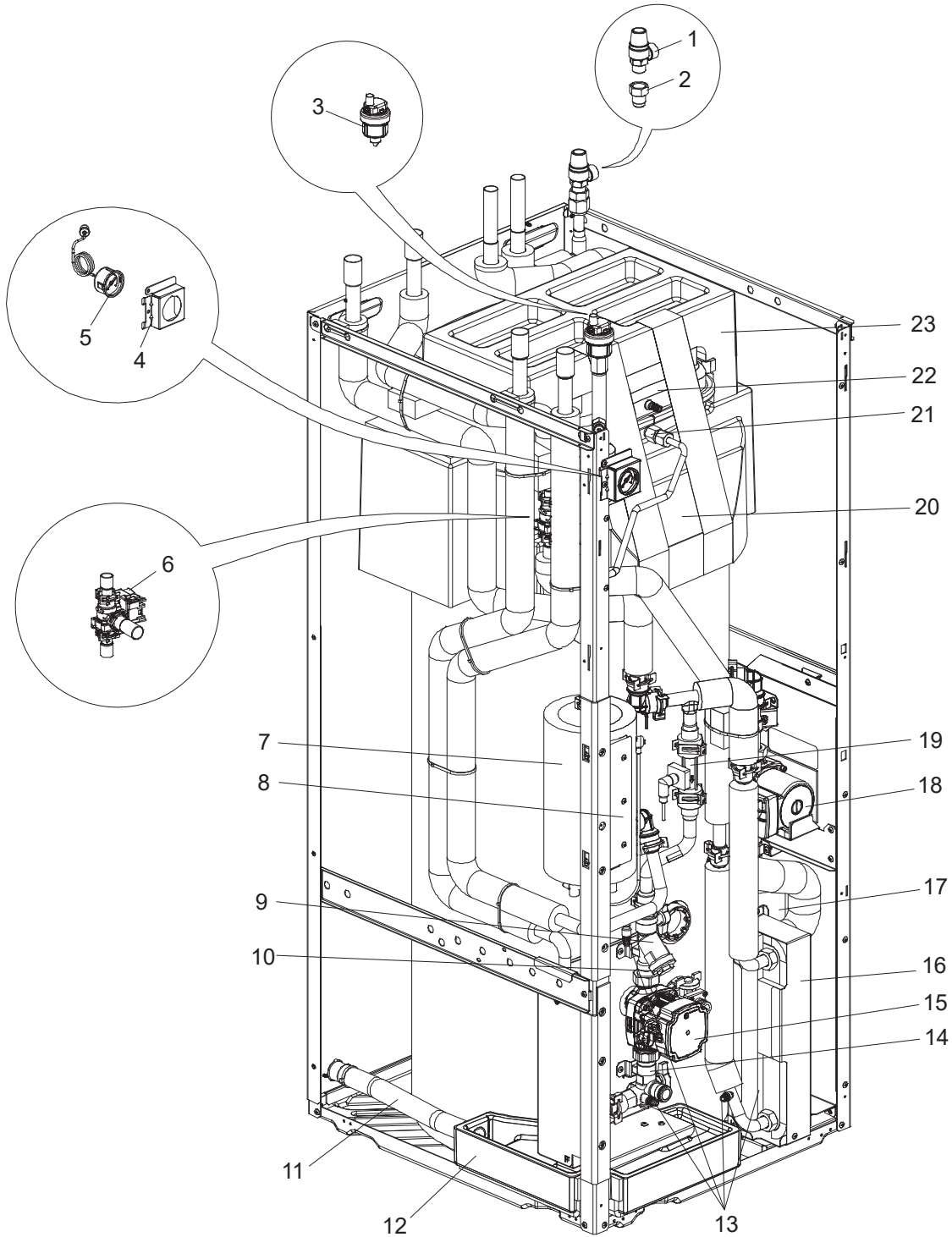

1. The part quantity below indicates the required number of pieces per unit.
 2. The circled No. indicates that the part is not shown in the figure

No.	Parts No.	Parts name	EHPT17X-VM2D.UK	EHPT17X-VM6D.UK	EHPT17X-VM9D.UK	ERPT17X-VM2D.UK	Wiring Diagram Symbol	Remarks [Drawing No.]
1	S70 C30 404	PRESSURE RELIEF VALVE	1	1	1	1		10 bar/ FOR SANITARY SIDE
2	S70 C70 096	FLARE JOINT	1	1	1	1		5/8F-R1/2
3	S70 C18 150	AIR VENT (AUTOMATIC)	1	1	1	1		
4	S70 C80 206	MANOMETER STAY	1	1	1	1		
5	S70 C20 205	MANOMETER	1	1	1	1		
6	S70 C34 406	3WAY VALVE	1	1	1	1		Small
7	S70 C42 441	BOOSTER HEATER	1			1	BH1, BH2	1 ø 230 V 2 kW
7	S70 C43 441	BOOSTER HEATER		1			BH1, BH2	
7	S70 C44 441	BOOSTER HEATER			1			
8	—	BOOSTER HEATER STAY	1	1		1		[RK00L196G01]
8	—	BOOSTER HEATER STAY			1			[RK00B922G01]
9	S70 C20 452	STRAINER VALVE	1	1	1	1		
10	S70 C28 460	STRAINER PACKING	1	1	1	1		FOR STRAINER
11	S70 C10 527	DRAIN HOSE				1		
12	S70 C20 529	DRAIN PAN ASSY				1		
13	S70 C10 358	DRAIN COCK/AIR VENT (WATER CAP ASSY 320)	4	4	4	4		FOR PRIMARY/ SANITARY CIRCUIT
14	S70 C20 356	PUMP VALVE	1	1	1	1		
15	S70 C11 355	WATER PUMP	1	1	1		UPM3	FOR PRIMARY CIRCUIT
16	S70 C13 355	WATER PUMP				1	UPM3K	
16	S70 C90 408	WATER COIL ASSY (W)	1	1	1	1		WATER/ WATER
17	S70 C60 357	SCALE TRAP	1	1	1	1		
18	S70 C05 355	WATER PUMP	1	1	1	1	UPSO	FOR SANITARY CIRCUIT
19	S70 C74 266	FLOW SENSOR (body & Cable)	1	1	1	1		
20	—	TANK CUSHION TOP	1	1	1	1		[RK25A422G02]
21	S70 C50 096	FLARE JOINT	1	1	1	1		3/8F-G3/8
22	S70 C15 402	EXPANSION VESSEL	1	1	1	1		12 L
23	—	EXPANSION VESSEL CUSHION	1	1	1	1		[RK25A423G01]
24	S70 C69 202	THERMISTOR (FLOW WATER TEMP & RETURN WATER TEMP)	1	1	1	1	THW1/2	
25	S70 C55 460	GASKET 1"	4	4	4	4		FOR CONNECTION OF WATER CIRCUIT
26	S70 C66 460	GASKET 3/4"	7	7	7	7		FOR CONNECTION OF WATER CIRCUIT
27	S70 C77 460	GASKET 3/8"	1	1	1	1		FOR ONLY EXPANSION VESSEL
28	S70 C88 460	GASKET 1/4"	1	1	1	1		FOR ONLY MANOMETER
29	S70 C23 460	O-RING	13	13	13	13		BLACK
30	S70 C01 800	GREASE	1*	1*	1*	1*		FOR QUICK CONNECTION/ 100g
31	S70 C10 465	FASTENER	13	13	13	13		FOR QUICK CONNECTION
32	S70 C45 097	ADJUST BOLT	4	4	4	4		ACCESSORY
33	S70 C26 460	O-RING	2	2	2	2		BLACK/ FOR FLOW SENSOR, 3WAY VALVE (Large)
34	S70 C30 460	O-RING	4	4	4	4		BLACK/ FOR 3WAY VALVE (Small), TANK
35	S70 C20 465	FASTENER	2	2	2	2		FOR FLOW SENSOR, 3WAY VALVE (Large)
36	S70 C40 465	FASTENER	4	4	4	4		FOR 3WAY VALVE (Small), TANK

Do not reuse the O-ring or strainer packing that was once removed, but be sure to replace with a new one.
 * Apply grease appropriately on the O-ring for the quick connection in the unit.

EHPT17X-VM2DR1.UK
ERPT17X-VM2DR1.UK

EHPT17X-VM6DR1.UK

EHPT17X-YM9DR1.UK

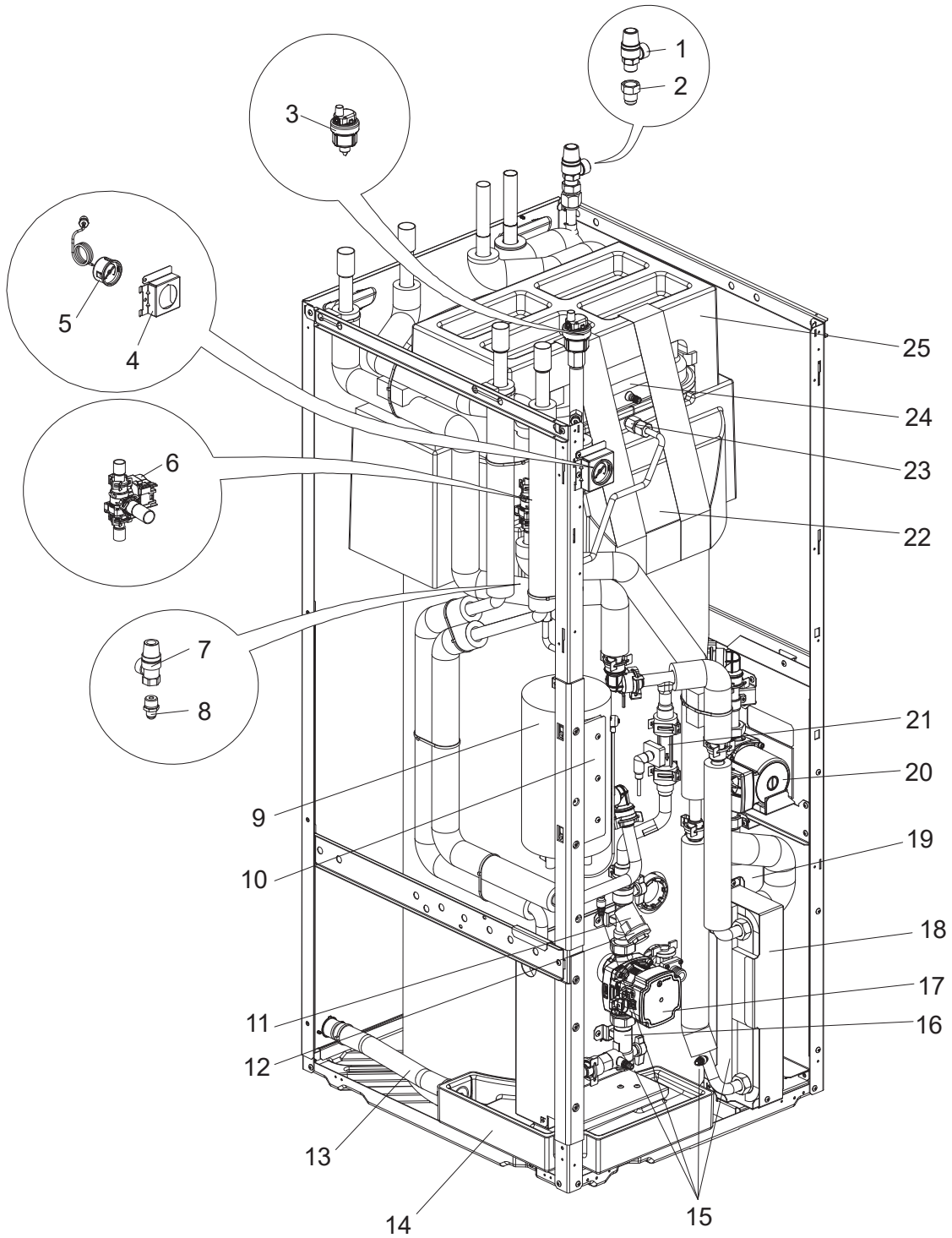

1. The part quantity below indicates the required number of pieces per unit.
2. The circled No. indicates that the part is not shown in the figure

No.	Parts No.	Parts name	EHPT17X-VM2DR1.UK	EHPT17X-VM6DR1.UK	EHPT17X-VM9DR1.UK	ERPT17X-VM2DR1.UK	Wiring Diagram Symbol	Remarks [Drawing No.]
1	S70 C30 404	PRESSURE RELIEF VALVE	1	1	1	1		10 bar/ FOR SANITARY SIDE
2	S70 C70 096	FLARE JOINT	1	1	1	1		5/8F-R1/2
3	S70 C18 150	AIR VENT (AUTOMATIC)	1	1	1	1		
4	S70 C80 206	MANOMETER STAY	1	1	1	1		
5	S70 C20 205	MANOMETER	1	1	1	1		
6	S70 C34 406	3WAY VALVE	1	1	1	1		Small
7	S70 C40 404	PRESSURE RELIEF VALVE	1	1	1	1		5 bar
8	S70 C60 096	FLARE JOINT	1	1	1	1		3/8F-R1/2
9	S70 C42 441	BOOSTER HEATER	1			1	BH1, BH2	1 ø 230 V 2 kW
9	S70 C43 441	BOOSTER HEATER		1			BH1, BH2	
9	S70 C44 441	BOOSTER HEATER			1			
10	—	BOOSTER HEATER STAY	1	1		1		[RK00L196G01]
10	—	BOOSTER HEATER STAY			1			[RK00B922G01]
11	S70 C20 452	STRAINER VALVE	1	1	1	1		
12	S70 C28 460	STRAINER PACKING	1	1	1	1		FOR STRAINER
13	S70 C10 527	DRAIN HOSE				1		
14	S70 C20 529	DRAIN PAN ASSY				1		
15	S70 C10 358	DRAIN COCK/AIR VENT (WATER CAP ASSY 320)	4	4	4	4		FOR PRIMARY/ SANITARY CIRCUIT
16	S70 C20 356	PUMP VALVE	1	1	1	1		
17	S70 C11 355	WATER PUMP	1	1	1		UPM3	
17	S70 C13 355	WATER PUMP				1	UPM3K	FOR PRIMARY CIRCUIT
18	S70 C90 408	WATER COIL ASSY (W)	1	1	1	1		WATER/ WATER
19	S70 C60 357	SCALE TRAP	1	1	1	1		
20	S70 C05 355	WATER PUMP	1	1	1	1	UPSO	FOR SANITARY CIRCUIT
21	S70 C74 266	FLOW SENSOR (body & Cable)	1	1	1	1		
22	—	TANK CUSHION TOP	1	1	1	1		[RK25A422G02]
23	S70 C50 096	FLARE JOINT	1	1	1	1		3/8F-G3/8
24	S70 C15 402	EXPANSION VESSEL	1	1	1	1		12 L
25	—	EXPANSION VESSEL CUSHION	1	1	1	1		[RK00L660G01]
26	S70 C69 202	THERMISTOR (FLOW WATER TEMP & RETURN WATER TEMP)	1	1	1	1	THW1/2	
27	S70 C55 460	GASKET 1"	4	4	4	4		FOR CONNECTION OF WATER CIRCUIT
28	S70 C66 460	GASKET 3/4"	7	7	7	7		FOR CONNECTION OF WATER CIRCUIT
29	S70 C77 460	GASKET 3/8"	1	1	1	1		FOR ONLY EXPANSION VESSEL
30	S70 C88 460	GASKET 1/4"	1	1	1	1		FOR ONLY MANOMETER
31	S70 C23 460	O-RING	13	13	13	13		BLACK
32	S70 C01 800	GREASE	1*	1*	1*	1*		FOR QUICK CONNECTION/ 100g
33	S70 C10 465	FASTENER	13	13	13	13		FOR QUICK CONNECTION
34	S70 C45 097	ADJUST BOLT	4	4	4	4		ACCESSORY
35	S70 C26 460	O-RING	2	2	2	2		BLACK/ FOR FLOW SENSOR, 3WAY VALVE (Large)
36	S70 C30 460	O-RING	4	4	4	4		BLACK/ FOR 3WAY VALVE (Small), TANK
37	S70 C20 465	FASTENER	2	2	2	2		FOR FLOW SENSOR, 3WAY VALVE (Large)
38	S70 C40 465	FASTENER	4	4	4	4		FOR 3WAY VALVE (Small),TANK

Do not reuse the O-ring or strainer packing that was once removed, but be sure to replace with a new one.
 * Apply grease appropriately on the O-ring for the quick connection in the unit.

EHPT20X-MED.UK
EHPT20X-YM9ED.UK
ERPT20X-VM2D.UK

EHPT20X-VM6D.UK
EHPT20X-TM9D.UK
ERPT20X-VM6D.UK

EHPT20X-YM9D.UK
ERPT20X-MD.UK

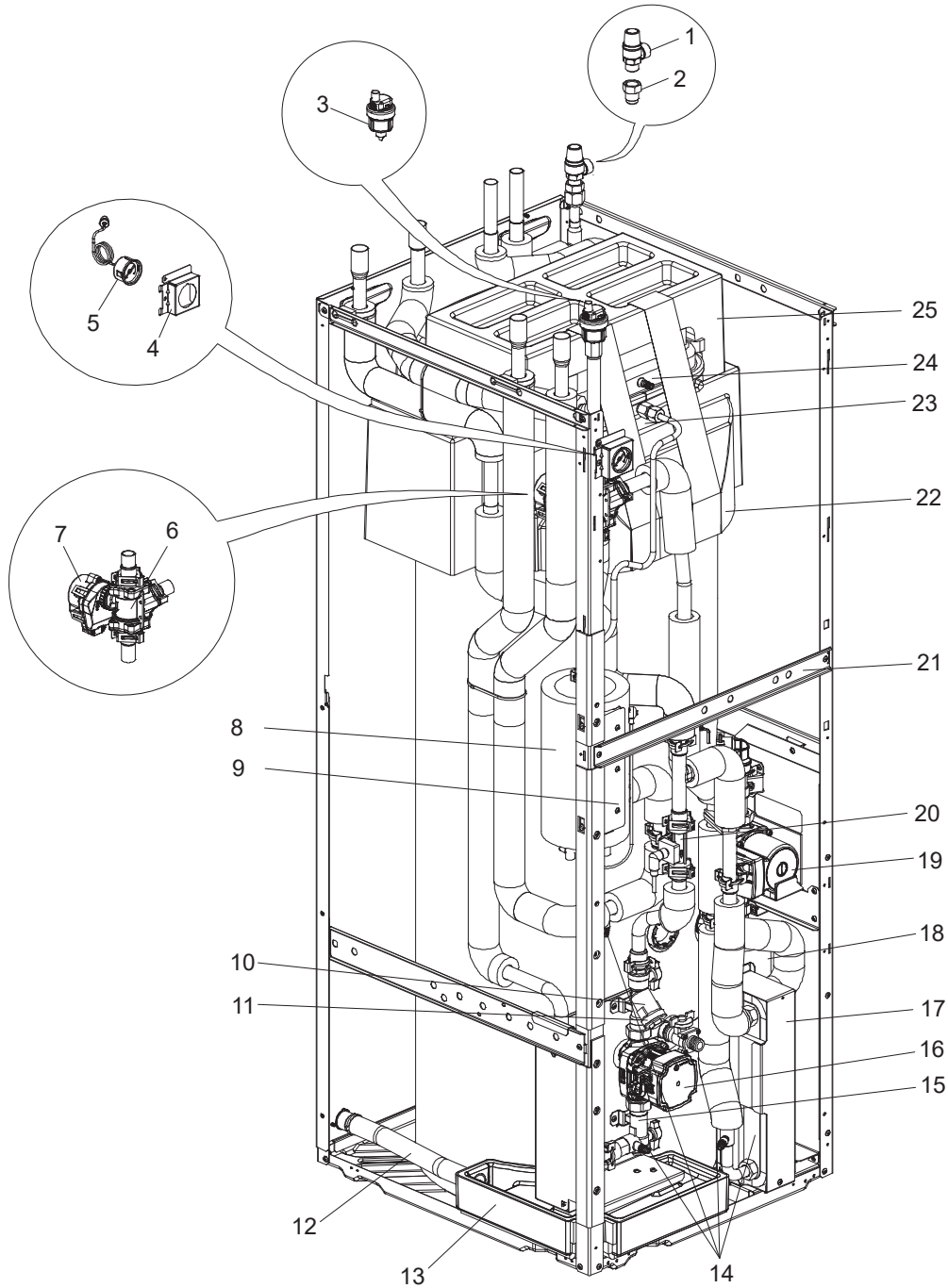

1. The part quantity below indicates the required number of pieces per unit.
2. The circled No. indicates that the part is not shown in the figure

No.	Parts No.	Parts name	EHPT20X-MED.UK	EHPT20X-VM6D.UK	EHPT20X-VM9D.UK	EHPT20X-VM9ED.UK	EHPT20X-TM9D.UK	ERT20X-MD.UK	ERT20X-VM2D.UK	ERT20X-VM6D.UK	Wiring Diagram Symbol	Remarks [Drawing No.]
1	S70 C30 404	PRESSURE RELIEF VALVE	1	1	1	1	1	1	1	1		10 bar/ FOR SANITARY SIDE
2	S70 C70 096	FLARE JOINT	1	1	1	1	1	1	1	1		5/8F-R1/2
3	S70 C18 150	AIR VENT (AUTOMATIC)	1	1	1	1	1	1	1	1		
4	S70 C80 206	MANOMETER STAY	1	1	1	1	1	1	1	1		
5	S70 C20 205	MANOMETER	1	1	1	1	1	1	1	1		
6	S70 C45 762	3WAY VALVE	1	1	1	1	1	1	1	1		5HP
7	S70 C45 762	3WAY VALVE (MOTOR)	1	1	1	1	1	1	1	1		
8	S70 C41 441	BOOSTER HEATER	1					1			BH1	
8	S70 C42 441	BOOSTER HEATER							1		BH1, BH2	1 ø 230 V 2 kW
8	S70 C43 441	BOOSTER HEATER		1						1	BH1, BH2	
8	S70 C44 441	BOOSTER HEATER			1	1						
8	S70 C45 441	BOOSTER HEATER					1					
9	—	BOOSTER HEATER STAY	1	1				1	1	1		[RK00L196G01]
9	—	BOOSTER HEATER STAY			1	1	1					[RK00B922G01]
10	S70 C20 452	STRAINER VALVE	1	1	1	1	1	1	1	1		
11	S70 C28 460	STRAINER PACKING	1	1	1	1	1	1	1	1		FOR STRAINER
12	S70 C10 527	DRAIN HOSE						1	1	1		
13	S70 C20 529	DRAIN PAN ASSY						1	1	1		
14	S70 C10 358	DRAIN COCK/AIR VENT (WATER CAP ASSY 320)	4	4	4	4	4	4	4	4		FOR PRIMARY/ SANITARY CIRCUIT
15	S70 C20 356	PUMP VALVE	1	1	1	1	1	1	1	1		
16	S70 C11 355	WATER PUMP	1	1	1	1	1				UPM3	FOR PRIMARY CIRCUIT
16	S70 C13 355	WATER PUMP						1	1	1	UPM3K	
17	S70 C85 408	WATER COIL ASSY (W)	1	1	1	1	1	1	1	1		WATER/ WATER
18	S70 C60 357	SCALE TRAP	1	1	1	1	1	1	1	1		
19	S70 C05 355	WATER PUMP	1	1	1	1	1	1	1	1	UPSO	FOR SANITARY CIRCUIT
20	S70 C74 266	FLOW SENSOR (body & Cable)	1	1	1	1	1	1	1	1		
21	—	DIV FRAME H	1	1	1	1	1	1	1	1		[BK02N520G03]
22	—	TANK CUSHION TOP	1	1	1	1	1	1	1	1		[RK25A422G02]
23	S70 C50 096	FLARE JOINT		1	1		1	1	1	1		3/8F-G3/8
24	S70 C15 402	EXPANSION VESSEL		1	1		1	1	1	1		12 L
25	—	EXPANSION VESSEL CUSHION	1	1	1	1	1	1	1	1		[RK25A423G01]
26	S70 C69 202	THERMISTOR (FLOW WATER TEMP & RETURN WATER TEMP)	1	1	1	1	1	1	1	1	THW1/2	
27	S70 C55 460	GASKET 1"	4	4	4	4	4	4	4	4		FOR CONNECTION OF WATER CIRCUIT
28	S70 C66 460	GASKET 3/4"	7	7	7	7	7	7	7	7		FOR CONNECTION OF WATER CIRCUIT
29	S70 C77 460	GASKET 3/8"		1	1		1	1	1	1		FOR ONLY EXPANSION VESSEL
30	S70 C88 460	GASKET 1/4"	1	1	1	1	1	1	1	1		FOR ONLY MANOMETER
31	S70 C23 460	O-RING	12	12	12	12	12	12	12	12		BLACK
32	S70 C01 800	GREASE	1*	1*	1*	1*	1*	1*	1*	1*		FOR QUICK CONNECTION
33	S70 C10 465	FASTENER	12	12	12	12	12	12	12	12		FOR QUICK CONNECTION
34	S70 C45 097	ADJUST BOLT	4	4	4	4	4	4	4	4		ACCESSORY
35	S70 C26 460	O-RING	5	5	5	5	5	5	5	5		BLACK/ FOR FLOW SENSOR, 3WAY VALVE (Large)
36	S70 C30 460	O-RING	1	1	1	1	1	1	1	1		BLACK/ FOR 3WAY VALVE (Small), TANK
37	S70 C20 465	FASTENER	5	5	5	5	5	5	5	5		FOR FLOW SENSOR, 3WAY VALVE (Large)
38	S70 C40 465	FASTENER	1	1	1	1	1	1	1	1		FOR 3WAY VALVE (Small),TANK

Do not reuse the O-ring or strainer packing that was once removed, but be sure to replace with a new one.
 * Apply grease appropriately on the O-ring for the quick connection in the unit.

EHPT20X-MEDR1.UK
EHPT20X-YM9EDR1.UK
ERPT20X-VM2DR1.UK

EHPT20X-VM6DR1.UK
EHPT20X-TM9DR1.UK
ERPT20X-VM6DR1.UK

EHPT20X-YM9DR1.UK
ERPT20X-MDR1.UK

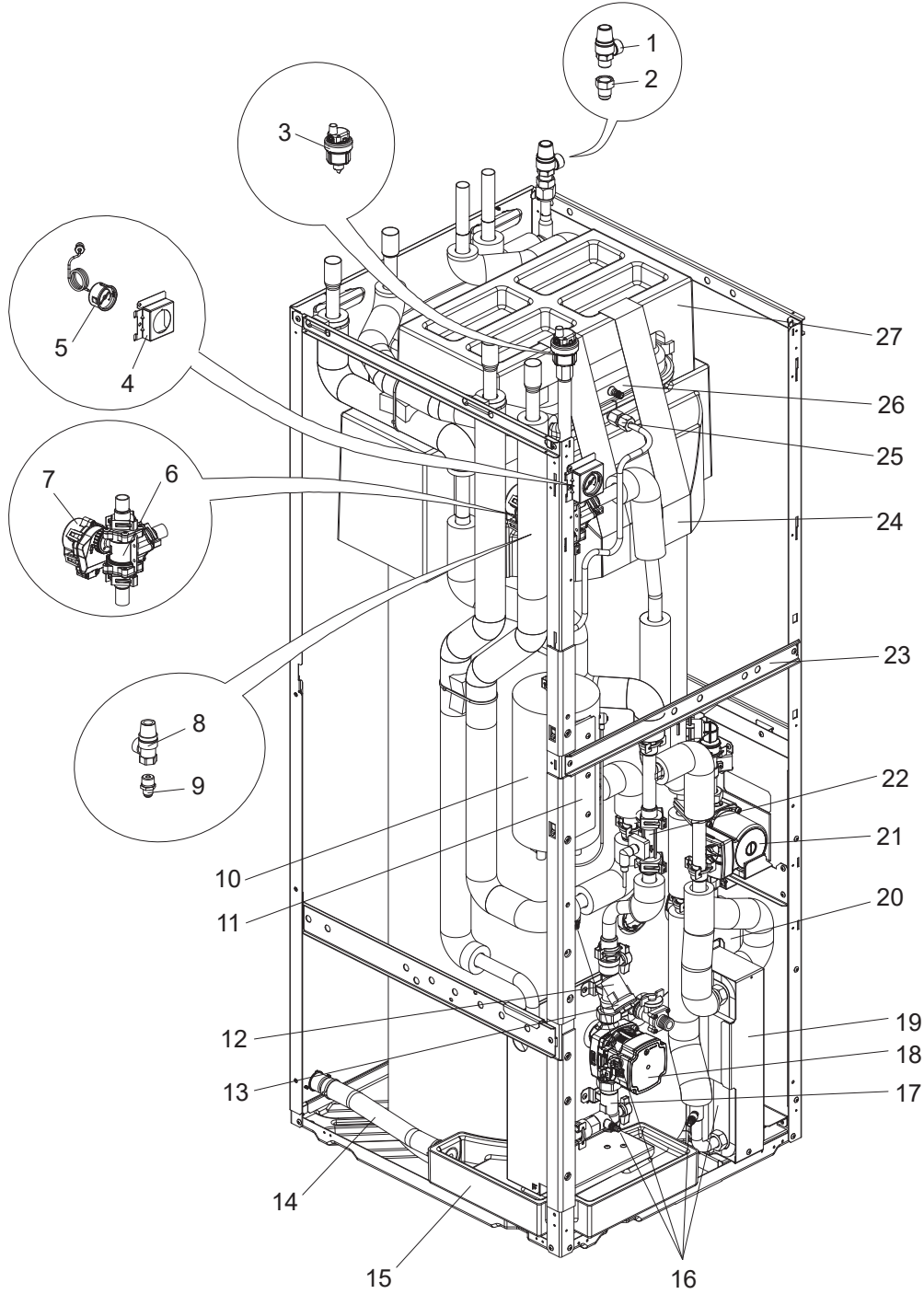

1. The part quantity below indicates the required number of pieces per unit.
2. The circled No. indicates that the part is not shown in the figure

No.	Parts No.	Parts name	EHPT20X-MEDR1.UK	EHPT20X-VM6DR1.UK	EHPT20X-YM9DR1.UK	EHPT20X-YM9EDR1.UK	EHPT20X-TM9DR1.UK	ERPT20X-MDR1.UK	ERPT20X-VM2DR1.UK	ERPT20X-VM6DR1.UK	Wiring Diagram Symbol	Remarks [Drawing No.]
1	S70 C30 404	PRESSURE RELIEF VALVE	1	1	1	1	1	1	1	1		10 bar/ FOR SANITARY SIDE
2	S70 C70 096	FLARE JOINT	1	1	1	1						5/8F-R1/2
3	S70 C18 150	AIR VENT (AUTOMATIC)	1	1	1	1	1	1	1	1		
4	S70 C80 206	MANOMETER STAY	1	1	1	1	1	1	1	1		
5	S70 C20 205	MANOMETER	1	1	1	1	1	1	1	1		
6	S70 C45 762	3WAY VALVE	1	1	1	1	1	1	1	1		5HP
7	S70 C45 762	3WAY VALVE (MOTOR)	1	1	1	1	1	1	1	1		
8	S70 C40 404	PRESSURE RELIEF VALVE		1	1		1	1	1	1		5 bar
9	S70 C60 096	FLARE JOINT		1	1		1	1	1	1		3/8F-R1/2
10	S70 C41 441	BOOSTER HEATER	1					1			BH1	
10	S70 C42 441	BOOSTER HEATER							1		BH1, BH2	1 ø 230 V 2 kW
10	S70 C43 441	BOOSTER HEATER		1						1	BH1, BH2	
10	S70 C44 441	BOOSTER HEATER			1	1						
10	S70 C45 441	BOOSTER HEATER					1					
11	—	BOOSTER HEATER STAY	1	1				1	1	1		[RK00L196G01]
11	—	BOOSTER HEATER STAY			1	1	1					[RK00B922G01]
12	S70 C20 452	STRAINER VALVE	1	1	1	1	1	1	1	1		
13	S70 C28 460	STRAINER PACKING	1	1	1	1	1	1	1	1		FOR STRAINER
14	S70 C10 527	DRAIN HOSE						1	1	1		
15	S70 C20 529	DRAIN PAN ASSY						1	1	1		
16	S70 C10 358	DRAIN COCK/AIR VENT (WATER CAP ASSY 320)	4	4	4	4	4	4	4	4		FOR PRIMARY/ SANITARY CIRCUIT
17	S70 C20 356	PUMP VALVE	1	1	1	1	1	1	1	1		
18	S70 C11 355	WATER PUMP	1	1	1	1	1				UPM3	
18	S70 C13 355	WATER PUMP						1	1	1	UPM3K	FOR PRIMARY CIRCUIT
19	S70 C85 408	WATER COIL ASSY (W)	1	1	1	1	1	1	1	1		WATER/ WATER
20	S70 C60 357	SCALE TRAP	1	1	1	1	1	1	1	1		
21	S70 C05 355	WATER PUMP	1	1	1	1	1	1	1	1	UPSO	FOR SANITARY CIRCUIT
22	S70 C74 266	FLOW SENSOR (body & Cable)	1	1	1	1	1	1	1	1		
23	—	DIV FRAME H	1	1	1	1	1	1	1	1		[BK02N520G03]
24	—	TANK CUSHION TOP	1	1	1	1	1	1	1	1		[RK25A422G02]
25	S70 C50 096	FLARE JOINT		1	1		1	1	1	1		3/8F-G3/8
26	S70 C15 402	EXPANSION VESSEL		1	1		1	1	1	1		12 L
27	—	EXPANSION VESSEL CUSHION		1	1		1	1	1	1		[RK25A423G01]
⑳	S70 C69 202	THERMISTOR (FLOW WATER TEMP & RETURN WATER TEMP)	1	1	1	1	1	1	1	1	THW1/2	
㉑	S70 C55 460	GASKET 1"	4	4	4	4	4	4	4	4		FOR CONNECTION OF WATER CIRCUIT
㉒	S70 C66 460	GASKET 3/4"	7	7	7	7	7	7	7	7		FOR CONNECTION OF WATER CIRCUIT
㉓	S70 C77 460	GASKET 3/8"		1	1		1	1	1	1		FOR ONLY EXPANSION VESSEL
㉔	S70 C88 460	GASKET 1/4"	1	1	1	1	1	1	1	1		FOR ONLY MANOMETER
㉕	S70 C23 460	O-RING	12	12	12	12	12	12	12	12		BLACK
㉖	S70 C01 800	GREASE	1*	1*	1*	1*	1*	1*	1*	1*		FOR QUICK CONNECTION
㉗	S70 C10 465	FASTENER	12	12	12	12	12	12	12	12		FOR QUICK CONNECTION
㉘	S70 C45 097	ADJUST BOLT	4	4	4	4	4	4	4	4		ACCESSORY
㉙	S70 C26 460	O-RING	5	5	5	5	5	5	5	5		BLACK/ FOR FLOW SENSOR, 3WAY VALVE (Large)
㉚	S70 C30 460	O-RING	1	1	1	1	1	1	1	1		BLACK/ FOR 3WAY VALVE (Small), TANK
㉛	S70 C20 465	FASTENER	5	5	5	5	5	5	5	5		FOR FLOW SENSOR, 3WAY VALVE (Large)
㉜	S70 C40 465	FASTENER	1	1	1	1	1	1	1	1		FOR 3WAY VALVE (Small), TANK

Do not reuse the O-ring or strainer packing that was once removed, but be sure to replace with a new one.
 * Apply grease appropriately on the O-ring for the quick connection in the unit.

EHPT20X-MHEDW.UK

EHPT20X-MHEDWR1.UK

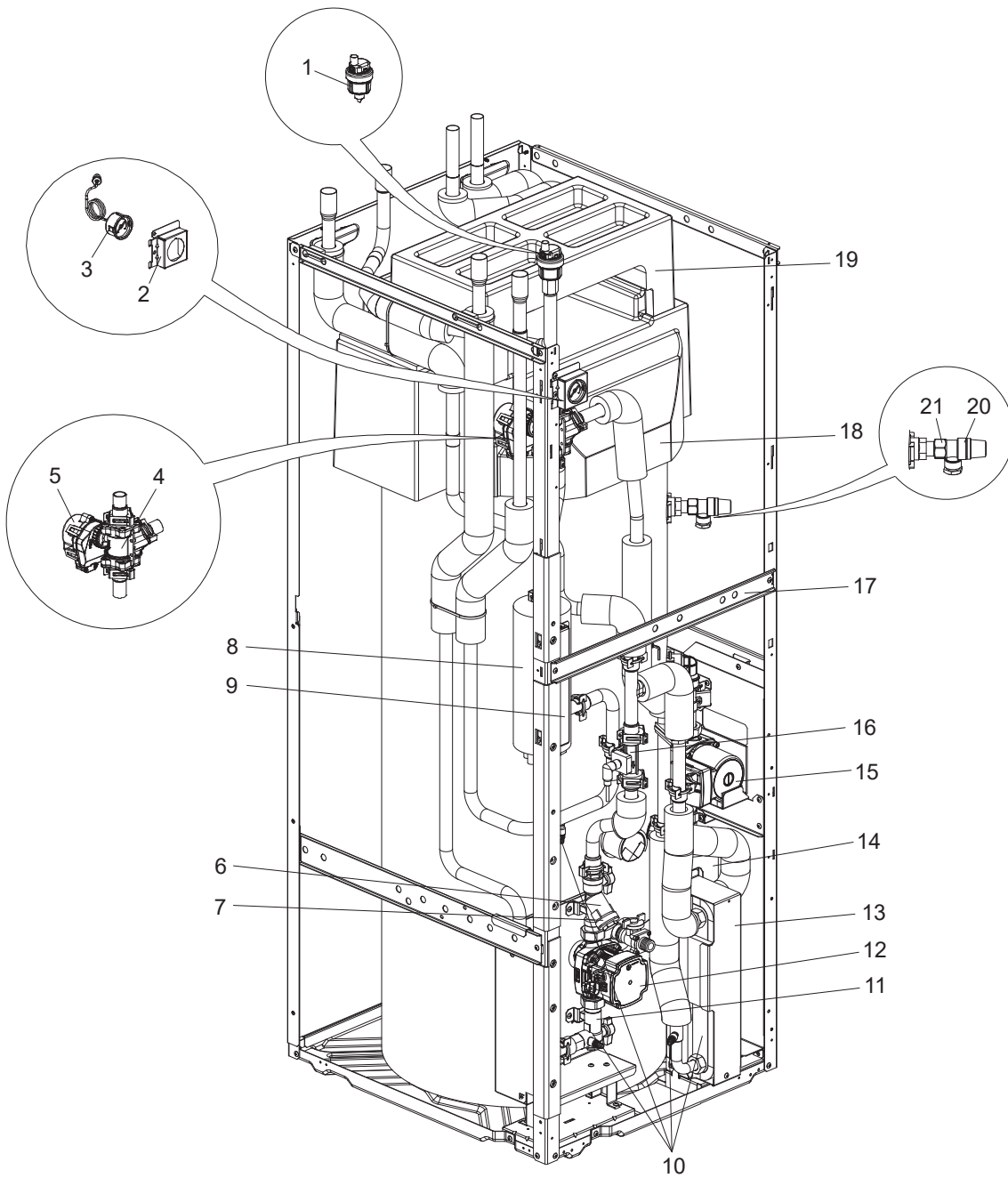

1. The part quantity below indicates the required number of pieces per unit.
2. The circled No. indicates that the part is not shown in the figure

No.	Parts No.	Parts name			Wiring Diagram Symbol	Remarks [Drawing No.]
			EHP20X-MHEDW.UK	EHP20X-MHEDWR1.UK		
1	S70 C18 150	AIR VENT (AUTOMATIC)	1	1		
2	S70 C80 206	MANOMETER STAY	1	1		
3	S70 C20 205	MANOMETER	1	1		
4	S70 C45 762	3WAY VALVE	1	1		5HP
5	S70 C45 762	3WAY VALVE (MOTOR)	1	1		
6	S70 C20 452	STRAINER VALVE	1	1		
7	S70 C28 460	STRAINER PACKING	1	1		FOR STRAINER
8	S70 C41 441	BOOSTER HEATER	1	1	BH1	
9	—	BOOSTER HEATER STAY	1	1		[RK00L196G01]
10	S70 C10 358	DRAIN COCK/AIR VENT (WATER CAP ASSY 320)	4	4		FOR PRIMARY/ SANITARY CIRCUIT
11	S70 C20 356	PUMP VALVE	1	1		
12	S70 C11 355	WATER PUMP	1	1	UPM3	FOR PRIMARY CIRCUIT
13	S70 C85 408	WATER COIL ASSY (W)	1	1		WATER/ WATER
14	S70 C60 357	SCALE TRAP	1	1		
15	S70 C05 355	WATER PUMP	1	1	UPSO	FOR SANITARY CIRCUIT
16	S70 C74 266	FLOW SENSOR (body & Cable)	1	1		
17	—	DIV FRAME H	1	1		[BK02N520G03]
18	—	TANK CUSHION TOP	1	1		[RK25A422G02]
19	—	EXPANSION VESSEL CUSHION	1			[RK25A423G01]
20	S70 C19 404	TEMPERATURE AND PRESSURE RELIEF VALVE	1	1		90°C/ 7bar, FOR TANK
21	S70 C20 405	JOINT	1	1		
22	S70 C69 202	THERMISTOR (FLOW WATER TEMP & RETURN WATER TEMP)	1	1	THW1/2	
23	S70 C55 460	GASKET 1"	2	2		FOR CONNECTION OF WATER CIRCUIT
24	S70 C66 460	GASKET 3/4"	2	2		FOR CONNECTION OF WATER CIRCUIT
25	S70 C88 460	GASKET 1/4"	1	1		FOR ONLY MANOMETER
26	S70 C20 460	PACKING WASHER 1"	2	2		FOR SANITARY SIDE OF UK MODEL
27	S70 C25 460	PACKING WASHER 3/4"	5	5		FOR SANITARY SIDE OF UK MODEL
28	S70 C23 460	O-RING	8	8		BLACK
29	S70 C30 460	O-RING	1	1		BLACK/ FOR 3WAY VALVE (Small), TANK
30	S70 C01 800	GREASE	1*	1*		FOR QUICK CONNECTION
31	S70 C10 465	FASTENER	13	13		FOR QUICK CONNECTION
32	S70 C45 097	ADJUST BOLT	4	4		ACCESSORY
33	S70 C26 460	O-RING	5	5		BLACK/ FOR FLOW SENSOR, 3WAY VALVE (Large)
34	S70 C27 460	O-RING	5	5		ORANGE/ FOR SANITARY SIDE OF UK MODEL
35	S70 C20 465	FASTENER	5	5		FOR FLOW SENSOR, 3WAY VALVE (Large)
36	S70 C40 465	FASTENER	1	1		FOR 3WAY VALVE (Small), TANK

Do not reuse the O-ring or strainer packing that was once removed, but be sure to replace with a new one.
 * Apply grease appropriately on the O-ring for the quick connection in the unit.

EHPT30X-MED.UK

EHPT30X-YM9ED.UK

ERPT30X-VM2ED.UK

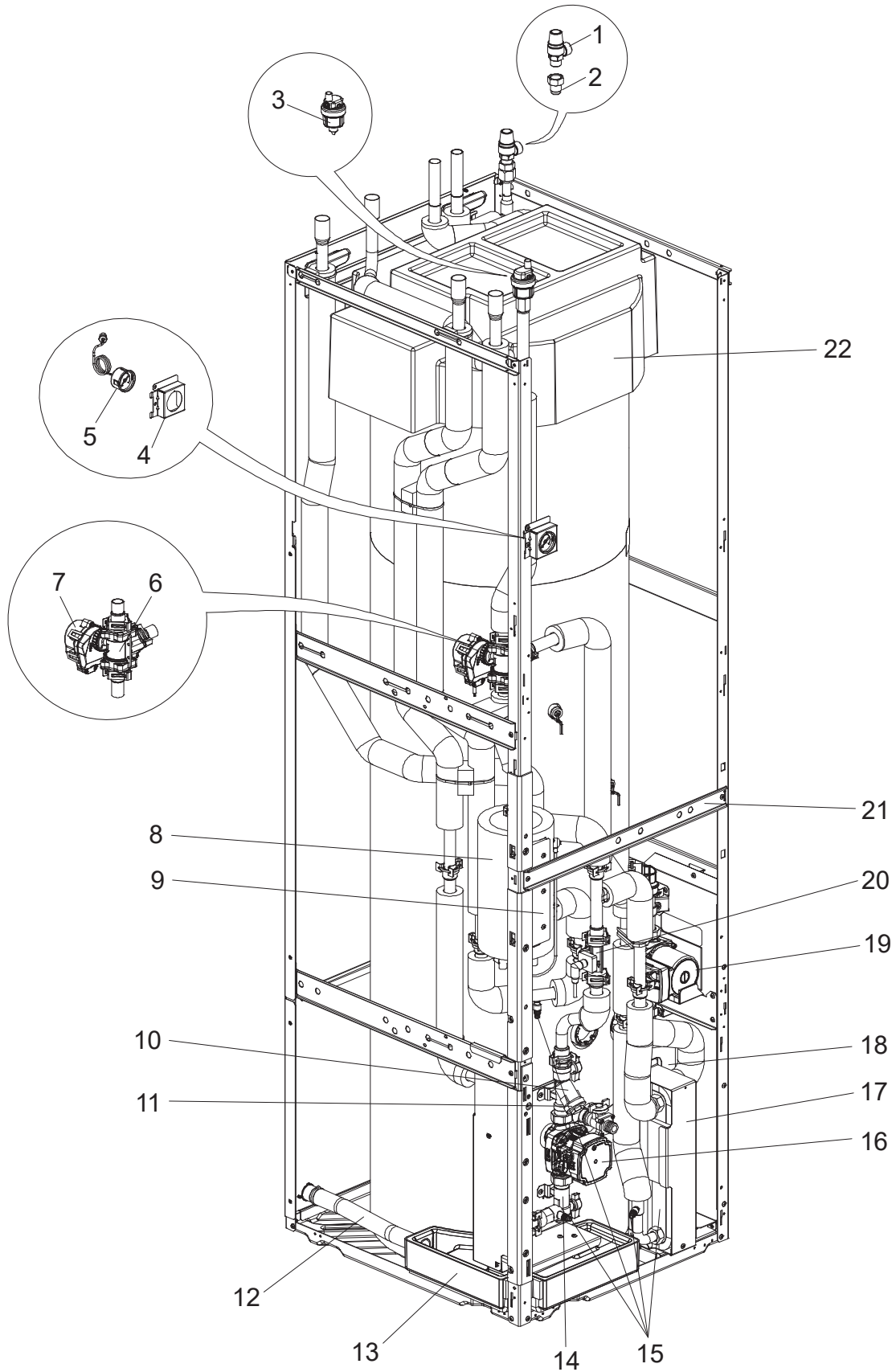

1. The part quantity below indicates the required number of pieces per unit.
 2. The circled No. indicates that the part is not shown in the figure

No.	Parts No.	Parts name	EHPT30X-MED.UK	EHPT30X-YM9ED.UK	ERPT30X-VM2ED.UK	Wiring Diagram Symbol	Remarks [Drawing No.]
1	S70 C30 404	PRESSURE RELIEF VALVE	1	1	1		10 bar/ FOR SANITARY SIDE
2	S70 C70 096	FLARE JOINT	1	1	1		5/8F-R1/2
3	S70 C18 150	AIR VENT (AUTOMATIC)	1	1	1		
4	S70 C80 206	MANOMETER STAY	1	1	1		
5	S70 C20 205	MANOMETER	1	1	1		
6	S70 C45 762	3WAY VALVE	1	1	1		5HP
7	S70 C45 762	3WAY VALVE (MOTOR)	1	1	1		
8	S70 C41 441	BOOSTER HEATER	1			BH1	1 ø 230 V 2 kW
8	S70 C42 441	BOOSTER HEATER			1	BH1, BH2	
8	S70 C44 441	BOOSTER HEATER		1			
9	—	BOOSTER HEATER STAY	1		1		[RK00L196G01]
9	—	BOOSTER HEATER STAY		1			[RK00B922G01]
10	S70 C20 452	STRAINER VALVE	1	1	1		
11	S70 C28 460	STRAINER PACKING	1	1	1		FOR STRAINER
12	S70 C10 527	DRAIN HOSE			1		
13	S70 C20 529	DRAIN PAN ASSY			1		
14	S70 C20 356	PUMP VALVE	1	1	1		
15	S70 C10 358	DRAIN COCK/AIR VENT (WATER CAP ASSY 320)	4	4	4		FOR PRIMARY/ SANITARY CIRCUIT
16	S70 C11 355	WATER PUMP	1	1		UPM3	FOR PRIMARY CIRCUIT
16	S70 C13 355	WATER PUMP			1	UPM3K	
17	S70 C85 408	WATER COIL ASSY (W)	1	1	1		WATER/ WATER
18	S70 C60 357	SCALE TRAP	1	1	1		
19	S70 C05 355	WATER PUMP	1	1	1	UPSO	FOR SANITARY CIRCUIT
20	S70 C74 266	FLOW SENSOR (body & Cable)	1	1	1		
21	—	DIV FRAME H	1	1	1		[BK02N520G03]
22	—	TANK CUSHION TOP	1	1	1		[RK25A412G02]
②③	S70 C69 202	THERMISTOR (FLOW WATER TEMP & RETURN WATER TEMP)	1	1	1	THW1/2	
②④	S70 C55 460	GASKET 1"	4	4	4		FOR CONNECTION OF WATER CIRCUIT
②⑤	S70 C66 460	GASKET 3/4"	7	7	7		FOR CONNECTION OF WATER CIRCUIT
②⑥	S70 C88 460	GASKET 1/4"	1	1	1		FOR ONLY MANOMETER
②⑦	S70 C23 460	O-RING	14	14	14		BLACK
②⑧	S70 C01 800	GREASE	1*	1*	1*		FOR QUICK CONNECTION
②⑨	S70 C10 465	FASTENER	14	14	14		FOR QUICK CONNECTION
③⑩	S70 C45 097	ADJUST BOLT	4	4	4		ACCESSORY
③①	S70 C26 460	O-RING	5	5	5		BLACK/ FOR FLOW SENSOR, 3WAY VALVE (Large)
③②	S70 C30 460	O-RING	1	1	1		BLACK/ FOR 3WAY VALVE (Small), TANK
③③	S70 C20 465	FASTENER	5	5	5		FOR FLOW SENSOR, 3WAY VALVE (Large)
③④	S70 C40 465	FASTENER	1	1	1		FOR 3WAY VALVE (Small), TANK

Do not reuse the O-ring or strainer packing that was once removed, but be sure to replace with a new one.
 * Apply grease appropriately on the O-ring for the quick connection in the unit.

EHPT30X-MEDR1.UK
ERPT30X-VM6EDR1.UK

EHPT30X-YM9EDR1.UK

ERPT30X-VM2EDR1.UK

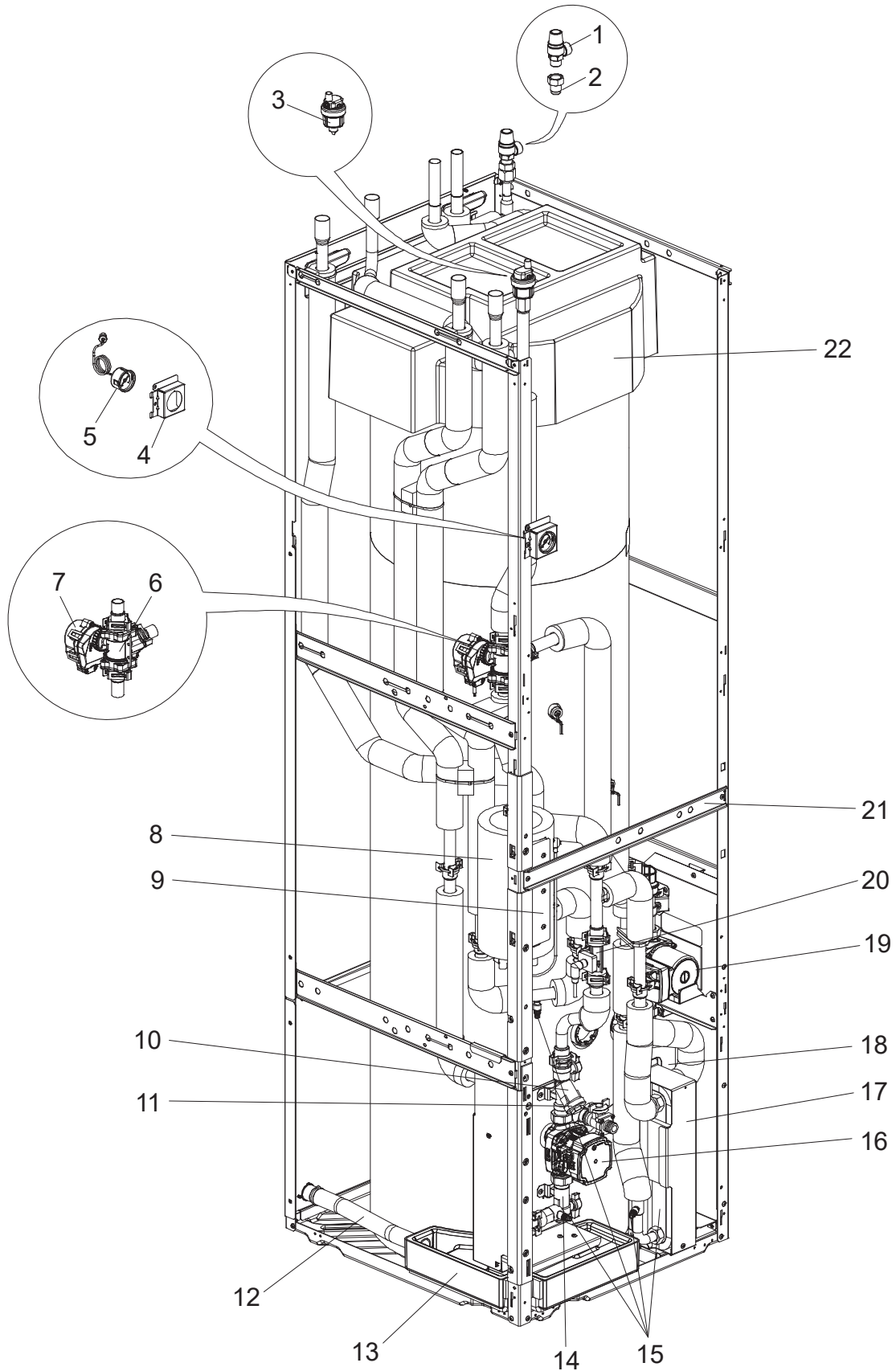

1. The part quantity below indicates the required number of pieces per unit.
2. The circled No. indicates that the part is not shown in the figure

No.	Parts No.	Parts name	EHPT30X-MEDR1.UK	EHPT30X-VM9EDR1.UK	ERPT30X-VM2EDR1.UK	ERPT30X-VM6EDR1.UK	Wiring Diagram Symbol	Remarks [Drawing No.]
1	S70 C30 404	PRESSURE RELIEF VALVE	1	1	1	1		10 bar/ FOR SANITARY SIDE
2	S70 C70 096	FLARE JOINT	1	1	1	1		5/8F-R1/2
3	S70 C18 150	AIR VENT (AUTOMATIC)	1	1	1	1		
4	S70 C80 206	MANOMETER STAY	1	1	1	1		
5	S70 C20 205	MANOMETER	1	1	1	1		
6	S70 C45 762	3WAY VALVE	1	1	1	1		5HP
7	S70 C45 762	3WAY VALVE (MOTOR)	1	1	1	1		
8	S70 C20 452	STRAINER VALVE	1	1	1	1		
9	S70 C28 460	STRAINER PACKING	1	1	1	1		FOR STRAINER
10	S70 C41 441	BOOSTER HEATER	1				BH1	1 ø 230 V 2 kW
10	S70 C42 441	BOOSTER HEATER			1		BH1, BH2	
10	S70 C43 441	BOOSTER HEATER				1	BH1, BH2	
10	S70 C44 441	BOOSTER HEATER		1				
11	—	BOOSTER HEATER STAY	1		1	1		[RK00L196G01]
11	—	BOOSTER HEATER STAY		1				[RK00B922G01]
12	S70 C10 358	DRAIN COCK/AIR VENT (WATER CAP ASSY 320)	4	4	4	4		FOR PRIMARY/ SANITARY CIRCUIT
13	S70 C20 356	PUMP VALVE	1	1	1	1		
14	S70 C10 527	DRAIN HOSE			1	1		
15	S70 C20 529	DRAIN PAN ASSY			1	1		
16	S70 C11 355	WATER PUMP	1	1			UPM3	FOR PRIMARY CIRCUIT
16	S70 C13 355	WATER PUMP			1	1	UPM3K	
17	S70 C85 408	WATER COIL ASSY (W)	1	1	1	1		WATER/ WATER
18	S70 C60 357	SCALE TRAP	1	1	1	1		
19	S70 C05 355	WATER PUMP	1	1	1	1	UPSO	FOR SANITARY CIRCUIT
20	S70 C74 266	FLOW SENSOR (body & Cable)	1	1	1	1		
21	—	DIV FRAME H	1	1	1	1		[BK02N520G03]
22	—	TANK CUSHION TOP	1	1	1	1		[RK25A412G02]
②③	S70 C69 202	THERMISTOR (FLOW WATER TEMP & RETURN WATER TEMP)	1	1	1	1	THW1/2	
②④	S70 C55 460	GASKET 1"	4	4	4	4		FOR CONNECTION OF WATER CIRCUIT
②⑤	S70 C66 460	GASKET 3/4"	7	7	7	7		FOR CONNECTION OF WATER CIRCUIT
②⑥	S70 C88 460	GASKET 1/4"	1	1	1	1		FOR ONLY MANOMETER
②⑦	S70 C23 460	O-RING	14	14	14	14		BLACK
②⑧	S70 C01 800	GREASE	1*	1*	1*	1*		FOR QUICK CONNECTION
②⑨	S70 C10 465	FASTENER	14	14	14	14		FOR QUICK CONNECTION
③⑩	S70 C45 097	ADJUST BOLT	4	4	4	4		ACCESSORY
③①	S70 C26 460	O-RING	5	5	5	5		BLACK/ FOR FLOW SENSOR, 3WAY VALVE (Large)
③②	S70 C30 460	O-RING	1	1	1	1		BLACK/ FOR 3WAY VALVE (Small), TANK
③③	S70 C20 465	FASTENER	5	5	5	5		FOR FLOW SENSOR, 3WAY VALVE (Large)
③④	S70 C40 465	FASTENER	1	1	1	1		FOR 3WAY VALVE (Small), TANK

Do not reuse the O-ring or strainer packing that was once removed, but be sure to replace with a new one.
 * Apply grease appropriately on the O-ring for the quick connection in the unit.

EHST17D-VM2D.UK
EHPT17X-VM6D.UK

ERST17D-VM2D.UK
EHPT17X-YM9D.UK

EHPT17X-VM2D.UK
ERPT17X-VM2D.UK

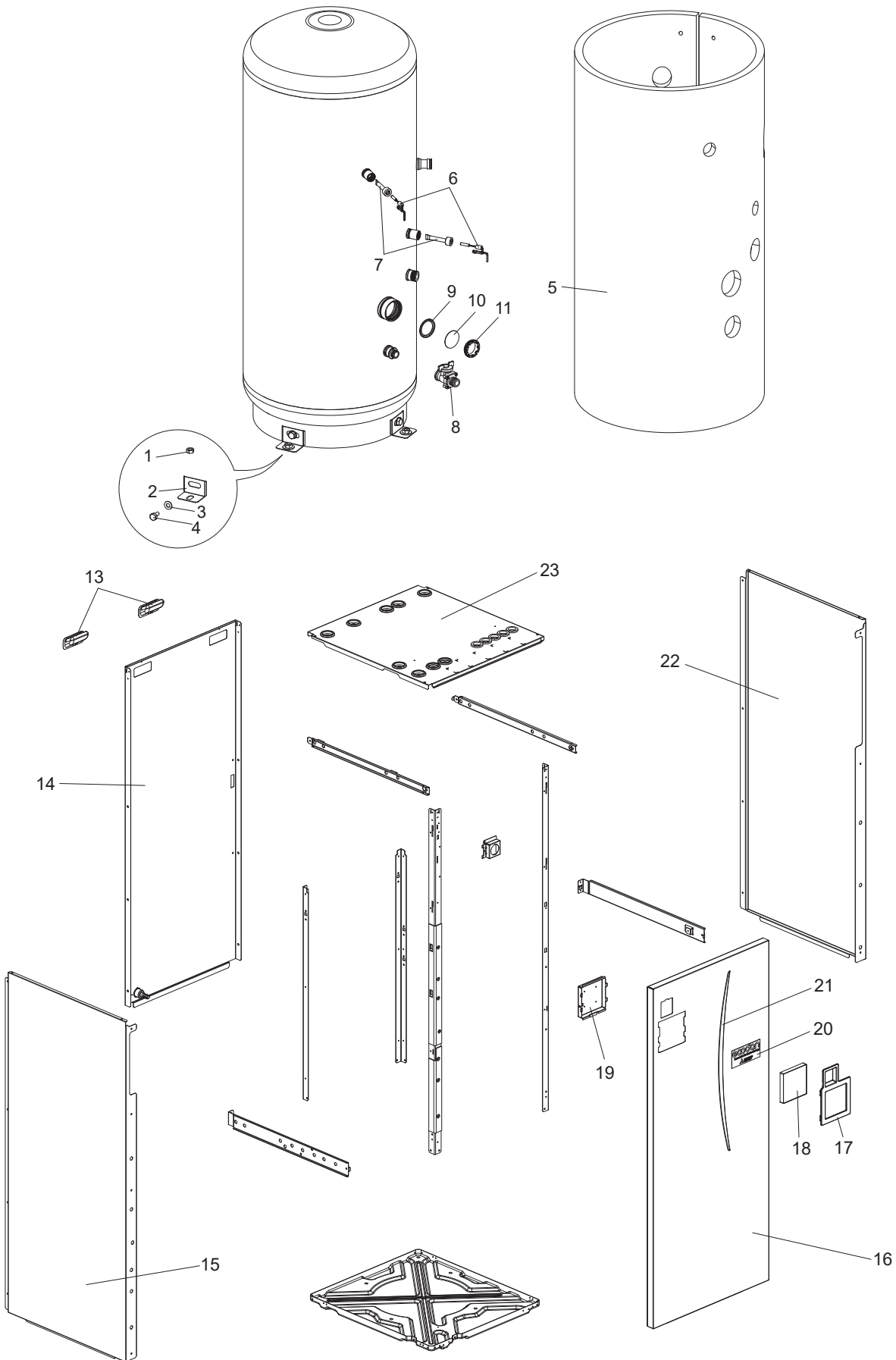

1. The part quantity below indicates the required number of pieces per unit.
2. The circled No. indicates that the part is not shown in the figure.

No.	Parts No.	Parts name	EHST17D-VM2D.UK	ERST17D-VM2D.UK	EHPT17X-VM2D.UK	EHPT17X-VM6D.UK	EHPT17X-VM9D.UK	ERPT17X-VM2D.UK	Wiring Diagram Symbol	Remarks [Drawing No.]
1	S70 C10 097	NUT	3	3	3	3	3	3		
2	S70 C61 097	WASHER	3	3	3	3	3	3		
3	S70 C30 042	TANK LEG	3	3	3	3	3	3		
4	S70 C20 097	WASHER	3	3	3	3	3	3		
5	S70 C30 097	BOLT	3	3	3	3	3	3		
6	S70 C65 042	TANK INSULATOR	1	1	1	1	1	1		
7	S70 C68 202	THERMISTOR (TANK WATER TEMP)	1	1	1	1	1	1	THW5	
8	S70 C11 525	STAT POCKET ASSEMBLY	1	1	1	1	1	1		
9	S70 C40 357	DRAIN COCK	1	1	1	1	1	1		FOR TANK
10	S70 C33 460	ELEMENT PLATE GASKET	1	1	1	1	1	1		
11	S70 C40 446	BLANKING PLATE	1	1	1	1	1	1		
12	S70 C60 097	BACKNUT	1	1	1	1	1	1		
13	S70 30L 655	HANDLE	2	2	2	2	2	2		
14	S70 C22 661	BACK PANEL			1	1	1			
14	S70 C26 661	BACK PANEL	1	1				1		
15	S70 C67 662	SIDE PANEL L	1	1	1	1	1	1		
16	S70 C35 668	FRONT PANEL	1	1	1	1	1	1		
17	—	MAIN REMOTE CONTROLLER SUPPORT	1	1	1	1	1	1		[BK00R897G01]
18	S70 C20 200	MAIN REMOTE CONTROLLER ASSY	1	1	1	1	1	1		
19	S70 C31 710	MAIN REMOTE CONTROLLER HOLDER	1	1	1	1	1	1		
20	S70 C25 699	BRAND LABEL	1	1	1	1	1	1		
21	S70 C30 699	LEAF LABEL	1	1	1	1	1	1		
22	S70 C72 662	SIDE PANEL R	1	1	1	1	1	1		
23	S70 C29 641	TOP PANEL DWG	1	1						
23	S70 C27 641	TOP PANEL DWG			1	1	1	1		
②4	S70 C21 699	WIRING DIAGRAM FOR FRONT PANEL	1	1	1			1		
②4	S70 C22 699	WIRING DIAGRAM FOR FRONT PANEL				1				
②4	S70 C23 699	WIRING DIAGRAM FOR FRONT PANEL					1			

ERST17D-VM2BD.UK

ERST17D-VM6BD.UK

ERST17D-YM9BD.UK

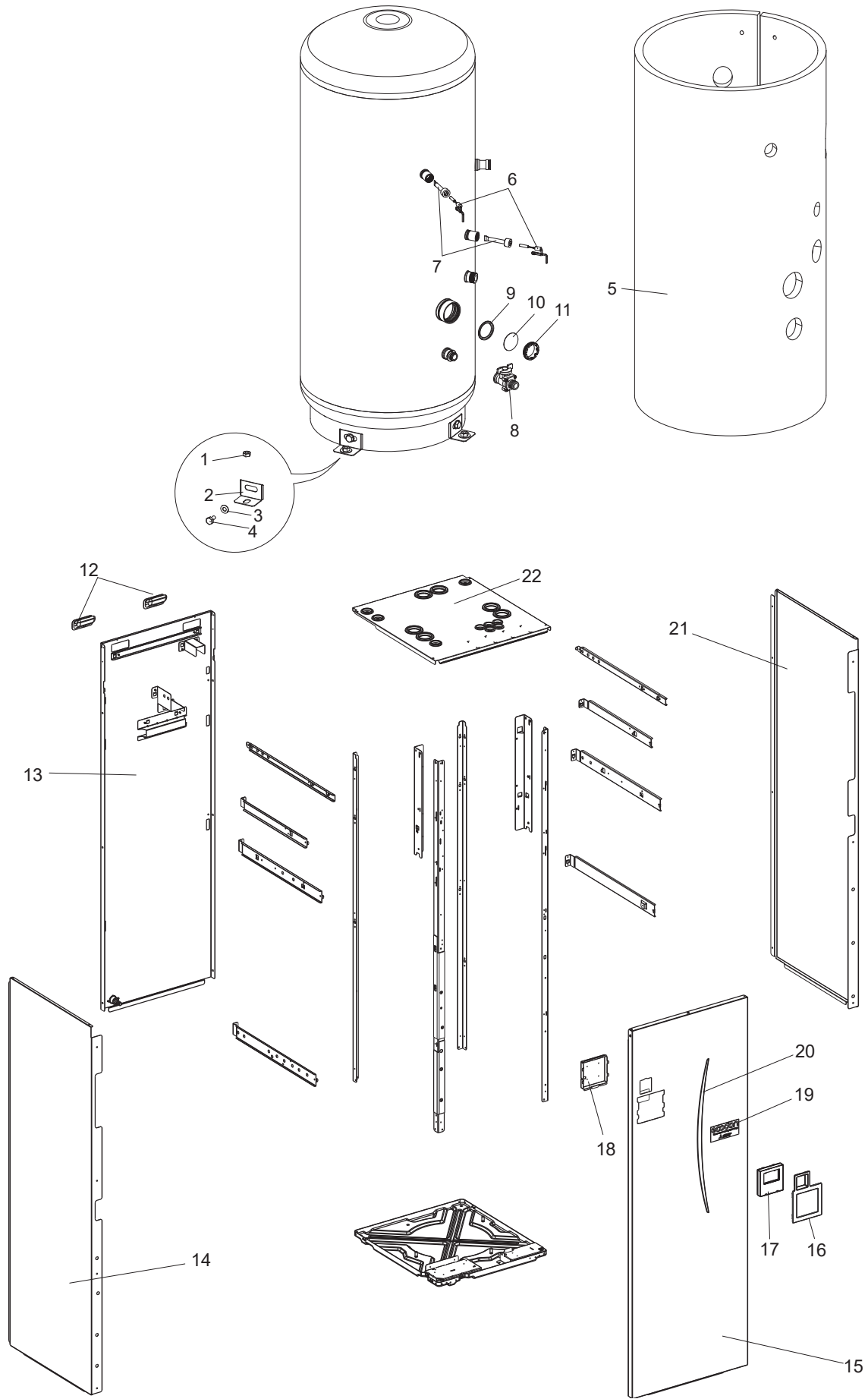

1. The part quantity below indicates the required number of pieces per unit.
2. The circled No. indicates that the part is not shown in the figure.

No.	Parts No.	Parts name	ERST17D-VM2BD.UK	ERST17D-VM6BD.UK	ERST17D-VM9BD.UK	Wiring Diagram Symbol	Remarks [Drawing No.]
1	S70 C10 097	NUT	3	3	3	M10	
2	S70 C30 042	TANK LEG	3	3	3		
3	S70 C20 097	WASHER	3	3	3		
4	S70 C30 097	BOLT	3	3	3	M10x20	
5	S70 C65 042	TANK INSULATOR	1	1	1		
6	S70 C68 202	THERMISTOR (TANK WATER TEMP)	1	1	1		
7	S70 C11 525	STAT POCKET ASSEMBLY	1	1	1		
8	S70 C40 357	DRAIN COCK	1	1	1		
9	S70 C33 460	ELEMENT PLATE GASKET	1	1	1		
10	S70 C40 446	BLANKING PLATE	1	1	1		
11	S70 C60 097	BACKNUT	1	1	1		
12	S70 30L 655	HANDLE	2	2	2		
13	S70 C30 661	BACK PANEL	1	1	1		
14	S70 C77 662	SIDE PANEL L	1	1	1		
15	S70 C36 668	FRONT PANEL	1	1	1		
16	—	MAIN REMOTE CONTROLLER SUPPORT	1	1	1		[BK00R897G01]
17	S70 C20 200	MAIN REMOTE CONTROLLER ASSY	1	1	1		
18	S70 C31 710	MAIN REMOTE CONTROLLER HOLDER	1	1	1		
19	S70 C25 699	BRAND LABEL	1	1	1		
20	S70 C30 699	LEAF LABEL	1	1	1		
21	S70 C78 662	SIDE PANEL R	1	1	1		
22	S70 C31 641	TOP PANEL ASSY	1	1	1		
②3	S70 C29 699	WIRING DIAGRAM FOR FRONT PANEL	1				
②3	S70 C31 699	WIRING DIAGRAM FOR FRONT PANEL		1			
②3	S70 C32 699	WIRING DIAGRAM FOR FRONT PANEL			1		

EHST17D-VM2DR1.UK
ERST17D-VM6DR1.UK
EHPT17X-YM9DR1.UK

EHST17D-YM9DR1.UK
EHPT17X-VM2DR1.UK
ERPT17X-VM2DR1.UK

ERST17D-VM2DR1.UK
EHPT17X-VM6DR1.UK

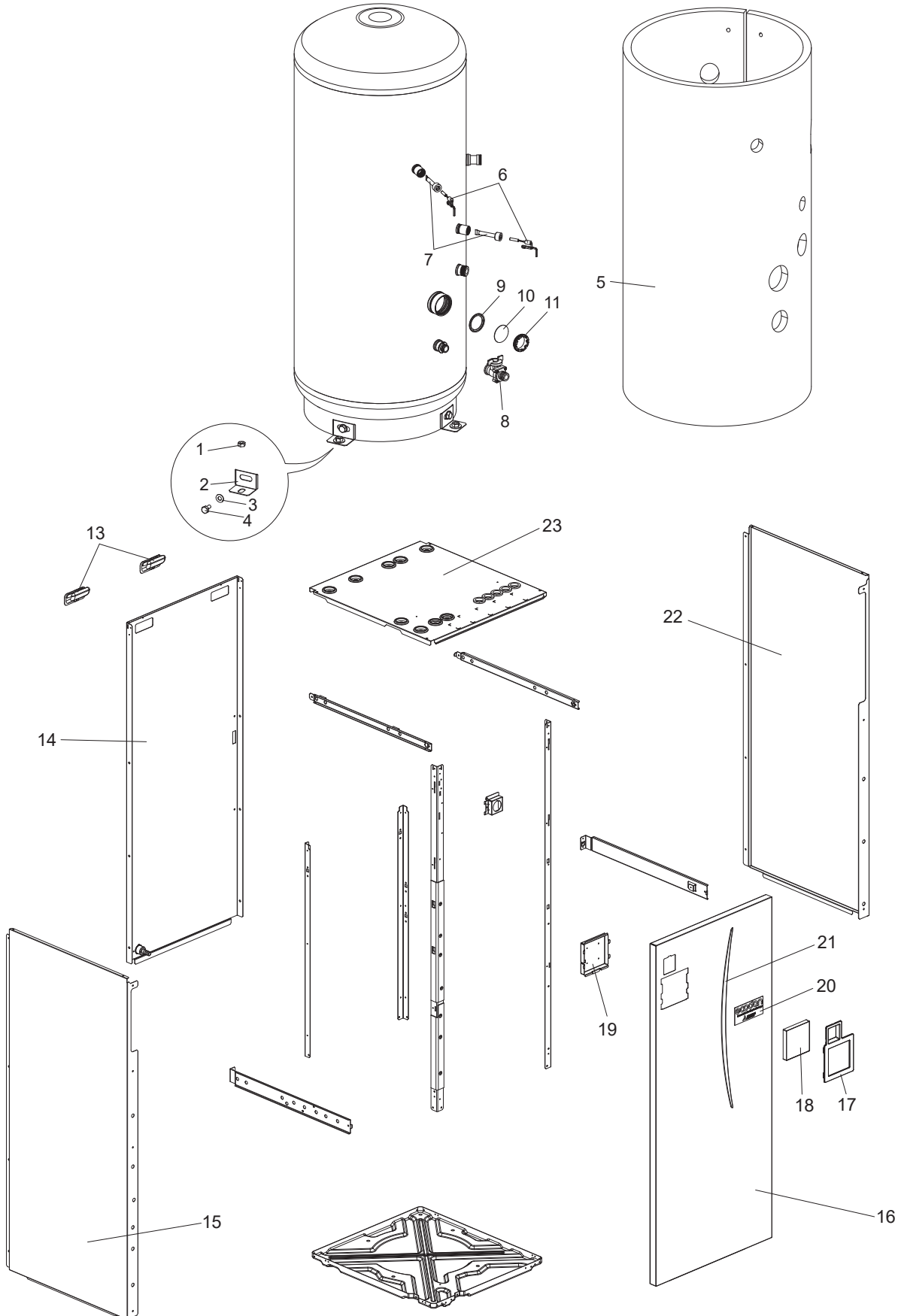

1. The part quantity below indicates the required number of pieces per unit.
2. The circled No. indicates that the part is not shown in the figure.

No.	Parts No.	Parts name	EHST17D-VM2DR1.UK	EHST17D-YM9DR1.UK	ERST17D-VM2DR1.UK	ERST17D-VM6DR1.UK	EHPT17X-VM2DR1.UK	EHPT17X-VM6DR1.UK	EHPT17X-YM9DR1.UK	ERPT17X-VM2DR1.UK	Wiring Diagram Symbol	Remarks [Drawing No.]
1	S70 C10 097	NUT	3	3	3	3	3	3	3	3		
2	S70 C61 097	WASHER	3	3	3	3	3	3	3	3		
3	S70 C30 042	TANK LEG	3	3	3	3	3	3	3	3		
4	S70 C20 097	WASHER	3	3	3	3	3	3	3	3		
5	S70 C30 097	BOLT	3	3	3	3	3	3	3	3		
6	S70 C65 042	TANK INSULATOR	1	1	1	1	1	1	1	1		
7	S70 C68 202	THERMISTOR (TANK WATER TEMP)	1	1	1	1	1	1	1	1	THW5	
8	S70 C11 525	STAT POCKET ASSEMBLY	1	1	1	1	1	1	1	1		
9	S70 C40 357	DRAIN COCK	1	1	1	1	1	1	1	1		FOR TANK
10	S70 C33 460	ELEMENT PLATE GASKET	1	1	1	1	1	1	1	1		
11	S70 C40 446	BLANKING PLATE	1	1	1	1	1	1	1	1		
12	S70 C60 097	BACKNUT	1	1	1	1	1	1	1	1		
13	S70 30L 655	HANDLE	2	2	2	2	2	2	2	2		
14	S70 C22 661	BACK PANEL	1	1			1	1	1			
14	S70 C26 661	BACK PANEL			1	1				1		
15	S70 C67 662	SIDE PANEL L	1	1	1	1	1	1	1	1		
16	S70 C35 668	FRONT PANEL	1	1	1	1		1	1	1		
17	—	MAIN REMOTE CONTROLLER SUPPORT	1	1	1	1	1	1	1	1		[BK00R897G01]
18	S70 C20 200	MAIN REMOTE CONTROLLER ASSY	1	1	1	1	1	1	1	1		
19	S70 C31 710	MAIN REMOTE CONTROLLER HOLDER	1	1	1	1	1	1	1	1		
20	S70 C25 699	BRAND LABEL	1	1	1	1	1	1	1	1		
21	S70 C30 699	LEAF LABEL	1	1	1	1	1	1	1	1		
22	S70 C72 662	SIDE PANEL R	1	1	1	1	1	1	1	1		
23	S70 C29 641	TOP PANEL DWG	1	1	1	1						
23	S70 C27 641	TOP PANEL DWG					1	1	1	1		
②4	S70 C21 699	WIRING DIAGRAM FOR FRONT PANEL	1		1		1			1		
②4	S70 C22 699	WIRING DIAGRAM FOR FRONT PANEL				1		1				
②4	S70 C23 699	WIRING DIAGRAM FOR FRONT PANEL		1					1			

EHST20D-MED.UK
 EHST20D-YM9D.UK
 ERST20D-VM2D.UK
 EHST20C-MED.UK
 EHST20C-YM9D.UK
 ERST20C-VM2D.UK

EHST20D-VM2D.UK
 EHST20D-YM9ED.UK
 EHST20C-VM2D.UK
 EHST20C-YM9ED.UK

EHST20D-VM6D.UK
 EHST20D-TM9D.UK
 EHST20C-VM6D.UK
 EHST20C-TM9D.UK

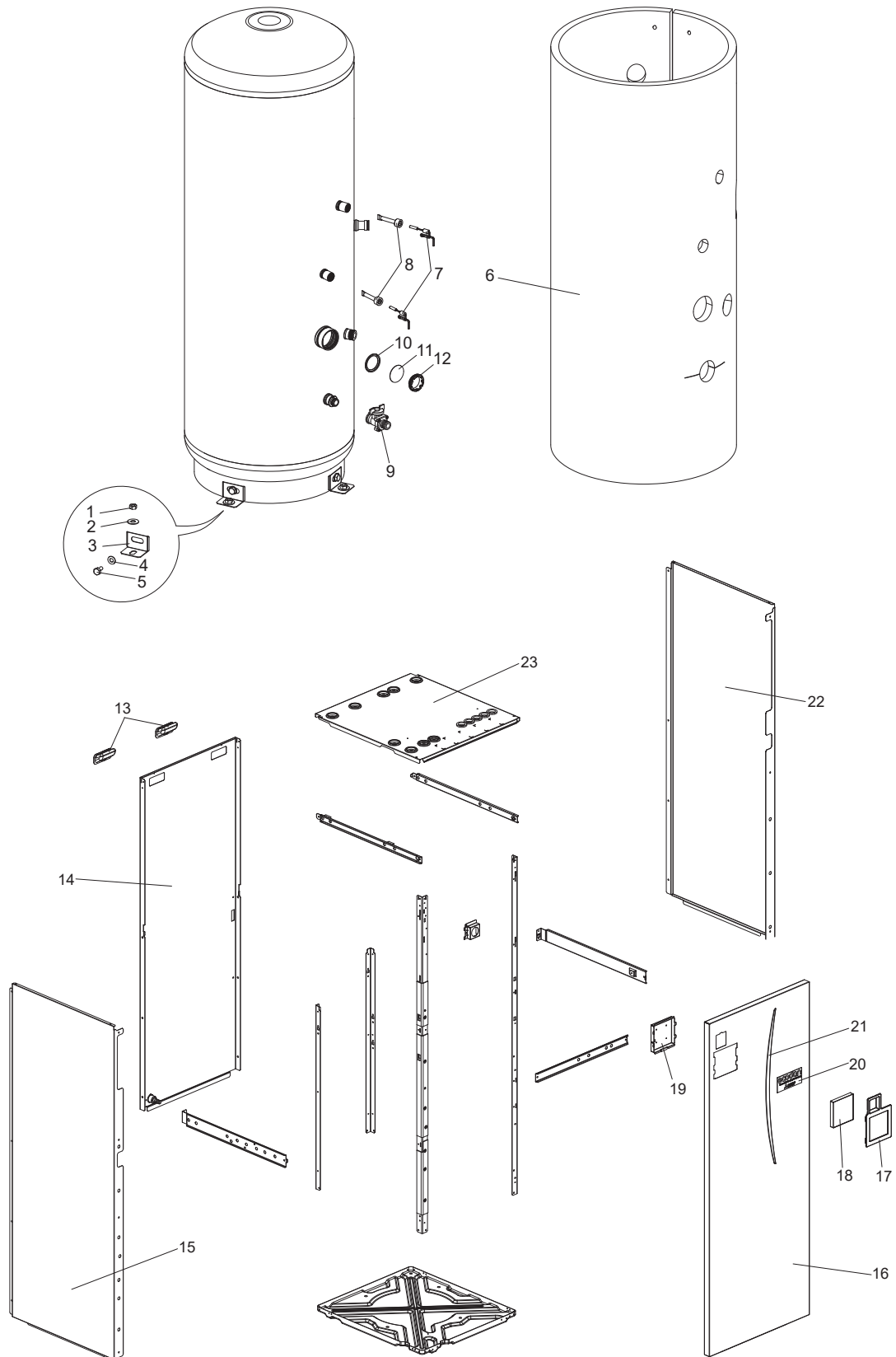

1. The part quantity below indicates the required number of pieces per unit.
2. The circled No. indicates that the part is not shown in the figure.

No.	Parts No.	Parts name															Wiring Diagram Symbol	Remarks [Drawing No.]
			EHST20D-MED.UK	EHST20D-VM2D.UK	EHST20D-VM6D.UK	EHST20D-YM9D.UK	EHST20D-YM9ED.UK	EHST20D-TM9D.UK	ERST20D-VM2D.UK	EHST20C-MED.UK	EHST20C-VM2D.UK	EHST20C-VM6D.UK	EHST20C-YM9D.UK	EHST20C-YM9ED.UK	ERST20C-TM9D.UK	ERST20C-VM2D.UK		
1	S70 C10 097	NUT	3	3	3	3	3	3	3	3	3	3	3	3	3			
2	S70 C61 097	WASHER	3	3	3	3	3	3	3	3	3	3	3	3	3			
3	S70 C30 042	TANK LEG	3	3	3	3	3	3	3	3	3	3	3	3	3			
4	S70 C20 097	WASHER	3	3	3	3	3	3	3	3	3	3	3	3	3			
5	S70 C30 097	BOLT	3	3	3	3	3	3	3	3	3	3	3	3	3			
6	S70 C75 042	TANK INSULATOR	1	1	1	1	1	1	1	1	1	1	1	1	1			
7	S70 C68 202	THERMISTOR (TANK WATER TEMP)	1	1	1	1	1	1	1	1	1	1	1	1	1	THW5		
8	S70 C11 525	STAT POCKET ASSEMBLY	1	1	1	1	1	1	1	1	1	1	1	1	1			
9	S70 C40 357	DRAIN COCK	1	1	1	1	1	1	1	1	1	1	1	1	1		FOR TANK	
10	S70 C33 460	ELEMENT PLATE GASKET	1	1	1	1	1	1	1	1	1	1	1	1	1			
11	S70 C40 446	BLANKING PLATE	1	1	1	1	1	1	1	1	1	1	1	1	1		FOR TANK	
12	S70 C60 097	BACKNUT	1	1	1	1	1	1	1	1	1	1	1	1	1			
13	S70 30L 655	HANDLE	2	2	2	2	2	2	2	2	2	2	2	2	2			
14	S70 C23 661	BACK PANEL	1	1	1	1	1	1		1	1	1	1	1	1			
14	S70 C25 661	BACK PANEL							1						1			
15	S70 C71 662	SIDE PANEL L	1	1	1	1	1	1	1	1	1	1	1	1	1			
16	S70 C22 668	FRONT PANEL	1	1	1	1	1	1	1	1	1	1	1	1	1			
17	—	MAIN REMOTE CONTROLLER SUPPORT	1	1	1	1	1	1	1	1	1	1	1	1	1		[BK00R897G01]	
18	S70 C20 200	MAIN REMOTE CONTROLLER ASSY	1	1	1	1	1	1	1	1	1	1	1	1	1			
19	S70 C31 710	MAIN REMOTE CONTROLLER HOLDER	1	1	1	1	1	1	1	1	1	1	1	1	1			
20	S70 C25 699	BRAND LABEL	1	1	1	1	1	1	1	1	1	1	1	1	1			
21	S70 C30 699	LEAF LABEL	1	1	1	1	1	1	1	1	1	1	1	1	1			
22	S70 C74 662	SIDE PANEL R	1	1	1	1	1	1	1	1	1	1	1	1	1			
23	S70 C30 641	TOP PANEL DWG	1	1	1	1	1	1	1	1	1	1	1	1	1			
②4	S70 C21 699	WIRING DIAGRAM FOR FRONT PANEL		1					1		1					1		
②4	S70 C22 699	WIRING DIAGRAM FOR FRONT PANEL			1							1						
②4	S70 C23 699	WIRING DIAGRAM FOR FRONT PANEL				1	1						1	1				
②4	S70 C24 699	WIRING DIAGRAM FOR FRONT PANEL						1								1		
②4	S70 C27 699	WIRING DIAGRAM FOR FRONT PANEL	1							1								

EHST20D-MEDR1.UK
 EHST20D-YM9DR1.UK
 ERST20D-VM2DR1.UK
 EHST20C-MEDR1.UK
 EHST20C-YM9DR1.UK
 ERST20C-VM2DR1.UK

EHST20D-VM2DR1.UK
 EHST20D-YM9EDR1.UK
 ERST20D-VM6DR1.UK
 EHST20C-VM2DR1.UK
 EHST20C-YM9EDR1.UK
 ERST20C-VM6DR1.UK

EHST20D-VM6DR1.UK
 EHST20D-TM9DR1.UK
 ERST20D-YM9DR1.UK
 EHST20C-VM6DR1.UK
 EHST20C-TM9DR1.UK
 ERST20C-YM9DR1.UK

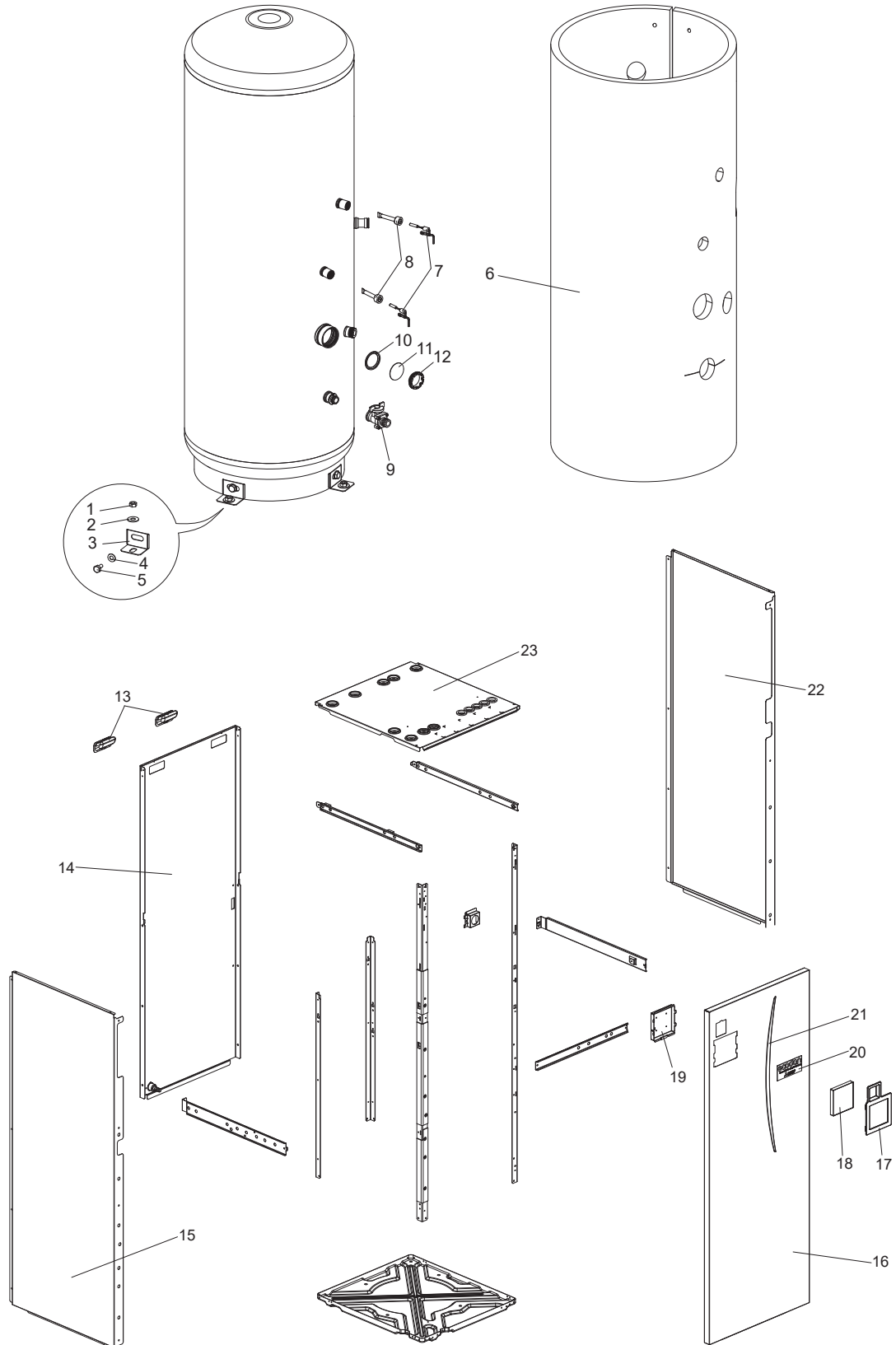

1. The part quantity below indicates the required number of pieces per unit.
2. The circled No. indicates that the part is not shown in the figure.

No.	Parts No.	Parts name	EHST20D-MEDR1.UK	EHST20D-VM2DR1.UK	EHST20D-VM6DR1.UK	EHST20D-YM9DR1.UK	EHST20D-YM9EDR1.UK	EHST20D-TM9DR1.UK	ERST20D-VM2DR1.UK	ERST20D-VM6DR1.UK	ERST20D-YM9DR1.UK	EHST20C-MEDR1.UK	EHST20C-VM2DR1.UK	EHST20C-VM6DR1.UK	EHST20C-YM9DR1.UK	EHST20C-YM9EDR1.UK	EHST20C-TM9DR1.UK	ERST20C-VM2DR1.UK	ERST20C-VM6DR1.UK	ERST20C-YM9DR1.UK	Wiring Diagram Symbol	Remarks [Drawing No.]	
			3	3	3	3	3	3	3	3	3	3	3	3	3	3	3	3	3	3			3
1	S70 C10 097	NUT	3	3	3	3	3	3	3	3	3	3	3	3	3	3	3	3	3	3			
2	S70 C61 097	WASHER	3	3	3	3	3	3	3	3	3	3	3	3	3	3	3	3	3	3	3		
3	S70 C30 042	TANK LEG	3	3	3	3	3	3	3	3	3	3	3	3	3	3	3	3	3	3	3		
4	S70 C20 097	WASHER	3	3	3	3	3	3	3	3	3	3	3	3	3	3	3	3	3	3	3		
5	S70 C30 097	BOLT	3	3	3	3	3	3	3	3	3	3	3	3	3	3	3	3	3	3	3		
6	S70 C75 042	TANK INSULATOR	1	1	1	1	1	1	1	1	1	1	1	1	1	1	1	1	1	1	1		
7	S70 C68 202	THERMISTOR (TANK WATER TEMP)	1	1	1	1	1	1	1	1	1	1	1	1	1	1	1	1	1	1	1	THW5	
8	S70 C11 525	STAT POCKET ASSEMBLY	1	1	1	1	1	1	1	1	1	1	1	1	1	1	1	1	1	1	1		
9	S70 C40 357	DRAIN COCK	1	1	1	1	1	1	1	1	1	1	1	1	1	1	1	1	1	1	1		FOR TANK
10	S70 C33 460	ELEMENT PLATE GASKET	1	1	1	1	1	1	1	1	1	1	1	1	1	1	1	1	1	1	1		
11	S70 C40 446	BLANKING PLATE	1	1	1	1	1	1	1	1	1	1	1	1	1	1	1	1	1	1	1		FOR TANK
12	S70 C60 097	BACKNUT	1	1	1	1	1	1	1	1	1	1	1	1	1	1	1	1	1	1	1		
13	S70 30L 655	HANDLE	2	2	2	2	2	2	2	2	2	2	2	2	2	2	2	2	2	2	2		
14	S70 C23 661	BACK PANEL	1	1	1	1	1	1				1	1	1	1	1	1						
14	S70 C25 661	BACK PANEL							1	1	1								1	1	1		
15	S70 C71 662	SIDE PANEL L	1	1	1	1	1	1	1	1	1	1	1	1	1	1	1	1	1	1	1		
16	S70 C22 668	FRONT PANEL	1	1	1	1	1	1	1	1	1	1	1	1	1	1	1	1	1	1	1		
17	—	MAIN REMOTE CONTROLLER SUPPORT	1	1	1	1	1	1	1	1	1	1	1	1	1	1	1	1	1	1	1		[BK00R897G01]
18	S70 C20 200	MAIN REMOTE CONTROLLER ASSY	1	1	1	1	1	1	1	1	1	1	1	1	1	1	1	1	1	1	1		
19	S70 C31 710	MAIN REMOTE CONTROLLER HOLDER	1	1	1	1	1	1	1	1	1	1	1	1	1	1	1	1	1	1	1		
20	S70 C25 699	BRAND LABEL	1	1	1	1	1	1	1	1	1	1	1	1	1	1	1	1	1	1	1		
21	S70 C30 699	LEAF LABEL	1	1	1	1	1	1	1	1	1	1	1	1	1	1	1	1	1	1	1		
22	S70 C74 662	SIDE PANEL R	1	1	1	1	1	1	1	1	1	1	1	1	1	1	1	1	1	1	1		
23	S70 C30 641	TOP PANEL DWG	1	1	1	1	1	1	1	1	1	1	1	1	1	1	1	1	1	1	1		
②4	S70 C21 699	WIRING DIAGRAM FOR FRONT PANEL		1					1				1							1			
②4	S70 C22 699	WIRING DIAGRAM FOR FRONT PANEL			1					1				1							1		
②4	S70 C23 699	WIRING DIAGRAM FOR FRONT PANEL				1	1				1				1	1					1		
②4	S70 C24 699	WIRING DIAGRAM FOR FRONT PANEL						1									1						
②4	S70 C27 699	WIRING DIAGRAM FOR FRONT PANEL	1									1											

EHPT20X-MED.UK
EHPT20X-YM9ED.UK
ERPT20X-MD.UK

EHPT20X-VM6D.UK
EHPT20X-TM9D.UK
ERPT20X-VM2D.UK

EHPT20X-YM9D.UK
ERPT20X-VM6D.UK

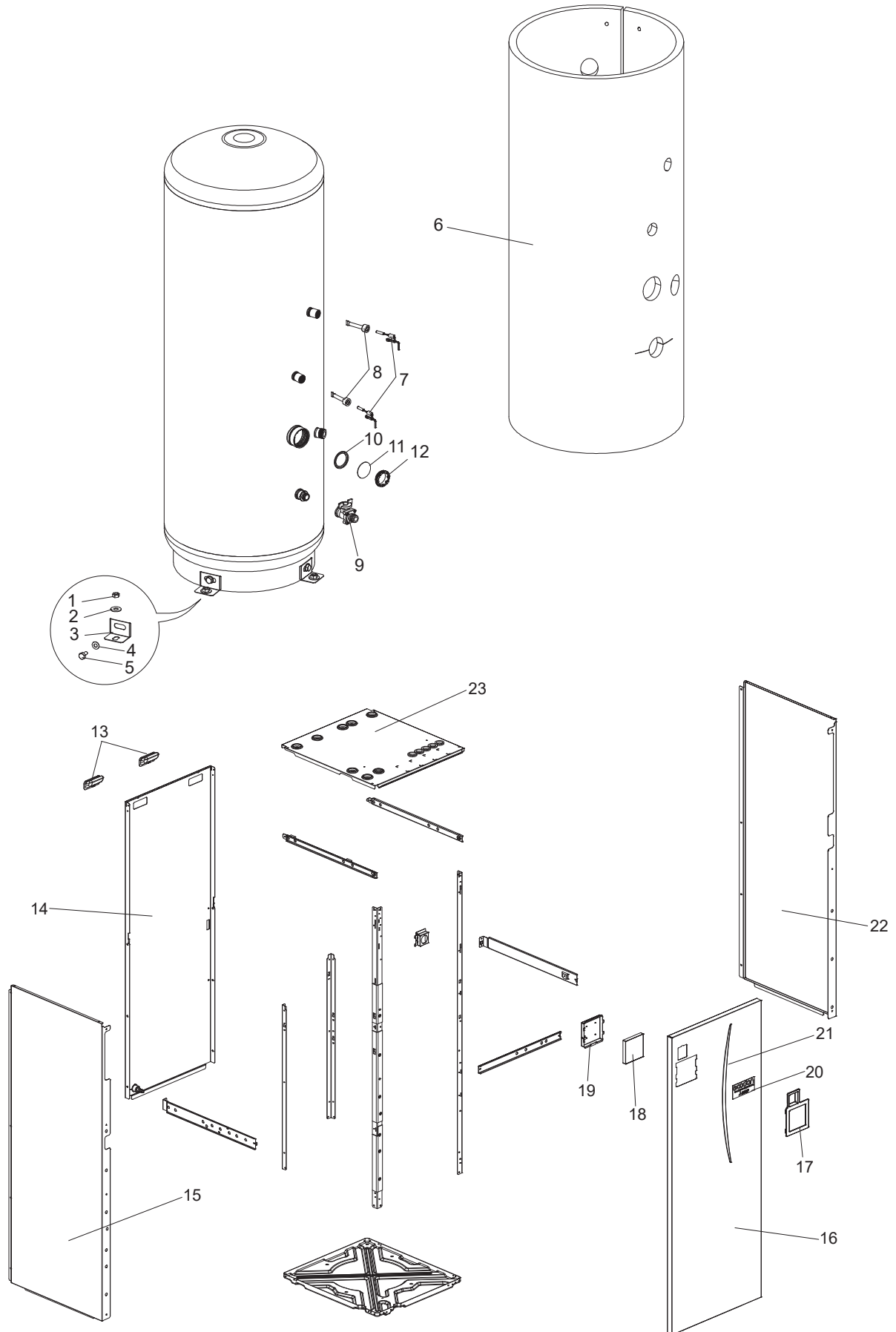

1. The part quantity below indicates the required number of pieces per unit.
2. The circled No. indicates that the part is not shown in the figure.

No.	Parts No.	Parts name	EHPT20X-MED.UK	EHPT20X-VM6D.UK	EHPT20X-YM9D.UK	EHPT20X-YM9ED.UK	EHPT20X-TM9D.UK	ERPT20X-MD.UK	ERPT20X-VM2D.UK	ERPT20X-VM6D.UK	Wiring Diagram Symbol	Remarks [Drawing No.]
1	S70 C10 097	NUT	3	3	3	3	3	3	3	3		
2	S70 C61 097	WASHER	3	3	3	3	3	3	3	3		
3	S70 C30 042	TANK LEG	3	3	3	3	3	3	3	3		
4	S70 C20 097	WASHER	3	3	3	3	3	3	3	3		
5	S70 C30 097	BOLT	3	3	3	3	3	3	3	3		
6	S70 C75 042	TANK INSULATOR	1	1	1	1	1	1	1	1		
7	S70 C68 202	THERMISTOR (TANK WATER TEMP)	1	1	1	1	1	1	1	1	THW5	
8	S70 C11 525	STAT POCKET ASSEMBLY	1	1	1	1	1	1	1	1		
9	S70 C40 357	DRAIN COCK	1	1	1	1	1	1	1	1		FOR TANK
10	S70 C33 460	ELEMENT PLATE GASKET	1	1	1	1	1	1	1	1		
11	S70 C40 446	BLANKING PLATE	1	1	1	1	1	1	1	1		FOR TANK
12	S70 C60 097	BACKNUT	1	1	1	1	1	1	1	1		
13	S70 30L 655	HANDLE	2	2	2	2	2	2	2	2		
14	S70 C23 661	BACK PANEL	1	1	1	1	1					
14	S70 C25 661	BACK PANEL						1	1	1		
15	S70 C71 662	SIDE PANEL L	1	1	1	1	1	1	1	1		
16	S70 C22 668	FRONT PANEL	1	1	1	1	1	1	1	1		
17	—	MAIN REMOTE CONTROLLER SUPPORT	1	1	1	1	1	1	1	1		[BK00R897G01]
18	S70 C20 200	MAIN REMOTE CONTROLLER ASSY	1	1	1	1	1	1	1	1		
19	S70 C31 710	MAIN REMOTE CONTROLLER HOLDER	1	1	1	1	1	1	1	1		
20	S70 C25 699	BRAND LABEL	1	1	1	1	1	1	1	1		
21	S70 C30 699	LEAF LABEL	1	1	1	1	1	1	1	1		
22	S70 C74 662	SIDE PANEL R	1	1	1	1	1	1	1	1		
23	S70 C26 641	TOP PANEL DWG	1	1	1	1	1	1	1	1		
(24)	S70 C21 699	WIRING DIAGRAM FOR FRONT PANEL							1			
(24)	S70 C22 699	WIRING DIAGRAM FOR FRONT PANEL		1						1		
(24)	S70 C23 699	WIRING DIAGRAM FOR FRONT PANEL			1	1						
(24)	S70 C24 699	WIRING DIAGRAM FOR FRONT PANEL					1					
(24)	S70 C27 699	WIRING DIAGRAM FOR FRONT PANEL	1					1				

EHPT20X-MEDR1.UK
EHPT20X-YM9EDR1.UK
ERPT20X-MDR1.UK

EHPT20X-VM6DR1.UK
EHPT20X-TM9DR1.UK
ERPT20X-VM2DR1.UK

EHPT20X-YM9DR1.UK
ERPT20X-VM6DR1.UK

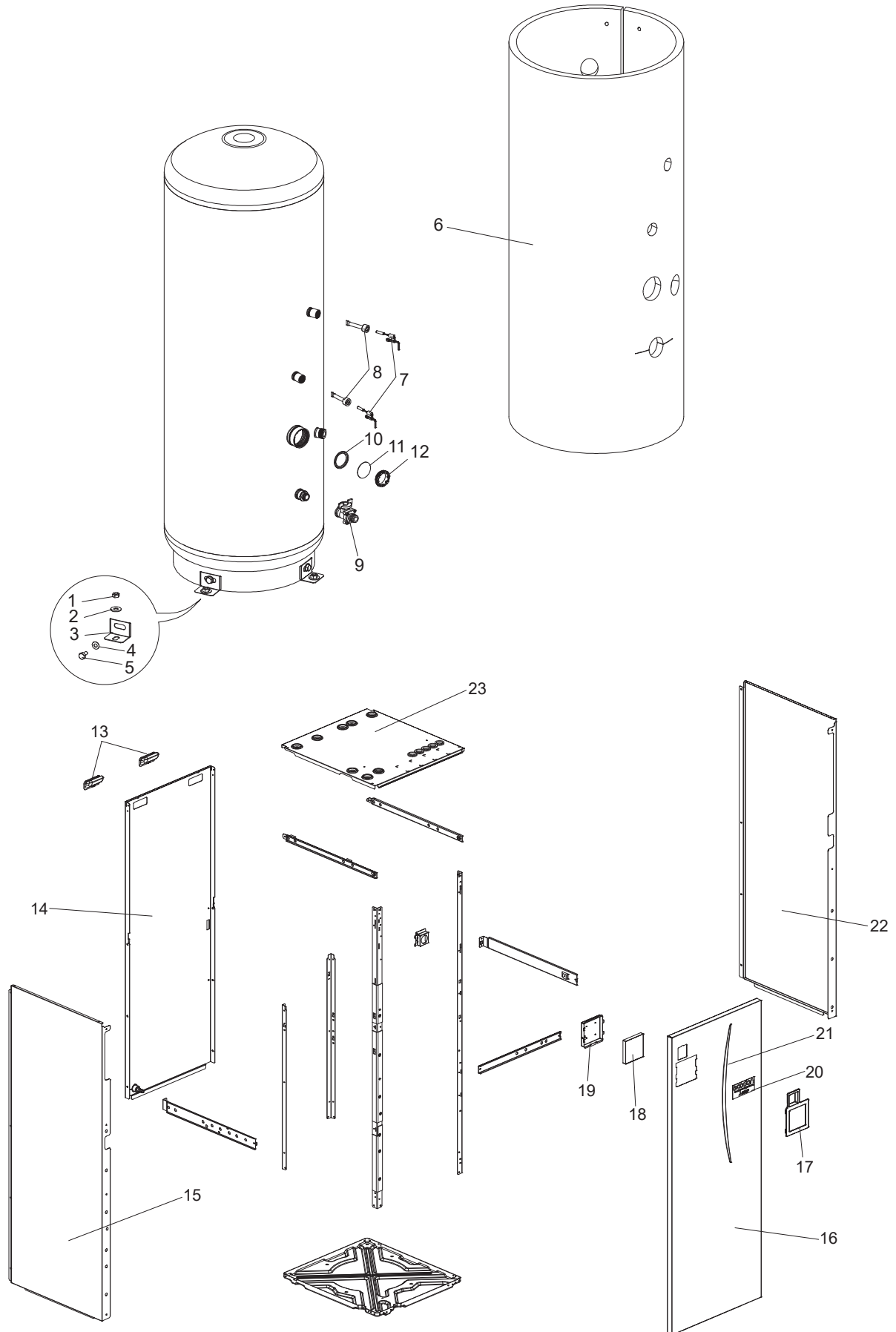

1. The part quantity below indicates the required number of pieces per unit.
2. The circled No. indicates that the part is not shown in the figure.

No.	Parts No.	Parts name	EHPT20X-MEDR1.UK	EHPT20X-VM6DR1.UK	EHPT20X-YM9DR1.UK	EHPT20X-YM9EDR1.UK	EHPT20X-TM9DR1.UK	ERPT20X-MDR1.UK	ERPT20X-VM2DR1.UK	ERPT20X-VM6DR1.UK	Wiring Diagram Symbol	Remarks [Drawing No.]
1	S70 C10 097	NUT	3	3	3	3	3	3	3	3		
2	S70 C61 097	WASHER	3	3	3	3	3	3	3	3		
3	S70 C30 042	TANK LEG	3	3	3	3	3	3	3	3		
4	S70 C20 097	WASHER	3	3	3	3	3	3	3	3		
5	S70 C30 097	BOLT	3	3	3	3	3	3	3	3		
6	S70 C75 042	TANK INSULATOR	1	1	1	1	1	1	1	1		
7	S70 C68 202	THERMISTOR (TANK WATER TEMP)	1	1	1	1	1	1	1	1	THW5	
8	S70 C11 525	STAT POCKET ASSEMBLY	1	1	1	1	1	1	1	1		
9	S70 C40 357	DRAIN COCK	1	1	1	1	1	1	1	1		FOR TANK
10	S70 C33 460	ELEMENT PLATE GASKET	1	1	1	1	1	1	1	1		
11	S70 C40 446	BLANKING PLATE	1	1	1	1	1	1	1	1		FOR TANK
12	S70 C60 097	BACKNUT	1	1	1	1	1	1	1	1		
13	S70 30L 655	HANDLE	2	2	2	2	2	2	2	2		
14	S70 C23 661	BACK PANEL	1	1	1	1	1					
14	S70 C25 661	BACK PANEL						1	1	1		
15	S70 C71 662	SIDE PANEL L	1	1	1	1	1	1	1	1		
16	S70 C22 668	FRONT PANEL	1	1	1	1	1	1	1	1		
17	—	MAIN REMOTE CONTROLLER SUPPORT	1	1	1	1	1	1	1	1		[BK00R897G01]
18	S70 C20 200	MAIN REMOTE CONTROLLER ASSY	1	1	1	1	1	1	1	1		
19	S70 C31 710	MAIN REMOTE CONTROLLER HOLDER	1	1	1	1	1	1	1	1		
20	S70 C25 699	BRAND LABEL	1	1	1	1	1	1	1	1		
21	S70 C30 699	LEAF LABEL	1	1	1	1	1	1	1	1		
22	S70 C74 662	SIDE PANEL R	1	1	1	1	1	1	1	1		
23	S70 C26 641	TOP PANEL DWG	1	1	1	1	1	1	1	1		
(24)	S70 C21 699	WIRING DIAGRAM FOR FRONT PANEL							1			
(24)	S70 C22 699	WIRING DIAGRAM FOR FRONT PANEL		1						1		
(24)	S70 C23 699	WIRING DIAGRAM FOR FRONT PANEL			1	1						
(24)	S70 C24 699	WIRING DIAGRAM FOR FRONT PANEL					1					
(24)	S70 C27 699	WIRING DIAGRAM FOR FRONT PANEL	1						1			

EHPT20X-MHEDW.UK

EHPT20X-MHEDWR1.UK

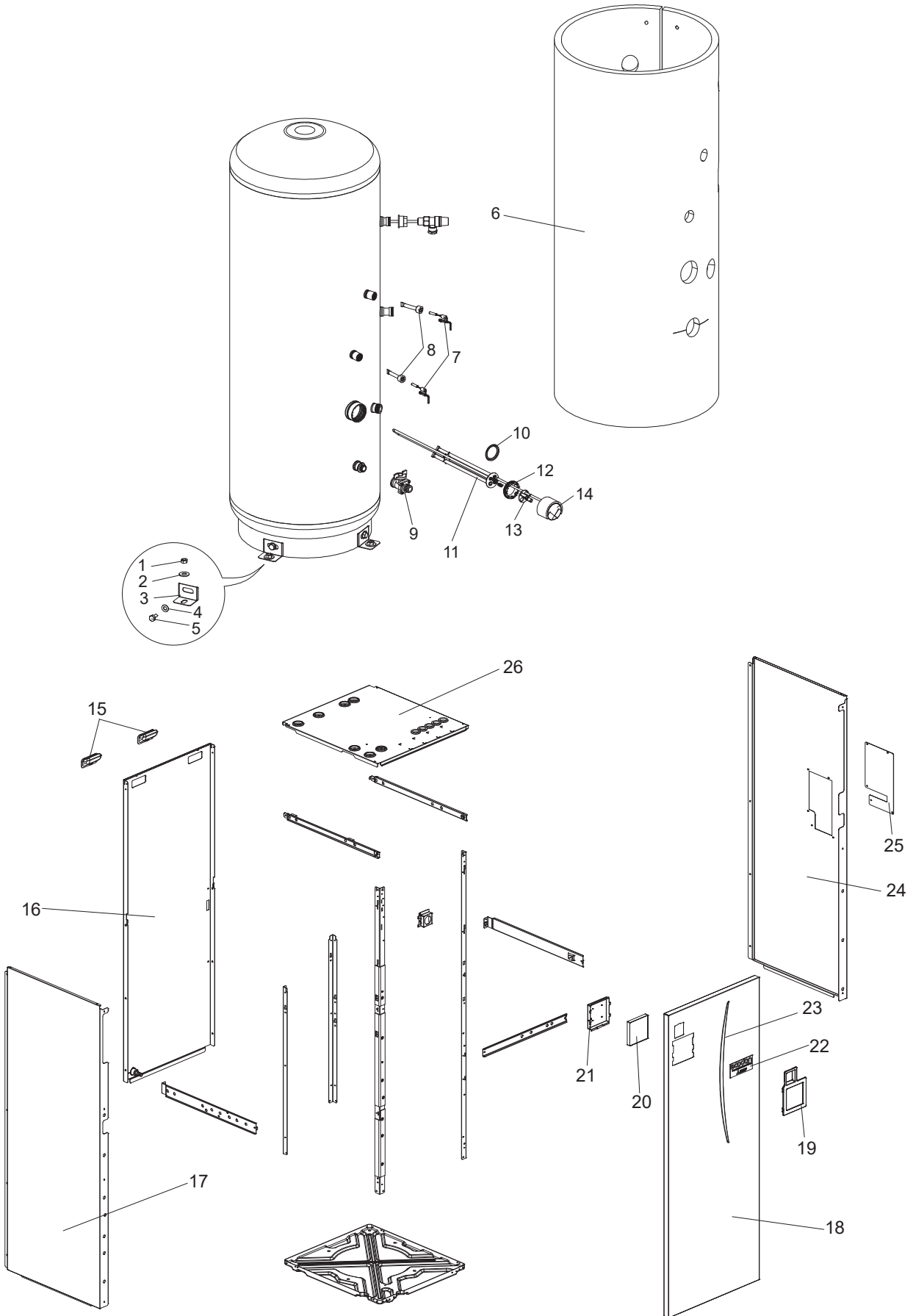

1. The part quantity below indicates the required number of pieces per unit.
2. The circled No. indicates that the part is not shown in the figure.

No.	Parts No.	Parts name			Wiring Diagram Symbol	Remarks [Drawing No.]
			EHPT20X-MHEDW.UK	EHPT20X-MHEDWR1.UK		
1	S70 C10 097	NUT	3	3		
2	S70 C61 097	WASHER	3	3		
3	S70 C30 042	TANK LEG	3	3		
4	S70 C20 097	WASHER	3	3		
5	S70 C30 097	BOLT	3	3		
6	S70 C75 042	TANK INSULATOR	1	1		
7	S70 C68 202	THERMISTOR (TANK WATER TEMP)	1	1	THW5	
8	S70 C11 525	STAT POCKET ASSEMBLY	1	1		
9	S70 C40 357	DRAIN COCK	1	1		FOR TANK
10	S70 C33 460	ELEMENT PLATE GASKET	1	1		
11	S70 C50 445	IMMERSION HEATER	1	1	IH	
12	S70 C60 097	BACKNUT	1	1		
13	S70 C33 461	ELEMENT PLATE TERMINAL COVER	1	1		
14	S70 C08 201	THERMOSTAT	1	1	IHT	
15	S70 30L 655	HANDLE	2	2		
16	S70 C23 661	BACK PANEL	1	1		
17	S70 C71 662	SIDE PANEL L	1	1		
18	S70 C22 668	FRONT PANEL	1	1		
19	—	MAIN REMOTE CONTROLLER SUPPORT	1	1		[BK00R897G01]
20	S70 C20 200	MAIN REMOTE CONTROLLER ASSY	1	1		
21	S70 C31 710	MAIN REMOTE CONTROLLER HOLDER	1	1		
22	S70 C25 699	BRAND LABEL	1	1		
23	S70 C30 699	LEAF LABEL	1	1		
24	S70 C76 662	SIDE PANEL R	1	1		
25	S70 C40 670	VM PLATE	1	1		
26	S70 C25 641	TOP PANEL DWG	1	1		
(27)	S70 C26 699	WIRING DIAGRAM FOR FRONT PANEL	1	1		

EHST30D-MED.UK
 EHST30D-TM9ED.UK
 EHST30C-MED.UK
 EHST30C-TM9ED.UK
 EHPT30X-MED.UK

EHST30D-VM6ED.UK
 ERST30D-VM2ED.UK
 EHST30C-VM6ED.UK
 ERST30C-VM2ED.UK
 EHPT30X-VM6ED.UK

EHST30D-YM9ED.UK
 EHST30C-YM9ED.UK
 ERPT30X-VM2ED.UK

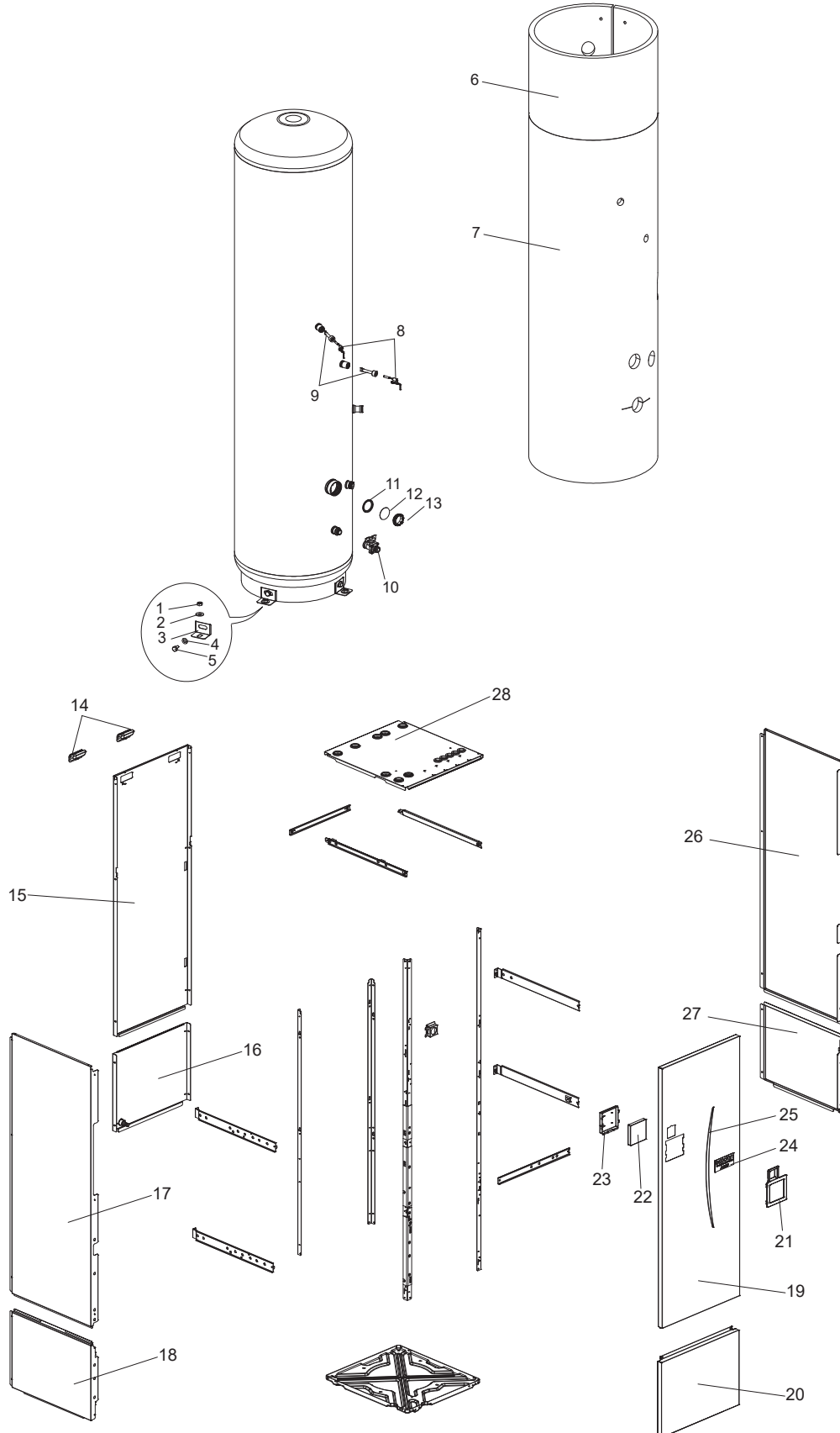

1. The part quantity below indicates the required number of pieces per unit.
2. The circled No. indicates that the part is not shown in the figure.

No.	Parts No.	Parts name	EHST30D-MED.UK	EHST30D-VM6ED.UK	EHST30D-YM9ED.UK	EHST30D-TM9ED.UK	ERST30D-VM2ED.UK	EHST30C-MED.UK	EHST30C-VM6ED.UK	EHST30C-YM9ED.UK	EHST30C-TM9ED.UK	ERST30C-VM2ED.UK	EHPT30X-MED.UK	EHPT30X-YM9ED.UK	ERPT30X-VM2ED.UK	Wiring Diagram Symbol	Remarks [Drawing No.]
			3	3	3	3	3	3	3	3	3	3	3	3	3		
1	S70 C10 097	NUT	3	3	3	3	3	3	3	3	3	3	3	3	3		
2	S70 C61 097	WASHER	3	3	3	3	3	3	3	3	3	3	3	3	3		
3	S70 C30 042	TANK LEG	3	3	3	3	3	3	3	3	3	3	3	3	3		
4	S70 C20 097	WASHER	3	3	3	3	3	3	3	3	3	3	3	3	3		
5	S70 C30 097	BOLT	3	3	3	3	3	3	3	3	3	3	3	3	3		
6	S70 C35 042	TANK INSULATOR TOP	1	1	1	1	1	1	1	1	1	1	1	1	1		
7	S70 C45 042	TANK INSULATOR UNDER	1	1	1	1	1	1	1	1	1	1	1	1	1		
8	S70 C68 202	THERMISTOR (TANK WATER TEMP)	1	1	1	1	1	1	1	1	1	1	1	1	1	THW5	
9	S70 C11 525	STAT POCKET ASSEMBLY	1	1	1	1	1	1	1	1	1	1	1	1	1		
10	S70 C40 357	DRAIN COCK	1	1	1	1	1	1	1	1	1	1	1	1	1		FOR TANK
11	S70 C33 460	ELEMENT PLATE GASKET	1	1	1	1	1	1	1	1	1	1	1	1	1		
12	S70 C40 446	BLANKING PLATE	1	1	1	1	1	1	1	1	1	1	1	1	1		FOR TANK
13	S70 C60 097	BACKNUT	1	1	1	1	1	1	1	1	1	1	1	1	1		
14	S70 30L 655	HANDLE	2	2	2	2	2	2	2	2	2	2	2	2	2		
15	S70 C20 661	BACK PANEL (TOP)	1	1	1	1	1	1	1	1	1	1	1	1	1		
16	S70 C21 661	BACK PANEL (UNDER)	1	1	1	1		1	1	1	1		1	1			
16	S70 C28 661	BACK PANEL (UNDER)					1						1		1		
17	S70 C63 662	SIDE PANEL L -TOP	1	1	1	1	1	1	1	1	1	1	1	1	1		
18	S70 C61 662	SIDE PANEL L-UNDER ASSY	1	1	1	1	1	1	1	1	1	1	1	1	1		
19	S70 C33 668	FRONT PANEL-TOP	1	1	1	1	1	1	1	1	1	1	1	1	1		
20	S70 C32 668	FRONT PANEL-UNDER	1	1	1	1	1	1	1	1	1	1	1	1	1		
21	—	MAIN REMOTE CONTROLLER SUPPORT	1	1	1	1	1	1	1	1	1	1	1	1	1		[BK00R897G01]
22	S70 C20 200	MAIN REMOTE CONTROLLER ASSY	1	1	1	1	1	1	1	1	1	1	1	1	1		
23	S70 C31 710	MAIN REMOTE CONTROLLER HOLDER	1	1	1	1	1	1	1	1	1	1	1	1	1		
24	S70 C25 699	BRAND LABEL	1	1	1	1	1	1	1	1	1	1	1	1	1		
25	S70 C30 699	LEAF LABEL	1	1	1	1	1	1	1	1	1	1	1	1	1		
26	S70 C66 662	SIDE PANEL R - TOP	1	1	1	1	1	1	1	1	1	1	1	1	1		
27	S70 C64 662	SIDE PANEL R - UNDER	1	1	1	1	1	1	1	1	1	1	1	1	1		
28	S70 C30 641	TOP PANEL DWG	1	1	1	1	1	1	1	1	1	1					
28	S70 C26 641	TOP PANEL DWG											1	1	1		
②9	S70 C21 699	WIRING DIAGRAM FOR FRONT PANEL					1						1		1		
②9	S70 C22 699	WIRING DIAGRAM FOR FRONT PANEL		1					1								
②9	S70 C23 699	WIRING DIAGRAM FOR FRONT PANEL			1					1				1			
②9	S70 C24 699	WIRING DIAGRAM FOR FRONT PANEL				1					1						
②9	S70 C27 699	WIRING DIAGRAM FOR FRONT PANEL	1					1					1				

EHST30D-MEDR1.UK
 EHST30D-TM9EDR1.UK
 ERST30D-YM9EDR1.UK
 EHST30C-MEDR1.UK
 EHST30C-TM9EDR1.UK
 ERST30C-YM9EDR1.UK
 EHPT30X-MEDR1.UK
 ERPT30X-VM6EDR1.UK

EHST30D-VM6EDR1.UK
 ERST30D-VM2EDR1.UK

EHST30C-VM6EDR1.UK
 ERST30C-VM2EDR1.UK

EHPT30X-YM9EDR1.UK

EHST30D-YM9EDR1.UK
 ERST30D-VM6EDR1.UK

EHST30C-YM9EDR1.UK
 ERST30C-VM6EDR1.UK

ERPT30X-VM2EDR1.UK

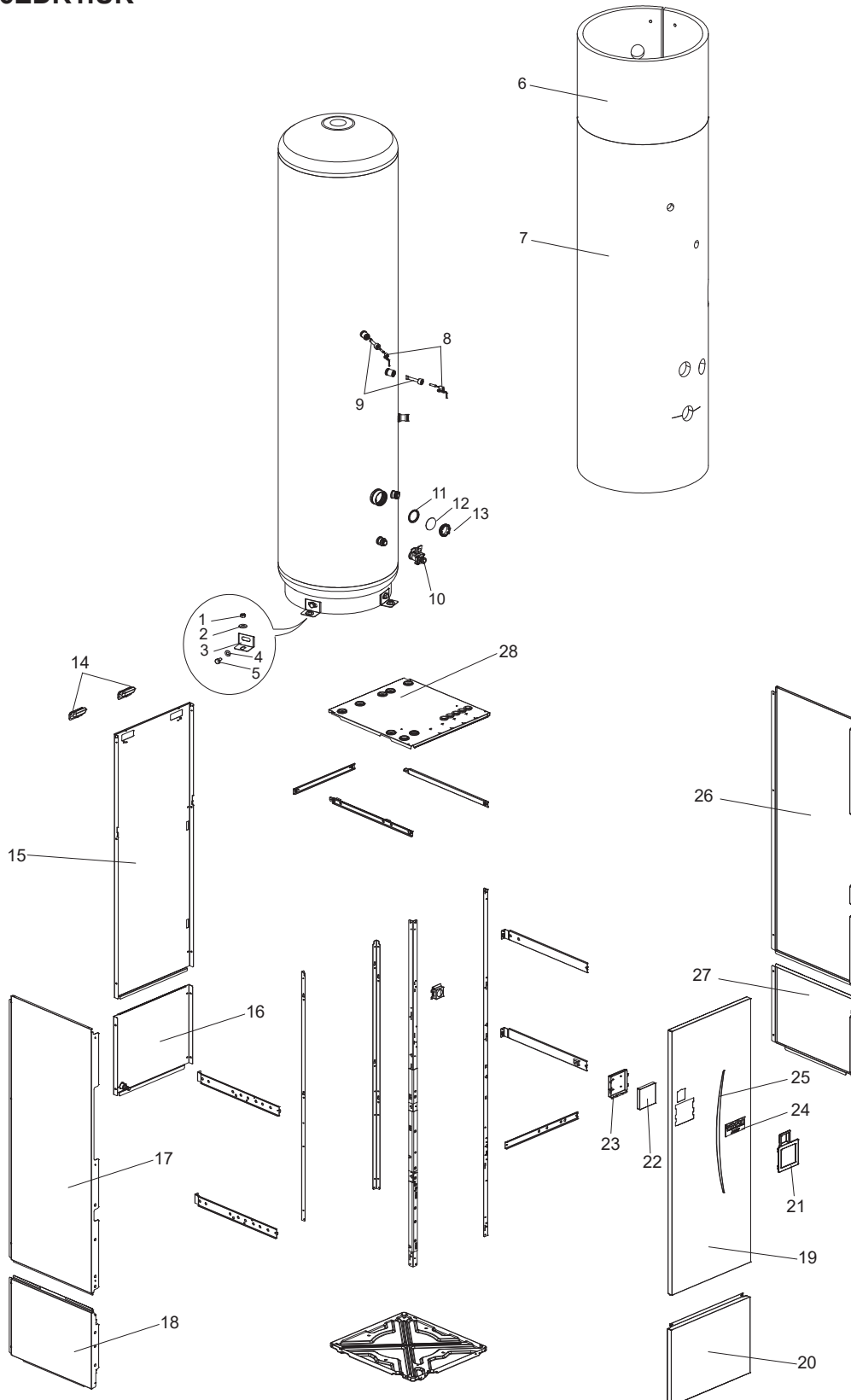

1. The part quantity below indicates the required number of pieces per unit.
2. The circled No. indicates that the part is not shown in the figure.

No.	Parts No.	Parts name	EHST30D-MEDR1.UK																Wiring Diagram Symbol	Remarks [Drawing No.]
			EHST30D-VM6EDR1.UK	EHST30D-VM9EDR1.UK	EHST30D-TM9EDR1.UK	ERST30D-VM2EDR1.UK	ERST30D-VM6EDR1.UK	ERST30D-VM9EDR1.UK	EHST30C-MEDR1.UK	EHST30C-VM6EDR1.UK	EHST30C-VM9EDR1.UK	ERST30C-TM9EDR1.UK	ERST30C-VM2EDR1.UK	ERST30C-VM6EDR1.UK	ERST30C-VM9EDR1.UK	EHPT30X-MEDR1.UK	EHPT30X-VM9EDR1.UK	ERPT30X-VM2EDR1.UK		
1	S70 C10 097	NUT	3	3	3	3	3	3	3	3	3	3	3	3	3	3	3	3		
2	S70 C61 097	WASHER	3	3	3	3	3	3	3	3	3	3	3	3	3	3	3	3		
3	S70 C30 042	TANK LEG	3	3	3	3	3	3	3	3	3	3	3	3	3	3	3	3		
4	S70 C20 097	WASHER	3	3	3	3	3	3	3	3	3	3	3	3	3	3	3	3		
5	S70 C30 097	BOLT	3	3	3	3	3	3	3	3	3	3	3	3	3	3	3	3		
6	S70 C35 042	TANK INSULATOR TOP	1	1	1	1	1	1	1	1	1	1	1	1	1	1	1	1		
7	S70 C45 042	TANK INSULATOR UNDER	1	1	1	1	1	1	1	1	1	1	1	1	1	1	1	1		
8	S70 C68 202	THERMISTOR (TANK WATER TEMP)	1	1	1	1	1	1	1	1	1	1	1	1	1	1	1	1	THW5	
9	S70 C11 525	STAT POCKET ASSEMBLY	1	1	1	1	1	1	1	1	1	1	1	1	1	1	1	1		
10	S70 C40 357	DRAIN COCK	1	1	1	1	1	1	1	1	1	1	1	1	1	1	1	1		FOR TANK
11	S70 C33 460	ELEMENT PLATE GASKET	1	1	1	1	1	1	1	1	1	1	1	1	1	1	1	1		
12	S70 C40 446	BLANKING PLATE	1	1	1	1	1	1	1	1	1	1	1	1	1	1	1	1		FOR TANK
13	S70 C60 097	BACKNUT	1	1	1	1	1	1	1	1	1	1	1	1	1	1	1	1		
14	S70 30L 655	HANDLE	2	2	2	2	2	2	2	2	2	2	2	2	2	2	2	2		
15	S70 C20 661	BACK PANEL (TOP)	1	1	1	1	1	1	1	1	1	1	1							
15	S70 C27 661	BACK PANEL (TOP)												1	1	1	1	1		
16	S70 C21 661	BACK PANEL (UNDER)	1	1	1	1				1	1	1	1				1	1		
16	S70 C28 661	BACK PANEL (UNDER)				1	1	1					1	1	1			1	1	
17	S70 C63 662	SIDE PANEL L -TOP	1	1	1	1	1	1	1	1	1	1	1	1	1	1	1	1		
18	S70 C61 662	SIDE PANEL L-UNDER ASSY	1	1	1	1	1	1	1	1	1	1	1	1	1	1	1	1		
19	S70 C33 668	FRONT PANEL-TOP	1	1	1	1	1	1	1	1	1	1	1	1	1	1	1	1		
20	S70 C32 668	FRONT PANEL-UNDER	1	1	1	1	1	1	1	1	1	1	1	1	1	1	1	1		
21	—	MAIN REMOTE CONTROLLER SUPPORT	1	1	1	1	1	1	1	1	1	1	1	1	1	1	1	1		[BK00R897G01]
22	S70 C20 200	MAIN REMOTE CONTROLLER ASSY	1	1	1	1	1	1	1	1	1	1	1	1	1	1	1	1		
23	S70 C31 710	MAIN REMOTE CONTROLLER HOLDER	1	1	1	1	1	1	1	1	1	1	1	1	1	1	1	1		
24	S70 C25 699	BRAND LABEL	1	1	1	1	1	1	1	1	1	1	1	1	1	1	1	1		
25	S70 C30 699	LEAF LABEL	1	1	1	1	1	1	1	1	1	1	1	1	1	1	1	1		
26	S70 C66 662	SIDE PANEL R - TOP	1	1	1	1	1	1	1	1	1	1	1	1	1	1	1	1		
27	S70 C64 662	SIDE PANEL R - UNDER	1	1	1	1	1	1	1	1	1	1	1	1	1	1	1	1		
28	S70 C30 641	TOP PANEL DWG	1	1	1	1	1	1	1	1	1	1	1	1	1					
28	S70 C26 641	TOP PANEL DWG															1	1	1	1
②9	S70 C21 699	WIRING DIAGRAM FOR FRONT PANEL				1							1					1		
②9	S70 C22 699	WIRING DIAGRAM FOR FRONT PANEL		1			1			1				1					1	
②9	S70 C23 699	WIRING DIAGRAM FOR FRONT PANEL			1			1			1				1		1			
②9	S70 C24 699	WIRING DIAGRAM FOR FRONT PANEL				1						1								
②9	S70 C27 699	WIRING DIAGRAM FOR FRONT PANEL	1							1							1			

MHEDW

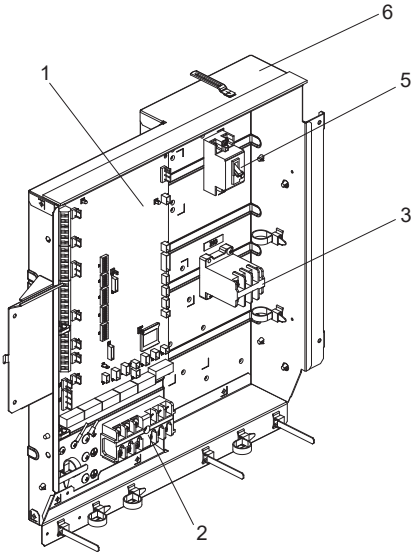

VM2D

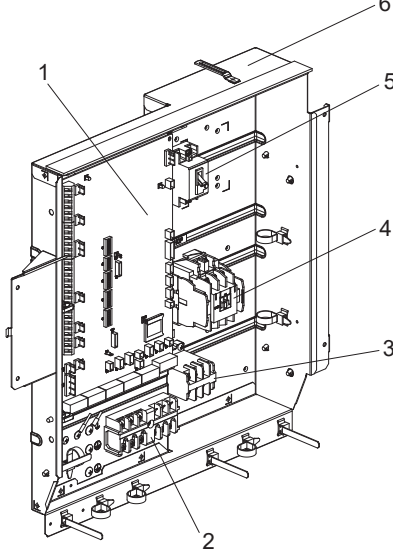

VM6D

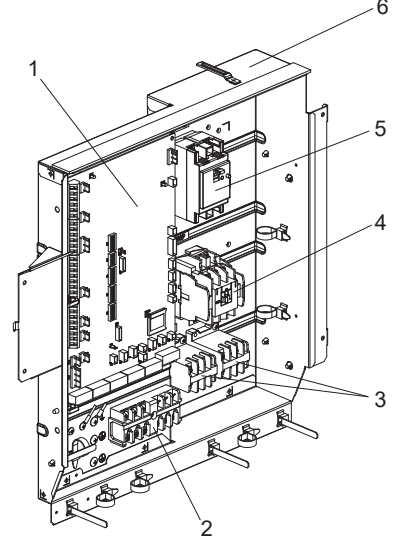

1. The part quantity below indicates the required number of pieces per unit.
 2. The circled No. indicates that the part is not shown in the figure.

No.	Parts No.	Parts name																		Remarks [Drawing No.]				
			EHST17D-VM2D.UK	ERST17D-VM2D.UK	EHST20D-MED.UK	EHST20D-VM2D.UK	ERST20D-VM2D.UK	EHST20C-MED.UK	EHST20C-VM2D.UK	ERST20C-VM2D.UK	EHST30D-MED.UK	ERST30D-VM2ED.UK	EHST30C-MED.UK	ERST30C-VM2ED.UK	EHPT17X-VM2D.UK	ERPT17X-VM2D.UK	EHPT20X-MED.UK	EHPT20X-MHEDW.UK	ERPT20X-MD.UK		ERPT20X-VM2D.UK	EHPT30X-MED.UK	ERPT30X-VM2ED.UK	
1	S70 C86 315	ATW CONTROLLER	1	1	1	1	1	1	1	1	1	1	1	1	1	1	1	1	1	1	1	1	1	
2	S70 C20 515	TERMINAL BED	1	1	1	1	1	1	1	1	1	1	1	1	1	1	1	1	1	1	1	1	1	6P (#250LNE+S123)
3	S70 C39 708	CONTACTOR	1	1		1	1		1	1		1	1	1	1		1		1		1		30 A	
4	S70 C49 708	CONTACTOR	1	1		1	1		1	1		1	1	1	1				1		1		45 A	
5	S70 C20 239	EARTH LEAKAGE BREAKER	1	1		1	1		1	1		1	1	1	1		1		1		1		1 ø 20 A	
6	—	CONTROL BOX	1	1	1	1	1	1	1	1	1	1	1	1	1	1	1	1	1	1	1	1	[RK00A887G01]	

1. The part quantity below indicates the required number of pieces per unit.
 2. The circled No. indicates that the part is not shown in the figure.

No.	Parts No.	Parts name								Remarks [Drawing No.]
			EHST20D-VM6D.UK	EHST20C-VM6D.UK	EHST30D-VM6ED.UK	EHST30C-VM6ED.UK	EHPT17X-VM6D.UK	EHPT20X-VM6D.UK	ERPT20X-VM6D.UK	
1	S70 C86 315	ATW CONTROLLER	1	1	1	1	1	1	1	
2	S70 C20 515	TERMINAL BED	1	1	1	1	1	1	1	6P (#250LNE+S123)
3	S70 C39 708	CONTACTOR	2	2	2	2	2	2	2	30 A
4	S70 C49 708	CONTACTOR	1	1	1	1	1	1	1	45 A
5	S70 C60 239	EARTH LEAKAGE BREAKER	1	1	1	1	1	1	1	1 ø 40 A
6	—	CONTROL BOX	1	1	1	1	1	1	1	[RK00A887G01]



YM9D

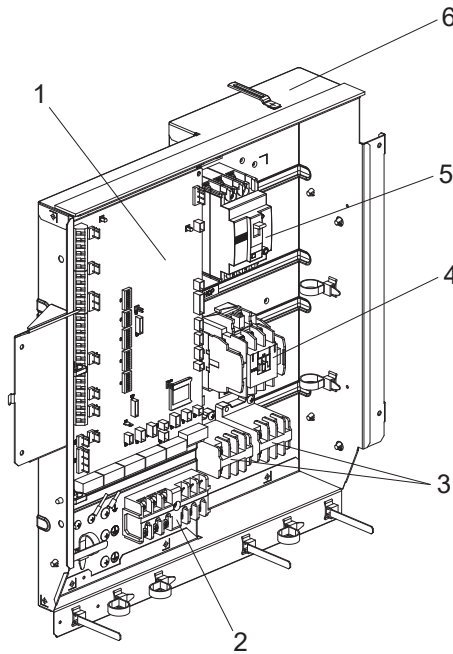

- 1. The part quantity below indicates the required number of pieces per unit.
- 2. The circled No. indicates that the part is not shown in the figure.

No.	Parts No.	Parts name															Remarks [Drawing No.]	
			EHST20D-YM9D.UK	EHST20D-YM9ED.UK	EHST20D-TM9D.UK	EHST20C-YM9D.UK	EHST20C-YM9ED.UK	EHST20C-TM9D.UK	EHST30D-YM9ED.UK	EHST30D-TM9ED.UK	EHST30C-YM9ED.UK	EHST30C-TM9ED.UK	EHPT17X-YM9D.UK	EHPT20X-YM9D.UK	EHPT20X-YM9ED.UK	EHPT20X-TM9D.UK		EHPT30X-YM9ED.UK
1	S70 C86 315	ATW CONTROLLER	1	1	1	1	1	1	1	1	1	1	1	1	1	1	1	
2	S70 C20 515	TERMINAL BED	1	1	1	1	1	1	1	1	1	1	1	1	1	1	1	6P (#250LNE+S123)
3	S70 C39 708	CONTACTOR	2	2	2	2	2	2	2	2	2	2	2	2	2	2	2	30 A
4	S70 C49 708	CONTACTOR	1	1	1	1	1	1	1	1	1	1	1	1	1	1	1	45 A
5	S70 C70 239	EARTH LEAKAGE BREAKER	1	1	1	1	1	1	1	1	1	1	1	1	1	1	1	3 ø 30 A
6	—	CONTROL BOX	1	1	1	1	1	1	1	1	1	1	1	1	1	1	1	[RK00A887G01]

VM2BD

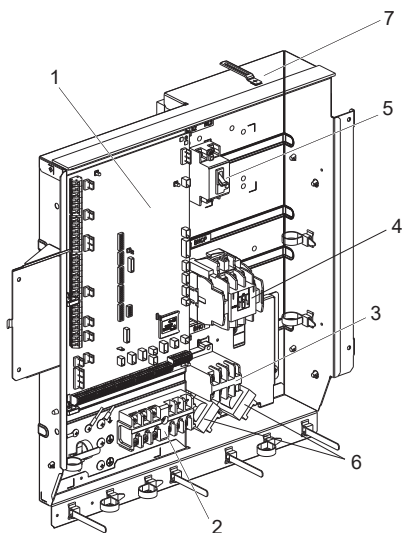

VM6BD

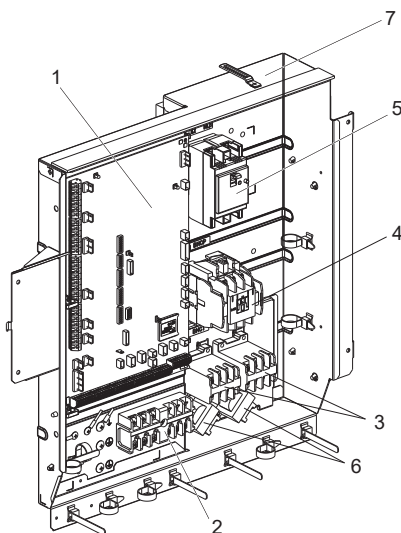

YM9BD

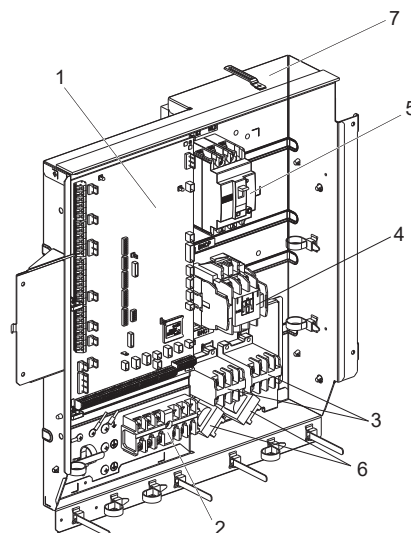

1. The part quantity below indicates the required number of pieces per unit.

2. The circled No. indicates that the part is not shown in the figure.

No.	Parts No.	Parts name	ERST17D-VM2BD.UK	ERST17D-VM6BD.UK	ERST17D-YM9BD.UK	Remarks [Drawing No.]
1	S70 C45 315	ATW CONTROLLER	1	1	1	
2	S70 C20 515	TERMINAL BED	1	1	1	6P (#250LNE+S123)
3	S70 C39 708	CONTACTOR	1	2	2	30 A
4	S70 C49 708	CONTACTOR	1	1	1	45 A
5	S70 C20 239	EARTH LEAKAGE BREAKER	1			1 ø 20 A
5	S70 C60 239	EARTH LEAKAGE BREAKER		1		1 ø 40 A
5	S70 C70 239	EARTH LEAKAGE BREAKER			1	3 ø 30 A
6	S70 K97 259	REACTOR	2	2	2	
7	—	CONTROL BOX	1	1	1	[RK00A887G01]

MHEDW

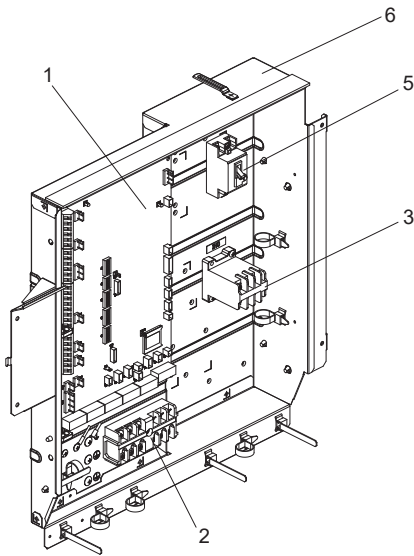

VM2D

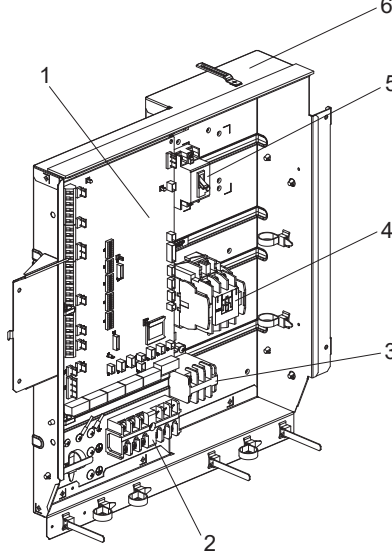

VM6D

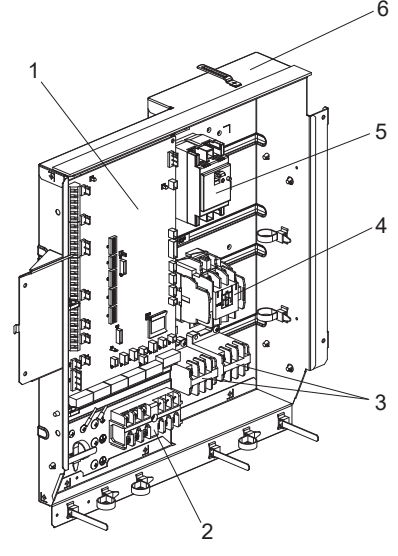

1. The part quantity below indicates the required number of pieces per unit.
2. The circled No. indicates that the part is not shown in the figure.

No.	Parts No.	Parts name																	Remarks [Drawing No.]					
			EHST17D-VM2DR1.UK	ERST17D-VM2DR1.UK	EHST20D-MEDR1.UK	EHST20D-VM2DR1.UK	ERST20D-VM2DR1.UK	EHST20C-MEDR1.UK	EHST20C-VM2DR1.UK	ERST20C-VM2DR1.UK	EHST30D-MEDR1.UK	ERST30D-VM2EDR1.UK	EHST30C-MEDR1.UK	ERST30C-VM2EDR1.UK	EHPT17X-VM2DR1.UK	ERPT17X-VM2DR1.UK	EHPT20X-MEDR1.UK	ERPT20X-MEDWR1.UK		ERPT20X-MDR1.UK	ERPT20X-VM2DR1.UK	EHPT30X-MEDR1.UK	ERPT30X-VM2EDR1.UK	
1	S70 C86 315	ATW CONTROLLER	1	1	1	1	1	1	1	1	1	1	1	1	1	1	1	1	1	1	1	1	1	
2	S70 C20 515	TERMINAL BED	1	1	1	1	1	1	1	1	1	1	1	1	1	1	1	1	1	1	1	1	1	6P (#250LNE+S123)
3	S70 C39 708	CONTACTOR	1	1		1	1		1	1		1	1	1		1		1		1		1	30 A	
4	S70 C49 708	CONTACTOR	1	1		1	1		1	1		1	1	1		1		1		1		1	45 A	
5	S70 C20 239	EARTH LEAKAGE BREAKER	1	1		1	1		1	1		1	1	1		1		1		1		1	1 ø 20 A	
6	—	CONTROL BOX	1	1	1	1	1	1	1	1	1	1	1	1	1	1	1	1	1	1	1	1	[RK00A887G01]	

1. The part quantity below indicates the required number of pieces per unit.
2. The circled No. indicates that the part is not shown in the figure.

No.	Parts No.	Parts name																	Remarks [Drawing No.]				
			ERST17D-VM6DR1.UK	EHST20D-VM6DR1.UK	ERST20D-VM6DR1.UK	EHST20C-VM6DR1.UK	ERST20C-VM6DR1.UK	EHST30D-VM6EDR1.UK	ERST30D-VM6EDR1.UK	EHST30C-VM6EDR1.UK	ERST30C-VM6EDR1.UK	EHPT17X-VM6DR1.UK	ERPT17X-VM6DR1.UK	EHPT20X-VM6DR1.UK	ERPT20X-VM6DR1.UK	ERPT30X-VM6EDR1.UK							
1	S70 C86 315	ATW CONTROLLER	1	1	1	1	1	1	1	1	1	1	1	1	1	1	1	1	1	1	1	1	
2	S70 C20 515	TERMINAL BED	1	1	1	1	1	1	1	1	1	1	1	1	1	1	1	1	1	1	1	1	6P (#250LNE+S123)
3	S70 C39 708	CONTACTOR	2	2	2	2	2	2	2	2	2	2	2	2	2	2	2	2	2	2	2	2	30 A
4	S70 C49 708	CONTACTOR	1	1	1	1	1	1	1	1	1	1	1	1	1	1	1	1	1	1	1	1	45 A
5	S70 C60 239	EARTH LEAKAGE BREAKER	1	1	1	1	1	1	1	1	1	1	1	1	1	1	1	1	1	1	1	1	1 ø 40 A
6	—	CONTROL BOX	1	1	1	1	1	1	1	1	1	1	1	1	1	1	1	1	1	1	1	1	[RK00A887G01]

YM9D

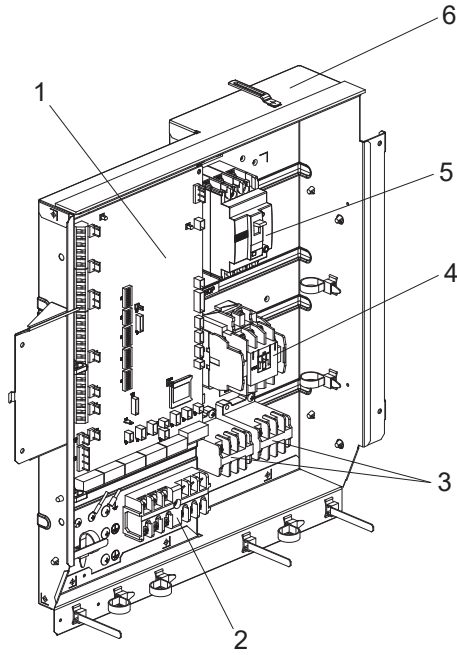

1. The part quantity below indicates the required number of pieces per unit.
2. The circled No. indicates that the part is not shown in the figure.

No.	Parts No.	Parts name																		Remarks [Drawing No.]				
			EHST17D-YM9DR1.UK	EHST20D-YM9DR1.UK	EHST20D-YM9EDR1.UK	EHST20D-TM9DR1.UK	ERST20D-YM9DR1.UK	EHST20C-YM9DR1.UK	EHST20C-YM9EDR1.UK	EHST20C-TM9DR1.UK	ERST20C-YM9DR1.UK	EHST30D-YM9EDR1.UK	EHST30D-TM9EDR1.UK	ERST30D-YM9EDR1.UK	EHST30C-YM9EDR1.UK	EHST30C-TM9EDR1.UK	ERST30C-YM9EDR1.UK	EHPT17X-YM9DR1.UK	EHPT20X-YM9DR1.UK		EHPT20X-YM9EDR1.UK	EHPT20X-TM9DR1.UK	EHPT30X-YM9EDR1.UK	
1	S70 C86 315	ATW CONTROLLER	1	1	1	1	1	1	1	1	1	1	1	1	1	1	1	1	1	1	1	1	1	
2	S70 C20 515	TERMINAL BED	1	1	1	1	1	1	1	1	1	1	1	1	1	1	1	1	1	1	1	1	1	6P (#250LNE+S123)
3	S70 C39 708	CONTACTOR	2	2	2	2	2	2	2	2	2	2	2	2	2	2	2	2	2	2	2	2	2	30 A
4	S70 C49 708	CONTACTOR	1	1	1	1	1	1	1	1	1	1	1	1	1	1	1	1	1	1	1	1	1	45 A
5	S70 C70 239	EARTH LEAKAGE BREAKER	1	1	1	1	1	1	1	1	1	1	1	1	1	1	1	1	1	1	1	1	1	3 ø 30 A
6	—	CONTROL BOX	1	1	1	1	1	1	1	1	1	1	1	1	1	1	1	1	1	1	1	1	1	[RK00A887G01]

2

OPTIONAL PARTS

Part Name	Part No.
EHPT ACCESSORIES for UK *	PAC-WK02UK-E

* Optional parts for EHPT20X-MHEDW

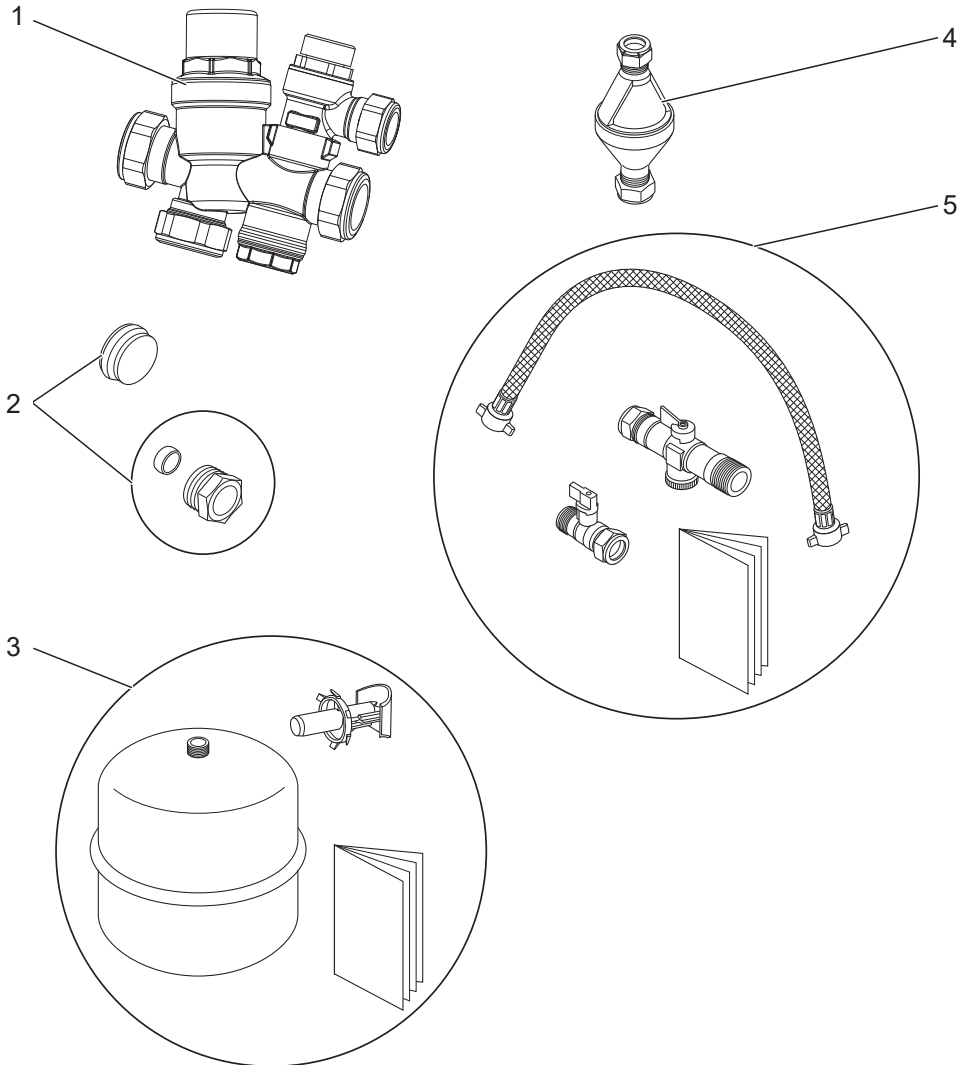

1. The part quantity below indicates the required number of pieces per unit.
2. The circled No. indicates that the part is not shown in the figure.

No.	Parts No.	Parts name	EHPT20X-MHEDW.UK	EHPT20X-MHEDWR1.UK	Wiring Diagram Symbol	Remarks
1	S70 C20 359	Unvented inlet control group (Pressure reducing valve/Strainer/ Check valves/Expansion relief valve)	1	1		Pressure reducing valve:3.5 bar Expansion relief valve:6.0 bar
2	S70 C01 460	Accessory pack :Blanking cap, Olive & compression nut	1	1		22mm, 15mm
3	S70 C20 402	Expansion vessel 18L	1	1		R3/4"
4	S70 C02 460	Tundish	2	2		15 mm, 22 mm
5	S70 C03 460	Filling loop	1	1		15 mm

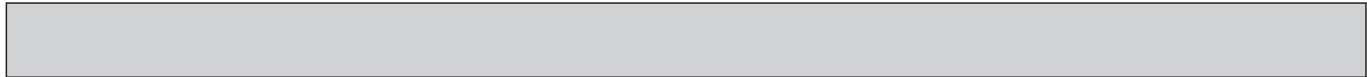

Part Name	Part No.
IMMERSION HEATER (1 Ph 1 kW)	PAC-IH01V2-E
IMMERSION HEATER (1 Ph 3 kW)	PAC-IH03V2-E
WIRELESS REMOTE CONTROLLER	PAR-WT50R-E
WIRELESS RECEIVER	PAR-WR51R-E
REMOTE SENSOR	PAC-SE41TS-E
THERMISTOR	PAC-TH011-E
HIGH TEMPERATURE THERMISTOR (5 m)	PAC-TH012HT-E
HIGH TEMPERATURE THERMISTOR (30 m)	PAC-TH012HTL-E
ecodan Wi-Fi INTERFACE	MAC-567IF-E1
EXPANSION VESSEL	PAC-EVP12-E1 *
2-ZONE KIT	PAC-TZ02-E
JOINT PIPE (ø6.35 → ø9.52)	PAC-SG72RJ-E
JOINT PIPE (ø12.7 → ø15.88)	PAC-SG74RJ-E

* Optional part for E***T***-M*ED* series.

MITSUBISHI ELECTRIC CORPORATION

HEAD OFFICE: TOKYO BUILDING, 2-7-3, MARUNOUCHI, CHIYODA-KU, TOKYO 100-8310, JAPAN

©Copyright 2019 MITSUBISHI ELECTRIC CORPORATION
Issued: Nov. 2021 No. OCB714 REVISED EDITION-D
Issued: Jan. 2021 No. OCB714 REVISED EDITION-C
Issued: Oct. 2020 No. OCB714 REVISED EDITION-B
Issued: Mar. 2020 No. OCB714 REVISED EDITION-A
Published: Nov. 2019 No. OCB714
Made in Japan

Specifications are subject to change without notice.