

The Renewable Solutions Provider

Making a World of Difference

Hybrid Heating Systems

Heat Pumps Working with a Traditional Boiler



Air Conditioning | Heating
Ventilation | Controls



The name Mitsubishi is synonymous with excellence

Founded in 1921, Mitsubishi Electric is now a global, market leading environmental technologies manufacturer. In the UK, the Living Environmental Systems Division provides proven solutions that heat, cool, ventilate and control our buildings in some of the most energy efficient ways possible.

Increasing energy bills, the need to reduce carbon emissions and the raft of challenging legislation are driving the demand for alternative forms of heating to improve energy efficiency.

Mitsubishi Electric has specifically designed the Ecodan range for UK homes and buildings. Ecodan air source heat pumps provide renewable energy to challenge traditional heating methods, whilst meeting the energy and carbon reduction demands of today and beyond.

We believe that global climate challenges need local solutions. Our aim is to help individuals and businesses reduce the energy consumption of their buildings and their running costs.

At Mitsubishi Electric we have evolved and today we offer advanced environmental systems that really can make a world of difference.





Our **Hybrid Ecodan heating systems** deliver efficient, renewable heating in tandem with a traditional boiler

The Heating challenge that we all face



■ Ecodan System



In March 2012 the DECC (Department for Energy and Climate Change) published a document entitled 'The Future of Heating: A strategic framework for low carbon heat in the UK'. This highlighted the challenges in the way we use our heat, and also looked at low carbon alternatives for the future.

In the UK the majority of energy we use is to provide heating to our buildings. Most of this heat is generated by burning fossil fuels - 80% alone comes from burning gas and this alone accounts for 30% of the UK's greenhouse gas emissions.

Much of the attention is placed on improving the thermal performance of new build properties, whereas 80% of the properties we will be living in by 2050 are already built. This is a major focus area, and these buildings may need a mixture of solutions to allow them to perform better.

A further report was published a year later in March 2013: "The Future of Heating: Meeting the challenge" and leads on from the strategic framework document to look at practical solutions to delivering carbon reduction in buildings. The report outlines several transitional steps and technologies to help get to a truly low carbon, renewable future. One of these transitional technologies is Hybrid or Bivalent heat pumps.

The desire to move off-gas grid heating to renewable technologies like heat pumps is strong, with many Governmental policies choosing this model as an easy win. Through mixing traditional technologies and new renewable heat pumps, many properties on the gas grid would be able to make a cost-effective change to reduce both carbon emissions and running costs. This will allow for our dependency on gas to gradually decrease and provide time to invest in the national infrastructure required to serve many electrically driven heating systems.

The report models the uptake in these transitional technologies to show that in 2030 approximately 26% of the UK's heating energy output will be met by air source heat pumps alone, and as much as 56% will be met by hybrid systems.

A hybrid system allows heat pumps to efficiently deliver the majority of the energy requirements, and for a traditional boiler to provide the peak output when outdoor conditions fall below a point where heating in this way is more cost effective.

The report also goes on to highlight the steps that are needed within our energy infrastructure in order to make the change from traditional fossil fuels to low carbon heating.

Ecodan Heat Pump Heating Systems

Mitsubishi Electric has developed Ecodan to operate as a hybrid/bivalent system, allowing users to upgrade their traditional heating system by installing and running a heat pump alongside it.

Heating UK homes with Ecodan air source heat pumps is now a viable and credible alternative to traditional methods and can help to combat rising energy bills through greater efficiency.

By using an Ecodan to provide space heating and hot water, it is possible to reduce a home's CO₂ emissions and running costs. Ecodan uses inverter-driven heat pump technology to harvest and upgrade free, renewable energy from the outdoor air to deliver heating and hot water, even in temperatures as low as -20°C.

For every 1kW of input electrical energy, Ecodan harvests and upgrades renewable heat from the outdoor air to provide the home with an average of at least 3.2kW of heat output.^{*1}

Outstanding benefits:

- Achieves level 4 of the Code for Sustainable Homes with no additional measures and can be even higher when used in conjunction with other improvements
- Improves energy use leading to lower running costs and CO₂ emissions
- 5% VAT rating on capital and install costs
- Low noise levels
- MELCloud Wi-Fi control of Ecodan system from anywhere in the world
- SD Card commissioning and logging
- MCS approved

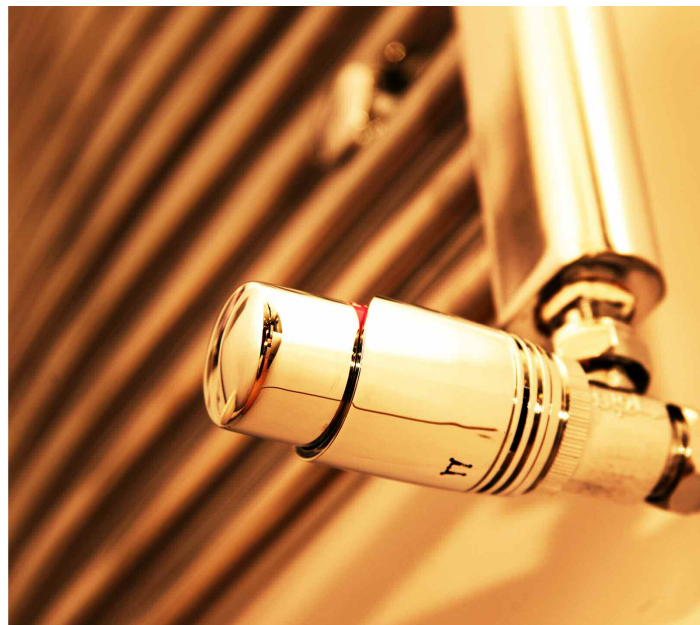

^{*1} The overall system efficiency and energy savings will depend on the comparison with your current heating system, satisfactory system design and installation, and operational settings i.e. how you use the heating system.

Hybrid heating systems deliver a perfect solution for the future

By using Ecodan as part of a hybrid system this means that all the benefits of lower running costs for the vast majority of the year can be taken advantage of, and when the outdoor conditions fall below a point where the heat pump is no longer the most efficient heat source, the system can switch over to the traditional boiler.

Bringing together an already existing traditional boiler and a renewable heat pump means the investment can be much more flexible, for example; if you already have a combi-boiler your hot water can remain delivered by this system while the heat pump can provide space heating for the majority of the year.



Typical example of a Hybrid system utilising Ecodan and an existing combi boiler

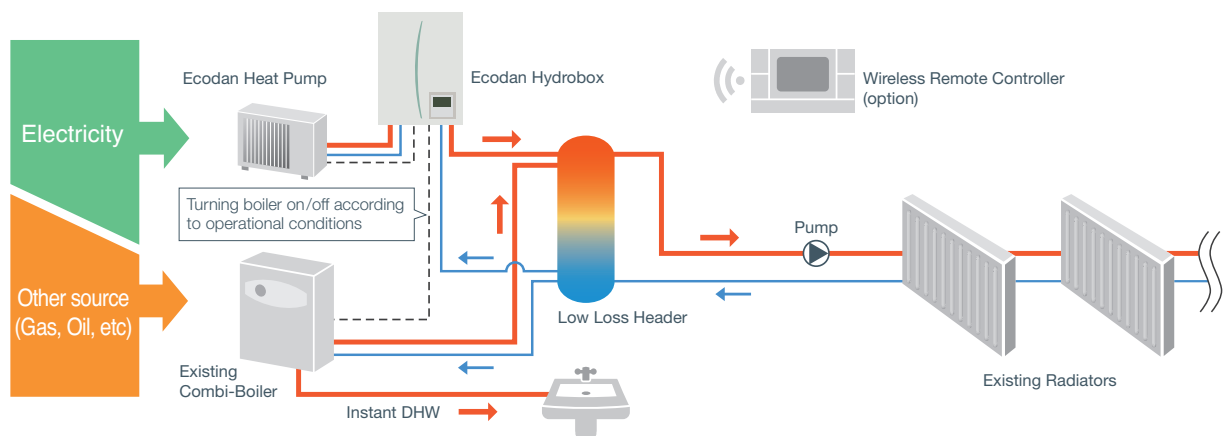

▲ Hybrid system example application 1

Typical example of a Hybrid system utilising Ecodan and an existing boiler and hot water cylinder

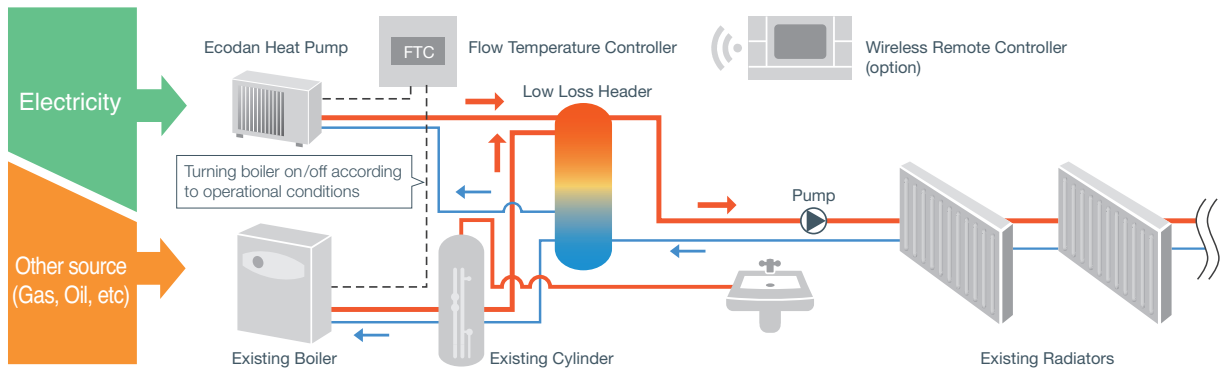

▲ Hybrid system example application 2

Controlling your Hybrid heating system

There are various different settings for boiler switchover when using Ecodan as part of a hybrid system:

Cost	Energy price information is stored on the Ecodan's SD card prior to set up. Heat Source switchover occurs whenever the Ecodan determines which heat source has the lowest running costs.
Ambient Temperature	An outdoor temperature switchover point is chosen by the installer, the outdoor temperature is constantly monitored, and whenever the set outdoor temperature is reached the boiler will automatically switch on.
CO₂ Emissions	Similar to the way in which the Ecodan can switch heat sources based on cost, it can do the same in respect of CO ₂ emissions. Once data is input on to the SD card prior to set up, Ecodan will determine which heat source is most efficient based on CO ₂ emissions.
Heat Pump Failure	In the unlikely case of an Ecodan failure, a signal will be sent to the boiler to switch on as backup.
External Input	Heat source switchover can also be enabled from an external input, such as a third party thermostat, Building Energy Management System (BEMS) or potentially a utility provider signal.

Typical semi detached houses showing both Standard and Hybrid Ecodan heating applications

Standard house

In this example Ecodan is being used as the sole heating and hot water system, fully optimised to deliver maximum efficiency and comfort.

Up to 6 Ecodan units of the same capacity (up to 84kW) can be operated as one system.



Intelligent Control

Ecodan's load and weather compensation feature will monitor indoor and outdoor temperatures and adjust the system flow temperatures to suit.

This makes sure that energy use is kept at a minimum, whilst ensuring comfort is always at a maximum for the user.

↓ Hybrid house

In this example Ecodan is being used in conjunction with an existing boiler to maximise efficiency, run costs and CO₂ emissions.

Ecodan can switch between heat sources based on various parameters such as; temperature, cost, CO₂ emissions, unit failure and also via an external input if required. This allows the homeowner to have an individual system set up that is customised as they wish.

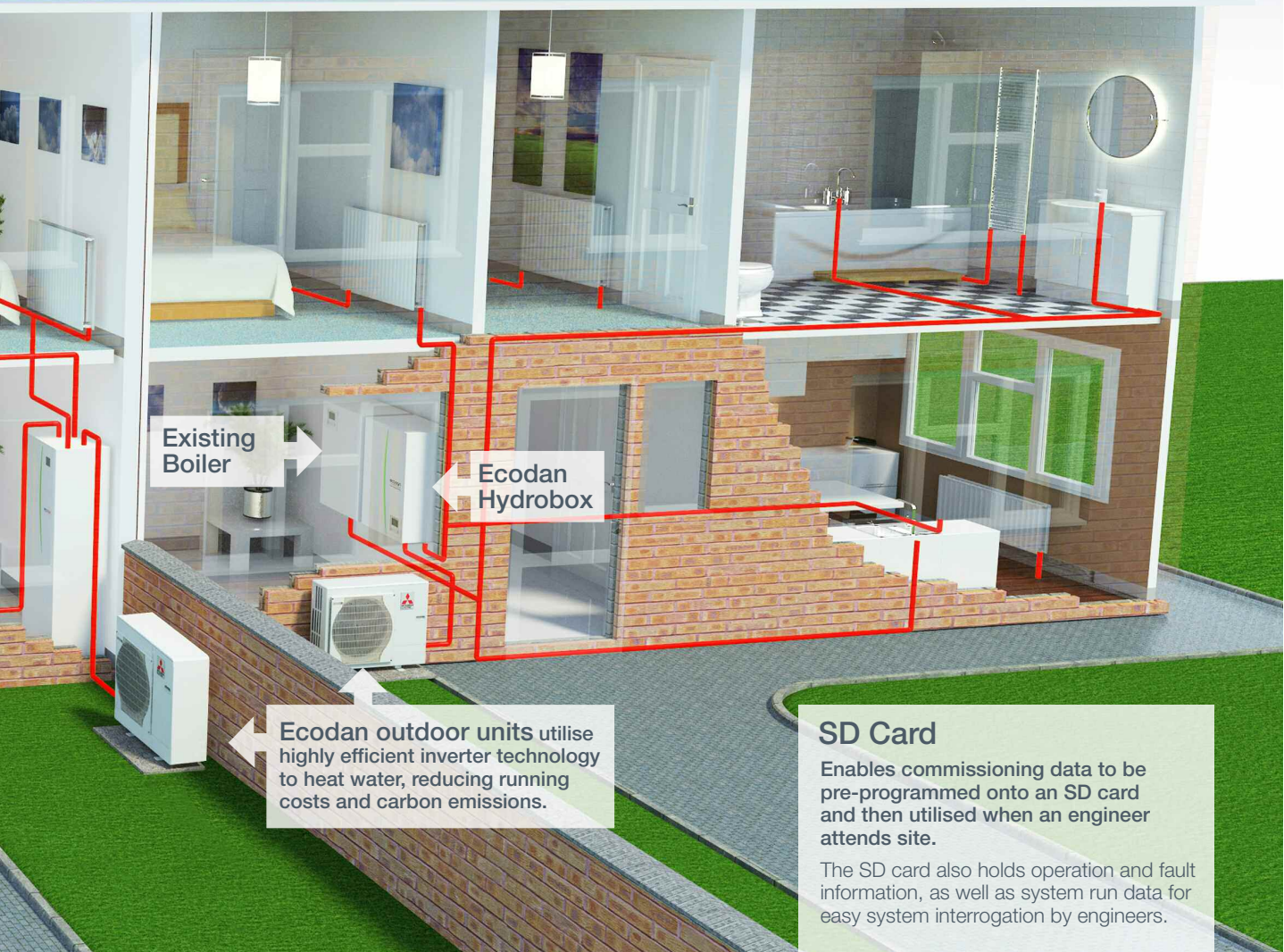

Heating Power Coverage of a Property

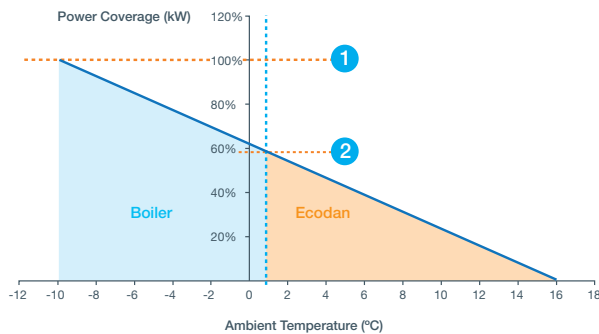

Heating Energy Coverage of a Property

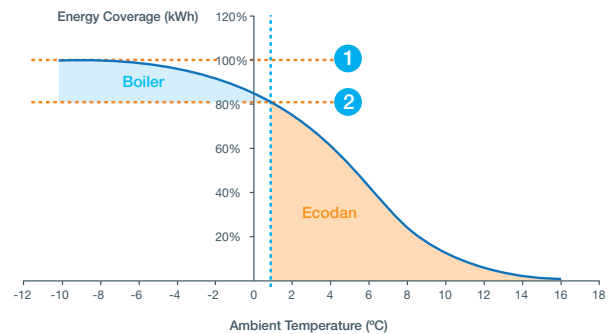

Example 1: On-gas grid 3-bed detached property

Fuel Cost: Electricity Price 13.5p/kWh / Gas Price 4p/kWh

DHW = Domestic Hot Water

Technology	Capital Cost	Additional Investment	Running Cost Reduction	Rate of Return	Pay Back (Years)
Heating and DHW by Gas Combi-Boiler	£2,000	£0	-	0%	-
Heating and DHW by 8.5kW Ecodan Heat Pump 1	£7,900	£5,900	4.4%	0%	7.6
Hybrid - Heating by 5kW Ecodan Heat Pump and DHW/Back Up Heating by Combi-Boiler 2	£3,600	£1,600	2.9%	27%	3.1

In this example the owner of the property has a 10 year old combi-boiler which is requiring an increasing number of maintenance visits for small problems. The owner is considering buying a new boiler in the summer period to ensure there are no problems during the next winter.

- This is a perfect time to invest in a new Ecodan hybrid heat pump - allowing you to run your boiler for only 25% of the year, therefore extending its life.
- Radiators can remain unchanged as the boiler will be used when the ambient temperature drops too low.
- The system allows you to take advantage of RHI by metering the output of the renewable Ecodan.
- The hybrid control on the Ecodan intelligently turns on/off the boiler to achieve the lowest running cost and highest levels of comfort.

Example 2: Off-gas grid old uninsulated property

Fuel Cost: Electricity Price 13.5p/kWh / Oil Price 5.5p/kWh

DHW = Domestic Hot Water

Technology	Capital Cost	Additional Investment	Running Cost Reduction	Rate of Return	Pay Back (Years)
Heating and DHW by Oil Combi-Boiler	£0	£0	-	0%	-
Heating and DHW by 11.2kW Ecodan Heat Pump 1	£8,500	£8,500	30.5%	6%	5.8
Hybrid - Heating by 8.5kW Ecodan Heat Pump and DHW/Back Up Heating by Combi-Boiler 2	£4,300	£4,300	21.4%	16%	4.2

In this example the owners have an older off-gas grid property with a high heat load and that is not very well insulated. They are worried about their oil bills continually increasing and have been told in the past that a heat pump is unable to deliver a solution to their building.

- New hybrid functionality on the Ecodan heat pumps mean this type of building can now use a heat pump.
- Radiators can remain unchanged as the oil boiler will be used when the ambient temperature drops too low.
- The system allows you to take advantage of RHI by metering the output of the renewable Ecodan.
- The hybrid control on the Ecodan intelligently turns on/off the boiler to achieve the lowest running cost and highest levels of comfort.

Heat pumps help keep bills down in hybrid installation

The installation of an Ecodan system into a 3-bedroom detached house in Bedfordshire has demonstrated how effectively the heat pump will work in conjunction with traditional heating systems to maximise efficiency and reduce both installation costs and emissions.

The 5kW Ecodan and pre-plumbed 180-litre cylinder was installed in April 2013, and is working as a hybrid heating system with a gas boiler and a wood burning stove to provide all the heating and hot water the family needs.

The timber-framed, brick-clad house was built in 2006 and with a young baby in the home the family has a high hot water demand. "It's important for us that we have hot water whenever we want it and to also keep our son's bedroom at a pre-set level of 20°C," explains Alice Knight the homeowner.

The system has been set up so that the Ecodan wireless thermostat in the baby's bedroom becomes the 'master' unit during the night ensuring that the temperature is constant. The hot water is also set to automatically replenish whenever the cylinder temperature drops below 43°C, which suits the family's lifestyle as it ensures that there is always hot water on demand. Despite this hot water requirement, the system has returned a COP (Coefficient of Performance) of 3.0.

The family has also programmed the individual prices of gas and electricity into the Ecodan's control system, so that it can decide when it is best to run the heat pump or the gas boiler to maintain comfort levels in the most cost efficient way possible. This way, the family knows that the gas boiler will only come on when it demonstrates that it is the most economical means of heating the home.

The home has a floor space of 105m² and is divided into two 'electronic' heating zones with priority switching between upstairs and downstairs based on which areas of the house are being occupied during different times of the day. Due to the hybrid configuration most of the original radiators could also be retained.

The house has an EPC (Energy Performance Certificate) rating of 'C' for energy efficiency, with heat losses calculated at 4.3kW at -3°C outdoor temperature and 21°C indoor. The Knight family is also expecting to benefit from around £500 a year in payments from the Renewable Heat Incentive.



"We have been delighted with the heating and especially the constant temperature it provides," says Alice. "The system has also quickly adapted to suit our lifestyle and controls both the heat pump and the gas boiler, so we really don't need to worry about anything."

For real world performance monitoring of different sites around the UK, take a look at the Ecodan Dashboard: dashboard.mitsubishielectric.co.uk

Veteran embraces renewable technologies with hybrid heating system

A former WW2 veteran has shown the way to a sustainable future with the installation of a hybrid Ecodan air source heat pump to work alongside his existing gas boiler.



Mr Durward of Newick, Lewes who flew Lancaster bombers, describes himself as a 'gadget man' and always willing to experiment with new ideas, so when he heard about the possibility of reducing the heating bills for himself and his wife by installing an Ecodan system, he was eager to investigate. "Heat pumps seem to offer a real solution to the problems associated with fossil fuel heating, which is no longer a sustainable way of keeping our homes warm," he explained.

With the installation of an 8.5kW Ecodan monobloc air source heat pump and packaged hydrobox, Mr Durward now has a renewable heating system which also qualifies for the Renewable Heat Incentive (RHI). Designed specifically with a bivalent function for use in conjunction with conventional boilers, the hydrobox is pre-plumbed and wired for faster installation and also offers simplified SD card commissioning. With the capability of providing two-zone space heating via a modern, simplified graphical controller, the system ensures that the Durward's are able to completely control their heating.

Mr Durward has always had a fascination for self-sufficiency and has already sunk a borehole down to 200 feet to supply water to the property. "I put in a solar thermal system over 35 years ago which worked well but I have now changed this to a Photovoltaic system to generate our own electricity," he added.

East Sussex-based Payne's Heating and Plumbing Services, who are an Accredited Ecodan Installer and renewable specialist, fitted both the heat pump and the PV system. At Mr Durward's request, they have also incorporated a power diverter, which transfers any excess electricity generated to the immersion heater, giving the couple regular free tanks of piping hot water.

The Durward's had an upgrade to a new high efficiency condensing boiler fitted alongside the hybrid Ecodan system. However, this has had such little use since the introduction of the heat pump that Mr Durward received a call from his utility company, which believed there might be a mistake due to the low energy reading.

Designed specifically to integrate Ecodan with a third party cylinder the hydrobox is pre-plumbed and wired for faster installation and also connects to a wireless remote controller.

"Mr Durward is delighted with the way the system is working and we often use him as a contact for other clients looking at similar works," explained Dave Crock of Paynes Heating and Plumbing Services.

Mitsubishi Electric has also arranged for a MELCloud Wi-Fi system to be installed so that the heat pump can be monitored and Mr Durward can control and alter his system from either his armchair or anywhere else in the world.

Making a world of difference with Ecodan



www.greengateway.mitsubishielectric.co.uk

Mitsubishi Electric UK's commitment to the environment



Hybrid heating systems using an Ecodan offer a real opportunity for reductions in running costs and carbon emissions.

With renewable energy targets and carbon reduction pressure on our legacy stock coming up to similar levels as our new buildings, we need to start taking real steps towards finding a solution. Hybrid heating systems allow property owners to make a cost effective change and meet the challenges head on.

Installing and running Ecodan systems as part of a hybrid heating system, can not only deliver carbon emissions reductions today, but as the electrical grid becomes cleaner with the advent of solar PV, wind farms and high efficiency power stations, these buildings will continue to deliver increased emission savings long into the future.

This legacy stock of buildings is not going away, but with the help of Ecodan technology we have a real opportunity to deliver highly efficient renewable heating solutions, whilst providing hard cash savings through the reduction of running and maintenance costs.

Mitsubishi Electric are also committed to lowering our own production emissions levels and those generated by our equipment during their lifetime. Our Green Gateway philosophy strives to improve energy efficiency and take a more responsible approach to energy use, helping the nation to achieve its climate goals.

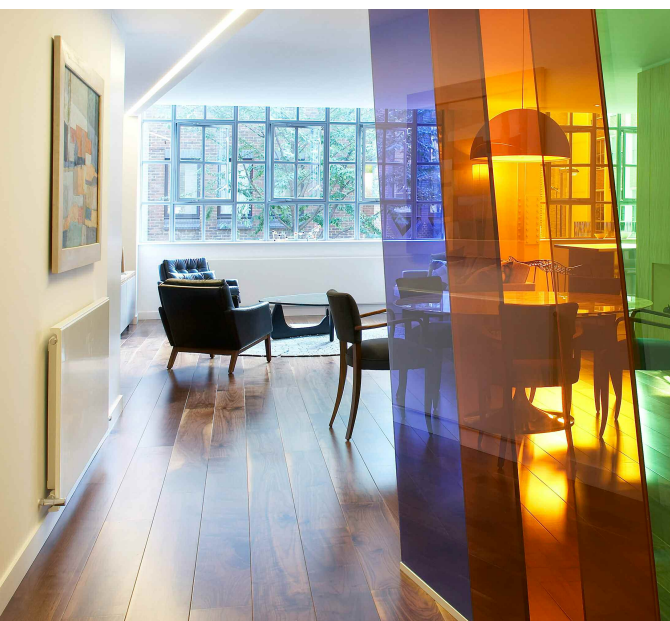

The Ecodan Hybrid heating system allows consumers to have the best of both worlds in one single heating system





Telephone: 01707 282880

email: heating@meuk.mee.com

web: heating.mitsubishielectric.co.uk

UNITED KINGDOM Mitsubishi Electric Europe Living Environmental Systems Division
Travellers Lane, Hatfield, Hertfordshire, AL10 8XB, England
General Enquiries Telephone: 01707 282880 Fax: 01707 278881

IRELAND Mitsubishi Electric Europe Westgate Business Park, Ballymount, Dublin 24, Ireland
Telephone: Dublin (01) 419 8800 Fax: Dublin (01) 419 8890 International code: (003531)

Country of origin: United Kingdom – Japan – Thailand – Malaysia. ©Mitsubishi Electric Europe 2014. Mitsubishi and Mitsubishi Electric are trademarks of Mitsubishi Electric Europe B.V. The company reserves the right to make any variation in technical specification to the equipment described, or to withdraw or replace products without prior notification or public announcement. Mitsubishi Electric is constantly developing and improving its products. All descriptions, illustrations, drawings and specifications in this publication present only general particulars and shall not form part of any contract. All goods are supplied subject to the Company's General Conditions of Sale, a copy of which is available on request. Third-party product and brand names may be trademarks or registered trademarks of their respective owners.

Printed in August 2014 SAP No.270378



www.greengateway.mitsubishielectric.co.uk

Mitsubishi Electric UK's commitment to the environment



Follow us @meuk_les
Follow us @green_gateway



Connect with Green Gateway



[mitsubishielectric2](https://www.youtube.com/mitsubishielectric2)