

SERVICE MANUAL

R744

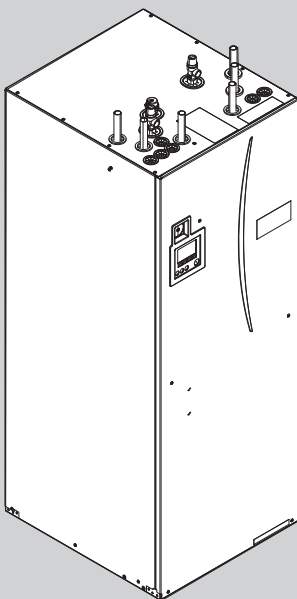
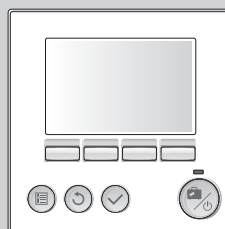
 Cylinder Unit
 [Model Name]

EHPT20Q-VM2EA

Note:

- This manual describes service data of cylinder unit only.
- RoHS compliant products have <G> mark on the spec name plate.

• Please void GCH15010 REVISED EDITION-B.


Cylinder Unit

**MAIN REMOTE
CONTROLLER**

CONTENTS

1. REFERENCE MANUAL	2
2. SAFETY NOTICES	3
3. SPECIFICATIONS	4
4. PART NAMES AND FUNCTIONS	5
5. OUTLINES AND DIMENSIONS	6
6. WIRING DIAGRAM	8
7. FIELD WIRING	11
8. WATER SYSTEM DIAGRAM	12
9. CONTROLS	14
10. TROUBLESHOOTING	36
11. DISASSEMBLY PROCEDURE	51
12. SERVICE AND MAINTENANCE	79

PARTS CATALOG (GCB15010)

OUTDOOR UNIT'S SERVICE MANUAL

Service Ref.	Service Manual No.
QUHZ-W40VA	GHH15010

Please read the following safety precautions carefully.

⚠ WARNING:
Precautions that **MUST** be observed to prevent injuries or death.

⚠ CAUTION:
Precautions that **MUST** be observed to prevent damage to unit.

Intended use

- This product is designed and intended for domestic.
- This appliance is not intended for use by persons (including children) with reduced physical, sensory or mental capabilities, or lack of experience and knowledge, unless they have been given supervision or instruction concerning the use of the appliance by a person responsible for their safety. Children should be supervised to ensure they **DO NOT** play with the appliance or its associated controls.

This Installation Manual along with the Operational Manual should be left with the product after installation for future reference.
Mitsubishi Electric is NOT responsible for the failure of locally-supplied parts.

- Be sure to perform periodical maintenance.
- Be sure to follow your local regulations.
- Be sure to follow the instructions provided in this manual.

⚠ WARNING

Mechanical

- The cylinder unit and outdoor unit **MUST** not be installed, disassembled, relocated, altered or repaired by the user. Ask an authorised installer or technician. If the unit is installed improperly or modified after installation by the user water leakage, electric shock or fire may result.
- The outdoor unit should be securely fixed to a hard level surface capable of bearing its weight.
- The cylinder unit should be positioned on a hard level surface capable of supporting its filled weight to prevent excessive sound or vibration.
- Do not position furniture or electrical appliances below the outdoor unit or cylinder unit.
- The discharge pipework from the emergency devices of the cylinder unit should be installed according to local law / regulations.
- Only use accessories and replacement parts authorised by Mitsubishi Electric. These should only be fitted by a qualified technician.

Electrical

- All electrical work should be performed by a qualified technician according to local regulations and the instructions given in this manual.
- The units **MUST** be powered by a dedicated power supply and the correct voltage and circuit breakers **MUST** be used.
- Wiring should be in accordance with national wiring regulations. Connections **MUST** be made securely and without tension on the terminals.
- Earth unit correctly.

General

- Keep children and pets away from both the cylinder unit and outdoor unit.
- Do not use the hot water produced by the heat pump directly for drinking or cooking. This could cause illness to the user.
- Do not stand on the units.
- Do not touch switches with wet hands.
- Annual maintenance checks on both the cylinder unit and the outdoor unit should be conducted by a suitable qualified person.
- Do not place containers with liquids on top of the cylinder unit. If they leak or spill onto the cylinder unit damage to the unit and/or fire could occur.
- Do not place any heavy items on top of the cylinder unit or the outdoor unit.
- The use of any refrigerant other than that specified for the system will cause mechanical failure or system malfunction or unit breakdown. In the worst case, this could lead to a serious impediment to securing product safety.
- In heating mode, to avoid the heat emitters being damaged by excessively hot water, set the target flow temperature to a minimum of 2°C below the maximum allowable temperature of all the heat emitters.

⚠ CAUTION

- Use clean water that meets local quality standards on the primary circuit.
- The outdoor unit should be installed in an area with sufficient airflow according to the diagrams in the outdoor unit installation manual.
- The cylinder unit should be located inside to minimise heat loss.
- Water pipe-runs on the primary circuit between outdoor and indoor unit should be kept to a minimum to reduce heat loss.
- Ensure condensate from outdoor unit is piped away from the base to avoid puddles of water.
- Remove as much air as possible from the primary and secondary (potable) circuits.
- Refrigerant leakage may cause suffocation. Provide ventilation in accordance with EN378-1.
- Be sure to wrap insulation around the piping. Direct contact with the bare piping may result in burns.
- Never put batteries in your mouth for any reason to avoid accidental ingestion.
- Battery ingestion may cause choking and/or poisoning.
- Install the unit on a rigid structure to prevent excessive sound or vibration during operation.
- Do not transport the cylinder unit with water inside the thermal store tank. This could cause damage to the unit.
- If power to the cylinder unit is to be turned off (or system switched off) for a long time, the water should be drained.
- If unused for a long period, before operation is resumed, secondary (potable) circuit should be flushed through with potable water.
- Preventative measures should be taken against water hammer, such as installing a Water Hammer Arrestor on the primary water circuit, as directed by the manufacturer.

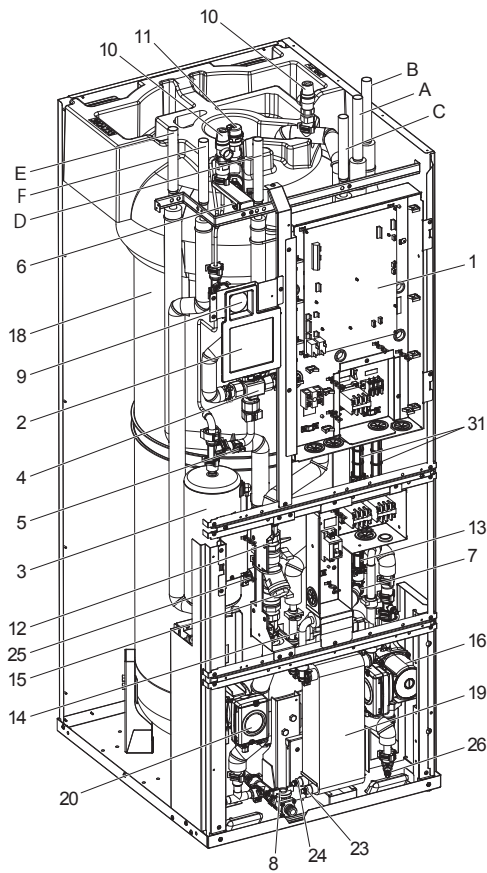
Product specification

Model name		EHPT20Q-VM2EA	
Modes		Space & DHW heating	
Nominal thermal store tank volume		200 L	
Overall unit dimensions		1600 × 595 × 680 mm (Height × Width × Depth)	
Weight (empty)		77 kg	
Weight (full)		283 kg	
Primary expansion vessel (Accessory item)	Nominal volume		18 L
	Charge pressure		1.0 bar (100 kPa)
Safety device	Water circuit (Thermal store tank)	Control thermistor (THW1)	42 - 72 °C
		Control thermistor (THW3)	80 °C
		Pressure relief valve (2 No. devices)	3.0 bar (300 kPa)
		Flow sensor	Min. flow 1.3 L/min
		Manual reset thermostat	90 °C
	Booster heater	Manual reset thermostat	90 °C
		Thermal Cut-out (for dry run prevention)	121 °C
Primary circuit circulating pump	Thermal store and space heating		Grundfos Solar PML 25-145 180
	Hot water supply		Grundfos Solar PML 25-145 180
Connections	Primary circuit		ϕ 22.0
	Secondary (potable) circuit		ϕ 22.0
Target temperature range	Space heating	Flow temperature *1	25 - 60 °C
		Room temperature	10 - 30 °C
	DHW supply maximum temperature		40 - 70 °C
Guaranteed operating range	Ambient *2		0 - 35 °C (80%RH)
	Outdoor temperature		- 15 - 35 °C
Electrical data	Control board	Power supply (Phase, voltage, frequency)	230V N~ 50 Hz
		Current	12.8 A
		Breaker (Local supply)	20 A
	Booster heater	Power supply (Phase, voltage, frequency)	230V N~ 50 Hz
		Capacity	2 kW
		Current	8.7 A
		Breaker	16 A
Sound power level		40 dB(A)	
Maximum secondary (potable) water supply pressure		10 bar (1 MPa)	
Maximum primary working pressure		2.5 bar (250 kPa)	
Minimum primary working pressure		1.0 bar (100 kPa)	

*1 Depending on the ambient conditions, it may not reach the set temperature.

*2 The cylinder's environment MUST be frost-free.

Component Parts EHPT20Q-VM2EA



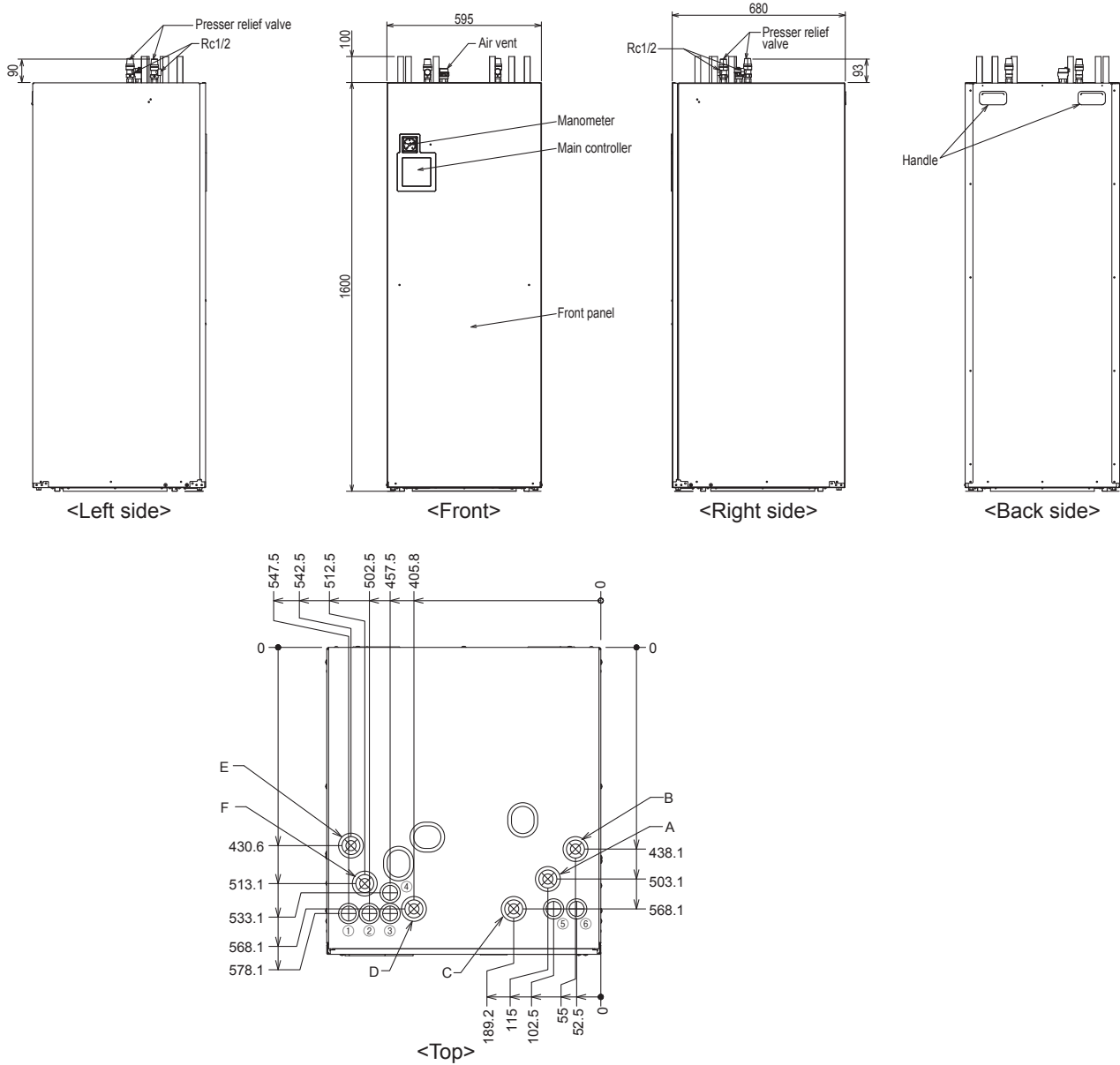
<Note>

Make sure to correctly install the Mitsubishi Electric Accessory Parts (e.g. Primary expansion vessel, Tundish and Filling loop) in the field.

No.	Part name	EHPT20Q-VM2EA
A	DHW outlet pipe	✓
B	Cold water inlet pipe	✓
C	Water pipe (Space heating return connection)	✓
D	Water pipe (Space heating flow connection)	✓
E	Water pipe (Flow from heat pump connection)	✓
F	Water pipe (Return to heat pump connection)	✓
1	Control and electrical box	✓
2	Main controller	✓
3	Booster heater with thermostat	✓
4	3-way valve	✓
5	Manual thermostat	✓
6	Manual air vent (above tank)	✓
7	Manual air vent (above pump A)	✓
8	Drain valve (Primary circuit)	✓
9	Manometer	✓
10	Primary pressure relief valve (3bar)	✓
11	Automatic air vent	✓
12	Flow sensor 1 (For space heating)	✓
13	Flow sensor A (Secondary (Potable) circuit)	✓
14	Flow sensor B (Primary circuit)	✓
15	Strainer valve	✓
16	Water circulation pump A (For hot water supply to plate heat exchanger)	✓
17	Pump valve	✓
18	Primary thermal store tank	✓
19	Plate heat exchanger (Water - Water)	✓
20	Water circulation pump 1 (For thermal store and space heating)	✓
21	THW1 (Flow water temp. thermistor)	✓
22	THW2 (Return water temp. thermistor)	✓
23	Drain cock (HEX) (Secondary (Potable) circuit)	✓
24	Drain cock (HEX) (Primary circuit)	✓
25	Drain cock (Booster heater)	✓
26	Drain cock (For pump A)	✓
27	THW5A (Stored water temp. thermistor (upper))	✓
28	THW5B (Stored water temp. thermistor (lower))	✓
29	THW3 (Flow water temp. thermistor 2 (to tank))	✓
30	THW4 (DHW supply temp. thermistor)	✓
31	Electrical isolation pipe	✓
32	Primary expansion vessel (Accessory item)	—
33	Drain pipe (Local supply)	—
34	Tundish (Accessory item)	—
35	Isolating valve (Local supply)	—
36	Magnetic filter (Local supply) (Recommended)	—
37	Strainer (Local supply)	—
38	Filling loop (Ball valves, check valves and flexible hose) (Accessory item)	—
39	Thermo mix valve (recommended) (Local supply)	—

5-1. Technical Drawings

<Unit: mm>



Letter	Pipe and cable description	Connection size/type	Pipe or cable length (Max.)
A	DHW outlet connection	22 mm/Compression	—
B	Cold water inlet connection	22 mm/Compression	—
C	Space heating return connection	22 mm/Compression	65 m
D	Space heating flow connection	22 mm/Compression	65 m
E	Flow from heat pump connection (No plate heat exchanger)	22 mm/Compression	15 m
F	Return to heat pump connection (No plate heat exchanger)	22 mm/Compression	15 m
①	Booster heater inlet (Power cable 230 V)	Run booster heater cable	—
②	Main power inlet (Power cable 230 V)	Run power cable	—
③	Cylinder unit - outdoor unit cable (Power cable 230V)	Run cylinder unit -outdoor unit cable	15 m
④	Output cable inlet	Run output cable	—
⑤	Signal input cable inlet	Run signal input cables and remote sensor wires	—
⑥	Wireless receiver and Wi-Fi interface cable inlet	Run wireless receiver cable and ecodan Wi-Fi interface (option) cable	—

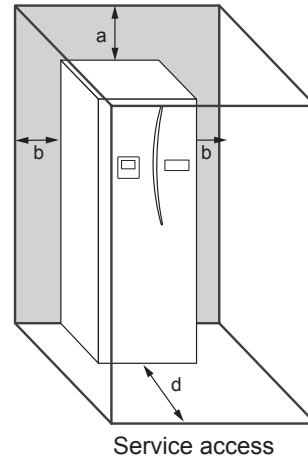
< Table 5.1 >

5-2. Service access diagrams

Service access	
Parameter	Dimension (mm)
a	300
b	150
c (distance behind unit not visible in the right figure)	10
d	500

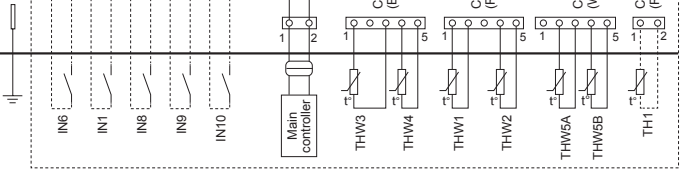
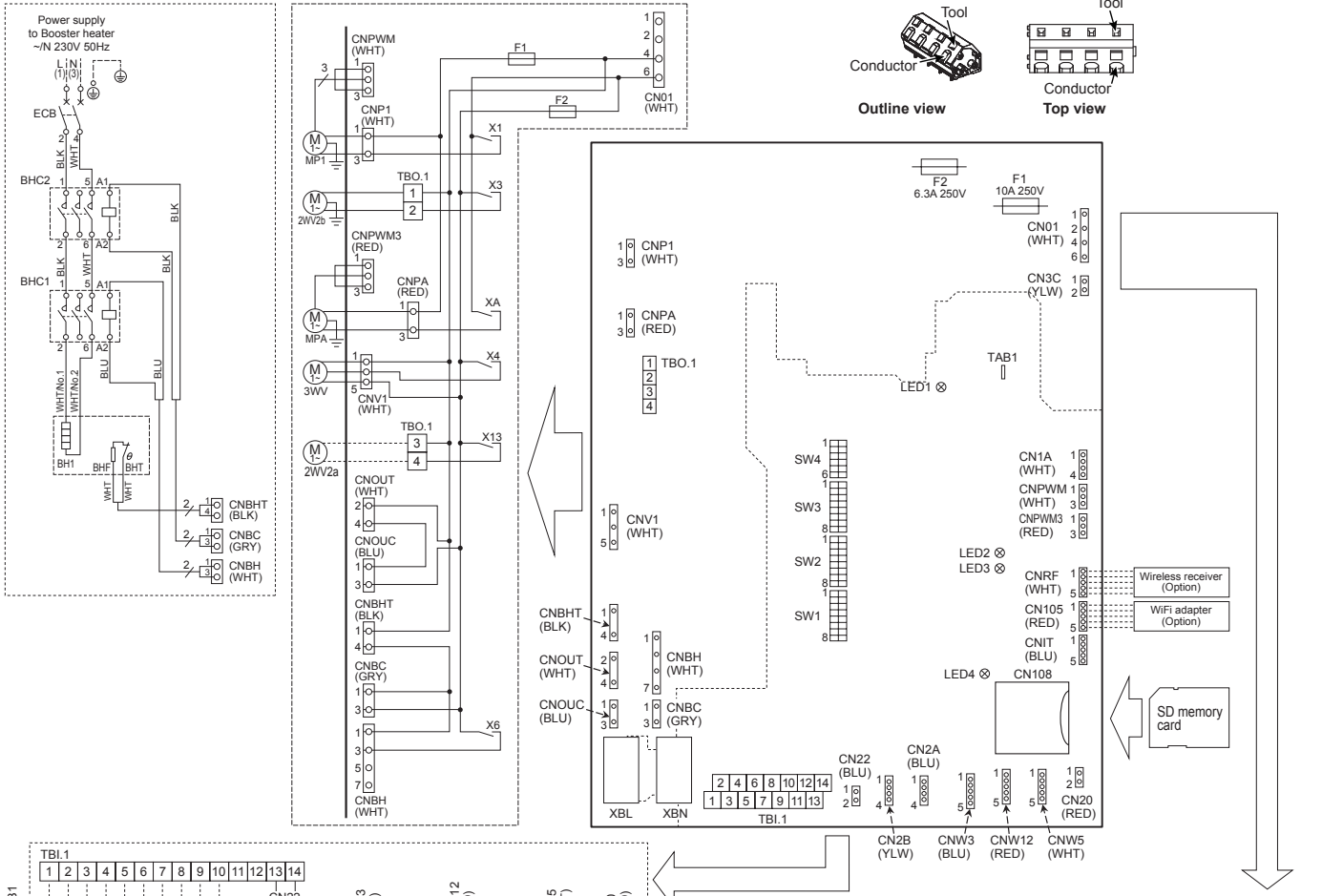
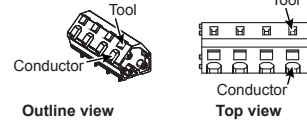
Sufficient space MUST be left for the provision of discharge pipework as detailed in National and Local Building Regulations.

The cylinder unit must be located indoors and in a frost-free environment, for example in a utility room, to minimise heat loss from stored water.

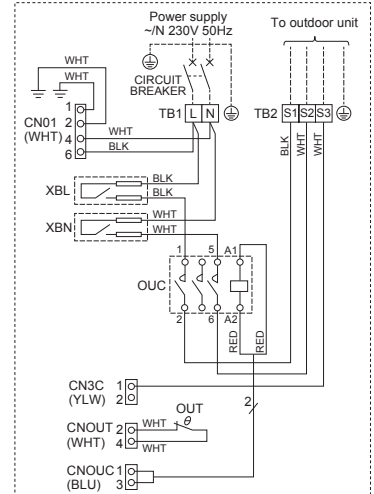


6-1-1 Cylinder unit WIRING DIAGRAM <EHPT20Q-VM2EA>

<How to use TBO.1>
Connect them using either way as shown below.



- Symbols used in wiring diagram are, : connector, : terminal block.
- Indoor unit and outdoor unit connecting wires have polarities, make sure to match terminal numbers (S1, S2, S3) for correct wirings.
- Since the outdoor unit side electric wiring may change, be sure to check the outdoor unit electric wiring diagram for service.



Symbol	Name
TB1	Terminal block <Power supply>
TB2	Terminal block <Outdoor unit>
ECB	Earth leakage circuit breaker for booster heater
MP1	Water circulation pump 1 (Thermal store & space heating)
MPA	Water circulation pump A (Hot water supply)
3WV	3-way valve
2WV2a	2-way valve (For Zone 1)(Local supply)
2WV2b	2-way valve (For Zone 2)(Local supply)
BHT	Thermostat for booster heater
BHF	Thermal fuse for booster heater
BH1	Booster heater 1
BHC1	Contactor for booster heater
BHC2	Contactor for booster heater protection
OUT	Thermostat for outdoor unit
OCU	Contactor for outdoor unit

Symbol	Name
TH1	Thermistor (Room temp.)(Option)
THW1	Thermistor (Flow water temp.)
THW2	Thermistor (Return water temp.)
THW3	Thermistor (Flow water (to tank) temp.)
THW4	Thermistor (DHW supply temp.)
THW5A	Thermistor (Stored water (upper) temp.)
THW5B	Thermistor (Stored water (lower) temp.)
IN1	Room thermostat 1 (Local supply)
IN6	Room thermostat 2 (Local supply)
IN8	Electric energy meter 1 (Local supply)
IN9	Electric energy meter 2 (Local supply)
IN10	Heat meter (Local supply)

INDOOR CONTROLLER (FTC)	
TBO.1	Terminal block <Outputs>
TBI.1	Terminal block <Signal Inputs>
F1	Fuse (T10AL250V)
F2	Fuse (T6.3AL250V)
SW1-4	DIP switch *See Table 3
X1-13	Relay
XBL	Relay for outdoor unit
XBN	Relay for outdoor unit
LED1	Power supply
LED2	Power supply (Main controller)
LED3	Communication (Outdoor unit)
LED4	Reading or writing data to SD card
CNPWM	Pump speed control signal for MP1
CNPWM3	Pump speed control signal for MPA
CN108	SD card connector
Flow sensor 1	For space heating
Flow sensor A	Potable side
Flow sensor B	Primary side

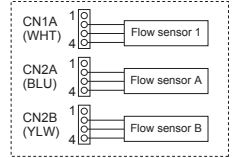


Table 1 Signal Inputs

Name	Terminal block	Connector	Item	OFF (Open)	ON (Short)
IN1	TBI.1	3-4	Room thermostat 1 input	Refer to SW2-1 in <Table 3 DIP Switch Functions>.	
IN6	TBI.1	1-2	Room thermostat 2 input	Refer to SW3-1 in <Table 3 DIP Switch Functions>.	
IN8	TBI.1	5-6	Electric energy meter 1	Refer to installation manual.	
IN9	TBI.1	7-8	Electric energy meter 2		
IN10	TBI.1	9-10	Heat meter		

Table 2 Outputs

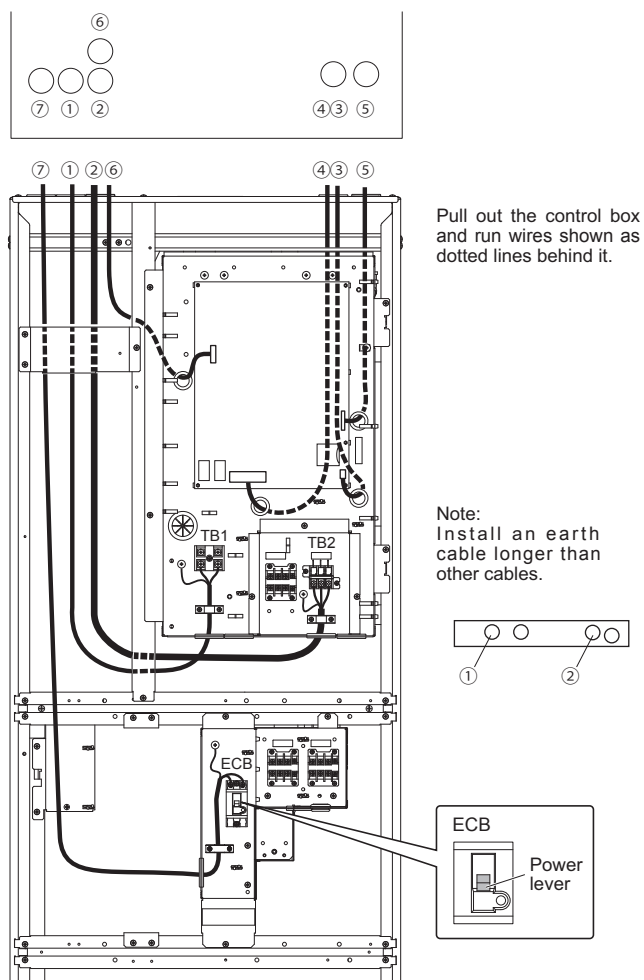
Name	Terminal block	Connector	Item	OFF	ON
OUT1	—	CNP1	Water circulation pump1 output (Space heating & DHW)	OFF	ON
OUT3	TBO.1	1-2	2-way valve 2b output *1	OFF	ON
OUT4	—	CNV1	3-way valve output	Heating	DHW
OUT6	—	CNBH 1-3	Booster heater output	OFF	ON
OUT13	TBO.1	3-4	2-way valve 2a output *1	OFF	ON
OUTA	—	CNPA	Water circulation pump A output	OFF	ON
OUTB	—	—	Relay for outdoor unit	OFF	ON

Do not connect to the terminals that are indicated as "—" in the "Terminal block" field.
*1. For 2-zone valve ON/OFF control.

6-1-2 Electrical Connection

All electrical work should be carried out by a suitably qualified technician. Failure to comply with this could lead to electrocution, fire, and death. It will also invalidate product warranty. All wiring should be according to national wiring regulations.

Breaker abbreviation	Meaning
ECB	Earth leakage circuit breaker for booster heater
TB1	Terminal block 1
TB2	Terminal block 2



<Figure 6.1>

⚠ CAUTION

This product contains electrostatic-sensitive components that can be damaged if handled incorrectly. To prevent any electrostatic damage, ensure you are electrically grounded / earthed in order to discharge any possible static electricity build-up.

- The outdoor unit can only be powered via Cylinder unit.
- Connections should be made to the terminals as indicated in the figures to the left below.
- The wires (① ~ ⑦) MUST NOT be bundled together with other wires having different number. (Refer to <Figure 6.1>)

- Ⓐ Locally supplied wiring should be inserted through the inlets situated on the top of the cylinder unit. (Refer to <Table 5.1>.)
- Ⓑ Wiring should be fed down the left hand side of the control and electrical box and clamped in place using clips provided.
- Ⓒ The wires should be inserted individually through the cable inlets on the control board (Figure 6.1).
- ③ Remote sensor wire
 - ④ Signal input cable
 - ⑤ Wireless receiver (option) (PAR-WR51R-E) and Wi-Fi interface (option) (PAC-WF010-E) cable
 - ⑥ Output cable
- Ⓓ Connect the power cable for the Cylinder unit to TB1. ...①
- ① Power cable
- Ⓔ Connect the outdoor unit – cylinder unit connecting cable to TB2. ...②
- ② Cylinder unit - Outdoor unit cable
- Ⓕ Connect the power cable for the booster heater to ECB. ...⑦
- ⑦ Power cable for Booster heater

- Make sure that ECB is ON. *1
- On completion of wiring, ensure main controller cable is connected to the relay connector.

Note: *1 When the ECB is turned off, push down the power lever without pressing the test button.

⚠ WARNING

When confirming the operation of the ECB, make sure that the ECB can be turned ON/OFF by the power lever before pressing the test button. If the ECB cannot be turned ON/OFF by the power lever, stop using the ECB and replace it.

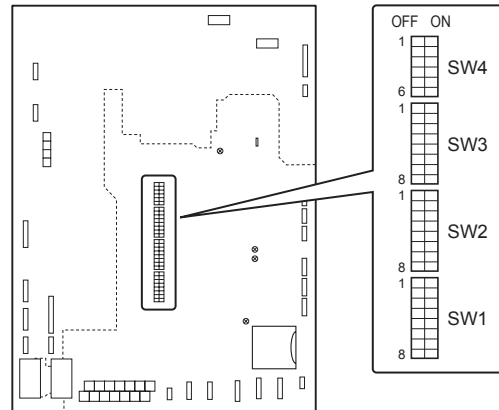
6-2 DIP Switch Functions

Located on the FTC printed circuit board are 4 sets of small white switches known as DIP switches. The DIP switch number is printed on the circuit board next to the relevant switches. The word ON is printed on the circuit board and on the DIP switch block itself. To move the switch you will need to use a pin or the corner of a thin metal ruler or similar.

DIP switch settings are listed in the table below.

Before changing any switch settings, ensure the power supplies to both cylinder unit and outdoor unit are turned OFF.

Before changing the DIP switch setting, confirm that the power supply earth cable is securely connected and prevent the FTC from being applied with static electricity (e.g. touch a case body etc.). Otherwise, it may cause a failure of the FTC due to the static electricity.



DIP switch	Function	OFF	ON	Default settings: Indoor unit model	
SW1	SW1-1	—	—	OFF	
	SW1-2	—	—	OFF	
	SW1-3	—	—	OFF	
	SW1-4	—	—	OFF	
	SW1-5	—	—	OFF	
	SW1-6	—	—	OFF	
	SW1-7	—	—	OFF	
	SW1-8	Wireless remote controller	WITHOUT Wireless remote controller	WITH Wireless remote controller	OFF
SW2	SW2-1	Room thermostat1 input (IN1) logic change	Zone1 operation stop at thermostat short	Zone1 operation stop at thermostat open	OFF
	SW2-2	—	—	—	OFF
	SW2-3	—	—	—	OFF
	SW2-4	—	—	—	OFF
	SW2-5	Automatic switch to backup heat source operation (When outdoor unit stops by error)	Inactive	Active *1	OFF
	SW2-6	—	—	—	OFF
	SW2-7	—	—	—	OFF
	SW2-8	—	—	—	OFF
SW3	SW3-1	Room thermostat 2 input (IN6) logic change	Zone2 operation stop at thermostat short	Zone2 operation stop at thermostat open	OFF
	SW3-2	—	—	—	OFF
	SW3-3	—	—	—	OFF
	SW3-4	Electric energy meter	WITHOUT Electric energy meter	WITH Electric energy meter	OFF
	SW3-5	—	—	—	OFF
	SW3-6	2-zone valve ON/OFF control	Inactive	Active	OFF
	SW3-7	—	—	—	OFF
	SW3-8	Heat meter	WITHOUT Heat meter	WITH Heat meter	OFF
SW4	SW4-1	—	—	—	OFF
	SW4-2	—	—	—	OFF
	SW4-3	—	—	—	OFF
	SW4-4	Indoor unit only operation (during installation work) *2	Inactive	Active	OFF
	SW4-5	Emergency mode (Heater only operation)	Normal	Emergency mode (Heater only operation)	OFF *3
	SW4-6	—	—	—	OFF

Note: *1. For safety reasons, this function is not available for certain errors.

(In that case, system operation MUST be stopped and only the water circulation pump keeps running.)

*2. Space heating and DHW can be operated only in indoor unit, like an electric boiler. (Refer to Installation manual "5.4 Indoor unit only operation".)

*3. If emergency mode is no longer required, return the switch to OFF position.

Automatic switch to backup heat source operation

Back-up heat source operation (*1) will automatically run when the outdoor unit stops abnormally. To enable the function, switch DIP SW 2-5 to ON.

To clear the fault(s), reset the power breaker on the indoor unit.

<Applicable error codes (*2)>

E6 to E9, EC, FC, FD, U1 to U4, UP

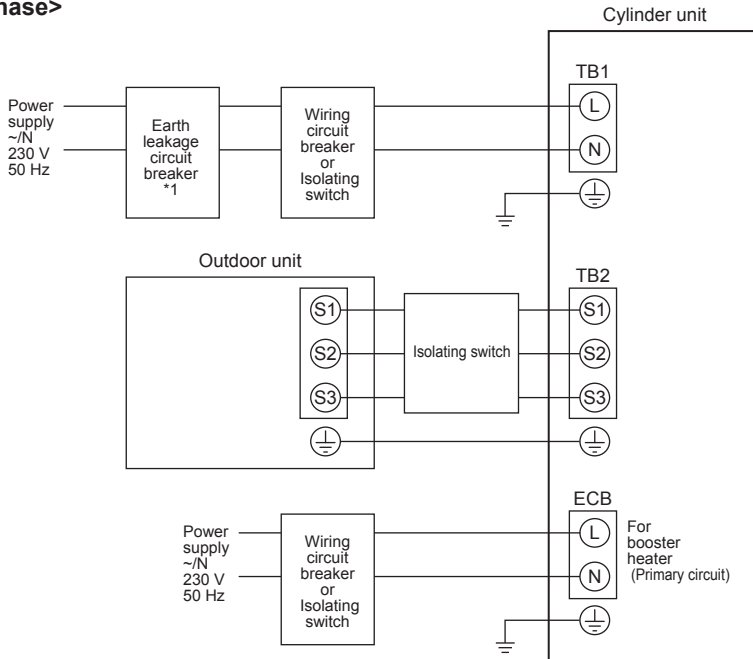
(*1) Prolonged running of the back-up operation may affect the life of the heat source.

(*2) For safety reasons, this function is not available for certain faults. (System operation must be stopped and only pump keeps running.)

Breaker abbreviation	Meaning
ECB	Earth leakage circuit breaker for booster heater
TB1	Terminal block 1
TB2	Terminal block 2

Outdoor unit powered via cylinder unit

<1 phase>



Tightening torque

TB1	2.0 ~ 2.5 Nm
TB2	2.0 ~ 2.5 Nm
ECB	1.3 ~ 1.7 Nm
earth	2.0 ~ 2.5 Nm

Electrical connections 1 phase

*1. Current sensitivity 10 mA, operating time 0.1 s.

If the installed earth leakage circuit breaker does not have an over-current protection function, install a breaker with that function along the same power line.

Description	Power supply	Capacity	Breaker	Wiring
Booster heater (Primary circuit)	230V N~ 50 Hz	2 kW	16 A *2 *3	3 × 2.5 mm ²

Cylinder unit power supply			~N 230 V 50 Hz	
Cylinder unit input capacity		*2		16 A
Main switch (Breaker)				
Wiring	Cylinder unit power supply (including earth cable)			3 × Min. 2.5
Wiring No. × size (mm ²)	Cylinder unit - Outdoor unit (including earth cable) *4			4 × Min. 2.5
Circuit rating	Cylinder unit L - N	*5		230 V AC
	Cylinder unit - Outdoor unit S1 - S2	*5		230 V AC
	Cylinder unit - Outdoor unit S2 - S3	*5		24 V DC

*2. A breaker with at least 3.0 mm contact separation in each pole shall be provided.

The breaker shall be provided to ensure disconnection of all active phase conductors of the supply.

*3. Use a breaker with an over-current protection function.

*4. Max. 15 m

*5. The values given in the table above are not always measured against the ground value.

Note: 1. Wiring size **MUST** comply with the applicable local and national codes.

2. Cylinder unit/outdoor unit connecting cables shall not be lighter than polychloroprene sheathed flexible cable. (Design 60245 IEC 57)

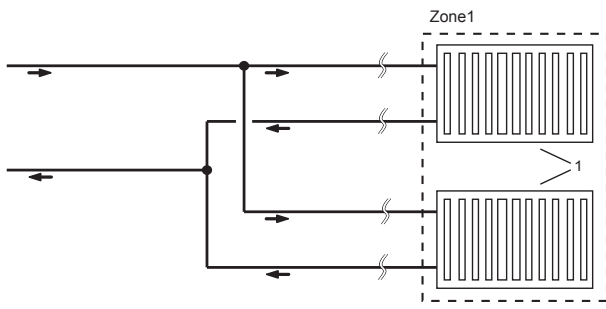
Cylinder unit power supply cables shall not be lighter than polychloroprene sheathed flexible cable. (Design 60227 IEC 53)

3. Install an earth longer than other cables.

4. Please keep enough output capacity of power supply for each heater. The lack of the power supply capacity may possibly cause chattering.

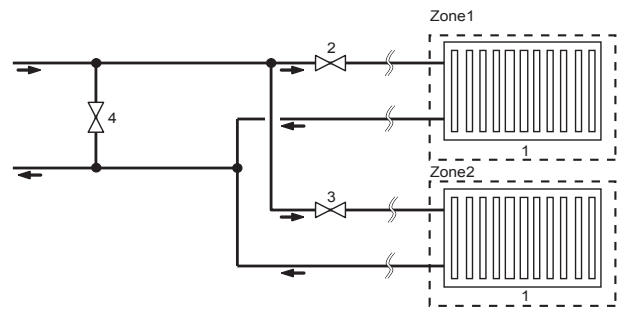
Local system

1-zone temperature control



1. Heat emitters (e.g. radiator, fan coil unit) (local supply)
2. Zone1 2-way valve (local supply)
3. Zone2 2-way valve (local supply)
4. Auto-bypass valve (local supply)

1-zone temperature control (2-zone valve ON/OFF control)



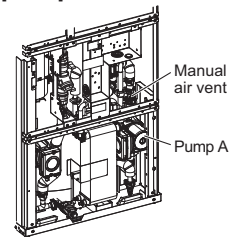
Filling the System (Primary Circuit)

Note: Make sure to turn OFF the booster heater power supply before filling the system

1. Check all connections including factory fitted ones are tight.
2. Insulate pipework between cylinder unit and outdoor unit.
3. Open the automatic air vent to enable automatic air bleeding function.
4. Thoroughly clean and flush, system of all debris. (see section 4.2 in the installation manual.)
5. Fill primary heating circuit with water and suitable anti-freeze as necessary.
Always use a new filling loop with double check valve when filling the primary circuit to avoid back flow contamination of water supply.
Do not use an old filling loop.
Do Not turn ON the system until the system is fully charged of water.

IMPORTANT <Air discharging of pump A>

1. Attach the accessory rubber hose to the manual air vent above pump A to prevent water from dripping on to the pump during the air bleeding operation.
2. Open the drain cock of the manual air vent and discharge the air.
3. Open a tap and confirm that hot water is supplied after approximately 30 minutes from the beginning of thermal store operation.



Note: If the air is not sufficiently discharged, hot water is not supplied and an error occurs. Continue to discharge the air until smooth delivery of hot water.

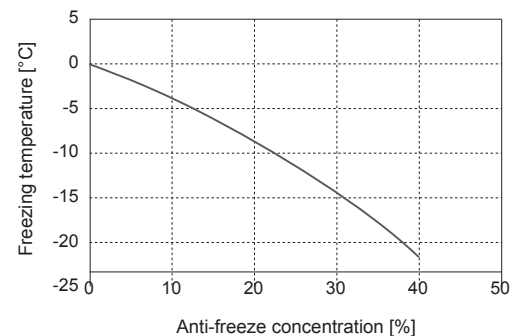
- Open the two manual air vents after filling the system (refer to the following section) .
- Anti-freeze should always be used for packaged model systems (see section 4.2 in the installation manual). Corrosion inhibitor should be used in both split model and packaged model systems.
- Figure on the right shows freezing temperature against anti-freeze concentration. This figure is an example for FERNOX ALPHI-11. For other anti-freeze, please refer to relevant manual.
- When connecting metal pipes of different materials insulate the joints to prevent a corrosive reaction taking place which will damage the pipework.

6. Check for leakages. If leakage is found, retighten the nut onto the connections.
7. Pressurise system to 1 bar with all the water in thermal store tank cold.
(If the system is pressurised with the water in thermal store tank hot, air inclusion in pump may be caused by the pressure drop of the system that occurs if the hot water gets cold.)
8. Release all trapped air using air vents during and following heating period.
9. Top up with water as necessary. (If pressure is below 1 bar)

Note:

- Automatic air vents **MUST** be installed at the highest point of the primary system. The slightest amount of air in the system can reduce efficiencies and even cause the cylinder unit to fault.
- Confirm the following if the air cannot be discharged.
 - Air discharging of radiators
 - Air discharging from isolating valves

(If necessary, turn on the pump 1 using Manual operation (refer to page 18).)



Filling the cylinder unit (Secondary (Potable) circuit)

Initial fill and flush procedure:

Ensure all pipe joints and fittings are tight and secure.

Open the most distant DHW tap/outlet.

Slowly/gradually open the mains water supply to begin filling the secondary (potable) circuit / pipework.

Allow most distant tap to run free and release/purge residual air and any impurities that may have resulted from the installation work.

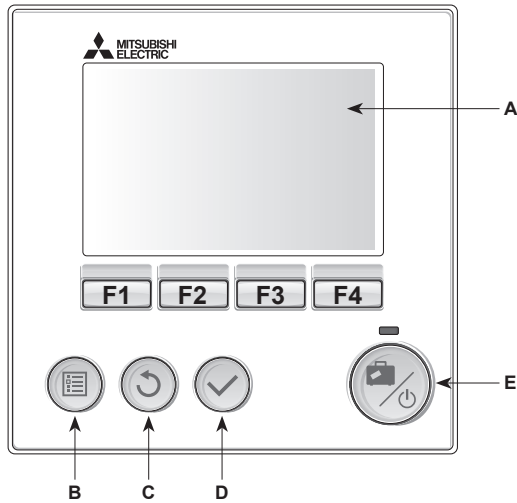
Close tap/outlet to retain fully charged system and resume system commissioning.

Draining the cylinder unit

WARNING: DRAINED WATER MAY BE VERY HOT

1. Before attempting to drain the cylinder unit isolate from the electrical supply to prevent the booster heaters burning out.
When the ECB is turned off, push down the power lever without pressing the test button.
 2. Isolate cold water feed to secondary (potable) circuit.
 3. Attach a hose to the drain cock (No.4 on the front side of heat exchanger shown in "WATER CIRCUIT DIAGRAM" on page 12).*1
Open a hot water tap to start draining without a vacuum.
Open the drain cock of the heat exchanger .
 4. When the secondary (potable) circuit is drained close drain cock and hot tap.
 5. Draining procedure of the thermal store tank (primary circuit) is as follows.
 - (1) Open the cap of the pressure relief valve to reduce the pressure of the thermal store tank to 0 bar.
 - (2) Attach a hose to the manual air vent (No. 12 above the thermal store tank shown in "WATER CIRCUIT DIAGRAM" on page 12).*1
Open the manual air vent.
 - (3) Check that the pump valves and the strainer valve are opened.
Open the drain valve (No.13 shown in "WATER CIRCUIT DIAGRAM" on page 12) to drain the water in the thermal store tank.
 - (4) Open all other drain cocks. (No.3 shown in "WATER CIRCUIT DIAGRAM" on page 12 and drain cocks of outdoor unit)
 - (5) Water remains in the strainer still after the cylinder unit was drained. Drain the strainer by removing the strainer cover.
- *1. The hose should be able to withstand heat as the draining water could be very hot.

9-1. Main Controller



<Main controller parts>

Letter	Name	Function
A	Screen	Screen in which all information is displayed
B	Menu	Access to system settings for initial set up and modifications.
C	Back	Return to previous menu.
D	Confirm	Used to select or save. (Enter key)
E	Power/Holiday	If system is switched off pressing once will turn system on. Pressing again when system is switched on will enable Holiday Mode. Holding the button down for 3 secs will turn the system off. (*1)
F1-4	Function keys	Used to scroll through menu and adjust settings. Function is determined by the menu screen visible on screen A.

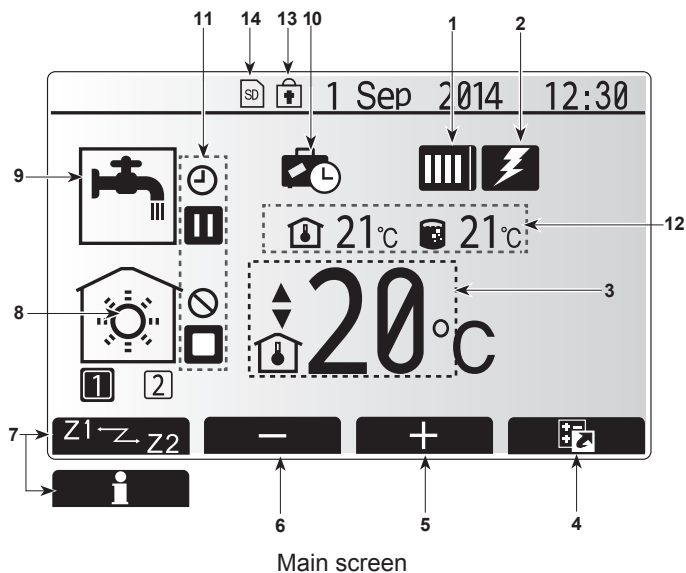
*1

When the system is switched off or the power supply is disconnected, the cylinder unit protection functions (e.g. freeze stat function) will NOT operate. Please beware that without these safety functions enabled the cylinder unit and installation may potentially become exposed to damage.

<Main screen icons>

	Icon	Description
1		'Heat pump' is running.
		Defrosting.
		Emergency heating.
2	Electric heater	When this icon is displayed the 'Electric heaters' (booster heater) are in use.
3		Target flow temperature
		Target room temperature
		Compensation curve
4	OPTION	Pressing the function button below this icon will display the option screen.
5	+	Increase desired temperature.
6	-	Decrease desired temperature.
7	Z1 Z2	Pressing the function button below this icon switches between Zone1 and Zone2.
	Information	Pressing the function button below this icon displays the information screen.
8	Space heating mode	Heating mode Zone1 or Zone2
9	DHW mode	Domestic hot water heating mode
10	Holiday mode	When this icon is displayed 'Holiday mode' activated.
11		Timer is activated.
		Prohibited
		Server control is activated.
		Stand-by
		Stopped
		Operating
12		Current room temperature
		Current water temperature of thermal store tank
13		The Menu button is locked or the switching of the operation modes between DHW and Heating operations are disabled in the Option screen.(*2)
14		SD memory card is inserted. Normal operation.
		SD memory card is inserted. Abnormal operation.

*2 To lock or unlock the Menu, press the BACK and CONFIRM keys simultaneously for 3 seconds.



Main screen

9-2. Setting the Main Controller

After the power has been connected to the outdoor and cylinder units (See chapter 7) the initial system settings can be entered via the main controller .

1. Check all breakers and other safety devices are correctly installed and turn on power to the system.
2. When the main controller is switched on for the first time, the screen automatically goes to Initial settings menu, Date/Time setting screen.
3. Main controller will automatically start up. Wait approximately one minute whilst the control menus load.
4. When the controller is ready a blank screen with a line running across the top will be displayed.
5. Press button E (Power) (refer to page 14) to turn on the system. Before turning on the system, perform initial settings as instructed below.

9-3. Main Settings Menu

The main settings menu can be accessed by pressing the MENU button. To reduce the risk of untrained end users altering the settings accidentally there are two access levels to the main settings; and the service section menu is password protected.

User Level – Short press

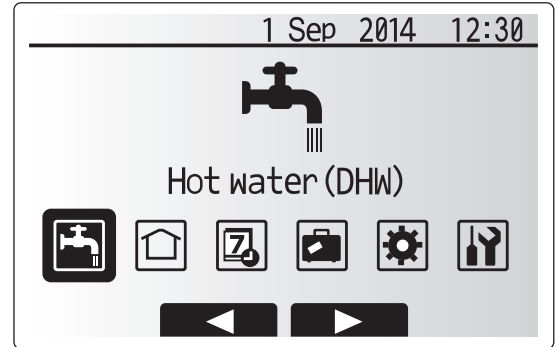
If the MENU button is pressed once for a short time the main settings will be displayed but without the edit function. This will enable the user to view current settings but **NOT** change the parameters.

Installer Level – Long press

If the MENU button is pressed down for 3 secs the main settings will be displayed with all functionality available.

The following items can be viewed and/or edited (dependent on access level).

- Domestic Hot water (DHW)
- Heating
- Schedule timer
- Holiday mode
- Initial settings
- Service (Password protected)



Main menu



Long Press

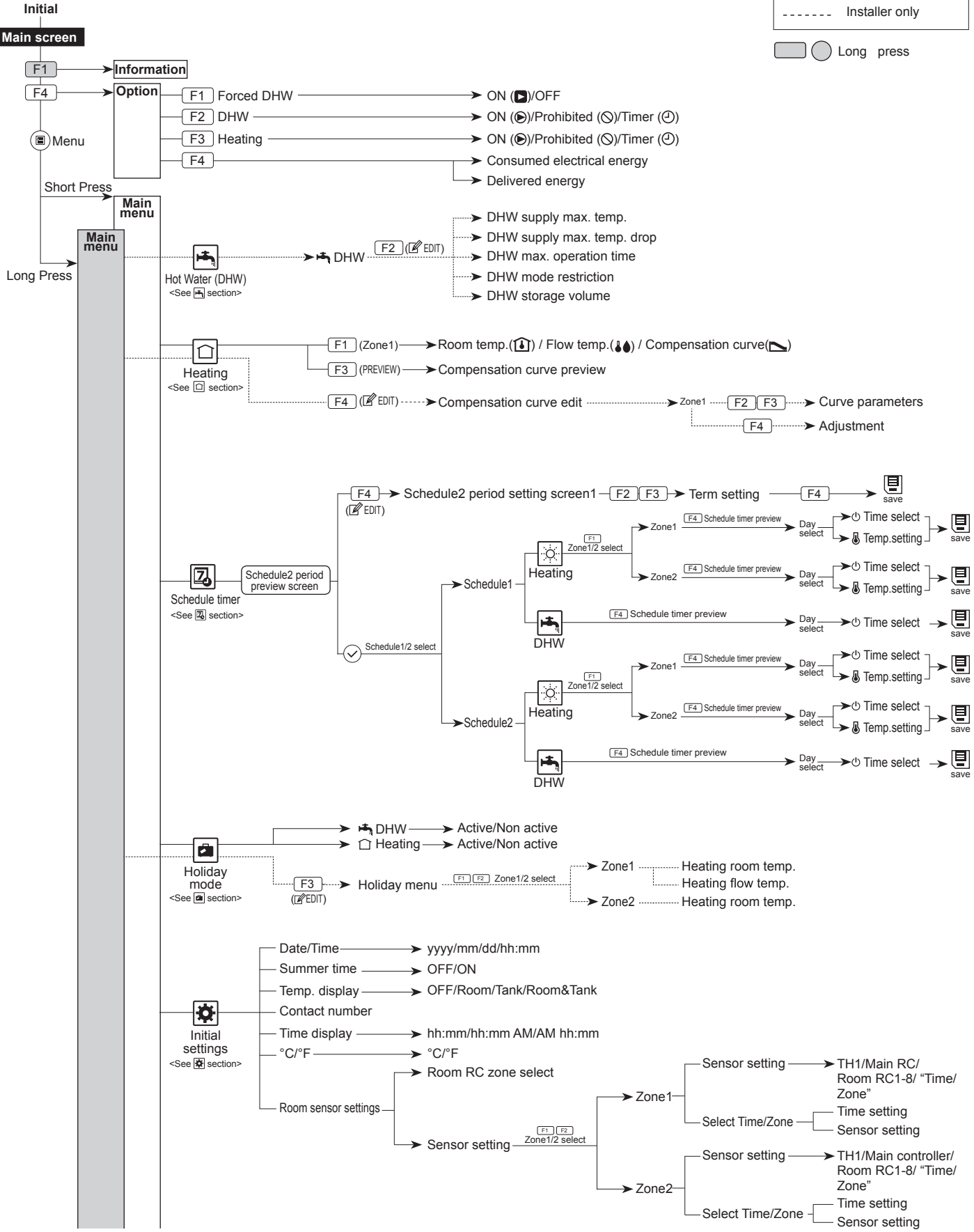


General Operation

- To find the icon that you wish to set, use the F2 and F3 buttons to move between the icons.
- The highlighted icon will appear as a larger version of the center of the screen.
- Press CONFIRM to select and edit the highlighted mode.
- Follow the <Main Controller Menu Tree> for further setting, using ◀ ▶ buttons for scrolling or F1 to F4 for selecting.

<Main Controller Menu Tree>

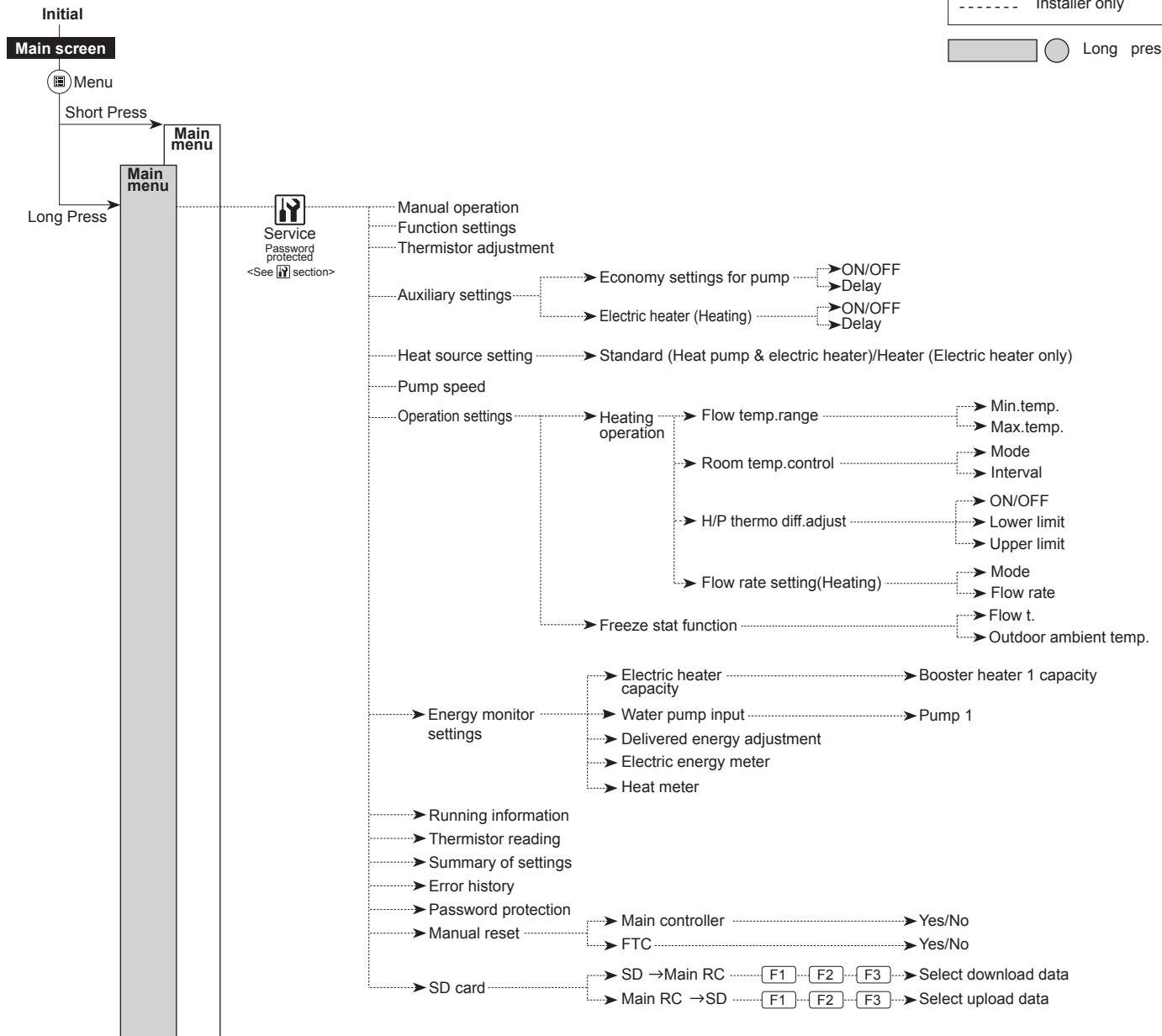
Unrestricted access
 Installer only
 Long press



<Continued to next page.>

<Main Controller Menu Tree>

— Unrestricted access
 - - - - - Installer only
 [Grey Box] [Circle] Long press



<Continued from the previous page.>

9-4. Service Menu

The service menu provides functions for use by installer or service engineer. It is **NOT** intended the home owner alters settings within this menu. It is for this reason password protection is required to prevent unauthorised access to the service settings.

The factory default password is "0000".

Follow the procedure described in General Operation for the set up operation.

The service menu is navigated using the F1 and F2 buttons to scroll through the functions. The menu is split across several screens and is comprised of the following functions;

1. Manual operation
2. Function settings
3. Thermistor adjustment
4. Auxiliary settings
5. Heat source setting
6. Pump speed
7. Operation settings
8. Energy monitor settings
9. External input settings
10. Running information
11. Thermistor reading
12. Summary of settings
13. Error history
14. Password protection
15. Manual reset
16. SD card

Many functions can not be set whilst the indoor unit is running. The installer should turn off the unit before trying to set these functions. If the installer attempts to change the settings whilst the unit is running the main remote controller will display a reminder message prompting the installer to stop operation before continuing. By selecting "Yes" the unit will cease operation.

<Manual operation>

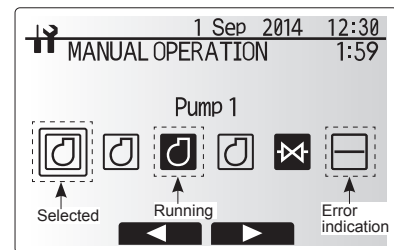
During the filling of the system the water circulation pump and 3-way valve can be manually overridden using manual operation mode.

When manual operation is selected a small timer icon appears in the screen. The function selected will only remain in manual operation for a maximum of 2 hours. This is to prevent accidental permanent override of the FTC.

► Example

Pressing F3 /D button will switch manual operation mode ON for the main 3-way valve. When filling of the thermal store tank is complete the installer should access this menu again and press F3 /D to deactivate manual operation of the part. Alternatively after 2 hours manual operation mode will no longer be active and FTC will resume control of the part.

Manual operation and heat source setting can not be selected if the system is running. A screen will be displayed asking the installer to stop the system before these modes can be activated. The system automatically stops 2 hours after the last operation.



Manual operation menu screen

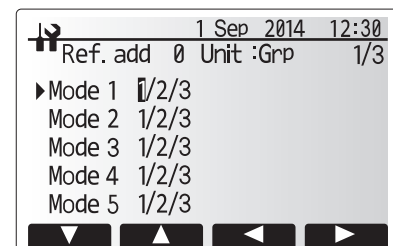
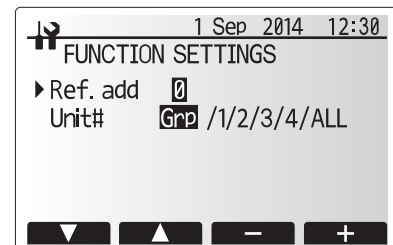
<Function settings>

Function Setting allows the setting of auto recovery after power failure only.

1. From the service menu use F1 and F2 to highlight Function Setting.
 2. Press CONFIRM.
 3. Ensure the Ref address and unit number are displayed to the right.
 4. Press CONFIRM.
 5. Use F3 and F4 to highlight either 1/2/3 (see below).
- Note: Changes can ONLY be made to Mode 1.
6. Press CONFIRM.

Mode 1 Setting number meanings

- 1 - Power failure automatic recovery NOT available
- 2 - Power failure automatic recovery AVAILABLE (Approx 4-minute delay after power is restored.)
- 3 - NO FUNCTION

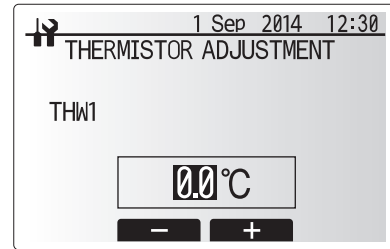


<Thermistor adjustment>

This function allows adjustments to be made to the thermistor readings from -10 – 10°C in 0.5°C intervals.

- THW1: Thermistor (Flow water temp.)
- THW2: Thermistor (Return water temp.)
- THW3: Thermistor (Flow water temp.(to tank))
- THW4: Thermistor (DHW supply temp.)
- THW5A: Thermistor (Stored water temp.(upper))
- THW5B: Thermistor (Stored water temp. (lower))
- THW6: Thermistor (Zone1 flow temp.)
- THW7: Thermistor (Zone1 return temp.)
- THW8: Thermistor (Zone2 flow temp.)
- THW9: Thermistor (Zone2 return temp.)
- THWB1: Thermistor (Boiler flow temp.)
- THWB2: Thermistor (Boiler return temp.)

Note : THW6-9,THWB1-B2 can not be adjusted.

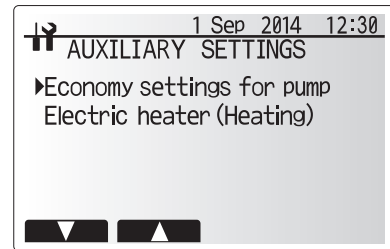


<Auxiliary settings>

This function is used to set the parameters for any auxiliary parts used in the system

Menu subtitle	Function/ Description
Economy settings for pump	Water pump stops automatically a specified period of time from when operation is finished.
Delay	Time before pump switches off*1
Electric heater (Heating)	To select "WITH booster heater (ON)" or "WITHOUT booster heater (OFF)" in Heating mode.
Delay	The minimum time required for the booster heater to turn ON after Heating mode has started.

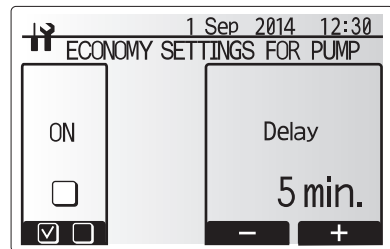
*1. Decreasing "time before pump switched off" may increase the duration of stand-by in Heating mode.



Auxiliary settings menu screen

Economy settings for pump

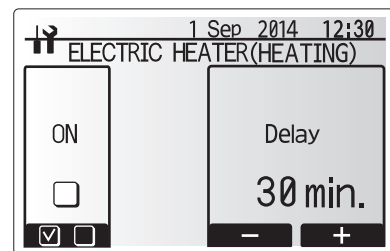
1. From the Auxiliary settings menu highlight Economy Settings for water circulation pump.
2. Press CONFIRM.
3. The economy settings for water circulation pump screen is displayed.
4. Use button F1 to switch the economy settings ON/OFF.
5. Use buttons F3 and F4 to adjust the time the water circulation pump 1 will run. (3 - 60 minutes)



Economy settings for pump screen

Electric heater (Heating)

1. From the Auxiliary settings menu highlight Electric heater (Heating).
2. Press CONFIRM.
3. The Electric heater (Heating) screen is displayed.
4. Press F1 button to switch the function ON/OFF.
5. Use F3 and F4 buttons to adjust the time period of heat pump only operation before the booster heater will assist in space heating. (5 -180 minutes)



Electric heater (Heating) screen

<Heat source setting>

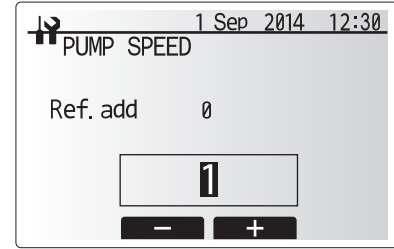
The default heat source setting is heat pump and booster heater present in the system to be operational. This is referred to as Standard operation on the menu.



Heat source setting screen

<Pump speed>

1. From the Service menu highlight Pump speed.
2. Press CONFIRM.
3. The Pump speed screen is displayed.
4. Use F2 and F3 buttons to set the pump speed of the water circulation pump between 1 and 5.



Pump speed setting screen

<Operation settings>

Heating operation

This function allows operational setting of flow temperature range from the Ecodan and also the time interval at which the FTC collects and processes data for the auto adaptation mode.

1. Heating operation for auto adaptation mode

Menu subtitle		Function	Range	Unit	Default
Flow temp. range	Minimum temp.	To minimize the loss by frequent ON and OFF in mild outdoor ambient temperature seasons.	25 - 45	°C	40
	Maximum temp.	To set max. possible flow temperature according to the type of heat emitters.	35 - 60	°C	50
Room temp. control	Mode	Setting for Room temp. control At Fast mode, target outlet water temperature is set higher than the one set at normal mode. This reduces the time to reach the target room-temperature when the room temperature is relatively low.*	Normal/ Fast	--	Normal
	Interval	Selectable according to the heat emitter type and the materials of floor (i.e. radiators, floor heating-thick, -thin concrete, wood, etc.)	10 ~ 60	mins.	10
Heat pump thermo diff.adjust	On/Off	To minimize the loss by frequent ON and OFF in mild outdoor ambient-temperature seasons.	On/Off	—	On
	Lower limit	Prohibits heat pump operation until the flow temperature drops below the target flow temperature plus lower limit value.	-9 - -1	°C	-5
	Upper limit	Allows heat pump operation until the flow temperature rises above the target flow temperature plus upper limit value.	+3 - +15	°C	+9

< Heating operation(Room temp.control table) >

Note:

1. The minimum flow temperature that prohibits heat pump operation is 20°C.
2. The maximum flow temperature that allows heat pump operation equals to the maximum temperature set in the Flow temp. range menu.

* Fast mode is not most efficient and will result in increased running cost when compared to normal mode.

2.Heating operation for auto adaptation, compensation curve, and flow temp. control

Menu subtitle		Function	Range	Unit	Default
Flow rate setting	Mode	Auto mode automatically selects a flow rate from 3 to 7 L/min appropriate for effective operation according to Room temp. control. Manual mode targets Flow rate setting value. ※Select Manual mode except for Room temp. control.	Auto/ Manual	—	Auto
	Flow rate	Select the target circulation flow rate for heating at Manual mode. ※Be aware of the shortage of required flow rate for each heat emitters.	3 - 8	L/min	7

Note: Recommended flow rate setting at Manual mode is listed below.

- When the Flow temp. is high (e.g. radiator) recommended flow rate is low
- When the Flow temp. is low (e.g. underfloor heating) recommended flow rate is high.
- Low flow rate setting with low flow temp. may cause frequent ON/OFF operation of pump.

Freeze stat function

Menu subtitle	Function/ Description
Freeze stat function	An operational function to prevent the water circuit from freezing when outdoor ambient temperature drops.
Flow t.	The target outlet water temperature at water circuit when operating in Freeze stat function. *2
Outdoor ambient temp.	Minimum outdoor ambient temperature which freeze stat function will begin to operate, (3 - 20°C) or choose**. If asterisk (**) is chosen freeze stat function is deactivated. (i.e. primary water freeze risk)"

*1. When the system is turned off, freeze stat function is not enabled.

*2. Flow t. is fixed to 20°C and unchangeable.

<Energy monitor settings>

1. General description

End user can monitor accumulated*1 'Consumed electrical energy' and 'Delivered energy' in each operation mode*2 on the main controller.

*1 Monthly and Year to date

*2 - DHW operation

- Space heating

Refer to "9-3. Main Settings Menu" for how to check the energy, and "6-2. DIP switch Functions" for the details on DIP-SW setting.

Either one of the following two method is used for monitoring.

Note: The method 1 should be used as a guide. If greater accuracy is required, then method 2 should be used.

(1) Calculation internally

Electricity consumption is calculated internally based on the energy consumption of outdoor unit, electric booster heater, pump1 and other auxiliaries.

Produced heat is calculated internally by multiplying delta T (Flow and Return temp.) and flow rate measured by the factory fitted sensors.

Set the electric booster heater capacity and water pump(s) input according to indoor unit model. (Refer to the menu tree in "9-3. Main Settings Menu")

	Booster heater	Pump1*1
Default	2kW	*** (factory fitted pump)
EHPT20Q-VM2EA	2kW	***

*1 "****" displayed in the energy monitor setting mode means the factory fitted pump is connected as pump 1 so that the input is automatically calculated.

When anti-freeze solution (propylene glycol) is used for primary water circuit, set the produced energy adjustment if necessary.

For further detail of above, refer to "9-3. Main Settings Menu".

Note: Consumed electric energy of pump A is automatically calculated by the system.

(2) Actual measurement by external meter (locally supplied)

FTC has external input terminals for 2 'Electric energy meters' and a 'Heat meter'.

If two 'Electric energy meters' are connected, the 2 recorded values will be combined at the FTC and shown on the main controller.

(e.g. Meter 1 for main power line, Meter 2 for booster heater power line)

Refer to the [Signal inputs] section in "6. WIRING DIAGRAM" for more information on connectable electric energy meter and heat meter.

• Connectable electric energy meter and heat meter

- Pulse meter type Voltage free contact for 12VDC detection by FTC (TBI.1 5, 7 and 9 pin have a positive voltage.)
- Pulse duration Minimum ON time: 40ms
 Minimum OFF time: 100ms
- Possible unit of pulse 0.1 pulse/kwh 1 pulse/kwh 10 pulse/kwh
 100 pulse/kwh 1000 pulse/kwh

Those values can be set by the main remote controller. (Refer to the menu tree in "9-3. Main Settings Menu".)

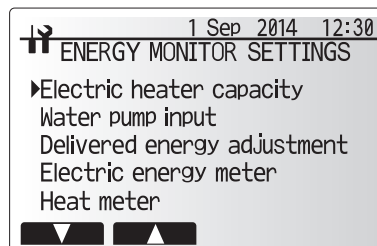
2. Settings using the main remote controller

In this menu, all parameters required to record the consumed electrical energy and the delivered heat energy which is displayed on the main remote controller can be set. The parameters are an electric heater capacity, supply power of water pump and heat meter pulse.

Follow the procedure described in General Operation for the set up operation.

For Pump 1, *** can be also set besides this setting.

In the case *** is selected, the system acknowledges "factory fitted pump" is selected.



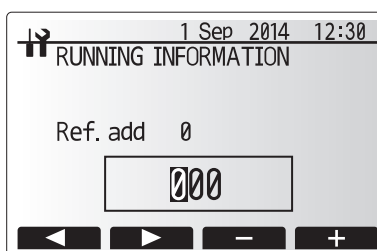
Energy monitor settings menu screen

<Running information>

This function shows current temperature and other data of main component parts of the indoor unit.

1. From the Service menu highlight Running information.
2. Press CONFIRM.
3. Press F3 and F4 buttons to set the Ref. address. *1
4. Use the function buttons to enter index code for the component to be viewed.
(See the Table 9-4-1 for component index codes.)
5. Press CONFIRM.

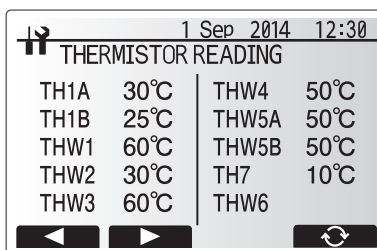
*1 For multiple outdoor units control system only.



<Thermistor reading>

This function shows the current readings of thermistors located on the water circuit

Thermistor	Description	Thermistor	Description
TH1A	Zone 1 room temperature	THW6	Zone 1 flow water temperature
TH1B	Zone 2 room temperature	THW7	Zone 1 return water temperature
THW1	Flow water temp. thermistor	THW8	Zone 2 flow water temperature
THW2	Return water temp. thermistor	THW9	Zone 2 return water temperature
THW3	Flow water temp. thermistor 2 (to tank)	THWB1	Boiler flow water temperature
THW4	DHW supply temp. thermistor	THWB2	Boiler return water temperature
THW5A	Stored water temp. thermistor (upper)		
THW5B	Stored water temp. thermistor (lower)		
TH7	Ambient (outdoor) temperature		

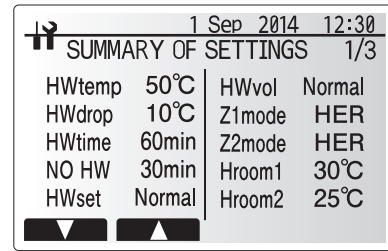


<Summary of settings>

This function shows the current installer/user entered settings.

Abbreviation	Explanation
HWtemp	DHW supply max. temp.
HWdrop	DHW supply max. temp. drop
HWtime	DHW max operation time
NO HW	DHW mode restriction
HWset	DHW operation mode (Normal)
HWvol	DHW storage volume
Z1 mode	Operation mode
	- HER (Heating room temperature)
	- HE (Heating flow temperature)
	- HCC (Heating compensation curve)
Z2 mode	Operation mode
	- HER (Heating room temperature)
	- HE (Heating flow temperature)
	- HCC (Heating compensation curve)

Abbreviation	Explanation
Hroom 1	Heating target room temperature
Hroom 2	Heating target room temperature
Hflow 1	Heating target flow temperature
Hflow 2	Heating target flow temperature
Croom 1	Cooling target room temperature
Croom 2	Cooling target room temperature
Cflow 1	Cooling target flow temperature
Cflow 2	Cooling target flow temperature
FSflow	Freeze stat function flow temperature
FSout	Freeze stat function ambient temperature



<Error history>

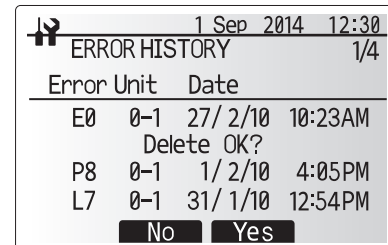
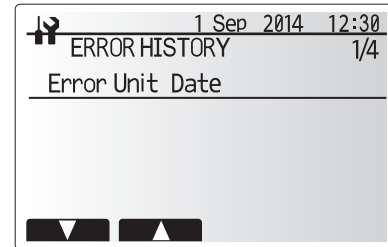
Error history allows the service engineer to view previous Error codes, the unit address and the date on which they occurred. Up to 16 Error codes can be stored in the history the most recent Error event is displayed at the top of the list.

1. From the service menu select Error history
2. Press CONFIRM.

Please see chapter 10-4. for error code diagnosis and actions.

To delete an Error history item;

1. From Error history screen press F4 button (Rubbish bin icon)
2. Then press F3 button (Yes).



<Password protection>

Password protection is available to prevent unauthorised access to the service menu by untrained persons.

1. From the service menu use F1 and F2 buttons to scroll through list until Password protection is highlighted.
2. Press CONFIRM.
3. When password input screen is displayed use buttons F1 and F2 to move left and right between the four digits, F3 to lower the selected digit by 1, and F4 to increase the selected digit by 1.
4. When you have input your password press CONFIRM.

5. The password verify screen is displayed.
6. To verify your new password press button F3.
7. Your password is now set and the completion screen is displayed.



Password input screen



Password verify screen

Resetting the password

If you forget the password you entered, or have to service a unit somebody else installed, you can reset the password to the factory default of **0000**.

1. From the main settings menu scroll down the functions until Service Menu is highlighted.
2. Press CONFIRM.
3. You will be prompted to enter a password.
4. Hold down buttons F3 and F4 together for 3 secs
5. You will be asked if you wish to continue and reset the password to default setting.
6. To reset press button F3.
7. The password is now reset to **0000**.

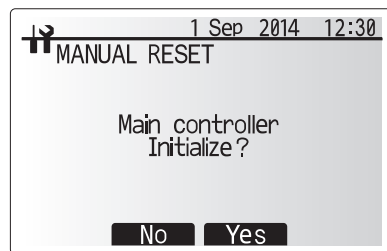
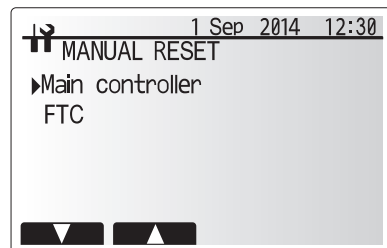


Completion screen

<Manual reset>

Should you wish to restore the factory settings at any time you should use the manual reset function. Please note this will reset ALL functions to the factory default settings.

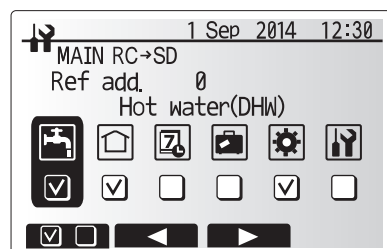
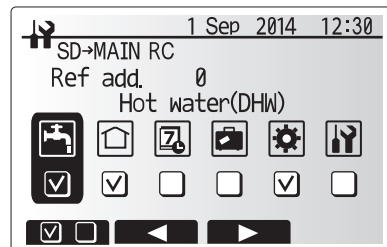
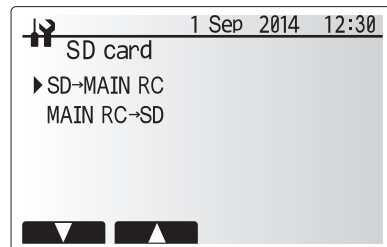
1. From the service menu use F1 and F2 buttons to scroll through list until Manual Reset is highlighted.
2. Press CONFIRM.
3. The Manual reset screen is displayed.
4. Choose either Manual Reset for FTC or Main remote controller.
5. Press F3 button to confirm manual reset of chosen device.



<SD card>

The use of an SD memory card simplifies the main remote controller settings in the field.

*Ecodan service tool (for use with PC tool) is necessary for the setting.



SD → Main RC

1. From the SD card setting use F1 and F2 buttons to scroll through list until "SD → Main RC" is highlighted.
 2. Press CONFIRM.
 3. Press F3 and F4 buttons to set the Ref. address. *1
 4. Use F1, F2 and F3 buttons to select a menu to write to the main remote controller.
 5. Press CONFIRM to start downloading.
 6. Wait for a few minutes until "Complete!" appears.
- *1 For multiple outdoor units control system only.

Main RC → SD

1. From the SD card setting use F1 and F2 buttons to scroll through list until Main RC → SD is highlighted.
 2. Press CONFIRM.
 3. Press F3 and F4 buttons to set the Ref. address. *1
 4. Use F1, F2 and F3 buttons to select a menu to write to the SD memory card.
 5. Press CONFIRM to start uploading.
 6. Wait for a few minutes until "Complete!" appears.
- *1 For multiple outdoor units control system only.

<Table 9-4-1>

Request code	Request content	Range	Unit
154	Water circulation pump 1 - Accumulated operating time (after reset)	0 - 9999	10 hours
158	Water circulation pump A - Accumulated operating time (after reset)	0 - 9999	10 hours
162	Indoor unit - DIP SW1 setting information	Refer to detail contents described hereinafter.	—
163	Indoor unit - DIP SW2 setting information	Refer to detail contents described hereinafter.	—
164	Indoor unit - DIP SW3 setting information	Refer to detail contents described hereinafter.	—
165	Indoor unit - DIP SW4 setting information	Refer to detail contents described hereinafter.	—
166	Indoor unit - DIP SW5 setting information	Refer to detail contents described hereinafter.	—
175	Indoor unit - Output signal information	Refer to detail contents described hereinafter.	—
176	Indoor unit - Input signal information	Refer to detail contents described hereinafter.	—
190	Indoor unit - Software version 1st 4 digits	Refer to Note below.	—
191	Indoor unit - Software version last 4 digits	Refer to Note below.	—
340	Water circulation pump 1 - Accumulated operating time reset	—	—
344	Water circulation pump A - Accumulated operating time reset	—	—
504	Indoor unit - Zone 1 room temp. (TH1A)	-39 - 88	°C
506	Indoor unit - Return water temp. (THW2)	-39 - 110	°C
507	Indoor unit - Zone 2 room temp. (TH1B)	-39 - 88	°C
508	Indoor unit - Stored water temp. (lower)(THW5B)	-39 - 110	°C
510	Indoor unit - Outside air temp. (TH7)	-39 - 88	°C
511	Indoor unit - Flow water temp. (THW1)	-39 - 110	°C
533	Indoor unit - Flow water temp. (THW3)	-39 - 110	°C
534	Indoor unit - DHW supply temp. (THW4)	-39 - 110	°C
535	Indoor unit - Stored water temp. (upper)(THW5A)	-39 - 110	°C
540	Flow rate for space heating (Flow sensor 1)	0 - 255	0.1L/min.
541	Flow rate of the secondary (Potable) circuit (Flow sensor A)	0 - 255	0.1L/min.
542	Flow rate of the primary circuit (Flow sensor B)	0 - 255	0.1L/min.
550	Indoor unit - Error postponement history 1 (latest)	Displays postponement code. ("—" is displays if no postponement code is present.)	—
551	Indoor unit - Operation control at time of error	0 Standard, 1 Heater	—
552	Indoor unit - Operation mode at time of error	0 OFF, 1 DHW, 2 Heating 5 Freeze protection, 6 Operation stop, 7 Defrost	—
553	Indoor unit - Output signal information at time of error	Refer to detail contents described hereinafter	—
554	Indoor unit - Input signal information at time of error	Refer to detail contents described hereinafter	—
555	Indoor unit - Zone 1 room temp. (TH1A) at time of error	-39 - 88	°C
556	Indoor unit - Zone 2 room temp. (TH1B) at time of error	-39 - 88	°C
558	Indoor unit - Flow water temp. (THW1) at time of error	-39 - 110	°C
559	Indoor unit - Return water temp. (THW2) at time of error	-39 - 110	°C
560	Indoor unit - Stored water temp.(lower) (THW5) at time of error	-39 - 110	°C
567	Indoor unit - Failure (P1/L5) thermistor	0 Failure thermistor is none, 1 TH1A, 2 TH2, 3 THW1, 4 THW2, 5 THWB1, 6 THW5B, 7 THWB2, 8 TH1B, 9 THW3, A THW6, B THW7, C THW8, D THW9, E THW4, F THW5A	—
569	Operated Flow switch / Flow sensor at time of failure (L7)	0 No operated flow switch, 1 Flow switch 1, 2 Flow switch 2, 3 Flow switch 3, 4 Flow sensor 1, 5 Flow sensor B	—
571	Flow rate for space heating at time of error (Flow sensor 1)	0 - 255	0.1L/min.
572	Indoor unit - Flow water temp. (THW3) at time of error	-39 - 110	°C
573	Indoor unit - DHW supply temp. (THW4) at time of error	-39 - 110	°C
574	Indoor unit - Stored water temp. (upper)(THW5A) at time of error	-39 - 110	°C
575	Indoor unit - Failure (LF) folw sensor	0 Failure flow sensor is none, 1 Flow sensor 1, 2 Flow sensor A, 3 Flow sensor B	—
576	Indoor unit - Failure (LU) pump	0 Failure pump is none, 1 Water circulation pump 1, 2 Water circulation pump A	—
578	Flow rate of the secondary (Potable) circuit (Flow sensor A) at time of error	0 - 255	0.1L/min.
579	Flow rate of the primary circuit (Flow sensor B) at time of error	0 - 255	0.1L/min.

Note

Request codes 103 to 105 indicate error histories of both indoor and outdoor units.

As only four digits can be displayed at one time the software version number is displayed in two halves.

Enter code 190 to see the first four digits and code 191 to see the last four digits.

For example software version No. 5.01 A000, when code 190 is entered 0501 is displayed, when code 191 is entered A000 is displayed.

Indoor unit switch setting display (Request code: 162 to 166)

0: OFF 1: ON

SW1, SW2, SW3, SW4, SW5								Display
1	2	3	4	5	6	7	8	
0	0	0	0	0	0	0	0	00 00
1	0	0	0	0	0	0	0	00 01
0	1	0	0	0	0	0	0	00 02
1	1	0	0	0	0	0	0	00 03
0	0	1	0	0	0	0	0	00 04
1	0	1	0	0	0	0	0	00 05
0	1	1	0	0	0	0	0	00 06
1	1	1	0	0	0	0	0	00 07
0	0	0	1	0	0	0	0	00 08
1	0	0	1	0	0	0	0	00 09
0	1	0	1	0	0	0	0	00 0A
1	1	0	1	0	0	0	0	00 0B
0	0	1	1	0	0	0	0	00 0C
1	0	1	1	0	0	0	0	00 0D
0	1	1	1	0	0	0	0	00 0E
1	1	1	1	0	0	0	0	00 0F
0	0	0	0	1	0	0	0	00 10
1	0	0	0	1	0	0	0	00 11
0	1	0	0	1	0	0	0	00 12
1	1	0	0	1	0	0	0	00 13
0	0	1	0	1	0	0	0	00 14
1	0	1	0	1	0	0	0	00 15
0	1	1	0	1	0	0	0	00 16
1	1	1	0	1	0	0	0	00 17
0	0	0	1	1	0	0	0	00 18
1	0	0	1	1	0	0	0	00 19
0	1	0	1	1	0	0	0	00 1A
1	1	0	1	1	0	0	0	00 1B
0	0	1	1	1	0	0	0	00 1C
1	0	1	1	1	0	0	0	00 1D
0	1	1	1	1	0	0	0	00 1E
1	1	1	1	1	0	0	0	00 1F
0	0	0	0	0	1	0	0	00 20
1	0	0	0	0	1	0	0	00 21
0	1	0	0	0	1	0	0	00 22
1	1	0	0	0	1	0	0	00 23
0	0	1	0	0	1	0	0	00 24
1	0	1	0	0	1	0	0	00 25
0	1	1	0	0	1	0	0	00 26
1	1	1	0	0	1	0	0	00 27
0	0	0	1	0	1	0	0	00 28
1	0	0	1	0	1	0	0	00 29
0	1	0	1	0	1	0	0	00 2A
1	1	0	1	0	1	0	0	00 2B
0	0	1	1	0	1	0	0	00 2C
1	0	1	1	0	1	0	0	00 2D
0	1	1	1	0	1	0	0	00 2E
1	1	1	1	0	1	0	0	00 2F
0	0	0	0	1	1	0	0	00 30
1	0	0	0	1	1	0	0	00 31
0	1	0	0	1	1	0	0	00 32
1	1	0	0	1	1	0	0	00 33
0	0	1	0	1	1	0	0	00 34
1	0	1	0	1	1	0	0	00 35
0	1	1	0	1	1	0	0	00 36
1	1	1	0	1	1	0	0	00 37
0	0	0	1	1	1	0	0	00 38
1	0	0	1	1	1	0	0	00 39
0	1	0	1	1	1	0	0	00 3A
1	1	0	1	1	1	0	0	00 3B
0	0	1	1	1	1	0	0	00 3C
1	0	1	1	1	1	0	0	00 3D
0	1	1	1	1	1	0	0	00 3E
1	1	1	1	1	1	0	0	00 3F

0: OFF 1: ON

SW1, SW2, SW3, SW4, SW5								Display
1	2	3	4	5	6	7	8	
0	0	0	0	0	0	1	0	00 40
1	0	0	0	0	0	1	0	00 41
0	1	0	0	0	0	1	0	00 42
1	1	0	0	0	0	1	0	00 43
0	0	1	0	0	0	1	0	00 44
1	0	1	0	0	0	1	0	00 45
0	1	1	0	0	0	1	0	00 46
1	1	1	0	0	0	1	0	00 47
0	0	0	1	0	0	1	0	00 48
1	0	0	1	0	0	1	0	00 49
0	1	0	1	0	0	1	0	00 4A
1	1	0	1	0	0	1	0	00 4B
0	0	1	1	0	0	1	0	00 4C
1	0	1	1	0	0	1	0	00 4D
0	1	1	1	0	0	1	0	00 4E
1	1	1	1	0	0	1	0	00 4F
0	0	0	0	1	0	1	0	00 50
1	0	0	0	1	0	1	0	00 51
0	1	0	0	1	0	1	0	00 52
1	1	0	0	1	0	1	0	00 53
0	0	1	0	1	0	1	0	00 54
1	0	1	0	1	0	1	0	00 55
0	1	1	0	1	0	1	0	00 56
1	1	1	0	1	0	1	0	00 57
0	0	0	1	1	0	1	0	00 58
1	0	0	1	1	0	1	0	00 59
0	1	0	1	1	0	1	0	00 5A
1	1	0	1	1	0	1	0	00 5B
0	0	1	1	1	0	1	0	00 5C
1	0	1	1	1	0	1	0	00 5D
0	1	1	1	1	0	1	0	00 5E
1	1	1	1	1	0	1	0	00 5F
0	0	0	0	0	1	1	0	00 60
1	0	0	0	0	1	1	0	00 61
0	1	0	0	0	1	1	0	00 62
1	1	0	0	0	1	1	0	00 63
0	0	1	0	0	1	1	0	00 64
1	0	1	0	0	1	1	0	00 65
0	1	1	0	0	1	1	0	00 66
1	1	1	0	0	1	1	0	00 67
0	0	0	1	0	1	1	0	00 68
1	0	0	1	0	1	1	0	00 69
0	1	0	1	0	1	1	0	00 6A
1	1	0	1	0	1	1	0	00 6B
0	0	1	1	0	1	1	0	00 6C
1	0	1	1	0	1	1	0	00 6D
0	1	1	1	0	1	1	0	00 6E
1	1	1	1	0	1	1	0	00 6F
0	0	0	0	1	1	1	0	00 70
1	0	0	0	1	1	1	0	00 71
0	1	0	0	1	1	1	0	00 72
1	1	0	0	1	1	1	0	00 73
0	0	1	0	1	1	1	0	00 74
1	0	1	0	1	1	1	0	00 75
0	1	1	0	1	1	1	0	00 76
1	1	1	0	1	1	1	0	00 77
0	0	0	1	1	1	1	0	00 78
1	0	0	1	1	1	1	0	00 79
0	1	0	1	1	1	1	0	00 7A
1	1	0	1	1	1	1	0	00 7B
0	0	1	1	1	1	1	0	00 7C
1	0	1	1	1	1	1	0	00 7D
0	1	1	1	1	1	1	0	00 7E
1	1	1	1	1	1	1	0	00 7F

Indoor unit switch setting display (Request code: 162 to 166)

0: OFF 1: ON

SW1, SW2, SW3, SW4, SW5								Display
1	2	3	4	5	6	7	8	
0	0	0	0	0	0	0	1	00 80
1	0	0	0	0	0	0	1	00 81
0	1	0	0	0	0	0	1	00 82
1	1	0	0	0	0	0	1	00 83
0	0	1	0	0	0	0	1	00 84
1	0	1	0	0	0	0	1	00 85
0	1	1	0	0	0	0	1	00 86
1	1	1	0	0	0	0	1	00 87
0	0	0	1	0	0	0	1	00 88
1	0	0	1	0	0	0	1	00 89
0	1	0	1	0	0	0	1	00 8A
1	1	0	1	0	0	0	1	00 8B
0	0	1	1	0	0	0	1	00 8C
1	0	1	1	0	0	0	1	00 8D
0	1	1	1	0	0	0	1	00 8E
1	1	1	1	0	0	0	1	00 8F
0	0	0	0	1	0	0	1	00 90
1	0	0	0	1	0	0	1	00 91
0	1	0	0	1	0	0	1	00 92
1	1	0	0	1	0	0	1	00 93
0	0	1	0	1	0	0	1	00 94
1	0	1	0	1	0	0	1	00 95
0	1	1	0	1	0	0	1	00 96
1	1	1	0	1	0	0	1	00 97
0	0	0	1	1	0	0	1	00 98
1	0	0	1	1	0	0	1	00 99
0	1	0	1	1	0	0	1	00 9A
1	1	0	1	1	0	0	1	00 9B
0	0	1	1	1	0	0	1	00 9C
1	0	1	1	1	0	0	1	00 9D
0	1	1	1	1	0	0	1	00 9E
1	1	1	1	1	0	0	1	00 9F
0	0	0	0	0	1	0	1	00 A0
1	0	0	0	0	1	0	1	00 A1
0	1	0	0	0	1	0	1	00 A2
1	1	0	0	0	1	0	1	00 A3
0	0	1	0	0	1	0	1	00 A4
1	0	1	0	0	1	0	1	00 A5
0	1	1	0	0	1	0	1	00 A6
1	1	1	0	0	1	0	1	00 A7
0	0	0	1	0	1	0	1	00 A8
1	0	0	1	0	1	0	1	00 A9
0	1	0	1	0	1	0	1	00 AA
1	1	0	1	0	1	0	1	00 AB
0	0	1	1	0	1	0	1	00 AC
1	0	1	1	0	1	0	1	00 AD
0	1	1	1	0	1	0	1	00 AE
1	1	1	1	0	1	0	1	00 AF
0	0	0	0	1	1	0	1	00 B0
1	0	0	0	1	1	0	1	00 B1
0	1	0	0	1	1	0	1	00 B2
1	1	0	0	1	1	0	1	00 B3
0	0	1	0	1	1	0	1	00 B4
1	0	1	0	1	1	0	1	00 B5
0	1	1	0	1	1	0	1	00 B6
1	1	1	0	1	1	0	1	00 B7
0	0	0	1	1	1	0	1	00 B8
1	0	0	1	1	1	0	1	00 B9
0	1	0	1	1	1	0	1	00 BA
1	1	0	1	1	1	0	1	00 BB
0	0	1	1	1	1	0	1	00 BC
1	0	1	1	1	1	0	1	00 BD
0	1	1	1	1	1	0	1	00 BE
1	1	1	1	1	1	0	1	00 BF

0: OFF 1: ON

SW1, SW2, SW3, SW4, SW5								Display
1	2	3	4	5	6	7	8	
0	0	0	0	0	0	1	1	00 C0
1	0	0	0	0	0	1	1	00 C1
0	1	0	0	0	0	1	1	00 C2
1	1	0	0	0	0	1	1	00 C3
0	0	1	0	0	0	1	1	00 C4
1	0	1	0	0	0	1	1	00 C5
0	1	1	0	0	0	1	1	00 C6
1	1	1	0	0	0	1	1	00 C7
0	0	0	1	0	0	1	1	00 C8
1	0	0	1	0	0	1	1	00 C9
0	1	0	1	0	0	1	1	00 CA
1	1	0	1	0	0	1	1	00 CB
0	0	1	1	0	0	1	1	00 CC
1	0	1	1	0	0	1	1	00 CD
0	1	1	1	0	0	1	1	00 CE
1	1	1	1	0	0	1	1	00 CF
0	0	0	0	1	0	1	1	00 D0
1	0	0	0	1	0	1	1	00 D1
0	1	0	0	1	0	1	1	00 D2
1	1	0	0	1	0	1	1	00 D3
0	0	1	0	1	0	1	1	00 D4
1	0	1	0	1	0	1	1	00 D5
0	1	1	0	1	0	1	1	00 D6
1	1	1	0	1	0	1	1	00 D7
0	0	0	1	1	0	1	1	00 D8
1	0	0	1	1	0	1	1	00 D9
0	1	0	1	1	0	1	1	00 DA
1	1	0	1	1	0	1	1	00 DB
0	0	1	1	1	0	1	1	00 DC
1	0	1	1	1	0	1	1	00 DD
0	1	1	1	1	0	1	1	00 DE
1	1	1	1	1	0	1	1	00 DF
0	0	0	0	0	1	1	1	00 E0
1	0	0	0	0	1	1	1	00 E1
0	1	0	0	0	1	1	1	00 E2
1	1	0	0	0	1	1	1	00 E3
0	0	1	0	0	1	1	1	00 E4
1	0	1	0	0	1	1	1	00 E5
0	1	1	0	0	1	1	1	00 E6
1	1	1	0	0	1	1	1	00 E7
0	0	0	1	0	1	1	1	00 E8
1	0	0	1	0	1	1	1	00 E9
0	1	0	1	0	1	1	1	00 EA
1	1	0	1	0	1	1	1	00 EB
0	0	1	1	0	1	1	1	00 EC
1	0	1	1	0	1	1	1	00 ED
0	1	1	1	0	1	1	1	00 EE
1	1	1	1	0	1	1	1	00 EF
0	0	0	0	1	1	1	1	00 F0
1	0	0	0	1	1	1	1	00 F1
0	1	0	0	1	1	1	1	00 F2
1	1	0	0	1	1	1	1	00 F3
0	0	1	0	1	1	1	1	00 F4
1	0	1	0	1	1	1	1	00 F5
0	1	1	0	1	1	1	1	00 F6
1	1	1	0	1	1	1	1	00 F7
0	0	0	1	1	1	1	1	00 F8
1	0	0	1	1	1	1	1	00 F9
0	1	0	1	1	1	1	1	00 FA
1	1	0	1	1	1	1	1	00 FB
0	0	1	1	1	1	1	1	00 FC
1	0	1	1	1	1	1	1	00 FD
0	1	1	1	1	1	1	1	00 FE
1	1	1	1	1	1	1	1	00 FF

Output signal display (Request code: 175/553)

Please refer to Table 2 on relevant wiring diagram whilst using the following.

0: OFF 1: ON

OUT								Display
1		3	4			6		
0	0	0	0	0	0	0	0	xx 00
1	0	0	0	0	0	0	0	xx 01
0	1	0	0	0	0	0	0	xx 02
1	1	0	0	0	0	0	0	xx 03
0	0	1	0	0	0	0	0	xx 04
1	0	1	0	0	0	0	0	xx 05
0	1	1	0	0	0	0	0	xx 06
1	1	1	0	0	0	0	0	xx 07
0	0	0	1	0	0	0	0	xx 08
1	0	0	1	0	0	0	0	xx 09
0	1	0	1	0	0	0	0	xx 0A
1	1	0	1	0	0	0	0	xx 0B
0	0	1	1	0	0	0	0	xx 0C
1	0	1	1	0	0	0	0	xx 0D
0	1	1	1	0	0	0	0	xx 0E
1	1	1	1	0	0	0	0	xx 0F
0	0	0	0	1	0	0	0	xx 10
1	0	0	0	1	0	0	0	xx 11
0	1	0	0	1	0	0	0	xx 12
1	1	0	0	1	0	0	0	xx 13
0	0	1	0	1	0	0	0	xx 14
1	0	1	0	1	0	0	0	xx 15
0	1	1	0	1	0	0	0	xx 16
1	1	1	0	1	0	0	0	xx 17
0	0	0	1	1	0	0	0	xx 18
1	0	0	1	1	0	0	0	xx 19
0	1	0	1	1	0	0	0	xx 1A
1	1	0	1	1	0	0	0	xx 1B
0	0	1	1	1	0	0	0	xx 1C
1	0	1	1	1	0	0	0	xx 1D
0	1	1	1	1	0	0	0	xx 1E
1	1	1	1	1	0	0	0	xx 1F
0	0	0	0	0	1	0	0	xx 20
1	0	0	0	0	1	0	0	xx 21
0	1	0	0	0	1	0	0	xx 22
1	1	0	0	0	1	0	0	xx 23
0	0	1	0	0	1	0	0	xx 24
1	0	1	0	0	1	0	0	xx 25
0	1	1	0	0	1	0	0	xx 26
1	1	1	0	0	1	0	0	xx 27
0	0	0	1	0	1	0	0	xx 28
1	0	0	1	0	1	0	0	xx 29
0	1	0	1	0	1	0	0	xx 2A
1	1	0	1	0	1	0	0	xx 2B
0	0	1	1	0	1	0	0	xx 2C
1	0	1	1	0	1	0	0	xx 2D
0	1	1	1	0	1	0	0	xx 2E
1	1	1	1	0	1	0	0	xx 2F
0	0	0	0	1	1	0	0	xx 30
1	0	0	0	1	1	0	0	xx 31
0	1	0	0	1	1	0	0	xx 32
1	1	0	0	1	1	0	0	xx 33
0	0	1	0	1	1	0	0	xx 34
1	0	1	0	1	1	0	0	xx 35
0	1	1	0	1	1	0	0	xx 36
1	1	1	0	1	1	0	0	xx 37
0	0	0	1	1	1	0	0	xx 38
1	0	0	1	1	1	0	0	xx 39
0	1	0	1	1	1	0	0	xx 3A
1	1	0	1	1	1	0	0	xx 3B
0	0	1	1	1	1	0	0	xx 3C
1	0	1	1	1	1	0	0	xx 3D
0	1	1	1	1	1	0	0	xx 3E
1	1	1	1	1	1	0	0	xx 3F

0: OFF 1: ON

OUT								Display
1		3	4			6		
0	0	0	0	0	0	1	0	xx 40
1	0	0	0	0	0	1	0	xx 41
0	1	0	0	0	0	1	0	xx 42
1	1	0	0	0	0	1	0	xx 43
0	0	1	0	0	0	1	0	xx 44
1	0	1	0	0	0	1	0	xx 45
0	1	1	0	0	0	1	0	xx 46
1	1	1	0	0	0	1	0	xx 47
0	0	0	1	0	0	1	0	xx 48
1	0	0	1	0	0	1	0	xx 49
0	1	0	1	0	0	1	0	xx 4A
1	1	0	1	0	0	1	0	xx 4B
0	0	1	1	0	0	1	0	xx 4C
1	0	1	1	0	0	1	0	xx 4D
0	1	1	1	0	0	1	0	xx 4E
1	1	1	1	0	0	1	0	xx 4F
0	0	0	0	1	0	1	0	xx 50
1	0	0	0	1	0	1	0	xx 51
0	1	0	0	1	0	1	0	xx 52
1	1	0	0	1	0	1	0	xx 53
0	0	1	0	1	0	1	0	xx 54
1	0	1	0	1	0	1	0	xx 55
0	1	1	0	1	0	1	0	xx 56
1	1	1	0	1	0	1	0	xx 57
0	0	0	1	1	0	1	0	xx 58
1	0	0	1	1	0	1	0	xx 59
0	1	0	1	1	0	1	0	xx 5A
1	1	0	1	1	0	1	0	xx 5B
0	0	1	1	1	0	1	0	xx 5C
1	0	1	1	1	0	1	0	xx 5D
0	1	1	1	1	0	1	0	xx 5E
1	1	1	1	1	0	1	0	xx 5F
0	0	0	0	0	1	1	0	xx 60
1	0	0	0	0	1	1	0	xx 61
0	1	0	0	0	1	1	0	xx 62
1	1	0	0	0	1	1	0	xx 63
0	0	1	0	0	1	1	0	xx 64
1	0	1	0	0	1	1	0	xx 65
0	1	1	0	0	1	1	0	xx 66
1	1	1	0	0	1	1	0	xx 67
0	0	0	1	0	1	1	0	xx 68
1	0	0	1	0	1	1	0	xx 69
0	1	0	1	0	1	1	0	xx 6A
1	1	0	1	0	1	1	0	xx 6B
0	0	1	1	0	1	1	0	xx 6C
1	0	1	1	0	1	1	0	xx 6D
0	1	1	1	0	1	1	0	xx 6E
1	1	1	1	0	1	1	0	xx 6F
0	0	0	0	1	1	1	0	xx 70
1	0	0	0	1	1	1	0	xx 71
0	1	0	0	1	1	1	0	xx 72
1	1	0	0	1	1	1	0	xx 73
0	0	1	0	1	1	1	0	xx 74
1	0	1	0	1	1	1	0	xx 75
0	1	1	0	1	1	1	0	xx 76
1	1	1	0	1	1	1	0	xx 77
0	0	0	1	1	1	1	0	xx 78
1	0	0	1	1	1	1	0	xx 79
0	1	0	1	1	1	1	0	xx 7A
1	1	0	1	1	1	1	0	xx 7B
0	0	1	1	1	1	1	0	xx 7C
1	0	1	1	1	1	1	0	xx 7D
0	1	1	1	1	1	1	0	xx 7E
1	1	1	1	1	1	1	0	xx 7F

Output signal display (Request code: 175/553)

Please refer to Table 2 on relevant wiring diagram whilst using the following.

0: OFF 1: ON

OUT								Display
1		3	4		6			
0	0	0	0	0	0	0	1	xx 80
1	0	0	0	0	0	0	1	xx 81
0	1	0	0	0	0	0	1	xx 82
1	1	0	0	0	0	0	1	xx 83
0	0	1	0	0	0	0	1	xx 84
1	0	1	0	0	0	0	1	xx 85
0	1	1	0	0	0	0	1	xx 86
1	1	1	0	0	0	0	1	xx 87
0	0	0	1	0	0	0	1	xx 88
1	0	0	1	0	0	0	1	xx 89
0	1	0	1	0	0	0	1	xx 8A
1	1	0	1	0	0	0	1	xx 8B
0	0	1	1	0	0	0	1	xx 8C
1	0	1	1	0	0	0	1	xx 8D
0	1	1	1	0	0	0	1	xx 8E
1	1	1	1	0	0	0	1	xx 8F
0	0	0	0	1	0	0	1	xx 90
1	0	0	0	1	0	0	1	xx 91
0	1	0	0	1	0	0	1	xx 92
1	1	0	0	1	0	0	1	xx 93
0	0	1	0	1	0	0	1	xx 94
1	0	1	0	1	0	0	1	xx 95
0	1	1	0	1	0	0	1	xx 96
1	1	1	0	1	0	0	1	xx 97
0	0	0	1	1	0	0	1	xx 98
1	0	0	1	1	0	0	1	xx 99
0	1	0	1	1	0	0	1	xx 9A
1	1	0	1	1	0	0	1	xx 9B
0	0	1	1	1	0	0	1	xx 9C
1	0	1	1	1	0	0	1	xx 9D
0	1	1	1	1	0	0	1	xx 9E
1	1	1	1	1	0	0	1	xx 9F
0	0	0	0	0	1	0	1	xx A0
1	0	0	0	0	1	0	1	xx A1
0	1	0	0	0	1	0	1	xx A2
1	1	0	0	0	1	0	1	xx A3
0	0	1	0	0	1	0	1	xx A4
1	0	1	0	0	1	0	1	xx A5
0	1	1	0	0	1	0	1	xx A6
1	1	1	0	0	1	0	1	xx A7
0	0	0	1	0	1	0	1	xx A8
1	0	0	1	0	1	0	1	xx A9
0	1	0	1	0	1	0	1	xx AA
1	1	0	1	0	1	0	1	xx AB
0	0	1	1	0	1	0	1	xx AC
1	0	1	1	0	1	0	1	xx AD
0	1	1	1	0	1	0	1	xx AE
1	1	1	1	0	1	0	1	xx AF
0	0	0	0	1	1	0	1	xx B0
1	0	0	0	1	1	0	1	xx B1
0	1	0	0	1	1	0	1	xx B2
1	1	0	0	1	1	0	1	xx B3
0	0	1	0	1	1	0	1	xx B4
1	0	1	0	1	1	0	1	xx B5
0	1	1	0	1	1	0	1	xx B6
1	1	1	0	1	1	0	1	xx B7
0	0	0	1	1	1	0	1	xx B8
1	0	0	1	1	1	0	1	xx B9
0	1	0	1	1	1	0	1	xx BA
1	1	0	1	1	1	0	1	xx BB
0	0	1	1	1	1	0	1	xx BC
1	0	1	1	1	1	0	1	xx BD
0	1	1	1	1	1	0	1	xx BE
1	1	1	1	1	1	0	1	xx BF

0: OFF 1: ON

OUT								Display
1		3	4		6			
0	0	0	0	0	0	1	1	xx C0
1	0	0	0	0	0	1	1	xx C1
0	1	0	0	0	0	1	1	xx C2
1	1	0	0	0	0	1	1	xx C3
0	0	1	0	0	0	1	1	xx C4
1	0	1	0	0	0	1	1	xx C5
0	1	1	0	0	0	1	1	xx C6
1	1	1	0	0	0	1	1	xx C7
0	0	0	1	0	0	1	1	xx C8
1	0	0	1	0	0	1	1	xx C9
0	1	0	1	0	0	1	1	xx CA
1	1	0	1	0	0	1	1	xx CB
0	0	1	1	0	0	1	1	xx CC
1	0	1	1	0	0	1	1	xx CD
0	1	1	1	0	0	1	1	xx CE
1	1	1	1	0	0	1	1	xx CF
0	0	0	0	1	0	1	1	xx D0
1	0	0	0	1	0	1	1	xx D1
0	1	0	0	1	0	1	1	xx D2
1	1	0	0	1	0	1	1	xx D3
0	0	1	0	1	0	1	1	xx D4
1	0	1	0	1	0	1	1	xx D5
0	1	1	0	1	0	1	1	xx D6
1	1	1	0	1	0	1	1	xx D7
0	0	0	1	1	0	1	1	xx D8
1	0	0	1	1	0	1	1	xx D9
0	1	0	1	1	0	1	1	xx DA
1	1	0	1	1	0	1	1	xx DB
0	0	1	1	1	0	1	1	xx DC
1	0	1	1	1	0	1	1	xx DD
0	1	1	1	1	0	1	1	xx DE
1	1	1	1	1	0	1	1	xx DF
0	0	0	0	0	1	1	1	xx E0
1	0	0	0	0	1	1	1	xx E1
0	1	0	0	0	1	1	1	xx E2
1	1	0	0	0	1	1	1	xx E3
0	0	1	0	0	1	1	1	xx E4
1	0	1	0	0	1	1	1	xx E5
0	1	1	0	0	1	1	1	xx E6
1	1	1	0	0	1	1	1	xx E7
0	0	0	1	0	1	1	1	xx E8
1	0	0	1	0	1	1	1	xx E9
0	1	0	1	0	1	1	1	xx EA
1	1	0	1	0	1	1	1	xx EB
0	0	1	1	0	1	1	1	xx EC
1	0	1	1	0	1	1	1	xx ED
0	1	1	1	0	1	1	1	xx EE
1	1	1	1	0	1	1	1	xx EF
0	0	0	0	1	1	1	1	xx F0
1	0	0	0	1	1	1	1	xx F1
0	1	0	0	1	1	1	1	xx F2
1	1	0	0	1	1	1	1	xx F3
0	0	1	0	1	1	1	1	xx F4
1	0	1	0	1	1	1	1	xx F5
0	1	1	0	1	1	1	1	xx F6
1	1	1	0	1	1	1	1	xx F7
0	0	0	1	1	1	1	1	xx F8
1	0	0	1	1	1	1	1	xx F9
0	1	0	1	1	1	1	1	xx FA
1	1	0	1	1	1	1	1	xx FB
0	0	1	1	1	1	1	1	xx FC
1	0	1	1	1	1	1	1	xx FD
0	1	1	1	1	1	1	1	xx FE
1	1	1	1	1	1	1	1	xx FF

Output signal display (Request code: 175/553)

Please refer to Table 2 on relevant wiring diagram whilst using the following.

0: OFF 1: ON

OUT								Display
				13	A	B		
0	0	0	0	0	0	0	0	00 xx
1	0	0	0	0	0	0	0	01 xx
0	1	0	0	0	0	0	0	02 xx
1	1	0	0	0	0	0	0	03 xx
0	0	1	0	0	0	0	0	04 xx
1	0	1	0	0	0	0	0	05 xx
0	1	1	0	0	0	0	0	06 xx
1	1	1	0	0	0	0	0	07 xx
0	0	0	1	0	0	0	0	08 xx
1	0	0	1	0	0	0	0	09 xx
0	1	0	1	0	0	0	0	0A xx
1	1	0	1	0	0	0	0	0B xx
0	0	1	1	0	0	0	0	0C xx
1	0	1	1	0	0	0	0	0D xx
0	1	1	1	0	0	0	0	0E xx
1	1	1	1	0	0	0	0	0F xx
0	0	0	0	1	0	0	0	10 xx
1	0	0	0	1	0	0	0	11 xx
0	1	0	0	1	0	0	0	12 xx
1	1	0	0	1	0	0	0	13 xx
0	0	1	0	1	0	0	0	14 xx
1	0	1	0	1	0	0	0	15 xx
0	1	1	0	1	0	0	0	16 xx
1	1	1	0	1	0	0	0	17 xx
0	0	0	1	1	0	0	0	18 xx
1	0	0	1	1	0	0	0	19 xx
0	1	0	1	1	0	0	0	1A xx
1	1	0	1	1	0	0	0	1B xx
0	0	1	1	1	0	0	0	1C xx
1	0	1	1	1	0	0	0	1D xx
0	1	1	1	1	0	0	0	1E xx
1	1	1	1	1	0	0	0	1F xx
0	0	0	0	0	1	0	0	20 xx
1	0	0	0	0	1	0	0	21 xx
0	1	0	0	0	1	0	0	22 xx
1	1	0	0	0	1	0	0	23 xx
0	0	1	0	0	1	0	0	24 xx
1	0	1	0	0	1	0	0	25 xx
0	1	1	0	0	1	0	0	26 xx
1	1	1	0	0	1	0	0	27 xx
0	0	0	1	0	1	0	0	28 xx
1	0	0	1	0	1	0	0	29 xx
0	1	0	1	0	1	0	0	2A xx
1	1	0	1	0	1	0	0	2B xx
0	0	1	1	0	1	0	0	2C xx
1	0	1	1	0	1	0	0	2D xx
0	1	1	1	0	1	0	0	2E xx
1	1	1	1	0	1	0	0	2F xx
0	0	0	0	1	1	0	0	30 xx
1	0	0	0	1	1	0	0	31 xx
0	1	0	0	1	1	0	0	32 xx
1	1	0	0	1	1	0	0	33 xx
0	0	1	0	1	1	0	0	34 xx
1	0	1	0	1	1	0	0	35 xx
0	1	1	0	1	1	0	0	36 xx
1	1	1	0	1	1	0	0	37 xx
0	0	0	1	1	1	0	0	38 xx
1	0	0	1	1	1	0	0	39 xx
0	1	0	1	1	1	0	0	3A xx
1	1	0	1	1	1	0	0	3B xx
0	0	1	1	1	1	0	0	3C xx
1	0	1	1	1	1	0	0	3D xx
0	1	1	1	1	1	0	0	3E xx
1	1	1	1	1	1	0	0	3F xx

0: OFF 1: ON

OUT								Display
				13	A	B		
0	0	0	0	0	0	1	0	40 xx
1	0	0	0	0	0	1	0	41 xx
0	1	0	0	0	0	1	0	42 xx
1	1	0	0	0	0	1	0	43 xx
0	0	1	0	0	0	1	0	44 xx
1	0	1	0	0	0	1	0	45 xx
0	1	1	0	0	0	1	0	46 xx
1	1	1	0	0	0	1	0	47 xx
0	0	0	1	0	0	1	0	48 xx
1	0	0	1	0	0	1	0	49 xx
0	1	0	1	0	0	1	0	4A xx
1	1	0	1	0	0	1	0	4B xx
0	0	1	1	0	0	1	0	4C xx
1	0	1	1	0	0	1	0	4D xx
0	1	1	1	0	0	1	0	4E xx
1	1	1	1	0	0	1	0	4F xx
0	0	0	0	1	0	1	0	50 xx
1	0	0	0	1	0	1	0	51 xx
0	1	0	0	1	0	1	0	52 xx
1	1	0	0	1	0	1	0	53 xx
0	0	1	0	1	0	1	0	54 xx
1	0	1	0	1	0	1	0	55 xx
0	1	1	0	1	0	1	0	56 xx
1	1	1	0	1	0	1	0	57 xx
0	0	0	1	1	0	1	0	58 xx
1	0	0	1	1	0	1	0	59 xx
0	1	0	1	1	0	1	0	5A xx
1	1	0	1	1	0	1	0	5B xx
0	0	1	1	1	0	1	0	5C xx
1	0	1	1	1	0	1	0	5D xx
0	1	1	1	1	0	1	0	5E xx
1	1	1	1	1	0	1	0	5F xx
0	0	0	0	0	1	1	0	60 xx
1	0	0	0	0	1	1	0	61 xx
0	1	0	0	0	1	1	0	62 xx
1	1	0	0	0	1	1	0	63 xx
0	0	1	0	0	1	1	0	64 xx
1	0	1	0	0	1	1	0	65 xx
0	1	1	0	0	1	1	0	66 xx
1	1	1	0	0	1	1	0	67 xx
0	0	0	1	0	1	1	0	68 xx
1	0	0	1	0	1	1	0	69 xx
0	1	0	1	0	1	1	0	6A xx
1	1	0	1	0	1	1	0	6B xx
0	0	1	1	0	1	1	0	6C xx
1	0	1	1	0	1	1	0	6D xx
0	1	1	1	0	1	1	0	6E xx
1	1	1	1	0	1	1	0	6F xx
0	0	0	0	1	1	1	0	70 xx
1	0	0	0	1	1	1	0	71 xx
0	1	0	0	1	1	1	0	72 xx
1	1	0	0	1	1	1	0	73 xx
0	0	1	0	1	1	1	0	74 xx
1	0	1	0	1	1	1	0	75 xx
0	1	1	0	1	1	1	0	76 xx
1	1	1	0	1	1	1	0	77 xx
0	0	0	1	1	1	1	0	78 xx
1	0	0	1	1	1	1	0	79 xx
0	1	0	1	1	1	1	0	7A xx
1	1	0	1	1	1	1	0	7B xx
0	0	1	1	1	1	1	0	7C xx
1	0	1	1	1	1	1	0	7D xx
0	1	1	1	1	1	1	0	7E xx
1	1	1	1	1	1	1	0	7F xx

* Displayed only when the request code is 553.

Output signal display (Request code: 175/553)

Please refer to Table 2 on relevant wiring diagram whilst using the following.

0: OFF 1: ON

OUT								Display
				13	A	B		
0	0	0	0	0	0	1	80 xx	
1	0	0	0	0	0	1	81 xx	
0	1	0	0	0	0	1	82 xx	
1	1	0	0	0	0	1	83 xx	
0	0	1	0	0	0	1	84 xx	
1	0	1	0	0	0	1	85 xx	
0	1	1	0	0	0	1	86 xx	
1	1	1	0	0	0	1	87 xx	
0	0	0	1	0	0	1	88 xx	
1	0	0	1	0	0	1	89 xx	
0	1	0	1	0	0	1	8A xx	
1	1	0	1	0	0	1	8B xx	
0	0	1	1	0	0	1	8C xx	
1	0	1	1	0	0	1	8D xx	
0	1	1	1	0	0	1	8E xx	
1	1	1	1	0	0	1	8F xx	
0	0	0	0	1	0	1	90 xx	
1	0	0	0	1	0	1	91 xx	
0	1	0	0	1	0	1	92 xx	
1	1	0	0	1	0	1	93 xx	
0	0	1	0	1	0	1	94 xx	
1	0	1	0	1	0	1	95 xx	
0	1	1	0	1	0	1	96 xx	
1	1	1	0	1	0	1	97 xx	
0	0	0	1	1	0	1	98 xx	
1	0	0	1	1	0	1	99 xx	
0	1	0	1	1	0	1	9A xx	
1	1	0	1	1	0	1	9B xx	
0	0	1	1	1	0	1	9C xx	
1	0	1	1	1	0	1	9D xx	
0	1	1	1	1	0	1	9E xx	
1	1	1	1	1	0	1	9F xx	
0	0	0	0	0	1	0	A0 xx	
1	0	0	0	0	1	0	A1 xx	
0	1	0	0	0	1	0	A2 xx	
1	1	0	0	0	1	0	A3 xx	
0	0	1	0	0	1	0	A4 xx	
1	0	1	0	0	1	0	A5 xx	
0	1	1	0	0	1	0	A6 xx	
1	1	1	0	0	1	0	A7 xx	
0	0	0	1	0	1	0	A8 xx	
1	0	0	1	0	1	0	A9 xx	
0	1	0	1	0	1	0	AA xx	
1	1	0	1	0	1	0	AB xx	
0	0	1	1	0	1	0	AC xx	
1	0	1	1	0	1	0	AD xx	
0	1	1	1	0	1	0	AE xx	
1	1	1	1	0	1	0	AF xx	
0	0	0	0	1	1	0	B0 xx	
1	0	0	0	1	1	0	B1 xx	
0	1	0	0	1	1	0	B2 xx	
1	1	0	0	1	1	0	B3 xx	
0	0	1	0	1	1	0	B4 xx	
1	0	1	0	1	1	0	B5 xx	
0	1	1	0	1	1	0	B6 xx	
1	1	1	0	1	1	0	B7 xx	
0	0	0	1	1	1	0	B8 xx	
1	0	0	1	1	1	0	B9 xx	
0	1	0	1	1	1	0	BA xx	
1	1	0	1	1	1	0	BB xx	
0	0	1	1	1	1	0	BC xx	
1	0	1	1	1	1	0	BD xx	
0	1	1	1	1	1	0	BE xx	
1	1	1	1	1	1	0	BF xx	

0: OFF 1: ON

OUT								Display
				13	A	B		
0	0	0	0	0	1	1	C0 xx	
1	0	0	0	0	1	1	C1 xx	
0	1	0	0	0	1	1	C2 xx	
1	1	0	0	0	1	1	C3 xx	
0	0	1	0	0	1	1	C4 xx	
1	0	1	0	0	1	1	C5 xx	
0	1	1	0	0	1	1	C6 xx	
1	1	1	0	0	1	1	C7 xx	
0	0	0	1	0	1	1	C8 xx	
1	0	0	1	0	1	1	C9 xx	
0	1	0	1	0	1	1	CA xx	
1	1	0	1	0	1	1	CB xx	
0	0	1	1	0	1	1	CC xx	
1	0	1	1	0	1	1	CD xx	
0	1	1	1	0	1	1	CE xx	
1	1	1	1	0	1	1	CF xx	
0	0	0	0	1	0	1	D0 xx	
1	0	0	0	1	0	1	D1 xx	
0	1	0	0	1	0	1	D2 xx	
1	1	0	0	1	0	1	D3 xx	
0	0	1	0	1	0	1	D4 xx	
1	0	1	0	1	0	1	D5 xx	
0	1	1	0	1	0	1	D6 xx	
1	1	1	0	1	0	1	D7 xx	
0	0	0	1	1	0	1	D8 xx	
1	0	0	1	1	0	1	D9 xx	
0	1	0	1	1	0	1	DA xx	
1	1	0	1	1	0	1	DB xx	
0	0	1	1	1	0	1	DC xx	
1	0	1	1	1	0	1	DD xx	
0	1	1	1	1	0	1	DE xx	
1	1	1	1	1	0	1	DF xx	
0	0	0	0	0	1	1	E0 xx	
1	0	0	0	0	1	1	E1 xx	
0	1	0	0	0	1	1	E2 xx	
1	1	0	0	0	1	1	E3 xx	
0	0	1	0	0	1	1	E4 xx	
1	0	1	0	0	1	1	E5 xx	
0	1	1	0	0	1	1	E6 xx	
1	1	1	0	0	1	1	E7 xx	
0	0	0	1	0	1	1	E8 xx	
1	0	0	1	0	1	1	E9 xx	
0	1	0	1	0	1	1	EA xx	
1	1	0	1	0	1	1	EB xx	
0	0	1	1	0	1	1	EC xx	
1	0	1	1	0	1	1	ED xx	
0	1	1	1	0	1	1	EE xx	
1	1	1	1	0	1	1	EF xx	
0	0	0	0	1	1	1	F0 xx	
1	0	0	0	1	1	1	F1 xx	
0	1	0	0	1	1	1	F2 xx	
1	1	0	0	1	1	1	F3 xx	
0	0	1	0	1	1	1	F4 xx	
1	0	1	0	1	1	1	F5 xx	
0	1	1	0	1	1	1	F6 xx	
1	1	1	0	1	1	1	F7 xx	
0	0	0	1	1	1	1	F8 xx	
1	0	0	1	1	1	1	F9 xx	
0	1	0	1	1	1	1	FA xx	
1	1	0	1	1	1	1	FB xx	
0	0	1	1	1	1	1	FC xx	
1	0	1	1	1	1	1	FD xx	
0	1	1	1	1	1	1	FE xx	
1	1	1	1	1	1	1	FF xx	

Input signal display (Request code: 176/554)

Please refer to Table 1 on relevant wiring diagram whilst using the following.

0: OFF (open) 1: ON (short)

IN								Display
1				6		8		
0	0	0	0	0	0	0	0	00 00
1	0	0	0	0	0	0	0	00 01
0	1	0	0	0	0	0	0	00 02
1	1	0	0	0	0	0	0	00 03
0	0	1	0	0	0	0	0	00 04
1	0	1	0	0	0	0	0	00 05
0	1	1	0	0	0	0	0	00 06
1	1	1	0	0	0	0	0	00 07
0	0	0	1	0	0	0	0	00 08
1	0	0	1	0	0	0	0	00 09
0	1	0	1	0	0	0	0	00 0A
1	1	0	1	0	0	0	0	00 0B
0	0	1	1	0	0	0	0	00 0C
1	0	1	1	0	0	0	0	00 0D
0	1	1	1	0	0	0	0	00 0E
1	1	1	1	0	0	0	0	00 0F
0	0	0	0	1	0	0	0	00 10
1	0	0	0	1	0	0	0	00 11
0	1	0	0	1	0	0	0	00 12
1	1	0	0	1	0	0	0	00 13
0	0	1	0	1	0	0	0	00 14
1	0	1	0	1	0	0	0	00 15
0	1	1	0	1	0	0	0	00 16
1	1	1	0	1	0	0	0	00 17
0	0	0	1	1	0	0	0	00 18
1	0	0	1	1	0	0	0	00 19
0	1	0	1	1	0	0	0	00 1A
1	1	0	1	1	0	0	0	00 1B
0	0	1	1	1	0	0	0	00 1C
1	0	1	1	1	0	0	0	00 1D
0	1	1	1	1	0	0	0	00 1E
1	1	1	1	1	0	0	0	00 1F
0	0	0	0	0	1	0	0	00 20
1	0	0	0	0	1	0	0	00 21
0	1	0	0	0	1	0	0	00 22
1	1	0	0	0	1	0	0	00 23
0	0	1	0	0	1	0	0	00 24
1	0	1	0	0	1	0	0	00 25
0	1	1	0	0	1	0	0	00 26
1	1	1	0	0	1	0	0	00 27
0	0	0	1	0	1	0	0	00 28
1	0	0	1	0	1	0	0	00 29
0	1	0	1	0	1	0	0	00 2A
1	1	0	1	0	1	0	0	00 2B
0	0	1	1	0	1	0	0	00 2C
1	0	1	1	0	1	0	0	00 2D
0	1	1	1	0	1	0	0	00 2E
1	1	1	1	0	1	0	0	00 2F
0	0	0	0	1	1	0	0	00 30
1	0	0	0	1	1	0	0	00 31
0	1	0	0	1	1	0	0	00 32
1	1	0	0	1	1	0	0	00 33
0	0	1	0	1	1	0	0	00 34
1	0	1	0	1	1	0	0	00 35
0	1	1	0	1	1	0	0	00 36
1	1	1	0	1	1	0	0	00 37
0	0	0	1	1	1	0	0	00 38
1	0	0	1	1	1	0	0	00 39
0	1	0	1	1	1	0	0	00 3A
1	1	0	1	1	1	0	0	00 3B
0	0	1	1	1	1	0	0	00 3C
1	0	1	1	1	1	0	0	00 3D
0	1	1	1	1	1	0	0	00 3E
1	1	1	1	1	1	0	0	00 3F

0: OFF (open) 1: ON (short)

IN								Display
1				6		8		
0	0	0	0	0	0	1	0	00 40
1	0	0	0	0	0	1	0	00 41
0	1	0	0	0	0	1	0	00 42
1	1	0	0	0	0	1	0	00 43
0	0	1	0	0	0	1	0	00 44
1	0	1	0	0	0	1	0	00 45
0	1	1	0	0	0	1	0	00 46
1	1	1	0	0	0	1	0	00 47
0	0	0	1	0	0	1	0	00 48
1	0	0	1	0	0	1	0	00 49
0	1	0	1	0	0	1	0	00 4A
1	1	0	1	0	0	1	0	00 4B
0	0	1	1	0	0	1	0	00 4C
1	0	1	1	0	0	1	0	00 4D
0	1	1	1	0	0	1	0	00 4E
1	1	1	1	0	0	1	0	00 4F
0	0	0	0	1	0	1	0	00 50
1	0	0	0	1	0	1	0	00 51
0	1	0	0	1	0	1	0	00 52
1	1	0	0	1	0	1	0	00 53
0	0	1	0	1	0	1	0	00 54
1	0	1	0	1	0	1	0	00 55
0	1	1	0	1	0	1	0	00 56
1	1	1	0	1	0	1	0	00 57
0	0	0	1	1	0	1	0	00 58
1	0	0	1	1	0	1	0	00 59
0	1	0	1	1	0	1	0	00 5A
1	1	0	1	1	0	1	0	00 5B
0	0	1	1	1	0	1	0	00 5C
1	0	1	1	1	0	1	0	00 5D
0	1	1	1	1	0	1	0	00 5E
1	1	1	1	1	0	1	0	00 5F
0	0	0	0	0	1	1	0	00 60
1	0	0	0	0	1	1	0	00 61
0	1	0	0	0	1	1	0	00 62
1	1	0	0	0	1	1	0	00 63
0	0	1	0	0	1	1	0	00 64
1	0	1	0	0	1	1	0	00 65
0	1	1	0	0	1	1	0	00 66
1	1	1	0	0	1	1	0	00 67
0	0	0	1	0	1	1	0	00 68
1	0	0	1	0	1	1	0	00 69
0	1	0	1	0	1	1	0	00 6A
1	1	0	1	0	1	1	0	00 6B
0	0	1	1	0	1	1	0	00 6C
1	0	1	1	0	1	1	0	00 6D
0	1	1	1	0	1	1	0	00 6E
1	1	1	1	0	1	1	0	00 6F
0	0	0	0	1	1	1	0	00 70
1	0	0	0	1	1	1	0	00 71
0	1	0	0	1	1	1	0	00 72
1	1	0	0	1	1	1	0	00 73
0	0	1	0	1	1	1	0	00 74
1	0	1	0	1	1	1	0	00 75
0	1	1	0	1	1	1	0	00 76
1	1	1	0	1	1	1	0	00 77
0	0	0	1	1	1	1	0	00 78
1	0	0	1	1	1	1	0	00 79
0	1	0	1	1	1	1	0	00 7A
1	1	0	1	1	1	1	0	00 7B
0	0	1	1	1	1	1	0	00 7C
1	0	1	1	1	1	1	0	00 7D
0	1	1	1	1	1	1	0	00 7E
1	1	1	1	1	1	1	0	00 7F

Input signal display (Request code: 176/554)

0: OFF (open) 1: ON (short)

IN								Display
1				6		8		
0	0	0	0	0	0	0	1	00 80
1	0	0	0	0	0	0	1	00 81
0	1	0	0	0	0	0	1	00 82
1	1	0	0	0	0	0	1	00 83
0	0	1	0	0	0	0	1	00 84
1	0	1	0	0	0	0	1	00 85
0	1	1	0	0	0	0	1	00 86
1	1	1	0	0	0	0	1	00 87
0	0	0	1	0	0	0	1	00 88
1	0	0	1	0	0	0	1	00 89
0	1	0	1	0	0	0	1	00 8A
1	1	0	1	0	0	0	1	00 8B
0	0	1	1	0	0	0	1	00 8C
1	0	1	1	0	0	0	1	00 8D
0	1	1	1	0	0	0	1	00 8E
1	1	1	1	0	0	0	1	00 8F
0	0	0	0	1	0	0	1	00 90
1	0	0	0	1	0	0	1	00 91
0	1	0	0	1	0	0	1	00 92
1	1	0	0	1	0	0	1	00 93
0	0	1	0	1	0	0	1	00 94
1	0	1	0	1	0	0	1	00 95
0	1	1	0	1	0	0	1	00 96
1	1	1	0	1	0	0	1	00 97
0	0	0	1	1	0	0	1	00 98
1	0	0	1	1	0	0	1	00 99
0	1	0	1	1	0	0	1	00 9A
1	1	0	1	1	0	0	1	00 9B
0	0	1	1	1	0	0	1	00 9C
1	0	1	1	1	0	0	1	00 9D
0	1	1	1	1	0	0	1	00 9E
1	1	1	1	1	0	0	1	00 9F
0	0	0	0	0	1	0	1	00 A0
1	0	0	0	0	1	0	1	00 A1
0	1	0	0	0	1	0	1	00 A2
1	1	0	0	0	1	0	1	00 A3
0	0	1	0	0	1	0	1	00 A4
1	0	1	0	0	1	0	1	00 A5
0	1	1	0	0	1	0	1	00 A6
1	1	1	0	0	1	0	1	00 A7
0	0	0	1	0	1	0	1	00 A8
1	0	0	1	0	1	0	1	00 A9
0	1	0	1	0	1	0	1	00 AA
1	1	0	1	0	1	0	1	00 AB
0	0	1	1	0	1	0	1	00 AC
1	0	1	1	0	1	0	1	00 AD
0	1	1	1	0	1	0	1	00 AE
1	1	1	1	0	1	0	1	00 AF
0	0	0	0	1	1	0	1	00 B0
1	0	0	0	1	1	0	1	00 B1
0	1	0	0	1	1	0	1	00 B2
1	1	0	0	1	1	0	1	00 B3
0	0	1	0	1	1	0	1	00 B4
1	0	1	0	1	1	0	1	00 B5
0	1	1	0	1	1	0	1	00 B6
1	1	1	0	1	1	0	1	00 B7
0	0	0	1	1	1	0	1	00 B8
1	0	0	1	1	1	0	1	00 B9
0	1	0	1	1	1	0	1	00 BA
1	1	0	1	1	1	0	1	00 BB
0	0	1	1	1	1	0	1	00 BC
1	0	1	1	1	1	0	1	00 BD
0	1	1	1	1	1	0	1	00 BE
1	1	1	1	1	1	0	1	00 BF

0: OFF (open) 1: ON (short)

IN								Display
1				6		8		
0	0	0	0	0	0	1	1	00 C0
1	0	0	0	0	0	1	1	00 C1
0	1	0	0	0	0	1	1	00 C2
1	1	0	0	0	0	1	1	00 C3
0	0	1	0	0	0	1	1	00 C4
1	0	1	0	0	0	1	1	00 C5
0	1	1	0	0	0	1	1	00 C6
1	1	1	0	0	0	1	1	00 C7
0	0	0	1	0	0	1	1	00 C8
1	0	0	1	0	0	1	1	00 C9
0	1	0	1	0	0	1	1	00 CA
1	1	0	1	0	0	1	1	00 CB
0	0	1	1	0	0	1	1	00 CC
1	0	1	1	0	0	1	1	00 CD
0	1	1	1	0	0	1	1	00 CE
1	1	1	1	0	0	1	1	00 CF
0	0	0	0	1	0	1	1	00 D0
1	0	0	0	1	0	1	1	00 D1
0	1	0	0	1	0	1	1	00 D2
1	1	0	0	1	0	1	1	00 D3
0	0	1	0	1	0	1	1	00 D4
1	0	1	0	1	0	1	1	00 D5
0	1	1	0	1	0	1	1	00 D6
1	1	1	0	1	0	1	1	00 D7
0	0	0	1	1	0	1	1	00 D8
1	0	0	1	1	0	1	1	00 D9
0	1	0	1	1	0	1	1	00 DA
1	1	0	1	1	0	1	1	00 DB
0	0	1	1	1	0	1	1	00 DC
1	0	1	1	1	0	1	1	00 DD
0	1	1	1	1	0	1	1	00 DE
1	1	1	1	1	0	1	1	00 DF
0	0	0	0	0	1	1	1	00 E0
1	0	0	0	0	1	1	1	00 E1
0	1	0	0	0	1	1	1	00 E2
1	1	0	0	0	1	1	1	00 E3
0	0	1	0	0	1	1	1	00 E4
1	0	1	0	0	1	1	1	00 E5
0	1	1	0	0	1	1	1	00 E6
1	1	1	0	0	1	1	1	00 E7
0	0	0	1	0	1	1	1	00 E8
1	0	0	1	0	1	1	1	00 E9
0	1	0	1	0	1	1	1	00 EA
1	1	0	1	0	1	1	1	00 EB
0	0	1	1	0	1	1	1	00 EC
1	0	1	1	0	1	1	1	00 ED
0	1	1	1	0	1	1	1	00 EE
1	1	1	1	0	1	1	1	00 EF
0	0	0	0	1	1	1	1	00 F0
1	0	0	0	1	1	1	1	00 F1
0	1	0	0	1	1	1	1	00 F2
1	1	0	0	1	1	1	1	00 F3
0	0	1	0	1	1	1	1	00 F4
1	0	1	0	1	1	1	1	00 F5
0	1	1	0	1	1	1	1	00 F6
1	1	1	0	1	1	1	1	00 F7
0	0	0	1	1	1	1	1	00 F8
1	0	0	1	1	1	1	1	00 F9
0	1	0	1	1	1	1	1	00 FA
1	1	0	1	1	1	1	1	00 FB
0	0	1	1	1	1	1	1	00 FC
1	0	1	1	1	1	1	1	00 FD
0	1	1	1	1	1	1	1	00 FE
1	1	1	1	1	1	1	1	00 FF

■ Indoor unit only operation

In indoor unit only operation, an operation without connecting outdoor unit is possible. When in Indoor unit only operation the main control has control functions.

<Heater>

Heating for DHW and heating is provided by the booster heater.

• Activating indoor unit only operation mode

To activate indoor unit only operation see the following:

1. Switch OFF the breaker for the indoor unit.
2. Change DIP switch SW4-4 and SW4-5 to ON.
3. Switch ON the breaker.
4. Indoor unit only operation is now activated.

• Deactivating indoor unit only operation mode

To deactivate indoor unit only operation see the following:

1. Switch OFF the breaker for the indoor unit.
2. Change DIP switch SW4-4 and SW4-5 to OFF.
3. Switch ON the breaker.
4. Indoor unit only operation is now deactivated.

	Indoor unit only operation
Indoor unit	Necessary
Heat pump	Not necessary
Main remote controller	Necessary
DIP switch setting	Electric heater SW4-4 ON, SW4-5 ON
Setting range for flow temp.	25 - 60°C Selectable
Setting range for tank temp.	40 - 70°C Selectable

■ Emergency operation

In emergency operation, an operation without connecting outdoor unit and main remote controller is possible.

When in Emergency operation the main control has NO control functions.

Heating flow temp. is restarted 40°C and DHW supply max.temp. is restricted 50°C. *1

<Heater>

Heating for DHW and space heating is provided by the booster heater.

• Activating emergency operation mode

To activate emergency operation see the following:

1. Switch OFF the breaker for the indoor unit .
2. Change DIP switch SW4-5 to ON.
3. Switch ON the breaker.
4. Emergency operation is now activated.

• Deactivating emergency operation mode

To deactivate emergency operation see the following:

1. Switch OFF the breaker for the indoor unit .
2. Change DIP switch SW4-5 to OFF.
3. Switch ON the breaker.
4. Emergency operation is now deactivated.

	Emergency operation
Indoor unit	Necessary
Heat pump	Not necessary
Main remote controller	Not necessary
DIP switch setting	Electric heater SW4-5 ON
Setting range for flow temp.	Fixed at 40°C
Setting range for tank temp.	Fixed at 55°C *1

*1 Default setting is 50°C. Once system has started running, emergency operation runs at the latest set temp.

WARNING

Do not attempt to change the DIP switches whilst the breaker are ON as this could result in ELECTROCUTION.

10-1. Troubleshooting

<Summary of self diagnosis based on Error Codes and Service Procedures>

Present and past Error codes are logged and displayed on the main remote controller or control board of the outdoor unit.

Please refer to the table below and subsequent explanations to diagnose and remedy typical problems that may occur in the field.

Unit Condition	Error Code	Action
Reoccurring problem	Displayed	Use table 10-4. "Self diagnosis and action" to identify fault and correct.
	Not Displayed	Use table 10-5. "Troubleshooting by inferior phenomena" to identify fault and correct.
Non reoccurring problem	Logged	1. Check temporary causes of defects such as the operation of safety devices on the refrigerant/water circuit including compressor, poor wiring, electrical noise etc. Re-check the symptom and the installation environment, weather conditions at time of fault etc. 2. Reset Error code logs, Service the unit and restart system.
	Not Logged	1. Recheck the abnormal symptom 2. Identify cause of problem and take corrective action according to Table 10-5. "Troubleshooting by inferior phenomena" 3. If no obvious problem can be found continue to operate the unit.

NOTE

Electrical components should only be replaced as a final option. Please follow instructions in Tables 10-4. and 10-5. Error Codes and Inferior Phenomena fully before resorting to replacing parts.

10-2. Test Run

Before a test run

- After installation of outdoor unit, pipework and electrical wiring, recheck that there is no water leakage, loosened connections or miswiring.
- Measure impedance between the ground and the power supply terminal block (L,N) on the outdoor and indoor units with suitable (500V) ohmmeter. Resistance should be $\geq 1.0M\Omega$.
- Read the Installation and Operation Manuals fully especially the safety requirements before carrying out any test runs.

10-3. Malfunction diagnosis method by main remote controller

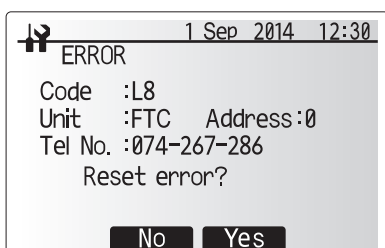
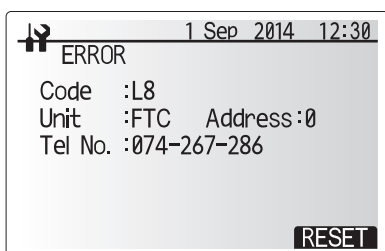
If during start up or operation a malfunction occurs the error code screen may be displayed on the main remote controller.

The error code screen shows the following; code, unit, ref. address, and telephone number of installer (only if previously entered by the installer)

Please note in the case of some malfunctions an error code is not generated please refer to table 10-5. for more details.

To reset

1. To reset the main remote controller press F4 button (Reset).
2. Then press F3 (Yes) to confirm.



10-4. Self diagnosis and action

Check if DIP SW is set correctly. (Refer to Section 6-2.)

Error code	Title and display conditions	Possible Cause	Diagnosis and action
L3	<p>Circulation water temperature overheat protection <DHW/Heating/FS/OS> Error code displayed when THW1 detects a temp. $\geq 80^{\circ}\text{C}$ for 10 consecutive seconds or THW2 detects a temp. $\geq 80^{\circ}\text{C}$ for 10 consecutive seconds or THW3 detects a temp. $\geq 80^{\circ}\text{C}$ for 10 consecutive seconds.</p> <p>DHW : Domestic hot water mode Heating : Heating mode FS : Freeze stat OS : Operation stop TH1A/B : Room temp. thermistor THW1 : Flow water temp. thermistor THW2 : Return water temp. thermistor THW3 : Flow water temp. thermistor 2 (to tank) THW4 : DHW supply temp. thermistor THW5A : Stored water temp. thermistor (upper) THW5B : Stored water temp. thermistor (lower)</p>	<ol style="list-style-type: none"> 1. Reduced flow in primary water circuit Due to 1 or more of the following; Faulty pump, insufficient air purge, blocked strainer, leak in water circuit. 2. Valve operation fault 3. 2-way valve (local supply) actuator fault 4. 3-way valve actuator fault 5. Booster heater relay (CNBH) operating fault 6. Power supply voltage increase 7. THW1 or THW2 has become detached from its holder. 8. THW1 or THW2 or THW3 fault 9. FTC board failure 	<ol style="list-style-type: none"> 1. Check circulation pump (See 10-6. for how to check). Open air vent to remove trapped air. Check the strainer for blockages. Check the primary water circuit for leaks. Check that the flow amount is within the recommended range during heating operation. Refer to Procedure 5 in "11. DISASSEMBLY PROCEDURE." 2. Check valves on primary water circuit are installed level. 3. Electrically test to determine fault 4. 1) Electrically test to determine fault. 2) Operate 3-way valve manually using the main remote controller. (Refer to <Manual operation> in 9-4). 3) Replace 3-way valve coil. 4) Replace 3-way valve. (Refer to Procedure 6 in "11. DISASSEMBLY PROCEDURE.") 5. Electrically test the relays (CNBH) to determine fault. See 10-6. for how to check. 6. Check the supply voltage. 7. Visually inspect location and reattach as necessary. 8. Check resistance of thermistor against table in section 10-6. Compare FTC detected temperature to hand held detector. 9. Replace board.
L4	<p>Tank water temperature overheat protection <DHW/Heating/FS/OS> Error code display when THW5A detects a temp. $\geq 95^{\circ}\text{C}$ for 10 consecutive seconds.</p>	<ol style="list-style-type: none"> 1. 3-way valve actuator fault 2. THW5A fault 3. FTC board failure 	<ol style="list-style-type: none"> 1. 1) Electrically test to determine fault. 2) Operate 3-way valve manually using the main remote controller. (Refer to <Manual operation> in 9-4). 3) Replace 3-way valve coil. 4) Replace 3-way valve. (Refer to Procedure 6 in "11. DISASSEMBLY PROCEDURE.") 2. Check resistance of thermistor against table in section 10-6. Compare FTC detected temperature to hand held detector. 3. Replace board.



Error code	Title and display conditions	Possible Cause	Diagnosis and action																																							
P1/L5	<p>Indoor unit temperature thermistor failure * The thermistors subject to failure can be checked in "Request code: 567" in "Running information"</p> <p><DHW/Heating/LP/FS/OS> Error code displayed when thermistor is at open or short (see table).</p>	<ol style="list-style-type: none"> Connector/terminal wire has become detached or loose wiring. Thermistor fault FTC board failure The thermistor on the wireless remote controller or the main remote controller may be defective. (when Room temp. is chosen for the Heating operation and when Main remote controller or Room RC 1-8 is chosen for the Room Sensor setting in the Initial setting) 	<ol style="list-style-type: none"> Visually check the terminals and connections and reattaches appropriate. Check resistance of thermistor against table in section 10-6. Compare FTC detected temperature to hand held detector. Replace board. Replace wireless remote controller or main remote controller. 																																							
	<table border="1"> <thead> <tr> <th rowspan="2">Error code</th> <th colspan="2">Thermistor</th> <th rowspan="2">Open detection</th> <th rowspan="2">Short detection</th> </tr> <tr> <th>Symbol</th> <th>Name</th> </tr> </thead> <tbody> <tr> <td>P1</td> <td>TH1A/TH1B</td> <td>Room temperature thermistor</td> <td>-39°C or below</td> <td>88.5°C or above</td> </tr> <tr> <td rowspan="5">L5</td> <td>THW1</td> <td>Flow water temperature thermistor</td> <td>-39°C or below</td> <td>111°C or above</td> </tr> <tr> <td>THW2</td> <td>Return water temperature thermistor</td> <td>-39°C or below</td> <td>111°C or above</td> </tr> <tr> <td>THW3</td> <td>Flow water temp. thermistor (to tank)</td> <td>-39°C or below</td> <td>111°C or above</td> </tr> <tr> <td>THW4</td> <td>DHW supply temp. thermistor</td> <td>-39°C or below</td> <td>111°C or above</td> </tr> <tr> <td>THW5A</td> <td>Stored water temp. thermistor (upper)</td> <td>-39°C or below</td> <td>111°C or above</td> </tr> <tr> <td></td> <td>THW5B</td> <td>Stored water temp. thermistor (lower)</td> <td>-39°C or below</td> <td>111°C or above</td> </tr> </tbody> </table>				Error code	Thermistor		Open detection	Short detection	Symbol	Name	P1	TH1A/TH1B	Room temperature thermistor	-39°C or below	88.5°C or above	L5	THW1	Flow water temperature thermistor	-39°C or below	111°C or above	THW2	Return water temperature thermistor	-39°C or below	111°C or above	THW3	Flow water temp. thermistor (to tank)	-39°C or below	111°C or above	THW4	DHW supply temp. thermistor	-39°C or below	111°C or above	THW5A	Stored water temp. thermistor (upper)	-39°C or below	111°C or above		THW5B	Stored water temp. thermistor (lower)	-39°C or below	111°C or above
Error code	Thermistor		Open detection	Short detection																																						
	Symbol	Name																																								
P1	TH1A/TH1B	Room temperature thermistor	-39°C or below	88.5°C or above																																						
L5	THW1	Flow water temperature thermistor	-39°C or below	111°C or above																																						
	THW2	Return water temperature thermistor	-39°C or below	111°C or above																																						
	THW3	Flow water temp. thermistor (to tank)	-39°C or below	111°C or above																																						
	THW4	DHW supply temp. thermistor	-39°C or below	111°C or above																																						
	THW5A	Stored water temp. thermistor (upper)	-39°C or below	111°C or above																																						
	THW5B	Stored water temp. thermistor (lower)	-39°C or below	111°C or above																																						
L6	<p>Circulation water freeze protection <DHW/Heating/FS/OS> Error code displayed when THW1 detects a temp. ≤ 1°C for 10 consecutive seconds or THW2 detects a temp. ≤ 3°C for 10 consecutive seconds.</p> <p><u>Exception</u> Error code will not be displayed if; FS function is disabled, For 10 minutes after water circulation pump1 is switched on.</p>	<ol style="list-style-type: none"> Reduced flow in primary water circuit Due to 1 or more of the following; Faulty pump, insufficient air purge, blocked strainer, leak in water circuit Valve operation fault 2-way valve (local supply) actuator fault 3-way valve actuator fault THW1 or THW2 has become detached from its holder. THW1 or THW2 fault FTC board failure 	<ol style="list-style-type: none"> Check circulation pump (See 10-6. for how to check). Open air vent to remove trapped air. Check the strainer for blockages. Check the primary water circuit for leaks. Check that the flow amount is within the recommended range during heating operation. Refer to Procedure 5 in "11. DISASSEMBLY PROCEDURE." Check valves on primary water circuit are installed level. Electrically test to determine fault 1) Electrically test to determine fault. 2) Operate 3-way valve manually using the main remote controller. (Refer to <Manual operation> in 9-4). 3) Replace 3-way valve coil. 4) Replace 3-way valve. (Refer to Procedure 6 in "11. DISASSEMBLY PROCEDURE." Visually inspect location and reattach as necessary. Check resistance of thermistor against table in section 10-6. Compare FTC detected temperature to hand held detector. Replace board. 																																							
L8	<p>Heating operation error * "3" is displayed in "Request code: 567" in "Running information". <Heating/FS> If a), b) and c) occur, L8 is displayed; a) No change on THW1 (under 1°C for 20 minutes from unit starts operation) b) No change on THW1 (under 1°C for 10 minutes from booster heater starts operation) c) THW1 - THW2 < -5°C (for 10 minutes continuously)</p>	<ol style="list-style-type: none"> THW1 has become detached from its holder. Booster heater fault THW1 or THW2 fault FTC board failure 	<ol style="list-style-type: none"> Visually inspect location and reattach as necessary. Electrically test to determine fault. See 10-6. for how to check. Check resistance of thermistor against table in section 10-6. Compare FTC detected temperature to hand held detector. Replace board. 																																							



Error code	Title and display conditions	Possible Cause	Diagnosis and action
L9	<p>Low primary circuit (Heat source side) flow rate detected by flow sensor * "4" is displayed in "Request code: 569" in "Running information". <Heating> Error code displayed when flow sensor detects low flow rate for 10 seconds.</p>	<ol style="list-style-type: none"> 1. Reduced flow in primary water circuit Due to 1 or more of the following; Faulty pump, insufficient air purge, blocked strainer, leak in water circuit. 2. Valve operation fault 3. 2-way valve (local supply) actuator fault 4. Connector wire has become detached or loose wiring. 5. Flow sensor 1 fault 6. FTC board failure 	<ol style="list-style-type: none"> 1. Check circulation pump (See 10-6. for how to check). Open air vent to remove trapped air. Check the strainer for blockages. Check the primary water circuit for leaks. Check that the flow amount is within the recommended range during heating operation. Refer to Procedure 5 in "11. DISASSEMBLY PROCEDURE." 2. Check valves on primary water circuit are installed level. 3. Electrically test to determine fault 4. Visually check the CN1A connector and reattach if necessary. 5. Electrically test to determine fault. See 10-6. for how to check. 6. Replace board.
	<p>Low primary circuit (Heat source side) flow rate detected by flow sensor * "5" is displayed in "Request code: 569" in "Running information". <DHM/Heating/LP/LS> Error code displayed when flow sensor detects low flow rate for 10 seconds.</p> <p><u>Exception</u> While hot water is not supplied.</p>	<ol style="list-style-type: none"> 1. Reduced flow in primary water circuit Due to 1 or more of the following; Faulty pump, insufficient air purge, blocked strainer, leak in water circuit. 2. Valve operation fault 3. 2-way valve (local supply) actuator fault 4. Connector wire has become detached or loose wiring. 5. Flow sensor B fault 6. FTC board failure 	<ol style="list-style-type: none"> 1. Check circulation pump (See 10-6. for how to check). Open air vent to remove trapped air. Check the strainer for blockages. Check the primary water circuit for leaks. Check that the flow amount is within the recommended range during heating operation. Refer to Procedure 5 in "11. DISASSEMBLY PROCEDURE." 2. Check valves on primary water circuit are installed level. 3. Electrically test to determine fault 4. Visually check the CN2B connector and reattach if necessary. 5. Electrically test to determine fault. See 10-6. for how to check. 6. Replace board.
LF	<p>Flow sensor failure "" is displayed in "Request code : 575" in "Running information". * ... 1 : Flow sensor 1 2 : Flow sensor A 3 : Flow sensor B</p>		<p>Check flow sensor cable for damage or loose connections.</p>
LP	<p>DHW supply temperature overheat protection <HW/HT/FS/OS> Error code displayed when THW4 detects a temp $\geq 70^{\circ}\text{C}$ for 5 consecutive seconds.</p> <p><u>Exception</u> Error code will not be displayed if; While there is no hot water supply, For 30 seconds after hot water supply start, DHW supply max. temp. is set to more than 61°C, For 24 hours after DHW supply max. temp. is changed from more than 61°C to less than 60°C.</p>	<ol style="list-style-type: none"> 1. Thermal store tank water temperature is high ($\text{THW5A} \geq 70^{\circ}\text{C}$) 2. THW4 fault 3. FTC board failure 	<ol style="list-style-type: none"> 1. Refer to L3/L4. 2. Check resistance of thermistor against table in section 10-6. 3. Replace board.
LU	<p>Water circulation pump failure "" is displayed in "Request code:576" in "Running information". * ... 1: Water circulation pump 1 2: Water circulation pump A <HW/HT/FS/OS> Error code displayed when PWM feedback signal is set to 83~92% for 10 consecutive seconds.</p> <p><u>Exception</u> Water circulation pump is OFF.</p>	<ol style="list-style-type: none"> 1. Power supply voltage increase 2. Connector/terminal wire has become detached or loose wiring 3. Water circulation pump is locked 4. Water circulation pump reaching the end of life 5. Water circulation pump fault 6. FTC board failure 	<ol style="list-style-type: none"> 1. Check the supply voltage. 2. Visually check the terminals and connectors and reattaches appropriate. 3. to 5. Turn the power to the indoor unit OFF and then ON. Power to both the indoor unit and outdoor unit should be switched OFF then ON. If the LU code is still displayed the water circulation pump should be replaced. 6. Replace board.



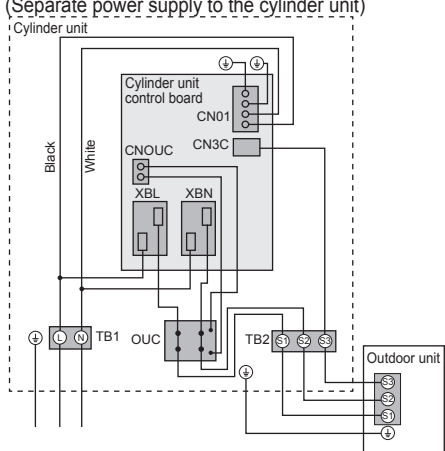
Error code	Title and display conditions	Possible Cause	Diagnosis and action
P1	Indoor unit temperature thermistor (TH1) failure	Refer to error codes (P1/L5).	
P2	Indoor unit temperature thermistor (TH2) failure	Refer to error codes (P1/L5).	
E0/E4	<p>Main remote controller communication failure (Reception error)</p> <p>Error code E0 is displayed if main remote controller does not receive any signal from the indoor unit for ref. address "0" for 3 minutes.</p> <p>Error code E4 is displayed if indoor unit does not receive any data from the main remote controller for 3 mins or indoor unit does not receive any signal from the main remote controller for 2 minutes.</p>	<ol style="list-style-type: none"> Contact failure with transmission cable Wiring procedure not observed. (Cable length/cable diameter/number of indoor units/number of main remote controllers) Fault on the indoor unit FTC board section controlling Ref. address "0" Fault with the main remote controller circuit board Electrical noise causes interference with transmission/reception of data for main remote controller. 	<ol style="list-style-type: none"> Check that main remote controller cable is not extended. Check main remote controller and FTC common wiring max cable length 500 m. Only use 2 core cable. Only connect 1 main remote controller to 1 FTC indoor unit board. to 5. <p>If the problem is not solved by the above measures then: Turn the power to the indoor unit OFF and then ON. Power to both the indoor unit and outdoor unit should be switched OFF then ON.</p> <p>If the E0/E4 code is still displayed the FTC and/ or the main remote controller circuit board should be replaced.</p>
E3/E5	<p>Main remote controller communication failure (Transmission error)</p> <p>Error code E3 is displayed if the main remote controller can not find an empty transmission path and thus fails to transmit for 6 secs or the data received by the main remote controller is different to what was sent (by the main remote controller) 30 consecutive times.</p> <p>Error code E5 is displayed if the FTC can not find an empty transmission path for 3 minutes and thus cannot transmit or the data sent by the FTC is different to what was expected 30 consecutive times.</p>	<ol style="list-style-type: none"> 2 or more main remote controllers have been connected to the FTC. Fault with main remote controller transmission/receiving circuit board Fault with the main remote controller circuit board Electrical noise causes interference with transmission/reception of data for main remote controller. 	<ol style="list-style-type: none"> Only connect 1 main remote controller to 1 FTC indoor unit board. to 4. <p>Turn the power to the indoor unit OFF and then ON. Power to both the indoor unit and outdoor unit should be switched OFF then ON.</p> <p>If the E3/E5 code is still displayed the FTC and/or the main remote controller circuit board should be replaced.</p>
E6	<p>Indoor/outdoor communication failure (Reception error)</p> <p>Error code E6 is displayed if after the power is switched ON to the indoor unit, the FTC board does not receive any signal or the signal received is not complete for 5 seconds, or after a period of operation the FTC board does not receive any signal or the signal received is not complete for 3 minutes.</p>	<ol style="list-style-type: none"> Contact failure/short circuit/miswiring Fault with outdoor unit transmission/receiving circuit board Fault with FTC transmission/receiving circuit board Electrical noise causes interference with FTC-Outdoor unit transmission cable. 	<p>* Check the LED display on the outdoor unit circuit board. Refer to the outdoor unit service manual.</p> <ol style="list-style-type: none"> Check the connections on the indoor and outdoor unit have not become loose and that the connecting cable is not damaged. Check that there is not false wiring. to 4. <p>Turn the power to the indoor unit OFF and then ON. Power to both the indoor unit and outdoor units should be switched OFF then ON.</p> <p>If the E6 code is still displayed the FTC and/ or the outdoor unit circuit board should be replaced.</p>
E7	<p>Indoor/outdoor communication failure (Transmission error)</p> <p>Error code E7 is displayed if despite the FTC board sending signal "0", signal "1" is received 30 consecutive times.</p>	<ol style="list-style-type: none"> Fault with FTC transmission/receiving circuit board Electrical noise causes interference with power supply. Electrical noise causes interference with FTC-outdoor unit transmission cable. 	<ol style="list-style-type: none"> to 3. <p>Turn the power to the indoor unit OFF and then ON. Power to both the indoor unit and outdoor unit should be switched OFF then ON.</p> <p>If the E7 code is still displayed the FTC circuit board should be replaced.</p>
E1/E2	<p>Main remote controller control board failure</p> <p>Error code E1 displayed if main remote controller can not access it is non volatile (non power dependent) memory.</p> <p>Error code E2 is displayed when there is a fault with the main remote controller's internal clock.</p>	<ol style="list-style-type: none"> Fault with the main remote controller circuit board 	<ol style="list-style-type: none"> Replace main remote controller circuit board.



Error code	Title and display conditions	Possible Cause	Diagnosis and action
J0	<p>Indoor unit/wireless receiver communication failure Error code J0 is displayed when the FTC can not receive data from the wireless receiver for 1 minute.</p>	<ol style="list-style-type: none"> 1. Connection fault with wireless receiver-FTC connection 2. Fault with FTC receiving circuit board 3. Fault with wireless receiver's transmission circuit board 4. Electrical noise causes interference with wireless receiver communication cable. 	<ol style="list-style-type: none"> 1. Check the connections to the wireless receiver and FTC have not become loose and that the connecting cable is not damaged. 2. to 4. Turn the power to the indoor unit OFF and then ON. Power to both the indoor unit and outdoor unit should be switched OFF then ON. If the J0 code is still displayed the FTC and/or the wireless receiver circuit board should be replaced.
J1 to J8	<p>Wireless remote controller/wireless receiver communication failure (Reception error) Error code displayed if wireless receiver receives no/incomplete data from the wireless remote controller for 15 consecutive minutes.</p> <p>The digit after the J refers to the address of the wireless remote controller that has the error. E.g. Error code "J3" refers to a communication fault between the wireless receiver and wireless remote control with address 3.</p>	<ol style="list-style-type: none"> 1. Battery on wireless remote controller maybe flat 2. The wireless remote controller is out of range of the wireless receiver. 3. Fault with wireless remote controller transmission circuit board 4. Fault with wireless receiver's reception circuit board 	<ol style="list-style-type: none"> 1 Check and replace the battery if necessary the wireless remote controller battery. 2. to 4. Reposition the wireless remote controller closer to the receiver and perform a communication test. For procedure refer to wireless remote controller installation manual. If "OK" is displayed then the cause of the J1 to J8 error was the controller was out of range of the receiver. The wireless remote controller should be installed within range of the receiver. If "Err" is displayed replace wireless remote controller with a new controller and perform the pairing procedure. If after this procedure the "Err" code is still displayed the fault is with the receiver unit (attached to the indoor unit). The receiver unit should be replaced with a new part and the original remote controller can be reconnected. If "OK" is displayed then the fault is with the remote controller and this should be replaced.

Note: To cancel error codes please switch system off (press button F4 (RESET) on main remote controller).

10-5. Troubleshooting by inferior phenomena

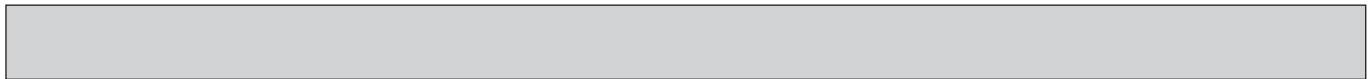
No.	Fault symptom	Possible cause	Explanation - Solution
1	Main remote controller display is blank.	<ol style="list-style-type: none"> There is no power supply to main remote controller. Power is supplied to main remote controller, however, the display on the main remote controller does not appear. 	<ol style="list-style-type: none"> Check LED2 on FTC. (See 6. WIRING DIAGRAM.) <ol style="list-style-type: none"> When LED2 is lit. Check for damage or contact failure of the main remote controller wiring. When LED2 is blinking. Refer to No. 5 below. When LED2 is not lit. Refer to No. 4 below. Check the following: <ul style="list-style-type: none"> Disconnection between the main remote controller cable and the FTC control board Failure of the main remote controller if "Please Wait" is not displayed. Refer to No. 2 below if "Please Wait" is displayed.
2	"Please Wait" remains displayed on the main remote controller.	<ol style="list-style-type: none"> "Please Wait" is displayed for up to 6 minutes. Communication failure between the main remote controller and FTC. Communication failure between FTC and outdoor unit. 	<ol style="list-style-type: none"> Normal operation 3. Main remote controller start up checks/procedure. <ol style="list-style-type: none"> If "0%" or "50-99%" is displayed below "Please Wait" there is a communication error between the main remote controller and the FTC control board. <ul style="list-style-type: none"> Check wiring connections on the main remote controller. Replace the main remote controller or the FTC control board. If "1-49%" is displayed there is a communication error between the outdoor unit's and FTC's control boards. <ul style="list-style-type: none"> Check the wiring connections on the outdoor unit control board and the FTC control board. (Ensure S3 is securely wired with no damage. (See 7. FIELD WIRING.)) Replace the outdoor unit's and/or the FTC's control boards.
3	The main screen appears with a press of the "ON" button, but disappears in a second.	The main remote controller operations do not work for a while after the settings are changed in the service menu. This is because the system takes time to apply the changes.	<p>Normal operation</p> <p>The cylinder unit is applying updated settings made in the service menu. Normal operation will start shortly.</p>
4	LED2 on FTC is off. (See 6. WIRING DIAGRAM.)	<p>When LED1 on FTC is also off. (See 6. WIRING DIAGRAM.)</p> <ol style="list-style-type: none"> FTC is not supplied with 220 to 240V AC. There are problems in the method of connecting the connectors. FTC failure. 	<ol style="list-style-type: none"> Check the voltage across the L and N terminals on the indoor power supply terminal block 1. (See 7. FIELD WIRING.) <ul style="list-style-type: none"> When the voltage is not 220 to 240V AC, check for faulty wiring to power supply. When the voltage is 220 to 240V AC, go to 2. below. Check for faulty wiring between the connectors. <ul style="list-style-type: none"> When the connectors are wired incorrectly re-wire them correctly referring to below. (See 7. FIELD WIRING and a wiring diagram on the control and electrical box cover.) <p>Modified settings (Separate power supply to the cylinder unit)</p>  <ol style="list-style-type: none"> If there is no problem with the wiring, go to 3. below. 3. Check the FTC control board. <ul style="list-style-type: none"> Check the fuse on FTC control board. Check for faulty wiring. If there is no problem with the wiring, the FTC control board is faulty



No.	Fault symptom	Possible cause	Explanation - Solution
5	LED2 on FTC is blinking. (See 6. WIRING DIAGRAM)	<p>When LED1 is also blinking on FTC . Faulty wiring between FTC and outdoor unit</p> <p>When LED1 on FTC is lit.</p> <ol style="list-style-type: none"> 1. Faulty wiring in main remote controller Multiple indoor units have been wired to a single outdoor unit. 2. Short-circuited wiring in main remote controller 3. Main remote controller failure 	<p>Check for faulty wiring between FTC and outdoor unit.</p> <ol style="list-style-type: none"> 1. Check for faulty wiring in main remote controller. The number of indoor units that can be wired to a single outdoor unit is one. Additional indoor units must be wired individually to a single outdoor unit. 2,3. Remove main remote controller wires and check LED2 on FTC. (See 6. WIRING DIAGRAM.) <ul style="list-style-type: none"> • If LED2 is blinking check for short circuits in the main remote controller wiring. • If LED2 is lit, wire the main remote controller again and: <ul style="list-style-type: none"> - if LED2 is blinking, the main remote controller is faulty; - if LED2 is lit, faulty wiring of the main remote controller has been corrected.
6	LED4 on FTC is off. (See 6. WIRING DIAGRAM)	<ol style="list-style-type: none"> 1. SD memory card is NOT inserted into the memory card slot with correct orientation. 2. Not an SD standards compliant memory card. 	<ol style="list-style-type: none"> 1. Correctly insert SD memory card in place until a click is heard. 2. Use an SD standards compliant memory card. (Refer to installation manual, "5.6 Using SD memory card".)
	LED4 on FTC is blinking. (See 6. WIRING DIAGRAM)	<ol style="list-style-type: none"> 1. Full of data. 2. Write-protected. 3. NOT formatted. 4. Formatted in NTFS file system. 	<ol style="list-style-type: none"> 1. Move or delete data, or replace SD memory card with a new one. 2. Release the write-protect switch. 3. Refer to installation manual, "5.6 Using SD memory card". 4. FTC is Not compatible with NTFS file system. Use an SD memory card formatted in FAT file system.
7	No water at hot tap.	<ol style="list-style-type: none"> 1. Cold main off 2. Strainer (local supply) blocked. 	<ol style="list-style-type: none"> 1. Check and open stop cock. 2. Isolate water supply and clean strainer.
8	Cold water at tap.	<ol style="list-style-type: none"> 1. Hot water run out. 2. Prohibit, schedule timer or holiday mode selected. 3. Heat pump not working. 4. Booster heater cut-out tripped. 5. The earth leakage circuit breaker for booster heater breaker (ECB1) tripped. 6. The booster heater thermal cut-out has tripped and cannot be reset using the manual reset button. 7. 3-way valve fault 8. Air inclusion in pump A 9. System or power OFF 10. Flow sensor fault 11. Supply flow rate is low 	<ol style="list-style-type: none"> 1. Ensure DHW mode is operating and wait for thermal store tank to re-heat. 2. Check settings and change as appropriate. 3. Check heat pump – consult outdoor unit service manual. 4. Check booster heater thermostat and press reset button if safe. Reset button is located on the side of booster heater, covered with black rubber cap. See 4. PART NAMES AND FUNCTIONS to find out its position. 5. Check the cause and reset if safe. 6. Check resistance across the thermal cut-out, if open then the connection is broken and the booster heater will have to be replaced. Contact your Mitsubishi Electric dealer. 7. Check plumbing/wiring to 3-way valve. <ul style="list-style-type: none"> (i) Manually override 3-way valve using the main remote controller. (Refer to <Manual operation> in section 9-4.) If the valve does not still function, go to (ii) below. (ii) Replace 3-way valve coil. If the valve does not still function, go to (iii) below. (iii) Replace 3-way valve. (Refer to 11. DISASSEMBLY PROCEDURE.) 8. Open the air vent above pump A (refer to page 25). 9. Turn on the power / system. 10. If "0" is displayed in "Request code : 541" in "Running information" replace flow sensor A. 11. Increase the supply amount.
9	Water heating takes longer.	<ol style="list-style-type: none"> 1. Heat pump not working. 2. Booster heater cut-out tripped. 3. Booster heater breaker (ECB1) tripped. 4. The booster heater thermal cut-out has tripped and cannot be reset using the manual reset button. 5. Flow rate of the primary circuit may be reduced. 6. 3-way valve failure 	<ol style="list-style-type: none"> 1. Check heat pump – consult outdoor unit service manual. 2. Check booster heater thermostat and press reset button if safe. Reset button is located on the side of booster heater, covered with black rubber cap. See 4. PART NAMES AND FUNCTIONS to find out its position. 3. Check the cause and reset if safe. 4. Check resistance across the thermal cut-out, if open then connection is broken and the booster heater will have to be replaced. Contact your Mitsubishi Electric dealer. 5. Check the following items <ul style="list-style-type: none"> • Check for trapped air in water pump 1 (primary circuit). • Check water pump (primary circuit) for malfunction. (Refer to section 10-6.) • Check the pipe for blockage. 6. Check plumbing/wiring to 3-way valve. <ul style="list-style-type: none"> (i) Manually override 3-way valve using the main remote controller. (Refer to <Manual operation> in section 9-4.) If the valve does not still function, go to (ii) below. (ii) Replace 3-way valve motor. If the valve does not still function, go to (iii) below. (iii) Replace 3-way valve. (Refer to 11. DISASSEMBLY PROCEDURE.)



No.	Fault symptom	Possible cause	Explanation - Solution
10	Temperature of DHW tank water dropped.	<p>When DHW operation is not running, the DHW tank emits heat and the water temperature decreases to a certain level. If water in the DHW tank is reheated frequently because of a significant drop in water temperature, check for the following.</p> <ol style="list-style-type: none"> 1. Insulation material coming loose or off. 2. 3-way valve failure 	<ol style="list-style-type: none"> 1. Fix insulation. 2. Check plumbing/wiring to 3-way valve. <ol style="list-style-type: none"> (i) Manually override 3-way valve using the main remote controller. (Refer to <Manual operation> in section 9-4.) If the valve does not still function, go to (ii) below. (ii) Replace 3-way valve motor. If the valve does not still function, go to (iii) below. (iii) Replace 3-way valve. (Refer to 11. DISASSEMBLY PROCEDURE.)
11	Hot or warm water from cold tap.	Heat of hot water pipe is transferred to cold water pipe.	Insulate/re-route pipework.
12	Water leakage	<ol style="list-style-type: none"> 1. Poorly sealed connections of water circuit components 2. Water circuit components reaching the end of life 	<ol style="list-style-type: none"> 1. Tighten connections as required. 2. Refer to PARTS CATALOG for expected part lifetimes and replace them as necessary.
13	Heating system does not reach the set temperature.	<ol style="list-style-type: none"> 1. Prohibit, schedule timer or holiday mode selected. 2. The temperature sensor is located in a room that has a different temperature relative to that of the rest of the house. 3. Heat pump not working. 4. Booster heater cut-out tripped. 5. Booster heater breaker (ECB1) tripped. 6. The booster heater thermal cut-out tripped and can not be reset using the manual reset button. 7. Incorrectly sized heat emitter. 8. 3-way valve failure 9. Battery problem (*wireless control only) 	<ol style="list-style-type: none"> 1. Check settings and change as appropriate. 2. Relocate the temperature sensor to a more suitable room. 3. Check heat pump – consult outdoor unit service manual. 4. Check booster heater thermostat and press reset button if safe. Reset button is located on the side of booster heater, covered with black rubber cap. (See 4. PART NAMES AND FUNCTIONS for position.) 5. Check the cause of the trip and reset if safe. 6. Check resistance across the thermal cut-out, if open then the connection is broken and the booster heater will have to be replaced. Contact your Mitsubishi Electric dealer. 7. Check the heat emitter surface area is adequate. Increase size if necessary. 8. Check plumbing/wiring to 3-way valve. <ol style="list-style-type: none"> (i) Manually override 3-way valve using the main remote controller. (Refer to <Manual operation> in 9-4). If the 3-way valve does not function, go to (ii) below. (ii) Replace 3-way valve motor. If the 3-way valve coil is replaced but the 3-way valve does not function go to (iii) below. (iii) Replace 3-way valve. (Refer to 11. DISASSEMBLY PROCEDURE.) 9. Check the battery power and replace if flat.
14	In 2-zone valve ON/OFF control, only Zone2 does not reach the set temperature.	<ol style="list-style-type: none"> 1. When Zone1 and Zone2 are both in heating mode, the hot water temperature in Zone2 does not exceed that in Zone1. 2. Faulty wiring of 2-way valve 3. Faulty installation of 2-way valve 4. Incorrect setting of Running time 5. 2-way valve failure 	<ol style="list-style-type: none"> 1. Normal action no action necessary. 2. Refer to installation manual, "5.3 2-zone valve ON/OFF control". 3. Check for correct installation. (Refer to the manual included with each motorized mixing valve.) 4. Check for correct setting of Running time. 5. Inspect 2-way valve. (Refer to the manual included with each 2-way valve.)



No.	Fault symptom	Possible cause	Explanation - Solution
15	After DHW operation room temperature rises slightly.	At the end of the DHW mode operation the 3-way valve diverts hot water away from the DHW circuit into space heating circuit. This is done to prevent the cylinder unit components from overheating. The amount of hot water directed into the space heating circuit varies according to the type of the system and of the pipe run between the plate heat exchanger and the cylinder unit.	Normal operation no action necessary.
16	The room temperature rises during DHW operation.	3-way valve failure	Check the 3-way valve. (i) Manually override 3-way valve using the main remote controller. (Refer to <Manual operation> in 9-4). If the 3-way valve does not function, go to (ii) below. (ii) Replace 3-way valve coil. If the 3-way valve coil is replaced but the 3-way valve does not function go to (iii) below. (iii) Replace 3-way valve. (Refer to 11. DISASSEMBLY PROCEDURE.)
17	Water discharges from pressure relief valve. (Primary circuit)	<ol style="list-style-type: none"> If continual – pressure relief valve could bite foreign objects and the valve seat may be damaged. If intermittent – expansion vessel charge may have reduced/bladder perished. Heating circuit is closed and pump is running. 	<ol style="list-style-type: none"> Turn the handle on the pressure relief valve several turns. If leakage persists, replace the pressure relief valve with a new one. Check pressure in expansion vessel. Recharge to 1 bar if necessary. If bladder perished replace expansion vessel with a new one. Open the heating circuit.
18	Noisy water circulation pump	Air in water circulation pump.	Use manual and automatic air vents to remove air from system. Top up water if necessary to achieve 1 bar on primary circuit.
19	Noise during hot water draw off typically worse in the morning.	<ol style="list-style-type: none"> Loose airing cupboard pipework. Air in water circulation pump A. 	<ol style="list-style-type: none"> Install extra pipe fastening clips. Use manual and automatic air vents to remove air from system. Top up water if necessary to achieve 1 bar on primary circuit.
20	Mechanical noise heard coming from the cylinder unit.	<ol style="list-style-type: none"> Heaters switching on/off. 3-way valve changing position between DHW and heating mode. 	Normal operation no action necessary.
21	Water circulation pump runs for a short time unexpectedly.	Water circulation pump jam prevention mechanism (routine) to inhibit the build-up of scale.	Normal operation no action necessary.
22	Milky/Cloudy water (Sanitary circuit)	Oxygenated water	Water from any pressurised system will release oxygen bubbles when water is running. The bubbles will settle out.
23	Heating mode has been on standby for a long time (does not start operation smoothly.)	The time of "Delay" set in "Economy settings for pump" is too short. (Go to "Service menu" → "Auxiliary settings" → "Economy settings for pump").	Increase the time of "Delay" in "Economy settings for pump".
24	The cylinder unit that was running in the heating mode before power failure is running in the DHW mode after power recovery.	The cylinder unit is designed to run in an operation mode with a higher priority (i.e. DHW mode in this case) at power recovery.	<ul style="list-style-type: none"> Normal operation. After the DHW max. operation time has elapsed or the DHW supply max. temperature has been reached, the DHW mode switches to the other mode (e.g. Heating mode).



No.	Fault symptom	Possible cause	Explanation - Solution																
25	<p>The energy monitor value seems not correct.</p> <p>Note: There could be some discrepancies between the actual and the calculated values. If you seek for accuracy, please make sure to connect power meter(s) and heat meter to FTC board. Both should be locally supplied.</p>	<p>1. Incorrect setting of the energy monitor</p> <p>2. Non-connectable type of external meter (local supply) is connected.</p> <p>3. External meter (local supply) failure</p> <p>4. FTC board failure</p>	<p>1. Check the setting by following the procedure below. (1) Check if the DIP switch is set as the table below.</p> <table border="1"> <tr> <td colspan="2">Consumed electric energy</td> <td colspan="2">Delivered heat energy</td> </tr> <tr> <td>SW3-4</td> <td>Electric energy meter (Local supply)</td> <td>SW3-8</td> <td>Heat meter (Local supply)</td> </tr> <tr> <td>OFF</td> <td>Without</td> <td>OFF</td> <td>Without</td> </tr> <tr> <td>ON</td> <td>With</td> <td>ON</td> <td>With</td> </tr> </table> <p>(2) In the case external electric energy meter and/or heat meter is not used, check if the setting for electric heater and water pump 1 input is correct by referring to <Energy monitor setting> in section 9-4.</p> <p>(3) In the case external electric energy meter and/or heat meter is used, check if the unit of output pulse on external meter matches with the one set at the main remote controller by referring to <Energy monitor setting> in section 9-4.</p> <p>2. Check if the external meter (local supply) is connectable type by referring to <Energy monitor setting>" in section 9-4.</p> <p>3. Check if signal is sent to IN8 to IN10 properly. (Refer to section 6. WIRING DIAGRAM) Replace the external heat meter if defective.</p> <p>4. Check the FTC control board. • Check for faulty wiring. • If no problem found with the wiring, the FTC control board is faulty. Replace the board.</p>	Consumed electric energy		Delivered heat energy		SW3-4	Electric energy meter (Local supply)	SW3-8	Heat meter (Local supply)	OFF	Without	OFF	Without	ON	With	ON	With
Consumed electric energy		Delivered heat energy																	
SW3-4	Electric energy meter (Local supply)	SW3-8	Heat meter (Local supply)																
OFF	Without	OFF	Without																
ON	With	ON	With																

Annual Maintenance

It is essential that the cylinder unit is serviced at least once a year by a qualified individual. Any spare parts required should be purchased from Mitsubishi Electric. NEVER bypass safety devices or operate the unit without them being fully operational.

<Annual maintenance points>

Use the Annual Maintenance Log Book as a guide to carrying out the necessary checks on the cylinder unit and outdoor unit.

10-6. Checking component parts' function

Part Name	Check Points				
<p>Water circulation pump (primary circuit , pump1 · A)</p>	<p><Water circulation pump (primary circuit) characteristics></p> <p style="text-align: center;">Pump speed</p>				
<p><Recommended water flow rate range></p> <table border="1" data-bbox="165 797 636 851"> <thead> <tr> <th>Outdoor unit</th> <th>Water flow rate range [L/min]</th> </tr> </thead> <tbody> <tr> <td>QUHZ-W40VA</td> <td>3.0 - 8.0</td> </tr> </tbody> </table>	Outdoor unit	Water flow rate range [L/min]	QUHZ-W40VA	3.0 - 8.0	
Outdoor unit	Water flow rate range [L/min]				
QUHZ-W40VA	3.0 - 8.0				

Part Name

Flow sensor (1,A,B)

part name	symbol
Flow sensor 1	CN1A
Flow sensor A	CN2A
Flow sensor B	CN2B

Check Points

Flow sensor 1 , B

Flow sensor A

Booster heater

Thermostat (90 °C) and thermal cut out (121 °C)

2kW heater (230V, 1 phase)

Measure the resistance between the terminals with a tester.

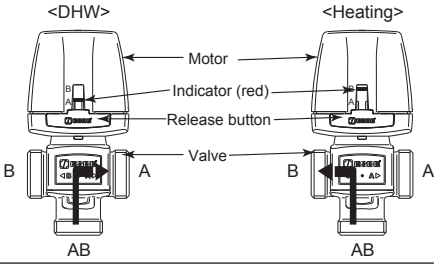
Terminal	Normal	Abnormal
9-10	80(±20)mΩ	Open or Short

Terminal	Normal	Abnormal
1-2	26.5(+3/-1.3)Ω	Open or Short

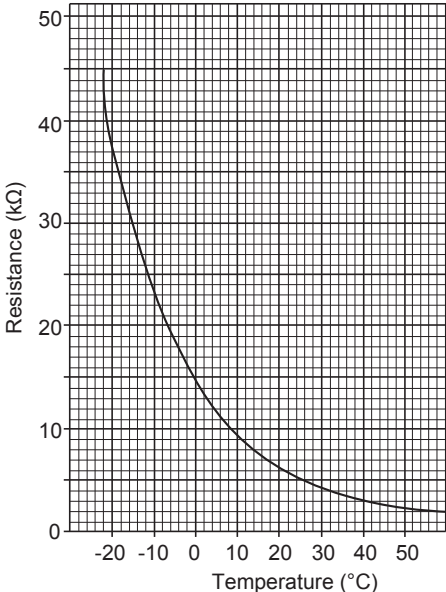
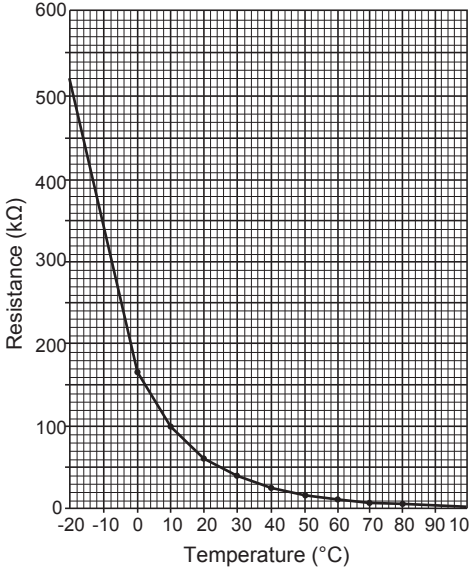
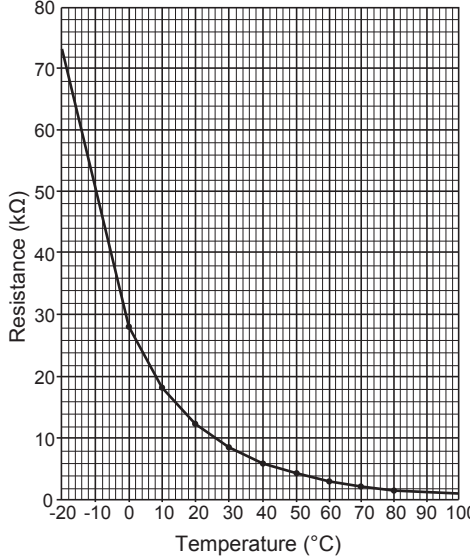
Earth leakage circuit breaker for heater

If a short circuit occurs on the booster heater, or each power line, a short-circuit breaker will trip and power source will be blocked. Eliminate the causes of short circuit and then turn on the breaker again.

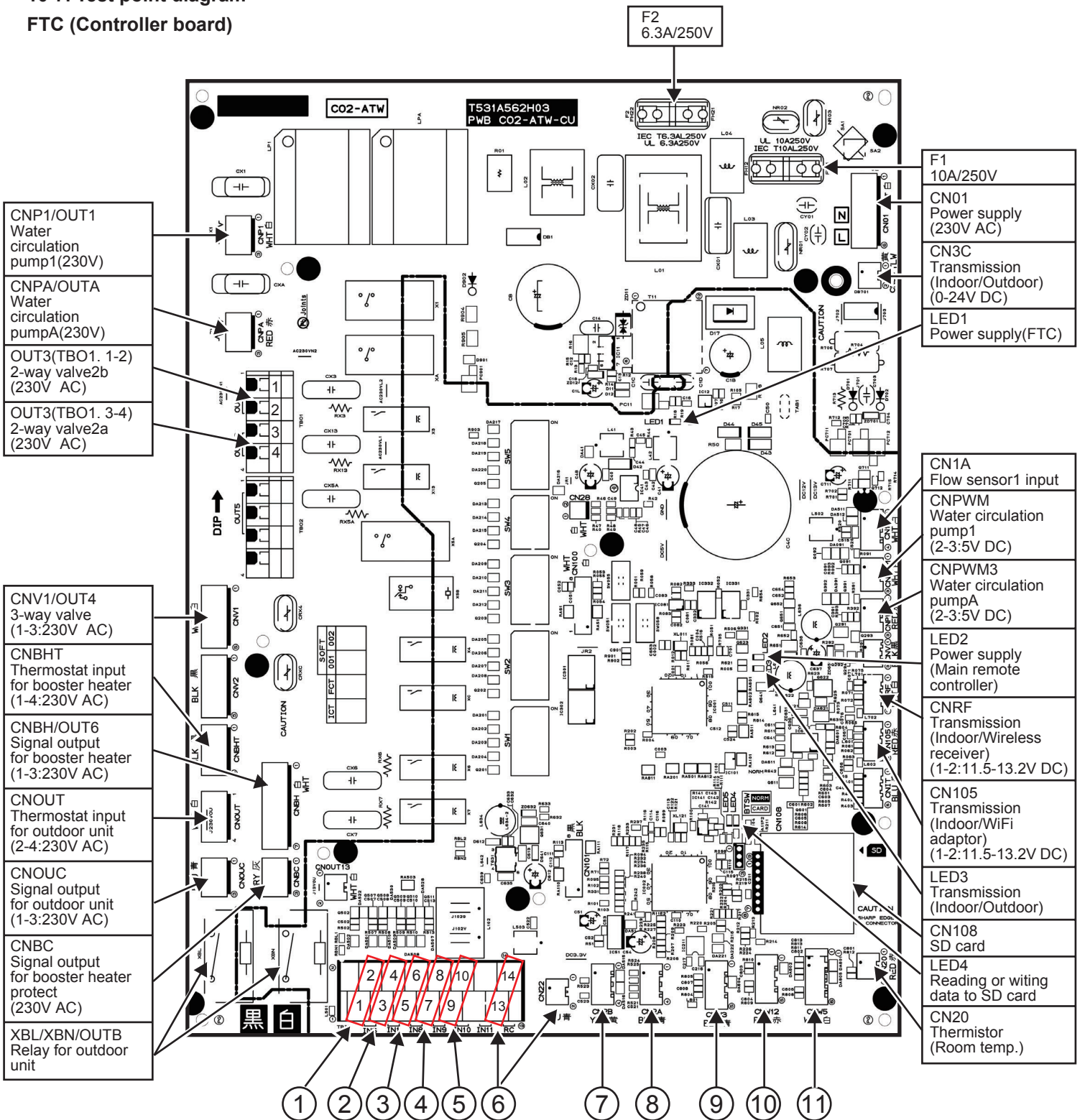


Part Name	Check Points												
<p>3-way valve</p> 	<p>(1) Check the movement of the red indicator. The red indicator normally points to A in DHW mode and to B in Heating mode as shown to the left.</p> <p>(2) If each indicator position is correct but the 3-way valve does not work properly, the motor may not fit onto the valve securely, so remove the motor by pressing the release button, and reinstall it.</p>												
<p>Thermistors</p>	<p>Disconnect the connector then measure the resistance with a tester. (At ambient temperatures of 10 - 30°C.)</p> <table border="1" data-bbox="879 611 1302 815"> <thead> <tr> <th>Thermistor</th> <th>Normal</th> <th>Abnormal</th> </tr> </thead> <tbody> <tr> <td>TH1</td> <td>4.3 - 9.5 kΩ</td> <td>Open or short</td> </tr> <tr> <td>THW1 THW2 THW3 THW4</td> <td>98.3 - 39.5 kΩ</td> <td>Open or short</td> </tr> <tr> <td>THW5A THW5B</td> <td>18.1 - 8.5 kΩ</td> <td>Open or short</td> </tr> </tbody> </table>	Thermistor	Normal	Abnormal	TH1	4.3 - 9.5 kΩ	Open or short	THW1 THW2 THW3 THW4	98.3 - 39.5 kΩ	Open or short	THW5A THW5B	18.1 - 8.5 kΩ	Open or short
Thermistor	Normal	Abnormal											
TH1	4.3 - 9.5 kΩ	Open or short											
THW1 THW2 THW3 THW4	98.3 - 39.5 kΩ	Open or short											
THW5A THW5B	18.1 - 8.5 kΩ	Open or short											

<Thermistor Characteristics Charts>

<p>• Room temperature thermistor (TH1)</p> <p>Thermistor R0 = 15kΩ ± 3% B constant = 3480 ± 2%</p> $R_t = 15 \exp \left\{ 3480 \left(\frac{1}{273+t} - \frac{1}{273} \right) \right\}$ <table border="1"> <tr><td>0°C</td><td>15kΩ</td></tr> <tr><td>10°C</td><td>9.6kΩ</td></tr> <tr><td>20°C</td><td>6.3kΩ</td></tr> <tr><td>25°C</td><td>5.2kΩ</td></tr> <tr><td>30°C</td><td>4.3kΩ</td></tr> <tr><td>40°C</td><td>3.0kΩ</td></tr> </table> 	0°C	15kΩ	10°C	9.6kΩ	20°C	6.3kΩ	25°C	5.2kΩ	30°C	4.3kΩ	40°C	3.0kΩ	<p>• Flow water temperature thermistor (THW1) • Return water temperature thermistor (THW2) • Flow water temperature thermistor2 (to tank)(THW3) • DHW supply temperature thermistor (THW4)</p> <p>Thermistor R0 = 17.6kΩ ± 3% B constant = 3970 ± 2%</p> $R_t = 17.6 \exp \left\{ 3970 \left(\frac{1}{273+t} - \frac{1}{323} \right) \right\}$ <table border="1"> <tr><td>0°C</td><td>166.8kΩ</td></tr> <tr><td>10°C</td><td>99.8kΩ</td></tr> <tr><td>20°C</td><td>61.9kΩ</td></tr> <tr><td>30°C</td><td>39.6kΩ</td></tr> <tr><td>40°C</td><td>26.1kΩ</td></tr> <tr><td>50°C</td><td>17.6kΩ</td></tr> <tr><td>60°C</td><td>12.2kΩ</td></tr> <tr><td>70°C</td><td>8.6kΩ</td></tr> <tr><td>80°C</td><td>6.2kΩ</td></tr> </table> 	0°C	166.8kΩ	10°C	99.8kΩ	20°C	61.9kΩ	30°C	39.6kΩ	40°C	26.1kΩ	50°C	17.6kΩ	60°C	12.2kΩ	70°C	8.6kΩ	80°C	6.2kΩ	<p>• Stored water temperature thermistor (upper) (THW5A) • Stored water temperature thermistor (lower) (THW5B)</p> <p>Thermistor R0 = 5.1kΩ ± 2% B constant = 3300 ± 2%</p> $R_t = 5.1 \exp \left\{ 3300 \left(\frac{1}{273+t} - \frac{1}{318} \right) \right\}$ <table border="1"> <tr><td>0°C</td><td>28.2kΩ</td></tr> <tr><td>10°C</td><td>18.4kΩ</td></tr> <tr><td>20°C</td><td>12.4kΩ</td></tr> <tr><td>30°C</td><td>8.5kΩ</td></tr> <tr><td>40°C</td><td>6.0kΩ</td></tr> <tr><td>50°C</td><td>4.4kΩ</td></tr> <tr><td>60°C</td><td>3.2kΩ</td></tr> <tr><td>70°C</td><td>2.4kΩ</td></tr> <tr><td>80°C</td><td>1.8kΩ</td></tr> </table> 	0°C	28.2kΩ	10°C	18.4kΩ	20°C	12.4kΩ	30°C	8.5kΩ	40°C	6.0kΩ	50°C	4.4kΩ	60°C	3.2kΩ	70°C	2.4kΩ	80°C	1.8kΩ
0°C	15kΩ																																																	
10°C	9.6kΩ																																																	
20°C	6.3kΩ																																																	
25°C	5.2kΩ																																																	
30°C	4.3kΩ																																																	
40°C	3.0kΩ																																																	
0°C	166.8kΩ																																																	
10°C	99.8kΩ																																																	
20°C	61.9kΩ																																																	
30°C	39.6kΩ																																																	
40°C	26.1kΩ																																																	
50°C	17.6kΩ																																																	
60°C	12.2kΩ																																																	
70°C	8.6kΩ																																																	
80°C	6.2kΩ																																																	
0°C	28.2kΩ																																																	
10°C	18.4kΩ																																																	
20°C	12.4kΩ																																																	
30°C	8.5kΩ																																																	
40°C	6.0kΩ																																																	
50°C	4.4kΩ																																																	
60°C	3.2kΩ																																																	
70°C	2.4kΩ																																																	
80°C	1.8kΩ																																																	

**10-7. Test point diagram
FTC (Controller board)**



① IN6 (TBI.1 1-2) Room thermostat 2 input	② IN1 (TBI.1 3-4) Room thermostat 1 input	③ IN8 (TBI.1 5-6) Electric energy meter 1	④ IN9 (TBI.1 7-8) Electric energy meter 2	⑤ IN10 (TBI.1 9-10) Heat meter	⑥ CN22/RC (TBI.1 13-14) Main remote controller (10.4-13.7V DC)
⑦ CN2B Flow sensorB input	⑧ CN2A Flow sensorA input	⑨ CNW3 Thermistor (1-3:Flow water (to tank) temp.) (4-5:DHV supply temp.)	⑩ CNW12 Thermistor (1-2:Flow water temp.) (3-4:Return water temp.)	⑪ CNW5 Thermistor (2-3:Stored water (upper) temp.) (4-5:Stored water (lower)temp.)	

DISASSEMBLY PROCEDURE

1. How to remove the front panel

< Front Panel >

(1) Remove the 5 screws of the front panel. (Figure 1)

(2) Pull out the bottom of the front panel.

< CAUTION >

During regular use, the cylinder unit is connected to the main controller by a lead wire. So, the lead wire might be disconnected or broken if the front panel is removed with great force.

2. How to remove the main controller

< Main controller >

(1) Looking at the rear of the front panel, press the resin notched section of the main controller holder, remove the claws (total 6) from the front panel, and remove the main controller holder. (Photo 2-1 and 2-2)

(2) Slide the main controller support upwards, and remove the support together with the main controller from the front panel.

< CAUTION >

Take care to prevent the main controller lead wire from being cut since it passes through the cutout on the main controller support.

PHOTOS

Figure 1

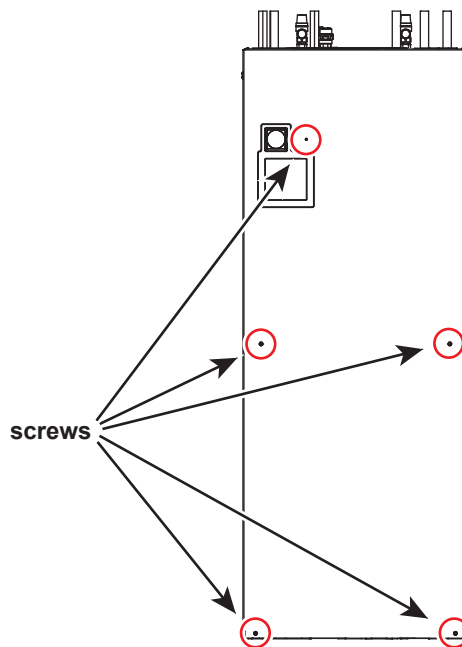
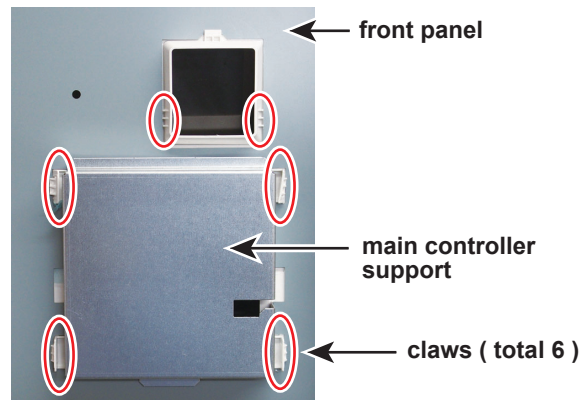
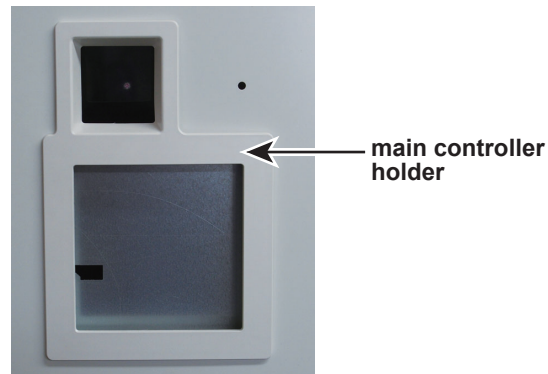


Photo 2-1



The backside of the front panel

Photo 2-2



DISASSEMBLY PROCEDURE

3. How to remove the controller board

< Controller board >

(1) Disconnect all lead wires connected to the controller board in the controller box.

(2) Remove the resin parts (total 12) connected to the controller box from the controller board, and remove the controller board.

< CAUTION(1) >

Before removing the controller board, discharge static electricity. Also, pay attention to electric shock.

< CAUTION(2) >

Lead wires are color-coded by cable straps at board connections. When installing the board, check the color of the cable straps to ensure that lead wires are connected correctly.

4. How to remove the electrical parts

< Electrical parts >

(1) Disconnect all lead wires connected to electrical parts.

(2) Remove all screws that connect lead wires to the mount cont, and then remove electric parts.

< CAUTION(1) >

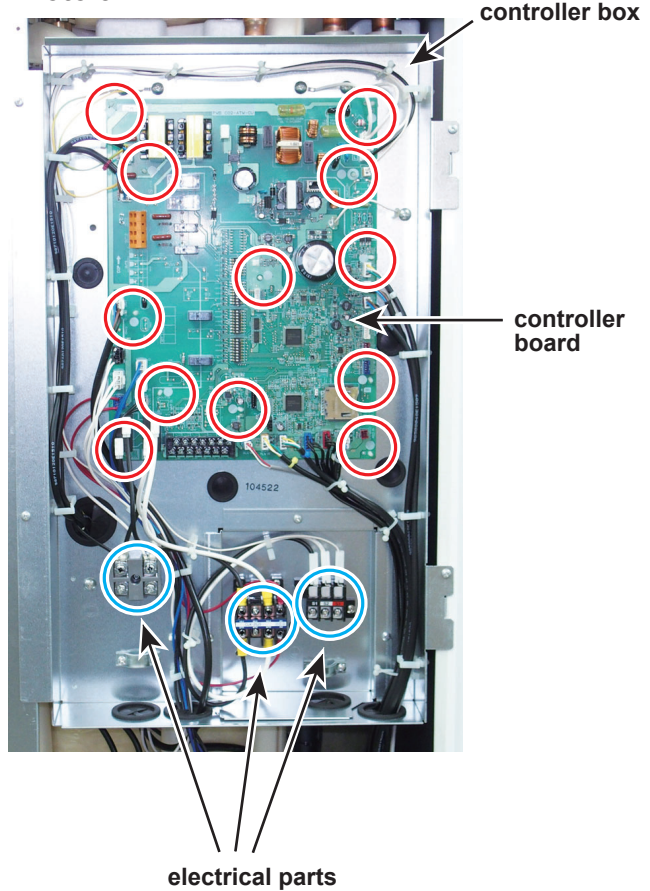
Before removing electrical parts, discharge static electricity. Also, pay attention to electric shock.

< CAUTION(2) >

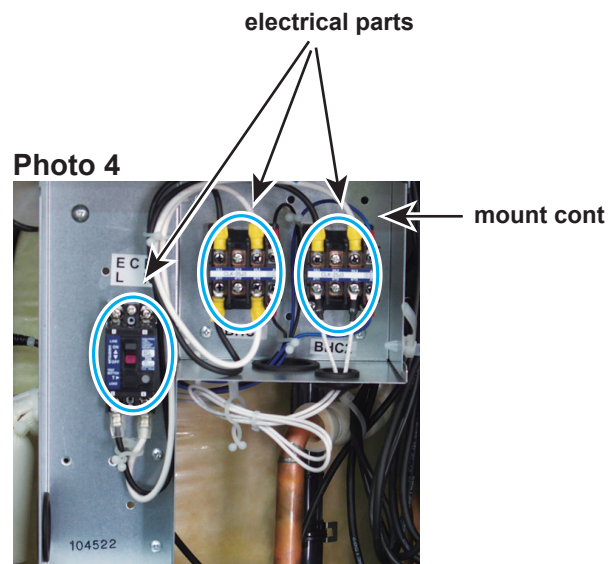
Lead wires are color-coded by cable straps at their connections. When connecting lead wires, check the color of the cable straps to ensure that lead wires are connected correctly.

PHOTOS

Photo 3



 Red round mark: Resin parts (total 12) connected to the controller box



DISASSEMBLY PROCEDURE

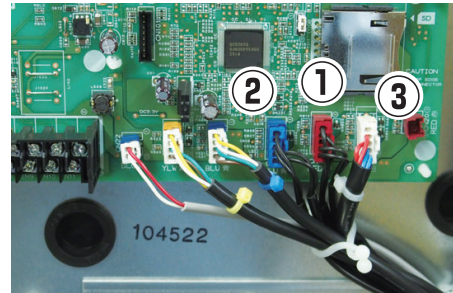
5. How to remove the thermistor

There are three kinds thermistor in total as follows.
Each connector of thermistors is correspond to ①~③ in Photo 5-1.

- ① Thermistor - THW1,THW2
- ② Thermistor - THW3,THW4
- ③ Thermistor - THW5A,THW5B

PHOTOS

Photo 5-1



- ① CNW12 connector (RED)
- ② CNW3 connector (BLUE)
- ③ CNW5 connector (WHITE)

5-1. How to remove the thermistor THW1,THW2

(1) Remove the front panel.

(2) Remove the copper clamps of the thermistor THW1,THW2 from the pipes.(Photo 5-2)

(3) Disconnect the connector (RED) of the thermistor THW1,THW2 from the controller board.(Photo 5-3)

< CAUTION(1) >

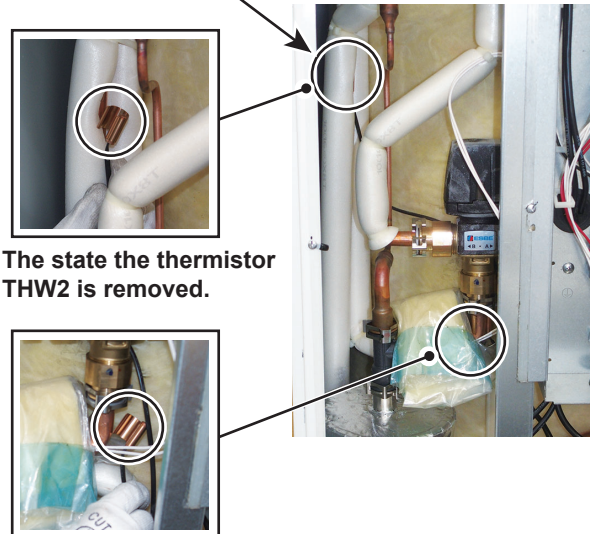
Take care NOT to pull the lead wire strongly when removing the thermistor.

< CAUTION(2) >

When placing a new thermistor, place it in the original position where it was removed.

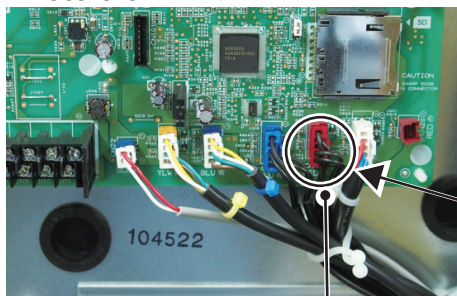
Photo 5-2

< CAUTION >
The thermistor is located inside insulation.



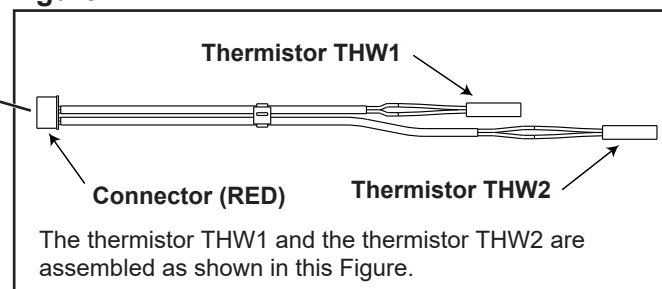
The state the thermistor THW1 is removed.

Photo 5-3



Connector (RED) of thermistor THW1,THW2

Figure 2-1



DISASSEMBLY PROCEDURE

5-2. How to remove the thermistor THW3, THW4

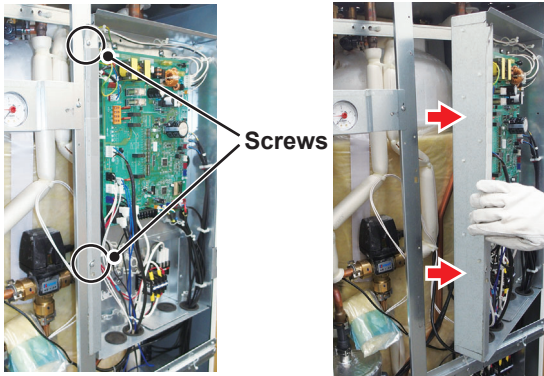
(1) Remove the front panel.

(2) Remove the copper clamps of the thermistor THW3, THW4 from the pipes. (Photo 5-4)

(3) Disconnect the connector (BLUE) of the thermistor THW3, THW4 from the controller board. (Photo 5-5)

< CAUTION(1) >

To remove the thermistor THW3, remove the two screws securing the controller box. Pull the controller box forward about 30 degrees, then it makes easy to remove the copper clamp of the thermistor THW3. (Below photos)



Before pulling the controller box forward



After pulling the controller box forward about 30 degrees

< CAUTION(2) >

Take care NOT to pull the lead wire strongly when removing the thermistor.

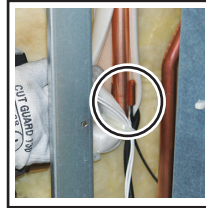
< CAUTION(3) >

When placing a new thermistor, place it in the original position where it was removed.

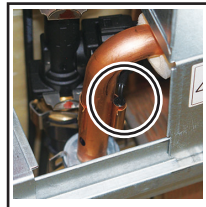
PHOTOS

Photo 5-4

< CAUTION >
The thermistor is located inside insulation.



Thermistor THW3



Thermistor THW4

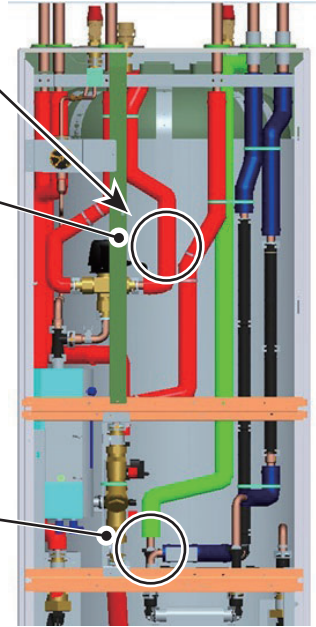
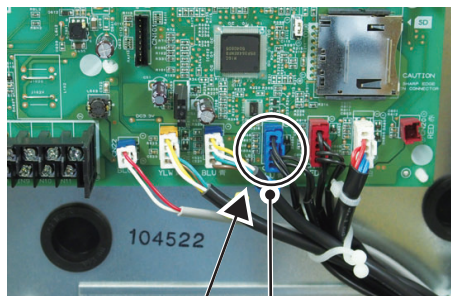
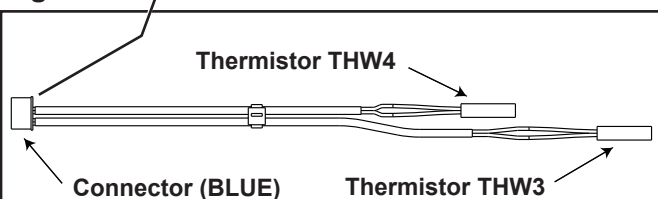


Photo 5-5



Connector (BLUE) of thermistor THW3, THW4

Figure 2-2



The thermistor THW3 and the thermistor THW4 are assembled as shown in this Figure.

DISASSEMBLY PROCEDURE

5-3. How to remove the thermistor THW5A, THW5B

(1) Remove the front, right, left, and rear panels. (Photo 5-6) (Refer to section 6-1 and 6-2)

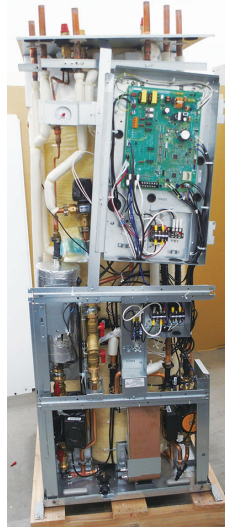
(2) Remove all tapes securing the insulation first, then remove two sheets of insulation around the tank. (Photo 5-7, Photo 5-8, and Photo 5-9)

< CAUTION(1) >

Take care NOT to break the plastic bag covering the insulation when removing the tapes securing the insulation. If the plastic bag is broken, repair with tape or other materials.

PHOTOS

Photo 5-6



Removal of the front, right, left, and rear panels.

Photo 5-7



Tape

First layer of insulation (outside)

Photo 5-8



First layer of insulation (outside)

Tape

Second layer of insulation (inside)

First layer of insulation (outside)

Photo 5-9



Second layer of insulation (inside)

From the previous page.

DISASSEMBLY PROCEDURE

(3) Remove the thermistor THW5A, THW5B from the tank, then disconnect the connector (WHITE) for thermistor THW5A, THW5B from the controller board. Remove cable clamps and cable bands in the lead wire, then remove the thermistor THW5A, THW5B from the tank. (Photo 5-10, Photo 5-11)

< CAUTION(2) >

Take care NOT to pull the lead wire strongly when removing the thermistor.

< CAUTION(3) >

Pay attention to the front and back sides of thermistor when placing it. Place it correctly in the same state as when removing it. (Photo 5-12)

< CAUTION(4) >

Place two sheets of insulation in the original position. When placing two sheets of insulation, be sure to secure them with tape in the same state as before their removal.

PHOTOS

Photo 5-10

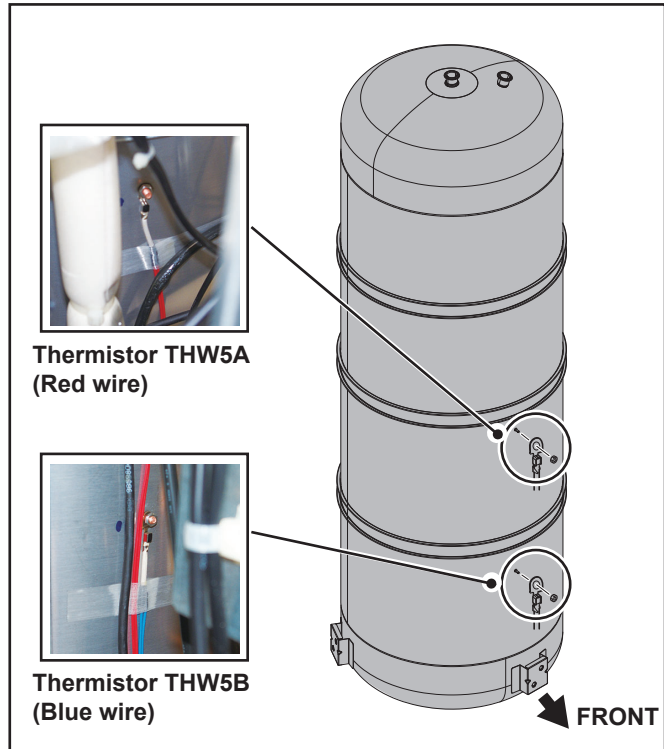
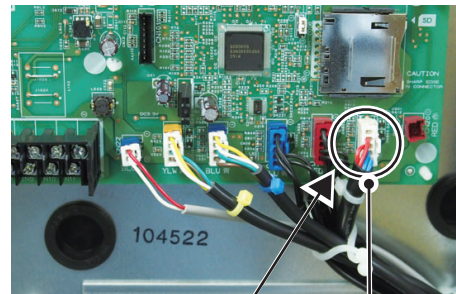


Photo 5-11



Connector (WHITE) of thermistor THW5A, THW5B

Figure 2-3

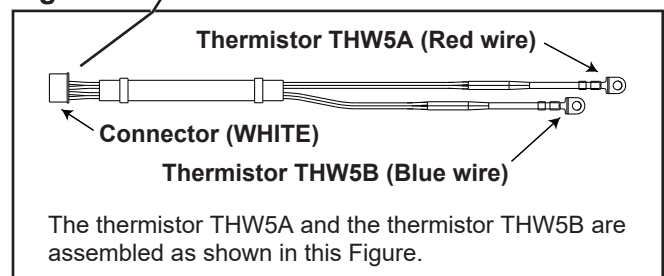
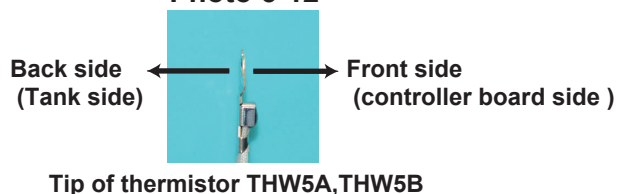


Photo 5-12



DISASSEMBLY PROCEDURE

6-1. How to remove the Side panels (R,L)

(1) Remove the 12 screws of the top panel.(Figure 3)

(2) Remove the 10 screws of the rear panel.(Figure 4)

(3) Remove the 2 screws of the stay-pipe of the upper side panel.(Figure 3 and 4)

(4) Remove the 4 screws of the fixing plate.(Figure 3)

(5) Remove the 3 screws of the base plate.(Figure 3)
Remove the 3 screws of the base plate.(Figure 4)

< CAUTION >

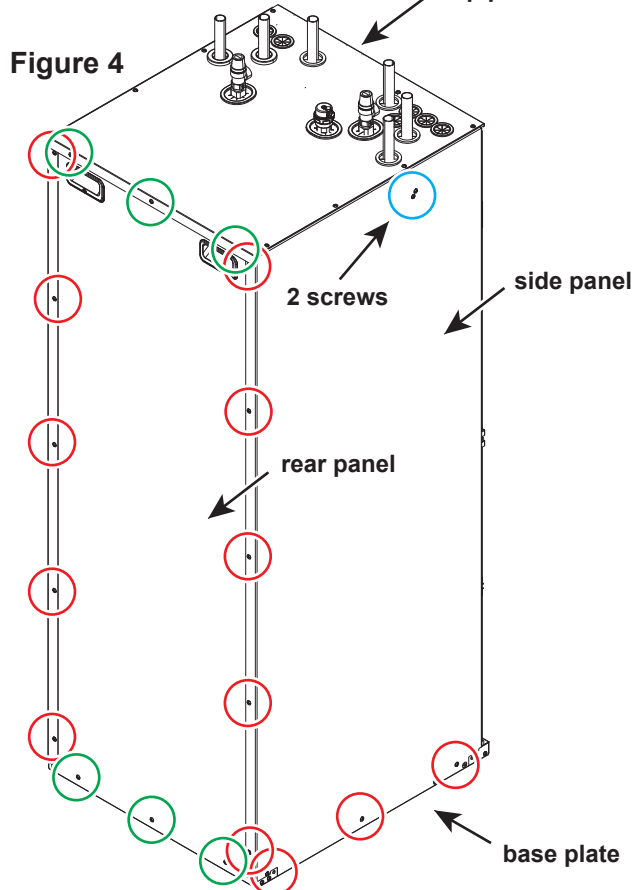
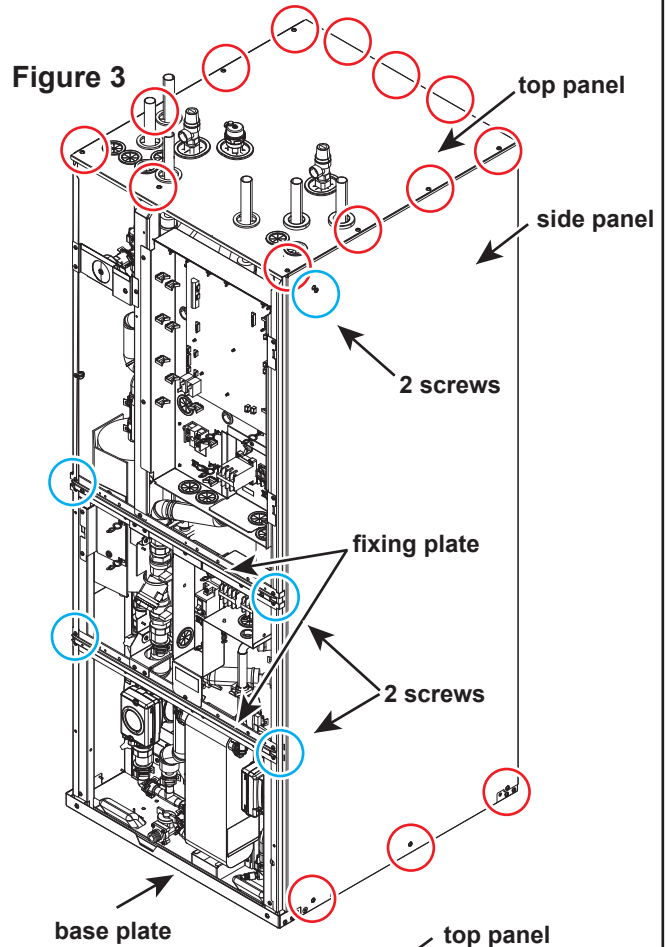
When removing panels, wear protective gloves to prevent cuts and other injuries.

6-2. How to remove the Rear panel

(1) Remove the 3 screws of the top panel.(Figure 4)

(2) Remove the 3 screws of the base plate.(Figure 4)

PHOTOS



DISASSEMBLY PROCEDURE

7. How to remove water pump1 (primary circuit)/pump valve

< Water pump1 >

(Water pump lower left in the cylinder unit)

(1) Remove the front panel .

(2) Disconnect the CNP1 connector, the earth cable and the CNPWM connector in the controller box. (Photo 7-1 and 7-2)

(3) Release the water pump lead wire from the cable clamps ,the cable strap in the control box and the bands below the controller box.(Photo 7-3 and 7-4)

(4) Open the pressure relief valve cap and lower the tank internal pressure.(Photo 7-5)

(5) When removing the pump valve, open the drain valve to drain all water. (Photo 7-6)

< CAUTION >

After this step, recoat the removed earth cable with RTV silicone rubber (KE-3490).(Photo 7-1)

PHOTOS

Photo 7-1 (Larger scale of the (A) part)

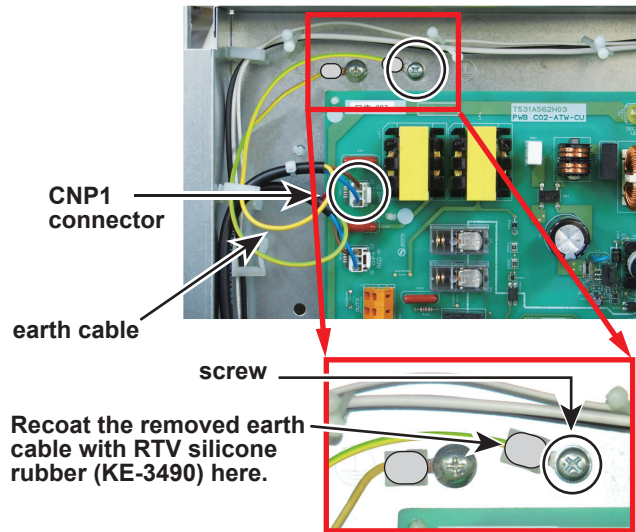


Photo 7-2 (Larger scale of the (B) part)

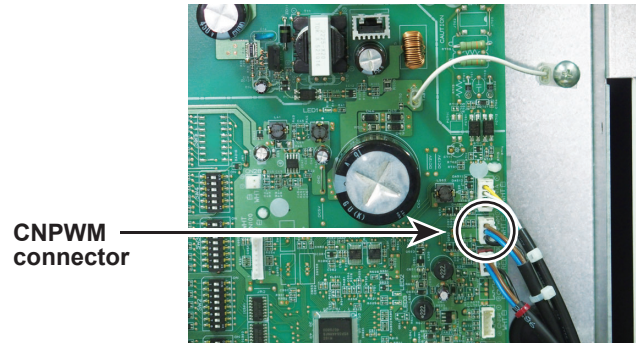
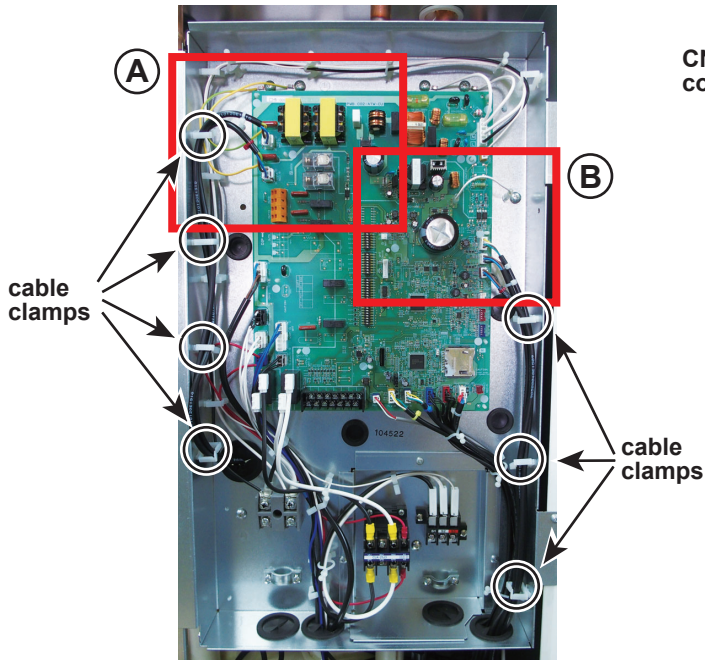


Photo 7-3



controller box

Photo 7-4

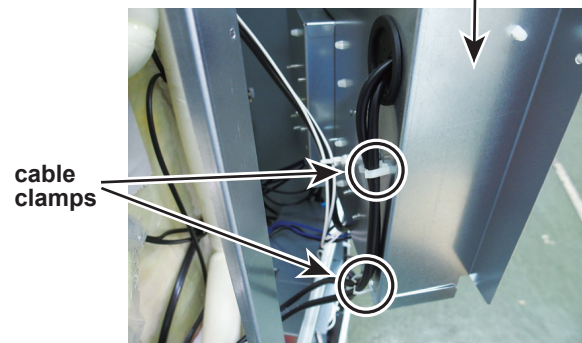


Photo 7-5

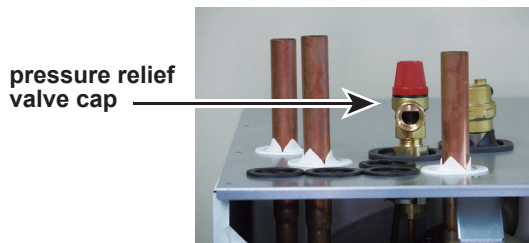
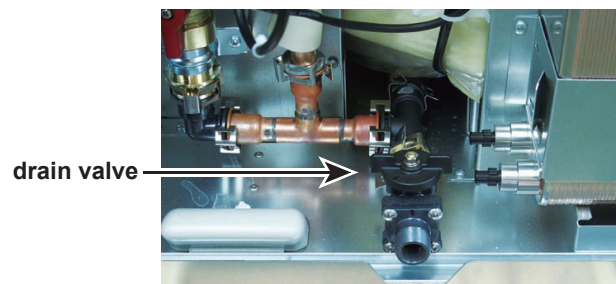


Photo 7-6

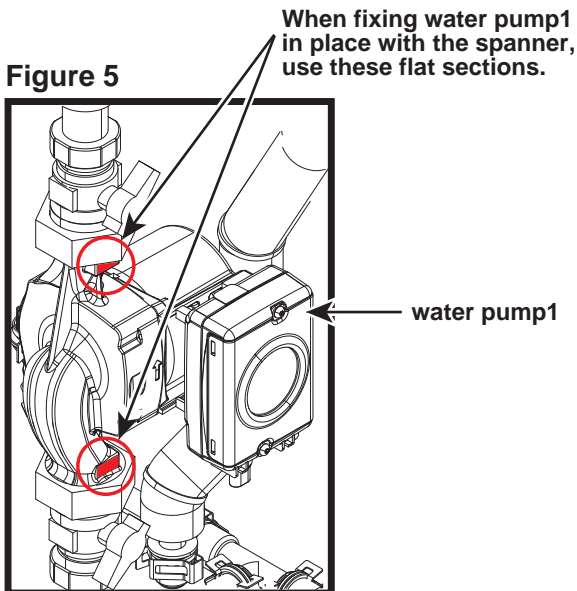


From the previous page.

DISASSEMBLY PROCEDURE

- (6) Close (OFF) the pump valve (Photo 7-7)
- When the pump valve handle is stiff, use a tool to grip the handle and turn it carefully.
 - When opening or closing the pump valve, ensure to do so fully, not halfway.

- (7) Remove the water pump1 by removing the two G1 1/2" nuts using the two spanners: one to hold the G1 1/2" nut and the other to turn the other side of G1 1/2" nut. Remove the water pump by sliding it horizontally. (Photo 7-7 and Figure 5).
- When reinstalling the G1 1/2" nuts, use new G1 1/2" gaskets.
 - Set the water pump in the way that the stamped flowarrow pointing up.



< Pump valve >

- (8) Remove the pump valve stay by removing the 2 screws. (Photo 7-8 and 7-9)
- Reuse the removed pump valve stay and the pump valve stay fixing screws.

- (9) Remove the pump valve by detaching the quick connection. (Photo 7-8 and 7-9)
- Take it off the pump valve on the water pump 1 earlier and slowly to drain water in pump 1 from the drain valve.
 - When reinstalling the quick connection, use new O-ring.

Note: Skip Steps (2) and (3) above when replacing the pump valve only.

PHOTOS

Photo 7-7

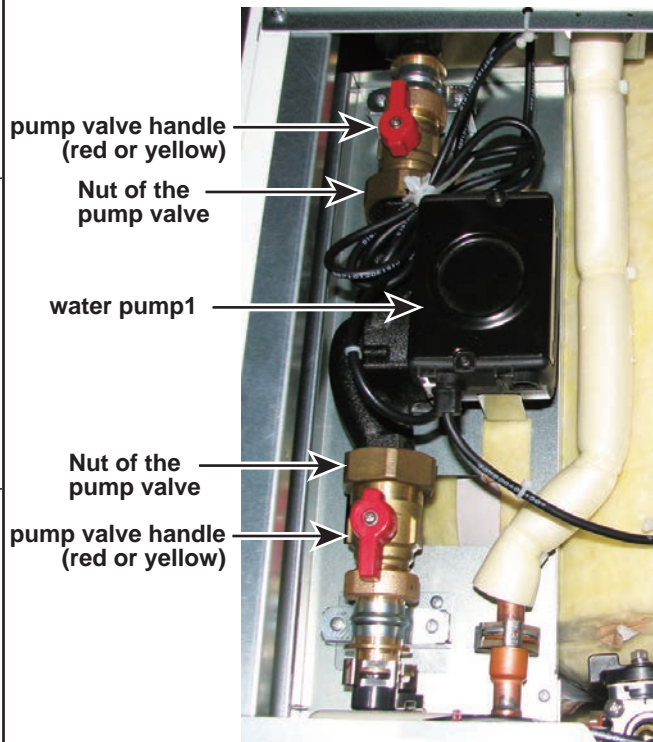


Photo 7-8

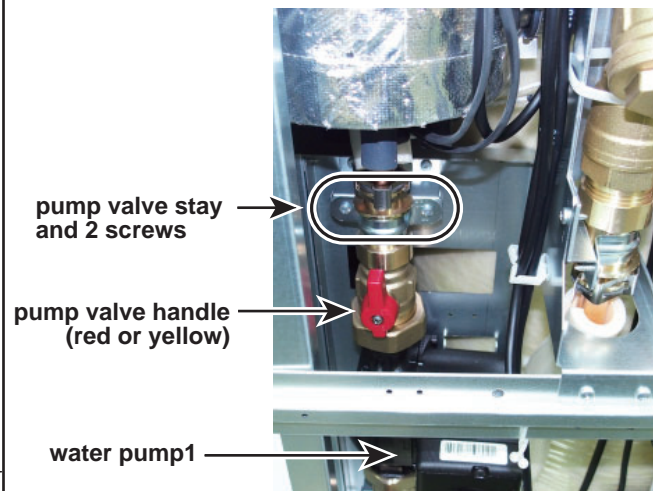
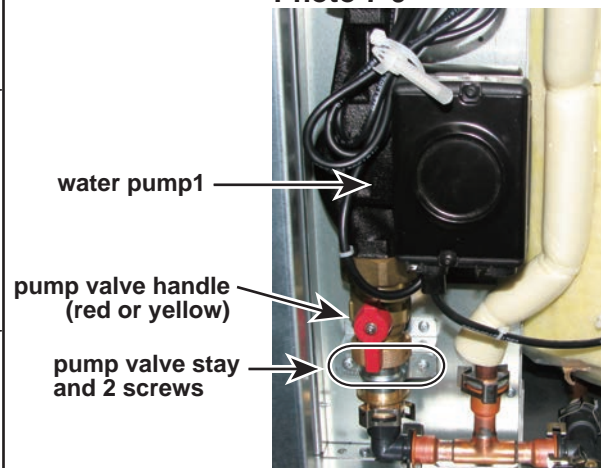


Photo 7-9



DISASSEMBLY PROCEDURE

8. How to remove the water pump A (primary circuit)

< Water pump A >

(Water pump lower right in the cylinder unit)

(1) Remove the front panel.

(2) Disconnect the CNPA connector, the earth cable and the CNPWM3 connector in the control box. (Photo 8-1 and 8-2)

(3) Release the water pump lead wire from the cable clamps and the bands below the control box. (Photos 8-3 and 8-4)

(4) Open the pressure relief valve cap and lower the tank internal pressure. (Photo 8-5)

< CAUTION >

After this step, recoat the removed earth cable with RTV silicone rubber (KE-3490). (Photo 8-1)

PHOTOS

Photo 8-1 (Larger scale of the (A) part)

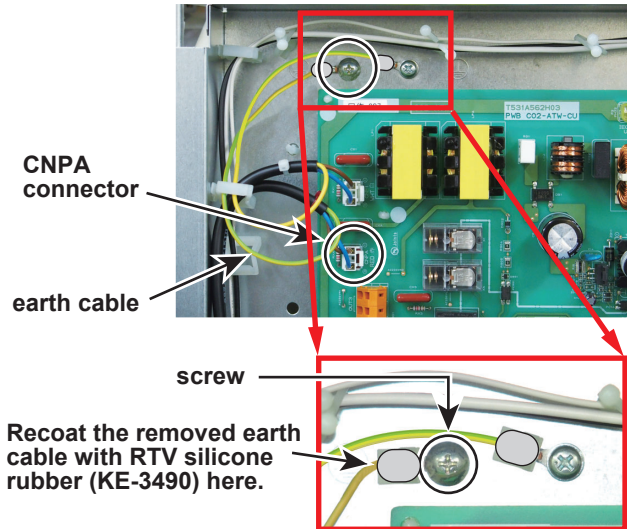


Photo 8-2 (Larger scale of the (B) part)

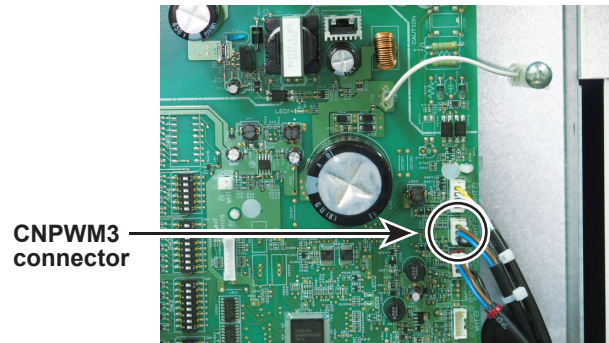


Photo 8-3

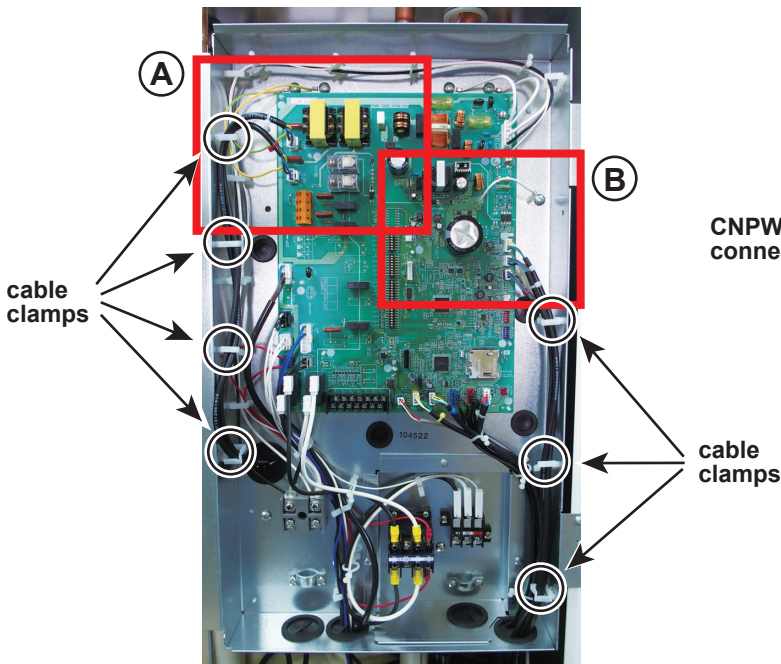
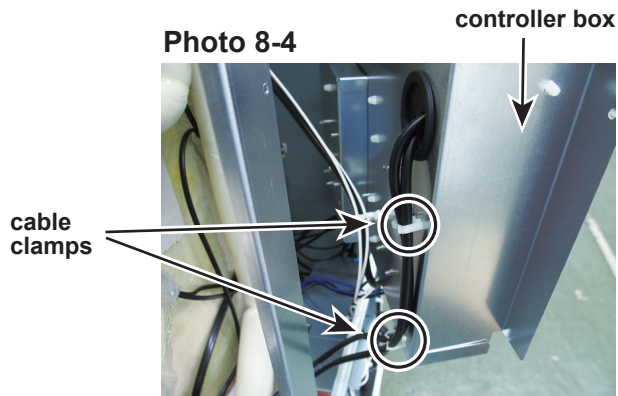
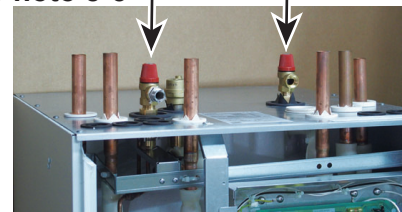


Photo 8-4



pressure relief valve caps

Photo 8-5



DISASSEMBLY PROCEDURE

(5) Open the drain cocks of the water pump A top and bottom and drain away water in the water pump A. (Photo 8-6)

(6) Remove the two G1 1/2" nut stays by removing the 4 screws. (Photo 8-7 and 8-8)

- Reuse the removed the G1 1/2" nut stay and the G1 1/2" nut stay fixing screws.

(7) Remove the G1 1/2" nut stay by detaching the quick connection.

- When reinstalling the quick connection, use new O-ring.

(8) Remove the water pump A (primary circuit) by removing the two G1 1/2" nuts using the 2 spanners, one to hold the G1 1/2" nut and the other to turn the other side of G1 1/2" nut.

- When reinstalling the G1 1/2" nuts, use a new G1 1/2" gaskets.
- Set the water pump in the way that the stamped flow arrow pointing up.

- If it is difficult to remove water pump A, remove the fixing support for HEX, slide HEX, and then remove water pump A.

PHOTOS

Photo 8-6

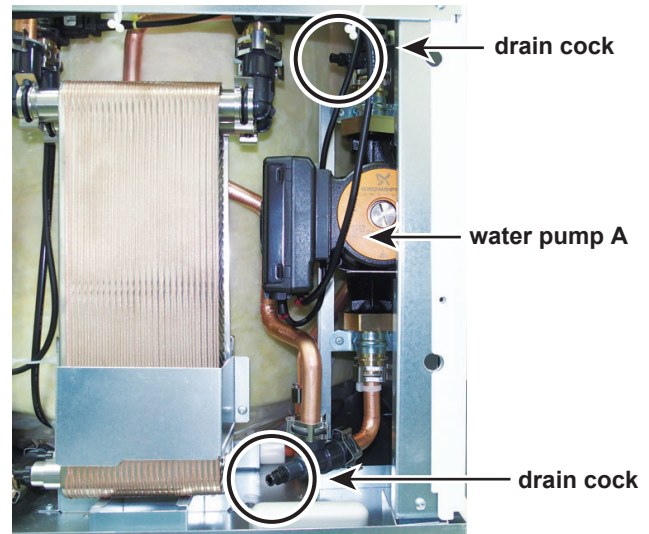


Photo 8-7

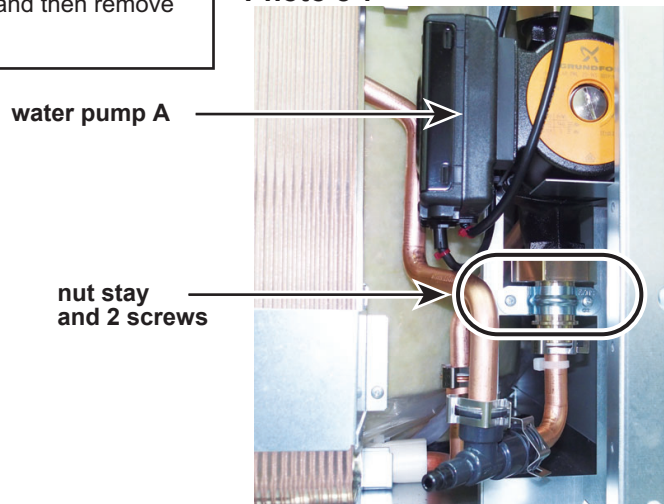
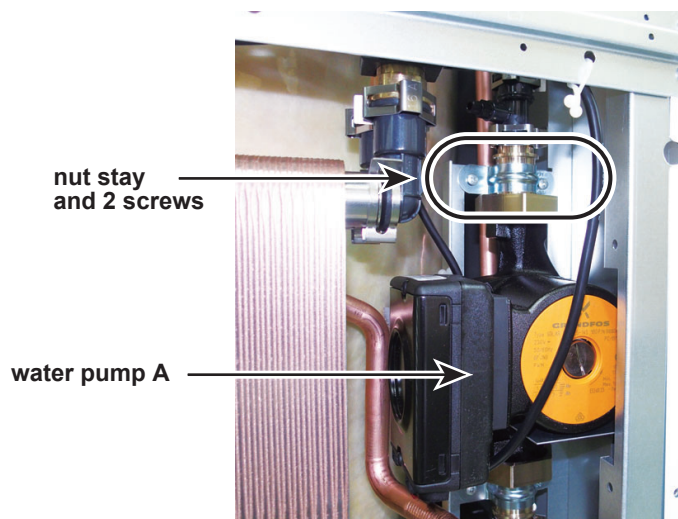


Photo 8-8



DISASSEMBLY PROCEDURE

9. How to remove the strainer valve

< Strainer valve >

(1) Remove the front panel.

(2) Release the band on the strainer valve. Release the lead wire from the cable clamps. (Photos 9-1)

- Released bands are used for protecting against vibration and as a measure to prevent falling during transportation. They do not need to be retied after this procedure.

(3) Open the pressure relief valve cap and lower the tank internal pressure. (Photo 9-2)

(4) Open the drain valve to drain all water. (Photo 9-3)

(5) Remove the 2 screws (only near side) on the 2 strainer valve stay. (Photo 9-4 and 9-6)

- IF it is difficult to remove the 2 screws on the 2 strainer valve stay, remove the 4 screws on the strainer valve stay, slide the strainer valve stay. (Photo 9-5)
- Reuse the removed strainer valve stay and the strainer valve stay fixing screws.

PHOTOS

Photo 9-1

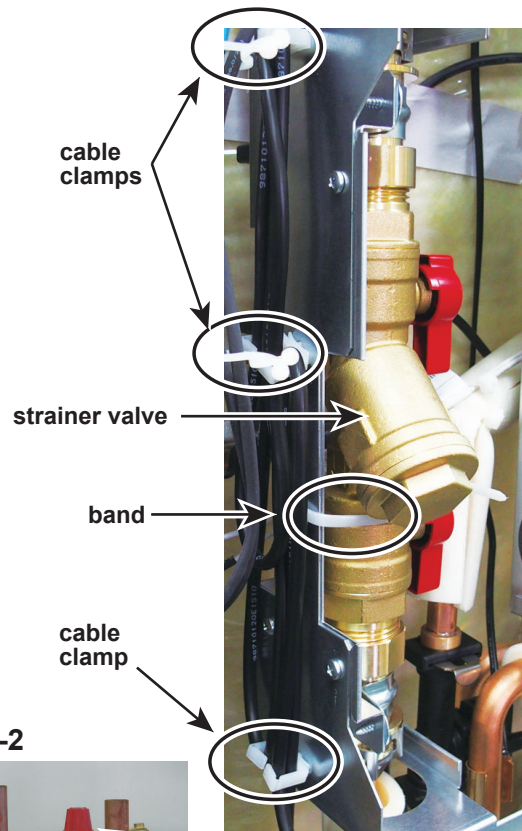
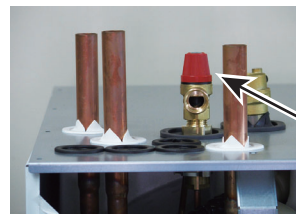
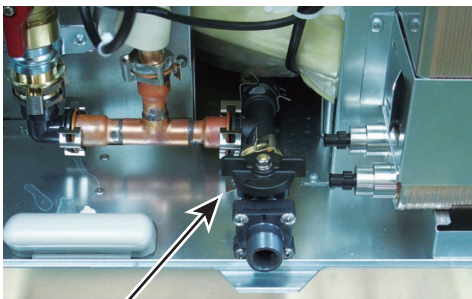


Photo 9-2



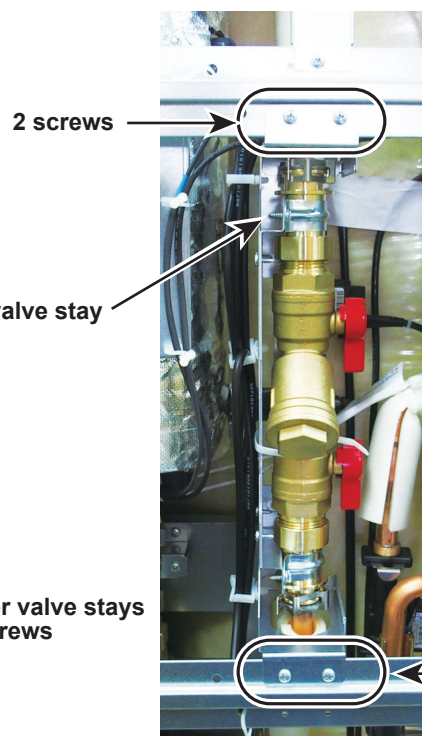
pressure relief valve cap

Photo 9-3



drain valve

Photo 9-5



strainer valve stay

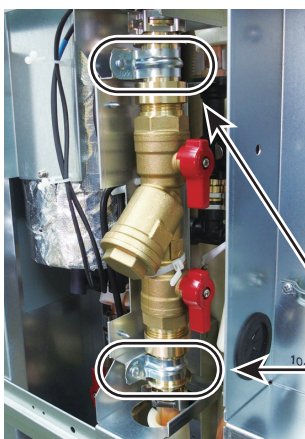
2 strainer valve stays and 2 screws

Photo 9-6



2 screws

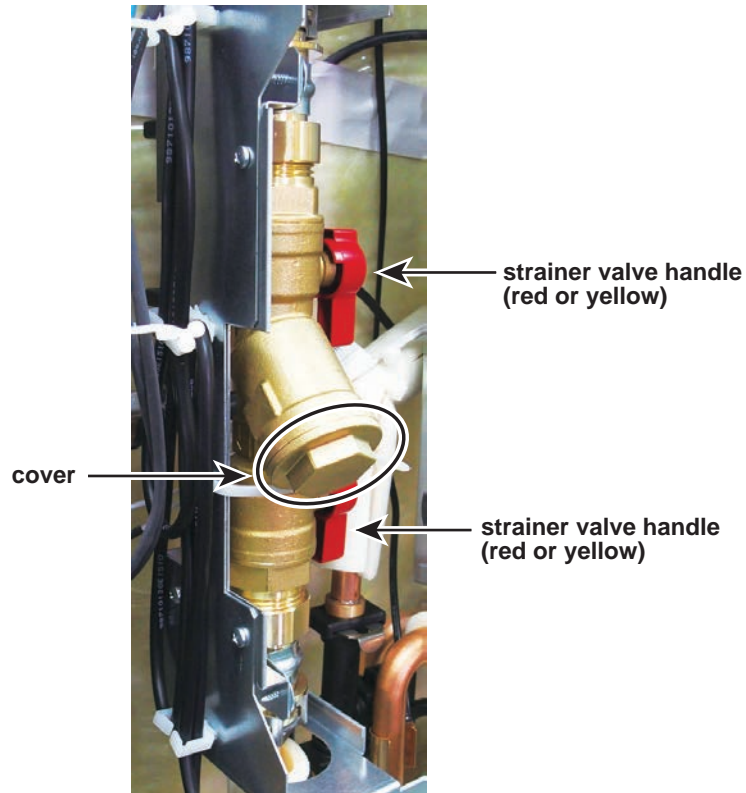
Photo 9-4



From the previous page.

DISASSEMBLY PROCEDURE	PHOTOS
<p>(6) Remove the strainer valve by detaching the quick connection.</p> <ul style="list-style-type: none">• When reinstalling the quick connection, use a new O-ring.• Take it off upper the strainer valve earlier and slowly to drain the water in the strainer from the drain valve.	
<p>< Strainer cover (debris recovery) ></p> <p>(7) Remove the cover using two spanners: one to hold the strainer valve and the other to turn the cover. (Photo 9-7)</p> <ul style="list-style-type: none">• Be sure to reattach the mesh after washing it.• When reinstalling the cover, use a new packing. <p>Note: When only cleaning the strainer valve, skip steps (2), (4), (5), and (6).</p> <p>Note: Close two valves before cleaning the strainer valve.</p>	

Photo 9-7



DISASSEMBLY PROCEDURE

10. How to remove the 3-WAY VALVE / 3-WAY VALVE MOTOR

< 3-WAY VALVE / 3-WAY VALVE MOTOR >

(1) Remove the front panel.

(2) Disconnect the CNV1 connector on the controller board. (Photo 10-1 and 10-2)

(3) Release the 3-way valve motor lead wire from the cable clamps, the quick connection and the cable strap in the controller box and the cable band below the controller box. (Photos 10-3 and 10-4)

• Remove the 2 screws on the left side of the control box and open it.

PHOTOS

Photo 10-1

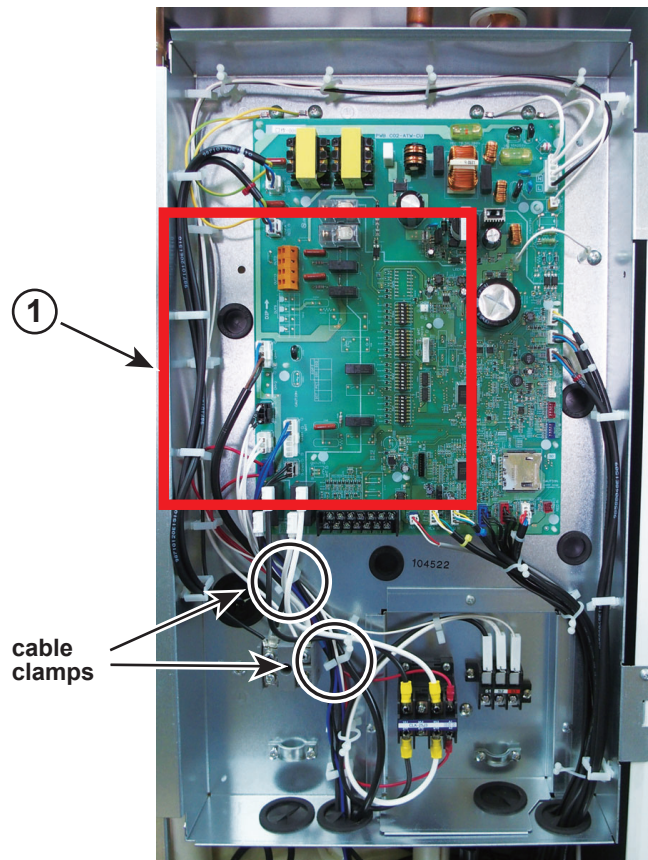


Photo 10-2 (Larger scale of the ① part)

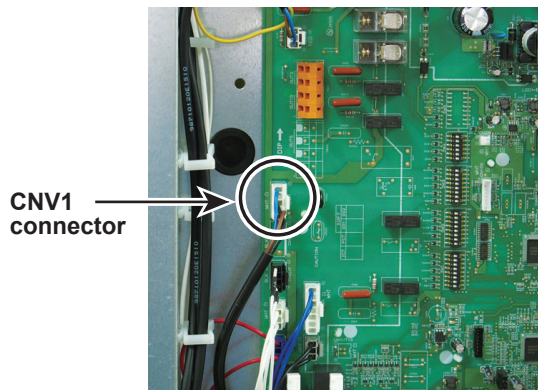


Photo 10-3

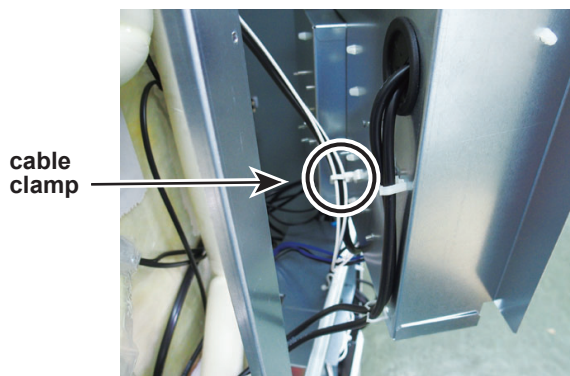
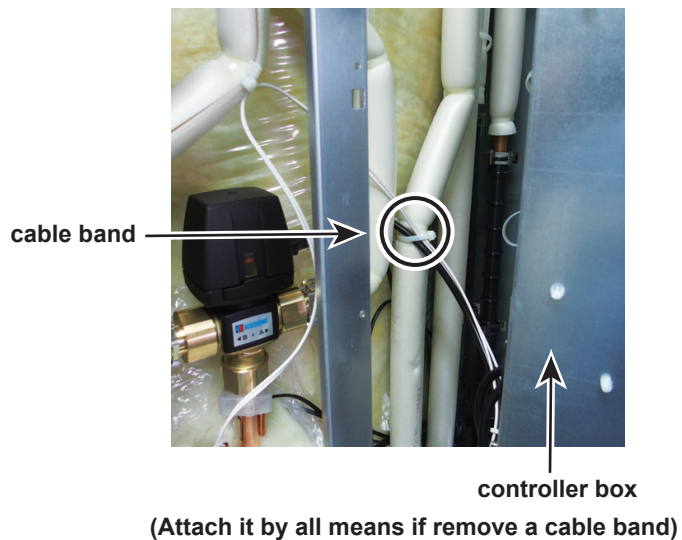


Photo 10-4



From the previous page.

DISASSEMBLY PROCEDURE

(4) Remove the 3-way valve motor from the 3-way valve by pressing the button on the 3-way valve motor (viewed from the front of the cylinder unit). (Photos 10-5)

- Press the button also when reinstalling the 3-way valve motor.

(5) Open the pressure relief valve cap and lower the tank internal pressure.(Photo 10-6)

(6) Close(OFF) the pump valve and strainer valve.(- Photo 10-7 and 10-8)

- When the pump valve/strainer valve handle is stiff, use a tool to grip the handle and turn it carefully.
- When opening or closing the pump valve/strainer valve, ensure to do so fully, not halfway.

PHOTOS

Photo 10-5

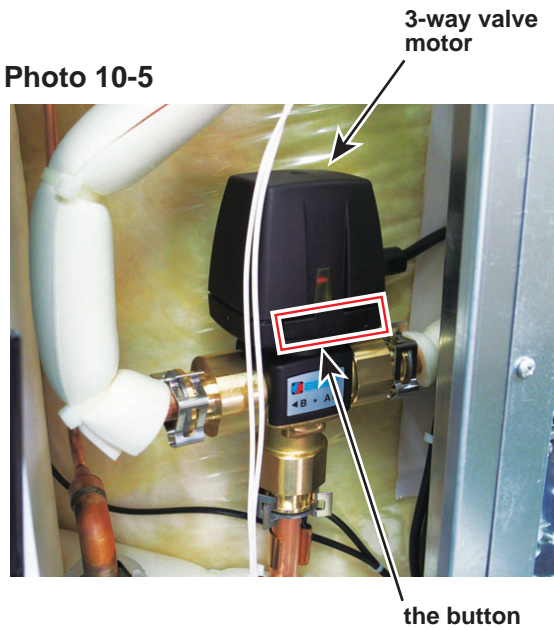


Photo 10-6

pressure relief valve cap

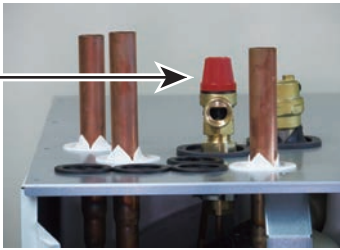


Photo 10-7

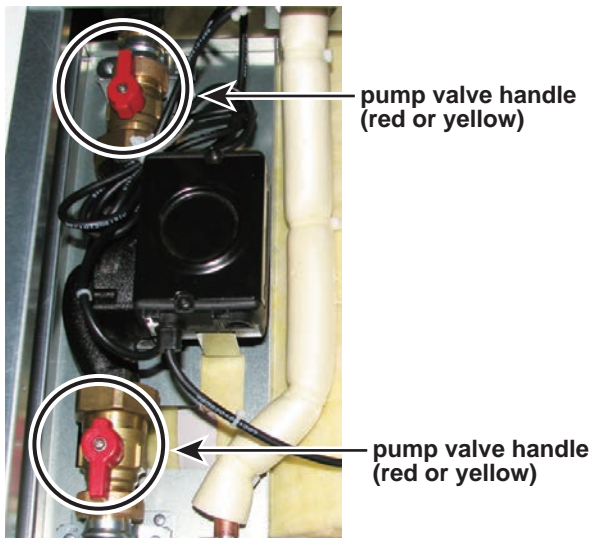
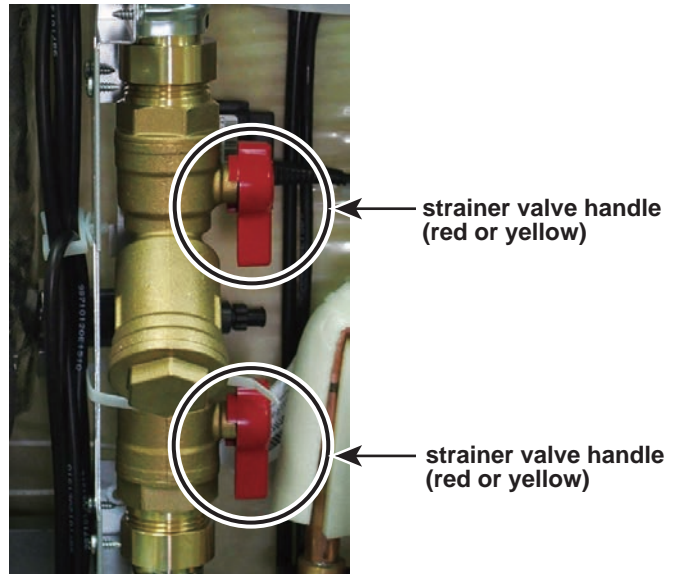


Photo 10-8



From the previous page.

DISASSEMBLY PROCEDURE

(7) Install the drain cock hose at the drain cock of the booster heater inlet (lower right), and drain water. (photo 10-9)

(8) Remove the quick connection of the 3 nuts (bottom, left and right) connected to the 3-way valve, and drain water in the 3-way valve from the booster heater inlet. Since water builds up on the A side of the 3-way valve, hold a cloth or similar item against the A side when removing the nuts to prevent water spilling inside.

< CAUTION >

There may be hot water remaining in the 3-way valve.

(9) Remove the 3-way valve by removing the 3 G1" nuts in the order of the bottom, left and right using two spanners: one to hold the 3-way valve and the other to turn each nut.

- When reinstalling the G1" nuts, use new G1" gaskets. A and B shown represent the right and the left directions of the 3-way valve, respectively.

Note:

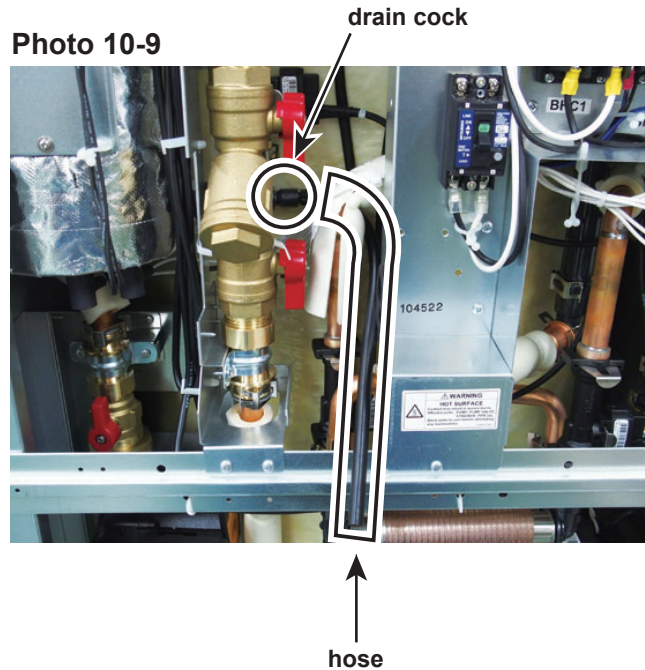
Before replacing the motor, be sure to power off the cylinder unit.
Failure to do so may cause electric shock or cause the 3-way valve to malfunction.

Note:

When installing the 3-way valve, check again that the quick connection are installed.
When replacing the 3-way valve, take care not to become injured by touching the left side edge of the controller box.

PHOTOS

Photo 10-9





DISASSEMBLY PROCEDURE

PHOTOS

11. How to remove the pressure relief valve / air vent / manometer

< Pressure relief valve >

- (1) Remove the front panel.
- (2) Open the pressure relief valve cap and lower the tank internal pressure.(Photo 11-1)
- (3) Remove the quick connection, and then remove the pressure relief valve together with the nipple from the pipe.(Photo 11-1 and 11-2)
- (4) Using two spanners, remove the screw and the pressure relief valve.

< Pressure air vent >

- (1) Remove the front panel.
- (2) Open the pressure relief valve cap and lower the tank internal pressure.(Photo 11-3)
- (3) Using two spanners, remove the screw and the pressure air vent.(Photo 11-4,11-5,11-6)

Photo 11-1

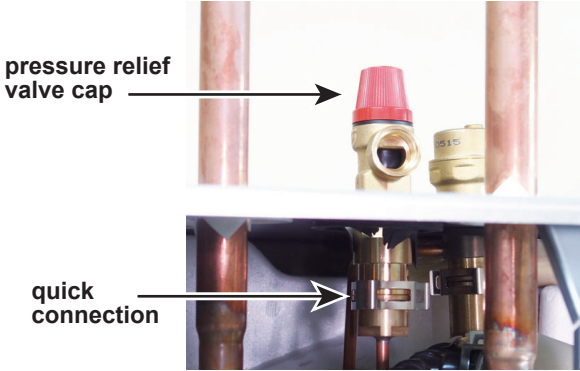


Photo 11-2

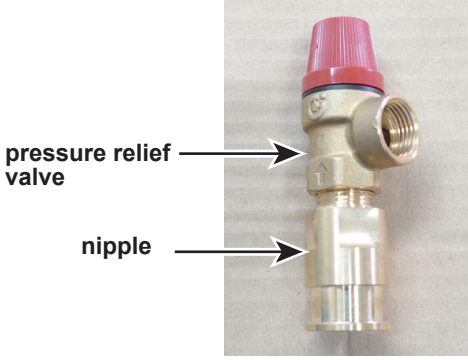


Photo 11-3

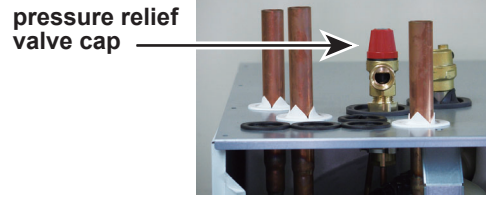
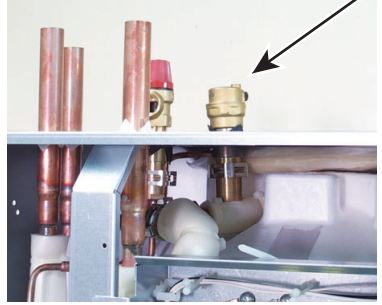


Photo 11-4

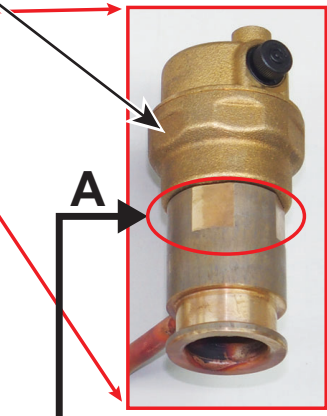


pressure air vent (Turn it with the spanner and take it off)

Photo 11-5

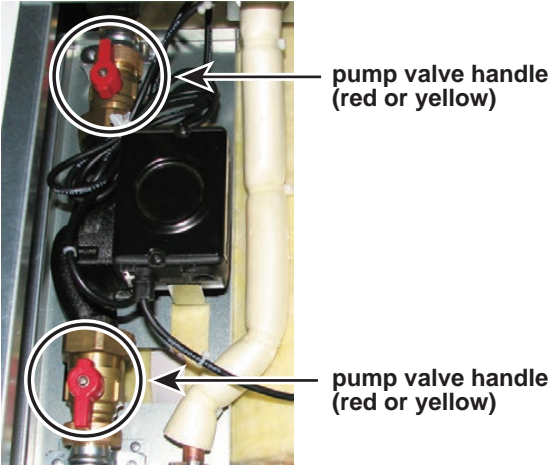
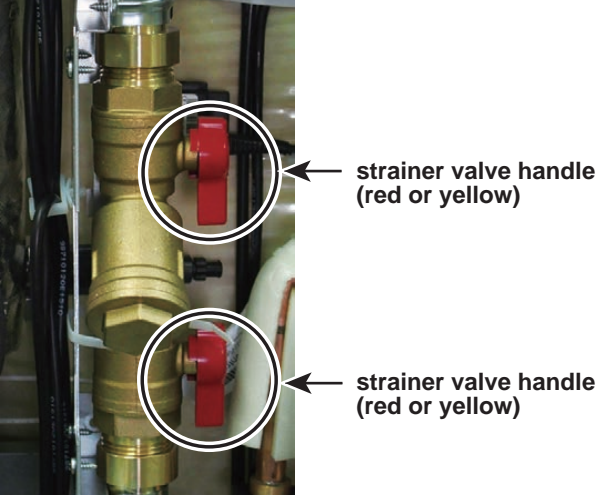
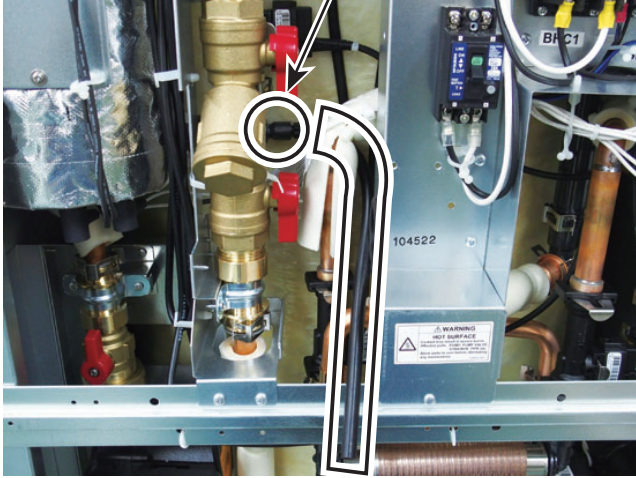


Photo 11-6



When fixing pressure air vent in place with the spanner, use these flat sections A.

From the previous page.

DISASSEMBLY PROCEDURE	PHOTOS
<p data-bbox="97 338 268 365">< Manometer ></p> <hr/> <p data-bbox="140 427 432 454">(1) Remove the front panel.</p> <hr/> <p data-bbox="140 521 727 577">(2) Open the pressure relief valve cap and lower the tank internal pressure.(Photo 11-3)</p> <hr/> <p data-bbox="140 645 727 701">(3) Close(OFF) the pump valve and strainer valve.(- Photo 11-7 and 11-8)</p> <ul data-bbox="140 701 727 813" style="list-style-type: none">• When the pump valve/strainer valve handle is stiff, use a tool to grip the handle and turn it carefully.• When opening or closing the pump valve/strainer valve, ensure to do so fully, not halfway. <hr/> <p data-bbox="140 891 727 969">(4) Install the drain cock hose at the drain cock of the booster heater inlet (lower right), and drain water.(Photo 11-9)</p>	<p data-bbox="821 320 975 347">Photo 11-7</p>  <p data-bbox="821 869 975 896">Photo 11-8</p>  <p data-bbox="400 1491 553 1518">Photo 11-9</p>  <p data-bbox="738 1469 863 1496">drain cock</p> <p data-bbox="719 2107 778 2134">hose</p>

From the previous page.

DISASSEMBLY PROCEDURE	PHOTOS
<p>(5) Remove the three screws securing the fixing support for the manometer, remove the quick connection at the rear of the manometer, and remove the manometer together with the fixing support.(Photo 11-10 and 11-11)</p>	
<p>(6) Remove the two screws securing the manometer, and then remove the manometer and nipple.(Photo 11-12 and 11-13)</p>	

Photo 11-10

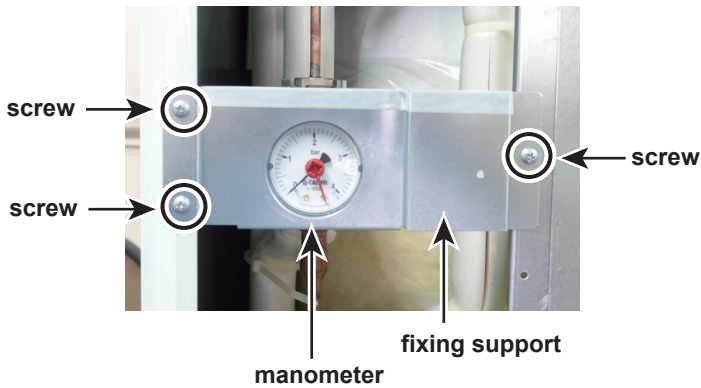


Photo 11-11

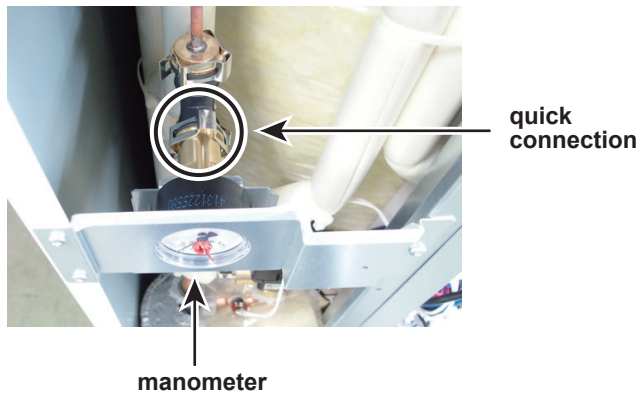


Photo 11-12

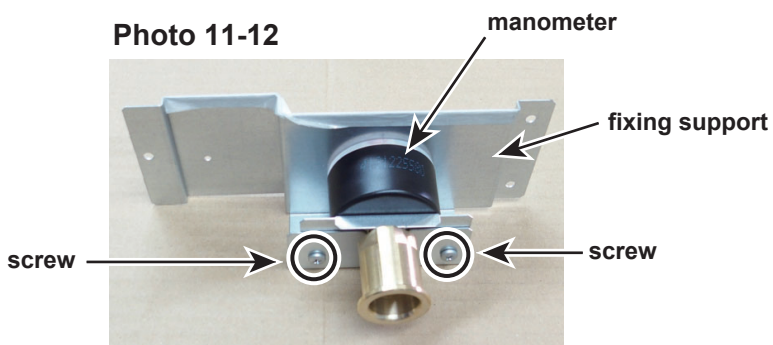
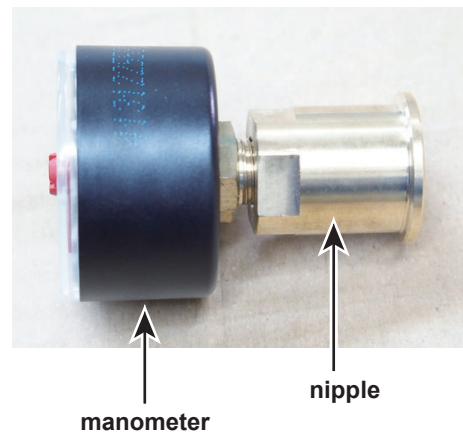


Photo 11-13



DISASSEMBLY PROCEDURE

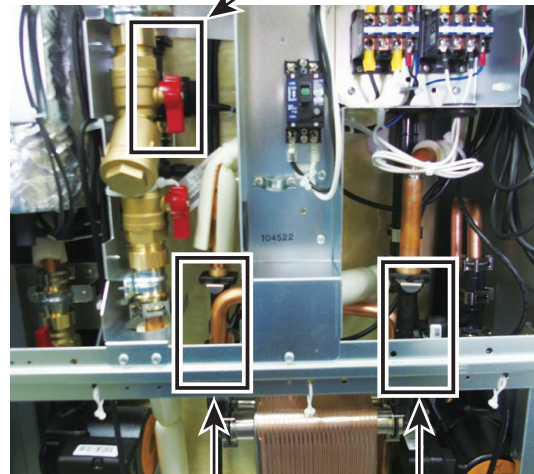
12. How to remove the flow sensor1(primary circuit)

< Flow Sensor 1 >

- (1) Remove the front panel.
- (2) Disconnect the CN1A connector in the controller box. (Photo 12-2 and 12-3)
- (3) Release the flow sensor lead wire from the cable clamps and the bands below the control box. (Photos 12-2 and 12-4)
- (4) Open the pressure relief valve caps and lower the tank internal pressure.(Photo 12-5)

PHOTOS

Photo 12-1



Flow sensor B Flow sensor A

Photo 12-2

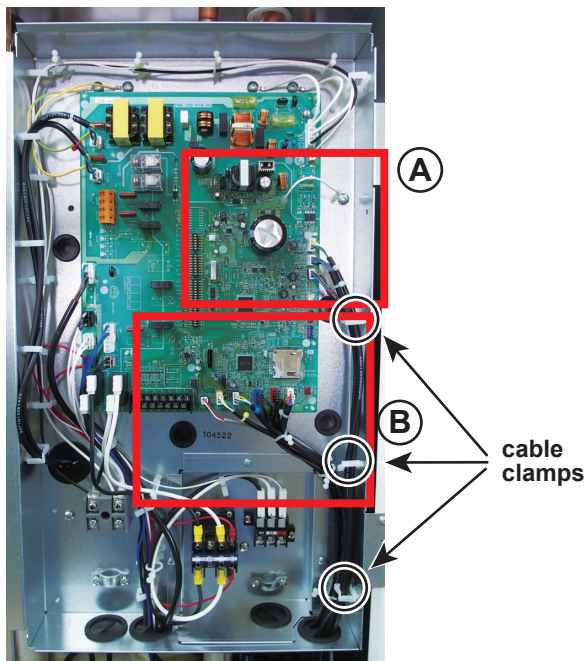
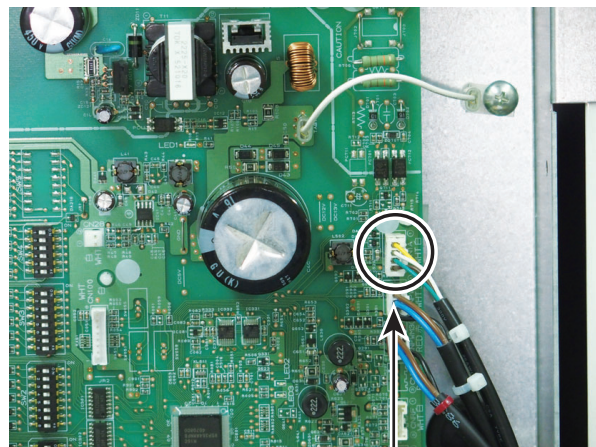
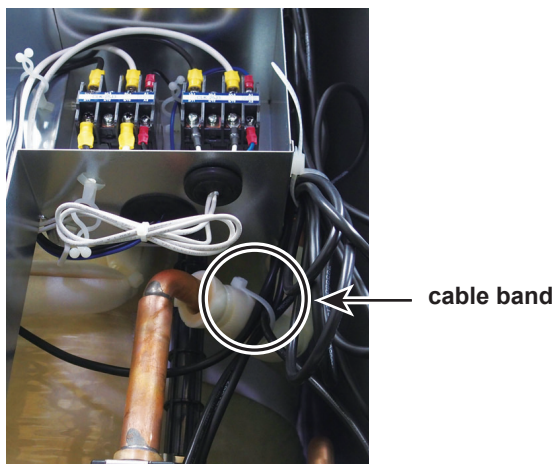


Photo 12-3 (Larger scale of the (A) part)



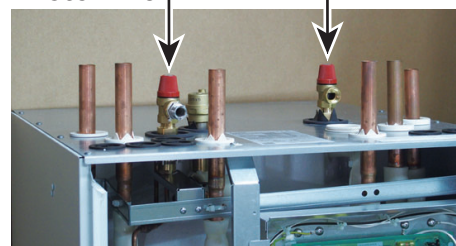
CN1A connector

Photo 12-4



pressure relief valve caps

Photo 12-5



DISASSEMBLY PROCEDURE

(5) Close(OFF) the pump valve and strainer valve.(- Photo 12-6 and 12-7)

- When the pump valve/strainer valve handle is stiff, use a tool to grip the handle and turn it carefully.
- When opening or closing the pump valve/strainer valve, ensure to do so fully, not halfway.

(6) Install the drain cock hose at the drain cock of the booster heater inlet (lower right), and drain water.(Photo 12-8)

(7) Remove the flow sensor. (Photo 12-1 and 12-8)

- Draw out the quick connection to the front side and remove.
- Be sure to set the flow sensor so that the direction of flow arrow is facing downwards.
- When replacing the flow sensor, be sure to use a new O-ring.

PHOTOS

Photo 12-6

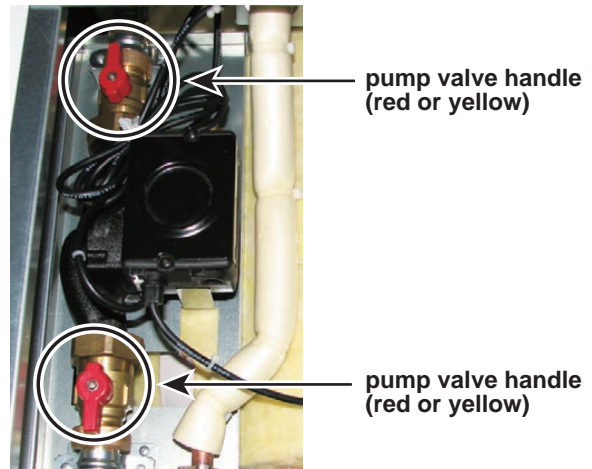
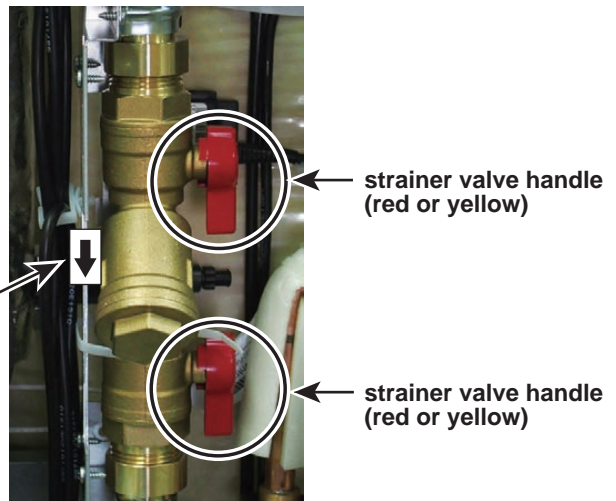
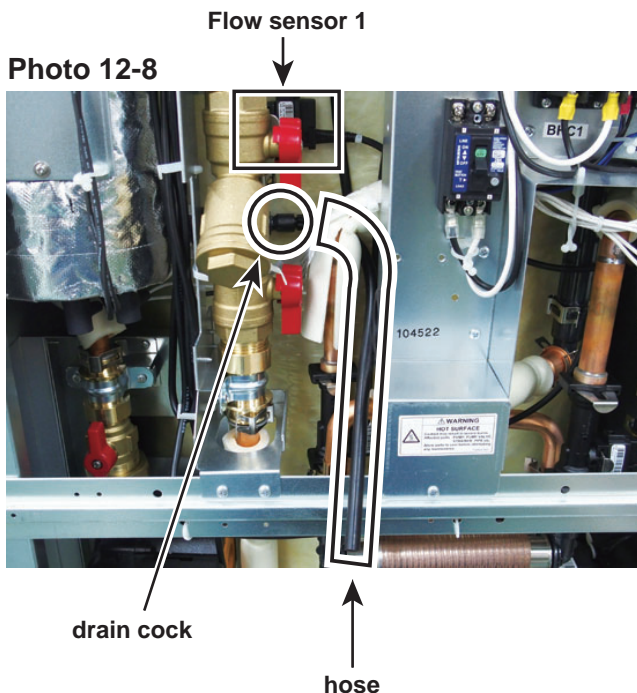


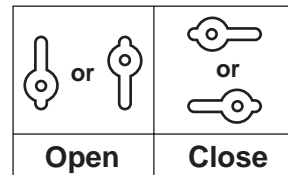
Photo 12-7



The direction that the water flows through. (There is a downward arrow.)



< pump valve and strainer valve >



DISASSEMBLY PROCEDURE

13. How to remove the flow sensor B (primary circuit)

< Flow Sensor B >

- (1) Remove the front panel.
- (2) Disconnect the CN2B connector in the controller box. (Photo 13-1)
- (3) Release the flow sensor lead wire from the cable clamps and the bands below the controller box. (Photos 13-1 and 13-2)
- (4) Open the pressure relief valve caps and lower the tank internal pressure. (Photo 13-3)
- (5) Open the drain cock (Primary side) below the HEX to drain water inside. (Photo 13-4)
- (6) Remove the flow sensor B. (Photo 13-5)
 - Draw out the quick connection to the front side and remove.
 - Be sure to set the flow sensor B so that the direction of flow arrow is facing downwards.
 - When replacing the flow sensor B, be sure to use a new O-ring.

PHOTOS

Photo 13-1

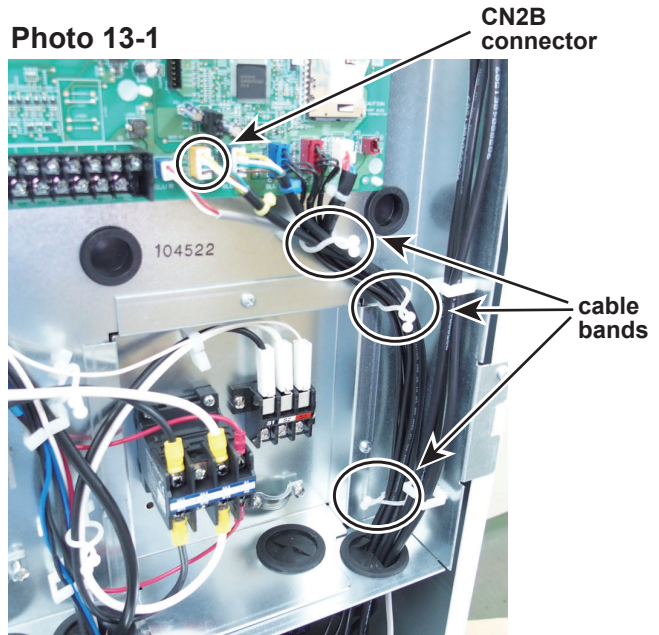
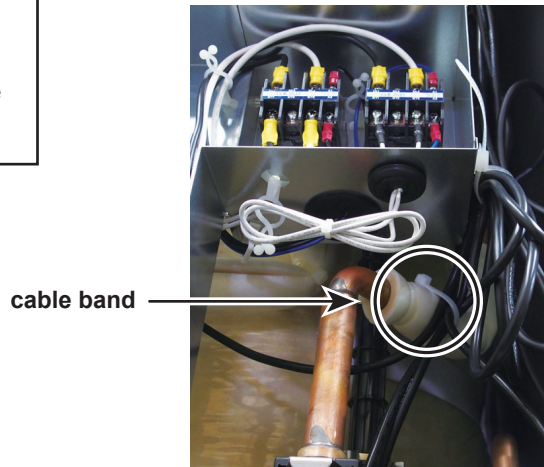


Photo 13-2



pressure relief valve caps
Photo 13-3

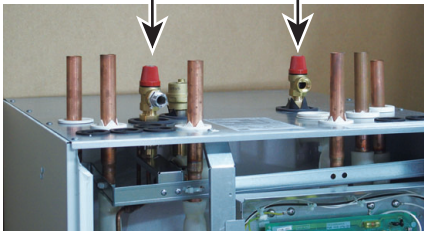


Photo 13-4

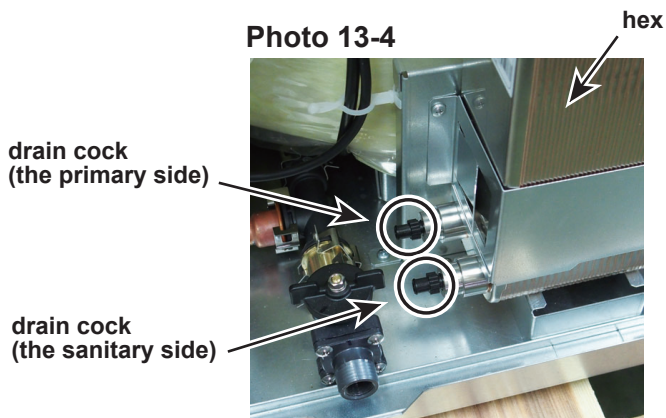
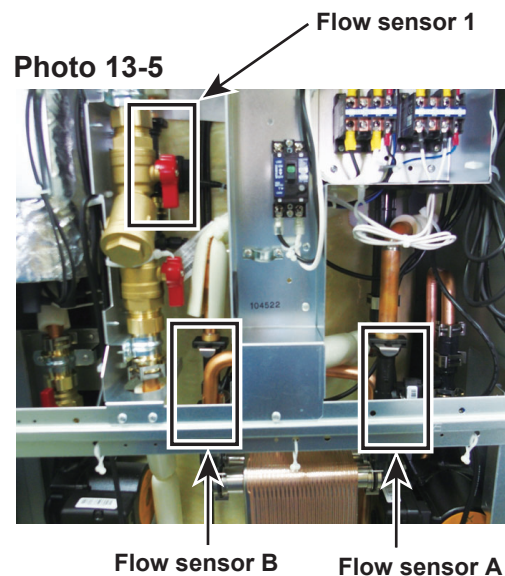
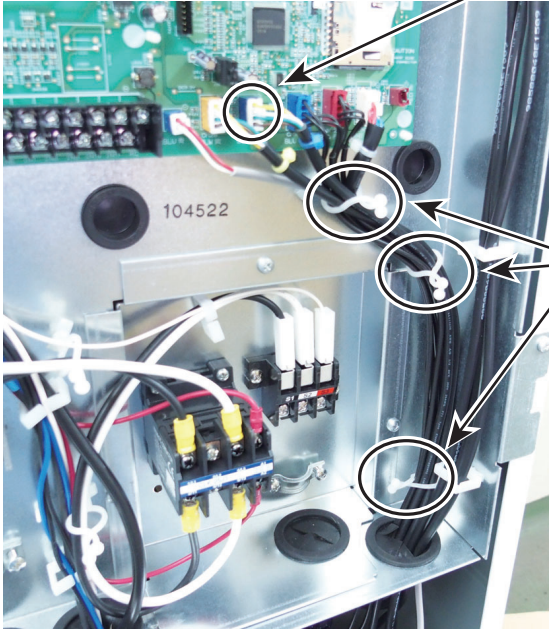
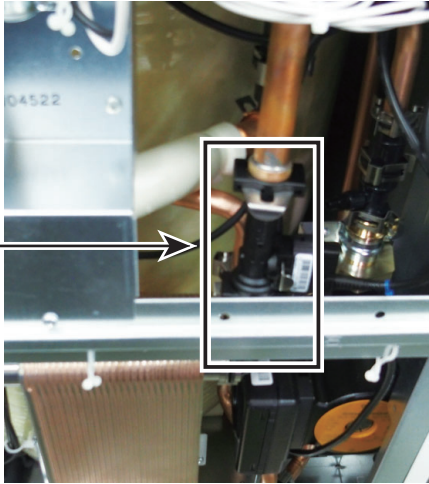


Photo 13-5



From the previous page.

DISASSEMBLY PROCEDURE	PHOTOS
<p>14. How to remove the flow sensor A (Sanitary circuit)</p> <p>< Flow Sensor A ></p> <hr/> <p>(1) Remove the front panel.</p> <hr/> <p>(2) Disconnect the CN2A connector in the controller box. (Photo 14-1)</p> <hr/> <p>(3) Release the flow sensor lead wire from the cable clamps and the bands below the controller box. (Photos 13-2 and 14-1)</p> <hr/> <p>(4) Stop water flow at the water source.</p> <hr/> <p>(5) Open the drain cock (Sanitary side) below the HEX to drain water inside. (Photo 13-3)</p> <hr/> <p>(6) Remove the flow sensor A. (Photo 12-1 and 14-2)</p> <ul style="list-style-type: none">• Draw out the quick connection to the front side and remove.• Be sure to set the flow sensor A so that the direction of flow arrow is facing downwards.• When replacing the flow sensor A, be sure to use a new O-ring. <hr/>	<p>Photo 14-1</p>  <p>CN2A connector</p> <p>cable bands</p> <p>104522</p> <p>Photo 14-2</p>  <p>Flow sensor A</p>

From the previous page.

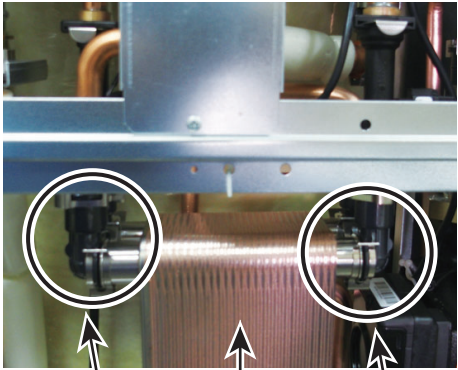
DISASSEMBLY PROCEDURE	PHOTOS
<p>15. How to remove the HEX(Primary and Sanitary circuit)</p> <p>< HEX ></p> <hr/> <p>(1) Remove the front panel.</p> <hr/> <p>(2) Stop water flow at the water source.</p> <hr/> <p>(3) Open the pressure relief valve cap and lower the tank internal pressure.(Photo 12-5)</p> <hr/> <p>(4) Drain water inside the HEX using the drain cock (Primary circuit) and the drain cock (Sanitary circuit). (Photo 13-4)</p> <hr/> <p>(5) Detach 4 quick connections.(Photo 15-1)</p> <hr/> <p>(6) Remove the 2 screws to remove the cover. (Photo 15-2 and 15-3)</p> <ul style="list-style-type: none">• Reuse the cover and the screws. <hr/> <p>(7) Remove the HEX and drain cock (Sanitary circuit).</p> <ul style="list-style-type: none">• When reinstalling the drain cock (sanitary circuit) and O-ring, use a new one.	<p>Photo 15-1</p>  <p>2 quick connections HEX 2 quick connections</p>

Photo 15-2

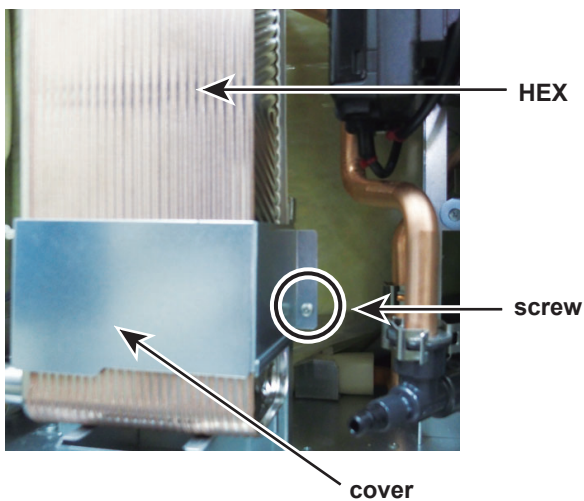
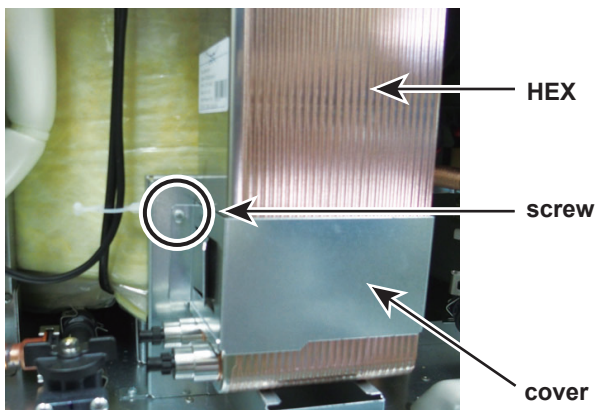


Photo 15-3



DISASSEMBLY PROCEDURE

16. How to remove the booster heater

Note.

There are 2 types of booster heater specifications.

One is with insulation, and the other is without insulation.

The insulation sheet (transparent resin) is required to prevent contact between insulation of the booster heater and Side panel.

If using no insulation of the booster heater, the insulation sheet is not needed to use, because surface of the booster heater doesn't contact with Side panel.

For more detail, please refer to page 75-2.

< booster heater >

(1) Remove the front panel.

(2) Disconnect the CNBHT connector on the controller board, and the booster heater lead wires wired to the BHC2 contactor respectively and release the lead wires from the quick connection, the cable clamp, the cable strap, the coated clamp and the band. (Photo 16-1, 16-2, 16-3, 16-4 and 16-5)

(3) Open the pressure relief valve cap and lower the tank internal pressure. (Photo 16-6)

PHOTOS

Photo 16-1

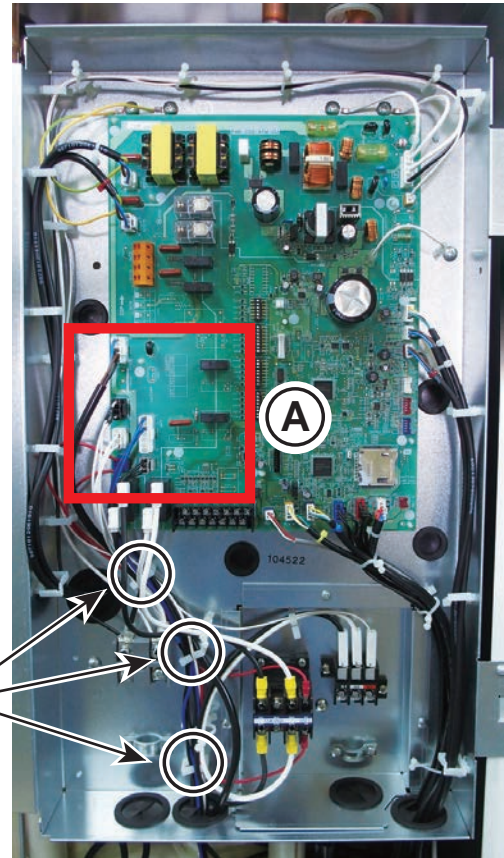
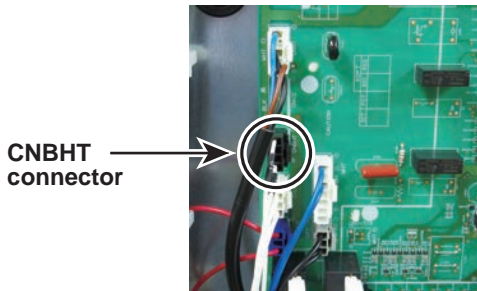


Photo 16-2 (Larger scale of the A part)



cable clamps

Photo 16-3

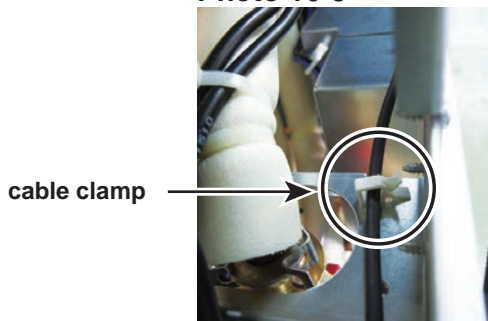


Photo 16-5

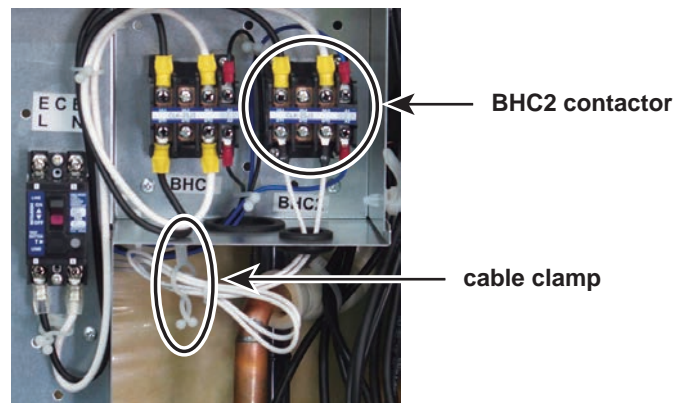


Photo 16-4

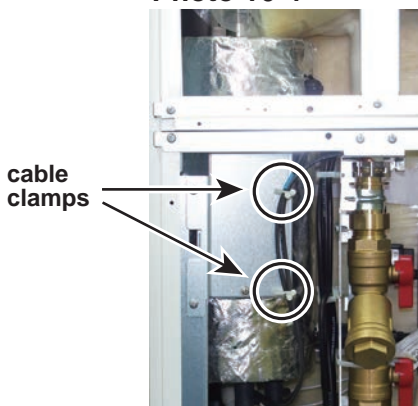
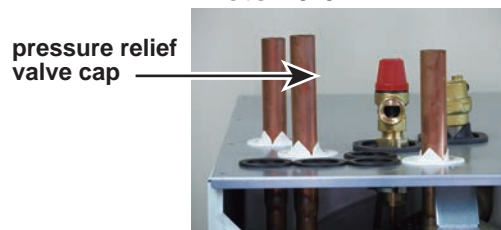


Photo 16-6



PHOTOS

TYPE1
(without the insulation of the booster heater)

TYPE2
(with the insulation of the booster heater)

TYPE 1 has been adopted since December 2021, and TYPE2 service parts will eventually disappear. Please note, in case of using Type2 as a service part, make sure to install in combination with the insulation sheet (transparent resin).



Photo 16-14-1
Booster heater assembly

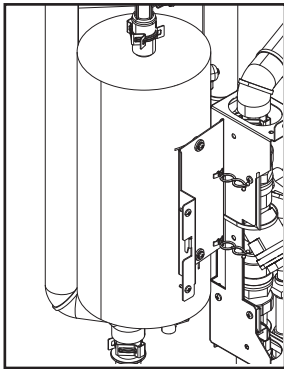
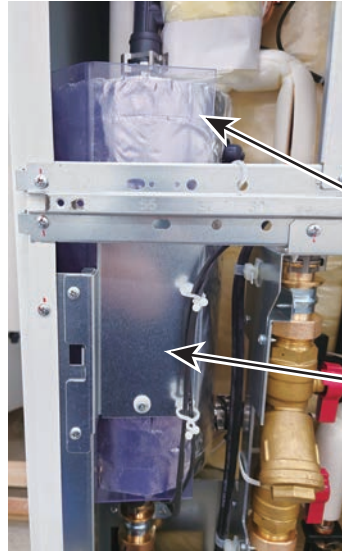


Photo 16-14-2
Booster heater assembly drawing



Photo 16-14-3
Booster heater without insulation

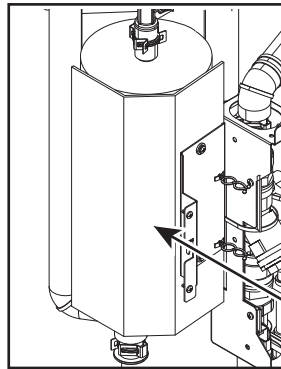
Note. In case of TYPE2, the insulation sheet (transparent resin) MUST be installed from electrical insulation reason.



booster heater with insulation

insulation sheet (transparent resin)

Photo 16-15-1
Booster heater assembly



insulation sheet (transparent resin)

Photo 16-15-2
Booster heater assembly drawing



booster heater with insulation

Photo 16-15-3
Booster heater with insulation

DISASSEMBLY PROCEDURE

(4) Close(OFF) the pump valve and strainer valve.(- Photo 16-7 and 16-8)

- When the pump valve/strainer valve handle is stiff, use a tool to grip the handle and turn it carefully.
- When opening or closing the pump valve/strainer valve, ensure to do so fully, not halfway.

(5) Install the drain cock hose at the drain cock of the booster heater inlet (lower right), and drain water.(Photo 16-9)

(6) Detach the 2 quick connections (Inlet and outlet of booster heater)(Photo 16-10 and 16-11)

- When reinstalling the quick connections, use new O-rings.

PHOTOS

Photo 16-7

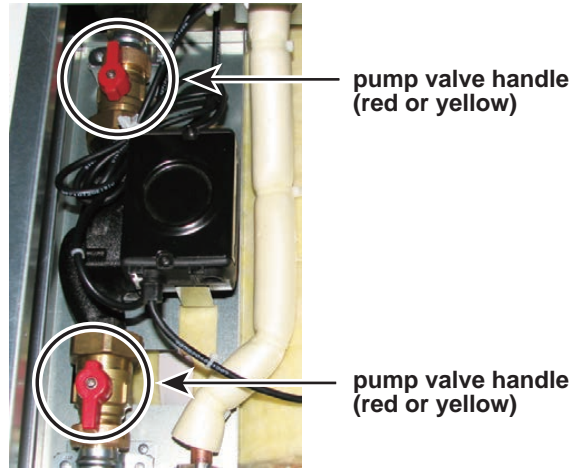


Photo 16-8

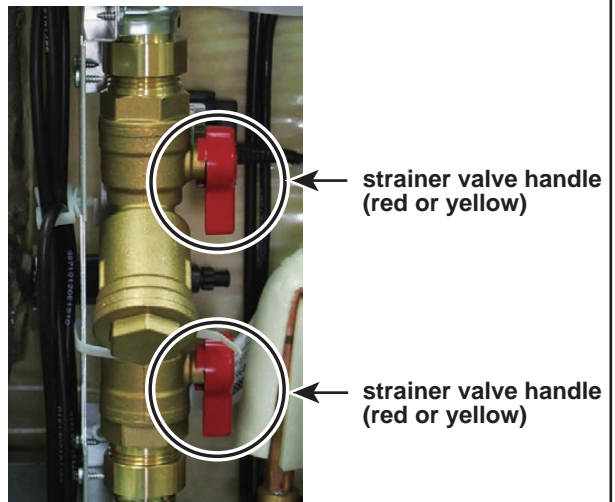
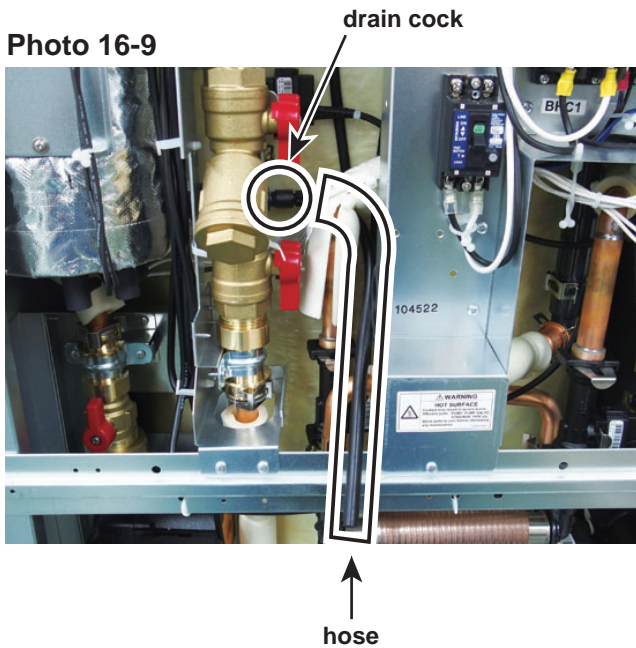


Photo 16-9



< pump valve and strainer valve >

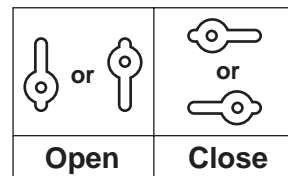


Photo 16-10

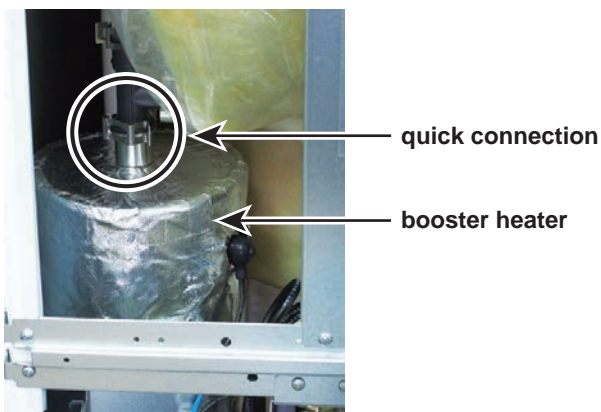
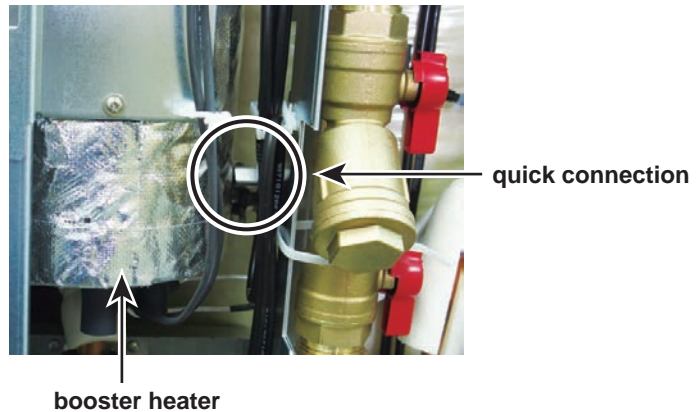


Photo 16-11



DISASSEMBLY PROCEDURE

(7) Remove all screws attached to the fixing plate, and then remove the fixing plate.(Photo 16-12)

(8) Remove the 2 screws(A) that hold the heater stay onto the front frame(L). Lift the booster heater slightly and remove the booster heater with the heater stay from the front frame(L). (Photo 16-12)

(9) Remove the 2 screws(B), and remove the heater stay from the booster heater.(Photo 16-12)

- Also replace the insulation washers that are provided on the screw of the heater stays.
- In case of using the booster heater with insulation, also replace the insulation sheets that are provided on surface of the booster heater.

17. How to remove the thermostat

< thermostat >

(1) Remove the front panel.

(2) Peel off the insulation on head of the thermostat in order to reveal the thermostat.(Photo 16-13)

(3) Pull out the thermostat, and disconnect the lead wires from the thermostat.(Photo 17)

- When installing the thermostat, install it at the top side of the pipe as shown in the photo.

Note:

Before replacing the thermostat, be sure to power off the cylinder unit.
Failure to do so may cause electric shock or cause the thermostat to malfunction.

PHOTOS

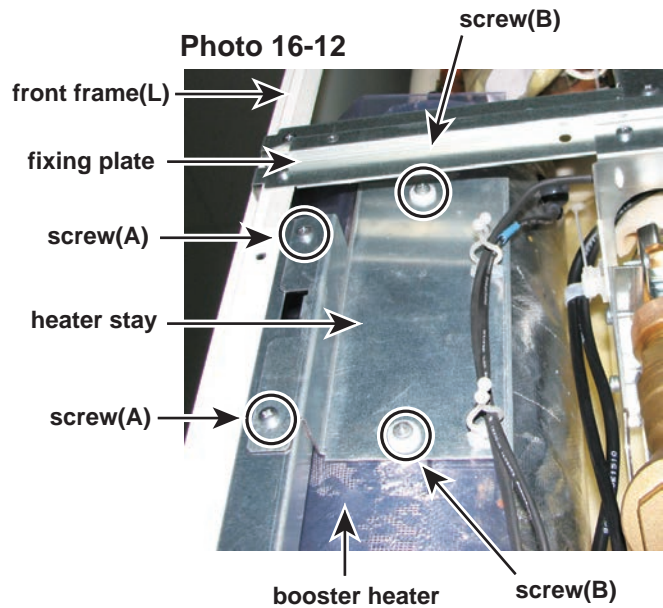


Photo 16-13

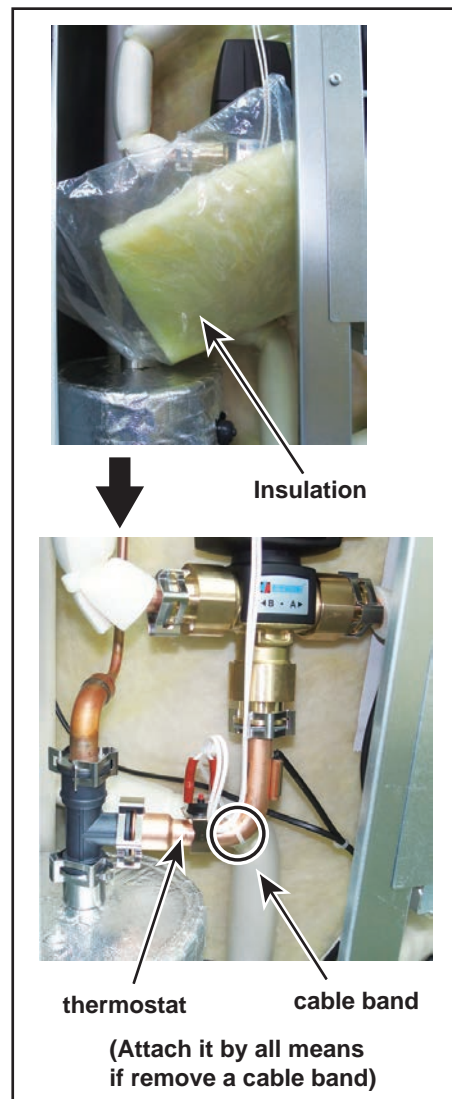
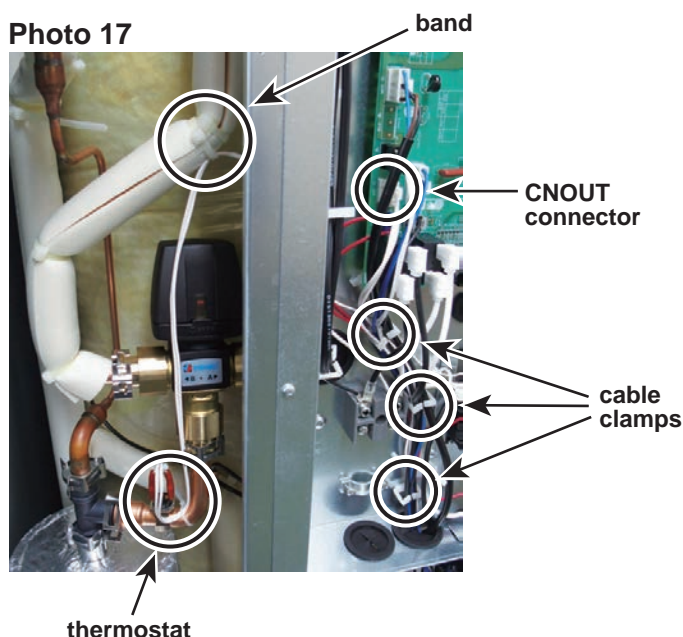


Photo 17



Notes on replacing the parts

When installing the parts that are not listed above, observe the tightening torques in accordance with Table 11-1. Always use a new O-ring or gasket.

Table 11-1

	Size [inch]	Recommended tightening torque [Nm]
Gasket	G1 1/2	30 ± 2
	G1	42 ± 2
	G1/2	11 ± 2
	G1/4	17 ± 2
O-ring	Air vent (Automatic)	18 ± 3
	Air vent (manual)	0.25 ± 0.05
	Drain cock	0.25 ± 0.05

After the procedure is complete, ensure that no water leaks.

Engineers Forms

Should settings be changed from default, please enter and record new setting in 'Field Setting' column. This will ease resetting in the future should the system use change or the circuit board need to be replaced.

Commissioning / Field settings record sheet

Main controller screen			Parameters	Default setting	Field setting	Notes	
Main	Zone1 heating room temp.		10°C - 30°C	20°C			
	Zone2 heating room temp. *5		10°C - 30°C	20°C			
	Zone1 heating flow temp.		25°C - 60°C	45°C			
	Zone1 heating compensation curve		-9°C - + 9°C	0°C			
	Holiday mode		Active/Non active/Set time	—			
Option	Forced DHW operation		On/Off	—			
	DHW		On/Off/Timer	On			
	Heating		On/Off/Timer	On			
	Energy monitor		Consumed electric energy/Produced energy	—			
	DHW supply max. temp.		40°C - 70°C	55°C			
Setting	Hot water (DHW)		DHW supply temp. drop	15°C - 30°C	15°C		
	DHW max. operation time		30 - 120 mins	60 mins			
	DHW mode restriction		30 - 120 mins	30 mins			
	DHW storage volume		Normal/Energy save	Normal			
	Heating	Compensation curve	Hi flow temp. set point	Zone1 operation mode	Room temp/Flow temp/Compensation curve	Room temp	
			Lo flow temp. set point	Zone1 outdoor ambient temp.	-30°C - +33°C	-15°C	
				Zone1 flow temp.	25°C - 60°C	50°C	
			Adjust	Zone1 outdoor ambient temp.	-28°C - +35°C	35°C	
				Zone1 flow temp.	25°C - 60°C	25°C	
			Zone1 outdoor ambient temp.		-29°C - +34°C	—	
	Zone1 flow temp.		25°C - 60°C	—			
	DHW		Active/Non active	Non active			
	Heating		Active/Non active	Active			
	Zone1 heating room temp.		10°C - 30°C	15°C			
	Zone2 heating room temp. *5		10°C - 30°C	15°C			
	Zone1 heating flow temp.		25°C - 60°C	35°C			
	°C/°F		°C/°F	°C			
	Summer time		On/Off	Off			
	Temp. display		Room/Tank/Room&tank /Off	Off			
	Time display		hh:mm/hh:mm AM/AM hh:mm	hh:mm			
Room sensor settings for Zone1		TH1/Main RC/Room RC1-8/"Time/Zone"	TH1				
Room sensor settings for Zone2 *1		TH1/Main RC/Room RC1-8/"Time/Zone"	TH1				
Room RC zone select *1		Zone1/Zone2	Zone1				
Service menu	Thermistor adjustment	THW1	-10°C - +10°C	0°C			
		THW2	-10°C - +10°C	0°C			
		THW3	-10°C - +10°C	0°C			
		THW4	-10°C - +10°C	0°C			
		THW5A	-10°C - +10°C	0°C			
		THW5B	-10°C - +10°C	0°C			
	Auxiliary settings	Economy settings for pump.		On/Off *3	On		
		Delay (3 - 60 mins)		10 mins			
		Electric heater (Heating)	Space heating: On (used)/Off (not used)		On		
	Electric heater delay timer (5 - 180 mins)		30 mins				
	Pump speed		Pump speed(1 - 5)	4			
	Heat source setting		Standard/Heater	Standard			
Operation settings	Heating operation	Flow temp.range *2	Min.temp.(25 - 45°C)	40°C			
		Room temp.control *2	Mode(Normal /Fast)	Normal			
		Interval(10 - 60min)	10 mins				
	Heat pump thermo diff.adjust *2	On/Off *3		On			
		Lower limit(-9 - -1°C)		-5°C			
		Upper limit(+3 - +15°C)		9°C			
Flow rate settings	Mode(Auto/Manual)		Auto				
	Flow rate(3 - 8L/min)		7L/min				
Freeze stat function *4		Outdoor ambient temp. (3 - 20°C) / **	5°C				
Energy monitor settings	Electric heater capacity	Booster heater 1 capacity	0 - 30kW	2kW			
	Water pump input	Pump 1	0 - 200W or ***(factory fitted pump)	***			
	Delivered energy adjustment		-50 - +50%	0%			
	Electric energy meter		0.1/1/10/100/1000 pulse/kWh	1 pulse/kWh			
Heat meter		0.1/1/10/100/1000 pulse/kWh	1 pulse/kWh				

*1 The settings related to Zone2 can be switched only when 2 zone temperature control is enabled (when DIP SW2-6 and SW 2-7 are ON).

*2 Valid only when operating in Room temp. control mode.

*3 On: the function is active; Off: the function is inactive.

*4 If asterisk (**) is chosen freeze stat function is deactivated. (i.e. primary water freeze risk)

*5 The settings related to Zone2 can be switched only when 2-Zone valve ON/OFF control is active.



Annual Maintenance Log Book

Contractor name		Engineer name	
Site name		Site number	
Cylinder unit maintenance record sheet			
Warranty number		Model number	
		Serial number	
No.	Mechanical	Frequency	Notes
1	Turn OFF water supply, drain potable circuit, remove mesh from strainer clean and replace in strainer. *1		
2	Drop the primary/heating system pressure to zero check and if necessary top up the expansion vessel (1 bar). Air valve of expansion vessel is TR-412.		
3	Check and if necessary top up the concentration of anti-freeze/inhibitor (if used in the system).		
4	Top up the primary/heating system using a temporary backflow prevention filling loop		
5	Open the pressure relief valves. Check for unrestricted discharge to the tundish and that the valves reseal correctly. Check there are no blockages in the tundish and associated pipework and re-pressurise to 1 bar.		
6	Heat system and check pressure does not rise above 3 bar and no water is released from the safety valves.		
7	Release any air from the system.		
8	To check the 3-way valve for inside leaks, confirm that the temperature of the heat emitter does not rise when running the DHW mode.		
Electrical		Frequency	Notes
1	Check condition of cables.		
2	Check rating and fuse fitted on the electricity supply.		
3	Check and record the operation voltage.		
Controller		Frequency	Notes
1	Check field settings against factory recommendations.		
2	Check operation of motorized valves ensure they reseal correctly.		
3	Check battery power of wireless thermostat and replace if necessary.		
Outdoor heat pump unit maintenance record sheet			
Model number		Serial number	
	Mechanical	Frequency	Notes
1	Inspect grill and air inlet for trapped debris/damage.		
2	Check condensate drain provision.		
3	Check integrity of water pipework and insulation.		
4	Check all electrical connections.		

* Checks should be carried out once a year.

*1 Be sure to reattach the mesh after washing.

Note: Within the first couple of months of installation, remove and clean the cylinder unit's strainer mesh plus any that are fitted external to the cylinder unit. This is especially important when installing on an existing system.

In addition to annual servicing, it is necessary to replace or inspect some parts after a certain period of system operation. Please see tables below for detailed instructions. Replacement and inspection of parts should always be done by a competent person with relevant training and qualifications.

Parts which require regular replacement

Parts	Replace every	Possible failures
Pressure relief valve (PRV) Air vent (Auto) Manometer	6 years	Water leakage

Parts which require regular inspection

Parts	Check every	Possible failures
Water circulation pump 1	50,000 hrs (7 years)	Water circulation pump failure

Parts which must NOT be reused when servicing

- * O-ring
- * Gasket

mitsubishi electric corporation

HEAD OFFICE : TOKYO BLDG., 2-7-3, MARUNOUCHI, CHIYODA-KU, TOKYO 100-8310, JAPAN

©Copyright 2015 MITSUBISHI ELECTRIC CORPORATION

Distributed in Jul. 2022 No. GCH15010 REVISED EDITION-C
Distributed in Feb. 2022 No. GCH15010 REVISED EDITION-B
Distributed in Jul. 2021 No. GCH15010 REVISED EDITION-A
Distributed in Dec. 2015 No. GCH15010
Made in Japan

New publication, effective Dec. 2015
Specifications are subject to change without notice.