

PRE-PLUMBED UNVENTED MAINS PRESSURE
WATER HEATER WITH FTC6 CONTROL SYSTEM.
FOR USE WITH ECODAN PUZ-(H)WM
AIR SOURCE HEAT PUMP RANGE.

January 2022

Doc. No. 607431

INSTALLATION MANUAL

EHPT15X-UKHLDW1S
EHPT17X-UKHLDW1S
EHPT15X-UKHDW1S
EHPT17X-UKHDW1S
EHPT21X-UKHDW1S
EHPT21X-UKHDW1L
EHPT25X-UKHDW1L
EHPT30X-UKHDW1L

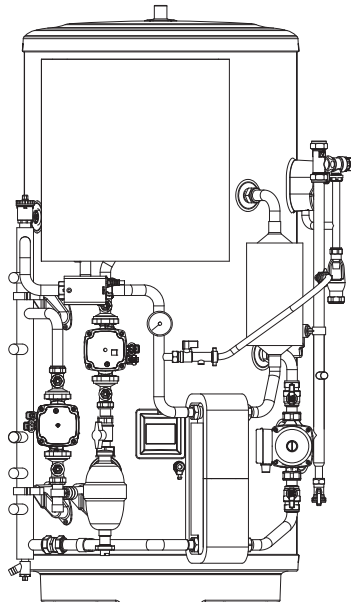

**IMPORTANT: PLEASE READ AND UNDERSTAND THESE INSTRUCTIONS
BEFORE COMMENCING INSTALLATION.
PLEASE LEAVE THIS MANUAL WITH THE CUSTOMER FOR FUTURE REFERENCE.**

CONTENTS

SAFETY NOTICES	2
INTRODUCTION.....	4
GENERAL REQUIREMENTS	6
INSTALLATION – GENERAL	18
INSTALLATION - DISCHARGE	21
INSTALLATION - HEAT PUMP PRIMARY CIRCUIT.....	24
INSTALLATION - WI-FI ADAPTER.....	37
INSTALLATION - IMMERSION HEATER ELECTRICAL SUPPLY	37
SYSTEM SET UP.....	38
COMMISSIONING	49
ENVIRONMENTAL INFORMATION	52
LOCAL APPLICATION FACTORS.....	52
TECHNICAL SUPPORT	52

SAFETY NOTICES

Please read the following safety precautions carefully.





⚠ WARNING:
Precautions that must be observed to prevent injuries or death.

⚠ CAUTION:
Precautions that must be observed to prevent damage to unit.

This installation manual along with the user manual should be left with the product after installation for future reference.
Mitsubishi Electric is not responsible for the failure of locally-supplied parts.

- Be sure to perform periodical maintenance.
- Be sure to follow your local regulations.
- Be sure to follow the instructions provided in this manual.

MEANINGS OF SYMBOLS DISPLAYED ON THE UNIT

	WARNING (Risk of fire)	This mark is for R32 refrigerant only. Refrigerant type is written on nameplate of outdoor unit. In case that refrigerant type is R32, this unit uses a flammable refrigerant. If refrigerant leaks and comes in contact with fire or heating part, it will create harmful gas and there is risk of fire.
	Read the OPERATION MANUAL carefully before operation.	
	Service personnel are required to carefully read the OPERATION MANUAL and INSTALLATION MANUAL before operation.	
	Further information is available in the OPERATION MANUAL, INSTALLATION MANUAL, and the likes.	

SAFETY NOTICES

⚠️ ⚠️ WARNING

Mechanical

- The cylinder unit and outdoor unit must not be installed, disassembled, relocated, altered or repaired by the user. Ask an authorised installer or technician. If the unit is installed improperly or modified after installation, water leakage, electric shock or fire may result.
- The outdoor unit should be securely fixed to a hard level surface capable of bearing its weight.
- The cylinder unit should be positioned on a hard level surface capable of supporting its filled weight to prevent excessive sound or vibration.
- Do not position furniture or electrical appliances below the outdoor unit or cylinder unit.
- The discharge pipework from the emergency devices of the cylinder unit should be installed according to local law.
- Only use accessories and replacement parts authorised by Mitsubishi Electric ask a qualified technician to fit the parts.

Electrical

- All electrical work should be performed by a qualified technician according to local regulations and the instructions given in this manual.
- The units must be powered by a dedicated power supply and the correct voltage and circuit breakers must be used.
- Wiring should be in accordance with national wiring regulations. Connections must be made securely and without tension on the terminals.
- Earth unit correctly.

General

- Keep children and pets away from both the cylinder unit and outdoor unit.
- Do not use the hot water produced by the heat pump directly for drinking or cooking. This could cause illness to the user.
- Do not stand on the units.
- Do not touch switches with wet hands.
- Annual maintenance checks on both the cylinder unit and the outdoor unit should be conducted by a qualified person.
- Do not place containers with liquids on top of the cylinder unit. If they leak or spill onto the cylinder unit damage to the unit and/or fire could occur.
- Do not place any heavy items on top of the cylinder unit.
- When installing, relocating, or servicing the cylinder unit, use only the heat pump's specified refrigerant to charge the refrigerant lines. Do not mix it with any other refrigerant and do not allow air to remain in the lines. If air is mixed with the refrigerant, then it can be the cause of abnormal high pressure in the refrigerant line, and may result in an explosion and other hazards.
- The use of any refrigerant other than that specified for the system will cause mechanical failure or system malfunction or unit breakdown. In the worst case, this could lead to a serious impediment to securing product safety.
- In heating mode, to avoid the heat emitters being damaged by excessively hot water, set the target flow temperature to a minimum of 2°C below the maximum allowable temperature of all the heat emitters. For Zone2, set the target flow temperature to a minimum of 5°C below the maximum allowable flow temperature of all the heat emitters in Zone2 circuit.
- Do not install the unit where combustible gases may leak, be produced, flow, or accumulate. If combustible gas accumulates around the unit, fire or explosion may result.
- Do not use means to accelerate the defrosting process or to clean, other than those recommended by the manufacturer.
- The appliance shall be stored in a room without continuously operating ignition sources (for example: open flames, an operating gas appliance or an operating electric heater).
- Do not pierce or burn.
- Be aware that refrigerants may not contain an odour.
- Pipe-work shall be protected from physical damage.
- The installation of pipe-work shall be kept to a minimum.
- Compliance with national gas regulations shall be observed.
- Keep any required ventilation openings clear of obstruction.
- Do not use low temperature solder alloy in case of brazing the refrigerant pipes.

⚠️ CAUTION

- Use clean water that meets local quality standards on the primary circuit.
- The outdoor unit should be installed in an area with sufficient airflow according to the diagrams in the outdoor unit installation manual.
- The cylinder unit should be located inside to minimise heat loss.
- Water pipe-runs on the primary circuit between outdoor and indoor unit should be kept to a minimum to reduce heat loss.
- Ensure condensate from outdoor unit is piped away from the base to avoid puddles of water.
- Remove as much air as possible from the primary and DHW circuits.
- Refrigerant leakage may cause suffocation. Provide ventilation in accordance with EN378-1.
- Be sure to wrap insulation around the piping. Direct contact with the bare piping may result in burns or frostbite.
- Never put batteries in your mouth for any reason to avoid accidental ingestion.
- Battery ingestion may cause choking and/or poisoning.
- Do not transport the cylinder unit with water inside the DHW tank. This could cause damage to the unit.
- If power to the cylinder unit is to be turned off (or system switched off) for a long time, the water should be drained.
- If unused for a long period, before operation is resumed, DHW tank should be flushed through with potable water.
- Preventative measures should be taken against water hammer, such as installing a Water Hammer Arrestor on the primary water circuit, as directed by the manufacturer.

As for the handling of refrigerant, refer to the outdoor unit installation manual.

INTRODUCTION

This range of factory pre-plumbed and wired unvented water heaters are specifically designed for use with the Ecodan PUZ- (H)WM Air Source Heat Pump range. The cylinder is manufactured in the UK from top quality materials and meets all the latest relevant safety and constructional standards. The high grade Duplex stainless steel cylinder offers exceptional strength and corrosion resistance. Its performance, control system and insulation levels exceed the latest requirements of Building Regulation Part L.

The unvented water heater can be fed directly from the cold water mains supply to the property without the need for separate feed cisterns or vent pipes. It is supplied fitted with all its necessary inlet and safety controls for compliance with Building Regulations. Also fitted are heat pump circulating pump, heating zone 1 circulating pump, DHW circulating pump, primary to DHW plate to plate heat exchanger, 3 way diverter valve, magnetic and cyclonic filter, scale trap, heat pump flow and return thermistors, two cylinder thermistors, primary circuit drain off valve, DHW circuit drain off valve, DHW secondary return tapping (210L+ only), low loss header, flow sensor, automatic air vent, primary filling loop and pressure gauge, a cylinder thermal cut-out, WI-Fi adaptor and FTC6 controller. The pumps, motorised valve and thermal controls are supplied pre-wired. The DHW expansion vessel is supplied loose for installation at a convenient position within the property. An electric immersion heater is also fitted to enable the unit to be heated should the heat pump require supplementary heating or be turned off.

NOTE: When using a sealed heating system, adequate provision for expansion within the primary circuit MUST be provided by fitting a primary circuit expansion vessel. Primary circuit expansion cannot be accommodated within the Air Source Heat Pump cylinder. A primary circuit pressure relief valve is fitted within the Ecodan PUZ-(H)WM air source heat pump outdoor unit.

The safety valves fitted to the Air Source Heat Pump cylinder protect the water heater only. Failure to provide adequate primary system pressure relief when using a sealed heating system will invalidate the Heat Pump warranty. Consult the Heat Pump installation instructions for further advice.

IMPORTANT NOTE TO THE INSTALLER

The pre-plumbed cylinder is specifically designed to be installed in conjunction with a Ecodan PUZ-(H)WM air source heat pump. The pre-plumbed cylinder is available in either STANDARD 22mm, STANDARD 28mm or SLIMLINE models. Please read these instructions before commencing installation. Unvented cylinders are a controlled service as defined in the latest edition of the building regulations and should only be carried out by a competent, qualified installer. The relevant regulations are:

England and Wales - Building Regulation Part G Section G3

Scotland - Technical Standard Section 4

Northern Ireland - Building Regulation Part F

After installation the Benchmark log book and included commissioning sheets must be completed and left along with these instructions with the householder for future reference.

Any water distribution and central heating installation must comply with the relevant recommendations of the current version of the Regulations and British Standards listed below:

Building Regulations

IEE Requirements for Electrical Installations (BS 7671)

Water Regulations

Manual Handling Operations Regulations

British Standards BS6798, BS5449, BS5540:1, BS5540:2, BS8558 and BS7593

Health and Safety Document No. 635

Only qualified and/or competent individuals should install the Ecodan system. Mitsubishi Electric's notes must not be taken as overriding statutory obligations.

An annual inspection of the system will be required to ensure safe, long term operation.

The information in this manual is provided to assist generally in the selection of equipment. The responsibility for the selection and specification of the equipment must however, remain with the installer and any designers or consultants concerned with the design, specification and installation of the system. Please note: Mitsubishi Electric does not therefore accept any responsibility for matters of design, selection or specification or for the effectiveness of an installation containing one of its products unless specifically requested to do so and expressly agreed in writing by Mitsubishi Electric at production stage.

All goods are sold subject to Mitsubishi Electric's Terms and Conditions of Sale.

Important Note:

Included with the Ecodan product is information about how to register the Mitsubishi Electric user guarantee. Please direct the end user to register within 3 months of commissioning and ensure they benefit from the applicable standard guarantee for their Ecodan heat pump and any cylinder or interfacing equipment purchased from Mitsubishi Electric by you as installer. The guarantee applies where the installation address is in England, Scotland or Wales only and for domestic use.

This registration should be completed only by the end user/system owner so please ensure that the information about how to register the Mitsubishi Electric user guarantee reaches them. There are various options to register the guarantee and details can be found online at <https://les.mitsubishielectric.co.uk> The registration is logged by our warranty department. In the unlikely event of failure of the Ecodan heat pump or any such cylinder or interfacing equipment purchased from Mitsubishi Electric, registration of the guarantee ensures that warranty claims are processed efficiently. For further information on the Mitsubishi Electric user guarantee please contact us by email: ecodan.service@meuk.mee.com or telephone 0161 866 6064.

Please Note:

If you do not register the Mitsubishi Electric user guarantee then the product will only be guaranteed to the user by Mitsubishi Electric for 12 months from the date of commissioning.

Our commercial guarantee to your user does not affect your user's statutory rights or any consumer rights under applicable national legislation.

NOTE: This manual is for revision A products only, manufactured on or after week 8 2022 see DATA label and drawing below for details

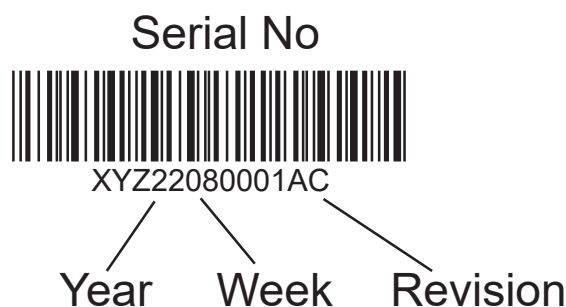

GENERAL REQUIREMENTS

IMPORTANT: THIS APPLIANCE CAN BE USED BY CHILDREN AGED FROM 8 YEARS AND ABOVE AND PERSONS WITH REDUCED PHYSICAL SENSORY OR MENTAL CAPABILITIES OR LACK OF EXPERIENCE AND KNOWLEDGE IF THEY HAVE BEEN GIVEN SUPERVISORY OR INSTRUCTION CONCERNING USE OF THE APPLIANCE IN A SAFE WAY AND UNDERSTAND THE HAZARDS INVOLVED. CHILDREN SHALL NOT PLAY WITH THE APPLIANCE. CLEANING AND USER MAINTENANCE SHALL NOT BE MADE BY CHILDREN WITHOUT SUPERVISION.

WARNING: Do not switch on if there is a possibility that the water in the heater is frozen.

COMPONENT CHECK LIST: Before commencing installation check that all the components for your Air Source Heat Pump cylinder are contained in the package. The following components are supplied with your unit:

Factory fitted:

- Temperature and Pressure Relief Valve (set at 90°C/10bar)
- Immersion heater and over-temperature cut-out
- Expansion relief valve (comprises of expansion valve and check valve)
- Tundish
- Heat pump circulating pump - Grundfos UPM3L 25-75 130AZA
- Heating zone 1 circulating pump - Grundfos UPM3 AUTO 25-70 130
- DHW circulating pump - Grundfos UPSO 15-60 CIL 2
- 3 Way motorised diverter valve
- Primary to DHW plate to plate heat exchanger
- Primary drain off valve & DHW drain off valve
- Fernox TF1 Sigma Magnetic filter
- Primary circuit filling loop
- Primary circuit pressure gauge
- Scale trap
- Low loss header
- Flow sensor
- Flow water temp and return water temp thermistors
- Cylinder temp thermistors
- Automatic air vent
- WI-Fi adaptor
- SD Card
- FTC6 Controller

Supplied loose:

- Main Remote Controller & Remote Controller Cable (10m)
- FTC instructions
- Potable water expansion vessel + bracket
- Cold water combination valve (comprises pressure reducing valve, strainer, check valve)

STORAGE AND HANDLING

Prior to installation the Pre-plumbed cylinder unit must be stored vertically upright on a secure, level surface in a dry, frost free environment. Take note of the weight of the product and follow safe working practices when lifting, moving or manipulating into position. DO NOT use the pre-plumbed pipework for lifting or positioning the cylinder. It is the responsibility of the installer to ensure all mechanical joints on the cylinder and pre-plumbed pipework are checked for tightness prior to filling the system, as these can become loose during transportation and positioning of the unit.

SITING THE UNIT

The Pre-plumbed cylinder unit must be vertically floor mounted. It can be placed anywhere convenient provided the discharge pipe(s) from its safety valves can be correctly installed and all pre-fitted ancillary parts can be accessed for servicing and/or maintenance. Areas that are subject to freezing must be avoided. Ensure that the floor is of sufficient strength to support the "full" weight of the unit (Table 1, page 7). Pipe runs should be kept as short as possible for maximum economy.

Additional automatic air vents (AAV) (not supplied) may be required at high points in the primary system where pipework is located above the level of the cylinder. After filling the system (primary circuit), release all trapped air using air vents during and following heating period and top up with water as necessary. After removing the air, automatic air vent(s) MUST be closed.

WATER SUPPLY

Bear in mind that the water supply to the property will be supplying both the hot and cold water requirements simultaneously. It is recommended that the maximum water demand is assessed and the water supply checked to ensure this demand can be satisfactorily met.

NOTE: A high water pressure will not always guarantee high flow rates.

Wherever possible the cylinder supply pipe should be 22mm. We suggest the minimum supply requirements should be 1.5 bar pressure and 20 litres per minute flow rate. However, at these values outlet flow rates may be poor if several outlets are used simultaneously. The higher the available pressure and flow rate the better the system performance.

The cylinder has an operating pressure of 3.5 bar which is controlled by the cold water combination valve assembly. The cold water combination valve assembly can be connected to a maximum inlet pressure of 16 bar.

IMPORTANT INSTALLATION NOTE

WHERE THE INLET SUPPLY TO THE PRESSURE REDUCING VALVE (PRV) IS ROUTED THROUGH A HEATED SPACE AND IS FITTED WITH A CHECK VALVE OR OTHER FITTING THAT WOULD PREVENT BACK FLOW, HIGH PRESSURES CAN BE EXPERIENCED IN THE INLET PIPE DUE TO WARMING THAT CAN CAUSE DAMAGE TO THE PRV OR OTHER FITTINGS ON THE INLET SUPPLY. IN THESE CIRCUMSTANCES, THE INSTALLATION OF A MEANS TO ACCOMMODATE EXPANSION AND THUS LIMIT THE PRESSURE RISE IN THE INLET PIPE IS RECOMMENDED. REFER TO THE INSTALLATION SECTION FOR FURTHER DETAILS.

OUTLET/TERMINAL FITTINGS (TAPS, ETC.)

The Pre-plumbed cylinder can be used in conjunction with most types of terminal fittings, plumbing fittings and pipework. However, the rated pressures of any fittings selected should be checked for compatibility before installation.

NOTE: Accessories, plumbing fittings and pipe work should have a rated operating pressure of at least 8 bar. Outlets situated higher than the cylinder will give outlet pressures lower than that at the unit, a 10m height difference will result in a 1 bar pressure reduction at the outlet fitting.

LIMITATIONS

The Pre-plumbed cylinder should not be used in association with any of the following:

- Solid fuel boilers or any other boiler in which the energy input is not under effective thermostatic control, unless additional and appropriate safety measures are installed.
- Ascending spray type bidets or any other class 1 back syphonage risk require that a type A air gap be employed.
- Steam heating plants unless additional and appropriate safety devices are installed.
- Situations where maintenance is likely to be neglected or safety devices tampered with.
- Water supplies that have either inadequate pressure or where the supply may be intermittent.
- Situations where it is not possible to safely pipe away any discharge from the safety valves.
- In areas where the water consistently contains a high proportion of solids, e.g. suspended matter that could block the strainer unless adequate filtration can be ensured.

OPERATIONAL SUMMARY

Maximum mains supply pressure	1.6 MPa (16 bar)
Operating pressure	0.35 MPa (3.5 bar)
Expansion vessel pressure	0.35 MPa (3.5 bar)
Maximum design (Rated) pressure	0.8 MPa (8 bar)
Expansion relief valve setting	0.8 MPa (8 bar)
T&P relief valve setting	90°C/1.0 MPa (10 bar)
T&P relief valve manufacturers ref	RWC PTEM 510003
Maximum primary circuit pressure	0.3 MPa (3 bar)
Maximum heating fluid temperature	85°C
Storage capacity	See Table 1 below
Weight when full	See Table 1 below

OUTLINE SPECIFICATIONS

The cylinders are designed, constructed and tested for compliance with BS EN 12897:2016

Outer casing: White pre-painted corrosion resistant steel

Water container: Duplex stainless steel. 100% pressure tested to 1.5 MPa (15 bar).

Thermal insulation: CFC/HCFC free fire retardant expanded polyurethane foam with zero ozone depletion potential. It has a Global Warming Potential (GWP) of 3.1. Nominal thickness: Standard units 60mm - Slimline units 50mm.

Table 1 - Unit Weights & Standing Heat Loss

Model Type	Nominal Capacity (litres)	Weight of full unit (kg)	Weight of unit (kg)	Standing Heat Loss	
				per day (kWh/24h)	per year (kWh/365d)
Standard	150	205	55	1.15	419.7
Standard	170	228	58	1.23	448.9
Standard	210 (Small)	274	64	1.53	558.5
Standard	210 (Large)	278	68	1.53	558.2
Standard	250	324	74	1.80	657.0
Standard	300	382	82	2.06	751.9
Slimline	150	209	59	1.40	511.0
Slimline	170	233	63	1.59	580.4

Fig. 1 - Parts Identification

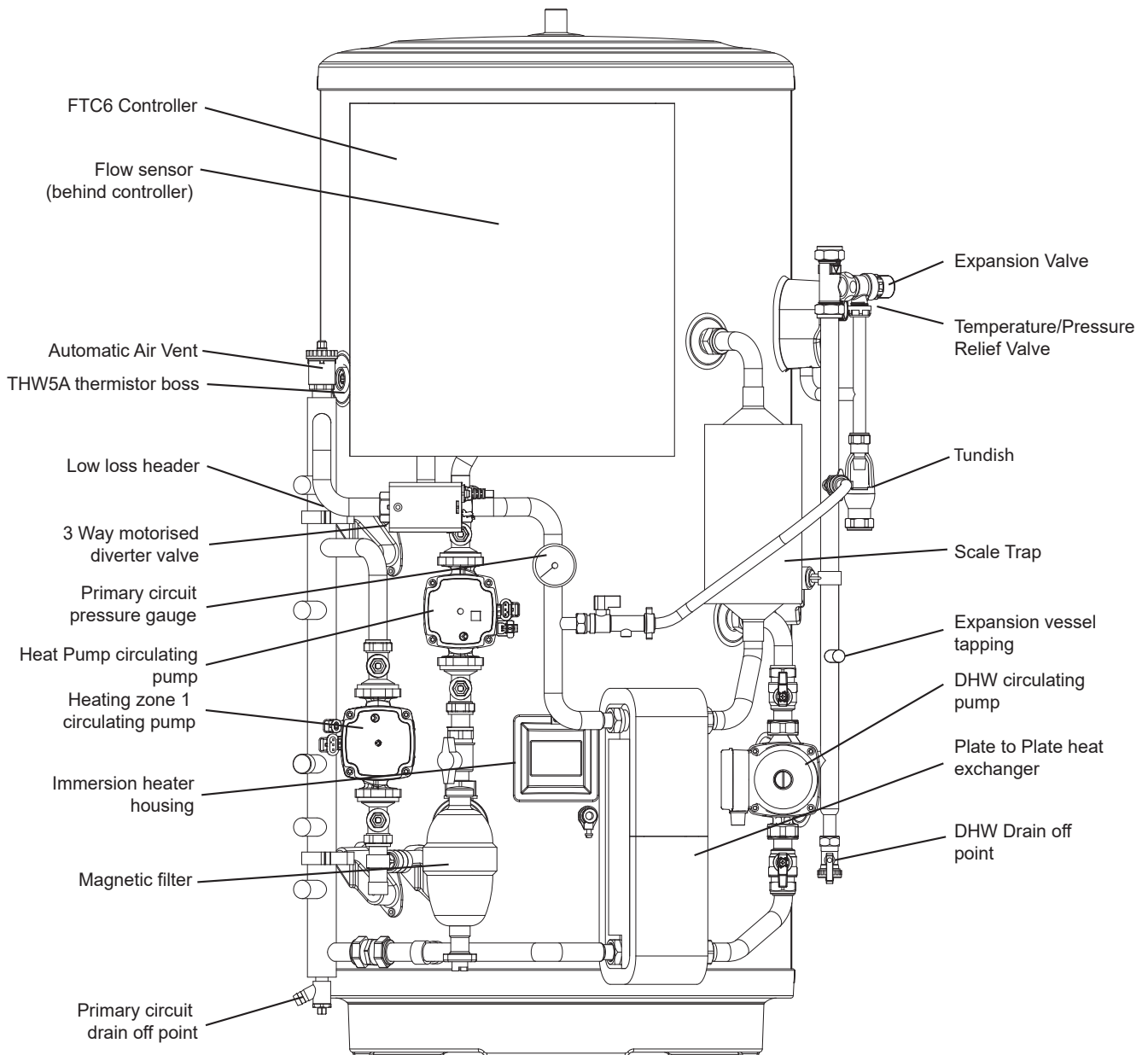

Indicative Performance

Nominal capacity (litres)	Type	Hot water capacity (litres)	Reheat time (minutes)	Nominal heat input (kW)
150	Slimline	144	92	4.83
170	Slimline	175	69	7.85
150	Standard	153	65	7.20
300	Standard	301	172	5.38
				Average 6.32

NOTE: Heating times achieved using an Air Source Heat Pump with variable output power and boost heating to 60°C using a 3kW immersion heater and a primary (heat pump) flow rate of 20 l/min. Test method in accordance with EN12897:2006

Fig. 2a - Dimensions and EU Product Fiche - 28mm Standard Models

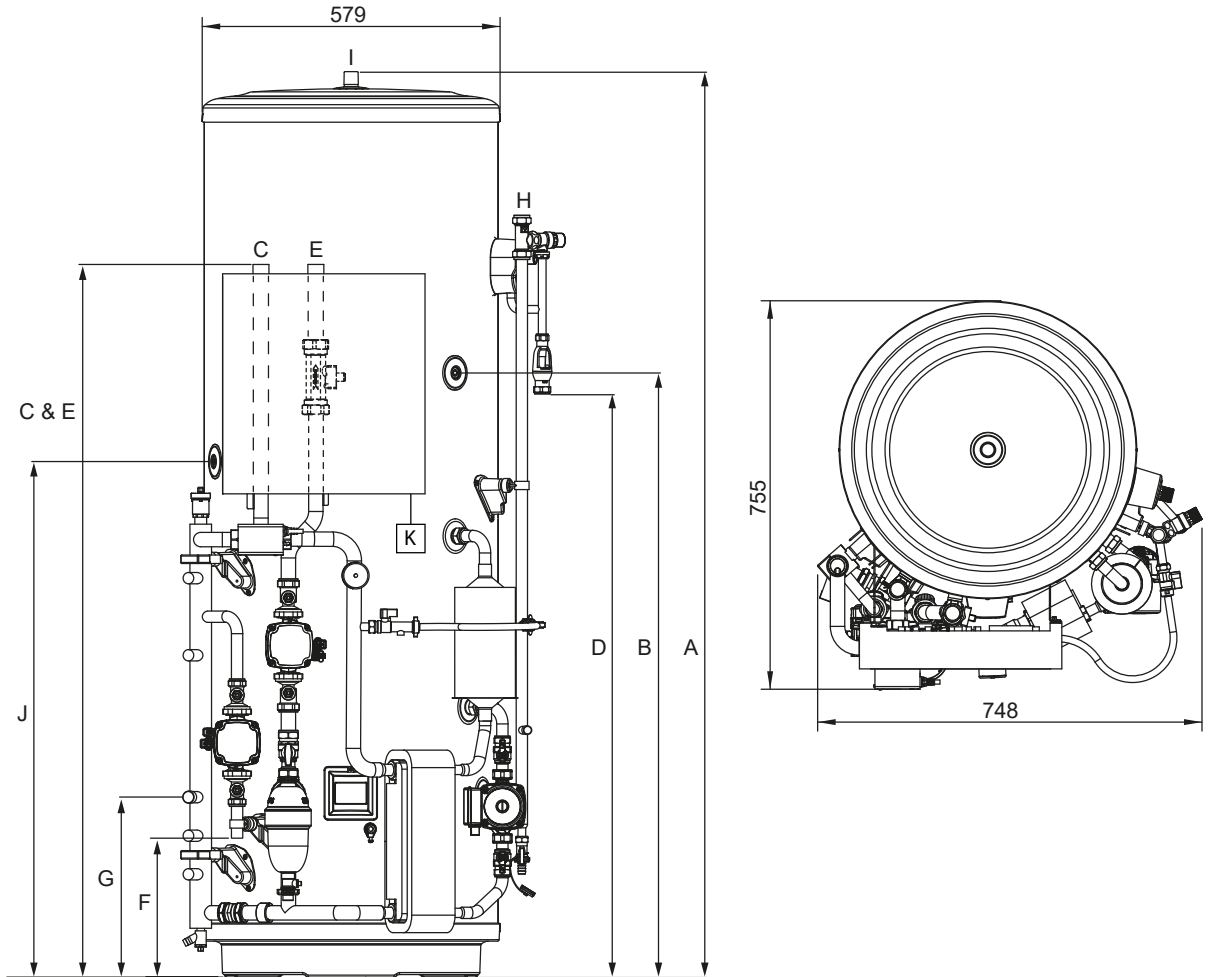

KEY

- A OVERALL HEIGHT
- B SECONDARY RETURN TAPPING
- C HEAT PUMP FLOW CONNECTION (28mm O/D COPPER)
- D TUNDISH OUTLET CONNECTION (22mm COMPRESSION)
- E HEAT PUMP RETURN CONNECTION (28mm O/D COPPER)
- F HEATING ZONE 1 CIRCUIT FLOW CONNECTION (22mm O/D COPPER)
- G HEATING ZONE 1 CIRCUIT RETURN CONNECTION (22mm O/D COPPER)
- H COLD WATER INLET CONNECTION (22mm COMPRESSION)
- I HOT WATER OUTLET CONNECTION (22mm COMPRESSION / 3/4" BSP M)
- J THW5A SENSOR POCKET
- K WI-FI ADAPTOR (INCLUDED, INSTALLER TO LOCATE AND MOUNT)

CAPACITY	210	250	300
A	1509	1761	2075
B	1050	1175	1385
C	1370	1370	1370
D	880	1136	1450
E	1370	1370	1370
F	270	270	270
G	350	350	350
J	925	1005	1193
K	Installer to locate and mount		

MODEL	EHPT21X-UKHDW1L	EHPT25X-UKHDW1L	EHPT30X-UKHDW1L
Energy efficiency class	C	C	C
Standing loss in W	65.0	75.0	85.8
Storage volume V in Litres	210	250	300
Technical parameters in accordance with European Commission regulations 814/2013 and 812/2013			

Fig. 2b - Dimensions and EU Product Fiche - 22mm Standard Models

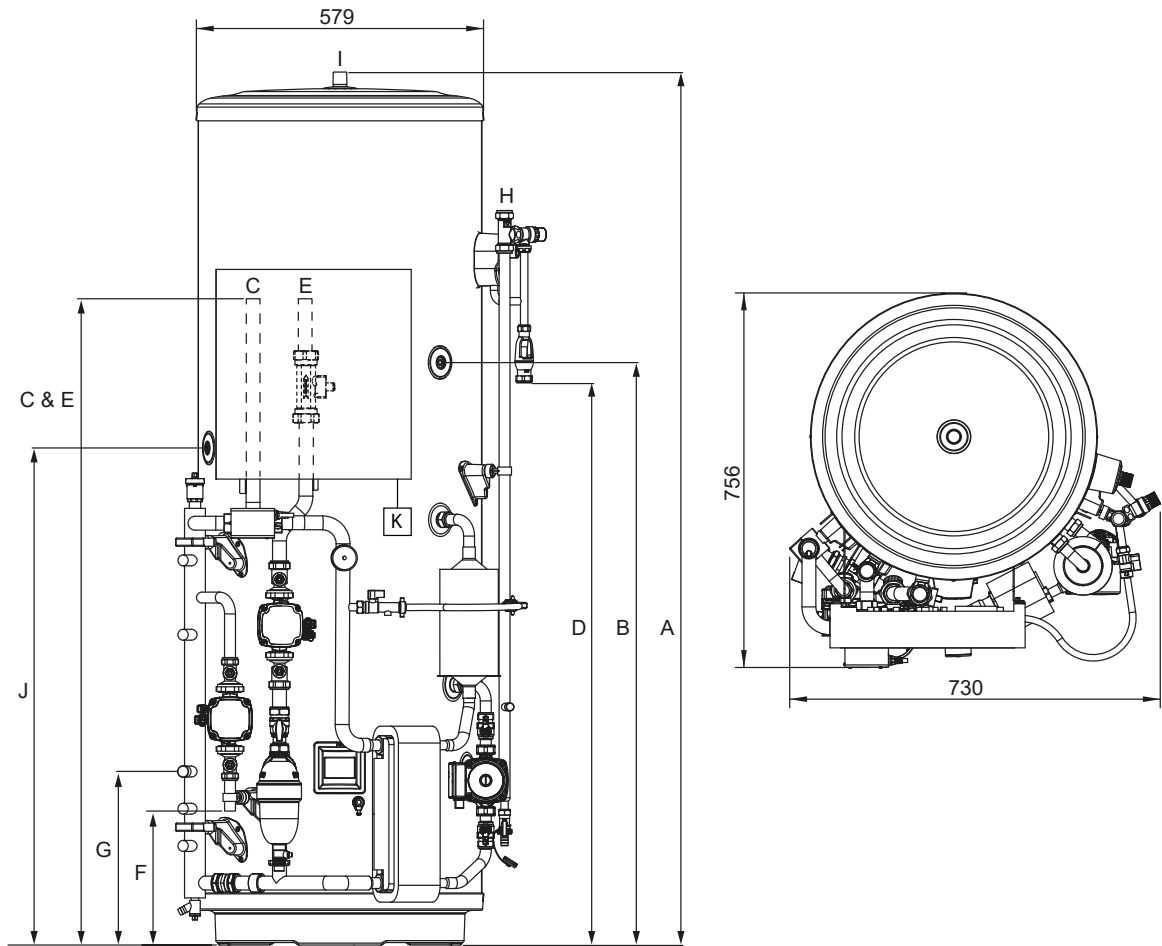

KEY

- A OVERALL HEIGHT
- B SECONDARY RETURN TAPPING (NOT FITTED TO EHPT15X-UKHDW1S/ EHPT17X-UKHDW1S)
- C HEAT PUMP FLOW CONNECTION (22mm O/D COPPER)
- D TUNDISH OUTLET CONNECTION (22mm COMPRESSION)
- E HEAT PUMP RETURN CONNECTION (22mm O/D COPPER)
- F HEATING ZONE 1 CIRCUIT FLOW CONNECTION (22mm O/D COPPER)
- G HEATING ZONE 1 CIRCUIT RETURN CONNECTION (22mm O/D COPPER)
- H COLD WATER INLET CONNECTION (22mm COMPRESSION)
- I HOT WATER OUTLET CONNECTION (22mm COMPRESSION / 3/4" BSP M)
- J THW5A SENSOR POCKET
- K WI-FI ADAPTOR (INCLUDED, INSTALLER TO LOCATE AND MOUNT)

CAPACITY	150	170	210
A	1131	1257	1509
B	Not fitted	Not fitted	1050
C	1122	1122	1122
D	505	630	880
E	1122	1122	1122
F	194	194	194
G	350	350	350
J	675	815	925
K	Installer to locate and mount		

MODEL	EHPT15X-UKHDW1S	EHPT17X-UKHDW1S	EHPT21X-UKHDW1S
Energy efficiency class	B	B	C
Standing loss in W	47.9	51.2	63.7
Storage volume V in Litres	150	170	210
Technical parameters in accordance with European Commission regulations 814/2013 and 812/2013			

Fig. 2c - Dimensions and EU Product Fiche - 22mm Slimline Models

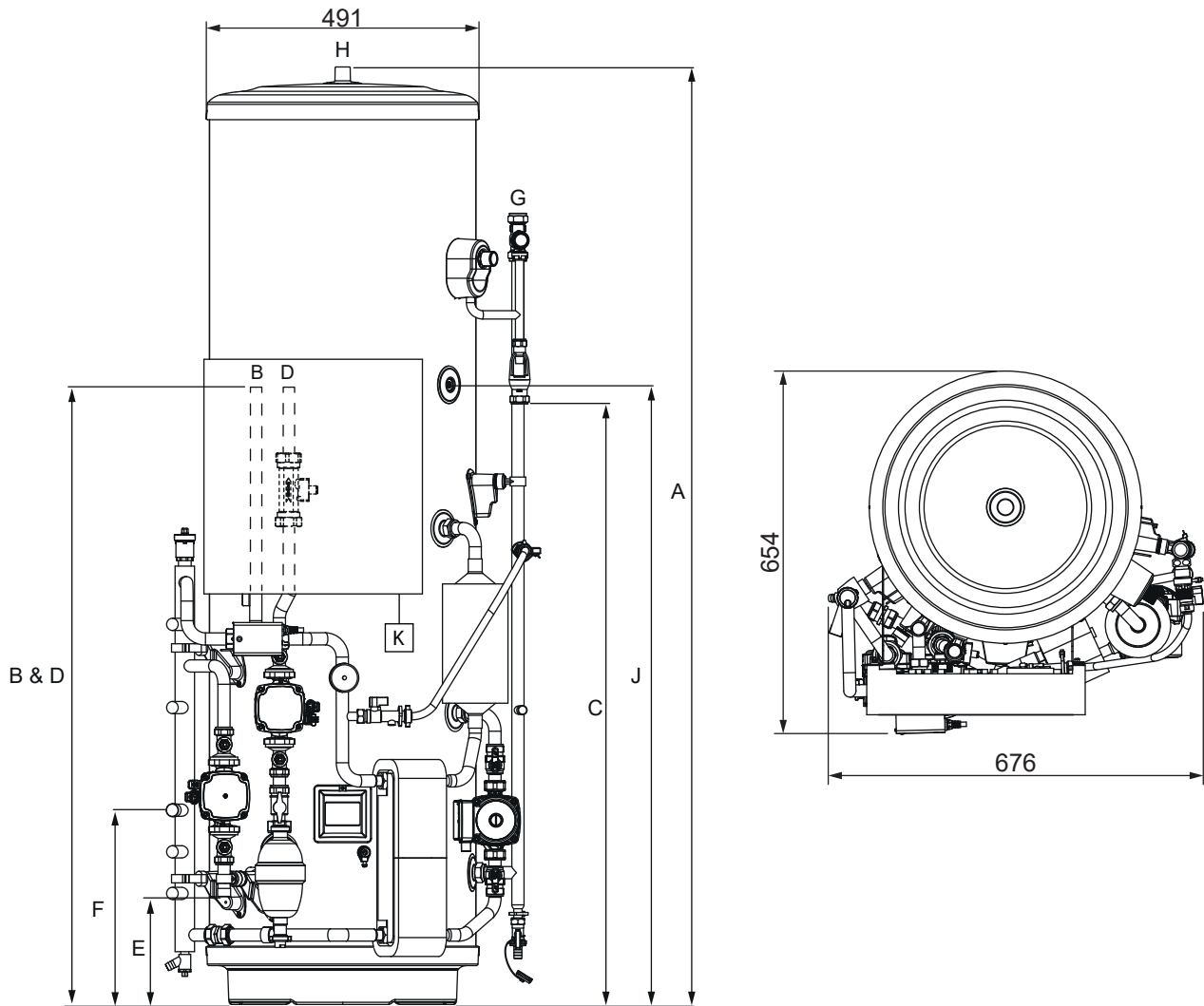

KEY

- A OVERALL HEIGHT
- B HEAT PUMP FLOW CONNECTION (22mm O/D COPPER)
- C TUNDISH OUTLET CONNECTION (22mm COMPRESSION)
- D HEAT PUMP RETURN CONNECTION (22mm O/D COPPER)
- E HEATING ZONE 1 CIRCUIT FLOW CONNECTION (22mm O/D COPPER)
- F HEATING ZONE 1 CIRCUIT RETURN CONNECTION (22mm O/D COPPER)
- G COLD WATER INLET CONNECTION (22mm COMPRESSION)
- H HOT WATER OUTLET CONNECTION (22mm COMPRESSION / 3/4" BSP M)
- J THW5A SENSOR POCKET
- K WI-FI ADAPTOR (INCLUDED, INSTALLER TO LOCATE AND MOUNT)

CAPACITY	150	170
A	1516	1690
B	1127	1127
C	909	1083
D	1127	1127
E	194	194
F	350	350
J	943	1117
K	Installer to locate and mount	

MODEL	EHPT15X-UKHLDW1S	EHPT17X-UKHLDW1S
Energy efficiency class	C	C
Standing loss in W	58.3	66.3
Storage volume V in Litres	150	170
Technical parameters in accordance with European Commission regulations 814/2013 and 812/2013		

Table 2 - STANDARD Cylinder Technical Data

UNIT		STANDARD						
		150	170	210 (Small)	210 (Large)	250	300	
Nominal hot water capacity (litres)		14/17/24/32/40 l/min						
Water		Primary flow rate (H) WM 50/60/85/112/140						
Pump		Heat Pump - Grundfos UPM3L 25-75 130AZA Heating - Grundfos UPM3 AUTO 25-70 130 DHW - Grundfos UPSO 15-60 CIL2						
Connection size Heating/DHW (mm)		22/22						
DHW Expansion vessel (litres)		12 18 18 18 24 24						
Charge pressure (MPa (bar))		0.35 (3.5)						
Control thermistor (°C)		80						
Pressure Relief Valve (MPa (bar))		0.3 (3.0) Contained within outdoor unit						
Control thermistor (°C)		75						
Over-temperature cut-out (°C)		80 +/- 5						
Temp/Pressure Relief Valve (°C/MPa (bar))		90 / 1.0 (10.0)						
Expansion valve (MPa (bar))		0.8 (8.0)						
Width		730	730	730	748	748	748	748
Depth		756	756	756	755	755	755	755
Height		1131	1257	1509	1509	1761	2075	2075
Weight empty/full (kg)		55/205	58/228	64/274	68/278	74/324	82/382	82/382
Materials		Vessel Insulation Expanded polyurethane (PU) 60						
Nominal thickness (mm)		60						
Standing heat loss (kWh/24h)		1.15	1.23	1.53	1.53	1.80	1.80	2.09
Ozone Depletion Potential		zero						
Global Warming Potential		3.1						
Electrical supply		220 - 240 V ~, 50Hz						
Phase		single						
Fuse rating - MCB Size (A)		16						
Electrical supply		220 - 240 V ~, 50Hz						
Phase		single						
Rating (kW at 240V)		3						
Max current (A)		13						
Fuse rating - MCB Size (A)		16						
Mechanical zones		DHW and 1 heating zone *						
Optional wireless room thermostat and wireless receiver		PAR-WT50-E controller & PAR-WR51-E receiver						

* Optional 2-zone accessory pack available

Table 3 - SLIMLINE Cylinder Technical Data

UNIT		SLIMLINE	
Nominal hot water capacity (litres)		150	170
Water	Primary flow rate (H)WM50/60/85	14/17/24 l/min	
	Pump	Heat Pump - Grundfos UPM3L 25-75 130AZA Heating - Grundfos UPM3 AUTO 25-70 130 DHW - Grundfos UPSO 15-60 CIL2	
Connection size Heating/DHW (mm)		22/22	
DHW Expansion vessel (litres)		12	18
Charge pressure (MPa (bar))		0.35 (3.5)	
Safety devices	Control thermistor (°C)	80	
	Pressure Relief Valve (MPa (bar))	0.3 (3.0) Contained within outdoor unit	
DHW circuit		75	
Over-temperature cut-out (°C)		80 +/- 5	
Temp/Pressure Relief Valve (°C/MPa (bar))		90 / 1.0 (10.0)	
Expansion valve (MPa (bar))		0.8 (8.0)	
Dimensions (mm)	Width	676	676
	Depth	654	654
	Height	1516	1690
Weight empty/full (kg)		59/209	63/233
Materials	Vessel	Duplex stainless steel	
	Insulation	Expanded polyurethane (PU)	
Nominal thickness (mm)		50	
Standing heat loss (kWh/24h)		1.40	1.59
Ozone Depletion Potential		zero	
Global Warming Potential		3.1	
Electrical data	Electrical supply	220 - 240 V ~, 50Hz	
	Phase	single	
	Fuse rating - MCB Size (A)	16	
	Electrical supply	220 - 240 V ~, 50Hz	
	Phase	single	
	Rating (kW at 240V)	3	
	Max current (A)	13	
	Fuse rating - MCB Size (A)	16	
Mechanical zones		DHW and 1 heating zone*	
Optional wireless room thermostat and wireless receiver		PAR-WT50-E controller & PAR-WR51-E receiver	

*Optional 2-zone accessory pack available

HEAT PUMP CIRCULATION PUMP (GRUNDFOS UPM3L 25-75 130AZA)

Graph 1 - UPM3L 25-75 130AZA Performance Curves

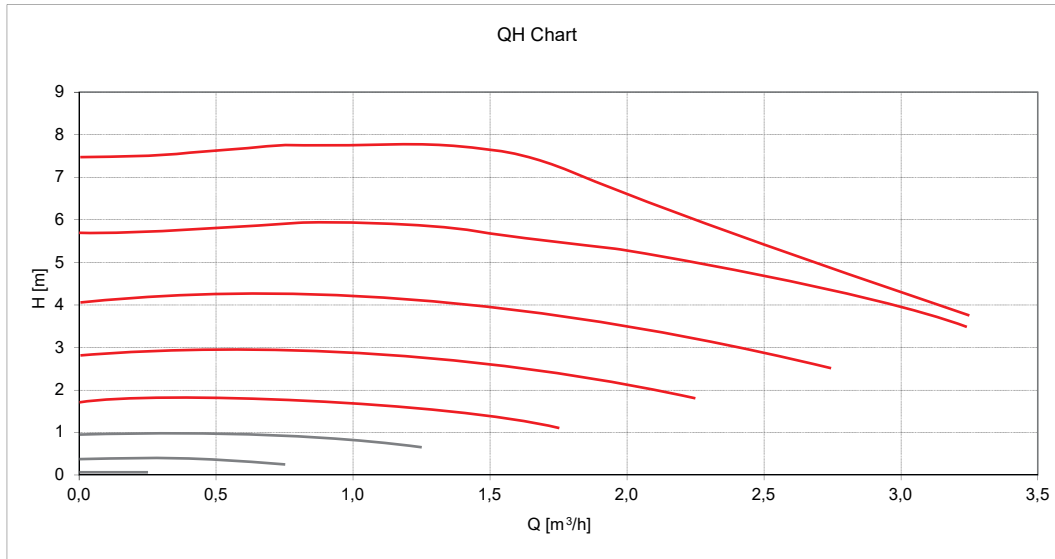

Five pump speed control is available via FTC6 control.

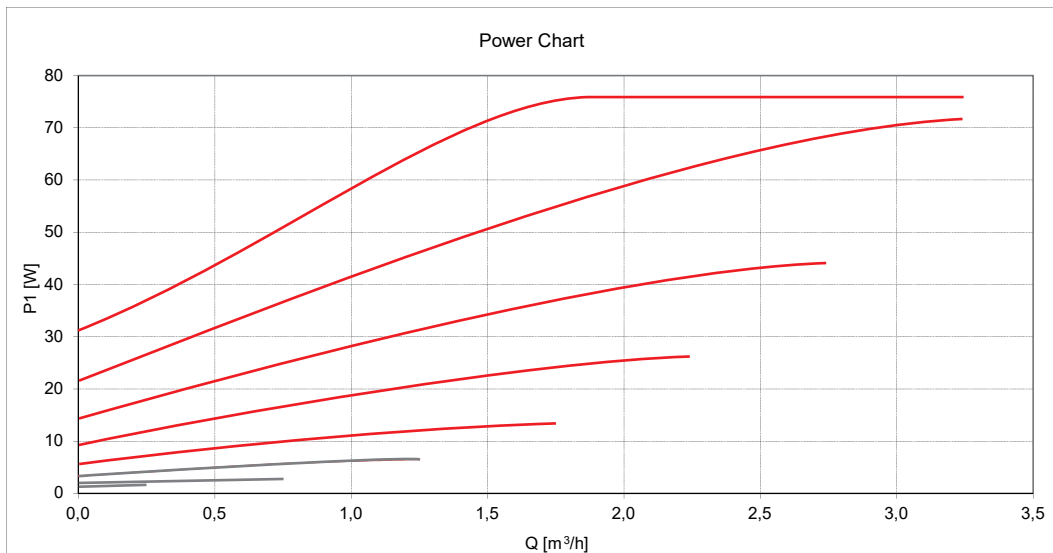

Pump speed can be selected by main remote controller setting (see Graph 1, red curves).

Adjust the pump speed setting so that the flow rate in the primary circuit is appropriate for the outdoor unit installed.

It may be necessary to add an additional pump to the system depending on the length and lift of the primary circuit. If the additional pump(s) have current greater than 1A please use appropriate relay. If the second pump is being used in the primary circuit between the cylinder unit and the outdoor unit then the signal cable should be wired to TBO.1 terminals 1 and 2 (OUT1). In this position the pump speed MUST match the speed of the cylinder unit's in-built pump.

HEATING ZONE 1 CIRCULATION PUMP (GRUNDFOS UPM3 AUTO 25-70 130)

When you switch on the pump it will run to the pre-set position or the last setting. The diagram below shows the current operation status.

To change the pump setting, follow below:



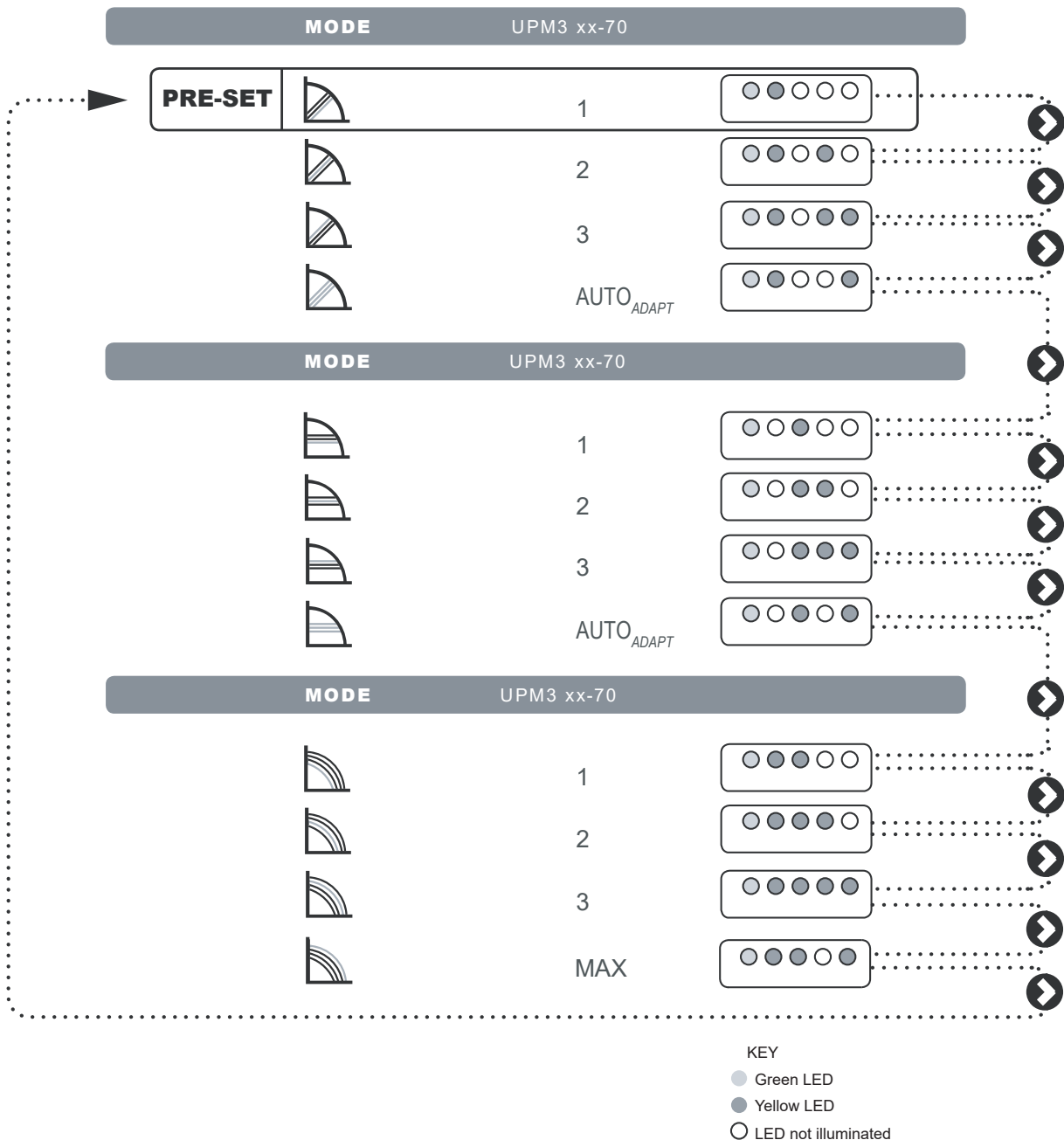

- Press the '⏸' to switch to the settings view. The LEDs show the current setting for 2 seconds.
- Release '⏸' for more than 2 seconds. The user interface shows the current performance in "operation status".
- Press '⏸' for more than 2 seconds and the circulator switches to "setting selection". The LEDs flash and show the current setting mode. Please note that if the key lock is disabled, the circulator will not switch to "setting selection". In this case, unlock the key lock by pressing the button for 10 seconds.
- During a period of 10 seconds, press shortly on the '⏸' and the pump switches to the next setting.
- To select between the settings, instantly press the button until you find the setting you want. If you pass the setting, you will need to continue until the setting appears again. It is not possible to go back.
- Release '⏸' for more than 10 seconds and the user interfaces switches back to the performance view and the last setting is stored.
- Press '⏸' and the display switches to the setting view and the LEDs show the current setting for 2 seconds.
- Release '⏸' for more than 2 seconds and the user interface switches back to the performance view.



Control Mode explanation





Proportional pressure

The head pressure is reduced at falling heat demand and increased at rising heat demand.
 The duty point of the circulator will move up or down on the selected proportional pressure curve depending on the heat demand in the system.

-  PP1: Lowest proportional pressure curve
-  PP2: Intermediate proportional pressure curve
-  PP3: Highest proportional pressure curve
-  AUTO_{ADAPT}

Constant pressure

The head pressure is kept constant, irrespective of the heat demand.
 The duty point of the circulator will move out or in on the selected constant pressure curve, depending on the heat demand in the system.

-  CP1: Lowest constant pressure curve
-  CP2: Intermediate constant pressure curve
-  CP3: Highest constant pressure curve
-  AUTO_{ADAPT}

Constant curve

The circulator runs on a constant curve, which means that it runs at a constant speed or power.

The duty point of the circulator moves up or down the selected curve, depending on the heat demand in the system.



Graph 2 - UPM3 performance curve

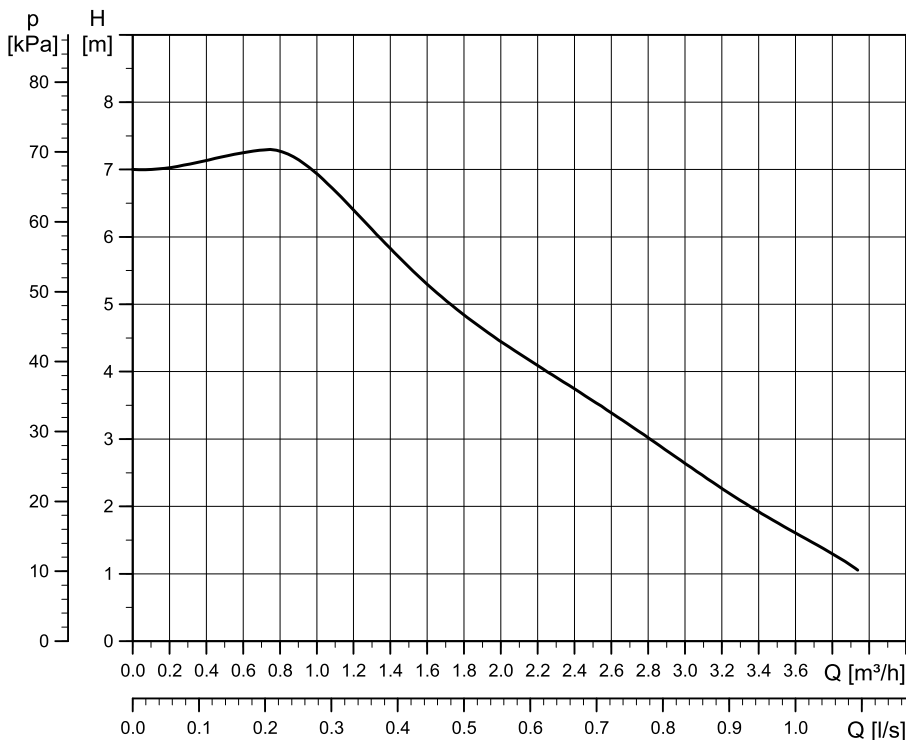

Graph 3 - Cylinder Pressure Drop

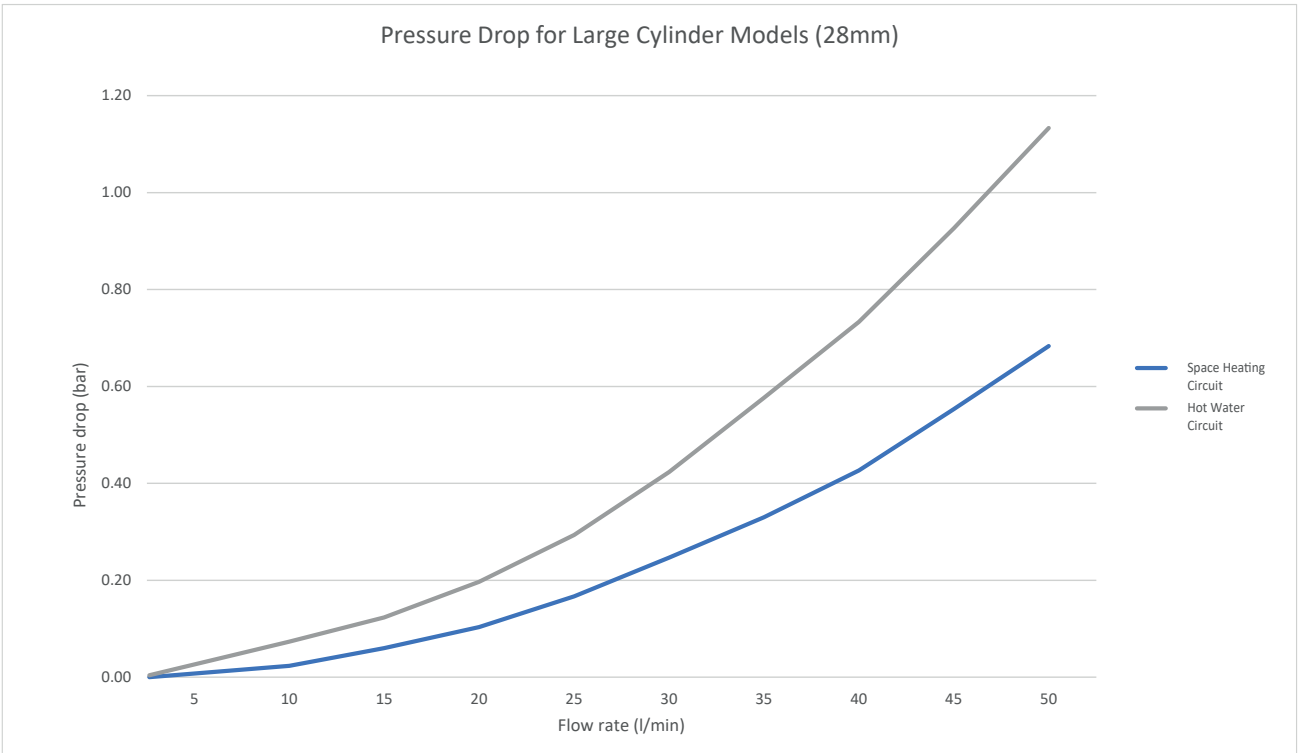
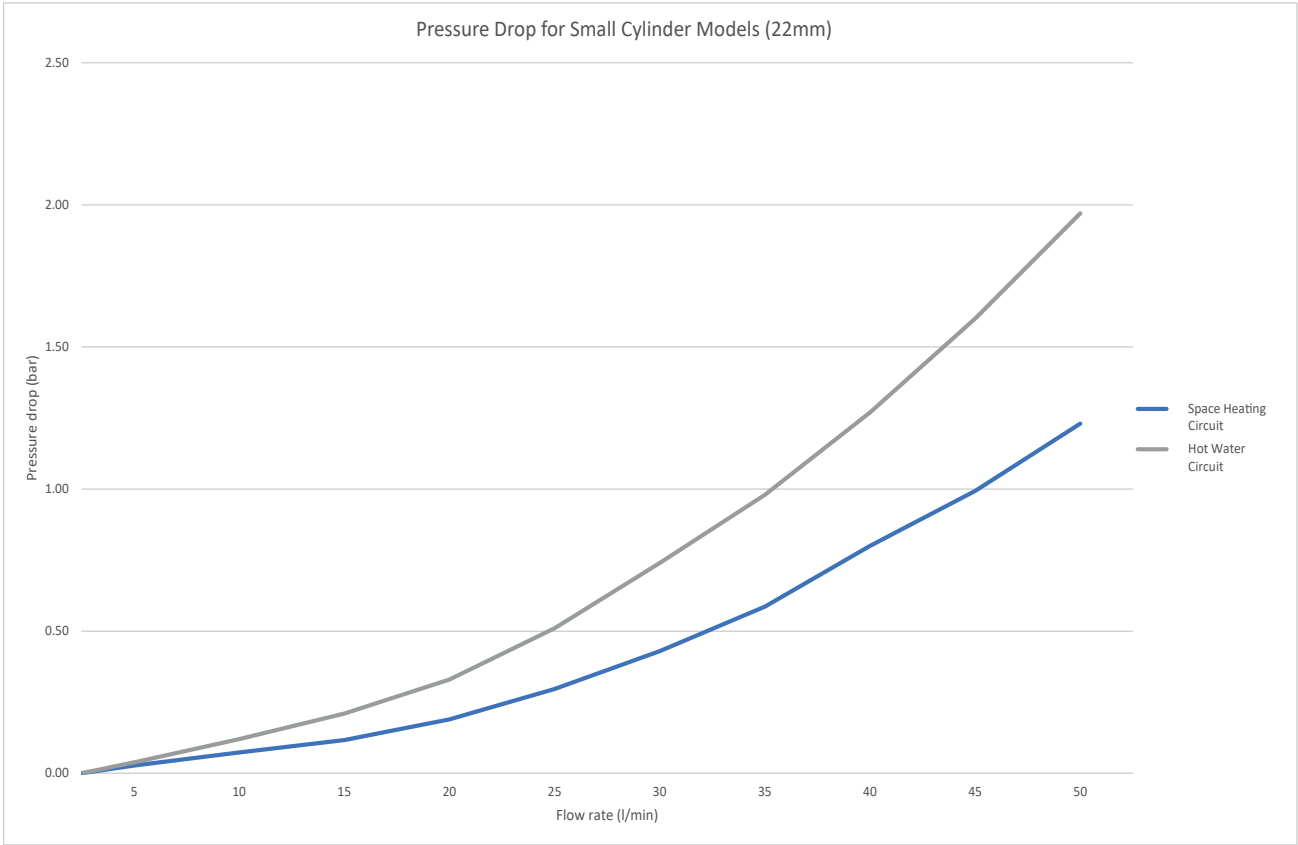

INSTALLATION – GENERAL

PIPE FITTINGS

The connection points to the heating system are in 22mm copper pipe. The use of appropriately sized COMPRESSION FITTINGS is recommended when connecting to the pipes. Solder fittings can be used, but extreme care must be taken to ensure any ancillary components in close proximity are not damaged by heat. Push fit type fittings can be used for connection to the copper pipes.

The inlet connection to the cold water combination valve is 22mm compression. The cylinder outlet fitting is suitable for connection to 22mm o/dia pipe (compression nut and olive supplied). The outlet is also threaded 3/4" BSP male parallel should threaded pipe connections be preferred.

COLD FEED

A 22mm cold water supply is recommended, however, if a 15mm (1/2") supply exists which provides sufficient flow, this may be used. More flow noise may be experienced from small bore pipes due to the increased water velocity through them.

A stopcock or servicing valve should be incorporated into the cold water supply to enable the cylinder and its associated controls to be isolated and serviced.

PRESSURE REDUCING VALVE (Fig. 3 below)

The 3.5 bar pressure reducing valve can be connected anywhere on the cold water mains supply prior to the Air Source Heat Pump cylinder. There is no requirement to site it close to the unit, it can be located at a point where the mains supply enters the premises if this is more convenient but a non-return valve must be installed just after the reducing valve for ease of maintenance.

PRV WARNING: IF THERE IS AN UPSTREAM CHECK VALVE OR FITTING WHICH MAY PREVENT BACK FLOW THEN HIGH PRESSURES CAN BE EXPERIENCED DUE TO AMBIENT TEMPERATURES WHICH CAN CAUSE DAMAGE TO THE VALVES AND FITTINGS

Fig. 3 - Pressure reducing valve

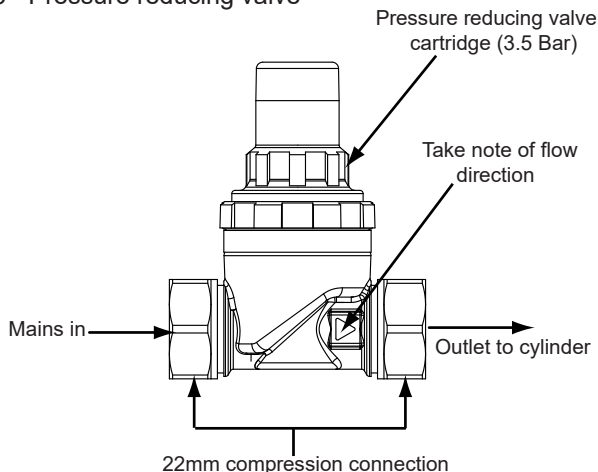
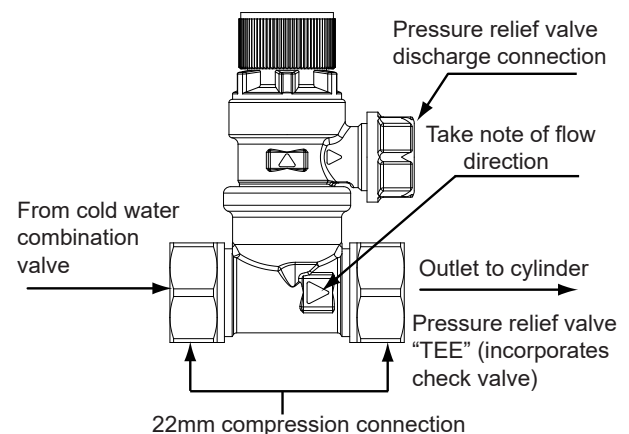

Fig. 4 - Pressure relief valve (8 bar)



PRESSURE RELIEF VALVE (Fig. 4 above)

Should a balanced pressure cold water supply be required to cold water outlets such as thermostatic shower mixer valves or combination taps, the cold water balanced draw off connection should be taken from between the pressure reducing valve and the pressure relief valve (see Fig. 4 above). Branches to cold drinking water outlets should be taken directly from the mains supply.

EXPANSION VESSEL

The expansion vessel accommodates expansion that results from heating the water inside the unit. The expansion vessel is pre-charged at 3.5 bar. The expansion vessel must be connected between the expansion valve (see Fig. 4 above) and the cylinder by connecting it to the expansion vessel tapping on the cold feed pipe (see Fig. 1 for position of tapping). The location of the expansion vessel should allow access to recharge the pressure as and when necessary, this can be done using a normal car foot pump. It is recommended that the expansion vessel is adequately supported. An expansion vessel wall mounting bracket is supplied for this purpose and should be fitted.

TUNDISH

The tundish is supplied factory fitted. Ensure it is not positioned directly over any electrical device in case any water splashes occur in the event of a safety valve discharge.

CHECKS

The function of the following safety components of the cylinder unit should be checked on installation for any abnormalities;

- Pressure relief valve (Primary circuit and Tank)
- Expansion vessel pre-charge (gas charge pressure)

DRAIN TAPS

Drain taps are fitted to both the primary system pipe work and to the cold water inlet to facilitate draining the unit or indirect heating circuit for maintenance purposes. It is recommended that the outlet point of the drain pipe work be at least 1 metre below the level of the heater (this can be achieved by attaching a hose pipe to the drain tap outlet spigot).

HOT WATER OUTLET

Ideally the pipe work from the cylinder to the outlet fittings should be in 22mm pipe with short runs of 15mm pipe to showers and basin taps. Small bore pipe can also be used to suit some taps, but runs should be of minimum length. Pipe sizes may vary due to system design.

SECONDARY CIRCULATION

If secondary circulation is required it is recommended that it be connected to the cylinder as shown in Fig. 5 below via a swept tee joint into the cold feed to the unit. **Note: 210L, 250L & 300L Standard models only have a secondary return tapping.**

The secondary return pipe should be in 15mm pipe and incorporate a check valve to prevent back flow. A suitable WRAS approved bronze circulation pump will be required. On large systems, due to the increase in system water content, it may be necessary to fit an additional expansion vessel to the secondary circuit. This should be done if the capacity of the secondary circuit exceeds 10 litres.

Pipe capacity (copper):

15mm O.D. = 0.13 l/m (10 litres = 77m)

22mm O.D. = 0.38 l/m (10 litres = 26m)

28mm O.D. = 0.55 l/m (10 litres = 18m)

Fig. 5 - Secondary circulation connection

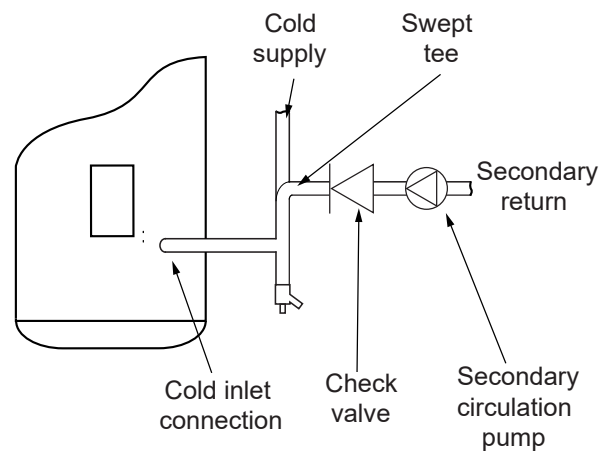

WARNINGS

- i) Under no circumstances should the factory fitted temperature/pressure relief valve be removed other than by authorised service personnel. To do so will invalidate any guarantee or claim.
- ii) The cold water combination valve must be fitted to the mains water supply to the unit.
- iii) No control or safety valves should be tampered with.
- iv) The discharge pipe should not be blocked or used for any other purpose.
- v) No other valves should be placed between the expansion relief valve and the cylinder.

INSULATION OF PIPEWORK

- i) All exposed water pipework should be insulated to prevent unnecessary heat loss and condensation.
- ii) Cold and hot water pipework should not be run close together where possible, to avoid unwanted heat transfer.
- iii) Pipework between outdoor heat pump unit and cylinder unit should be insulated with suitable pipe insulation material with a thermal conductivity of ≤ 0.04 W/mK.

Fig. 6 - T&P Relief Valve insulation

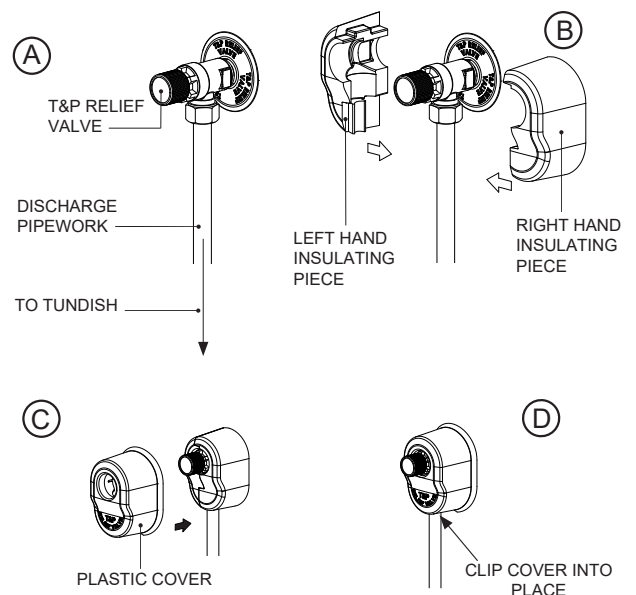
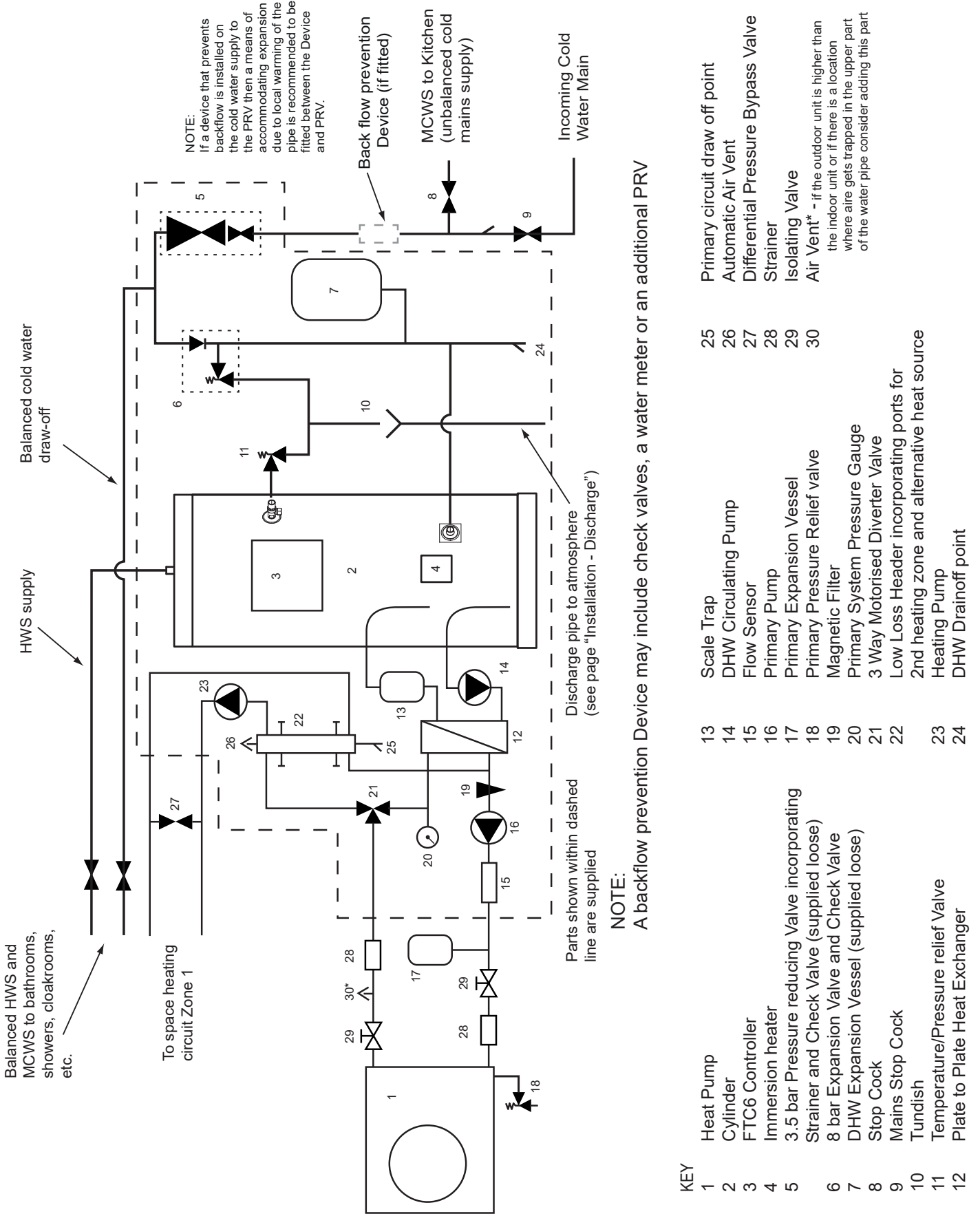

Fig. 7 - Schematic installation diagram



KEY

- | | | | |
|----|---|----|---|
| 1 | Heat Pump | 25 | Primary circuit draw off point |
| 2 | Cylinder | 26 | Automatic Air Vent |
| 3 | FTC6 Controller | 27 | Differential Pressure Bypass Valve |
| 4 | Immersion heater | 28 | Strainer |
| 5 | 3.5 bar Pressure reducing Valve incorporating Strainer and Check Valve (supplied loose) | 29 | Isolating Valve |
| 6 | 8 bar Expansion Valve and Check Valve | 30 | Air Vent* - if the outdoor unit is higher than the indoor unit or if there is a location where air gets trapped in the upper part of the water pipe consider adding this part |
| 7 | DHW Expansion Vessel (supplied loose) | | |
| 8 | Stop Cock | | |
| 9 | Mains Stop Cock | | |
| 10 | Tundish | | |
| 11 | Temperature/Pressure relief Valve | | |
| 12 | Plate to Plate Heat Exchanger | | |
| 13 | Scale Trap | | |
| 14 | DHW Circulating Pump | | |
| 15 | Flow Sensor | | |
| 16 | Primary Pump | | |
| 17 | Primary Expansion Vessel | | |
| 18 | Primary Pressure Relief valve | | |
| 19 | Magnetic Filter | | |
| 20 | Primary System Pressure Gauge | | |
| 21 | 3 Way Motorised Diverter Valve | | |
| 22 | Low Loss Header incorporating ports for 2nd heating zone and alternative heat source | | |
| 23 | Heating Pump | | |
| 24 | DHW Drainoff point | | |

INSTALLATION - DISCHARGE

It is a requirement of Building Regulation G3 that any discharge from an unvented system is conveyed to where it is visible, but will not cause danger to persons in or about the building. The tundish and discharge pipes should be fitted in accordance with the requirements and guidance notes of Building Regulation G3. The G3 Requirements and Guidance section 3.50 - 3.63 are reproduced in the following sections of this manual. For discharge pipe arrangements not covered by G3 Guidance advice should be sought from your local Building Control Officer. Any discharge pipe connected to the pressure relief devices (Expansion Valve and Temperature/Pressure Relief Valve) must be installed in a continuously downward direction and in a frost free environment.

Water may drip from the discharge pipe of the pressure relief device. This pipe must be left open to the atmosphere. The pressure relief device is to be operated regularly to remove lime deposits and to verify that it is not blocked.

G3 REQUIREMENT

"...there shall be precautions...to ensure that the hot water discharged from safety devices is safely conveyed to where it is visible but will not cause danger to persons in or about the building."

Notes:

Discharge pipe-work D2 can now be a plastic pipe but only pipes that have been tested to a minimum 110°C must be used. Discharge pipe D2 can now be plumbed into the soil stack but only soil stacks that can handle temperatures of 99°C or greater should be used.

The following extract is taken from the latest G3 Regulations

Discharge pipe D1

3.50 Safety devices such as temperature relief valves or combined temperature and pressure and pressure relief valves (see paragraphs 3.13 or 3.18) should discharge either directly or by way of a manifold via a short length of metal pipe (D1) to a tundish.

3.51 The diameter of discharge pipe (D1) should be not less than the nominal outlet size of the safety device, e.g. temperature relief valve.

3.52 Where a manifold is used it should be sized to accept and discharge the total discharge from the discharge pipes connected to it.

3.53 Where valves other than the temperature and pressure relief valve from a single unvented hot water system discharge by way of the same manifold that is used by the safety devices, the manifold should be factory fitted as part of the hot water storage system unit or package.

Tundish

3.54 The tundish should be vertical, located in the same space as the unvented hot water storage system and be fitted as close as possible to, and lower than, the valve, with no more than 600mm of pipe between the valve outlet and the tundish (Fig. 8 & Table 4, page 23).

Note: To comply with the Water Supply (Water Fittings) Regulations, the tundish should incorporate a suitable air gap.

3.55 Any discharge should be visible at the tundish. In addition, where discharges from safety devices may not be apparent, e.g. in dwellings occupied by people with impaired vision or mobility, consideration should be given to the installation of a suitable safety device to warn when discharge takes place, e.g. electronically operated.

Discharge pipe D2

3.56 The discharge pipe (D2) from the tundish should:

- (a) have a vertical section of pipe at least 300mm long below the tundish before any elbows or bends in the pipework (see Diagram 1, G3), (Fig. 8, page 23); and
- (b) be installed with a continuous fall thereafter of at least 1 in 200.

3.57 The discharge pipe (D2) should be made of:

- (a) metal; or
- (b) other material that has been demonstrated to be capable of safely withstanding temperatures of the water discharged and is clearly and permanently marked to identify the product and performance standard (e.g. as specified in the relevant part of BS 7291-1:2006 *Thermostatic pipes and fittings for hot and cold water for domestic purposes and heating installations in buildings, General requirements*).

3.58 The discharge pipe (D2) should be at least one pipe size larger than the nominal outlet size of the safety device unless its total equivalent hydraulic resistance exceeds that of a straight pipe 9m long, i.e. for discharge pipes between 9m and 18m the equivalent resistance length should be at least two sizes larger than the nominal outlet size of the safety device; between 18 and 27m at least 3 sizes larger, and so on; bends must be taken into account in calculating the flow resistance. (See Diagram 1, Table 1, G3), (Fig. 8 & Table 4, page 23) and the worked example.

Note: An alternative approach for sizing discharge pipes would be to follow Annex D, section D.2 of BS 6700:2006 +A1:2009 *Specification for design, installation, testing and maintenance of services supplying water for domestic use within buildings and their curtilages*.

3.59 Where a single common discharge pipe serves more than one system, it should be at least one pipe size larger than the largest individual discharge pipe(D2) to be connected.

3.60 The discharge pipe should not be connected to a soil discharge stack unless it can be demonstrated that that the soil discharge stack is capable of safely withstanding temperatures of the water discharged, in which case, it should:

- (a) contain a mechanical seal, not incorporating a water trap, which allows water into the branch pipe without allowing foul air from the drain to be ventilated through the tundish;
- (b) be a separate branch pipe with no sanitary appliances connected to it;
- (c) if plastic pipes are used as branch pipes carrying discharge from a safety device they should be either polybutalene (PB) or cross linked polyethylene (PE-X) to Class S of BS 7291-2:2006 or Class S of BS 7291-3:2006 respectively; and
- (d) be continuously marked with a warning that no sanitary appliances should be connected to the pipe.

Note:

1. Plastic pipes should be joined and assembled with fittings appropriate to the circumstances in which they are used as set out in BS EN ISO 1043-1:2002 *Plastics. Symbols and abbreviated terms. Basic polymers and their special characteristics*.
2. Where pipes cannot be connected to the stack it may be possible to route a dedicated pipe alongside or in close proximity to the discharge stack.

Termination of discharge pipe

3.61 The discharge pipe (D2) from the tundish should terminate in a safe place where there is no risk to persons in the vicinity of the discharge.

3.62 Examples of acceptable discharge arrangements are:

- (b) to a trapped gully with the end of the pipe below a fixed grating and above the water seal;
- (c) downward discharges at low level; i.e. up to 100mm above external surfaces such as car parks, hard standings, grassed areas etc. are acceptable providing that a wire cage or similar guard is positioned to prevent contact, whilst maintaining visibility; and
- (d) discharges at high level: e.g. into a metal hopper and metal downpipe with the end of the discharge pipe clearly visible or onto a roof capable of withstanding high temperature discharges of water and 3m from any plastic guttering system that would collect such discharges.

3.63 The discharge would consist of high temperature water and steam. Asphalt, roofing felt and non-metallic rainwater goods may be damaged by such discharges.

Worked example of discharge pipe sizing

Fig. 8, page 23: shows a G1/2 temperature relief valve with a discharge pipe (D2) having 4 No. elbows and length of 7m from the tundish to the point of discharge.

From Table 4, page 23:

Maximum resistance allowed for a straight length of 22mm copper discharge pipe (D2) from a G1/2 temperature relief valve is 9.0m.

Subtract the resistance for 4 No. 22mm elbows at 0.8m each = 3.2m

Therefore the permitted length equates to: 5.8m

5.8m is less than the actual length of 7m therefore calculate the next largest size.

Maximum resistance allowed for a straight length of 28mm pipe (D2) from a G1/2 temperature relief valves equates to 18m. Subtract the resistance of 4 No. 28mm elbows at 1.0m each = 4.0m

Therefore the maximum permitted length equates to: 14m

As the actual length is 7m, a 28mm (D2) copper pipe will be satisfactory.

WARNINGS:

- Under no circumstances should the factory fitted temperature/pressure relief valve be removed other than by a competent person. To do so will invalidate any guarantee or claim.
- The cold water combination valve assembly must be fitted on the water supply to the Pre-plumbed cylinder.
- No control or safety valves should be tampered with or used for any other purpose.
- The discharge pipe should not be blocked or used for any other purpose.
- The tundish should not be located adjacent to any electrical components.

Table 4 - Sizing of copper discharge pipe (D2) for common temperature relief valve outlet sizes

VALVE OUTLET SIZE	MINIMUM SIZE OF DISCHARGE PIPE D1	MINIMUM SIZE OF DISCHARGE PIPE D2 FROM TUNDISH	MAXIMUM RESISTANCE ALLOWED, EXPRESSED AS A LENGTH OF STRAIGHT PIPE (i.e. NO ELBOWS OR BENDS)	RESISTANCE CREATED BY EACH ELBOW OR BEND
G 1/2	15mm	22mm 28mm 35mm	UP TO 9m UP TO 18m UP TO 27m	0.8m 1.0m 1.4m
G 3/4	22mm	28mm 35mm 42mm	UP TO 9m UP TO 18m UP TO 27m	1.0m 1.4m 1.7m
G1	28mm	35mm 42mm 54mm	UP TO 9m UP TO 18m UP TO 27m	1.4m 1.7m 2.3m

NOTE: The above table is based on copper tube. Plastic pipes may be of different bore and resistance. Sizes and maximum lengths of plastic should be calculated using data prepared for the type of pipe being used.

Fig. 8: Typical discharge pipe arrangement (extract from latest Building Regulation G3 Guidance section 3.5)

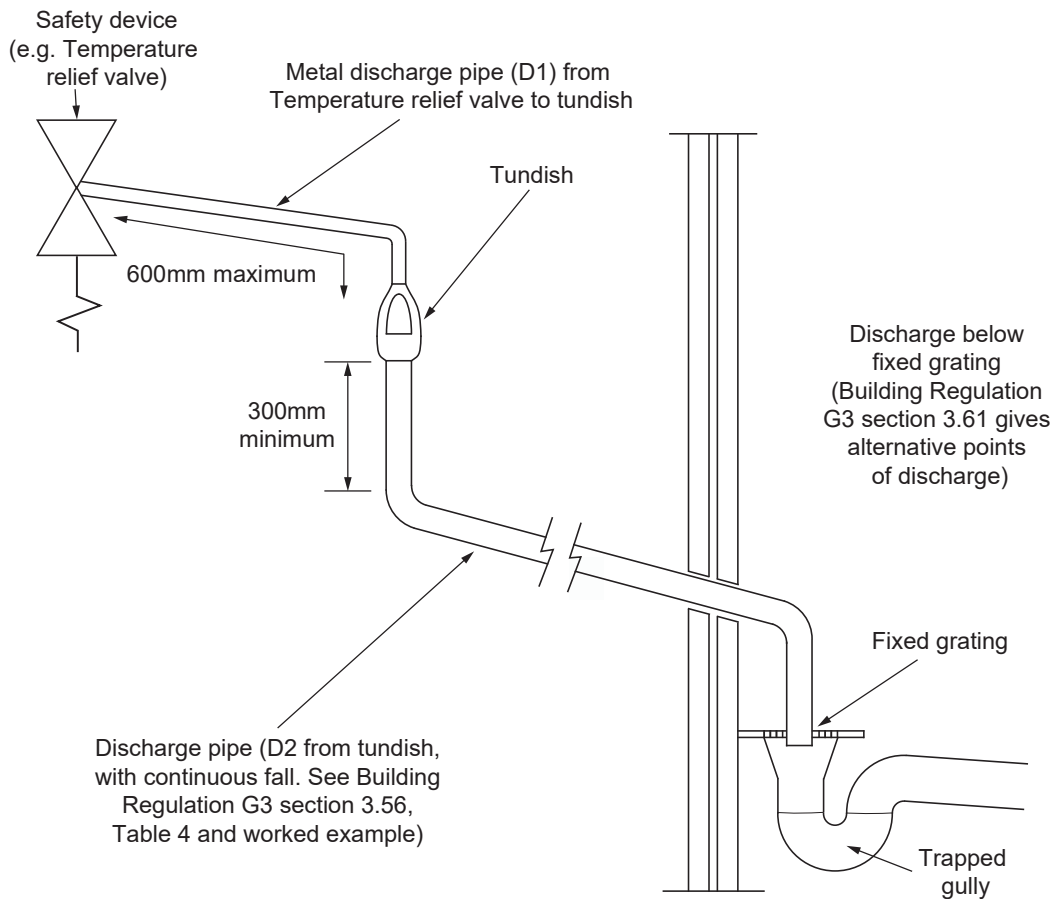

INSTALLATION - HEAT PUMP PRIMARY CIRCUIT

HEAT PUMP SELECTION

- The Pre-plumbed cylinders are suitable for use with the Ecodan PUZ-(H)WM Air Source heat pumps listed in Table 6 below
- If in doubt consult Mitsubishi Electric for further advice.
- Solid fuel boilers or any other boiler in which the energy input is not under effective thermostatic control unless additional and appropriate safety measures are installed should NOT be used.
- The primary circuit must be a sealed system type, maximum primary circuit pressure 3 bar.
- The primary flow from the heat pump MUST be pumped. Gravity circulation will not work due to the special design of the primary heat exchanger.
- The heat pump cannot be vented through the Pre-plumbed cylinder unit.

Table 6 - Heat Pump and Cylinder Combinations

	EHPT15X-UK HLDW1S	EHPT17X-UK HLDW1S	EHPT15X-UK HDW1S	EHPT17X-UK HDW1S	EHPT21X-UK HDW1S	EHPT21X-UK HDW1L	EHPT25X-UK HDW1L	EHPT30X-UK HDW1L
PUZ-WM50VHA	x	x	x	x	x			
PUZ-WM60VAA	x	x	x	x	x	x	x	
PUZ-WM85V(Y)AA	x	x	x	x	x	x	x	x
PUZ-WM112V(Y)AA						x	x	x
PUZ-HWM140V(Y)HA						x	x	x

PUZ-WM60VAA compatible with both 210L cylinders; small variant recommended.

PUZ-WM85V(Y)AA compatible with both 210L cylinders; large variant recommended.

PRIMARY PIPEWORK

Pipework above the flow sensor must be a straight length of at least 5x DN of the device before any bends are installed.
Small cylinder models = 95mm minimum straight length. Large cylinder models = 125mm straight length.

WATER QUALITY AND SYSTEM PREPARATION

General

The water in both primary and DHW circuits should be clean and with a pH value of 6.5 to 8.0

The following values should not be exceeded in the water supply conditions:

Calcium: 100mg/L

Ca hardness: 250mg/L

Copper: 0.3mg/L

Chloride: 100mg/L

Other constituents should comply with European Directive 98/83 EC

In known hard water areas, to minimise any scaling the stored DHW temperature should be restricted to 55°C

Anti-freeze

Anti-freeze solutions MUST use Propylene glycol with a toxicity rating of Class 1 as listed in the Clinical Toxicology of Commercial Products, 5th Edition

Note:

1. Ethylene glycol is toxic and MUST NOT be used in the primary water circuit in case of any cross contamination of the potable water circuit
2. For 2 zone valve ON/OFF control, Propylene glycol MUST be used

New and Existing Installations (primary water circuit)

Before connecting the outdoor unit, thoroughly cleanse the primary pipework of building debris, solder, fluxes, etc. using a suitable chemical cleansing agent.

Flush the system to remove the chemical cleanser

Add a combined inhibitor and anti-freeze solution to prevent damage to the pipework and system components.

Corrosion inhibitor should always be used.

When using chemical cleansers and inhibitors always follow the manufacturer's instructions and ensure the product is appropriate for the materials used in the water circuit.

Minimum required water volume and required primary flow rates.

Outdoor heat pump unit	Min water volume	Required flow rate
PUZ-WM50VHA	7	14.3 L/min
PUZ-WM60VAA	9	17.2 L/min
PUZ-WM85V(Y)AA	12	24.4 L/min
PUZ-WM112V(Y)AA	16	32.1 L/min
PUZ-HWM140V(Y)HA	20	40.1 L/min

If the interlock operation of primary and secondary pump is available ensure minimum water volume in primary and secondary circuit. If the interlock of operation of primary and secondary pump is not available ensure minimum water volume in only primary circuit. In case of shortage of minimum water volume install a buffer tank.

SIZING EXPANSION VESSELS

Expansion vessel volume must fit the local system water volume.

To size an expansion vessel for the heating circuit the following formula and graph can be used.

$$V = \frac{\varepsilon \times G}{1 - \frac{P^1 + 0.098}{P^2 + 0.098}}$$

Where;

V : Necessary expansion vessel volume [L]

ε : Water expansion coefficient

G : Total volume of water in the system [L]

P¹ : Expansion vessel setting pressure [MPa]

P² : Max. pressure during operation [MPa]

Graph below is for the following values

ε : at 70°C = 0.0229

P¹ : 0.1 MPa

P² : 0.3 MPa

*A 30% safety margin has been added.

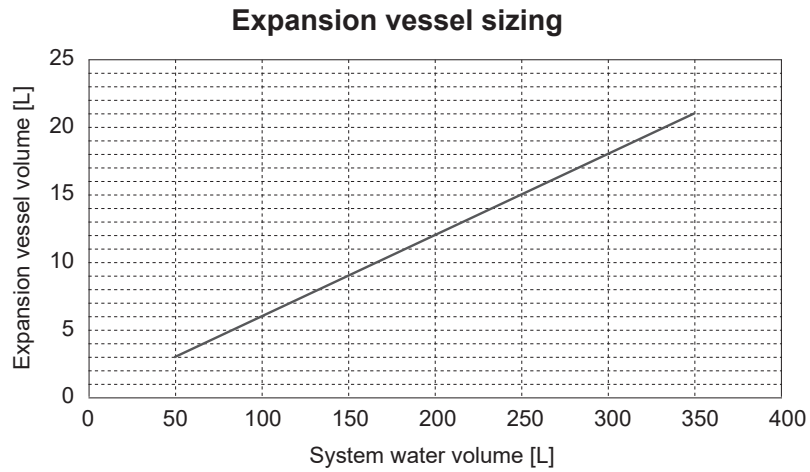

MAIN REMOTE CONTROLLER - FLOW SENSOR FLOW RATE RANGE

Adjust the flow sensor minimum flow rate setting from the default value of 5L/min to the required value of 7L/min for the following models only: EHPT21X-UKHDW1L, EHPT25X-UKHDW1L & EHPT30X-UKHDW1L

The flow sensor flow rate settings can be accessed via the auxiliary settings within the service menu.

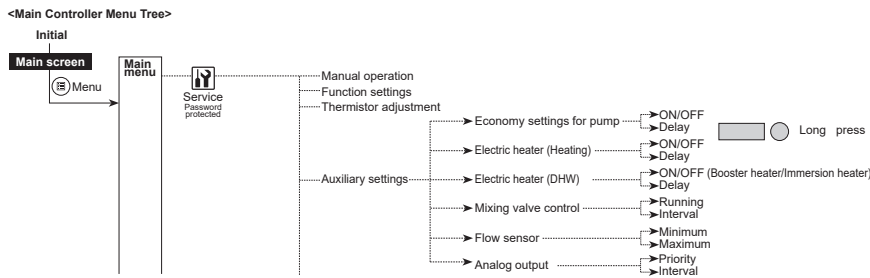

MAIN REMOTE CONTROLLER - HEAT PUMP FLOW RATE RANGE

Set the heat pump flow rate settings according to the specific model of heat pump installed.

The heat pump flow rate settings can be accessed via the heat pump settings within the service menu.

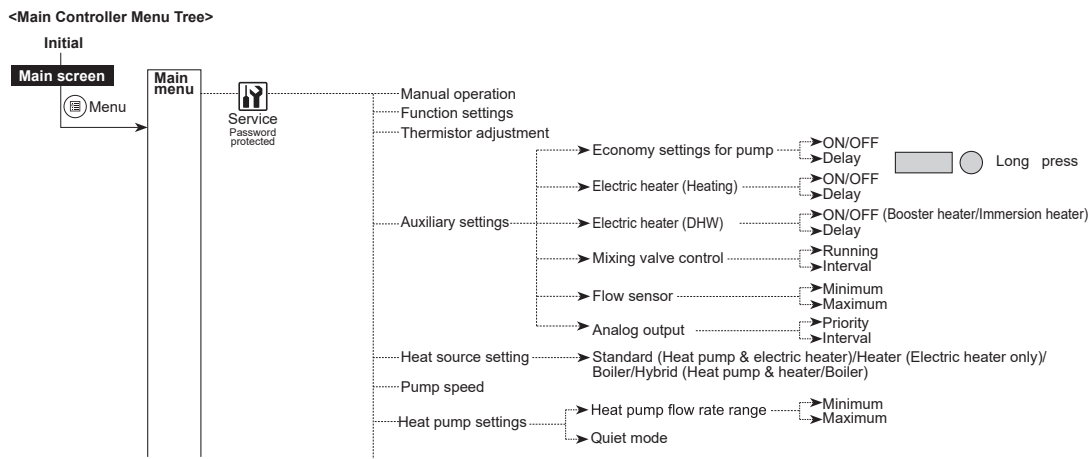

Heat Pump Flow Rate Table		
Model	Minimum (L/min)	Maximum (L/min)
PUZ-WM50VHA	7	14
PUZ-WM60VAA	9	17
PUZ-WM85V(Y)AA	11	24
PUZ-WM112V(Y)AA	15	32
PUZ-HWM140V(Y)HA	18	40

MAIN REMOTE CONTROLLER - FLOW RATE LOOK UP

The heat pump primary flow rate can be viewed by inputting request code 540 into the running information setting within the service menu.

WIRING

All electrical wiring should be carried out by a competent electrician and be in accordance with the latest I.E.E. Wiring Regulations.

The Pre-plumbed cylinder thermal controls and circulating pumps are factory pre-wired. Further wiring will be required between the FTC6 controller, the programmer, room temperature sensor and the Heat Pump. Additional controls and wiring will be required if a second space heating zone is to be fitted to the installation.

Any thermal controls and over-temperature thermal cut-outs MUST NOT be bypassed.

The mains supply must be via a double pole isolating switch with a contact separation of at least 3mm in both poles. The supply must be fused 16 amp. A supply cable of minimum 2.5mm² cross sectional area should be used.

THIS APPLIANCE MUST BE EARTHED

HEATING SYSTEM CONTROLS

The controls provided with the Air Source Heat Pump pre-plumbed cylinder will ensure the safe operation of the unit within a central heating system.

Connection to the various system components is made via the FTC6 Controller fitted to the front of the Pre-plumbed cylinder, refer to the Manual supplied for the FTC6 Controller and the terminal identification labels within the FTC6 Controller to aid in connecting the various external system components such as the mains supply, programmer and heat pump. The wiring to the external components is made using flexible cable, this should be secured using the integral cable grips located in the FTC6 Controller.

Provision is made for the connection of a second space heating zone (connections supplied blanked off). Additional controls will be necessary to control the operation of the second space heating zone. Connection terminals are provided and identified in the FTC6 Controller to enable any wiring to be connected to the same central position.

Fig. 9 - Optional 2 zone control pack - plumbing schematic

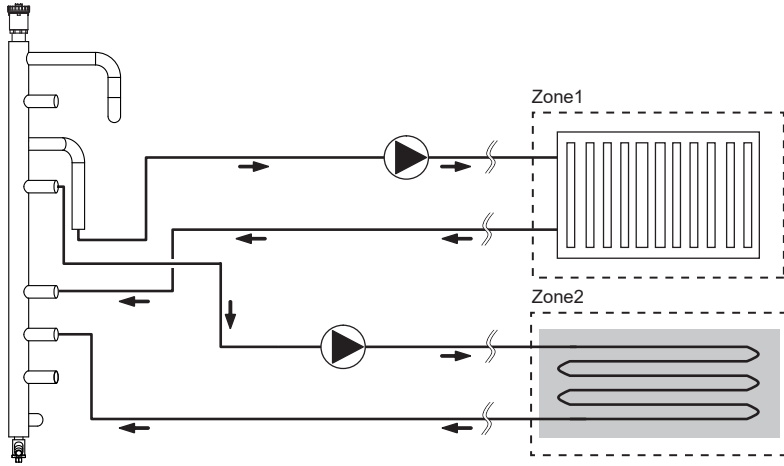

Fig. 10 - Optional 2 zone control pack - component wiring

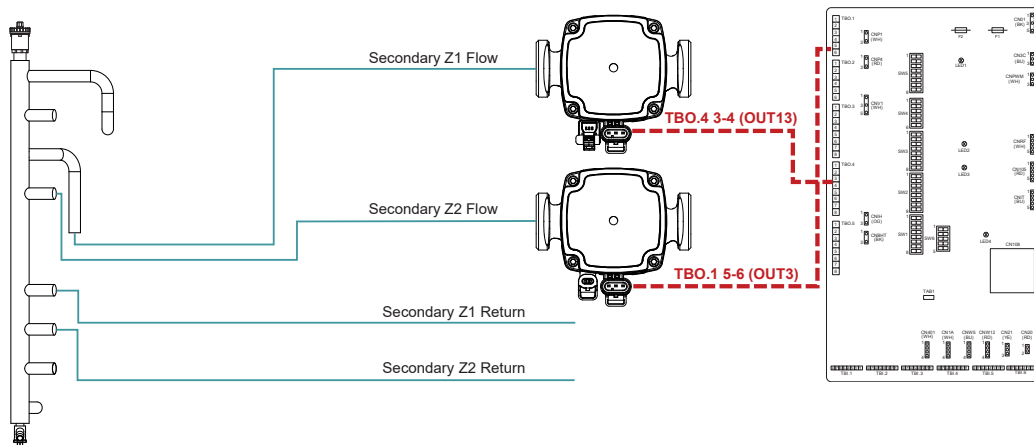

Fig. 11 - Optional 2 zone control pack – dip switch settings

DIP switch	Function	OFF	ON	Default settings: Indoor unit model
SW1	SW1-1 Boiler	WITHOUT Boiler	WITH Boiler	OFF
	SW1-2 Heat pump maximum outlet water temperature	55°C	60°C	ON
	SW1-3 DHW tank	WITHOUT DHW tank	WITH DHW tank	ON
	SW1-4 Immersion heater	WITHOUT Immersion heater	WITH Immersion heater	ON
	SW1-5 Booster heater	WITHOUT Booster heater	WITH Booster heater	OFF
	SW1-6 Booster heater function	For heating only	For heating and DHW	OFF
	SW1-7 Outdoor unit type	Split type	Packaged type	ON
	SW1-8 Wireless remote controller	WITHOUT Wireless remote controller	WITH Wireless remote controller	OFF
SW2	SW2-1 Room thermostat1 input (IN1) logic change	Zone1 operation stop at thermostat short	Zone1 operation stop at thermostat open	ON
	SW2-2 Flow switch1 input (IN2) logic change	Failure detection at short	Failure detection at open	OFF
	SW2-3 Booster heater capacity restriction	Inactive	Active	OFF
	SW2-4 Cooling mode function	Inactive	Active	OFF
	SW2-5 Automatic switch to backup heat source operation (When outdoor unit stops by error)	Inactive	Active	OFF
	SW2-6 Mixing tank	WITHOUT Mixing tank	WITH Mixing tank	OFF
	SW2-7 2-zone temperature control	Inactive	Active	OFF
	SW2-8 Flow sensor	WITHOUT Flow sensor	WITH Flow sensor	ON
SW3	SW3-1 Room thermostat 2 input (IN6) logic change	Zone2 operation stop at thermostat short	Zone2 operation stop at thermostat open	ON
	SW3-2 Flow switch 2 and 3 input logic change	Failure detection at short	Failure detection at open	OFF
	SW3-3	—	—	OFF
	SW3-4 Electric energy meter	WITHOUT Electric energy meter	WITH Electric energy meter	OFF
	SW3-5 Heating mode function	Inactive	Active	ON
	SW3-6 2-zone valve ON/OFF control	Inactive	Active	OFF
	SW3-7 Heat exchanger for DHW	Coil in tank	External plate HEX	ON
	SW3-8 Heat meter	WITHOUT Heat meter	WITH Heat meter	OFF
SW4	SW4-1 Multiple outdoor unit control	Inactive	Active	OFF
	SW4-2 Position of multiple outdoor unit control	Sub	Main	OFF
	SW4-3	—	—	OFF
	SW4-4 Indoor unit only operation (during installation work)	Inactive	Active	OFF
	SW4-5 Emergency mode (Heater only operation)	Normal	Emergency mode (Heater only operation)	OFF
	SW4-6 Emergency mode (Boiler operation)	Normal	Emergency mode (Boiler operation)	OFF
SW5	SW5-1	—	—	OFF
	SW5-2 Advanced auto adaptation	Inactive	Active	ON
	SW5-3	—	—	OFF
	SW5-4	—	—	OFF
	SW5-5	—	—	OFF
	SW5-6	—	—	OFF
	SW5-7	—	—	OFF
	SW5-8	—	—	OFF
SW6	SW6-1	—	—	OFF
	SW6-2	—	—	OFF
	SW6-3 Pressure sensor	Inactive	Active	OFF
	SW6-4 Analog output signal (0-10V)	Inactive	Active	OFF
	SW6-5	—	—	OFF

SW3-6 - ON

Fig. 12 - Optional 2 zone twin temperature control pack - plumbing schematic

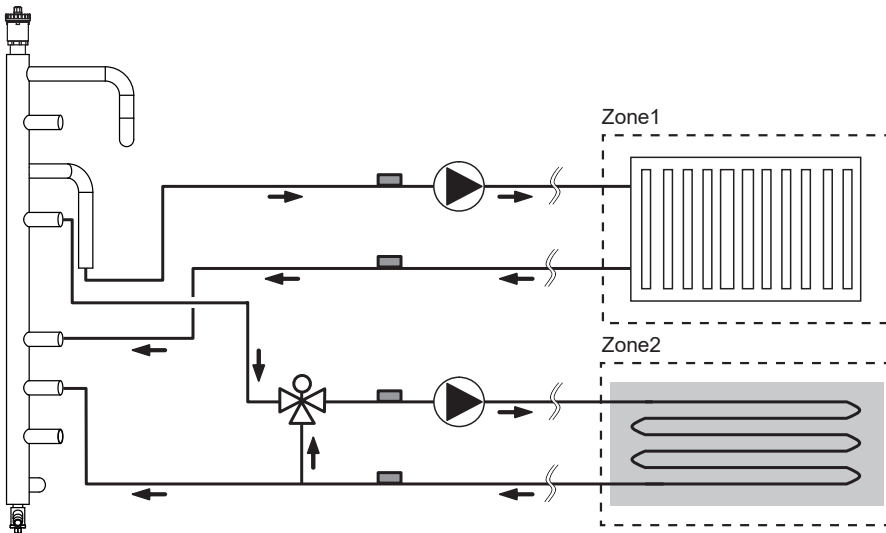

Fig. 13 - Optional 2 zone twin temperature control pack - component wiring

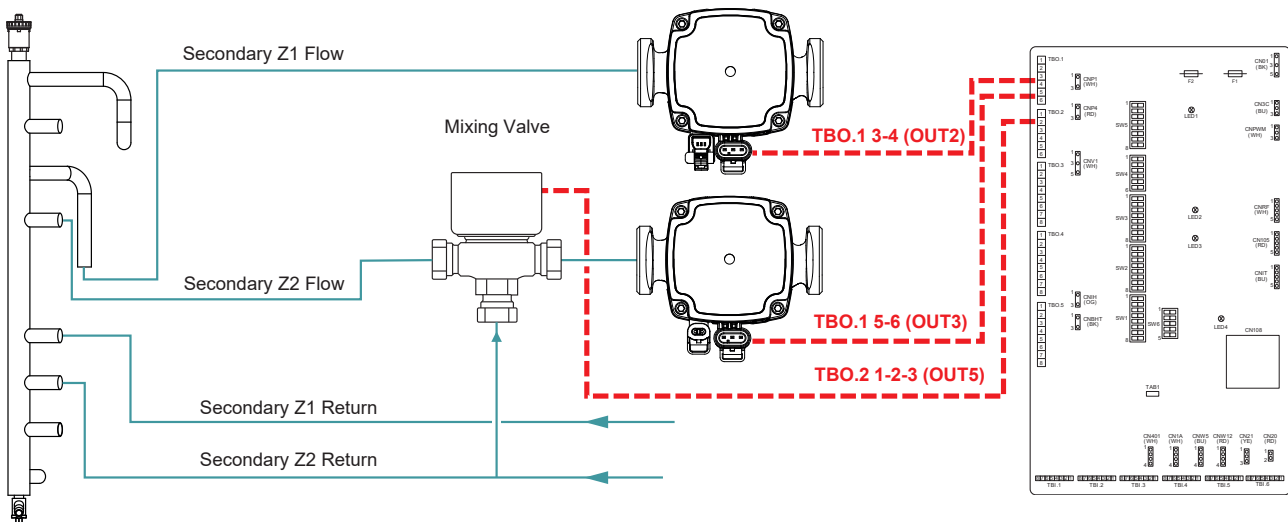

Fig. 14 - Optional 2 zone twin temperature control pack - sensor wiring

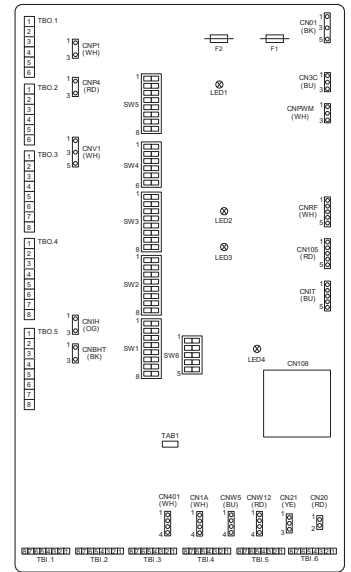
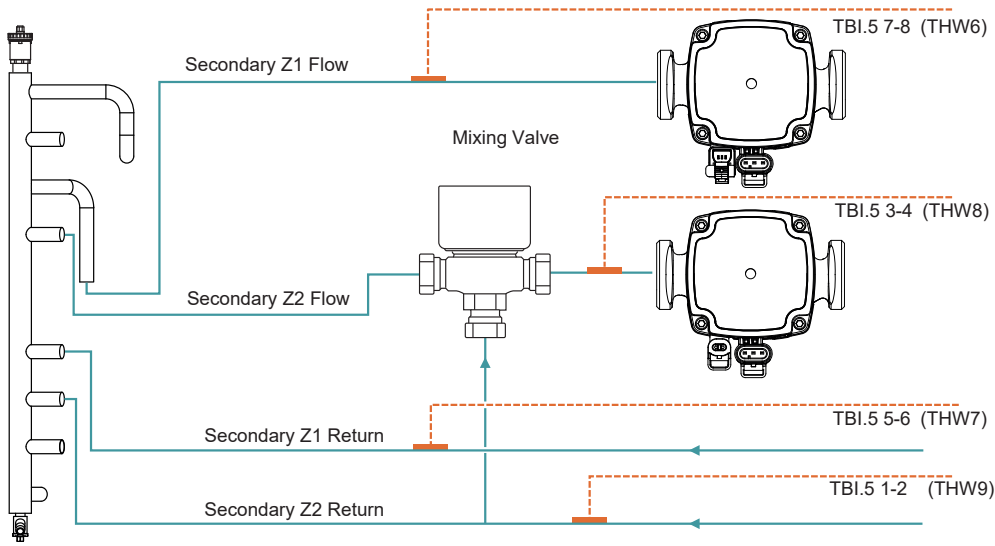

Fig. 15 - Optional 2 zone twin temperature control pack - dip switch settings

DIP switch	Function	OFF	ON	Default settings: Indoor unit model!
SW1	SW1-1 Boiler	WITHOUT Boiler	WITH Boiler	OFF
	SW1-2 Heat pump maximum outlet water temperature	55°C	60°C	ON
	SW1-3 DHW tank	WITHOUT DHW tank	WITH DHW tank	ON
	SW1-4 Immersion heater	WITHOUT Immersion heater	WITH Immersion heater	ON
	SW1-5 Booster heater	WITHOUT Booster heater	WITH Booster heater	OFF
	SW1-6 Booster heater function	For heating only	For heating and DHW	OFF
	SW1-7 Outdoor unit type	Split type	Packaged type	ON
	SW1-8 Wireless remote controller	WITHOUT Wireless remote controller	WITH Wireless remote controller	OFF
SW2	SW2-1 Room thermostat 1 input (IN1) logic change	Zone1 operation stop at thermostat short	Zone1 operation stop at thermostat open	ON
	SW2-2 Flow switch 1 input (IN2) logic change	Failure detection at short	Failure detection at open	OFF
	SW2-3 Booster heater capacity restriction	Inactive	Active	OFF
	SW2-4 Cooling mode function	Inactive	Active	OFF
	SW2-5 Automatic switch to backup heat source operation (When outdoor unit stops by error)	Inactive	Active	OFF
	SW2-6 Mixing tank	WITHOUT Mixing tank	WITH Mixing tank	OFF
	SW2-7 2-zone temperature control	Inactive	Active	OFF
	SW2-8 Flow sensor	WITHOUT Flow sensor	WITH Flow sensor	ON
SW3	SW3-1 Room thermostat 2 input (IN6) logic change	Zone2 operation stop at thermostat short	Zone2 operation stop at thermostat open	ON
	SW3-2 Flow switch 2 and 3 input logic change	Failure detection at short	Failure detection at open	OFF
	SW3-3	—	—	OFF
	SW3-4 Electric energy meter	WITHOUT Electric energy meter	WITH Electric energy meter	OFF
	SW3-5 Heating mode function	Inactive	Active	ON
	SW3-6 2-zone valve ON/OFF control	Inactive	Active	OFF
	SW3-7 Heat exchanger for DHW	Coil in tank	External plate HEX	ON
	SW3-8 Heat meter	WITHOUT Heat meter	WITH Heat meter	OFF
SW4	SW4-1 Multiple outdoor unit control	Inactive	Active	OFF
	SW4-2 Position of multiple outdoor unit control	Sub	Main	OFF
	SW4-3	—	—	OFF
	SW4-4 Indoor unit only operation (during installation work)	Inactive	Active	OFF
	SW4-5 Emergency mode (Heater only operation)	Normal	Emergency mode (Heater only operation)	OFF
	SW4-6 Emergency mode (Boiler operation)	Normal	Emergency mode (Boiler operation)	OFF
SW5	SW5-1	—	—	OFF
	SW5-2 Advanced auto adaptation	Inactive	Active	ON
	SW5-3	—	—	OFF
	SW5-4	—	—	OFF
	SW5-5	—	—	OFF
	SW5-6	—	—	OFF
	SW5-7	—	—	OFF
	SW5-8	—	—	OFF
SW6	SW6-1	—	—	OFF
	SW6-2	—	—	OFF
	SW6-3 Pressure sensor	Inactive	Active	OFF
	SW6-4 Analog output signal (0-10V)	Inactive	Active	OFF
	SW6-5	—	—	OFF

SW2-6- ON
SW2-7- ON

Fig. 16 - Wiring of Motorised Mixing valve

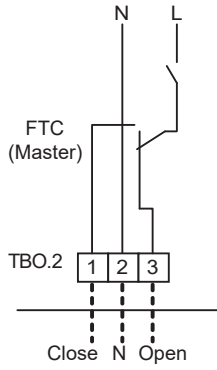

Fig. 17 - Schematic of Motorised Mixing Valve hydraulic connections

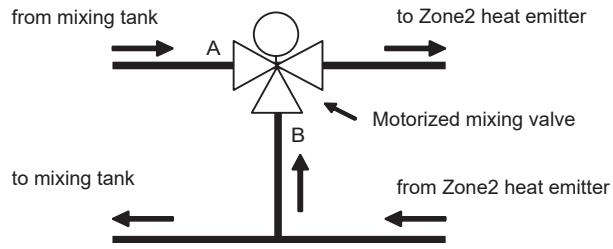
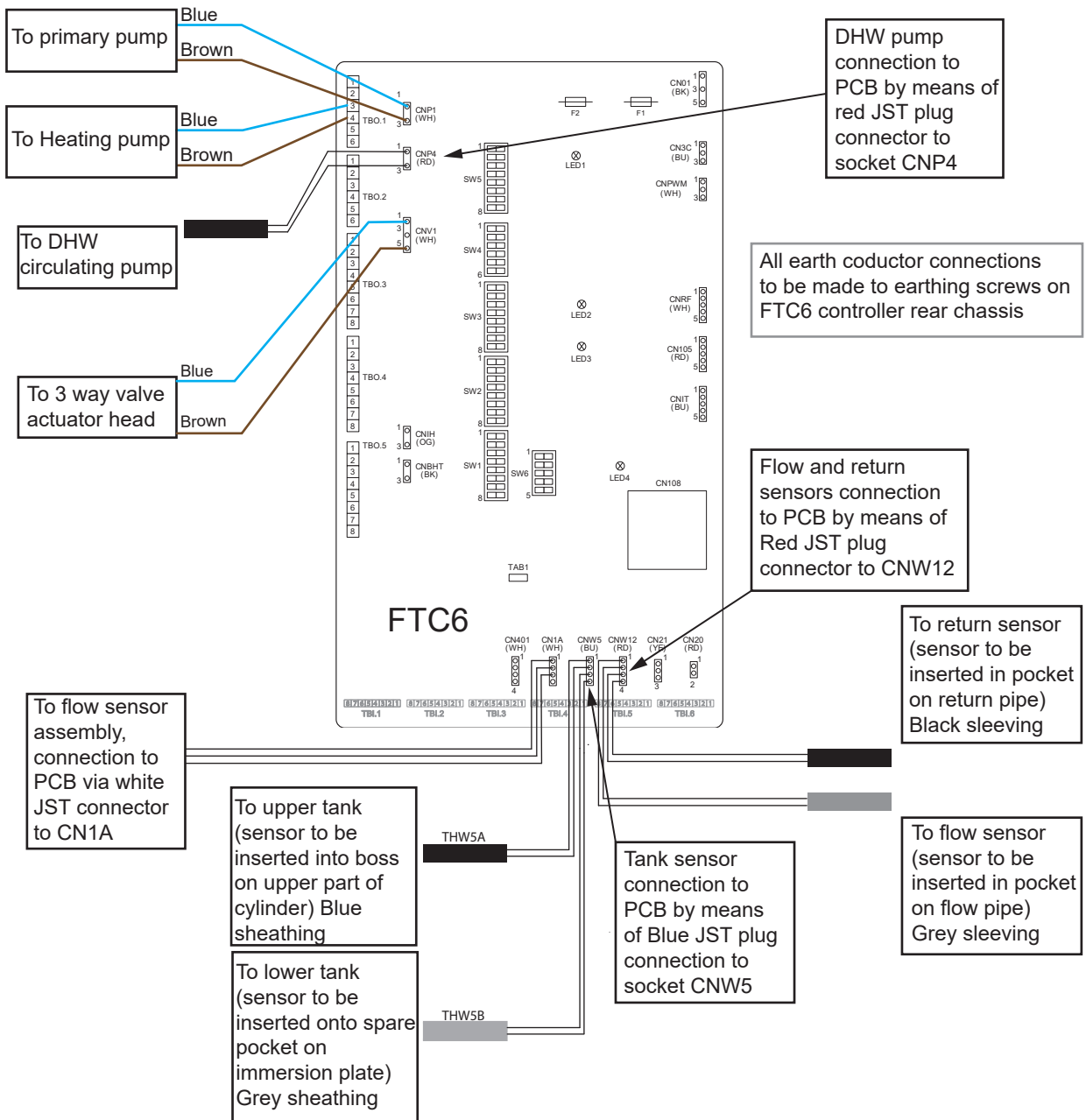

Fig. 18 - Factory made connections to FTC6 controller



ELECTRICAL WORK

All electrical work should be carried out by a suitably qualified technician. Failure to comply with this could lead to electrocution, fire, and death. It will also invalidate product warranty. All wiring should be according to national wiring regulations.

FTC (Master) powered by independent source

If FTC (Master) and outdoor units have separate power supplies, the following requirements MUST be carried out:

- **FTC (Master) unit electrical box connector connections changed. (see Fig. 19)**
 - **Outdoor unit DIP switch settings changed to SW8-3 ON.**
 - **Turn on the outdoor unit before the FTC (Master).**
 - **Power by independent source is not available for particular models of outdoor unit model.**
- For more detail, refer to the connecting outdoor unit installation manual.

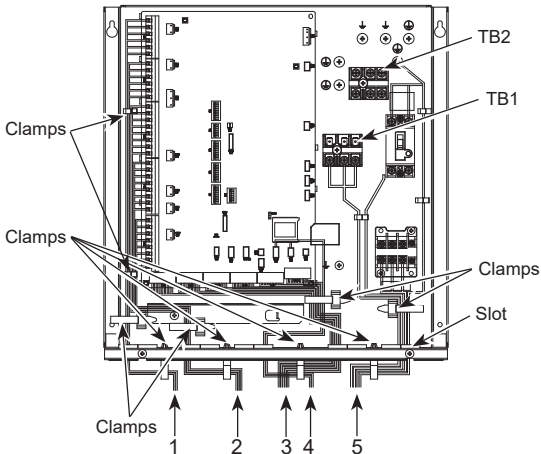

- 1 High voltage cables (OUTPUT)
- 2 High voltage cables (OUTPUT)
- 3 Low voltage cables (INPUT) and wireless receiver's cable
- 4 Thermistor cables
- 5 Power cables

Wiring for PAC-IF07*B-E

- Notes: 1. Do not run the low voltage cables through a slot that the high voltage cables go through.
 2. Do not run other cables except low voltage cables through a slot that the wireless receiver's cable goes through.
 3. Do not bundle power cables together with other cables.
 4. Bundle cables as figure above by using clamps.

<1 phase>

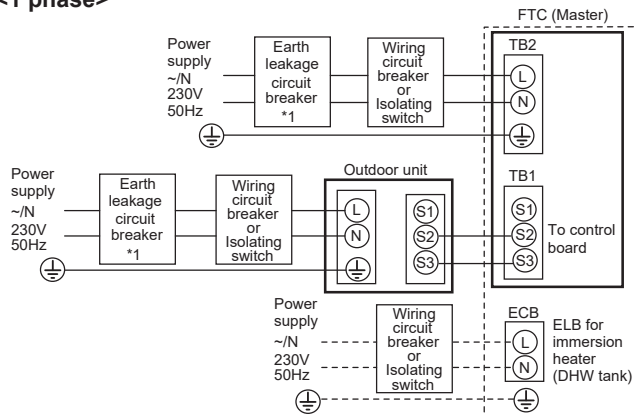

<3 phase>

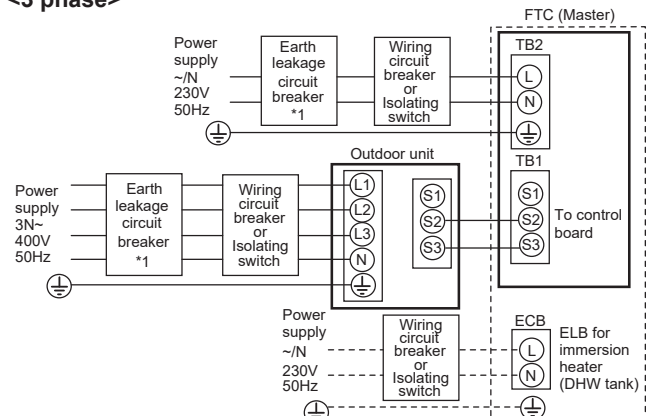

□ : PAC-IF071B-E

□ : PAC-IF072/073B-E

Electrical connections 1 phase/3 phase

*1. If the installed earth leakage circuit breaker does not have an over-current protection function, install a breaker with that function along the same power line.

A breaker with at least 3.0 mm contact separation in each pole shall be provided. Use earth leakage breaker (NV).

The breaker shall be provided to ensure disconnection of all active phase conductors of the supply.

Note: In accordance with IEE regulations the circuit breaker/isolating switch located on the outdoor unit should be installed with lockable devices (health and safety).

FTC (Master) power supply		~N 230 V 50 Hz
FTC (Master) input capacity		*1 16 A
Main switch (Breaker)		
Wiring No. Wiring size (mm ²) × size (mm ²)	FTC (Master) power supply	2 × Min. 1.5
	FTC (Master) power supply earth	1 × Min. 1.5
	FTC (Master) - Outdoor unit	*2 2 × Min. 0.3
	FTC (Master) - Outdoor unit earth	—
Circuit rating	FTC (Master) L - N	*3 230V AC
	FTC (Master) - Outdoor unit S1 - S2	*3 —
	FTC (Master) - Outdoor unit S2 - S3	*3 24V DC

*2. Max. 120 m

*3. The values given in the table above are not always measured against the ground value.

- Notes: 1. Wiring size must comply with the applicable local and national codes.
 2. FTC (Master) unit/outdoor unit connecting cords shall not be lighter than polychloroprene sheathed flexible cord. (Design 60245 IEC 57)
 FTC (Master) unit power supply cords shall not be lighter than polychloroprene sheathed flexible cord. (Design 60227 IEC 53)
 3. Install an earth longer than other cables.
 4. Please keep enough output capacity of power supply for each individual heater. Insufficient power supply capacity might cause chattering.

Connecting inputs/outputs

Signal inputs

Name	Terminal block	Connector	Item	OFF (Open)	ON (Short)
IN1	TBI.1 7-8	—	Room thermostat 1 input *1	Refer to SW2-1	
IN2	TBI.1 5-6	—	Flow switch 1 input	Refer to SW2-2	
IN3	TBI.1 3-4	—	Flow switch 2 input (Zone1)	Refer to SW3-2	
IN4	TBI.1 1-2	—	Demand control input	Normal	Heat source OFF/ Boiler operation *3
IN5	TBI.2 7-8	—	Outdoor thermostat input *2	Standard operation	Heater operation/ Boiler operation *3
IN6	TBI.2 5-6	—	Room thermostat 2 input *1	Refer to SW3-1	
IN7	TBI.2 3-4	—	Flow switch 3 input (Zone2)	Refer to SW3-2	
IN8	TBI.3 7-8	—	Electric energy meter 1	*4	
IN9	TBI.3 5-6	—	Electric energy meter 2		
IN10	TBI.2 1-2	—	Heat meter		
IN11	TBI.3 3-4	—	Smart grid ready input	*5	
IN12	TBI.3 1-2	—	Flow sensor input	*6	
INA1	TBI.4 1-3	CN1A	Flow sensor input	*6	

- *1. Set the ON/OFF cycle time of the room thermostat for 10 minutes or more; otherwise the compressor may be damaged.
- *2. If using outdoor thermostat for controlling operation of heaters, the lifetime of the heaters and related parts may be reduced.
- *3. To turn on the boiler operation, use the main remote controller to select "Boiler" in "External input setting" screen in the service menu.
- *4. Connectable electric energy meter and heat meter
 - Pulse type Voltage free contact for 12VDC detection by FTC (TBI.2 1 pin, TBI.3 5 and 7 pins have a positive voltage.)
 - Pulse duration Minimum ON time: 40ms
Minimum OFF time: 100ms
 - Possible unit of pulse 0.1 pulse/kWh 1 pulse/kWh 10 pulse/kWh
100 pulse/kWh 1000 pulse/kWh

Those values can be set by the main remote controller. (Refer to the menu tree in "7.2 Main remote controller".)
- *5. As for the smart grid ready, refer to "4.9 Smart grid ready".
- *6. Connectable flow sensor
 - Power supply 5 V DC
 - Measuring range 5 to 100 L/min
Those values can be set by the main remote controller. (Refer to <Auxiliary setting> on this page.)
 - Flow signal 0.5 V (at minimum flow rate) to 3.5 V (at maximum flow rate)

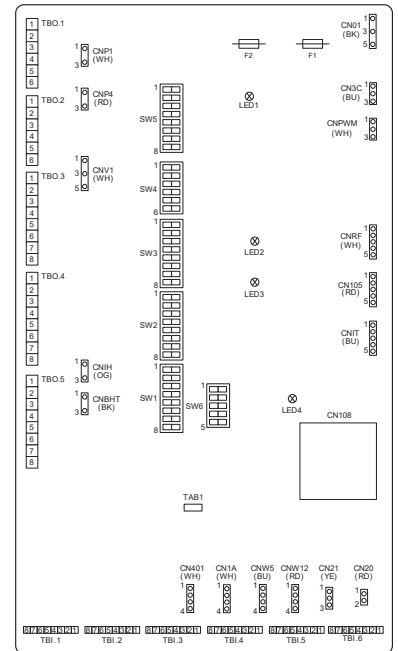

Wiring specification and local supply parts

Item	Name	Model and specifications
Signal input function	Signal input wire	Use sheathed vinyl coated cord or cable. Max. 30 m Wire type: CV, CVS or equivalent Wire size: Stranded wire 0.13 mm ² to 0.52 mm ² Solid wire: ø0.4 mm to ø0.8 mm
	Switch	Non-voltage "a" contact signals Remote switch: minimum applicable load 12 V DC, 1 mA

Note:
Stranded wire should be processed with insulation-covered bar terminal (DIN46228-4 standard compatible type).

<Auxiliary settings>

This function is used to set the parameters for any auxiliary parts used in the system

Menu subtitle	Function/ Description
Economy settings for pump	Water pump stops automatically in certain period of time from when operation is finished.
Delay	Time before pump switched off*1
Electric heater (Heating)	To select "WITH booster heater (ON)" or "WITHOUT booster heater (OFF)" in Heating mode.
Delay	The minimum time required for the booster heater to turn ON from after Heating mode has started.
Electric heater (DHW)	To select "WITH (ON)" or "WITHOUT (OFF)" booster heater or immersion heater individually in DHW mode.
Delay	The minimum time required for the booster heater or immersion heater to turn ON from after DHW mode has started. (This setting is applied for both booster and immersion heater.)
Mixing valve control *2	Running Period from valve fully open (at a hot water mixing ratio of 100%) to valve fully closed (at a cold water mixing ratio of 100%)
Interval	Interval (min) to control the Mixing valve.
Flow sensor	Minimum The minimum flow rate to be detected at Flow sensor.
Maximum	The maximum flow rate to be detected at Flow sensor.

- *1. Decreasing "time before pump switched off" may increase the duration of stand-by in Heating/Cooling mode.
- *2. Set the Running time according to the specifications of the actuator of each mixing valve. It is recommended to set the interval to 2 minutes that is a default value. With the interval set longer, it could take longer to warm up a room.

■ Thermistor inputs

Name	Terminal block	Connector	Item	Optional part model
TH1	—	CN20	Thermistor (Room temp.) (Option) *1	PAC-SE41TS-E
TH2	—	CN21	Thermistor (Ref. liquid temp.) *2	—
THW1	—	CNW12 1-2	Thermistor (Flow water temp.)	—
THW2	—	CNW12 3-4	Thermistor (Return water temp.)	—
THW5A	—	CNW5 1-2	Thermistor (DHW tank upper water temp.)	—
THW5B	—	CNW5 3-4	Thermistor (DHW tank water temp.)	—
THW6	TBI.5 7-8	—	Thermistor (Zone1 flow water temp.) (Option) *1	PAC-TH011-E
THW7	TBI.5 5-6	—	Thermistor (Zone1 return water temp.) (Option) *1	PAC-TH011-E
THW8	TBI.5 3-4	—	Thermistor (Zone2 flow water temp.) (Option) *1	PAC-TH011-E
THW9	TBI.5 1-2	—	Thermistor (Zone2 return water temp.) (Option) *1	PAC-TH011-E
THWB1	TBI.6 7-8	—	Thermistor (Boiler flow water temp.) (Option) *1	PAC-TH012HT(L)-E
THW10	TBI.6 5-6	—	Thermistor (Mixing tank water temp.) (Option) *1	PAC-TH012HT(L)-E

Ensure to wire thermistor wirings away from the power line and/or OUT1 to 16 wirings.

*1. The maximum length of the thermistor wiring is 30 m.

The length of the optional thermistors are 5 m. If you need to splice and extend the wirings, following points must be carried out.

1) Connect the wirings by soldering.

2) Insulate each connecting point against dust and water. Stranded wire should be processed with insulation-covered bar terminal (DIN46228-4 standard compatible type).

*2. Except PAC-IF072/073B-E.

■ Outputs

Name	Terminal block	Connector	Item	OFF	ON	Signal/Max. current	Max. total current
OUT1	TBO.1 1-2	CNP1	Water circulation pump 1 output (Space heating/cooling & DHW)	OFF	ON	230 V AC 1.0 A Max. (Inrush current 40A Max.)	4.0A (a)
OUT2	TBO.1 3-4	—	Water circulation pump 2 output (Space heating/cooling for Zone1)	OFF	ON	230 V AC 1.0 A Max. (Inrush current 40A Max.)	
OUT3	TBO.1 5-6	—	Water circulation pump 3 output (Space heating/cooling for Zone2) *1 2-way valve 2b output *2	OFF	ON	230 V AC 1.0 A Max. (Inrush current 40A Max.)	
OUT4	TBO.2 4-6	CNV1	3-way valve (2-way valve 1) output	Heating	DHW	230 V AC 0.1 A Max.	3.0 A (b)
OUT5	TBO.2 1-2 TBO.2 2-3	—	Mixing valve output *1	Stop	Close Open	230 V AC 0.1 A Max.	
OUT6	TBO.5 5-6	—	Booster heater 1 output	OFF	ON	230 V AC 0.5 A Max. (Relay)	
OUT7	TBO.5 7-8	—	Booster heater 2 output	OFF	ON	230 V AC 0.5 A Max. (Relay)	
OUT8	TBO.4 7-8	—	Cooling signal output	OFF	ON	230 V AC 0.5 A Max.	
OUT9	TBO.4 5-6	CNIH	Immersion heater output	OFF	ON	230 V AC 0.5 A Max. (Relay)	—
OUT10	TBO.3 1-2	—	Boiler output	OFF	ON	non-voltage contact ·220 - 240 V AC (30 V DC) 0.5 A or less ·10 mA 5 V DC or more	
OUT11	TBO.3 5-6	—	Error output	Normal	Error	230 V AC 0.5 A Max.	3.0 A (b)
OUT12	TBO.3 7-8	—	Defrost output	Normal	Defrost	230 V AC 0.5 A Max.	
OUT13	TBO.4 3-4	—	2-way valve 2a output *2	OFF	ON	230 V AC 0.1 A Max.	
OUT14	—	CNP4	Water circulation pump 4 output (DHW)	OFF	ON	230 V AC 1.0 A Max.	4.0 A (a)
OUT15	TBO.4 1-2	—	Comp ON signal	OFF	ON	230 V AC 0.5 A Max.	3.0 A (b)
OUT16	TBO.3 3-4	—	Heating/Cooling thermo ON signal	OFF	ON	non-voltage contact ·220 - 240 V AC (30V DC) 0.5 A or less ·10 mA 5 V DC or more	—
OUTA1	TBI.4 7-8	—	Analog output	—	—	0 - 10 V DC 5 mA max.	—
BC	TBO.5 3-4	—	Booster heater protection output	OFF (BHT open)	ON (BHT short)	230 V AC 0.5 A Max.	—
BHT	TBO.5 1-2	CNBHT	Thermostat for booster heater	Thermostat Normal: short	High temp. : open	—	—

Do not connect to the terminals that are indicated as “—” in the “Terminal block” field.

*1 For 2-zone temperature control.

*2 For 2-zone valve ON/OFF control.

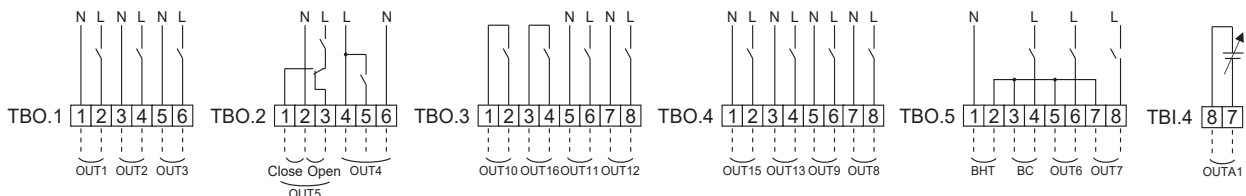

Wiring specification and local supply parts

Item	Name	Model and specifications
External output function	Outputs wire	Use sheathed vinyl coated cord or cable. Max. 30 m Wire type: CV, CVS or equivalent Wire size: Stranded wire 0.25 mm ² to 1.5 mm ² Solid wire: 0.25 mm ² to 1.5 mm ²

Note:

- When the FTC is powered via outdoor unit, the maximum grand total current of (a)+(b) is 3.0 A.
- Do not connect multiple water circulation pumps directly to each output (OUT1, OUT2, and OUT3). In such a case, connect them via (a) relay(s).
- Connect an appropriate surge absorber to OUT10 (TBO.3 1-2) depending on the load at site.
- Stranded wire should be processed with insulation-covered bar terminal (DIN46228-4 standard compatible type).

How to use TBO.1 to 5

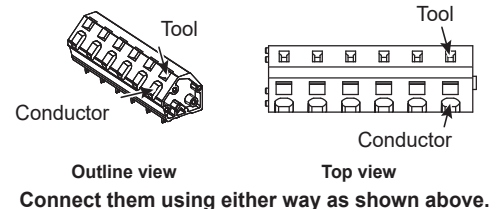

Connect them using either way as shown above.

DIP Switch Functions

Located on the FTC printed circuit board are 6 sets of small white switches known as DIP switches. The DIP switch number is printed on the circuit board next to the relevant switches. The word ON is printed on the circuit board and on the DIP switch block itself. To move the switch you will need to use a pin or the corner of a thin metal ruler or similar.

Only an authorised installer can change DIP switch setting under one's own responsibility according to the installation condition. Make sure to turn off both indoor unit and outdoor unit power supplies before changing the switch settings.

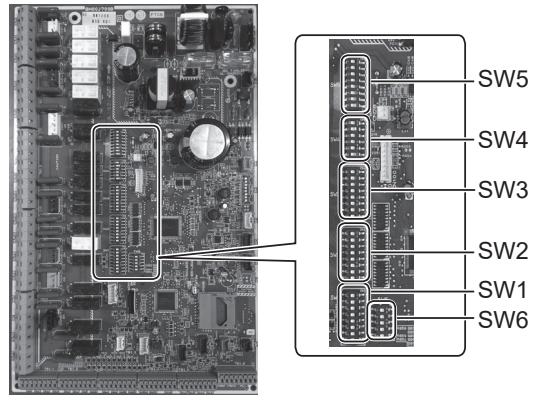

DIP switch		Function	OFF	ON	Default settings: Indoor unit model
SW1	SW1-1	Boiler	WITHOUT Boiler	WITH Boiler	OFF
	SW1-2	Heat pump maximum outlet water temperature	55°C	60°C	ON
	SW1-3	DHW tank	WITHOUT DHW tank	WITH DHW tank	ON
	SW1-4	Immersion heater	WITHOUT Immersion heater	WITH Immersion heater	ON
	SW1-5	Booster heater	WITHOUT Booster heater	WITH Booster heater	OFF
	SW1-6	Booster heater function	For heating only	For heating and DHW	OFF
	SW1-7	Outdoor unit type	Split type	Packaged type	ON
	SW1-8	Wireless remote controller	WITHOUT Wireless remote controller	WITH Wireless remote controller	OFF
SW2	SW2-1	Room thermostat1 input (IN1) logic change	Zone1 operation stop at thermostat short	Zone 1 operation stop at thermostat open	ON
	SW2-2	Flow switch1 input (IN2) logic change	Failure detection at short	Failure detection at open	OFF
	SW2-3	Booster heater capacity restriction	Inactive	Active	OFF
	SW2-4	Cooling mode function	Inactive	Active	OFF
	SW2-5	Automatic switch to backup heat source operation (When outdoor unit stops by error)	Inactive	Active	OFF
	SW2-6	Mixing tank	WITHOUT Mixing tank	WITH Mixing tank	OFF
	SW2-7	2-zone temperature control	Inactive	Active	OFF
	SW2-8	Flow sensor	WITHOUT Flow sensor	WITH Flow sensor	ON
SW3	SW3-1	Room thermostat 2 input (IN6) logic change	Zone2 operation stop at thermostat short	Zone2 operation stop at thermostat open	ON
	SW3-2	Flow switch 2 and 3 input logic change	Failure detection at short	Failure detection at open	OFF
	SW3-3	—	—	—	OFF
	SW3-4	Electric energy meter	WITHOUT Electric energy meter	WITH Electric energy meter	OFF
	SW3-5	Heating mode function	Inactive	Active	ON
	SW3-6	2-zone valve ON/OFF control	Inactive	Active	OFF
	SW3-7	Heat exchanger for DHW	Coil in tank	External plate HEX	ON
	SW3-8	Heat meter	WITHOUT Heat meter	WITH Heat meter	OFF
SW4	SW4-1	Multiple outdoor unit control	Inactive	Active	OFF
	SW4-2	Position of multiple outdoor unit control	Sub	Main	OFF
	SW4-3	—	—	—	OFF
	SW4-4	Indoor unit only operation (during installation work)	Inactive	Active	OFF
	SW4-5	Emergency mode (Heater only operation)	Normal	Emergency mode (Heater only operation)	OFF
	SW4-6	Emergency mode (Boiler operation)	Normal	Emergency mode (Boiler operation)	OFF
SW5	SW5-1	—	—	—	OFF
	SW5-2	Advanced auto adaptation	Inactive	Active	ON
	SW5-3	—	—	—	OFF
	SW5-4	—	—	—	OFF
	SW5-5	—	—	—	OFF
	SW5-6	—	—	—	OFF
	SW5-7	—	—	—	OFF
	SW5-8	—	—	—	OFF
SW6	SW6-1	—	—	—	OFF
	SW6-2	—	—	—	OFF
	SW6-3	Pressure sensor	Inactive	Active	OFF
	SW6-4	Analog output signal (0-10V)	Inactive	Active	OFF
	SW6-5	—	—	—	OFF

Using SD memory card

FTC is equipped with an SD memory card interface.

Using an SD memory card can simplify main remote controller settings and can store operating logs. *1

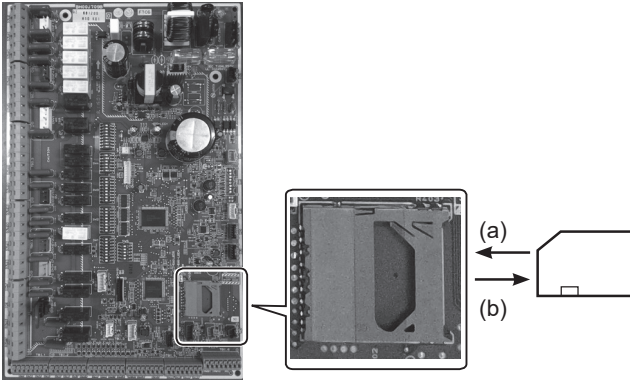

FTC (Main)

<Handling precautions>

- (1) Use an SD memory card that complies with the SD standards. Check that the SD memory card has a logo on it of those shown to the right.
- (2) SD memory cards to the SD standards include SD, SDHC, mini SD, micro SD, and micro SDHC memory cards. The capacities are available up to 32 GB. Choose that with a maximum allowable temperature of 55°C.
- (3) When the SD memory card is a mini SD, mini SDHC, micro SD, or micro SDHC memory card, use an SD memory card converter adapter.
- (4) Before writing to the SD memory card, release the write-protect switch.



- (5) Before inserting or ejecting an SD memory card, make sure to power off the system. If an SD memory card is inserted or ejected with the system powered on, the stored data could be corrupted or the SD memory card be damaged. *An SD memory card is live for a whilst after the system is powered off. Before insertion or ejection wait until the LED lamps on the FTC control board are all off.
- (6) The read and write operations have been verified using the following SD memory cards, however, these operations are not always guaranteed as the specifications of these SD memory cards could change.

Manufacturer	Model	Tested in
Verbatim	#44015	Mar. 2012
SanDisk	SDSDB-002G-B35	Oct. 2011
Panasonic	RP-SDP04GE1K	Oct. 2011
Arvato	2GB PS8032 TSB 24nm MLC	Jun. 2012
Arvato	2GB PS8035 TSB A19nm MLC	Jul. 2014
SanDisk	SDSDUN-008G-G46	Oct. 2016
Verbatim	#43961	Oct. 2016
Verbatim	#44018	Oct. 2016
VANTASTEK	VSDHC08	Sep.2017







Before using a new SD memory card (including the card that comes with the unit), always check that the SD memory card can be safely read and written to by the FTC controller.

<How to check read and write operations>

- a) Check for correct wiring of power supply to the system.
(Do not power on the system at this point.)
 - b) Insert an SD memory card.
 - c) Power on the system.
 - d) The LED4 lamp lights if the read and write operations are successfully completed. If the LED4 lamp continues blinking or does not light, the SD memory card cannot be read or written to by the FTC controller.
- (7) Make sure to follow the instruction and the requirement of the SD memory card's manufacturer.
 - (8) Format the SD memory card if determined unreadable in step (6). This could make it readable.
Download an SD card formatter from the following site.
SD Association homepage: <https://www.sdcard.org/home/>
 - (9) FTC supports FAT file system but not NTFS file system.
 - (10) Mitsubishi Electric is not liable for any damages, in whole or in part, including failure of writing to an SD memory card, and corruption and loss of the saved data, or the like. Back up saved data as necessary.
 - (11) Do not touch any electronic parts on the FTC control board when inserting or ejecting an SD memory card, or else the control board could fail.

- (a) For insertion, push on the SD memory card until it clicks into place.
- (b) For ejection, push on the SD memory card until it clicks.

Note: To avoid cutting fingers, do not touch sharp edges of the SD memory card connector (CN108) on the FTC control board.

Logos
  
  
Capacities
2 GB to 32 GB *2
SD speed classes
All

- * The SD Logo is a trademark of SD-3C, LLC.
The mini SD logo is a trademark of SD-3C, LLC.
The micro SD logo is a trademark of SD-3C, LLC.

*1 To edit main remote controller settings or to check operating data, an Ecodan service tool (for use with PC) is required.

*2 A 2-GB SD memory card stores up to 30 days of operation logs.

INSTALLATION - Wi-Fi ADAPTER

The pre-plumbed cylinder units are supplied fitted with a Wi-Fi adapter which can be used to easily pair your Ecodan system to the internet to enable remote control, monitoring, maintenance and technical support. The Wi-Fi adapter is pre-wired to the FTC controller and is contained within a transport bag at the front of the unit.

The installer must locate and mount the Wi-Fi adapter in a suitable location with good Wi-Fi signal strength (i.e. NOT within the FTC controller and not nearby automatic control devices such as automatic doors or fire alarms).

Please refer to the specific installation manual and setup quick reference guide provided. An instructional video is also available via the QR code.



INSTALLATION - IMMERSION HEATER ELECTRICAL SUPPLY

The pre-plumbed cylinder units are supplied fitted with an immersion heater which can be used to supplement the Air Source Heat Pump heating input. The immersion heater is located within the controls housing. Refer to Fig. 20 below for details of wiring of the immersion heater. **The mains supply circuit to the immersion heater must be protected by a suitable fuse and double pole isolating switch with a contact separation of at least 3mm in both poles. THE IMMERSION HEATER MUST BE EARTHED.** The supply cable for the immersion heater must be a minimum of 2.5mm² 3 core HO5 VV-F sheathed. Do NOT energise the heater until the DHW tank is full of water. Also do NOT energise any immersion heater if any sterilisation chemicals remain in the DHW tank as this will cause premature failure of the heater.

DO NOT BYPASS THE THERMAL CUT-OUT IN ANY CIRCUMSTANCES

Fig. 20 - Immersion heater wiring

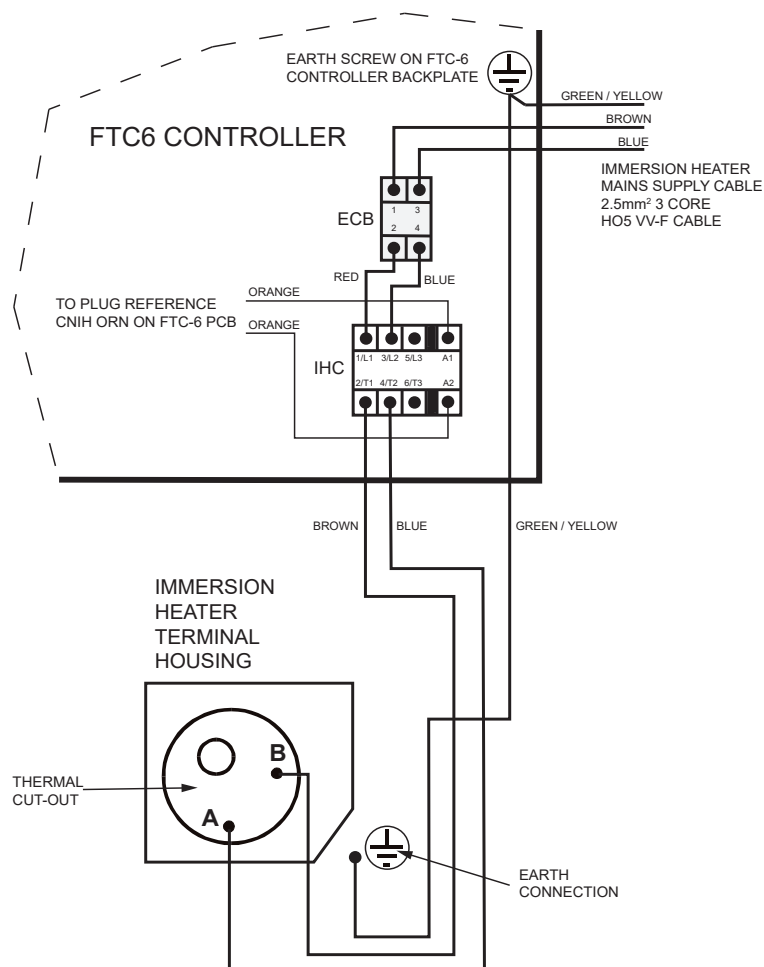

SYSTEM SET UP

Main remote controller

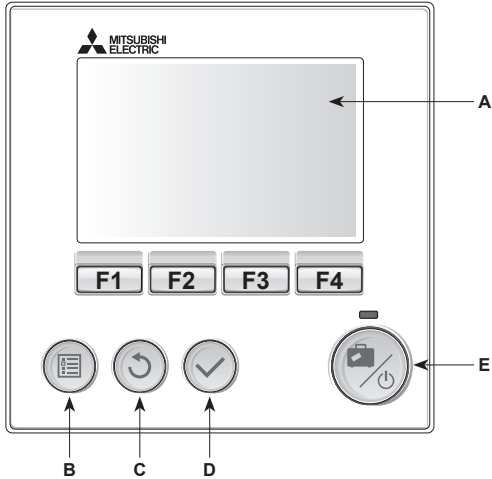

<Main remote controller parts>

Letter	Name	Function
A	Screen	Screen in which all information is displayed.
B	Menu	Access to system settings for initial set up and modifications.
C	Back	Return to previous menu.
D	Confirm	Used to select or save. (Enter key)
E	Power/Holiday	If system is switched off pressing once will turn system ON. Pressing again when system is switched on will enable Holiday Mode. Holding the button down for 3 secs will turn the system off. (*1)
F1-4	Function keys	Used to scroll through menu and adjust settings. Function is determined by the menu screen visible on screen A.

*1

When the system is switched off or the power supply is disconnected, the indoor unit protection functions (e.g. freeze stat. function) will NOT operate. Please beware that without these safety functions enabled the indoor unit may potentially become exposed to damage.

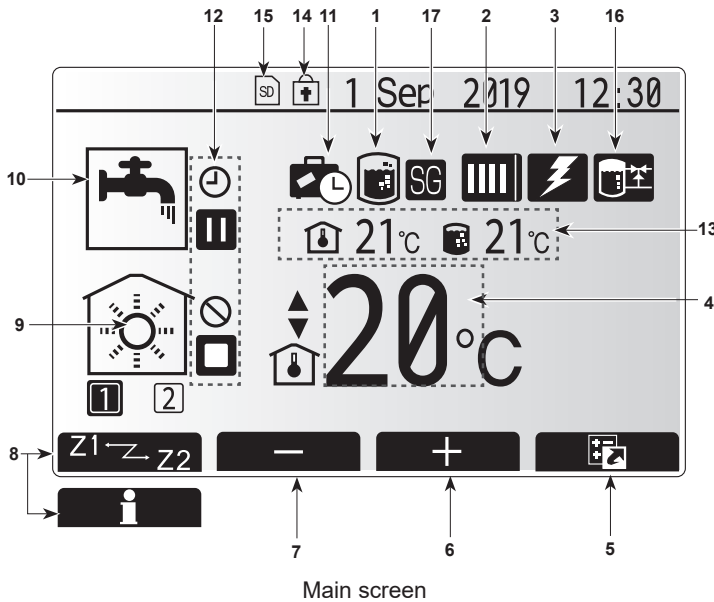

<Main screen icons>

	Icon	Description
1	Legionella prevention	When this icon is displayed 'Legionella prevention mode' is active.
2	Heat pump	'Heat pump' is running.
		Defrosting
		Emergency heating
		'Quiet mode' is activated.
3	Electric heater	When this icon is displayed the 'Electric heaters' (booster or immersion heater) are in use.
4	Target temperature	Target flow temperature
		Target room temperature
		Compensation curve
5	OPTION	Pressing the function button below this icon will display the option screen.
6	+	Increase desired temperature.
7	-	Decrease desired temperature.
8	Z1 Z2	Pressing the function button below this icon switches between Zone1 and Zone2.
		Information
9	Space heating (cooling) mode	Heating mode Zone1 or Zone2
		Cooling mode Zone1 or Zone2
10	DHW mode	Normal or ECO mode
11	Holiday mode	When this icon is displayed 'Holiday mode' activated.
12	Timer	Timer
		Prohibited
		Server control
		Stand-by
		Stand-by (*2)
		Stop
		Operating
13	Current temperature	Current room temperature
		Current water temperature of DHW tank
14	Lock	The Menu button is locked or the switching of the operation modes between DHW and Heating operations are disabled in the Option screen. (*3)
15	SD	SD memory card is inserted. Normal operation.
		SD memory card is inserted. Abnormal operation.
16	Buffer tank control	When this icon is displayed 'Buffer tank control' is active.
17	Smart grid ready	When this icon is displayed, 'Smart grid ready' is active.

*2 This unit is in Stand-by whilst other indoor unit(s) is in operation by priority.

*3 To lock or unlock the Menu, press the BACK and CONFIRM keys simultaneously for 3 seconds.

■ [Initial setting wizard]

When the main remote controller is switched on for the first time, the screen automatically goes to Language setting screen, Date/Time setting screen and main settings menu screen in order. Enter the desired number using the function keys and press CONFIRM.

Note:

<[HEATER CAPACITY RESTRICTION]>

This setting restricts the booster heater capacity. It is NOT possible to change the setting after starting up.

If you do not have any special requirements (such as building regulations) in your country, skip this setting (select "No").

- [Hot water (DHW/Legionella)]
- [Heating]/[Cooling]
- [Operation (ON/Prohibited/Timer)]
- [Pump speed]
- [Heat pump flow rate range]
- [Mixing valve control]
- [HEATER CAPACITY RESTRICTION]

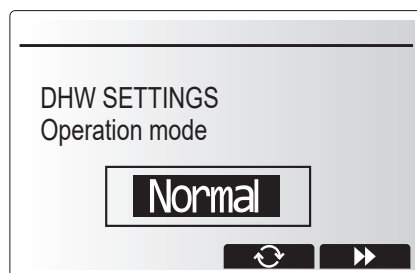
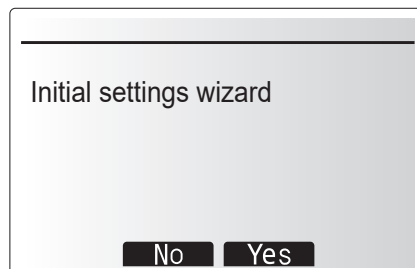

■ Main Settings Menu

The main settings menu can be accessed by pressing the MENU button. To reduce the risk of untrained end users altering the settings accidentally there are two access levels to the main settings; and the service section menu is password protected.

User Level – Short press

If the MENU button is pressed once for a short time the main settings will be displayed but without the edit function. This will enable the user to view current settings but **NOT** change the parameters.

Installer Level – Long press

If the MENU button is pressed down for 3 seconds the main settings will be displayed with all functionality available.

The colour of ◀▶ buttons is inverted, as per figure on right.

The following items can be viewed and/or edited (dependent on access level).

- [Domestic Hot water (DHW)]
- [Heating/Cooling]
- [Schedule timer]
- [Holiday mode]
- [Initial settings]
- [Service (Password protected)]

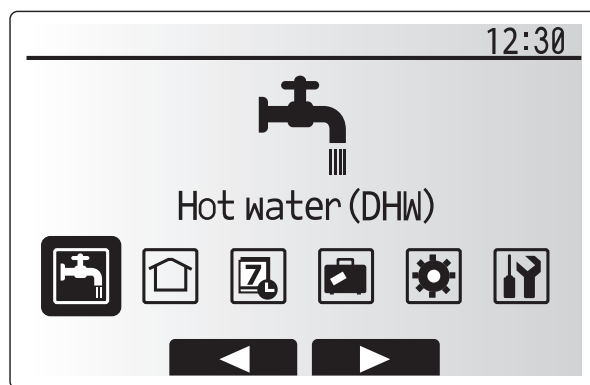

Main menu

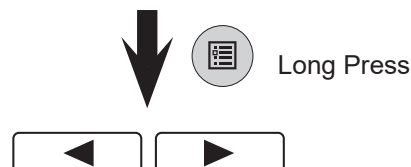

<Main Controller Menu Tree>

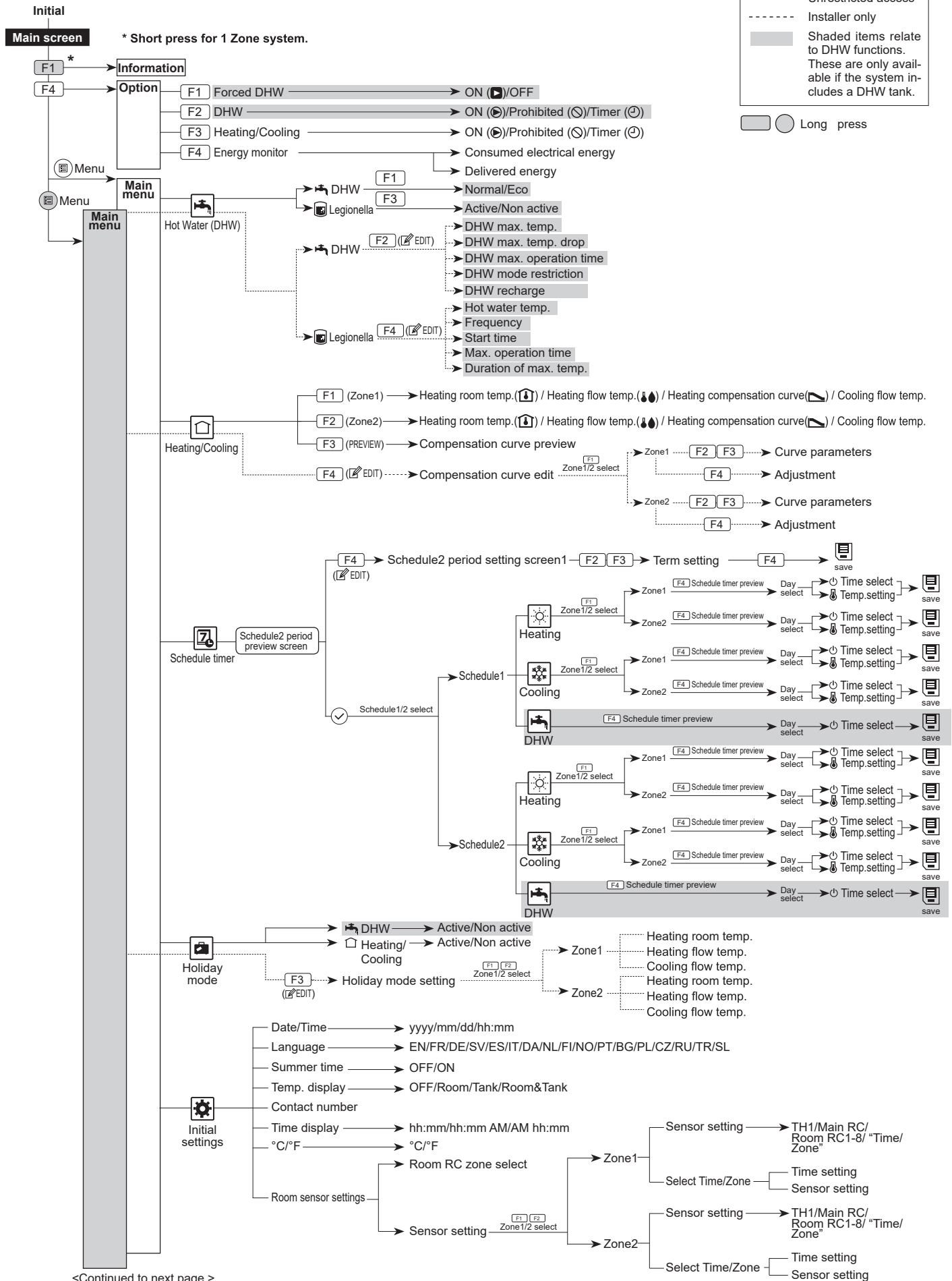

— Unrestricted access
 - - - - - Installer only
 ■ Shaded items relate to DHW functions. These are only available if the system includes a DHW tank.
 ◻ ◯ Long press

<Continued to next page.>

<Continued from the previous page.>

<Main Controller Menu Tree>

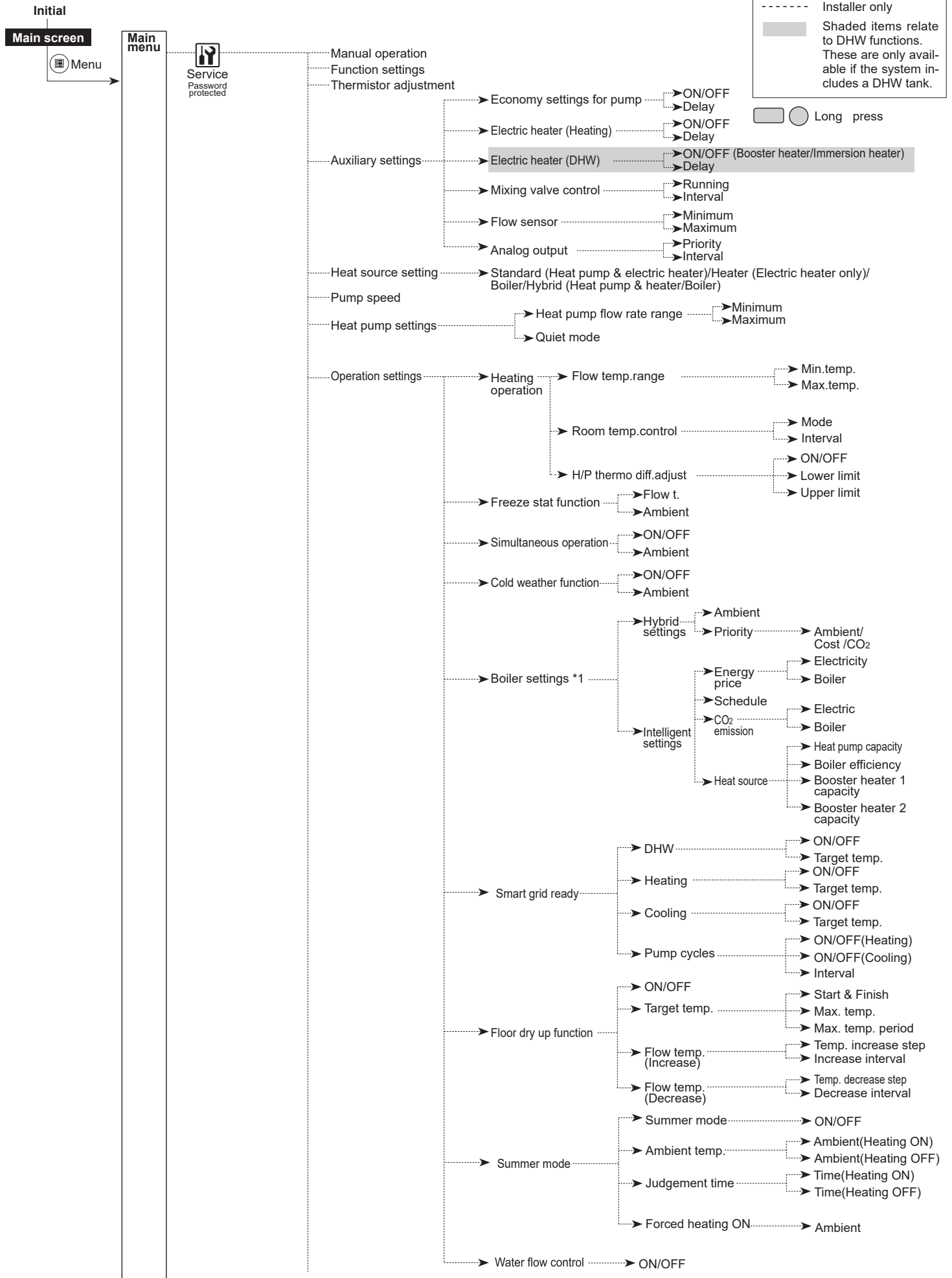

— Unrestricted access
 - - - - - Installer only
 ■ Shaded items relate to DHW functions. These are only available if the system includes a DHW tank.

□ ○ Long press

*1 For more details, refer to the installation manual of PAC-TH012HT(L)-E.

<Continued from the previous page.>

<Main Controller Menu Tree>

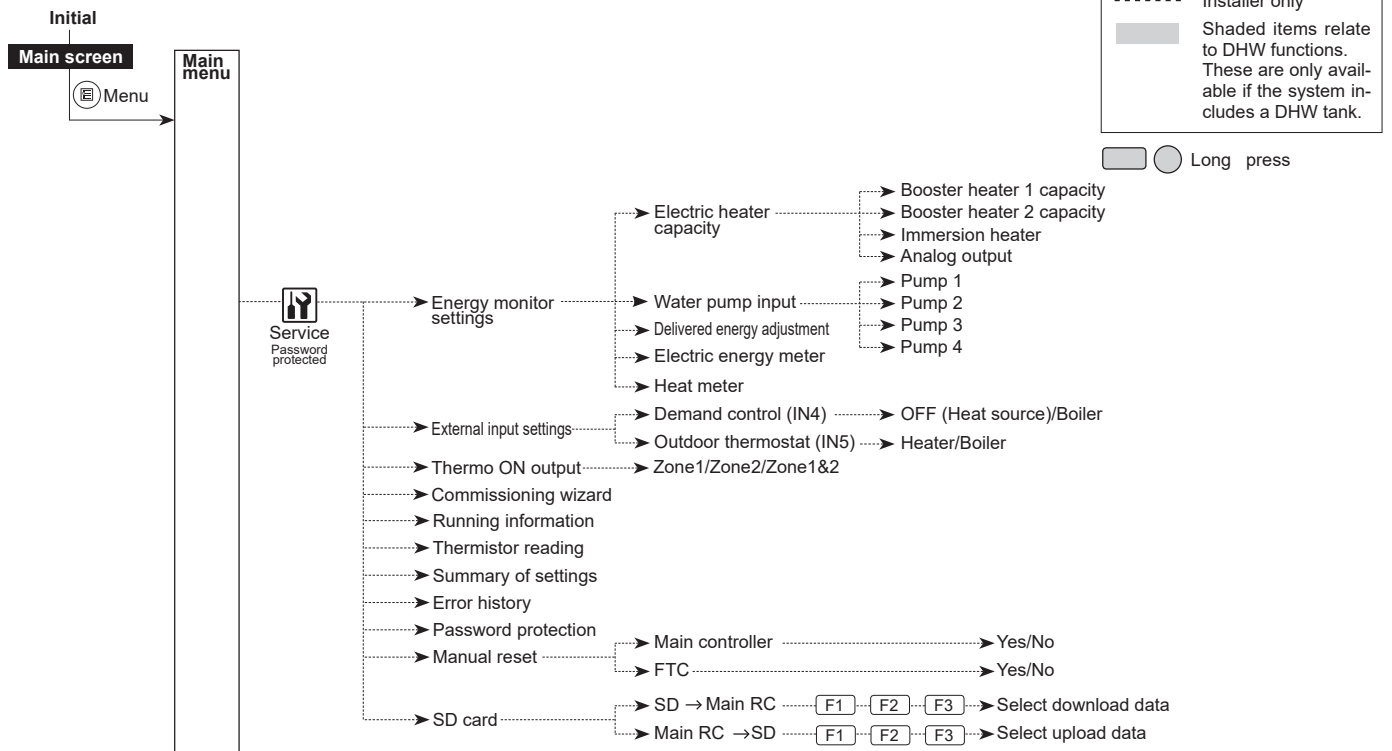

Domestic Hot Water (DHW)/Legionella Prevention

The domestic hot water and legionella prevention menus control the operation of DHW tank heat ups.

DHW mode settings

1. Highlight the hot water icon and press CONFIRM.
2. Use button F1 to switch between Normal and ECO heating modes.
3. To edit the mode, press down the MENU button for 3 seconds, then select "hot water".
4. Press F2 key to display the HOTWATER (DHW) SETTING menu.
5. Use F2 and F3 keys to scroll through the menu selecting each component in turn by pressing CONFIRM. See the table below for description of each setting.
6. Enter the desired number using the function keys and press CONFIRM.

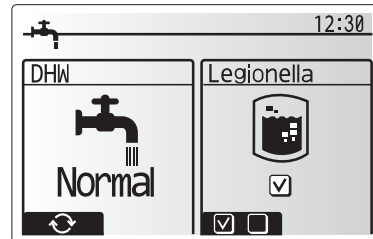

Menu subtitle	Function	Range	Unit	Default value
DHW max. temp.	Desired temperature of stored hot water	40 - 60	°C	50
DHW max. temp. drop	Difference in temperature between DHW max. temp. and the temperature at which DHW mode restarts	5 - 30 *	°C	10
DHW max. operation time	Max. time allowed for stored water heating DHW mode	30 - 120	min	60
DHW mode restriction	The time period after DHW mode when space heating has priority over DHW mode temporarily preventing further stored water heating (Only when DHW max. operation time has passed.)	30 - 120	min	30

* When the DHW max. temp is set over 55 °C, the temperature at which DHW mode restarts must be less than 50 °C to protect the device.

<Eco mode>

DHW mode can run in either 'Normal' or 'Eco' mode. Normal mode will heat the water in the DHW tank more quickly using the full power of the heat pump. Eco mode takes a little longer to heat the water in the DHW tank but the energy used is reduced. This is because heat pump operation is restricted using signals from the FTC based on measured DHW tank temperature.

Note: The actual energy saved in Eco mode will vary according to outdoor ambient temperature.

<[DHW recharge]>

Select the amount of DHW tank.

Return to the DHW/legionella prevention menu.

Legionella Prevention Mode settings (LP mode)

1. Use button F3 to choose legionella mode active YES/NO.
2. To edit the legionella function, press down the MENU button for 3 seconds and select "hot water", then press F4 key.
3. Use F1 and F2 keys to scroll through the menu selecting each subtitle in turn by pressing CONFIRM. See the table below for description of each setting.
4. Enter the desired number using the function keys and press CONFIRM.

During Legionella Prevention Mode the temperature of the stored water is increased above 60°C to inhibit legionella bacterium growth. It is strongly recommended that this is done at regular intervals. Please check local regulations for the recommended frequency of heat ups.

Please note that LP mode uses the assistance of electric heaters to supplement the energy input of the heat pump. Heating water for long periods of time is not efficient and will increase running costs. The installer should give careful consideration to the necessity of legionella prevention treatment whilst not wasting energy by heating the stored water for excessive time periods. The end user should understand the importance of this feature.
ALWAYS COMPLY WITH LOCAL AND NATIONAL GUIDANCE FOR YOUR COUNTRY REGARDING LEGIONELLA PREVENTION.

Note: When failures occur on the FTC unit, the LP mode may not function normally.

Menu subtitle	Function	Range	Unit	Default value
Hot water temp.	Desired temp. of stored hot water	60–70	°C	65
Frequency	Time between LP mode DHW tank heat up	1–30	day	15
Start time	Time when LP mode will begin	0:00–23:00	-	03:00
Max. operation time	Maximum time allowed for LP mode DHW tank heat	1–5	hour	3
Duration of max. temp.	The time period after LP mode desired water temp. has been reached	1–120	min	30

Initial Settings

<Room sensor settings>

For room sensor settings it is important to choose the correct room sensor depending on the heating mode the system will operate in.

1. From the Initial settings menu select Room sensor settings.

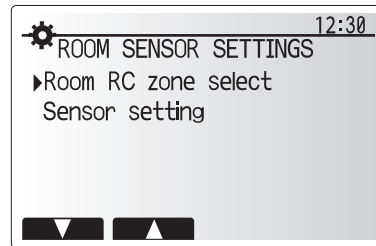

2. When 2-zone temperature control is active and wireless remote controllers are available, from Room RC zone select screen, select zone No. to assign to each remote controller.

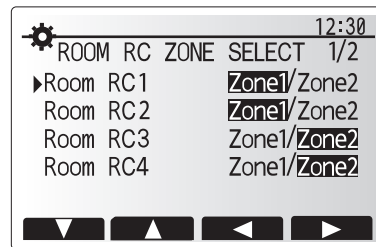

3. From Sensor setting screen, select a room sensor to be used for monitoring the room temperature from Zone1 and Zone2 separately.

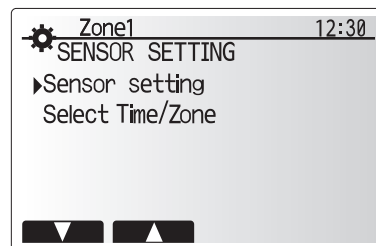

4. From Sensor setting screen, select Time/Zone to make it possible to use different room sensors according to the time schedule set in the Select Time/Zone menu. The room sensors can be switched up to 4 times within 24 hours.

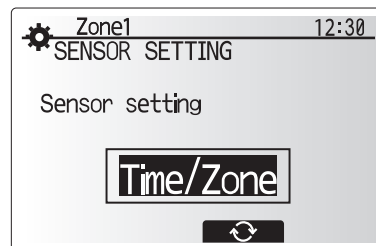

[Service] Menu

The service menu provides functions for use by installer or service engineer. It is NOT intended the home owner alters settings within this menu. It is for this reason password protection is required to prevent unauthorised access to the service settings.

The factory default password is "0000".

Follow the procedure described in General Operation for the set up operation.

Many functions can not be set whilst the indoor unit is running. The installer should turn off the unit before trying to set these functions. If the installer attempts to change the settings whilst the unit is running the main remote controller will display a reminder message prompting the installer to stop operation before continuing. By selecting "Yes" the unit will cease operation.

<[Manual operation]>

During the filling of the system the primary circuit circulation pump and 3-way valve can be manually overridden using manual operation mode.

When manual operation is selected a small timer icon appears in the screen.

When selected, this function will only remain in manual operation for a maximum of 2 hours. This is to prevent accidental permanent override of the FTC.

► Example

Pressing F3 button will switch manual operation mode ON for the main 3-way valve. When filling of the DHW tank is complete the installer should access this menu again and press F3 to deactivate manual operation of the part. Alternatively after 2 hours manual operation mode will no longer be active and FTC can resume control of the cylinder unit.

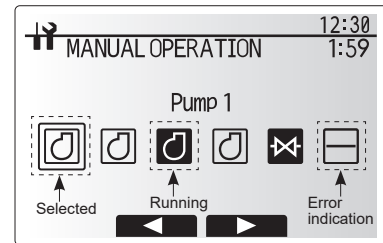

Manual operation menu screen

Manual operation and heat source setting can not be selected if the system is running. A screen will be displayed asking the installer to stop the system before these modes can be activated. The system automatically stops 2 hours after last operation.

<[Auxiliary settings]>

Refer to Page 33.

<Operation settings>

Heating operation

This function allows operational setting of flow temperature range from the Ecodan and also the time interval at which the FTC collects and processes data for the auto adaptation mode.

Menu subtitle		Function	Range	Unit	Default
Flow temp. range	Minimum temp.	To minimize the loss by frequent ON and OFF in mild outdoor ambient temperature seasons.	20 - 45	°C	30
	Maximum temp.	To set max. possible flow temperature according to the type of heat emitters.	35 - 60	°C	50
Room temp. control	Mode	Setting for Room temp. control At Fast mode, target outlet water temperature is set higher than the one set at normal mode. This reduces the time to reach the target room temperature when the room temperature is relatively low.*	Normal/ Fast	—	Normal
	Interval	Selectable according to the heat emitter type and the materials of floor (i.e. radiators, floor heating-thick, -thin concrete, wood, etc.)	10 - 60	min	10
Heat pump thermo diff.adjust	On/Off	To minimize the loss by frequent ON and OFF in mild outdoor ambient temperature seasons.	On/Off	—	On
	Lower limit	Prohibits heat pump operation until the flow temperature drops below the target flow temperature plus lower limit value.	-9 - -1	°C	-5
	Upper limit	Allows heat pump operation until the flow temperature rises above the target flow temperature plus upper limit value.	+3 - +5	°C	+5

Heating operation (Room temp. control table)

Note:

1. The minimum flow temperature that prohibits heat pump operation is 20°C.
2. The maximum flow temperature that allows heat pump operation equals to the maximum temperature set in the Flow temp. range menu.

* Fast mode is not efficient and will increase running cost when compared to normal mode.

Freeze stat function

Menu subtitle	Function/ Description
Freeze stat function *1	An operational function to prevent the water circuit from freezing when outdoor ambient temperature drops.
Flow t.	The target outlet water temperature at water circuit when operating in Freeze stat function. *2
Outdoor ambient temp.	Minimum outdoor ambient temperature which freeze stat function will begin to operate, (3 - 20°C) or choose**. If asterisk (**) is chosen freeze stat function is deactivated. (i.e. primary water freeze risk)"

*1. When the system is turned off, freeze stat function is not enabled.

*2. Flow t. is fixed to 20°C and unchangeable.

Simultaneous Operation

For periods of very low outside temperature this mode can be used. Simultaneous operation allows both DHW and space heating to run together by using the heat pump and/or booster heater to provide space heating whilst only the immersion heater provides heating for DHW. This operation is only available if BOTH a DHW tank AND immersion heater are present on the system.

- Range of outdoor ambient temperature at which simultaneous operation starts is -30°C to 10°C (default -15°C).
- System shall automatically return to routine operation. This will happen when the outdoor ambient temperature rises above the selected temperature for this specific mode of operation.

<[Floor dry up function]>

The Floor dry up function automatically changes the target hot water temperature in stages to gradually dry concrete when this particular type of underfloor heating system is installed.

Upon completion of the operation the system stops all the operations except the Freeze stat. operation.

For Floor dry up function, the target flow temp. of Zone1 is the same as that of Zone2.

- This function is not available when a PUAZ-FRP outdoor unit is connected.
- Disconnect wiring to external inputs of room thermostat, demand control, and outdoor thermostat, or the target flow temperature may not be maintained.

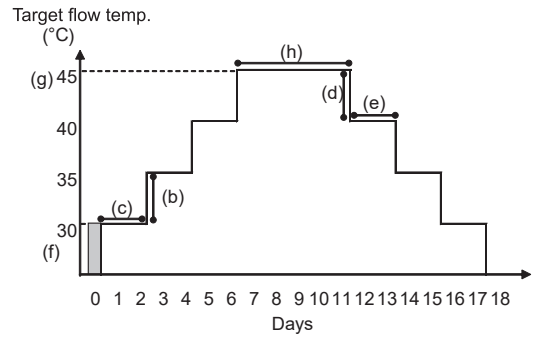

Functions	Symbol	Description	Option/Range	Unit	Default	
Floor dry up function	a	Set the function to ON and power on the system using the main remote controller, and the dry up heating operation will start.	On/Off	—	Off	
Flow temp. (increase)	Flow temp. increase step	b	Sets the increase step of the target flow temperature.	+1 - +10	°C	+5
	Increase interval	c	Sets the period for which the same target flow temperature is maintained.	1 - 7	day	2
Flow temp. (decrease)	Flow temp. decrease step	d	Sets the decrease step of the target flow temperature.	-1 - -10	°C	-5
	Decrease interval	e	Sets the period for which the same target flow temperature is maintained.	1 - 7	day	2
Target temperature	Start & Finish	f	Sets the target flow temperature at the start and the finish of the operation.	20 - 60	°C	30
	Max. target temp.	g	Sets the maximum target flow temperature.	20 - 60	°C	45
	Max. temp. period	h	Sets the period for which the maximum target flow temperature is maintained.	1 - 20	day	5

<Energy monitor settings>

In this menu, all parameters required to record the consumed electrical energy and the delivered heat energy which is displayed on the main remote controller can be set. The parameters are an electric heater capacity, supply power of water pump and heat meter pulse.

<External input settings>

Demand control(IN4)

The selection of "OFF", whilst a signal is being sent to IN4, forcefully stops all the heat source operations and the selection of "Boiler" stops operations of heat pump and electric heater and performs boiler operation.

Outdoor thermostat (IN5)

The selection of "Heater", whilst a signal is being sent to IN5, performs electric-heater-only operation and the selection of "Boiler" performs boiler operation.

<[Password protection]>

Password protection is available to prevent unauthorised access to the service menu by untrained persons.

Resetting the password

If you forget the password you entered, or have to service a unit somebody else installed, you can reset the password to the factory default of **0000**.

1. From the main settings menu scroll down the functions until Service Menu is highlighted.
2. Press CONFIRM.
3. You will be prompted to enter a password.
4. Hold down buttons F3 and F4 together for 3 seconds.
5. You will be asked if you wish to continue and reset the password to default setting.
6. To reset press button F3.
7. The password is now reset to **0000**.

<[Manual reset]>

Should you wish to restore the factory settings at any time you should use the manual reset function. Please note this will reset ALL functions to the factory default settings.



Password input screen



Password verify screen

Engineers Forms

Should settings be changed from default, please enter and record new setting in 'Field Setting' column. This will ease resetting in the future should the system use change or the circuit board need to be replaced.

Commissioning/Field settings record sheet

Main remote controller screen		Parameters	Default setting	Field setting	Notes		
Main		Zone1 heating room temp.	10°C - 30°C	20°C			
		Zone2 heating room temp. *14	10°C - 30°C	20°C			
		Zone1 heating flow temp.	20°C - 60°C	45°C			
		Zone2 heating flow temp. *1	20°C - 60°C	35°C			
		Zone1 cooling flow temp. *12	5°C - 25°C	15°C			
		Zone2 cooling flow temp. *12	5°C - 25°C	20°C			
		Zone1 heating compensation curve	-9°C - + 9°C	0°C			
		Zone2 heating compensation curve *1	-9°C - + 9°C	0°C			
Option		Holiday mode	Active/Non active/Set time	—			
		Forced DHW operation	On/Off	—			
		DHW	On/Off/Timer	On			
		Heating/Cooling	On/Off/Timer	On			
Setting	DHW *13	Operation mode	Normal/Eco *16	Normal			
		DHW max. temp.	40°C - 60°C *2	50°C			
		DHW temp. drop	5°C - 30°C	10°C			
		DHW max. operation time	30 - 120 min	60 min			
		DHW mode restriction	30 - 120 min	30 min			
		DHW recharge	Large/Standard	Large *19			
	Legionella prevention *13	Active	Yes/No	Yes			
		Hot water temp.	60°C - 70°C *2	65°C			
		Frequency	1 - 30 days	15 days			
		Start time	00.00 - 23.00	03.00			
		Max. operation time	1 - 5 hours	3 hours			
		Duration of maximum temp.	1 - 120 min	30 min			
	Heating/ Cooling *12	Zone1 operation mode	Heating room temp./ Heating flow temp./ Heating compensation curve/ Cooling flow temp.	Room temp.			
		Zone2 operation mode *1	Heating room temp./ Heating flow temp./ Heating compensation curve/ Cooling flow temp.	Compensation curve			
	Compensation curve	Hi flow temp. set point	Zone1 outdoor ambient temp.	-30°C - +33°C *3	-15°C		
			Zone1 flow temp.	20°C - 60°C	50°C		
			Zone2 outdoor ambient temp. *1	-30°C - +33°C *3	-15°C		
			Zone2 flow temp. *1	20°C - 60°C	40°C		
			Lo flow temp. set point	Zone1 outdoor ambient temp.	-28°C - +35°C *4	35°C	
				Zone1 flow temp.	20°C - 60°C	25°C	
		Zone2 outdoor ambient temp. *1		-28°C - +35°C *4	35°C		
		Zone2 flow temp. *1		20°C - 60°C	25°C		
		Adjust		Zone1 outdoor ambient temp.	-29°C - +34°C *5	—	
				Zone1 flow temp.	20°C - 60°C	—	
			Zone2 outdoor ambient temp. *1	-29°C - +34°C *5	—		
			Zone2 flow temp. *1	20°C - 60°C	—		
	Holiday		DHW *13	Active/Non active	Non active		
			Heating/ Cooling *12	Active/Non active	Active		
		Zone1 heating room temp.	10°C - 30°C	15°C			
		Zone2 heating room temp. *14	10°C - 30°C	15°C			
		Zone1 heating flow temp.	20°C - 60°C	35°C			
		Zone2 heating flow temp. *1	20°C - 60°C	25°C			
		Zone1 cooling flow temp. *12	5°C - 25°C	25°C			
Zone2 cooling flow temp. *12		5°C - 25°C	25°C				
Initial settings		Language	EN/FR/DE/SV/ES/IT/DA/NL/FI/NO/PT/BG/PL/CZ/RU/TR/SL	EN			
		°C/°F	°C/°F	°C			
	Summer time	On/Off	Off				
	Temp. display	Room/DHW tank/Room&DHW tank /Off	Off				
	Time display	hh:mm/hh:mm AM/AM hh:mm	hh:mm				
	Room sensor settings for Zone1	TH1/Main RC/Room RC1-8/"Time/Zone"	TH1				
	Room sensor settings for Zone2 *1	TH1/Main RC/Room RC1-8/"Time/Zone"	TH1				
	Room RC zone select *1	Zone1/Zone2	Zone1				

(Continued to next page.)

■ Engineers Forms

Commissioning/Field settings record sheet

Main remote controller screen			Parameters		Default setting	Field setting	Notes	
Setting	Service menu	Thermistor adjustment	THW1	-10°C - +10°C	0°C			
			THW2	-10°C - +10°C	0°C			
THW5B	-10°C - +10°C		0°C					
THW6	-10°C - +10°C		0°C					
THW7	-10°C - +10°C		0°C					
THW8	-10°C - +10°C		0°C					
THW9	-10°C - +10°C		0°C					
THW10	-10°C - +10°C		0°C					
THWB1	-10°C - +10°C		0°C					
			Auxiliary settings	Economy settings for pump.		On/Off *6	On	
		Electric heater (Heating)		Space heating: On (used)/Off (not used)	On			
		Electric heater (DHW) *13		Electric heater delay timer (5 - 180 min)	30 min			
		Mixing valve control		Booster heater	DHW: On (used)/Off (not used)	On		
				Immersion heater		DHW: On (used)/Off (not used)	On	
				Electric heater delay timer (15 - 30 min)	15 min			
				Running (10 - 240 sec)	120 sec			
				Interval (1 - 30 min)	2 min			
		Flow sensor *18		Minimum (0 - 100 L/min)	5 L/min			
				Maximum (0 - 100 L/min)		100 L/min		
		Analog output		Interval (1 - 30 min)	5 min			
				Priority (Normal/High)		Normal		
		Pump speed	DHW	Pump speed (1 - 5)	5			
			Heating/Cooling	Pump speed (1 - 5)	5			
		Heat source setting	Standard/Heater/Boiler/Hybrid *7		Standard			
		Heat pump setting	Heat pump flow rate range		Minimum (0 - 100 L/min)	5 L/min		
					Maximum (0 - 100 L/min)	100 L/min		
			Quiet mode		Day (Mon - Sun)	—		
					Time	0:00 - 23:45		
				Quiet level (Normal/ Level1/ Level2)	Normal			
Operation settings	Heating operation *8	Flow temp.range *10	Min.temp. (20 - 45°C)		30°C			
			Max.temp. (35 - 60°C)		50°C			
		Room temp.control *15	Mode (Normal/Fast)		Normal			
			Interval (10 - 60min)		10min			
	Heat pump thermo diff.adjust		On/Off *6		On			
			Lower limit (-9 - -1°C)		-5°C			
			Upper limit (+3 - +5°C)		5°C			
	Freeze stat function *11		Outdoor ambient temp. (3 - 20°C) / **		5°C			
	Simultaneous operation (DHW/ Heating)		On/Off *6		Off			
			Outdoor ambient temp. (-30 - +10°C) *3		-15°C			
	Cold weather function		On/Off *6		Off			
			Outdoor ambient temp. (-30 - -10°C) *3		-15°C			
	Boiler operation		Hybrid settings		Outdoor ambient temp. (-30 - +10°C) *3	-15°C		
					Priority mode (Ambient/Cost/CO ₂) *17	Ambient		
					Outdoor ambient temp. rise (+1 - +5 °C)	+3 °C		
			Intelligent settings		Energy price *9	Electricity (0.001 - 999 */kWh)	0.5 */kWh	
CO ₂ emission					Boiler (0.001 - 999 */kWh)	0.5 */kWh		
					Electricity (0.001 - 999 kg -CO ₂ /kWh)	0.5 kg -CO ₂ / kWh		
Heat source		Boiler (0.001 - 999 kg -CO ₂ /kWh)		0.5 kg -CO ₂ / kWh				
		Heat pump capacity (1 - 40 kW)		11.2 kW				
		Boiler efficiency (25 - 150%)		80%				
		Booster heater 1 capacity (0 - 30 kW)		2 kW				
		Booster heater 2 capacity (0 - 30 kW)		4 kW				

(Continued to next page.)

■ Engineers Forms

Commissioning/Field settings record sheet (continued from the previous page)

Main remote controller screen				Parameters		Default setting	Field setting	Notes
	Service menu	Operation settings	Smart grid ready	DHW	On/Off		Off	
				Target temp(+1- +20°C) / -- (Non active)		--		
				Heating	On/Off		Off	
					Target temp.	Switch-on recommendation (20 - 60°C)	50°C	
						Switch-on command (20 - 60°C)	55°C	
				Cooling	On/Off		Off	
					Target temp.	Switch-on recommendation (5 - 25°C)	15°C	
						Switch-on command (5 - 25°C)	10°C	
			Pump cycles	Heating (On/Off)		On		
				Cooling (On/Off)		On		
				Interval (10-120 min)		10 min		
			Floor dry up function	On/Off *6		Off		
				Target temp.	Start&Finish (20 - 60°C)	30°C		
					Max. temp. (20 - 60°C)	45°C		
					Max. temp. period (1 - 20 days)	5 days		
				Flow temp. (Increase)	Temp. increase step (+1 - +10°C)	+5°C		
					Increase interval (1 - 7 days)	2 days		
				Flow temp. (Decrease)	Temp. decrease step (-1 - -10°C)	-5°C		
					Decrease interval (1 - 7 days)	2 days		
				Summer mode	On/Off		Off	
	Outdoor ambient temp.	Heating ON (4-19°C)			10°C			
		Heating OFF (5-20°C)	15°C					
	Judgement time	Heating ON (1-48 hours)	6 hours					
		Heating OFF (1-48 hours)	6 hours					
	Forced heating ON (-30 - 10°C)	5 °C						
	Water flow control	On/Off		Off				
	Energy monitor settings	Electric heater capacity	Booster heater 1 capacity	0 - 30 kW	2 kW			
			Booster heater 2 capacity	0 - 30 kW	4 kW			
			Immersion heater capacity	0 - 30 kW	0 kW			
			Analog output	0 - 30 kW	0 kW			
		Delivered energy adjustment		-50 - +50%	0%			
		Water pump input	Pump 1	0 - 200 W or ***(factory fitted pump)		***		
			Pump 2	0 - 200 W		0 W		
			Pump 3	0 - 200 W		0 W		
			Pump 4 *19	0 - 200 W		72 W		
		Electric energy meter		0.1/1/10/100/1000 pulse/kWh		1 pulse/kWh		
	Heat meter		0.1/1/10/100/1000 pulse/kWh		1 pulse/kWh			
	External input settings	Demand control (IN4)		Heat source OFF/Boiler operation		Boiler operation		
		Outdoor thermostat (IN5)		Heater operation/Boiler operation		Boiler operation		
	Thermo ON output		Zone1/Zone2/Zone1&2		Zone1&2			

*1 The settings related to Zone2 can be switched only when 2 Zone temperature control is enabled (when DIP SW2-6 and SW 2-7 are ON).

*2 For the model without both booster and immersion heater, it may not reach the set temperature depending on the outside ambient temperature.

*3 The lower limit is -15°C depending on the connected outdoor unit.

*4 The lower limit is -13°C depending on the connected outdoor unit.

*5 The lower limit is -14°C depending on the connected outdoor unit.

*6 On: the function is active; Off: the function is inactive.

*7 When DIP SW1-1 is set to OFF "WITHOUT Boiler" or SW2-6 is set to OFF "WITHOUT Mixing tank", neither Boiler nor Hybrid can be selected.

*8 Valid only when operating in Room temp. control mode.

*9 *** of **/kWh" represents currency unit (e.g. € or £ or the like)

*10 Valid only when operating in Heating room temperature.

*11 If asterisk (**) is chosen freeze stat function is deactivated. (i.e. primary water freeze risk)

12 Cooling mode settings are available for ERS model only.

*13 Only available if DHW tank present in system.

*14 The settings related to Zone2 can be switched only when 2-zone temperature control or 2-zone valve ON/OFF control is active.

*15 When DIP SW5-2 is set to OFF, the function is active.

*16 When the hydrobox is connected with a PUMY-P outdoor unit, the mode is fixed to "Normal".

*17 When the hydrobox is connected with a PUMY-P outdoor unit, the mode is fixed to "Ambient".

*18 Do not change the setting since it is set according to the specification of flow sensor attached to the hydrobox.

*19 This setting is valid for only cylinder units.

COMMISSIONING

At the time of commissioning, please ensure the Commissioning Checklist is completed for the installation.

CYLINDER UNIT - INITIAL FILL PROCEDURE

- BEFORE FILLING CHECK AND TIGHTEN ALL MECHANICAL JOINTS AND CONNECTIONS IN CASE THESE HAVE LOOSENED DURING TRANSIT.
- Check expansion vessel pre-charge pressure. The vessel is supplied pre-charged to 3.5 bar to match the control pressure of the pressure reducing valve. The pre-charge pressure is checked using a car tyre gauge by unscrewing the plastic cap opposite the water connection.
- Check all connections for tightness including the immersion heater(s). An immersion heater key spanner is supplied for this purpose.
- Ensure the drain cock is CLOSED.
- Open a hot tap furthest from the cylinder.
- Open the cylinder isolating valve to fill the unit. When water flows from the tap, allow to run for a few minutes to thoroughly flush through any residue, dirt or swarf, then close the tap.
- Open successive hot taps to purge the system of air.
- Ensure all hot taps are closed to retain system charge.

CYLINDER UNIT - SYSTEM CHECKS

- Check all water connections for leaks and rectify as necessary.
- Turn off water supply to the cylinder.
- Remove the Pressure Reducing Valve head work to access the strainer mesh, clean and re-fit.
- Manually open, for a few seconds, each relief valve in turn, checking that water is discharged and runs freely through the tundish and out at the discharge point.
- Ensure that the valve(s) re-seat satisfactorily and reinstate the cylinder water supply.

CYLINDER UNIT - INITIAL FLUSH PROCEDURE

- Energise system to heat-up cylinder unit contents to a temperature of approx. 30 - 40°C.
- Flush/drain the water contents to remove any residue/impurities resulting from the installation works.
- Use the cylinder unit drain cock to safely discharge the warmed water to drain via a suitable hose.
- On completion, close drain cock, re-fill system and resume system commissioning.

DOMESTIC HOT WATER (DHW) CIRCULATION

Ensure the DHW circulation pump is set to speed setting II to ensure optimum DHW heating performance. Failure to do so can result in excessive use of the back-up immersion heater or lower storage temperatures than required.

PRIMARY CIRCUIT - FILLING THE SYSTEM

- Check and charge expansion vessel.
- Check all connections including factory fitted ones are tight.
- Insulate pipework between cylinder and outdoor unit.
- Thoroughly clean and flush, system of all debris. (see page 24 for instruction.)
- Fill cylinder unit with potable water. Fill primary heating circuit with water and suitable anti-freeze and inhibitor as necessary.
Always use a filling loop with double check valve when filling the primary circuit to avoid back flow contamination of water supply.
- Check for leakages. If leakage is found, retighten the screws onto the connections.
- Pressurise system to 1 bar.
- Release all trapped air using air vents during and following heating period.
- Top up with water as necessary. (If pressure is below 1 bar)
- After removing the air, automatic air vent **MUST** be closed.

Fernox HP5-c frost protection levels:

10% Concentration provides frost protection to -4°C

20% Concentration provides frost protection to -9°C

30% Concentration provides frost protection to -14°C

Switch on the electrical supply to the Air Source Heat Pump and immersion heater. Programme the Air Source Heat Pump Main Remote Controller as detailed in the previous System Set Up chapter. Set the controller for hot water operation only. After a short delay the heat pump circulating pump on the return to the Heat Pump and the DHW circulating pump should run and the Heat Pump operate. The temperature of the primary flow to the cylinder should increase, if it does not, check for a wiring or piping error.

Allow the cylinder unit to heat up.

Select the heating only function on the controller. The heat pump circulating pump and the heating zone 1 circulating pump should run and the Heat Pump operates. The primary flow to the low loss header and the secondary flow to the heating zone 1 circuit should become hot, if it does not check for a wiring or piping error.

The minimum hot water setting is 40°C. The maximum hot water setting is 60°C. In hard water areas a maximum of 55°C is recommended.

When the heating and hot water temperatures are reached, the pumps should stop running and the Heat Pump stop operating.

Check that no water is discharged from either the expansion valve or temperature and pressure relief valve during the heating cycle. If the user temperatures or "On" and "Off" times have been adjusted for commissioning purposes, the main remote controller should be reset to the desired settings. The operation of the user controls should be demonstrated to the user and the main remote controller installation and user instructions left with them for future reference.

ENVIRONMENTAL INFORMATION

Products are manufactured from many recyclable materials. At the end of their useful life they should be disposed of at a Local Authority Recycling Centre in order to realise the full environmental benefits.

Insulation is by means of an approved CFC/HCFC free polyurethane foam with an ozone depletion factor of zero.

WEEE Declaration

Disposal of Waste Equipment by Users in Private Household in the European Union.



This symbol on the product indicates that this product must not be disposed of with your other household waste. Instead, it is your responsibility to dispose of your waste equipment by handing it over to a designated collection point for the recycling of waste electrical equipment.

The separate collection and recycling of your waste equipment at the time of disposal will help to conserve natural resources and ensure that it is recycled in a manner that protects human health and the environment.

For more information about where you can drop off your waste equipment for recycling, please contact your local city office, your household waste disposal service or the company where this product was purchased.

LOCAL APPLICATION FACTORS

Additional Requirements for using R32 Refrigerant

1. Important Notice (Fire safety)

R32 is flammable refrigerant (classified as A2L - lower flammability), and the fire safety warranty for the whole system (including outdoor unit) must be done by your side.

Conformity of regulations (e.g. IEC 60335) and laws must be confirmed on the system by your side.

2. Pressure relief valve

PUZ-(H)WM(50/60/85/112/140)(V/Y)(H/A)A outdoor units contain a 0.3 (3.0) MPa (bar) pressure relief valve.

Do not attach an additional pressure relief valve to the heating (cooling) circuit on EHPT(15/17/21/25/30)X-UKH(L) DW1(S-L).

TECHNICAL SUPPORT

Residential Heating & Ventilation Telephone: 01707 278666

MELSmart Customer Services & Support: 0161 866 6089

Option 1 - Air Conditioning Technical

Option 4 - Heating Technical

Option 2 - Spares

Option 5 - Returns

Option 3 - Warranty

Option 6 - Product Training & Site Services

Email: livingenvironmentalsystems@meuk.mee.com

Website: les.mitsubishielectric.co.uk

UNITED KINGDOM

Mitsubishi Electric Europe B.V. UK Branch

Living Environmental Systems Division

Travellers Lane

Hatfield

Hertfordshire

AL10 8XB

General Enquiries

Telephone: 01707 282880

Fax: 01707 278881