

Service Handbook

Model

PUHY-P200, P250, P300, P350, P400, P450, P500YNW-A(1/2)

PUHY-P400, P450, P500, P550, P600, P650, P700, P750, P800, P850, P900YSNW-A(1/2)

PUHY-P950, P1000, P1050, P1100, P1150, P1200, P1250, P1300, P1350YSNW-A(1/2)

PUHY-EP200, EP250, EP300, EP350, EP400, EP450, EP500YNW-A(1/2)

PUHY-EP400, EP450, EP500, EP550, EP600, EP650, EP700, EP750, EP800, EP850, EP900YSNW-A(1/2)

PUHY-EP950, EP1000, EP1050, EP1100, EP1150, EP1200, EP1250, EP1300, EP1350YSNW-A(1/2)

Safety Precautions

•Please read the following safety precautions carefully before installing the unit to ensure safety.



WARNING

Indicates a risk of death or serious injury.



CAUTION

Indicates a risk of serious injury or structural damage.

- Make sure that this manual is passed on to the end user to retain for future reference.
- Retain this manual for future reference. When the unit is reinstalled or repaired, have this manual available to those who provide these services. Make sure that this manual is passed on to any future users.

All electric work must be performed by qualified personnel.

Air tightness test must be performed by qualified personnel.

General Precautions



WARNING

Do not use refrigerant other than the type indicated in the manuals provided with the unit and on the nameplate. Doing so may cause the unit or pipes to burst, or result in explosion or fire during use, during repair, or at the time of disposal of the unit. It may also be in violation of applicable laws. **MITSUBISHI ELECTRIC CORPORATION** cannot be held responsible for malfunctions or accidents resulting from the use of the wrong type of refrigerant.

Do not install the unit in a place where large amounts of oil, steam, organic solvents, or corrosive gases, such as sulfuric gas, are present or where acidic/alkaline solutions or sprays containing sulfur are used frequently. These substances can compromise the performance of the unit or cause certain components of the unit to corrode, which can result in refrigerant leakage, water leakage, injury, electric shock, malfunctions, smoke, or fire.

Do not try to defeat the safety features of the unit or make unauthorized setting changes. Forcing the unit to operate the unit by defeating the safety features of the devices such as the pressure switch or the temperature switch, making unauthorized changes to the switch settings, or using accessories other than the ones recommended by Mitsubishi Electric may result in smoke, fire, or explosion.

To reduce the risk of shorting, current leakage, electric shock, malfunctions, smoke, or fire, do not splash water on electric parts.

To reduce the risk of electric shock, malfunctions, smoke or fire, do not operate the switches/buttons or touch other electrical parts with wet hands.

To reduce the risk of pipe burst and explosion, do not allow gas refrigerant and refrigerant oil to be trapped in the refrigerant circuit.

To reduce the risk of burns or frost bites, do not touch the refrigerant pipes or refrigerant circuit components with bare hands during and immediately after operation.

To reduce the risk of burns, do not touch any electrical parts with bare hands during or immediately after stopping operation.

To reduce the risk of injury from falling tools, keep children away while installing, inspecting, or repairing the unit.

Keep the space well ventilated. Refrigerant can displace air and cause oxygen starvation. If leaked refrigerant comes in contact with a heat source, toxic gas may be generated.

Always replace a fuse with one with the correct current rating. The use of improperly rated fuses or a substitution of fuses with steel or copper wire may result in bursting, fire or explosion.

To reduce the risk of electric shock, smoke, and fire due to infiltration of dust and water, properly install all required covers and panels on the terminal box and control box.

CAUTION

To reduce the risk of being caught in rotating parts, electric shock, and burns, do not operate the unit without all required panels and guards being installed.

To reduce the risk of injury, do not sit, stand, or place objects on the unit.

To reduce the risk of water leakage and malfunctions, do not turn off the power immediately after stopping operation. Leave the unit turned on for at least 5 minutes before turning off the power.

Do not install the unit over things that are vulnerable to water damage from condensation dripping.

To reduce the risk of injury, electric shock, and malfunctions, do not touch or allow cables to come in contact with the edges of components.

To reduce the risk of injury, do not touch the heat exchanger fins or sharp edges of components with bare hands.

To reduce the risk of injury from units falling or falling over, periodically check the installation base for damage.

Consult an authorized agency for the proper disposal of the unit. Refrigerant oil and refrigerant that may be left in the unit pose a risk of fire, explosion, or environmental pollution.

Always wear protective gears when touching electrical components on the unit. Several minutes after the power is switched off, residual voltage may still cause electric shock.

To reduce the risk of electric shock and burns, always wear protective gear when working on units.

To reduce the risk of injury, do not insert fingers or foreign objects into air inlet/outlet grills. If the unit is left on a damaged base, it may fall and cause injury.

To reduce the risk of injury, always wear protective gear when working on units.

Do not release refrigerant into the atmosphere. Collect and reuse the refrigerant, or have it properly disposed of by an authorized agency. Refrigerant poses environmental hazards if released into the air.

Transportation and Installation

WARNING

Lift the unit by placing the slings at designated locations. Support the outdoor unit securely at four points to keep it from slipping and sliding. If the unit is not properly supported, it may fall and cause personal injury.

CAUTION

To reduce the risk of injury, do not carry the product by the PP bands that are used on some packages.

To reduce the risk of injury, products weighing 20 kg or more should be carried by two or more people.

Installation

WARNING

Do not install the unit where there is a risk of leaking flammable gas. If flammable gas accumulates around the unit, it may ignite and cause a fire or explosion.

To reduce the risk of injury from coming in contact with units, install units where they are not accessible to people other than maintenance personnel.

To reduce the risk of injury, properly dispose of the packing materials so that children will not play with them.

Properly dispose of the packing materials. Plastic bags pose suffocation hazard to children.

All drainage work should be performed by the dealer or qualified personnel according to the instructions detailed in the Installation Manual. Improper drainage work may cause water leakage and resultant damage to the furnishings.

Remove packing materials from the unit before operating the unit. Note that some accessories may be taped to the unit. Properly install all accessories that are required. Failing to remove the packing materials or failing to install required accessories may result in refrigerant leakage, oxygen deprivation, smoke, or fire.

Consult your dealer and take appropriate measures to safeguard against refrigerant leakage and resultant oxygen starvation. An installation of a refrigerant gas detector is recommended.

Any additional parts must be installed by the dealer or qualified personnel. Only use the parts specified by Mitsubishi Electric. Installation by unauthorized personnel or use of unauthorized parts or accessories may result in water leakage, electric shock, or fire.

Take appropriate safety measures against wind gusts and earthquakes to prevent the unit from toppling over and causing injury.

To reduce the risk of injury from units falling or falling over, install the unit on a surface that is strong enough to support its weight.

CAUTION

Do not install the unit over things that are vulnerable to water damage. Provide an adequate collective drainage system for the drain water from unit as necessary.

To reduce the risk of damage to the unit and resultant electric leak and electric shock, keep small animals, snow, and rain water from entering the unit by closing the gap in the pipe and wire access holes.

To reduce the risk of rain water or drain water from entering the room and damaging the interior, drainage work must be performed by your dealer or qualified personnel according to the instructions detailed in the Installation Manual.

Piping Work

WARNING

To reduce the risk of injury, including frost bites, that may result from being blasted with refrigerant, use caution when operating the refrigerant service valve. If refrigerant leaks out and comes in contact with an open flame, toxic gases may be generated.

To reduce the risk of refrigerant catching fire and causing burns, remove the refrigerant gas and the residual refrigerant oil in the pipes before heating them.

To reduce the risk of pipe damage, refrigerant leakage, and oxygen deprivation, use pipes that meet the pipe thickness specifications, which vary by the type of refrigerant used, pipe diameter, and pipe material.

To reduce the risk of pipe burst or explosion, evacuate the refrigerant circuit using a vacuum pump, and do not purge the system with refrigerant.

To reduce the risk of explosion and deterioration of refrigerant oil caused by chloride, do not use oxygen, flammable gas, or refrigerant that contains chloride as a pressurizing gas.

To prevent explosion, do not heat the unit with refrigerant gas in the refrigerant circuit.

To reduce the risk of oxygen deprivation and gas poisoning, check for gas leakage and keep fire sources away.

Insulate pipe connections after completing the air tightness test. Performing an air tightness test with the pipe being insulated may lead to failure to detect refrigerant leakage and cause oxygen deprivation.

To reduce the risk of pipe damage and resultant refrigerant leakage and oxygen deprivation, keep the field-installed pipes out of contact with the edges of components.

CAUTION

To reduce the risk of pipe bursting and explosion due to abnormal pressure rise, do not allow any substances other than R410A (such as air) to enter the refrigerant circuit.

To keep the ceiling and floor from getting wet due to condensation, properly insulate the pipes.

Wiring Work

WARNING

To reduce the risk of wire breakage, overheating, smoke, and fire, keep undue force from being applied to the wires.

To reduce the risk of wire breakage, overheating, smoke, or fire, properly secure the cables in place and provide adequate slack in the cables so as not to stress the terminals.

All electric work must be performed by a qualified electrician according to the local regulations, standards, and the instructions detailed in the Installation Manual. Capacity shortage to the power supply circuit or improper installation may result in malfunction, electric shock, smoke, or fire.

To reduce the risk of electric shock, smoke, or fire, install an earth leakage breaker on the power supply to each unit.

Use properly rated breakers and fuses (earth leakage breaker, local switch <switch + fuse>, no-fuse breaker). The use of a breaker with a breaking capacity greater than the specified capacity may cause electric shock, malfunctions, smoke, or fire.

To reduce the risk of current leakage, overheating, smoke, or fire, use properly rated cables with adequate current carrying capacity.

Proper grounding must be provided by a licensed electrician.

Do not connect the grounding wire to a gas pipe, water pipe, lightning rod, or telephone wire. Improper grounding may result in electric shock, smoke, fire, or malfunction due to electrical noise interference.

CAUTION

To reduce the risk of current leakage, wire breakage, smoke, or fire, keep the wiring out of contact with the refrigerant pipes and other parts, especially sharp edges.

Relocation and Repairs

WARNING

To reduce the risk of refrigerant leakage, water leakage, injury, electric shock, and fire, units should only be moved or repaired by your dealer or qualified personnel.

To reduce the risk of wire shorting, electric leak, electric shock, smoke, or fire, do not perform maintenance work in the rain.

To reduce the risk of injury, electric shock, and fire, properly reinstall all removed components after completing repair work.

CAUTION

To reduce the risk of wire shorting, electric shock, malfunctions, or fire, keep circuit boards dust free, and do not touch them with your hands or tools.

To reduce the risk of refrigerant and water leakage, check the pipe supports and insulation for damage during inspection or repair, and replace or repair the ones that are found to be deteriorated.

Additional Precautions

To avoid damage to the unit, use appropriate tools to install, inspect, or repair the unit.

Direct the blazing torch flame away from the adjacent cables and sheet metal to keep them from being overheated and damaged.

To reduce the risk of malfunction, turn on the power at least 12 hours before starting operation, and leave the power turned on throughout the operating season.

Prepare tools for exclusive use with R410A. Do not use the following tools if they have been used with the conventional refrigerant (R22): gauge manifold, charging hose, refrigerant leak detector, check valve, refrigerant charge spout, vacuum gauge, and refrigerant recovery equipment. R410A does not contain chloride, so leak detectors for use with older types of refrigerants will not detect an R410A leak. Infiltration of the residual refrigerant, refrigerant oil, or water on these tools may cause the refrigerant oil in the new system to deteriorate or damage the compressor.

Recover all refrigerant in the units, and dispose of it properly according to any applicable laws and regulations.

Provide a maintenance access to allow for the inspection of pipes above the ceiling or the buried pipes.

To reduce the risk of the vacuum pump oil backflowing into the refrigerant cycle and causing the refrigerant oil to deteriorate, use a vacuum pump with a check valve.

Take appropriate measures against electrical noise interference when installing the air conditioners in hospitals or facilities with radio communication capabilities. Inverter, high-frequency medical, or wireless communication equipment as well as power generators may cause the air conditioning system to malfunction. Air conditioning system may also adversely affect the operation of these types of equipment by creating electrical noise.

Have a set of tools for exclusive use with R410A. Consult your nearest Mitsubishi Electric Dealer.

To reduce the risk of damage to the unit, leave the valves on the unit closed until refrigerant charging is completed.

Keep dust, dirt, and water off charging hose and flare tool. Infiltration of dust, dirt, or water into the refrigerant circuit may cause the refrigerant oil to deteriorate or damage the compressor.

Place a wet towel on the refrigerant service valve before brazing the pipes to keep its temperature from rising above 120°C and damaging the surrounding equipment.

Use refrigerant piping and couplings that meet the applicable standards. For refrigerant pipes, use pipes made of phosphorus deoxidized copper. Keep the inner and outer surfaces of pipes and couplings clean and free of such contaminants as sulfur, oxides, dust, dirt, shaving particles, oil, and moisture. Failure to follow these directions may result in the deterioration of refrigerant oil or compressor damage.

Store the piping materials indoors, and keep both ends of the pipes sealed until immediately before brazing. Keep elbows and other joints in plastic bags. Infiltration of dust, dirt, or water into the refrigerant circuit may cause the refrigerant oil to deteriorate or damage the compressor.

Apply ester oil, ether oil, or a small amount of alkyl benzene to flares and flanges. The use and accidental infiltration of mineral oil into the system may cause the refrigerant oil to deteriorate or damage the compressor.

To reduce the risk of oxidized film from entering the refrigerant pipe and causing the refrigerant oil to deteriorate or damaging the compressor, braze pipes under nitrogen purge.

Do not use the existing refrigerant piping. A large amount of chloride that is contained in the residual refrigerant and refrigerant oil in the existing piping may cause the refrigerant oil in the new unit to deteriorate or damage the compressor.

Charge refrigerant in the liquid state. If refrigerant is charged in the gas phase, the composition of the refrigerant in the cylinder will change, compromising the unit's performance.

Do not use a charging cylinder. The use of a charging cylinder will change the composition of the refrigerant, compromising the unit's performance.

Charge the system with an appropriate amount of refrigerant in the liquid phase. Refer to the relevant sections in the manuals to calculate the appropriate amount of refrigerant to be charged. Refrigerant overcharge or undercharge may result in performance drop or abnormal stop of operation.

To reduce the risk of power capacity shortage, always use a dedicated power supply circuit.

To reduce the risk of both the breaker on the product side and the upstream breaker from tripping and causing problems, split the power supply system or provide protection coordination between the earth leakage breaker and no-fuse breaker.

Have a backup system, if failure of the unit has a potential for causing significant problems or damages.

Only qualified personnel may touch the USB port in the control box.

CONTENTS

Chapter 1 Check Before Servicing

1-1	Preparation for Piping Work.....	1
1-2	Handling and Characteristics of Piping Materials, Refrigerant, and Refrigerant Oil.....	3
1-3	Working with Refrigerant Piping.....	8
1-4	Precautions for Wiring.....	12
1-5	Cautionary notes on installation environment and maintenance.....	14

Chapter 2 Restrictions

2-1	System Configurations.....	1
2-2	Types and Maximum Allowable Length of Cables.....	3
2-3	Switch Settings.....	4
2-4	M-NET Address Settings.....	5
2-5	Demand Control Overview.....	10
2-6	System Connection Example.....	12
2-7	Example System with an MA Remote Controller.....	13
2-8	Example System with an ME Remote Controller.....	23
2-9	Example System with an MA and an ME Remote Controller.....	25
2-10	Restrictions on Refrigerant Pipes.....	27

Chapter 3 Major Components, Their Functions and Refrigerant Circuits

3-1	External Appearance and Refrigerant Circuit Components of Outdoor Unit.....	1
3-2	Outdoor Unit Refrigerant Circuit Diagrams.....	15
3-3	Functions of the Major Components of Outdoor Unit.....	19
3-4	Functions of the Major Components of Indoor Unit.....	23

Chapter 4 Electrical Components and Wiring Diagrams

4-1	Outdoor Unit Circuit Board Arrangement.....	1
4-2	Outdoor Unit Circuit Board Components.....	11
4-3	Outdoor Unit Electrical Wiring Diagrams.....	29
4-4	Transmission Booster Electrical Wiring Diagrams.....	35

Chapter 5 Control

5-1	Dipswitch Functions and Factory Settings.....	1
5-2	Outdoor Unit Control.....	10

Chapter 6 Test Run

6-1	Read before Test Run.....	1
6-2	Operation Characteristics and Refrigerant Charge.....	2
6-3	Evaluating and Adjusting Refrigerant Charge.....	2
6-4	The Following Symptoms Are Normal.....	7

Chapter 7 Troubleshooting Using Error Codes

7-1	Error Code and Preliminary Error Code Lists.....	1
7-2	Error Code Definitions and Solutions: Codes [0 - 999].....	6
7-3	Error Code Definitions and Solutions: Codes [1000 - 1999].....	8
7-4	Error Code Definitions and Solutions: Codes [2000 - 2999].....	12
7-5	Error Code Definitions and Solutions: Codes [3000 - 3999].....	18
7-6	Error Code Definitions and Solutions: Codes [4000 - 4999].....	21
7-7	Error Code Definitions and Solutions: Codes [5000 - 5999].....	38
7-8	Error Code Definitions and Solutions: Codes [6000 - 6999].....	46
7-9	Error Code Definitions and Solutions: Codes [7000 - 7999].....	68
7-10	Unit Error Code Definitions and Solutions: Codes [Er91 - Er99].....	76

CONTENTS

Chapter 8 Troubleshooting Based on Observed Symptoms

8-1	MA Remote Controller Problems	1
8-2	ME remote Controller Problems	5
8-3	Refrigerant Control Problems	10
8-4	Checking Transmission Waveform and for Electrical Noise Interference	15
8-5	Pressure Sensor Circuit Configuration and Troubleshooting Pressure Sensor Problems	18
8-6	Troubleshooting Solenoid Valve Problems	22
8-7	Troubleshooting Outdoor Unit Fan Problems	24
8-8	Troubleshooting LEV Problems.....	25
8-9	Troubleshooting Inverter Problems	31
8-10	Control Circuit	49
8-11	Measures for Refrigerant Leakage	56
8-12	Individual air-tightness testing of outdoor unit.....	58
8-13	Parts Replacement Instructions <Type A/Type A1/Type A2>	59
8-14	Troubleshooting Problems Using the LED Status Indicators on the Outdoor Unit.....	158
8-15	4250 Troubleshooting	159

Chapter 9 USB Function

9-1	Service Overview.....	1
9-2	Operation Data Collection and Storage Functions	5
9-3	Software Rewrite Function on the USB.....	9
9-4	Maintenance LED Display and Troubleshooting.....	11

Chapter 10 LED Status Indicators on the Outdoor Unit Circuit Board

10-1	LED Status Indicators	1
10-2	LED Status Indicators Table.....	4

Chapter 1 Check Before Servicing

1-1	Preparation for Piping Work	1
1-1-1	Read before Servicing	1
1-1-2	Tool Preparation	2
1-2	Handling and Characteristics of Piping Materials, Refrigerant, and Refrigerant Oil.....	3
1-2-1	Piping Materials	3
1-2-2	Storage of Piping Materials.....	5
1-2-3	Pipe Processing.....	5
1-2-4	Differences in Refrigerant Properties.....	6
1-2-5	Refrigerant Oil.....	7
1-3	Working with Refrigerant Piping	8
1-3-1	Pipe Brazing.....	8
1-3-2	Air Tightness Test.....	9
1-3-3	Vacuum Drying	10
1-3-4	Refrigerant Charging.....	11
1-4	Precautions for Wiring	12
1-5	Cautionary notes on installation environment and maintenance	14



1-1 Preparation for Piping Work

1-1-1 Read before Servicing

1. Check the type of refrigerant used in the system to be serviced.

Refrigerant Type

Multi air conditioner for building application CITY MULTI:R410A

2. Check the symptoms exhibited by the unit to be serviced.

Refer to this service handbook for symptoms relating to the refrigerant cycle.

3. Thoroughly read the safety precautions at the beginning of this manual.

4. Preparing necessary tools: Prepare a set of tools to be used exclusively with each type of refrigerant.

For information about the correct use of tools, refer to the following page(s). [1-1-2 Tool Preparation]

5. Verification of the connecting pipes: Verify the type of refrigerant used for the unit to be moved or replaced.

- Use refrigerant pipes made of phosphorus deoxidized copper. Keep the inner and outer surfaces of the pipes clean and free of such contaminants as sulfur, oxides, dust, dirt, shaving particles, oil, and water.
- These types of contaminants inside the refrigerant pipes may cause the refrigerant oil to deteriorate.

6. If there is a leak of gaseous refrigerant and the remaining refrigerant is exposed to an open flame, a poisonous gas hydrofluoric acid may form. Keep workplace well ventilated.

Note

- Install new pipes immediately after removing old ones to keep moisture out of the refrigerant circuit.
- The use of refrigerant that contains chloride, such as R22, will cause the refrigerating machine oil to deteriorate.

1-1-2 Tool Preparation

Prepare the following tools and materials necessary for installing and servicing the unit.

Tools for use with R410A (Adaptability of tools that are for use with R22 or R407C)

1. To be used exclusively with R410A (not to be used if used with R22 or R407C)

Tools/Materials	Use	Notes
Gauge Manifold	Evacuation and refrigerant charging	Higher than 5.09MPa[738psi] on the high-pressure side
Charging Hose	Evacuation and refrigerant charging	The hose diameter is larger than the conventional model.
Refrigerant Recovery Cylinder	Refrigerant recovery	
Refrigerant Cylinder	Refrigerant charging	The refrigerant type is indicated. The cylinder is pink.
Charging Port on the Refrigerant Cylinder	Refrigerant charging	The charge port diameter is larger than that of the current port.
Flare Nut	Connection of the unit with the pipes	Use Type-2 Flare nuts.

2. Tools and materials that may be used with R410A with some restrictions

Tools/Materials	Use	Notes
Gas Leak Detector	Gas leak detection	The ones for use with HFC refrigerant may be used.
Vacuum Pump	Vacuum drying	May be used if a check valve adapter is attached.
Flare Tool	Flare processing	Flare processing dimensions for the piping in the system using the new refrigerant differ from those of R22. Refer to the following page(s). [1-2-1 Piping Materials]
Refrigerant Recovery Equipment	Refrigerant recovery	May be used if compatible with R410A.

3. Tools and materials that are used with R22 or R407C that may also be used with R410A

Tools/Materials	Use	Notes
Vacuum Pump with a Check Valve	Vacuum drying	
Bender	Bending pipes	
Torque Wrench	Tightening flare nuts	Only the flare processing dimensions for pipes that have a diameter of $\phi 12.7$ (1/2") and $\phi 15.88$ (5/8") have been changed.
Pipe Cutter	Cutting pipes	
Welder and Nitrogen Cylinder	Welding pipes	
Refrigerant Charging Meter	Refrigerant charging	
Vacuum Gauge	Vacuum level check	

4. Tools and materials that must not be used with R410A

Tools/Materials	Use	Notes
Charging Cylinder	Refrigerant charging	Prohibited to use
Tools containing abrasive materials	Pipe cutting, cut edge treatment	Prohibited to use

Tools for R410A must be handled with special care to keep moisture and dust from infiltrating the cycle.

1-2 Handling and Characteristics of Piping Materials, Refrigerant, and Refrigerant Oil

1-2-1 Piping Materials

Do not use the existing piping!

1. Copper pipe materials

O-material (Annealed)	Soft copper pipes (annealed copper pipes). They can easily be bent with hands.
1/2H-material (Drawn)	Hard copper pipes (straight pipes). They are stronger than the O-material (Annealed) at the same radial thickness.

- The distinction between O-materials (Annealed) and 1/2H-materials (Drawn) is made based on the strength of the pipes themselves.
- O-materials (Annealed) can easily be bent with hands.
- 1/2H-materials (Drawn) are considerably stronger than O-material (Annealed) at the same thickness.

2. Types of copper pipes

Maximum working pressure	Refrigerant type
3.45 MPa [500psi]	R22, R407C etc.
4.30 MPa [624psi]	R410A etc.

3. Piping materials/Radial thickness

Use refrigerant pipes made of phosphorus deoxidized copper.
 The operation pressure of the units that use R410A is higher than that of the units that use R22.
 Use pipes that have at least the radial thickness specified in the chart below.
 (Pipes with a radial thickness of 0.7 mm or less may not be used.)

Pipe size (mm[in])	Radial thickness (mm)	Type
ø6.35 [1/4"]	0.8t	O-material (Annealed)
ø9.52 [3/8"]	0.8t	
ø12.7 [1/2"]	0.8t	
ø15.88 [5/8"]	1.0t	
ø19.05 [3/4"]	1.0t	1/2H-material, H-material (Drawn)
ø22.2 [7/8"]	1.0t	
ø25.4 [1"]	1.0t	
ø28.58 [1-1/8"]	1.0t	
ø31.75 [1-1/4"]	1.1t	
ø34.93 [1-3/8"]	1.2t	
ø41.28 [1-5/8"]	1.4t	

- Annealed pipes have been used for older model units when a diameter of the pipe is up to ø19.05 (3/4"). For a system that uses R410A, use pipes that are made with 1/2H-material (Drawn). (Annealed pipes may be used for pipes with a diameter of ø19.05 (3/4") and a radial thickness of 1.2 t).
- The figures in the radial thickness column are based on the Japanese standards and provided only as a reference. Use pipes that meet the local standards.

4. Thickness and refrigerant type indicated on the piping materials

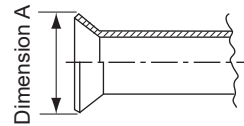
Ask the pipe manufacturer for the symbols indicated on the piping material for new refrigerant.

5. Flare processing (O-material (Annealed) and OL-material only)

The flare processing dimensions for the pipes that are used in the R410A system are larger than those in the R22 system.

Flare processing dimensions (mm[in])

Pipe size (mm[in])	A dimension (mm)	
	R410A	R22, R407C
ø6.35 [1/4"]	9.1	9.0
ø9.52 [3/8"]	13.2	13.0
ø12.7 [1/2"]	16.6	16.2
ø15.88 [5/8"]	19.7	19.4
ø19.05 [3/4"]	24.0	23.3



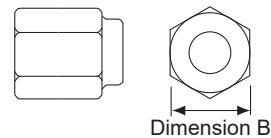
If a clutch-type flare tool is used to flare the pipes in the system using R410A, the length of the pipes must be between 1.0 and 1.5 mm. For margin adjustment, a copper pipe gauge is necessary.

6. Flare nut

The flare nut type has been changed to increase the strength. The size of some of the flare nuts have also been changed.

Flare nut dimensions (mm[in])

Pipe size (mm[in])	B dimension (mm)	
	R410A	R22, R407C
ø6.35 [1/4"]	17.0	17.0
ø9.52 [3/8"]	22.0	22.0
ø12.7 [1/2"]	26.0	24.0
ø15.88 [5/8"]	29.0	27.0
ø19.05 [3/4"]	36.0	36.0



The figures in the radial thickness column are based on the Japanese standards and provided only as a reference. Use pipes that meet the local standards.

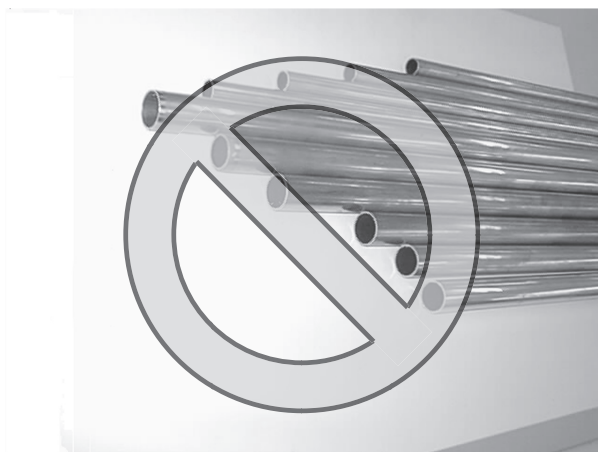
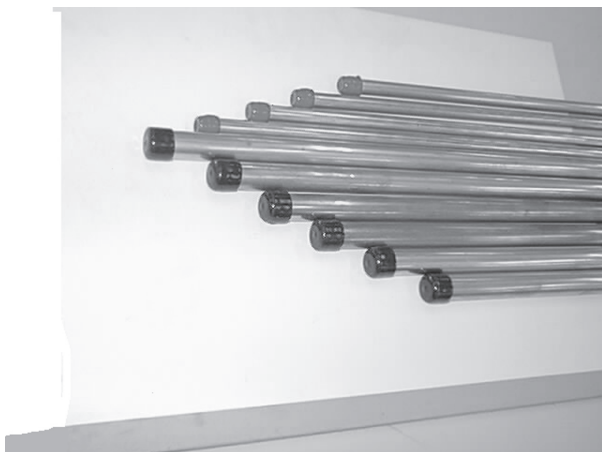
1-2-2 Storage of Piping Materials

1. Storage location



Store the pipes to be used indoors. (Warehouse at site or owner's warehouse)
If they are left outdoors, dust, dirt, or moisture may infiltrate and contaminate the pipe.

2. Sealing the pipe ends



Both ends of the pipes should be sealed until just before brazing.
Keep elbow pipes and T-joints in plastic bags.

Refrigerant oil is highly hygroscopic and is likely to degrade and cause compressor failure if moisture infiltrates into the system. Storage of piping materials requires stringent management.

1-2-3 Pipe Processing

Use a small amount of ester oil, ether oil, or alkylbenzene to coat flares and flanges.
Prevent the particles that are generated during pipe cutting or cut edge treatment from entering the pipes. If abrasive materials contained in sandpaper or cutting tools enter the refrigerant circuit, they may cause the compressor, valves, or other refrigerant circuit components to fail.

Note

- Use a minimum amount of oil.
- Use only ester oil, ether oil, and alkylbenzene.
- To deburr pipes, use a reamer or other deburring tools, not sandpaper.
- To cut pipes, use a pipe cutter, not a grinder or other tools that use abrasive materials.
- When cutting or deburring pipes, do not allow cutting chips or other foreign matters to enter the pipes.
- If cutting chips or other foreign matters enter pipes, wipe them off the inside of the pipes.

1-2-4 Differences in Refrigerant Properties

1. Chemical property

As with R22, R410A is low in toxicity and chemically stable nonflammable refrigerant. However, because the specific gravity of vapor refrigerant is greater than that of air, leaked refrigerant in a closed room will accumulate at the bottom of the room and may cause hypoxia. If exposed to an open flame, refrigerant will generate poisonous gases. Do not perform installation or service work in a confined area.

	HFC Refrigerant		HCFC Refrigerant
	R410A	R407C	R22
	R32/R125	R32/R125/R134a	R22
Composition (wt%)	(50/50)	(23/25/52)	(100)
Type of Refrigerant	Pseudo-azeotropic Refrigerant	Non-azeotropic Refrigerant	Single Refrigerant
Chloride	Not included	Not included	Included
Safety Class	A1/A1	A1/A1	A1
Molecular Weight	72.6	86.2	86.5
Boiling Point (°C/°F)	-51.4/-60.5	-43.6/-46.4	-40.8/-41.4
Steam Pressure (25°C,MPa/77°F,psi) (gauge)	1.557/226	0.9177/133	0.94/136
Saturated Steam Density (25°C,kg/m ³ /77°F,psi)	64.0	42.5	44.4
Flammability	Nonflammable	Nonflammable	Nonflammable
Ozone Depletion Coefficient (ODP) ^{*1}	0	0	0.055
Global Warming Coefficient (GWP) ^{*2}	2088	1774	1810
Refrigerant Charging Method	Refrigerant charging in the liquid state	Refrigerant charging in the liquid state	Refrigerant charging in the gaseous state
Replenishment of Refrigerant after a Refrigerant Leak	Available	Available	Available

*1 When CFC11 is used as a reference

*2 When CO₂ is used as a reference

2. Refrigerant composition

R410A is a pseudo-azeotropic HFC blend and can almost be handled the same way as a single refrigerant, such as R22. To be safe, however, draw out the refrigerant from the cylinder in the liquid phase. If the refrigerant in the gaseous phase is drawn out, the composition of the remaining refrigerant will change and become unsuitable for use. If the refrigerant leaks out, it may be replenished.

3. Pressure characteristics

The pressure in the system using R410A is 1.6 times as great as that in the system using R22.

Temperature (°C/°F)	Pressure (gauge)		
	R410A	R407C	R22
	MPa/psi	MPa/psi	MPa/psi
-20/-4	0.30/44	0.18/26	0.14/20
0/32	0.70/102	0.47/68	0.40/58
20/68	1.34/194	0.94/136	0.81/117
40/104	2.31/335	1.44/209	1.44/209
60/140	3.73/541	2.44/354	2.33/338
65/149	4.17/605	2.75/399	2.60/377

1-2-5 Refrigerant Oil

1. Refrigerating machine oil in the HFC refrigerant system

HFC type refrigerants use a refrigerating machine oil different from that used in the R22 system. Note that the ester oil used in the system has properties that are different from commercially available ester oil.

Refrigerant	Refrigerating machine oil
R22	Mineral oil
R407C	Ester oil
R410A	Ester oil

2. Effects of contaminants*1

Refrigerating machine oil used in the HFC system must be handled with special care to keep contaminants out. The table below shows the effect of contaminants in the refrigerating machine oil on the refrigeration cycle.

3. The effects of contaminants in the refrigerating machine oil on the refrigeration cycle.

Cause		Symptoms	Effects on the refrigerant cycle
Water infiltration		Frozen expansion valve and capillary tubes	Clogged expansion valve and capillary tubes Poor cooling performance Compressor overheat Motor insulation failure Burnt motor Coppering of the orbiting parts Lock Burn-in on the orbiting parts
	Hydrolysis	Sludge formation and adhesion Acid generation Oxidization Oil degradation	
Air infiltration		Oxidization	
Infiltration of contaminants	Dust, dirt	Adhesion to expansion valve and capillary tubes	Clogged expansion valve, capillary tubes, and drier Poor cooling performance Compressor overheat
		Infiltration of contaminants into the compressor	Burn-in on the orbiting parts
	Mineral oil etc.	Sludge formation and adhesion	Clogged expansion valve and capillary tubes Poor cooling performance Compressor overheat
		Oil degradation	Burn-in on the orbiting parts

*1. Contaminants is defined as moisture, air, processing oil, dust/dirt, wrong types of refrigerant, and refrigerating machine oil.

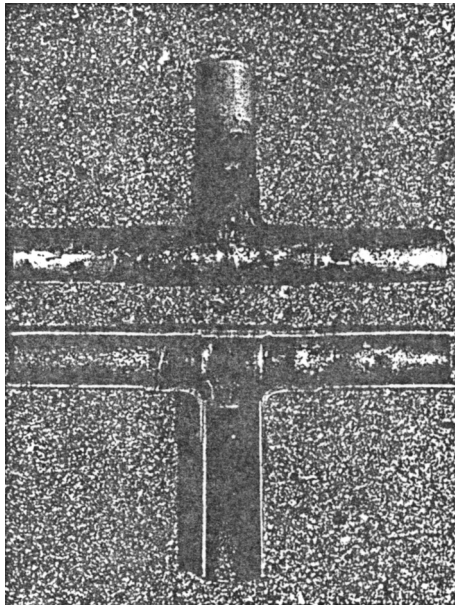
1-3 Working with Refrigerant Piping

1-3-1 Pipe Brazing

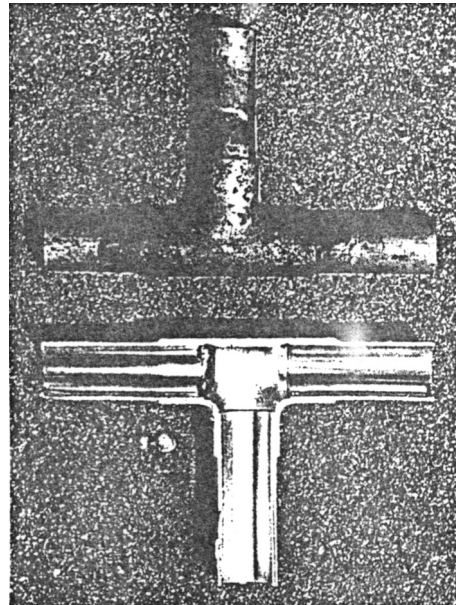
Perform brazing with special care to keep foreign objects (such as oxide scale, copper powder, water, and dust) out of the refrigerant system.

Example: Inside the brazed connection

Use of no inert gas during brazing



Use of inert gas during brazing



1. Items to be strictly observed

- Do not conduct refrigerant piping work outdoors if raining.
- Use inert gas during brazing.
- Use a brazing material (BCuP-3) that requires no flux when brazing between copper pipes or between a copper pipe and copper coupling.
- If installed refrigerant pipes are not immediately connected to the equipment, then braze and seal both ends.

2. Reasons

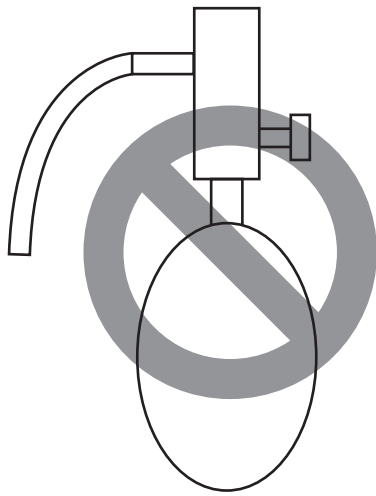
- Refrigerant oil is highly hygroscopic and is likely to cause unit failure if moisture infiltrates into the system.
- Residual flux in the refrigerant circuit will cause sludge to form.

3. Notes

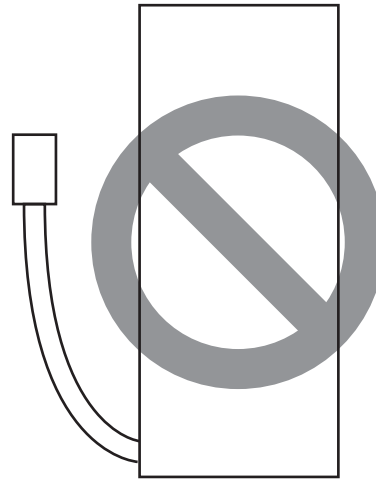
Do not use commercially available antioxidants because they may cause the pipes to corrode or refrigerating machine oil to deteriorate.

1-3-2 Air Tightness Test

Note that a refrigerant leak detector for R22 will not detect an R410A leak.



Halide torch



R22 leakage detector

1. Items to be strictly observed

- Pressurize the equipment with nitrogen up to the design pressure (4.15MPa[601psi]), and then judge the equipment's air tightness, taking temperature variations into account.
- Refrigerant R410A must be charged in its liquid state (vs. gaseous state).

2. Reasons

- Oxygen, if used for an air tightness test, poses a risk of explosion. (Only use nitrogen to check air tightness.)
- Refrigerant R410A must be charged in its liquid state. If gaseous refrigerant in the cylinder is drawn out first, the composition of the remaining refrigerant in the cylinder will change and become unsuitable for use.

3. Notes

Procure a leak detector that is specifically designed to detect an HFC leak. A leak detector for R22 will not detect an HFC(R410A) leak.

1-3-3 Vacuum Drying



(Photo1) 15010H



(Photo2) 14010

Recommended vacuum gauge:
ROBINAIR 14010 Thermistor Vacuum Gauge

1. Vacuum pump with a reverse-flow check valve (Photo1)

To prevent the vacuum pump oil from flowing into the refrigerant circuit during power OFF or power failure, use a vacuum pump with a reverse-flow check valve.
A reverse-flow check valve may also be added to the vacuum pump currently in use.

2. Standard of vacuum degree (Photo 2)

Use a vacuum pump that attains 0.5Torr(65Pa) or lower degree of vacuum after 5 minutes of operation, and connect it directly to the vacuum gauge. Use a pump well-maintained with an appropriate lubricant. A poorly maintained vacuum pump may not be able to attain the desired degree of vacuum.

3. Required precision of vacuum gauge

Use a vacuum gauge that registers a vacuum degree of 5Torr(650Pa) and measures at intervals of 1Torr(130Pa). (A recommended vacuum gauge is shown in Photo2.)
Do not use a commonly used gauge manifold because it cannot register a vacuum degree of 5Torr(650Pa).

4. Evacuation time

•After the degree of vacuum has reached 5Torr(650Pa), evacuate for an additional 1 hour. (A thorough vacuum drying removes moisture in the pipes.) When the outside temperature drops below 1°C (or when the saturation pressure drops below 656 Pa), continue vacuum drying for another 1 hour after the vacuum degree has reached the saturated vapor pressure of the water (ice) at the outside temperature. When performing vacuum drying at a low outside temperature, use a vacuum gauge appropriate for the temperature range.

Degree of vacuum (reference)

Outdoor temp.	-20°C (-4°F)	-15°C (5°F)	-10°C (14°F)	-5°C (23°F)	0°C (32°F)
Degree of vacuum	0.77 Torr (103 Pa)	1.24 Torr (165 Pa)	1.95 Torr (260 Pa)	3.01 Torr (402 Pa)	4.58 Torr (611 Pa)

* Degrees of vacuum shown above are obtained based on the saturated vapor pressure of ice.

* In a system using water heat exchangers, circulate water to prevent the water in the heat exchangers from freezing during vacuum drying.

- Verify that the vacuum degree has not risen by more than 1Torr(130Pa) 1hour after evacuation. A rise by less than 1Torr(130Pa) is acceptable.
- If the vacuum is lost by more than 1Torr(130Pa), conduct evacuation, following the instructions in section 6. Special vacuum drying.

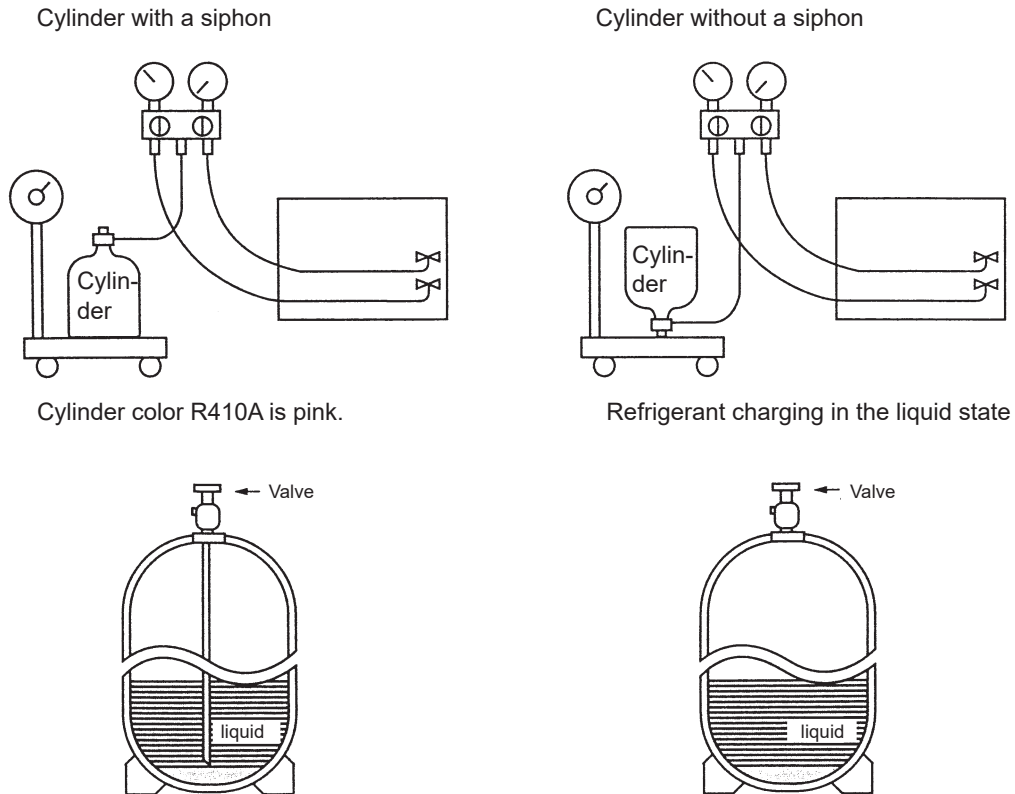
5. Procedures for stopping vacuum pump

To prevent the reverse flow of vacuum pump oil, open the relief valve on the vacuum pump side, or draw in air by loosening the charge hose, and then stop the operation.
The same procedures should be followed when stopping a vacuum pump with a reverse-flow check valve.

6. Special vacuum drying

- When 5Torr(650Pa) or lower degree of vacuum cannot be attained after 3 hours of evacuation, it is likely that water has penetrated the system or that there is a leak.
- If water infiltrates the system, break the vacuum with nitrogen. Pressurize the system with nitrogen gas to 0.5kgf/cm²G(0.05MPa) and evacuate again. Repeat this cycle of pressurizing and evacuation either until the degree of vacuum below 5Torr(650Pa) is attained or until the pressure stops rising.
- Only use nitrogen gas for vacuum breaking. (The use of oxygen may result in an explosion.)

1-3-4 Refrigerant Charging



1. Reasons

R410A is a pseudo-azeotropic HFC blend (boiling point R32=-52°C[-62°F], R125=-49°C[-52°F]) and can almost be handled the same way as a single refrigerant, such as R22. To be safe, however, draw out the refrigerant from the cylinder in the liquid phase. If the refrigerant in the gaseous phase is drawn out, the composition of the remaining refrigerant will change and become unsuitable for use.

2. Notes

When using a cylinder with a siphon, refrigerant is charged in the liquid state without the need for turning it upside down. Check the type of the cylinder on the label before use.

If the refrigerant leaks out, it may be replenished. The entire refrigerant does not need to be replaced. (Charge refrigerant in the liquid state.)

Refer to the following page(s).[8-11 Measures for Refrigerant Leakage]

1-4 Precautions for Wiring

- Control boxes house high-voltage and high-temperature electrical parts.
- They may still remain energized or hot after the power is turned off.
- When opening or closing the front cover of the control box, keep out of contact with the internal parts.
Before inspecting the inside of the control box, turn off the power, leave the unit turned off for at least 10 minutes, and check that the voltage across pins 1 and 5 of connector RYPN has dropped to 20 VDC or less.
It will take approximately 10 minutes until the voltage is discharged after power off.
- Disconnect the relay connectors (RYFAN 1 and RYFAN 2) on the outdoor unit fan before performing maintenance work.
Before connecting or disconnecting the connector, check that the outdoor unit fan is stopped and that the voltage across pins 1 and 5 of connector RYPN has dropped to 20 VDC or less.
If the outdoor unit fan is rotated by external forces such as strong winds, the main circuit capacitor can be charged and cause an electric shock.
Refer to the wiring nameplate for details.
Reconnect the relay connectors (RYFAN 1 and RYFAN 2) after completion of maintenance work.
- Before turning on the power, make sure the power-supply wire is properly connected. Also, perform a voltage check at the power-supply terminal block. (Refer to item (5) in section [6-1 Read before Test Run])
- The compressor will become energized upon power-on. Note that the compressor will stay energized even when the compressor is stopped.
It is energized to evaporate the liquid refrigerant that has accumulated in the compressor.
- Before connecting wiring to TB7, check that the voltage has dropped below 20 VDC.
- When a system controller is connected to the centralized control transmission cable to which power is supplied from the outdoor unit (power jumper on the outdoor unit is connected to CN40), be aware that power can be supplied to the centralized control transmission and the system controller may detect an error and send an error notice if the outdoor unit fan is rotated by external forces, such as strong winds, even when power to the outdoor unit is turned off.
- When replacing the internal electrical components of the control box, tighten the screws to the recommended tightening torque as specified below.

Recommended tightening torque for the internal electrical components of the control box

Screw	Recommended tightening torque (N·m)
M3	0.69
M4	1.47
M5	2.55
M6	2.75
M8	6.20

*1 When replacing semiconductor modules (e.g., INV board, fan board), apply heatsink silicone evenly to the semiconductor module on the back of the circuit board. Next, tighten the screws holding the semiconductor module to one-third of the specified torque, and then tighten the screws to the specified torque.

*2 Deviating from the recommended tightening torque may cause damage to the unit or its parts.

Take the following steps to ensure that the screws are properly tightened.

- 1) Ensure that the spring washers are parallel to the terminal block.

Even if the tightening torque is observed, if the washers are not parallel to the terminal block, then the semiconductor module is not installed properly.



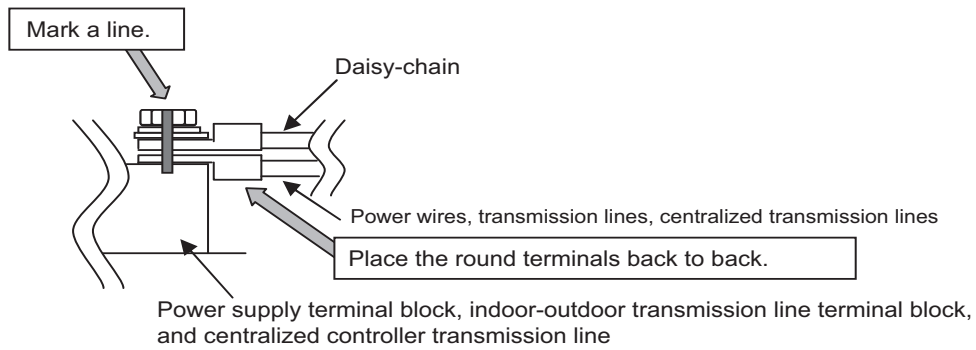
2) Check the wires are securely fastened to the screw terminals.

•**Screw the screws straight down so as not to damage the screw threads.**

Hold the two round terminals back to back to ensure that the screw will screw down straight.

•**After tightening the screw, mark a line through the screw head, washer, and terminals with a permanent marker.**

Example



Poor contact caused by loose screws may result in overheating and fire.
Continued use of the damaged circuit board may cause overheating and fire.

1-5 Cautionary notes on installation environment and maintenance

Heavy-salt resistant specification does not mean that corrosion and rust are 100% preventable. Take the following precautions for installation and maintenance of packaged air conditioners.

- 1) Install the units where they are not directly exposed to excessive amounts of splashes of ocean water or salty air as much as possible even when the units are heavy-salt resistant.
- 2) Avoid installing a sun shade over the outdoor unit, so that rain will wash away salt deposits off the unit.
- 3) Install the unit horizontally to ensure proper water drainage from the base of the unit. Accumulation of water in the base of the outdoor unit will significantly accelerate corrosion.
- 4) Periodically wash salt deposits off the unit, especially when the unit is installed in a coastal area.
- 5) Repair all noticeable scratches after installation and during maintenance.
- 6) Periodically check the unit, and apply anti-rust agent and replace corroded parts as necessary.

Chapter 2 Restrictions

2-1	System Configurations	1
2-2	Types and Maximum Allowable Length of Cables	3
2-3	Switch Settings	4
2-4	M-NET Address Settings	5
2-4-1	Address Settings List	5
2-4-2	Outdoor Unit Power Jumper Connector Connection.....	6
2-4-3	Outdoor Unit Centralized Controller Switch Setting	6
2-4-4	Room Temperature Detection Position Selection	6
2-4-5	Start/Stop Control of Indoor Units	7
2-4-6	Miscellaneous Settings	7
2-4-7	Various Control Methods Using the Signal Input/Output Connector on Outdoor Unit	8
2-5	Demand Control Overview	10
2-6	System Connection Example	12
2-7	Example System with an MA Remote Controller	13
2-7-1	Single Refrigerant System (Automatic Indoor/Outdoor Address Startup).....	13
2-7-2	Single Refrigerant System with Two or More LOSSNAY Units	15
2-7-3	Grouped Operation of Units in Separate Refrigerant Circuits.....	17
2-7-4	System with a Connection of System Controller to Centralized Control Transmission Line.....	19
2-7-5	System with a Connection of System Controller to Indoor-Outdoor Transmission Line	21
2-8	Example System with an ME Remote Controller	23
2-8-1	System with a Connection of System Controller to Centralized Control Transmission Line.....	23
2-9	Example System with an MA and an ME Remote Controller	25
2-9-1	System with a Connection of System Controller to Centralized Control Transmission Line.....	25
2-10	Restrictions on Refrigerant Pipes	27
2-10-1	Restrictions on Refrigerant Pipe Length	27
2-10-2	Restrictions on Refrigerant Pipe Size	30



2-1 System Configurations

1. Table of compatible indoor units

The table below summarizes the types of indoor units that are compatible with different types of outdoor units.

(1) Standard series

Outdoor units		Composing units			Maximum total capacity of connectable indoor units	Maximum number of connectable indoor units	Types of connectable indoor units
P200	YNW-A(1/2)	-	-	-	100 - 260	20	P10 - P250/M20 - M140 models R410A series indoor units
P250	YNW-A(1/2)	-	-	-	125 - 325	25	
P300	YNW-A(1/2)	-	-	-	150 - 390	30	
P350	YNW-A(1/2)	-	-	-	175 - 455	35	
P400	YNW-A(1/2)	-	-	-	200 - 520	40	
P450	YNW-A(1/2)	-	-	-	225 - 585	45	
P500	YNW-A(1/2)	-	-	-	250 - 650	50	
P400	YSNW-A(1/2)	P200	P200	-	200 - 520	40	
P450	YSNW-A(1/2)	P250	P200	-	225 - 585	45	
P500	YSNW-A(1/2)	P250	P250	-	250 - 650	50	
P550	YSNW-A(1/2)	P300	P250	-	275 - 715		
P600	YSNW-A(1/2)	P300	P300	-	300 - 780		
P650	YSNW-A(1/2)	P400	P250	-	325 - 845		
P700	YSNW-A(1/2)	P350	P350	-	350 - 910		
P750	YSNW-A(1/2)	P400	P350	-	375 - 975		
P800	YSNW-A(1/2)	P450	P350	-	400 - 1040		
P850	YSNW-A(1/2)	P450	P400	-	425 - 1105		
P900	YSNW-A(1/2)	P450	P450	-	450 - 1170		
P950	YSNW-A(1/2)	P350	P350	P250	475 - 1235		
P1000	YSNW-A(1/2)	P400	P350	P250	500 - 1300		
P1050	YSNW-A(1/2)	P400	P400	P250	525 - 1365		
P1100	YSNW-A(1/2)	P400	P350	P350	550 - 1430		
P1150	YSNW-A(1/2)	P400	P400	P350	575 - 1495		
P1200	YSNW-A(1/2)	P400	P400	P400	600 - 1560		
P1250	YSNW-A(1/2)	P450	P400	P400	625 - 1625		
P1300	YSNW-A(1/2)	P450	P450	P400	650 - 1690		
P1350	YSNW-A(1/2)	P450	P450	P450	675 - 1755		

Note

- 1) "Maximum total capacity of connectable indoor units" refers to the sum of the numeric values in the indoor unit model names.
- 2) If the total capacity of the indoor units that are connected to a given outdoor unit exceeds the capacity of the outdoor unit, the indoor units will not be able to perform at the rated capacity when they are operated simultaneously. Select a combination of units so that the total capacity of the connected indoor units is at or below the capacity of the outdoor unit whenever possible.
- 3) Type A and Type A1 outdoor units cannot be used in combination.
Type A and Type A2 outdoor units cannot be used in combination.
Type A1 and Type A2 outdoor units cannot be used in combination.

(2) High COP series

Outdoor units		Composing units			Maximum total capacity of connectable indoor units	Maximum number of connectable indoor units	Types of connectable indoor units
EP200	YNW-A(1/2)	-	-	-	100 - 260	20	P10 - P250/M20 - M140 models R410A series indoor units
EP250	YNW-A(1/2)	-	-	-	125 - 325	25	
EP300	YNW-A(1/2)	-	-	-	150 - 390	30	
EP350	YNW-A(1/2)	-	-	-	175 - 455	35	
EP400	YNW-A(1/2)	-	-	-	200 - 520	40	
EP450	YNW-A(1/2)	-	-	-	225 - 585	45	
EP500	YNW-A(1/2)	-	-	-	250 - 650	50	
EP400	YSNW-A(1/2)	EP200	EP200	-	200 - 520	40	
EP450	YSNW-A(1/2)	EP250	EP200	-	225 - 585	45	
EP500	YSNW-A(1/2)	EP250	EP250	-	250 - 650	50	
EP550	YSNW-A(1/2)	EP300	EP250	-	275 - 715		
EP600	YSNW-A(1/2)	EP300	EP300	-	300 - 780		
EP650	YSNW-A(1/2)	EP400	EP250	-	325 - 845		
EP700	YSNW-A(1/2)	EP350	EP350	-	350 - 910		
EP750	YSNW-A(1/2)	EP400	EP350	-	375 - 975		
EP800	YSNW-A(1/2)	EP450	EP350	-	400 - 1040		
EP850	YSNW-A(1/2)	EP450	EP400	-	425 - 1105		
EP900	YSNW-A(1/2)	EP450	EP450	-	450 - 1170		
EP950	YSNW-A(1/2)	EP350	EP350	EP250	475 - 1235		
EP1000	YSNW-A(1/2)	EP400	EP350	EP250	500 - 1300		
EP1050	YSNW-A(1/2)	EP400	EP400	EP250	525 - 1365		
EP1100	YSNW-A(1/2)	EP400	EP350	EP350	550 - 1430		
EP1150	YSNW-A(1/2)	EP400	EP400	EP350	575 - 1495		
EP1200	YSNW-A(1/2)	EP400	EP400	EP400	600 - 1560		
EP1250	YSNW-A(1/2)	EP450	EP400	EP400	625 - 1625		
EP1300	YSNW-A(1/2)	EP450	EP450	EP400	650 - 1690		
EP1350	YSNW-A(1/2)	EP450	EP450	EP450	675 - 1755		

Note

- 1) "Maximum total capacity of connectable indoor units" refers to the sum of the numeric values in the indoor unit model names.
- 2) If the total capacity of the indoor units that are connected to a given outdoor unit exceeds the capacity of the outdoor unit, the indoor units will not be able to perform at the rated capacity when they are operated simultaneously. Select a combination of units so that the total capacity of the connected indoor units is at or below the capacity of the outdoor unit whenever possible.
- 3) Type A and Type A1 outdoor units cannot be used in combination.
Type A and Type A2 outdoor units cannot be used in combination.
Type A1 and Type A2 outdoor units cannot be used in combination.

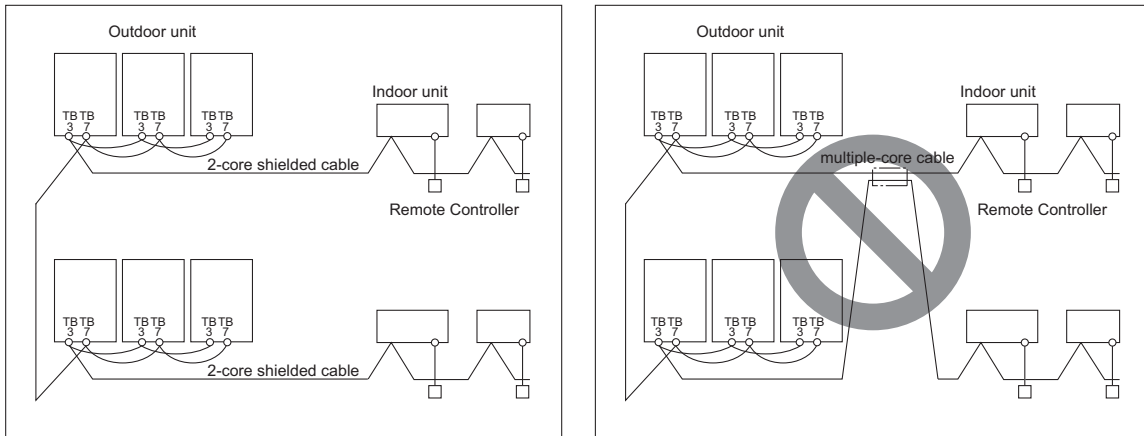
2-2 Types and Maximum Allowable Length of Cables

1. Wiring work

(1) Notes

- 1) Have all electrical work performed by an authorized electrician according to the local regulations and instructions in this manual.
- 2) Install external transmission cables at least 5cm [1-31/32"] away from the power supply cable to avoid noise interference. (Do not put the control cable and power supply cable in the same conduit tube.)
- 3) Provide grounding for the outdoor unit as required.
- 4) Run the cable from the electric box of the indoor or outdoor unit in such way that the box is accessible for servicing.
- 5) Do not connect power supply wiring to the terminal block for transmission cable. Doing so will damage the electronic components on the terminal block.
- 6) Use 2-core shielded cables as transmission cables.

Do not use a single multiple-core cable to connect indoor units that belong to different refrigerant systems. Doing so may result in signal transmission errors and malfunctions..



TB3: Terminal block for indoor-outdoor transmission line TB7: Terminal block for centralized control

- 7) When extending the transmission cable, be sure to extend the shield wire.

(2) Control wiring

Different types of control wiring are used for different systems. Before performing wiring work, refer to the following page(s).
 [2-7 Example System with an MA Remote Controller]
 [2-8 Example System with an ME Remote Controller]
 [2-9 Example System with an MA and an ME Remote Controller]

Types and maximum allowable length of cables

Control lines are categorized into 2 types: transmission line and remote controller line.

Use the appropriate type of cables and observe the maximum allowable length specified for a given system. If a given system has a long transmission line or if a noise source is located near the unit, place the unit away from the noise source to reduce noise interference.

- 1) M-NET transmission line

Cable type	Facility type	All facility types
	Type	Shielded cable CVVS, CPEVS, MVVS
	Number of cores	2-core cable
	Cable size	Larger than 1.25mm ² [AWG16]
Maximum transmission line distance between the outdoor unit and the farthest indoor unit		200 m [656ft] max.
Maximum transmission line distance for centralized control and Indoor/outdoor transmission line (Maximum line distance via outdoor unit)		1000 m [3280ft] (500 m [1640ft]) max. ^{*1} *The maximum overall line length from the power supply unit on the transmission lines for centralized control to each outdoor unit or to the system controller is 200m [656ft] max. ^{*1} If a given system includes one or more unit or remote controller that does not support the maximum allowable cable distance of 1,000 m [3280 ft], the maximum allowable cable distance in the system will be 500 m [1640 ft]. Refer to the latest catalog for information on which units and remote controllers support the maximum allowable cable distance of 1,000 m [3280 ft].

2) Remote controller wiring

		MA remote controller ^{*1}	ME remote controller ^{*2}	
			10 m or less	Over 10 m
Cable type	Type	VCTF, VCTFK, CVV, VVR, VVF, VCT	Shielded cables CVVS, CPEVS, and MVVS	
	Number of cores	2-core cable	2-core cable (one pair (P) for a single wire)	
	Cable size	0.3 to 1.25mm ² ^{*3} ^{*5} [AWG22 to 16]	0.3 to 1.25mm ² ^{*3} [AWG22 to 16]	1.25mm ² or more ^{*3} [AWG16 or more]
Maximum overall line length		200 m [656ft] max. ^{*4}	10 m [32ft] max.	The section of the cable that exceeds 10m [32ft] must be included in the maximum indoor-outdoor transmission line distance.

*1 MA remote controller refers to MA remote controller (PAR-4XMAA, PAR-3XMAA ("X" represents 0 or later), PAR-CT01MA, PAR-21MAA), MA simple remote controller, and wireless remote controller.

*2 PAR-U02MEDA, PAR-F27MEA

*3 The use of cables that are smaller than 0.75mm² (AWG18) is recommended for easy handling.

*4 70 m [229 ft] max for PAR-CT01MA

*5 To wire PAR-CT01MA, PAR-4XMAA, PAR-3XMAA ("X" represents 0 or later), and Simple MA remote controller, use a wire with a diameter of 0.3 mm² [AWG22].

2-3 Switch Settings

1. Switch setting

The necessary switch settings depend on system configuration. Before performing wiring work, refer to the following page(s).

[2-7 Example System with an MA Remote Controller]

[2-8 Example System with an ME Remote Controller]

[2-9 Example System with an MA and an ME Remote Controller]

If the switch settings are changed while the unit is being powered, those changes will not take effect, and the unit will not function properly.

Units on which to set the switches		Symbol	Units to which the power must be shut off
CITY MULTI indoor unit	Main/sub unit	IC	Outdoor units ^{*3} and Indoor units
LOSSNAY, OA processing unit ^{*1}		LC	Outdoor units ^{*3} and LOSSNAY
ATW	Water Hex Unit	AU	Outdoor units and Water Hex Unit
Air handling kit		IC	Outdoor units ^{*3} or field supplied air handling unit
ME remote controller	Main/sub remote controller	RC	Outdoor units ^{*3}
MA remote controller ^{*4}	Main/sub remote controller	MA	Indoor units
CITY MULTI outdoor unit ^{*2}		OC,OS1,OS2	Outdoor units ^{*3} ^{*5}

*1. Applicable when LOSSNAY units are connected to the indoor-outdoor transmission line.

*2. The outdoor units in the same refrigerant circuit are automatically designated as OC, OS1, and OS2 in the order of capacity from large to small (if two or more units have the same capacity, in the order of address from small to large).

*3. Turn off the power to all the outdoor units in the same refrigerant circuit.

*4. When setting the switch SW4 of the control board, set it with the outdoor unit power on. Refer to the following page(s).
[5-1-1 Outdoor Unit Switch Functions and Factory Settings]

2-4 M-NET Address Settings

2-4-1 Address Settings List

1. M-NET Address settings

(1) Address settings table

The need for address settings and the range of address setting depend on the configuration of the system.

Unit or controller		Address setting range	Setting method	Factory setting
CITY MULTI indoor unit	Main/sub unit	00, 01 to 50 ^{*1*6}	Assign the smallest address to the main indoor unit in the group, and assign sequential address numbers to the rest of the indoor units in the same group. ⁴	00
M-NET adapter				
M-NET control interface				
Free Plan adapter				
LOSSNAY, OA processing unit Air handling kit	Water Hex Unit	00, 01 to 50 ^{*1*6}	Assign an arbitrary but unique address to each of these units after assigning an address to all indoor units.	00
ATW				
ME remote controller	Main remote controller	101 to 150	Add 100 to the smallest address of all the indoor units in the same group.	101
	Sub remote controller	151 to 200 ^{*2}	Add 150 to the smallest address of all the indoor units in the same group.	
MA remote controller		No address settings required. (The main/sub setting must be made if 2 remote controllers are connected to the system.)		Main
CITY MULTI outdoor unit		00, 51 to 100 ^{*1,*3,*6}	Assign sequential addresses to the outdoor units in the same refrigerant circuit. The outdoor units in the same refrigerant circuit are automatically designated as OC and OS. ^{*5}	00
System controller	Group remote controller	201 to 250	Assign an address that equals the sum of the smallest group number of the group to be controlled and 200.	201
	System remote controller		Assign an arbitrary but unique address within the range listed on the left to each unit.	
	ON/OFF remote controller		Assign an address that equals the sum of the smallest group number of the group to be controlled and 200.	
	Schedule timer (compatible with M-NET)		Assign an arbitrary but unique address within the range listed on the left to each unit.	
	Central controller AE-200 AG-150A GB-50ADA G(B)-50A	000, 201 to 250	Assign an arbitrary but unique address within the range listed on the left to each unit. The address must be set to "000" to control the K-control unit.	000
LM adapter	201 to 250	Assign an arbitrary but unique address within the range listed on the left to each unit.	247	

*1. Address setting is not required for a City Multi system that consists of a single refrigerant circuit (with some exceptions).

*2. To set the ME remote controller address to "200", set the rotary switches to "00".

*3. To set the outdoor unit address to "100," set the rotary switches to "50."

*4. Some indoor units have 2 or 3 controller boards that require address settings.

No. 2 controller board address must be equal to the sum of the No. 1 controller board address and 1, and the No.3 controller board address must equal to the No. 1 controller address and 2.

*5. The outdoor units in the same refrigerant circuit are automatically designated as OC, OS1, and OS2 in the order of capacity from large to small (if two or more units have the same capacity, in the order of address from small to large).

*6. If a given address overlaps any of the addresses that are assigned to other units, use a different, unused address within the setting range.

2-4-2 Outdoor Unit Power Jumper Connector Connection

There are limitations on the total number of units that are connectable to each refrigerant system. Refer to the DATABOOK for details.

System configuration	Connection to the system controller	Power supply unit for transmission lines	Group operation of units in a system with multiple outdoor units	Power supply switch connector connection
System with one outdoor unit	—	—	—	CN41 (Factory setting)
System with multiple outdoor units	Not connected	—	Not grouped	Disconnect the male connector from the female power supply switch connector (CN41) and connect it to the female power supply switch connector (CN40) on only one of the outdoor units.*2 *Connect the S (shielded) terminal on the terminal block (TB7) on the outdoor unit whose CN41 was replaced with CN40 to the ground terminal (r) on the electric box.
		Not required	Grouped	
	With connection to the indoor unit system	Not required	Grouped/not grouped	
		Not required*1 (Powered from the outdoor unit)	Grouped/not grouped	
With connection to the centralized control system	Required*1	Grouped/not grouped	CN41 (Factory setting)	

*1 The need for a power supply unit for transmission lines depends on the system configuration. Some controllers, such as GB-50ADA, have a function to supply power to the transmission lines.

*2 The replacement of the power jumper connector from CN41 to CN40 must be performed on only one outdoor unit in the system.

2-4-3 Outdoor Unit Centralized Controller Switch Setting

System configuration	Centralized control switch (SW5-1) settings *1
Connection to the system controller Not connected	OFF (Factory setting)
Connection to the system controller Connected *2	ON

*1 Set SW5-1 on all outdoor units in the same refrigerant circuit to the same setting.

*2 When only the LM adapter is connected, leave SW5-1 to OFF (as it is).

2-4-4 Room Temperature Detection Position Selection

To stop the fan during heating Thermo-OFF (SW1-7 and 1-8 on the indoor units to be set to ON), use the built-in thermistor on the remote controller or an optional thermistor.

- 1) To use the built-in sensor on the remote controller, set the SW1-1 to ON.
(Factory setting: SW1-1 set to "OFF".)
 - ♦Some models of remote controllers are not equipped with a built-in temperature sensor. Use the built-in temperature sensor on the indoor unit instead.
 - ♦When using the built-in sensor on the remote controller, install the remote controller where room temperature can be detected. (Note) Factory setting for SW1-1 on the indoor unit of the All-Fresh Models is ON.
- 2) When an optional temperature sensor is used, set SW1-1 to OFF, and set SW3-8 to ON.
 - ♦When using an optional temperature sensor, install it where room temperature can be detected.

The built-in sensor of the remote controller can be selected from the function selection window of the remote controllers PAR-CT01MA, PAR-4XMAA, or PAR-3XMAA ("X" represents 0 or later). See the installation manual of the remote controller for detail.

2-4-5 Start/Stop Control of Indoor Units

Each indoor unit (or group of indoor units) can be controlled individually by setting SW 1-9 and 1-10.

Function	Operation of the indoor unit when the operation is resumed after the unit was stopped	Setting (SW1) ^{*4 *5}	
		9	10
Power ON/OFF by the plug ^{*1,*2,*3}	Indoor unit will go into operation regardless of its operation status before power off (power failure). (In approx. 5 minutes)	OFF	ON
Automatic restoration after power failure	Indoor unit will go into operation if it was in operation when the power was turned off (or cut off due to power failure). (In approx. 5 minutes)	ON	OFF
	Indoor unit will remain stopped regardless of its operation status before power off (power failure).	OFF	OFF

- *1. Do not shut off power to the outdoor units. Doing so will cut off the power supply to the compressors and the heater on the outdoor units and may result in compressor malfunction when operation is restored after a power failure.
- *2. Not applicable to units with a built-in drain pump and humidifier.
- *3. Models with a built-in drain pump cannot be turned on/off by the plug individually. All the units in the same refrigerant circuits will be turned on or off by the plug.
- *4. Requires that the dipswitch settings for all the units in the group be made.
- *5. To control the external input to and output from the air conditioners with the PLC software for general equipment via the AE-200, set SW1-9 and SW1-10 to ON. With these settings made, the power start-stop function becomes disabled. To use the auto recovery function after power failure while these settings are made, set SW1-5 to ON.

2-4-6 Miscellaneous Settings

Cooling-only setting for the indoor unit: Cooling only model (Factory setting: SW3-1 "OFF.")
 When using indoor unit as a cooling-only unit, set SW3-1 to ON.

2-4-7 Various Control Methods Using the Signal Input/Output Connector on Outdoor Unit

(1) Various connection options

Type	Usage	Function	Terminal to be used ¹	Option
Input	Prohibiting cooling/heating operation (thermo OFF) by an external input to the outdoor unit. *It can be used as the DEMAND control device for each system.	DEMAND (level)	CN3D ^{*2}	Adapter for external input (PAC-SC36NA-E)
	Performs a low level noise operation of the outdoor unit by an external input to the outdoor unit. * It can be used as the silent operation device for each refrigerant system.	Low-noise mode (level) ^{*3*4}		
	Forces the outdoor unit to perform a fan operation by receiving signals from the snow sensor. ^{*5*7}	Snow sensor signal input (level)	CN3S	
	Cooling/heating operation can be changed by an external input to the outdoor unit.	Auto-changeover	CN3N	
	The operation mode of the unit can be changed from normal cooling operation (performance priority) to energy-saving cooling mode by an external signal input. The unit will automatically slide the evaporating temperature depending on the ΔT °C. (Control activate: ΔT is 1°C or lower.)	Energy-saving mode ^{*9} (Shifts evaporating temp. depending on the load)	CN3K	
Output	How to extract signals from the outdoor unit *It can be used as an operation status display device. *It can be used for an interlock operation with external devices.	Operation status of the compressor ^{*5}	CN51	Adapter for external output (PAC-SC37SA-E)
		Error status ^{*6*8}		

*1 For details, refer to section (2) Example of wiring connection.

*2 For details, refer to section (2) Example of wiring connection and other relevant sections in the manual. [2-5 Demand Control Overview]

*3 Low-noise mode is valid when Dip SW6-8 on the outdoor unit is set to OFF. When DIP SW6-8 is set to ON, 4 levels of on-DEMAND are possible, using different configurations of low-noise mode input and DEMAND input settings. When 2 or more outdoor units exist in one refrigerant circuit system, 8 levels of on-DEMAND are possible. When 3 outdoor units exist in one refrigerant circuit system, 12 levels of on-DEMAND are possible.

*4 By setting Dip SW6-7, the Low-noise mode can be switched between the Capacity priority mode and the Low-noise priority mode.
When SW6-7 is set to ON: The Low-noise mode always remains effective.
When SW6-7 is set to OFF: The Low-noise mode is cancelled when certain outside temperature or pressure criteria are met, and the unit goes into normal operation (capacity priority mode).

Low-noise mode is effective in case SW6-7 is set to OFF.		Capacity priority mode becomes effective in case SW6-7 is set to OFF.	
Cooling	Heating	Cooling	Heating
TH7 < 30°C [86°F] and 63HS1 < 3.13 MPa [454 psi]	TH7 > 3°C [37°F] and 63LS > 0.45 MPa [65 psi]	TH7 > 35°C [95°F] or 63HS1 > 3.43 MPa [497 psi]	TH7 < 0°C [32°F] or 63LS < 0.38 MPa [55 psi]

*5 If multiple outdoor units are connected to the same refrigerant circuit, signal input/output settings need to be made for each outdoor unit.

*6 Take out signals from the outdoor unit that is designated as OC if multiple outdoor units in the same system.

*7 If the formula TH7>5°C holds true, the fan will not go into operation when the contact receives signal input.

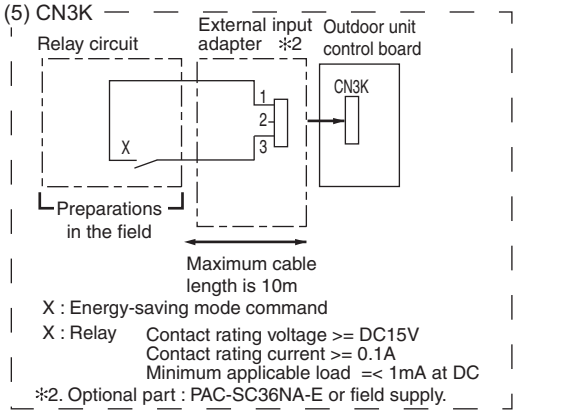
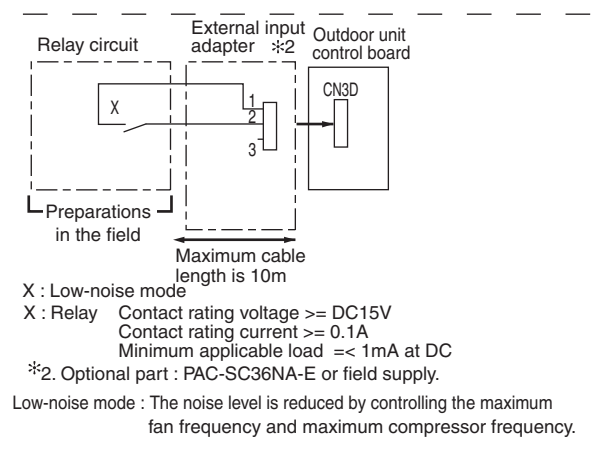
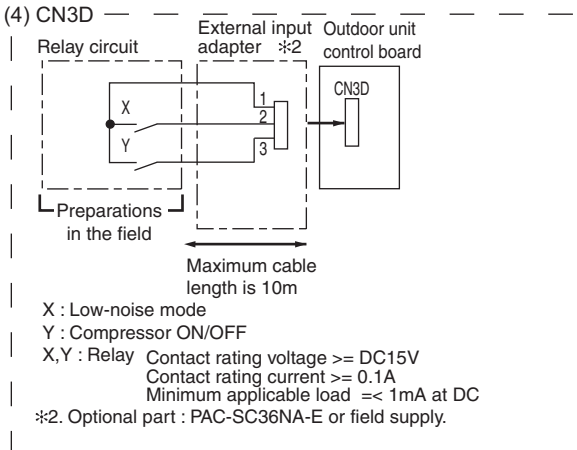
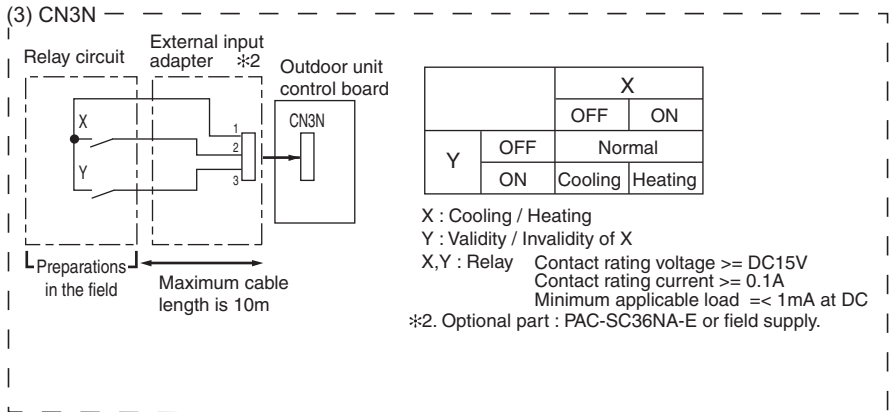
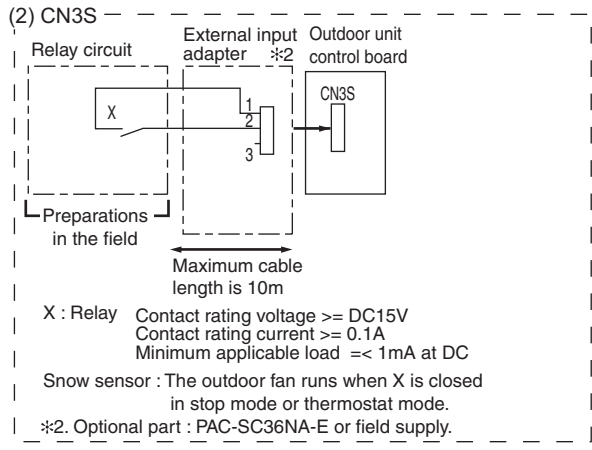
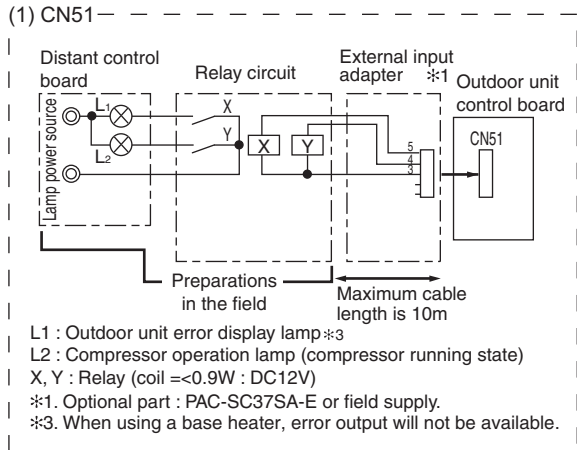
*8 When using a base heater, change the setting using SW4. When using a base heater, error output will not be available.

*9 This control can be enabled also from the system controller. For the procedure, refer to the manual of the system controller.

(2) Example of wiring connection

CAUTION

- 1) Wiring should be covered by insulation tube with supplementary insulation.
- 2) Use relays or switches with IEC or equivalent standard.
- 3) The electric strength between accessible parts and control circuit should have 2750V or more.



2-5 Demand Control Overview

(1) General outline of control

Demand control is performed by using the external signal input to the 1-2 and 1-3 pins of CN3D on the outdoor units (OC, OS1, and OS2).

Between 2 and 12 steps of demand control is possible by setting DIP SW6-8 on the outdoor units (OC, OS1, and OS2).

No	Demand control switch	DipSW6-8			Input to CN3D *2
		OC	OS1	OS2	
(a)	2 steps(0-100%)	OFF	OFF	OFF	OC
(b)	4 steps(0-50-75-100%)	ON	OFF	OFF	OC
(c)		OFF	ON	OFF	OS1
(d)		OFF	OFF	ON	OS2
(e)	8 steps(0-25-38-50-63-75-88-100%)	ON	ON	OFF	OC and OS1
(f)		ON	OFF	ON	OC and OS2
(g)		OFF	ON	ON	OS1 and OS2
(h)	12 steps(0-17-25-34-42-50-59-67-75-84-92-100%)	ON	ON	ON	OC, OS1, and OS2

*1. Available demand functions

(E)P200-(E)P500YNW models (single-outdoor-unit system): 2 and 4 steps shown in the rows (a) and (b) in the table above only.

(E)P400-(E)P900YSNW models (two-outdoor-unit system OC+OS1): 2-8 steps shown in the rows (a), (b), (c), and (e) in the table above only.

(E)P950-(E)P1350YSNW models (three-outdoor-unit system OC+OS1+OS2): 2-12 steps shown in the rows (a)-(h) in the table above.

*2. External signal is input to CN3D on the outdoor unit whose SW6-8 is set to ON. When SW6-8 is set to OFF on all outdoor units, the signal is input to the CN3D on the OC.

Outdoor units whose SW6-8 is set to ON are selectable in a single refrigerant system.

*3. If wrong sequence of steps are taken, the units may go into the Thermo-OFF (compressor stop) mode.

Ex) When switching from 100% to 50%

(Incorrect) 100% to 0% to 50% : The units may go into the Thermo-OFF mode.

(Correct) 100% to 75% to 50%

*4. The percentage of the demand listed in the table above is an approximate value based on the compressor volume and does not necessarily correspond with the actual capacity.

*5. Notes on using demand control in combination with the low-noise mode

To enable the low-noise mode, it is necessary to short-circuit 1-2 pin of CN3D on the outdoor unit whose SW6-8 is set to OFF.

When SW6-8 is set to ON on all outdoor units, the following operations cannot be performed.

- ♦Performing 4-step demand in combination with the low-noise operation in a single-outdoor-unit system.
- ♦Performing 8-step demand in combination with the low-noise operation in a two-outdoor-unit system.
- ♦Performing 12-step demand in combination with the low-noise operation in a three-outdoor-unit system.

(2) Contact input and control content

1) SW6-8: OFF (Compressor ON/OFF, Low-noise mode)

CN3D 1-3P	Compressor ON/OFF *1
Open	Compressor ON
Close	Compressor OFF

CN3D 1-2P	Low-noise mode*2
Open	OFF
Close	ON

*1. When SW6-8 on the outdoor unit in one refrigerant circuit system is set to ON , this function cannot be used.

*2. This function and the 4 levels or 8 levels on-DEMAND function can be used together. Input the order to CN3D 1-2P on the outdoor unit whose SW6-8 is set to OFF.

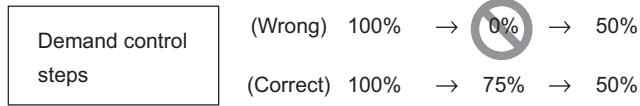
2) When SW6-8 on one outdoor unit in one refrigerant circuit system is set to ON (4 levels of on-DEMAND) (*3)

	CN3D 1-2P	
CN3D 1-3P	Open	Short-circuit
Open	100% (No DEMAND)	75%
Short-circuit	0% (Compressor OFF)	50%

*3. Input the order to CN3D on the outdoor unit whose SW6-8 is set to ON.

Note the following steps to be taken when using the STEP DEMAND

(Example) When switching from 100% to 50%



If the step listed as the wrong example above is taken, thermo may go off.
 The percentage of the demand listed in the table above is an approximate value based on the compressor volume and does not necessarily correspond with the capacity.
 When this function is enabled, the night mode cannot be enabled.

3) When SW6-8 on the two outdoor units in one refrigerant circuit system is set to ON (8 levels of on-DEMAND) (*4, *5)

8 levels of on-DEMAND		No.2 CN3D				
		1-2P	Open		Short-circuit	
No.1 CN3D	1-2P	1-3P	Open	Short-circuit	Open	Short-circuit
	Open	Open	100%	50%	88%	75%
		Short-circuit	50%	0%	38%	25%
	Short-circuit	Open	88%	38%	75%	63%
Short-circuit		75%	25%	63%	50%	

*4. Input the order to CN3D on the outdoor unit whose SW6-8 is set to ON.

*5. CN3D of No. 1, 2, 3 can be selected arbitrary with the outdoor unit whose SW6-8 is set to ON.

4) When SW6-8 on the all outdoor units in one refrigerant circuit system is set to ON (12 levels of on-DEMAND) (*4)

12 levels of on-DEMAND	No.2 CN3D	1-2P	Open							
		1-3P	Open				Short-circuit			
	No.3 CN3D	1-2P	Open		Short-circuit		Open		Short-circuit	
No.1 CN3D	1-2P	1-3P	Open	Short-circuit	Open	Short-circuit	Open	Short-circuit	Open	Short-circuit
	Open	Open	100%	67%	92%	84%	67%	34%	59%	50%
		Short-circuit	67%	34%	59%	50%	34%	0%	25%	17%
	Short-circuit	Open	92%	59%	84%	75%	59%	25%	50%	42%
Short-circuit		84%	50%	75%	67%	50%	17%	42%	34%	

12 levels of on-DEMAND	No.2 CN3D	1-2P	Short-circuit							
		1-3P	Open				Short-circuit			
	No.3 CN3D	1-2P	Open		Short-circuit		Open		Short-circuit	
No.1 CN3D	1-2P	1-3P	Open	Short-circuit	Open	Short-circuit	Open	Short-circuit	Open	Short-circuit
	Open	Open	92%	59%	84%	75%	84%	50%	75%	67%
		Short-circuit	59%	25%	50%	42%	50%	17%	42%	34%
	Short-circuit	Open	84%	50%	75%	67%	75%	42%	67%	59%
Short-circuit		75%	42%	67%	59%	67%	34%	59%	50%	

*3. Input the order to CN3D on the outdoor unit whose SW6-8 is set to ON.

*4. CN3D of No. 1, 2, 3 can be selected arbitrary with the outdoor unit whose SW6-8 is set to ON.

2-6 System Connection Example

Examples of typical system connection are shown below.
Refer to the Installation Manual that came with each device or controller for details.

(1) An example of a system to which an MA remote controller is connected

	System configuration	Connection to the system controller	Address start up for indoor and outdoor units	Notes
1	System with one outdoor unit	NO	Automatic address setup	
2	System with one outdoor unit	NO	Manual address setup	Connection of multiple LOSSNAY units
3	Grouping of units in a system with multiple outdoor units	NO	Manual address setup	
4	System with one outdoor unit	With connection to transmission line for centralized control	Manual address setup	
5	System with one outdoor unit	With connection to indoor-outdoor transmission line	Manual address setup	

(2) An example of a system to which an ME remote controller is connected

	System configuration	Connection to the system controller	Address start up for indoor and outdoor units	Notes
1	System with one outdoor unit	With connection to transmission line for centralized control	Manual address setup	

(3) An example of a system to which both MA remote controller and ME remote controller are connected

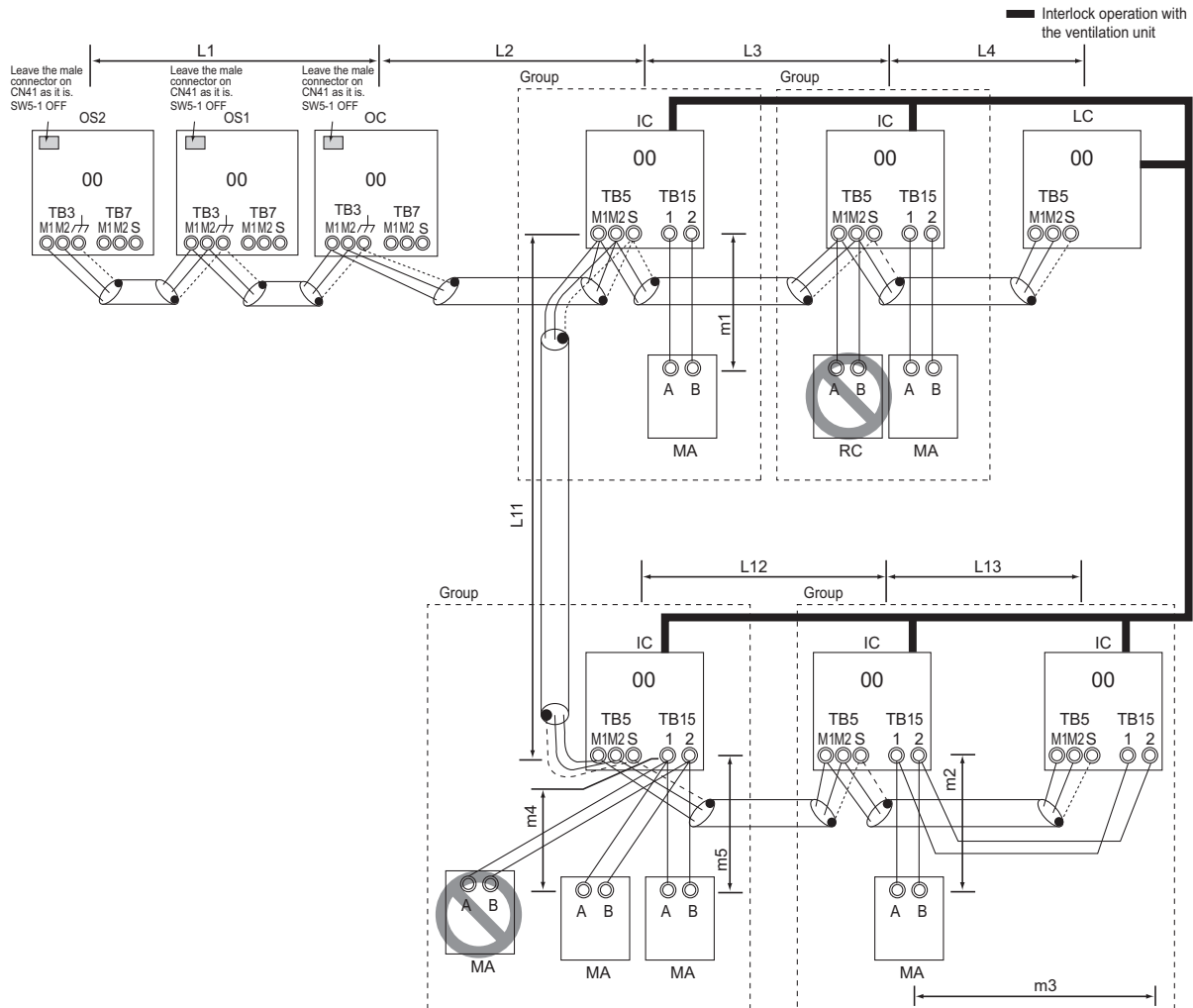
	System configuration	Connection to the system controller	Address start up for indoor and outdoor units	Notes
1	System with one outdoor unit	With connection to transmission line for centralized control	Manual address setup	

*MA remote controller and ME remote controller cannot both be connected to the same group.

2-7 Example System with an MA Remote Controller

2-7-1 Single Refrigerant System (Automatic Indoor/Outdoor Address Startup)

(1) Sample control wiring



(2) Cautions

- ME remote controller and MA remote controller cannot both be connected to the same group of indoor units.
- No more than 2 MA remote controllers can be connected to a group of indoor units.
When a PAR-CT01MA, PAR-4XMAA, or PAR-3XMAA ("X" represents 0 or later) is connected to a group, no other MA remote controllers can be connected to the same group.
- A transmission booster is required in a system to which more than 32 indoor units (26 units if one or more indoor units of the 200 model or above is connected) are connected.
- Automatic address setup is not available if start-stop input (CN32, CN51, CN41) is used for a group operation of indoor units or when multiple indoor units with different functions are grouped in the same group. Refer to the following page(s). [2-7-2 Single Refrigerant System with Two or More LOSSNAY Units]
- For information about connecting two or more LOSSNAY units to a system, refer to the following page(s). [2-7-2 Single Refrigerant System with Two or More LOSSNAY Units]

(3) Maximum allowable length

- Indoor/outdoor transmission line
Maximum distance (1.25mm² [AWG16] or larger)
 $L1 + L2 + L3 + L4 \leq 200\text{m} [656\text{ft}]$
 $L1 + L2 + L11 + L12 + L13 \leq 200\text{m} [656\text{ft}]$
- Transmission line for centralized control
No connection is required.
- MA remote controller wiring
Maximum overall line length (0.3 to 1.25mm² [AWG22 to 16])
 $m1 \leq 200\text{m} [656\text{ft}]$
 $m2 + m3 \leq 200\text{m} [656\text{ft}]$
 $m4 + m5 \leq 200\text{m} [656\text{ft}] * 1$
*1 70m [229 ft] for PAR-CT01MA (single remote controller only)
*To wire PAR-CT01MA, PAR-4XMAA, PAR-3XMAA ("X" represents 0 or later), and Simple MA remote controller, use a wire with a diameter of 0.3mm² [AWG22].

(4) Wiring method

- 1) Indoor/outdoor transmission line
 Daisy-chain terminals M1 and M2 on the terminal block for indoor-outdoor transmission line (TB3) on the outdoor units (OC, OS1, OS2) (Note), and terminals M1 and M2 on the terminal block for indoor-outdoor transmission line (TB5) on each indoor unit (IC). (Non-polarized two-wire)
 •Only use shielded cables.

Note

The outdoor units in the same refrigerant circuit are automatically designated as OC, OS1, and OS2 in the order of capacity from large to small (if two or more units have the same capacity, in the order of address from small to large).

Shielded cable connection

Daisy-chain the ground terminal (\overline{H}) on the outdoor units (OC, OS1, OS2), and the S terminal on the terminal block (TB5) on the indoor unit (IC) with the shield wire of the shielded cable.

- 2) Transmission line for centralized control
 No connection is required.
- 3) MA remote controller wiring
 Connect terminals 1 and 2 on the terminal block for MA remote controller line (TB15) on the indoor unit (IC) to the terminal block on the MA remote controller (MA). (Non-polarized two-wire)

When 2 remote controllers are connected to the system

When 2 remote controllers are connected to the system, connect terminals 1 and 2 of the terminal block (TB15) on the indoor unit (IC) to the terminal block on the two MA remote controllers.

- Set one of the MA remote controllers to sub. (Refer to MA remote controller function selection or the installation manual for the MA remote controller for the setting method.)

(5) Address setting method

Procedures	Unit or controller		Address setting range	Setting method	Notes	Factory setting
1	Indoor unit	Main unit	IC	No settings required.	For information about how to perform a group operation of indoor units that feature different functions, refer to the following page(s). [2-7-2 Single Refrigerant System with Two or More LOSSNAY Units]	00
		Sub unit	IC			
2	LOSSNAY		LC	No settings required.	-	00
3	MA remote controller	Main remote controller	MA	No settings required.	Settings to be made according to the remote controller function selection	Main
		Sub remote controller	MA	Sub remote controller		
4	Outdoor unit (Note)		OC OS1 OS2	No settings required.	-	00

Note

The outdoor units in the same refrigerant circuit are automatically designated as OC, OS1, and OS2. The outdoor units are designated as OC, OS1, and OS2 in the order of capacity from large to small (if two or more units have the same capacity, in the order of address from small to large).

od.)

Group operation of indoor units

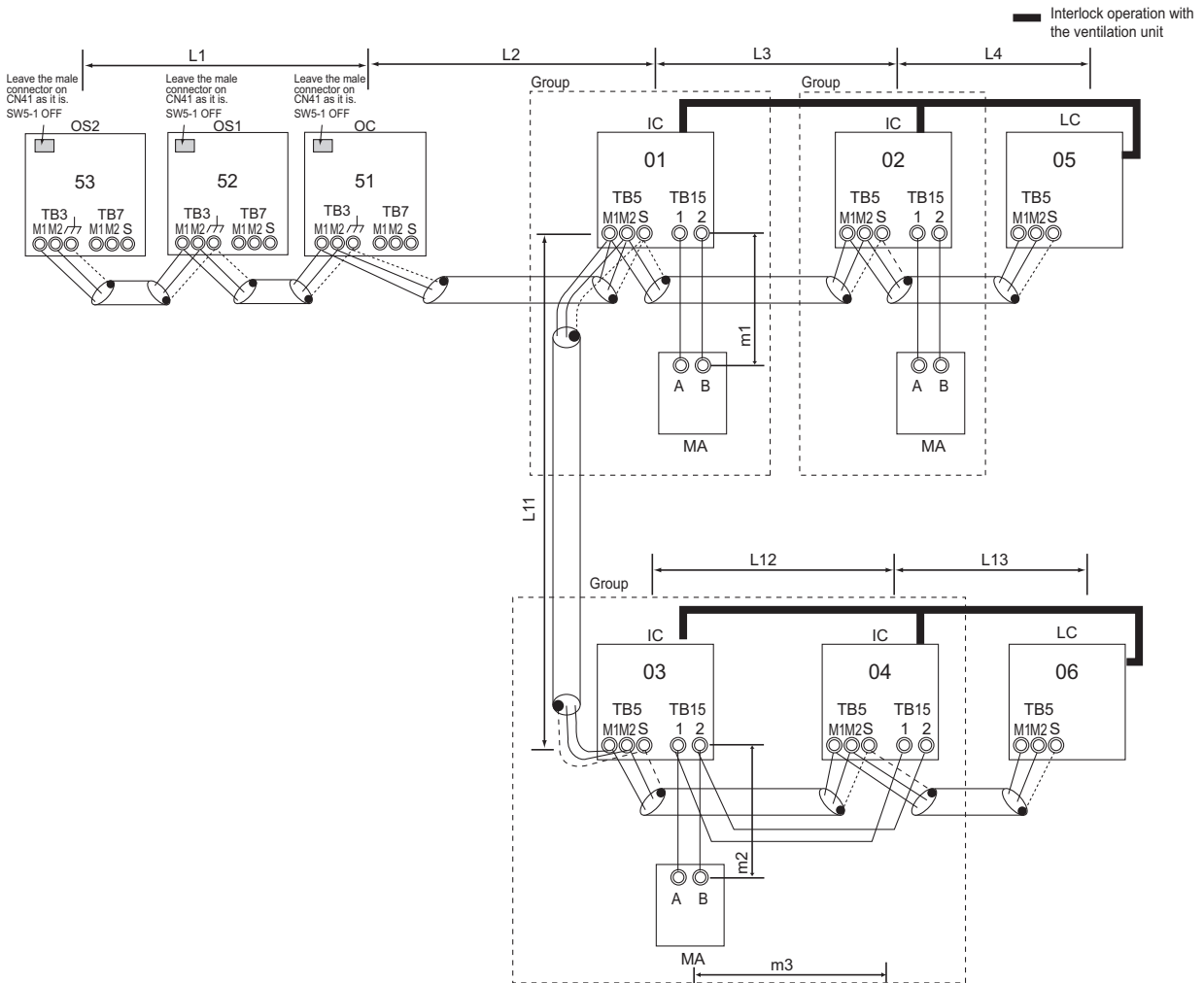
To perform a group operation of indoor units (IC), daisy-chain terminals 1 and 2 on the terminal block (TB15) on all indoor units (IC) in the same group, and then connect terminals 1 and 2 on the terminal block (TB15) on the indoor unit on one end to the terminal block on the MA remote controller. (Non-polarized two-wire)

- When performing a group operation of indoor units that have different functions, "Automatic indoor/outdoor address setup" is not available.

- 4) LOSSNAY connection
 Connect terminals M1 and M2 on the terminal block (TB5) on the indoor unit (IC) to the appropriate terminals on the terminal block (TB5) on LOSSNAY (LC). (Non-polarized two-wire)
 •Interlock operation setting with all the indoor units in the same system will automatically be made. (It is required that the Lossnay unit be turned on before the outdoor unit.)
 •For information about certain types of systems (1. Systems in which the LOSSNAY unit is interlocked with only part of the indoor units, 2. Systems in which the LOSSNAY unit is operated independently from the indoor units, 3. Systems in which more than 16 indoor units are interlocked with the LOSSNAY unit, and 4. Systems to which two or more LOSSNAY units are connected), refer to the following page(s). [2-7-2 Single Refrigerant System with Two or More LOSSNAY Units]
- 5) Switch setting
 No address settings required.
- 6) When replacing the control board on only some of the outdoor units, delete all connection information. (Refer to [5-1-1 Outdoor Unit Switch Functions and Factory Settings] for information on switch functions.)

2-7-2 Single Refrigerant System with Two or More LOSSNAY Units

(1) Sample control wiring



(2) Cautions

- 1) ME remote controller and MA remote controller cannot both be connected to the same group of indoor units.
- 2) No more than 2 MA remote controllers can be connected to a group of indoor units.
When a PAR-CT01MA, PAR-4XMAA, or PAR-3XMAA ("X" represents 0 or later) is connected to a group, no other MA remote controllers can be connected to the same group.
- 3) A transmission booster is required in a system to which more than 32 indoor units (26 units if one or more indoor units of the 200 model or above is connected) are connected.

•Refer to the DATABOOK for further information about how many booster units are required for a given system.

(3) Maximum allowable length

- 1) Indoor/outdoor transmission line
Same as 2-7-1
- 2) Transmission line for centralized control
No connection is required.
- 3) MA remote controller wiring
Same as 2-7-1

(4) Wiring method

1) Indoor/outdoor transmission line

Same as 2-7-1

Shielded cable connection

Same as 2-7-1

2) Transmission line for centralized control

No connection is required.

3) MA remote controller wiring

Same as 2-7-1

When 2 remote controllers are connected to the system

Same as 2-7-1

Group operation of indoor units

Same as 2-7-1

4) LOSSNAY connection

Connect terminals M1 and M2 on the terminal block (TB5) on the indoor unit (IC) to the appropriate terminals on the terminal block (TB5) on LOSSNAY (LC). (Non-polarized two-wire)

♦Interlock setting between the indoor units and LOSSNAY units must be entered on the remote controller. For information about how to interlock the operation of indoor and LOSSNAY units, refer to the remote controller installation manual.

5) Switch setting

Address setting is required as follows.

(5) Address setting method

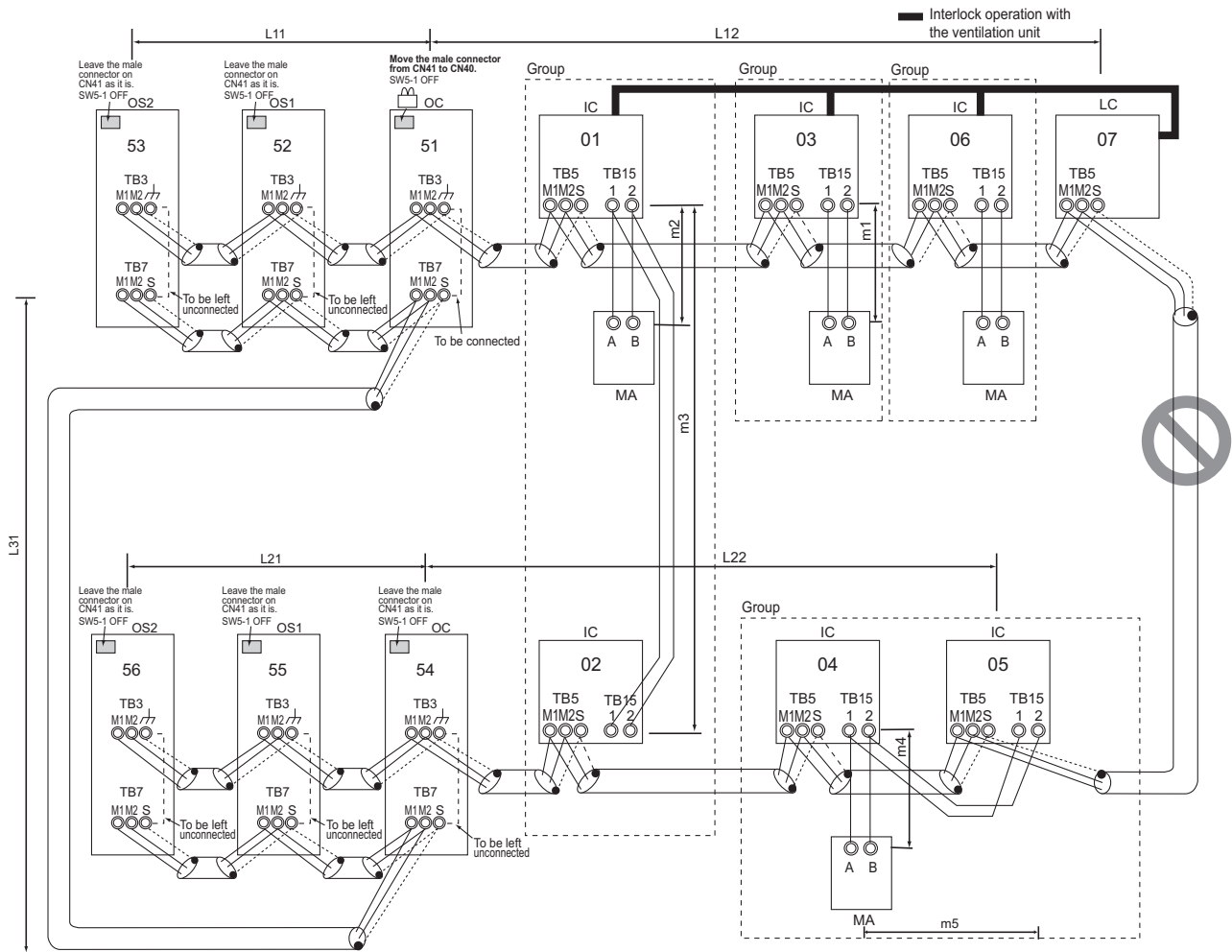
Procedures	Unit or controller			Address setting range	Setting method	Notes	Factory setting
1	Indoor unit	Main unit	IC	01 to 50	Assign the smallest address to the main unit in the group.	To perform a group operation of indoor units that have different functions, designate the indoor unit in the group with the greatest number of functions as the main unit.	00
		Sub unit			Assign sequential numbers starting with the address of the main unit in the same group +1. (Main unit address +1, main unit address +2, main unit address +3, etc.)		
2	LOSSNAY		LC	01 to 50	Assign an arbitrary but unique address to each of these units after assigning an address to all indoor units.	None of these addresses may overlap any of the indoor unit addresses.	00
3	MA remote controller	Main remote controller	MA	No settings required.	-		Main
		Sub remote controller	MA	Sub remote controller	Settings to be made according to the remote controller function selection		
4	Outdoor unit		OC OS1 OS2	51 to 100	Assign sequential address to the outdoor units in the same refrigerant circuit. The outdoor units are automatically designated as OC, OS1, and OS2.(Note)	To set the address to 100, set the rotary switches to 50.	00

Note

The outdoor units in the same refrigerant circuit are automatically designated as OC, OS1, and OS2. The outdoor units are designated as OC, OS1, and OS2 in the order of capacity from large to small (if two or more units have the same capacity, in the order of address from small to large).

2-7-3 Grouped Operation of Units in Separate Refrigerant Circuits

(1) Sample control wiring



(2) Cautions

- 1) ME remote controller and MA remote controller can not both be connected to the same group of indoor units.
 - 2) No more than 2 MA remote controllers can be connected to a group of indoor units.
When a PAR-CT01MA, PAR-4XMAA, or PAR-3XMAA ("X" represents 0 or later) is connected to a group, no other MA remote controllers can be connected to the same group.
 - 3) Do not connect the terminal blocks (TB5) on the indoor units that are connected to different outdoor units with each other.
 - 4) Replacement of male power jumper connector (CN41) must be performed only on one of the outdoor units.
 - 5) Provide grounding to S terminal on the terminal block for transmission line for centralized control (TB7) on only one of the outdoor units.
 - 6) A transmission booster is required in a system to which more than 32 indoor units (26 units if one or more indoor units of the 200 model or above is connected) are connected.
- Refer to the DATABOOK for further information about how many booster units are required for a given system.

(3) Maximum allowable length

- 1) Indoor/outdoor transmission line
Maximum distance (1.25mm² [AWG16] or larger)
L11+L12 ≤ 200m [656ft]
L21+L22 ≤ 200m [656ft]
- 2) Transmission line for centralized control
L21+L31 ≤ 200m [656ft]
- 3) MA remote controller wiring
Same as 2-7-1
- 4) Maximum line distance via outdoor unit (1.25mm² [AWG16] or larger)
L12(L11)+L31+L22(L21) ≤ 1000 m [3280ft] (500 m [1640ft])^{*1}

^{*1} If a given system includes one or more unit or remote controller that does not support the maximum allowable cable distance of 1,000 m [3280 ft], the maximum allowable cable distance in the system will be 500 m [1640 ft]. Refer to the latest catalog for information on which units and remote controllers support the maximum allowable cable distance of 1,000 m [3280 ft].

(4) Wiring method

- 1) Indoor/outdoor transmission line
Same as 2-7-1
•Only use shielded cables.

Shielded cable connection

Same as 2-7-1

- 2) Transmission line for centralized control

Daisy-chain terminals M1 and M2 on the terminal block for transmission line for centralized control (TB7) on the outdoor units (OC) in different refrigerant circuits and on the OC, OS1, and OS2 (Note a) in the same refrigerant circuit

If a power supply unit is not connected to the transmission line for centralized control, replace the power jumper connector on the control board from CN41 to CN40 on only one of the outdoor units.

Note

- a) The outdoor units in the same refrigerant circuit are automatically designated as OC, OS1, and OS2 in the order of capacity from large to small (if two or more units have the same capacity, in the order of address from small to large).
- b) When not daisy-chaining TB7's on the outdoor units in the same refrigerant circuit, connect the transmission line for centralized control to TB7 on the OC (Note a). To maintain centralized control even during an OC failure or

- a power failure, daisy-chain TB7 of OC, OS1, and OS2. (If there is a problem with the outdoor unit whose power jumper was moved from CN41 to CN40, centralized control is not possible, even if TB7's are daisy-chained).
- c) When connecting TB7, only commence after checking that the voltage is below 20 VDC.

- Only use shielded cables.

Shielded cable connection

Daisy-chain the S terminal on the terminal block (TB7) on the outdoor units (OC, OS1, OS2) with the shield wire of the shielded cable. Short-circuit the earth terminal (\oplus) and the S terminal on the terminal block (TB7) on the outdoor unit whose power jumper connector is mated with CN40.

- 3) MA remote controller wiring

Same as 2-7-1

When 2 remote controllers are connected to the system

Same as 2-7-1

Group operation of indoor units

Same as 2-7-1

- 4) LOSSNAY connection

Same as 2-7-2

- 5) Switch setting

Address setting is required as follows.

(5) Address setting method

Procedures	Unit or controller			Address setting range	Setting method	Notes	Factory setting
1	Indoor unit	Main unit	IC	01 to 50	Assign the smallest address to the main unit in the group.	To perform a group operation of indoor units that have different functions, designate the indoor unit in the group with the greatest number of functions as the main unit.	00
		Sub unit			Assign sequential numbers starting with the address of the main unit in the same group +1. (Main unit address +1, main unit address +2, main unit address +3, etc.)		
2	LOSSNAY		LC	01 to 50	Assign an arbitrary but unique address to each of these units after assigning an address to all indoor units.	None of these addresses may overlap any of the indoor unit addresses.	00
3	MA remote controller	Main remote controller	MA	No settings required.	-		Main
		Sub remote controller	MA	Sub remote controller	Settings to be made according to the remote controller function selection		
4	Outdoor unit		OC OS1 OS2	51 to 100	Assign sequential address to the outdoor units in the same refrigerant circuit. The outdoor units are automatically designated as OC, OS1, and OS2. (Note)	To set the address to 100, set the rotary switches to 50.	00

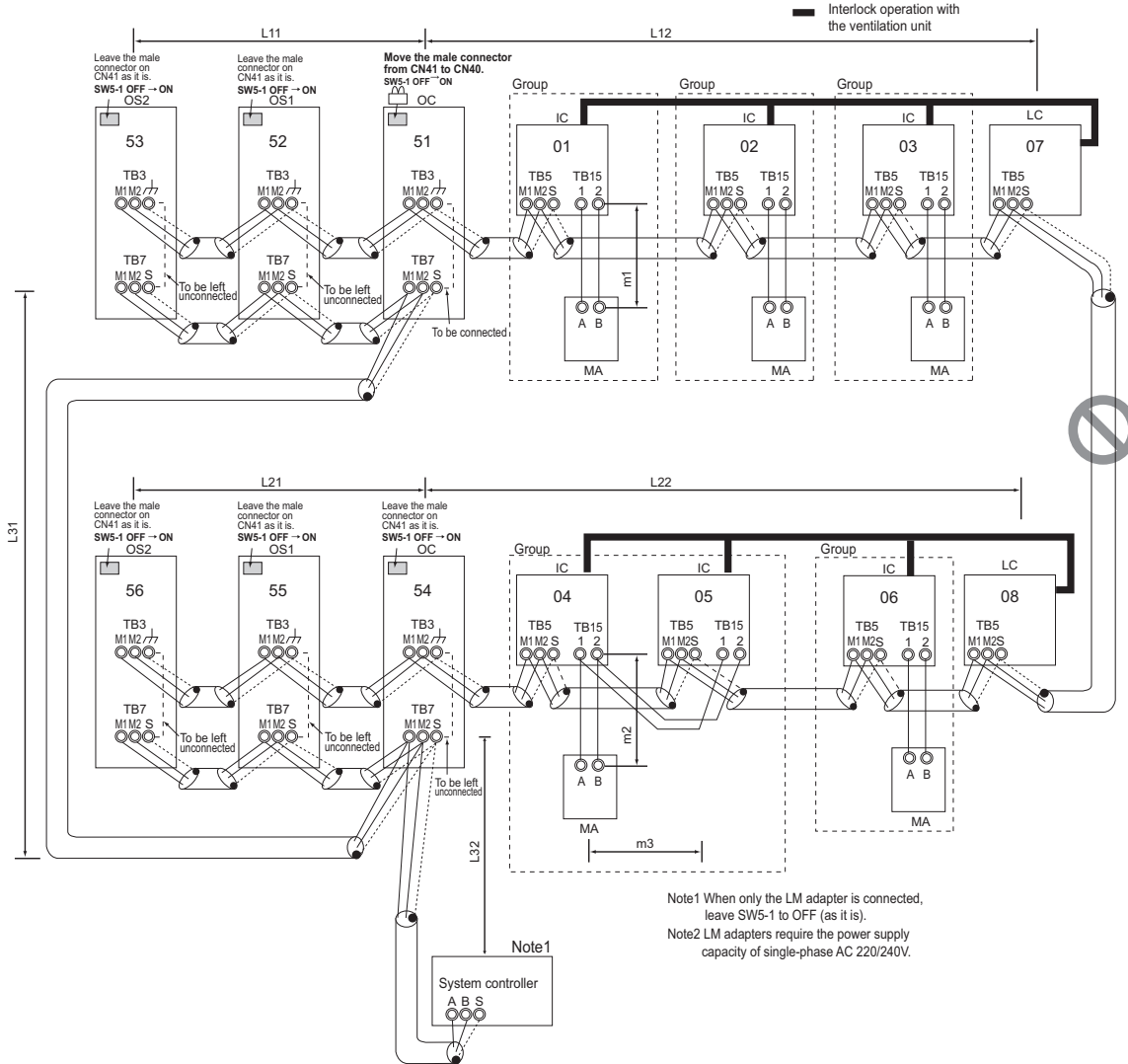
Note

The outdoor units in the same refrigerant circuit are automatically designated as OC, OS1, and OS2. The outdoor units are designated as OC, OS1, and OS2 in the order of capacity from large to small (if two or more units have the same capacity, in the order of address from small to large).

2-7-4 System with a Connection of System Controller to Centralized Control Transmission Line

(1) Sample control wiring

An example of a system in which a system controller is connected to the transmission cable for the centralized control system and the power is supplied from the outdoor unit



(2) Cautions

- 1) ME remote controller and MA remote controller cannot both be connected to the same group of indoor units.
- 2) No more than 2 MA remote controllers can be connected to a group of indoor units.
When a PAR-CT01MA, PAR-4XMAA, or PAR-3XMAA ("X" represents 0 or later) is connected to a group, no other MA remote controllers can be connected to the same group.
- 3) Do not connect the terminal blocks (TB5) on the indoor units that are connected to different outdoor units with each other.
- 4) Replacement of male jumper connector (CN41) must be performed only on one of the outdoor units (not required if power to the transmission line for centralized control is supplied from a controller with a power supply function, such as GB-50ADA).
- 5) Short-circuit the shield terminal (S terminal) and the earth terminal (r) on the terminal block for transmission line for centralized control (TB7) on the outdoor unit whose power jumper connector is mated with CN40.
- 6) A transmission booster is required in a system to which more than 32 indoor units (26 units if one or more indoor units of the 200 model or above is connected) are connected.
*Refer to the DATABOOK for further information about how many booster units are required for a given system.
- 7) When a power supply unit is connected to the transmission line for centralized control, leave the power jumper connector on

CN41 as it is (factory setting).

(3) Maximum allowable length

- 1) Indoor/outdoor transmission line
Same as 2-7-3
 - 2) Transmission line for centralized control
 $L_{31}+L_{32}(L_{21}) \leq 200\text{m}$ [656ft]
 - 3) MA remote controller wiring
Same as 2-7-1
 - 4) Maximum line distance via outdoor unit (1.25mm² [AWG16] or larger)
 $L_{32}+L_{31}+L_{12}(L_{11}) \leq 1000\text{ m}$ [3280ft] (500 m [1640ft])^{*1}
 $L_{32}+L_{22}(L_{21}) \leq 1000\text{ m}$ [3280ft] (500 m [1640ft])^{*1}
 $L_{12}(L_{11})+L_{31}+L_{22}(L_{21}) \leq 1000\text{ m}$ [3280ft] (500 m [1640ft])^{*1}
- *1 If a given system includes one or more unit or remote controller that does not support the maximum allowable cable distance of 1,000 m [3280 ft], the maximum allowable cable distance in the system will be 500 m [1640 ft]. Refer to the latest catalog for information on which units and remote controllers support the maximum allowable cable distance of 1,000 m [3280 ft].

(4) Wiring method

- 1) Indoor/outdoor transmission line

Same as 2-7-1

Shielded cable connection

Same as 2-7-1

- 2) Transmission line for centralized control

Daisy-chain terminals A and B on the system controller, terminals M1 and M2 on the terminal block for transmission line for centralized control (TB7) on the outdoor units (OC) in different refrigerant circuits and on the outdoor units (OC, OS1, and OS2) in the same refrigerant circuit. (Note b)

If a power supply unit is not connected to the transmission line for centralized control, replace the power jumper connector on the control board from CN41 to CN40 on only one of the outdoor units.

If a system controller is connected, set the central control switch (SW5-1) on the control board of all outdoor units to "ON."

Note

- a) The outdoor units in the same refrigerant circuit are automatically designated as OC, OS1, and OS2 in the order of capacity from large to small (if two or more units have the same capacity, in the order of address from small to large).
- b) When not daisy-chaining TB7's on the outdoor units in the same refrigerant circuit, connect the transmission line for centralized control to TB7 on the OC (Note a). To maintain centralized control even during an OC failure or a power failure, daisy-chain TB7 of OC, OS1, and OS2. (If there is a problem with the outdoor unit whose power jumper was moved from CN41 to CN40, centralized con-

- trol is not possible, even if TB7's are daisy-chained).
- c) When connecting TB7, only commence after checking that the voltage is below 20 VDC.

•Only use shielded cables.

Shielded cable connection

Daisy-chain the S terminal on the terminal block (TB7) on the outdoor units (OC, OS1, OS2) with the shield wire of the shielded cable. Short-circuit the earth terminal (⌚) and the S terminal on the terminal block (TB7) on the outdoor unit whose power jumper connector is mated with CN40.

- 3) MA remote controller wiring

Same as 2-7-1

When 2 remote controllers are connected to the system

Same as 2-7-1

Group operation of indoor units

Same as 2-7-1

- 4) LOSSNAY connection

Connect terminals M1 and M2 on the terminal block (TB5) on the indoor unit (IC) to the appropriate terminals on the terminal block for indoor-outdoor transmission line (TB5) on LOSSNAY (LC). (Non-polarized 2-core cable)

•Indoor units must be interlocked with the LOSSNAY unit using the system controller. (Refer to the operation manual for the system controller for the setting method.) Interlock setting from the remote controller is required if the ON/OFF remote controller alone or the LM adapter alone is connected.

- 5) Switch setting

Address setting is required as follows.

(5) Address setting method

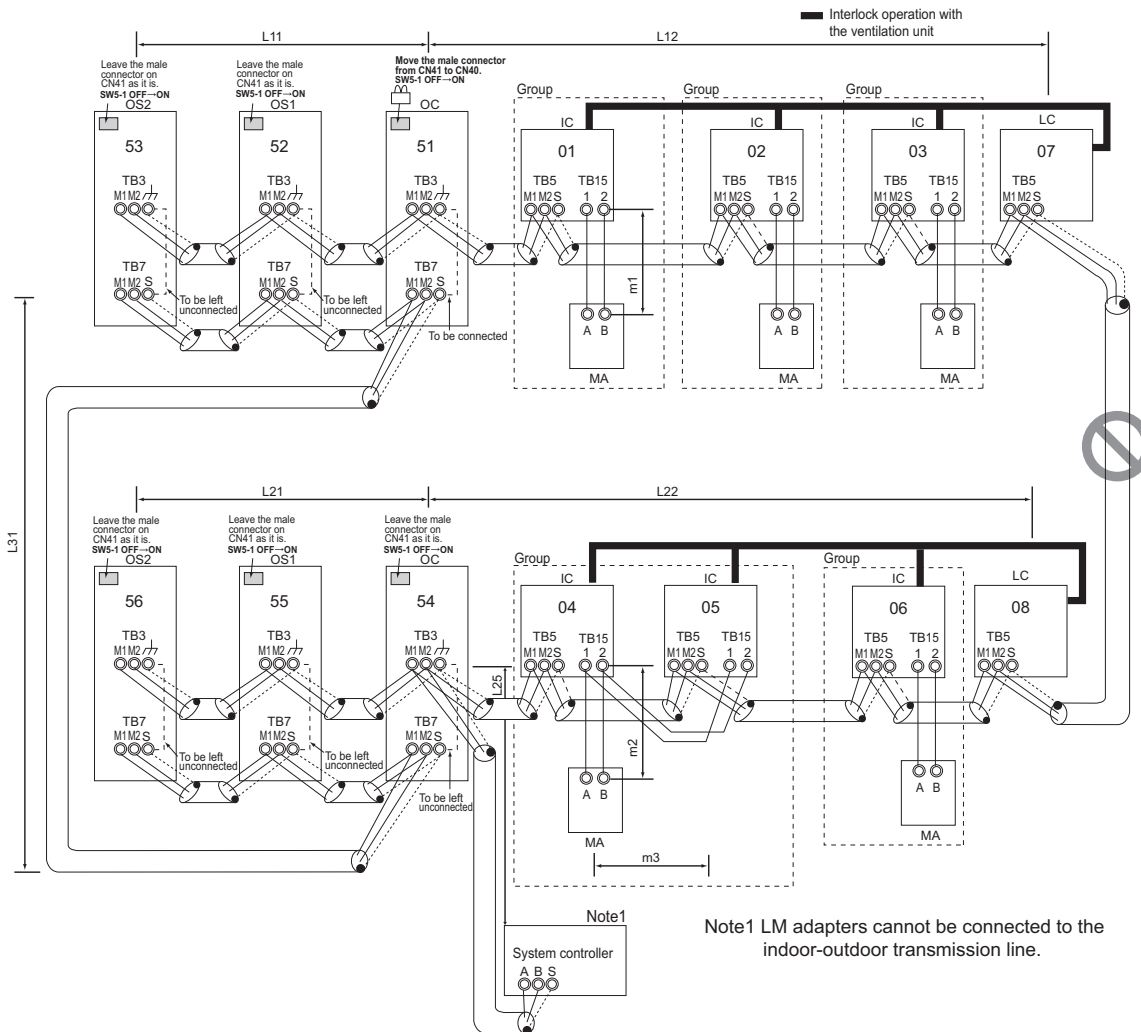
Procedures	Unit or controller			Address setting range	Setting method	Notes	Factory setting	
1	Indoor unit	Main unit	IC	01 to 50	Assign the smallest address to the main unit in the group. Assign sequential numbers starting with the address of the main unit in the same group +1. (Main unit address +1, main unit address +2, main unit address +3, etc.)	To perform a group operation of indoor units that have different functions, designate the indoor unit in the group with the greatest number of functions as the main unit.	00	
		Sub unit						
2	LOSSNAY			LC	01 to 50	Assign an arbitrary but unique address to each of these units after assigning an address to all indoor units.	None of these addresses may overlap any of the indoor unit addresses.	00
3	MA remote controller	Main remote controller	MA	No settings required.	-	Enter the same indoor unit group settings on the system controller as the ones that were entered on the MA remote controller.	Main	
		Sub remote controller	MA	Sub remote controller	Settings to be made according to the remote controller function selection			
4	Outdoor unit		OC OS1 OS2	51 to 100	Assign sequential address to the outdoor units in the same refrigerant circuit. The outdoor units are automatically designated as OC, OS1, and OS2. (Note)	To set the address to 100, set the rotary switches to 50.	00	

Note

The outdoor units in the same refrigerant circuit are automatically designated as OC, OS1, and OS2. The outdoor units are designated as OC, OS1, and OS2 in the order of capacity from large to small (if two or more units have the same capacity, in the order of address from small to large).

2-7-5 System with a Connection of System Controller to Indoor-Outdoor Transmission Line

(1) Sample control wiring



(2) Cautions

- 1) ME remote controller and MA remote controller cannot both be connected to the same group of indoor units.
 - 2) No more than 2 MA remote controllers can be connected to a group of indoor units. When a PAR-CT01MA, PAR-4XMAA, or PAR-3XMAA ("X" represents 0 or later) is connected to a group, no other MA remote controllers can be connected to the same group.
 - 3) Do not connect the terminal blocks (TB5) on the indoor units that are connected to different outdoor units with each other.
 - 4) Replacement of male power jumper connector (CN41) must be performed only on one of the outdoor units (not required if power to the transmission line for centralized control is supplied from a controller with a power supply function, such as GB-50ADA).
 - 5) Provide grounding to S terminal on the terminal block for transmission line for centralized control (TB7) on only one of the outdoor units.
 - 6) A maximum of three system controllers can be connected to the indoor-outdoor transmission line. (AE-200, AG-150A, GB-50ADA, or G(B)-50A are not connectable.)
 - 7) When the total number of indoor units exceeds 26, it may not be possible to connect a system controller on the indoor-outdoor transmission line.
- In a system to which more than 18 indoor units including one or more indoor units of 200 model or above are connected,

there may be cases in which the system controller cannot be connected to the indoor-outdoor transmission line.
 •Refer to the DATABOOK for further information about how many booster units are required for a given system.

(3) Maximum allowable length

- 1) Indoor/outdoor transmission line
 Maximum distance (1.25mm² [AWG16] or larger)
 $L11+L12 \leq 200\text{m}$ [656ft]
 $L21+L22 \leq 200\text{m}$ [656ft]
 $L25 \leq 200\text{m}$ [656ft]
- 2) Transmission line for centralized control
 $L31+L21 \leq 200\text{m}$ [656ft]
- 3) MA remote controller wiring
 Same as 2-7-1
- 4) Maximum line distance via outdoor unit (1.25mm² [AWG16] or larger)
 $L25+L31+L12(L11) \leq 1000\text{ m}$ [3280ft] (500 m [1640ft])^{*1}
 $L12(L11)+L31+L22(L21) \leq 1000\text{ m}$ [3280ft] (500 m [1640ft])^{*1}

^{*1} If a given system includes one or more unit or remote controller that does not support the maximum allowable cable distance of 1,000 m [3280 ft], the maximum allowable cable distance in the system will be 500 m [1640 ft]. Refer to the latest catalog for information on which units and remote controllers support the maximum allowable cable distance of 1,000 m [3280 ft].

(4) Wiring method

- 1) Indoor/outdoor transmission line
 Daisy-chain terminals M1 and M2 on the terminal block for indoor-outdoor transmission line (TB3) on the outdoor units (OC, OS1, OS2) (Note a), terminals M1 and M2 on the terminal block for indoor-outdoor transmission line (TB5) on each indoor unit (IC), and the S terminal on the system controller. (Non-polarized two-wire)
 •Only use shielded cables.

Note

- a) The outdoor units in the same refrigerant circuit are automatically designated as OC, OS1, and OS2. The outdoor units are designated as OC, OS1, and OS2 in the order of capacity from large to small (if two or more units have the same capacity, in the order of address from small to large).

Shielded cable connection

Daisy-chain the ground terminal (⏏) on the outdoor units (OC, OS1, OS2), the S terminal on the terminal block (TB5) on the indoor unit (IC), and the S terminal on the system controller with the shield wire of the shielded cable.

- 2) Transmission line for centralized control

Daisy-chain terminals M1 and M2 on the terminal block for transmission line for centralized control (TB7) on the outdoor units (OC) in different refrigerant circuits and on the OC, OS1, and OS2 in the same refrigerant circuit. (Note b)

If a power supply unit is not connected to the transmission line for centralized control, replace the power jumper connector on the control board from CN41 to CN40 on only one of the outdoor units.

Set the central control switch (SW5-1) on the control board of all outdoor units to "ON."

Note

- b) When not daisy-chaining TB7's on the outdoor units in the

(5) Address setting method

Procedures	Unit or controller			Address setting range	Setting method	Notes	Factory setting
1	Indoor unit	Main unit	IC	01 to 50	Assign the smallest address to the main unit in the group.	To perform a group operation of indoor units that have different functions, designate the indoor unit in the group with the greatest number of functions as the main unit.	00
		Sub unit			Assign sequential numbers starting with the address of the main unit in the same group +1. (Main unit address +1, main unit address +2, main unit address +3, etc.)		
2	LOSSNAY		LC	01 to 50	Assign an arbitrary but unique address to each of these units after assigning an address to all indoor units.	None of these addresses may overlap any of the indoor unit addresses.	00
3	MA remote controller	Main remote controller	MA	No settings required.	-	Enter the same indoor unit group settings on the system controller as the ones that were entered on the MA remote controller.	Main
		Sub remote controller	MA	Sub remote controller	Settings to be made according to the remote controller function selection		
4	Outdoor unit		OC OS1 OS2	51 to 100	Assign sequential address to the outdoor units in the same refrigerant circuit. The outdoor units are automatically designated as OC, OS1, and OS2. (Note)	To set the address to 100, set the rotary switches to 50.	00

Note

The outdoor units in the same refrigerant circuit are automatically designated as OC, OS1, and OS2. The outdoor units are designated as OC, OS1, and OS2 in the order of capacity from large to small (if two or more units have the same capacity, in the order of address from small to large).

same refrigerant circuit, connect the transmission line for centralized control to TB7 on the OC (Note a). To maintain centralized control even during an OC failure or a power failure, daisy-chain TB7 of OC, OS1, and OS2. (If there is a problem with the outdoor unit whose power jumper was moved from CN41 to CN40, centralized control is not possible, even if TB7's are daisy-chained).

- c) When connecting TB7, only commence after checking that the voltage is below 20 VDC.
 •Only use shielded cables.

Shielded cable connection

Daisy-chain the S terminal on the terminal block (TB7) on the outdoor units (OC, OS1, OS2) with the shield wire of the shielded cable. Short-circuit the earth terminal (⏏) and the S terminal on the terminal block (TB7) on the outdoor unit whose power jumper connector is mated with CN40.

- 3) MA remote controller wiring

Same as 2-7-1

When 2 remote controllers are connected to the system

Same as 2-7-1

Group operation of indoor units

Same as 2-7-1

- 4) LOSSNAY connection

Connect terminals M1 and M2 on the terminal block (TB5) on the indoor units (IC) to the appropriate terminals on the terminal block for indoor-outdoor transmission line (TB5) on LOSSNAY (LC). (Non-polarized two-wire)

•Indoor units must be interlocked with the LOSSNAY unit using the system controller. (Refer to the operation manual for the system controller for the setting method.) Interlock setting from the remote controller is required if the ON/OFF remote controller alone is connected.

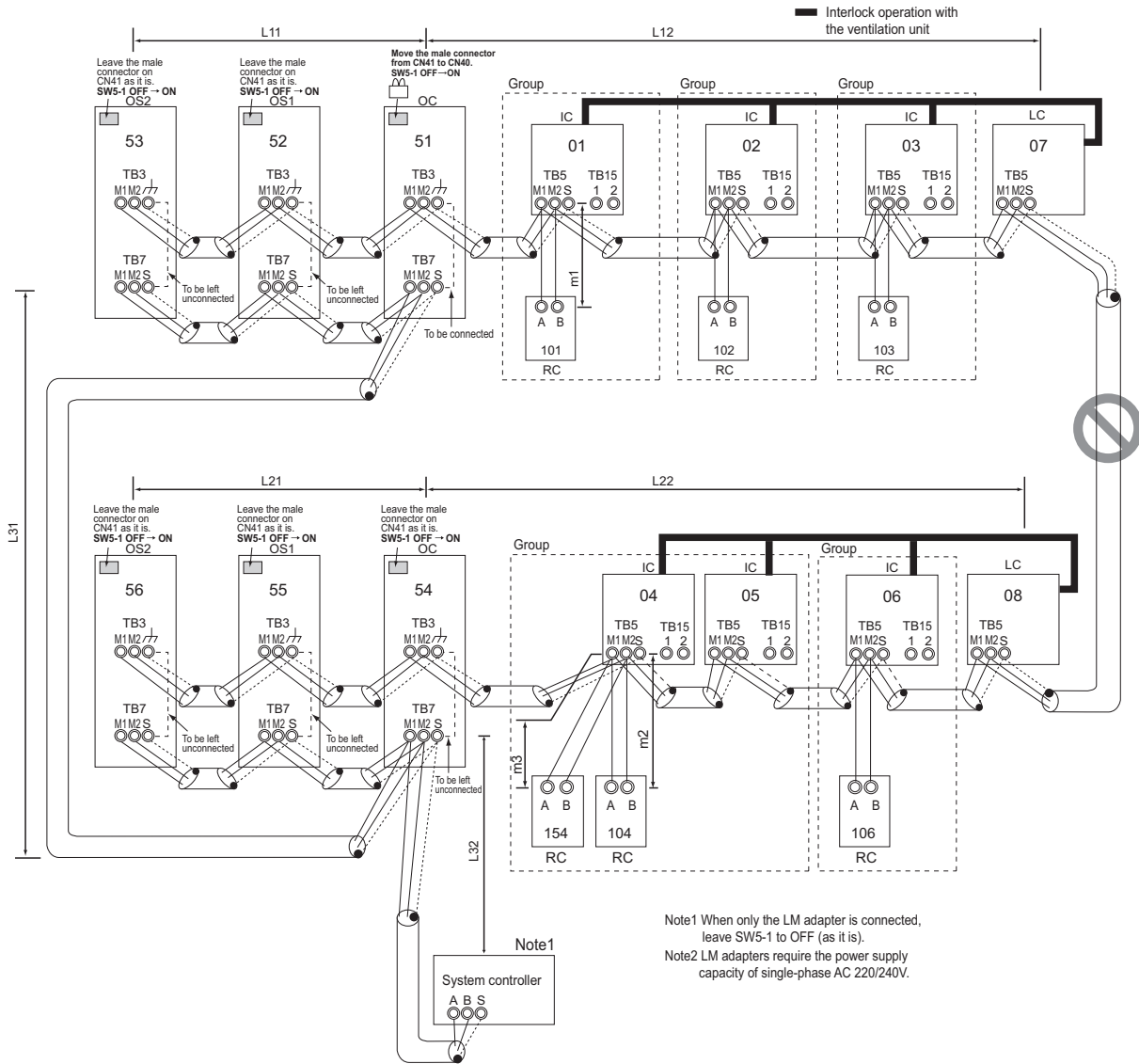
- 5) Switch setting

Address setting is required as follows.

2-8 Example System with an ME Remote Controller

2-8-1 System with a Connection of System Controller to Centralized Control Transmission Line

(1) Sample control wiring



(2) Cautions

- 1) ME remote controller and MA remote controller cannot both be connected to the same group of indoor units.
- 2) No more than 2 ME remote controllers can be connected to a group of indoor units.
- 3) Do not connect the terminal blocks (TB5) on the indoor units that are connected to different outdoor units with each other.
- 4) Replacement of male power jumper connector (CN41) must be performed only on one of the outdoor units (not required if power to the transmission line for centralized control is supplied from a controller with a power supply function, such as GB-50ADA).
- 5) Provide an electrical path to ground for the S terminal on the terminal block for centralized control (TB7) on only one of the outdoor units.
- 6) A transmission booster must be connected to a system in which the total number of connected indoor units exceeds 20.
- 7) A transmission booster is required in a system to which more than 16 indoor including one or more indoor units of the 200 model or above are connected.
- Refer to the DATABOOK for further information about how many booster units are required for a given system.
- 8) When a power supply unit is connected to the transmission line

for centralized control, leave the power jumper connector on CN41 as it is (factory setting).

(3) Maximum allowable length

- 1) Indoor/outdoor transmission line
Same as 2-7-3
- 2) Transmission line for centralized control
Same as 2-7-4
- 3) M-NET remote controller wiring
Maximum overall line length
(0.3 to 1.25mm² [AWG22 to 16])
m1 ≤ 10m [32ft]
m2+m3 ≤ 10m [32ft]
If the standard-supplied cable must be extended, use a cable with a diameter of 1.25mm² [AWG16]. The section of the cable that exceeds 10m [32ft] must be included in the maximum indoor-outdoor transmission line distance described in 1).
*When connected to the terminal block on the Simple remote controller, use cables that meet the following cable size specifications: 0.75 - 1.25 mm² [AWG18-14].
- 4) Maximum line distance via outdoor unit
(1.25 mm² [AWG16] min.)
Same as 2-7-4

(4) Wiring method

- 1) Indoor/outdoor transmission line
Same as 2-7-1
Shielded cable connection
Same as 2-7-1
- 2) Transmission line for centralized control
Same as 2-7-4
Shielded cable connection
Same as 2-7-4
- 3) ME remote controller wiring
ME remote controller is connectable anywhere on the indoor-outdoor transmission line.

When 2 remote controllers are connected to the system

- Refer to the section on Switch Setting.
- Performing a group operation (including the group operation of units in different refrigerant circuits).**
Refer to the section on Switch Setting.
- 4) LOSSNAY connection
Same as 2-7-4
- 5) Switch setting
Address setting is required as follows.

(5) Address setting method

Procedures	Unit or controller			Address setting range	Setting method	Notes	Factory setting
1	Indoor unit	Main unit	IC	01 to 50	Assign the smallest address to the main unit in the group.	To perform a group operation of indoor units that have different functions, designate the indoor unit in the group with the greatest number of functions as the main unit.	00
		Sub unit			Assign sequential numbers starting with the address of the main unit in the same group +1. (Main unit address +1, main unit address +2, main unit address +3, etc.)		
2	LOSSNAY		LC	01 to 50	Assign an arbitrary but unique address to each of these units after assigning an address to all indoor units.	None of these addresses may overlap any of the indoor unit addresses.	00
3	ME remote controller	Main remote controller	RC	101 to 150	Add 100 to the main unit address in the group	<ul style="list-style-type: none"> •It is not necessary to set the 100s digit. •To set the address to 200, set the rotary switches to 00. 	101
		Sub remote controller	RC	151 to 200	Add 150 to the main unit address in the group		
4	Outdoor unit		OC OS1 OS2	51 to 100	Assign sequential address to the outdoor units in the same refrigerant circuit. The outdoor units are automatically designated as OC, OS1, and OS2. (Note)	To set the address to 100, set the rotary switches to 50.	00

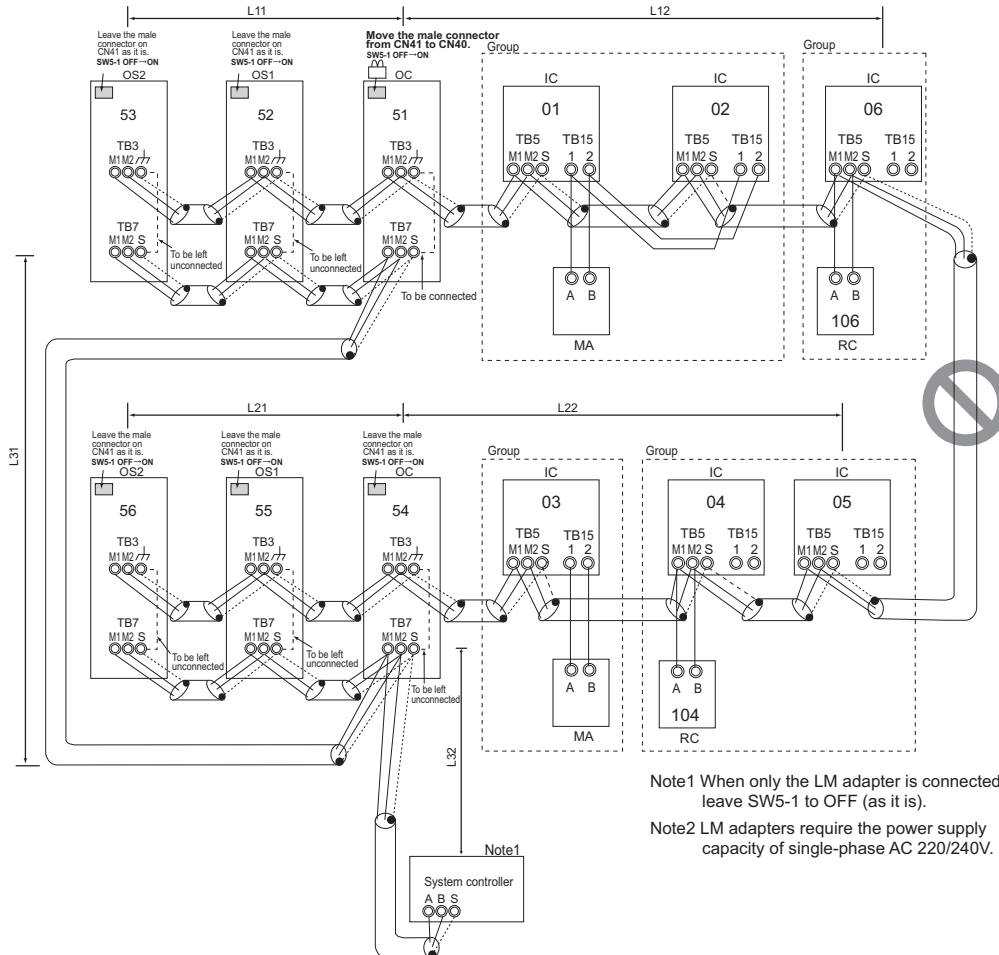
Note

The outdoor units in the same refrigerant circuit are automatically designated as OC, OS1, and OS2. The outdoor units are designated as OC, OS1, and OS2 in the order of capacity from large to small (if two or more units have the same capacity, in the order of address from small to large).

2-9 Example System with an MA and an ME Remote Controller

2-9-1 System with a Connection of System Controller to Centralized Control Transmission Line

(1) Sample control wiring



(2) Cautions

- 1) Be sure to connect a system controller.
- 2) ME remote controller and MA remote controller cannot both be connected to the same group of indoor units.
- 3) Assign to the indoor units connected to the MA remote controller addresses that are smaller than those of the indoor units that are connected to the ME remote controller.
- 4) No more than 2 ME remote controllers can be connected to a group of indoor units.
- 5) No more than 2 MA remote controllers can be connected to a group of indoor units.
When a PAR-CT01MA, PAR-4XMAA, or PAR-3XMAA ("X" represents 0 or later) is connected to a group, no other MA remote controllers can be connected to the same group.
- 6) Do not connect the terminal blocks (TB5) on the indoor units that are connected to different outdoor units with each other.
- 7) Replacement of male power jumper connector (CN41) must be performed only on one of the outdoor units (not required if power to the transmission line for centralized control is supplied from a controller with a power supply function, such as GB-50ADA).
- 8) Provide an electrical path to ground for the S terminal on

- 9) the terminal block for centralized control (TB7) on only one of the outdoor units.
- 9) A transmission booster must be connected to a system in which the total number of connected indoor units exceeds 20.
- 10) A transmission booster is required in a system to which more than 16 indoor including one or more indoor units of the 200 model or above are connected.
 - Refer to the DATABOOK for further information about how many booster units are required for a given system.
- 11) When a power supply unit is connected to the transmission line for centralized control, leave the power jumper connector on CN41 as it is (factory setting).

(3) Maximum allowable length

- 1) Indoor/outdoor transmission line
Same as 2-7-3
- 2) Transmission line for centralized control
Same as 2-7-4
- 3) MA remote controller wiring
Same as 2-7-1
- 4) M-NET remote controller wiring
Same as 2-8-1
- 5) Maximum line distance via outdoor unit (1.25 mm² [AWG16] min.)
Same as 2-7-4

(4) Wiring method

- 1) Indoor/outdoor transmission line
Same as 2-7-1
Shielded cable connection
Same as 2-7-1
- 2) Transmission line for centralized control
Same as 2-7-4
Shielded cable connection
Same as 2-7-4
- 3) MA remote controller wiring
Same as 2-7-1
When 2 remote controllers are connected to the system

- Same as 2-7-1
Group operation of indoor units
Same as 2-7-1
- 4) ME remote controller wiring
Same as 2-8-1
When 2 remote controllers are connected to the system
Same as 2-7-1
Group operation of indoor units
Same as 2-7-1
- 5) LOSSNAY connection
Same as 2-7-4
- 6) Switch setting
Address setting is required as follows.

(5) Address setting method

Proce- dures	Unit or controller				Address setting range	Setting method	Notes	Factory setting
1	Opera- tion with the MA re- mote con- troller	In- door unit	Main unit	IC	01 to 50	Assign the smallest address to the main unit in the group.	<ul style="list-style-type: none"> ♦Assign an address smaller than that of the indoor unit that is connected to the ME remote controller. ♦Enter the same indoor unit group settings on the system controller as the ones that were entered on the MA remote controller. ♦To perform a group operation of indoor units that have different functions, designate the indoor unit in the group with the greatest number of functions as the main unit. 	00
			Sub unit			Assign sequential numbers starting with the address of the main unit in the same group +1. (Main unit address +1, main unit address +2, main unit address +3, etc.)		
	MA re- mote con- troller	Main re- mote con- troller	MA	No settings required.	-			Main
		Sub remote controller	MA	Sub remote controller	Settings to be made according to the remote controller function selection			
2	Opera- tion with the ME re- mote con- troller	In- door unit	Main unit	IC	01 to 50	Assign the smallest address to the main unit in the group.	<ul style="list-style-type: none"> ♦Enter the indoor unit group settings on the system controller (MELANS). ♦Assign an address larger than those of the indoor units that are connected to the MA remote controller. ♦To perform a group operation of indoor units that have different functions, designate the indoor unit in the group with the greatest number of functions as the main unit. 	00
			Sub unit			Assign sequential numbers starting with the address of the main unit in the same group +1. (Main unit address +1, main unit address +2, main unit address +3, etc.)		
	ME re- mote con- troller	Main re- mote con- troller	RC	101 to 150	Add 100 to the main unit address in the group.	<ul style="list-style-type: none"> ♦It is not necessary to set the 100s digit. ♦To set the address to 200, set the rotary switches to 00. 		101
		Sub remote controller	RC	151 to 200	Add 150 to the main unit address in the group.			
3	LOSSNAY			LC	01 to 50	Assign an arbitrary but unique address to each of these units after assigning an address to all indoor units.	None of these addresses may overlap any of the indoor unit addresses.	00
4	Outdoor unit			OC OS1 OS2	51 to 100	Assign sequential address to the outdoor units in the same refrigerant circuit. The outdoor units are automatically designated as OC, OS1, and OS2. (Note)	To set the address to 100, set the rotary switches to 50.	00

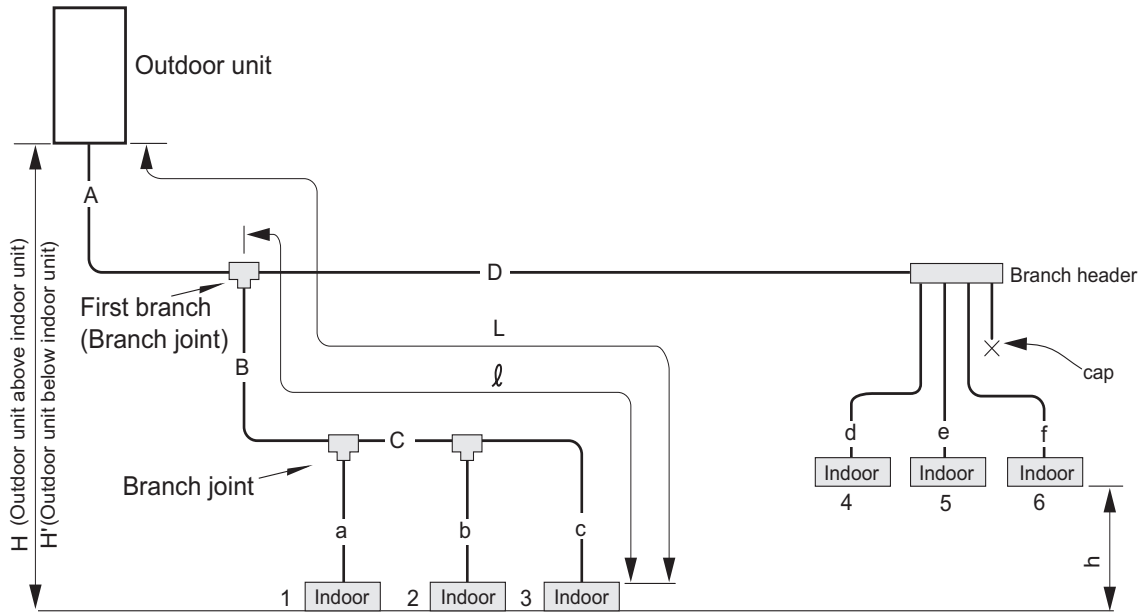
Note

The outdoor units in the same refrigerant circuit are automatically designated as OC, OS1, and OS2. The outdoor units are designated as OC, OS1, and OS2 in the order of capacity from large to small (if two or more units have the same capacity, in the order of address from small to large).

2-10 Restrictions on Refrigerant Pipes

2-10-1 Restrictions on Refrigerant Pipe Length

(1) (E)P200 - (E)P500YNW models



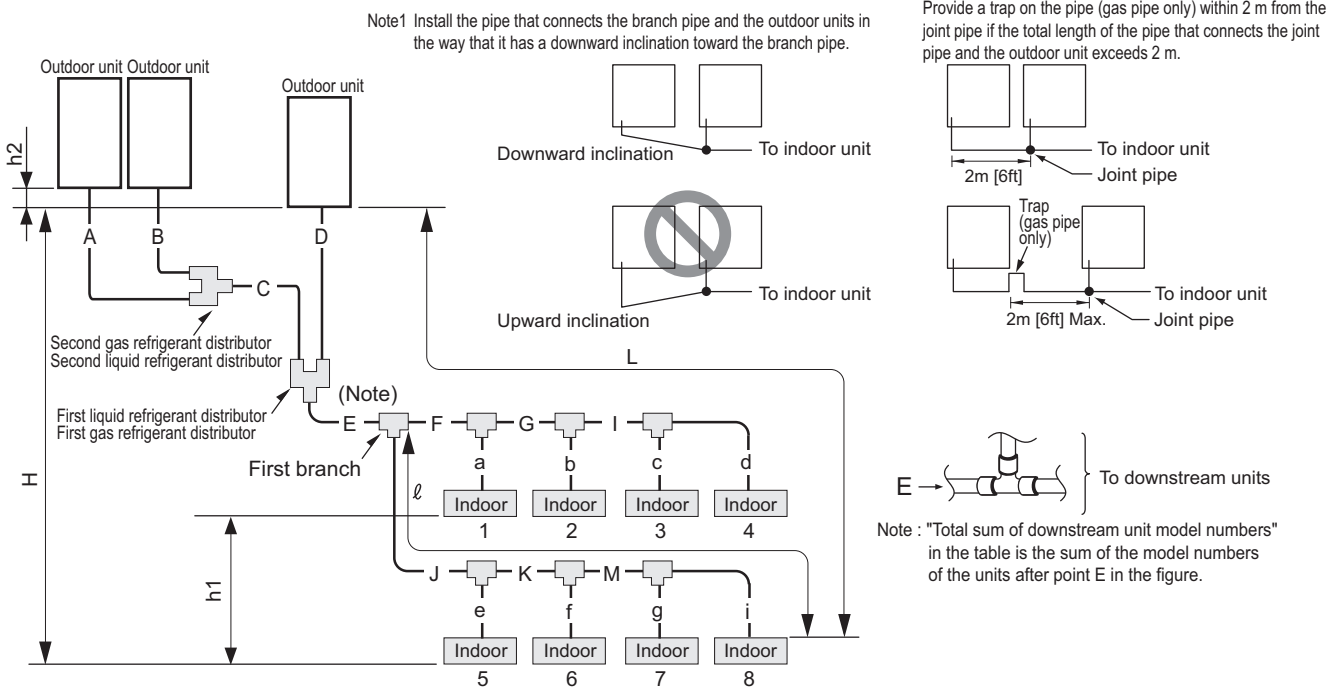
Unit: m [ft]

Operation		Pipe sections	Allowable length of pipes	
Length	Total pipe length	A+B+C+D +a+b+c+d+e+f	1000 [3280] or less	
	Total pipe length (L) from the outdoor unit to the farthest indoor unit	A+B+C+c or A+D+f	165 [541] or less (Equivalent length 190 [623] or less)	
	Total pipe length from the first branch to the farthest indoor unit (l)	B+C+c or D+f	40 [131] or less ^{*1}	
Height difference	Between indoor and outdoor units	Outdoor unit above indoor unit	H	50 [164] or less
		Outdoor unit below indoor unit	H'	40 [131] or less
	Between indoor units	h	15 [49] or less ^{*2}	

*1. If the piping length exceeds 40 meters (but does not exceed 90 meters), use one-size larger pipes for all the liquid pipes beyond 40 meters. In the figure above, the pipes whose size should be increased by one size are indicated by "C," "b," and "c" when the piping length exceeds 40 meters at point C.

*2. If the vertical difference between indoor units exceeds 15 meters (but does not exceed 30 meters), use one-size larger liquid pipes for piping between the first branch and the relevant indoor units. In the figure above, the pipes whose size should be increased by one size are indicated by "B," "C," "a," "b," and "c" when the "h" exceeds 15 meters.

(2) (E)P400 - (E)P1350YSNW models



Unit: m [ft]

Operation		Pipe sections	Allowable length of pipes
Length	Between outdoor units	A+B+C+D	10 [32] or less
	Total pipe length	A+B+C+D+E+F+G+I+J+K+M+a+b+c+d+e+f+g+i	1000 [3280] or less
	Total pipe length (L) from the outdoor unit to the farthest indoor unit	A(B)+C+E+J+K+M+i	165 [541] or less (Equivalent length 190 [623] or less)
	Total pipe length from the first branch to the farthest indoor unit (ℓ)	G+I+J+i	40 [131] or less ^{*1}
Height difference	Between indoor and outdoor units	H	50 [164] or less (40 [131] or below if outdoor unit is below indoor unit)
	Between indoor units	h1	15 [49] or less ^{*2}
	Between outdoor units	h2	0.1[0.3] or less

*1. If the piping length exceeds 40 meters (but does not exceed 90 meters), use one-size larger pipes for all the liquid pipes beyond 40 meters. In the figure above, the pipes whose size should be increased by one size are indicated by "l," "c," and "d" when the piping length exceeds 40 meters at point l.

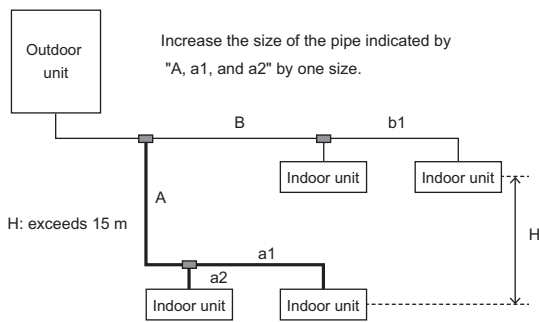
*2. If the vertical difference between indoor units exceeds 15 meters (but does not exceed 30 meters), use one-size larger liquid pipes for piping between the first branch and the relevant indoor units. In the figure above, the pipes whose size should be increased by one size are indicated by "J," "K," "M," "e," "f," "g," and "i" when the "h1" exceeds 15 meters.

See the next page for the detailed description of the sample application above.

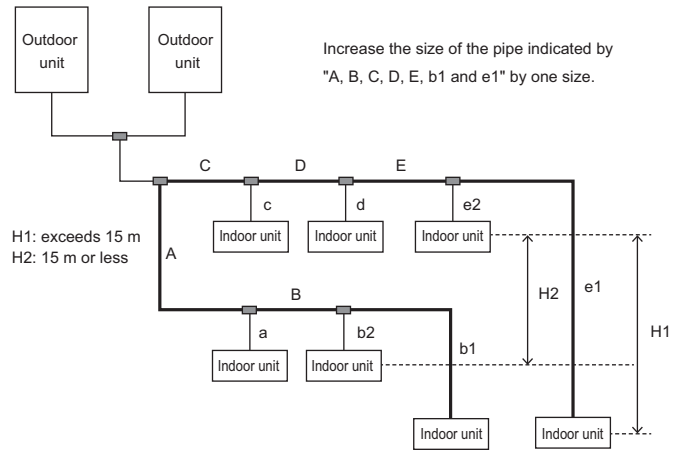
When the vertical separation between indoor units exceeds 15 m

Outdoor unit above indoor unit

example 1

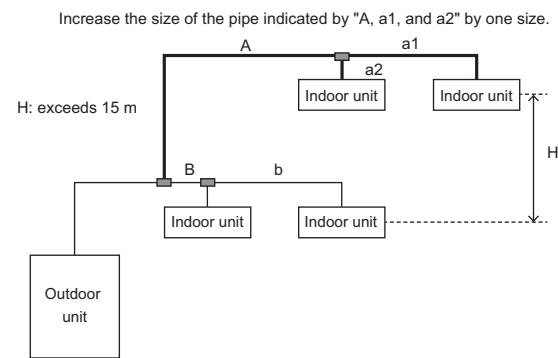


example 2



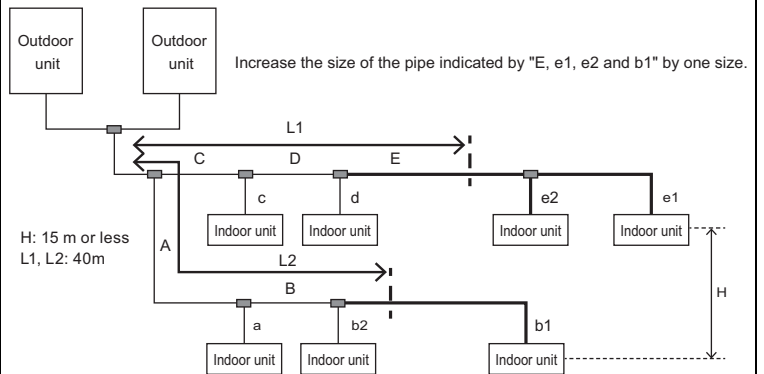
Outdoor unit below indoor unit

example 3



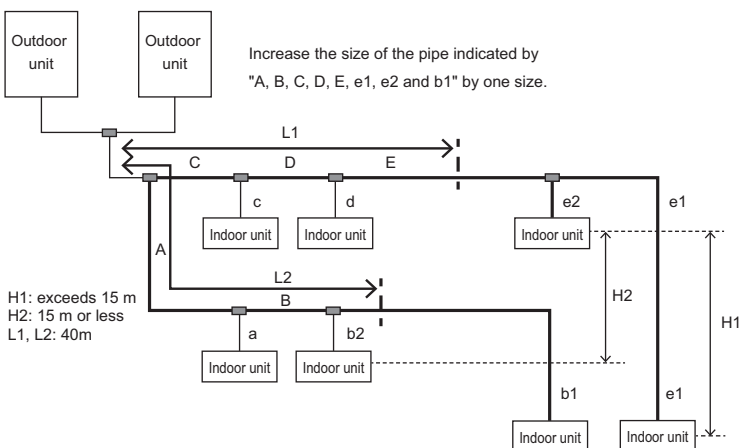
When the distance from the first branch to the farthest indoor unit exceeds 40 m

example 4



When the distance from the first branch to the farthest indoor unit exceeds 40 m and the vertical separation between indoor units exceeds 15 m

example 5



2-10-2 Restrictions on Refrigerant Pipe Size

(1) Diameter of the refrigerant pipe between the outdoor unit and the first branch (outdoor unit pipe size)

Outdoor unit set name (total capacity)	Liquid pipe size (mm) [inch]	Gas pipe size (mm) [inch]
200 model	ø9.52 [3/8"]	ø22.2 [7/8"]
250 model	ø9.52 [3/8"] ^{*1}	ø22.2 [7/8"]
300 model	ø9.52 [3/8"] ^{*2}	ø22.2 [7/8"] ^{*3}
350 model	ø12.7 [1/2"]	ø28.58 [1-1/8"]
400 model	ø12.7 [1/2"]	ø28.58 [1-1/8"]
450 model	ø15.88 [5/8"]	ø28.58 [1-1/8"]
500 model	ø15.88 [5/8"]	ø28.58 [1-1/8"]
550 model	ø15.88 [5/8"]	ø28.58 [1-1/8"]
600 model	ø15.88 [5/8"]	ø28.58 [1-1/8"]
650 model	ø15.88 [5/8"]	ø28.58 [1-1/8"]
700 - 800 model	ø19.05 [3/4"]	ø34.93 [1-3/8"]
850 - 1350 model	ø19.05 [3/4"]	ø41.28 [1-5/8"]

*1. Use ø12.7 [1/2"] pipes if the piping length to the farthest indoor unit exceeds 90 m [295 ft].

*2. Use ø12.7 [1/2"] pipes if the piping length to the farthest indoor unit exceeds 40 m [131 ft].

*3. Use ø28.58 [1-1/8"] pipes for EP300 models.

(2) Size of the refrigerant pipe between the first branch and the indoor unit (indoor unit pipe size)

model	Pipe diameter (mm) [inch]	
10 - 50 models	Liquid pipe	ø6.35 [1/4"]
	Gas pipe	ø12.7 [1/2"]
63 - 140 models	Liquid pipe	ø9.52 [3/8"]
	Gas pipe	ø15.88 [5/8"]
200 model	Liquid pipe	ø9.52 [3/8"]
	Gas pipe	ø19.05 [3/4"]
250 model	Liquid pipe	ø9.52 [3/8"]
	Gas pipe	ø22.2 [7/8"]
400 model	Liquid pipe	ø12.7 [1/2"]
	Gas pipe	ø28.58 [1-1/8"]
500 model	Liquid pipe	ø15.88 [5/8"]
	Gas pipe	ø28.58 [1-1/8"]

(3) Size of the refrigerant pipe between the branches for connection to indoor units

Total capacity of the downstream units	Liquid pipe size (mm) [inch]	Gas pipe size (mm) [inch]
- 140	ø9.52 [3/8"]	ø15.88 [5/8"]
P141 - P200	ø9.52 [3/8"]	ø19.05 [3/4"]
P201 - P300	ø9.52 [3/8"]	ø22.2 [7/8"]
P301 - P400	ø12.7 [1/2"]	ø28.58 [1-1/8"]
P401 - P650	ø15.88 [5/8"]	ø28.58 [1-1/8"]
P651 - P800	ø19.05 [3/4"]	ø34.93 [1-3/8"]
P801 -	ø19.05 [3/4"]	ø41.28 [1-5/8"]

(4) Size of the refrigerant pipe between the first distributor and the second distributor

Liquid pipe size (mm) [inch]	Gas pipe size (mm) [inch]
ø19.05 [3/4"]	ø34.93 [1-3/8"]

(5) Size of the refrigerant pipe between the first distributor or the second distributor and outdoor units

	Liquid pipe size (mm) [inch]	Gas pipe size (mm) [inch]
200 model	ø9.52 [3/8"]	ø22.2 [7/8"]
250 model		
300 model	ø12.7 [1/2"]	ø28.58 [1-1/8"]
350 model		
400 model		
450 model	ø15.88 [5/8"] ^{*1}	

*1. Use ø12.7 [1/2"] pipes for use in a P650 system.

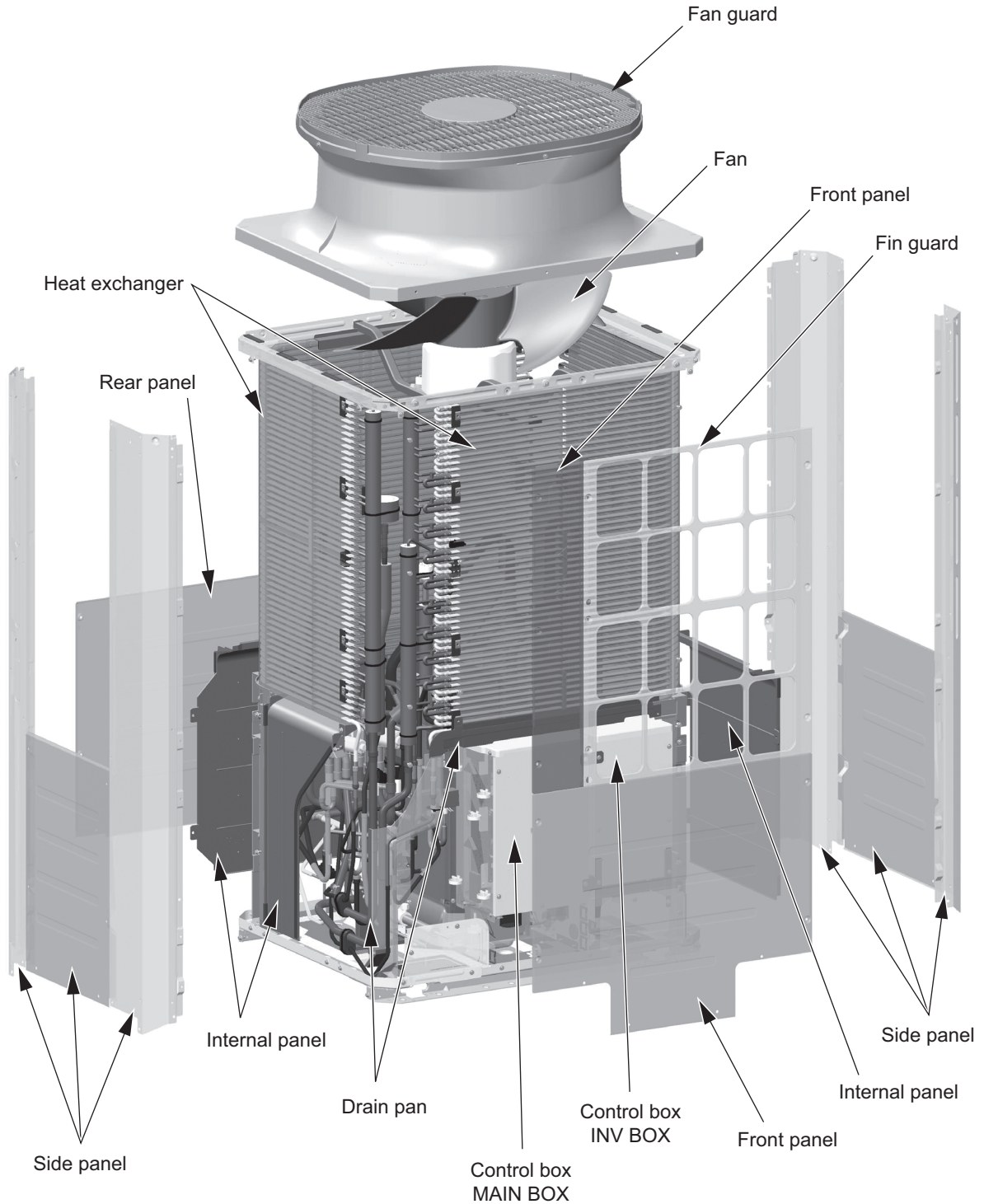
Chapter 3 Major Components, Their Functions and Refrigerant Circuits

3-1	External Appearance and Refrigerant Circuit Components of Outdoor Unit.....	1
3-1-1	External Appearance of Outdoor Unit	1
3-1-2	Outdoor Unit Refrigerant Circuits	4
3-2	Outdoor Unit Refrigerant Circuit Diagrams	15
3-3	Functions of the Major Components of Outdoor Unit.....	19
3-4	Functions of the Major Components of Indoor Unit.....	23

3-1 External Appearance and Refrigerant Circuit Components of Outdoor Unit

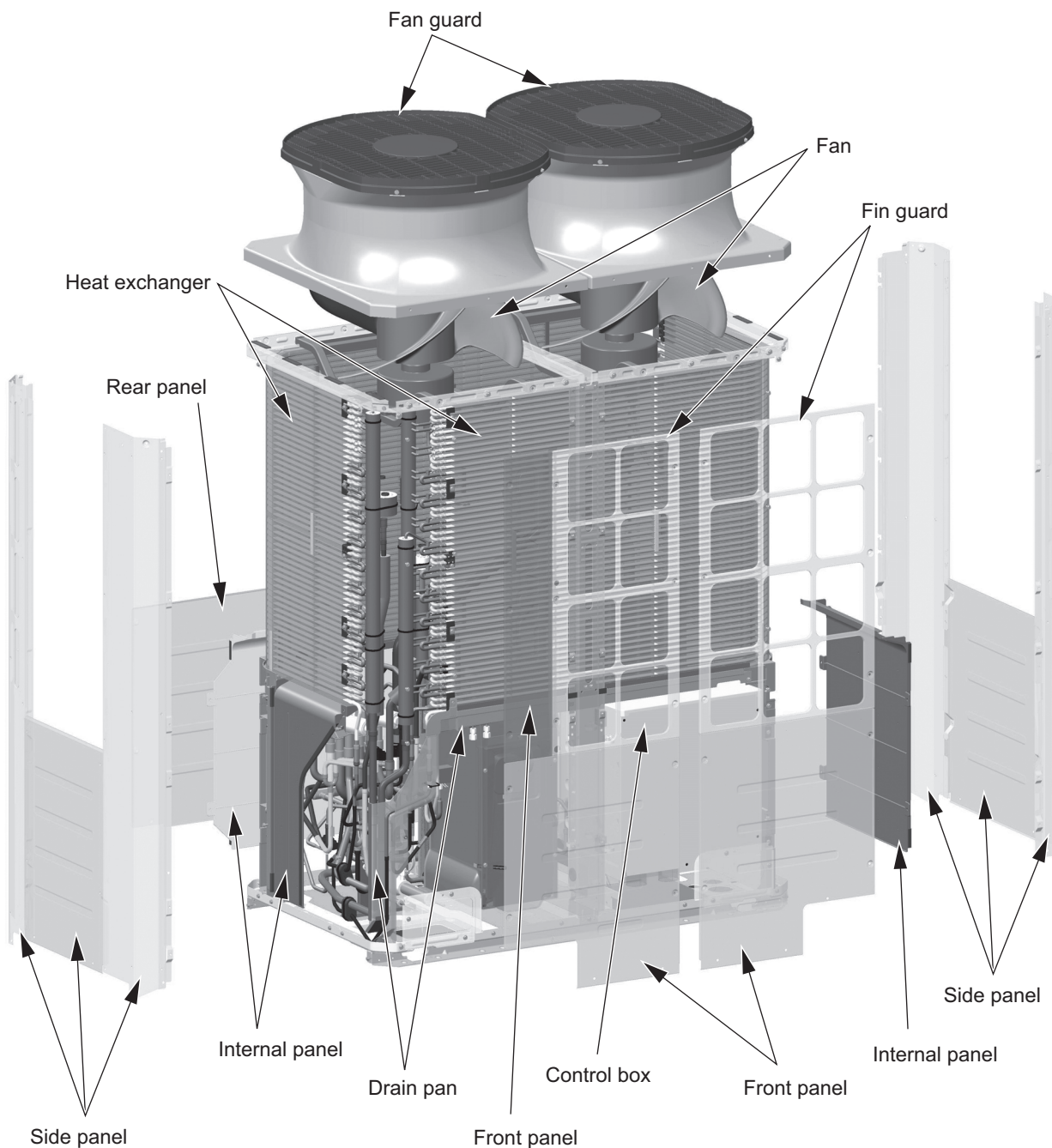
3-1-1 External Appearance of Outdoor Unit

- (1) PUHY-P200, P250, P300YNW-A(1/2)
PUHY-EP200, EP250, EP300YNW-A(1/2)

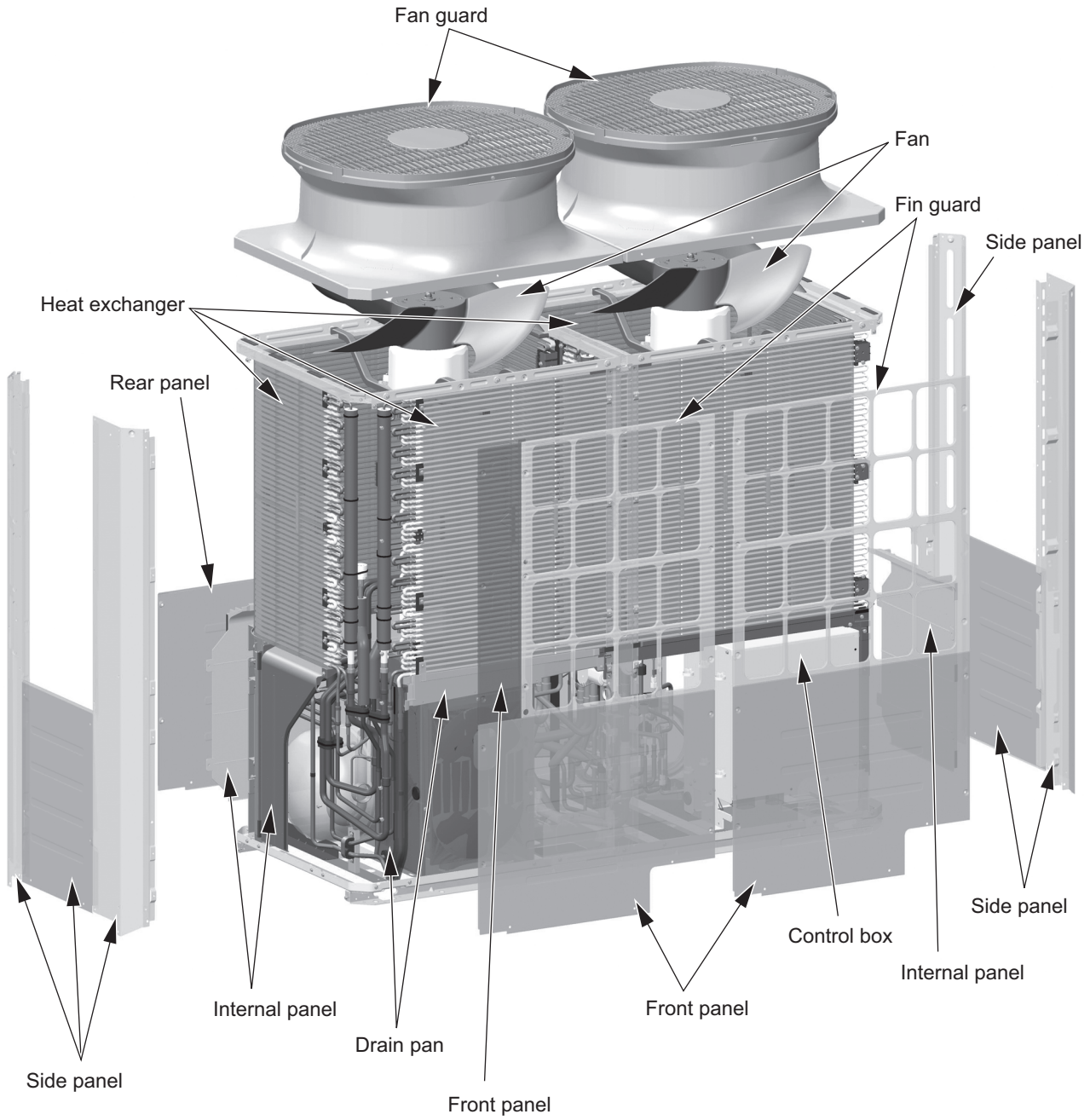


**(2) PUHY-P350, P400, P450YNW-A(1/2)
PUHY-EP350, EP400, EP450YNW-A(1/2)**

3 Major Components, Their Functions and Refrigerant Circuits

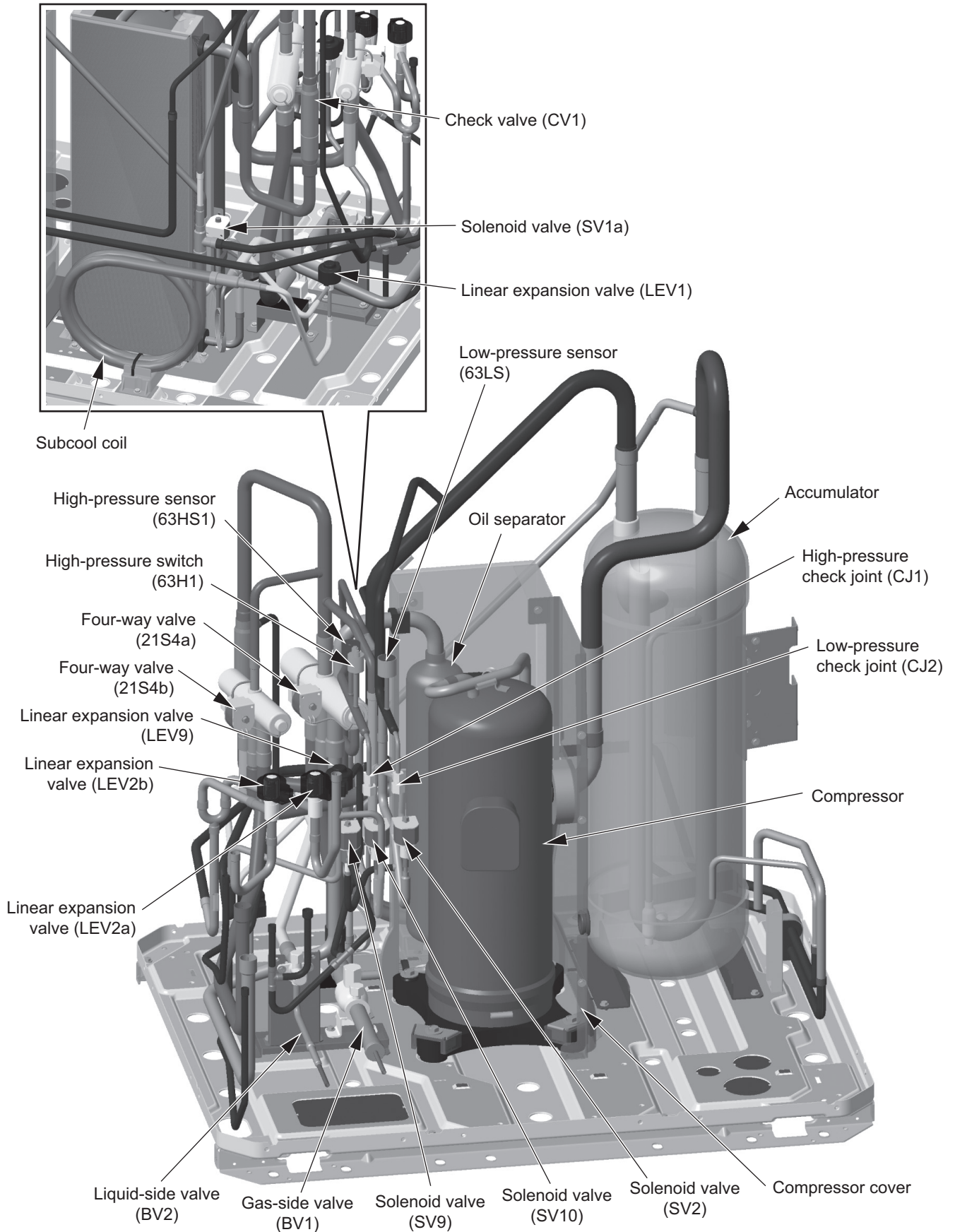


**(3) PUHY-P500YNW-A(1/2)
PUHY-EP500YNW-A(1/2)**

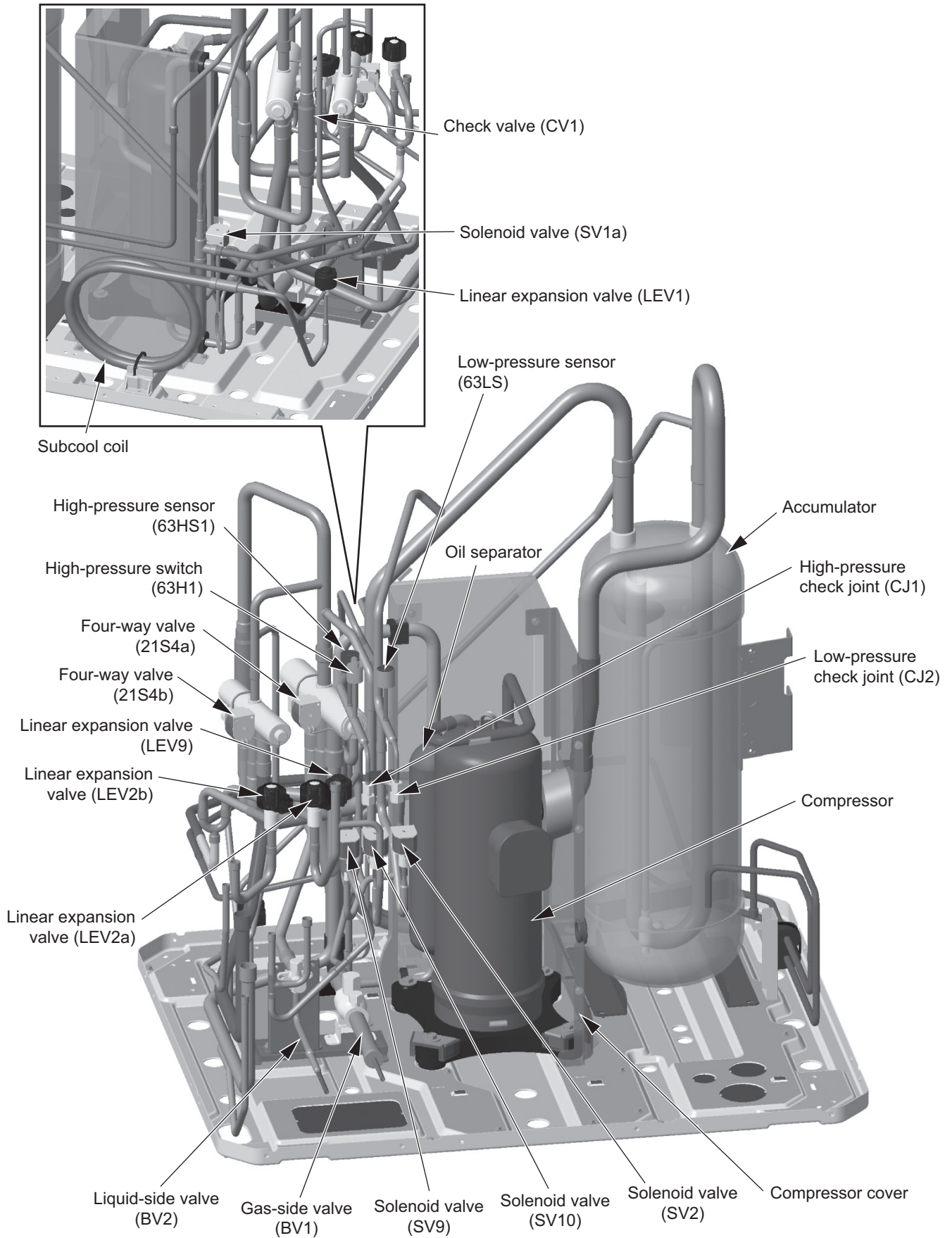


3-1-2 Outdoor Unit Refrigerant Circuits

(1) PUHY-P200, P250, P300YNW-A

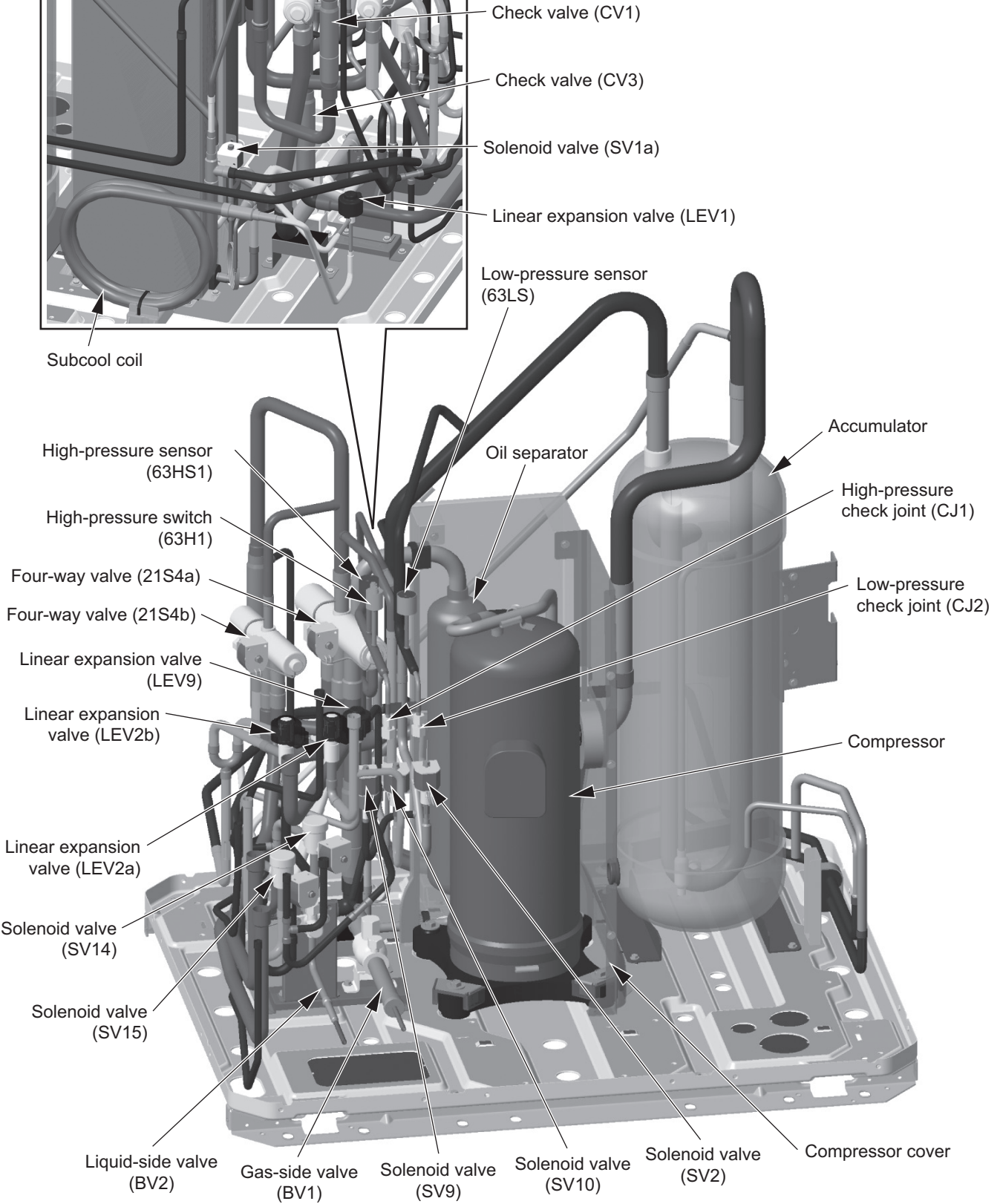
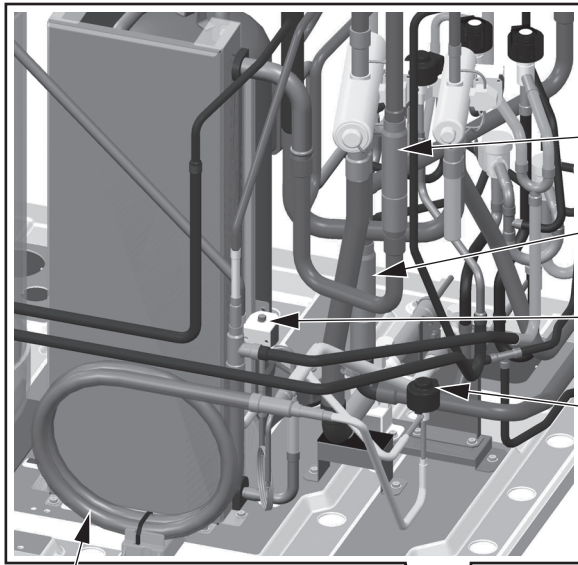


(2) PUHY-P200, P250, P300YNW-A1/2

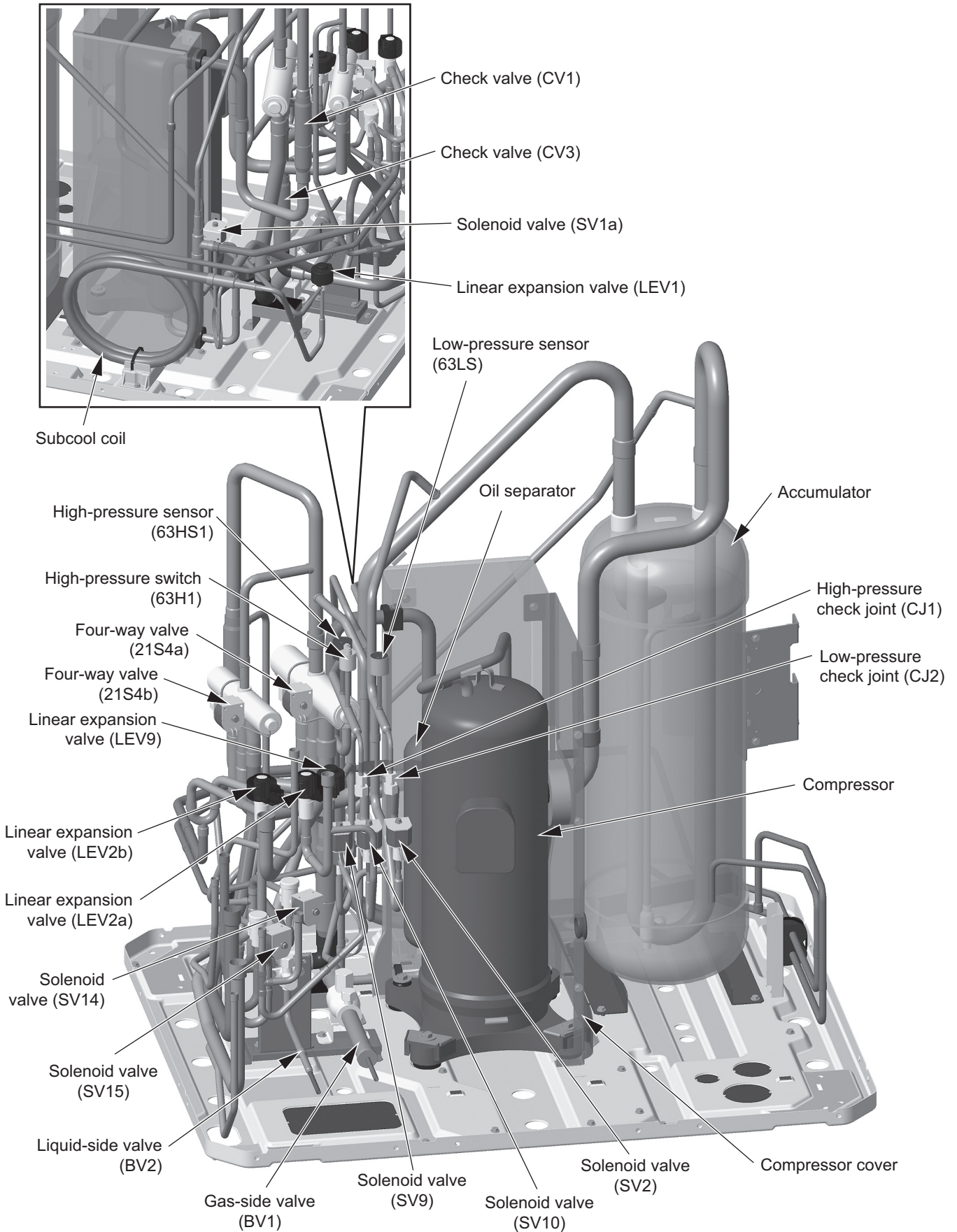


(3) PUHY-EP200, EP250, EP300YNW-A

3 Major Components, Their Functions and Refrigerant Circuits

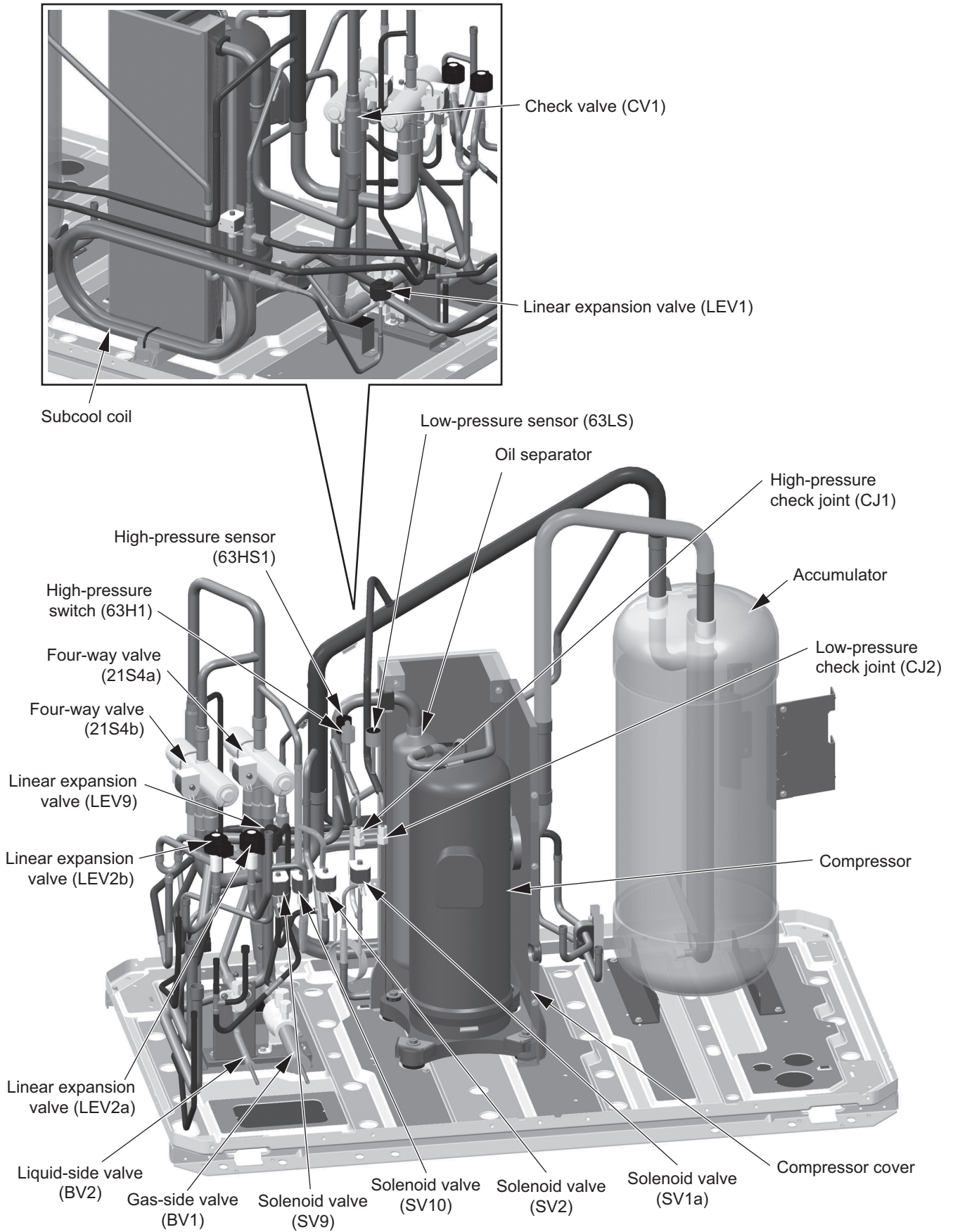


(4) PUHY-EP200, EP250, EP300YNW-A1/2

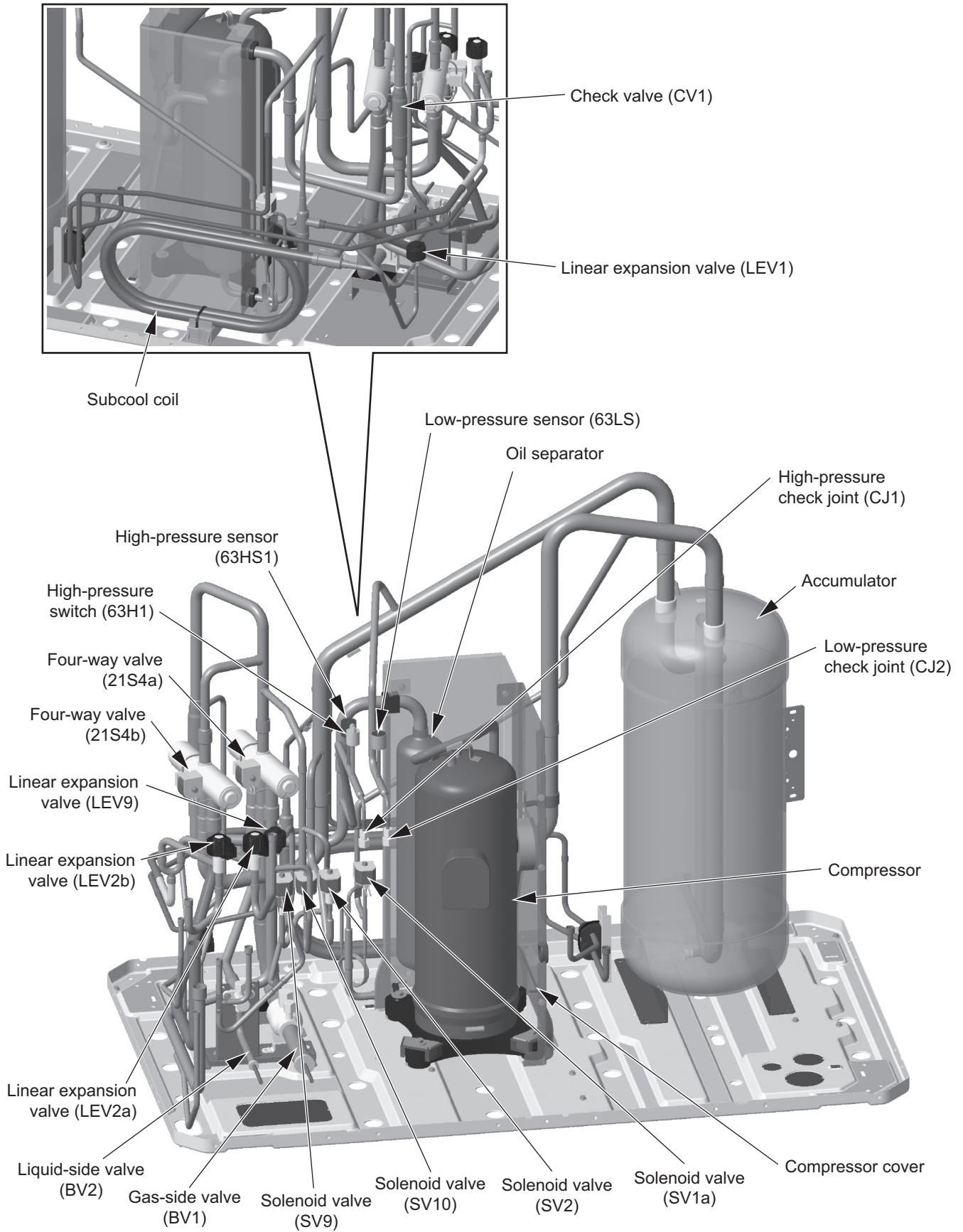


(5) PUHY-P350, P400, P450YNW-A

3 Major Components, Their Functions and Refrigerant Circuits

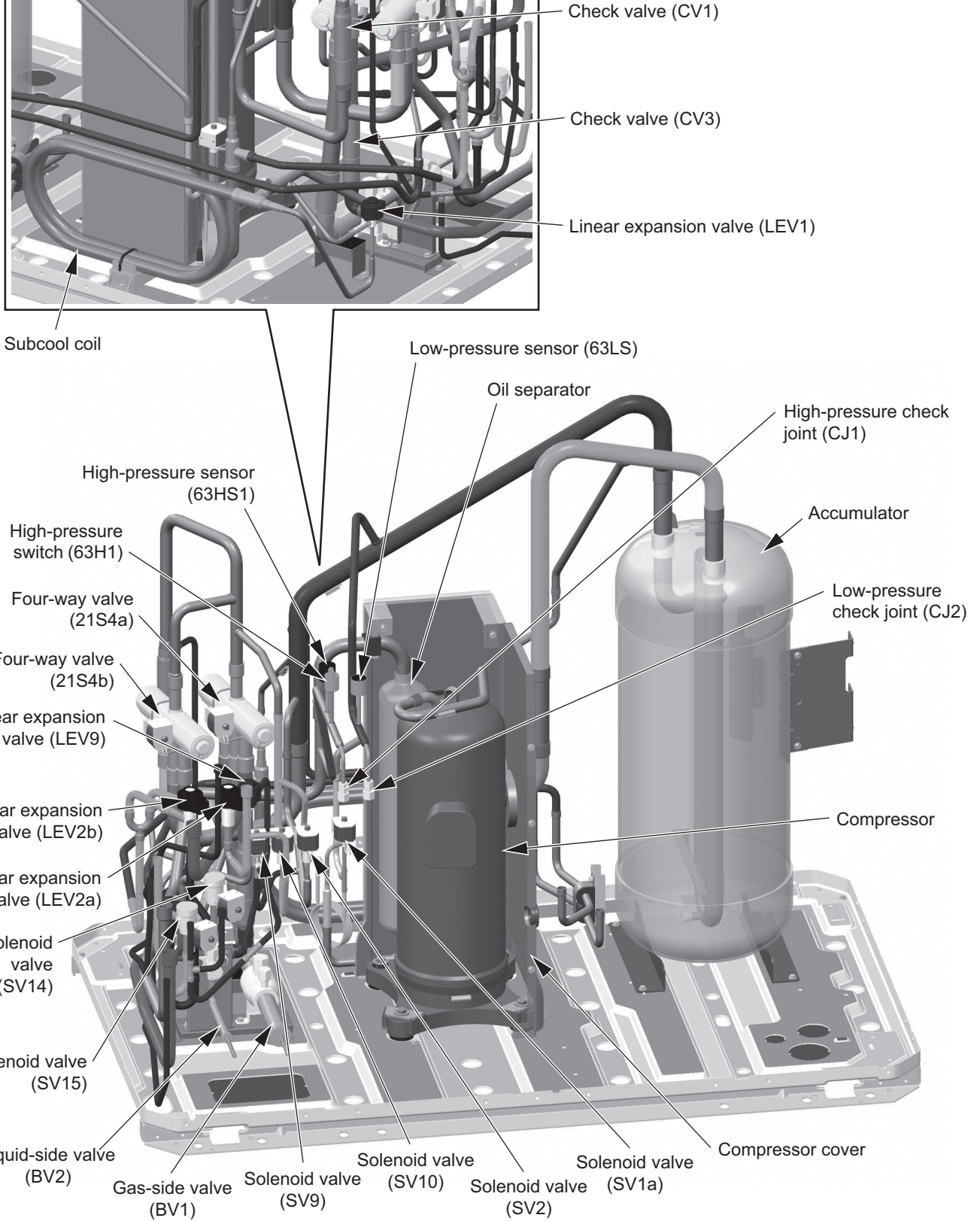
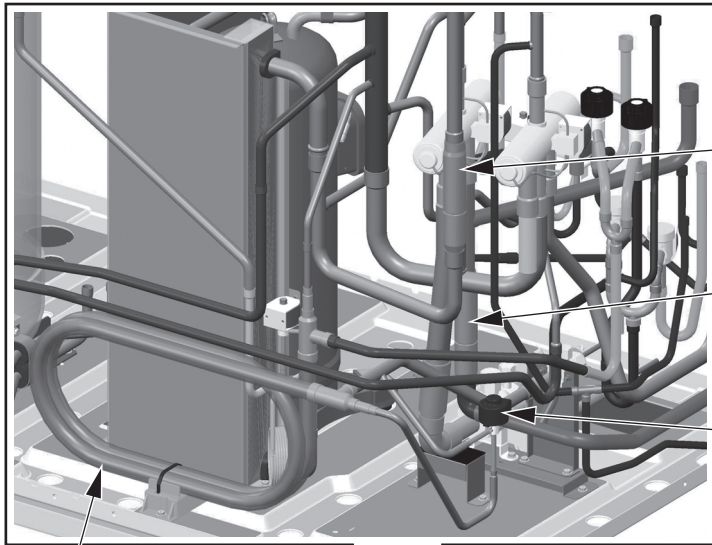


(6) PUHY-P350, P400, P450YNW-A1/2

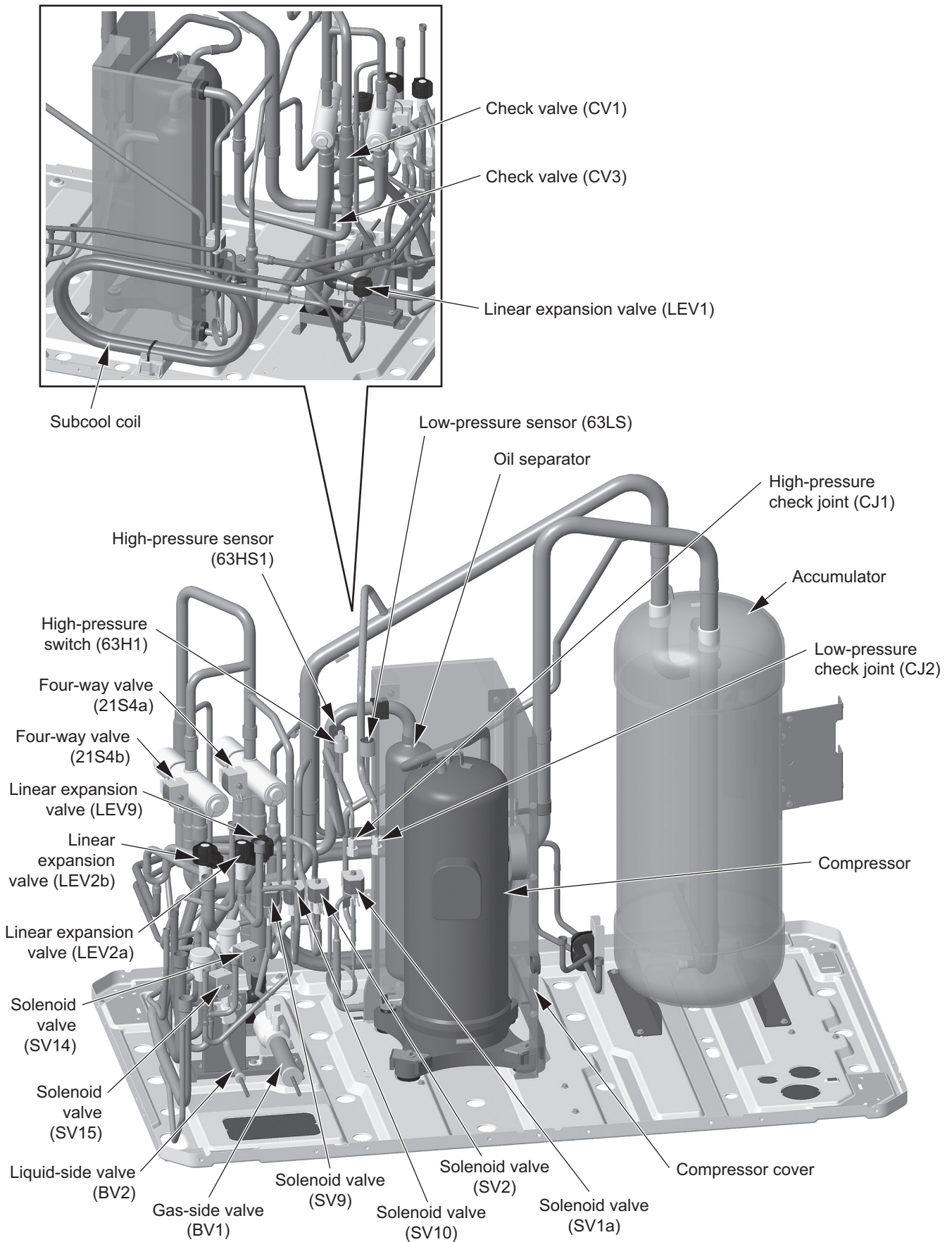


(7) PUHY-EP350, EP400, EP450YNW-A

3 Major Components, Their Functions and Refrigerant Circuits



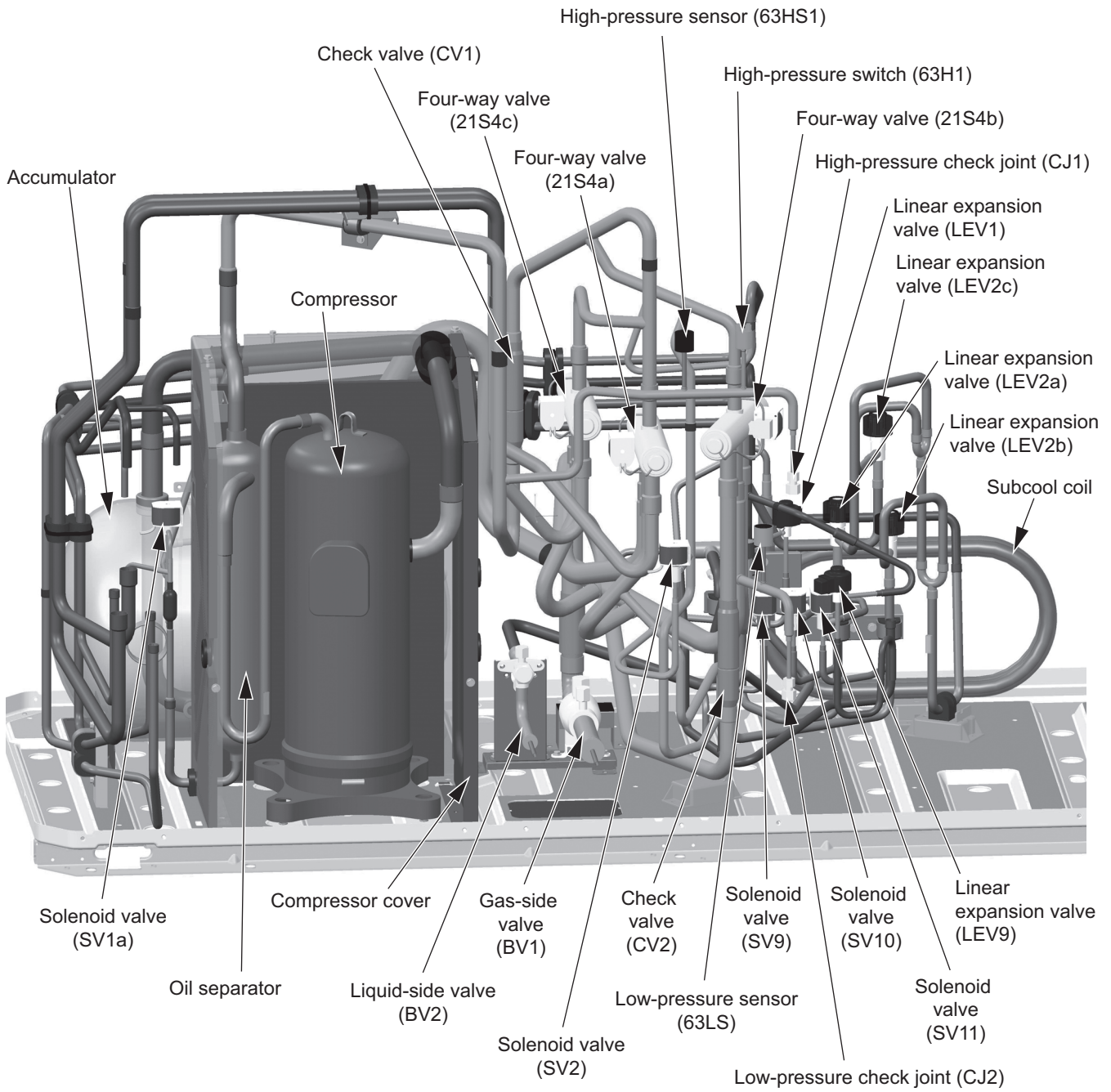
(8) PUHY-EP350, EP400, EP450YNW-A1/2



(9) PUHY-(E)P500YNW-A

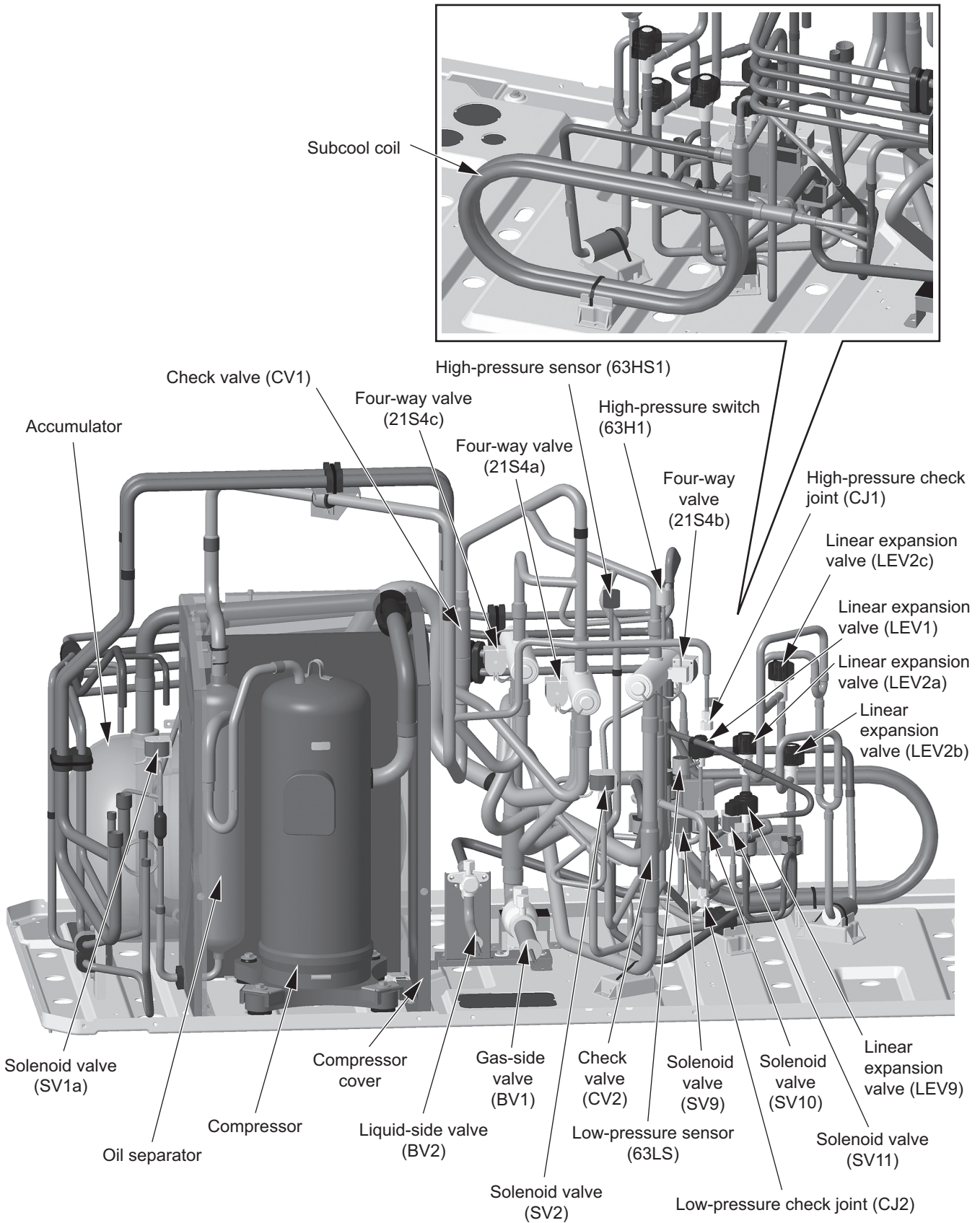
* Products manufactured in July 2020 and earlier

3 Major Components, Their Functions and Refrigerant Circuits



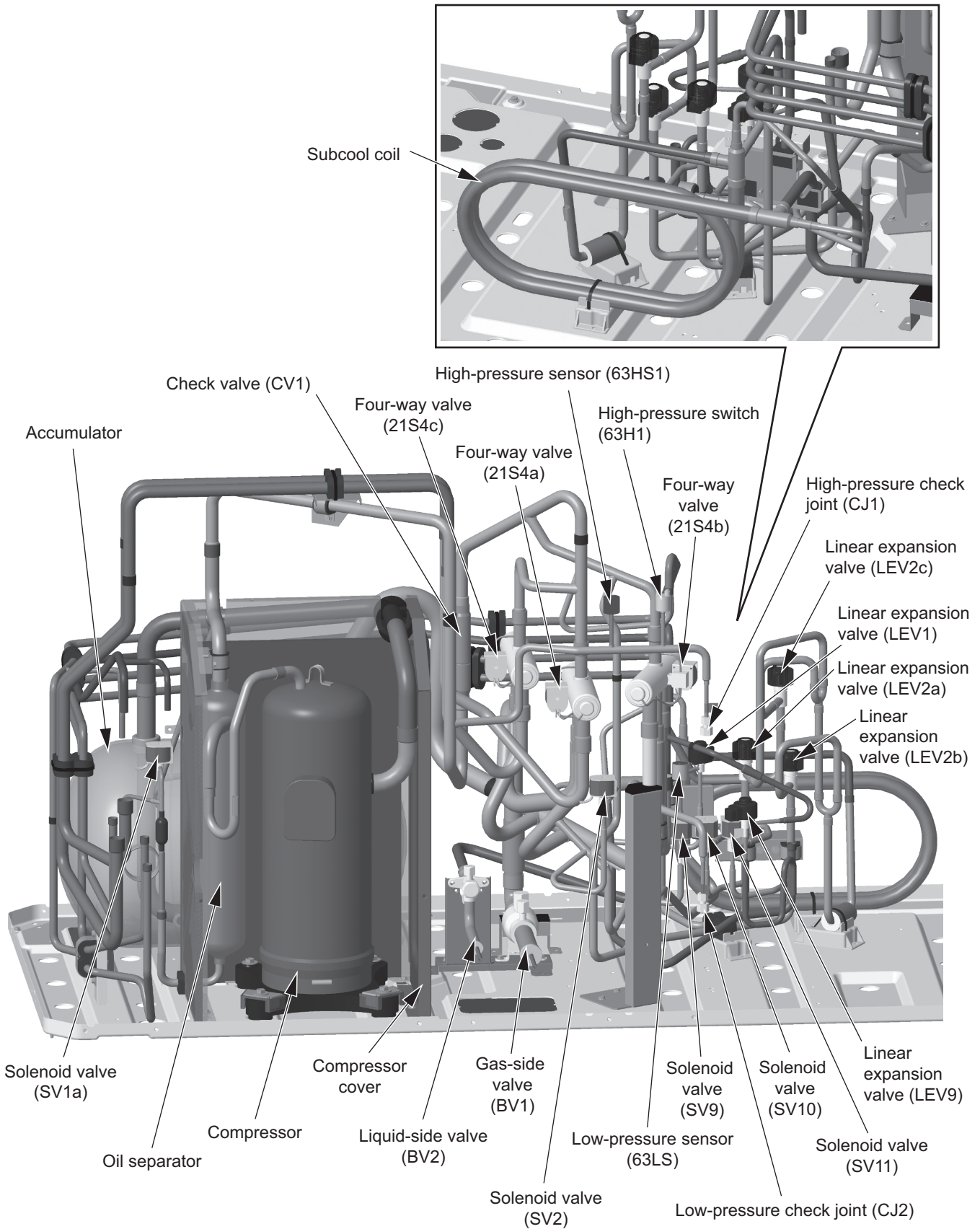
(10) PUHY-(E)P500YNW-A1/2

* Products manufactured in July 2020 and earlier



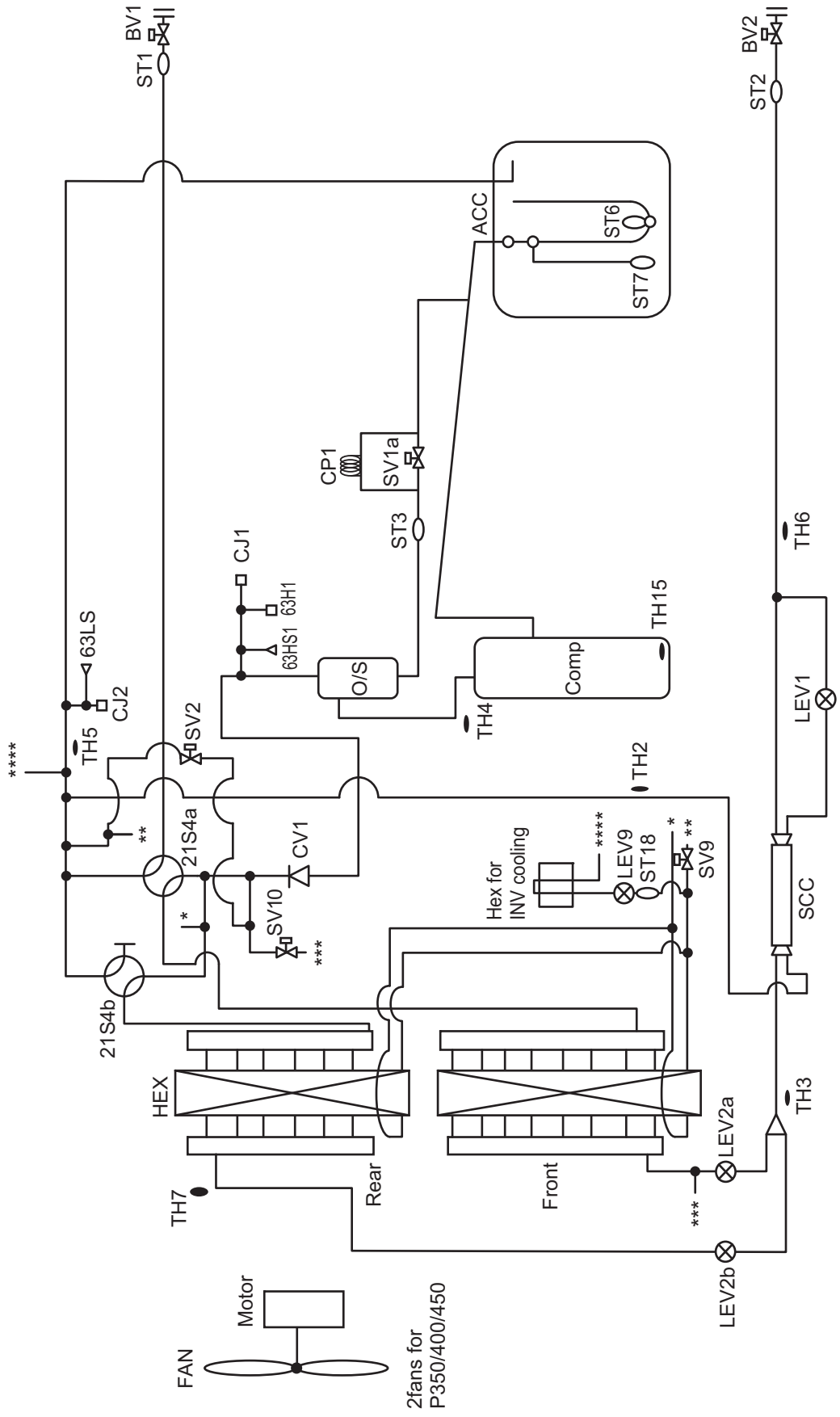
(11) PUHY-(E)P500YNW-A(1/2)

* Products manufactured in August 2020 and later



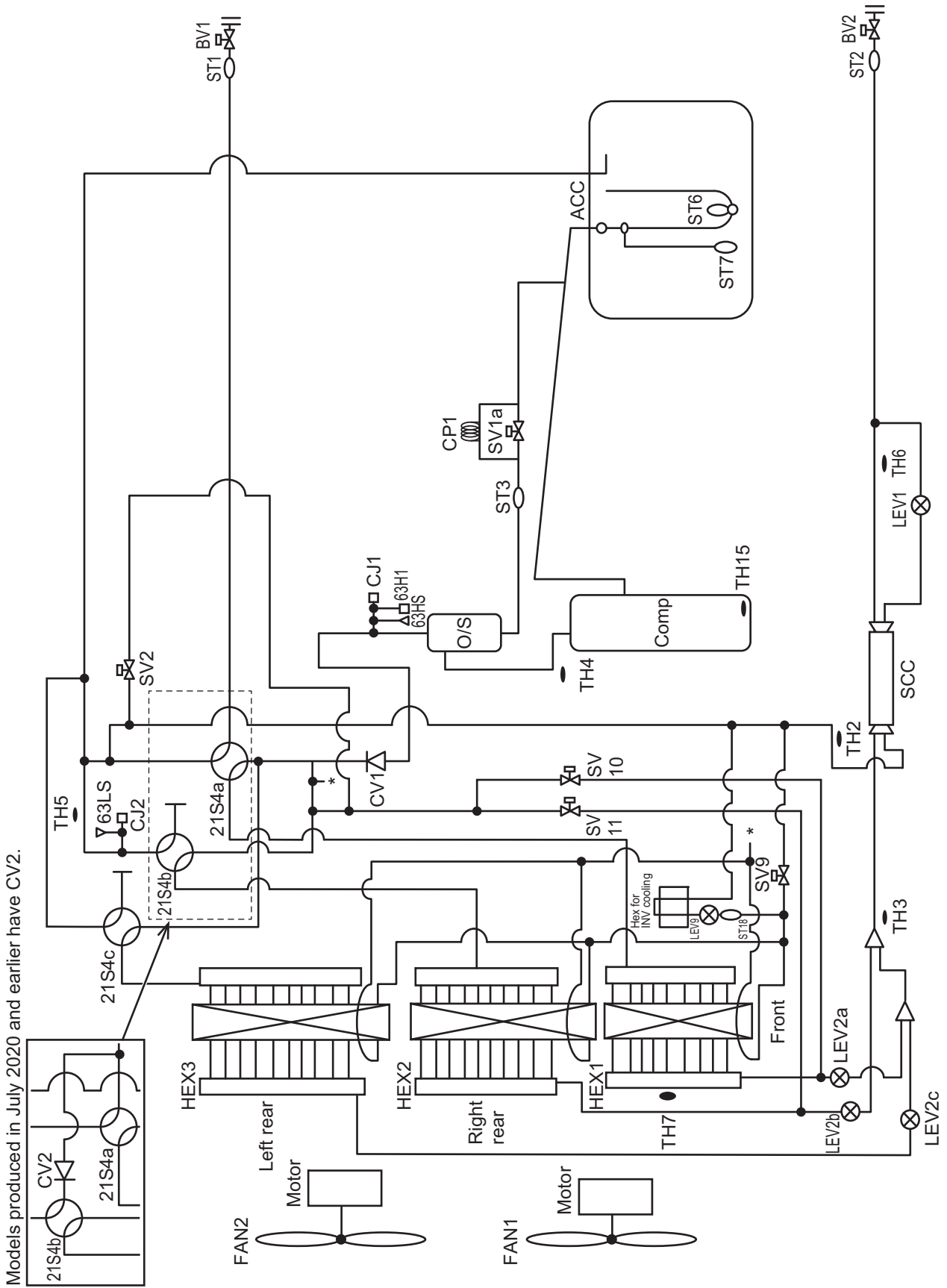
3-2 Outdoor Unit Refrigerant Circuit Diagrams

(1) PUHY-P200-P450YNW-A(1/2)

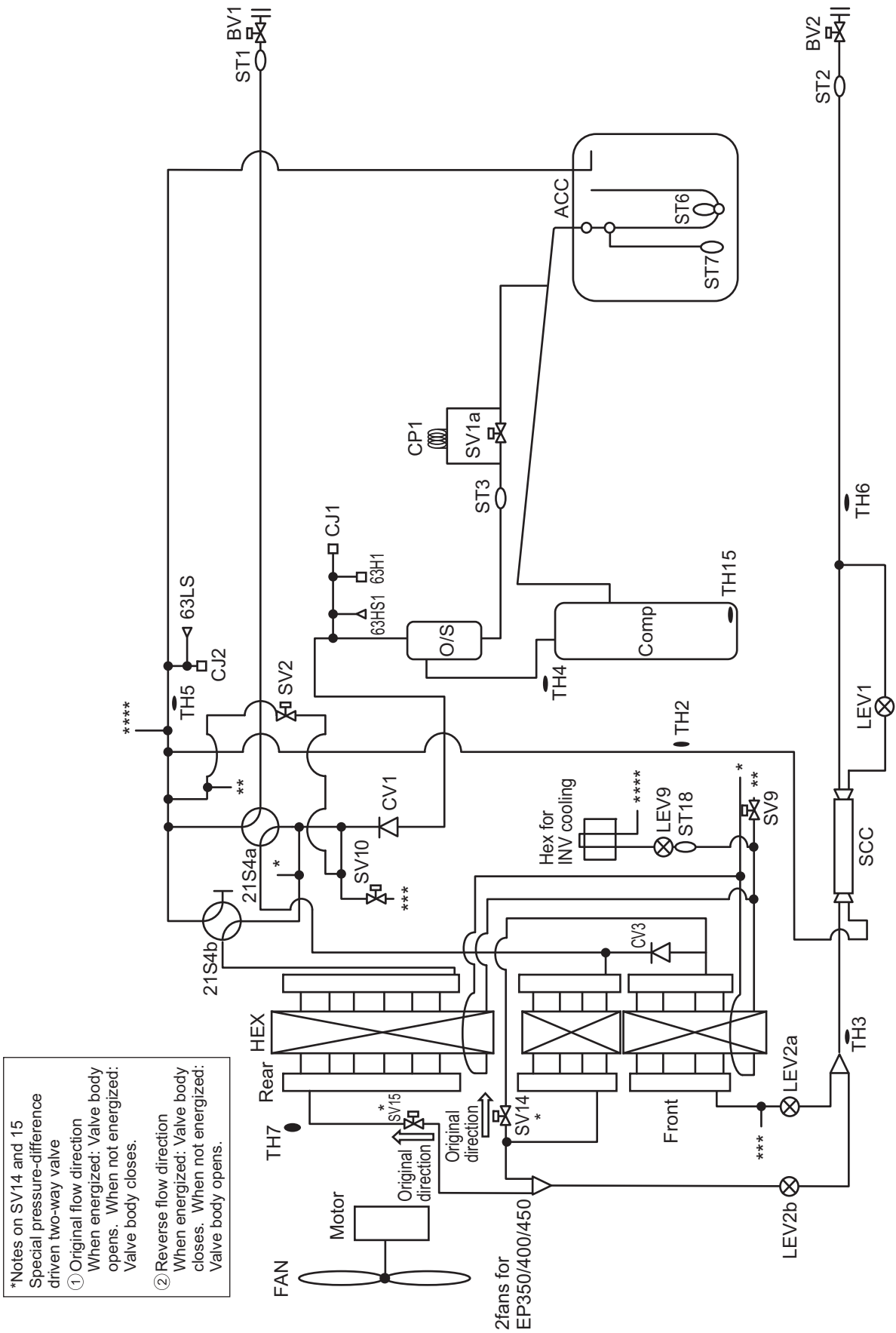


(2) PUHY-P500YNW-A(1/2)

3 Major Components, Their Functions and Refrigerant Circuits



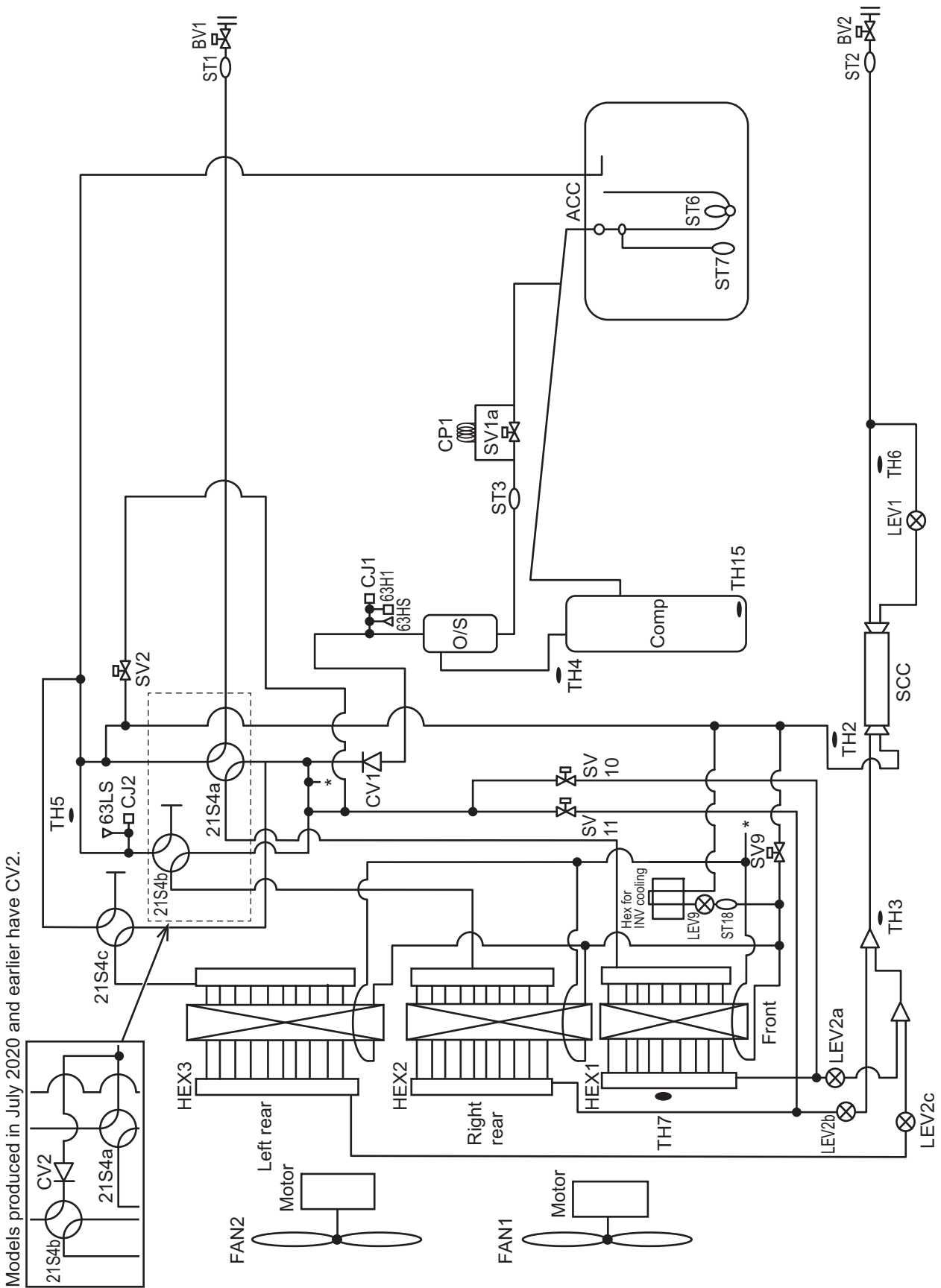
(3) PUHY-EP200-EP450YNW-A(1/2)



*Notes on SV14 and 15
 Special pressure-difference driven two-way valve
 ① Original flow direction
 When energized: Valve body opens. When not energized: Valve body closes.
 ② Reverse flow direction
 When energized: Valve body closes. When not energized: Valve body opens.

(4) PUHY-EP500YNW-A(1/2)

3 Major Components, Their Functions and Refrigerant Circuits



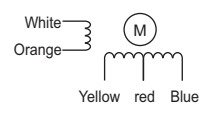
3-3 Functions of the Major Components of Outdoor Unit

Part name	Symbols (functions)	Notes	Usage	Specifications	Check method
Com-pressor	MC1 (Comp1)		Adjusts the amount of circulating refrigerant by adjusting the operating frequency based on the operating pressure data	<p>Type A (E)P200, (E)P250 models Low-pressure shell scroll compressor wirewound resistance 20°C [68°F] : 0.325 Ω</p> <p>Type A1/2 P200, P250 models Low-pressure shell scroll compressor wirewound resistance 20°C [68°F] : 0.72 Ω</p> <p>EP200, EP250 models Low-pressure shell scroll compressor wirewound resistance 20°C [68°F] : 0.325 Ω</p> <p>Types A and A1/2 (common to both) (E)P300, (E)P350 models Low-pressure shell scroll compressor wirewound resistance 20°C [68°F] : 0.192 Ω</p> <p>(E)P400, (E)P450 model Low-pressure shell scroll compressor wirewound resistance 20°C [68°F] : 0.192 Ω</p> <p>(E)P500 models Low-pressure shell scroll compressor wirewound resistance 20°C [68°F] : 0.219 Ω</p>	
High pressure sensor	63HS1		<ol style="list-style-type: none"> 1) Detects high pressure 2) Regulates frequency and provides high-pressure protection 	<p>Pressure 0~4.15 MPa [601psi] Vout 0.5~3.5V 0.071V/0.098 MPa [14psi] Pressure [MPa] =1.38 x Vout [V]-0.69 Pressure [psi] =(1.38 x Vout [V] - 0.69) x 145</p> <p>1 GND (Black) 2 Vout (White) 3 Vcc (DC5V) (Red)</p>	
Low pressure sensor	63LS		<ol style="list-style-type: none"> 1) Detects low pressure 2) Provides low-pressure protection 3) Defrost control during heating operation 	<p>Pressure 0~1.7 MPa [247psi] Vout 0.5~3.5V 0.173V/0.098 MPa [14psi] Pressure [MPa] =0.566 x Vout [V] - 0.283 Pressure [psi] =(0.566 x Vout [V] - 0.283) x 145</p> <p>1 GND (Black) 2 Vout (White) 3 Vcc (DC5V) (Red)</p>	
Pressure switch	63H1		<ol style="list-style-type: none"> 1) Detects high pressure 2) Provides high-pressure protection 	4.15MPa[601psi] OFF setting	

Part name	Symbols (functions)	Notes	Usage	Specifications	Check method	
Thermistor	TH4 (Discharge temperature)		1) Detects discharge air temperature 2) Provides high-pressure protection 0°C[32°F] :698 kΩ 10°C[50°F] :413 kΩ 20°C[68°F] :250 kΩ 30°C[86°F] :160 kΩ 40°C[104°F] :104 kΩ 50°C[122°F] :70 kΩ 60°C[140°F] :48 kΩ 70°C[158°F] :34 kΩ 80°C[176°F] :24 kΩ 90°C[194°F] :17.5 kΩ 100°C[212°F] :13.0 kΩ 110°C[230°F] :9.8 kΩ	Degrees Celsius $R_{120} = 7.465k\Omega$ $R_{25/120} = 4057$ $R_t = 7.465 \exp\{4057(\frac{1}{273+t} - \frac{1}{393})\}$	Resistance check	
	TH2 (Pipe temperature)		LEV 1 is controlled based on the TH2, TH3, and TH6 values.	Degrees Celsius $R_0 = 15k\Omega$ $R_{0/80} = 3460$ $R_t = 15 \exp\{3460 (\frac{1}{273+t} - \frac{1}{273})\}$	Resistance check	
	TH3 (Pipe temperature)		1) Controls frequency 2) LEV1 is controlled based on the subcool at heat exchange outlet that is obtained based on the HPS data and TH3 value.	0°C[32°F] :15 kΩ 10°C[50°F] :9.7 kΩ 20°C[68°F] :6.4 kΩ 25°C[77°F] :5.3 kΩ 30°C[86°F] :4.3 kΩ 40°C[104°F] :3.1 kΩ		
	TH7 (Outdoor temperature)		1) Detects outdoor air temperature 2) Controls fan operation			
	TH5 (Pipe temperature)		LEV2 are controlled based on the 63LS and TH5 values.			
	TH6 (Pipe temperature)		Controls LEV1 based on TH2, TH3, and TH6 data.			
	TH15 (Compressor shell bottom temperature)		Detects compressor shell bottom temperature			
	THHS Inverter heat sink temperature			Inverter overheating protection	Degrees Celsius $R_{50} = 17k\Omega$ $R_{25/120} = 4016$ $R_t = 17 \exp\{4016 (\frac{1}{273+t} - \frac{1}{323})\}$	
	THL DCL temperature			DCL overheat protection	Degrees Celsius $R_{100} = 3.3k\Omega$ $B_{0/100} = 3970$ $R_t = 3.3 \exp\{3970 (\frac{1}{273+t} - \frac{1}{373})\}$	

[3-3 Functions of the Major Components of Outdoor Unit]

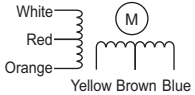
Part name	Symbols (functions)	Notes	Usage	Specifications	Check method
Solenoid valve	SV1a Discharge-suction bypass		1) High/low pressure bypass at start-up and stopping, and capacity control during low-load operation 2) High-pressure-rise prevention	AC220-240V Open while being powered/ closed while not being powered	Continuity check with a tester
	SV2		Makes excessive refrigerant in the accumulator evaporate	Open while being powered/ closed while not being powered	
	SV9		High-pressure-rise prevention	Open while being powered/ closed while not being powered	
	SV10		Continuous heating cycle mode	Open while being powered/ closed while not being powered	
	SV11		Continuous heating cycle mode	Open while being powered/ closed while not being powered	
	SV14, 15	EP200-EP450 models only	Controls outdoor unit heat exchanger capacity	(1) Normal direction flow Open while being powered/ closed while not being powered (2) Reverse direction flow Closed while being powered/ open while not being powered	
Linear expansion valve	LEV1 (SC control)		Adjusts the amount of bypass flow from the liquid pipe on the outdoor unit during cooling	DC12V Opening of a valve driven by a stepping motor 0-480 pulses	Same as indoor LEV The resistance value differs from that of the indoor LEV. Refer to the following page(s). [8-8 Troubleshooting LEV Problems]
	LEV9 (Refrigerant flow adjustment)		Adjusts the flow of refrigerant bypassed from the pipe for cooling the control board when the control board temperature rises		
	LEV2a (Refrigerant flow adjustment)		Adjusts refrigerant flow during heating Cut off the refrigerant flow during continuous heating cycle	DC12V Opening of a valve driven by a stepping motor 2100 pulses (Max. 3000 pulses)	Continuity Test with a Tester. Continuity between white and orange. Continuity between yellow, red, and blue.
	LEV2b (Refrigerant flow adjustment)				
	LEV2c (Refrigerant flow adjustment)	(E)P500 model only			
4-way valve	21S4a		Changeover between heating and cooling	AC220-240V Dead: cooling cycle Live: heating cycle	Continuity check with a tester
	21S4b		1) Changeover between heating and cooling 2) Controls outdoor unit heat exchanger capacity	AC220-240V Dead: cooling cycle Outdoor unit heat exchanger capacity at 100% Live: heating cycle Outdoor unit heat exchanger capacity at 25%, 50% or heating cycle	
	21S4c	(E)P500 models only			



[3-3 Functions of the Major Components of Outdoor Unit]

Part name	Symbols (functions)	Notes	Usage	Specifications	Check method
Fan motor	FAN motor 1,2	FAN motor 2 is only on the (E)P350-(E)P500 models.	Regulates the heat exchanger capacity by adjusting the operating frequency and operating the propeller fan based on the operating pressure.	AC380-400V, 920W *The (E)P200-300/500 models and (E)P350-450 models are equipped with different types of fan motors.	

3-4 Functions of the Major Components of Indoor Unit

Part Name	Symbol (functions)	Notes	Usage	Specification	Check method
Linear expansion valve	LEV		1) Adjusts superheat at the indoor heat exchanger outlet during cooling 2) Adjusts subcool at the indoor unit heat exchanger outlet during heating	DC12V Opening of stepping motor driving valve 0-(1800) pulses	Continuity Test with a Tester. Continuity between white, red, and orange. Continuity between yellow, brown, and blue. 
Thermistor	TH1 (Suction air temperature)		Indoor unit control (Thermo)	$R_0=15k\Omega$ $R_0/R_t=3460$ $R_t = 15 \exp\{3460(\frac{1}{273+t} - \frac{1}{273})\}$ 0°C [32°F]:15 kΩ 10°C [50°F]:9.7 kΩ 20°C [68°F]:6.4 kΩ 25°C [77°F]:5.3 kΩ 30°C [86°F]:4.3 kΩ 40°C [104°F]:3.1 kΩ	Resistance check
	TH2 (Pipe temperature)		1) Indoor unit control (Frost prevention, Hot adjust) 2) LEV control during heating operation (subcool detection).		
	TH3 (Gas pipe temperature)		LEV control during cooling operation (superheat detection)		
	TH4 (Outdoor air temperature)*1		Indoor unit control (Thermo)		
	Temperature sensor (Indoor air temperature)		Indoor unit control (Thermo)		

*1. Indicates gas pipe temperature on the PKFY-P VHM-E and PKFY-P VKM-E models.

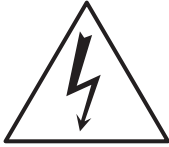
Chapter 4 Electrical Components and Wiring Diagrams

4-1	Outdoor Unit Circuit Board Arrangement.....	1
4-1-1	Outdoor Unit Control Box.....	1
4-2	Outdoor Unit Circuit Board Components	11
4-2-1	Control Board.....	11
4-2-2	Power-supply board (PS Board)	13
4-2-3	Inverter Board (INV Board)	15
4-2-4	Fan Board	19
4-2-5	Noise Filter.....	21
4-2-6	Filter Board	26
4-2-7	Capacitor Board (CAP Board).....	27
4-3	Outdoor Unit Electrical Wiring Diagrams	29
4-4	Transmission Booster Electrical Wiring Diagrams	35

4-1 Outdoor Unit Circuit Board Arrangement

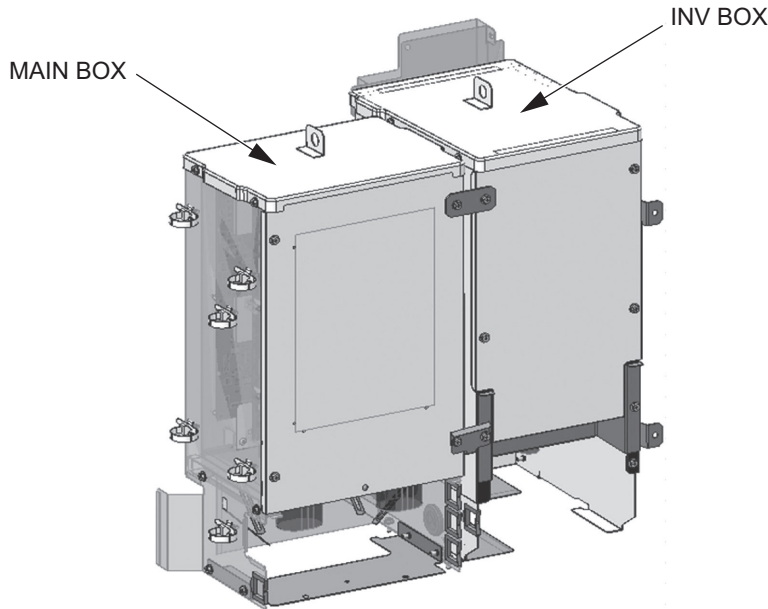
4-1-1 Outdoor Unit Control Box

<HIGH VOLTAGE WARNING>



- Control box houses high-voltage parts.
- When opening or closing the front panel of the control box, do not let it come into contact with any of the internal components.
- Before inspecting the inside of the control box, turn off the power, keep the unit off for at least 10 minutes, and confirm that the voltage of the capacitor in the main circuit has dropped to 20 VDC or less.

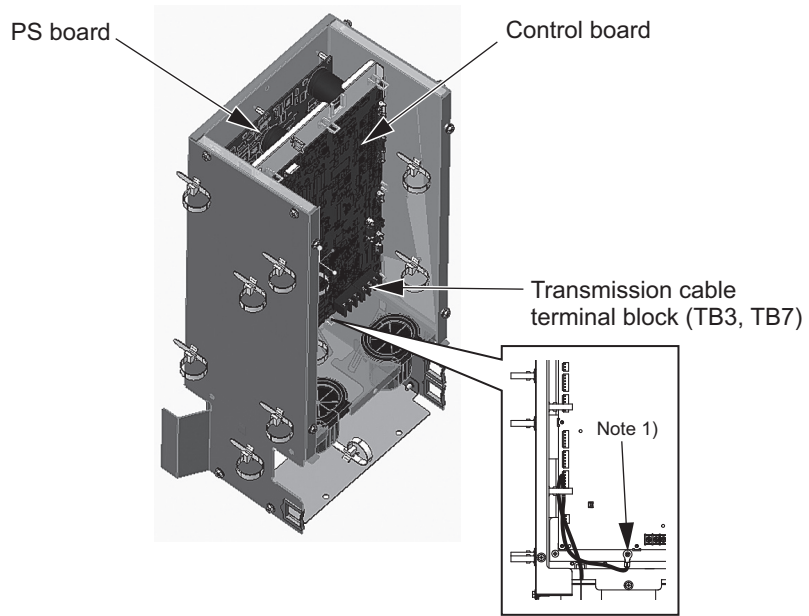
(1) PUHY-(E)P200, (E)P250, (E)P300YNW-A



Note

- 1) Exercise caution not to damage the front panel of the control box. Damage to this part affect the waterproof and dust proof properties of the control box and may result in damage to its internal components.
- 2) Faston terminals have a locking function. Make sure the cable heads are securely locked in place. Press the tab on the terminals to remove them.
- 3) Control box houses high temperature parts. Be well careful even after turning off the power source.
- 4) **Perform the service after disconnecting the relay connector in the INV box (RYFAN1). Before plugging in or unplugging connectors, check that the outdoor unit fan is not rotating and that the voltage across Pin 1 (+) and Pin 5 (-) of connector RYPN in the INV box is 20 VDC or less. The capacitor may collect a charge and cause an electric shock when the outdoor unit fan rotates in windy conditions.** Refer to the wiring nameplate for details.
- 5) To connect wiring to TB7 in the MAIN BOX, check that the voltage is 20 VDC or below.
- 6) After servicing, reconnect the relay connector (RYFAN1) in the INV box as it was.
- 7) When opening or closing the front panel of the control box, do not touch any of the internal components. Before inspecting inside the control box, turn off the power to the unit, leave it turned off for at least 10 minutes, and check that the voltage across Pin 1 (+) and Pin 5 (-) of connector RYPN in the INV box is 20 VDC or less. It takes about 10 minutes to discharge electricity after the power supply is turned off.
- 8) When the power is on, the compressor is energized even while it is stopped. Before turning on the power, disconnect all power supply wires from the compressor terminal block, and measure the insulation resistance of the compressor. Check the compressor for a ground fault. If the insulation resistance is 1.0 MΩ or below, connect all power supply wires to the compressor and turn on the power to the outdoor unit. It is energized to evaporate the liquid refrigerant that has accumulated in the compressor.

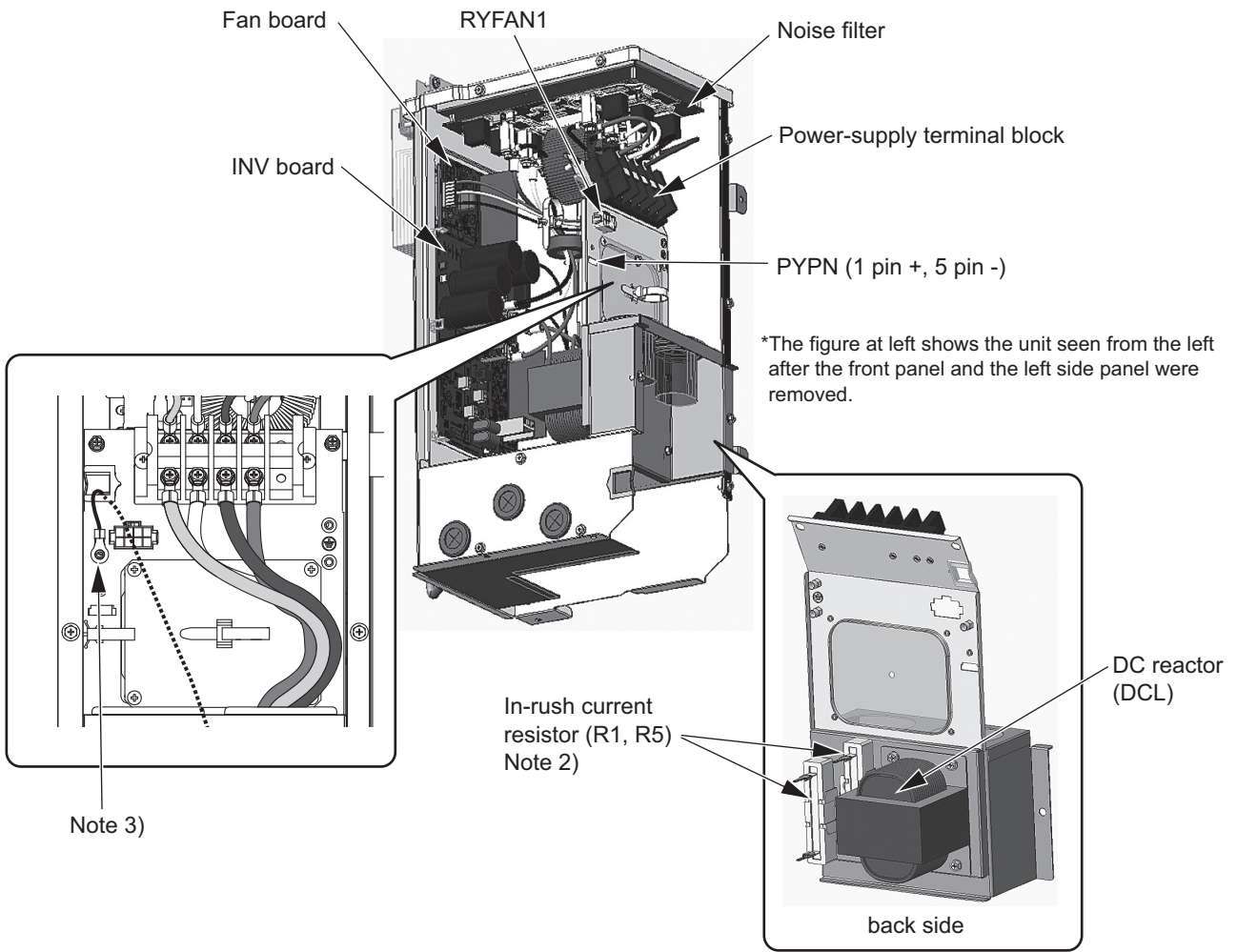
MAIN BOX



Note

- 1) Leave the grounding connected during maintenance.

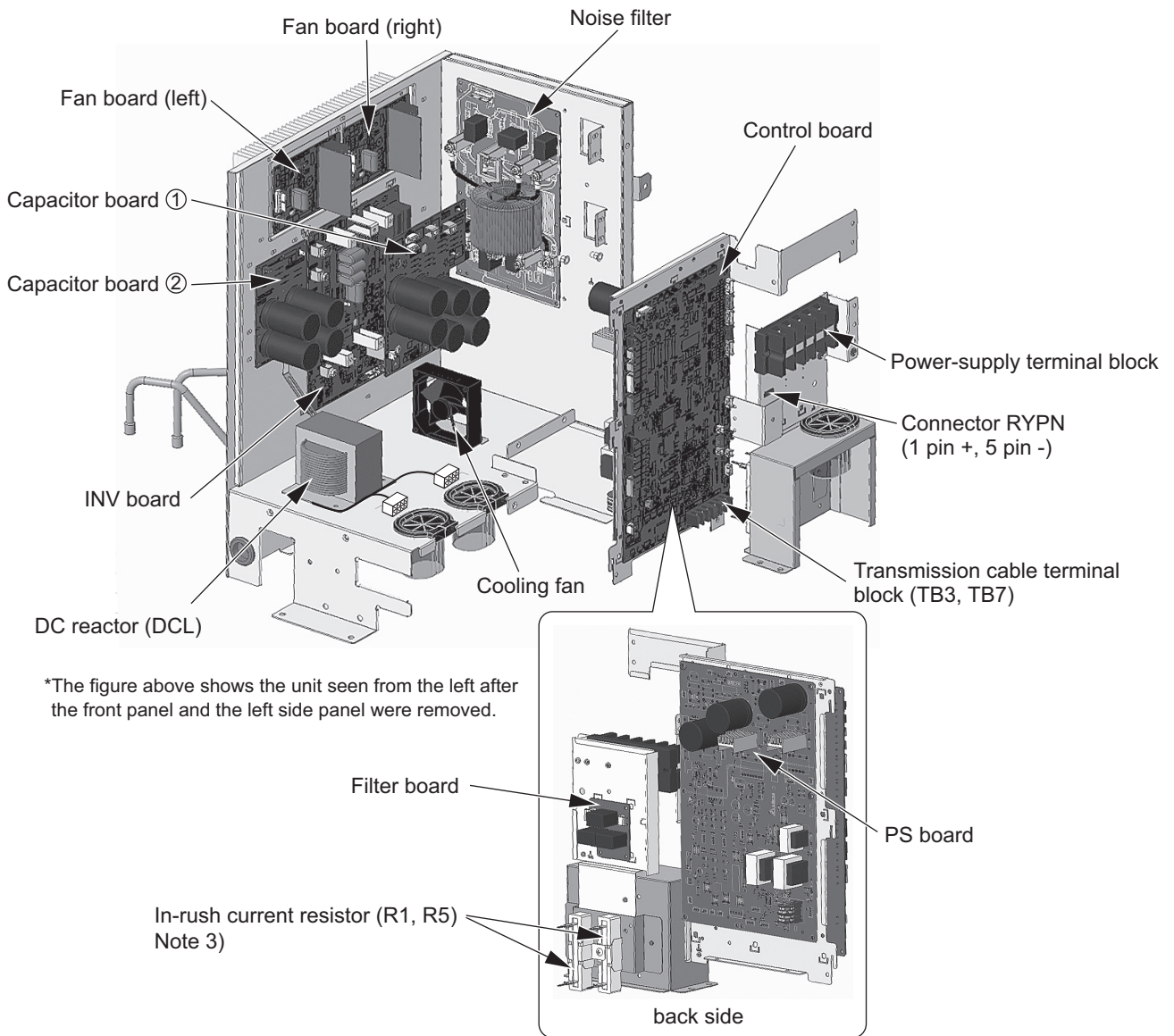
INV BOX



Note

- 1) Refrigerant pipes are connected to the back of the INV box. Do not forcibly pull out the INV box. Doing so may result in deformation of the pipe.
- 2) A Faston terminal on the inrush current resistor has a locking function. Check that the terminal is securely locked in place. Press the tab in the middle of the terminal to remove it.
- 3) Leave the grounding connected during maintenance.

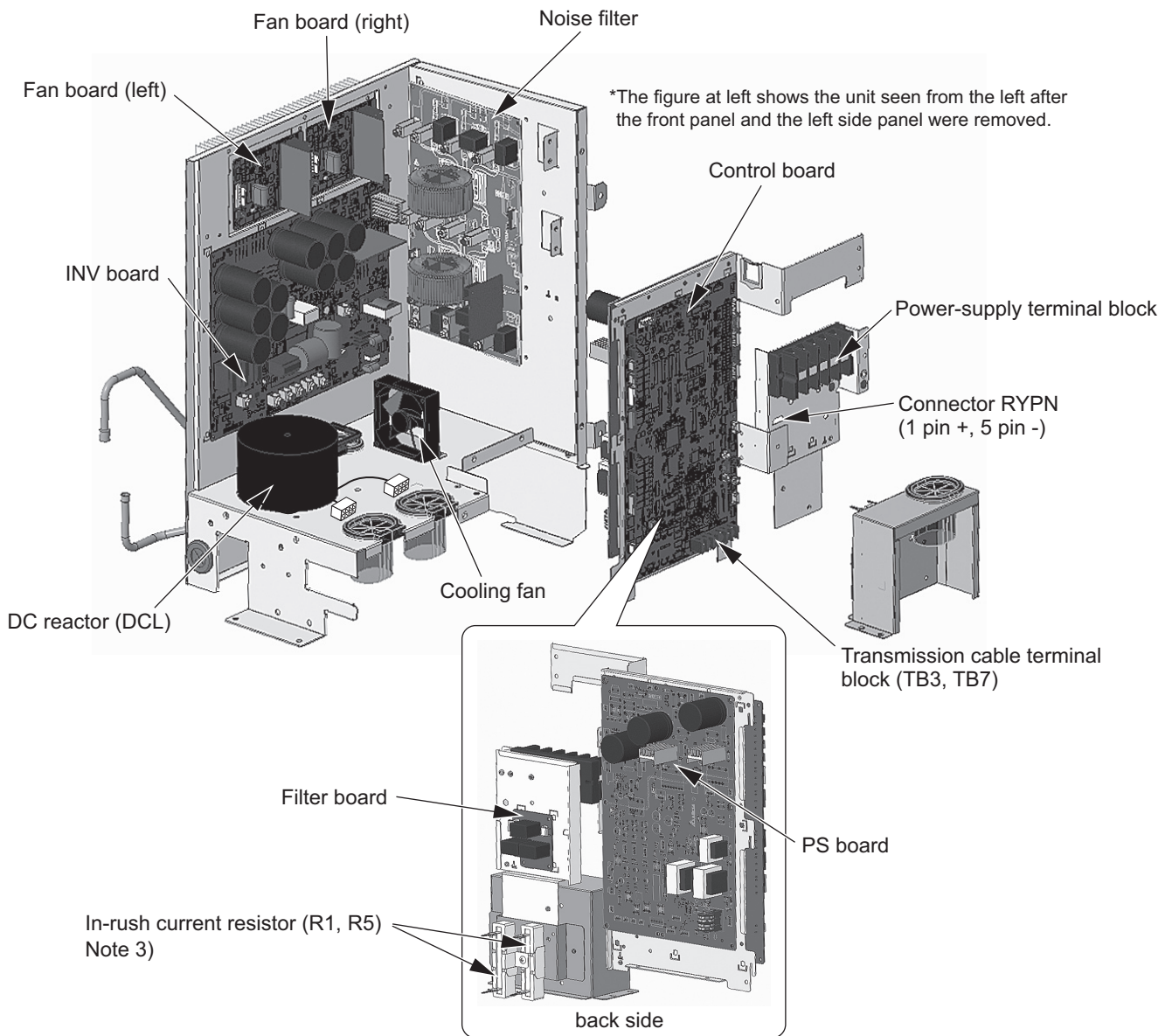
(2) PUHY-(E)P350, (E)P400, (E)P450YNW-A



Note

- 1) Refrigerant pipes are connected to the back of the control box. Do not forcibly pull out the control box. Doing so may result in deformation of the pipe.
- 2) Exercise caution not to damage the front panel of the control box. Damage to this part affect the waterproof and dust proof properties of the control box and may result in damage to its internal components.
- 3) A Faston terminal on the inrush current resistor has a locking function. Check that the terminal is securely locked in place. Press the tab in the middle of the terminal to remove it.
- 4) Control box houses high temperature parts. Be well careful even after turning off the power source.
- 5) **Perform the service after disconnecting the relay connector in the INV box (RYFAN1 and RYFAN2). Before plugging in or unplugging connectors, check that the outdoor unit fan is not rotating and that the voltage across Pin 1 (+) and Pin 5 (-) of connector RYPN in the INV box is 20 VDC or less. The capacitor may collect a charge and cause an electric shock when the outdoor unit fan rotates in windy conditions.** Refer to the wiring nameplate for details.
- 6) To connect wiring to TB7, check that the voltage is 20 VDC or below.
- 7) After servicing, reconnect the relay connector (RYFAN1 and RYFAN2) in the INV box as it was.
- 8) When opening or closing the front panel of the control box, do not touch any of the internal components. Before inspecting inside the control box, turn off the power to the unit, leave it turned off for at least 10 minutes, and check that the voltage across Pin 1 (+) and Pin 5 (-) of connector RYPN in the INV box is 20 VDC or less. It takes about 10 minutes to discharge electricity after the power supply is turned off.
- 9) When the power is on, the compressor is energized even while it is stopped. Before turning on the power, disconnect all power supply wires from the compressor terminal block, and measure the insulation resistance of the compressor. Check the compressor for a ground fault. If the insulation resistance is 1.0 MΩ or below, connect all power supply wires to the compressor and turn on the power to the outdoor unit. It is energized to evaporate the liquid refrigerant that has accumulated in the compressor.

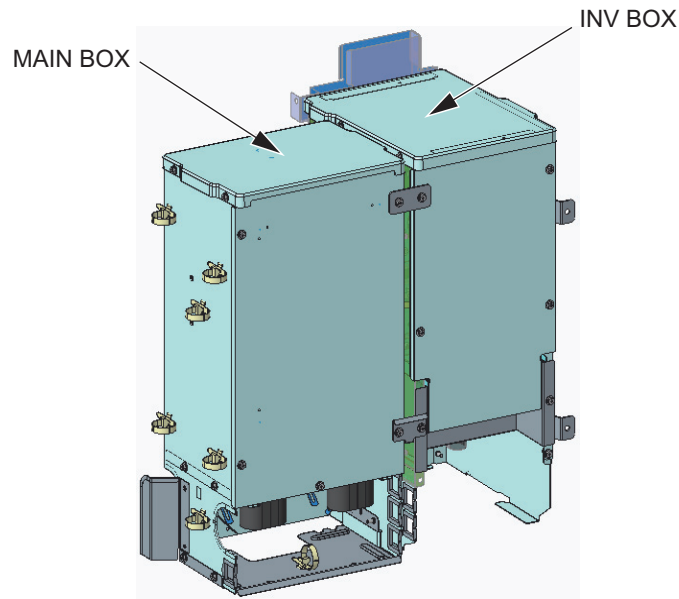
(3) PUHY-(E)P500YNW-A



Note

- 1) Refrigerant pipes are connected to the back of the control box. Do not forcibly pull out the control box. Doing so may result in deformation of the pipe.
- 2) Exercise caution not to damage the front panel of the control box. Damage to this part affect the waterproof and dust proof properties of the control box and may result in damage to its internal components.
- 3) A Faston terminal on the inrush current resistor has a locking function. Check that the terminal is securely locked in place. Press the tab in the middle of the terminal to remove it.
- 4) Control box houses high temperature parts. Be well careful even after turning off the power source.
- 5) **Perform the service after disconnecting the relay connector in the INV box (RYFAN1 and RYFAN2). Before plugging in or unplugging connectors, check that the outdoor unit fan is not rotating and that the voltage across Pin 1 (+) and Pin 5 (-) of connector RYPN in the INV box is 20 VDC or less. The capacitor may collect a charge and cause an electric shock when the outdoor unit fan rotates in windy conditions.** Refer to the wiring nameplate for details.
- 6) To connect wiring to TB7, check that the voltage is 20 VDC or below.
- 7) After servicing, reconnect the relay connector (RYFAN1 and RYFAN2) in the INV box as it was.
- 8) When opening or closing the front panel of the control box, do not touch any of the internal components. Before inspecting inside the control box, turn off the power to the unit, leave it turned off for at least 10 minutes, and check that the voltage across Pin 1 (+) and Pin 5 (-) of connector RYPN in the INV box is 20 VDC or less. It takes about 10 minutes to discharge electricity after the power supply is turned off.
- 9) When the power is on, the compressor is energized even while it is stopped. Before turning on the power, disconnect all power supply wires from the compressor terminal block, and measure the insulation resistance of the compressor. Check the compressor for a ground fault. If the insulation resistance is 1.0 MΩ or below, connect all power supply wires to the compressor and turn on the power to the outdoor unit. It is energized to evaporate the liquid refrigerant that has accumulated in the compressor.

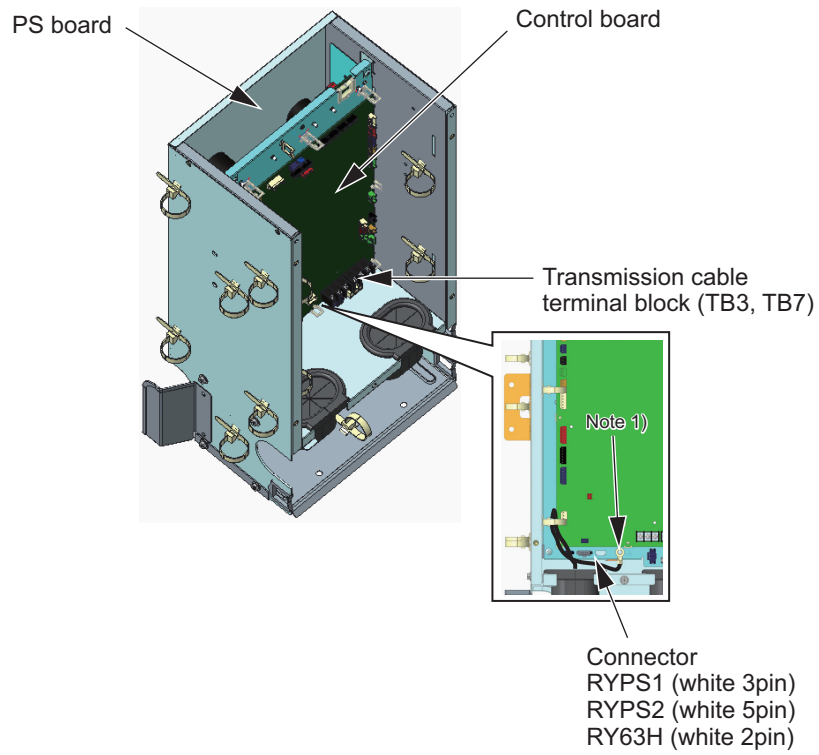
(4) PUHY-(E)P200, (E)P250, (E)P300YNW-A1/2



Note

- 1) Exercise caution not to damage the front panel of the control box. Damage to this part affect the waterproof and dust proof properties of the control box and may result in damage to its internal components.
- 2) Faston terminals have a locking function. Make sure the cable heads are securely locked in place. Press the tab on the terminals to remove them.
- 3) Control box houses high temperature parts. Be well careful even after turning off the power source.
- 4) **Perform the service after disconnecting the relay connector in the INV box (RYFAN1). Before plugging in or unplugging connectors, check that the outdoor unit fan is not rotating and that the voltage across Pin 1 (+) and Pin 5 (-) of connector RYPN in the INV box is 20 VDC or less. The capacitor may collect a charge and cause an electric shock when the outdoor unit fan rotates in windy conditions.** Refer to the wiring nameplate for details.
- 5) To connect wiring to TB7 in the MAIN BOX, check that the voltage is 20 VDC or below.
- 6) After servicing, reconnect the relay connector (RYFAN1) in the INV box as it was.
- 7) When opening or closing the front panel of the control box, do not touch any of the internal components. Before inspecting inside the control box, turn off the power to the unit, leave it turned off for at least 10 minutes, and check that the voltage across Pin 1 (+) and Pin 5 (-) of connector RYPN in the INV box is 20 VDC or less. It takes about 10 minutes to discharge electricity after the power supply is turned off.
- 8) When the power is on, the compressor is energized even while it is stopped. Before turning on the power, disconnect all power supply wires from the compressor terminal block, and measure the insulation resistance of the compressor. Check the compressor for a ground fault. If the insulation resistance is 1.0 MΩ or below, connect all power supply wires to the compressor and turn on the power to the outdoor unit. It is energized to evaporate the liquid refrigerant that has accumulated in the compressor.

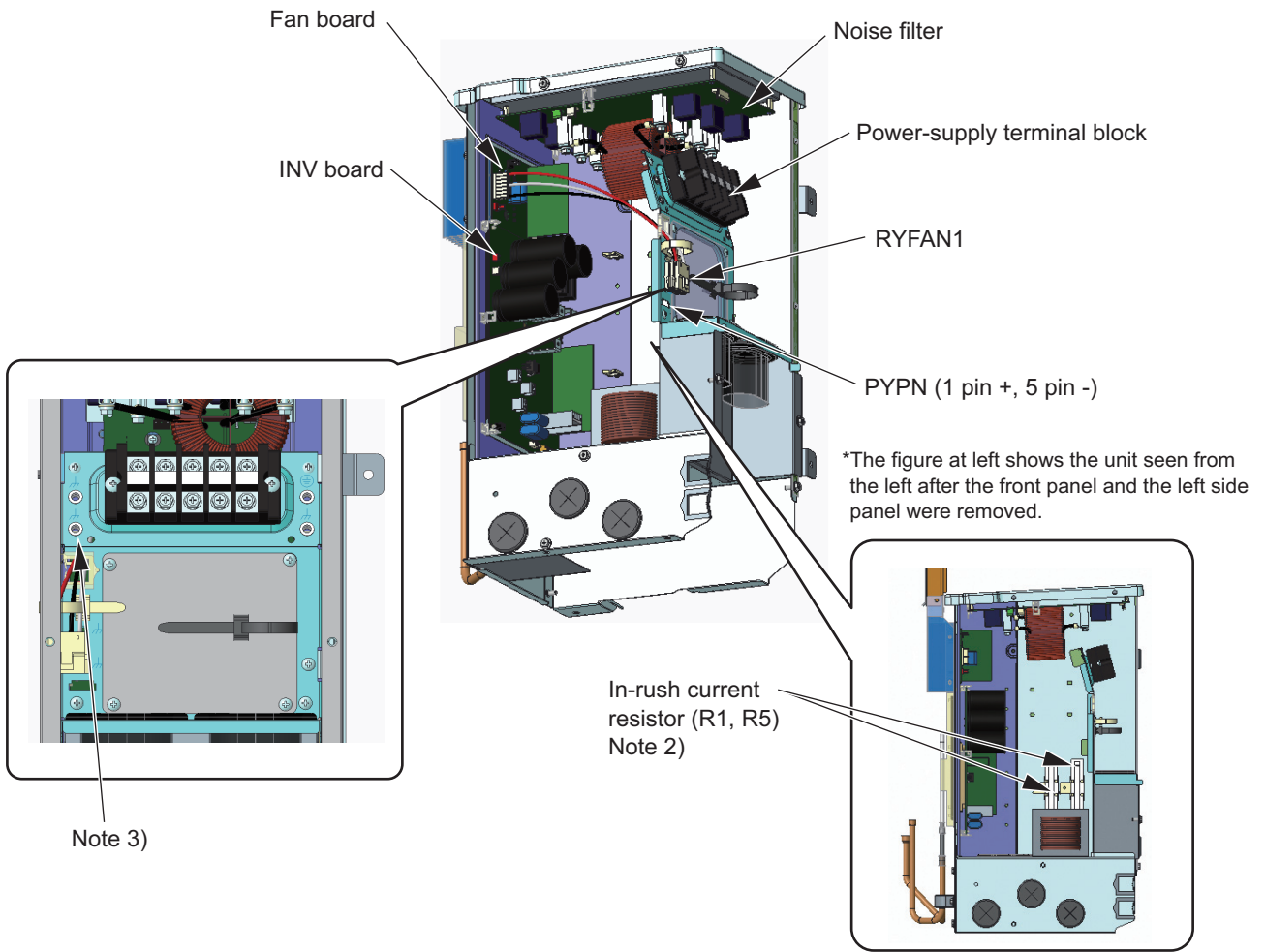
MAIN BOX



Note

1) Leave the grounding connected during maintenance.

INV BOX

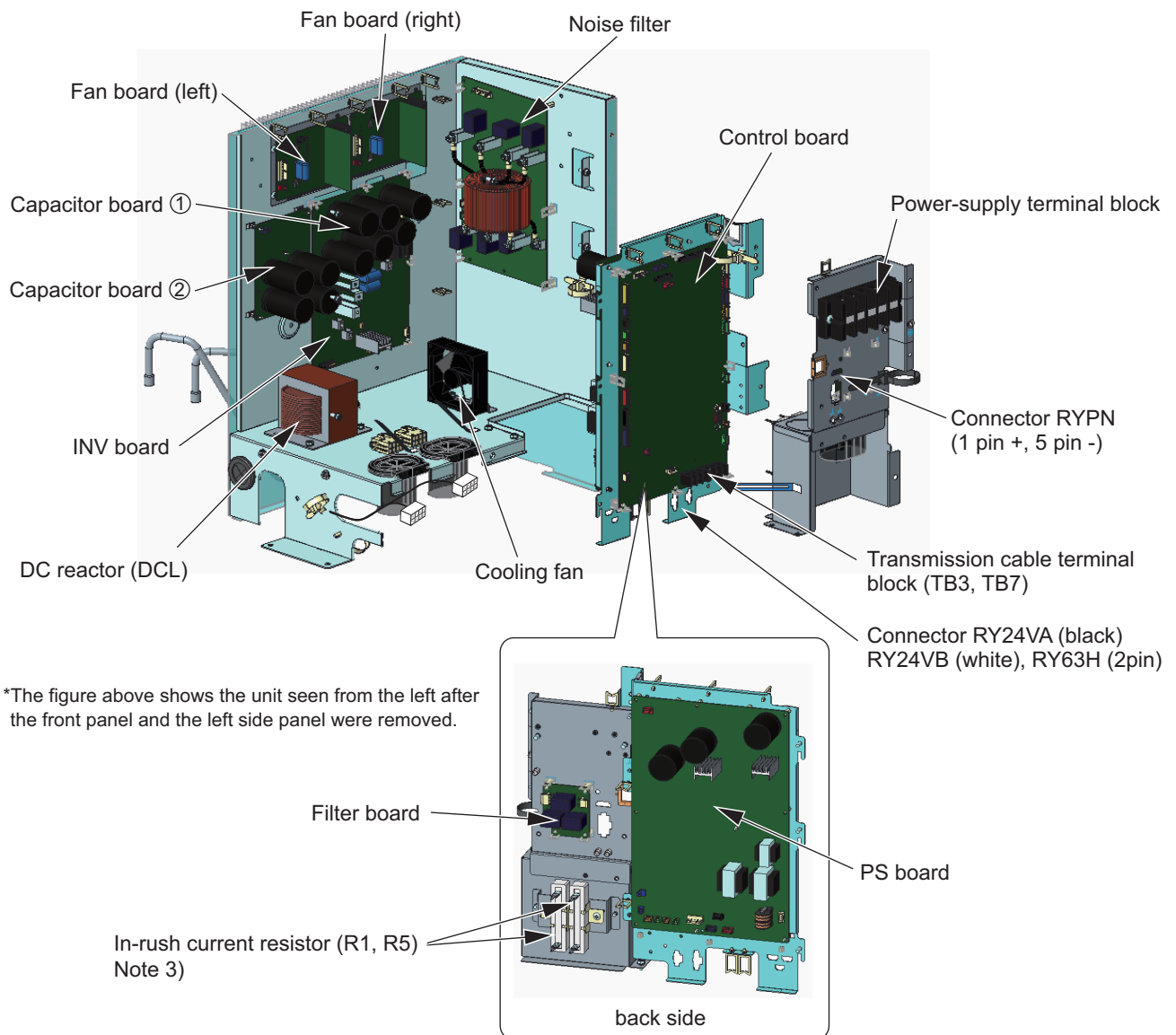


*The figure at left shows the unit seen from the left after the front panel and the left side panel were removed.

Note

- 1) Refrigerant pipes are connected to the back of the INV box. Do not forcibly pull out the INV box. Doing so may result in deformation of the pipe.
- 2) A Faston terminal on the inrush current resistor has a locking function. Check that the terminal is securely locked in place. Press the tab in the middle of the terminal to remove it.
- 3) Leave the grounding connected during maintenance.

(5) PUHY-(E)P350, (E)P400, (E)P450YNW-A1/2

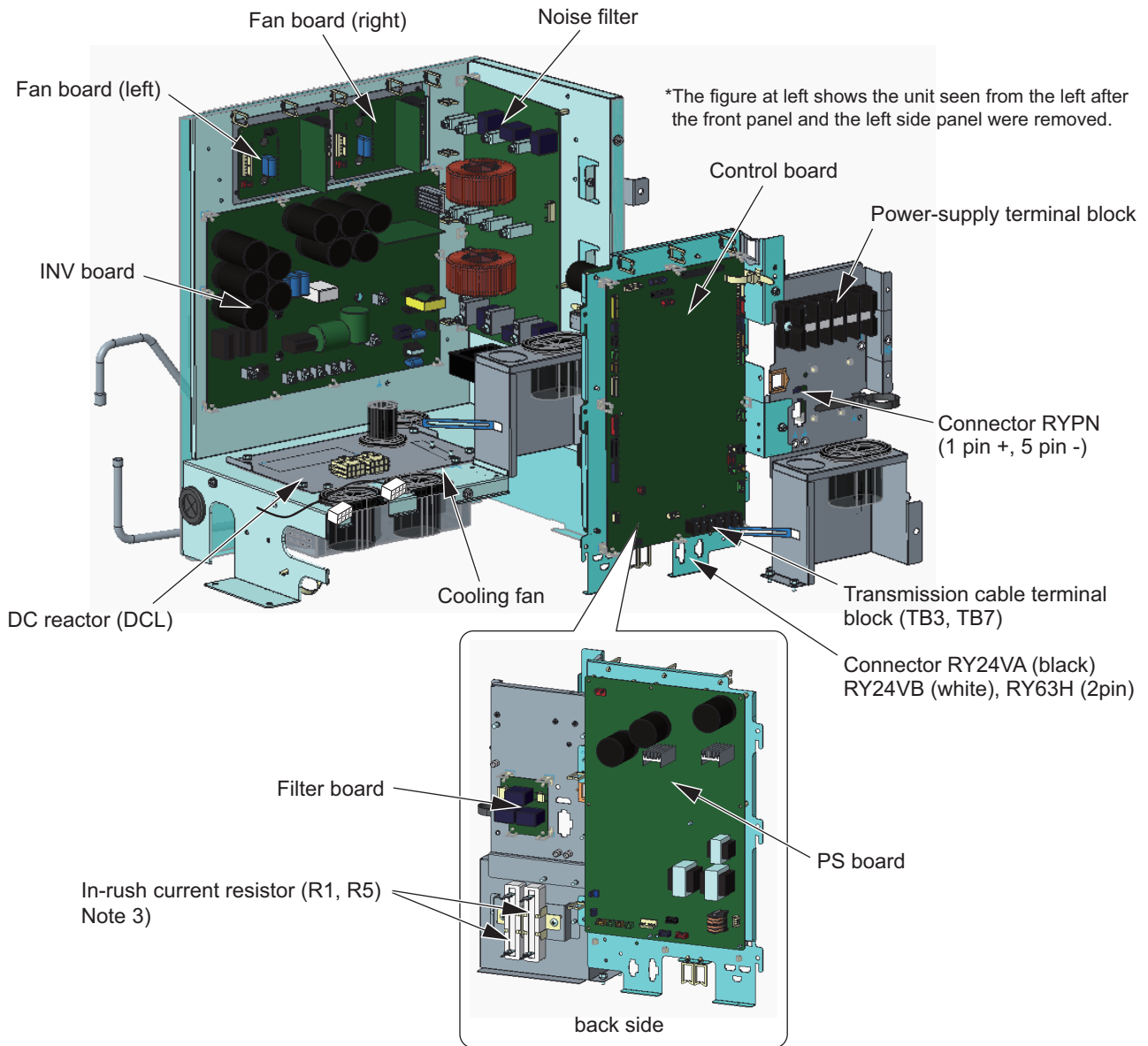


*The figure above shows the unit seen from the left after the front panel and the left side panel were removed.

Note

- 1) Refrigerant pipes are connected to the back of the control box. Do not forcibly pull out the control box. Doing so may result in deformation of the pipe.
- 2) Exercise caution not to damage the front panel of the control box. Damage to this part affect the waterproof and dust proof properties of the control box and may result in damage to its internal components.
- 3) A Faston terminal on the inrush current resistor has a locking function. Check that the terminal is securely locked in place. Press the tab in the middle of the terminal to remove it.
- 4) Control box houses high temperature parts. Be well careful even after turning off the power source.
- 5) **Perform the service after disconnecting the relay connector in the INV box (RYFAN1 and RYFAN2). Before plugging in or unplugging connectors, check that the outdoor unit fan is not rotating and that the voltage across Pin 1 (+) and Pin 5 (-) of connector RYPN in the INV box is 20 VDC or less. The capacitor may collect a charge and cause an electric shock when the outdoor unit fan rotates in windy conditions.** Refer to the wiring nameplate for details.
- 6) To connect wiring to TB7, check that the voltage is 20 VDC or below.
- 7) After servicing, reconnect the relay connector (RYFAN1 and RYFAN2) in the INV box as it was.
- 8) When opening or closing the front panel of the control box, do not touch any of the internal components. Before inspecting inside the control box, turn off the power to the unit, leave it turned off for at least 10 minutes, and check that the voltage across Pin 1 (+) and Pin 5 (-) of connector RYPN in the INV box is 20 VDC or less. It takes about 10 minutes to discharge electricity after the power supply is turned off.
- 9) When the power is on, the compressor is energized even while it is stopped. Before turning on the power, disconnect all power supply wires from the compressor terminal block, and measure the insulation resistance of the compressor. Check the compressor for a ground fault. If the insulation resistance is 1.0 MΩ or above, connect all power supply wires to the compressor and turn on the power to the outdoor unit. It is energized to evaporate the liquid refrigerant that has accumulated in the compressor.

(6) PUHY-(E)P500YNW-A1/2



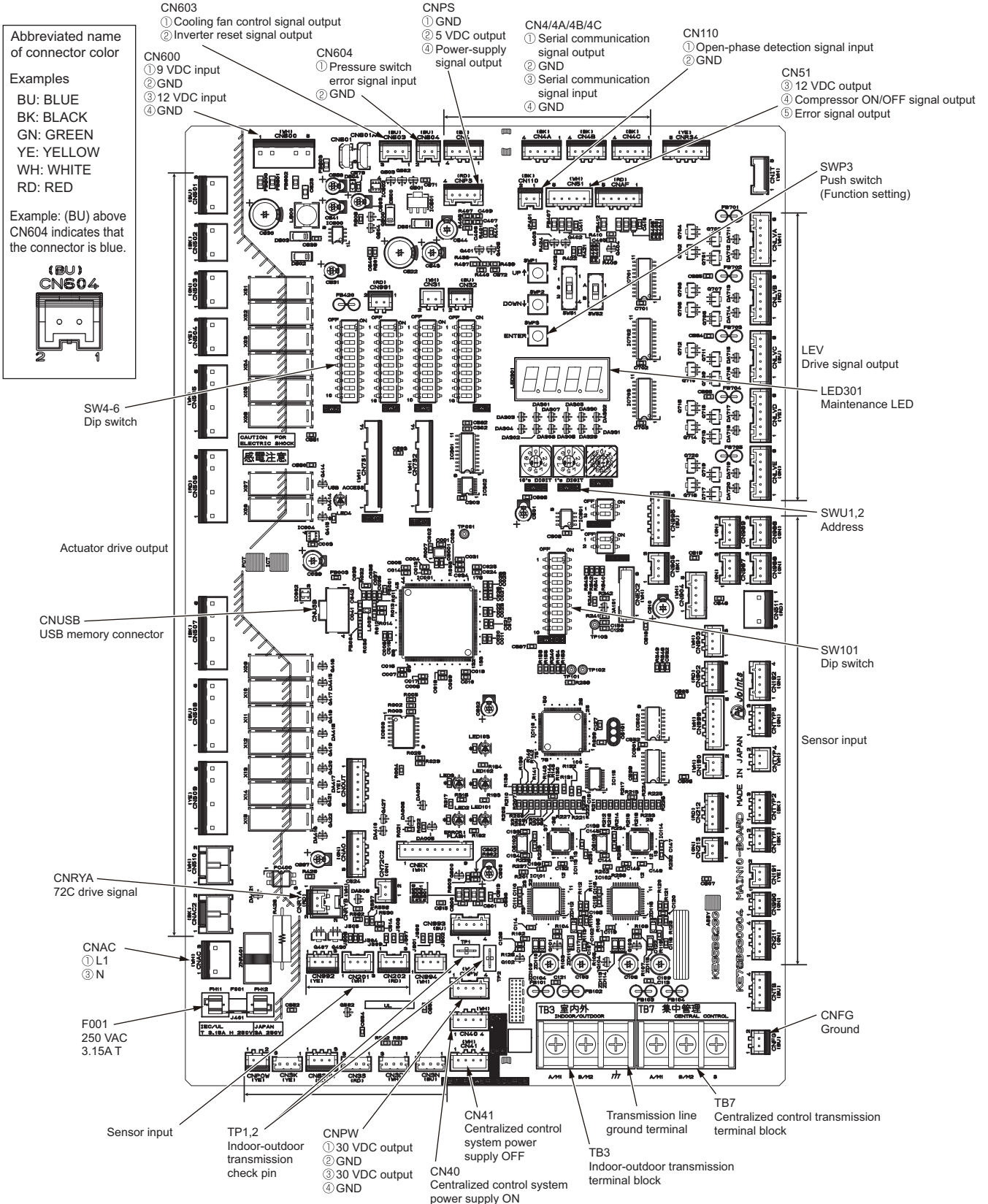
Note

- 1) Refrigerant pipes are connected to the back of the control box. Do not forcibly pull out the control box. Doing so may result in deformation of the pipe.
- 2) Exercise caution not to damage the front panel of the control box. Damage to this part affect the waterproof and dust proof properties of the control box and may result in damage to its internal components.
- 3) A Faston terminal on the inrush current resistor has a locking function. Check that the terminal is securely locked in place. Press the tab in the middle of the terminal to remove it.
- 4) Control box houses high temperature parts. Be well careful even after turning off the power source.
- 5) **Perform the service after disconnecting the relay connector in the INV box (RYFAN1 and RYFAN2). Before plugging in or unplugging connectors, check that the outdoor unit fan is not rotating and that the voltage across Pin 1 (+) and Pin 5 (-) of connector RYPN in the INV box is 20 VDC or less. The capacitor may collect a charge and cause an electric shock when the outdoor unit fan rotates in windy conditions.** Refer to the wiring nameplate for details.
- 6) To connect wiring to TB7, check that the voltage is 20 VDC or below.
- 7) After servicing, reconnect the relay connector (RYFAN1 and RYFAN2) in the INV box as it was.
- 8) When opening or closing the front panel of the control box, do not touch any of the internal components. Before inspecting inside the control box, turn off the power to the unit, leave it turned off for at least 10 minutes, and check that the voltage across Pin 1 (+) and Pin 5 (-) of connector RYPN in the INV box is 20 VDC or less. It takes about 10 minutes to discharge electricity after the power supply is turned off.
- 9) When the power is on, the compressor is energized even while it is stopped. Before turning on the power, disconnect all power supply wires from the compressor terminal block, and measure the insulation resistance of the compressor. Check the compressor for a ground fault. If the insulation resistance is 1.0 MΩ or above, connect all power supply wires to the compressor and turn on the power to the outdoor unit. It is energized to evaporate the liquid refrigerant that has accumulated in the compressor.

4-2 Outdoor Unit Circuit Board Components

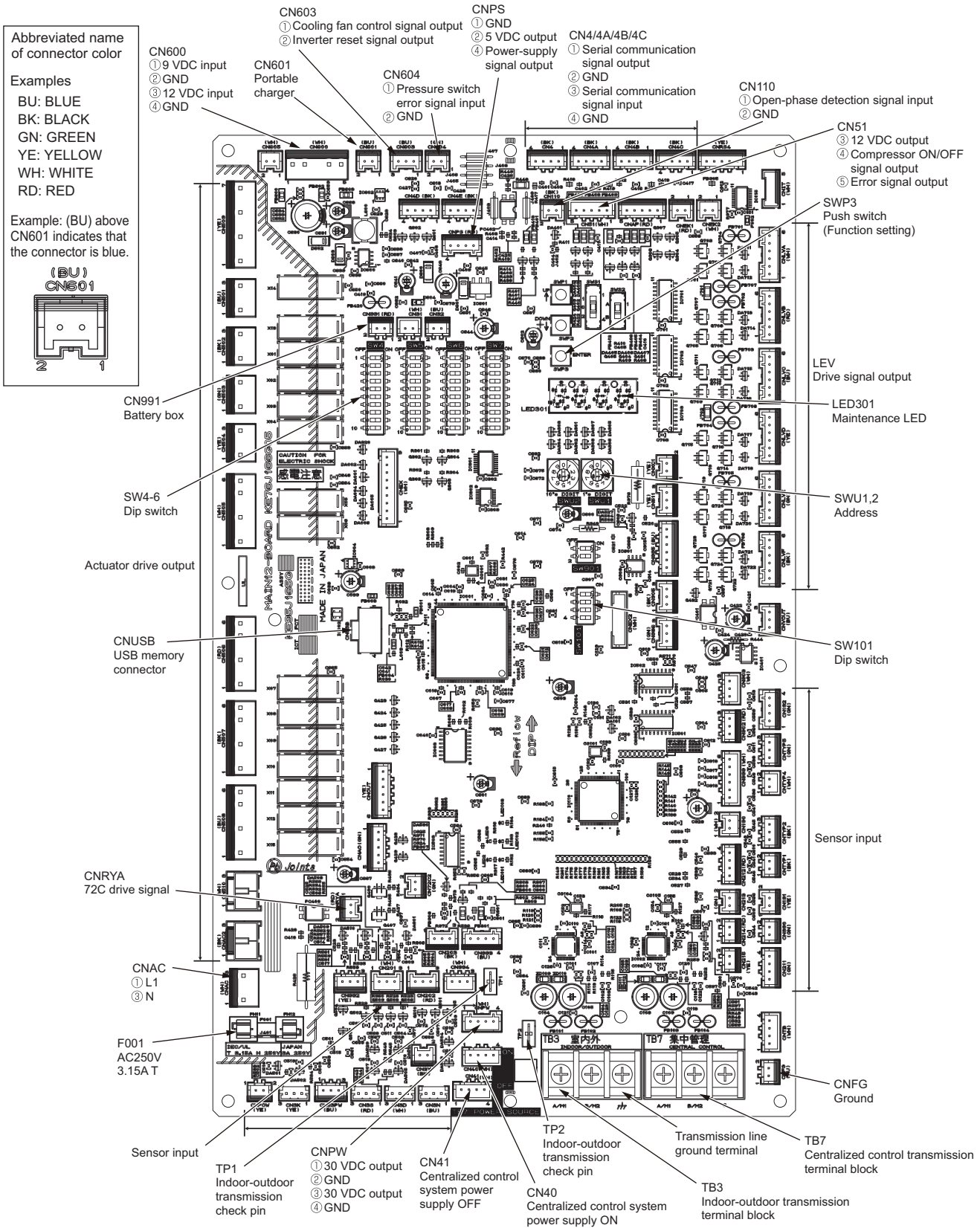
4-2-1 Control Board

(1) YNW-A



*For information about the display of SW4 function settings, refer to the following page(s). [5-1-1 Outdoor Unit Switch Functions and Factory Settings]

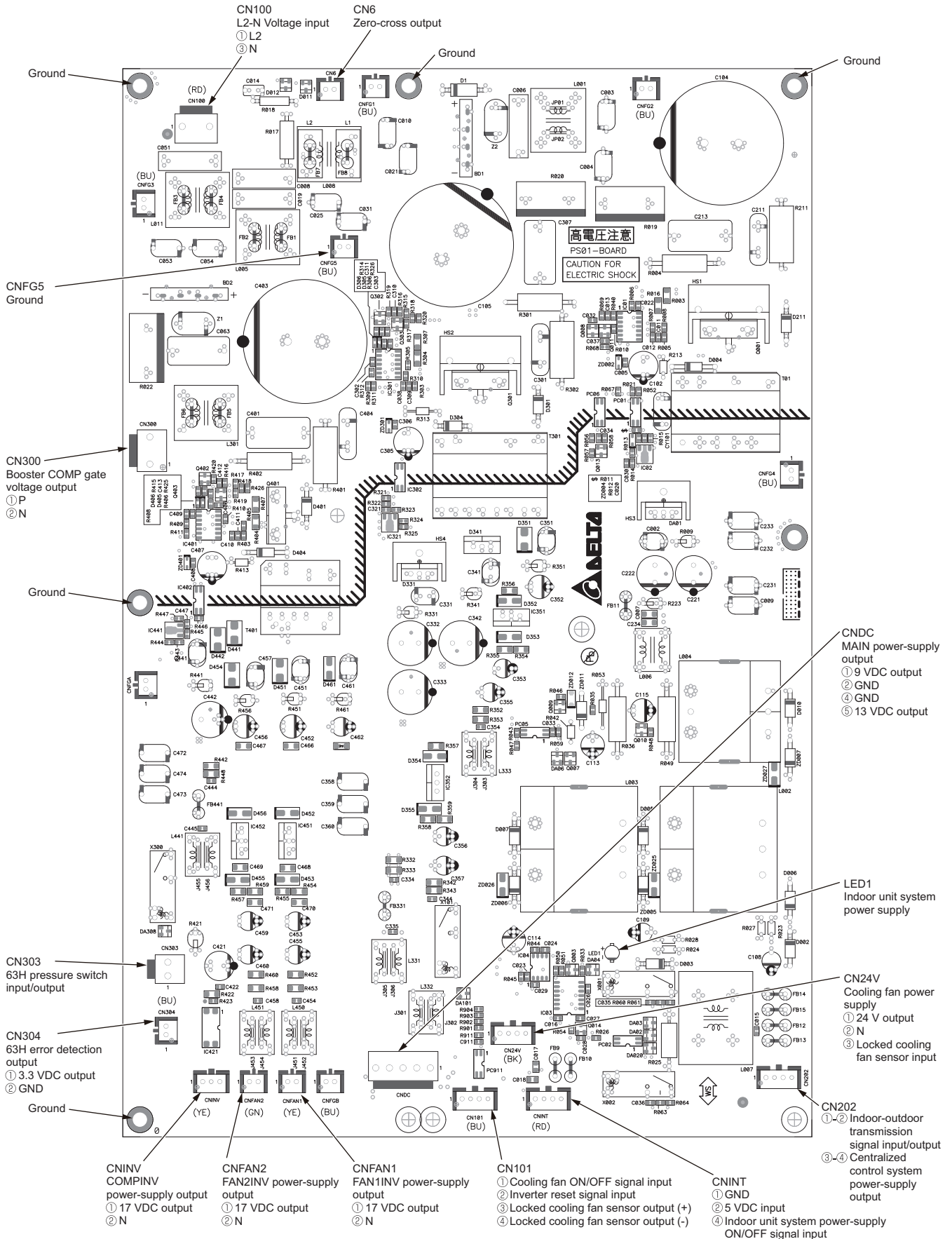
(2) YNW-A1/2



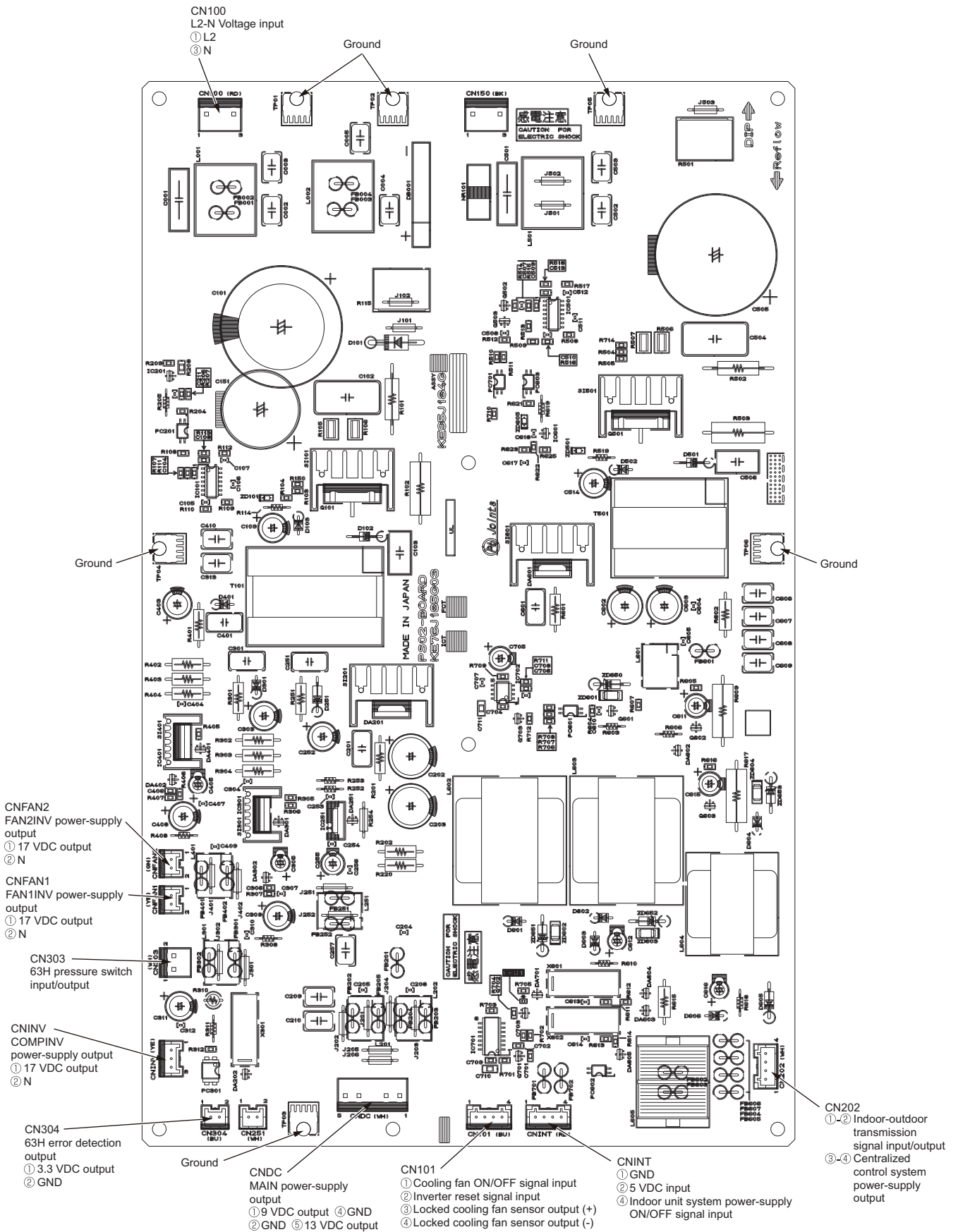
*For information about the display of SW4 function settings, refer to the following page(s). [5-1-1 Outdoor Unit Switch Functions and Factory Settings]

4-2-2 Power-supply board (PS Board)

(1) PUHY-(E)P200, (E)P250, (E)P300, (E)P350, (E)P400, (E)P450, (E)P500YNW-A
 PUHY-(E)P350, (E)P400, (E)P450, (E)P500YNW-A1/2

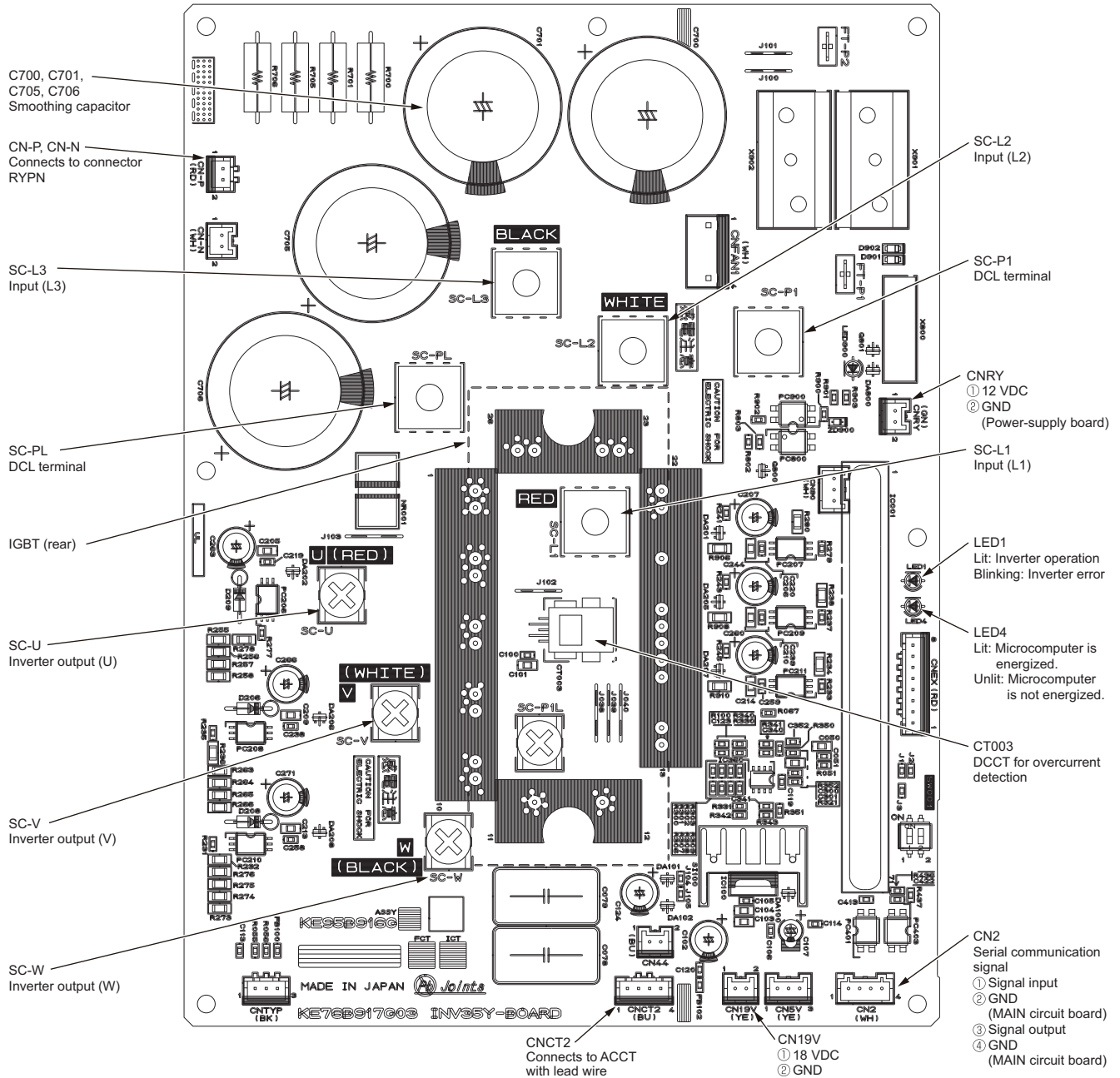


(2) PUHY-(E)P200, (E)P250, (E)P300YNW-A1/2



4-2-3 Inverter Board (INV Board)

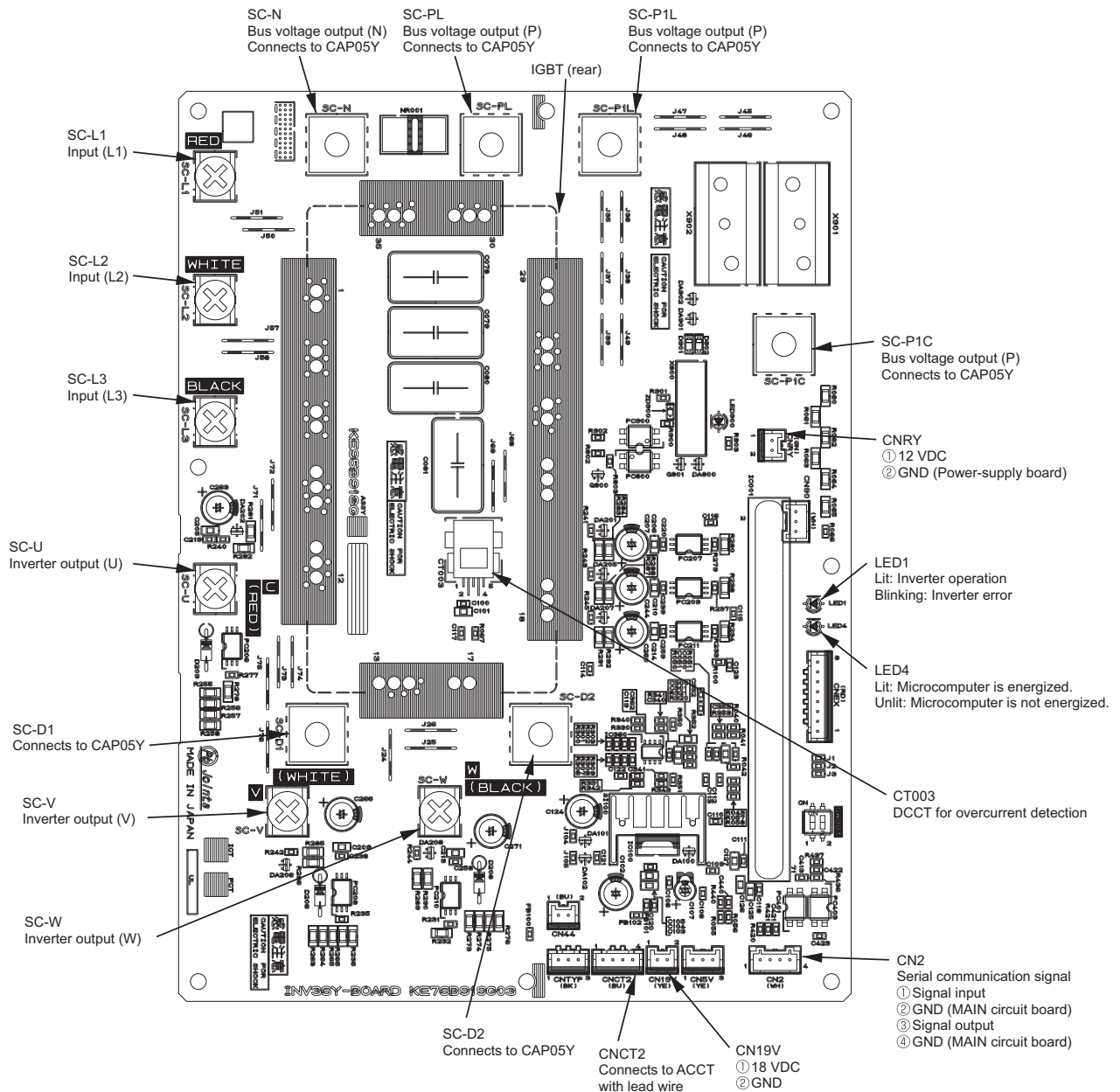
(1) PUHY-(E)P200, (E)P250, (E)P300YNW-A(1/2)



Note

- 1) When opening or closing the front panel of the control box, do not let it come into contact with any of the internal components. Before inspecting the inside of the control box, turn off the power, keep the unit off for at least 10 minutes, and confirm that the voltage across pins 1 and 5 of connector RYPN has dropped to 20 VDC or less. It takes about 10 minutes to discharge electricity after the power supply is turned off.
- 2) A Faston terminal on the inrush current resistor has a locking function. Make sure the cable heads are securely locked in place. Press the tab on the terminals to remove them.
- 3) Control box houses high temperature parts. Be well careful even after turning off the power source.
- 4) **Perform the service after disconnecting the relay connector (RYFAN1). Before plugging in or unplugging connectors, check that the outdoor unit fan is not rotating and that the voltage across pins 1 and 5 of connector RYPN is 20 VDC or less. The capacitor may collect a charge and cause an electric shock when the outdoor unit fan rotates in windy conditions.** Refer to the wiring nameplate for details.
- 5) After servicing, reconnect the relay connector (RYFAN1) of the fan as it was.
- 6) When the power is turned on, the compressor is energized even while it is not operating. Before turning on the power, disconnect all power supply wires from the compressor terminal block, and measure the insulation resistance of the compressor. Check the compressor for a ground fault. If the insulation resistance is 1.0 MΩ or below, connect all power supply wires to the compressor and turn on the power to the outdoor unit. The liquid refrigerant in the compressor will evaporate by energizing the compressor.

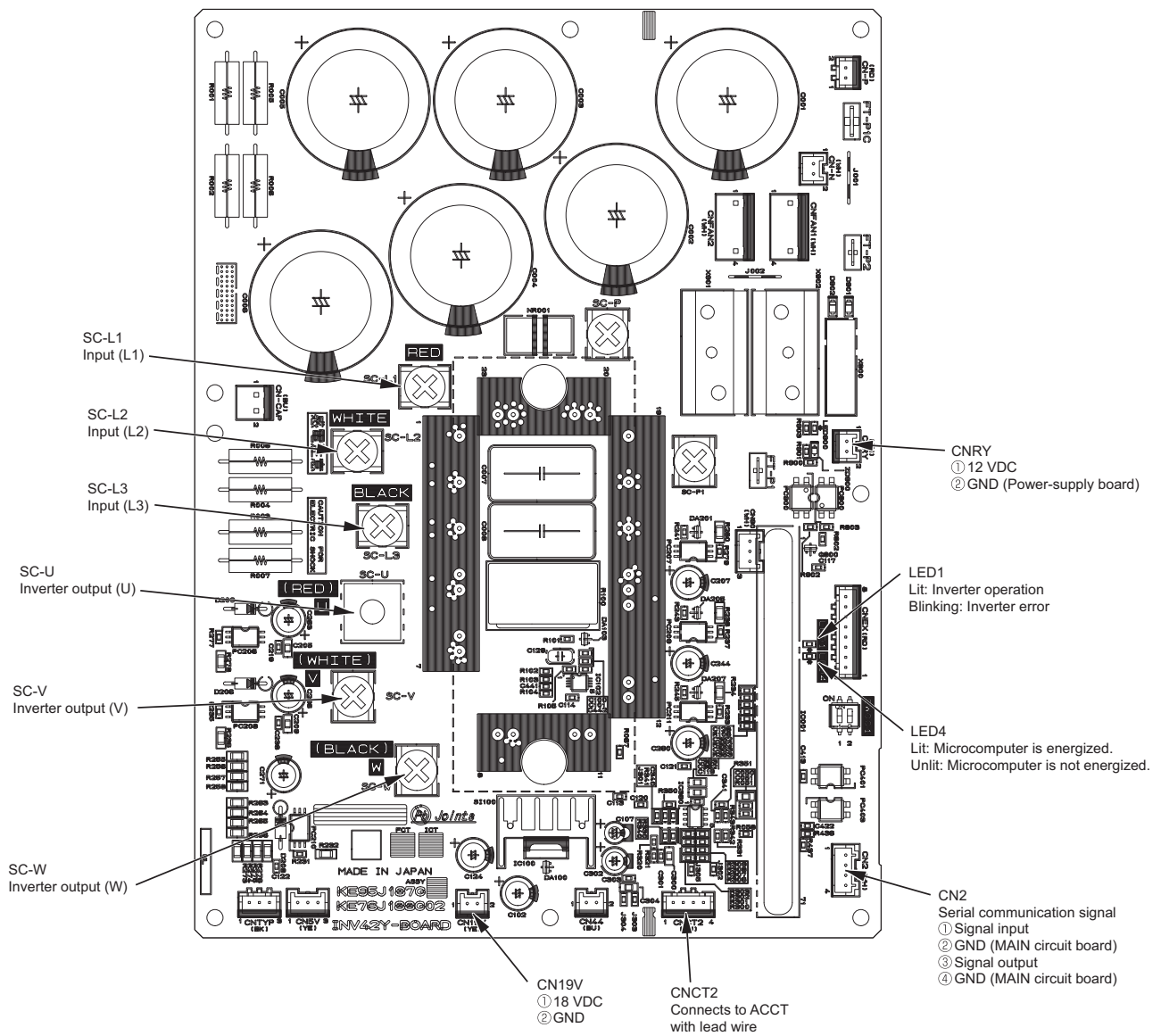
(2) PUHY-(E)P350, (E)P400, (E)P450YNW-A



Note

- 1) When opening or closing the front panel of the control box, do not let it come into contact with any of the internal components. Before inspecting the inside of the control box, turn off the power, keep the unit off for at least 10 minutes, and confirm that the voltage across pins 1 and 5 of connector RYPN has dropped to 20 VDC or less. It takes about 10 minutes to discharge electricity after the power supply is turned off.
- 2) A Faston terminal on the inrush current resistor has a locking function. Make sure the cable heads are securely locked in place. Press the tab on the terminals to remove them.
- 3) Control box houses high temperature parts. Be well careful even after turning off the power source.
- 4) **Perform the service after disconnecting the relay connector (RYFAN1, RYFAN2). Before plugging in or unplugging connectors, check that the outdoor unit fan is not rotating and that the voltage across pins 1 and 5 of connector RYPN is 20 VDC or less. The capacitor may collect a charge and cause an electric shock when the outdoor unit fan rotates in windy conditions.** Refer to the wiring nameplate for details.
- 5) After servicing, reconnect the relay connector (RYFAN1, RYFAN2) of the fan as it was.
- 6) When the power is on, the compressor or heater is energized even while the compressor is stopped. Before turning on the power, disconnect all power supply wires from the compressor terminal block, and measure the insulation resistance of the compressor. Check the compressor for a ground fault. If the insulation resistance is 1.0 MΩ or below, connect all power supply wires to the compressor and turn on the power to the outdoor unit. It is energized to evaporate the liquid refrigerant that has accumulated in the compressor.

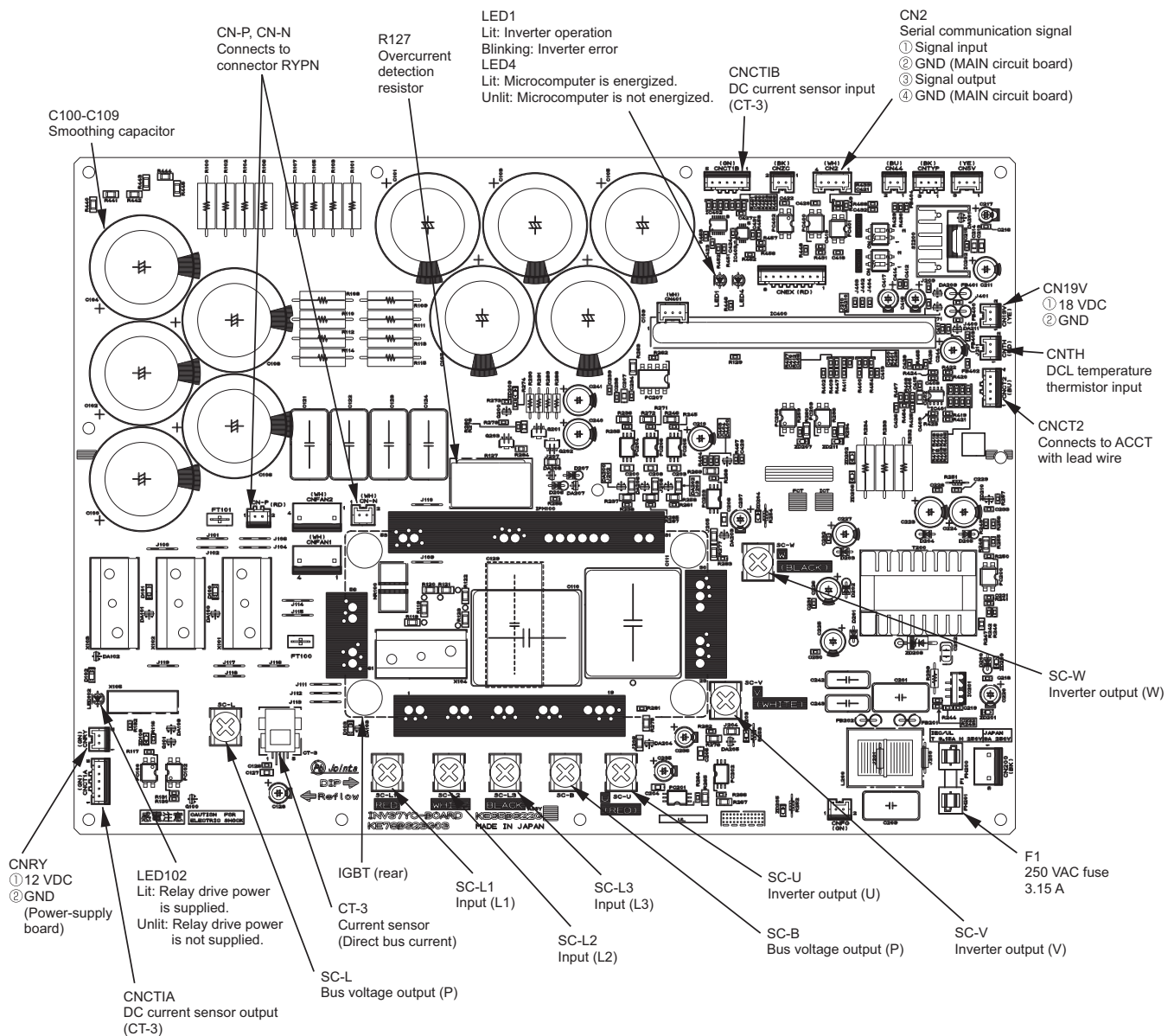
(3) PUHY-(E)P350, (E)P400, (E)P450YNW-A1/2



Note

- 1) When opening or closing the front panel of the control box, do not let it come into contact with any of the internal components. Before inspecting the inside of the control box, turn off the power, keep the unit off for at least 10 minutes, and confirm that the voltage across pins 1 and 5 of connector RYPN has dropped to 20 VDC or less. It takes about 10 minutes to discharge electricity after the power supply is turned off.
- 2) A Faston terminal on the inrush current resistor has a locking function. Make sure the cable heads are securely locked in place. Press the tab on the terminals to remove them.
- 3) Control box houses high temperature parts. Be well careful even after turning off the power source.
- 4) **Perform the service after disconnecting the relay connector (RYFAN1, RYFAN2). Before plugging in or unplugging connectors, check that the outdoor unit fan is not rotating and that the voltage across pins 1 and 5 of connector RYPN is 20 VDC or less. The capacitor may collect a charge and cause an electric shock when the outdoor unit fan rotates in windy conditions.** Refer to the wiring nameplate for details.
- 5) After servicing, reconnect the relay connector (RYFAN1, RYFAN2) of the fan as it was.
- 6) When the power is on, the compressor or heater is energized even while the compressor is stopped. Before turning on the power, disconnect all power supply wires from the compressor terminal block, and measure the insulation resistance of the compressor. Check the compressor for a ground fault. If the insulation resistance is 1.0 MΩ or above, connect all power supply wires to the compressor and turn on the power to the outdoor unit. It is energized to evaporate the liquid refrigerant that has accumulated in the compressor.

(4) PUHY-(E)P500YNW-A(1/2)

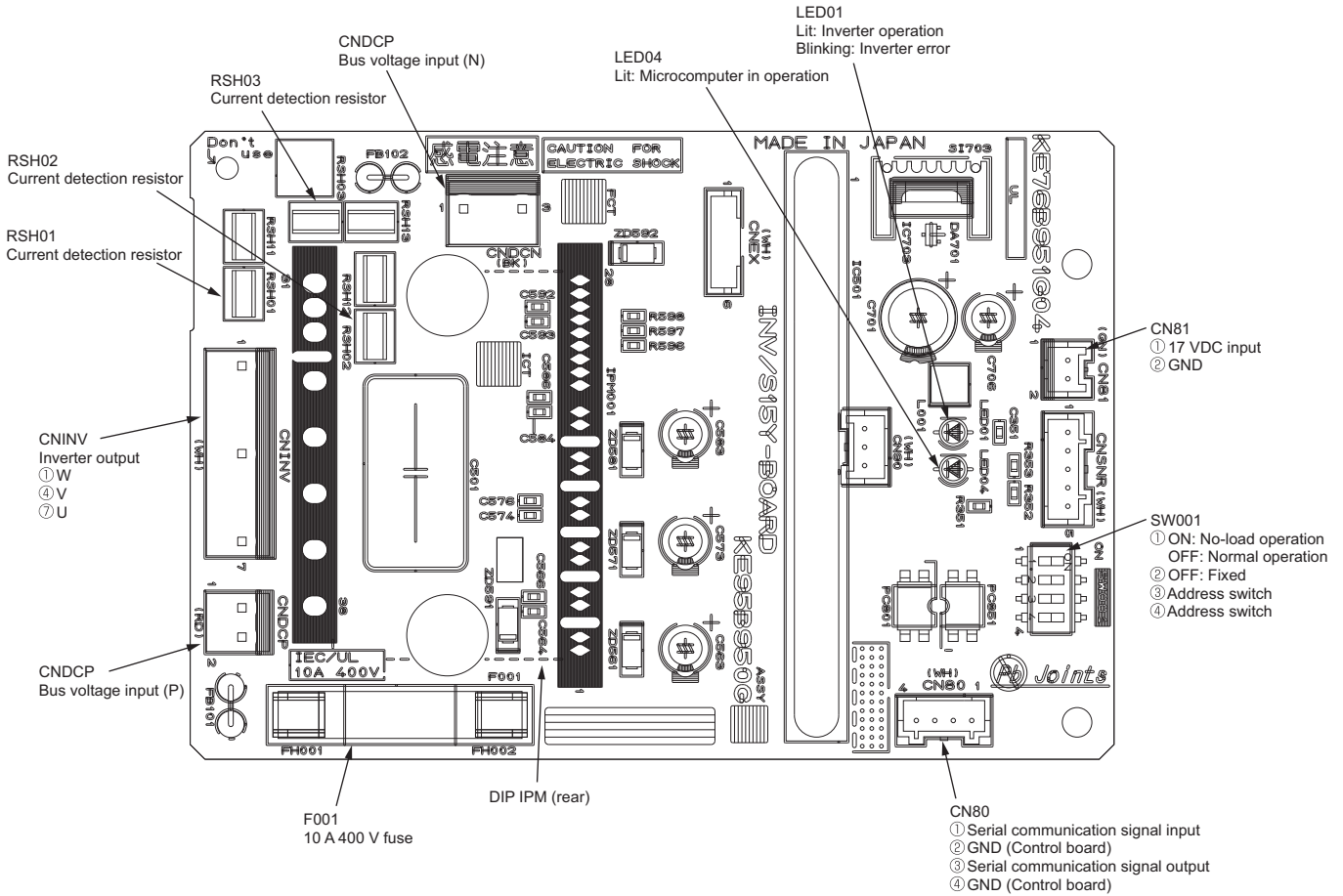


Note

- 1) When opening or closing the front panel of the control box, do not let it come into contact with any of the internal components. Before inspecting the inside of the control box, turn off the power, keep the unit off for at least 10 minutes, and confirm that the voltage across pins 1 and 5 of connector RYPN has dropped to 20 VDC or less. It takes about 10 minutes to discharge electricity after the power supply is turned off.
- 2) A Faston terminal on the inrush current resistor has a locking function. Make sure the cable heads are securely locked in place. Press the tab on the terminals to remove them.
- 3) Control box houses high temperature parts. Be well careful even after turning off the power source.
- 4) **Perform the service after disconnecting the relay connector (RYFAN1, RYFAN2). Before plugging in or unplugging connectors, check that the outdoor unit fan is not rotating and that the voltage across pins 1 and 5 of connector RYPN is 20 VDC or less. The capacitor may collect a charge and cause an electric shock when the outdoor unit fan rotates in windy conditions.** Refer to the wiring nameplate for details.
- 5) After servicing, reconnect the relay connector (RYFAN1, RYFAN2) of the fan as it was.
- 6) When the power is turned on, the compressor is energized even while it is not operating. Before turning on the power, disconnect all power supply wires from the compressor terminal block, and measure the insulation resistance of the compressor. Check the compressor for a ground fault. If the insulation resistance is 1.0 MΩ or below, connect all power supply wires to the compressor and turn on the power to the outdoor unit. The liquid refrigerant in the compressor will evaporate by energizing the compressor.

4-2-4 Fan Board

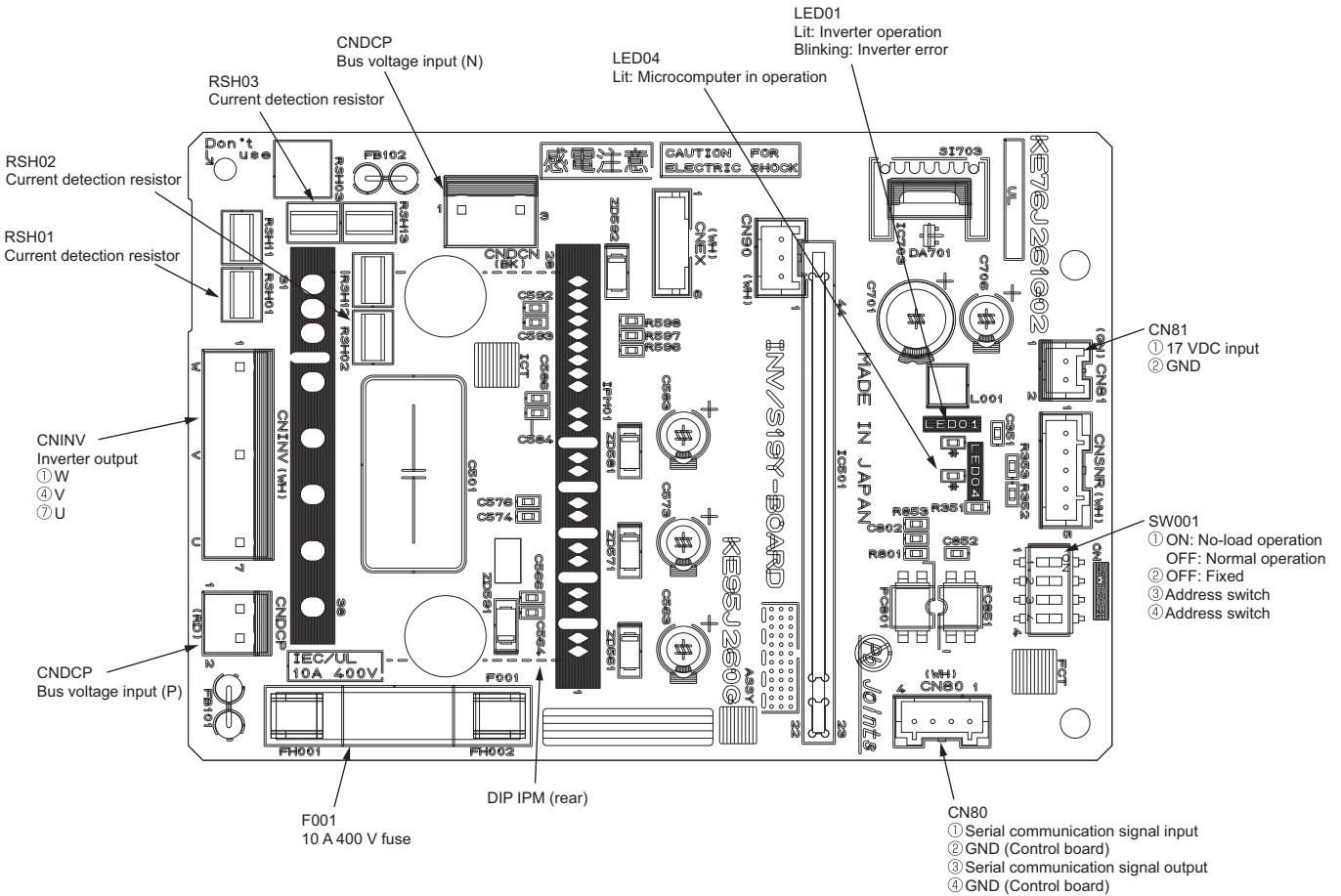
(1) YNW-A



Note

- 1) When opening or closing the front panel of the control box, do not let it come into contact with any of the internal components. Before inspecting the inside of the control box, turn off the power, keep the unit off for at least 10 minutes, and confirm that the capacitor voltage (inverter main circuit) has dropped to 20 VDC or less. It takes about 10 minutes to discharge electricity after the power supply is turned off.
- 2) Control box houses high temperature parts. Be well careful even after turning off the power source.
- 3) **Perform the service after disconnecting the relay connector (RYFAN1, RYFAN2). Before plugging in or unplugging connectors, check that the outdoor unit fan is not rotating and that the voltage across pins 1 and 5 of connector RYPN is 20 VDC or less. The capacitor may collect a charge and cause an electric shock when the outdoor unit fan rotates in windy conditions.** Refer to the wiring nameplate for details.
- 4) To connect wiring to TB7, check that the voltage is 20 VDC or below.
- 5) After servicing, reconnect the relay connector (RYFAN1, RYFAN2) of the fan as it was.

(2) YNW-A1/2

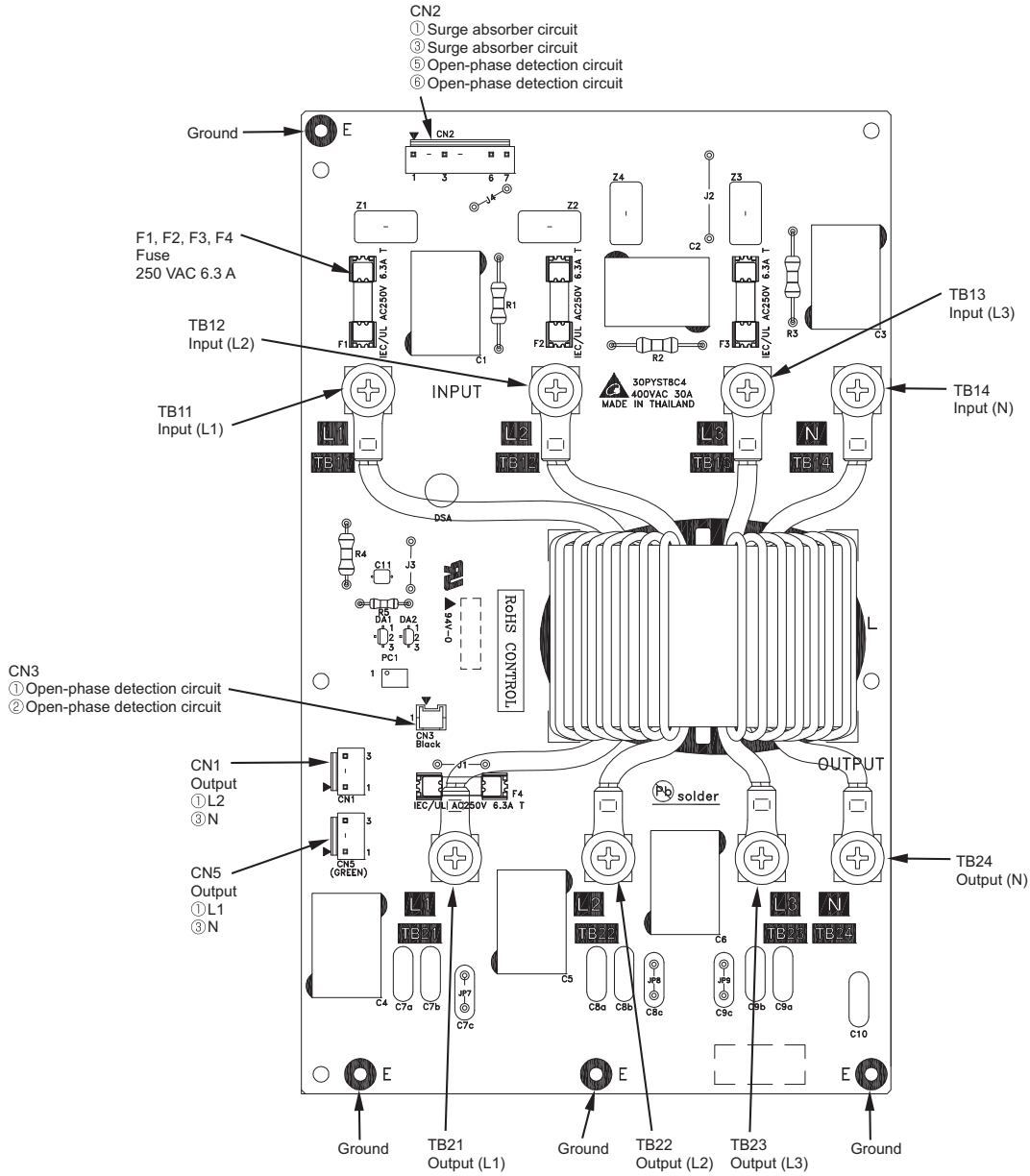


Note

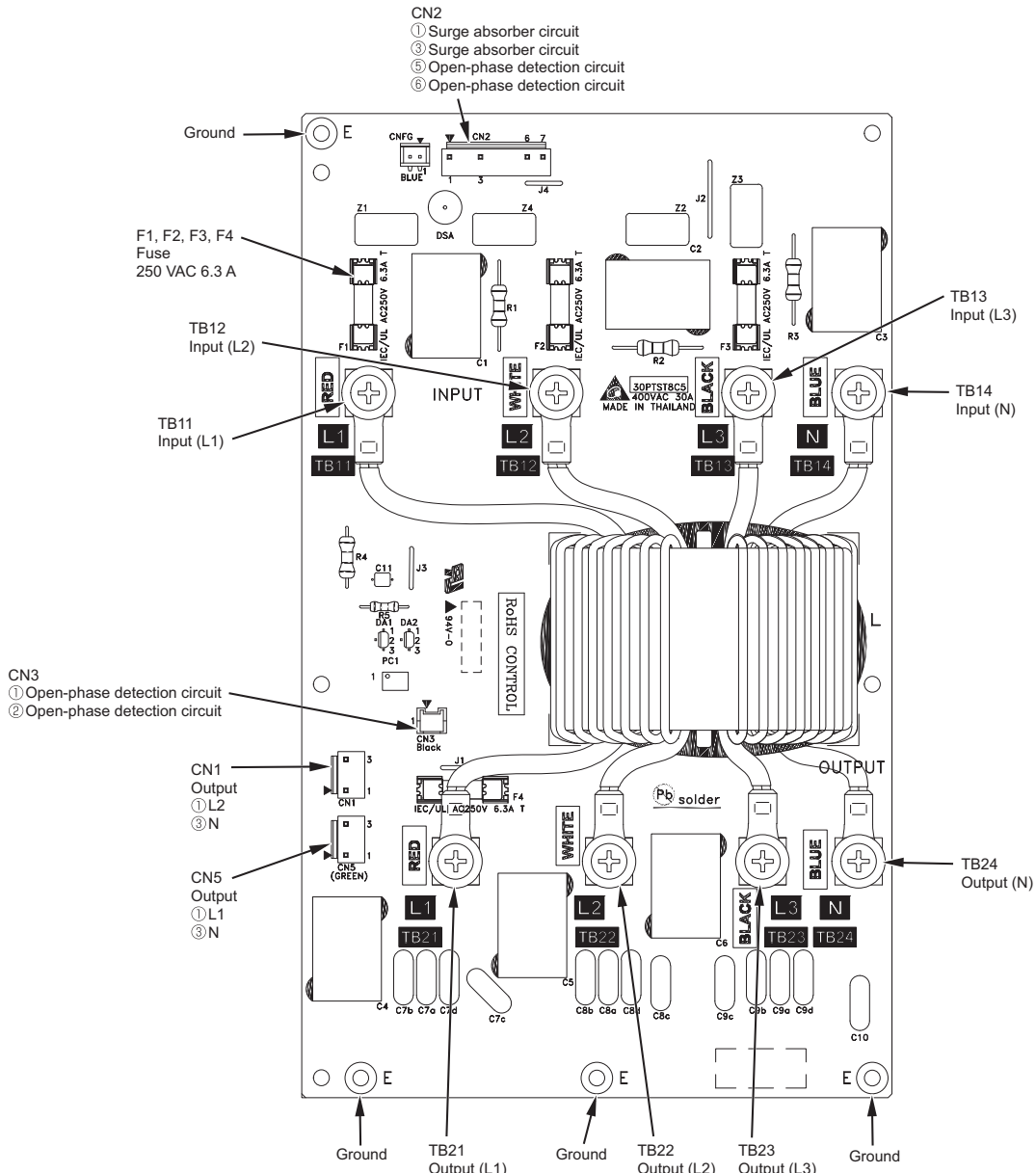
- 1) When opening or closing the front panel of the control box, do not let it come into contact with any of the internal components. Before inspecting the inside of the control box, turn off the power, keep the unit off for at least 10 minutes, and confirm that the capacitor voltage (inverter main circuit) has dropped to 20 VDC or less. It takes about 10 minutes to discharge electricity after the power supply is turned off.
- 2) Control box houses high temperature parts. Be well careful even after turning off the power source.
- 3) **Perform the service after disconnecting the relay connector (RYFAN1, RYFAN2). Before plugging in or unplugging connectors, check that the outdoor unit fan is not rotating and that the voltage across pins 1 and 5 of connector RYPN is 20 VDC or less. The capacitor may collect a charge and cause an electric shock when the outdoor unit fan rotates in windy conditions. Refer to the wiring nameplate for details.**
- 4) To connect wiring to TB7, check that the voltage is 20 VDC or below.
- 5) After servicing, reconnect the relay connector (RYFAN1, RYFAN2) of the fan as it was.

4-2-5 Noise Filter

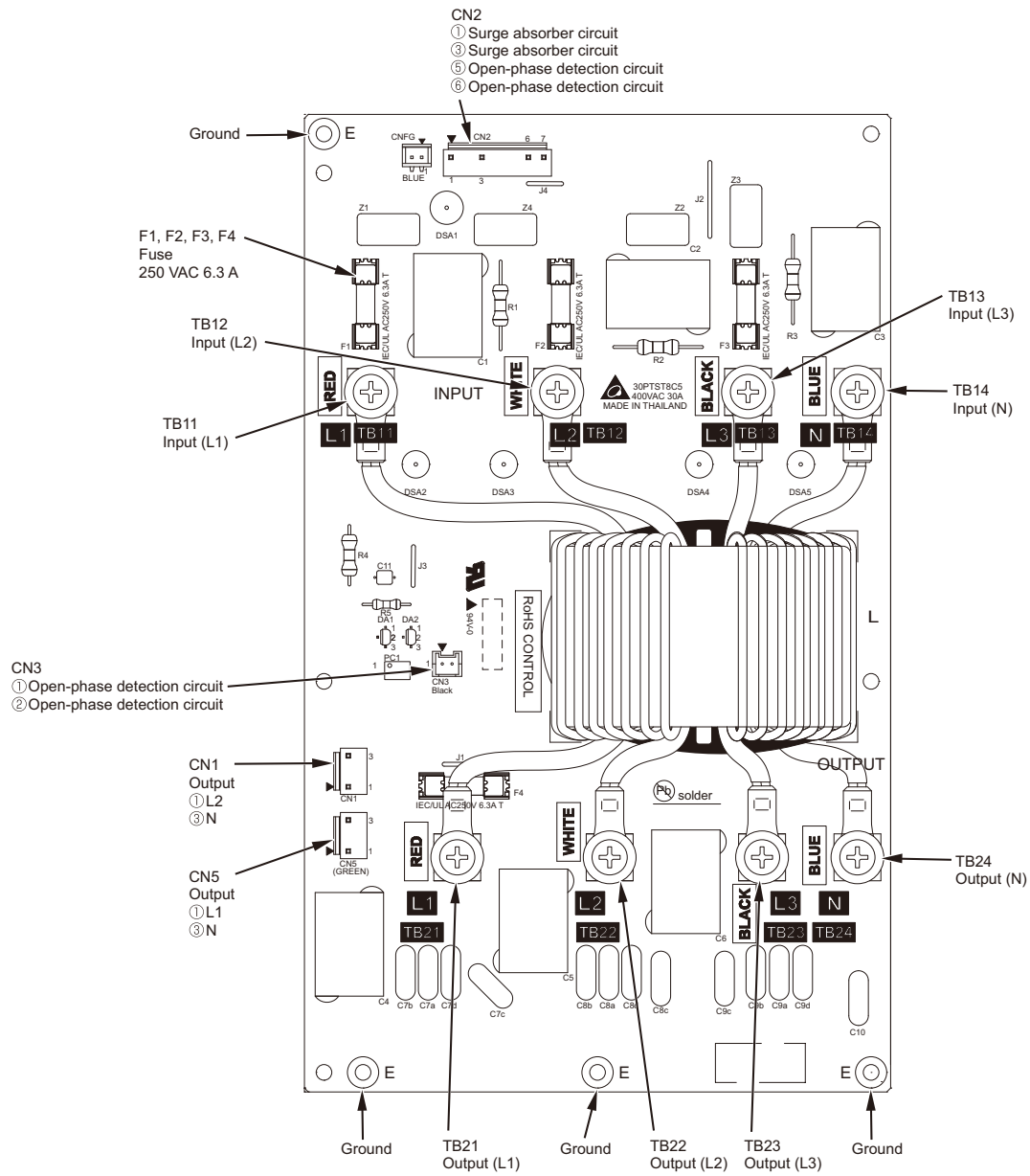
(1) PUHY-(E)P200, (E)P250, (E)P300, (E)P350, (E)P400, (E)P450YNW-A



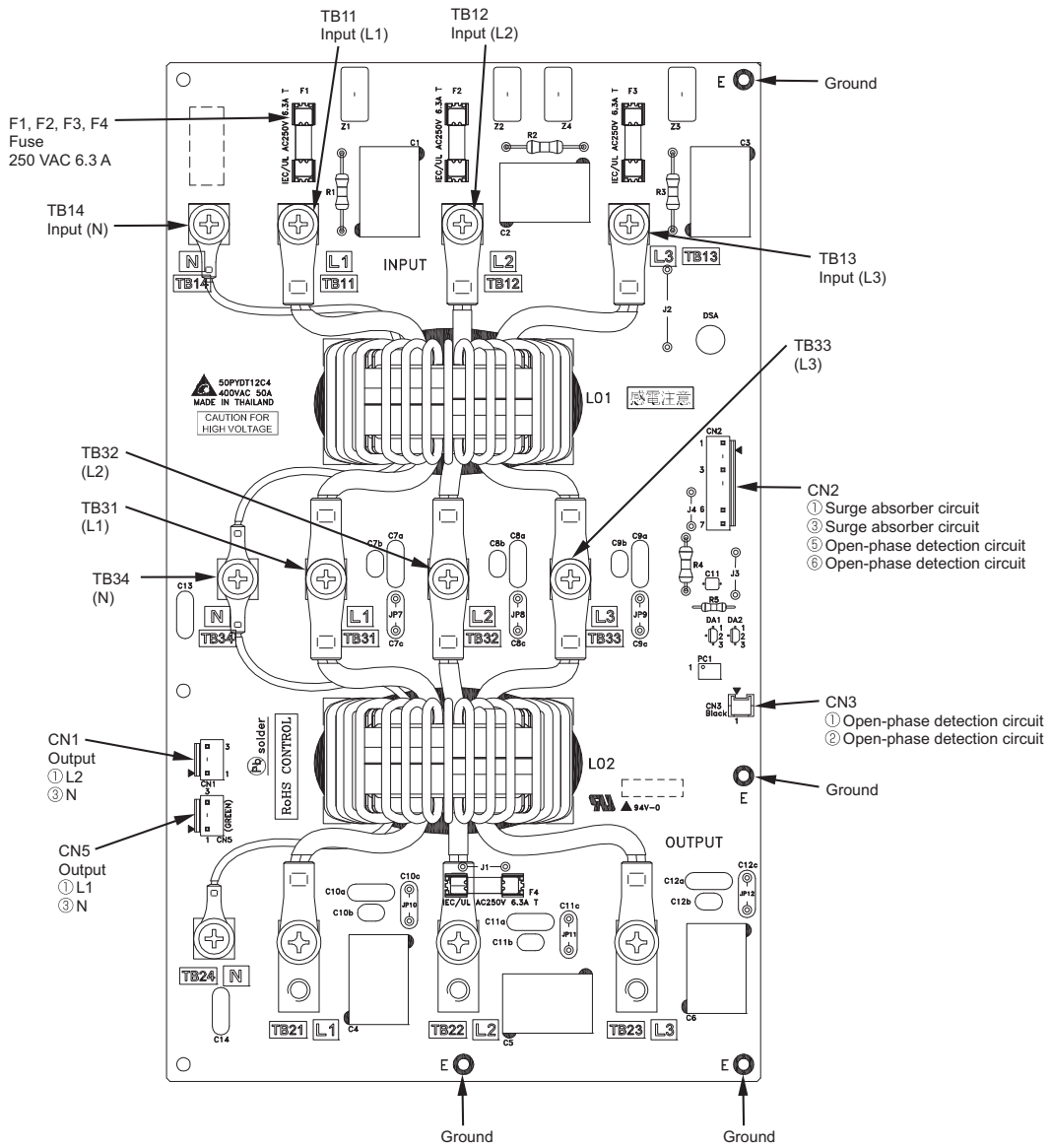
(2) PUHY-(E)P200, (E)P250, (E)P300, (E)P350, (E)P400, (E)P450YNW-A1



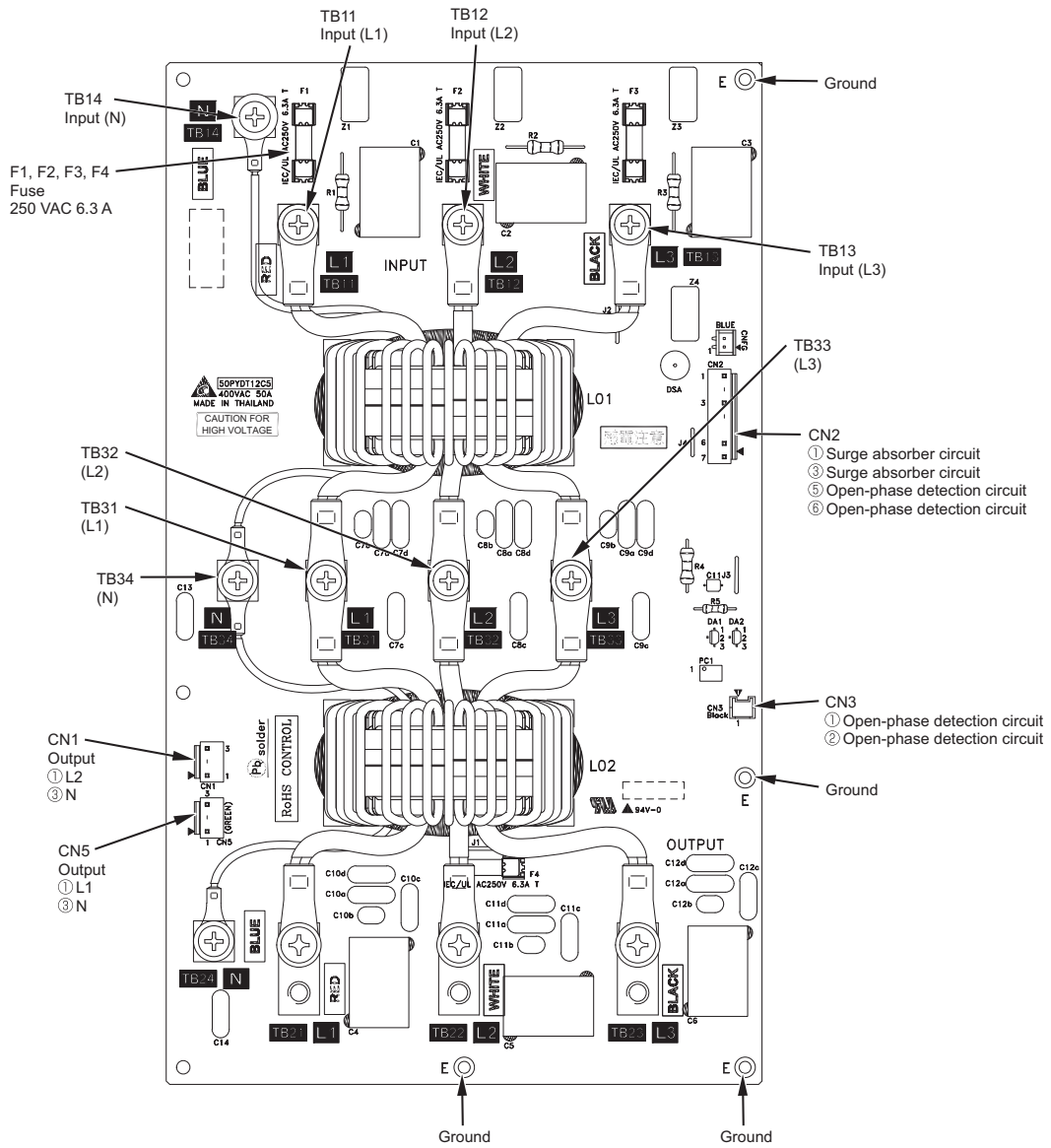
(3) PUHY-(E)P200, (E)P250, (E)P300, (E)P350, (E)P400, (E)P450YNW-A2



(4) PUHY-(E)P500YNW-A

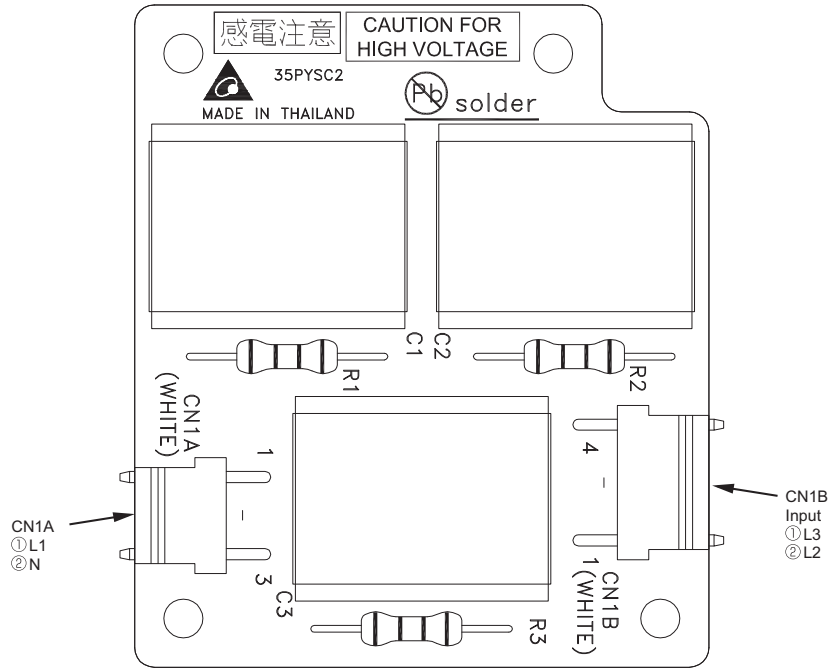


(5) PUHY-(E)P500YNW-A1/2



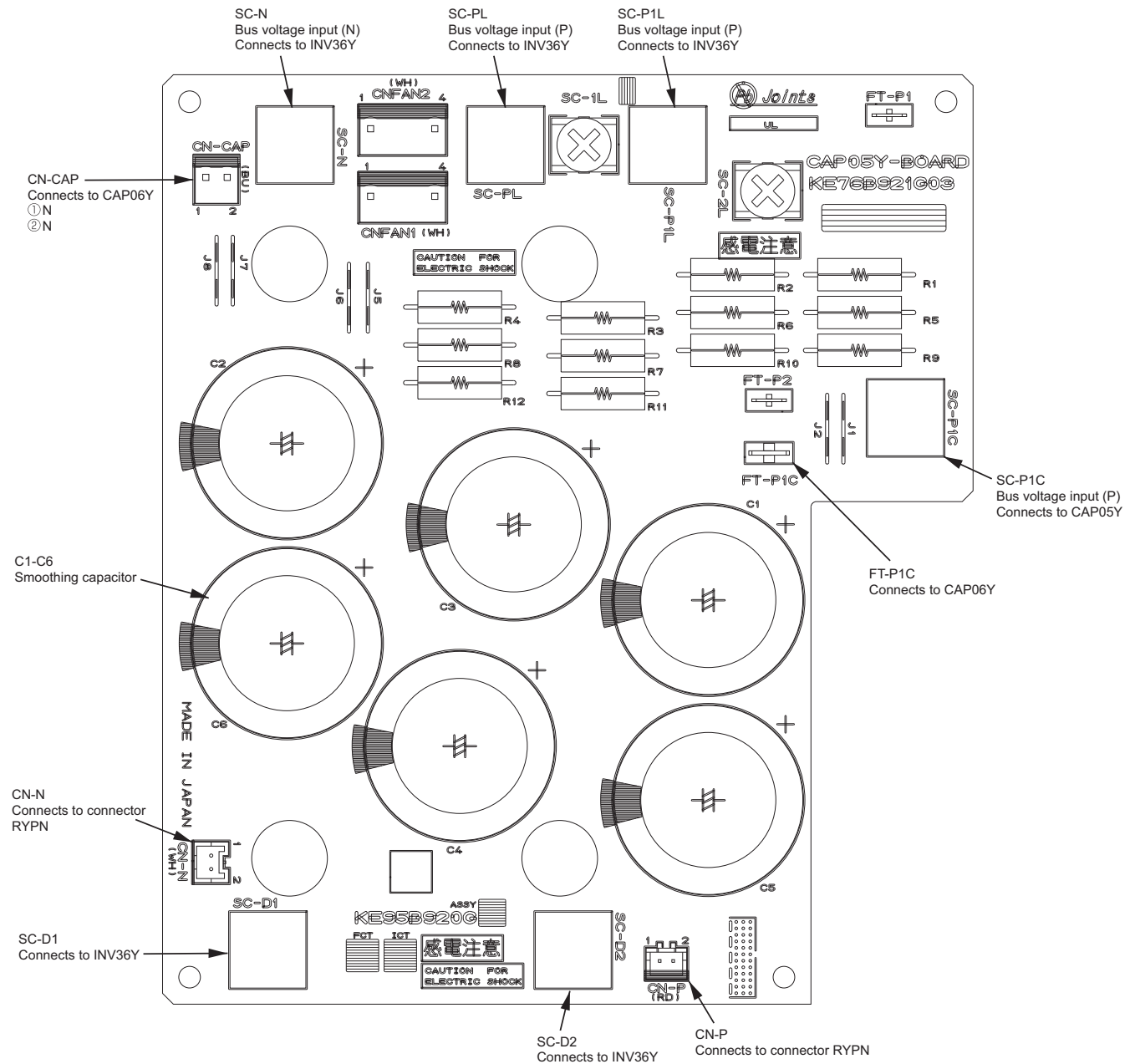
4-2-6 Filter Board

- (1) PUHY-(E)P350, (E)P400, (E)P450, (E)P500YNW-A
PUHY-(E)P500YNW-A1/2



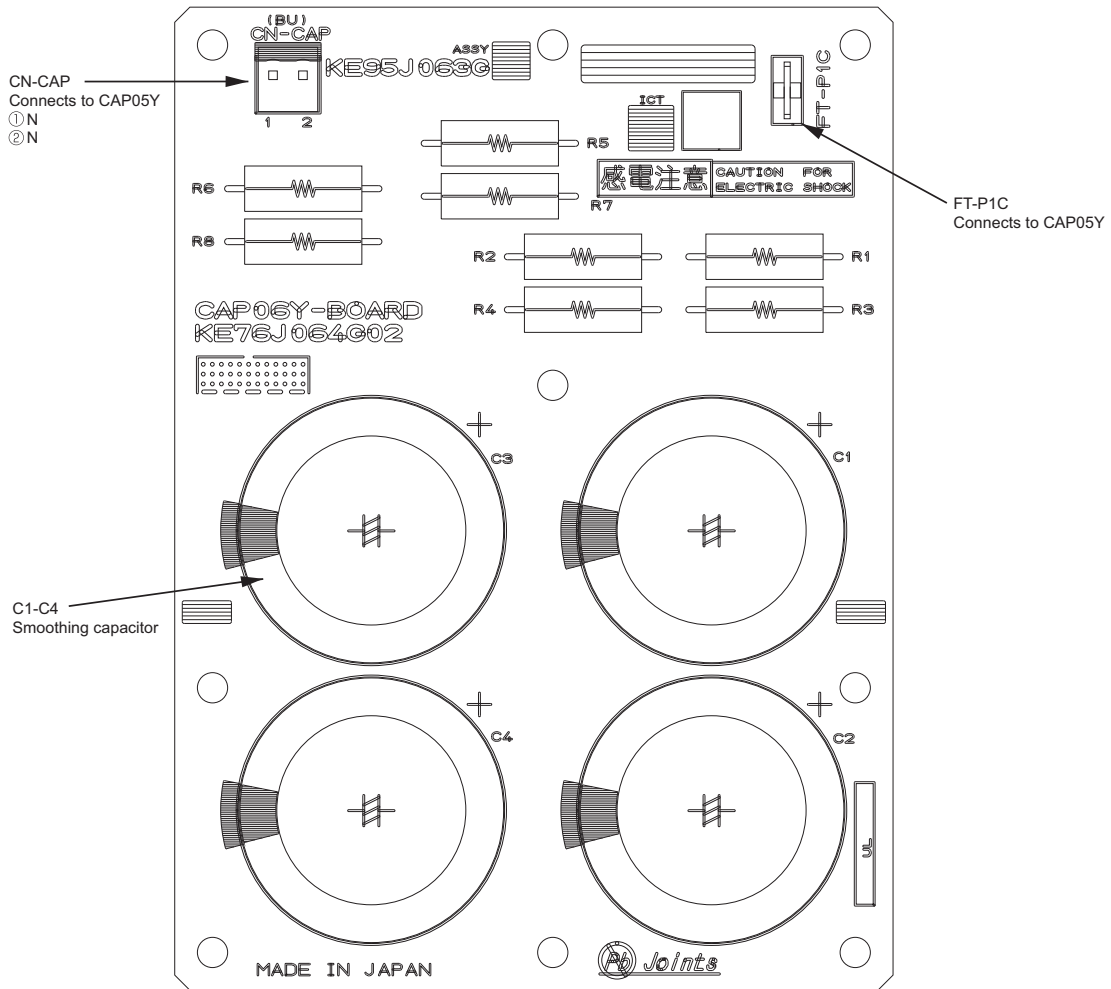
4-2-7 Capacitor Board (CAP Board)

(1) PUHY-(E)P350, (E)P400, (E)P450YNW-A



- Note**
- 1) When opening or closing the front panel of the control box, do not let it come into contact with any of the internal components. Before inspecting the inside of the control box, turn off the power, keep the unit off for at least 10 minutes, and confirm that the capacitor voltage (inverter main circuit) has dropped to 20 VDC or less. It takes about 10 minutes to discharge electricity after the power supply is turned off.
 - 2) A Faston terminal on the inrush current resistor has a locking function. Make sure the cable heads are securely locked in place. Press the tab on the terminals to remove them.
 - 3) Control box houses high temperature parts. Be well careful even after turning off the power source.
 - 4) **Perform the service after disconnecting the relay connector (RYFAN1, RYFAN2). Before plugging in or unplugging connectors, check that the outdoor unit fan is not rotating and that the voltage across pins 1 and 5 of connector RYPN is 20 VDC or less. The capacitor may collect a charge and cause an electric shock when the outdoor unit fan rotates in windy conditions. Refer to the wiring nameplate for details.**
 - 5) After servicing, reconnect the relay connector (RYFAN1, RYFAN2) of the fan as it was.

(2) PUHY-(E)P350, (E)P400, (E)P450YNW-A(1/2)

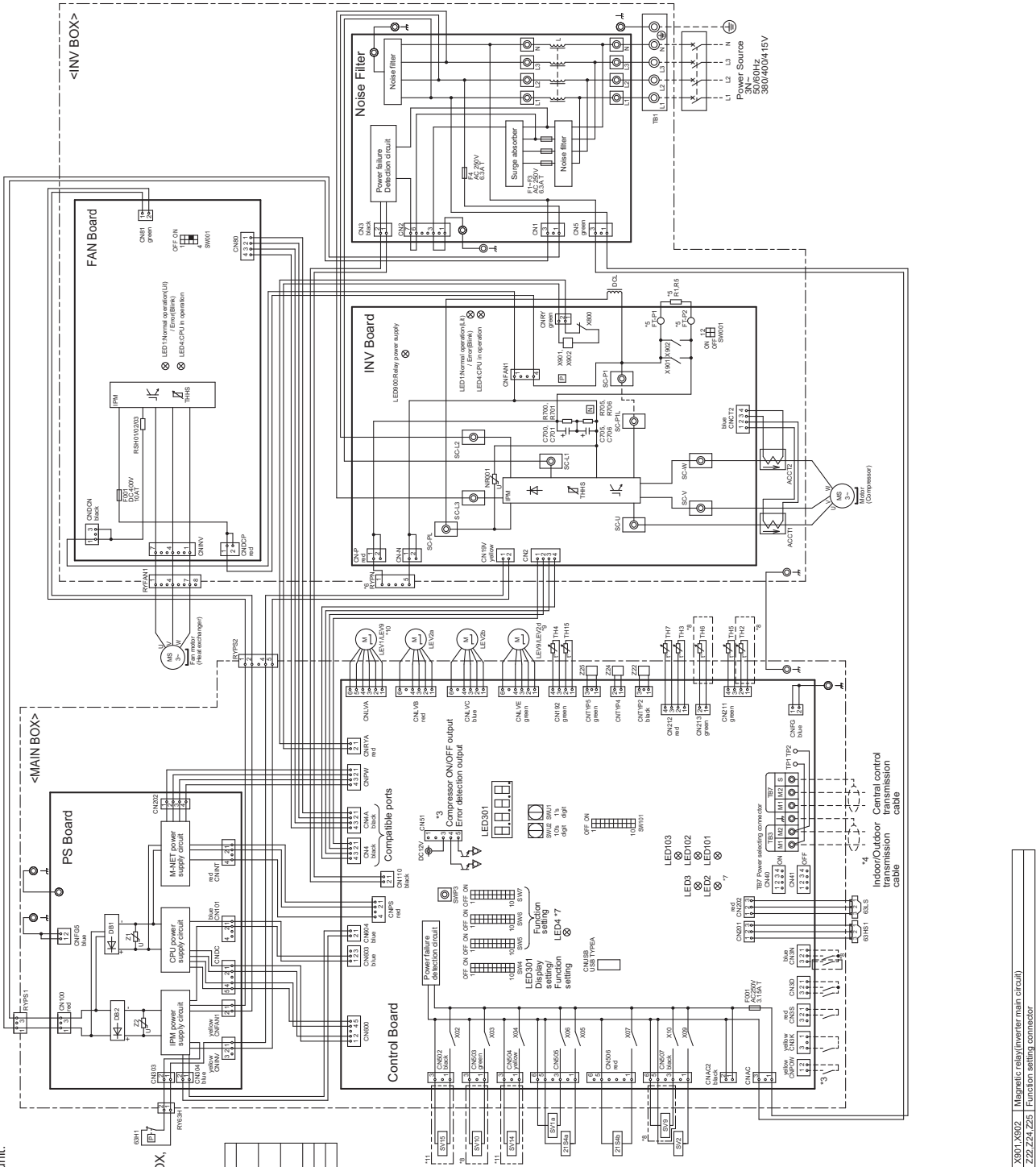


Note

- 1) When opening or closing the front panel of the control box, do not let it come into contact with any of the internal components. Before inspecting the inside of the control box, turn off the power, keep the unit off for at least 10 minutes, and confirm that the capacitor voltage (inverter main circuit) has dropped to 20 VDC or less. It takes about 10 minutes to discharge electricity after the power supply is turned off.
- 2) A Faston terminal on the inrush current resistor has a locking function. Make sure the cable heads are securely locked in place. Press the tab on the terminals to remove them.
- 3) Control box houses high temperature parts. Be well careful even after turning off the power source.
- 4) **Perform the service after disconnecting the relay connector (RYFAN1, RYFAN2). Before plugging in or unplugging connectors, check that the outdoor unit fan is not rotating and that the voltage across pins 1 and 5 of connector RYPN is 20 VDC or less. The capacitor may collect a charge and cause an electric shock when the outdoor unit fan rotates in windy conditions.** Refer to the wiring nameplate for details.
- 5) After servicing, reconnect the relay connector (RYFAN1, RYFAN2) of the fan as it was.

4-3 Outdoor Unit Electrical Wiring Diagrams

(1) PUHY-(E)P200, (E)P250, (E)P300YNW-A



- *1. Single-dotted lines indicate wiring not supplied with the unit.
- *2. Dot-dash lines indicate the control box boundaries.
- *3. Refer to the Data book for connecting input/output signal connectors.
- *4. Daisy-chain terminals (TB3) on the outdoor units in the same refrigerant system together.
- *5. Faston terminals have a locking function. Make sure the terminals are securely locked in place after insertion. Press the tab on the terminals to removed them.
- *6. Control box houses high-voltage parts. Before inspecting the inside of the MAIN BOX or INV BOX, turn off the power, keep the unit off for at least 10 minutes, and confirm that the voltage of the connector RYPN on INV BOX has dropped to DC20V or less.
- *7. Control board LED display.

LED02	Normal operation(LI/In stop)(Unit)
LED03	SW4-10 is OFF and in operation(LI/In stop)(Unit)
LED04	SW4-1-10 are OFF
LED01	Function setting by SW4
LED102	Normal operation(LI/In stop)(Unit)
LED103	Normal operation(LI/In stop)(Unit)
LED104	Normal operation(LI/In stop)(Unit)
LED105	Normal operation(LI/In stop)(Unit)
LED106	Normal operation(LI/In stop)(Unit)
LED107	Normal operation(LI/In stop)(Unit)
LED108	Normal operation(LI/In stop)(Unit)
LED109	Normal operation(LI/In stop)(Unit)
LED110	Normal operation(LI/In stop)(Unit)
LED111	Normal operation(LI/In stop)(Unit)
LED112	Normal operation(LI/In stop)(Unit)
LED113	Normal operation(LI/In stop)(Unit)
LED114	Normal operation(LI/In stop)(Unit)
LED115	Normal operation(LI/In stop)(Unit)
LED116	Normal operation(LI/In stop)(Unit)
LED117	Normal operation(LI/In stop)(Unit)
LED118	Normal operation(LI/In stop)(Unit)
LED119	Normal operation(LI/In stop)(Unit)
LED120	Normal operation(LI/In stop)(Unit)
LED121	Normal operation(LI/In stop)(Unit)
LED122	Normal operation(LI/In stop)(Unit)
LED123	Normal operation(LI/In stop)(Unit)
LED124	Normal operation(LI/In stop)(Unit)
LED125	Normal operation(LI/In stop)(Unit)
LED126	Normal operation(LI/In stop)(Unit)
LED127	Normal operation(LI/In stop)(Unit)
LED128	Normal operation(LI/In stop)(Unit)
LED129	Normal operation(LI/In stop)(Unit)
LED130	Normal operation(LI/In stop)(Unit)
LED131	Normal operation(LI/In stop)(Unit)
LED132	Normal operation(LI/In stop)(Unit)
LED133	Normal operation(LI/In stop)(Unit)
LED134	Normal operation(LI/In stop)(Unit)
LED135	Normal operation(LI/In stop)(Unit)
LED136	Normal operation(LI/In stop)(Unit)
LED137	Normal operation(LI/In stop)(Unit)
LED138	Normal operation(LI/In stop)(Unit)
LED139	Normal operation(LI/In stop)(Unit)
LED140	Normal operation(LI/In stop)(Unit)
LED141	Normal operation(LI/In stop)(Unit)
LED142	Normal operation(LI/In stop)(Unit)
LED143	Normal operation(LI/In stop)(Unit)
LED144	Normal operation(LI/In stop)(Unit)
LED145	Normal operation(LI/In stop)(Unit)
LED146	Normal operation(LI/In stop)(Unit)
LED147	Normal operation(LI/In stop)(Unit)
LED148	Normal operation(LI/In stop)(Unit)
LED149	Normal operation(LI/In stop)(Unit)
LED150	Normal operation(LI/In stop)(Unit)
LED151	Normal operation(LI/In stop)(Unit)
LED152	Normal operation(LI/In stop)(Unit)
LED153	Normal operation(LI/In stop)(Unit)
LED154	Normal operation(LI/In stop)(Unit)
LED155	Normal operation(LI/In stop)(Unit)
LED156	Normal operation(LI/In stop)(Unit)
LED157	Normal operation(LI/In stop)(Unit)
LED158	Normal operation(LI/In stop)(Unit)
LED159	Normal operation(LI/In stop)(Unit)
LED160	Normal operation(LI/In stop)(Unit)
LED161	Normal operation(LI/In stop)(Unit)
LED162	Normal operation(LI/In stop)(Unit)
LED163	Normal operation(LI/In stop)(Unit)
LED164	Normal operation(LI/In stop)(Unit)
LED165	Normal operation(LI/In stop)(Unit)
LED166	Normal operation(LI/In stop)(Unit)
LED167	Normal operation(LI/In stop)(Unit)
LED168	Normal operation(LI/In stop)(Unit)
LED169	Normal operation(LI/In stop)(Unit)
LED170	Normal operation(LI/In stop)(Unit)
LED171	Normal operation(LI/In stop)(Unit)
LED172	Normal operation(LI/In stop)(Unit)
LED173	Normal operation(LI/In stop)(Unit)
LED174	Normal operation(LI/In stop)(Unit)
LED175	Normal operation(LI/In stop)(Unit)
LED176	Normal operation(LI/In stop)(Unit)
LED177	Normal operation(LI/In stop)(Unit)
LED178	Normal operation(LI/In stop)(Unit)
LED179	Normal operation(LI/In stop)(Unit)
LED180	Normal operation(LI/In stop)(Unit)
LED181	Normal operation(LI/In stop)(Unit)
LED182	Normal operation(LI/In stop)(Unit)
LED183	Normal operation(LI/In stop)(Unit)
LED184	Normal operation(LI/In stop)(Unit)
LED185	Normal operation(LI/In stop)(Unit)
LED186	Normal operation(LI/In stop)(Unit)
LED187	Normal operation(LI/In stop)(Unit)
LED188	Normal operation(LI/In stop)(Unit)
LED189	Normal operation(LI/In stop)(Unit)
LED190	Normal operation(LI/In stop)(Unit)
LED191	Normal operation(LI/In stop)(Unit)
LED192	Normal operation(LI/In stop)(Unit)
LED193	Normal operation(LI/In stop)(Unit)
LED194	Normal operation(LI/In stop)(Unit)
LED195	Normal operation(LI/In stop)(Unit)
LED196	Normal operation(LI/In stop)(Unit)
LED197	Normal operation(LI/In stop)(Unit)
LED198	Normal operation(LI/In stop)(Unit)
LED199	Normal operation(LI/In stop)(Unit)
LED200	Normal operation(LI/In stop)(Unit)

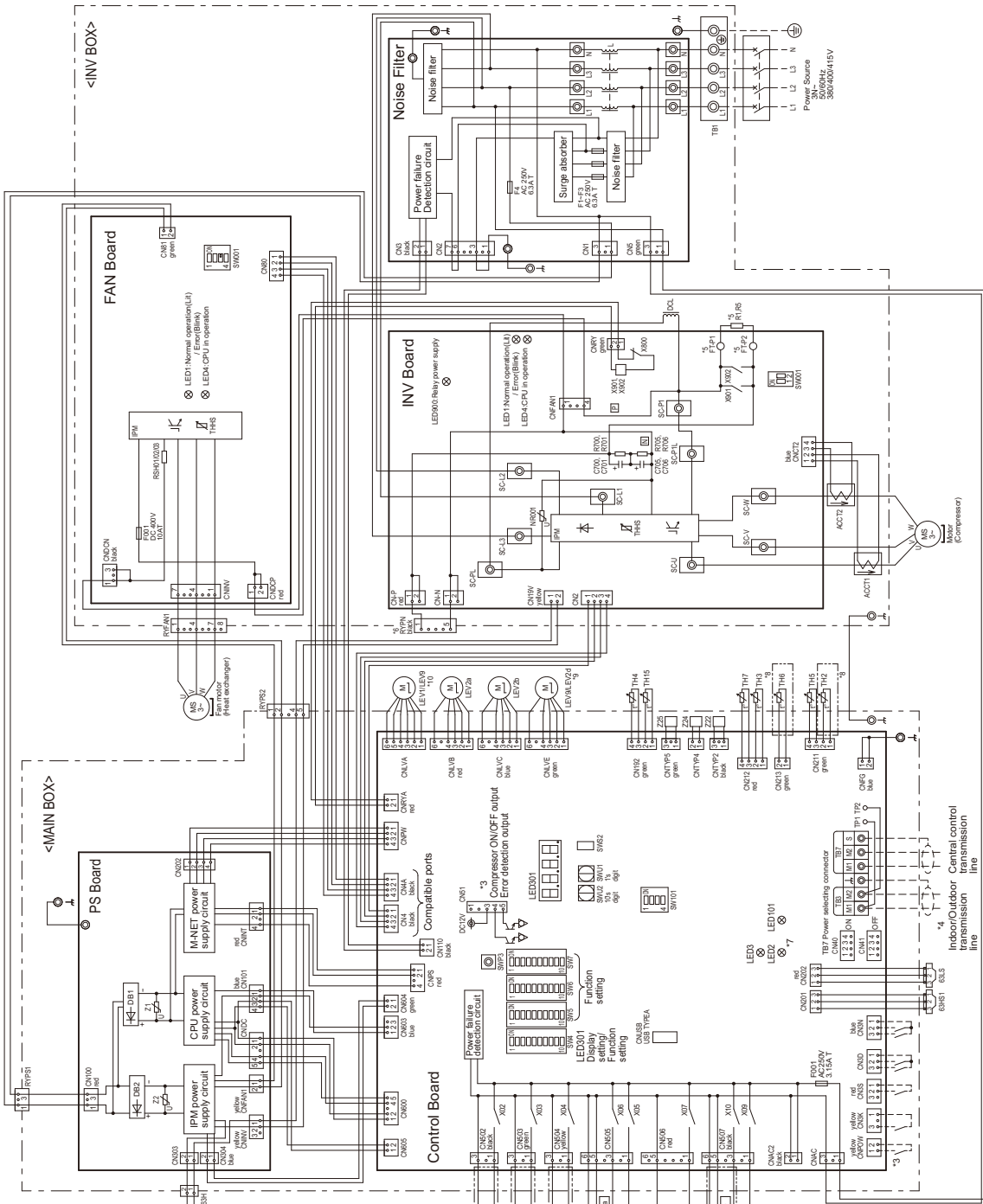
<Symbol explanation>

Symbol	Explanation
Z1S4b	Cooling/Heating switching
63H	Pressure switch
63H1	Pressure switch
63H2	Pressure switch
63H3	Pressure switch
63H4	Pressure switch
63H5	Pressure switch
63H6	Pressure switch
63H7	Pressure switch
63H8	Pressure switch
63H9	Pressure switch
63H10	Pressure switch
63H11	Pressure switch
63H12	Pressure switch
63H13	Pressure switch
63H14	Pressure switch
63H15	Pressure switch
63H16	Pressure switch
63H17	Pressure switch
63H18	Pressure switch
63H19	Pressure switch
63H20	Pressure switch
63H21	Pressure switch
63H22	Pressure switch
63H23	Pressure switch
63H24	Pressure switch
63H25	Pressure switch
63H26	Pressure switch
63H27	Pressure switch
63H28	Pressure switch
63H29	Pressure switch
63H30	Pressure switch
63H31	Pressure switch
63H32	Pressure switch
63H33	Pressure switch
63H34	Pressure switch
63H35	Pressure switch
63H36	Pressure switch
63H37	Pressure switch
63H38	Pressure switch
63H39	Pressure switch
63H40	Pressure switch
63H41	Pressure switch
63H42	Pressure switch
63H43	Pressure switch
63H44	Pressure switch
63H45	Pressure switch
63H46	Pressure switch
63H47	Pressure switch
63H48	Pressure switch
63H49	Pressure switch
63H50	Pressure switch
63H51	Pressure switch
63H52	Pressure switch
63H53	Pressure switch
63H54	Pressure switch
63H55	Pressure switch
63H56	Pressure switch
63H57	Pressure switch
63H58	Pressure switch
63H59	Pressure switch
63H60	Pressure switch
63H61	Pressure switch
63H62	Pressure switch
63H63	Pressure switch
63H64	Pressure switch
63H65	Pressure switch
63H66	Pressure switch
63H67	Pressure switch
63H68	Pressure switch
63H69	Pressure switch
63H70	Pressure switch
63H71	Pressure switch
63H72	Pressure switch
63H73	Pressure switch
63H74	Pressure switch
63H75	Pressure switch
63H76	Pressure switch
63H77	Pressure switch
63H78	Pressure switch
63H79	Pressure switch
63H80	Pressure switch
63H81	Pressure switch
63H82	Pressure switch
63H83	Pressure switch
63H84	Pressure switch
63H85	Pressure switch
63H86	Pressure switch
63H87	Pressure switch
63H88	Pressure switch
63H89	Pressure switch
63H90	Pressure switch
63H91	Pressure switch
63H92	Pressure switch
63H93	Pressure switch
63H94	Pressure switch
63H95	Pressure switch
63H96	Pressure switch
63H97	Pressure switch
63H98	Pressure switch
63H99	Pressure switch
63H100	Pressure switch

4 Electrical Components and Wiring Diagrams

(2) PUHY-(E)P200, (E)P250, (E)P300YNW-A1/2

4 Electrical Components and Wiring Diagrams



- *1. Single-dotted lines indicate wiring not supplied with the unit.
- *2. Dot-dash lines indicate the control box boundaries.
- *3. Refer to the Data book for connecting input/output signal connectors.
- *4. Daisy-chain terminals (TB3) on the outdoor units in the same refrigerant system together.
- *5. Faston terminals have a locking function. Make sure the terminals are securely locked in place after insertion. Press the tab on the terminals to removed them.
- *6. Control box houses high-voltage parts. Before inspecting the inside of the MAIN BOX or INV BOX, turn off the power, keep the unit off for at least 10 minutes, and confirm that the voltage of the connector RYPN on INV BOX has dropped to DC20V or less.
- *7. Control board LED display.

LED2	Normal operation (L/Normal)
LED3	SW10 is OFF and SW9 is ON (In operation (L/In stop (U/H))
LED4	SW10 is ON and SW9 is OFF (Function setting by SW4 enable (L/Usable (U/H))
LED101	Normal operation (L/Normal)

- *8. Difference of appliance.

Model name	Appliance
PUHY	Air conditioner
PUHY	Water heater
PUHY	Water pump
PUHY	Water pump
PUHY	Water pump
PUHY	Water pump
- *9. Difference of appliance.

Model name	Appliance
PUHY-PPURY	Water pump
PUHY-EP	Water pump
- *10. Difference of appliance.

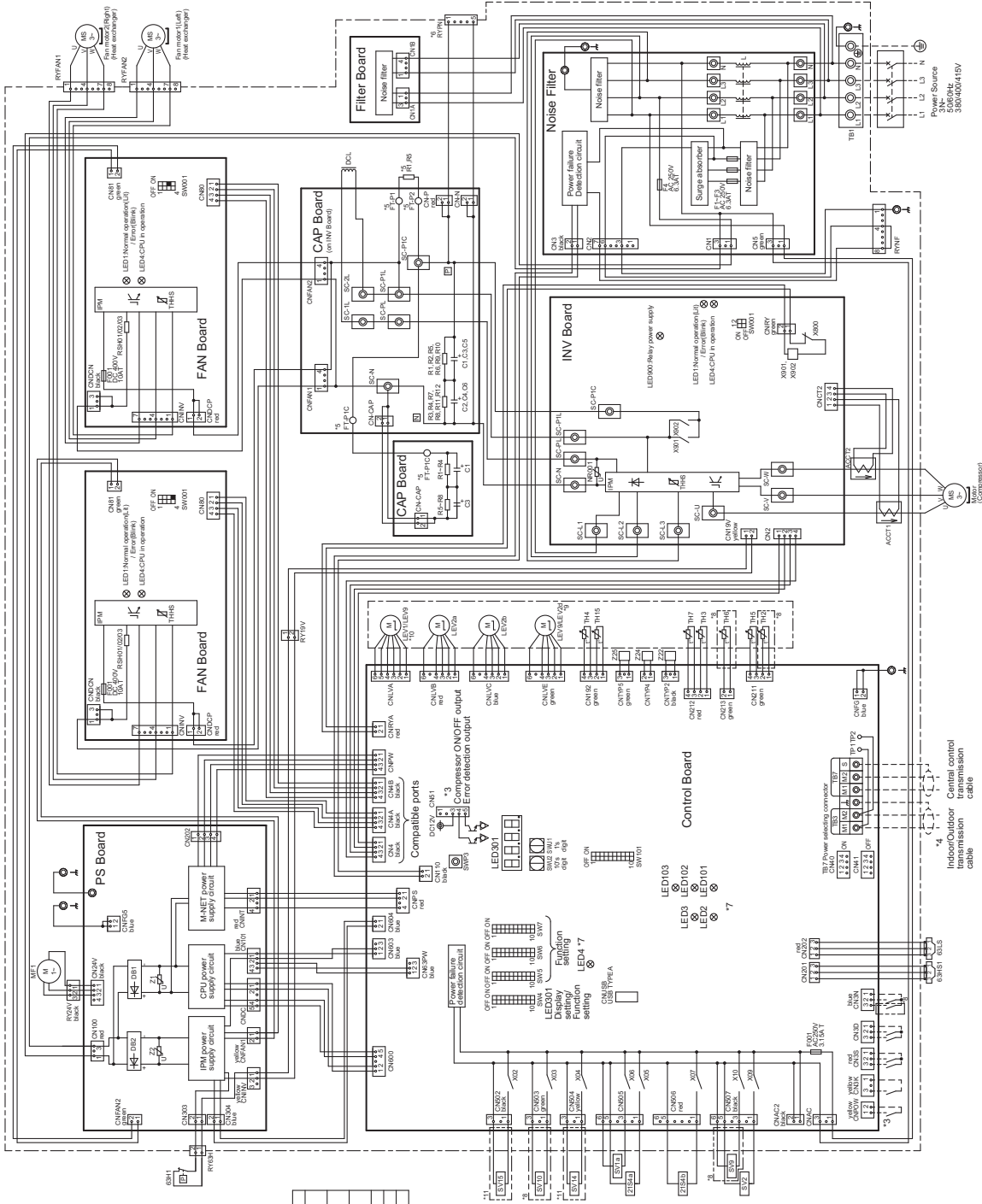
Model name	Appliance
PUHY	Water pump
PUHY	Water pump
PUHY	Water pump
PUHY	Water pump
PUHY	Water pump
PUHY	Water pump
- *11. Difference of appliance.

Model name	Appliance
PUHY-PPURY	Water pump
PUHY-EP	Water pump

<Symbol explanation>

Symbol	Explanation
Z1S4a	Coil/heating switching
Z1S4b	4-way valve
63H1	Pressure switch
63H2	Pressure switch
63S1	Pressure switch
63S2	Pressure switch
C700.C701	Current sensor (AC)
C705.C706	Capacitor (inverter main circuit)
DC	DC reactor
L	Choke coil (for high frequency noise reduction)
LEV1~10	Pressure sensor
LEV2a.b	Pressure sensor
LEV2a~9	Pressure sensor
LEV9.9.10	Pressure sensor
RTLS	Resistor
RSB010203	Refrigerant sensor
SV1a	Shutoff valve
SV2	Shutoff valve
SV9.9	Shutoff valve
SV10.9	Shutoff valve
SV14.15.11	Shutoff valve
TB1	Terminal block
TB2	Terminal block
TB2.9	Terminal block
TH3	Thermistor
TH4	Thermistor
TH5	Thermistor
TH6.9	Thermistor
TH7	Thermistor
TH15	Thermistor
Y01.Y02	Relay (inverter main circuit)
Z22.Z4.Z5	Function setting connector

(3) PUHY-(E)P350, (E)P400, (E)P450YNW-A



- *1. Single-dotted lines indicate wiring not supplied with the unit.
- *2. Dot-dash lines indicate the control box boundaries.
- *3. Refer to the Data book for connecting input/output signal connectors.
- *4. Daisy-chain terminals (TB3) on the outdoor units in the same refrigerant system together.
- *5. Faston terminals have a locking function. Make sure the terminals are securely locked in place after insertion. Press the tab on the terminals to removed them.
- *6. Control box houses high-voltage parts. Before inspecting the inside of the control box, turn off the power, keep the unit off for at least 10 minutes, and confirm that the voltage of the connector RYPN has dropped to DC20V or less.
- *7. Control board LED display.

LED3	Normal operation(L)/Error(Blink)
LED4	Normal operation(L)/Error(Blink)
LED5	Normal operation(L)/Error(Blink)
LED6	Normal operation(L)/Error(Blink)
LED7	Normal operation(L)/Error(Blink)
LED8	Normal operation(L)/Error(Blink)
LED9	Normal operation(L)/Error(Blink)
LED10	Normal operation(L)/Error(Blink)
LED11	Normal operation(L)/Error(Blink)

<Symbol explanation>

Symbol	Explanation
21S4a	Cooling/heating switching
21S4b	Pressure sensor
69H1	Pressure switch
69HS1	Pressure sensor
69LS	Low pressure sensor
ACCT/ACCTZ	Current sensor(AC)
CI-CB	Capacitor (inverter main circuit)
L	Inductor
LEV1 *10	Pressure sensor
LEV2/4b	Pressure sensor
LEV2/4 *9	Pressure sensor
LEV9 *9,10	Pressure sensor
MF1	Fan motor(for cooling in control box)
R1.5	Resistor
RSH0/102/03	Relay
SV1a	Solenoid valve
SV2	Solenoid valve
SV9 *9	Solenoid valve
SV10 *9	Solenoid valve
SV14,15 *11	Solenoid valve
TB1	Terminal block
TB7	Terminal block
TB8	Terminal block
TH2 *8	Thermistor
TH3	Thermistor
TH4	Thermistor
TH5	Thermistor
TH6 *8	Thermistor
TH7	Thermistor
TH8	Thermistor
TH9	Thermistor
X901, X902	Relay
Z22.24.25	Function setting connector

- *8. Difference of appliance.

Model name	Appliance
PUHY	LEV1
PUHY-EP	LEV9
- *9. Difference of appliance.

Model name	Appliance
PUHY	LEV9
PUHY-EP	LEV2/4
- *10. Difference of appliance.

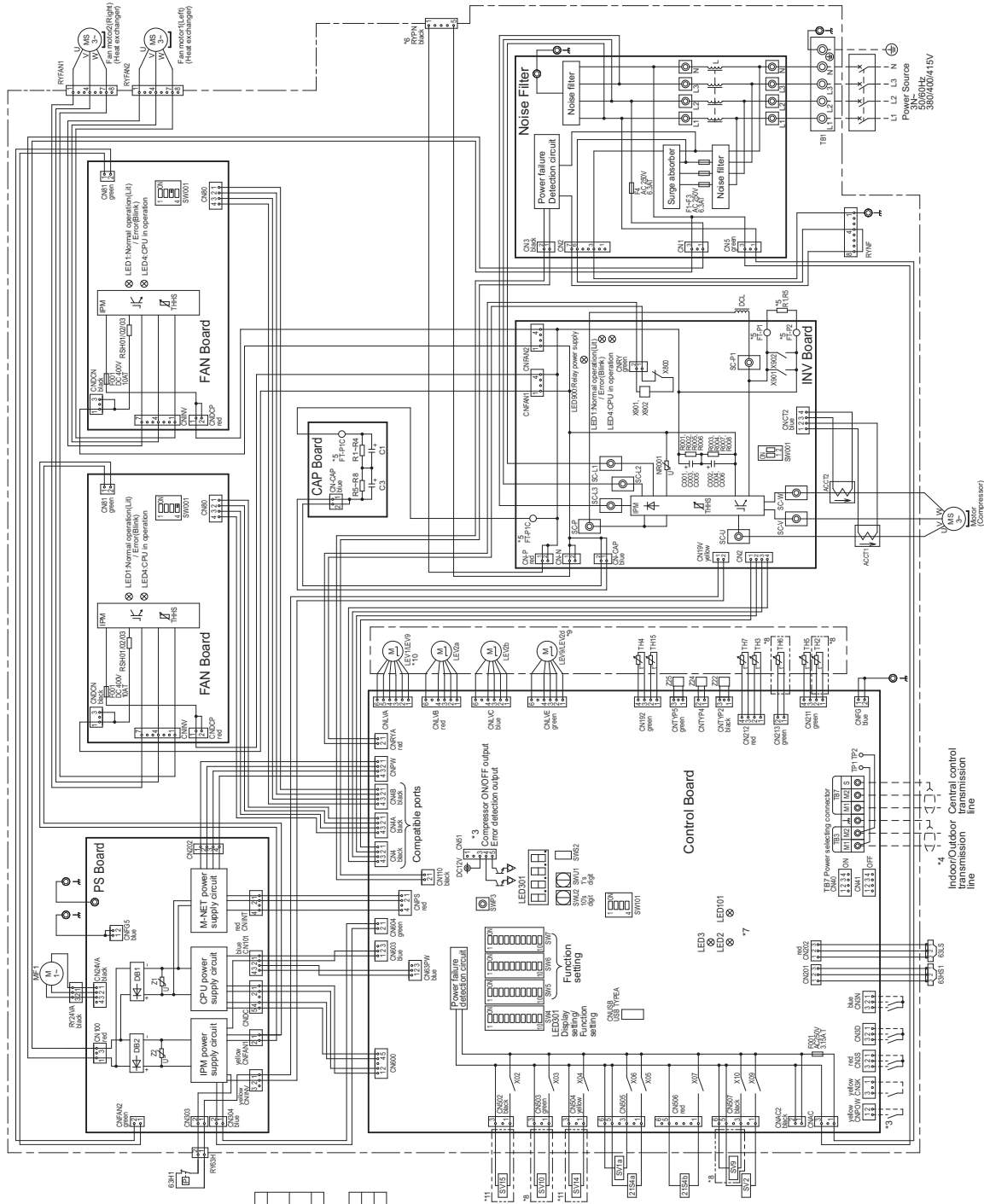
Model name	Appliance
PUHY	LEV1
PUHY-EP	LEV9
- *11. Difference of appliance.

Model name	Appliance
PUHY-P, PUHY	*11 do not exist
PUHY-EP	*11 exist

4 Electrical Components and Wiring Diagrams

(4) PUHY-(E)P350, (E)P400, (E)P450YNW-A1/2

4 Electrical Components and Wiring Diagrams



- *1. Single-dotted lines indicate wiring not supplied with the unit.
- *2. Dot-dash lines indicate the control box boundaries.
- *3. Refer to the Data book for connecting input/output signal connectors.
- *4. Daisy-chain terminals (TB3) on the outdoor units in the same refrigerant system together.
- *5. Faston terminals have a locking function. Make sure the terminals are securely locked in place after insertion. Press the tab on the terminals to removed them.
- *6. Control box houses high-voltage parts. Before inspecting the inside of the control box, turn off the power, keep the unit off for at least 10 minutes, and confirm that the voltage of the connector RYPN has dropped to DC20V or less.
- *7. Control board LED display.

LED2	Normal operation(LV>Error/Blank)
LED3	SW6-10 is OFF and In operation(LV in stop/Unit)
	SW6-1 to 10 are OFF
	SW6-10 is ON
	Function setting by SW4 enable(LV/Disable/Unit)
LED101	Normal operation(LVIC Error/Unit)

*8. Difference of appliance.

Model name	Appliance
PUHY	'8 exist
PUHY	'9 do not exist
PUHY	'11 exist

*9. Difference of appliance.

Model name	Appliance
PUHY	LEV9
PUHY	LEV20

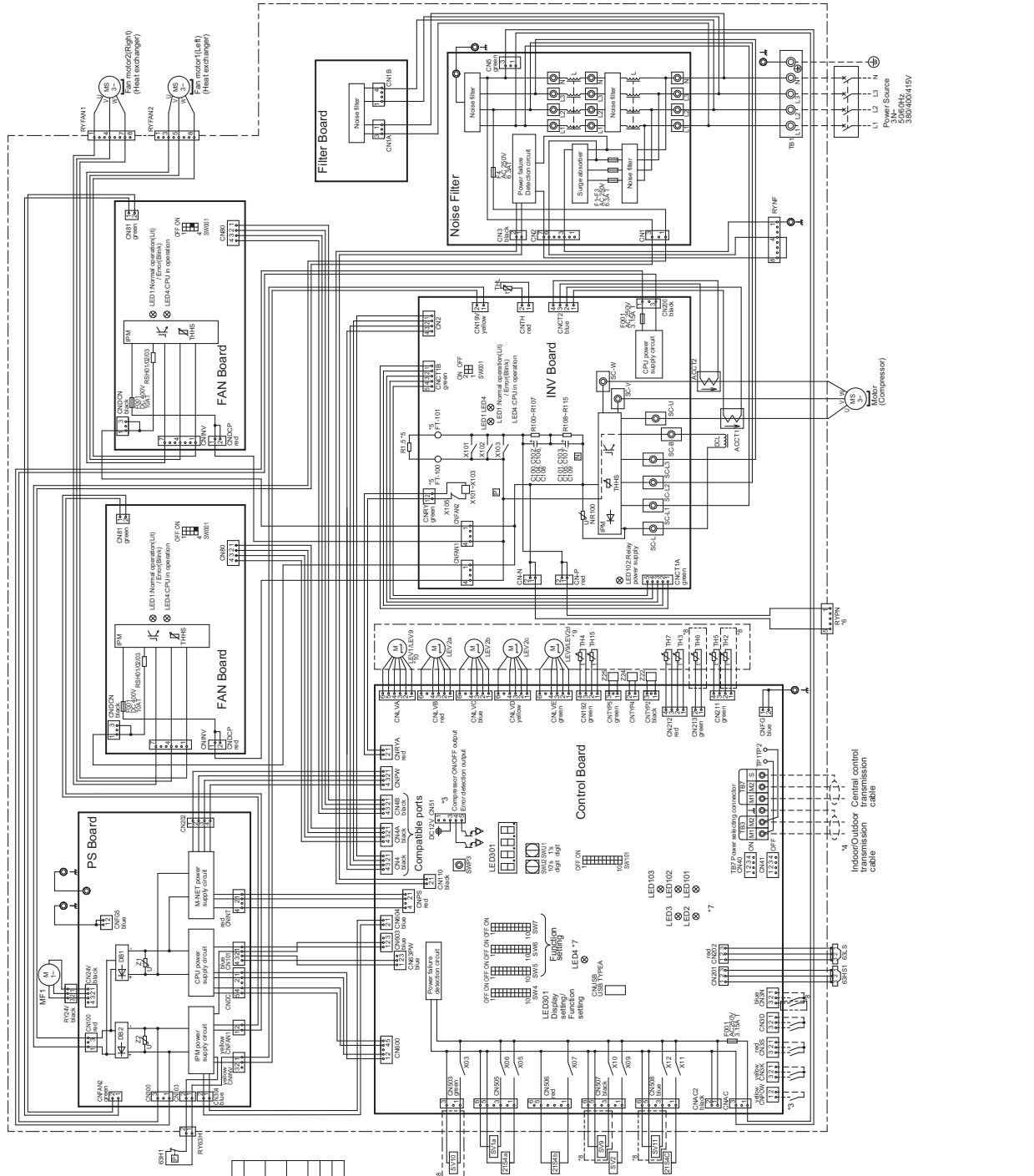
*10. Difference of appliance.

Model name	Appliance
PUHY	LEV1
PUHY	LEV9

<Symbol explanation>

Symbol	Explanation
21S4a	Cooling/Heating switching
21S4b	Heat exchanger capacity control(only PUHY model)
63H1	Pressure switch
63HS1	High pressure protection for the outdoor unit
63LS	Discharge pressure sensor
ACCT1 ACCT2	Low pressure
C1.C3.	Current sensor(AC)
CO01~CO06	Capacitor (inverter main circuit)
DC reactor	DC reactor
L	Choke coil (for high frequency noise reduction)
LEV1 *10	HIC bypass. Controls refrigerant flow in HIC circuit
LEV2a,b	Pressure control. Refrigerant flow rate control
LEV9 *9,10	Heat exchanger for inverter
MF1	Fan motor(for cooling in control box)
RT5	Resistor
RSH01/02/03	For rough current prevention
SV1a	Solenoid valve
SV2	For opening/closing the bypass circuit under the O/S
SV9 *9	For opening/closing the discharge suction bypass
SV10 *8	For opening/closing the bypass circuit
SV14,15 *11	For continuous heating (cooling/heating)
TB1	Terminal block
TB3	Power supply transmission line
TB7	Central control transmission line
TH2 *8	Subcool bypass outlet temperature
TH3	Pipe temperature
TH4	Discharge pipe temperature
TH5	ACC inlet pipe temperature
TH6 *8	Subcooled liquid refrigerant temperature
TH7	OA temperature
TH15	Compressor shell bottom temperature
X901.X902	IPM temperature
Z22,Z24,Z25	Magnetic relay(inverter main circuit) Function setting connector

(5) PUHY-(E)P500YNW-A



- *1. Single-dotted lines indicate wiring not supplied with the unit.
- *2. Dot-dash lines indicate the control box boundaries.
- *3. Refer to the Data book for connecting input/output signal connectors.
- *4. Daisy-chain terminals (TB3) on the outdoor units in the same refrigerant system together.
- *5. Faston terminals have a locking function. Make sure the terminals are securely locked in place after insertion. Press the tab on the terminals to removed them.
- *6. Control box houses high-voltage parts. Before inspecting the inside of the control box turn off the power, keep the unit off for at least 10 minutes, and confirm that the voltage of the connector RYPN has dropped to DC20V or less.
- *7. Control board LED display.

LED3	Normal operation(LED/Normal/Blank)
SW6-10	is OFF and In operation(L/Unit step/Unit)
SW6-1 to 5	is OFF
SW6-10	is ON
Function setting by SW4	enabled(L/Unit/Blank/Unit)
- *8. Difference of appliance.

Model name	Appliance
PUHY	Appliance
PUHY	Appliance
- *9. Difference of appliance.

Model name	Appliance
PUHY	Appliance
PUHY	Appliance
- *10. Difference of appliance.

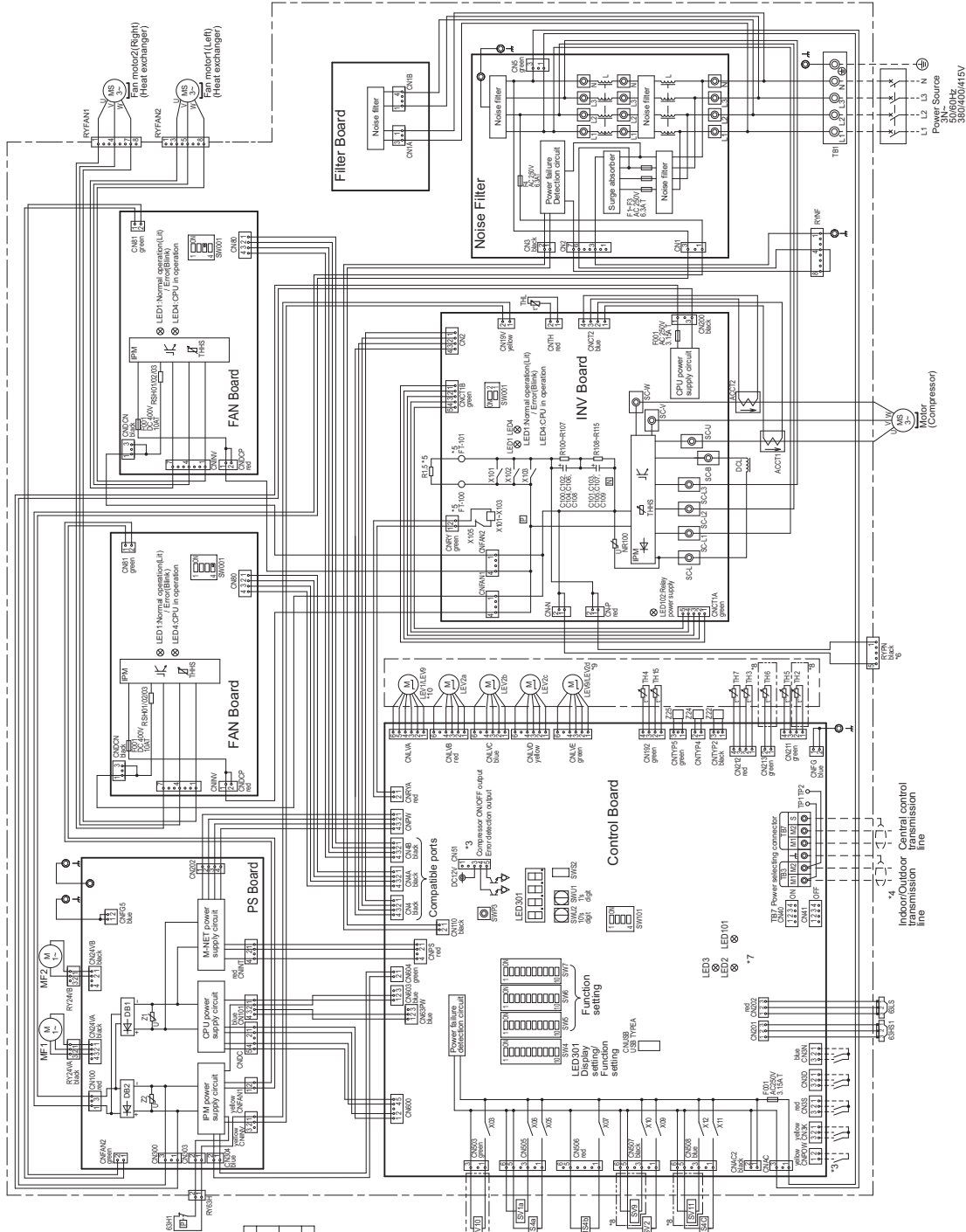
Model name	Appliance
PUHY	Appliance
PUHY	Appliance

<Symbol explanation>

Symbol	Explanation
21S4a	Cooling/heating switching
21S4b,c	Heat exchanger capacity control (only PUHY mode)
63H1	Cooling/heating switching
63H51	Overcurrent protection for the outdoor unit
63LS	Discharge pressure
ACCT1/ACCT2	Pressure sensor
C100-C109	Current sensor (AC)
DCL	Capacitor (inverter main circuit)
L	Choke coil (for high frequency noise reduction)
LEV1 *10	H/C bypass/Controls refrigerant flow in H/C circuit
LEV2a,b,c	Pressure control/Refrigerant flow rate control
LEV2d *9	Pressure control/Refrigerant flow rate control
LEV9 *9,10	Heat exchanger for inverter
M1	Fan motor (for cooling in control box)
R1.5	Resistor
RS-810/203	For current detection
SV18	Solenoid valve
SV2	For opening/closing the bypass circuit under the O/S
SV9 *8	For opening/closing the bypass circuit
TB1	Power supply
TB2	Terminal block
TH2 *8	For continuous heating
TH3	Indoor/outdoor transmission cable
TH4	Subcooled liquid outlet temperature
TH5	Pipe temperature
TH6	Discharge pipe temperature
TH6 *8	ACC inlet pipe temperature
TH7	Subcooled liquid refrigerant temperature
TH8	O/A temperature
TH9	Compressor shell bottom temperature
TH15	IPM temperature
X101-X103	Magnetic relay (inverter main circuit)
Z22.24-25	Function setting connector

(6) PUHY-(E)P500YNW-A1/2

4 Electrical Components and Wiring Diagrams



- *1. Single-dotted lines indicate wiring not supplied with the unit.
- *2. Dot-dash lines indicate the control box boundaries.
- *3. Refer to the Data book for connecting input/output signal connectors.
- *4. Daisy-chain terminals (TB3) on the outdoor units in the same refrigerant system together.
- *5. F-astion terminals have a locking function. Make sure the terminals are securely locked in place after insertion. Press the tab on the terminals to removed them.
- *6. Control box houses high-voltage parts. Before inspecting the inside of the control box, turn off the power, keep the unit off for at least 10 minutes, and confirm that the voltage of the connector RYPN has dropped to DC20V or less.
- *7. Control board LED display.
 - LED3 Normal operation(L)/Error(Blank)
 - LED2 SW6-10 is OFF and In operation(L)/In stop(Unlck)
 - LED1 SW6-10 is ON Function setting by SW4 (enable/L)/Disable(Unlck)
 - LED101 Normal operation(L)/IC Error(Unlck)

***8. Difference of appliance.**

Model name	Appliance
PUHY	3 ex-st
PUJY	3 do not ex-st

***9. Difference of appliance.**

Model name	Appliance
PUHY	LEV9
PUJY	LEV2d

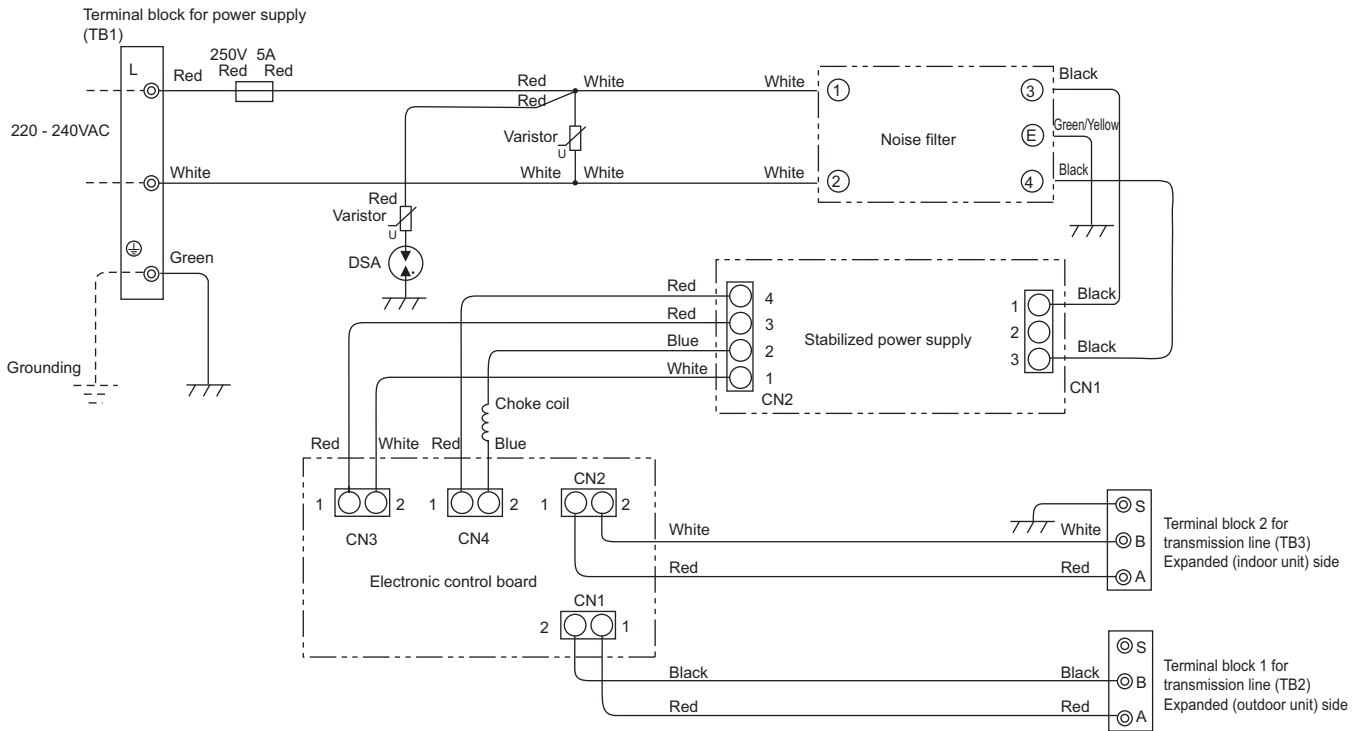
***10. Difference of appliance.**

Model name	Appliance
PUHY	LEV1
PUJY	LEV9

<Symbol explanation>

Symbol	Explanation
Z1S4b	Expansion
Z1S4b.c	Cooling/heating switching (only PUHY model)
63H1	Cooling/heating switching outdoor unit
63HS1	Pressure switch
63LS1	Discharge pressure sensor
C100-C102	High pressure protection for the inverter main circuit
DCI	DC reactor
LEV1*10	Choke coil (for high frequency noise reduction)
LEV2a,b,c	Linear expansion valve
LEV2d*9	Pressure control, Refrigerant flow rate control
LEV9*9,10	Pressure control, Refrigerant flow rate control
MF1,2	Heat exchanger for inverter cooling in control box
RL1,2	Fan motor for cooling in control box
RS401/02/03	Resistor For inrush current prevention
SV1a	For current detection
SV2	Solenoid valve For opening/closing the bypass suction bypass
SV9*8	For opening/closing the discharge suction bypass
SV10,11*8	For continuous heating
TB1	Power supply
TB3	Terminal block Indoor/Outdoor transmission line
TB7	Central control transmission line
TH1*8	Subcool bypass outlet temperature
TH3	Pipe temperature
TH4	Discharge pipe temperature
TH5	ACC inlet pipe temperature
TH6*8	Subcooled liquid refrigerant temperature
TH7	CA temperature
TH8	CA temperature
TH9	Compressor shell bottom temperature
X101-X103	Magnetic relay (inverter main circuit)
Z22,24,25	Function setting connector

4-4 Transmission Booster Electrical Wiring Diagrams



Chapter 5 Control

5-1	Dipswitch Functions and Factory Settings	1
5-1-1	Outdoor Unit Switch Functions and Factory Settings	1
5-1-2	Indoor Unit Switch Functions and Factory Settings	7
5-1-3	Remote Controller Switch Functions and Factory Settings	8
5-2	Outdoor Unit Control	10
5-2-1	Overview	10
5-2-2	Rotation Control	10
5-2-3	Initial Control	10
5-2-4	Startup Control	10
5-2-5	Refrigerant Bypass Control	11
5-2-6	Frequency Control	13
5-2-7	Defrost Operation Control	14
5-2-8	Continuous heating mode control	17
5-2-9	Refrigerant Recovery Control	18
5-2-10	Outdoor Unit Fan Control	19
5-2-11	Subcool Coil Control (Linear Expansion Valve <LEV1>)	20
5-2-12	Refrigerant Flow Control (Linear Expansion Valves <LEV2a, LEV2b, and LEV2c>)	20
5-2-13	Control of Controller Cooling Function (Electronic Expansion Valve <LEV9>)	20
5-2-14	Control at Initial Startup	20
5-2-15	Emergency Operation Mode	23
5-2-16	Operation Mode	26
5-2-17	Demand Control	26
5-2-18	Control of IH energization without the compressor in operation	26

5-1 Dipswitch Functions and Factory Settings

5-1-1 Outdoor Unit Switch Functions and Factory Settings

(1) Control board

Switch		Function	Function according to switch setting		Switch setting timing	Units that require switch setting (Note 2)
			OFF	ON		
SWU	1-2	Unit address setting	Set to 00 or 51-100 with the dial switch		Before power on	C
SW5	1	Centralized control switch	Without connection to the centralized controller	With connection to the centralized controller	Before power on	B
	2	Deletion of connection information	Normal control	Deletion	Before power on	A
	3	-	Preset before shipment (Varies with unit type and model)			-
	4	-				-
	5	-				-
	6	-				-
	7	-				-
	8	-				-
SW6	1	-	-	-	-	-
	2	COP priority setting (at low outside temperature)*	Heating capacity priority control mode	Heating COP priority mode	Before power on	A
	3	-	-	-	-	-
	4	Model setting (outdoor unit/high static pressure setting)	Function depends on the setting combination with the SW6-5 setting (Note 6). (Factory setting: OFF)		Before power on	C
	5	Model setting (outdoor unit/high static pressure setting)	Function depends on the setting combination with the SW6-4 setting (Note 6). (Factory setting: OFF)		Before power on	C
	6	-	-	-	-	-
	7	Performance-priority/low-noise mode setting	Performance-priority mode (Note 3)	Quiet-priority mode (Note 5)	Anytime after power on	A
	8	Low-noise mode/step demand switching	Low-noise mode (Note 4)	Step demand mode	Before power on	C
	9	-	-	-	-	-
	10	Self-diagnosis monitor display / SW4 function setting mode switching	Self-diagnosis monitor display	SW4 function setting mode	Anytime after power on	C


* Available on Type A. (For Type A1/2, see SW4 (No. 935).)

Switch		Function	Function according to switch setting		Switch setting timing	Units that require switch setting (Note 2)
			OFF	ON		
SW7	1	Enables or disables the detection of the following types of inverter compressor errors ACCT, DCCT sensor error(5301 Detail code 115, 116) ACCT, DCCT sensor circuit error(5301 Detail code 117, 118) IPM open-phase/CNCT2 connection error(5301 Detail code 119) Wiring connection error(5301 Detail code 120)	Error detection enabled	Error detection disabled (no-load operation allowed)	Any time after power on	C
	2	Enables or disables no-load operation of the left fan inverter The unit continues no-load operation for 30 seconds and comes to an error stop. See the relevant pages for details: [8-9-9 Checking the Fan Board for Damage at No Load]	No-load operation disabled	No-load operation enabled	Any time after power on	C
	3					-
	4	Enables or disables no-load operation of the right fan inverter The unit continues no-load operation for 30 seconds and comes to an error stop. See the relevant pages for details: [8-9-9 Checking the Fan Board for Damage at No Load]	No-load operation disabled	No-load operation enabled	Any time after power on	C
	5	-	-	-	-	-
	6	-	-	-	-	-
	7	-	-	-	-	-
	8	-	-	-	-	-
	9	Switches between the normal startup mode and the USB writer rewrite mode	Normal startup mode	USB writer rewrite mode	Before power on	C
	10	-	-	-	-	-

Note

- 1) Unless otherwise specified, leave the switch to OFF where indicated by "-", which may be set to OFF for a reason.
- 2) A: Only the switch on OC needs to be set for the setting to be effective.
 B: The switches on both the OC and OS need to be set to the same setting for the setting to be effective.
 C: The switches on both the OC and OS need to be set.
- 3) When set to the performance-priority mode, the low-noise mode will be terminated, and the units will operate in the normal mode.
 Cooling: Ambient temperature or the high pressure is high.
 Heating: When the outside air temperature is low or when the low pressure is low. Refer to the following page(s). [2-4-7 Various Control Methods Using the Signal Input/Output Connector on Outdoor Unit]
- 4) Operation noise is reduced by controlling the compressor frequencies and the rotation speed of the outdoor unit fans. CN3D needs to be set. Refer to the following page(s). [2-4-7 Various Control Methods Using the Signal Input/Output Connector on Outdoor Unit]
- 5) Operation noise is reduced by limiting the frequency of the compressor and rotation speed of the outdoor unit fan.
- 6) External static pressure setting depends on the setting combination of SW6-5 and SW6-4 settings as shown in the table below.

		SW6-5	
		OFF	ON
SW6-4	OFF	0Pa	30Pa
	ON	60Pa	80Pa

- 7) Keep SW7-1, -2, and -4 set to OFF during normal operation. Leaving these switches to ON will disable the error-detection function and can lead to equipment damage.
- 8) Shaded areas () indicate factory settings.

(2) Additional dipswitch settings at time of shipment

Switch		Function	Function according to switch setting		Switch setting timing	Units that require switch setting (Note 2)		
			OFF (LED3 Unlit)	ON (LED3 Lit)				
SW4 SW6-10: OFF	1-10 1:ON, 0:OFF	Self-diagnosis/operation monitor			Anytime after power on	C		
SW4 1-10 [0:OFF, 1:ON] (Note 1) SW6-10:ON	No.769	1000000011	Test run mode: ON/OFF	Stops all ICs	Sends a test-run signal to all IC	Anytime after power on	A	
	No.817	1000110011	Starts up drive recorder	Enabled	Disabled	Anytime after power on	A	
	No.818	0100110011	Data collection during an error (Note 10)	Disabled	Enabled	Anytime after power on	A	
	No.832	0000001011	Cumulative compressor operation time deletion	Retained	Cleared	Any time after being energized (When changed from OFF to ON)	C	
	No.848	0000101011	Continuous heating cycle function	Disabled	Enabled	After being energized and while the compressor is stopped	B	
	No.852	0010101011	Shifts evaporating temp. depending on the load.	Depends on the setting combination with No. 853 (Note 6) (Factory setting: OFF)		Anytime after power on	A	
	No.853	1010101011	Shifts evaporating temp. depending on the load.	Depends on the setting combination with No. 852 (Note 6) (Factory setting: OFF)		Anytime after power on	A	
	No.891	1101111011	Smooth auto-shift startup mode	Disabled	Enabled	After being energized and while the compressor is stopped	A	
	No.896	0000000111	Clearance of error history	OC	Retained (IC/OC)	Deleted (IC/OC)	Anytime after power on (OFF→ON)	C
				OS	Retained (OS)	Deleted (OS)		
	No.897	1000000111	High sensible heat operation setting	Depends on the combined setting with No. 900 (Note 4) (Factory setting: OFF)		After being energized and while the compressor is stopped	A	
	No.900	0010000111	High sensible heat operation setting	Depends on the combined setting with No. 897 (Note 4) (Factory setting: OFF)		After being energized and while the compressor is stopped	A	
	No.912	0000100111	Pump down function	Normal control	Pump down operation	After being energized and while the compressor is stopped	A	
	No.913	1000100111	Forced defrost (Note 3)	Normal control	Forced defrost starts	Anytime after power on 10 minutes after the completion of defrost operation (OFF→ON) or 10 minutes after compressor start-up (OFF→ON)	D	
	No.915	1100100111	Defrost start temperature (Note 3)	(E)P200 - 300: -13°C [9°F] (E)P350 - 500: -11°C [12°F]	-8°C [18°F]	Anytime after power on	B	
	No.916	0010100111	Defrost end temperature Changes the defrost timer setting (Note 3)	Depends on the combined setting with No. 918 (Note 3) (Factory setting: OFF)		Anytime after power on	B	
	No.918	0110100111	Defrost end temperature Changes the defrost timer setting (Note 3)	Depends on the combined setting with No. 916 (Note 3) (Factory setting: OFF)		Anytime after power on (OFF→ON)	B	
	No.921	1001100111	Temperature unit display	°C	°F	Anytime after power on	C	
	No.922	0101100111	Refrigerant amount adjustment	Normal control	Refrigerant amount adjust mode	Anytime after power on (except during initial startup/becomes ineffective 90 minutes after compressor started up.)	A	
	No.932	0010010111	Heating backup	Disabled	Enabled	Anytime after power on	A	
	No.933	1010010111	Snow sensor setting	Effective only when TH7 ≤ 5 is true or the snow sensor contact input is on.	Effective when TH7 ≤ 5 is true	Anytime after power on	C	
	No.934	0110010111	Snow sensor setting	Continuous fan operation (FAN=50%)	Intermittent fan operation (The fan operates in the cycle of being in operation at 100% capacity for 5 minutes and then stops and remains stopped for 30 minutes.)	Anytime after power on	C	
	No.935*	1110010111	COP priority setting (at low outside temperature)	Heating capacity priority control mode	COP priority mode	After power on and while the compressor is stopped	A	
	No.964	0010001111	Target evaporation temperature setting	Depends on the setting combination with No. 982 (Note 5) (Factory setting: OFF)		Anytime after power on	A	
	No.972	0011001111	Automatic cooling/heating mode (IC with the smallest address)	Normal control	Automatic cooling/heating mode	Before power on (After configuring the setting, perform a power reset.)	A	
	No.982	0110101111	Target evaporation temperature setting	Depends on the setting combination with No. 964 (Note 5) (Factory setting: OFF)		Anytime after power on	A	
	No.988	0011101111	Refrigerant recovery/Evacuation (LEV2, LEV1, SV2 open)	Disabled	Enabled	After being energized and when units are stopped	C	
	No.997	1010011111	Multiple-stage low-noise setting	See note 9 below. (Factory setting: OFF)		After power on and while the compressor is stopped	A	
No.1006	0111011111							

* Available on Type A1/2.

[5-1 Dipswitch Functions and Factory Settings]

Note

- 1) To change the settings, set SW6-10 to ON, set SW4, and press and hold SWP3 for 2 seconds or longer (OFF↔ON). LED3 will light up when the switch setting is ON, and lights off when OFF. Use the LED3 display to confirm that the settings are properly made. The settings will need to be set again when the control board is replaced. Write down the settings on the electrical wiring drawing label.
- 2) A: Only the switch on OC needs to be set for the setting to be effective.
 B: The switches on both the OC and OS need to be set to the same setting for the setting to be effective.
 C: The switches on both the OC and OS need to be set.
 D: The switch on either the OC or OS needs to be set.
- 3) For details, refer to the following page(s). [5-2-7 Defrost Operation Control]
- 4) The table below shows the combinations of the settings for items No. 897 and No. 900 and the target evaporating temperature setting that corresponds to each combination.

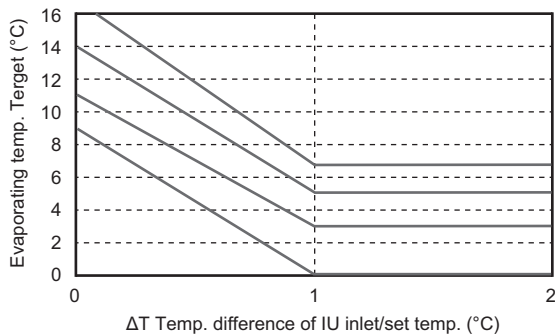
Switch		No.900	
		OFF	ON
No.897	OFF	0°C [32°F]	9°C [48°F]
	ON	6°C [43°F]	14°C [57°F]

- 5) The table below shows the combinations of the settings for items No. 964 and No. 982 and the target evaporating temperature setting that corresponds to each combination.

Switch		No.982	
		OFF	ON
No.964	OFF	0°C [32°F]	-4°C [25°F]
	ON	-2°C [28°F]	-6°C [21°F]

- 6) The table below shows the combination of the settings for items No.852 and No.853 and the target evaporating temperature (target ET) setting that corresponds to each combination when energy-saving mode is activated. Refer to the following page(s). [2-4-7 Various Control Methods Using the Signal Input/Output Connector on Outdoor Unit]

Switch No.852	OFF	ON	OFF	ON
Switch No.853	OFF	OFF	ON	ON
Target ET max	9°C [48°F]	11°C [52°F]	14°C [57°F]	17°C [63°F]
Target ET min	0°C [32°F]	3°C [37°F]	5°C [41°F]	6°C [43°F]



- 7) Unless otherwise specified, leave the switch to OFF where indicated by "-", which may be set to OFF for a reason.
- 8) The settings that are configured with SW4 (SW6-10: ON) will automatically be stored on the indoor units that support the new function*. The stored settings will automatically be restored when the outdoor unit control board is replaced.
 If none of the connected indoor units supports the new function, no configuration information will be saved. If this is the case, manually record the settings configuration on the control box panel.
 *The new function is supported on most units that are manufactured in December of 2012 and later. Depending on the model, this function may be added on later date. Ask your dealer for further details.
- 9) The multiple-stage low-noise function controls the fan by targeting the capacities shown in the table below.

Switch		No.1006	
		OFF	ON
No.997	OFF	50%	60%
	ON	85%	70%

- 10) For details, refer to the following page(s). [9-2-3 Collecting Operation Data]
- 11) Shaded areas () indicate factory settings.

(3) Fan board

Switch		Function	Function according to switch setting		Switch setting timing
			OFF	ON	
SW1	1	Enabling/Disabling no-load operation No-load operation will continue for approximately 30 seconds, and then the unit will come to an abnormal stop. For details, refer to the following page(s). [8-9-9 Checking the Fan Board for Damage at No Load]	No-load operation disabled	No-load operation enabled	Anytime after power on
	2	-	-	-	-
	3	Address setting. See the notes below.	0	5	Before power on
	4	Address setting. See the notes below.	0	6	Before power on

Note

- Only the addresses are preset before shipment (All other switches are set to OFF.) Unless otherwise specified, leave the switch to OFF where indicated by "-", which may be set to OFF for a reason.
- To set the address for a unit with one fan, only set SW1-3 to ON (= address 5). To set the addresses for a unit with two fans, set SW1-3 on the fan board on the right side (when seen from the front of the control box) to ON (= address 5) and set SW1-4 on the left fan board to ON (= address 6).
- Leave SW1-1 to OFF during normal operation. Setting this switch to ON will disable the error detection function and may result in equipment damage.

5-1-2 Indoor Unit Switch Functions and Factory Settings

(1) Dipswitches

1) SW1,3

Switch		Function	Function according to switch setting		Switch setting timing	Notes
			OFF	ON		
SW1	1	Room temperature detection position	Indoor unit inlet	Built-in sensor on the remote controller	While the unit is stopped (Remote controller OFF)	Set to ON (built-in sensor on the remote controller) on All Fresh (PEFY-VMH-F) model units
	2	Clogged filter detection	Not available	Available		
	3	Filter check reminder time setting	100h	2500h		
	4	Outside air intake	Disabled	Enabled		Always set to OFF on PKFY-VBM model units
	5	Remote display option	Fan output	Thermo-ON signal		
	6	Humidifier control	During heating operation	Always on while in the heating mode		
	7	Fan speed setting for Heating Thermo-OFF	Very Low	Low		
		Forced heating operation at OA temp of 5°C or below	Not available	Available		Applicable to All Fresh model units (PEFY-VMH-F) only
	8	Fan speed setting for Heating Thermo-OFF	According to the SW1-7 setting	Preset speed		
		-	-	-		Applicable to All Fresh model units (PEFY-VMH-F) only
9	Self-recovery after power failure	Disabled	Enabled			
10	Power source start-stop	Disabled	Enabled			
SW3	1	Unit model selection	Heat pump	Cooling only	While the unit is stopped (Remote controller OFF)	
	2	Louver	Not available	Available		
	3	Vane	Not available	Available		
	4	Vane swing function	Not available	Available		Always set to OFF on PKFY-VBM model units
	5	-	-	-		
	6	Vane angle limit setting for cooling operation	Downblow B,C	Horizontal		Always set to Downblow B or C on PKFY-VBM model units
		Initial vane position	Enabled	Disabled		PLFY-VLMD model only
	7	Automatic LEV value conversion function	Not available	Available		
	8	Heating 4°C [39.2°F] up	Enabled	Disabled		Set to OFF on floor-standing (PFFY) type units
	9	SHm setting	2°C [35.6°F]	5°C [41°F]		The setting depends on the model and type.
10	SCm setting	10°C [50°F]	15°C [59°F]	The setting depends on the model and type.		

Note 1. Settings in the shaded areas are factory settings. (Refer to the table below for the factory setting of the switches whose factory settings are not indicated by the shaded cells.)

Note 2. If both SW1-7 and SW1-8 are set to ON, the fan remains stopped during heating Thermo-OFF.

To prevent incorrect temperature detection due to a build-up of warm air around the indoor unit, use the built-in temperature sensor on the remote controller (SW1-1) instead of the one on the indoor unit inlet thermistor.

Note 3. By setting SW3-1, SW1-7, and SW1-8 to a certain configuration, the fan can be set to remain stopped during cooling Thermo-OFF. See the table below for details.

Switch setting			Fan speed during Thermo-OFF		Cooling-only/heat pump	
SW3-1	SW1-7	SW1-8	Heating	Cooling		
OFF	OFF	OFF	Very Low	Preset speed	Heat pump	
	ON		Low			
	OFF	ON	Preset speed			
	ON		Stop			
ON	OFF	OFF	-	Preset speed	Cooling-only	
	ON		-			
	OFF	ON	-			Stop
	ON		Stop			Stop

Note 4. Switch settings vary with indoor units models. Refer to the Service Handbook for indoor units for details.

2) SW2

Model	P10	P15	P20	P25	P32	P40	P50	P63
Capacity (model) code	2	3	4	5	6	8	10	13
SW2 setting								
Model	P71	P80	P100	P125	P140	P200	P250	
Capacity (model) code	14	16	20	25	28	40	50	
SW2 setting								



The figure at left shows that the switches 1 through 5 are set to ON and 6 through 10 are set to OFF.

Note

The setting timing for SW2 is before power is turned on.

(2) Address switch

Actual indoor unit address setting varies in different systems. Refer to the installation manual for the outdoor unit for details on how to make the address setting.

Each address is set with a combination of the settings for the 10's digit and 1's digit.

(Example)

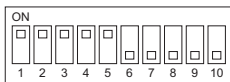
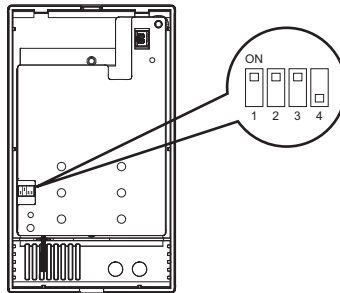
When setting the address to "3", set the 1's digit to 3, and the 10's digit to 0.

When setting the address to "25", set the 1's digit to 5, and the 10's digit to 2.

5-1-3 Remote Controller Switch Functions and Factory Settings

(1) MA simple remote controller (PAC-YT52CRA)

There are switches on the back of the top case. Remote controller Main/Sub and other function settings are performed using these switches. Ordinarily, only change the Main/Sub setting of SW1. (The factory settings are ON for SW1, 2, and 3 and OFF for SW4.)



The figure at left shows that the switches 1 through 5 are set to ON and 6 through 10 are set to OFF.

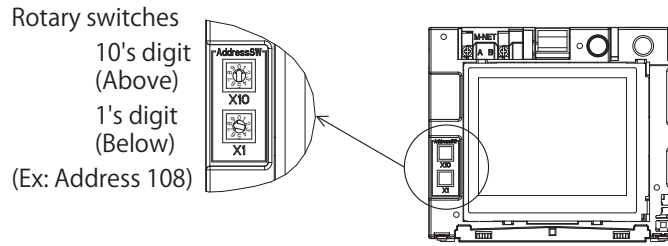
SW No.	SW contents Main	ON	OFF	Comment	Switch setting timing
1	Remote controller Main/Sub setting	Main	Sub	Set one of the two remote controllers at one group to "ON".	Before power on
2	Temperature display units setting	Celsius	Fahrenheit	When the temperature is displayed in [Fahrenheit], set to "OFF".	Before power on
3	Cooling/heating display in AUTO mode	Yes	No	When you do not want to display "Cooling" and "Heating" in the AUTO mode, set to "OFF".	Before power on
4	Indoor temperature display	Yes	No	When you want to display the indoor temperature, set to "ON".	Before power on

Note

The MA remote controllers (PAR-4XMAA, PAR-3XMAA ("X" represents 0 or later), PAR-CT01MA, PAR-21MAA) do not have the switches listed above. Refer to the installation manual for the function setting.

(2) ME remote controller (PAR-U02MEDA)

Set the address of the remote controller with the rotary switch.



	Address range	Address setting method
Main remote controller	101 to 150	Address that equals the lowest address of the group plus 100
Sub remote controller	151 to 200	Address that equals the lowest address of the group plus 150

Rotary switch setting	Address
01 to 99	101-199 with the 100's digit automatically set to 1
00	200

- * The factory setting for the rotary switches is 01.
- ** M-NET address can be changed with or without the power being applied to the controller. The use of any other tool or applying too much load may damage the switch. The screen will jump to the [Start-up] screen. Group information for indoor units and AHC units will be deleted, but the rest of the information will be retained.

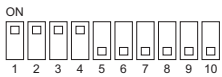
Note

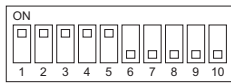
To set the address, turn the rotary switch with a precision slotted screwdriver [(-), 2.0 mm (1/16 in) (W)] to a torque of less than 19.6 N to avoid the damage to the rotary switches.

5-2 Outdoor Unit Control

5-2-1 Overview

- The outdoor units are designated as OC, OS1 and OS2 in the order of capacity from large to small (if two or more units have the same capacity, in the order of address from small to large).
- The setting of outdoor unit can be verified by using the self-diagnosis switch (SW4).

SW4 (SW6-10:OFF)	Display
	<ul style="list-style-type: none"> •The unit is designated as the OC: "OC" appears on the display. •The unit is designated as OS1: "OS-1" appears on the display •The unit is designated as OS2: "OS-2" appears on the display.

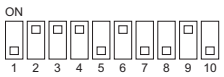


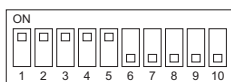
The figure at left shows that the switches 1 through 5 are set to ON and 6 through 10 are set to OFF.

- The OC determines the operation mode and the control mode, and it also communicates with the indoor units.
- The OS exercises autonomous distributed control (over defrost, error detection, and actuator control etc.) according to the operation/control mode signals that are sent from the OC.

5-2-2 Rotation Control

- At the initial startup, outdoor units start up in the order of "OC, OS1 and OS2." After two or more hours of operation, the startup sequence changes to "OS1, OS2 and OC" or "OS2, OC and OS1".
- Startup sequence rotation is performed while all the indoor units are stopped. (Even after two hours of operation, startup sequence rotation is not performed while the compressor is in operation.)
- For information about rotation control at initial startup, refer to the following page(s). [5-2-14 Control at Initial Startup]
- Performing startup sequence rotation does not change the basic operation of OC and OS. Only startup sequence is changed.
- Startup sequence of the outdoor units can be checked with the self-diagnosis switch (SW4) on the OC.

SW4 (SW6-10:OFF)	Display
	<ul style="list-style-type: none"> •OC→OS1→OS2: "OC" and the OC address appear alternately on the display. •OS1→OS2→OC: "OS-1" and the OS1 address appear alternately on the display. •OS2→OC→OS1: "OS-2" and the OS2 address appear alternately on the display.



The figure at left shows that the switches 1 through 5 are set to ON and 6 through 10 are set to OFF.

5-2-3 Initial Control

- When the power is turned on, the initial processing of the microcomputer is given top priority.
- During the initial processing, control processing of the operation signal is suspended. (The control processing is resumed after the initial processing is completed. Initial processing involves data processing in the microcomputer and initial setting of each of the LEV opening. This process will take up to 5 minutes.)
- During the initial processing, the LED monitor on the outdoor unit's control board displays S/W version → refrigerant type → Model and capacity → and communication address in turn every second.

5-2-4 Startup Control

- The upper limit of frequency during the first 3 minutes of the operation is 50 Hz.
- When the power is turned on, normal operation will start after the initial start-up mode (to be described later) has been completed (with a restriction on the frequency).

5-2-5 Refrigerant Bypass Control

Bypass solenoid valves (SV1a), which bypass the high- and low- pressure sides, perform the following functions.

(1) Bypass solenoid valve (SV1a) (ON = Open), (SV2) (ON = Open), (SV9) (ON = Open)

Operation	SV1a	
	ON	OFF
When starting-up the compressor of each outdoor unit	ON for 4 minutes.	
After the restoration of thermo or 3 minutes after restart	ON for 4 minutes.	
During cooling or heating operation with the compressor stopped	Always ON. Exception: OFF when 63HS1-63LS is 0.2 MPa [29 psi] or less	
After the operation has stopped	ON for 3 minutes. Exception: OFF when 63HS1-63LS is 0.2 MPa [29 psi] or less	
During defrost operation	ON	
During compressor operation at Fmin frequency in the cooling mode and when the low pressure (63LS) drops (three or more minutes after compressor startup)	When low pressure (63LS) drops below 0.23 MPa [33 psi].	When low pressure (63LS) exceeds 0.38 MPa [55 psi].
The following conditions are met during the heating mode: Compressor frequency after power on is greater than 0. The low pressure (63LS) drops (One or more minutes after compressor startup if the cumulative compressor operation time is one hour or less; three or more minutes if the cumulative compressor operation time is one hour or more)	When the low pressure (63LS) drops below 0.12 MPa [17 psi]	When the low pressure (63LS) rises above 0.16 MPa [23 psi]
When high pressure (63HS1) rises	When 63HS1 exceeds 3.62 MPa [525 psi]	When 63HS1 is 3.43MPa [497 psi] or below in 30 seconds

Operation	SV2	
	ON	OFF
During defrost	Always ON	
When returning to normal operation after completion of the defrost cycle	ON for 5 minutes	After 5 minutes have passed
At startup	When TH7<= -20, SV2 stays on for 5 minutes after startup or until the condition 63HS < 1.96 MPa (284 psi) is met	Other than on the left
Others	Always OFF	

Operation	SV9	
	ON	OFF
When high pressure (63HS1) rises during the heating operation	When 63HS1 exceeds 3.50MPa [507psi]	When 63HS1 is or below 2.70Mpa [391psi]
During defrost	Always ON	
Others	Always OFF	

5 Control

Operation	SV10	
	ON	OFF
When Continuous heating mode	(E)P200-P450: Front part of heat exchanger is being defrosted. (E)P500: Front part of heat exchanger is being defrosted.	Other than on the left *(E)P200-450: When the rear part of heat exchanger is being defrosted, 21S4b will be OFF. *(E)P500: When the left part of heat exchanger is being defrosted, 21S4c will be OFF.

Operation	SV11	
	ON	OFF
When Continuous heating mode	(E)P500: Right part of heat exchanger is being defrosted.	Other than on the left *(E)P500: When the left part of heat exchanger is being defrosted, 21S4c will be OFF.

5-2-6 Frequency Control

- Depending on the capacity required, the frequency of the compressor is controlled to keep constant evaporation temperature (0°C [32°F] = 0.71 MPa [103 psi]) during cooling operation, and condensing temperature (49°C [120°F] = 2.88 MPa [418 psi]) during heating operation.
- The table below summarizes the operating frequency ranges of the inverter compressor during normal operation.
- The OS in the multiple-outdoor-unit system operates at the actual compressor frequency value that is calculated by the OS based on the preliminary compressor frequency value that the OC determines.

Model	Frequency/cooling (Hz)		Frequency/heating (Hz)	
	Max	Min	Max	Min
P200 model	52	10	71	24
P250 model	65	10	91	24
P300 model	74	14	103	27
P350 model	91	14	122	18
P400 model	97	17	123	22
P450 model	111	17	129	22
P500 model	123	19	129	37
EP200 model	52	10	71	20
EP250 model	65	10	91	20
EP300 model	74	14	103	27
EP350 model	91	14	122	18
EP400 model	97	17	123	22
EP450 model	111	17	129	22
EP500 model	123	19	129	37

Note

The maximum frequency during heating operation is affected by the outdoor air temperature and the control mode to a certain extent.

(1) Pressure limit

The upper limit of high pressure (63HS1) is preset, and when it exceeds the upper limit, the frequency is decreased every 15 seconds.

- The actuation pressure is when the high-pressure reading on 63HS1 is 3.58MPa[519psi].

(2) Discharge temperature limit

Discharge temperature (TH4) of the compressor in operation is monitored, and when it exceeds the upper limit, the frequency is decreased every minute.

- Operating temperature is 115°C [239°F].

(3) Periodic frequency control

Frequency control other than the ones performed at start-up, upon status change, and for protection is called periodic frequency control (convergent control) and is performed in the following manner.

Periodic control cycle

Periodic control is performed after the following time has passed

- 30 seconds after either compressor start-up or the completion of defrost operation
- 30 seconds after frequency control based on discharge temperature or pressure limit

The amount of frequency change

The amount of frequency change is controlled to approximate the target value based on the evaporation temperature (Te) and condensing temperature (Tc).

5-2-7 Defrost Operation Control

(1) Starting the defrost operation

•The defrost cycle will start when all of the following three conditions are met: outside temperature, cumulative compressor operation time, and evaporating temperature under <Condition 1>, <Condition 2>, or <Condition 3> are met.

	Condition 1	Condition 2	Condition 3
Outside temperature (TH7)	-5°C [23°F] or above	-5°C [23°F] or below	
Cumulative compressor operation time	After the time shown in the table below has elapsed (Note 2)		After the time shown in the table below has elapsed (Note 3)
Evaporating temperature (Te)	The evaporating temperature has stayed below the temperature in the table below (Note1) for 3 minutes	$(T_e \leq 1.1 \times TH7 - 7.5)$ continued for 3 minutes or $\{1.5 + 0.02 \times (20 + TH7)\} > 63LS$ continued for 3 minutes	The evaporating temperature has stayed below the temperature in the table below (Note1) for 3 minutes

Note

1) Evaporating temperature (Te)

	(E)P200 - 300	(E)P350 - 500
SW4 (915) OFF	-13 °C	-11 °C
SW4 (915) ON	-8 °C	-8 °C

2) <Condition 1> and <Condition 2> Cumulative compressor operation time in the Heating mode

Function setting		SW4 (918)	
		OFF	ON
SW4 (916)	OFF	50	90
	ON	50	40

3) <Condition 3> Cumulative compressor operation time in the Heating mode

Function setting		
SW4 (916)	OFF	250
	ON	150

- The defrost cycle will not start if other outdoor units are in the defrost cycle or until a minimum of 10 minutes have passed since the completion of the last defrost cycle.
- If 10 minutes have passed since compressor startup or since the completion of a defrost cycle, a forced defrost cycle can be started by setting DIP SW4(913) to ON.
- Under <Condition 1> or <Condition 2>, even when the defrost-prohibit timer is set to 90 minutes, the actual defrost-prohibit time for the next defrost cycle will be 50 minutes if the last defrost cycle took 12 minutes or 15 minutes (when SW4 (916) and SW4 (918) are set to ON).
- Under <Condition 3>, even when the defrost-prohibit timer is set to 250 minutes, the actual defrost-prohibit time for the next defrost cycle will be 150 minutes if the last defrost cycle took 12 minutes or 15 minutes (when SW4 (916) and SW4 (918) are set to ON).
- Under <Condition 3>, even when the defrost-prohibit timer is set to 150 minutes, the actual defrost-prohibit time for the next defrost cycle will be 50 minutes if the last defrost cycle took 12 minutes or 15 minutes (when SW4 (916) and SW4 (918) are set to ON).
- All units in the heating mode will simultaneously go into the defrost cycle in a system with multiple units. The units that are not in operation may or may not go into the defrost cycle, depending on the cumulative operation time of their compressors.

(2) Defrost operation

Compressor frequency	Model	Compressor frequency	
Compressor frequency	Standard	P200-250 models	79 Hz
		P300 model	86 Hz
		P350-400 models	103 Hz
		P450 model	113 Hz
		P500 model	147 Hz
	High COP	EP200-250 models	91 Hz
		EP300 model	100 Hz
		EP350 model	107 Hz
		EP400-450 models	117 Hz
		EP500 model	147 Hz
Outdoor unit fan	Stopped		
SV1a	ON		
21S4a	OFF		
21S4b, 21S4c	OFF		
SV2	ON		
SV9	ON		
SV10,SV11	OFF (Closed)		
SV14 ^{*1}	ON (Open)		
SV15 ^{*1}	OFF (Open)		
LEV1	0 pulses ^{*2}		
LEV2a	1500 pulses (P200-300) 3000 pulses (P350-500, EP200-500)		
LEV2b	3000 pulses (P200-500, EP500) 41 pulses (EP200-450)		
LEV2c	3000 pulses (P500, EP500)		

*1. Only the EP200 through 450 models have SV14 and SV15.

*2. This value may be greater than 0 pulse depending on the 63LS and TH4 status.

(3) Stopping the defrost operation

- The defrost cycle ends when 12 minutes or 15 minutes (when SW4 (916) and SW4 (918) are set to ON) have passed since the beginning of the cycle, or when the pipe temperature (TH3) exceeding the values shown in the table below has been continuously detected for 4 minutes (when SW4 (916) is set to OFF) or for 2 minutes (when SW4 (916) is set to ON).
- The defrost cycle will not end for two minutes once started unless one of the following conditions is met : Pipe temperature reaches 25°C [77°F] and SW4 (916) is set to OFF or $\alpha^{*1} = 25 + TH7^{\circ}C [77^{\circ}F + TH7]$ and SW4 (916) is set to ON.
*1 (5°C [41°F] ≤ α ≤ 25°C [77°F]).
- In the multiple-outdoor-unit system, defrosting is stopped on all units at the same time.

Model	TH3		
	SW4 (916) OFF	SW4 (916) ON	
		SW4 (918) OFF	SW4 (918) ON
(E)P200 - (E)P300 models	10°C [50°F]	5°C [41°F]	25°C [77°F]
(E)P350 - (E)P500 models	7°C [45°F]	5°C [41°F]	25°C [77°F]

(4) Problems during defrost operation

- If a problem is detected during defrost operation, the operation will be stopped, and the defrost prohibition time based on the integrated compressor operation time will be set to 20 minutes.

(5) Change in the number of operating indoor units during defrost operation

- Even when there is a change in the number of operating indoor units during defrost operation, the operation will continue, and an adjustment will be made after the completion of the defrost operation.
- Defrost operation will be continued, even if the indoor units stop or under the Thermo-OFF conditions until it has run its course.

5-2-8 Continuous heating mode control

(1) Continuous heating mode start conditions

- Continuous heating mode will start when all the conditions listed in the table below are met (outside temperature, cumulative compressor operation time, and evaporating temperature).
- SW4 (848) must be set to ON to perform Continuous heating mode.

Outside temperature (TH7)	2.0 °C [35.6 °F] to 7.0 °C [44.6 °F]
Cumulative compressor operation time	After 10 minutes at 2.0 °C [35.6 °F] to 3.5 °C [38.3 °F] has elapsed After 20 minutes at 3.6 °C [38.5 °F] to 7.0 °C [44.6 °F] has elapsed
Evaporating temperature (Te)	After 3 minutes at 0°C [32°F] to -25 °C [-13°F] has elapsed

(2) Valve operation during Continuous heating cycle

1) (E)P200-450

	Front (bottom) HEX in defrost cycle	Rear (front) HEX in defrost cycle
Outdoor unit fan*1	Left fan: Fixed time control Right fan: 0%	Right fan: 0% Left fan: Fixed time control
SV1a	OFF	
SV2	OFF	
SV9	OFF	
SV10	ON	OFF
21S4a	ON	ON
21S4b	ON	OFF
SV14*2	OFF (Closed)	OFF (Closed)
SV15*2	ON (Open)	OFF (Open)

*1. Only the fixed-time control is available on (E)P200-300 models.

*2. SV14 and SV15 are only on EP200-450 models.

2) (E)P500

	Front (right) HEX in defrost cycle	Left HEX in defrost cycle
Outdoor unit fan	Left fan: Fixed time control Right fan: 0%	Left fan: 0% Right fan: Fixed time control
SV1a	In operation	
SV2	OFF	
SV9	OFF	
SV10	ON	OFF
SV11	ON	OFF
21S4a	ON	ON
21S4b	ON	ON
21S4c	ON	OFF

5-2-9 Refrigerant Recovery Control

Recovery of refrigerant is performed during heating operation to prevent the refrigerant from accumulating inside the unit while it is stopped (unit in fan mode), or inside the indoor unit that is in cooling mode or in heating mode with thermo off. It is also performed during cooling operation to prevent an excessive amount of refrigerant from accumulating in the outdoor heat exchanger.

(1) During heating operation

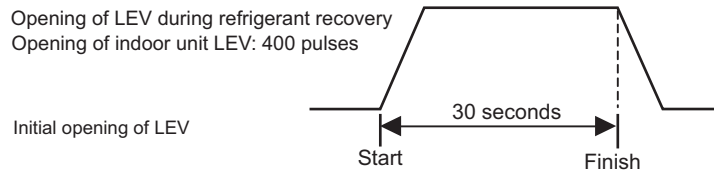
Starting refrigerant recovery mode

The refrigerant recovery mode in heating starts when all of the following three conditions are met:

- 15 minutes have passed since the completion of previous refrigerant recovery.
- TH4 > 115°C [239°F]
- Frequencies below 50 Hz

Refrigerant recovery

- 1) Refrigerant is recovered with the LEV on the applicable indoor unit (unit under stopping mode, fan mode, cooling, heating with thermo off) being opened for 30 seconds.



- 2) Periodic capacity control of the outdoor units and periodic LEV control of the indoor units will be suspended during refrigerant recovery operation; they will be performed after the recovery has been completed.

(2) During cooling operation

Starting refrigerant recovery mode

The refrigerant recovery mode starts when all the following conditions are met:

- 30 minutes have passed since the completion of previous refrigerant recovery.
- When the unit keeps running for 3 minutes in a row or more with high discharge temperature
- TH4 > 105°C [221°F] or 63HS1 > 3.43 MPa [497 psi] (35 kg/cm²G) and SC0 > 10°C [50°F]

Refrigerant recovery

The opening of LEV1 is increased and periodic control begins again.

5-2-10 Outdoor Unit Fan Control

(1) Control method

- Depending on the capacity required, the rotation speed of the outdoor unit fan is controlled by the inverter, targeting a constant evaporation temperature of (0°C [32°F]= 0.71 MPa [103 psi]) during cooling operation and constant condensing temperature of (49°C [120°F]= 2.88 MPa [418 psi]) during heating operation.
- The OS in the multiple-outdoor-unit system operates at the actual outdoor unit fan control value that is calculated by the OS based on the preliminary outdoor unit fan control value that the OC determines.

(2) Control

- Outdoor unit fan stops while the compressor is stopped (except in the presence of input from snow sensor).
- The fan operates at full speed for 5 seconds after start-up.(Only when TH7<0°C [32°F])
- The outdoor unit fan stops during defrost operation.

(3) Outdoor heat exchanger capacity control pattern

- Outdoor fan rotation control is supported.
- As the operation pattern number decreases, the capacity of the outdoor heat exchanger decreases. As the operation pattern number increases, the cooling capacity increases.
- In each mode, the four-way valve and the expansion valve operate as shown in the table below. The expansion valve may open or close during the refrigerant equalization control. See [5-2-12 Refrigerant Flow Control (Linear Expansion Valves <LEV2a, LEV2b, and LEV2c>)]

Model	Operation mode	Operation patterns	Four-way valve ^{*2}			LEV		
			21S4a	21S4b	21S4c	LEV2a	LEV2b	LEV2c
P200, P250, P300 models	Cooling	1	OFF	ON	-	2100	41	-
		2	OFF	OFF	-	2100	2100	-
	Heating	1	ON	ON	-	*1	*1	-
		Defrost	1	OFF	OFF	-	1500	3000
P350, P400, P450 models	Cooling	1	OFF	ON	-	2100	41	-
		2	OFF	OFF	-	2100	2100	-
	Heating	1	ON	ON	-	*1	*1	-
		Defrost	1	OFF	OFF	-	3000	3000
EP200, EP250, EP300, EP350, EP400, EP450 models	Cooling	1	OFF	ON	-	3000	3000	-
		2	OFF	ON	-	3000	41	-
		3	OFF	OFF	-	3000	41	-
	Heating	1	ON	ON	-	*1	*1	-
		Defrost	1	OFF	OFF	-	3000	41
(E)P500 models	Cooling	1	OFF	ON	ON	2100	41	41
		2	OFF	OFF	ON	2100	2100	41
		3	OFF	OFF	OFF	2100	2100	2100
	Heating	1	ON	ON	ON	*1	*1	*1
		Defrost	1	OFF	OFF	OFF	3000	3000

*1 See [5-2-12 Refrigerant Flow Control (Linear Expansion Valves <LEV2a, LEV2b, and LEV2c>)]

*2 OFF: Refrigerant flow in cooling operation, ON: Refrigerant flow in heating operation

5-2-11 Subcool Coil Control (Linear Expansion Valve <LEV1>)

- The OC, OS1, and OS2 controls the subcool coil individually.
- The LEV is controlled every 30 seconds to maintain constant the subcool at the outdoor unit heat exchanger outlet that is calculated from the values of high pressure (63HS1) and liquid piping temperature (TH3), or the superheat that is calculated from the values of low pressure (63LS) and the bypass outlet temperature (TH2) of the subcool coil.
- LEV opening is controlled based on the values of the inlet (TH6) and the outlet (TH3) temperatures of the subcool coil, high pressure (63HS1), and discharge temperature (TH4). In a single-outdoor-unit system, the LEV is closed (0) in the heating mode, while the compressor is stopped, and during cooling Thermo-OFF. In a multiple-outdoor-unit system, the LEV closes (0) during heating operation, while the compressor is stopped, or during cooling Thermo-OFF. The LEV opens to a specified position when 15 minutes have passed after Thermo-OFF. (65 pulses)
- During the defrost cycle, normally, the valve initially operates at 0 pulses, although it may operate at higher pulses depending on the 63LS and TH4 status.

5-2-12 Refrigerant Flow Control (Linear Expansion Valves <LEV2a, LEV2b, and LEV2c>)

- Refrigerant flow is controlled by each unit in the combined models during heating. Refrigerant flow control is performed by the OC, OS1, and OS2 individually.
- Valve opening is controlled based on the values of high pressure (63HS1), discharge temperature (TH4), low pressure (63LS), and piping temperature (TH5).
- The valve moves to the predetermined position while the unit is stopped.
- See [5-2-10 Outdoor Unit Fan Control] for the operation of LEV2 in different operation modes.

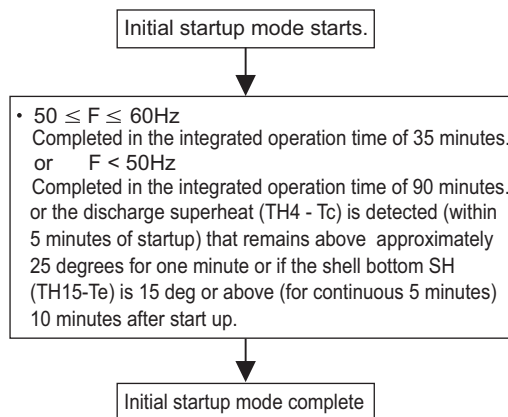
5-2-13 Control of Controller Cooling Function (Electronic Expansion Valve <LEV9>)

- Control of controller cooling function is performed individually for OC, OS1, and OS2.
- The opening of LEV9 is adjusted every three seconds to keep the controller heatsink temperature (THHS) below the threshold value, which is determined by the setting of the outside temperature (TH7).

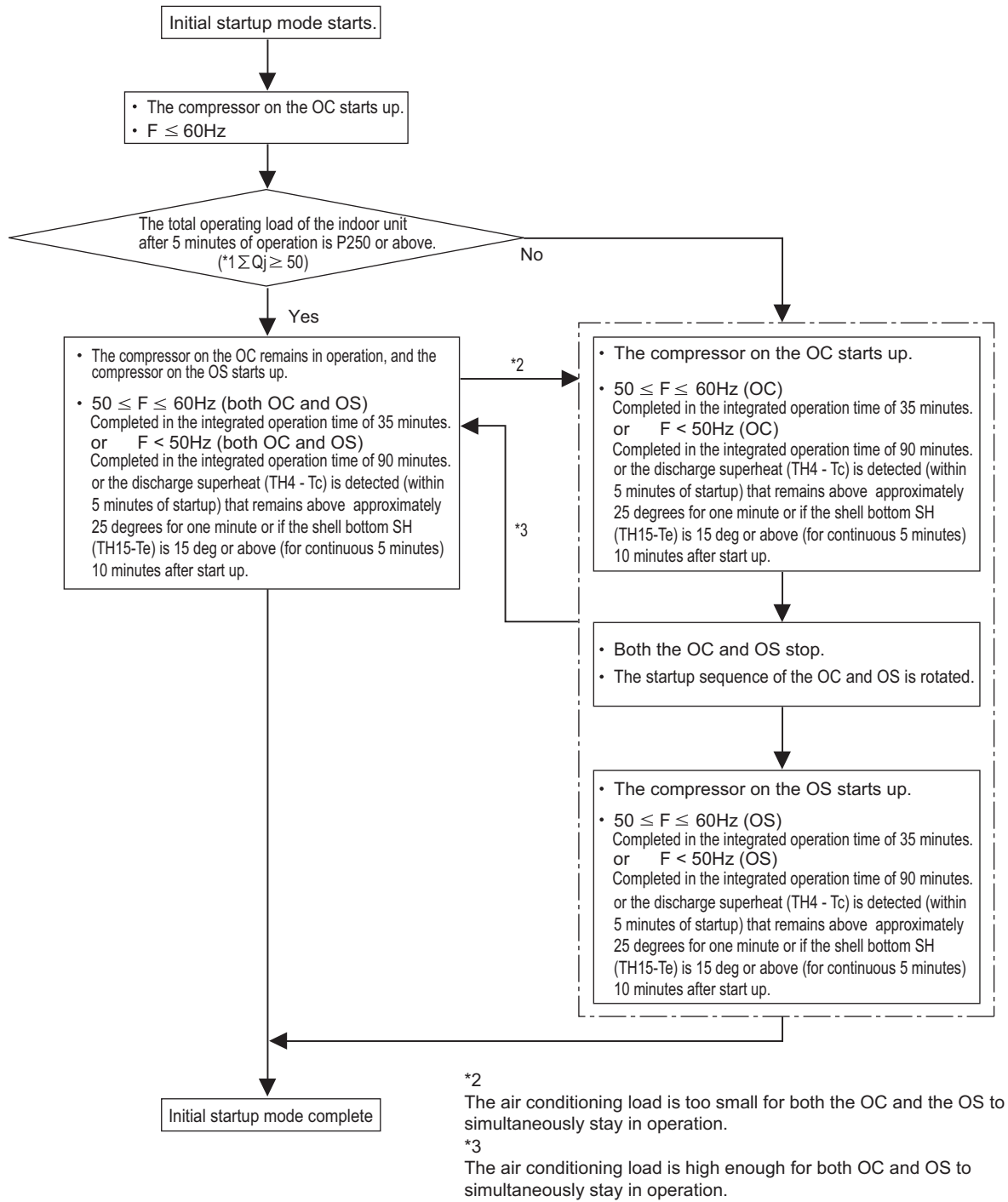
5-2-14 Control at Initial Startup

- When started up for the first time before 12 hours have elapsed after power on, the unit goes into the initial startup mode.
- At the completion of the initial operation mode on the OC, OS1, and OS2, they will go into the normal control mode.

(1) (E)P200 - (E)P500YNW models



(2) (E)P400 - (E)P900YSNW models

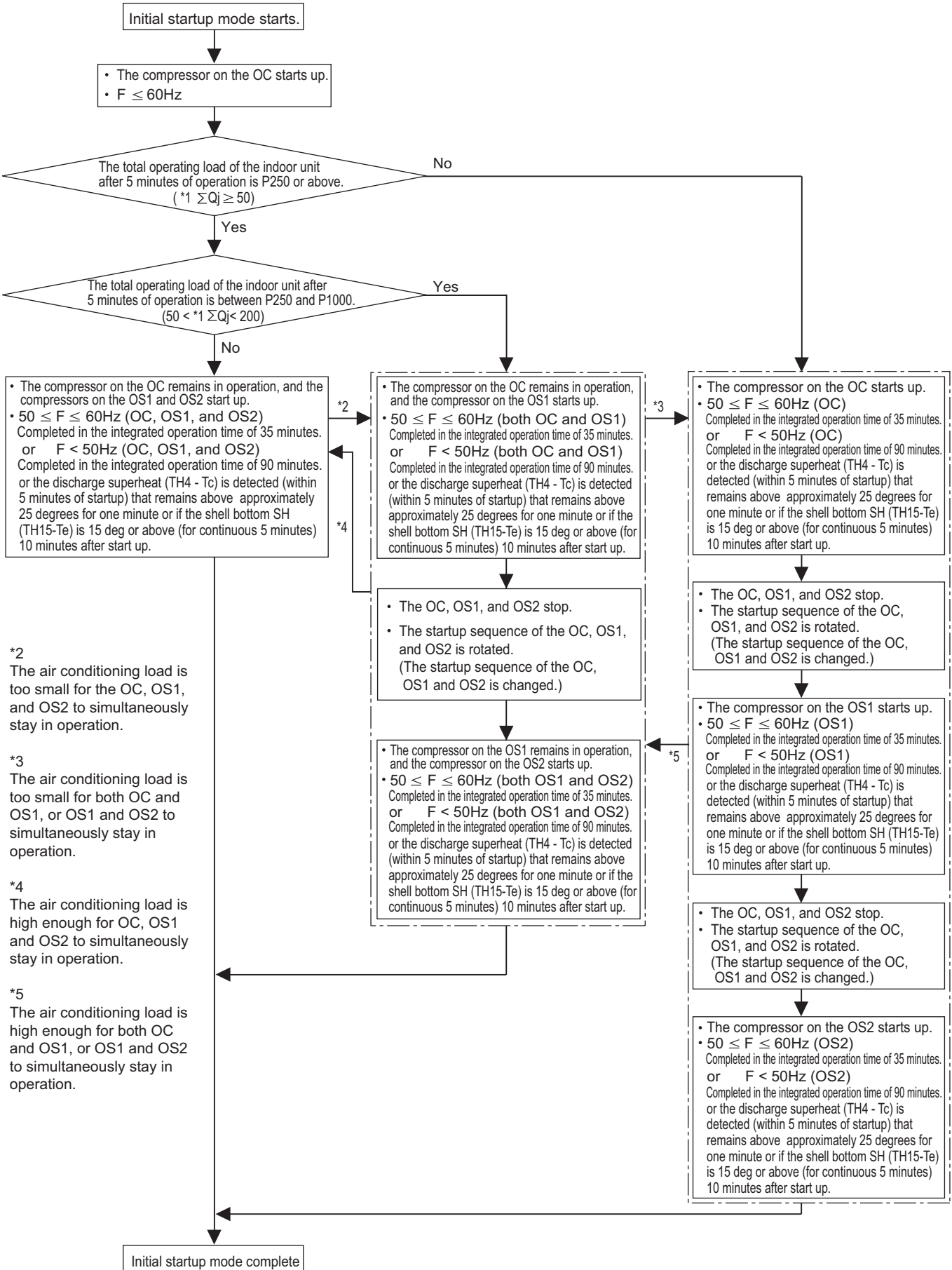


*1 ΣQj: Total capacity (models) code

For information about capacity codes, refer to the following page(s). [5-1-2 Indoor Unit Switch Functions and Factory Settings]

(3) (E)P950 - (E)P1350YSNW models

5 Control



*2
The air conditioning load is too small for the OC, OS1, and OS2 to simultaneously stay in operation.

*3
The air conditioning load is too small for both OC and OS1, or OS1 and OS2 to simultaneously stay in operation.

*4
The air conditioning load is high enough for OC, OS1 and OS2 to simultaneously stay in operation.

*5
The air conditioning load is high enough for both OC and OS1, or OS1 and OS2 to simultaneously stay in operation.

*1 ΣQj: Total capacity (models) code

For information about capacity codes, refer to the following page(s).[5-1-2 Indoor Unit Switch Functions and Factory Settings]

5-2-15 Emergency Operation Mode

1. Problems with the outdoor unit

•Emergency operation mode is a mode in which outdoor units that are operating normally take over the operation of the outdoor units that are experiencing problems. ((E)P400-(E)P900YSNW models go into an emergency operation mode when one outdoor unit is in trouble, and (E)P950-(E)P1350YSNW models go into an emergency operation mode when one or two outdoor units are in trouble.)

•This mode can be started by performing an error reset via the remote controller.

(1) Starting the emergency operation

- 1) When an error occurs, the error source and the error code will be displayed on the display on the remote controller.
- 2) The error is reset using the remote controller.
- 3) If an error code appears that permits an emergency operation in step 1) above, (See the table below.), the retry operation starts.
- 4) If the same error is detected during the retry operation (step 3 above), an emergency operation can be started by resetting the error via the remote controller.

Error codes that permit an emergency operation (Applicable to both OC and OS)

Trouble source		Error codes that permit an emergency operation	Error code description
Compressor Fan motor Inverter		0403	Serial communication error
		4220,4225,4226	Bus voltage drop
		4230,4235	Heatsink overheat protection
		4240,4245	Overload protection
		4250,4255,4256	Overcurrent relay trip
		5110	Heatsink temperature sensor failure (THHS)
		5120	DCL temperature sensor circuit fault
		5301	Current sensor/circuit failure
	5305,5306	Position error	
Thermistor	TH2	5102	Subcool heat exchanger bypass outlet temperature sensor failure
	TH3	5103	Pipe temperature sensor failure
	TH4	5104	Discharge temperature sensor failure
	TH5	5105	Accumulator inlet temperature sensor failure
	TH6	5106	Subcool heat exchanger liquid outlet sensor failure
	TH7	5107	Outside air temperature sensor failure
	TH15	5115	Compressor shell bottom temperature sensor fault
Power		4102	Open phase
		4115	Power supply sync signal abnormality

Emergency operation pattern (2 outdoor units)

		OC failure pattern	OS failure pattern
OC		Trouble	Normal
OS		Normal	Trouble
Emergency operation	Cooling	Permitted	Permitted
	Heating	Permitted	Permitted
Maximum total capacity of indoor units (Note 1)		60%	

Emergency operation pattern (3 outdoor units)

		OC failure pattern	OS1 failure pattern	OS2 failure pattern	OC, OS1 failure pattern	OC, OS2 failure pattern	OS1, OS2 failure pattern
OC		Trouble	Normal	Normal	Trouble	Trouble	Normal
OS1		Normal	Trouble	Normal	Trouble	Normal	Trouble
OS2		Normal	Normal	Trouble	Normal	Trouble	Trouble
Emergency operation	Cooling	Permitted	Permitted	Permitted	Permitted	Permitted	Permitted
	Heating	Permitted	Permitted	Permitted	Permitted	Permitted	Permitted
Maximum total capacity of indoor units (Note 1)		60%			40%		

(Note 1) If an attempt is made to put into operation a group of indoor units whose total capacity exceeds the maximum allowable capacity, some of the indoor units will go into the same condition as Thermo-OFF.

(2) Ending the emergency operation

1) End conditions

When one of the following conditions is met, emergency operation stops, and the unit makes an error stop.

- When the integrated operation time of compressor in cooling mode has reached four hours.
- When the integrated operation time of compressor in heating mode has reached two hours.
- When an error is detected that does not permit the unit to perform an emergency operation.

2) Control at or after the completion of emergency operation

- At or after the completion of emergency operation, the compressor stops, and the error code reappears on the remote controller.
- If another error reset is performed at the completion of an emergency mode, the unit repeats the procedures in section (1) above.
- To stop the emergency mode and perform a current-carrying operation after correcting the error, perform a power reset.

2. Communication circuit failure or when some of the outdoor units are turned off

This is a temporary operation mode in which the outdoor unit that is not in trouble operates when communication circuit failure occurs or when some of the outdoor units are turned off.

(1) Starting the emergency operation (When the OC is in trouble)

- 1) When an error occurs, the error source and the error code appear on the display on the remote controller.
- 2) Reset the error via the remote controller to start an emergency operation.

Precautions before servicing the unit

- When the OC is in trouble, the OS temporarily takes over the OC's function and performs an emergency operation. When this happens, the indoor unit connection information are changed.
- In a system that has a billing function, a message indicating that the billing system information has an error may appear on the TG-2000A. Even if this message appears, do not change (or set) the refrigerant system information on the TG-2000A. After the completion of an emergency operation, the correct connection information will be restored.

(2) Starting the emergency operation (When the OS is in trouble)

1) A communication error occurs. → An emergency operation starts in approximately six minutes.

Error codes that permit an emergency operation (Applicable to both OC and OS)

Trouble source	Error codes that permit an emergency operation	Error code description
Circuit board failure or the power to the outdoor units is off	6607	No acknowledgement error
	6608	No response error

Emergency operation pattern (2 outdoor units)

		OC failure pattern	OS failure pattern
OC		Trouble	Normal
OS		Normal	Trouble
Emergency operation	Cooling	Permitted	Permitted
	Heating	Permitted	Permitted
Maximum total capacity of indoor units (Note 1)		Capacity that matches the total capacity of the operable outdoor units	

Emergency operation pattern (3 outdoor units)

		OC failure pattern	OS1 failure pattern	OS2 failure pattern	OC, OS1 failure pattern	OC, OS2 failure pattern	OS1, OS2 failure pattern
OC		Trouble	Normal	Normal	Trouble	Trouble	Normal
OS1		Normal	Trouble	Normal	Trouble	Normal	Trouble
OS2		Normal	Normal	Trouble	Normal	Trouble	Trouble
Emergency operation	Cooling	Permitted	Permitted	Permitted	Permitted	Permitted	Permitted
	Heating	Permitted	Permitted	Permitted	Permitted	Permitted	Permitted
Maximum total capacity of indoor units (Note 1)		Indoor unit capacity that matches the total capacity of the operable outdoor units					

(Note 1) If an attempt is made to put into operation a group of indoor units whose total capacity exceeds the maximum allowable capacity, some of the indoor units will go into the same condition as Thermo-OFF.

(3) Ending the emergency operation

When communication is restored, the emergency mode is cancelled, and the units go into the normal operation mode.

5-2-16 Operation Mode

(1) Indoor unit operation mode

The operation mode can be selected from the following 5 modes using the remote controller.

1	Cooling mode
2	Heating mode
3	Dry mode
4	Fan mode
5	Stopping mode

(2) Outdoor unit operation mode

1	Cooling mode	All indoor units in operation are in cooling mode.
2	Heating mode	All indoor units in operation are in heating mode.
3	Stopping mode	All indoor units are in fan mode or stopping mode.

Note

When the outdoor unit is performing a cooling operation, the operation mode of the connected indoor units that are not in the cooling mode (Stopped, Fan, Thermo-OFF) cannot be changed to heating from the remote controller. If this attempt is made, "Heating" will flash on the remote controller. The opposite is true when the outdoor unit is performing a heating operation. (The first selection has the priority.)

5-2-17 Demand Control

Cooling/heating operation can be prohibited (Thermo-OFF) by an external input to the indoor units.

Note

When DIP SW6-8 is set to ON, the 4-step DEMAND control is enabled.
 Eight-step demand control is possible in the system with two outdoor units.
 Twelve-step demand control is possible in the system with three outdoor units.

For details, refer to the following page(s). [2-4-7 Various Control Methods Using the Signal Input/Output Connector on Outdoor Unit]

5-2-18 Control of IH energization without the compressor in operation

IH is used to heat the compressor motor on the stopped outdoor unit to make liquid refrigerant in the compressor evaporate or to keep liquid refrigerant from flooding the compressor.

- Initial power on after power is turned on: Stays on for 12 hours, and then transitions to the operation that is performed while the compressor is stopped
- When the compressor is stopped: Stays on for 30 minutes after the compressor stopped, and then repeats the on-off cycle at 30-minute intervals
- Lit LED1 on the INV board indicates that the INV board is energized by an IH.

Chapter 6 Test Run

6-1	Read before Test Run	1
6-2	Operation Characteristics and Refrigerant Charge	2
6-3	Evaluating and Adjusting Refrigerant Charge	2
6-3-1	Refrigerant Overcharge and undercharge	2
6-3-2	Checking the Refrigerant Charge during Operation.....	2
6-3-3	Maximum refrigerant charge	3
6-3-4	Refrigerant Charge Adjustment Mode	5
6-4	The Following Symptoms Are Normal	7

6-1 Read before Test Run

(1) Check for refrigerant leak and loose cables and connectors.

(2) When opening or closing the front panel of the control box, do not let it come into contact with any of the internal components.

Note

- Before inspecting the inside of the control box, turn off the power, leave the unit turned off for at least 10 minutes, and check that the voltage across pins 1 and 5 of connector RYPN has dropped to 20 VDC or less. (It takes approximately 10 minutes to discharge electricity after the power is turned off.)
- Control box houses high temperature parts. Be well careful even after turning off the power source.
- Disconnect the relay connectors (RYFAN 1 and RYFAN 2) on the outdoor unit fan before performing maintenance work. (Before connecting or disconnecting the connector, check that the outdoor unit fan is stopped and that the voltage across pins 1 and 5 of connector RYPN has dropped to 20 VDC or less. If the outdoor unit fan is turned by strong winds, the main circuit capacitor will be energized and poses an electric shock hazard. Refer to the wiring diagram name plate for details.
- To connect wiring to TB7, check that the voltage is 20 VDC or below.
- Reconnect the relay connectors (RYFAN 1 and RYFAN 2) on the outdoor unit fan after completion of maintenance work.

(3) Measure the insulation resistance between the power supply terminal block and the ground with a 500V megger and make sure it reads at least 1.0Mohm.

Note

- Do not operate the unit if the insulation resistance is below 1.0Mohm.
- Do not apply megger voltage to the terminal block for transmission line. Doing so will damage the controller board.
- The insulation resistance between the power supply terminal block and the ground could go down to close to 1Mohm immediately after installation or when the power is kept off for an extended period of time because of the accumulation of refrigerant in the compressor.
- If insulation resistance is 1 MΩ or below, by turning on the main power and keeping it on for at least 12 hours, the refrigerant in the compressor will evaporate and the insulation resistance will go up.
- Do not measure the insulation resistance of the terminal block for transmission line for the unit remote controller.

(4) When the power is turned on, the compressor is energized even while it is not operating.

Note

- Before turning on the power, disconnect all power supply wires from the compressor terminal block, and measure the insulation resistance of the compressor.
- Check the compressor for a ground fault. If the insulation resistance is 1.0 MΩ or below, connect all power supply wires to the compressor and turn on the power to the outdoor unit. (The liquid refrigerant in the compressor will evaporate by energizing the compressor.)
- Make sure both the gas and liquid valves are fully opened.

(5) Check the phase sequence and the voltage of the power supply.

When the voltage is out of the $\pm 10\%$ range, or when the phase voltage difference is more than 2%, please discuss the counter-measure with the customer.

(6) [When a transmission booster is connected]

Turn on the transmission booster before turning on the outdoor units.

Note

- If the outdoor units are turned on first, the connection information for the refrigerant circuit may not be properly recognized.
- In case the outdoor units are turned on before the transmission booster is turned on, perform a power reset on the outdoor units after turning on the power booster.

(7) Turn on the main power at least 12 hours before test run.

Note

Insufficient powering time may result in compressor damage.

(8) When a power supply unit is connected to the transmission line for centralized control(*), perform a test run with the power supply unit being energized. Leave the power jumper connector on CN41 as it is (factory setting).

*Includes the cases where power is supplied to the transmission line from a system controller with a power-supply function

6-2 Operation Characteristics and Refrigerant Charge

It is important to have a clear understanding of the characteristics of refrigerant and the operating characteristics of air conditioners before attempting to adjust the refrigerant amount in a given system.

- The following shows items of particular importance.
- 1) During cooling operation, the amount of refrigerant in the accumulator is the smallest when all indoor units are in operation.
 - 2) During heating operation, the amount of refrigerant in the accumulator is the largest when all indoor units are in operation.
 - 3) General tendency of discharge temperature
 - Discharge temperature tends to rise when the system is short on refrigerant.
 - Changing the amount of refrigerant in the system while there is refrigerant in the accumulator has little effect on the discharge temperature.
 - The higher the pressure, the more likely it is for the discharge temperature to rise.
 - The lower the pressure, the more likely it is for the discharge temperature to rise.
 - 4) When the amount of refrigerant in the system is adequate, the compressor shell temperature is 10 to 60°C [18 to 108°F] higher than the low pressure saturation temperature (Te).
 - If the temperature difference between the compressor shell temperature and low pressure saturation temperature (Te) is smaller than 5°C [9°F], an overcharging of refrigerant is suspected.

6-3 Evaluating and Adjusting Refrigerant Charge

6-3-1 Refrigerant Overcharge and undercharge

Overcharging or undercharging of refrigerant can cause the following symptoms:
 Before attempting to adjust the amount of refrigerant in the system, thoroughly check the operating conditions of the system. Then, adjust the refrigerant amount by running the unit in the refrigerant amount adjust mode.

The system comes to an abnormal stop, displaying 1500 (overcharged refrigerant) on the controller.	Overcharged refrigerant
The operating frequency does not reach the set frequency, and there is a problem with performance.	Insufficient refrigerant amount
The system comes to an abnormal stop, displaying 1102 (abnormal discharge temperature) on the controller.	

6 Test Run

6-3-2 Checking the Refrigerant Charge during Operation

Operate all indoor units in either cooling or heating mode, and check such items as discharge temperature, subcooling, low pressure, suction temperature, and shell bottom temperature to estimate the amount of refrigerant in the system.

Symptoms	Conclusion
Discharge temperature is high. (Normal discharge temperature is below 100°C [212°F].) *	Slightly undercharged refrigerant
Low pressure is unusually low.	
Suction superheat is large. (Normal suction superheat is less than 20°C [36°F].)	
Compressor shell bottom temperature is high. (The difference between the compressor shell bottom temperature and low pressure saturation temperature (Te) is greater than 60°C [108°F].)	Slightly overcharged refrigerant
Discharge superheat is small. (Normal discharge superheat is greater than 10°C [18°F].)	
Compressor shell bottom temperature is low. (The difference between the compressor shell bottom temperature and low pressure saturation temperature (Te) is less than 5°C [9°F].)	

* The temperature may temporarily exceed 100°C [212°F] depending on the refrigerant distribution within the system.

6-3-3 Maximum refrigerant charge

There is a limit to the amount of refrigerant that can be charged into a unit. Regardless of the amount yielded by the formula above, observe the maximum refrigerant charge in the table below.

♦P200-500YNW-A(1/2)

Total index of the outdoor units	P200	P250	P300	P350	P400	P450	P500
Factory charge (kg)	6.5	6.5	6.5	9.8	9.8	10.8	10.8
Maximum additional refrigerant charge on site (kg)	15.9	22.9	23.4	24.4	24.9	33.1	34.0
Maximum refrigerant charge (kg)	22.4	29.4	29.9	34.2	34.7	43.9	44.8

♦P400-1350YSNW-A(1/2)

Total index of the outdoor units	P400	P450	P500	P550	P600	P650	P700
Factory charge (kg)	13.0	13.0	13.0	13.0	13.0	16.3	19.6
Maximum additional refrigerant charge on site (kg)	32.0	32.0	32.9	34.7	34.7	35.7	45.7
Maximum refrigerant charge (kg)	45.0	45.0	45.9	47.7	47.7	52.0	65.3

Total index of the outdoor units	P750	P800	P850	P900	P950	P1000	P1050
Factory charge (kg)	19.6	20.6	20.6	21.6	23.8	26.1	26.1
Maximum additional refrigerant charge on site (kg)	45.7	46.0	47.8	48.2	47.1	46.8	46.8
Maximum refrigerant charge (kg)	65.3	66.6	68.4	69.8	70.9	72.9	72.9

Total index of the outdoor units	P1100	P1150	P1200	P1250	P1300	P1350
Factory charge (kg)	29.4	29.4	29.4	30.4	31.4	32.4
Maximum additional refrigerant charge on site (kg)	47.0	47.0	47.0	49.1	49.5	49.8
Maximum refrigerant charge (kg)	76.4	76.4	76.4	79.5	80.9	82.2

♦EP200-500YNW-A(1/2)

Total index of the outdoor units	EP200	EP250	EP300	EP350	EP400	EP450	EP500
Factory charge (kg)	6.5	6.5	6.5	9.8	10.8	10.8	10.8
Maximum additional refrigerant charge on site (kg)	15.9	22.9	23.4	24.4	25.2	33.1	34.0
Maximum refrigerant charge (kg)	22.4	29.4	29.9	34.2	36.0	43.9	44.8

•EP400-1350YSNW-A(1/2)

Total index of the outdoor units	EP400	EP450	EP500	EP550	EP600	EP650	EP700
Factory charge (kg)	13.0	13.0	13.0	13.0	13.0	17.3	19.6
Maximum additional refrigerant charge on site (kg)	32.0	32.0	32.9	34.7	34.7	36.0	45.7
Maximum refrigerant charge (kg)	45.0	45.0	45.9	47.7	47.7	53.3	65.3

Total index of the outdoor units	EP750	EP800	EP850	EP900	EP950	EP1000	EP1050
Factory charge (kg)	20.6	20.6	21.6	21.6	23.8	27.1	28.1
Maximum additional refrigerant charge on site (kg)	46.0	46.0	48.2	48.2	47.1	47.2	47.5
Maximum refrigerant charge (kg)	66.6	66.6	69.8	69.8	70.9	74.3	75.6

Total index of the outdoor units	EP1100	EP1150	EP1200	EP1250	EP1300	EP1350
Factory charge (kg)	30.4	31.4	32.4	32.4	32.4	32.4
Maximum additional refrigerant charge on site (kg)	47.3	47.7	48.0	49.8	49.8	49.8
Maximum refrigerant charge (kg)	77.7	79.1	80.4	82.2	82.2	82.2

6-3-4 Refrigerant Charge Adjustment Mode

Follow the procedures below to add or extract refrigerant as necessary depending on the operation mode.

When the function switch (SW4 (922)) on the main board on the outdoor unit (OC only) is turned to ON, the unit goes into the refrigerant amount adjust mode, and the following sequence is followed.

Note

The unit will not go into the refrigerant amount adjust mode when the switch on the OS is set to ON.

Operation

When the unit is in the refrigerant amount adjust mode, the LEV on the indoor unit does not open as fully as it normally does during cooling operation to secure subcooling.

Note

- 1) Using the flowchart on the next page, adjust the refrigerant charge. Check the TH4, TH3, TH2, TH6, Te, and Tc values of OC, OS1, and OS2 by setting the diagnostic switch (SW4 (SW6-10: OFF) first, and use these values to diagnose the refrigerant charge.
- 2) There may be cases when the refrigerant amount may seem adequate for a short while after starting the unit in the refrigerant amount adjust mode but turn out to be inadequate later on (when the refrigerant system stabilizes).

When the amount of refrigerant is truly adequate.

TH3-TH6 on the outdoor unit is 5°C [41°F] or above and SH on the indoor unit is between 5 and 15°C [41 and 59°F].

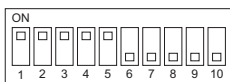
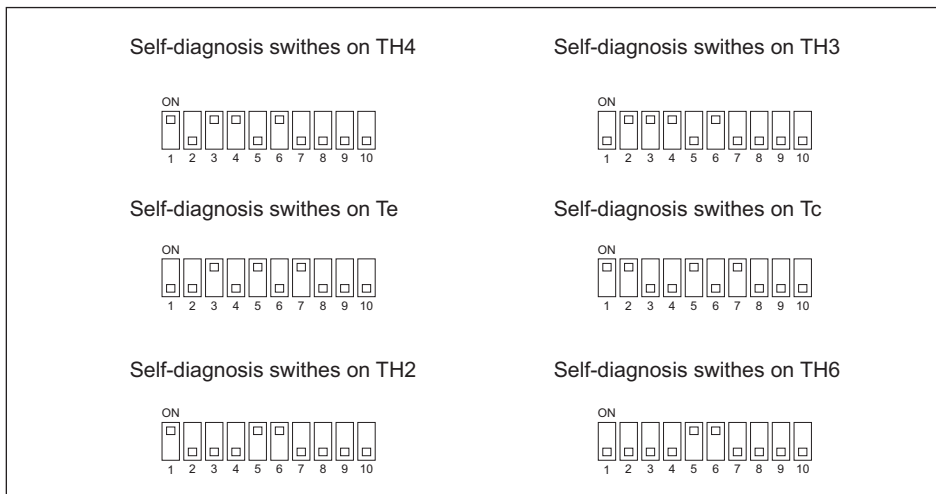
The refrigerant amount may seem adequate at the moment, but may turn out to be inadequate later on.

TH3-TH6 on the outdoor unit is 5°C [41°F] or less and SH on the indoor unit is 5°C [41°F] or less.

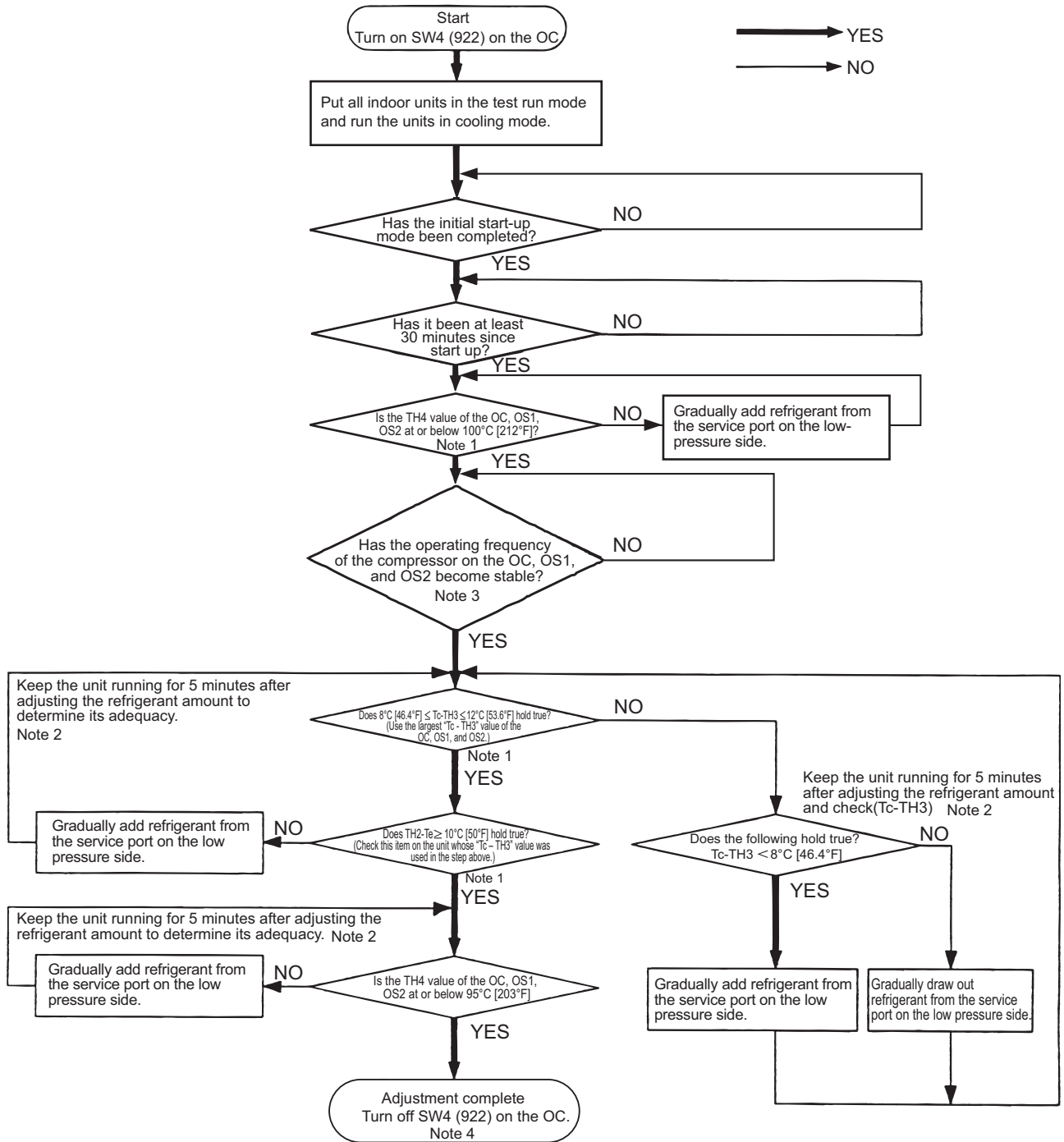
Wait until the TH3-TH6 reaches 5°C [41°F] or above and the SH of the indoor unit is between 5 and 15°C [41 and 59°F] to determine that the refrigerant amount is adequate.

- 3) If the high pressure is not at least 2.0 MPa [290 psi], a correct judgment will not be possible for refrigerant adjustment. Perform the adjustment when the outdoor air temperature is at least 20°C [68°F].
- 4) Refrigerant amount adjust mode automatically ends 90 minutes after beginning. When this happens, by turning off the SW4 (922) and turning them back on, the unit will go back into the refrigerant amount adjust mode.

SW4 settings



The figure at left shows that the switches 1 through 5 are set to ON and 6 through 10 are set to OFF.



For information about Notes 1 through 4 in the flowchart, refer to items 1) through 4) on the previous page.

CAUTION

Do not release the extracted refrigerant into the air.

CAUTION

Charge liquid refrigerant (as opposed to gaseous refrigerant) into the system.

- If gaseous refrigerant is charged into the system, the composition of the refrigerant in the cylinder will change and may result in performance loss.

6-4 The Following Symptoms Are Normal

Symptoms	Remote controller display	Cause
The indoor unit does not start after starting cooling (heating) operation.	"Cooling (heating)" icon blinks on the display.	The unit cannot perform a heating (cooling) operation when other indoor units on the same refrigerant system, are performing a cooling (heating) operation.
The auto vane adjusts its position by itself.	Normal display	After an hour of cooling operation with the auto vane in the vertical position, the vane may automatically move into the horizontal position. Louver blades will automatically move into the horizontal position while the unit is in the defrost mode, pre-heating stand-by mode, or when the thermostat triggers unit off.
The fan speed changes during heating.	Normal display	Very Low fan speed when "Thermo-OFF." Changes from Very Low to pre-set fan speed when "Thermo-ON" depending on pipe temperature.
The fan stops during heating operation.	Defrost	The fan remains stopped during defrost operation.
The fan keeps running after the unit has stopped.	Unlit	When the auxiliary heater is turned on, the fan operates for one minute after stopping to dissipate heat.
The fan speed does not reach the set speed when operation switch is turned on.	STAND BY	The fan operates at extra low speed for 5 minutes after it is turned on or until the pipe temperature reaches 35°C[95°F], then it operates at low speed for 2 minutes, and finally it operates at the set speed. (Pre-heating stand-by)
When the main power is turned on, the display shown on the right appears on the indoor unit remote controller for 5 minutes.	"HO" or "PLEASE WAIT" icons blink on the display.	The system is starting up. Wait until the blinking display of "HO" or "PLEASE WAIT" go off.
The drain pump keeps running after the unit has stopped.	Unlit	The drain pump stays in operation for three minutes after the unit in the cooling mode is stopped.
The drain pump is running while the unit is stopped.	Unlit	When drain water is detected, the drain pump goes into operation even while the unit is stopped.
Indoor unit makes noise during cooling/heating changeover.	Normal display	This noise is made when the refrigerant circuit is reversed and is normal.
Sound of the refrigerant flow is heard from the indoor unit immediately after starting operation.	Normal display	This is caused by the transient instability of the refrigerant flow and is normal.
Warm air sometimes comes out of the indoor units that are not in the heating mode.	Normal display	This is due to the fact that the LEVs on some of the indoor units are kept slightly open to prevent the refrigerant in the indoor units that are not operating in the heating mode from liquefying and accumulating in the compressor. It is part of a normal operation.

Chapter 7 Troubleshooting Using Error Codes

7-1	Error Code and Preliminary Error Code Lists	1
7-2	Error Code Definitions and Solutions: Codes [0 - 999]	6
7-2-1	Error Code [0403]	6
7-2-2	Error Code [0404]	7
7-3	Error Code Definitions and Solutions: Codes [1000 - 1999]	8
7-3-1	Error Code [1102]	8
7-3-2	Error Code [1301]	9
7-3-3	Error Code [1302] (during operation)	10
7-3-4	Error Code [1302] (at startup)	11
7-3-5	Error Code [1500]	11
7-4	Error Code Definitions and Solutions: Codes [2000 - 2999]	12
7-4-1	Error Code [2500] (Models with a drain sensor)	12
7-4-2	Error Code [2500] (Models with a float switch)	13
7-4-3	Error Code [2502] (Models with a drain sensor)	14
7-4-4	Error Code [2502] (Models with a float switch)	15
7-4-5	Error Code [2503]	16
7-4-6	Error Code [2600]	17
7-4-7	Error Code [2601]	17
7-5	Error Code Definitions and Solutions: Codes [3000 - 3999]	18
7-5-1	Error Code [3121]	18
7-5-2	Error Code [3511]	19
7-5-3	Error Code [3512]	20
7-6	Error Code Definitions and Solutions: Codes [4000 - 4999]	21
7-6-1	Error Code [4102]	21
7-6-2	Error Code [4106]	22
7-6-3	Error Code [4109]	22
7-6-4	Error Code [4114]	23
7-6-5	Error Code [4116]	23
7-6-6	Error Code [4121]	23
7-6-7	Error Code [4124]	24
7-6-8	Error Code [4220, 4225, 4226] Detail Code 108.....	25
7-6-9	Error Code [4220, 4225, 4226] Detail Code 109.....	26
7-6-10	Error Code [4220] Detail Code 110.....	26
7-6-11	Error Code [4220, 4225, 4226] Detail Code 111, 112.....	27
7-6-12	Error Code [4220] Detail Code 123.....	27
7-6-13	Error Code [4220] Detail Code 129.....	28
7-6-14	Error Code [4220, 4225, 4226] Detail Code 131.....	28
7-6-15	Error Code [4230] Detail Code 125.....	29
7-6-16	Error Code [4235, 4236] Detail Code 125.....	30
7-6-17	Error Code [4230] Detail Code 126.....	30
7-6-18	Error Code [4240, 4245, 4246]	31
7-6-19	Error Code [4250, 4255, 4256] Detail Code 101.....	32
7-6-20	Error Code [4250, 4255, 4256] Detail Code 104.....	33
7-6-21	Error Code [4250, 4255, 4256] Detail Code 105.....	34
7-6-22	Error Code [4250, 4255, 4256] Detail Code 106 and 107.....	35
7-6-23	Error Code [4250] Detail Code 121, 128, and 122.....	36
7-6-24	Error Code [4255, 4256] Detail Code 137.....	36

7-6-25	Error Code [4260]	37
7-7	Error Code Definitions and Solutions: Codes [5000 - 5999]	38
7-7-1	Error Code [5101, 5102, 5103, 5104]	38
7-7-2	Error Code [5102,5103,5104,5105,5106,5107,5115]	39
7-7-3	Error Code [5110]	40
7-7-4	Error Code [5120]	41
7-7-5	Error Code [5201]	41
7-7-6	Error Code [5301] Detail Code 115	42
7-7-7	Error Code [5301] Detail Code 117	42
7-7-8	Error Code [5301] Detail Code 119	43
7-7-9	Error Code [5301] Detail Code 120	43
7-7-10	Error Code [5301] Detail Code 127	44
7-7-11	Error Code [5305, 5306] Detail Code 135	44
7-7-12	Error Code [5305, 5306] Detail Code 136	45
7-7-13	Error Code [5701]	45
7-8	Error Code Definitions and Solutions: Codes [6000 - 6999]	46
7-8-1	Error Code [6201]	46
7-8-2	Error Code [6202]	46
7-8-3	Error Code [6600]	47
7-8-4	Error Code [6601]	48
7-8-5	Error Code [6602]	49
7-8-6	Error Code [6603]	50
7-8-7	Error Code [6606]	50
7-8-8	Error Code [6607] Error Source Address = Outdoor Unit (OC)	51
7-8-9	Error Code [6607] Error Source Address = Indoor Unit (IC)	52
7-8-10	Error Code [6607] Error Source Address = LOSSNAY (LC)	54
7-8-11	Error Code [6607] Error Source Address = ME Remote Controller	55
7-8-12	Error Code [6607] Error Source Address = System Controller	56
7-8-13	Error Code [6607] All Error Source Addresses	57
7-8-14	Error Code [6607] No Error Source Address	58
7-8-15	Error Code [6608]	59
7-8-16	Error Code [6831]	60
7-8-17	Error Code [6832]	61
7-8-18	Error Code [6833]	62
7-8-19	Error Code [6834]	63
7-8-20	Error Code [6840]	64
7-8-21	Error Code [6841]	64
7-8-22	Error Code [6842]	65
7-8-23	Error Code [6843]	66
7-8-24	Error Code [6846]	67
7-9	Error Code Definitions and Solutions: Codes [7000 - 7999]	68
7-9-1	Error Code [7100]	68
7-9-2	Error Code [7101]	69
7-9-3	Error Code [7102]	70
7-9-4	Error Code [7105]	71
7-9-5	Error Code [7106]	71
7-9-6	Error Code [7110]	72
7-9-7	Error Code [7111]	72
7-9-8	Error Code [7113]	73

7-9-9	Error Code [7117]	74
7-9-10	Error Code [7130]	75
7-10	Unit Error Code Definitions and Solutions: Codes [Er91 - Er99]	76
7-10-1	Error Code [Er91].....	76

7-1 Error Code and Preliminary Error Code Lists

Error Code	Preliminary error code	Error (preliminary) detail code	Error code definition	Searched unit				Notes
				Outdoor unit	Indoor unit	LOSSNAY	Remote controller	
0403	4300 4305 4306	1 5 6 (Note)	Serial communication error/Panel communication error	○	○			(page 6)
0404	-	-	Indoor unit control-related errors		○			(page 7)
0900	-	-	Test run			○		
1102	1202	-	Discharge temperature fault	○				(page 8)
1301	-	-	Low pressure fault	○				(page 9)
1302	1402	-	High pressure fault	○				(page 10)
1500	1600	-	Refrigerant overcharge	○				(page 11)
-	1605	-	Preliminary suction pressure fault	○				
2500	-	-	Drain sensor submergence		○			(page 12)
2502	-	-	Drain pump fault		○			(page 14)
2503	-	-	Drain sensor (Thd) fault		○	○		(page 16)
2600	-	-	Water leakage			○		(page 17)
2601	-	-	Water supply cutoff			○		(page 17)
3121	-	-	Out-of-range outside air temperature	○				(page 18)
3511	3611	-	Refrigerant overcooling	○				(page 19)
3512	3612	-	Locked cooling fan	○				(page 20)
4102	4152	-	Open phase	○				(page 21)
4106	-	-	Transmission power supply fault	○				(page 22)
4109	-	-	Fan operation status detection error		○			(page 22)
4114	-	-	Indoor unit fan motor error		○			(page 23)
4116	-	-	RPM error/Motor error		○	○		(page 23)
4121	4171	-	Function setting error	○				(page 23)
4124	-	-	Electric system not operate due to damper abnormality		○			(page 24)
4220 4225 4226 (Note)	4320 4325 4326 (Note)	[0]	Backup operation	○				
		[108]	Abnormal bus voltage drop (Software detection)	○				(page 25)
		[109]	Abnormal bus voltage rise (Software detection)	○				(page 26)
		[110]	BUS voltage error (Hardware detection)	○				(page 26)
		[111]	Logic error	○				(page 27)
		[112]	Logic error	○				(page 27)
		[123]	Voltage boost control error	○				(page 27)
		[129]	Control power-supply fault	○				(page 28)
	[131]	Low bus voltage at startup	○				(page 28)	
4230 4235 4236	4330 4335 4336	[125]	Heatsink overheat protection	○				(page 29)

Error Code	Preliminary error code	Error (preliminary) detail code	Error code definition	Searched unit				Notes
				Outdoor unit	Indoor unit	LOSSNAY	Remote controller	
4230	4330	[126]	DCL temperature fault	O				(page 30)
4240 4245 4246	4340	-	Overload protection	O				(page 31)
4250 4255 4256 (Note)	4350 4355 4356 (Note)	[0]	Backup operation	O				
		[101]	IPM error	O				(page 32)
		[104]	Short-circuited IPM/Ground fault	O				(page 33)
		[105]	Overcurrent error due to short-circuited motor	O				(page 34)
		[106]	Instantaneous overcurrent (S/W detection)	O				(page 35)
		[107]	Overcurrent (effective value)(S/W detection)	O				(page 35)
		[121]	DCL overcurrent breaker error (hardware detection)	O				(page 36)
		[122]	DCL overcurrent breaker error (software detection)	O				(page 36)
4250	4350	[128]	DCL overcurrent breaker error (hardware detection)	O				(page 36)
4255 4256	4355 4356	[137]	Step-out fault	O				(page 36)
4260	-	-	Heatsink overheat protection at startup	O				(page 37)
5101	1202	-	Temperature sensor fault	Return air temperature (TH21)		O		(page 38)
				OA processing unit inlet temperature (TH4)			O	(page 38)
5102	1217	-	Temperature sensor fault	Indoor unit pipe temperature (TH22)		O		(page 38)
				OA processing unit pipe temperature (TH2)			O	(page 38)
				HIC bypass circuit outlet temperature (TH2)	O			(page 39)
5103	1205	00	Temperature sensor fault	Indoor unit gas-side pipe temperature (TH23)		O		(page 38)
				OA processing unit gas-side pipe temperature (TH3)			O	(page 38)
				Pipe temperature at heat-exchanger outlet (TH3)	O			(page 39)
5104	1202	-	Temperature sensor fault	OA processing unit intake air temperature (TH1)			O	(page 38)
				Outside temperature (TH24)		O		(page 38) Detectable only by the All-Fresh type indoor units
				Outdoor unit discharge temperature (TH4)	O			(page 39)
5105	1204	-	Temperature sensor fault	Accumulator inlet temperature (TH5)	O			(page 39)
5106	1216	-	Temperature sensor fault	HIC circuit outlet temperature (TH6)	O			(page 39)
5107	1221	-	Temperature sensor fault	Outside temperature (TH7)	O			(page 39)

Error Code	Preliminary error code	Error (preliminary) detail code	Error code definition		Searched unit				Notes
					Outdoor unit	Indoor unit	LOSSNAY	Remote controller	
5115			Temperature sensor fault	Shell bottom temperature (TH15)	O				(page 39)
5110	1214	[0]	Backup operation		O				
		01	Temperature sensor fault	Heatsink temperature (THHS)	O				(page 40)
5120	1248	[0]	Backup operation		O				
		01	Temperature sensor fault	DCL(THL)	O				(page 41)
5201	-	-	High-pressure sensor fault (63HS1)		O				(page 41)
5301	4300	[0]	Backup operation		O				
		[115]	ACCT sensor fault		O				(page 42)
		[117]	ACCT sensor circuit fault		O				(page 42)
		[119]	Open-circuited IPM/Loose ACCT connector		O				(page 43)
		[120]	Faulty ACCT wiring		O				(page 43)
		[127]	DCL electric current circuit error		O				(page 44)
5305 5306	4305 4306	[0]	Backup operation		O				
		[135]	Current sensor fault		O				(page 44)
		[136]	Current sensor circuit fault		O				(page 45)
5701	-	-	Loose float switch connector			O			(page 45)
6201	-	-	Remote controller board fault (nonvolatile memory error)					O	(page 46)
6202	-	-	Remote controller board fault (clock IC error)					O	(page 46)
6600	-	[001]	Detection of overlapped address in centralized control system		O	O	O	O	(page 47)
		[002]	Detection of overlapped address in indoor unit system		O	O	O	O	(page 47)
6601	-	[001]	Detection of polarity setting error in centralized control system					O	(page 48)
		[002]	Detection of polarity setting error in indoor unit system					O	(page 48)
6602	-	[001]	Transmission processor hardware error in centralized control system		O	O	O	O	(page 49)
		[002]	Transmission processor hardware error in indoor unit system		O	O	O	O	(page 49)
6603	-	[001]	Transmission Bus-Busy error in centralized control system		O	O	O	O	(page 50)
		[002]	Transmission Bus-Busy error in indoor unit system		O	O	O	O	(page 50)
6606	-	[003]	Communication error between device processor on circuit board and M-NET processor		O	O	O	O	(page 50)
6607	-	-	No-Ack error		O	O	O	O	(page 51)
6608	-	-	No response error		O	O	O	O	(page 59)
6831	-	-	MA controller signal reception error (No signal reception)			O		O	(page 60)
6832	-	-	MA remote controller signal transmission error (Synchronization error)			O		O	(page 61)
6833	-	-	MA remote controller signal transmission error (Hardware error)			O		O	(page 62)

Error Code	Preliminary error code	Error (preliminary) detail code	Error code definition	Searched unit				Notes
				Outdoor unit	Indoor unit	LOSSNAY	Remote controller	
6834	-	-	MA controller signal reception error (Start bit detection error)		O		O	(page 63)
6840	-	-	Indoor/outdoor unit communication error		O			(page 64)
6841	-	-	A control communication synchronism not recover		O			(page 64)
6842	-	-	A control communication transmission/reception hardware trouble		O			(page 65)
6843	-	-	A control communication start bit detection error		O			(page 66)
6846	-	-	Start-up time over		O			(page 67)
7100	-	-	Total capacity error	O				(page 68)
7101	-	-	Capacity code setting error	O	O	O		(page 69)
7102	-	-	Wrong number of connected units	O				(page 70)
7105	-	-	Address setting error	O				(page 71)
7106	-	-	Attribute setting error			O		(page 71)
7110	-	-	Connection information signal transmission/reception error	O				(page 72)
7111	-	-	Remote controller sensor fault		O	O		(page 72)
7113	-	-	Function setting error (improper connection of CNTYP)	O				(page 73)
7117	-	-	Model setting error	O				(page 74)
7130	-	-	Incompatible unit combination	O				(page 75)
Er91	-	-	Firmware update error	O				(page 76)

Note

The last digit in the check error codes in the 4000's and 5000's and two-digit detail codes indicate if the codes apply to compressor inverter on fan inverter.

Example

Code 4225 (detail code 108): Bus voltage drop in the fan inverter system

Code 4230 : Heatsink overheat protection in the compressor inverter system

The last digit	Inverter system
0 or 1	Compressor inverter system
5 or 6	Fan inverter system

<Compressor inverter>

INV board	Outdoor units	Overload protection I _{max} (Arms)	Current effective value error (Arms)	Current peak value error (A _{peak})	Temperature protection TOL (°C)
INV35Y	P200	19	23	39	95
	P250				
	P300				
INV36Y INV42Y	P350	27	33	56	
	P400				
	P450				
INV37YC	P500				

<Fan inverter>

INV board	Outdoor units	Overload protection I _{max} (Arms)	Current effective value error (Arms)	Current peak value error (A _{peak})	Temperature protection TOL (°C)
INVS/15Y INVS/19Y	P200	3.9	Off	7.0	Off
	P250				
	P300				
	P350	4.5		8.5	
	P400				
	P450				
	P500	3.9		7.0	

7-2 Error Code Definitions and Solutions: Codes [0 - 999]

7-2-1 Error Code [0403]

1. Error code definition

Serial communication error

2. Error definition and error detection method

Serial communication error between the control board and the INV board on the compressor, and between the control board and the Fan board

Detail code 1: Between the control board and the INV board

Detail code 5, 6: Between the control board and the Fan board

3. Cause, check method and remedy

(1) Faulty wiring

Check the following wiring connections.

- 1) Between Control board and Fan board

Control board	FAN board
CN4A	CN80
CN4B	CN80

- 2) Between control board and INV board

Control board	INV board
CN4	CN2

- 3) Between power-supply board and INV board

Power-supply board	INV board
CNINV	CN19V

- 4) Between power-supply board and Fan board

Power-supply board	FAN board
CNFAN1	CN81
CNFAN2	CN81

(2) PS board failure

Replace the PS board if the LED on the INV board, Fan board, or control board is not lit.

Using the detail codes, check the status of the LEDs on the circuit boards below.

Detail code 1: LED on the INV board

Detail code 5: LED on the right Fan board

Detail code 6: LED on the left Fan board

*When the power-supply board is normal, all LEDs will be lit.

(3) INV board failure, Fan board failure and Control board failure

If the problem persists after a power reset, replace the INV board, FAN board, or control board.

(4) Incorrect DIPSW setting on the Fan board

Make sure the DIPSW on the Fan board are set as follows.

- Models with a single fan

DIPSW 1-3: ON

(All other switches: OFF)

- Models with two fans

DIPSW 1-3 on the right Fan board: ON (All other switches: OFF)

DIPSW 1-4 on the left Fan board: ON (All other switches: OFF)

7-2-2 **Error Code [0404]**

1. Error code definition

Indoor unit control-related errors

2. Error definition and error detection method

Indoor controller board

Abnormal if data cannot be read normally from the nonvolatile memory of the indoor controller board.

3. Cause, check method and remedy

Cause	Check method and remedy
Defective indoor controller board	Replace indoor controller board.

Note: Refer also to the Service Handbook for the indoor units.

7-3 Error Code Definitions and Solutions: Codes [1000 - 1999]

7-3-1 Error Code [1102]

1. Error code definition

Discharge temperature fault

2. Error definition and error detection method

- 1) If the discharge temperature of 120 °C [248°F] or more is detected during the operation (the first detection), the outdoor unit stops once, turns to anti-restart mode for 3 minutes, and restarts after 3 minutes automatically.
- 2) If the discharge temperature of 120° C [248°F] or more is detected again (the second detection) within 30 minutes after the second stop of the outdoor unit described above, the mode will be changed to 3 - minute restart mode, then the outdoor unit will restart in 3 minutes.
- 3) If the discharge temperature of 120°C [248°F] or more is detected (the 30th detection) within 30 minutes after the stop of the outdoor unit described above (regardless of the first or the 29th stop), the outdoor unit will make an error stop, and the error code "1102" will be displayed.
- 4) If the discharge temperature of 120°C [248°F] or more is detected more than 30 minutes after the previous stop of the outdoor unit, the detection is regarded as the first detection, and the operation described in step 1 above will start.
- 5) For 30 minutes after the stop (the first stop or the second stop) of the outdoor unit, preliminary errors will be displayed on the LED display.

3. Cause, check method and remedy

Cause	Check method and remedy
(1) Gas leak, gas shortage	Refer to the following page(s). [6-3 Evaluating and Adjusting Refrigerant Charge]
(2) Overload operation	Check operating conditions and operation status of indoor/ outdoor units.
(3) LEV failure on the indoor unit (4) Outdoor unit LEV1 actuation failure Outdoor unit LEV2 actuation failure	Perform a cooling or heating operation to check the operation. Cooling: Indoor unit LEV, LEV1, LEV2 Heating: Indoor unit LEV, LEV2 Refer to the following page(s). [8-8 Troubleshooting LEV Problems]
(5) Closed refrigerant service valve	Confirm that the refrigerant service valve is fully open.
(6) Outdoor fan (including fan parts) failure, motor failure, or fan controller malfunction Rise in discharge temp. by low pressure drawing for (3) - (6).	Check the fan on the outdoor unit. Refer to the following page(s). [8-7 Troubleshooting Outdoor Unit Fan Problems]
(7) Gas leak between low and high pressures (4-way valve failure, Compressor failure, Solenoid valve (SV1a) failure)	Perform a cooling or heating operation and check the operation.
(8) Thermistor failure (TH4)	Refer to the following page(s). [7-7-2 Error Code [5102,5103,5104,5105,5106,5107,5115]]
(9) Input circuit failure on the controller board thermistor	Check the inlet air temperature on the LED monitor.

7-3-2 Error Code [1301]

1. Error code definition

Low pressure fault

2. Error definition and error detection method

When starting the compressor from Stop Mode for the first time if low pressure reads 0.098MPa [14psi] immediately before start-up, the operation immediately stops.

3. Cause, check method and remedy

Cause	Check method and remedy
(1) Inner pressure drop due to a leakage.	Refer to the following page(s). [8-5-3 Comparing the Low-Pressure Sensor Measurement and Gauge Pressure]
(2) Low pressure sensor failure	
(3) Short-circuited pressure sensor cable due to torn outer rubber	
(4) A pin on the male connector is missing.	
(5) Disconnected wire	
(6) Failure of the low pressure input circuit on the controller board	

Note

When a shut-off valve is installed as a safety measure, closing of the valve may cause this error.

7-3-3 Error Code [1302] (during operation)

1. Error code definition

High pressure fault 1 (Outdoor unit)

2. Error definition and error detection method

- 1) If the pressure of 3.78MPa [548psi] or higher is detected by the pressure sensor during operation (the first detection), the outdoor stops once, turns to antirestart mode for 3 minutes, and restarts after 3 minutes automatically.
- 2) If the pressure of 3.78MPa [548psi] or higher is detected by the pressure sensor again (the second detection) within 30 minutes after the first stop of the outdoor unit, the outdoor unit stops once, turns to anti-restart mode for 3 minutes, and restarts after 3 minutes automatically.
- 3) If the pressure of 3.87MPa [561psi] or higher is detected by the pressure sensor (the third detection) within 30 minutes of the second stop of the outdoor unit, the outdoor unit will make an error stop, and the error code "1302" will be displayed.
- 4) If the pressure of 3.78MPa [548psi] or higher is detected more than 30 minutes after the stop of the outdoor unit, the detection is regarded as the first detection, and the operation described in step 1 above will start.
- 5) For 30 minutes after the stop of the outdoor unit, preliminary errors will be displayed on the LED display.
- 6) The outdoor unit makes an error stop immediately when not only the pressure sensor but also the pressure switch detects $4.15^{+0,-0.15}$ MPa [$601^{+0,-22}$ psi]
- 7) Open phase due to unstable power supply voltage may cause the pressure switch to malfunction or cause the units to come to an abnormal stop.

3. Cause, check method and remedy

Cause	Check method and remedy
(1) Outdoor unit LEV2 actuation failure -> Cooling Indoor unit LEV actuation failure -> Heating	Perform a cooling or heating operation to check the operation. Cooling: Outdoor unit LEV2 Heating: Indoor unit LEV Refer to the following page(s). [8-8 Troubleshooting LEV Problems]
(2) Closed refrigerant service valve	Confirm that the refrigerant service valve is fully open.
(3) Short cycle on the indoor unit side (4) Clogged filter on the indoor unit (5) Reduced air flow due to dirty fan on the indoor unit fan (6) Dirty heat exchanger of the indoor unit (7) Indoor fan (including fan parts) failure or motor failure Rise in high pressure caused by lowered condensing capacity in heating operation for (2) - (7).	Check the indoor units for problems and correct them, if any.
(8) Short cycle on the outdoor unit (9) Dirty heat exchanger of the outdoor unit	Check the outdoor units for problems and correct them, if any.
(10) Outdoor fan (including fan parts) failure, motor failure, or fan controller malfunction Rise in discharge temp. by low pressure drawing for (8) - (10).	Check the fan on the outdoor unit. Refer to the following page(s). [8-7 Troubleshooting Outdoor Unit Fan Problems]
(11) Solenoid valve (SV1a) malfunction (The by-pass valve (SV1a) can not control rise in high pressure).	Refer to the following page(s). [8-6 Troubleshooting Solenoid Valve Problems]
(12) Thermistor failure (TH3, TH7)	Refer to the following page(s). [7-7-2 Error Code [5102,5103,5104,5105,5106,5107,5115]]
(13) Pressure sensor failure	Refer to the following page(s). [8-5-1 Comparing the High-Pressure Sensor Measurement and Gauge Pressure]
(14) Failure of the thermistor input circuit and pressure sensor input circuit on the controller board	Check the temperature and the pressure of the sensor with LED monitor.
(15) Thermistor mounting problem (TH3, TH7)	Check the temperature and the pressure of the sensor with LED monitor.
(16) Disconnected male connector on the pressure switch (63H1) or disconnected wire	Check the temperature and the pressure of the sensor with LED monitor.
(17) Voltage drop caused by unstable power supply voltage	Check the input voltage at the power supply terminal block (TB1).

7-3-4 Error Code [1302] (at startup)

1. Error code definition

High pressure fault 2 (Outdoor unit)

2. Error definition and error detection method

If the pressure of 0.098MPa [14psi] or lower is registered on the pressure sensor immediately before start-up, it will trigger an abnormal stop, and error code "1302" will be displayed.

3. Cause, check method and remedy

Cause	Check method and remedy
(1) Inner pressure drop due to a leakage.	Refer to the following page(s). [8-5-1 Comparing the High-Pressure Sensor Measurement and Gauge Pressure]
(2) Pressure sensor failure	
(3) Shorted-circuited pressure sensor cable due to torn outer rubber	
(4) A pin on the male connector on the pressure sensor is missing or contact failure	
(5) Disconnected pressure sensor cable	
(6) Failure of the pressure sensor input circuit on the controller board	
(7) Open phase in the power-supply due to improper power-supply wiring	Refer to item (5) in section [6-1 Read before Test Run].

7-3-5 Error Code [1500]

1. Error code definition

Refrigerant overcharge

2. Error definition and error detection method

An error can be detected by the discharge temperature superheat.

- 1) If the formula "ToilSH (shell bottom SH) $\leq 10^{\circ}\text{C}$ [50°F]" is satisfied during operation (first detection), the outdoor unit stops, goes into the 3-minute restart mode, and starts up in three minutes.
- 2) If the formula "TdSH $\leq 10^{\circ}\text{C}$ [50°F]" is satisfied again within 30 minutes of the fifth stoppage of the outdoor unit (sixth detection), the unit comes to an abnormal stop, and the error code "1500" appears.
- 3) If the formula "ToilSH (shell bottom SH) $\leq 10^{\circ}\text{C}$ [50°F]" is satisfied 30 minutes or more after the first stoppage of the outdoor unit, the same sequence as Item 1) above (first detection) is followed.
- 4) For 30 minutes after the stop of the outdoor unit, preliminary errors will be displayed on the LED display.

3. Cause, check method and remedy

Cause	Check method and remedy
(1) Overcharged refrigerant	Refer to the following page(s). [6-3 Evaluating and Adjusting Refrigerant Charge]
(2) Thermistor input circuit failure on the control board	Check the temperature and pressure readings on the sensor that are displayed on the LED monitor.
(3) Faulty mounting of thermistor (TH15)	Check the temperature and pressure readings on the thermistor that are displayed on the LED monitor.
(4) Outdoor unit LEV2 actuation failure -> Heating	Refer to the following page(s). [8-8 Troubleshooting LEV Problems]

7-4 Error Code Definitions and Solutions: Codes [2000 - 2999]

7-4-1 Error Code [2500] (Models with a drain sensor)

1. Error code definition

Drain sensor submergence

2. Error definition and error detection method

- 1) If an immersion of the drain sensor in the water is detected while the unit is in any mode other than the Cool/Dry mode and when the drain pump goes from OFF to ON, this condition is considered preliminary water leakage. While this error is being detected, humidifier output cannot be turned on.
- 2) If the immersion of the sensor in the water is detected four consecutive times at an hour interval, this is considered water leakage, and "2500" appears on the monitor.
- 3) Detection of water leakage is also performed while the unit is stopped.
- 4) Preliminary water leakage is cancelled when the following conditions are met:
 - ♦One hour after the preliminary water leakage was detected, it is not detected that the drain pump goes from OFF to ON.
 - ♦The operation mode is changed to Cool/Dry.
 - ♦The liquid pipe temperature minus the inlet temperature is -10°C [-18°F] or less.

3. Cause, check method and remedy

Cause	Check method and remedy
(1) Drain water drainage problem ♦Clogged drain pump ♦Clogged drain piping ♦Backflow of drain water from other units	Check for proper drainage.
(2) Adhesion of water drops to the drain sensor ♦Trickling of water along the lead wire ♦Rippling of drain water caused by filter clogging	1) Check for proper lead wire installation. 2) Check for clogged filter.
(3) Failure of the relay circuit for the solenoid valve	Replace the relay.
(4) Indoor unit control board failure ♦Drain sensor circuit failure	If the above item checks out OK, replace the indoor unit control board.

7-4-2 Error Code [2500] (Models with a float switch)

1. Error code definition

Drain sensor submergence

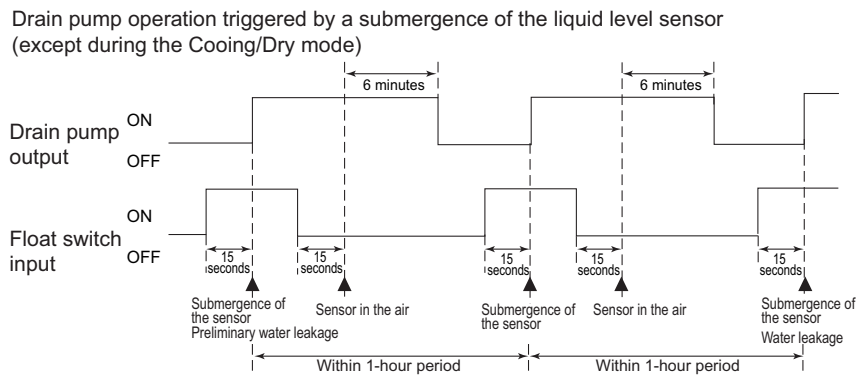
2. Error definition and error detection method

- 1) If an immersion of the float switch in the water is detected while the unit is in any mode other than the Cool/Dry mode and when the drain pump goes from OFF to ON, this condition is considered preliminary water leakage. While this error is being detected, humidifier output cannot be turned on.
- 2) If the drain pump turns on within one hour after preliminary water leakage is detected and the above-mentioned condition is detected two consecutive times, water leakage error water leakage is detected, and "2500" appears on the monitor.
- 3) Detection of water leakage is also performed while the unit is stopped.
- 4) Preliminary water leakage is cancelled when the following conditions are met:
 - One hour after the preliminary water leakage was detected, it is not detected that the drain pump goes from OFF to ON.
 - The operation mode is changed to Cool/Dry.
 - The liquid pipe temperature minus the inlet temperature is - 10°C [-18°F] or less.

3. Cause, check method and remedy

Cause	Check method and remedy
(1) Drain water drainage problem •Clogged drain pump •Clogged drain piping •Backflow of drain water from other units	Check for proper drainage.
(2) Stuck float switch Check for slime in the moving parts of the float switch.	Check for normal operation of the float switch.
(3) Float switch failure	Check the resistance with the float switch turned on and turned off.

<Reference>



7-4-3 Error Code [2502] (Models with a drain sensor)

1. Error code definition

Drain pump fault

2. Error definition and error detection method

- 1) Make the drain sensor thermistor self-heat by passing current through it. If the temperature rise is small, it is interpreted that the sensor is immersed in water. This condition is considered to be a preliminary error, and the unit goes into the 3-minute restart delay mode.
- 2) If another episode of the above condition is detected during the preliminary error, this is considered a drain pump error, and "2502" appears on the monitor.
- 3) This error is always detected while the drain pump is in operation.
- 4) The following criteria are met when the criteria for the forced stoppage of outdoor unit (system stoppage) are met.
 - *"Liquid pipe temperature-inlet temperature $\leq -10^{\circ}\text{C}$ [-18°F]" has been detected for 30 minutes.
 - *The immersion of drain sensor is detected 10 consecutive times.
 - *The conditions that are listed under items 1) through 3) above are always met before the criteria for the forced stoppage of the outdoor unit.
- 5) The indoor unit that detected the conditions that are listed in item 4) above brings the outdoor unit in the same refrigerant circuit to an error stop (compressor operation prohibited), and the outdoor unit brings all the indoor units in the same refrigerant circuit that are in any mode other than Fan or Stop to an error stop. "2502" appears on the monitor of the units that came to an error stop.
- 6) Forced stoppage of the outdoor unit
 Detection timing: The error is detected whether the unit is in operation or stopped.
- 7) Ending criteria for the forced stoppage of outdoor unit
 Power reset the indoor unit that was identified as the error source and the outdoor unit that is connected to the same refrigerant circuit.
 Forced stoppage of the outdoor unit cannot be cancelled by stopping the unit via the remote controller.
 (Note) Items 1) - 3) and 4) - 7) are detected independently from each other.

Note

The address and attribute that appear on the remote controller are those of the indoor unit (or OA processing unit) that caused the error.

3. Cause, check method and remedy

Cause	Check method and remedy
(1) Drain pump failure	Check for proper functioning of the drain pump.
(2) Drain water drainage problem <ul style="list-style-type: none"> •Clogged drain pump •Clogged drain piping 	Check for proper drainage.
(3) Adhesion of water drops to the drain sensor <ul style="list-style-type: none"> •Trickling of water along the lead wire •Rippling of drain water caused by filter clogging 	1) Check for proper lead wire installation. 2) Check for clogged filter.
(4) Indoor unit control board failure <ul style="list-style-type: none"> •Drain pump drive circuit failure •Drain heater output circuit failure 	If the above item checks out OK, replace the indoor unit control board.
(5) Wrong dipswitch setting on the indoor unit controller board <ul style="list-style-type: none"> •Dipswitch for the new indoor unit controller board was wrongly set to "unit model without drain pump" instead of "unit model with drain pump" when the board was replaced. 	Check for proper dipswitch model setting on the indoor unit controller board.

7-4-4 Error Code [2502] (Models with a float switch)

1. Error code definition

Drain pump fault

2. Error definition and error detection method

- 1) The immersion of sensor tip in water is detected by the ON/OFF signal from the float switch.
 - *Submergence of the sensor
When it is detected that the float switch has been ON for 15 seconds, it is interpreted that the sensor tip is immersed in water.
 - *Sensor in the air
When it is detected that the float switch has been OFF for 15 seconds, it is interpreted that the sensor tip is not immersed in water.
- 2) If it is detected that the float switch has been ON for 3 minutes after the immersion of the sensor tip was detected, this is considered a drain pump failure, and "2502" appears on the monitor.
 - *The total time it takes for this error to be detected is 3 minutes and 15 seconds, including the time it takes for the first immersion of the sensor tip to be detected.
- 3) Detection of drain pump failure is performed while the unit is stopped.
- 4) The following criteria are met when the criteria for the forced stoppage of outdoor unit (system stoppage) are met.
 - *"Liquid pipe temperature-inlet temperature $\leq -10^{\circ}\text{C}$ [-18°F]" has been detected for 30 minutes.
 - *It is detected by the float switch that the sensor tip has been immersed in water for 15 minutes or more.
 - *The conditions that are listed under items 1) through 3) above are always met before the criteria for the forced stoppage of the outdoor unit.
- 5) The indoor unit that detected the conditions that are listed in item 4) above brings the outdoor unit in the same refrigerant circuit to an error stop (compressor operation prohibited), and the outdoor unit brings all the indoor units in the same refrigerant circuit that are in any mode other than Fan or Stop to an error stop. "2502" appears on the monitor of the units that came to an error stop.
- 6) Forced stoppage of the outdoor unit
Detection timing: The error is detected whether the unit is in operation or stopped.
- 7) Ending criteria for the forced stoppage of outdoor unit
Power reset the indoor unit that was identified as the error source and the outdoor unit that is connected to the same refrigerant circuit.
Forced stoppage of the outdoor unit cannot be cancelled by stopping the unit via the remote controller.
(Note) Items 1) - 3) and 4) - 7) are detected independently from each other.

Note

The address and attribute that appear on the remote controller are those of the indoor unit (or OA processing unit) that caused the error.

3. Cause, check method and remedy

Cause		Check method and remedy
(1)	Drain pump failure	Check for proper functioning of the drain pump mechanism
(2)	Drain water drainage problem •Clogged drain pump •Clogged drain piping	Check for proper drainage.
(3)	Stuck float switch Check for slime in the moving parts of the float switch.	Check for normal operation of the float switch.
(4)	Float switch failure	Check the resistance with the float switch turned on and turned off.
(5)	Indoor unit control board failure •Drain pump drive circuit failure •Float switch input circuit failure	Replace indoor unit control board.
(6)	Wrong dipswitch setting on the indoor unit controller board •Dipswitch for the new indoor unit controller board was wrongly set to "unit model without drain pump" instead of "unit model with drain pump" when the board was replaced.	Check for proper dipswitch model setting on the indoor unit controller board.

7-4-5 Error Code [2503]

1. Error code definition

Drain sensor (Thd) fault

2. Error definition and error detection method

- If the open or short circuit of the thermistor has been detected for 30 seconds, this condition is considered to be a preliminary error, and the unit goes into the 3-minute restart delay mode.
- If another episode of the above condition is detected during the preliminary error, this is considered a drain sensor error.(If the short or open circuit of the thermistor is no longer detected, normal operation will be restored in 3 minutes.)
- This error is detected when one of the following conditions are met.
 - *During Cool/Dry operation
 - *Liquid pipe temperature minus inlet temperature is equal to or smaller than -10°C [-18°F] (except during the defrost cycle)
 - *When the liquid temperature thermistor or suction temperature thermistor or short or open circuited.
 - *Drain pump is in operation.
 - *One hour has elapsed since the drain sensor went off.
 - Short: 90°C [194 °F] or above
 - Open: - 20°C [-4 °F] or below

3. Cause, check method and remedy

Cause	Check method and remedy
(1) Faulty connector (CN31) insertion.	1) Check for connector connection failure. Reinsert the connector, restart the operation, and check for proper operation.
(2) Broken or semi-broken thermistor wire	2) Check for a broken thermistor wire.
(3) Thermistor failure	3) Check the resistance of the thermistor. 0°C[32 °F]:6.0 kΩ 10°C[50 °F]:3.9 kΩ 20°C[68°F]:2.6 kΩ 30°C[86°F]:1.8 kΩ 40°C[104 °F]:1.3 kΩ
(4) Indoor unit control board (error detection circuit) failure	4) Replace the indoor unit control board if the problem recurs when the unit is operated with the No.-1 and No.-2 pins on the drain sensor connector (CN31) being short-circuited. If the above item checks out OK, there are no problems with the drain sensor. Turn off the power and turn it back on.

7-4-6 **Error Code [2600]**

1. Error code definition

Water leakage

2. Cause, check method and remedy

Check that water does not leak from the pipes in such as the humidifier.

7-4-7 **Error Code [2601]**

1. Error code definition

Water supply cutoff

2. Cause, check method and remedy

Cause		Check method and remedy
(1)	The water tank of the humidifier is empty.	Check the amount of supply water. Check for the solenoid valve and for the connection.
(2)	The solenoid valve for humidification is OFF.	Check the connector.
(3)	Disconnected float switch	Check the connecting part.
(4)	Poor operation of float switch	Check for the float switch.
(5)	Frozen water tank	Turn off the power source of the water tank to defrost, and turn it on again.

7-5 Error Code Definitions and Solutions: Codes [3000 - 3999]

7-5-1 Error Code [3121]

1. Error code definition

Out-of-range outside air temperature

2. Error definition and error detection method

- When the thermistor temperature of -28°C[-18°F] or below has continuously been detected for 3 minutes during heating operation (during compressor operation), the unit makes an error stop and "3121" appears on the display. (Use the OC thermistor temperature to determine when two outdoor units are in operation.)
- The compressor restarts when the thermistor temperature is -26°C[-15°F] or above (both OC and OS) during error stop. (The error display needs to be canceled by setting the remote controller.)
- Outdoor temperature error is canceled if the units stop during error stop. (The error display needs to be canceled by setting the remote controller.)

3. Cause, check method and remedy

Check the following factors if an error is detected, without drop in the outdoor temperature.

Cause	Check method and remedy
(1) Thermistor failure	Check thermistor resistance.
(2) Pinched lead wire	Check for pinched lead wire.
(3) Torn wire coating	Check for wire coating.
(4) A pin on the male connector is missing or contact failure	Check connector.
(5) Disconnected wire	Check for wire.
(6) Thermistor input circuit failure on the control board	Check the intake temperature of the sensor with the LED monitor. When the temperature is far different from the actual temperature, replace the control board.

<Reference>

Short detection
Open detection
 TH7 110 °C [230 °F] and above (0.4 kΩ) -40 °C [-40 °F] and below (130 kΩ)

7-5-2 Error Code [3511]

1. Error code definition

Refrigerant overcooling

2. Error definition and error detection method

- 1) If the condition "THHS \leq A^{*1} °C remains true for continuous 6 minutes and 30 seconds" is met (for the first time) during operation, the outdoor unit will stop, go into the three-minute restart delay mode, and then automatically resume operation after three minutes have passed.
- 2) If the condition "THHS \leq A^{*1} °C remains true for continuous 6 minutes and 30 seconds" is met again (for the second time) within 30 minutes of the first stoppage of the outdoor unit explained above, the outdoor unit will stop, go into the three-minute restart delay mode, and then automatically resume operation after three minutes have passed.
- 3) If the condition "THHS \leq A^{*1} °C remains true for continuous 6 minutes and 30 seconds" is met again (for the third time) within 30 minutes of the second stoppage of the outdoor unit explained above and before the condition "THHS $>$ A^{*1} °C remains true for continuous 2 minutes" has been met, the unit will come to an abnormal stop, and this error will be indicated as "3511."
- 4) If the condition "THHS \leq A^{*1} °C remains true for continuous 6 minutes and 30 seconds" is met (regardless of the first or second time) after 30 minutes of the first occurrence or after the condition "THHS $>$ A^{*1} °C remains true for continuous 2 minutes" has been met, it is considered as the first occurrence, and the unit will follow the same behavior as the one described in item 1) above.
- 5) For 30 minutes after the stoppage of the outdoor unit, or the period up to the time when the condition "THHS $>$ A^{*1} °C remains true for continuous 2 minutes" has been met is considered as a preliminary error, and this state will be indicated on the LED.

*1 During cooling: A = Outside temperature TH7; During heating: A = Evaporation temperature Te

3. Cause, check method and remedy

Cause	Check method and remedy
(1) Outdoor unit LEV9 malfunction	Check the operation of unit in the Cooling or in the Heating mode. LEV9 Refer to [8-8 Troubleshooting LEV Problems].
(2) THHS failure	1) Check the IGBT on the INV board for proper mounting. 2) Check the THHS sensor reading on the LED. → Replace the INV board if the THHS value is abnormal.
(3) Thermistor failure (TH7)	Resistance value of the thermistor
(4) Low-pressure sensor fault	Refer to [8-5 Pressure Sensor Circuit Configuration and Troubleshooting Pressure Sensor Problems]

7-5-3 Error Code [3512]

1. Error code definition

Cooling fan locking

2. Error definition and error detection method

♦The motor on the cooling fan locks during operation.

3. Cause, check method and remedy

Cause		Check method and remedy
(1)	Locked cooling fan motor	Check the fan blades for objects obstructing the rotation of the cooling fan.
(2)	Cooling fan motor trouble	Disconnect the wiring from the cooling fan motor, and check the insulation resistance and the coil resistance of the motor. Replace the motor if problems are found. Criteria for insulation failure: Insulation failure if below 1 MΩ Wire disconnection: Normal if coil resistance is between 56 and 65 Ω
(3)	Contact failure	Check the wiring between CN101 and CN63PW. Check the wiring between CN24V and RY24V. Check the RY24V terminal block for problems.
(4)	Circuit board fault	If no problems are found with the items above, replace the control board and the PS board.

7-6 Error Code Definitions and Solutions: Codes [4000 - 4999]

7-6-1 Error Code [4102]

1. Error code definition

Open phase

2. Error definition and error detection method

- An open phase of the power supply (L1 phase, N phase) was detected at power on.
- The L3 phase current is outside of the specified range.
- When an open phase is detected (L3-phase or N-phase in the power supply) is detected at the start of operation.

Note

The open phase of the power supply may not always be detected if a power voltage from another circuit is applied.

3. Cause, check method and remedy

Cause	Check method and remedy
(1) Power supply problem •Open phase voltage of the power supply •Power supply voltage drop	<ul style="list-style-type: none"> •Check the input voltage to the power supply terminal block TB1. •Possible open phase in the power-supply due to improper power-supply wiring. (Refer to item (5) in section [6-1 Read before Test Run].)
(2) Noise filter problem •Coil problem •Circuit board failure	<ul style="list-style-type: none"> •Check the coil connections. •Check for coil burnout.
(3) Wiring failure	<p>Check the wiring between CN5 on the noise filter and CNAC on the control board.</p> <p>Check the wiring between CN3 on the noise filter and CN110 on the control board.</p>
(4) Blown fuse	<p>Check for a blown fuse (F001) on the control board.</p> <p>→If a blown fuse is found, check for a short-circuiting or earth fault of the actuator.</p> <p>Check for a blown fuse (F3) on the noise filter.</p> <p>→If a blown fuse is found, check for a short-circuiting or earth fault of the actuator.</p>
(5) Control board failure	<p>Replace the control board if none of the above is causing the problem.</p>

7-6-2 Error Code [4106]

1. Error code definition

<Transmission power supply fault Error detail code FF (Outdoor unit)>

2. Error definition and error detection method

Transmission power output failure

3. Cause

- 1) Wiring failure
- 2) Transmission power supply cannot output voltage because overcurrent was detected.
- 3) Voltage cannot be output due to transmission power supply problem.
- 4) Transmission voltage detection circuit failure

4. Check method and remedy

Check the transmission power supply circuit on all outdoor units in a given refrigerant circuit for problems. [8-10-2 Troubleshooting Problems with Outdoor Unit Transmission Power Supply Circuit]

1. Error code definition

<Transmission power supply fault other than error detail code FF (Outdoor unit)>

2. Error definition and error detection method

Transmission power reception failure

3. Cause

One of the outdoor units stopped supplying power, but no other outdoor units start supplying power.

4. Check method and remedy

Check the transmission power supply circuit on all outdoor units in a given refrigerant circuit for problems. [8-10-2 Troubleshooting Problems with Outdoor Unit Transmission Power Supply Circuit]

7-6-3 Error Code [4109]

1. Error code definition

Indoor unit fan operation error

2. Error definition and error detection method

- 1) Connector CN28 has remained open-circuited for 100 consecutive seconds during operation.

3. Cause, check method and remedy

Cause	Check method and remedy
(1) Auxiliary relay fault	The coil or the wiring of the auxiliary relay connected to CN28 is faulty.
(2) Connector (CN28) is disconnected.	Check the connector for proper connection.
(3) Blown fuse	Check the fuse on the control circuit board.
(4) Motor error (thermistor error inside the motor)	Check the unit fan for proper operation in the test run mode. If no problems are found with items 1 through 3 above and the fan does not operate, replace the motor.

7-6-4 Error Code [4114]

1. Error code definition

Indoor unit fan motor error

2. Error definition and error detection method

When the fan motor output from the indoor unit circuit board is ON and when the rotation speed input from the fan motor cannot be detected for 30 seconds or more

3. Cause, check method and remedy

Cause	Check method and remedy
(1) Fan motor connector contact failure	Check the fan motor connector CNMF for proper connection.
(2) Indoor unit circuit board failure	Remove the fan motor connector CNMF and check the voltage at the indoor unit circuit board. Testing point 1. 280 VDC (Between CNMF1 (+) and CNMF4 (-)) 2. 15 VDC (Between CNMF5 (+) and CNMF4 (-)) Replace the indoor unit circuit board if the voltage is abnormal. If the 4114 error persists after the indoor unit circuit board is replaced, replace the fan motor as well.
(3) Fan motor fault	Replace the fan motor if the voltage is normal in step (2) above. If the 4114 error persists after the fan motor is replaced, replace the indoor unit circuit board as well.

7-6-5 Error Code [4116]

1. Error code definition

RPM error/Motor error

2. Error definition and error detection method

♦LOSSNAY

- *The motor keep running even if the power is OFF.
- *The thermal overload relay is ON. (Only for the three-phase model)

♦Indoor unit

If detected less than 180rpm or more than 2000rpm, the indoor unit will restart and keep running for 3 minutes.If detected again, the display will appear.

3. Cause, check method and remedy

Cause	Check method and remedy
(1) Board failure	Replace the board.
(2) Motor malfunction	Check for the motor and the solenoid switch.
(3) Solenoid switch malfunction	

7-6-6 Error Code [4121]

1. Error code definition

Function setting error

2. Error source, cause, check method and remedy

Error source	Cause	Check method and remedy
Outdoor unit	(1) Dip switch setting error on the control board	Check the SW6-1 setting on the control board
	(2) Connector connection error on the control board	Check that nothing is connected to the connector CNAF on the control board.
	(3) Control board failure	Replace the control board if no problems are found with the two items above.

7-6-7 Error Code [4124]

1. Error code definition

Electric system not operate due to damper abnormality

2. Error definition and error detection method

When the damper is not located at the designated position.

3. Cause, check method and remedy

When the damper is not located at the designated position.

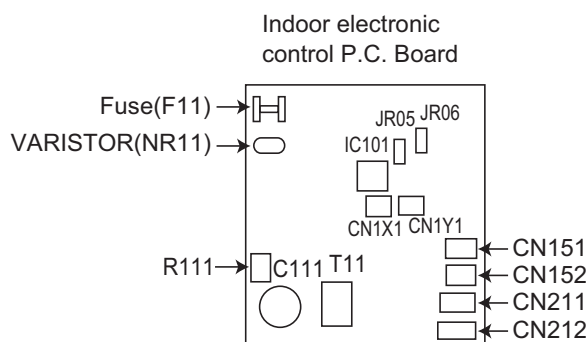
- 1) Check there is something that interferes the opening or closing movement of the damper.
- 2) If damper does not open or close, turn OFF the power supply and measure the resistance of the damper lock motors (ML1, ML2) and the damper motor (MV2).

The resistance value is normal each. →Replace the indoor electronic control P.C. board.

The resistance value is not normal each. →Replace the motor that indicates the abnormal value.

Part name	Check method and criteria	Figure	
Damper lock motor Right(ML1)	Measure the resistance between the terminals with a tester. (Part temperature: 10°C ~ 30°C)		
Damper lock motor Left(ML2)	Color of the lead wire		Normal
	BRN-other one		235Ω~255Ω
Damper motor (MV2)	Measure the resistance between the terminals with a tester. (Part temperature: 10°C ~ 30°C)		
	Color of the lead wire		Normal
	BRN-other one		282Ω~306Ω

- 3) If damper opens or closes, measure the voltage between CN1X1 (+) and (-) and the voltage between CN1Y1 (+) and (-) during the damper open by pressing VANE CONTROL button.
There is not 0V DC between CN1X1 (+) and (-). →Replace the damper limit switch (open)
There is not 5V DC between CN1X1 (+) and (-). →Replace the damper limit switch (close)
- 4) If damper opens or closes and voltages in 3) are normal, measure the voltage between CN1X1 (+) and (-) and the voltage between CN1Y1 (+) and (-) during the damper close by pressing VANE CONTROL button.
There is not 5V DC between CN1X1 (+) and (-). →Replace the damper limit switch (open)
There is not 0V DC between CN1X1 (+) and (-). →Replace the damper limit switch (close)
There is 5V DC between CN1X1 (+) and (-) and 0V DC between CN1X1 (+) and (-). →Replace the indoor electronic control P.C. board.



Note: Refer also to the Service Handbook for the indoor units.

7-6-8 Error Code [4220, 4225, 4226] Detail Code 108

1. Error code definition

Abnormal bus voltage drop (Detail code 108)

2. Error definition and error detection method

If Vdc 289V or less is detected during Inverter operation. (S/W detection)

3. Cause, check method and remedy

(1) Power supply environment

Check the power-supply wiring for an open phase. Refer to item (5) in section [6-1 Read before Test Run].

Find out if there was a (momentary) power failure.

Check whether the power voltage (Between L1 and L2, L2 and L3, and L1 and L3) is 342V or less across all phases.

(2) Voltage drop detected

4220

INV35Y and INV37YC

•Check the voltage at relay connector RYPN while the inverter is stopped.

If the voltage is 420 V or above, check the following items.

- 1) Check the LED monitor to see if the bus voltage is above 289 V, and replace the inverter board if it is 289 V or below.
- 2) Check the coil (L) connections and for broken wiring.
- 3) Check the wiring connections between noise filter board and INV board.
- 4) If the problem persists after reboot, replace the INV board.

If the voltage is below 420 V, check the following items.

- 1) Check the coil (L) connections and for broken wiring.
- 2) Check the wiring connections between noise filter board and INV board and between INV board and R1 through R5.
- 3) Check the in-rush current resistor. Refer to the following page(s). [8-9-14 Simple Check on Inverter Circuit Components]
- 4) If the problem persists after reboot, replace the INV board.

INV36Y and INV42Y

•Check the voltage at relay connector RYPN while the inverter is stopped.

If the voltage is 420 V or above, check the following items.

- 1) Check the LED monitor to see if the bus voltage is above 289 V, and replace the inverter board if it is 289 V or below.
- 2) Check the coil (L) connections and for broken wiring.
- 3) Check the wiring connections between noise filter board and INV board and between INV board and capacitor board.
- 4) If the problem persists after reboot, replace the INV board.

If the voltage is below 420 V, check the following items.

- 1) Check the coil (L) connections and for broken wiring.
- 2) Check the wiring connections between noise filter board and INV board, between INV board and capacitor board, and between INV board and R1 through R5.
- 3) Check the in-rush current resistor. Refer to the following page(s). [8-9-14 Simple Check on Inverter Circuit Components]
- 4) If the problem persists after reboot, replace the INV board.

4225, 4226

•Check the voltage at relay connector RYPN while the inverter is stopped. If the voltage is below 420 V, check the following items.

- 1) Check for proper connections of noise filter coil and DC reactor, and for broken wiring.
- 2) Check the wiring connections between INV board and FAN board.
- 3) Check item for 4220

Replace the FAN board if no problems are found.

•Check the voltage at connector RYPN while the inverter is stopped. If the voltage is 420 V or above, check the following items.

- 1) Check the state of the wiring connections between the INV board and the Fan board.
- 2) Check contents 4220

Replace the Fan board if no problems are found.

(3) Control board failure

Check that 12VDC is applied to connector CN72 on the control board while the inverter is operating. If voltage is absent or the wrong voltage is applied, check the fuse F01. Replace the control board if no problems are found with the fuse.

Note

For inverter-related error codes, refer to the following page(s). [8-9 Troubleshooting Inverter Problems]

7-6-9 **Error Code [4220, 4225, 4226] Detail Code 109**

1. Error code definition

Abnormal bus voltage rise (Detail code 109)

2. Error definition and error detection method

If $V_{dc} \geq 830V$ is detected during inverter operation.

3. Cause, check method and remedy

(1) Different voltage connection

Check the power supply voltage on the power supply terminal block (TB1).

(2) INV board failure

If the problem recurs, replace the INV board or fan board.

In the case of 4220: INV board

In the case of 4225 and 4226: Fan board

Note

For inverter-related error codes, refer to the following page(s). [8-9 Troubleshooting Inverter Problems]

7-6-10 **Error Code [4220] Detail Code 110**

1. Error code definition

VDC error (Detail code 110)

2. Error definition and error detection method

BUS voltage error When V_{dc} is equal to or greater than 814 volts (hardware detection)

3. Cause, check method and remedy

Details of 4220 error: See No. 108 and 109.

Also see error details No. 129 of 4220 error (applicable to INV37YC only).

Note

For inverter-related error codes, refer to the following page(s). [8-9 Troubleshooting Inverter Problems]

7-6-11 Error Code [4220, 4225, 4226] Detail Code 111, 112

1. Error code definition

Logic error (Detail code 111, 112)

2. Error definition and error detection method

Hardware error

If only the hardware error logic circuit operates, and no identifiable error is detected.

3. Cause, Check method and remedy

In the case of 4220

Cause	Check method and remedy
(1) External noise	Refer to the following page(s). [8-9-2 Checking the Inverter Board Error Detection Circuit]
(2) INV board failure	

In the case of 4225 and 4226

Cause	Check method and remedy
(1) External noise	Refer to the following page(s). [8-9-8 Checking the Fan Board Error Detection Circuit at No Load] [8-9-9 Checking the Fan Board for Damage at No Load] [8-9-10 Checking the Fan Board for Damage with Load]
(2) Fan board failure	

Note

For inverter-related error codes, refer to the following page(s). [8-9 Troubleshooting Inverter Problems]

7-6-12 Error Code [4220] Detail Code 123

1. Error code definition

Voltage boost control error (Detail code 123)(outdoor unit)

2. Error definition and error detection method

When a drop in power supply voltage or a malfunction in the booster circuit is detected

3. Cause, check method and remedy

Cause	Check method and remedy
(1) Inverter-output-related items	Refer to the following page(s). [8-9-2 Checking the Inverter Board Error Detection Circuit] Refer to the following page(s). [8-9-3 Checking the Compressor for Ground Fault and Coil Resistance Problems] Refer to the following page(s). [8-9-4 Checking the Inverter for Damage at No-Load] Refer to the following page(s). [8-9-5 Checking the Inverter for Damage during Compressor Operation] Refer to the following page(s). [8-9-11 Checking the Installation Conditions]

Note

For inverter-related error codes, refer to the following page(s). [8-9 Troubleshooting Inverter Problems]

7-6-13 **Error Code [4220] Detail Code 129**

1. Error code definition

Control power supply error (Detail code 129)(outdoor unit)

2. Error definition and error detection method

INV35Y, INV36Y, and INV42Y

Detection of insufficient drive voltage for relays on INV board

INV37YC

Detection of insufficient drive voltage for relays on INV board or for IGBT

3. Cause, check method and remedy

Cause	Check method and remedy
(1) Contact failure	<p><INV35Y, INV36Y, and INV42Y></p> <p>Check the connectors CNRY on INV board and CNRYA on MAIN board for proper connections.</p> <p><INV37YC></p> <p>Check the connectors CNRY on INV board and CNRYA on MAIN board for proper connections.</p> <p>Check the connectors CN200 on INV board and CN300 on PS board for proper connections.</p>
(2) Voltage check	<p>Disconnect the connector CNRYA from the control board and check the voltage at the connector CNRYA. If a voltage of 13 V is not output, replace the control board and the PS board.</p>
(3) Inverter board failure	<p>If the problem persists after reboot, replace the INV board.</p>

Note

For inverter-related error codes, refer to the following page(s). [8-9 Troubleshooting Inverter Problems]

7-6-14 **Error Code [4220, 4225, 4226] Detail Code 131**

1. Error code definition

Low bus voltage at startup (Detail code 131)

2. Error definition and error detection method

When $V_{dc} \leq 289$ V is detected just before the inverter operation.

3. Cause, check method and remedy

(1) Inverter main circuit failure

Same as detail code 108 of 4220 error

Note

For inverter-related error codes, refer to the following page(s). [8-9 Troubleshooting Inverter Problems]

7-6-15 Error Code [4230] Detail Code 125

1. Error code definition

Heatsink overheat protection (Detail code 125)

2. Error definition and error detection method

When the heat sink temperature (THHS) remains at or above TOH is detected.

models	TOH
INV35Y, INV36Y, INV42Y	100°C
INV37YC	94°C

3. Cause, check method and remedy

Cause	Check method and remedy
(1) Fan board failure	Refer to the following page(s). [8-9-8 Checking the Fan Board Error Detection Circuit at No Load] [8-9-9 Checking the Fan Board for Damage at No Load] [8-9-10 Checking the Fan Board for Damage with Load]
(2) THHS failure	1) Check for proper installation of the INV board and FAN board IGBT. (Check for proper installation of the IGBT heatsink.) 2) Check the THHS sensor reading on the LED monitor. →If an abnormal value appears, replace the INV board.
(3) Outdoor unit LEV9 malfunction	Check the operation of the unit in the Cooling or in the Heating mode. LEV9 Refer to the following page(s). [8-8 Troubleshooting LEV Problems]
(4) Low-pressure sensor fault	Refer to the following page(s). [8-5 Pressure Sensor Circuit Configuration and Troubleshooting Pressure Sensor Problems]

Note

For inverter-related error codes, refer to the following page(s). [8-9 Troubleshooting Inverter Problems]

7-6-16 Error Code [4235, 4236] Detail Code 125

1. Error code definition

Heatsink overheat protection (Detail code 125) (outdoor unit)

2. Error definition and error detection method

Detection of fan INV heatsink temperature (THHS) ≥ 100°C

3. Cause, check method and remedy

Cause	Check method and remedy
(1) FAN board fault	Refer to the following page(s). [8-9-8 Checking the Fan Board Error Detection Circuit at No Load] [8-9-9 Checking the Fan Board for Damage at No Load] [8-9-10 Checking the Fan Board for Damage with Load]
(2) Outdoor unit fan failure	1) Check the outdoor unit fan for proper operation. Check the fan motor if problems are found with the operation of the fan. Refer to the following page(s). [8-9-7 Checking the Fan Motor for Ground Fault and Coil Resistance Problems]
(3) Air passage blockage	1) Check the heatsink and the duct for blockage. Refer to the following page(s). [8-9-16 Checking the Fan Inverter Heatsink for Clogging]
(4) THHS failure	1) Check the IGBT heatsink for proper mounting. 2) Check the THHS sensor reading on the LED. → Replace the INV board if the THHS value is abnormal.

Note

For inverter-related error codes, refer to the following page(s). [8-9 Troubleshooting Inverter Problems]

7-6-17 Error Code [4230] Detail Code 126

1. Error code definition

DCL temperature fault (Detail code 126)(outdoor unit)

2. Error definition and error detection method

When DCL temperature that equals or exceeds 150°C is detected (applicable to INV37YC only)

3. Cause, check method and remedy

Cause	Check method and remedy
(1) Contact failure	Check the connector CNTH on the INV board for proper connection.
(2) DCL temperature sensor fault	Disconnect the connector (CNTH), and measure the resistance of the DCL temperature sensor. Replace the DCL temperature sensor if the value is abnormal. Refer to [3-3 Functions of the Major Components of Outdoor Unit].
(3) INV board failure	Replace the INV board if the problem persists after the operation is resumed.

Note

For inverter-related error codes, refer to the following page(s). [8-9 Troubleshooting Inverter Problems]

7-6-18 Error Code [4240, 4245, 4246]

1. Error code definition

Overload protection

2. Error definition and error detection method

If the output current of "(Iac) > I_{max} (Arms)" or "THHS > TOL" is continuously detected for 10 minutes during inverter operation. Refer to the following page(s). [7-1 Error Code and Preliminary Error Code Lists]

3. Cause, check method and remedy

Cause	Check method and remedy
(1) IPM contact failure	Check the IPM and cooling plate for proper contact. (Remove the inverter board, and check the IPM heatsink grease.)
(2) Air passage blockage	Check that the heat sink cooling air passage is not blocked
(3) Power supply environment	Power supply voltage is 342 V or above.
(4) Inverter, FAN board failure	Refer to the following page(s). [8-9 Troubleshooting Inverter Problems]
(5) Compressor failure	Check that the compressor has not overheated during operation. → Check the refrigerant circuit (oil return section). Refer to the following page(s). [8-9-3 Checking the Compressor for Ground Fault and Coil Resistance Problems]
(6) The model selection switches (SW5-3 - 5-8) on the outdoor unit are set incorrectly.	Check the setting for the model selection switch on the outdoor unit (Dipswitches SW5-3 - 5-8 on the outdoor unit control board). For switch settings, refer to the following page(s). [7-9-2 Error Code [7101]]

Note

For inverter-related error codes, refer to the following page(s). [8-9 Troubleshooting Inverter Problems]

7-6-19 Error Code [4250, 4255, 4256] Detail Code 101

1. Error code definition

IPM error (Detail code 101)

2. Error definition and error detection method

In the case of 4250

If an overcurrent is detected by the overcurrent detection circuit CT003 (R127 when INV37YC) on the INV board.

In the case of 4255 and 4256

IPM error signal is detected.

3. Cause, check method and remedy

In the case of 4250

Cause	Check method and remedy
(1) Inverter output related	Refer to the following page(s). [8-9-2 Checking the Inverter Board Error Detection Circuit] [8-9-3 Checking the Compressor for Ground Fault and Coil Resistance Problems] [8-9-4 Checking the Inverter for Damage at No-Load] [8-9-5 Checking the Inverter for Damage during Compressor Operation] [8-9-11 Checking the Installation Conditions] Check the IGBT module resistance value of the INV board, if no problems are found. [8-9-15 Troubleshooting Problems with IGBT Module]
(2) The model selection switches (SW5-3 - 5-8) on the outdoor unit are set incorrectly.	Check the setting for the model selection switch on the outdoor unit (Dipswitches SW5-3 - 5-8 on the outdoor unit control board). For switch settings, refer to the following page(s). [7-9-2 Error Code [7101]]
(3) Open phase in the power-supply due to improper power-supply wiring.	Refer to item (5) in section [6-1 Read before Test Run].

In the case of 4255 and 4256

Cause	Check method and remedy
(1) Fan motor abnormality	Refer to the following page(s). [8-9-7 Checking the Fan Motor for Ground Fault and Coil Resistance Problems]
(2) Fan board failure	Refer to the following page(s). [8-9-8 Checking the Fan Board Error Detection Circuit at No Load] [8-9-9 Checking the Fan Board for Damage at No Load] [8-9-10 Checking the Fan Board for Damage with Load]

Note

For inverter-related error codes, refer to the following page(s). [8-9 Troubleshooting Inverter Problems]

7-6-20 Error Code [4250, 4255, 4256] Detail Code 104

1. Error code definition

Short-circuited IPM/Ground fault (Detail code 104)

2. Error definition and error detection method

When IPM/IGBT short damage or grounding on the load side is detected just before starting the inverter.

3. Cause, check method and remedy

In the case of 4250

Cause	Check method and remedy
(1) Grounding fault compressor	Refer to the following page(s). [8-9-3 Checking the Compressor for Ground Fault and Coil Resistance Problems]
(2) Inverter output related	Refer to the following page(s). [8-9-2 Checking the Inverter Board Error Detection Circuit] [8-9-3 Checking the Compressor for Ground Fault and Coil Resistance Problems] [8-9-4 Checking the Inverter for Damage at No-Load] [8-9-5 Checking the Inverter for Damage during Compressor Operation] [8-9-11 Checking the Installation Conditions]
(3) Open phase in the power-supply due to improper power-supply wiring	Refer to item (5) in section [6-1 Read before Test Run]

In the case of 4255 and 4256

Cause	Check method and remedy
(1) Grounding fault of fan motor	Refer to the following page(s). [8-9-7 Checking the Fan Motor for Ground Fault and Coil Resistance Problems]
(2) Fan board failure	Refer to the following page(s). [8-9-8 Checking the Fan Board Error Detection Circuit at No Load] [8-9-9 Checking the Fan Board for Damage at No Load] [8-9-10 Checking the Fan Board for Damage with Load]

Note

For inverter-related error codes, refer to the following page(s). [8-9 Troubleshooting Inverter Problems]

7-6-21 Error Code [4250, 4255, 4256] Detail Code 105

1. Error code definition

Overcurrent error due to short-circuited motor (Detail code 105)

2. Error definition and error detection method

When a short is detected on the load side just before starting the inverter operation.

3. Cause, Check method and remedy

In the case of 4250

Cause	Check method and remedy
(1) Short - circuited compressor	Refer to the following page(s). [8-9-3 Checking the Compressor for Ground Fault and Coil Resistance Problems]
(2) Output wiring	Check for a short circuit.

In the case of 4255 and 4256

Cause	Check method and remedy
(1) Short - circuited fan motor	Refer to the following page(s). [8-9-7 Checking the Fan Motor for Ground Fault and Coil Resistance Problems]
(2) Output wiring	Check for a short circuit.

Note

For inverter-related error codes, refer to the following page(s). [8-9 Troubleshooting Inverter Problems]

7-6-22 Error Code [4250, 4255, 4256] Detail Code 106 and 107

1. Error code definition

Instantaneous overcurrent (Detail code 106)
Overcurrent (effective value) (Detail code 107)

2. Error definition and error detection method

When a current above the specified value is detected by the electric current sensor.
Refer to the relevant pages for the details of model names and the specified values.

3. Cause, check method and remedy

In the case of 4250

Cause	Check method and remedy
(1) Inverter output related	Refer to the following page(s). [8-9-2 Checking the Inverter Board Error Detection Circuit] [8-9-3 Checking the Compressor for Ground Fault and Coil Resistance Problems] [8-9-4 Checking the Inverter for Damage at No-Load] [8-9-5 Checking the Inverter for Damage during Compressor Operation] [8-9-11 Checking the Installation Conditions] Check the IGBT module resistance value of the INV board, if no problems are found. [8-9-15 Troubleshooting Problems with IGBT Module]
(2) The model selection switches (SW5-3 - 5-8) on the outdoor unit are set incorrectly.	Check the setting for the model selection switch on the outdoor unit (Dipswitches SW5-3 - 5-8 on the outdoor unit control board). For switch settings, refer to the following page(s). [7-9-2 Error Code [7101]]

In the case of 4255 and 4256

Cause	Check method and remedy
(1) Fan board failure	Refer to the following page(s). [8-9-8 Checking the Fan Board Error Detection Circuit at No Load] [8-9-9 Checking the Fan Board for Damage at No Load] [8-9-10 Checking the Fan Board for Damage with Load]
(2) Outdoor unit fan failure	Check the outdoor unit fan for proper operation. Check the fan motor if problems are found with the operation of the fan. Refer to the following page(s). [8-9-7 Checking the Fan Motor for Ground Fault and Coil Resistance Problems]
(3) Air passage blockage	Check that the heat sink cooling air passage is not blocked
(4) The model selection switches (SW5-3 - 5-8) on the outdoor unit are set incorrectly.	Check the setting for the model selection switch on the outdoor unit (Dipswitches SW5-3 - 5-8 on the outdoor unit control board). For switch settings, refer to the following page(s). [7-9-2 Error Code [7101]]

Note

For inverter-related error codes, refer to the following page(s). [8-9 Troubleshooting Inverter Problems]

7-6-23 Error Code [4250] Detail Code 121, 128, and 122

1. Error code definition

DCL overcurrent error (H/W) (Detail code 121 and 128)(outdoor unit) DCL overcurrent error (S/W) (Detail code 122) (outdoor unit)

2. Error definition and error detection method

When a DCL overcurrent is detected by the electric current sensor

3. Cause, check method and remedy

Cause	Check method and remedy
(1) Inverter-output-related items	Refer to the following page(s). [8-9-2 Checking the Inverter Board Error Detection Circuit] Refer to the following page(s). [8-9-3 Checking the Compressor for Ground Fault and Coil Resistance Problems] Refer to the following page(s). [8-9-4 Checking the Inverter for Damage at No-Load] Refer to the following page(s). [8-9-5 Checking the Inverter for Damage during Compressor Operation] Refer to the following page(s). [8-9-11 Checking the Installation Conditions]

Note

For inverter-related error codes, refer to the following page(s). [8-9 Troubleshooting Inverter Problems]

7-6-24 Error Code [4255, 4256] Detail Code 137

1. Error code definition

Motor synchronization loss (Detail code 137)

2. Error definition and error detection method

Fan motor locking was detected during operation.

3. Cause, check method and remedy

Cause	Check method and remedy
(1) Fan motor locking	Check the fan blades for objects obstructing fan rotation.
(2) Fan motor failure	Refer to the following page(s). [8-9-7 Checking the Fan Motor for Ground Fault and Coil Resistance Problems]
(3) Fan board failure	Refer to the following page(s). [8-9-8 Checking the Fan Board Error Detection Circuit at No Load] [8-9-9 Checking the Fan Board for Damage at No Load] [8-9-10 Checking the Fan Board for Damage with Load]

Note

For inverter-related error codes, refer to the following page(s). [8-9 Troubleshooting Inverter Problems]

7-6-25 **Error Code [4260]**

1. Error code definition

Heatsink overheat protection at startup

2. Error definition and error detection method

When heatsink temperature (THHS) remains at or above TOH for 10 minutes or longer after inverter startup

models	TOH
INV35Y, 36Y, 42Y	100°C
INV37YC	94°C

3. Cause, check method and remedy

Same as 4230 error

7-7 Error Code Definitions and Solutions: Codes [5000 - 5999]

7-7-1 Error Code [5101, 5102, 5103, 5104]

1. Error code definition

5101

Return air temperature sensor (TH21) fault (Indoor unit)
Return air temperature sensor (TH4) fault (OA processing unit)

5102

Pipe temperature sensor (TH22) fault (Indoor unit)
Pipe temperature sensor (TH2) fault (OA processing unit)

5103

Gas-side pipe temperature sensor (TH23) fault (Indoor unit)
Gas-side pipe temperature sensor (TH3) fault (OA processing unit)

5104

Intake air temperature sensor (TH1) fault (OA processing unit)
Intake air temperature sensor (TH24) fault (All-fresh (100% outdoor air) type indoor unit)

2. Error definition and error detection method

•If a short or an open is detected during thermostat ON, the outdoor unit turns to anti-restart mode for 3 minutes. When the error is not restored after 3 minutes (if restored, the outdoor unit runs normally), the outdoor unit makes an error stop.

Short: detectable at 90°C [194°F] or higher

Open: detectable at -40°C [-40°F] or lower

•Sensor error at gas-side cannot be detected under the following conditions.

*During heating operation

*During cooling operation for 3 minutes after the compressor turns on.

3. Cause, check method and remedy

Cause		Check method and remedy
(1)	Thermistor failure	Check the thermistor resistor.
(2)	Connector contact failure	0°C [32°F]: 15 kΩ
(3)	Disconnected wire or partial disconnected thermistor wire	10°C [50°F]: 9.7 kΩ
(4)	Unattached thermistor or contact failure	20°C [68°F]: 6.4 kΩ
(5)	Indoor board (detection circuit) failure	30°C [86°F]: 4.3 kΩ
		40°C [104°F]: 3.1 kΩ
		Check the connector contact.
		When no fault is found, the indoor board is a failure.

7-7-2 **Error Code [5102,5103,5104,5105,5106,5107,5115]**

1. Error code definition

5102

HIC bypass circuit outlet temperature sensor (TH2) fault (Outdoor unit)

5103

Heat exchanger outlet temperature sensor (TH3) fault (Outdoor unit)

5104

Discharge temperature sensor (TH4) fault (Outdoor unit)

5105

Accumulator inlet temperature sensor (TH5) fault (Outdoor unit)

5106

HIC circuit outlet temperature sensor (TH6) fault (Outdoor unit)

5107

Outside temperature sensor (TH7) fault (Outdoor unit)

5115

Shell bottom temperature sensor (TH15) error (outdoor unit)

2. Error definition and error detection method

- When a short (high temperature intake) or an open (low temperature intake) of the thermistor is detected (the first detection), the outdoor unit stops, turns to anti-restart mode for 3 minutes, and restarts when the detected temperature of the thermistor.
- When a short or an open is detected again (the second detection) after the first restart of the outdoor unit, the outdoor unit stops, turns to anti-restart mode for 3 minutes, and restarts in 3 minutes when the detected temperature is within the normal range.
- When a short or an open is detected again (the third detection) after the previous restart of the outdoor unit, the outdoor unit makes an error stop.
- When a short or an open of the thermistor is detected just before the restart of the outdoor unit, the outdoor unit makes an error stop, and the error code "5102", "5103", "5104", "5105", "5106", "5107" or "5115" will appear.
- During 3-minute antirestart mode, preliminary errors will be displayed on the LED display.
- A short or an open described above is not detected for 10 minutes after the compressor start, during defrost mode, or for 3 minutes after defrost mode.

3. Cause, check method and remedy

Cause	Check method and remedy
(1) Thermistor failure	Check thermistor resistance.
(2) Pinched lead wire	Check for pinched lead wire.
(3) Torn wire coating	Check for wire coating.
(4) A pin on the male connector is missing or contact failure	Check connector.
(5) Disconnected wire	Check for wire.
(6) Thermistor input circuit failure on the control board	Check the intake temperature of the sensor with the LED monitor. When the temperature is far different from the actual temperature, replace the control board.

<Reference>

	Short detection	Open detection
TH2	70°C [158°F] and above (0.4kΩ)	-40°C [-40°F] and below (130kΩ)
TH3	110°C [230°F] and above (0.4kΩ)	-40°C [-40°F] and below (130kΩ)
TH4	240°C [464°F] and above (0.57kΩ)	0°C [32°F] and below (698kΩ)
TH5	70°C [158°F] and above (0.4kΩ)	-40°C [-40°F] and below (130kΩ)
TH6	70°C [158°F] and above (1.14kΩ)	-40°C [-40°F] and below (130kΩ)
TH7	110°C [230°F] and above (0.4kΩ)	-40°C [-40°F] and below (130kΩ)
TH15	110°C [230°F] and above (0.4kΩ)	-40°C [-40°F] and below (130kΩ)

7-7-3 Error Code [5110]

1. Error code definition

Heatsink temperature sensor (THHS) fault (Detail code 01)

2. Error definition and error detection method

When a short or an open of THHS is detected just before or during the inverter operation.

3. Cause, check method and remedy

Cause	Check method and remedy
(1) INV board failure	If the problem recurs when the unit is put into operation, replace the INV board.

Note

For inverter-related error codes, refer to the following page(s). [8-9 Troubleshooting Inverter Problems]

7-7-4 **Error Code [5120]**

1. Error code definition

DCL temperature sensor circuit fault (Detail code 01)(outdoor unit)

2. Error definition and error detection method

When an open phase or a short circuit of the temperature sensor is detected immediately before inverter startup or during operation (applicable to INV37YC only)

3. Cause, check method and remedy

INV37YC

Cause	Check method and remedy
(1) Contact failure	Check the connector (CNTH) on the inverter board for proper connection.
(2) DCL temperature sensor	Disconnect the connector (CNTH), check the resistance value of the DCL temperature sensor. Replace the DCL if the resistance is as follows: 0.5 kΩ or below (short-circuit) or 1963 kΩ or above (open-circuit).
(3) INV board failure	If the problem persists after restart operation, replace the inverter board.

Note

For inverter-related error codes, refer to the following page(s). [8-9 Troubleshooting Inverter Problems]

7-7-5 **Error Code [5201]**

1. Error code definition

High-pressure sensor fault (63HS1)

2. Error definition and error detection method

- If the high pressure sensor detects 0.098MPa [14psi] or less during the operation, the outdoor unit stops once, turns to anti-restart mode for 3 minutes, and restarts after 3 minutes when the detected high pressure sensor is 0.098MPa [14psi] or more.
- If the high pressure sensor detects 0.098MPa [14psi] or less just before the restart, the outdoor unit makes an error stop, and the error code "5201" will appear.
- During 3-minute antirestart mode, preliminary errors will be displayed on the LED display.
- A error is not detected for 3 minutes after the compressor start, during defrost operation, or 3 minutes after defrost operation.

3. Cause, check method and remedy

Cause	Check method and remedy
(1) High pressure sensor failure	Refer to the following page(s). [8-5-1 Comparing the High-Pressure Sensor Measurement and Gauge Pressure]
(2) Pressure drop due to refrigerant leak	
(3) Torn wire coating	
(4) A pin on the male connector is missing or contact failure	
(5) Disconnected wire	
(6) High pressure sensor input circuit failure on the control board	

7-7-6 Error Code [5301] Detail Code 115

1. Error code definition

ACCT sensor fault (Detail code 115)

2. Error definition and error detection method

When the formula "output current < 1.8 Arms" remains satisfied for 10 seconds while the inverter is in operation.

3. Cause, check method and remedy

Cause	Check method and remedy
(1) Contact failure	Check the connector (CNCT2) on the INV board for proper connection.
(2) INV output phase loss	Check the output wire for proper connection.
(3) ACCT sensor failure	Refer to the following page(s). [8-9-14 Simple Check on Inverter Circuit Components]
(4) Compressor failure	Refer to the following page(s). [8-9-3 Checking the Compressor for Ground Fault and Coil Resistance Problems]
(5) INV board failure	Replace the INV board if the problem persists after the operation is resumed.

Note

For inverter-related error codes, refer to the following page(s). [8-9 Troubleshooting Inverter Problems]

7-7-7 Error Code [5301] Detail Code 117

1. Error code definition

ACCT sensor circuit fault (Detail code 117)

2. Error definition and error detection method

When an error value is detected with the ACCT detection circuit just before the inverter starts

3. Cause, check method and remedy

Cause	Check method and remedy
(1) INV board failure	Refer to the following page(s). [8-9-2 Checking the Inverter Board Error Detection Circuit] [8-9-4 Checking the Inverter for Damage at No-Load] [8-9-5 Checking the Inverter for Damage during Compressor Operation]
(2) Compressor failure	Refer to the following page(s). [8-9-3 Checking the Compressor for Ground Fault and Coil Resistance Problems]

Note

For inverter-related error codes, refer to the following page(s). [8-9 Troubleshooting Inverter Problems]

7-7-8 Error Code [5301] Detail Code 119

1. Error code definition

Open-circuited IPM/Loose ACCT connector (Detail code 119)

2. Error definition and error detection method

Presence of enough current cannot be detected during the self-diagnostic operation immediately before inverter startup.

3. Cause, check method and remedy

Cause	Check method and remedy
(1) ACCT sensor disconnection	Check the connector CNCT2 on the INV board for proper connection. Check the ACCT for proper connection.
(2) ACCT sensor failure	Refer to the following page(s). [8-9-14 Simple Check on Inverter Circuit Components]
(3) Inverter failure	Refer to the following page(s). [8-9-4 Checking the Inverter for Damage at No-Load] [8-9-5 Checking the Inverter for Damage during Compressor Operation]
(4) Compressor failure	Refer to the following page(s). [8-9-3 Checking the Compressor for Ground Fault and Coil Resistance Problems]

Note

For inverter-related error codes, refer to the following page(s). [8-9 Troubleshooting Inverter Problems]

7-7-9 Error Code [5301] Detail Code 120

1. Error code definition

Faulty ACCT wiring (Detail code 120)

2. Error definition and error detection method

Presence of target current cannot be detected during the self-diagnostic operation immediately before startup.

3. Cause, check method and remedy

Cause	Check method and remedy
(1) ACCT sensor connection error	Check the ACCT for proper connection. Refer to the following page(s). [8-9-14 Simple Check on Inverter Circuit Components]
(2) ACCT sensor failure	Refer to the following page(s). [8-9-14 Simple Check on Inverter Circuit Components]
(3) Inverter failure	Refer to the following page(s). [8-9-4 Checking the Inverter for Damage at No-Load] [8-9-5 Checking the Inverter for Damage during Compressor Operation]
(4) Compressor failure	Refer to the following page(s). [8-9-3 Checking the Compressor for Ground Fault and Coil Resistance Problems]

Note

For inverter-related error codes, refer to the following page(s). [8-9 Troubleshooting Inverter Problems]

7-7-10 Error Code [5301] Detail Code 127

1. Error code definition

DCL electric current circuit error (Detail code 127)(outdoor unit)

2. Error definition and error detection method

When an abnormal value in the DCL electric current sensor detection circuit is detected

3. Cause, check method and remedy

Cause	Check method and remedy
(1) Contact failure	Check the wiring between CNCT1A and CNCT1B.
(2) Incorrect installation	Check the wiring on the SC-L terminal.
(3) INV board failure	If the problem persists after restart operation, replace the inverter board.

Note

For inverter-related error codes, refer to the following page(s). [8-9 Troubleshooting Inverter Problems]

7-7-11 Error Code [5305, 5306] Detail Code 135

1. Error code definition

Current sensor fault (Detail code 135)

2. Error definition and error detection method

Detection of output current below 0.2 Arms for 10 continuous seconds while fan motor is in operation

3. Cause, check method and remedy

Cause	Check method and remedy
(1) Open output phase of fan board	Check the output wiring from the fan board for proper connection.
(2) Fan motor error	Refer to the following page(s). [8-9-7 Checking the Fan Motor for Ground Fault and Coil Resistance Problems]
(3) Fan board failure	Refer to the following page(s). [8-9-8 Checking the Fan Board Error Detection Circuit at No Load] [8-9-9 Checking the Fan Board for Damage at No Load] [8-9-10 Checking the Fan Board for Damage with Load]

Note

For inverter-related error codes, refer to the following page(s). [8-9 Troubleshooting Inverter Problems]

7-7-12 **Error Code [5305, 5306] Detail Code 136**

1. Error code definition

Current sensor/circuit fault (Detail code 136)

2. Error definition and error detection method

Detection of abnormal value by the current detection circuit before the startup of fan motor

3. Cause, check method and remedy

Cause	Check method and remedy
(1) Fan board fault	Refer to the following page(s). [8-9-8 Checking the Fan Board Error Detection Circuit at No Load] [8-9-9 Checking the Fan Board for Damage at No Load] [8-9-10 Checking the Fan Board for Damage with Load]

Note

For inverter-related error codes, refer to the following page(s). [8-9 Troubleshooting Inverter Problems]

7-7-13 **Error Code [5701]**

1. Error code definition

Loose float switch connector

2. Error definition and error detection method

Detection of the disconnected float switch (open-phase condition) during operation

3. Cause, check method and remedy

(1) CN4F disconnection or contact failure

Check for disconnection of the connector (CN4F) on the indoor unit control board.

7-8 Error Code Definitions and Solutions: Codes [6000 - 6999]

7-8-1 Error Code [6201]

1. Error code definition

Remote controller board fault (nonvolatile memory error)

2. Error definition and error detection method

This error is detected when the data cannot be read out from the built-in nonvolatile memory on the remote controller.

3. Cause, check method and remedy

(1) Remote controller failure

Replace the remote controller.

7-8-2 Error Code [6202]

1. Error code definition

Remote controller board fault (clock IC error)

2. Error definition and error detection method

This error is detected when the built-in clock on the remote controller is not properly functioning.

3. Cause, check method and remedy

(1) Remote controller failure

Replace the remote controller.

7-8-3 Error Code [6600]

1. Error code definition

Address overlap

2. Error definition and error detection method

An error in which signals from more than one indoor units with the same address are received

Detail code 001: Detection of overlapped address in centralized control system

Detail code 002: Detection of overlapped address in indoor unit system

Note

The address and attribute that appear on the remote controller indicate the controller that detected the error.

3. Cause, check method and remedy

Cause	Check method and remedy
(1) Two or more of the following have the same address: Outdoor units, indoor units, LOSSNAY units, controllers such as ME remote controllers. <Example> 6600 "01" appears on the remote controller Unit #01 detected the error. Two or more units in the system have 01 as their address.	♦Find the unit that has the same address as that of the error source. Once the unit is found, correct the address. Then, turn off the outdoor units, indoor units, and LOSSNAY units, keep them all turned off for at least five minutes, and turn them back on. ♦When air conditioning units are operating normally despite the address overlap error Check the transmission wave shape and noise on the transmission line.
(2) Signals are distorted by the noise on the transmission line.	Refer to the following page(s). [8-4 Checking Transmission Waveform and for Electrical Noise Interference]

7-8-4 Error Code [6601]

1. Error code definition

Polarity setting error

2. Error definition and error detection method

The error detected when transmission processor cannot distinguish the polarities of the M-NET transmission line.

Detail code 001: Detection of polarity setting error in centralized control system

Detail code 002: Detection of polarity setting error in indoor unit system

3. Cause, check method and remedy

Cause	Check method and remedy
(1) No voltage is applied to the M-NET transmission line that AE-200E/AG-150A/GB-50ADA/PAC-YG50ECA/BAC-HD150 are connected to.	Check if power is supplied to the M-NET transmission line of the AE-200E/AG-150A/GB-50ADA/PAC-YG50ECA/BAC-HD150, and correct any problem found.
(2) M-NET transmission line to which AE-200E/AG-150A/GB-50ADA/PAC-YG50ECA/BAC-HD150 are connected is short-circuited.	
(3) When two or more power supplies are connected to the M-NET	

7-8-5 Error Code [6602]

1. Error code definition

Transmission processor hardware error

2. Error definition and error detection method

Although "0" was surely transmitted by the transmission processor, "1" is displayed on the transmission line.

Detail code 001: Transmission processor hardware error in centralized control system

Detail code 002: Transmission processor hardware error in indoor unit system

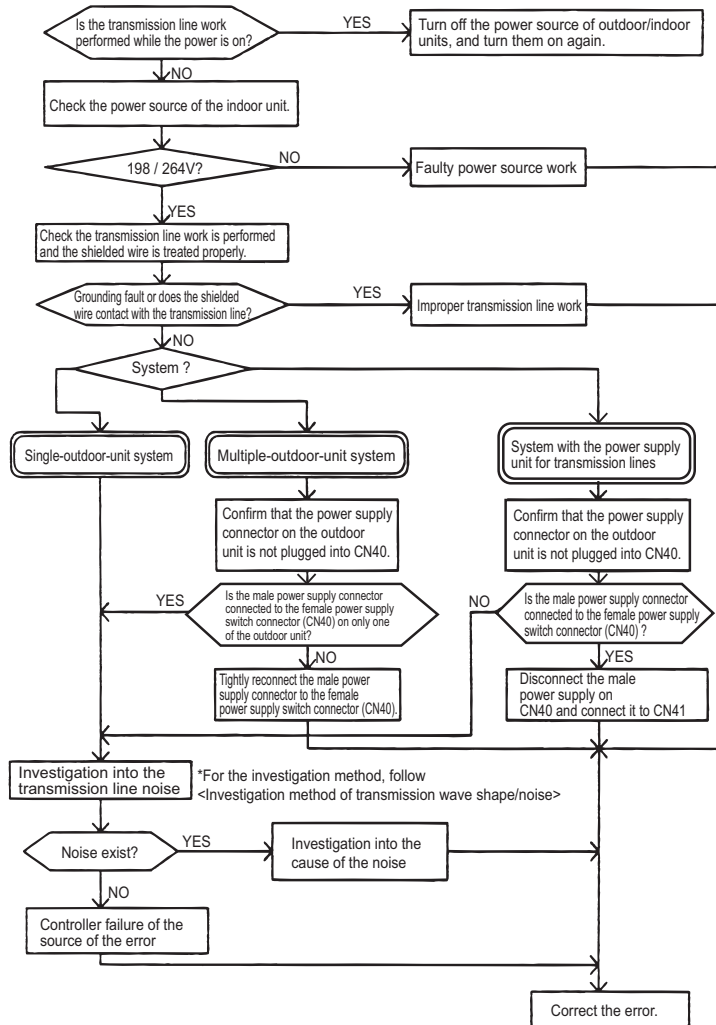
Note

The address/attribute appeared on the display on the remote controller indicates the controller where an error occurred.

3. Cause

- 1) When the wiring work of or the polarity of either the indoor or outdoor transmission line is performed or is changed while the power is on, the transmitted data will collide, the wave shape will be changed, and an error will be detected.
- 2) Grounding fault of the transmission line
- 3) When grouping the indoor units that are connected to different outdoor units, the male power supply connectors on the multiple outdoor units are connected to the female power supply switch connector (CN40).
- 4) When the power supply unit for transmission lines is used in the system connected with MELANS, the male power supply connector is connected to the female power supply switch connector (CN40) on the outdoor unit.
- 5) Controller failure of the source of the error
- 6) When the transmission data is changed due to the noise on the transmission line
- 7) Voltage is not applied on the transmission line for centralized control (in case of grouped indoor units connected to different outdoor units or in case of the system connected with MELANS)

4. Check method and remedy



7-8-6 Error Code [6603]

1. Error code definition

Transmission line bus busy error

2. Error definition and error detection method

- Generated error when the command cannot be transmitted for 4-10 minutes in a row due to bus-busy
 - Generated error when the command cannot be transmitted to the transmission line for 4-10 minutes in a row due to noise
- Detail code 001: Transmission Bus-Busy error in centralized control system
 Detail code 002: Transmission Bus-Busy error in indoor unit system

Note

The address/attribute appeared on the display on the remote controller indicates the controller where an error occurred.

3. Cause, check method and remedy

Cause		Check method and remedy
(1)	The transmission processor cannot be transmitted as the short-wavelength voltage like noise exists consecutively on the transmission line.	Check the transmission wave shape and noise on the transmission line. Refer to the following page(s). [8-4 Checking Transmission Waveform and for Electrical Noise Interference] → No noise indicates that the error source controller is a failure. → If noise exists, investigate the noise.
(2)	Error source controller failure	

7-8-7 Error Code [6606]

1. Error code definition

Communication error between device processor and transmission processor or M-NET processor

2. Error definition and error detection method

Communication error between device processor on circuit board and transmission processor or M-NET processor
 Detail code 003: Communication error between device processor on circuit board and M-NET processor

Note

The address/attribute appeared on the display on the remote controller indicates the controller where an error occurred.

3. Cause, check method and remedy

Cause		Check method and remedy
(1)	Data is not properly transmitted due to accidental erroneous operation of the controller of the error source.	Turn off the power source of the outdoor and the indoor units.(When the power source is turned off separately, the microcomputer will not be reset, and the error will not be corrected.) → If the same error occurs, the error source controller is a failure.
(2)	Error source controller failure	

7-8-8 Error Code [6607] Error Source Address = Outdoor Unit (OC)

1. Error code definition

No ACK error

2. Error definition and error detection method

The error is detected when no acknowledgement (ACK signal) is received after the transmission. (eg. When the data is transmitted six times in a row with 30 seconds interval, the error is detected on the transmission side.)

Note

The address/attribute appeared on the display on the remote controller indicates the controller which did not provide the response (ACK).

3. Cause, check method and remedy

Cause		Check method and remedy	
(1)	Incidental cause	1)	Check whether Error Code [Er91] is displayed on the service LED on the outdoor unit.
(2)	Contact failure of transmission line of OC or IC	2)	If the code is not displayed, turn off the power to the outdoor unit, and then turn it back on.
(3)	Decrease of transmission line voltage/signal by exceeding acceptable range of transmission wiring. Farthest: 200 m [656ft] or less Remote controller wiring: 10m [32ft] or less	3)	If the error is accidental, it will run normally. If not, check the causes (2) - (5). * Skip check item 1) on the outdoor unit whose firmware does not need to be updated.
(4)	Erroneous sizing of transmission line (Not within the range below). Wire diameter: 1.25mm ² [AWG16] or more		
(5)	Outdoor unit control board failure		
(6)	Firmware update error on the outdoor unit		

7-8-9 Error Code [6607] Error Source Address = Indoor Unit (IC)

1. Error code definition

No ACK error

2. Error definition and error detection method

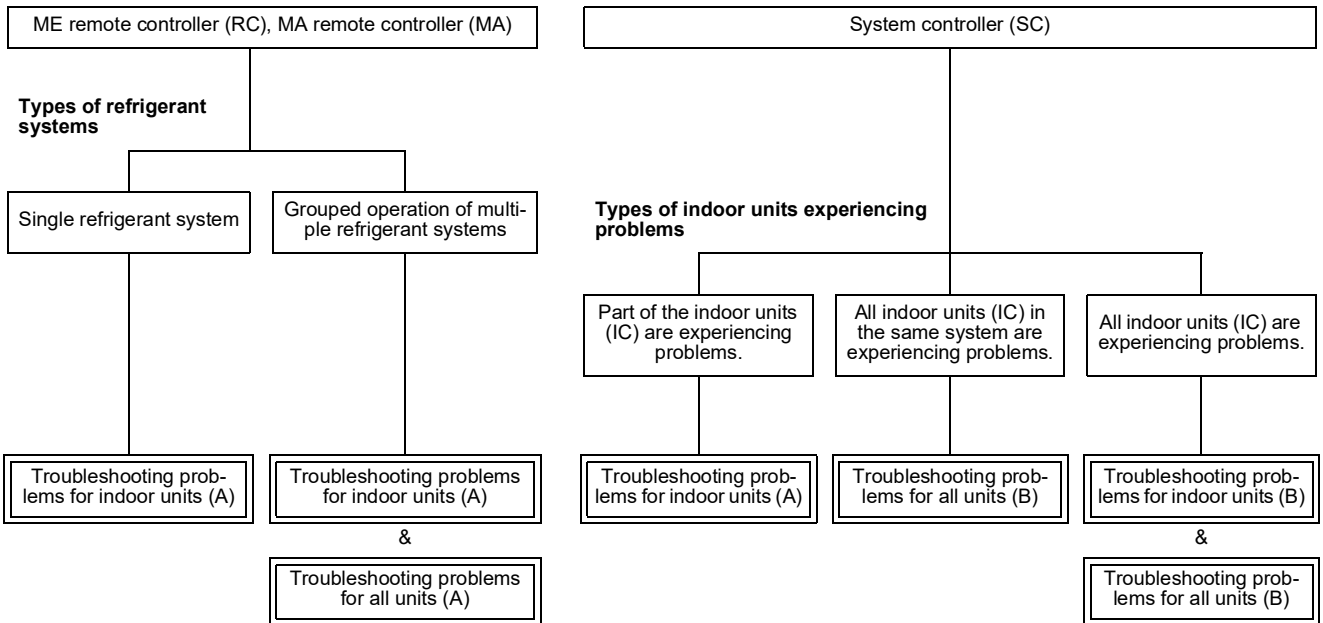
The error is detected when no acknowledgement (ACK signal) is received after the transmission. (eg. When the data is transmitted six times in a row with 30 seconds interval, the error is detected on the transmission side.)

Note

The address/attribute appeared on the display on the remote controller indicates the controller which did not provide the response (ACK).

3. Cause, check method and remedy

Error display



(1) Troubleshooting problems for indoor units (A)

Cause	Check method and remedy
(1) Incidental cause	1) Turn off the outdoor/indoor units for 5 or more minutes, and turn them on again.
(2) When IC unit address is changed or modified during operation.	2) If the error is accidental, it will run normally. If not, check the causes (2) - (6).
(3) Faulty or disconnected IC transmission wiring	
(4) Disconnected IC connector (CN2M)	
(5) Indoor unit controller failure	
(6) ME remote controller failure	

(2) Troubleshooting problems for indoor units (B)

Cause		Check method and remedy	
(1)	When the power supply unit for transmission lines is used and the male power supply connector is connected to the female power supply switch connector (CN40) for the transmission line for centralized control	1)	Check voltage of the transmission line for centralized control. •20 V or more: Check (1) on the left. •Less than 20 V: Check (2) on the left.
(2)	Disconnection or shutdown of the power source of the power supply unit for transmission line		
(3)	System controller (MELANS) malfunction	2)	Check the causes of the error indicated by the error codes listed in items (1) through (3) in the "Cause" column.

7-8-10 Error Code [6607] Error Source Address = LOSSNAY (LC)

1. Error code definition

No ACK error

2. Error definition and error detection method

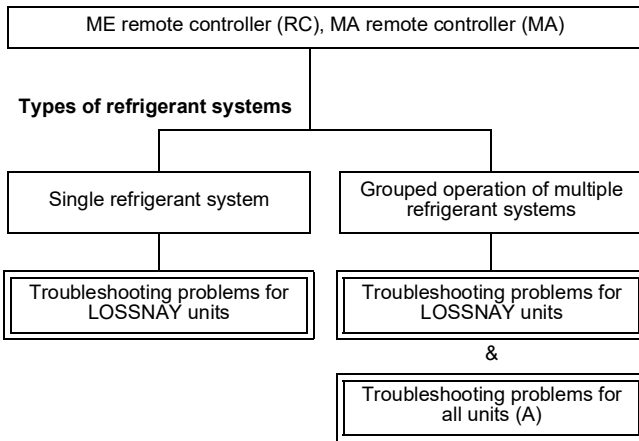
The error is detected when no acknowledgement (ACK signal) is received after the transmission. (eg. When the data is transmitted six times in a row with 30 seconds interval, the error is detected on the transmission side.)

Note

The address/attribute appeared on the display on the remote controller indicates the controller which did not provide the response (ACK).

3. Cause, check method and remedy

Error display



(1) Troubleshooting problems for LOSSNAY units

Cause	Check method and remedy
(1) Incidental cause	1) Turn off the power source of LOSSNAY and turn it on again.
(2) The power source of LOSSNAY has been shut off.	2) If the error is accidental, it will run normally. If not, check the causes (2) - (6).
(3) When the address of LOSSNAY is changed in the middle of the operation	
(4) Faulty or disconnected transmission wiring of LOSSNAY	
(5) Disconnected connector (CN1) on LOSSNAY	
(6) Controller failure of LOSSNAY	

7-8-11 Error Code [6607] Error Source Address = ME Remote Controller

1. Error code definition

No ACK error

2. Error definition and error detection method

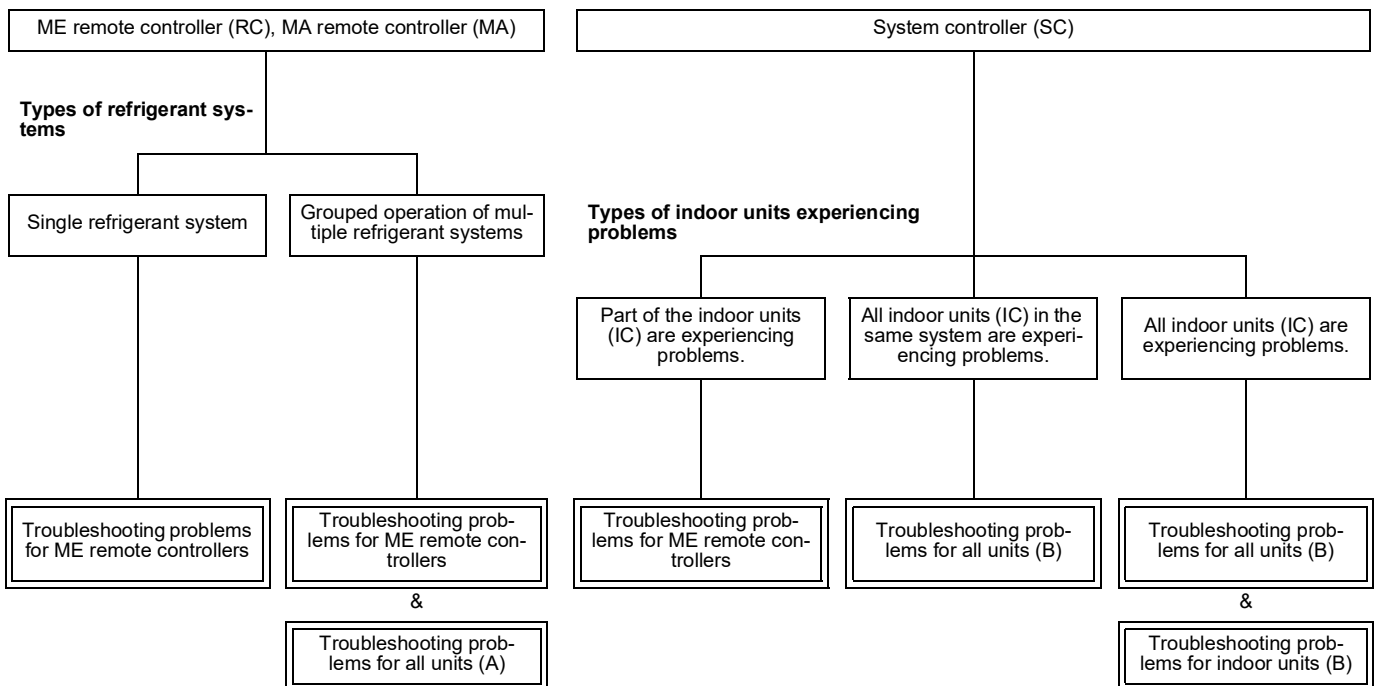
The error is detected when no acknowledgement (ACK signal) is received after the transmission. (eg. When the data is transmitted six times in a row with 30 seconds interval, the error is detected on the transmission side.)

Note

The address/attribute appeared on the display on the remote controller indicates the controller which did not provide the response (ACK).

3. Cause, check method and remedy

Error display



(1) Troubleshooting problems for ME remote controllers

Cause	Check method and remedy
(1) Incidental cause	1) Turn off the power source of the outdoor unit for 5 minutes or more, and turn it on again.
(2) Faulty transmission wiring at IC unit side.	2) If not, check the causes (2) - (5).
(3) Faulty wiring of the transmission line for ME remote controller	
(4) When the address of ME remote controller is changed in the middle of the operation	
(5) ME remote controller failure	

7-8-12 Error Code [6607] Error Source Address = System Controller

1. Error code definition

No ACK error

2. Error definition and error detection method

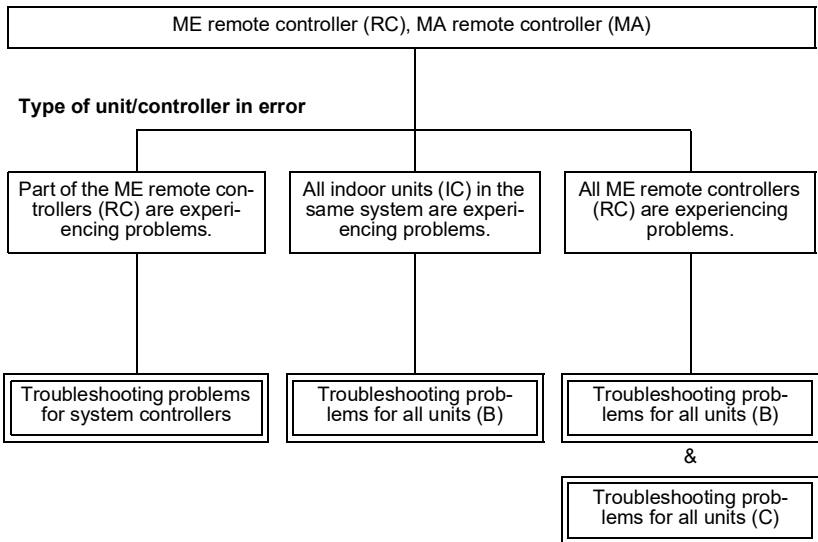
The error is detected when no acknowledgement (ACK signal) is received after the transmission. (eg. When the data is transmitted six times in a row with 30 seconds interval, the error is detected on the transmission side.)

Note

The address/attribute appeared on the display on the remote controller indicates the controller which did not provide the response (ACK).

3. Cause, check method and remedy

Error display



(1) Troubleshooting problems for system controllers

Cause	Check method and remedy
(1) Incidental cause	1) Turn off the power source of the outdoor unit for 5 minutes or more, and turn it on again.
(2) Faulty wiring of the transmission line for ME remote controller	2) If not, check the causes (2) - (4).
(3) When the address of ME remote controller is changed in the middle of the operation	
(4) ME remote controller failure	

7-8-13 Error Code [6607] All Error Source Addresses

1. Error code definition

No ACK error

2. Error definition and error detection method

The error is detected when no acknowledgement (ACK signal) is received after the transmission. (eg. When the data is transmitted six times in a row with 30 seconds interval, the error is detected on the transmission side.)

Note

The address/attribute appeared on the display on the remote controller indicates the controller which did not provide the response (ACK).

3. Cause, check method and remedy

(1) Troubleshooting problems for all units (A)

Cause	Check method and remedy
(1) Disconnection or short circuit of the transmission line for the outdoor unit on the terminal block for centralized control line connection (TB7) (2) When multiple outdoor units are connected and the power source of one of the outdoor units has been shut off. (3) The male power supply connector of the outdoor unit is not connected to the female power supply switch connector (CN40). (4) The male power supply connectors on 2 or more outdoor units are connected to the female power supply switch connector (CN40) for centralized control. If an error occurs, after the unit runs normally once, the following causes may be considered. ♦Total capacity error (7100) ♦Capacity code error (7101) ♦Error in the number of connected units (7102) ♦Address setting error (7105)	1) Check the causes of (1) - (4). If the cause is found, correct it. If no cause is found, check 2). 2) Check the LED displays for troubleshooting on other remote controllers whether an error occurs. ♦When an error is present Check the causes of the error indicated by the error codes listed in item (4) in the "Cause" column. ♦When no errors are present Indoor unit circuit board failure

(2) Troubleshooting problems for all units (B)

Cause	Check method and remedy
(1) Total capacity error (7100) (2) Capacity code error (7101) (3) Error in the number of connected units (7102) (4) Address setting error (7105) (5) Disconnection or short circuit of the transmission line for the outdoor unit on the terminal block for centralized control line connection (TB7) (6) Turn off the power source of the outdoor unit (7) Malfunction of electrical system for the outdoor unit	1) Check the LED display for troubleshooting on the outdoor unit. ♦When an error is present Check the causes of the error indicated by the error codes listed in items (1) through (4) in the "Cause" column. ♦When no errors are present Check the causes of the error indicated by the error codes listed in items (5) through (7) in the "Cause" column.

(3) Troubleshooting problems for all units (C)

Cause	Check method and remedy
(1) When the power supply unit for transmission lines is used and the male power supply connector is connected to the female power supply switch connector (CN40) for the transmission line for centralized control (2) Disconnection or shutdown of the power source of the power supply unit for transmission line (3) System controller (MELANS) malfunction	Check the causes of the error indicated by the error codes listed in items (1) through (3) in the "Cause" column.

7-8-14 Error Code [6607] No Error Source Address

1. Error code definition

No ACK error

2. Error definition and error detection method

The error is detected when no acknowledgement (ACK signal) is received after the transmission. (eg. When the data is transmitted six times in a row with 30 seconds interval, the error is detected on the transmission side.)

Note

The address/attribute appeared on the display on the remote controller indicates the controller which did not provide the response (ACK).

3. Cause, check method and remedy

Cause	Check method and remedy
(1) Although the address of ME remote controller has been changed after the group is set using ME remote controller, the indoor unit is keeping the memory of the previous address. The same symptom will appear for the registration with SC.	Delete unnecessary information of non-existing address which some indoor units have. Use either of the following two methods for deletion.
(2) Although the address of LOSSNAY has been changed after the interlock registration of LOSSNAY is made using ME remote controller, the indoor unit is keeping the memory of the previous address.	1) Address deletion by ME remote controller Delete unnecessary address information using the manual setting function of ME remote controller. Refer to the ME remote controller instructions manual for detail. 2) Deletion of connection information of the outdoor unit by the deleting switch Note that the above method will delete all the group settings set via the ME remote controller and all the interlock settings between LOSSNAY units and indoor units. Procedures 1) Turn off the power source of the outdoor unit, and wait for 5 minutes. 2) Turn on the dip switch (SW5-2) on the outdoor unit control board. 3) Turn on the power source of the outdoor unit, and wait for 5 minutes. 4) Turn off the power source of the outdoor unit, and wait for 5 minutes. 5) Turn off the dip switch (SW5-2) on the outdoor unit control board. 6) Turn on the power source of the outdoor unit.

7-8-15 **Error Code [6608]**

1. Error code definition

No response error

2. Error definition and error detection method

- When no response command is returned although acknowledgement (ACK) is received after transmission, an error is detected.
- When the data is transmitted 10 times in a row with 3 seconds interval, an error is detected on the transmission side.

Note

The address/attribute appeared on the display on the remote controller indicates the controller where an error occurred.

3. Cause

- 1) The transmission line work is performed while the power is on, the transmitted data will collide, and the wave shape will be changed.
- 2) The transmission is sent and received repeatedly due to noise.
- 3) Decrease of transmission line voltage/signal by exceeding acceptable range of transmission wiring.
Farthest: 200m [656ft] or less
Remote controller wiring: 12m [39ft] or less
- 4) The transmission line voltage/signal is decreased due to erroneous sizing of transmission line.
Wire diameter: 1.25mm²[AWG16] or more

4. Check method and remedy

- 1) When an error occurs during commissioning, turn off the power sources for the outdoor unit, indoor unit, and LOSSNAY for 5 or more minutes, and then turn them on again.
 - When they return to normal operation, the cause of the error is the transmission line work performed with the power on.
 - If an error occurs again, check the cause 2).
- 2) Check 3) and 4) above.
 - If the cause is found, correct it.
 - If no cause is found, check 3).
- 3) Check the transmission waveform, and check the transmission line for electrical noise. For details, refer to the following page(s). [8-4 Checking Transmission Waveform and for Electrical Noise Interference]
Noise is the most possible cause of the error "6608".

7-8-16 Error Code [6831]

1. Error code definition

MA remote controller signal reception error (No signal reception)

2. Error definition and error detection method

- Communication between the MA remote controller and the indoor unit is not done properly.
- No proper data has been received for 3 minutes.

3. Cause

- 1) Contact failure of the remote controller lines of MA remote controller or the indoor unit.
- 2) All the remote controllers are set to SUB.
- 3) Failure to meet wiring regulations
 - Wire length
 - Wire size
 - Number of remote controllers
 - Number of indoor units
- 4) The remote controller is removed after the installation without turning the power source off.
- 5) Noise interference on the remote controller transmission lines
- 6) Faulty circuit that is on the indoor board and performs transmission/ reception of the signal from the remote controller
- 7) Problems with the circuit on the remote controller that sends or receives the signals from the remote controller

4. Check method and remedy

- 1) Check for disconnected or loose transmission lines for the indoor units or MA remote controllers.
- 2) Confirm that the power is supplied to the main power source and the remote controller line.
- 3) Confirm that MA remote controller's capacity limit is not exceeded.
- 4) Check the sub/main setting of the MA remote controllers. One of them must be set to MAIN.
- 5) Diagnose the remote controller (described in the remote controller installation manual).
[OK]: no problems with the remote controller (check the wiring regulations)
[NG]: Replace the MA remote controller.
[6832, 6833, ERC]: Due to noise interference <Go to 6>
- 6) Check the transmission waveform, and check the MA remote controller line for electrical noise. For details, refer to the following page(s). [8-4 Checking Transmission Waveform and for Electrical Noise Interference]
- 7) When no problems are found with items 1) through 6), replace the indoor unit board or the MA remote controller.
The following status can be confirmed on LED1 and 2 on the indoor unit board.
 - If LED1 is lit, the main power source of the indoor unit is turned on.
 - If LED2 is lit, the MA remote controller line is being powered.

7-8-17 **Error Code [6832]**

1. Error code definition

MA remote controller signal transmission error (Synchronization error)

2. Error definition and error detection method

- MA remote controller and the indoor unit is not done properly.
- Failure to detect opening in the transmission path and unable to send signals
 - *Indoor unit: 3 minutes
 - *Remote controller: 6 seconds

3. Cause

- 1) Contact failure of the remote controller lines of MA remote controller or the indoor unit
- 2) 2 or more remote controllers are set to MAIN
- 3) Overlapped indoor unit address
- 4) Noise interference on the remote controller lines
- 5) Failure to meet wiring regulations
 - Wire length
 - Wire size
 - Number of remote controllers
 - Number of indoor units
- 6) Problems with the circuit on the remote controller that sends or receives the signals from the remote controller

4. Check method and remedy

- 1) Check for disconnected or loose transmission lines for the indoor units or MA remote controllers.
- 2) Confirm that the power is supplied to the main power source and the remote controller line.
- 3) Confirm that MA remote controller's capacity limit is not exceeded.
- 4) Check the sub/main setting of the MA remote controllers. One of them must be set to MAIN.
- 5) Diagnose the remote controller (described in the remote controller installation manual).
 - [OK]: no problems with the remote controller (check the wiring regulations)
 - [NG]: Replace the MA remote controller.
 - [6832, 6833, ERC]: Due to noise interference <Go to 6>
- 6) Check the transmission waveform, and check the MA remote controller line for electrical noise. For details, refer to the following page(s). [8-4 Checking Transmission Waveform and for Electrical Noise Interference]
- 7) When no problems are found with items 1) through 6), replace the indoor unit board or the MA remote controller. The following status can be confirmed on LED1 and 2 on the indoor unit board.
 - If LED1 is lit, the main power source of the indoor unit is turned on.
 - If LED2 is lit, the MA remote controller line is being powered.

7-8-18 **Error Code [6833]**

1. Error code definition

MA remote controller signal transmission error (Hardware error)

2. Error definition and error detection method

- Communication between the MA remote controller and the indoor unit is not done properly.
- An error occurs when the transmitted data and the received data differ for 30 times in a row.

3. Cause

- 1) Contact failure of the remote controller lines of MA remote controller or the indoor unit
- 2) 2 or more remote controllers are set to MAIN
- 3) Overlapped indoor unit address
- 4) Noise interference on the remote controller lines
- 5) Failure to meet wiring regulations
 - Wire length
 - Wire size
 - Number of remote controllers
 - Number of indoor units
- 6) Problems with the circuit on the remote controller that sends or receives the signals from the remote controller

4. Check method and remedy

- 1) Check for disconnected or loose transmission lines for the indoor units or MA remote controllers.
- 2) Confirm that the power is supplied to the main power source and the remote controller line.
- 3) Confirm that MA remote controller's capacity limit is not exceeded.
- 4) Check the sub/main setting of the MA remote controllers. One of them must be set to MAIN.
- 5) Diagnose the remote controller (described in the remote controller installation manual).
[OK]: no problems with the remote controller (check the wiring regulations)
[NG]: Replace the MA remote controller.
[6832, 6833, ERC]: Due to noise interference <Go to 6>
- 6) Check the transmission waveform, and check the MA remote controller line for electrical noise. For details, refer to the following page(s). [8-4 Checking Transmission Waveform and for Electrical Noise Interference]
- 7) When no problems are found with items 1) through 6), replace the indoor unit board or the MA remote controller.
The following status can be confirmed on LED1 and 2 on the indoor unit board.
 - If LED1 is lit, the main power source of the indoor unit is turned on.
 - If LED2 is lit, the MA remote controller line is being powered.

7-8-19 **Error Code [6834]**

1. Error code definition

MA remote controller signal reception error (Start bit detection error)

2. Error definition and error detection method

- Communication between the MA remote controller and the indoor unit is not done properly.
- No proper data has been received for 2 minutes.

3. Cause

- 1) Contact failure of the remote controller lines of MA remote controller or the indoor unit.
- 2) All the remote controllers are set to SUB.
- 3) Failure to meet wiring regulations
 - Wire length
 - Wire size
 - Number of remote controllers
 - Number of indoor units
- 4) The remote controller is removed after the installation without turning the power source off.
- 5) Noise interference on the remote controller transmission lines
- 6) Faulty circuit that is on the indoor board and performs transmission/ reception of the signal from the remote controller
- 7) Problems with the circuit on the remote controller that sends or receives the signals from the remote controller

4. Check method and remedy

- 1) Check for disconnected or loose transmission lines for the indoor units or MA remote controllers.
- 2) Confirm that the power is supplied to the main power source and the remote controller line.
- 3) Confirm that MA remote controller's capacity limit is not exceeded.
- 4) Check the sub/main setting of the MA remote controllers. One of them must be set to MAIN.
- 5) Diagnose the remote controller (described in the remote controller installation manual).
 - [OK]: no problems with the remote controller (check the wiring regulations)
 - [NG]: Replace the MA remote controller.
 - [6832, 6833, ERC]: Due to noise interference <Go to 6>
- 6) Check the transmission waveform, and check the MA remote controller line for electrical noise. For details, refer to the following page(s). [8-4 Checking Transmission Waveform and for Electrical Noise Interference]
- 7) When no problems are found with items 1) through 6), replace the indoor unit board or the MA remote controller. The following status can be confirmed on LED1 and 2 on the indoor unit board.
 - If LED1 is lit, the main power source of the indoor unit is turned on
 - If LED2 is lit, the MA remote controller line is being powered.

7-8-20 Error Code [6840]

1. Error code definition

Indoor-outdoor communication: Reception error

2. Error definition and error detection method

- Abnormal if indoor controller board could not receive any signal normally for 6 minutes after turning the power on
- Abnormal if indoor controller board could not receive any signal normally for 3 minutes.
- Consider the unit as abnormal under the following condition. When 2 or more indoor units are connected to an outdoor unit, indoor controller board could not receive a signal for 3 minutes from outdoor controller circuit board, a signal which allows outdoor controller circuit board to transmit signals.

3. Cause, check method and remedy

Cause	Check method and remedy
(1) Contact failure, short circuit or miswiring (converse wiring) of indoor/outdoor unit connecting wire.	Check disconnecting or looseness of indoor /outdoor unit connecting wire of indoor unit or outdoor unit. Check all the units in case of twin/triple/quadruple indoor unit system.
(2) Defective transmitting receiving circuit of outdoor controller circuit board.	
(3) Defective transmitting receiving circuit of indoor controller board.	
(4) Noise has entered into indoor/outdoor unit connecting wire.	
(5) Defective fan motor	Turn the power off, and detach fan motor from connector (CNF1, 2). Then turn the power on again. If abnormality is not displayed, replace fan motor. If abnormality is displayed, replace outdoor controller circuit board.
(6) Defective rush current resistor of outdoor power circuit board	Check the rush current resistor on outdoor power circuit board with tester. If open is detected, replace the power circuit board.

Note: Refer also to the Service Handbook for the indoor units.

7-8-21 Error Code [6841]

1. Error code definition

A control communication synchronism not recover

2. Error definition and error detection method

Indoor/outdoor unit communication error (Outdoor unit)

- Abnormal if "0" receiving is detected 30 times continuously though outdoor controller circuit board has transmitted "1".
- Abnormal if outdoor controller circuit board could not find blank of transmission path for 3 minutes.

3. Cause, check method and remedy

Cause	Check method and remedy
(1) Indoor/outdoor unit connecting wire has contact failure.	Check disconnection or looseness of indoor/ outdoor unit connecting wire.
(2) Defective communication circuit of outdoor controller circuit board.	
(3) Noise has entered power supply.	
(4) Noise has entered indoor/outdoor unit connecting wire.	

Note: Refer also to the Service Handbook for the indoor units.

7-8-22 **Error Code [6842]**

1. Error code definition

Indoor-outdoor communication: **Transmission error**

2. Error definition and error detection method

Indoor/outdoor unit communication error (Transmitting error)

Abnormal if "1" receiving is detected 30 times continuously though indoor controller board has transmitted "0".

3. Cause, check method and remedy

Cause		Check method and remedy
(1)	Defective transmitting receiving circuit of indoor controller board	Turn the power off, and on again to check. If abnormality generates again, replace indoor controller board.
(2)	Noise has entered into power supply.	
(3)	Noise has entered into outdoor control wire.	

Note: Refer also to the Service Handbook for the indoor units.

7-8-23 Error Code [6843]

1. Error code definition

A control communication start bit detection error

2. Error definition and error detection method

Indoor/outdoor unit communication error

- Abnormal if indoor controller board could not receive any signal normally for 6 minutes after turning the power on.
- Abnormal if indoor controller board could not receive any signal normally for 3 minutes.
- Consider the unit as abnormal under the following condition. When 2 or more indoor units are connected to an outdoor unit, indoor controller board could not receive a signal for 3 minutes from outdoor controller circuit board, a signal which allows outdoor controller circuit board to transmit signals.

3. Cause, check method and remedy

Cause		Check method and remedy
(1)	Contact failure, short circuit or miswiring (converse wiring) of indoor/outdoor unit connecting wire	Check disconnecting or looseness of indoor /outdoor unit connecting wire of all indoor units or outdoor units.
(2)	Defective transmitting receiving circuit of outdoor controller circuit board.	Turn the power off, and on again to check. If abnormality generates again, replace indoor controller board or outdoor controller circuit board. Note: other indoor controller board may have defect.
(3)	Defective transmitting receiving circuit of indoor controller board.	
(4)	Noise has entered into indoor/outdoor unit connecting wire.	
(5)	Defective fan motor	Turn the power off, and detach fan motor from connector (CNF1, 2). Then turn the power on again. If abnormality is not displayed, replace fan motor. If abnormality is displayed, replace outdoor controller circuit board.
(6)	Defective rush current resistor of outdoor power circuit board	Check the rush current resistor on outdoor power circuit board with tester. If open is detected, replace the power circuit board.

1. Error code definition

A control communication start bit detection error

2. Error definition and error detection method

Indoor/outdoor unit communication error (Outdoor unit)

Abnormal if outdoor controller circuit board could not receive anything normally for 3 minutes.

3. Cause, check method and remedy

Cause		Check method and remedy
(1)	Contact failure of indoor/outdoor unit connecting wire	Check disconnection or looseness of indoor/ outdoor unit connecting wire of indoor or outdoor units.
(2)	Defective communication circuit of outdoor controller circuit board	Turn the power off, and on again to check. Replace indoor controller board or outdoor controller circuit board if abnormality is displayed again.
(3)	Defective communication circuit of indoor controller board	
(4)	Noise has entered into indoor/outdoor unit connecting wire.	

Note: Refer also to the Service Handbook for the indoor units.

7-8-24 **Error Code [6846]**

1. Error code definition

Start-up time over

2. Error definition and error detection method

Start-up time over The unit cannot finish start-up process within 4 minutes after power on.

3. Cause, check method and remedy

Cause		Check method and remedy
(1)	Contact failure of indoor/outdoor unit connecting wire	Check disconnection or looseness or polarity of indoor/outdoor unit connecting wire of indoor and outdoor units.
(2)	Diameter or length of indoor/outdoor unit connecting wire is out of specified capacity.	Check the following: Diameter of the cables used for indoor-outdoor lines; maximum line distance between indoor and outdoor units (max. 50 m); maximum line distance between indoor units (daisy-changed cables) (max. 30 m); and if flat cables such as VVF is used, make sure they are connected in the order of S1, S2, and S3.
(3)	2 or more outdoor units have refrigerant address "0". (In case of group control)	When units are controlled as groups, check the refrigerant address (SW1 (3-6) on the outdoor unit control board settings) for duplicates.
(4)	Noise has entered into power supply or indoor/outdoor unit connecting wire.	Check the transmission lines for problems.

Note: Refer also to the Service Handbook for the indoor units.

7-9 Error Code Definitions and Solutions: Codes [7000 - 7999]

7-9-1 Error Code [7100]

1. Error code definition

Total capacity error

2. Error definition and error detection method

The model total of indoor units in the system with one outdoor unit exceeds limitations.

3. Error source, cause, check method and remedy,

After troubleshooting the error using the check methods and remedies shown below, turn the power back on.

Error source	Cause	Check method and remedy																																																																																		
Outdoor unit	(1) The model total of indoor units in the system with one outdoor unit exceeds the following table. <table border="1" style="margin-left: 20px;"> <thead> <tr> <th>Model</th> <th>Qj Total</th> </tr> </thead> <tbody> <tr><td>200 model</td><td>53</td></tr> <tr><td>250 model</td><td>69</td></tr> <tr><td>300 model</td><td>86</td></tr> <tr><td>350 model</td><td>96</td></tr> <tr><td>400 model</td><td>108</td></tr> <tr><td>450 model</td><td>121</td></tr> <tr><td>500 model</td><td>138</td></tr> <tr><td>550 model</td><td>155</td></tr> <tr><td>600 model</td><td>172</td></tr> <tr><td>650 model</td><td>177</td></tr> <tr><td>700 model</td><td>190</td></tr> <tr><td>750 model</td><td>207</td></tr> <tr><td>800 model</td><td>224</td></tr> <tr><td>850 model</td><td>241</td></tr> <tr><td>900 model</td><td>248</td></tr> <tr><td>950 model</td><td>254</td></tr> <tr><td>1000 model</td><td>270</td></tr> <tr><td>1050 model</td><td>284</td></tr> <tr><td>1100 model</td><td>296</td></tr> <tr><td>1150 model</td><td>312</td></tr> <tr><td>1200 model</td><td>324</td></tr> <tr><td>1250 model</td><td>338</td></tr> <tr><td>1300 model</td><td>351</td></tr> <tr><td>1350 model</td><td>365</td></tr> </tbody> </table>	Model	Qj Total	200 model	53	250 model	69	300 model	86	350 model	96	400 model	108	450 model	121	500 model	138	550 model	155	600 model	172	650 model	177	700 model	190	750 model	207	800 model	224	850 model	241	900 model	248	950 model	254	1000 model	270	1050 model	284	1100 model	296	1150 model	312	1200 model	324	1250 model	338	1300 model	351	1350 model	365	1) Check the Qj total (capacity code total) of indoor units connected. 2) Check the Qj setting (capacity code) of the connected indoor unit set by the switch (SW2 on indoor unit board). When the model name set by the switch is different from that of the unit connected, turn off the power source of the outdoor and the indoor units, and change the setting of the Qj (capacity code). 3) Indoor unit Qj table <table border="1" style="margin-left: 20px;"> <thead> <tr> <th>Model</th> <th>Qj</th> </tr> </thead> <tbody> <tr><td>10</td><td>2</td></tr> <tr><td>15</td><td>3</td></tr> <tr><td>20</td><td>4</td></tr> <tr><td>25</td><td>5</td></tr> <tr><td>32</td><td>6</td></tr> <tr><td>40</td><td>8</td></tr> <tr><td>50</td><td>10</td></tr> <tr><td>63</td><td>13</td></tr> <tr><td>71</td><td>14</td></tr> <tr><td>80</td><td>16</td></tr> <tr><td>100</td><td>20</td></tr> <tr><td>125</td><td>25</td></tr> <tr><td>140</td><td>28</td></tr> <tr><td>200</td><td>40</td></tr> <tr><td>250</td><td>50</td></tr> </tbody> </table>	Model	Qj	10	2	15	3	20	4	25	5	32	6	40	8	50	10	63	13	71	14	80	16	100	20	125	25	140	28	200	40	250	50
	Model	Qj Total																																																																																		
	200 model	53																																																																																		
250 model	69																																																																																			
300 model	86																																																																																			
350 model	96																																																																																			
400 model	108																																																																																			
450 model	121																																																																																			
500 model	138																																																																																			
550 model	155																																																																																			
600 model	172																																																																																			
650 model	177																																																																																			
700 model	190																																																																																			
750 model	207																																																																																			
800 model	224																																																																																			
850 model	241																																																																																			
900 model	248																																																																																			
950 model	254																																																																																			
1000 model	270																																																																																			
1050 model	284																																																																																			
1100 model	296																																																																																			
1150 model	312																																																																																			
1200 model	324																																																																																			
1250 model	338																																																																																			
1300 model	351																																																																																			
1350 model	365																																																																																			
Model	Qj																																																																																			
10	2																																																																																			
15	3																																																																																			
20	4																																																																																			
25	5																																																																																			
32	6																																																																																			
40	8																																																																																			
50	10																																																																																			
63	13																																																																																			
71	14																																																																																			
80	16																																																																																			
100	20																																																																																			
125	25																																																																																			
140	28																																																																																			
200	40																																																																																			
250	50																																																																																			
	(2) The model selection switches (SW5-3 - 5-8) on the outdoor unit are set incorrectly. <table border="1" style="margin-left: 20px;"> <thead> <tr> <th rowspan="2">Model</th> <th colspan="6">SW5</th> </tr> <tr> <th>3</th> <th>4</th> <th>5</th> <th>6</th> <th>7</th> <th>8</th> </tr> </thead> <tbody> <tr><td>P200 model</td><td>OFF</td><td>ON</td><td>OFF</td><td>OFF</td><td>ON</td><td rowspan="7" style="vertical-align: middle;">*1</td></tr> <tr><td>P250 model</td><td>ON</td><td>ON</td><td>OFF</td><td>OFF</td><td>ON</td></tr> <tr><td>P300 model</td><td>OFF</td><td>OFF</td><td>ON</td><td>OFF</td><td>ON</td></tr> <tr><td>P350 model</td><td>OFF</td><td>ON</td><td>ON</td><td>OFF</td><td>ON</td></tr> <tr><td>P400 model</td><td>ON</td><td>ON</td><td>ON</td><td>OFF</td><td>ON</td></tr> <tr><td>P450 model</td><td>OFF</td><td>OFF</td><td>OFF</td><td>ON</td><td>ON</td></tr> <tr><td>P500 model</td><td>ON</td><td>OFF</td><td>OFF</td><td>ON</td><td>ON</td></tr> </tbody> </table> <p style="margin-left: 20px;">*1 ON: EP model; OFF: P model</p>	Model	SW5						3	4	5	6	7	8	P200 model	OFF	ON	OFF	OFF	ON	*1	P250 model	ON	ON	OFF	OFF	ON	P300 model	OFF	OFF	ON	OFF	ON	P350 model	OFF	ON	ON	OFF	ON	P400 model	ON	ON	ON	OFF	ON	P450 model	OFF	OFF	OFF	ON	ON	P500 model	ON	OFF	OFF	ON	ON	Check the setting for the model selection switch on the outdoor unit (Dipswitches SW5-3 - 5-8 on the outdoor unit control board).																										
Model	SW5																																																																																			
	3	4	5	6	7	8																																																																														
P200 model	OFF	ON	OFF	OFF	ON	*1																																																																														
P250 model	ON	ON	OFF	OFF	ON																																																																															
P300 model	OFF	OFF	ON	OFF	ON																																																																															
P350 model	OFF	ON	ON	OFF	ON																																																																															
P400 model	ON	ON	ON	OFF	ON																																																																															
P450 model	OFF	OFF	OFF	ON	ON																																																																															
P500 model	ON	OFF	OFF	ON	ON																																																																															
	(3) The outdoor unit and the auxiliary unit (OS) that is connected to the same system are not properly connected.	Confirm that the TB3 on the OC and OS are properly connected.																																																																																		

7-9-2 Error Code [7101]

1. Error code definition

Capacity code setting error

2. Error definition and error detection method

Connection of incompatible (wrong capacity code) indoor unit or outdoor unit

3. Error source, cause, check method and remedy

After troubleshooting the error using the check methods and remedies shown below, turn the power back on.

Error source	Cause	Check method and remedy																																																								
Outdoor unit Indoor unit	(1) The model name (capacity code) set by the switch (SW2) is wrong. *The capacity of the indoor unit can be confirmed by the self-diagnosis function (SW1 operation) of the outdoor unit.	1) Check the model name (capacity code) of the indoor unit which has the error source address set by the switch (SW2 on indoor unit board). When the model name set by the switch is different from that of the unit connected, turn off the power source of the outdoor and the indoor units, and change the setting of the capacity code.																																																								
Outdoor unit	(2) The model selection switches (SW5-3 - 5-8) on the outdoor unit are set incorrectly. <table border="1" style="margin-left: auto; margin-right: auto;"> <thead> <tr> <th rowspan="2">Model</th> <th colspan="6">SW5</th> </tr> <tr> <th>3</th> <th>4</th> <th>5</th> <th>6</th> <th>7</th> <th>8</th> </tr> </thead> <tbody> <tr> <td>P200 model</td> <td>OFF</td> <td>ON</td> <td>OFF</td> <td>OFF</td> <td>ON</td> <td rowspan="6" style="text-align: center; vertical-align: middle;">*1</td> </tr> <tr> <td>P250 model</td> <td>ON</td> <td>ON</td> <td>OFF</td> <td>OFF</td> <td>ON</td> </tr> <tr> <td>P300 model</td> <td>OFF</td> <td>OFF</td> <td>ON</td> <td>OFF</td> <td>ON</td> </tr> <tr> <td>P350 model</td> <td>OFF</td> <td>ON</td> <td>ON</td> <td>OFF</td> <td>ON</td> </tr> <tr> <td>P400 model</td> <td>ON</td> <td>ON</td> <td>ON</td> <td>OFF</td> <td>ON</td> </tr> <tr> <td>P450 model</td> <td>OFF</td> <td>OFF</td> <td>OFF</td> <td>ON</td> <td>ON</td> </tr> <tr> <td>P500 model</td> <td>ON</td> <td>OFF</td> <td>OFF</td> <td>ON</td> <td>ON</td> </tr> </tbody> </table> *1 ON: EP model; OFF: P model	Model	SW5						3	4	5	6	7	8	P200 model	OFF	ON	OFF	OFF	ON	*1	P250 model	ON	ON	OFF	OFF	ON	P300 model	OFF	OFF	ON	OFF	ON	P350 model	OFF	ON	ON	OFF	ON	P400 model	ON	ON	ON	OFF	ON	P450 model	OFF	OFF	OFF	ON	ON	P500 model	ON	OFF	OFF	ON	ON	Check the setting for the model selection switch on the outdoor unit (Dipswitches SW5-3 - 5-8 on the outdoor unit control board).
Model	SW5																																																									
	3	4	5	6	7	8																																																				
P200 model	OFF	ON	OFF	OFF	ON	*1																																																				
P250 model	ON	ON	OFF	OFF	ON																																																					
P300 model	OFF	OFF	ON	OFF	ON																																																					
P350 model	OFF	ON	ON	OFF	ON																																																					
P400 model	ON	ON	ON	OFF	ON																																																					
P450 model	OFF	OFF	OFF	ON	ON																																																					
P500 model	ON	OFF	OFF	ON	ON																																																					

7-9-3 Error Code [7102]

1. Error code definition

Wrong number of connected units

2. Error definition and error detection method

The number of connected indoor units is "0" or exceeds the allowable value.

3. Error source, cause, check method and remedy

After troubleshooting the error using the check methods and remedies shown below, turn the power back on.

Error source	Cause	Check method and remedy																
Outdoor unit	<p>(1) Number of indoor units connected to the outdoor terminal block (TB3) for indoor/ outdoor transmission lines exceeds limitations described below.</p> <table border="1" style="margin-left: 20px;"> <thead> <tr> <th>Number of units</th> <th>Restriction on the number of units</th> </tr> </thead> <tbody> <tr> <td rowspan="6">Total number of indoor units</td> <td>20 : 200 model</td> </tr> <tr> <td>25 : 250 model</td> </tr> <tr> <td>30 : 300 model</td> </tr> <tr> <td>35 : 350 model</td> </tr> <tr> <td>40 : 400 model</td> </tr> <tr> <td>45 : 450 model</td> </tr> <tr> <td>50 : 500 - 1350 models</td> </tr> <tr> <td>Total number of LOSSNAY units (During auto address start-up only)</td> <td>0 or 1</td> </tr> <tr> <td rowspan="3">Total number of outdoor units</td> <td>1 : (E)P200 - (E)P500YNW models</td> </tr> <tr> <td>2 : (E)P400 - (E)P900 YSNW models</td> </tr> <tr> <td>3 : (E)P950 - (E)P1350 YSNW models</td> </tr> </tbody> </table> <p>(2) Disconnected transmission line of the outdoor unit</p> <p>(3) Short-circuited transmission line When (2) and (3) apply, the following display will appear.</p> <ul style="list-style-type: none"> ◆ME remote controller Nothing appears on the remote controller because it is not powered. ◆MA remote controller "HO" or "PLEASE WAIT" blinks. <p>(4) The model selection switch (SW5-7) on the outdoor unit is set to OFF. (Normally set to ON)</p> <p>(5) Outdoor unit address setting error The outdoor units in the same refrigerant circuit do not have sequential address numbers.</p>	Number of units	Restriction on the number of units	Total number of indoor units	20 : 200 model	25 : 250 model	30 : 300 model	35 : 350 model	40 : 400 model	45 : 450 model	50 : 500 - 1350 models	Total number of LOSSNAY units (During auto address start-up only)	0 or 1	Total number of outdoor units	1 : (E)P200 - (E)P500YNW models	2 : (E)P400 - (E)P900 YSNW models	3 : (E)P950 - (E)P1350 YSNW models	<p>1) Check whether the number of units connected to the outdoor terminal block (TB3) for indoor/ outdoor transmission lines does not exceed the limitation. (See (1) and (2) on the left.)</p> <p>2) Check (2) - (3) on the left.</p> <p>3) Check whether the transmission line for the terminal block for centralized control (TB7) is not connected to the terminal block for the indoor/outdoor transmission line (TB3).</p> <p>4) Check the setting for the model selection switch on the outdoor unit (Dipswitches SW5-7 on the outdoor unit control board).</p>
Number of units	Restriction on the number of units																	
Total number of indoor units	20 : 200 model																	
	25 : 250 model																	
	30 : 300 model																	
	35 : 350 model																	
	40 : 400 model																	
	45 : 450 model																	
50 : 500 - 1350 models																		
Total number of LOSSNAY units (During auto address start-up only)	0 or 1																	
Total number of outdoor units	1 : (E)P200 - (E)P500YNW models																	
	2 : (E)P400 - (E)P900 YSNW models																	
	3 : (E)P950 - (E)P1350 YSNW models																	

7-9-4 Error Code [7105]

1. Error code definition

Address setting error

2. Error definition and error detection method

Erroneous setting of OC unit address

3. Error source, cause, check method and remedy

Error source	Cause	Check method and remedy
Outdoor unit	Erroneous setting of OC unit address The address of outdoor unit is not being set to 51 - 100.	Check that the address of OC unit is set to 51-100. Reset the address if it stays out of the range, while shutting the power source off.

7-9-5 Error Code [7106]

1. Error code definition

Attribute setting error

2. Error source, cause, check method and remedy

After troubleshooting the error using the check methods and remedies shown below, turn the power back on.

Error source	Cause	Check method and remedy						
-	A remote controller for use with indoor units, such as the MA remote controller, is connected to the OA processing unit whose attribute is FU.	<p>To operate the OA processing unit directly via a remote controller for use with indoor units, such as the MA remote controller, set the DIP SW 3-1 on the OA processing unit to ON.</p> <table border="1"> <tr> <td>Operation Method</td> <td>SW3-1</td> </tr> <tr> <td>Interlocked operation with the indoor unit</td> <td>OFF</td> </tr> <tr> <td>Direct operation via the MA remote controller</td> <td>ON</td> </tr> </table>	Operation Method	SW3-1	Interlocked operation with the indoor unit	OFF	Direct operation via the MA remote controller	ON
Operation Method	SW3-1							
Interlocked operation with the indoor unit	OFF							
Direct operation via the MA remote controller	ON							

7-9-6 Error Code [7110]

1. Error code definition

Connection information signal transmission/reception error

2. Error definition and error detection method

The given indoor unit is inoperable because it is not properly connected to the outdoor unit in the same system.

3. Error source, cause, check method and remedy

After troubleshooting the error using the check methods and remedies shown below, turn the power back on.

Error source	Cause	Check method and remedy
Outdoor unit	(1) Power to the transmission booster is cut off.	1) Confirm that the power to the transmission booster is not cut off by the booster being connected to the switch on the indoor unit. (The unit will not function properly unless the transmission booster is turned on.) →Reset the power to the outdoor unit.
	(2) Power resetting of the transmission booster and outdoor unit.	
	(3) Wiring failure between OC and OS	2) Confirm that the TB3 on the OC and OS are properly connected. 3) Check the model selection switch on the outdoor unit (Dipswitch SW5-7 on the control board.).
	(4) Broken wire between OC and OS.	
	(5) The model selection switch (SW5-7) on the outdoor unit is set to OFF. (Normally set to ON)	

7-9-7 Error Code [7111]

1. Error code definition

Remote controller sensor fault

2. Error definition and error detection method

This error occurs when the temperature data is not sent although the remote controller sensor is specified.

3. Error source, cause, check method and remedy

After troubleshooting the error using the check methods and remedies shown below, turn the power back on.

Error source	Cause	Check method and remedy
Indoor unit OA processing unit	The remote controller without the temperature sensor (the wireless remote controller or the ME compact remote controller (mounted type)) is used and the remote controller sensor for the indoor unit is specified. (SW1-1 is ON.)	Replace the remote controller with the one with built-in temperature sensor.

7-9-8 Error Code [7113]

1. Error code definition

Function setting error (improper connection of CNTYP)

2. Error source, cause, check method and remedy

After troubleshooting the error using the check methods and remedies shown below, turn the power back on.

Error source	Cause	Check method and remedy
Outdoor unit	(1) Wiring fault	(Detail code 15)
	(2) Loose connectors, short-circuit, contact failure	1) Check the connector CNTYP5 on the control board for proper connection.
		2) Check the connector CNTYP4 on the control board for proper connection.
	(3) Incompatible control board and INV board (replacement with a wrong circuit board)	(Detail code 14)
		1) Check the connector CNTYP4 on the control board for proper connection.
	(4) DIP SW setting error on the control board	2) Check the settings of SW5-3 through SW5-6 on the control board.
		(Detail code 12)
1) Check the settings of SW5-3 through SW5-6 on the control board.		
2) Check the connector CNTYP2 on the control board for proper connection.		
(4) DIP SW setting error on the control board	3) Check the connector CNTYP5 on the control board for proper connection.	
	4) Check the connector CNTYP on the INV board for proper connection.	
	(Detail code 16)	
	1) Check the settings of SW5-3 through SW5-6 on the control board.	
	2) Check the connector CNTYP5 on the control board for proper connection.	
(4) DIP SW setting error on the control board	3) Check the connector CNTYP2 on the control board for proper connection.	
	4) Check the wiring between the control board and INV board. Refer to the following page(s). [7-2-1 Error Code [0403]]	
	5) Check the connector CNTYP on the INV board for proper connection.	
(4) DIP SW setting error on the control board	(Detail code 0, 1, 5, 6)	
	1) Check the wiring between the control board and INV board. Refer to the following page(s). [7-2-1 Error Code [0403]]	
	2) Check the settings of SW5-3 through SW5-6 on the control board.	
(4) DIP SW setting error on the control board	3) Check the connector CNTYP5 on the control board for proper connection.	
	(Detail code Miscellaneous)	
		*If a set-model-name identification error occurs, check the detail code on the unit on which the error occurred. The detail code that appears on other units will be different from the ones shown above.

7-9-9 Error Code [7117]

1. Error code definition

Model setting error

2. Error source, cause, check method and remedy

After troubleshooting the error using the check methods and remedies shown below, turn the power back on.

Error source	Cause	Check method and remedy
Outdoor unit	(1) Wiring fault	(Detail code 15) 1) Check the connector CNTYP5 on the control board for proper connection.
	(2) Loose connectors, short-circuit, contact failure	(Detail code 14) 1) Check the connector CNTYP4 on the control board for proper connection.
		(Detail code 12) 1) Check the connector CNTYP2 on the control board for proper connection. 2) Check the connector CNTYP5 on the control board for proper connection. 3) Check the connector CNTYP on the INV board for proper connection.
		(Detail code 16) 1) Check the connector CNTYP5 on the control board for proper connection. 2) Check the connector CNTYP2 on the control board for proper connection. 3) Check the wiring between the control board and INV board. Refer to the following page(s). [7-2-1 Error Code [0403]] 4) Check the connector CNTYP on the INV board for proper connection.
		(Detail code 0, 1, 5, 6) 1) Check the wiring between the control board and INV board. Refer to the following page(s). [7-2-1 Error Code [0403]] 2) Check the settings of SW5-3 through SW5-6 on the control board. 3) Check the connector CNTYP5 on the control board for proper connection.
		(Detail code Miscellaneous) *If a set-model-name identification error occurs, check the detail code on the unit on which the error occurred. The detail code that appears on other units will be different from the ones shown above.

7-9-10 Error Code [7130]

1. Error code definition

Incompatible unit combination

2. Error definition and error detection method

The check code will appear when the indoor units with different refrigerant systems are connected or when the combination of the outdoor units is not as per [2-1 System Configurations].

3. Error source, cause, check method and remedy

After troubleshooting the error using the check methods and remedies shown below, turn the power back on.

Error source	Cause	Check method and remedy
Outdoor unit	(1) Indoor units for use with different refrigerant systems The connected indoor unit is for use with R22 or R407C. Incorrect type of indoor units are connected. The M-NET connection adapter is connected to the indoor unit system in a system in which the Slim Model (A control) of units are connected to the M-NET.	Check the connected indoor unit model. Check whether the connecting adapter for M-NET is not connected to the indoor unit. (Connect the M-NET adapter to the centralized control system.)
	(2) Combination of outdoor units Incorrect combination of outdoor units OC and OS. Only the combinations listed in [2-1 System Configurations] are allowed.	Check the model name of the outdoor units (OC) and (OS). Check whether the combination of the outdoor units is as per [2-1 System Configurations].

7-10 Unit Error Code Definitions and Solutions: Codes [Er91 - Er99]

7-10-1 Error Code [Er91]

1. Error code definition

Firmware update error (outdoor unit)

2. Error definition and error detection method

The error code will be displayed when the outdoor unit fails to write the firmware update program.

3. Error source, cause, check method and remedy

Error source	Cause	Check method and remedy
Outdoor unit	(1) Failure of the microcomputer or the flash memory on the control board	Replacement of the control board

Chapter 8 Troubleshooting Based on Observed Symptoms


8-1	MA Remote Controller Problems	1
8-1-1	The LCD Does Not Light Up.	1
8-1-2	The LCD Momentarily Lights Up and Then Goes Off.	2
8-1-3	"HO" and "PLEASE WAIT" Do Not Go Off the Screen.	3
8-1-4	Air Conditioning Units Do Not Operate When the ON Button Is Pressed.	4
8-2	ME remote Controller Problems	5
8-2-1	The LCD Does Not Light Up.	5
8-2-2	The LCD Momentarily Lights Up and Then Goes Off.	6
8-2-3	"HO" or "Waiting for ..." Does Not Go Off the Screen.....	7
8-2-4	"88", "Request denied." Appears on the LCD.	9
8-3	Refrigerant Control Problems	10
8-3-1	Units in the Cooling Mode Do Not Operate at Expected Capacity.....	10
8-3-2	Units in the Heating Mode Do Not Operate at Expected Capacity.	12
8-3-3	Outdoor Units Stop at Irregular Times.	14
8-4	Checking Transmission Waveform and for Electrical Noise Interference	15
8-4-1	M-NET.....	15
8-4-2	MA Remote Controller	17
8-5	Pressure Sensor Circuit Configuration and Troubleshooting Pressure Sensor Problems	18
8-5-1	Comparing the High-Pressure Sensor Measurement and Gauge Pressure	18
8-5-2	High-Pressure Sensor Configuration (63HS1).....	19
8-5-3	Comparing the Low-Pressure Sensor Measurement and Gauge Pressure.....	20
8-5-4	Low-Pressure Sensor Configuration (63LS).....	21
8-6	Troubleshooting Solenoid Valve Problems	22
8-7	Troubleshooting Outdoor Unit Fan Problems	24
8-8	Troubleshooting LEV Problems	25
8-8-1	General Overview on LEV Operation.....	25
8-8-2	Possible Problems and Solutions	28
8-8-3	Coil Removal Instructions	29
8-9	Troubleshooting Inverter Problems	31
8-9-1	Inverter-Related Problems and Solutions	31
8-9-2	Checking the Inverter Board Error Detection Circuit.....	33
8-9-3	Checking the Compressor for Ground Fault and Coil Resistance Problems	33
8-9-4	Checking the Inverter for Damage at No-Load	34
8-9-5	Checking the Inverter for Damage during Compressor Operation.....	35
8-9-6	Checking the Converter for Damage during Compressor Operation	37
8-9-7	Checking the Fan Motor for Ground Fault and Coil Resistance Problems	37
8-9-8	Checking the Fan Board Error Detection Circuit at No Load	37
8-9-9	Checking the Fan Board for Damage at No Load.....	38
8-9-10	Checking the Fan Board for Damage with Load	39
8-9-11	Checking the Installation Conditions.....	40
8-9-12	Solutions for the Main Breaker Trip	40
8-9-13	Solutions for the Main Earth Leakage Breaker Trip	41
8-9-14	Simple Check on Inverter Circuit Components	42
8-9-15	Troubleshooting Problems with IGBT Module	43
8-9-16	Checking the Fan Inverter Heatsink for Clogging	48
8-10	Control Circuit	49
8-10-1	Control Power Supply Function Block.....	49

8-10-2	Troubleshooting Problems with Outdoor Unit Transmission Power Supply Circuit	52
8-11	Measures for Refrigerant Leakage	56
8-12	Individual air-tightness testing of outdoor unit	58
8-13	Parts Replacement Instructions <Type A/Type A1/Type A2>	59
8-13-1	Ensuring Maintenance Space (Preparation for the Maintenance of Refrigerant Circuit Parts) <Type A> ...	59
8-13-2	Ensuring Maintenance Space (Preparation for the Maintenance of Refrigerant Circuit Parts) <Type A1/Type A2> ..	63
8-13-3	Notes on Wiring Installation <Type A/Type A1/Type A2>	67
8-13-4	Four-way Valve and Check Valve Replacement Procedure <Type A>	71
8-13-5	Four-way Valve and Check Valve Replacement Procedure <Type A1/Type A2>	87
8-13-6	Compressor Replacement Procedure <Type A>	103
8-13-7	Compressor Replacement Procedure <Type A1/Type A2>	105
8-13-8	Removal Instructions for the Control Box <Type A>	109
8-13-9	Removal Instructions for the Control Box <Type A1/Type A2>	112
8-13-10	Maintenance Procedure for the Drain Pan <Type A/Type A1/Type A2>	115
8-13-11	Maintenance Procedures for the Heat Exchanger <Type A>	121
8-13-12	Maintenance Procedures for the Heat Exchanger <Type A1/Type A2>	138
8-13-13	Accumulator Replacement Procedure <Type A/Type A1/Type A2>	154
8-14	Troubleshooting Problems Using the LED Status Indicators on the Outdoor Unit	158
8-15	4250 Troubleshooting	159

8-1 MA Remote Controller Problems

8-1-1 The LCD Does Not Light Up.

1. Phenomena

Even if the operation button on the remote controller is pressed, the display remains unlit and the unit does not start running. (Power indicator () is unlit and no lines appear on the remote controller.)

2. Cause

- 1) The power is not supplied to the indoor unit.
 - The main power of the indoor unit is not on.
 - The connector on the indoor unit board has come off.
 - The fuse on the indoor unit board has melted.
 - Transformer failure and disconnected wire of the indoor unit.
- 2) Incorrect wiring for the MA remote controller
 - Disconnected wire for the MA remote controller or disconnected line to the terminal block.
 - Short-circuited MA remote controller wiring
 - Incorrect wiring of the MA remote controller cables
 - Incorrect connection of the MA remote wiring to the terminal block for transmission line (TB5) on the indoor unit
 - Wiring mixup between the MA remote controller cable and 220-240 VAC power supply cable
 - Reversed connection of the wire for the MA remote controller and the M-NET transmission line on the indoor unit
- 3) The number of the MA remote controllers that are connected to an indoor unit exceeds the allowable range (2 units).
- 4) The length or the diameter of the wire for the MA remote controller are out of specification.
- 5) Short circuit of the wire for the remote display output of the outdoor unit or reversed polarity connection of the relay.
- 6) The indoor unit board failure
- 7) MA remote controller failure

3. Check method and remedy

- 1) Check the voltage at the MA remote controller terminals.
 - If the voltage is between DC 9 and 12V, the remote controller is a failure.
 - If no voltage is applied, check the causes 1) and 3) and if the cause is found, correct it.
If no cause is found, refer to 2).
- 2) Disconnect the remote controller cable from TB15 (MA remote controller terminal) on the indoor unit, and check the voltage across the terminals on TB15.
 - If the voltage is between DC 9 and 12 V, check the causes 2) and 4) and if the cause is found, correct it.
 - If no voltage is applied, check the cause 1) and if the cause is found, correct it.
If no cause is found, check the wire for the remote display output (relay polarity).
If no further cause is found, replace the indoor unit board.

8-1-2 The LCD Momentarily Lights Up and Then Goes Off.

1. Phenomena

When the remote controller operation SW is turned on, the operation status briefly appears on the display, then it goes off, and the display lights out immediately, and the unit stops.

2. Cause

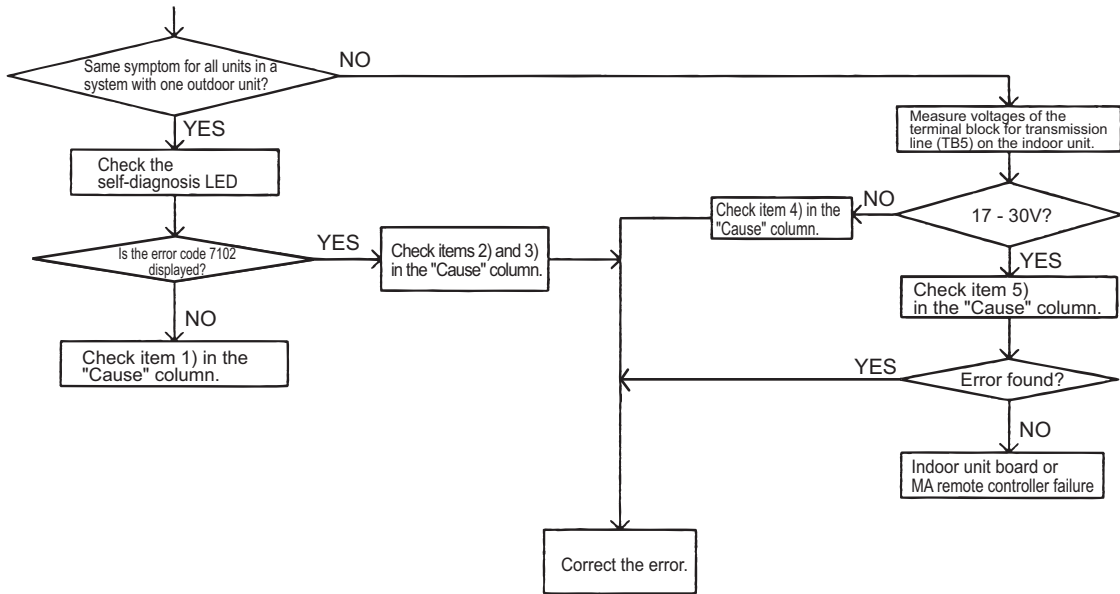
- 1) The power for the M-NET transmission line is not supplied from the outdoor unit. For details, refer to the following page(s).[8-10-2 Troubleshooting Problems with Outdoor Unit Transmission Power Supply Circuit]
- 2) Short circuit of the transmission line.
- 3) Incorrect wiring of the M-NET transmission line on the outdoor unit.

- Disconnected wire for the MA remote controller or disconnected line to the terminal block.
- The indoor transmission line is connected incorrectly to the transmission terminal block for centralized controller (TB7).
- The male power supply connectors on the multiple outdoor units are connected to the female power supply switch connector (CN40).
In the system to which the power supply unit for transmission lines is connected, the male power supply connector is connected to the female power supply switch connector (CN40) on the outdoor unit.

- 4) Disconnected M-NET transmission line on the indoor unit side.
- 5) Disconnected wire between the terminal block for M-NET line (TB5) of the indoor unit and the indoor unit board (CN2M) or disconnected connector.

3. Check method and remedy

When 2) and 3) above apply, check code 7102 will be displayed on the self-diagnosis LED.



8-1-3 "HO" and "PLEASE WAIT" Do Not Go Off the Screen.

1. Phenomena

"HO" or "PLEASE WAIT" display on the remote controller does not disappear, and no operation is performed even if the button is pressed. ("HO" or "PLEASE WAIT" display will normally turn off 5 minutes later after the power on.)

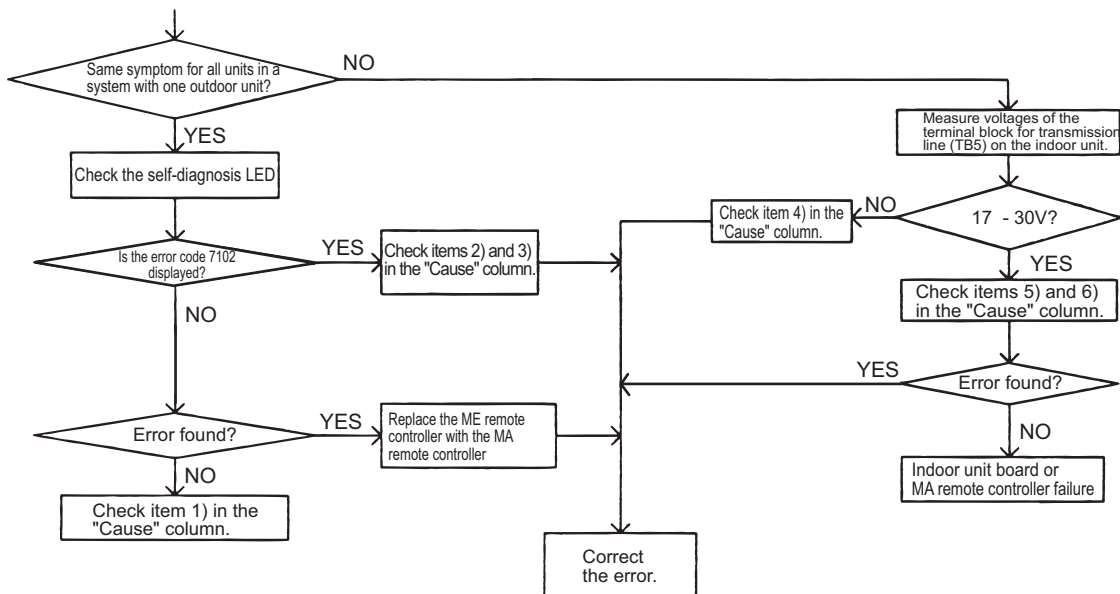
2. Cause

- 1) The power for the M-NET transmission line is not supplied from the outdoor unit. For details, refer to the following page(s). [8-10-2 Troubleshooting Problems with Outdoor Unit Transmission Power Supply Circuit]
- 2) Short-circuited transmission line
- 3) Incorrect wiring of the M-NET transmission line on the outdoor unit.
 - Disconnected wire for the MA remote controller or disconnected line to the terminal block.
 - The indoor transmission line is connected incorrectly to the transmission terminal block for centralized controller (TB7).
 - The male power supply connectors on the multiple outdoor units are connected to the female power supply switch connector (CN40).

In the system to which the power supply unit for transmission lines is connected, the male power supply connector is connected to the female power supply switch connector (CN40) on the outdoor unit
- 4) Disconnected M-NET transmission line on the indoor unit.
- 5) Disconnected wire between the terminal block for M-NET line (TB5) of the indoor unit and the indoor unit board (CN2M) or disconnected connector.
- 6) Incorrect wiring for the MA remote controller
 - Short-circuited wire for the MA remote controller
 - Disconnected wire for the MA remote controller (No.2) and disconnected line to the terminal block.
 - Reversed daisy-chain connection between groups
 - Incorrect wiring for the MA remote controller to the terminal block for transmission line connection (TB5) on the indoor unit
 - The M-NET transmission line is connected incorrectly to the terminal block (TB15) for the MA remote controller.
- 7) The sub/main setting of the MA remote controller is set to sub.
- 8) 2 or more main MA remote controllers are connected.
- 9) Indoor unit board failure (MA remote controller communication circuit)
- 10) Remote controller failure
- 11) Outdoor unit failure (Refer to the following page(s). [8-14 Troubleshooting Problems Using the LED Status Indicators on the Outdoor Unit])

3. Check method and remedy

When 2) and 3) above apply, check code 7102 will be displayed on the self-diagnosis LED.



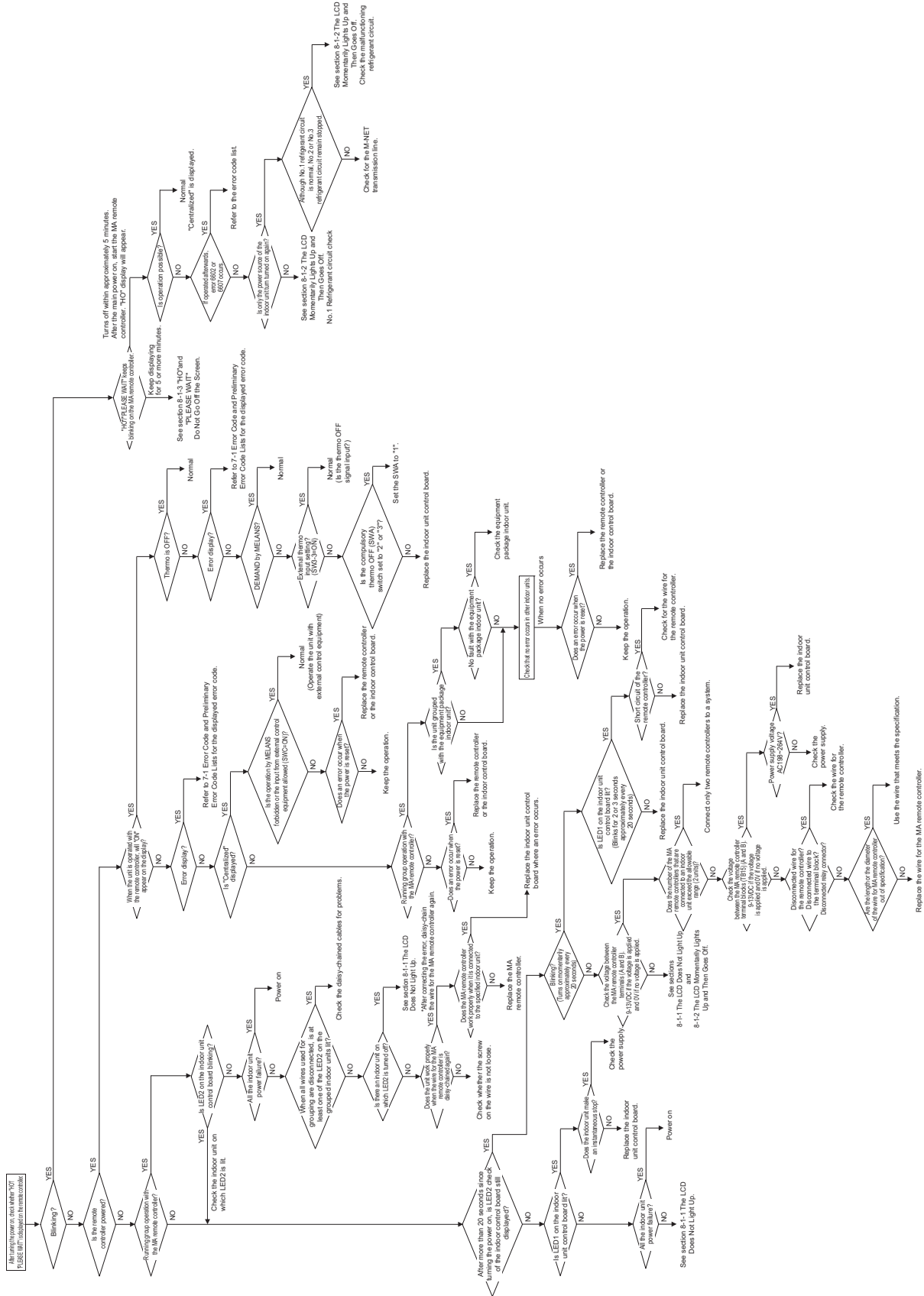
8-1-4 Air Conditioning Units Do Not Operate When the ON Button Is Pressed.

1. Phenomena

Even if the operation button on the remote controller is pressed, the indoor and the outdoor units do not start running.

2. Check method and remedy

8 Troubleshooting Based on Observed Symptoms



8-2 ME remote Controller Problems

8-2-1 The LCD Does Not Light Up.

1. Phenomena

Even if the operation button on the remote controller is pressed, the display remains unlit and the unit does not start running. (Remote controller is not powered.)

2. Cause

- 1) The power for the M-NET transmission line is not supplied from the outdoor unit.
- 2) Short circuit of the transmission line.
- 3) Incorrect wiring of the M-NET transmission line on the outdoor unit.
 - Disconnected wire for the MA remote controller or disconnected line to the terminal block.
 - The indoor transmission line is connected incorrectly to the transmission terminal block for centralized controller (TB7).
- 4) Disconnected transmission line on the remote controller.
- 5) Remote controller failure
- 6) Outdoor unit failure (For details, refer to the following page(s). [8-14 Troubleshooting Problems Using the LED Status Indicators on the Outdoor Unit])

3. Check method and remedy

- 1) Check voltage of the transmission terminal block for of the ME remote controller.
 - If voltage between is 17V and 30V → ME remote controller failure
 - When voltage is 17V or less → For details, refer to the following page(s). [8-10-2 Troubleshooting Problems with Outdoor Unit Transmission Power Supply Circuit]
- 2) **When 2) and 3) above apply, check code 7102 will be displayed on the self-diagnosis LED.**

8-2-2 The LCD Momentarily Lights Up and Then Goes Off.

1. Phenomena

When the remote controller operation SW is turned on, a temporary operation display is indicated, and the display lights out immediately.

2. Cause

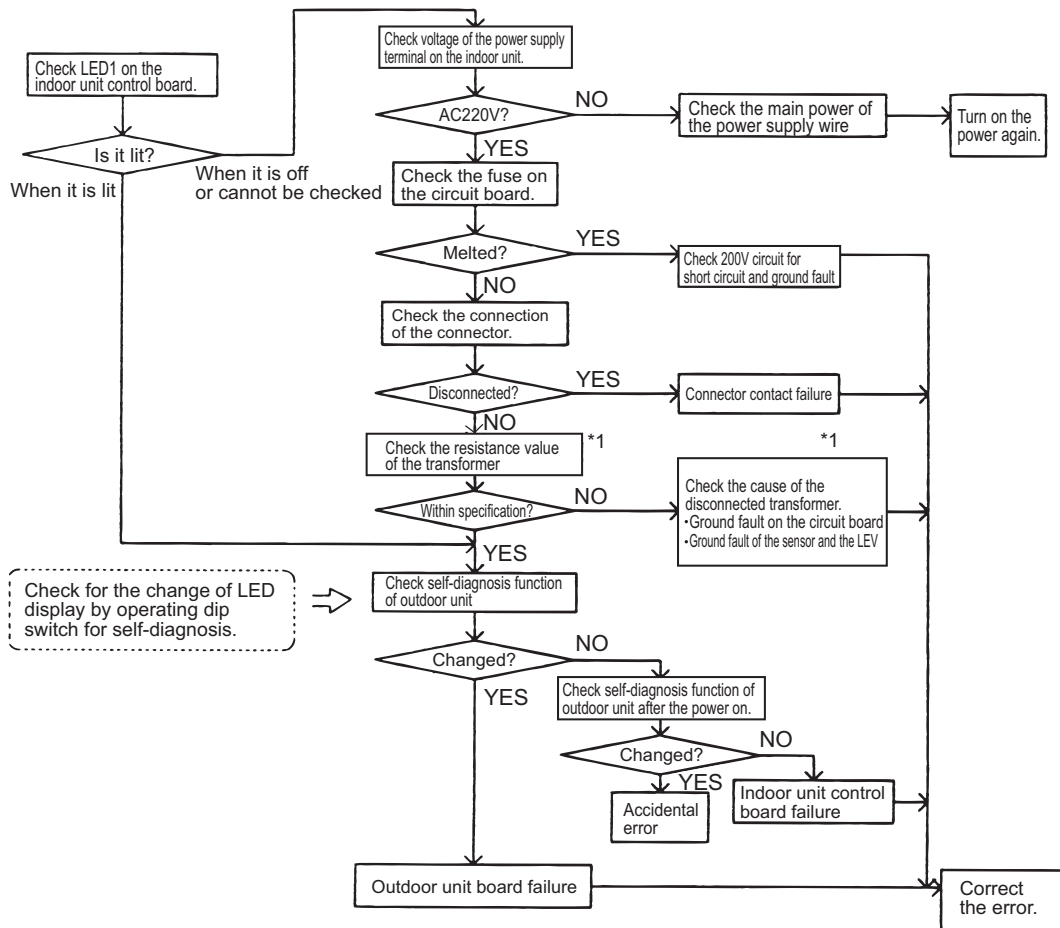
1) The power is not supplied to the indoor unit.

- The main power of the indoor unit (AC220V) is not on.
- The connector on the indoor unit board has come off.
- The fuse on the indoor unit board has melted.
- Transformer failure and disconnected wire of the indoor unit
- The indoor unit board failure

2) The outdoor control board failure

As the indoor unit does not interact with the outdoor unit, the outdoor unit model cannot be recognized.

3. Check method and remedy



*1. Refer to the parts catalog "transformer check".

8-2-3 "HO" or "Waiting for ..." Does Not Go Off the Screen.

1. Phenomena

"HO" or "Waiting for ..." display on the remote controller does not disappear, and no operation is performed even if the button is pressed.

2. Cause

Without using MELANS

- 1) Outdoor unit address is set to "00"
- 2) A wrong address is set.
 - The address of the indoor unit that is connected to the remote controller is incorrect. (It should equal the ME remote controller address minus 100.)
 - A wrong address is set to the ME remote controller. (100 must be added to the address of the indoor unit.)
- 3) Faulty wiring of the terminal block for transmission line (TB5) of the indoor unit in the same group with the remote controller.
- 4) The centralized control switch (SW5-1) on the outdoor unit is set to ON.
- 5) Disconnection or faulty wiring of indoor unit transmission line.
- 6) Disconnection between the terminal block for M-NET line connection (TB5) of the indoor unit and the male connector (CN2M)
- 7) The male power supply connectors on 2 or more outdoor units are connected to the female power supply switch connector (CN40) for the transmission line for centralized control.
- 8) Outdoor unit control board failure
- 9) Indoor unit control board failure
- 10) Remote controller failure

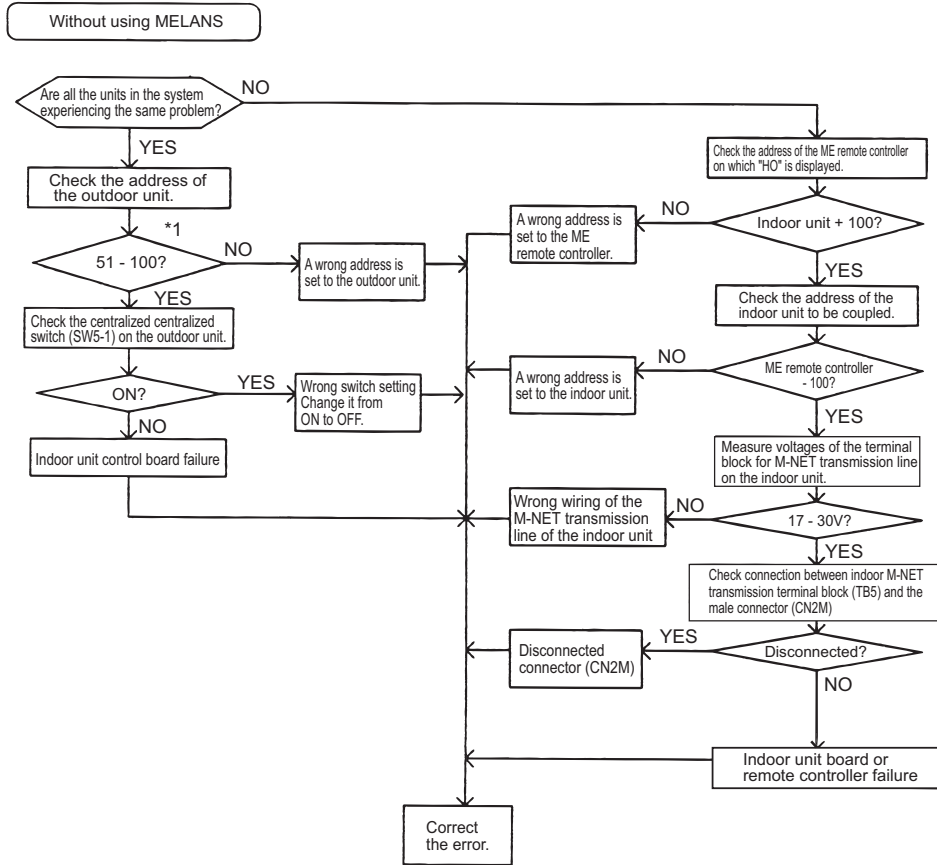
Interlocking control with MELANS

- 1) No group registration is made using MELANS. (The indoor unit and the ME remote controller are not grouped.)
- 2) Disconnected transmission line for centralized control (TB7) of the outdoor unit
- 3) The male power supply connector is connected to CN40 on more than one outdoor unit, or the connector is connected to CN40 on the outdoor unit in the system to which a power supply unit for transmission line is connected.

Using MELANS

- 1) When MELANS is used, "HO" or "Waiting for ..." display on the remote controller will disappear when the indoor unit and the local remote controller (ME remote controller) are grouped.
If "HO" does not disappear after the registration, check items 1) through 3) in the "Cause" column of the section on interlocked control with MELANS.

3. Check method and remedy



*1. When the outdoor unit address is set to 1 - 50, the address will be forcibly set to 100.

8-2-4 "88", "Request denied." Appears on the LCD.

1. Phenomena

"88", "Request denied." appears on the remote controller when the address is registered or confirmed.

2. Cause, check method and remedy

Cause	Check method and remedy
An error occurs when the address is registered or confirmed. (common)	
1. A wrong address is set to the unit to be coupled.	(1) Confirm the address of unit to be coupled.
2. The transmission line of the unit to be coupled is disconnected or is not connected.	(2) Check the connection of transmission line.
3. Circuit board failure of the unit to be coupled	(3) Check voltage of the terminal block for transmission line of the unit to be coupled.
4. Improper transmission line work	1) Normal if voltage is between 17 and 30 VDC. 2) Check (5) in case other than 1).
Generates at interlocking registration between LOSSNAY and the indoor unit	
5. The power of LOSSNAY is OFF.	(4) Check for the main power of LOSSNAY.
Generates at confirmation of controllers used in the system in which the indoor units connected to different outdoor units are grouped	
6. The power of the outdoor unit to be confirmed has been cut off.	(5) Check the power supply of the outdoor unit which is coupled with the unit to be confirmed.
7. Transmission line is disconnected from the terminal block for central control system connection (TB7) on the outdoor unit.	(6) Check that the transmission line for centralized control (TB7) of the outdoor unit is not disconnected.
8. When the indoor units connected to different outdoor units are grouped without MELANS, the male power supply connector is not connected to the female power supply switch connector (CN40) for the transmission line for centralized control.	(7) Check voltage of the transmission line for centralized control.
9. The male power supply connectors on 2 or more outdoor units are connected to the female power supply switch connector (CN40) for the transmission line for centralized control.	1) Normal when voltage is between 10V and 30V
10. In the system to which MELANS is connected, the male power supply connector is connected to the female power supply switch connector (CN40) for the transmission line for centralized control.	2) Check 8 - 11 described on the left in case other than 1).
11. Short circuit of the transmission line for centralized control	

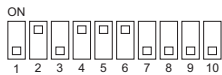

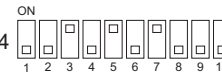

8-3 Refrigerant Control Problems

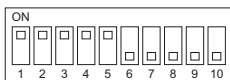
8-3-1 Units in the Cooling Mode Do Not Operate at Expected Capacity.

1. Phenomena

Although cooling operation starts with the normal remote controller display, the capacity is not enough

2. Cause, check method and remedy

Cause	Check method and remedy
<p>1. Compressor frequency does not rise sufficiently.</p> <ul style="list-style-type: none"> ♦Faulty detection of pressure sensor. ♦Protection works and compressor frequency does not rise due to high discharge temperature ♦Protection works and compressor frequency does not rise due to high pressure ♦Pressure drops excessively. 	<p>(1) Check pressure difference between the detected pressure by the pressure sensor and the actual pressure with self-diagnosis LED. → If the accurate pressure is not detected, check the pressure sensor. Refer to the following page(s). [8-5-1 Comparing the High-Pressure Sensor Measurement and Gauge Pressure]</p> <p>Note: Lower inlet pressure by the low pressure sensor than the actual pressure causes insufficient capacity. SW4 setting (SW6-10: OFF)</p> <p>High pressure sensor SW4 </p> <p>Low pressure sensor SW4 </p> <p>(2) Check temperature difference between the evaporating temperature (Te) and the target evaporating temperature (Tem) with self-diagnosis LED.</p> <p>Note: Higher Te than Tem causes insufficient capacity. SW4 setting (SW6-10: OFF)</p> <p>Evaporating temperature Te SW4 </p> <p>Target evaporating temperature Tem SW4 </p> <p>Note: Protection works and compressor frequency does not rise even at higher Te than Tem due to high discharge temperature and high pressure. At high discharge temperature: Refer to the following page(s). [7-3-1 Error Code [1102]] At high pressure: Refer to the following page(s). [7-3-3 Error Code [1302] (during operation)]</p>
<p>2. Indoor unit LEV malfunction</p> <ul style="list-style-type: none"> ♦Insufficient refrigerant flows due to LEV malfunction (not enough opening) or protection works and compressor frequency does not rise due to pressure drop. ♦Refrigerant leak from LEV on the stopping unit causes refrigerant shortage on the running unit. 	<p>Refer to the following page(s). [8-8 Troubleshooting LEV Problems]</p>



The figure at left shows that the switches 1 through 5 are set to ON and 6 through 10 are set to OFF.

8 Troubleshooting Based on Observed Symptoms

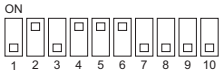
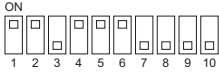
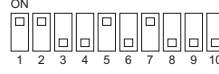
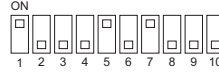
Cause	Check method and remedy
3. RPM error of the outdoor unit FAN ♦Motor failure or board failure, or airflow rate decrease due to clogging of the heat exchanger ♦The fan is not properly controlled as the outdoor temperature cannot be precisely detected by the temperature sensor. ♦The fan is not properly controlled as the pressure cannot be precisely detected by the pressure sensor.	Refer to the following page(s). [8-7 Troubleshooting Outdoor Unit Fan Problems] [7-3-3 Error Code [1302] (during operation)]
4. Long piping length The cooling capacity varies greatly depending on the pressure loss. (When the pressure loss is large, the cooling capacity drops.)	Check the piping length to determine if it is contributing to performance loss. Piping pressure loss can be estimated from the temperature difference between the indoor unit heat exchanger outlet temperature and the saturation temperature (Te) of 63LS. →Correct the piping.
5. Piping size is not proper (thin)	
6. Insufficient refrigerant amount Protection works and compressor frequency does not rise due to high discharge temperature.	Refer to item 1 (Compressor frequency does not rise sufficiently.) on the previous page. Refer to the following page(s). [6-3 Evaluating and Adjusting Refrigerant Charge]
7. Clogging by foreign object	Check the temperature difference between in front of and behind the place where the foreign object is clogging the pipe (upstream side and downstream side). When the temperature drops significantly, the foreign object may clog the pipe. → Remove the foreign object inside the pipe.
8. The indoor unit inlet temperature is excessively low. (Less than 15°C [59°F] WB)	Check the inlet air temperature and for short cycling. Change the environment where the indoor unit is used.
9. Compressor failure The amount of circulating refrigerant decreases due to refrigerant leak in the compressor.	Check the discharge temperature to determine if the refrigerant leaks, as it rises if there is a leak.
10. LEV1 malfunction Sufficient liquid refrigerant is not be supplied to the indoor unit as sufficient sub cool cannot be secured due to LEV1 malfunction.	Refer to the following page(s). [8-8 Troubleshooting LEV Problems] It most likely happens when there is little difference or no difference between TH3 and TH6.
11. TH3, TH6 and 63HS1 sensor failure or damaged wiring LEV1 is not controlled normally.	♦Check the thermistor. ♦Check wiring.
12. LEV2 actuation failure A drop in the low pressure that is caused either by a blockage of liquid pipe or by a pressure loss and the resultant slowing of refrigerant flow causes a tendency for the discharge temperature to rise.	Refer to the following page(s). [8-8 Troubleshooting LEV Problems]
13. LEV9 malfunction Not enough refrigerant is provided to the indoor or outdoor unit due to high-low pressure bypass that results from the malfunction of LEV9.	Refer to the following page(s). [8-8 Troubleshooting LEV Problems]
14. Open phase in the power-supply due to improper power-supply wiring	Make sure that the power-supply wiring is properly connected. (Refer to item (5) in section [6-1 Read before Test Run].) Possible open phase.

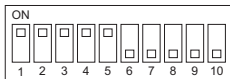
8-3-2 Units in the Heating Mode Do Not Operate at Expected Capacity.

1. Phenomena

Although heating operation starts with the normal remote controller display, the capacity is not enough.

2. Cause, check method and remedy

Cause	Check method and remedy
<p>1. Compressor frequency does not rise sufficiently.</p> <ul style="list-style-type: none"> ♦Faulty detection of pressure sensor. ♦Protection works and compressor frequency does not rise due to high discharge temperature ♦Protection works and compressor frequency does not rise due to high pressure. 	<p>(1) Check pressure difference between the detected pressure by the pressure sensor and the actual pressure with self-diagnosis LED. → If the accurate pressure is not detected, check the pressure sensor. Refer to the following page(s). [8-5-1 Comparing the High-Pressure Sensor Measurement and Gauge Pressure]</p> <p>Note: Higher inlet pressure by the high pressure sensor than the actual pressure causes insufficient capacity. SW4 setting (SW6-10: OFF)</p> <p>High pressure sensor SW4 </p> <p>Low pressure sensor SW4 </p> <p>(2) Check the difference between the condensing temperature (Tc) and the target condensing temperature (Tcm) with self-diagnosis LED.</p> <p>Note: Higher Tc than Tcm causes insufficient capacity. SW4 setting (SW6-10: OFF)</p> <p>Condensing temperature Tc SW4 </p> <p>Target condensing temperature Tcm SW4 </p> <p>Note: Protection works and compressor frequency does not rise even at lower Tc than Tcm due to high discharge temperature and high pressure. At high discharge temperature: Refer to the following page(s). [7-3-1 Error Code [1102]] At high pressure: Refer to the following page(s). [7-3-3 Error Code [1302] (during operation)]</p>



The figure at left shows that the switches 1 through 5 are set to ON and 6 through 10 are set to OFF.

Cause	Check method and remedy
2. Indoor unit LEV malfunction Insufficient refrigerant flows due to LEV malfunction (not enough opening).	Refer to the following page(s). [8-8 Troubleshooting LEV Problems]
3. Temperature reading error on the indoor unit piping temperature sensor If the temperature reading on the sensor is higher than the actual temperature, it makes the subcool seem smaller than it is, and the LEV opening decreases too much.	Check the thermistor.
4. RPM error of the outdoor unit FAN •Motor failure or board failure, or airflow rate decrease, pressure drop due to clogging of the heat exchanger leading to high discharge temperature •The fan is not properly controlled as the temperature cannot be precisely detected with the piping sensor.	Refer to the following page(s). [8-7 Troubleshooting Outdoor Unit Fan Problems]
5. Insulation failure of the refrigerant piping	
6. Long piping length Excessively long piping on the high pressure side causes pressure loss leading to increase in the high pressure.	Confirm that the characteristic of capacity drop due to piping length. → Change the pipe
7. Piping size is not proper (thin)	
8. Clogging by foreign object	Check the temperature difference between the upstream and the downstream of the pipe section that is blocked. Since blockage in the extended section is difficult to locate, operate the unit in the cooling cycle, and follow the same procedures that are used to locate the blockage of pipe during cooling operation. → Remove the blockage in the pipe.
9. The indoor unit inlet temperature is excessively high. (exceeding 28°C [82°F])	Check the inlet air temperature and for short cycling. Change the environment where the indoor unit is used.
10. Insufficient refrigerant amount Protection works and compressor frequency does not rise due to low discharge temperature Refrigerant recovery operation is likely to start.	Refer to item 1 (Compressor frequency does not rise sufficiently.) on the previous page. Refer to the following page(s). [6-3 Evaluating and Adjusting Refrigerant Charge]
11. Compressor failure (same as in case of cooling)	Check the discharge temperature.
12. LEV2 actuation failure A drop in the low pressure that is caused either by a blockage of liquid pipe or by a pressure loss and the resultant slowing of refrigerant flow causes a tendency for the discharge temperature to rise.	Refer to the following page(s). [8-8 Troubleshooting LEV Problems]
13. LEV9 malfunction Not enough refrigerant is provided to the indoor or outdoor unit due to high-low pressure bypass that results from the malfunction of LEV9.	Refer to the following page(s). [8-8 Troubleshooting LEV Problems]
14. Open phase in the power-supply due to improper power-supply wiring	Make sure that the power-supply wiring is properly connected. (Refer to item (5) in section [6-1 Read before Test Run].) Possible open phase.

8-3-3 Outdoor Units Stop at Irregular Times.

1. Phenomena

Outdoor unit stops at times during operation.

2. Cause, check method and remedy

Cause	Check method and remedy
<p>The first stop is not considered as an error, as the unit turns to anti-restart mode for 3 minutes as a preliminary error.</p> <p>Error mode</p> <ol style="list-style-type: none"> 1. Abnormal high pressure 2. Abnormal discharge air temperature 3. Heatsink thermistor failure 4. Thermistor failure 5. Pressure sensor failure 6. Over-current break 7. Refrigerant overcharge 8. Refrigerant cooling error <p>Note1: Frost prevention tripping only under cooling mode may be considered in addition to the above. (Freeze protection is detected by one or all indoor units.)</p> <p>Note2: Even the second stop is not considered as an error when some specified errors occur. (eg. The third stop is considered as an error when the thermistor error occurs.)</p>	<ol style="list-style-type: none"> (1) Check the mode operated in the past by displaying preliminary error history on LED display with SW4. (2) Reoperate the unit to find the mode that stops the unit by displaying preliminary error history on LED display with SW4. <p>→ Refer to the reference page for each error mode. *Display the indoor piping temperature with SW4 to check whether the freeze proof operation runs properly, and check the temperature.</p> <p>Refer to the following page(s). [10 LED Status Indicators on the Outdoor Unit Circuit Board]</p>

8-4 Checking Transmission Waveform and for Electrical Noise Interference

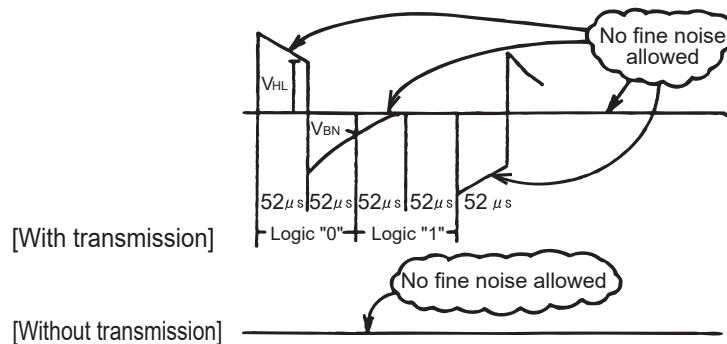
8-4-1 M-NET

Control is performed by exchanging signals between the outdoor unit and the indoor unit (ME remote controller) through M-NET transmission. Noise interference on the transmission line will interrupt the normal transmission, leading to erroneous operation.

(1) Symptoms caused by noise interference on the transmission line

Cause	Erroneous operation	Error code	Error code definition
Noise interference on the transmission line	Signal is transformed and will be misjudged as the signal of another address.	6600	Address overlap
	Transmission wave pattern is transformed due to the noise creating a new signal	6602	Transmission processor hardware error
	Transmission wave pattern is transformed due to the noise, and will not be received normally leading to no acknowledgement (ACK).	6607	No ACK error
	Transmission cannot be performed due to the fine noise.	6603	Transmission line bus busy error
	Transmission is successful; however, the acknowledgement (ACK) or the response cannot be received normally due to the noise.	6607 6608	No ACK error No response error

(2) Wave shape check



Wave shape check

Check the wave pattern of the transmission line with an oscilloscope. The following conditions must be met.

- Small wave pattern (noise) must not exist on the transmission signal. (Minute noise (approximately 1V) can be generated by DC-DC converter or the inverter operation; however, such noise is not a problem when the shield of the transmission line is grounded.)
- The sectional voltage level of transmission signal should be as follows.

Logic	Voltage level of the transmission line
0	$V_{HL} = 2.5V$ or higher
1	$V_{BN} = 1.3V$ or below

(3) Check method and remedy

1) Measures against noise

Check the followings when noise exists on the wave or the errors described in (1) occur.

	Error code definition	Remedy
Check that the wiring work is performed according to wiring specifications.	1. The transmission line and the power line are not wired too closely.	Isolate the transmission line from the power line (5cm [1-31/32"] or more). Do not insert them in the same conduit.
	2. The transmission line is not bundled with that for another systems.	The transmission line must be isolated from another transmission line. When they are bundled, erroneous operation may be caused.
	3. The specified wire is used for the transmission line.	Use the specified transmission line. Type: Shielded wire CVVS/CPEVS/MVVS (For ME remote controller) Diameter: 1.25mm ² [AWG16] or more (Remote controller wire: 0.3 - 1.25mm ² [AWG22-16])
	4. When the transmission line is daisy-chained on the indoor unit terminals, are the shields daisy-chained on the terminals, too?	The transmission is two-wire daisy-chained. The shielded wire must be also daisy-chained. When the shielded cable is not daisy-chained, the noise cannot be reduced enough.
Check that the grounding work is performed according to grounding specifications.	5. Is the shield of the indoor-outdoor transmission cable grounded to the earth terminal on the outdoor unit?	Connect the shield of the indoor-outdoor transmission cable to the earth terminal (⌚) on the outdoor unit. If no grounding is provided, the noise on the transmission line cannot escape leading to change of the transmission signal.
	6. Check the treatment method of the shield of the transmission line (for centralized control).	The transmission cable for centralized control is less subject to noise interference if it is grounded to the outdoor unit whose power jumper cable was moved from CN41 to CN40 or to the power supply unit. The environment against noise varies depending on the distance of the transmission lines, the number of the connected units, the type of the controllers to be connected, or the environment of the installation site. Therefore, the transmission line work for centralized control must be performed as follows. (1) When no grounding is provided: Ground the shield of the transmission cable by connecting to the outdoor unit whose power jumper connector was moved from CN41 to CN40 or to the power supply unit. (2) When an error occurs even though one point grounding is provided: Ground the shield on all outdoor units.

2) Check the followings when the error "6607" occurs, or "HO" appears on the display on the remote controller.

Error code definition	Remedy
7. The farthest distance of transmission line is 200m [656ft] or longer.	Check that the farthest distance from the outdoor unit to the indoor unit and to the remote controller is within 200m [656ft].
8. The types of transmission lines are different.	Use the specified transmission line. Type: Shielded wire CVVS/CPEVS/MVVS (For ME remote controller) Diameter: 1.25mm ² [AWG16] or more (Remote controller wire: 0.3-1.25mm ² [AWG22-16])
9. Outdoor unit circuit board failure	Replace the outdoor unit control board or the power supply board for the transmission line.
10. Indoor unit circuit board failure or remote controller failure	Replace the indoor unit circuit board or the remote controller.
11. The MA remote controller is connected to the M-NET transmission line.	Connect the MA remote controller to the terminal block for MA remote controller (TB15).

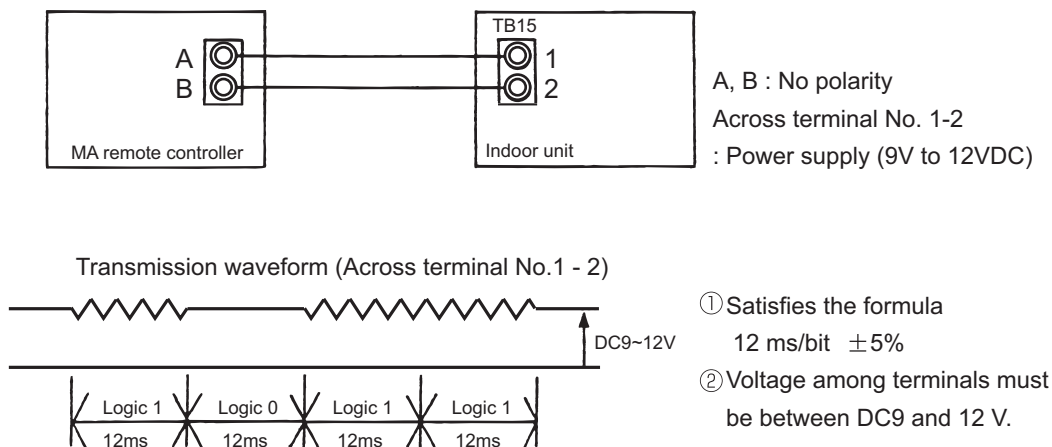
8-4-2 MA Remote Controller

The communication between the MA remote controller and the indoor unit is performed with current tone burst.

(1) Symptoms caused by noise interference on the transmission line

If noise is generated on the transmission line, and the communication between the MA remote controller and the indoor unit is interrupted for 3 minutes in a row, MA transmission error (6831) will occur.

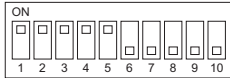
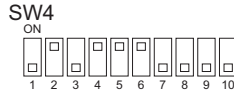
(2) Confirmation of transmission specifications and wave pattern



8-5 Pressure Sensor Circuit Configuration and Troubleshooting Pressure Sensor Problems

8-5-1 Comparing the High-Pressure Sensor Measurement and Gauge Pressure

By configuring the digital display setting switch (SW4 (when SW6-10 is set to OFF)) as shown in the figure below, the pressure as measured by the high-pressure sensor appears on the LED1 on the control board.



The figure at left shows that the switches 1 through 5 are set to ON and 6 through 10 are set to OFF.

8 Troubleshooting Based on Observed Symptoms

(1) While the sensor is stopped, compare the gauge pressure and the pressure displayed on self-diagnosis LED1.

- 1) When the gauge pressure is between 0 and 0.098MPa [14psi], internal pressure is caused due to gas leak.
- 2) When the pressure displayed on self-diagnosis LED1 is between 0 and 0.098MPa [14psi], the connector may be defective or be disconnected. Check the connector and go to (4).
- 3) When the pressure displayed on self-diagnosis LED1 exceeds 4.15MPa [601psi], go to (3).
- 4) If other than 1), 2) or 3), compare the pressures while the sensor is running. Go to (2).

(2) Compare the gauge pressure and the pressure displayed on self-diagnosis LED1 while the sensor is running. (Compare them by MPa [psi] unit.)

- 1) When the difference between both pressures is within 0.098MPa [14psi], both the high pressure sensor and the control board are normal.
- 2) When the difference between both pressures exceeds 0.098MPa [14psi], the high pressure sensor has a problem. (performance deterioration)
- 3) When the pressure displayed on self-diagnosis LED1 does not change, the high pressure sensor has a problem.

(3) Remove the high pressure sensor from the control board to check the pressure on the self-diagnosis LED1.

- 1) When the pressure displayed on self-diagnosis LED1 is between 0 and 0.098MPa [14psi], the high pressure sensor has a problem.
- 2) When the pressure displayed on self-diagnosis LED1 is approximately 4.15MPa [601psi], the control board has a problem.

(4) Remove the high pressure sensor from the control board, and short-circuit between the No.2 and 3 connectors (63HS1) to check the pressure with self-diagnosis LED1.

- 1) When the pressure displayed on the self-diagnosis LED1 exceeds 4.15MPa [601psi], the high pressure sensor has a problem.
- 2) If other than 1), the control board has a problem.

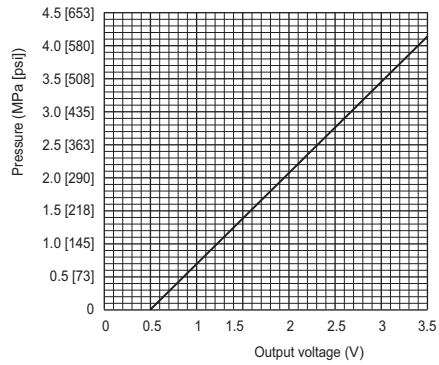
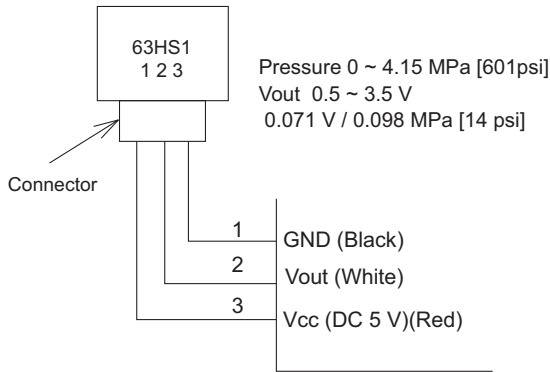
8-5-2 High-Pressure Sensor Configuration (63HS1)

The high pressure sensor consists of the circuit shown in the figure below. If DC 5V is applied between the red and the black wires, voltage corresponding to the pressure between the white and the black wires will be output, and the value of this voltage will be converted by the microcomputer. The output voltage is 0.071V per 0.098MPa [14psi].

Note

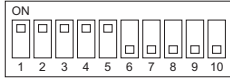
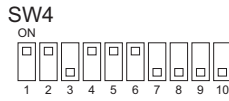
The pressure sensor on the body side is designed to connect to the connector. The connector pin number on the body side is different from that on the control board side.

	Body side	Control board side
Vcc	Pin 1	Pin 3
Vout	Pin 2	Pin 2
GND	Pin 3	Pin 1



8-5-3 Comparing the Low-Pressure Sensor Measurement and Gauge Pressure

By configuring the digital display setting switch (SW4 (when SW6-10 is set to OFF)) as shown in the figure below, the pressure as measured by the low-pressure sensor appears on the LED1 on the control board.



The figure at left shows that the switches 1 through 5 are set to ON and 6 through 10 are set to OFF.

8 Troubleshooting Based on Observed Symptoms

(1) While the sensor is stopped, compare the gauge pressure and the pressure displayed on self-diagnosis LED1.

- 1) When the gauge pressure is between 0 and 0.098MPa [14psi], internal pressure is caused due to gas leak.
- 2) When the pressure displayed on self-diagnosis LED1 is between 0 and 0.098MPa [14psi], the connector may be defective or be disconnected. Check the connector and go to (4).
- 3) When the pressure displayed on self-diagnosis LED1 exceeds 1.7MPa [247psi], go to (3).
- 4) If other than 1), 2) or 3), compare the pressures while the sensor is running. Go to (2).

(2) Compare the gauge pressure and the pressure displayed on self-diagnosis LED1 while the sensor is running. (Compare them by MPa [psi] unit.)

- 1) When the difference between both pressures is within 0.03MPa [4psi], both the low pressure sensor and the control board are normal.
- 2) When the difference between both pressures exceeds 0.03MPa [4psi], the low pressure sensor has a problem. (performance deterioration)
- 3) When the pressure displayed on the self-diagnosis LED1 does not change, the low pressure sensor has a problem.

(3) Remove the low pressure sensor from the control board to check the pressure with the self-diagnosis LED1 display.

- 1) When the pressure displayed on the self-diagnosis LED1 is between 0 and 0.098MPa [14psi], the low pressure sensor has a problem.
- 2) When the pressure displayed on self-diagnosis LED1 is approximately 1.7MPa [247psi], the control board has a problem.
 - When the outdoor temperature is 30°C [86°F] or less, the control board has a problem.
 - When the outdoor temperature exceeds 30°C [86°F], go to (5).

(4) Remove the low pressure sensor from the control board, and short-circuit between the No.2 and 3 connectors (63LS:CN202) to check the pressure with the self-diagnosis LED1.

- 1) When the pressure displayed on the self-diagnosis LED1 exceeds 1.7MPa [247psi], the low pressure sensor has a problem.
- 2) If other than 1), the control board has a problem.

(5) Remove the high pressure sensor (63HS1) from the control board, and insert it into the connector for the low pressure sensor (63LS) to check the pressure with the self-diagnosis LED1.

- 1) When the pressure displayed on the self-diagnosis LED1 exceeds 1.7MPa [247psi], the control board has a problem.
- 2) If other than 1), the low-pressure sensor has a problem.

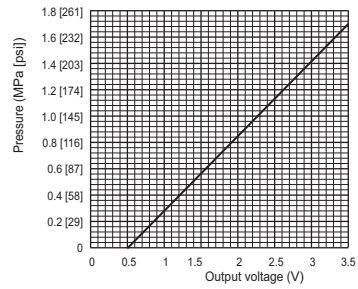
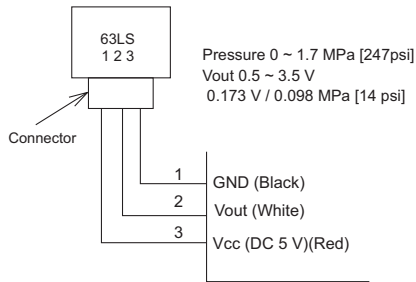
8-5-4 Low-Pressure Sensor Configuration (63LS)

The low pressure sensor consists of the circuit shown in the figure below. If DC5V is applied between the red and the black wires, voltage corresponding to the pressure between the white and the black wires will be output, and the value of this voltage will be converted by the microcomputer. The output voltage is 0.173V per 0.098MPa [14psi].

Note

The pressure sensor on the body side is designed to connect to the connector. The connector pin number on the body side is different from that on the control board side.

	Body side	Control board side
Vcc	Pin 1	Pin 3
Vout	Pin 2	Pin 2
GND	Pin 3	Pin 1





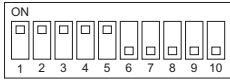
8-6 Troubleshooting Solenoid Valve Problems

Check whether the output signal from the control board and the operation of the solenoid valve match. Setting the self-diagnosis switch (SW4) as shown in the figure below causes the ON signal of each relay to be output to the LED's. Each LED shows whether the relays for the following parts are ON or OFF. LEDs light up when relays are ON.

Note

The circuits on some parts are closed when the relays are ON. Refer to the following instructions.

SW4 (SW6-10:OFF)		Display							
		LD1	LD2	LD3	LD4	LD5	LD6	LD7	LD8
	Upper	21S4a	SV10			SV1a		SV2	SV11
	Lower			21S4b					
	Upper					21S4c		SV9	
	Lower			SV14		SV15			



The figure at left shows that the switches 1 through 5 are set to ON and 6 through 10 are set to OFF.

- When a valve malfunctions, check if the wrong solenoid valve coil is not attached the lead wire of the coil is not disconnected, the connector on the board is not inserted wrongly, or the wire for the connector is not disconnected.

(1) 21S4a (4-way switching valve)

About this 4-way valve

When not powered:

Conducts electricity between the oil separator outlet and heat exchanger 1 (front heat exchanger), and between the gas ball valve (BV1) and the accumulator to complete the circuit for the cooling cycle.

When powered:

The electricity runs between the oil separator and the gas ball valve, and between the heat exchanger and the accumulator. This circulation is for heating.

Check the LED display and the intake and the discharge temperature for the 4-way valve to check whether the valve has no faults and the electricity runs between where and where. Do not touch the pipe when checking the temperature, as the pipe on the oil separator side will be hot.

Note

Do not give an impact from outside, as the outer hull will be deformed leading to the malfunction of the inner valve.

(2) 21S4b (4-way switching valve), 21S4c (4-way switching valve) (21S4c is only on the (E) P500 models.)

About this 4-way valve

When not powered:

Conducts electricity between the oil separator outlet and heat exchanger 2 (rear or right heat exchanger) (<21S4b>), and between the oil separator outlet and heat exchanger 3 (left exchanger) (<21S4c>) and opens and closes the heat exchanger circuit for the heating and cooling cycles.

When powered:

The electricity runs between the heat exchanger and the accumulator, and the valve opens or closes the heat exchanger circuit when cooling or heating.

Whether the valve has no fault can be checked by checking the LED display and the switching sound; however, it may be difficult to check by the sound, as the switching coincides with 21S4b or 21S4c. In this case, check the intake and the discharge temperature for the 4-way valve to check that the electricity runs between where and where.

Note

- Do not touch the valve when checking the temperature, as it will be hot.
- Do not give an impact from outside, as the outer hull will be deformed leading to the malfunction of the inner valve.

(3) SV1a (Bypass valve)

This solenoid valve opens when powered (Relay ON).

- 1) At compressor start-up, the SV1a turns on for 4 minutes, and the operation can be checked by the self-diagnosis LED display and the closing sound.
- 2) To check whether the valve is open or closed, check the change of the SV1a downstream piping temperature while the valve is being powered. Even when the valve is open, high-temperature refrigerant flows inside the capillary next to the valve. (Therefore, temperature of the downstream piping will not be low with the valve closed.)

(4) SV2 (solenoid valve)

This solenoid valve is a switching valve that opens when energized. Proper operation of this valve can be checked on the LED and by the switching sound.

(5) SV9 (Solenoid valve)

This solenoid valve is a switching valve that opens when energized. Proper operation of this valve can be checked on the LED display and by the switching sound.

(6) SV10 (Solenoid valve)

This solenoid valve is a switching valve that opens when energized. Proper operation of this valve can be checked on the LED display and by the switching sound.

(7) SV11 (Solenoid valve)

This solenoid valve is a switching valve that opens when energized. Proper operation of this valve can be checked on the LED display and by the switching sound.

(8) SV14 (solenoid valve)

This solenoid valve is a switching valve that opens when energized if the refrigerant flow is forward. It is closed when energized if the refrigerant flow is reversed. Proper operation of this valve can be checked on the LED and by the switching sound.

(9) SV15 (solenoid valve)

This solenoid valve is a switching valve that opens when energized if the refrigerant flow is forward. It is closed when energized if the refrigerant flow is reversed. Proper operation of this valve can be checked on the LED and by the switching sound.

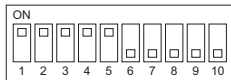
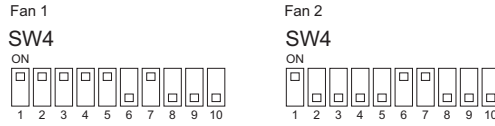
Note

Do not give an impact from outside, as the outer hull will be deformed leading to the malfunction of the inner valve.

8-7 Troubleshooting Outdoor Unit Fan Problems

(1) Fan motor (common items)

- To check the revolution of the fan, check the inverter output state on the self-diagnosis LED, as the inverter on the outdoor fan controls the revolutions of the fan.
- When starting the fan, the fan runs at full speed for 5 seconds.
- When setting the DIP SW4 (when SW6-10 is set to OFF) as shown in the figure below, the inverter output [%] will appear. 100% indicates the full speed and 0% indicates the stopping. (Fan No.2 is only on the (E)P350 - (E)P500 models.)



The figure at left shows that the switches 1 through 5 are set to ON and 6 through 10 are set to OFF.

- As the revolution of the fan changes under control, at the interphase or when the indoor unit operation capacity is low, the revolution of the fan may change.
- If the fan does not move or it vibrates, fan board problem or fan motor problem is suspected. When checking the fan motor for problems by shutting down the power, be sure to disconnect the motor wire from the fan board. (If a short-circuited fan board malfunctions, it will keep the fan motor from rotating smoothly.) For details, refer to the following page(s).
 [8-9-7 Checking the Fan Motor for Ground Fault and Coil Resistance Problems]
 [8-9-8 Checking the Fan Board Error Detection Circuit at No Load]
 [8-9-9 Checking the Fan Board for Damage at No Load]
 [8-9-10 Checking the Fan Board for Damage with Load]

8-8 Troubleshooting LEV Problems

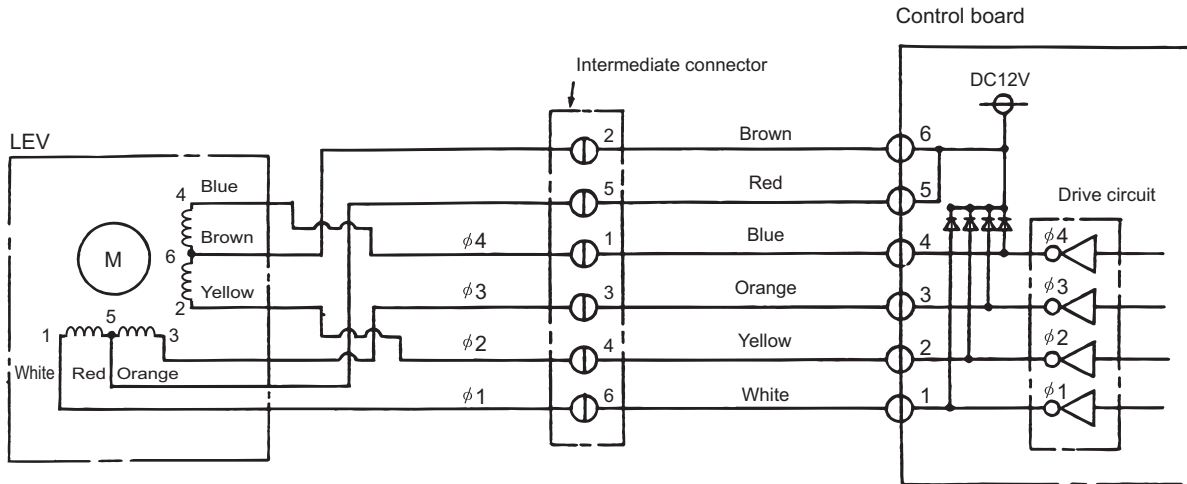
8-8-1 General Overview on LEV Operation

LEV (Indoor unit: Linear expansion valve) and LEV2 (Outdoor unit: Linear expansion valve) are stepping-motor-driven valves that operate by receiving the pulse signals from the indoor and outdoor unit control boards.

(1) Indoor LEV and Outdoor LEV (LEV2)

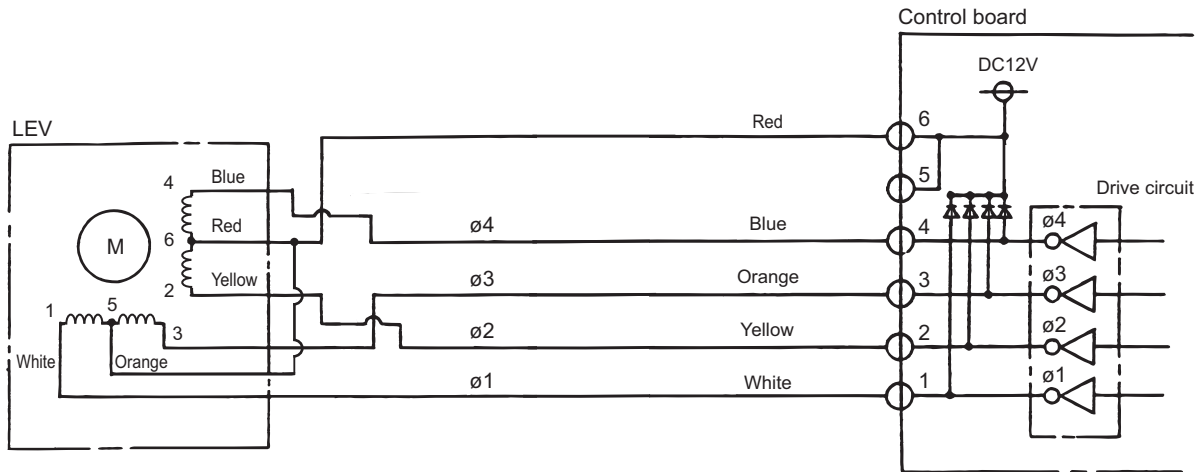
The valve opening changes according to the number of pulses.

1) Indoor unit control board and the LEV (Indoor unit: Linear expansion valve)



Note. The connector numbers on the intermediate connector and the connector on the control board differ. Check the color of the lead wire to judge the number.

2) Outdoor unit control board and the LEV (Outdoor unit: Linear expansion valve)



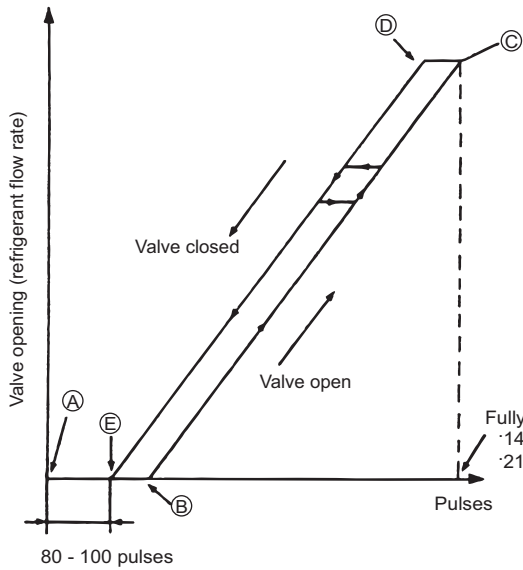
3) Pulse signal output and valve operation

Output (phase) number	Output state			
	1	2	3	4
φ 1	ON	OFF	OFF	ON
φ 2	ON	ON	OFF	OFF
φ 3	OFF	ON	ON	OFF
φ 4	OFF	OFF	ON	ON

Output pulses change in the following orders when the
 Valve is closed; 1 → 2 → 3 → 4 → 1
 Valve is open; 4 → 3 → 2 → 1 → 4

- *1. When the LEV opening angle does not change, all the output phases will be off.
- *2. When the output is open phase or remains ON, the motor cannot run smoothly, and rattles and vibrates.

4) LEV closing and opening operation



*Upon power on, the indoor unit control board sends a 2200 pulse signal to the indoor unit LEV and a 3200 pulse signal to the outdoor unit LEV to determine the valve position and always brings the valve to the position as indicated by "A" in the diagram.

When the valve operates smoothly, no sound from LEV or no vibration occurs, however, when the pulses change from E to A in the chart or the valve is locked, a big sound occurs.

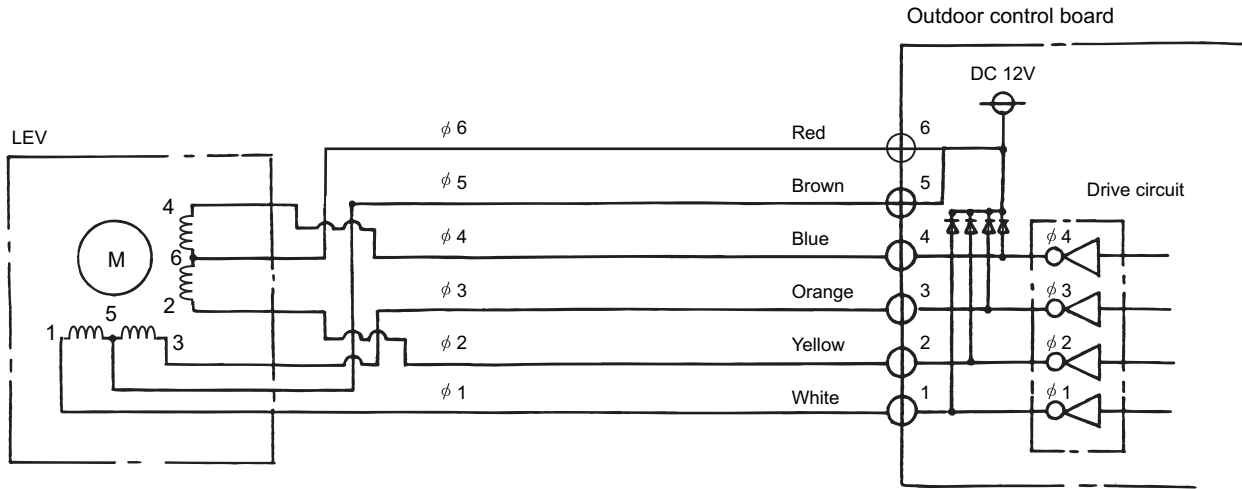
*Whether a sound is generated or not can be determined by holding a screwdriver against it, then placing your ear against the handle.

*1 The LEV opening may become greater depending on the operation status.

(2) Outdoor LEV (LEV1, LEV9)

The valve opening changes according to the number of pulses.

1) Connections between the outdoor control board and LEV1 (outdoor expansion valve)



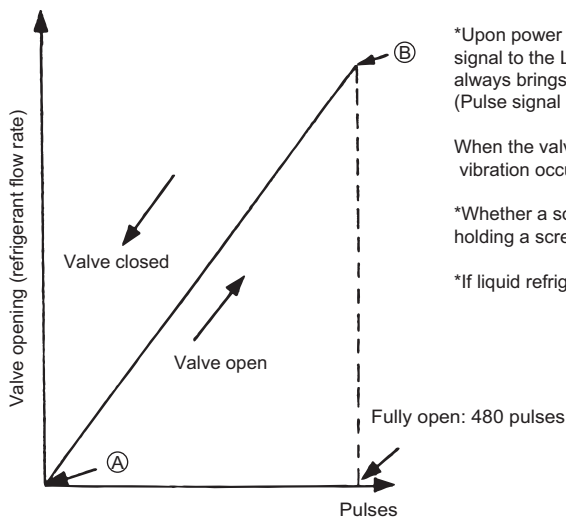
2) Pulse signal output and valve operation

Output (phase) number	Output state							
	1	2	3	4	5	6	7	8
φ 1	ON	OFF	OFF	OFF	OFF	OFF	ON	ON
φ 2	ON	ON	ON	OFF	OFF	OFF	OFF	OFF
φ 3	OFF	OFF	ON	ON	ON	OFF	OFF	OFF
φ 4	OFF	OFF	OFF	OFF	ON	ON	ON	OFF

Output pulses change in the following orders when the
 Valve is open; 1 → 2 → 3 → 4 → 5 → 6 → 7 → 8 → 1
 Valve is closed; 8 → 7 → 6 → 5 → 4 → 3 → 2 → 1 → 8

- *1. When the LEV opening angle does not change, all the output phases will be off.
- *2. When the output is open phase or remains ON, the motor cannot run smoothly, and rattles and vibrates.

3) LEV valve closing and opening operation



*Upon power on, the indoor unit control board sends a 520 pulse signal to the LEV to determine the valve position and always brings the valve to the position as indicated by "A" in the diagram. (Pulse signal is output for approximately 17 seconds.)

When the valve operates smoothly, there is no sound from the LEV and no vibration occurs, but when the valve is locked, noise is generated.

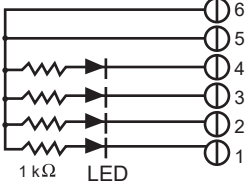
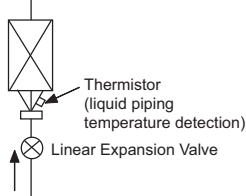
*Whether a sound is generated or not can be determined by holding a screwdriver against it, then placing your ear against the handle.

*If liquid refrigerant flows inside the LEV, the sound may become smaller.

8-8-2 Possible Problems and Solutions

Note

The specifications of the outdoor unit (outdoor LEV) and the indoor unit (indoor LEV) differ. Therefore, remedies for each failure may vary. Check the remedy specified for the appropriate LEV as indicated in the below column.

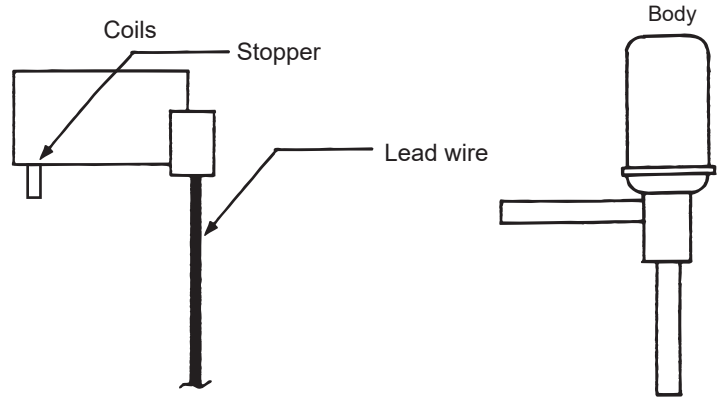
Malfunction mode	Judgment method	Remedy	Target LEV
Microcomputer driver circuit failure	<p>Disconnect the control board connector and connect the check LED as shown in the figure below.</p>  <p>Resistance : 0.25W 1kΩ LED : DC15V 20mA or more</p> <p>When the main power is turned on, the indoor unit circuit board outputs pulse signals to the indoor unit LEV for 10 seconds, and the outdoor unit circuit board outputs pulse signals to the outdoor unit LEV for 17 seconds. If any of the LED remains lit or unlit, the drive circuit is faulty.</p>	When the drive circuit has a problem, replace the control board.	Indoor Outdoor
LEV mechanism is locked	If the LEV is locked, the drive motor runs idle, and makes a small clicking sound. When the valve makes a closing and opening sound, the valve has a problem.	Replace the LEV.	Indoor Outdoor
Disconnected or short-circuited LEV motor coil	Measure the resistance between coils (red-white, red-orange, brown-yellow, brown-blue) with a tester. When the resistance is in the range of 150Ω ± 10%, the LEV is normal.	Replace the LEV coils.	Indoor
	Measure the resistance between coils (red-white, red-orange, red-yellow, red-blue) with a tester. When the resistance is in the range of 100Ω ± 10%, the LEV is normal.	Replace the LEV coils.	Outdoor (LEV2a, LEV2b, LEV2c)
	Measure the resistance between coils (red - white, red - orange, brown - yellow, brown - blue) with a tester. When the resistance is in the range of 46Ω ± 3%, the LEV is normal.	Replace the LEV coils.	Outdoor (LEV1, LEV9)
Incomplete sealing (leak from the valve)	<p>When checking the refrigerant leak from the indoor LEV, run the target indoor unit in the fan mode, and the other indoor units in the cooling mode. Then, check the liquid temperature (TH2) with the self-diagnosis LED. When the unit is running in the fan mode, the LEV is fully closed, and the temperature detected by the thermistor is not low. If there is a leak, however, the temperature will be low. If the temperature is extremely low compared with the inlet temperature displayed on the remote controller, the LEV is not properly sealed, however, if there is a little leak, it is not necessary to replace the LEV when there are no effects to other parts.</p> 	If there is a large amount of leakage, replace the LEV.	Indoor
Faulty wire connections in the connector or faulty contact	<ol style="list-style-type: none"> Check for loose pins on the connector and check the colors of the lead wires visually Disconnect the control board's connector and conduct a continuity check using a tester. 	Check the continuity at the points where an error occurs.	Indoor Outdoor

8-8-3 Coil Removal Instructions

(1) Outdoor unit LEV (LEV1, LEV9)

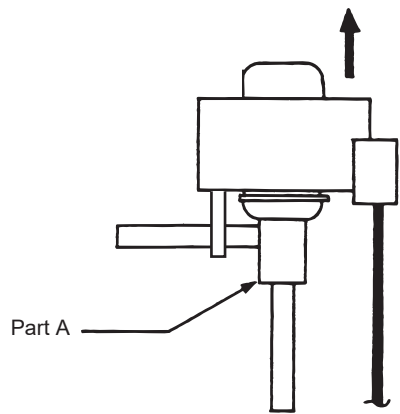
1) LEV component

As shown in the figure, the outdoor LEV is made in such a way that the coils and the body can be separated.



2) Removing the coils

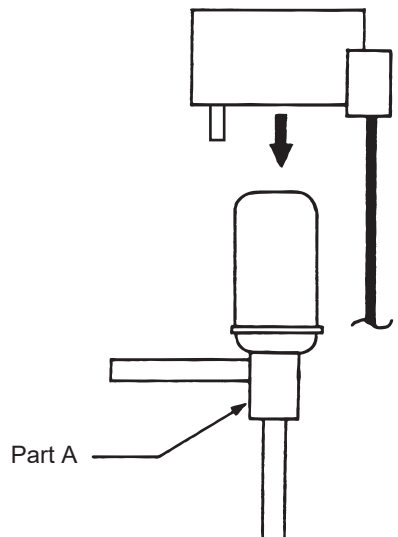
Fasten the body tightly at the bottom (Part A in the figure) so that the body will not move, then pull out the coils toward the top. If the coils are pulled out without the body gripped, undue force will be applied and the pipe will be bent.



3) Installing the coils

Fix the body tightly at the bottom (Part A in the figure) so that the body will not move, then insert the coils from the top, and insert the coil stopper securely in the pipe on the body.

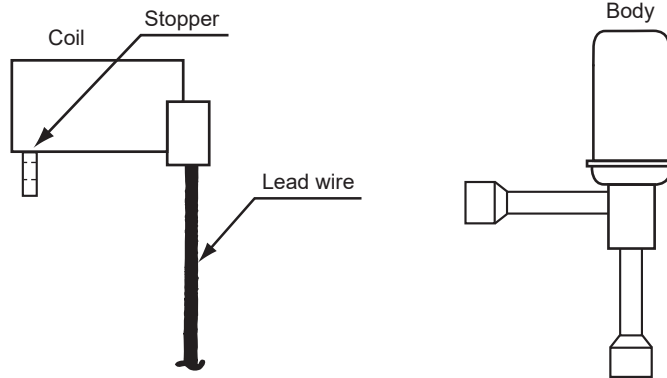
If the coils are pushed without the body gripped, undue force will be applied and the pipe will be bent. Hold the body when pulling out the coils to prevent so that the pipe will not be bent.



(2) Outdoor unit LEV (LEV2a, LEV2b, LEV2c)

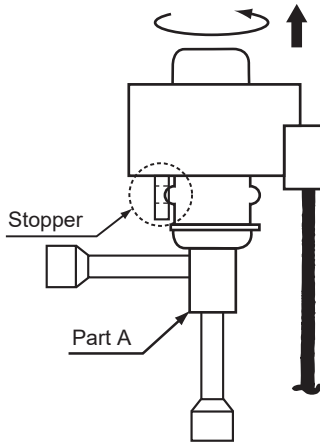
1) Components

The outdoor unit LEV consists of a coil and a valve body that can be separated from each other.



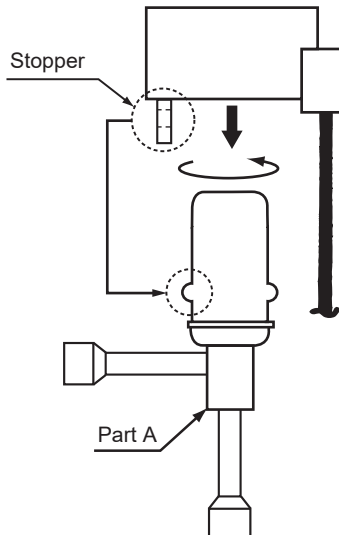
2) Removing the coil

Securely hold the LEV at the bottom (Part A in the figure), and turn the coil. After checking that the stopper is removed, pull up and out the coil. When removing the coil, hold the LEV body securely to prevent undue force from being placed on the pipe and bending the pipe.



3) Installing the coil

Securely hold the bottom of the LEV (Part A in the figure), insert the coil from above, and turn the coil until the coil stopper is properly installed on the LEV body.



8-9 Troubleshooting Inverter Problems

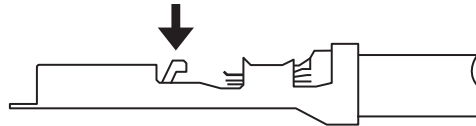
8-9-1 Inverter-Related Problems and Solutions

- Replace only the compressor if only the compressor is found to be defective. (Overcurrent will flow through the inverter if the compressor is damaged, however, the power supply is automatically cut when overcurrent is detected, protecting the inverter from damage. Make sure that the model selection switches on the outdoor unit (Dip switches SW5-3 through 5-8 on the outdoor unit control board) are set correctly. For switch settings, refer to the following page(s). [7-9-2 Error Code [7101]])
- Replace only the fan motor if only the fan motor is found to be defective. (Overcurrent will flow through the inverter if the fan motor is damaged, however, the power supply is automatically cut when overcurrent is detected, protecting the inverter from damage.)
- Replace the defective components if the inverter is found to be defective.
- If both the compressor and the inverter are found to be defective, replace the defective component(s) of both devices.

(1) Inverter-related problems: Troubleshooting and remedies

- 1) Inside the inverter is a large capacity electrolytic capacitor, and the residual voltage that remains after the main power is turned off presents a risk of electric shock. Before inspecting the inside of the control box, turn off the power, leave the unit turned off for at least 10 minutes, and check that the voltage across pins 1 (+) and 5 (-) of relay connector RYPN has dropped to 20 VDC or less. (It takes approximately 10 minutes to discharge electricity after the power is turned off.)
- 2) Perform the service after disconnecting the relay connectors of the outdoor unit fan (RYFAN1 and RYFAN2). Before plugging in or unplugging connectors, check that the outdoor unit fan is not rotating and that the voltage across Pin 1 (+) and Pin 5 (-) of connector RYPN is 20 VDC or less. The capacitor may collect a charge and cause an electric shock when the outdoor unit fan rotates in windy conditions. Refer to the wiring nameplate for details.
- 3) Reconnect the relay connectors (RYFAN 1 and RYFAN 2) after completion of maintenance work.
- 4) The IPM on the inverter becomes damaged if there are loose screws on connectors. If a problem occurs after replacing some of the parts, mixed up wiring is often the cause of the problem. Check for proper connection of the wiring, screws, connectors, and Faston terminals.
- 5) To avoid damage to the circuit board, do not connect or disconnect the inverter-related connectors with the main power turned on.
- 6) Faston terminals have a locking function. Make sure the terminals are securely locked in place after insertion.

Press the tab on the terminals to remove them.



- 7) When the IPM or IGBT is replaced, apply a thin layer of heat radiation grease that is supplied evenly to these parts. Wipe off any grease that may get on the wiring terminal to avoid terminal contact failure.
- 8) Faulty wiring to the compressor damages the compressor. Connect the wiring in the correct phase sequence.
- 9) When the power is turned on, the compressor is energized even while they are not operating. Before turning on the power, disconnect all power supply wires from the compressor terminal block, and measure the insulation resistance of the compressor. Check the compressor for a ground fault. If the insulation resistance is 1.0 MΩ or below, connect all power supply wires to the compressor, and turn on the power to the outdoor unit. (The liquid refrigerant in the compressor will evaporate by energizing the compressor.)

	Error display/failure condition	Measure/inspection item
[1]	Inverter related errors 4250, 4255, 4256, 4220, 4225, 4226, 4230, 4240, 4260, 5301, 5305, 5306, 0403	Implement solutions that correspond to the error codes or preliminary error codes. Refer to the following page(s). [7-1 Error Code and Preliminary Error Code Lists]
[2]	Main power breaker trip Measure the secondary voltage of the main power breaker before checking because the main power breaker may have been broken.	Refer to the following page(s). [8-9-12 Solutions for the Main Breaker Trip]
[3]	Main power earth leakage breaker trip Measure the secondary voltage of the main power earth leakage breaker before checking because the main power earth leakage breaker may have been broken.	Refer to the following page(s). [8-9-13 Solutions for the Main Earth Leakage Breaker Trip]
[4]	Only the compressor does not operate.	Check the inverter frequency on the LED monitor. If the frequency indicates that the units are in operation, refer to the following page(s). [8-9-5 Checking the Inverter for Damage during Compressor Operation]
[5]	The compressor vibrates violently at all times or makes an abnormal sound.	Refer to the following page(s). [8-9-5 Checking the Inverter for Damage during Compressor Operation]
[6]	Compressor rotation speed does not reach the specified speed.	<1> Check for problems with compressor current and heatsink temperature. <2> Check for imbalance in power supply voltage. *Approximate target: 3% or less.
[7]	Only the fan motor does not operate.	Check the inverter frequency on the LED monitor. If the frequency indicates that the units are in operation, refer to the following page(s). [8-9-8 Checking the Fan Board Error Detection Circuit at No Load] [8-9-9 Checking the Fan Board for Damage at No Load] [8-9-10 Checking the Fan Board for Damage with Load]
[8]	The fan motor shakes violently at all times or makes an abnormal sound.	Check the inverter frequency on the LED monitor. If the frequency indicates that the units are in operation, refer to the following page(s). [8-9-8 Checking the Fan Board Error Detection Circuit at No Load] [8-9-9 Checking the Fan Board for Damage at No Load] [8-9-10 Checking the Fan Board for Damage with Load]
[9]	Noise is picked up by the peripheral device	<1> Check that power supply wiring of the peripheral device does not run close to the power supply wiring of the outdoor unit. <2> Check if the inverter output wiring is not running parallel to the power supply wiring and the transmission lines. <3> Check that the shielded wire is used as the transmission line when it is required, and check that the grounding work is performed properly on the shielded wire. <4> Meg failure for electrical system other than the inverter <5> Attach a ferrite core to the inverter output wiring. (Contact the factory for details of the service part settings.) <6> Provide separate power supply to the air conditioner and other electric appliances. <7> If the problem suddenly appeared, inverter output may have had a ground fault. For details, refer to the following page(s). [8-9-5 Checking the Inverter for Damage during Compressor Operation] *Contact the factory for cases other than those listed above.
[10]	Sudden malfunction (as a result of external noise.)	<1> Check that the grounding work is performed properly. <2> Check that the shielded wire is used as the transmission line when it is required, and check that the grounding work is performed properly on the shielded wire. <3> Check that neither the transmission line nor the external connection wiring does not run close to another power supply system or does not run through the same conduit pipe. * Contact the factory for cases other than those listed above.

8-9-2 Checking the Inverter Board Error Detection Circuit

Items to be checked	Phenomena	Remedy
(1) Stop the unit. Remove power supply.	1) Overcurrent error Error code: 4250 Detail code: No. 101, 104, 105, 106, and 107	Replace the INV board.
(2) Disconnect the inverter output wires from the compressor terminals (U, V, W). ^{*1}	2) Logic error Error code: 4220 Detail code: No. 111	Replace the INV board.
(3) Apply power supply.	3) ACCT sensor circuit failure Error code: 5301 Detail code: No.117	Replace the INV board.
(4) Put the outdoor unit into operation.	4) IPM open Error code: 5301 Detail code: No.119	Normal

*1 Output voltage is present at the inverter output wiring terminal. To avoid short-circuiting and ground fault, do not let the terminal come in contact with the unit or the compressor, and use caution not to damage the terminal.

*2 Compressors on P200, P250, and P300 models are located in the back of the MAIN BOX. To disconnect the inverter output wiring, move the MAIN BOX out of the way first, and then disconnect the wiring from the terminal on the compressor. Refer to [8-13-1 Ensuring Maintenance Space (Preparation for the Maintenance of Refrigerant Circuit Parts) <Type A>] or [8-13-2 Ensuring Maintenance Space (Preparation for the Maintenance of Refrigerant Circuit Parts) <Type A1/Type A2>] for how to move the MAIN BOX.

8-9-3 Checking the Compressor for Ground Fault and Coil Resistance Problems

Items to be checked	Phenomena	Remedy
Disconnect the compressor wiring, and check the compressor Meg, and coil resistance.	1) Compressor Meg failure Error if less than 1 MΩ.	Check that there is no liquid refrigerant in the compressor. If there is none, replace the compressor.
	2) Compressor coil resistance failure ♦Type A Coil resistance value of 0.325 Ω (20°C [68°F]): (E) P200, (E) P250 models ♦Type A1/2 Coil resistance value of 0.72 Ω (20°C [68°F]): P200, P250 models Coil resistance value of 0.325 Ω (20°C [68°F]): EP200, EP250 models ♦Type A and A1/2 (common to both) Coil resistance value of 0.192 Ω (20°C [68°F]): (E) P300, (E) P350 models Coil resistance value of 0.192 Ω (20°C [68°F]): (E) P400, (E) P450 models Coil resistance value of 0.219 Ω (20°C [68°F]): (E) P500 model	Replace the compressor.

8-9-4 Checking the Inverter for Damage at No-Load

Items to be checked	Phenomena	Remedy
(1) Stop the unit. Remove power supply.	1) Inverter-related problems are detected.	Set SW7-1 on the MAIN board to ON, and go to [8-9-2 Checking the Inverter Board Error Detection Circuit]. *When the MAIN board software version is the following, this function will not be enabled. In such a case, update the software to the latest version. ♦(-A) Ver. 1.13 or earlier ♦(-A1/2) Ver. 21.20 or earlier
(2) Disconnect the inverter output wires from the compressor terminals (U, V, W). ^{*1}	2) Inverter voltage is not output at the terminals (U, V, and W)	Replace the INV board.
(3) Set SW7-1 on the MAIN board to ON.	3) There is a voltage imbalance between the wires. Greater than 5% imbalance or 5V	Replace the INV board.
(4) Apply power supply.		
(5) Put the outdoor unit into operation. Check the inverter output voltage after the inverter output frequency has stabilized.	4) There is no voltage imbalance between the wires.	Normal *When done checking, set SW7-1 on the MAIN board back to as it was.

*1 Output voltage is present at the inverter output wiring terminal. To avoid short-circuiting and ground fault, do not let the terminal come in contact with the unit or the compressor, and use caution not to damage the terminal.

*2 Compressors on P200, P250, and P300 models are located in the back of the MAIN BOX. To disconnect the inverter output wiring, move the MAIN BOX out of the way first, and then disconnect the wiring from the terminal on the compressor. Refer to [8-13-1 Ensuring Maintenance Space (Preparation for the Maintenance of Refrigerant Circuit Parts) <Type A>] or [8-13-2 Ensuring Maintenance Space (Preparation for the Maintenance of Refrigerant Circuit Parts) <Type A1/Type A2>] for how to move the MAIN BOX.

8-9-5 Checking the Inverter for Damage during Compressor Operation

Items to be checked	Phenomena	Remedy
Put the outdoor unit into operation. Check the inverter output voltage (at the compressor terminal) after the inverter output frequency has stabilized. <INV35Y, 36Y, 42Y>	1) Overcurrent-related problems occur immediately after compressor startup. Error code : 4250 Detail code : 101, 102, 106, 107	a. Check items [8-9-2 Checking the Inverter Board Error Detection Circuit] through [8-9-4 Checking the Inverter for Damage at No-Load] for problems. b. Check that high and low pressures are balanced. c. Check that no liquid refrigerant is present in the compressor and that there is no liquid backflow. →Go to "d." when the problem persists after compressor startup was repeated several times. d. Check that there is a pressure difference between high and low pressures after compressor start-up. →Check the high pressure with LED monitor for changes. Replace the compressor if there is no pressure difference. (the compressor may be locked.)
	2) There is a voltage imbalance between the wires after the inverter output voltage is stabilized. Greater than the larger of the following values: imbalance of 5% or 5V	Replace the INV board if there is a voltage imbalance. Check the belt heater for problems if there is no voltage imbalance. →When the error occurred, liquid refrigerant may have been present in the compressor.

Items to be checked	Phenomena	Remedy
<p><INV37YC></p>	<p>3) An overcurrent error occurs during operation. Error code : 4250 Detail code : 121,122</p>	<p>[8-9-6 Checking the Converter for Damage during Compressor Operation]</p>
	<p>4) An overcurrent error occurs immediately after compressor startup. Error code : 4250 Detail code :101,106,107,128</p>	<p>a. Check for refrigerant flooding. →When the problem persists after compressor startup was repeated several times, go to "d" after a certain time after energizing the compressor or the heater. If normal operation is restored, check the belt heater for problems.</p> <p>b. Check that there is a pressure difference between high and low pressures after compressor start-up. →Check the high pressure with LED monitor for changes. Replace the compressor if there is no pressure difference. (the compressor may be locked.)</p> <p>c. Check for interphase voltage imbalance.</p> <p>d. Replace the INV board if no problems were found with the items a or c.</p> <p>e. If the problem persists after replacing the inverter board, [8-9-3 Checking the Compressor for Ground Fault and Coil Resistance Problems]</p>
	<p>5) An overvoltage error occurs during operation. Error code : 4220 Detail code :109,110,112</p>	<p>[8-9-6 Checking the Converter for Damage during Compressor Operation]</p>
	<p>6) No problems were found with items 1) through 5).</p>	<p>Normal [8-9-6 Checking the Converter for Damage during Compressor Operation]</p>

8-9-6 Checking the Converter for Damage during Compressor Operation

Items to be checked	Phenomena	Remedy
(1) Operate the outdoor unit.	1) BUS voltage does not boost (does not change) BUS voltage does not boost to approximately between 650 and 750 VDC, or the following errors are detected. Error code : 4220 Detail code : 123	Replace the inverter board.
(2) Check the BUS voltage after the converter circuit went into operation and the BUS voltage has boost. *The voltage generally boost at or above 80 rps, depending on the power source voltage.	2) An overcurrent error occurs after converter circuit goes into operation. Error code : 4250 Detail code : 121,122	a.If the problem persists after startup, replace the inverter board. b.If the problem persists after replacing the inverter board, replace the DCL.
	3) An overvoltage error occurs after converter circuit goes into operation. Error code : 4220 Detail code : 109,110,112	a.If the problem persists after startup, replace the inverter board. b.If the problem persists after replacing the inverter board, replace the DCL.
	4) No problems were found with items 1) through 3).	Normal

8-9-7 Checking the Fan Motor for Ground Fault and Coil Resistance Problems

Items to be checked	Phenomena	Remedy
Remove fan motor winding. Check insulation resistance and coil resistance.	1) Fan motor insulation failure. If < 1 MΩ, Defect.	Change fan motor.
	2) Fan motor wire failure. Target coil resistance: Approx. 10 Ω. (Changes with temperature)	Change fan motor.

8-9-8 Checking the Fan Board Error Detection Circuit at No Load

Items to be checked	Phenomena	Remedy
(1) Stop the unit. Turn off the breaker. *Be sure to turn off the power.	1) An error other than current sensor error (5305, 5306: Detail code 135) is detected during operation.	Replace the fan board.
(2) Disconnect the output wiring to the fan motor. Disconnect connector RYFAN1. (On a model with two fan motors, RYFAN1 corresponds to the right fan and RYFAN2 corresponds to the left fan (when seen from the front).)	2) Current sensor fault Error code: 5305, 5306 Detail code: 135	Normal *When done checking, reconnect all connectors as they were. Unless they are properly reconnected, current sensor fault will not be resolved.
(3) Turn on the breaker.		
(4) Operate the unit.		

8-9-9 Checking the Fan Board for Damage at No Load

8 Troubleshooting Based on Observed Symptoms

Items to be checked	Phenomena	Remedy
(1) Stop the unit. Turn off the breaker. *Be sure to turn off the power.	1) An error other than the current sensor error (5305, 5306 Detail code 135) is detected within 30 seconds from the startup of operation.	Replace the fan board.
(2) To allow for the disconnection of output wiring from the fan motor, disconnect connector RYFAN1. (On a model with two fan motors, RYFAN1 corresponds to the right fan and RYFAN2 corresponds to the left fan (when seen from the front).)	2) Inter-wire voltage imbalance of 5 V or above	Replace the fan board.
(3) Set SW7-2 on the control board to ON. On a model with two fan motors, set SW7-2 (left fan when seen from the front) or SW7-4 (right fan when seen from the front) to ON.	3) No inter-wire voltage imbalance exists. A current sensor error (Detail code 135) is detected 30 seconds after the startup of operation, and the operation stops.	Normal *When done checking, reconnect all connectors as they were. Unless they are properly reconnected, current sensor fault will not be resolved.
(4) Turn on the breaker.		
(5) Operate the unit		

8-9-10 Checking the Fan Board for Damage with Load

Items to be checked	Phenomena	Remedy
(1) Turn off breaker.	1) The operation stops within 20 seconds of startup and a step-out error or an overcurrent error occurs. Check code: 4255, 4256 Detail code: 101, 106, 107, 137	Check for fan motor lock. →If locked, change for fan motor. If the same error is still present after changing fan motor, change Fan board. →If not locked, refer to 3) & 4).
(2) Turn on breaker.	2) Motor synchronization loss or electrical current overload during operation Check code: 4255, 4256 Detail code: 101, 106, 107, 137	a. Check for gusts or windy conditions. b. Go to [8-9-8 Checking the Fan Board Error Detection Circuit at No Load]if not windy. c. After checking [8-9-9 Checking the Fan Board for Damage at No Load], and there is no problem, change Fan board. d. If replacing Fan board doesn't resolve issue, change fan motor.
(3) Operate unit.	3) Sensor error during operation Check code: 5305, 5306 Detail code: 135, 136	a. Check for disconnection of fan inverter output wiring and for broken wiring. b. If the error is not associated with any of the items above, replace the fan board. c. Change fan motor if Fan board change doesn't resolve issue.
	4) Voltage overload error Check code: 4225, 4226 Detail code: 109	a. Check for gusts or windy conditions. b. Change Fan board if it is not windy.
(3) Operate unit.	5) Load short circuit Check code: 4255, 4256. Detail code: 105	a. Check [8-9-7 Checking the Fan Motor for Ground Fault and Coil Resistance Problems] and [8-9-8 Checking the Fan Board Error Detection Circuit at No Load]. If no problem, then check wiring for short circuit. b. If there is no problem with item a. above, change fan motor. c. If same error after motor change, change Fan board.
	6) After RPM has stabilized, voltage unbalance of 5%, or 5V.	a. If voltage is unbalanced, go to [8-9-8 Checking the Fan Board Error Detection Circuit at No Load] b. After checking [8-9-9 Checking the Fan Board for Damage at No Load], and there is no problem, change Fan board. c. If replacing Fan board doesn't resolve issue, change fan motor.

8-9-11 Checking the Installation Conditions

Items to be checked	Phenomena	Remedy
(1) Check refrigerant charge.	Overcharge of refrigerant	Return to correct refrigerant charge.
(2) Check outdoor unit branch installation.	The branch approach <500 mm.	Make branch approach >500mm
	Is the branch angle < ±15° to horizontal?	Make branch angle < ±15°

8-9-12 Solutions for the Main Breaker Trip

Note

Measure the secondary voltage of the main power breaker before checking because the main power breaker may have been broken.

	Items to be checked	Phenomena	Remedy
[1]	Check the breaker capacity.	Use of a non-specified breaker	Replace it with a specified breaker.
[2]	Perform Meg check between the terminals on the power terminal block TB1.	Zero to several ohm, or Meg failure	Check each part and wiring. Refer to the following page(s). [8-9-14 Simple Check on Inverter Circuit Components] •IGBT module •Rush current protection resistor •Electromagnetic relay •DC reactor
[3]	Turn on the power again and check again.	1) Main power breaker trip 2) No remote control display	
[4]	Turn on the outdoor unit and check that it operates normally.	1) Operates normally without tripping the main breaker. 2) Main power breaker trip	a) The wiring may have been short-circuited. Search for the wire that short-circuited, and repair it. b) If item a) above is not the cause of the problem, refer to [8-9-2 Checking the Inverter Board Error Detection Circuit] - [8-9-10 Checking the Fan Board for Damage with Load]

8-9-13 Solutions for the Main Earth Leakage Breaker Trip

Note

Measure the secondary voltage of the main power earth leakage breaker before checking because the main power earth leakage breaker may have been broken.

	Items to be checked	Phenomena	Remedy
[1]	Check the earth leakage breaker capacity and the sensitivity current.	Use of a non-specified earth leakage breaker	Replace with a regulation earth leakage breaker.
[2]	Check the resistance at the power supply terminal block TB1 with a megger.	Failure resistance value	Check each part and wiring. Refer to the following page(s). [8-9-14 Simple Check on Inverter Circuit Components] <ul style="list-style-type: none"> •IGBT module •Rush current protection resistor •Electromagnetic relay •DC reactor
[3]	Disconnect the compressor wirings and check the resistance of the compressor with a megger.	Failure compressor if the insulating resistance value is not in specified range. Failure when the insulating resistance value is 1 MΩ or less.	Check that there is no liquid refrigerant in the compressor. If there is none, replace the compressor.
[4]	Disconnect the fan motor wirings and check the resistance of the fan motor with a megger.	Failure fan motor if the insulating resistance value is not in specified range. Failure when the insulating resistance value is 1 MΩ or less.	Replace the fan motor.



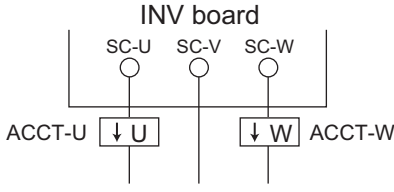
Earth leakage current measurement method

- For easy on-site measurement of the earth leakage current, enable the filter with a measurement instrument that has filter functions as below, clamp all the power supply wires, and measure.
Recommended measurement instrument: CLAMP ON LEAK HiTESTER 3283 made by HIOKI E.E. CORPORATION
- When measuring one device alone, measure near the device's power supply terminal block.

8-9-14 Simple Check on Inverter Circuit Components

Note

Turn off the power to the unit, and leave it turned off for at least 10 minutes. Check that the voltage across pins 1 (+) and 5 (-) of the connector RYPN1 is 20 VDC or less before removing components from the control box.

Part name	Judgment method																		
IGBT module	Refer to the following page(s). [8-9-15 Troubleshooting Problems with IGBT Module]																		
Rush current protection resistor R1, R5	Measure the resistance between terminals R1 and R5: $22 \Omega \pm 10\%$																		
Electromagnetic relay 72C	<p>This electromagnetic relay is rated at DC12V and is driven by a coil. Check the resistance between terminals</p> <p>P200-P450</p>  <table border="1" data-bbox="858 683 1361 896"> <thead> <tr> <th></th> <th>Check point</th> <th>Checking criteria</th> </tr> </thead> <tbody> <tr> <td>Coil</td> <td>INV board X901, X902 Across pins 1-2</td> <td>$160 \Omega \pm 10\%$</td> </tr> <tr> <td>Contact</td> <td>INV board FT-P1 and FT-P2 *Faston terminal removed</td> <td>INV board CNRY Open: ∞ INV board CNRY At a voltage input of 12 VDC: 0Ω</td> </tr> </tbody> </table> <p>P500</p>  <table border="1" data-bbox="858 956 1361 1169"> <thead> <tr> <th></th> <th>Check point</th> <th>Checking criteria</th> </tr> </thead> <tbody> <tr> <td>Coil</td> <td>INV board X101, X102, X103 Across pins 1-2</td> <td>$160 \Omega \pm 10\%$</td> </tr> <tr> <td>Contact</td> <td>INV board FT100 and FT101 *Faston terminal removed</td> <td>INV board CNRY Open: ∞ INV board CNRY At a voltage input of 12 VDC: 0Ω</td> </tr> </tbody> </table>		Check point	Checking criteria	Coil	INV board X901, X902 Across pins 1-2	$160 \Omega \pm 10\%$	Contact	INV board FT-P1 and FT-P2 *Faston terminal removed	INV board CNRY Open: ∞ INV board CNRY At a voltage input of 12 VDC: 0Ω		Check point	Checking criteria	Coil	INV board X101, X102, X103 Across pins 1-2	$160 \Omega \pm 10\%$	Contact	INV board FT100 and FT101 *Faston terminal removed	INV board CNRY Open: ∞ INV board CNRY At a voltage input of 12 VDC: 0Ω
	Check point	Checking criteria																	
Coil	INV board X901, X902 Across pins 1-2	$160 \Omega \pm 10\%$																	
Contact	INV board FT-P1 and FT-P2 *Faston terminal removed	INV board CNRY Open: ∞ INV board CNRY At a voltage input of 12 VDC: 0Ω																	
	Check point	Checking criteria																	
Coil	INV board X101, X102, X103 Across pins 1-2	$160 \Omega \pm 10\%$																	
Contact	INV board FT100 and FT101 *Faston terminal removed	INV board CNRY Open: ∞ INV board CNRY At a voltage input of 12 VDC: 0Ω																	
DC reactor DCL	<p>Measure the resistance between terminals: 1Ω or lower (almost 0Ω)</p> <p>Measure the resistance between terminals and the chassis: ∞</p>																		
Current sensor ACCT	<p>Disconnect the wiring connector from CNCT2, and measure the inter-terminal resistance: $280 \Omega \pm 30 \Omega$</p> <p>Between pins 1 and 2 (U-phase), pins 3 and 4 (W-phase)</p>  <p>*Check ACCT wiring for correct phase and direction.</p>																		

8-9-15 Troubleshooting Problems with IGBT Module

Measure the resistances between each pair of terminals on the IGBT with a tester, and use the results for troubleshooting. The terminals on the INV board are used for the measurement.

1) Notes on measurement

- Check the polarity before measuring. (On the tester, black normally indicates plus.)
- Check that the resistance is not open ($\infty \Omega$) or not shorted (to 0Ω).
- The values are for reference, and the margin of errors is allowed.
- The result that is more than double or half of the result that is measured at the same measurement point is not allowed.
- Disconnect all the wiring connected the INV board, and make the measurement.

2) Tester restriction

- Use the tester whose internal electrical power source is 1.5V or greater
- Use the dry-battery-powered tester.

Note

(The accurate diode-specific resistance cannot be measured with the button-battery-powered card tester, as the applied voltage is low.)

- Use a low-range tester if possible. A more accurate resistance can be measured.

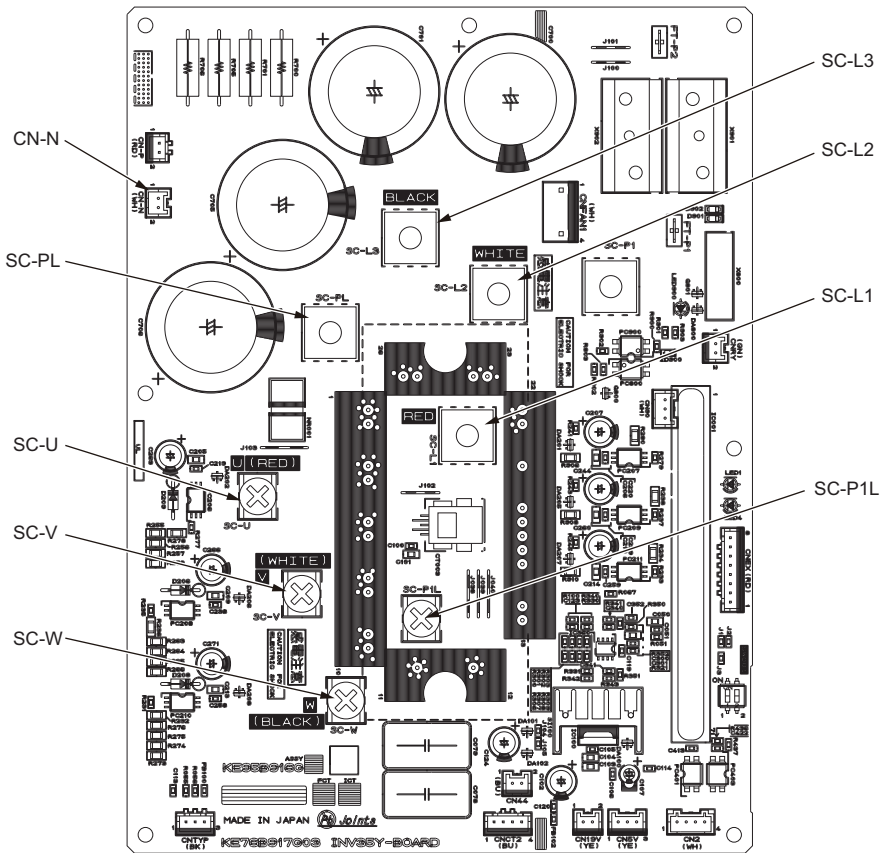
<INV35Y>

Reference resistance value

		Black (+)				
		SC-PL	CN-N	SC-L1	SC-L2	SC-L3
Red (-)	SC-PL	-	-	5-200 Ω	5-200 Ω	5-200 Ω
	CN-N	-	-	∞	∞	∞
	SC-L1	∞	5-200 Ω	-	-	-
	SC-L2	∞	5-200 Ω	-	-	-
	SC-L3	∞	5-200 Ω	-	-	-

		Black (+)				
		SC-P1L	CN-N	SC-U	SC-V	SC-W
Red (-)	SC-P1L	-	-	5-200 Ω	5-200 Ω	5-200 Ω
	CN-N	-	-	∞	∞	∞
	SC-U	∞	5-200 Ω	-	-	-
	SC-V	∞	5-200 Ω	-	-	-
	SC-W	∞	5-200 Ω	-	-	-

INV board outline drawing



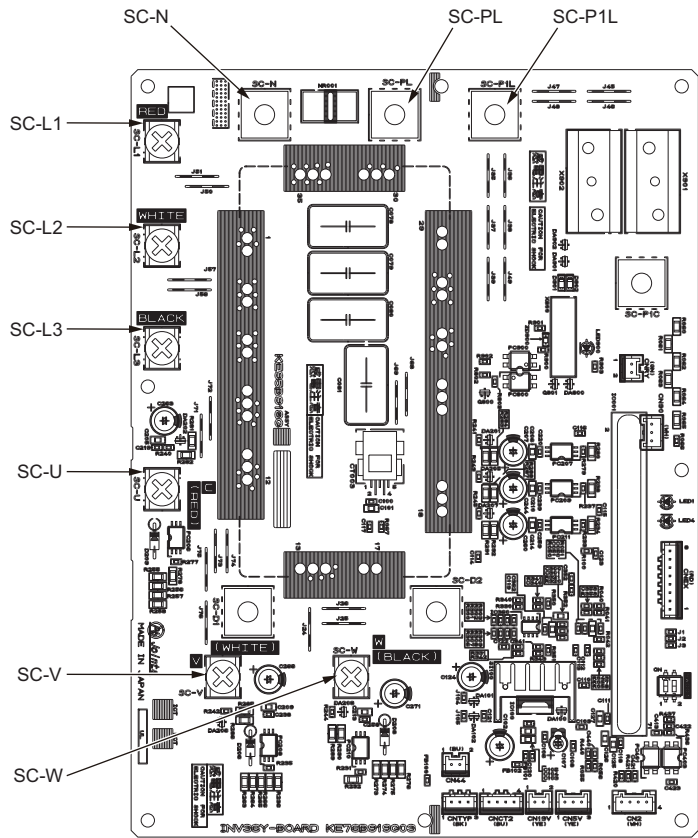
<INV36Y>

Reference resistance value

		Black (+)				
		SC-PL	SC-N	SC-L1	SC-L2	SC-L3L
Red (-)	SC-PL	-	-	5-200 Ω	5-200 Ω	5-200 Ω
	SC-N	-	-	∞	∞	∞
	SC-L1	∞	5-200 Ω	-	-	-
	SC-L2	∞	5-200 Ω	-	-	-
	SC-L3	∞	5-200 Ω	-	-	-

		Black (+)				
		SC-P1L	SC-N	SC-U	SC-V	SC-W
Red (-)	SC-P1L	-	-	5-200 Ω	5-200 Ω	5-200 Ω
	SC-N	-	-	∞	∞	∞
	SC-U	∞	5-200 Ω	-	-	-
	SC-V	∞	5-200 Ω	-	-	-
	SC-W	∞	5-200 Ω	-	-	-

INV board outline drawing



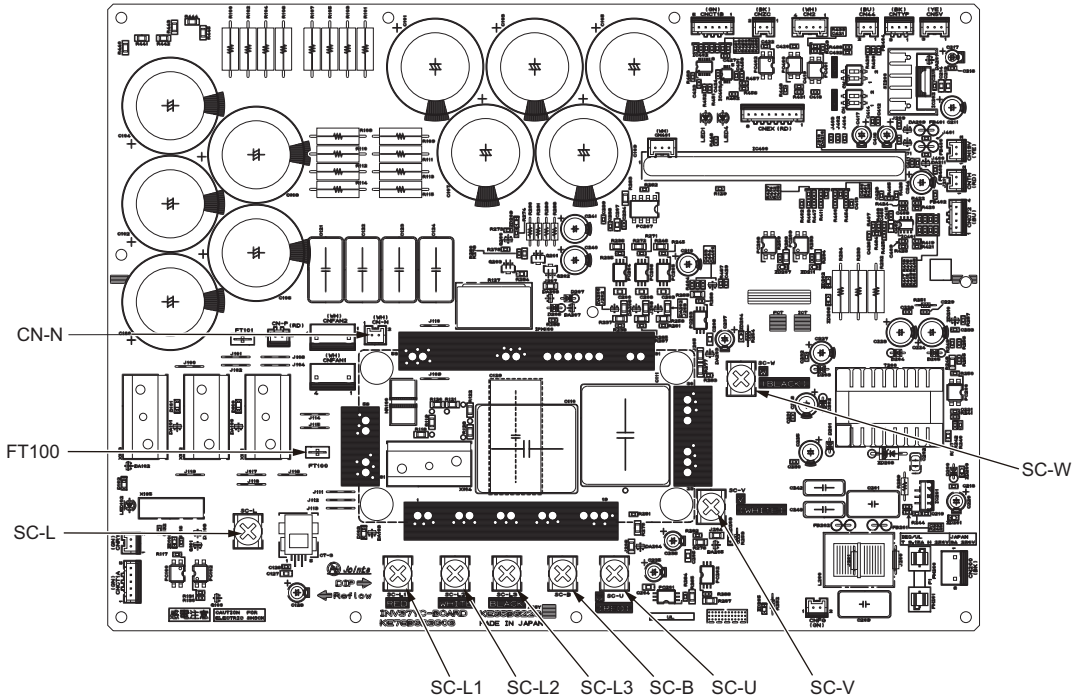
<INV37YC>

Reference resistance value

		Black (+)						
		SC-L1	SC-L2	SC-L3	SC-B	SC-L	FT100	CN-N
Red (-)	SC-L1	-	-	-	-	∞	-	5-200 Ω
	SC-L2	-	-	-	-	∞	-	5-200 Ω
	SC-L3	-	-	-	-	∞	-	5-200 Ω
	SC-B	-	-	-	-	-	∞	-
	SC-L	5-200 Ω	5-200 Ω	5-200 Ω	-	-	-	-
	FT100	-	-	-	5-200 Ω	-	-	-
	CN-N	∞	∞	∞	-	-	-	-

		Black (+)				
		FT100	CN-N	SC-U	SC-V	SC-W
Red (-)	FT100	-	-	5-200 Ω	5-200 Ω	5-200 Ω
	CN-N	-	-	∞	∞	∞
	SC-U	∞	5-200 Ω	-	-	-
	SC-V	∞	5-200 Ω	-	-	-
	SC-W	∞	5-200 Ω	-	-	-

INV board outline drawing



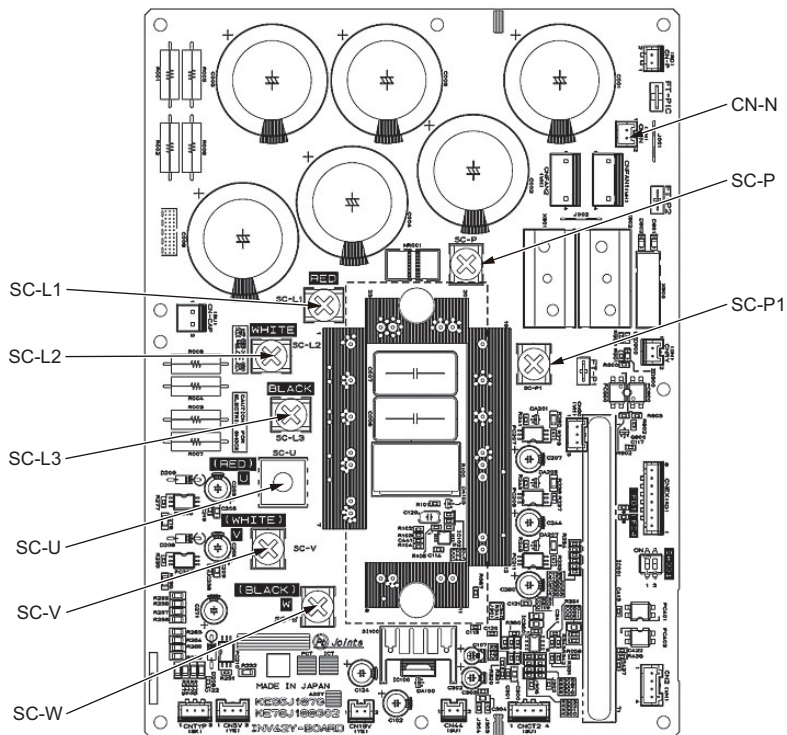
<INV42Y>

Reference resistance value

		Black (+)				
		SC-P	CN-N	SC-L1	SC-L2	SC-L3
Red (-)	SC-P	-	-	5-200 Ω	5-200 Ω	5-200 Ω
	CN-N	-	-	∞	∞	∞
	SC-L1	∞	5-200 Ω	-	-	-
	SC-L2	∞	5-200 Ω	-	-	-
	SC-L3	∞	5-200 Ω	-	-	-

		Black (+)				
		SC-P1	CN-N	SC-U	SC-V	SC-W
Red (-)	SC-P1	-	-	5-200 Ω	5-200 Ω	5-200 Ω
	CN-N	-	-	∞	∞	∞
	SC-U	∞	5-200 Ω	-	-	-
	SC-V	∞	5-200 Ω	-	-	-
	SC-W	∞	5-200 Ω	-	-	-

INV board outline drawing

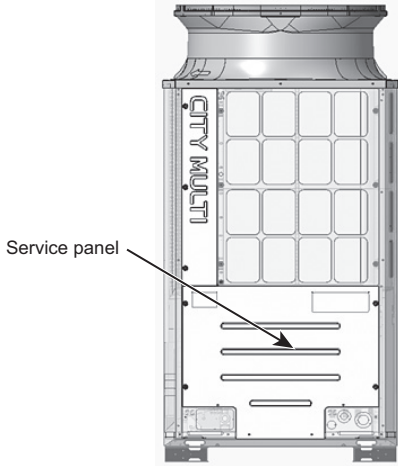


8-9-16 Checking the Fan Inverter Heatsink for Clogging

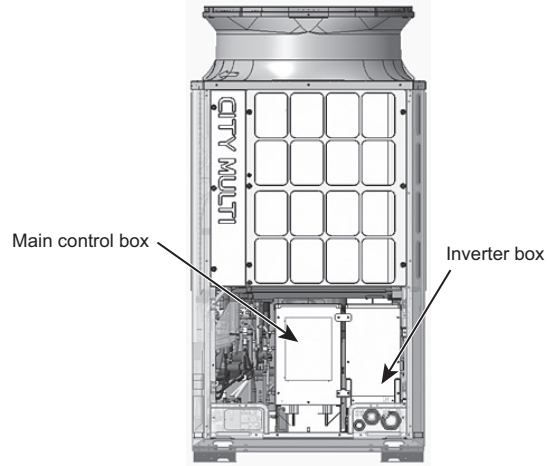
Check the fan inverter heatsink for clogging by removing part of the duct and checking inside the duct.

To remove the duct, follow the procedures 1) through 3) below.
Reassemble the components in the reverse order as they were removed.

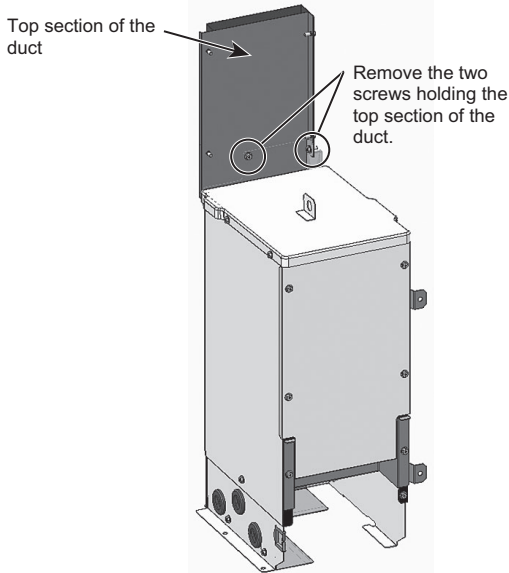
1) Remove the front service panel.



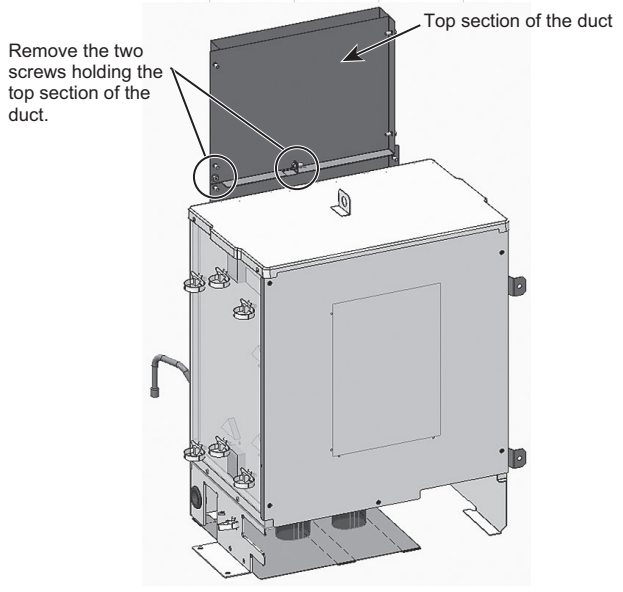
2) Remove the main control box (applicable to the (E)P200-300 models only).
On the (E)P350-550 models, it is not necessary to remove the control box.



3) Remove the upper section of the duct by unscrewing the screws on the control box (on the inverter box on the (E)P200-300 models) shown in the figure below.
Check inside the duct for clogging, and remove any foreign objects found.



(E)P200 - 300

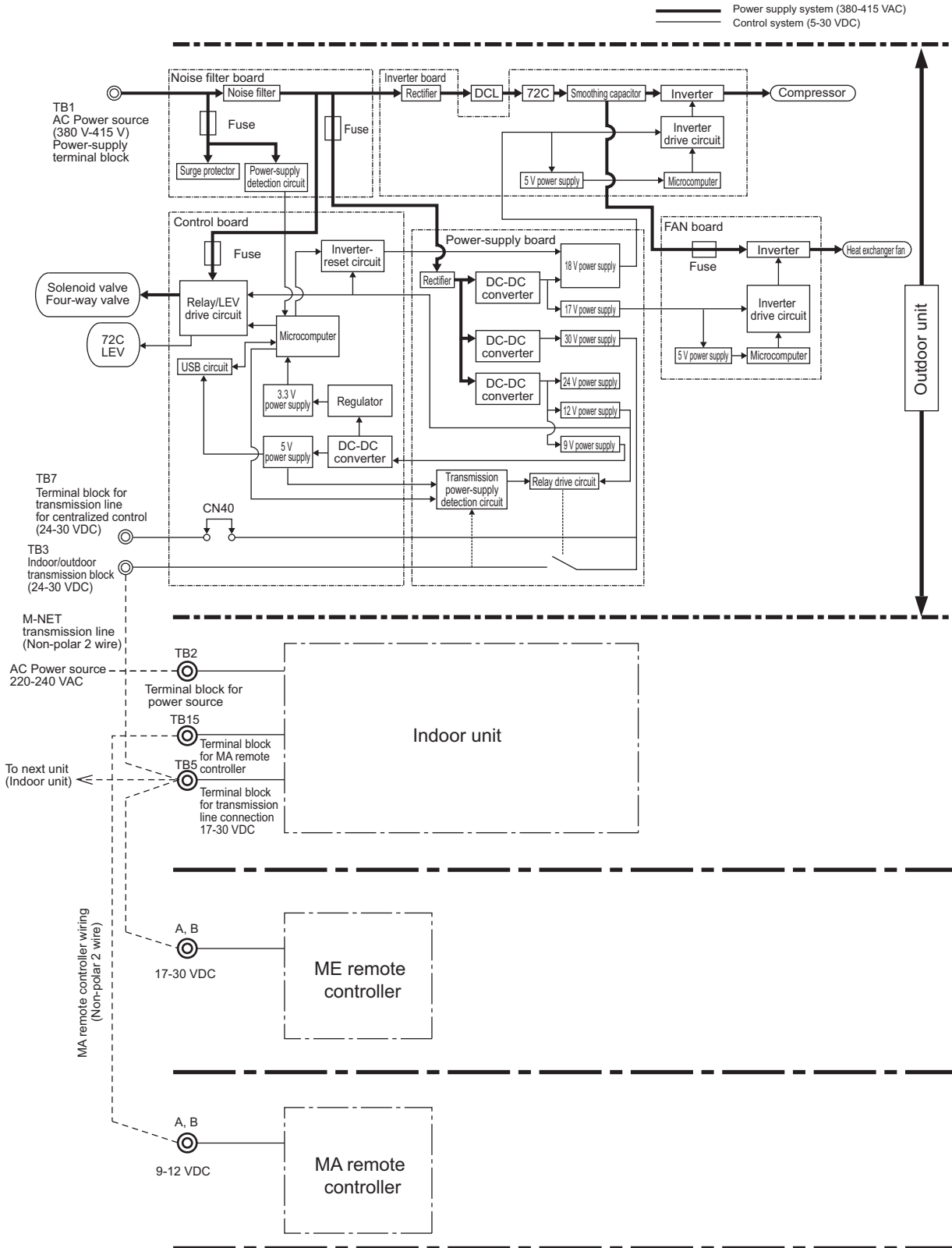


(E)P350 - 450

8-10 Control Circuit

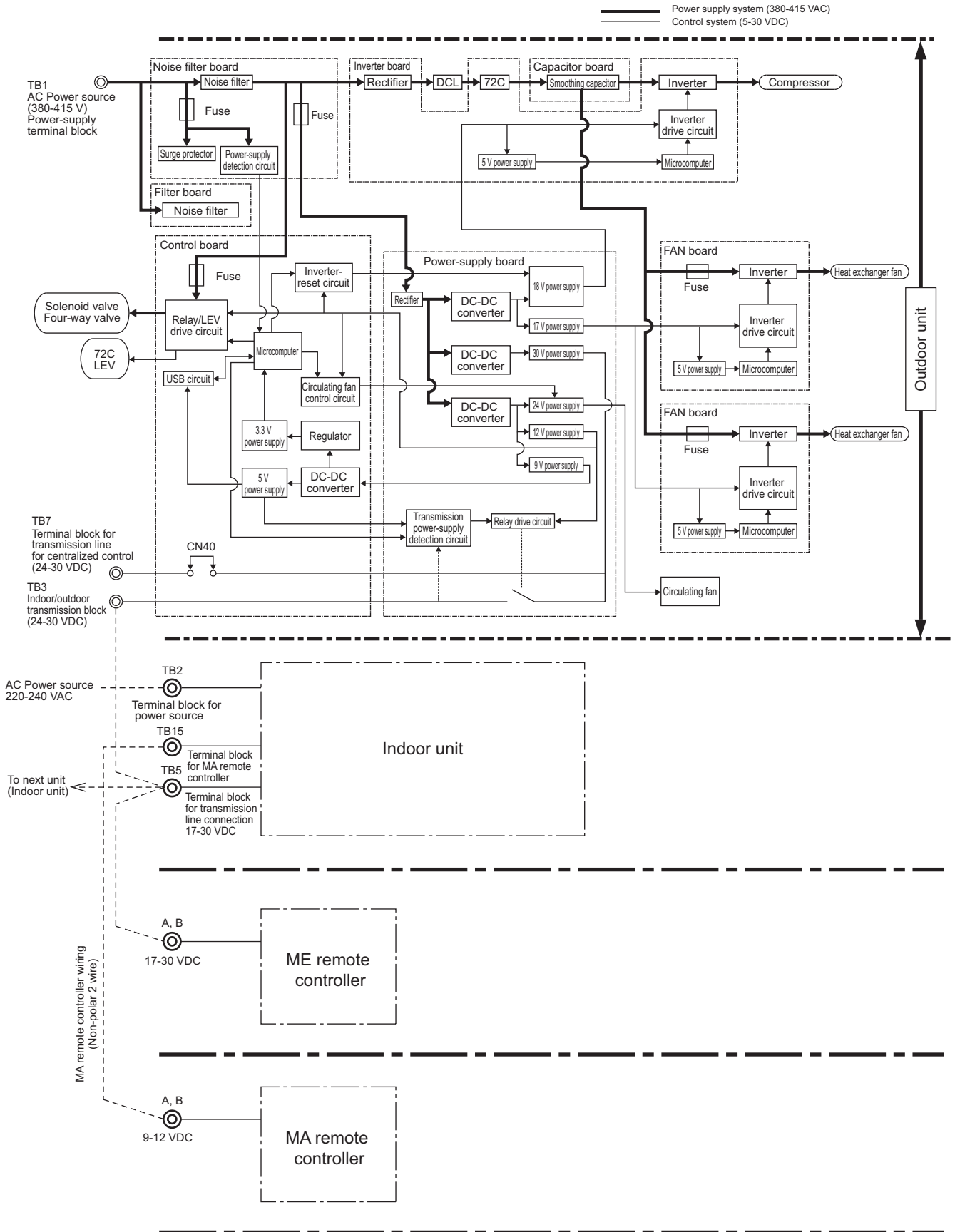
8-10-1 Control Power Supply Function Block

1) PUHY-(E)P200 - (E)P300YNW-A(1/2)



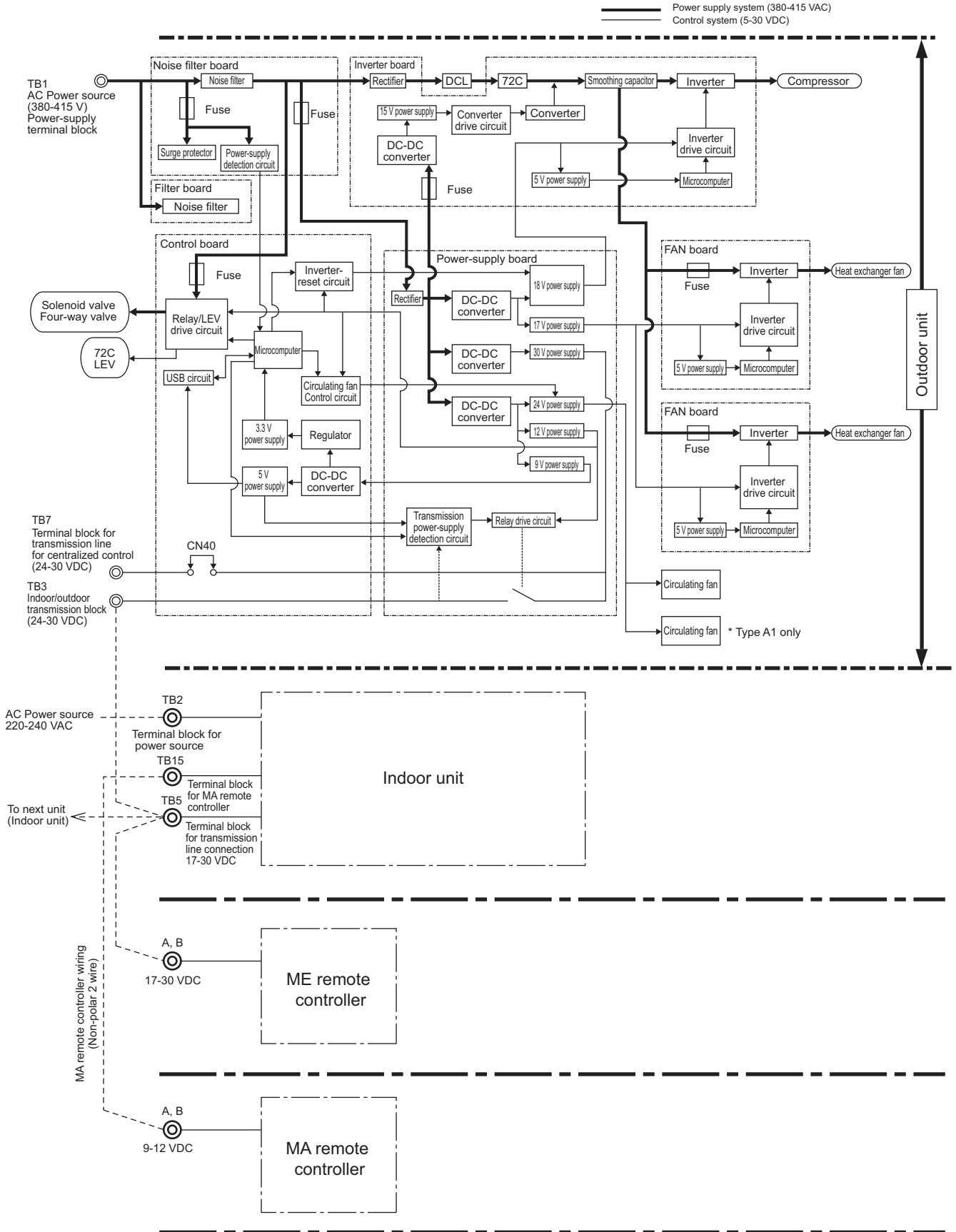
* MA remote controllers and ME remote controllers cannot be used together.
 (Both the ME and MA remote controller can be connected to a system controller.)

2) PUHY-(E)P350 - (E)P450YNW-A(1/2)



* MA remote controllers and ME remote controllers cannot be used together.
 (Both the ME and MA remote controller can be connected to a system with a system controller.)

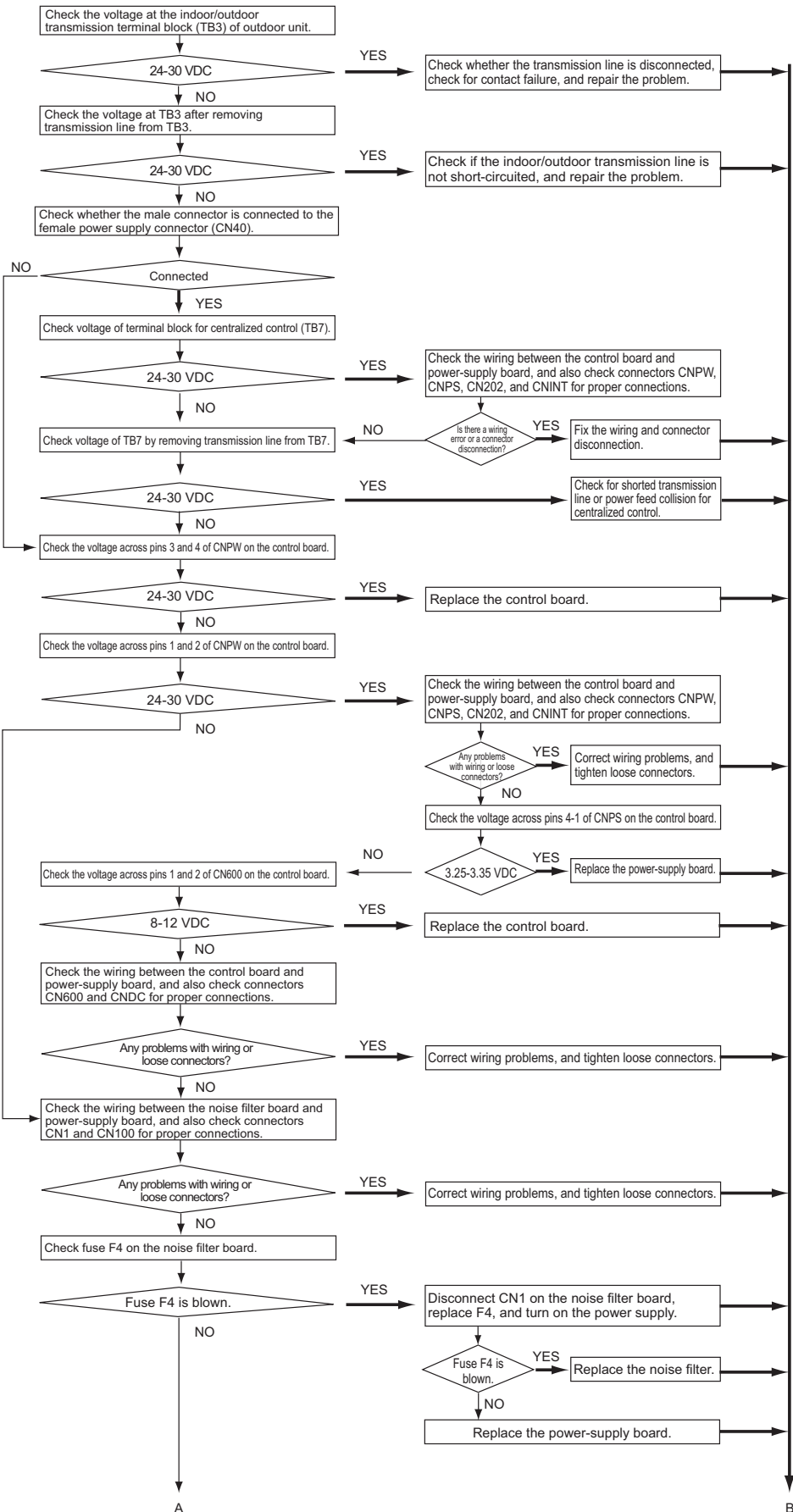
3) PUHY-(E)P500YNW-A(1/2)



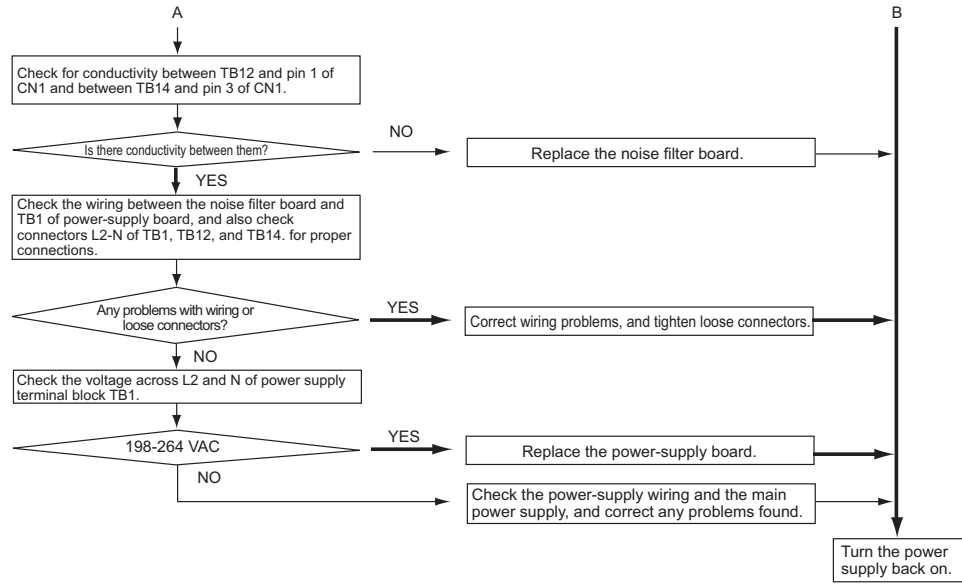
* MA remote controllers and ME remote controllers cannot be used together.
 (Both the ME and MA remote controller can be connected to a system with a system controller.)

8-10-2 Troubleshooting Problems with Outdoor Unit Transmission Power Supply Circuit

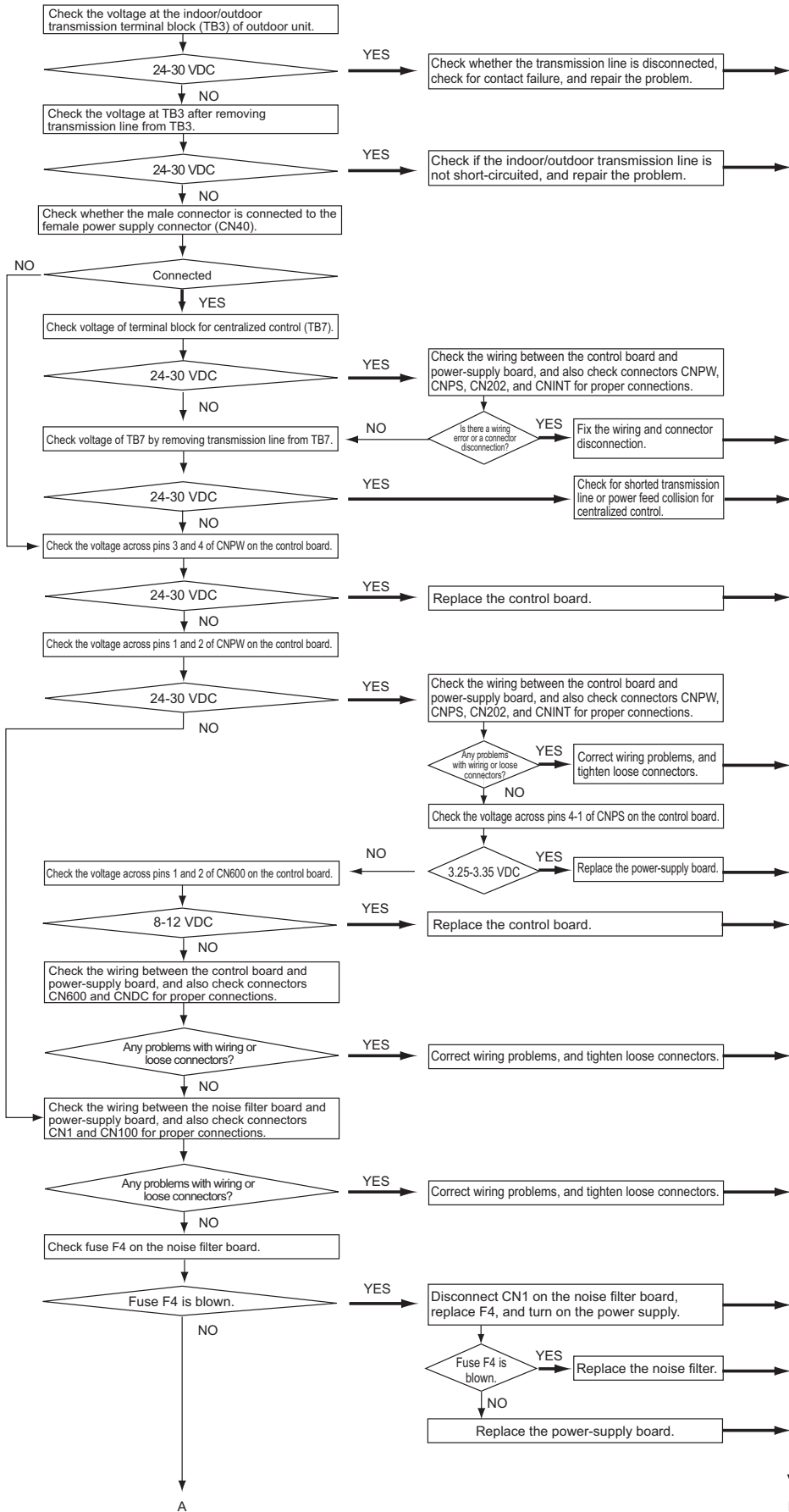
1) PUHY-(E)P200 - (E)P450YNW-A(1/2)

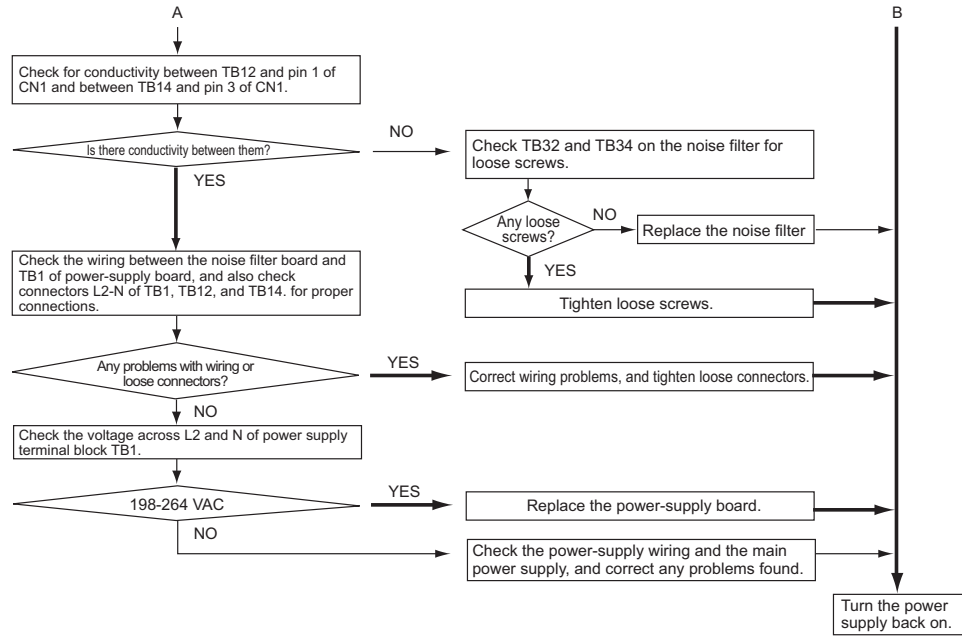


8 Troubleshooting Based on Observed Symptoms



2) PUHY-(E)P500YNW-A(1/2)





8-11 Measures for Refrigerant Leakage

1. Leak spot: In the case of extension pipe for indoor unit or optional unit (Cooling season)

- 1) Mount a pressure gauge on the service check joint (CJ2) on the low-pressure side.
- 2) Stop all the indoor units, and close the liquid service valve (BV2) inside the outdoor unit while the compressor is stopped.
- 3) Stop all the indoor units; turn on SW4 (912) on the outdoor unit control board while the compressor is being stopped.(Pump down mode will start, and all the indoor units will run in cooling test run mode.)
- 4) In the pump down mode (SW4 (912) is ON), all the indoor units will automatically stop when the low pressure (63LS) reaches 0.383MPa [55psi] or less or 15 minutes have passed after the pump mode started. Stop all the indoor units and compressors when the pressure indicated by the pressure gauge, which is on the check joint (CJ2) for low-pressure service, reaches 0.383MPa [55psi] or 20 minutes pass after the pump down operation is started.
- 5) Close the gas service valve (BV1) inside the outdoor unit.
- 6) Collect the refrigerant that remains in the extended pipe for the indoor unit or optional unit. Do not discharge refrigerant into the atmosphere when it is collected.
- 7) Repair the leak.
- 8) After repairing the leak, vacuum the extension pipe and the indoor unit or optional unit.
- 9) To adjust refrigerant amount, open the service valves (BV1 and BV2) inside the outdoor unit and turn off SW4 (912).

2. Leak spot: In the case of outdoor unit (Cooling season)

(1) Run all the indoor units in the cooling test run mode.

- 1) To run the indoor unit in test run mode, turn SW4 (769) from ON to OFF.
- 2) Change the setting of the remote controller for all the indoor units to the cooling mode.
- 3) Check that all the indoor units are performing a cooling operation.

(2) Check the values of Tc and TH6.

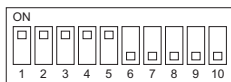
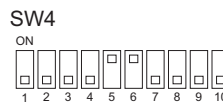
(To display the values on the LED screen, use the self-diagnosis switch (SW4 (when SW6-10 is set to OFF)) on the outdoor unit control board.)

- 1) When Tc-TH6 is 10°C [18°F] or more : See the next item (3).
- 2) When Tc-TH6 is less than 10°C [18°F] : After the compressor stops, collect the refrigerant inside the system, repair the leak, perform evacuation, and recharge new refrigerant. (Leak spot: 4. In the case of outdoor unit, handle in the same way as heating season.)

Tc self-diagnosis switch



TH6 self-diagnosis switch



The figure at left shows that the switches 1 through 5 are set to ON and 6 through 10 are set to OFF.

(3) Stop all the indoor units, and stop the compressor.

- 1) To stop all the indoor units and the compressors, turn SW4 (769) from ON to OFF.
- 2) Check that all the indoor units are being stopped.

(4) Close the service valves (BV1 and BV2).

(5) To prevent the liquid seal, extract small amount of refrigerant from the check joint of the liquid service valve (BV2), as the liquid seal may cause a malfunction of the unit.

In the cooling cycle, the section between check valve CV1 and LEV2 will form a closed circuit. Before recovering the refrigerant or evacuating the system, leave the unit in a stopped state for at least 30 minutes and then open LEV2 and switch SW4 (988) from OFF to ON so that LEV1 and LEV2 are in an open state. If this work is not performed, recovering the refrigerant or evacuating the system may not be possible. (After completion of work, set SW4 (988) from ON to OFF.)

(6) Collect the refrigerant that remains inside the outdoor unit. Do not discharge refrigerant into air into the atmosphere when it is collected.

(7) Repair the leak and conduct the airtightness test.

For how to conduct an air-tightness test for an outdoor unit alone, refer to [8-12 Individual air-tightness testing of outdoor unit].

- (8) After repairing the leak, replace the dryer with the new one, and perform evacuation inside the outdoor unit and optional unit.**
- (9) To adjust refrigerant amount, open the service valves (BV1 and BV2 when optional unit is installed) inside the outdoor unit.**

Note

When the power to the outdoor/indoor unit must be turned off to repair the leak after closing the service valves specified in (4), turn the power off in approximately one hour after the outdoor/indoor units stop.

- 1) When 30 minutes have passed after (4) on the previous page, the indoor unit lev turns from fully closed to slightly open to prevent the refrigerant seal.
LEV2 open when the outdoor unit remains stopped for 15 minutes to allow for the collection of refrigerant in the outdoor unit heat exchanger and to enable the evacuation of the outdoor unit heat exchanger.
If the power is turned off in less than 5 minutes, LEV2 may close, trapping high-pressure refrigerant in the outdoor unit heat exchanger and creating a highly dangerous situation.
- 2) Therefore, if the power source is turned off within 30 minutes, the lev remains fully closed and the refrigerant remains sealed. When only the power for the indoor unit is turned off, the indoor unit LEV turns from faintly open to fully closed.

3. Leak spot: In the case of extension pipe for indoor unit or optional unit (Heating season)

(1) Run all the indoor units in heating test run mode.

- 1) To run the indoor unit in test run mode, turn SW4 (769) from ON to OFF.
- 2) Change the setting of the remote controller for all the indoor units to the heating mode.
- 3) Check that all the indoor units are performing a heating operation.

(2) Stop all the indoor units, and stop the compressor.

- 1) To stop all the indoor units and the compressors, turn SW4 (769) from ON to OFF.
- 2) Check that all the indoor units are stopped.

(3) Close the service valves (BV1 and BV2).

(4) Collect the refrigerant that remains inside the indoor unit and optional unit. Do not discharge refrigerant into the atmosphere when it is collected.

(5) Repair the leak and conduct the airtightness test.

For how to conduct an air-tightness test for an outdoor unit alone, refer to [8-12 Individual air-tightness testing of outdoor unit].

(6) After repairing the leak, perform evacuation of the extension pipe for the indoor unit and optional unit, and open the service valves (BV1 and BV2) to adjust refrigerant.

4. Leak spot: In the case of outdoor unit (Heating season)

- 1) Collect the refrigerant in the entire system (outdoor unit, extended pipe and indoor unit). Do not discharge refrigerant into the atmosphere when it is collected. **In the cooling cycle, the section between check valve CV1 and LEV2 will form a closed circuit. Before recovering the refrigerant or evacuating the system, leave the unit in a stopped state for at least 15 minutes and then open LEV2 and switch SW4 (988) from OFF to ON so that LEV1 and LEV2 are in an open state. If this work is not performed, recovering the refrigerant or evacuating the system may not be possible. (After completion of work, set SW4 (988) from ON to OFF.)**
- 2) Repair the leak.
- 3) After repairing the leak, perform evacuation of the entire system, and calculate the standard amount of refrigerant to be added (for the outdoor unit, extension pipe, and indoor unit), and charge the refrigerant. For details, refer to the following page(s). [6-3-3 Maximum refrigerant charge]

Note

If the indoor or outdoor units need to be turned off for repairing leaks during Step 1) above, turn off the power approximately 1 hour after the units came to a stop.

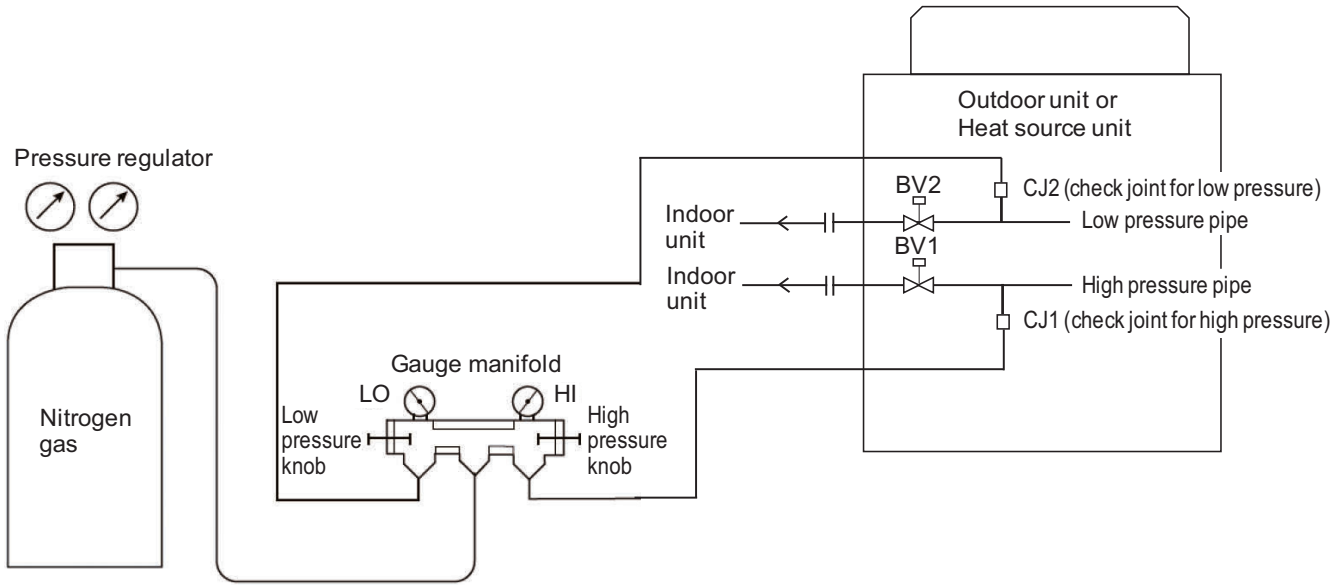
If the power is turned off in less than 15 minutes, LEV2 may close, trapping high-pressure refrigerant in the outdoor unit heat exchanger and creating a highly dangerous situation.

8-12 Individual air-tightness testing of outdoor unit

1. Tools

- 1) Gauge manifold
- 2) Nitrogen cylinder
- 3) Pressure regulator
- 4) Charging hose

2. Air-tightness test procedure



- 1) Check that no closed circuit is formed in the refrigerant circuit of the outdoor unit.
- 2) Fully close the refrigerant service valves (BV1 and BV2) of the outdoor unit.
- 3) Check that the pressure regulator is closed.
- 4) Connect the nitrogen cylinder to the pressure regulator.
- 5) Check that all knobs of the gauge manifold are closed.
- 6) Connect charging hoses to the high-pressure side, the low-pressure side, and the center of the gauge manifold.
- 7) Connect the gauge manifold (center) and the pressure regulator with a charging hose.
- 8) Connect the high-pressure side of the gauge manifold to the charging hose CJ1, and the low-pressure side to the charging hose CJ2.
- 9) Open the valve on the nitrogen cylinder.
- 10) Using the pressure regulator, adjust the pressure of the nitrogen to be applied to the outdoor unit.
Although the air-tightness test must normally be conducted at the air pressure of 4.15 MPa, when the area to be repaired has already been identified, a pressure of 0.8 MPa may be used as a simplified measure to identify the leakage point.
- 11) Slowly open the high-pressure side valve of the gauge manifold to supply nitrogen to the outdoor unit.
If the low-pressure side valve is opened first, it can raise the low-pressure side pressure (suction) above the high-pressure side pressure (discharge), which can cause the main shaft of the compressor to become tilted and malfunction.
- 12) When the pressure on the low-pressure side of the gauge manifold becomes close to the pressure on the high-pressure side, or after one minute has elapsed after the high-pressure side valve was opened, open the valve on the low-pressure side.
- 13) Keep supplying nitrogen for 5 to 10 minutes after the gauge manifold pressure reading reached the target pressure.
- 14) Check for leaks using a leak-detection agent (surfactant) in the areas where a leak was or replacement parts are brazed on.
If a leak is found, remove the nitrogen, repair the leak by brazing, and conduct an air-tightness test.
If brazing is done without removing the nitrogen, nitrogen gas may spew out of the leakage point, and brazing filler material may scatter.
- 15) After completion of the leak test, close the valve of the nitrogen cylinder.
- 16) Loosen the connector of the charging hose connected to the nitrogen cylinder, and release nitrogen.
Disconnect the charging hose after the nitrogen flow has died down.
Note that removing the hose with the internal pressure being applied, the hose can whip around and cause injury.
- 17) Close the valve of the pressure regulator.
- 18) Close all the knobs of the gauge manifold, and remove them from CJ1 and CJ2.

8-13 Parts Replacement Instructions <Type A/Type A1/Type A2>

8-13-1 Ensuring Maintenance Space (Preparation for the Maintenance of Refrigerant Circuit Parts) <Type A>

1. S-module

Take the following procedures to ensure sufficient maintenance space and good visibility.

- (1) Remove the front panel from the unit by unscrewing the eight screws. (See Figure 1.) *Figure 1 shows the unit without the front panel.
- (2) Remove the drain pan cover by unscrewing the screw and cutting the cable tie. (See Figures 2 and 3.)
When re-placing the drain pan cover after the completion of maintenance work, make sure that the silicon tube is properly placed on the defrost pipe, and then fix the drain pan cover in place with a cable tie. (Figures 2 and 3 show the cable ties to be cut.)
- (3) Remove the drain pan by unscrewing the two screws. (See Figure 2.)
Be sure to remove the two rod holders holding the check joints to the drain pan. (See Figure 3.)

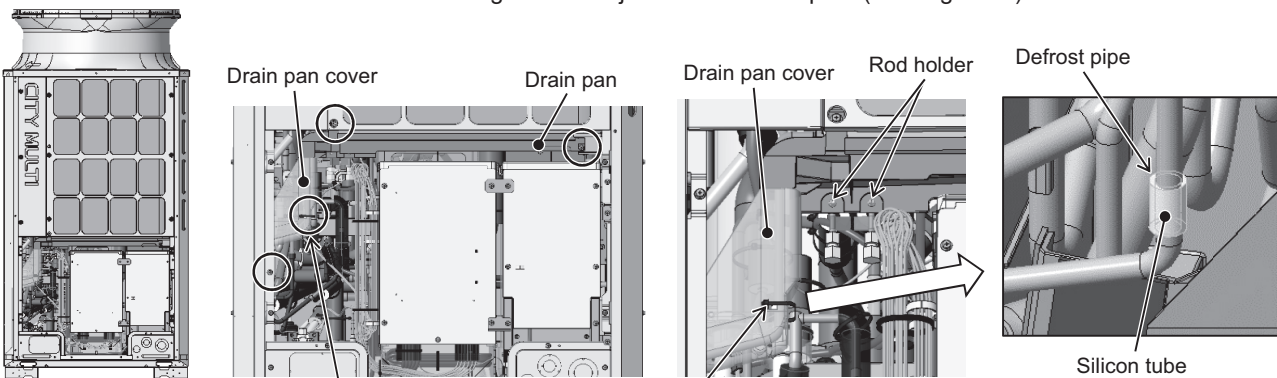


Figure 1 Cut the cable tie. Figure 2 Cut the cable tie. Figure 3

- (4) Remove the top attachment connecting the main control box and the inverter control box by unscrewing the two screws. (See Figure 4.)
- (5) Remove the bottom attachment connecting the main control box and the inverter control box by unscrewing the two screws. (See Figure 4.)
- (6) Remove the cover from the main control box by unscrewing the three screws. (See Figure 5.)
- (7) Cut the two cable ties holding the weak electrical wiring inside the main control box in place, and loosen the four cable straps holding the weak and strong electrical wirings. (See Figure 6.)
- (8) Cut the two cable ties holding the rubber bush at the bottom of the main control box. (See Figure 6.)
- (9) Cut the three cable ties and loosen the two cable straps holding the weak electrical wiring outside the main control box. (See Figure 7.)

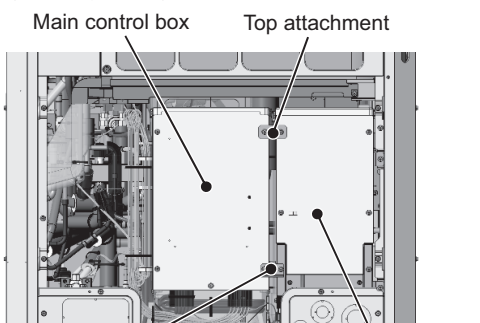


Figure 4

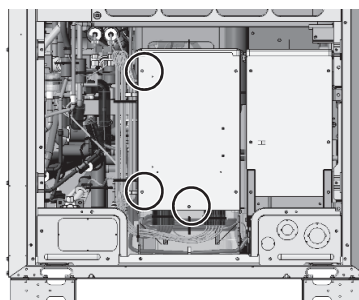


Figure 5

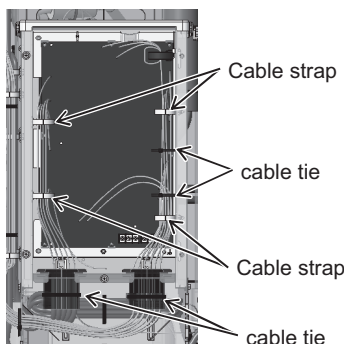


Figure 6

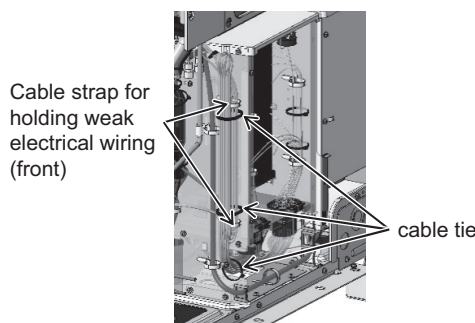
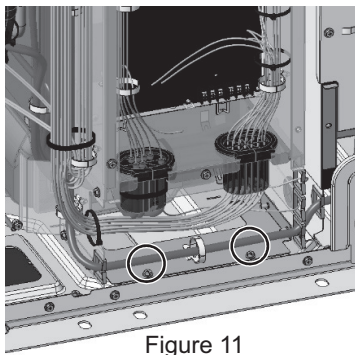
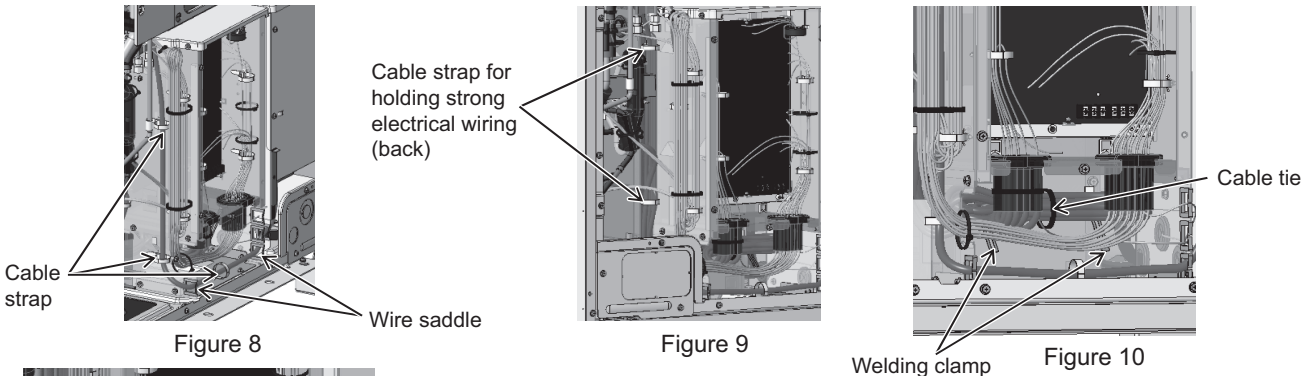
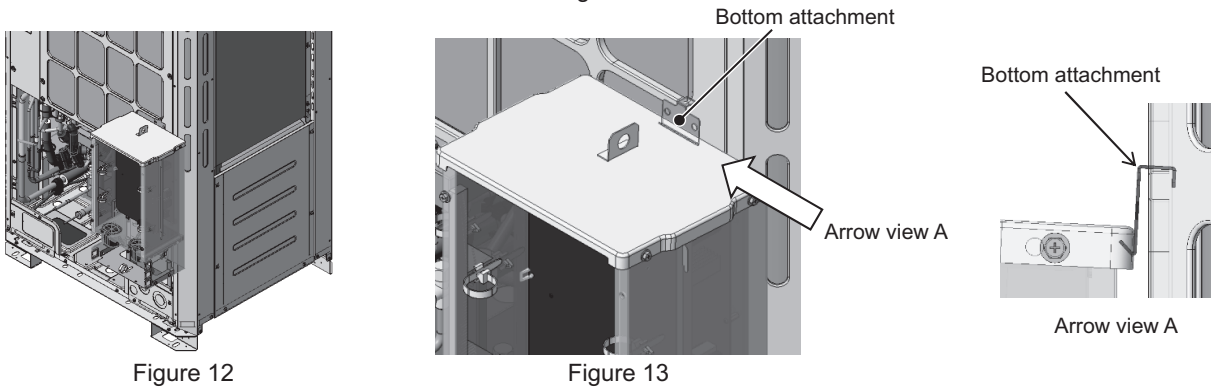


Figure 7

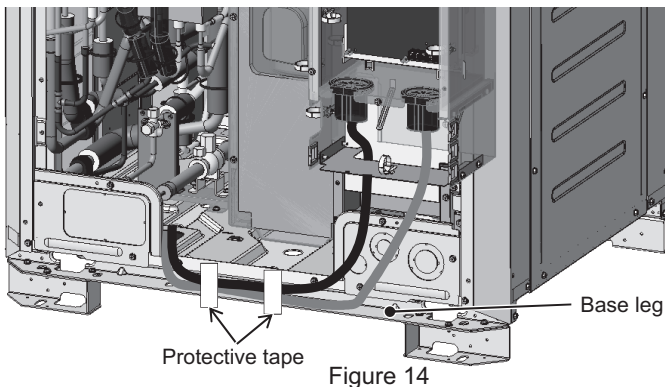
- (10) Loosen the three cable straps holding the motor wiring outside and at the bottom of the main control box, and remove the wire from the two wire saddles. (See Figure 8.)
- (11) Loosen the two cable straps holding the strong electrical wiring outside the main control box. (See Figure 9.)
- (12) Cut the cable tie and loosen the two welding clamps holding the strong electrical wiring at the bottom of the main control box. (See Figure 10.)
- (13) Unscrew the two screws holding the main control box. (See Figure 11.)



- (14) Make sure that no undue force is applied to the wires from which cable straps were removed in steps (7) through (12). Position the bottom attachment that was removed in step (5) above on the fin guard as shown in Figure 13, and then hook the main control box on the attachment as shown in Figure 12.



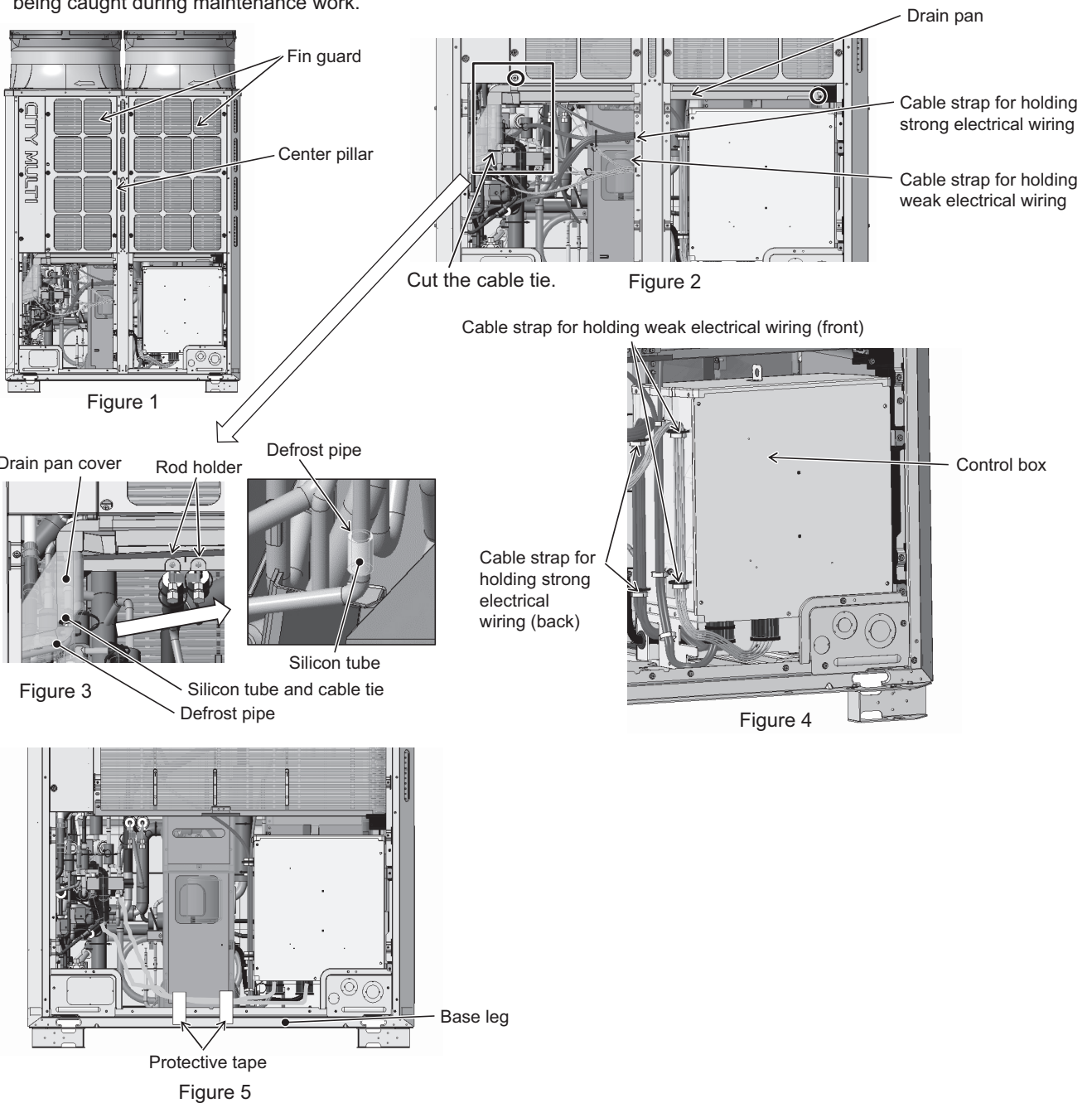
- (15) Place the excess weak and strong electrical wirings in the space at the base legs as shown in Figure 14 to keep them from being caught during maintenance work.



This step completes the procedure for ensuring maintenance space.

2. L-module

- (1) Remove the front panel from the unit by unscrewing the 14 screws. (See Figure 1.) *Figure 1 shows the unit without the front panel.
- (2) Remove the fin guard by unscrewing the 12 screws. (See Figure 1.)
- (3) Remove the cable straps holding the weak and strong electrical wirings. (See Figure 2.)
- (4) Remove the center pillar by unscrewing the five screws. (See Figure 1.)
- (5) Remove the drain pan cover by unscrewing the screw and cutting the cable tie. (See Figures 2 and 3.)
When re-placing the drain pan cover, make sure that the silicon tube is properly placed on the defrost pipe, and then fix the drain pan cover in place with a cable tie.
- (6) Remove the drain pan by unscrewing the two screws. (See Figure 2.)
Be sure to remove the two rod holders holding the check joints to the drain pan. (Figures 2 and 3 show the cable ties to be cut.)
- (7) Remove the two cable straps holding the weak electrical wiring and the two cable straps holding the strong electrical wiring from the control box. (See Figure 4.)
- (8) Place the excess weak and strong electrical wirings in the space at the base legs as shown in Figure 5 to keep them from being caught during maintenance work.



This step completes the procedure for ensuring maintenance space.

3. XL-module

Take the following procedures to ensure sufficient maintenance space and good visibility.

- (1) Remove the front panel from the unit by unscrewing the 14 screws. (See Figure 1.)
- (2) Remove the external temperature sensor wiring from the left drain pan by cutting the two cable ties. (See Figure 3.)
Unhook the pipe cover from the left drain pan. (See Figure 3.)
- (3) Remove the left drain pan by unscrewing the two screws. (See Figure 4.)
- (4) Remove the right drain pan by unscrewing the two screws. (See Figure 5.)
- (5) Remove the three cable straps from the center pillar. (See Figure 6.)
- (6) Remove the right and left fin guards and the center pillar by unscrewing the 18 screws. (See Figure 7.)

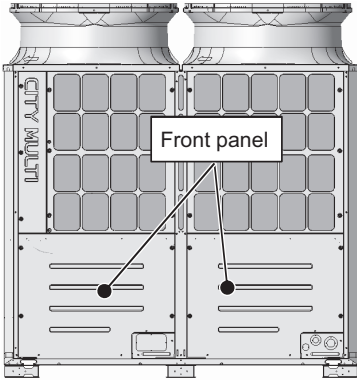


Figure 1

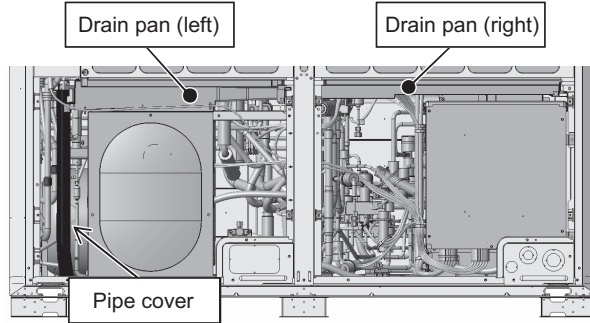


Figure 2

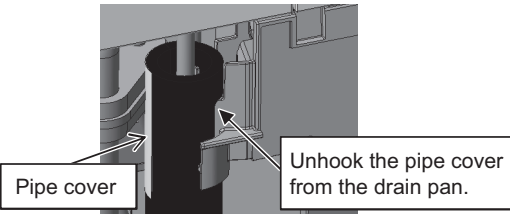
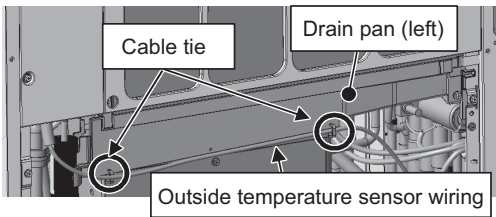


Figure 3

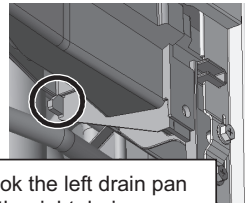
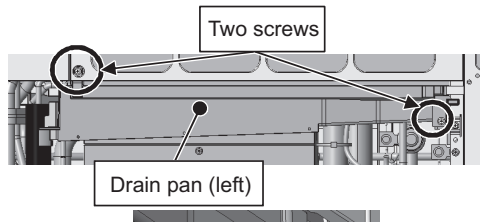


Figure 4

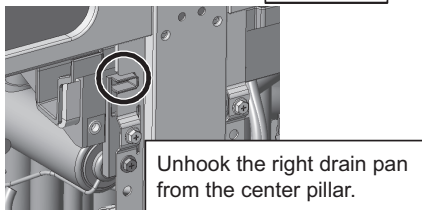
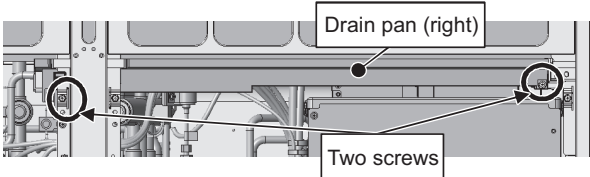


Figure 5

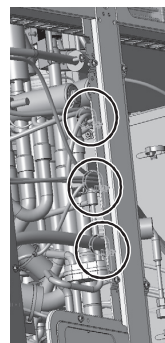


Figure 6

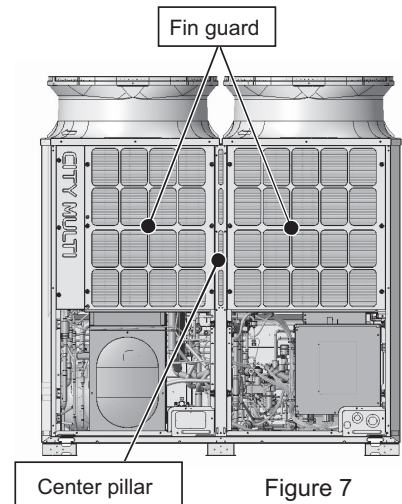


Figure 7

8-13-2 Ensuring Maintenance Space (Preparation for the Maintenance of Refrigerant Circuit Parts) <Type A1/Type A2>

1. S-module

Take the following procedures to ensure sufficient maintenance space and good visibility.

- (1) Remove the front panel from the unit by unscrewing the eight screws. (See Figure 1.) *Figure 1 shows the unit without the front panel.
- (2) Remove the drain pan cover by unscrewing the screw and cutting the cable tie. (See Figures 2 and 3.)
When re-placing the drain pan cover after the completion of maintenance work, make sure that the silicon tube is properly placed on the defrost pipe, and then fix the drain pan cover in place with a cable tie. (Figures 2 and 3 show the cable ties to be cut.)
- (3) Remove the drain pan by unscrewing the two screws. (See Figure 2.)
Be sure to remove the two rod holders holding the check joints to the drain pan. (See Figure 3.)

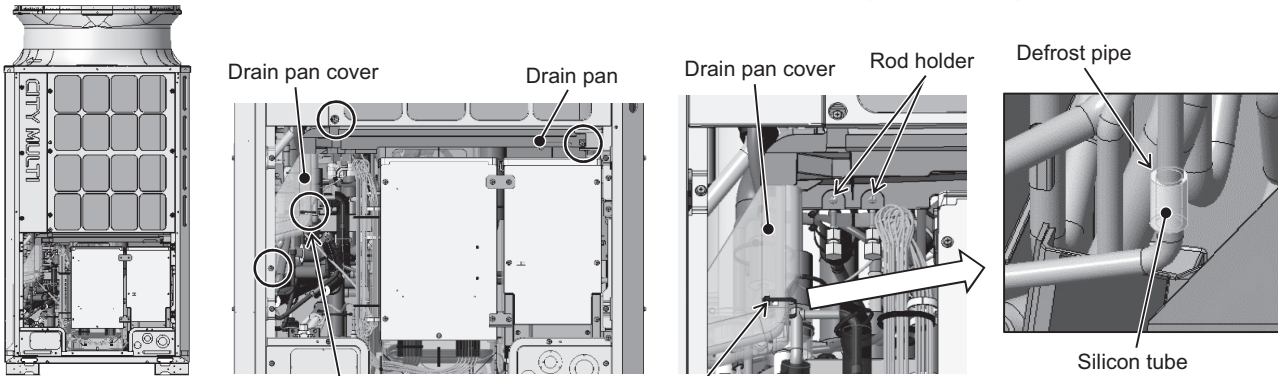


Figure 1 Cut the cable tie. Figure 2 Cut the cable tie. Figure 3

- (4) Remove the top attachment connecting the main control box and the inverter control box by unscrewing the two screws. (See Figure 4.)
- (5) Remove the bottom attachment connecting the main control box and the inverter control box by unscrewing the two screws. (See Figure 4.)
- (6) Remove the cover from the main control box by unscrewing the three screws. (See Figure 5.)
- (7) Cut the two cable ties holding the weak electrical wiring inside the main control box in place, and loosen the four cable straps holding the weak and strong electrical wirings. (See Figure 6.)
- (8) Cut the two cable ties holding the rubber bush at the bottom of the main control box. (See Figure 6.)
- (9) Cut the three cable ties and loosen the two cable straps holding the weak electrical wiring outside the main control box. (See Figure 7.)

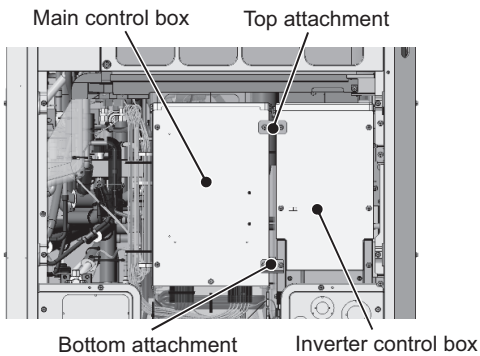


Figure 4

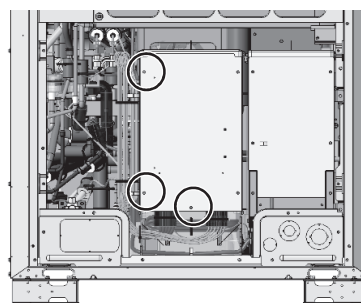


Figure 5

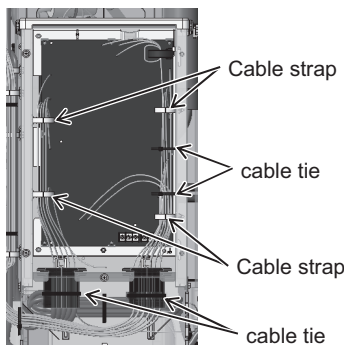


Figure 6

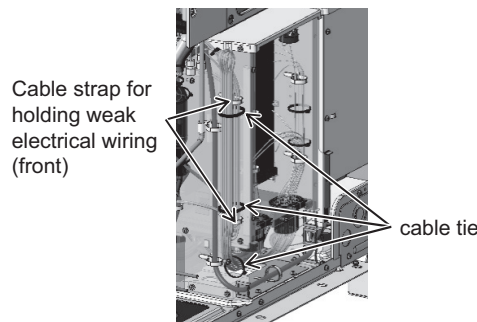
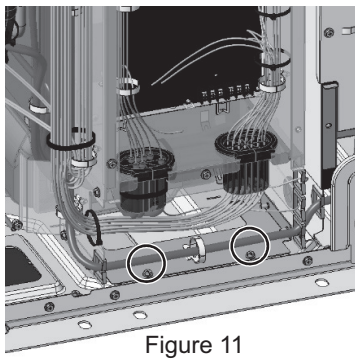
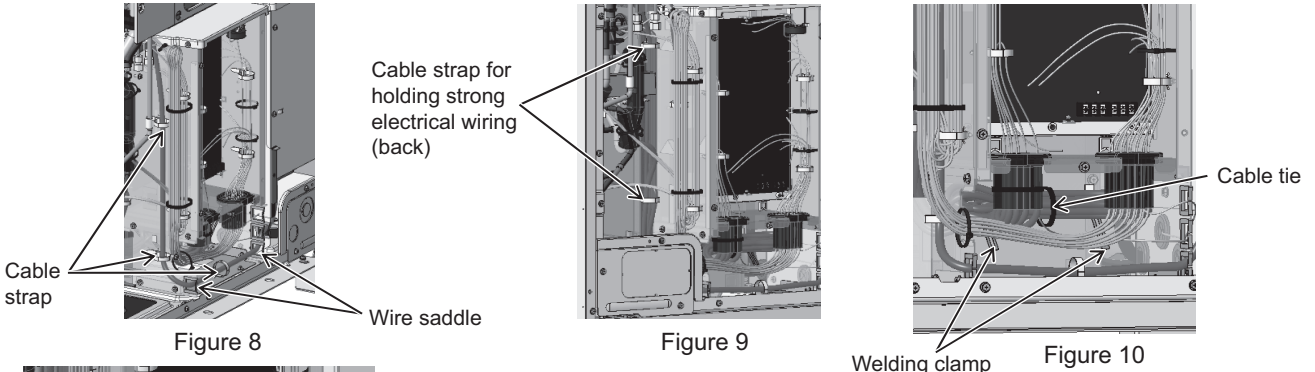
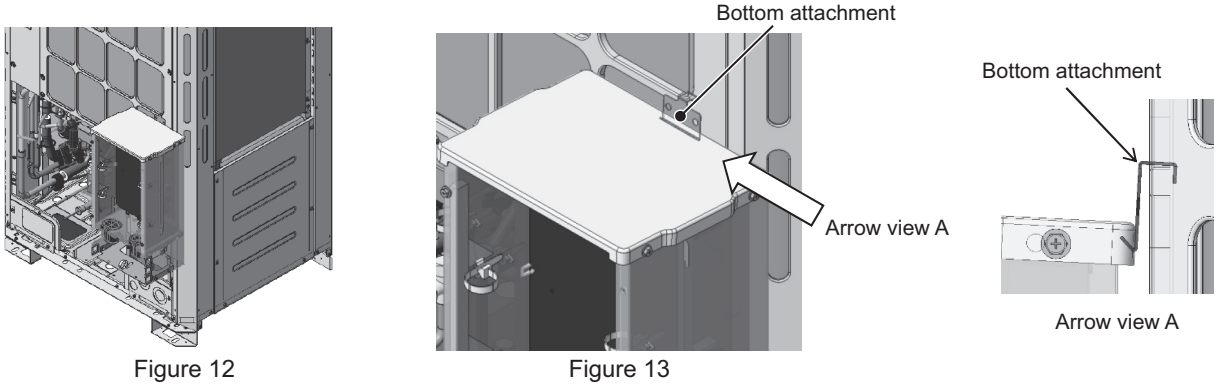


Figure 7

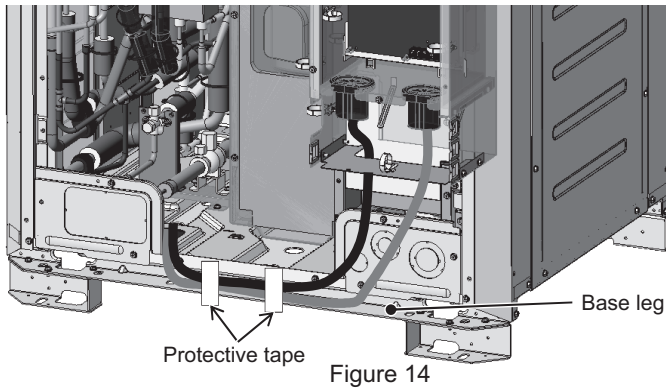
- (10) Loosen the three cable straps holding the motor wiring outside and at the bottom of the main control box, and remove the wire from the two wire saddles. (See Figure 8.)
- (11) Loosen the two cable straps holding the strong electrical wiring outside the main control box. (See Figure 9.)
- (12) Cut the cable tie and loosen the two welding clamps holding the strong electrical wiring at the bottom of the main control box. (See Figure 10.)
- (13) Unscrew the two screws holding the main control box. (See Figure 11.)



- (14) Make sure that no undue force is applied to the wires from which cable straps were removed in steps (7) through (12). Position the bottom attachment that was removed in step (5) above on the fin guard as shown in Figure 13, and then hook the main control box on the attachment as shown in Figure 12.



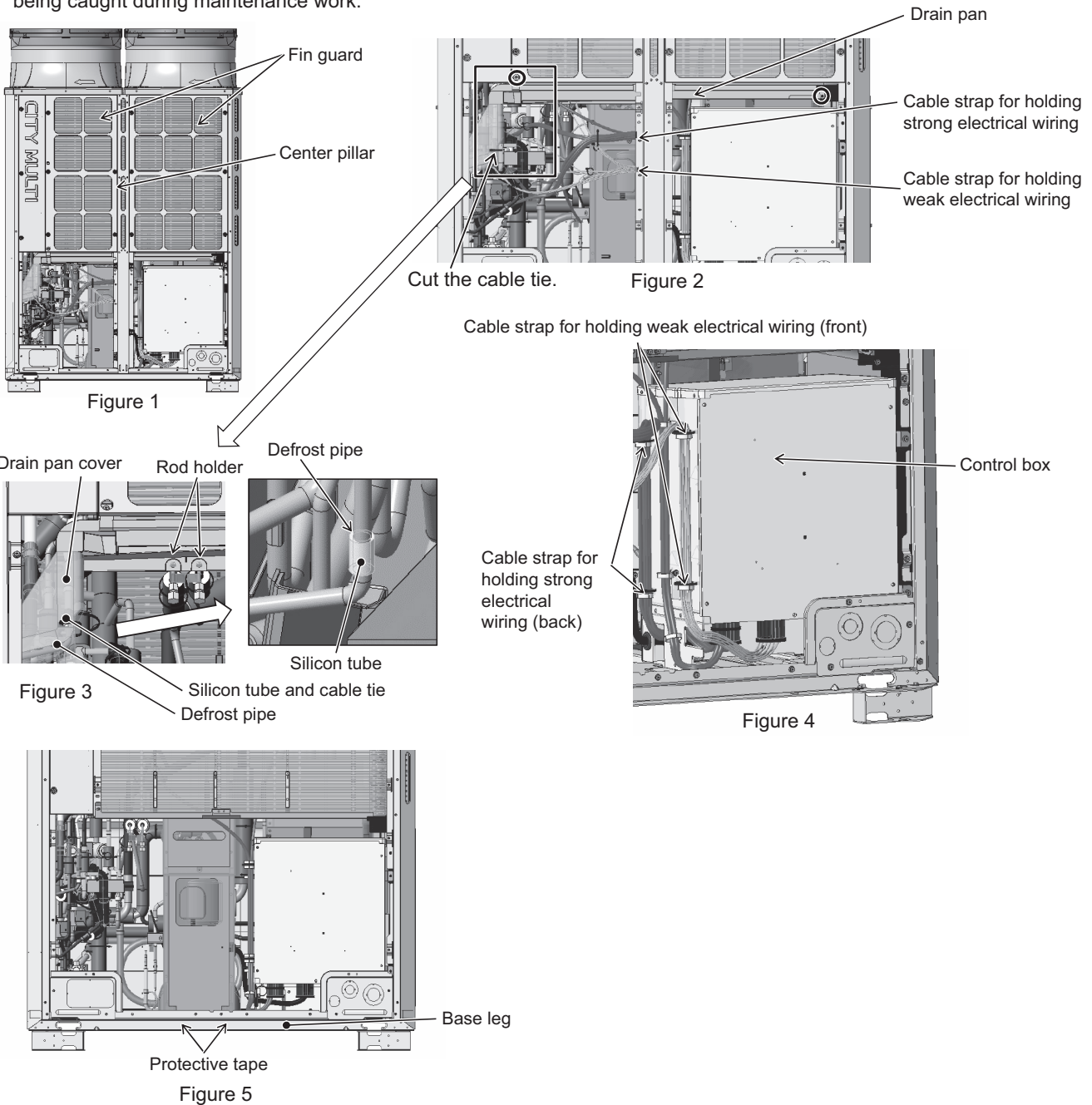
- (15) Place the excess weak and strong electrical wirings in the space at the base legs as shown in Figure 14 to keep them from being caught during maintenance work.



This step completes the procedure for ensuring maintenance space.

2. L-module

- (1) Remove the front panel from the unit by unscrewing the 14 screws. (See Figure 1.) *Figure 1 shows the unit without the front panel.
- (2) Remove the fin guard by unscrewing the 12 screws. (See Figure 1.)
- (3) Remove the cable straps holding the weak and strong electrical wirings. (See Figure 2.)
- (4) Remove the center pillar by unscrewing the five screws. (See Figure 1.)
- (5) Remove the drain pan cover by unscrewing the screw and cutting the cable tie. (See Figures 2 and 3.)
When re-placing the drain pan cover, make sure that the silicon tube is properly placed on the defrost pipe, and then fix the drain pan cover in place with a cable tie.
- (6) Remove the drain pan by unscrewing the two screws. (See Figure 2.)
Be sure to remove the two rod holders holding the check joints to the drain pan. (Figures 2 and 3 show the cable ties to be cut.)
- (7) Remove the two cable straps holding the weak electrical wiring and the two cable straps holding the strong electrical wiring from the control box. (See Figure 4.)
- (8) Place the excess weak and strong electrical wirings in the space at the base legs as shown in Figure 5 to keep them from being caught during maintenance work.



This step completes the procedure for ensuring maintenance space.

3. XL-module

Take the following procedures to ensure sufficient maintenance space and good visibility.

- (1) Remove the front panel from the unit by unscrewing the 14 screws. (See Figure 1.)
- (2) Remove the external temperature sensor wiring from the left drain pan by cutting the two cable ties. (See Figure 3.)
Unhook the pipe cover from the left drain pan. (See Figure 3.)
- (3) Remove the left drain pan by unscrewing the two screws. (See Figure 4.)
- (4) Remove the right drain pan by unscrewing the two screws. (See Figure 5.)
- (5) Remove the three cable straps from the center pillar. (See Figure 6.)
- (6) Remove the right and left fin guards and the center pillar by unscrewing the 18 screws. (See Figure 7.)

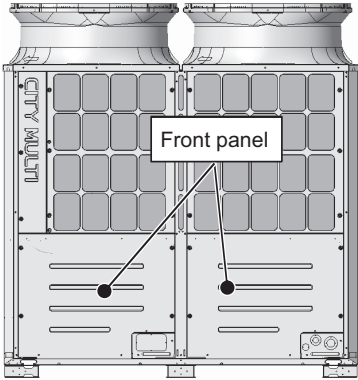


Figure 1

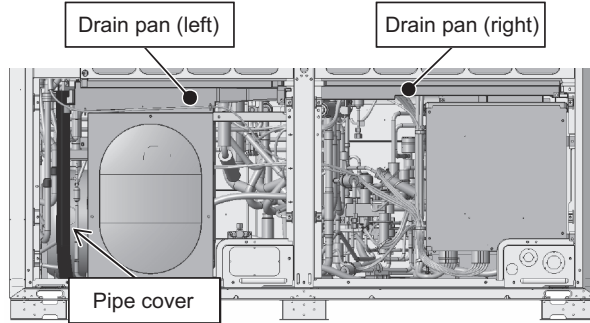


Figure 2

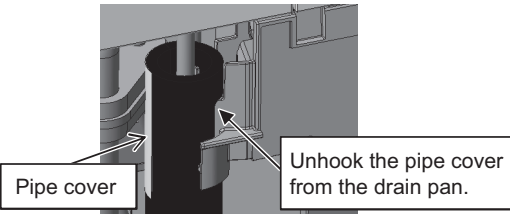
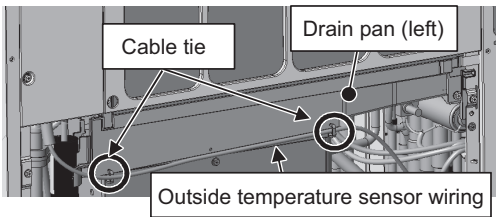


Figure 3

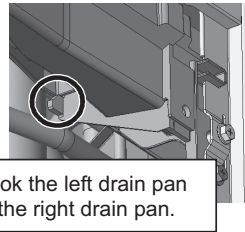
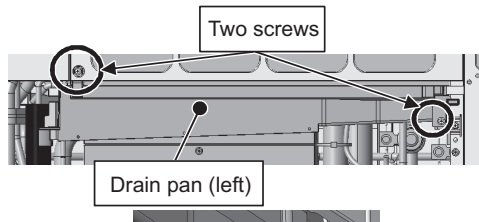


Figure 4

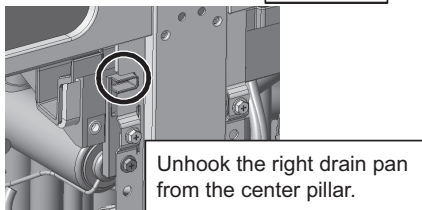
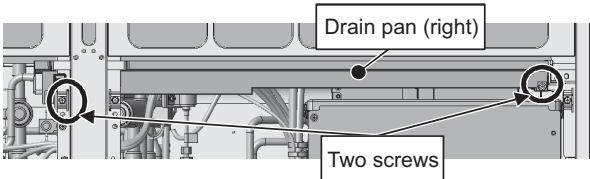


Figure 5

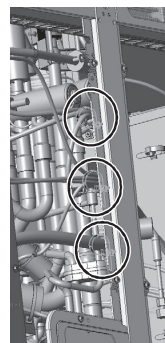


Figure 6

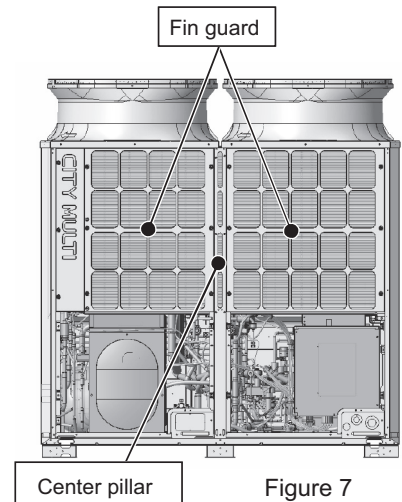


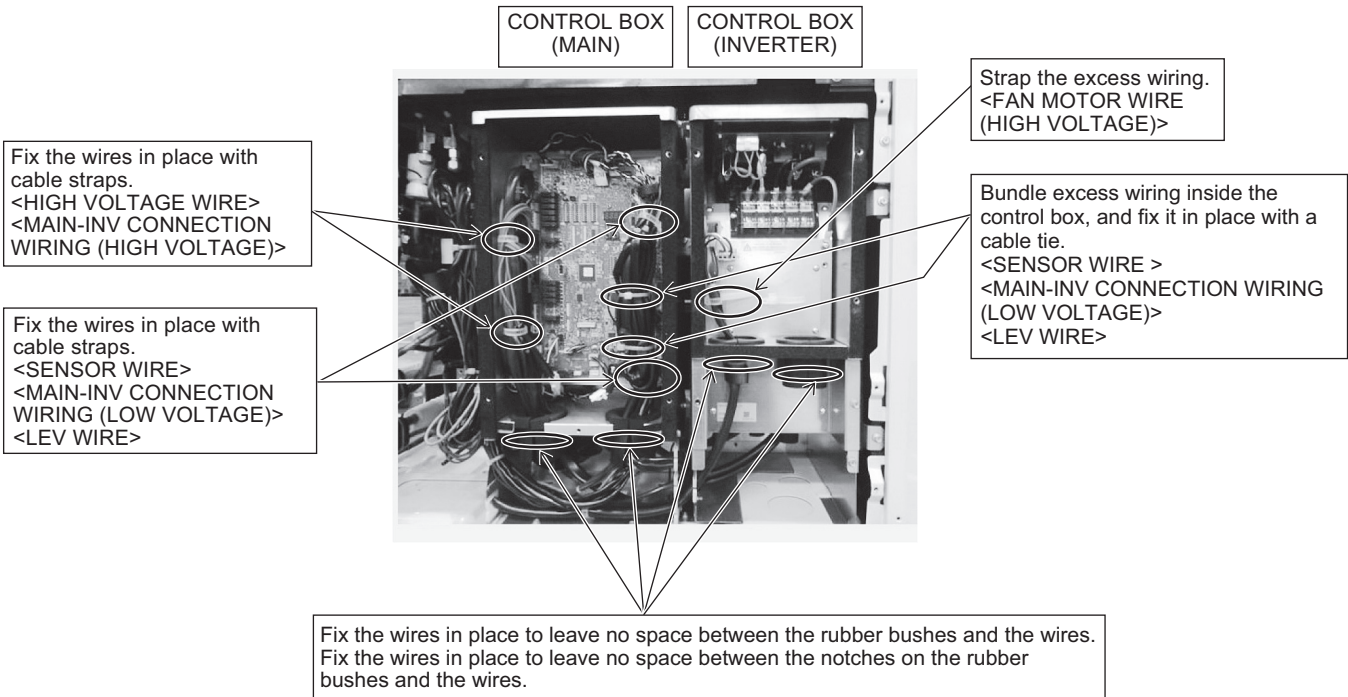
Figure 7

8-13-3 Notes on Wiring Installation <Type A/Type A1/Type A2>

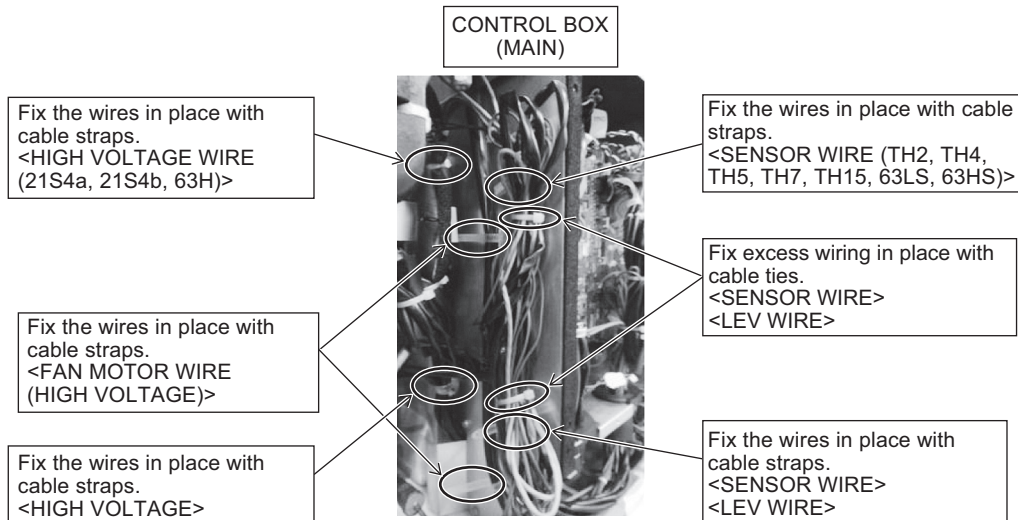
- If wiring was disconnected during maintenance, reconnect the wiring as follows.
- Isolate the strong and the weak electrical wiring to avoid noise interference.

(1) S-module

FRONT VIEW

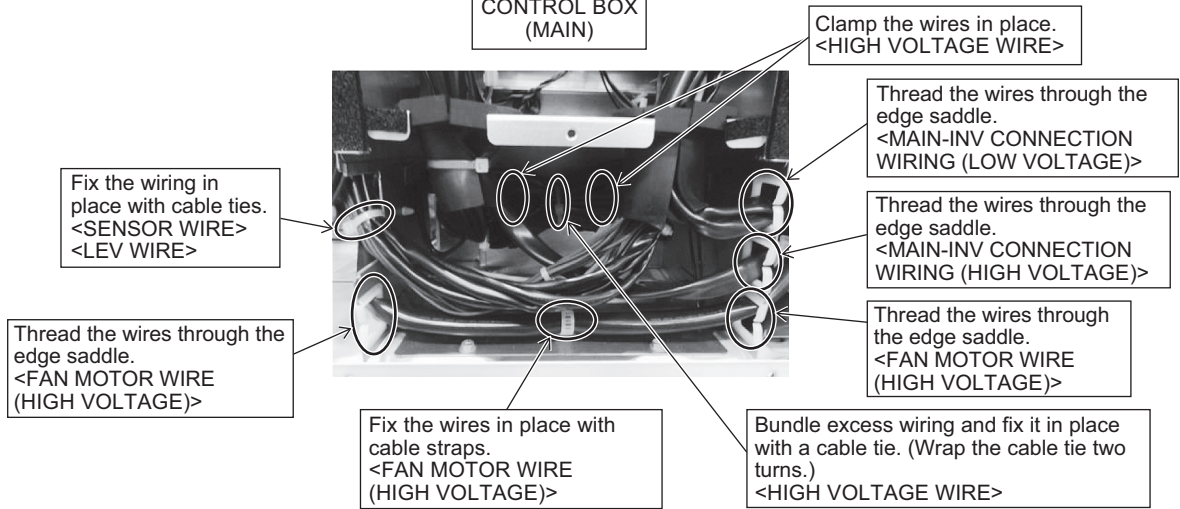


LEFT VIEW



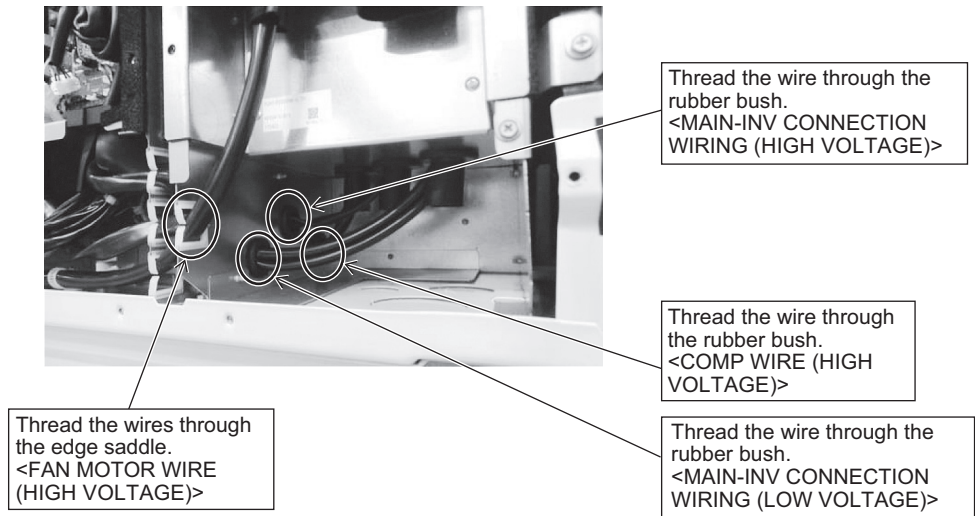
BOTTOM VIEW

CONTROL BOX
(MAIN)



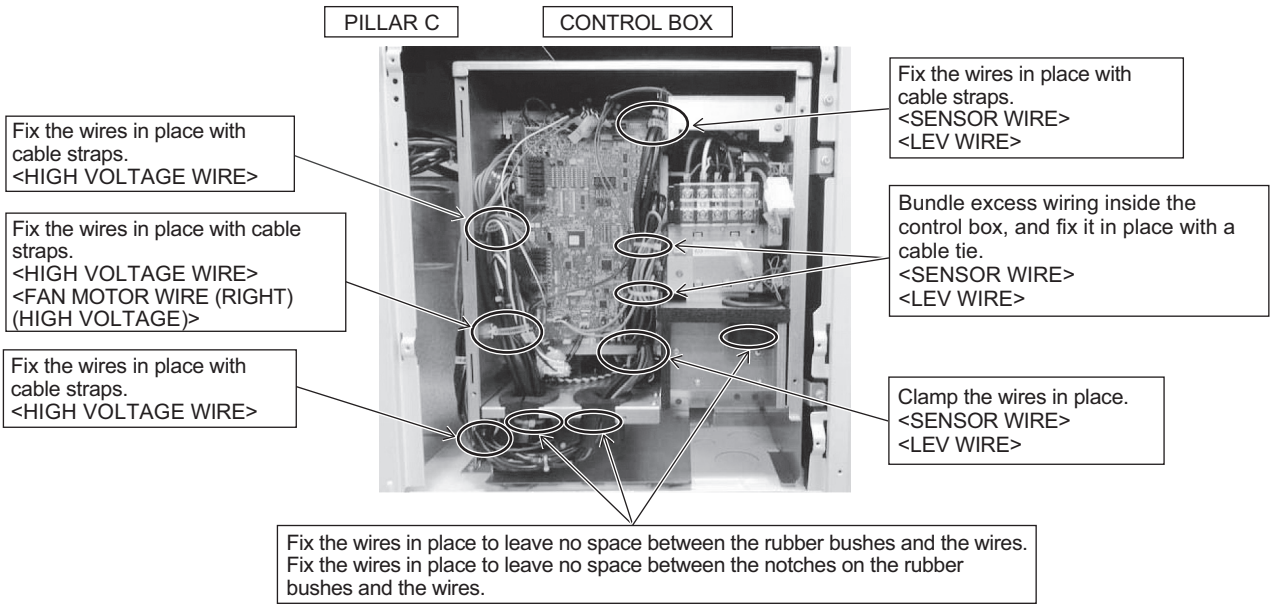
BOTTOM VIEW

CONTROL BOX
(INVERTER)

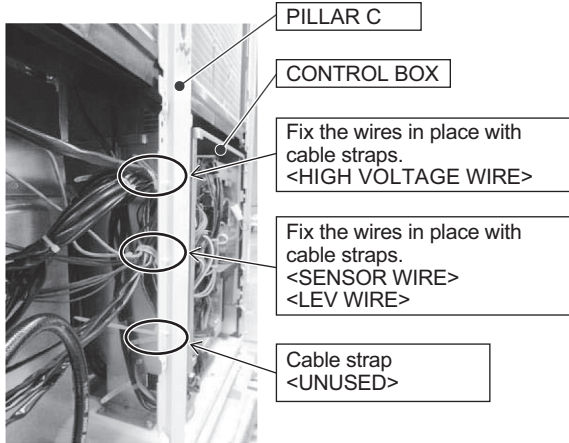


(2) L-module

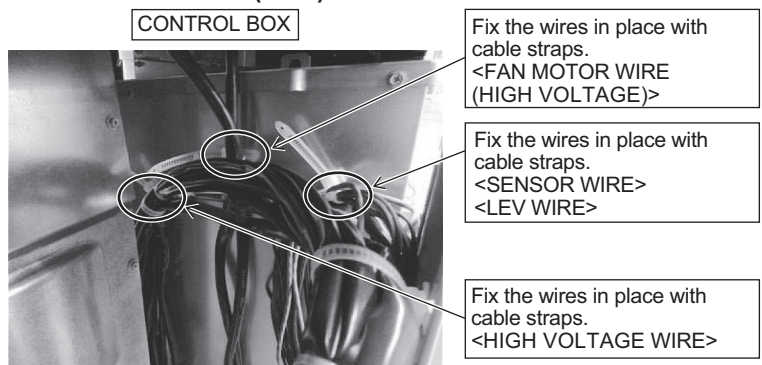
FRONT VIEW



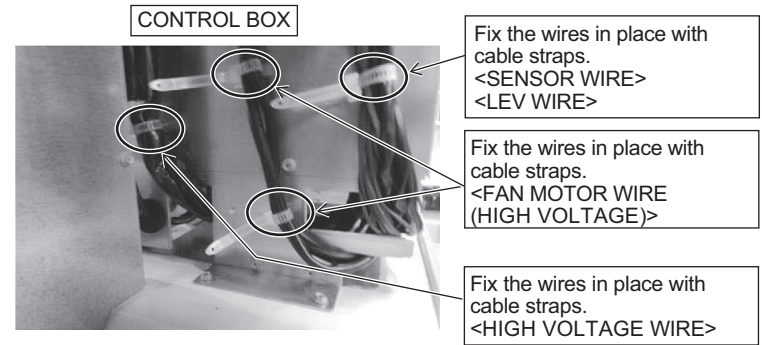
LEFT VIEW



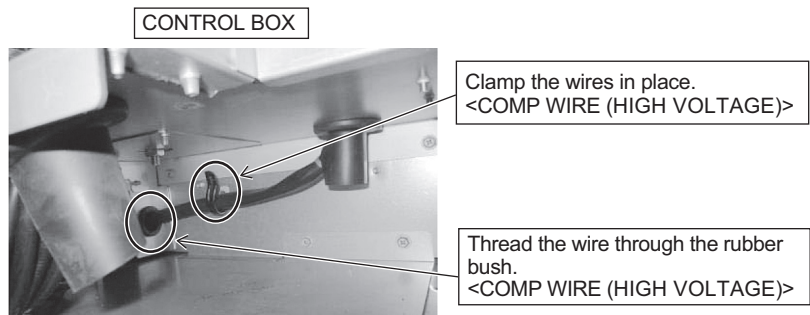
LEFT VIEW (TOP)



LEFT VIEW (BOTTOM)



BOTTOM VIEW



(3) XL-module

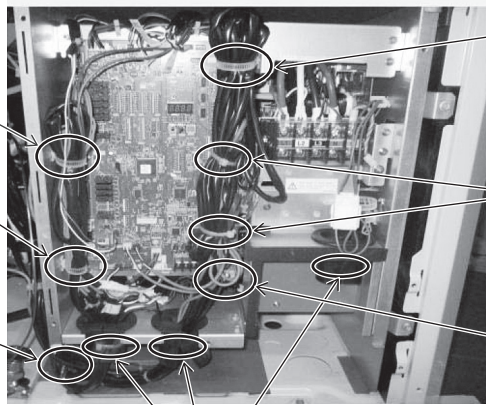
FRONT VIEW

CONTROL BOX

Fix the wires in place with cable straps.
<HIGH VOLTAGE WIRE>

Fix the wires in place with cable straps.
<HIGH VOLTAGE WIRE>
<FAN MOTOR WIRE (RIGHT) (HIGH VOLTAGE)>

Fix the wires in place with cable straps.
<HIGH VOLTAGE WIRE>



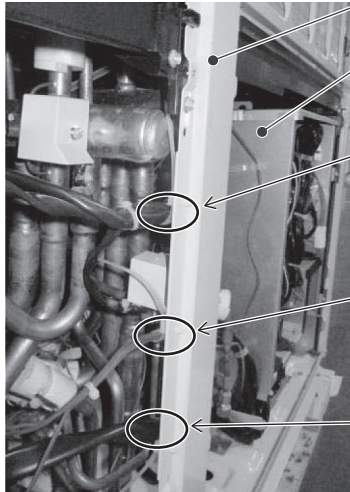
Fix the wires in place with cable straps.
<SENSOR WIRE>
<LEV WIRE>

Bundle excess wiring inside the control box, and fix it in place with a cable tie.
<SENSOR WIRE>
<LEV WIRE>

Clamp the wires in place.
<SENSOR WIRE>
<LEV WIRE>

Fix the wires in place to leave no space between the rubber bushes and the wires.
Fix the wires in place to leave no space between the notches on the rubber bushes and the wires.

LEFT VIEW



PILLAR C

CONTROL BOX

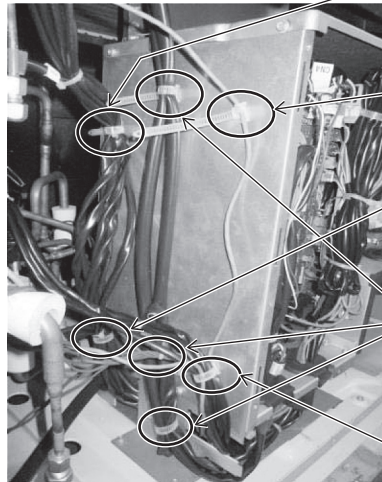
Fix the wires in place with cable straps.
<HIGH VOLTAGE WIRE (21S4a, 21S4c, SV1a, SV2)>

Fix the wires in place with cable straps.
<SENSOR WIRE (TH4, 5, 7, 15)>

Fix the wires in place with cable straps.
<COMP WIRE (HIGH VOLTAGE)>

LEFT VIEW

CONTROL BOX



Fix the wires in place with cable straps.
<HIGH VOLTAGE (21S4a, 21S4b, 21S4c, SV1a, SV2, 63H)>

Fix the wires in place with cable straps.
<63HS WIRE>

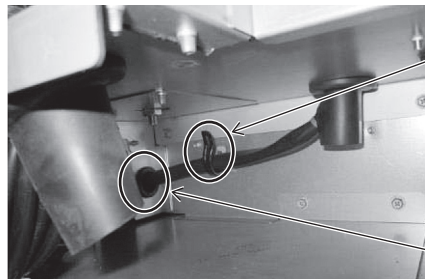
Fix the wires in place with cable straps.
<HIGH VOLTAGE WIRE>

Fix the wires in place with cable straps.
<FAN MOTOR WIRE (HIGH VOLTAGE)>

Fix the wires in place with cable straps.
<SENSOR WIRE>
<LEV WIRE>

BOTTOM VIEW

CONTROL BOX



Clamp the wires in place.
<COMP WIRE (HIGH VOLTAGE)>

Thread the wire through the rubber bush.
<COMP WIRE (HIGH VOLTAGE)>

8-13-4 Four-way Valve and Check Valve Replacement Procedure <Type A>

1. S, L-module (four-way valve (21S4a))

Explained below is the procedure for replacing four-way valve (21S4a) (on the right when seen from the front of the unit). Secure sufficient work space before starting maintenance work. (See 8-13-1 Ensuring Maintenance Space (Preparation for the Maintenance of Refrigerant Circuit Parts) <Type A>.)

- (1) Remove the top compressor cover by unscrewing the three screws. (See Figure 1.)
Remove the compressor cover by unhooking the hooks on the back.
- (2) Remove the front compressor cover by unscrewing the four screws. (See Figure 2.)
- (3) Cut the two cable ties holding TH4 and TH15, and remove the wiring from the rubber bush on the left compressor cover. (See Figure 3.)
- (4) Remove the left compressor cover by unscrewing the two screws. (See Figure 4.)

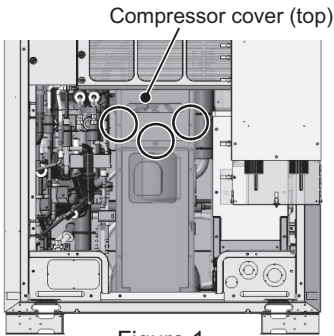


Figure 1

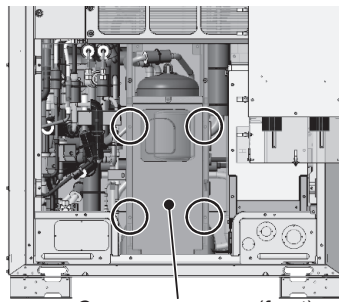


Figure 2

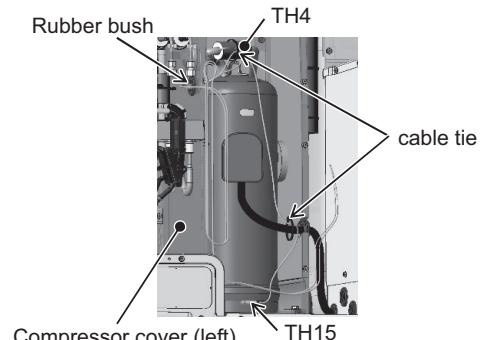


Figure 3

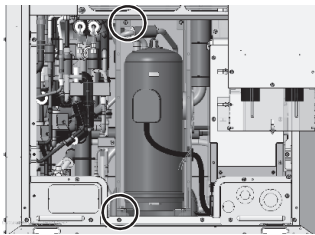


Figure 4

- (5) Remove the plastic cover and the coil holding solenoid valves 2, 9, and 10 (SV2, 9, and 10). Remove the thermal insulation shown in Figure 5. (See Figure 5.)

Solenoid valve coils 2, 9, and 10 (SV2, 9, and 10) and coil cover

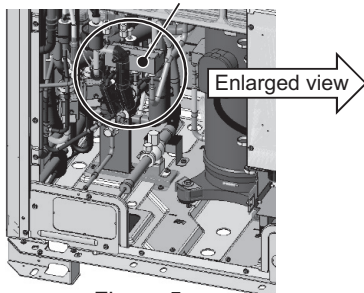
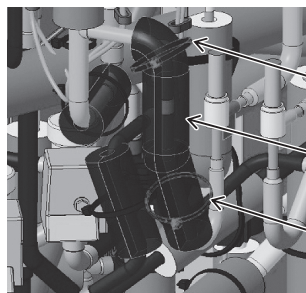


Figure 5



Cut the cable tie here.

Thermal insulation (180 mm x 70 mm x 10 mm thick)
*Included with the four-way valve replacement parts
Use the insulation material included with the four-way valve.

Cut the cable tie here.

- (6) Cut the cable tie on the rubber spacer to remove it. (See Figure 6.)

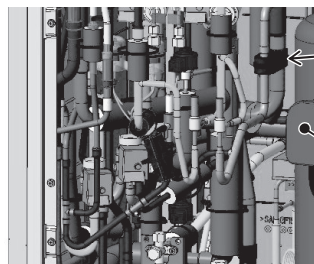
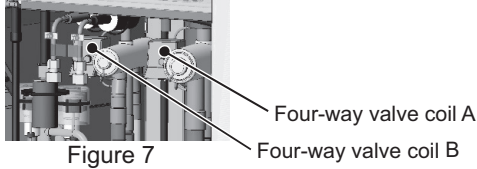


Figure 6

(7) Remove the plastic cover and the coil holding the four-way valve. (See Figure 7.)

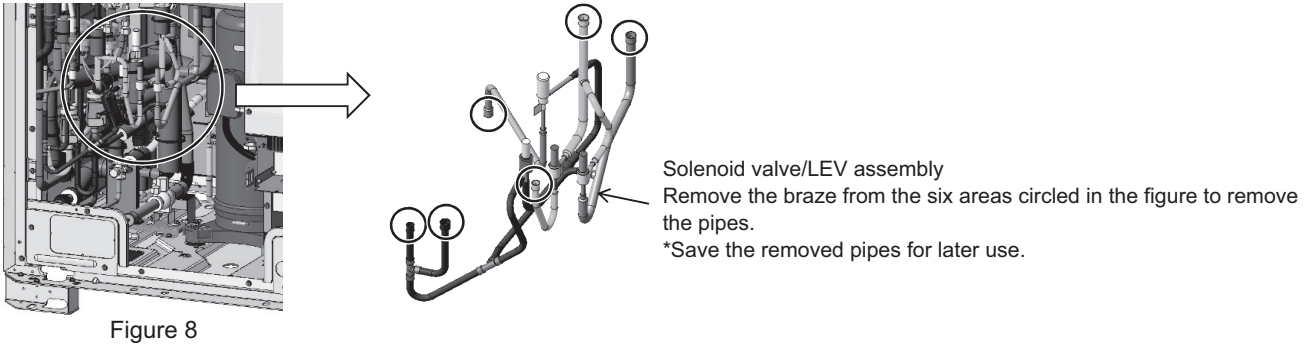


*Notes on replacing refrigerant circuit components (check valve, four-way valve, solenoid valve, and LEV)

- Be sure to perform non-oxidized brazing.
- Before heating the pipes, wrap the refrigerant circuit components with a wet towel to keep the temperature of the components from rising above 120°C.
- After brazing is done, check that the brazing is done properly and check for leaks before vacuum-drying the pipes.
- Direct the brazing torch flame away from the wiring and sheet metals inside the unit not to damage them.
- Wet felt sheets listed below (or its equivalent), and place them around the areas to be brazed to protect the heat exchanger, pipes, and pipe covers from being damaged from the brazing torch flame.
 Recommended felt sheets: Spatter felt 50CF-11 (5t x 1 m x 1 m) by TRUSCO Nakayama
 Felt sheets that meet the JIS standard (JIS A 1323 type A "Flame retardant testing method for spark droplets of welding and gas cutting on fabric sheets in construction works")

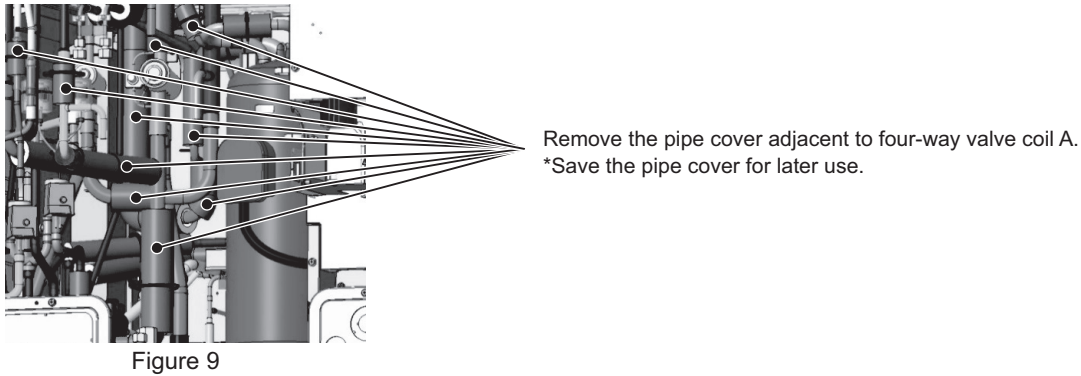
(8) Remove the solenoid valve and the LEV assembly at the front of the four-way valve at the brazed sections to ensure good visibility of the four-way valve.

Either remove or protect the solenoid valve coil, TH and LEV wirings, pipe cover, and plastic components to keep them from being damaged by the torch flame. (Remove the components by removing the braze from the six areas shown in Figure 8.)

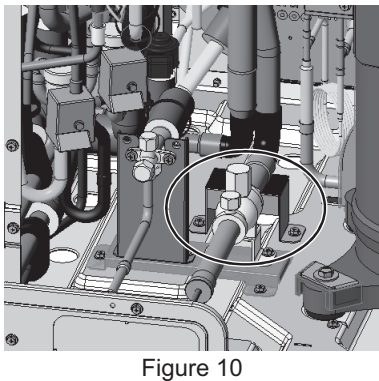


Replacement procedure for four-way valve (21S4a)

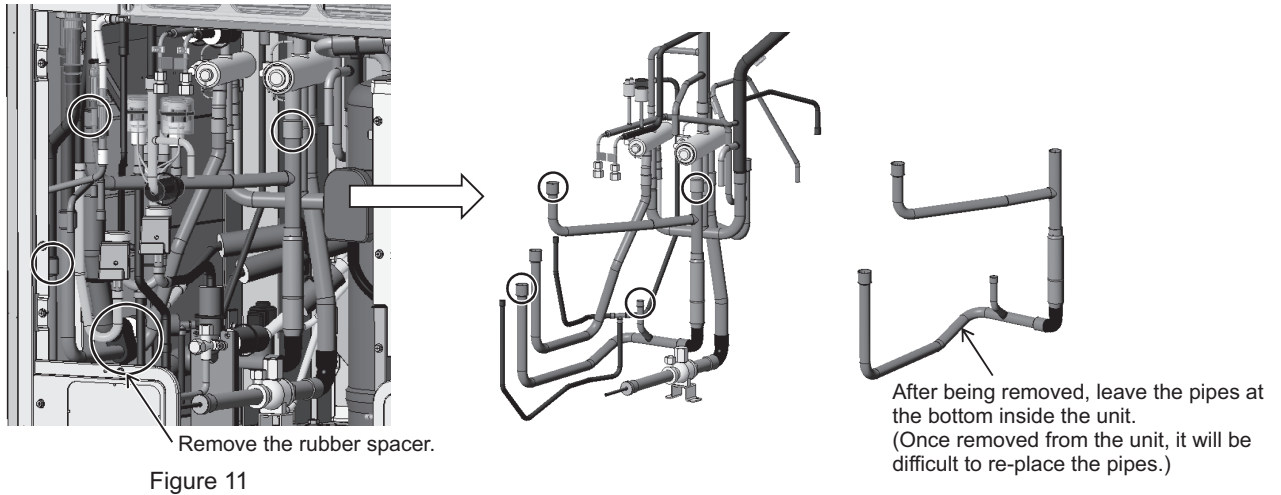
(9A) Remove the pipe covers adjacent to four-way valve (21S4a). (See Figure 9.)



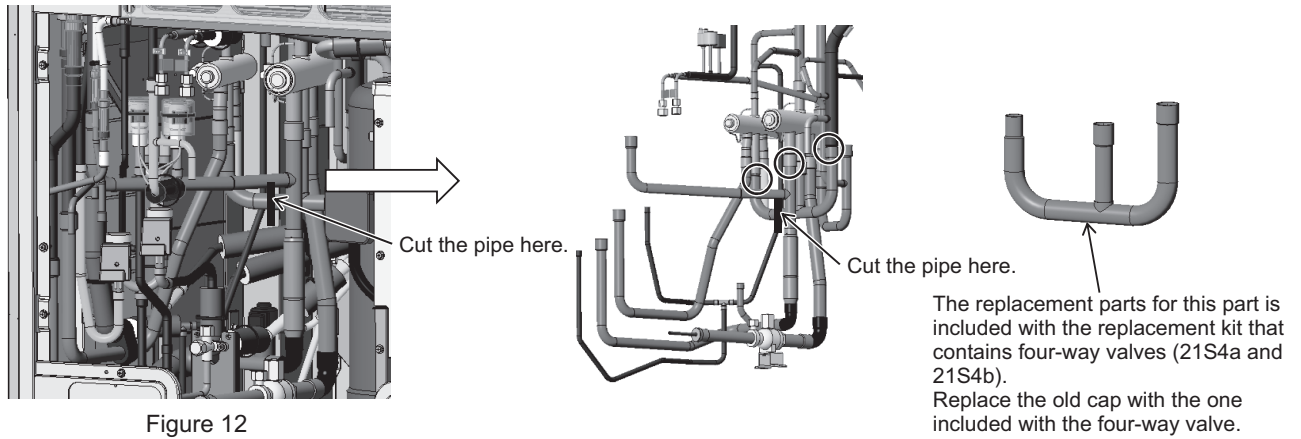
(10A) Remove the sheet metal screwed to the base below four-way valve (21S4a) by unscrewing the two screws. (See Figure 10.)



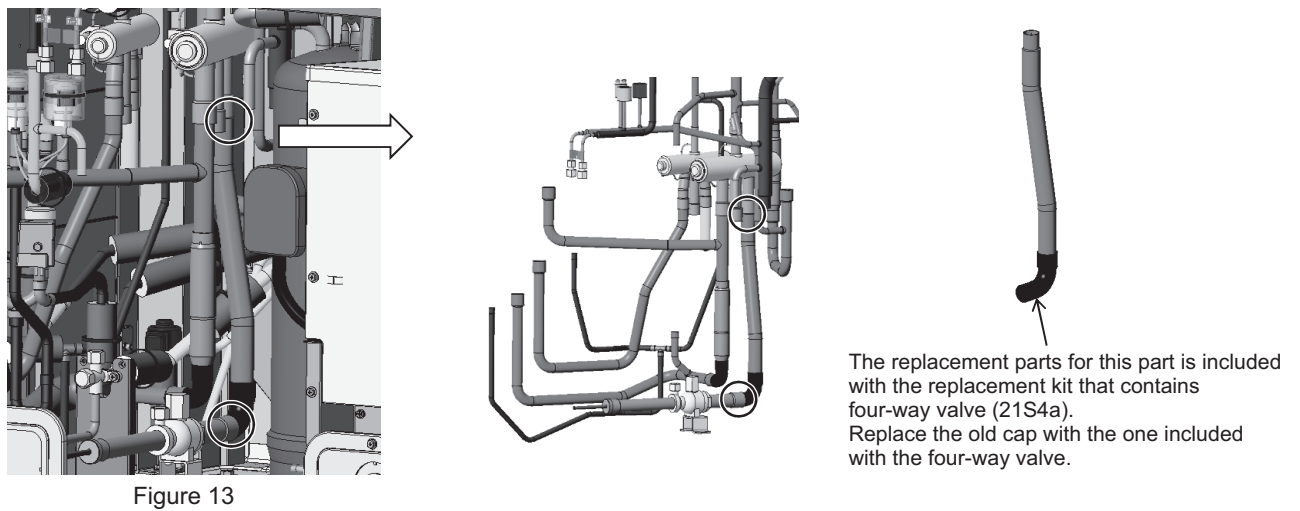
(11A) Remove the pipe below four-way valve (21S4a) and on the front by removing the braze at the four areas shown in Figure 11.



(12A) Cut the pipe below four-way valve (21S4a) and in the middle with a pipe cutter as shown in the figure. After cutting the pipe where indicated in the figure, remove the braze at the three areas shown in Figure 12.



(13A) Remove the pipe below four-way valve (21S4a) and on the back by removing the braze at the two areas on the bottom of the pipe shown in Figure 13. Then, remove the braze at the areas on the top of the pipe.



(14A) Remove four-way valve (21S4a) by removing the braze from the area above four-way valve (21S4a) as shown in Figure 14.

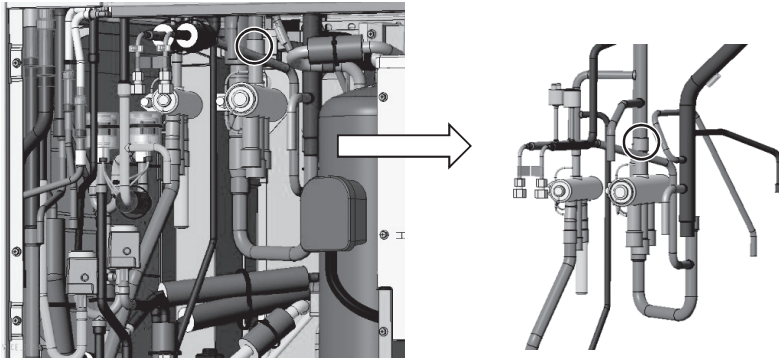
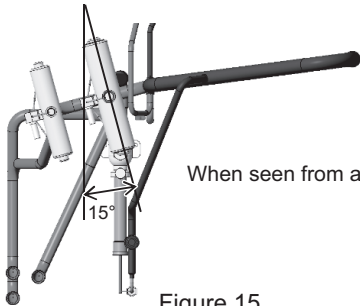


Figure 14

(15A) Mount a new four-way valve (21S4a). Figure 15 shows how to position a new four-way valve.



When seen from above, four-way valves (21S4a and 21S4b) are tilted by 15°.

Figure 15

(16A) To make it easier to connect four-way valve (21S4a), cut the pipe end below the raised hole (cut off the section covered with brazing filler) on the pipe with a pipe cutter. Cut the pipe with an expanded end that is included with four-way valve (21S4a) to the same length as the pipe that was removed from the on-site pipe. (See Figure 16.)

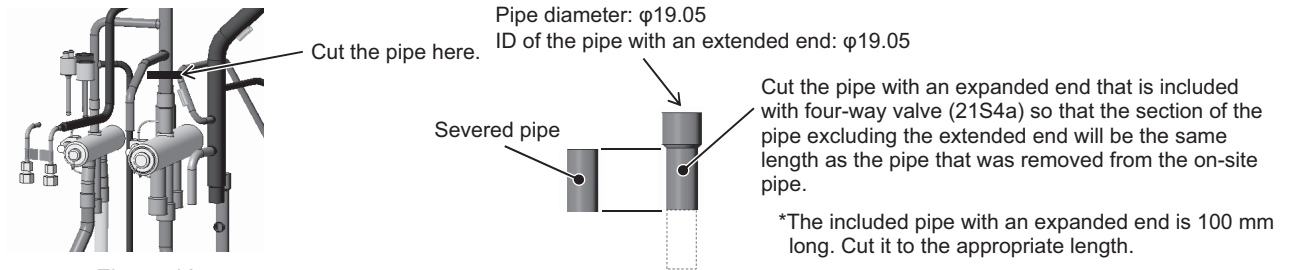


Figure 16

(17A) Mount four-way valve (21S4a) to the pipe below four-way valve (21S4a) and on the back. A total of four areas require brazing, including the area indicated in (16A) and the areas indicated in Figure 17.

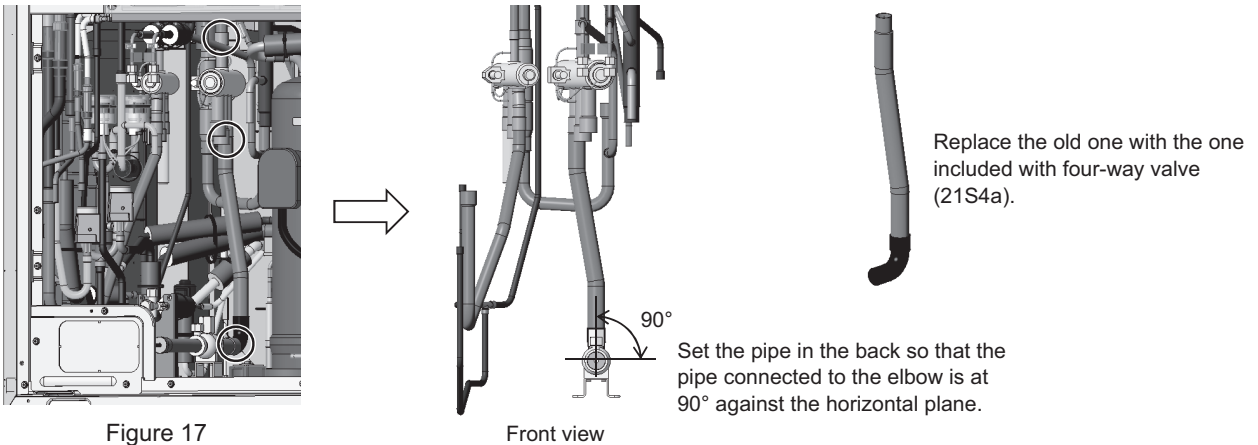


Figure 17

Front view

Set the pipe in the back so that the pipe connected to the elbow is at 90° against the horizontal plane.

(18A) Mount four-way valve (21S4a) to the pipe below four-way valve A and in the middle by brazing at the three areas. (See Figure 18.)

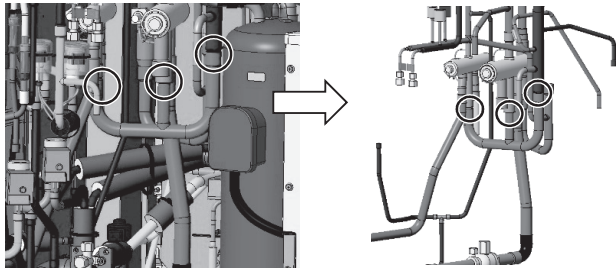
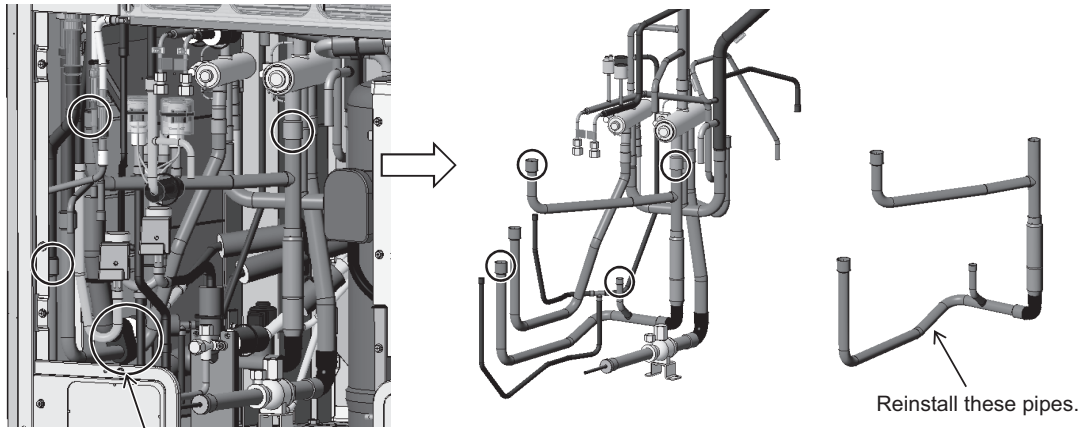


Figure 18

(19A) Mount four-way valve (21S4a) to the pipe below four-way valve (21S4a) and on the front by brazing at the four areas. (See Figure 19.)



Re-place the rubber spacer.

Figure 19

This step completes the replacement procedure for four-way valve (21S4a). Re-place the solenoid valve and LEV assembly that were removed in step (8) and all the pipe covers that were removed during the maintenance work as they were.

2. S, L-module (four-way valve (21S4b))

Explained below is the procedure for replacing four-way valve (21S4b) (on the left when seen from the front of the unit). Secure sufficient work space before starting maintenance work. (See 8-13-1 Ensuring Maintenance Space (Preparation for the Maintenance of Refrigerant Circuit Parts) <Type A>.)

(20B) Follow the same procedures ((1) through (8), (9A), and (12A)) for replacing four-way valve (21S4a).

(21B) Remove the pipe below four-way valve (21S4b) and on the front by removing the braze at the two areas shown in Figure 20.

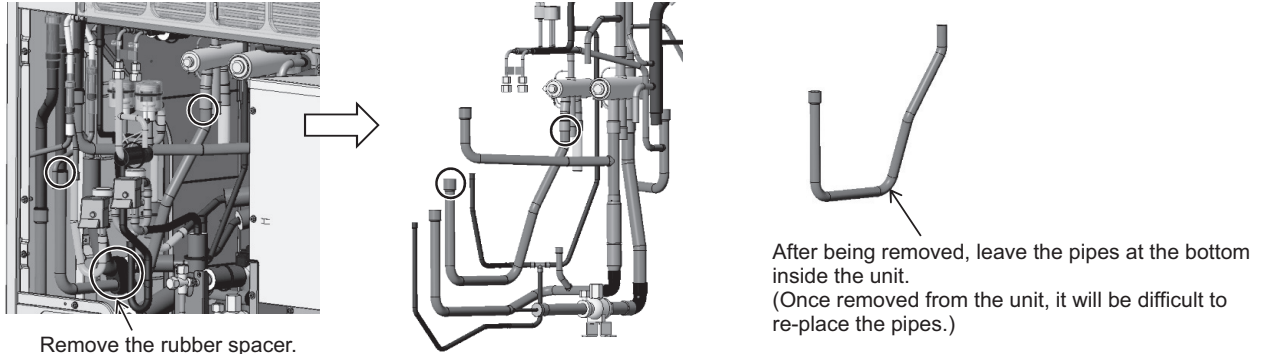


Figure 20

(22B) Remove four-way valve (21S4b) by removing the braze from the area above four-way valve (21S4b) as shown in Figure 21.

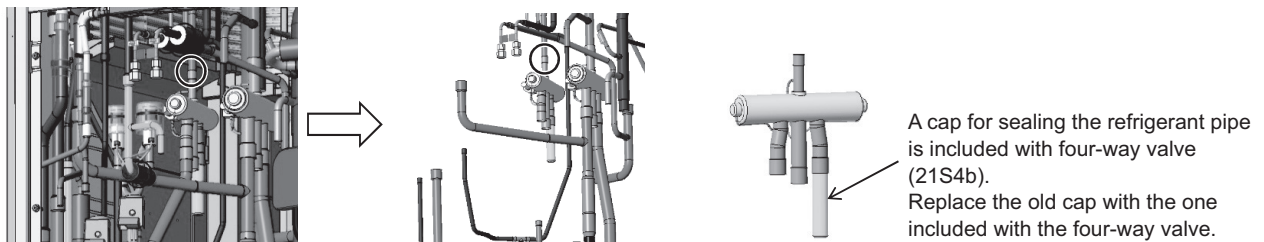


Figure 21

(23B) To make it easier to connect four-way valve (21S4b), cut the pipe end below the raised hole (cut off the section covered with brazing filler) on the pipe with a pipe cutter. Cut the pipe with an expanded or narrowed end that is included with four-way valve (21S4b) to the same length as the pipe that was removed from the on-site pipe. (See Figure 22.)

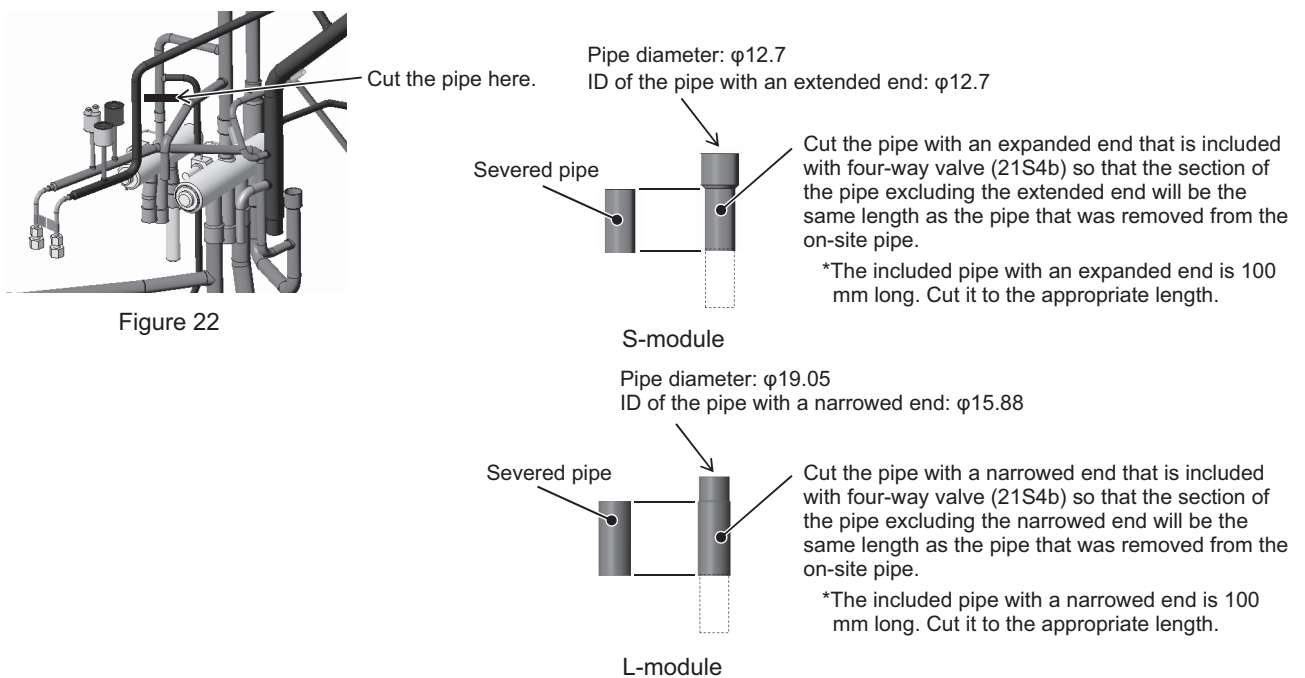


Figure 22

(24B) Mount four-way valve (21S4b) to the pipe below four-way valve (21S4b) and in the middle. A total of five areas require brazing, including the area indicated in (23B) and the areas indicated in Figure 23. Mount four-way valve (21S4b) horizontal to four-way valve (21S4a) as shown in (15A).

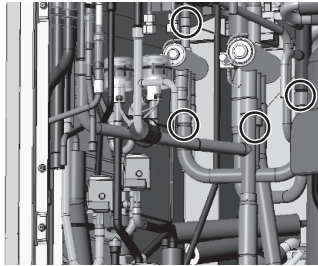
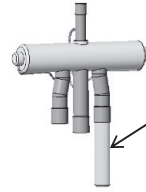
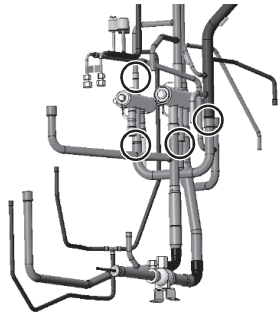
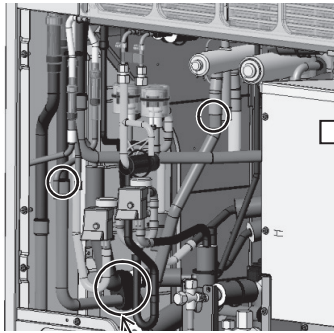


Figure 23



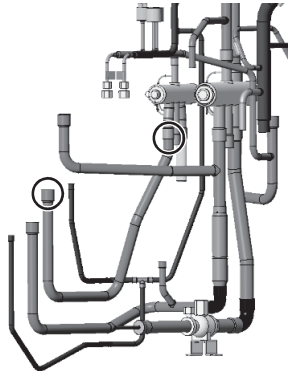
When installing four-way valve (21S4b), first braze the pipe outside the unit and then install it to the unit.

(25B) Install the pipe below four-way valve (21S4b) and on the front by brazing at the two areas shown in Figure 24.



Re-place the rubber spacer.

Figure 24



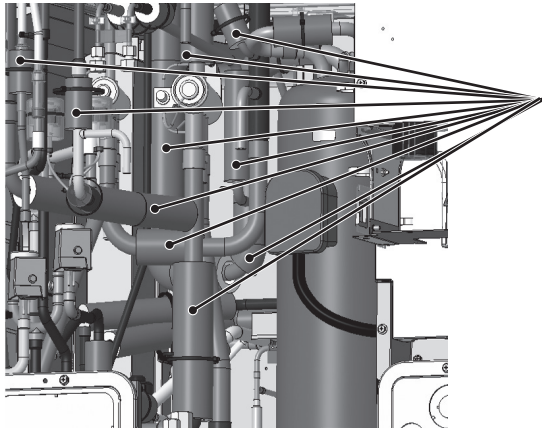
Reinstall these pipes.

This step completes the replacement procedure for four-way valve (21S4b). Re-place the solenoid valve and LEV assembly that were removed in step (8) and all the pipe covers that were removed during the maintenance work as they were.

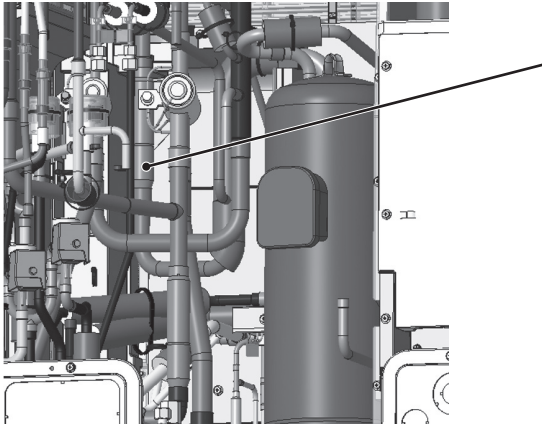
3. Replacing check valve (CV1) (S and L modules)

Follow the procedures below to remove check valve (CV1) located in the back of the four-way valve.

- (1) Follow the steps (1) through (9A) under item 1. S, L-module under 8-13-4 Four-way Valve and Check Valve Replacement Procedure <Type A> to Create Access to Check Valve (CV1).

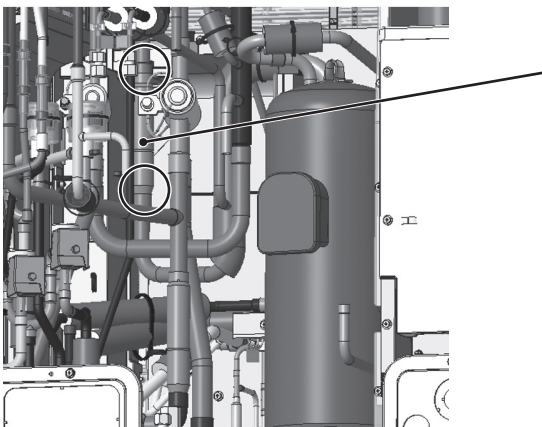


Remove the pipe cover near check valve (CV1).
*Save the cover for later use.



Check valve (CV1)

- (2) Remove the braze from two areas on check valve (CV1).



Check valve (CV1)

The above step completes the check valve (CV1) replacement procedure. Re-place the solenoid valve, LEV assembly, and pipe cover that were removed during maintenance work as they were.

4. XL-module (four-way valve (21S4a, 21S4b, and 21S4c))

* Products manufactured in July 2020 and earlier

Explained below is the procedure for replacing four-way valve (21S4a) (in the center when seen from the front of the unit), four-way valve (21S4b) (on the right when seen from the front of the unit), and four-way valve (21S4c) (on the left when seen from the front of the unit). (See Figure 1.)

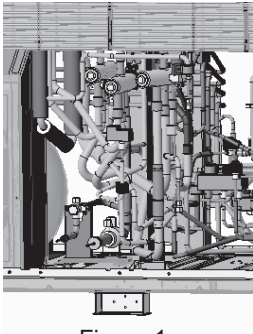
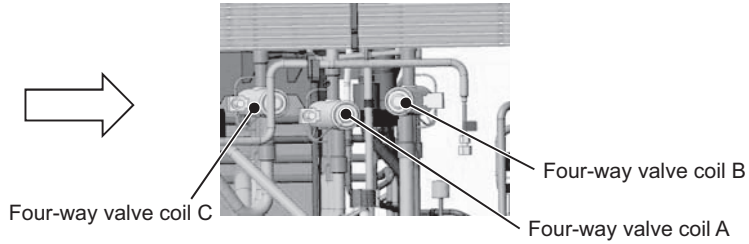


Figure 1



(1) Remove the wiring and sheet metal. (Screwed down with four screws) (See Figure 2.)

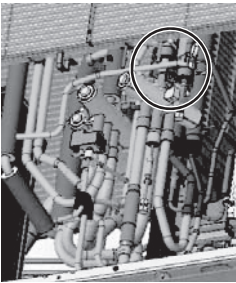
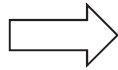


Figure 2



(2) Remove the coil (four-way valves (21S4a, 21S4b, and 21S4c), and solenoid valve (SV2)), coil cover, and wiring. (See Figure 3.)

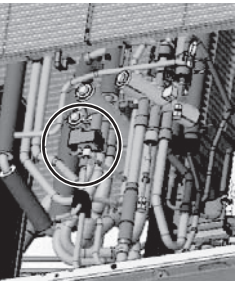
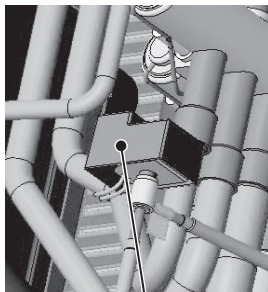
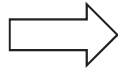


Figure 3



Solenoid valve (SV2) coil, and coil cover

(3) Remove the pipe cover and thermal insulation adjacent to the four-way valves. (See Figure 4.)

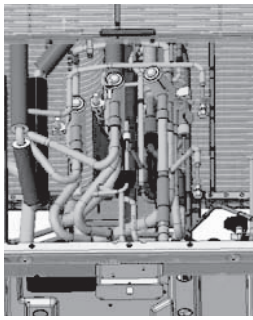
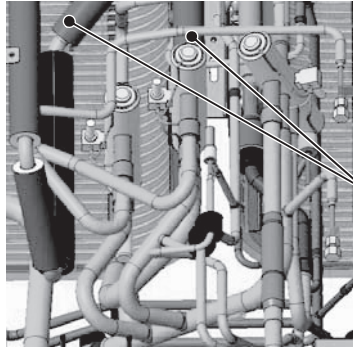
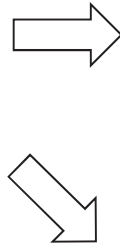
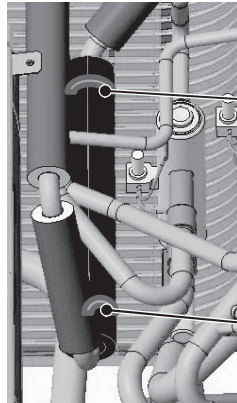


Figure 4



Remove the pipe cover adjacent to four-way valves.
*Save the pipe cover for later use.



Cut the cable tie here.

Thermal insulation (325 mm x 160 mm x 10 mm thick)
*The replacement parts for this part is included with the replacement kit that contains four-way valve.
Use the insulation material included with the four-way valve.

Cut the cable tie here.

*Notes on replacing refrigerant circuit components (check valve, four-way valve, solenoid valve, and LEV)

- Be sure to perform non-oxidized brazing.
- Before heating the pipes, wrap the refrigerant circuit components with a wet towel to keep the temperature of the components from rising above 120°C.
- After brazing is done, check that the brazing is done properly and check for leaks before vacuum-drying the pipes.
- Direct the brazing torch flame away from the wiring and sheet metals inside the unit not to damage them.
- Wet felt sheets listed below (or its equivalent), and place them around the areas to be brazed to protect the heat exchanger, pipes, and pipe covers from being damaged from the brazing torch flame.
Recommended felt sheets: Spatter felt 50CF-11 (5t x 1 m x 1 m) by TRUSCO Nakayama
Felt sheets that meet the JIS standard (JIS A 1323 type A "Flame retardant testing method for spark droplets of welding and gas cutting on fabric sheets in construction works")

(4) Remove the braze from the pipe between four-way valves (21S4a and 21S4b). (See Figure 5.)

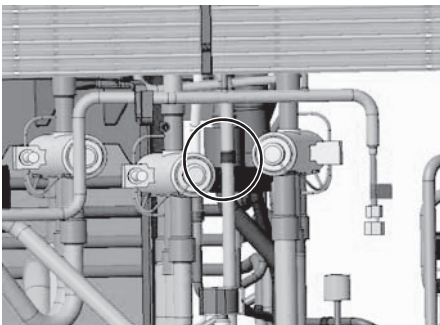


Figure 5

Replacement procedure for four-way valve (21S4a)

(5A) Remove the braze from the area above four-way valve (21S4a) as shown in Figure 6.

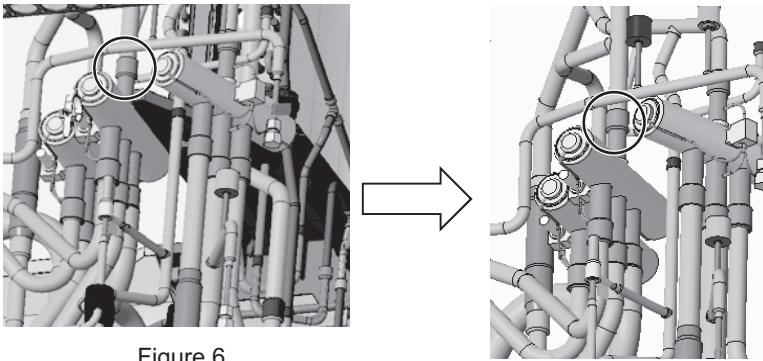


Figure 6

(6A) Remove the braze from the three areas below four-way valve (21S4a) as shown in Figure 7.

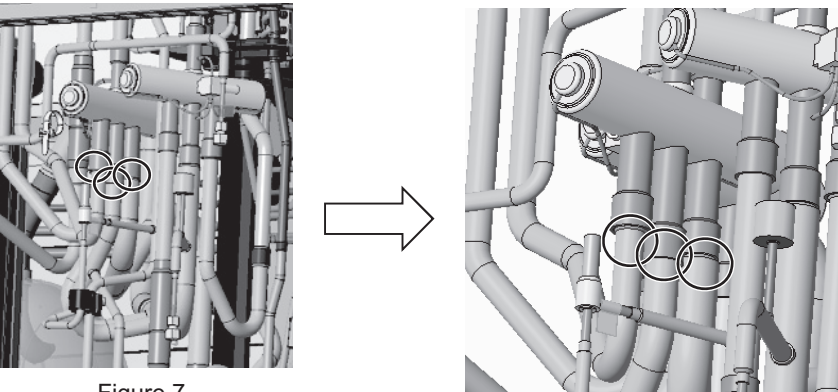


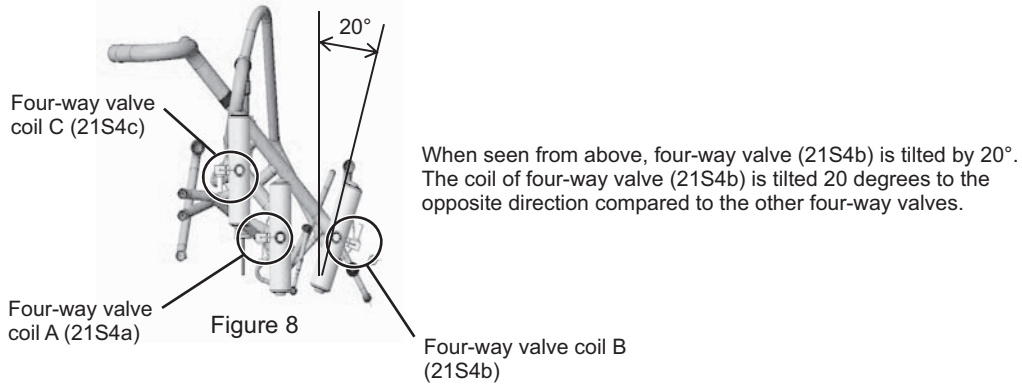
Figure 7

(7A) Mount a new four-way valve (21S4a).

Replacement procedure for four-way valve (21S4b)

(8B) Follow the same procedures as (5A) through (6A).

(9B) Mount a new four-way valve (21S4b). Figure 8 shows how to position a new four-way valve.



Replacement procedure for four-way valve (21S4c)
 (10C) Install a flame-protection plate. (See Figure 9.)

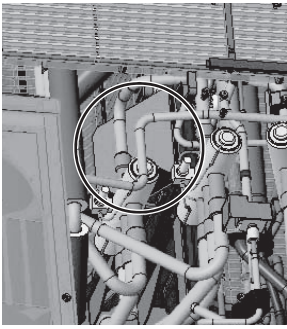
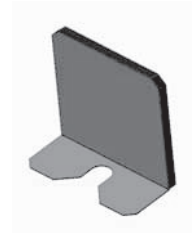
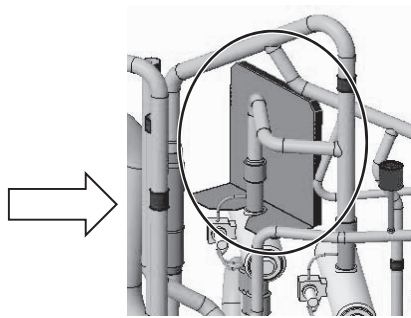


Figure 9



Flame-protection plate
 *Included with the replacement kit that contains four-way valve (21S4c)
 Remove the plate after replacing four-way valve (21S4c).

(11C) Remove the braze from the area above four-way valve (21S4c) as shown in Figure 10.

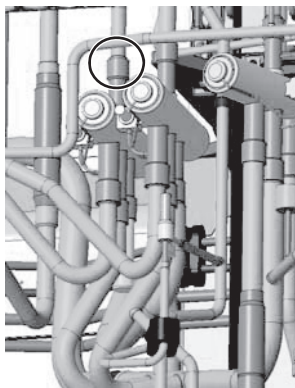
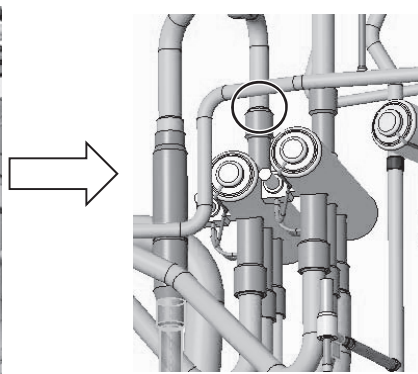


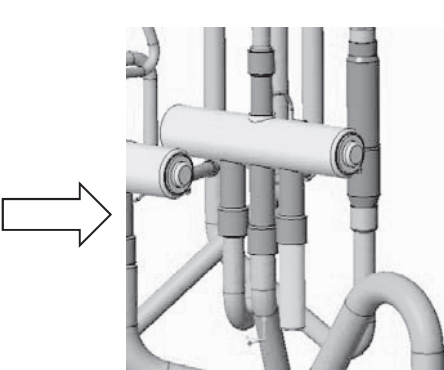
Figure 10



(12C) Remove the braze from the two areas below four-way valve (21S4c) as shown in Figure 11.

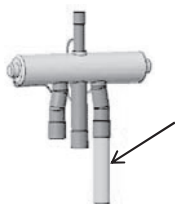


Figure 11



A cap for sealing the refrigerant pipe is included with the replacement kit that contains four-way valve (21S4c).
 Replace the old cap with the one included with the four-way valve.

(13C) Mount a new four-way valve (21S4c).



When installing four-way valve (21S4c), first braze the pipe outside the unit and then install it to the unit.

Figure 12

5. XL-module (four-way valve (21S4a, 21S4b, and 21S4c))

* Products manufactured in August 2020 and later

Explained below is the procedure for replacing four-way valve (21S4a) (in the center when seen from the front of the unit), four-way valve (21S4b) (on the right when seen from the front of the unit), and four-way valve (21S4c) (on the left when seen from the front of the unit). (See Figure 1.)

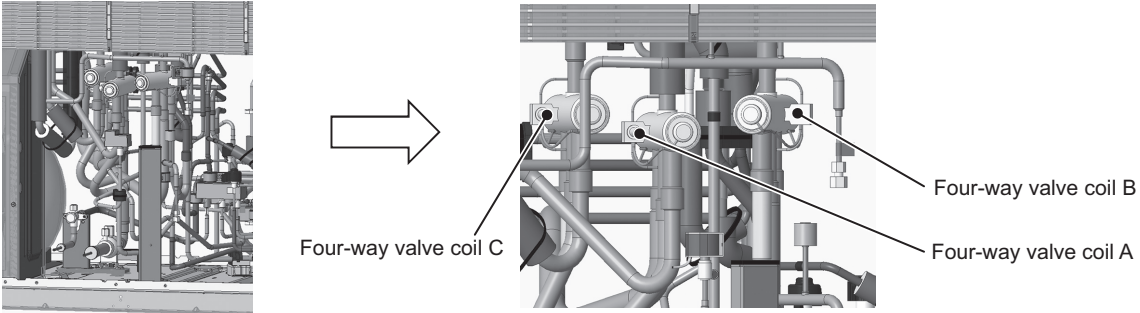


Figure 1

(1) Remove the wiring and sheet metal. (Screwed down with four screws) (See Figure 2.)

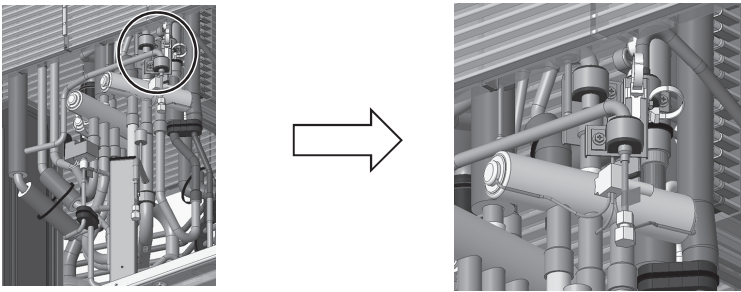


Figure 2

(2) Remove the coil (four-way valves (21S4a, 21S4b, and 21S4c), and solenoid valve (SV2)), coil cover, and wiring. (See Figure 3.)

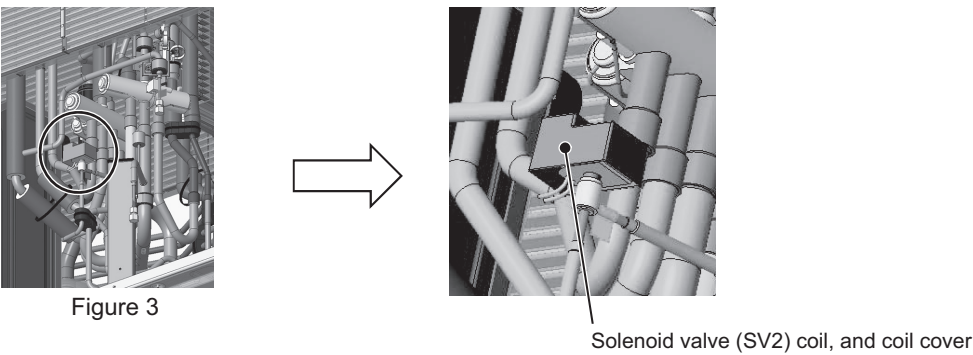
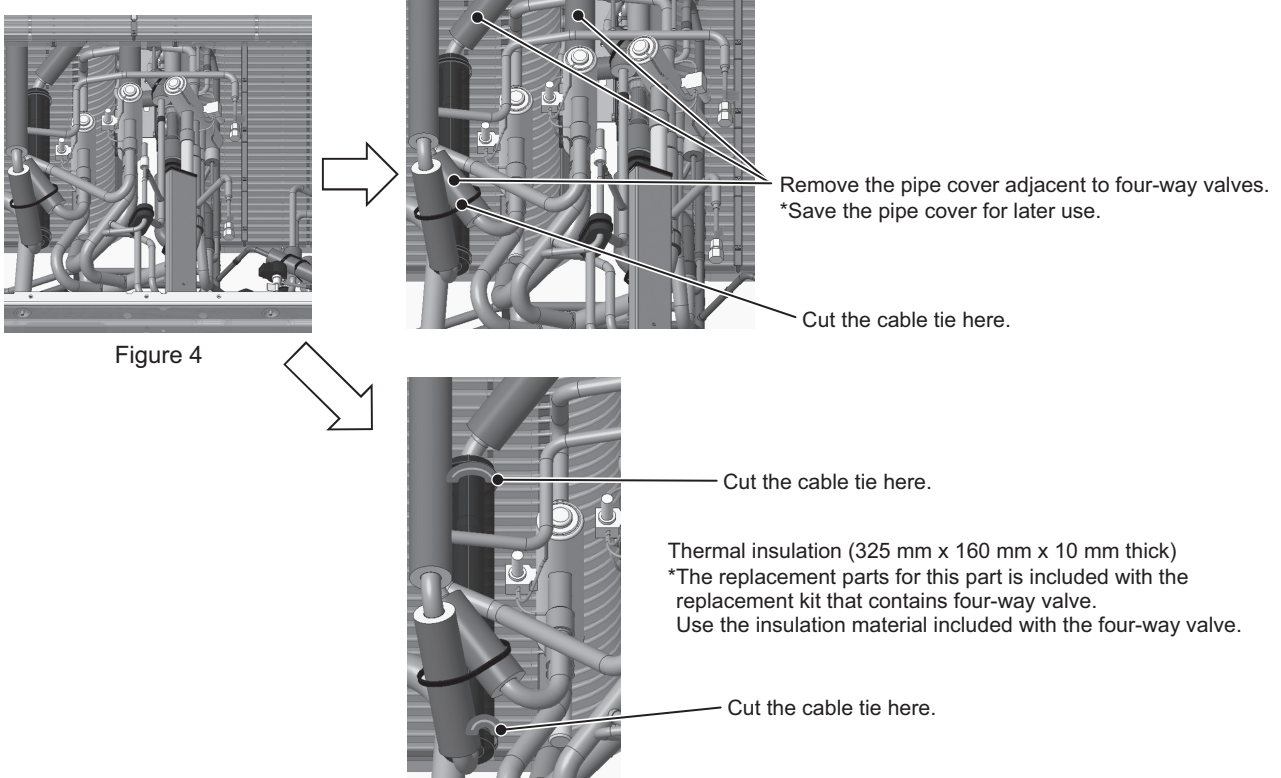


Figure 3

(3) Remove the pipe cover and thermal insulation adjacent to the four-way valves. (See Figure 4.)



*Notes on replacing refrigerant circuit components (check valve, four-way valve, solenoid valve, and LEV)

- Be sure to perform non-oxidized brazing.
- Before heating the pipes, wrap the refrigerant circuit components with a wet towel to keep the temperature of the components from rising above 120°C.
- After brazing is done, check that the brazing is done properly and check for leaks before vacuum-drying the pipes.
- Direct the brazing torch flame away from the wiring and sheet metals inside the unit not to damage them.
- Wet felt sheets listed below (or its equivalent), and place them around the areas to be brazed to protect the heat exchanger, pipes, and pipe covers from being damaged from the brazing torch flame.
Recommended felt sheets: Spatter felt 50CF-11 (5t x 1 m x 1 m) by TRUSCO Nakayama
Felt sheets that meet the JIS standard (JIS A 1323 type A "Flame retardant testing method for spark droplets of welding and gas cutting on fabric sheets in construction works")

(4) Remove the braze from the pipe between four-way valves (21S4a and 21S4b). (See Figure 5.)

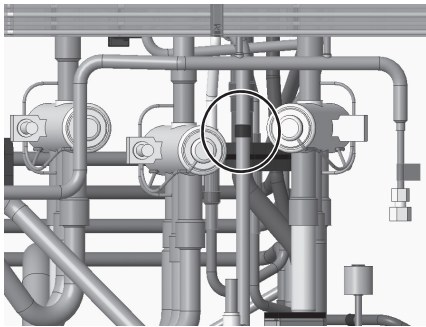


Figure 5

Replacement procedure for four-way valve (21S4a)

(5A) Remove the braze from the area above four-way valve (21S4a) as shown in Figure 6.

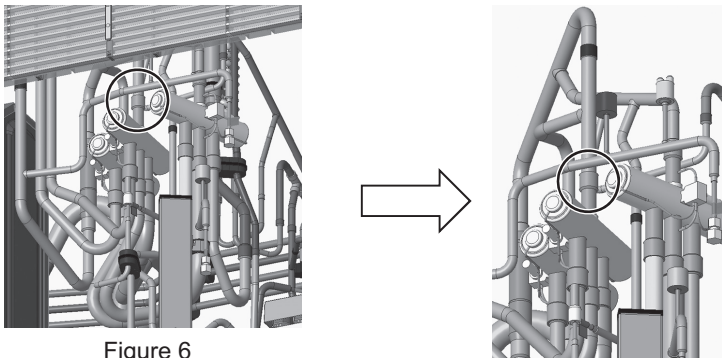


Figure 6

(6A) Remove the braze from the three areas below four-way valve (21S4a) as shown in Figure 7.

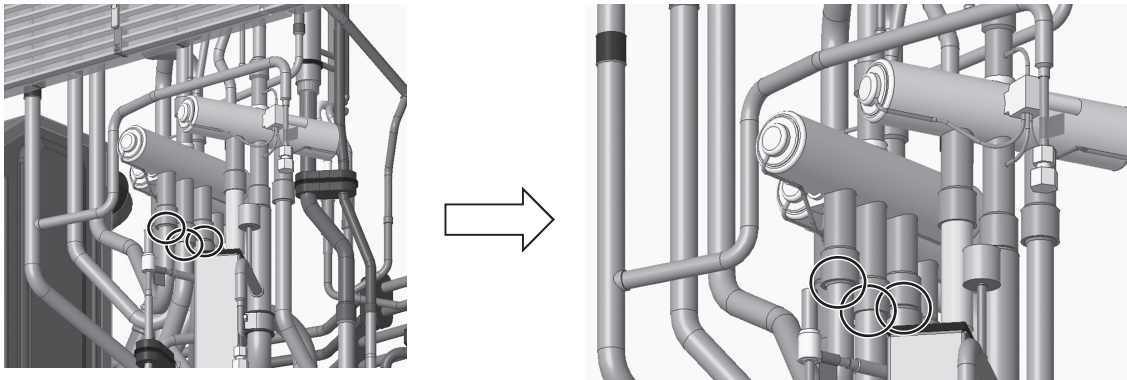


Figure 7

(7A) Mount a new four-way valve (21S4a).

Replacement procedure for four-way valve (21S4b)

(8B) Follow the same procedures as (5A) through (6A).

(9B) Mount a new four-way valve (21S4b). Figure 8 shows how to position a new four-way valve.

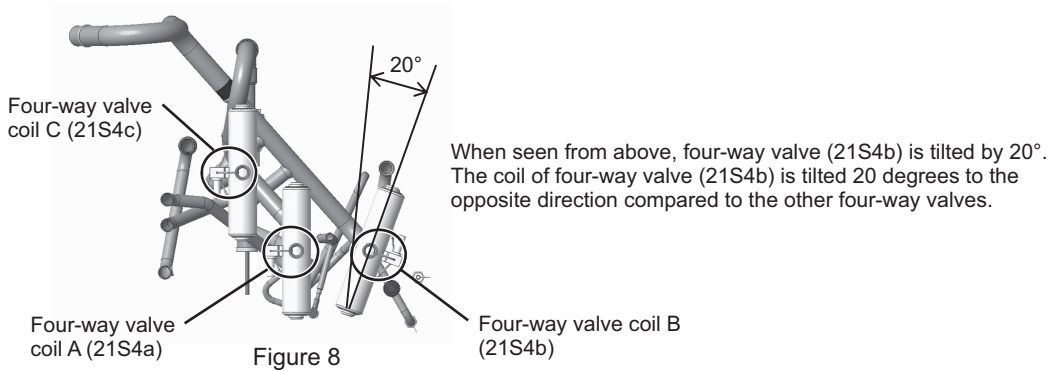


Figure 8

Replacement procedure for four-way valve (21S4c)
 (10C) Install a flame-protection plate. (See Figure 9.)

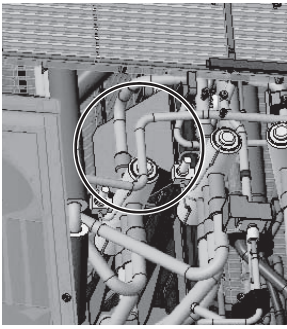
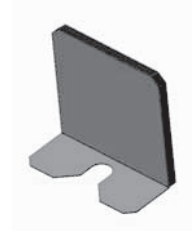
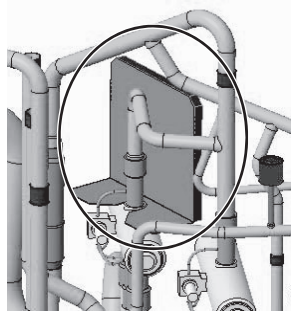


Figure 9



Flame-protection plate
 *Included with the replacement kit that contains four-way valve (21S4c)
 Remove the plate after replacing four-way valve (21S4c).

(11C) Remove the braze from the area above four-way valve (21S4c) as shown in Figure 10.

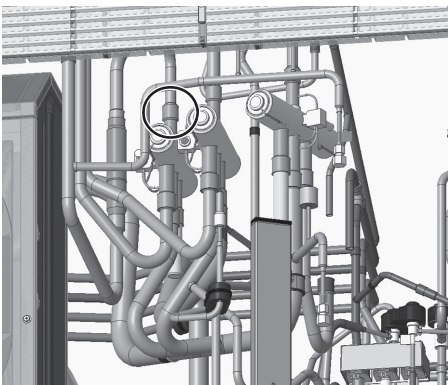
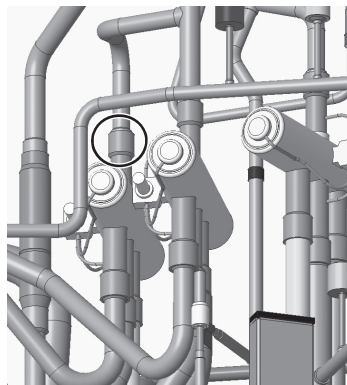


Figure 10



(12C) Remove the braze from the two areas below four-way valve (21S4c) as shown in Figure 11.

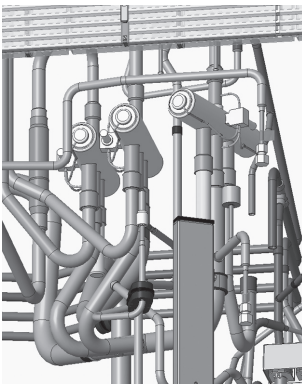
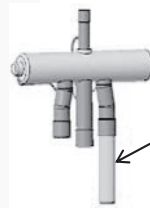
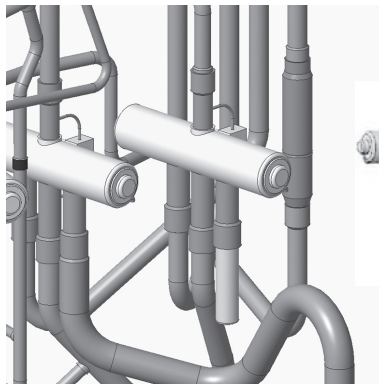


Figure 11



A cap for sealing the refrigerant pipe is included with the replacement kit that contains four-way valve (21S4c).
 Replace the old cap with the one included with the four-way valve.

(13C) Mount a new four-way valve (21S4c).



When installing four-way valve (21S4c), first braze the pipe outside the unit and then install it to the unit.

Figure 12

8-13-5 Four-way Valve and Check Valve Replacement Procedure <Type A1/Type A2>

1. S, L-module (four-way valve (21S4a))

Explained below is the procedure for replacing four-way valve (21S4a) (on the right when seen from the front of the unit). Secure sufficient work space before starting maintenance work. (See 8-13-2 Ensuring Maintenance Space (Preparation for the Maintenance of Refrigerant Circuit Parts) <Type A1/Type A2>.)

- (1) Remove the top compressor cover by unscrewing the three screws. (See Figure 1.)
Remove the compressor cover by unhooking the hooks on the back.
- (2) Remove the front compressor cover by unscrewing the four screws. (See Figure 2.)
- (3) Cut the two cable ties holding TH4 and TH15, and remove the wiring from the rubber bush on the left compressor cover. (See Figure 3.)
- (4) Remove the left compressor cover by unscrewing the two screws. (See Figure 4.)

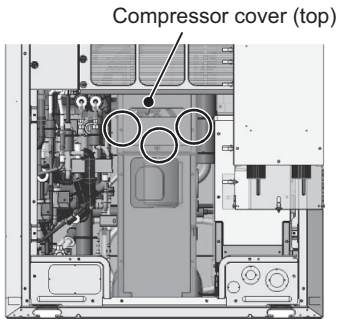
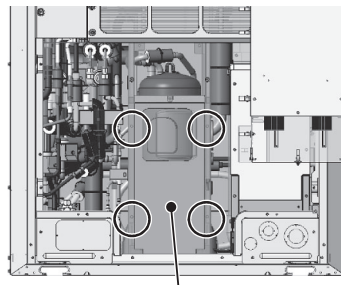


Figure 1



Compressor cover (front)
Figure 2

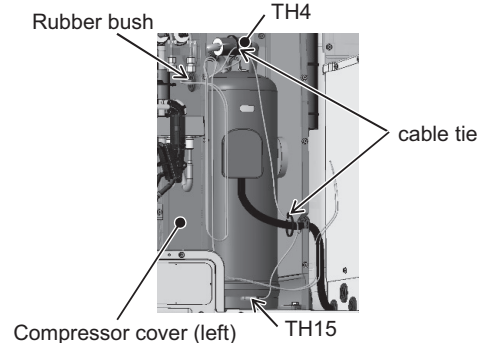


Figure 3

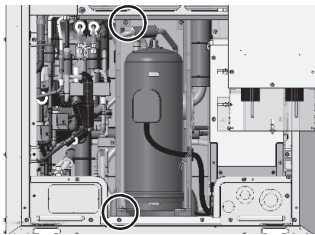


Figure 4

- (5) Remove the plastic cover and the coil holding solenoid valves 2, 9, and 10 (SV2, 9, and 10). Remove the thermal insulation shown in Figure 5. (See Figure 5.)

Solenoid valve coils 2, 9, and 10 (SV2, 9, and 10) and coil cover

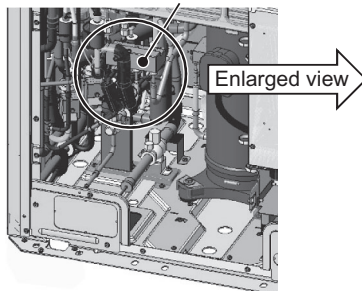
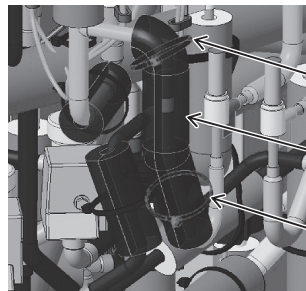


Figure 5

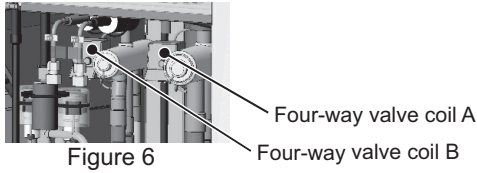


Cut the cable tie here.

Thermal insulation (180 mm x 70 mm x 10 mm thick)
*Included with the four-way valve replacement parts
Use the insulation material included with the four-way valve.

Cut the cable tie here.

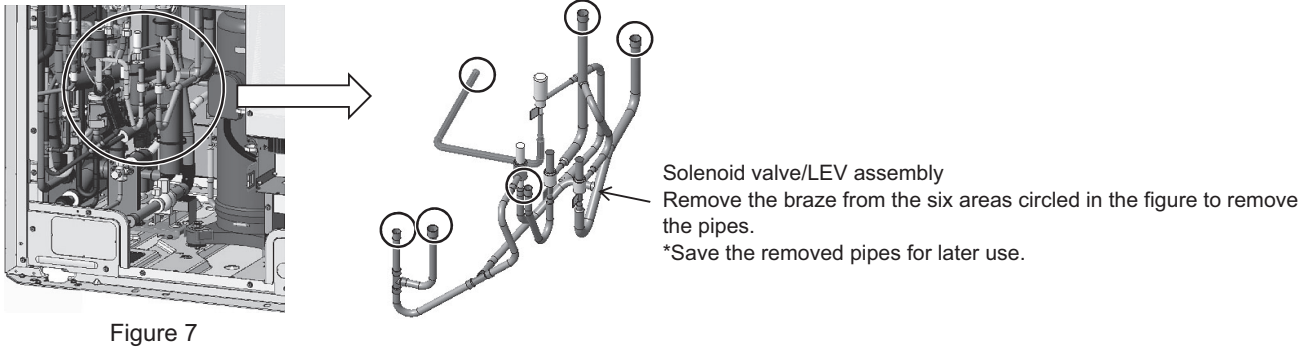
(6) Remove the plastic cover and the coil holding the four-way valve. (See Figure 6.)



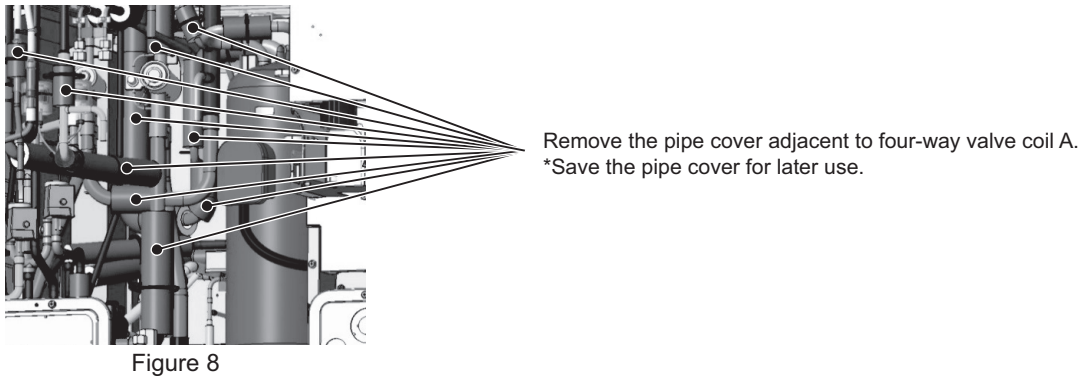
*Notes on replacing refrigerant circuit components (check valve, four-way valve, solenoid valve, and LEV)

- Be sure to perform non-oxidized brazing.
- Before heating the pipes, wrap the refrigerant circuit components with a wet towel to keep the temperature of the components from rising above 120°C.
- After brazing is done, check that the brazing is done properly and check for leaks before vacuum-drying the pipes.
- Direct the brazing torch flame away from the wiring and sheet metals inside the unit not to damage them.
- Wet felt sheets listed below (or its equivalent), and place them around the areas to be brazed to protect the heat exchanger, pipes, and pipe covers from being damaged from the brazing torch flame.
 Recommended felt sheets: Spatter felt 50CF-11 (5t x 1 m x 1 m) by TRUSCO Nakayama
 Felt sheets that meet the JIS standard (JIS A 1323 type A "Flame retardant testing method for spark droplets of welding and gas cutting on fabric sheets in construction works")

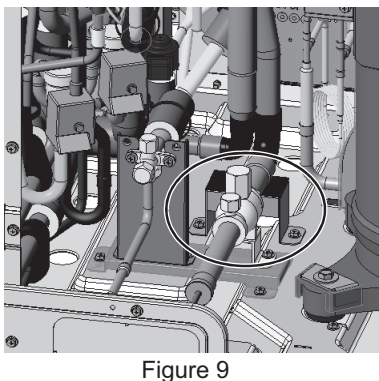
(7) Remove the solenoid valve and the LEV assembly at the front of the four-way valve at the brazed sections to ensure good visibility of the four-way valve.
 Either remove or protect the solenoid valve coil, TH and LEV wirings, pipe cover, and plastic components to keep them from being damaged by the torch flame. (Remove the components by removing the braze from the six areas shown in Figure 7.)



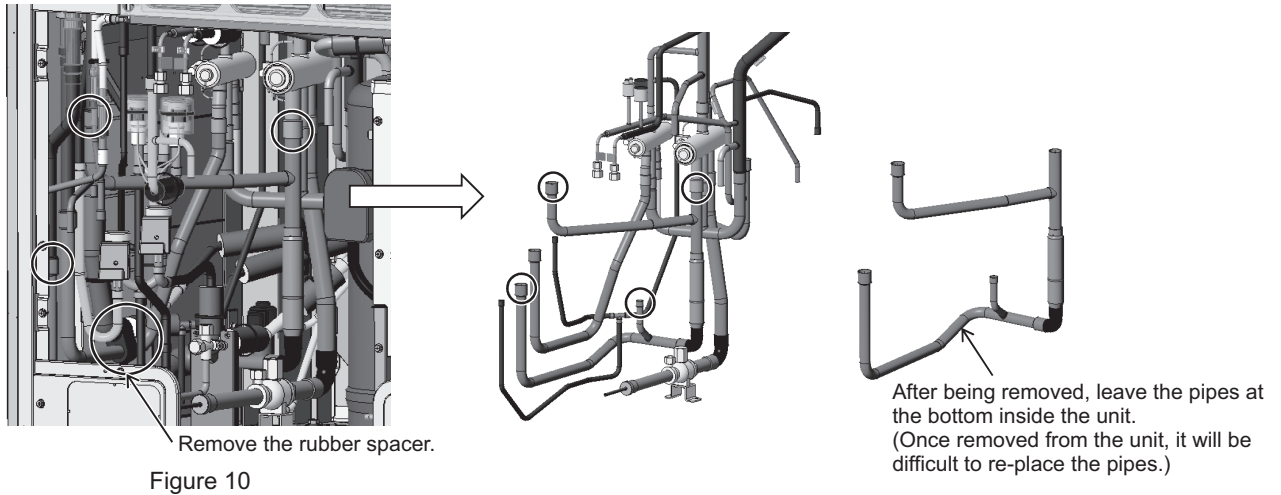
Replacement procedure for four-way valve (21S4a)
 (8A) Remove the pipe covers adjacent to four-way valve (21S4a). (See Figure 8.)



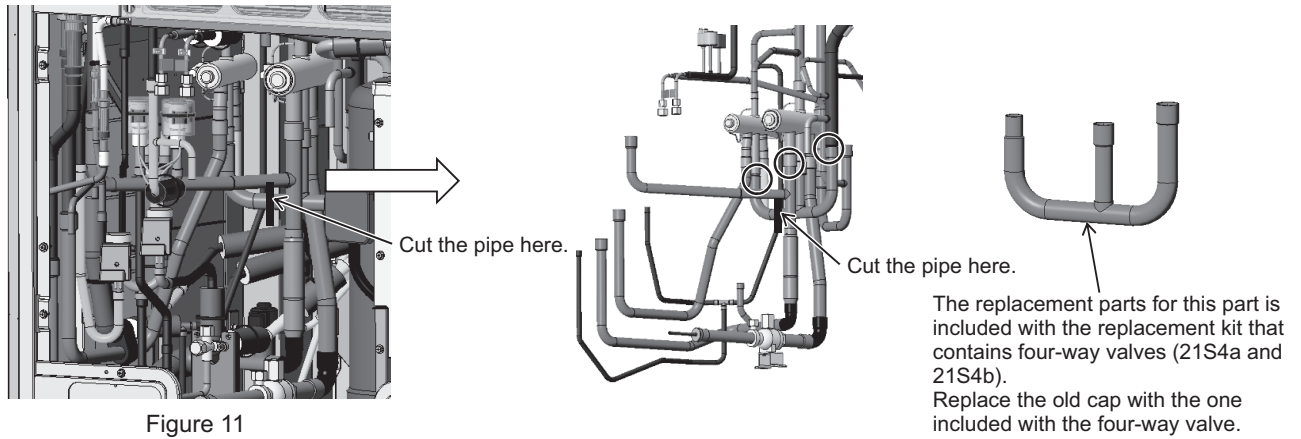
(9A) Remove the sheet metal screwed to the base below four-way valve (21S4a) by unscrewing the two screws. (See Figure 9.)



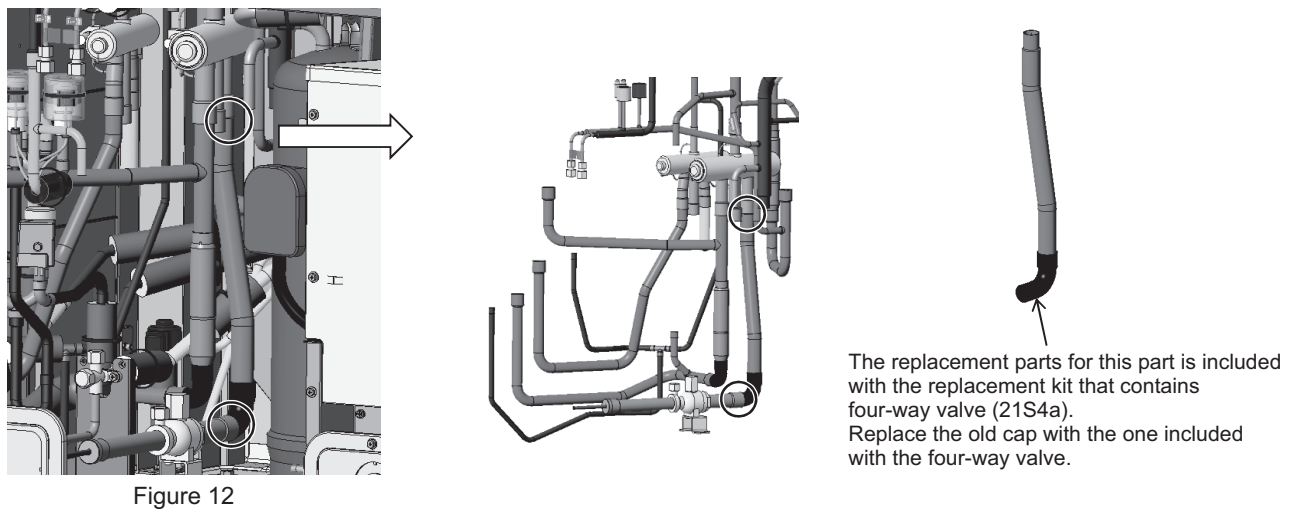
(10A) Remove the pipe below four-way valve (21S4a) and on the front by removing the braze at the four areas shown in Figure 10.



(11A) Cut the pipe below four-way valve (21S4a) and in the middle with a pipe cutter as shown in the figure. After cutting the pipe where indicated in the figure, remove the braze at the three areas shown in Figure 11.



(12A) Remove the pipe below four-way valve (21S4a) and on the back by removing the braze at the two areas on the bottom of the pipe shown in Figure 12. Then, remove the braze at the areas on the top of the pipe.



(13A) Remove four-way valve (21S4a) by removing the braze from the area above four-way valve (21S4a) as shown in Figure 13.

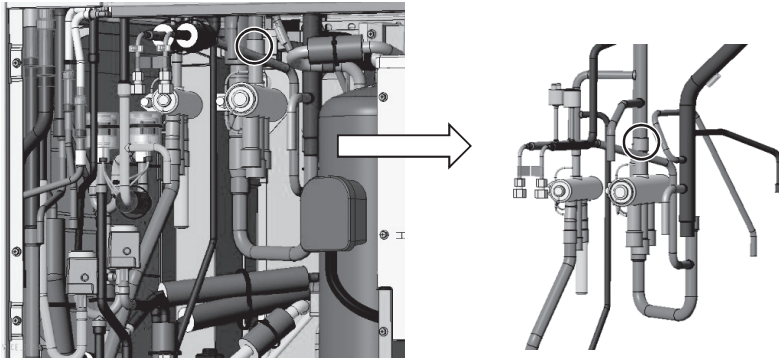
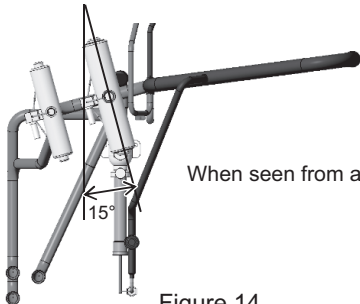


Figure 13

(14A) Mount a new four-way valve (21S4a). Figure 14 shows how to position a new four-way valve.



When seen from above, four-way valves (21S4a and 21S4b) are tilted by 15°.

Figure 14

(15A) To make it easier to connect four-way valve (21S4a), cut the pipe end below the raised hole (cut off the section covered with brazing filler) on the pipe with a pipe cutter. Cut the pipe with an expanded end that is included with four-way valve (21S4a) to the same length as the pipe that was removed from the on-site pipe. (See Figure 15.)

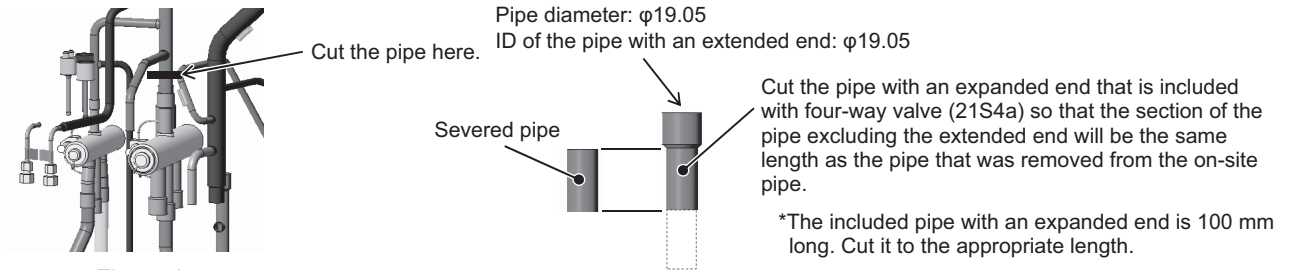


Figure 15

(16A) Mount four-way valve (21S4a) to the pipe below four-way valve (21S4a) and on the back. A total of four areas require brazing, including the area indicated in (15A) and the areas indicated in Figure 16.

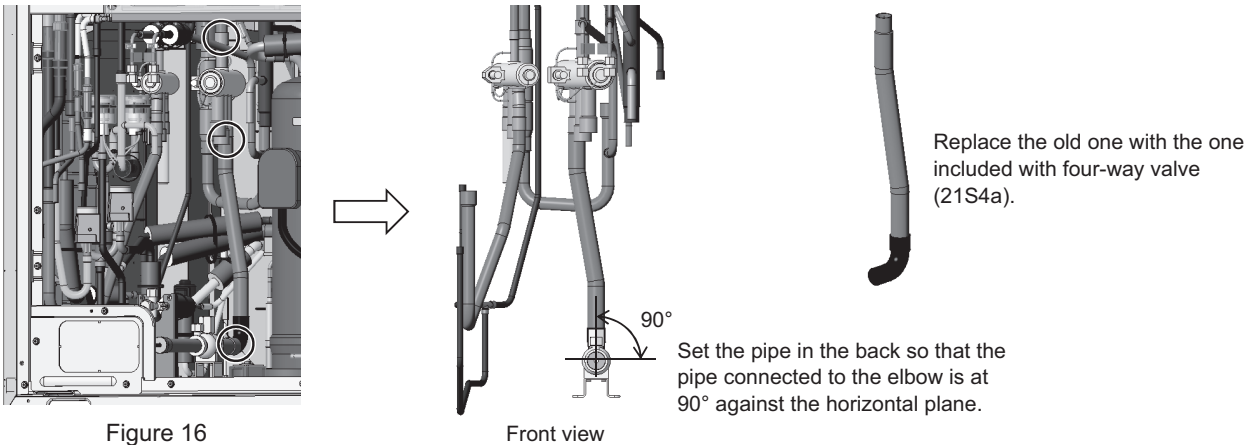


Figure 16

Front view

(17A) Mount four-way valve (21S4a) to the pipe below four-way valve A and in the middle by brazing at the three areas. (See Figure 17.)

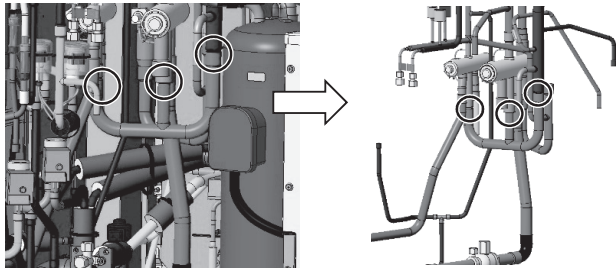
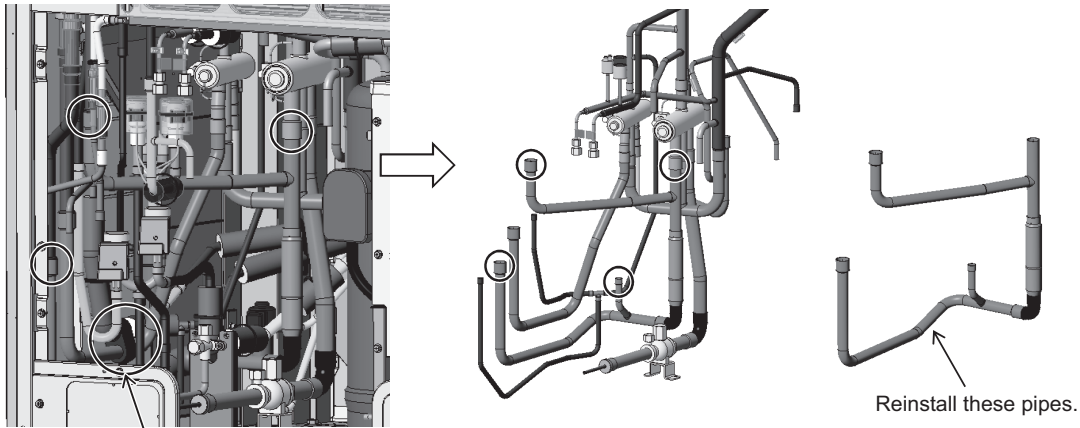


Figure 17

(18A) Mount four-way valve (21S4a) to the pipe below four-way valve (21S4a) and on the front by brazing at the four areas. (See Figure 18.)



Re-place the rubber spacer.

Figure 18

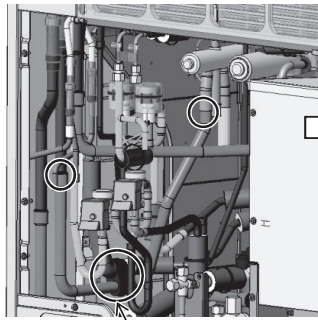
This step completes the replacement procedure for four-way valve (21S4a). Re-place the solenoid valve and LEV assembly that were removed in step (7) and all the pipe covers that were removed during the maintenance work as they were.

2. S, L-module (four-way valve (21S4b))

Explained below is the procedure for replacing four-way valve (21S4b) (on the left when seen from the front of the unit). Secure sufficient work space before starting maintenance work. (See 8-13-2 Ensuring Maintenance Space (Preparation for the Maintenance of Refrigerant Circuit Parts) <Type A1/Type A2>.)

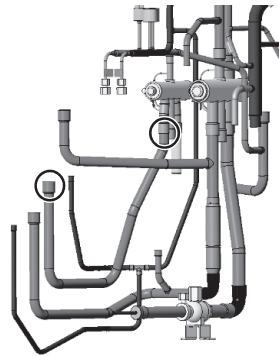
(19B) Follow the same procedures ((1) through (7), (8A), and (11A)) for replacing four-way valve (21S4a).

(20B) Remove the pipe below four-way valve (21S4b) and on the front by removing the braze at the two areas shown in Figure 19.



Remove the rubber spacer.

Figure 19



After being removed, leave the pipes at the bottom inside the unit. (Once removed from the unit, it will be difficult to re-place the pipes.)

(21B) Remove four-way valve (21S4b) by removing the braze from the area above four-way valve (21S4b) as shown in Figure 20.

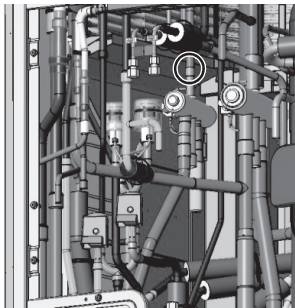
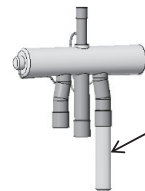
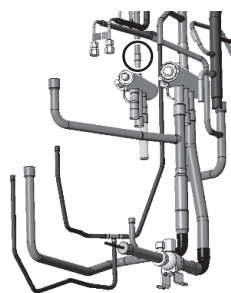


Figure 20



A cap for sealing the refrigerant pipe is included with four-way valve (21S4b). Replace the old cap with the one included with the four-way valve.

(22B) To make it easier to connect four-way valve (21S4b), cut the pipe end below the raised hole (cut off the section covered with brazing filler) on the pipe with a pipe cutter. Cut the pipe with an expanded or narrowed end that is included with four-way valve (21S4b) to the same length as the pipe that was removed from the on-site pipe. (See Figure 21.)

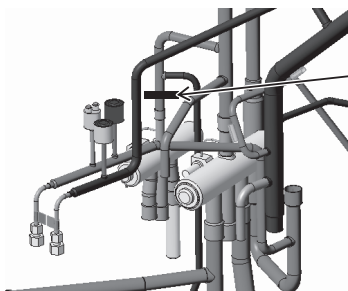
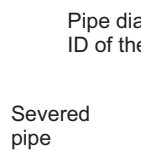


Figure 21

Cut the pipe here.

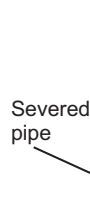


Pipe diameter: $\phi 12.7$
ID of the pipe with an extended end: $\phi 12.7$

Cut the pipe with an expanded end that is included with four-way valve (21S4b) so that the section of the pipe excluding the extended end will be the same length as the pipe that was removed from the on-site pipe.

*The included pipe with an expanded end is 100 mm long. Cut it to the appropriate length.

S-module



Pipe diameter: $\phi 19.05$
ID of the pipe with a narrowed end: $\phi 15.88$

Cut the pipe with a narrowed end that is included with four-way valve (21S4b) so that the section of the pipe excluding the narrowed end will be the same length as the pipe that was removed from the on-site pipe.

*The included pipe with a narrowed end is 100 mm long. Cut it to the appropriate length.

L-module

(23B) Mount four-way valve (21S4b) to the pipe below four-way valve (21S4b) and in the middle. A total of five areas require brazing, including the area indicated in (22B) and the areas indicated in Figure 22. Mount four-way valve (21S4b) horizontal to four-way valve (21S4a) as shown in (14A).

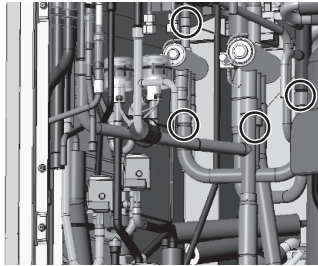
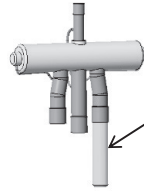
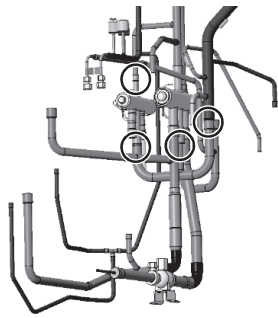
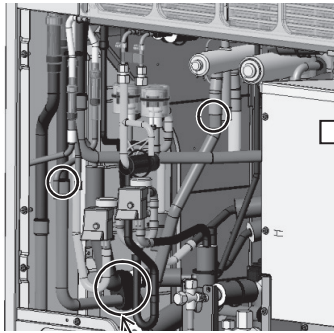


Figure 22



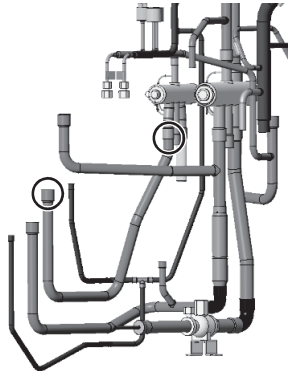
When installing four-way valve (21S4b), first braze the pipe outside the unit and then install it to the unit.

(24B) Install the pipe below four-way valve (21S4b) and on the front by brazing at the two areas shown in Figure 23.



Re-place the rubber spacer.

Figure 23



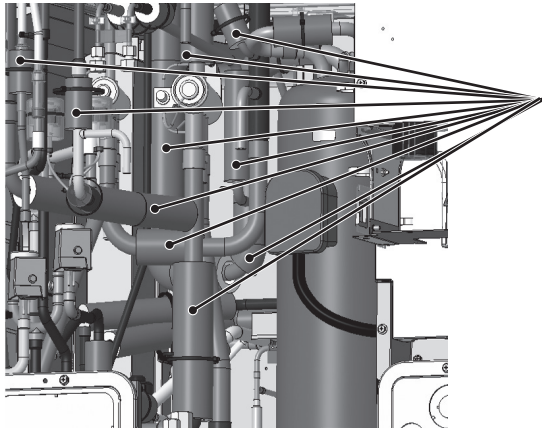
Reinstall these pipes.

This step completes the replacement procedure for four-way valve (21S4b). Re-place the solenoid valve and LEV assembly that were removed in step (7) and all the pipe covers that were removed during the maintenance work as they were.

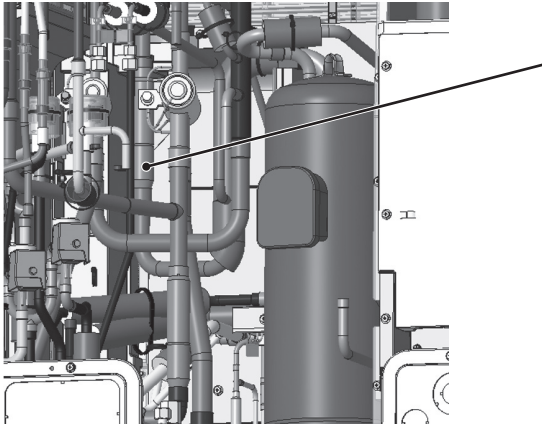
3. Replacing check valve (CV1) (S and L modules)

Follow the procedures below to remove check valve (CV1) located in the back of the four-way valve.

- (1) Follow the steps (1) through (8A) under item 1. S, L-module under 8-13-5 Four-way Valve and Check Valve Replacement Procedure <Type A1/Type A2> to Create Access to Check Valve (CV1).

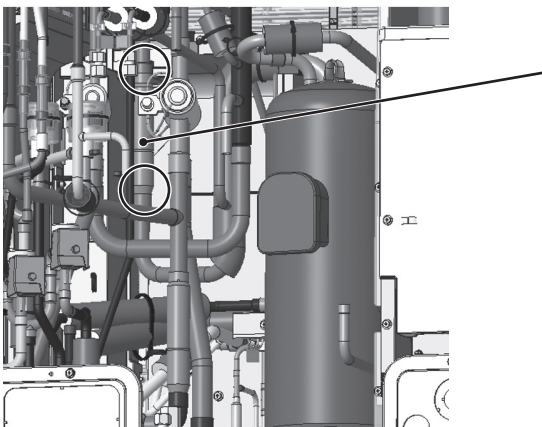


Remove the pipe cover near check valve (CV1).
*Save the cover for later use.



Check valve (CV1)

- (2) Remove the braze from two areas on check valve (CV1).



Check valve (CV1)

The above step completes the check valve (CV1) replacement procedure. Re-place the solenoid valve, LEV assembly, and pipe cover that were removed during maintenance work as they were.

4. XL-module (four-way valve (21S4a, 21S4b, and 21S4c))

* Products manufactured in July 2020 and earlier

Explained below is the procedure for replacing four-way valve (21S4a) (in the center when seen from the front of the unit), four-way valve (21S4b) (on the right when seen from the front of the unit), and four-way valve (21S4c) (on the left when seen from the front of the unit). (See Figure 1.)

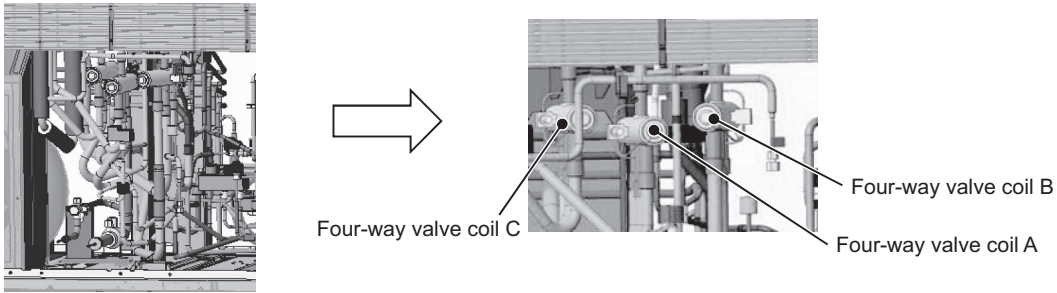


Figure 1

(1) Remove the wiring and sheet metal. (Screwed down with four screws) (See Figure 2.)

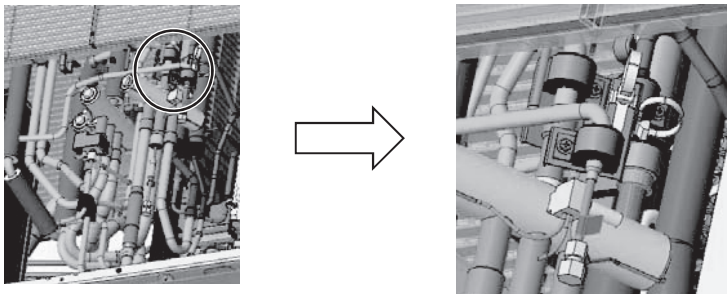


Figure 2

(2) Remove the coil (four-way valves (21S4a, 21S4b, and 21S4c), and solenoid valve (SV2)), coil cover, and wiring. (See Figure 3.)

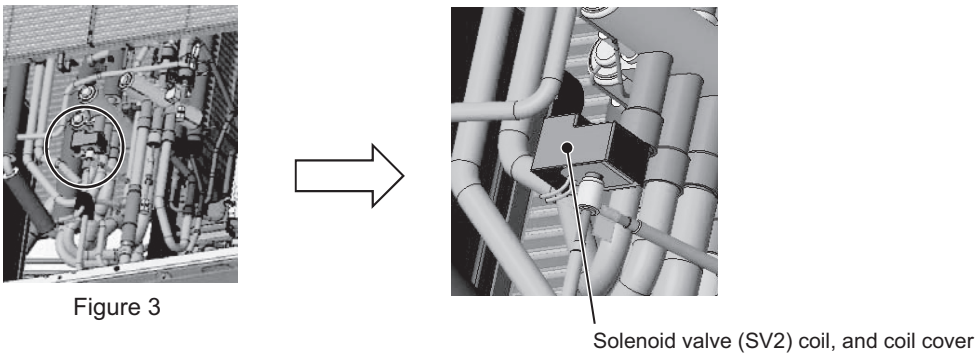


Figure 3

Solenoid valve (SV2) coil, and coil cover

(3) Remove the pipe cover and thermal insulation adjacent to the four-way valves. (See Figure 4.)

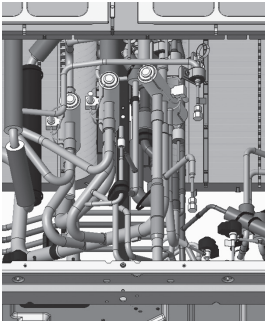
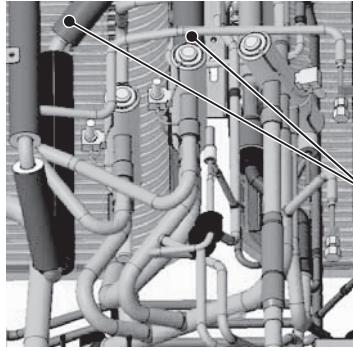
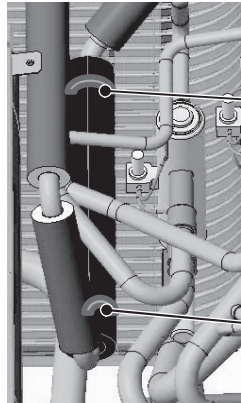


Figure 4



Remove the pipe cover adjacent to four-way valves.
*Save the pipe cover for later use.



Cut the cable tie here.

Thermal insulation (325 mm x 160 mm x 10 mm thick)
*The replacement parts for this part is included with the replacement kit that contains four-way valve.
Use the insulation material included with the four-way valve.

Cut the cable tie here.

*Notes on replacing refrigerant circuit components (check valve, four-way valve, solenoid valve, and LEV)

- Be sure to perform non-oxidized brazing.
- Before heating the pipes, wrap the refrigerant circuit components with a wet towel to keep the temperature of the components from rising above 120°C.
- After brazing is done, check that the brazing is done properly and check for leaks before vacuum-drying the pipes.
- Direct the brazing torch flame away from the wiring and sheet metals inside the unit not to damage them.
- Wet felt sheets listed below (or its equivalent), and place them around the areas to be brazed to protect the heat exchanger, pipes, and pipe covers from being damaged from the brazing torch flame.
Recommended felt sheets: Spatter felt 50CF-11 (5t x 1 m x 1 m) by TRUSCO Nakayama
Felt sheets that meet the JIS standard (JIS A 1323 type A "Flame retardant testing method for spark droplets of welding and gas cutting on fabric sheets in construction works")

(4) Remove the braze from the pipe between four-way valves (21S4a and 21S4b). (See Figure 5.)

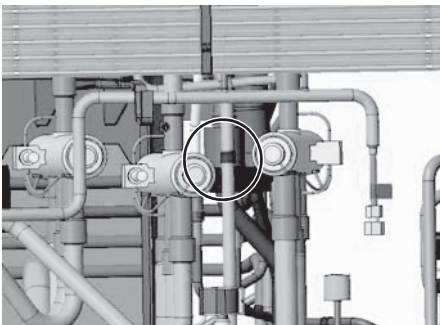


Figure 5

Replacement procedure for four-way valve (21S4a)

(5A) Remove the braze from the area above four-way valve (21S4a) as shown in Figure 6.

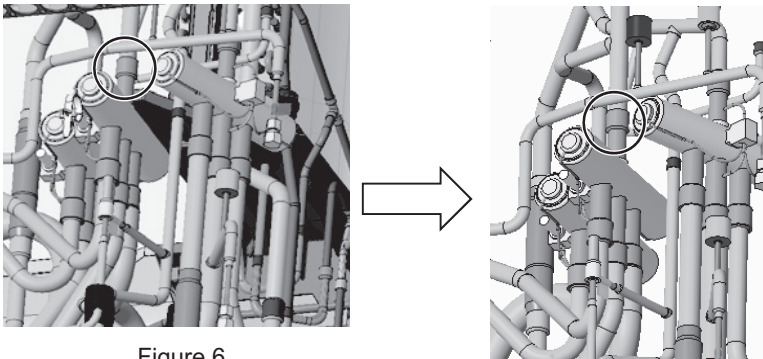


Figure 6

(6A) Remove the braze from the three areas below four-way valve (21S4a) as shown in Figure 7.

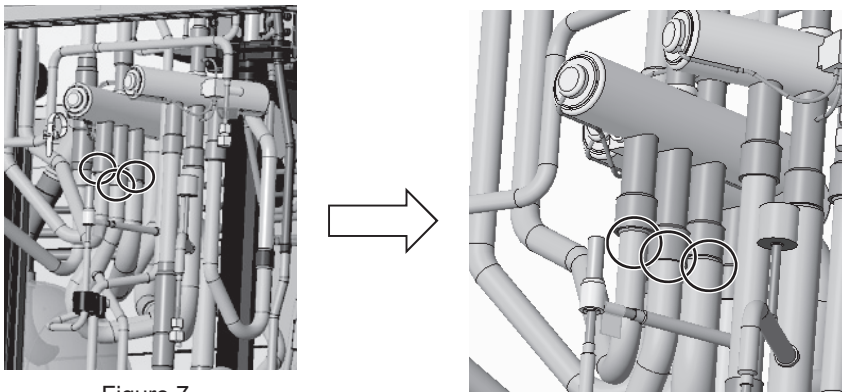


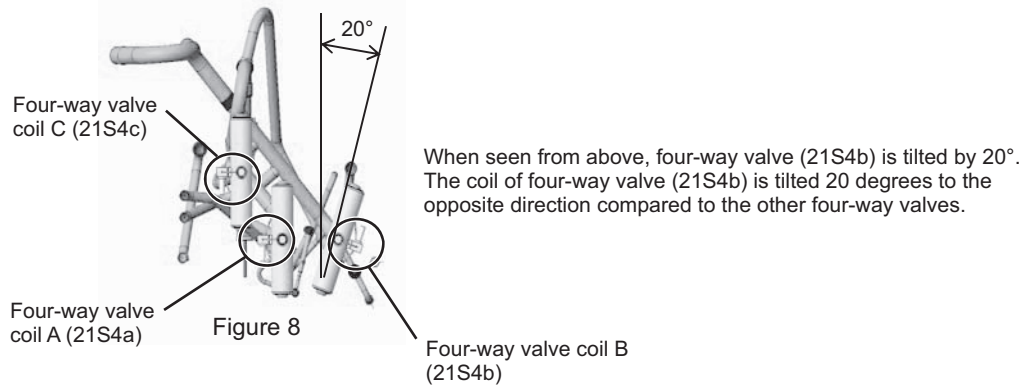
Figure 7

(7A) Mount a new four-way valve (21S4a).

Replacement procedure for four-way valve (21S4b)

(8B) Follow the same procedures as (5A) through (6A).

(9B) Mount a new four-way valve (21S4b). Figure 8 shows how to position a new four-way valve.



Replacement procedure for four-way valve (21S4c)
 (10C) Install a flame-protection plate. (See Figure 9.)

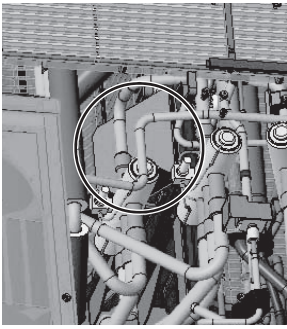
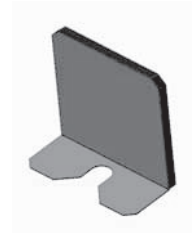
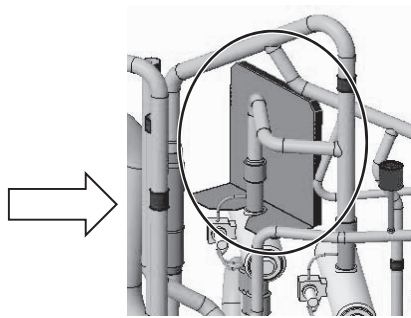


Figure 9



Flame-protection plate
 *Included with the replacement kit that contains four-way valve (21S4c)
 Remove the plate after replacing four-way valve (21S4c).

(11C) Remove the braze from the area above four-way valve (21S4c) as shown in Figure 10.

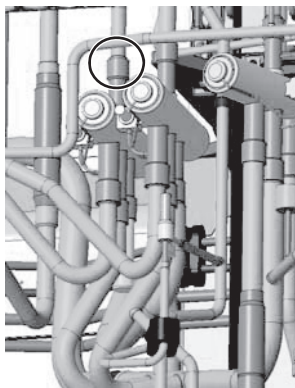
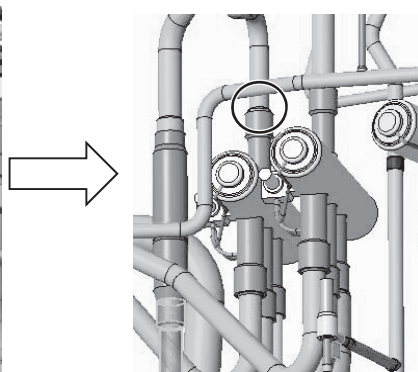


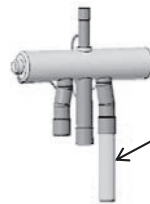
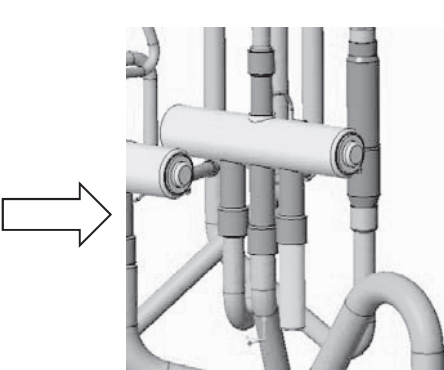
Figure 10



(12C) Remove the braze from the two areas below four-way valve (21S4c) as shown in Figure 11.

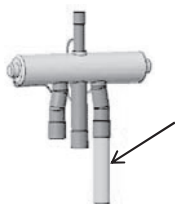


Figure 11



A cap for sealing the refrigerant pipe is included with the replacement kit that contains four-way valve (21S4c). Replace the old cap with the one included with the four-way valve.

(13C) Mount a new four-way valve (21S4c).



When installing four-way valve (21S4c), first braze the pipe outside the unit and then install it to the unit.

Figure 12

5. XL-module (four-way valve (21S4a, 21S4b, and 21S4c))

* Products manufactured in August 2020 and later

Explained below is the procedure for replacing four-way valve (21S4a) (in the center when seen from the front of the unit), four-way valve (21S4b) (on the right when seen from the front of the unit), and four-way valve (21S4c) (on the left when seen from the front of the unit). (See Figure 1.)

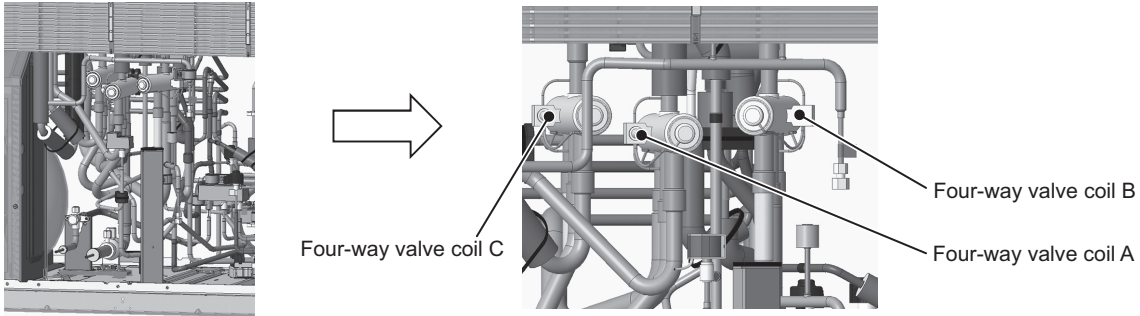


Figure 1

(1) Remove the wiring and sheet metal. (Screwed down with four screws) (See Figure 2.)

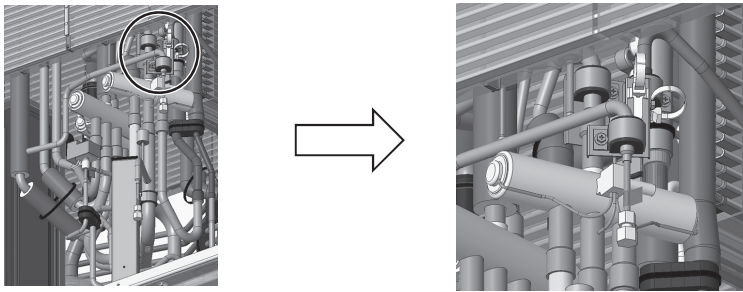


Figure 2

(2) Remove the coil (four-way valves (21S4a, 21S4b, and 21S4c), and solenoid valve (SV2)), coil cover, and wiring. (See Figure 3.)

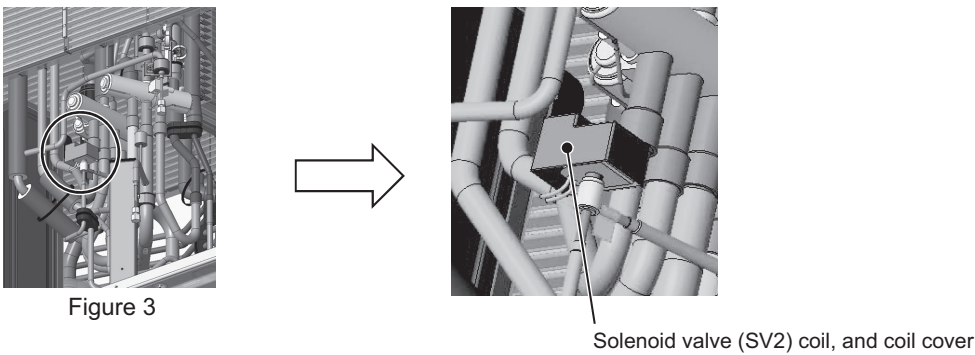
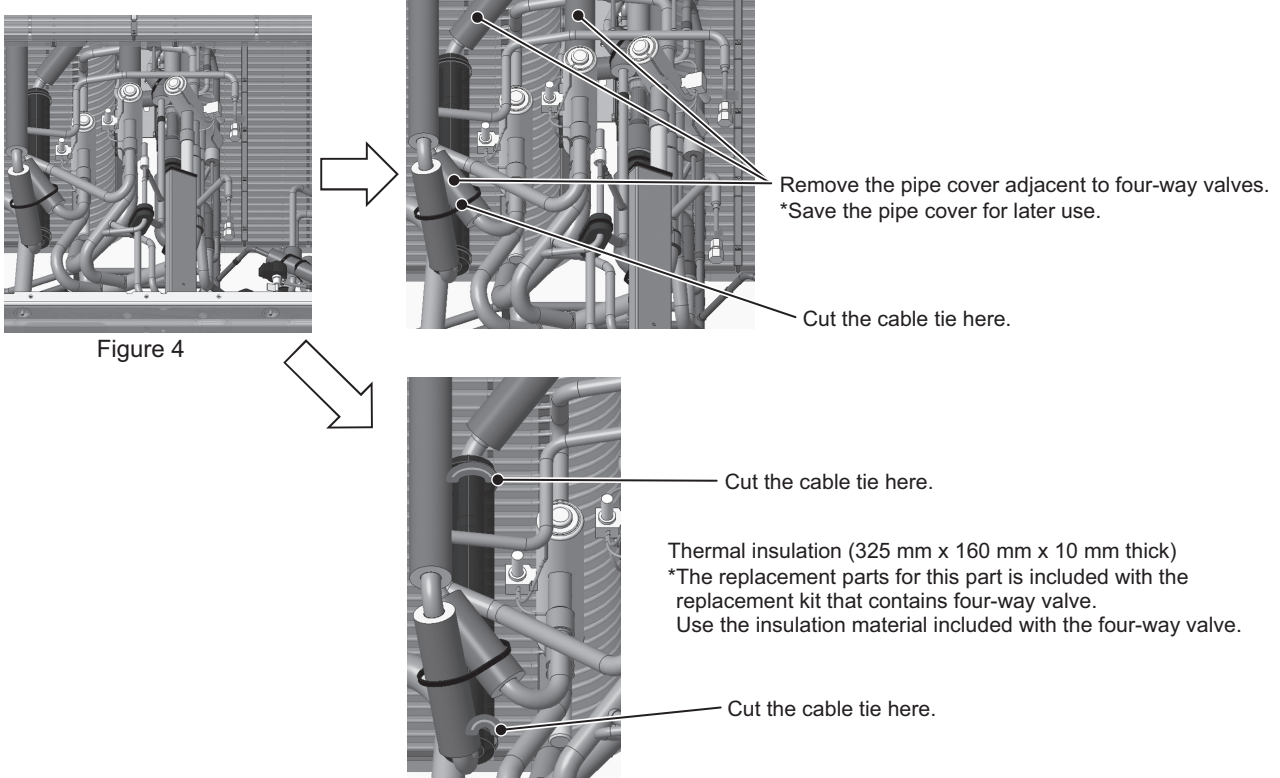


Figure 3

Solenoid valve (SV2) coil, and coil cover

(3) Remove the pipe cover and thermal insulation adjacent to the four-way valves. (See Figure 4.)



*Notes on replacing refrigerant circuit components (check valve, four-way valve, solenoid valve, and LEV)

- Be sure to perform non-oxidized brazing.
- Before heating the pipes, wrap the refrigerant circuit components with a wet towel to keep the temperature of the components from rising above 120°C.
- After brazing is done, check that the brazing is done properly and check for leaks before vacuum-drying the pipes.
- Direct the brazing torch flame away from the wiring and sheet metals inside the unit not to damage them.
- Wet felt sheets listed below (or its equivalent), and place them around the areas to be brazed to protect the heat exchanger, pipes, and pipe covers from being damaged from the brazing torch flame.
Recommended felt sheets: Spatter felt 50CF-11 (5t x 1 m x 1 m) by TRUSCO Nakayama
Felt sheets that meet the JIS standard (JIS A 1323 type A "Flame retardant testing method for spark droplets of welding and gas cutting on fabric sheets in construction works")

(4) Remove the braze from the pipe between four-way valves (21S4a and 21S4b). (See Figure 5.)

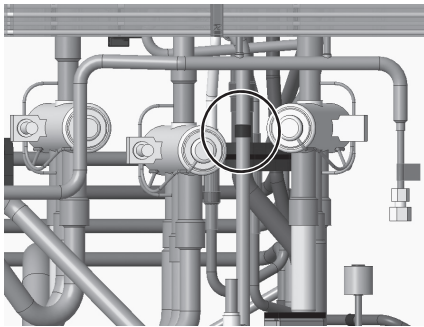


Figure 5

Replacement procedure for four-way valve (21S4a)

(5A) Remove the braze from the area above four-way valve (21S4a) as shown in Figure 6.

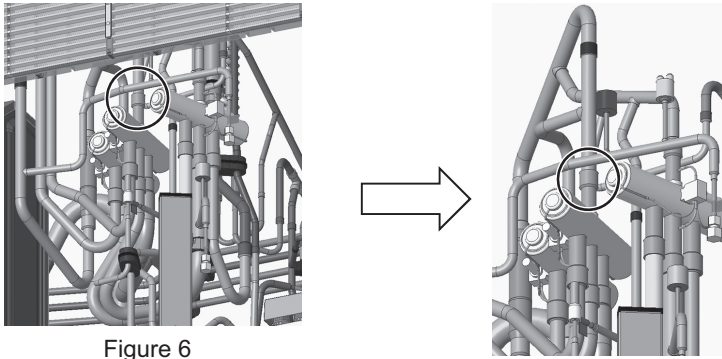


Figure 6

(6A) Remove the braze from the three areas below four-way valve (21S4a) as shown in Figure 7.

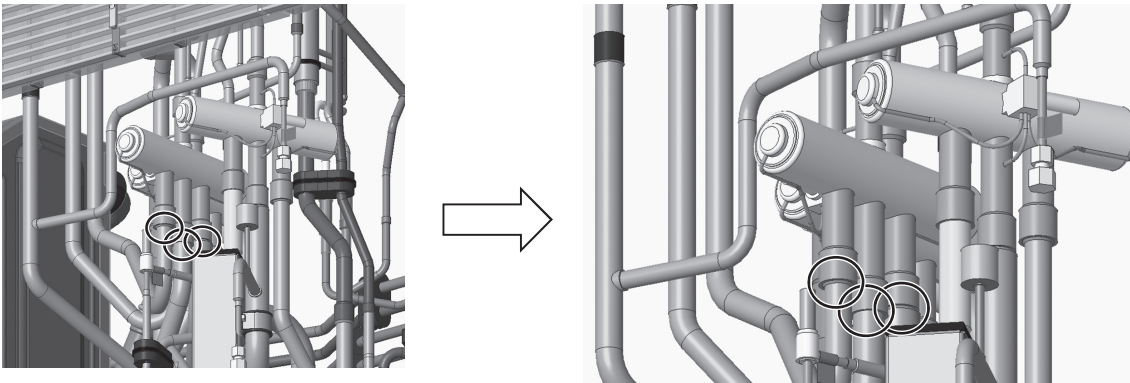


Figure 7

(7A) Mount a new four-way valve (21S4a).

Replacement procedure for four-way valve (21S4b)

(8B) Follow the same procedures as (5A) through (6A).

(9B) Mount a new four-way valve (21S4b). Figure 8 shows how to position a new four-way valve.

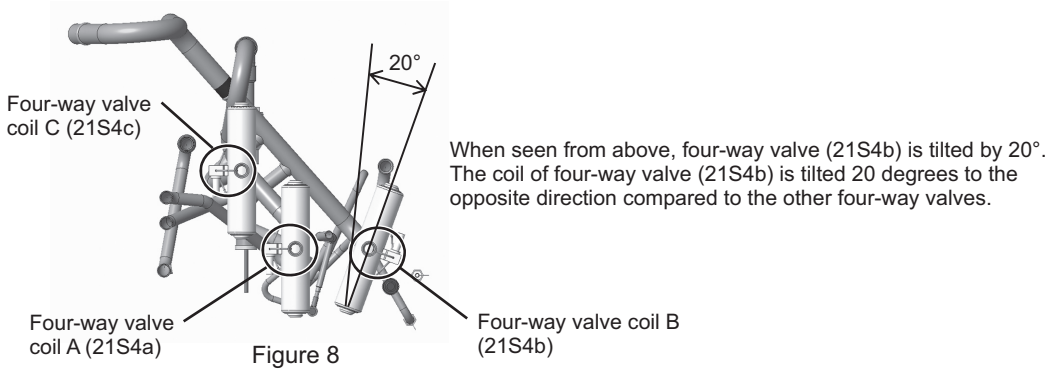


Figure 8

Replacement procedure for four-way valve (21S4c)
 (10C) Install a flame-protection plate. (See Figure 9.)

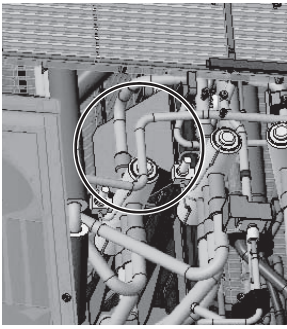
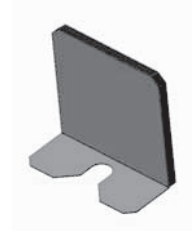
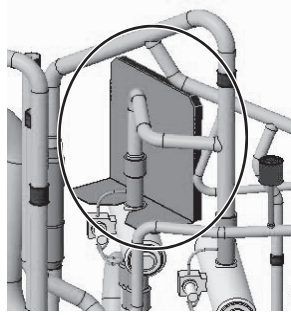


Figure 9



Flame-protection plate
 *Included with the replacement kit that contains four-way valve (21S4c)
 Remove the plate after replacing four-way valve (21S4c).

(11C) Remove the braze from the area above four-way valve (21S4c) as shown in Figure 10.

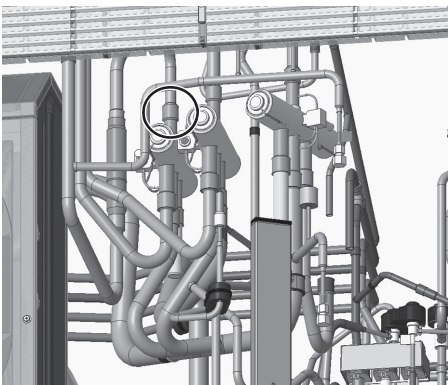
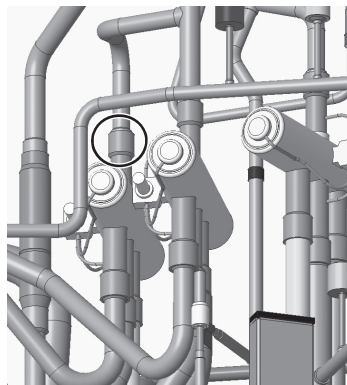


Figure 10



(12C) Remove the braze from the two areas below four-way valve (21S4c) as shown in Figure 11.

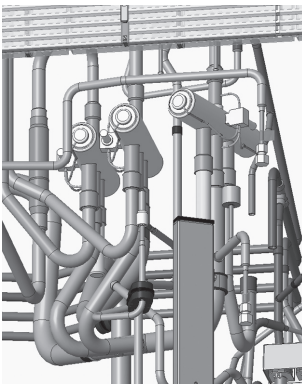
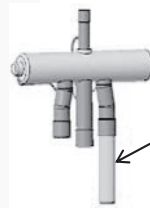
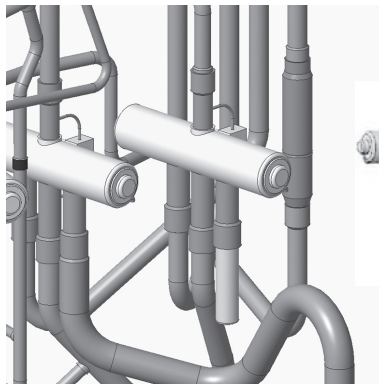


Figure 11



A cap for sealing the refrigerant pipe is included with the replacement kit that contains four-way valve (21S4c). Replace the old cap with the one included with the four-way valve.

(13C) Mount a new four-way valve (21S4c).



When installing four-way valve (21S4c), first braze the pipe outside the unit and then install it to the unit.

Figure 12

8-13-6 Compressor Replacement Procedure <Type A>

Explained below are the procedures for replacing the compressor. Secure sufficient work space before starting replacement work. (See 8-13-1 Ensuring maintenance space (Preparation for the Maintenance of Refrigerant Circuit Parts) <Type A>.)

- (1) Remove the top compressor cover by unscrewing the three screws. (See Figure 1.)
Remove the compressor cover by unhooking the hooks on the back.
- (2) Remove the front compressor cover by unscrewing the four screws. (See Figure 2.)
- (3) Cut the two cable ties holding TH4 and TH15, and remove the wiring from the rubber bush on the left compressor cover. (See Figure 3.)
- (4) Remove the right and left compressor covers by unscrewing the four screws. (See Figure 4.)

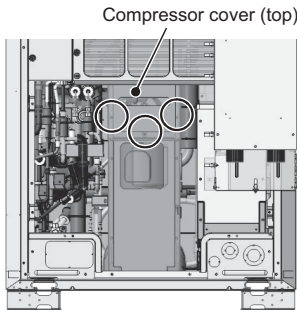


Figure 1

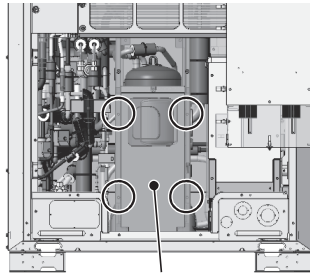


Figure 2

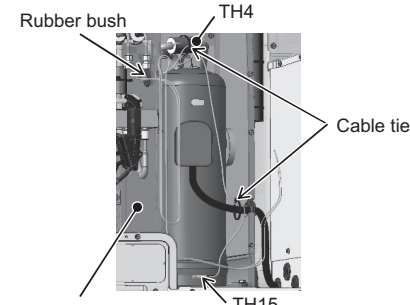


Figure 3

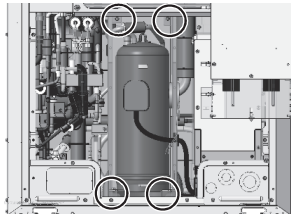


Figure 4

- (5) Remove thermal insulation 1 and thermal insulation 2. (See Figure 5.)
- (6) Remove the duct by unscrewing the two screws. (See Figure 6. Applicable to the S-module only)
- (7) Remove the pipe cover and the damper, and cut the suction pipe where indicated in Figure 7.
- (8) Remove the compressor discharge pipe by cutting the pipe where indicated in Figure 8 or by removing the braze.

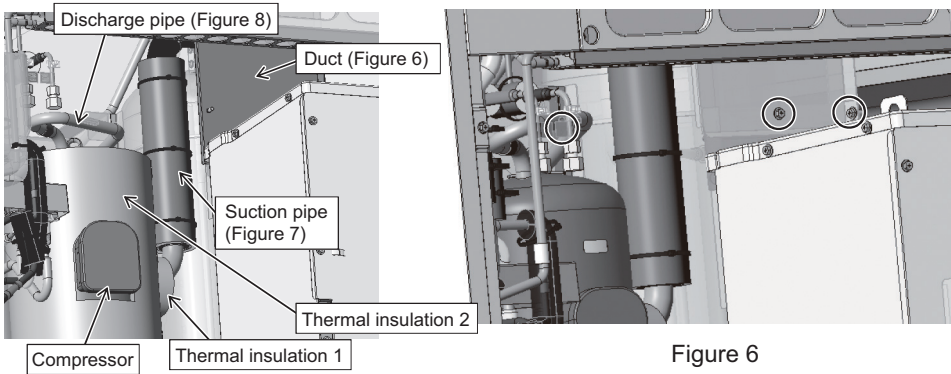


Figure 5

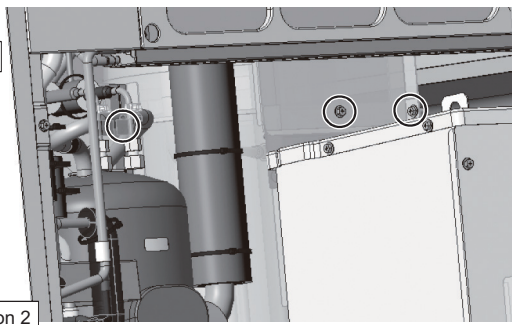


Figure 6

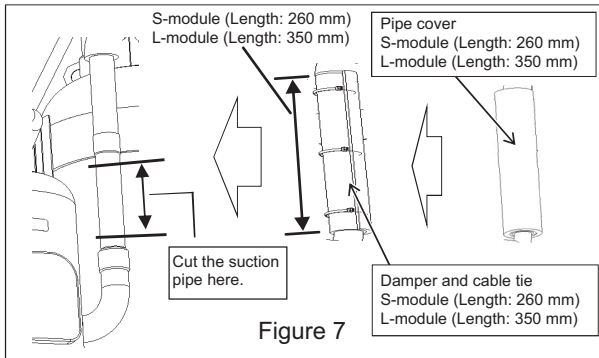


Figure 7

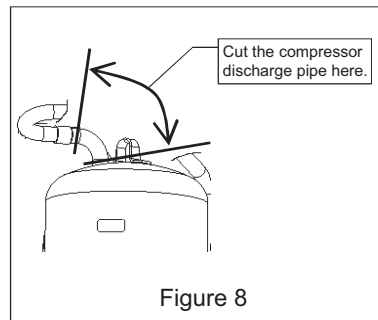


Figure 8

- (9) Remove the four bolts holding the compressor down. (See Figure 9.)
The two bolts in the front are also holding down the metal sheets.
- (10) Tilting the compressor will cause the refrigerant oil to leak. Seal the pipe where it was cut or removed at the brazed section.
- (11) After replacing the compressor, protect the surrounding components such as the control box, ACC, compressor cover, and damper with a fire protection panel (e.g., recommended felt soaked in water), and perform brazing. (See Figure 10.)

*Precautions for replacing the compressor

- Be sure to perform non-oxidized brazing.
- Before heating the pipes, wrap the refrigerant circuit components with a wet towel to keep the temperature of the components from rising above 120°C.
- After brazing is done, check that the brazing is done properly and check for leaks before vacuum-drying the pipes.
- Direct the brazing torch flame away from the wiring and sheet metals inside the unit not to damage them.
- Wet felt sheets listed below (or its equivalent), and place them around the areas to be brazed to protect the heat exchanger, pipes, and pipe covers from being damaged from the brazing torch flame.
Recommended felt sheets: Spatter felt 50CF-11 (5t x 1 m x 1 m) by TRUSCO Nakayama
Felt sheets that meet the JIS standard (JIS A 1323 type A "Flame retardant testing method for spark droplets of welding and gas cutting on fabric sheets in construction works")

- (12) The recommended tightening torque for the compressor fixing bolts is 3.0 N·m. Tighten the bolts using a torque-adjustable tool.
- (13) Re-place the compressor covers in the reverse order as they were removed.

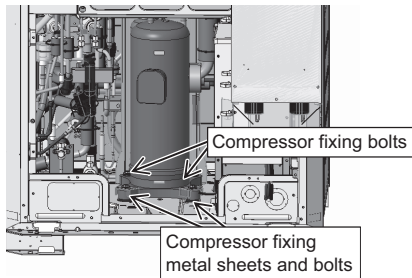


Figure 9

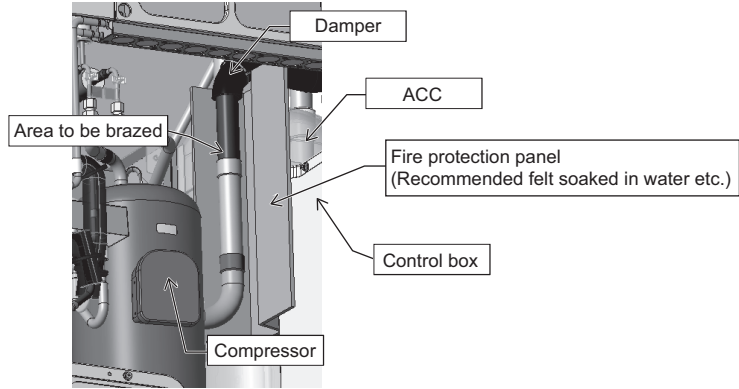


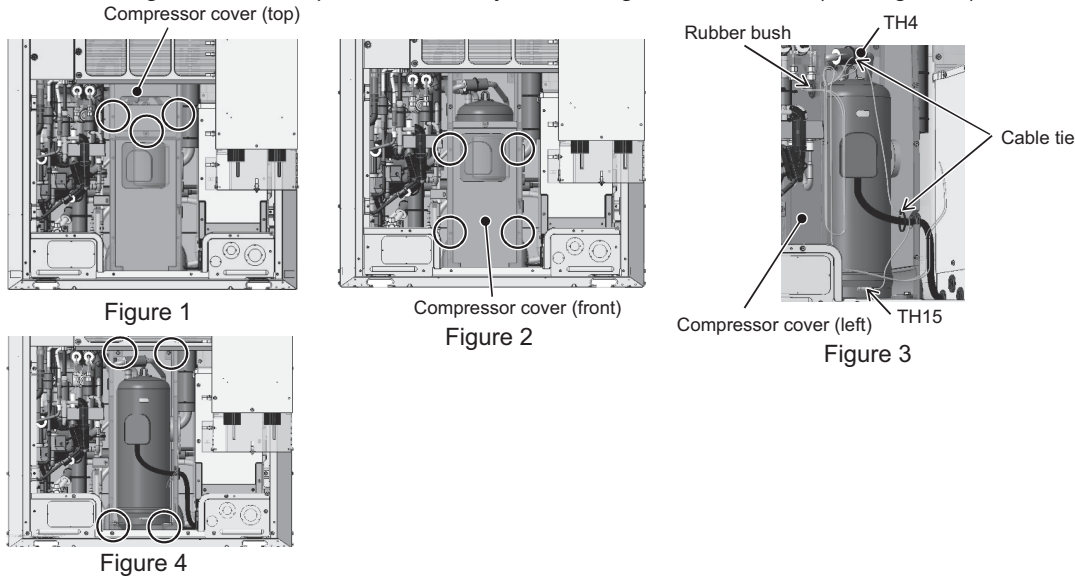
Figure 10

8-13-7 Compressor Replacement Procedure <Type A1/Type A2>

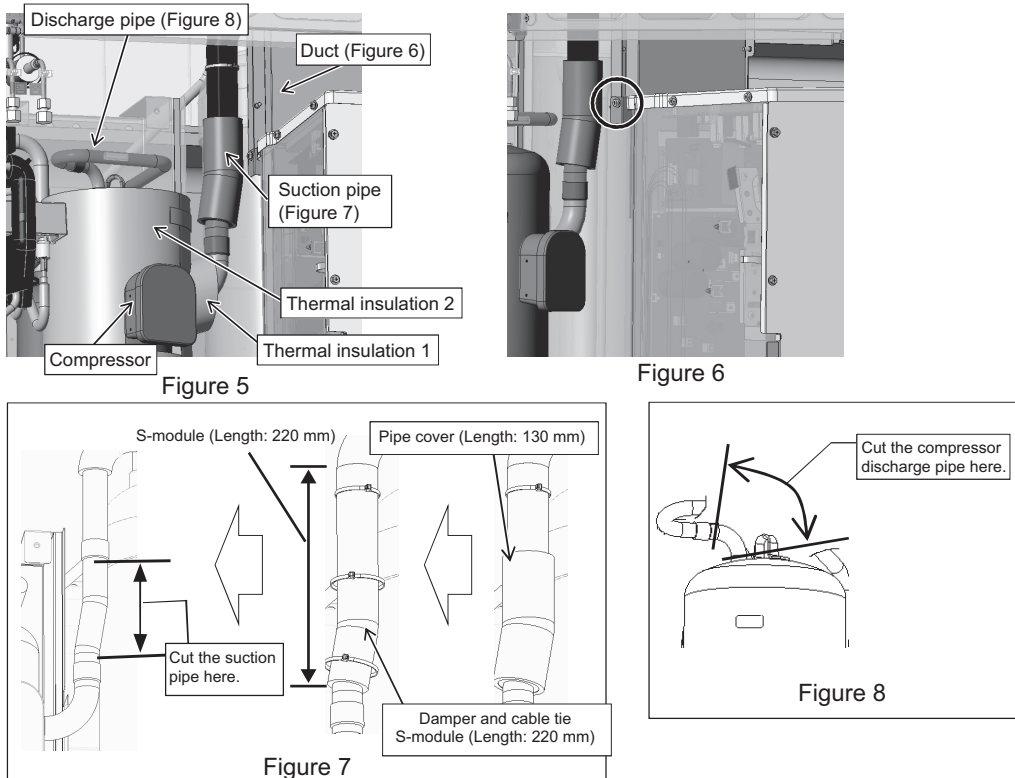
1. PUHY-P200, P250YNW-A1/2

Explained below are the procedures for replacing the compressor. Secure sufficient work space before starting replacement work. (See 8-13-2 Ensuring maintenance space (Preparation for the Maintenance of Refrigerant Circuit Parts) <Type A1/Type A2>.)

- (1) Remove the top compressor cover by unscrewing the three screws. (See Figure 1.)
Remove the compressor cover by unhooking the hooks on the back.
- (2) Remove the front compressor cover by unscrewing the four screws. (See Figure 2.)
- (3) Cut the two cable ties holding TH4 and TH15, and remove the wiring from the rubber bush on the left compressor cover. (See Figure 3.)
- (4) Remove the right and left compressor covers by unscrewing the four screws. (See Figure 4.)



- (5) Remove thermal insulation 1 and thermal insulation 2. (See Figure 5.)
- (6) Remove the duct by unscrewing the screw. (See Figure 6. Applicable to the S-module only)
- (7) Remove the pipe cover and the damper, and cut the suction pipe where indicated in Figure 7.
*When re-placing the pipe cover and the dumper, use the ones with the sizes shown in Figure 7, which are supplied with the replacement compressor.
- (8) Remove the compressor discharge pipe by cutting the pipe where indicated in Figure 8 or by removing the braze.



- (9) Remove the four bolts holding the compressor down. (See Figure 9.)
The two bolts in the front are also holding down the metal sheets.
- (10) Tilting the compressor will cause the refrigerant oil to leak. Seal the pipe where it was cut or removed at the brazed section.
- (11) After replacing the compressor, perform brazing using a wet recommended felt sheet. Use caution not to damage the control box, ACC, compressor cover, or damper. (See Figure 10.)

*Precautions for replacing the compressor

- Be sure to perform non-oxidized brazing.
- Before heating the pipes, wrap the refrigerant circuit components with a wet towel to keep the temperature of the components from rising above 120°C.
- After brazing is done, check that the brazing is done properly and check for leaks before vacuum-drying the pipes.
- Direct the brazing torch flame away from the wiring and sheet metals inside the unit not to damage them.
- Wet felt sheets listed below (or its equivalent), and place them around the areas to be brazed to protect the heat exchanger, pipes, and pipe covers from being damaged from the brazing torch flame.

Recommended felt sheets: Spatter felt 50CF-11 (5t x 1 m x 1 m) by TRUSCO Nakayama
Felt sheets that meet the JIS standard (JIS A 1323 type A "Flame retardant testing method for spark droplets of welding and gas cutting on fabric sheets in construction works")

- (12) The recommended tightening torque for the compressor fixing bolts is 3.0 N·m. Tighten the bolts using a torque-adjustable tool.
- (13) Re-place the compressor covers in the reverse order as they were removed.
* Hold the TH15 wiring using cable ties so that it does not come into contact with thermal insulation 2. (See Figures 3 and 5.)

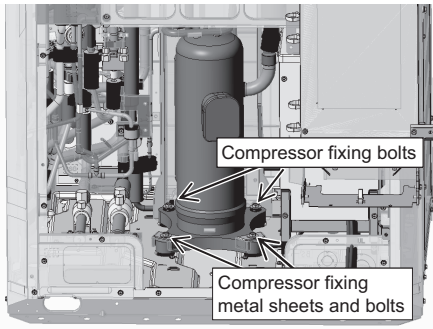


Figure 9

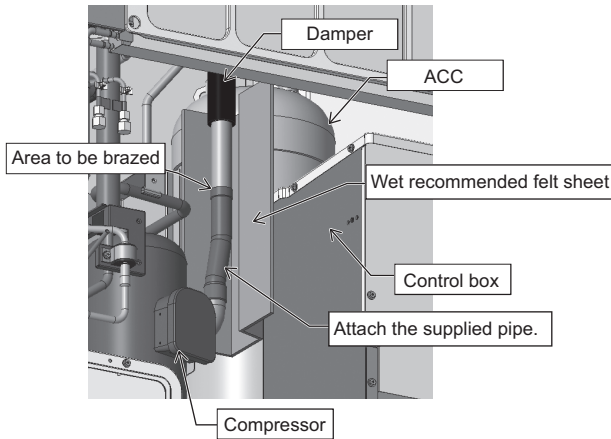
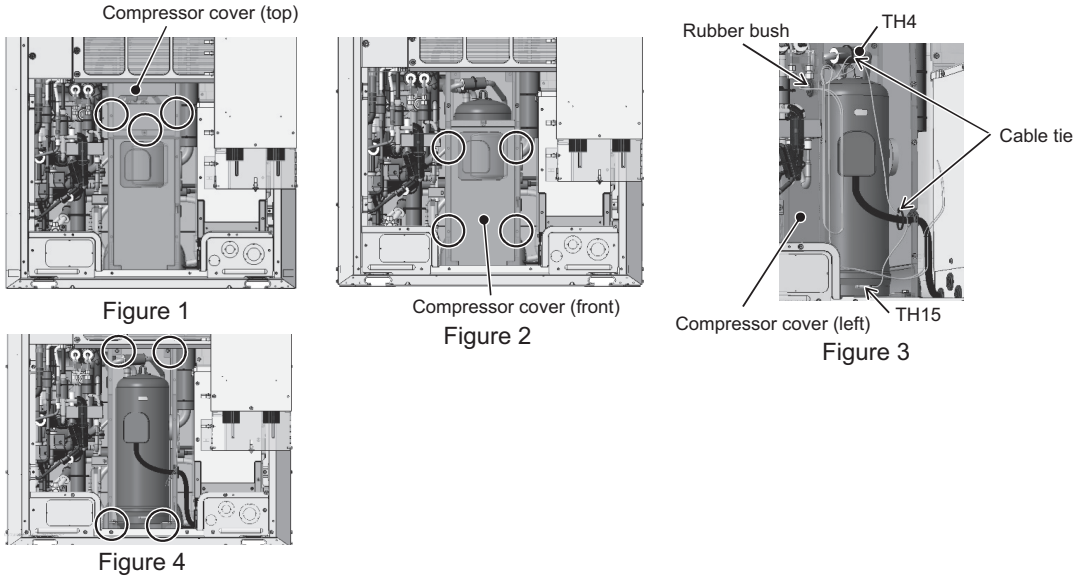


Figure 10

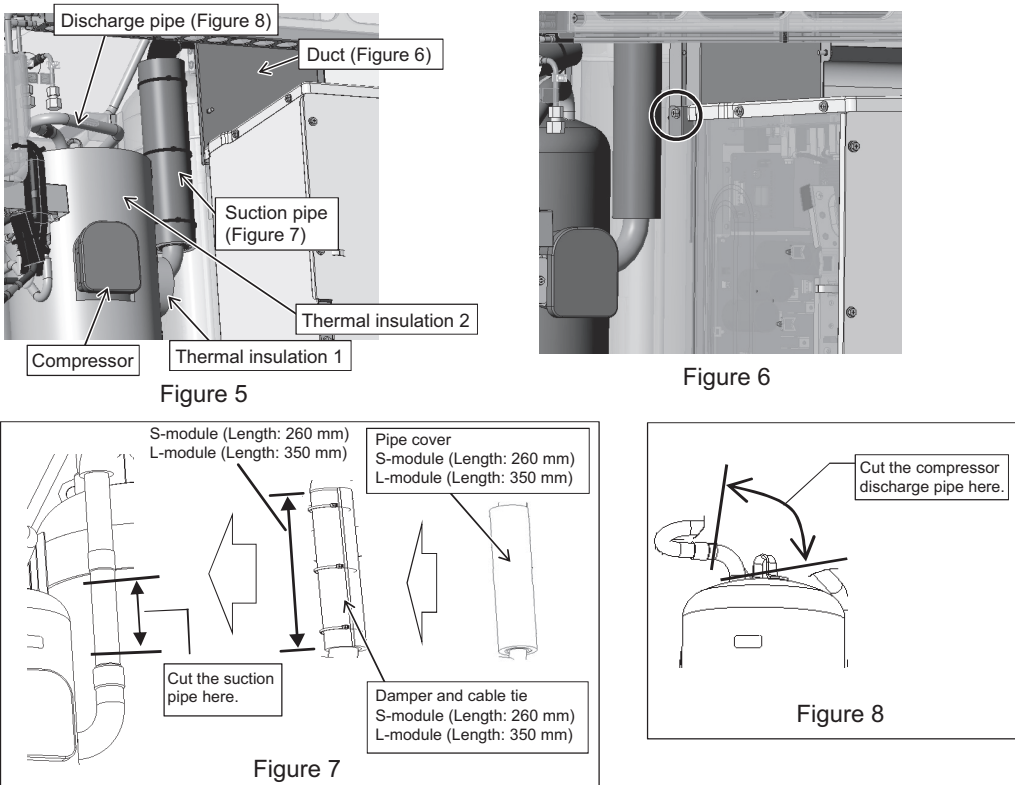
2. PUHY-P300, P350, P400, P450YNW-A1/2 PUHY-EP200, EP250, EP300, EP350, EP400, EP450YNW-A1/2

Explained below are the procedures for replacing the compressor. Secure sufficient work space before starting replacement work. (See 8-13-2 Ensuring maintenance space (Preparation for the Maintenance of Refrigerant Circuit Parts) <Type A1/Type A2>.)

- (1) Remove the top compressor cover by unscrewing the three screws. (See Figure 1.)
Remove the compressor cover by unhooking the hooks on the back.
- (2) Remove the front compressor cover by unscrewing the four screws. (See Figure 2.)
- (3) Cut the two cable ties holding TH4 and TH15, and remove the wiring from the rubber bush on the left compressor cover. (See Figure 3.)
- (4) Remove the right and left compressor covers by unscrewing the four screws. (See Figure 4.)



- (5) Remove thermal insulation 1 and thermal insulation 2. (See Figure 5.)
- (6) Remove the duct by unscrewing the screw. (See Figure 6. Applicable to the S-module only)
- (7) Remove the pipe cover and the damper, and cut the suction pipe where indicated in Figure 7.
*When re-placing the pipe cover and the dumper, use the ones with the sizes shown in Figure 7, which are supplied with the replacement compressor.
- (8) Remove the compressor discharge pipe by cutting the pipe where indicated in Figure 8 or by removing the braze.



- (9) Remove the four bolts holding the compressor down. (See Figure 9.)
The two bolts in the front are also holding down the metal sheets.
- (10) Tilting the compressor will cause the refrigerant oil to leak. Seal the pipe where it was cut or removed at the brazed section.
- (11) After replacing the compressor, perform brazing using a wet recommended felt sheet. Use caution not to damage the control box, ACC, compressor cover, or damper. (See Figure 10.)

*Precautions for replacing the compressor

- Be sure to perform non-oxidized brazing.
- Before heating the pipes, wrap the refrigerant circuit components with a wet towel to keep the temperature of the components from rising above 120°C.
- After brazing is done, check that the brazing is done properly and check for leaks before vacuum-drying the pipes.
- Direct the brazing torch flame away from the wiring and sheet metals inside the unit not to damage them.
- Wet felt sheets listed below (or its equivalent), and place them around the areas to be brazed to protect the heat exchanger, pipes, and pipe covers from being damaged from the brazing torch flame.
Recommended felt sheets: Spatter felt 50CF-11 (5t x 1 m x 1 m) by TRUSCO Nakayama
Felt sheets that meet the JIS standard (JIS A 1323 type A "Flame retardant testing method for spark droplets of welding and gas cutting on fabric sheets in construction works")

- (12) The recommended tightening torque for the compressor fixing bolts is 3.0 N·m. Tighten the bolts using a torque-adjustable tool.
- (13) Re-place the compressor covers in the reverse order as they were removed.
* Hold the TH15 wiring using cable ties so that it does not come into contact with thermal insulation 2.
(See Figures 3 and 5.)

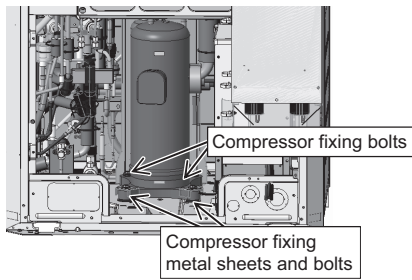


Figure 9

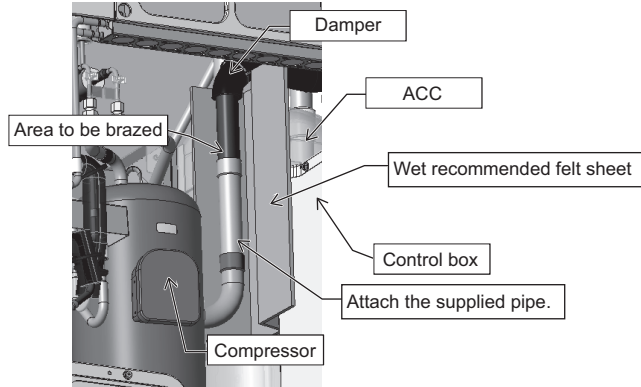
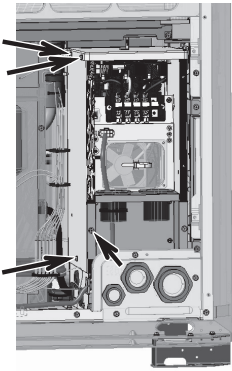


Figure 10

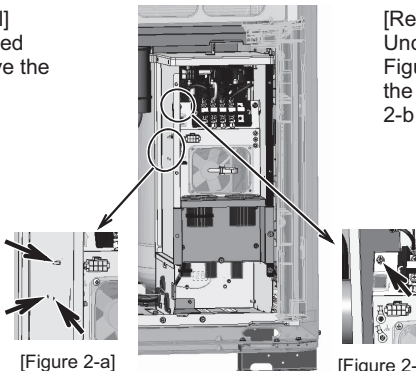
8-13-8 Removal Instructions for the Control Box <Type A>

1. S module (INV box)



[Figure 1]

[Removing the left outside panel]
Unscrew the four screws indicated with arrows in Figure 1 to remove the left outside panel.



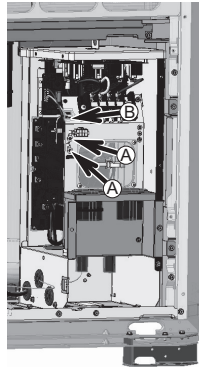
[Figure 2-a]

[Figure 2]

[Figure 2-b]

[Removing the left inside panel]
Unclamp the three clamps shown in Figure 2-a, and unscrew the screw on the left of the terminal board shown in 2-b to remove the left inside panel.

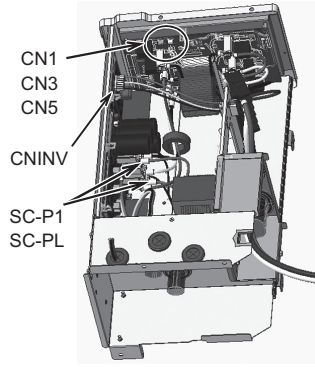
[Removing the ground wire]
Remove the two ground wires (screwed on) indicated by Arrow (A) in Figure 3-a, and unsaddle them from the saddle indicated by Arrow (B).



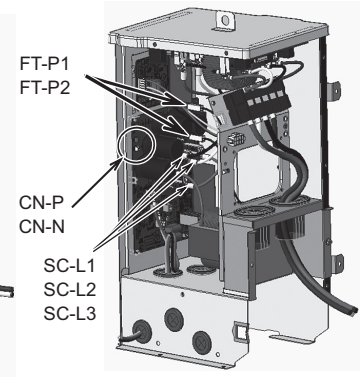
[Figure 3-a]

[Removing the wiring]
Remove the following connectors and the screw terminals.

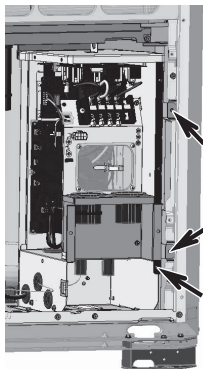
(See Figures 3-b and 3-c.)
CN1, CN3, and CN5 on the Noise Filter board
CNINV on the FAN INV board
CN-P, CN-N, FT-P1, FT-P2, SC-P1, SC-PL, SC-L1, SC-L2, and SC-L3 on the INV35 board



[Figure 3-b]

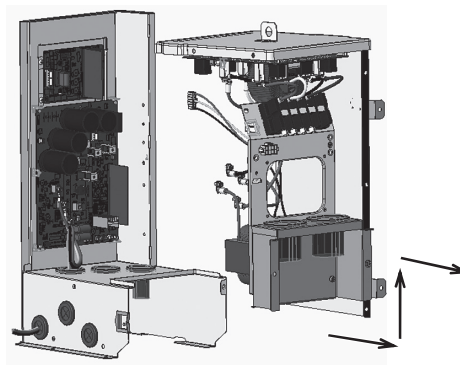


[Figure 3-c]



[Figure 4-a]

[Removing the terminal board, DCL, and top panel (Noise Filter board)]
Unscrew the three screws indicated by the arrows in Figure 4-a, and pull the DCL, the right side panel, and the top panel forward toward the front of the unit. Then, lift the back end of the top panel, and then pull the terminal board, the DCL, and the top panel (Noise Filter board) forward toward the front of the unit all together to remove them as one unit. (Figure 4-b.)

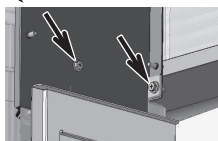


[Figure 4-b]

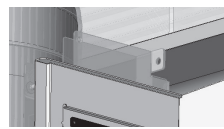


[Figure 5]

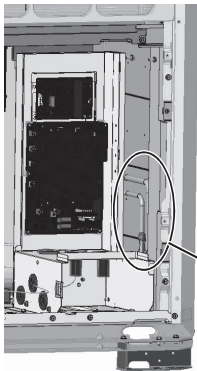
[Removing the duct]
Unscrew the two screws indicated with arrows in Figure 5-a, and pull up the duct to remove it. (Figure 5-b shows the unit after the duct was removed.)



[Figure 5-a]

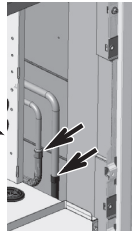


[Figure 5-b]



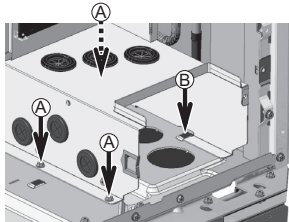
[Figure 6]

[Removing refrigerant cooling pipes]
 Remove the braze from the two areas indicated by the arrows in Figure 6-a.
 Before removing the pipes, collect the refrigerant.
 Protect the surrounding components from the brazing torch flame as necessary.

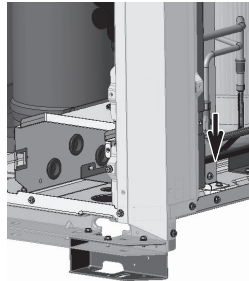


[Figure 6-a]

[Removing the remaining relevant components]
 Unscrew the three screws indicated with arrows ① in Figure 7.
 The arrow indicated with dotted lines is located where indicated with an arrow in Figure 7-a. (Accessible from the area where brazed pipes were removed)
 Pull the unscrewed part forward, and unhook the part indicated with Arrow ② to remove the part from the base of the unit.



[Figure 7]



[Figure 7-a]

- *Notes on replacing the control box (when replacing the refrigerant cooling pipes)
- Be sure to perform non-oxidized brazing.
 - Before heating the pipes, wrap the refrigerant circuit components with a wet towel to keep the temperature of the components from rising above 120°C.
 - After brazing is done, check that the brazing is done properly and check for leaks before vacuum-drying the pipes.
 - Direct the brazing torch flame away from the wiring and sheet metals inside the unit not to damage them.
 - Wet felt sheets listed below (or its equivalent), and place them around the areas to be brazed to protect the heat exchanger, pipes, and pipe covers from being damaged from the brazing torch flame.
 Recommended felt sheets: Spatter felt 50CF-11 (5t x 1 m x 1 m) by TRUSCO Nakayama
 Felt sheets that meet the JIS standard (JIS A 1323 type A "Flame retardant testing method for spark droplets of welding and gas cutting on fabric sheets in construction works")

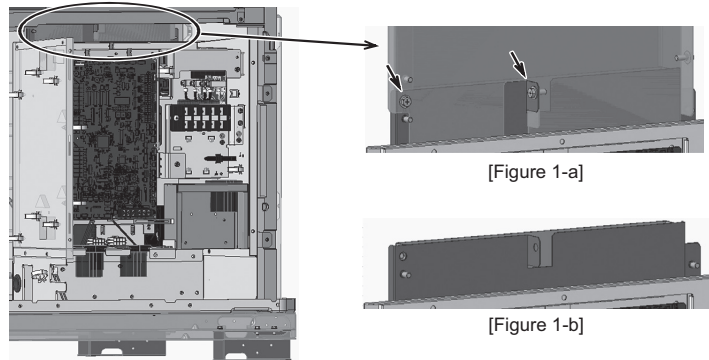
2. L/XL module

[Removing the duct]

Unscrew the two screws indicated with arrows in Figure 1-a, and pull up the duct to remove it.

(Figure 1-b shows the unit after the duct was removed.)

*The same procedures apply to both the L and the XL modules.



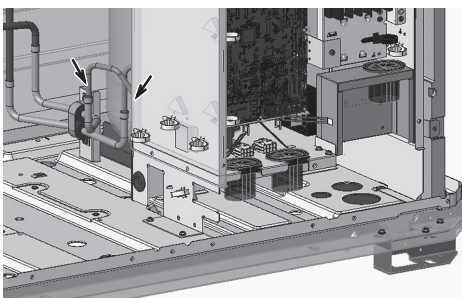
[Figure 1]

[Removing the refrigerant cooling pipes]

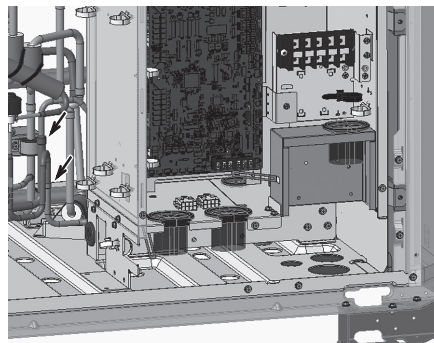
Remove the braze at the two areas indicated with arrows in Figure 2-a(L module), Figure 2-b (XL module).

Before removing the pipes, collect the refrigerant.

Refer to "Notes on replacing refrigerant circuit components."



[Figure 2-a]



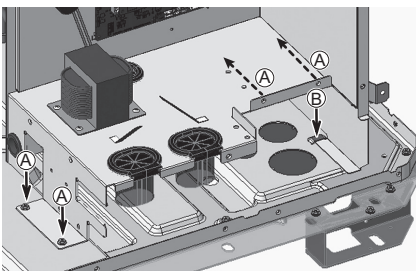
[Figure 2-b]

[Removing the remaining relevant components]

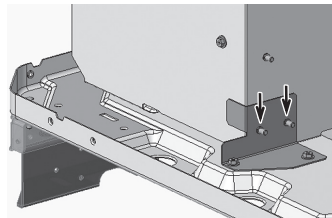
Unscrew the four screws indicated with arrows (A) in Figure 3.

The arrow indicated with dotted lines is located where indicated in Figure 3-a.

Pull the unscrewed part forward, and unhook the part indicated with Arrow (B) to remove the part from the base of the unit.



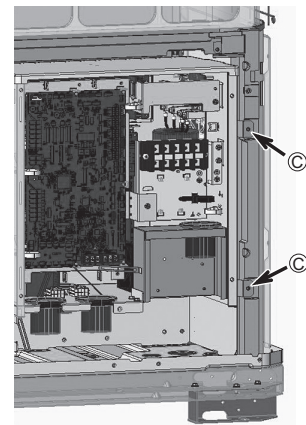
[Figure 3]



[Figure 3-a]

To remove the rest of the components from the pillar, unscrew the two screws indicated with Arrow (C) in Figure 4.

*The same procedures apply to both the L and the XL modules.



[Figure 4]

*Notes on replacing the control box (when replacing the refrigerant cooling pipes)

- Be sure to perform non-oxidized brazing.
- Before heating the pipes, wrap the refrigerant circuit components with a wet towel to keep the temperature of the components from rising above 120°C.
- After brazing is done, check that the brazing is done properly and check for leaks before vacuum-drying the pipes.
- Direct the brazing torch flame away from the wiring and sheet metals inside the unit not to damage them.
- Wet felt sheets listed below (or its equivalent), and place them around the areas to be brazed to protect the heat exchanger, pipes, and pipe covers from being damaged from the brazing torch flame.

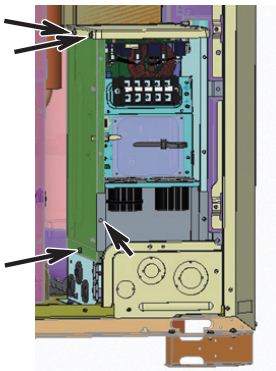
Recommended felt sheets: Spatter felt 50CF-11 (5t x 1 m x 1 m) by TRUSCO Nakayama

Felt sheets that meet the JIS standard (JIS A 1323 type A "Flame retardant testing method for spark droplets of welding and gas cutting on fabric sheets in construction works")

8-13-9 Removal Instructions for the Control Box <Type A1/Type A2>

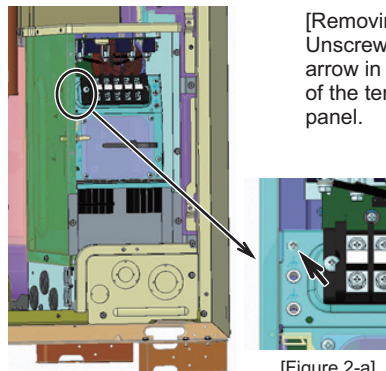
1. S module (INV box)

8 Troubleshooting Based on Observed Symptoms



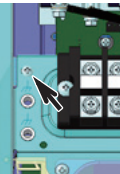
[Figure 1]

[Removing the left outside panel]
Unscrew the four screws indicated with arrows in Figure 1 to remove the left outside panel.



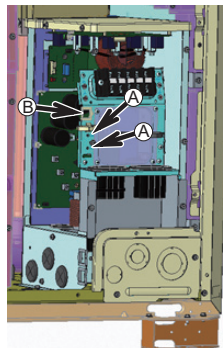
[Figure 2]

[Removing the left inside panel]
Unscrew the screw indicated with an arrow in Figure 2-a (located to the left of the terminal board) to remove the left panel.



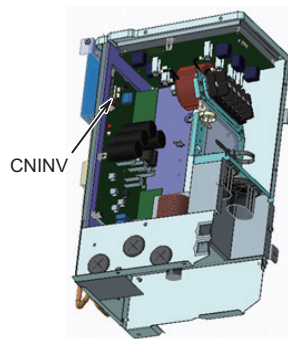
[Figure 2-a]

[Removing the ground wire]
Remove the two ground wires (screwed on) indicated by Arrow (A) in Figure 3-a, and unsaddle them from the saddle indicated by Arrow (B).

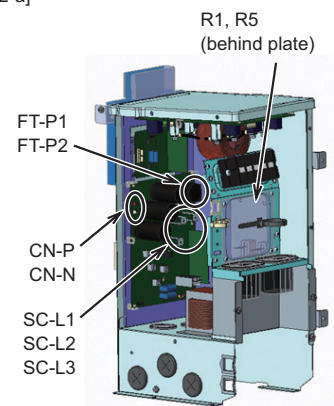


[Figure 3-a]

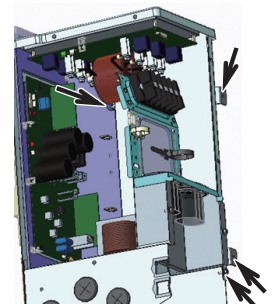
[Removing the wiring]
Remove the following connectors and the screw terminals.
(See Figures 3-b and 3-c.)
CNINV on the FAN INV board
CN-P, CN-N, FT-P1, FT-P2, SC-L1, SC-L2, and SC-L3 on the INV35 board
Terminals on R1 and R5



[Figure 3-b]

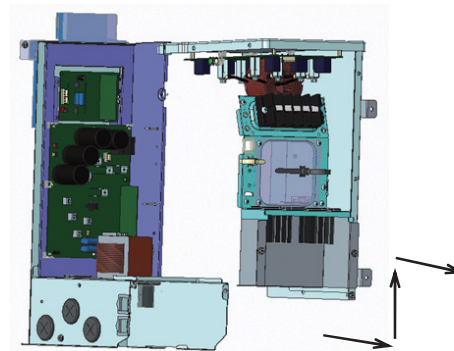


[Figure 3-c]

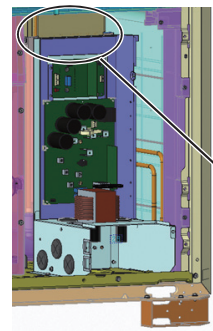


[Figure 4-a]

[Removing the terminal board and top panel (Noise Filter board)]
Unscrew the four screws indicated with arrows in Figure 4-a. Pull the right panel and the top panel forward. Lift the back end of the top panel and pull the terminal board and the top panel (Noise Filter board) together to remove them. (See Figure 4-b.)



[Figure 4-b]

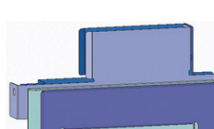


[Figure 5]

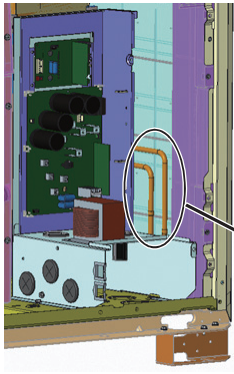
[Removing the duct]
Unscrew the screw indicated with arrows in Figure 5-a, and pull up the duct to remove it. (Figure 5-b shows the unit after the duct was removed.)



[Figure 5-a]

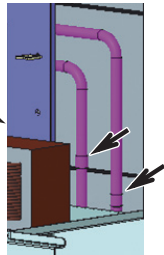


[Figure 5-b]



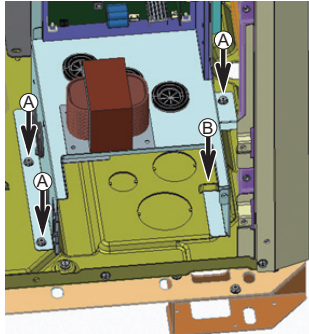
[Figure 6]

[Removing refrigerant cooling pipes]
 Remove the braze from the two areas indicated by the arrows in Figure 6-a.
 Before removing the pipes, collect the refrigerant.
 Protect the surrounding components from the brazing torch flame as necessary.



[Figure 6-a]

[Removing the remaining relevant components]
 Unscrew the three screws indicated with arrows ① in Figure 7.
 Pull the unscrewed part forward, and unhook the part indicated with Arrow ② to remove the part from the base of the unit.



[Figure 7]

*Notes on replacing the control box (when replacing the refrigerant cooling pipes)

- Be sure to perform non-oxidized brazing.
- Before heating the pipes, wrap the refrigerant circuit components with a wet towel to keep the temperature of the components from rising above 120°C.
- After brazing is done, check that the brazing is done properly and check for leaks before vacuum-drying the pipes.
- Direct the brazing torch flame away from the wiring and sheet metals inside the unit not to damage them.
- Wet felt sheets listed below (or its equivalent), and place them around the areas to be brazed to protect the heat exchanger, pipes, and pipe covers from being damaged from the brazing torch flame.
 Recommended felt sheets: Spatter felt 50CF-11 (5t x 1 m x 1 m) by TRUSCO Nakayama
 Felt sheets that meet the JIS standard (JIS A 1323 type A "Flame retardant testing method for spark droplets of welding and gas cutting on fabric sheets in construction works")

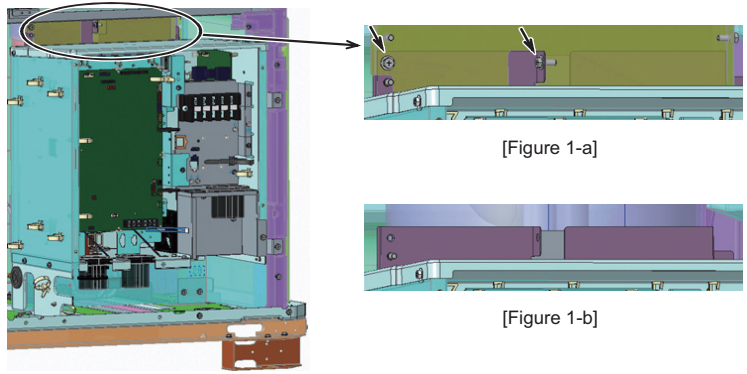
2. L/XL module

[Removing the duct]

Unscrew the two screws indicated with arrows in Figure 1-a, and pull up the duct to remove it.

(Figure 1-b shows the unit after the duct was removed.)

*The same procedures apply to both the L and the XL modules.



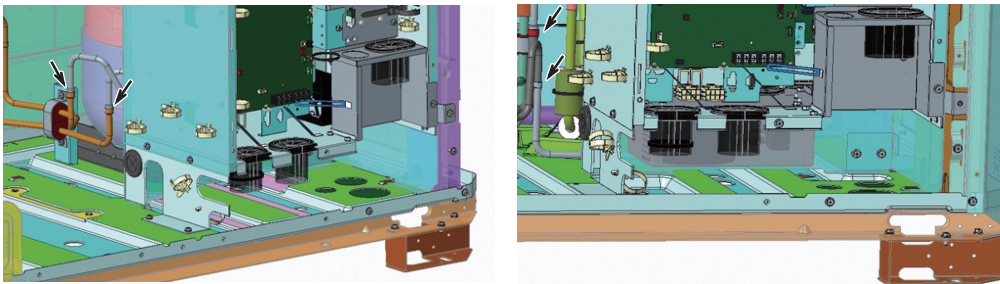
[Figure 1]

[Removing the refrigerant cooling pipes]

Remove the braze at the two areas indicated with arrows in Figure 2-a(L module), Figure 2-b (XL module).

Before removing the pipes, collect the refrigerant.

Refer to "Notes on replacing refrigerant circuit components."



[Figure 2-a]

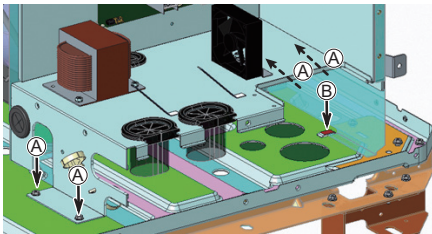
[Figure 2-b]

[Removing the remaining relevant components]

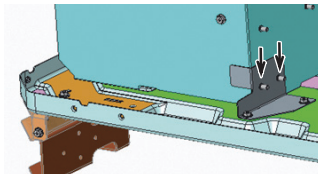
Unscrew the four screws indicated with arrows (A) in Figure 3.

The arrow indicated with dotted lines is located where indicated in Figure 3-a.

Pull the unscrewed part forward, and unhook the part indicated with Arrow (B) to remove the part from the base of the unit.



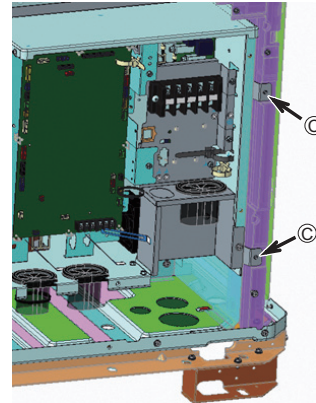
[Figure 3]



[Figure 3-a]

To remove the rest of the components from the pillar, unscrew the two screws indicated with Arrow (C) in Figure 4.

*The same procedures apply to both the L and the XL modules.



[Figure 4]

*Notes on replacing the control box (when replacing the refrigerant cooling pipes)

- Be sure to perform non-oxidized brazing.
- Before heating the pipes, wrap the refrigerant circuit components with a wet towel to keep the temperature of the components from rising above 120°C.
- After brazing is done, check that the brazing is done properly and check for leaks before vacuum-drying the pipes.
- Direct the brazing torch flame away from the wiring and sheet metals inside the unit not to damage them.
- Wet felt sheets listed below (or its equivalent), and place them around the areas to be brazed to protect the heat exchanger, pipes, and pipe covers from being damaged from the brazing torch flame.

Recommended felt sheets: Spatter felt 50CF-11 (5t x 1 m x 1 m) by TRUSCO Nakayama

Felt sheets that meet the JIS standard (JIS A 1323 type A "Flame retardant testing method for spark droplets of welding and gas cutting on fabric sheets in construction works")

8-13-10 Maintenance Procedure for the Drain Pan <Type A/Type A1/Type A2>

1. S-module

[Drain pan removal procedure]

- (1) Remove the front panel from the unit by unscrewing the eight screws. (See Figure 1.)
 - (2) Cut the cable tie, unscrew the screw, and pull out the drain pan cover toward the right. (See Figure 3.)
 - (3) Remove the two rod holders holding the check joints in place, using a wrench. (See Figure 4.)
 - (4) Remove the drain pan by unscrewing the two screws. (See Figure 5.)
 - (5) Clean the drain pan and the drain pan cover. (See Figure 6.)
- Remove dust and dirt from the drain groove.

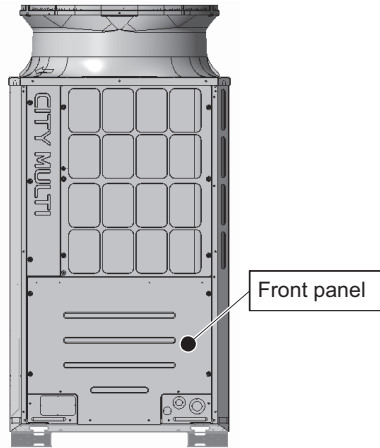


Figure 1

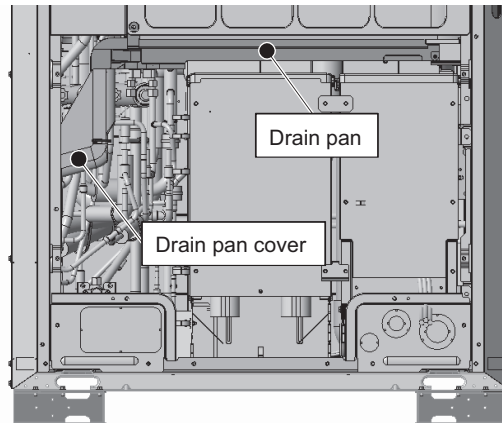


Figure 2

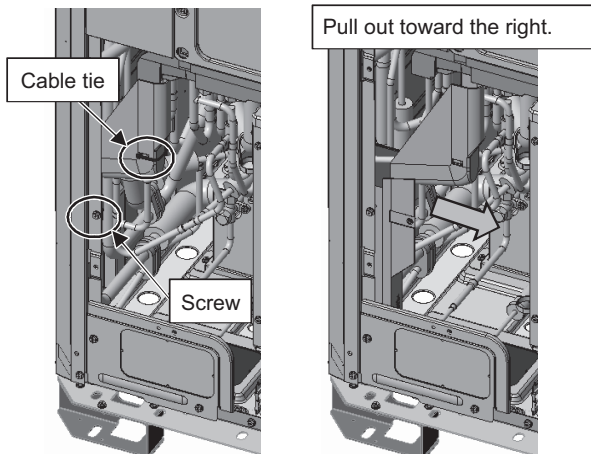


Figure 3

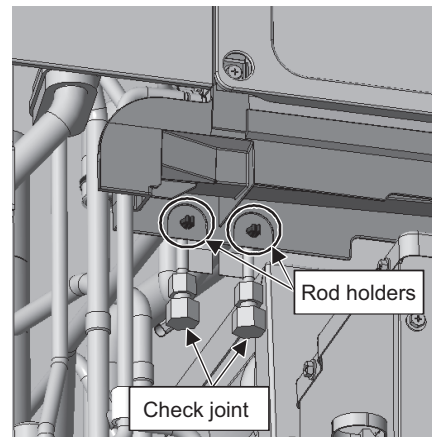


Figure 4

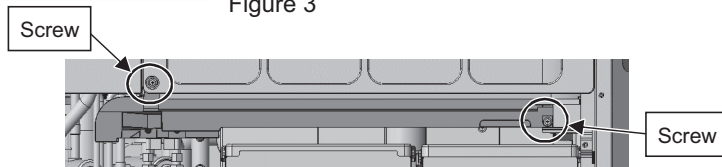


Figure 5

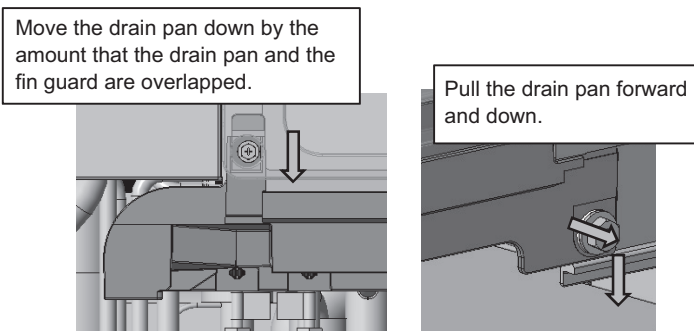
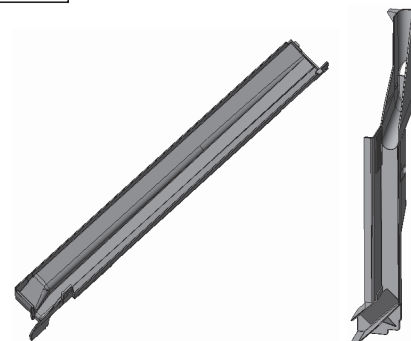


Figure 6



[Drain pan mounting procedure]

*Reuse the drain pan mounting screws that were removed from the replaced drain pan. (M5 x 16 mm with a nylon washer)

- (1) Screw down the drain pan with two screws. (See Figure 7.)
- (2) Hold the check joints to the drain pan with two rod holders. (See Figure 8.)
- (3) Make sure that the silicon tube is properly placed on the defrost pipe, and then place the drain pan cover. (See Figures 9 and 10.)
- (4) Thread a cable tie through the rectangle hole on the screwed-down drain cover, and hold the silicon tube and the defrost pipe together in place. (See Figure 11.)
- (5) Screw down the front panel with eight screws. (See Figure 12.)

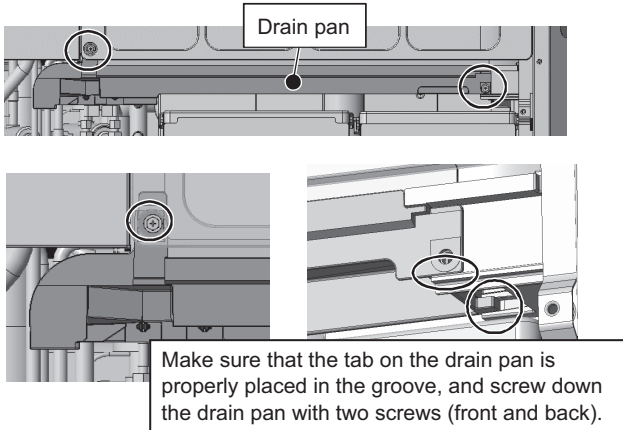


Figure 7

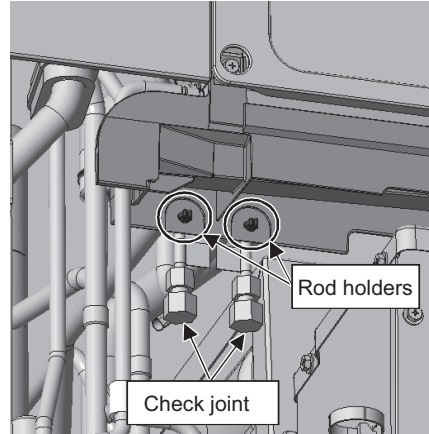


Figure 8

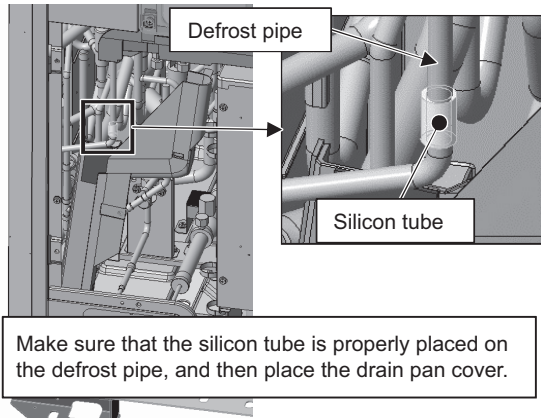


Figure 9

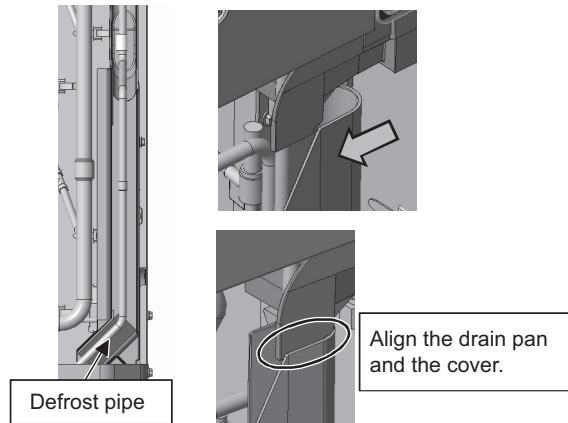


Figure 10

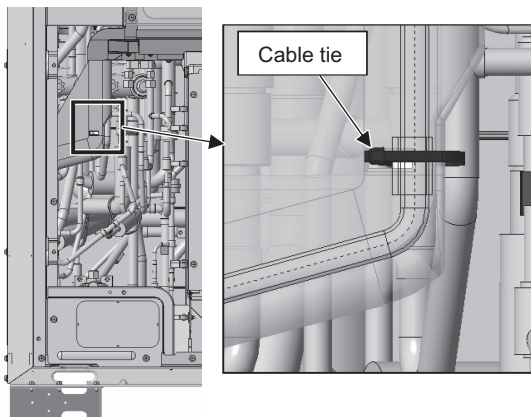


Figure 11

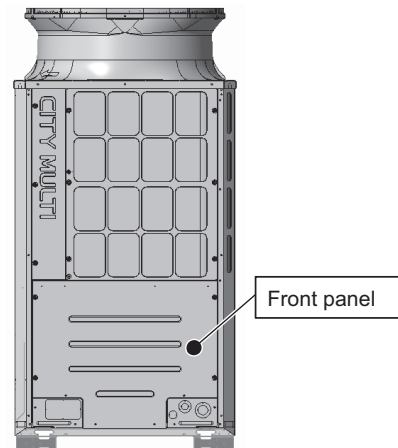
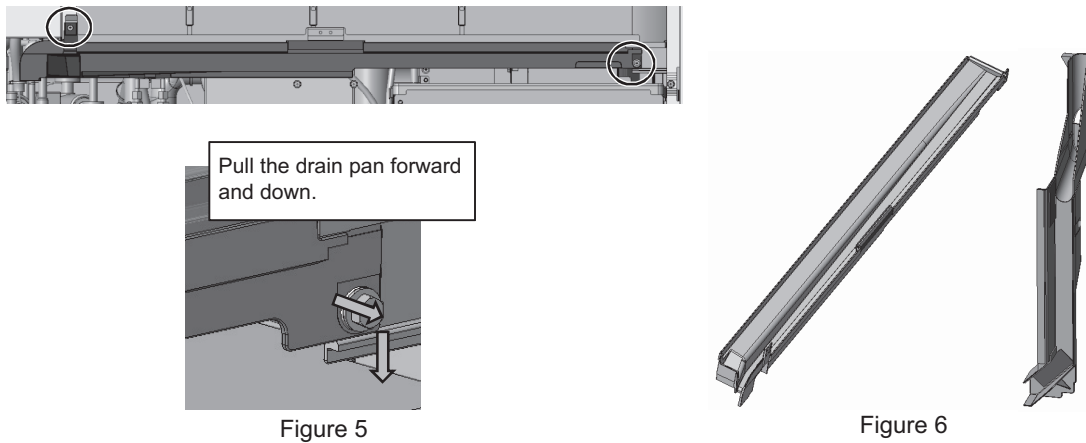
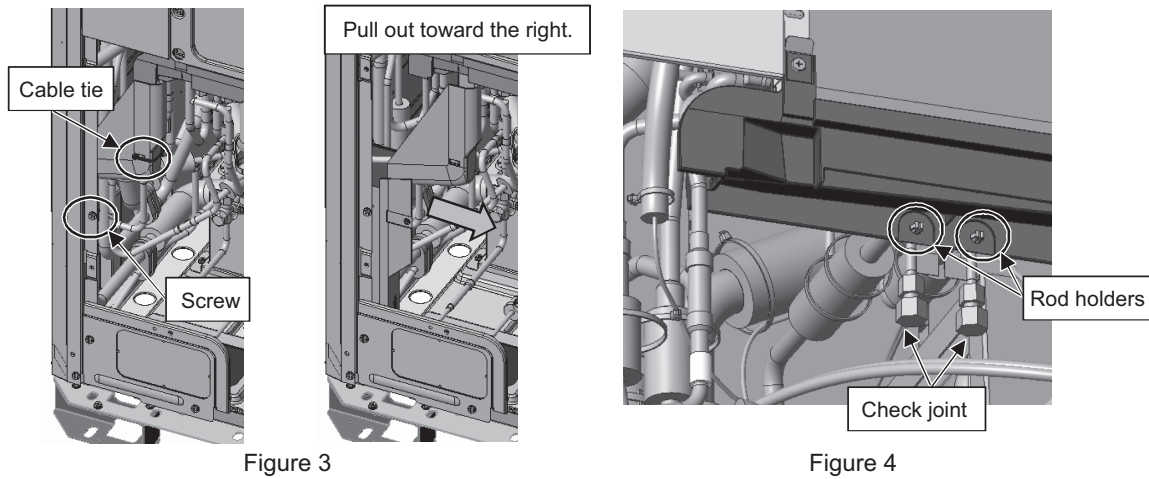
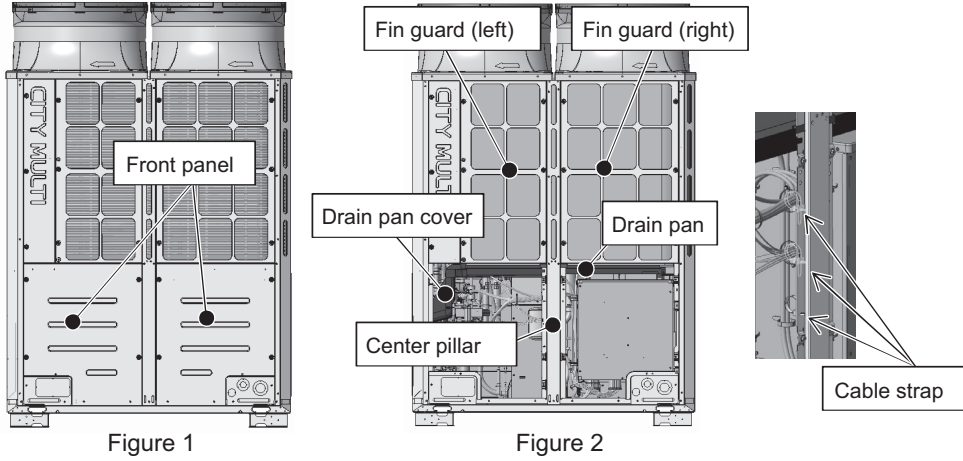


Figure 12

2. L-module

[Drain pan removal procedure]

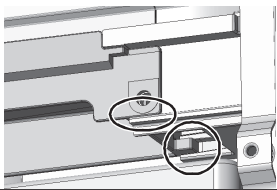
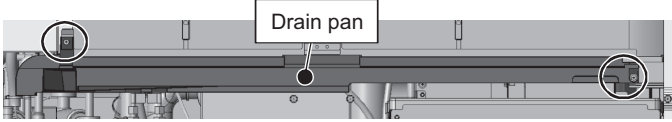
- (1) Remove the front panel from the unit by unscrewing the 14 screws. (See Figure 1.)
 - (2) Remove the fin guard and the center pillar by unscrewing the 11 screws shown in Figure 2. Remove the cable straps from the center pillar. (See Figure 2.)
 - (3) Cut the cable tie, unscrew the screw, and pull the drain cover out to the right. (See Figure 3.)
 - (4) Remove the two rod holders holding the check joints in place, using a wrench. (See Figure 4.)
 - (5) Remove the drain pan by unscrewing the two screws. (See Figure 5.)
 - (6) Clean the drain pan and the drain pan cover. (See Figure 6.)
- Remove dust and dirt from the drain groove.



[Drain pan mounting procedure]

*Reuse the drain pan mounting screws from the replaced drain pan. (M5 x 16 mm with a nylon washer)

- (1) Screw down the drain pan with two screws. (See Figure 7.)
- (2) Hold the check joints to the drain pan with two rod holders. (See Figure 8.)
- (3) Make sure that the silicon tube is properly placed on the defrost pipe, and then place the drain pan cover. Place the drain pan cover along the defrost pipe, and fit it to the drain pan. (See Figures 9 and 10.)
- (4) Thread a cable tie through the rectangle hole on the screwed-down drain cover, and hold the silicon tube and the defrost pipe together in place. (See Figure 11.)
- (5) Screw down the fin guards, center pillar, and front panel with 14 screws. (See Figure 12.)



Make sure that the tab on the drain pan is properly placed in the groove, and screw down the drain pan with two screws (front and back).

Figure 7

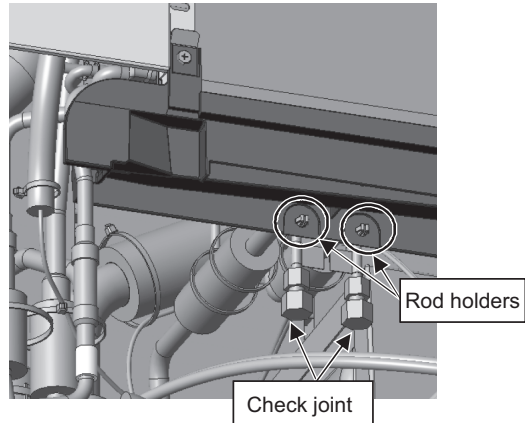
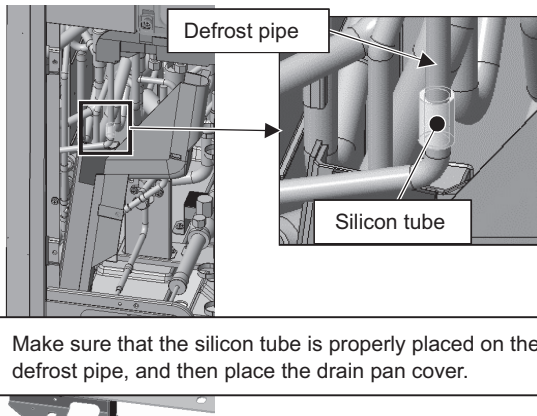


Figure 8



Make sure that the silicon tube is properly placed on the defrost pipe, and then place the drain pan cover.

Figure 9

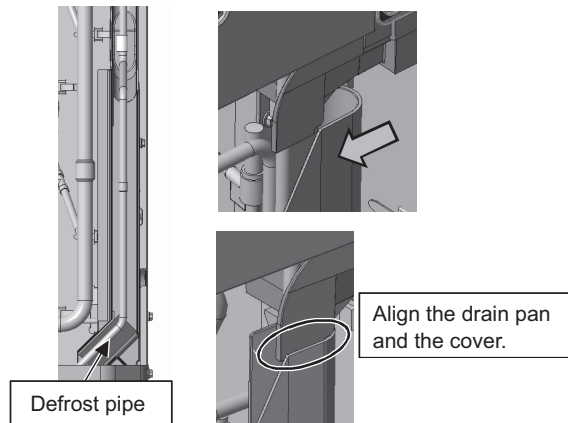


Figure 10

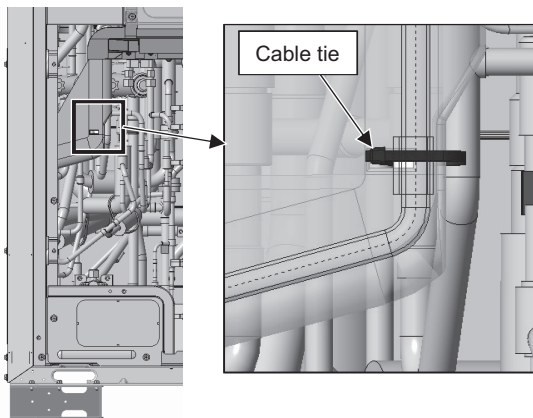


Figure 11

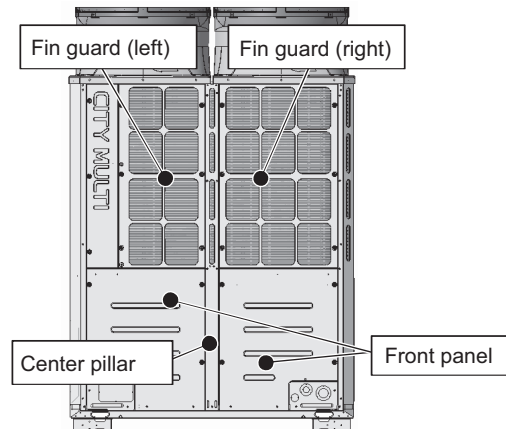


Figure 12

3. XL-module

[Drain pan removal procedure]

- (1) Remove the front panel from the unit by unscrewing the 14 screws. (See Figure 1.)
 - (2) Remove the external temperature sensor wiring from the left drain pan by cutting the two cable ties. Unhook the pipe cover from the left drain pan. (See Figure 3.)
 - (3) Remove the left drain pan by unscrewing the two screws. (See Figure 4.)
 - (4) Remove the right drain pan by unscrewing the two screws. (See Figure 5.)
 - (5) Clean inside the right and left drain pans. (See Figure 6.)
- Remove dust and dirt from the drain groove.

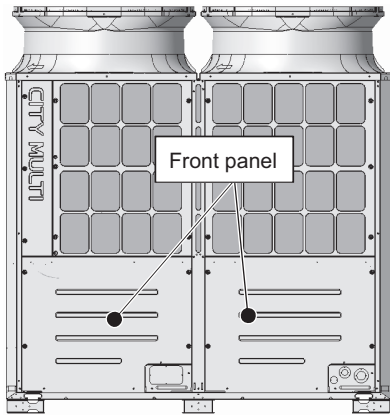


Figure 1

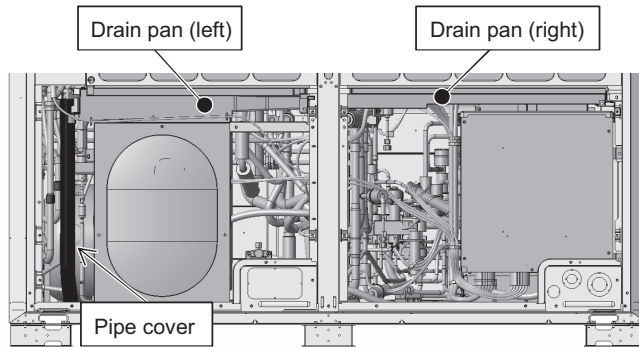


Figure 2

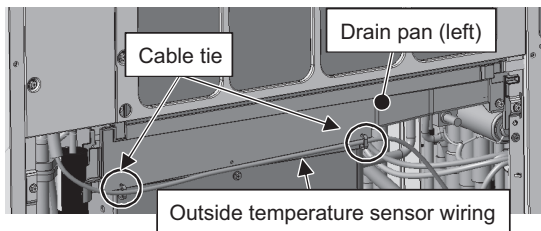


Figure 3

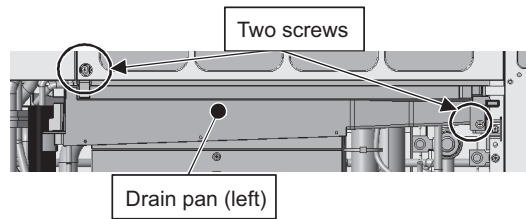
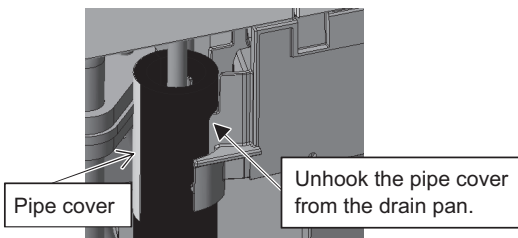


Figure 4

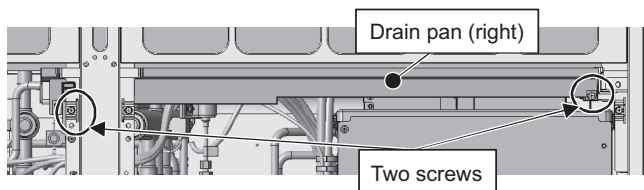
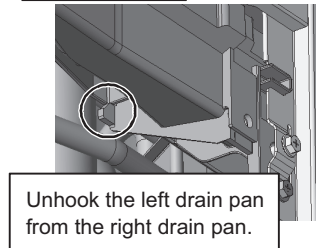


Figure 5

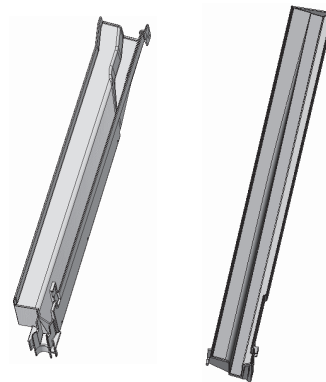
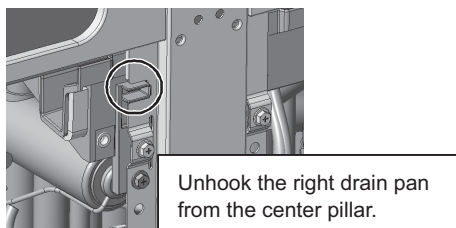


Figure 6

[Drain pan mounting procedure]

*Reuse the drain pan mounting screws that were removed from the replaced drain pan. (M5 x 16 mm with a nylon washer)

- (1) Screw down the right drain pan with two screws. (See Figure 7.)
- (2) Screw down the left drain pan with two screws. (See Figure 8.)
- (3) Hook the pipe cover on the left drain pan. (See Figure 9.)
- (4) Hold the external temperature sensor wiring to the left drain pan with two cable ties. (See Figure 10.)
- (5) Screw down the front panel. (See Figure 11.)

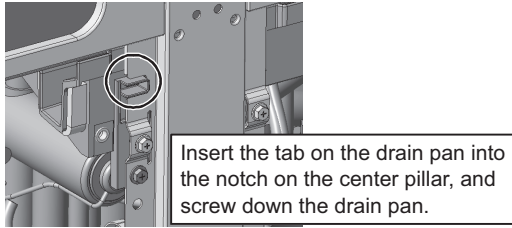
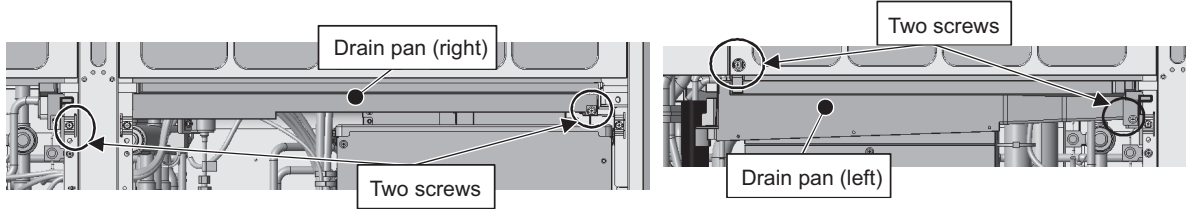


Figure 7

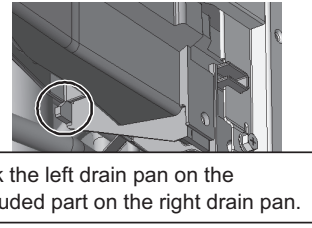


Figure 8

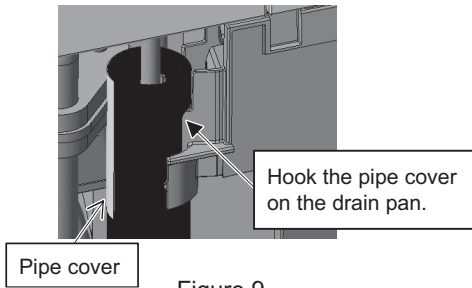


Figure 9

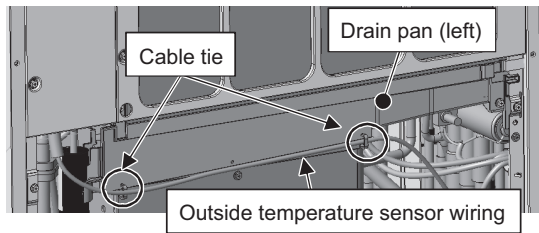


Figure 10

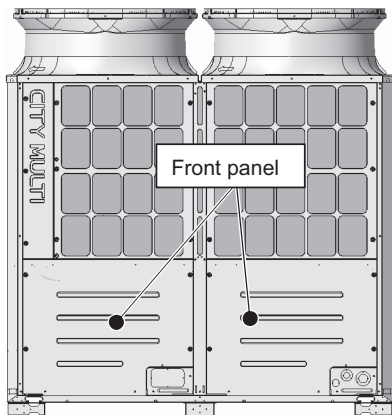
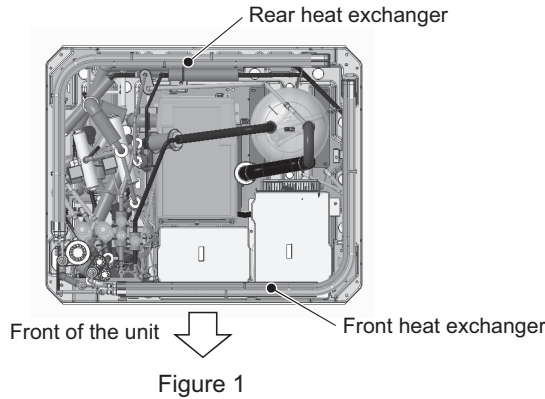


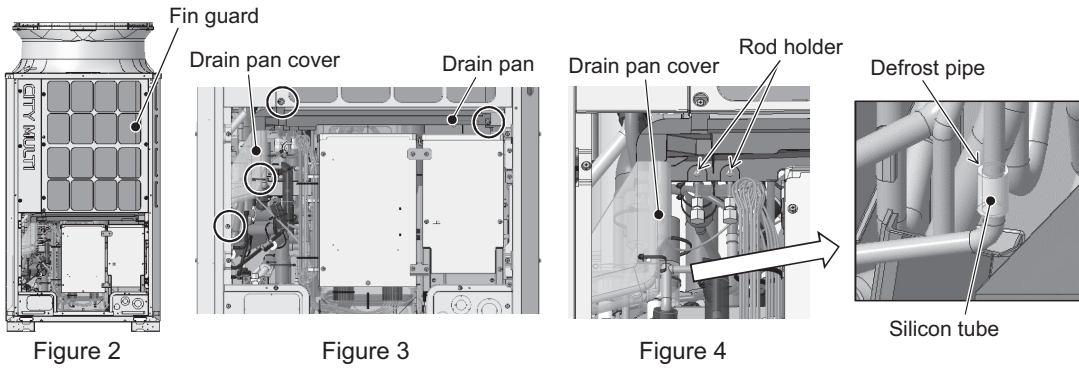
Figure 11

8-13-11 Maintenance Procedures for the Heat Exchanger <Type A>

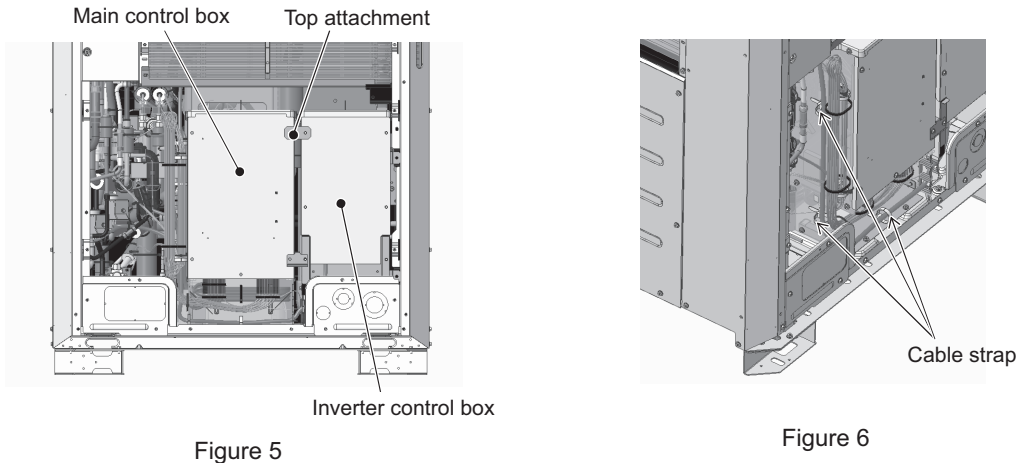
1. S-module



- (1) Remove the front panel from the unit by unscrewing the 8 screws. (See Figure 2.)
- (2) Remove the fin guard by unscrewing the 6 screws. (See Figure 2.)
- (3) Remove the drain cover by unscrewing the screw and cutting the cable tie. (See Figures 3 and 4.)
When re-placing the drain pan cover, make sure that the silicon tube is properly placed on the defrost pipe, and then fix the drain pan cover in place with a cable tie.
- (4) Remove the drain pan by unscrewing the 2 screws. (See Figure 3.)
Be sure to remove the two rod holders holding the check joints to the drain pan. (See Figure 4.)



- (5) Remove the top attachment that connects the main control box to the inverter control box by unscrewing the 2 screws. (See Figure 5.)
- (6) Remove the cover from the inverter control box by unscrewing the 3 screws. (See Figure 5.)
- (7) Remove the cable straps holding motor wiring. (See Figure 6.)



- (8) Remove the fan guard by unscrewing the 6 screws. (See Figure 7.)
- (9) Insert a spacer between the main control box and the heat exchanger.
- (10) Remove the motor ASSY by unscrewing the 4 screws, using caution not to damage the motor wiring or the fan. (See Figure 8.)

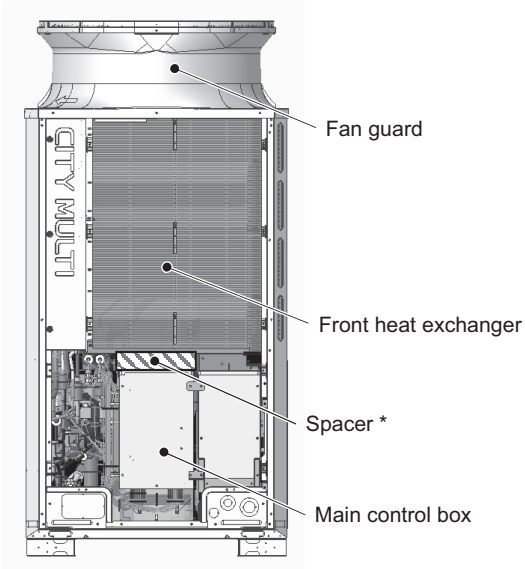


Figure 7

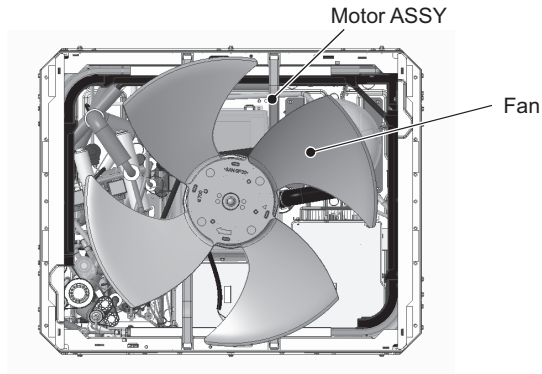


Figure 8

- (11) Remove the front pillar by unscrewing the 7 screws. (See Figure 9.)
- (12) Disconnect the TH7 sensor holder from the front pillar. (See Figure 9 Rear.)
- (13) Remove the TH7 wiring from the front heat exchanger by cutting the cable tie. (See Figure 10.)

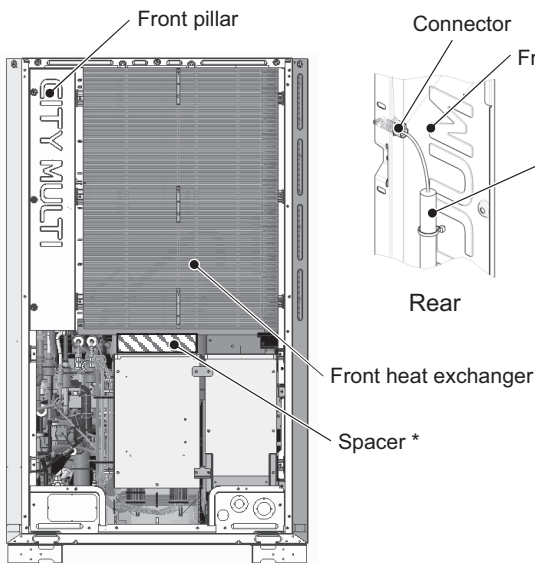


Figure 9

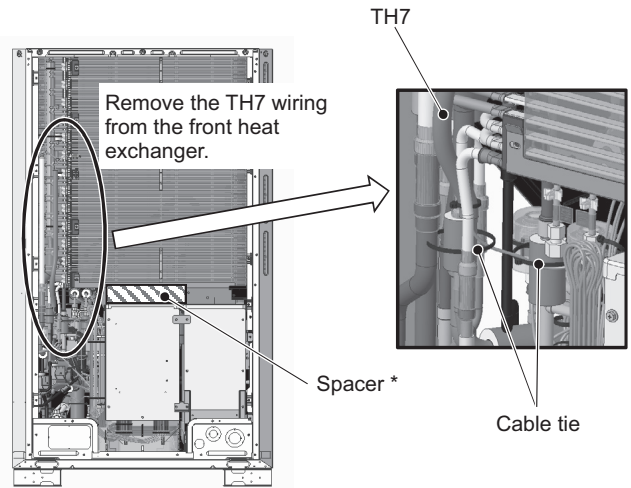


Figure 10

*Use the supplied spacers.
 Use the spacers 60 (D) X 250 (W) X 60 (H) when replacing the heat exchangers for the maintenance of the accumulator and the pipes.

- (14) To remove the front heat exchanger, first remove the front, left, and right frames by unscrewing the 10 screws. (See Figure 11.)
 To remove the rear heat exchanger, remove the rear frame in addition to the front, left, and the right frames by unscrewing the 12 screws. (See Figure 11.)
- (15) Unscrew the two screws each on the right and left panels. (See Figure 12 Right and Left.)
- (16) Remove the left front pillar by unscrewing the 9 screws on a standard model or 10 screws on a high-efficiency model. (See Figure 12 Front and Left.)
- (17) Remove the right front pillar by unscrewing the 5 screws. (See Figure 12 Front and Right.)

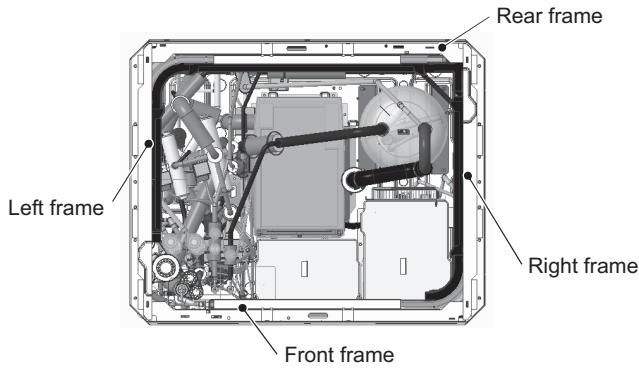


Figure 11

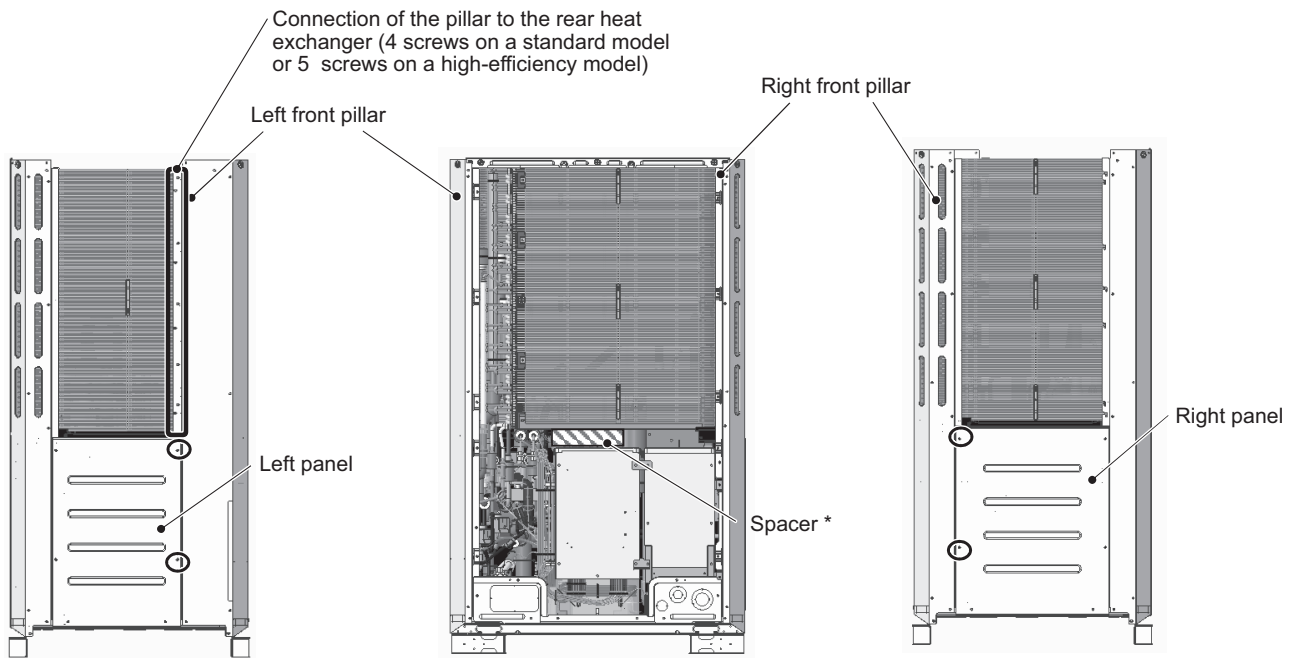


Figure 12 Left

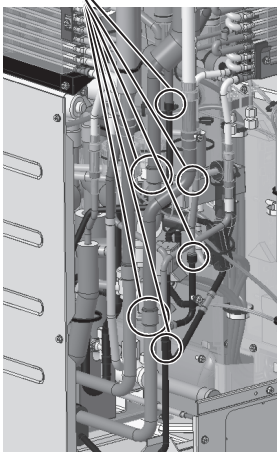
Figure 12 Front

Figure 12 Right

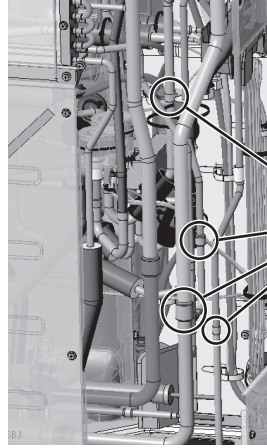
*Use the supplied spacers. Use the spacers 60 (D) X 250 (W) X 60 (H) when replacing the heat exchangers for the maintenance of the accumulator and the pipes.

(18) Before removing the front heat exchanger, protect the adjacent electrical components and the pipe covers with the recommended felt that is soaked in water, and then remove the braze from the areas shown in Figures 13 and 14. (High-efficiency front heat exchanger: 6 areas; Standard front heat exchanger: 4 areas)
 To remove the rear heat exchanger, remove the braze from four areas. (See Figures 15 and 16.)

Remove the braze from the areas encircled in the figure.



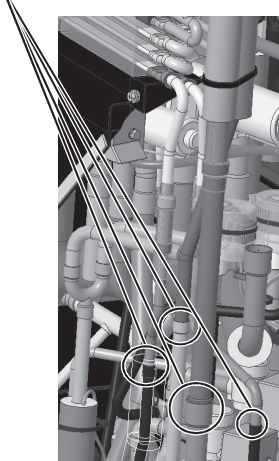
Removing the high-efficiency front heat exchanger (Figure 13)



Remove the braze from the areas encircled in the figure.

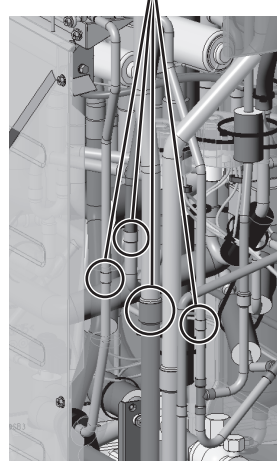
Removing the standard front heat exchanger (Figure 14)

Remove the braze from the areas encircled in the figure.



Removing the high-efficiency rear heat exchanger (Figure 15)

Remove the braze from the areas encircled in the figure.



Removing the standard rear heat exchanger (Figure 16)

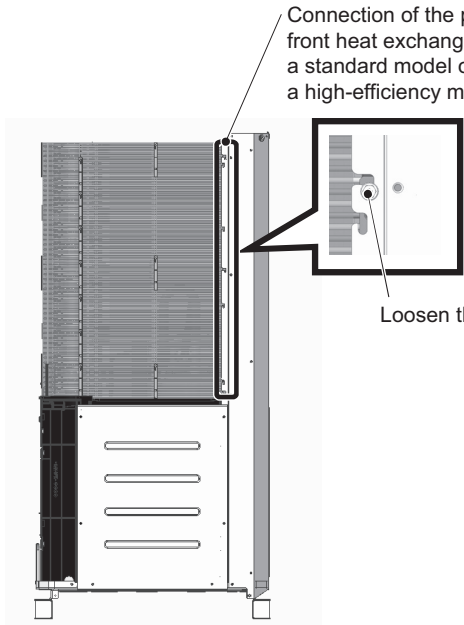
Notes for replacing refrigerant circuit components (heat exchanger)

- Be sure to perform non-oxidized brazing.
- After brazing is done, check that the brazing is done properly and check for leaks before vacuum-drying the pipes.
- Direct the brazing torch flame away from the wiring and sheet metals inside the unit not to damage them.
- Place the wet felt sheets listed below (or their equivalents) around the areas to be brazed to protect the heat exchanger, pipes, and pipe covers from being damaged from the brazing torch flame.

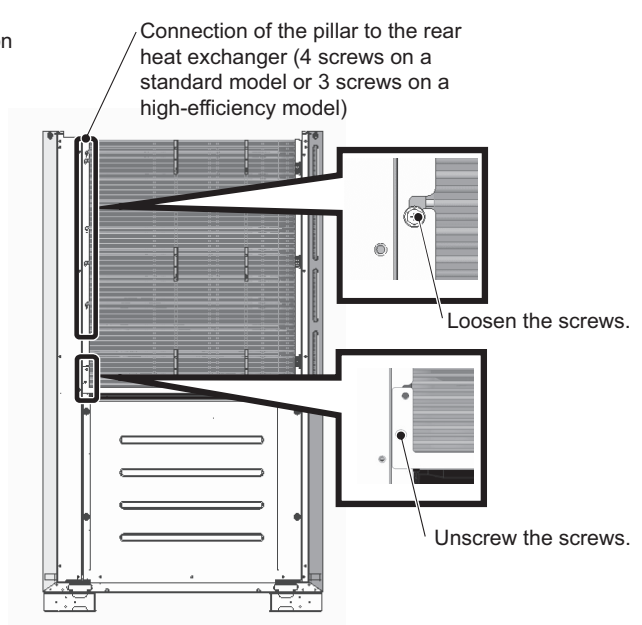
Recommended felt sheets: Spatter felt 50CF-11 (5t x 1 m x 1 m) by TRUSCO Nakayama

Felt sheets that meet the JIS standard (JIS A 1323 type A "Flame retardant testing method for spark droplets of welding and gas cutting on fabric sheets in construction works")

- (19) To remove the front heat exchanger, loosen the screws on the right side of the right rear pillar. (4 screws on a standard model or 3 screws on a high-efficiency model) (See Figure 17.)
 To remove the rear heat exchanger, loosen the screws on the back of the right rear pillar. (4 screws on a standard model or 3 screws on a high-efficiency model) (See Figure 18.)
 Remove the screw holding the pillar to the rear heat exchanger support. (See Figure 18.)

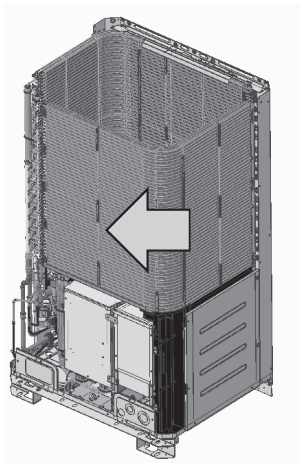


Removing the front heat exchanger (Figure 17)

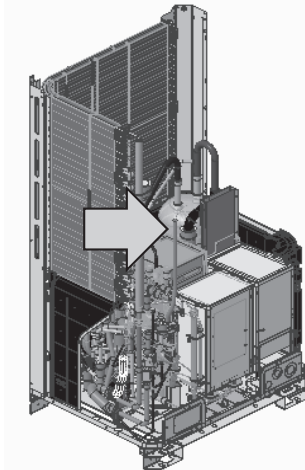


Removing the rear heat exchanger (Figure 18)

- (20) Remove the heat exchanger by diagonally lifting it up, using caution not to damage the fins or the pipes.



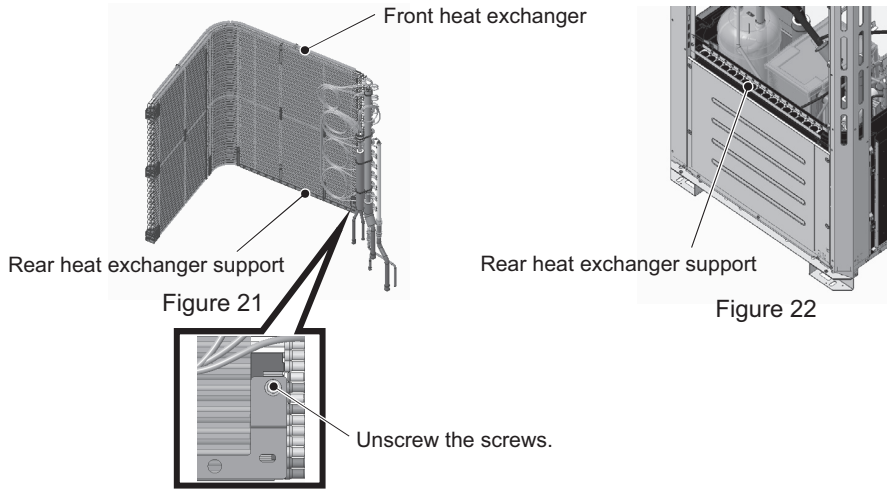
Removing the front heat exchanger (Figure 19)



Removing the rear heat exchanger (Figure 20)

(21) After removing the front and the rear heat exchangers, dispose of the front and the rear heat exchanger supports. (See Figures 21 and 22.)

The front and the rear heat exchanger supports do not need to be installed. (The front and the rear heat exchanger supports are for suppressing vibration during transportation.)



(22) Re-place the front and the rear heat exchangers in the reverse order as they were removed.
Re-place the components that were removed as they were.

2. L-module

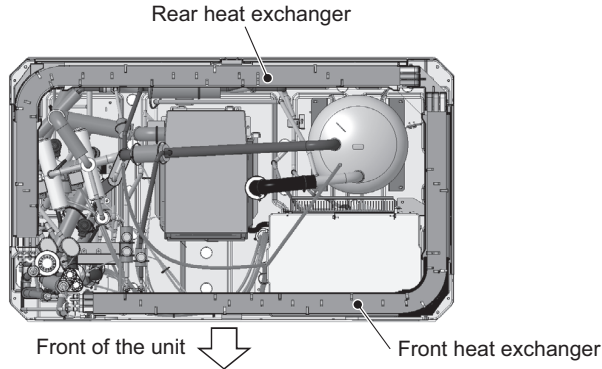


Figure 1

- (1) Remove the two front panels from the unit by unscrewing the 14 screws. (See Figure 2.)
- (2) Remove the fin guard by unscrewing the 12 screws. (See Figure 2.)
- (3) Remove the cable straps holding the weak and strong electrical wirings. (See Figure 3.)
- (4) Remove the center pillar by unscrewing the 5 screws. (See Figure 2.)
- (5) Remove the drain cover by unscrewing the screw and cutting the cable tie. (See Figures 3 and 4.)
When re-placing the drain pan cover, make sure that the silicon tube is properly placed on the defrost pipe, and then fix the drain pan cover in place with a cable tie.
- (6) Remove the drain pan by unscrewing the 2 screws. (See Figure 3.)
Be sure to remove the two rod holders holding the check joints to the drain pan. (See Figure 4.)

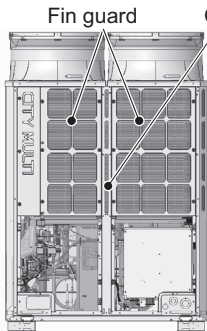


Figure 2

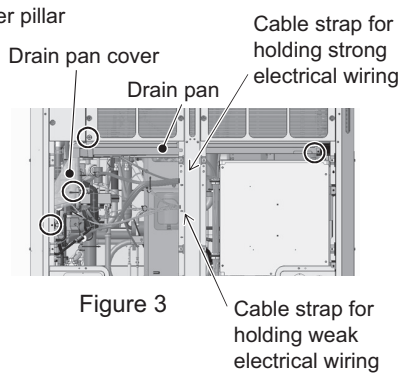


Figure 3

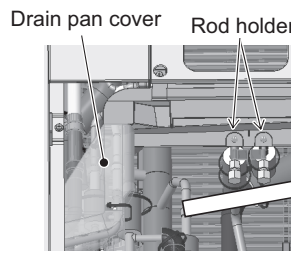
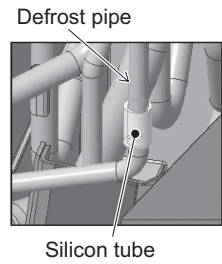


Figure 4



Silicon tube

- (7) Remove the cover from the control box by unscrewing the 5 screws. (See Figure 5.)
- (8) Remove the cable straps holding motor wiring. (See Figure 6.)

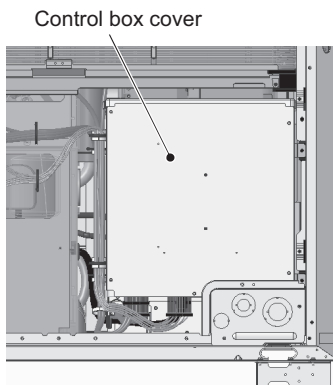


Figure 5

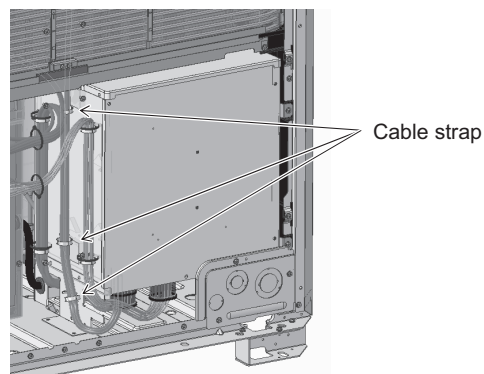


Figure 6

- (9) Remove the fan guard by unscrewing the 12 screws. (See Figure 7.)
- (10) Insert a spacer between the control box and the heat exchanger.
- (11) Remove the motor ASSY by unscrewing the 8 screws, using caution not to damage the motor wiring or the fan. (See Figure 8.)

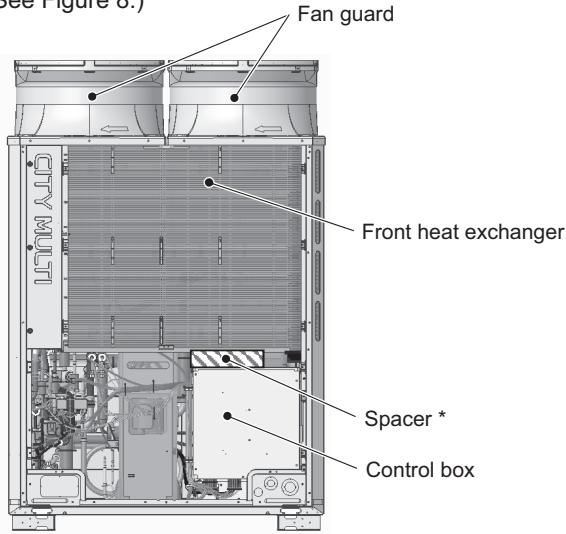


Figure 7

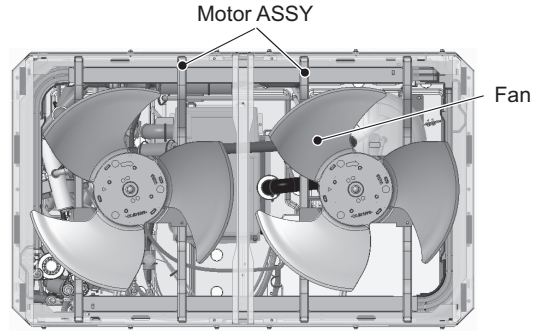


Figure 8

- (12) Remove the front pillar by unscrewing the 7 screws. (See Figure 9.)
- (13) Disconnect the TH7 sensor holder from the front pillar. (See Figure 9 Rear.)
- (14) Remove the TH7 wiring from the heat exchanger by cutting the cable tie. (See Figure 10.)

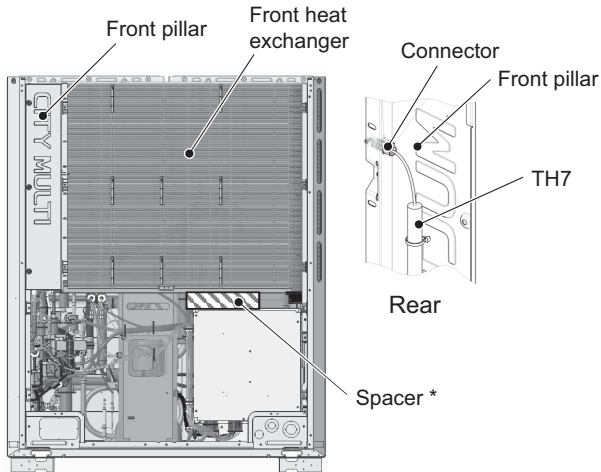


Figure 9

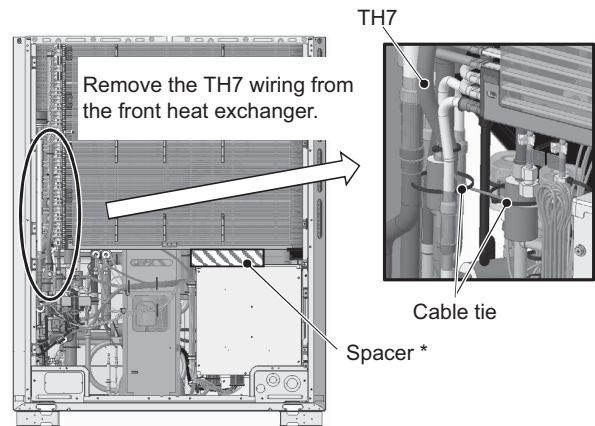


Figure 10

*Use the supplied spacers.
Use the spacers 60 (D) x 250 (W) x 60 (H) when replacing the heat exchangers for the maintenance of the accumulator and the pipes.

- (15) To remove the front heat exchanger, first remove the front, left, right, and center frames by unscrewing the 14 screws. (See Figure 11.)
 To remove the rear heat exchanger, remove the rear frame in addition to the front, left, right, and center frames by unscrewing the 16 screws. (See Figure 11.)
- (16) Unscrew the two screws each on the right and left panels. (See Figure 12 Right and Left.)
- (17) Remove the left front pillar by unscrewing the 9 screws on a standard model or 10 screws on a high-efficiency model. (See Figure 12 Front and Left.)
- (18) Remove the right front pillar by unscrewing the 5 screws. (See Figure 12 Front and Right)

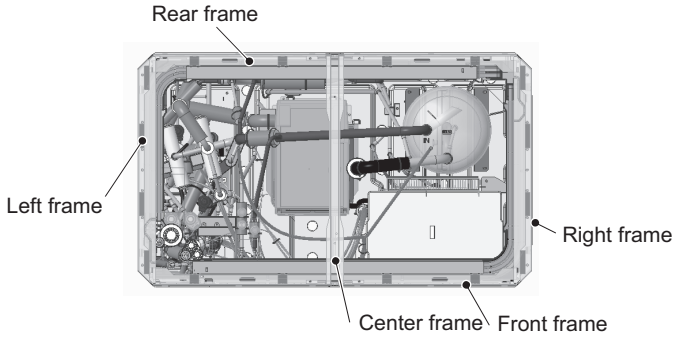


Figure 11

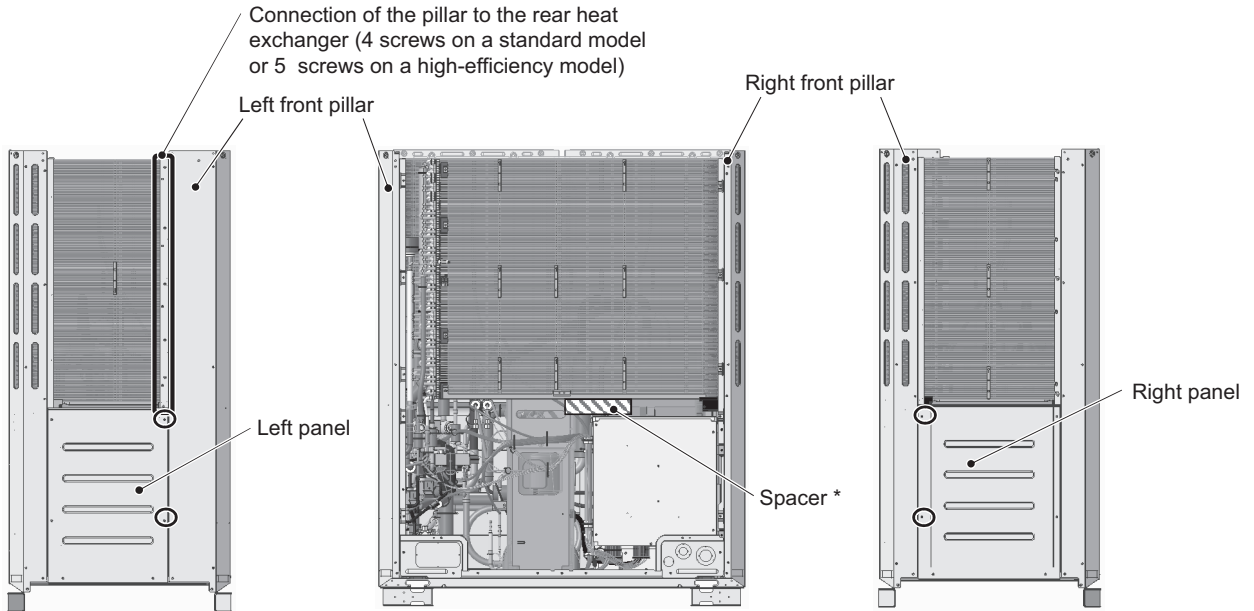


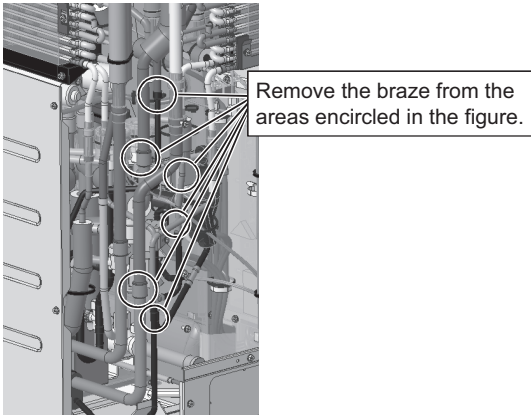
Figure 12 Left

Figure 12 Front

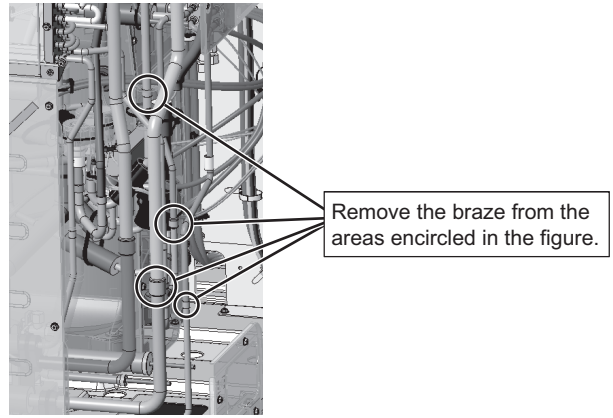
Figure 12 Right

*Use the supplied spacers. Use the spacers 60 (D) X 250 (W) X 60 (H) when replacing the heat exchangers for the maintenance of the accumulator and the pipes.

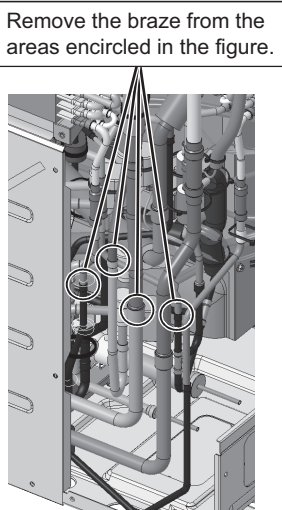
(19) Before removing the front heat exchanger, protect the adjacent electrical components and the pipe covers with the recommended felt that is soaked in water, and then remove the braze from the areas shown in Figures 13 and 14. (High-efficiency front heat exchanger: 6 areas; Standard front heat exchanger: 4 areas)
 To remove the rear heat exchanger, remove the braze from four areas. (See Figures 15 and 16.)



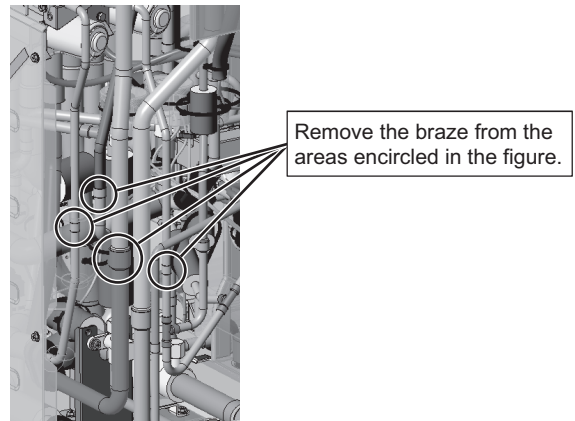
Removing the high-efficiency front heat exchanger (Figure 13)



Removing the standard front heat exchanger (Figure 14)



Removing the high-efficiency rear heat exchanger (Figure 15)



Removing the standard rear heat exchanger (Figure 16)

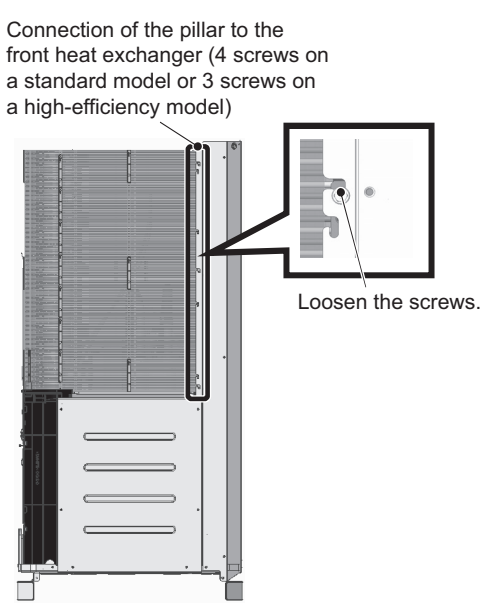
Notes for replacing refrigerant circuit components (heat exchanger)

- Be sure to perform non-oxidized brazing.
- After brazing is done, check that the brazing is done properly and check for leaks before vacuum-drying the pipes.
- Direct the brazing torch flame away from the wiring and sheet metals inside the unit not to damage them.
- Place the wet felt sheets listed below (or their equivalents) around the areas to be brazed to protect the heat exchanger, pipes, and pipe covers from being damaged from the brazing torch flame.

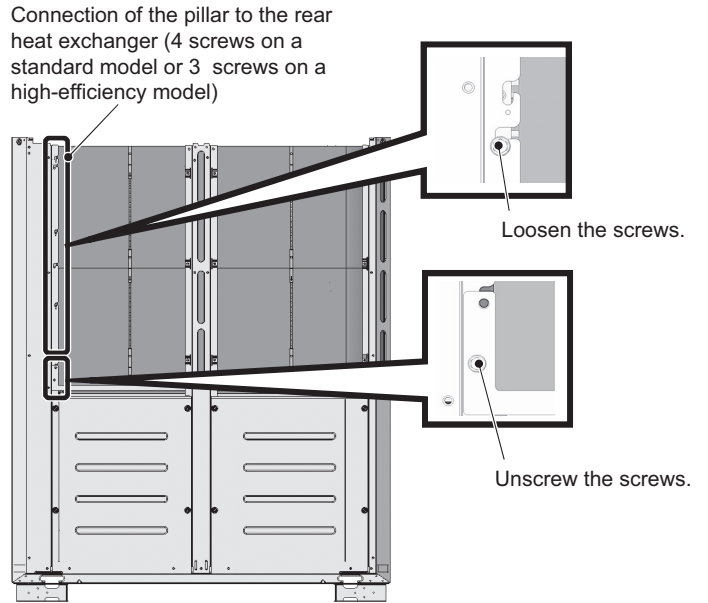
Recommended felt sheets: Spatter felt 50CF-11 (5t x 1 m x 1 m) by TRUSCO Nakayama

Felt sheets that meet the JIS standard (JIS A 1323 type A "Flame retardant testing method for spark droplets of welding and gas cutting on fabric sheets in construction works")

- (20) To remove the front heat exchanger, loosen the screws on the right side of the right rear pillar. (4 screws on a standard model or 3 screws on a high-efficiency model) (See Figure 17.)
 To remove the rear heat exchanger, loosen the screws on the back of the right rear pillar. (4 screws on a standard model or 3 screws on a high-efficiency model) (See Figure 18.)
 Remove the screw holding the pillar to the rear heat exchanger support.

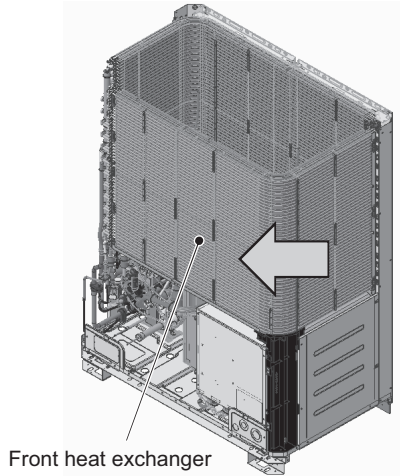


Removing the front heat exchanger (Figure 17)

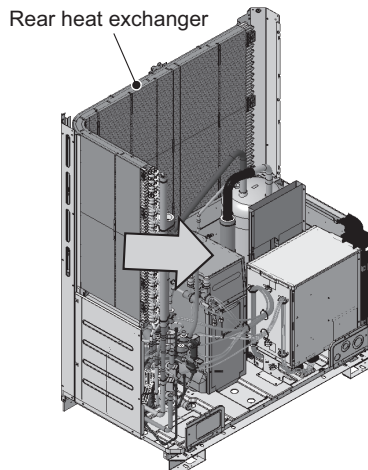


Removing the rear heat exchanger (Figure 18)

- (21) Remove the heat exchanger by diagonally lifting it up, using caution not to damage the fins or the pipes.

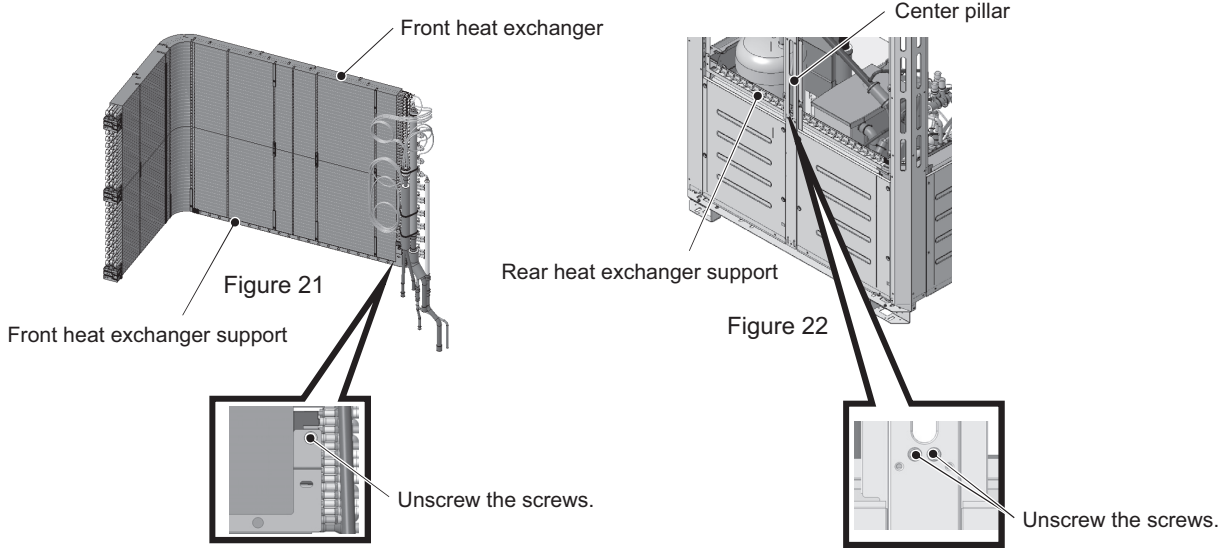


Removing the front heat exchanger (Figure 19)



Removing the rear heat exchanger (Figure 20)

(22) After removing the heat exchangers, dispose of the front and the rear heat exchanger supports. (See Figures 21 and 22.)
The front and the rear heat exchanger supports do not need to be installed. (The front and the rear heat exchanger supports are for suppressing vibration during transportation.)



(23) Re-place the front and the rear heat exchangers in the reverse order as they were removed.
Re-place the components that were removed as they were.

3. XL-module

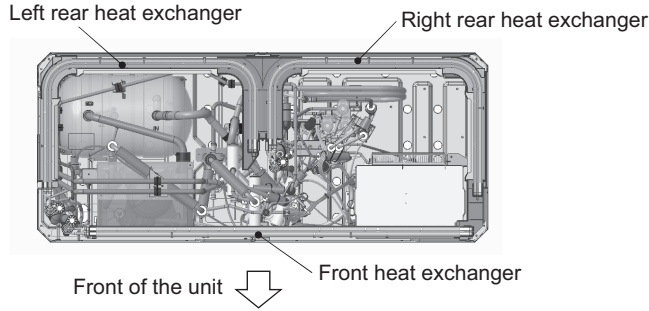


Figure 1

- (1) Remove the two front panels from the unit by unscrewing the 14 screws. (See Figure 2.)
- (2) Remove the fin guard by unscrewing the 12 screws. (See Figure 2.)
- (3) Remove pipe cover. (See Figure 3.)
- (4) Remove the left drain pan by unscrewing the two screws and cutting the two cable ties. (See Figure 3.)
- (5) Remove the right drain pan by unscrewing the 2 screws. (See Figure 3.)
- (6) Remove the 3 cable straps from the center pillar. (See Figure 4.)

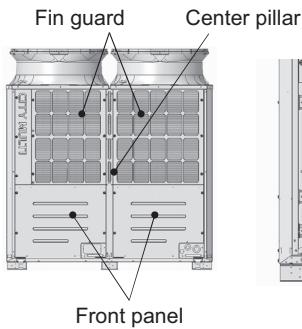


Figure 2

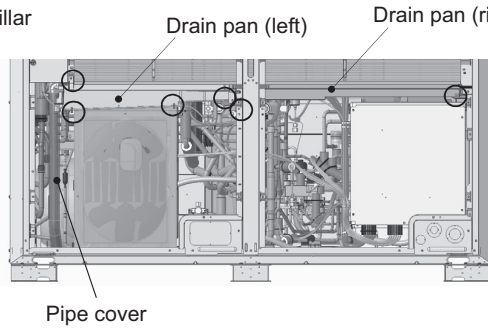


Figure 3

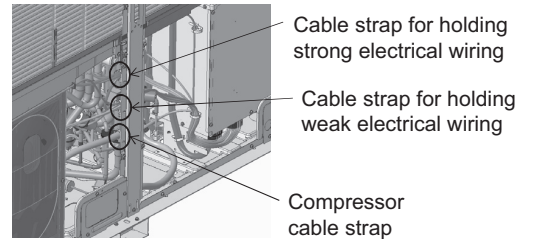


Figure 4

- (7) Remove the 3 cable straps holding motor wiring from the control box. (See Figure 5.)
- (8) Remove the fan guard by unscrewing the 12 screws. (See Figure 6.)
- (9) Unstrap the cable from the cable strap on the center frame. (See Figure 7.)
- (10) Remove the motor ASSY by unscrewing the 8 screws, using caution not to damage the motor wiring or the fan. (See Figure 7.)

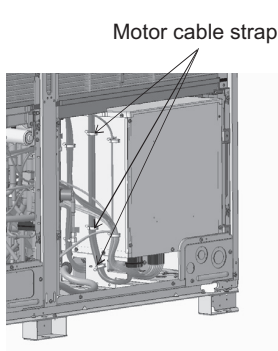


Figure 5

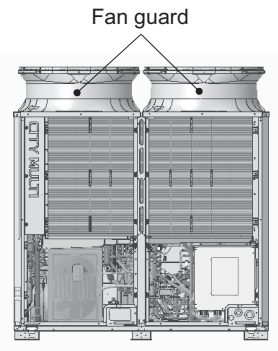


Figure 6

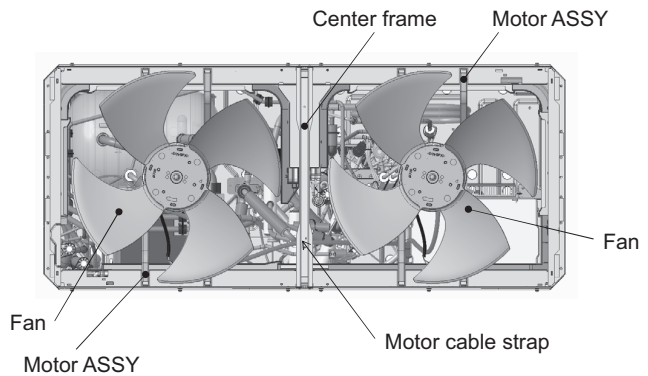
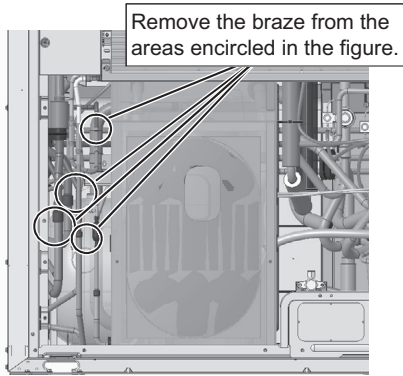
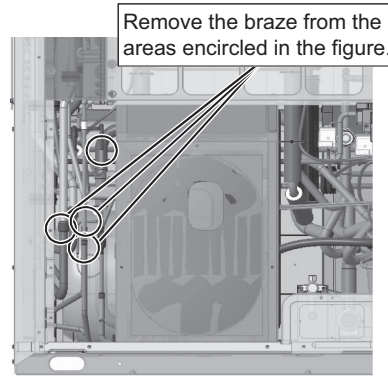


Figure 7

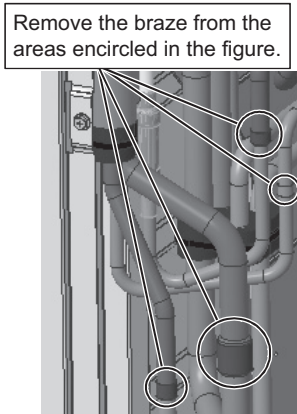
(11) Before removing the front heat exchanger, protect the surrounding electrical components and the pipe cover with a recommended felt soaked in water, and then remove the braze from four areas. (See Figures 8 and 9.)
 To remove the right and left rear heat exchangers, remove the braze from four areas. (See Figures 10 - 13.)



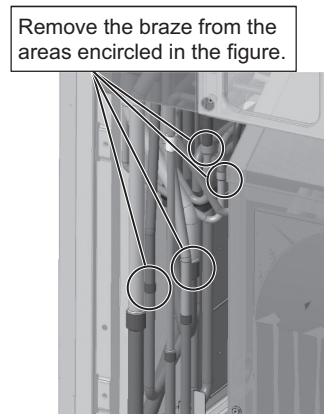
Removing the high-efficiency front heat exchanger (Figure 8)



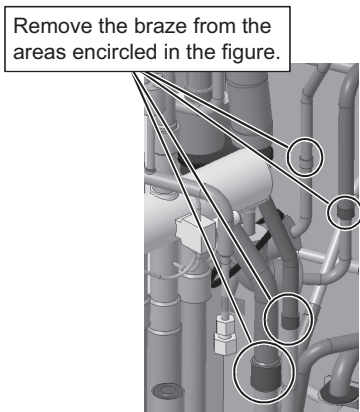
Removing the standard front heat exchanger (Figure 9)



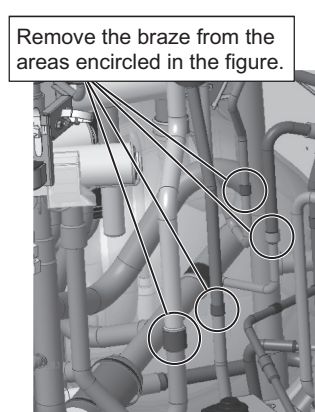
Removing the high-efficiency rear left heat exchanger (Figure 10)



Removing the standard rear left heat exchanger (Figure 11)



Removing the high-efficiency rear right heat exchanger (Figure 12)



Removing the standard rear right heat exchanger (Figure 13)

Notes for replacing refrigerant circuit components (heat exchanger)

- Be sure to perform non-oxidized brazing.
- After brazing is done, check that the brazing is done properly and check for leaks before vacuum-drying the pipes.
- Direct the brazing torch flame away from the wiring and sheet metals inside the unit not to damage them.
- Place the wet felt sheets listed below (or their equivalents) around the areas to be brazed to protect the heat exchanger, pipes, and pipe covers from being damaged from the brazing torch flame.

Recommended felt sheets: Spatter felt 50CF-11 (5t x 1 m x 1 m) by TRUSCO Nakayama

Felt sheets that meet the JIS standard (JIS A 1323 type A "Flame retardant testing method for spark droplets of welding and gas cutting on fabric sheets in construction works")

- (12) Remove the front pillar by unscrewing the 7 screws. (See Figure 14.)
- (13) Disconnect the TH7 sensor holder from the front pillar. (See Figure 14 Rear.)

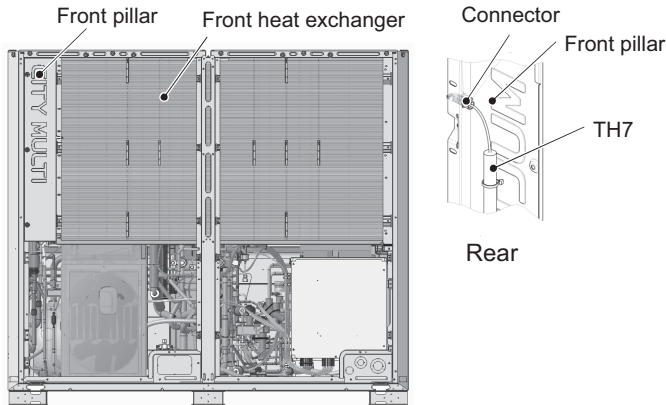


Figure 14

- (14) To remove the front heat exchanger, first remove the front, left, right, and center frames by unscrewing the 16 screws. (See Figure 15.)
To remove the right and left rear heat exchangers, remove the top and the rear frames in addition to the front, left, right, and center frames by unscrewing the 21 screws. (See Figure 15.)
- (15) Remove the center front pillar by unscrewing the 4 screws. (See Figure 16.)

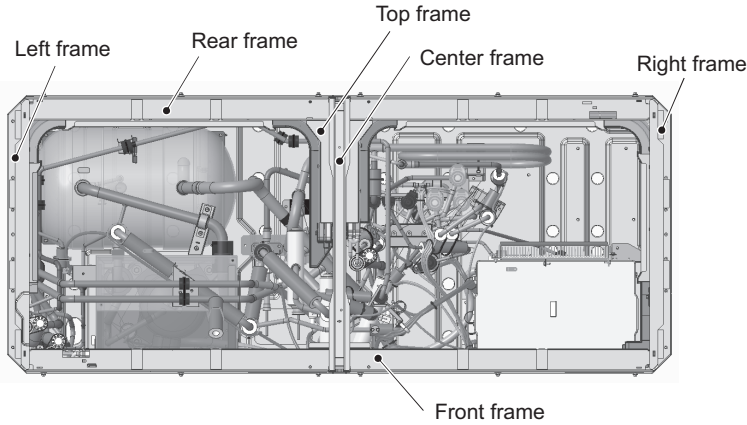


Figure 15

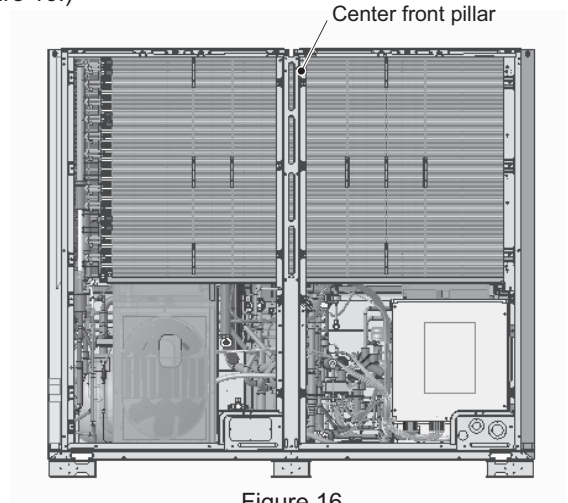
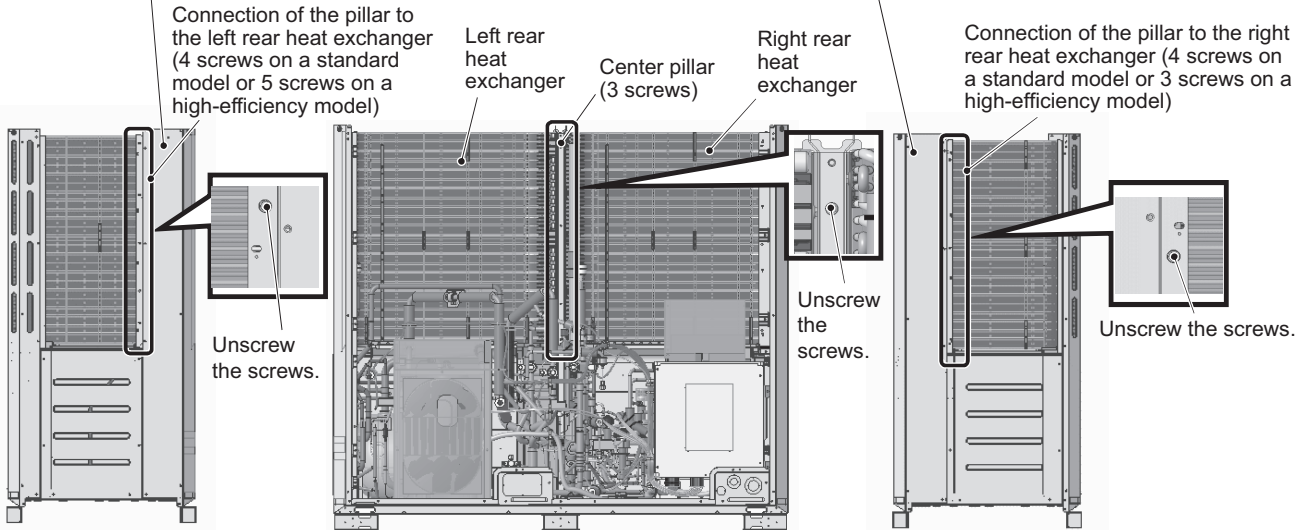
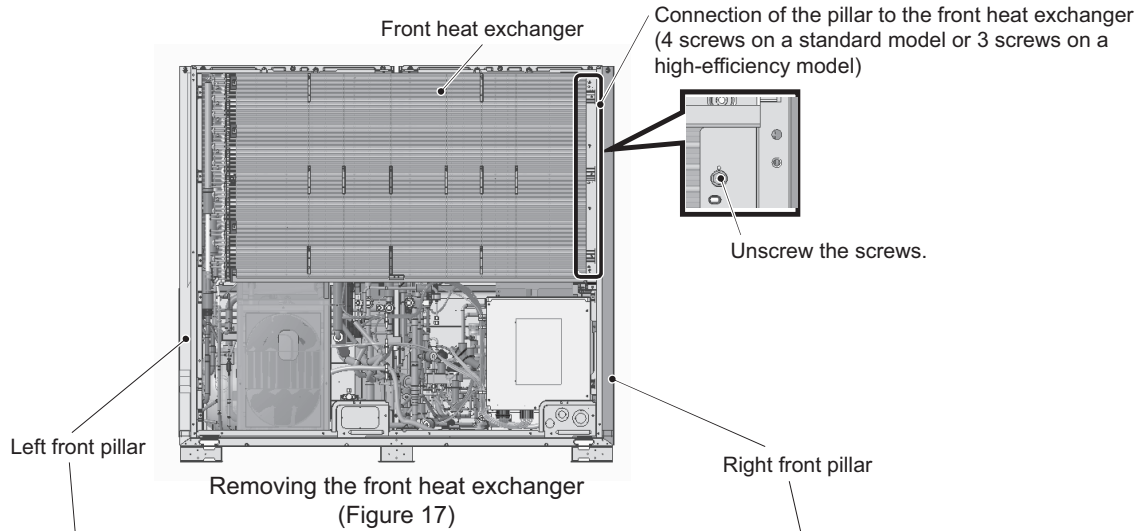
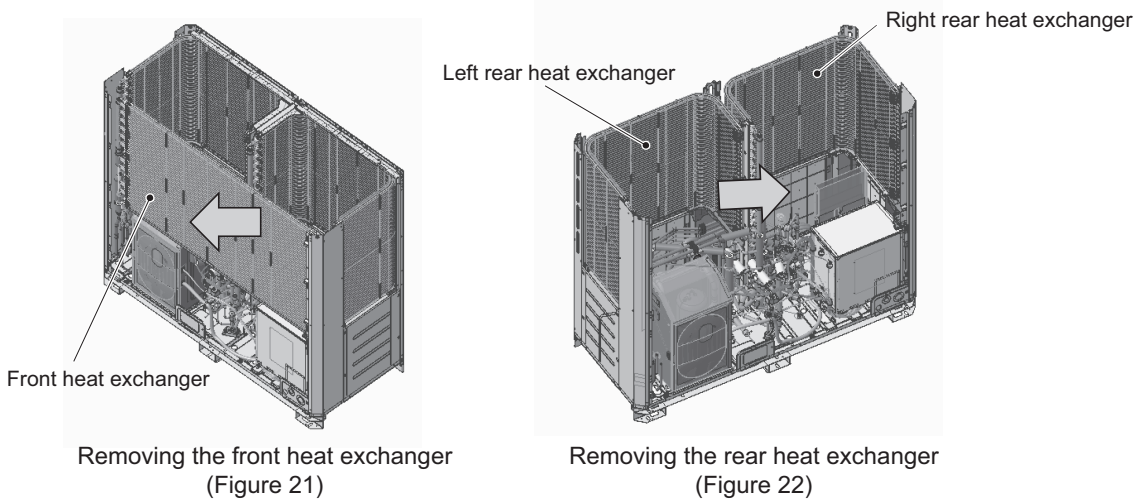


Figure 16

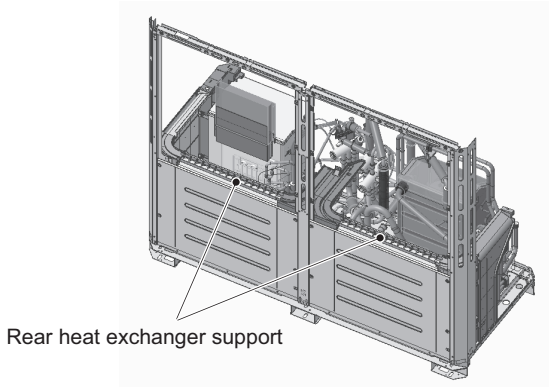
- (16) To remove the front heat exchanger, unscrew the screws on the front of the right front pillar. (4 screws on a standard model or 3 screws on a high-efficiency model) (See Figure 17.)
 To remove the left rear heat exchanger, unscrew the screws on the left side of the left front pillar and the screws on the front of the center pillar (7 screws on a standard model or 8 screws on a high-efficiency model.) (See Figures 18 and 19.)
 To remove the right rear heat exchanger, unscrew the screws on the right side of the right front pillar and the screws on the front of the center pillar (7 screws on a standard model or 6 screws on a high-efficiency model.) (See Figures 19 and 20.)



(17) Remove the heat exchanger by diagonally lifting it up, using caution not to damage the fins or the pipes.



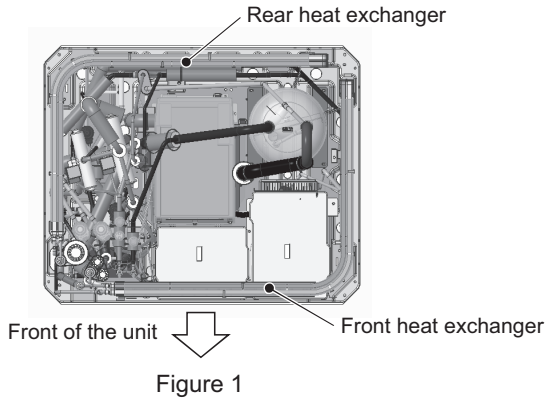
(18) After removing the rear heat exchanger, dispose of the rear heat exchanger support. (See Figure 23.)
The rear heat exchanger support does not need to be installed. (The rear heat exchanger support is for suppressing vibration during transportation.)



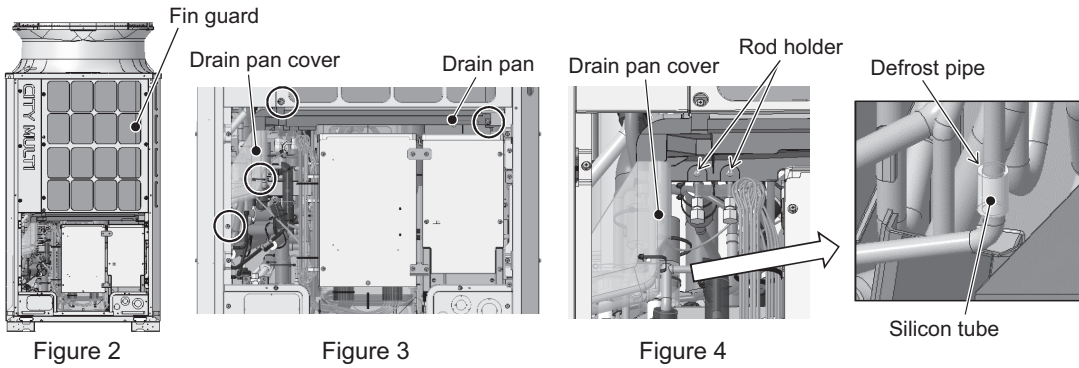
(19) Re-place the front and the rear heat exchangers in the reverse order as they were removed.
Re-place the components, except the rear heat exchanger support, that were removed as they were.

8-13-12 Maintenance Procedures for the Heat Exchanger <Type A1/Type A2>

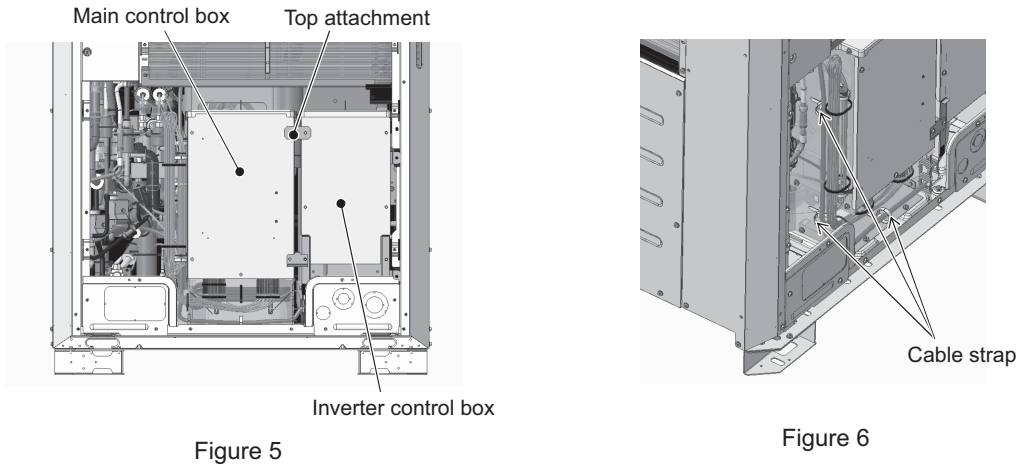
1. S-module



- (1) Remove the front panel from the unit by unscrewing the 8 screws. (See Figure 2.)
- (2) Remove the fin guard by unscrewing the 6 screws. (See Figure 2.)
- (3) Remove the drain cover by unscrewing the screw and cutting the cable tie. (See Figures 3 and 4.)
When re-placing the drain pan cover, make sure that the silicon tube is properly placed on the defrost pipe, and then fix the drain pan cover in place with a cable tie.
- (4) Remove the drain pan by unscrewing the 2 screws. (See Figure 3.)
Be sure to remove the two rod holders holding the check joints to the drain pan. (See Figure 4.)



- (5) Remove the top attachment that connects the main control box to the inverter control box by unscrewing the 2 screws. (See Figure 5.)
- (6) Remove the cover from the inverter control box by unscrewing the 3 screws. (See Figure 5.)
- (7) Remove the cable straps holding motor wiring. (See Figure 6.)



- (8) Remove the fan guard by unscrewing the 6 screws. (See Figure 7.)
- (9) Insert a spacer between the main control box and the heat exchanger.
- (10) Remove the motor ASSY by unscrewing the 4 screws, using caution not to damage the motor wiring or the fan. (See Figure 8.)

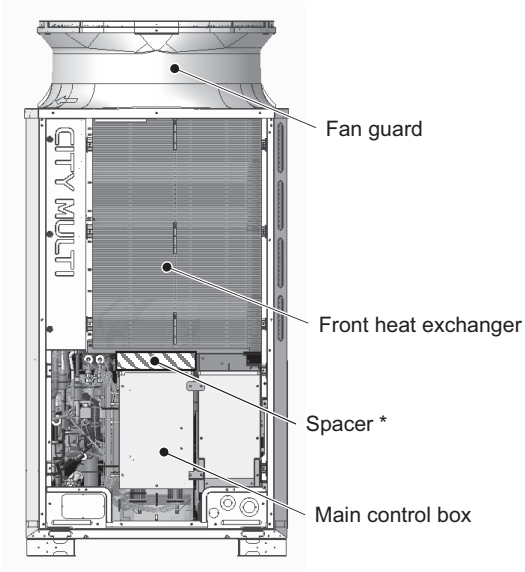


Figure 7

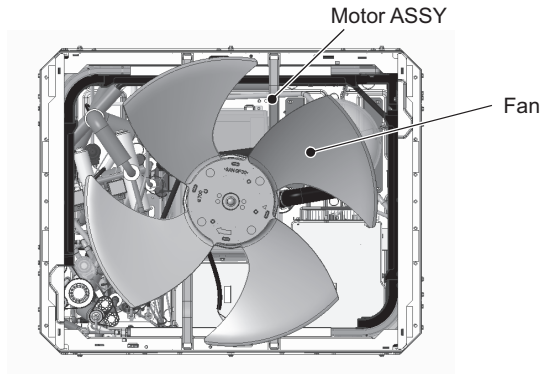


Figure 8

- (11) Remove the front pillar by unscrewing the 7 screws. (See Figure 9.)
- (12) Disconnect the TH7 sensor holder from the front pillar. (See Figure 9 Rear.)
- (13) Remove the TH7 wiring from the front heat exchanger by cutting the cable tie. (See Figure 10.)

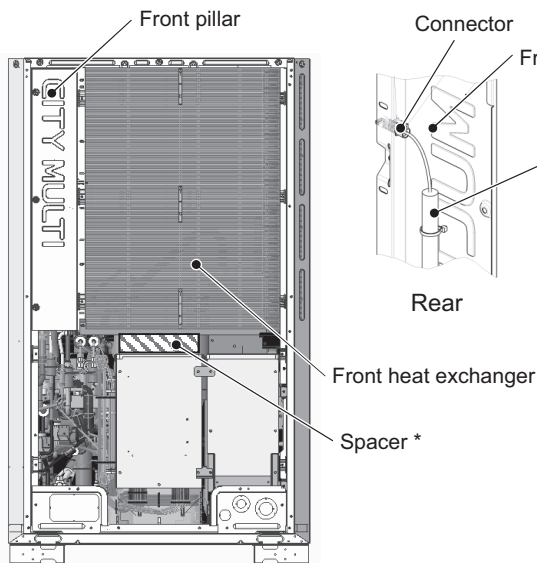


Figure 9

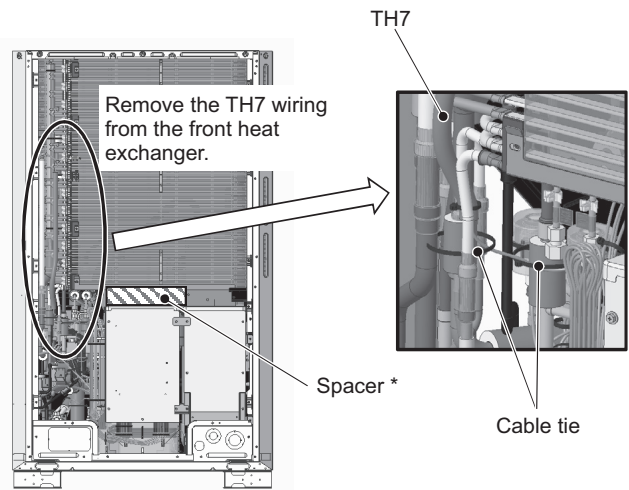


Figure 10

*Use the supplied spacers.
 Use the spacers 60 (D) X 250 (W) X 60 (H) when replacing the heat exchangers for the maintenance of the accumulator and the pipes.

- (14) To remove the front heat exchanger, first remove the front, left, and right frames by unscrewing the 10 screws. (See Figure 11.)
 To remove the rear heat exchanger, remove the rear frame in addition to the front, left, and the right frames by unscrewing the 12 screws. (See Figure 11.)
- (15) Unscrew the two screws each on the right and left panels. (See Figure 12 Right and Left.)
- (16) Remove the left front pillar by unscrewing the 9 screws on a standard model or 10 screws on a high-efficiency model. (See Figure 12 Front and Left.)
- (17) Remove the right front pillar by unscrewing the 5 screws. (See Figure 12 Front and Right.)

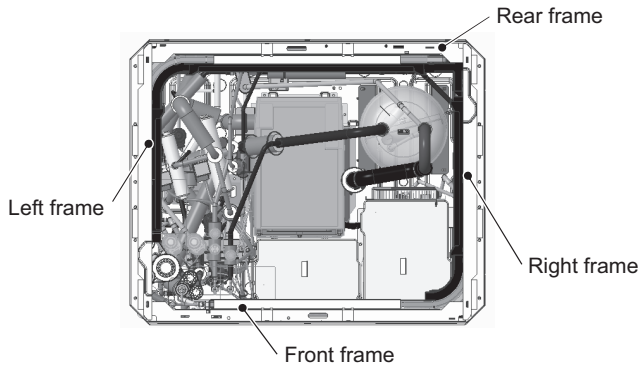


Figure 11

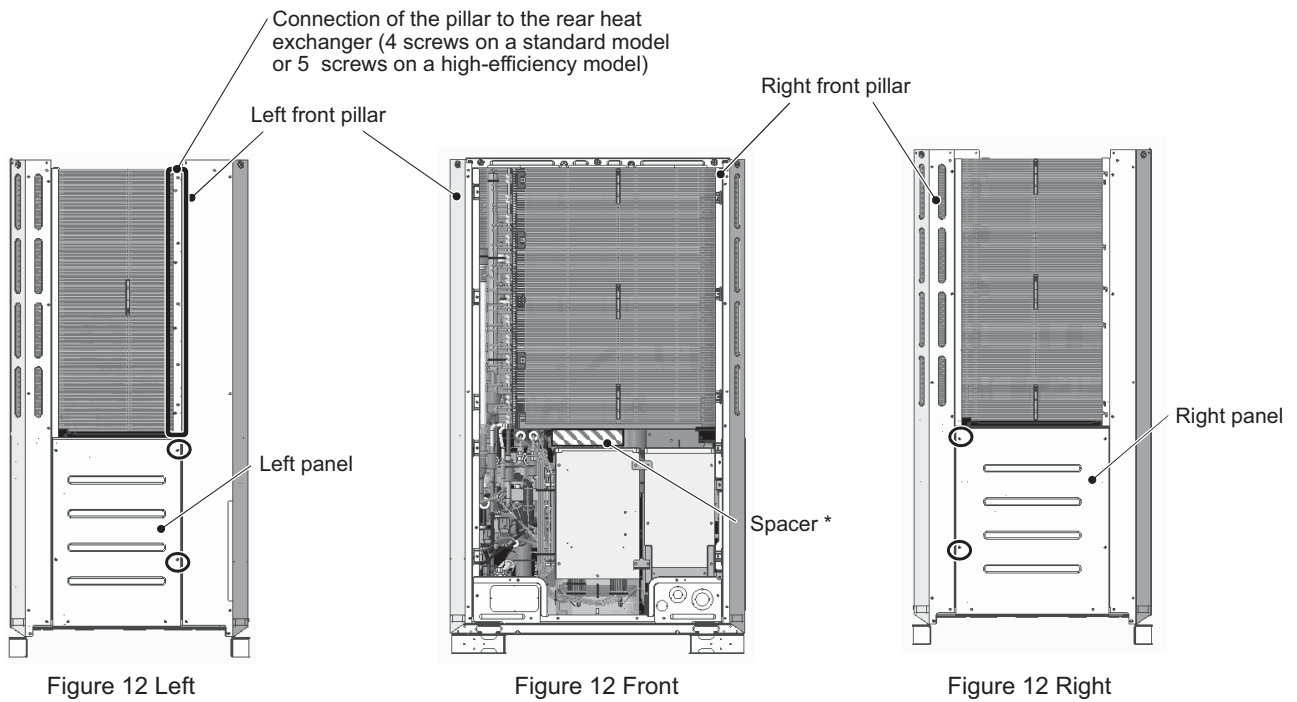


Figure 12 Left

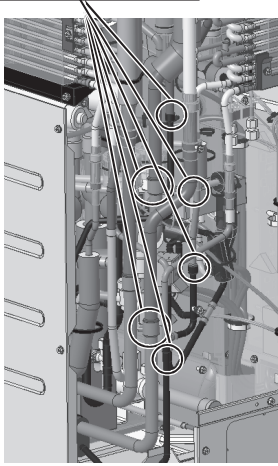
Figure 12 Front

Figure 12 Right

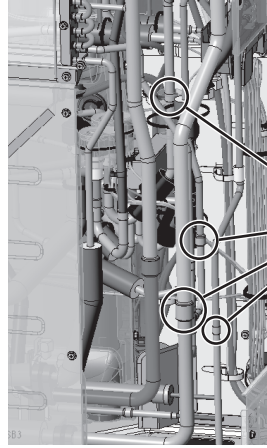
*Use the supplied spacers. Use the spacers 60 (D) X 250 (W) X 60 (H) when replacing the heat exchangers for the maintenance of the accumulator and the pipes.

- (18) Before removing the front heat exchanger, protect the adjacent electrical components and the pipe covers with the recommended felt that is soaked in water, and then remove the braze from the areas shown in Figures 13 and 14. (High-efficiency front heat exchanger: 6 areas; Standard front heat exchanger: 4 areas)
 To remove the rear heat exchanger, remove the braze from four areas. (See Figures 15 and 16.)

Remove the braze from the areas encircled in the figure.



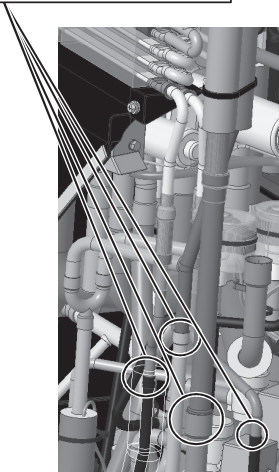
Removing the high-efficiency front heat exchanger (Figure 13)



Remove the braze from the areas encircled in the figure.

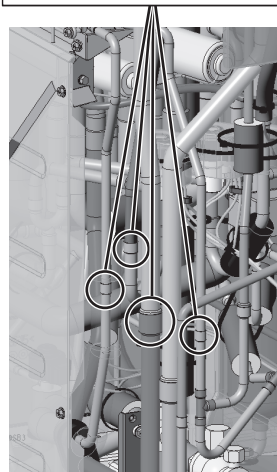
Removing the standard front heat exchanger (Figure 14)

Remove the braze from the areas encircled in the figure.



Removing the high-efficiency rear heat exchanger (Figure 15)

Remove the braze from the areas encircled in the figure.



Removing the standard rear heat exchanger (Figure 16)

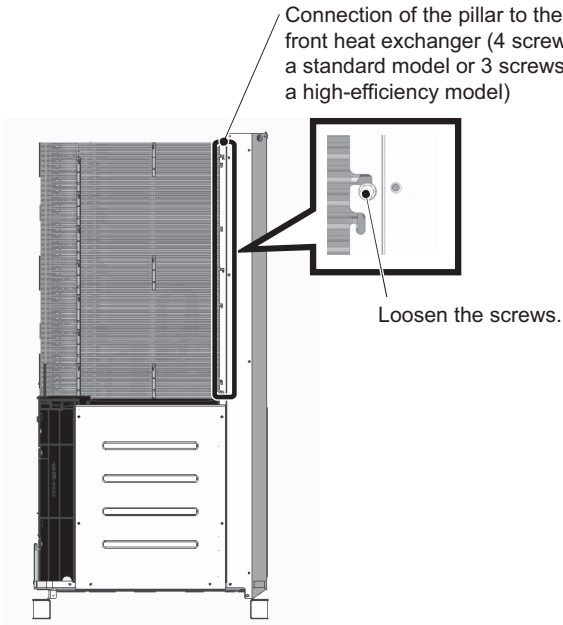
Notes for replacing refrigerant circuit components (heat exchanger)

- Be sure to perform non-oxidized brazing.
- After brazing is done, check that the brazing is done properly and check for leaks before vacuum-drying the pipes.
- Direct the brazing torch flame away from the wiring and sheet metals inside the unit not to damage them.
- Place the wet felt sheets listed below (or their equivalents) around the areas to be brazed to protect the heat exchanger, pipes, and pipe covers from being damaged from the brazing torch flame.

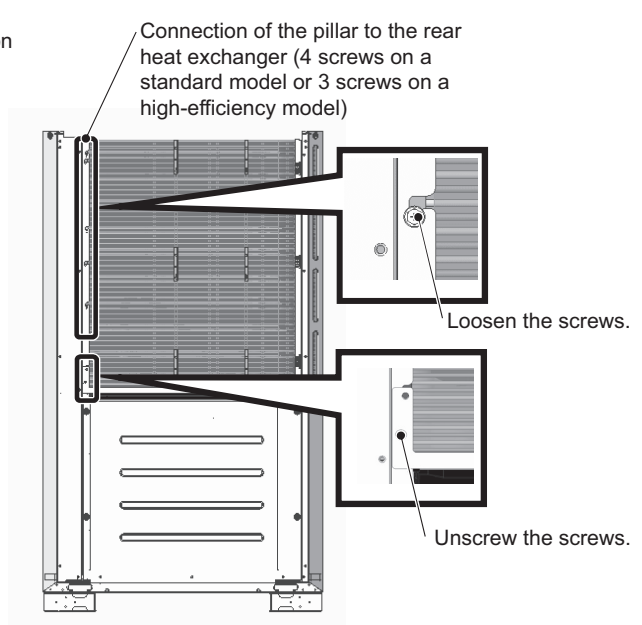
Recommended felt sheets: Spatter felt 50CF-11 (5t x 1 m x 1 m) by TRUSCO Nakayama

Felt sheets that meet the JIS standard (JIS A 1323 type A "Flame retardant testing method for spark droplets of welding and gas cutting on fabric sheets in construction works")

- (19) To remove the front heat exchanger, loosen the screws on the right side of the right rear pillar. (4 screws on a standard model or 3 screws on a high-efficiency model) (See Figure 17.)
 To remove the rear heat exchanger, loosen the screws on the back of the right rear pillar. (4 screws on a standard model or 3 screws on a high-efficiency model) (See Figure 18.)
 Remove the screw holding the pillar to the rear heat exchanger support. (See Figure 18.)

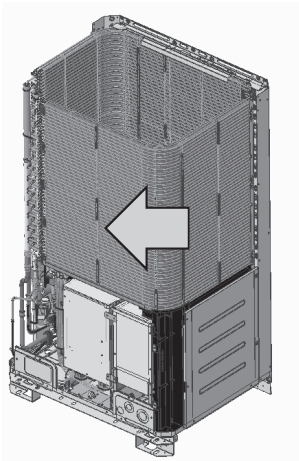


Removing the front heat exchanger (Figure 17)

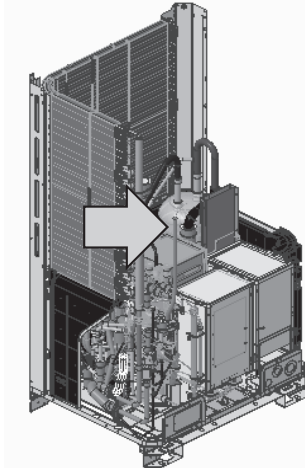


Removing the rear heat exchanger (Figure 18)

- (20) Remove the heat exchanger by diagonally lifting it up, using caution not to damage the fins or the pipes.



Removing the front heat exchanger (Figure 19)



Removing the rear heat exchanger (Figure 20)

- (21) Re-place the front and the rear heat exchangers in the reverse order as they were removed.
 Re-place the components that were removed as they were.

2. L-module

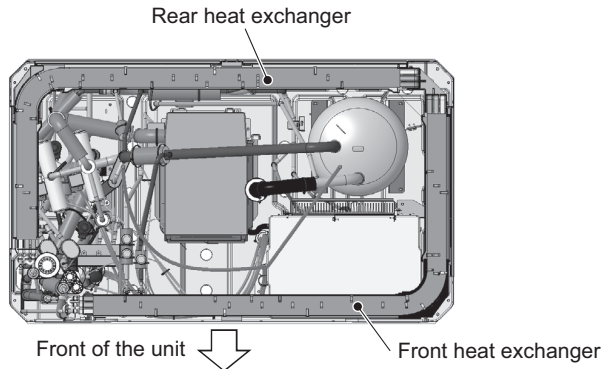


Figure 1

- (1) Remove the two front panels from the unit by unscrewing the 14 screws. (See Figure 2.)
- (2) Remove the fin guard by unscrewing the 12 screws. (See Figure 2.)
- (3) Remove the cable straps holding the weak and strong electrical wirings. (See Figure 3.)
- (4) Remove the center pillar by unscrewing the 5 screws. (See Figure 2.)
- (5) Remove the drain cover by unscrewing the screw and cutting the cable tie. (See Figures 3 and 4.)

When re-placing the drain pan cover, make sure that the silicon tube is properly placed on the defrost pipe, and then fix the drain pan cover in place with a cable tie.

- (6) Remove the drain pan by unscrewing the 2 screws. (See Figure 3.)
Be sure to remove the two rod holders holding the check joints to the drain pan. (See Figure 4.)

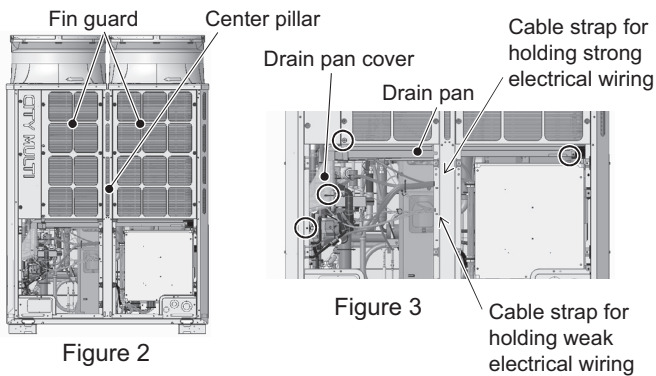


Figure 2

Figure 3

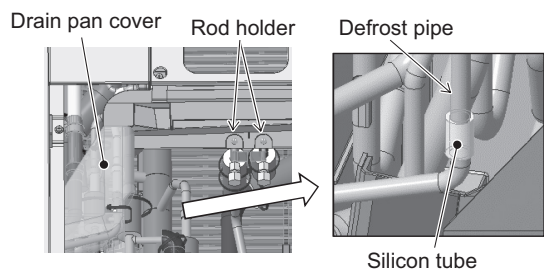


Figure 4

- (7) Remove the cover from the control box by unscrewing the 5 screws. (See Figure 5.)
- (8) Remove the cable straps holding motor wiring. (See Figure 6.)

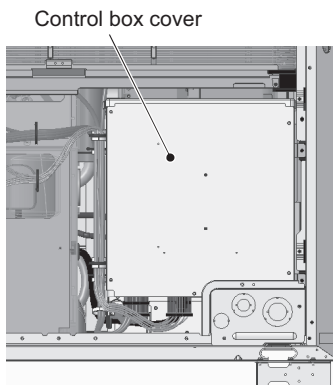


Figure 5

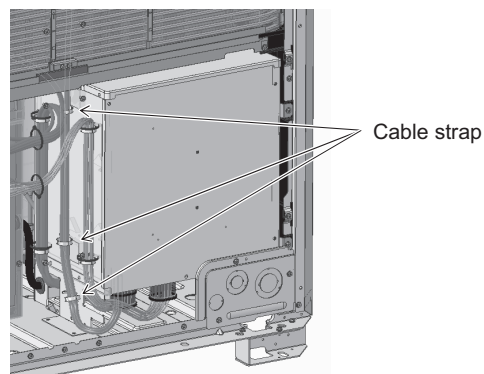


Figure 6

- (9) Remove the fan guard by unscrewing the 12 screws. (See Figure 7.)
- (10) Insert a spacer between the control box and the heat exchanger.
- (11) Remove the motor ASSY by unscrewing the 8 screws, using caution not to damage the motor wiring or the fan. (See Figure 8.)

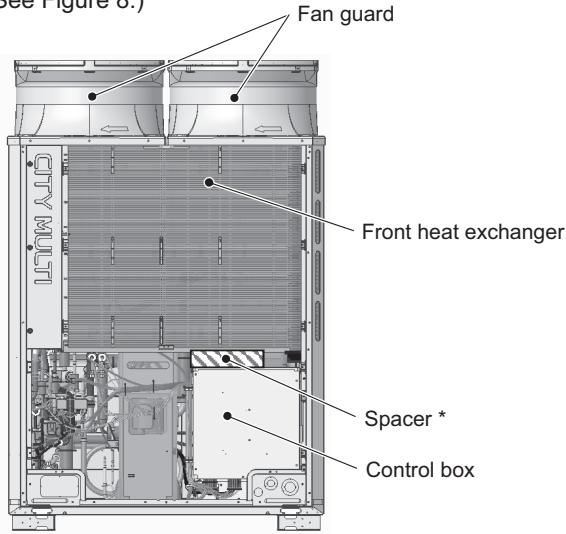


Figure 7

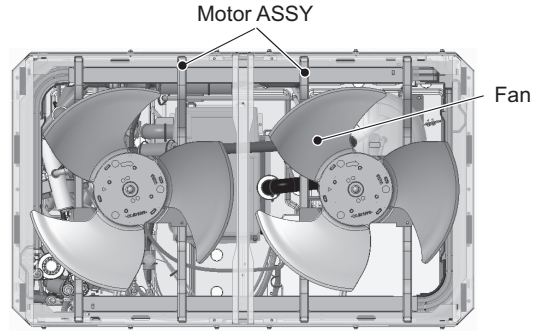


Figure 8

- (12) Remove the front pillar by unscrewing the 7 screws. (See Figure 9.)
- (13) Disconnect the TH7 sensor holder from the front pillar. (See Figure 9 Rear.)
- (14) Remove the TH7 wiring from the heat exchanger by cutting the cable tie. (See Figure 10.)

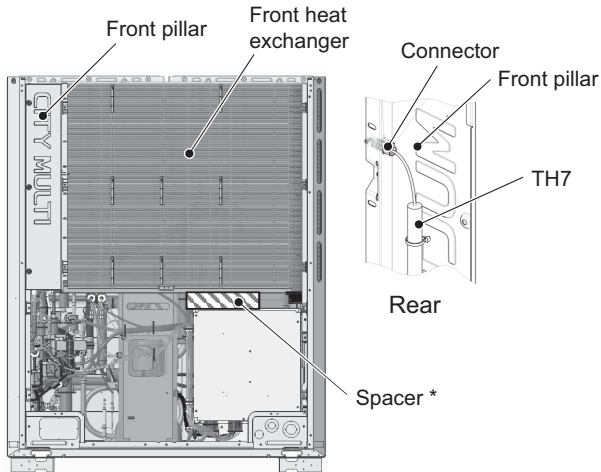


Figure 9

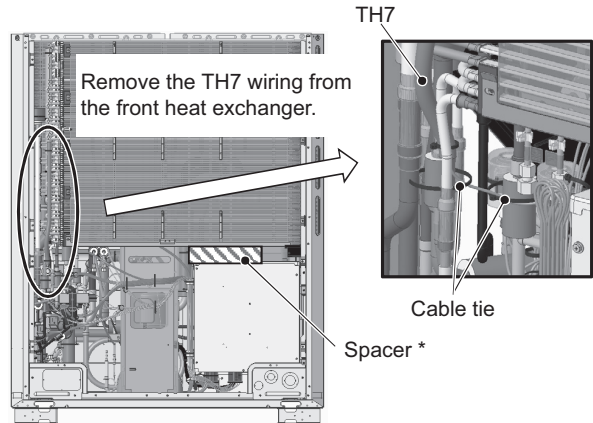


Figure 10

*Use the supplied spacers.

Use the spacers 60 (D) x 250 (W) x 60 (H) when replacing the heat exchangers for the maintenance of the accumulator and the pipes.

- (15) To remove the front heat exchanger, first remove the front, left, right, and center frames by unscrewing the 14 screws. (See Figure 11.)
 To remove the rear heat exchanger, remove the rear frame in addition to the front, left, right, and center frames by unscrewing the 16 screws. (See Figure 11.)
- (16) Unscrew the two screws each on the right and left panels. (See Figure 12 Right and Left.)
- (17) Remove the left front pillar by unscrewing the 9 screws on a standard model or 10 screws on a high-efficiency model. (See Figure 12 Front and Left.)
- (18) Remove the right front pillar by unscrewing the 5 screws. (See Figure 12 Front and Right)

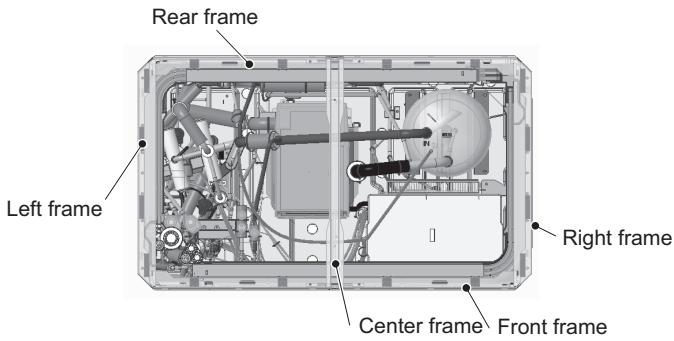


Figure 11

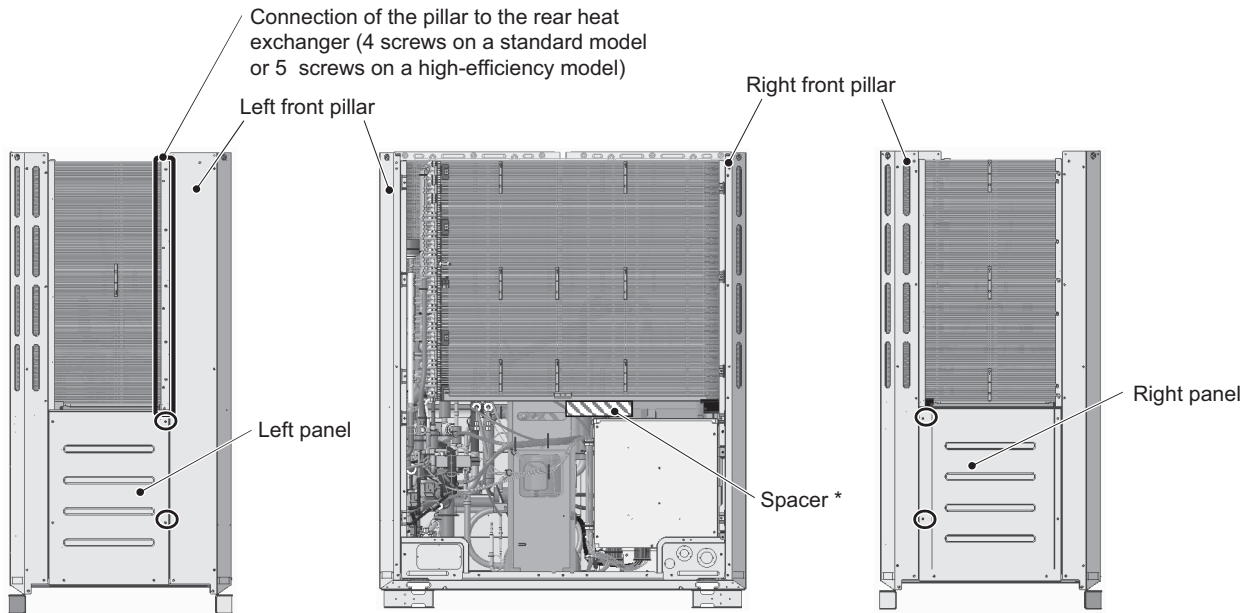


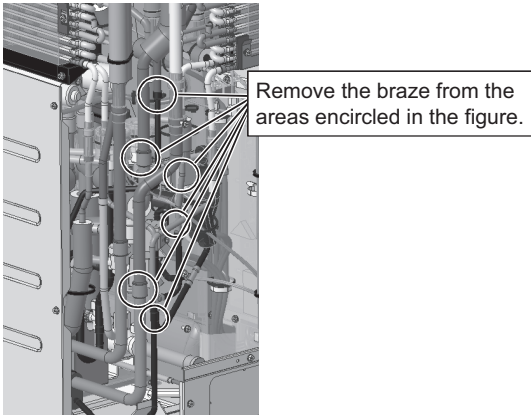
Figure 12 Left

Figure 12 Front

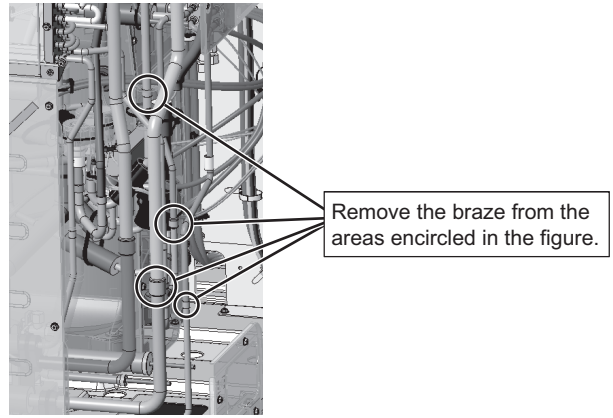
Figure 12 Right

*Use the supplied spacers. Use the spacers 60 (D) X 250 (W) X 60 (H) when replacing the heat exchangers for the maintenance of the accumulator and the pipes.

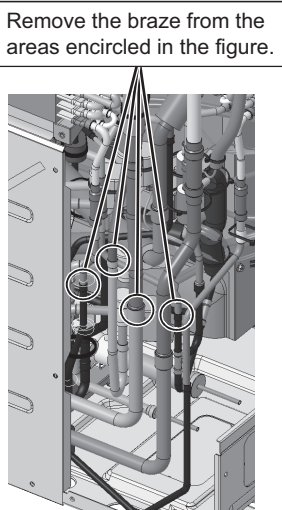
(19) Before removing the front heat exchanger, protect the adjacent electrical components and the pipe covers with the recommended felt that is soaked in water, and then remove the braze from the areas shown in Figures 13 and 14. (High-efficiency front heat exchanger: 6 areas; Standard front heat exchanger: 4 areas)
 To remove the rear heat exchanger, remove the braze from four areas. (See Figures 15 and 16.)



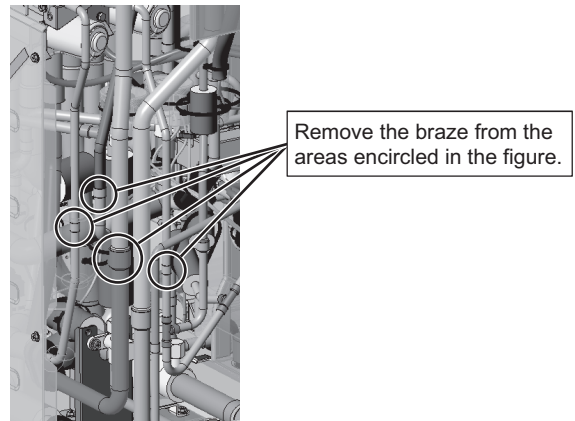
Removing the high-efficiency front heat exchanger (Figure 13)



Removing the standard front heat exchanger (Figure 14)



Removing the high-efficiency rear heat exchanger (Figure 15)



Removing the standard rear heat exchanger (Figure 16)

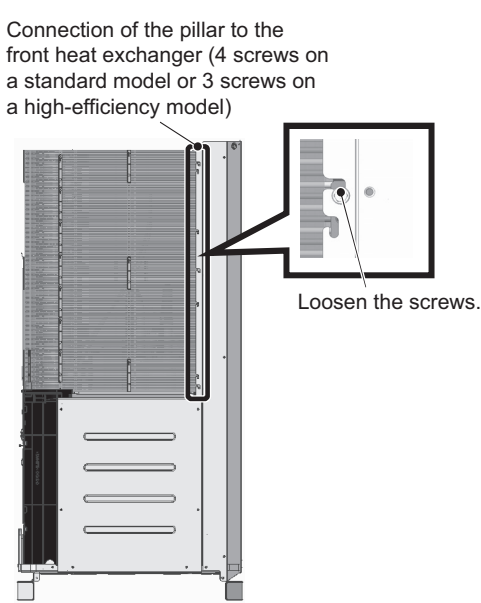
Notes for replacing refrigerant circuit components (heat exchanger)

- Be sure to perform non-oxidized brazing.
- After brazing is done, check that the brazing is done properly and check for leaks before vacuum-drying the pipes.
- Direct the brazing torch flame away from the wiring and sheet metals inside the unit not to damage them.
- Place the wet felt sheets listed below (or their equivalents) around the areas to be brazed to protect the heat exchanger, pipes, and pipe covers from being damaged from the brazing torch flame.

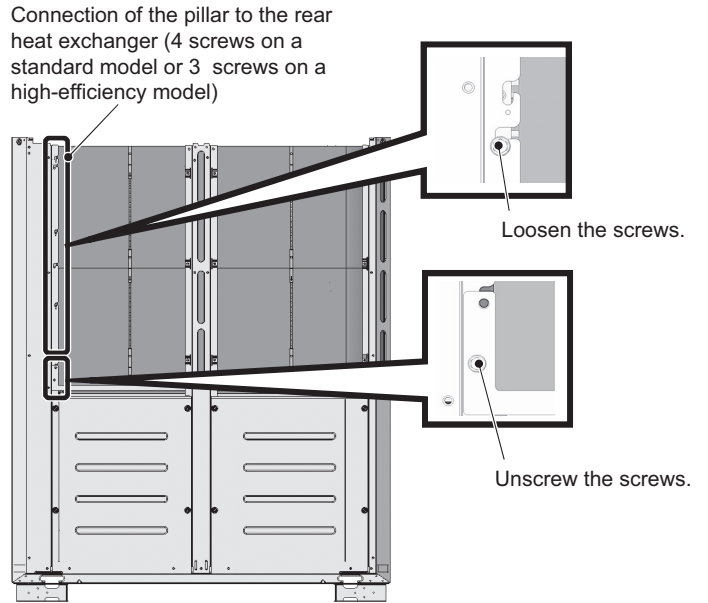
Recommended felt sheets: Spatter felt 50CF-11 (5t x 1 m x 1 m) by TRUSCO Nakayama

Felt sheets that meet the JIS standard (JIS A 1323 type A "Flame retardant testing method for spark droplets of welding and gas cutting on fabric sheets in construction works")

- (20) To remove the front heat exchanger, loosen the screws on the right side of the right rear pillar. (4 screws on a standard model or 3 screws on a high-efficiency model) (See Figure 17.)
 To remove the rear heat exchanger, loosen the screws on the back of the right rear pillar. (4 screws on a standard model or 3 screws on a high-efficiency model) (See Figure 18.)
 Remove the screw holding the pillar to the rear heat exchanger support.

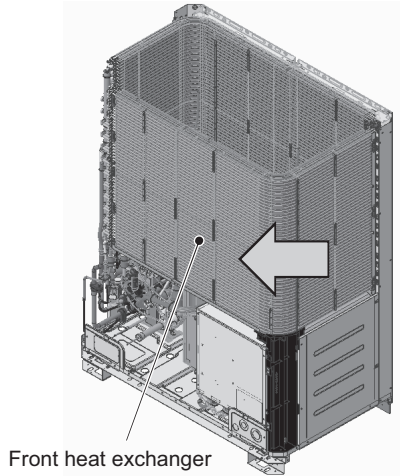


Removing the front heat exchanger (Figure 17)

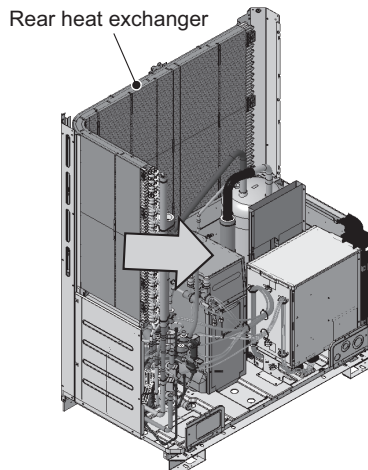


Removing the rear heat exchanger (Figure 18)

- (21) Remove the heat exchanger by diagonally lifting it up, using caution not to damage the fins or the pipes.

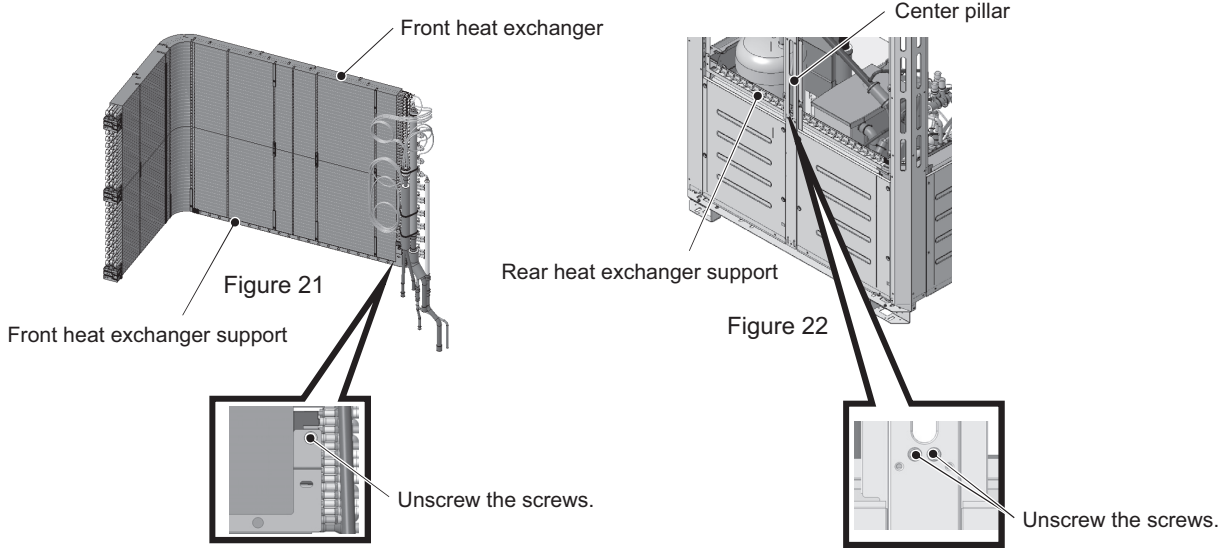


Removing the front heat exchanger (Figure 19)



Removing the rear heat exchanger (Figure 20)

(22) After removing the heat exchangers, dispose of the front and the rear heat exchanger supports. (See Figures 21 and 22.)
The front and the rear heat exchanger supports do not need to be installed. (The front and the rear heat exchanger supports are for suppressing vibration during transportation.)



(23) Re-place the front and the rear heat exchangers in the reverse order as they were removed.
Re-place the components that were removed as they were.

3. XL-module

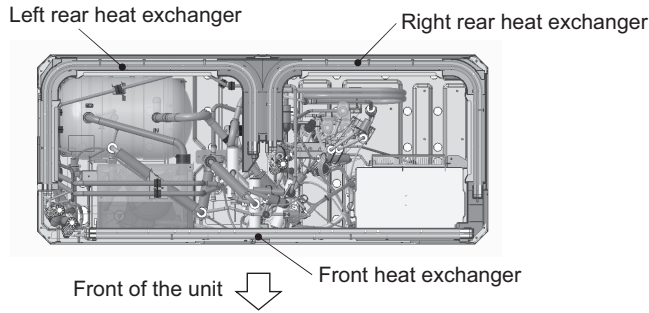


Figure 1

- (1) Remove the two front panels from the unit by unscrewing the 14 screws. (See Figure 2.)
- (2) Remove the fin guard by unscrewing the 12 screws. (See Figure 2.)
- (3) Remove pipe cover. (See Figure 3.)
- (4) Remove the left drain pan by unscrewing the two screws and cutting the two cable ties. (See Figure 3.)
- (5) Remove the right drain pan by unscrewing the 2 screws. (See Figure 3.)
- (6) Remove the 3 cable straps from the center pillar. (See Figure 4.)

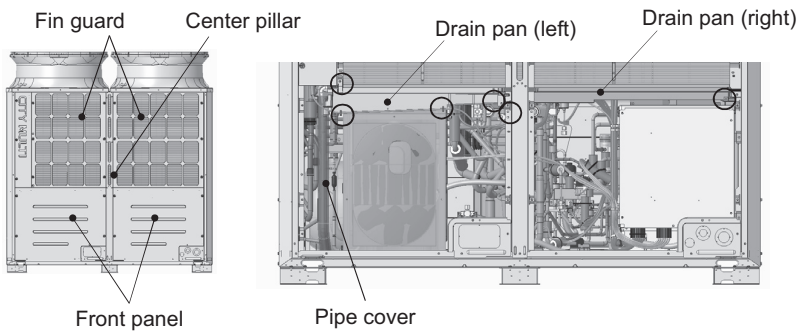


Figure 2

Figure 3

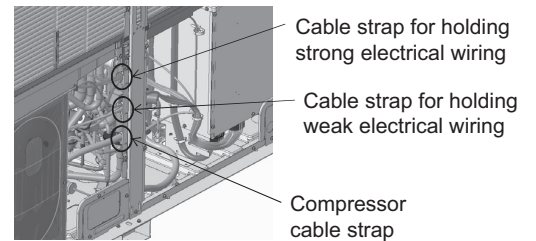


Figure 4

- (7) Remove the 3 cable straps holding motor wiring from the control box. (See Figure 5.)
- (8) Remove the fan guard by unscrewing the 12 screws. (See Figure 6.)
- (9) Unstrap the cable from the cable strap on the center frame. (See Figure 7.)
- (10) Remove the motor ASSY by unscrewing the 8 screws, using caution not to damage the motor wiring or the fan. (See Figure 7.)

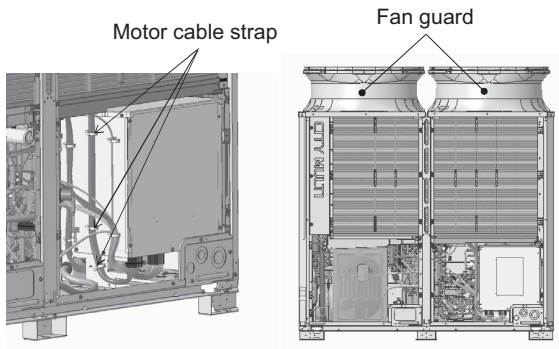


Figure 5

Figure 6

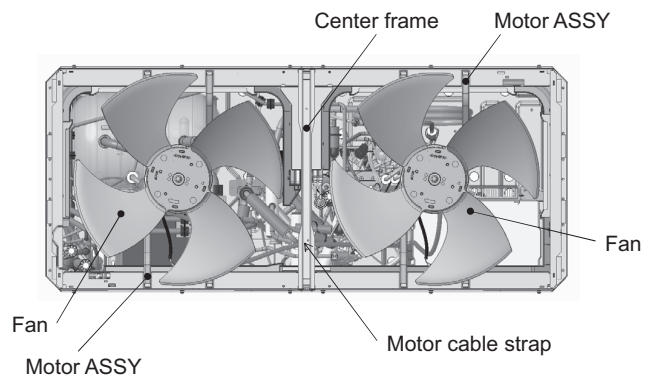
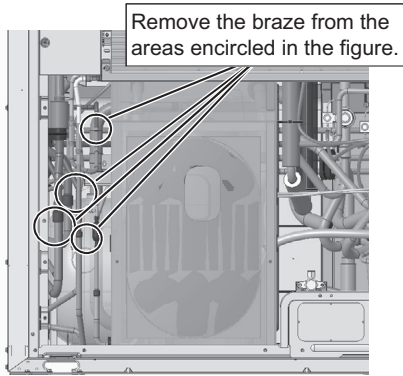
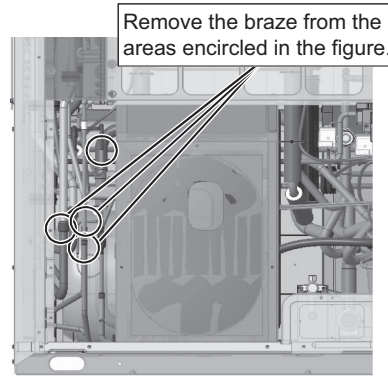


Figure 7

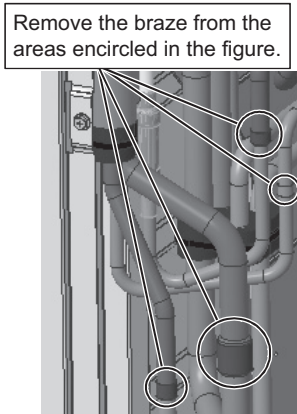
(11) Before removing the front heat exchanger, protect the surrounding electrical components and the pipe cover with a recommended felt soaked in water, and then remove the braze from four areas. (See Figures 8 and 9.)
 To remove the right and left rear heat exchangers, remove the braze from four areas. (See Figures 10 - 13.)



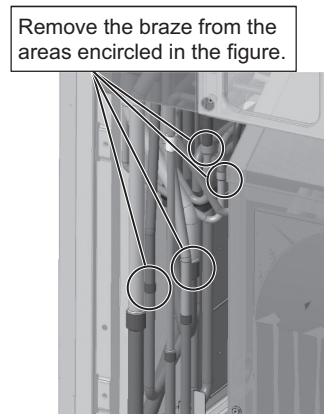
Removing the high-efficiency front heat exchanger (Figure 8)



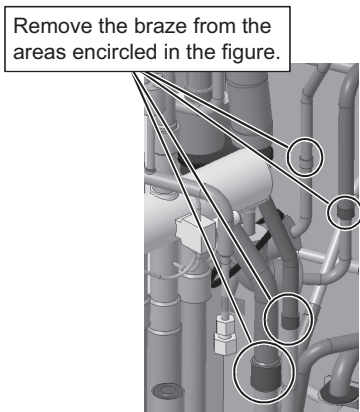
Removing the standard front heat exchanger (Figure 9)



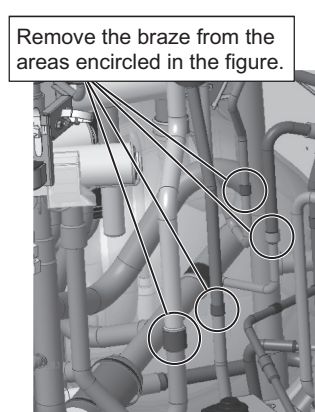
Removing the high-efficiency rear left heat exchanger (Figure 10)



Removing the standard rear left heat exchanger (Figure 11)



Removing the high-efficiency rear right heat exchanger (Figure 12)



Removing the standard rear right heat exchanger (Figure 13)

Notes for replacing refrigerant circuit components (heat exchanger)

- Be sure to perform non-oxidized brazing.
- After brazing is done, check that the brazing is done properly and check for leaks before vacuum-drying the pipes.
- Direct the brazing torch flame away from the wiring and sheet metals inside the unit not to damage them.
- Place the wet felt sheets listed below (or their equivalents) around the areas to be brazed to protect the heat exchanger, pipes, and pipe covers from being damaged from the brazing torch flame.

Recommended felt sheets: Spatter felt 50CF-11 (5t x 1 m x 1 m) by TRUSCO Nakayama

Felt sheets that meet the JIS standard (JIS A 1323 type A "Flame retardant testing method for spark droplets of welding and gas cutting on fabric sheets in construction works")

- (12) Remove the front pillar by unscrewing the 7 screws. (See Figure 14.)
- (13) Disconnect the TH7 sensor holder from the front pillar. (See Figure 14 Rear.)

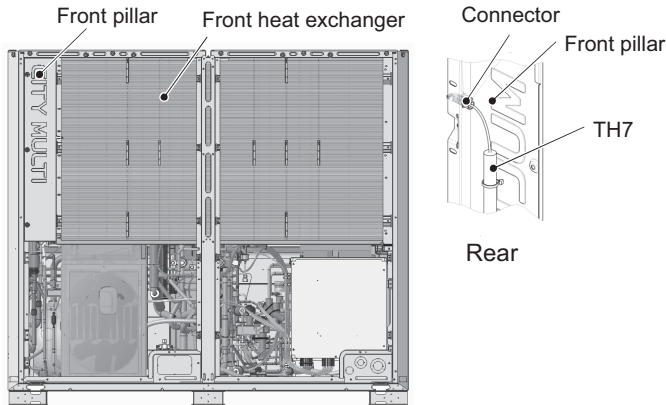


Figure 14

- (14) To remove the front heat exchanger, first remove the front, left, right, and center frames by unscrewing the 16 screws. (See Figure 15.)
To remove the right and left rear heat exchangers, remove the top and the rear frames in addition to the front, left, right, and center frames by unscrewing the 21 screws. (See Figure 15.)
- (15) Remove the center front pillar by unscrewing the 4 screws. (See Figure 16.)

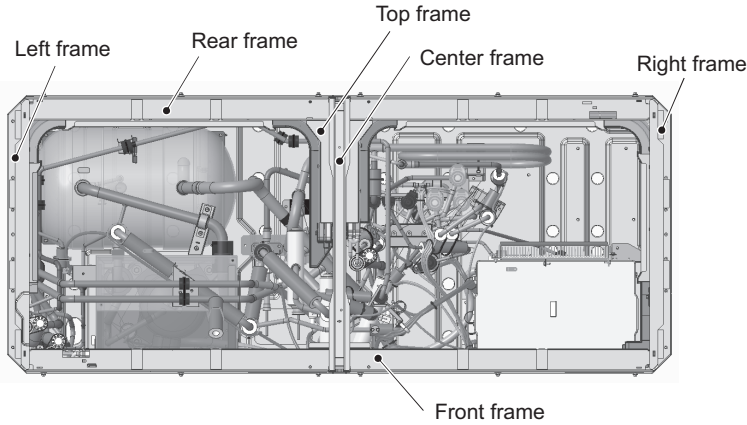


Figure 15

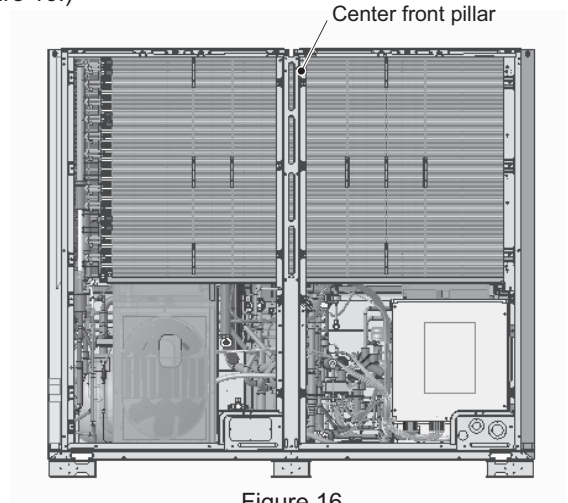
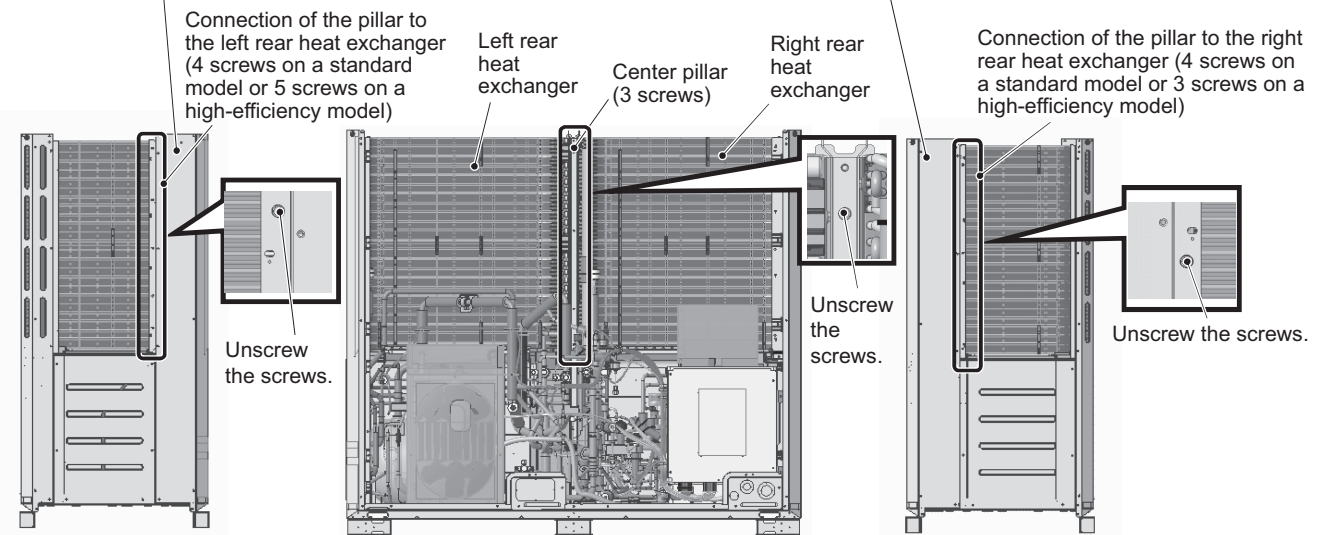
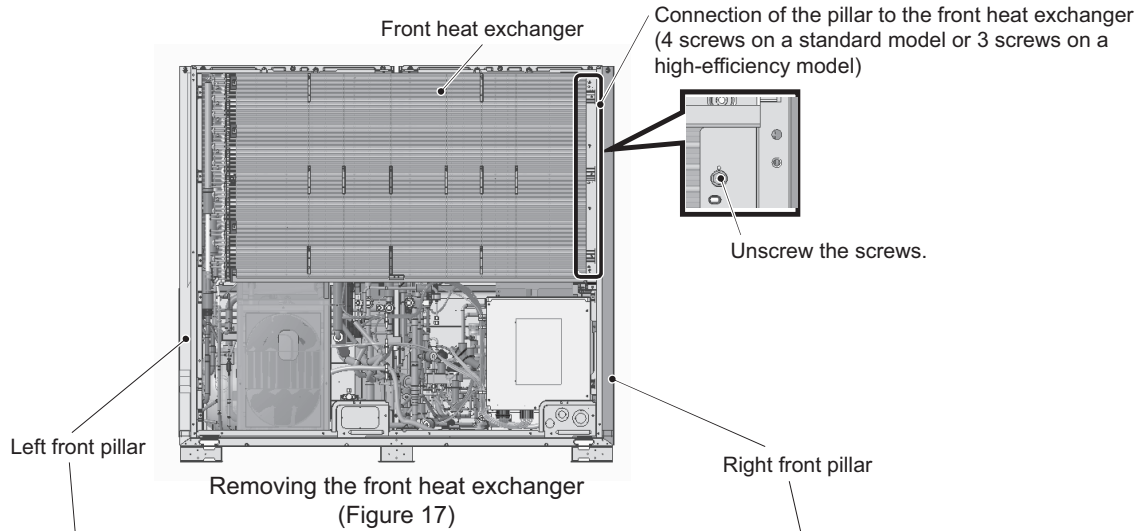


Figure 16

- (16) To remove the front heat exchanger, unscrew the screws on the front of the right front pillar. (4 screws on a standard model or 3 screws on a high-efficiency model) (See Figure 17.)
 To remove the left rear heat exchanger, unscrew the screws on the left side of the left front pillar and the screws on the front of the center pillar (7 screws on a standard model or 8 screws on a high-efficiency model.) (See Figures 18 and 19.)
 To remove the right rear heat exchanger, unscrew the screws on the right side of the right front pillar and the screws on the front of the center pillar (7 screws on a standard model or 6 screws on a high-efficiency model.) (See Figures 19 and 20.)

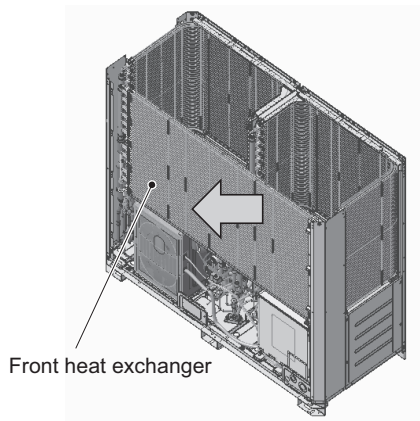


Removing the left rear heat exchanger (Figure 18)

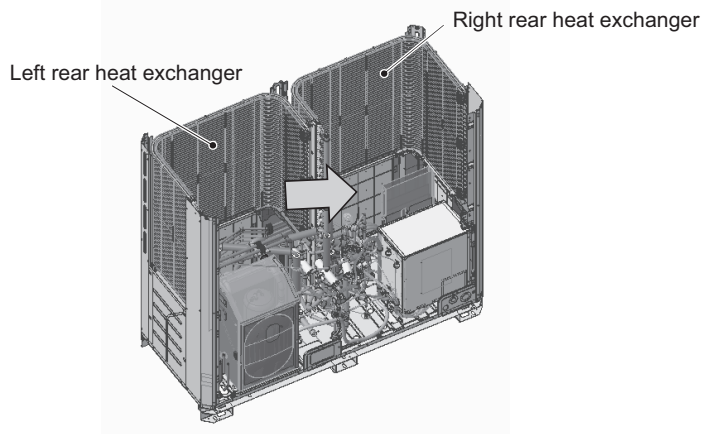
Removing the right and left rear heat exchangers (Figure 19)

Removing the right rear heat exchanger (Figure 20)

(17) Remove the heat exchanger by diagonally lifting it up, using caution not to damage the fins or the pipes.



Removing the front heat exchanger
(Figure 21)



Removing the rear heat exchanger
(Figure 22)

(18) Re-place the front and the rear heat exchangers in the reverse order as they were removed.
Re-place the components, except the rear heat exchanger support, that were removed as they were.

8-13-13 Accumulator Replacement Procedure <Type A/Type A1/Type A2>

1. S, L-module

- (1) Remove the front heat exchanger. Refer to 8-13-11 Maintenance Procedures for the Heat Exchanger <Type A> or 8-13-12 Maintenance Procedures for the Heat Exchanger <Type A1/Type A2> for details.
- (2) Remove the top, front, and right compressor covers. Refer to 8-13-6 Compressor Replacement Procedure <Type A> or 8-13-7 Compressor Replacement Procedure <Type A1/Type A2> for details.
- (3) Remove the duct from the control box. Refer to the control box replacement procedure for details.
- (4) Remove the right and inside (right) compressor panels by unscrewing the four screws. (Applicable only to the S-module. See Figures 1 and 2.)

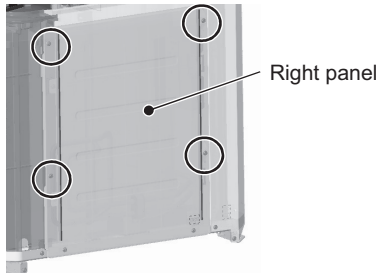


Figure 1

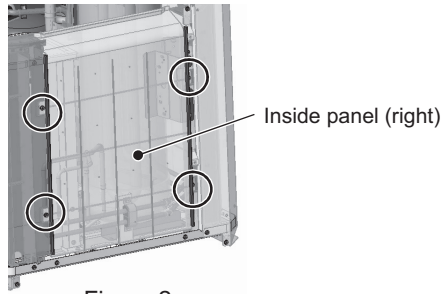


Figure 2

- (5) Unscrew the four screws from the right accumulator fixing plate. (See Figures 3 and 5.)
- (6) Unscrew the four screws from the rear accumulator fixing plate. (See Figures 3 and 4.)
- (7) Remove the four screws from the accumulator fixing base legs. (See Figure 6.)

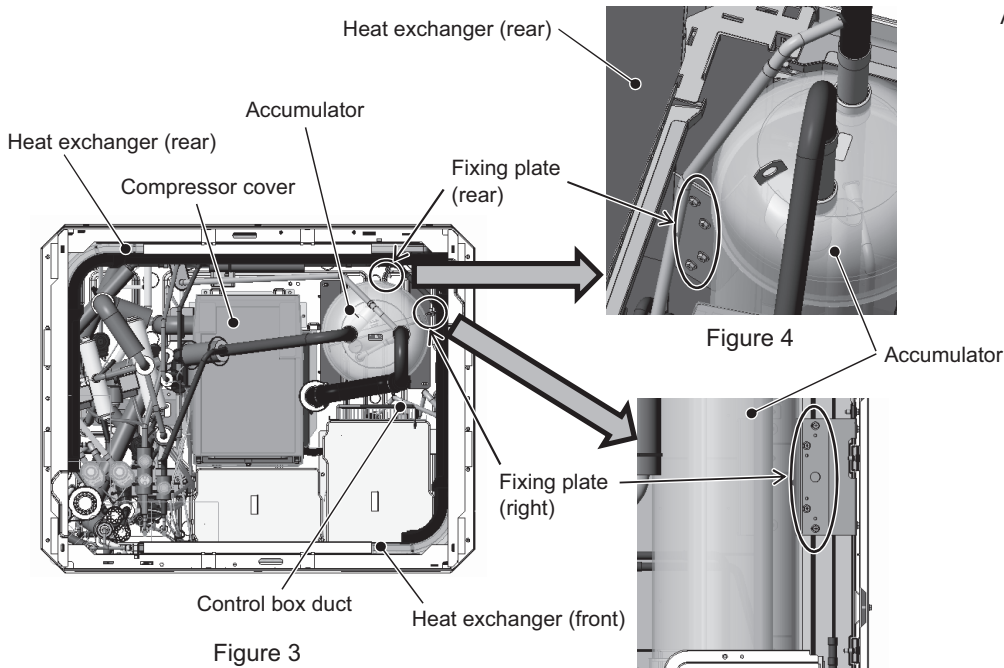


Figure 3

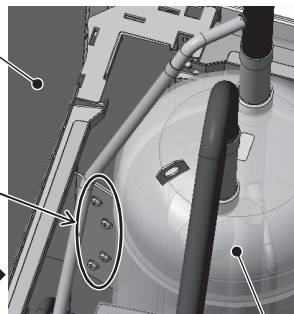


Figure 4

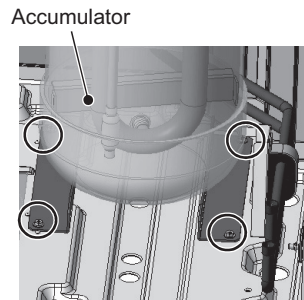


Figure 6

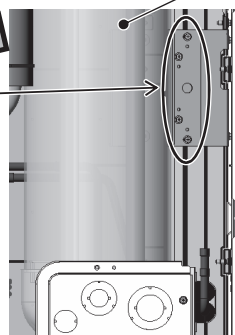
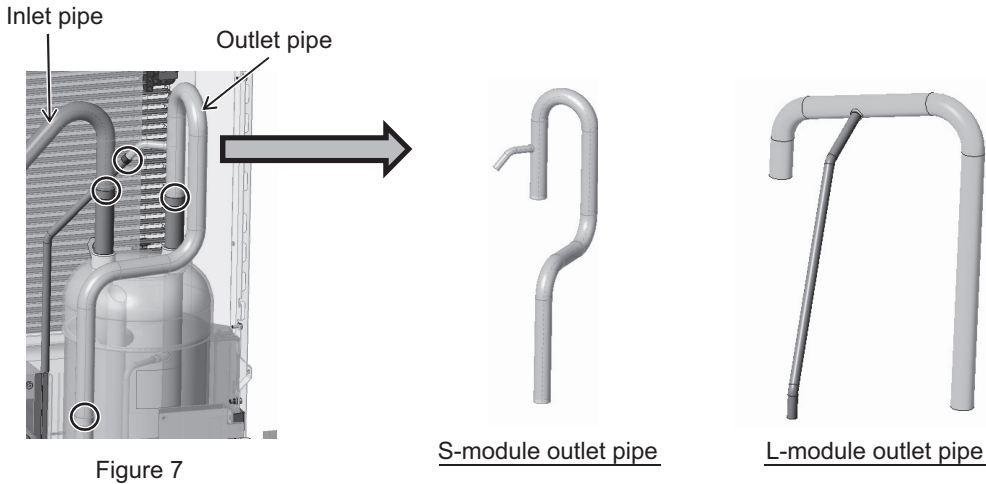


Figure 5

(8) Remove the braze at the four areas on the accumulator inlet and outlet pipes shown in Figure 7.



(9) Re-place the accumulator in the reverse order as it was removed.
Re-place the components that were removed as they were.

*Notes on replacing refrigerant circuit components (accumulator)

- Be sure to perform non-oxidized brazing.
- Before heating the pipes, wrap the refrigerant circuit components with a wet towel to keep the temperature of the components from rising above 120°C.
- After brazing is done, check that the brazing is done properly and check for leaks before vacuum-drying the pipes.
- Direct the brazing torch flame away from the wiring and sheet metals inside the unit not to damage them.
- Wet felt sheets listed below (or its equivalent), and place them around the areas to be brazed to protect the heat exchanger, pipes, and pipe covers from being damaged from the brazing torch flame.

Recommended felt sheets: Spatter felt 50CF-11 (5t x 1 m x 1 m) by TRUSCO Nakayama

Felt sheets that meet the JIS standard (JIS A 1323 type A "Flame retardant testing method for spark droplets of welding and gas cutting on fabric sheets in construction works")

2. XL-module

- (1) Remove the front heat exchanger. Refer to 8-13-11 Maintenance Procedures for the Heat Exchanger <Type A> or 8-13-12 Maintenance Procedures for the Heat Exchanger <Type A1/Type A2> for details.
- (2) Remove the top, front, and right compressor covers. Refer to 8-13-6 Compressor Replacement Procedure <Type A> or 8-13-7 Compressor Replacement Procedure <Type A1/Type A2> for details.
- (3) Remove the fixing plate 1 above four-way valve (21S4b), saddle, and rubber spacer by unscrewing the three screws shown in Figure 8.

Either remove or protect the wiring, pipe cover, and plastic components to keep them from being damaged by the torch flame.

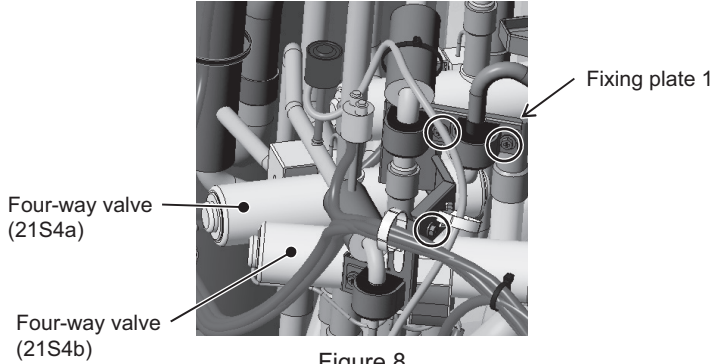


Figure 8

- (4) Remove the sheet metal, cable ties, and rubber spacers from the accumulator mounting plate by unscrewing the screw. (See Figure 9.)

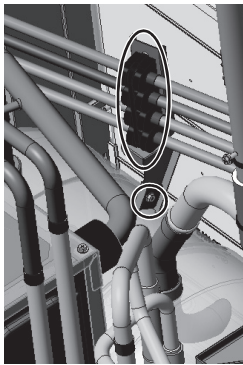


Figure 9

- (5) Remove the braze at the two areas on the accumulator outlet (suction) pipe. (See Figure 10.)
- (6) Remove the braze at the two areas on the accumulator inlet pipe. (See Figure 11.)

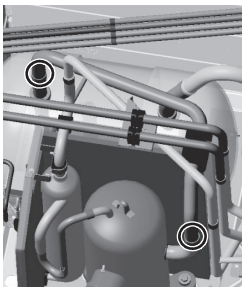


Figure 10

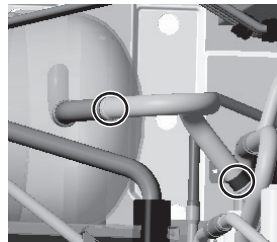
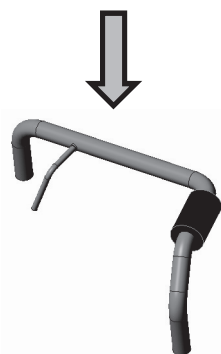


Figure 11



- (7) Remove the braze at the four areas on the four pipes on the back of the accumulator. (See Figure 12.)
- (8) Remove the braze at the six areas that are located on the right side of the four pipes on the back of the accumulator. (See Figure 13.)

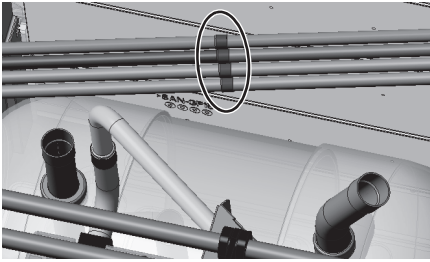


Figure 12

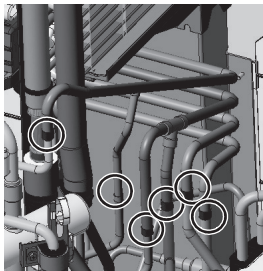
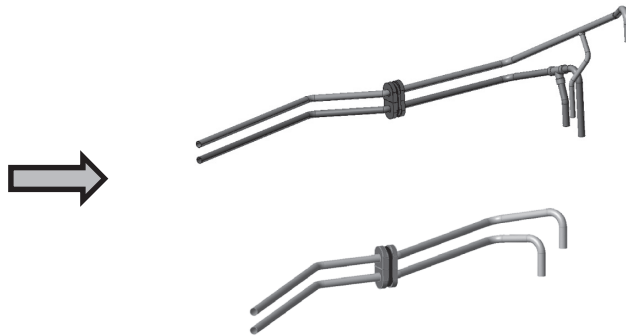


Figure 13



- (9) Re-place the accumulator in the reverse order as it was removed.
Re-place the components that were removed as they were.

8-14 Troubleshooting Problems Using the LED Status Indicators on the Outdoor Unit

If the LED error display appear as follows while all the SW4 switches and SW6-10 are set to OFF, check the items under the applicable item numbers below.

1. Error code appears on the LED display.

Refer to the following page(s). [7-1 Error Code and Preliminary Error Code Lists]

2. LED is blank.

Take the following troubleshooting steps.

- (1) Refer to the section on troubleshooting the transmission power supply circuit, if the voltage across pins 1 through 3 of CNDC on the control panel is outside the range between 220 VDC and 380 VDC. [8-10-2 Troubleshooting Problems with Outdoor Unit Transmission Power Supply Circuit]
- (2) If the LED error display becomes lit when the power is turned on with all the connectors on the control board except CNDC disconnected, there is a problem with the wiring to those connectors or with the connectors themselves.
- (3) If nothing appears on the display under item (2) above AND the voltage between pins 1 and 3 of CNDC is within the range between 220 VDC and 380 VDC, control board failure is suspected.

3. Only the software version appears on the LED display.

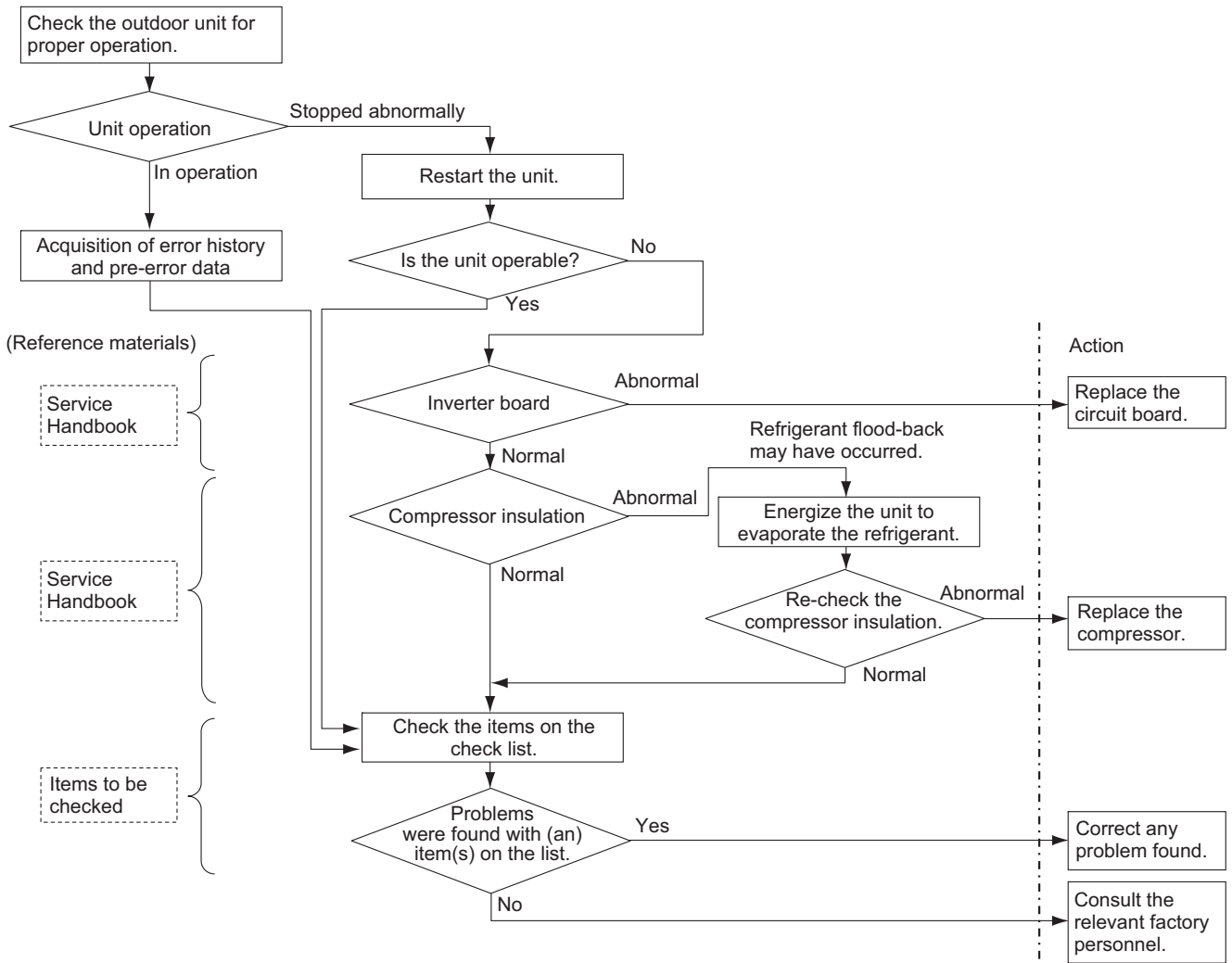
- (1) Only the software version appears while the transmission cables to TB3 and TB7 are disconnected.

- 1) Wiring failure between the control board and PS board. (CN62, CNPS, CNIT, CNS2, CN102)
- 2) If item 1) checks out OK, the transmission line power supply board failure is suspected.
- 3) If items 1) and 2) check out OK, control board failure is suspected.

- (2) If the LED shows the same display as the initial display upon disconnection of transmission lines (TB3, TB7), there is a problem with the transmission lines or with the connected devices. [10-1-2 Initial LED Display]

8-15 4250 Troubleshooting

1. 4250 Troubleshooting flowchart



8 Troubleshooting Based on Observed Symptoms

	Items to be checked when refrigerant flood-back occurred in the Cooling mode	Judgement		Items to be checked when refrigerant flood-back occurred in the Heating mode	Judgement
1	Check the total refrigerant charge. Check the piping system configuration and the total amount of refrigerant. If the piping system configuration is unknown, check the total amount of refrigerant in the system, using the Refrigerant Amount Adjustment mode. (See Service Handbook for details.)		1	Check the total refrigerant charge. Check the piping system configuration and the total amount of refrigerant. If the piping system configuration is unknown, check the total amount of refrigerant in the system, using the Refrigerant Amount Adjustment mode. (See Service Handbook for details.)	
2	Check for uneven distribution of refrigerant in the combined-unit system. Use the difference in the SCO values between the units to check for uneven distribution. Check the distributor kit between the outdoor units for correct installation (both liquid and gas).		2	Check for uneven distribution of refrigerant between the combined units. Use the difference in the discharge superheat of the compressors on the units to check for uneven distribution. Check the distributor kit between the outdoor units for correct installation (both liquid and gas).	
3	Check for refrigerant flood-back from the stopped indoor units. Check the heat exchanger temperature readings on TH2 and TH3. If the temperature has dropped to the same temperature of the indoor units in operation, refrigerant flood-back may be occurring.		3	If the degree of unevenness in No. 2 is great, check the distributor kit between the outdoor units for correct installation (both liquid and gas).	
4	Check for refrigerant flood-back through LEV1 on the outdoor unit. Regardless of the degree of opening of LEV1, check LEV1 on the outdoor unit for proper operation if the superheat on the bypass side is small. Check the valve body and the coil in accordance with the instructions provided in the Service Handbook		4	If the degree of unevenness in No. 2 is great, check the operation of LEV2 on the outdoor unit. Check the valve body and the coil in accordance with the instructions provided in the Service Handbook.	
5	Check for refrigerant flood-back from the operating indoor units. Check the heat exchanger temperature readings on TH2 and TH3. Regardless of the degree of opening of the LEV on the indoor units, a small superheat at the outlet suggests a possibility of refrigerant flood-back. Check the LEV on the indoor units for proper operation. Check the valve body and the coil in accordance with the instructions provided in the Service Handbook.		5	Check for refrigerant flood-back through LEV1 on the outdoor unit. Check for normal operation of LEV1 on the outdoor unit. Check the valve body and the coil in accordance with the instructions provided in the Service Handbook.	
6	Check for refrigerant flood-back from the stopped indoor units. Check the heat exchanger temperature readings on TH2 and TH3. If the temperature has dropped to the same temperature of the indoor units in operation, refrigerant flood-back may be occurring. Check LEV on the indoor units for proper operation. Check the valve body and the coil in accordance with the instructions provided in the Service Handbook.				

Chapter 9 USB Function

9-1	Service Overview	1
9-1-1	Function Overview	1
9-1-2	System Structure	2
9-1-3	Necessary Materials	4
9-2	Operation Data Collection and Storage Functions	5
9-2-1	Preparation	5
9-2-2	Storing Data on a USB Memory Stick	5
9-2-3	Collecting Operation Data	7
9-2-4	Precautions	8
9-3	Software Rewrite Function on the USB	9
9-3-1	Preparation	9
9-3-2	Rewriting Software	9
9-3-3	Precautions	10
9-4	Maintenance LED Display and Troubleshooting	11
9-4-1	Maintenance LED Display Content List	11
9-4-2	Troubleshooting	14



9-1 Service Overview

9-1-1 Function Overview

The control board has a USB port that allows the use of the following two functions.

1. Collection and storage of operation data

Operation information from indoor units, outdoor units, and other equipment and devices in the system are collected and stored in the flash memory in the control board of the outdoor unit (OC).

The data can be transferred and stored in a USB memory stick.

- Operation data in the multiple-outdoor-unit system will be saved on the OC unit.
- Attempting to collect the operation data from the OS unit will result in an error.

2. Software rewrite function

The software on outdoor units can be rewritten using a USB memory stick.

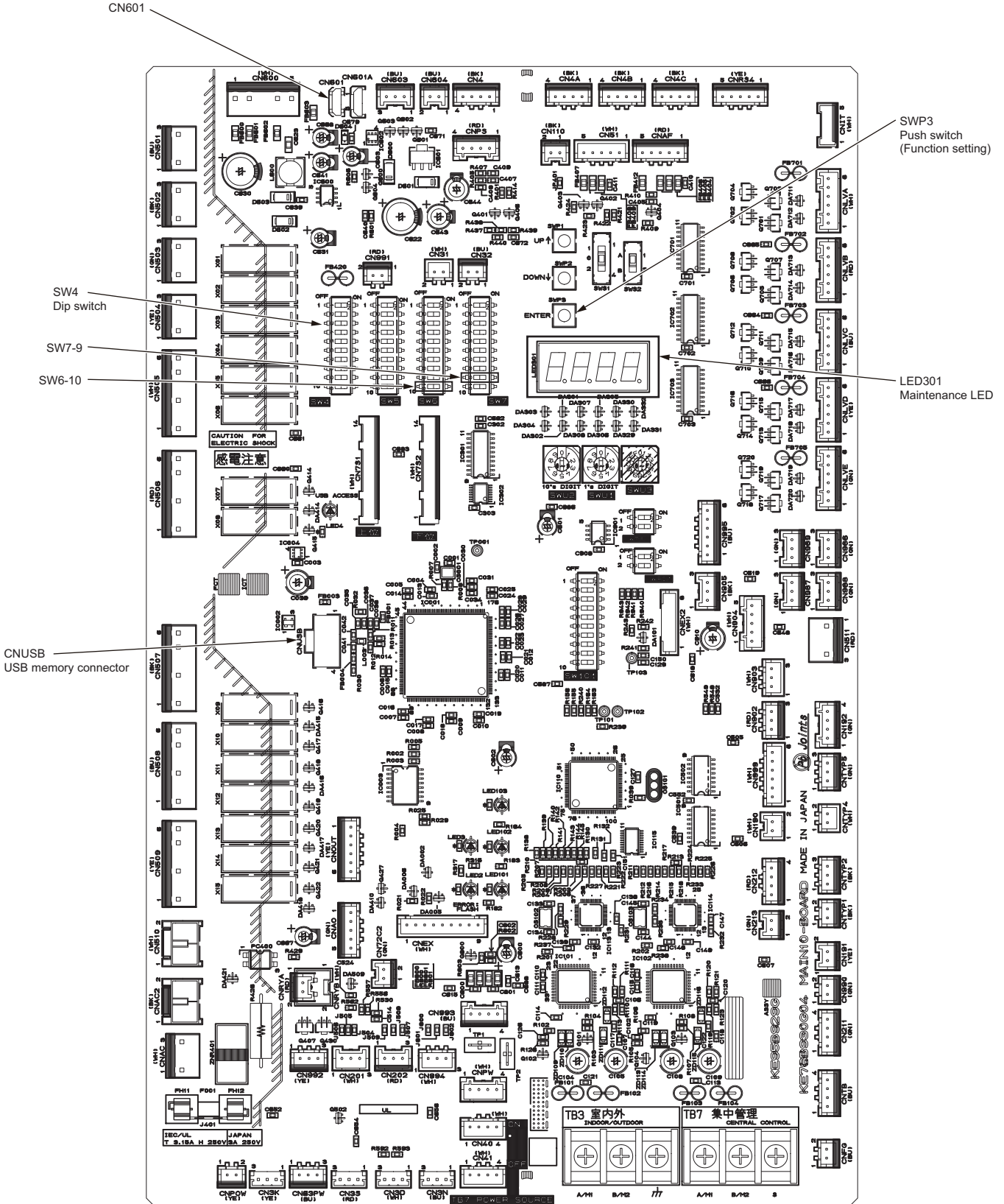
For detailed information about each function, refer to Section [9-2 Operation Data Collection and Storage Functions] and Section [9-3 Software Rewrite Function on the USB].

For information regarding the maintenance LED display content and regarding troubleshooting, refer to Section [9-4 Maintenance LED Display and Troubleshooting].

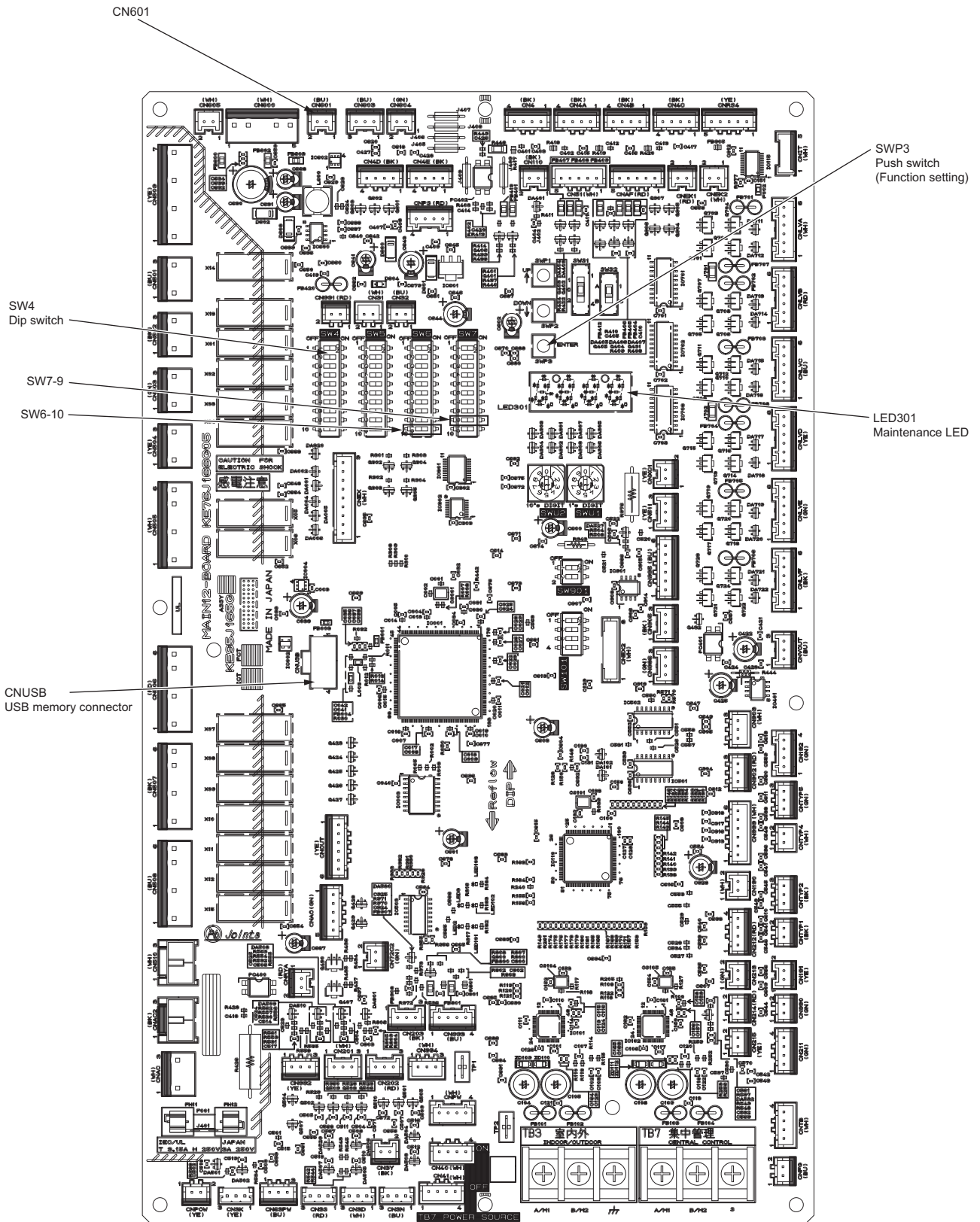
9-1-2 System Structure

(1) Control board on the outdoor unit

1) Type A



2) Type A1/A2



9-1-3 **Necessary Materials**

The use of the USB function requires a USB memory stick and a portable battery charger. See below for the types of USB memory stick and portable charger that can be used.

(1) USB memory stick

Use a USB memory stick that meets the following specifications.

- ♦USB 2.0 compatible
- ♦Formatted in FAT 32
- ♦Without a security function

(2) Portable battery charger

Use a portable battery charger that meets the following specifications for rewriting the software.

- ♦USB 2.0 compatible
- ♦Voltage and amperage rating of 5 V and 2.1 A (MAX)
- ♦Supports the energy-saving mode

A battery charger not compatible with the energy-saving mode may turn off while the data are being collected or while the S/W is being re-written, and these actions may not be completed successfully.

A LEAD WIRE ASSY USB is required to connect the control board and the portable charger.

Use a cable that meets the following specifications.

[Type A]

- ♦[Type A male] - [Micro B male] USB cable
The control board has a micro B female connector.

[Type A1/A2]

- ♦[Type A male] - [Male XA connector for the PCB] USB cable. For details of "LEAD WIRE ASSY USB", please contact the sales office.
The connector on the control board side is a female XA connector for the PCB.

9-2 Operation Data Collection and Storage Functions

Operation data of the units collected on the outdoor unit can be recorded in the flash memory of the control board. These data can also be exported to and recorded in a USB memory stick.

See Section [9-2-2 Storing Data on a USB Memory Stick] for information on storing data on a USB memory stick.

See Section [9-2-3 Collecting Operation Data] for information on the collection of operation data.

9-2-1 Preparation

A USB memory stick and a portable battery charger are required to store data on a USB memory stick (not supplied). Prepare a USB memory stick and a portable battery charger as described in Section [9-1-3 Necessary Materials].

9-2-2 Storing Data on a USB Memory Stick

Store operation data recorded in the flash memory on the control board in a USB memory stick.

The content of the stored file can be confirmed using the maintenance tool.

Operation data should be stored in a dedicated mode (Store Mode).

1. Procedure

(1) Preparation of a USB memory stick

- 1) Since the size of the saved file containing operation data is 50 MB, prepare a USB memory stick with 50 MB or more available memory. A USB memory stick which has other data in it may also be used. However, it is recommended to clear the remaining data in advance to prevent any malfunctions. The file containing the operation data is saved as a MNTXXX.MT file or in a MNTXXX folder. XXX represents a serial number from 000 to 100. A maximum of one-hundred MNT files or folders can be saved. To save more files or folders, delete unnecessary files or folders.

(2) Storing data on a USB memory stick

Data can be stored to a USB memory stick either with the main power to the outdoor unit (OC) turned on (Method 2) or off (Method 1). For safety reasons, it is recommended to store the data on a USB memory stick with the main power to the outdoor unit (OC) turned off (Method 1). If turning off the power is not feasible, take appropriate measures to ensure safety.

[Method 1 (recommended)] Storing data on a USB memory stick with the main power to the outdoor unit (OC) turned off

<Starting up the unit in the data storage mode>

- Turn off the main power to the outdoor unit (OC).
- Connect a USB memory stick to the USB port (CNUSB) on the control board.
- While holding down SWP3 (ENTER), connect the portable battery charger to the Micro-USB port (CN601) or the XA connector (CN601), and supply power to the control board.
 - Type A: Micro-USB port (CN601)
 - Type A1/A2: XA connector (CN601)
- [USB] will appear on the monitoring LED301. If "USB" does not appear, refer to Section 1.(1) in [9-4-2 Troubleshooting].



- When [USB] has appeared on the LED, lift the finger off SWP3 (ENTER). The unit is now in the data storage mode.

<Storing data>

- Press SWP3 (ENTER). If the data storage process has properly started, the progress (0-99) will be shown on the monitoring LED 301.
- [End] on the LED indicates successful completion of the data storage process.
 - *It takes approximately five minutes for the data storage process to be completed.



<Ending the data storage mode>

- When done storing data, disconnect the portable battery charger from the control board.
- Then disconnect the USB memory stick from the control board.
- Turn the main power to the outdoor unit (OC) back on.

•If the data collection process needs to be started, check the operation data collection status by following the procedures explained in [9-2-3 Collecting Operation Data]and making the necessary settings.

[Method 2] Storing data on a USB memory stick with the main power to the outdoor unit (OC) turned on
<Starting up the unit in the data storage mode>

- Stop the operation of all indoor units.
- Connect a USB memory stick to the USB port (CNUSB) on the control board of the outdoor unit (OC). Wait for five seconds until the USB memory stick is recognized.
- Press and hold SWP3 (ENTER) for approximately 10 seconds until [USB] appears on the monitoring LED 301.



•When [USB] has appeared on the LED, lift the finger off SWP3 (ENTER).
 The unit is now in the data storage mode.

<Storing data>

- Press SWP3 (ENTER). If the data storage process has properly started, the progress (0-99) will be shown on the monitoring LED 301.
- [End] on the LED indicates successful completion of the data storage process.
- *It takes approximately five minutes for the data storage process to be completed.



<Ending the data storage mode>

- When done storing data, disconnect the USB memory stick from the control board.
- Press and hold SWP3 (ENTER) for approximately 10 seconds until [End] disappears from the monitoring LED 301.
- Restart the indoor and outdoor units (OC) that were stopped to perform data storage.
- If the data collection process needs to be started, check the operation data collection status by following the procedures explained in [9-2-3 Collecting Operation Data]and making the necessary settings.

(3) Confirmation of stored file

Confirm that the operation data is stored in the USB memory stick. Insert the USB memory stick into a computer, and check the contents in the memory stick. There are two patterns depending on the outdoor unit software version as shown below.

- 1) When there are the following folder and three files in the USB memory stick
 Check that there are the following three files in the folder.
 Folder: MNTXXX
 File: DATAXXX.MT, INFXXX.MT, ETCXXX.MT
 "XXX" represents serial numbers from "000" to "100."
 These three files are needed for the maintenance tool. For details, see Maintenance Tool Manual.
- 2) When there are the following files in the USB memory stick
 Check that there is the following file in the memory stick.
 File: MNTXXX.MT
 "XXX" represents serial numbers from "000" to "100."

9-2-3 Collecting Operation Data

This function is used to collect the operation data of the outdoor and indoor units via M-NET, and record the data in the flash memory on the control board. When the memory is full, it is overwritten from the first segment. The settings for checking the status of operation data collection, for starting/ending data collection, and for continuing/stopping error-data collection are made, using the switches on the control board. The items to be set are shown in the table below. The data collection setting is enabled by default, and the setting for error data collection during an error is disabled by default.

Switch			Function	Operation set by the switch		Timing for switch operation	Unit for setting
SW6-10	SW4 (0: OFF, 1: ON)			OFF (LED3 OFF)	ON (LED3 ON)		
OFF	NO.28	00111000000	Data being collected	-	-	Anytime after power-on	OC setting necessary
ON	NO.817	10001100110	Data collection enabled	Enabled	Disabled	Anytime after power-on	OC setting necessary
ON	NO.818	01001100110	Data collection during an error	Disabled	Enabled	Anytime after power-on	OC setting necessary

*When setting the switch SW4 on the control board, make sure the outdoor unit is energized. Also use Section [5-1 Dipswitch Functions and Factory Settings] as a reference.

The procedure for making the operation data settings is shown below.

1. Operation procedure

(1) Status Confirmation

- 1) Confirm the current status of operation data collection by setting the switches on the control board following the table shown above.
 Switch setting: SW6-10: OFF
 SW4: 28
 Check the status on the maintenance LED display (LED301).
 * For details, refer to Section [9-4-1 Maintenance LED Display Content List]
 •When “ON” or “OFF” is displayed, go to step (2) and the later steps.
 •When “Err” is displayed, go to step (3) and the later steps.
 •When “F-Er” is displayed, it indicates an error in the flash memory on the control board.
 Refer to Section [9-4-2 Troubleshooting]

(2) Setting Start and End of data collection

- 1) Set the switches on the control board by following the table shown above.
 Switch setting: SW6-10: ON
 SW4: 817
- 2) Press SWP3 (ENTER). With each switch operation, the setting can be alternately switched ON and OFF.
- 3) After conducting step (1), check that the operating condition is stable.
 Data collection start: OFF (Enabled)
 Data collection end: ON (Disabled)
 Setting procedure is now complete.

(3) Settings for error-data collection during an error

- Stops or continues error-data collection when an error occurs.
- 1) Referring to the table above, set the control switches.
 Switch setting: SW6-10: ON
 SW4: 818
 Stop collecting error-data when an error occurs: OFF
 Continue collecting error-data when an error occurs: ON
 - 2) To set the switches, press SWP3 (ENTER). Each pressing of SWP3 (ENTER) toggles between ON and OFF. Error data in the 6000's and the 7000's will be collected, regardless of the SW4 (818) settings.

(4) Restarting data collection

- 1) If “Err” is shown, it indicates that data collection is being suspended for some reason, even though data collection is enabled. To restart, it is necessary to set the switches on the control board. Referring to (2)-1) and (2)-2), set the switches on the control board from OFF (original setting) to ON, and then to OFF again, and make sure the switches settings are indicated as being ON, following the instructions in (1)-1).

9-2-4 Precautions

For dealing with display on the maintenance LED and other problems, refer to Section [9-4 Maintenance LED Display and Troubleshooting].

1. Storage of data in a USB memory stick

- Take extra care regarding electric shock during the work on the control board, such as the insertion of the USB memory stick.
- Before starting in Normal Mode, remove the USB memory stick from the control board.
- Storing data in the USB memory stick may take a long time resulting in OS and communication errors. These errors affect neither storing process nor unit operation. If an error occurs, refer to [9-4-2 Troubleshooting].
- After normal startup, set the operation status of the air-conditioning units to the original status.
- USB memory sticks may become unusable due to unexpected damage or memory shortage. It is recommended to take extra USB memory sticks to the site.
- If only the OS is operated due to problems with the OC, collect data also from the OS by following the same operation procedure as for OC. Refer to Section [9-2-2 Storing Data on a USB Memory Stick].

2. Collection of operation data

- The collection of operation data does not start immediately after power-on, but does after ten minutes.
- When the operation data are being collected from AE-200/AE-50/EW-50 or the Maintenance Tool, the function to collect outdoor unit (OC) data with a USB memory stick will not be available for use.

9-3 Software Rewrite Function on the USB

The USB memory stick may be used to rewrite the software of the outdoor unit in the same way as using a ROM writer.

9-3-1 Preparation

- Prepare a USB memory stick and a portable battery charger.
A LEAD WIRE ASSY USB for connecting the control board and the charger is also necessary.
Make sure the portable battery charger is sufficiently charged.
- Prepare a countermeasure program file "*****.mot" for the intended model.
- Copy the software rewrite program file "*****.mot" onto the root folder of the USB memory stick.
Install only one program and only in the root folder of the USB memory stick.

9-3-2 Rewriting Software

The procedure is shown below.

1. Operation procedure

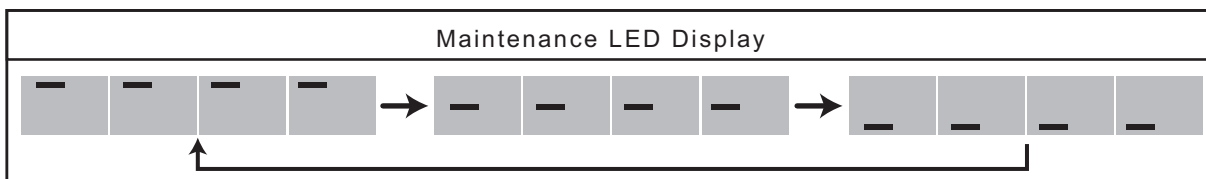
(1) Starting software rewrite mode

- 1) Shut down the power for the outdoor unit. Make sure the power for the control board is off.
This is done by confirming LED2 is off.
- 2) Turn on switches SW7-9 of the control board.
- 3) Insert the USB memory stick into the USB port (CNUSB) on the control board.
- 4) Connect the portable battery charger to the Micro-USB port (CN601) or the XA connector (CN601). The control board will turn on.
Type A: Micro-USB port (CN601)
Type A1/A2: XA connector (CN601)
- 5) Make sure the display "Pro" is shown on the maintenance LED (LED301)
This shows that Software Rewrite Mode has been started.



(2) Performing software rewriting

- 1) Wait for 5 seconds after "Pro" appeared on the LED, and press SWP3 (ENTER) to start software rewrite.
When the rewrite process is in progress, progress bars move as shown below.



- 2) If "End" is displayed on the LED, the rewrite process has been completed correctly. * Generally, this process takes about five minutes.



(3) Confirmation of operation

- 1) Disconnect the portable battery charger from the Micro-USB port (CN601) or the XA connector (CN601). The control board will turn off.
Type A: Micro-USB port (CN601)
Type A1/A2: XA connector (CN601)
- 2) Remove the USB memory stick from the USB port (CNUSB) on the control board.
- 3) Turn off the switches SW7-9 on the control board.
- 4) Turn on the outdoor unit, and check that the versions of the outdoor unit and the software are the same.
The version of the software may be found using the maintenance tool or other means.
Perform a test run, and check for normal operation.

9-3-3 Precautions

For dealing with the displays shown on the maintenance LED and other problems, refer to Section [9-4 Maintenance LED Display and Troubleshooting]

- Take care to choose the correct countermeasure program for the intended model and version.
Store only one software rewrite program on the USB memory stick.
If this requirement is not met, software rewrite may not start.
- Be cautious of electric shock when connecting an USB memory stick or a portable battery charger to the control board.
- Connect the portable battery charger to the LEAD WIRE ASSY USB and then to the control board.
- Make sure the portable battery charger is sufficiently charged. Rewrite error may occur if battery charge is insufficient.
- Take care not to forget to remove the USB memory stick in step (3) - 2) or forget to turn off SW7-9 in step (3) - 3). [9-3-2 Rewriting Software] If these precautions are not taken, the system may not start normally.
- When rewriting ended unsuccessfully, redo the procedure from step (1) - 3). [9-3-2 Rewriting Software]When rewriting ended unsuccessfully, the system may be started in Software Rewrite Mode instead of using the switches on the control board. Also refer to Section [9-4-2 Troubleshooting].
- If software cannot be successfully rewritten using an USB memory stick, use a ROM writer to rewrite the software.
- A battery charger not compatible with the energy-saving mode may turn off while the data are being collected or while the S/W is being re-written, and these actions may not be completed successfully.

9-4 Maintenance LED Display and Troubleshooting

9-4-1 Maintenance LED Display Content List

The following table shows the maintenance LED displays for each function.
When dealing with the errors shown on the display, refer to Section [9-4-2 Troubleshooting]

1. Storing data on a USB memory stick

No.	Switch	Meaning	Maintenance LED Display	Description
1	Not applicable	Storage Mode activated	U S b	"USB" Storage Mode to USB memory stick is active. Storage is enabled. See Section [9-4-2 Troubleshooting]1-(1) and 1- (2).
2		Storage in progress	0 ~ 99	0 to 99 is displayed. Status of the data storage to the USB memory stick is shown by the progress rate.
3		Storage completed	End	"END" The storage process has been completed successfully.
4		Error (USB memory side)	Er01	"Er01" The storage process cannot be started due to failure of the USB memory stick. See Section [9-4-2 Troubleshooting]1- (3).
			Er02	"Er02" The storage process was stopped due to failure of the USB memory stick during processing. See Section [9-4-2 Troubleshooting]1- (4).
5	Error (control board side)	Er10	"Er10" The storage process cannot be started due to failure of the control board. See Section [9-4-2 Troubleshooting]1- (5).	

2. Collecting operation data

No.	Switch	Meaning	Maintenance LED Display	Description
6	SW6-10: OFF SW4: No.28	Collection in progress	o n	“ON” OC is collecting operation data. A blinking display indicates that data collection is temporarily suspended. No switch setting is necessary. Data collection will be resumed automatically. See Section [9-4-2 Troubleshooting]2-(1).
7		Collection suspended	o f f	“OFF” Collection of operation data is suspended.
8		Flash memory error	f - e r	“F-er” Collection of operation data is suspended due to failure in the flash memory used to store operation data. It may be necessary to change the board. See Section [9-4-2 Troubleshooting]2-(2).
9		Error	e r r	“Err” Error was found due to the failure in units. After addressing the cause, data collection needs to be restated. See Section [9-4-2 Troubleshooting]2- (3).

- Collect data from both OC and OS from multiple-outdoor unit systems. System operation data are stored on OC, and compressor operation time of OS and switch settings are stored on OS.
- When importing the OS data to the Maintenance Tool, an import error may appear. This error indicates that no data are available for import and does not indicate equipment failure.

3. Rewriting software

No.	Switch	Meaning	Maintenance LED Display	Description
10	SW7-9: ON	Rewrite Mode activated		"PRO" Software rewrite mode is active. Software rewrite is enabled. See Section [9-4-2 Troubleshooting]3-(1), 3-(2) and 3- (3).
11		Rewrite in progress		Software rewrite is in progress. Bars are displayed in turn.
12		Software rewrite has been completed.		"END" Software rewrite has been completed successfully.
13		Error (USB memory side)		"Er01" Software rewrite process cannot be started due to failure of the USB memory stick. See Section [9-4-2 Troubleshooting]3- (4).
				"Er02" Software rewrite was stopped due to failure of the USB memory stick during the software rewrite process. See Section [9-4-2 Troubleshooting]3- (5).
14		Error (control board side)		"Er10" Software rewrite was not completed due to failure in deleting the existing software. See Section [9-4-2 Troubleshooting]3- (6).
				"Er11" Software rewrite has not been completed due to failure in writing new software. See Section [9-4-2 Troubleshooting]3- (6).

9-4-2 Troubleshooting

Troubleshooting of USB functions are shown below.

The displays on the maintenance LED described in Section [9-4-1 Maintenance LED Display Content List] may also be used as a reference.

1. Storing on a USB memory stick

(1) Maintenance LED does not display "USB."

(Meaning or Cause)

The system was not started in Storage Mode.

The USB memory stick is not connected. Or, switch SWP3 may not be pressed deeply enough.

(Solution)

Check the connection of the USB memory stick, and try again using Section [9-2-2 Storing Data on a USB Memory Stick] as a reference.

Hold down the switch SWP3 until "USB" is displayed on the maintenance LED.

If the problem persists, there may be a problem with the USB memory stick.

Check if the USB memory stick meets the specification described in Section [9-1-3 Necessary Materials](1) USB memory stick.

If compliance is confirmed, the USB memory stick may be broken. Replace it with a new one.

(2) Pressing the switch SWP3 does not start data storage, and the maintenance LED continues to display "USB."

(Meaning or Cause)

There may be a problem with the USB memory stick.

(Solution)

Check the connection of the USB memory stick.

If no problem is found, the USB memory stick may be at fault.

Check that the USB memory stick meets the specification described in Section [9-1-3 Necessary Materials](1) USB memory stick.

If compliance is confirmed, the USB memory stick may be broken. Replace it with a new one.

(3) Maintenance LED displays "Er01."

(Meaning or Cause)

• Because there was a problem regarding the USB memory before the start of data storage, data storage has not been completed.

• Error Er01 occurs when SWP3 on the control board is pressed to rewrite the software immediately after power is supplied to the USB-connected control board.

(When the software rewriting is started before the control board recognizes the USB memory stick.)

(Solution)

Check the connection of the USB memory stick.

If no problem is found, the USB memory stick may be at fault.

Check the following four items.

• After supplying power to the USB-connected control board, wait at least five seconds before pressing SWP3 on the control board to rewrite software because it takes approximately five seconds for the control board to recognize the USB memory stick.

• Compliance of the USB memory stick to the specification described in Section [9-1-3 Necessary Materials](1) USB memory stick.

• Available free space of the USB memory stick exceeding 50 MB.

• The maximum number of folders or files is not exceeded. When folders are created in the USB memory stick, the upper limit of folders is 101, including those files from "MNT000" to "MNT100." When files are created in the USB memory stick, the upper limit of files is 101, including those files from "MNT000.MT" to "MNT100.MT."

Delete unnecessary folders or files.

When there is no problem in the four items above, the USB memory stick may be broken. Replace it with a new one.

(4) Maintenance LED displays "Er02."

(Meaning or Cause)

Because there was a problem regarding the USB memory during data storage, data storage is unfinished.

For example, if the USB memory stick is disconnected during data storage, this display appears on the maintenance LED.

(Solution)

Check the connection of the USB memory stick.

If no problem was found, remove the USB memory stick from the control board and insert it again. Then conduct data storage referring to Section [9-2-2 Storing Data on a USB Memory Stick].

(5) Maintenance LED displays "Er10."

(Meaning or Cause)

Because there was a problem regarding the control board during data storage, data storage is unfinished.

(Solution)

Perform data storage again.

Remove the USB memory stick from the control board and insert it again. Then conduct data storage using Section [9-2-2 Storing Data on a USB Memory Stick] as a reference.

If this still does not correct the problem, there may be a problem with the control board.

(6) System does not start in Normal Mode.

(Meaning or Cause)

The USB memory stick may be left connected.

(Solution)

Remove the USB memory stick from the control board by referring to <Ending the data storage mode> under Section [9-2-2 Storing Data on a USB Memory Stick]. Then press SWP3 (ENTER). If the problem is not resolved, turn off the power to the outdoor unit, and restart the unit.

(7) Unit cannot be started in the data storage mode.

(Meaning or Cause)

There may be problems with the control board.

(Solution)

Take the two measures 1 and 2 explained in (2) Storing data on a USB memory stick in 1 Procedure under [9-2-2 Storing Data on a USB Memory Stick].

If the unit cannot be started up in the data storage mode by following either of the two methods 1 or 2, the control board may be malfunctioning.

2. Collecting operation data

(1) Maintenance LED displays blinking "ON."

(Meaning or Cause)

Despite data collection function being enabled, it is not started yet.

There may be two causes.

Firstly, the initialization process immediately after the system startup may have inhibited the start of data collection.

Secondly, M-NET communication may be underway to enable maintenance tools or collect AE-200/AE-50/EW-50 logs.

(Solution)

After a certain time, the problem will resolve itself, requiring no corrective actions.

(2) Maintenance LED displays "F-Er."

(Meaning or Cause)

Because there was a problem with the flash memory used to store operation data, the collection of operation data is unfinished.

(Solution)

Restart the outdoor unit, check the status of data collection.

If the LED displays "F-Er," the flash memory may be broken.

Depending on the local conditions, replace the control board.

When the flash memory is not working correctly, data collection and storage to a memory stick cannot be performed, but the outdoor unit itself functions normally.

(3) Maintenance LED displays blinking "Err."

(Meaning or Cause)

An error occurred in the unit, suspending data collection.

(Solution)

After resolving the error, resume data collection, referring to 1. Operation procedure (4) Restarting data collection under Section [9-2-3 Collecting Operation Data].

3. Rewriting software

(1) Maintenance LED does not display "Pro."

(Meaning or Cause)

The system is not started in Software Rewrite Mode.

Switches SW7-9 on the control board may not be in the ON position, or the portable charger may not be charged sufficiently.

(Solution)

Make sure switches SW7-9 are ON using Section [9-3-2 Rewriting Software] as a reference.

Restart using a fully charged portable charger or a different charger.

Check that the power-supply units (outdoor units/power-supply expansion unit) are turned off.

(2) Pressing the switch for starting the storage process does not start the process, and Maintenance LED continues to display "Pro."

(Meaning or Cause)

There may be a problem with the USB memory stick.

(Solution)

Check the connection of the USB memory stick.

If no problem is found, the USB memory stick may be at fault.

Check if the USB memory stick meets the specification described in Section [9-1-3 Necessary Materials](1) USB memory stick.

If compliance is confirmed, the USB memory stick may be broken. Replace it with a new one.

(3) At the time of the system start after "END" was displayed, Maintenance LED displays "Pro."

(Meaning or Cause)

The system was started in Software Rewrite Mode.

Switches SW7-9 on the control board may not be in the OFF position.

If the switches are in the OFF position, it means the software rewrite process has failed.

(Solution)

After turning off control board switches SW7-9, turn on the system again.

If the switches are in the OFF position, it means the software rewrite process has failed.

Try rewriting the software again by following the procedure detailed in 1 (1) Starting software rewrite mode under Section [9-3-2 Rewriting Software]. If the problem persists, rewrite the software, using a ROM writer.

(4) Maintenance LED displays "Er01."

(Meaning or Cause)

•Because an error occurred in the USB memory stick before the start of software rewrite, software rewrite has not been completed.

•Error Er01 occurs when SWP3 on the control board is pressed to rewrite the software immediately after power is supplied to the USB-connected control board.

(When the software rewriting is started before the control board recognizes the USB memory stick.)

(Solution)

Check the connection of the USB memory stick.

If no problem is found, the USB memory stick may be at fault.

Check the following five items.

•After supplying power to the USB-connected control board, wait at least five seconds before pressing SWP3 on the control board to rewrite software because it takes approximately five seconds for the control board to recognize the USB memory stick.

•Compliance of the USB memory stick to the specification of Section [9-1-3 Necessary Materials](1) USB memory stick.

•The countermeasure program file "*****.mot" for the intended model is used.

The countermeasure program is not for a different model or version.

•The countermeasure program file "*****.mot" is stored in the root folder. It is not stored in another folder.

•Make sure that the program file "*****.mot" is stored in the root folder of the USB memory and not in any folder created on the USB memory stick.

When there is no problem in the five items above, the USB memory stick may be broken. Replace it with a new one. After the check is completed, follow the procedure starting with the step explained in 1. Operation procedure (1) Starting software rewrite mode under [9-3-2 Rewriting Software].

(5) Maintenance LED displays "Er02."

(Meaning or Cause)

Software rewrite is suspended due to a problem with the USB memory stick during the software rewrite process. For example, if the USB memory stick is disconnected during data storage, this display appears on the maintenance LED.

(Solution)

Check the connection of the USB memory stick.

If no problems are found, follow the procedure starting with the step explained in 1. Operation procedure (1) Starting software rewrite mode under [9-3-2 Rewriting Software].

(6) Maintenance LED displays "Er10" or "Er11."

(Meaning or Cause)

Because there was a problem in the control board during the software rewrite process, software rewrite has not been completed.

(Solution)

Try rewriting the software again by following the procedure detailed in 1. Operation procedure (1) Starting software rewrite mode under Section [9-3-2 Rewriting Software]. If the problem persists, rewrite the software, using a ROM writer.

(7) Service monitor LED lights on off while the S/W is being re-written, and the process cannot be completed.

(Meaning or Cause)

The re-writing process may not have been completed due to a power supply interruption from the battery charger.

(Solution)

- Make sure the battery charger is compatible with the low-current mode.
- If a battery charger that is compatible with the low-current mode is not available, re-write the S/W using a ROM writer.

Chapter 10 LED Status Indicators on the Outdoor Unit Circuit Board

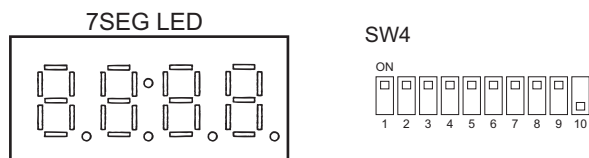
10-1	LED Status Indicators	1
10-1-1	How to Read the LED	1
10-1-2	Initial LED Display	2
10-1-3	Clock Memory Function	3
10-2	LED Status Indicators Table	4



10-1 LED Status Indicators

10-1-1 How to Read the LED

By setting the DIP SW 4-1 through 4-10 (Set SW6-10 to OFF.)(Switch number 10 is represented by 0), the operating condition of the unit can be monitored on the service monitor. (Refer to the table on the following pages for DIP SW settings.)
The service monitor uses 4-digit 7-segment LED to display numerical values and other types of information.



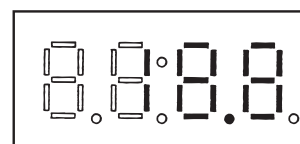
◆In the example above, 1 through 9 are set to ON, and 10 is set to OFF.

Pressure and temperature are examples of numerical values, and operating conditions and the on-off status of solenoid valve are examples of flag display.

1) Display of numerical values

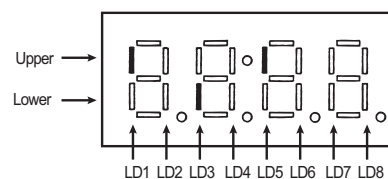
Example: When the pressure data sensor reads 18.8kg/cm² (Item No. 58)

- ◆The unit of pressure is in kg/cm²
- ◆ Use the following conversion formula to convert the displayed value into a value in SI unit.
Value in SI unit (MPa) = Displayed value (kg/cm²) x 0.098

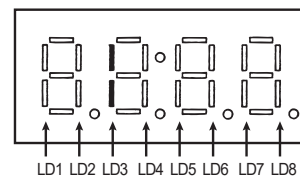


2) Flag display

Example: When 21S4a, 21S4b, SV1a are ON. (Item No. 3)



Example: 3-minutes restart mode (Item No. 14)



10-1-2 Initial LED Display

From power on until the completion of initial settings, the following information will be displayed on the monitor screen. (Displays No. 1 through No. 4 in order repeatedly.)

No	Item	Display	Remarks
1	Software version		[0103] : Version 1.03
2	Refrigerant type		[410] : R410A
3	Model and capacity		[H-20] : 20 HP For the first few minutes after power on, the capacity of each outdoor unit is displayed. Thereafter, the combined capacity is displayed.
4	Communication address		[51] : Address 51

After the initial settings have been completed, the information on these items can be checked by making the switch setting that corresponds to No. 517 in the LED display table.

Note

Only item No. 1 "Software Version" appears on the display if there is a wiring failure between the control board and the transmission line power supply board or if the circuit board has failed.

•How to convert HP capacity to Model name

HP capacity is the capacity of outdoor unit that is shown on LED display at initial setting. Please refer to the following table to convert from HP capacity to Model name.

HP	Model	HP	Model
8	(E)P200	32	(E)P800
10	(E)P250	34	(E)P850
12	(E)P300	36	(E)P900
14	(E)P350	38	(E)P950
16	(E)P400	40	(E)P1000
18	(E)P450	42	(E)P1050
20	(E)P500	44	(E)P1100
22	(E)P550	46	(E)P1150
24	(E)P600	48	(E)P1200
26	(E)P650	50	(E)P1250
28	(E)P700	52	(E)P1300
30	(E)P750	54	(E)P1350

10-1-3 Clock Memory Function

The outdoor unit has a simple clock function that enables the unit to calculate the current time with an internal timer by receiving the time set by the system controller, such as AG-150A.

If an error (including a preliminary error) occurs, the error history data and the error detection time are stored into the service memory.

The error detection time stored in the service memory and the current time can be seen on the service LED.

Note

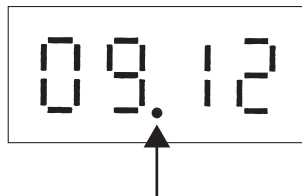
- 1) Use the time displayed on the service LED as a reference.
- 2) The date and the time are set to "00" by default. If a system controller that sets the time, such as AG-150A is not connected, the elapsed time and days since the first power on will be displayed. If the time set on a system controller is received, the count will start from the set date and the time.
- 3) The time is not updated while the power of the indoor unit is turned off. When the power is turned off and then on again, the count will resume from the time before the power was turned off. Thus, the time that differs the actual time will be displayed. (This also applies when a power failure occurs.)

The system controller, such as AG-150A, adjusts the time once a day. When the system controller is connected, the time will be automatically updated to the correct current time after the time set by the system controller is received. (The data stored into the memory before the set time is received will not be updated.)

(1) Reading the time data:

- 1) Time display

Example: 12 past 9

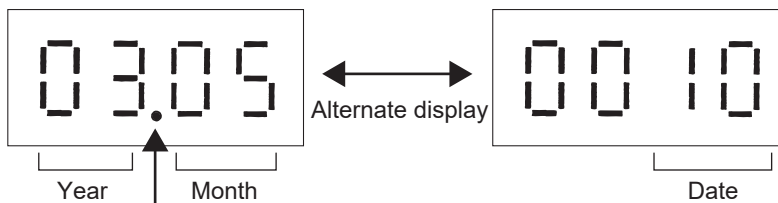


* Disappears if the time data is deviated due to a power failure, or if a system controller that sets the time is not connected.

- 2) Date display

•When the main controller that can set the time is connected

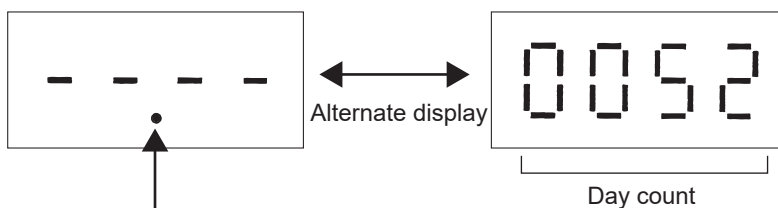
Example: May 10, 2003



* Appears between the year and the month, and nothing appears when the date is displayed.

•When the main controller that can set the time is not connected

Example: 52 days after power was turned on



* Appears between the year and the month, and nothing appears when the date is displayed.

10-2 LED Status Indicators Table

No.	SW4 (When SW6 - 10 is set to OFF) 1234567890	Item	Display										Unit ^{*1} (A, B) ^{*1}		Remarks				
			LD1	LD2	LD3	LD4	LD5	LD6	LD7	LD8	OC	OS							
0	0000000000	Relay output display 1 Lighting																A	A
		Check (error) display 1 OC/OS error	0000 to 9999 (Address and error codes highlighted)												B	B			
1	1000000000	Check (error) display 2 OC/OS error	0000 to 9999 (Address and error codes highlighted)												A	A	Display of the latest preliminary error If no preliminary errors are detected, "----" appears on the display.		
2	0100000000	Check (error) display 3 (Including IC and BC)	0000 to 9999 (Address and error codes highlighted)												B	B	If no errors are detected, "----" appears on the display.		
3	1100000000	Relay output display 2 Top	21S4a	SV10	CH11	SV1a					SV2	SV11					A	A	
		Relay output display 2 Bottom			21S4b	SV5b													
4	0010000000	Relay output display 3 Top				21S4c					SV9						A	A	
		Relay output display 3 Bottom			SV14	SV15													
7	1110000000	Special control															B	B	
		Emergency operation																	
9	1001000000	Communication demand capacity															B	B	
		Retry operation																	
10	0101000000	Contact point demand capacity															B	B	
		Emergency operation																	
11	1101000000	External signal (Open input contact point)															A	A	
		Contact point demand capacity																	
12	0011000000	External signal (Open input contact point)															A	A	
		Emergency operation																	
13	1011000000	External signal															A	A	
		Emergency operation																	
14	0111000000	Outdoor unit operation status															A	A	
		Emergency operation																	
15	1111000000	OC/OS identification															A	A	
		Emergency operation																	

*1 A: The condition of either OC or OS is displayed individually. B: The condition of the entire refrigerant system is displayed.

No.	Current data		Item	Display															Unit (A, B) ^{*1}		Remarks
	SW4 (When SW6-10 is set to OFF)	1234567890		LD1	LD2	LD3	LD4	LD5	LD6	LD7	LD8	LD8	OC	OS							
16	0000100000	1234567890	Indoor unit check	Unit No. 1	Unit No. 2	Unit No. 3	Unit No. 4	Unit No. 5	Unit No. 6	Unit No. 7	Unit No. 8	B					The lamp that corresponds to the unit that came to an abnormal stop lights. The lamp goes off when the error is reset. Each unit that comes to an abnormal unit will be given a sequential number in ascending order starting with 1.				
17	1000100000		Top	Unit No. 9	Unit No. 10	Unit No. 11	Unit No. 12	Unit No. 13	Unit No. 14	Unit No. 15	Unit No. 16										
18	0100100000		Bottom	Unit No. 17	Unit No. 18	Unit No. 19	Unit No. 20	Unit No. 21	Unit No. 22	Unit No. 23	Unit No. 24										
19	1100100000		Top	Unit No. 25	Unit No. 26	Unit No. 27	Unit No. 28	Unit No. 29	Unit No. 30	Unit No. 31	Unit No. 32										
20	0010100000		Bottom	Unit No. 33	Unit No. 34	Unit No. 35	Unit No. 36	Unit No. 37	Unit No. 38	Unit No. 39	Unit No. 40										
21	1010100000		Top	Unit No. 41	Unit No. 42	Unit No. 43	Unit No. 44	Unit No. 45	Unit No. 46	Unit No. 47	Unit No. 48										
22	0110100000		Bottom	Unit No. 49	Unit No. 50																
23	1110100000		Top	Unit No. 1	Unit No. 2	Unit No. 3	Unit No. 4	Unit No. 5	Unit No. 6	Unit No. 7	Unit No. 8	B					Lit during cooling Blinking during heating Unit while the unit is stopped or in the fan mode				
24	0001100000		Bottom	Unit No. 9	Unit No. 10	Unit No. 11	Unit No. 12	Unit No. 13	Unit No. 14	Unit No. 15	Unit No. 16										
25	1001100000		Top	Unit No. 17	Unit No. 18	Unit No. 19	Unit No. 20	Unit No. 21	Unit No. 22	Unit No. 23	Unit No. 24										
26	0101100000		Bottom	Unit No. 25	Unit No. 26	Unit No. 27	Unit No. 28	Unit No. 29	Unit No. 30	Unit No. 31	Unit No. 32										
27	1101100000		Top	Unit No. 33	Unit No. 34	Unit No. 35	Unit No. 36	Unit No. 37	Unit No. 38	Unit No. 39	Unit No. 40										
28	0011100000		Bottom	Unit No. 41	Unit No. 42	Unit No. 43	Unit No. 44	Unit No. 45	Unit No. 46	Unit No. 47	Unit No. 48										
28	0011100000		Drive recorder status	Drive recorder is stopped (OFF): "OFF" Drive recorder is in operation (ON): "ON" Drive recorder is in operation, but unable to start for a certain reason: "1"; "ON" flashes. On-board flash error: "F-Err" Drive recorder has automatically stopped due to a serious error in the system: "Err"															B		Lit when thermostat is on Unit when thermostat is off
39	1110010000		Outdoor unit Operation mode	Permissible stop	Standby	Cooling	Scheduled control	Heating				B									
42	0101010000		Outdoor unit control mode	Stop	Thermo OFF	Abnormal stop	Initial start up	Defrost	Oil balance	Low frequency oil recovery		A									
43	1101010000			Warm-up mode	Refrigerant recovery		Continuous heating 2	Continuous heating 1				A									
45	1011010000		TH4				-99.9 to 999.9					A									
46	0111010000		TH3				-99.9 to 999.9					A									
47	1111010000		TH7				-99.9 to 999.9					A									
48	0000110000		TH6				-99.9 to 999.9					A									
49	1000110000		TH2				-99.9 to 999.9					A									
50	0100110000		TH5				-99.9 to 999.9					A									
54	0110110000		TH9				-99.9 to 999.9					A									
56	0001110000		THHS1				-99.9 to 999.9					A									
58	0101110000		High-pressure sensor data				-99.9 to 999.9					A									
59	1101110000		Low-pressure sensor data				-99.9 to 999.9					A									
62	0111110000		TH15				-99.9 to 999.9					A									

*1 A: The condition of either OC or OS is displayed individually. B: The condition of the entire refrigerant system is displayed.

10 LED Status Indicators on the Outdoor Unit Circuit Board

No.	SW4 (When SW6-10 is set to OFF) 1234567890	Item	Display										Unit (A, B) ^{*1}		Remarks	
			LD1	LD2	LD3	LD4	LD5	LD6	LD7	LD8	OC	OS				
63	1111110000	TH11					-99.9 to 999.9							A	A	The unit is [°C]
78	0111001000	Σ Qj					0000 to 9999							B	B	
79	1111001000	Σ Qjc					0000 to 9999							B	B	
80	0000101000	Σ Qjh					0000 to 9999							B	B	
81	1000101000	Target Tc					-99.9 to 999.9							B		The unit is [°C]
82	0100101000	Target Te					-99.9 to 999.9							B		
83	1100101000	Tc					-99.9 to 999.9							A	A	
84	0010101000	Te					-99.9 to 999.9							A	A	
86	0110101000	Total frequencies (OC+OS)					0000 to 9999							B		Control data [Hz]
87	1110101000	Total frequency of each unit					0000 to 9999							A	A	
88	0001101000	COMP frequency					0000 to 9999							A	A	
91	1101101000	COMP operating frequency					0000 to 9999							A	A	The unit is [pps] Output frequency of the inverter depends on the type of compressor and equals the integer multiples (x1, x2 etc.) of the operating frequency of the compressor
92	0011101000	Number of times error occurred during IH crankcase heating by compressor motor					0000 to 9999							A	A	Number of times INV error occurred during IH crankcase heating by compressor motor
93	1011101000	All AK (OC+OS)					0000 to 9999							B		
94	0111101000	AK					0000 to 9999							A	A	
95	1111101000	FAN1					0000 to 9999							A	A	Fan output [%]
96	0000011000	Fan inverter output rpm (FAN1)					0000 to 9999							A	A	[rpm]
97	1000011000	FAN2					0000 to 9999							A	A	Fan output [%]
98	0100011000	Fan inverter output rpm (FAN2)					0000 to 9999							A	A	[rpm]
103	1110011000	LEV1					0000 to 9999							A	A	Outdoor LEV opening (Fully open: 480)
104	0001011000	LEV2a					0000 to 9999							A	A	Outdoor LEV opening (Fully open: 3000)
108	0011011000	COMP operating current(DC)					00.0 to 999.9							A	A	Peak value [A]
109	1011011000	LEV2b					0000 to 9999							A	A	Outdoor LEV opening (Fully open: 3000)
110	0111011000	LEV2c					0000 to 9999							A	A	Outdoor LEV opening (Fully open: 3000)
111	1111011000	COMP bus voltage					00.0 to 999.9							A	A	The unit is [V]
113	1000111000	LEV9					0000 to 9999							A	A	Outdoor LEV opening (Fully open: 480)
116	0010111000	Number of times the unit went into the mode to remedy wet vapor suction					0000 to 9999							B		
117	1010111000	COMP Operation time Upper 4 digits					0000 to 9999							A	A	The unit is [h]
118	0110111000	COMP Operation time Lower 4 digits					0000 to 9999							A	A	

*1 A: The condition of either OC or OS is displayed individually. B: The condition of the entire refrigerant system is displayed.

No.	SW4 (When SW6-10 is set to OFF) 1234567890	Item	Display										Unit (A, B) ^{*1}		Remarks	
			LD1	LD2	LD3	LD4	LD5	LD6	LD7	LD8	OC	OS				
121	1001111000	Backup mode	Abnormal pressure rise	High-pressure drop	Low-pressure drop	Abnormal Td rise								A	A	Stays lit for 90 seconds after the completion of backup control
123	1101111000	COMP number of start-stop events Upper 4 digits				0000 to 9999								A	A	Count-up at start-up The unit is [Time]
124	0011111000	COMP number of start-stop events Lower 4 digits				0000 to 9999								A	A	
129	1000000100	Integrated operation time of compressor (for rotation purpose)				0000 to 9999								B		The unit is [h]
178	0100110100	Error history 1				0000 to 9999								B	B	Address and error codes high-lighted
179	1100110100	Error details of inverter				Error details of inverter (0001-0120)								A	A	If no errors are detected, "----" appears on the display.
180	0010110100	Error history 2				0000 to 9999								B	B	Preliminary error information of the OS does not appear on the OC.
181	1010110100	Error details of inverter				Error details of inverter (0001-0120)								A	A	Neither preliminary error information of the OC nor error information of the IC appears on the OS.
182	0110110100	Error history 3				0000 to 9999								B	B	
183	1110110100	Error details of inverter				Error details of inverter (0001-0120)								A	A	
184	0001110100	Error history 4				0000 to 9999								B	B	
185	1001110100	Error details of inverter				Error details of inverter (0001-0120)								A	A	
186	0101110100	Error history 5				0000 to 9999								B	B	
187	1101110100	Error details of inverter				Error details of inverter (0001-0120)								A	A	
188	0011110100	Error history 6				0000 to 9999								B	B	
189	1011110100	Error details of inverter				Error details of inverter (0001-0120)								A	A	
190	0111110100	Error history 7				0000 to 9999								B	B	
191	1111110100	Error details of inverter				Error details of inverter (0001-0120)								A	A	
192	0000001100	Error history 8				0000 to 9999								B	B	
193	1000001100	Error details of inverter				Error details of inverter (0001-0120)								A	A	
194	0100001100	Error history 9				0000 to 9999								B	B	
195	1100001100	Error details of inverter				Error details of inverter (0001-0120)								A	A	
196	0010001100	Error history 10				0000 to 9999								B	B	
197	1010001100	Error details of inverter				Error details of inverter (0001-0120)								A	A	
198	0110001100	Error history of inverter (At the time of last data backup before error)				0000 to 9999								B	B	
199	1110001100	Error details of inverter				Error details of inverter (0001-0120)								A	A	

*1 A: The condition of either OC or OS is displayed individually. B: The condition of the entire refrigerant system is displayed.

10 LED Status Indicators on the Outdoor Unit Circuit Board

Error history

No.	SW4 (When SW6 - 10 is set to OFF) 1234567890	Item	Display										Unit (A, B) ^{*1}		Remarks	
			LD1	LD2	LD3	LD4	LD5	LD6	LD7	LD8	OC	OS				
201	1001001100	Outdoor unit operation status	Warm-up mode	3-minutes restart mode	Compressor in operation	Preliminary error	Error	3-minutes restart after instantaneous power failure	Preliminary low pressure error				A	A		
202	0101001100	OC/OS identification	Permissible stop	Standby	Cooling	OC/OS-1/OS-2						A	A			
205	1011001100	Outdoor unit Operation mode	Thermo OFF	Initial start up	Scheduled control	Heating							A	A		
208	0000101100	Outdoor unit control mode	Stop	Refrigerant recovery	Abnormal stop	Refrigerant recovery	Defrost	Oil balance	Low frequency oil recovery				A	A		
209	1000101100		Warm-up mode	COMP in operation	Warm-up mode	Continuous heating 2	Continuous heating 1						A	A		
211	1100101100	Relay output display 1 Lighting	COMP in operation	21S4a	SV10	72C	21S4c	OC	Always lit				A	A		
212	0010101100	Relay output display 2 Lighting	21S4a	CH11	SV5b	SV1a	SV2	SV11					A	A		
		Relay output display 3 Lighting	Bottom	21S4b										A	A	
213	1010101100	Relay output display 3 Lighting	Bottom	SV14	SV15	21S4c	SV9	SV11	Lit while power to the indoor units is being supplied				A	A		
216	0001101100	TH4				-99.9 to 999.9							A	A		The unit is [°C]
217	1001101100	TH3				-99.9 to 999.9							A	A		
218	0101101100	TH7				-99.9 to 999.9							A	A		
219	1101101100	TH6				-99.9 to 999.9							A	A		
220	0011101100	TH2				-99.9 to 999.9							A	A		
221	1011101100	TH6				-99.9 to 999.9							A	A		
227	1100011100	THHS1				-99.9 to 999.9							A	A		The unit is [°C]
229	1010011100	High-pressure sensor data				-99.9 to 999.9							A	A		The unit is [kgf/cm ²]
230	0110011100	Low-pressure sensor data				-99.9 to 999.9							A	A		The unit is [°C]
233	1001011100	TH15				-99.9 to 999.9							A	A		The unit is [°C]
249	1001111100	Σ Qj				0000 to 9999							B	B		
250	0101111100	Σ Qjc				0000 to 9999							B	B		
251	1101111100	Σ Qjh				0000 to 9999							B	B		
252	0011111100	Target Tc				-99.9 to 999.9							B	B		The unit is [°C]
253	1011111100	Target Te				-99.9 to 999.9							B	B		The unit is [°C]
254	0111111100	Tc				-99.9 to 999.9							A	A		The unit is [°C]
255	1111111100	Te				-99.9 to 999.9							A	A		The unit is [°C]
257	1000000010	Total frequencies (OC+OS)				0000 to 9999							B	B		Control data [Hz]
258	0100000010	Total frequency of each unit				0000 to 9999							A	A		
259	1100000010	COMP frequency				0000 to 9999							A	A		
262	0110000010	COMP operating frequency				0000 to 9999							A	A		The unit is [ps]
264	0001000010	All AK (OC+OS)				0000 to 9999							B	B		
265	1001000010	AK				0000 to 9999							A	A		
266	0101000010	FAN1				0000 to 9999							A	A		Fan inverter output [%]
267	1101000010	Fan inverter output rpm (FAN1)				0000 to 9999							A	A		[rpm]

*1 A: The condition of either OC or OS is displayed individually. B: The condition of the entire refrigerant system is displayed.

No.	SW4 (When SW6-10 is set to OFF) 1234567890	Item	Display								Unit (A, B) ^{*1}		Remarks	
			LD1	LD2	LD3	LD4	LD5	LD6	LD7	LD8	OC	OS		
268	0011000010	FAN2							0000 to 9999			A	A	Fan inverter output [%]
269	1011000010	Fan inverter output rpm (FAN2)							0000 to 9999			A	A	[rpm]
274	0100100010	LEV1							0000 to 9999			A	A	Outdoor LEV opening (Fully open: 480)
275	1100100010	LEV2a							0000 to 9999			A	A	Outdoor LEV opening (Fully open: 3000)
279	1110100010	COMP operating current (DC)							00.0 to 999.9			A	A	
282	0101100010	COMP bus voltage							00.0 to 999.9			A	A	The unit is [V]
283	1101100010	LEV2b							0000 to 9999			A	A	Outdoor LEV opening (Fully open: 3000)
284	0011100010	LEV2c							0000 to 9999			A	A	Outdoor LEV opening (Fully open: 3000)
286	0111100010	LEV9							0000 to 9999			A	A	Outdoor LEV opening (Fully open: 480)
288	0000010010	COMP Operation time Upper 4 digits							0000 to 9999			A	A	
289	1000010010	COMP Operation time Lower 4 digits							0000 to 9999			A	A	
294	0110010010	COMP number of start-stop events Upper 4 digits							0000 to 9999			A	A	Count-up at start-up The unit is [Time]
295	1110010010	COMP number of start-stop events Lower 4 digits							0000 to 9999			A	A	
300	0011010010	Integrated operation time of compressor (for rotation purpose)							0000 to 9999			B		The unit is [h]

*1 A: The condition of either OC or OS is displayed individually. B: The condition of the entire refrigerant system is displayed.

10 LED Status Indicators on the Outdoor Unit Circuit Board

[10 - 2 LED Status Indicators Table]

Current data

No.	SW4 (When SW6 - 10 is set to OFF) 1234567890	Item	Display										Unit (A, B)*1		Remarks
			LD1	LD2	LD3	LD4	LD5	LD6	LD7	LD8	OC	OS			
301	1011010010	Power supply unit	OC/OS-1/OS-2 ↔ Address										B		
302	0111010010	Start-up unit	OC/OS-1/OS-2 ↔ Address										B		

*1 A: The condition of either OC or OS is displayed individually. B: The condition of the entire refrigerant system is displayed.

Data on indoor unit system

No.	Item	Display										Unit (A, B) ^{*1}		Remarks		
		LD1	LD2	LD3	LD4	LD5	LD6	LD7	LD8	OC	OS					
SW4 (When SW6 - 10 is set to OFF)	1234567890															
351	IC1 Address/capacity code		0000 to 9999													Displayed alternately every 5 seconds
352	IC2 Address/capacity code		0000 to 9999													
353	IC3 Address/capacity code		0000 to 9999													
354	IC4 Address/capacity code		0000 to 9999													
355	IC5 Address/capacity code		0000 to 9999													
356	IC6 Address/capacity code		0000 to 9999													
357	IC7 Address/capacity code		0000 to 9999													
358	IC8 Address/capacity code		0000 to 9999													
359	IC9 Address/capacity code		0000 to 9999													
360	IC10 Address/capacity code		0000 to 9999													
361	IC11 Address/capacity code		0000 to 9999													
362	IC12 Address/capacity code		0000 to 9999													
363	IC13 Address/capacity code		0000 to 9999													
364	IC14 Address/capacity code		0000 to 9999													
365	IC15 Address/capacity code		0000 to 9999													
366	IC16 Address/capacity code		0000 to 9999													
367	IC17 Address/capacity code		0000 to 9999													
368	IC18 Address/capacity code		0000 to 9999													
369	IC19 Address/capacity code		0000 to 9999													
370	IC20 Address/capacity code		0000 to 9999													
371	IC21 Address/capacity code		0000 to 9999													
372	IC22 Address/capacity code		0000 to 9999													
373	IC23 Address/capacity code		0000 to 9999													
374	IC24 Address/capacity code		0000 to 9999													
375	IC25 Address/capacity code		0000 to 9999													
376	IC26 Address/capacity code		0000 to 9999													
377	IC27 Address/capacity code		0000 to 9999													
378	IC28 Address/capacity code		0000 to 9999													
379	IC29 Address/capacity code		0000 to 9999													
380	IC30 Address/capacity code		0000 to 9999													
381	IC31 Address/capacity code		0000 to 9999													
382	IC32 Address/capacity code		0000 to 9999													
383	IC33 Address/capacity code		0000 to 9999													
384	IC34 Address/capacity code		0000 to 9999													
385	IC35 Address/capacity code		0000 to 9999													
386	IC36 Address/capacity code		0000 to 9999													
387	IC37 Address/capacity code		0000 to 9999													
388	IC38 Address/capacity code		0000 to 9999													
389	IC39 Address/capacity code		0000 to 9999													
390	IC40 Address/capacity code		0000 to 9999													
391	IC41 Address/capacity code		0000 to 9999													
392	IC42 Address/capacity code		0000 to 9999													

*1 A: The condition of either OC or OS is displayed individually. B: The condition of the entire refrigerant system is displayed.

10 LED Status Indicators on the Outdoor Unit Circuit Board

Data on indoor unit system

No.	SW4 (When SW6-10 is set to OFF) 1234567890	Item	Display										Unit (A, B) ^{*1}		Remarks		
			LD1	LD2	LD3	LD4	LD5	LD6	LD7	LD8	OC	OS					
393	1001000110	IC43 Address/capacity code	0000 to 9999														Displayed alternately every 5 seconds
394	0101000110	IC44 Address/capacity code	0000 to 9999														
395	1101000110	IC45 Address/capacity code	0000 to 9999														
396	0011000110	IC46 Address/capacity code	0000 to 9999														
397	1011000110	IC47 Address/capacity code	0000 to 9999														
398	0111000110	IC48 Address/capacity code	0000 to 9999														
399	1111000110	IC49 Address/capacity code	0000 to 9999														
400	0000100110	IC50 Address/capacity code	0000 to 9999														
408	0001100110	IC1 Suction temperature	-99.9 to 999.9														
409	1001100110	IC2 Suction temperature	-99.9 to 999.9														
410	0101100110	IC3 Suction temperature	-99.9 to 999.9														
411	1101100110	IC4 Suction temperature	-99.9 to 999.9														
412	0011100110	IC5 Suction temperature	-99.9 to 999.9														
413	1011100110	IC6 Suction temperature	-99.9 to 999.9														
414	0111100110	IC7 Suction temperature	-99.9 to 999.9														
415	1111100110	IC8 Suction temperature	-99.9 to 999.9														
416	0000010110	IC9 Suction temperature	-99.9 to 999.9														
417	1000010110	IC10 Suction temperature	-99.9 to 999.9														
418	0100010110	IC11 Suction temperature	-99.9 to 999.9														
419	100010110	IC12 Suction temperature	-99.9 to 999.9														
420	0010010110	IC13 Suction temperature	-99.9 to 999.9														
421	1010010110	IC14 Suction temperature	-99.9 to 999.9														
422	0110010110	IC15 Suction temperature	-99.9 to 999.9														
423	1110010110	IC16 Suction temperature	-99.9 to 999.9														
424	0001010110	IC17 Suction temperature	-99.9 to 999.9														
425	1001010110	IC18 Suction temperature	-99.9 to 999.9														
426	0101010110	IC19 Suction temperature	-99.9 to 999.9														
427	1101010110	IC20 Suction temperature	-99.9 to 999.9														
428	0011010110	IC21 Suction temperature	-99.9 to 999.9														
429	1011010110	IC22 Suction temperature	-99.9 to 999.9														
430	0111010110	IC23 Suction temperature	-99.9 to 999.9														
431	1111010110	IC24 Suction temperature	-99.9 to 999.9														
432	0000110110	IC25 Suction temperature	-99.9 to 999.9														
433	1000110110	IC26 Suction temperature	-99.9 to 999.9														
434	0100110110	IC27 Suction temperature	-99.9 to 999.9														
435	1100110110	IC28 Suction temperature	-99.9 to 999.9														
436	0010110110	IC29 Suction temperature	-99.9 to 999.9														
437	1010110110	IC30 Suction temperature	-99.9 to 999.9														
438	0110110110	IC31 Suction temperature	-99.9 to 999.9														
439	1110110110	IC32 Suction temperature	-99.9 to 999.9														
440	0001110110	IC33 Suction temperature	-99.9 to 999.9														
441	1001110110	IC34 Suction temperature	-99.9 to 999.9														
442	0101110110	IC35 Suction temperature	-99.9 to 999.9														

*1 A: The condition of either OC or OS is displayed individually. B: The condition of the entire refrigerant system is displayed.

Data on indoor unit system		Item	Display										Unit		Remarks		
			LD1	LD2	LD3	LD4	LD5	LD6	LD7	LD8	OC	OS					
No.	SW4 (When SW6-10 is set to OFF)																
	1234567890																
443	1101110110	IC36 Suction temperature					-99.9 to 999.9								B		The unit is [°C]
444	0011110110	IC37 Suction temperature					-99.9 to 999.9										
445	1011110110	IC38 Suction temperature					-99.9 to 999.9										
446	0111110110	IC39 Suction temperature					-99.9 to 999.9										
447	1111110110	IC40 Suction temperature					-99.9 to 999.9										
448	0000011110	IC41 Suction temperature					-99.9 to 999.9										
449	1000011110	IC42 Suction temperature					-99.9 to 999.9										
450	0100011110	IC43 Suction temperature					-99.9 to 999.9										
451	1100011110	IC44 Suction temperature					-99.9 to 999.9										
452	0010011110	IC45 Suction temperature					-99.9 to 999.9										
453	1010011110	IC46 Suction temperature					-99.9 to 999.9										
454	0110011110	IC47 Suction temperature					-99.9 to 999.9										
455	1110011110	IC48 Suction temperature					-99.9 to 999.9										
456	0001001110	IC49 Suction temperature					-99.9 to 999.9										
457	1001001110	IC50 Suction temperature					-99.9 to 999.9										
458	0101001110	IC1 Liquid pipe temperature					-99.9 to 999.9								B		The unit is [°C]
459	1101001110	IC2 Liquid pipe temperature					-99.9 to 999.9										
460	0011001110	IC3 Liquid pipe temperature					-99.9 to 999.9										
461	1011001110	IC4 Liquid pipe temperature					-99.9 to 999.9										
462	0111001110	IC5 Liquid pipe temperature					-99.9 to 999.9										
463	1111001110	IC6 Liquid pipe temperature					-99.9 to 999.9										
464	0000101110	IC7 Liquid pipe temperature					-99.9 to 999.9										
465	1000101110	IC8 Liquid pipe temperature					-99.9 to 999.9										
466	0100101110	IC9 Liquid pipe temperature					-99.9 to 999.9										
467	1100101110	IC10 Liquid pipe temperature					-99.9 to 999.9										
468	0010101110	IC11 Liquid pipe temperature					-99.9 to 999.9										
469	1010101110	IC12 Liquid pipe temperature					-99.9 to 999.9										
470	0110101110	IC13 Liquid pipe temperature					-99.9 to 999.9										
471	1110101110	IC14 Liquid pipe temperature					-99.9 to 999.9										
472	0001101110	IC15 Liquid pipe temperature					-99.9 to 999.9										
473	1001101110	IC16 Liquid pipe temperature					-99.9 to 999.9										
474	0101101110	IC17 Liquid pipe temperature					-99.9 to 999.9										
475	1101101110	IC18 Liquid pipe temperature					-99.9 to 999.9										
476	0011101110	IC19 Liquid pipe temperature					-99.9 to 999.9										
477	1011101110	IC20 Liquid pipe temperature					-99.9 to 999.9										
478	0111101110	IC21 Liquid pipe temperature					-99.9 to 999.9										
479	1111101110	IC22 Liquid pipe temperature					-99.9 to 999.9										
480	0000111110	IC23 Liquid pipe temperature					-99.9 to 999.9										
481	1000011110	IC24 Liquid pipe temperature					-99.9 to 999.9										
482	0100011110	IC25 Liquid pipe temperature					-99.9 to 999.9										
483	1100011110	IC26 Liquid pipe temperature					-99.9 to 999.9										
484	0010011110	IC27 Liquid pipe temperature					-99.9 to 999.9										
485	1010011110	IC28 Liquid pipe temperature					-99.9 to 999.9										

*1 A: The condition of either OC or OS is displayed individually. B: The condition of the entire refrigerant system is displayed.

10 LED Status Indicators on the Outdoor Unit Circuit Board

Data on indoor unit system

No.	SW4 (When SW6-10 is set to OFF) 1234567890	Item	Display										Unit (A, B) ^{*1}		Remarks		
			LD1	LD2	LD3	LD4	LD5	LD6	LD7	LD8	OC	OS					
486	0110011110	IC29 Liquid pipe temperature															The unit is [°C]
487	1110011110	IC30 Liquid pipe temperature															
488	0001011110	IC31 Liquid pipe temperature															
489	1001011110	IC32 Liquid pipe temperature															
490	0101011110	IC33 Liquid pipe temperature															
491	1101011110	IC34 Liquid pipe temperature															
492	0011011110	IC35 Liquid pipe temperature															
493	1011011110	IC36 Liquid pipe temperature															
494	0111011110	IC37 Liquid pipe temperature															
495	1111011110	IC38 Liquid pipe temperature															
496	0000111110	IC39 Liquid pipe temperature															
497	1000111110	IC40 Liquid pipe temperature															
498	0100111110	IC41 Liquid pipe temperature															
499	1100111110	IC42 Liquid pipe temperature															
500	0010111110	IC43 Liquid pipe temperature															
501	1010111110	IC44 Liquid pipe temperature															
502	0110111110	IC45 Liquid pipe temperature															
503	1110111110	IC46 Liquid pipe temperature															
504	0001111110	IC47 Liquid pipe temperature															
505	1001111110	IC48 Liquid pipe temperature															
506	0101111110	IC49 Liquid pipe temperature															
507	1101111110	IC50 Liquid pipe temperature															

*1 A: The condition of either OC or OS is displayed individually. B: The condition of the entire refrigerant system is displayed.

Setting data

No.	SW4 (When SW6 - 10 is set to OFF) 1234567890	Item	Display								Unit (A, B)*1		Remarks
			LD1	LD2	LD3	LD4	LD5	LD6	LD7	LD8	OC	OS	
512	0000000001	Self-address	Alternate display of self address and unit model								A	A	
513	1000000001	IC/FU address	Count-up display of number of connected units								B		
514	0100000001	RC address	Count-up display of number of connected units								B		
516	0010000001	OS address	Count-up display of number of connected units								B		
517	1010000001	Version/Capacity	SW version → Refrigerant type → Model and capacity → Communication address								A	A	
518	0110000001	OC address	OC address display									B	

*1 A: The condition of either OC or OS is displayed individually. B: The condition of the entire refrigerant system is displayed.

10 LED Status Indicators on the Outdoor Unit Circuit Board

Data on indoor unit system

No.	SW4 (When SW6 - 10 is set to OFF) 1234567890	Item	Display										Unit (A, B) *1		Remarks	
			LD1	LD2	LD3	LD4	LD5	LD6	LD7	LD8	OC	OS				
523	1101000001	IC1 Gas pipe temperature														
524	0011000001	IC2 Gas pipe temperature														
525	1011000001	IC3 Gas pipe temperature														
526	0111000001	IC4 Gas pipe temperature														
527	1111000001	IC5 Gas pipe temperature														
528	0000100001	IC6 Gas pipe temperature														
529	1000100001	IC7 Gas pipe temperature														
530	0100100001	IC8 Gas pipe temperature														
531	1100100001	IC9 Gas pipe temperature														
532	0010100001	IC10 Gas pipe temperature														
533	1010100001	IC11 Gas pipe temperature														
534	0110100001	IC12 Gas pipe temperature														
535	1110100001	IC13 Gas pipe temperature														
536	0001100001	IC14 Gas pipe temperature														
537	1001100001	IC15 Gas pipe temperature														
538	0101100001	IC16 Gas pipe temperature														
539	1101100001	IC17 Gas pipe temperature														
540	0011100001	IC18 Gas pipe temperature														
541	1011100001	IC19 Gas pipe temperature														
542	0111100001	IC20 Gas pipe temperature														
543	1111100001	IC21 Gas pipe temperature														
544	0000010001	IC22 Gas pipe temperature														
545	1000010001	IC23 Gas pipe temperature														
546	0100010001	IC24 Gas pipe temperature														
547	1100010001	IC25 Gas pipe temperature														
548	0010010001	IC26 Gas pipe temperature														
549	1010010001	IC27 Gas pipe temperature														
550	0110010001	IC28 Gas pipe temperature														
551	1110010001	IC29 Gas pipe temperature														
552	0001010001	IC30 Gas pipe temperature														
553	1001010001	IC31 Gas pipe temperature														
554	0101010001	IC32 Gas pipe temperature														
555	1101010001	IC33 Gas pipe temperature														
556	0011010001	IC34 Gas pipe temperature														
557	1011010001	IC35 Gas pipe temperature														
558	0111010001	IC36 Gas pipe temperature														
559	1111010001	IC37 Gas pipe temperature														
560	0000110001	IC38 Gas pipe temperature														
561	1000110001	IC39 Gas pipe temperature														
562	0100110001	IC40 Gas pipe temperature														
563	1100110001	IC41 Gas pipe temperature														
564	0010110001	IC42 Gas pipe temperature														

*1 A: The condition of either OC or OS is displayed individually. B: The condition of the entire refrigerant system is displayed.

Data on indoor unit system													Unit (A, B) *1		Remarks																														
No.	SW4 (When SW6-10 is set to OFF)	Item	LD1	LD2	LD3	LD4	LD5	LD6	LD7	LD8	OC	OS	The unit is [°C]																																
565	1010110001	IC43 Gas pipe temperature				-99.9 to 999.9					B			The unit is [°C]																															
566	0110110001	IC44 Gas pipe temperature				-99.9 to 999.9							The unit is [°C]																																
567	1110110001	IC45 Gas pipe temperature				-99.9 to 999.9									The unit is [°C]																														
568	0001110001	IC46 Gas pipe temperature				-99.9 to 999.9										The unit is [°C]																													
569	1001110001	IC47 Gas pipe temperature				-99.9 to 999.9											The unit is [°C]																												
570	0101110001	IC48 Gas pipe temperature				-99.9 to 999.9												The unit is [°C]																											
571	1101110001	IC49 Gas pipe temperature				-99.9 to 999.9													The unit is [°C]																										
572	0011110001	IC50 Gas pipe temperature				-99.9 to 999.9														The unit is [°C]																									
573	1011110001	IC1SH				-99.9 to 999.9															The unit is [°C]																								
574	0111110001	IC2SH				-99.9 to 999.9																The unit is [°C]																							
575	1111110001	IC3SH				-99.9 to 999.9																	The unit is [°C]																						
576	0000010001	IC4SH				-99.9 to 999.9																		The unit is [°C]																					
577	1000010001	IC5SH				-99.9 to 999.9																			The unit is [°C]																				
578	0100010001	IC6SH				-99.9 to 999.9																				The unit is [°C]																			
579	1100010001	IC7SH				-99.9 to 999.9																					The unit is [°C]																		
580	0010001001	IC8SH				-99.9 to 999.9																						The unit is [°C]																	
581	1010001001	IC9SH				-99.9 to 999.9																							The unit is [°C]																
582	0110001001	IC10SH				-99.9 to 999.9																								The unit is [°C]															
583	1110001001	IC11SH				-99.9 to 999.9																									The unit is [°C]														
584	0001001001	IC12SH				-99.9 to 999.9																										The unit is [°C]													
585	1001001001	IC13SH				-99.9 to 999.9																											The unit is [°C]												
586	0101001001	IC14SH				-99.9 to 999.9																												The unit is [°C]											
587	1101001001	IC15SH				-99.9 to 999.9																													The unit is [°C]										
588	0011001001	IC16SH				-99.9 to 999.9																														The unit is [°C]									
589	1011001001	IC17SH				-99.9 to 999.9																															The unit is [°C]								
590	0111001001	IC18SH				-99.9 to 999.9																																The unit is [°C]							
591	1111001001	IC19SH				-99.9 to 999.9																																	The unit is [°C]						
592	0000101001	IC20SH				-99.9 to 999.9																																		The unit is [°C]					
593	1000101001	IC21SH				-99.9 to 999.9																																			The unit is [°C]				
594	0100101001	IC22SH				-99.9 to 999.9																																				The unit is [°C]			
595	1100101001	IC23SH				-99.9 to 999.9																																					The unit is [°C]		
596	0010101001	IC24SH				-99.9 to 999.9																																						The unit is [°C]	
597	1010101001	IC25SH				-99.9 to 999.9																																							The unit is [°C]
598	0110101001	IC26SH				-99.9 to 999.9																																							
599	1110101001	IC27SH				-99.9 to 999.9								The unit is [°C]																															
600	0001101001	IC28SH				-99.9 to 999.9							The unit is [°C]																																
601	1001101001	IC29SH				-99.9 to 999.9									The unit is [°C]																														
602	0101101001	IC30SH				-99.9 to 999.9										The unit is [°C]																													
603	1101101001	IC31SH				-99.9 to 999.9											The unit is [°C]																												
604	0011101001	IC32SH				-99.9 to 999.9												The unit is [°C]																											
605	1011101001	IC33SH				-99.9 to 999.9													The unit is [°C]																										
606	0111101001	IC34SH				-99.9 to 999.9														The unit is [°C]																									
607	1111101001	IC35SH				-99.9 to 999.9															The unit is [°C]																								

*1 A: The condition of either OC or OS is displayed individually. B: The condition of the entire refrigerant system is displayed.

10 LED Status Indicators on the Outdoor Unit Circuit Board

[10 - 2 LED Status Indicators Table]

Data on indoor unit system

No.	SW4 (When SW6-10 is set to OFF) 1234567890	Item	Display										Unit (A, B) *1		Remarks		
			LD1	LD2	LD3	LD4	LD5	LD6	LD7	LD8	OC	OS					
608	0000011001	IC36SH															The unit is [°C]
609	1000011001	IC37SH															
610	0100011001	IC38SH															
611	1100011001	IC39SH															
612	0010011001	IC40SH															
613	1010011001	IC41SH															
614	0110011001	IC42SH															
615	1110011001	IC43SH															
616	0001011001	IC44SH															
617	1001011001	IC45SH															
618	0101011001	IC46SH															
619	1101011001	IC47SH															
620	0011011001	IC48SH															
621	1011011001	IC49SH															
622	0111011001	IC50SH															
623	1111011001	IC1SC															
624	0000111001	IC2SC															
625	1000111001	IC3SC															
626	0100111001	IC4SC															
627	1100111001	IC5SC															
628	0010111001	IC6SC															
629	1010111001	IC7SC															
630	0110111001	IC8SC															
631	1110111001	IC9SC															
632	0001111001	IC10SC															
633	1001111001	IC11SC															
634	0101111001	IC12SC															
635	1101111001	IC13SC															
636	0011111001	IC14SC															
637	1011111001	IC15SC															
638	0111111001	IC16SC															
639	1111111001	IC17SC															
640	000000101	IC18SC															
641	100000101	IC19SC															
642	010000101	IC20SC															
643	110000101	IC21SC															
644	0010000101	IC22SC															
645	1010000101	IC23SC															
646	0110000101	IC24SC															
647	1110000101	IC25SC															
648	0001000101	IC26SC															
649	1001000101	IC27SC															
650	0101000101	IC28SC															

*1 A: The condition of either OC or OS is displayed individually. B: The condition of the entire refrigerant system is displayed.

Data on indoor unit system

No.	SW4 (When SW6-10 is set to OFF) 1234567890	Item	Display										Unit (A, B) *1		Remarks			
			LD1	LD2	LD3	LD4	LD5	LD6	LD7	LD8	OC	OS						
651	1101000101	IC29SC														B		The unit is [°C]
652	0011000101	IC30SC																
653	1011000101	IC31SC																
654	0111000101	IC32SC																
655	1111000101	IC33SC																
656	0000100101	IC34SC																
657	1000100101	IC35SC																
658	0100100101	IC36SC																
659	1100100101	IC37SC																
660	0010100101	IC38SC																
661	1010100101	IC39SC																
662	0110100101	IC40SC																
663	1110100101	IC41SC																
664	0001100101	IC42SC																
665	1001100101	IC43SC																
666	0101100101	IC44SC																
667	1101100101	IC45SC																
668	0011100101	IC46SC																
669	1011100101	IC47SC																
670	0111100101	IC48SC																
671	111100101	IC49SC																
672	0000010101	IC50SC																

*1 A: The condition of either OC or OS is displayed individually. B: The condition of the entire refrigerant system is displayed.

10 LED Status Indicators on the Outdoor Unit Circuit Board

[10 - 2 LED Status Indicators Table]

Setting data

No.	SW4 (When SW6 - 10 is set to OFF) 1234567890	Item	Display										Unit (A, B) ^{*1}		Remarks	
			LD1	LD2	LD3	LD4	LD5	LD6	LD7	LD8	OC	OS				
676	0010010101	INV board SW version					0.00 to 99.99							A	A	
679	1110010101	Fan board (address 5) SW version					0.00 to 99.99							A	A	
680	0001010101	Fan board (address 6) SW version					0.00 to 99.99							A	A	
688	0000110101	Current time					00:00 to 23:59							A	A	Hour: minute
689	1000110101	Current time -2					00:00 to 99.12/1 to 31							A	A	Year and month, and date alter- nate display
690	0100110101	Time of error detection 1					00:00 to 23:59							A	A	Hour: minute
691	1100110101	Time of error detection 1-2					00:00 to 99.12/1 to 31							A	A	Year and month, and date alter- nate display
692	0010110101	Time of error detection 2					00:00 to 23:59							A	A	Hour: minute
693	1010110101	Time of error detection 2-2					00:00 to 99.12/1 to 31							A	A	Year and month, and date alter- nate display
694	0110110101	Time of error detection 3					00:00 to 23:59							A	A	Hour: minute
695	1110110101	Time of error detection 3-2					00:00 to 99.12/1 to 31							A	A	Year and month, and date alter- nate display
696	0001110101	Time of error detection 4					00:00 to 23:59							A	A	Hour: minute
697	1001110101	Time of error detection 4-2					00:00 to 99.12/1 to 31							A	A	Year and month, and date alter- nate display
698	0101110101	Time of error detection 5					00:00 to 23:59							A	A	Hour: minute
699	1101110101	Time of error detection 5-2					00:00 to 99.12/1 to 31							A	A	Year and month, and date alter- nate display
700	0011110101	Time of error detection 6					00:00 to 23:59							A	A	Hour: minute
701	1011110101	Time of error detection 6-2					00:00 to 99.12/1 to 31							A	A	Year and month, and date alter- nate display
702	0111110101	Time of error detection 7					00:00 to 23:59							A	A	Hour: minute
703	1111110101	Time of error detection 7-2					00:00 to 99.12/1 to 31							A	A	Year and month, and date alter- nate display
704	000001101	Time of error detection 8					00:00 to 23:59							A	A	Hour: minute
705	100001101	Time of error detection 8-2					00:00 to 99.12/1 to 31							A	A	Year and month, and date alter- nate display
706	010001101	Time of error detection 9					00:00 to 23:59							A	A	Hour: minute
707	110001101	Time of error detection 9-2					00:00 to 99.12/1 to 31							A	A	Year and month, and date alter- nate display
708	0010001101	Time of error detection 10					00:00 to 23:59							A	A	Hour: minute
709	1010001101	Time of error detection 10-2					00:00 to 99.12/1 to 31							A	A	Year and month, and date alter- nate display
710	0110001101	Time of last data backup before error					00:00 to 23:59							A	A	Hour: minute
711	1110001101	Time of last data backup before error -2					00:00 to 99.12/1 to 31							A	A	Year and month, and date alter- nate display

*1 A: The condition of either OC or OS is displayed individually. B: The condition of the entire refrigerant system is displayed.

Data on indoor unit system

No.	Item	Display										Unit (A, B) ^{*1}		Remarks		
		LD1	LD2	LD3	LD4	LD5	LD6	LD7	LD8	OC	OS					
	SW4 (When SW6 - 10 is set to OFF)															
	1234567890															
714	IC1 LEV opening					0000 to 9999								B		Fully open: 2000
715	IC2 LEV opening					0000 to 9999										
716	IC3 LEV opening					0000 to 9999										
717	IC4 LEV opening					0000 to 9999										
718	IC5 LEV opening					0000 to 9999										
719	IC6 LEV opening					0000 to 9999										
720	IC7 LEV opening					0000 to 9999										
721	IC8 LEV opening					0000 to 9999										
722	IC9 LEV opening					0000 to 9999										
723	IC10 LEV opening					0000 to 9999										
724	IC11 LEV opening					0000 to 9999										
725	IC12 LEV opening					0000 to 9999										
726	IC13 LEV opening					0000 to 9999										
727	IC14 LEV opening					0000 to 9999										
728	IC15 LEV opening					0000 to 9999										
729	IC16 LEV opening					0000 to 9999										
730	IC17 LEV opening					0000 to 9999										
731	IC18 LEV opening					0000 to 9999										
732	IC19 LEV opening					0000 to 9999										
733	IC20 LEV opening					0000 to 9999										
734	IC21 LEV opening					0000 to 9999										
735	IC22 LEV opening					0000 to 9999										
736	IC23 LEV opening					0000 to 9999										
737	IC24 LEV opening					0000 to 9999										
738	IC25 LEV opening					0000 to 9999										
739	IC26 LEV opening					0000 to 9999										
740	IC27 LEV opening					0000 to 9999										
741	IC28 LEV opening					0000 to 9999										
742	IC29 LEV opening					0000 to 9999										
743	IC30 LEV opening					0000 to 9999										
744	IC31 LEV opening					0000 to 9999										
745	IC32 LEV opening					0000 to 9999										
746	IC33 LEV opening					0000 to 9999										
747	IC34 LEV opening					0000 to 9999										
748	IC35 LEV opening					0000 to 9999										
749	IC36 LEV opening					0000 to 9999										
750	IC37 LEV opening					0000 to 9999										
751	IC38 LEV opening					0000 to 9999										
752	IC39 LEV opening					0000 to 9999										
753	IC40 LEV opening					0000 to 9999										
754	IC41 LEV opening					0000 to 9999										
755	IC42 LEV opening					0000 to 9999										

*1 A: The condition of either OC or OS is displayed individually. B: The condition of the entire refrigerant system is displayed.

10 LED Status Indicators on the Outdoor Unit Circuit Board

[10 - 2 LED Status Indicators Table]

Data on indoor unit system		Item	Display										Unit (A, B) ^{*1}		Remarks		
			LD1	LD2	LD3	LD4	LD5	LD6	LD7	LD8	OC	OS					
No.	SW4 (When SW6-10 is set to OFF)																
	1234567890																
756	0010111101	IC43 LEV opening						0000 to 9999							B		Fully open: 2000
757	1010111101	IC44 LEV opening						0000 to 9999									
758	0110111101	IC45 LEV opening						0000 to 9999									
759	1110111101	IC46 LEV opening						0000 to 9999									
760	0001111101	IC47 LEV opening						0000 to 9999									
761	1001111101	IC48 LEV opening						0000 to 9999									
762	0101111101	IC49 LEV opening						0000 to 9999									
763	1101111101	IC50 LEV opening						0000 to 9999									
764	0011111101	IC1 Operation mode															
765	1011111101	IC2 Operation mode															
766	0111111101	IC3 Operation mode															
767	1111111101	IC4 Operation mode															
768	0000000011	IC5 Operation mode															
769	1000000011	IC6 Operation mode															
770	0100000011	IC7 Operation mode															
771	1100000011	IC8 Operation mode															
772	0010000011	IC9 Operation mode															
773	1010000011	IC10 Operation mode															
774	0110000011	IC11 Operation mode															
775	1110000011	IC12 Operation mode															
776	0001000011	IC13 Operation mode															
777	1001000011	IC14 Operation mode															
778	0101000011	IC15 Operation mode															
779	1101000011	IC16 Operation mode															
780	0011000011	IC17 Operation mode															
781	1011000011	IC18 Operation mode															
782	0111000011	IC19 Operation mode															
783	1111000011	IC20 Operation mode															
784	0000100011	IC21 Operation mode															
785	1000100011	IC22 Operation mode															
786	0100100011	IC23 Operation mode															
787	1100100011	IC24 Operation mode															
788	0010100011	IC25 Operation mode															
789	1010100011	IC26 Operation mode															
790	0110100011	IC27 Operation mode															
791	1110100011	IC28 Operation mode															
792	0001100011	IC29 Operation mode															
793	1001100011	IC30 Operation mode															
794	0101100011	IC31 Operation mode															
795	1101100011	IC32 Operation mode															
796	0011100011	IC33 Operation mode															

0000: Stop 0001: Ventilation 0002: Cooling 0003: Heating 0004: Dry

*1 A: The condition of either OC or OS is displayed individually. B: The condition of the entire refrigerant system is displayed.

Data on indoor unit system													Unit (A, B) ^{*1}		Remarks
No.	SW4 (When SW6-10 is set to OFF)	Item	LD1	LD2	LD3	LD4	LD5	LD6	LD7	LD8	OC	OS			
797	1011100011	IC34 Operation mode									B				
798	0111100011	IC35 Operation mode													
799	1111100011	IC36 Operation mode													
800	0000010011	IC37 Operation mode													
801	1000010011	IC38 Operation mode													
802	0100010011	IC39 Operation mode													
803	1100010011	IC40 Operation mode													
804	0010010011	IC41 Operation mode													
805	1010010011	IC42 Operation mode													
806	0110010011	IC43 Operation mode													
807	1110010011	IC44 Operation mode													
808	0001010011	IC45 Operation mode													
809	1001010011	IC46 Operation mode													
810	0101010011	IC47 Operation mode													
811	1101010011	IC48 Operation mode													
812	0011010011	IC49 Operation mode													
813	1011010011	IC50 Operation mode													
814	0111010011	IC1 filter						0000 to 9999			B				
815	1111010011	IC2 filter						0000 to 9999							
816	0000100011	IC3 filter						0000 to 9999							
817	1000100011	IC4 filter						0000 to 9999							
818	0100100011	IC5 filter						0000 to 9999							
819	1100100011	IC6 filter						0000 to 9999							
820	0010100011	IC7 filter						0000 to 9999							
821	1010100011	IC8 filter						0000 to 9999							
822	0110100011	IC9 filter						0000 to 9999							
823	1110100011	IC10 filter						0000 to 9999							
824	0001100011	IC11 filter						0000 to 9999							
825	1001100011	IC12 filter						0000 to 9999							
826	0101100011	IC13 filter						0000 to 9999							
827	1101100011	IC14 filter						0000 to 9999							
828	0011100011	IC15 filter						0000 to 9999							
829	1011100011	IC16 filter						0000 to 9999							
830	0111100011	IC17 filter						0000 to 9999							
831	1111100011	IC18 filter						0000 to 9999							
832	0000010111	IC19 filter						0000 to 9999							
833	1000010111	IC20 filter						0000 to 9999							
834	0100010111	IC21 filter						0000 to 9999							
835	1100010111	IC22 filter						0000 to 9999							
836	0010001011	IC23 filter						0000 to 9999							
837	1010001011	IC24 filter						0000 to 9999							
838	0110001011	IC25 filter						0000 to 9999							
839	1110001011	IC26 filter						0000 to 9999							

0000: Stop 0001: Ventilation 0002: Cooling 0003: Heating 0004: Dry

Hours since last maintenance [h]

*1 A: The condition of either OC or OS is displayed individually. B: The condition of the entire refrigerant system is displayed.

10 LED Status Indicators on the Outdoor Unit Circuit Board

[10 - 2 LED Status Indicators Table]

Data on indoor unit system

No.	SW4 (When SW6-10 is set to OFF) 1234567890	Item	Display										Unit (A, B) ^{*1}		Remarks		
			LD1	LD2	LD3	LD4	LD5	LD6	LD7	LD8	OC	OS					
840	0001001011	IC27 filter					0000 to 9999										Hours since last maintenance [h]
841	1001001011	IC28 filter					0000 to 9999										
842	0101001011	IC29 filter					0000 to 9999										
843	1101001011	IC30 filter					0000 to 9999										
844	0011001011	IC31 filter					0000 to 9999										
845	1011001011	IC32 filter					0000 to 9999										
846	0111001001	IC33 filter					0000 to 9999										
847	1111001011	IC34 filter					0000 to 9999										
848	0000101011	IC35 filter					0000 to 9999										
849	1000101011	IC36 filter					0000 to 9999										
850	0100101011	IC37 filter					0000 to 9999										
851	1100101011	IC38 filter					0000 to 9999										
852	0010101011	IC39 filter					0000 to 9999										
853	1010101011	IC40 filter					0000 to 9999										
854	0110101011	IC41 filter					0000 to 9999										
855	1110101011	IC42 filter					0000 to 9999										
856	0001101011	IC43 filter					0000 to 9999										
857	1001101011	IC44 filter					0000 to 9999										
858	0101101011	IC45 filter					0000 to 9999										
859	1101101011	IC46 filter					0000 to 9999										
860	0011101011	IC47 filter					0000 to 9999										
861	1011101011	IC48 filter					0000 to 9999										
862	0111101011	IC49 filter					0000 to 9999										
863	1111101011	IC50 filter					0000 to 9999										

*1 A: The condition of either OC or OS is displayed individually. B: The condition of the entire refrigerant system is displayed.

Other types of data

No.	SW4 (When SW6 - 10 is set to OFF) 1234567890	Item	Display								Unit (A, B) ^{*1}		Remarks		
			LD1	LD2	LD3	LD4	LD5	LD6	LD7	LD8	OC	OS			
871	1110011011	U-phase current effective value 1											A	A	The unit is [A]
872	0001011011	W-phase current effective value 1											A	A	
873	1001011011	Power factor phase angle 1											A	A	The unit is [deg]
880	0000111011	Control board Reset counter											A	A	The unit is [time]
881	1000111011	INV board Reset counter											A	A	
884	0010111011	Fan board (address 5) reset counter											A	A	The unit is [time]
885	1010111011	Fan board (address 6) reset counter											A	A	
980	0010101111	M-NET processor S/W version											A	A	

*1 A: The condition of either OC or OS is displayed individually. B: The condition of the entire refrigerant system is displayed.

Service Handbook

Model

PUHY-P200, P250, P300, P350, P400, P450, P500YNW-A(1/2)

PUHY-P400, P450, P500, P550, P600, P650, P700, P750, P800, P850, P900YSNW-A(1/2)

PUHY-P950, P1000, P1050, P1100, P1150, P1200, P1250, P1300, P1350YSNW-A(1/2)

PUHY-EP200, EP250, EP300, EP350, EP400, EP450, EP500YNW-A(1/2)

PUHY-EP400, EP450, EP500, EP550, EP600, EP650, EP700, EP750, EP800, EP850, EP900YSNW-A(1/2)

PUHY-EP950, EP1000, EP1050, EP1100, EP1150, EP1200, EP1250, EP1300, EP1350YSNW-A(1/2)

mitsubishi MITSUBISHI ELECTRIC CORPORATION

www.MitsubishiElectric.com