

INDOOR UNIT

No. OBB932

PARTS CATALOG

Models

- MSZ-AY25VG** - ET1
- MSZ-AY35VG** - ET1
- MSZ-AY42VG** - ET1
- MSZ-AY50VG** - ET1
- MSZ-AY25VGK** - E1, SC1, ET1, ER1
- MSZ-AY35VGK** - E1, SC1, ET1, ER1
- MSZ-AY42VGK** - E1, SC1, ET1, ER1
- MSZ-AY50VGK** - E1, SC1, ET1, ER1
- MSZ-AY25VGKP** - E1, SC1, ET1, ER1
- MSZ-AY35VGKP** - E1, SC1, ET1, ER1
- MSZ-AY42VGKP** - E1, SC1, ET1, ER1
- MSZ-AY50VGKP** - E1, SC1, ET1, ER1



CONTENTS

- 1. SERVICE PARTS LIST2
- 2. OPTIONAL PARTS 15

SERVICE MANUAL (OBH932)

1

SERVICE PARTS LIST

MSZ-AY25VG-ET1 MSZ-AY35VG-ET1 MSZ-AY42VG-ET1 MSZ-AY50VG-ET1

1-1. INDOOR UNIT STRUCTURAL PARTS

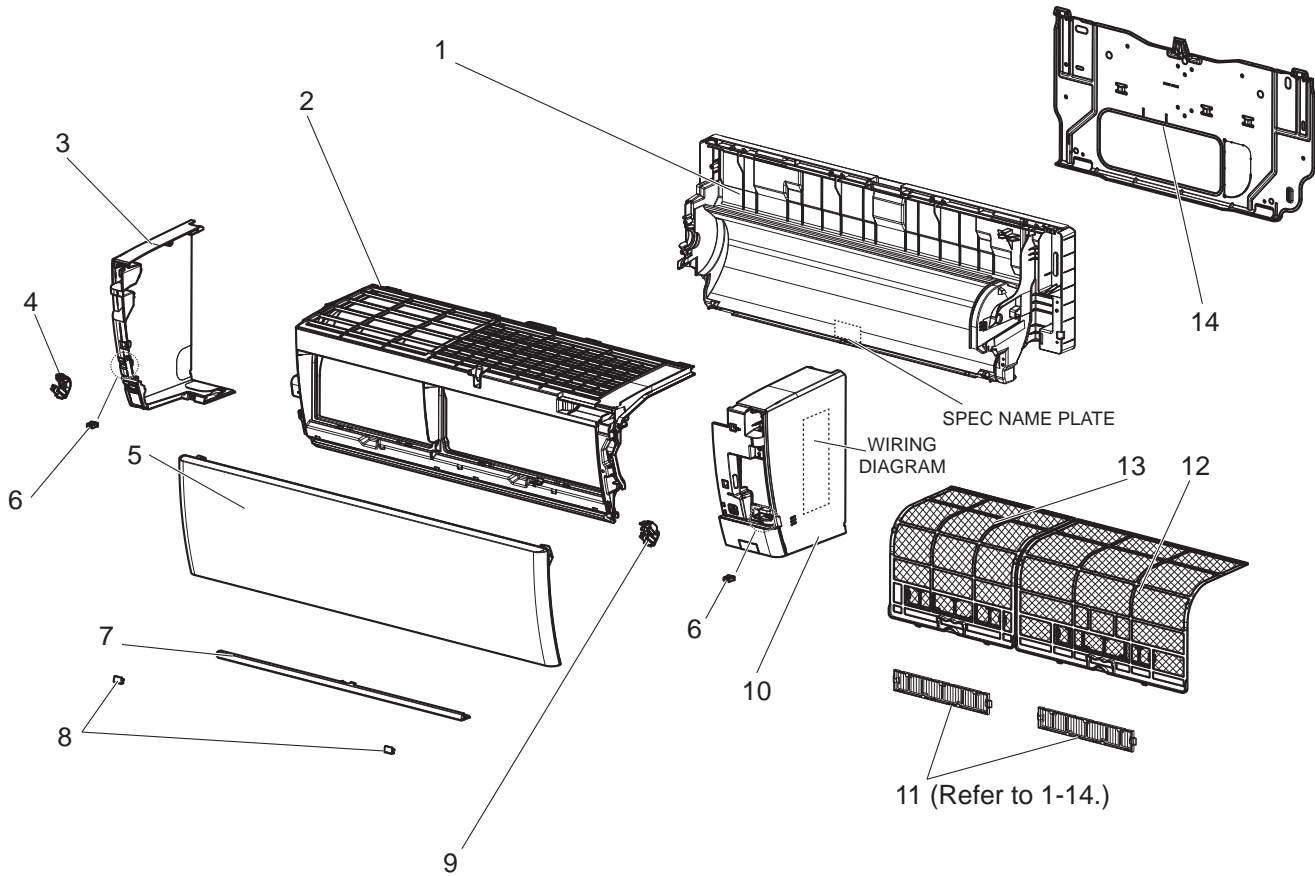

1-2. ACCESSORY AND REMOTE CONTROLLER

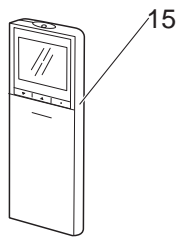

1-3. INDOOR UNIT HEAT EXCHANGER

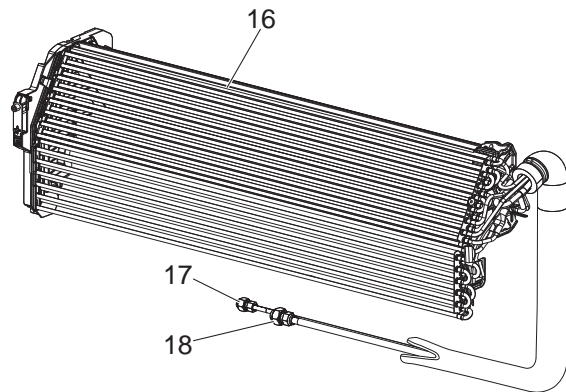

1-1. INDOOR UNIT STRUCTURAL PARTS

1. The part quantity below indicates the required number of pieces per unit.

No.	Part No.	Part name	MSZ-AY25VG - [ET1]	MSZ-AY35VG - [ET1]	MSZ-AY42VG - [ET1]	MSZ-AY50VG - [ET1]	Symbol in Wiring Diagram	Remarks
1	G2W 004 026	BOX ASSEMBLY	1	1	1	1		Not including SPEC NAME PLATE
2	G2W 002 003	PANEL (FRONT) ASSEMBLY	1	1	1	1		
3	G2W 002 020	PANEL (LEFT) ASSEMBLY	1	1	1	1		Includes No. 4,6
4	G2W 001 120	ARM HOLDER (LEFT)	1	1	1	1		
5	G2W 003 010	FRONT PANEL	1	1	1	1		
6	G2W 001 118	CATCH	2	2	2	2		
7	G2W 002 006	PANEL (UNDER) ASSEMBLY	1	1	1	1		
8	G2W 001 023	SCREW CAP	2	2	2	2		
9	G2W 002 120	ARM HOLDER (RIGHT)	1	1	1	1		
10	G2W 004 014	PANEL (RIGHT) ASSEMBLY	1	1	1	1		Includes No. 6, 9 Not including WIRING DIAGRAM
11	—	AIR CLEANING FILTER (V BLOCKING FILTER)	1	1	1	1		2 PCS/SET MAC2470FT-E
12	G2W 005 100	AIR FILTER_RIGHT	1	1	1	1		1 PC/SET
13	G2W 006 100	AIR FILTER_LEFT	1	1	1	1		1 PC/SET
14	G2W 003 115	INSTALLATION PLATE	1	1	1	1		

1-2. ACCESSORY AND REMOTE CONTROLLER

1. The part quantity below indicates the required number of pieces per unit.

No.	Part No.	Part name	MSZ-AY25VG - [ET1]	MSZ-AY35VG - [ET1]	MSZ-AY42VG - [ET1]	MSZ-AY50VG - [ET1]	Symbol in Wiring Diagram	Remarks
15	G2W 007 400	REMOTE CONTROLLER	1	1	1	1		SH22Q

1-3. INDOOR UNIT HEAT EXCHANGER

1. The part quantity below indicates the required number of pieces per unit.

No.	Part No.	Part name	MSZ-AY25VG - [ET1]	MSZ-AY35VG - [ET1]	MSZ-AY42VG - [ET1]	MSZ-AY50VG - [ET1]	Symbol in Wiring Diagram	Remarks
16	G2W 008 600	INDOOR HEAT EXCHANGER	1	1				Includes No. 17, 18
16	G2W 009 600	INDOOR HEAT EXCHANGER			1	1		Includes No. 17, 18
17	G2W 001 605	UNION (LIQUID)	1	1	1	1		'1/4" (ø6.35)
18	G2W 002 605	UNION (GAS)	1	1	1	1		'3/8" (ø9.52)

MSZ-AY25VG-ET1 MSZ-AY35VG-ET1 MSZ-AY42VG-ET1 MSZ-AY50VG-ET1
1-4. INDOOR UNIT ELECTRICAL PARTS AND FUNCTIONAL PARTS

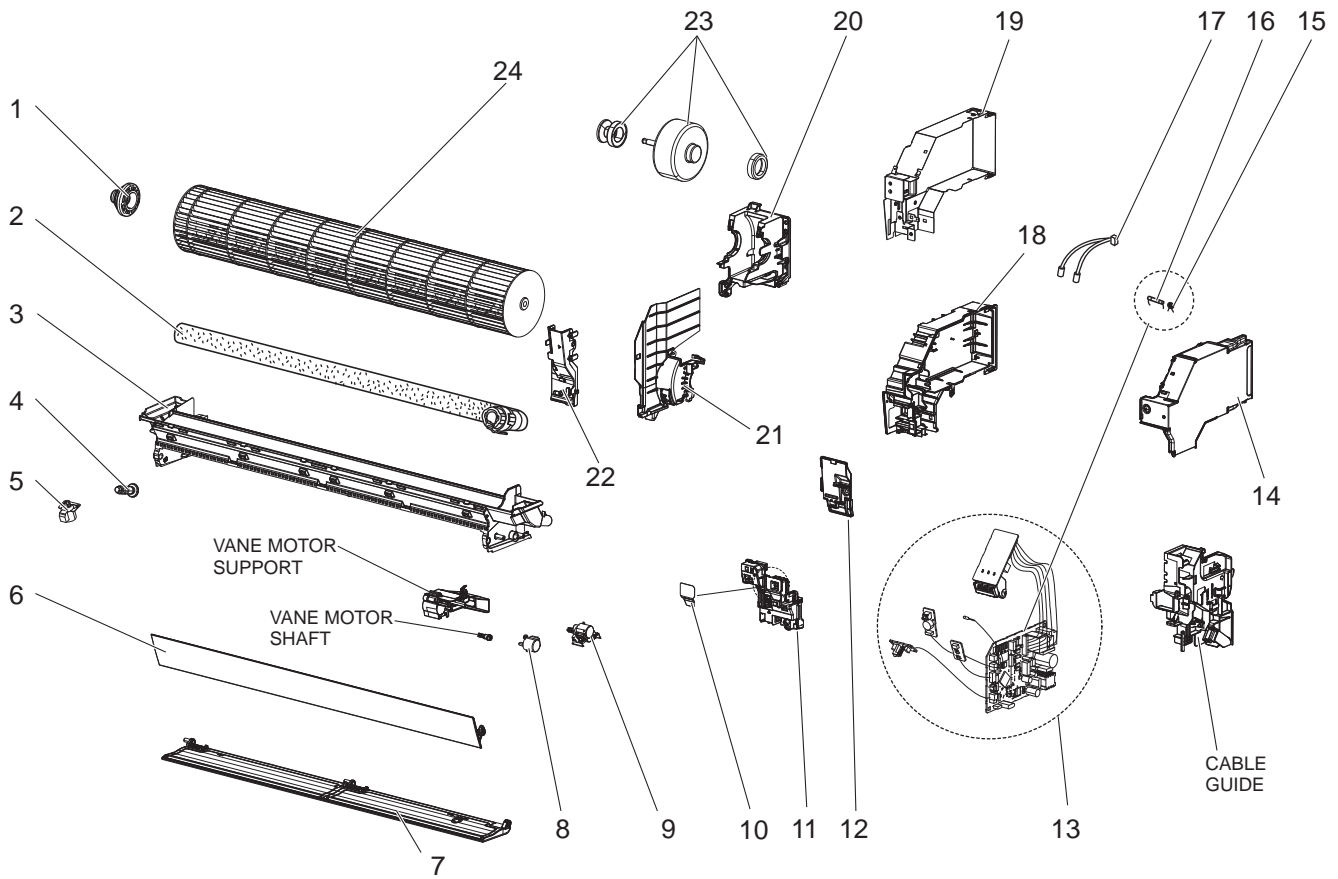

1-4. INDOOR UNIT ELECTRICAL PARTS AND FUNCTIONAL PARTS

1. The part quantity below indicates the required number of pieces per unit.
2. The circled No. indicates that the part is not shown in the figure.

No.	Part No.	Part name					Symbol in Wiring Diagram	Remarks [Drawing No.]
			MSZ-AY25VG- ^[ET1]	MSZ-AY35VG- ^[ET1]	MSZ-AY42VG- ^[ET1]	MSZ-AY50VG- ^[ET1]		
1	G2W 002 520	BEARING MOUNT ASSEMBLY	1	1	1	1		Includes sleeve bearing
2	G2W 001 110	DRAIN HOSE ASSEMBLY (SHORT)	1	1	1	1		L=520 mm
3	G2W 003 030	NOZZLE ASSEMBLY	1	1	1	1		
4	G2W 001 708	DRAIN CAP	1	1	1	1		
5	G2W 001 320	VANE MOTOR (VERTICAL)	1	1	1	1	MV3	RIGHT & LEFT
6	G2W 004 017	HORIZONTAL VANE (UPPER) ASSEMBLY	1	1	1	1		Includes shaft
7	G2W 005 017	HORIZONTAL VANE (LOWER) ASSEMBLY	1	1	1	1		Includes shaft
8	G2W 003 315	VANE MOTOR (HORIZONTAL) (UPPER)	1	1	1	1	MV1	UP & DOWN
9	G2W 002 315	VANE MOTOR (HORIZONTAL) (LOWER)	1	1	1	1	MV2	UP & DOWN
10	—	SWITCH SHEET	1	1	1	1		[DY79C587H01]
11	—	DISPLAY AND RECEIVER P.C. BOARD HOLDER ASSEMBLY	1	1	1	1		[DY25Y040G03]
12	—	V.A. CLAMP ASSEMBLY	1	1	1	1		[DK00G513G02]
13	G2W 033 410	ELECTRONIC CONTROL P.C. BOARD	1					Includes RECEIVER P.C. BOARD, DISPLAY P.C. BOARD, SWITCH/BUZZER P.C. BOARD, TERMINAL P.C. BOARD and ROOM TEMPERATURE THERMISTOR (RT11)
13	G2W 034 410	ELECTRONIC CONTROL P.C. BOARD		1				
13	G2W 035 410	ELECTRONIC CONTROL P.C. BOARD			1			
13	G2W 036 410	ELECTRONIC CONTROL P.C. BOARD				1		
14	—	PB-COVER (RIGHT)	1	1	1	1		[DK00G512G03]
15	G2W 001 425	VARISTOR	1	1	1	1	NR11	
16	G2W 002 422	FUSE	1	1	1	1	F11	T3.15AL250V
17	G2W 001 310	INDOOR COIL THERMISTOR	1	1			RT12, RT13	
18	G2W 002 310	INDOOR COIL THERMISTOR			1	1	RT12, RT13	
18	—	PB-COVER (LEFT)	1	1	1	1		[DY00Y064G01]
19	—	PB-BOX (LEFT)	1	1	1	1		[DY25Y063G03]
20	—	MOTOR BED	1	1	1	1		[SQ00C989G06]
21	G2W 003 103	MOTOR BAND	1	1	1	1		
22	—	WATER COVER	1	1	1	1		[JQ25Y260G01]
23	G2W 001 300	INDOOR FAN MOTOR	1	1	1	1	MF	RC0J30-□□, Includes FAN MOTOR RUBBER MOUNT (2 PCS/SET)
24	G2W 002 500	LINE FLOW FAN	1	1	1	1		
②5	—	LEAD WIRE	1	1	1	1		[SM00G912G01], Between CN151 on ELECTRONIC CONTROL P.C. BOARD and VANE MOTOR

MSZ-AY25VGK- [E1], [SC1], [ET1], [ER1]
MSZ-AY42VGK- [E1], [SC1], [ET1], [ER1]

MSZ-AY35VGK- [E1], [SC1], [ET1], [ER1]
MSZ-AY50VGK- [E1], [SC1], [ET1], [ER1]

1-5. INDOOR UNIT STRUCTURAL PARTS

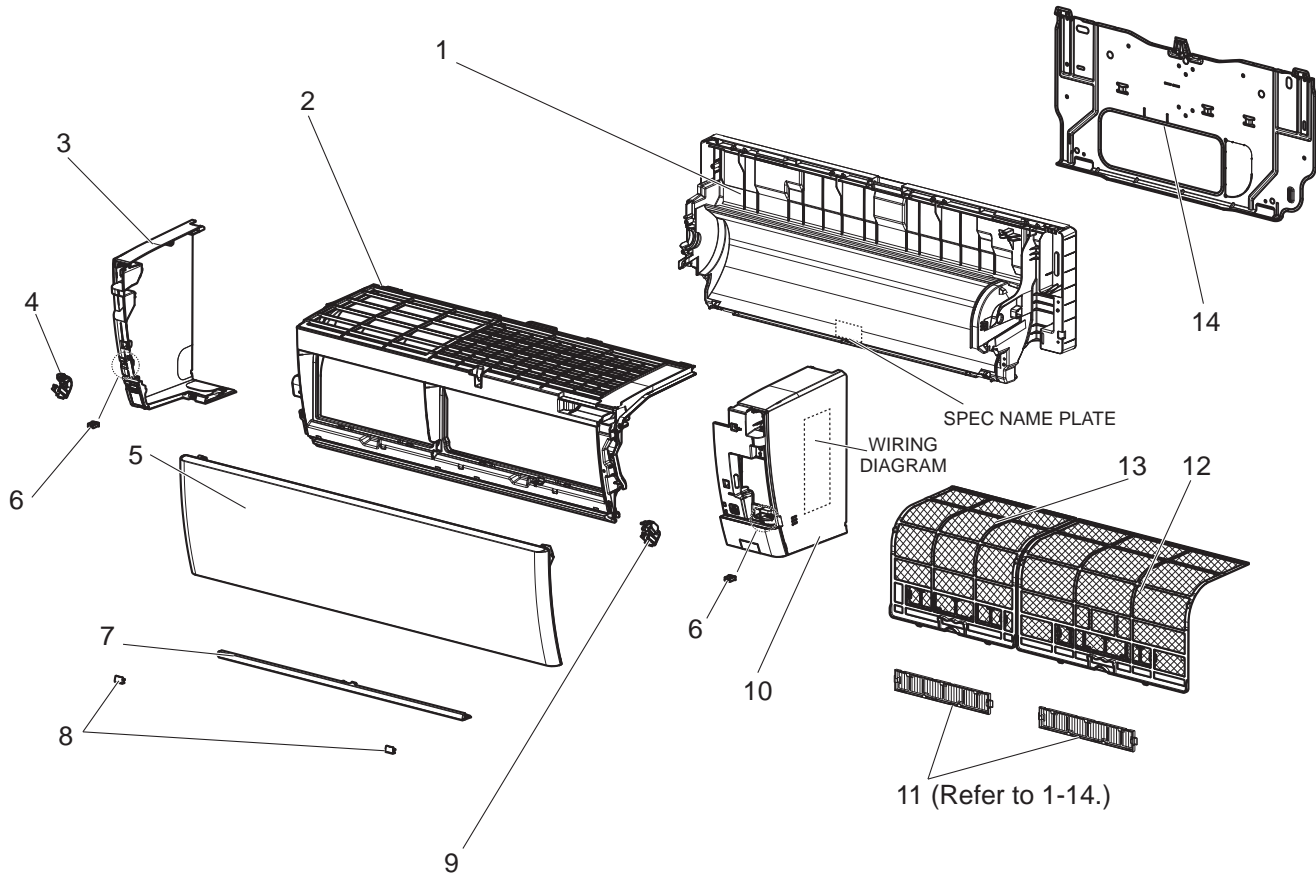

1-6. ACCESSORY AND REMOTE CONTROLLER

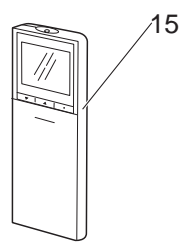

1-7. INDOOR UNIT HEAT EXCHANGER

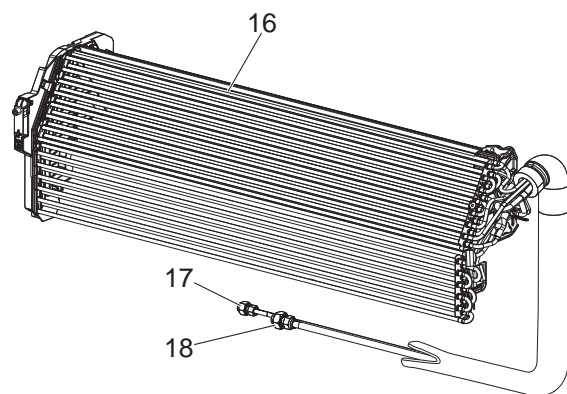

1-5. INDOOR UNIT STRUCTURAL PARTS

1. The part quantity below indicates the required number of pieces per unit.

No.	Part No.	Part name	MSZ-AY25VGK-[E1]	MSZ-AY25VGK-[SC1]	MSZ-AY25VGK-[ET1]	MSZ-AY25VGK-[ER1]	MSZ-AY35VGK-[E1]	MSZ-AY35VGK-[SC1]	MSZ-AY35VGK-[ET1]	MSZ-AY35VGK-[ER1]	MSZ-AY42VGK-[E1]	MSZ-AY42VGK-[SC1]	MSZ-AY42VGK-[ET1]	MSZ-AY42VGK-[ER1]	MSZ-AY50VGK-[E1]	MSZ-AY50VGK-[SC1]	MSZ-AY50VGK-[ET1]	MSZ-AY50VGK-[ER1]	Symbol in Wiring Diagram	Remarks
1	G2W 004 026	BOX ASSEMBLY	1	1	1	1	1	1	1	1	1	1	1	1	1	1	1	1		Not including SPEC NAME PLATE
2	G2W 002 003	PANEL (FRONT) ASSEMBLY	1	1	1	1	1	1	1	1	1	1	1	1	1	1	1	1		
3	G2W 002 020	PANEL (LEFT) ASSEMBLY	1	1	1	1	1	1	1	1	1	1	1	1	1	1	1	1		Includes No. 4, 6
4	G2W 001 120	ARM HOLDER (LEFT)	1	1	1	1	1	1	1	1	1	1	1	1	1	1	1	1		
5	G2W 003 010	FRONT PANEL	1	1	1	1	1	1	1	1	1	1	1	1	1	1	1	1		
6	G2W 001 118	CATCH	2	2	2	2	2	2	2	2	2	2	2	2	2	2	2	2		
7	G2W 002 006	PANEL (UNDER) ASSEMBLY	1	1	1	1	1	1	1	1	1	1	1	1	1	1	1	1		
8	G2W 001 023	SCREW CAP	2	2	2	2	2	2	2	2	2	2	2	2	2	2	2	2		
9	G2W 002 120	ARM HOLDER (RIGHT)	1	1	1	1	1	1	1	1	1	1	1	1	1	1	1	1		
10	G2W 004 014	PANEL (RIGHT) ASSEMBLY	1	1	1	1	1	1	1	1	1	1	1	1	1	1	1	1		Includes No. 6, 9 Not including WIRING DIAGRAM
11	—	AIR CLEANING FILTER (V BLOCKING FILTER)	1	1	1	1	1	1	1	1	1	1	1	1	1	1	1	1		2 PCS/SET MAC2470FT-E
12	G2W 005 100	AIR FILTER_RIGHT	1	1	1	1	1	1	1	1	1	1	1	1	1	1	1	1		1 PC/SET
13	G2W 006 100	AIR FILTER_LEFT	1	1	1	1	1	1	1	1	1	1	1	1	1	1	1	1		1 PC/SET
14	G2W 003 115	INSTALLATION PLATE	1	1	1	1	1	1	1	1	1	1	1	1	1	1	1	1		

1-6. ACCESSORY AND REMOTE CONTROLLER

1. The part quantity below indicates the required number of pieces per unit.

No.	Part No.	Part name	MSZ-AY25VGK-[E1]	MSZ-AY25VGK-[SC1]	MSZ-AY25VGK-[ET1]	MSZ-AY25VGK-[ER1]	MSZ-AY35VGK-[E1]	MSZ-AY35VGK-[SC1]	MSZ-AY35VGK-[ET1]	MSZ-AY35VGK-[ER1]	MSZ-AY42VGK-[E1]	MSZ-AY42VGK-[SC1]	MSZ-AY42VGK-[ET1]	MSZ-AY42VGK-[ER1]	MSZ-AY50VGK-[E1]	MSZ-AY50VGK-[SC1]	MSZ-AY50VGK-[ET1]	MSZ-AY50VGK-[ER1]	Symbol in Wiring Diagram	Remarks
15	G2W 007 400	REMOTE CONTROLLER	1																	SH22Q
15	G2W 008 400	REMOTE CONTROLLER		1												1				SH22S
15	G2W 009 400	REMOTE CONTROLLER				1								1						SH22Q

1-7. INDOOR UNIT HEAT EXCHANGER

1. The part quantity below indicates the required number of pieces per unit.

No.	Part No.	Part name	MSZ-AY25VGK-[E1]	MSZ-AY25VGK-[SC1]	MSZ-AY25VGK-[ET1]	MSZ-AY25VGK-[ER1]	MSZ-AY35VGK-[E1]	MSZ-AY35VGK-[SC1]	MSZ-AY35VGK-[ET1]	MSZ-AY35VGK-[ER1]	MSZ-AY42VGK-[E1]	MSZ-AY42VGK-[SC1]	MSZ-AY42VGK-[ET1]	MSZ-AY42VGK-[ER1]	MSZ-AY50VGK-[E1]	MSZ-AY50VGK-[SC1]	MSZ-AY50VGK-[ET1]	MSZ-AY50VGK-[ER1]	Symbol in Wiring Diagram	Remarks
16	G2W 008 600	INDOOR HEAT EXCHANGER	1																	Includes No. 17, 18
16	G2W 009 600	INDOOR HEAT EXCHANGER									1		1	1				1	1	Includes No. 17, 18
16	G2W 010 600	INDOOR HEAT EXCHANGER		1																Includes No. 17, 18
16	G2W 011 600	INDOOR HEAT EXCHANGER										1				1				Includes No. 17, 18
17	G2W 001 605	UNION (LIQUID)	1	1	1	1	1	1	1	1	1	1	1	1	1	1	1	1		'1/4" (ø6.35)
18	G2W 002 605	UNION (GAS)	1	1	1	1	1	1	1	1	1	1	1	1	1	1	1	1		'3/8" (ø9.52)

MSZ-AY25VGK- [E1], [SC1], [ET1], [ER1]
MSZ-AY42VGK- [E1], [SC1], [ET1], [ER1]

MSZ-AY35VGK- [E1], [SC1], [ET1], [ER1]
MSZ-AY50VGK- [E1], [SC1], [ET1], [ER1]

1-8. INDOOR UNIT ELECTRICAL PARTS AND FUNCTIONAL PARTS

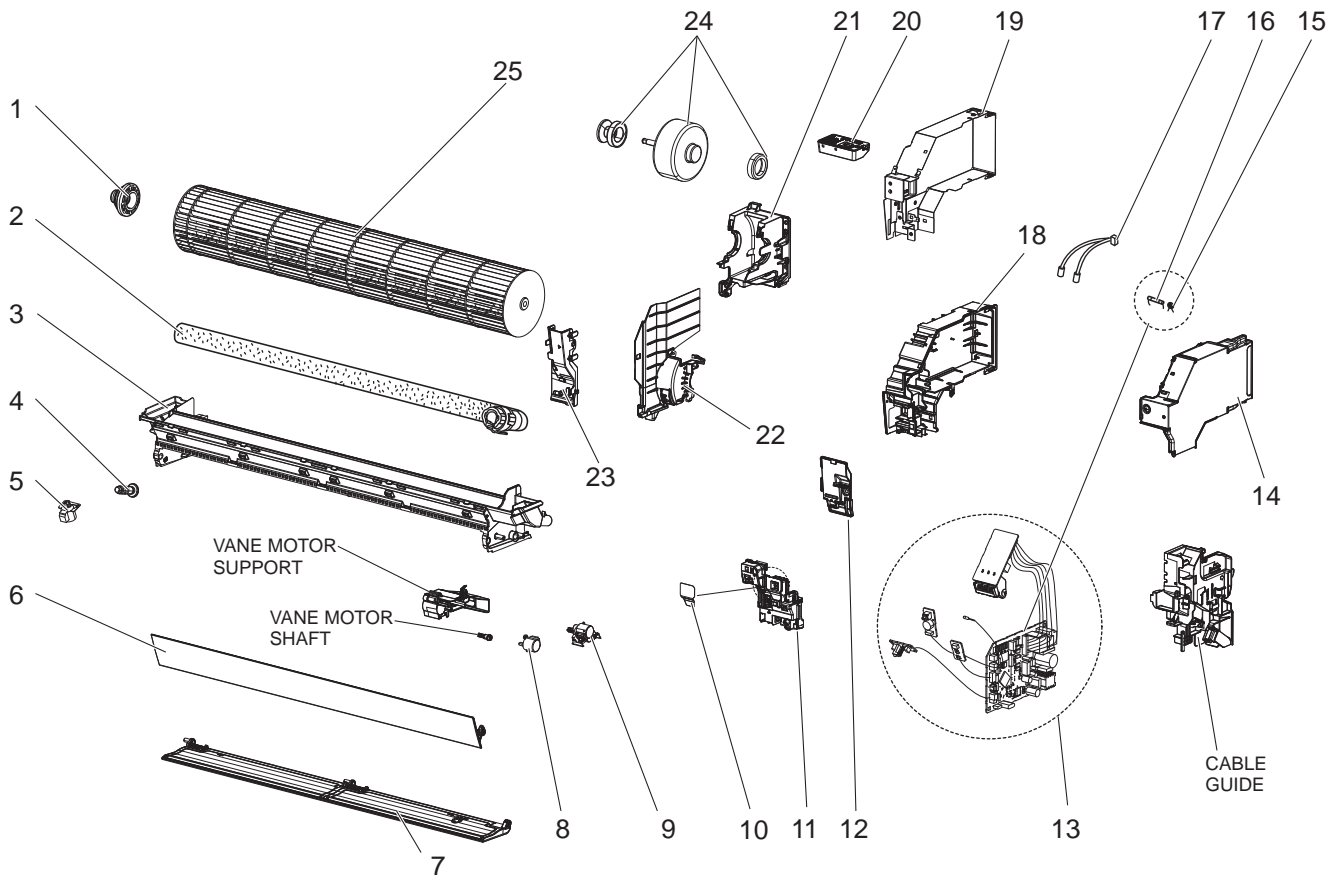

1-8. INDOOR UNIT ELECTRICAL PARTS AND FUNCTIONAL PARTS

- The part quantity below indicates the required number of pieces per unit.
- The circled No. indicates that the part is not shown in the figure.

No.	Part No.	Part name	MSZ-AY25VGK- <input type="checkbox"/>	MSZ-AY25VGK- <input type="checkbox"/>	MSZ-AY25VGK- <input type="checkbox"/>	MSZ-AY25VGK- <input type="checkbox"/>	MSZ-AY35VGK- <input type="checkbox"/>	MSZ-AY35VGK- <input type="checkbox"/>	MSZ-AY35VGK- <input type="checkbox"/>	MSZ-AY35VGK- <input type="checkbox"/>	MSZ-AY42VGK- <input type="checkbox"/>	MSZ-AY42VGK- <input type="checkbox"/>	MSZ-AY42VGK- <input type="checkbox"/>	MSZ-AY42VGK- <input type="checkbox"/>	MSZ-AY50VGK- <input type="checkbox"/>	MSZ-AY50VGK- <input type="checkbox"/>	MSZ-AY50VGK- <input type="checkbox"/>	MSZ-AY50VGK- <input type="checkbox"/>	Symbol in Wiring Diagram	Remarks [Drawing No.]	
			ET	SCI	ET	ERT	ET	SCI	ET	ERT	ET	SCI	ET	ERT	ET	SCI	ET	ERT			
1	G2W 002 520	BEARING MOUNT ASSEMBLY	1	1	1	1	1	1	1	1	1	1	1	1	1	1	1	1		Includes sleeve bearing	
2	G2W 001 110	DRAIN HOSE ASSEMBLY (SHORT)	1		1	1	1		1	1	1		1	1	1		1	1		L=520 mm	
2	G2W 002 110	DRAIN HOSE ASSEMBLY		1				1				1			1					L=670 mm	
3	G2W 003 030	NOZZLE ASSEMBLY	1	1	1	1	1	1	1	1	1	1	1	1	1	1	1	1			
4	G2W 001 708	DRAIN CAP	1	1	1	1	1	1	1	1	1	1	1	1	1	1	1	1			
5	G2W 001 320	VANE MOTOR (VERTICAL)	1	1	1	1	1	1	1	1	1	1	1	1	1	1	1	1	MV3	RIGHT & LEFT	
6	G2W 004 017	HORIZONTAL VANE (UPPER) ASSEMBLY	1	1	1	1	1	1	1	1	1	1	1	1	1	1	1	1		Includes shaft	
7	G2W 005 017	HORIZONTAL VANE (LOWER) ASSEMBLY	1	1	1	1	1	1	1	1	1	1	1	1	1	1	1	1		Includes shaft	
8	G2W 003 315	VANE MOTOR (HORIZONTAL) (UPPER)	1	1	1	1	1	1	1	1	1	1	1	1	1	1	1	1	MV1	UP & DOWN	
9	G2W 002 315	VANE MOTOR (HORIZONTAL) (LOWER)	1	1	1	1	1	1	1	1	1	1	1	1	1	1	1	1	MV2	UP & DOWN	
10	—	SWITCH SHEET	1	1	1	1	1	1	1	1	1	1	1	1	1	1	1	1		[DY79C587H01]	
11	—	DISPLAY AND RECEIVER P.C. BOARD HOLDER ASSEMBLY	1	1	1	1	1	1	1	1	1	1	1	1	1	1	1	1		[DY25Y040G03]	
12	—	V.A. CLAMP ASSEMBLY	1	1	1	1	1	1	1	1	1	1	1	1	1	1	1	1		[DK00G513G02]	
13	G2W 021 410	ELECTRONIC CONTROL P.C. BOARD	1		1	1														Includes RECEIVER P.C. BOARD, DISPLAY P.C. BOARD, SWITCH/BUZZER P.C. BOARD, TERMINAL P.C. BOARD and ROOM TEMPERATURE THERMISTOR (RT11)	
13	G2W 022 410	ELECTRONIC CONTROL P.C. BOARD					1	1													
13	G2W 023 410	ELECTRONIC CONTROL P.C. BOARD								1	1										
13	G2W 024 410	ELECTRONIC CONTROL P.C. BOARD												1		1	1				
13	G2W 029 410	ELECTRONIC CONTROL P.C. BOARD	1																		
13	G2W 030 410	ELECTRONIC CONTROL P.C. BOARD					1														
13	G2W 031 410	ELECTRONIC CONTROL P.C. BOARD								1											
13	G2W 032 410	ELECTRONIC CONTROL P.C. BOARD													1						
14	—	PB-COVER (RIGHT)	1	1	1	1	1	1	1	1	1	1	1	1	1	1	1	1			[DK00G512G03]
15	G2W 001 425	VARISTOR	1	1	1	1	1	1	1	1	1	1	1	1	1	1	1	1	NR11		
16	G2W 002 422	FUSE	1	1	1	1	1	1	1	1	1	1	1	1	1	1	1	1	F11	T3.15AL250V	
17	G2W 001 310	INDOOR COIL THERMISTOR	1	1	1	1	1	1	1	1									RT12, RT13		
17	G2W 002 310	INDOOR COIL THERMISTOR									1	1	1	1	1	1	1	1	RT12, RT13		
18	—	PB-COVER (LEFT)	1	1	1	1	1	1	1	1	1	1	1	1	1	1	1	1		[DY00Y064G01]	
19	—	PB-BOX (LEFT)	1	1	1	1	1	1	1	1	1	1	1	1	1	1	1	1		[DY25Y063G03]	
20	G2W 005 405	Wi-Fi INTERFACE MAC-577IF2-E	1	1	1	1	1	1	1	1	1	1	1	1	1	1	1	1		MAC-577IF2-E	
21	—	MOTOR BED	1	1	1	1	1	1	1	1	1	1	1	1	1	1	1	1		[SQ00C989G06]	
22	G2W 003 103	MOTOR BAND	1	1	1	1	1	1	1	1	1	1	1	1	1	1	1	1			
23	—	WATER COVER	1	1	1	1	1	1	1	1	1	1	1	1	1	1	1	1		[JQ25Y260G01]	
24	G2W 001 300	INDOOR FAN MOTOR	1	1	1	1	1	1	1	1	1	1	1	1	1	1	1	1	MF	RC0J30-□□, Includes FAN MOTOR RUBBER MOUNT (2 PCS/SET)	
25	G2W 002 500	LINE FLOW FAN	1	1	1	1	1	1	1	1	1	1	1	1	1	1	1	1			
②6	—	LEAD WIRE	1	1	1	1	1	1	1	1	1	1	1	1	1	1	1	1		[SM00G912G01], Between CN151 on ELECTRONIC CONTROL P.C. BOARD and VANE MOTOR	

MSZ-AY25VGKP - [E1], [SC1], [ET1], [ER1]

MSZ-AY35VGKP - [E1], [SC1], [ET1], [ER1]

MSZ-AY42VGKP - [E1], [SC1], [ET1], [ER1]

MSZ-AY50VGKP - [E1], [SC1], [ET1], [ER1]

1-9. INDOOR UNIT STRUCTURAL PARTS

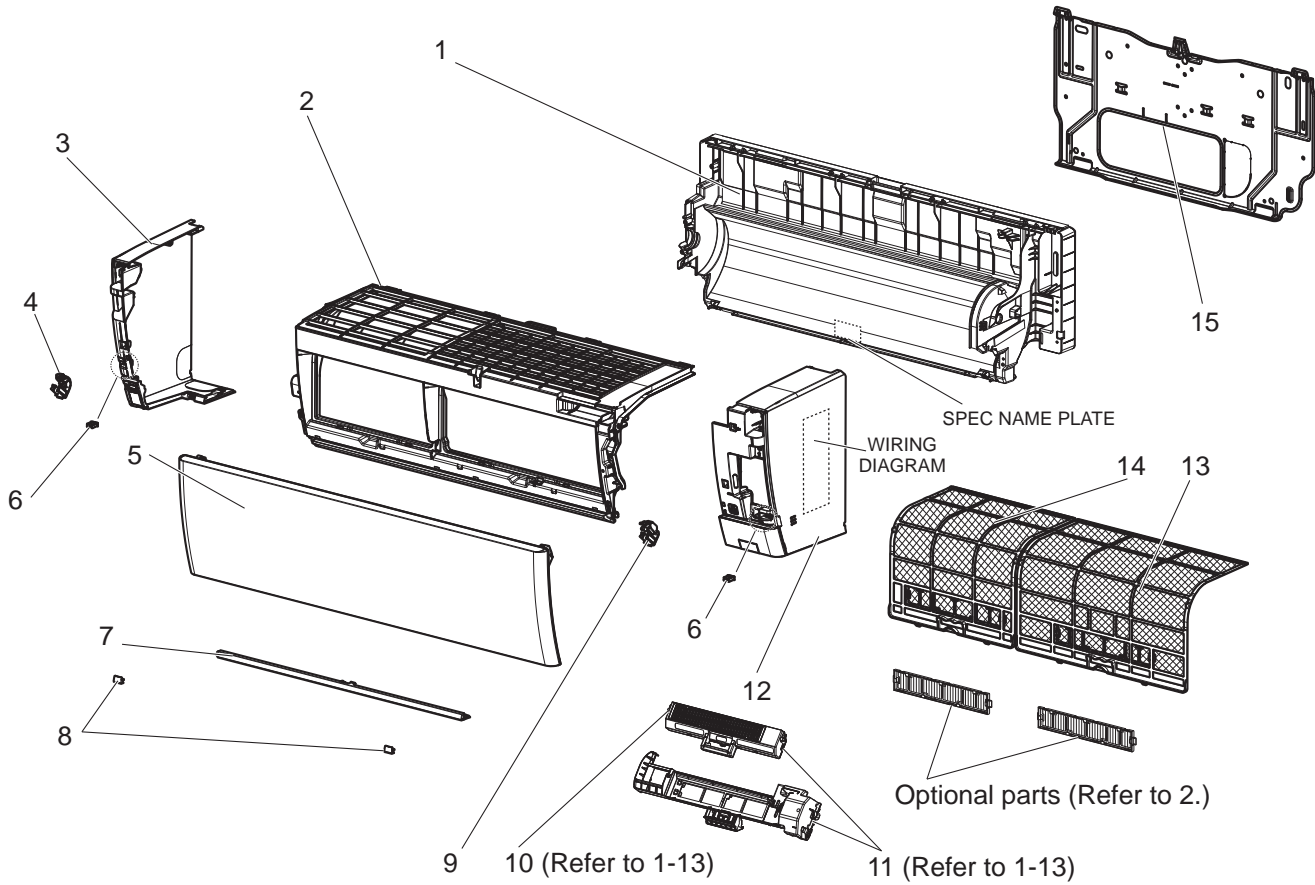

1-10. ACCESSORY AND REMOTE CONTROLLER

1-11. INDOOR UNIT HEAT EXCHANGER

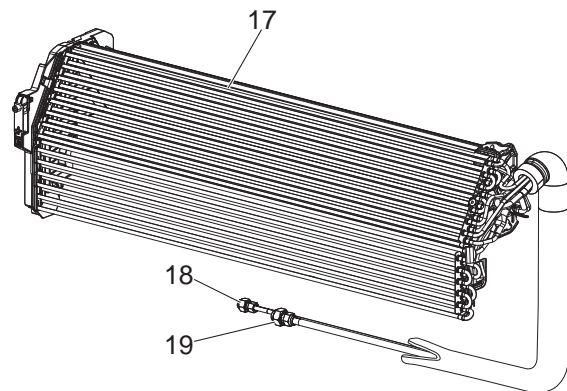
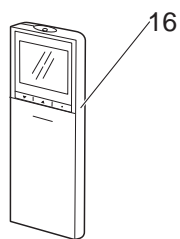

1-9. INDOOR UNIT STRUCTURAL PARTS

1. The part quantity below indicates the required number of pieces per unit.

No.	Part No.	Part name	MSZ-AY25VGKP-[ET]	MSZ-AY25VGKP-[SCI]	MSZ-AY25VGKP-[ETI]	MSZ-AY25VGKP-[ERI]	MSZ-AY35VGKP-[ET]	MSZ-AY35VGKP-[SCI]	MSZ-AY35VGKP-[ETI]	MSZ-AY35VGKP-[ERI]	MSZ-AY42VGKP-[ET]	MSZ-AY42VGKP-[SCI]	MSZ-AY42VGKP-[ETI]	MSZ-AY42VGKP-[ERI]	MSZ-AY50VGKP-[ET]	MSZ-AY50VGKP-[SCI]	MSZ-AY50VGKP-[ETI]	MSZ-AY50VGKP-[ERI]	Symbol in Wiring Diagram	Remarks
1	G2W 004 026	BOX ASSEMBLY	1	1	1	1	1	1	1	1	1	1	1	1	1	1	1	1		Not including SPEC NAME PLATE
2	G2W 002 003	PANEL (FRONT) ASSEMBLY	1	1	1	1	1	1	1	1	1	1	1	1	1	1	1	1		
3	G2W 002 020	PANEL (LEFT) ASSEMBLY	1	1	1	1	1	1	1	1	1	1	1	1	1	1	1	1		Includes No. 4, 6
4	G2W 001 120	ARM HOLDER (LEFT)	1	1	1	1	1	1	1	1	1	1	1	1	1	1	1	1		
5	G2W 003 010	FRONT PANEL	1	1	1	1	1	1	1	1	1	1	1	1	1	1	1	1		
6	G2W 001 118	CATCH	2	2	2	2	2	2	2	2	2	2	2	2	2	2	2	2		
7	G2W 002 006	PANEL (UNDER) ASSEMBLY	1	1	1	1	1	1	1	1	1	1	1	1	1	1	1	1		
8	G2W 001 023	SCREW CAP	2	2	2	2	2	2	2	2	2	2	2	2	2	2	2	2		
9	G2W 002 120	ARM HOLDER (RIGHT)	1	1	1	1	1	1	1	1	1	1	1	1	1	1	1	1		
10	G2W 001 418	AIR PURIFYING DEVICE	1	1	1	1	1	1	1	1	1	1	1	1	1	1	1	1		
11	G2W 001 428	AIR PURIFYING DEVICE SUPPORT	1	1	1	1	1	1	1	1	1	1	1	1	1	1	1	1		
12	G2W 003 014	PANEL (RIGHT) ASSEMBLY	1	1	1	1	1	1	1	1	1	1	1	1	1	1	1	1		Includes No. 6, 9 Not including WIRING DIAGRAM
13	G2W 005 100	AIR FILTER_RIGHT	1	1	1	1	1	1	1	1	1	1	1	1	1	1	1	1		1 PC/SET
14	G2W 006 100	AIR FILTER_LEFT	1	1	1	1	1	1	1	1	1	1	1	1	1	1	1	1		1 PC/SET
15	G2W 003 115	INSTALLATION PLATE	1	1	1	1	1	1	1	1	1	1	1	1	1	1	1	1		

1-10. ACCESSORY AND REMOTE CONTROLLER

1. The part quantity below indicates the required number of pieces per unit.

No.	Part No.	Part name	MSZ-AY25VGKP-[ET]	MSZ-AY25VGKP-[SCI]	MSZ-AY25VGKP-[ETI]	MSZ-AY25VGKP-[ERI]	MSZ-AY35VGKP-[ET]	MSZ-AY35VGKP-[SCI]	MSZ-AY35VGKP-[ETI]	MSZ-AY35VGKP-[ERI]	MSZ-AY42VGKP-[ET]	MSZ-AY42VGKP-[SCI]	MSZ-AY42VGKP-[ETI]	MSZ-AY42VGKP-[ERI]	MSZ-AY50VGKP-[ET]	MSZ-AY50VGKP-[SCI]	MSZ-AY50VGKP-[ETI]	MSZ-AY50VGKP-[ERI]	Symbol in Wiring Diagram	Remarks
16	G2W 010 400	REMOTE CONTROLLER	1				1								1					SH22R
16	G2W 011 400	REMOTE CONTROLLER		1				1								1				SH22T
16	G2W 012 400	REMOTE CONTROLLER				1								1					1	SH22R

1-11. INDOOR UNIT HEAT EXCHANGER

1. The part quantity below indicates the required number of pieces per unit.

No.	Part No.	Part name	MSZ-AY25VGKP-[ET]	MSZ-AY25VGKP-[SCI]	MSZ-AY25VGKP-[ETI]	MSZ-AY25VGKP-[ERI]	MSZ-AY35VGKP-[ET]	MSZ-AY35VGKP-[SCI]	MSZ-AY35VGKP-[ETI]	MSZ-AY35VGKP-[ERI]	MSZ-AY42VGKP-[ET]	MSZ-AY42VGKP-[SCI]	MSZ-AY42VGKP-[ETI]	MSZ-AY42VGKP-[ERI]	MSZ-AY50VGKP-[ET]	MSZ-AY50VGKP-[SCI]	MSZ-AY50VGKP-[ETI]	MSZ-AY50VGKP-[ERI]	Symbol in Wiring Diagram	Remarks
17	G2W 008 600	INDOOR HEAT EXCHANGER	1			1				1										Includes No. 18, 19
17	G2W 009 600	INDOOR HEAT EXCHANGER									1		1	1			1	1		Includes No. 18, 19
17	G2W 010 600	INDOOR HEAT EXCHANGER		1					1											Includes No. 18, 19
17	G2W 011 600	INDOOR HEAT EXCHANGER										1				1				Includes No. 18, 19
18	G2W 001 605	UNION (LIQUID)	1	1	1	1	1	1	1	1	1	1	1	1	1	1	1	1		'1/4" (ø6.35)
19	G2W 002 605	UNION (GAS)	1	1	1	1	1	1	1	1	1	1	1	1	1	1	1	1		'3/8" (ø9.52)

MSZ-AY25VGKP - [E1, SC1, ET1, ER1]
MSZ-AY42VGKP - [E1, SC1, ET1, ER1]

MSZ-AY35VGKP - [E1, SC1, ET1, ER1]
MSZ-AY50VGKP - [E1, SC1, ET1, ER1]

1-12. INDOOR UNIT ELECTRICAL PARTS AND FUNCTIONAL PARTS

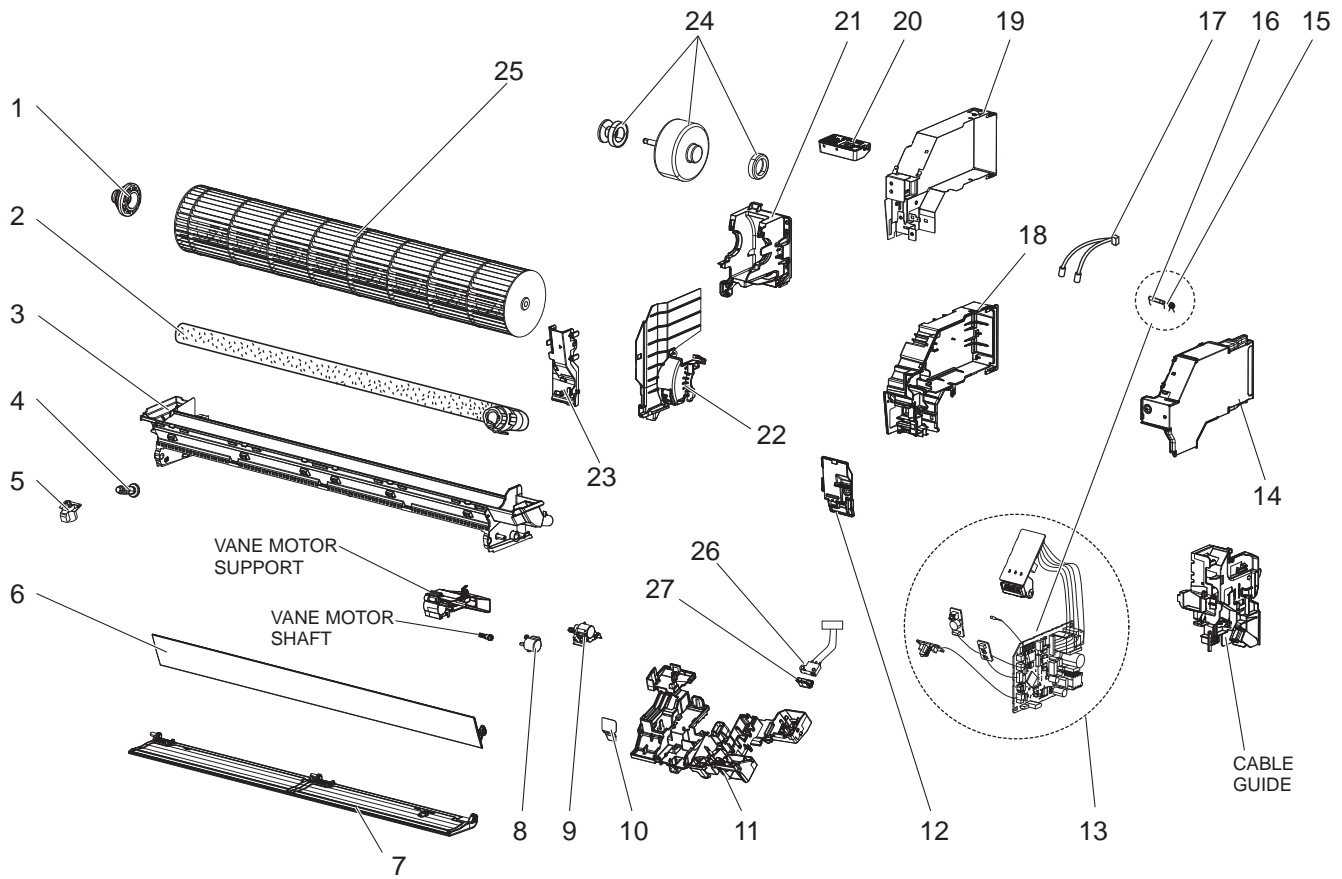

1-12. INDOOR UNIT ELECTRICAL PARTS AND FUNCTIONAL PARTS

- The part quantity below indicates the required number of pieces per unit.
- The circled No. indicates that the part is not shown in the figure.

No.	Part No.	Part name	MSZ-AY25VGKP	ET	MSZ-AY25VGKP	SCI	MSZ-AY25VGKP	ETI	MSZ-AY25VGKP	ERI	MSZ-AY35VGKP	ET	MSZ-AY35VGKP	SCI	MSZ-AY35VGKP	ETI	MSZ-AY35VGKP	ERI	MSZ-AY42VGKP	ET	MSZ-AY42VGKP	SCI	MSZ-AY42VGKP	ETI	MSZ-AY42VGKP	ERI	MSZ-AY50VGKP	ET	MSZ-AY50VGKP	SCI	MSZ-AY50VGKP	ETI	MSZ-AY50VGKP	ERI	Symbol in Wiring Diagram	Remarks [Drawing No.]		
			1	1	1	1	1	1	1	1	1	1	1	1	1	1	1	1	1	1	1	1	1	1	1	1	1	1	1	1	1	1	1	1			1	
1	G2W 002 520	BEARING MOUNT ASSEMBLY	1	1	1	1	1	1	1	1	1	1	1	1	1	1	1	1	1	1	1	1	1	1	1	1	1	1	1	1	1	1	1	1		Includes sleeve bearing		
2	G2W 001 110	DRAIN HOSE ASSEMBLY (SHORT)	1		1	1	1				1	1	1			1	1	1			1	1	1		1	1		1	1						L=520 mm			
2	G2W 002 110	DRAIN HOSE ASSEMBLY		1							1										1						1								L=670 mm			
3	G2W 003 030	NOZZLE ASSEMBLY	1	1	1	1	1	1	1	1	1	1	1	1	1	1	1	1	1	1	1	1	1	1	1	1	1	1	1	1	1	1	1	1				
4	G2W 001 708	DRAIN CAP	1	1	1	1	1	1	1	1	1	1	1	1	1	1	1	1	1	1	1	1	1	1	1	1	1	1	1	1	1	1	1	1				
5	G2W 001 320	VANE MOTOR (VERTICAL)	1	1	1	1	1	1	1	1	1	1	1	1	1	1	1	1	1	1	1	1	1	1	1	1	1	1	1	1	1	1	1	1	MV3	RIGHT & LEFT		
6	G2W 004 017	HORIZONTAL VANE (UPPER) ASSEMBLY	1	1	1	1	1	1	1	1	1	1	1	1	1	1	1	1	1	1	1	1	1	1	1	1	1	1	1	1	1	1	1	1		Includes shaft		
7	G2W 005 017	HORIZONTAL VANE (LOWER) ASSEMBLY	1	1	1	1	1	1	1	1	1	1	1	1	1	1	1	1	1	1	1	1	1	1	1	1	1	1	1	1	1	1	1	1		Includes shaft		
8	G2W 003 315	VANE MOTOR (HORIZONTAL) (UPPER)	1	1	1	1	1	1	1	1	1	1	1	1	1	1	1	1	1	1	1	1	1	1	1	1	1	1	1	1	1	1	1	MV1	UP & DOWN			
9	G2W 002 315	VANE MOTOR (HORIZONTAL) (LOWER)	1	1	1	1	1	1	1	1	1	1	1	1	1	1	1	1	1	1	1	1	1	1	1	1	1	1	1	1	1	1	1	MV2	UP & DOWN			
10	—	SWITCH SHEET	1	1	1	1	1	1	1	1	1	1	1	1	1	1	1	1	1	1	1	1	1	1	1	1	1	1	1	1	1	1	1		[DY79C587H01]			
11	—	DISPLAY AND RECEIVER P.C. BOARD HOLDER ASSEMBLY	1	1	1	1	1	1	1	1	1	1	1	1	1	1	1	1	1	1	1	1	1	1	1	1	1	1	1	1	1	1	1	1		[DY25Y040G03]		
12	—	V.A. CLAMP ASSEMBLY	1	1	1	1	1	1	1	1	1	1	1	1	1	1	1	1	1	1	1	1	1	1	1	1	1	1	1	1	1	1	1	1		[DK00G513G02]		
13	G2W 017 410	ELECTRONIC CONTROL P.C. BOARD	1		1	1																														Includes RECEIVER		
13	G2W 018 410	ELECTRONIC CONTROL P.C. BOARD									1		1	1																						P.C. BOARD, DISPLAY		
13	G2W 019 410	ELECTRONIC CONTROL P.C. BOARD													1		1	1																		P.C. BOARD, SWITCH/		
13	G2W 020 410	ELECTRONIC CONTROL P.C. BOARD																								1		1	1							BUZZER P.C. BOARD,		
13	G2W 025 410	ELECTRONIC CONTROL P.C. BOARD		1																																TERMINAL P.C.		
13	G2W 026 410	ELECTRONIC CONTROL P.C. BOARD									1																										BOARD and ROOM	
13	G2W 027 410	ELECTRONIC CONTROL P.C. BOARD														1																					TEMPERATURE	
13	G2W 028 410	ELECTRONIC CONTROL P.C. BOARD																									1										THERMISTOR (RT11)	
14	—	PB-COVER (RIGHT)	1	1	1	1	1	1	1	1	1	1	1	1	1	1	1	1	1	1	1	1	1	1	1	1	1	1	1	1	1	1	1	1		[DK00G512G03]		
15	G2W 001 425	VARISTOR	1	1	1	1	1	1	1	1	1	1	1	1	1	1	1	1	1	1	1	1	1	1	1	1	1	1	1	1	1	1	1	1	NR11			
16	G2W 002 422	FUSE	1	1	1	1	1	1	1	1	1	1	1	1	1	1	1	1	1	1	1	1	1	1	1	1	1	1	1	1	1	1	1	1	F11	T3.15AL250V		
17	G2W 001 310	INDOOR COIL THERMISTOR	1	1	1	1	1	1	1	1	1	1	1																								RT12, RT13	
17	G2W 002 310	INDOOR COIL THERMISTOR															1	1	1	1	1	1	1	1	1	1	1	1	1	1	1	1	1	1		RT12, RT13		
18	—	PB-COVER (LEFT)	1	1	1	1	1	1	1	1	1	1	1	1	1	1	1	1	1	1	1	1	1	1	1	1	1	1	1	1	1	1	1	1		[DY00Y064G01]		
19	—	PB-BOX (LEFT)	1	1	1	1	1	1	1	1	1	1	1	1	1	1	1	1	1	1	1	1	1	1	1	1	1	1	1	1	1	1	1	1	1		[DY25Y063G03]	
20	G2W 005 405	Wi-Fi INTERFACE MAC-577IF2-E	1	1	1	1	1	1	1	1	1	1	1	1	1	1	1	1	1	1	1	1	1	1	1	1	1	1	1	1	1	1	1	1	1		MAC-577IF2-E	
21	—	MOTOR BED	1	1	1	1	1	1	1	1	1	1	1	1	1	1	1	1	1	1	1	1	1	1	1	1	1	1	1	1	1	1	1	1	1		[SQ00C989G06]	
22	G2W 003 103	MOTOR BAND	1	1	1	1	1	1	1	1	1	1	1	1	1	1	1	1	1	1	1	1	1	1	1	1	1	1	1	1	1	1	1	1	1	1		
23	—	WATER COVER	1	1	1	1	1	1	1	1	1	1	1	1	1	1	1	1	1	1	1	1	1	1	1	1	1	1	1	1	1	1	1	1	1		[JQ25Y259G01]	
24	G2W 001 300	INDOOR FAN MOTOR	1	1	1	1	1	1	1	1	1	1	1	1	1	1	1	1	1	1	1	1	1	1	1	1	1	1	1	1	1	1	1	1	MF	RC0J30-□□, Includes FAN MOTOR RUBBER MOUNT (2 PCS/SET)		
25	G2W 002 500	LINE FLOW FAN	1	1	1	1	1	1	1	1	1	1	1	1	1	1	1	1	1	1	1	1	1	1	1	1	1	1	1	1	1	1	1	1	1			
26	G2W 001 325	INTERLOCK SWITCH	1	1	1	1	1	1	1	1	1	1	1	1	1	1	1	1	1	1	1	1	1	1	1	1	1	1	1	1	1	1	1	1	1	1		
27	—	SW ARM	1	1	1	1	1	1	1	1	1	1	1	1	1	1	1	1	1	1	1	1	1	1	1	1	1	1	1	1	1	1	1	1	1		[DY25J061G03]	
②8	—	LEAD WIRE	1	1	1	1	1	1	1	1	1	1	1	1	1	1	1	1	1	1	1	1	1	1	1	1	1	1	1	1	1	1	1	1	1		[SM00G912G01], Between CN151 on ELECTRONIC CONTROL P.C. BOARD and VANE MOTOR	

1-13. AIR PURIFYING DEVICE

Every 3 months:

- Remove dirt by a vacuum cleaner.

When dirt cannot be removed by vacuum cleaning:

- Soak the filter together with its frame in lukewarm water and rinse it.
- After washing, dry it well in shade.

NOTE 1: Clean the filters regularly for best performance and to reduce power consumption.

NOTE 2: Dirty filters cause condensation in the air conditioner which will contribute to the growth of fungi such as mold. It is therefore recommended to clean air filters every 2 weeks.

NOTE 3: The air purifying device does not function for safety for a couple minutes after the operation starts or the front panel is opened/closed.

NOTE 4: Do not disassemble the air purifying device.

NOTE 5: Do not touch any parts other than the frame of the air purifying device.

Model
MSZ-AY25VGKP-[E1], [SC1], [ET1], [ER1]
MSZ-AY35VGKP-[E1], [SC1], [ET1], [ER1]
MSZ-AY42VGKP-[E1], [SC1], [ET1], [ER1]
MSZ-AY50VGKP-[E1], [SC1], [ET1], [ER1]

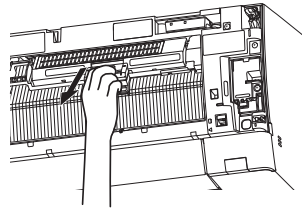

1-14. AIR CLEANING FILTER (V BLOCKING FILTER)

Every 3 months:

- Remove dirt by a vacuum cleaner.

When dirt cannot be removed by vacuum cleaning:

- Soak the filter and its frame in lukewarm water before rinsing it.
- After washing, dry it well in shade. Install all tabs of the air filter.

Every year:

- Replace it with a new air cleaning filter for best performance.

NOTE 1: Clean the filters regularly for best performance and to reduce power consumption.

NOTE 2: Dirty filters cause condensation in the air conditioner which will contribute to the growth of fungi such as mold. It is therefore recommended to clean air filters every 2 weeks.

Model	Part No.
MSZ-AY25VG-[ET1]	MAC-2470FT-E
MSZ-AY35VG-[ET1]	
MSZ-AY42VG-[ET1]	
MSZ-AY50VG-[ET1]	
MSZ-AY25VGK-[E1], [SC1], [ET1], [ER1]	
MSZ-AY35VGK-[E1], [SC1], [ET1], [ER1]	
MSZ-AY42VGK-[E1], [SC1], [ET1], [ER1]	
MSZ-AY50VGK-[E1], [SC1], [ET1], [ER1]	

Pull to remove from the air filter

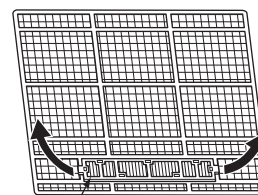

Air cleaning filter

2-1. AIR CLEANING FILTER (V BLOCKING FILTER)

Every 3 months:

- Remove dirt by a vacuum cleaner.

When dirt cannot be removed by vacuum cleaning:

- Soak the filter and its frame in lukewarm water before rinsing it.
- After washing, dry it well in shade. Install all tabs of the air filter.

Every year:

- Replace it with a new air cleaning filter for best performance.

NOTE 1: Clean the filters regularly for best performance and to reduce power consumption.

NOTE 2: Dirty filters cause condensation in the air conditioner which will contribute to the growth of fungi such as mold. It is therefore recommended to clean air filters every 2 weeks.

Model	Part No.
MSZ-AY25VG- ET1	MAC-2470FT-E
MSZ-AY35VG- ET1	
MSZ-AY42VG- ET1	
MSZ-AY50VG- ET1	
MSZ-AY25VGK- E1 , SC1 , ET1 , ER1	
MSZ-AY35VGK- E1 , SC1 , ET1 , ER1	
MSZ-AY42VGK- E1 , SC1 , ET1 , ER1	
MSZ-AY50VGK- E1 , SC1 , ET1 , ER1	
MSZ-AY25VGKP- E1 , SC1 , ET1 , ER1	
MSZ-AY35VGKP- E1 , SC1 , ET1 , ER1	
MSZ-AY42VGKP- E1 , SC1 , ET1 , ER1	
MSZ-AY50VGKP- E1 , SC1 , ET1 , ER1	

Pull to remove from the air filter

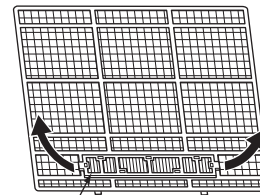

Air cleaning filter

mitsubishi electric corporation

HEAD OFFICE: TOKYO BUILDING, 2-7-3, MARUNOUCHI, CHIYODA-KU, TOKYO 100-8310, JAPAN

© Copyright 2022 MITSUBISHI ELECTRIC CORPORATION
Published: Dec. 2022. No. OBB932
Made in Japan

Specifications are subject to change without notice.