

CYLINDER UNIT

EHPT20Q-VM2EA

INSTALLATION MANUAL

FOR INSTALLER**English**

For safe and correct use, read this Manual and the outdoor unit installation manual thoroughly before installing the cylinder unit. This Installation Manual should be kept safe with the unit or in an accessible place for future reference. Cylinder unit "EHPT20Q-VM2EA" is compatible only with the outdoor unit (Model name : QUHZ-W40VA). English is the original language. The other languages versions are translation of the original.

INSTALLATIONSHANDBUCH

FÜR INSTALLATEUR**Deutsch**

Lesen Sie für eine sichere und ordnungsgemäße Verwendung vor der Installation des Hydraulikmoduls inkl. Speicher dieses Handbuch und das Installationshandbuch der Außeneinheit. Bewahren Sie dieses Installationshandbuch zum späteren Nachschlagen mit dem Gerät oder an einem gut zugänglichen Ort sicher auf. Das Hydraulikmodul inkl. Speicher „EHPT20Q-VM2EA“ ist nur mit dieser Außeneinheit kompatibel (Gerätebezeichnung: QUHZ-W40VA). Die Originalsprache ist Englisch. Die anderen Sprachversionen sind vom Original übersetzt.

MANUEL D'INSTALLATION

POUR L'INSTALLATEUR**Français**

Pour une utilisation sûre et correcte, lisez soigneusement ce manuel et le manuel d'installation de l'unité extérieure avant d'installer l'Ecodan hydrobox duo. Ce manuel d'installation doit être conservé en lieu sûr avec l'unité ou dans un endroit accessible pour consultation ultérieure. L'Ecodan hydrobox duo « EHPT20Q-VM2EA » n'est compatible qu'avec l'unité extérieure (Nom de modèle : QUHZ-W40VA). L'anglais est la langue originale. Les versions fournies dans d'autres langues sont des traductions de l'original.

INSTALLATIEHANDLEIDING

VOOR DE INSTALLATEUR**Nederlands**

Voor een veilig en correct gebruik dient u grondig deze handleiding te lezen en de installatiehandleiding van de buitenunit, voordat u de cilinder installeert. Deze installatiehandleiding dient voor toekomstig gebruik op een veilige bij de unit te worden bewaard of op een andere acceptabele plaats. Cilinder "EHPT20Q-VM2EA" is alleen compatibel met de buitenunit (modelnaam : QUHZ-W40VA). Engels is de oorspronkelijke taal. De andere taalversies zijn vertalingen van het origineel.

MANUAL DE INSTALACIÓN

PARA EL INSTALADOR**Español**

Para un uso correcto y seguro, lea detalladamente este manual y el manual de instalación de la unidad exterior antes de instalar el hydrobox duo. Este manual de instalación debe guardarse en un lugar seguro junto con la unidad o en un lugar accesible para futura referencia. El hydrobox duo "EHPT20Q-VM2EA" solo es compatible con la unidad exterior (nombre del modelo: QUHZ-W40VA). El idioma original del documento es el inglés. Las versiones en los demás idiomas son traducciones del original.

MANUALE DI INSTALLAZIONE

PER INSTALLATORI**Italiano**

Per un utilizzo sicuro e corretto, prima di installare l'Hydrotank, leggere questo manuale e il manuale di installazione dell'unità esterna. Conservare questo manuale di installazione insieme all'unità o in un luogo a portata di mano per le consultazioni future. Hydrotank "EHPT20Q-VM2EA" è compatibile unicamente con l'unità esterna (modello: QUHZ-W40VA). Il testo originale è redatto in lingua inglese. Le altre versioni linguistiche rappresentano traduzioni dell'originale.

INSTALLATIONSMANUAL

TIL INSTALLATØREN**Dansk**

For at opnå sikker og korrekt brug skal denne manual og installationsmanualen til ude delen læses grundigt igennem, inden tank modulet (unit) installeres. Denne installationsmanual skal opbevares sammen med modulet eller på et tilgængeligt sted af hensyn til fremtidig reference. Tank modulet (unit) "EHPT20Q-VM2EA" er kun kompatibel med ude delen (modelnavn: QUHZ-W40VA). Engelsk er det oprindelige sprog. De andre sprogversioner er oversættelser af originalen.

INSTALLATIONSMANUAL

TILL INSTALLATÖREN**Svenska**

Säkerställ säkert och korrekt bruk genom att läsa igenom denna manual samt installationsmanualen till utomhusenheten innan cylindertanken installeras. Installationsmanualen ska förvaras tillsammans med enheten eller på en lättåtkomlig plats för framtida bruk. Cylindertanken "EHPT20Q-VM2EA" är kompatibel enbart med utomhusenheten (modellnamn: QUHZ-W40VA). Engelska är originalspråket. De övriga språkversionerna är översättningar av originalet.



INSTALLASJONSMANUAL

FOR INSTALLATØR**Norsk**

For sikker og korrekt bruk, les denne håndboken og installeringshåndboken for utendørsenheten grundig før du installerer sylinderenheten. Denne installeringshåndboken skal oppbevares trygt sammen med enheten eller på et tilgjengelig sted for fremtidig referanse. Sylinderenheten "EHPT20Q-VM2EA" er kun kompatibel med utendørsenheten (Modellnavn: QUHZ-W40VA). Engelsk er originalspråket. De andre språkversjonene er oversettelser av originalen.

Contents

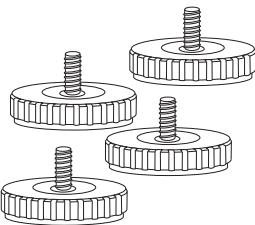
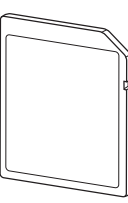
1. Safety Notices.....	3
2. Introduction.....	5
3. Technical Information	5
4. Installation.....	11
4.1 Location	11
4.2 Water Quality and System Preparation	13
4.3 Water Pipework.....	15
4.4 Safety Device Discharge Arrangements (G3)	20
4.5 Electrical Connection.....	22
5. System Set Up	24
5.1 DIP Switch Functions.....	24
5.2 Connecting inputs/outputs.....	25
5.3 2-zone valve ON/OFF control	27
5.4 Indoor unit only operation (during installation work).....	27
5.5 Remote Controller Options	28
5.6 Using SD memory card.....	29
5.7 Main Controller	30
6. Commissioning.....	37
7. Case of DHW only use	38
8. Service and Maintenance.....	40

Accessories (Included)		
Adjustable feet	SD memory card	Hose (rubber)
		
4	1	1

Abbreviations and glossary

No.	Abbreviations/Word	Description
1	Compensation curve mode	Space heating incorporating outdoor ambient temperature compensation
2	COP	Coefficient of Performance (The efficiency of the heat pump)
3	Cylinder unit	Indoor primary thermal store tank and component plumbing parts
4	DHW mode	Domestic hot water heating mode for showers, sinks, etc.
5	Flow temperature	Temperature at which water is delivered to the primary circuit for thermal store or space heating
6	Freeze stat function	Space heating control routine to prevent water pipes freezing
7	FTC	Flow temperature controller (the circuit board within cylinder unit that controls the system.)
8	Heating mode	Space heating through radiators or Underfloor heating
9	PRV	Pressure relief valve
10	Return temperature	Temperature at which water is returned from the primary circuit for thermal store and space heating
11	TRV	Thermostatic radiator valve – a valve on the entrance or exit of the radiator panel to control its heat output

1 Safety Notices

Please read the following safety precautions carefully.

⚠ WARNING
Precautions that **MUST** be observed to prevent injuries or death.

⚠ CAUTION
Precautions that **MUST** be observed to prevent damage to unit.

Intended use

- This product is designed and intended for domestic.
- This appliance is not intended for use by persons (including children) with reduced physical, sensory or mental capabilities, or lack of experience and knowledge, unless they have been given supervision or instruction concerning the use of the appliance by a person responsible for their safety. Children should be supervised to ensure they **DO NOT** play with the appliance or its associated controls.
- This appliance can be used by children aged from 8 years and above and persons with reduced physical, sensory or mental capabilities or lack of experience and knowledge if they have been given supervision or instruction concerning use of the appliance in a safe way and understand the hazards involved. Children shall not play with the appliance. Cleaning and user maintenance shall not be made by children without supervision.

This Installation Manual along with the Operational Manual should be left with the product after installation for future reference.

Mitsubishi Electric is NOT responsible for the failure of locally-supplied parts.

- Be sure to perform periodical maintenance.
- Be sure to follow your local regulations.
- Be sure to follow the instructions provided in this manual.

⚠ WARNING

Mechanical

- The cylinder unit and outdoor unit **MUST** not be installed, disassembled, relocated, altered or repaired by the user. Ask an authorised installer or technician. If the unit is installed improperly or modified after installation by the user water leakage, electric shock or fire may result.
- The outdoor unit should be securely fixed to a hard level surface capable of bearing its weight.
- The cylinder unit should be positioned on a hard level surface capable of supporting its filled weight to prevent excessive sound or vibration.
- Do not position furniture or electrical appliances below the outdoor unit or cylinder unit.
- The discharge pipework from the emergency devices of the cylinder unit should be installed according to local law / regulations.
- Only use accessories and replacement parts authorised by Mitsubishi Electric. These should only be fitted by a qualified technician.

Electrical

- All electrical work should be performed by a qualified technician according to local regulations and the instructions given in this manual.
- The units **MUST** be powered by a dedicated power supply and the correct voltage and circuit breakers **MUST** be used.
- Wiring should be in accordance with national wiring regulations. Connections **MUST** be made securely and without tension on the terminals.
- Earth unit correctly.

1 Safety Notices

⚠ WARNING

General

- Keep children and pets away from both the cylinder unit and outdoor unit.
- Do not use the hot water produced by the heat pump directly for drinking or cooking. This could cause illness to the user.
- Do not stand on the units.
- Do not touch switches with wet hands.
- Annual maintenance checks on both the cylinder unit and the outdoor unit should be conducted by a suitable qualified person.
- Do not place containers with liquids on top of the cylinder unit. If they leak or spill onto the cylinder unit damage to the unit and/or fire could occur.
- Do not place any heavy items on top of the cylinder unit or the outdoor unit.
- The use of any refrigerant other than that specified for the system will cause mechanical failure or system malfunction or unit breakdown. In the worst case, this could lead to a serious impediment to securing product safety.
- In heating mode, to avoid the heat emitters being damaged by excessively hot water, set the target flow temperature to a minimum of 2°C below the maximum allowable temperature of all the heat emitters.

⚠ CAUTION

- Use clean water that meets local quality standards on the primary circuit.
- The outdoor unit should be installed in an area with sufficient airflow according to the diagrams in the outdoor unit installation manual.
- The cylinder unit should be located inside to minimise heat loss.
- Water pipe-runs on the primary circuit between outdoor and indoor units should be kept to a minimum to reduce heat loss.
- Ensure condensate from outdoor unit is piped away from the base to avoid puddles of water.
- Remove as much air as possible from the primary and secondary (potable) circuits.
- Refrigerant leakage may cause suffocation. Provide ventilation in accordance with EN378-1.
- Be sure to wrap insulation around the piping. Direct contact with the bare piping may result in burns.
- Never put batteries in your mouth for any reason to avoid accidental ingestion.
- Battery ingestion may cause choking and/or poisoning.
- Install the unit on a rigid structure to prevent excessive sound or vibration during operation.
- Do not transport the cylinder unit with water inside the thermal store tank. This could cause damage to the unit.
- If power to the cylinder unit is to be turned off (or system switched off) for a long time, the water should be drained.
- If unused for a long period, before operation is resumed, secondary (potable) circuit should be flushed through with potable water.
- Preventative measures should be taken against water hammer, such as installing a Water Hammer Arrestor on the primary water circuit, as directed by the manufacturer.

2 Introduction

The purpose of this Installation Manual is to instruct competent persons how to safely and efficiently install and commission the cylinder unit system. The target readers of this manual are competent plumbers and/or refrigeration engineers who have attended and passed the requisite Mitsubishi Electric product training and have appropriate qualifications for installation of an unvented hot water cylinder unit specific to their country.

3 Technical Information

Product specification

Model name		EHPT20Q-VM2EA		
Modes		Space & DHW heating		
Nominal thermal store tank volume		200 L		
Overall unit dimensions		1600 × 595 × 680 mm (Height × Width × Depth)		
Weight (empty)		77 kg		
Weight (full)		283 kg		
Primary expansion vessel (Accessory item)	Nominal volume	18 L or 25 L		
	Charge pressure	1.0 bar (100 kPa)		
Safety device	Water circuit (Thermal store tank)	Control thermistor (THW1)	42 - 72°C	
		Control thermistor (THW3)	80 °C	
		Pressure relief valve (2 No. devices)	3.0 bar (300 kPa)	
		Flow sensor	Min. flow 1.3 L/min	
	Booster heater	Manual reset thermostat	90 °C	
		Thermal Cut-out (for dry run prevention)	121 °C	
Primary circuit circulating pump	Thermal store and space heating	Grundfos Solar PML 25-145 180		
	Hot water supply	Grundfos Solar PML 25-145 180		
Connections	Primary circuit	ø 22.0		
	Secondary (potable) circuit	ø 22.0		
Target temperature range	Space heating	Flow temperature *1	25 - 60 °C	
		Room temperature	10 - 30 °C	
	DHW supply maximum temperature		40 - 70 °C	
Guaranteed operating range	Ambient *2	0 - 35 °C (80%RH)		
	Outdoor temperature	- 15 - 35 °C		
Electrical data	Control board	Power supply (Phase, voltage, frequency)	230V N ~ 50 Hz	
		Current	12.8 A	
		Breaker (Local supply)	20 A	
	Booster heater	Power supply (Phase, voltage, frequency)	230V N ~ 50 Hz	
		Capacity	2 kW	
		Current	8.7 A	
Breaker		16 A		
Sound power level		40 dB(A)		
Maximum secondary (potable) water supply pressure		10 bar (1 MPa)		
Maximum primary working pressure		2.5 bar (250 kPa)		
Minimum primary working pressure		1.0 bar (100 kPa)		

*1 Depending on the ambient conditions, it may not reach the set temperature.

*2 The cylinder's environment MUST be frost-free.

<Table 3.1>

3 Technical Information

Component Parts

EHPT20Q-VM2EA

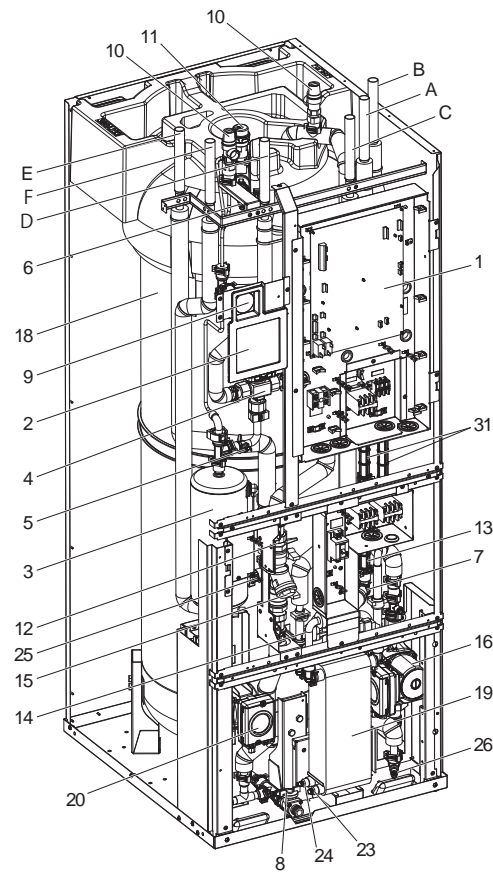

<Figure 3.1>

No.	Part name	EHPT20Q-VM2EA
A	DHW outlet pipe	✓
B	Cold water inlet pipe	✓
C	Water pipe (Space heating return connection)	✓
D	Water pipe (Space heating flow connection)	✓
E	Water pipe (Flow from heat pump connection)	✓
F	Water pipe (Return to heat pump connection)	✓
1	Control and electrical box	✓
2	Main controller	✓
3	Booster heater with thermostat	✓
4	3-way valve	✓
5	Manual thermostat	✓
6	Manual air vent (above tank)	✓
7	Manual air vent (above pump A)	✓
8	Drain valve (Primary circuit)	✓
9	Manometer	✓
10	Primary pressure relief valve (3bar)	✓
11	Automatic air vent	✓
12	Flow sensor 1 (For space heating)	✓
13	Flow sensor A (Secondary (Potable) circuit)	✓
14	Flow sensor B (Primary circuit)	✓
15	Strainer valve	✓
16	Water circulation pump A (For hot water supply to plate heat exchanger)	✓
17	Pump valve	✓
18	Primary thermal store tank	✓
19	Plate heat exchanger (Water - Water)	✓
20	Water circulation pump 1 (For thermal store and space heating)	✓
21	THW1 (Flow water temp. thermistor)	✓
22	THW2 (Return water temp. thermistor)	✓
23	Drain cock (HEX) (Secondary (Potable) circuit)	✓
24	Drain cock (HEX) (Primary circuit)	✓
25	Drain cock (Booster heater)	✓
26	Drain cock (For pump A)	✓
27	THW5A (Stored water temp. thermistor (upper))	✓
28	THW5B (Stored water temp. thermistor (lower))	✓
29	THW3 (Flow water temp. thermistor 2 (to tank))	✓
30	THW4 (DHW supply temp. thermistor)	✓
31	Electrical isolation pipe	✓
32	Primary expansion vessel (Accessory item)	—
33	Drain pipe (Local supply)	—
34	Tundish (Accessory item)	—
35	Isolating valve (Local supply)	—
36	Magnetic filter (Local supply) (Recommended)	—
37	Strainer (Local supply)	—
38	Filling loop (Ball valves, check valves and flexible hose) (Accessory item)	—
39	Thermo mix valve (recommended) (Local supply)	—

<Table 3.2>

<Note>

Make sure to correctly install the Mitsubishi Electric Accessory Parts (e.g. Primary expansion vessel, Tundish and Filling loop) in the field. (See Page 8 and 16 - 19.)

3 Technical Information

<Unit: mm>

Technical Drawings

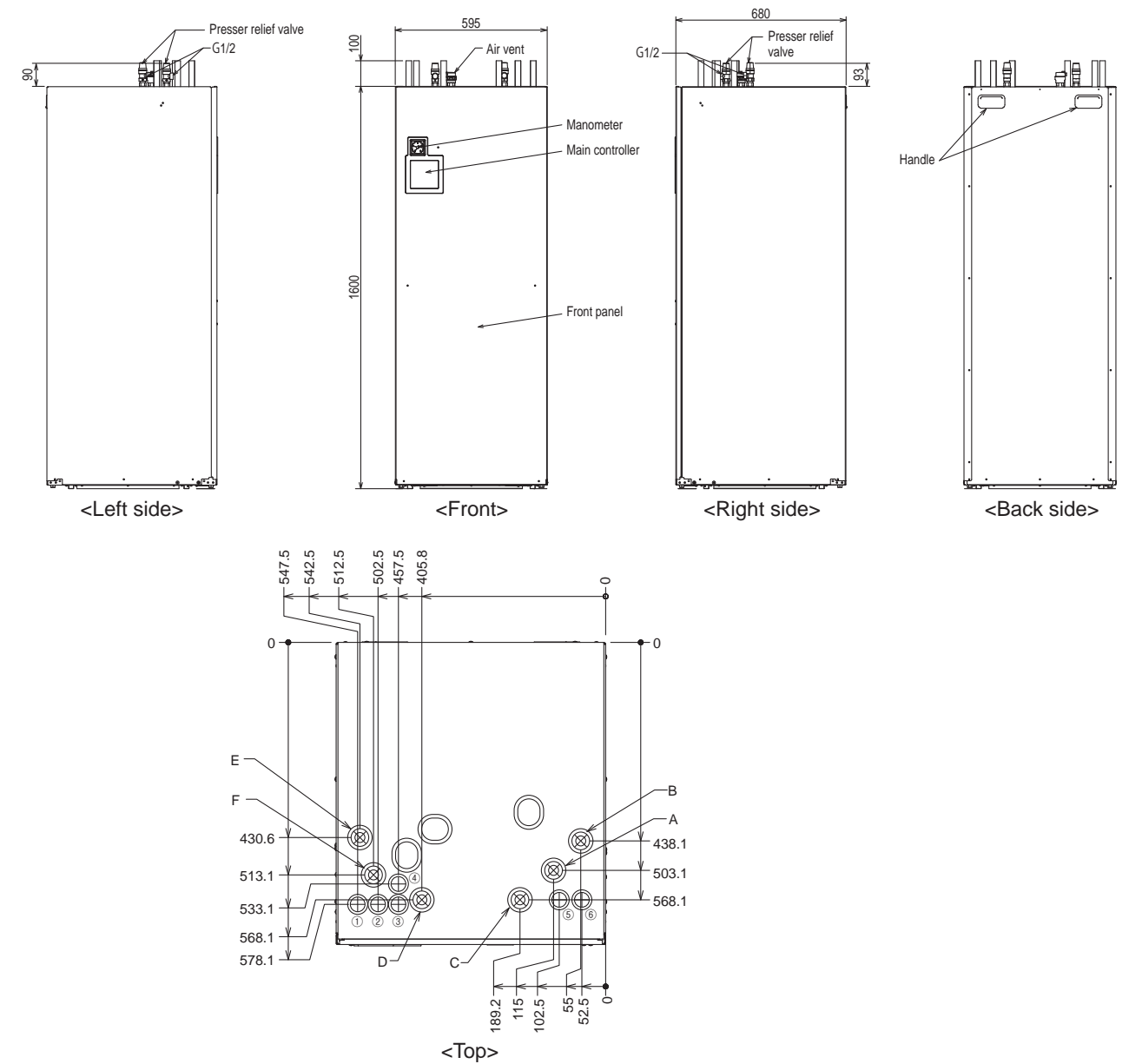

Letter	Pipe and cable description	Connection size/type	Pipe or cable length (Max.)
A	DHW outlet connection	22 mm/Compression	—
B	Cold water inlet connection (Inlet from Mains water supply)	22 mm/Compression	—
C	Space heating return connection	22 mm/Compression	65 m
D	Space heating flow connection	22 mm/Compression	65 m
E	Flow from heat pump connection (No plate heat exchanger)	22 mm/Compression	15 m
F	Return to heat pump connection (No plate heat exchanger)	22 mm/Compression	15 m
①	Booster heater inlet (Power cable 230 V)	Run booster heater cable	—
②	Main power inlet (Power cable 230 V)	Run power cable	—
③	Cylinder unit - outdoor unit cable (Power cable 230V)	Run cylinder unit -outdoor unit cable	15 m
④	Output cable inlet	Run output cable	—
⑤	Signal input cable inlet	Run signal input cables and remote sensor wires	—
⑥	Wireless receiver and Wi-Fi interface cable inlet	Run wireless receiver cable and ecodan Wi-Fi interface (option) cable	—

<Table 3.3>

3 Technical Information

Water circuit diagram

*1 Refer to the following section [Local system].

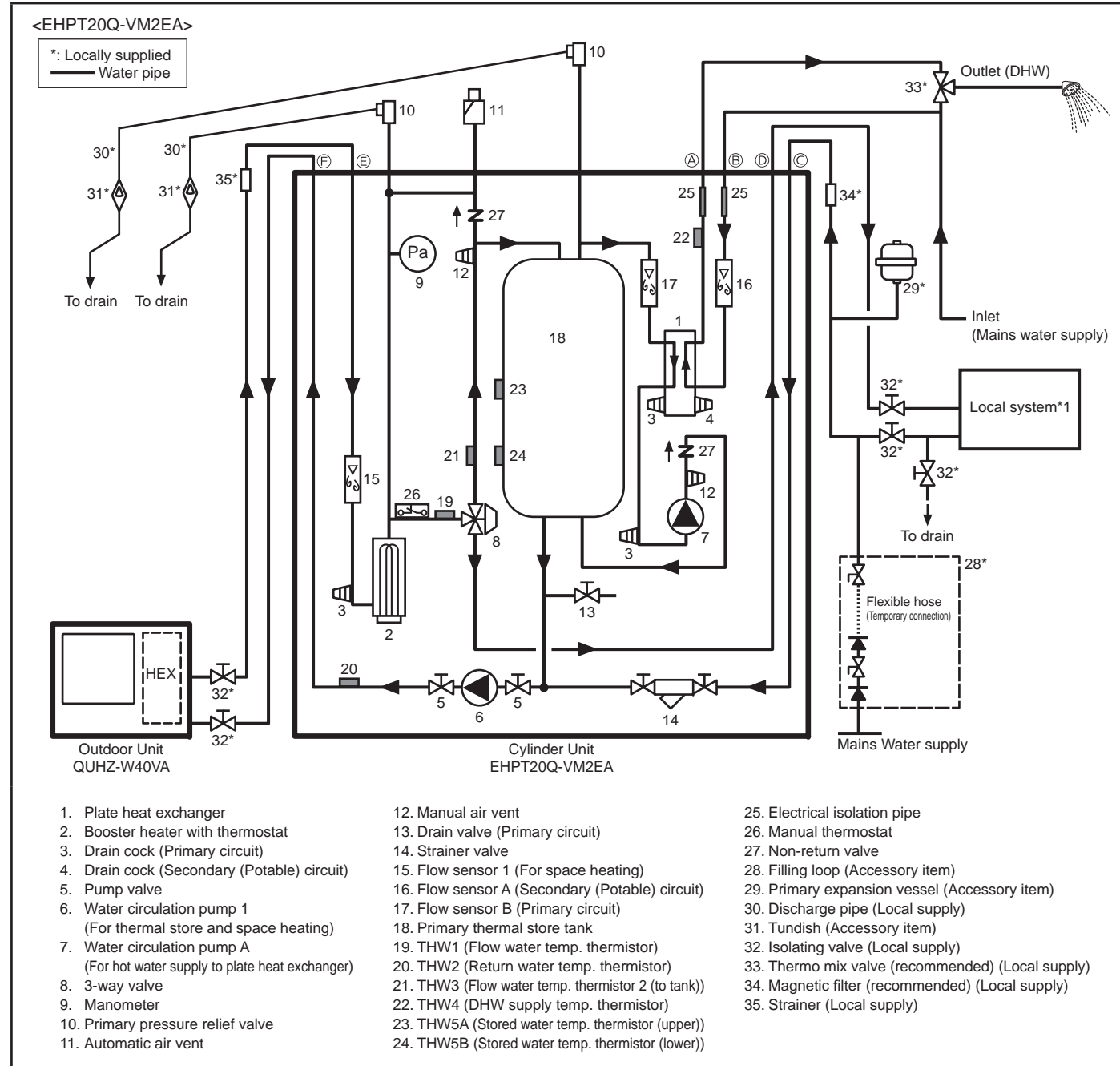

<Figure 3.2>

<Case of DHW only use>

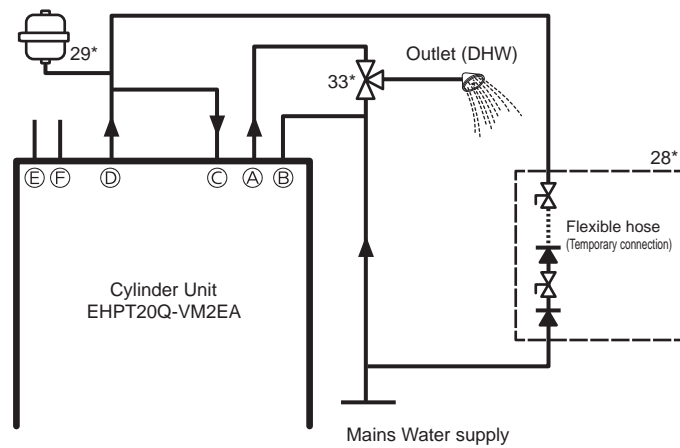

<Figure 3.3>

3 Technical Information

Note:

- To enable draining of the cylinder unit, an isolating valve should be positioned on both the inlet and outlet pipework.
- Within the building, be sure to install a maintainable strainer (Item 35) on the inlet pipework to the cylinder unit. Similarly, on the return pipework from space heating circuit, it is also recommended to install a maintainable magnetic filter (Item 34).
- Suitable drain pipework should be attached to all pressure relief valves in accordance with national regulations.
- When using components made from different metals or connecting pipes made of different metals insulate the joints to prevent any corrosive reaction taking place which may damage the pipework.
- Filling loop's flexible hose must be removed following the filling procedure. Item provided with unit as loose accessory.
- Install primary expansion vessel to the return circuit of space heating and ensure clear water passage between cylinder unit and primary expansion vessel.

Model name	EHPT20Q-VM2EA
Maximum secondary (potable) water supply pressure	10 bar (1 MPa)
Primary expansion vessel charge pressure	1.0 bar (100 kPa)
Primary pressure relief valves set pressure (2 No. devices)	3.0 bar (300 kPa)
Booster heater specification	2 kW, 230 V
Primary thermal store capacity (Tank capacity)	200 L
Mass of the unit when full	283 kg
Maximum primary working pressure	2.5 bar (250 kPa)
Minimum primary working pressure	1.0 bar (100 kPa)

<Table 3.4>

Note:

- Maximum primary water supply pressure is 10 bar (1 MPa).
- At commissioning stage, please adjust water pressure within primary circuit to 1 bar (100 kPa).

3 Technical Information

Local system

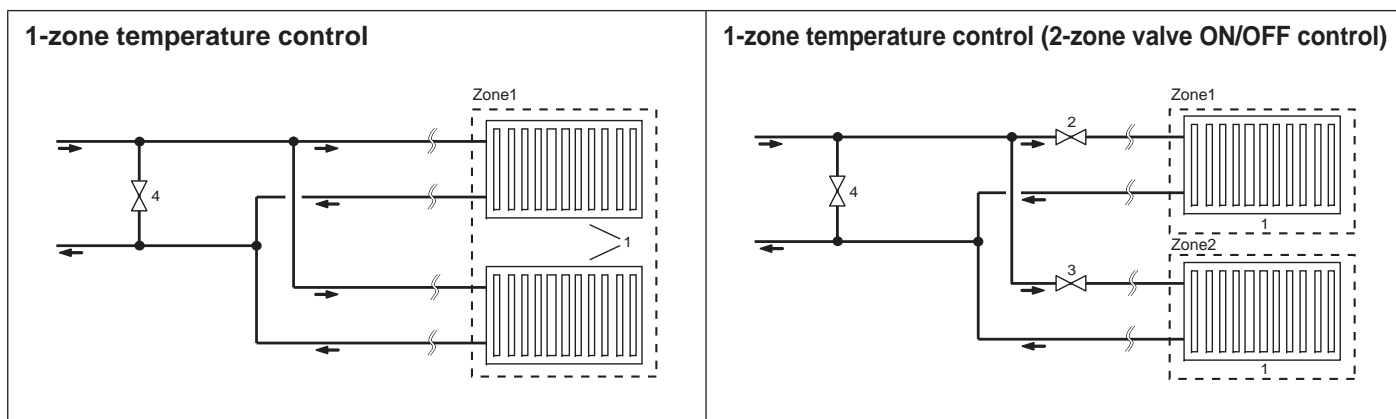

1. Heat emitters (e.g. radiator, fan coil unit) (local supply)
2. Zone1 2-way valve (local supply)
3. Zone2 2-way valve (local supply)
4. Auto-bypass valve (local supply)

Energy monitoring

End user can monitor accumulated*1 'Consumed electrical energy' and 'Delivered energy' in each operation mode*2 on the main controller.

- *1 Monthly and Year to date
- *2 - DHW operation
- Space heating

Refer to "5.7 Main controller" for how to check the energy, and "5.1 DIP switch functions" for the details on DIP-SW setting. Either one of the following two method is used for monitoring.

Note: The method 1 should be used as a guide. If greater accuracy is required, then method 2 should be used.

1. Calculation internally

Electricity consumption is calculated internally based on the energy consumption of outdoor unit, electric booster heater, pump1 and other auxiliaries. Produced heat is calculated internally by multiplying delta T (Flow and Return temp.) and flow rate measured by the factory fitted sensors. Set the electric booster heater capacity and water pump(s) input according to indoor unit model. (Refer to the menu tree in "5.7 Main controller")

	Booster heater	Pump1*1
Default	2kW	***(factory fitted pump)
EHPT20Q-VM2EA	2kW	***

<Table 3.5>

*1 "****" displayed in the energy monitor setting mode means the factory fitted pump is connected as pump 1 so that the input is automatically calculated.

When anti-freeze solution (propylene glycol) is used for primary water circuit, set the produced energy adjustment if necessary. For further detail of above, refer to "5.7 Main controller".

Note: Consumed electric energy of pump A is automatically calculated by the system.

2. Actual measurement by external meter (locally supplied)

FTC has external input terminals for 2 'Electric energy meters' and a 'Heat meter'. If two 'Electric energy meters' are connected, the 2 recorded values will be combined at the FTC and shown on the main controller. (e.g. Meter 1 for main power line, Meter 2 for booster heater power line)

Refer to the [Signal inputs] section in "5.2 Connecting inputs/outputs" for more information on connectable electric energy meter and heat meter.

4 Installation

<Preparation before the installation and service>

- Prepare the proper tools.
- Prepare the proper protection.
- Allow parts to cool before attempting any maintenance.
- Provide adequate ventilation.
- After stopping the operation of the system, turn off the power-supply breaker and remove the power plug.
- Discharge the capacitor before commencing work involving the electrical parts.

<Precautions during service>

- Do not perform work involving electrical parts with wet hands.
- Do not pour water or liquid into the electrical parts.
- Do not touch the refrigerant.
- Do not touch the hot or cold surfaces in the refrigerant cycle.
- When the repair or the inspection of the circuit needs to be carried out without turning off the power, exercise great caution not to touch any live parts.
- Do not attach any external pump to the system.

4.1 Location

Transportation and Handling

Cylinder unit is delivered on a wooden pallet base with cardboard protection.

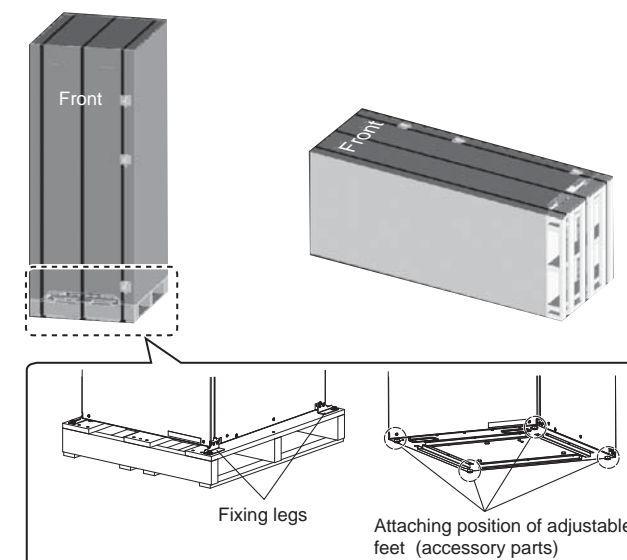

<Figure 4.1.1>

Care should be taken when transporting the cylinder unit that the casing is not damaged by impact. Do not remove the protective packaging until cylinder unit has reached its final location. This will help protect the structure and control panel.

- The cylinder unit can be transported either vertically or horizontally. If transported horizontally the panel marked 'Front' must be facing **UPWARDS** <Figure 4.1.1>.
- The cylinder unit should ALWAYS be moved by a minimum of 2 people.
- When you carry a cylinder unit, please use the handle of the unit upper part.
- Before using, make sure they are securely attached.
- Please carefully remove fixing legs, wooden base and any other packaging.

Suitable Location

Before installation the cylinder unit should be stored in a frost-free weatherproof location. Units must NOT be stacked.

- The cylinder unit should be installed indoors in a frost free weather proof location.
- Install the cylinder unit where it is not exposed to water/excessive moisture.
- Install the cylinder unit only where the difference in height between the bottom of the cylinder unit and the bottom of the outdoor unit is less than 5 m (see Figure 4.1.2).
- The cylinder unit should be positioned on a level surface capable of supporting it's filled weight. (Adjustable feet (accessory parts) can be used to ensure unit is level) (see Figure 4.1.1)
- When using the adjustable feet, ensure that the floor is strong enough.
- When fitted, the adjustable feet should only be extended and used to level and stabilise the unit. And weight load should be evenly spread.
- Care should be taken that minimum distances around and in front of the unit for service access are observed <Figure 4.1.3>.
- Secure the cylinder unit to prevent it from potentially being knocked over.

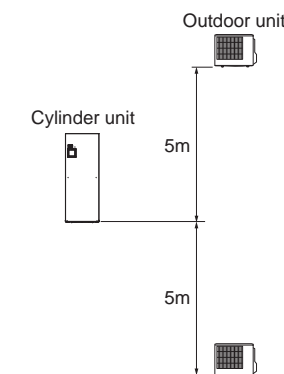

<Figure 4.1.2>

4 Installation

Service access diagrams

Service access	
Parameter	Dimension (mm)
a	300
b	150
c (distance behind unit not visible in Figure 4.1.3)	10
d	500

<Table 4.1.1>

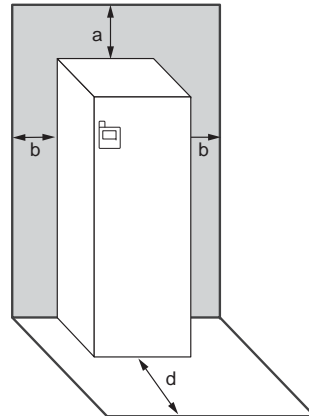

<Figure 4.1.3>
Service access

Sufficient space MUST be left for the provision of discharge pipework as detailed in National and Local Building Regulations.

The cylinder unit must be located indoors and in a frost-free environment, for example in a utility room, to minimise heat loss from stored water.

Room Thermostat

If fitting a new room thermostat for this system;

- Position it out of direct sunlight and draughts
- Position it on an internal wall
- Position it away from internal heat sources
- Position it in a room without a TRV on the radiator/heat emitter.

Note:

Do not position the thermostat excessively close to the external wall. The thermostat may detect the temperature of the wall, which could affect appropriate control of the room temperature.

- Position it approx. 1.5 m from floor level

Repositioning

If you need to move the cylinder unit to a new position FULLY DRAIN the cylinder unit before moving to avoid damage to the unit. Also, take care to protect building fabrics (floor and wall finishes).

4 Installation

4.2 Water Quality and System Preparation

General

- The water in both primary and secondary (potable) circuit should be clean and with pH value of 6.5-8.0.
- The followings are the maximum values;
Calcium: 100mg/L, Ca hardness: 250mg/L
Chlorine: 100mg/L, Copper: 0.3mg/L
Iron/Manganese: 0.5mg/L
- Other constituents should be to European Directive 98/83 EC standards.
- In known hard water areas, to prevent/minimise scaling, it is beneficial to restrict the routine stored water temperature (DHW supply max. temp.) to 65°C or less.

Anti-Freeze

Suitable anti-freeze MUST be used in ALL installations.

Anti-freeze solution MUST be propylene glycol with a toxicity rating of Class 1 as listed in Clinical Toxicology of Commercial Products, 5th Edition.

Note:

1. Ethylene glycol anti-freeze is TOXIC. Therefore it MUST NOT be used in the primary water circuit in case of any cross-contamination of the secondary (potable) circuit.
2. For 2-zone valve ON/OFF control, propylene glycol solution MUST be used.

New Installation (primary water circuit)

- Before connecting outdoor unit, thoroughly cleanse pipework of building debris, solder etc using a suitable chemical cleansing agent.
- Flush the system to remove chemical cleanser.
- Add a combined inhibitor and anti-freeze solution to prevent damage to the pipework and system components.

Existing Installation (primary water circuit)

- Before connecting outdoor unit the existing heating circuit MUST be chemically cleansed to remove existing dirt and debris from the heating circuit.
- Flush the system to remove chemical cleanser.
- Add a combined inhibitor and anti-freeze solution to prevent damage to the pipework and system components.

When using chemical cleansers and inhibitors always follow manufacturer's instructions and ensure the product is appropriate for the materials used in the water circuit

4 Installation

How to access Internal Components and Control and Electrical Box

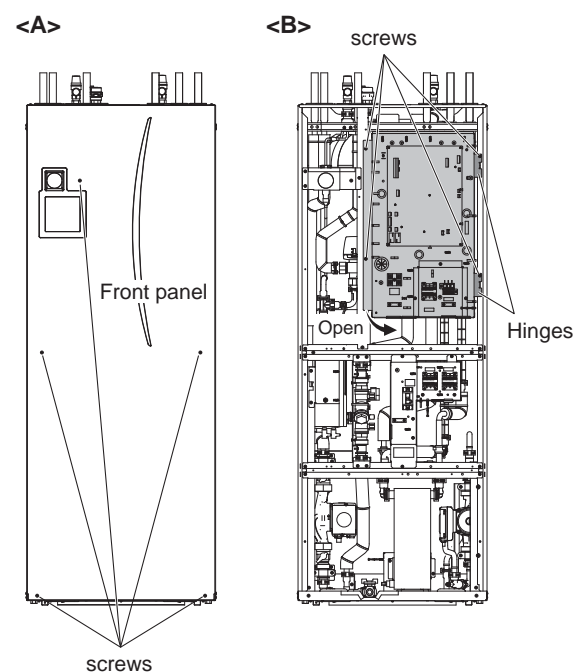

<Figure 4.2.1>

<A> Opening the front panel

1. Remove the five screws.
2. Slide front panel downwards slightly and open carefully.
3. Disconnect the relay connector connecting main controller cable and the control board cable using the quick-connector.

 Accessing the back of control and electrical box

The control and electrical box has four holding screws and is hinged on the right hand side.

1. Remove the holding screws on the control and electrical box.
2. The control and electrical box can then be swung opened / closed on the right hand hinges.

Note:

After servicing, re-assemble and re-secure all cables using straps provided. Reconnect main controller cable to its relay connector. Replace front panel and re-secure screws at base.

Minimum amount of water required in the space heating circuit

32 L

Note: The volume of heat emitters and external pipes should be included.

Reference:

Minimum water quantity [L]		
Primary circuit	Thermal store tank	200 L
	Space heating circuit	32 L
Secondary (potable) circuit		2 L

<Table 4.2.1>

4 Installation

4.3 Water Pipework

Hot Water Pipework

The cylinder unit is UNVENTED. When installing unvented indirect hot water systems building regulations part G3 (England and Wales), P3 (Scotland) and P5 (Northern Ireland) should be adhered to. If outside of the UK please adhere to your own country's regulations for unvented hot water systems.

Connect the flow for the DHW to pipe A (Figure 3.1). The function of the following safety components of the system should be checked on installation for any abnormalities;

- Pressure relief valve (Primary circuit)
- Primary expansion vessel pre-charge / gas charge pressure (Accessory item)

The instruction on the following pages regarding safe discharge of hot water from Safety devices should be followed carefully.

- The pipework will become very hot, so should be insulated to prevent burns.
- When connecting pipework, ensure that no foreign objects such as dirt or debris enter the pipe.

Cold Water Pipework

Cold water to the suitable standard (see section 4.2) should be introduced to the system by connecting pipe B (Figure 3.1) using appropriate fittings.

Negative pressure prevention

To prevent negative pressure effecting water circuit, installer should install pipework or use appropriate devices.

Hydraulic filter work

Install a hydraulic filter or strainer (local supply) at the water intake ("Pipe E" in Fig.3.1)

Pipework Connections

Connections to the cylinder unit should be made using the 22 mm compression as appropriate. Do not over-tighten compression fittings as this will lead to deformation of the delivering and potential leaks.

Note: To weld the pipes in the field, ensure the pipes on the cylinder unit are cooled using wet towel etc.

Insulation of Pipework

- All exposed water pipework should be insulated to prevent unnecessary heat loss and condensation. To prevent condensate entering the cylinder unit, the pipework and connections at the top of the cylinder unit should be carefully insulated.
- Cold and hot water pipework should not be run close together where possible, to avoid unwanted heat transfer.
- Pipework between outdoor heat pump unit and cylinder unit should be insulated with suitable pipe insulation material with a thermal conductivity of $\leq 0.04 \text{ W/m} \cdot \text{K}$.

4 Installation

Filling the System (Primary Circuit)

Note: Make sure to turn OFF the booster heater power supply before filling the system

1. Check all connections including factory fitted ones are tight.
2. Insulate pipework between cylinder unit and outdoor unit.
3. Open the automatic air vent to enable automatic air bleeding function.
4. Thoroughly clean and flush, system of all debris. (see section 4.2 for instruction.)
5. Fill primary heating circuit with water and suitable anti-freeze as necessary.

Always use a new filling loop with double check valve when filling the primary circuit to avoid back flow contamination of water supply.

Do not use an old filling loop.

Do Not turn ON the system until the system is fully charged of water.

- Open the two manual air vents after filling the system (refer to the following section) .
- Anti-freeze should always be used for packaged model systems (see section 4.2 for instruction). Corrosion inhibitor should be used in both split model and packaged model systems.
- When connecting metal pipes of different materials insulate the joints to prevent a corrosive reaction taking place which will damage the pipework.

6. Check for leakages. If leakage is found, retighten the nut onto the connections.
7. Pressurise system to 1 bar with all the water in thermal store tank cold.
(If the system is pressurised with the water in thermal store tank hot, air inclusion in pump may be caused by the pressure drop of the system that occurs if the hot water gets cold.)
8. Release all trapped air using air vents during and following heating period.
9. Top up with water as necessary. (If pressure is below 1 bar)

Note: • Automatic air vents MUST be installed at the highest point of the primary system. The slightest amount of air in the system can reduce efficiencies and even cause the cylinder unit to fault.
• Confirm the following if the air cannot be discharged.
• Air discharging of radiators
• Air discharging from isolating valves
(If necessary, turn on the pump 1 using Manual operation (refer to page 35).)

IMPORTANT<Air discharging of pump A>

1. Attach the accessory rubber hose to the manual air vent above pump A to prevent water from dripping on to the pump during the air bleeding operation.
2. Open the drain cock of the manual air vent and discharge the air.
3. Open a tap and confirm that hot water is supplied after approximately 30 minutes from the beginning of thermal store operation.

Note: If the air is not sufficiently discharged, hot water is not supplied and an error occurs. Continue to discharge the air until smooth delivery of hot water.

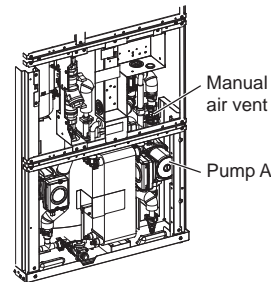

4 Installation

Sizing Primary Expansion Vessels

Primary expansion vessel volume MUST fit the local system water volume.
To size an expansion vessel for the heating circuit the following formula and graph can be used.

$$V = \frac{\epsilon \times G}{1 - \frac{P_1 + 0.098}{P_2 + 0.098}}$$

Where;

- V : Necessary expansion vessel volume [L]
- ϵ : Water expansion coefficient
- G : Total volume of water in the system [L]
- P_1 : Expansion vessel setting pressure [MPa]
- P_2 : Max pressure during operation [MPa]

Graph to the right is for the following values

ϵ : at 70 °C = 0.0229

P_1 : 0.1 MPa

P_2 : 0.3 MPa

*A 30% safety margin has been added.

Primary expansion vessel sizing

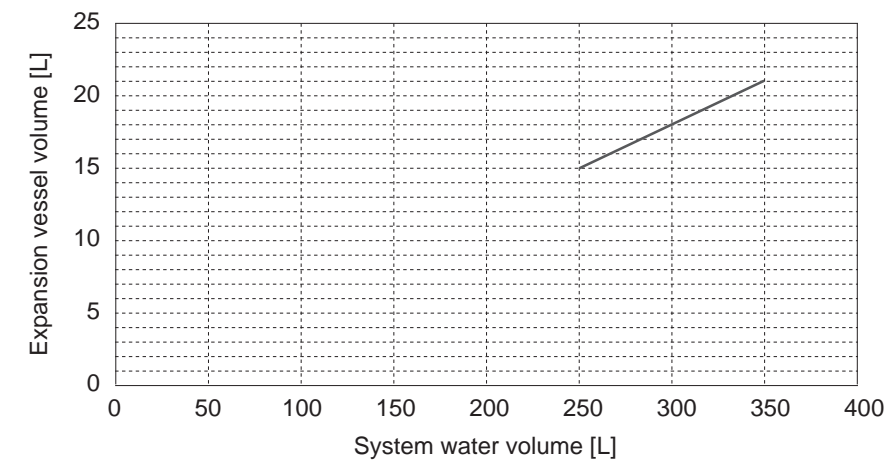

<Figure 4.3.1>

4 Installation

Flow rate setting

Circulation flow rate of EHPT20Q-VM2EA unit is determined by settings of "Flow rate setting" and "pump speed".

1. Primary circuit for thermal store and space heating

In the space heating operation, circulation flow rate can be selected by main controller setting. (refer to page 36) Pump 1 automatically operates to adjust the flow rate to the setting. Auto setting automatically selects a flow rate appropriate for effective operation.

In the thermal store operation, circulation flow rate is automatically selected to adjust the hot water temperature to the main remote controller setting and pump 1 automatically operates.

In other operations (ex. Freeze stat operation, Emergency mode, Indoor unit only operation), pump 1 operates at a pump speed selected by main controller setting. (See Figure 4.3.2)

Adjust the pump speed setting so that the flow rate in the primary circuit is appropriate for the outdoor unit installed. (see Table 4.3.1)

Outdoor unit	Water flow rate range [L/min]
QUHZ-W40VA	3.0 - 8.0

<Table 4.3.1>

* If the water flow rate exceeds 9.0L/min, the flow speed will be greater than 1.5m/s, which could erode the pipes.

* In case of "Compensation curve mode" or "Flow temp. mode" please select "Manual" mode then choose flow rate manually from 3.0 to 8.0 L/min. If "Auto" mode is selected, flow rate will be fixed at "7.0 L/min".

2. Primary circuit for hot water supply

Pump A automatically operates regardless of the flow rate the settings.

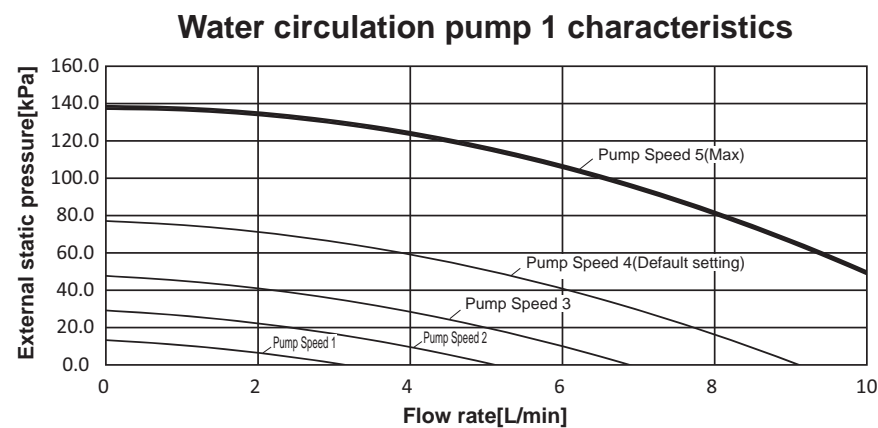

<Figure 4.3.2>

* The performance showing Figure 4.3.2 includes pressure drop of both cylinder unit and outdoor unit. Before installation, please check if the maximum performance of water circulation pump 1 can accommodate the pressure drop of external heating circuit.

4 Installation

Safety Device Connections

The primary pressure relief valves on the primary side needs appropriate discharge pipework.

Note:

- Do not secure the screws excessively when connecting the Discharge pipe, otherwise this may result in damage to the cylinder unit.
- Pressure relief valve connections should not be used for any other purpose.

*1 In accordance with Building Regulations a tundish MUST be fitted into the pipework within 500 mm of the safety device. Due to the distance between the two safety devices it may be necessary to fit each safety device with its own tundish before you run the pipework together to a safe discharge. (See Figure 4.3.3)

Diagram part No.	Description	Connection size	Connection type
10	Pressure relief valve	G 1/2	Female

<Table 4.3.2>

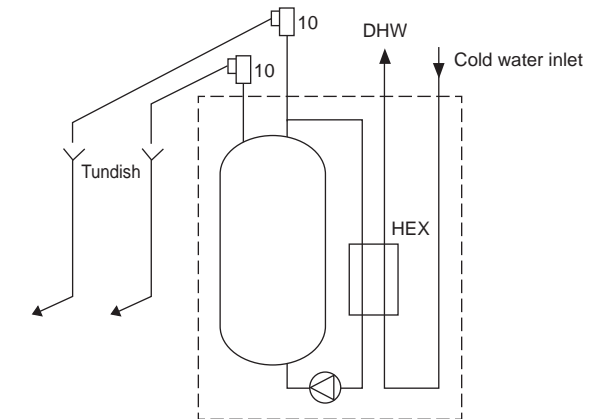

<Figure 4.3.3>

Always refer to local regulations when installing discharge pipework. Install discharge pipework in a frost-free environment. It is necessary to provide appropriate drainage from the pressure relief valve situated on top of the cylinder unit to prevent damage to the unit and the surrounding area from any steam or hot water released. Relief valves MUST NOT be used for any other purpose.

4 Installation

4.4 Safety Device Discharge Arrangements (G3)

The following instructions are a requirement of UK Building Regulations and MUST be adhered to. If you are in any doubt please seek advice from local building planning office.

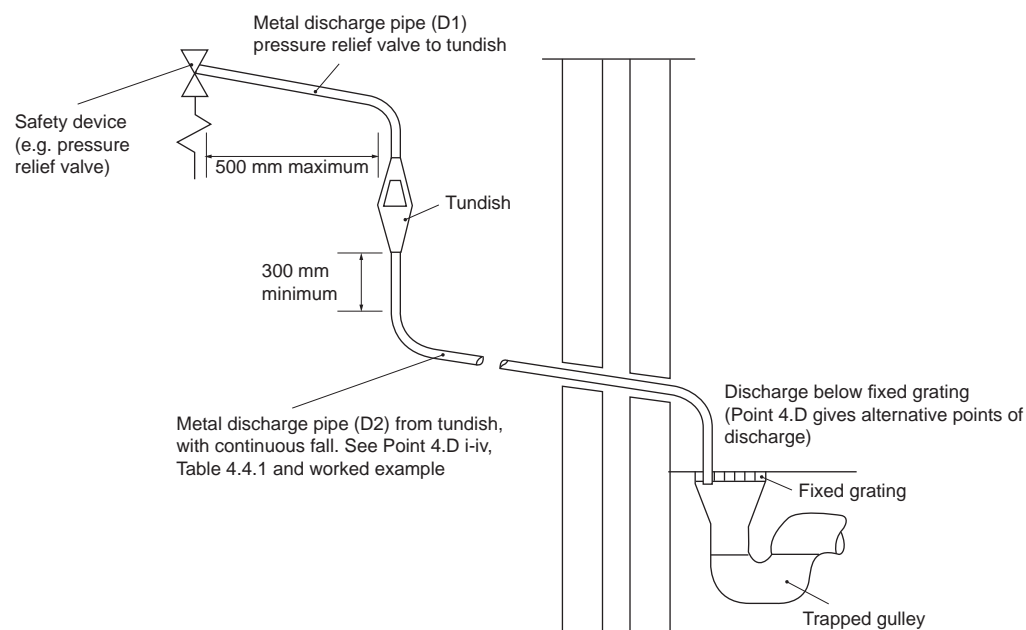

<Figure 4.4.1>

Valve outlet size	Minimum size of discharge pipe D1	Minimum size of discharge pipe D2 from tundish	Maximum resistance allowed, expressed as a length of straight pipe (no elbows or bends)	Resistance created by each elbow or bend
G 1/2	15 mm	22 mm	Up to 9 m	0.8 m
		28 mm	Up to 18 m	1.0 m
		35 mm	Up to 27 m	1.4 m
G 3/4	22 mm	28 mm	Up to 9 m	1.0 m
		35 mm	Up to 18 m	1.4 m
		42 mm	Up to 27 m	1.7 m
G1	28 mm	35 mm	Up to 9 m	1.4 m
		42 mm	Up to 18 m	1.7 m
		54 mm	Up to 27 m	2.3 m

<Table 4.4.1>

1. Connect the tundish and route the discharge pipe as shown in Figure 4.4.1.
2. The tundish should be fitted vertically and as close to the safety device as possible and within 500 mm of the device.
3. The tundish should be visible to occupants and positioned away from electrical devices.
4. The discharge pipe (D2) from the tundish should terminate in a safe place where there is no risk to persons in the vicinity of the discharge, be of metal construction and:

- A) Be at least one pipe size larger than the nominal outlet size of the safety device unless its total equivalent hydraulic resistance exceeds that of a straight pipe 9 m long i.e. discharge pipes between 9 m and 18 m equivalent resistance length should be at least two sizes larger than the nominal outlet size of the safety device, between 18 and 27 m at least 3 sizes larger, and so on. Bends MUST be taken into account in calculating the flow resistance. Refer to Figure 4.4.1, Table 4.4.1 and the worked example. An alternative approach for sizing discharge pipes would be to follow BS 6700: 1987 specification for design installation, testing and maintenance of services supplying water for domestic use within buildings and their cartridges.
- B) Have a vertical section of pipe at least 300 mm long, below the tundish before any elbows or bends in the pipework.
- C) Be installed with a continuous fall.

4 Installation

D) Have discharges visible at both the tundish and the final point of discharge but where this is not possible or is practically difficult there should be clear visibility at one or other of these locations. Examples of acceptable discharge arrangements are:

- i. Ideally below a fixed grating and above the water seal in a trapped gully.
- ii. Downward discharges at low level; i.e. up to 100 mm above external surfaces such as car parks, hard standings, grassed areas etc. are acceptable providing that where children may play or otherwise come into contact with discharges a wire cage or similar guard is positioned to prevent contact, whilst maintaining visibility.
- iii. Discharges at high level; e.g. into a metal hopper and metal down pipe with the end of the discharge pipe clearly visible (tundish visible or not) or onto a roof capable of withstanding high temperature discharges of water and 3 m from any plastic guttering system that would collect such discharges (tundish visible).
- iv. Where a single pipe serves a number of discharges, such as in blocks of flats, the number served should be limited to not more than 6 systems so that any installation discharging can be traced reasonably easily. The single common discharge pipe should be at least one pipe size larger than the largest individual discharge pipe (D2) to be connected. If unvented hot water storage systems are installed where discharges from safety devices may not be apparent i.e. in dwellings occupied by blind, infirm or disabled people, consideration should be given to the installation of an electronically operated device to warn when discharge takes place.

Note:

The discharge will consist of scalding water and steam. Asphalt, roofing felt and nonmetallic rainwater goods may be damaged by such discharges. Discharges MUST be positioned in a frost-free location.

Worked example:

The example below is for a G $\frac{1}{2}$ pressure relief valve with a discharge pipe (D2) having 4 No. elbows and length of 7 m from the tundish to the point of discharge. Discharges MUST be positioned in a frost-free location.

From Table 4.4.1: Maximum resistance allowed for a straight length of 22 mm copper discharge pipe (D2) from a G $\frac{1}{2}$ pressure relief valve is: 9.0 m subtract the resistance for 4 No. 22 mm elbows at 0.8 m each = 3.2 m. Therefore the maximum permitted length equates to: 5.8 m. 5.8 m is less than the actual length of 7 m, therefore calculate the next largest size. Maximum resistance allowed for a straight length of 28 mm pipe (D2) from a G $\frac{1}{2}$ pressure relief valve equates to: 18 m. Subtract the resistance for 4 No. 28 mm elbows at 1.0 m each = 4 m. Therefore the maximum permitted length equates to: 14 m. As the actual length is 7 m, a 28 mm (D2) copper pipe will be satisfactory.

4 Installation

4.5 Electrical Connection

All electrical work should be carried out by a suitably qualified technician. Failure to comply with this could lead to electrocution, fire, and death. It will also invalidate product warranty. All wiring should be according to national wiring regulations.

⚠ WARNING

When confirming the operation of the ECB, make sure that the ECB can be turned ON/OFF by the power lever before pressing the test button. If the ECB cannot be turned ON/OFF by the power lever, stop using the ECB and replace it.

⚠ CAUTION

This product contains electrostatic-sensitive components that can be damaged if handled incorrectly. To prevent any electrostatic damage, ensure you are electrically grounded / earthed in order to discharge any possible static electricity build-up.

Breaker abbreviation	Meaning
ECB	Earth leakage circuit breaker for booster heater
TB1	Terminal block 1
TB2	Terminal block 2

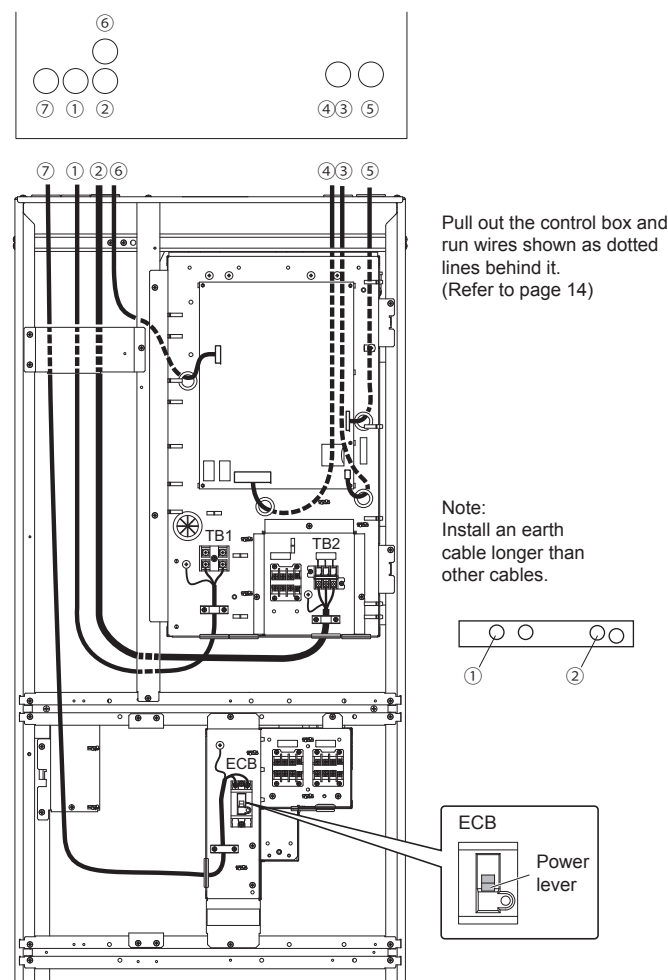

<Figure 4.5.1>

- The outdoor unit can only be powered via Cylinder unit.
- Connections should be made to the terminals as indicated in the figures to the left below.
- The wires (① ~ ⑦) MUST NOT be bundled together with other wires having different number. (Refer to <Figure 4.5.1>)

- Locally supplied wiring should be inserted through the inlets situated on the top of the cylinder unit. (Refer to <Table 3.3>.)
- Wiring should be fed down the left hand side of the control and electrical box and clamped in place using clips provided.
- The wires should be inserted individually through the cable inlets on the control board (Figure 4.5.1).
 - Remote sensor wire
 - Signal input cable
 - Wireless receiver (option) (PAR-WR51R-E) and Wi-Fi interface (option) (PAC-WF010-E, MAC-5671F-E, MAC-5871F-E) cable
 - Output cable
- Connect the power cable for the Cylinder unit to TB1. ... ①
 - Power cable
- Connect the outdoor unit – cylinder unit connecting cable to TB2. ... ②
 - Cylinder unit - Outdoor unit cable
- Connect the power cable for the booster heater to ECB. ... ⑦
 - Power cable for Booster heater

- Make sure that ECB is ON. *1
- On completion of wiring, ensure main controller cable is connected to the relay connector.

Note: *1 When the ECB is turned off, push down the power lever without pressing the test button.

4 Installation

Outdoor unit powered via cylinder unit

<1 phase>

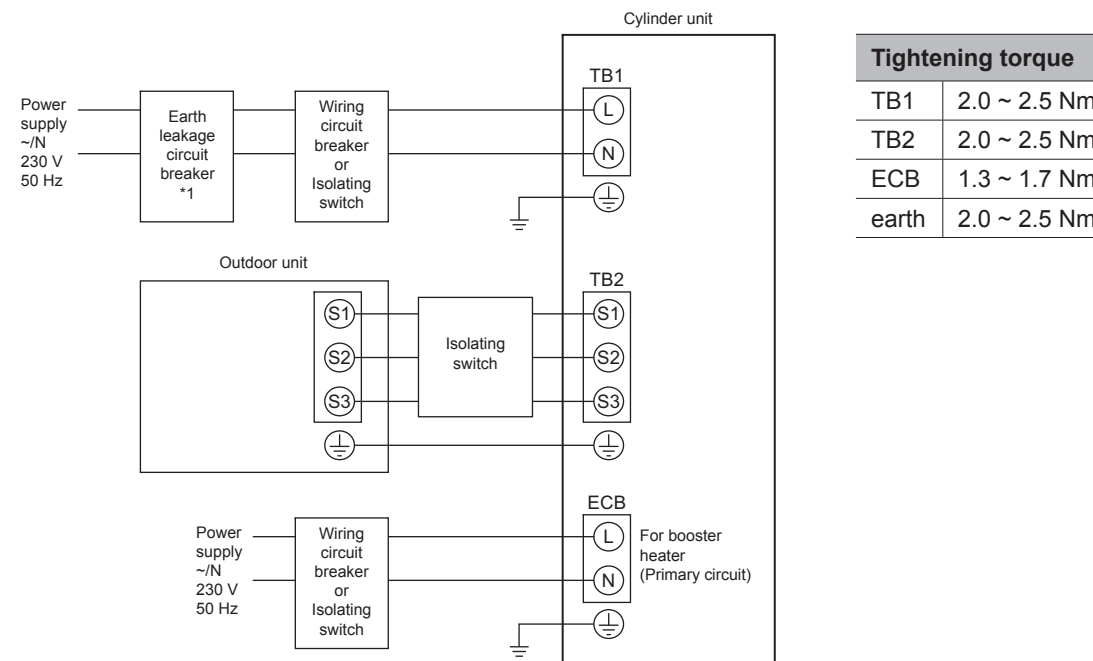

<Figure 4.5.2>
Electrical connections 1 phase

- *1. Current sensitivity 10 mA, operating time 0.1 s.
If the installed earth leakage circuit breaker does not have an over-current protection function, install a breaker with that function along the same power line.

Description	Power supply	Capacity	Breaker	Wiring
Booster heater (Primary circuit)	230V N~ 50 Hz	2 kW	16 A *2 *3	3 × 2.5 mm ²
Cylinder unit power supply	~N 230 V 50 Hz			
Cylinder unit input capacity Main switch (Breaker)	*2			20 A
Wiring	Cylinder unit power supply (including earth cable)		3 × Min. 2.5	
Wiring No. × size (mm ²)	Cylinder unit - Outdoor unit (including earth cable) *4		4 × Min. 2.5	
Circuit rating	Cylinder unit L - N		*5 230 V AC	
	Cylinder unit - Outdoor unit S1 - S2		*5 230 V AC	
	Cylinder unit - Outdoor unit S2 - S3		*5 24 V DC	

- *2. A breaker with at least 3.0 mm contact separation in each pole shall be provided.
The breaker shall be provided to ensure disconnection of all active phase conductors of the supply.
*3. Use a breaker with an over-current protection function.
*4. Max. 15 m
*5. The values given in the table above are not always measured against the ground value.

Note:

- Wiring size MUST comply with the applicable local and national codes.
- Cylinder unit/outdoor unit connecting cables shall not be lighter than polychloroprene sheathed flexible cable. (Design 60245 IEC 57) Cylinder unit power supply cables shall not be lighter than polychloroprene sheathed flexible cable. (Design 60227 IEC 53)
- Install an earth longer than other cables.
- Please keep enough output capacity of power supply for each heater. The lack of the power supply capacity may possibly cause chattering.

5 System Set Up

5.1 DIP Switch Functions

Located on the FTC printed circuit board are 4 sets of small white switches known as DIP switches. The DIP switch number is printed on the circuit board next to the relevant switches. The word ON is printed on the circuit board and on the DIP switch block itself. To move the switch you will need to use a pin or the corner of a thin metal ruler or similar.

DIP switch settings are listed below in Table 5.1.1. Before changing any switch settings, ensure the power supplies to both cylinder unit and outdoor unit are turned OFF.

Before changing the DIP switch setting, confirm that the power supply earth cable is securely connected and prevent the FTC from being applied with static electricity (e.g. touch a case body etc.). Otherwise, it may cause a failure of the FTC due to the static electricity.

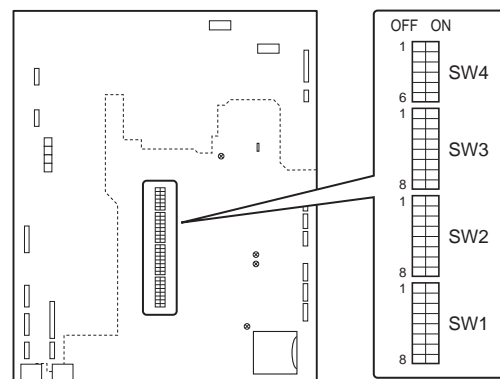

<Figure 5.1.1>

DIP switch	Function	OFF	ON	Default settings: Indoor unit model	
SW1	SW1-1	—	—	OFF	
	SW1-2	—	—	OFF	
	SW1-3	—	—	OFF	
	SW1-4	—	—	OFF	
	SW1-5	—	—	OFF	
	SW1-6	—	—	OFF	
	SW1-7	—	—	OFF	
	SW1-8	Wireless remote controller	WITHOUT Wireless remote controller	WITH Wireless remote controller	OFF
SW2	SW2-1	Room thermostat1 input (IN1) logic change	Zone1 operation stop at thermostat short	Zone1 operation stop at thermostat open	OFF
	SW2-2	—	—	—	OFF
	SW2-3	—	—	—	OFF
	SW2-4	—	—	—	OFF
	SW2-5	Automatic switch to backup heat source operation (When outdoor unit stops by error)	Inactive	Active *1	OFF
	SW2-6	—	—	—	OFF
	SW2-7	—	—	—	OFF
	SW2-8	—	—	—	OFF
SW3	SW3-1	Room thermostat 2 input (IN6) logic change	Zone2 operation stop at thermostat short	Zone2 operation stop at thermostat open	OFF
	SW3-2	—	—	—	OFF
	SW3-3	—	—	—	OFF
	SW3-4	Electric energy meter	WITHOUT Electric energy meter	WITH Electric energy meter	OFF
	SW3-5	—	—	—	OFF
	SW3-6	2-zone valve ON/OFF control	Inactive	Active	OFF
	SW3-7	—	—	—	OFF
	SW3-8	Heat meter	WITHOUT Heat meter	WITH Heat meter	OFF
SW4	SW4-1	—	—	—	OFF
	SW4-2	—	—	—	OFF
	SW4-3	—	—	—	OFF
	SW4-4	Indoor unit only operation (during installation work) *2	Inactive	Active	OFF
	SW4-5	Emergency mode (Heater only operation)	Normal	Emergency mode (Heater only operation)	OFF *3
	SW4-6	—	—	—	OFF

<Table 5.1.1>

Note:

- *1. For safety reasons, this function is not available for certain errors. (In that case, system operation MUST be stopped and only the water circulation pump keeps running.)
- *2. Space heating and DHW can be operated only in indoor unit, like an electric boiler. (Refer to "5.4 Indoor unit only operation".)
- *3. If emergency mode is no longer required, return the switch to OFF position.

5 System Set Up

5.2 Connecting inputs/outputs

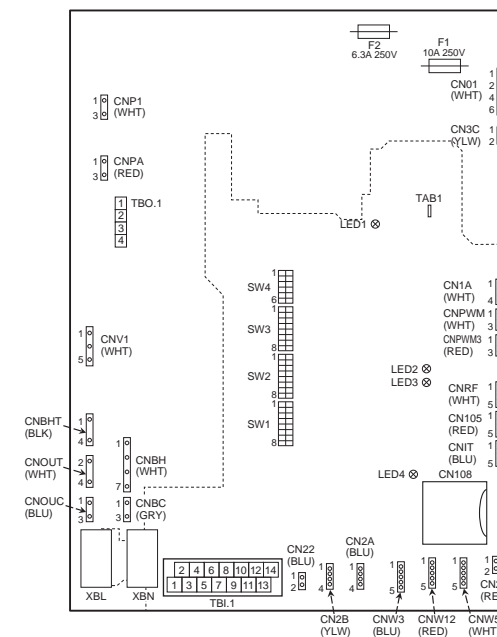

<Figure 5.2.1>

When the wires are wired to adjacent terminals use ring terminals and insulate the wires.

Note:

Before connecting a wire to the TBI.1, confirm that the power supply earth cable is securely connected and prevent the FTC from being applied with static electricity (e.g. touch a case body etc.). Otherwise, it may cause a failure of the FTC due to the static electricity.

Signal inputs

Name	Terminal block	Connector	Item	OFF (Open)	ON (Short)
IN1	TBI.1 3-4	—	Room thermostat 1 input	Refer to SW2-1 in <5.1 DIP Switch Functions>.	
IN6	TBI.1 1-2	—	Room thermostat 2 input	Refer to SW3-1 in <5.1 DIP Switch Functions>.	
IN8	TBI.1 5-6	—	Electric energy meter 1	*1	
IN9	TBI.1 7-8	—	Electric energy meter 2		
IN10	TBI.1 9-10	—	Heat meter		

*1. Connectable electric energy meter and heat meter

- Pulse type Voltage free contact for 12VDC detection by FTC (TBI.1 5, 7 and 9 pins have positive voltage.)
- Pulse duration Minimum ON time: 40ms
Minimum OFF time: 100ms
- Possible unit of pulse 0.1 pulse/kwh 1 pulse/kwh 10 pulse/kwh
100 pulse/kwh 1000 pulse/kwh

Those values can be set by the main controller. (Refer to the menu tree in "5.7 Main Controller".)

Wiring specification and local supply parts

Item	Name	Model and specifications
Signal input function	Signal input wire	Use sheathed vinyl coated cord or cable. Max. 10 m Wire type: CV, CVS or equivalent Wire size: Stranded wire 0.13 mm ² to 1.25 mm ² Solid wire: ø0.4 mm to ø1.2 mm
	Switch	Non-voltage "a" contact signals Remote switch: minimum applicable load 12V DC, 1mA

Thermistor inputs

Name	Terminal block	Connector	Item	Optional part model
TH1	—	CN20	Thermistor (Room temp.) (Option)	PAC-SE41TS-E

Ensure to wire thermistor wirings away from the power line and/or OUT3 to 13 wirings. Do not splice the wiring to extend or shorten it, otherwise this could affect correct monitoring of each temperature. If the wiring is too long, bundle it with a strap to adjust the length in the cylinder unit.(see the photograph on the right)

- *1. The maximum length of the thermistor wiring out of the cylinder unit is 5 m. When the wires are wired to adjacent terminals, use ring terminals and electrically insulate the wires.

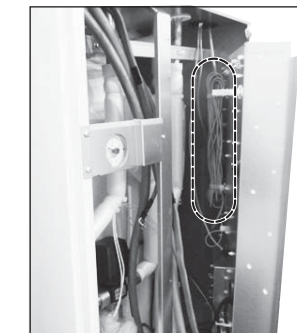

5 System Set Up

Outputs

Name	Terminal block	Connector	Item	OFF	ON	Signal/Max current	Max. total current
OUT3	TBO.1.1-2	—	2-way valve 2b output *1	OFF	ON	230V AC 0.1A Max.	0.2A
OUT13	TBO.1.3-4	—	2-way valve 2a output *1	OFF	ON	230V AC 0.1A Max.	

*1 For 2-zone valve ON/OFF control.

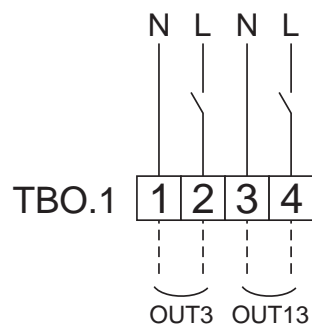

How to use TBO.1

Wiring specification and local supply parts

Item	Name	Model and specifications
External output function	Outputs wire	Use sheathed vinyl coated cord or cable. Max. 30 m Wire type: CV, CVS or equivalent Wire size: Stranded wire 0.25 mm ² to 1.5 mm ² Solid wire: ø0.57 mm ² to ø1.2 mm ²

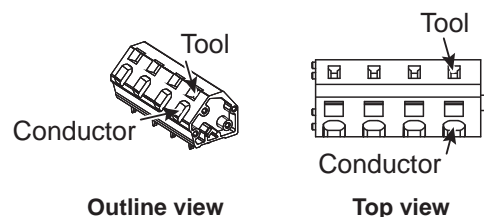

Connect them using either way as shown above.

<Figure 5.2.2>

Note:

*1. Stranded wire should be processed with insulation-covered bar terminal (DIN46228-4 standard compatible type).

5 System Set Up

5.3 2-zone valve ON/OFF control

Opening /closing 2-way valve provides a simple 2-Zone control.
Flow temperature is common for Zone1 and 2.

1. Pipework

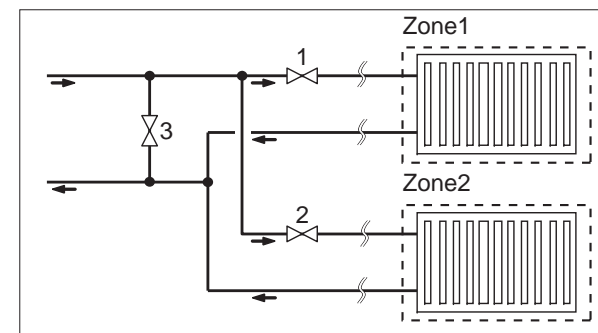

1. Zone1 2-way valve 2a (local supply)
2. Zone2 2-way valve 2b (local supply)
3. Auto by-pass valve (local supply) *1

*1 For safety protection, it is recommended to install an auto by-pass valve.

Note: Freeze stat function is deactivated whilst this control is ON.
Therefore, ensure that anti-freeze solution is used to minimise freezing risk. For anti-freeze instruction, see page 13.

2. DIP switch

Turn DIP switch 3-6 ON.

3. 2-way valve 2a (for Zone1) / 2-way valve 2b (for Zone2)

Electrically wire 2-way valve 2a and 2b to the appropriate external output terminals.
(Refer to "External outputs" in 5.2)

4. Room thermostat connection

Heating operation mode	Zone1	Zone2
Room temp. control (Auto adaptation) *2	<ul style="list-style-type: none"> • Wireless remote controller (option) • Room temperature thermistor (option) 	<ul style="list-style-type: none"> • Wireless remote controller (option)
Compensation curve or flow temp. control	<ul style="list-style-type: none"> • Wireless remote controller (option) *3 • Room temperature thermostat (local supply) 	<ul style="list-style-type: none"> • Wireless remote controller (option) *3 • Room temperature thermostat (local supply)

*2 Ensure to install the room thermostat for Zone1 in main room since the Room temp. control for Zone1 is prioritized.

*3 In this case, the wireless remote controller can be used as a thermostat.

5.4 Indoor unit only operation (during installation work)

In the case when DHW or heating operation is required prior to connection of the outdoor unit; i.e. during installation work, the booster heater in cylinder unit can feasibly be engaged as the sole heat source (short - term operating condition). For this scenario, the installer will have to form a temporary pipe loop connection across cylinder's heat pump connections.

1. To start operation

- Check if the indoor unit power supply is OFF, and turn DIP switch 4-4 and 4-5 ON.
- Turn ON the indoor unit power supply.

2. To end operation*

- Turn OFF the indoor unit power supply.
- Turn DIP switch 4-4 and 4-5 OFF.

* When the indoor unit only operation is ended, ensure to check over the settings after outdoor unit is properly connected and ready for use.

Note:

1. Prolonged running of this mode of operation may affect the life of the booster heater.
2. When the indoor unit only operation is engaged, if the Water circulation pump 1 is set on low speed, DHW supply temperature may become higher than the desired water temperature set on the main controller.

5 System Set Up

5.5 Remote Controller Options

The cylinder unit comes factory fitted with a main controller. This incorporates a thermistor for temperature monitoring and a graphical user interface to enable set-up, view current status and input scheduling functions. The main controller is also used for servicing purposes. This facility is accessed via password protected service menus.

To provide the best efficiency Mitsubishi Electric recommends using automatic adaptation function based on room temperature. To use this function a room thermistor needs to be present in a main living area. This can be done in a number of ways the most convenient are detailed below.

Refer to heating section of this manual for instructions on how to set compensation curve, Flow temp. or Room temp. (Auto adaptation).

For instructions on how to set the thermistor input for the FTC please refer to Initial settings section.

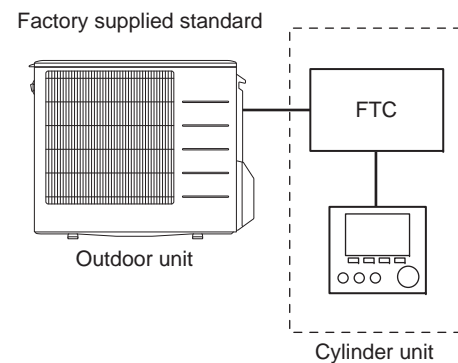

The factory setting for space heating mode is set to Room temp. (auto adaptation). If there is no room sensor present in the system, this setting MUST be changed to either Compensation curve mode or Flow temp. mode.

1-zone temperature control

Control option A	
<p>This option features the main controller and the Mitsubishi Electric wireless remote controller. The wireless remote controller is used to monitor room temperature and can be used to make changes to the space heating settings, boost DHW and switch to holiday mode without having to directly use the main controller. If more than one wireless remote controller is used, the most recently requested temperature setting will commonly be applied to all rooms by the central control system regardless of which wireless remote controller was used. No hierarchy exists across these remote controllers. Wire the wireless receiver to FTC by referring to the wireless remote controller instruction manual. Turn DIP SW1-8 to ON. Before operation configure the wireless remote controller to transmit and receive data by referring to the wireless remote controller installation manual.</p>	
Control option B	
<p>This option features the main controller and the Mitsubishi Electric thermistor wired to FTC. The thermistor is used to monitor room temperature but can not make any changes in control operation. Any changes to DHW MUST be made using the main controller mounted on the cylinder unit. Wire the thermistor to the TH1 connector on FTC. The number of room temperature thermistors that can be connected to FTC is always one.</p>	
Control option C (Flow temp. or compensation curve only)	
<p>This option features the main controller and a locally supplied thermostat wired to FTC. The thermostat is used to set the maximum temperature for heating room. Any changes to DHW MUST be made using main controller mounted on the cylinder unit. The thermostat is wired to IN1 in TBI.1 on FTC. The number of thermostats that can be connected to FTC is always one.</p> <p>★ A single wireless remote controller may also be used as a thermostat (rather than a room thermostat).</p> <p>In such a case, the system would also necessitate wireless receiver on cylinder unit to receive the remote controller's signal / feedback.</p>	

Note:

2-zone temperature control is not available.
2-zone valve on/off control is available.

5 System Set Up

5.6 Using SD memory card

The cylinder unit is equipped with an SD memory card interface in FTC.

Using an SD memory card can simplify main controller settings and can store operating logs. *1

Note: Before inserting or ejecting an SD memory card, confirm that the power supply earth cable is securely connected and prevent the FTC from being applied with static electricity (e.g. touch a case body etc.). Otherwise, it may cause a failure of the FTC due to the static electricity.

<Handling precautions>

- Use an SD memory card that complies with the SD standards. Check that the SD memory card has a logo on it as those shown on lower right figure.
- SD memory cards to the SD standards include SD, SDHC, miniSD, micro SD, and microSDHC memory cards. The capacities are available up to 32 GB. Choose that with a maximum allowable temperature of 55°C.
- When the SD memory card is a miniSD, miniSDHC, microSD, or micro SDHC memory card, use an SD memory card converter adapter.
- Before writing to the SD memory card, release the write-protect switch.
- Before inserting or ejecting an SD memory card, make sure to power OFF the system. If an SD memory card is inserted or ejected with the system powered ON, the stored data could be corrupted or the SD memory card be damaged. *An SD memory card is live for a short duration after the system is powered off. Before insertion or ejection wait until the LED lamps on the FTC control board are all off.
- The read and write operations have been verified using the following SD memory cards, however, these operations are not always guaranteed as the specifications of these SD memory cards could change.



Manufacturer	Model	Tested in
Silicon Power	SP004GBSDH004V10	Jan. 2015
	SP008GBSDH004V10	Jul. 2018

Before using a new SD memory card (including the card that comes with the unit), always check that the SD memory card can be safely read and written to by the FTC controller.

<How to check read and write operations>

- Check for correct wiring of power supply to the system. For more details, refer to section 4.5. (Do NOT power on the system at this point.)
 - Insert an SD memory card.
 - Power on the system.
 - The LED4 lamp lights up if the read and write operations are successfully completed. If the LED4 lamp continues blinking or does not light up, the SD memory card cannot be read or written to by the FTC controller.
- Make sure to follow the instruction and the requirement of the SD memory card's manufacturer.
 - Format the SD memory card if determined unreadable in step (6). This could make it readable. Download an SD card formatter from the following site. SD Association homepage: <https://www.sdcard.org/home/>
 - FTC supports FAT file system but not NTFS file system.
 - Mitsubishi Electric is not liable for any damages, in whole or in part, including failure of writing to an SD memory card, and corruption and loss of the saved data, or the like. Back up saved data as necessary.
 - Do not touch any electronic parts on the FTC control board when inserting or ejecting an SD memory card, or else the control board could fail.

- For insertion, push on the SD memory card until it clicks into place.
- For ejection, push on the SD memory card until it clicks.

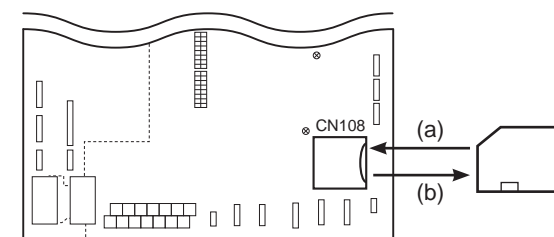

Note:

To avoid cutting fingers, do not touch sharp edges of the SD memory card connector (CN108) on the FTC control board.

Logos
Capacities
2 GB to 32 GB *2
SD speed classes
All

• The SD Logo is a trademark of SD-3C, LLC.
The miniSD logo is a trademark of SD-3C, LLC.
The microSD logo is a trademark of SD-3C, LLC.

*1 To edit main controller settings or to check operating data, an Ecodan service tool (for use with PC) is required.

*2 A 2-GB SD memory card stores up to 30 days of operation logs.

5 System Set Up

5.7 Main Controller

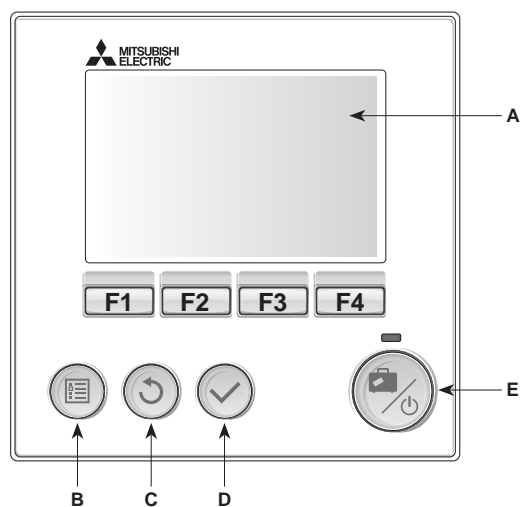

<Main controller parts>

Letter	Name	Function
A	Screen	Screen in which all information is displayed
B	Menu	Access to system settings for initial set up and modifications.
C	Back	Return to previous menu.
D	Confirm	Used to select or save. (Enter key)
E	Power/Holiday	If system is switched off pressing once will turn system on. Pressing again when system is switched on will enable Holiday Mode. Holding the button down for 3 secs will turn the system off. (*1)
F1-4	Function keys	Used to scroll through menu and adjust settings. Function is determined by the menu screen visible on screen A.

*1

When the system is switched off or the power supply is disconnected, the cylinder unit protection functions (e.g. freeze stat function) will NOT operate. Please beware that without these safety functions enabled the cylinder unit and installation may potentially become exposed to damage.

<Main screen icons>

Icon	Description
1	Heat pump 'Heat pump' is running. Defrosting. Emergency heating.
2	Electric heater When this icon is displayed the 'Electric heaters' (booster heater) are in use.
3	Target temperature Target flow temperature Target room temperature Compensation curve
4	OPTION Pressing the function button below this icon will display the option screen.
5	+ Increase desired temperature.
6	- Decrease desired temperature.
7	Z1 Z2 Pressing the function button below this icon switches between Zone1 and Zone2.
Information	Pressing the function button below this icon displays the information screen.
8	Space heating mode Heating mode Zone1 or Zone2
9	DHW mode Domestic hot water heating mode
10	Holiday mode When this icon is displayed 'Holiday mode' activated.
11	Timer is activated. Prohibited Server control is activated. Stand-by Stopped Operating
12	Current temperature Current room temperature Current water temperature of thermal store tank
13	The Menu button is locked or the switching of the operation modes between DHW and Heating operations are disabled in the Option screen. (*2)
14	SD memory card is inserted. Normal operation. SD memory card is inserted. Abnormal operation.

*2 To lock or unlock the Menu, press the BACK and CONFIRM keys simultaneously for 3 seconds.

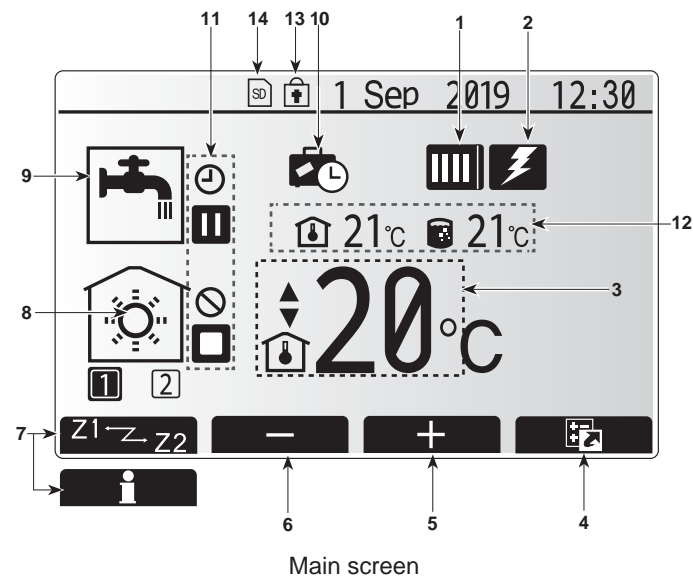

Main screen

5 System Set Up

Setting the Main Controller

After the power has been connected to the outdoor and cylinder units (See chapter 4.5) the initial system settings can be entered via the main controller.

1. Check all breakers and other safety devices are correctly installed and turn on power to the system.
2. When the main controller is switched on for the first time, the screen automatically goes to Initial settings menu, Language setting screen and Date/Time setting screen.
3. Main controller will automatically start up. Wait approximately one minute whilst the control menus load.
4. When the controller is ready a blank screen with a line running across the top will be displayed.
5. Press button E (Power) (refer to page 23) to turn on the system. Before turning on the system, perform initial settings as instructed below.

Main Settings Menu

The main settings menu can be accessed by pressing the MENU button. To reduce the risk of untrained end users altering the settings accidentally there are two access levels to the main settings; and the service section menu is password protected.

User Level – Short press

If the MENU button is pressed once for a short time the main settings will be displayed but without the edit function. This will enable the user to view current settings but NOT change the parameters.

Installer Level – Long press

If the MENU button is pressed down for 3 secs the main settings will be displayed with all functionality available.

The following items can be viewed and/or edited (dependent on access level).

- Domestic Hot water (DHW)
- Heating
- Schedule timer
- Holiday mode
- Initial settings
- Service (Password protected)

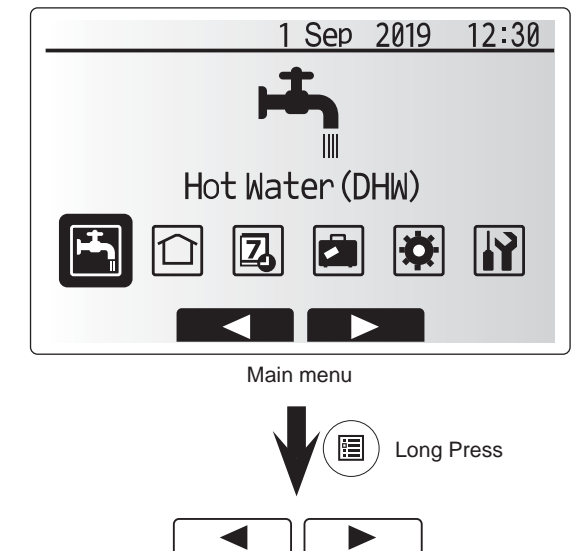

General Operation

- To find the icon that you wish to set, use the F2 and F3 buttons to move between the icons.
- The highlighted icon will appear as a larger version of the center of the screen.
- Press CONFIRM to select and edit the highlighted mode.
- Follow the <Main Controller Menu Tree> for further setting, using ◀▶ buttons for scrolling or F1 to F4 for selecting.

5 System Set Up

<Main Controller Menu Tree>

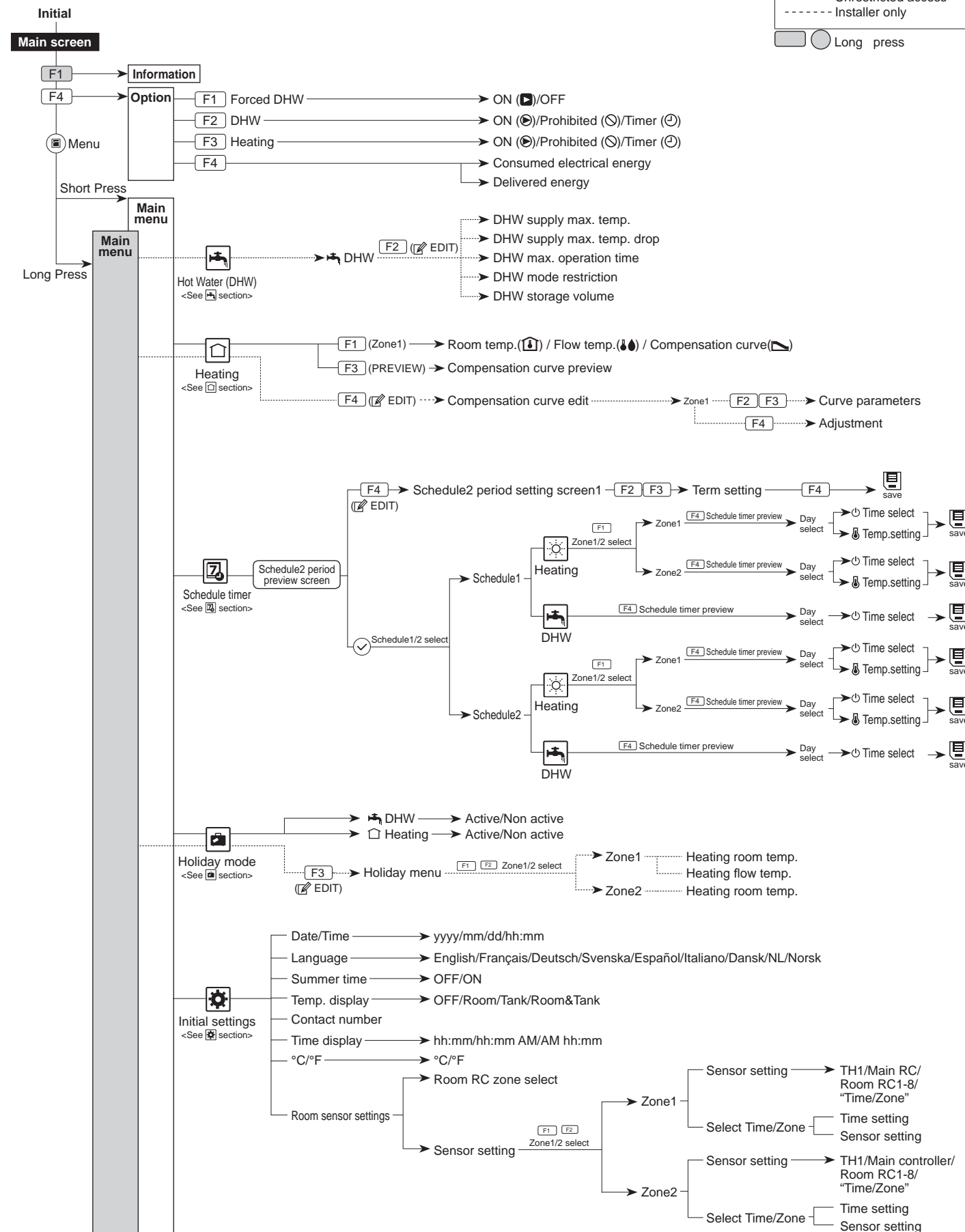

<Continued to next page.>

5 System Set Up

<Main Controller Menu Tree>

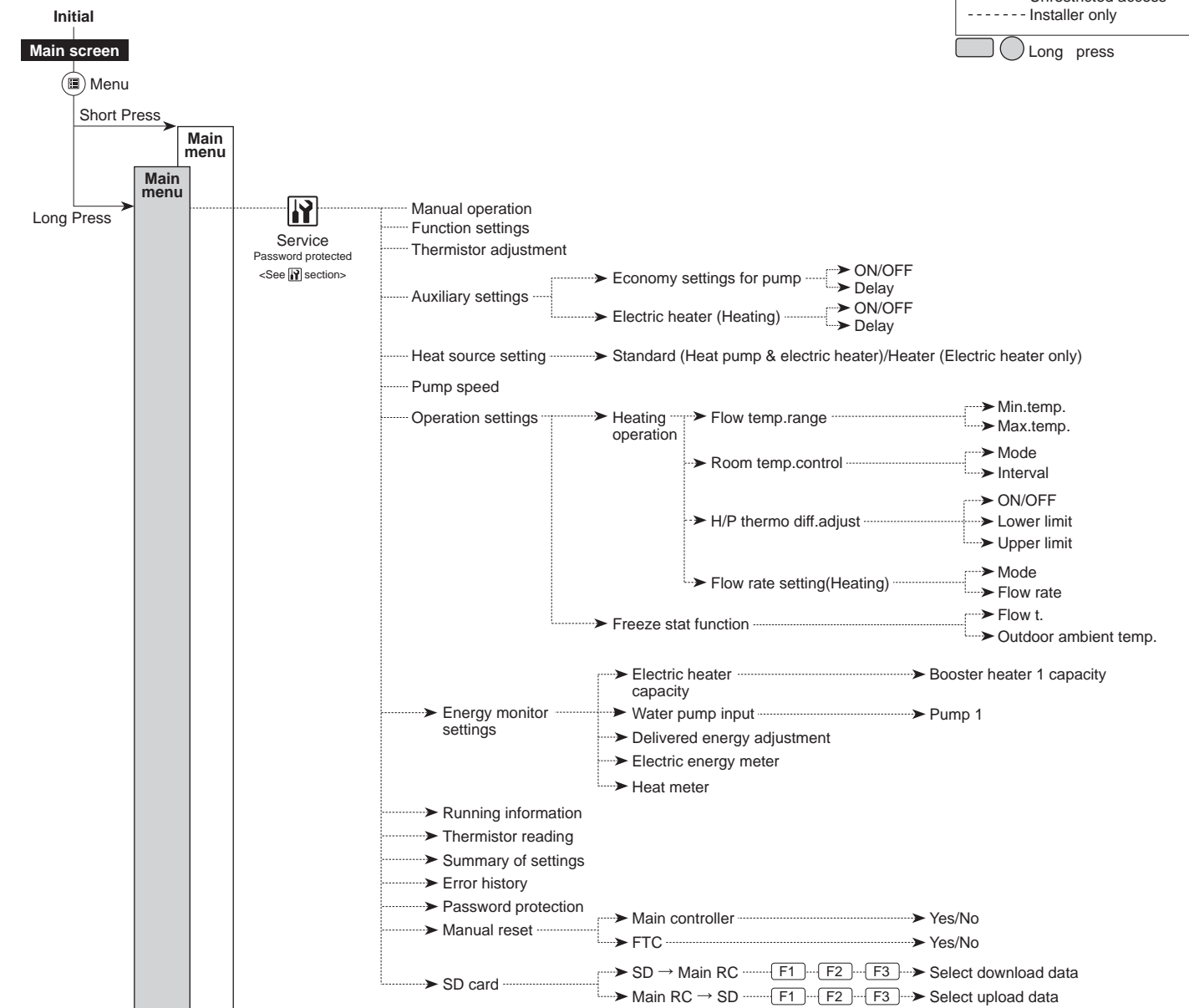

<Continued from the previous page.>

5 System Set Up

Domestic Hot Water (DHW)

► For further detail about operation, refer to Operation manual.

Heating

► For further detail about operation, refer to Operation manual.

Schedule timer

Scheduled timer can be set in two ways, for example; one for summer and the other for winter. (Refer to as "Schedule 1" and "Schedule 2" respectively.) Once the term (months) for the Schedule 1 is specified, rest of the term will be specified as Schedule 2. In each Schedule, an operational pattern of modes (Heating / DHW) can be set.

If no operational pattern is set for Schedule2, only the pattern for Schedule 1 will be valid. If Schedule 2 is set to full-year (i.e. March to Feb.), only the operational pattern for Schedule 2 will be valid.

Follow the procedure described in General Operation (Page 24) for the set up operation.

Setting the schedule timer

The preview screen allows you to view the current settings. In 2-zone heating operation, press F1 to switch between Zone1 and Zone2. Days of the week are displayed across the top of the screen. Where day appears underlined the settings are the same for all those days underlined.

Hours of the day and night are represented as a bar across the main part of the screen.

Where the bar is solid black, space heating/DHW (whichever is selected) is allowed.

When scheduling heating, button F1 changes the scheduled variable between time and temperature. This enables a lower temperature to be set for a number of hours e.g. a lower temperature may be required at night when the occupants are sleeping.

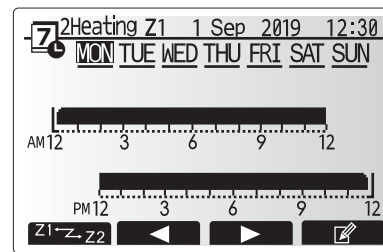

Preview screen

- The schedule timer for space heating and DHW are set in the same way. However for DHW only time can be used as scheduling variable.
- A small rubbish bin character is also displayed choosing this icon will delete the last unsaved action.
- It is necessary to use the SAVE function F4 button to save settings. CONFIRM does not act as SAVE for this menu.

Holiday mode

► For further detail about operation, refer to Operation manual.

Initial Settings

From the Initial settings menu the installer can set the following.

- Date/Time
 - *Be sure to set it to the local standard time.
- Language
- Summer time
- Temp. display
- Contact number
- Time display
- °C/°F
- Room sensor settings

Follow the procedure described in General Operation for the set up operation.

<Room sensor settings>

For room sensor settings it is important to choose the correct room sensor depending on the heating mode the system will operate in.

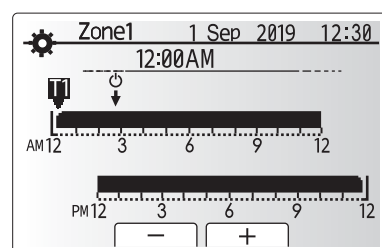

Time/Zone schedule setting screen

Menu subtitle	Description																				
Room RC zone select	When 2-zone valve on/off control is active and wireless remote controllers are available, from Room RC zone select screen, select zone No. to assign to each remote controller.																				
Sensor setting	From sensor setting screen, select a room sensor to be used for monitoring the room temperature from Zone1 and Zone2 separately. <table border="1" style="margin-left: 20px;"> <thead> <tr> <th rowspan="2">Control option (page 21)</th> <th colspan="2">Corresponding initial settings room sensor</th> </tr> <tr> <th>Zone 1</th> <th>Zone 2</th> </tr> </thead> <tbody> <tr> <td>A</td> <td>Room RC 1-8 (one each for Zone1 and Zone2)</td> <td>*1</td> </tr> <tr> <td>B</td> <td>TH1</td> <td>*1</td> </tr> <tr> <td>C</td> <td>*1</td> <td>*1</td> </tr> </tbody> </table> <p>When different room sensors are used according to the time schedule</p> <table border="1" style="margin-left: 20px;"> <thead> <tr> <th>Control option (page 21)</th> <th>Zone 1</th> <th>Zone 2</th> </tr> </thead> <tbody> <tr> <td>Time/ Zone*2</td> <td></td> <td>*1</td> </tr> </tbody> </table>	Control option (page 21)	Corresponding initial settings room sensor		Zone 1	Zone 2	A	Room RC 1-8 (one each for Zone1 and Zone2)	*1	B	TH1	*1	C	*1	*1	Control option (page 21)	Zone 1	Zone 2	Time/ Zone*2		*1
Control option (page 21)	Corresponding initial settings room sensor																				
	Zone 1	Zone 2																			
A	Room RC 1-8 (one each for Zone1 and Zone2)	*1																			
B	TH1	*1																			
C	*1	*1																			
Control option (page 21)	Zone 1	Zone 2																			
Time/ Zone*2		*1																			
<p>*1. Not specified (if a locally-supplied room thermostat is used) Room RC 1-8 (one each for Zone1 and Zone2) (if a wireless remote controller is used as a room thermostat)</p> <p>*2. From sensor setting screen, select Time/Zone to make it possible to use different room sensors according to the time schedule set in the Select Time/ Zone menu. The room sensors can be switched up to 4 times within 24 hours.</p>																					

5 System Set Up

Service Menu

The service menu provides functions for use by installer or service engineer. It is NOT intended the home owner alters settings within this menu. It is for this reason password protection is required to prevent unauthorised access to the service settings.

The factory default password is "0000".

Follow the procedure described in General Operation for the set up operation.

The service menu is navigated using the F1 and F2 buttons to scroll through the functions. The menu is split across several screens and is comprised of the following functions;

1. Manual operation
2. Function settings
3. Thermistor adjustment
4. Auxiliary settings
5. Heat source setting
6. Pump speed
7. Operation settings
8. Energy monitor settings
9. Running information
10. Thermistor reading
11. Summary of settings
12. Error history
13. Password protection
14. Manual reset
15. SD card

In this Installation Manual, instructions will be given only for the following functions;

1. Manual operation
2. Auxiliary settings
3. Heat source setting
4. Pump speed
5. Operation settings
6. Energy monitor settings
7. Password protection
8. Manual reset
9. SD card

Information on the other functions can be found by consulting the Service Manual.

Many functions can not be set whilst the indoor unit is running. The installer should turn off the unit before trying to set these functions. If the installer attempts to change the settings whilst the unit is running the main controller will display a reminder message prompting the installer to stop operation before continuing. By selecting "Yes" the unit will cease operation.

<Manual operation>

During the filling of the system the water circulation pump and 3-way valve can be manually overridden using manual operation mode.

When manual operation is selected a small timer icon appears in the screen. The function selected will only remain in manual operation for a maximum of 2 hours. This is to prevent accidental permanent override of the FTC.

► Example

Pressing F3 /D button will switch manual operation mode ON for the main 3-way valve. When filling of the thermal store tank is complete the installer should access this menu again and press F3 /D to deactivate manual operation of the part. Alternatively after 2 hours manual operation mode will no longer be active and FTC will resume control of the part.

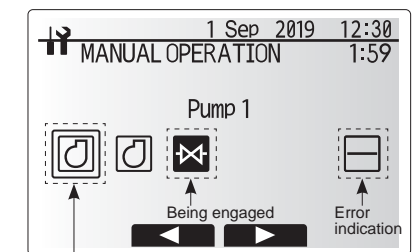

Being considered (before selection)

Manual operation menu screen

<Auxiliary settings>

This function is used to set the parameters for any auxiliary parts used in the system

Menu subtitle	Function/ Description
Economy settings for pump	Water pump stops automatically a specified period of time from when operation is finished.
Delay	Time before pump switches off*1
Electric heater (Heating)	To select "WITH booster heater (ON)" or "WITHOUT booster heater (OFF)" in Heating mode.
Delay	The minimum time required for the booster heater to turn ON after Heating mode has started.

*1. Decreasing "time before pump switched off" may increase the duration of stand-by in Heating mode.

<Heat source setting>

The default heat source setting is heat pump and booster heater present in the system to be operational.

This is referred to as Standard operation on the menu.

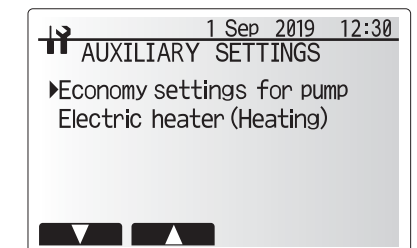

Auxiliary settings menu screen

5 System Set Up

<Operation settings>

Heating operation

This function allows operational setting of flow temperature range from the Ecodan and also the time interval at which the FTC collects and processes data for the auto adaptation mode.

1. Heating operation for auto adaptation mode

Menu subtitle	Function	Range	Unit	Default	
Flow temp. range	Minimum temp.	To minimize the loss by frequent ON and OFF in mild outdoor ambient temperature seasons.	25 - 45	°C	40
	Maximum temp.	To set max. possible flow temperature according to the type of heat emitters.	35 - 60	°C	50
Room temp. control	Mode	Setting for Room temp. control At Fast mode, target outlet water temperature is set higher than the one set at normal mode. This reduces the time to reach the target room temperature when the room temperature is relatively low.*	Normal/ Fast	--	Normal
	Interval	Selectable according to the heat emitter type and the materials of floor (i.e. radiators, floor heating-thick, -thin concrete, wood, etc.)	10 ~ 60	mins.	10
Heat pump thermo diff.adjust	On/Off	To minimize the loss by frequent ON and OFF in mild outdoor ambient-temperature seasons.	On/Off	—	On
	Lower limit	Prohibits heat pump operation until the flow temperature drops below the target flow temperature plus lower limit value.	-9 - -1	°C	-5
	Upper limit	Allows heat pump operation until the flow temperature rises above the target flow temperature plus upper limit value.	+3 - +15	°C	+9

<Table 5.7.1> Heating operation(Room temp.control table)

Note:

1. The minimum flow temperature that prohibits heat pump operation is 20°C.
2. The maximum flow temperature that allows heat pump operation equals to the maximum temperature set in the Flow temp. range menu.

* Fast mode is not most efficient and will result in increased running cost when compared to normal mode.

2.Heating operation for auto adaptation, compensation curve, and flow temp. control

Menu subtitle	Function	Range	Unit	Default	
Flow rate setting	Mode	Auto mode automatically selects a flow rate from 3 to 7 L/min appropriate for effective operation according to Room temp. control. Manual mode targets Flow rate setting value. ※ Select Manual mode except for Room temp. control.	Auto */ Manual	—	Auto
	Flow rate	Select the target circulation flow rate for heating at Manual mode. ※ Be aware of the shortage of required flow rate for each heat emitters.	3 - 8	L/min	7

<Table 5.7.2>

Note: Recommended flow rate setting at Manual mode is listed below.

- When the Flow temp. is high (e.g. radiator) recommended flow rate is low.
- When the Flow temp. is low (e.g. underfloor heating) recommended flow rate is high.
- Low flow rate setting with low flow temp. may cause frequent ON/OFF operation of pump.

* In case of "Compensation curve mode" or "Flow temp. mode" selected, even if flow rate setting is "Auto" mode, flow rate will be fixed at "7.0 L/min".

Freeze stat function

Menu subtitle	Function/ Description
Freeze stat function	An operational function to prevent the water circuit from freezing when outdoor ambient temperature drops.
Flow t.	The target outlet water temperature at water circuit when operating in Freeze stat function.
	Outdoor ambient temp. Minimum outdoor ambient temperature which freeze stat function will begin to operate, (3 - 20°C) or choose**. If asterisk (**) is chosen freeze stat function is deactivated. (i.e. primary water freeze risk)"

Note:

1. When the system is turned off, freeze stat function is not enabled.
2. Flow t. is fixed at 20°C and unchangeable.

5 System Set Up

<Energy monitor settings>

In this menu, all parameters required to record the consumed electrical energy and the delivered heat energy which is displayed on the main controller can be set. The parameters are an electric booster heater capacity, supply power of water pumps and heat meter pulse.

Follow the procedure described in General Operation for the set up operation.

For Pump 1, *** can be also set besides this setting.

In the case *** is selected, the system acknowledges "factory fitted pump" is selected.

Refer to the section [Energy Monitor] in "3. Technical Information"

<Password protection>

Password protection is available to prevent unauthorised access to the service menu by untrained persons.

Resetting the password

If you forget the password you entered, or have to service a unit somebody else installed, you can reset the password to the factory default of 0000.

1. From the main settings menu scroll down the functions until Service Menu is highlighted.
2. Press CONFIRM.
3. You will be prompted to enter a password.
4. Hold down buttons F3 and F4 together for 3 secs.
5. You will be asked if you wish to continue and reset the password to default setting.
6. To reset press button F3.
7. The password is now reset to 0000.

<Manual reset>

Should you wish to restore the factory settings at any time, you should use the manual reset function. However, please note this will reset ALL functions to the factory default settings.

<SD card>

The use of an SD memory card simplifies the main controller settings in the field.

* Ecodan service tool (for use with PC tool) is necessary for the setting.



Password input screen



Password verify screen

6 Commissioning

Pre-commissioning exercises- secondary (potable) circuit

Initial fill and flush procedure:

Ensure all pipe joints and fittings are tight and secure.

Open the most distant DHW tap/outlet.

Slowly/gradually open the mains water supply to begin filling the secondary (potable) circuit / pipework.

Allow most distant tap to run free and release/purge residual air and any impurities that may have resulted from the installation work.

Close tap/outlet to retain fully charged system and resume system commissioning.

Commissioning exercises

Energise system to heat-up cylinder unit.

Open the most distant tap and confirm that hot water is smoothly delivered.

7 Case of DHW only use

7-1. Pipework Connections

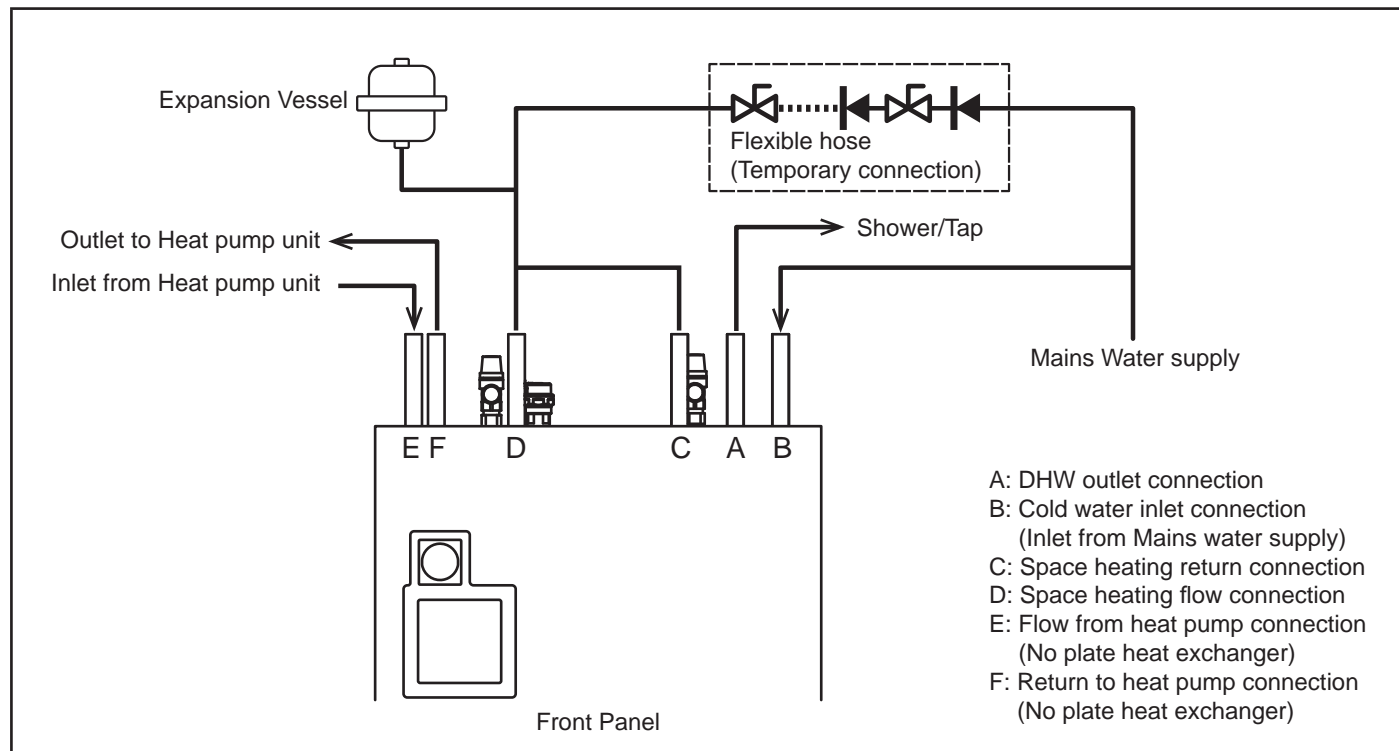

<Figure 7.1.1>

<Pipework procedure>

1. Provide a branch on connecting pipe C & D and connect Filling Loop.
2. Install an Expansion Vessel on the branch piping between Cylinder unit and Filling Loop.
3. Connect other Pipes (A, B, E, F) as showing <Figure 7.1.1> and page 7- 8.

7-2. Electrical work

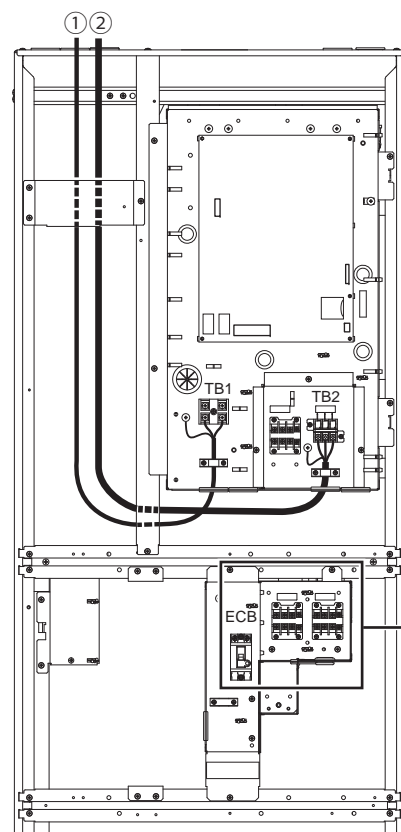

<Figure 7.1.2>

<Electrical work>

1. Connect the power cable for the cylinder unit to TB1 (①).
 2. Connect the outdoor unit – cylinder unit connecting cable to TB2 (②).
- No need to connect the power cable for the booster heater to ECB.

7 Case of DHW only use

7-3. Main controller setting (Deactivation of Heating operation)

When using DHW only operation, set the main controller settings according to the following procedure.

<Deactivation of Heating operation>

- ① Press the F4 button on "Home screen" (see Figure.7.2.1) to proceed to "Option screen" (see Figure.7.2.2).
- ② To deactivate heating operation, press "F3 button" several times on "Option screen" (see Figure.7.2.2) until mark is displayed as Heating operation status.
- ③ Press C button, then return to the home screen.

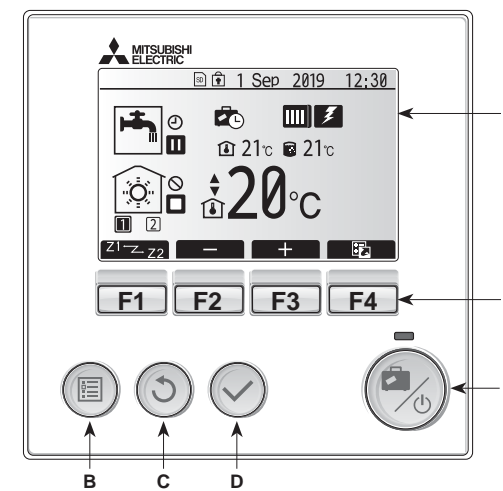

<Figure 7.2.1>

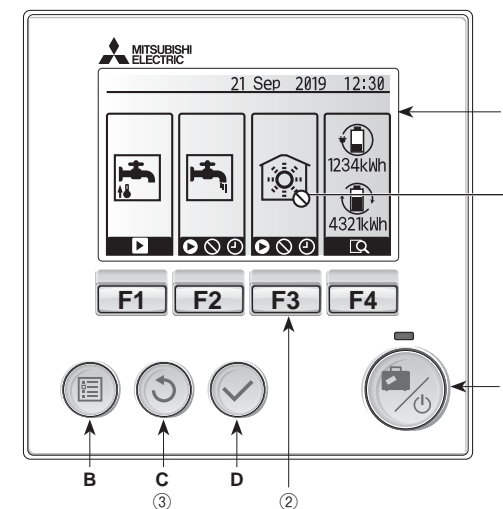

<Figure 7.2.2>

8 Service and Maintenance

The indoor cylinder unit is UNVENTED. Under UK law* the system MUST be serviced once a year by a qualified individual. Servicing and maintenance of the outdoor unit should only be done by a Mitsubishi Electric trained technician with relevant qualifications and experience. Any electrical work should be done by a tradesperson with the appropriate electrical qualifications. Any maintenance or At no time should the system be operating with the safety devices by-passed or plugged. 'DIY' fixes done by a non-accredited person could invalidate the Warranty and/or result in damage to the cylinder unit and injury to the person.

* Building regulations – England & Wales Part G3, Scotland P3, Northern Ireland P5.

Basic Troubleshooting for Cylinder Unit

The following table is to be used as a guide to possible problems. It is not exhaustive and all problems should be investigated by the installer or another competent person. Users should not attempt to repair the system themselves.

At no time should the system be operating with the safety devices by-passed or plugged.

Fault symptom	Possible cause	Solution
Cold water at taps	System or power input is OFF.	Turn on the power/system.
	DHW is scheduled "OFF"	Check schedule settings and change if necessary.
	All reserves of hot water from thermal store tank have been used.	Ensure DHW mode is operating and wait for thermal store tank to re-heat.
	Heat pump or booster heater not working	Contact installer.
	Air exists within pump A	Open the air vent above pump A (refer to page 16).
	Flow sensor jam / defect	Contact installer.
Heating system does not get up to set temperature.	Supply flow rate is low	Increase the delivery amount. (open tap further.)
	Prohibit, schedule or holiday mode selected	Check settings and change as appropriate.
	Incorrectly sized radiators or low flow rate setting	Contact installer.
	The room in which the temperature sensor is located is at a different temperature to the rest of the house.	Reposition the temperature sensor to a more suitable room.
Heat emitter is hot in the DHW mode. (The room temperature rises.)	Battery problem *wireless control only	Check the battery power and replace if flat.
	The 3-way valve may have foreign objects in it, or hot water may flow to the heating side due to abnormal malfunctions.	Contact installer.
Schedule function inhibits the system from operating but the outdoor unit is operational.	Freeze stat function may be active, to prevent freezing.	Normal operation no action necessary.
Pump runs without reason for short time.	Pump jam prevention control routine to inhibit the build up of scale.	Normal operation no action necessary.
Mechanical noise (minor) heard coming from cylinder unit	Booster heater switching on/off	Normal operation no action required.
	Pump operates during hot water supply	Normal operation no action necessary.
	3-way valve changing position between DHW and heating mode.	Normal operation no action necessary.
Abnormal cylinder noise during delivery of domestic hot water supply	Air present in pump A	Open the air vent above pump A (refer to page 16). If the symptoms persist contact installer.
Noisy pipework	Air trapped in the system	Try bleeding radiators (if present) If the symptoms persist contact installer.
	Loosely supported pipe work.	Contact installer.
Water discharges from one of the pressure relief valves	The system has overheated or overpressurised	Switch off power to the cylinder unit and the booster heater then contact installer.
Small amounts of water drip from one of the pressure relief valves.	Dirt may be preventing proper tight seal in the valve	Twist the valve cap in the direction indicated until a click is heard. This will release a small amount of water flushing dirt from the valve. Be very careful the water released will be hot. Should the valve continue to drip contact installer as the rubber seal may be damaged and need replacing.
An error code appears in the main controller display.	The indoor or outdoor unit is reporting an abnormal condition	Make a note of the error code number plus any other observation(s) and contact installer.

<Power failure>

All setting will be saved for 1 week with no power, after 1 week Date/Time ONLY will be saved.

For more details, refer to the service manual.

<Draining the cylinder unit and its primary heating circuit (local)>

- Before attempting to drain the cylinder unit isolate from the electrical supply to prevent the booster heaters burning out. When the ECB is turned off, push down the power lever without pressing the test button.
- Isolate cold water feed to secondary (potable) circuit.
- Attach a hose to the drain cock (No.4 on the front side of heat exchanger shown in Figure 3.2).^{*1} Open a hot water tap to start draining without a vacuum. Open the drain cock of the heat exchanger.
- When the secondary (potable) circuit is drained close drain cock and hot tap.
- Draining procedure of the thermal store tank (primary circuit) is as follows.
 - Open the cap of the pressure relief valve to reduce the pressure of the thermal store tank to 0 bar.
 - Attach a hose to the manual air vent (No. 12 above the thermal store tank shown in Figure 3.2).^{*1} Open the manual air vent.
 - Check that the pump valves and the strainer valve are opened. Open the drain valve (No.13 shown in Figure 3.2) to drain the water in the thermal store tank.
 - Open all other drain cocks. (No.3 shown in Figure 3.2 and drain cocks of outdoor unit)
 - Water remains in the strainer still after the cylinder unit was drained. Drain the strainer by removing the strainer cover.

*1. The hose should be able to withstand heat as the draining water could be very hot.



8 Service and Maintenance

Error Codes

Code	Error	Action
L3	Circulation water temperature overheat protection	Flow rate may be reduced check for; <ul style="list-style-type: none"> Water leakage Strainer blockage Clogging of piping Water circulation pump function (Error code may display during filling of primary circuit, complete filling and reset error code.)
L4	Thermal store tank water temperature overheat protection	Check resistance across the thermistor (THW1, THW3, THW5A).
L5	Indoor unit temperature thermistor (THW1, THW2, THW3, THW4, THW5A, THW5B) failure	Check resistance across the thermistor.
L6	Circulation water freeze protection	See Action for L3.
L8	Heating operation error	Re-attach any thermistors that have become dislodged.
L9	Low primary circuit flow rate detected by flow sensor (flow sensors1,B)	See Action for L3. If the flow sensor itself does not work, replace it. Discharge the air for primary circuit. Turn on the pump A and pump 1 using Manual operation to flush debris on the flow sensor. Caution: The pump valves may be hot, please take care.
LF	Flow sensor failure (flow sensors1,A,B)	Check flow sensor cable for damage or loose connections.
LP	DHW supply temperature overheat protection	See Action for L3. Check detection value of thermistor is the same as the actual temperature. Check resistance across the thermistor (Cylinder unit and outdoor unit)
LU	Water circulation pump failure	Check cloggings of the pump with foreign materials. Check water circulation pump cable for damage or loose connections. Caution : The pump valves may be hot, please take care
J0	Communication failure between FTC and wireless receiver	Check connection cable for damage or loose connections.
P1	Thermistor (Room temp.) (TH1) failure	Check resistance across the thermistor. Check the room sensor settings.(page 33)
J1 - J8	Communication failure between wireless receiver and wireless remote controller	Check wireless remote controller's battery is not flat. Check the pairing between wireless receiver to wireless remote controller. Test the wireless communication. (See the manual of wireless system)
E0 - E5	Communication failure between main controller and FTC	Check connection cable for damage or loose connections.
E6 - EF	Communication failure between FTC and outdoor unit	Check that the outdoor unit has not been turned off. Check connection cables for damage and miswiring or loose connections. Press the reset button and recover the system after lowering the temperature if the thermostat of outdoor unit operates. Refer to outdoor unit service manual.
U*, F*	Outdoor unit failure	Refer to outdoor unit service manual.

Note: To cancel error codes please press F4 button or switch system OFF (Press button E on Main Controller for 3 secs).

Annual Maintenance

It is essential that the cylinder unit is serviced at least once a year by a qualified individual. Any spare parts required should be purchased from Mitsubishi Electric. Never bypass safety devices or operate the unit without them being fully operational. For more details, refer to service handbook.

Note: Within the first couple of months of installation, remove and clean the cylinder unit's strainer plus any strainer and magnetic filter that may be fitted external to the cylinder unit. This is especially important when installing on an existing system.

In addition to annual servicing it is necessary to replace or inspect some parts after a certain period of system operation. Please see tables below for detailed instructions. Replacement and inspection of parts should always be done by a competent person with relevant training and qualifications.

Parts which require regular replacement

Parts	Replace every	Possible failures
Pressure relief valve (PRV) Air vent (Auto) Manometer	6 years	Water leakage

Parts which require regular inspection

Parts	Check every	Possible failures
Water circulation pump1	50,000 hrs (7 years)	Water circulation pump failure

Parts which must NOT be reused when servicing

- * O-ring
- * Gasket

8 Service and Maintenance

Engineers Forms

Should settings be changed from default, please enter and record new setting in 'Field Setting' column. This will ease resetting in the future should the system use change or the circuit board need to be replaced.

Commissioning / Field settings record sheet

Main controller screen		Parameters	Default setting	Field setting	Notes	
Main	Zone1 heating room temp.		10°C - 30°C	20°C		
	Zone2 heating room temp. *5		10°C - 30°C	20°C		
	Zone1 heating flow temp.		25°C - 60°C	45°C		
	Zone1 heating compensation curve		-9°C - + 9°C	0°C		
	Holiday mode		Active/Non active/Set time	—		
Option	Forced DHW operation		On/Off	—		
	DHW		On/Off/Timer	On		
	Heating		On/Off/Timer	On		
	Energy monitor		Consumed electric energy/Produced energy	—		
Setting	Hot water (DHW)		DHW supply max. temp.	40°C - 70°C	55°C	
			DHW supply temp. drop	15°C - 30°C	15°C	
			DHW max. operation time	30 - 120 mins	60 mins	
			DHW mode restriction	30 - 120 mins	30 mins	
			DHW storage volume	Normal/Energy save	Normal	
	Heating		Zone1 operation mode	Room temp/Flow temp/Compensation curve	Room temp	
	Compensation curve	Hi flow temp. set point	Zone1 outdoor ambient temp.	-30°C - +33°C	-15°C	
			Zone1 flow temp.	25°C - 60°C	50°C	
		Lo flow temp. set point	Zone1 outdoor ambient temp.	-28°C - +35°C	35°C	
			Zone1 flow temp.	25°C - 60°C	25°C	
		Adjust	Zone1 outdoor ambient temp.	-29°C - +34°C	—	
			Zone1 flow temp.	25°C - 60°C	—	
	Holiday		DHW	Active/Non active	Non active	
			Heating	Active/Non active	Active	
			Zone1 heating room temp.	10°C - 30°C	15°C	
			Zone2 heating room temp. *5	10°C - 30°C	15°C	
			Zone1 heating flow temp.	25°C - 60°C	35°C	
	Initial settings		°C/°F	°C/°F	°C	
			Summer time	On/Off	Off	
			Temp. display	Room/Tank/Room&tank /Off	Off	
		Time display	hh:mm/hh:mm AM/AM hh:mm	hh:mm		
		Room sensor settings for Zone1	TH1/Main RC/Room RC1-8/"Time/Zone"	TH1		
		Room sensor settings for Zone2 *1	TH1/Main RC/Room RC1-8/"Time/Zone"	TH1		
		Room RC zone select *1	Zone1/Zone2	Zone1		
Service menu	Thermistor adjustment	THW1	-10°C - +10°C	0°C		
		THW2	-10°C - +10°C	0°C		
		THW3	-10°C - +10°C	0°C		
		THW4	-10°C - +10°C	0°C		
		THW5A	-10°C - +10°C	0°C		
		THW5B	-10°C - +10°C	0°C		
	Auxiliary settings		Economy settings for pump.	On/Off *3 Delay (3 - 60 mins)	On 10 mins	
			Electric heater (Heating)	Space heating: On (used)/Off (not used) Electric heater delay timer (5 - 180 mins)	On 30 mins	
			Pump speed	Pump speed(1 - 5)	4	
			Heat source setting	Standard/Heater	Standard	
	Operation settings	Heating operation	Flow temp.range *2	Min.temp.(25 - 45°C) Max.temp.(35 - 60°C)	40°C 50°C	
			Room temp.control *2	Mode(Normal /Fast) Interval(10 - 60min)	Normal 10 mins	
			Heat pump thermo diff.adjust *2	On/Off *3 Lower limit(-9 - -1°C) Upper limit(+3 - +15°C)	On -5°C 9°C	
				Flow rate settings	Mode(Auto/Manual) *6 Flow rate(3 - 8L/min)	Auto 7L/min
				Freeze stat function *4	Outdoor ambient temp. (3 - 20°C) / **	5°C
		Energy monitor settings	Electric heater capacity	Booster heater 1 capacity	0 - 30kW	2kW
	Water pump input		Pump 1	0 - 200W or ***(factory fitted pump)	***	
	Delivered energy adjustment		-50 - +50%	0%		
	Electric energy meter		0.1/1/10/100/1000 pulse/kWh	1 pulse/kWh		
	Heat meter		0.1/1/10/100/1000 pulse/kWh	1 pulse/kWh		

*1 The settings related to Zone2 can be switched only when 2 zone temperature control is enabled (when DIP SW2-6 and SW 2-7 are ON).

*2 Valid only when operating in Room temp. control mode.

*3 On: the function is active; Off: the function is inactive.

*4 If asterisk (**) is chosen freeze stat function is deactivated. (i.e. primary water freeze risk)

*5 The settings related to Zone2 can be switched only when 2-Zone valve ON/OFF control is active.

*6 In case of "Compensation curve mode" or "Flow temp. mode" selected, even if flow rate setting is "Auto" mode, flow rate will be fixed at "7.0 L/min".

UK DECLARATION OF CONFORMITY

**mitsubishi electric corporation,
tokyo bldg., 2-7-3, marunouchi, chiyoda-ku, tokyo 100-8310, japan**

hereby declares under its sole responsibility that the heating system components described below for use in residential, commercial and light-industrial environments:

mitsubishi electric, ehpt20q-vm2ea, quhz-w40va

Note: Its serial number is on the nameplate of the product.

Legislation

Low Voltage	The Electrical Equipment (Safety) Regulations 2016
Machinery	The Supply of Machinery (Safety) Regulations 2008
Electromagnetic Compatibility	The Electromagnetic Compatibility Regulations 2016
RoHS	The Restriction of the Use of Certain Hazardous Substances in Electrical and Electronic Equipment Regulations 2012
Energy - related Products	The Ecodesign for Energy-Related Products and Energy Information (Amendment) (EU Exit) Regulations 2019

Issued date: 9 Jun. 2021

Satoshi TANZAWA
General Manager, Quality Assurance Dept.

Revised date: 18 Apr. 2022

JAPAN

Installers: Please be sure to put your full contact address/telephone number on this manual before handing it to the customer.

MITSUBISHI ELECTRIC CORPORATION

HEAD OFFICE :

TOKYO BUILDING 2-7-3, MARUNOUCHI, CHIYODA-KU, TOKYO 100-8310, JAPAN

IMPORTER in Europe :

- MITSUBISHI ELECTRIC AIR CONDITIONNING SYSTEMS EUROPE LTD.
NETTLEHILL ROAD, HOUSTOUN INDUSTRIAL ESTATE, LIVINGSTON, EH54 5EQ,
SCOTLAND, U.K.
- MITSUBISHI ELECTRIC EUROPE B.V.
UK BRANCH : TRAVELLERS LANE, HATFIELD, HERTS., AL10 8XB, ENGLAND, U.K
IRISH BRANCH : WESTGATE BUSINESS PARK, BALLYMOUNT, DUBLIN 24, IRELAND
FRENCH BRANCH : 25, BOULEVARD DES BOUVETS, 92741 NANTERRE CEDEX, FRANCE
GERMAN BRANCH : MITSUBISHI - ELECTRIC - PLATZ 1, 40882 RATINGEN, GERMANY
NORWEGIAN BRANCH : GNEISVEIEN 2D, 1914 YTRE ENEBAKK, NORWAY
SCANDINAVIAN BRANCH : HAMMARBACKEN 14, P.O. BOX 750 SE-19127, SOLLENTUNA, SWEDEN.

Printed in Japan