

Packaged Air-Conditioners INDOOR UNIT

PEA-M200,250LA2

INSTALLATION MANUAL	FOR INSTALLER	English
INSTALLATIONSHANDBUCH	FÜR INSTALLATEURE	Deutsch
MANUEL D'INSTALLATION	POUR L'INSTALLATEUR	Français
INSTALLATIEHANDLEIDING	VOOR DE INSTALLATEUR	Nederlands
MANUAL DE INSTALACIÓN	PARA EL INSTALADOR	Español
MANUALE DI INSTALLAZIONE	PER L'INSTALLATORE	Italiano
ΕΓΧΕΙΡΙΔΙΟ ΟΔΗΓΙΩΝ ΕΓΚΑΤΑΣΤΑΣΗΣ	ΓΙΑ ΑΥΤΟΝ ΠΟΥ ΚΑΝΕΙ ΤΗΝ ΕΓΚΑΤΑΣΤΑΣΗ	Ελληνικό
MANUAL DE INSTALAÇÃO	PARA O INSTALADOR	Português
INSTALLATIONSMANUAL	TIL INSTALLATØREN	Dansk
INSTALLATIONSMANUAL	FÖR INSTALLATÖREN	Svenska
MONTAJ ELKİTABI	MONTÖR İÇİN	Türkçe
РУКОВОДСТВО ПО УСТАНОВКЕ	ДЛЯ УСТАНОВИТЕЛЯ	Русский
ПОСІБНИК З УСТАНОВЛЕННЯ	ДЛЯ СПЕЦІАЛІСТА З МОНТАЖУ	Українська
РЪКОВОДСТВО ЗА МОНТАЖ	ЗА МОНТАЖНИКА	Български
INSTRUKCJA MONTAŻU	DLA INSTALATORA	Polski
INSTALLASJONSHÅNDBOK	FOR MONTØR	Norsk
ASENNUSOPAS	ASENTAJALLE	Suomi
INSTALAČNÍ PŘÍRUČKA	PRO MONTÁŽNÍ PRACOVNÍKY	Čeština
NÁVOD NA INŠTALÁCIU	PRE MONTÉRA	Slovenčina
TELEPÍTÉSI KÉZIKÖNYV	A TELEPÍTŐ RÉSZÉRE	Magyar
NAMESTITVENI PRIROČNIK	ZA MONTERJA	Slovenščina
MANUAL DE INSTALARE	PENTRU INSTALATOR	Română
PAIGALDUSJUHEND	PAIGALDAJALE	Eesti
MONTĀŽAS ROKASGRĀMATA	UZSTĀDĪŠANAS SPECIĀLISTAM	Latviski
MONTAVIMO VADOVAS	SKIRTA MONTUOTOJUI	Lietuviškai
PRIRUČNIK ZA POSTAVLJANJE	ZA INSTALATERA	Hrvatski
UPUTSTVO ZA UGRADNJU	ZA MONTERA	Srpski

Contents

1. Safety precautions	2	6. Refrigerant piping work	6
2. Selecting the installation location	3	7. Duct work	8
3. Selecting an installation site & Accessories	3	8. Electrical work	9
4. Fixing hanging bolts	5	9. Test run	14
5. Installing the unit	5	10. Maintenance	18

Note:
The phrase "Wired remote controller" in this installation manual refers only to the PAR-41MAA. If you need any information for the other remote controller, please refer to either the installation manual or initial setting manual which are included in these boxes.

1. Safety precautions

- ▶ Before installing the unit, make sure you read all the "Safety precautions".
- ▶ The "Safety precautions" provide very important points regarding safety. Make sure you follow them.
- ▶ Please report to or take consent by the supply authority before connection to the system.

MEANINGS OF SYMBOLS ON THE UNIT

	WARNING (Risk of fire)	This symbol is only for R32 refrigerant. The type of the refrigerant used is written on the nameplate on the outdoor unit. R32 refrigerant is flammable. If the refrigerant leaks, or comes in contact with fire or parts that generate heat, it may create harmful gas and pose a risk of fire.
		Read the OPERATION MANUAL carefully before operation.
		Service personnel are required to carefully read the OPERATION MANUAL and INSTALLATION MANUAL before operation.
		Further information is available in the OPERATION MANUAL, INSTALLATION MANUAL, and the like.

Symbols used in the text

- Warning:**
Could lead to death, serious injury, etc.
- Caution:**
Could lead to serious injury in particular environments when operated incorrectly.
 - After reading this manual, be sure to keep it together with the instruction manual in a handy place on the customer's site.

Symbols put on the unit

- : Indicates an action that must be avoided.
- : Indicates that important instructions must be followed.
- : Indicates a part which must be grounded.
- : Indicates that caution should be taken with rotating parts.
- : Indicates that the main switch must be turned off before servicing.
- : Beware of electric shock.
- : Beware of hot surface.

- Warning:**
 - Carefully read the labels affixed to the main unit.
 - Do not install it by yourself (customer).
Incomplete installation could cause injury due to fire, electric shock, the unit falling or leakage of water. Consult the dealer from whom you purchased the unit or special installer.
 - Servicing shall be performed only as recommended by the manufacturer.
 - This appliance is not intended for use by persons (including children) with reduced physical, sensory or mental capabilities, or lack of experience and knowledge, unless they have been given supervision or instruction concerning use of the appliance by a person responsible for their safety.
 - Install the unit securely in a place which can bear the weight of the unit.
When installed in an insufficient strong place, the unit could fall causing injured.
 - Use the specified wires to connect the indoor and outdoor units securely and attach the wires firmly to the terminal board connecting sections so the stress of the wires is not applied to the sections.
Incomplete connecting and fixing could cause fire.
 - Do not use intermediate connection of the power cord or the extension cord and do not connect many devices to one AC outlet.
It could cause a fire or an electric shock due to defective contact, defective insulation, exceeding the permissible current, etc.
 - Check that the refrigerant gas does not leak after installation has completed.
 - Perform the installation securely referring to the installation manual.
Incomplete installation could cause a personal injury due to fire, electric shock, the unit falling or leakage of water.
 - This appliance is intended to be used by expert or trained users in shops, in light industry and on farms, or for commercial use by lay persons.
 - Perform electrical work according to the installation manual and be sure to use an exclusive circuit.
If the capacity of the power circuit is insufficient or there is incomplete electrical work, it could result in a fire or an electric shock.
 - If the supply cord is damaged, it must be replaced by the manufacturer, its service agent or similarly qualified persons in order to avoid a hazard.
 - Attach the electrical part cover to the indoor unit and the service panel to the outdoor unit securely.
If the electrical part cover in the indoor unit and/or the service panel in the outdoor unit are not attached securely, it could result in a fire or an electric shock due to dust, water, etc.

- Be sure to use the part provided or specified parts for the installation work. The use of defective parts could cause an injury or leakage of water due to a fire, an electric shock, the unit falling, etc.
- Ventilate the room if refrigerant leaks during operation. If the refrigerant comes in contact with a flame, poisonous gases will be released.
- Children should be supervised to ensure that they do not play with the appliance.
- When installing, relocating, or servicing the air conditioner, use only the specified refrigerant written on the outdoor unit to charge the refrigerant lines. Do not mix the refrigerant with any other refrigerant, and do not allow air to remain in the lines.
 - If air is mixed with the refrigerant, then it may cause abnormal high pressure in the refrigerant lines, resulting in an explosion and other hazards.
 - The use of any refrigerant other than that specified for the system will cause mechanical failure, system malfunction, or unit breakdown. In the worst case, this could lead to a serious impediment to securing product safety.
 - It may also be in violation of applicable laws.
 - MITSUBISHI ELECTRIC CORPORATION cannot be held responsible for malfunctions or accidents resulting from the use of the wrong type of refrigerant.
- This indoor unit should be installed in a room which is equal to or larger than the floor space specified in the outdoor unit installation manual. Refer to the outdoor unit installation manual.
- Only use means recommended by the manufacturer to accelerate the defrosting process or to clean.
- This indoor unit shall be stored in a room that has no continuously-operating ignition device such as open flame, gas appliance, or electrical heater.
- Do not pierce a hole in or burn this indoor unit or refrigerant lines.
- Be aware that the refrigerant may be odour-free.
- Pipe-work shall be protected from physical damage.
- The installation of pipe-work shall be kept to a minimum.
- Compliance with national gas regulations shall be observed.
- Keep any required ventilation openings clear of obstruction.
- Do not use low temperature solder alloy when brazing the refrigerant pipes.
- When performing brazing work, be sure to ventilate the room sufficiently. Make sure that there are no hazardous or flammable materials nearby. When performing the work in a closed room, small room, or similar location, make sure that there are no refrigerant leaks before performing the work. If refrigerant leaks and accumulates, it may ignite or poisonous gases may be released.

1. Safety precautions

- For installation and relocation work, follow the instructions in the installation manual and use tools and pipe components specifically made for using with refrigerant specified in the outdoor unit installation manual.
- If the air conditioner is installed in a small room or closed room, measures must be taken to prevent the refrigerant concentration in the room from exceeding the safety limit in the event of refrigerant leakage. Should the refrigerant leak and cause the concentration limit to be exceeded, hazards due to lack of oxygen in the room may result.

⚠ Warning:

If one or more rooms are connected to the unit using a duct system, make sure:

⚠ Caution:

- **Perform grounding.**
Do not connect the ground wire to a gas pipe, water pipe arrester or telephone ground wire. Defective grounding could cause an electric shock.
- **Do not install the unit in a place where an inflammable gas leaks.**
If gas leaks and accumulates in the area surrounding the unit, it could cause an explosion.
- **Install a ground leakage breaker depending on the installation place (where it is humid).**
If a ground leakage breaker is not installed, it could cause an electric shock.

- Install the unit in a space with at least a minimum floor area defined in the installation manual for the outdoor unit.
- no auxiliary devices, which may be a potential ignition source, are installed in the duct work;
- only auxiliary devices approved by the manufacturer are used in the duct work;
- an air inlet or outlet is connected directly with a room by ducting. Do NOT use spaces such as a false ceiling as a duct for the air inlet or outlet.
- Do NOT install operating ignition sources (example: open flames, an operating gas appliance or an operating electric heater) in the duct work.

- Perform the drainage/piping work securely according to the installation manual.
If there is a defect in the drainage/piping work, water could drop from the unit and household goods could be wet and damaged.
- Do not run the unit when it is separated.
- The appliance shall be stored so as to prevent mechanical damage from occurring.

2. Selecting the installation location

2.1. Indoor unit

- Where airflow is not blocked.
- Where cool air spreads over the entire room.
- Where it is not exposed to direct sunshine.
- At a distance 1 m or more away from your TV and radio (to prevent picture from being distorted or noise from being generated).
- In a place as far away as possible from fluorescent and incandescent lights (so the infrared remote control can operate the air conditioner normally).
- Where the air filter can be removed and replaced easily.

⚠ Warning:

Mount the indoor unit into a ceiling strong enough to withstand the weight of the unit.

2.2. Outdoor unit

- Where it is not exposed to strong wind.
- Where airflow is good and dustless.
- Where it is not exposed to rain and direct sunshine.
- Where neighbours are not annoyed by operation sound or hot air.
- Where rigid wall or support is available to prevent the increase of operation sound or vibration.
- Where there is no risk of combustible gas leakage.
- When installing the unit at a high level, be sure to fix the unit legs.
- Where it is at least 3 m away from the antenna of TV set or radio. (Otherwise, images would be disturbed or noise would be generated.)
- Install the unit horizontally.

⚠ Caution:

Avoid the following places for installation where air conditioner trouble is liable to occur.

- **Where there is too much machine oil.**
- **Salty environment as seaside areas.**
- **Hot-spring areas.**
- **Where sulfide gas exists.**
- **Other special atmospheric areas.**

3. Selecting an installation site & Accessories

- Select a site with sturdy fixed surface sufficiently durable against the weight of unit.
- Before installing unit, the routing to carry in unit to the installation site should be determined.
- Select a site where the unit is not affected by entering air.
- Select a site where the flow of supply and return air is not blocked.
- Select a site where refrigerant piping can easily be led to the outside.
- Select a site which allows the supply air to be distributed fully in room.
- Do not install unit at a site with oil splashing or steam in much quantity.
- Do not install unit at a site where combustible gas may generate, flow in, stagnate or leak.
- Do not install unit at a site where equipment generating high frequency waves (a high frequency wave welder for example) is provided.
- Do not install unit at a site where fire detector is located at the supply air side. (Fire detector may operate erroneously due to the heated air supplied during heating operation.)
- When special chemical product may scatter around such as site chemical plants and hospitals, full investigation is required before installing unit. (The plastic components may be damaged depending on the chemical product applied.)
- If the unit is run for long hours when the air above the ceiling is at high temperature/high humidity (dew point above 26 °C), dew condensation may be produced in the indoor unit. When operating the units in this condition, add insulation material (10-20 mm) to the entire surface of the indoor unit to avoid dew condensation.

3.1. Install the indoor unit on a ceiling strong enough to sustain its weight

Secure enough access space to allow for the maintenance, inspection, and replacement of the motor, fan, drain pump, heat exchanger, and electric box in one of the following ways.

Select an installation site for the indoor unit so that its maintenance access space will not be obstructed by beams or other objects.

- (1) When a space of 500 mm or more is available below the unit between the unit and the ceiling (Fig. 3-1-1)
 - Create access door 1 and 2 as shown in Fig. 3-1-2.
- (2) When a space of less than 500 mm is available below the unit between the unit and the ceiling (At least 20 mm of space should be left below the unit as shown in Fig. 3-1-3.)
 - Create access door 1 diagonally below the electric box and access door 3 below the unit as shown in Fig. 3-1-4.

3. Selecting an installation site & Accessories

[Fig. 3-1-1]

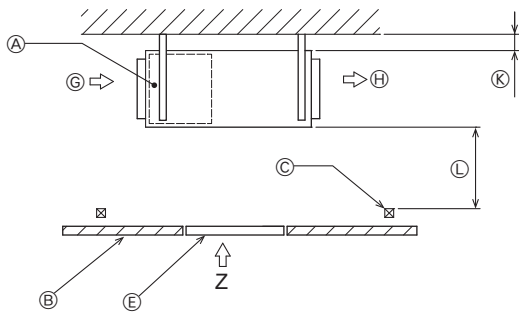

- (A) Control box
- (B) Ceiling
- (C) Ceiling beam
- (D) Access door 1 (450 x 450)
- (E) Access door 2 (600 x 600)
- (F) Access door 3
- (G) Air inlet
- (H) Air outlet
- (I) Bottom of indoor unit
- (J) Maintenance access space
- (K) Min. 20 mm
- (L) Min. 500 mm

⚠ Warning:

The unit must be securely installed on a structure that can sustain its weight. If the unit is mounted on an unstable structure, it may fall down causing injuries.

⚠ Warning:

- This unit should be installed in rooms which exceed the floor space specified in outdoor unit installation manual. Refer to outdoor unit installation manual.
- Install the indoor unit at least 2.5 m above floor or ground level. For appliances not accessible to the general public.
- Refrigerant pipes connection shall be accessible for maintenance purpose.

[Fig. 3-1-2] (Viewed from the direction of the arrow Z)

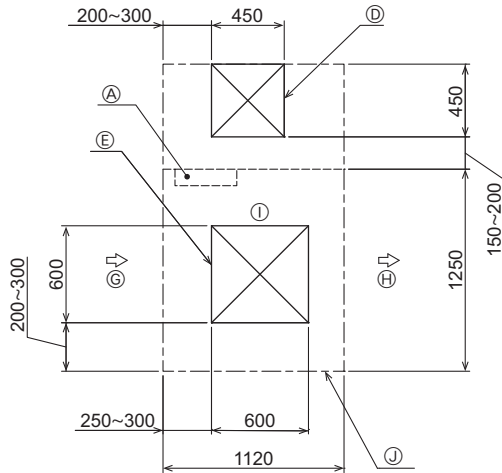

3.2. Securing installation and service space

- Select the optimum direction of supply airflow according to the configuration of the room and the installation position.
- As the piping and wiring are connected at the bottom and side surfaces, and the maintenance is made at the same surfaces, allow a proper space properly. For the efficient suspension work and safety, provide a space as much as possible.

3.3. Indoor unit accessories

The unit is provided with the following accessories:

For PEA-M200/250LA2

No.	Name	Quantity
①	Insulation pipe 125 mm (small)	1
②	Insulation pipe 125 mm (large)	1
③	Tie band	7
④	Drain socket	1
⑤	Washer	8
⑥	Reducer 25.4-22.2 mm	1
⑦	Reducer 12.7-9.52 mm	1

[Fig. 3-1-3]

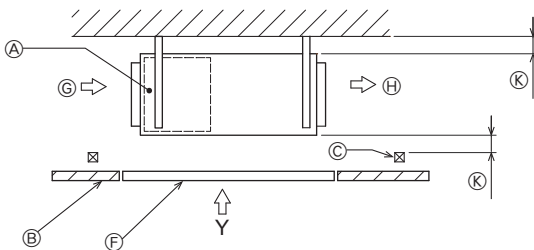

[Fig. 3-1-4] (Viewed from the direction of the arrow Y)

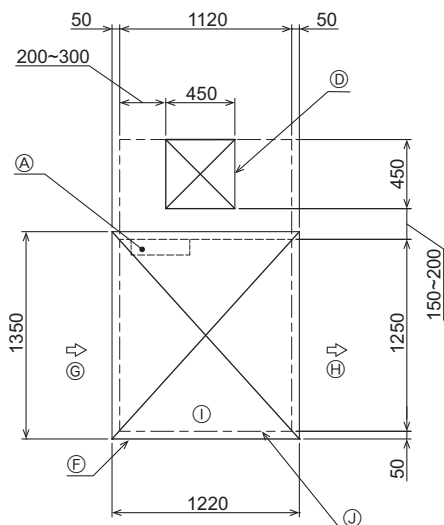

4. Fixing hanging bolts

4.1. Fixing hanging bolts

[Fig. 4-1]

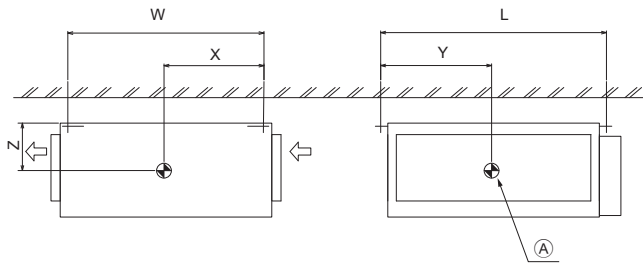

(A) Center of gravity

(Give site of suspension strong structure.)

Center of gravity and Product Weight

Model name	W (mm)	L (mm)	X (mm)	Y (mm)	Z (mm)	Product Weight (kg)
PEA-M200,250LA2	1034	1326	479	701	250	88

Hanging structure

- Ceiling: The ceiling structure varies from building to one another. For detailed information, consult your construction company.
 - If necessary, reinforce the hanging bolts with anti-quake supporting members as countermeasures against earthquakes.
 - * Use M10 for hanging bolts and anti-quake supporting members (field supply).
- ① Reinforcing the ceiling with additional members (edge beam, etc.) must be required to keep the ceiling at level and to prevent the ceiling from vibrations.
 - ② Cut and remove the ceiling members.
 - ③ Reinforce the ceiling members, and add other members for fixing the ceiling boards.

5. Installing the unit

5.1. Moving the unit to ceiling space

(1) When the fan unit does not need to be separated from the coil unit

- ① Bring the indoor unit to an installation site as it is packed.
- ② To hang the indoor unit, use a lifting machine to lift and pass through the hanging bolts. [Fig. 5-1-1]

[Fig. 5-1-1]

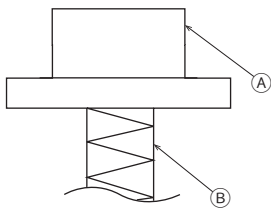

(A) Unit body
(B) Lifting machine

(2) When the fan unit needs to be separated from the coil unit

- ① Bring the indoor unit to an installation site as it is packed.
- ② Before separating the fan unit from the coil unit, remove the control box cover and cover (A) to remove the cable of the heat exchanger thermistor. [Fig. 5-1-2]

[Fig. 5-1-2]

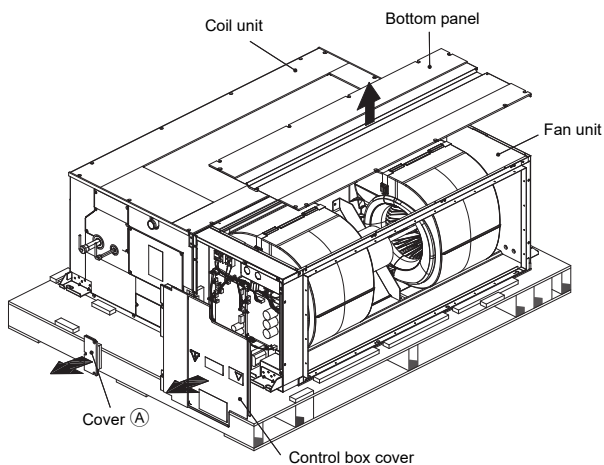

- ③ Remove the connector (CN44) of the thermistor cable from the circuit board. [Fig. 5-1-3]

[Fig. 5-1-3]

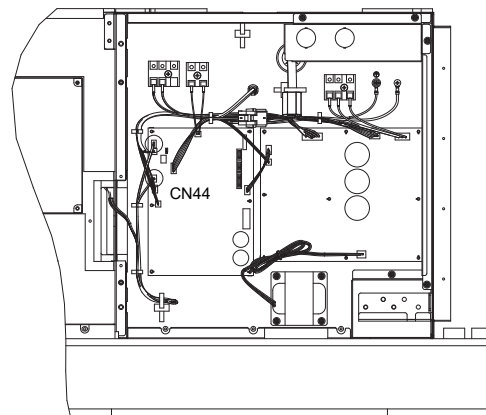

5. Installing the unit

- ④ Remove all the screws (A) through (F) connected to the coil unit from inside of the fan box to separate the fan unit. Screw holes (G) and (H) shown in Fig. 5-1-4 are double-snowman-shaped. Do not unscrew the screws (G), (H), (I) and (J) all the way; only loosen them partway. To separate the fan unit from the coil unit, lift the fan unit and move it away from the coil unit. The coil unit has an insulation material attached to its bottom (on the drain-pan side). Do not drag the coil unit when moving it. [Fig. 5-1-4]
* Remove the bottom panel of fan unit if screws (A) through (F) are not easy to remove.

[Fig. 5-1-4]

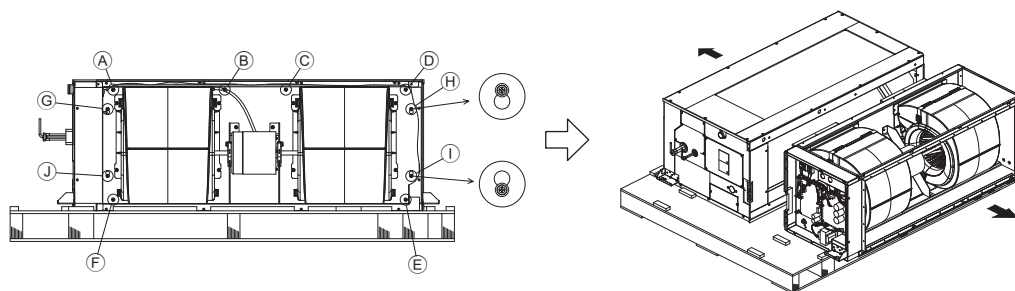

- ⑤ After moving the unit to the ceiling space, thread the screws (G), (H), (I) and (J) through the double-snowman-shaped holes on the fan unit, and re-tighten the screws (A) through (H) to connect the fan unit and the coil unit.

- ⑥ Reconnect the thermistor cable to the circuit board, and close the control box cover and cover (A).

* If the bottom panel was removed in step ④, reinstall it to the fan unit.

5.2. Hanging the unit body

- (1) Attach a washer and nut(s) to each suspension bolt. (The nuts are to be supplied locally.)

- (2) Fit the indoor unit to each suspension bolt.

- (3) Make sure that the unit is positioned level, then tighten each nut.

[Fig. 5-2-1]

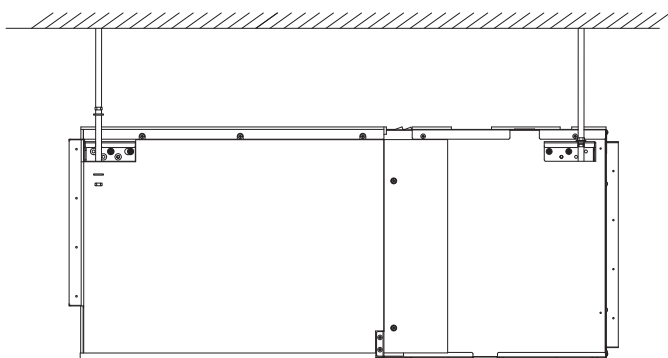

⚠ Caution:

Do not suspend either the fan unit or the coil unit alone. The two units must be connected to each other before being suspended.

[Fig. 5-2-2]

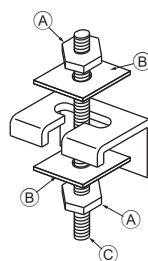

- (A) Nuts (field supply)
(B) Washer (accessory)
(C) M10 hanging bolt (field supply)

5.3. Confirming the unit's position and fixing hanging bolts

- ▶ Ensure that the hanging bolt nuts are tightened to fix the hanging bolts.
- ▶ To ensure that drain is discharged, be sure to hang the unit at level using a level.

⚠ Caution:

Install the unit in horizontal position. If the side with drain port is installed higher, water leakage may be caused.

6. Refrigerant piping work

6.1. Refrigerant pipe

[Fig. 6-1]

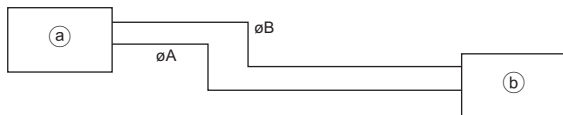

- (a) Indoor unit
(b) Outdoor unit

Model	A	B	Outdoor unit
PEA-M200LA2	ø22.2	ø9.52	PUZ-M200YDA
	ø25.4 *Reducer Accessory	ø9.52	PUZ-M200YKA2 PUZ-ZM200YKA2 PUHZ-P200YKA3 PUHZ-ZRP200YKA3
PEA-M250LA2	ø22.2	ø9.52	PUZ-M250YDA
	ø25.4 *Reducer Accessory	ø12.7 *Reducer Accessory	PUZ-M250YKA2 PUZ-ZM250YKA2 PUHZ-P250YKA3 PUHZ-ZRP250YKA3

Refer to the Instruction Manual that came with the outdoor unit for the restrictions on the height difference between units and for the amount of additional refrigerant charge.

Avoid the following places for installation where air conditioner trouble is liable to occur.

- Where there is too much oil such as for machine or cooking.
- Salty environment as seaside areas.
- Hot-spring areas.
- Where sulfide gas exists.
- Other special atmospheric areas.
- This unit has brazed connections on both indoor and outdoor sides. [Fig. 6-1]
- Insulate both refrigerant and drainage piping completely to prevent condensation.

Piping preparation

- Refrigerant pipes of 3, 5, 7, 10 and 15 m are available as optional items.

(1) Table below shows the specifications of pipes commercially available.

Model	Pipe	Outside diameter		Min. wall thickness	Insulation thickness	Insulation material
		mm	inch			
PEA-M200	For liquid	9.52	3/8	0.8 mm	8 mm	Heat resisting foam plastic 0.045 specific gravity
		22.2	7/8	1.0 mm	8 mm	
PEA-M250	For gas	25.4	1	1.0 mm	8 mm	
		9.52	3/8	0.8 mm	8 mm	
	For liquid	12.7	1/2	0.8 mm	8 mm	
		22.2	3/8	1.0 mm	8 mm	
	For gas	25.4	1	1.0 mm	8 mm	

- (2) Ensure that the 2 refrigerant pipes are well insulated to prevent condensation.

- (3) Refrigerant pipe bending radius must be 10 cm or more.

6. Refrigerant piping work

⚠ Caution:
Using careful insulation of specified thickness. Excessive thickness prevents storage behind the indoor unit and smaller thickness causes dew drippage.

⚠ Warning:
To reduce the risk of fire, embed or protect the refrigerant pipes. Damage to the refrigerant pipes can lead to fire.

6.2. Refrigerant piping work

This piping work must be done in accordance with the installation manuals for outdoor unit.

- For constraints on pipe length and allowable difference of elevation, refer to the outdoor unit manual.
- The method of pipe connection is brazing connection.

⚠ Caution:
• Install the refrigerant piping for the indoor unit in accordance with the following.

1. Cut the tip of the indoor unit piping, remove the gas, and then remove the brazed cap.

[Fig. 6-2-1]

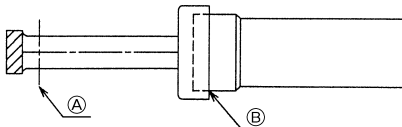

- Ⓐ Cut here
- Ⓑ Remove brazed cap

2. Pull out the thermal insulation on the site refrigerant piping, braze the unit piping, and replace the insulation in its original position. Wrap the piping with insulating tape.

Note:
• When blazing the refrigerant pipes, be sure to blaze, after covering a wet cloth to the pipes of the units in order to prevent it from burning and shrinking by heat.

[Fig. 6-2-2]

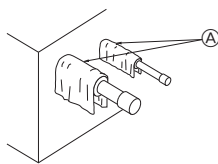

- Ⓐ Cool by a wet cloth

• Pay strict attention when wrapping the copper piping since wrapping the piping may cause condensation instead of preventing it.

[Fig. 6-2-3]

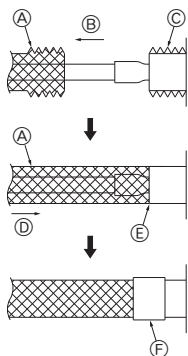

- Ⓐ Thermal insulation
- Ⓑ Pull out insulation
- Ⓒ Wrap with damp cloth
- Ⓓ Return to original position
- Ⓔ Ensure that there is no gas here
- Ⓕ Wrap with insulating tape

Cautions On Refrigerant Piping

- ▶ Be sure to use non-oxidative brazing for brazing to ensure that no foreign matter or moisture enter into the pipe.
- ▶ Be sure to apply refrigerating machine oil over the flare connection seating surface and tighten the connection using a double spanner.
- ▶ Provide a metal brace to support the refrigerant pipe so that no load is imparted to the indoor unit end pipe. This metal brace should be provided 50 cm away from the indoor unit's flare connection.

⚠ Warning:
Do not use refrigerant other than the type indicated in the manuals provided with the unit and on the nameplate.

- Doing so may cause the unit or pipes to burst, or result in explosion or fire during use, during repair, or at the time of disposal of the unit.
- It may also be in violation of applicable laws.
- MITSUBISHI ELECTRIC CORPORATION cannot be held responsible for malfunctions or accidents resulting from the use of the wrong type of refrigerant.

⚠ Caution:

- Use refrigerant piping made of C1220 (Cu-DHP) phosphorus deoxidized copper as specified in the JIS H3300 "Copper and copper alloy seamless pipes and tubes". In addition, be sure that the inner and outer surfaces of the pipes are clean and free of hazardous sulphur, oxides, dust/dirt, shaving particles, oils, moisture, or any other contaminant.
- Never use existing refrigerant piping.
 - The large amount of chlorine in conventional refrigerant and refrigerator oil in the existing piping will cause the new refrigerant to deteriorate.
- Store the piping to be used during installation indoors and keep both ends of the piping sealed until just before brazing.
 - If dust, dirt, or water gets into the refrigerant cycle, the oil will deteriorate and the compressor may fail.

6.3. Purging procedures leak test

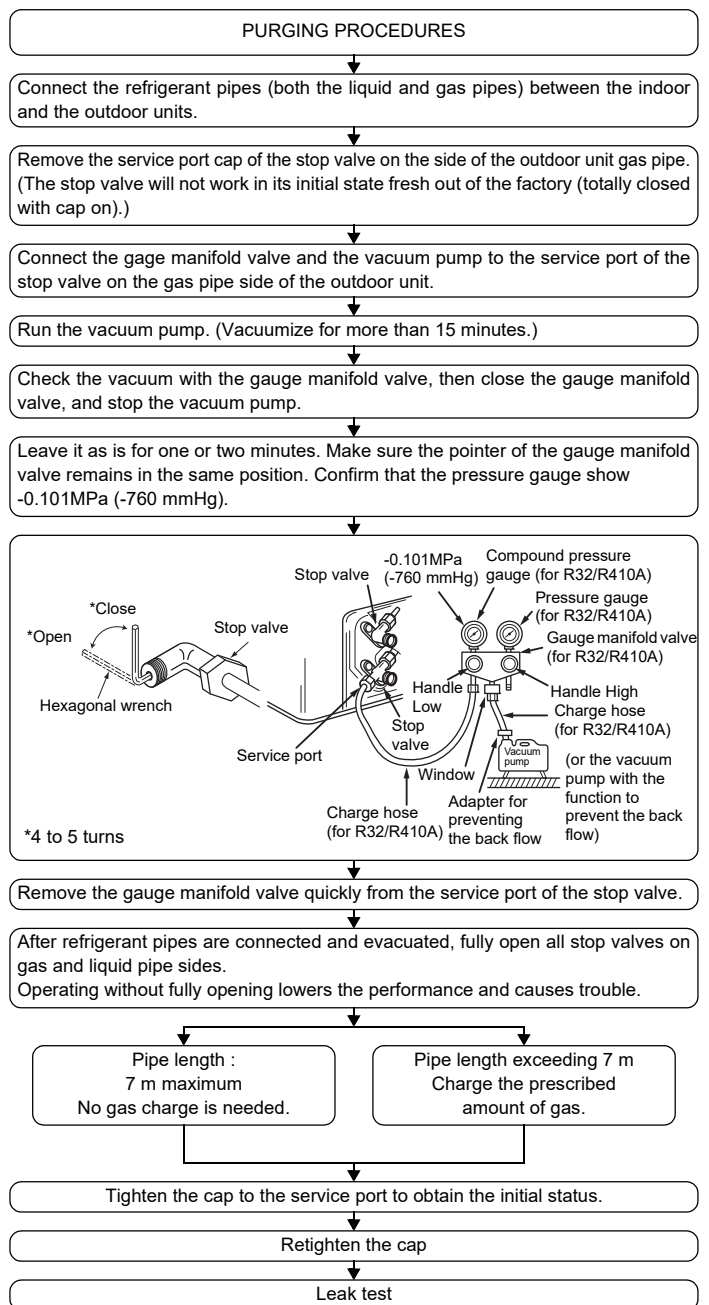

6. Refrigerant piping work

6.4. Drain piping work

- Ensure that the drain piping is downward (pitch of more than 1/100) to the outdoor (discharge) side. Do not provide any trap or irregularity on the way.
- Ensure that any cross-wise drain piping is less than 20 m (excluding the difference of elevation). If the drain piping is long, provide metal braces to prevent it from waving. Never provide any air vent pipe. Otherwise drain may be ejected.
- Use a hard vinyl chloride pipe VP-25 (with an external diameter of 32 mm) for drain piping.
- Ensure that collected pipes are 10 cm lower than the unit body's drain port.
- Do not provide any odor trap at the drain discharge port.
- Put the end of the drain piping in a position where no odor is generated.
- Do not put the end of the drain piping in any drain where ionic gases are generated.

[Fig. 6-4-1]

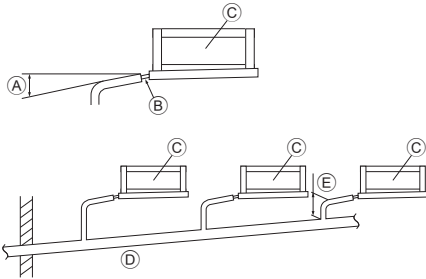

- Ⓐ Downward slope 1/100 or more
- Ⓑ Drain hose (Accessory)
- Ⓒ Indoor unit
- Ⓓ Collective piping
- Ⓔ Maximize this length to approx. 10 cm

1. Insert the drain hose (accessory) into the drain port.
(The drain hose must not be bent more than 45° to prevent the hose from breaking or clogging.)
The connecting part between the indoor unit and the drain hose may be disconnected at the maintenance. Fix the part with the accessory band, not be adhered.
2. Attach the drain pipe (O.D. ø32 PVC TUBE, field supply).
(Attach the pipe with glue for the hard vinyl chloride pipe, and fix it with the band (small, accessory).)
3. Perform insulation work on the drain pipe (O.D. ø32 PVC TUBE) and on the socket (including elbow).

[Fig. 6-4-2]

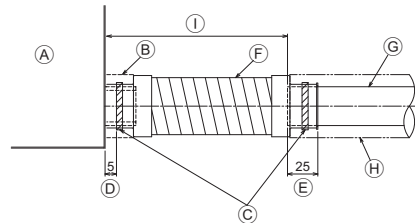

- Ⓐ Indoor unit
- Ⓑ Insulation pipe 25 mm (small) (accessory)
- Ⓒ Tie band (short)
- Ⓓ Band fixing part
- Ⓔ Insertion margin
- Ⓕ Drain hose (accessory)
- Ⓖ Drain pipe (O.D. ø32 PVC TUBE, field supply)
- Ⓗ Insulating material (field supply)
- Ⓖ Max. 150 ± 5 mm

7. Duct work

- Connect canvas duct between unit and duct.
- Do not install the unit above the cooking or food processing area.

[Fig. 7-1]

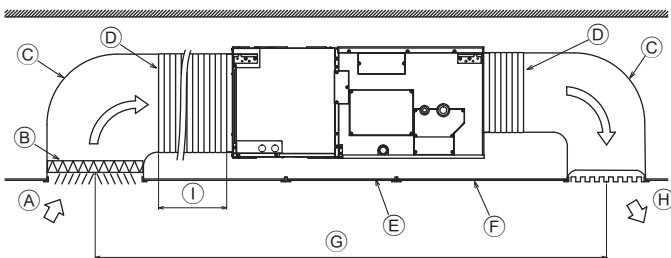

- Ⓐ Air inlet
- Ⓑ Air filter (supplied at site)
- Ⓒ Duct
- Ⓓ Canvas duct
- Ⓔ Access door
- Ⓕ Ceiling
- Ⓖ Ensure sufficient length to prevent short cycling
- Ⓗ Air outlet
- Ⓖ Keep duct-work length 850 mm or more

- Use incombustible material for duct parts.
- Provide full insulation to inlet duct flange and outlet duct to prevent condensation.
- Be sure to change the position of air filter to a position where it can be serviced.

⚠ Caution:

- **Inlet duct of 850 mm or more should be constructed.**
To connect the air conditioner main body and the duct for potential equalization.
- To reduce the risk of injury from metal sheet edges, wear protective gloves.
- To connect the air conditioner main body and the duct for potential equalization.
- The noise from the intake will increase dramatically if intake is fitted directly beneath the main body. Intake should therefore be installed as far away from the main body as possible.
- Install sufficient thermal insulation to prevent condensation forming on outlet duct flanges and outlet ducts.
- Keep the distance between the inlet grille and the fan over 850 mm.
If it is less than 850 mm, install a safety guard not to touch the fan.
- To avoid electrical noise interference, do not run transmission lines at the bottom of the unit.

8. Electrical work

Precautions on electrical wiring

⚠ Warning:

Electrical work should be done by qualified electrical engineers in accordance with "Engineering Standards For Electrical Installation" and supplied installation manuals. Special circuits should also be used. If the power circuit lacks capacity or has an installation failure, it may cause a risk of electric shock or fire.

1. Be sure to install an earth leakage breaker to the power.
2. Install the unit to prevent that any of the control circuit cables (remote controller, transmission cables) is brought in direct contact with the power cable outside the unit.
3. Ensure that there is no slack on all wire connections.
4. Some cables (power, remote controller, transmission cables) above the ceiling may be bitten by mouses. Use as many metal pipes as possible to insert the cables into them for protection.
5. Never connect the power cable to leads for the transmission cables. Otherwise the cables would be broken.
6. Be sure to connect control cables to the indoor unit, remote controller, and the outdoor unit.
7. Put the unit to the ground on the outdoor unit side.

⚠ Caution:

- Be sure to put the unit to the ground on the outdoor unit side. Do not connect the earth cable to any gas pipe, water pipe, lightning rod, or telephone earth cable. Incomplete grounding may cause a risk of electric shock.
- If the supply cord is damaged, it must be replaced by the manufacturer, its service agent or similarly qualified persons in order to avoid a hazard.

Types of control cables

1. Wiring transmission cables

Note:

- Transmission cables shall not be lighter than polychloroprene sheathed flexible cord. (Design 60245 IEC 57)

- Cable diameter
More than 1.5 mm²
- Cable length
Less than 80 m.
- Circuit rating
S1 - S2: 230V AC
S2 - S3: 24V DC

* The figures are not always against the ground.

S3 terminal has 24V DC against S2 terminal. However between S3 and S1, these terminals are not electrically insulated by the transformer or other device.

2. Remote controller cables

	MA remote controller
Types of cables	Sheathed 2-core cable (unshielded) CVV
Cable diameter	0.3 to 1.25 mm ²
Length	Less than 500 m

Notes:

1. Wiring size must comply with the applicable local and national code.
2. Power supply cords and indoor unit/outdoor unit connecting cords shall not be lighter than polychloroprene sheathed flexible cord. (Design 60245 IEC57)
3. Install an earth longer than other cables.
4. Indoor and outdoor connecting wires have polarities. Make sure to match the terminal number (S1, S2, S3) for correct wirings.
5. Wiring for remote controller cable shall be apart (5 cm, 2 inch or more) from power source wiring so that it is not influenced by electric noise from power source wiring.
6. The appliance shall be installed in accordance with national wiring regulations.

8.1. Power supply wiring

- Power supply cords of appliances shall not be lighter than design 60245 IEC 57 or 60227 IEC 57.
- A switch with at least 3 mm contact separation in each pole shall be provided by the Air conditioner installation.

Power cable size: more than 1.6 mm²

[Fig. 8-1-1]

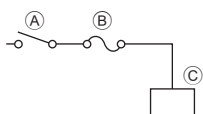

- Ⓐ Switch 16 A
- Ⓑ Overcurrent protection 16 A
- Ⓒ Indoor unit

[Selecting non-fuse breaker (NF) or earth leakage breaker (NV)]

To select NF or NV instead of a combination of Class B fuse with switch, use the

following:

- In the case of Class B fuse rated 15 A or 20 A,
NF model name (MITSUBISHI): NF30-CS (15 A) (20 A)
NV model name (MITSUBISHI): NV30-CA (15 A) (20 A)

Use an earth leakage breaker with a sensitivity of less than 30 mA 0.1 s.

⚠ Caution:

Do not use anything other than the correct capacity breaker and fuse. Using fuse, wire or copper wire with too large capacity may cause a risk of malfunction or fire.

A breaker with at least 3.0 mm contact board separation in each pole shall be provided.

8.2. Connecting remote controller, indoor and outdoor transmission cables

⚠ Warning:

- The compressor will not operate unless the indoor/outdoor transmission phase connection is correct.
- The connection wiring between the outdoor and indoor units can be extended up to a maximum of 50 meters, and the total extension including the crossover wiring between rooms is a maximum of 80 m.
- Connect indoor unit TB4 and terminal block for indoor-outdoor transmission line. (polar 3-core)
Cable 3-core 1.5 mm², in conformity with design 60245 IEC 57.
- Install a remote controller following the manual supplied with the remote controller.
- Connect the "1" and "2" on indoor unit TB15 to a MA remote controller. (Non-polarized 2-wire)
- Connect the remote controller's transmission cable within 10 m using a 0.75 mm² core cable. If the distance is more than 10 m, use a 1.25 mm² junction cable.

[Fig. 8-2-1] MA Remote controller

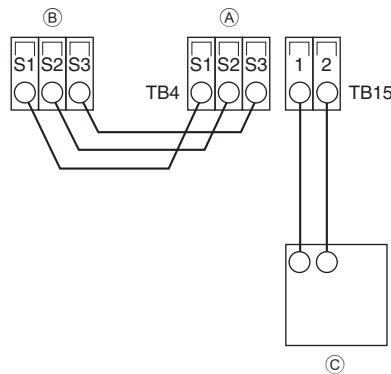

- Ⓐ Terminal block for indoor transmission cable
- Ⓑ Terminal block for outdoor transmission cable
- Ⓒ Remote controller

- DC 9 to 13 V between 1 and 2 (MA remote controller)

[Fig. 8-2-2] MA Remote controller

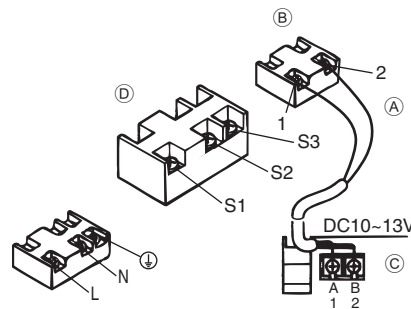

- Ⓐ Non-polarized
- Ⓑ TB15
- Ⓒ Remote Controller
- Ⓓ TB4

⚠ Caution:

Install wiring so that it is not tight and under tension. Wiring under tension may break, or overheat and burn.

8. Electrical work

8.3. Connecting electrical connections

Verify that the model name on the operating instructions on the cover of the control box is the same as the model name on the nameplate.

1. Remove the 2 screws holding the terminal box cover in place.

[Fig. 8-3-1]

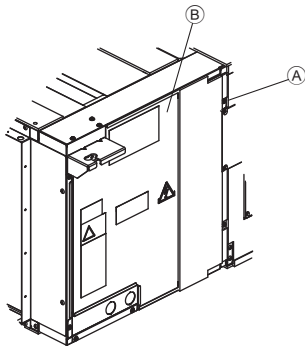

- A Screw holding cover (2pcs)
- B Cover

Note:

Ensure that the wiring is not pinched when fitting the terminal box cover. Pinching the wiring may cut it.

⚠ Caution:

Install wiring so that it is not tight and under tension. Wiring under tension may break, or overheat and burn.

2. Open knockout holes

(Recommend to use a screwdriver or the like for this work.)

[Fig. 8-3-2]

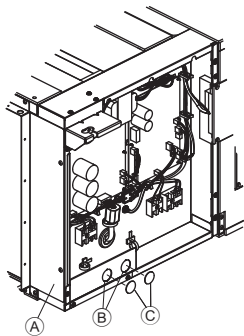

- A Control box
- B Knockout hole
- C Remove

3. Fix power source wiring to control box by using buffer bushing for tensile force. (PG connection or the like.) Connect transmission wiring to transmission terminal block through the knockout hole of control box using ordinary bushing.

4. Connect the power source, Earth, transmission and remote controller wiring. The dismantling of the terminal bed box is not needed.

[Fig. 8-3-3]

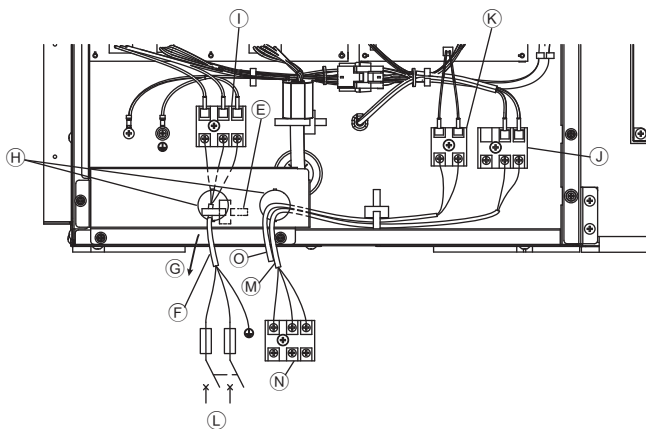

- E Use PG bushing to keep the weight of the cable and external force from being applied to the power supply terminal connector. Use a cable tie to secure the cable. Wind the wire around the cable strap once to keep it from being pulled out.
- F Power source wiring
- G Tensile force
- H PG connection or the like.

- I Power source terminal bed
- J Terminal bed for indoor transmission
- K Terminal bed for remote controller
- L To 1-phase power source
- M Transmission line
- N Terminal bed for outdoor transmission line
- O Transmission line to the remote controller

[Transmission cable connection]

[Fig. 8-3-4]

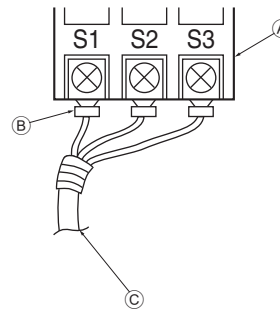

- A Terminal bed
- B Round terminal
- C Transmission cable (polar)

5. After wiring is complete, make sure again that there is no slack on the connections, and attach the cover onto the control box in the reverse order removal.

Notes:

- Do not pinch the cables or wires when attaching the terminal bed box cover. Doing so may cause a risk of disconnection.
- When accommodating the terminal bed box, make sure that the connectors on the box side are not removed. If removed, it cannot operate normally.

8.4. Remote controller (wireless remote controller (option))

8.4.1. For wireless remote controller (option)

1) Installation area

- Area in which the remote controller is not exposed to direct sunshine.
- Area in which there is no near by heating source.
- Area in which the remote controller is not exposed to cold (or hot) winds.
- Area in which the remote controller can be operated easily.
- Area in which the remote controller is beyond the reach of children.

* The signal can travel up to approximately 7 meters (in a straight line) within 45 degrees to both right and left of the center line of the receiver.

2) Installing procedures

Refer to the installation manual that comes with each remote controller for details.

8.4.2. Signal Receiving Unit

1) Sample system connection

[Fig. 8-4-1]

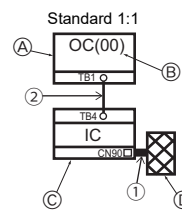

- ① Signal receiving unit wiring
- ② Indoor/outdoor wiring

- A Outdoor unit
- B Refrigerant address
- C Indoor unit
- D Signal receiving unit

Only the wiring from the signal receiving unit and between the remote controllers is shown in [Fig. 8-4-1]. The wiring differs depending on the unit to be connected or the system to be used.

For details on restrictions, refer to the installation manual or the service handbook that came with the unit.

1. Connecting to Mr. SLIM air conditioner

(1) Standard 1:1

① Connecting the signal receiving unit

Connect the signal receiving unit to the CN90 (Connect to the wireless remote controller board) on the indoor unit using the supplied remote controller wire. Connect the signal receiving units to all the indoor units.

2) Installing procedures

Refer to the installation manual that comes with each remote controller for details.

8. Electrical work

8.4.3. Setting

1) Setting the pair number switch

[Fig. 8-4-2]

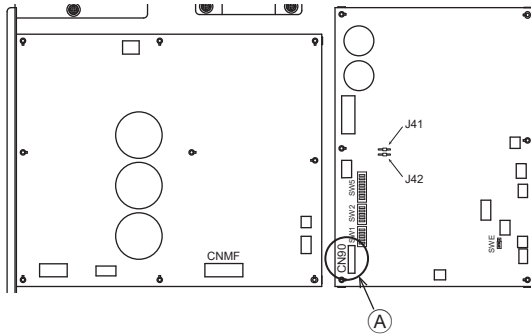

1. Setting method

Assign the same pair number to the wireless remote controller as that of the indoor unit. If not doing so, the remote controller cannot be operated. Refer to the installation manual that came with the wireless remote controller for how to set pair numbers of wireless remote controllers.

Position of daisy wire on the controller circuit board on the indoor unit.

Controller circuit board on the indoor unit (reference)

[Fig. 8-4-2]

Ⓐ CN90: Connector for remote controller wire connection

For pair number settings, the following 4 patterns (A-D) are available.

Pair number setting pattern	Pair number on remote controller side	Indoor controller circuit board side Point where the daisy wire is disconnected
A	0	Not disconnected
B	1	J41 disconnected
C	2	J42 disconnected
D	3-9	J41 and J42 disconnected

2. Setting example

(1) To use the units in the same room

[Fig. 8-4-3]

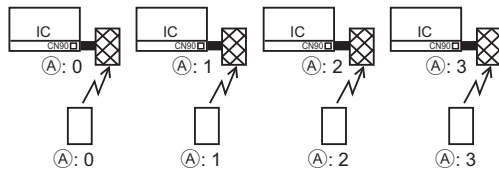

Ⓐ Pair number

① Separate setting

Assign a different pair number to each indoor unit to operate each indoor unit by its own wireless remote controller.

[Fig. 8-4-4]

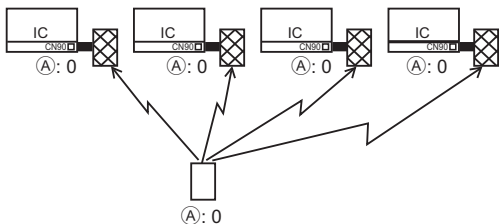

Ⓐ Pair number

② Single setting

Assign the same pair number to all the indoor units to operate all the indoor units by a single wireless remote controller.

[Fig. 8-4-5]

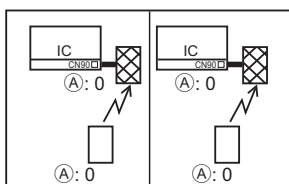

Ⓐ Pair number

(2) To use the units in different rooms

Assign the same pair number to the wireless remote controller as that of the indoor unit. (Leave the setting as it is at purchase.)

2) Setting the Model No.

- ① Insert batteries.
- ② Press the SET button with something sharp at the end.
 - MODEL SELECT blinks and Model No. lighted.
- ③ Press the temp (M) (A) button to set the Model No.
- ④ Press the SET button with something sharp at the end.
 - MODEL SELECT and Model No. are lighted for three seconds, then turned off.

Indoor Unit Model	Model No.
PEA	026

8.5. Function settings

8.5.1. For wired remote controller

① [Fig. 8-5-1]

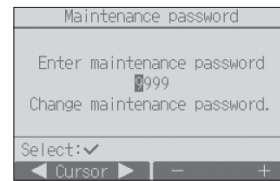

Note: Maintenance password is required.

Press Setting on the Main window, and select "Service" to set the maintenance settings.

When the Service menu is selected, a window will appear asking for the password. To enter the current maintenance password (4 numerical digits), move the cursor to the digit you want to change with the [F1] or [F2] button, and set each number (0 through 9) with the [F3] or [F4] button. Then, press the [SELECT] button.

Note:

- The initial maintenance password is "9999." Change the default password as necessary to prevent unauthorized access. Have the password available for relevant personnel.
- If you forget your maintenance password, you can initialize the password to the default password "9999" by pressing and holding the [F1] button for ten seconds on the maintenance password setting screen.
- Air conditioning units may need to be stopped to make certain settings. There may be some settings that cannot be made when the system is centrally controlled.

② [Fig. 8-5-2]

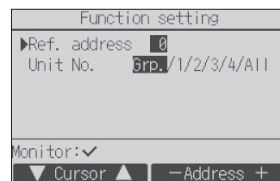

- Select "Service" from the Main menu, and press the [SELECT] button.
- Select "Function setting" with the [F1] or [F2] button, and press the [SELECT] button.
- Set the indoor unit refrigerant addresses and unit numbers with the [F1] through [F4] buttons, and then press the [SELECT] button to confirm the current setting.

<Checking the Indoor unit No.>

When the [SELECT] button is pressed, the target indoor unit will start fan operation. If the unit is common or when running all units, all indoor units for the selected refrigerant address will start fan operation.

③ [Fig. 8-5-3]

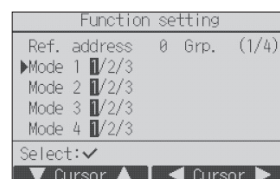

- When data collection from the indoor units is completed, the current settings appears highlighted. Non-highlighted items indicate that no function settings are made. Screen appearance varies depending on the "Unit No." setting.

8. Electrical work

④ [Fig. 8-5-4]

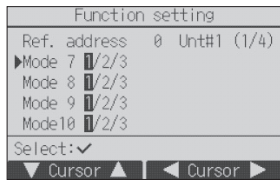

- Use the [F1] or [F2] button to move the cursor to select the mode number, and change the setting number with the [F3] or [F4] button.

⑤ [Fig. 8-5-5]

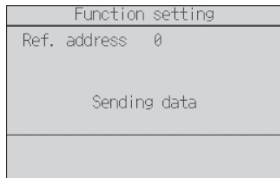

- When the settings are completed, press the [SELECT] button to send the setting data from the remote controller to the indoor units.
- When the transmission is successfully completed, the screen will return to the Function setting screen.

8.5.2. For wireless remote controller

[Fig. 8-5-6]

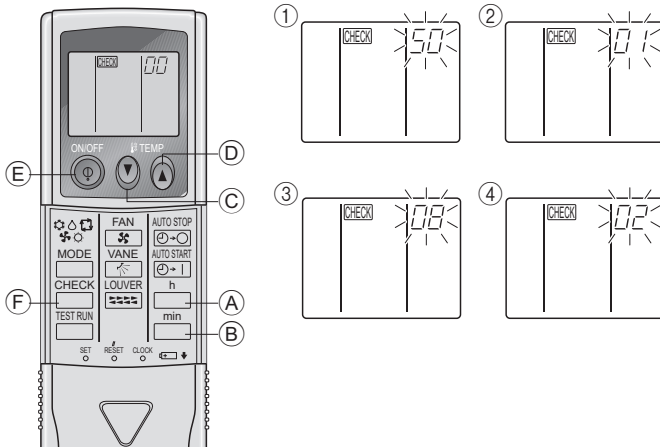

- Ⓐ Hour button
- Ⓑ Minute button
- Ⓒ TEMP button
- Ⓓ TEMP button
- Ⓔ ON/OFF button
- Ⓕ CHECK button

1. Changing the external static pressure setting.

- Be sure to change the external static pressure setting depending on the duct and the grill used.

① Go to the function select mode

- Press the CHECK button (F) twice continuously.

(Start this operation from the status of remote controller display turned off.)

CHECK is lighted and "00" blinks.

- Press the TEMP button (C) once to set "50". Direct the wireless remote controller toward the receiver of the indoor unit and press the Hour button (A).

② Setting the unit number

- Press the TEMP button (C) and (D) to set the unit number to 01-04 or AL. Direct the wireless remote controller toward the receiver of the indoor unit and press the Minute button (B).

③ Selecting a mode

- Enter 08 to change the external static pressure setting using the (C) and (D) buttons.

Direct the wireless remote controller toward the receiver of the indoor unit and press the Hour button (A).

- Current setting number:
- 1 = 1 beep (one second)
 - 2 = 2 beeps (one second each)
 - 3 = 3 beeps (one second each)

④ Selecting the setting number

- Use the (C) and (D) buttons to change the external static pressure setting to be used.

Direct the wireless remote controller toward the sensor of the indoor unit and press the Hour button (A).

⑤ To set the external static pressure

- Repeat steps (3) and (4) to set the mode number to 10.

⑥ Complete function selection

- Direct the wireless remote controller toward the sensor of the indoor unit and press the ON/OFF button (E).

Note:

- Whenever changes are made to the function settings after installation or maintenance, be sure to record the changes with a mark in the "Check" column of the Function table.

8.5.3. Changing the power voltage setting (Function table 1)

- Be sure to change the power voltage setting depending on the voltage used.

8. Electrical work

Function table 1

Select unit number 00

Mode	Settings	Mode no.	Setting no.	Initial setting	Check
Power failure automatic recovery (AUTO RESTART FUNCTION)	Not available	01	1	*2	
	Available *1		2	*2	
Indoor temperature detecting	Indoor unit operating average	02	1	○	
	Set by indoor unit's remote controller		2		
	Remote controller's internal sensor		3		
LOSSNAY connectivity	Not Supported	03	1	○	
	Supported (indoor unit is not equipped with outdoor-air intake)		2		
	Supported (indoor unit is equipped with outdoor-air intake)		3		
Power voltage	240V	04	1		
	220V, 230V		2	○	
Auto mode	Energy saving cycle automatically enabled	05	1	○	
	Energy saving cycle automatically disabled		2		

Function table 2

Select unit numbers 01 to 04 or all units (AL [wired remote controller]/07 [wireless remote controller])

Mode	Settings	Mode no.	Setting no.	Initial setting	Check	
Filter sign	100 Hr	07	1			
	2500 Hr		2			
	No filter sign indicator		3	○		
External static pressure	External static pressure	08	1	○		
	75 Pa (before shipment)		Setting no. of mode no. 08	Setting no. of mode no. 10	2	
	100 Pa		1	1	3	
	150 Pa	10	1	○		
	200 Pa		1	2		
	250 Pa		2	2		
Mode setting	Normal mode	09	1	○		
	High airflow mode		2			

*1 When the power supply returns, the air conditioner will start 3 minutes later.

*2 Power failure automatic recovery initial setting depends on the connecting outdoor unit.

Note: When the function of an indoor unit were changed by function selection after the end of installation, always indicate the contents by entering a ○ or other mark in the appropriate check filed of the tables.

9. Test run

9.1. Before test run

- ▶ After completing installation and the wiring and piping of the indoor and outdoor units, check for refrigerant leakage, looseness in the power supply or control wiring, wrong polarity, and no disconnection of one phase in the supply.
- ▶ Use a 500-volt megohmmeter to check that the resistance between the power supply terminals and ground is at least 1.0 MΩ.
- ▶ Do not carry out this test on the control wiring (low voltage circuit) terminals.

⚠ Warning:

Do not use the air conditioner if the insulation resistance is less than 1.0 MΩ. Insulation resistance

After installation or after the power source to the unit has been cut for an extended period, the insulation resistance will drop below 1 MΩ due to refrigerant accumulating in the compressor. This is not a malfunction. Perform the following procedures.

1. Remove the wires from the compressor and measure the insulation resistance of the compressor.
2. If the insulation resistance is below 1 MΩ, the compressor is faulty or the resistance dropped due the accumulation of refrigerant in the compressor.
3. After connecting the wires to the compressor, the compressor will start to warm up after power is supplied. After supplying power for the times indicated below, measure the insulation resistance again.

- The insulation resistance drops due to accumulation of refrigerant in the compressor. The resistance will rise above 1 MΩ after the compressor is warmed up for two to three hours.
(The time necessary to warm up the compressor varies according to atmospheric conditions and refrigerant accumulation.)
 - To operate the compressor with refrigerant accumulated in the compressor, the compressor must be warmed up at least 12 hours to prevent breakdown.
4. If the insulation resistance rises above 1 MΩ, the compressor is not faulty.

⚠ Caution:

- **The compressor will not operate unless the power supply phase connection is correct.**
- **Turn on the power at least 12 hours before starting operation.**
- Starting operation immediately after turning on the main power switch can result in severe damage to internal parts. Keep the power switch turned on during the operational season.

9.2. Test run

9.2.1. Using wired remote controller

- Make sure to read operation manual before test run. (Especially items to secure safety)

Step 1 Turn on the power.

- Remote controller: The system will go into startup mode, and the remote controller power lamp (green) and "PLEASE WAIT" will blink. While the lamp and message are blinking, the remote controller cannot be operated. Wait until "PLEASE WAIT" is not displayed before operating the remote controller. After the power is turned on, "PLEASE WAIT" will be displayed for approximately 2 minutes.
 - Indoor controller board: LED 1 will be lit up, LED 2 will be lit up (if the address is 0) or off (if the address is not 0), and LED 3 will blink.
 - Outdoor controller board: LED 1 (green) and LED 2 (red) will be lit up. (After the startup mode of the system finishes, LED 2 will be turned off.) If the outdoor controller board uses a digital display, [-] and [-] will be displayed alternately every second.
- If the operations do not function correctly after the procedures in step 2 and thereafter are performed, the following causes should be considered and eliminated if they are found.
(The symptoms below occur during the test run mode. "Startup" in the table means the LED display written above.)

Symptoms in test run mode		Cause
Remote Controller Display	OUTDOOR BOARD LED Display < > indicates digital display.	
Remote controller displays "PLEASE WAIT", and cannot be operated.	After "startup" is displayed, only green lights up. <00>	• After power is turned on, "PLEASE WAIT" is displayed for 2 minutes during system startup. (Normal)
After power is turned on, "PLEASE WAIT" is displayed for 3 minutes, then error code is displayed.	After "startup" is displayed, green(once) and red(once) blink alternately. <F1> After "startup" is displayed, green(once) and red(twice) blink alternately. <F3, F5, F9>	• Incorrect connection of outdoor terminal block. (R, S, T and S1, S2, S3) • Outdoor unit's protection device connector is open.
No display appears even when remote controller operation switch is turned on. (Operation lamp does not light up.)	After "startup" is displayed, green(twice) and red(once) blink alternately. <EA, Eb>	• Incorrect wiring between the indoor and outdoor unit. (Polarity is wrong for S1, S2, S3) • Remote controller transmission wire short.
	After "startup" is displayed, only green lights up. <00>	• There is no outdoor unit of address 0. (Address is other than 0.) • Remote controller transmission wire open.
Display appears but soon disappears even when remote controller is operated.	After "startup" is displayed, only green lights up. <00>	• After canceling function selection, operation is not possible for about 30 seconds. (Normal)

9. Test run

Step 2 Switch the remote controller to "Test run".

- ① Select "Test run" from the Service menu, and press the [SELECT] button.
[Fig. 9-2-1]



- ② Select "Test run" from the Test run menu, and press the [SELECT] button.
[Fig. 9-2-2]

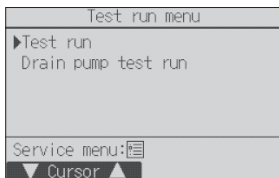

- ③ The test run operation starts, and the Test run operation screen is displayed.

Step 3 Perform the test run and check the airflow temperature.

- ① Press the [F1] button to change the operation mode.

Cooling mode: Check that cool air blows from the unit.
Heating mode: Check that warm air blows from the unit.

- For description of each check code, refer to the following table.

① Check code	Symptom	Remark
P1	Intake sensor error	For details, check the LED display of the outdoor controller board.
P2, P9	Pipe (Liquid or 2-phase pipe) sensor error	
E6, E7	Indoor/outdoor unit communication error	
P4	Drain sensor error	
P5	Drain pump error	
PA	Forced compressor error	
P6	Freezing/Overheating safeguard operation	
EE	Communication error between indoor and outdoor units	
P8	Pipe temperature error	
E4	Remote controller signal receiving error	
Fb	Indoor unit control system error (memory error, etc.)	
E0, E3	Remote controller transmission error	
E1, E2	Remote controller control board error	
E9	Indoor/outdoor unit communication error (Transmitting error) (Outdoor unit)	
UP	Compressor overcurrent interruption	
U3, U4	Open/short of outdoor unit thermistors	
UF	Compressor overcurrent interruption (When compressor locked)	
U2	Abnormal high discharging temperature/49C worked/insufficient refrigerant	
U1, Ud	Abnormal high pressure (63H worked)/Overheating safeguard operation	
U5	Abnormal temperature of heat sink	
U8	Outdoor unit fan safeguard stop	
U6	Compressor overcurrent interruption/Abnormal of power module	
U7	Abnormality of super heat due to low discharge temperature	
U9, UH	Abnormality such as overvoltage or voltage shortage and abnormal synchronous signal to main circuit/ Current sensor error	
Others	Other errors (Refer to the technical manual for the outdoor unit.)	

- On wired remote controller

- ① Check code displayed in the LCD.

Step 4 Confirm the operation of the outdoor unit fan.

The speed of the outdoor unit fan is controlled in order to control the performance of the unit. Depending on the ambient air, the fan will rotate at a slow speed and will keep rotating at that speed unless the performance is insufficient. Therefore, the outdoor wind may cause the fan to stop rotating or to rotate in the opposite direction, but this is not a problem.

Step 5 Stop the test run.

- ① Press the [ON/OFF] button to stop the test run. (The Test run menu will appear.)
Note: If an error is displayed on the remote controller, see the table below.

9. Test run

9.2.2. Using wireless remote controller (option)

[Fig. 9-2-3]

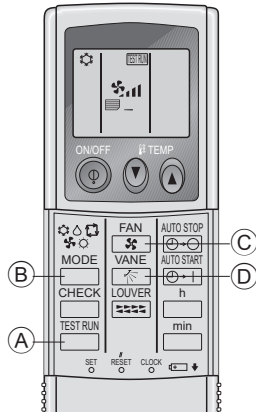

- Ⓐ TEST RUN button
- Ⓑ MODE button
- Ⓒ FAN button
- Ⓓ VANE button

- ① Turn on the power to the unit at least 12 hours before the test run.
- ② Press the TEST RUN button (A) twice continuously.
(Start this operation from the status of remote controller display turned off.)
(TEST RUN) and current operation mode are displayed.
- ③ Press the MODE button (B) to activate COOL mode, then check whether cool air is blown out from the unit.
- ④ Press the MODE button (B) to activate HEAT mode, then check whether warm air is blown out from the unit.
- ⑤ Press the FAN button (C) and check whether fan speed changes.
- ⑥ Press the VANE button (D) and check whether the auto vane operates properly.
- ⑦ Press the ON/OFF button to stop the test run.

Note:

- Point the remote controller towards the indoor unit receiver while following steps ② to ⑦.
- It is not possible to run the in FAN, DRY or AUTO mode.

[Output pattern A] Errors detected by indoor unit

Wireless remote controller Beeper sounds/OPERATION INDICATOR lamp flashes (Number of times)	Wired remote controller Check code	Symptom	Remark
1	P1	Intake sensor error	
2	P2, P9	Pipe (Liquid or 2-phase pipe) sensor error	
3	E6, E7	Indoor/outdoor unit communication error	
4	P4	Drain sensor error	
5	P5	Drain pump error	
6	P6	Freezing/Overheating safeguard operation	
7	EE	Communication error between indoor and outdoor units	
8	P8	Pipe temperature error	
9	E4	Remote controller signal receiving error	
10	-	-	
11	-	-	
12	Fb	Indoor unit control system error (memory error, etc.)	
14	PL	Refrigerant circuit abnormal	
No sound	--	No corresponding	

[Output pattern B] Errors detected by unit other than indoor unit (outdoor unit, etc.)

Wireless remote controller Beeper sounds/OPERATION INDICATOR lamp flashes (Number of times)	Symptom	Remark
1	Indoor/outdoor unit communication error (Transmitting error) (Outdoor unit)	For details, check the LED display of the outdoor controller board.
2	Compressor overcurrent interruption	
3	Open/short of outdoor unit thermistors	
4	Compressor overcurrent interruption (When compressor locked)	
5	Abnormal high discharging temperature/49C worked/ insufficient refrigerant	
6	Abnormal high pressure (63H worked)/ Overheating safeguard operation	
7	Abnormal temperature of heat sink	
8	Outdoor unit fan protection stop	
9	Compressor overcurrent interruption/Abnormal of power module	
10	Abnormality of super heat due to low discharge temperature	
11	Abnormality such as overvoltage or voltage shortage and abnormal synchronous signal to main circuit/Current sensor error	
12	-	
13	-	
14	Other errors (Refer to the technical manual for the outdoor unit.)	

*1 If the beeper does not sound again after the initial two beeps to confirm the self-check start signal was received and the OPERATION INDICATOR lamp does not come on, there are no error records.

*2 If the beeper sounds three times continuously "beep, beep, beep (0.4 + 0.4 + 0.4 sec.)" after the initial two beeps to confirm the self-check start signal was received, the specified refrigerant address is incorrect.

- On wireless remote controller
The continuous buzzer sounds from receiving section of indoor unit.
Blink of operation lamp
- On wired remote controller
Check code displayed on the LCD.

9. Test run

- If the unit cannot be operated properly after the above test run has been performed, refer to the following table to remove the cause.

Symptom		Cause
Wired remote controller	LED 1, 2 (PCB in outdoor unit)	
PLEASE WAIT	For about 2 minutes following power-on After LED 1, 2 are lighted, LED 2 is turned off, then only LED 1 is lighted. (Correct operation)	• For about 2 minutes after power-on, operation of the remote controller is not possible due to system start-up. (Correct operation)
PLEASE WAIT → Error code	After about 2 minutes has expired following power-on	• Connector for the outdoor unit's protection device is not connected. • Reverse or open phase wiring for the outdoor unit's power terminal block (L1, L2, L3)
Display messages do not appear even when operation switch is turned ON (operation lamp does not light up).		• Incorrect wiring between indoor and outdoor units (incorrect polarity of S1, S2, S3) • Remote controller wire short

On the wireless remote controller with conditions above, following phenomena takes place.

- No signals from the remote controller are accepted.
- OPE lamp is blinking.
- The buzzer makes a short ping sound.

Note:

Operation is not possible for about 30 seconds after cancellation of function selection. (Correct operation)

For description of each LED (LED1, 2, 3) provided on the indoor controller, refer to the following table.

LED 1 (power for microcomputer)	Indicates whether control power is supplied. Make sure that this LED is always lit.
LED 2 (power for remote controller)	Indicates whether power is supplied to the remote controller. This LED lights only in the case of the indoor unit which is connected to the outdoor unit refrigerant address "0".
LED 3 (communication between indoor and outdoor units)	Indicates state of communication between the indoor and outdoor units. Make sure that this LED is always blinking.

9.3. AUTO RESTART FUNCTION

Indoor controller board

This model is equipped with the AUTO RESTART FUNCTION.

When the indoor unit is controlled with the remote controller, the operation mode, set temperature, and the fan speed are memorized by the indoor controller board. The auto restart function sets to work the moment the power has restored after power failure, then, the unit will restart automatically.

Set the AUTO RESTART FUNCTION using the remote controller. (Mode no.01)

10. Maintenance

10.1. Refrigerant charge

[Fig. 10-1]

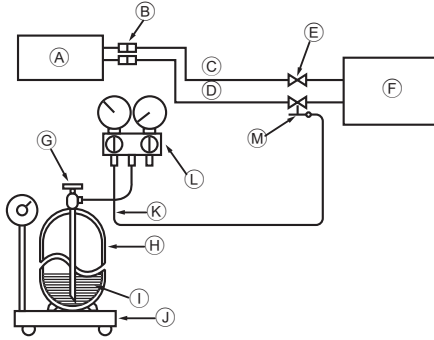

- Ⓐ Indoor unit
- Ⓑ Union
- Ⓒ Liquid pipe
- Ⓓ Gas pipe
- Ⓔ Stop valve
- Ⓕ Outdoor unit
- Ⓖ Refrigerant gas cylinder operating valve
- Ⓗ Refrigerant gas cylinder for R32/R410A with siphon
- Ⓘ Refrigerant (liquid)
- Ⓙ Electronic scale for refrigerant charging
- Ⓚ Charge hose (for R32/R410A)
- Ⓛ Gauge manifold valve (for R32/R410A)
- Ⓜ Service port

1. Connect gas cylinder to the service port of stop valve (3-way).
2. Execute air purge of the pipe (or hose) coming from refrigerant gas cylinder.
3. Replenish specified amount of refrigerant, while running the air conditioner for cooling.

Note:

In case of adding refrigerant, comply with the quantity specified for the refrigerating cycle.

⚠ Caution:

- Do not discharge the refrigerant into the atmosphere.
Take care not to discharge refrigerant into the atmosphere during installation, reinstallation, or repairs to the refrigerant circuit.
- For additional charging, charge the refrigerant from liquid phase of the gas cylinder.
If the refrigerant is charged from the gas phase, composition change may occur in the refrigerant inside the cylinder and the outdoor unit. In this case, ability of the refrigerating cycle decreases or normal operation can be impossible. However, charging the liquid refrigerant all at once may cause the compressor to be locked. Thus, charge the refrigerant slowly.

To maintain the high pressure of the gas cylinder, warm the gas cylinder with warm water (under 40°C) during cold season. But never use naked fire or steam.



AIR CONDITIONER INDOOR UNIT

MODEL _____ SERVICE REF. _____

OPERATE	<COOLING>						<HEATING>					
RATED VOLTAGE	220		230		240		220		230		240	
FREQUENCY	50	60	50	60	50	60	50	60	50	60	50	60
RATED INPUT<INDOOR ONLY>	kW											
RATED CURRENT<INDOOR ONLY>	A											

PHASE _____ ~/N

REFRIGERANT _____ R32/R410A

ALLOWABLE PRESSURE _____ 4.15 MPa

IP CODE _____ IP20

WEIGHT _____ kg

SERIAL No. _____

YEAR OF MANUFACTURE _____

MITSUBISHI ELECTRIC CORPORATION

MITSUBISHI ELECTRIC CONSUMER PRODUCTS (THAILAND) CO., LTD.
700/406 MOO 7, TAMBON DON HUA ROH, AMPHUR MUANG, CHONBURI 20000, THAILAND
MADE IN THAILAND

This product is designed and intended for use in the residential,
commercial and light-industrial environment.

Please be sure to put the contact address/telephone number on
this manual before handing it to the customer.

MITSUBISHI ELECTRIC CORPORATION

HEAD OFFICE: TOKYO BLDG., 2-7-3, MARUNOUCHI, CHIYODA-KU, TOKYO 100-8310, JAPAN