

Air-cooled Chilling Unit

e-series

DATA BOOK

MODEL

EAHV-M1500YCL(-N)(-BS)

EAHV-M1800YCL(-N)(-BS)

EACV-M1500YCL(-N)(-BS)

EACV-M1800YCL(-N)(-BS)

CONTENTS

EAHV-M-YCL(-N), EACV-M-YCL(-N)

1. Product Specifications	2
1-1. Specifications.....	2
1-2. External Dimensions	6
1-3. Center of Gravity.....	18
1-4. Electrical Wiring Diagrams.....	19
1-5. Optional parts	24
2. Product Data	30
2-1. Capacity tables	30
2-2. Sound pressure levels	63
2-3. Vibration levels	66
2-4. Salt Protection Specifications	67
3. Installation.....	68
3-1. Selecting the Installation Site.....	68
3-2. Unit Installation	71
4. System Design.....	73
4-1. Water Pipe Installation	73
5. Wiring Design.....	83
5-1. System Configurations.....	83
5-2. Electrical Wiring Installation.....	109
6. Controller	112
6-1. PAR-W31MAA specifications	112

1. Product Specifications

1-1. Specifications

Model		FAHV-M1500YCL(-N)(-BS)		
Power source		3-phase 4-wire 380-400-415V 50/60Hz		
Cooling capacity *1		kW	150.00	
		kcal/h	129,000	
		BTU/h	511,800	
	Power input	kW	44.73	
	EER		3.35	
	IPLV *6		6.42	
Water flow rate	m ³ /h	25.8		
Cooling capacity (EN14511) *2		kW	149.18	
		kcal/h	128,295	
		BTU/h	509,002	
	Power input	kW	45.55	
	EER		3.28	
	Eurovent efficiency class		A	
	SEER		5.52	
	ηsc	%	217.8	
	Water flow rate	m ³ /h	25.8	
	Heating capacity *3		kW	150.00
		kcal/h	129,000	
		BTU/h	511,800	
Power input		kW	42.61	
COP			3.52	
Water flow rate		m ³ /h	25.8	
Heating capacity (EN14511) *4		kW	150.82	
		kcal/h	129,705	
		BTU/h	514,598	
	Power input	kW	43.43	
	COP		3.47	
	SCOP Low/Medium		3.31/2.88	
	ηsh Low/Medium	%	129.0/112.0	
	Water flow rate	m ³ /h	25.8	
Current input	Cooling current 380-400-415V *1	A	76 - 72 - 69	
	Heating current 380-400-415V *3	A	72 - 68 - 66	
	Maximum current	A	120	
Water pressure drop *1	Standard piping	kPa	56	
	Inside header piping	kPa	134	
Temp range	Cooling	°C	Outlet water 4~30 *7	
		°F	Outlet water 39.2~86 *7	
	Heating	°C	Outlet water 25~55 *7	
		°F	Outlet water 77~131 *7	
	Outdoor (Cooling)	°C	-15~-52 *7	
		°F	5~125.6 *7	
	Outdoor (Heating)	°C	-20~-43 *7	
		°F	4~-109.4 *7	
Circulating water volume range	m ³ /h	12.9~43.0		
Sound pressure level (measured in anechoic room) at 1m *1	dB (A)	65		
Sound power level (measured in anechoic room) *1	dB (A)	83		
Diameter of water pipe (Standard piping)	Inlet	mm (in)	65A (2 1/2B) housing type joint	
	Outlet	mm (in)	65A (2 1/2B) housing type joint	
Diameter of water pipe (Inside header piping)	Inlet	mm (in)	150A (6B) housing type joint	
	Outlet	mm (in)	150A (6B) housing type joint	
External finish		Polyester powder coating steel plate		
External dimension H × W × D	mm	2350 × 3400 × 1080		
Net weight	Standard piping	kg (lbs)	1280 (2822)	
	Inside header piping	kg (lbs)	1307 (2881)	
Design pressure	R32	MPa	4.15	
	Water	MPa	1.0	
Heat exchanger	Water side	Stainless steel plate and copper brazing		
	Air side	Salt-resistant cross fin & aluminium tube		
Compressor	Type	Inverter scroll hermetic compressor		
	Maker	MITSUBISHI ELECTRIC CORPORATION		
	Starting method	Inverter		
	Quantity	4		
	Motor output	kW	11.5 × 4	
	Lubricant	MEL46EH		
Fan	Air flow rate	m ³ /min	270 × 4	
		L/s	4500 × 4	
		cfm	9534 × 4	
	Type, Quantity	Propeller fan × 4		
	Starting method	Inverter		
	Motor output	kW	0.92 × 4	
External static press.	Pa	20		
Protection	High pressure protection	High pres.Sensor & High pres.Switch at 4.15MPa (601psi)		
	Inverter circuit	Over-heat protection, Over current protection		
	Compressor	Over-heat protection		
Refrigerant	Type × charge	R32 × 11.5 (kg) × 4 *5		
	Control	LEV		

Notes:

- *1 Under normal cooling conditions at outdoor temp 35°CDB/24°CWB (95°FDB / 75.2°FWB) outlet water temp 7°C (44.6°F) inlet water temp 12°C (53.6°F). Pump input is not included in cooling capacity and power input.
- *2 Under normal cooling conditions at outdoor temp 35°CDB/24°CWB (95°FDB/75.2°FWB) outlet water temp 7°C (44.6°F) inlet water temp 12°C (53.6°F). Pump input is included in cooling capacity and power input based on EN14511.
- *3 Under normal heating conditions at outdoor temp 7°CDB/6°CWB (44.6°FDB/42.8°FWB) outlet water temp 45°C (113°F) inlet water temp 40°C (104°F). Pump input is not included in heating capacity and power input.
- *4 Under normal heating conditions at outdoor temp 7°CDB/6°CWB (44.6°FDB/42.8°FWB) outlet water temp 45°C (113°F) inlet water temp 40°C (104°F). Pump input is included in heating capacity and power input based on EN14511.
- *5 Amount of factory-charged refrigerant is 3 (kg) × 4. Please add the refrigerant at the field.
- *6 IPLV is calculated in accordance with AHRI 550-590.
- *Please don't use the steel material for the water piping.
- *Please always make water circulate, or pull the circulation water out completely when not in use.
- *Please do not use groundwater or well water in direct.
- *The water circuit must be closed circuit.
- *Due to continuous improvement, the above specifications may be subject to change without notice.
- *This model doesn't equip with a pump.
- *7 Please refer to 2-1-5. Operation temperature range.

Unit converter

kcal/h	= kW × 860
BTU/h	= kW × 3,412
lbs	= kg/0.4536
cfm	= m ³ /min × 35.31

EAHV-M-YCL(-N), EACV-M-YCL(-N)

1. Product Specifications

Model		FAHV-M1800YCL(-N)-(-BS)	
Power source		3-phase 4-wire 380-400-415V 50/60Hz	
Cooling capacity *1		kW	180.00
		kcal/h	154.800
		BTU/h	614.160
	Power input	kW	57.02
	EER		3.16
	IPLV *6		6.31
	Water flow rate	m ³ /h	31.0
Cooling capacity (EN14511) *2		kW	178.80
		kcal/h	153.768
		BTU/h	610.066
	Power input	kW	58.22
	EER		3.07
	Eurovent efficiency class		B
	SEER		5.36
nsc	%	211.4	
Water flow rate	m ³ /h	31.0	
Heating capacity *3		kW	180.00
		kcal/h	154.800
		BTU/h	614.160
	Power input	kW	53.09
	COP		3.39
Water flow rate	m ³ /h	31.0	
Heating capacity (EN14511) *4		kW	181.20
		kcal/h	155.832
		BTU/h	618.254
	Power input	kW	54.29
	COP		3.34
	SCOP Low/Medium		3.31/2.88
	nsh Low/Medium	%	129.0/112.0
Water flow rate	m ³ /h	31.0	
Current input	Cooling current 380-400-415V *1	A	96 - 91 - 88
	Heating current 380-400-415V *3	A	90 - 85 - 82
	Maximum current	A	120
Water pressure drop *1	Standard piping	kPa	79
	Inside header piping	kPa	190
Temp range	Cooling	°C	Outlet water 4~30 *7
		°F	Outlet water 39.2~86 *7
	Heating	°C	Outlet water 25~55 *7
		°F	Outlet water 77~131 *7
	Outdoor (Cooling)	°C	-15~52 *7
		°F	5~125.6 *7
Outdoor (Heating)	°C	-20~43 *7	
	°F	-4~109.4 *7	
Circulating water volume range		m ³ /h	12.9~43.0
Sound pressure level (measured in anechoic room) at 1m *1		dB (A)	67
Sound power level (measured in anechoic room) *1		dB (A)	85
Diameter of water pipe (Standard piping)	Inlet	mm (in)	65A (2 1/2B) housing type joint
	Outlet	mm (in)	65A (2 1/2B) housing type joint
Diameter of water pipe (Inside header piping)	Inlet	mm (in)	150A (6B) housing type joint
	Outlet	mm (in)	150A (6B) housing type joint
External finish		Polyester powder coating steel plate	
External dimension H × W × D		mm	2350 × 3400 × 1080
Net weight	Standard piping	kg (lbs)	1280 (2822)
	Inside header piping	kg (lbs)	1307 (2881)
Design pressure	R32	MPa	4.15
	Water	MPa	1.0
Heat exchanger	Water side	Stainless steel plate and copper brazing	
	Air side	Salt-resistant cross fin & aluminium tube	
Compressor	Type	Inverter scroll hermetic compressor	
	Maker	MITSUBISHI ELECTRIC CORPORATION	
	Starting method	Inverter	
	Quantity	4	
	Motor output	kW	11.5 × 4
	Lubricant	MEL46EH	
	Fan	Air flow rate	m ³ /min
L/s			4500 × 4
cfm			9534 × 4
Type, Quantity		Propeller fan × 4	
Starting method		Inverter	
Motor output		kW	0.92 × 4
Protection	High pressure protection	High pres Sensor & High pres Switch at 4.15MPa (601psi)	
	Inverter circuit	Over-heat protection, Over current protection	
	Compressor	Over-heat protection	
Refrigerant	Type × charge	R32 × 11.5 (kg) × 4 *5	
	Control	LEV	

Notes:	Unit converter
*1 Under normal cooling conditions at outdoor temp 35°CDB/24°CWB (95°FDB / 75.2°FWB) outlet water temp 7°C (44.6°F) inlet water temp 12°C (53.6°F). Pump input is not included in cooling capacity and power input.	kcal/h = kW × 860
*2 Under normal cooling conditions at outdoor temp 35°CDB/24°CWB (95°FDB/75.2°FWB) outlet water temp 7°C (44.6°F) inlet water temp 12°C (53.6°F). Pump input is included in cooling capacity and power input based on EN14511.	BTU/h = kW × 3,412
*3 Under normal heating conditions at outdoor temp 7°CDB/6°CWB (44.6°FDB/42.8°FWB) outlet water temp 45°C (113°F) inlet water temp 40°C (104°F). Pump input is not included in heating capacity and power input.	lbs = kg/0.4536
*4 Under normal heating conditions at outdoor temp 7°CDB/6°CWB (44.6°FDB/42.8°FWB) outlet water temp 45°C (113°F) inlet water temp 40°C (104°F). Pump input is included in heating capacity and power input based on EN14511.	cfm = m ³ /min × 35.31
*5 Amount of factory-charged refrigerant is 3 (kg) × 4. Please add the refrigerant at the field.	
*6 IPLV is calculated in accordance with AHRI 550-590.	
*Please don't use the steel material for the water piping.	
*Please always make water circulate, or pull the circulation water out completely when not in use.	
*Please do not use groundwater or well water in direct.	
*The water circuit must be closed circuit.	
*Due to continuous improvement, the above specifications may be subject to change without notice.	
*This model doesn't equip with a pump.	
*7 Please refer to 2-1-6. Operation temperature range.	

1. Product Specifications

EAHV-M-YCL(-N), EACV-M-YCL(-N)

Model		EACV-M1500YCL(-N)(-BS)		
Power source		3-phase 4-wire 380-400-415V 50/60Hz		
Cooling capacity *1	kW	150.00		
		kcal/h		129,000
		BTU/h		511,800
	Power input	kW		44.73
		EER		3.35
		IPLV *4		6.42
		Water flow rate		m ³ /h
Cooling capacity(EN14511) *2	kW	149.18		
		kcal/h		128,295
		BTU/h		509,002
	Power input	kW		45.55
		EER		3.28
	Eurovent efficiency class		A	
	SEER		5.52	
	ηsc	%	217.8	
	Water flow rate		m ³ /h	25.8
Current input	Cooling current 380-400-415V *1	A	76 - 72 - 69	
	Maximum current	A	120	
Water pressure drop *1	Standard piping	kPa	56	
	Inside header piping	kPa	134	
Temp range	Cooling	°C	Outlet water 4~30 *5	
		°F	Outlet water 39.2~86 *5	
	Outdoor	°C	-15~52 *5	
		°F	5~125.6 *5	
Circulating water volume range		m ³ /h	12.9~43.0	
Sound pressure level (measured in anechoic room) at 1m *1		dB (A)	65	
Sound power level (measured in anechoic room) *1		dB (A)	83	
Diameter of water pipe (Standard piping)	Inlet	mm (in)	65A (2 1/2B) housing type joint	
	Outlet	mm (in)	65A (2 1/2B) housing type joint	
Diameter of water pipe (Inside header piping)	Inlet	mm (in)	150A (6B) housing type joint	
	Outlet	mm (in)	150A (6B) housing type joint	
External finish		Polyester powder coating steel plate		
External dimension H × W × D		mm	2350 × 3400 × 1080	
Net weight	Standard piping	kg (lbs)	1039 (2291)	
	Inside header piping	kg (lbs)	1067 (2352)	
Design pressure	R32	MPa	4.15	
	Water	MPa	1.0	
Heat exchanger	Water side	Stainless steel plate and copper brazing		
	Air side	Salt-resistant corrugated fin & aluminium micro channel		
Compressor	Type	Inverter scroll hermetic compressor		
	Maker	MITSUBISHI ELECTRIC CORPORATION		
	Starting method	Inverter		
	Quantity	4		
	Motor output	kW	11.5 × 4	
	Lubricant	MEL46EH		
Fan	Air flow rate	m ³ /min	270 × 4	
		L/s	4500 × 4	
		cfm	9534 × 4	
	Type, Quantity	Propeller fan × 4		
	Starting method	Inverter		
Motor output	kW	0.92 × 4		
	External static press.	Pa	20	
Protection	High pressure protection	High pres.Sensor & High pres.Switch at 4.15MPa (601psi)		
	Inverter circuit	Over-heat protection, Over current protection		
	Compressor	Over-heat protection		
Refrigerant	Type × charge	R32 × 4.7 (kg) × 4 *3		
	Control	LEV		

Notes:	Unit converter
*1 Under normal cooling conditions at outdoor temp 35°CDB/24°CWB (95°FDB/75.2°FWB) outlet water temp 7°C (44.6°F) inlet water temp 12°C (53.6°F). Pump input is not included in cooling capacity and power input.	kcal/h = kW × 860
*2 Under normal cooling conditions at outdoor temp 35°CDB/24°CWB (95°FDB/75.2°FWB) outlet water temp 7°C (44.6°F) inlet water temp 12°C (53.6°F). Pump input is included in cooling capacity and power input based on EN14511.	BTU/h = kW × 3,412
*3 Amount of factory-charged refrigerant is 3 (kg) × 4. Please add the refrigerant at the field.	lbs = kg/0.4536
*4 IPLV is calculated in accordance with AHRI 550-590.	cfm = m ³ /min × 35.31
*Please don't use the steel material for the water piping.	
*Please always make water circulate, or pull the circulation water out completely when not in use.	
*Please do not use groundwater or well water in direct.	
*The water circuit must be closed circuit.	
*Due to continuous improvement, the above specifications may be subject to change without notice.	
*This model doesn't equip with a pump.	
*5 Please refer to 2-1-6. Operation temperature range.	

1. Product Specifications

Model			EACV-M1800YCL(-N)-(BS)
Power source			3-phase 4-wire 380-400-415V 50/60Hz
Cooling capacity *1		kW	180.00
		kcal/h	154,800
		BTU/h	614,160
	Power input	kW	57.02
	EER		3.16
	IPLV *4		6.31
	Water flow rate	m ³ /h	31.0
Cooling capacity(EN14511) *2		kW	178.80
		kcal/h	153,768
		BTU/h	610,066
	Power input	kW	58.22
	EER		3.07
	Eurovent efficiency class		B
	SEER		5.36
	η _{sc}	%	211.4
	Water flow rate	m ³ /h	31.0
Current input	Cooling current 380-400-415V *1	A	96 - 91 - 88
	Maximum current	A	120
Water pressure drop *1	Standard piping	kPa	79
	Inside header piping	kPa	190
Temp range	Cooling	°C	Outlet water 4~30 *5
		°F	Outlet water 39.2~86 *5
	Outdoor	°C	-15~52 *5
		°F	5~125.6 *5
Circulating water volume range		m ³ /h	12.9~43.0
Sound pressure level (measured in anechoic room) at 1m *1		dB (A)	67
Sound power level (measured in anechoic room) *1		dB (A)	85
Diameter of water pipe (Standard piping)	Inlet	mm (in)	65A (2 1/2B) housing type joint
	Outlet	mm (in)	65A (2 1/2B) housing type joint
Diameter of water pipe (Inside header piping)	Inlet	mm (in)	150A (6B) housing type joint
	Outlet	mm (in)	150A (6B) housing type joint
External finish			Polyester powder coating steel plate
External dimension H × W × D		mm	2350 × 3400 × 1080
Net weight	Standard piping	kg (lbs)	1039 (2291)
	Inside header piping	kg (lbs)	1067 (2352)
Design pressure	R32	MPa	4.15
	Water	MPa	1.0
Heat exchanger	Water side		Stainless steel plate and copper brazing
	Air side		Salt-resistant corrugated fin & aluminium micro channel
Compressor	Type		Inverter scroll hermetic compressor
	Maker		mitsubishi electric corporation
	Starting method		Inverter
	Quantity		4
	Motor output	kW	11.5 × 4
	Lubricant		MEL46EH
Fan	Air flow rate	m ³ /min	270 × 4
		L/s	4500 × 4
		cfm	9534 × 4
	Type, Quantity		Propeller fan × 4
	Starting method		Inverter
	Motor output	kW	0.92 × 4
	External static press.	Pa	20
Protection	High pressure protection		High pres.Sensor & High pres.Switch at 4.15MPa (601psi)
	Inverter circuit		Over-heat protection, Over current protection
	Compressor		Over-heat protection
Refrigerant	Type × charge		R32 × 4.7 (kg) × 4 *3
	Control		LEV

Notes:	Unit converter
*1 Under normal cooling conditions at outdoor temp 35°CDB/24°CWB (95°FDB/75.2°FWB) outlet water temp 7°C (44.6°F) inlet water temp 12°C (53.6°F). Pump input is not included in cooling capacity and power input.	kcal/h = kW × 860
*2 Under normal cooling conditions at outdoor temp 35°CDB/24°CWB (95°FDB/75.2°FWB) outlet water temp 7°C (44.6°F) inlet water temp 12°C (53.6°F). Pump input is included in cooling capacity and power input based on EN14511.	BTU/h = kW × 3,412
*3 Amount of factory-charged refrigerant is 3 (kg) × 4. Please add the refrigerant at the field.	lbs = kg/0.4536
*4 IPLV is calculated in accordance with AHR! 550-590.	cfm = m ³ /min × 35.31
*Please don't use the steel material for the water piping.	
*Please always make water circulate, or pull the circulation water out completely when not in use.	
*Please do not use groundwater or well water in direct.	
*The water circuit must be closed circuit.	
*Due to continuous improvement, the above specifications may be subject to change without notice.	
*This model doesn't equip with a pump.	
*5 Please refer to 2-1-6. Operation temperature range.	

1. Product Specifications

1-2. External Dimensions

EAHV-M1500, 1800YCL(-BS)

Unit: mm

NO.	NAME	DESCRIPTION
1)	COOL (HOT) WATER INLET	2"/øB HOUSING TYPE JOINT ATTACHED (x 1)
2)	COOL (HOT) WATER OUTLET	2"/øB HOUSING TYPE JOINT ATTACHED (x 1)
3)	DRAIN OPENING	R1½ EXTERNAL THREAD
4)	POWER CABLE INLET	ø66 x 1 OR ø89 x 1
5)	SIGNAL CABLE INLET (LOW CURRENT CABLE)	ø34 x 2
6)	SIGNAL CABLE INLET (HIGH CURRENT CABLE)	ø34

[SERVICE SPACES AROUND THE UNIT]

1. WHEN INSTALLING THE UNIT, BE SURE TO LEAVE A SERVICE SPACE FOR MAINTENANCE AND INSPECTION AROUND THE UNIT.
2. ENSURE THAT THERE ARE NOT ANY WALLS OR OTHER OBJECTS AROUND THE UNIT THAT PREVENT THE UNIT FROM DRAWING IN AIR.

SERVICE SPACE

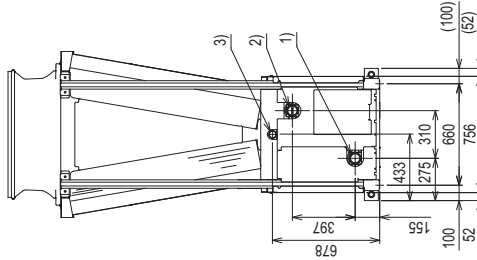
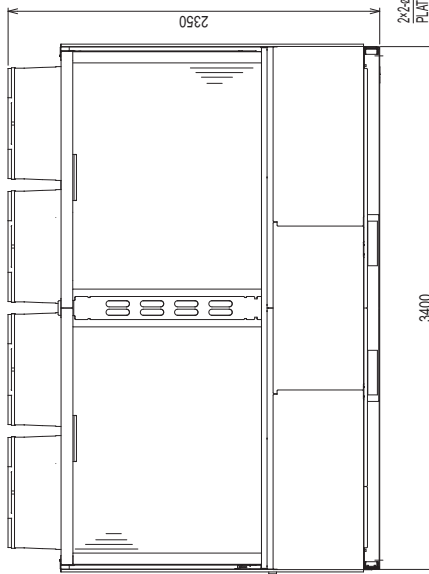
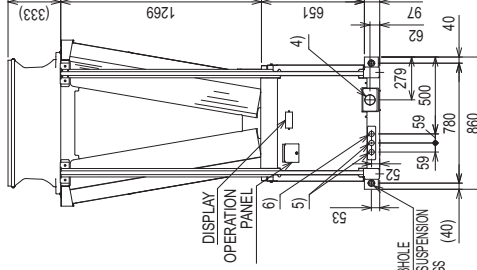
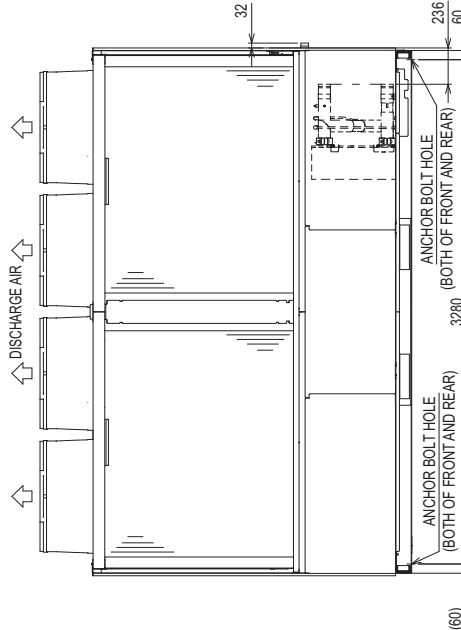
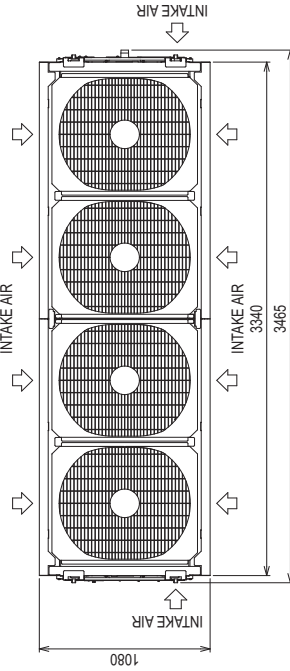
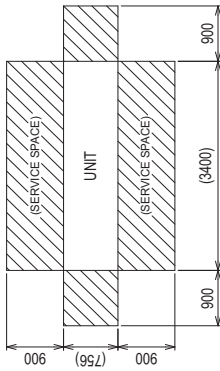

NOTE 1. CONNECT COOL (HOT) WATER PIPES WHILE MAKING SURE OF CONNECTING THE INLETS AND OUTLETS CORRECTLY.

NOTE 2. INTRUSION OF FOREIGN MATERIALS INTO THE HEAT EXCHANGER MAY CAUSE PERFORMANCE DEGRADATION OR FREEZING. BE SURE TO INSTALL CLEANABLE STRAINER (20 MESH MIN.) TO THE INLET OF COOL (HOT) WATER PIPES.

NOTE 3. FOR HOW TO DRAW IN POWER CABLES OR CONNECT COOL (HOT) WATER PIPES, REFER TO THE SEPARATE DOCUMENT.

NOTE 4. THE HOUSING TYPE JOINTS FOR CONNECTING A COOL (HOT) WATER INLET AND OUTLET SHOULD BE PREPARED ON SITE.

[INSTALLATION ON FOUNDATION]

1. SECURELY FIX THE UNIT WITH BOLTS TO KEEP THE UNIT FROM FALLING DOWN DURING EARTHQUAKES.
2. INSTALL THE UNIT ON A FOUNDATION MADE OF CONCRETE OR IRON.
3. NOISE AND VIBRATIONS FROM THE UNIT MAY BE TRANSMITTED THROUGH THE FLOOR AND WALLS. PROVIDE ADEQUATE PROTECTION AGAINST NOISE AND VIBRATION.
4. ANCHOR BOLTS SHOULD BE PREPARED ON SITE.
5. WHEN BUILDING THE FOUNDATION, TAKE THE FLOOR STRENGTH, AND PIPING AND WIRING ROUTES INTO CONSIDERATION.

SURFACES TOUCHING THE FOUNDATION

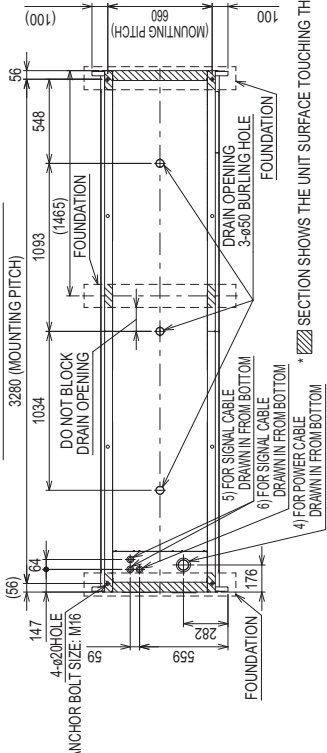

* SECTION SHOWS THE UNIT SURFACE TOUCHING THE FOUNDATION.

EAHV-M-YCL(-N), EACV-M-YCL(-N)

1. Product Specifications

EAHV-M1500, 1800YCL(-BS)

Unit: mm

NO.	NAME	DESCRIPTION
1)	COOL (HOT) WATER INLET	2 1/8" HOUSING TYPE JOINT ATTACHED (x1)
2)	COOL (HOT) WATER OUTLET	2 1/8" HOUSING TYPE JOINT ATTACHED (x1)
3)	DRAIN OPENING	R1 1/2" EXTERNAL THREAD
4)	POWER CABLE INLET	ø66 x 1 OR ø68 x 1
5)	SIGNAL CABLE INLET (LOW CURRENT CABLE)	ø34 x 2
6)	SIGNAL CABLE INLET (HIGH CURRENT CABLE)	ø34

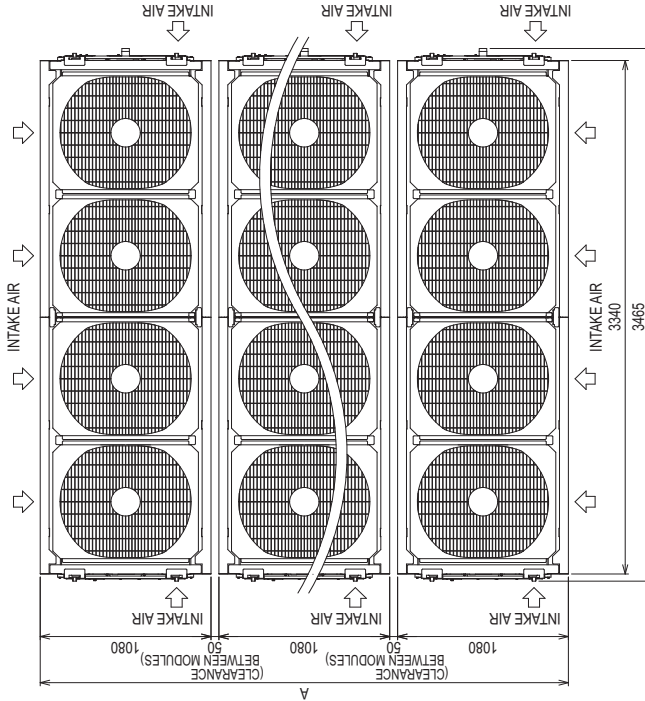

MODULE COUNT	A	B (HANGING HOLE COUNT)	C (FOUNDATION HOLE COUNT)
1 MODULE	1080	1	1
2 MODULES	2210	2	2
3 MODULES	3340	3	3
4 MODULES	4470	4	4
5 MODULES	5600	5	5
6 MODULES	6730	6	6
7 MODULES	7860	7	7
8 MODULES	8990	8	8
9 MODULES	10120	9	9
10 MODULES	11250	10	10
11 MODULES	12380	11	11
12 MODULES	13510	12	12

- NOTE 1. CONNECT COOL (HOT) WATER PIPES WHILE MAKING SURE OF CONNECTING THE INLETS AND OUTLETS CORRECTLY.
- NOTE 2. INTRUSION OF FOREIGN MATERIALS INTO THE HEAT EXCHANGER MAY CAUSE PERFORMANCE DEGRADATION OR FREEZING.
- NOTE 3. BE SURE TO INSTALL CLEANABLE STRAINER (20 MESH MIN.) TO THE INLET OF COOL (HOT) WATER PIPES.
- NOTE 4. REFER TO THE SEPARATE DOCUMENT FOR HOW TO DRAW IN POWER CABLES OR CONNECT COOL (HOT) WATER PIPES.
- NOTE 5. THE HOUSING TYPE JOINTS FOR CONNECTING A COOL (HOT) WATER INLET AND OUTLET SHOULD BE PREPARED ON SITE.
- NOTE 6. THE VALUES OF A TO C IN THE FIGURE ARE AS FOLLOWS.

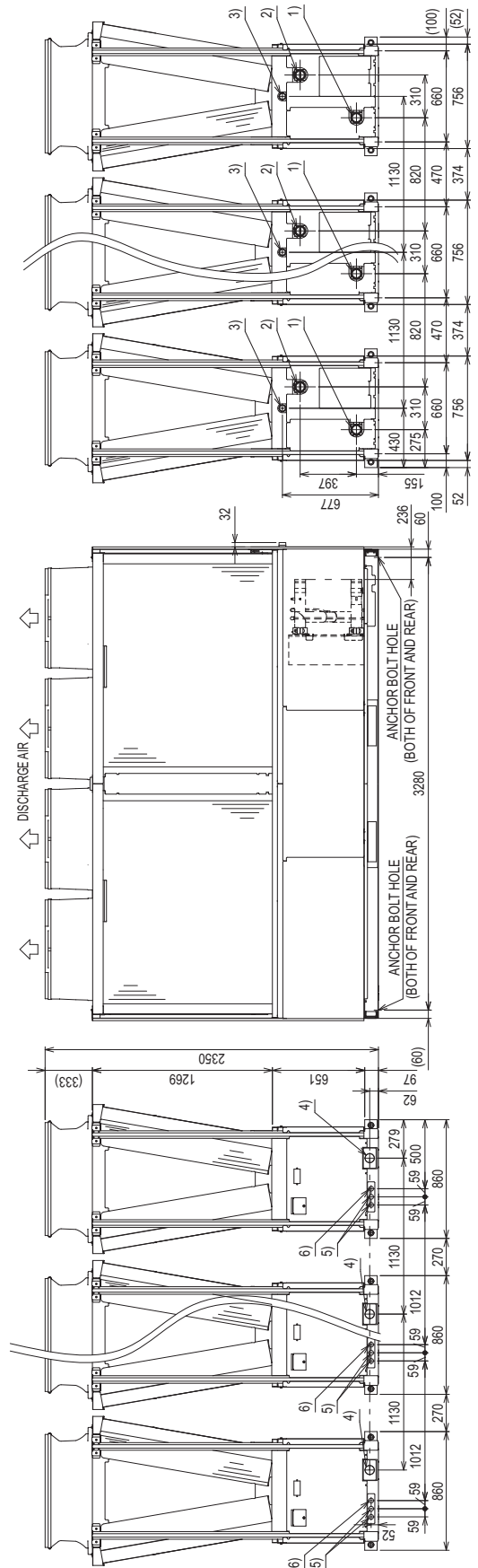

EAHV-M1500, 1800YCL(-BS)

Unit: mm

EAHV-M-YCL(-N), EACV-M-YCL(-N)

SERVICE SPACES AROUND THE UNIT

1. WHEN INSTALLING THE UNIT, BE SURE TO LEAVE A SERVICE SPACE FOR MAINTENANCE AND INSPECTION AROUND THE UNIT.
2. ENSURE THAT THERE ARE NOT ANY WALLS OR OTHER OBJECTS AROUND THE UNIT THAT PREVENT THE UNIT FROM DRAWING IN AIR.

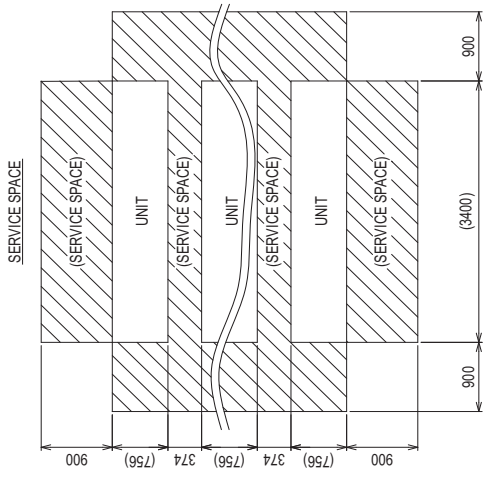

FOUNDATION CONSTRUCTION

1. THE FOUNDATION SHOULD BE MADE OF CONCRETE OR STEEL CAPABLE OF BEARING THE OPERATING MASS OF THE UNIT. THE FOUNDATION SHOULD ALLOW FOR WIRING.
2. A CONCRETE FOUNDATION REQUIRES ITS TOP FACE TO BE LEVEL AND FINISHED WITH MORTAR.
3. ANCHOR BOLTS SHOULD BE PREPARED ON SITE.

SURFACES TOUCHING THE FOUNDATION

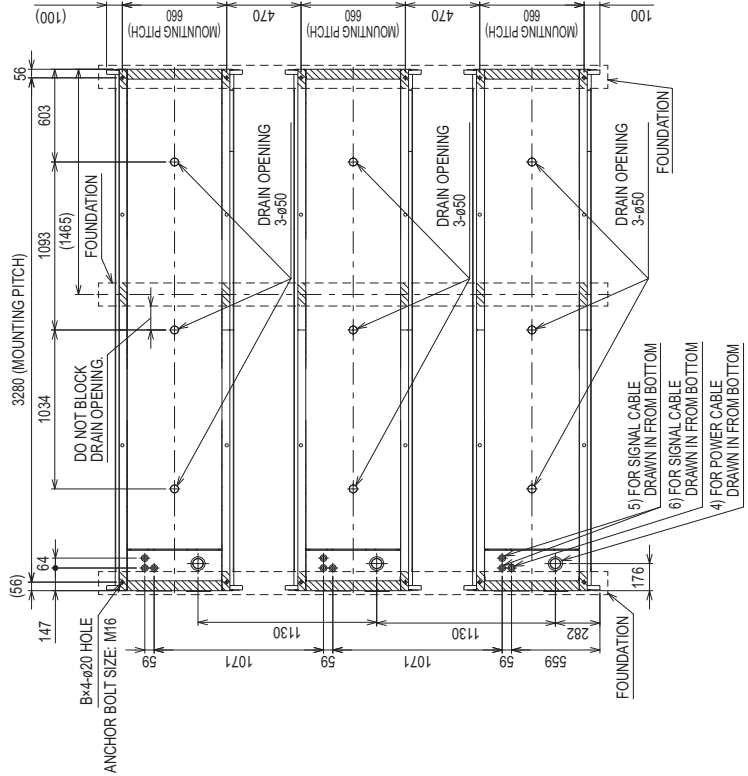

* SECTION SHOWS THE UNIT SURFACE TOUCHING THE FOUNDATION.

1. Product Specifications

EACV-M1500, 1800YCL(-BS)

Unit: mm

NO.	NAME	DESCRIPTION
1)	COOL WATER INLET	2 1/8" HOUSING TYPE JOINT ATTACHED (x 1)
2)	COOL WATER OUTLET	2 1/8" HOUSING TYPE JOINT ATTACHED (x 1)
3)	DRAIN OPENING	R 1 1/2" EXTERNAL THREAD
4)	POWER CABLE INLET	ø66 x 1 OR ø89 x 1
5)	SIGNAL CABLE INLET (LOW CURRENT CABLE)	ø34 x 2
6)	SIGNAL CABLE INLET (HIGH CURRENT CABLE)	ø34

SERVICE SPACES AROUND THE UNIT

1. WHEN INSTALLING THE UNIT, BE SURE TO LEAVE A SERVICE SPACE FOR MAINTENANCE AND INSPECTION AROUND THE UNIT.
2. ENSURE THAT THERE ARE NOT ANY WALLS OR OTHER OBJECTS AROUND THE UNIT THAT PREVENT THE UNIT FROM DRAWING IN AIR.

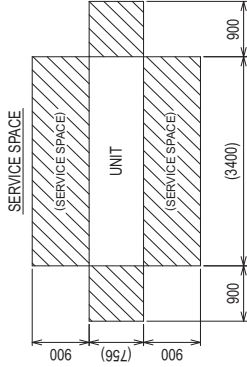

- NOTE 1.** CONNECT COOL WATER PIPES WHILE MAKING SURE OF CONNECTING THE INLETS AND OUTLETS CORRECTLY.
- NOTE 2.** INTRUSION OF FOREIGN MATERIALS INTO THE HEAT EXCHANGER MAY CAUSE PERFORMANCE DEGRADATION OR FREEZING. BE SURE TO INSTALL CLEANABLE STRAINER (20 MESH MIN.) TO THE INLET OF COOL WATER PIPES.
- NOTE 3.** FOR HOW TO DRAW IN POWER CABLES OR CONNECT COOL WATER PIPES, REFER TO THE SEPARATE DOCUMENT.
- NOTE 4.** THE HOUSING TYPE JOINTS FOR CONNECTING A COOL WATER INLET AND OUTLET SHOULD BE PREPARED ON SITE.

INSTALLATION ON FOUNDATION

1. SECURELY FIX THE UNIT WITH BOLTS TO KEEP THE UNIT FROM FALLING DOWN DURING EARTHQUAKES.
2. INSTALL THE UNIT ON A FOUNDATION MADE OF CONCRETE OR IRON.
3. NOISE AND VIBRATIONS FROM THE UNIT MAY BE TRANSMITTED THROUGH THE FLOOR AND WALLS. PROVIDE ADEQUATE PROTECTION AGAINST NOISE AND VIBRATION.
4. ANCHOR BOLTS SHOULD BE PREPARED ON SITE.
5. WHEN BUILDING THE FOUNDATION, TAKE THE FLOOR STRENGTH, AND PIPING AND WIRING ROUTES INTO CONSIDERATION.

SURFACES TOUCHING THE FOUNDATION

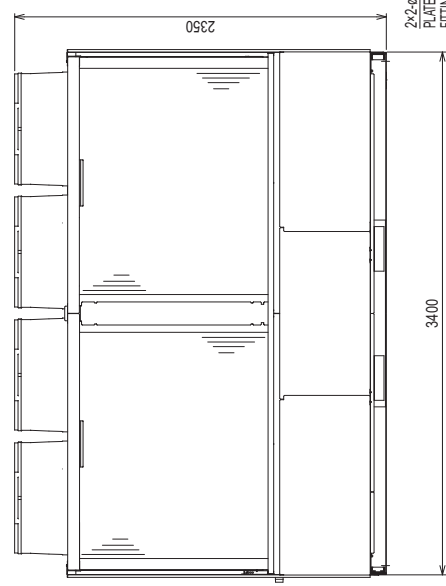
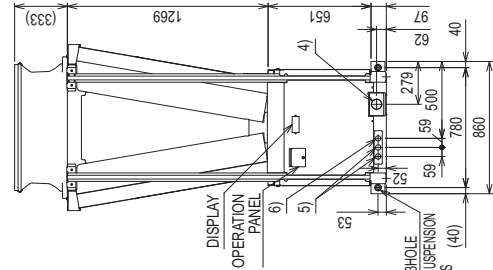
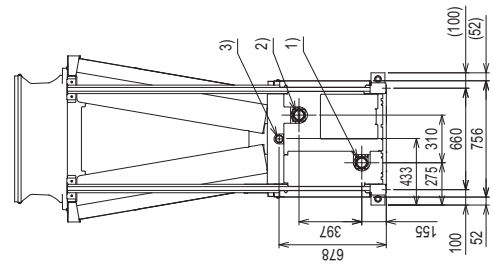
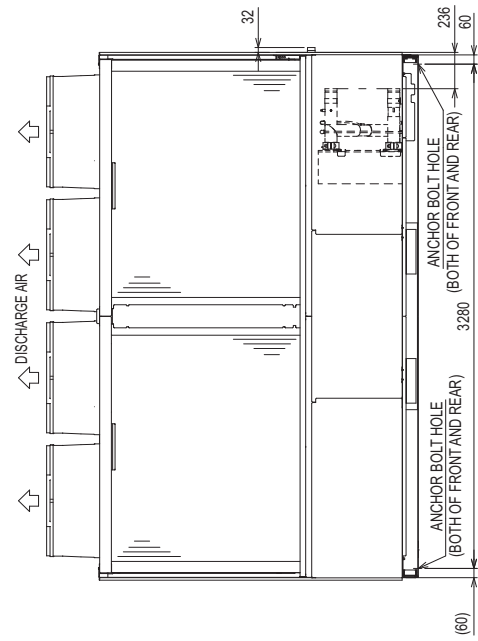
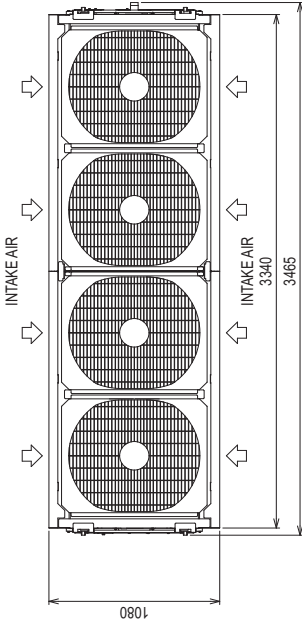
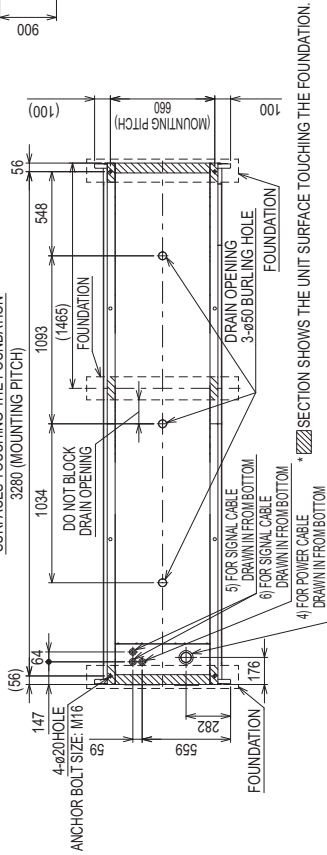

1. Product Specifications

EACV-M1500, 1800YCL(-BS)

Unit: mm

NO.	NAME	DESCRIPTION
1)	COOL WATER INLET	2 1/2" B HOUSING TYPE JOINT ATTACHED (x 1)
2)	COOL WATER OUTLET	2 1/2" B HOUSING TYPE JOINT ATTACHED (x 1)
3)	DRAIN OPENING	R 1 1/2" EXTERNAL THREAD
4)	POWER CABLE INLET	ø66 x TOR ø69 x 1
5)	SIGNAL CABLE INLET (LOW CURRENT CABLE)	ø34 x 2
6)	SIGNAL CABLE INLET (HIGH CURRENT CABLE)	ø34

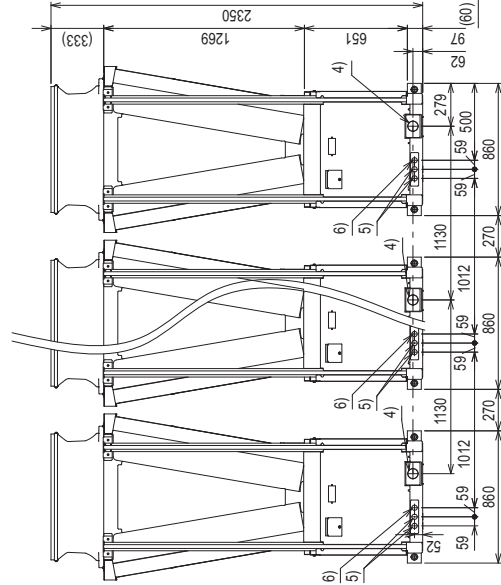
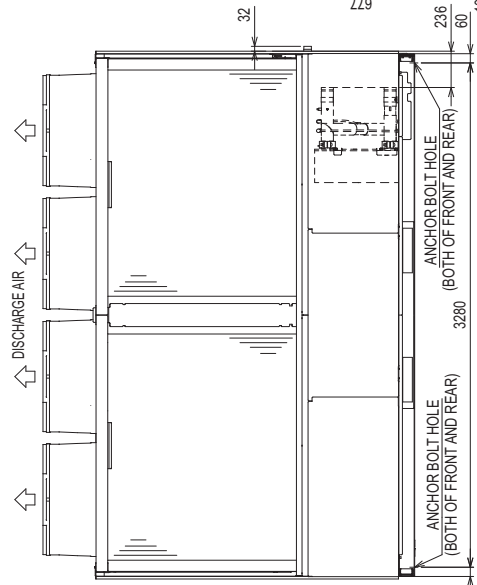
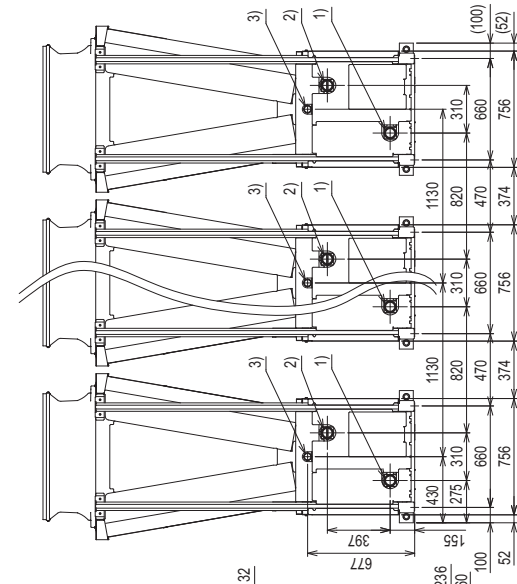
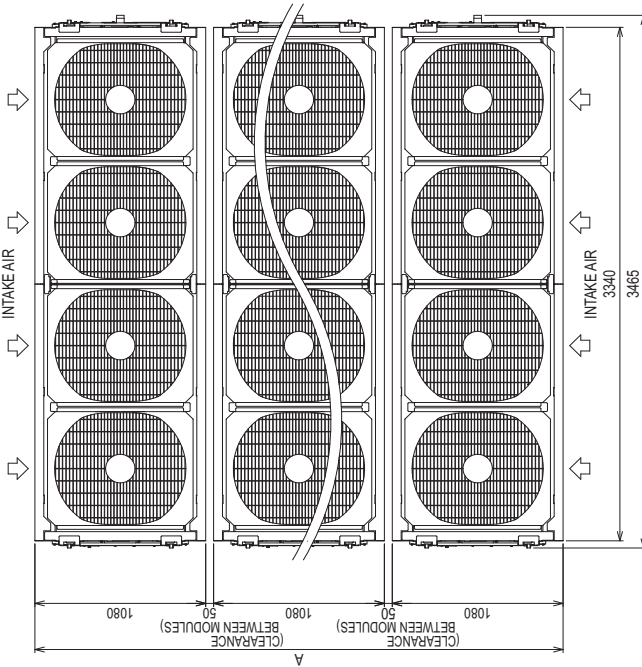

MODULE COUNT	A	B	C
	(HANGING HOLE COUNT)	(HANGING HOLE COUNT)	(FOUNDATION HOLE COUNT)
1 MODULE	1080	1	1
2 MODULES	2210	2	2
3 MODULES	3340	3	3
4 MODULES	4470	4	4
5 MODULES	5600	5	5
6 MODULES	6730	6	6
7 MODULES	7860	7	7
8 MODULES	8990	8	8
9 MODULES	10120	9	9
10 MODULES	11250	10	10
11 MODULES	12380	11	11
12 MODULES	13510	12	12

- NOTE 1. CONNECT COOL WATER PIPES WHILE MAKING SURE OF CONNECTING THE INLETS AND OUTLETS CORRECTLY.
- NOTE 2. INTRUSION OF FOREIGN MATERIALS INTO THE HEAT EXCHANGER MAY CAUSE PERFORMANCE DEGRADATION OR FREEZING. BE SURE TO INSTALL CLEANABLE STRAINER (20 MESH MIN.) TO THE INLET OF COOL WATER PIPES.
- NOTE 3. FOR HOW TO DRAW IN POWER CABLES OR CONNECT COOL WATER PIPES, REFER TO THE SEPARATE DOCUMENT.
- NOTE 4. THE HOUSING TYPE JOINTS FOR CONNECTING A COOL WATER INLET AND OUTLET SHOULD BE PREPARED ON SITE.
- NOTE 5. THE VALUES OF A TO C IN THE FIGURE ARE AS FOLLOWS.

1. Product Specifications

EACV-M1500, 1800YCL(-BS)

Unit: mm

SERVICE SPACES AROUND THE UNIT

1. WHEN INSTALLING THE UNIT, BE SURE TO LEAVE A SERVICE SPACE FOR MAINTENANCE AND INSPECTION AROUND THE UNIT.
2. ENSURE THAT THERE ARE NOT ANY WALLS OR OTHER OBJECTS AROUND THE UNIT THAT PREVENT THE UNIT FROM DRAWING IN AIR.

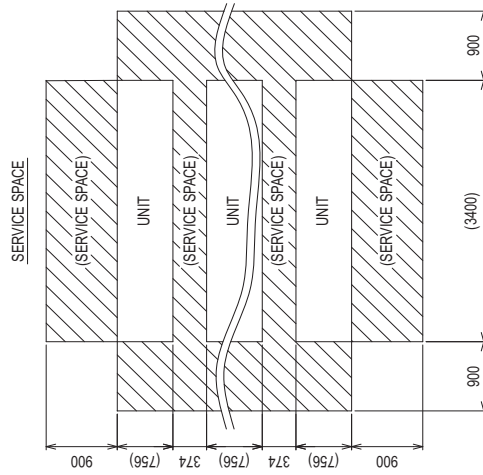

FOUNDATION CONSTRUCTION

1. THE FOUNDATION SHOULD BE MADE OF CONCRETE OR STEEL CAPABLE OF BEARING THE OPERATING MASS OF THE UNIT. THE FOUNDATION SHOULD ALLOW FOR WIRING.
2. A CONCRETE FOUNDATION REQUIRES ITS TOP FACE TO BE LEVEL AND FINISHED WITH MORTAR.
3. ANCHOR BOLTS SHOULD BE PREPARED ON SITE.

SURFACES TOUCHING THE FOUNDATION

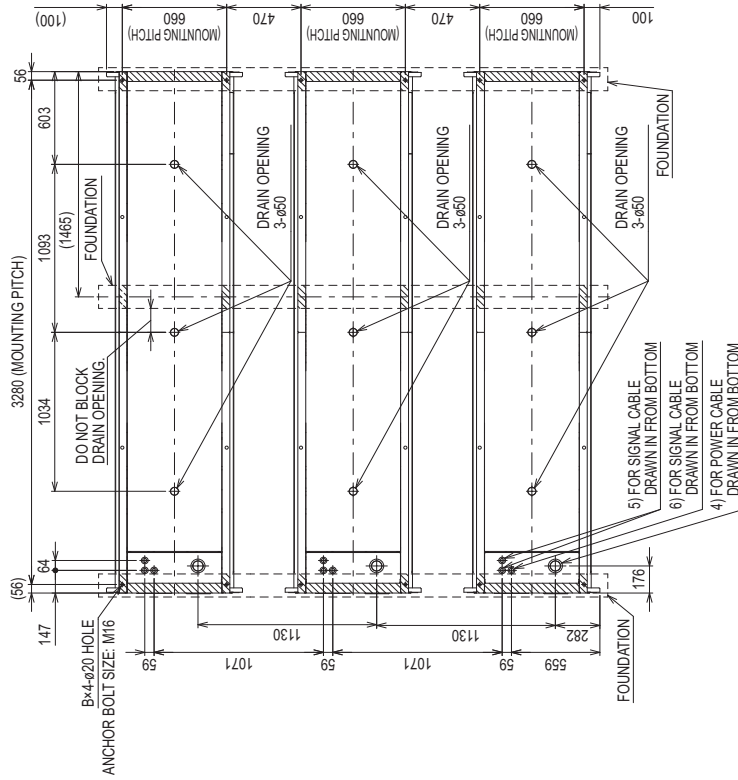

* SECTION SHOWS THE UNIT SURFACE TOUCHING THE FOUNDATION

1. Product Specifications

EAHV-M1500, 1800YCL-N(-BS)

Unit: mm

NO.	NAME	DESCRIPTION
1)	COOL (HOT) WATER INLET	6B HOUSING TYPE JOINT ATTACHED (x 1)
2)	COOL (HOT) WATER OUTLET	6B HOUSING TYPE JOINT ATTACHED (x 1)
3)	DRAIN OPENING	R1/2 EXTERNAL THREAD
4)	POWER CABLE INLET	ø68 x 1 OR ø89 x 1
5)	SIGNAL CABLE INLET (LOW CURRENT CABLE)	ø34 x 2
6)	SIGNAL CABLE INLET (HIGH CURRENT CABLE)	ø34

SERVICE SPACES AROUND THE UNIT

1. WHEN INSTALLING THE UNIT, BE SURE TO LEAVE A SERVICE SPACE FOR MAINTENANCE AND INSPECTION AROUND THE UNIT.
2. ENSURE THAT THERE ARE NOT ANY WALLS OR OTHER OBJECTS AROUND THE UNIT THAT PREVENT THE UNIT FROM DRAWING IN AIR.

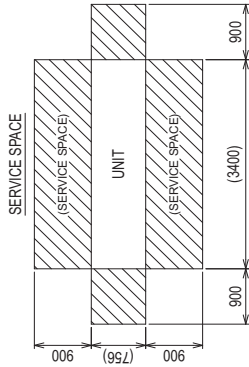

- NOTE 1.** CONNECT COOL (HOT) WATER PIPES WHILE MAKING SURE OF CONNECTING THE INLETS AND OUTLETS CORRECTLY.
NOTE 2. INTRUSION OF FOREIGN MATERIALS INTO THE HEAT EXCHANGER MAY CAUSE PERFORMANCE DEGRADATION OR FREEZING. BE SURE TO INSTALL CLEANABLE STRAINER (20 MESH MIN.) TO THE INLET OF COOL (HOT) WATER PIPES.
NOTE 3. FOR HOW TO DRAW IN POWER CABLES OR CONNECT COOL (HOT) WATER PIPES, REFER TO THE SEPARATE DOCUMENT.
NOTE 4. THE HOUSING TYPE JOINTS FOR CONNECTING A COOL (HOT) WATER INLET AND OUTLET SHOULD BE PREPARED ON SITE.

INSTALLATION ON FOUNDATION

1. SECURELY FIX THE UNIT WITH BOLTS TO KEEP THE UNIT FROM FALLING DOWN DURING EARTHQUAKES.
2. INSTALL THE UNIT ON A FOUNDATION MADE OF CONCRETE OR IRON.
3. NOISE AND VIBRATIONS FROM THE UNIT MAY BE TRANSMITTED THROUGH THE FLOOR AND WALLS. PROVIDE ADEQUATE PROTECTION AGAINST NOISE AND VIBRATION.
4. ANCHOR BOLTS SHOULD BE PREPARED ON SITE.
5. WHEN BUILDING THE FOUNDATION, TAKE THE FLOOR STRENGTH, AND PIPING AND WIRING ROUTES INTO CONSIDERATION.

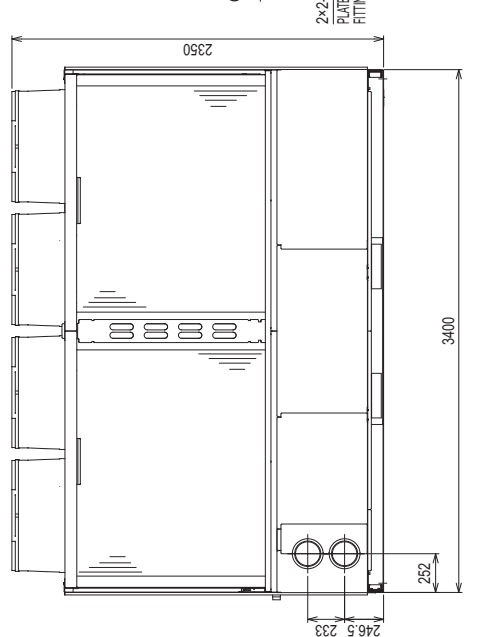
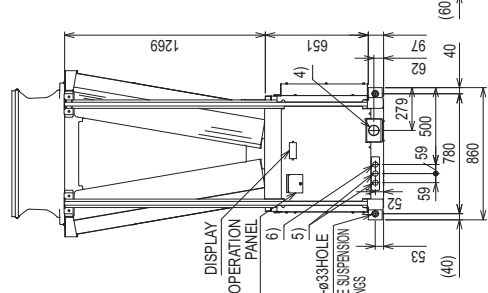
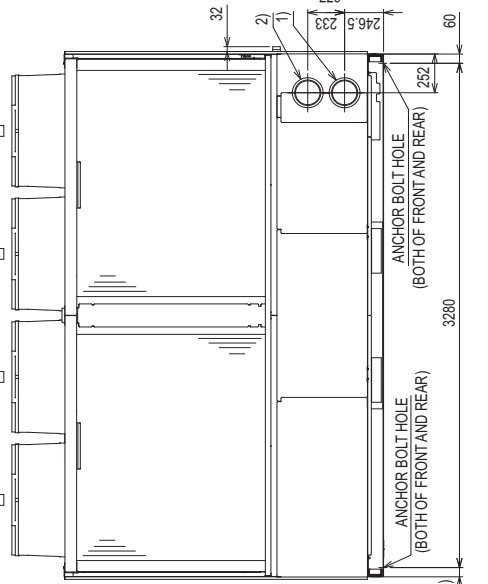
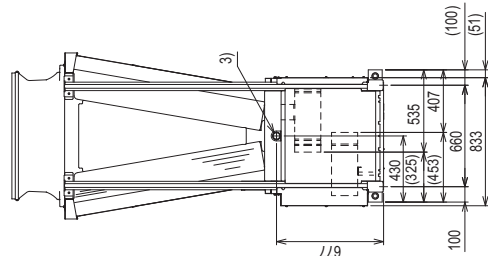
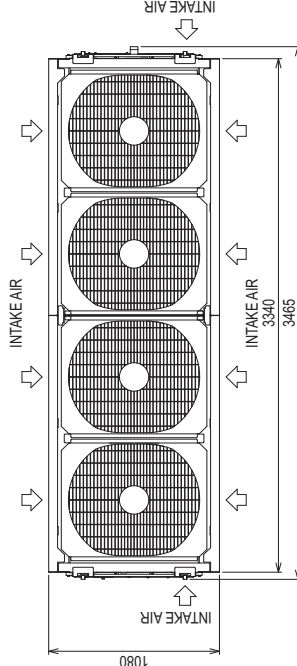
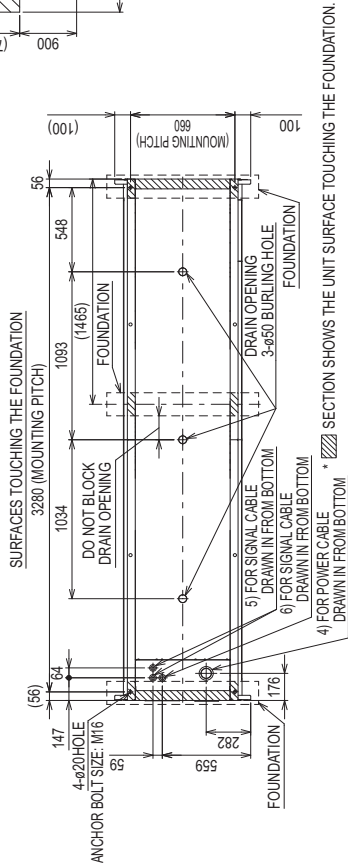

1. Product Specifications

EAHV-M1500, 1800YCL-N(-BS)

Unit: mm

NO.	NAME	DESCRIPTION
1)	COOL (HOT) WATER INLET	68 HOUSING TYPE JOINT ATTACHED (x 1)
2)	COOL (HOT) WATER OUTLET	68 HOUSING TYPE JOINT ATTACHED (x 1)
3)	DRAIN OPENING	R1½ EXTERNAL THREAD
4)	POWER CABLE INLET	ø86 x 1 OR ø89 x 1
5)	SIGNAL CABLE INLET (LOW CURRENT CABLE)	ø34 x 2
6)	SIGNAL CABLE INLET (HIGH CURRENT CABLE)	ø34

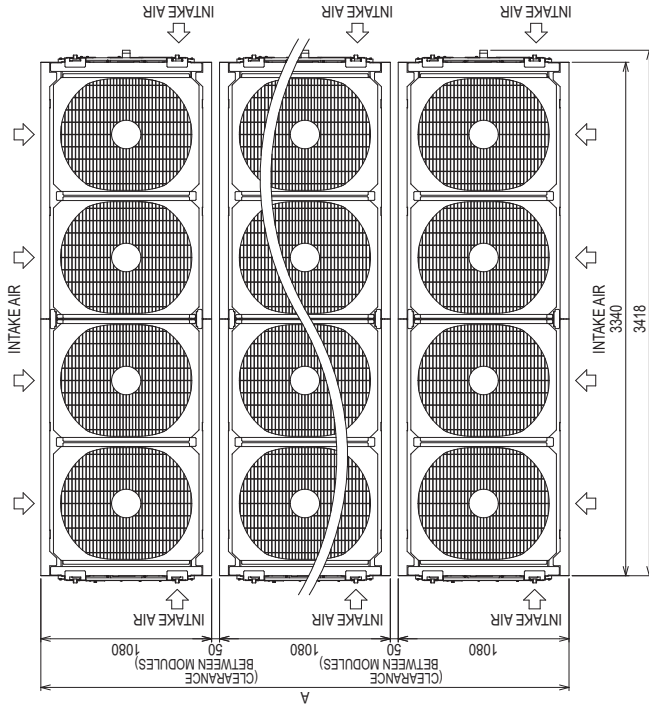

- NOTE 1. CONNECT COOL (HOT) WATER PIPES WHILE MAKING SURE OF CONNECTING THE INLETS AND OUTLETS CORRECTLY.
- NOTE 2. INTRUSION OF FOREIGN MATERIALS INTO THE HEAT EXCHANGER MAY CAUSE PERFORMANCE DEGRADATION OR FREEZING. BE SURE TO INSTALL CLEANABLE STRAINER (20 MESH MIN.) TO THE INLET OF COOL (HOT) WATER PIPES.
- NOTE 3. FOR HOW TO DRAW IN POWER CABLES OR CONNECT COOL (HOT) WATER PIPES, REFER TO THE SEPARATE DOCUMENT.
- NOTE 4. THE HOUSING TYPE JOINTS FOR CONNECTING A COOL (HOT) WATER INLET AND OUTLET SHOULD BE PREPARED ON SITE.
- NOTE 5. THE VALUES OF A TO C IN THE FIGURE ARE AS FOLLOWS.

MODULE COUNT	A (FOUNDATION HOLE COUNT)	B
1 MODULE	1080	1
2 MODULES	2210	2
3 MODULES	3340	3
4 MODULES	4470	4
5 MODULES	5600	5
6 MODULES	6730	6

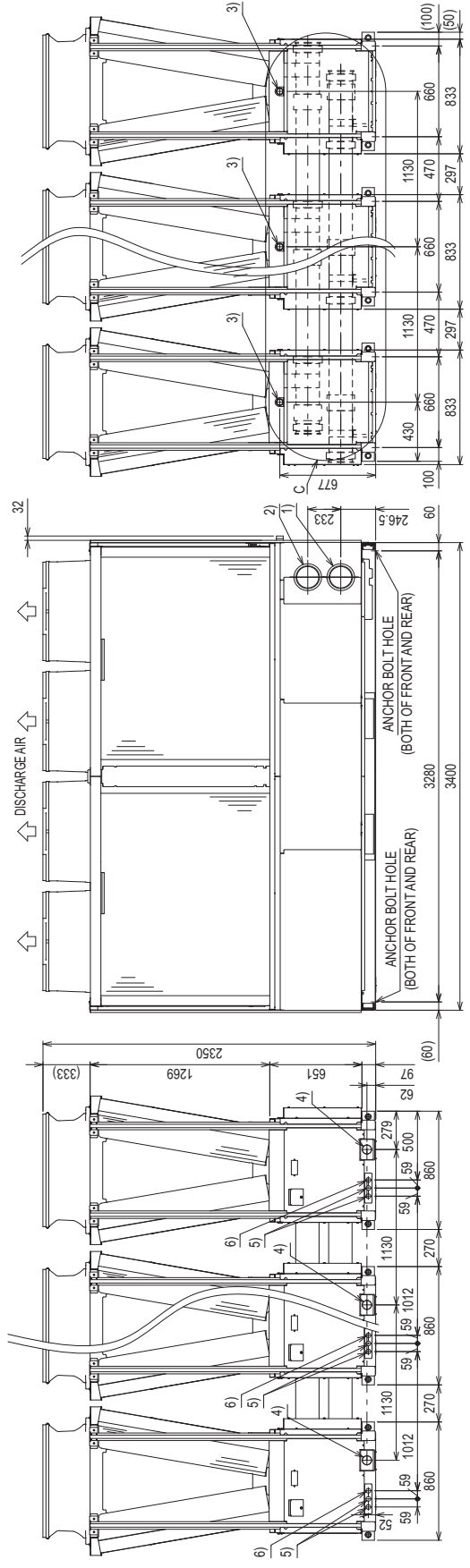

EAHV-M-YCL(-N), EACV-M-YCL(-N)

1. Product Specifications

EAHV-M-YCL(-N), EACV-M-YCL(-N)

EAHV-M1500, 1800YCL-N(-BS)

Unit: mm

* COOL (HOT) WATER RIGHT PICKER SPECIFICATION

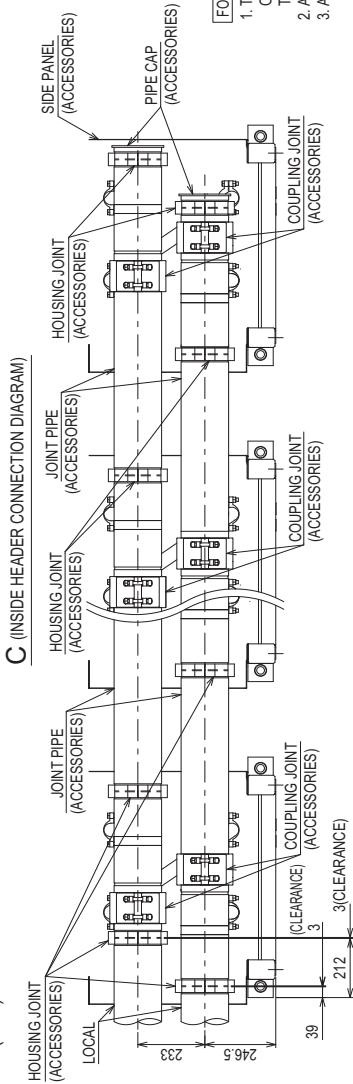

* COOL (HOT) WATER LEFT PICKER SPECIFICATION

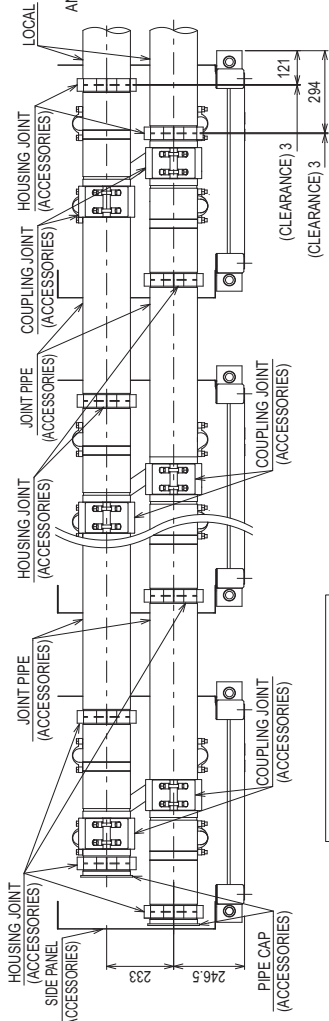

FOUNDATION CONSTRUCTION

1. THE FOUNDATION SHOULD BE MADE OF CONCRETE OR STEEL CAPABLE OF BEARING THE OPERATING MASS OF THE UNIT.
2. A CONCRETE FOUNDATION REQUIRES ITS TOP FACE TO BE LEVEL AND FINISHED WITH MORTAR.
3. ANCHOR BOLTS SHOULD BE PREPARED ON SITE.

SURFACES TOUCHING THE FOUNDATION

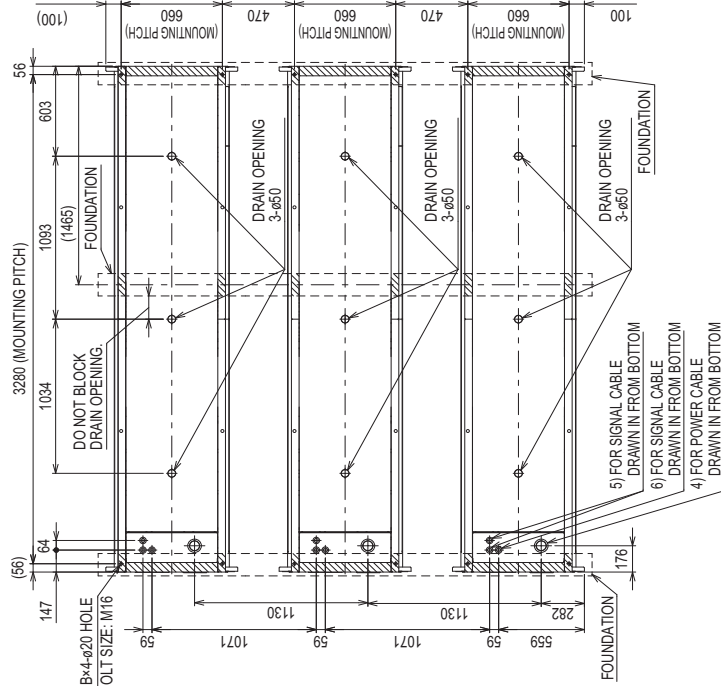

* SECTION SHOWS THE UNIT SURFACE TOUCHING THE FOUNDATION.

SERVICE SPACES AROUND THE UNIT

1. WHEN INSTALLING THE UNIT, BE SURE TO LEAVE A SERVICE SPACE FOR MAINTENANCE AND INSPECTION AROUND THE UNIT.
2. ENSURE THAT THERE ARE NOT ANY WALLS OR OTHER OBJECTS AROUND THE UNIT THAT PREVENT THE UNIT FROM DRAWING IN AIR.

SERVICE SPACE

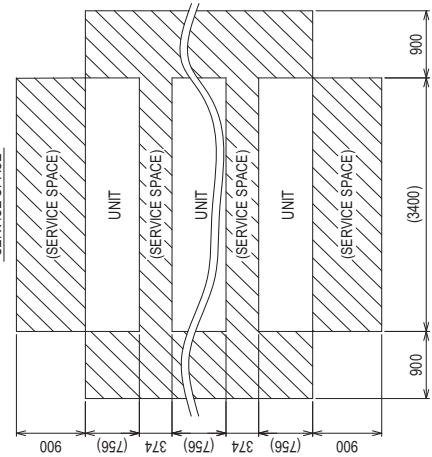

1. Product Specifications

EACV-M1500, 1800YCL-N(-BS)

Unit: mm

NO.	NAME	DESCRIPTION
1)	COOL WATER INLET	6B HOUSING TYPE JOINT ATTACHED (x 1)
2)	COOL WATER OUTLET	6B HOUSING TYPE JOINT ATTACHED (x 1)
3)	DRAIN OPENING	R1½ EXTERNAL THREAD
4)	POWER CABLE INLET	ø66 x 1 OR ø83 x 1
5)	SIGNAL CABLE INLET (LOW CURRENT CABLE)	ø34 x 2
6)	SIGNAL CABLE INLET (HIGH CURRENT CABLE)	ø34

SERVICE SPACES AROUND THE UNIT
 1. WHEN INSTALLING THE UNIT, BE SURE TO LEAVE A SERVICE SPACE FOR MAINTENANCE AND INSPECTION AROUND THE UNIT.
 2. ENSURE THAT THERE ARE NOT ANY WALLS OR OTHER OBJECTS AROUND THE UNIT THAT PREVENT THE UNIT FROM DRAWING IN AIR.

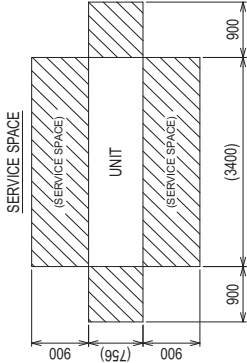

NOTE 1. CONNECT COOL WATER PIPES WHILE MAKING SURE OF CONNECTING THE INLETS AND OUTLETS CORRECTLY.
NOTE 2. INTRUSION OF FOREIGN MATERIALS INTO THE HEAT EXCHANGER MAY CAUSE PERFORMANCE DEGRADATION OR FREEZING. BE SURE TO INSTALL CLEANABLE STRAINER (20 MESH MIN.) TO THE INLET OF COOL WATER PIPES.
NOTE 3. FOR HOW TO DRAW IN POWER CABLES OR CONNECT COOL WATER PIPES, REFER TO THE SEPARATE DOCUMENT.
NOTE 4. THE HOUSING TYPE JOINTS FOR CONNECTING A COOL WATER INLET AND OUTLET SHOULD BE PREPARED ON SITE.

INSTALLATION ON FOUNDATION
 1. SECURELY FIX THE UNIT WITH BOLTS TO KEEP THE UNIT FROM FALLING DOWN DURING EARTHQUAKES.
 2. INSTALL THE UNIT ON A FOUNDATION MADE OF CONCRETE OR IRON.
 3. NOISE AND VIBRATIONS FROM THE UNIT MAY BE TRANSMITTED THROUGH THE FLOOR AND WALLS. PROVIDE ADEQUATE PROTECTION AGAINST NOISE AND VIBRATION.
 4. ANCHOR BOLTS SHOULD BE PREPARED ON SITE.
 5. WHEN BUILDING THE FOUNDATION, TAKE THE FLOOR STRENGTH, AND PIPING AND WIRING ROUTES INTO CONSIDERATION.

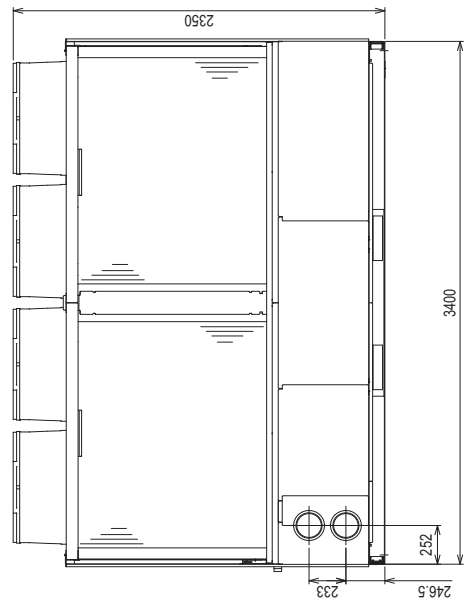
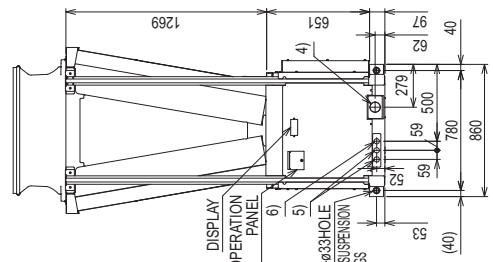
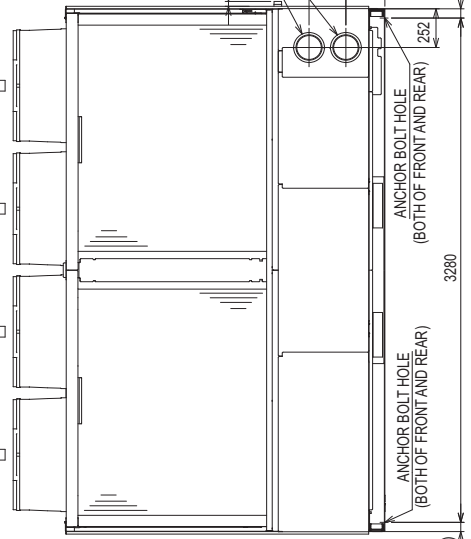
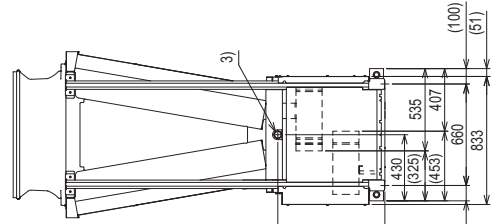
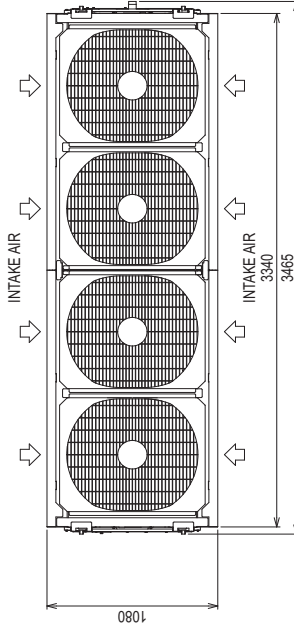
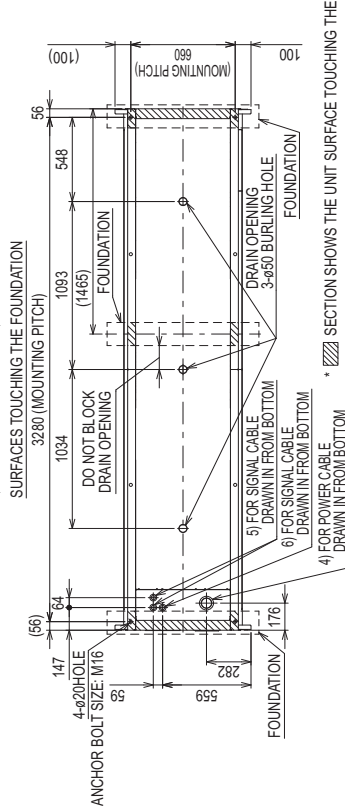

1. Product Specifications

EAHV-M-YCL(-N), EACV-M-YCL(-N)

EACV-M1500, 1800YCL-N(-BS)

Unit: mm

NO.	NAME	DESCRIPTION
1)	COOL WATER INLET	8B HOUSING TYPE JOINT ATTACHED (*1)
2)	COOL WATER OUTLET	8B HOUSING TYPE JOINT ATTACHED (*1)
3)	DRAIN OPENING	R1½ EXTERNAL THREAD
4)	POWER CABLE INLET	ø66 × 1 OR ø89 × 1
5)	SIGNAL CABLE INLET (LOW CURRENT CABLE)	ø34 × 2
6)	SIGNAL CABLE INLET (HIGH CURRENT CABLE)	ø34

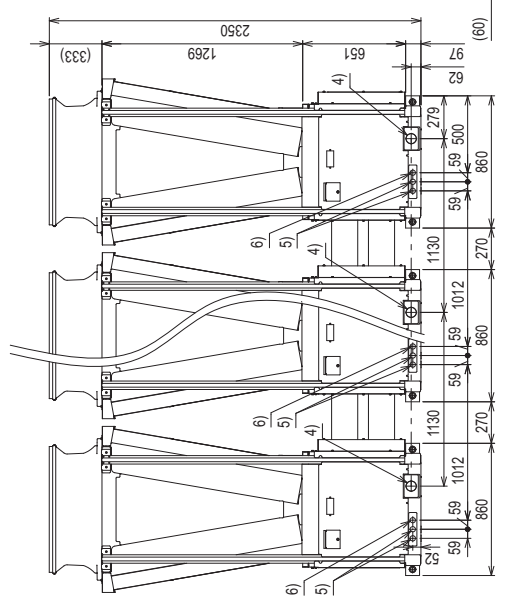
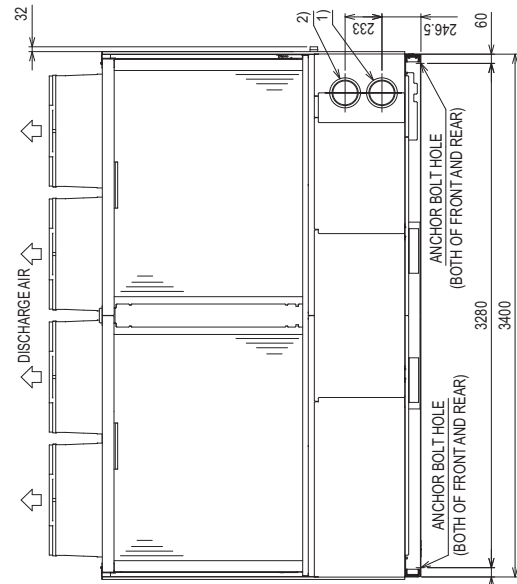
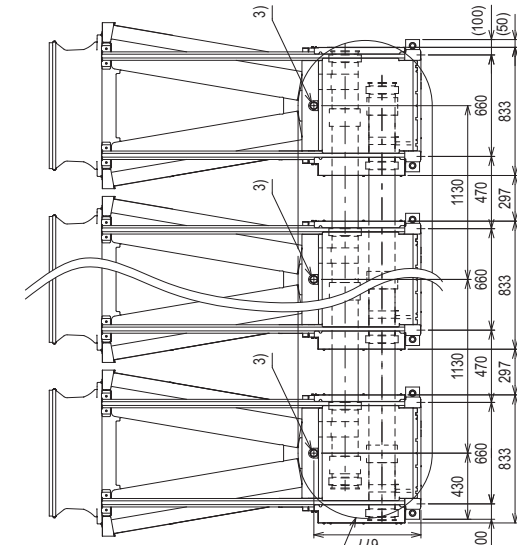
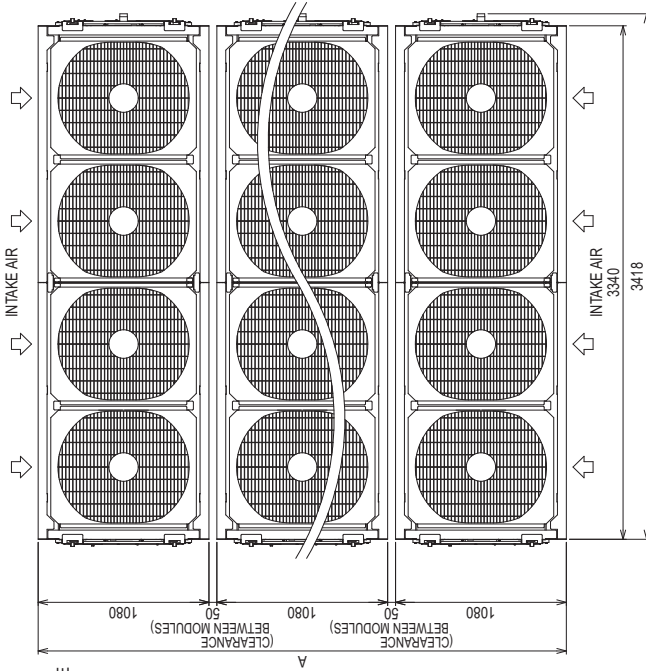

- NOTE 1. CONNECT COOL WATER PIPES WHILE MAKING SURE OF CONNECTING THE INLETS AND OUTLETS CORRECTLY.
- NOTE 2. INTRUSION OF FOREIGN MATERIALS INTO THE HEAT EXCHANGER MAY CAUSE PERFORMANCE DEGRADATION OR FREEZING. BE SURE TO INSTALL CLEANABLE STRAINER (20 MESH MIN.) TO THE INLET OF COOL WATER PIPES.
- NOTE 3. FOR HOW TO DRAW IN POWER CABLES OR CONNECT COOL WATER PIPES, REFER TO THE SEPARATE DOCUMENT.
- NOTE 4. THE HOUSING TYPE JOINTS FOR CONNECTING A COOL WATER INLET AND OUTLET SHOULD BE PREPARED ON SITE.
- NOTE 5. THE VALUES OF A TO C IN THE FIGURE ARE AS FOLLOWS.

MODULE COUNT	A (FOUNDATION HOLE COUNT)	B
1 MODULE	1080	1
2 MODULES	2210	2
3 MODULES	3340	3
4 MODULES	4470	4
5 MODULES	5600	5
6 MODULES	6730	6

1. Product Specifications

EACV-M1500, 1800YCL-N(-BS)

Unit: mm

* COOL (HOT) WATER RIGHT PICKER SPECIFICATION C (INSIDE HEADER CONNECTION DIAGRAM)

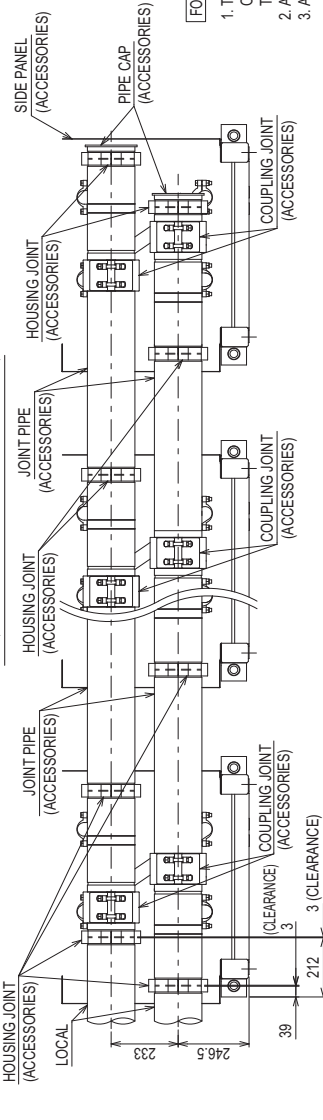

* COOL (HOT) WATER LEFT PICKER SPECIFICATION

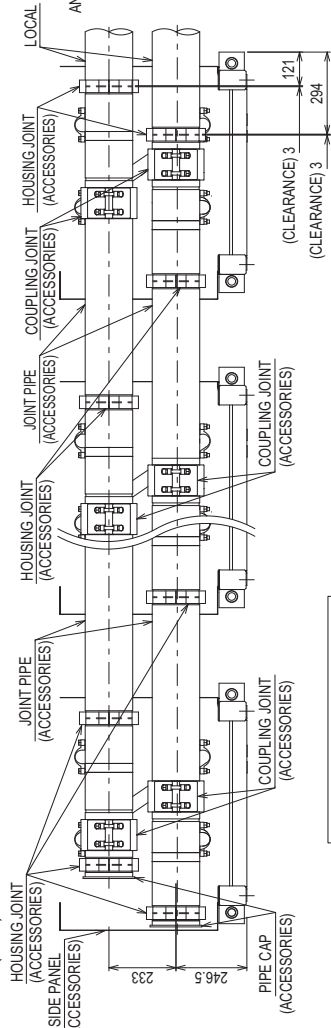

FOUNDATION CONSTRUCTION

1. THE FOUNDATION SHOULD BE MADE OF CONCRETE OR STEEL CAPABLE OF BEARING THE OPERATING MASS OF THE UNIT.
2. THE FOUNDATION SHOULD ALLOW FOR WIRING.
3. A CONCRETE FOUNDATION REQUIRES ITS TOP FACE TO BE LEVEL AND FINISHED WITH MORTAR.
4. ANCHOR BOLTS SHOULD BE PREPARED ON SITE.

SURFACES TOUCHING THE FOUNDATION

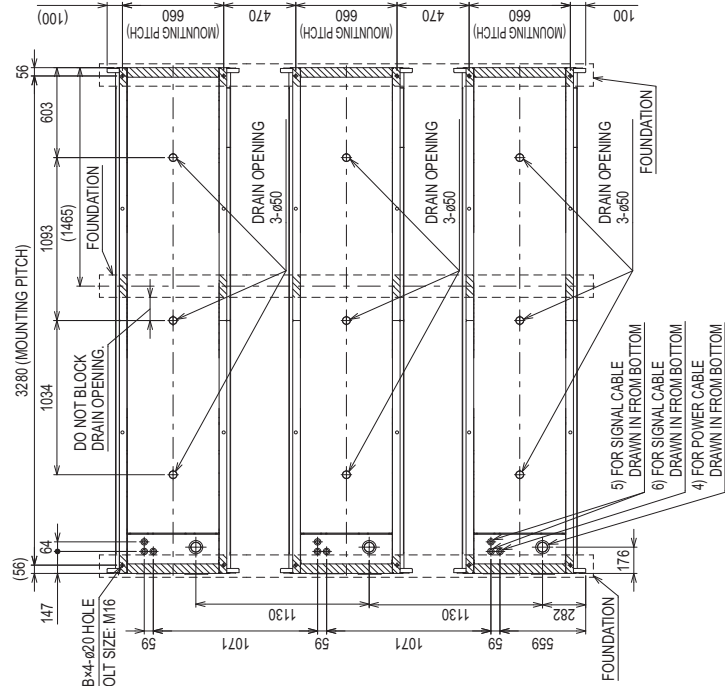

* SECTION SHOWS THE UNIT SURFACE TOUCHING THE FOUNDATION.

SERVICE SPACES AROUND THE UNIT

1. WHEN INSTALLING THE UNIT, BE SURE TO LEAVE A SERVICE SPACE FOR MAINTENANCE AND INSPECTION AROUND THE UNIT.
2. ENSURE THAT THERE ARE NOT ANY WALLS OR OTHER OBJECTS AROUND THE UNIT THAT PREVENT THE UNIT FROM DRAWING IN AIR.

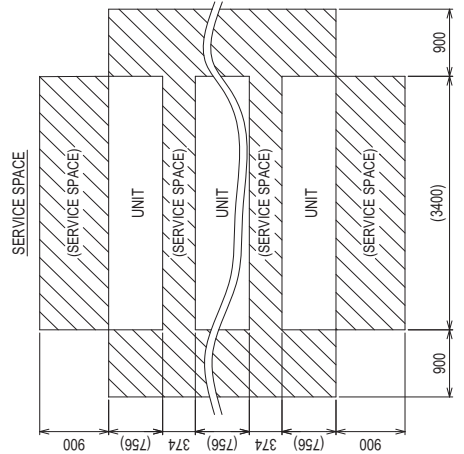

1. Product Specifications

1-3. Center of Gravity

The center of gravity position is shown with the  mark.

Standard piping type

Unit: mm

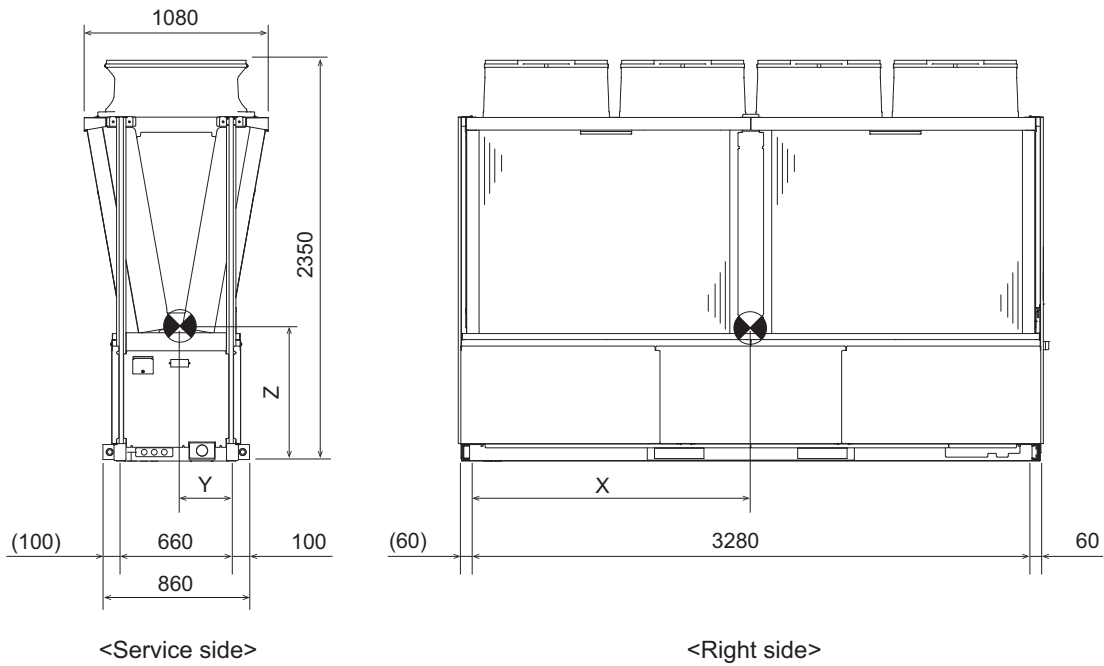

Inside header piping type

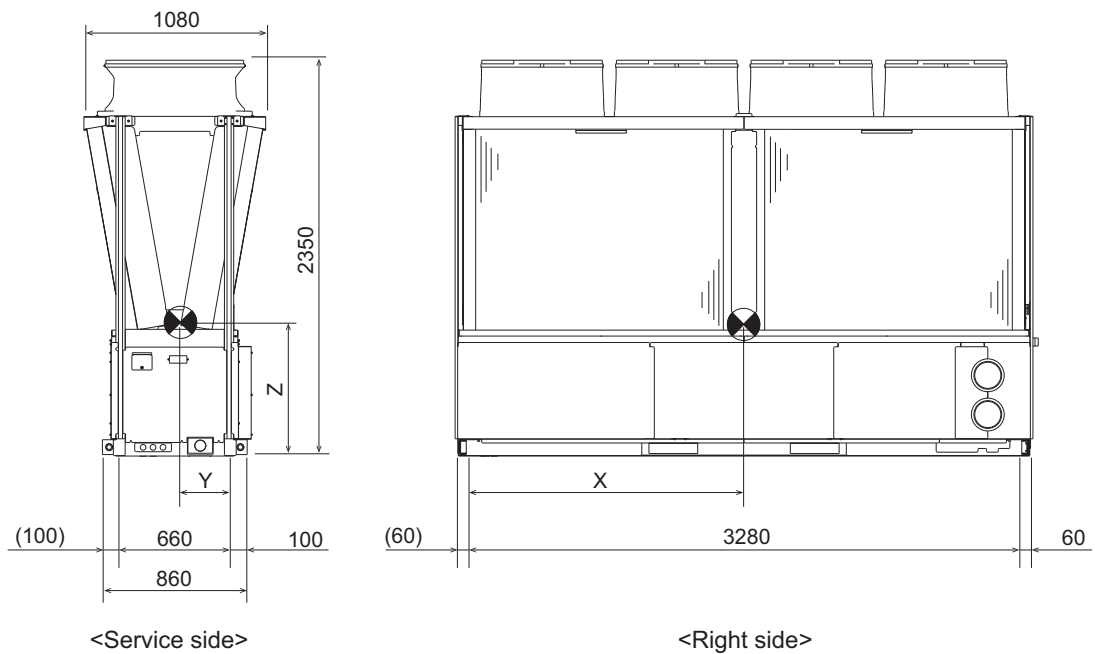

Unit: mm

Model	X	Y	Z
EAHV-M1500,1800YCL(-BS)	1610	350	790
EACV-M1500,1800YCL(-BS)	1620	350	730
EAHV-M1500,1800YCL-N(-BS)	1710	350	760
EACV-M1500,1800YCL-N(-BS)	1740	350	705

EAHV-M-YCL(-N), EACV-M-YCL(-N)

1. Product Specifications

1-4. Electrical Wiring Diagrams

EAHV-M1500, 1800YCL (-N)(-BS)
EACV-M1500, 1800YCL (-N)(-BS)

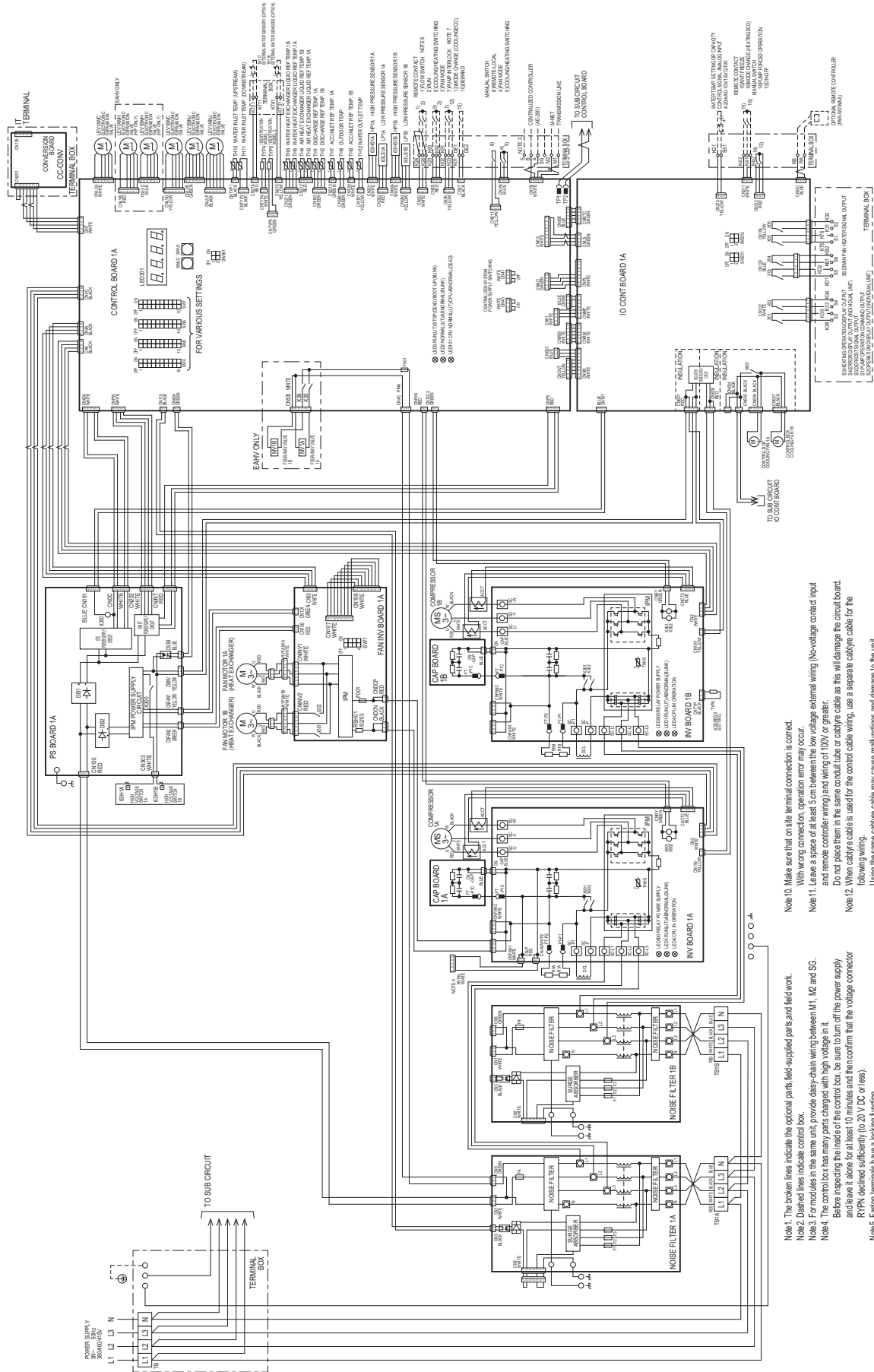

- Note 1. The broken lines indicate the optional parts field-supplied parts and field work.
- Note 2. Dashed lines indicate control box.
- Note 3. For modules in the same unit, provideaisy-chain wiring between H1, H2 and S6.
- Note 4. The control box has many parts changed with high voltage in it.
Before inspecting the inside of the control box, be sure to turn off the power supply and leave it alone for at least 10 minutes and then confirm that the voltage connector P12V is discharged sufficiently (to 20 V DC or less).
- Note 5. Eaton terminals have a locking function.
Press the tab in the middle of the terminals to remove them.
Check that the tabs are securely locked in place after insertion.
- Note 6. Remove the short circuit wire between terminals K23 and K24 to connect a flow switch.
- Note 7. Be sure to connect the wire from terminals W01 and K02 to the interlock contact on the pump.
A short-circuit may cause abnormal stop or malfunctions.
- Note 8. Operation signals can be received from through the No-voltage contact.
- Note 9. Use a 420mA signal output device with insulation.
Feeding 500mA or more current may damage the circuit board.
- Note 10. Make sure that on-site terminal connection is correct.
With wrong connection, operation error may occur.
- Note 11. Leave a space of at least 5cm between the low voltage external wiring (No-voltage contact input and remote controller wiring) and wiring of 100V or greater.
Do not place them in the same conduit, tube or cable tray as this will damage the circuit board.
- Note 12. When cable wiring is used for the control cable wiring, use a separate cable tray for the following wiring.
Using the same cable tray may cause malfunctions and damage to the unit.
(a) Remote controller wiring
(b) Optional remote controller wiring
(c) No-voltage contact input wiring
(d) No-voltage contact output wiring
- Note 13. Use a contact that carries 1200A, 120V for No-voltage contact input.
When the power voltage is 380V-480V, 415V, No-voltage contact output will be 220VAC-230VAC-240VAC.
The current range must be between 10mA and 1A.

MAIN CIRCUIT

EAHV-M-YCL(-N), EACV-M-YCL(-N)

1. Product Specifications

EAHV-M1500, 1800YCL (-N)(-BS)
EACV-M1500, 1800YCL (-N)(-BS)

EAHV-M-YCL(-N), EACV-M-YCL(-N)

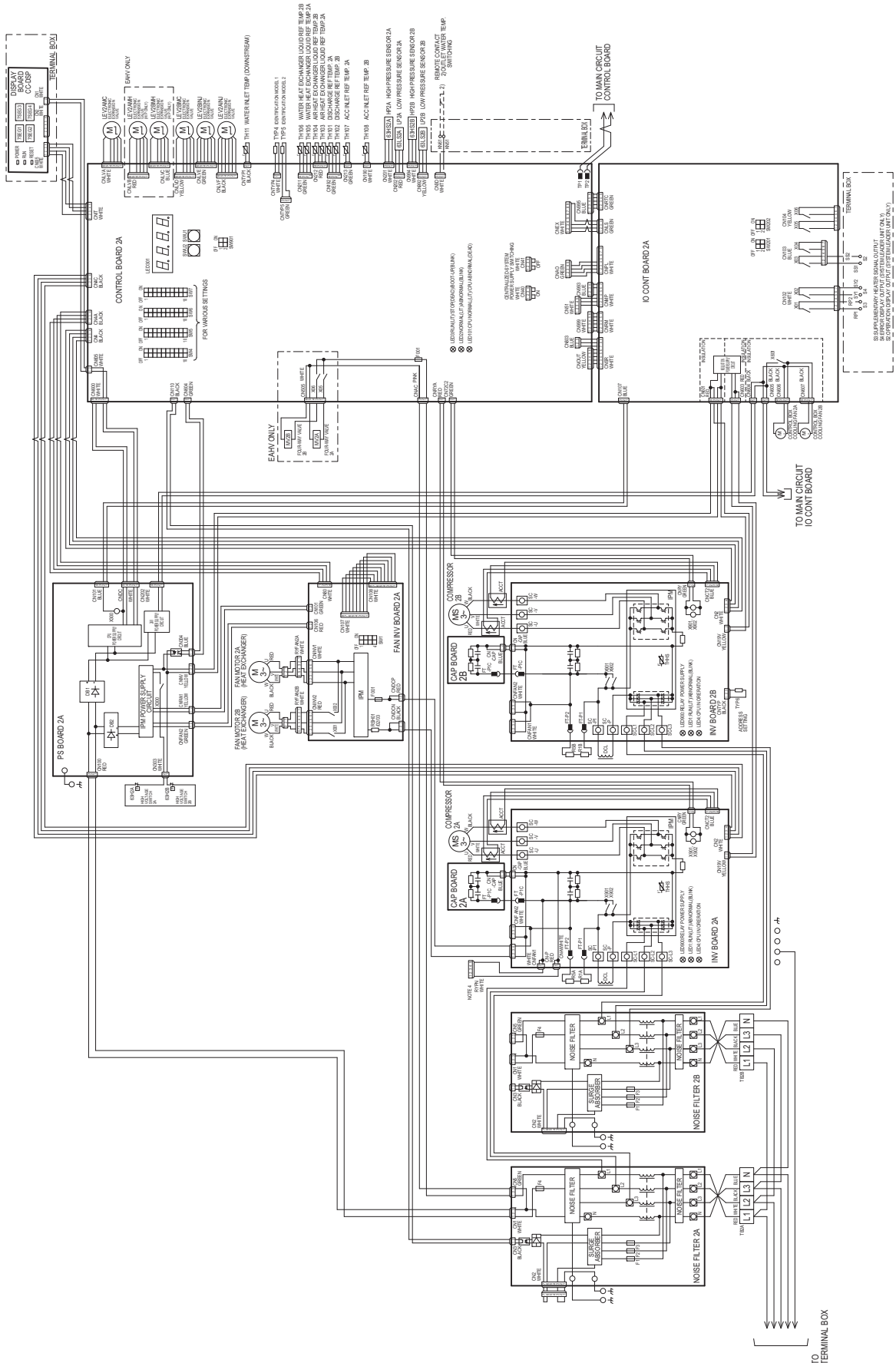

SUB CIRCUIT

1. Product Specifications

When using a local controller, refer to the table below for the types of input/output signals that are available and the operations that correspond to the signals.

External Input/Output

Input type	Dry contact		ON (Close)	OFF (Open)	Terminal block	
	(a)UNIT OPERATION	Run/Stop	The unit will go into operation when the water temperature drops below the preset temperature.	The unit will stop except when the unit is in the Anti-Freeze mode.	K23-K26	
	(b)MODE CHANGE *EAHV	Heating ECO/Heating	Heating ECO mode (EAHV: When "COOLING/HEATING SWITCHING" contact (item (j)) below) is ON, this mode is enabled.)	Heating mode (EAHV: When "COOLING/HEATING SWITCHING" contact (item (j)) below) is ON, this mode is enabled.)	K40-K42	
	(c)MODE CHANGE (Cooling ECO)	Cooling ECO/Cooling	Cooling ECO mode (When "COOLING/HEATING SWITCHING" contact (item (j)) below) is OFF, this mode is enabled.)	Cooling mode (When "COOLING/HEATING SWITCHING" contact (item (j)) below) is OFF, this mode is enabled.)	K01-K03	
	(d)FAN MODE	Forced/Normal	When the outdoor temperature is 5°C or less, the fan will remain in operation after the compressor has stopped.	The fan will stop when the compressor stops.	K91-K92	
	(e)ANTI FREEZE *EAHV	On/Off	The unit will operate in the Anti-Freeze mode (with the target temperature 25°C) when the contact status of (a) "UNIT OPERATION" is "Stop" or the ON/OFF button on the remote controller is turned off. (EAHV: When "COOLING/HEATING SWITCHING" contact (item (j)) below) is ON, this mode is enabled.)	The unit will operate according to the status of the "UNIT OPERATION" contact (item (a) above) or the ON/OFF command from the remote controller.	K40-K41	
	(f)FLOW SWITCH	Normal/Error	The unit is allowed to operate.	The unit will not operate.	K23-K24	
	(g)PUMP INTERLOCK	Normal/Error	The unit is allowed to operate.	The unit will not operate.	K01-K02	
	(h)PEAK-DEMAND CONTROL	On/Off	The unit will operate at or below the maximum capacity level that was set for the Peak-demand control setting.	The unit will operate at or below the maximum capacity.	DE1-DE2	
	(i)OUTLET WATER TEMP SWITCHING	2nd/1st	Setting temp 2 (Refer to page 100 Settings table)	Setting temp 1 (Refer to page 100 Settings table)	KN51-KN61	
	(j)COOLING/HEATING SWITCHING *EAHV	Heating/ Cooling	Heating mode	Cooling mode	K91-K93	
	Analog					Terminal block
	Input type		Action			
	(k)WATER TEMP SETTING/CAPACITY CONTROL SIGNAL	Water temperature or capacity control signal can be set by using the external analog input to the CN421 on the MAIN circuit board. One analog input type can be selected from the following types: 4-20 mA, 1-5 V, 0-10 V, or 2-10 V. *Use a 4-20 mA signal output device with insulation.			SG1(+)-KG1(-)	
	(l)EXTERNAL WATER SENSOR 1 (option)	For simultaneous operating group			KT11-KT21	
(m)EXTERNAL WATER SENSOR 2 (option)	For identical water system group			KT31-KT41		
Output type	Contact type		Conditions in which the contact closes (turns on)	Conditions in which the contact opens (turns off)	Terminal block	
	(n)ERROR INDICATOR (Individual unit)	Close/Open	The unit has made an abnormal stop.	During normal operation	K33-K34	
	(o)ERROR INDICATOR (System leader unit only)	Close/Open	The unit in the system has made an abnormal stop.	During normal operation	SY1-SY2	
	(p)OPERATION INDICATOR (Individual unit)	Close/Open	The unit operation output is ON.	The unit operation output is OFF.	K31-K32	
	(q)OPERATION INDICATOR (System leader unit only)	Close/Open	The "UNIT OPERATION" contact (item (a) above) or the ON/OFF button on the remote controller is ON.	The "UNIT OPERATION" contact (item (a) above) or the ON/OFF button on the remote controller is OFF.	SS1-SS2	
	(r)PUMP OPERATION COMMAND	Close/Open	The pump will operate according to the status of the "UNIT OPERATION" contact or the ON/OFF button on the remote controller button.	Under all conditions other than the ones listed on the left	K75-K76	
	(s)SUPPLEMENTARY HEATER SIGNAL	Close/Open	Water and outdoor temperature has dropped below a setting water temperature and a set outdoor temperature.	Water temperature is at or above a set water temperature +2°C or the outdoor temperature is at or above a set outdoor temperature +2°C.	RP1-RP2	
	(t)DEFROST SIGNAL	Close/Open	The unit is in defrost mode.	The unit is not in defrost mode.	KD1-KD2	
	(u)DRAIN PAN HEATER SIGNAL	Close/Open	Outdoor temperature has dropped below a set outdoor temperature.	Outdoor temperature is at or above a set outdoor temperature +2°C.	KB1-KB2	
	(v)HEATING OPERATION DISPLAY	Close/Open	The unit is in heating mode.	The unit is in cooling mode.	K38-K39	
RC/M-NET	REMOTE CONTROLLER	PAR-W31MAA			RA-RB	
	Centralized controller	AE-200			A-B	
	M-NET				M1-M2	

1. Product Specifications

Input and output correspondence table

*When wiring on site, check the operation during the commissioning.

		Terminal block	ON	OFF	System leader unit	Group leader unit	SUB unit
No-voltage contact input	Run	K23-K26	Run	Stop	○	-	-
	Fan mode	K91-K92	Forced	Normal	○	-	-
	Cooling/Heating switching	K91-K93	Heating	Cooling	○	-	-
	Pump interlock	K01-K02	Normal	Error	○	○	○*
	Anti freeze	K40-K41	ON	OFF	○	-	-
	Flow switch	K23-K24	Normal	Error	○	○	○*
	Outlet water temp. switching	KN51-KN61	2nd	1st	○	-	-
	Demand	DE1-DE2	ON	OFF	○	-	-
	Mode change (Heating ECO)	K40-K42	Heating ECO	Heating	○	-	-
	Mode change (Cooling ECO)	K01-K03	Cooling ECO	Cooling	○	-	-
Analog input	Water temp. setting / Capacity control signal	SG1(+)-KG1(-)	4-20mA,0-10,2-10V,1-5V		○	-	-
	External water sensor 1 (Option)	KT11-KT21	For simultaneous operating group		○	○	-
	External water sensor 2 (Option)	KT31-KT41	For identical water system group		○	-	-
No-voltage contact output	Supplementary heater signal output	RP1-RP2	During the low outdoor and water temperature is ON.		○	○	○
	Defrost signal output	KD1-KD2	During the defrosting operation is ON.		○	○	○
	Heating operation display	K38-K39	Heating	Cooling	○	○	○
	Operation display output (Individual unit)	K31-K32	ON while the unit is operating.		○	○	○
	Error display output (Individual unit)	K33-K34	While abnormally stop is ON.		○	○	○
	Pump operation command output	K75-K76	ON is when the pump is required.		○	○	○*
	Drain pan heater signal output	KB1-KB2	During the low outdoor temperature is ON.		○	○	○
	Operation display output (System leader unit only)	SS1-SS2	ON while any of the units is operating.		○	-	-
	Error display output (System leader unit only)	SY1-SY2	ON when any of the units in the system has come to an abnormal stop.		○	-	-
RC	Remote controller	RA-RB	PAR-W31MAA		○	-	-
	Centralized controller	A-B	AE-200		○	-	-

○: Input and output signal is enabled.

-: Invalid

*Invalid when the one pump system

External signal interface

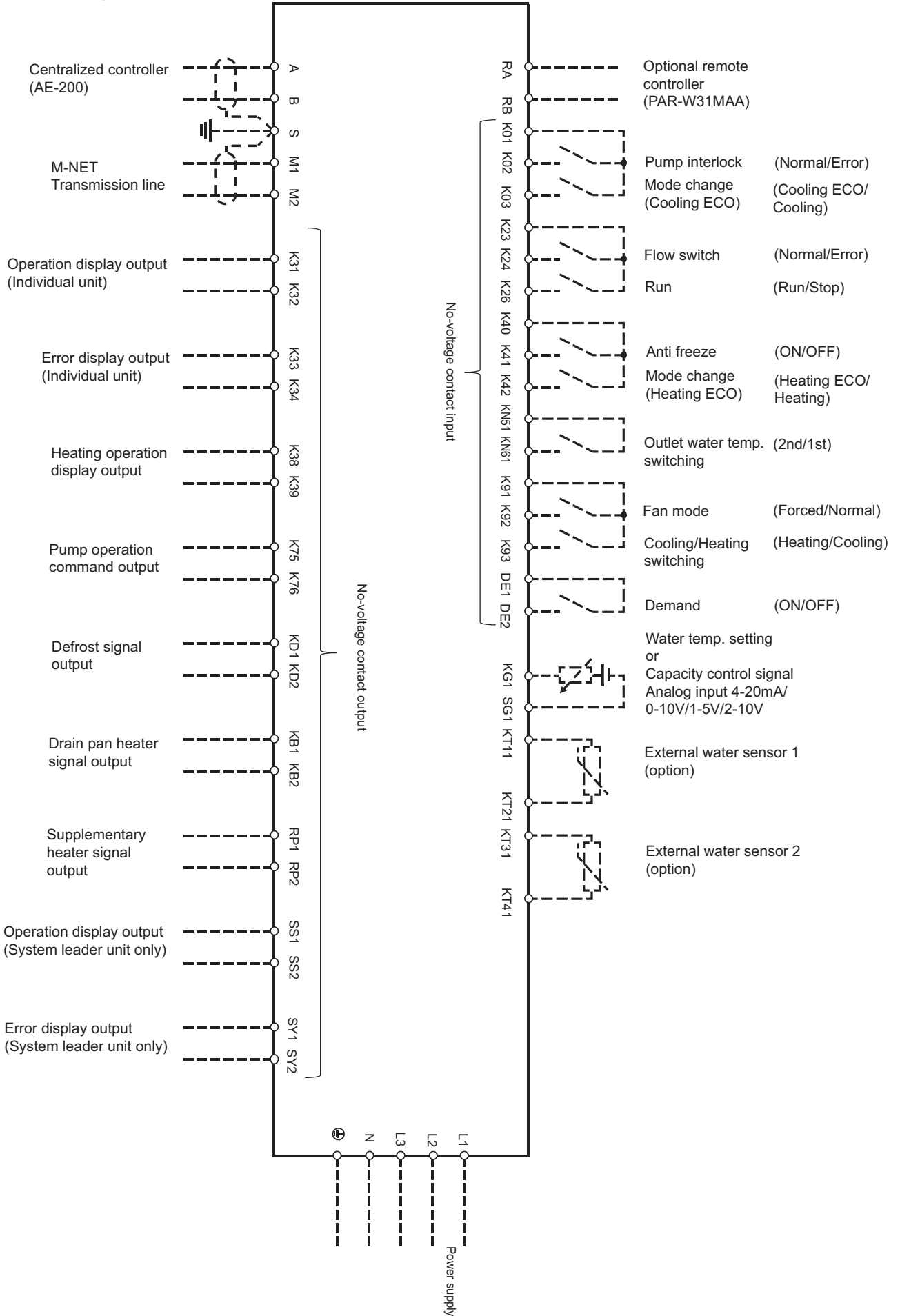

1. Product Specifications

1-5. Optional parts

1-5-1. Piping Kit EC-01HK (Only for Inside header (-N))

Refer to Installation/Instructions Manual.

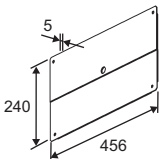
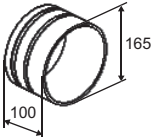
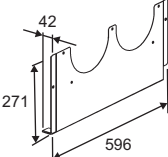
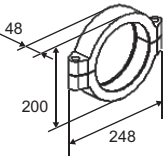
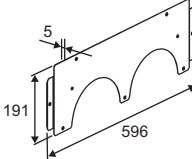
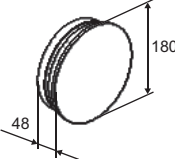
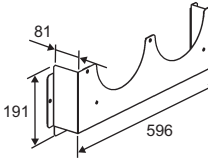
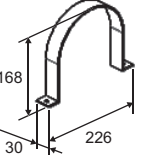
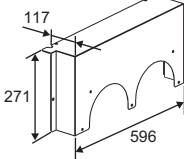
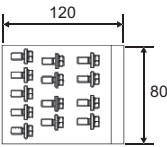
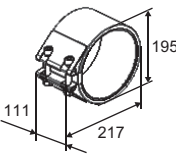
No.	Parts name	Size and shape	Quantity	No.	Parts name	Size and shape	Quantity
1	SIDE PANEL		1	7	JOINT PIPE (SHORT)		2
2	PANEL BL		1	8	VICTAULIC JOINT		4
3	PANEL BR		1	9	PIPE CAP		2
4	PANEL SL		1	10	SADDLE		1
5	PANEL SR		1	11	BOLT M5		1
6	STRAUB JOINT		2				

EAHV-M-YCL(-N), EACV-M-YCL(-N)

1. Product Specifications

1-5-2. Connection Piping Kit EC-02HK (Only for Inside header (-N))

Refer to Installation/Instructions Manual.

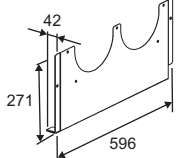
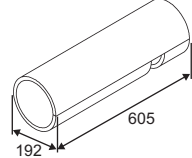
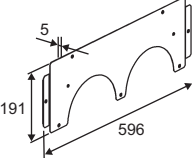
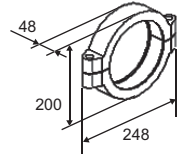
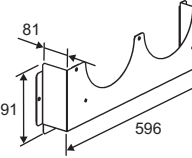
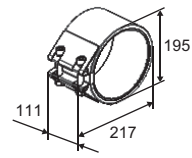
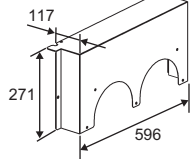
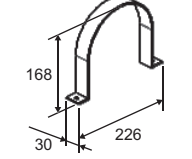
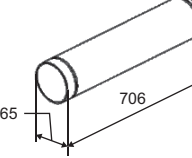
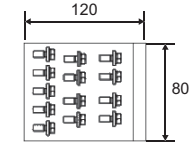
No.	Parts name	Size and shape	Quantity	No.	Parts name	Size and shape	Quantity
1	PANEL BL		1	6	PIPE COVER		2
2	PANEL BR		1	7	VICTAULIC JOINT		2
3	PANEL SL		1	8	STRAUB JOINT		2
4	PANEL SR		1	9	SADDLE		2
5	JOINT PIPE (LONG)		2	10	BOLT M5		1

1. Product Specifications

1-5-3. Fin Guard EC-130FG

Parts list

EAHV-M-YCL(-N), EACV-M-YCL(-N)

FIN GUARD		FRAME 1	
(1)	<p>1517 874 4 pcs.</p>	(2)	<p>1592 4 pcs.</p>
FRAME 2		FRAME 3	
(3)	<p>868 8 pcs.</p>	(4)	<p>580 4 pcs.</p>
		SCREWS	
		(5)	<p>12 96 pcs.</p>

1. Product Specifications

Installing the fin guard

(1) Attach three types of frames at each positions.

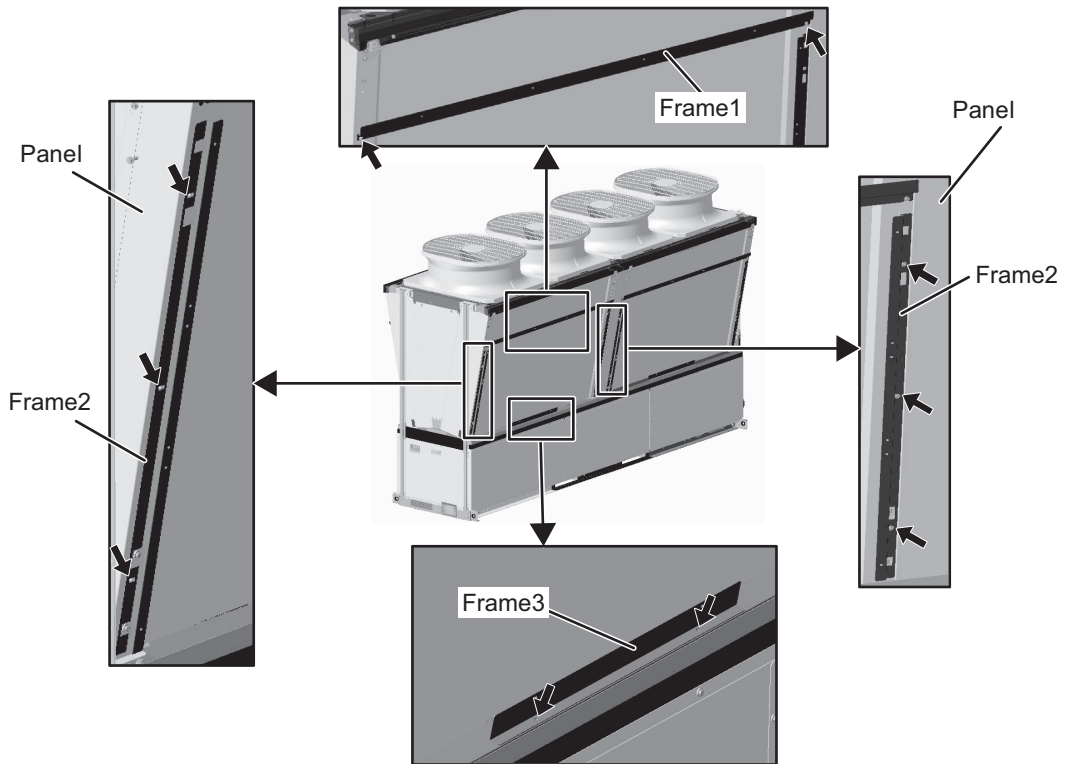

Screw down Frames 1, 2 and 3 on the panel with M5 screws at the 10 positions with arrows in the figure.
 *Screw down Frames 1, 2 and 3 in the same way on the other side.

(2) Attach the fin guards to the four side.

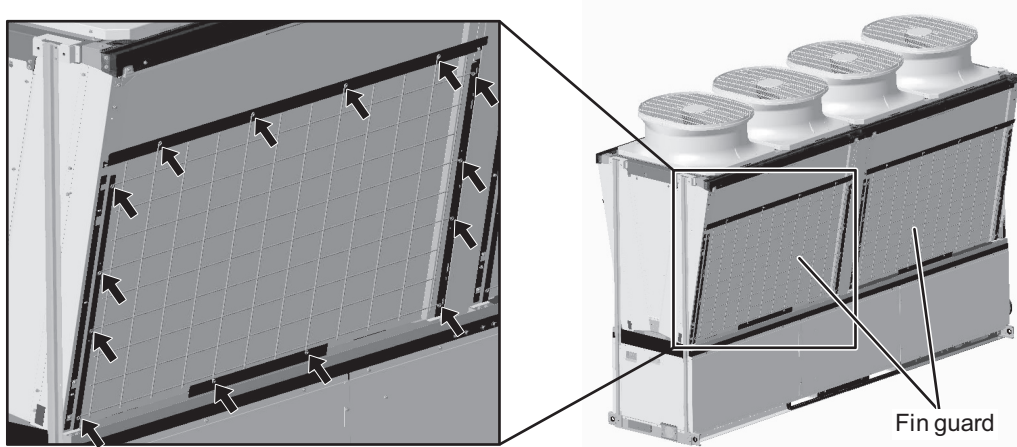

Screw down the fin guards on the frame with M5 screws at the 14 positions with arrows in the figure.

•In the case of two units

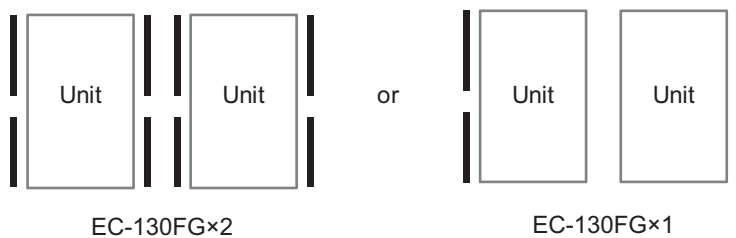

1. Product Specifications

1-5-4. Remote controller PAR-W31MAA

Refer to 6-1. PAR-W31MAA specifications.

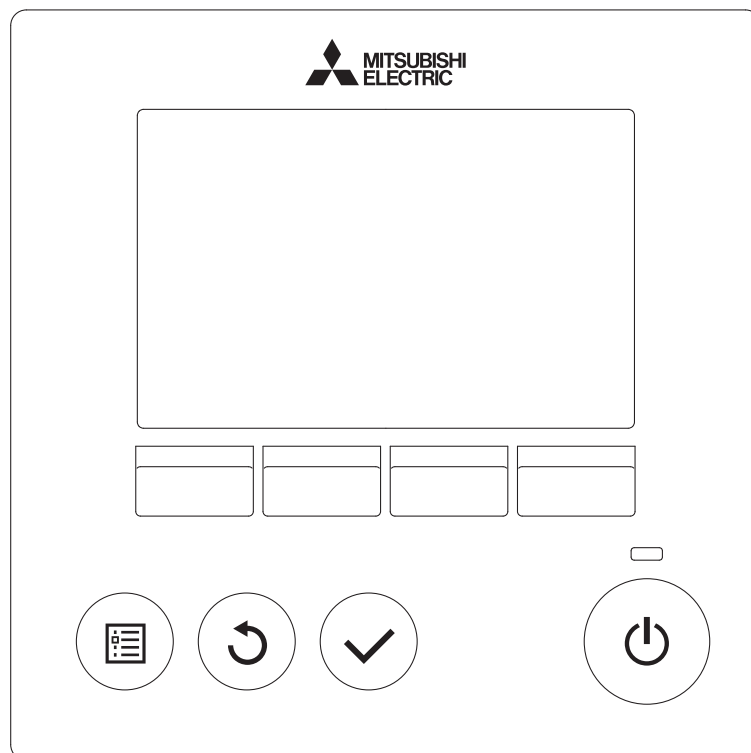

EAHV-M-YCL(-N), EACV-M-YCL(-N)

1. Product Specifications

1-5-5. External water temperature sensor TW-TH16

1. Parts that are required to install an external water temperature sensor
 - (1) External water temperature sensor
 - (2) Wiring to connect the sensor and the unit*
 - (3) Wiring terminals to connect the wiring to the sensor and the terminal block on the unit
(Four for M4 screws)*

* Items (1) and (2) are field supplied.

Wire specifications

Wire size	2-core cable Min. 1.25 mm ²
Type	CVVS or CPEVS
Maximum length	20 m

2. Installing the external water temperature sensor

- Install the external water temperature sensor where the water pipes merge or on the load-side tank as shown in the figure below.
- Install horizontally or vertically on top of the pipe.
- When installing horizontally, make sure the wire faces down.

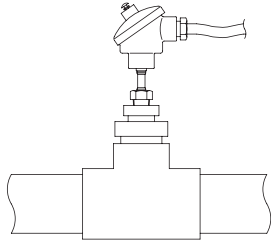

Vertical installation

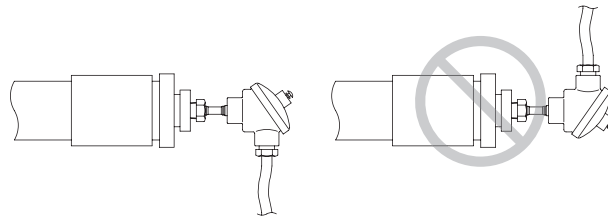

Horizontal installation

3. Wiring the external water temperature sensor

Connect the external temperature sensor wiring to the terminal block in the control box on the unit as shown in the figure below.

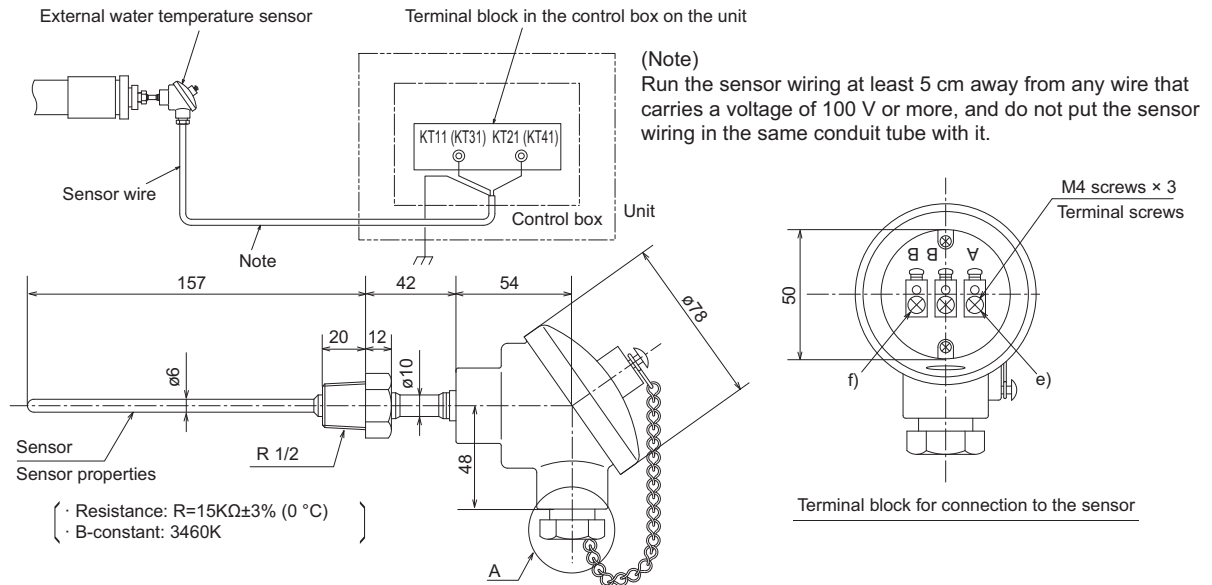

Connect the sensor wiring to terminals KT11 and KT21 (or KT31 and KT41) of the terminal block in the control box on the unit. Connect the shield to the earth terminal.

Thread the wire to the external water temperature sensor through parts b) through d) as shown in the figure at right. Attach M4 terminals (field-supplied) to the wires, and connect them to e) and f) (terminals A and B).

Cut the shield wire. Do not connect it to the terminal. (Connect the shield on the unit side to the ground terminal.)

After the wire is connected, securely tighten the tightening screw d), and then caulk the gap between the wire a) and the tightening screw to keep water from entering.

*1 In a multiple module connection system, install the temperature sensor where the cold/hot water from each module is sufficiently mixed to provide a representative temperature.

*2 The temperature sensor must be installed on a pipe between the outlet of the unit and the entrance to the load-side system.

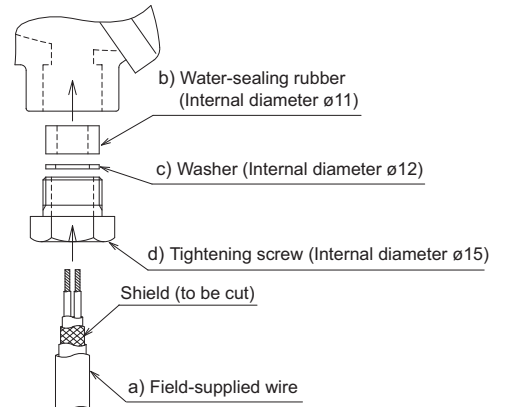

Detailed view of the area labeled "A" in the figure above

2. Product Data

2-1. Capacity tables

2-1-1. Correction by temperature

[Cold/hot water outlet/inlet temperature difference 5°C]

EAHV-M1500YCL

EACV-M1500YCL

■ Cooling Capacity [Water]

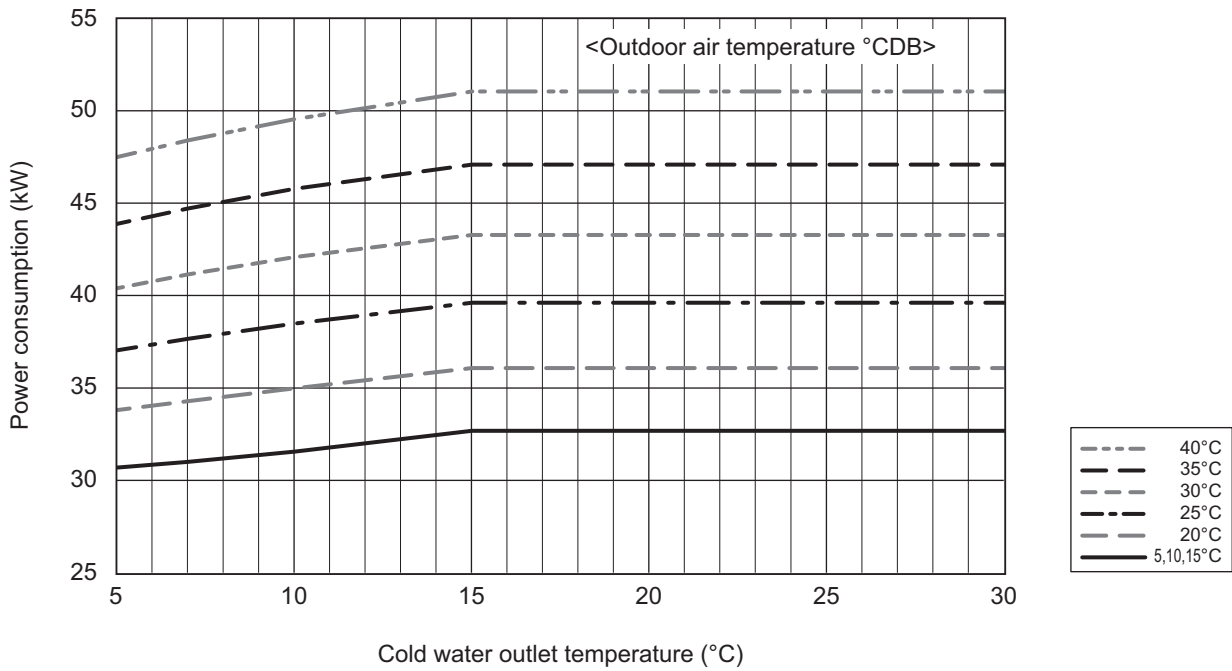
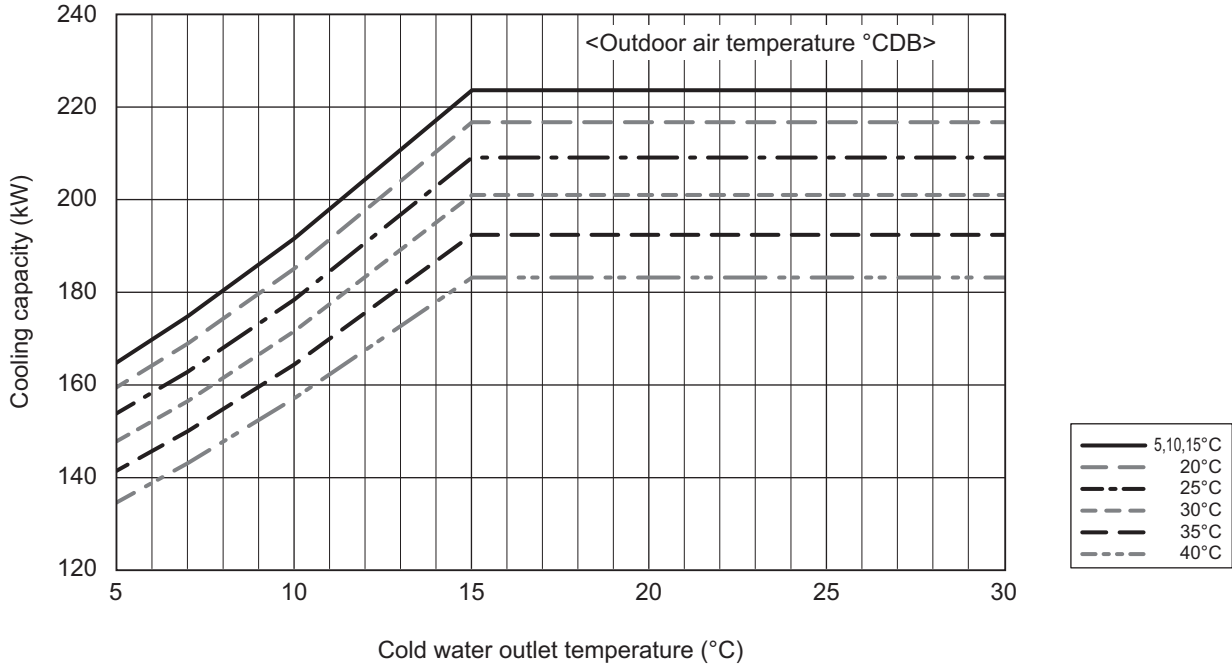

2. Product Data

[Cold/hot water outlet/inlet temperature difference 5°C]

EAHV-M1500YCL

■ Heating Capacity

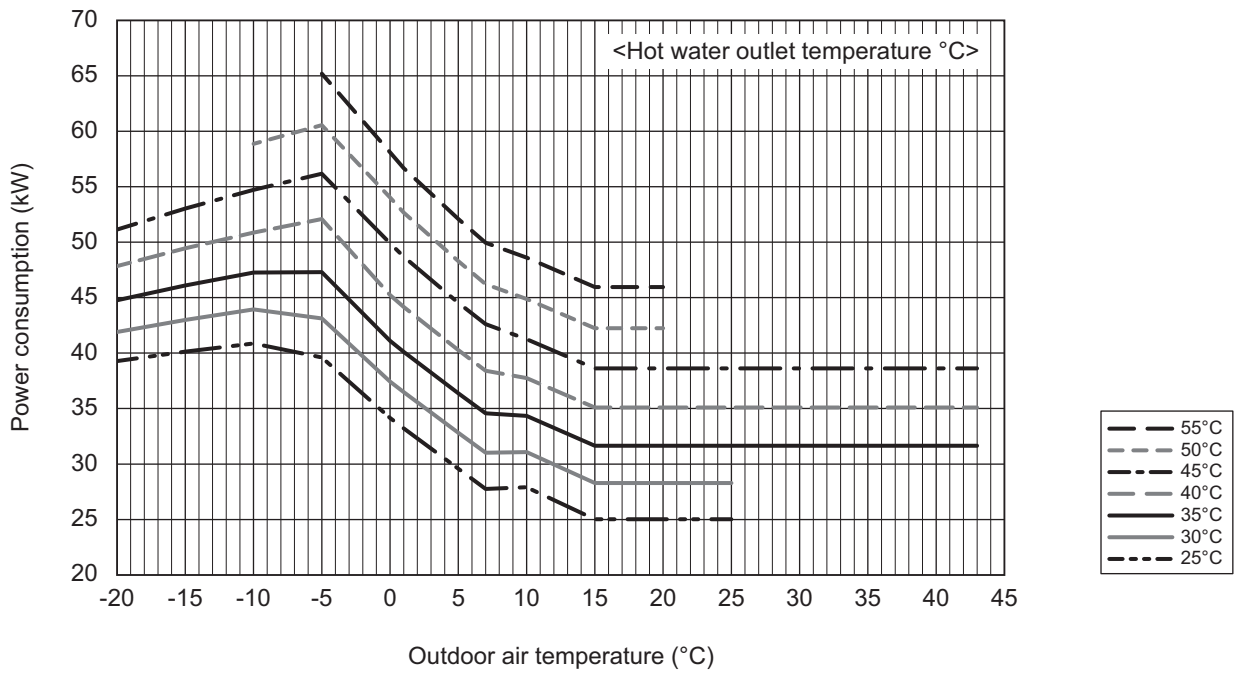
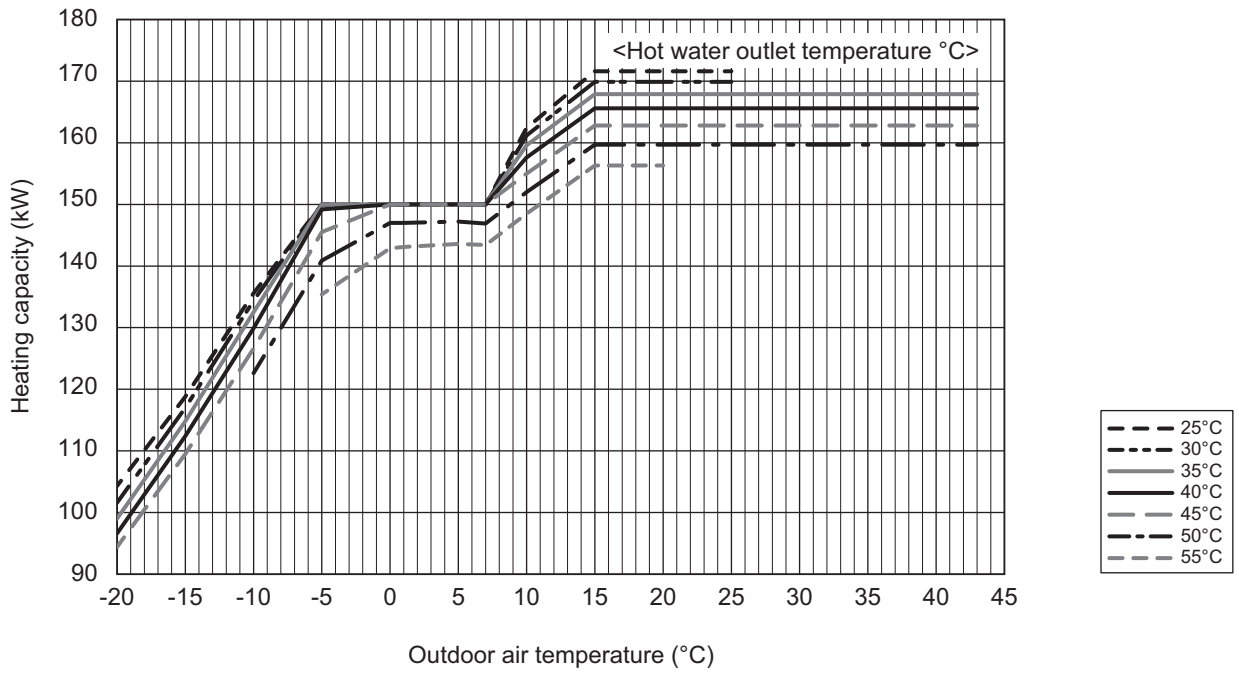

2. Product Data

[Cold/hot water outlet/inlet temperature difference 5°C]

EAHV-M1800YCL
EACV-M1800YCL

■ Cooling Capacity [Water]

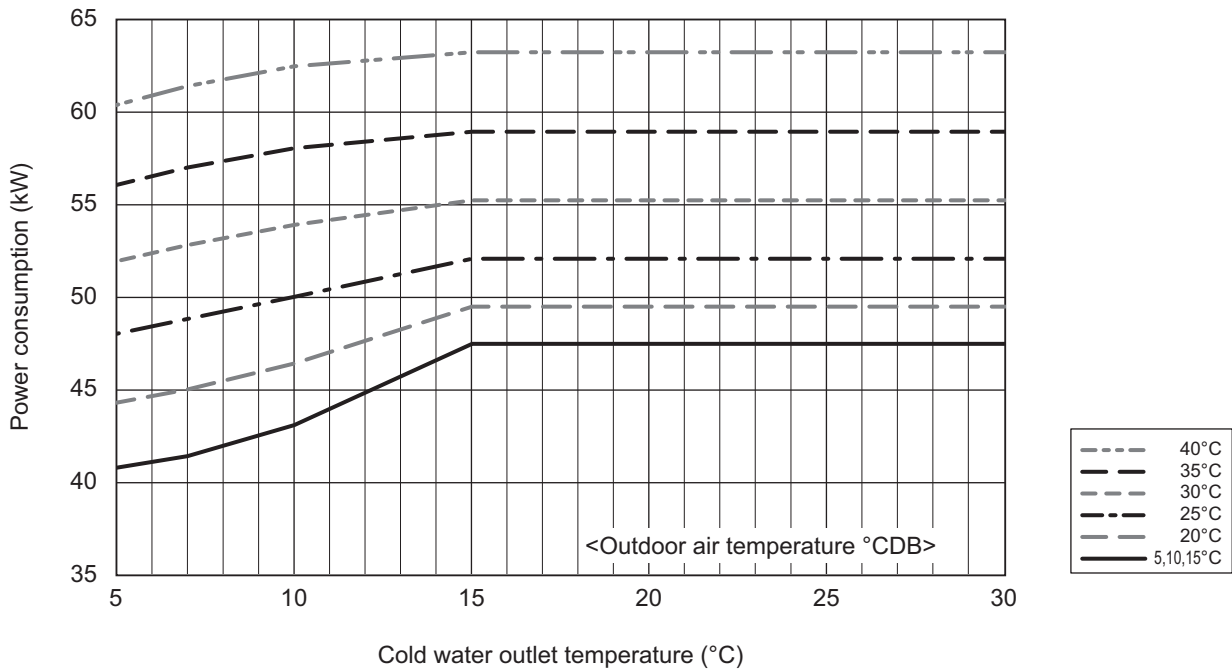
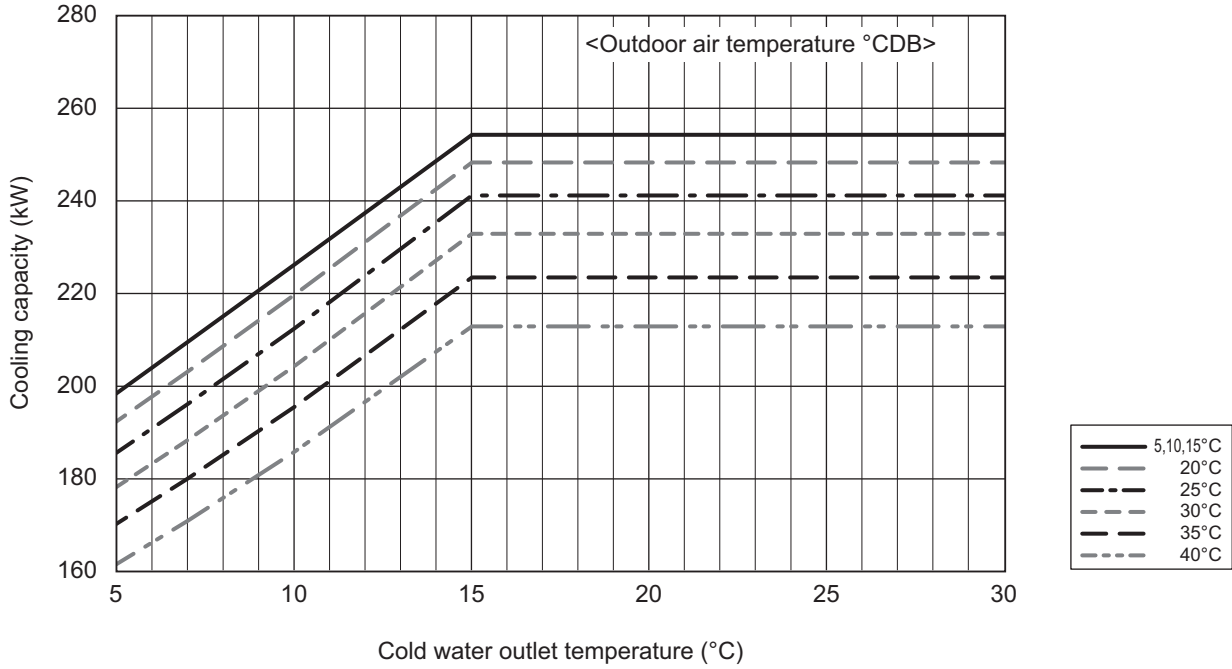

2. Product Data

[Cold/hot water outlet/inlet temperature difference 5°C]

EAHV-M1800YCL

■ Heating Capacity

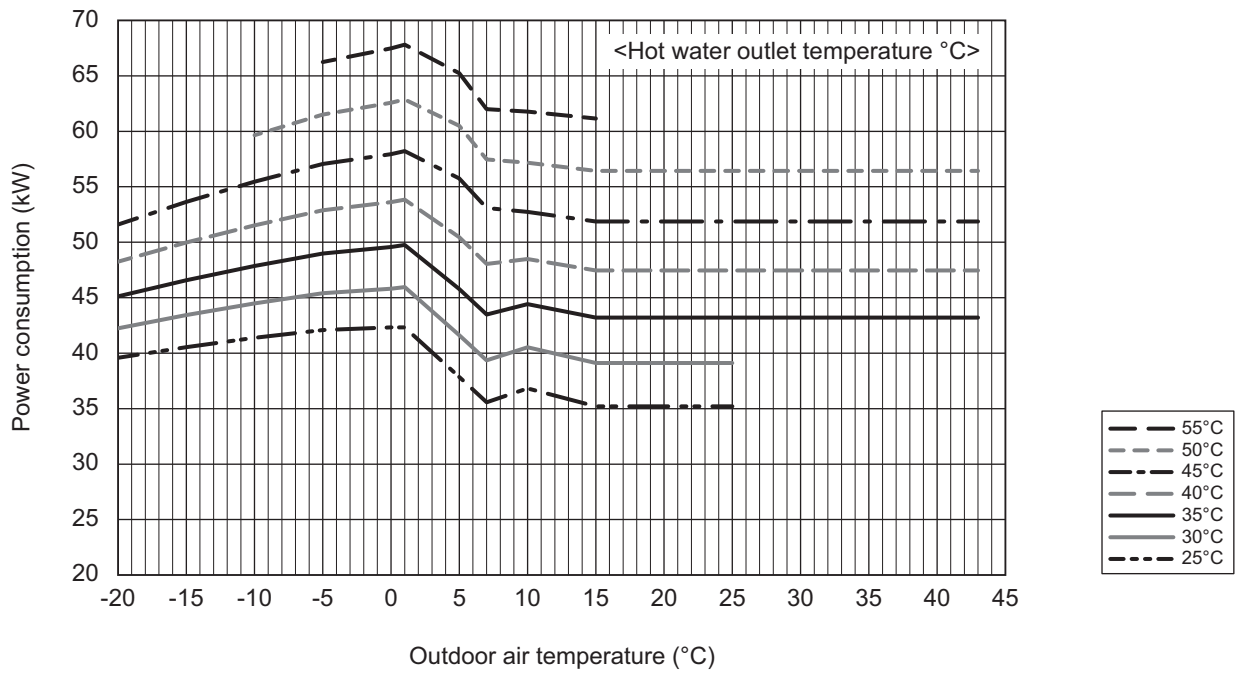
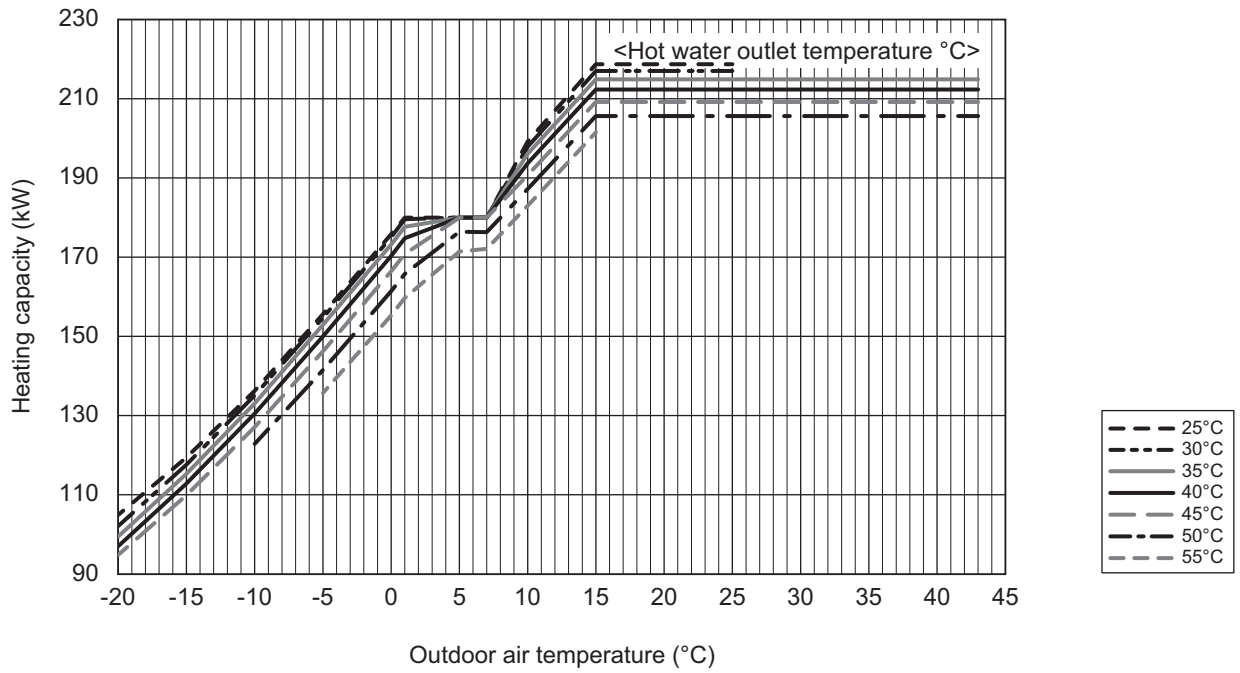

2. Product Data

[Cold/hot water outlet/inlet temperature difference 7°C]

EAHV-M1500YCL
EACV-M1500YCL

■ Cooling Capacity [Water]

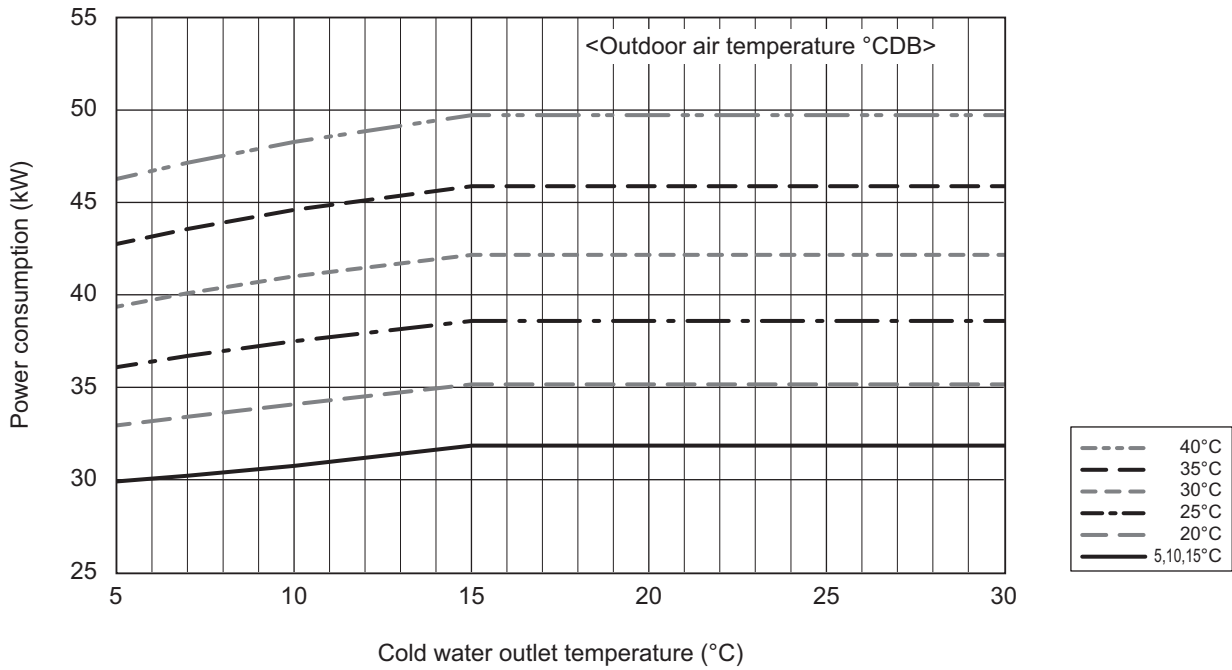
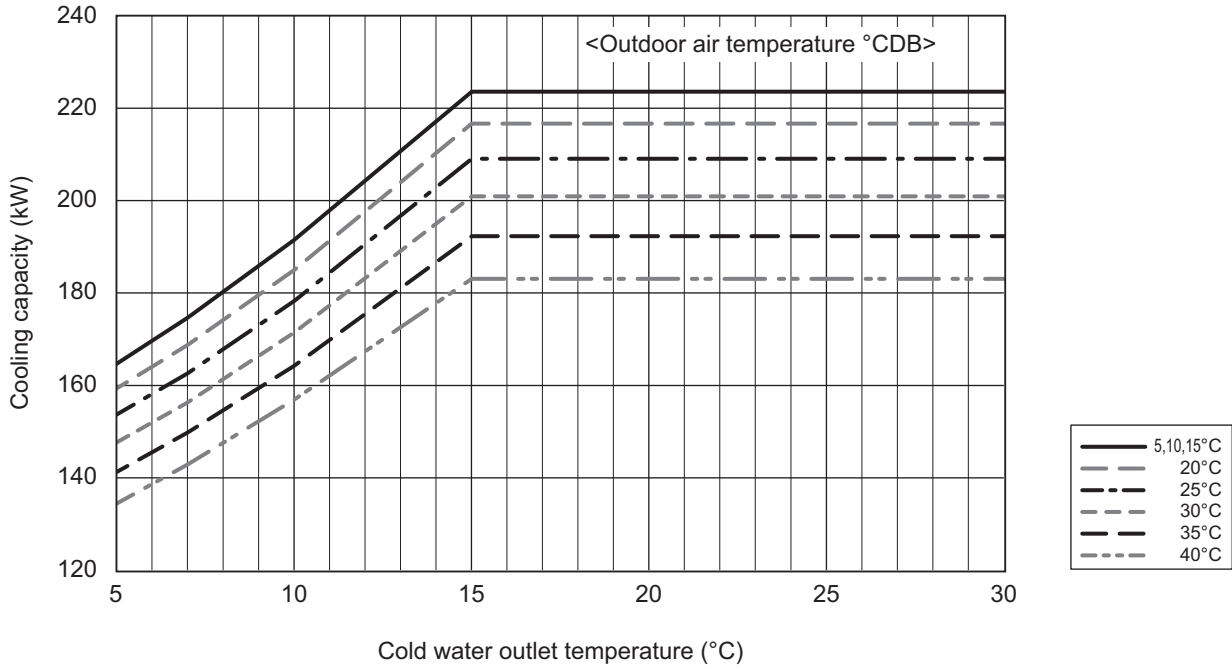

2. Product Data

[Cold/hot water outlet/inlet temperature difference 7°C]

EAHV-M1500YCL

■ Heating Capacity

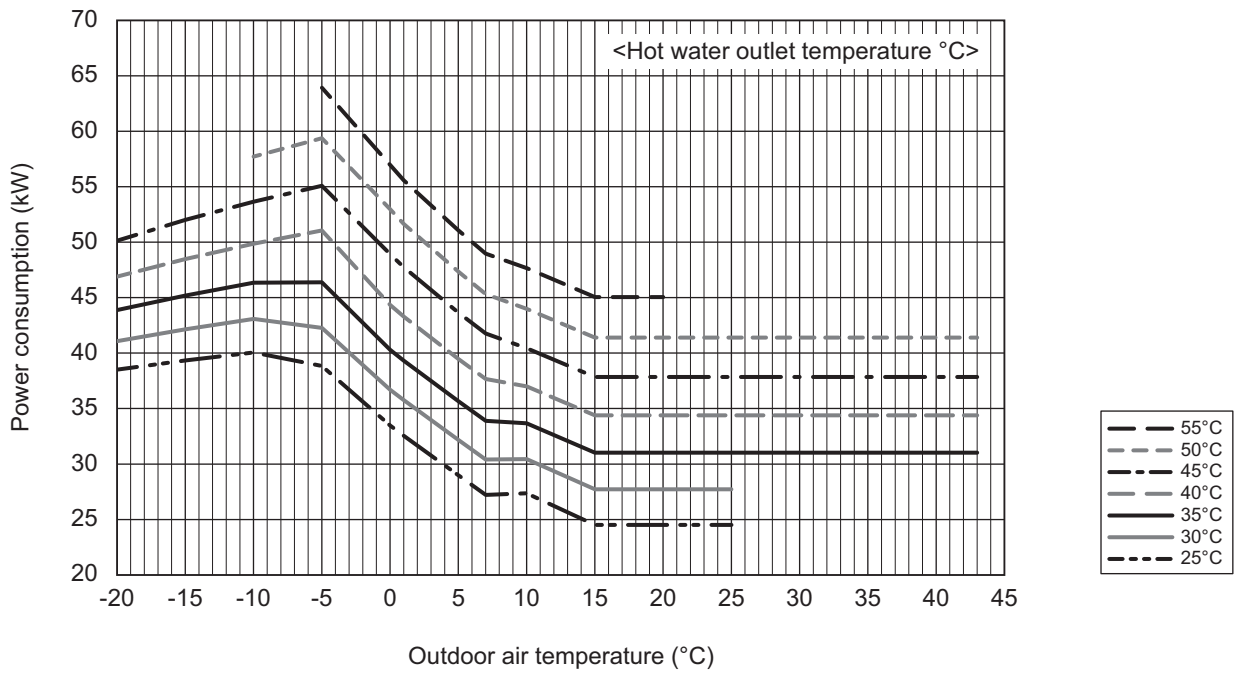
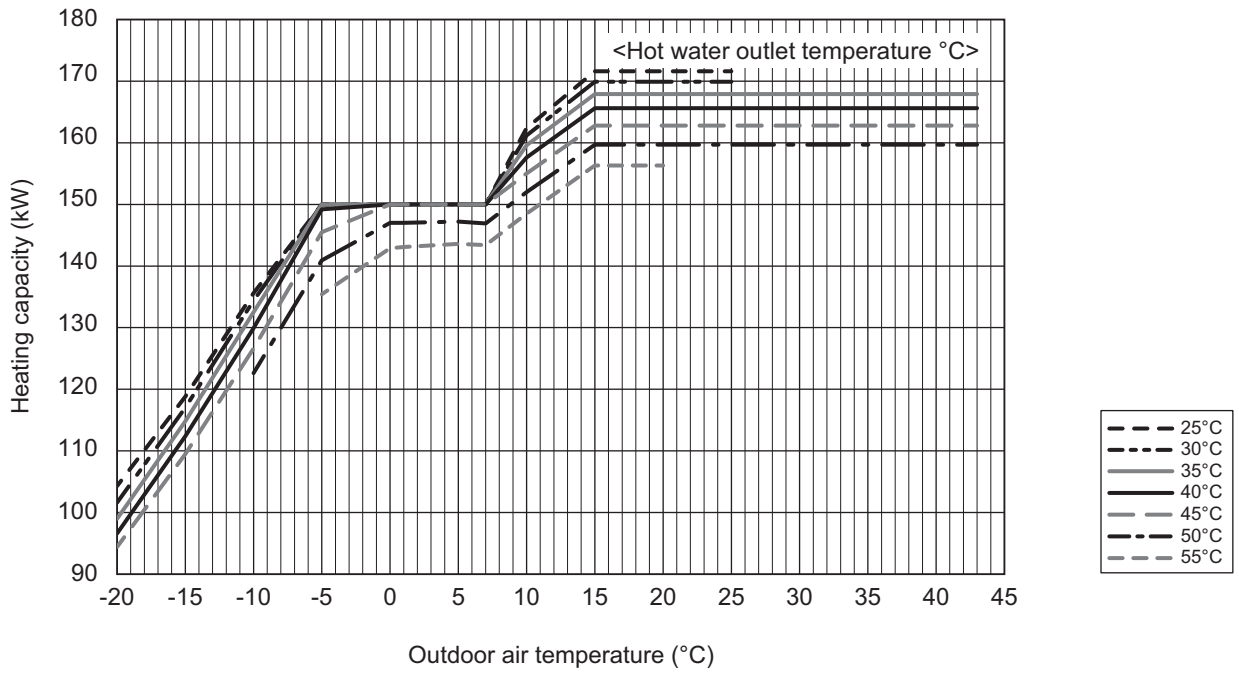

2. Product Data

[Cold/hot water outlet/inlet temperature difference 7°C]

EAHV-M1800YCL
EACV-M1800YCL

■ Cooling Capacity [Water]

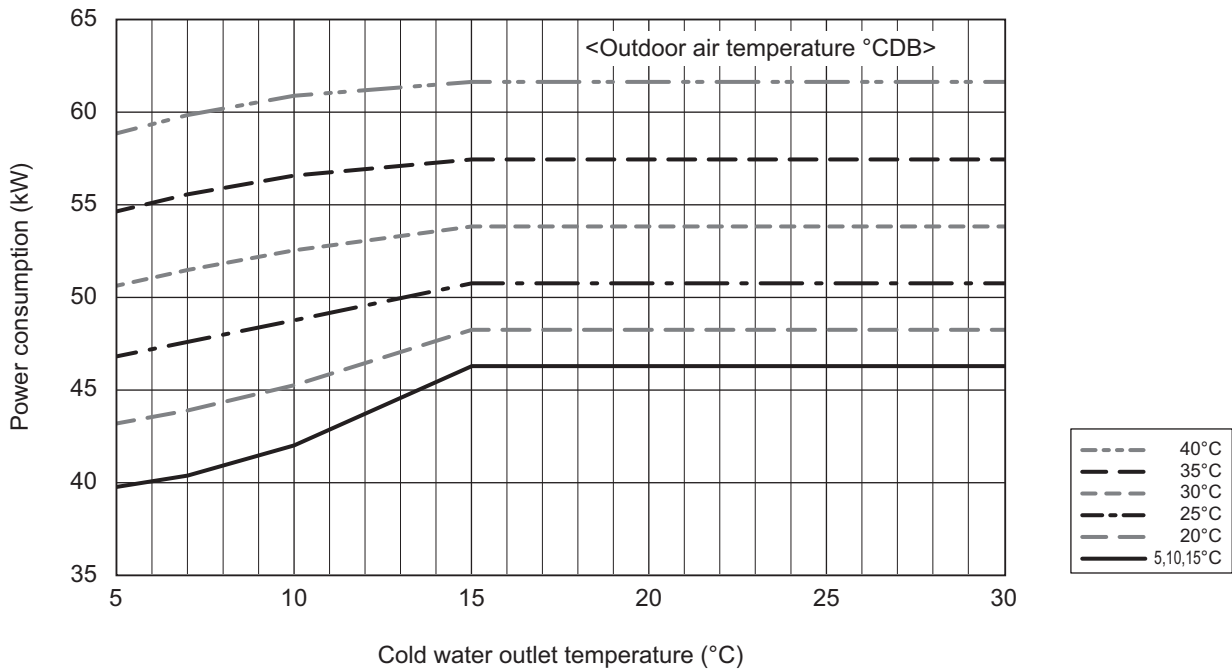
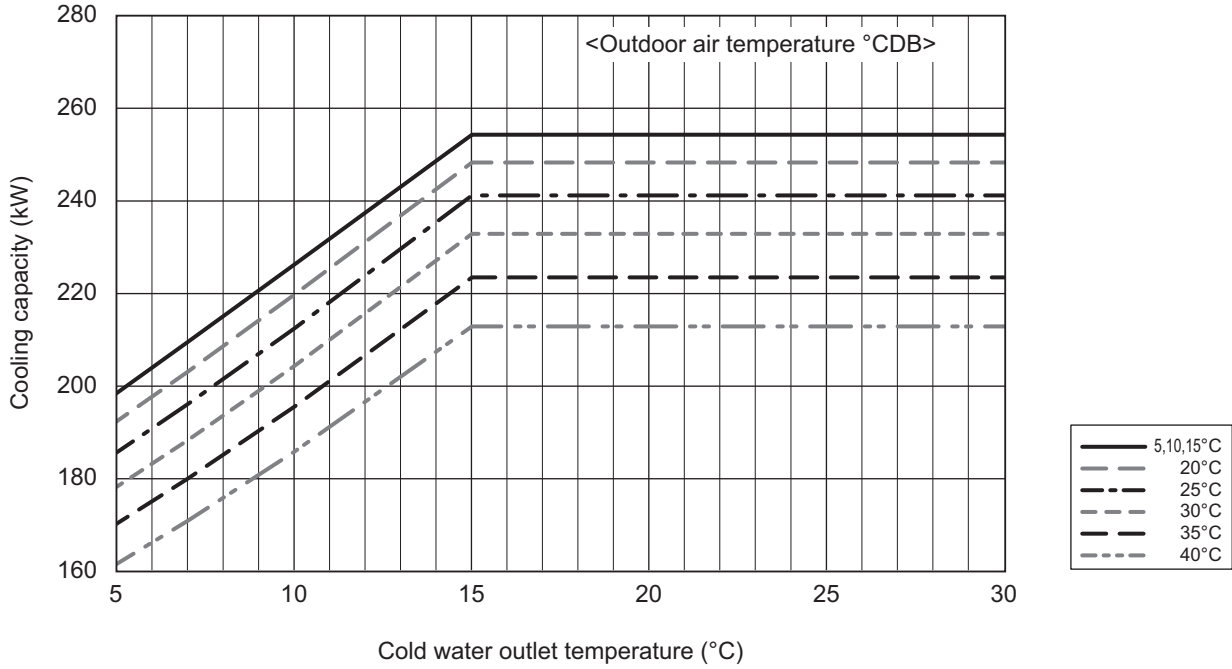

2. Product Data

[Cold/hot water outlet/inlet temperature difference 7°C]

EAHV-M1800YCL

■ Heating Capacity

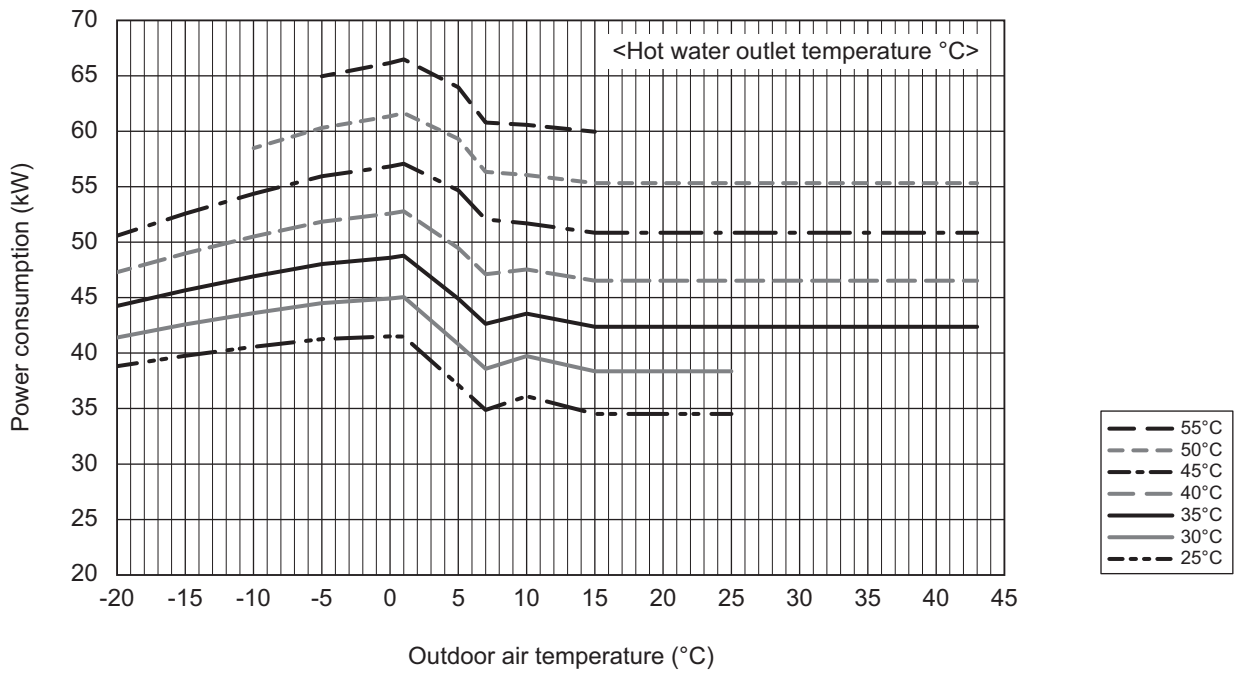
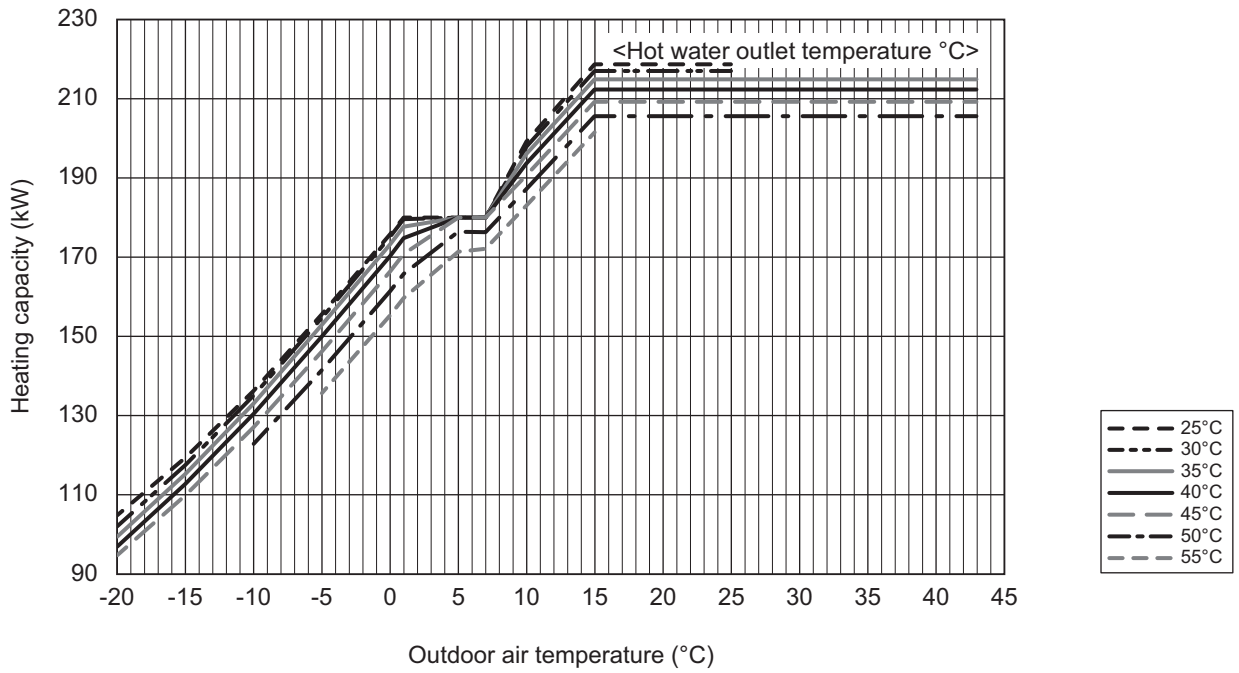

2. Product Data

[Cold/hot water outlet/inlet temperature difference 10°C]

EAHV-M1500YCL
EACV-M1500YCL

■ Cooling Capacity [Water]

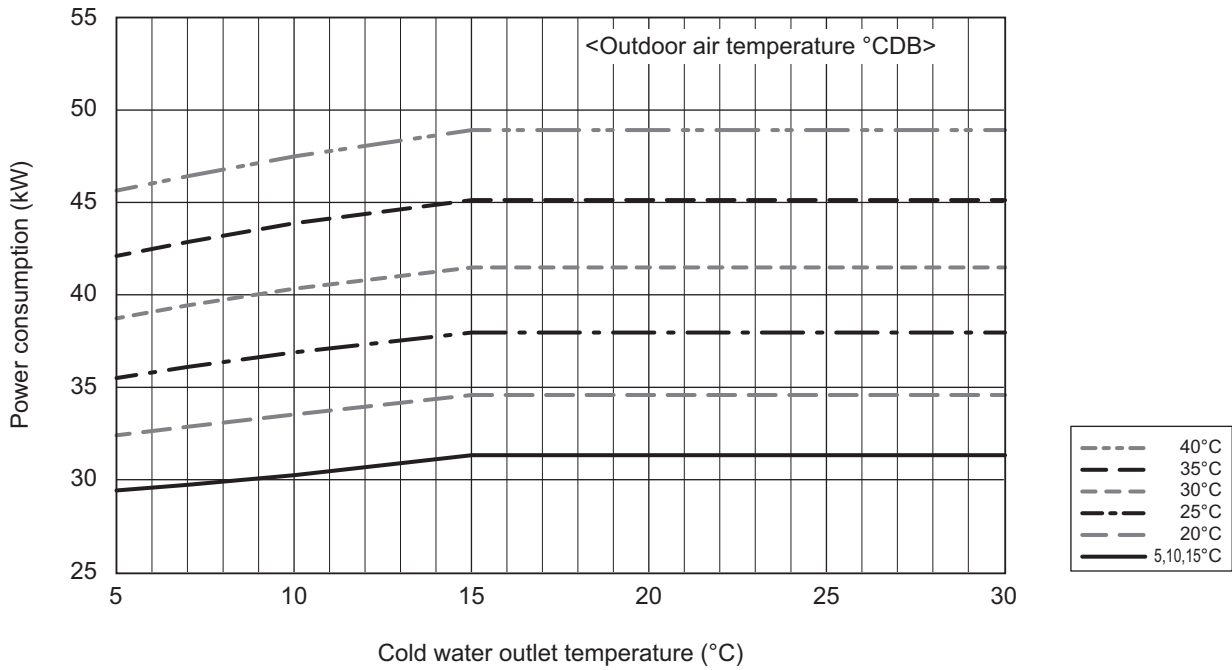
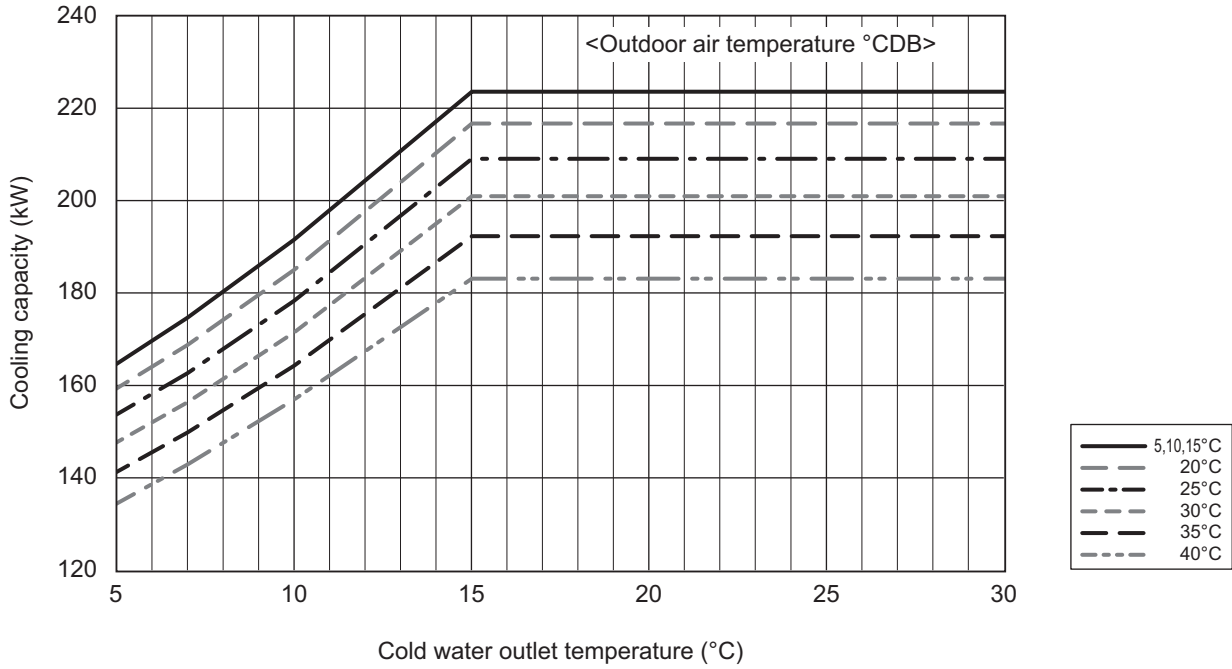

2. Product Data

[Cold/hot water outlet/inlet temperature difference 10°C]

EAHV-M1500YCL

■ Heating Capacity

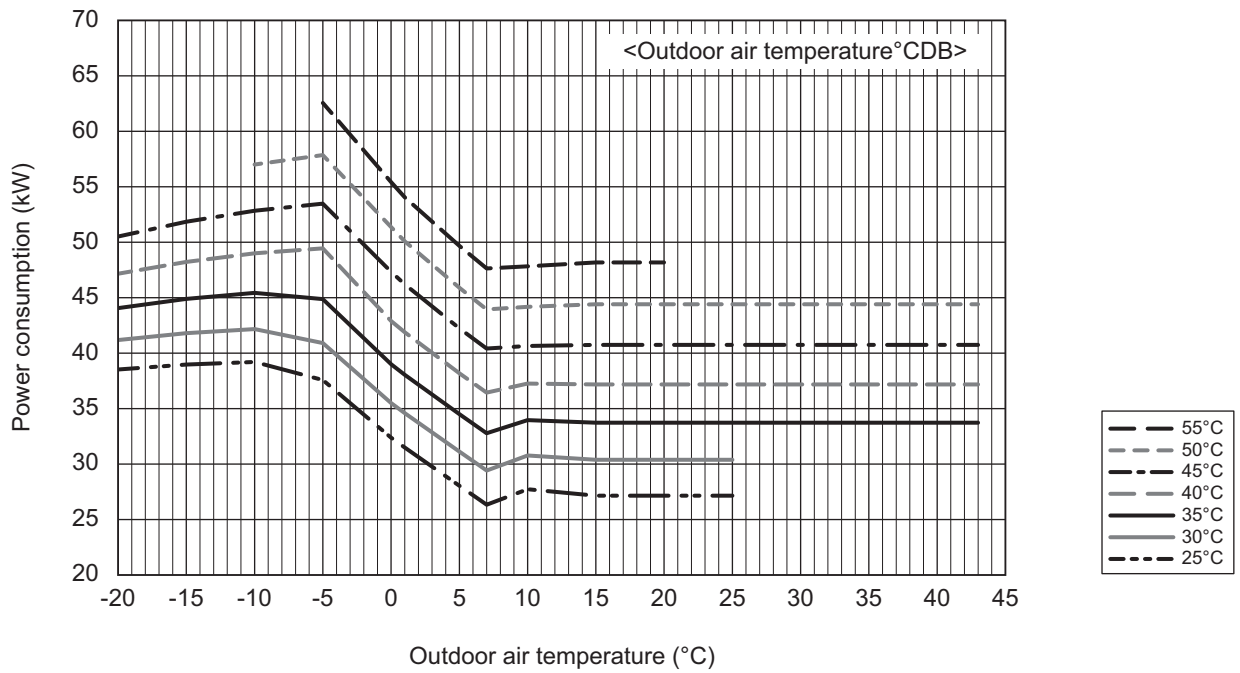
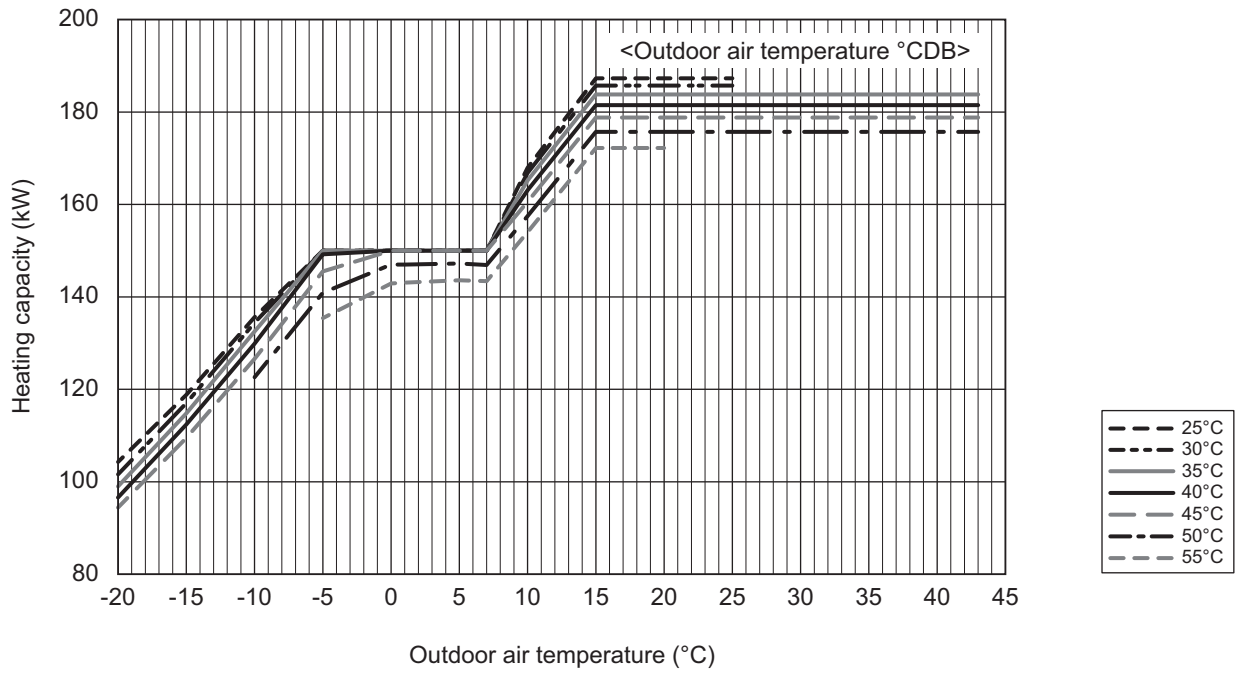

2. Product Data

[Cold/hot water outlet/inlet temperature difference 10°C]

EAHV-M1800YCL
EACV-M1800YCL

■ Cooling Capacity [Water]

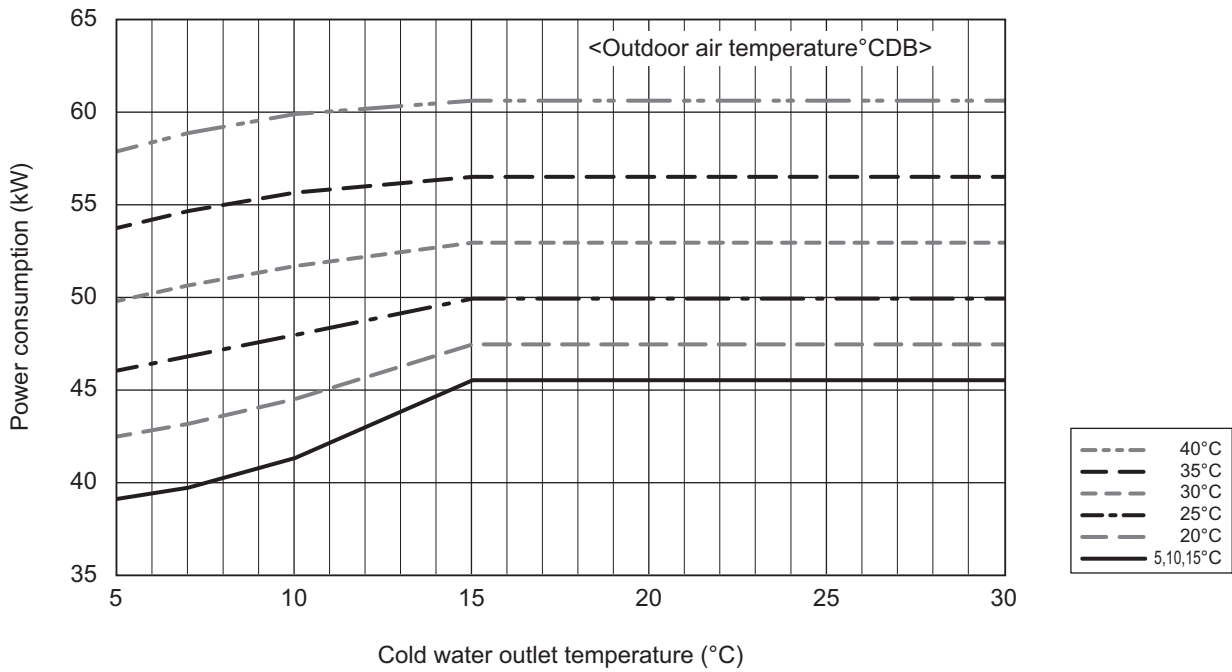
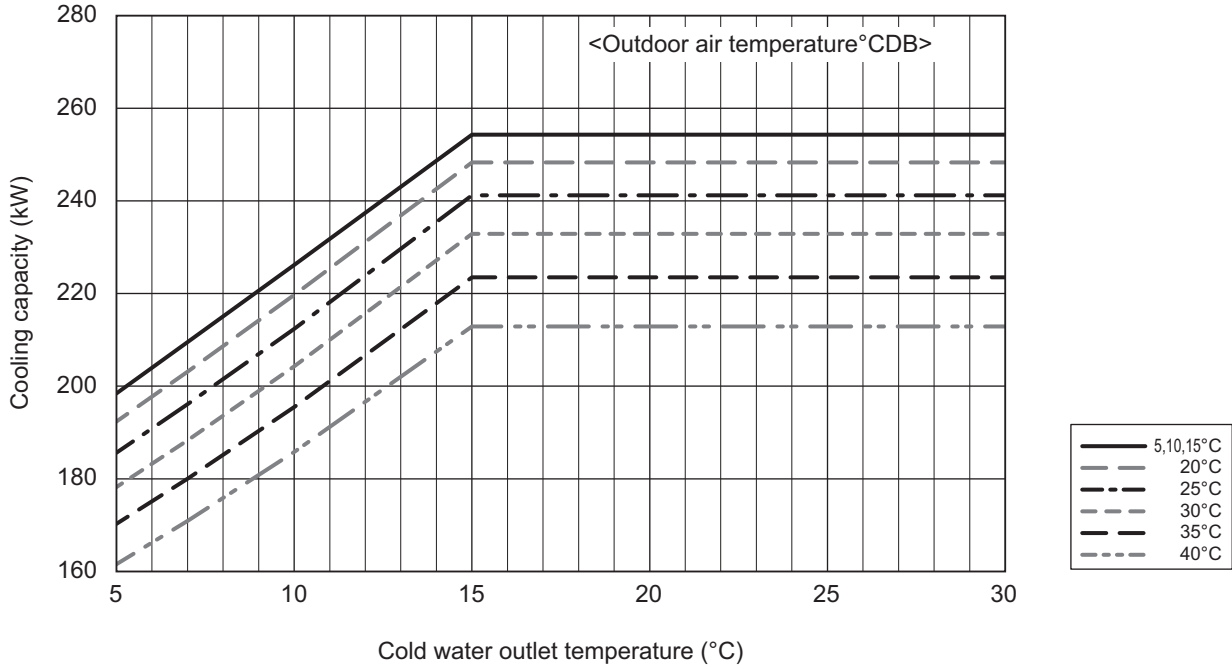

2. Product Data

[Cold/hot water outlet/inlet temperature difference 10°C]

EAHV-M1800YCL

■ Heating Capacity

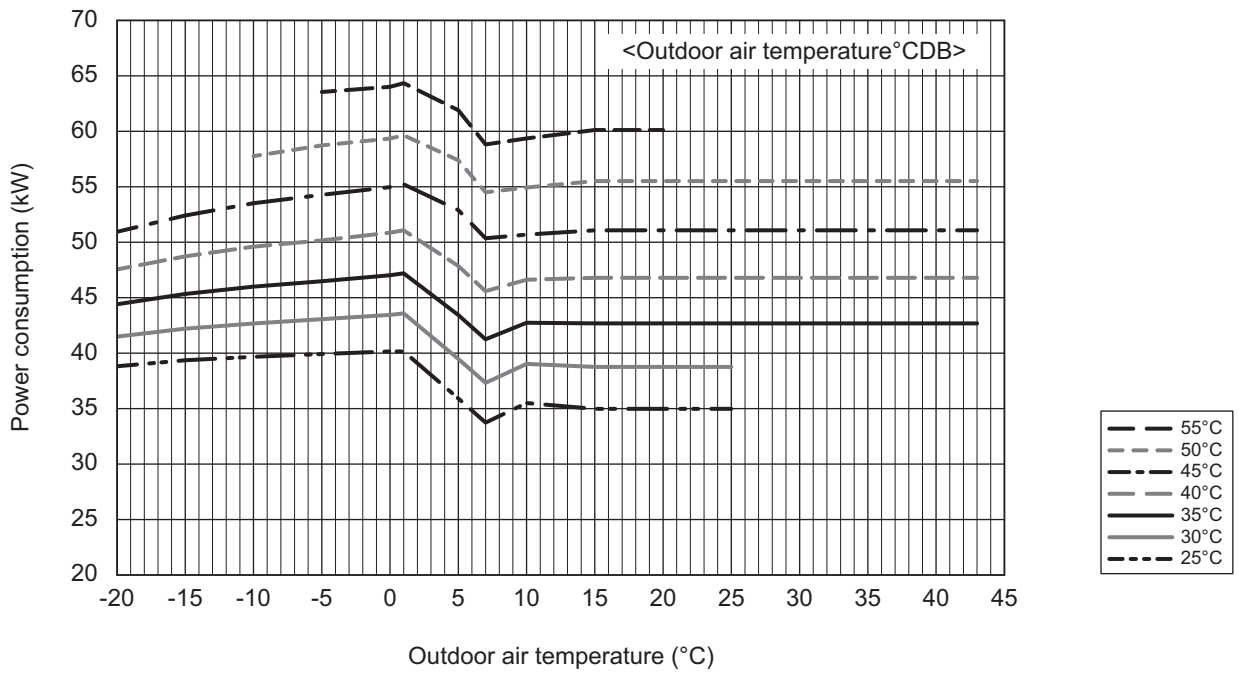
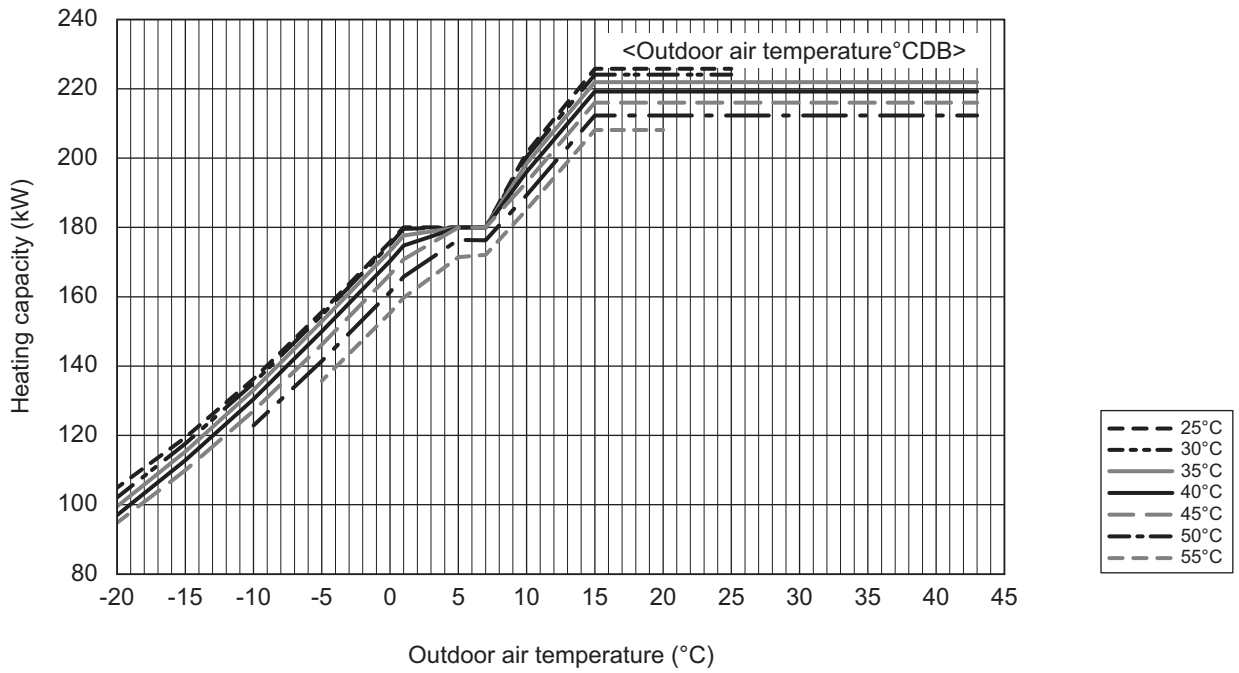

2. Product Data

Cooling capacity: Cold water outlet/inlet temperature difference 5°C

Capacity change mode: Capacity priority

MODEL			EAHV-M1500YCL, EACV-M1500YCL													
Cold water outlet temperature	Outdoor air temperature °CDB		-15	-10	-5	0	5	10	15	20	25	30	35	40	43	52
	4	Cooling capacity	kW	159.8	159.8	159.8	159.8	159.8	159.8	159.8	154.8	149.4	143.5	137.2	130.4	126.1
Power consumption		kW	30.59	30.59	30.59	30.59	30.59	30.59	30.59	33.61	36.76	40.05	43.48	47.05	49.26	22.76
Cold water flow rate		m ³ /h	27.5	27.5	27.5	27.5	27.5	27.5	27.5	26.6	25.7	24.7	23.6	22.4	21.7	12.9
Water pressure drop		Standard piping	kPa	63	63	63	63	63	63	59	56	52	47	43	41	16
		Inside header piping	kPa	151	151	151	151	151	151	143	133	124	114	104	97	38
7	Cooling capacity	kW	174.8	174.8	174.8	174.8	174.8	174.8	174.8	168.9	162.8	156.5	150.0	143.1	139.0	49.6
	Power consumption	kW	31.06	31.06	31.06	31.06	31.06	31.06	31.06	34.33	37.70	41.17	44.73	48.40	50.64	22.80
	Cold water flow rate	m ³ /h	30.1	30.1	30.1	30.1	30.1	30.1	30.1	29.1	28.0	26.9	25.8	24.6	23.9	12.9
	Water pressure drop	Standard piping	kPa	74	74	74	74	74	74	70	65	60	56	51	49	16
		Inside header piping	kPa	179	179	179	179	179	179	168	157	146	134	123	117	38
10	Cooling capacity	kW	191.6	191.6	191.6	191.6	191.6	191.6	191.6	185.1	178.4	171.6	164.4	157.1	151.5	54.3
	Power consumption	kW	31.61	31.61	31.61	31.61	31.61	31.61	31.61	35.02	38.52	42.11	45.79	49.55	51.24	22.80
	Cold water flow rate	m ³ /h	33.0	33.0	33.0	33.0	33.0	33.0	33.0	31.8	30.7	29.5	28.3	27.0	26.1	12.9
	Water pressure drop	Standard piping	kPa	88	88	88	88	88	88	83	77	72	66	61	57	16
		Inside header piping	kPa	213	213	213	213	213	213	200	186	173	160	147	137	38
15	Cooling capacity	kW	223.6	223.6	223.6	223.6	223.6	223.6	223.6	216.7	209.1	201.0	192.4	183.2	171.8	62.9
	Power consumption	kW	32.73	32.73	32.73	32.73	32.73	32.73	32.73	36.12	39.64	43.30	47.10	51.04	50.92	22.73
	Cold water flow rate	m ³ /h	38.5	38.5	38.5	38.5	38.5	38.5	38.5	37.3	36.0	34.6	33.1	31.5	29.5	12.9
	Water pressure drop	Standard piping	kPa	118	118	118	118	118	118	111	104	97	89	81	72	16
		Inside header piping	kPa	286	286	286	286	286	286	269	252	233	215	196	173	38
20	Cooling capacity	kW	-	223.6	223.6	223.6	223.6	223.6	223.6	216.7	209.1	201.0	192.4	183.2	171.8	62.9
	Power consumption	kW	-	32.73	32.73	32.73	32.73	32.73	32.73	36.12	39.64	43.30	47.10	51.04	50.92	22.73
	Cold water flow rate	m ³ /h	-	38.5	38.5	38.5	38.5	38.5	38.5	37.3	36.0	34.6	33.1	31.5	29.5	12.9
	Water pressure drop	Standard piping	kPa	-	118	118	118	118	118	111	104	97	89	81	72	16
		Inside header piping	kPa	-	286	286	286	286	286	269	252	233	215	196	173	38
25	Cooling capacity	kW	-	223.6	223.6	223.6	223.6	223.6	223.6	216.7	209.1	201.0	192.4	183.2	171.8	-
	Power consumption	kW	-	32.73	32.73	32.73	32.73	32.73	32.73	36.12	39.64	43.30	47.10	51.04	50.92	-
	Cold water flow rate	m ³ /h	-	38.5	38.5	38.5	38.5	38.5	38.5	37.3	36.0	34.6	33.1	31.5	29.5	-
	Water pressure drop	Standard piping	kPa	-	118	118	118	118	118	111	104	97	89	81	72	-
		Inside header piping	kPa	-	286	286	286	286	286	269	252	233	215	196	173	-
30	Cooling capacity	kW	-	223.6	223.6	223.6	223.6	223.6	223.6	216.7	209.1	201.0	192.4	183.2	-	-
	Power consumption	kW	-	32.73	32.73	32.73	32.73	32.73	32.73	36.12	39.64	43.30	47.10	51.04	-	-
	Cold water flow rate	m ³ /h	-	38.5	38.5	38.5	38.5	38.5	38.5	37.3	36.0	34.6	33.1	31.5	-	-
	Water pressure drop	Standard piping	kPa	-	118	118	118	118	118	111	104	97	89	81	-	-
		Inside header piping	kPa	-	286	286	286	286	286	269	252	233	215	196	-	-

* Pump doesn't include.

* Hatching area shows outlet/inlet temperature difference under 5°C.

2. Product Data

Cooling capacity: Cold water outlet/inlet temperature difference 5°C

Capacity change mode: Capacity priority

MODEL			EAHV-M1800YCL, EACV-M1800YCL														
Cold water outlet temperature	Outdoor air temperature °CDB		-15	-10	-5	0	5	10	15	20	25	30	35	40	43	52	
	4	Cooling capacity		kW	192.9	192.9	192.9	192.9	192.9	192.9	192.9	187.0	180.4	173.2	165.4	156.9	151.5
Power consumption		kW	40.50	40.50	40.50	40.50	40.50	40.50	40.50	43.97	47.64	51.52	55.60	59.88	62.55	25.36	
Cold water flow rate		m ³ /h	33.2	33.2	33.2	33.2	33.2	33.2	33.2	32.2	31.0	29.8	28.4	27.0	26.1	12.9	
Water pressure drop		Standard piping	kPa	89	89	89	89	89	89	89	84	79	73	67	61	57	16
		Inside header piping	kPa	216	216	216	216	216	216	216	204	190	176	161	146	137	38
7	Cooling capacity		kW	209.5	209.5	209.5	209.5	209.5	209.5	209.5	203.1	196.1	188.3	180.0	170.9	165.1	53.5
	Power consumption		kW	41.44	41.44	41.44	41.44	41.44	41.44	41.44	45.04	48.84	52.83	57.02	61.41	64.14	25.42
	Cold water flow rate		m ³ /h	36.0	36.0	36.0	36.0	36.0	36.0	36.0	34.9	33.7	32.4	31.0	29.4	28.4	12.9
	Water pressure drop	Standard piping	kPa	104	104	104	104	104	104	104	99	92	85	79	71	67	16
		Inside header piping	kPa	252	252	252	252	252	252	252	238	223	206	189	172	161	38
10	Cooling capacity		kW	226.2	226.2	226.2	226.2	226.2	226.2	226.2	219.7	212.4	204.3	195.5	185.8	170.4	58.7
	Power consumption		kW	43.11	43.11	43.11	43.11	43.11	43.11	43.11	46.44	50.04	53.92	58.06	62.48	59.62	25.42
	Cold water flow rate		m ³ /h	38.9	38.9	38.9	38.9	38.9	38.9	38.9	37.8	36.5	35.1	33.6	32.0	29.3	12.9
	Water pressure drop	Standard piping	kPa	121	121	121	121	121	121	121	114	107	100	92	83	71	16
		Inside header piping	kPa	292	292	292	292	292	292	292	276	259	241	221	201	171	38
15	Cooling capacity		kW	254.3	254.3	254.3	254.3	254.3	254.3	254.3	248.3	241.2	232.9	223.5	212.9	177.8	70.1
	Power consumption		kW	47.50	47.50	47.50	47.50	47.50	47.50	47.50	49.51	52.09	55.24	58.95	63.24	52.06	25.30
	Cold water flow rate		m ³ /h	43.7	43.7	43.7	43.7	43.7	43.7	43.7	42.7	41.5	40.1	38.4	36.6	30.6	12.9
	Water pressure drop	Standard piping	kPa	151	151	151	151	151	151	151	144	137	128	118	108	77	16
		Inside header piping	kPa	366	366	366	366	366	366	366	349	330	309	286	260	185	38
20	Cooling capacity		kW	-	254.3	254.3	254.3	254.3	254.3	254.3	248.3	241.2	232.9	223.5	212.9	177.8	70.1
	Power consumption		kW	-	47.50	47.50	47.50	47.50	47.50	47.50	49.51	52.09	55.24	58.95	63.24	52.06	25.30
	Cold water flow rate		m ³ /h	-	43.7	43.7	43.7	43.7	43.7	43.7	42.7	41.5	40.1	38.4	36.6	30.6	12.9
	Water pressure drop	Standard piping	kPa	-	151	151	151	151	151	151	144	137	128	118	108	77	16
		Inside header piping	kPa	-	366	366	366	366	366	366	349	330	309	286	260	185	38
25	Cooling capacity		kW	-	254.3	254.3	254.3	254.3	254.3	254.3	248.3	241.2	232.9	223.5	212.9	177.8	-
	Power consumption		kW	-	47.50	47.50	47.50	47.50	47.50	47.50	49.51	52.09	55.24	58.95	63.24	52.06	-
	Cold water flow rate		m ³ /h	-	43.7	43.7	43.7	43.7	43.7	43.7	42.7	41.5	40.1	38.4	36.6	30.6	-
	Water pressure drop	Standard piping	kPa	-	151	151	151	151	151	151	144	137	128	118	108	77	-
		Inside header piping	kPa	-	366	366	366	366	366	366	349	330	309	286	260	185	-
30	Cooling capacity		kW	-	254.3	254.3	254.3	254.3	254.3	254.3	248.3	241.2	232.9	223.5	212.9	-	-
	Power consumption		kW	-	47.50	47.50	47.50	47.50	47.50	47.50	49.51	52.09	55.24	58.95	63.24	-	-
	Cold water flow rate		m ³ /h	-	43.7	43.7	43.7	43.7	43.7	43.7	42.7	41.5	40.1	38.4	36.6	-	-
	Water pressure drop	Standard piping	kPa	-	151	151	151	151	151	151	144	137	128	118	108	-	-
		Inside header piping	kPa	-	366	366	366	366	366	366	349	330	309	286	260	-	-

* Pump doesn't include.

* Hatching area shows outlet/inlet temperature difference under 5°C.

2. Product Data

Cooling capacity: Cold water outlet/inlet temperature difference 7°C

Capacity change mode: Capacity priority

MODEL			EAHV-M1500YCL, EACV-M1500YCL														
Cold water outlet temperature	Outdoor air temperature °CDB		-15	-10	-5	0	5	10	15	20	25	30	35	40	43	52	
	4	Cooling capacity	kW	159.8	159.8	159.8	159.8	159.8	159.8	159.8	154.8	149.4	143.5	137.2	130.4	126.1	45.3
Power consumption		kW	29.81	29.81	29.81	29.81	29.81	29.81	29.81	32.75	35.82	39.03	42.37	45.85	48.00	22.76	
Cold water flow rate		m ³ /h	19.6	19.6	19.6	19.6	19.6	19.6	19.6	19.0	18.4	17.6	16.9	16.0	15.5	12.9	
Water pressure drop		Standard piping	kPa	34	34	34	34	34	34	34	32	30	28	26	24	22	16
		Inside header piping	kPa	81	81	81	81	81	81	81	77	72	67	61	56	53	38
7	Cooling capacity	kW	174.8	174.8	174.8	174.8	174.8	174.8	174.8	168.9	162.8	156.5	150.0	143.1	139.0	49.6	
	Power consumption	kW	30.27	30.27	30.27	30.27	30.27	30.27	30.27	33.45	36.74	40.12	43.59	47.16	49.35	22.80	
	Cold water flow rate	m ³ /h	21.5	21.5	21.5	21.5	21.5	21.5	21.5	20.8	20.0	19.2	18.4	17.6	17.1	12.9	
	Water pressure drop	Standard piping	kPa	40	40	40	40	40	40	40	38	35	33	30	28	26	16
		Inside header piping	kPa	96	96	96	96	96	96	96	90	84	78	72	66	63	38
10	Cooling capacity	kW	191.6	191.6	191.6	191.6	191.6	191.6	191.6	185.1	178.4	171.6	164.4	157.1	151.5	54.3	
	Power consumption	kW	30.80	30.80	30.80	30.80	30.80	30.80	30.80	34.13	37.54	41.03	44.62	48.28	49.93	22.80	
	Cold water flow rate	m ³ /h	23.5	23.5	23.5	23.5	23.5	23.5	23.5	22.7	21.9	21.1	20.2	19.3	18.6	12.9	
	Water pressure drop	Standard piping	kPa	47	47	47	47	47	47	47	44	41	39	36	33	31	16
		Inside header piping	kPa	113	113	113	113	113	113	113	106	99	92	85	79	74	38
15	Cooling capacity	kW	223.6	223.6	223.6	223.6	223.6	223.6	223.6	216.7	209.1	201.0	192.4	183.2	171.8	62.9	
	Power consumption	kW	31.89	31.89	31.89	31.89	31.89	31.89	31.89	35.20	38.63	42.19	45.90	49.74	49.62	22.73	
	Cold water flow rate	m ³ /h	27.5	27.5	27.5	27.5	27.5	27.5	27.5	26.6	25.7	24.7	23.6	22.5	21.1	12.9	
	Water pressure drop	Standard piping	kPa	63	63	63	63	63	63	63	59	55	52	48	44	39	16
		Inside header piping	kPa	151	151	151	151	151	151	151	143	133	124	114	104	93	38
20	Cooling capacity	kW	-	223.6	223.6	223.6	223.6	223.6	223.6	216.7	209.1	201.0	192.4	183.2	171.8	62.9	
	Power consumption	kW	-	31.89	31.89	31.89	31.89	31.89	31.89	35.20	38.63	42.19	45.90	49.74	49.62	-	
	Cold water flow rate	m ³ /h	-	27.5	27.5	27.5	27.5	27.5	27.5	26.6	25.7	24.7	23.6	22.5	21.1	12.9	
	Water pressure drop	Standard piping	kPa	-	63	63	63	63	63	63	59	55	52	48	44	39	16
		Inside header piping	kPa	-	151	151	151	151	151	151	143	133	124	114	104	93	38
25	Cooling capacity	kW	-	223.6	223.6	223.6	223.6	223.6	223.6	216.7	209.1	201.0	192.4	183.2	171.8	-	
	Power consumption	kW	-	31.89	31.89	31.89	31.89	31.89	31.89	35.20	38.63	42.19	45.90	49.74	49.62	-	
	Cold water flow rate	m ³ /h	-	27.5	27.5	27.5	27.5	27.5	27.5	26.6	25.7	24.7	23.6	22.5	21.1	-	
	Water pressure drop	Standard piping	kPa	-	63	63	63	63	63	63	59	55	52	48	44	39	-
		Inside header piping	kPa	-	151	151	151	151	151	151	143	133	124	114	104	93	-
30	Cooling capacity	kW	-	223.6	223.6	223.6	223.6	223.6	223.6	216.7	209.1	201.0	192.4	183.2	-	-	
	Power consumption	kW	-	31.89	31.89	31.89	31.89	31.89	31.89	35.20	38.63	42.19	45.90	49.74	-	-	
	Cold water flow rate	m ³ /h	-	27.5	27.5	27.5	27.5	27.5	27.5	26.6	25.7	24.7	23.6	22.5	-	-	
	Water pressure drop	Standard piping	kPa	-	63	63	63	63	63	63	59	55	52	48	44	-	-
		Inside header piping	kPa	-	151	151	151	151	151	151	143	133	124	114	104	-	-

* Pump doesn't include.

* Hatching area shows outlet/inlet temperature difference under 7°C.

2. Product Data

Cooling capacity: Cold water outlet/inlet temperature difference 7°C

Capacity change mode: Capacity priority

MODEL			EAHV-M1800YCL, EACV-M1800YCL													
Cold water outlet temperature	Outdoor air temperature °CDB		-15	-10	-5	0	5	10	15	20	25	30	35	40	43	52
	4	Cooling capacity	kW	192.9	192.9	192.9	192.9	192.9	192.9	192.9	187.0	180.4	173.2	165.4	156.9	151.5
Power consumption		kW	39.47	39.47	39.47	39.47	39.47	39.47	39.47	42.85	46.42	50.20	54.18	58.35	60.95	25.36
Cold water flow rate		m ³ /h	23.7	23.7	23.7	23.7	23.7	23.7	23.7	23.0	22.2	21.3	20.3	19.3	18.6	12.9
Water pressure drop		Standard piping	kPa	48	48	48	48	48	48	45	42	39	36	33	31	16
		Inside header piping	kPa	115	115	115	115	115	115	108	101	94	86	78	74	38
7	Cooling capacity	kW	209.5	209.5	209.5	209.5	209.5	209.5	209.5	203.1	196.1	188.3	180.0	170.9	165.1	53.5
	Power consumption	kW	40.38	40.38	40.38	40.38	40.38	40.38	40.38	43.89	47.59	51.48	55.56	59.84	62.50	25.42
	Cold water flow rate	m ³ /h	25.7	25.7	25.7	25.7	25.7	25.7	25.7	25.0	24.1	23.1	22.1	21.0	20.3	12.9
	Water pressure drop	Standard piping	kPa	56	56	56	56	56	56	53	49	46	42	38	36	16
		Inside header piping	kPa	134	134	134	134	134	134	126	118	110	101	92	86	38
10	Cooling capacity	kW	226.2	226.2	226.2	226.2	226.2	226.2	226.2	219.7	212.4	204.3	195.5	185.8	170.4	58.7
	Power consumption	kW	42.01	42.01	42.01	42.01	42.01	42.01	42.01	45.25	48.76	52.54	56.58	60.88	58.10	25.42
	Cold water flow rate	m ³ /h	27.8	27.8	27.8	27.8	27.8	27.8	27.8	27.0	26.1	25.1	24.0	22.8	20.9	12.9
	Water pressure drop	Standard piping	kPa	64	64	64	64	64	64	61	57	53	49	45	38	16
		Inside header piping	kPa	155	155	155	155	155	155	146	137	128	118	107	91	38
15	Cooling capacity	kW	254.3	254.3	254.3	254.3	254.3	254.3	254.3	248.3	241.2	232.9	223.5	212.9	177.8	70.1
	Power consumption	kW	46.29	46.29	46.29	46.29	46.29	46.29	46.29	48.25	50.76	53.83	57.44	61.62	50.73	25.30
	Cold water flow rate	m ³ /h	31.2	31.2	31.2	31.2	31.2	31.2	31.2	30.5	29.6	28.6	27.5	26.2	21.8	12.9
	Water pressure drop	Standard piping	kPa	80	80	80	80	80	80	76	72	68	63	57	41	16
		Inside header piping	kPa	193	193	193	193	193	193	184	174	163	151	138	99	38
20	Cooling capacity	kW	-	254.3	254.3	254.3	254.3	254.3	254.3	248.3	241.2	232.9	223.5	212.9	177.8	70.1
	Power consumption	kW	-	46.29	46.29	46.29	46.29	46.29	46.29	48.25	50.76	53.83	57.44	61.62	50.73	25.30
	Cold water flow rate	m ³ /h	-	31.2	31.2	31.2	31.2	31.2	31.2	30.5	29.6	28.6	27.5	26.2	21.8	12.9
	Water pressure drop	Standard piping	kPa	-	80	80	80	80	80	76	72	68	63	57	41	16
		Inside header piping	kPa	-	193	193	193	193	193	184	174	163	151	138	99	38
25	Cooling capacity	kW	-	254.3	254.3	254.3	254.3	254.3	254.3	248.3	241.2	232.9	223.5	212.9	177.8	-
	Power consumption	kW	-	46.29	46.29	46.29	46.29	46.29	46.29	48.25	50.76	53.83	57.44	61.62	50.73	-
	Cold water flow rate	m ³ /h	-	31.2	31.2	31.2	31.2	31.2	31.2	30.5	29.6	28.6	27.5	26.2	21.8	-
	Water pressure drop	Standard piping	kPa	-	80	80	80	80	80	76	72	68	63	57	41	-
		Inside header piping	kPa	-	193	193	193	193	193	184	174	163	151	138	99	-
30	Cooling capacity	kW	-	254.3	254.3	254.3	254.3	254.3	254.3	248.3	241.2	232.9	223.5	212.9	-	-
	Power consumption	kW	-	46.29	46.29	46.29	46.29	46.29	46.29	48.25	50.76	53.83	57.44	61.62	-	-
	Cold water flow rate	m ³ /h	-	31.2	31.2	31.2	31.2	31.2	31.2	30.5	29.6	28.6	27.5	26.2	-	-
	Water pressure drop	Standard piping	kPa	-	80	80	80	80	80	76	72	68	63	57	-	-
		Inside header piping	kPa	-	193	193	193	193	193	184	174	163	151	138	-	-

* Pump doesn't include.

* Hatching area shows outlet/inlet temperature difference under 7°C.

2. Product Data

Cooling capacity: Cold water outlet/inlet temperature difference 10°C

Capacity change mode: Capacity priority

MODEL			EAHV-M1500YCL, EACV-M1500YCL													
Cold water outlet temperature	Outdoor air temperature °CDB		-15	-10	-5	0	5	10	15	20	25	30	35	40	43	52
	4	Cooling capacity	kW	159.8	159.8	159.8	159.8	159.8	159.8	159.8	154.8	149.4	143.5	137.2	130.4	126.1
Power consumption		kW	29.33	29.33	29.33	29.33	29.33	29.33	29.33	32.22	35.24	38.42	41.76	45.27	47.47	22.76
Cold water flow rate		m ³ /h	13.7	13.7	13.7	13.7	13.7	13.7	13.7	13.3	12.9	12.9	12.9	12.9	12.9	12.9
Water pressure drop		Standard piping	kPa	18	18	18	18	18	18	18	17	16	16	16	16	16
		Inside header piping	kPa	43	43	43	43	43	43	40	38	38	38	38	38	38
7	Cooling capacity	kW	174.8	174.8	174.8	174.8	174.8	174.8	174.8	168.9	162.8	156.5	150.0	143.1	139.0	49.6
	Power consumption	kW	29.78	29.78	29.78	29.78	29.78	29.78	29.78	32.91	36.14	39.47	42.88	46.43	48.62	22.80
	Cold water flow rate	m ³ /h	15.0	15.0	15.0	15.0	15.0	15.0	15.0	14.5	14.0	13.5	12.9	12.9	12.9	12.9
	Water pressure drop	Standard piping	kPa	21	21	21	21	21	21	21	20	19	17	16	16	16
		Inside header piping	kPa	50	50	50	50	50	50	47	44	41	38	38	38	38
10	Cooling capacity	kW	191.6	191.6	191.6	191.6	191.6	191.6	191.6	185.1	178.4	171.6	164.4	157.1	151.5	54.3
	Power consumption	kW	30.30	30.30	30.30	30.30	30.30	30.30	30.30	33.57	36.93	40.37	43.90	47.50	49.12	22.80
	Cold water flow rate	m ³ /h	16.5	16.5	16.5	16.5	16.5	16.5	16.5	15.9	15.3	14.8	14.1	13.5	13.0	12.9
	Water pressure drop	Standard piping	kPa	25	25	25	25	25	25	25	23	22	20	19	18	16
		Inside header piping	kPa	59	59	59	59	59	59	55	52	48	45	41	39	38
15	Cooling capacity	kW	223.6	223.6	223.6	223.6	223.6	223.6	223.6	216.7	209.1	201.0	192.4	183.2	171.8	62.9
	Power consumption	kW	31.38	31.38	31.38	31.38	31.38	31.38	31.38	34.63	38.00	41.51	45.15	48.93	48.81	22.73
	Cold water flow rate	m ³ /h	19.2	19.2	19.2	19.2	19.2	19.2	19.2	18.6	18.0	17.3	16.5	15.8	14.8	12.9
	Water pressure drop	Standard piping	kPa	33	33	33	33	33	33	33	31	29	27	25	23	21
		Inside header piping	kPa	78	78	78	78	78	78	74	69	64	59	54	49	38
20	Cooling capacity	kW	-	223.6	223.6	223.6	223.6	223.6	223.6	216.7	209.1	201.0	192.4	183.2	171.8	-
	Power consumption	kW	-	31.38	31.38	31.38	31.38	31.38	31.38	34.63	38.00	41.51	45.15	48.93	48.81	-
	Cold water flow rate	m ³ /h	-	19.2	19.2	19.2	19.2	19.2	19.2	18.6	18.0	17.3	16.5	15.8	14.8	12.9
	Water pressure drop	Standard piping	kPa	-	33	33	33	33	33	33	31	29	27	25	23	21
		Inside header piping	kPa	-	78	78	78	78	78	74	69	64	59	54	49	38
25	Cooling capacity	kW	-	223.6	223.6	223.6	223.6	223.6	223.6	216.7	209.1	201.0	192.4	183.2	171.8	-
	Power consumption	kW	-	31.38	31.38	31.38	31.38	31.38	31.38	34.63	38.00	41.51	45.15	48.93	48.81	-
	Cold water flow rate	m ³ /h	-	19.2	19.2	19.2	19.2	19.2	19.2	18.6	18.0	17.3	16.5	15.8	14.8	-
	Water pressure drop	Standard piping	kPa	-	33	33	33	33	33	33	31	29	27	25	23	21
		Inside header piping	kPa	-	78	78	78	78	78	74	69	64	59	54	49	-
30	Cooling capacity	kW	-	223.6	223.6	223.6	223.6	223.6	223.6	216.7	209.1	201.0	192.4	183.2	-	-
	Power consumption	kW	-	31.38	31.38	31.38	31.38	31.38	31.38	34.63	38.00	41.51	45.15	48.93	-	-
	Cold water flow rate	m ³ /h	-	19.2	19.2	19.2	19.2	19.2	19.2	18.6	18.0	17.3	16.5	15.8	-	-
	Water pressure drop	Standard piping	kPa	-	33	33	33	33	33	33	31	29	27	25	23	-
		Inside header piping	kPa	-	78	78	78	78	78	74	69	64	59	54	-	-

* Pump doesn't include.

* Hatching area shows outlet/inlet temperature difference under 10°C.

2. Product Data

Cooling capacity: Cold water outlet/inlet temperature difference 10°C

Capacity change mode: Capacity priority

MODEL			EAHV-M1800YCL, EACV-M1800YCL													
Cold water outlet temperature	Outdoor air temperature °CDB		-15	-10	-5	0	5	10	15	20	25	30	35	40	43	52
	4	Cooling capacity	kW	192.9	192.9	192.9	192.9	192.9	192.9	192.9	187.0	180.4	173.2	165.4	156.9	151.5
Power consumption		kW	38.83	38.83	38.83	38.83	38.83	38.83	38.83	42.15	45.67	49.39	53.30	57.40	59.96	25.36
Cold water flow rate		m ³ /h	16.6	16.6	16.6	16.6	16.6	16.6	16.6	16.1	15.5	14.9	14.2	13.5	13.0	12.9
Water pressure drop		Standard piping	kPa	25	25	25	25	25	25	24	22	21	19	18	16	16
		Inside header piping	kPa	60	60	60	60	60	60	56	53	49	45	41	39	38
7	Cooling capacity	kW	209.5	209.5	209.5	209.5	209.5	209.5	209.5	203.1	196.1	188.3	180.0	170.9	165.1	53.5
	Power consumption	kW	39.73	39.73	39.73	39.73	39.73	39.73	39.73	43.18	46.82	50.65	54.66	58.87	61.49	25.42
	Cold water flow rate	m ³ /h	18.0	18.0	18.0	18.0	18.0	18.0	18.0	17.5	16.9	16.2	15.5	14.7	14.2	12.9
	Water pressure drop	Standard piping	kPa	29	29	29	29	29	29	28	26	24	22	20	19	16
		Inside header piping	kPa	69	69	69	69	69	69	66	62	57	53	48	45	38
10	Cooling capacity	kW	226.2	226.2	226.2	226.2	226.2	226.2	226.2	219.7	212.4	204.3	195.5	185.8	170.4	58.7
	Power consumption	kW	41.33	41.33	41.33	41.33	41.33	41.33	41.33	44.52	47.97	51.69	55.66	59.90	57.15	25.42
	Cold water flow rate	m ³ /h	19.5	19.5	19.5	19.5	19.5	19.5	19.5	18.9	18.3	17.6	16.8	16.0	14.7	12.9
	Water pressure drop	Standard piping	kPa	33	33	33	33	33	33	32	30	28	26	24	20	16
		Inside header piping	kPa	80	80	80	80	80	80	76	71	66	61	56	48	38
15	Cooling capacity	kW	254.3	254.3	254.3	254.3	254.3	254.3	254.3	248.3	241.2	232.9	223.5	212.9	177.8	70.1
	Power consumption	kW	45.54	45.54	45.54	45.54	45.54	45.54	45.54	47.46	49.94	52.96	56.51	60.63	49.91	25.30
	Cold water flow rate	m ³ /h	21.9	21.9	21.9	21.9	21.9	21.9	21.9	21.4	20.7	20.0	19.2	18.3	15.3	12.9
	Water pressure drop	Standard piping	kPa	41	41	41	41	41	41	40	37	35	33	30	22	16
		Inside header piping	kPa	99	99	99	99	99	99	95	90	84	78	71	52	38
20	Cooling capacity	kW	-	254.3	254.3	254.3	254.3	254.3	254.3	248.3	241.2	232.9	223.5	212.9	177.8	70.1
	Power consumption	kW	-	45.54	45.54	45.54	45.54	45.54	45.54	47.46	49.94	52.96	56.51	60.63	49.91	25.30
	Cold water flow rate	m ³ /h	-	21.9	21.9	21.9	21.9	21.9	21.9	21.4	20.7	20.0	19.2	18.3	15.3	12.9
	Water pressure drop	Standard piping	kPa	-	41	41	41	41	41	40	37	35	33	30	22	16
		Inside header piping	kPa	-	99	99	99	99	99	95	90	84	78	71	52	38
25	Cooling capacity	kW	-	254.3	254.3	254.3	254.3	254.3	254.3	248.3	241.2	232.9	223.5	212.9	177.8	-
	Power consumption	kW	-	45.54	45.54	45.54	45.54	45.54	45.54	47.46	49.94	52.96	56.51	60.63	49.91	-
	Cold water flow rate	m ³ /h	-	21.9	21.9	21.9	21.9	21.9	21.9	21.4	20.7	20.0	19.2	18.3	15.3	-
	Water pressure drop	Standard piping	kPa	-	41	41	41	41	41	40	37	35	33	30	22	-
		Inside header piping	kPa	-	99	99	99	99	99	95	90	84	78	71	52	-
30	Cooling capacity	kW	-	254.3	254.3	254.3	254.3	254.3	254.3	248.3	241.2	232.9	223.5	212.9	-	-
	Power consumption	kW	-	45.54	45.54	45.54	45.54	45.54	45.54	47.46	49.94	52.96	56.51	60.63	-	-
	Cold water flow rate	m ³ /h	-	21.9	21.9	21.9	21.9	21.9	21.9	21.4	20.7	20.0	19.2	18.3	-	-
	Water pressure drop	Standard piping	kPa	-	41	41	41	41	41	40	37	35	33	30	-	-
		Inside header piping	kPa	-	99	99	99	99	99	95	90	84	78	71	-	-

* Pump doesn't include.

* Hatching area shows outlet/inlet temperature difference under 10°C.

2. Product Data

Heating capacity: Hot water outlet/inlet temperature difference 5°C

Capacity change mode: Capacity priority

MODEL			EAHV-M1500YCL														
Hot water outlet temperature	Outdoor air temperature °CDB		-20	-15	-10	-5	0	5	10	15	20	25	30	35	40	43	
25	Heating capacity		kW	104.3	118.8	135.6	150.0	150.0	150.0	167.9	187.3	187.3	187.3	-	-	-	-
	Power consumption		kW	39.28	40.14	40.87	39.62	34.15	29.57	29.23	28.63	28.63	28.63	-	-	-	-
	Hot water flow rate		m ³ /h	17.9	20.4	23.3	25.8	25.8	25.8	28.9	32.2	32.2	32.2	-	-	-	-
	Water pressure drop	Standard piping	kPa	29	36	46	56	56	56	69	85	85	85	-	-	-	-
Inside header piping		kPa	69	87	111	134	134	134	166	204	204	204	-	-	-	-	
30	Heating capacity		kW	101.6	117.0	134.4	150.0	150.0	150.0	166.8	185.7	185.7	185.7	-	-	-	-
	Power consumption		kW	41.91	43.00	43.94	43.13	37.44	32.82	32.45	32.04	32.04	32.04	-	-	-	-
	Hot water flow rate		m ³ /h	17.5	20.1	23.1	25.8	25.8	25.8	28.7	31.9	31.9	31.9	-	-	-	-
	Water pressure drop	Standard piping	kPa	28	35	46	56	56	56	68	83	83	83	-	-	-	-
Inside header piping		kPa	66	85	110	134	134	134	164	201	201	201	-	-	-	-	
35	Heating capacity		kW	99.0	114.8	132.5	150.0	150.0	150.0	165.2	183.8	183.8	183.8	183.8	183.8	183.8	183.8
	Power consumption		kW	44.76	46.10	47.27	47.31	41.11	36.38	35.80	35.56	35.56	35.56	35.56	35.56	35.56	35.56
	Hot water flow rate		m ³ /h	17.0	19.7	22.8	25.8	25.8	25.8	28.4	31.6	31.6	31.6	31.6	31.6	31.6	31.6
	Water pressure drop	Standard piping	kPa	26	34	45	56	56	56	67	82	82	82	82	82	82	82
Inside header piping		kPa	63	82	107	134	134	134	161	197	197	197	197	197	197	197	
40	Heating capacity		kW	96.6	112.4	129.9	149.2	150.0	150.0	163.1	181.5	181.5	181.5	181.5	181.5	181.5	181.5
	Power consumption		kW	47.84	49.45	50.87	52.09	45.23	40.27	39.27	39.20	39.20	39.20	39.20	39.20	39.20	39.20
	Hot water flow rate		m ³ /h	16.6	19.3	22.3	25.7	25.8	25.8	28.1	31.2	31.2	31.2	31.2	31.2	31.2	31.2
	Water pressure drop	Standard piping	kPa	25	33	43	55	56	56	65	80	80	80	80	80	80	80
Inside header piping		kPa	60	79	103	133	134	134	157	192	192	192	192	192	192	192	
45	Heating capacity		kW	94.4	109.5	126.6	145.5	150.0	150.0	160.6	178.8	178.8	178.8	178.8	178.8	178.8	178.8
	Power consumption		kW	51.15	53.05	54.73	56.19	49.91	44.53	42.86	42.95	42.95	42.95	42.95	42.95	42.95	42.95
	Hot water flow rate		m ³ /h	16.2	18.8	21.8	25.0	25.8	25.8	27.6	30.8	30.8	30.8	30.8	30.8	30.8	30.8
	Water pressure drop	Standard piping	kPa	24	32	41	53	56	56	63	78	78	78	78	78	78	78
Inside header piping		kPa	57	75	98	127	134	134	153	187	187	187	187	187	187	187	
50	Heating capacity		kW	-	-	122.6	140.9	147.0	147.2	157.5	175.7	175.7	175.7	175.7	175.7	175.7	175.7
	Power consumption		kW	-	-	58.87	60.56	54.03	48.29	46.58	46.82	46.82	46.82	46.82	46.82	46.82	46.82
	Hot water flow rate		m ³ /h	-	-	21.1	24.2	25.3	25.3	27.1	30.2	30.2	30.2	30.2	30.2	30.2	30.2
	Water pressure drop	Standard piping	kPa	-	-	39	50	54	54	61	75	75	75	75	75	75	75
Inside header piping		kPa	-	-	92	120	129	130	147	181	181	181	181	181	181	181	
55	Heating capacity		kW	-	-	-	135.4	142.9	143.6	154.0	172.2	172.2	-	-	-	-	-
	Power consumption		kW	-	-	-	65.21	58.11	52.10	50.42	50.80	50.80	-	-	-	-	-
	Hot water flow rate		m ³ /h	-	-	-	23.3	24.6	24.7	26.5	29.6	29.6	-	-	-	-	-
	Water pressure drop	Standard piping	kPa	-	-	-	46	51	52	59	72	72	-	-	-	-	-
Inside header piping		kPa	-	-	-	111	123	124	141	174	174	-	-	-	-	-	

* Pump doesn't include.

EAHV-M-YCL(-N), EACV-M-YCL(-N)

2. Product Data

Heating capacity: Hot water outlet/inlet temperature difference 5°C

Capacity change mode: Capacity priority

MODEL			EAHV-M1800YCL														
Hot water outlet temperature	Outdoor air temperature °CDB		-20	-15	-10	-5	0	5	10	15	20	25	30	35	40	43	
25	Heating capacity		kW	104.9	119.4	136.3	155.6	175.8	180.0	201.5	225.8	225.8	225.8	-	-	-	-
	Power consumption		kW	39.59	40.55	41.38	42.09	42.33	37.86	37.42	36.88	36.88	36.88	-	-	-	-
	Hot water flow rate		m ³ /h	18.0	20.5	23.4	26.8	30.2	31.0	34.7	38.8	38.8	38.8	-	-	-	-
	Water pressure drop	Standard piping	kPa	29	37	47	60	75	79	97	120	120	120	-	-	-	-
		Inside header piping	kPa	70	88	113	144	181	189	234	291	291	291	-	-	-	-
30	Heating capacity		kW	102.1	117.6	135.1	154.7	175.1	180.0	200.3	224.1	224.1	224.1	-	-	-	-
	Power consumption		kW	42.24	43.43	44.48	45.40	45.81	41.62	41.14	40.85	40.85	40.85	-	-	-	-
	Hot water flow rate		m ³ /h	17.6	20.2	23.2	26.6	30.1	31.0	34.5	38.5	38.5	38.5	-	-	-	-
	Water pressure drop	Standard piping	kPa	28	36	46	59	75	79	96	119	119	119	-	-	-	-
		Inside header piping	kPa	66	86	111	142	180	189	232	287	287	287	-	-	-	-
35	Heating capacity		kW	99.5	115.3	133.1	152.9	173.2	180.0	198.4	221.9	221.9	221.9	221.9	221.9	221.9	221.9
	Power consumption		kW	45.13	46.57	47.86	48.99	49.57	45.79	45.05	45.00	45.00	45.00	45.00	45.00	45.00	45.00
	Hot water flow rate		m ³ /h	17.1	19.8	22.9	26.3	29.8	31.0	34.1	38.2	38.2	38.2	38.2	38.2	38.2	38.2
	Water pressure drop	Standard piping	kPa	27	35	45	58	73	79	94	116	116	116	116	116	116	116
		Inside header piping	kPa	63	83	108	139	176	189	228	282	282	282	282	282	282	282
40	Heating capacity		kW	97.0	112.8	130.5	150.0	170.3	180.0	196.0	219.2	219.2	219.2	219.2	219.2	219.2	219.2
	Power consumption		kW	48.24	49.97	51.52	52.88	53.62	50.45	49.15	49.33	49.33	49.33	49.33	49.33	49.33	49.33
	Hot water flow rate		m ³ /h	16.7	19.4	22.4	25.8	29.3	31.0	33.7	37.7	37.7	37.7	37.7	37.7	37.7	37.7
	Water pressure drop	Standard piping	kPa	25	33	43	56	71	79	92	114	114	114	114	114	114	114
		Inside header piping	kPa	60	79	104	134	171	189	222	275	275	275	275	275	275	275
45	Heating capacity		kW	94.8	109.9	127.1	146.2	166.4	180.0	193.0	216.0	216.0	216.0	216.0	216.0	216.0	216.0
	Power consumption		kW	51.59	53.63	55.45	57.05	57.95	55.75	53.44	53.83	53.83	53.83	53.83	53.83	53.83	53.83
	Hot water flow rate		m ³ /h	16.3	18.9	21.9	25.1	28.6	31.0	33.2	37.2	37.2	37.2	37.2	37.2	37.2	37.2
	Water pressure drop	Standard piping	kPa	24	32	41	53	68	79	89	111	111	111	111	111	111	111
		Inside header piping	kPa	58	76	99	128	163	189	216	268	268	268	268	268	268	268
50	Heating capacity		kW	-	-	122.9	141.5	161.4	176.4	189.3	212.3	212.3	212.3	212.3	212.3	212.3	212.3
	Power consumption		kW	-	-	59.65	61.51	62.57	60.49	57.91	58.51	58.51	58.51	58.51	58.51	58.51	58.51
	Hot water flow rate		m ³ /h	-	-	21.1	24.3	27.8	30.3	32.6	36.5	36.5	36.5	36.5	36.5	36.5	36.5
	Water pressure drop	Standard piping	kPa	-	-	39	50	64	76	86	107	107	107	107	107	107	107
		Inside header piping	kPa	-	-	93	121	154	182	208	259	259	259	259	259	259	259
55	Heating capacity		kW	-	-	-	135.7	155.3	171.4	185.1	208.1	208.1	-	-	-	-	-
	Power consumption		kW	-	-	-	66.25	67.48	65.24	62.58	63.37	63.37	-	-	-	-	-
	Hot water flow rate		m ³ /h	-	-	-	23.3	26.7	29.5	31.8	35.8	35.8	-	-	-	-	-
	Water pressure drop	Standard piping	kPa	-	-	-	46	60	72	83	103	103	-	-	-	-	-
		Inside header piping	kPa	-	-	-	112	143	173	200	249	249	-	-	-	-	-

* Pump doesn't include.

2. Product Data

Heating capacity: Hot water outlet/inlet temperature difference 7°C

Capacity change mode: Capacity priority

MODEL			EAHV-M1500YCL														
Hot water outlet temperature	Outdoor air temperature °CDB		-20	-15	-10	-5	0	5	10	15	20	25	30	35	40	43	
25	Heating capacity		kW	104.3	118.8	135.6	150.0	150.0	150.0	167.9	187.3	187.3	187.3	-	-	-	-
	Power consumption		kW	38.53	39.36	40.07	38.85	33.48	28.99	28.66	28.07	28.07	28.07	-	-	-	-
	Hot water flow rate		m ³ /h	12.9	14.6	16.7	18.4	18.4	18.4	20.6	23.0	23.0	23.0	-	-	-	-
	Water pressure drop	Standard piping	kPa	16	20	25	30	30	30	37	45	45	45	-	-	-	-
Inside header piping		kPa	38	48	60	72	72	72	89	109	109	109	-	-	-	-	
30	Heating capacity		kW	101.6	117.0	134.4	150.0	150.0	150.0	166.8	185.7	185.7	185.7	-	-	-	-
	Power consumption		kW	41.19	42.16	43.08	42.29	36.71	32.18	31.82	31.42	31.42	31.42	-	-	-	-
	Hot water flow rate		m ³ /h	12.9	14.4	16.5	18.4	18.4	18.4	20.5	22.8	22.8	22.8	-	-	-	-
	Water pressure drop	Standard piping	kPa	16	20	25	30	30	30	37	45	45	45	-	-	-	-
Inside header piping		kPa	38	46	59	72	72	72	88	107	107	107	-	-	-	-	
35	Heating capacity		kW	99.0	114.8	132.5	150.0	150.0	150.0	165.2	183.8	183.8	183.8	183.8	183.8	183.8	183.8
	Power consumption		kW	44.07	45.20	46.35	46.39	40.31	35.67	35.10	34.87	34.87	34.87	34.87	34.87	34.87	34.87
	Hot water flow rate		m ³ /h	12.9	14.1	16.3	18.4	18.4	18.4	20.3	22.6	22.6	22.6	22.6	22.6	22.6	22.6
	Water pressure drop	Standard piping	kPa	16	19	24	30	30	30	36	44	44	44	44	44	44	44
Inside header piping		kPa	38	45	58	72	72	72	86	105	105	105	105	105	105	105	
40	Heating capacity		kW	96.6	112.4	129.9	149.2	150.0	150.0	163.1	181.5	181.5	181.5	181.5	181.5	181.5	181.5
	Power consumption		kW	47.18	48.49	49.88	51.08	44.35	39.49	38.51	38.44	38.44	38.44	38.44	38.44	38.44	38.44
	Hot water flow rate		m ³ /h	12.9	13.8	16.0	18.3	18.4	18.4	20.0	22.3	22.3	22.3	22.3	22.3	22.3	22.3
	Water pressure drop	Standard piping	kPa	16	18	23	30	30	30	35	43	43	43	43	43	43	43
Inside header piping		kPa	38	43	56	72	72	72	84	103	103	103	103	103	103	103	
45	Heating capacity		kW	94.4	109.5	126.6	145.5	150.0	150.0	160.6	178.8	178.8	178.8	178.8	178.8	178.8	178.8
	Power consumption		kW	50.51	52.02	53.66	55.10	48.94	43.66	42.03	42.11	42.11	42.11	42.11	42.11	42.11	42.11
	Hot water flow rate		m ³ /h	12.9	13.5	15.6	17.9	18.4	18.4	19.7	22.0	22.0	22.0	22.0	22.0	22.0	22.0
	Water pressure drop	Standard piping	kPa	16	17	22	29	30	30	34	42	42	42	42	42	42	42
Inside header piping		kPa	38	41	53	68	72	72	82	100	100	100	100	100	100	100	
50	Heating capacity		kW	-	-	122.6	140.9	147.0	147.2	157.5	175.7	175.7	175.7	175.7	175.7	175.7	175.7
	Power consumption		kW	-	-	57.72	59.38	52.98	47.35	45.67	45.91	45.91	45.91	45.91	45.91	45.91	45.91
	Hot water flow rate		m ³ /h	-	-	15.1	17.3	18.1	18.1	19.4	21.6	21.6	21.6	21.6	21.6	21.6	21.6
	Water pressure drop	Standard piping	kPa	-	-	21	27	29	29	33	40	40	40	40	40	40	40
Inside header piping		kPa	-	-	50	65	70	70	79	97	97	97	97	97	97	97	
55	Heating capacity		kW	-	-	-	135.4	142.9	143.6	154.0	172.2	172.2	-	-	-	-	
	Power consumption		kW	-	-	-	63.94	56.98	51.09	49.44	49.81	49.81	-	-	-	-	
	Hot water flow rate		m ³ /h	-	-	-	16.6	17.6	17.6	18.9	21.2	21.2	-	-	-	-	
	Water pressure drop	Standard piping	kPa	-	-	-	25	28	28	32	39	39	-	-	-	-	
Inside header piping		kPa	-	-	-	60	66	67	76	93	93	-	-	-	-		

* Pump doesn't include.

* Hatching area shows outlet/inlet temperature difference under 7°C.

2. Product Data

Heating capacity: Hot water outlet/inlet temperature difference 7°C

Capacity change mode: Capacity priority

MODEL			EAHV-M1800YCL														
Hot water outlet temperature	Outdoor air temperature °CDB		-20	-15	-10	-5	0	5	10	15	20	25	30	35	40	43	
25	Heating capacity		kW	104.9	119.4	136.3	155.6	175.8	180.0	201.5	225.8	225.8	225.8	-	-	-	-
	Power consumption		kW	38.82	39.76	40.57	41.27	41.51	37.12	36.69	36.16	36.16	36.16	-	-	-	-
	Hot water flow rate		m ³ /h	12.9	14.7	16.7	19.1	21.6	22.1	24.8	27.7	27.7	27.7	-	-	-	-
	Water pressure drop	Standard piping	kPa	16	20	26	32	40	42	52	64	64	64	-	-	-	-
		Inside header piping	kPa	38	48	61	77	97	101	124	154	154	154	-	-	-	-
30	Heating capacity		kW	102.1	117.6	135.1	154.7	175.1	180.0	200.3	224.1	224.1	224.1	-	-	-	-
	Power consumption		kW	41.50	42.58	43.61	44.52	44.92	40.81	40.34	40.05	40.05	40.05	-	-	-	-
	Hot water flow rate		m ³ /h	12.9	14.4	16.6	19.0	21.5	22.1	24.6	27.5	27.5	27.5	-	-	-	-
	Water pressure drop	Standard piping	kPa	16	20	25	32	40	42	51	63	63	63	-	-	-	-
		Inside header piping	kPa	38	47	60	76	96	101	123	152	152	152	-	-	-	-
35	Heating capacity		kW	99.5	115.3	133.1	152.9	173.2	180.0	198.4	221.9	221.9	221.9	221.9	221.9	221.9	221.9
	Power consumption		kW	44.42	45.66	46.93	48.04	48.60	44.90	44.17	44.12	44.12	44.12	44.12	44.12	44.12	44.12
	Hot water flow rate		m ³ /h	12.9	14.2	16.4	18.8	21.3	22.1	24.4	27.3	27.3	27.3	27.3	27.3	27.3	27.3
	Water pressure drop	Standard piping	kPa	16	19	24	31	39	42	50	62	62	62	62	62	62	62
		Inside header piping	kPa	38	45	58	75	94	101	121	149	149	149	149	149	149	149
40	Heating capacity		kW	97.0	112.8	130.5	150.0	170.3	180.0	196.0	219.2	219.2	219.2	219.2	219.2	219.2	219.2
	Power consumption		kW	47.56	49.00	50.52	51.85	52.58	49.47	48.19	48.37	48.37	48.37	48.37	48.37	48.37	48.37
	Hot water flow rate		m ³ /h	12.9	13.9	16.0	18.4	20.9	22.1	24.1	26.9	26.9	26.9	26.9	26.9	26.9	26.9
	Water pressure drop	Standard piping	kPa	16	18	24	30	38	42	49	61	61	61	61	61	61	61
		Inside header piping	kPa	38	43	56	72	91	101	118	146	146	146	146	146	146	146
45	Heating capacity		kW	94.8	109.9	127.1	146.2	166.4	180.0	193.0	216.0	216.0	216.0	216.0	216.0	216.0	216.0
	Power consumption		kW	50.93	52.59	54.37	55.94	56.82	54.66	52.40	52.78	52.78	52.78	52.78	52.78	52.78	52.78
	Hot water flow rate		m ³ /h	12.9	13.5	15.6	18.0	20.4	22.1	23.7	26.5	26.5	26.5	26.5	26.5	26.5	26.5
	Water pressure drop	Standard piping	kPa	16	18	23	29	37	42	48	59	59	59	59	59	59	59
		Inside header piping	kPa	38	41	54	69	87	101	115	142	142	142	142	142	142	142
50	Heating capacity		kW	-	-	122.9	141.5	161.4	176.4	189.3	212.3	212.3	212.3	212.3	212.3	212.3	212.3
	Power consumption		kW	-	-	58.49	60.31	61.35	59.31	56.78	57.37	57.37	57.37	57.37	57.37	57.37	57.37
	Hot water flow rate		m ³ /h	-	-	15.1	17.4	19.8	21.7	23.3	26.1	26.1	26.1	26.1	26.1	26.1	26.1
	Water pressure drop	Standard piping	kPa	-	-	21	27	35	41	46	57	57	57	57	57	57	57
		Inside header piping	kPa	-	-	50	65	83	97	111	137	137	137	137	137	137	137
55	Heating capacity		kW	-	-	-	135.7	155.3	171.4	185.1	208.1	208.1	-	-	-	-	-
	Power consumption		kW	-	-	-	64.96	66.17	63.97	61.36	62.14	62.14	-	-	-	-	-
	Hot water flow rate		m ³ /h	-	-	-	16.7	19.1	21.1	22.7	25.6	25.6	-	-	-	-	-
	Water pressure drop	Standard piping	kPa	-	-	-	25	32	39	44	55	55	-	-	-	-	-
		Inside header piping	kPa	-	-	-	60	77	92	106	132	132	-	-	-	-	-

* Pump doesn't include.

* Hatching area shows outlet/inlet temperature difference under 7°C.

2. Product Data

Heating capacity: Hot water outlet/inlet temperature difference 10°C

Capacity change mode: Capacity priority

MODEL			EAHV-M1500YCL														
Hot water outlet temperature	Outdoor air temperature °CDB		-20	-15	-10	-5	0	5	10	15	20	25	30	35	40	43	
25	Heating capacity		kW	104.3	118.8	135.6	150.0	150.0	150.0	167.9	187.3	187.3	187.3	-	-	-	-
	Power consumption		kW	38.53	38.98	39.20	37.59	32.40	28.05	27.73	27.16	27.16	27.16	-	-	-	-
	Hot water flow rate		m ³ /h	12.9	12.9	12.9	12.9	12.9	12.9	14.4	16.1	16.1	16.1	-	-	-	-
	Water pressure drop	Standard piping	kPa	16	16	16	16	16	16	20	24	24	24	-	-	-	-
		Inside header piping	kPa	38	38	38	38	38	38	47	57	57	57	-	-	-	-
30	Heating capacity		kW	101.6	117.0	134.4	150.0	150.0	150.0	166.8	185.7	185.7	185.7	-	-	-	-
	Power consumption		kW	41.19	41.81	42.19	40.92	35.52	31.14	30.78	30.40	30.40	30.40	-	-	-	-
	Hot water flow rate		m ³ /h	12.9	12.9	12.9	12.9	12.9	12.9	14.3	16.0	16.0	16.0	-	-	-	-
	Water pressure drop	Standard piping	kPa	16	16	16	16	16	16	19	23	23	23	-	-	-	-
		Inside header piping	kPa	38	38	38	38	38	38	46	56	56	56	-	-	-	-
35	Heating capacity		kW	99.0	114.8	132.5	150.0	150.0	150.0	165.2	183.8	183.8	183.8	183.8	183.8	183.8	183.8
	Power consumption		kW	44.07	44.89	45.45	44.88	39.00	34.51	33.96	33.74	33.74	33.74	33.74	33.74	33.74	33.74
	Hot water flow rate		m ³ /h	12.9	12.9	12.9	12.9	12.9	12.9	14.2	15.8	15.8	15.8	15.8	15.8	15.8	15.8
	Water pressure drop	Standard piping	kPa	16	16	16	16	16	16	19	23	23	23	23	23	23	23
		Inside header piping	kPa	38	38	38	38	38	38	45	55	55	55	55	55	55	55
40	Heating capacity		kW	96.6	112.4	129.9	149.2	150.0	150.0	163.1	181.5	181.5	181.5	181.5	181.5	181.5	181.5
	Power consumption		kW	47.18	48.24	49.00	49.45	42.91	38.20	37.25	37.19	37.19	37.19	37.19	37.19	37.19	37.19
	Hot water flow rate		m ³ /h	12.9	12.9	12.9	12.9	12.9	12.9	14.0	15.6	15.6	15.6	15.6	15.6	15.6	15.6
	Water pressure drop	Standard piping	kPa	16	16	16	16	16	16	19	23	23	23	23	23	23	23
		Inside header piping	kPa	38	38	38	38	38	38	44	54	54	54	54	54	54	54
45	Heating capacity		kW	94.4	109.5	126.6	145.5	150.0	150.0	160.6	178.8	178.8	178.8	178.8	178.8	178.8	178.8
	Power consumption		kW	50.51	51.86	52.85	53.49	47.35	42.25	40.66	40.75	40.75	40.75	40.75	40.75	40.75	40.75
	Hot water flow rate		m ³ /h	12.9	12.9	12.9	12.9	12.9	12.9	13.8	15.4	15.4	15.4	15.4	15.4	15.4	15.4
	Water pressure drop	Standard piping	kPa	16	16	16	16	16	16	18	22	22	22	22	22	22	22
		Inside header piping	kPa	38	38	38	38	38	38	43	52	52	52	52	52	52	52
50	Heating capacity		kW	-	-	122.6	140.9	147.0	147.2	157.5	175.7	175.7	175.7	175.7	175.7	175.7	175.7
	Power consumption		kW	-	-	57.01	57.86	51.38	45.91	44.19	44.42	44.42	44.42	44.42	44.42	44.42	44.42
	Hot water flow rate		m ³ /h	-	-	12.9	12.9	12.9	12.9	13.5	15.1	15.1	15.1	15.1	15.1	15.1	15.1
	Water pressure drop	Standard piping	kPa	-	-	16	16	16	16	18	21	21	21	21	21	21	21
		Inside header piping	kPa	-	-	38	38	38	38	42	51	51	51	51	51	51	51
55	Heating capacity		kW	-	-	-	135.4	142.9	143.6	154.0	172.2	172.2	-	-	-	-	-
	Power consumption		kW	-	-	-	62.56	55.43	49.67	47.83	48.19	48.19	-	-	-	-	-
	Hot water flow rate		m ³ /h	-	-	-	12.9	12.9	12.9	13.2	14.8	14.8	-	-	-	-	-
	Water pressure drop	Standard piping	kPa	-	-	-	16	16	16	17	21	21	-	-	-	-	-
		Inside header piping	kPa	-	-	-	38	38	38	40	49	49	-	-	-	-	-

* Pump doesn't include.

* Hatching area shows outlet/inlet temperature difference under 10°C.

2. Product Data

Heating capacity: Hot water outlet/inlet temperature difference 10°C

Capacity change mode: Capacity priority

MODEL			EAHV-M1800YCL														
Hot water outlet temperature	Outdoor air temperature °CDB		-20	-15	-10	-5	0	5	10	15	20	25	30	35	40	43	
25	Heating capacity		kW	104.9	119.4	136.3	155.6	175.8	180.0	201.5	225.8	225.8	225.8	-	-	-	-
	Power consumption		kW	38.82	39.36	39.67	39.93	40.16	35.92	35.50	34.99	34.99	34.99	-	-	-	-
	Hot water flow rate		m ³ /h	12.9	12.9	12.9	13.4	15.1	15.5	17.3	19.4	19.4	19.4	-	-	-	-
	Water pressure drop	Standard piping	kPa	16	16	16	17	21	22	27	33	33	33	-	-	-	-
		Inside header piping	kPa	38	38	38	41	51	53	65	80	80	80	-	-	-	-
30	Heating capacity		kW	102.1	117.6	135.1	154.7	175.1	180.0	200.3	224.1	224.1	224.1	-	-	-	-
	Power consumption		kW	41.50	42.21	42.68	43.07	43.46	39.48	39.03	38.75	38.75	38.75	-	-	-	-
	Hot water flow rate		m ³ /h	12.9	12.9	12.9	13.3	15.1	15.5	17.2	19.3	19.3	19.3	-	-	-	-
	Water pressure drop	Standard piping	kPa	16	16	16	17	21	22	27	33	33	33	-	-	-	-
		Inside header piping	kPa	38	38	38	40	50	53	64	78	78	78	-	-	-	-
35	Heating capacity		kW	99.5	115.3	133.1	152.9	173.2	180.0	198.4	221.9	221.9	221.9	221.9	221.9	221.9	221.9
	Power consumption		kW	44.42	45.34	45.99	46.48	47.03	43.44	42.74	42.69	42.69	42.69	42.69	42.69	42.69	42.69
	Hot water flow rate		m ³ /h	12.9	12.9	12.9	13.1	14.9	15.5	17.1	19.1	19.1	19.1	19.1	19.1	19.1	19.1
	Water pressure drop	Standard piping	kPa	16	16	16	17	21	22	26	32	32	32	32	32	32	32
		Inside header piping	kPa	38	38	38	39	49	53	63	77	77	77	77	77	77	77
40	Heating capacity		kW	97.0	112.8	130.5	150.0	170.3	180.0	196.0	219.2	219.2	219.2	219.2	219.2	219.2	219.2
	Power consumption		kW	47.56	48.73	49.61	50.17	50.87	47.86	46.63	46.80	46.80	46.80	46.80	46.80	46.80	46.80
	Hot water flow rate		m ³ /h	12.9	12.9	12.9	12.9	14.6	15.5	16.9	18.9	18.9	18.9	18.9	18.9	18.9	18.9
	Water pressure drop	Standard piping	kPa	16	16	16	16	20	22	26	32	32	32	32	32	32	32
		Inside header piping	kPa	38	38	38	38	48	53	61	75	75	75	75	75	75	75
45	Heating capacity		kW	94.8	109.9	127.1	146.2	166.4	180.0	193.0	216.0	216.0	216.0	216.0	216.0	216.0	216.0
	Power consumption		kW	50.93	52.41	53.52	54.28	54.98	52.89	50.70	51.07	51.07	51.07	51.07	51.07	51.07	51.07
	Hot water flow rate		m ³ /h	12.9	12.9	12.9	12.9	14.3	15.5	16.6	18.6	18.6	18.6	18.6	18.6	18.6	18.6
	Water pressure drop	Standard piping	kPa	16	16	16	16	19	22	25	31	31	31	31	31	31	31
		Inside header piping	kPa	38	38	38	38	46	53	60	73	73	73	73	73	73	73
50	Heating capacity		kW	-	-	122.9	141.5	161.4	176.4	189.3	212.3	212.3	212.3	212.3	212.3	212.3	212.3
	Power consumption		kW	-	-	57.76	58.74	59.36	57.39	54.94	55.51	55.51	55.51	55.51	55.51	55.51	55.51
	Hot water flow rate		m ³ /h	-	-	12.9	12.9	13.9	15.2	16.3	18.3	18.3	18.3	18.3	18.3	18.3	18.3
	Water pressure drop	Standard piping	kPa	-	-	16	16	18	21	24	30	30	30	30	30	30	30
		Inside header piping	kPa	-	-	38	38	43	51	58	71	71	71	71	71	71	71
55	Heating capacity		kW	-	-	-	135.7	155.3	171.4	185.1	208.1	208.1	-	-	-	-	-
	Power consumption		kW	-	-	-	63.54	64.02	61.89	59.37	60.12	60.12	-	-	-	-	-
	Hot water flow rate		m ³ /h	-	-	-	12.9	13.4	14.7	15.9	17.9	17.9	-	-	-	-	-
	Water pressure drop	Standard piping	kPa	-	-	-	16	17	20	23	29	29	-	-	-	-	-
		Inside header piping	kPa	-	-	-	38	41	48	55	69	69	-	-	-	-	-

* Pump doesn't include.

* Hatching area shows outlet/inlet temperature difference under 10°C.

2. Product Data

2-1-2. Capacity table

EER for cooling [Water]

EAHV-M1500YCL, EACV-M1500YCL

Water flow rate 25.8 m³/h

EAHV-M-YCL(-N), EACV-M-YCL(-N)

Capacity	Air temp (°C D.B)	Outlet water temp (°C)						
		4	7	10	15	20	25	30
150kW (100%)	-15	5.51	6.31	7.37	10.09	-	-	-
	-10	5.51	6.31	7.37	10.09	10.09	10.09	10.09
	-5	5.51	6.31	7.37	10.09	10.09	10.09	10.09
	0	5.51	6.31	7.37	10.09	10.09	10.09	10.09
	5	5.51	6.31	7.37	10.09	10.09	10.09	10.09
	10	5.51	6.31	7.37	10.09	10.09	10.09	10.09
	15	5.51	6.31	7.37	10.09	10.09	10.09	10.09
	20	4.73	5.36	6.13	8.02	8.02	8.02	8.02
	25	-	4.57	5.18	6.54	6.54	6.54	6.54
	30	-	3.91	4.41	5.44	5.44	5.44	5.44
	35	-	3.35	3.78	4.59	4.59	4.59	4.59
	40	-	-	3.26	3.93	3.93	3.93	3.93
	43	-	-	2.98	-	-	-	-
	45	-	-	-	-	-	-	-
50	-	-	-	-	-	-	-	
52	-	-	-	-	-	-	-	
112.5kW (75%)	-15	6.31	7.27	8.65	12.20	-	-	-
	-10	6.31	7.27	8.65	12.20	12.20	12.20	12.20
	-5	6.31	7.27	8.65	12.20	12.20	12.20	12.20
	0	6.31	7.27	8.65	12.20	12.20	12.20	12.20
	5	6.31	7.27	8.65	12.20	12.20	12.20	12.20
	10	6.31	7.27	8.65	12.20	12.20	12.20	12.20
	15	6.31	7.27	8.65	12.20	12.20	12.20	12.20
	20	5.42	6.10	7.06	9.44	9.44	9.44	9.44
	25	4.67	5.17	5.86	7.49	7.49	7.49	7.49
	30	4.02	4.42	4.93	6.09	6.09	6.09	6.09
	35	3.46	3.80	4.19	5.04	5.04	5.04	5.04
	40	2.98	3.28	3.60	4.25	4.25	4.25	4.25
	43	2.71	3.00	3.30	3.87	3.87	3.87	3.87
	45	-	2.83	3.12	3.64	3.64	3.64	-
50	-	-	-	-	-	-	-	
52	-	-	-	-	-	-	-	
75kW (50%)	-15	7.02	8.55	10.78	16.97	-	-	-
	-10	7.02	8.55	10.78	16.97	16.97	16.97	16.97
	-5	7.02	8.55	10.78	16.97	16.97	16.97	16.97
	0	7.02	8.55	10.78	16.97	16.97	16.97	16.97
	5	7.02	8.55	10.78	16.97	16.97	16.97	16.97
	10	7.02	8.55	10.78	16.97	16.97	16.97	16.97
	15	7.02	8.55	10.78	16.97	16.97	16.97	16.97
	20	5.95	6.99	8.45	12.21	12.21	12.21	12.21
	25	5.04	5.76	6.71	9.07	9.07	9.07	9.07
	30	4.29	4.79	5.43	6.96	6.96	6.96	6.96
	35	3.67	4.03	4.47	5.48	5.48	5.48	5.48
	40	3.15	3.42	3.74	4.44	4.44	4.44	4.44
	43	2.88	3.12	3.39	3.95	3.95	3.95	3.95
	45	2.72	2.94	3.18	3.67	3.67	3.67	-
50	-	-	-	3.09	3.09	-	-	
52	-	-	-	-	-	-	-	
37.5kW (25%)	-15	6.97	8.43	10.50	15.89	-	-	-
	-10	6.98	8.43	10.50	15.89	15.89	15.89	15.89
	-5	6.98	8.43	10.50	15.89	15.89	15.89	15.89
	0	6.98	8.43	10.50	15.89	15.89	15.89	15.89
	5	6.98	8.43	10.50	15.89	15.89	15.89	15.89
	10	6.98	8.43	10.50	15.89	15.89	15.89	15.89
	15	6.98	8.43	10.50	15.89	15.89	15.89	15.89
	20	5.86	6.81	8.17	11.65	11.65	11.65	11.65
	25	4.95	5.58	6.48	8.74	8.74	8.74	8.74
	30	4.19	4.62	5.22	6.71	6.71	6.71	6.71
	35	3.58	3.89	4.30	5.27	5.27	5.27	5.27
	40	3.08	3.30	3.60	4.27	4.27	4.27	4.27
	43	2.59	3.02	3.27	3.79	3.79	3.79	3.79
	45	2.38	2.84	3.07	3.52	3.52	3.52	-
50	1.97	2.10	2.65	2.97	2.97	-	-	
52	1.83	1.95	-	-	-	-	-	

2. Product Data

EER for cooling [Water]

EAHV-M1800YCL, EACV-M1800YCL

Water flow rate 31.0 m³/h

Capacity	Air temp (°C D.B)	Outlet water temp (°C)						
		4	7	10	15	20	25	30
180kW (100%)	-15	4.98	5.64	6.49	9.11	-	-	-
	-10	4.98	5.64	6.49	9.11	9.11	9.11	9.11
	-5	4.98	5.64	6.49	9.11	9.11	9.11	9.11
	0	4.98	5.64	6.49	9.11	9.11	9.11	9.11
	5	4.98	5.64	6.49	9.11	9.11	9.11	9.11
	10	4.98	5.64	6.49	9.11	9.11	9.11	9.11
	15	4.98	5.64	6.49	9.11	9.11	9.11	9.11
	20	4.36	4.91	5.57	7.35	7.35	7.35	7.35
	25	3.79	4.25	4.78	6.09	6.09	6.09	6.09
	30	-	3.68	4.13	5.10	5.10	5.10	5.10
	35	-	3.16	3.56	4.34	4.34	4.34	4.34
	40	-	-	3.04	3.72	3.72	3.72	3.72
	43	-	-	-	-	-	-	-
	45	-	-	-	-	-	-	-
50	-	-	-	-	-	-	-	
52	-	-	-	-	-	-	-	
135kW (75%)	-15	5.90	6.66	7.83	11.37	-	-	-
	-10	5.90	6.66	7.83	11.37	11.37	11.37	11.37
	-5	5.89	6.66	7.83	11.37	11.37	11.37	11.37
	0	5.90	6.66	7.83	11.37	11.37	11.37	11.37
	5	5.90	6.66	7.83	11.37	11.37	11.37	11.37
	10	5.90	6.66	7.83	11.37	11.37	11.37	11.37
	15	5.90	6.66	7.83	11.37	11.37	11.37	11.37
	20	5.15	5.74	6.58	9.05	9.05	9.05	9.05
	25	4.48	4.95	5.57	7.30	7.30	7.30	7.30
	30	3.88	4.27	4.75	5.97	5.97	5.97	5.97
	35	3.34	3.68	4.07	4.97	4.97	4.97	4.97
	40	2.85	3.16	3.50	4.19	4.19	4.19	4.19
	43	2.58	2.88	3.20	3.81	3.81	3.81	3.81
	45	-	2.70	3.02	3.59	3.59	3.59	-
50	-	-	-	-	-	-	-	
52	-	-	-	-	-	-	-	
90kW (50%)	-15	6.79	7.68	9.18	14.40	-	-	-
	-10	6.79	7.68	9.18	14.40	14.40	14.40	14.40
	-5	6.79	7.68	9.18	14.40	14.40	14.40	14.40
	0	6.79	7.68	9.18	14.40	14.40	14.40	14.40
	5	6.79	7.68	9.18	14.40	14.40	14.40	14.40
	10	6.79	7.68	9.18	14.40	14.40	14.40	14.40
	15	6.79	7.68	9.18	14.40	14.40	14.40	14.40
	20	5.83	6.50	7.60	11.15	11.15	11.15	11.15
	25	4.99	5.50	6.29	8.67	8.67	8.67	8.67
	30	4.27	4.66	5.23	6.84	6.84	6.84	6.84
	35	3.65	3.96	4.38	5.49	5.49	5.49	5.49
	40	3.13	3.39	3.70	4.48	4.48	4.48	4.48
	43	2.86	3.09	3.37	4.00	4.00	4.00	4.00
	45	2.69	2.91	3.16	3.71	3.71	3.71	-
50	-	-	-	3.14	3.14	-	-	
52	-	-	-	-	-	-	-	
45kW (25%)	-15	7.77	9.43	8.81	13.76	-	-	-
	-10	7.77	9.43	8.81	13.76	13.76	13.76	13.76
	-5	7.77	9.43	8.81	13.76	13.76	13.76	13.76
	0	7.77	9.43	8.81	13.76	13.76	13.76	13.76
	5	7.77	9.43	8.81	13.76	13.76	13.76	13.76
	10	7.77	9.43	8.81	13.76	13.76	13.76	13.76
	15	7.77	9.43	8.81	13.76	13.76	13.76	13.76
	20	6.46	7.61	7.32	10.71	10.71	10.71	10.71
	25	5.24	5.99	6.06	8.36	8.36	8.36	8.36
	30	4.25	4.75	5.55	6.61	6.61	6.61	6.61
	35	3.45	3.79	4.30	5.31	5.31	5.31	5.31
	40	2.84	3.07	3.39	4.34	4.34	4.34	4.34
	43	2.54	2.72	2.97	3.88	3.88	3.88	3.88
	45	2.37	2.52	2.73	3.61	3.61	3.61	-
50	2.00	2.10	2.24	2.53	2.53	-	-	
52	1.87	1.96	2.08	2.32	2.32	-	-	

2. Product Data

COP for heating [Water]

EAHV-M1500YCL

Water flow rate 25.8 m³/h

EAHV-M-YCL(-N), EACV-M-YCL(-N)

Capacity	Air temp (°C D.B)	Outlet water temp (°C)						
		25	30	35	40	45	50	55
150kW (100%)	-20	-	-	-	-	-	-	-
	-15	-	-	-	-	-	-	-
	-10	-	-	-	-	-	-	-
	-5	3.79	3.48	3.17	-	-	-	-
	0	4.39	4.01	3.65	3.32	3.01	-	-
	5	5.07	4.57	4.12	3.72	3.37	-	-
	7	5.40	4.84	4.34	3.90	3.52	-	-
	10	6.00	5.30	4.71	4.20	3.77	3.39	3.05
	15	7.42	6.34	5.50	4.82	4.26	3.79	3.40
	20	7.42	6.34	5.50	4.82	4.26	3.79	3.40
	25	7.42	6.34	5.50	4.82	4.26	3.79	3.40
	30	7.42	6.34	5.50	4.82	4.26	3.79	3.40
	35	7.42	6.34	5.50	4.82	4.26	3.79	3.40
	40	7.42	6.34	5.50	4.82	4.26	3.79	-
43	7.42	6.34	5.50	4.82	4.26	-	-	
112.5kW (75%)	-20	-	-	-	-	-	-	-
	-15	3.06	2.80	2.54	-	-	-	-
	-10	3.55	3.25	2.96	2.70	2.45	2.22	-
	-5	4.02	3.65	3.31	3.01	2.72	2.47	2.24
	0	4.59	4.13	3.71	3.34	3.01	2.71	2.44
	5	5.38	4.77	4.23	3.76	3.35	2.99	2.67
	7	5.79	5.09	4.48	3.96	3.51	3.12	2.78
	10	6.53	5.64	4.91	4.30	3.78	3.34	2.96
	15	8.18	6.82	5.79	4.98	4.32	3.79	3.34
	20	8.18	6.82	5.79	4.98	4.32	3.79	3.34
	25	8.18	6.82	5.79	4.98	4.32	3.79	3.34
	30	8.18	6.82	5.79	4.98	4.32	3.79	3.34
	35	8.18	6.82	5.79	4.98	4.32	3.79	3.34
	40	8.18	6.82	5.79	4.98	4.32	3.79	-
43	8.18	6.82	5.79	4.98	4.32	-	-	
75kW (50%)	-20	2.92	2.60	2.33	2.11	1.91	-	-
	-15	3.23	2.88	2.57	2.31	2.08	-	-
	-10	3.56	3.18	2.84	2.53	2.27	2.03	-
	-5	4.01	3.58	3.18	2.82	2.50	2.22	1.97
	0	4.62	4.10	3.63	3.20	2.81	2.46	2.16
	5	5.47	4.78	4.19	3.67	3.20	2.79	2.43
	7	5.88	5.10	4.45	3.88	3.38	2.94	2.56
	10	6.61	5.65	4.87	4.22	3.67	3.19	2.78
	15	8.20	6.77	5.71	4.87	4.20	3.65	3.18
	20	8.20	6.77	5.71	4.87	4.20	3.65	3.18
	25	8.20	6.77	5.71	4.87	4.20	3.65	3.18
	30	8.20	6.77	5.71	4.87	4.20	3.65	3.18
	35	8.20	6.77	5.71	4.87	4.20	3.65	3.18
	40	8.20	6.77	5.71	4.87	4.20	3.65	-
43	8.20	6.77	5.71	4.87	4.20	-	-	
37.5kW (25%)	-20	2.79	2.32	1.94	1.64	1.40	-	-
	-15	2.97	2.56	2.19	1.86	1.58	-	-
	-10	3.28	2.89	2.52	2.18	1.85	1.55	-
	-5	3.89	3.48	3.11	2.57	2.23	1.88	1.55
	0	4.51	4.01	3.54	3.13	2.74	2.41	1.95
	5	5.33	4.67	4.09	3.59	3.13	2.72	2.36
	7	5.73	4.97	4.34	3.79	3.30	2.86	2.49
	10	6.40	5.47	4.73	4.11	3.57	3.10	2.69
	15	7.81	6.49	5.49	4.70	4.05	3.52	3.06
	20	7.81	6.49	5.49	4.70	4.05	3.52	3.06
	25	7.81	6.49	5.49	4.70	4.05	3.52	3.06
	30	7.81	6.49	5.49	4.70	4.05	3.52	3.06
	35	7.81	6.49	5.49	4.70	4.05	3.52	3.06
	40	7.81	6.49	5.49	4.70	4.05	3.52	-
43	7.81	6.49	5.49	4.70	4.05	-	-	

2. Product Data

COP for heating [Water]

EAHV-M1800YCL

Water flow rate 31.0 m³/h

Capacity	Air temp (°C D.B)	Outlet water temp (°C)						
		25	30	35	40	45	50	55
180kW (100%)	-20	-	-	-	-	-	-	-
	-15	-	-	-	-	-	-	-
	-10	-	-	-	-	-	-	-
	-5	-	-	-	-	-	-	-
	0	-	-	-	-	-	-	-
	5	4.75	4.32	3.93	3.57	3.23	-	-
	7	5.06	4.57	4.14	3.75	3.39	-	-
	10	5.62	5.02	4.50	4.04	3.64	3.29	2.97
	15	6.90	5.99	5.26	4.65	4.14	3.71	3.33
	20	6.90	5.99	5.26	4.65	4.14	3.71	3.33
	25	6.90	5.99	5.26	4.65	4.14	3.71	3.33
	30	6.90	5.99	5.26	4.65	4.14	3.71	3.33
	35	6.90	5.99	5.26	4.65	4.14	3.71	3.33
	40	6.90	5.99	5.26	4.65	4.14	3.71	-
43	6.90	5.99	5.26	4.65	4.14	-	-	
135kW (75%)	-20	-	-	-	-	-	-	-
	-15	-	-	-	-	-	-	-
	-10	3.30	3.04	-	-	-	-	-
	-5	3.78	3.47	3.17	2.89	2.63	2.36	2.06
	0	4.37	3.96	3.59	3.26	2.95	2.67	2.41
	5	5.17	4.62	4.13	3.70	3.32	2.99	2.69
	7	5.58	4.95	4.39	3.91	3.49	3.13	2.81
	10	6.32	5.51	4.84	4.27	3.79	3.37	3.01
	15	8.02	6.75	5.77	5.00	4.37	3.85	3.41
	20	8.02	6.75	5.77	5.00	4.37	3.85	3.41
	25	8.02	6.75	5.77	5.00	4.37	3.85	3.41
	30	8.02	6.75	5.77	5.00	4.37	3.85	3.41
	35	8.02	6.75	5.77	5.00	4.37	3.85	3.41
	40	8.02	6.75	5.77	5.00	4.37	3.85	-
43	8.02	6.75	5.77	5.00	4.37	-	-	
90kW (50%)	-20	2.91	2.64	2.40	2.18	1.97	-	-
	-15	3.18	2.88	2.62	2.38	2.16	-	-
	-10	3.53	3.19	2.88	2.60	2.35	2.12	-
	-5	4.03	3.61	3.24	2.90	2.59	2.32	2.08
	0	4.71	4.19	3.73	3.30	2.92	2.58	2.29
	5	5.65	4.95	4.34	3.81	3.34	2.93	2.57
	7	6.11	5.32	4.63	4.04	3.54	3.09	2.71
	10	6.94	5.93	5.11	4.43	3.85	3.36	2.94
	15	8.79	7.22	6.07	5.18	4.46	3.88	3.39
	20	8.79	7.22	6.07	5.18	4.46	3.88	3.39
	25	8.79	7.22	6.07	5.18	4.46	3.88	3.39
	30	8.79	7.22	6.07	5.18	4.46	3.88	3.39
	35	8.79	7.22	6.07	5.18	4.46	3.88	3.39
	40	8.79	7.22	6.07	5.18	4.46	3.88	-
43	8.79	7.22	6.07	5.18	4.46	-	-	
45kW (25%)	-20	2.85	2.39	2.03	1.76	1.54	-	-
	-15	3.08	2.65	2.29	1.97	1.70	-	-
	-10	3.41	3.00	2.63	2.28	1.95	1.67	-
	-5	3.82	3.40	3.01	2.64	2.29	1.96	1.66
	0	4.29	3.81	3.39	3.00	2.64	2.30	1.96
	5	5.47	4.81	4.23	3.71	3.25	2.62	2.29
	7	5.91	5.15	4.50	3.93	3.43	3.00	2.41
	10	6.67	5.71	4.93	4.28	3.72	3.24	2.83
	15	8.27	6.85	5.78	4.94	4.26	3.70	3.23
	20	8.27	6.85	5.78	4.94	4.26	3.70	3.23
	25	8.27	6.85	5.78	4.94	4.26	3.70	3.23
	30	8.27	6.85	5.78	4.94	4.26	3.70	3.23
	35	8.27	6.85	5.78	4.94	4.26	3.70	3.23
	40	8.27	6.85	5.78	4.94	4.26	3.70	-
43	8.27	6.85	5.78	4.94	4.26	-	-	

EAHV-M-YCL(-N), EACV-M-YCL(-N)

2. Product Data

2-1-3. Correction by relative humidity

[EAHV]

■ Heating capacity correction diagram (relative humidity correction diagram)

The heating capacity changes depending on the relative humidity.

When the relative humidity is other than RH=85%, correct the capacity based on the following graph.

[Example] When the outdoor air temperature = 0°C and relative humidity RH=50%
 Heating capacity in performance diagram × 0.926 <Correction value> = Heating capacity after correction

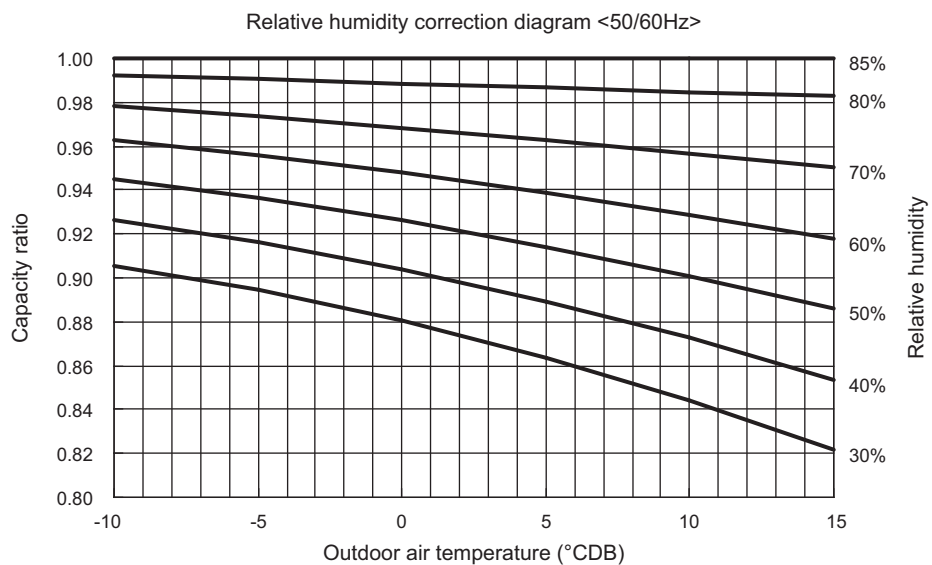

■ Heating capacity reduction factor by frosting (reference)

Outdoor air temperature (DB)	-7°C	-5°C	-3°C	0°C	3°C	5°C	7°C
Heating capacity reduction factor	0.87	0.87	0.86	0.84	0.87	0.98	1.00

* In the actual setup status, there are factors (weather, outside wind, relative humidity, etc.) other than outdoor air temperature, so consider the above factors as references.

2. Product Data

2-1-4. Correction by water flow rate

EAHV-M1500YCL
EACV-M1500YCL

■ Cooling

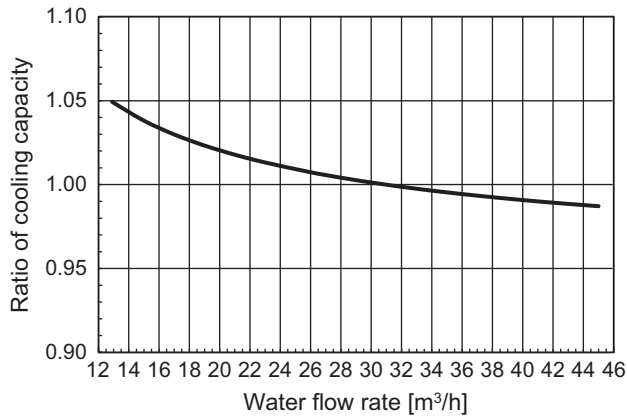

*Conditions
Outdoor temperature 35°C
Outlet water temperature 7°C

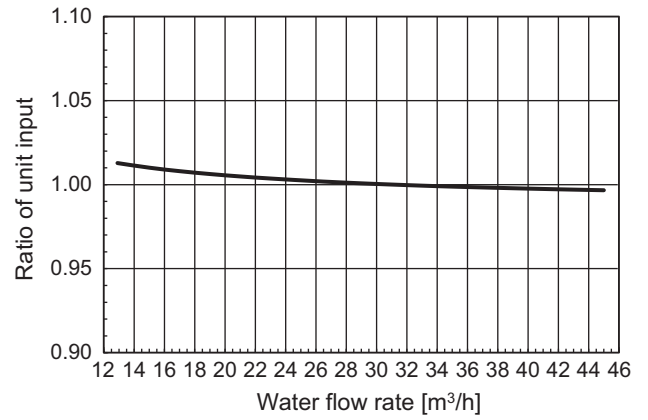

*Conditions
Outdoor temperature 35°C
Outlet water temperature 7°C

■ Heating

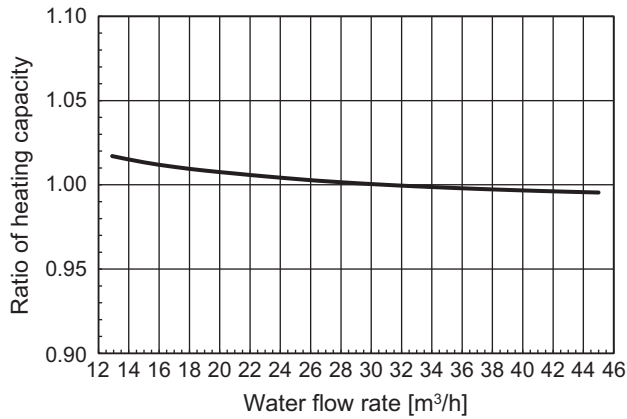

*Conditions
Outdoor temperature 7°C
Outlet water temperature 45°C

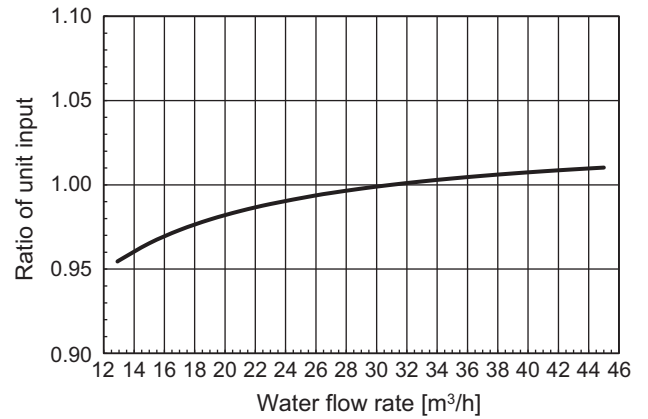

*Conditions
Outdoor temperature 7°C
Outlet water temperature 45°C

2. Product Data

EAHV-M1800YCL
EACV-M1800YCL

■ Cooling

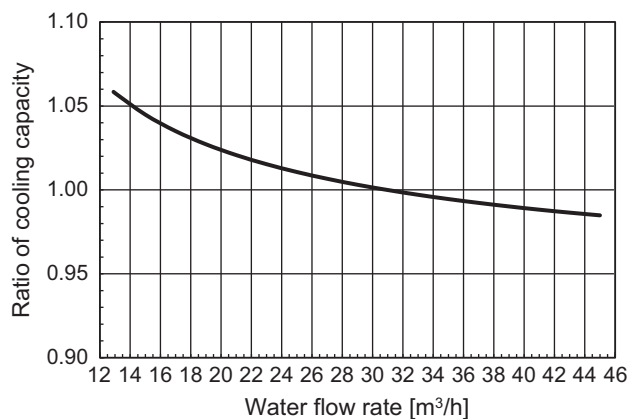

*Conditions
Outdoor temperature 35°C
Outlet water temperature 7°C

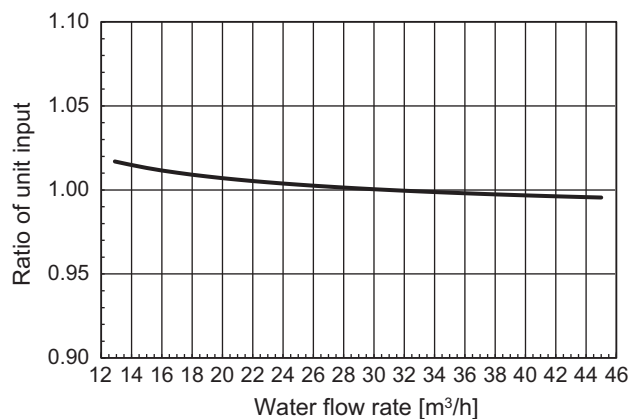

*Conditions
Outdoor temperature 35°C
Outlet water temperature 7°C

■ Heating

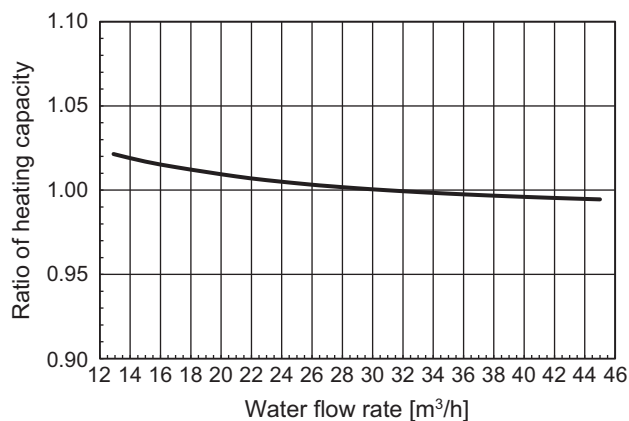

*Conditions
Outdoor temperature 7°C
Outlet water temperature 45°C

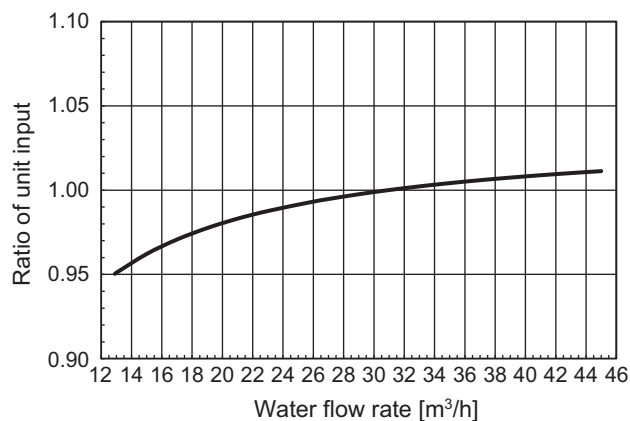

*Conditions
Outdoor temperature 7°C
Outlet water temperature 45°C

2. Product Data

2-1-5. Water pressure drop

EAHV-M1500, 1800YCL
EACV-M1500, 1800YCL
[Water]

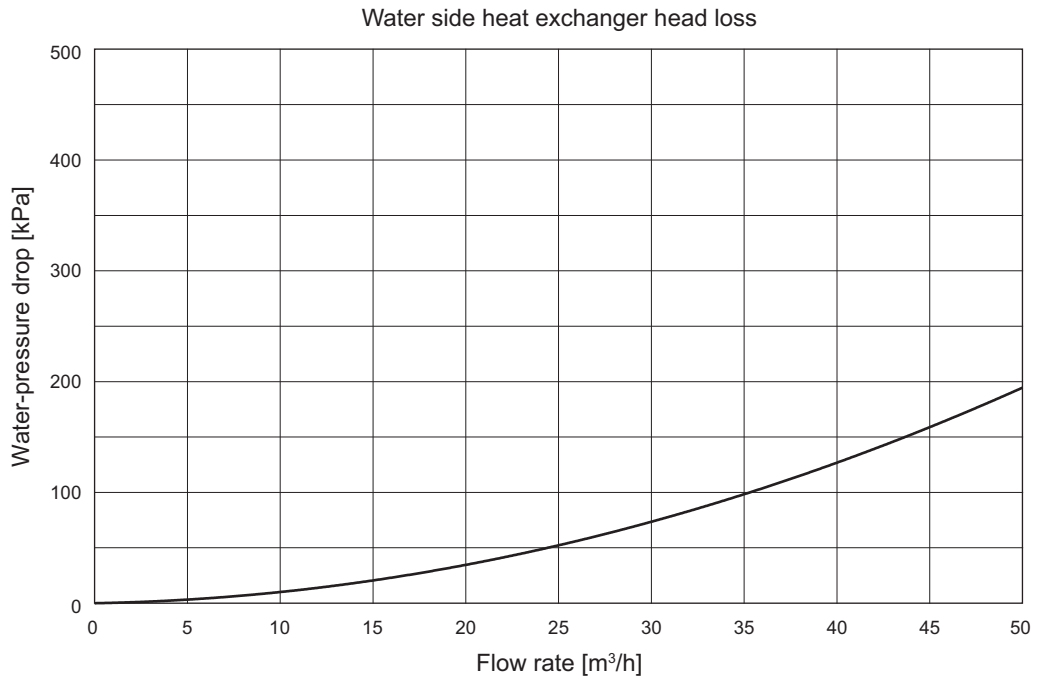

EAHV-M1500, 1800YCL-N
EACV-M1500, 1800YCL-N
[Water]

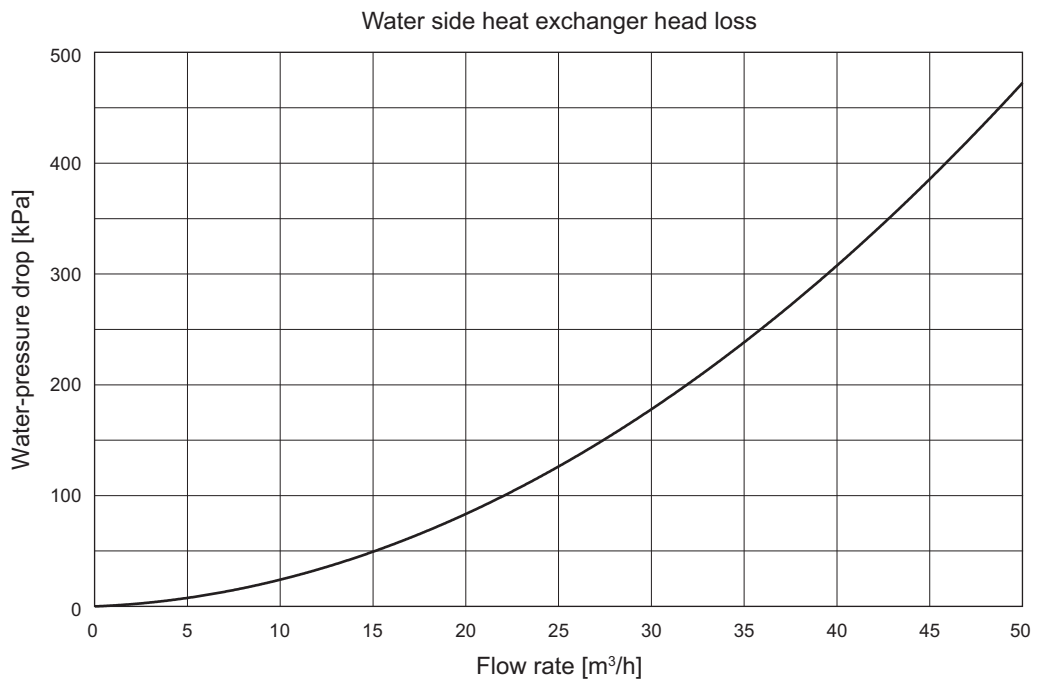

2. Product Data

2-1-6. Operation temperature range

EAHV-M1500, 1800YCL(-N)(-BS)

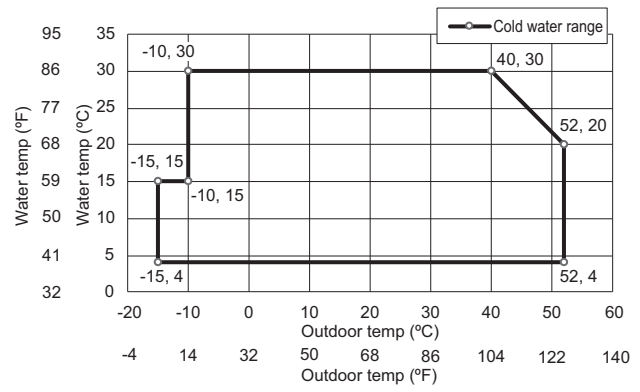
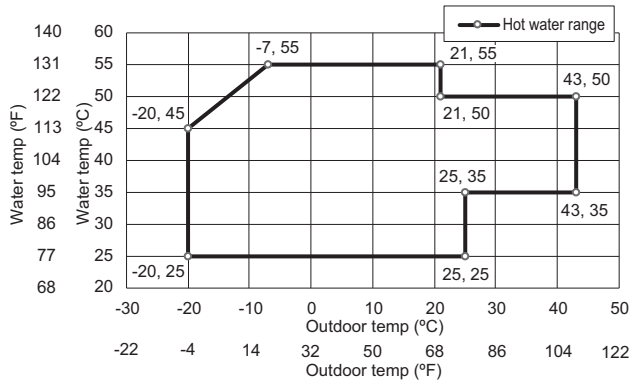

EACV-M1500, 1800YCL(-N)(-BS)

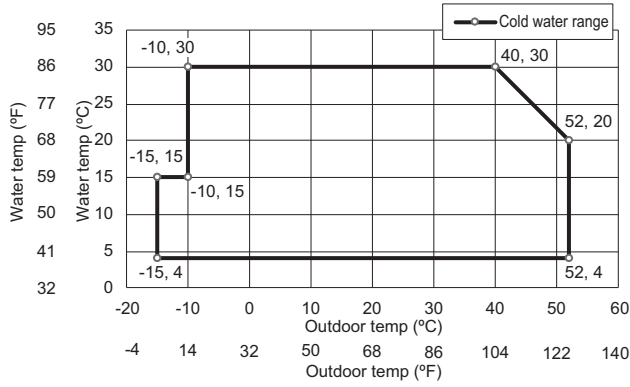

EAHV-M-YCL(-N), EACV-M-YCL(-N)

2. Product Data

2-2. Sound pressure levels

Measurement condition
 EAHV-M1500, 1800YCL
 EACV-M1500, 1800YCL

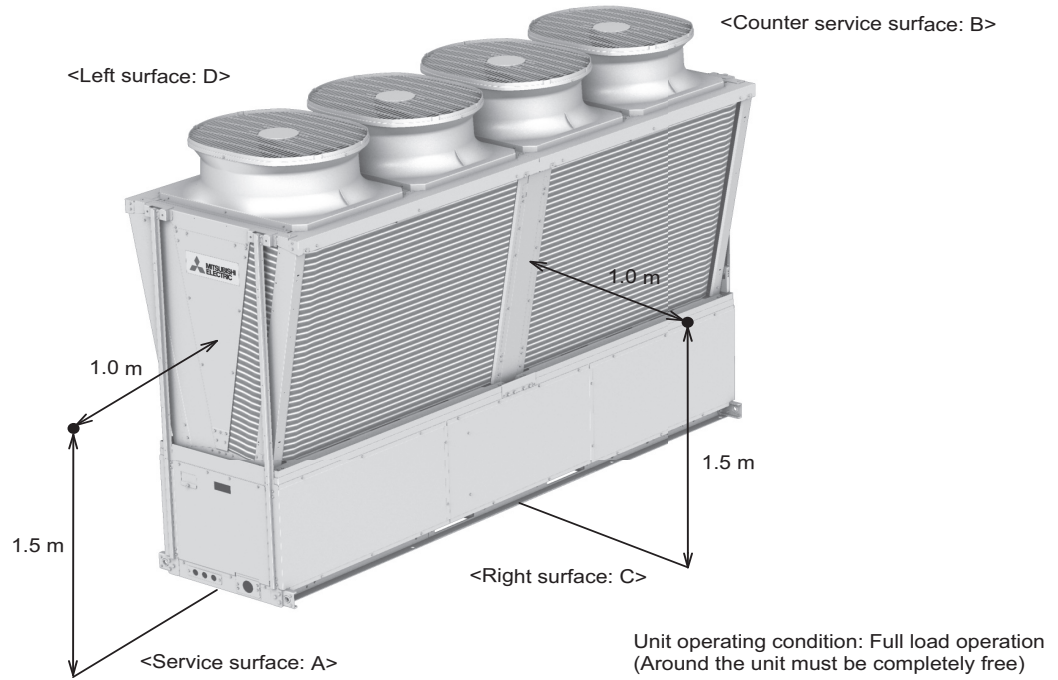

Sound pressure level

The following values are the planned value.

Sound pressure level dB <A> (anechoic room level)		
Measurement location	EAHV-M1500YCL EACV-M1500YCL	EAHV-M1800YCL EACV-M1800YCL
Service surface: A	65	67
Counter service surface: B	65	67
Right surface: C	68	71
Left surface: D	69	71

* The above values are obtained by converting the values measured in location with less echo sound to the anechoic room level. The values could be larger than those values if the operating conditions are different or the measuring location is affected by echo sound. (It could be roughly 4 dB to 6 dB higher though it depends on the installation conditions.)
 Regarding the installation, consider the effect of echo sound, implement soundproof treatment as necessary.

2. Product Data

EAHV-M1500YCL
EACV-M1500YCL

EAHV-M-YCL(-N), EACV-M-YCL(-N)

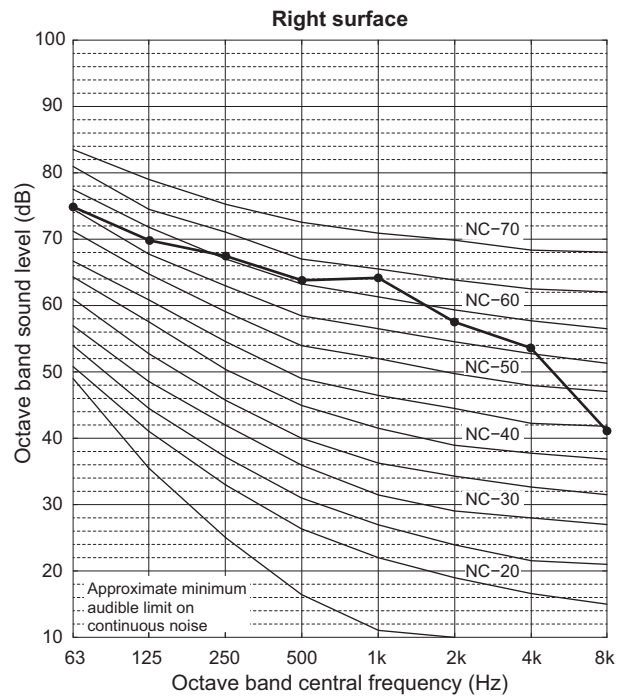
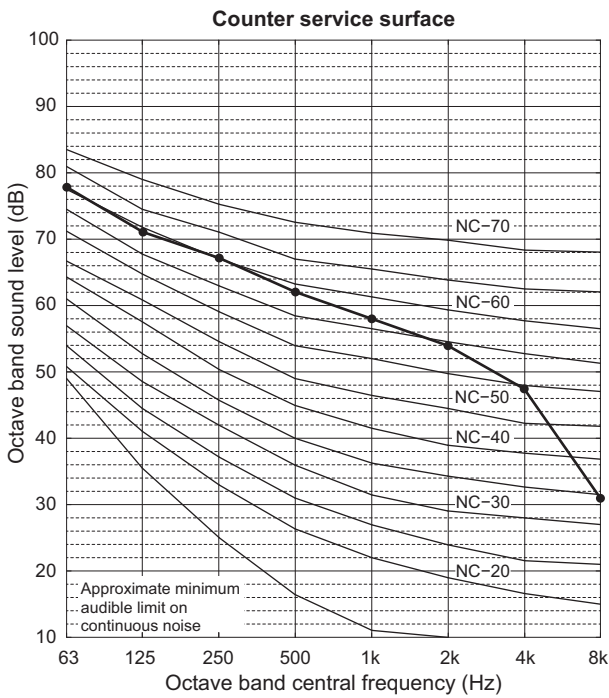
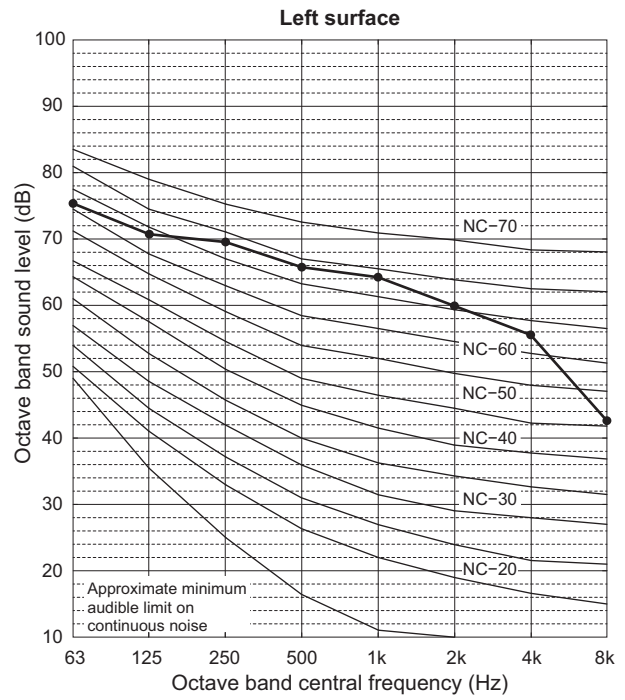
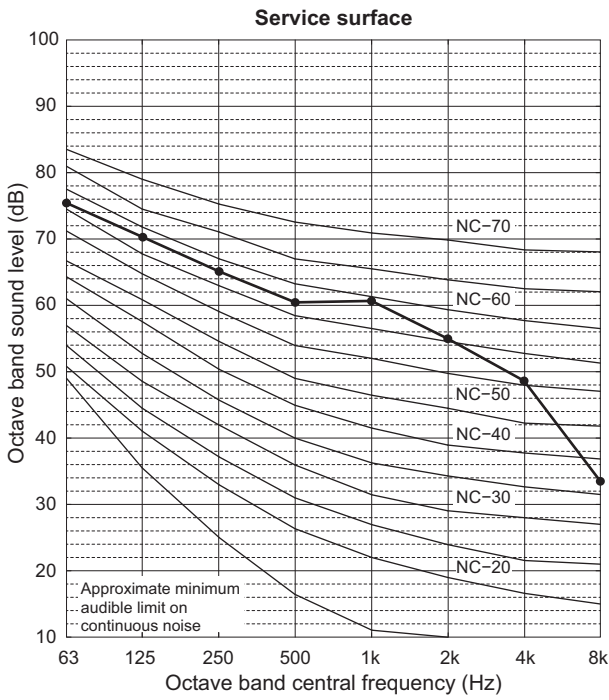

2. Product Data

EAHV-M1800YCL
EACV-M1800YCL

EAHV-M-YCL(-N), EACV-M-YCL(-N)

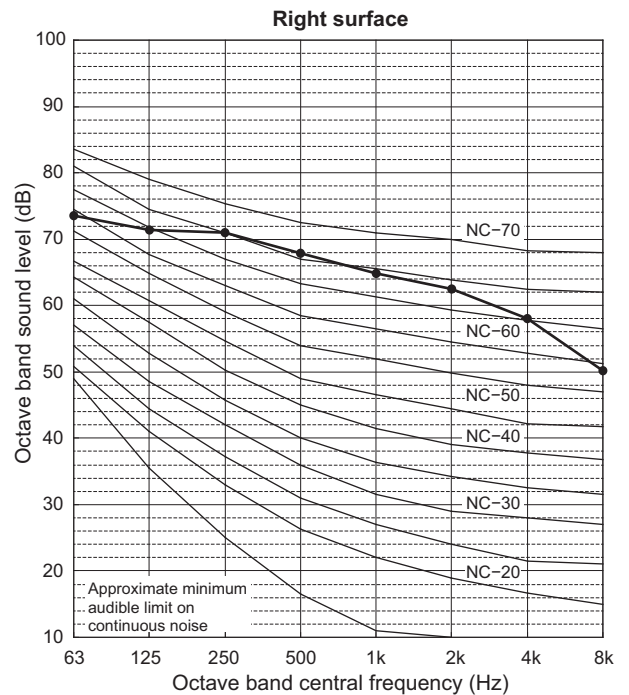
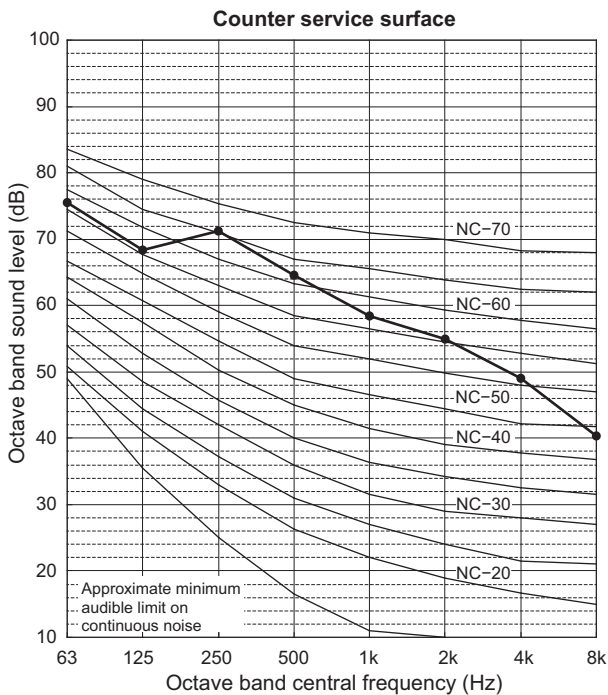
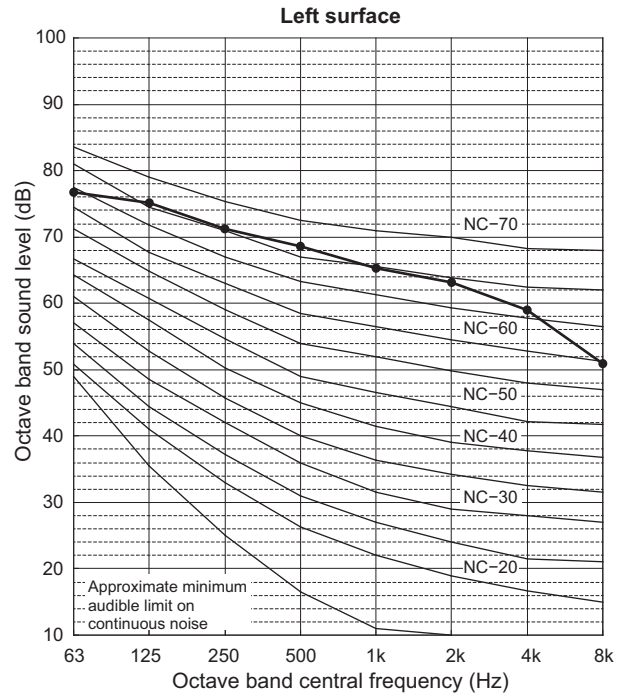
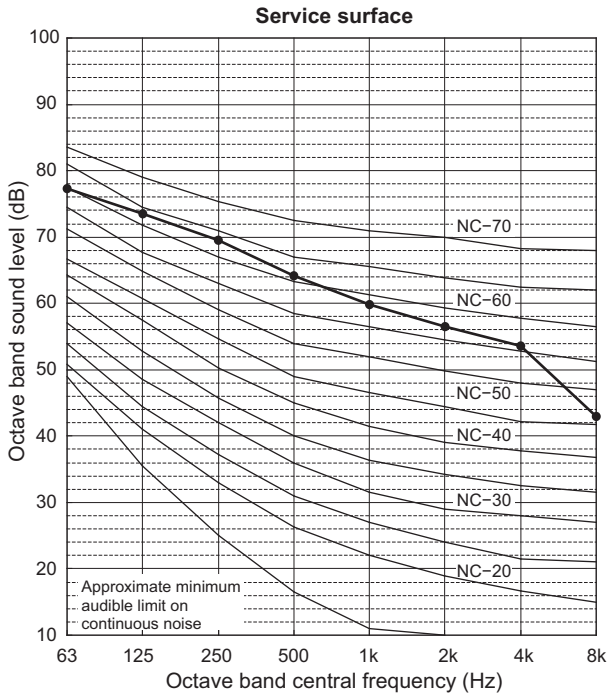

2. Product Data

2-3. Vibration levels

EAHV-M1500, 1800YCL
EACV-M1500, 1800YCL

EAHV-M-YCL(-N), EACV-M-YCL(-N)

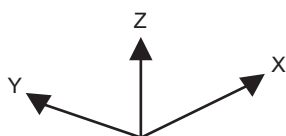
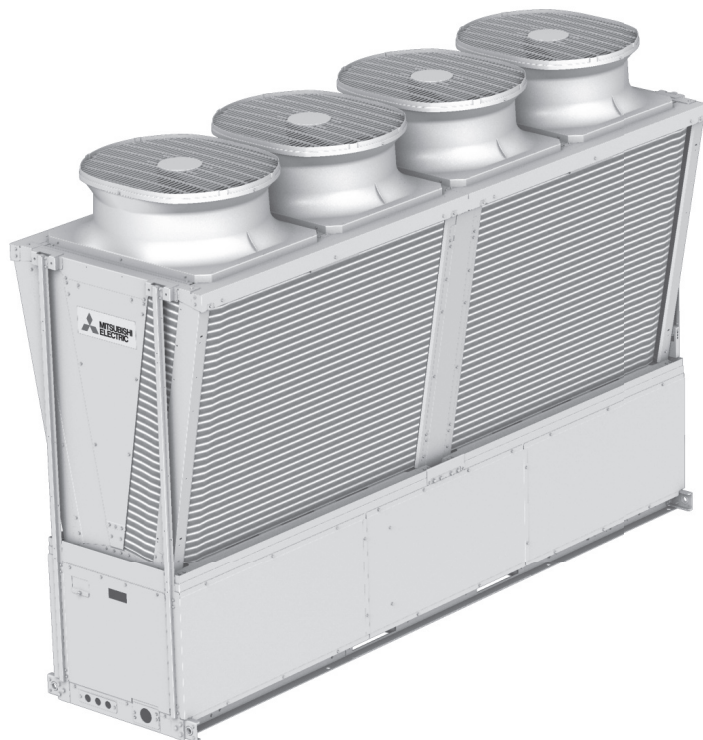

unit: μm (one side amplitude effective value)

	X	Y	Z
A	1	4	3
B	1	2	4
C	1	2	3
D	1	4	3

* The above values are the planned value.

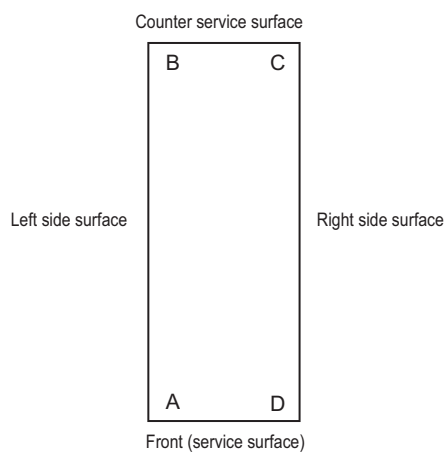

Note

- Unit operation condition
 - Full load operation
- Unit installation conditions
 - Directly placed on the surface plate in the test room in the Works

2. Product Data

2-4. Salt Protection Specifications

No.	Name	Base material	EAHV/EACV		Surface treatment	Treatment thickness	
			standard	salt damage protection		External	Internal
1	Fan guard Bell mouth	Polypropylene resin	●	●	-	-	-
2	Panel	Alloyed galvanized sheet	●		Polyester resin coating	30 μm or more	-
				●	Polyester resin coating	70 μm or more	70 μm or more
3	Fan	AS resin	●	●	-	-	-
4	Motor	Unsaturated polyester resin	●	●	-	-	-
5	Motor support	Galvanized sheet	●	●	-	-	-
6	Heat exchanger (Only fin)	Aluminum fin	●	●	Zinc coating	1 μm or more	-
7	Bottom frame (Including drain pan)	Alloyed galvanized sheet	●	●	Polyester resin coating	70 μm or more	70 μm or more
8	Compressor	Carbon steel	●	●	Epoxy resin coating	13 μm or more	13 μm or more
9	Pillar	Alloyed galvanized sheet	●		Polyester resin coating	30 μm or more	-
				●	Polyester resin coating	70 μm or more	70 μm or more
10	Water-side heat exchanger (Including water piping)	Stainless steel	●	●	-	-	-
11	Electrical parts box	Galvanized sheet	●	●	-	-	-
12	Printed circuit board	Composite material <CEM-3>	●	●	Polyurethane coating	20 μm or more	20 μm or more
13	Terminal box	Galvanized sheet	●	●	-	-	-
14	Receiver	Carbon steel	●		Phenolic modified alkyd resin dip	30 μm or more	-
				●	Epoxy resin and polyurethane resin coating	70 μm or more	-
15	Accumulator	Carbon steel	●		Phenolic modified alkyd resin dip	30 μm or more	-
				●	Epoxy resin and polyurethane resin coating	70 μm or more	-
16	Saddle (Water piping)	Stainless steel	●	●	-	-	-
17	Fin guard (Option)	Iron wires	●	●	Polyethylene resin coating	300 μm or more	300 μm or more
18	Screw	Stainless steel, Carbon steel	●	●	Zinc-nickel alloy plating + Geomet filming (only carbon steel screw)	-	-

Application Guide

		Distance from sea		
		300 m	500 m	1 km
Direct sea breeze	Facing inland sea	BS	STD	
	Facing ocean		BS	
	Island location		BS	
Indirect sea breeze	Facing inland sea	BS		STD
	Facing ocean		BS	
	Island location		BS	

Caution;

- 1 Set the outdoor unit to the place with rare direct sea breeze.
- 2 Don't attach a sunshade. A rain will clean the attached salt.
- 3 Set the outdoor unit horizontally. The water should not keep in the unit.
- 4 Please wash the outdoor unit periodically.
- 5 Repair the scratch on the panel as soon as possible.
- 6 Inspect periodically. Paint or change parts if necessary.

3. Installation

3-1. Selecting the Installation Site

3-1-1. Installation Conditions

Select the installation site in consultation with the client.

Select a site to install the unit that meets the following conditions:

- The unit will not be subject to heat from other heat sources.
- The noise from the unit will not be a problem.
- The unit will not be exposed to strong winds.
- Water from the unit can be drained properly.
- Enough space for installation and service as shown in 3-1. Selecting the Installation Site.
- There is a possibility of injuring with the fin of the heat exchanger, so abide by following contents.

- 1) Appliances are not accessible to the general public.
- 2) Limit the installation to a place where the general public cannot touch the product.
- 3) When installing in a location where the general public can touch the product, install the optional fin guard.

Option Parts: EC-130FG

When two units are joined

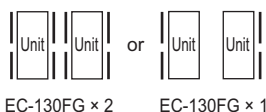

1. Protection against winds

- Pay attention to the wind direction and installation location to ensure that the air heat exchanger is not directly exposed to strong winds.
- If unable to avoid strong winds, install wind breaking hoods or walls, etc.

2. Cold Climate Installation

Observe the following when installing the units in areas where snow or strong winds prevail.

- Avoid direct exposure to rain, winds, and snow.
- If the unit is installed in the direct line of rain, winds, or snow, install snow hoods. Use a snow net or snow fence as necessary to protect the unit.
- Install the unit on a base approximately twice as high as the expected snowfall.
- If the unit of heating mode is continuously operated for a long time with the outdoor temperature below the freezing point, install a heater at the drain pan of the unit to prevent freezing of drain.

3. Weight

		Net weight (kg)	Operating weight (kg)
EAHV	Standard piping	1280	1315
	Inside header piping	1307	1382
EACV	Standard piping	1039	1074
	Inside header piping	1067	1142

* Weight of the optional parts: EC-01HK (30 kg), EC-02HK (44 kg), EC-130FG (20 kg)

3. Installation

3-1-2. Installation Space Requirement

1. Single unit installation

(1) Required space

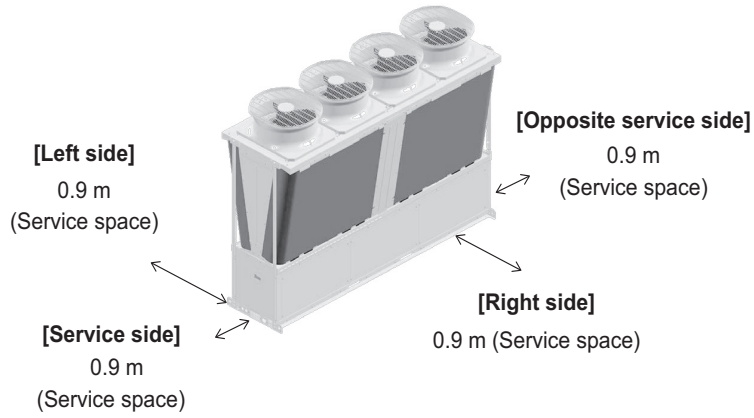

(2) If entire surrounding area enclosed by walls (but vent holes installed at bottom of wall)

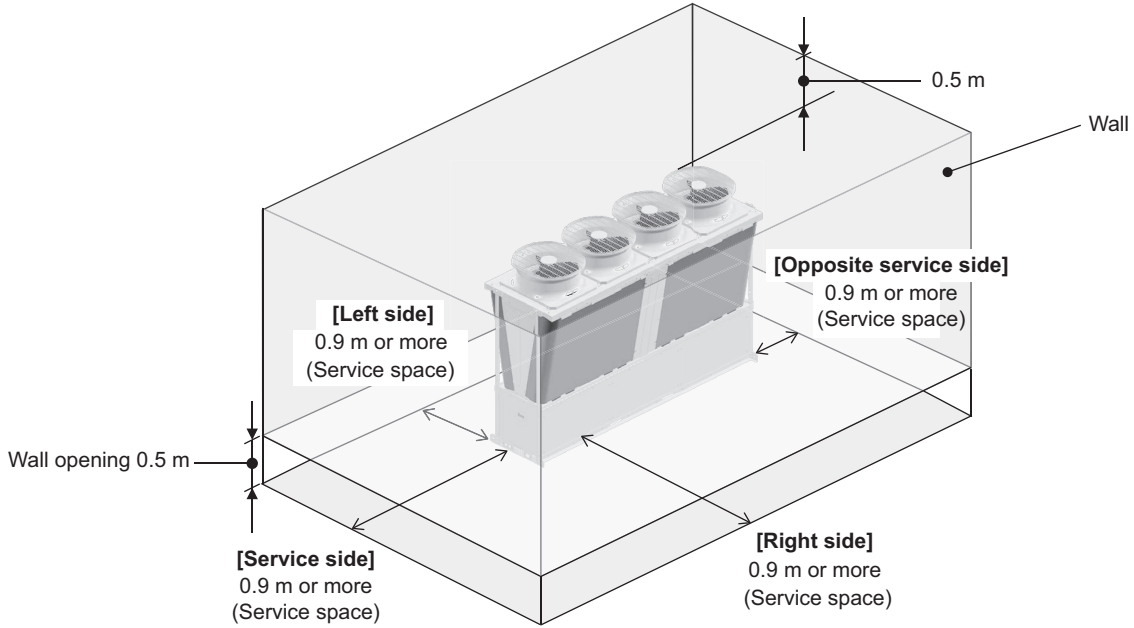

*Wall height 2.9 m (unit height (2.4 m + 0.5 m))

*Vent holes: 0.5 m from floor

*Even if installed as shown in this figure, a short cycle may occur due to the influence of wind.

3. Installation

2. Multiple unit installation

(1) Required space

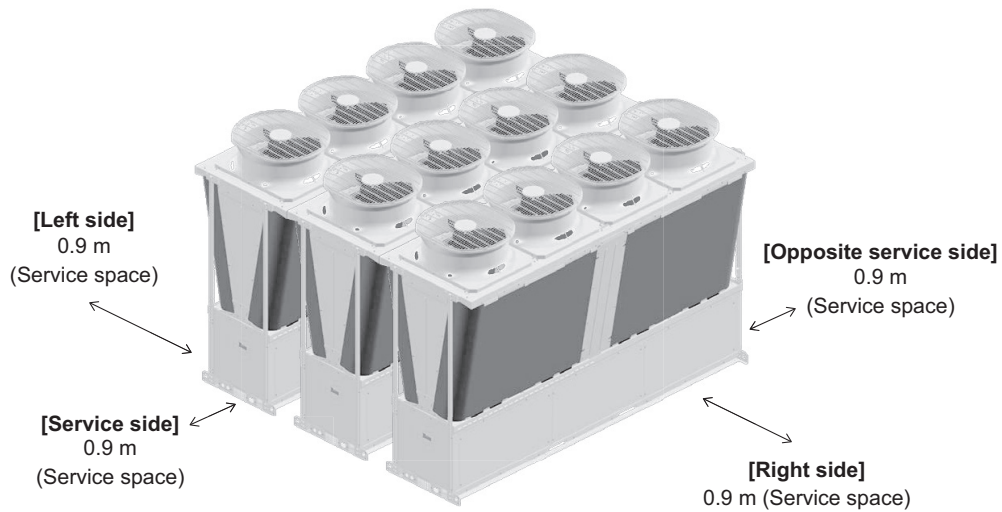

(2) If entire surrounding area enclosed by walls (but vent holes installed at bottom of wall)

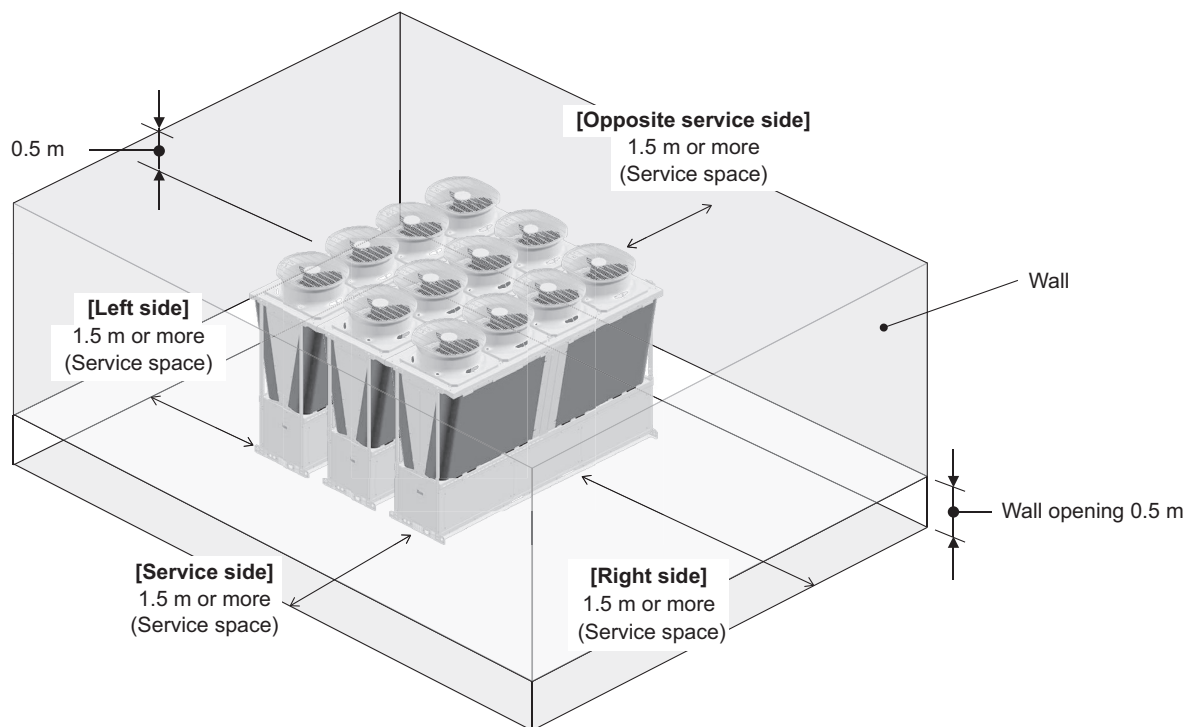

*Wall height 2.9 m (unit height (2.4 m + 0.5 m))

*Vent holes: 0.5 m from floor

*Even if installed as shown in this figure, a short cycle may occur due to the influence of wind.

3. Installation

3-2. Unit Installation

Units should be installed only by personnel certified by Mitsubishi Electric.

3-2-1. Product suspension method

- If transporting the product suspended, use the two suspension sections at the front and rear.
- Always feed rope through the four suspension sections so that the unit is not subjected to shocks.
- Use two ropes that are 10 m or longer. (Use four ropes that are 5 m or longer.)
- Use suspension equipment that is capable of supporting the weight of the product.
- Always suspend the product in four sections. (do not suspend the product two sections as this is dangerous)
- Use the appropriate protective pads to ensure that the rope does not rub against the outer panel.
- Refer to the center of gravity position shown in 1-3. Center of Gravity, and suspend the unit while taking care to prevent a deviated center of gravity.

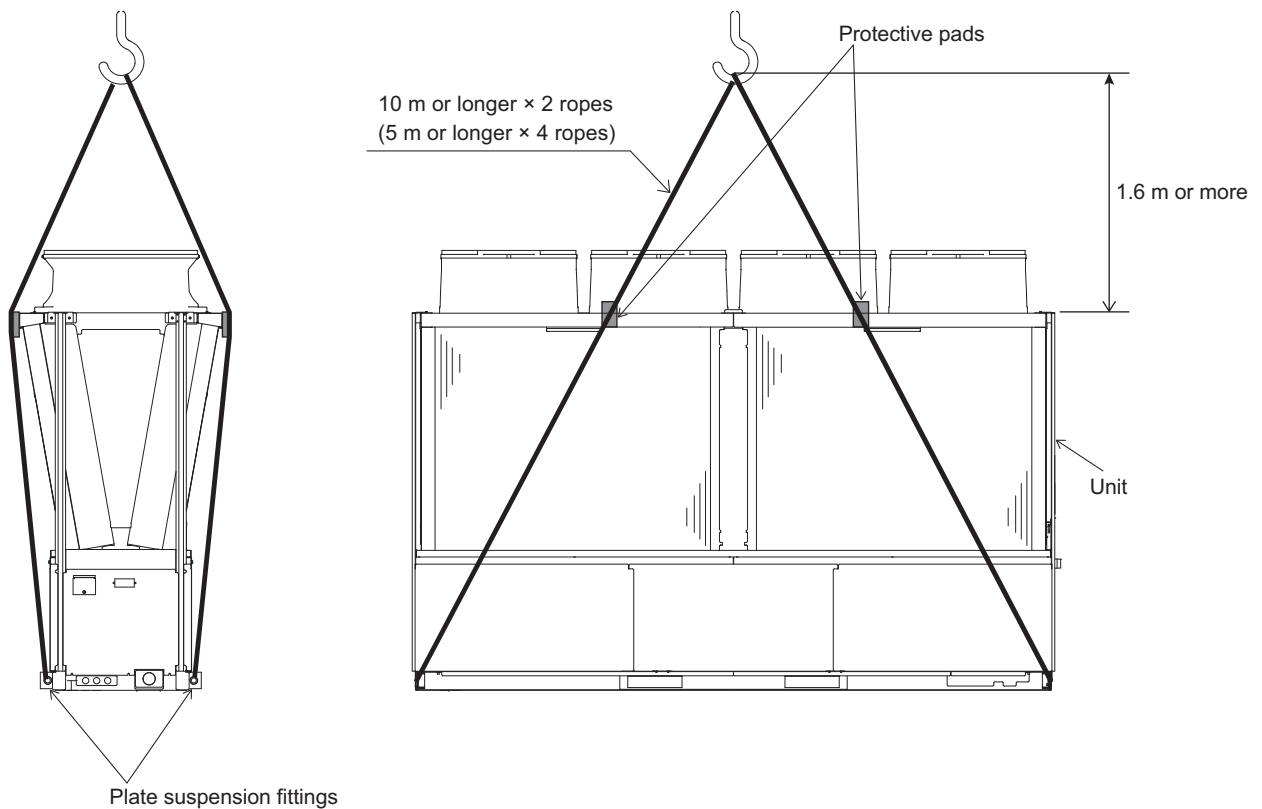

Warning:

- Lift the unit by placing the slings at designated locations. Support the unit securely at four points to keep it from slipping and sliding. If the unit is not properly supported, it may fall and cause personal injury.

3. Installation

3-2-2. Installation on foundation

- Securely fix the unit with bolts to keep the unit from falling down during earthquakes.
- Install the unit on a foundation made of concrete or iron.
- Noise and vibrations from the unit may be transmitted through the floor and walls. Provide adequate protection against noise and vibration. (Such as using damper pads)

⚠ Warning:

- Be sure to install the unit on a surface strong enough to withstand its weight to keep the unit from falling down and causing injury.
- Provide adequate protection against earthquakes. Improper installation may cause the unit to fall down, resulting in personal injury.

When building the foundation, take the floor strength, and piping and wiring routes into consideration. When using damper pads, be sure to attach them to all corners of the unit.

Bolt size	Number
M16	4

Unit: mm

[Enlarged view]

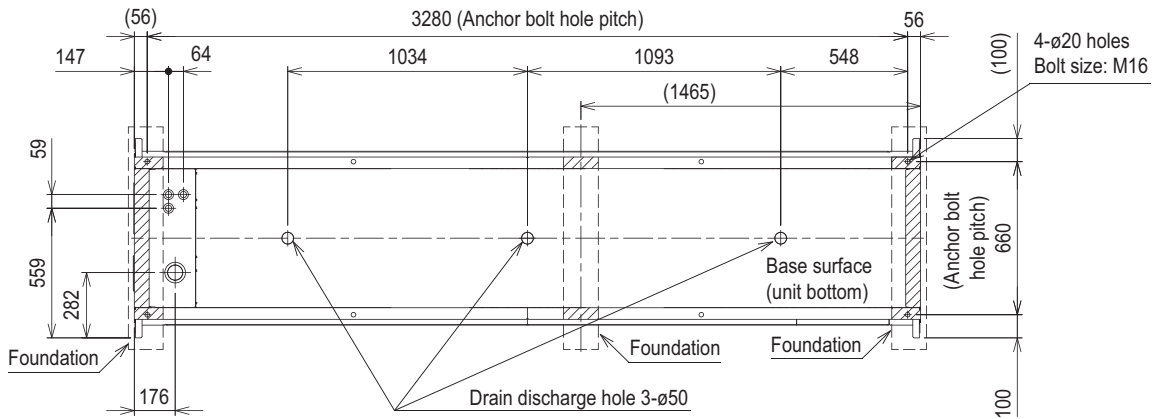
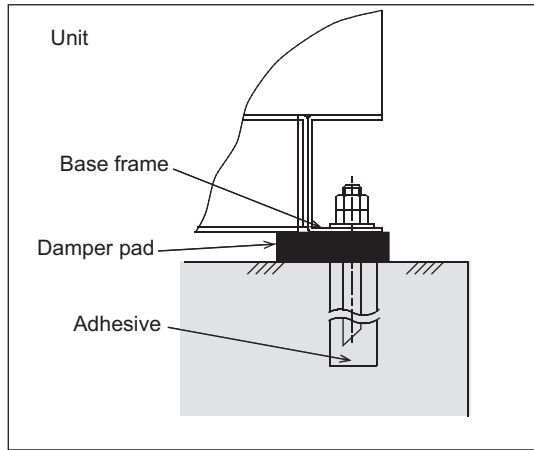

* show mounting surface.

EAHV-M-YCL(-N), EACV-M-YCL(-N)

4. System Design

4-1. Water Pipe Installation

4-1-1. Schematic Piping Diagram and Piping System Components

Water circuit

Please build the water circuit so that it is a closed system.

Do not use water directly for showers or other applications.

Do not allow other heat source water to mix with the water circuit.

Build a water circuit as inlet water temperature fluctuation is within 5°C/10 minutes.

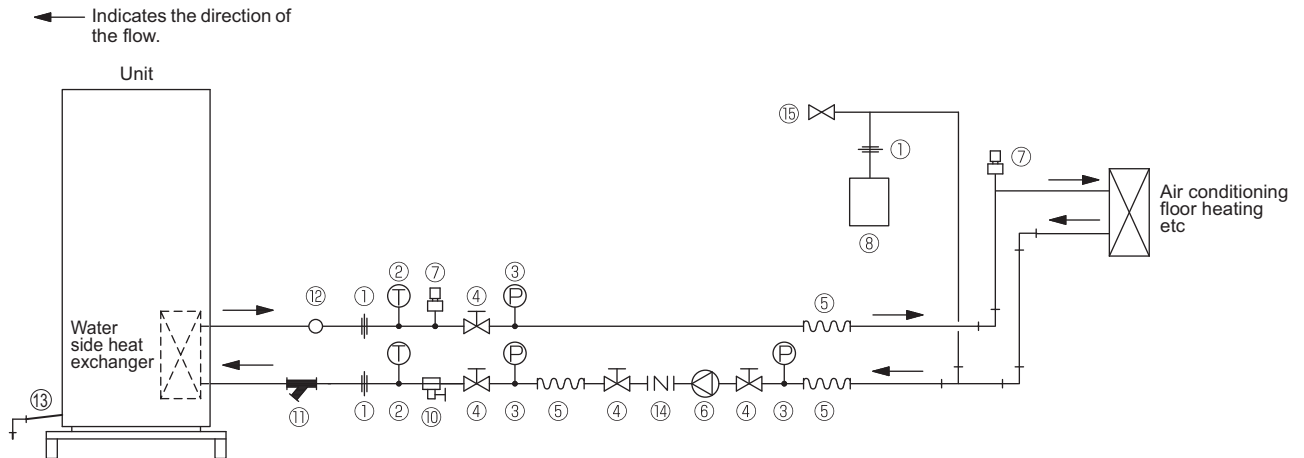

① Union joints/flange joints	Required to allow for a replacement of equipment.
② Thermometer	Required to check the performance and monitor the operation of the units.
③ Water pressure gauge	Recommended for checking the operation status.
④ Valve	Required to allow for a replacement or cleaning of the flow adjuster.
⑤ Flexible joint	Recommended to prevent the noise and vibration from the pump from being transmitted.
⑥ Pump	Use a pump that is large enough to compensate for the total water pressure loss and supply sufficient water to the unit.
⑦ Automatic air vent valve	Install automatic air vent valves where air accumulates. Even in the case of a failure of the water-side heat exchanger in the unit, the refrigerant may leak from the automatic air vent valve. To prevent accidents resulted from refrigerant leakage, install the unit where leaked refrigerant will not accumulate, such as outdoors.
⑧ Closed expansion tank	Install a closed expansion tank to accommodate expanded water and to supply water.
⑨ Water pipe	Use pipes that allow for easy air purging, and provide adequate insulation.
⑩ Drain valve	Install drain valves so that water can be drained for servicing.
⑪ Strainer	Install a strainer near the unit to keep foreign materials from entering the water-side head exchanger.
⑫ Flow switch	Required to protect the unit.
⑬ Drain pipe	Install the drain pipe with a downward inclination of between 1/100 and 1/200. To prevent drain water from freezing in winter, install the drain pipe as steep an angle as practically possible and minimize the straight line. For cold climate installation, take an appropriate measure (e.g., drain heater) to prevent the drain water from freezing.
⑭ Check valve	Required to prevent the backward flow.
⑮ Safety valve	Install a safety valve near the closed expansion tank. Even in the case of a failure of the water-side heat exchanger in the unit, the refrigerant may leak from the safety valve. To prevent accidents resulted from refrigerant leakage, install the unit where leaked refrigerant will not accumulate, such as outdoors.

4. System Design

4-1-2. Standard piping type

EAHV-M-YCL(-N), EACV-M-YCL(-N)

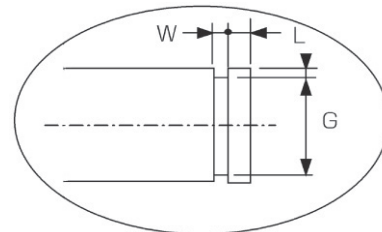
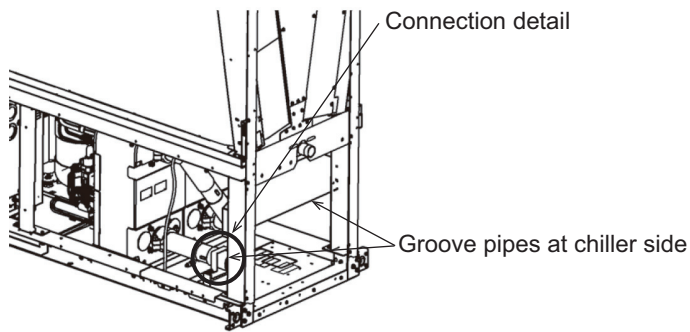
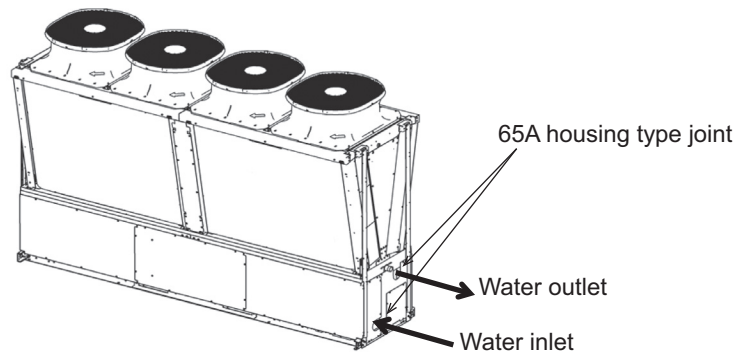

The dimension of the groove pipe at the chiller side

Victaulic standard groove specifications

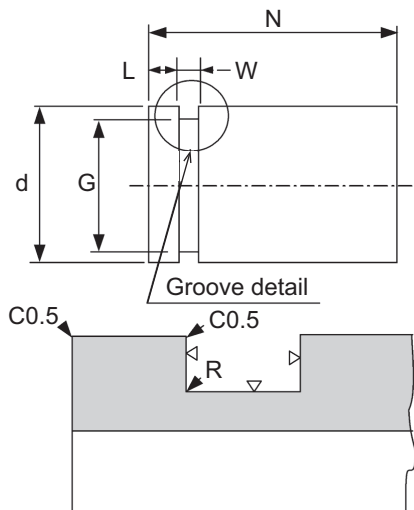

(Unit: mm)

	Pipe size
	2-1/2B (65A)
d	ø76.1
G	ø72.2 ⁺⁰ _{-0.4}
W	8.7 ⁺⁰ _{-0.7}
L	15.88 ⁺⁰ _{-0.7}
N	50
R	1.0

4. System Design

4-1-3. Inside header piping type

1. Inside header piping connection

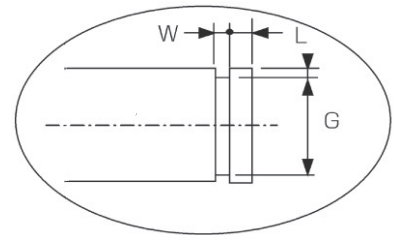
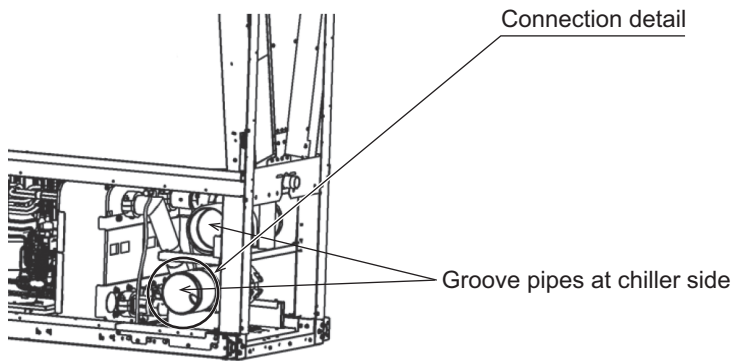
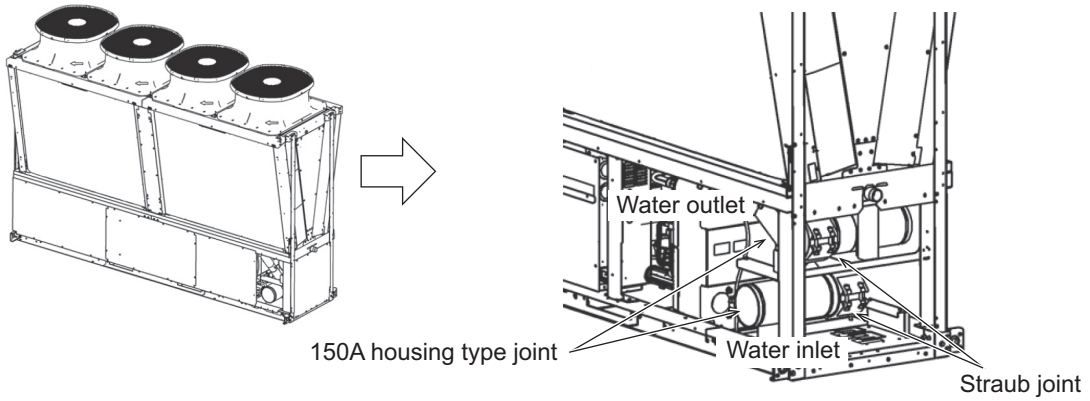

The dimension of the groove pipe at the chiller side

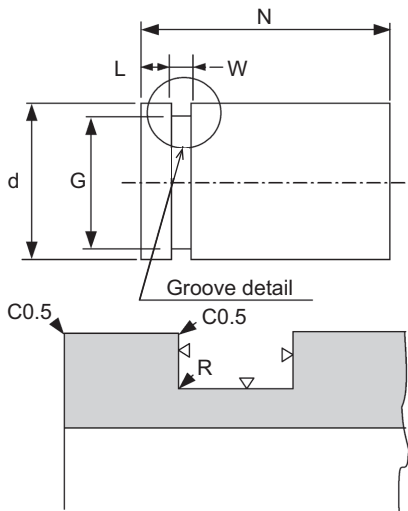

(Unit: mm)

	Pipe size 6B (150A)
d	ø165.1
G	ø160.8
W	8.7 $^{+0.7}_{-0}$
L	15.9 $^{+0.7}_{-0}$
N	50.0
R	1.0

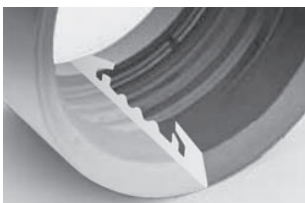

The seal rubber has a lip construction to improve water stopping performance.

Adjust the Straub position to that the marking on both sides is visible.

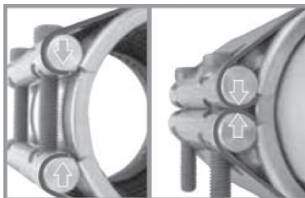

The bolts need only be tightened until the casing is sealed (metal touches). Consequently, the procedure can be carried out accurately by anyone to the same level, regardless of worker proficiency or the type of pipe.

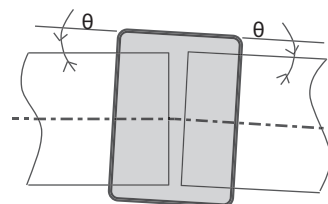
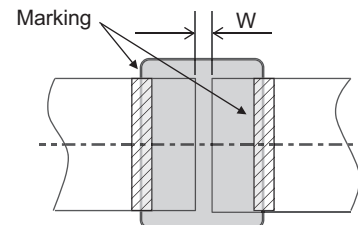

- Allowable tolerance for gaps and tilting
Pipe gap tolerance [W]: 0 to 25 mm
Allowable pipe tilt angle [θ]: ±2°

4. System Design

2. Inside header piping connection with joint pipe (LONG)

The joint pipe (LONG) size is included in the optional parts EC-02HK and can be used to secure wider working space.

♦The joint pipe (LONG) can be extended from its original size with a locally procured piping.

Inside header piping type unit (Multiple unit installation)

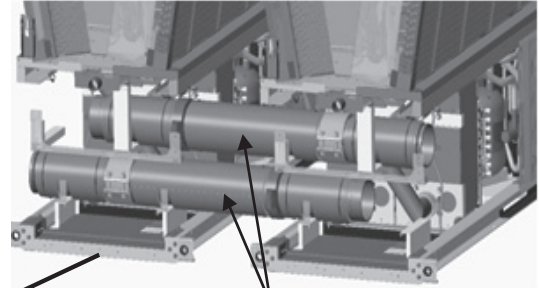
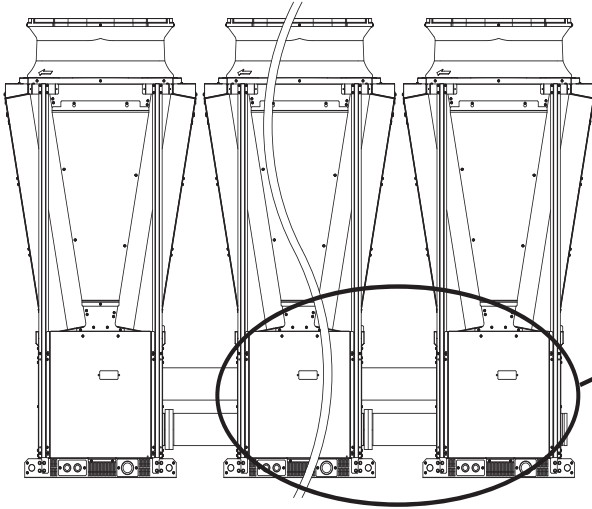

JOINT PIPE (LONG)

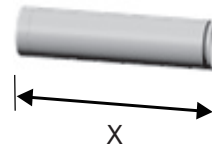

(Unit: mm)

	JOINT PIPE (LONG) size X
Original size	706
Max size	1232

* The joint pipe (LONG) size can be changed $706 \leq X \leq 1232$.

(Unit: mm)

	Pipe size 6B (150A)
d	ø165.1
G	ø160.8
W	8.7 $^{+0.7}_{-0}$
L	15.9 $^{+0.7}_{-0}$
X	$706 \leq X \leq 1232$
Y	43.0
Z	7.5

Material: SUS304

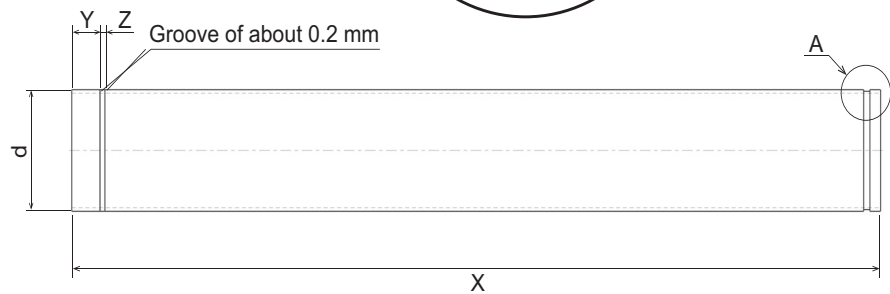
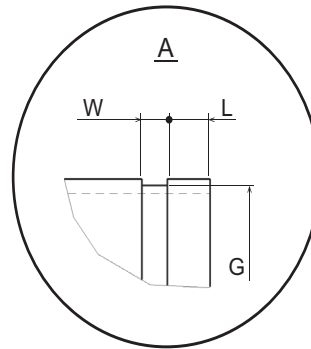

4-1-4. Notes on pipe corrosion

Water processing and water quality control

Poor-quality circulating water can cause scale build-up and corrosion in the water-side heat exchanger, reducing heat-exchange performance. Properly control the quality of the circulating water.

- ♦Removing foreign objects and impurities in the pipes
During installation, keep foreign objects, such as welding and sealant fragments and rust, out of the pipes.

♦Water Quality Control

- (1) Poor-quality water can corrode or scale up the heat exchanger. Regular water treatment is recommended.

Water circulation systems using open heat storage tanks are particularly prone to corrosion.

When using an open heat storage tank, install a water-to-water heat exchanger, and use a closed-loop circuit.

If a water supply tank is installed, keep contact with air to a minimum, and keep the level of dissolved oxygen in the water no higher than 1 mg/ℓ.

- (2) Water quality standard

Items		Lower mid-range temperature water system Water Temp. ≤ 60°C		Higher mid-range temperature water system Water Temp. > 60°C		Tendency	
		Recirculating water	Make-up water	Recirculating water	Make-up water	Corrosive	Scale-forming
Standard items	pH (25 °C)	7.0 ~ 8.0	7.0 ~ 8.0	7.0 ~ 8.0	7.0 ~ 8.0	○	○
	Electric conductivity (mS/m) (25 °C) (μs/cm) (25 °C)	30 or less [300 or less]	30 or less [300 or less]	30 or less [300 or less]	30 or less [300 or less]	○	○
	Chloride ion (mg Cl/ℓ)	50 or less	50 or less	30 or less	30 or less	○	
	Sulfate ion (mg SO ₄ ²⁻ /ℓ)	50 or less	50 or less	30 or less	30 or less	○	
	Acid consumption (pH4.8) (mg CaCO ₃ /ℓ)	50 or less	50 or less	50 or less	50 or less		○
	Total hardness (mg CaCO ₃ /ℓ)	70 or less	70 or less	70 or less	70 or less		○
	Calcium hardness (mg CaCO ₃ /ℓ)	50 or less	50 or less	50 or less	50 or less		○
	Ionic silica (mg SiO ₂ /ℓ)	30 or less	30 or less	30 or less	30 or less		○
Reference items	Iron (mg Fe/ℓ)	1.0 or less	0.3 or less	1.0 or less	0.3 or less	○	○
	Copper (mg Cu/ℓ)	1.0 or less	1.0 or less	1.0 or less	0.1 or less	○	
	Sulfide ion (mg S ²⁻ /ℓ)	Not to be detected	Not to be detected	Not to be detected	Not to be detected	○	
	Ammonium ion (mg NH ₄ ⁺ /ℓ)	0.3 or less	0.1 or less	0.1 or less	0.1 or less	○	
	Residual chlorine (mg Cl/ℓ)	0.25 or less	0.3 or less	0.1 or less	0.3 or less	○	
	Free carbon dioxide (mg CO ₂ /ℓ)	0.4 or less	4.0 or less	0.4 or less	4.0 or less	○	
Ryzner stability index	-	-	-	-	○	○	

Reference: Guideline of Water Quality for Refrigeration and Air Conditioning Equipment. (JRA GL02E-1994)

- (3) Please consult with a water quality control specialist about water quality control methods and water quality calculations before using anti-corrosive solutions for water quality management.

- (4) When replacing an air conditioner (including when only the heat exchanger is replaced), first analyze the water quality and check for possible corrosion.
Corrosion can occur in water systems in which there has been no signs of corrosion. If the water quality level has dropped, adjust the water quality before replacing the unit.

- (5) Suspended solids in the water

Sand, pebbles, suspended solids, and corrosion products in water can damage the heating surface of the heat exchanger and cause corrosion. Install a good quality strainer (20 mesh or better) at the inlet of the unit to filter out suspended solids.

Removing foreign substances from the water system

Consider installing a settlement tank or a bypass strainer to remove foreign substances from the water system.

Select a strainer capable of handling two to three percent of the circulating water. The figure below shows a sample system with a bypass strainer.

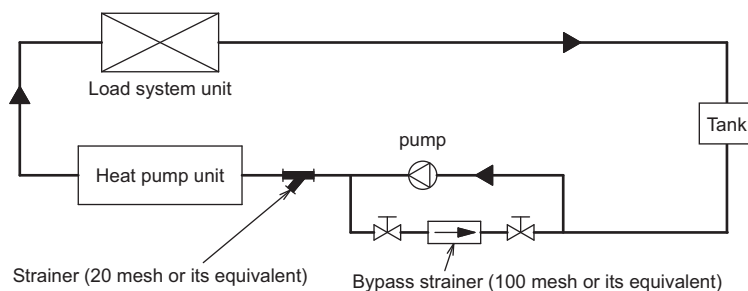

4. System Design

(6) Connecting pipes made from different materials

If different types of metals are placed in direct contact with each other, the contact surface will corrode.

Install an insulating material between pipes that are made of different materials to keep them out of direct contact with each other.

(7) Piping material

Use hot water output piping material that can withstand heat of 60°C or more. Use hot water input piping material that can withstand the maximum input water temperature. All piping must be made of SUS or similar material to withstand corrosion.

4-1-5. Installing the Strainer and Flow Switch

1. Installing the strainer

Install a strainer on the inlet pipe near the unit to filter out suspended solids and prevent clogging or corrosion of the heat exchanger.

Install a strainer in a way that allows for easy access for cleaning, and instruct the user to clean it regularly.

Operating the units with a clogged strainer may cause the units to make an abnormal stop. Select a location to install a strainer, taking into consideration the installation angle, insulation thickness, and maintenance space.

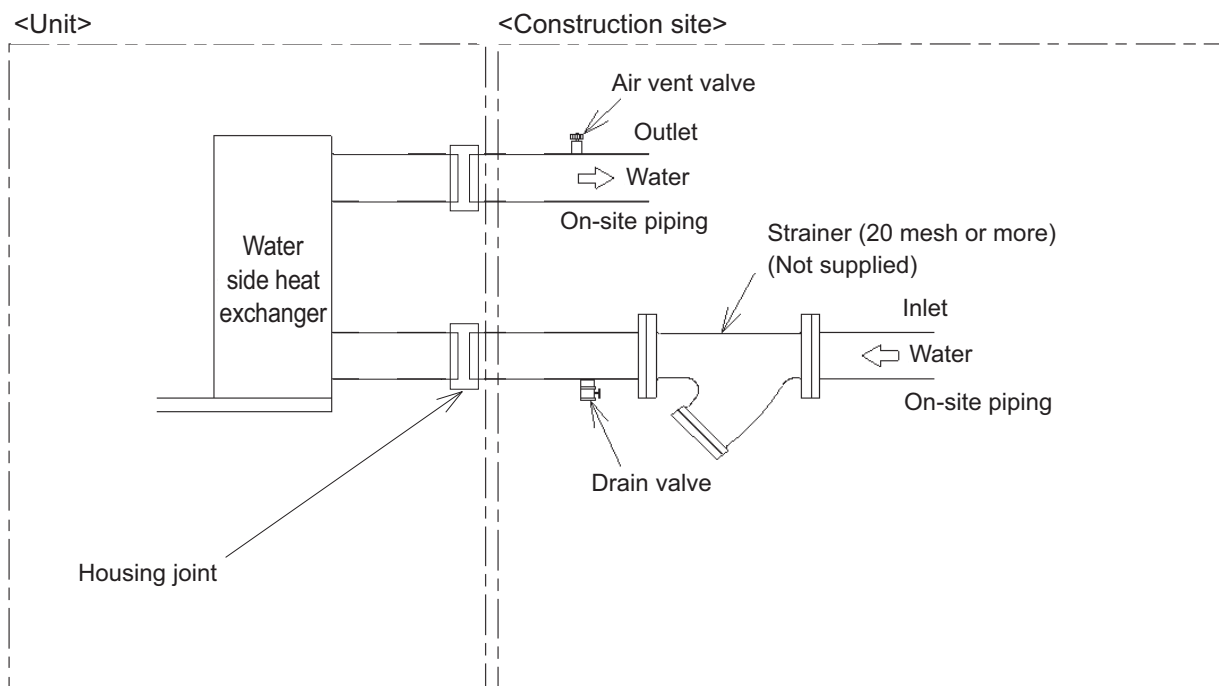

2. Installing a flow switch

Install a flow switch that meets the following specifications on the water pipe.

Connect the flow switch to the flow switch contact on the unit.

Minimum flow rate = 12.9 m³/h (215 L/min)

Unit usage range (water flow rate): 12.9 - 45.0 m³/h

4-1-6. Ensuring enough water in the water circuit

1. Required amount of water (for single unit)

If the amount of water in the water circuit (circulating water circuit) is insufficient, the unit operation hours may become shorter or the amount of water temperature change to be controlled may become extremely large.

Also, the defrost operation during the heating mode may not function properly. Refer to the table below for the minimum amount of water required in the circuit.

If the water pipe is too short to keep enough amount of water, install a cushion tank in the water pipe to ensure enough amount of water.

Model	Minimum amount of water (ℓ)
EAHV-M1500, 1800YCL	1650
EACV-M1500, 1800YCL	850

(1) Calculating the required amount of water in the water circuit

The required amount of water in the water circuit can be obtained from the following formula.

(Required amount of water in the water circuit) = (Amount of water that can be held in the water pipe) + (Amount of water that can be held in the heat source unit) + (Amount of water that can be held in the load-side unit)

The amount of water that can be held per meter of the water pipe (ℓ/m)

Pipe size					
2 1/2B (65A)	3B (80A)	4B (100A)	5B (125A)	6B (150A)	8B (200A)
3.77	5.16	8.87	13.23	18.91	32.44

The amount of water that can be held in the heat source unit (ℓ)

Standard	Inside header piping type
35	75

(2) Inlet/Outlet pipe connection size and material

The table below shows the inlet/outlet pipe connection size.

Inlet/Outlet pipe connection size

Piping type	Inlet pipe connection	Outlet pipe connection
Standard	65A housing type joint (Field-supplied Victaulic joint)	65A housing type joint (Field-supplied Victaulic joint)
Inside header piping type	150A housing type joint (Field-supplied Victaulic joint)	150A housing type joint (Field-supplied Victaulic joint)

4. System Design

2. Required amount of water (for multiple units)

The total water volume required for an air conditioning system is determined by whichever operation (cooling or heating) requires more water.

Cooling operation: 850 L per unit

Heating operation: 1650 L per unit

The total water volume required for a system is the sum of the water required for each unit in the system.

The total water volume required for a system is the sum of the water required for all units that simultaneously go into the defrost mode in the same water system.

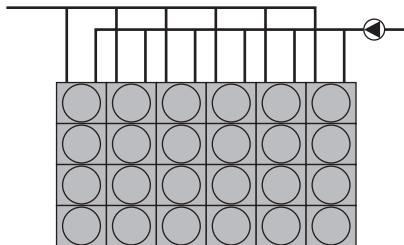

The system shown above requires six times the volume of water required for a single unit.

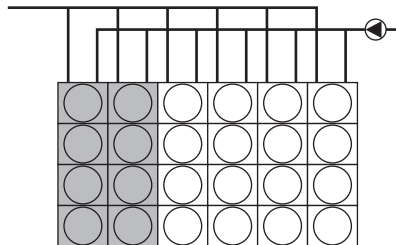

Two units operate in the defrost mode while the function to suppress the simultaneous operation of multiple units in the defrost mode is enabled.

Requires twice as much water as a system with a single unit

(1) Simultaneous operation of multiple units in the defrost mode

This operation is performed to keep multiple units from simultaneously operating in the defrost mode which leads to a sudden decrease in supply temperature.

This function sets the ratio of units that can simultaneously be operated in the defrost mode in the same water system and the ratio of units that can simultaneously be operated in the groups that are concurrently operated, and suppresses the number of units that operate in the defrost mode at the same time.

Ratio of units that are operable in the defrost mode in the same system	40% (Enabled)
Ratio of units that are operable in the defrost mode in the groups that are concurrently operated	35% (Enabled)

Calculation results less than 1 unit will be rounded up to 1 unit.

Calculation results more than 1 unit will be rounded down to the nearest integer.

The representative unit of the system and the representative unit of the simultaneously operated groups send a command to allow defrost operation to the unit that meets the defrost conditions, ensuring that the total number of units operating in the defrost mode will not exceed the set value.

*Each unit will not go into the defrost mode until it receives a command to allow defrost operation. However, if a command to allow defrost operation is not sent within 60 minutes after the defrost conditions are met, defrost operation will start regardless of the above settings.

*If set to a value lower than the default value, defrost operation may not be performed properly. Additionally, this may cause multiple units to go into the defrost mode simultaneously. Do not set this value below the default value.

4. System Design

Example system with 18 EAHV-M1500YCL units (with 6 simultaneously operated groups)

There are 7 units ($18 \text{ units} \times 40\% = 7.2 \text{ units} \rightarrow 7 \text{ units}$) that are simultaneously operable in the defrost mode within the system. Among the simultaneously operated groups, a total of 6 units in 6 groups ($3 \text{ units} \times 35\% = 1.05 \text{ unit} \rightarrow 1 \text{ unit}$, $1 \text{ unit} \times 6 \text{ groups} = 6 \text{ units}$) can simultaneously perform defrost operation. The maximum number of units that can simultaneously perform defrost operation in this system is 6.

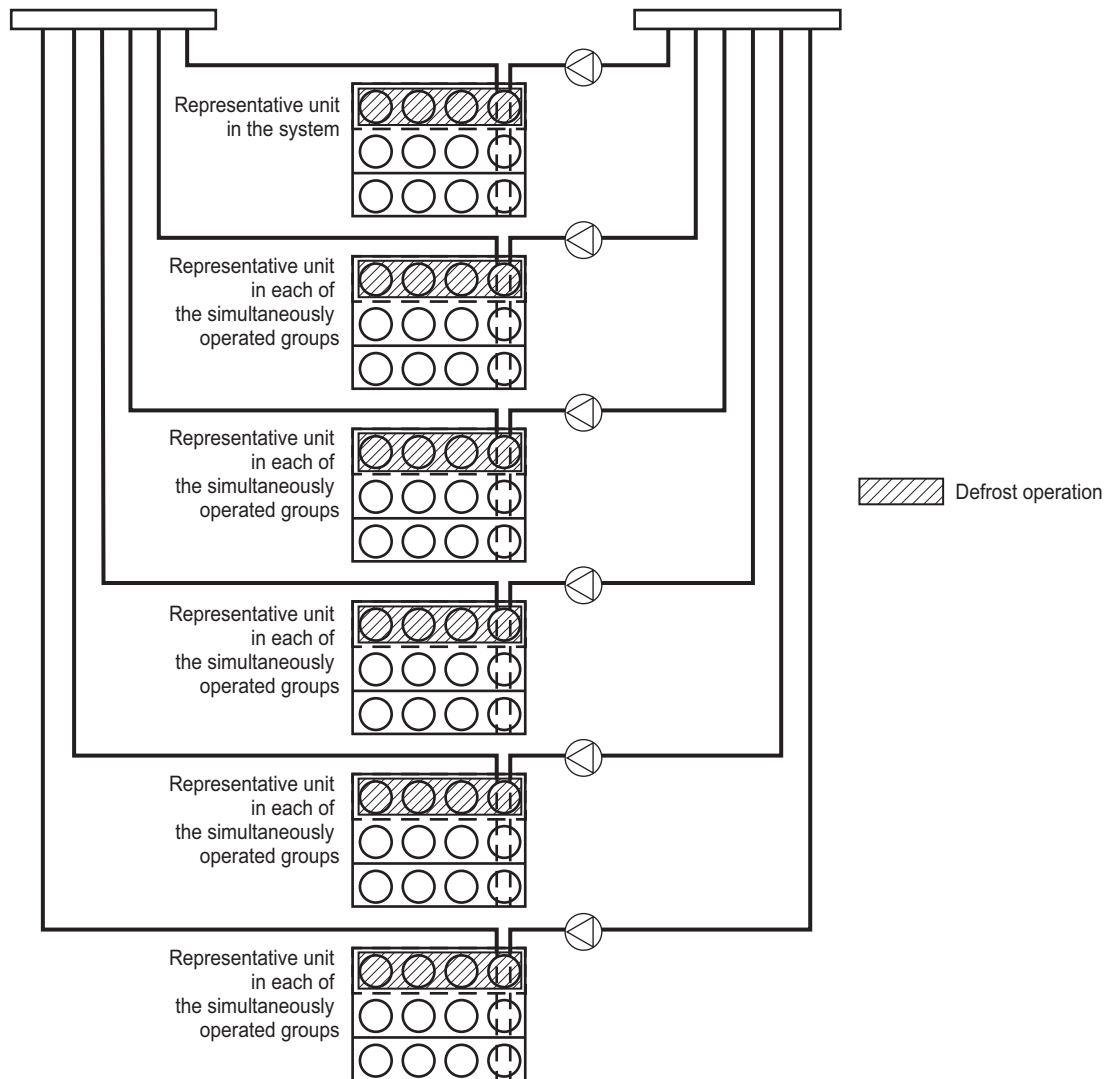

- 1) Unit that are operated from the local remote controller are operable in the defrost mode, regardless of the status of the function to suppress simultaneous defrost operation. However, during defrosting, this unit is counted as a unit in the defrost mode toward simultaneous defrost prevention control among other units that are operated remotely.
- 2) The input signal to force the unit to operate in the defrost mode is effective regardless of the setting of simultaneous defrost prevention control for units that are operated both remotely and locally.
- 3) The unit that is triggered into the defrost mode by this input signal is also counted as a unit in the defrost mode toward simultaneous defrost prevention control among other units that are operated remotely.

4. System Design

4-1-7. Water Piping Size and Location

1. Standard piping type

Unit: mm

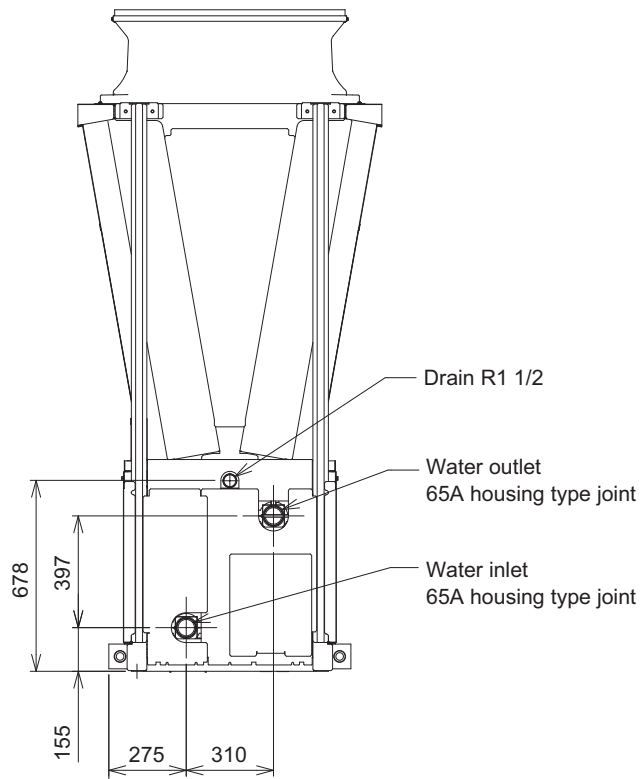

2. Inside header piping type

Unit: mm

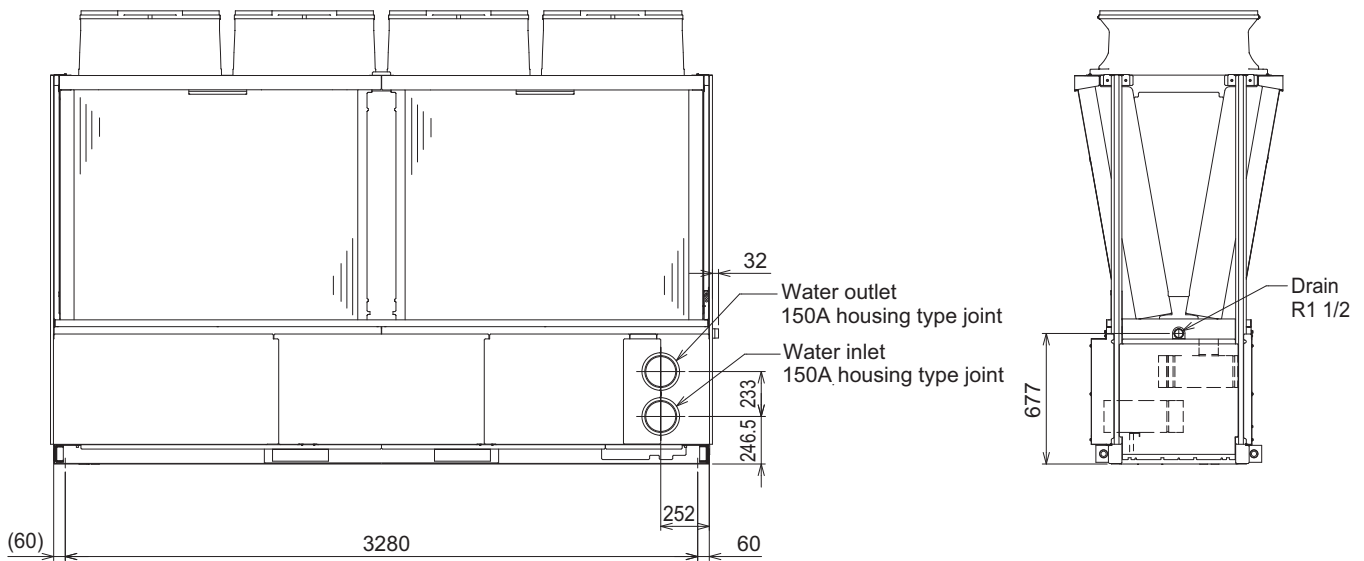

5. Wiring Design

5-1. System Configurations

The system must be configured only by personnel certified by Mitsubishi Electric.

5-1-1. Schematic Diagrams of Individual and Multiple Module Connection Systems

(1) Individual system

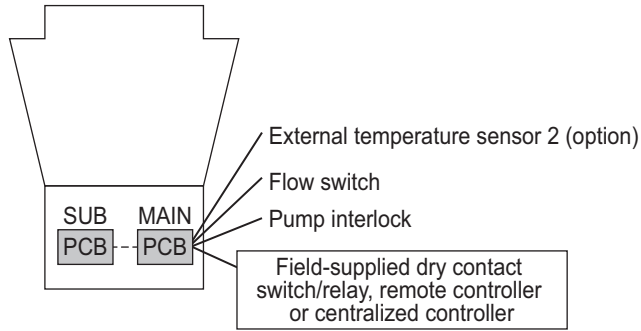

Refer to the sections "Switch Types and the Factory Settings" and "Configuring the settings" for further details.

(2) Multiple module connection system (Max.24 modules)

System leader unit	The unit controls the identical water system group.
Group leader unit	The unit transmits the command from the system leader unit to the sub unit.
Sub unit	The unit is other than leader unit.

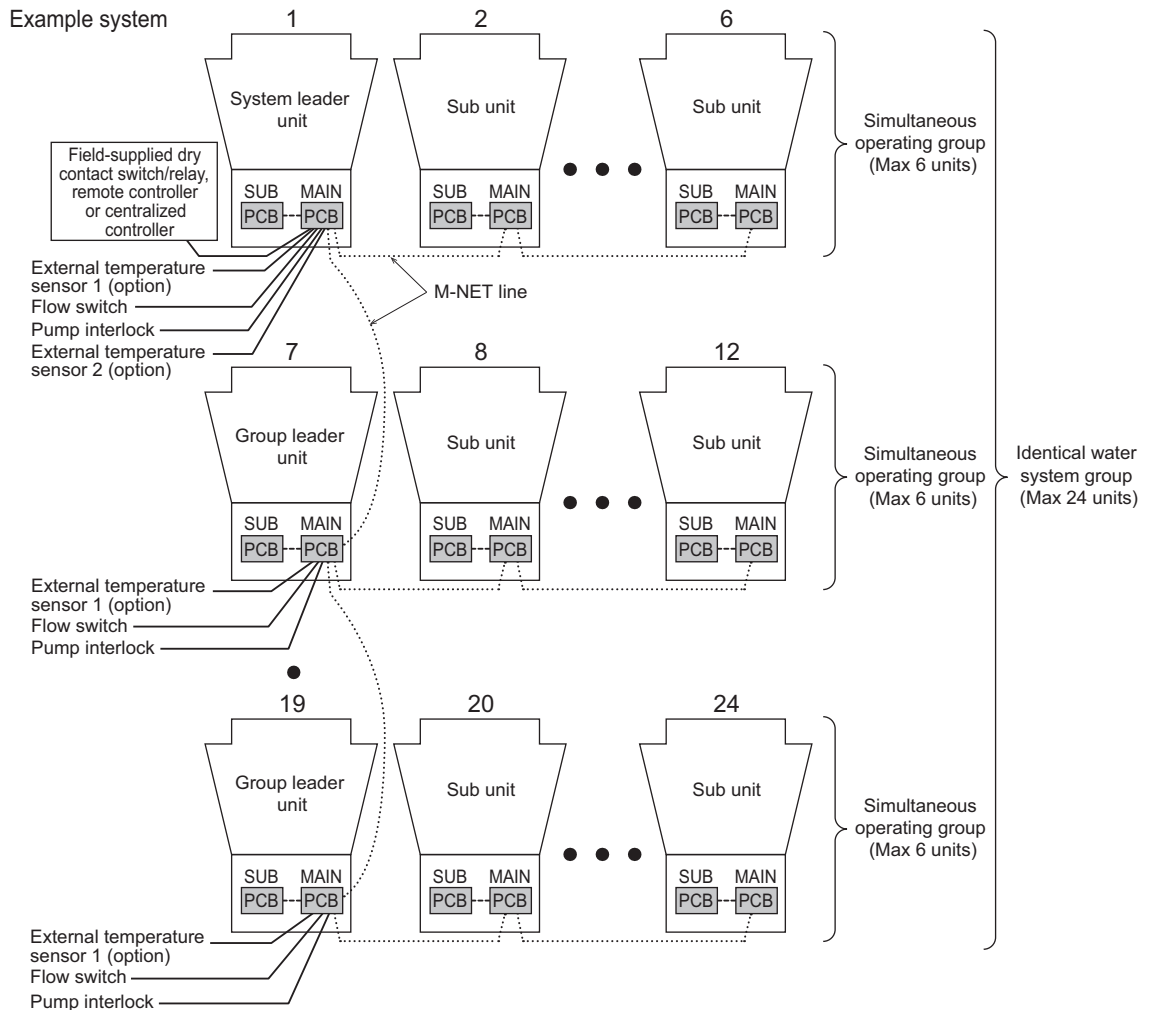

Refer to the sections "Switch Types and the Factory Settings" and "Configuring the settings" for further details.

5-1-2. Switch Types and the Factory Settings

(1) Switch names and functions

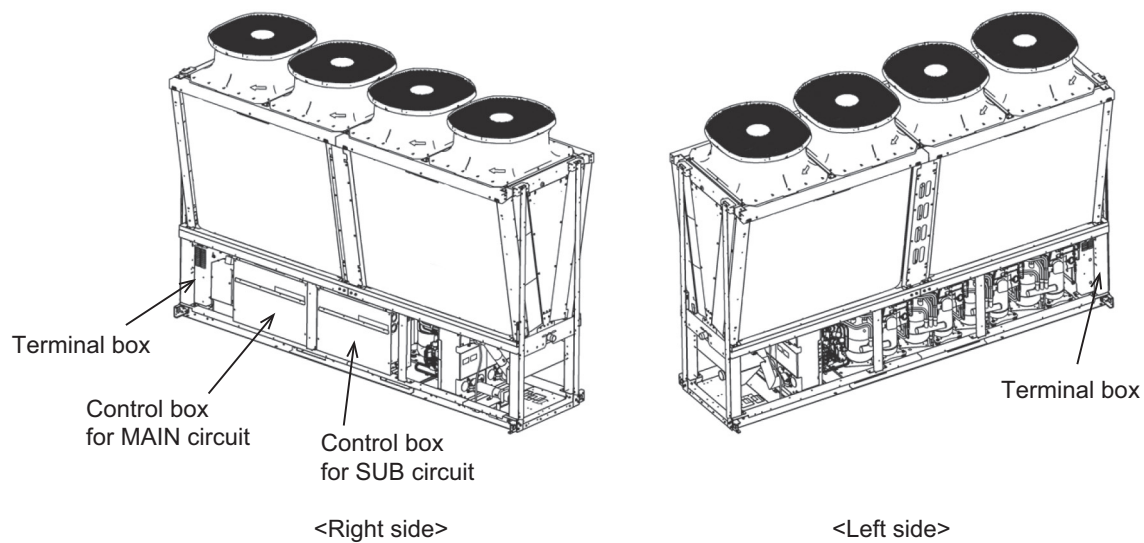

There are three main ways to set the settings as follows:

- 1) Dip switches (SW4 - SW7)
- 2) Dip switches used in combination with the push switches
- 3) Rotary switches

See next page for how these switches are used to set certain items.

5. Wiring Design

Different types of switches on the PCB

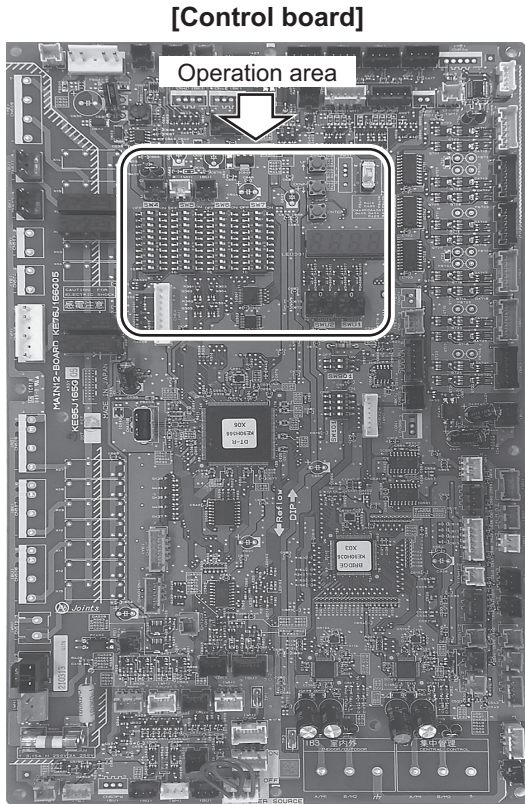

[Enlarged view of operation area]

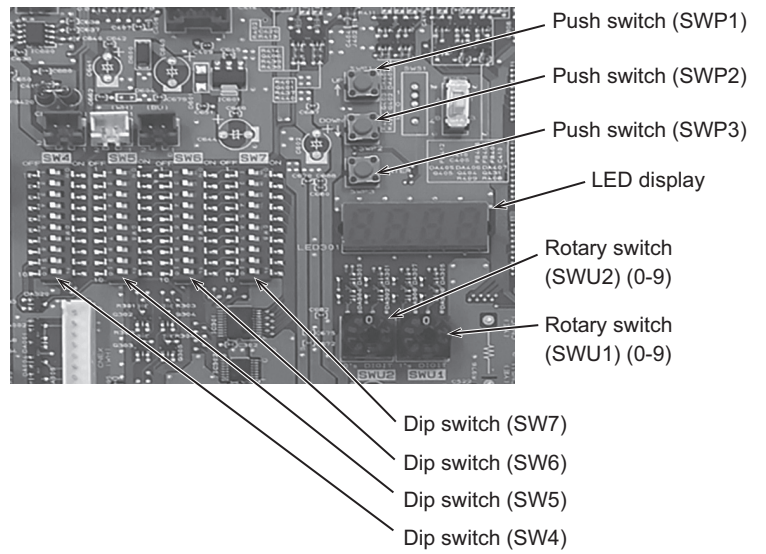

EAHV-M-YCL(-N), EACV-M-YCL(-N)

			Initial Setting	
			MAIN circuit	SUB circuit
Rotary switch	SWU1	Sets the 1's digit of the unit address.	"1"	"1"
	SWU2	Sets the 10's digit of the unit address.	"0"	"5"
Push switch	SWP1	Use for increasing the setting value.	-	-
	SWP2	Use for decreasing the setting value.	-	-
	SWP3	Use for changing and deciding the setting value.	-	-
Dip switch	SW4-7	Select a setting which is decided with a combination of switch numbers.	-	-

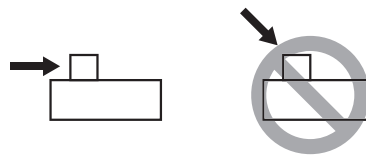
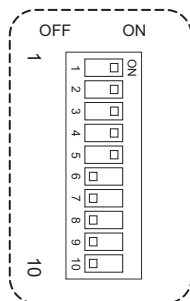

Slide the dip switches:
do not push down the switches.

Example: on the upper figure.
1 to 5 are "ON" and 6 to 10 are
"OFF".

5. Wiring Design

(2) Factory Switch Settings (Dip switch settings table)

SW	Function	Usage	Factory setting		OFF setting	ON setting	System leader unit	Group leader unit	SUB unit	Setting timing	
			MAIN circuit	SUB circuit							
SW4	1	Settings change or view the settings	These switches are used for setting change with push switch SWP 1, 2 and 3.	OFF	OFF	The 7-segment LED display is changed.	Depends on the setting	Depends on the setting	Depends on the setting	Depends on the setting	
	2										
	3										
	4										
	5										
	6										
	7										
	8										
	9										
	10										
SW5	1	Model setting	-	-	Leave the setting as it is.		-	-	-	At a reset	
	2	System setting	Set the duties to each unit.	OFF	-	System leader unit : ON ON Group leader unit : ON OFF Sub unit : OFF OFF	Required	Required	Required	At a reset	
	3										
	4	Water-temperature control 1 (option)	Selects either the external water temperature sensor or the built-in sensor to be used to control water temperature. (Simultaneous operating group)	OFF	-	Built-in sensor on the unit	External water temperature sensor 1	Required	Required	Required	At a reset
	5	Water-temperature control 2 (option)	Selects target temperature correction control. (Identical water system group)	OFF	-	OFF	ON (External water sensor 2 is required.)	Required	Fixed OFF	Fixed OFF	At a reset
	6	Multiple unit control	Selects optimum control of number of operating units.	OFF	-	Ineffective	Effective	Required	Fixed OFF	Fixed OFF	At a reset
	7	Analog input setting	Allows or disallows the analog signals from a remote location.	OFF	-	Disallows the external analog signals.	Allows the external analog signals.	Required	Fixed OFF	Fixed OFF	At a reset
	8	Analog input signal switching	Selects either the water temperature or the capacity control ratio. (Effective only when SW5-7 is set to ON.)	OFF	-	Water temperature	Capacity control ratio	Required	Fixed OFF	Fixed OFF	At a reset
	9	BMS setting *		OFF	-	No input from BMS	Input from BMS	Required	Fixed OFF	Fixed OFF	At a reset
	10	BMS group setting		OFF	OFF	Leader units	Simultaneous operating group units	Fixed OFF	Fixed OFF	Fixed OFF	Any time
SW6	1	Analog input type setting	Selects analog input 4-20mA/0-10V/1-5V/2-10V. (Effective only when SW5-7 is set to ON and SW5-9 is set to OFF.)	OFF	-	1 / 2		Required	Fixed OFF	Fixed OFF	Any time
	2					4-20mA: OFF OFF 1-5V: ON OFF 0-10V: OFF ON 2-10V: ON ON					
	3	Model setting		OFF	OFF	Leave the setting as it is.		Fixed OFF	Fixed OFF	Fixed OFF	Any time
	4										
	5										
	6										
	7										
	8	Auto restart after power failure	Enables or disables the automatic restoration of operation after power failure (in the same mode as the unit was in before a power failure).	ON	ON	An alarm will be issued when power is restored after a power outage. The alarm will be reset when the power is turned off and then turned back on.	Automatically restores operation after power failure.	Required	Required	Required	Any time
	10	Model setting		OFF	OFF	Leave the setting as it is.		Fixed OFF	Fixed OFF	Fixed OFF	Any time

"-" in the table indicates that the function in the corresponding row will be disabled regardless of the actual switch setting. The factory setting for these items is OFF.

* Connection to a BMS requires an installation of Procon A1M (Modbus interface), which is available from MITSUBISHI ELECTRIC UK. Use a BMS with insulation.

SW5-7	SW5-8	SW5-9	Input from BMS
ON	OFF	ON	Target temperature
ON	ON	ON	Capacity
OFF	OFF	ON	Outdoor temperature

5-1-3. Configuring the Settings

The settings must be set only by a qualified personnel.

1. System configuration

(1) Set the dip switches.

Switch settings on the MAIN circuit

Set the dip switches (labeled A in the figure at right) that correspond to the items below, according to the local system.

- Water temperature control based on the external water temperature reading
- Analog signals from a remote location

Refer to "Dip switch settings table" for further details.

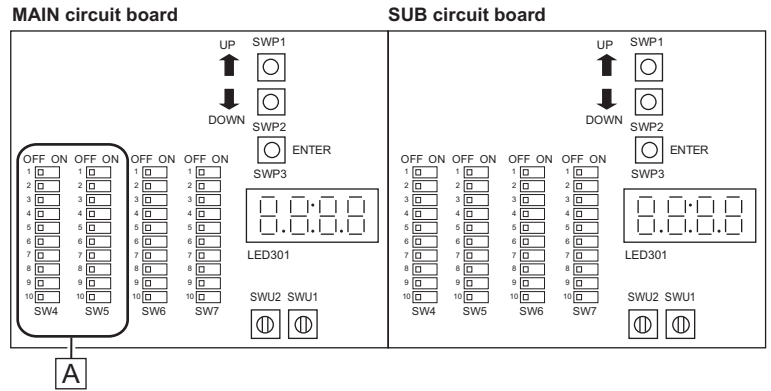

(2) Set the rotary switches. (Address setting)

Example of address setting

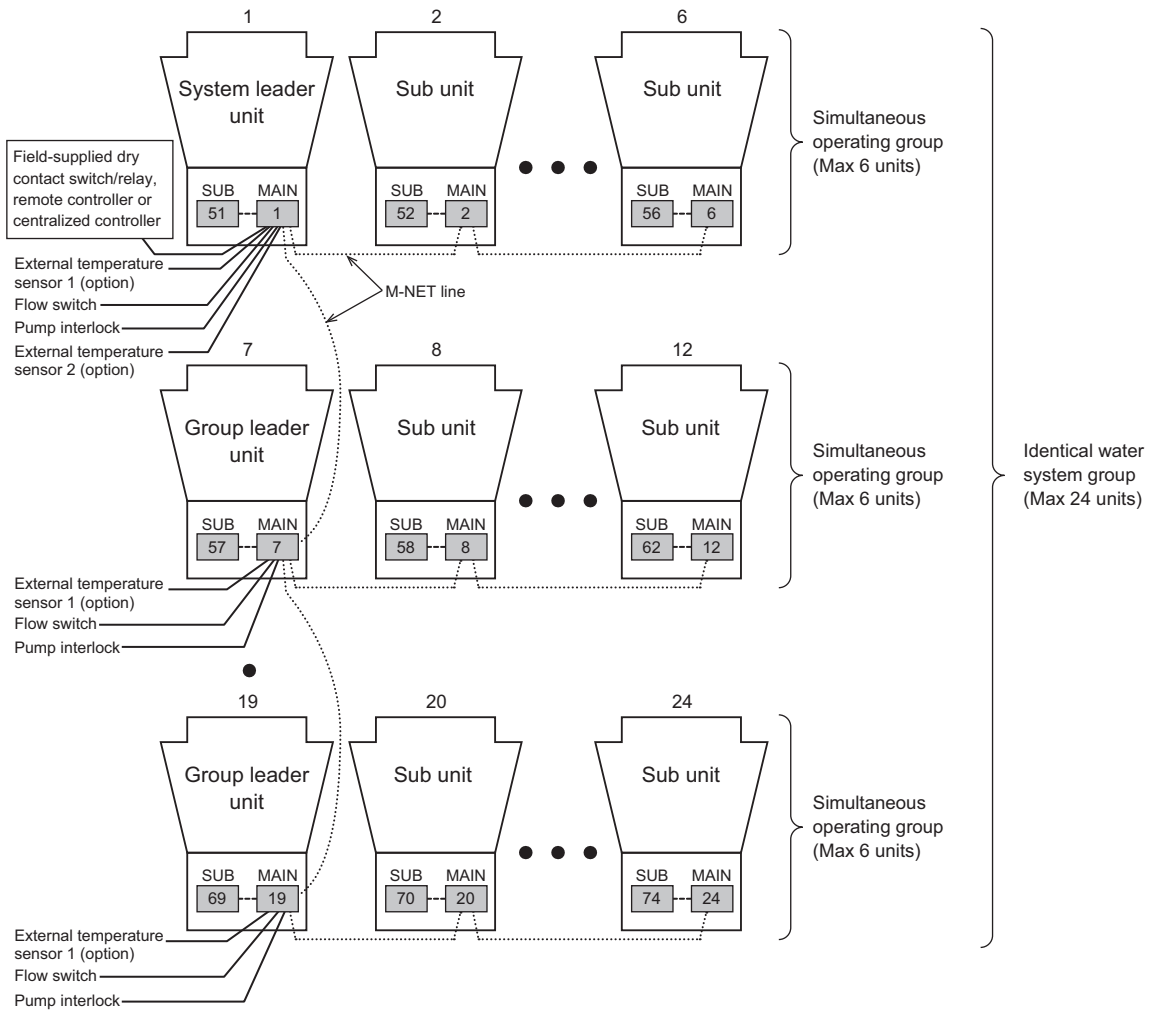

The figure at left shows that the switches 1 through 5 are set to ON and 6 through 10 are set to OFF.

5. Wiring Design

Setting the switches on the system leader unit

Make sure the address of the MAIN circuit on the main module is set to "1" (labeled A in the figure at right) and that the address of the SUB circuit on the main module is set to "51" (labeled B in the figure at right).

The address of each SUB circuit should equal the sum of the MAIN circuit address on the same module and 50.

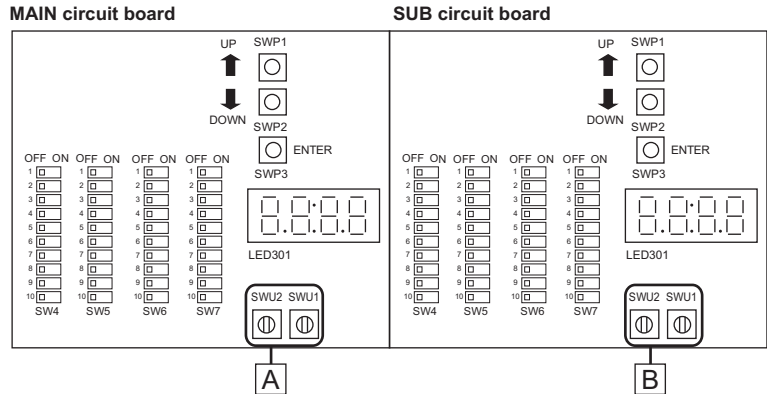

Setting the switches on the group leader unit and the sub unit

MAIN circuit

(1) Set the MAIN circuit addresses with the rotary switches. (labeled A in the figure). Set the 10's digit with SWU2, and set the 1's digit with SWU1. Assign sequential addresses to the MAIN circuit on all sub modules starting with 2.

SUB circuit

(2) Set the SUB circuit addresses with the rotary switches (labeled B in the figure). Set the 10's digit with SWU2, and set the 1's digit with SWU1. Assign sequential addresses to the SUB circuit on all sub modules starting with 52.

(3) Set the M-NET power supply.

When connecting a system leader unit and a group leader unit to a multiple units connection system, the connector connected to CN41 on the MAIN circuit board (Address 1) must be disconnected and then connected to CN40.

*Leave the connector connected to CN41 when using an AE-200 as the centralized controller.

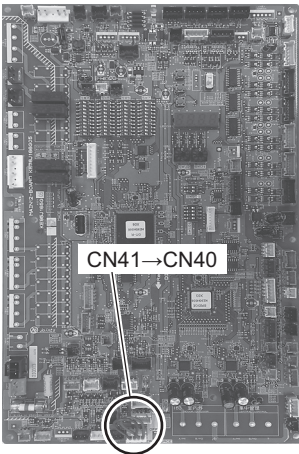

Address 1	All addresses other than Address 1
Move the connector from CN41 to CN40.	Leave the connector connected to CN41.

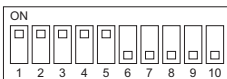

The figure at left shows that the switches 1 through 5 are set to ON and 6 through 10 are set to OFF.

Selector switch settings

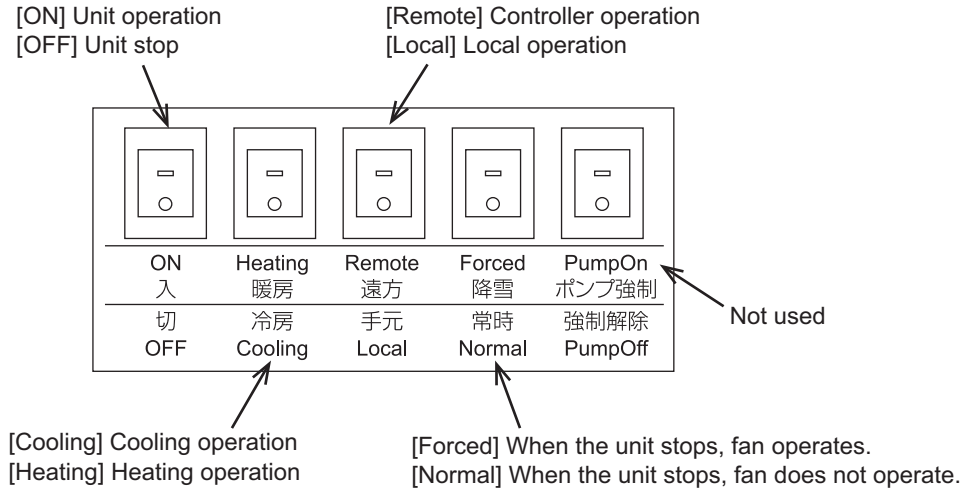

CAUTION

- Do not open the terminal cover, when selector switches are operated.

Display

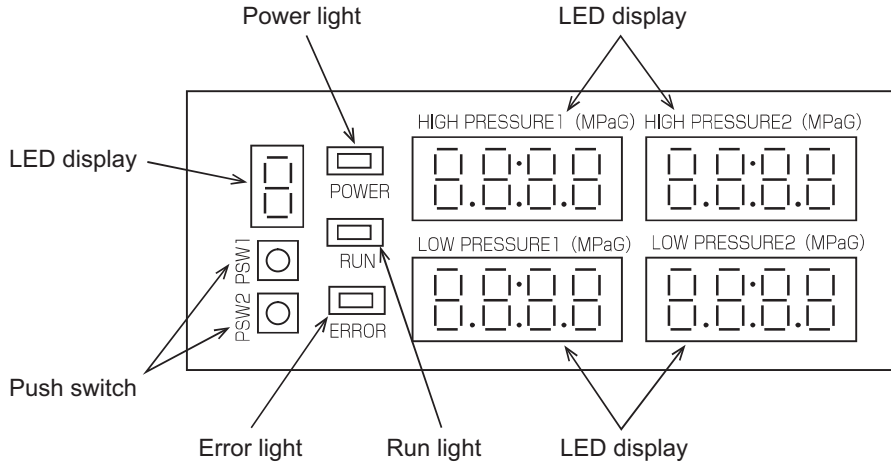

The positions of the selector switch and the display

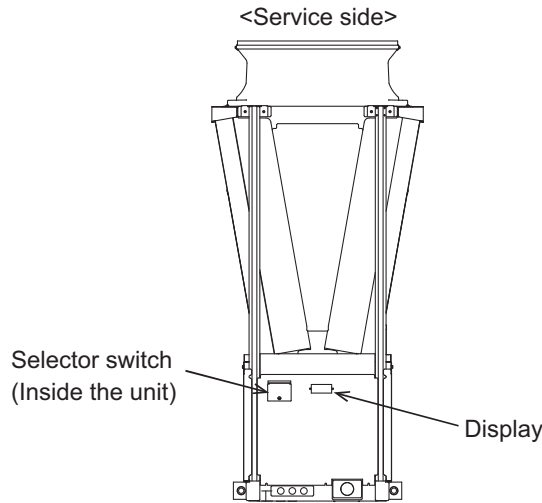

5. Wiring Design

Priority order of the water-temperature-setting-input-signal sources

Water temperature can be controlled by using the signals from the four types of input sources listed below. The setting for the item with higher priority will override the settings for the items with lower priorities. The water temperature will be controlled according to the temperature setting in the "Target water temperature" column that corresponds to a specific combination of the settings for the four items.

No-voltage contact input K91-K93 ON: Heating (EAHV)

Priority 1	Priority 2	Priority 3	Priority 4			Target water temperature	
No-voltage contact input K40-K41 Anti-freeze	Analog input or BMS (SW 5-9: ON)	No-voltage contact input K40-K42 Mode change	Remote controller PAR-W31MAA Input from centralized controller AE-200 or BMS (*3)				
ON	Ineffective	Ineffective	No remote controller	Manual setting	Schedule setting	25°C	
OFF	SW5-7: ON	Ineffective	-	Ineffective	Ineffective	Temperature setting for the analog signal input	
	SW5-7: OFF	OFF (Heating)	ON (Heating ECO)	-	Ineffective	Ineffective	Heating ECO
			When no RC is used	-	-	-	Heating
			-	Anti-freeze	-	-	25°C
			-	Heating ECO	-	-	Heating ECO
			-	Heating	-	-	Heating
			-	Cooling (*1)	-	-	Cooling
-	-	-	-	When schedule has been set (*2)	Target water temp is controlled according to the setting on the remote controller.		

*1 This mode is disabled in EAHV.

*2 EAHV can also set Cooling.

*3 AE-200 and BMS cannot both be simultaneously connected. Only connect one or the other.

No-voltage contact input K91-K93 OFF: Cooling (EAHV, EACV)

* When the operation mode is Cooling, K40-K41 (Anti-freeze) and K40-K42 (Mode change) are disabled.

Priority 1	Priority 2	Priority 3			Target water temperature	
Analog input or BMS (SW5-9: ON)	No-voltage contact input K01-K03 Mode Change (Cooling ECO)	Remote controller PAR-W31MAA Input from centralized controller AE-200 or BMS (*3)				
SW5-7: ON	Ineffective	No remote controller	Manual setting	Schedule setting	Temperature setting for the analog signal input	
SW5-7: OFF	ON (Cooling ECO)	-	Ineffective	Ineffective	Cooling ECO	
	OFF (Cooling)	When no RC is used	-	-	-	Cooling
		-	Anti freeze (*1)	-	-	25°C
		-	Heating ECO (*1)	-	-	Heating ECO
		-	Heating (*1)	-	-	Heating
		-	Cooling	-	-	Cooling
		-	-	-	-	When schedule has been set (*2)

*1 This mode is disabled in EACV.

*2 EAHV can also set Heating or Heating ECO.

*3 AE-200 and BMS cannot both be simultaneously connected. Only connect one or the other.

Priority order of the operation signal sources

	No-voltage contact	Remote controller PAR-W31MAA	Input from centralized controller AE-200 or BMS	
Unit operation (Run/Stop)	The last setting has priority.			
Operation mode	Cooling *1	The last setting has priority.		
	Cooling ECO *1*2	OFF	Cooling ECO can not be set from the remote controller or the centralized controller.	
		ON		
	Heating *1	The last setting has priority.		
	Heating ECO *1*3	OFF	The last setting has priority.	
		ON	Ineffective	
Anti-freeze *3	OFF	The last setting has priority.		
	ON	Ineffective		
Fan mode (The contact ON has priority.)	OFF	The last setting has priority.		
	ON	Ineffective		

*1 When the Anti-freeze contact is ON during heating operation, the setting change is ineffective.

*2 Changing by contact is effective during cooling operation.

*3 Changing by contact is effective during heating operation.

2. Making the settings

Use the LED display and the three push switches (SWP1 (↑), SWP2 (↓), and SWP3 (Enter)) to change the current settings on the circuit board and to monitor various monitored values.

(1) Setting procedures

Take the following steps to set the push switches SWP1 through SWP3. These switches must be set after the dip switch SW1 has been set.

1)

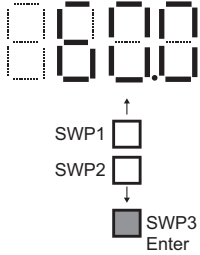

Normally a value of setting item appears on the display.



Press SWP3 (Enter) to enable the configuration changes.

2)

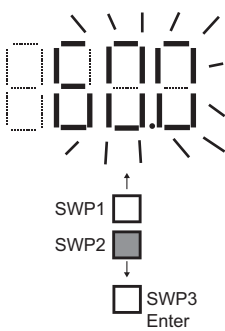

The current setting value will blink.



The left figure shows that the current setting value is "60.0." To decrease this value to 58.0, for example, press SWP2 (↓). Press SWP1 (↑) to increase the value.

3)

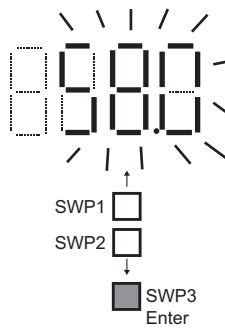

When the desired value is displayed (58.0 in the example at left), press SWP3 (Enter).



The displayed value will stop blinking and stay lit.

A lit LED indicates that the new setting has been saved.

* Pressing SWP1 (↑) or SWP2 (↓) will change the blinking setting value, but the change will not be saved until SWP3 (Enter) is pressed. Press and hold SWP1 (↑) or SWP2 (↓) for one second or longer to fast forward through the numbers.

5. Wiring Design

(2) Table of settings items





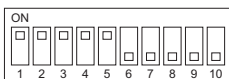

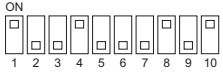

Set dip switch SW7-1, SW7-2, and SW4 as shown in the table below to set the value for the items in the "Setting item" column.

No.	Dip switch setting *1	Dip switch setting (SW4) *2	Setting Item	Default	Need or non-need to set the setting *5						Notes
					System		Group		Sub		
					M	S	M	S	M	S	
1	SW7-1 ON		Setting temp 1 (Cooling mode) *3	7°C	○	—	—	—	—	—	Range 4-30°C
2	SW7-1 ON		Setting temp 2 (Cooling mode) *3	7°C	○	—	—	—	—	—	Range 4-30°C
3	SW7-1 ON		Setting temp 1 (Heating mode) *4	45°C	○	—	—	—	—	—	Range 25-55°C
4	SW7-1 ON		Setting temp 2 (Heating mode) *4	45°C	○	—	—	—	—	—	Range 25-55°C
5	SW7-1 ON		Setting water temp A at Heating ECO mode *4	52°C	○	—	—	—	—	—	Range 25-55°C
6	SW7-1 ON		Setting outdoor temp A at Heating ECO mode *4	-7°C	○	—	—	—	—	—	Range -30-50°C
7	SW7-1 ON		Setting water temp B at Heating ECO mode *4	30°C	○	—	—	—	—	—	Range 25-55°C
8	SW7-1 ON		Setting outdoor temp B at Heating ECO mode *4	12°C	○	—	—	—	—	—	Range -30-50°C
9	SW7-1 ON		Setting water temp C at Heating ECO mode *4	42°C	○	—	—	—	—	—	Range 25-55°C
10	SW7-1 ON		Setting outdoor temp C at Heating ECO mode *4	2°C	○	—	—	—	—	—	Range -30-50°C
11	SW7-2 ON		Setting water temp D at Cooling ECO mode *3	11.5°C	○	—	—	—	—	—	Range 4-30°C
12	SW7-2 ON		Setting outdoor temp D at Cooling ECO mode *3	20°C	○	—	—	—	—	—	Range -20-55°C
13	SW7-2 ON		Setting water temp E at Cooling ECO mode *3	7°C	○	—	—	—	—	—	Range 4-30°C
14	SW7-2 ON		Setting outdoor temp E at Cooling ECO mode *3	35°C	○	—	—	—	—	—	Range -20-55°C
15	SW7-2 ON		Setting water temp F at Cooling ECO mode *3	10°C	○	—	—	—	—	—	Range 4-30°C
16	SW7-2 ON		Setting outdoor temp F at Cooling ECO mode *3	25°C	○	—	—	—	—	—	Range -20-55°C
17	SW7-1 ON		Peak-demand control signal input source	0	○	—	—	—	—	—	0: Dry contact 1: PAR-W31MAA
18	SW7-1 ON		Maximum peak-demand capacity	100%	○	—	—	—	—	—	Range 60-100%

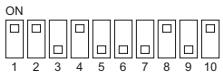
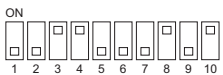
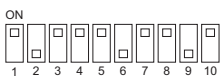
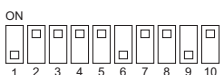
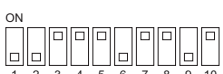

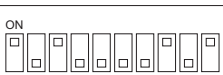
The figure at left shows that the switches 1 through 5 are set to ON and 6 through 10 are set to OFF.

5. Wiring Design

No.	Dip switch setting *1	Dip switch setting (SW4) *2	Setting Item	Default	Need or non-need to set the setting *5						Notes
					System		Group		Sub		
					M	S	M	S	M	S	
19	SW7-1 ON		Preset temp. A (Cooling)	4°C	○	—	—	—	—	—	Range 4-30°C
20	SW7-1 ON		Preset temp. B (Cooling)	30°C	○	—	—	—	—	—	Range 4-30°C
21	SW7-1 ON		Preset temp. A (Heating)	25°C	○	—	—	—	—	—	Range 25-55°C
22	SW7-1 ON		Preset temp. B (Heating)	55°C	○	—	—	—	—	—	Range 25-55°C
23	SW7-1 ON		Supplementary heater operation water temp *4	40°C	○	—	○	—	○	—	Range 0-55°C
24	SW7-1 ON		Supplementary heater operation outdoor temp *4	-10°C	○	—	○	—	○	—	Range -30-50°C
25	SW7-1 ON		Drain pan heater operation outdoor temp	0°C	○	—	○	—	○	—	Range -40-20°C
26	SW7-1 ON		Thermo differential 1 (Cooling mode) *3, *6	3°C	○	—	○	—	○	—	Range 0.2-5°C
27	SW7-1 ON		Thermo differential 2 (Cooling mode) *3, *6	2°C	○	—	○	—	○	—	Range 0.2-5°C
28	SW7-1 ON		Thermo differential 1 (Heating mode) *4, *6	3°C	○	—	○	—	○	—	Range 0.2-5°C
29	SW7-1 ON		Thermo differential 2 (Heating mode) *4, *6	2°C	○	—	○	—	○	—	Range 0.2-5°C
30	SW7-1 ON		Year setting	-	○	—	—	—	—	—	
31	SW7-1 ON		Month/Date setting	-	○	—	—	—	—	—	
32	SW7-1 ON		Current time	-	○	—	—	—	—	—	

*1: Only the switches designated in the table must be set to ON. (The other switches must be OFF.)

*2: Do not apply undue force when changing the Dip switch settings as this may cause malfunctions.

*3: They are enabled during the cooling. (EAHV, EACV)

*4: They are enabled during the heating. (EAHV)

*5: System: System leader unit

Group: Group leader unit

Sub: Sub unit

M: MAIN circuit

S: SUB circuit

*6: Thermo - ON/OFF temperature conditions (water temperature control)

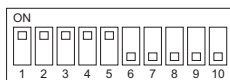

The figure at left shows that the switches 1 through 5 are set to ON and 6 through 10 are set to OFF.

5. Wiring Design

EAHV-M-YCL(-N), EACV-M-YCL(-N)

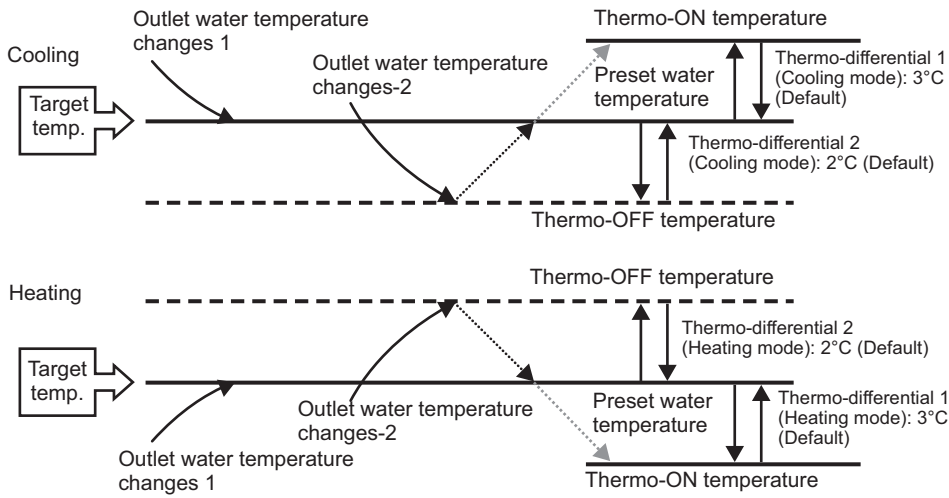

When the water temperature is controlled based on the outlet water temperature, compressor frequency will be controlled in the way that the target water temperature will be maintained.

5. Wiring Design

3. Setting procedures

(1) System setting

<1>Making the settings for the initial start-up process

(A) Single unit

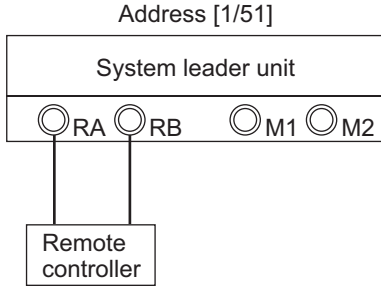

: 1, 2, 3, 4

Setting address 1

- 1) Turn off the power.
 - 2) System leader unit (Address 1 SW5-2, 5-3: ON)
 - 3) Turn the power back on.
 - Address 1 → LED display [EEEE]
 - Address 51 → LED display [9999]
 - 4) SW7: 1, 2, 3, 4 ON and ENTER for 5 seconds. (Initializes the system)
 - Address 1 → LED display [9999] → [FFFF]
 - Address 51 → LED display [9999] → [__|__]
 - 5) SW7: 1, 2, 3, 4 OFF
- Start-up process complete
- Address 1 → LED display [__|__]
 - Address 51 → LED display [__|__]

*No settings are required for address 51.

(B) One system leader unit and two sub units (1 group, 3 units in the group)

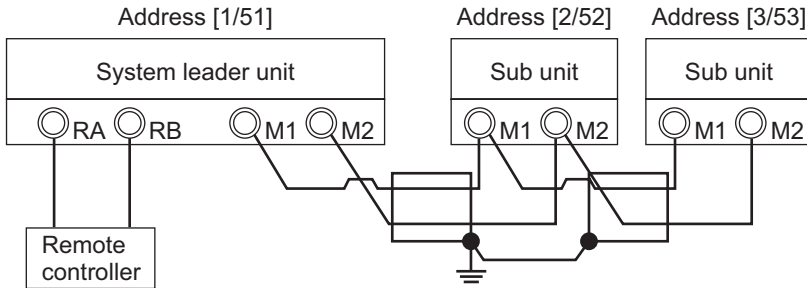

Setting address 1

- 1) Turn off the power.
 - 2) System leader unit (Address 1 SW5-2, 5-3: ON)
 - 3) Turn the power back on.
 - Address 1 → LED display [EEEE]
 - Address 51 → LED display [9999]
 - 4) Setting the number of units for the group
 - SW7: 1 ON
 - SW4: 1, 2, 3, 4, 8, 10 ON
 - Press ENTER once.
 - ↓
 - Address 1 → LED display [1]
 - ↓
 - Press UP twice.
 - ↓
 - Address 1 → LED display [3]
 - ↓
 - Press ENTER once.
 - SW4: 1, 2, 3, 4, 8, 10 OFF
 - 5) SW7: 1, 2, 3, 4 ON and ENTER for 5 seconds. (Initializes the system)
 - Address 1 → LED display [9999] → [FFFF]
 - Address 51 → LED display [9999] → [__|__]
 - 6) SW7: 1, 2, 3, 4 OFF
- Start-up process complete
- Address 1 → LED display [__|__]
 - Address 51 → LED display [__|__]

*No settings are required for any address other than for address 1.

*The default setting for the number of units in a group is 1.
The maximum number of units per group is 6.

(C) System leader unit and group leader unit (3 groups, 1 unit in each group)

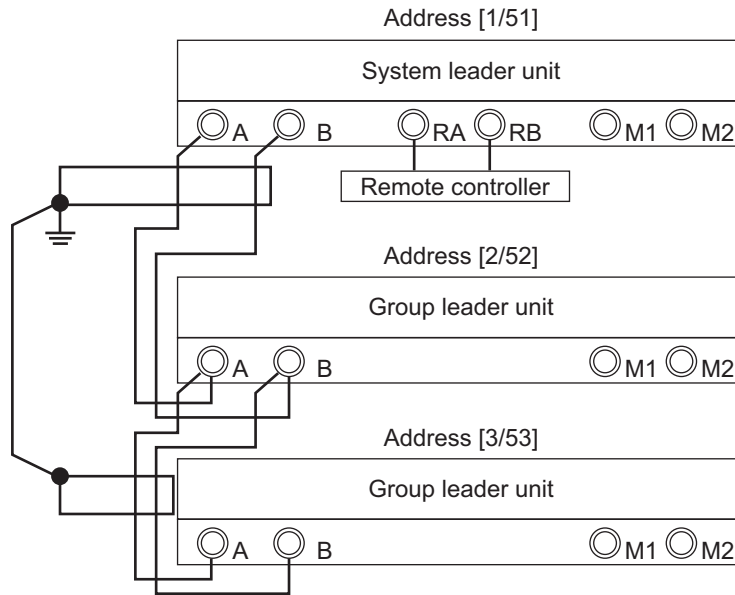

(1) Setting address 1

- 1) Turn off the power.
- 2) System leader unit (Address 1 SW5-2, 5-3: ON)
- 3) Turn the power back on.

Address 1 → LED display [EEEE]

Address 51 → LED display [9999]

4) Setting the number of units for each group

*The default setting for the number of units in a group is 1.

5) Setting the number of groups

SW7: 1 ON

Press ENTER once.

SW4: 5, 8, 10 ON

↓

Address 1 → LED display [1]

↓

Press UP twice.

↓

Address 1 → LED display [3]

↓

Press ENTER once.

SW4: 5, 8, 10 OFF

*The default setting for the number of units in a group is 1.

The maximum number of groups is 24.

(2) Setting address 2

- 1) Turn off the power.
- 2) Group leader unit (SW5-2: ON)
- 3) Turn the power back on.

Address 2 → LED display [EEEE]

Address 52 → LED display [9999]

4) Setting the number of units for each group

*The default setting for the number of units in a group is 1.

5) SW7: 1, 2, 3, 4 ON and ENTER for 5 seconds.

(Initializes the system)

Address 2 → LED display [9999] → [FFFF]

Address 52 → LED display [9999] → [__|__]

6) SW7: 1, 2, 3, 4 OFF

Start-up process complete

Address 2 → LED display [__|__]

Address 52 → LED display [__|__]

*Address 3 (Group leader unit) is set in the same way as above.)

(3) Setting address 1 (second time)

1) SW7: 1, 2, 3, 4 ON and ENTER for 5 seconds.

(Initializes the system. System leader unit initialized last)

Address 1 → LED display [9999] → [FFFF]

Address 51 → LED display [9999] → [__|__]

Start-up process complete

Address 1 → LED display [__|__]

Address 51 → LED display [__|__]

2) SW7: 1, 2, 3, 4 OFF

(D) System leader unit, Group leader unit and Sub unit (2 groups, 3 units in each group)

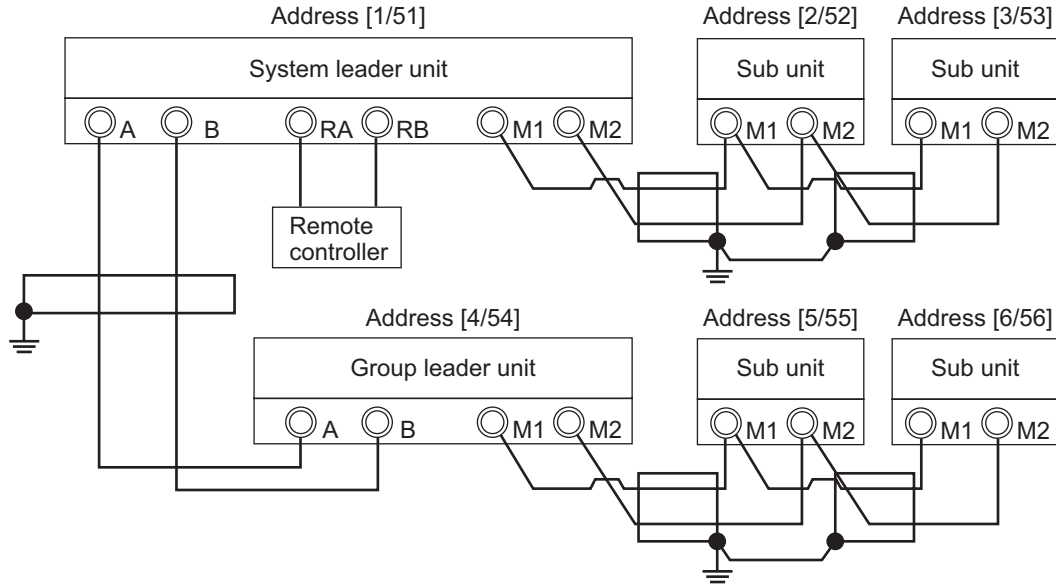

- (1) Setting address 1
- 1) Turn off the power.
 - 2) System leader unit (Address 1 SW5-2, 5-3: ON)
 - 3) Turn the power back on.

Address 1 → LED display [EEEE]
 Address 51 → LED display [9999]

- 4) Setting the number of units for each group

SW7: 1 ON
 Press ENTER once.
 SW4: 1, 2, 3, 4, 8, 10 ON

↓
 Address 1 → LED display [1]

↓
 Press UP twice.

↓
 Address 1 → LED display [3]

↓
 Press ENTER once.
 SW4: 1, 2, 3, 4, 8, 10 OFF

*The default setting for the number of units in a group is 1.
 The maximum number of units per group is 6.

- 5) Setting the number of groups

SW7: 1 ON
 Press ENTER once.
 SW4: 5, 8, 10 ON

↓
 Address 1 → LED display [1]

↓
 Press UP twice.

↓
 Address 1 → LED display [2]

↓
 Press ENTER once.
 SW4: 5, 8, 10 OFF

*The default setting for the number of units in a group is 1.
 The maximum number of units per group is 24.

- (2) Setting address 4
- 1) Turn off the power.
 - 2) Group leader unit (SW5-2: ON)
 - 3) Turn the power back on.

Address 4 → LED display [EEEE]
 Address 54 → LED display [9999]

- 4) Setting the number of units for each group

SW7: 1 ON
 Press ENTER once.
 SW4: 1, 2, 3, 4, 8, 10 ON

↓
 Address 4 → LED display [1]

↓
 Press UP twice.

↓
 Address 4 → LED display [3]

↓
 Press ENTER once.
 SW4: 1, 2, 3, 4, 8, 10 OFF

*No group number settings are required for address 4 (Group leader unit).

- 5) SW7: 1, 2, 3, 4 ON and ENTER for 5 seconds.
 (Initializes the system)

Address 4 → LED display [9999] → [FFFF]
 Address 54 → LED display [9999] → [____|_|]

- 6) SW7: 1, 2, 3, 4 OFF

Start-up process complete
 Address 4 → LED display [____|_|]
 Address 54 → LED display [____|_|]

- (3) Setting address 1 (second time)

- 1) SW7: 1, 2, 3, 4 ON and ENTER for 5 seconds.

(Initializes the system. System leader unit initialized last)
 Address 1 → LED display [9999] → [FFFF]
 Address 51 → LED display [9999] → [____|_|]

- 2) SW7: 1, 2, 3, 4 OFF

Start-up process complete
 Address 1 → LED display [____|_|]
 Address 51 → LED display [____|_|]

*No settings are required for any address other than for addresses 1 and 4.

5. Wiring Design

<2>Multiple unit control

By setting SW5-6 to ON for address 1, optimum control of number of operating units will be performed.
All units will simultaneously operate when SW5-6 is set to OFF.

(A) System leader unit, group leader unit, and sub unit

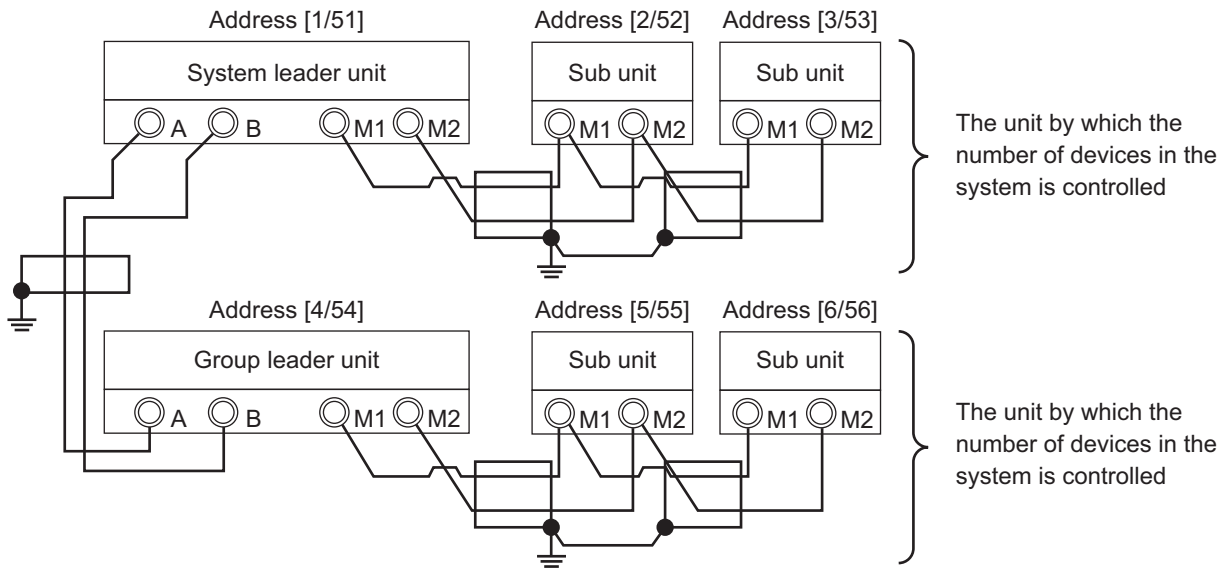

(B) System leader unit and group leader unit

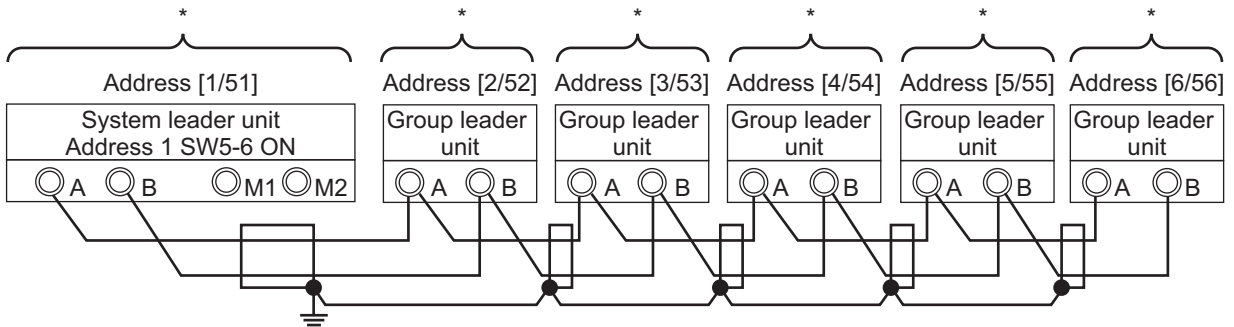

*The unit by which the number of devices in the system is controlled

5. Wiring Design

<3>Example of system configuration
Optimum control of number of operating units

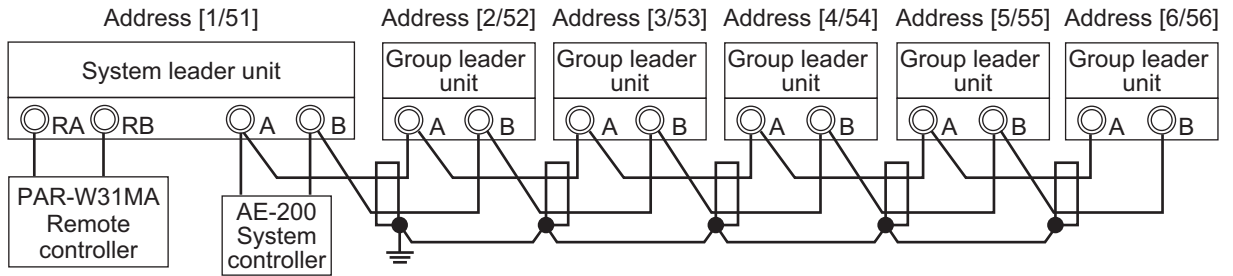

Settings table

Setting item	SW7-1	DIP SW	SW4	Setting timing	System leader unit		Simultaneous operation Group leader unit		Simultaneous operation Group leader unit		Simultaneous operation Group leader unit		Simultaneous operation Group leader unit			
					1		2		3		4		5		6	
					MAIN	SUB	MAIN	SUB	MAIN	SUB	MAIN	SUB	MAIN	SUB	MAIN	SUB
M-NET address	-	-	-	At a reset	1	51	2	52	3	53	4	54	5	55	6	56
M-NET power supply	-	-	-	-	CN40	CN41	CN41	CN41	CN41	CN41	CN41	CN41	CN41	CN41	CN41	CN41
System settings	-	5-2	-	At a reset	ON	-	ON	-	ON	-	ON	-	ON	-	ON	-
	-	5-3	-	At a reset	ON	-	OFF	-	OFF	-	OFF	-	OFF	-	OFF	-
Number of groups	ON	-	ON 1 2 3 4 5 6 7 8 9 10	At a reset	6	-	1	-	1	-	1	-	1	-	1	-
Number of units per group	ON	-	ON 1 2 3 4 5 6 7 8 9 10	At a reset	1	-	1	-	1	-	1	-	1	-	1	-
Multiple unit control	-	5-6	-	At a reset	ON	-	OFF	-	OFF	-	OFF	-	OFF	-	OFF	-

*The shaded cells indicate the settings that requires changes from the default settings.

*Some settings require the following after the settings were changed: A power reset, or setting SW7: 1, 2, 3, 4 ON, and pressing and holding ENTER for 5 seconds.

*When using an AE-200 as the centralized controller, leave the M-NET power supply connector as it is.

<4>Setting the pump system

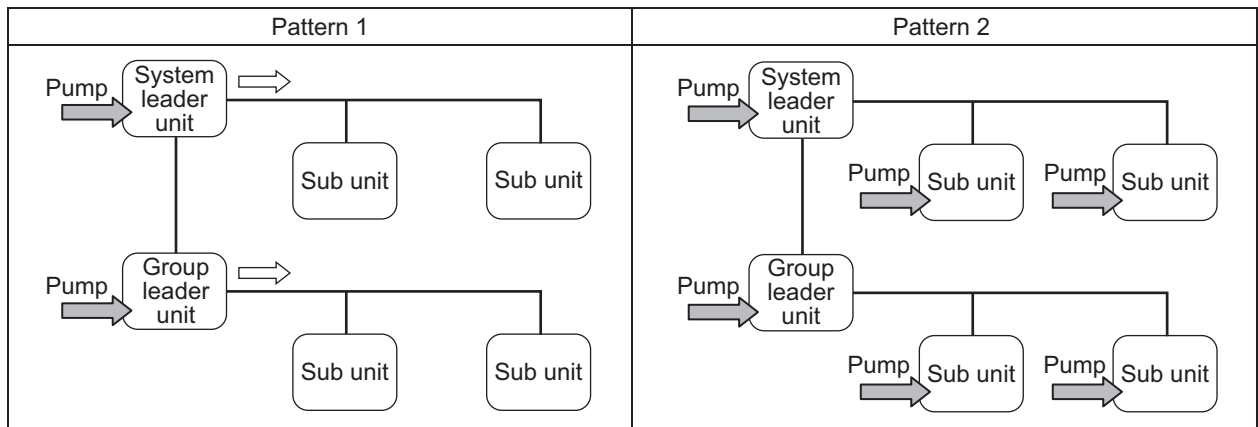

Setting item	SW7-1	DIPSW	SW4	Factory setting		Note
				MAIN	SUB	
Pump setting	ON	-	ON 1 2 3 4 5 6 7 8 9 10	0	-	0: Pattern 1, 1: Pattern 2

*Pump settings must be made on the MAIN circuit on all units.

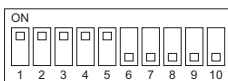

The figure at left shows that the switches 1 through 5 are set to ON and 6 through 10 are set to OFF.

5. Wiring Design

(2) Water-temperature setting

Different water temperature settings can be set for different modes.











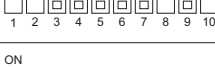

Set the dip switches on the circuit board as follows to make the settings for the items described in this section.

Press the push switch SWP3 to enable the configuration changes.

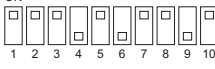
Press the push switches SWP1 (↑) or SWP2 (↓) to increase or decrease the value.

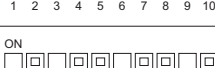
When the desired value is displayed, press SWP3 to save the setting value.

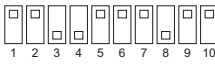
Settings table

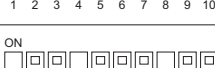
No.	Dip switch setting *1	Dip switch setting (SW4)	Setting Item	Initial value	Unit	Setting			Setting change from an optional remote controller (PAR-W31MAA) *2
						Increments	Lower limit	Upper limit	
1	SW7-1 ON		Setting temp 1 (Cooling mode) *3	7	°C	0.1°C	4	30	Possible
2	SW7-1 ON		Setting temp 2 (Cooling mode) *4	7	°C	0.1°C	4	30	Possible
3	SW7-1 ON		Setting temp 1 (Heating mode) *3	45	°C	0.1°C	25	55	Possible
4	SW7-1 ON		Setting temp 2 (Heating mode) *4	45	°C	0.1°C	25	55	Possible
5	SW7-1 ON		Setting water temp A at Heating ECO mode	52	°C	0.1°C	25	55	Not possible
6	SW7-1 ON		Setting outdoor temp A at Heating ECO mode	-7	°C	0.1°C	-30	50	Not possible
7	SW7-1 ON		Setting water temp B at Heating ECO mode	30	°C	0.1°C	25	55	Not possible
8	SW7-1 ON		Setting outdoor temp B at Heating ECO mode	12	°C	0.1°C	-30	50	Not possible
9	SW7-1 ON		Setting water temp C at Heating ECO mode	42	°C	0.1°C	25	55	Not possible
10	SW7-1 ON		Setting outdoor temp C at Heating ECO mode	2	°C	0.1°C	-30	50	Not possible
11	SW7-2 ON		Setting water temp D at Cooling ECO mode	11.5	°C	0.1°C	4	30	Not possible
12	SW7-2 ON		Setting outdoor temp D at Cooling ECO mode	20	°C	0.1°C	-20	55	Not possible
13	SW7-2 ON		Setting water temp E at Cooling ECO mode	7	°C	0.1°C	4	30	Not possible
14	SW7-2 ON		Setting outdoor temp E at Cooling ECO mode	35	°C	0.1°C	-20	55	Not possible
15	SW7-2 ON		Setting water temp F at Cooling ECO mode	10	°C	0.1°C	4	30	Not possible
16	SW7-2 ON		Setting outdoor temp F at Cooling ECO mode	25	°C	0.1°C	-20	55	Not possible

*1 Only the switches designated in the table must be set to ON. (The other switches must be OFF.)

*2 Temperature setting increments: 0.5°C

*3 No-voltage contact KN51-KN61: OFF

*4 No-voltage contact KN51-KN61: ON

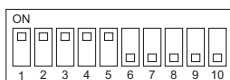

The figure at left shows that the switches 1 through 5 are set to ON and 6 through 10 are set to OFF.

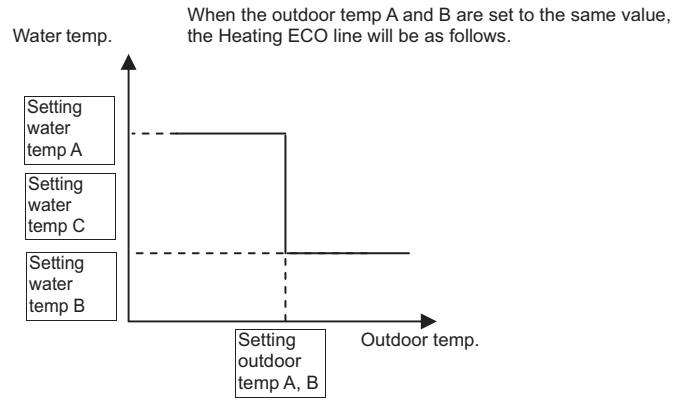
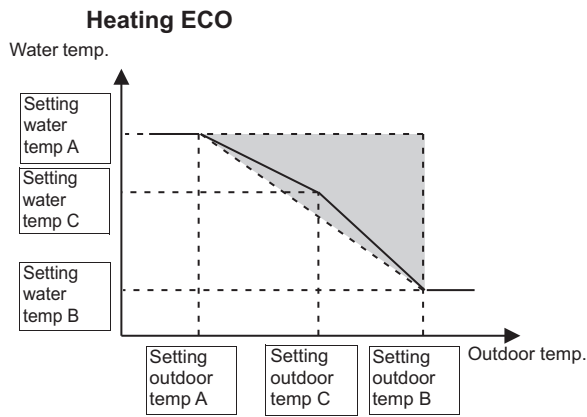

* Always use a value for setting C that is between setting value A and setting value B.

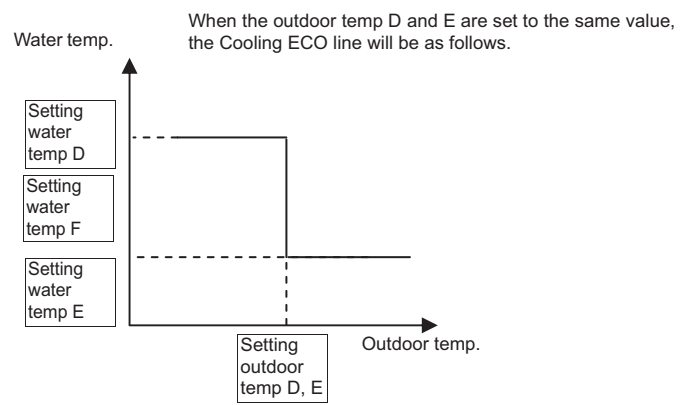
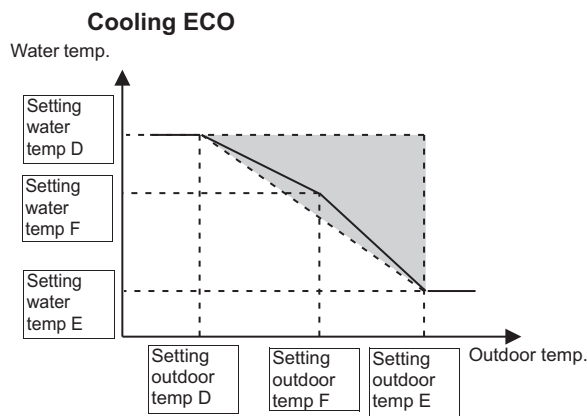

* Always use a value for setting C that is between setting value D and setting value E.

5. Wiring Design

(3) Peak-demand control operation

Peak-demand control is a function used to control the power consumptions of the units.

The compressor's maximum operating frequency will be controlled according to the peak-demand control signal.

Set the dip switches on the circuit board as follows to make the settings for the items described in this section.

Press the push switch SWP3 to enable the configuration changes.

Press the push switches SWP1 (↑) or SWP2 (↓) to increase or decrease the value.

When the desired value is displayed, press SWP3 to save the setting value.

Settings table

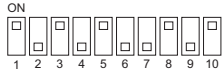
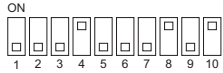
No.	Dip switch setting (SW7-1)	Dip switch setting (SW4)	Setting Item	Initial value	Unit	Setting			Setting change from an optional remote controller (PAR-W31MAA)
						Increments	Lower limit	Upper limit	
1	ON		Peak-demand control signal input source	0	-	1	0	1	Not possible
2	ON		Maximum peak-demand capacity	100	%	1%	60	100	Not possible

(4) Remote water temperature or capacity control ratio setting input signal type

When SW5-7 is ON, SW5-8 is OFF, and SW5-9 is OFF, external analog signals can be used to set the water temperatures.

When SW5-7 and SW5-8 are ON, external analog signals can be used to set the capacity control ratio.

Analog input type can be selected from the following four types:

4-20 mA

0-5 V

0-10 V

2-10 V

Select SW6-1 and SW6-2 to set the type of analog input signal from a remote location.

Set the dip switches on the circuit board as follows to change the settings.

	SW201-1	SW201-2	SW6-1	SW6-2
4-20 mA	ON	ON	OFF	OFF
1-5 V	OFF	ON	ON	OFF
0-10 V	OFF	OFF	OFF	ON
2-10 V	OFF	OFF	ON	ON

* Incorrectly setting SW201 may cause damage to the circuit board.

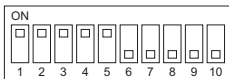

The figure at left shows that the switches 1 through 5 are set to ON and 6 through 10 are set to OFF.

[IO cont board]

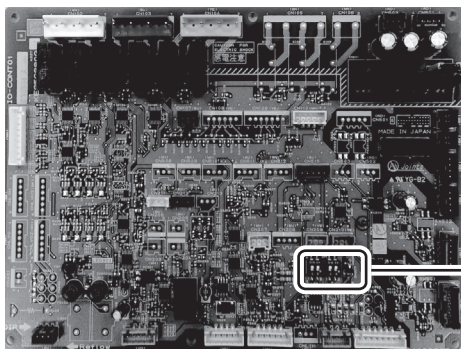

[Enlarged view of operation area]

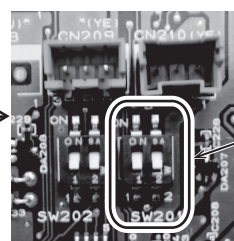

Dip switch (SW201)

5. Wiring Design

(5) Setting the water temperature using analog signal input

When dip switch SW5-7 is set to ON (Enable external input), SW5-8 is set to OFF, and SW5-9 is set to OFF, the target water temperature varies with the preset temperatures A and B and the type of analog input signal.

Set the dip switches on the circuit board as follows to make the settings for the items described in this section.

Press the push switch SWP3 to enable the configuration changes.

Press the push switches SWP1 (↑) or SWP2 (↓) to increase or decrease the value.

When the desired value is displayed, press SWP3 to save the setting value.

Settings table

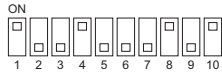
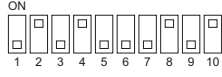
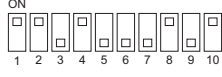
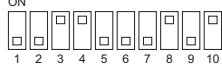
No.	Dip switch setting (SW7-1)	Dip switch setting (SW4)	Setting Item	Initial value	Unit	Setting			Setting change from an optional remote controller (PAR-W31MAA)
						Increments	Lower limit	Upper limit	
1	ON		Preset temp. A (Cooling)	4	°C	1°C	4	30	Not possible
2	ON		Preset temp. B (Cooling)	30	°C	1°C	4	30	Not possible
3	ON		Preset temp. A (Heating)	25	°C	1°C	25	55	Not possible
4	ON		Preset temp. B (Heating)	55	°C	1°C	25	55	Not possible

* Due to the resistance of the wire that is connected to the analog input, the preset temperature may not properly be sent. If this is the case, check the current value of the analog input, and adjust the output value of the connected signal output device. Refer to the table below for how to display the value of the analog input.

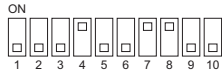
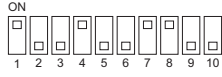
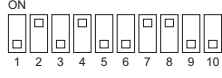
No.	Dip switch setting (SW7-1)	Dip switch setting (SW4)	Monitorable items	Unit
1	OFF		Current value (4-20 mA)	mA
2	OFF		5V voltage value (1-5 V)	V
3	OFF		10V voltage value (0-10 V or 2-10 V)	V

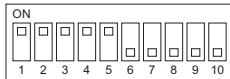

The figure at left shows that the switches 1 through 5 are set to ON and 6 through 10 are set to OFF.

- When the water temperature setting input signal type is 4-20 mA

- External analog input signal of 4 mA: Preset temp. A
- External analog input signal of 20 mA: Preset temp. B
- External analog input signal of between 6 and 18 mA: the preset temperature will be linearly interpolated.

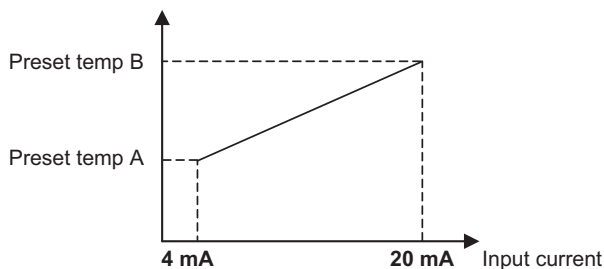

5. Wiring Design

- When the water temperature setting input signal type is 0-10 V
 - External analog input signal of 0 V: Preset temp. A
 - External analog input signal of 10 V: Preset temp. B
 - External analog input signal of between 0 and 10 V: the preset temperature will be linearly interpolated.

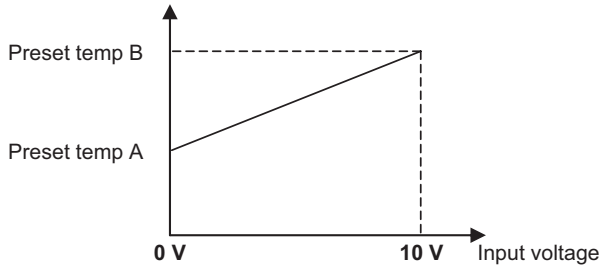

- When the water temperature setting input signal type is 1-5 V
 - External analog input signal of 1 V: Preset temp. A
 - External analog input signal of 5 V: Preset temp. B
 - External analog input signal of between 1 and 5 V: the preset temperature will be linearly interpolated.

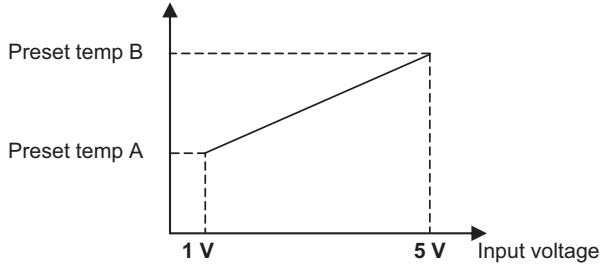

- When the water temperature setting input signal type is 2-10 V
 - External analog input signal of 2 V: Preset temp. A
 - External analog input signal of 10 V: Preset temp. B
 - External analog input signal of between 2 and 10 V: the preset temperature will be linearly interpolated.

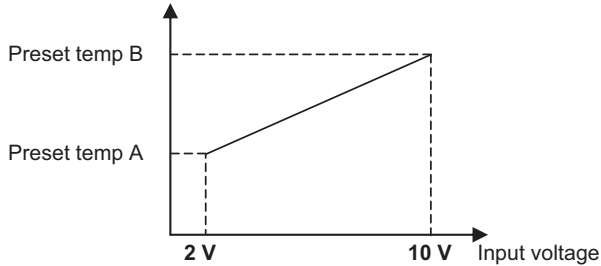

(6) Setting the capacity control ratio using analog signal input

When dip switch SW5-7 is set to ON (Enable external input), SW5-8 is set to ON, and SW5-9 is set to OFF, the capacity control ratio varies with the type of analog input signal.

- When the capacity control setting input signal type is 4-20 mA
 - External analog input signal of 4 mA: 0%
 - External analog input signal of 20 mA: 100%
 - External analog input signal of between 4 and 20 mA: the percent will be linearly interpolated.

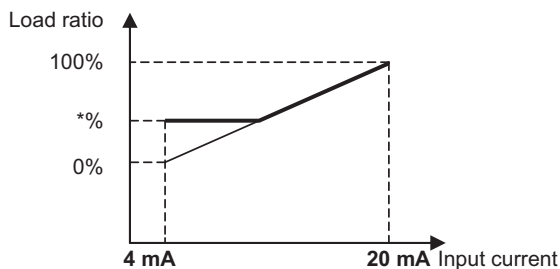

5. Wiring Design

- When the capacity control setting input signal type is 0-10 V
 - External analog input signal of 0 V: 0%
 - External analog input signal of 10 V: 100%
 - External analog input signal of between 0 and 10 V: the percent will be linearly interpolated.

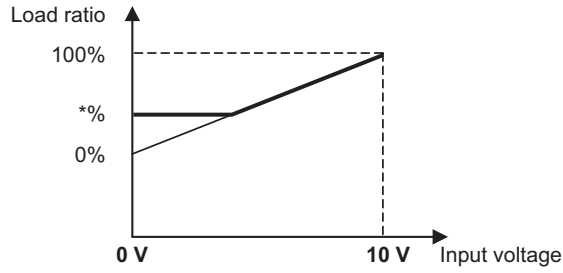

- When the capacity control setting input signal type is 1-5 V
 - External analog input signal of 1 V: 0%
 - External analog input signal of 5 V: 100%
 - External analog input signal of between 1 and 5 V: the percent will be linearly interpolated.

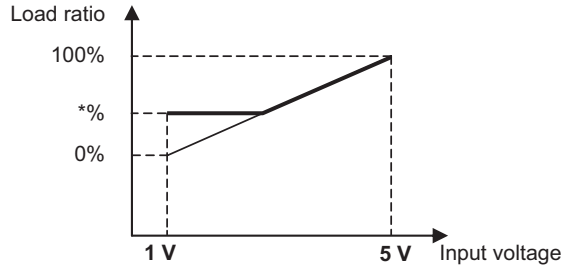

- When the capacity control setting input signal type is 2-10 V
 - External analog input signal of 2 V: 0%
 - External analog input signal of 10 V: 100%
 - External analog input signal of between 2 and 10 V: the percent will be linearly interpolated.

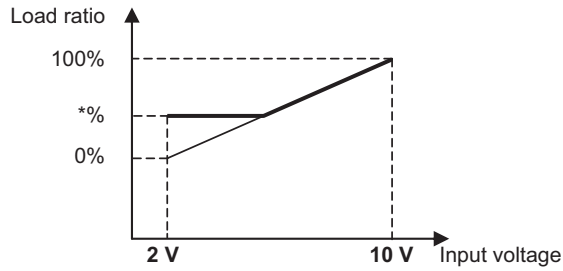

*%: The compressor runs at the lowest frequency.

5. Wiring Design

(7) Setting the supplementary heater signal output conditions

A temperature at which the signal output to operate supplementary heaters can be selected.

Supplementary heater signal output conditions

The operation command signal is ON and at least one of the following two conditions is met.

[1] Water-temperature control option (SW5-4) is set to OFF, the inlet water temperature drops below a set water temperature, and the outdoor temperature drops below a set outdoor temperature.

[2] Water-temperature control option (SW5-4) is set to ON, the external water temperature sensor reading (TH117) drops below a set water temperature, and the outdoor temperature drops below a set outdoor temperature.

The supplementary heater signal is output from RP1-RP2.

Supplementary heater signal output stop conditions

The operation command signal is OFF or at least one of the following two conditions is met.

[1] The inlet water temperature is at or above a set water temperature +2°C or the outdoor temperature is at or above a set outdoor temperature +2°C.

[2] External water temperature sensor reading (TH117) is at or above a set water temperature +2°C.

Set the dip switches on the circuit board as follows to make the settings for the items described in this section.

Press the push switch SWP3 to enable the configuration changes.

Press the push switches SWP1 (↑) or SWP2 (↓) to increase or decrease the value.

When the desired value is displayed, press SWP3 to save the setting value.

Settings table

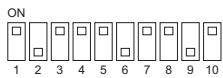
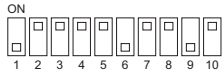
No.	Dip switch setting (SW7-1)	Dip switch setting (SW4)	Setting Item	Initial value	Unit	Setting			Setting change from an optional remote controller (PAR-W31MAA)
						Increments	Lower limit	Upper limit	
1	ON		Supplementary heater operation water temp	40	°C	0.1°C	0	55	Not possible
2	ON		Supplementary heater operation outdoor temp	-10		0.1°C	-30	50	Not possible

(8) Setting the drain pan heater signal output condition

A temperature at which the signal output to operate drain pan heaters can be selected.

Drain pan heater signal output condition

The following condition is met.

- ♦The outdoor temperature drops below a set outdoor temperature.

The drain pan signal is output from KB1-KB2.

Drain pan heater signal output stop condition

The following condition is met.

- ♦The outdoor temperature is at or above a set outdoor temperature +2°C.

Set the dip switches on the circuit board as follows to make the settings for the items described in this section.

Press the push switch SWP3 to enable the configuration changes.

Press the push switches SWP1 (↑) or SWP2 (↓) to increase or decrease the value.

When the desired value is displayed, press SWP3 to save the setting value.

Settings table

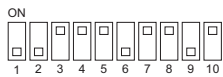
No.	Dip switch setting (SW7-1)	Dip switch setting (SW4)	Setting Item	Initial value	Unit	Setting			Setting change from an optional remote controller (PAR-W31MAA)
						Increments	Lower limit	Upper limit	
1	ON		Drain pan heater operation outdoor temp	0	°C	1°C	-40	20	Not possible



The figure at left shows that the switches 1 through 5 are set to ON and 6 through 10 are set to OFF.

5. Wiring Design

(9) External temperature sensor control

An optional External temperature sensor (TW-TH16) is required.

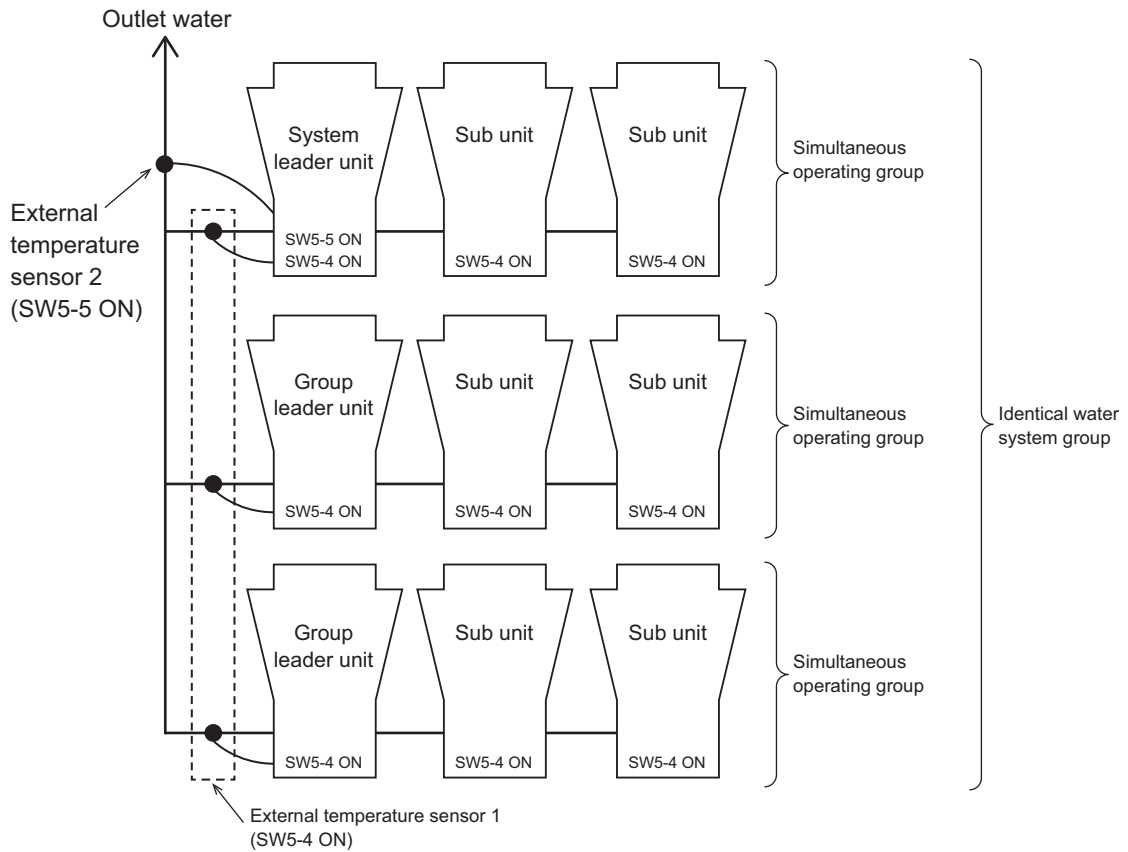

External temperature sensor 1

Used to control the water temperature of simultaneous operating group.

External temperature sensor 2

The water outlet temperature of each unit in the identical water system group is corrected to bring the water temperature at the merged section of the outlet water pipes toward the target temperature.

5. Wiring Design

(10) Demand operation

The demand function can reduce the power consumption.

Single unit control

In the case of single unit control, the unit is operated up to the specified demand limit.

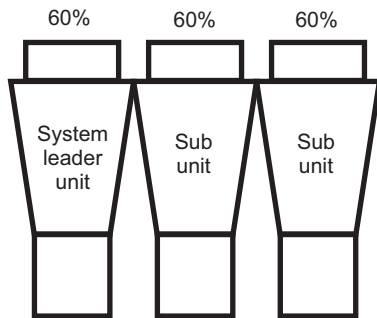

Multiple unit control

In the case of multiple unit control, the number of operating units are limited by demand value.

When the demand value is 70%, the group operate such as below figure.

3 groups x demand 70% => 2 groups operation

(=2.1 (-> round down to the decimal point ->) ≈2)

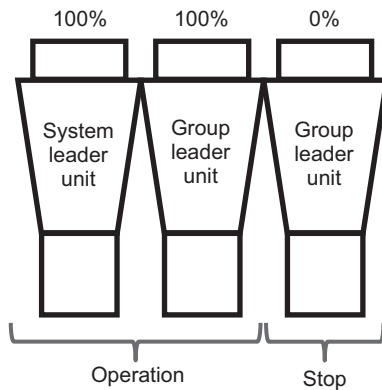

*In the case of multiple unit control, the demand capacity may not actually be the capacity because it sets the number of operable units.

Other examples)

Even if you set demand capacity to 90% in the case of 2 sets, the number of operable units will be only 1 (round down to the decimal point).

The operating capacity of one group is 50%.

(In the case of multiple unit control, the frequency of each unit is controlled within the range of 0 to 100% regardless of the demand capacity.)

5. Wiring Design

5-2. Electrical Wiring Installation

5-2-1. Main Power Supply Wiring and Switch Capacity

Schematic Drawing of Wiring (Example)

- <A> Switch (with current breaking capability)
- Current leakage breaker
- <C> unit

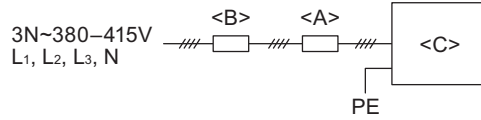

Main power supply wire size, switch capacities, and system impedance

Model	Minimum wire thickness (mm ²)			Current leakage breaker	Local switch (A)		No-fuse breaker (A)	Max. Permissible System Impedance
	Main cable	Branch	Ground		Capacity	Fuse		
EACV/EAHV-M1500/1800YCL	35	-	35	160 A 200 mA 0.1 sec. or less	150	150	160	0.06 Ω

- 1) Use a dedicated power supply for each unit. Ensure that each unit is wired individually.
- 2) When installing wiring, consider ambient conditions (e.g., temperature).
- 3) The wire size is the minimum value for metal conduit wiring. If voltage drop is a problem, use a wire that is one size thicker. Make sure the power-supply voltage does not drop more than 5%.
- 4) Specific wiring requirements should adhere to the wiring regulations of the region.
- 5) Power supply cords of appliances shall not be lighter than polychloroprene sheathed flexible cord (design 60245 IEC57).
- 6) A switch with at least 3 mm contact separation in each pole shall be provided by the Air Conditioner installer.
- 7) Do not install a phase advancing capacitor on the motor. Doing so may damage the capacitor and result in fire.

⚠ WARNING

- ♦ Be sure to use specified wires and ensure no external force is imparted to terminal connections. Loose connections may cause overheating and fire.
- ♦ Be sure to use the appropriate type of overcurrent protection switch. Note that overcurrent may include direct current.

⚠ CAUTION

- ♦ Some installation sites may require an installation of an earth leakage breaker for the inverter. If no earth leakage breaker is installed, there is a danger of electric shock.
- ♦ Only use properly rated breakers and fuses. Using a fuse or wire of the wrong capacity may cause malfunction or fire.

Note

- ♦ This device is intended for the connection to a power supply system with a maximum permissible system impedance shown in the above table at the interface point (power service box) of the user's supply.
- ♦ Ensure that this device is connected only to a power supply system that fulfills the requirements above. If necessary, consult the public power supply company for the system impedance at the interface point.
- ♦ This equipment complies with IEC 61000-3-12 provided that the short-circuit power S_{sc} is greater than or equal to $S_{sc} (*1)$ at the interface point between the user's supply and the public system. It is the responsibility of the installer or user of the equipment to ensure, in consultation with the distribution network operator if necessary, that the equipment is connected only to a supply with a short-circuit power S_{sc} greater than or equal to $S_{sc} (*1)$.

*1

S _{sc} (MVA)
10.35

Control cable specifications

Remote controller cable	Size	0.3 mm ² (Max. 250 m total)
	Recommended cable types	2-core sheathed cable
M-NET cable between units *2	Size	Min. 1.25 mm ² (Max. 200 m total)
	Recommended cable types	Shielded cable CVVS, CPEVS or MVVS
External input wire size		Min. 0.3 mm ²
External output wire size		1.25 mm ²

*2 Use a CVVS or CPEVS cable (Max. total length of 250 m) if there is a source of electrical interference nearby (e.g., factory) or the total length of control wiring exceeds 200 m.

5. Wiring Design

5-2-2. Cable Connections

1. Schematic Diagram of a Unit and Terminal Block Arrangement

(Unit: mm)

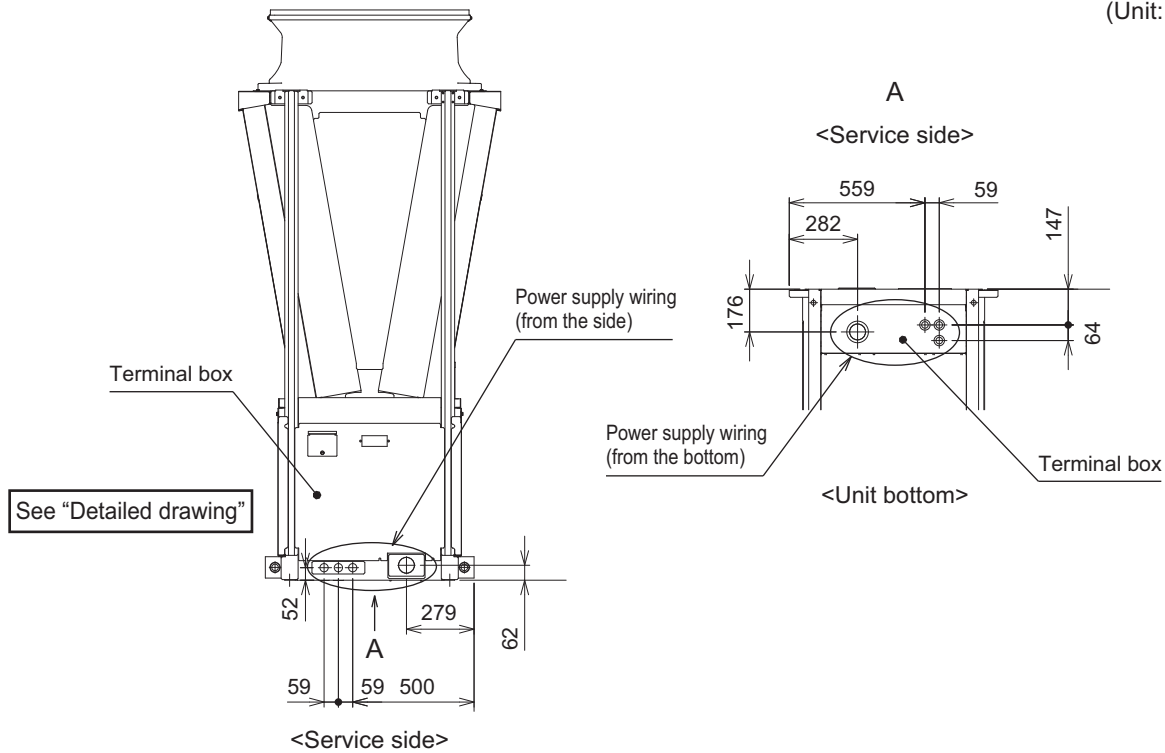

Detailed drawing

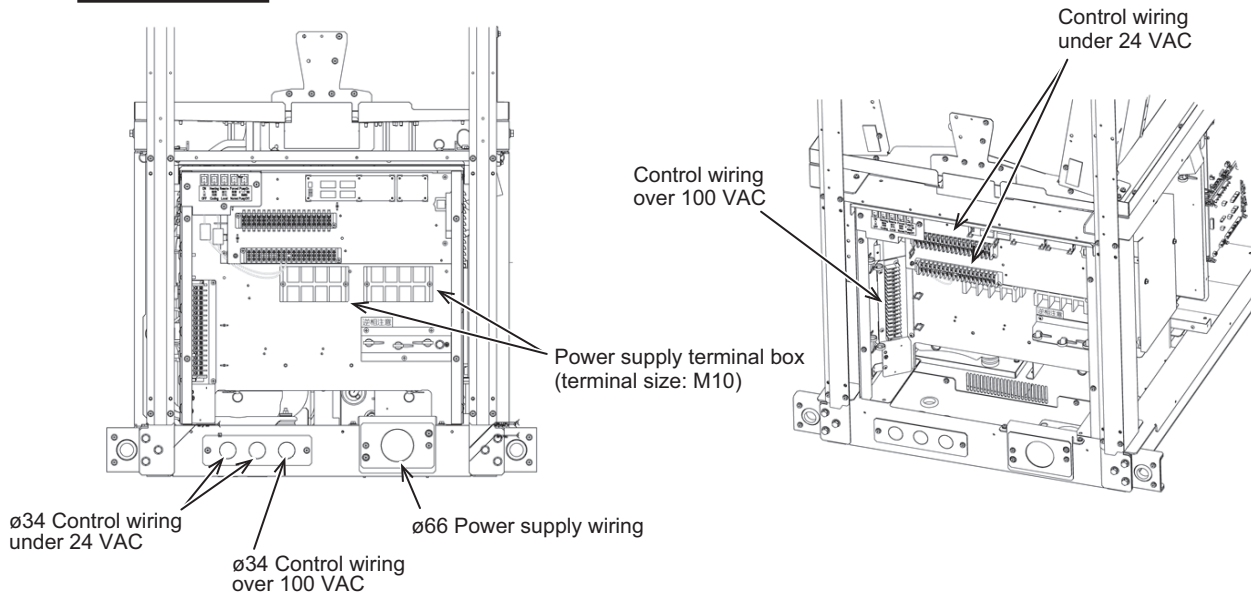

- (1) Remove the front terminal box cover.
- (2) Wire the power supply and control wires. The terminal box is covered with a bush.
Cut the bush before connecting wires to the terminal box.
- (3) Fasten the power supply wires by the cable strap.
- (4) Secure the cable conduit, and then waterproof the area around the pipe with silicon, etc.
- (5) Reattach the terminal box cover.

5. Wiring Design

2. Precautions when fastening screws

- * Faulty contacts due to loose screws may cause overheating and fire.
- * Using the circuit board while it is damaged may cause overheating and fire.

<1> Screw fastening torque

Power supply terminal block, M8 screw: **10 to 13.5 N·m**

Use the following methods to check that the screws have been fastened.

- 1) Check that the spring washer is in a parallel position.
 - * If the screw is biting into the washer, simply fastening the screw to the specified torque cannot determine whether it has been installed properly.

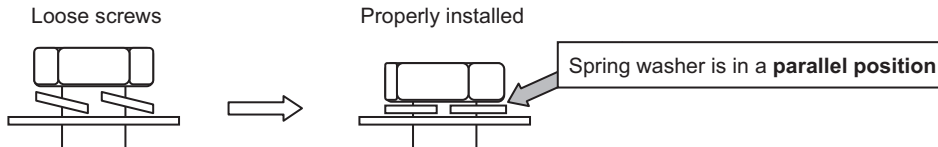

- 2) Check that the wiring does not move at the screw terminal.
 - <2> Take extra care not to ruin the screw thread due to fastening the screw at an angle.
 - * To prevent fastening the screw at an angle, install the round terminals so they are back to back.
- <3> After fastening the screw, use a permanent marker to tick off the screw head, washer and terminal.

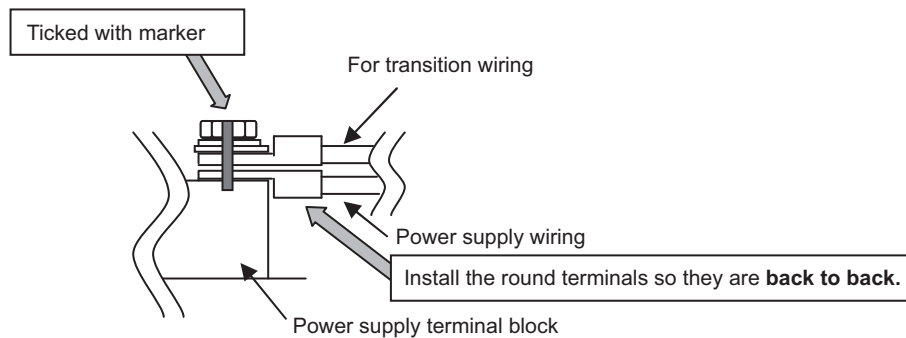

3. Installing the conduit tube

- Always use a conduit to run the power supply wiring.
- Select the conduit size based on the hole.
- The cable conduits must be prepared locally.
- Do not store the 24VDC or less low-voltage circuit and 100VAC or higher main circuit and control circuit cables in the same multi-core cable, or bundle them together.
- Attach cable conduits securely to the foundation, etc. to ensure that excessive loads are not applied to the power supply terminal box.
- Seal the area around the cable conduit connection to ensure that no water penetrates the cable conduit connection port.

6. Controller

6-1. PAR-W31MAA specifications

Item	Description	Operations	Display
ON/OFF	Runs and stops the operation of a group of units	○	○
Operation mode switching	Switches between Heating/Heating ECO/Anti-freeze/Cooling * Available operation modes vary depending on the unit to be connected. * Switching limit setting can be made via a remote controller.	○	○
Water temperature setting	Temperature can be set within the ranges below. (in increments of 0.5°C or 0.5°F) Heating 25°C ~ 55°C Heating ECO 25°C ~ 55°C Anti-freeze 25°C Cooling 4°C ~ 30°C * The settable range varies depending on the unit to be connected.	○	○
Water temperature display	-20°C ~ 90°C (in increments of 0.5°C or 0.5°F) * The settable range varies depending on the unit to be connected.	×	○
Permit/Prohibit local operation	Individually prohibits operations of each local remote control function: ON/OFF, Operation modes, water temperature setting, Circulating water replacement warning reset. * Upper level controller may not be connected depending on the unit to be connected.	×	○
Weekly scheduler	ON/OFF/Water temperature setting can be done up to 6 times one day in the week. (in increments of a minute)	○	○
Error	When an error is currently occurring on a unit, the afflicted unit and the error code are displayed.	×	○
Self check (Error history)	Searches the latest error history by pressing the CHECK button twice.	○	○
LANGUAGE setting	The language on the dot matrix LCD can be changed. (11 languages) English/French/German/Swedish/Spanish/Italian/Danish/Dutch/Finnish/Norwegian/Portuguese	○	○
Operation locking function	Remote controller operation can be locked or unlocked. • All-switch locking • Locking except ON/OFF switch	○	○

⚠ Warning

- Do not use refrigerant other than the type indicated in the manuals provided with the unit and on the nameplate.
 - Doing so may cause the unit or pipes to burst, or result in explosion or fire during use, repair, or at the time of disposal of the unit.
 - It may also be in violation of applicable laws.
 - MITSUBISHI ELECTRIC CORPORATION cannot be held responsible for malfunctions or accidents resulting from the use of the wrong type of refrigerant.
- Our chilling units contain a fluorinated greenhouse gas, R32.

MITSUBISHI ELECTRIC CORPORATION

www.MitsubishiElectric.com