

**ecodan**

Wireless Remote Controller  
and Receiver

**PAR-WT60R-E**

**PAR-WR61R-E**

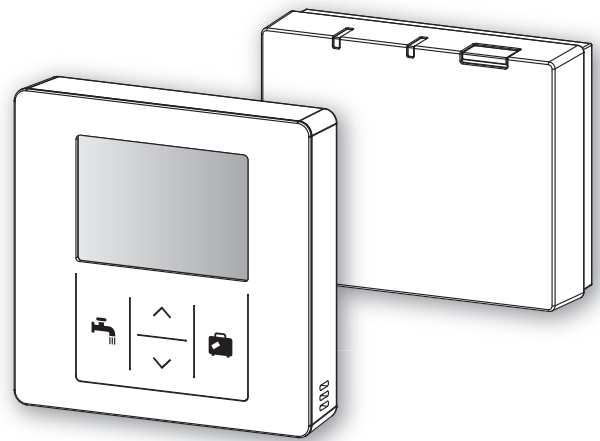

INSTALLATION MANUAL  
INSTALLATIONSHANDBUCH  
MANUEL D'INSTALLATION  
INSTALLATIEHANDLEIDING  
MANUAL DE INSTALACIÓN  
MANUALE DI INSTALLAZIONE  
ΕΓΧΕΙΡΙΔΙΟ ΟΔΗΓΙΩΝ ΕΓΚΑΤΑΣΤΑΣΗΣ  
MANUAL DE INSTALAÇÃO  
INSTALLATIONSMANUAL  
INSTALLATIONSMANUAL  
РЪКОВОДСТВО ЗА МОНТАЖ  
INSTRUKCJA MONTAŻU  
INSTALLASJONSHÅNDBOK  
ASENNUSOPAS  
INSTALAČNÍ PŘÍRUČKA  
NÁVOD NA INŠTALÁCIU  
TELEPÍTÉSI KÉZIKÖNYV  
NAMESTITVENI PRIROČNIK  
MANUAL DE INSTALARE  
PAIGALDUSJUHEND  
MONTĀŽAS ROKASGRĀMATA  
MONTAVIMO VADOVAS  
PRIRUČNIK ZA POSTAVLJANJE  
UPUTSTVO ZA UGRADNJU

FOR INSTALLER

FÜR INSTALLATEUR

POUR L'INSTALLATEUR

VOOR DE INSTALLATEUR

PARA EL INSTALADOR

PER L'UTENTE

ΓΙΑ ΑΥΤΟΝ ΠΟΥ ΚΑΝΕΙ ΤΗΝ ΕΓΚΑΤΑΣΤΑΣΗ

PARA O INSTALADOR

TIL INSTALLATØREN

FÖR INSTALLATÖREN

ЗА МОНТАЖНИКА

DLA INSTALATORA

FOR MONTØR

ASENTAJALLE

PRO MONTÁŽNÍ PRACOVNÍKY

PRE MONTÉRA

A TELEPÍTŐ RÉSZÉRE

ZA MONTERJA

PENTRU INSTALATOR

PAIGALDAJALE

UZSTĀDĪŠANAS SPECIĀLISTAM

SKIRTA MONTUOTOJUI

ZA INSTALATERA

ZA MONTERA

English (EN)

Deutsch (DE)

Français (FR)

Nederlands (NL)

Español (ES)

Italiano (IT)

Ελληνικό (EL)

Português (PT)

Dansk (DA)

Svenska (SV)

Български (BG)

Polski (PL)

Norsk (NO)

Suomi (FI)

Čeština (CS)

Slovenčina (SK)

Magyar (HU)

Slovenščina (SL)

Română (RO)

Eesti (ET)

Latviski (LV)

Lietuviškai (LT)

Hrvatski (HR)

Srpski (SR)

This manual explains installation of the PAR-WR61R-E wireless receiver and the PAR-WT60R-E wireless remote controller, and settings of these devices. Before installing the devices, read this manual thoroughly. After reading, be sure to hand this manual to the user.



## Contents

For safe and correct use, please read this manual thoroughly before installing the PAR-WT60R-E and PAR-WR61R-E devices.

1. Safety Precautions .....	1	6.4. Communication Test .....	11
2. Accessories and Installation Tool .....	3	6.5. Displaying or Hiding Room Temperature ...	11
3. Before using ATW wireless system .....	3	6.6. Automatic Zone No. Display .....	11
4. Installing Wireless Receiver .....	4	7. Wireless Receiver Operation.....	12
4.1. Connecting to Cylinder unit .....	4	7.1. Functions of Buttons and Displays ..	12
4.2. Connecting to Hydrobox.....	7	7.2. Turning on Power .....	13
5. Pairing process.....	8	7.3. Wireless Receiver Functions.....	13
6. Setting wireless remote controllers.....	10	8. Specifications .....	13
6.1. Viewing Address Number.....	10	9. FAQ .....	14
6.2. Pairing .....	10		
6.3. Selecting the Temperature Unit ...	10		

## 1. Safety Precautions

- The precautions mentioned below are important to use the device safely. Be sure to understand and follow them.
- The following hazardous classification shows the likelihood and severity of hazards if a person does not follow the instructions contained on the following signs.

 <b>Warning</b>	Indicates a hazardous situation which, if a person does not follow the instructions, could result in death or serious injury.
 <b>Caution</b>	Indicates a potentially hazardous situation that, if a person does not follow the instructions, may result in bodily injury or property damage.

### **Warning**

#### ► Installation

Do not use the device in particular environments.

Do not use the device in particular environments where the following substances are present in large amounts: oil, vapour, organic solvent, corrosive gas (such as ammonia, sulphuric compounds, and acid or the like), or where acid or alkali solution, or particular sprays are used frequently. This could affect operating performance, or cause corrosion, which could result in electrical shock, breakdown, smoke generation, or fire.

Do not place the devices in an environment where flammable gas may occur, stay, flow in, or leak.

Build-up of flammable gas could result in fire or explosion.

## ⚠ Warning

The device must be installed by a dealer or an authorised technician according to the appropriate installation manual.	If the device is installed improperly, electric shock or fire could result.
Do not place the device in an environment that exposes it to large amounts of vapor or condensation.	Electric shock, fire, or breakdown could result.
<b>► Wiring</b>	
The wireless receiver's maximum voltage is 12V DC. Do not connect 230V AC power source to the wireless receiver.	Breakdown, ignition, or fire could result.
Connections must be made securely and without tension or external force on the terminals.	If connections are made improperly, breaking of wire, heat generation, or fire could result.
<b>► Others</b>	
Do not use sharp objects to touch the buttons.	Electric shock or breakdown may result.
Do not touch or operate the device with wet hands.	Electric shock or breakdown may result.
Do not wash the device with water or solution or the like.	Electric shock or breakdown may result.
When installing or repairing the device, ask a dealer or a qualified technician.	If the device is not installed properly, electric shock, smoke generation, or fire could result from entry of dust or water.
Do not disassemble or modify.	

EN

## ⚠ Caution

Do not drop the device.	This could break the case or affect the device enough to make it inoperable.
Install the device in a place capable of bearing its own weight .	If the device is not installed securely or properly, the wireless receiver may fall.

### ■ Disposal

**This symbol mark is for EU countries only.**



**This symbol mark is according to the directive 2002/96/EC Article 10 Information for users and Annex IV, and/or to the directive 2006/66/EC Article 20 Information for end-users and Annex II.**

Your MITSUBISHI ELECTRIC product is designed and manufactured with high quality materials and components which can be recycled and/or reused. This symbol means that electrical and electronic equipment, batteries and accumulators, at their end-of-life, should be disposed of separately from your household waste. If a chemical symbol is printed beneath the symbol, this chemical symbol means that the battery or accumulator contains a heavy metal at a certain concentration.

This will be indicated as follows: Hg: mercury (0.0005%), Cd; cadmium (0.002 %), Pb: lead (0.004%)  
In the European Union there are separate collection systems for used electrical and electronic products, batteries and accumulators.

Please, dispose of this equipment, batteries and accumulators correctly at your local community waste collection/recycling centre.

Please, help us to conserve the environment we live in!

## 2. Accessories and Installation Tool

### ■ Included parts

The following items are included in the box.

Part name	Qty
① Wireless receiver <PAR-WR61R-E> (2 m long cable included)	1
② Bracket	1
③ Flat head screw (4.1 × 6)	4
④ Installation and setting manual	1

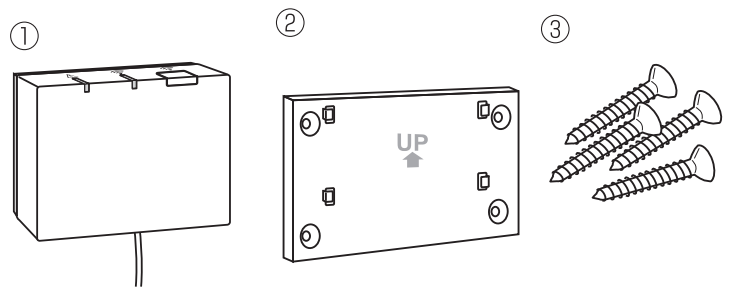

\* Installing of the devices requires a Phillips-head screwdriver (No.2 6 mm).

### ■ How to read the year of manufacture

The year of manufacture is indicated on the wireless remote controller and receiver as below.

L \* \* \* \* \* S   \* \* \* \* \*

Month of manufacture : 1,2,3,4,5,6,7,8,9,X(10),Y(11),Z(12)

Year of manufacture (western calendar) 2=2022, 3=2023

## 3. Before using ATW wireless system

Following is the summary of the procedure for installing and setting the wireless system.

### 1. Devices and manuals required to set and install the wireless system

- ① PAR-WT60R-E wireless remote controller
- ② PAR-WR61R-E wireless receiver
- ③ ATW wireless system installation and setting manual (this manual)
- ④ Wireless remote controller operation manual (hereinafter abbreviated as OM)
- ⑤ Ecodan system installation manual (hereinafter abbreviated as IM)

### 2. Installing and setting procedure

- ① Power off the ecodan system.
- ② Install the wireless receiver on the ecodan system.  
(See "4. Installing the Wireless Receiver" in this manual.)

**When installing the wireless receiver, be sure to set the SW1-8 on the control board to ON. (See "5.1 DIP Switch Functions" in IM. )**

- ③ Power on the ecodan system, and the LEDs will blink on the receiver for 3 seconds.
- ④ Place two AA alkaline batteries in the wireless remote controller.  
(See "·Batteries" in "4. Before Operation" in OM.)
- ⑤ Perform pairing process between the wireless receiver and the remote controller.  
(See "5. Pairing process" in this manual.)

**The wireless receiver does not go through a pairing process unless the ecodan system is off. When the system is ON, be sure to turn it off before beginning the pairing process.**

- ⑥ Test wireless communication between the wireless remote controller and the wireless receiver.  
(See "6.4. Communication Test" in "6. Setting wireless remote controllers" in this manual.)
- ⑦ Position the wireless remote controller in an appropriate place.  
(See "4. Before Operation" in OM.)
- ⑧ To set the wireless remote controller as a room sensor that monitors room temperature, see "Main remote controller Options" in IM.
- ⑨ Use the main controller to set the ecodan system to the room temp. (🏠) mode.  
When the flow temp. (🌡️) mode or the compensation curve (📈) mode is selected, the wireless remote controller will operate as a thermostat. (See "Main remote controller" in IM.)

**When the remote controller set as a room sensor runs out of battery or gets a communication error during room temp. mode, the room temp. mode will automatically switch to the compensation curve mode.  
The room temp. mode will be restored by battery replacement or solution of communication error.**

**Installation and setting of the wireless remote controller is complete. To set additional wireless remote controllers, repeat Step ⑤ to ⑧.**

## 4. Installing Wireless Receiver

### 4.1. Connecting to Cylinder unit

**\* Before installation, be sure to turn off the main power supply.**

- ① Remove the two screws that hold the front panel, and remove the panel.
- ② Remove the screw and pull the control and electrical box so that the control and electrical box is swung toward you from left.

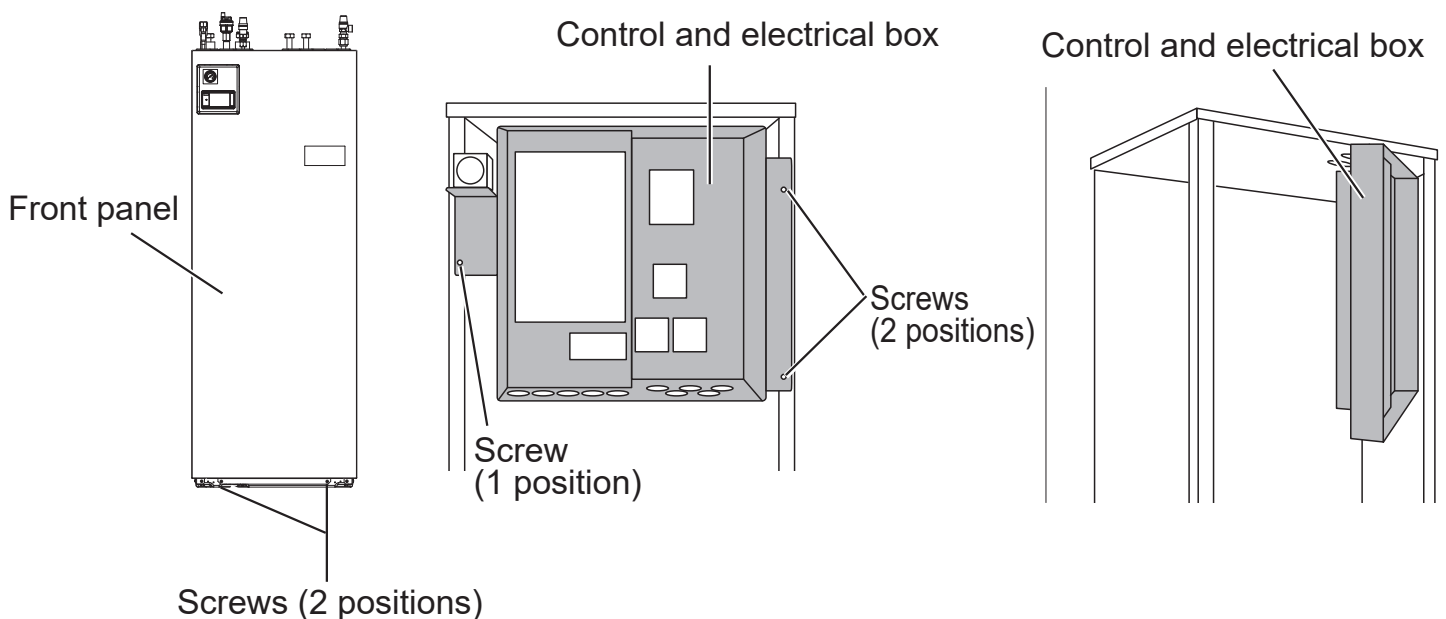

**If the removed front panel is set aside away from the indoor unit, ensure the relay connector on Main remote controller is disconnected.**

- ③ Run the receiver's cable into the cylinder unit through the inlet as shown on the figure.

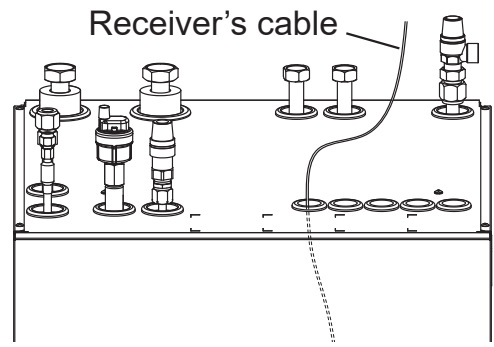

**Do not run the receiver's cable through an inlet that a power cable goes through and do not bundle the cable together with a power cable.**

- ④ Route the cable out the back of the control and electrical box, and run the cable into the box through the shown inlet in the underside of the box.

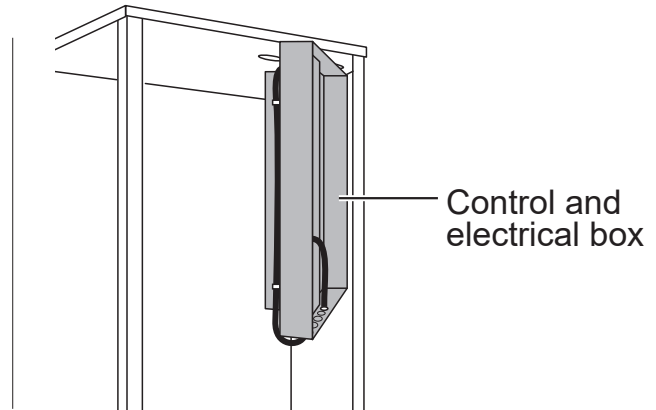
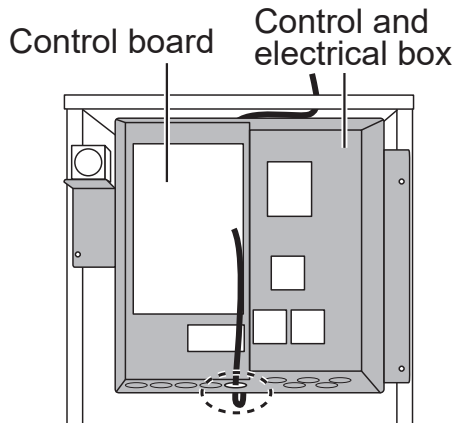

- ⑤ Connect the cable connector to the CNRF terminal on the control board. Switch ON SW1-8.

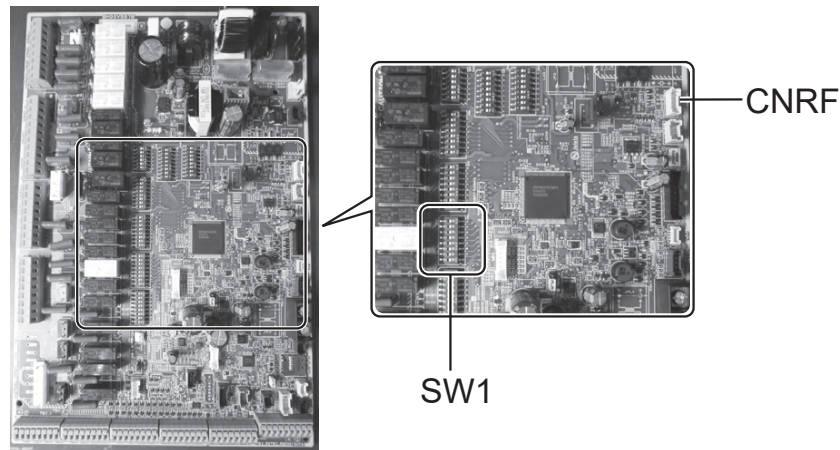

- ⑥ Remove excessive slack on the cable, then secure the cable with a cable fastener and 2 cable straps on the upper side and center on the back of control and electrical box.

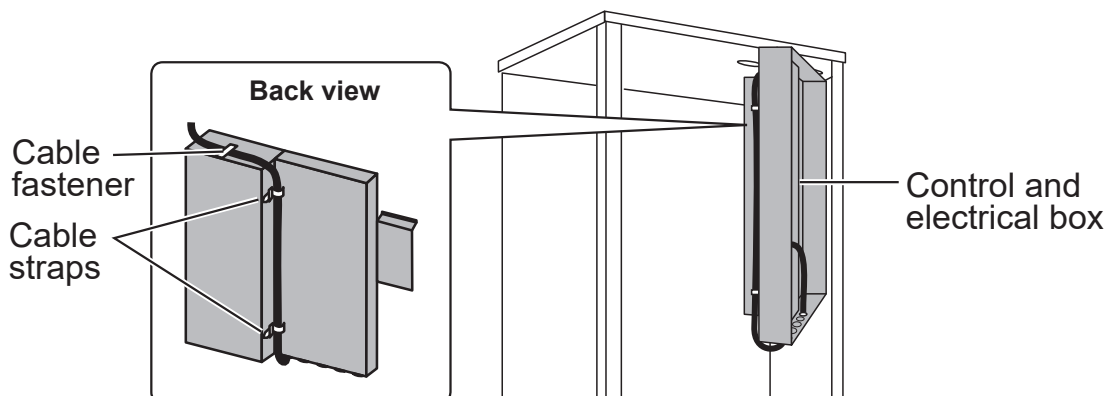

⑦ Place the control and electrical box back in the original position and reinstall the 3 screws.

⑧ Check the maximum reach of the cable and install the bracket on the wall with screws.

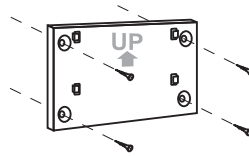

**Do not excessively pull the cable when checking the maximum reach.**



**<Notice>**

- **Do not overtighten the screws.**
  - ▶ The bracket may deform or break.
- **When installing the bracket, select an interference-free space.**
  - ▶ Keep the installing area at least 10 cm away from metal or a wall box. If unable to do so, always place the room wireless remote controllers in locations where the communication test determines that the wireless remote controllers are fully capable of communication with the wireless receiver.
- **Do not install the bracket with screws on the exterior casing of the cylinder unit.**
  - ▶ The internal parts may be damaged, which could result in breakdown of the indoor unit.
- **Do not install the bracket where the receiver could be exposed to moisture or leaked water from piping connections above.**
  - ▶ The wireless receiver subjected to moisture or leaked water could cause electric shock, fire, or its breakdown.

EN

⑨ Place the wireless receiver on the fixed bracket. Hook the holes on the back of the wireless receiver onto the projections on the bracket, and fix the wireless receiver in place.

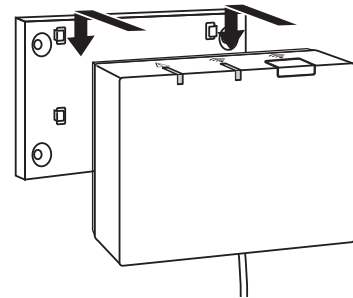

**<Notice>**

- **Do not place the wireless receiver inside the cylinder unit.**
  - ▶ Both the wireless receiver and its wire may break due to heat inside the indoor unit.
- **Do not let the wireless receiver stand on top of the cylinder unit. Always fix the wireless receiver onto the bracket.**
  - ▶ Wireless communication performance may be affected.
- **Do not pull the cable excessively.**
  - ▶ Breakdown, ignition, or fire may result.
- **Do not have the wireless receiver suspended.**
  - ▶ Breakdown, ignition, or fire may result.

⑩ Fix the front panel with screws.

## 4.2. Connecting to Hydrobox

\* Before installation, be sure to turn off the main power supply.

- ① Remove the two screws that hold the front panel, and remove the panel.

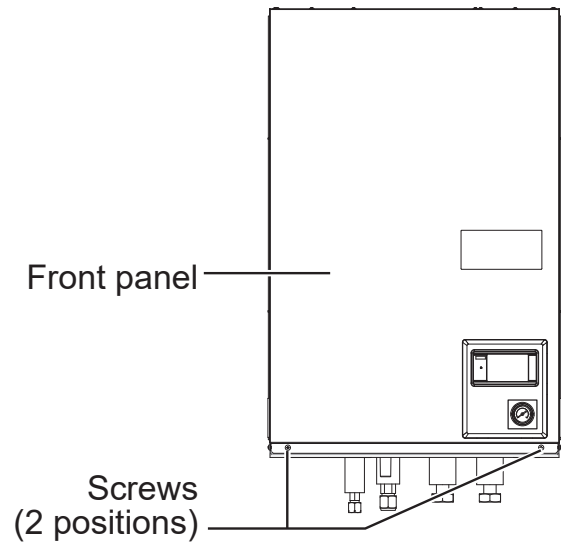

- ② Route the receiver's cable into the hydrobox through the leftmost inlet at the bottom of the unit. Then route into the control and electrical box through the shown inlet at the bottom of the control and electrical box.

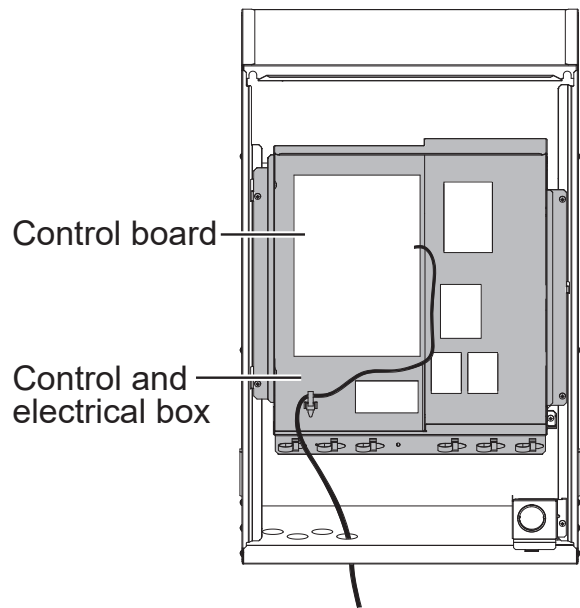

- Do not bundle the receiver cable with a power cable.
- Do not run the cable through an inlet that a power cable goes through.

Refer to ⑤, ⑦, and ⑧ in "4.1. Connecting to Cylinder unit" in this manual for the procedures ③ and ④.

**When installing the wireless receiver, observe the following.**

- Keep the other electric or electronic devices (e.g. radio, induction heating cooker, microwave oven, refrigerator, and mobile phone or the like) at least 50 cm away from the wireless receiver.
- Place the wireless receiver in an interference-free area and keep the wireless receiver away from metal.

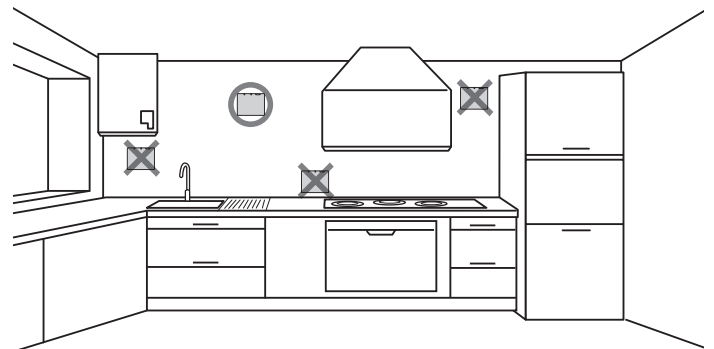

Refer to ⑨ and ⑩ in "4.1. Connecting to Cylinder unit" in this manual for the procedures ⑤ and ⑥.



## 5. Pairing process

- If the wireless remote controller is not paired, the indoor unit cannot be operated using the remote controller.
- Before using the wireless remote controllers, always ensure to go through a pairing process.
- Pairing is NOT possible unless the ecodan system is off. When the ecodan system is ON, be sure to turn it off before starting the pairing process.
- The wireless receiver is also needed for pairing, so please make sure to operate the wireless remote controller near the wireless receiver.
- Do not pair multiple wireless remote controllers with the receiver at the same time.



- When the remote controller operating, be sure to touch the buttons with your fingers or Stylus pen.
- ▶ The operation panel may not work properly in the following cases.

- \* The operation panel or your finger is wet or dirty.
- \* The operation panel is touched with a gloved finger or a finger with a bandage.
- \* The operation panel is touched with a sharp-pointed instrument.



If the operation panel does not respond to touch on the screen, release your finger from the screen and touch it again.



Touching the screen again without pause may result in false detection. Touching on the screen strongly does not enhance the detection sensitivity.

The response of operation panel depends on the ambient temperature and humidity, physical condition of the user, and operating conditions of the electric appliances.

- ① Press  button on the wireless receiver for 3 seconds or more until orange  LED blinks.

The pairing mode is cancelled by pressing  button.

- ② Touch,  and  buttons simultaneously for at least 3 seconds until the mode number blinks.

- ③ Touch  or  button to set the mode number to "1" and touch  button.

<Receiver Top view>

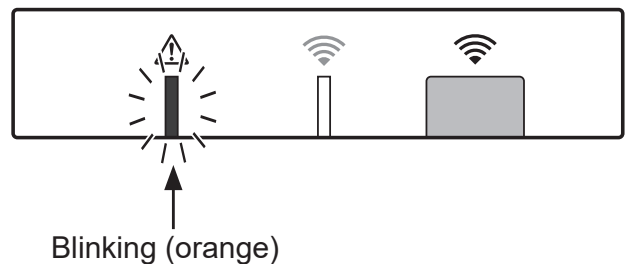



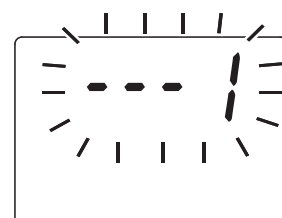
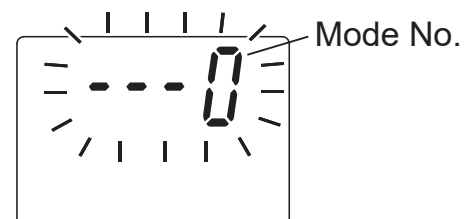

<Remote controller Display>



- ④ When  button is touched in the middle of setting, the screen returns to the previous indication.

**When  appears on the display, do not perform pairing. The power may be turned off in the middle of pairing, which may lose the pairing information.**

- ⑤ Touch  or  button to select a pairing address, and touch  button to set the address. " - " (no setting) is displayed initially. Choose a number from 1 to 8.

After touching  button, the wireless remote controller starts communication with the wireless receiver.

**When using multiple wireless remote controllers in one ecodan system, be sure to set different address for each remote controller.**

- ⑥ When the pairing process has been successfully performed, "ok" is shown on the remote controller and green  LED steadily lights on the wireless receiver.

When "Err" appears on the remote controller and green  LED on the wireless receiver blinks, correctly repeat the same process from step 5.

Even if the pairing process failed, the wireless receiver stays in the pairing mode for 5 minutes unless cancelled.

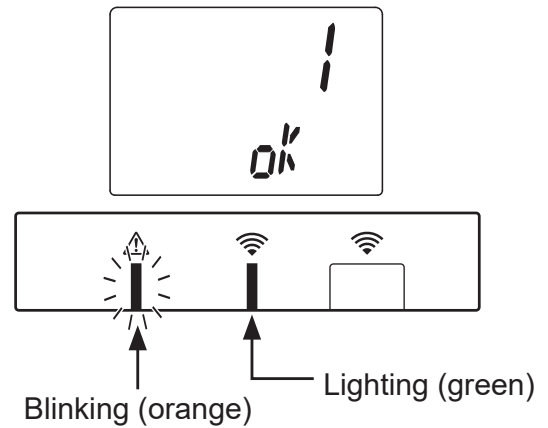

<Pairing is successful>

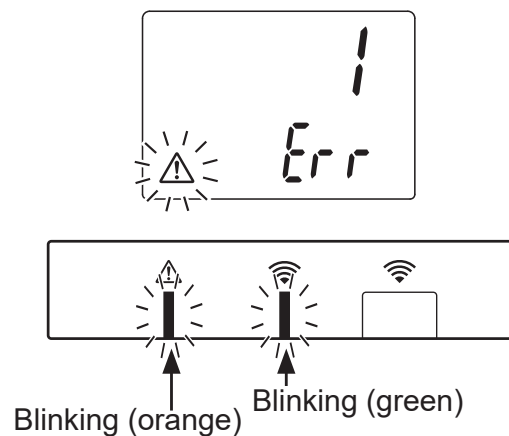

<Pairing is unsuccessful>









### <<Main causes that prevent successful pairing>>

- **The wireless receiver does not enter the pairing mode.**
  - ▶ Press  button for 3 seconds or more until orange  LED blinks. Make sure to turn off the ecodan system by main controller.
- **Pairing is attempted outside the transmission range of the wireless receiver.**
  - ▶ Adjust the distance between the wireless receiver and remote controller, and so try again. If the distance is excessively short, pairing may fail. Keep the distance of about 50 cm.
- **The wireless remote controller has been already paired with the wireless receiver.**
  - ▶ The pairing address assigned to a wireless remote controller cannot be changed by remote controller. Use the wireless receiver to reset pairing information. (Refer to "(3) Resetting pairing information" in "7.3. Wireless Receiver Functions".)

**Even when power fails or when the batteries run down, the pairing information will be kept.**

## 6. Setting wireless remote controllers

- ① Touch,  and  buttons simultaneously for at least 3 seconds until the mode number blinks.
- ② Touch  or  button to choose a mode number.
- ③ Confirm setting by touching  button. The display stops blinking and lights steadily.

When  button is touched in the middle of setting, the screen returns to the previous indication.

<Remote controller Display>

Mode No.

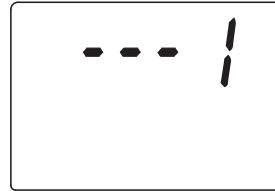
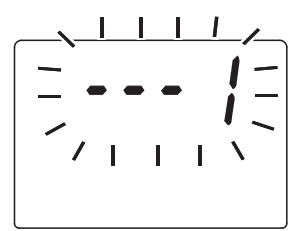
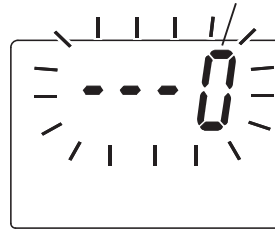

Mode No.	Names	Functions	Initial settings
0	Pairing address display	To view the own pairing address of the wireless remote controller.	
1	Pairing	To perform a pairing process with the wireless receiver.	
2	Temperature unit	To select °C or °F.	°C
3	Communication test	Communication test with the wireless receiver.	
4	Room temperature display	Actual room temperature display	ON
5	Automatic zone no. display	To enable or disable automatic zone no. display.	OFF

### 6.1. Viewing Address Number (Mode No. 0)

Set the mode no. to "0".

<Remote controller Display>

The display to the right shows that the address is set to "2".

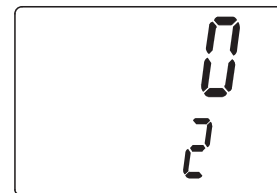

### 6.2. Pairing (Mode No. 1)



For details, refer to "5. Pairing process".

### 6.3. Selecting the Temperature Unit (Mode No. 2)

Set the mode no. to "2".

The temperature reading can be selected between Celsius (°C) or Fahrenheit (°F).

<Remote controller Display>

Touch  or  button to select °C or °F and touch  button to confirm the selection.

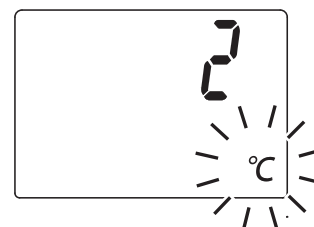

## 6.4. Communication Test (Mode No. 3)

Set the mode no. to "3".

Communication test is performed between the wireless remote controller and the wireless receiver.

When the display shows "OK", this indicates that the communication between the remote controller and the receiver is established. If "Err" is shown, the wireless remote controller is not communicating with the wireless receiver.

Do not leave the wireless remote controller in a location where the communication test results in "Err".



**Before conducting the communication test, ensure that the wireless remote controller goes through a pairing process.**

**Do not conduct the communication test on multiple remote controllers at the same time.**

## 6.5. Displaying or Hiding Room Temperature (Mode No. 4)

Set the mode no. to "4".

Select either displaying or hiding the room temperature.

Touch  or  button to select displaying or hiding the room temperature, and touch  button to save the setting.

**Hiding** : " - - - ".

**Displaying** : Actual room temperature is displayed

When the indoor unit is operating, the room temperature display shows the actual room temperature (18°C) above and the set temperature (20°C) below as shown in the figure to the right. The measurable temperature range is from 0°C to 40°C.

<Remote controller Display>

**If the measured room temperature is out of 0°C to 40°C range, the room temperature display blinks.**





**When the wireless remote controller is installed on a bracket, room temperature might not be accurate being affected by the wall temperature.**

**Perform a test run and place the remote controller where the room temperature can be correctly detected.**

## 6.6. Automatic Zone No. Display (Mode No. 5)

Set the mode no. to "5".

When the automatic zone no. display is active, a zone number assigned to the remote controller is displayed for 3 seconds after temperature setting.

Touch  or  button to select between "- - -" and  $z_1$  or  $z_2$ , and touch  button to save setting.

**Inactive** : "- - -".

**Active** : The zone no. ( $z_1$  or  $z_2$ ) assigned to the remote controller is shown.

## 7. Wireless Receiver Operation

The wireless receiver is powered by indoor unit. It communicates with the wireless remote controller(s), and transmits to the indoor unit the operation status and commands received from the wireless remote controlle(s). The wireless receiver has two modes available: pairing mode and pairing reset mode.

### 7.1. Functions of Buttons and Displays

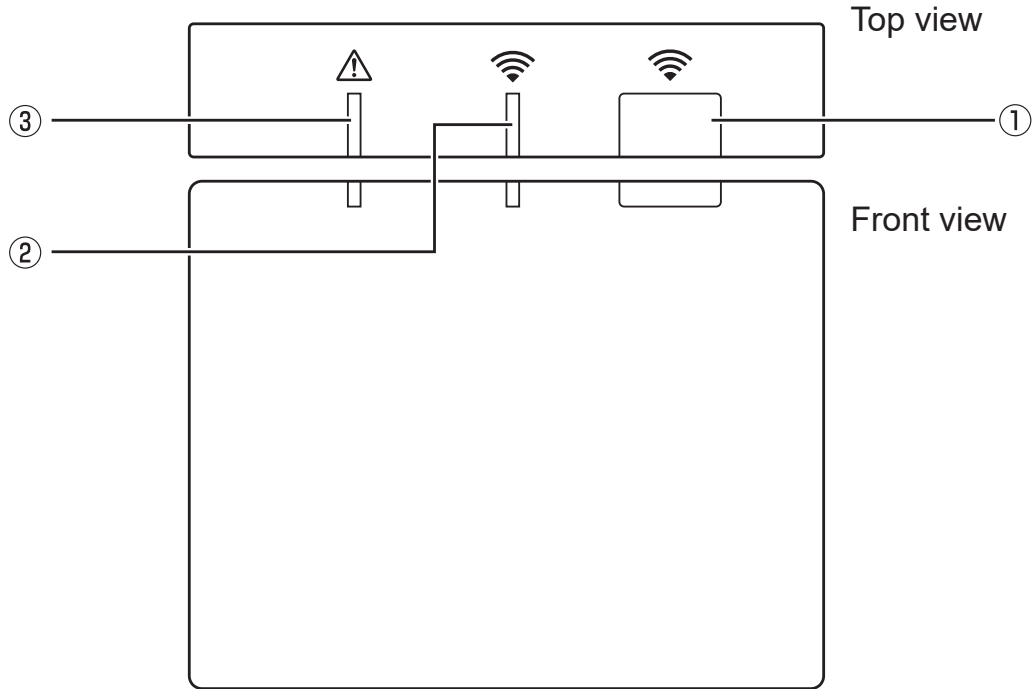



Number	Item	Description
①	Setting button	To switch operating mode.
②	Communication LED (green)	To indicate that the wireless receiver is communicating.
③	Operation LED (orange)	To show operating status of the wireless receiver.

The following table shows the operating and illuminating status of the LEDs.

Operation LED (orange)	Communication LED (green)	Description
Blinking	Blinking	Power is ON (for 3 seconds).
Off	Off	Normal mode: Not paired
Off	On	Normal mode: Paired
Off	Blinking	Normal mode: Communicating
Blinking	Off	Performing a pairing process
Blinking	On	Pairing: Successful
Blinking	Blinking	Pairing: Unsuccessful
On	On	Pairing information is cleared.

## 7.2. Turning on Power



When the wireless receiver is powered by indoor unit after installation, green  LED and orange  LED blink for 3 seconds.

Power ON



## 7.3. Wireless Receiver Functions

### (1) Normal mode

When the wireless receiver is paired with a wireless remote controller, green  LED comes on. When the wireless receiver is communicating with a wireless remote controller, green  LED blinks.

Not paired

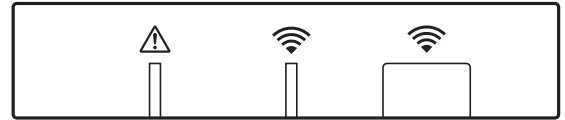

Paired



Transmitting





### (2) Pairing mode

For details, refer to "5. Pairing process" in this manual.

### (3) Resetting pairing information

Once pairing information has been cleared, ALL the wireless remote controllers need go through a pairing process again.



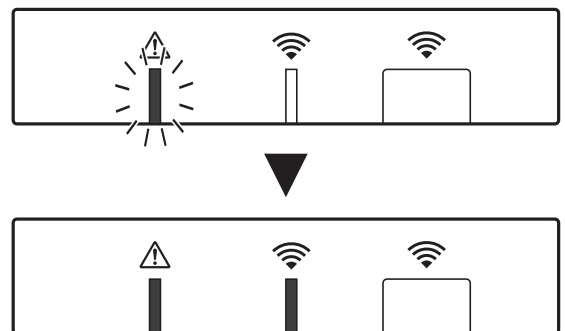

Press  button for 5 seconds or more until  and  LED light while pairing mode is active. All the pairing information is cleared.



## 8. Specifications

Item	Description
Power source	12V DC (powered by indoor unit)
Operating temperature and humidity requirements	Temperature: 0 to 40°C Humidity 30 to 90%RH (No condensation)
Weight	150 g (excluding a cable)
Dimension (W×H×D)	100 mm × 80 mm × 30 mm
Transmitter power level (MAX)	10 dBm
Frequency	868.3 MHz

## 9. FAQ

<i>Questions</i>	<i>Answers</i>
How many wireless remote controllers are allowed to be paired?	Up to 8 controllers.
What should be noted about Pairing?	<ul style="list-style-type: none"> <li>• The same address cannot be assigned to multiple remote controllers</li> <li>• If the same address is assigned to multiple controllers, the address can be assigned to only the last paired remote controller.</li> <li>• Once the remote controller is paired, its pairing address cannot be changed by remote controller. Use the wireless receiver to reset pairing information.</li> </ul>
What causes a communication error between the wireless remote controller and wireless receiver?	<p>Check the following possible causes.</p> <ul style="list-style-type: none"> <li>• The batteries on the wireless remote controller are running out.</li> <li>• The transmitted signal does not reach the wireless receiver.</li> <li>• The wireless remote controller is not paired.</li> </ul>
What measures should be taken when the room temp. display indicates “1” with  and LED light blinks?	The indoor unit or outdoor unit has a failure. Refer to the indications on the main controller and take appropriate measures. Please also check installation and service manuals for the indoor unit.
What measures should be taken when the room temp. display indicates “2” with  and LED light blinks?	The thermistor inside the wireless remote controller has a failure. Check the resistance of the thermistor. (When the room temperature is between 0 and 40°C, the resistance must be between 5 and 28 kΩ.)
What measures should be taken when the room temp. display indicates “3” with  and LED light blinks?	<p>A communication error occurs between the wireless remote controller and the wireless receiver. Check the following possible causes.</p> <ul style="list-style-type: none"> <li>• The signal that is transmitted by the wireless remote controller does not reach the wireless receiver.</li> <li>• The wireless remote controller is not paired.</li> </ul>
What measures should be taken when the room temp. display indicates “4” with  and LED light blinks?	<p>A communication error occurs between the wireless receiver and the indoor unit. Check the following possible causes.</p> <ul style="list-style-type: none"> <li>• The cable connecting between the wireless receiver and the indoor unit has severed.</li> <li>• The wireless receiver is not correctly connected to the indoor unit.</li> </ul>
What measures should be taken when the room temp. display indicates “E” with  and LED light blinks?	<p>Backup heater is running due to a failure of the indoor unit or the outdoor unit.</p> <p>Check the error code displayed on the main controller and take appropriate measures accordingly.</p> <p>The holiday mode is NOT available during backup heater only operation.</p>

Hereby, MITSUBISHI ELECTRIC CORPORATION declares that the radio equipment type PAR-WT60R-E, PAR-WR61R-E is in compliance with Directive 2014/53/EU.

The full text of the EU declaration of conformity is available at the following internet address:

<https://www12.mitsubishielectric.com/>

Hiermit erklärt MITSUBISHI ELECTRIC CORPORATION, dass der Funkanlagentyp PAR-WT60R-E, PAR-WR61R-E der Richtlinie 2014/53/EU entspricht.

Der vollständige Text der EU-Konformitätserklärung ist unter der folgenden Internetadresse verfügbar:

<https://www12.mitsubishielectric.com/>

Le soussigné, MITSUBISHI ELECTRIC CORPORATION, déclare que l'équipement radioélectrique du type PAR-WT60R-E, PAR-WR61R-E est conforme à la directive 2014/53/UE.

Le texte complet de la déclaration UE de conformité est disponible à l'adresse internet suivante:

<https://www12.mitsubishielectric.com/>

Hierbij verklaar ik, MITSUBISHI ELECTRIC CORPORATION, dat het type radioapparatuur PAR-WT60R-E, PAR-WR61R-E conform is met Richtlijn 2014/53/EU.

De volledige tekst van de EU-conformiteitsverklaring kan worden geraadpleegd op het volgende internetadres:

<https://www12.mitsubishielectric.com/>

Por la presente, MITSUBISHI ELECTRIC CORPORATION declara que el tipo de equipo radioeléctrico PAR-WT60R-E, PAR-WR61R-E es conforme con la Directiva 2014/53/UE.

El texto completo de la declaración UE de conformidad está disponible en la dirección Internet siguiente:

<https://www12.mitsubishielectric.com/>

Il fabbricante, MITSUBISHI ELECTRIC CORPORATION, dichiara che il tipo di apparecchiatura radio PAR-WT60R-E, PAR-WR61R-E è conforme alla direttiva 2014/53/UE.

Il testo completo della dichiarazione di conformità UE è disponibile al seguente indirizzo Internet:

<https://www12.mitsubishielectric.com/>

Με την παρούσα, η MITSUBISHI ELECTRIC CORPORATION δηλώνει ότι ο τύπος ραδιοεξοπλισμού PAR-WT60R-E, PAR-WR61R-E συμμορφώνεται με την οδηγία 2014/53/ΕΕ.

Το πλήρες κείμενο της δήλωσης συμμόρφωσης ΕΕ διατίθεται στην ακόλουθη διεύθυνση internet:

<https://www12.mitsubishielectric.com/>

O(a) abaixo assinado(a) MITSUBISHI ELECTRIC CORPORATION declara que o presente tipo de equipamento de rádio PAR-WT60R-E, PAR-WR61R-E está em conformidade com a Diretiva 2014/53/UE.

O texto integral da declaração de conformidade está disponível no seguinte endereço de Internet:

<https://www12.mitsubishielectric.com/>

Hermed erklærer MITSUBISHI ELECTRIC CORPORATION, at radioudstyrstypen PAR-WT60R-E, PAR-WR61R-E er i overensstemmelse med direktiv 2014/53/EU.

EU-overensstemmelseserklæringens fulde tekst kan findes på følgende internetadresse:

<https://www12.mitsubishielectric.com/>

Härmed försäkrar MITSUBISHI ELECTRIC CORPORATION att denna typ av radioutrustning PAR-WT60R-E, PAR-WR61R-E överensstämmer med direktiv 2014/53/EU.

Den fullständiga texten till EU-försäkran om överensstämmelse finns på följande webbadress:

<https://www12.mitsubishielectric.com/>

С настоящото MITSUBISHI ELECTRIC CORPORATION декларира, че радиосъоръжението тип PAR-WT60R-E, PAR-WR61R-E е в съответствие с изискванията на директива 2014/53/ЕС.

Пълният текст на ЕС декларацията за съответствие можете да намерите на следния интернет адрес:

<https://www12.mitsubishielectric.com/>

Firma MITSUBISHI ELECTRIC CORPORATION niniejszym oświadcza, że typ urządzenia radiowego PAR-WT60R-E, PAR-WR61R-E jest zgodny z dyrektywą 2014/53/UE.

Pełny tekst deklaracji zgodności UE jest dostępny pod następującym adresem internetowym:

<https://www12.mitsubishielectric.com/>



MITSUBISHI ELECTRIC CORPORATION erklærer at PAR-WT60R-E, PAR-WR61R-E er i overensstemmelse med direktiv 2014/53/EU.

Samsvarserklæringen i fulltekst er tilgjengelig på følgende internettsadresse:

<https://www12.mitsubishielectric.com/>

MITSUBISHI ELECTRIC CORPORATION vakuuttaa, että radiolaitetyyppi PAR-WT60R-E, PAR-WR61R-E on direktiivin 2014/53/EU mukainen.

EU-vaatimustenmukaisuusvakuutuksen täysimittainen teksti on saatavilla seuraavassa internetosoitteessa:

<https://www12.mitsubishielectric.com/>

Společnost MITSUBISHI ELECTRIC CORPORATION tímto prohlašuje, že rádiové zařízení typu PAR-WT60R-E, PAR-WR61R-E je v souladu se směrnicí 2014/53/EU.

Úplné znění EU prohlášení o shodě je k dispozici na této internetové adrese:

<https://www12.mitsubishielectric.com/>

Spoločnosť MITSUBISHI ELECTRIC CORPORATION týmto vyhlasuje, že rádiové zariadenie typu PAR-WT60R-E, PAR-WR61R-E je v súlade so smernicou 2014/53/EÚ.

Úplné znenie vyhlásenia o zhode EÚ je k dispozícii na tejto internetovej adrese:

<https://www12.mitsubishielectric.com/>

A MITSUBISHI ELECTRIC CORPORATION ezennel kijelenti, hogy a PAR-WT60R-E, PAR-WR61R-E típusú rádióberendezés megfelel a 2014/53/EU direktíva előírásainak.

Az EU megfelelőségi nyilatkozat teljes szövege a következő webhelyen érhető el:

<https://www12.mitsubishielectric.com/>

MITSUBISHI ELECTRIC CORPORATION izjavlja, da je radijska oprema tipa PAR-WT60R-E, PAR-WR61R-E skladna z Direktivo 2014/53/EU.

Celotno besedilo izjave EU o skladnosti je na voljo na naslednjem spletnem naslovu:

<https://www12.mitsubishielectric.com/>

Prin prezenta, MITSUBISHI ELECTRIC CORPORATION declară că tipul de echipament radio PAR-WT60R-E, PAR-WR61R-E este în conformitate cu directiva 2014/53/UE.

Textul complet al declarației de conformitate UE este disponibil la următoarea adresă de internet:

<https://www12.mitsubishielectric.com/>

Käesolevaga deklareerib MITSUBISHI ELECTRIC CORPORATION, et raadioseadmed PAR-WT60R-E, PAR-WR61R-E vastavad direktiivile 2014/53/EL.

Euroopa Liidu vastavusdeklaratsiooni täistekst on saadaval järgmisel internetiaadressil:

<https://www12.mitsubishielectric.com/>

Ar šo MITSUBISHI ELECTRIC CORPORATION paziņo, ka radio aprīkojums PAR-WT60R-E, PAR-WR61R-E atbilst Direktīvas 2014/53/ES prasībām.

Pilns ES atbilstības deklarācijas teksts ir pieejams šajā interneta adresē:

<https://www12.mitsubishielectric.com/>

Šiuo dokumentu „MITSUBISHI ELECTRIC CORPORATION“ pareiškia, kad radijo įranga, kurios tipas PAR-WT60R-E, PAR-WR61R-E, atitinka Direktyvą 2014/53/ES.

Visą ES atitikties deklaracijos tekstą galima rasti internete adresu:

<https://www12.mitsubishielectric.com/>

Ovime MITSUBISHI ELECTRIC CORPORATION izjavlja da je radiooprema vrste PAR-WT60R-E, PAR-WR61R-E u skladu s direktivom 2014/53/EU.

Cijeli tekst EU izjave o skladnosti dostupan je na sljedećoj internetskoj adresi:

<https://www12.mitsubishielectric.com/>

Kompanija MITSUBISHI ELECTRIC CORPORATION ovim izjavlja da je radio-oprema tipa PAR-WT60R-E, PAR-WR61R-E u skladu sa Direktivom 2014/53/EU.

Kompletan tekst EU deklaracije o usaglašenosti je dostupan na sledećoj internet adresi:

<https://www12.mitsubishielectric.com/>

Hereby, MITSUBISHI ELECTRIC CORPORATION declares that the radio equipment type PAR-WT60R-E, PAR-WR61R-E is in compliance with the Radio Equipment Regulations 2017.  
The full text of the UK declaration of conformity is available at the following internet address:  
<https://www12.mitsubishielectric.com/>

This software includes the work that is distributed in the Apache License 2.0.  
Apache License  
Version 2.0, January 2004  
<http://www.apache.org/licenses/>

=====  
CMSIS  
=====

Copyright (c) 2009-2021 Arm Limited. All rights reserved.  
SPDX-License-Identifier: Apache-2.0  
Licensed under the Apache License, Version 2.0 (the License); you may not use this file except in compliance with the License.  
You may obtain a copy of the License at  
[www.apache.org/licenses/LICENSE-2.0](http://www.apache.org/licenses/LICENSE-2.0)  
Unless required by applicable law or agreed to in writing, software distributed under the License is distributed on an AS IS BASIS, WITHOUT WARRANTIES OR CONDITIONS OF ANY KIND, either express or implied. See the License for the specific language governing permissions and limitations under the License.