

HOT WATER HEAT PUMP

# DATA BOOK

MODEL

# QAHV-N560YA-HPB(-BS)

# CONTENTS

---

## HOT WATER HEAT PUMP

1. Product Specifications .....	2
1-1. Specifications.....	2
1-2. External Dimensions .....	3
1-3. Center of Gravity.....	4
1-4. Electrical Wiring Diagrams.....	5
1-5. Optional parts .....	7
2. Product Data .....	12
2-1. Capacity tables .....	12
2-2. Sound pressure levels .....	22
2-3. Vibration levels .....	23
3. Installation.....	24
3-1. Selecting the Installation Site.....	24
3-2. Unit Installation .....	28
4. System Design.....	34
4-1. Water Pipe Installation .....	34
4-2. QAHV Secondary side control .....	38
5. Wiring Design.....	45
5-1. System Configurations.....	45
5-2. Electrical Wiring Installation .....	46
6. Controller .....	49
6-1. PAR-W31MAA specifications .....	49

# 1. Product Specifications

## 1-1. Specifications

QAHV-N-YA-HPB

Model			QAHV-N560YA-HPB
Power Source			3-phase 4-wire 380-400-415V 50Hz
Capacity *1		kW	40
		kcal/h	34400
		Btu/h	136480
	Power input	kW	10.31
	Current input	A	17.8-16.9-16.3
	COP(kW/kW)		3.88
Capacity *2		kW	40
		kcal/h	34400
		Btu/h	136480
	Power input	kW	10.97
	Current input	A	20.0-19.0-18.3
	COP(kW/kW)		3.65
Capacity *3		kW	40
		kcal/h	34400
		Btu/h	136480
	Power input	kW	11.6
	Current input	A	20.4-19.4-18.7
	COP(kW/kW)		3.44
Maximum current input			A 33.8
Allowable external pump head			77kPa
Temperature range	Inlet water temp		5-63°C 41-145.4°F
	Outlet water temp		55-90°C (when the secondary side control is enabled: 55-80°C) 131-194°F (when the secondary side control is enabled: 131-176°F)
	Outdoor temp	D.B.	-25-43°C -13-109.4°F
Sound Pressure level (measured 1m below the unit in an anechoic room) *1			dB(A) 56
Water pipe diameter and type	Inlet	mm(in.)	19.05(Rc 3/4"), screw pipe
	Outlet	mm(in.)	19.05(Rc 3/4"), screw pipe
External finish			Acrylic painted steel plate <MUNSELL 5Y 8/1 or similar>
External dimension H x W x D			mm 1837(1777 not including legs) x 1220 x 760 in. 72.3(69.9 not including legs) x 48.0
Net weight			kg(lbs) 400(882)
Design Pressure	R744	MPa	14
	Water	MPa	0.5
Heat exchanger	Water-side		Copper tube coil
	Air-side		Plate fin and copper tube
Compressor	Type		Inverter scroll hermetic compressor
	Maker		MITSUBISHI ELECTRIC CORPORATION
	Starting method		Inverter
	Motor output	kW	11.0
	Case heater	W	45
	Lubricant		PAG
FAN	Air flow rate	m <sup>3</sup> /min	220
		L/s	3666
		cfm	7768
	Type x Quantity		Propeller fan
	Control, Driving mechanism		Inverter-control, Direct-driven by motor
Motor output	kW	0.92	
HIC (HIC: Heat inter-changer) circuit			Copper pipe
Protection	High pressure protection		High pres.Sensor & High pres.Switch at 14MPa(643psi)
	Inverter circuit		Overheat and overcurrent protection
	Compressor		Overheat protection
	Fan motor		Thermal switch
Defrosting method			Auto-defrost mode (Hot gas)
Refrigerant	Type x original charge		CO <sub>2</sub> (R744) 6.50kg
	Flow and temperature control		LEV

Notes:	Unit converter
*1.Under Normal heating conditions at the outdoor temp, 16°CDB/12°CWB(60.8°FDB/53.6°FWB), the outlet water temperature 65°C(149°F), and the inlet water temperature 17°C(62.6°F)	kcal/h =kW x 860
*2.Under Normal heating conditions at the outdoor temp, 7°CDB/6°CWB(44.6°FDB/42.8°FWB), the outlet water temperature 65°C(149°F), and the inlet water temperature 9°C(48.2°F)	BTU/h =kW x 3,412
*3.Under Normal heating conditions at the outdoor temp, 7°CDB/6°CWB(44.6°FDB/42.8°FWB), the outlet water temperature 65°C(149°F), and the inlet water temperature 15°C(59.0°F)	cfm =m <sup>3</sup> /min x 35.31
*Due to continuing improvements, specifications may be subject to change without notice	lbs =kg/0.4536
*Do not use steel pipes as water pipes.	
*Keep the water circulated at all times. Blow the water out of the pipes if the unit will not be used for an extended period time.	
*Do not use ground water or well water	
*Do not install the unit in an environment where the wet bulb temperature exceeds 32°C	
*The water circuit must use the closed circuit	
*There is a possibility that the unit may abnormally stop when it operates outside its operating range. Provide backup (ex.boiler start with error display output signal (blue CN511 1-3)) for abnormal stop.	

# 1. Product Specifications

## 1-2. External Dimensions

QAHV-N560YA-HPB(-BS)

Unit: mm

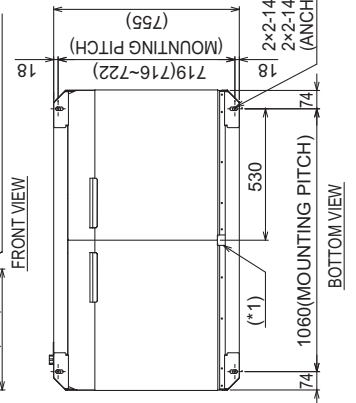
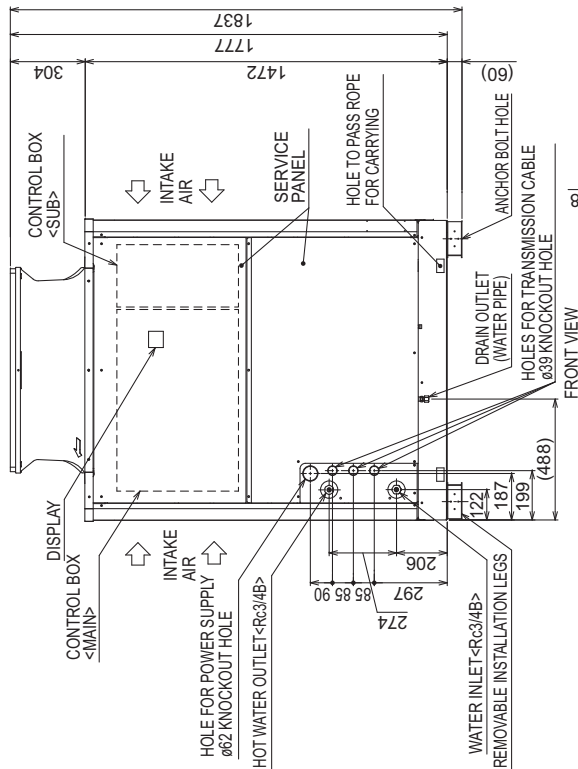
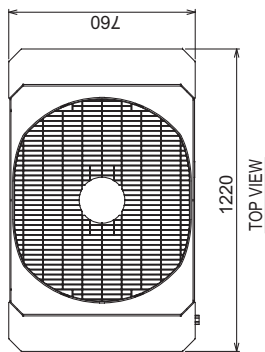
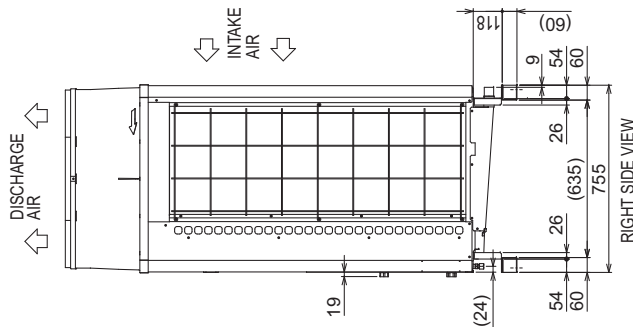
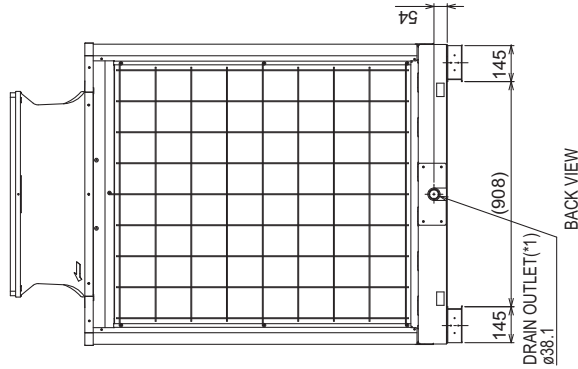
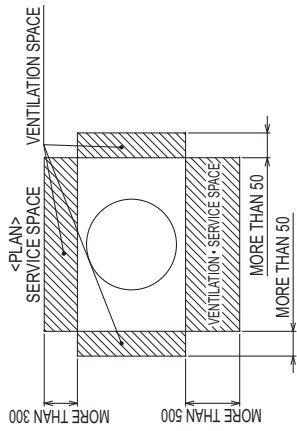

The specification of the product is for the improvement a previous notice and might change.

# 1. Product Specifications

## 1-3. Center of Gravity

QAHV-N560YA-HPB(-BS)

Unit: mm

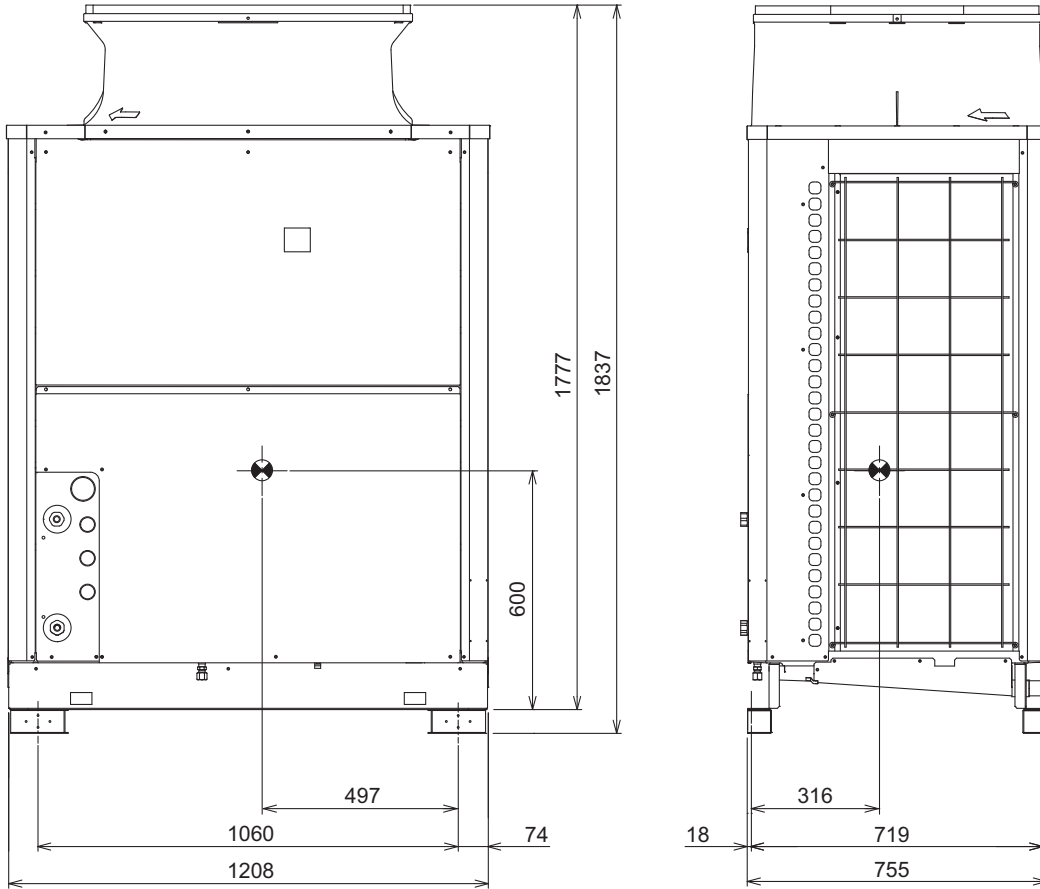

QAHV-N-YA-HPB

# 1. Product Specifications

## 1-4. Electrical Wiring Diagrams

### QAHV-N560YA-HPB(-BS)

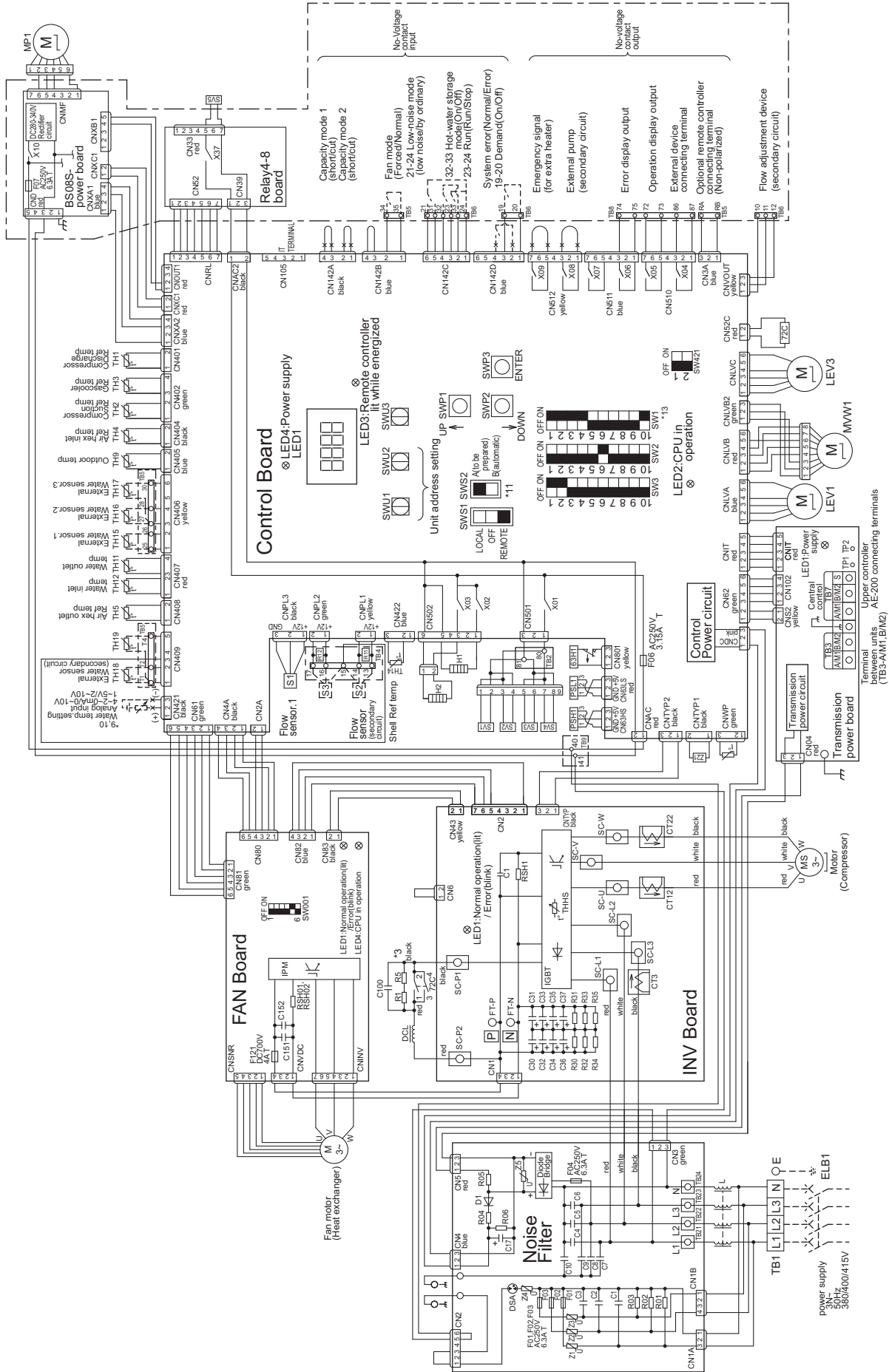

\* Capacity mode table

mode	input
Max capacity operation	Capacity mode 1 (cut)
Energy saving operation 1 (factory setting)	Capacity mode 1, 2 (short)
Energy saving operation 2	Capacity mode 1 (short), Capacity mode 2 (cut)

Symbol explanation

Symbol	explanation
CT12	
CT22	Ac current sensor
CT3	
C100	Capacitor (Electrolysis)
DCL	DC reactor
F01	
F02	
F03	
F04	Fuse
F06	
F07	
F121	
H1	Crankcase heater (for heating the compressor)
H2	Electric heater (Antifreeze)
LEV1	Electronic expansion valve (Main circuit)
LEV3	Electronic expansion valve (Injection)
M	Fan motor
MP1	Pump motor
MS	Compressor motor
MVW1	Water flow control valve
PSH1	High pressure sensor
PSL1	Low pressure sensor
R11	Resistance (for Water flow rate sensor 2)
R12	Resistance (for Water flow rate sensor 3)
R1	
R5	Electrical resistance
SV1	Solenoid valve (Defrost)1
SV2	Solenoid valve (Defrost)2
SV3	Solenoid valve (Defrost)3
SV4	Solenoid valve (Defrost)4
SV5	Solenoid valve (Injection circuit)
S1	Water flow rate sensor
THHS	IGBT temperature
TH1~5,9,11,12,14	Thermistor
Z21	Function setting connector
63H1	High pressure switch
72C	Electromagnetic relay (Inverter main circuit)
*TH15~18	Thermistor
*S2,3	Water flow rate sensor
<ELB1>	Earth leakage breaker

\* of symbol item is the optional parts, <> is field-supplied parts.

- Note**
- The broken lines indicate the optional parts, field-supplied parts, and field work.
  - Dashed lines indicate sub box
  - Faston terminals have a locking function.  
Press the tab in the middle of the terminals to remove them.  
Check that the terminals are securely locked in place after insertion.
  - The symbols of the field connecting terminals are as follows.  
o: Terminal block x: Connection by cutting the short circuit wire  
The method of input signal of operation can choose one of optimal remote controller or no-voltage input.
  - Leave a space of at least 5 cm between the low voltage external wiring (no-voltage contact input and remote controller wiring) and wiring of 100V or greater. Do not place them in the same conduit tube or cable as this will damage the circuit board.
  - When cable is used for the control cable wiring, use a separate cable for the following wiring.  
Using the same cable may cause malfunctions and damage to the unit.
    - Optional remote controller wiring
    - No-voltage contact input wiring
    - No-voltage contact output wiring
    - Remote water temperature setting
  - Use a contact that takes 12VDC 1mA for no-voltage contact input.
  - Need to select either Water temperature setting input signal.  
Set the SW421 as shown in the table below.

	SW421-1	SW421-2
4~20mA	ON	ON
0~10V	OFF	OFF
1~5V	OFF	ON
2~10V	OFF	OFF

- Use a 4-20mA signal output device with insulation.  
Feeding 30mA or more current may damage the circuit board.
- For prevention of damage of the pump, SWS2 is set in "A"(factory setting).  
Change the slide switch SWS2 [B(automatic)] in Test Run.
- Use a contact that takes 250VAC, 10mA or above, and 1A or below for no-voltage contact output.
- How to set the SW1 1-5 settings (model setting) vary with the manufacturing year/month of the product. See the electrical wiring diagram on the control box for detailed information about switch settings.

## 1. Product Specifications

### 1-5. Optional parts

#### 1-5-1. Remote controller PAR-W31MAA

Refer to 6-1. PAR-W31MAA specifications.

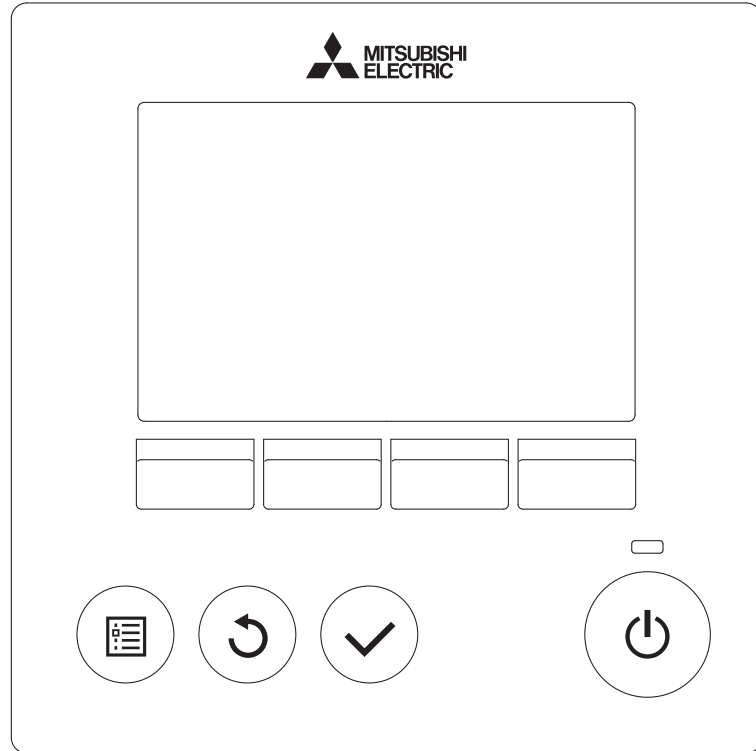



# 1. Product Specifications

## 1-5-2. Secondary circuit kit Q-1SCK

This kit contains External water temperature sensor TW-TH16-E and Flow sensor kit for use on the secondary side of hot water heat pump (QAHV) units. Make sure the following parts are included.

### External water temperature sensor TW-TH16-E

\* The size and length noted are approximate.

Parts	Shape	Specification	Quantity
① Thermistor		A: 157 mm B: 42 mm C: 54 mm D: 48 mm	1 pc

### Flow sensor kit

Parts	Shape	Specification	Quantity
① Flow sensor		A: 71.5 mm * 129 mm including the coupler B: $\phi$ 30 mm Wiring length: 1.9 m	1 pc
② O-ring		A: 15.8 mm B: 2.4 mm C: 20.6 mm	2 pcs
③ Quick fastener		A: 38.6 mm B: 15 mm C: 14 mm	2 pcs
④ Coupler 1 (IN-side)		Thread: R3/4 Hex 30 A: 36 mm	1 pc
⑤ Coupler 2 (OUT-side)		Thread: R3/4 Hex 30 A: 43.2 mm	1 pc
⑥ Cable tie (2 types)		Long cable tie A: 380 mm B: 4.7 mm	2 pcs + 1 spare
		Short cable tie A: 100 mm B: 2.5 mm	1 pc + 1 spare

# 1. Product Specifications

## External water temperature sensor TW-TH16

### 1. Parts that are required to install an external water temperature sensor

- A) External water temperature sensor
  - B) Wiring to connect the sensor and the unit\*
  - C) Wiring terminals to connect the wiring to the sensor and the terminal block on the unit  
(Four for M4 screws)\*
- \* Items B) and C) are field supplied.

#### Wiring specifications

Size	2-core cable (Min.1.25 mm <sup>2</sup> )
Type	CVVS or CPEVS
Maximum length	20 m

### 2. Installing the external water temperature sensor

- Install the external water temperature sensor where the water pipes merge or on the load-side tank.
- Install horizontally or vertically on top of the pipe.
- When installing horizontally, make sure the wiring faces down.

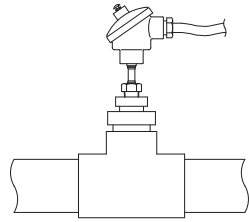

Vertical installation

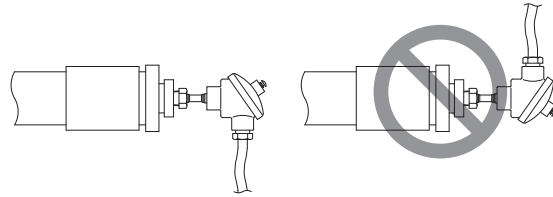

Horizontal installation

### 3. Wiring the external water temperature sensor

Connect the external water temperature sensor wiring to the terminal block in the control box on the unit as shown in the figure below.

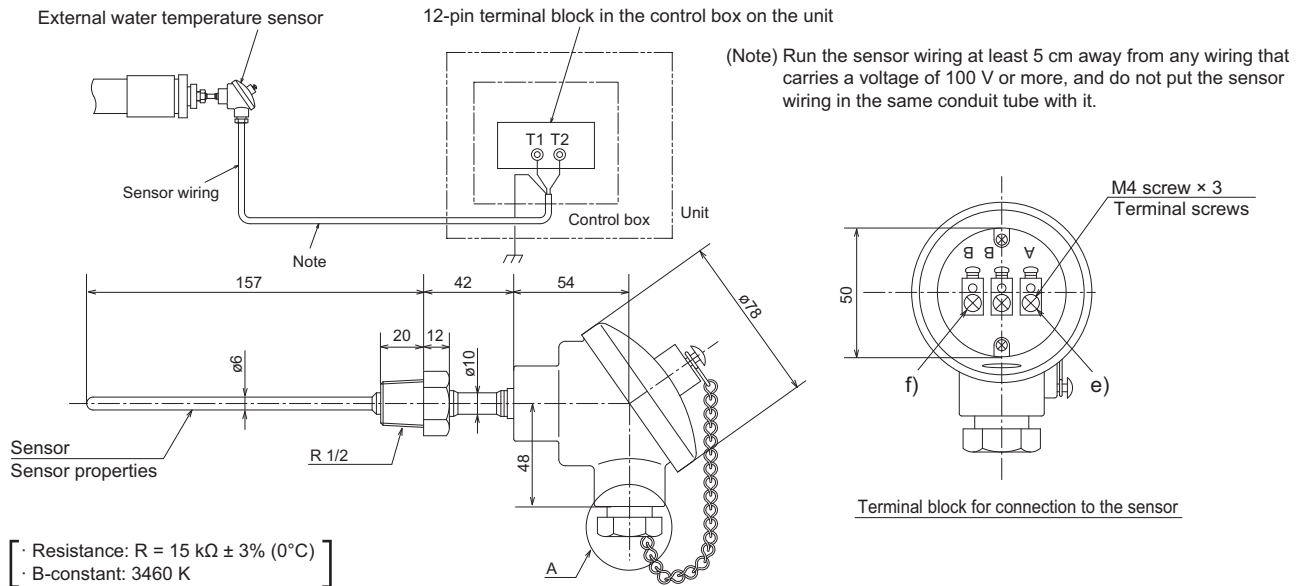

Connect the sensor wiring to terminals T1 and T2 of the 12-pin terminal block in the control box on the unit.

Connect the shield to the earth terminal.

Thread the wiring to the external water temperature sensor through parts b) through d) as shown in the figure at right. Attach M4 terminals (not supplied) to the wirings, and connect them to e) and f) (terminals A and B).

After the wiring is connected, securely tighten the tightening screw d), and then caulk the gap between the wiring a) and the tightening screw to keep water from entering.

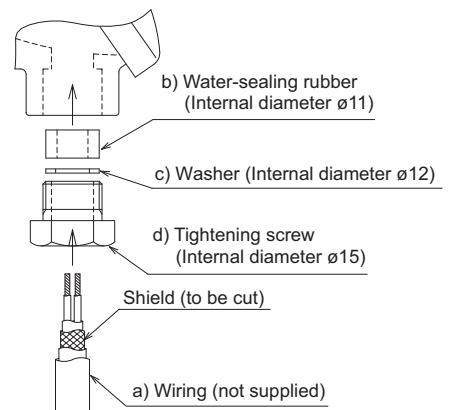

Detailed view of the area labeled "A" in the figure above

# 1. Product Specifications

## Flow sensor kit

### 1. Tools and materials needed for an installation of the flow sensor

Have the following tools and materials ready before starting.

	Materials	Quantity
1	Flow sensor	1
2	O-ring	2
3	Quick fastener	2
4	Coupler 1 (IN-side)	1
5	Coupler 2 (OUT-side)	1
6	Cable tie (short)	1
7	Cable tie (long)	1 to 2

\*1 Size: HEX 30

Tightening torque: 50 N·m ± 10%

\*2 Only use silicon grease.

\*3 Select the following type of extension wiring.

Wiring diameter	0.812 mm or larger
Type	CVVS or CPEVS
Maximum length	20 m

\*4 Select the type of terminal block that meets the following.

- Water-proof
- Usable at or above 15 V
- Terminal screw diameter of M3.5 or M4

	Tools and locally procured materials
1	Screwdriver
2	Torque wrench (spanner) *1
3	Grease *2
4	Extension wiring *3
5	Terminal block *4

### 2. Flow sensor installation

Install the flow sensor on the pipe by following steps (1) through (3) below.

Install the flow sensor between the secondary-side pump and the heat exchanger.

Refer to the Installation/Operation Manual of QAHV-N560YA-HPB for details.

#### (1) Install an O-ring on the flow sensor and coupler 2 (OUT-side).

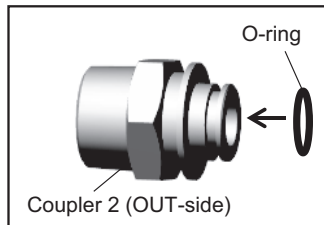
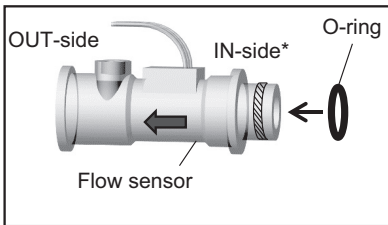

Both of the parts shown at left have a groove on the smaller end. Apply grease to the O-rings, and then fit them into the groove.

\* The end with a smaller bore is the IN-side. Be sure to install them in the correct orientation.

#### (2) Connect a coupler to the pipe, and connect the flow sensor.

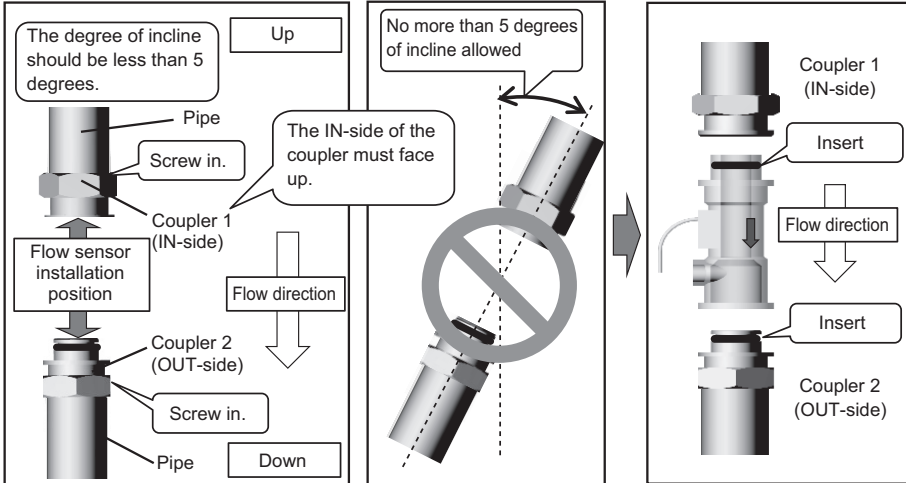

Attach the coupler to the pipe so that **the IN-side of the coupler faces up and the OUT-side of the coupler faces down. (Water flows from top to bottom.) The incline of the pipe should not exceed 5 degrees.**

Keep the sensor away from water.

**The flow sensor is 71.5 mm long.**

**Keep an appropriate distance between the couplers.**

Fit the flow sensor to the coupler.

#### (3) Install the quick fastener on the pipe.

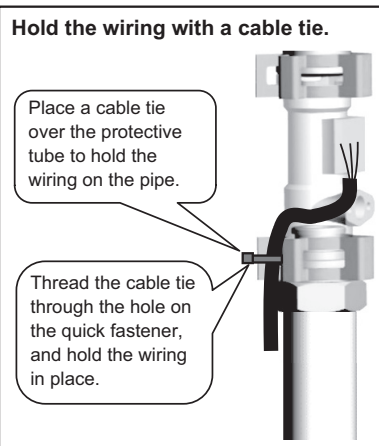
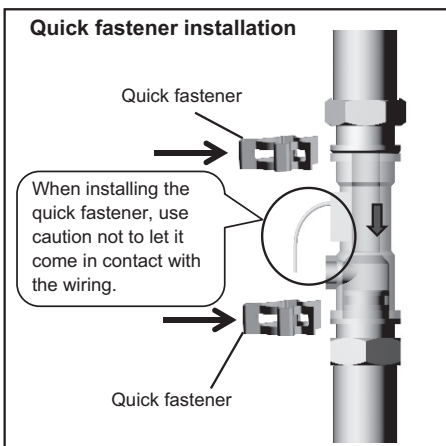

Insert the flow sensor into the couplers, and then fit the quick fasteners where the flow sensor and the couplers are connected to each other. Keep the quick fasteners out of contact with the wiring so as not to damage the wiring. Hold the wiring to the quick fastener with a (short) cable tie as shown in the figure to keep the wiring from being damaged.

Extend the length of the wiring as necessary, using a terminal block. Keep the wiring and the terminal block dry.

# 1. Product Specifications

## 3. Flow sensor wiring connection

Connect the wiring by following steps (1) through (4) below.

### (1) Open the panel.

Using a screwdriver, remove the SERVICE PANEL and the CONTROL BOX (SUB) cover.

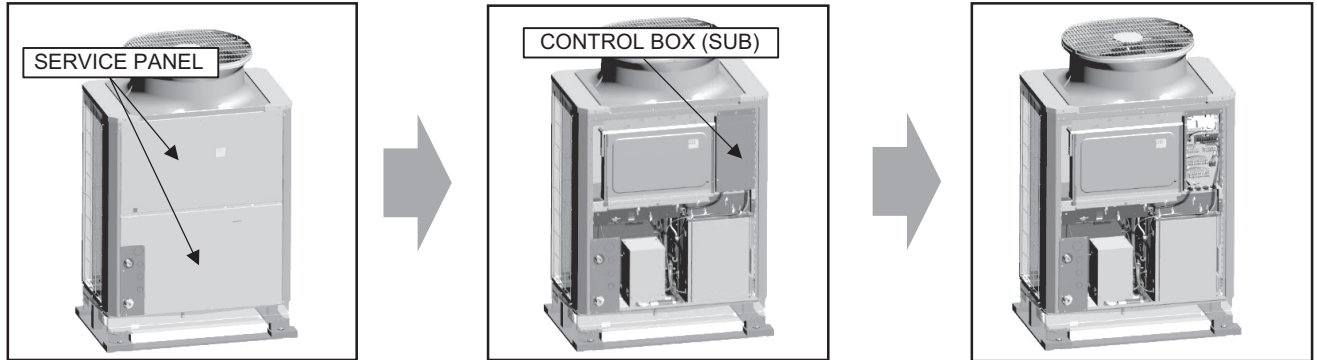

### (2) Thread the wiring into the unit.

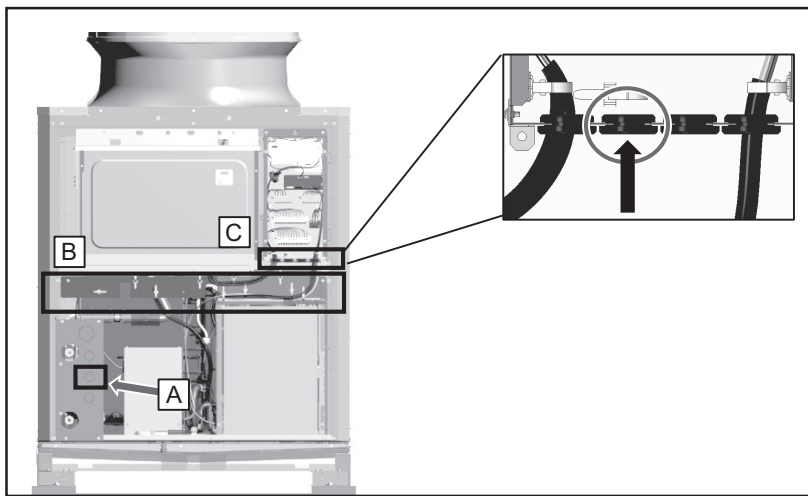

- ① Thread the flow sensor wiring through A in the figure.
- ② Hold the wiring with the cable strap inside the unit indicated as B in the figure to keep it out of contact with the pipes and other components.
- ③ Thread the wiring through the rubber bush indicated as C in the figure (second one from the left).

\* Refer to the Installation/Operation Manual of QAHV-N560YA-HPB for the detailed explanation on how to open the part indicated as A and how to route the wiring indicated as B in the figure.

\* Perform wiring work for the flow output adjustment device and the thermistor at the same time.

### (3) Connect the wiring.

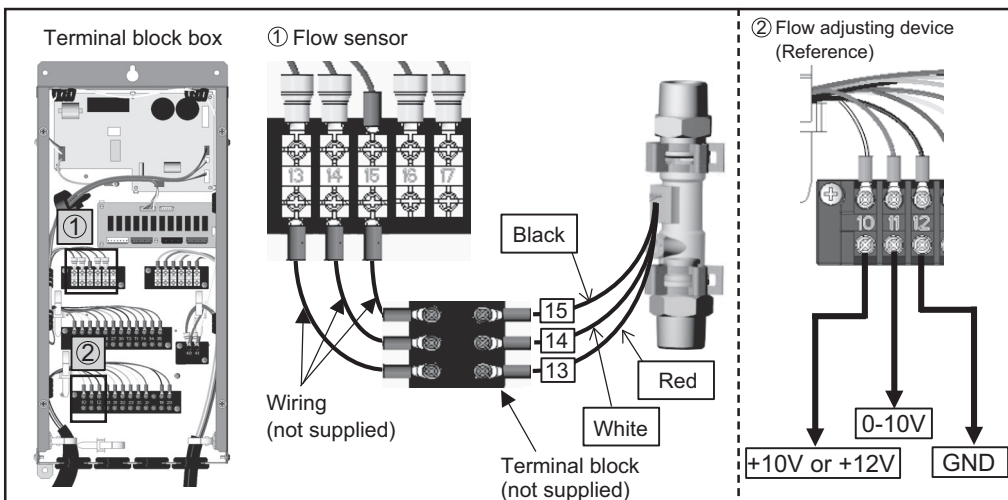

Connect the flow sensor wiring to the terminal block inside the BOX. The numbers on the wirings correspond to the numbers on the terminal block. Connect each wiring to the correct terminal. When done, hold the excess wiring with the supplied cable tie (long). Also, hold the wirings in place with a cable tie (long) where indicated as B in the figure to keep them out of contact with the pipes and other components.

### (4) Close the panel.

Using a screwdriver, re-place the SERVICE PANEL and the CONTROL BOX (SUB) cover.

## 4. Cautionary notes

Note the following when performing wiring work.

- Turn off the power before performing wiring work to avoid electrocution.
- Watch for sharp edges of sheet metal.
- Keep external wiring at least 5 cm away from wiring that carries 100 V or higher.
- Do not bundle the wiring together with strong current wiring.
- Connect wiring in a way that minimizes electrical noise interference. Shield the wiring to minimize external effects.
- Install the flow sensor indoors, and insulate it as necessary to keep it from being exposed to subzero temperatures.
- Keep the wiring and the terminal block dry.

## 2. Product Data

### 2-1. Capacity tables

#### 2-1-1. Correction by temperature

Outlet water temperature 60~70°C  
Energy saving operation 1 mode

QAHV-N560YA-HPB(-BS)

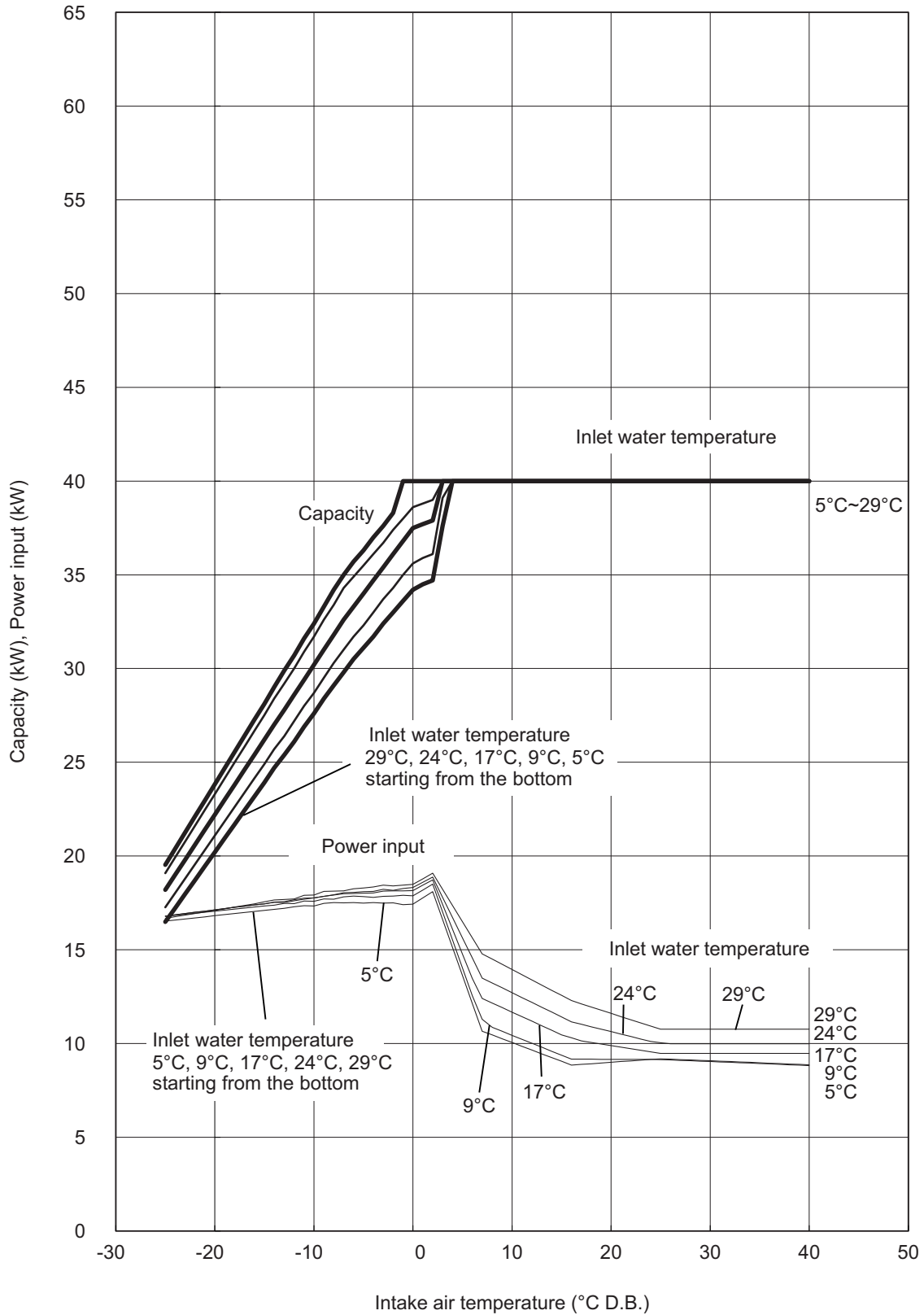

## 2. Product Data

Outlet water temperature 80°C  
Energy saving operation 1 mode

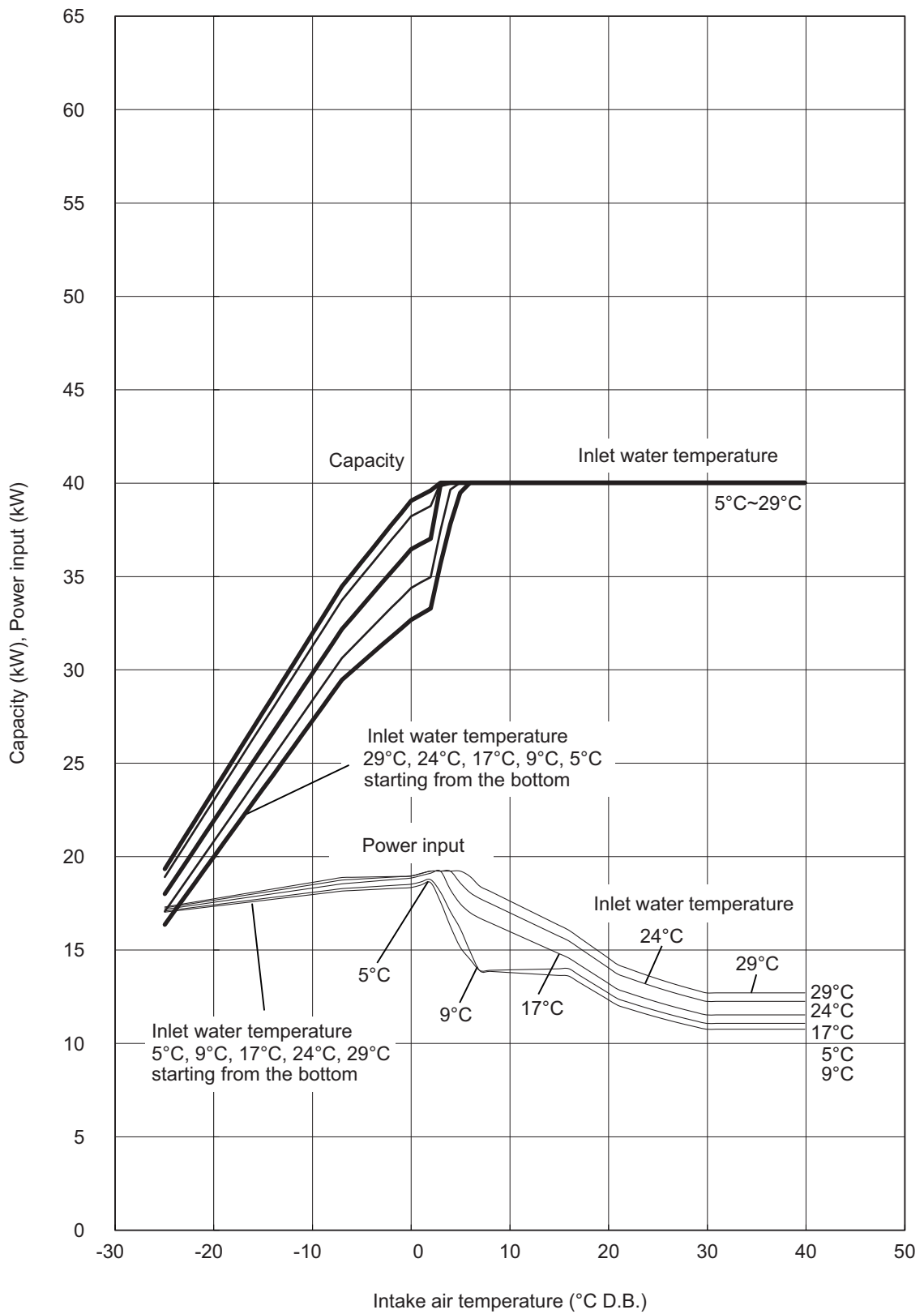

## 2. Product Data

Outlet water temperature 90°C  
 Energy saving operation 1 mode

QAHV-N-YA-HPB

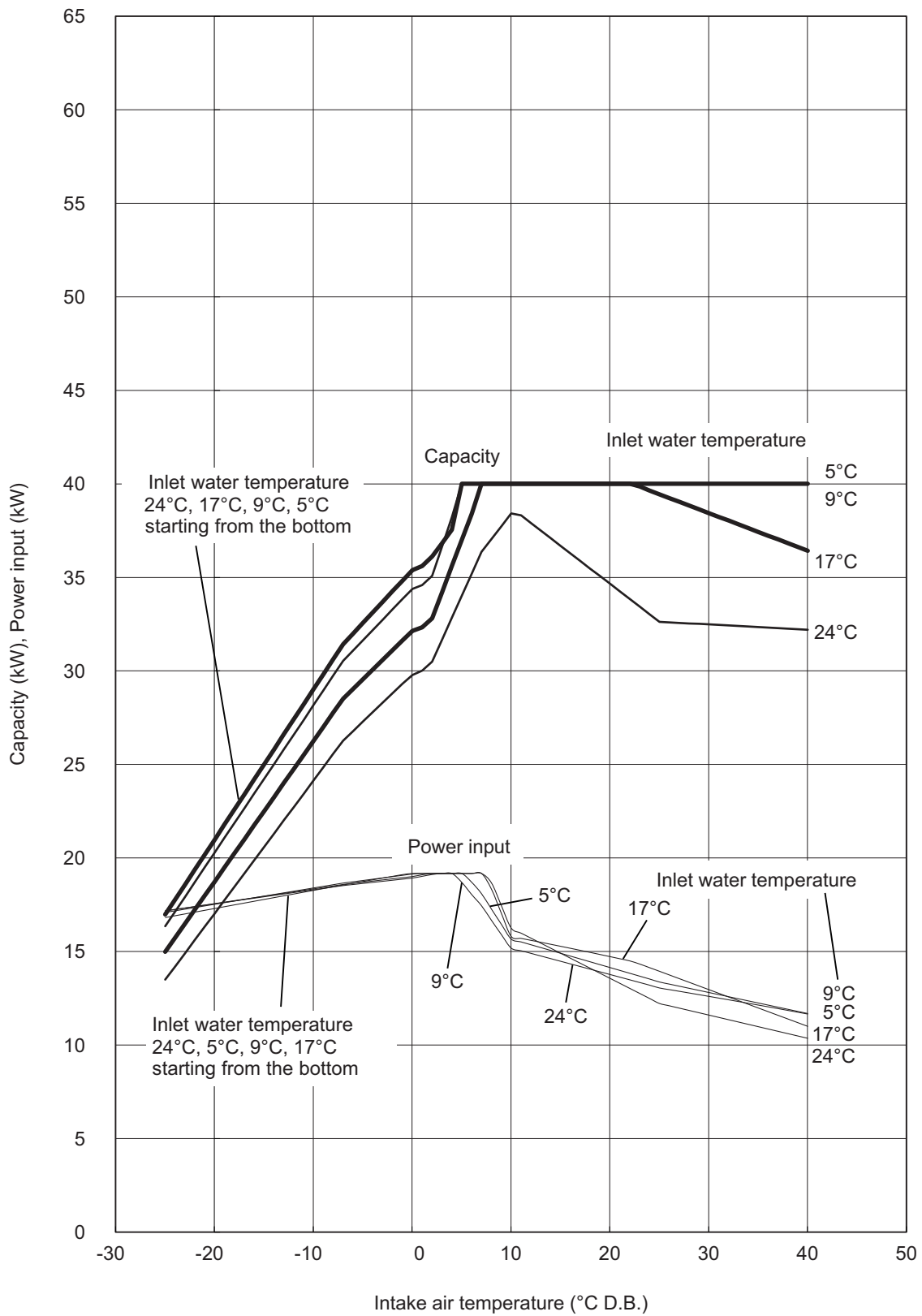

## 2. Product Data

Outlet water temperature 60~70°C  
Max capacity operation mode

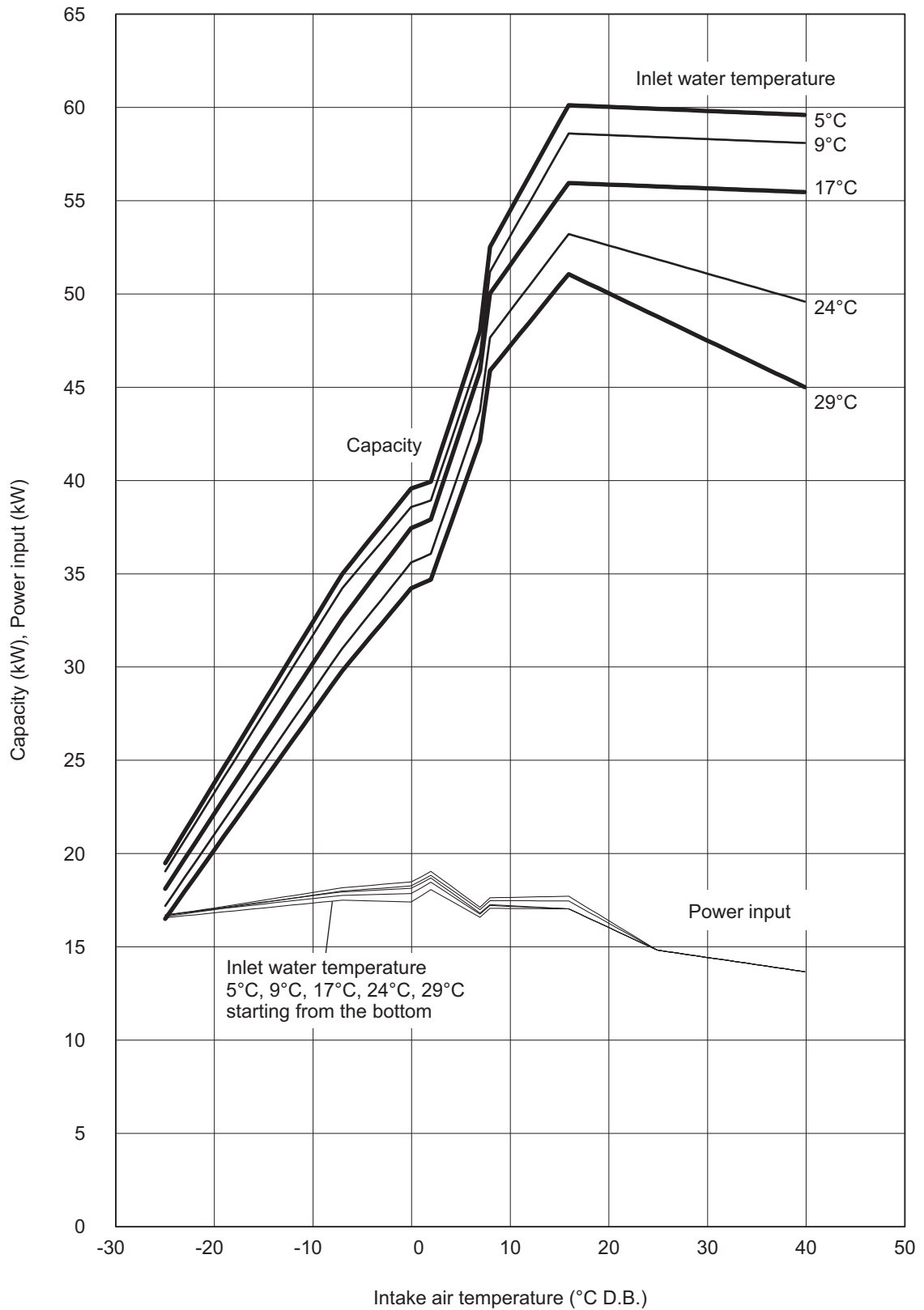



## 2. Product Data

Outlet water temperature 80°C  
Max capacity operation mode

QAHV-N-YA-HPB

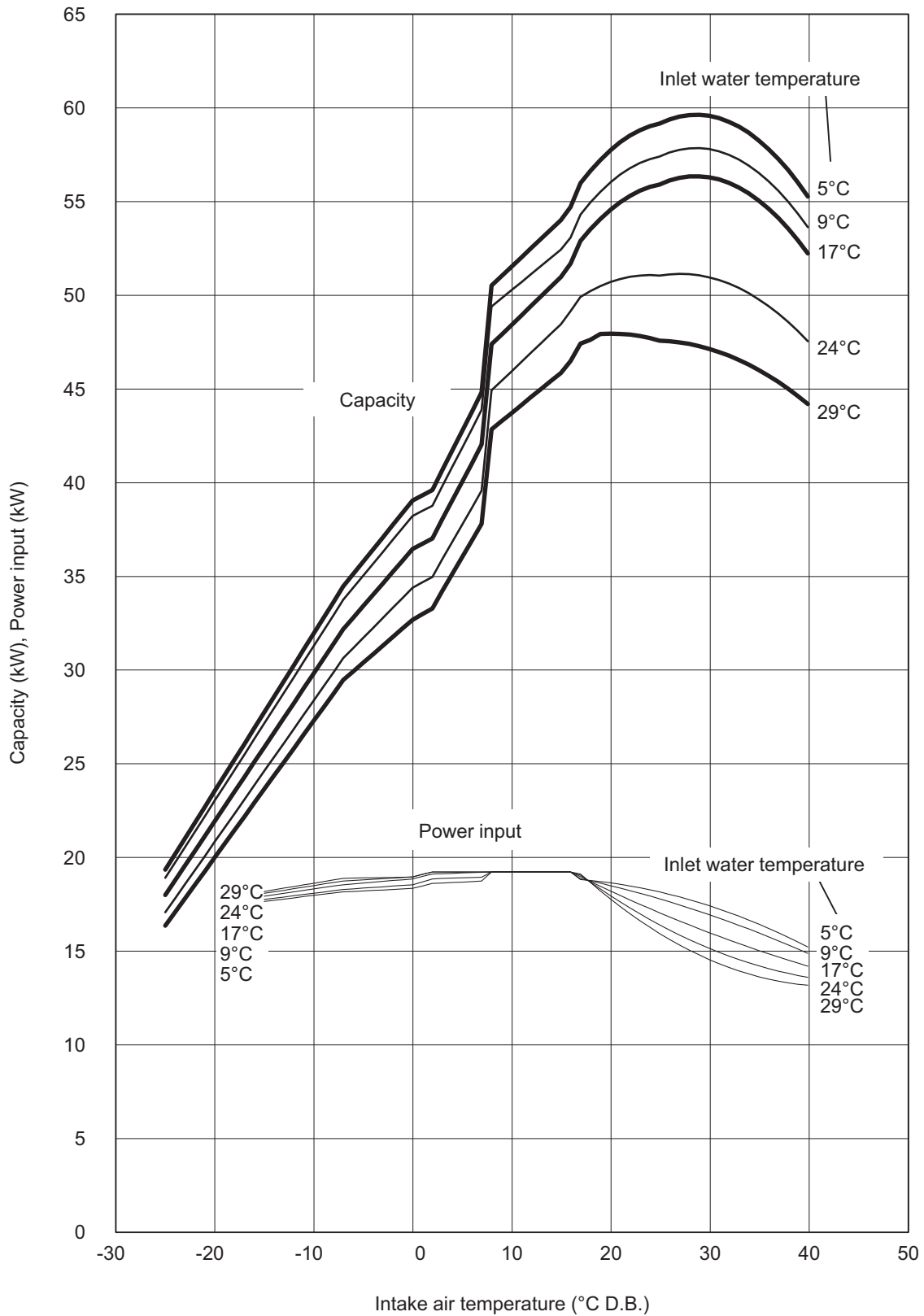

## 2. Product Data

Outlet water temperature 90°C  
 Max capacity operation mode

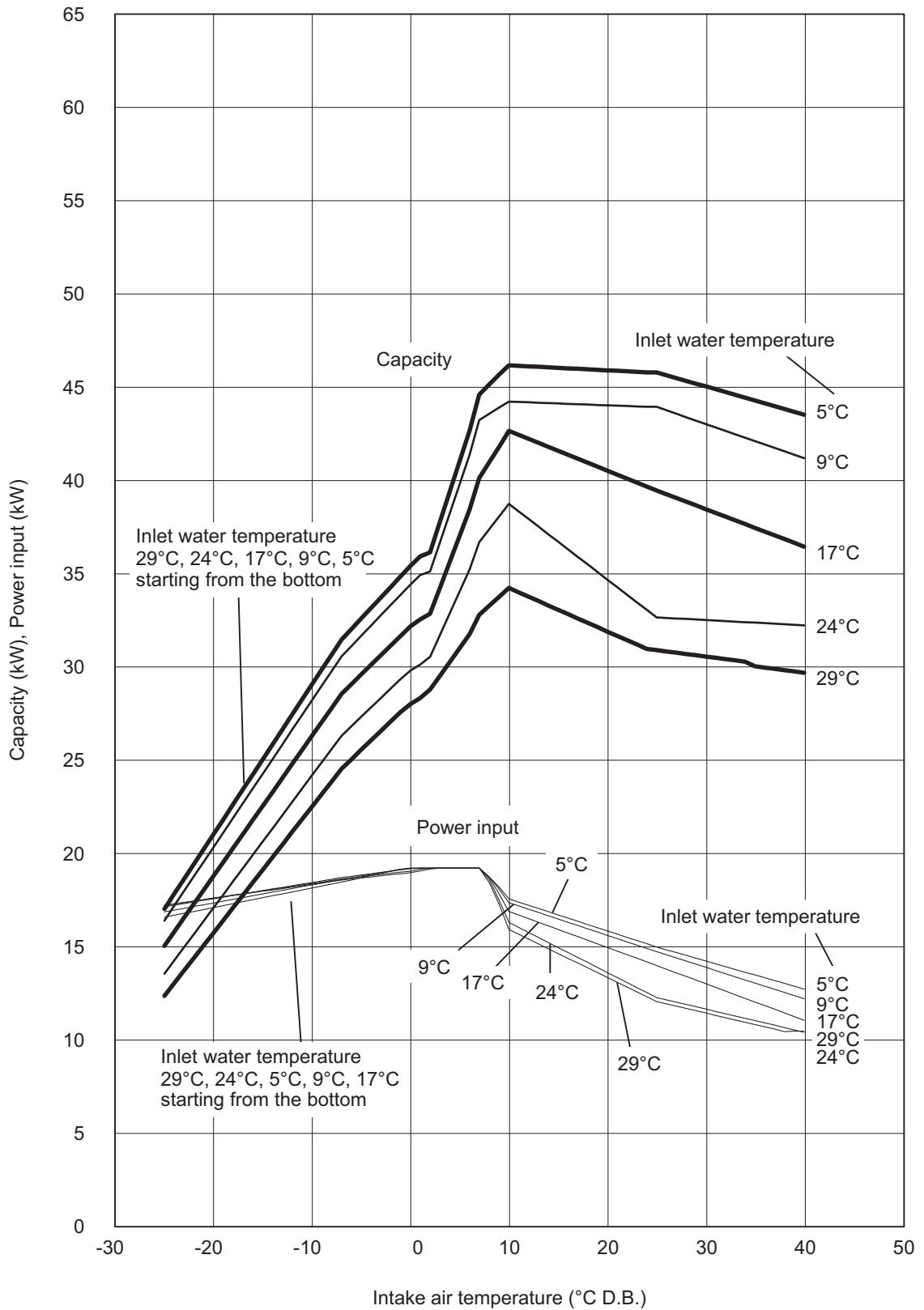

## 2. Product Data

Outlet water temperature 60~70°C  
Energy saving operation 2 mode

QAHV-N-YA-HPB

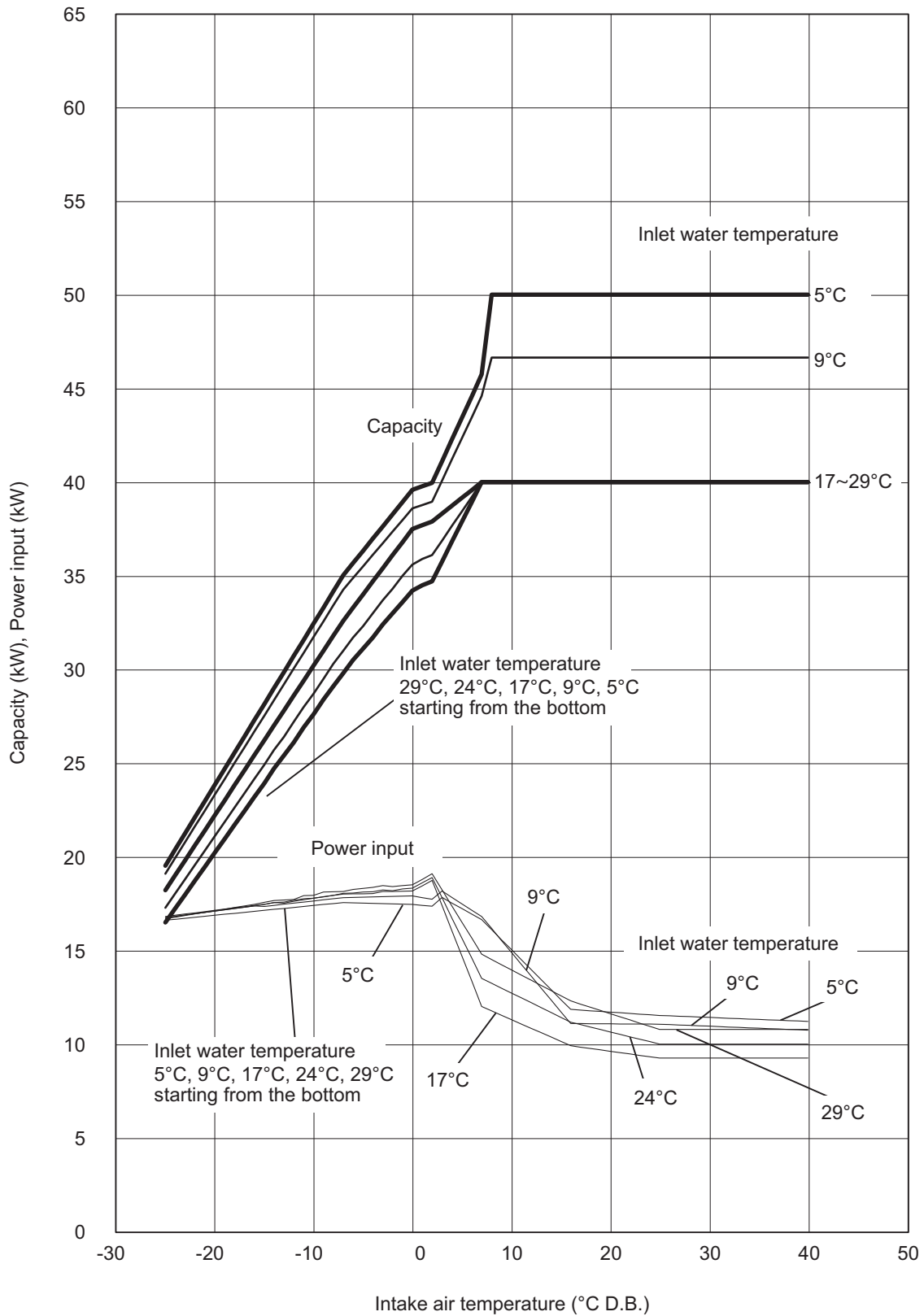

## 2. Product Data

Outlet water temperature 80°C  
Energy saving operation 2 mode

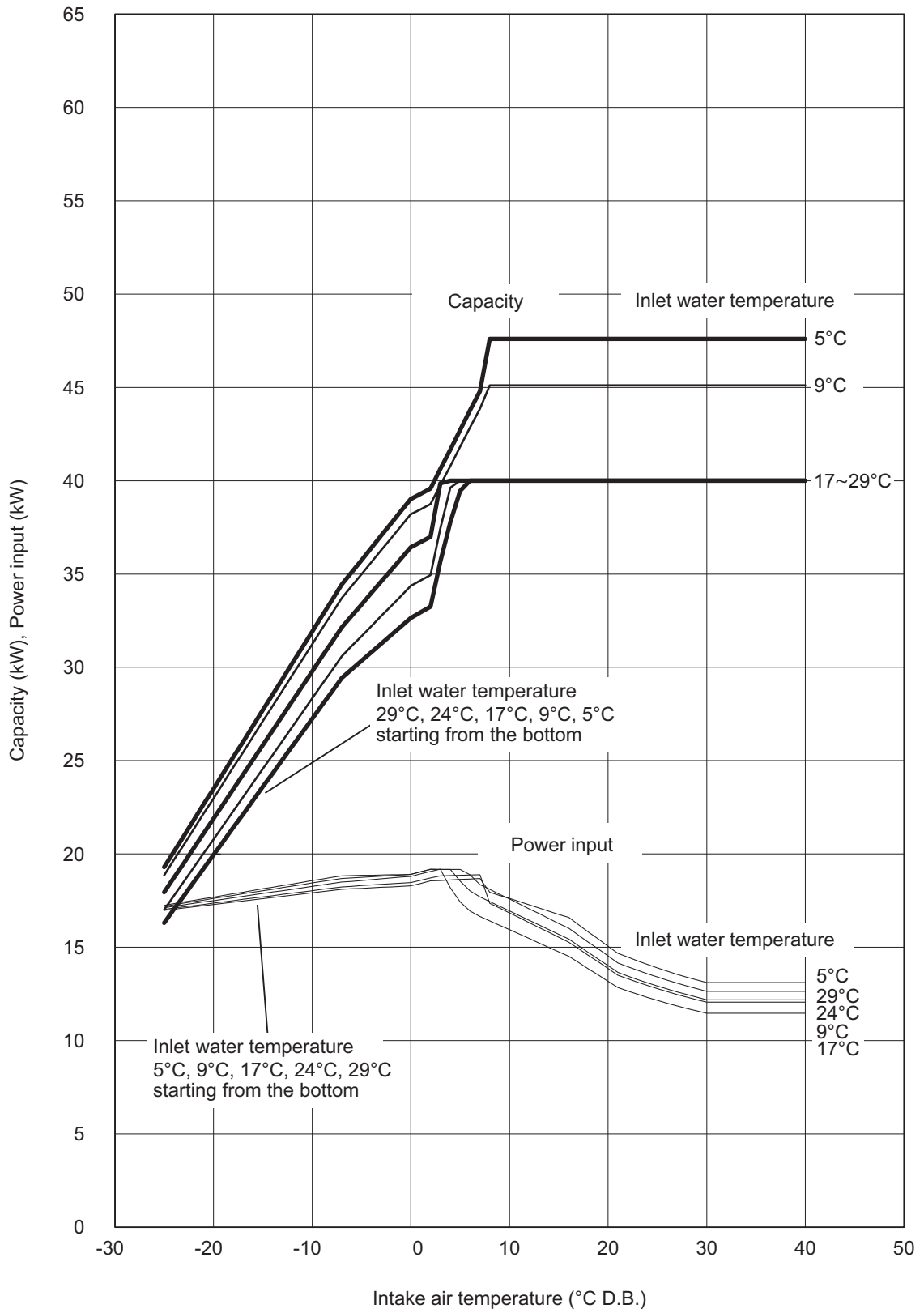

## 2. Product Data

Outlet water temperature 90°C  
 Energy saving operation 2 mode

QAHV-N-YA-HPB

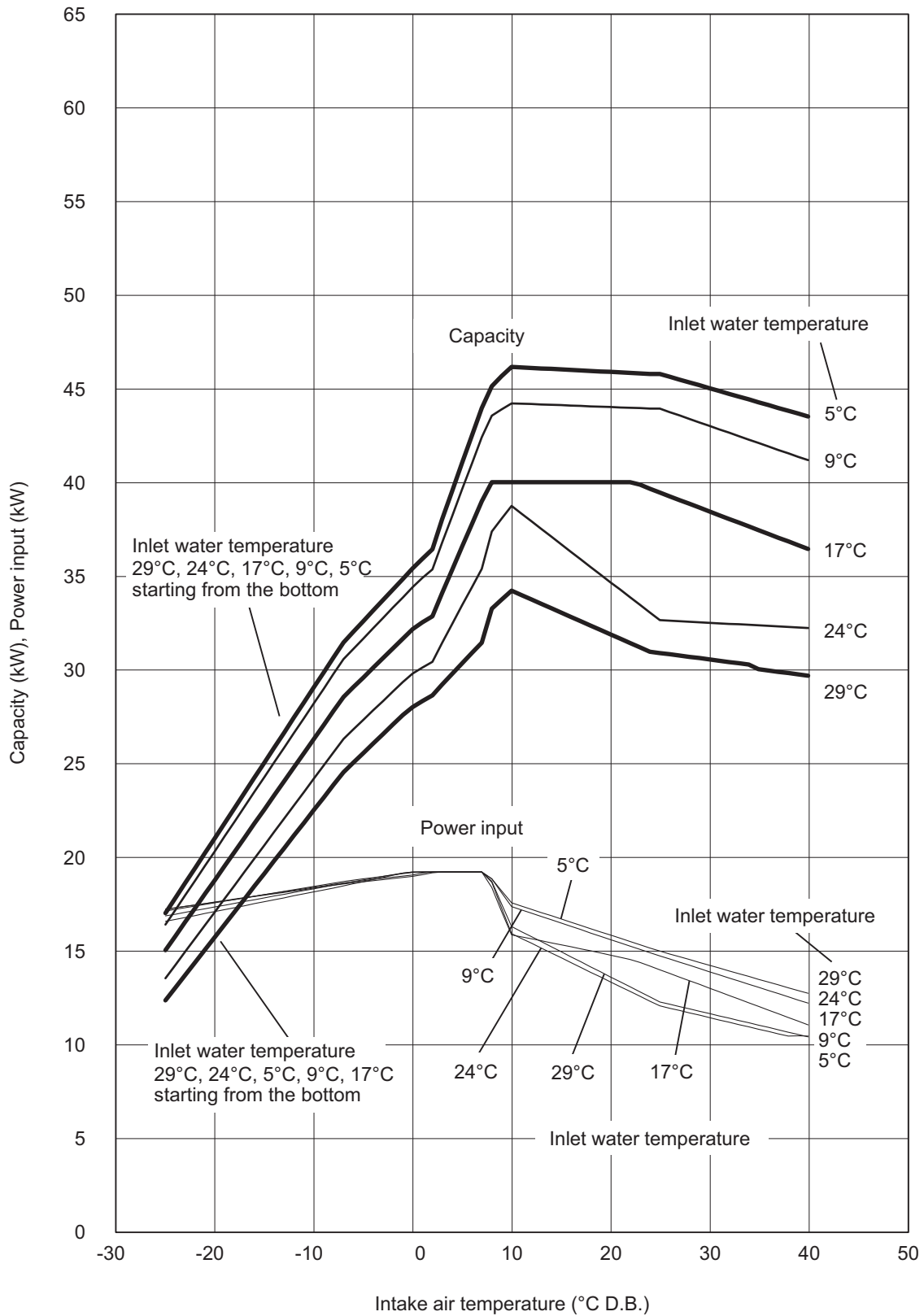

## 2. Product Data

### 2-1-2. Correction by relative humidity

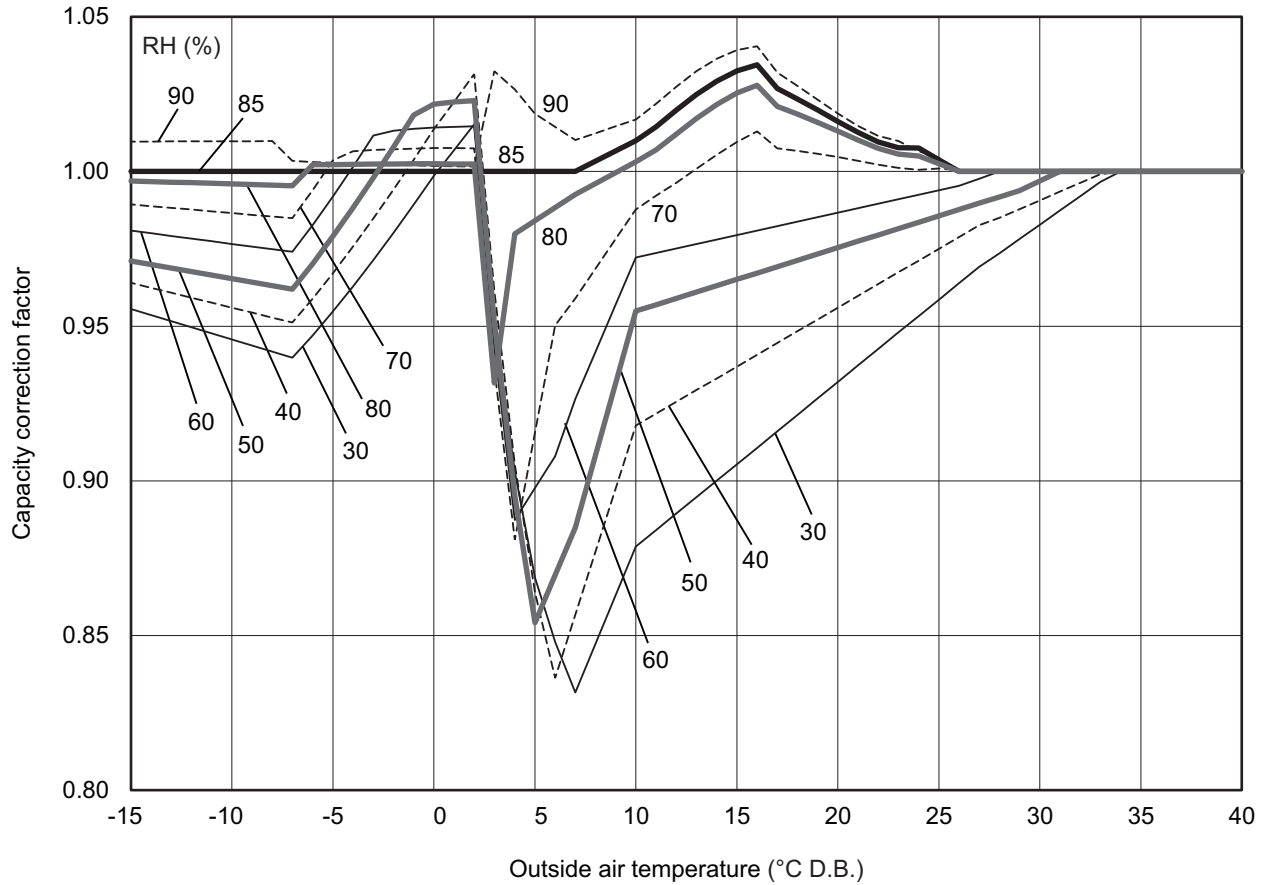

### 2-1-3. Operation temperature range

Upper limit value of water temperature

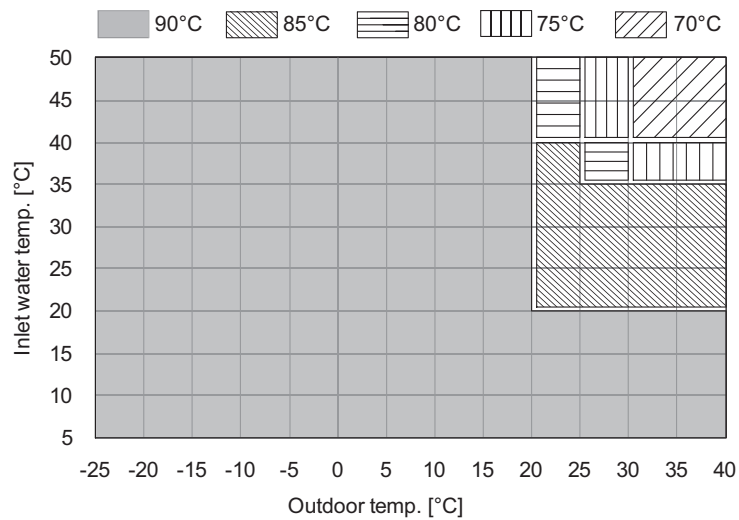

## 2. Product Data

### 2-2. Sound pressure levels

Measurement condition

QAHV-N560YA-HPB(-BS)

QAHV-N-YA-HPB

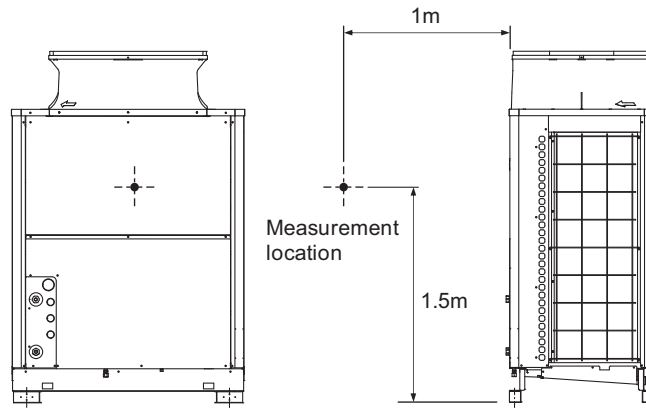

#### Sound Pressure Level: 56.0 / 58.0 dB (Spring, Autumn/Winter)

Operation condition... Spring, Autumn: Outdoor temp.: 16°CDB/12°CWB, Inlet water temp.: 17°C, Outlet water temp.: 65°C  
 Winter: Outdoor temp.: 7°CDB/6°CWB, Inlet water temp.: 9°C, Outlet water temp.: 65°C

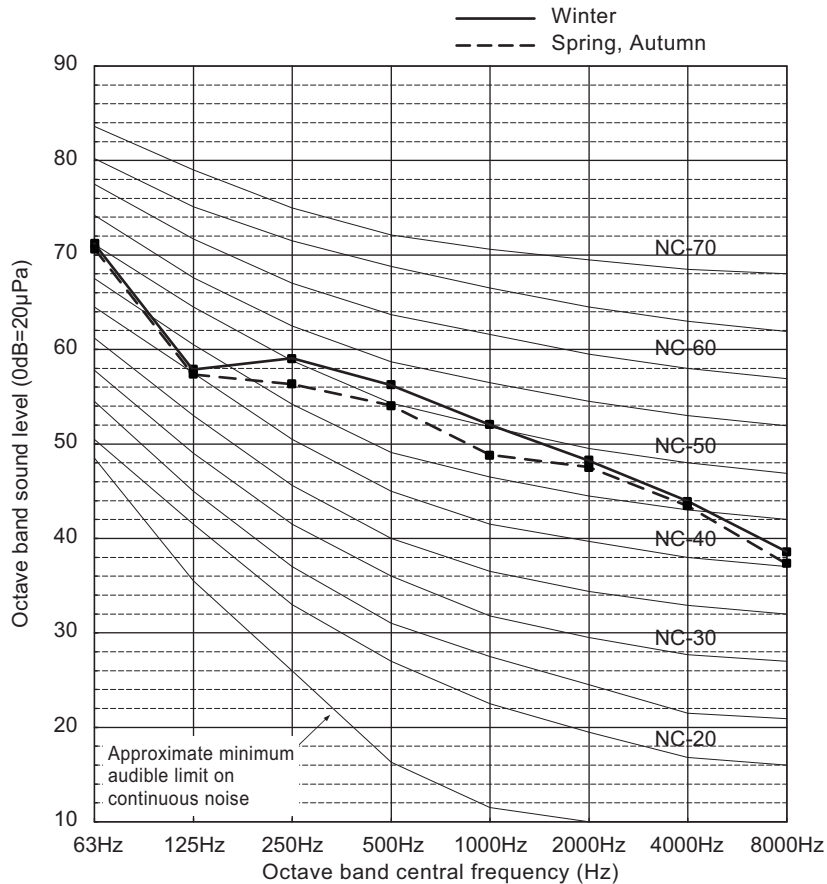

## 2. Product Data

### 2-3. Vibration levels

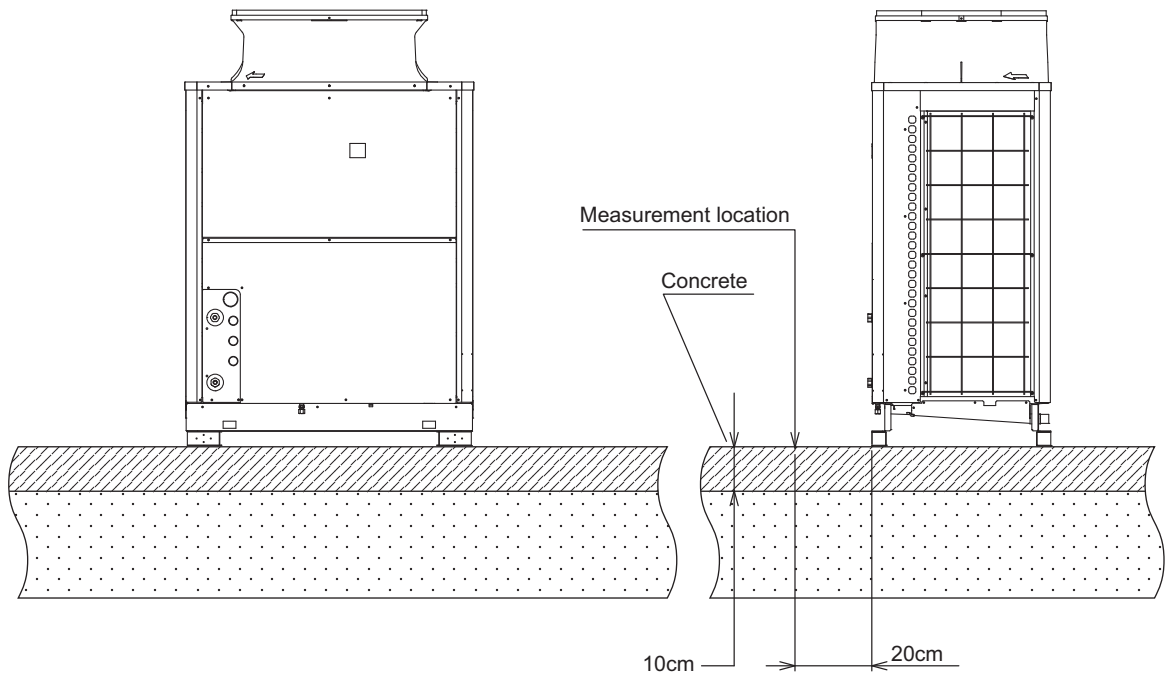

Model	Vibration Levels [dB]
QAHV-N560YA-HPB(-BS)	47 or less



## 3. Installation

### 3-1. Selecting the Installation Site

#### 3-1-1. Installation Conditions

##### Select the installation site in consultation with the client.

Select a site to install the outdoor unit that meets the following conditions:

- The unit will not be subject to heat from other heat sources.
- The noise from the unit will not be a problem.
- The unit will not be exposed to strong winds.
- Water from the unit can be drained properly.
- The space requirements as shown in 3-1-2. Installation Space Requirements.

##### 1. Protection against winds

Using the figures at right as a reference, provide adequate protection against winds. A unit installed alone is vulnerable to strong winds.

Select the installation site carefully to minimize the effect of winds.

When installing a unit in a place where the wind always blows from the same direction, install the unit so that the outlet faces away from the direction of the wind.

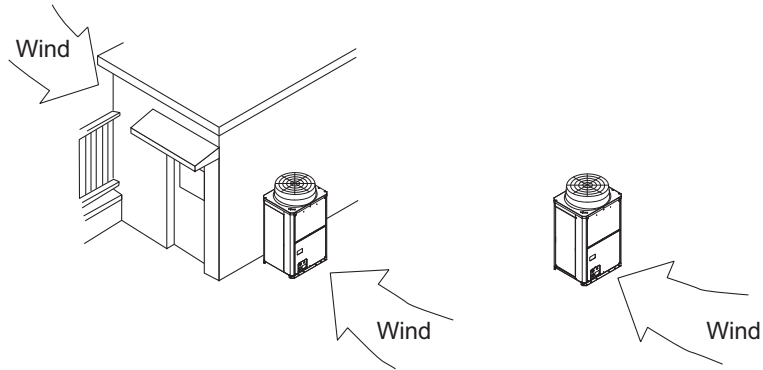

- Install the outdoor unit in a place where it is not exposed to direct wind, such as behind a building.

- Install the outdoor unit so that the outlet/inlet faces away from the wind.

##### 2. Cold Climate Installation

Observe the following when installing the units in areas where snow or strong winds prevail.

- Avoid direct exposure to rain, winds, and snow.
- Icicles that may form under the foundation can fall and inflict personal injury or property damage. Select the installation site carefully to reduce these risks, especially when installing the unit on a roof.
- If the units are installed in the direct line of rain, winds, or snow, install the optional snow hood (on both the discharge and suction ducts). Use a snow net or snow fence as necessary to protect the unit.
- Install the unit on a base approximately twice as high as the expected snowfall.
- If the unit is continuously operated for a long time with the outside air temperature below the freezing point, install a heater at the base of the unit to prevent the water from freezing at the unit bottom.
- When using the unit in an outdoor temperature of  $-15^{\circ}\text{C}$  or below, install a drain pan (with heater whose capacity is 320 W or more) at the bottom surface of the unit.

### 3. Installation

#### 3-1-2. Installation Space Requirements

Provide sufficient space around the unit for effective operation, efficient air movement, and ease of access for maintenance.

##### 1. Single unit installation

(1) When all walls are within their height limits\*.

[mm]

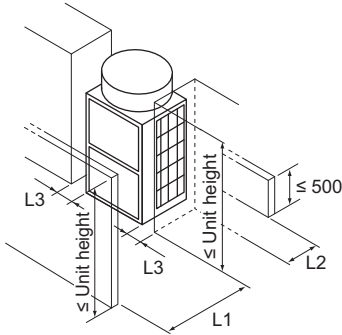

\* Height limit

Front/Right/Left	Same height or lower than the overall height of the unit
Rear	500 mm or lower from the unit bottom

	Required minimum distance [mm]		
	L1 (Front)	L2 (Rear)	L3 (Right/Left)
When the distance behind the unit (L2) needs to be small	500	300	50

(2) When one or more walls exceed their height limits\*.

When the wall(s) at the front and/or the right/left exceed(s) their height limits

When the wall at the rear exceeds its height limit

When all walls exceed their height limits

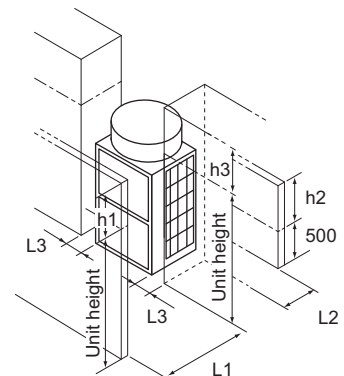
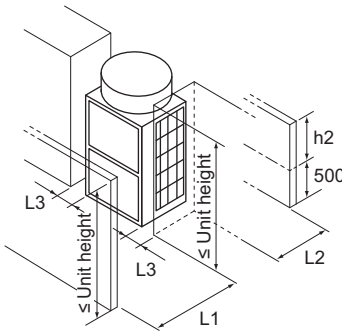
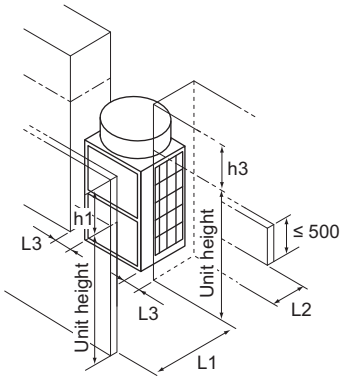

Add the dimension that exceeds the height limit (shown as "h1" through "h3" in the figures) to L1, L2, and L3 as shown in the table below.

	Required minimum distance [mm]		
	L1 (Front)	L2 (Rear)	L3 (Right/Left)
When the distance behind the unit (L2) needs to be small	500 + h1	300 + h2	50 + h3

### 3. Installation

#### 2. Multiple unit installation

When installing multiple units, make sure to take into consideration factors such as providing enough space for people to pass through, ample space between blocks of units, and sufficient space for airflow. (The areas marked with Ⓐ in the figures below must be left open.)

In the same way as with the single unit installation, add the dimension that exceeds the height limit (shown as "h1" through "h3" in the figures) to L1, L2, and L3 as shown in the tables below.

##### (1) Side-by-side installation

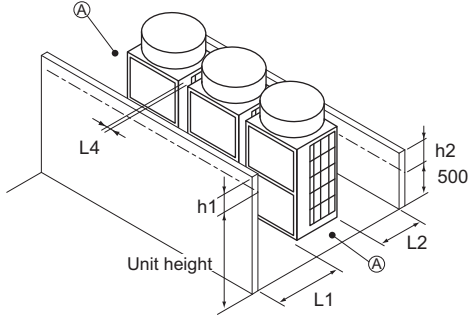

[mm]

Required minimum distance [mm]		
L1 (Front)	L2 (Rear)	L4 (Between)
$500 + h1$	$300 + h2$	100

Ⓐ Leave open in two directions.

##### (2) Face-to-face installation

When there are walls in the front and rear of the block of units

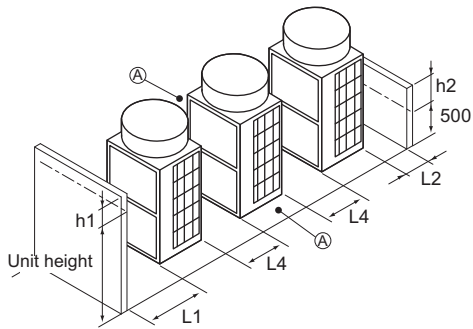

Required minimum distance [mm]		
L1 (Front)	L2 (Rear)	L4 (Between)
500	300	500

Ⓐ Leave open in two directions.

When there is a wall on either the right or left side of the block of units

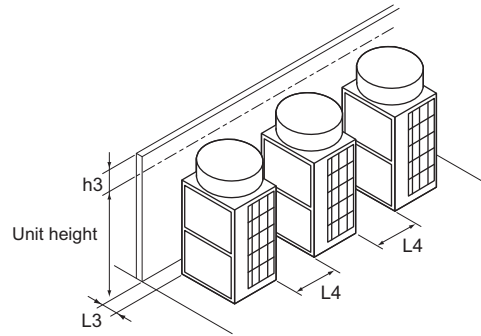

Required minimum distance [mm]	
L3 (Right/Left)	L4 (Between)
$50 + h3$	500

### 3. Installation

#### 3. Combination of face-to-face and side-by-side installations

When there are walls in the front and rear of the block of units

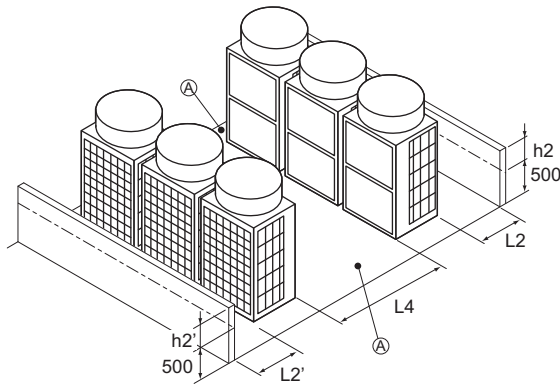

Required minimum distance [mm]		
L2 (Right)	L2' (Left)	L4 (Between)
$300 + h_2$	$300 + h_2'$	1000

Ⓐ Leave open in two directions.

When there are two walls in an L-shape

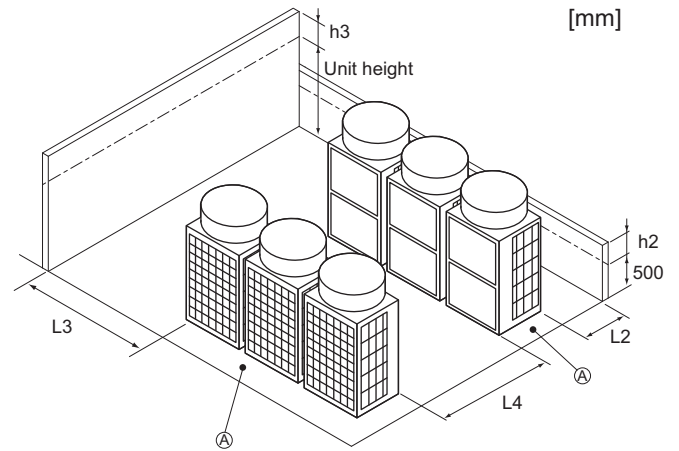

Required minimum distance [mm]		
L2 (Right)	L3 (Right/Left)	L4 (Between)
$300 + h_2$	$1000 + h_3$	1000

#### 3-1-3. System installation restrictions

##### ♦Piping length restrictions

The maximum piping length is 60 m. Make sure that the piping length between the secondary side unit and the heat exchanger is 60 m or less.

Select appropriate diameter pipes to prevent negative pressure from the pumping head and the pressure loss in the pipes. Pumping head (when maximum flow rate is 17 l/min): 77 kPa

##### ♦Installation height restrictions

- When the unit is installed above the storage tank

Decide the height so that the unit inlet water pressure will not be negative for the tank pressure.

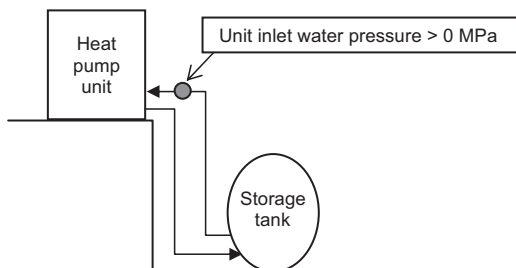

- When the unit is installed below the storage tank

Decide the height so that the unit inlet water pressure will be 0.5 MPa or below for the tank pressure.

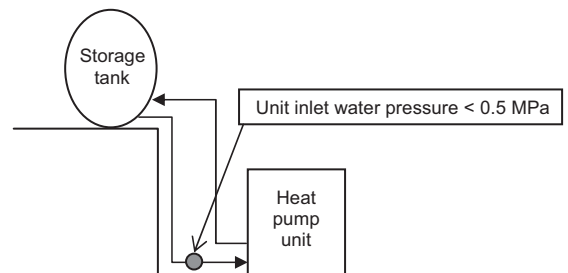

### 3. Installation

#### 3-2. Unit Installation

Units should be installed only by personnel certified by Mitsubishi Electric.

- Securely fix the unit with bolts to keep the unit from falling down during earthquakes or due to strong winds.
- Install the unit on a foundation made of concrete or iron.
- Noise and vibrations from the unit may be transmitted through the floor and walls. Provide adequate protection against noise and vibration.
- Build the foundation in such way that the corners of the installation legs are securely supported as shown in the figure below. When using rubber vibration isolators, make sure they are large enough to cover the entire width of the unit's legs. If the corners of the legs are not firmly seated, the legs may bend.
- The projecting length of the anchor bolt should be less than 30 mm.
- This unit is not designed to be installed using hole-in anchor bolts unless brackets are used to support the four corners of the unit.
- The legs on the unit are detachable.
- Detaching the legs  
Loosen the three screws on the legs to detach each leg (two each in the front and back). If the finish coat becomes damaged when detaching the legs, be sure to touch it up.

#### ⚠ WARNING

- **Be sure to install the unit on a surface strong enough to withstand its weight to keep the unit from falling down and causing injury.**
- **Provide adequate protection against strong winds and earthquakes. Improper installation may cause the unit to fall down, resulting in personal injury.**

When building the foundation, take the floor strength, water drainage during operation, and piping and wiring routes into consideration.

Precautions for routing the pipes and wires underneath the unit without detachable legs

When routing the pipes and wires underneath the unit, make sure that the foundation will not block the piping access holes. Also, make sure the foundation is at least 100 mm high so that the piping can pass under the unit.

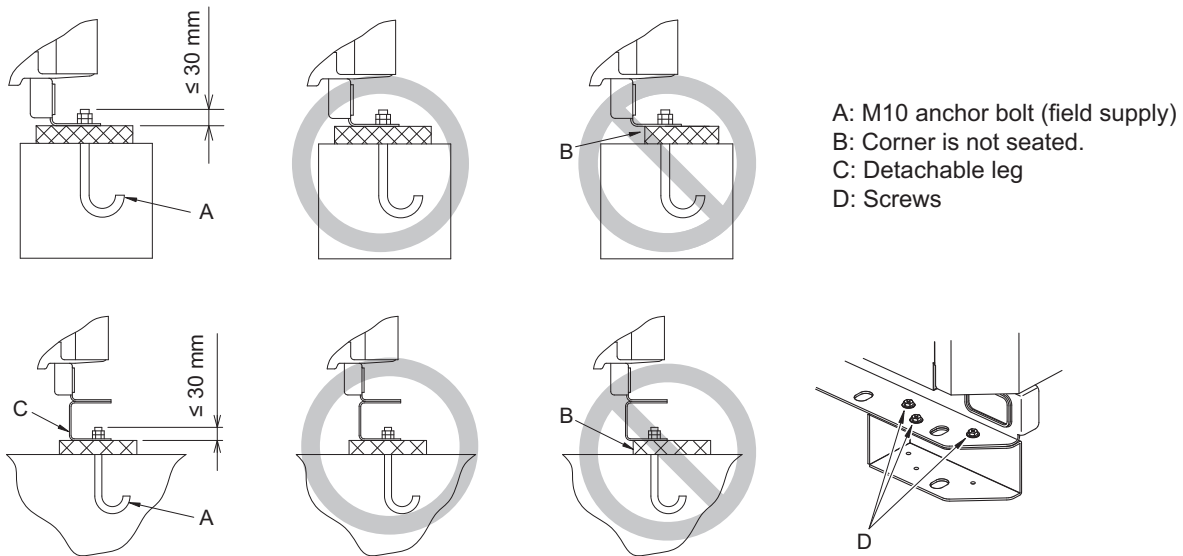

### 3. Installation

#### 3-2-1. Important notes for system design

##### 1. Applicable system

**Note**

- This product cannot be connected directly to a faucet. Supply all water (including the water supply to mixed water circuit) from a water tank or a make-up tank.

This product is designed for use in the types of systems shown below.

(1) Example QAHV circuit with the usage of only the water storage mode

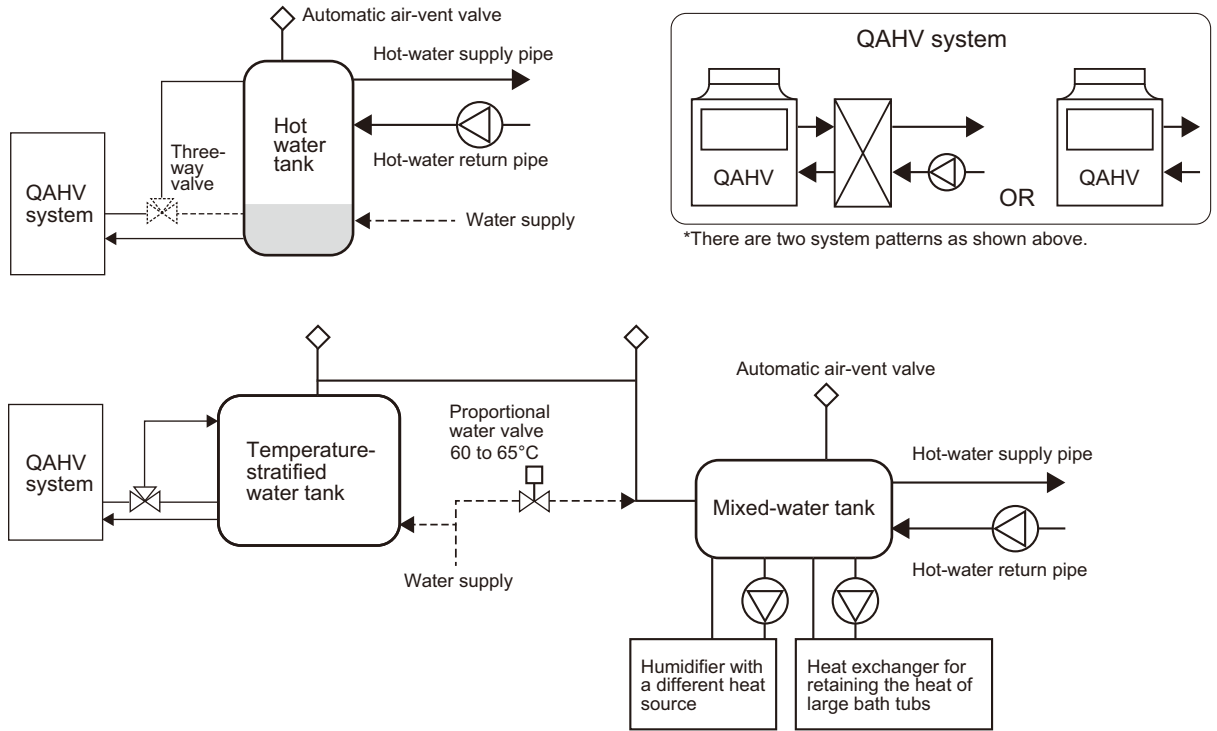

(2) Example QAHV circuit with multiple hot water storage tanks

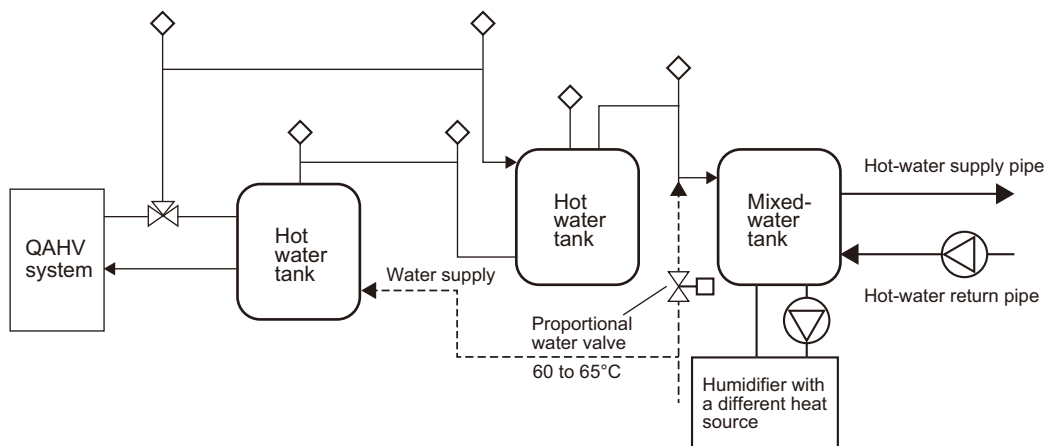

The figure above shows an example of a circuit with two hot water tanks.

Install a three-way valve so that it will always direct water to the downstream of the hot water tank except while the unit is operated in the hot water storage mode, including the time while the unit is stopped. The water is circulated in the circuit in the downstream of the hot water tank while the unit is stopped and performing freezing protection, and also when the pump is in the residual operation mode after the unit stopped operating in the water storage mode to keep the temperature stratification.

### 3. Installation

---

#### Note

- ♦Make sure the proper temperature stratification in the hot water tank is maintained. If the temperature stratification in the hot water tank is lost and the temperature of the lower layer of the water in the hot water tank rises too high, the operation time of the QAHV units may be extended greatly. Also, the amount of dissolved air in the supply water that bubbles up may increase due to the temperature fluctuations while the water is being supplied, which can cause erosion of the water pipe and reduction in wall thickness.

#### 2. Important notes for installation location

Select the installation location for the unit in consideration of the following.

- ♦Do not install the unit in a place where it is subject to radiant heat from other heat sources.
- ♦The noise from the unit will not be a problem for the neighbors.
- ♦Install the unit where the unit will not be exposed to strong winds.
- ♦Properly install the unit on load-bearing surface.
- ♦Note that drain water is discharged from the unit during operation.
- ♦Do not install the unit where there is a risk of flammable gas leaks. To reduce the risk of fire, do not install the unit in a location where a flammable gas may be present.
- ♦Do not install the unit where acidic solution or chemical sprays (sulfur-based) are frequently used.
- ♦Do not install the unit in a place where large amounts of oil, steam, or sulfide gas are present.

### 3. Installation

#### 3. Important notes for piping designs

##### (1) General notes

- Strainer: Install a strainer (60 mesh or finer) near the water inlet of the QAHV to keep the debris out.
- Flexible joint: Install a flexible joint at the inlet and the outlet of the QAHV to isolate the vibration.
- Gate valve, drain valve: Install gate valves and drain valves that are necessary for cleaning the hot water tank, cleaning the heat exchanger in the QAHV, and replacing the unit.
- Piping and insulation material: For hot water supply pipes, select the pipes made of the material that is heat resistant to at least 90°C (SUS, copper, Cross-linked polyethylene, polybutene).  
For inlet pipes, select the material that is resistant to the maximum inlet water temperature. For all pipes, select corrosion-resistant materials, such as SUS, copper, and resin.
- Drain pipe: When installing a drain pipe for QAHV units, provide a large inclination and keep its horizontal section short to keep the rain water from freezing in winter.
- Freeze protection in winter: In cold climate regions, install a freeze protection heater on all pipes to keep the pipes from freezing in winter.

##### (2) Water-supply pipe

Be sure to connect the water-supply pipe to the hot water tank.

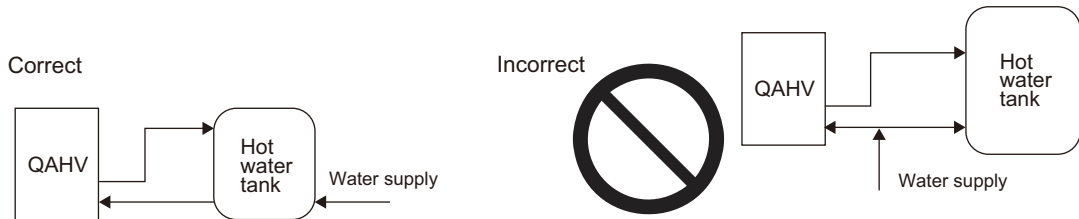

If the water-supply pipe is connected to the inlet pipe of QAHV, sudden fluctuations in the inlet water temperature during operation (instant 5 K/min or greater or continuous 1 K/min or greater) can cause the unit to come to an abnormal stop (high-pressure, refrigerant gas cooler outlet temperature) or causes the hot water supply temperature to drop.

##### (3) Outlet check valve (required when multiple QAHV units are installed)

When connecting multiple QAHV units, install a check valve on the outlet pipe of each unit. Otherwise, a circuit is formed in the unit(s) where hot water backflows when some of the units are operated in the defrost mode or when they are stopped due to an error. Then, other units will come to an abnormal stop due to a sudden change in inlet water temperature.

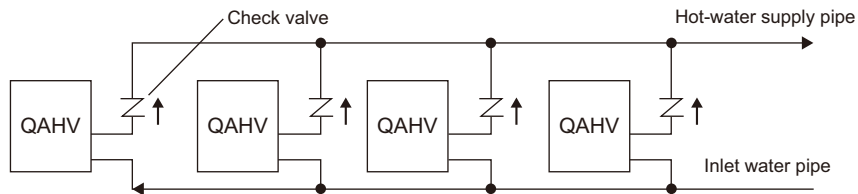



### 3. Installation

QAHV-N-YA-HPB

#### (4) Automatic air-vent valve and air separator

An automatic air-vent valve needs to be installed at the highest point of the piping in a closed circuit. Because undissolved air bubbles are present in the hot-water supply pipe of QAHV, any pipe with a downward inclination needs to be branched before the start of the inclination, and an upward pipe with an automatic air-vent valve at its tip needs to be connected.

When a large number of QAHV units are connected, the amount of air bubbles will also increase, and the branch pipe or the automatic air-vent valve may not be able to handle the bubbles quickly enough.

If this happens, an air separator may be required to maintain sufficient space volume. Provide a 1/200 or greater upward inclination toward the air-vent valve to keep air pockets from forming inside the pipe, and be sure to install an automatic air-vent valve where air pockets can possibly form.

#### Note

◆ If the horizontal section of the pipe is at a point below the water-supply outlet of QAHV, create a vertical section of the pipe near the unit, and install an automatic air-vent valve to it.

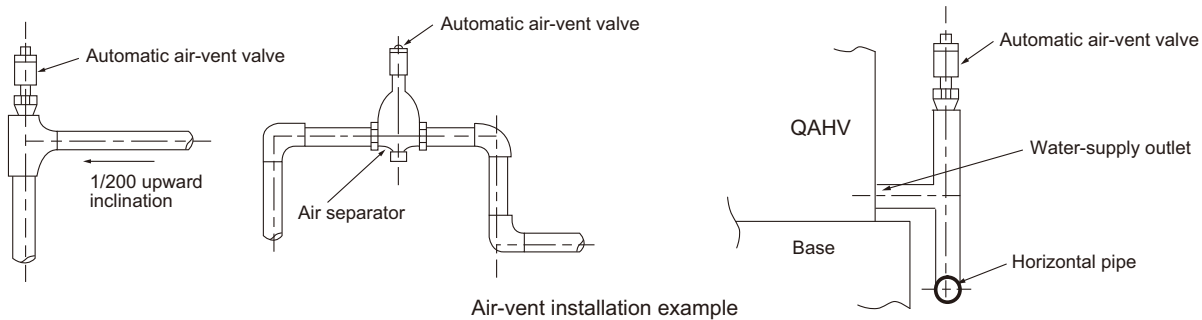

#### (5) Safety valve

For a closed circuit, a safety valve (relief valve) must be installed to keep the water circuit from bursting. Also, a relief pipe must be installed to keep the water (or hot water) from the unit from splashing the passersby.

#### (6) Vacuum breaker

Install a vacuum breaker (negative pressure valve) to the hot water tank when supplying water to the floor below. Otherwise, when the hot water supply load unexpectedly rises, the supply water shortage can cause a negative pressure inside the hot water tank and cause the tank to become deformed.

The same applies to supplying water to the floor above. Install a vacuum breaker (negative pressure valve) to the hot water tank.

#### (7) Expansion tank

$$\text{Required capacity } V_t = K \cdot V_s / (1 - P / (P + \Delta P))$$

K: Water expansion coefficient

V<sub>s</sub>: Water volume in the system

P: System pressure (make-up water pressure + circulation pump head + atmospheric pressure)

ΔP: Pressure difference between the maximum system pressure and the pressure at startup  
= Safety valve setting pressure × 0.9 – (make-up water pressure + circulation pump head)

If this value is small, the required expansion volume will rise.

System temperature (T) °C	Make-up water temperature (t) °C						
	5	10	15	20	25	30	35
30	0.0034	0.0032	0.0026	0.0017	0.0005		
35	0.0048	0.0046	0.0040	0.0031	0.0019	0.0005	
40	0.0066	0.0063	0.0057	0.0049	0.0037	0.0023	0.0006
45	0.0084	0.0082	0.0075	0.0067	0.0055	0.0041	0.0025
50	0.0104	0.0103	0.0099	0.0092	0.0082	0.0070	0.0055
55	0.0126	0.0126	0.0121	0.0114	0.0102	0.0081	0.0078
60	0.0150	0.0149	0.0145	0.0138	0.0128	0.0118	0.0102
65	0.0176	0.0175	0.0171	0.0164	0.0154	0.0142	0.0127
70	0.0203	0.0202	0.0198	0.0191	0.0181	0.0169	0.0154
75	0.0232	0.0230	0.0226	0.0219	0.0209	0.0197	0.0183
80	0.0262	0.0262	0.0257	0.0250	0.0240	0.0228	0.0214
85	0.0294	0.0293	0.0289	0.0282	0.0272	0.0260	0.0246
90	0.0327	0.0327	0.0323	0.0316	0.0306	0.0293	0.0279
95	0.0363	0.0362	0.0358	0.0351	0.0341	0.0329	0.0314

<Table Water expansion coefficient K>

### 3. Installation

---

#### 4. Water quality standard

Use the water that meets the standard listed on page 36.

The use of water that does not meet the quality standard may result in scaling and corrosion.

#### 5. Important notes for facilities with a long period of an absence of hot-water supply load

##### (1) Hygiene control

Leave the power switch of the hot-water supply system on to keep the hygienic condition of the hot water tank.

Hot water that was kept in the hot water tank or in the pipe for a long period is not fit for bathing or other human use from the hygienic viewpoint. Before stopping the operation of unit, keep the amount of hot water to a minimum, and drain all water (use for non human use) from the supply end before restarting operation, and use the newly filled water for bathing and for other human use.

##### **Note**

•If the water is expelled from the pipe to prepare for the stoppage of the unit, the unit will require a trial run (water filling and air-vent) before the unit is operated again. Please have your maintenance provider perform a trail run.

##### (2) Freeze protection in winter

Freeze protection measures for water circuits need to be taken when the outside temperature drops to 0°C or below. Leave the power switch of the hot-water facility and the freeze protection heater for the pipes on at all times.

If no power is supplied to the units out of operation, hot water needs to be removed from the piping. The heat exchanger of industrial QAHV will sustain freeze damage if the water is not drained from the pipes properly. Please have the drainage work provided by your maintenance provider.

The unit will require a trial run (water filling and air-vent) before the unit is operated again. Please have your maintenance provider perform a trail run.

## 4. System Design

### 4-1. Water Pipe Installation

#### 4-1-1. Schematic Piping Diagram and Piping System Components

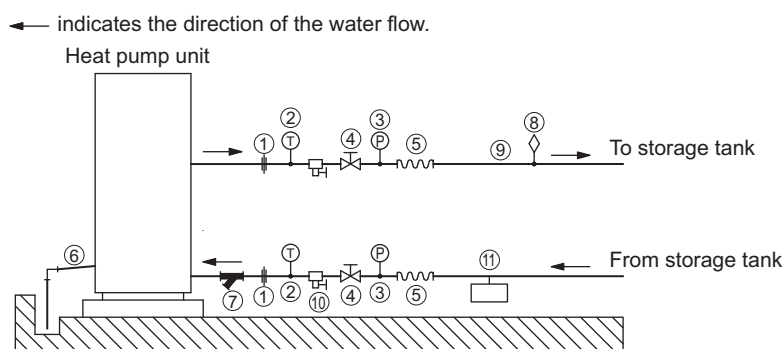

Water piping diagram

①	Union joints/flange joints	Required to allow for a replacement of equipment.
②	Thermometer	Required to check the performance and monitor the operation of the units.
③	Water pressure gauge	Recommended for checking the operation status.
④	Valve	Required to allow for a replacement or cleaning of the flow adjuster.
⑤	Flexible joint	Recommended to prevent the noise and vibration from the pump from being transmitted.
⑥	Drain pipe	Install the drain pipe with a downward inclination of between 1/100 and 1/200. To prevent drain water from freezing in winter, install the drain pipe as steep an angle as practically possible and minimize the straight line. For cold climate installation, take an appropriate measure (e.g., drain heater) to prevent the drain water from freezing.
⑦	Strainer	Install a strainer with 60 mesh or better near the unit to keep foreign materials from entering the water-side head exchanger.
⑧	Air vent valve	Install air venting valves to the places where air can accumulate. Automatic air vent valves are effective.
⑨	Water pipe	Use pipes that allow for easy air purging, and provide adequate insulation.
⑩	Drain valve	Install drain valves so that water can be drained for servicing.
⑪	Expansion tank	Select an expansion tank that is suitable for the system.

\* Form a closed-loop water system for the indirect heat-exchange system. (Refer to section 4-2-2 for cautionary notes on configuring a system using indirect heat exchangers on the secondary side.)

\* Installing a freezing prevention heater

- (1) In cold areas (where the outside temperature drops below freezing), provide a freezing prevention heater at all local pipes to prevent spontaneous freezing.
- (2) After the heater is installed, check outside temperature +25°C is ensured at the EcoCute inlet/outlet pipe joint section (at outside temperature -25°C, joint section 0°C or higher).
- (3) Depending on the local piping material, prevent overheating by selecting a self temperature adjustment type heater or other method.

## 4. System Design

### Heater installation example

Use an insulation material that can withstand the temperature of 100°C and higher.

Recommended material:  
Glass wool, rock wool

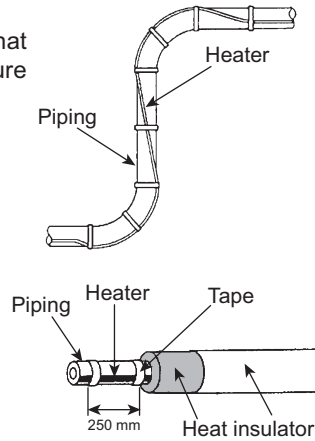

Joint section 0°C or higher

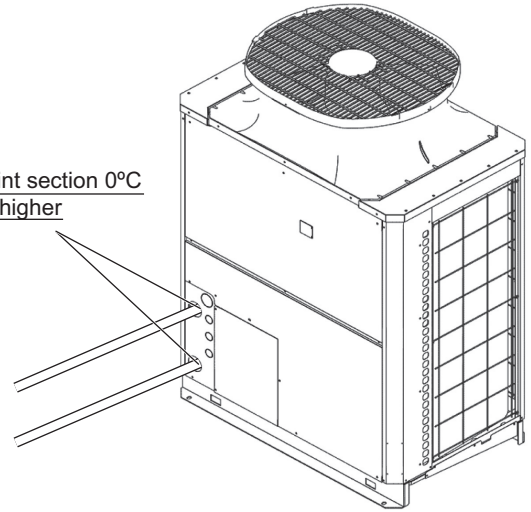

### Pipe size and insulation thickness

Pipe size	Insulation thickness [mm]
25A or less	30
32A	40

#### \* 3-way valve installation

Please connect 3-way valve on the lower part of the storage tank except when the unit is in operation.

Anti-freezing operation will keep the water in the tank circulated and water storage tanks can become thermally stratified.

- > : Anti-freezing operation  
Residual running of the pump
- > : Hot water storage operation

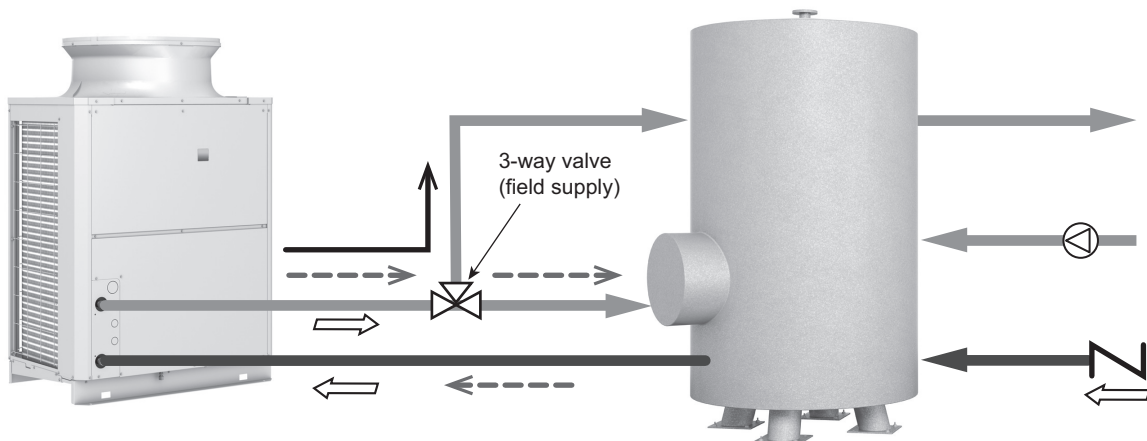

## 4. System Design

### 4-1-2. Notes on pipe Corrosion

#### Water treatment and water quality control

Poor-quality circulating water can cause the water-side heat exchanger to scale up or corrode, reducing heat exchange performance. Properly control the quality of the circulating water.

- Removing foreign objects and impurities in the pipes

During installation, keep foreign objects, such as welding and sealant fragments and rust, out of the pipes.

- Water Quality Control

(1) Poor-quality water can corrode or scale up the heat exchanger. Regular water treatment is recommended. When using the unit, install a water-to-water heat exchanger etc., and use a closed-loop circuit on the unit side.

(2) Water quality standard

Industrial QAHV water standard

Use the make-up water that meets the water-quality standard. The figures in parentheses indicate the standard that can be used under certain conditions.

Items		Higher mid-range temperature water system Water Temp. > 60°C	Make-up water criteria (with secondary side control enabled) Water Temp. > 60°C	Tendency	
		Recirculating water	Recirculating water	Corrosive	Scale-forming
Standard items	pH (25°C)	6.5 ~ 8.0	6.5 ~ 8.0	O	O
	Electric conductivity (mS/m) (25°C)	30 or less	30 or less	O	O
	(µs/cm) (25°C)	[300 or less]	[300 or less]		
	Chloride ion (mg Cl <sup>-</sup> /ℓ)	30 or less	30 or less	O	
	Sulfate ion (mg SO <sub>4</sub> <sup>2-</sup> /ℓ)	30 or less	30 or less	O	
	Acid consumption (pH4.8) (mg CaCO <sub>3</sub> /ℓ)	50 or less (65 or less)*1	50 or less (65 or less)*1		O
	Calcium hardness (mg CaCO <sub>3</sub> /ℓ)	6.5 ≤ pH ≤ 7.5: 90 or less 7.5 ≤ pH ≤ 8.0: 50 or less	250 or less		O
Ionic silica (mg SiO <sub>2</sub> /ℓ)	30 or less (50 or less)*2	30 or less (50 or less)*2		O	
Reference items	Iron (mg Fe/ℓ)	0.3 or less	0.3 or less	O	O
	Copper (mg Cu/ℓ)	0.1 or less	0.1 or less	O	
	Sulfide ion (mg S <sup>2-</sup> /ℓ)	Not to be detected	Not to be detected	O	
	Ammonium ion (mg NH <sub>4</sub> <sup>+</sup> /ℓ)	0.1 or less	0.1 or less	O	
	Residual chlorine (mg Cl/ℓ)	0.3 or less	0.3 or less	O	
	Free carbon dioxide (mg CO <sub>2</sub> /ℓ)	10.0 or less	10.0 or less	O	

Reference: Guideline of Water Quality for Refrigeration and Air Conditioning Equipment. (JRA GL02E-1994)

\*1 Acid consumption is also called M alkalinity.

Acid consumption exceeding 50 will cause calcium carbonate scaling. If the acid consumption value is between 50 and 65, annual chemical cleansing will be required.

If the acid consumption exceeds 65, a water softener must be installed to keep the calcium hardness to 25 or below.

Acid consumption rises in winter. Conduct a regular water-quality inspection in winter whenever possible.

\*2 Ionic silica can cause calcium scale that is hard to remove. If the acid consumption is 50 or below, the figure in the parentheses is the maximum allowable value.

(3) Please consult with a water quality control specialist about water quality control methods and water quality calculations before using anti-corrosive solutions for water quality management.

(4) When replacing an air conditioner (including when only the heat exchanger is replaced), first analyze the water quality and check for possible corrosion.

Corrosion can occur in water systems in which there has been no signs of corrosion. If the water quality level has dropped, adjust the water quality before replacing the unit.

(5) Suspended solids in the water

Sand, pebbles, suspended solids, and corrosion products in water can damage the heating surface of the heat exchanger and cause corrosion. Install a good quality strainer (60 mesh or better) at the inlet of the unit to filter out suspended solids.

(6) Connecting pipes made from different materials

If different types of metals are placed in direct contact with each other, the contact surface will corrode.

Install an insulating material between pipes that are made of different materials to keep them out of direct contact with each other.

## 4. System Design

### 4-1-3. Pipe gradient and air venting valve (Outlet hot water pipe)

During the hot water storage operation, the air dissolved in the water is discharged in the form of bubbling from the outlet hot water pipe to quickly raise low-temperature water to the required temperature. When the air accumulates in the pipe, the resistance of the water circuit will increase and the flow rate will extremely decrease. Because of this, an installation of automatic air venting valves is required when there is a pipe that slopes down in the outlet hot water pipe. Install the pipe with an upward gradient of 1/200 or more toward the air vent to prevent air accumulation in the pipe. Also, install air venting valves to the places where air can accumulate. The installation example is shown below.

#### Note

- If the crosscut pipe is located lower than the hot water outlet of the heat pump unit, raise the pipe near the unit and install an automatic air venting valve.

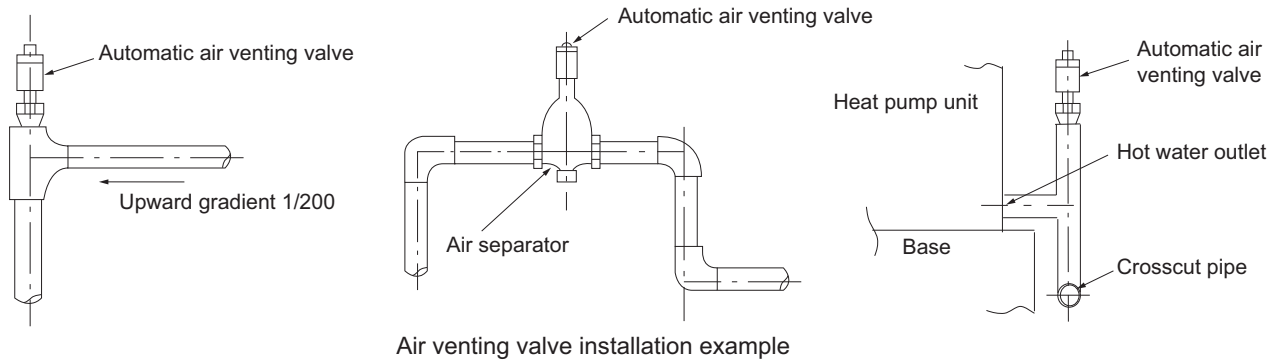

### 4-1-4. Outlet check valve (When installing multiple units)

When connecting multiple units with pipes in parallel, install a check valve at the outlet pipe of each unit. If a check valve is not installed, a circuit in which warm water flows back will be created in some units during the defrost cycle or abnormal stop, and other units will come to an abnormal stop due to sudden change of the inlet water temperature.

### 4-1-5. Water Pipe Hole Size and Location

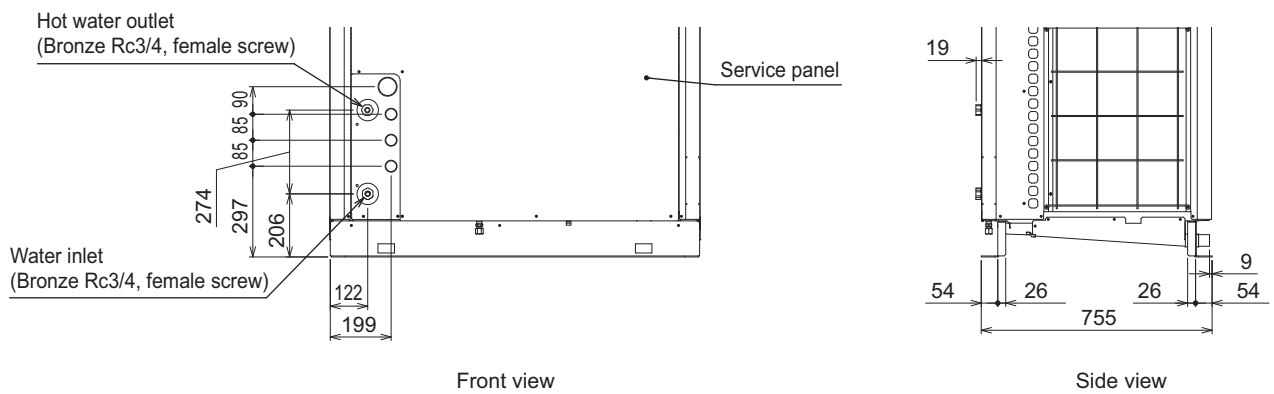

4-2. QAHV Secondary side control

4-2-1. General description and purpose of secondary side control

Secondary side control is a control method to raise the hot water temperature in the tank by using another heat exchanger added between the tank and the existing heat exchanger.

By incorporating the secondary side control to the QAHV, the need to assemble a pump control on-site is eliminated, and the system construction in cases where water exceeding the QAHV water quality standard is used is now easier.

(1) System diagram

Secondary side control system

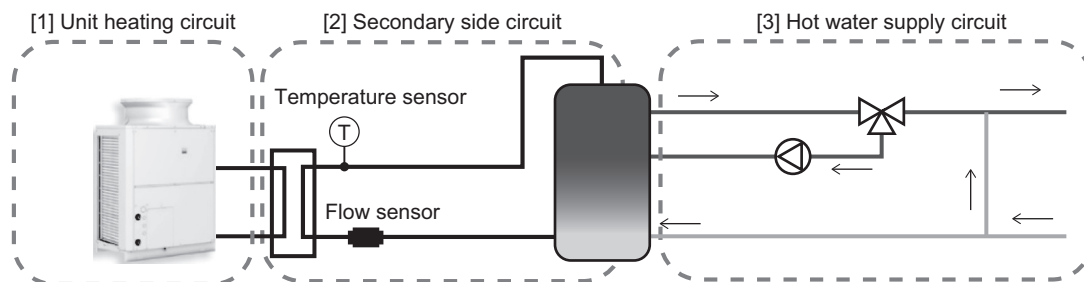

System overview

The system using the secondary side control is roughly split into the following three elements: [1] Unit heating circuit, [2] Secondary side circuit, and [3] Hot water supply circuit. The hot water heated in the unit heating circuit [1] and the cold water from the lower section of the tank are heat-exchanged in the secondary side circuit [2], and then the high-temperature water flows into the hot water storage tank. The heated hot water in the hot water storage tank is supplied to the customer via the hot water supply circuit [3].

•Control target

Based on the data of the flow rate sensor and temperature thermistor installed on the secondary side, the output of secondary side pump is adjusted by QAHV (adjusts by 0-10 V output).

•Purpose

Adjusting the pump output on the secondary side maintains the target outlet hot water temp. and prevents acute rising of water inlet temp. to QAHV.

•Overview on pump operation in different operation modes (○: operated, ×: stopped)

Operation modes	Primary side	Secondary side
Hot water storage mode	○	○
Defrost operation mode	×	×
Anti freezing operation	○	○
At the end of hot water storage mode, before and after defrost operation (*)	○	○

(2) Difference between systems with and without secondary side control

	Without secondary side control	With secondary side control
Diagram		
Water quality standard Calcium hardness (mg CaCO <sub>3</sub> /ℓ)	6.5 ≤ pH ≤ 7.5: 90 or less 7.5 ≤ pH ≤ 8.0: 50 or less	pH ≤ 250 or less
Hot water supply temperature range	55-90°C	Unit: 55-90°C Secondary side: 55-80°C
Control target	Unit	Unit, secondary side pump, and secondary side flow adjusting device

4-2-2. Schematic Piping Diagram and Piping System Components

Secondary side control system

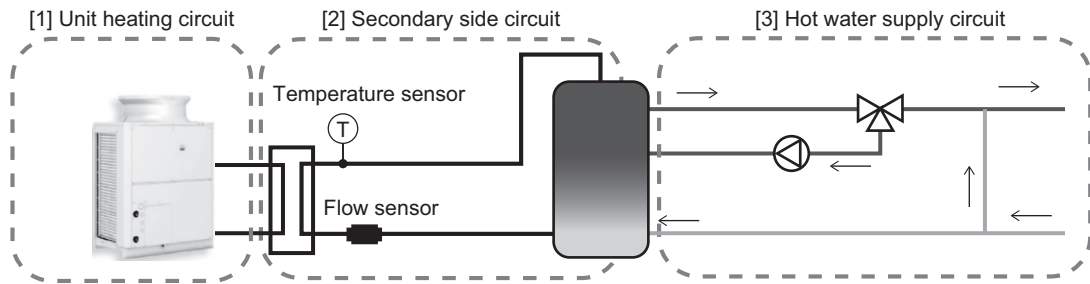

(1) Notes on configuring and selecting components

1) Points to note for secondary side water piping

[1] Details on components in the unit heating circuit

\* For details, refer to page 34.

[2] Details on components in heat exchanger heating circuit

Schematic Piping Diagram and Piping System Components for secondary circuit

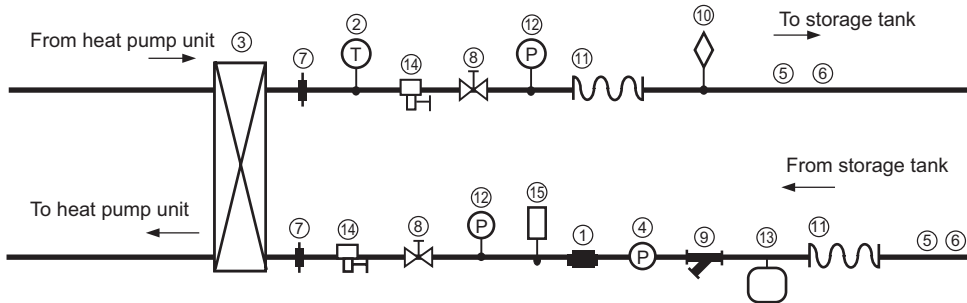

No.	Component	Application	Remarks and notes on selecting and installing components
①	Flow sensor (Optional parts)	Measures and controls the secondary side flow rate.	Be sure to install this component between the downstream of the flow rate adjustment device and the heat exchanger.
②	Temperature sensor (Optional parts)	Measures and controls the secondary side outlet hot water temperature.	Install this component at the outlet of the heat exchanger. Install the sensor near the heat exchanger outlet (within 1 meter of the heat exchanger outlet).
③	Plate heat exchanger	Exchanges heat between hot water output from the unit and water input from the tank.	Select a heat exchanger that is appropriate for the capacity.
④	Pump + Flow rate adjustment device	Outputs hot water from the secondary side and adjusts the flow rate.	Select a pump and flow rate adjustment device that are suitable for the system. Install them at the lower outlet of the tank.
⑤	Water piping	Water flow channel	Be sure to perform insulation work. Select pipes that allow for easy air bleeding.
⑥	Anti-freeze heater	Prevents pipe damage due to freezing of the water circuit.	This component needs to be installed in a location where an ambient temperature may fall to 0°C or less.
⑦	Union joint	Improves the workability of replacing equipment.	Install these components in the two places of the chilled water passage section and the high temperature water passage section to enable replacement.
⑧	Valve	Improves the workability of cleaning the heat exchanger and replacing parts.	Install these components in the two places of the chilled water passage section and the high temperature water passage section to enable replacement.
⑨	Strainer	Prevents foreign materials from entering into the heat exchanger.	Install a strainer with 60 mesh or better near the heat exchanger.
⑩	Air vent valve	Bleeds air from the pipe.	Install air vents in places where there is a risk of air accumulating.
⑪	Flexible joint	Prevents the propagation of vibration.	These components need to be installed in consideration of the pipe load as pipes are easily damaged by bending.
⑫	Water pressure gauge	Used to check the operation status.	Attach this component to each piping section to check the water pressure.
⑬	Expansion tank	Absorbs excessive water pressure due to expansion caused by a rise in temperature.	Select an expansion tank that is suitable for the system.
⑭	Drain valve	Improves workability of replacing equipment.	Install these components in the two places of the chilled water passage section and the high temperature water passage section to enable replacement.
⑮	Safety valve	Prevents rupturing of the water circuit.	Be sure to provide an escape pipe to prevent discharged water from spraying on passersby.



### 4-2-3. Selection criteria for heat exchanger

The values below are reference values under the following conditions.

Operation mode: Energy operation mode 1; Secondary side circuit outlet hot water temperature: 65°C; Inlet temperature: 10°C. Determine the specifications based on the actual usage conditions.

Step 1 Determination of prerequisites for selection

1. Heat exchanger capacity 40000 W
2. Estimation of outlet hot water and inlet water temperatures  
As a guide, select a heat exchanger of which the temperature difference between the high temperature section and the low temperature section will be 5°C or below.
- 2-1. Outlet hot water temperature (when secondary side outlet hot water temperature is set to 65°C (setting at the time of shipment))
  - ♦ Secondary side circuit outlet hot water temperature: 65°C
  - ♦ Unit outlet hot water temperature: 70°C
- 2-2. Inlet water temperature
  - ♦ Secondary side inlet water temperature: 10°C
  - ♦ Unit inlet water temperature: 15°C
3. Used flow rate  
(40000 W)/(70-15)°C/4200 J/kg•K) × 60 s = 10.4 kg/min ≈ 10.4 ℓ/min

Step 2 Determination of model

Notes on selection

- ♦ Select a heat exchanger that allows water to pass through both of the flow channels.
- ♦ Select a heat exchanger so that the pressure applied to the heat exchanger in the on-site system will not exceed the maximum operating pressure of the heat exchanger.
- ♦ Select a heat exchanger that allows flowing at a flow rate of maximum 30 ℓ/min.
- ♦ Select a heat exchanger with a capacity of at least 40000 W.
- ♦ Ensure that the shearing stress at the flow rate to be used will be 16 Pa or more. (Refer to step 4.)
- \* To increase the shearing stress:
  - ♦ When the area per plate is equal, select a vertically long heat exchanger.
  - ♦ Select a heat exchanger of which NTU is high (although the heat transfer capacity improves as NTU increases, the pressure loss becomes high).

Step 3 Determination of specifications of the heat exchanger

Determine the model of heat exchanger and number of plates in consultation with the heat exchanger manufacturer based on the above requirements.

\* To determine the number of plates, calculate the number of plates while referring to the example below.

Values to use when determining the number of plates:

- 1) Overall heat transfer coefficient of corresponding heat exchanger
- 2) Heat transfer area per plate

Calculation method

- a) Obtain the data of 1) and 2) from the heat exchanger manufacturer.
- b) Estimate the number of plates of the heat exchanger.
- c) Check that the number of transfer units for the corresponding number of plates matches between NTU1 and NTU2 (NTU1=NTU2).  
If they are matched, select a heat exchanger having the corresponding number of plates. If they are not matched, change the number of plates and then return to B to perform the calculation again.

$$NTU 1 = \frac{\Delta T}{\Delta T}$$

$$NTU 2 = \frac{K \times A}{V \times C}$$

ΔT1: Temperature difference between inlet and outlet

ΔT: Temperature difference of high temperature part (low temperature part)

K: Overall heat transfer coefficient (W/m<sup>2</sup>K)

A: Total heat transfer area (m<sup>2</sup>)

G: Total mass flow rate (kg/s)

C: Specific heat (J/kg•K)

## 4. System Design

### Step 4 Calculation of the shearing stress

Calculate the shearing stress using the following method.

Values required for calculation

- Relationship between flow rate and pressure loss of corresponding heat exchanger (Obtain the data from the heat exchanger manufacturer.)

Calculation method

Calculate the shearing stress using the following formula.

$$\tau = \frac{\Delta P}{4} * \frac{\text{Representative length of 1 channel}}{\text{Effective length}}$$

Effective length:

Length between water inlet and water outlet  
(refer to the figure on the right)

Representative length of 1 channel:

Distance between plates  
(refer to the figure on the right) × 2

$\Delta P$ : Pressure loss

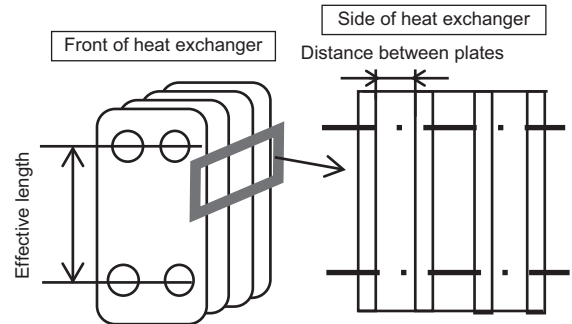

A shearing stress of 16 Pa or higher is required to reduce the amount of scale that adheres.

If the shearing stress is low:

- Select a vertically short shape.
- Change the shape of the plates.

Reselect a heat exchanger that will increase the shearing stress by following methods described above.

## 4. System Design

### 4-2-4. Configuration method and selection criteria of flow rate adjustment device

In this system, a flow rate adjustment device is installed in the secondary side circuit to perform secondary side flow rate adjustment control by outputting 0 to 10 V from the unit.

\* 10-V or 12-V power supply is not supplied. Please prepare a DC power supply.

The following shows a system configuration example of the flow rate adjustment device and notes on the system configuration.

The following three system types are recommended as flow rate adjustment devices:

1. System using a three-way valve
2. System using a two-way valve
3. System using an inverter

Power supply	Item code 1517	Control range
10V	0	For 0–10 V analog output control using an input power supply of 10 V. (Note that the analog output voltage can drop by up to approximately 20% due to attenuation.)
12V	1	For 2–10 V analog output control using an input power supply of 12 V. Set to 1 to use the equipment (inverter with a built-in pump, etc.) that requires an analog input voltage of 10 V. The minimum analog output value is changeable by setting the digitally set setting 1515. Note: The minimum allowable input voltage of the equipment to be connected to the analog output is 12 V.

#### 1. System using a three-way valve

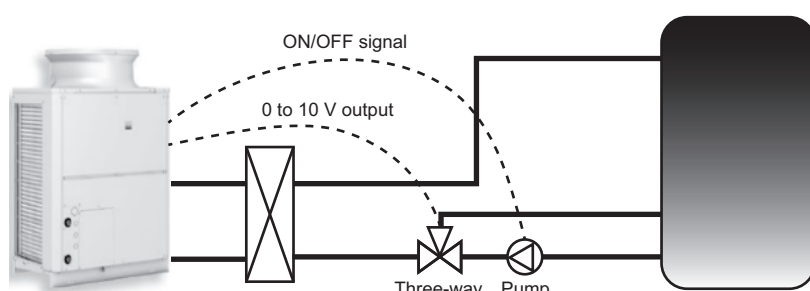

#### Overview of system

This system has a pump provided at the outlet of the tank and a three-way valve provided downstream of the pump, and adjusts the flow rate by controlling the opening and closing of the three-way valve.

	Flow rate output device	Flow rate adjustment device
	Pump	Three-way valve
Wiring connection places	1-3 of CN512 of control board (ON/OFF output)	Sub box terminal block No. 10, 11, 12

#### Notes on selection method and system configuration

##### Notes on pump selection and connection

- ♦ Calculate the total pump head according to the system at the site and then select a pump capable of outputting the minimum flow rate of about 3 l/min and maximum flow rate of about 30 l/min with the necessary pump head for the piping at the site.
- ♦ When selecting the pump, please note that output at a high flow rate will not occur if the flow rate with the pump head of the system at the site is low, and output at a low flow rate will not occur if the flow rate is too high.
- ♦ Be sure to check that the flow rate becomes 20 to 30 l/min at the maximum output during a flow rate adjustment test run.
- \* If the flow rate is not within the range of 20 to 30 l/min, select a different pump or adjust the maximum frequency using an inverter, etc. so that the maximum flow rate of 20 to 30 l/min is achieved.
- \* To select a proper pump, first select a pump that supports slightly high flow rate, and then adjust the frequency with an inverter so that the flow rate becomes 20 to 30 l/min at the maximum output. (In that case, an inverter is necessary to be prepared separately.)

##### Notes on three-way valve selection and connection

- ♦ Use a valve that is capable of adjusting the flow rate with a 0 to 10 V input.
- ♦ Calculate the Cv value and select a valve that supports an appropriate rate.
- ♦ Select a valve of which the ratio of the maximum flow rate and the minimum flow rate will be at least 1:10.
- ♦ Place the three-way valve downstream of the pump. Connect one outlet to the heat exchanger. Connect the other outlet to the lower part of the tank.
- ♦ Carefully read the instruction manual and use the three-way valve in accordance with the usage procedures.

2. System using a two-way valve

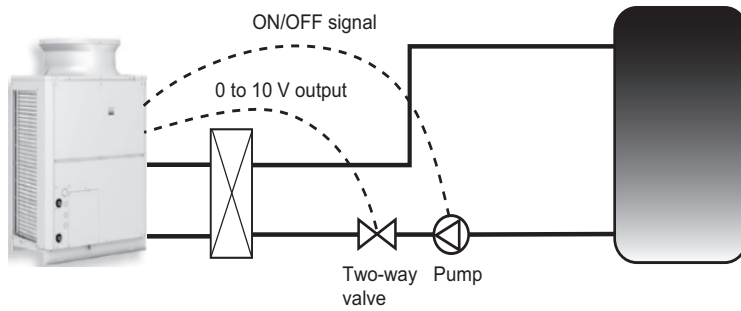

Overview of system

This system has a pump provided at the outlet of the tank and a two-way valve provided downstream of the pump, and adjusts the flow rate by controlling the opening and closing of the two-way valve.

	Flow rate output device	Flow rate adjustment device
	Pump	Two-way valve
Wiring connection places	1-3 of CN512 of control board (ON/OFF output)	Sub box terminal block No. 10, 11, 12

Notes on pump selection and connection

Select a pump in the same way as for a system with a three-way valve.

Notes on two-way valve selection and connection

- Use a valve that is capable of adjusting the flow rate with a 0 to 10 V input.
- Calculate the Cv value and select a valve that supports an appropriate rate.
- Select a valve of which the ratio of the maximum flow rate and the minimum flow rate will be at least 1:10.
- There are various kinds of two-way valve (such as ball valve, butterfly valve, and globe valve), and there are valves suitable for flow rate adjustment and valves that are not suitable for flow rate adjustment. Therefore be sure to select a two-way valve of a kind capable of precisely controlling the flow rate, such as a butterfly valve or globe valve.
- Place the two-way valve downstream of the pump.
- Carefully read the instruction manual and use the two-way valve in accordance with the usage procedures.

3. System using an inverter

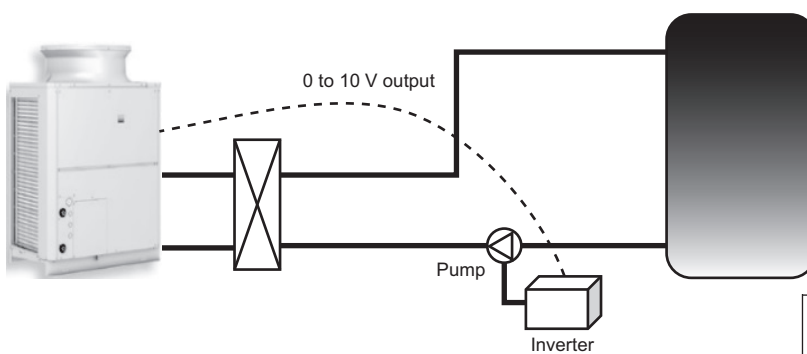

Overview of system

This system has a pump provided at the outlet of the tank and an inverter connected to the pump, and adjusts the flow rate by changing the frequency of the inverter.

	Flow rate output device	Flow rate adjustment device
	Pump	Inverter
Wiring connection places	-	Sub box terminal block No. 10, 11, 12

Notes on pump selection and connection

Select a pump in basically the same way as for a system with a three-way valve or two-way valve.

- Select a pump that can be used also at a low frequency (6 Hz or less).  
(The motor may be seized depending on the pump selected as this control is performed at a low frequency.)
- Select a pump of which flow rate at 100% output is between 20 to 30 l/min.

Notes on inverter selection and connection

- The inverter needs to be able to adjust output with a 0 to 10 V input.
- Select an inverter that will not cause the seizing of the motor.
- Configure the settings so that the flow rate on the secondary side will become 0 l/min when the unit is not operating.
- Carefully read the instruction manual and use the inverter in accordance with the usage procedures.

## 4. System Design

### 4-2-5. When connecting multiple units

To connect multiple units, configure one secondary side circuit system for each unit as shown in the figure below.  
(Install a heat exchanger, flow sensor, and thermistor for each unit.)

\* The system shown on the right cannot be configured when Secondary circuit kit Q-1SCK is used. When not using Secondary circuit kit Q-1SCK, the system shown on the right is possible.

QAHV-N-YA-HPB

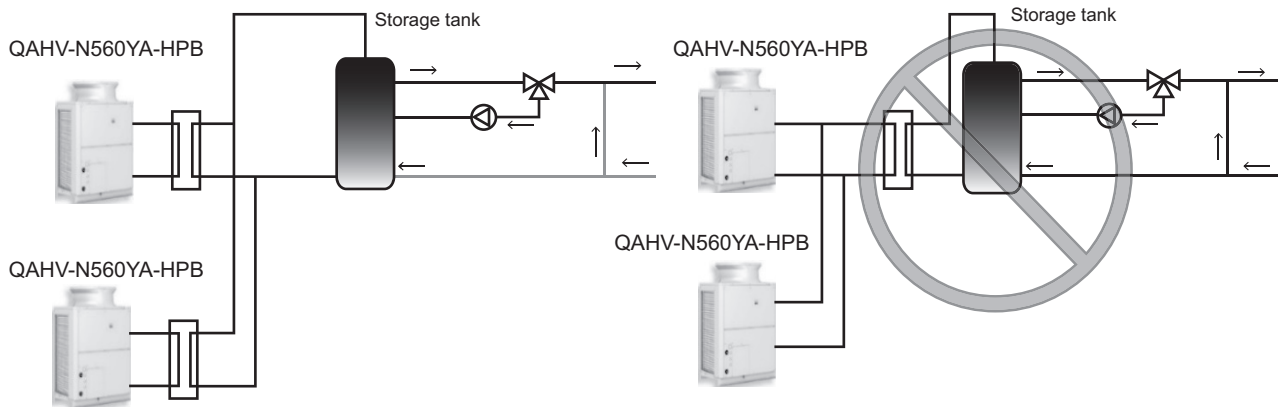

## 5. Wiring Design

### 5-1. System Configurations

#### 1. Types of control cables

Control cable wiring	Remote controller cable	Size	0.3 - 1.25 mm <sup>2</sup> (Max. 200 m total) *2
		Recommended cable types	CVV
	M-NET cable between units *1	Size	More than 1.25 mm <sup>2</sup> (Max. 120 m total)
		Recommended cable types	Shielding wire CVVS, CPEVS or MVVS
	External input wire size		Min. 0.3 mm <sup>2</sup>
External output wire size		1.25 mm <sup>2</sup>	

\*1. Use a CVVS or CPEVS cable (Max. total length of 200 m) if there is a source of electrical interference near by (e.g., factory) or the total length of control wiring exceeds 120 m.

\*2. When the wiring length exceeds 10 m, use wire of 1.25 mm<sup>2</sup>.

#### 2. System Configuration

##### (1) Individual system

\* Each unit is operated individually by connecting a dry contact switch/relay to each unit.

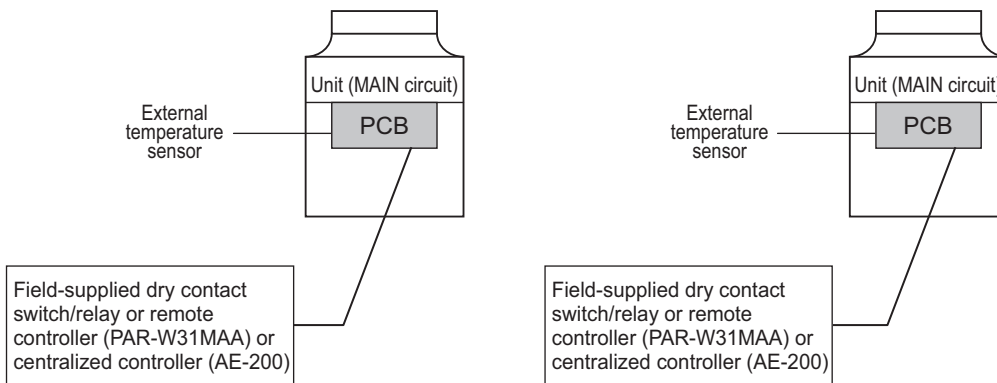

##### (2) Multiple system (2-16 units)

\* A group of unit that consists of one main unit and up to 15 sub units is operated collectively by connecting an external water temperature sensor and a dry contact switch/relay to the main unit.

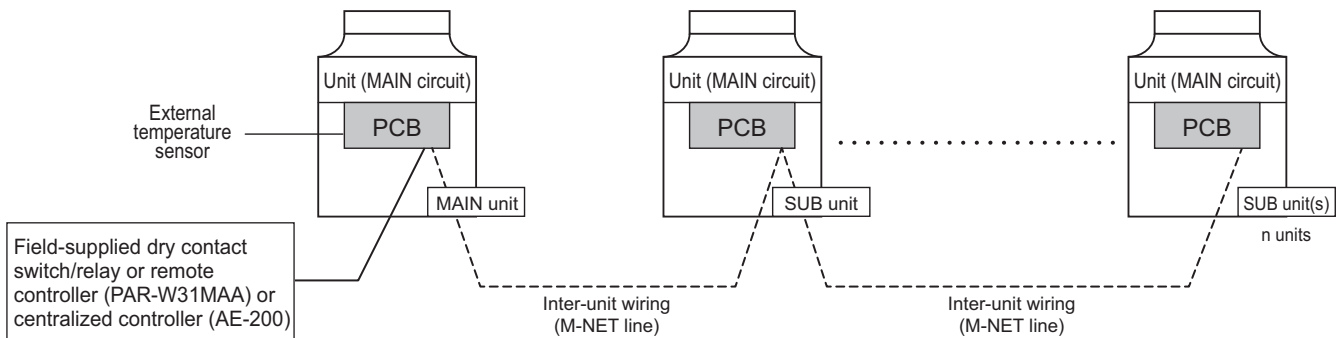

## 5. Wiring Design

### 5-2. Electrical Wiring Installation

#### 5-2-1. Main Power Supply Wiring and Switch Capacity

Schematic Drawing of Wiring (Example)

- <A> Switch (with current breaking capability)
- <B> Current leakage breaker
- <C> Outdoor unit

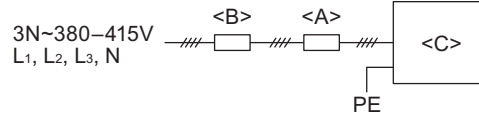

Main power supply wire size, switch capacities, and system impedance

Model	Minimum wire thickness (mm <sup>2</sup> )			Current leakage breaker	Local switch (A)		No-fuse breaker (A)	Max. Permissible System Impedance
	Main cable	Branch	Ground		Capacity	Fuse		
QAHV-N560YA-HPB	10	-	10	63 A 100 mA 0.1 sec. or less	63	63	63	0.21 Ω

- 1) Use a dedicated power supply for each unit. Ensure that each unit is wired individually.
- 2) When installing wiring, consider ambient conditions (e.g., temperature, sunlight, rain).
- 3) The wire size is the minimum value for metal conduit wiring. If voltage drop is a problem, use a wire that is one size thicker. Make sure the power-supply voltage does not drop more than 10%.
- 4) Specific wiring requirements should adhere to the wiring regulations of the region.
- 5) Power supply cords of appliances for outdoor use shall not be lighter than polychloroprene sheathed flexible cord (design 60245 IEC57).
- 6) A switch with at least 3 mm contact separation in each pole shall be provided by the Air Conditioner installer.
- 7) Do not install a phase advancing capacitor on the motor. Doing so may damage the capacitor and result in fire.
- 8) Depending on the installation conditions (power-supply imbalance, etc.), the amount of current may increase. Select a breaker with proper capacity to suit the local usage conditions.

#### ⚠ WARNING

- ◆ Be sure to use specified wires and ensure no external force is imparted to terminal connections. Loose connections may cause overheating and fire.
- ◆ Be sure to use the appropriate type of overcurrent protection switch. Note that overcurrent may include direct current.

#### ⚠ CAUTION

- ◆ Some installation sites may require an installation of an earth leakage breaker for the inverter. If no earth leakage breaker is installed, there is a danger of electric shock.
- ◆ Only use properly rated breakers and fuses. Using a fuse or wire of the wrong capacity may cause malfunction or fire.

#### Note

- ◆ This device is intended for the connection to a power supply system with a maximum permissible system impedance shown in the above table at the interface point (power service box) of the user's supply.
- ◆ Ensure that this device is connected only to a power supply system that fulfills the requirements above. If necessary, consult the public power supply company for the system impedance at the interface point.
- ◆ This equipment complies with IEC 61000-3-12 provided that the short-circuit power  $S_{sc}$  is greater than or equal to  $S_{sc}(*2)$  at the interface point between the user's supply and the public system. It is the responsibility of the installer or user of the equipment to ensure, in consultation with the distribution network operator if necessary, that the equipment is connected only to a supply with a short-circuit power  $S_{sc}$  greater than or equal to  $S_{sc}(*2)$ .

$S_{sc}(*2)$

$S_{sc}$ (MVA)
2.62 Ω

## 5. Wiring Design

### 5-2-2. Cable Connections

#### 1. Schematic Diagram of a Unit and Terminal Block Arrangement

To remove the front panel of the control box, unscrew the four screws and pull the panel forward and then down.

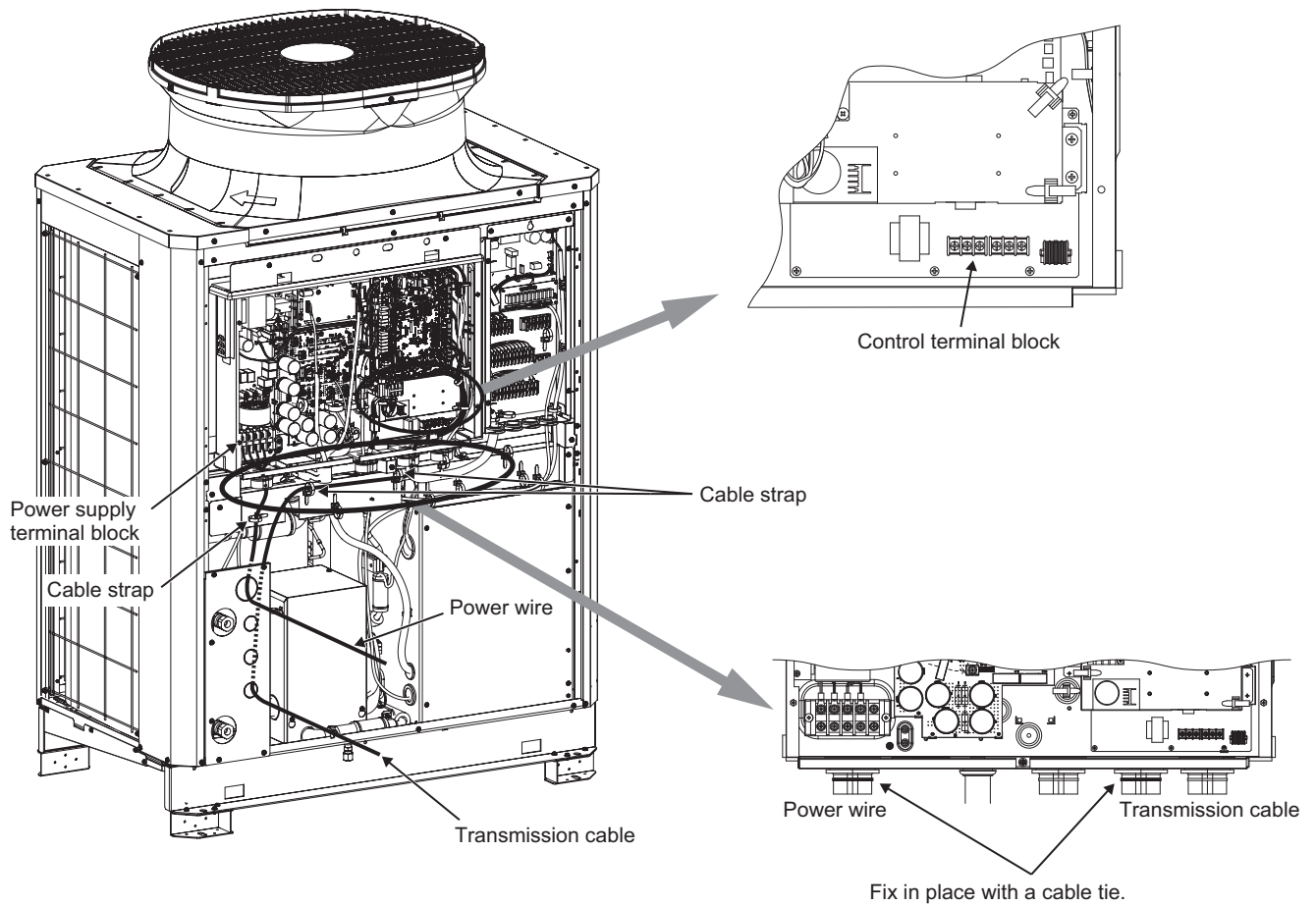

**Important:** Power supply cables larger than 25 mm<sup>2</sup> in diameter are not connectable to the power supply terminal block (TB2). Use a pull box to connect them.

#### 2. Installing the conduit tube

- Punch out the knockout hole for wire routing at the bottom of the front panel with a hammer.
- When putting wires through knockout holes without protecting them with a conduit tube, deburr the holes and protect the wires with protective tape.
- If damage from animals is a concern, use a conduit tube to narrow the opening.

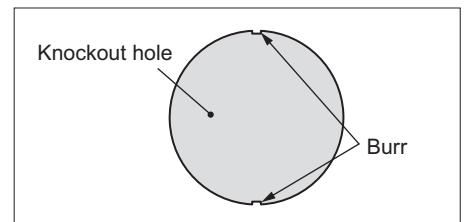



## 5. Wiring Design

Note:

- Make sure the cables are not coming out of the rubber bushing cut.

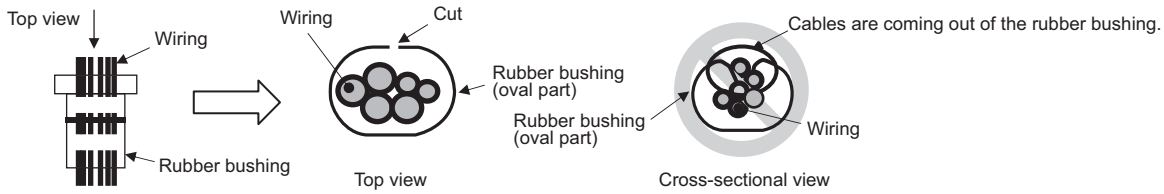

- When threading the wiring through the rubber bushing, make sure the rubber bushing will not come off the sheet metal on the control box guard.

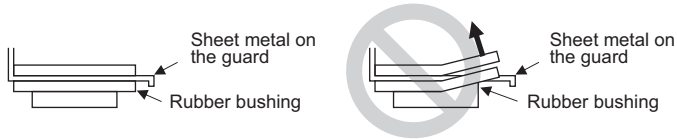

- When tying the supplied tie band around the rubber bushing, make sure to leave no gap between the ends.

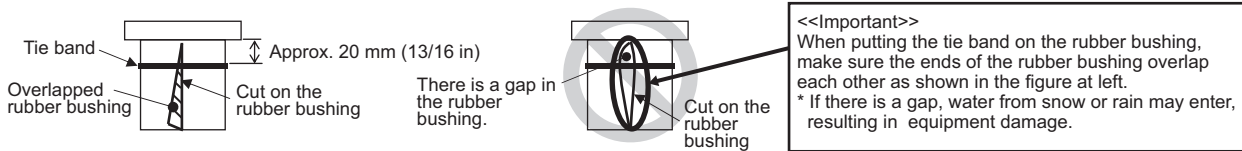

A power wire exceeding the specified power wire thickness cannot be connected to the power terminal block (TB2).

Use a separate pull box.

To ensure that the transmission cable is not affected by electrical noise from the power cable, route the power cable away from the transmission cable (distance of at least 5 cm).

## 6. Controller

### 6-1. PAR-W31MAA specifications

Item	Description	Operations	Display
ON/OFF	Runs and stops the operation of a group of units	○	○
Operation mode switching	Switches between Mode 1/Mode 2/Mode 3 * Available operation modes vary depending on the unit to be connected. * Switching limit setting can be made via a remote controller.	○	○
Water temperature setting	Temperature can be set within the ranges below. (in increments of 0.5°C or 0.5°F) 40°C ~ 90°C * The settable range varies depending on the unit to be connected.	○	○
Water temperature display	10°C ~ 90°C (in increments of 0.5°C or 0.5°F) * The settable range varies depending on the unit to be connected.	×	○
Permit/Prohibit local operation	Individually prohibits operations of each local remote control function: ON/OFF, Operation modes, water temperature setting, Circulating water replacement warning reset. * Upper level controller may not be connected depending on the unit to be connected.	×	○
Weekly scheduler	ON/OFF/Water temperature setting can be done up to 8 times one day in the week. (in increments of a minute)	○	○
Error	When an error is currently occurring on a unit, the afflicted unit and the error code are displayed.	×	○
Self check (Error history)	Searches the latest error history by selecting "CHECK" from the Main menu.	○	○
LANGUAGE setting	The language on the dot matrix LCD can be changed. (11 languages) English/French/German/Swedish/Spanish/Italian/Danish/Dutch/Finnish /Norwegian/Portuguese	○	○

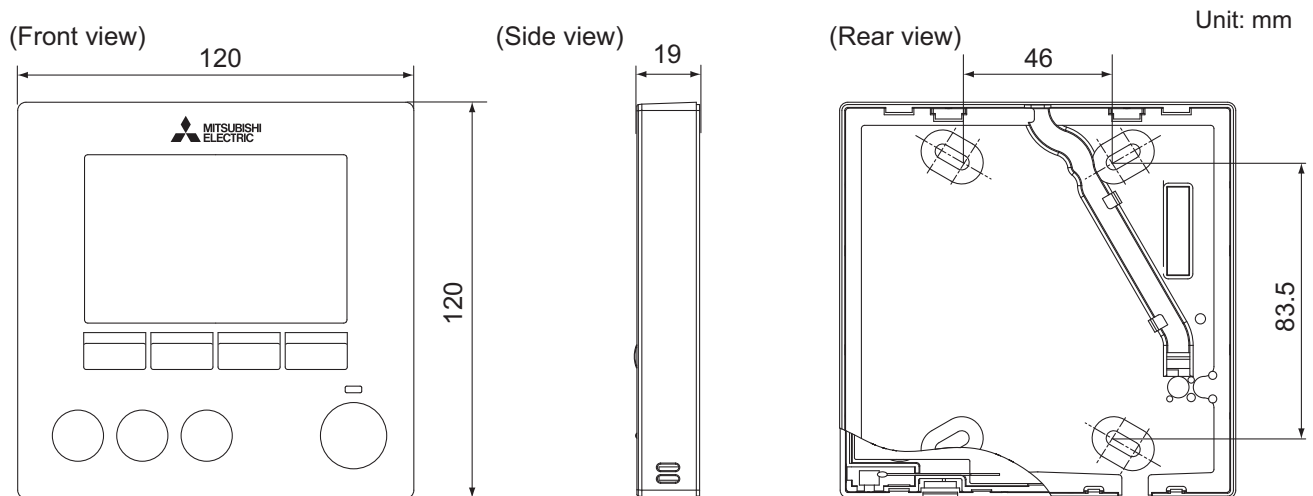



**⚠ Warning**

- Do not use refrigerant other than the type indicated in the manuals provided with the unit and on the nameplate.
  - Doing so may cause the unit or pipes to burst, or result in explosion or fire during use, repair, or at the time of disposal of the unit.
  - It may also be in violation of applicable laws.
  - MITSUBISHI ELECTRIC CORPORATION cannot be held responsible for malfunctions or accidents resulting from the use of the wrong type of refrigerant.

**mitsubishi** **ELECTRIC CORPORATION**

[www.MitsubishiElectric.com](http://www.MitsubishiElectric.com)