

PARTS CATALOG

[Model Name]	[Service Ref.]
EHPT17X-VM2E	EHPT17X-VM2E.UK
EHPT17X-VM6E	EHPT17X-VM6E.UK
EHPT17X-YM9E	EHPT17X-YM9E.UK
EHPT20X-MEHEW	EHPT20X-MEHEW.UK
EHPT20X-TM9E	EHPT20X-TM9E.UK
EHPT20X-YM9E	EHPT20X-YM9E.UK
EHPT30X-YM9EE	EHPT30X-YM9EE.UK
ERPT17X-VM2E	ERPT17X-VM2E.UK
ERPT20X-VM2E	ERPT20X-VM2E.UK
ERPT20X-VM6E	ERPT20X-VM6E.UK
ERPT20X-YM9E	ERPT20X-YM9E.UK
ERPT30X-VM2EE	ERPT30X-VM2EE.UK
ERPT30X-VM6EE	ERPT30X-VM6EE.UK
ERPT30X-YM9EE	ERPT30X-YM9EE.UK

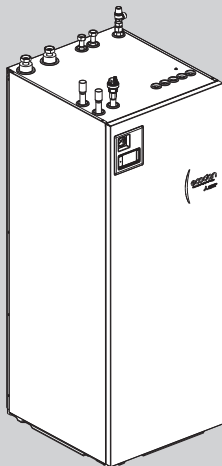
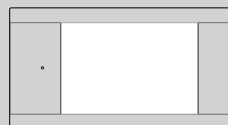

CYLINDER UNIT

 MAIN REMOTE
CONTROLLER

CONTENTS

1. SERVICE PARTS LIST 2
2. OPTIONAL PARTS 20

SERVICE MANUAL (OCH814)

EHPT17X-VM2E.UK
ERPT17X-VM2E.UK

EHPT17X-VM6E.UK

EHPT17X-YM9E.UK

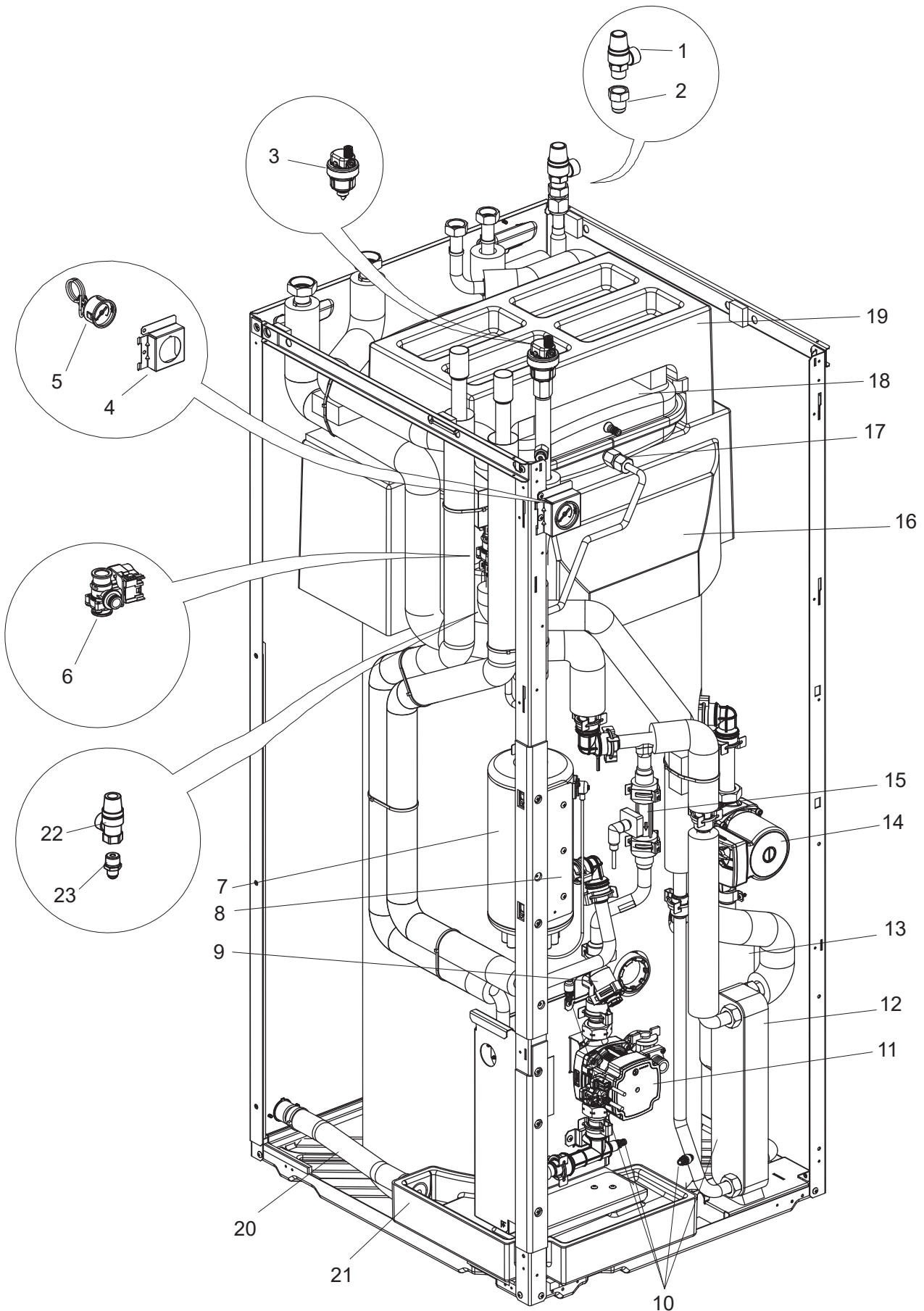

1. The part quantity below indicates the required number of pieces per unit.
2. The circled No. indicates that the part is not shown in the figure.

No.	Parts No.	Parts name	EHPT17X-VM2E.UK	EHPT17X-VM6E.UK	EHPT17X-VM9E.UK	ERPT17X-VM2E.UK	Wiring Diagram Symbol	Remarks [Drawing No.]
1	S70 C30 404	PRESSURE RELIEF VALVE	1	1	1	1		10 bar/ for sanitary side
2	S70 C70 096	FLARE JOINT	1	1	1	1		5/8F-R1/2
3	S70 C18 150	AIR VENT (AUTOMATIC)	1	1	1	1		
4	S70 C80 206	MANOMETER STAY	1	1	1	1		
5	S70 C20 205	MANOMETER	1	1	1	1		
6	S70 C34 406	3WAY VALVE	1	1	1	1		Small
7	S70 C42 441	BOOSTER HEATER	1			1	BH1	
7	S70 C43 441	BOOSTER HEATER		1			BH1, BH2	
7	S70 C44 441	BOOSTER HEATER			1		BH1, BH2	
8	—	BOOSTER HEATER STAY	1	1		1		[RK00L196G02]
8	—	BOOSTER HEATER STAY			1			[RK00B922G02]
9	S70 C01 452	MAGNETIC FILTER	1	1	1	1		
10	S70 C11 358	DRAIN COCK/AIR VENT (WATER CAP ASSY 320)	4	4	4	4		For primary/sanitary circuit
11	S70 C11 355	WATER PUMP	1	1	1		MP1	For primary circuit
11	S70 C13 355	WATER PUMP				1	MP1	For primary circuit
12	S70 C03 408	WATER COIL ASSY (W)	1	1	1	1		Water/water
13	S70 C60 357	SCALE TRAP	1	1	1	1		
14	S70 C05 355	WATER PUMP	1	1	1	1	MP4	For sanitary circuit
15	S70 C74 266	FLOW SENSOR (BODY & CABLE)	1	1	1	1		
16	—	TANK CUSHION TOP	1	1	1	1		[DX25A644G01]
17	S70 C50 096	FLARE JOINT	1	1	1	1		3/8F-G3/8
18	S70 C15 402	EXPANSION VESSEL	1	1	1	1		12L
19	—	EXPANSION VESSEL CUSHION	1	1	1	1		[RK00L660G01]
20	S70 C10 527	DRAIN HOSE				1		
21	—	DRAIN PAN ASSY				1		[RK00A988G04]
22	S70 C40 404	PRESSURE RELIEF VALVE 5 BAR	1	1	1	1		5 bar
23	S70 C60 096	JOINT (PRESSURE RELIEF VALVE)	1	1	1	1		3/8F-R1/2
24	S70 C45 097	ADJUST BOLT	4	4	4	4		Accessory
25	S70 C26 460	O-RING	2	2	2	2		Black/for flow sensor, 3way valve (large)
26	S70 C55 460	GASKET 1"	6	6	6	6		For connection of water circuit
27	S70 C66 460	GASKET 3/4"	9	9	9	9		For connection of water circuit
28	S70 C88 460	GASKET 1/4"	1	1	1	1		For only manometer
29	S70 C23 460	O-RING	14	14	14	14		Black
30	S70 C01 800	GREASE	1*	1*	1*	1*		For quick connection
31	S70 C40 465	FASTENER	4	4	4	4		For 3way valve(small), tank
32	S70 C20 465	FASTENER	2	2	2	2		For flow sensor, 3way valve (large)
33	S70 C12 202	THERMISTOR (FLOW WATER TEMP & RETURN WATER TEMP)	1	1	1	1	THW 1/2	
34	S70 C10 465	FASTENER	13	13	13	13		For quick connection
35	S70 C30 460	O-RING	4	4	4	4		Black/for 3way valve (small), tank
36	S70 C77 460	GASKET 3/8"	1	1	1	1		For only expansion vessel

Do not reuse the O-ring or gasket that was once removed, but be sure to replace with a new one.
 * Apply grease appropriately on the O-ring for the quick connection in the unit.

EHPT20X-YM9E.UK
ERPT20X-VM6E.UK

EHPT20X-TM9E.UK
ERPT20X-YM9E.UK

ERPT20X-VM2E.UK

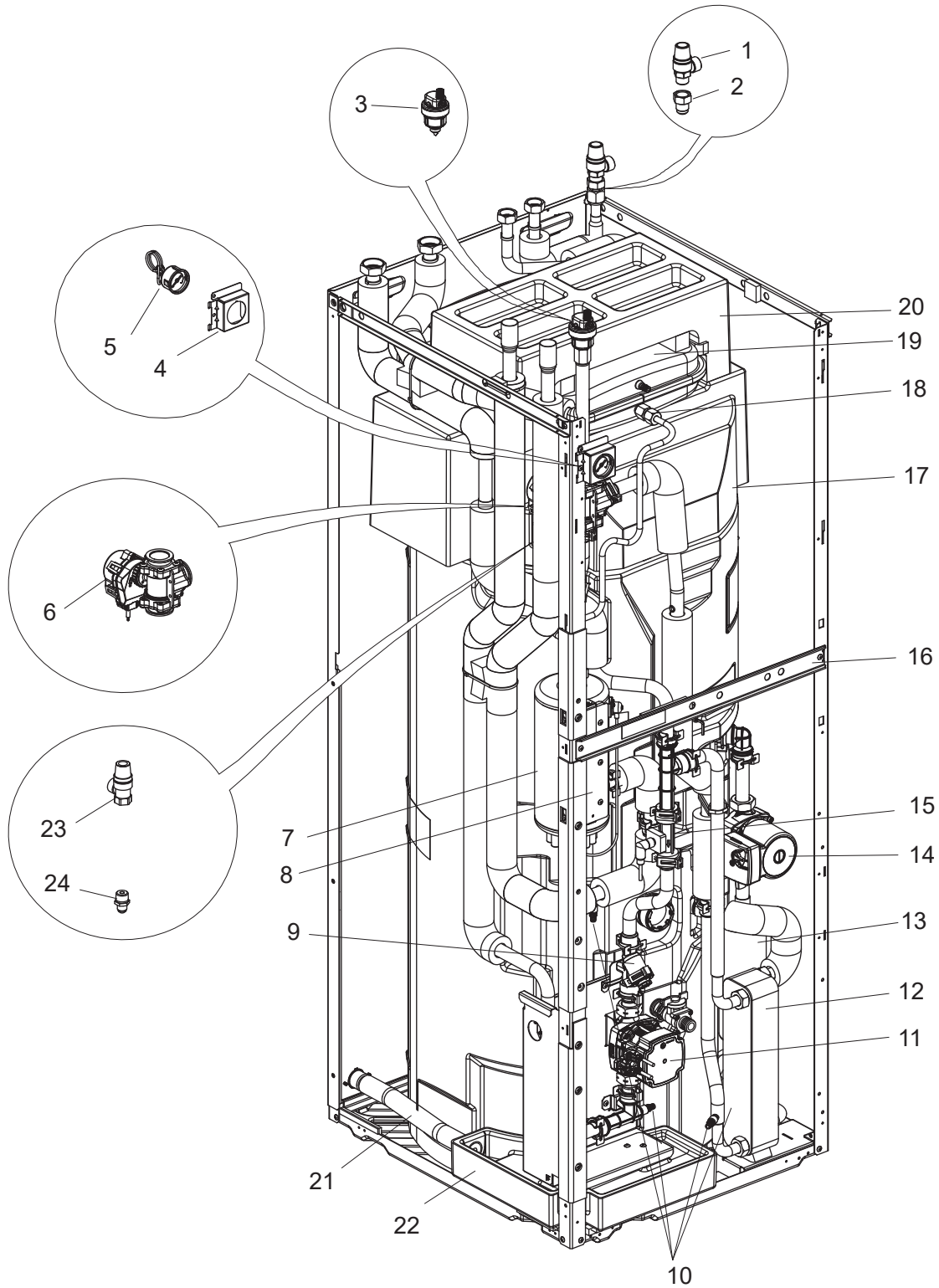

1. The part quantity below indicates the required number of pieces per unit.
2. The circled No. indicates that the part is not shown in the figure.

No.	Parts No.	Parts name	EHPT20X-VM9E.UK	EHPT20X-TM9E.UK	ERPT20X-V2ME.UK	ERPT20X-VM6E.UK	ERPT20X-VM9E.UK	Wiring Diagram Symbol	Remarks [Drawing No.]
1	S70 C30 404	PRESSURE RELIEF VALVE	1	1	1	1	1		10 bar/ for sanitary side
2	S70 C70 096	FLARE JOINT	1	1	1	1	1		5/8F-R1/2
3	S70 C18 150	AIR VENT (AUTOMATIC)	1	1	1	1	1		
4	S70 C80 206	MANOMETER STAY	1	1	1	1	1		
5	S70 C20 205	MANOMETER	1	1	1	1	1		
6	S70 C35 406	3WAY VALVE	1	1	1	1	1		5HP
7	S70 C42 441	BOOSTER HEATER			1			BH1	
7	S70 C43 441	BOOSTER HEATER				1		BH1, BH2	
7	S70 C44 441	BOOSTER HEATER	1				1	BH1, BH2	
7	S70 C45 441	BOOSTER HEATER		1				BH1, BH2	
8	—	BOOSTER HEATER STAY			1	1			[RK00L196G02]
8	—	BOOSTER HEATER STAY	1	1			1		[RK00B922G02]
9	S70 C01 452	MAGNETIC FILTER	1	1	1	1	1		
10	S70 C11 358	DRAIN COCK/AIR VENT (WATER CAP ASSY 320)	4	4	4	4	4		For primary/sanitary circuit
11	S70 C11 355	WATER PUMP	1	1				MP1	For primary circuit
11	S70 C13 355	WATER PUMP			1	1	1	MP1	For primary circuit
12	S70 C02 408	WATER COIL ASSY (W)	1	1	1	1	1		Water/water
13	S70 C60 357	SCALE TRAP	1	1	1	1	1		
14	S70 C05 355	WATER PUMP	1	1	1	1	1	MP4	For sanitary circuit
15	S70 C74 266	FLOW SENSOR (BODY & CABLE)	1	1	1	1	1		
16	—	DIV FRAME ASSY	1	1	1	1	1		[JQ00C373G01]
17	—	TANK CUSHION TOP	1	1	1	1	1		[DX25A644G01]
18	S70 C50 096	FLARE JOINT	1	1	1	1	1		3/8F-G3/8
19	S70 C15 402	EXPANSION VESSEL	1	1	1	1	1		12L
20	—	EXPANSION VESSEL CUSHION	1	1	1	1	1		[RK00L660G01]
21	S70 C10 527	DRAIN HOSE			1	1	1		
22	—	DRAIN PAN ASSY			1	1	1		[RK00A988G04]
23	S70 C40 404	PRESSURE RELIEF VALVE 5 BAR	1	1	1	1	1		5 bar
24	S70 C60 096	JOINT (PRESSURE RELIEF VALVE)	1	1	1	1	1		3/8F-R1/2
(25)	S70 C45 097	ADJUST BOLT	4	4	4	4	4		Accessory
(26)	S70 C26 460	O-RING	5	5	5	5	5		Black/for flow sensor, 3way valve (large)
(27)	S70 C55 460	GASKET 1"	6	6	6	6	6		For connection of water circuit
(28)	S70 C66 460	GASKET 3/4"	9	9	9	9	9		For connection of water circuit
(29)	S70 C88 460	GASKET 1/4"	1	1	1	1	1		For only manometer
(30)	S70 C23 460	O-RING	13	13	13	13	13		Black
(31)	S70 C01 800	GREASE	1*	1*	1*	1*	1*		For quick connection
(32)	S70 C40 465	FASTENER	1	1	1	1	1		For 3way valve(small), tank
(33)	S70 C20 465	FASTENER	5	5	5	5	5		For flow sensor, 3way valve (large)
(34)	S70 C12 202	THERMISTOR (FLOW WATER TEMP & RETURN WATER TEMP)	1	1	1	1	1	THW 1/2	
(35)	S70 C10 465	FASTENER	12	12	12	12	12		For quick connection
(36)	S70 C30 460	O-RING	1	1	1	1	1		Black/for 3way valve (small), tank
(37)	S70 C77 460	GASKET 3/8"	1	1	1	1	1		For only expansion vessel

Do not reuse the O-ring or gasket that was once removed, but be sure to replace with a new one.
 * Apply grease appropriately on the O-ring for the quick connection in the unit.

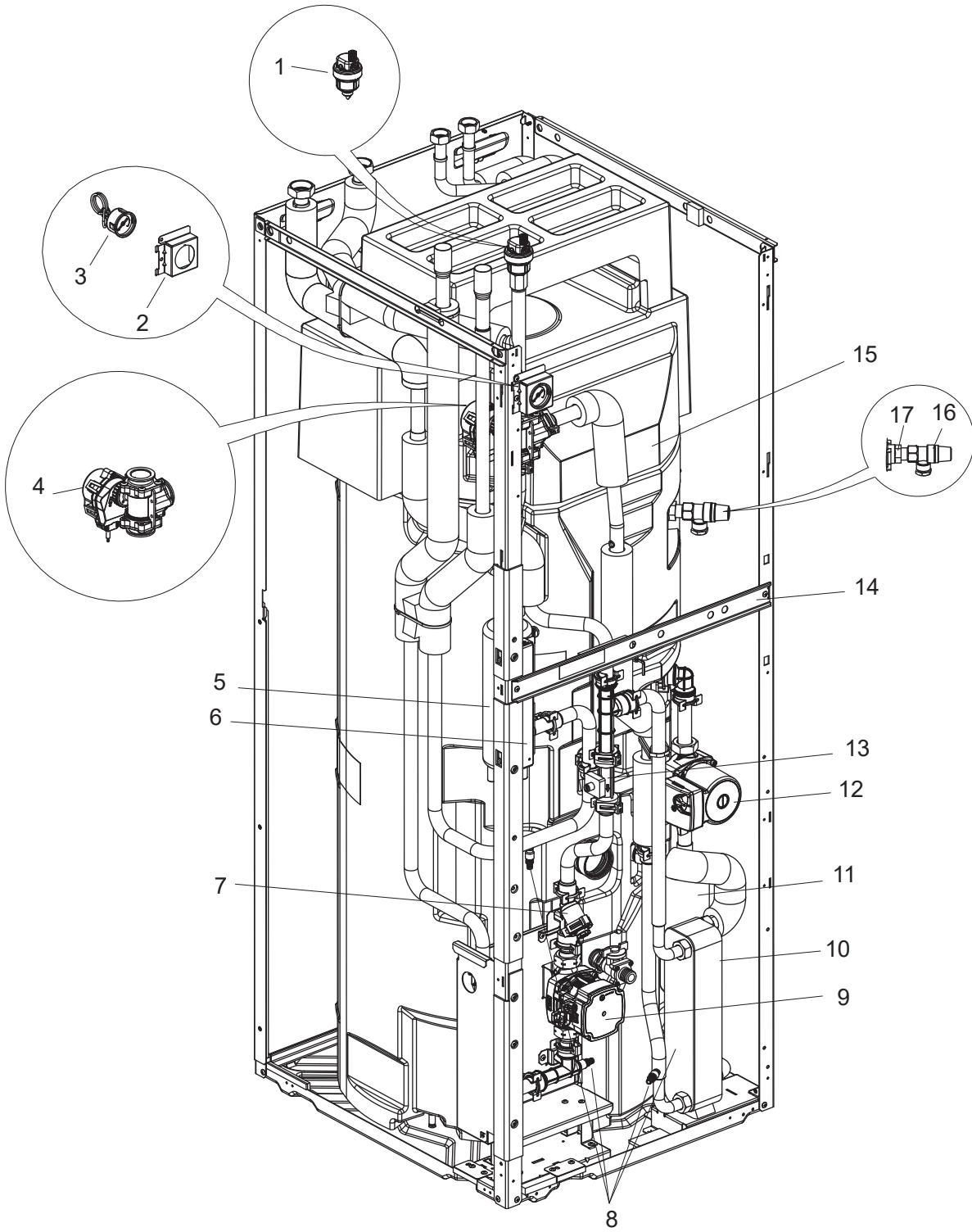

1. The part quantity below indicates the required number of pieces per unit.
2. The circled No. indicates that the part is not shown in the figure.

No.	Parts No.	Parts name	EHP20X-MEHEW.UK	Wiring Diagram Symbol	Remarks [Drawing No.]
1	S70 C18 150	AIR VENT (AUTOMATIC)	1		
2	S70 C80 206	MANOMETER STAY	1		
3	S70 C20 205	MANOMETER	1		
4	S70 C35 406	3WAY VALVE	1		5HP
5	S70 C41 441	BOOSTER HEATER	1		
6	—	BOOSTER HEATER STAY	1		[RK00L196G02]
7	S70 C01 452	MAGNETIC FILTER	1		
8	S70 C11 358	DRAIN COCK/AIR VENT (WATER CAP ASSY 320)	4		For primary/sanitary circuit
9	S70 C11 355	WATER PUMP	1	MP1	For primary circuit
10	S70 C02 408	WATER COIL ASSY (W)	1		Water/water
11	S70 C60 357	SCALE TRAP	1		
12	S70 C05 355	WATER PUMP	1	MP4	For sanitary circuit
13	S70 C74 266	FLOW SENSOR (BODY & CABLE)	1		
14	—	DIV FRAME ASSY	1		[JQ00C373G01]
15	—	TANK CUSHION TOP	1		[DX25A644G01]
16	S70 C19 404	TEMPERATURE AND PRESSURE RELIEF VALVE	1		90°C/ 7bar, for tank
17	S70 C20 405	JOINT (TEMPERATURE AND PRESSURE RELIEF VALVE)	1		
18	S70 C45 097	ADJUST BOLT	4		Accessory
19	S70 C26 460	O-RING	5		Black/for flow sensor, 3way valve (large)
20	S70 C55 460	GASKET 1"	4		For connection of water circuit
21	S70 C66 460	GASKET 3/4"	2		For connection of water circuit
22	S70 C88 460	GASKET 1/4"	1		for only manometer
23	S70 C23 460	O-RING	11		Black
24	S70 C01 800	GREASE	1*		For quick connection
25	S70 C40 465	FASTENER	1		For 3way valve(small), tank
26	S70 C20 465	FASTENER	5		For flow sensor, 3way valve (large)
27	S70 C12 202	THERMISTOR (FLOW WATER TEMP & RETURN WATER TEMP)	1	THW1/2	
28	S70 C10 465	FASTENER	13		For quick connection
29	S70 C20 460	O-RING	1		Red/for temperature and pressure relief valve
30	S70 G20 460	PACKING WASHER 1"	2		For sanitary side of UK model
31	S70 C25 460	PACKING WASHER 3/4"	7		For sanitary side of UK model
32	S70 C27 460	O-RING	3		Orange/ for sanitary side of UK model

Do not reuse the O-ring or gasket that was once removed, but be sure to replace with a new one.
 * Apply grease appropriately on the O-ring for the quick connection in the unit.

EHPT30X-YM9EE.UK
ERPT30X-YM9EE.UK

ERPT30X-VM2EE.UK

ERPT30X-VM6EE.UK

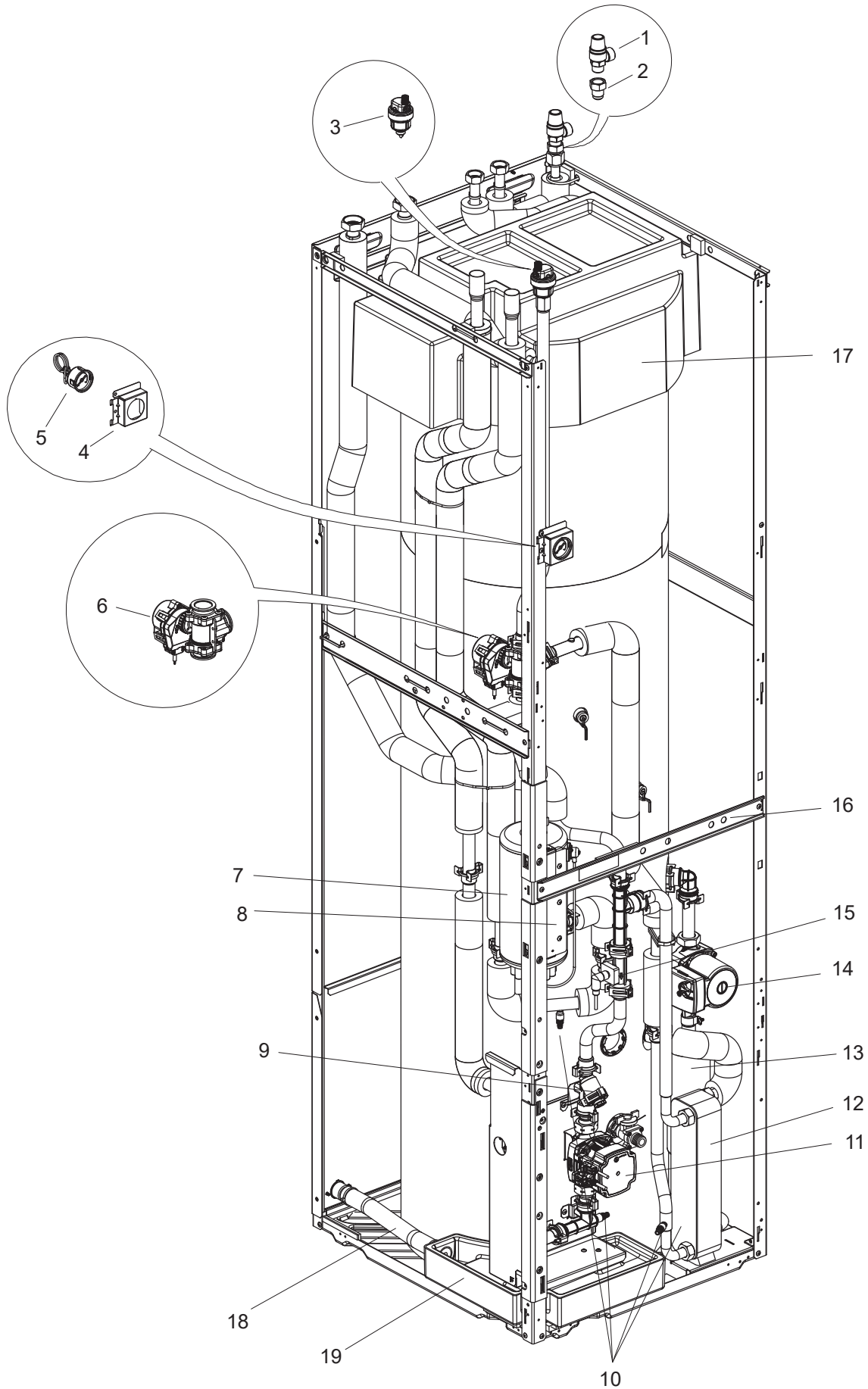

1. The part quantity below indicates the required number of pieces per unit.
 2. The circled No. indicates that the part is not shown in the figure.

No.	Parts No.	Parts name	EHPT30X-VM9EE.UK	ERPT30X-VM2EE.UK	ERPT30X-VM6EE.UK	ERPT30X-VM9EE.UK	Wiring Diagram Symbol	Remarks [Drawing No.]
1	S70 C30 404	PRESSURE RELIEF VALVE	1	1	1	1		10 bar/ For sanitary side
2	S70 C70 096	FLARE JOINT	1	1	1	1		5/8F-R1/2
3	S70 C18 150	AIR VENT (AUTOMATIC)	1	1	1	1		
4	S70 C80 206	MANOMETER STAY	1	1	1	1		
5	S70 C20 205	MANOMETER	1	1	1	1		
6	S70 C35 406	3WAY VALVE	1	1	1	1		5HP
7	S70 C42 441	BOOSTER HEATER		1			BH1	
7	S70 C43 441	BOOSTER HEATER			1		BH1, BH2	
7	S70 C44 441	BOOSTER HEATER	1			1	BH1, BH2	
8	—	BOOSTER HEATER STAY		1	1			[RK00L196G02]
8	—	BOOSTER HEATER STAY	1			1		[RK00B922G02]
9	S70 C01 452	MAGNETIC FILTER	1	1	1	1		
10	S70 C11 358	DRAIN COCK/AIR VENT (WATER CAP ASSY 320)	4	4	4	4		For primary/sanitary circuit
11	S70 C11 355	WATER PUMP	1				MP1	For primary circuit
11	S70 C13 355	WATER PUMP		1	1	1	MP1	For primary circuit
12	S70 C02 408	WATER COIL ASSY (W)	1	1	1	1		Water/water
13	S70 C60 357	SCALE TRAP	1	1	1	1		
14	S70 C05 355	WATER PUMP	1	1	1	1	MP4	For sanitary circuit
15	S70 C74 266	FLOW SENSOR (BODY & CABLE)	1	1	1	1		
16	—	DIV FRAME ASSY	1	1	1	1		[JQ00C373G01]
17	—	TANK CUSHION TOP	1	1	1	1		[RK25A412G02]
18	S70 C10 527	DRAIN HOSE		1	1	1		
19	—	DRAIN PAN ASSY		1	1	1		[RK00A988G04]
20	S70 C45 097	ADJUST BOLT	4	4	4	4		Accessory
21	S70 C26 460	O-RING	5	5	5	5		Black/for flow sensor, 3way valve (large)
22	S70 C55 460	GASKET 1"	6	6	6	6		For connection of water circuit
23	S70 C66 460	GASKET 3/4"	9	9	9	9		For connection of water circuit
24	S70 C88 460	GASKET 1/4"	1	1	1	1		For only manometer
25	S70 C23 460	O-RING	17	17	17	17		Black
26	S70 C01 800	GREASE	1*	1*	1*	1*		For quick connection
27	S70 C40 465	FASTENER	1	1	1	1		For 3way valve(small), tank
28	S70 C20 465	FASTENER	5	5	5	5		For flow sensor, 3way valve (large)
29	S70 C12 202	THERMISTOR (FLOW WATER TEMP & RETURN WATER TEMP)	1	1	1	1	THW1/2	
30	S70 C10 465	FASTENER	16	16	16	16		For quick connection
31	S70 C30 460	O-RING	1	1	1	1		Black/for 3way valve (small), tank

Do not reuse the O-ring or gasket that was once removed, but be sure to replace with a new one.
 * Apply grease appropriately on the O-ring for the quick connection in the unit.

EHPT17X-VM2E.UK
ERPT17X-VM2E.UK

EHPT17X-VM6E.UK

EHPT17X-YM9E.UK

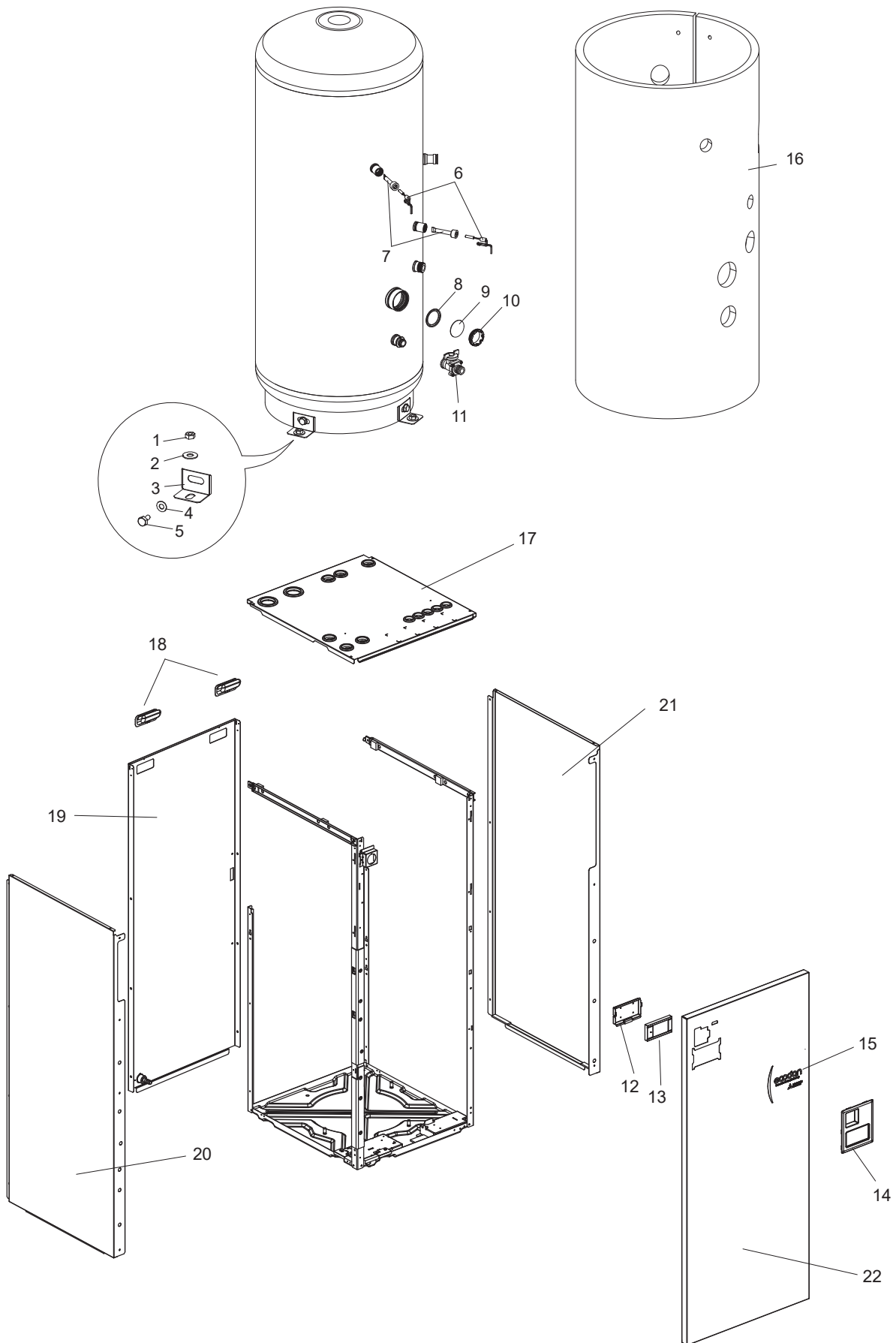

1. The part quantity below indicates the required number of pieces per unit.
2. The circled No. indicates that the part is not shown in the figure.

No.	Parts No.	Parts name	EHPT17X-VM2E.UK	EHPT17X-VM6E.UK	EHPT17X-VM9E.UK	ERPT17X-VM2E.UK	Wiring Diagram Symbol	Remarks [Drawing No.]
1	S70 C10 097	NUT	3	3	3	3		
2	S70 C61 097	WASHER	3	3	3	3		
3	S70 C30 042	TANK LEG	3	3	3	3		
4	S70 C20 097	WASHER	3	3	3	3		
5	S70 C30 097	BOLT	3	3	3	3		
6	S70 C68 202	THERMISTOR (TANK WATER TEMP)	1	1	1	1	THW5	
7	S70 C11 525	STAT POCKET ASSEMBLY	2	2	2	2		
8	S70 C33 460	ELEMENT PLATE GASKET	1	1	1	1		
9	S70 C40 446	BLANKING PLATE	1	1	1	1		For tank
10	S70 C60 097	BACKNUT	1	1	1	1		
11	S70 C40 357	DRAIN COCK	1	1	1	1		For tank
12	S70 C10 711	MAIN REMOTE CONTROLLER SUPPORT	1	1	1	1		
13	S70 C81 200	MAIN REMOTE CONTROLLER ASSY	1	1	1	1		
14	S70 C41 710	MAIN REMOTE CONTROLLER HOLDER	1	1	1	1		
15	S70 C40 699	BRAND LABEL	1	1	1	1		
16	S70 C65 042	TANK INSLATOR	1	1	1	1		
17	S70 C34 641	TOP PANEL ASSY	1	1	1	1		
18	S70 30L 655	HANDLE	2	2	2	2		
19	S70 C22 661	BACK PANEL	1	1	1			
19	S70 C26 661	BACK PANEL				1		
20	S70 C67 662	SIDE PANEL L	1	1	1	1		
21	S70 C07 662	SIDE PANEL R	1	1	1	1		
22	S70 C38 668	FRONT PANEL	1	1	1	1		
(23)	S70 C33 699	WIRING DIAGRAM FOR FRONT PANEL	1			1		
(23)	S70 C34 699	WIRING DIAGRAM FOR FRONT PANEL		1				
(23)	S70 C35 699	WIRING DIAGRAM FOR FRONT PANEL			1			

EHPT20X-YM9E.UK
ERPT20X-VM6E.UK

EHPT20X-TM9E.UK
ERPT20X-YM9E.UK

ERPT20X-VM2E.UK

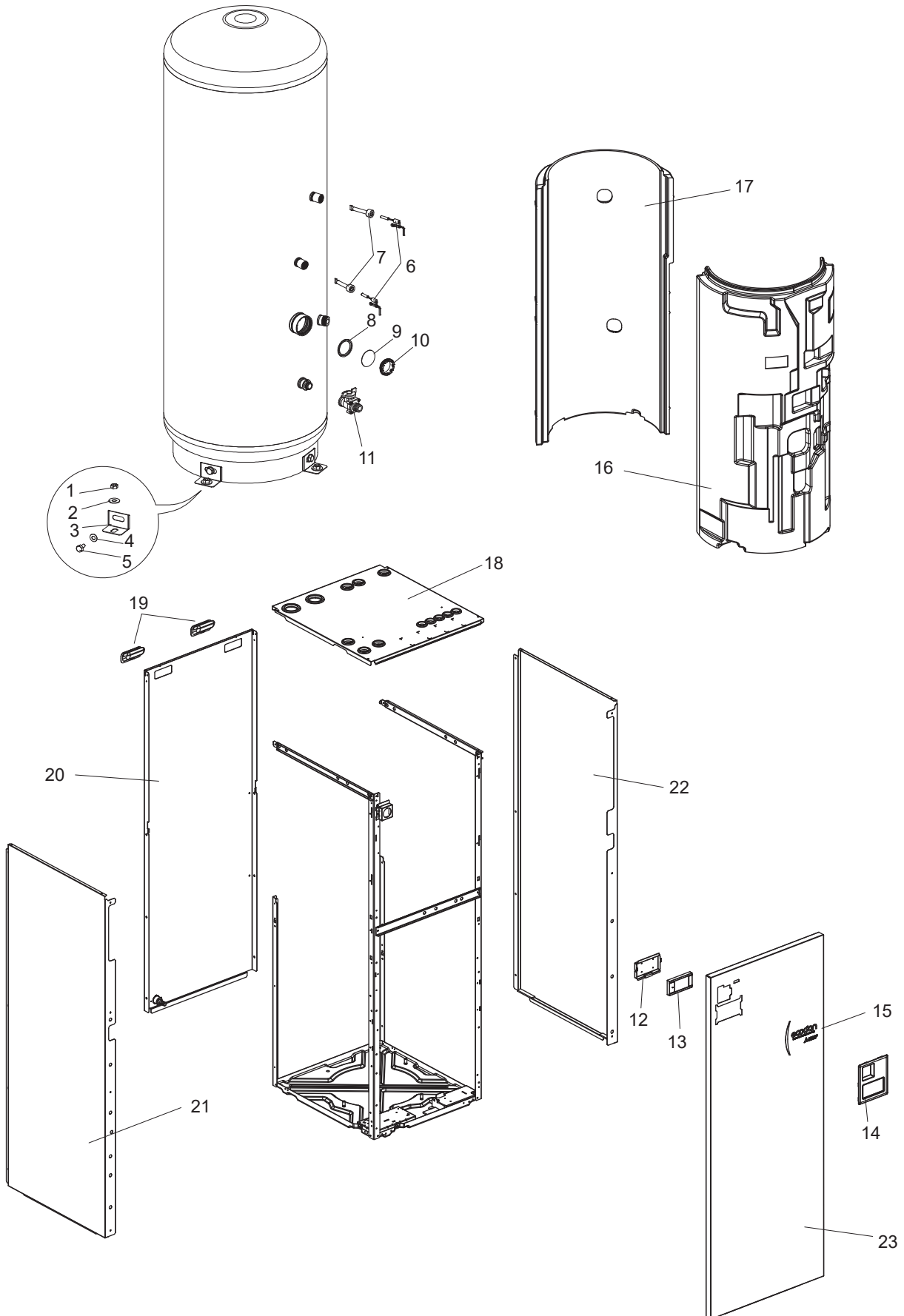

1. The part quantity below indicates the required number of pieces per unit.
2. The circled No. indicates that the part is not shown in the figure.

No.	Parts No.	Parts name						Wiring Diagram Symbol	Remarks [Drawing No.]
			EHPT20X-YM9E.UK	EHPT20X-TM9E.UK	ERPT20X-VM2E.UK	ERPT20X-VM6E.UK	ERPT20X-YM9E.UK		
1	S70 C10 097	NUT	3	3	3	3	3		
2	S70 C61 097	WASHER	3	3	3	3	3		
3	S70 C30 042	TANK LEG	3	3	3	3	3		
4	S70 C20 097	WASHER	3	3	3	3	3		
5	S70 C30 097	BOLT	3	3	3	3	3		
6	S70 C68 202	THERMISTOR (TANK WATER TEMP)	1	1	1	1	1	THW5	
7	S70 C11 525	STAT POCKET ASSEMBLY	2	2	2	2	2		
8	S70 C33 460	ELEMENT PLATE GASKET	1	1	1	1	1		
9	S70 C40 446	BLANKING PLATE	1	1	1	1	1		For tank
10	S70 C60 097	BACKNUT	1	1	1	1	1		
11	S70 C40 357	DRAIN COCK	1	1	1	1	1		For tank
12	S70 C10 711	MAIN REMOTE CONTROLLER SUPPORT	1	1	1	1	1		
13	S70 C81 200	MAIN REMOTE CONTROLLER ASSY	1	1	1	1	1		
14	S70 C41 710	MAIN REMOTE CONTROLLER HOLDER	1	1	1	1	1		
15	S70 C40 699	BRAND LABEL	1	1	1	1	1		
16	—	TANK EPS FRONT	1	1	1	1	1		[DX25A642G01]
17	—	TANK EPS BACK	1	1	1	1	1		[DX25A643G01]
18	S70 C33 641	TOP PANEL ASSY	1	1	1	1	1		
19	S70 30L 655	HANDLE	2	2	2	2	2		
20	S70 C23 661	BACK PANEL	1	1					
20	S70 C25 661	BACK PANEL			1	1	1		
21	S70 C73 662	SIDE PANEL L	1	1	1	1	1		
22	S70 C74 662	SIDE PANEL R	1	1	1	1	1		
23	S70 C39 668	FRONT PANEL	1	1	1	1	1		
(24)	S70 C33 699	WIRING DIAGRAM FOR FRONT PANEL			1				
(24)	S70 C34 699	WIRING DIAGRAM FOR FRONT PANEL				1			
(24)	S70 C35 699	WIRING DIAGRAM FOR FRONT PANEL	1				1		
(24)	S70 C36 699	WIRING DIAGRAM FOR FRONT PANEL		1					

EHPT20X-MEHEW.UK

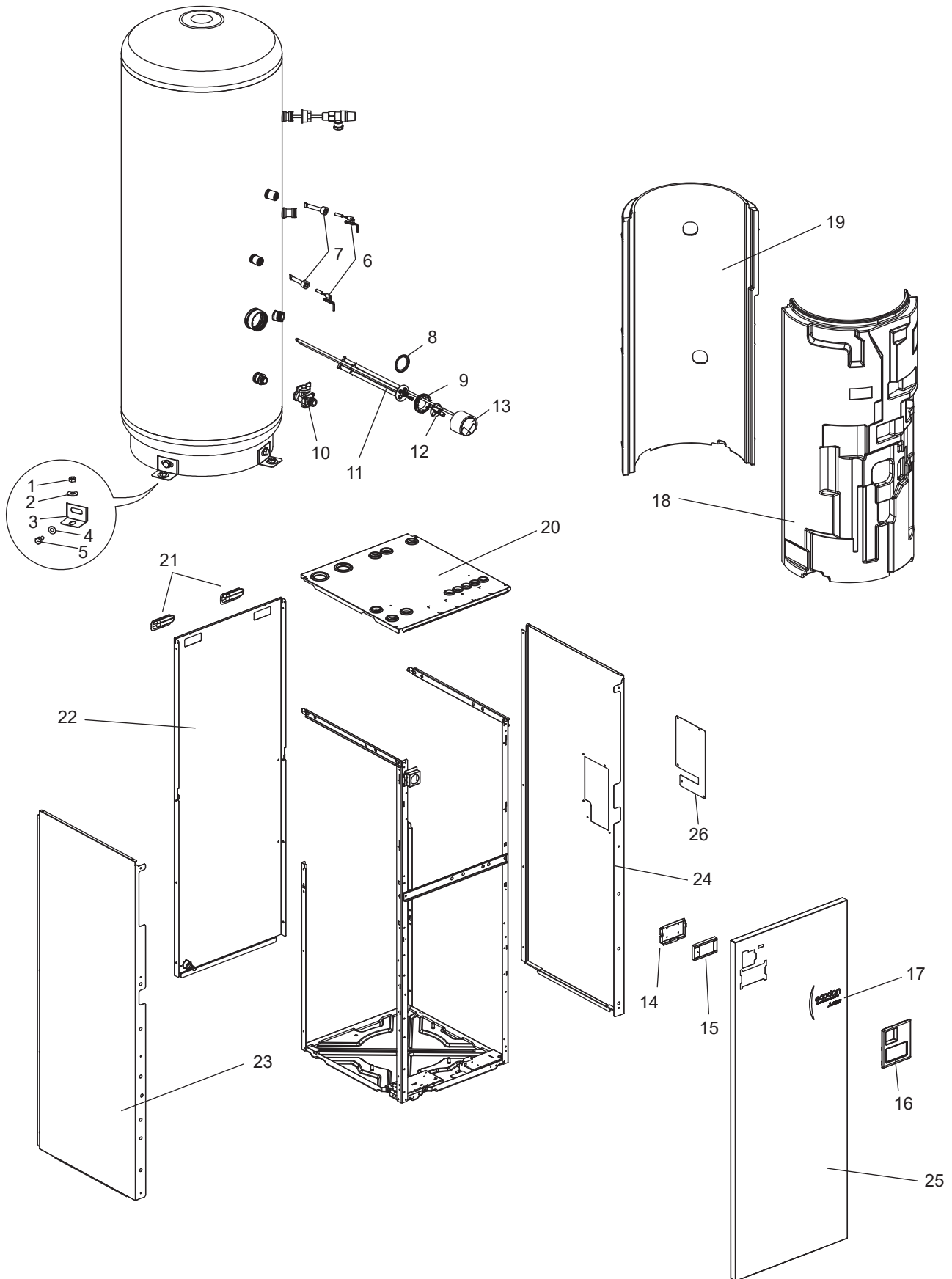

1. The part quantity below indicates the required number of pieces per unit.
2. The circled No. indicates that the part is not shown in the figure.

No.	Parts No.	Parts name	EHPT20X-MEHEW.UK	Wiring Diagram Symbol	Remarks [Drawing No.]
1	S70 C10 097	NUT	3		
2	S70 C61 097	WASHER	3		
3	S70 C30 042	TANK LEG	3		
4	S70 C20 097	WASHER	3		
5	S70 C30 097	BOLT	3		
6	S70 C68 202	THERMISTOR (TANK WATER TEMP)	1	THW5	
7	S70 C11 525	STAT POCKET ASSEMBLY	2		
8	S70 C33 460	ELEMENT PLATE GASKET	1		
9	S70 C60 097	BACKNUT	1		
10	S70 C40 357	DRAIN COCK	1		For tank
11	S70 C50 445	IMMERSION HEATER	1	IH	
12	S70 C33 461	ELEMENT PLATE TERMINAL COVER	1		
13	S70 C08 201	THERMOSTAT	1	IHT	
14	S70 C10 711	MAIN REMOTE CONTROLLER SUPPORT	1		
15	S70 C81 200	MAIN REMOTE CONTROLLER ASSY	1		
16	S70 C41 710	MAIN REMOTE CONTROLLER HOLDER	1		
17	S70 C40 699	BRAND LABEL	1		
18	—	TANK EPS FRONT	1		[DX25A642G02]
19	—	TANK EPS BACK	1		[DX25A643G01]
20	S70 C32 641	TOP PANEL ASSY	1		
21	S70 30L 655	HANDLE	2		
22	S70 C23 661	BACK PANEL	1		
23	S70 C73 662	SIDE PANEL L	1		
24	S70 C76 662	SIDE PANEL R	1		
25	S70 C39 668	FRONT PANEL	1		
26	S70 C40 670	V/M PLATE	1		
(27)	S70 C37 699	WIRING DIAGRAM FOR FRONT PANEL	1		

EHPT30X-YM9EE.UK
ERPT30X-YM9EE.UK

ERPT30X-VM2EE.UK

ERPT30X-VM6EE.UK

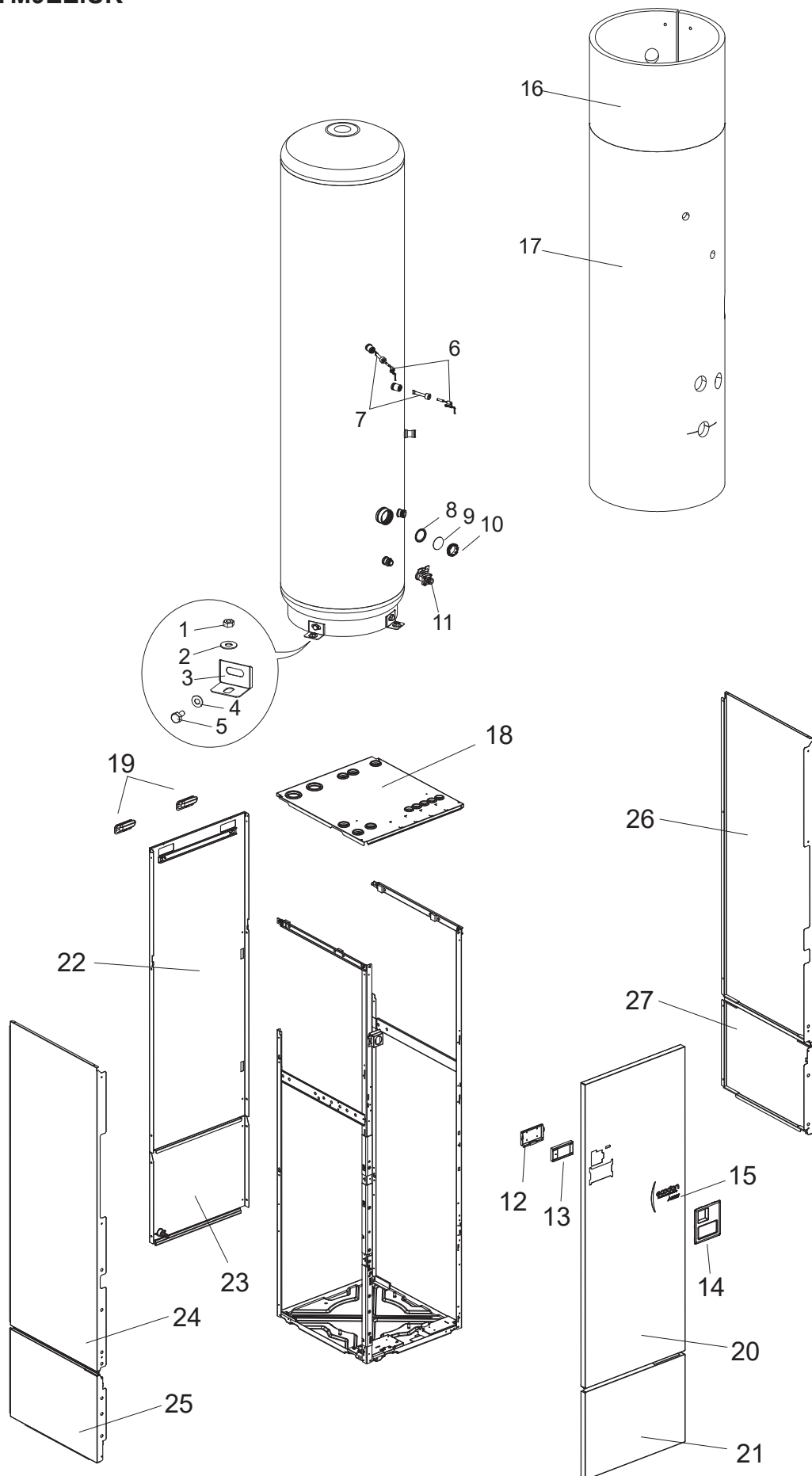

1. The part quantity below indicates the required number of pieces per unit.
2. The circled No. indicates that the part is not shown in the figure.

No.	Parts No.	Parts name					Wiring Diagram Symbol	Remarks [Drawing No.]
			EHPT30X-YM9EE.UK	ERPT30X-VM2EE.UK	ERPT30X-VM6EE.UK	ERPT30X-YM9EE.UK		
1	S70 C10 097	NUT	3	3	3	3		
2	S70 C61 097	WASHER	3	3	3	3		
3	S70 C30 042	TANK LEG	3	3	3	3		
4	S70 C20 097	WASHER	3	3	3	3		
5	S70 C30 097	BOLT	3	3	3	3		
6	S70 C68 202	THERMISTOR (TANK WATER TEMP)	1	1	1	1	THW5	
7	S70 C11 525	STAT POCKET ASSEMBLY	2	2	2	2		
8	S70 C33 460	ELEMENT PLATE GASKET	1	1	1	1		
9	S70 C40 446	BLANKING PLATE	1	1	1	1		For tank
10	S70 C60 097	BACKNUT	1	1	1	1		
11	S70 C40 357	DRAIN COCK	1	1	1	1		For tank
12	S70 C10 711	MAIN REMOTE CONTROLLER SUPPORT	1	1	1	1		
13	S70 C81 200	MAIN REMOTE CONTROLLER ASSY	1	1	1	1		
14	S70 C41 710	MAIN REMOTE CONTROLLER HOLDER	1	1	1	1		
15	S70 C40 699	BRAND LABEL	1	1	1	1		
16	S70 C35 042	TANK INSLATOR TOP	1	1	1	1		
17	S70 C45 042	TANK INSLATOR UNDER	1	1	1	1		
18	S70 C33 641	TOP PANEL ASSY	1	1	1	1		
19	S70 30L 655	HANDLE	2	2	2	2		
20	S70 C37 668	FRONT PANEL - TOP	1	1	1	1		
21	S70 C32 668	FRONT PANEL - UNDER	1	1	1	1		
22	S70 C20 661	BACK PANEL (TOP)	1	1	1	1		
23	S70 C21 661	BACK PANEL UNDER	1					
23	S70 C28 661	BACK PANEL UNDER		1	1	1		
24	S70 C63 662	SIDE PANEL L - TOP	1	1	1	1		
25	S70 C61 662	SIDE PANEL L - UNDER	1	1	1	1		
26	S70 C66 662	SIDE PANEL R - TOP	1	1	1	1		
27	S70 C64 662	SIDE PANEL R - UNDER	1	1	1	1		
(28)	S70 C33 699	WIRING DIAGRAM FOR FRONT PANEL		1				
(28)	S70 C34 699	WIRING DIAGRAM FOR FRONT PANEL			1			
(28)	S70 C35 699	WIRING DIAGRAM FOR FRONT PANEL	1			1		

MEHEW

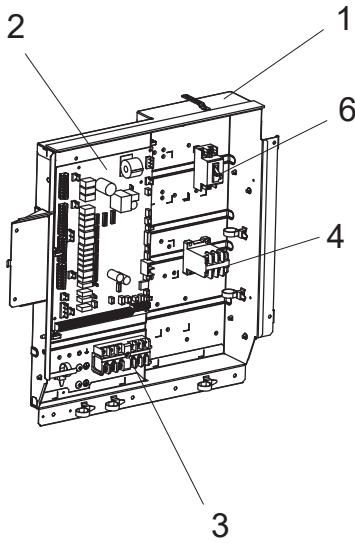

VM2E

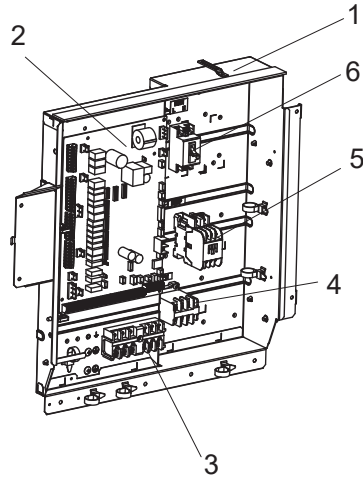

VM6E

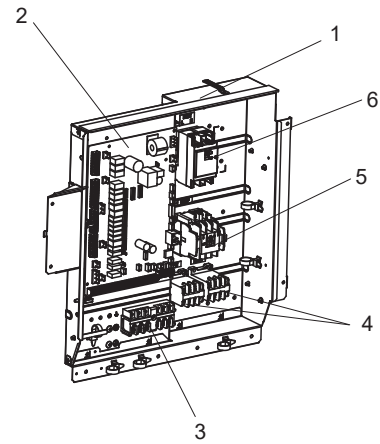

1. The part quantity below indicates the required number of pieces per unit.
2. The circled No. indicates that the part is not shown in the figure.

No.	Parts No.	Parts name						Remarks [Drawing No.]
			EHPT17X-VM2E.UK	ERPT17X-VM2E.UK	EHPT20X-MEHEW.UK	ERPT20X-V2ME.UK	ERPT30X-VM2EE.UK	
1	S70 C10 501	CONTROL BOX	1	1	1	1	1	
2	S70 C87 315	ATW CONTROLLER	1	1	1	1	1	
3	S70 C20 515	TERMINAL BED	1	1	1	1	1	6P (#250LNE+S123)
4	S70 C39 708	CONTACTOR	1	1	1	1	1	30 A
5	S70 C49 708	CONTACTOR	1	1		1	1	45 A
6	S70 C20 239	EARTH LEAKAGE BREAKER	1	1	1	1	1	1 ø 20 A

1. The part quantity below indicates the required number of pieces per unit.
2. The circled No. indicates that the part is not shown in the figure.

No.	Parts No.	Parts name				Remarks [Drawing No.]
			EHPT17X-VM6E.UK	ERPT20X-VM6E.UK	ERPT30X-VM6EE.UK	
1	S70 C10 501	CONTROL BOX	1	1	1	
2	S70 C87 315	ATW CONTROLLER	1	1	1	
3	S70 C20 515	TERMINAL BED	1	1	1	6P (#250LNE+S123)
4	S70 C39 708	CONTACTOR	2	2	2	30 A
5	S70 C49 708	CONTACTOR	1	1	1	45 A
6	S70 C60 239	EARTH LEAKAGE BREAKER	1	1	1	1 ø 40 A



YM9E/TM9E

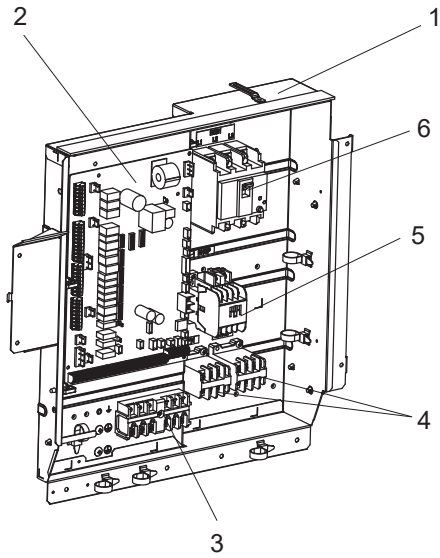

- 1. The part quantity below indicates the required number of pieces per unit.
- 2. The circled No. indicates that the part is not shown in the figure.

No.	Parts No.	Parts name							Remarks [Drawing No.]
			EHPT17X-YM9E.UK	EHPT20X-YM9E.UK	EHPT20X-TM9E.UK	ERPT20X-YM9E.UK	EHPT30X-YM9EE.UK	ERPT30X-YM9EE.UK	
1	S70 C10 501	CONTROL BOX	1	1	1	1	1	1	
2	S70 C87 315	ATW CONTROLLER	1	1	1	1	1	1	
3	S70 C20 515	TERMINAL BED	1	1	1	1	1	1	6P (#250LNE+S123)
4	S70 C39 708	CONTACTOR	2	2	2	2	2	2	30 A
5	S70 C49 708	CONTACTOR	1	1	1	1	1	1	45 A
6	S70 C90 239	EARTH LEAKAGE BREAKER	1	1	1	1	1	1	3 ø 30 A

2

OPTIONAL PARTS

Part Name	Part No.
EHPT ACCESSORIES for UK *	PAC-WK02UK-E

* Optional parts for EHPT20X-MEHEW

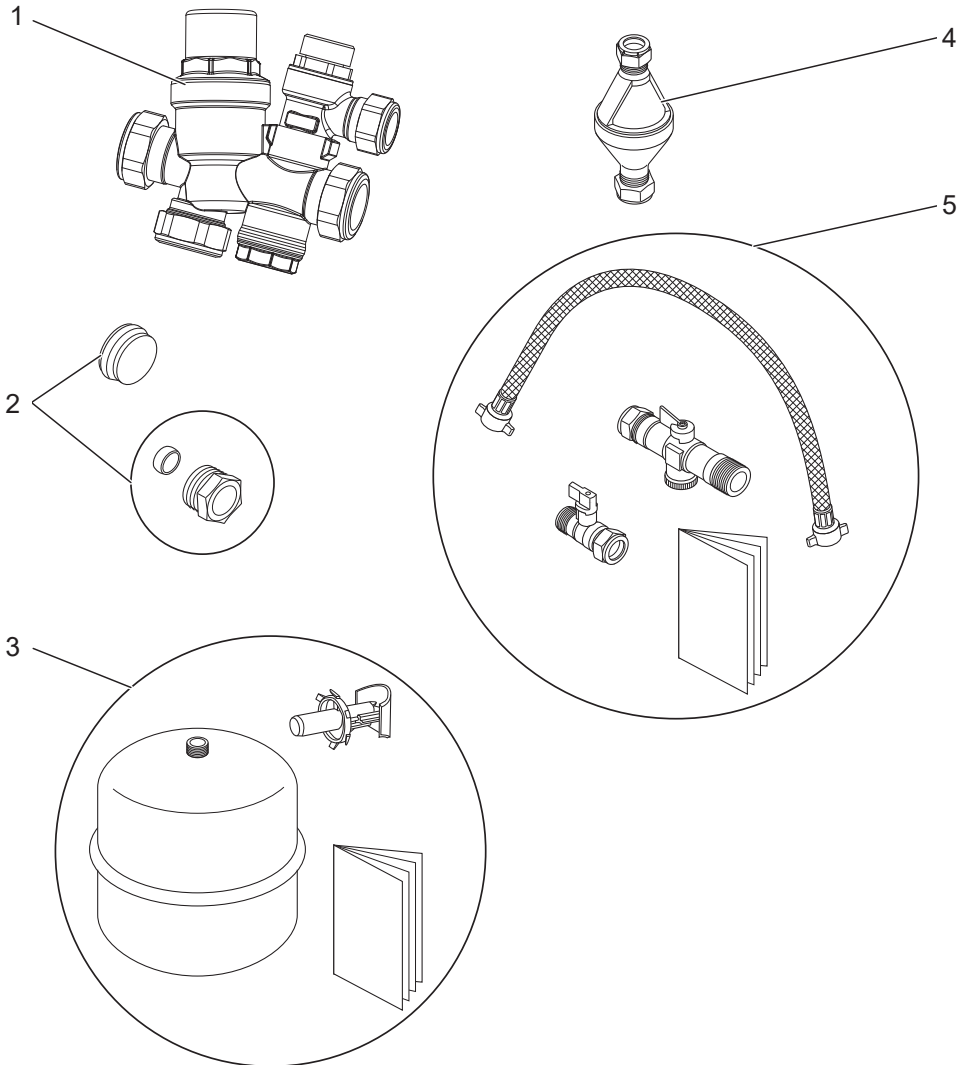

1. The part quantity below indicates the required number of pieces per unit.
 2. The circled No. indicates that the part is not shown in the figure.

No.	Parts No.	Parts name	EHPT20X-MEHEW.UK	Wiring Diagram Symbol	Remarks
1	S70 C20 359	Unvented inlet control group (Pressure-reducing valve/Strainer/Check valves/Expansion relief valve)	1		Pressure reducing valve:3.5 bar Expansion relief valve:6.0 bar
2	S70 C01 460	Accessory pack :Blanking cap, Olive & compression nut	1		22mm, 15mm
3	S70 C20 402	Expansion vessel 18L	1		R3/4"
4	S70 C02 460	Tundish	2		15 mm, 22 mm
5	S70 C03 460	Filling loop	1		15 mm



Part Name	Part No.
IMMERSION HEATER (1 Ph 1 kW)	PAC-IH01V2-E
IMMERSION HEATER (1 Ph 3 kW)	PAC-IH03V2-E
WIRELESS REMOTE CONTROLLER	PAR-WT60R-E
WIRELESS RECEIVER	PAR-WR61R-E
REMOTE SENSOR	PAC-SE41TS-E
THERMISTOR	PAC-TH011-E
HIGH TEMPERATURE THERMISTOR (5 m)	PAC-TH012HT-E
HIGH TEMPERATURE THERMISTOR (30 m)	PAC-TH012HTL-E
ecodan Wi-Fi INTERFACE	MAC-587IF-E1
EXPANSION VESSEL	PAC-EVP12-E1 *
2-ZONE KIT	PAC-TZ02-E2
JOINT PIPE (ø6.35 → ø9.52)	PAC-SG72RJ-E
JOINT PIPE (ø12.7 → ø15.88)	PAC-SG74RJ-E

* Optional part for E***T***-M*EE* series.

MITSUBISHI ELECTRIC CORPORATION

HEAD OFFICE: TOKYO BUILDING, 2-7-3, MARUNOUCHI, CHIYODA-KU, TOKYO 100-8310, JAPAN
