

P series

<u>A.1 CEILING CASSETTE (PLA)</u>	<u>A-5</u>	CEILING CASSETTE
<u>A.2 WALL-MOUNTED (PKA)</u>	<u>A-139</u>	WALL-MOUNTED
<u>A.3 CEILING-SUSPENDED (PCA)</u>	<u>A-173</u>	CEILING SUSPENDED
<u>A.4 CEILING-SUSPENDED for Professional kitchen (PCA-HA)</u>	<u>A-237</u>	CEILING SUSPENDED for Kitchen
<u>A.5 FLOOR-STANDING (PSA)</u>	<u>A-249</u>	FLOOR-STANDING
<u>A.6 CEILING-CONCEALED (PEAD/PEA)</u>	<u>A-283</u>	CEILING CONCEALED
<u>A.7 REMOTE CONTROLLER & TROUBLE SHOOTING</u>	<u>A-413</u>	REMOTE CONTROLLER & TROUBLE SHOOTING
<u>A.8 OUTDOOR UNIT</u>	<u>A-431</u>	OUTDOOR UNIT
<u>A.9 MULTI SYSTEM</u>	<u>A-577</u>	MULTI SYSTEM

S series

<u>B.1 600×600 CEILING CASSETTE (SLZ)</u>	<u>B-3</u>	600×600 CEILING CASSETTE
<u>B.2 CEILING-CONCEALED (SEZ)</u>	<u>B-39</u>	CEILING CONCEALED
<u>B.3 FLOOR-STANDING(SFZ)</u>	<u>B-83</u>	FLOOR-STANDING
<u>B.4 OUTDOOR UNIT (SUZ)</u>	<u>B-117</u>	OUTDOOR UNIT

M series

<u>C.1 WALL-MOUNTED</u>	<u>C-5</u>	WALL-MOUNTED
<u>C.2 FLOOR-STANDING</u>	<u>C-551</u>	FLOOR-STANDING
<u>C.3 CEILING CASSETTE</u>	<u>C-625</u>	CEILING CASSETTE
<u>C.4 MULTI SYSTEM</u>	<u>C-663</u>	MULTI SYSTEM

OPTIONAL PARTS

D-1

OPTIONAL PARTS

M series Model List

C.1 WALL-MOUNTED.....C-5

Indoor unit

MSZ-RW25VG	MSZ-AP60VG	MSZ-EF42VGW
MSZ-RW35VG	MSZ-AP60VGK	MSZ-EF42VGKW
MSZ-RW50VG	MSZ-AP71VG	MSZ-EF42VGB
MSZ-LN18VG2W	MSZ-AP71VGK	MSZ-EF42VGKB
MSZ-LN18VG2V	MSZ-HR25VF	MSZ-EF42VGS
MSZ-LN18VG2B	MSZ-HR25VFK	MSZ-EF42VGKS
MSZ-LN18VG2R	MSZ-HR35VF	MSZ-EF50VGW
MSZ-LN25VG2W	MSZ-HR35VFK	MSZ-EF50VGKW
MSZ-LN25VG2V	MSZ-HR42VF	MSZ-EF50VGB
MSZ-LN25VG2B	MSZ-HR42VFK	MSZ-EF50VGKB
MSZ-LN25VG2R	MSZ-HR50VF	MSZ-EF50VGS
MSZ-LN35VG2W	MSZ-HR50VFK	MSZ-EF50VGKS
MSZ-LN35VG2V	MSZ-HR60VF	MSZ-BT20VG
MSZ-LN35VG2B	MSZ-HR60VFK	MSZ-BT20VGK
MSZ-LN35VG2R	MSZ-HR71VF	MSZ-BT25VG
MSZ-LN50VG2W	MSZ-HR71VFK	MSZ-BT25VGK
MSZ-LN50VG2V	MSY-TP35VF	MSZ-BT35VG
MSZ-LN50VG2B	MSY-TP50VF	MSZ-BT35VGK
MSZ-LN50VG2R	MSZ-FH25VE2	MSZ-BT50VG
MSZ-LN60VG2W	MSZ-FH35VE2	MSZ-BT50VGK
MSZ-LN60VG2V	MSZ-FH50VE2	MSZ-DW25VF
MSZ-LN60VG2B	MSZ-EF18VGW	MSZ-DW35VF
MSZ-LN60VG2R	MSZ-EF18VGKW	MSZ-DW50VF
MSZ-FT25VG	MSZ-EF18VGB	MSZ-SF15VA
MSZ-FT25VGK	MSZ-EF18VGKB	MSZ-SF20VA
MSZ-FT35VG	MSZ-EF18VGS	MSZ-SF25VE3
MSZ-FT35VGK	MSZ-EF18VGKS	MSZ-SF35VE3
MSZ-FT50VG	MSZ-EF22VGW	MSZ-SF42VE3
MSZ-FT50VGK	MSZ-EF22VGKW	MSZ-SF50VE3
MSZ-AY25VG	MSZ-EF22VGB	MSZ-GF60VE2
MSZ-AY25VGK	MSZ-EF22VGKB	MSZ-GF71VE2
MSZ-AY25VGKP	MSZ-EF22VGS	MSZ-WN25VA
MSZ-AY35VG	MSZ-EF22VGKS	MSZ-WN35VA
MSZ-AY35VGK	MSZ-EF25VGW	MSZ-DM25VA
MSZ-AY35VGKP	MSZ-EF25VGKW	MSZ-DM35VA
MSZ-AY42VG	MSZ-EF25VGB	MSZ-HJ25VA
MSZ-AY42VGK	MSZ-EF25VGKB	MSZ-HJ35VA
MSZ-AY42VGKP	MSZ-EF25VGS	MSZ-HJ50VA
MSZ-AY50VG	MSZ-EF25VGKS	MSZ-HJ60VA
MSZ-AY50VGK	MSZ-EF35VGW	MSZ-HJ71VA
MSZ-AY50VGKP	MSZ-EF35VGKW	
MSZ-AP15VG	MSZ-EF35VGB	
MSZ-AP15VGK	MSZ-EF35VGKB	
MSZ-AP20VG	MSZ-EF35VGS	
MSZ-AP20VGK	MSZ-EF35VGKS	

Outdoor unit

MUZ-RW25VGHZ	MUZ-BT20VG
MUZ-RW35VGHZ	MUZ-BT25VG
MUZ-RW50VGHZ	MUZ-BT35VG
MUZ-LN25VG2	MUZ-BT50VG
MUZ-LN25VGHZ2	MUZ-DW25VF
MUZ-LN35VG2	MUZ-DW35VF
MUZ-LN35VGHZ2	MUZ-DW50VF
MUZ-LN50VG2	MUZ-SF25VE
MUZ-LN50VGHZ2	MUZ-SF25VEH
MUZ-LN60VG2	MUZ-SF35VE
MUZ-FT25VGHZ	MUZ-SF35VEH
MUZ-FT35VGHZ	MUZ-SF42VE
MUZ-FT50VGHZ	MUZ-SF42VEH
MUZ-AY25VG	MUZ-SF50VE
MUZ-AY25VGH	MUZ-SF50VEH
MUZ-AY35VG	MUZ-GF60VE
MUZ-AY35VGH	MUZ-GF71VE
MUZ-AY42VG	MUZ-WN25VA
MUZ-AY42VGH	MUZ-WN35VA
MUZ-AY50VG	MUZ-DM25VA
MUZ-AY50VGH	MUZ-DM35VA
MUZ-AP15VG	MUZ-HJ25VA
MUZ-AP20VG	MUZ-HJ35VA
MUZ-AP60VG	MUZ-HJ50VA
MUZ-AP71VG	MUZ-HJ60VA
MUZ-HR25VF	MUZ-HJ71VA
MUZ-HR35VF	
MUZ-HR42VF	
MUZ-HR50VF	
MUZ-HR60VF	
MUZ-HR71VF	
MUY-TP35VF	
MUY-TP50VF	
MUZ-FH25VE	
MUZ-FH25VEHZ	
MUZ-FH35VE	
MUZ-FH35VEHZ	
MUZ-FH50VE	
MUZ-FH50VEHZ	
MUZ-EF25VG	
MUZ-EF25VGH	
MUZ-EF35VG	
MUZ-EF35VGH	
MUZ-EF42VG	
MUZ-EF50VG	

WALL-MOUNTED

FLOOR-STANDING

CEILING CASSETTE

MULTI-SYSTEM

C.2 FLOOR-STANDINGC-551

Indoor unit	Outdoor unit
MFZ-KW25VG	MUFZ-KW25VGHZ
MFZ-KW35VG	MUFZ-KW35VGHZ
MFZ-KW50VG	MUFZ-KW50VGHZ
MFZ-KW60VG	MUFZ-KW60VGHZ
MFZ-KT25VG	
MFZ-KT35VG	
MFZ-KT50VG	
MFZ-KT60VG	

C.3 CEILING CASSETTE.....C-625

Indoor unit
MLZ-KP25VF
MLZ-KP35VF
MLZ-KP50VF
MLZ-KY20VG

C.4 MULTI SYSTEM.....C-663

Outdoor unit
MXZ-2F33VF4
MXZ-2F42VF4
MXZ-2F53VF4
MXZ-2F53VFH4
MXZ-3F54VF4
MXZ-3F68VF4
MXZ-4F72VF4
MXZ-4F80VF4
MXZ-4F83VF2
MXZ-5F102VF2
MXZ-6F120VF2
MXZ-2F53VFHZ2
MXZ-4F83VFHZ2
MXZ-2D33VA
MXZ-2D42VA2
MXZ-2D53VA2
MXZ-2D53VAH2
MXZ-2E53VAHZ
MXZ-3E54VA
MXZ-3E68VA
MXZ-4E72VA
MXZ-4E83VA
MXZ-4E83VAHZ
MXZ-5E102VA
MXZ-6D122VA2
MXZ-2DM40VA
MXZ-3DM50VA
MXZ-2HA40VF2
MXZ-2HA50VF2
MXZ-3HA50VF2
PXZ-4F75VG
PXZ-5F85VG

M series

M series Models

COMBINATION OF SINGLE SPLIT TYPE

Type			Model Name		Type			Model Name		
			Indoor unit	Outdoor unit				Indoor unit	Outdoor unit	
M series	Inverter	Heat pump	MSZ-RW25VG	MUZ-RW25VGHZ	M series	Inverter	Heat pump	MSZ-AY50VG	MUZ-AY50VG MUZ-AY50VGH	
			MSZ-RW35VG	MUZ-RW35VGHZ				MSZ-AY50VGK	MUZ-AY50VG MUZ-AY50VGH	
			MSZ-RW50VG	MUZ-RW50VGHZ				MSZ-AY50VGKP	MUZ-AY50VG MUZ-AY50VGH	
			MSZ-LN18VG2W	Multi connection only				MSZ-AP15VG	MUZ-AP15VG	
			MSZ-LN18VG2V					MSZ-AP15VGK		
			MSZ-LN18VG2B					MUZ-LN25VG2 MUZ-LN25VGHZ2	MSZ-AP20VG	MUZ-AP20VG
			MSZ-LN18VG2R						MSZ-AP20VGK	
			MSZ-LN25VG2W	MUZ-LN25VG2 MUZ-LN25VGHZ2				MSZ-AP60VG	MUZ-AP60VG	
			MSZ-LN25VG2V					MSZ-AP60VGK		
			MSZ-LN25VG2B	MUZ-LN25VG2 MUZ-LN25VGHZ2				MSZ-AP71VG	MUZ-AP71VG	
			MSZ-LN25VG2R					MSZ-AP71VGK		
			MSZ-LN35VG2W	MUZ-LN35VG2 MUZ-LN35VGHZ2				MSZ-HR25VF	MUZ-HR25VF	
			MSZ-LN35VG2V					MSZ-HR25VFK		
			MSZ-LN35VG2B	MUZ-LN35VG2 MUZ-LN35VGHZ2				MSZ-HR35VF	MUZ-HR35VF	
			MSZ-LN35VG2R					MSZ-HR35VFK		
			MSZ-LN50VG2W	MUZ-LN50VG2 MUZ-LN50VGHZ2				MSZ-HR42VF	MUZ-HR42VF	
			MSZ-LN50VG2V					MSZ-HR42VFK		
			MSZ-LN50VG2B	MUZ-LN50VG2 MUZ-LN50VGHZ2				MSZ-HR50VF	MUZ-HR50VF	
			MSZ-LN50VG2R					MSZ-HR50VFK		
			MSZ-LN60VG2W	MUZ-LN60VG2 MUZ-LN60VGHZ2				MSZ-HR60VF	MUZ-HR60VF	
			MSZ-LN60VG2V					MSZ-HR60VFK		
			MSZ-LN60VG2B	MUZ-LN60VG2 MUZ-LN60VGHZ2				MSZ-HR71VF	MUZ-HR71VF	
			MSZ-LN60VG2R					MSZ-HR71VFK		
			MSZ-FT25VG	MUZ-FT25VGHZ				MSY-TP35VF	MUJY-TP35VF	
			MSZ-FT25VGK					MSY-TP50VF		
			MSZ-FT35VG	MUZ-FT35VGHZ				MSZ-FH25VE2	MUZ-FH25VE MUZ-FH25VEHZ	
			MSZ-FT35VGK					MSZ-FH35VE2	MUZ-FH35VE MUZ-FH35VEHZ	
			MSZ-FT50VG	MUZ-FT50VGHZ				MSZ-FH50VE2	MUZ-FH50VE MUZ-FH50VEHZ	
			MSZ-FT50VGK					MSZ-EF18VGW	Multi connection only	
			MSZ-AY25VG	MUZ-AY25VG MUZ-AY25VGH						
			MSZ-AY25VGK	MUZ-AY25VG MUZ-AY25VGH						
			MSZ-AY25VGKP	MUZ-AY25VG MUZ-AY25VGH						
			MSZ-AY35VG	MUZ-AY35VG MUZ-AY35VGH						
			MSZ-AY35VGK	MUZ-AY35VG MUZ-AY35VGH						
			MSZ-AY35VGKP	MUZ-AY35VG MUZ-AY35VGH						
			MSZ-AY42VG	MUZ-AY42VG MUZ-AY42VGH						
			MSZ-AY42VGK	MUZ-AY42VG MUZ-AY42VGH						
			MSZ-AY42VGKP	MUZ-AY42VG MUZ-AY42VGH						
								MSZ-EF18VGB		
								MSZ-EF18VGBK		
								MSZ-EF18VGS		
								MSZ-EF18VGKS		
								MSZ-EF22VGW		
								MSZ-EF22VGKW		
								MSZ-EF22VGB		
		MSZ-EF22VGBK								
		MSZ-EF22VGS								
		MSZ-EF22VGKS								
		MSZ-EF25VGW	MUZ-EF25VG MUZ-EF25VGH							
		MSZ-EF25VGKW	MUZ-EF25VG MUZ-EF25VGH							
		MSZ-EF25VGB	MUZ-EF25VG MUZ-EF25VGH							
		MSZ-EF25VGBK	MUZ-EF25VG MUZ-EF25VGH							
		MSZ-EF25VGS	MUZ-EF25VG MUZ-EF25VGH							
		MSZ-EF25VGKS	MUZ-EF25VG MUZ-EF25VGH							

Type		Model Name		
		Indoor unit	Outdoor unit	
M series	Inverter	Heat pump	MSZ-EF35VGW	MUZ-EF35VG MUZ-EF35VGH
			MSZ-EF35VGKW	MUZ-EF35VG MUZ-EF35VGH
			MSZ-EF35VGB	MUZ-EF35VG MUZ-EF35VGH
			MSZ-EF35VGKB	MUZ-EF35VG MUZ-EF35VGH
			MSZ-EF35VGS	MUZ-EF35VG MUZ-EF35VGH
			MSZ-EF35VGKS	MUZ-EF35VG MUZ-EF35VGH
			MSZ-EF42VGW	MUZ-EF42VG
			MSZ-EF42VGKW	
			MSZ-EF42VGB	
			MSZ-EF42VGKB	
			MSZ-EF42VGS	MUZ-EF42VG
			MSZ-EF42VGKS	
			MSZ-EF50VGW	MUZ-EF50VG
			MSZ-EF50VGKW	
			MSZ-EF50VGB	MUZ-EF50VG
			MSZ-EF50VGKB	
			MSZ-EF50VGS	MUZ-EF50VG
			MSZ-EF50VGKS	
			MSZ-BT20VG	MUZ-BT20VG
			MSZ-BT20VGK	
			MSZ-BT25VG	MUZ-BT25VG
			MSZ-BT25VGK	
			MSZ-BT35VG	MUZ-BT35VG
			MSZ-BT35VGK	
			MSZ-BT50VG	MUZ-BT50VG
			MSZ-BT50VGK	
			MSZ-DW25VF	MUZ-DW25VF
			MSZ-DW35VF	MUZ-DW35VF
			MSZ-DW50VF	MUZ-DW50VF
			MSZ-SF15VA	Multi connection only
			MSZ-SF20VA	
			MSZ-SF25VE3	MUZ-SF25VE MUZ-SF25VEH
			MSZ-SF35VE3	MUZ-SF35VE MUZ-SF35VEH
			MSZ-SF42VE3	MUZ-SF42VE MUZ-SF42VEH
			MSZ-SF50VE3	MUZ-SF50VE MUZ-SF50VEH
			MSZ-GF60VE2	MUZ-GF60VE
			MSZ-GF71VE2	MUZ-GF71VE
			MSZ-WN25VA	MUZ-WN25VA
			MSZ-WN35VA	MUZ-WN35VA
			MSZ-DM25VA	MUZ-DM25VA
			MSZ-DM35VA	MUZ-DM35VA
			MSZ-HJ25VA	MUZ-HJ25VA
MSZ-HJ35VA	MUZ-HJ35VA			
MSZ-HJ50VA	MUZ-HJ50VA			
MSZ-HJ60VA	MUZ-HJ60VA			
MSZ-HJ71VA	MUZ-HJ71VA			

Type			Model Name	
			Indoor unit	Outdoor unit
Floor- Standing	Inverter	Heat pump	MFZ-KW25VG	MUFZ-KW25VGHZ
			MFZ-KW35VG	MUFZ-KW35VGHZ
			MFZ-KW50VG	MUFZ-KW50VGHZ
			MFZ-KW60VG	MUFZ-KW60VGHZ
			MFZ-KT25VG	SUZ-M25VA
			MFZ-KT35VG	SUZ-M35VA
Ceiling Cassette	Inverter	Heat pump	MLZ-KP25VF	SUZ-M25VA
			MLZ-KP35VF	SUZ-M35VA
			MLZ-KP50VF	SUZ-M50VA
			MLZ-KY20VG	Multi connection only

M series

Indoor Unit Compatibility Table

■MXZ Series R32

Possible combinations of outdoor units and indoor units are shown below.

Indoor Unit		Outdoor Unit	Inverter Models Heat Pump Type															
			MXZ- ^{*3} 2F33VF4	MXZ- ^{*3} 2F42VF4	MXZ- ^{*3} 2F53VF(H)4	MXZ- ^{*3} 2F53VFHZ2	MXZ- ^{*3} 3F54VF4	MXZ- ^{*3} 3F68VF4	MXZ- ^{*3} 4F72VF4	MXZ- ^{*3} 4F80VF4	MXZ- ^{*3} 4F83VF2	MXZ- ^{*3} 4F83VFHZ2	MXZ- ^{*3} 5F102VF2	MXZ- ^{*3} 6F120VF2	MXZ- ^{*3} 2HA40VF2	MXZ- ^{*3} 2HA50VF2	MXZ- ^{*3} 3HA50VF2	
M series	Wall-Mounted	MSZ-RW25VG	●	●	●	●	●	●	●	●	●	●	●	●				
		MSZ-RW35VG		●	●	●	●	●	●	●	●	●	●	●				
		MSZ-RW50VG																
		MSZ-LN18VG2(W)(V)(R)(B)	●	●	●	●	●	●	●	●	●	●	●	●				
		MSZ-LN25VG2(W)(V)(R)(B)	●	●	●	●	●	●	●	●	●	●	●	●				
		MSZ-LN35VG2(W)(V)(R)(B)		●	●	●	●	●	●	●	●	●	●	●				
		MSZ-LN50VG2(W)(V)(R)(B)					●	●	●	●	●	●	●	●				
		MSZ-FT25VG					●					●						
		MSZ-FT35VG					●					●						
		MSZ-FT50VG																
		MSZ-AP15VG(K)	●	●	●	●	●	●	●	●	●	●	●	●				
		MSZ-AP20VG(K)	●	●	●	●	●	●	●	●	●	●	●	●				
		MSZ-AY25VG(K)	●	●	●	●	●	●	●	●	●	●	●	●				
		MSZ-AY35VG(K)		●	●	●	●	●	●	●	●	●	●	●				
		MSZ-AY42VG(K)			●	●	●	●	●	●	●	●	●	●				
		MSZ-AY50VG(K)				●	●	●	●	●	●	●	●	●				
		MSZ-AP60VG(K)						●	●	●	●	●	●	●				
		MSZ-AP71VG(K)										●	●	●				
		MSZ-EF18VG(K)(W)(B)(S)	●	●	●	●	●	●	●	●	●	●	●	●				
		MSZ-EF22VG(K)(W)(B)(S)	●	●	●	●	●	●	●	●	●	●	●	●				
	MSZ-EF25VG(K)(W)(B)(S)	●	●	●	●	●	●	●	●	●	●	●	●					
	MSZ-EF35VG(K)(W)(B)(S)		●	●	●	●	●	●	●	●	●	●	●					
	MSZ-EF42VG(K)(W)(B)(S)			●	●	●	●	●	●	●	●	●	●					
	MSZ-EF50VG(K)(W)(B)(S)				●	●	●	●	●	●	●	●	●					
	MSZ-BT20VG(K)	●	●	●	●	●	●	●	●	●	●	●	●					
	MSZ-BT25VG(K)	●	●	●	●	●	●	●	●	●	●	●	●					
	MSZ-BT35VG(K)		●	●	●	●	●	●	●	●	●	●	●					
	MSZ-BT50VG(K)																	
	MSZ-HR25VF(K)														●	●	●	
	MSZ-HR35VF(K)														●	●	●	
MSZ-HR42VF(K)															●	●		
MSZ-HR50VF(K)																●		
MSZ-HR60VF(K)																		
MSZ-HR71VF(K)																		
Floor-Standing	MFZ-KT25VG	●	●	●	●	●	●	●	●	●	●	●						
	MFZ-KT35VG		●	●	●	●	●	●	●	●	●	●						
	MFZ-KT50VG					●	●	●	●	●	●	●						
	1-way Cassette	MLZ-KP25VF	●	●	●	●	●	●	●	●	●	●	●					
		MLZ-KP35VF		●	●	●	●	●	●	●	●	●	●					
		MLZ-KP50VF					●	●	●	●	●	●	●					
MLZ-KY20VG	●	●	●	●	●	●	●	●	●	●	●	●						
S series	2x2 Cassette	SLZ-M15FA2	●	●	●	●	●	●	●	●	●	●	●					
		SLZ-M25FA2	●	●	●	●	●	●	●	●	●	●	●					
		SLZ-M35FA2		●	●	●	●	●	●	●	●	●	●					
		SLZ-M50FA2					●	●	●	●	●	●	●					
	Ceiling-Concealed	SEZ-M25DA2 ^{*2}	●	●	●	●	●	●	●	●	●	●	●					
		SEZ-M25DAL2 ^{*2}	●	●	●	●	●	●	●	●	●	●	●					
		SEZ-M35DA2		●	●	●	●	●	●	●	●	●	●					
		SEZ-M35DAL2		●	●	●	●	●	●	●	●	●	●					
		SEZ-M50DA2					●	●	●	●	●	●	●					
		SEZ-M50DAL2					●	●	●	●	●	●	●					
		SEZ-M60DA2						●	●	●	●	●	●					
		SEZ-M60DAL2						●	●	●	●	●	●					
	SEZ-M71DA2										●	●	●					
	SEZ-M71DAL2										●	●	●					
	Concealed Floor-Standing	SFZ-M25VA	●	●	●	●	●	●	●	●	●	●	●					
		SFZ-M35VA		●	●	●	●	●	●	●	●	●	●					
		SFZ-M50VA					●	●	●	●	●	●	●					
		SFZ-M60VA						●	●	●	●	●	●					
SFZ-M71VA											●	●	●					
P series	Ceiling-Suspended	PCA-M50KA2					●	●	●	●								
		PCA-M60KA2						●	●	●								
		PCA-M71KA2																
	Ceiling-Concealed	PEAD-M35JA2					● ^{*1}	● ^{*1}	● ^{*1}	● ^{*1}	● ^{*1}	● ^{*1}	● ^{*1}	● ^{*1}				
		PEAD-M35JAL2					● ^{*1}	● ^{*1}	● ^{*1}	● ^{*1}	● ^{*1}	● ^{*1}	● ^{*1}	● ^{*1}				
		PEAD-M50JA2					● ^{*1}	● ^{*1}	● ^{*1}	● ^{*1}	● ^{*1}	● ^{*1}	● ^{*1}	● ^{*1}				
		PEAD-M50JAL2					● ^{*1}	● ^{*1}	● ^{*1}	● ^{*1}	● ^{*1}	● ^{*1}	● ^{*1}	● ^{*1}				
		PEAD-M60JA2										● ^{*1}	● ^{*1}	● ^{*1}				
		PEAD-M60JAL2										● ^{*1}	● ^{*1}	● ^{*1}				
		PEAD-M71JA2										● ^{*1}	● ^{*1}	● ^{*1}				
PEAD-M71JAL2										● ^{*1}	● ^{*1}	● ^{*1}						

*1 Maximum total current of indoor units: 3A or less

*2 SEZ-M25 cannot be connected with MXZ-2F3F/4F when total capacity of connected indoor units is equivalent to outdoor capacity (capacity ratio is 1).

*3 MXZ outdoor units are not designed to operate with a single indoor unit with one-to-one piping work. Please install at least two indoor units.

*4 P series cannot be connected with MXZ-4F83VFHZ2 when ampere limit adjustment function is operated.

C.1 WALL-MOUNTED

C.1.1	SPECIFICATIONS	C-6
	C.1.1.1 Inverter.....	C-6
C.1.2	OUTLINES AND DIMENSIONS.....	C-30
	C.1.2.1 Indoor Unit.....	C-30
	C.1.2.2 Outdoor Unit.....	C-46
C.1.3	WIRING DIAGRAM.....	C-63
	C.1.3.1 Indoor Unit.....	C-63
	C.1.3.2 Outdoor Unit.....	C-84
C.1.4	REFRIGERANT SYSTEM DIAGRAM	C-109
	C.1.4.1 Inverter.....	C-109
C.1.5	PERFORMANCE CURVES	C-133
	C.1.5.1 Inverter.....	C-134
	C.1.5.2 Powerful Heating Heat Pump.....	C-162
	C.1.5.3 Inverter/Powerful Heating Heat Pump.....	C-170
C.1.6	PERFORMANCE DATA.....	C-193
	C.1.6.1 Inverter.....	C-193
C.1.7	NOISE CRITERIA CURVES	C-322
	C.1.7.1 Indoor Unit.....	C-322
	C.1.7.2 Outdoor Unit.....	C-338
C.1.8	TEMPERATURE AND AIR FLOW DISTRIBUTIONS	C-355
C.1.9	OPERATION AND ACTUATOR CONTROL	C-415
	C.1.9.1 MSZ-RW•VG Series.....	C-415
	C.1.9.2 MSZ-LN•VG2 Series	C-428
	C.1.9.3 MSZ-FT•VG/K Series.....	C-440
	C.1.9.4 MSZ-AY•VG/K/KP Series.....	C-450
	C.1.9.5 MSZ-AP•VG/K Series	C-460
	C.1.9.6 MSZ-HR•VF Series	C-477
	C.1.9.7 MSY-TP•VF Series.....	C-482
	C.1.9.8 MSZ-FH•VE2 Series	C-492
	C.1.9.9 MSZ-EF•VG/K, SF•VE3 Series	C-501
	C.1.9.10 MSZ-BT•VG/K Series	C-509
	C.1.9.11 MSZ-DW•VF Series	C-514
	C.1.9.12 MSZ-SF•VA Series.....	C-519
	C.1.9.13 MSZ-GF•VE2 Series	C-526
	C.1.9.14 MSZ-WN•VA Series	C-534
	C.1.9.15 MSZ-DM•VA Series.....	C-539
	C.1.9.16 MSZ-HJ•VA Series.....	C-544
C.1.10	CAPACITY CORRECTION RATIO CURVE FOR PIPING LENGTH	C-549

C.1.1 SPECIFICATIONS

C.1.1.1 Inverter

Indoor Unit		MSZ-RW25VG	MSZ-RW35VG	MSZ-RW50VG		
Outdoor Unit		MUZ-RW25VGHZ	MUZ-RW35VGHZ	MUZ-RW50VGHZ		
Refrigerant		R32	R32	R32		
Power Supply		Outdoor power supply	Outdoor power supply	Outdoor power supply		
Source		230/Single/50	230/Single/50	230/Single/50		
Cooling	Design load	kW	2.5	3.5	5.0	
	Annual electricity consumption ^(*)	kWh/a	78	130	230	
	SEER		11.2	9.4	7.6	
	Energy efficiency class		A+++	A+++	A++	
	Capacity	Rated	kW	2.5	3.5	5.0
		Min-Max	kW	0.9-3.5	1.0-4.0	1.4-5.8
	SHF		0.99	0.94	0.82	
	Total Input	Rated	kW	0.435	0.77	1.38
	EER		5.75	4.55	3.62	
	EEL Rank		A	A	A	
Heating (Average Season)	Design load	kW	3.2(-10°C)	4.0(-10°C)	6.0(-10°C)	
	Declared Capacity	at reference design temperature	kW	3.2(-10°C)	4.0(-10°C)	6.0(-10°C)
		at bivalent temperature	kW	3.2(-10°C)	4.0(-10°C)	6.0(-10°C)
		at operation limit temperature	kW	2.6(-30°C)	2.6(-30°C)	4.0(-30°C)
	Back up heating capacity	kW	0.0(-10°C)	0.0(-10°C)	0.0(-10°C)	
	Annual electricity consumption ^(*)	kWh/a	856	1097	1800	
	SCOP		5.2	5.1	4.6	
	Energy efficiency class		A+++	A+++	A++	
	Capacity	Rated	kW	3.2	4.0	6.0
		Min - Max	kW	0.8-6.3	1.1-7.0	1.8-8.7
Total Input	Rated	kW	0.58	0.81	1.45	
COP		5.52	4.94	4.14		
EEL Rank		A	A	A		
Heating (Warmer Season)	Design load	kW	1.8(2°C)	2.2(2°C)	3.3(2°C)	
	Declared Capacity	at reference design temperature	kW	1.8(2°C)	2.2(2°C)	3.3(2°C)
		at bivalent temperature	kW	1.8(2°C)	2.2(2°C)	3.3(2°C)
		at operation limit temperature	kW	2.6(-30°C)	2.6(-30°C)	4.0(-30°C)
	Back up heating capacity	kW	0.0(2°C)	0.0(2°C)	0.0(2°C)	
	Annual electricity consumption ^(*)	kWh/a	372	469	715	
	SCOP		6.7	6.5	6.4	
	Energy efficiency class		A+++	A+++	A+++	
	Operating Current (Max)	A	9.81	11.22	15.17	
	Indoor Unit	Input	Rated	kW	0.21	0.22
Operating Current (Max)		A	0.21	0.22	0.37	
Dimensions		HxWxD	mm	305 × 998 × 247	305 × 998 × 247	305 × 998 × 247
Weight			kg	14.5	14.5	14.5
Air Volume (SLo-Lo-Mid-Hi-Shi ^(*) (Dry/Wet))		Cooling	m ³ /min	5.1 - 6.5 - 9.0 - 11.5 - 13.7	5.1 - 6.9 - 9.0 - 11.5 - 14.1	7.8 - 9.5 - 11.1 - 13.1 - 16.2
		Heating	m ³ /min	5.1 - 7.8 - 9.5 - 11.7 - 14.1	5.1 - 7.8 - 9.5 - 11.7 - 14.5	7.8 - 10.7 - 12.5 - 14.7 - 18.2
Sound Level (SPL) (SLo-Lo-Mid-Hi-SHi ^(*))		Cooling	dB(A)	19 - 23 - 29 - 36 - 42	19 - 24 - 29 - 36 - 43	26 - 30 - 34 - 39 - 45
		Heating	dB(A)	19 - 25 - 30 - 36 - 41	19 - 25 - 30 - 36 - 42	25 - 32 - 37 - 41 - 46
Sound Level (PWL)		Cooling	dB(A)	58	59	59
Outdoor Unit		Dimensions	HxWxD	mm	714 × 800 × 285	714 × 800 × 285
	Weight		kg	39.5	40	54
	Air Volume	Cooling	m ³ /min	35.1	37.8	49.3
		Heating	m ³ /min	37.8	37.8	55.6
	Sound Level (SPL)	Cooling	dB(A)	46	49	51
		Heating	dB(A)	49	50	54
	Sound Level (PWL)	Cooling	dB(A)	60	61	64
	Operating Current (Max)	A	9.6	11	14.8	
	Breaker Size	A	10	12	16	
	Ext.Piping	Diameter	Liquid/Gas	mm	6.35 / 9.52	6.35 / 9.52
Max.Length		Out-In	m	20	20	30
Max.Height		Out-In	m	12	12	15
Guaranteed Operating Range (Outdoor)	Cooling	°C	-10 ~ +46	-10 ~ +46	-10 ~ +46	
	Heating	°C	-30 ~ +24	-30 ~ +24	-30 ~ +24	

(*) Energy consumption based on standard test results. Actual energy consumption will depend on how the appliance is used and where it is located.

(*) SHi: Super High.

Indoor Unit			MSZ-LN18VG2	MSZ-LN25VG2	MSZ-LN35VG2	MSZ-LN50VG2	MSZ-LN60VG2	
Outdoor Unit			for Multi connection	MUZ-LN25VG2	MUZ-LN35VG2	MUZ-LN50VG2	MUZ-LN60VG2	
Refrigerant			R32	R32	R32	R32	R32	
Power Supply			Outdoor Power supply	Outdoor Power supply	Outdoor Power supply	Outdoor Power supply	Outdoor Power supply	
Source			230/Single/50	230/Single/50	230/Single/50	230/Single/50	230/Single/50	
Outdoor (V/Phase/Hz)								
Cooling	Design load	kW	-	2.5	3.5	5.0	6.1	
	Annual electricity consumption ^(*)	kWh/a	-	83	129	205	285	
	SEER		-	10.5	9.5	8.5	7.5	
	Energy efficiency class			-	A+++	A+++	A+++	A++
	Capacity	Rated	kW	-	2.5	3.5	5.0	6.1
		Min-Max	kW	-	1.0-3.5	0.8-4.0	1.0-6.0	1.4-6.9
	SHF		-	0.97	0.9	0.77	0.75	
	Total Input	Rated	kW	-	0.485	0.820	1.380	1.790
	EER		-	5.15	4.27	3.62	3.41	
	EEL Rank			-	A	A	A	A
Heating (Average Season)	Design load	kW	-	3.0(-10°C)	3.6(-10°C)	4.5(-10°C)	6.0(-10°C)	
	Declared Capacity	at reference design temperature	kW	-	3.0(-10°C)	3.6(-10°C)	4.5(-10°C)	6.0(-10°C)
		at bivalent temperature	kW	-	3.0(-10°C)	3.6(-10°C)	4.5(-10°C)	6.0(-10°C)
		at operation limit temperature	kW	-	2.5(-15°C)	3.2(-15°C)	4.2(-15°C)	6.0(-15°C)
	Back up heating capacity	kW	-	0.0(-10°C)	0.0(-10°C)	0.0(-10°C)	0.0(-10°C)	
	Annual electricity consumption ^(*)	kWh/a	-	807	987	1369	1816	
	SCOP		-	5.2	5.1	4.6	4.6	
	Energy efficiency class			-	A+++	A+++	A++	A++
	Capacity	Rated	kW	-	3.2	4.0	6.0	6.8
		Min-Max	kW	-	0.7-5.4	0.9-6.3	1.0-8.2	1.8-9.3
Total Input	Rated	kW	-	0.600	0.820	1.480	1.810	
COP		-	5.33	4.88	4.05	3.76		
EEL Rank			-	A	A	A	A	
Heating (Warmer Season)	Design load	kW	-	1.7(2°C)	2.0(2°C)	2.5(2°C)	3.3(2°C)	
	Declared Capacity	at reference design temperature	kW	-	1.7(2°C)	2.0(2°C)	2.5(2°C)	3.3(2°C)
		at bivalent temperature	kW	-	1.7(2°C)	2.0(2°C)	2.5(2°C)	3.3(2°C)
		at operation limit temperature	kW	-	2.5(-15°C)	3.2(-15°C)	4.2(-15°C)	6.0(-15°C)
	Back up heating capacity	kW	-	0.0(2°C)	0.0(2°C)	0.0(2°C)	0.0(2°C)	
	Annual electricity consumption ^(*)	kWh/a	-	369	431	602	780	
	SCOP		-	6.4	6.5	5.8	5.9	
Energy efficiency class			-	A+++	A+++	A+++	A+++	
Operating Current (Max)		A	-	7.1	9.9	13.9	15.2	
Indoor Unit	Input	Rated	kW	0.027	0.027	0.027	0.034	
	Operating Current (Max)		A	0.3	0.3	0.3	0.4	
	Dimensions	H x W x D	mm	307 x 890 x 233	307 x 890 x 233	307 x 890 x 233	307 x 890 x 233	
	Weight		kg	14.5(W)15.5(V,R,B)	14.5(W)15.5(V,R,B)	14.5(W)15.5(V,R,B)	15(W)16(V,R,B)	
	Air Volume (SLo-Lo-Mid-Hi-SHi ^(*) (Dry/Wet))	Cooling	m ³ /min	4.7-5.9-7.1-9.2-12.4	4.7-5.9-7.1-9.2-12.4	4.7-5.9-7.1-9.2-13.0	5.7-7.6-8.8-10.6-13.9	7.1-8.8-10.6-12.7-15.7
		Heating	m ³ /min	4.5-6.6-7.5-11.0-13.9	4.5-6.6-7.5-11.0-13.9	4.5-6.6-7.5-11.0-13.9	5.4-6.4-8.5-10.7-15.7	6.6-9.5-11.5-13.6-15.7
	Sound Level (SPL) (SLo-Lo-Mid-Hi-SHi ^(*))	Cooling	dB(A)	19-23-29-36-42	19-23-29-36-42	19-24-29-36-43	27-31-35-39-46	29-37-41-45-49
		Heating	dB(A)	19-24-29-38-45	19-24-29-38-45	19-24-29-38-45	25-29-34-39-47	29-37-41-45-49
	Sound Level (PWL)	Cooling	dB(A)	58	58	59	60	65
	Outdoor Unit	Dimensions	H x W x D	mm	-	550 x 800 x 285	550 x 800 x 285	714 x 800 x 285
Weight			kg	-	33	34	40	
Air Volume		Cooling	m ³ /min	-	34.3	34.3	40	48.8
		Heating	m ³ /min	-	32.7	32.7	40.5	55.0
Sound Level (SPL)		Cooling	dB(A)	-	46	49	51	55
		Heating	dB(A)	-	49	50	54	55
Sound Level (PWL)		Cooling	dB(A)	-	60	61	64	65
Operating Current (Max)			A	-	6.8	9.6	13.5	
Breaker Size			A	-	10	10	16	
Ext.Piping		Diameter	Liquid/Gas	mm	-	6.35 / 9.52	6.35 / 9.52	6.35 / 9.52
	Max.Length	Out-In	m	-	20	20	30	
	Max.Height	Out-In	m	-	12	12	15	
Guaranteed Operating Range (Outdoor)	Cooling	°C	-	-10 ~ +46	-10 ~ +46	-10 ~ +46	-10 ~ +46	
	Heating	°C	-	-15 ~ +24	-15 ~ +24	-15 ~ +24	-15 ~ +24	

(*) Energy consumption based on standard test results. Actual energy consumption will depend on how the appliance is used and where it is located.

(*) SHi: Super High.

Indoor Unit			MSZ-LN25VG2	MSZ-LN35VG2	MSZ-LN50VG2		
Outdoor Unit			MUZ-LN25VGHZ2	MUZ-LN35VGHZ2	MUZ-LN50VGHZ2		
Refrigerant			R32	R32	R32		
Power Supply			Outdoor Power supply 230/Single/50	Outdoor Power supply 230/Single/50	Outdoor Power supply 230/Single/50		
Cooling	Source						
	Outdoor (V/Phase/Hz)						
	Design load	kW	2.5	3.5	5.0		
	Annual electricity consumption ^(*)	kWh/a	83	130	230		
	SEER		10.5	9.4	7.6		
	Energy efficiency class		A+++	A+++	A++		
	Capacity	Rated	kW	2.5	3.5	5.0	
		Min-Max	kW	0.8-3.5	0.8-4.0	1.4-5.8	
	SHF		0.97	0.9	0.77		
	Total Input	Rated	kW	0.485	0.820	1.380	
EER		5.15	4.27	3.62			
EEL Rank			A	A	A		
Heating (Average Season)	Design load	kW	3.2(-10°C)	4.0(-10°C)	6.0(-10°C)		
	Declared Capacity	at reference design temperature	kW	3.2(-10°C)	4.0(-10°C)	6.0(-10°C)	
		at bivalent temperature	kW	3.2(-10°C)	4.0(-10°C)	6.0(-10°C)	
		at operation limit temperature	kW	2.3(-25°C)	3.1(-25°C)	4.7(-25°C)	
	Back up heating capacity	kW	0.0(-10°C)	0.0(-10°C)	0.0(-10°C)		
	Annual electricity consumption ^(*)	kWh/a	861	1098	1826		
	SCOP		5.2	5.1	4.6		
	Energy efficiency class		A+++	A+++	A++		
	Capacity	Rated	kW	3.2	4.0	6.0	
		Min-Max	kW	0.8-6.3	0.9-6.6	1.8-8.7	
Total Input	Rated	kW	0.600	0.820	1.480		
COP		5.33	4.88	4.05			
EEL Rank			A	A	A		
Heating (Warmer Season)	Design load	kW	1.8(2°C)	2.2(2°C)	3.3(2°C)		
	Declared Capacity	at reference design temperature	kW	1.8(2°C)	2.2(2°C)	3.3(2°C)	
		at bivalent temperature	kW	1.8(2°C)	2.2(2°C)	3.3(2°C)	
		at operation limit temperature	kW	2.3(-25°C)	3.1(-25°C)	4.7(-25°C)	
	Back up heating capacity	kW	0.0(2°C)	0.0(2°C)	0.0(2°C)		
	Annual electricity consumption ^(*)	kWh/a	382	467	767		
	SCOP		6.6	6.5	5.9		
Energy efficiency class		A+++	A+++	A+++			
Operating Current (Max)	A	9.9	10.5	15.2			
Indoor Unit	Input	Rated	kW	0.027	0.034		
	Operating Current (Max)	A	0.3	0.3	0.4		
	Dimensions	H x W x D	mm	307 x 890 x 233	307 x 890 x 233	307 x 890 x 233	
	Weight		kg	14.5(W)15.5(V,R,B)	14.5(W)15.5(V,R,B)	15(W)16(V,R,B)	
	Air Volume (SLo-Lo-Mid-Hi-SHi ^(*) (Dry/Wet))	Cooling	m³/min	4.7-5.9-7.1-9.2-12.4	4.7-5.9-7.1-9.2-13.0	5.7-7.6-8.9-10.6-13.9	
		Heating	m³/min	4.5-6.6-7.5-11.0-13.9	4.5-6.6-7.5-11.0-13.9	5.4-6.4-8.5-10.7-15.7	
	Sound Level (SPL) (SLo-Lo-Mid-Hi-SHi ^(*))	Cooling	dB(A)	19-23-29-36-42	19-24-29-36-43	27-31-35-39-46	
		Heating	dB(A)	19-24-29-38-45	19-24-29-38-45	25-29-34-39-47	
	Sound Level (PWL)	Cooling	dB(A)	58	59	60	
	Outdoor Unit	Dimensions	H x W x D	mm	550 x 800 x 285	550 x 800 x 285	880 x 840 x 330
		Weight		kg	34	36	53
		Air Volume	Cooling	m³/min	34.3	34.3	48.8
			Heating	m³/min	32.7	32.7	55.0
Sound Level (SPL)		Cooling	dB(A)	46	49	51	
		Heating	dB(A)	49	50	54	
Sound Level (PWL)		Cooling	dB(A)	60	61	64	
Operating Current (Max)		A	9.6	9.6	14.8		
Breaker Size		A	10	12	16		
Ext.Piping		Diameter	Liquid/Gas	mm	6.35 / 9.52	6.35 / 9.52	6.35 / 9.52
	Max.Length	Out-In	m	20	20	30	
	Max.Height	Out-In	m	12	12	15	
Guaranteed Operating Range (Outdoor)	Cooling	°C	-10 ~ +46	-10 ~ +46	-10 ~ +46		
	Heating	°C	-25 ~ +24	-25 ~ +24	-25 ~ +24		

(*) Energy consumption based on standard test results. Actual energy consumption will depend on how the appliance is used and where it is located.

(*) SHi: Super High.

SPECIFICATIONS

WALL-MOUNTED

Indoor Unit		MSZ-FT25VG/K	MSZ-FT35VG/K	MSZ-FT50VG/K	
Outdoor Unit		MUZ-FT25VGHZ	MUZ-FT35VGHZ	MUZ-FT50VGHZ	
Refrigerant		R32	R32	R32	
Power Supply	Source	Outdoor Power supply	Outdoor Power supply	Outdoor Power supply	
	Outdoor (V/Phase/Hz)	230/Single/50	230/Single/50	230/Single/50	
Cooling	Design load	kW	2.5	3.5	
	Annual electricity consumption ^(*)	kWh/a	101	142	
	SEER		8.6	8.6	
		Energy efficiency class	A+++	A+++	
	Capacity	Rated	kW	2.5	3.5
		Min-Max	kW	0.8-3.5	0.8-4.0
	SHF		0.95	0.8	
	Total Input	Rated	kW	0.580	0.910
	EER		4.31	3.85	
		EEL Rank	A	A	
Heating (Average Season)	Design load	kW	3.2(-10°C)	4.0(-10°C)	
	Declared Capacity	at reference design temperature	kW	3.2(-10°C)	4.0(-10°C)
		at bivalent temperature	kW	3.2(-10°C)	4.0(-10°C)
		at operation limit temperature	kW	3.0(-25°C)	3.4(-25°C)
	Back up heating capacity	kW	0.0(-10°C)	0.0(-10°C)	
	Annual electricity consumption ^(*)	kWh/a	973	1216	
	SCOP		4.6	4.6	
		Energy efficiency class	A++	A++	
	Capacity	Rated	kW	3.2	4.0
		Min	kW	0.9	0.9
		Max at 7°C	kW	6.2	6.6
		Max at -15°C	kW	3.6	4.4
		Max at -25°C	kW	3.0	3.4
	Total Input	Rated	kW	0.760	1.020
	COP		4.21	3.92	
	EEL Rank	A	A		
Heating (Warmer Season)	Design load	kW	1.8(2°C)	2.2(2°C)	
	Declared Capacity	at reference design temperature	kW	1.8(2°C)	2.2(2°C)
		at bivalent temperature	kW	1.8(2°C)	2.2(2°C)
		at operation limit temperature	kW	3.0(-25°C)	3.4(-25°C)
	Back up heating capacity	kW	0.0(2°C)	0.0(2°C)	
	Annual electricity consumption ^(*)	kWh/a	432	527	
	SCOP		5.8	5.8	
		Energy efficiency class	A+++	A+++	
	Operating Current (Max)	A	10.0	11.6	
		Rated	kW	0.039	0.047
Indoor Unit	Input	A	0.4	0.4	
	Operating Current (Max)	A	0.4	0.4	
	Dimensions	HxWxD	mm	280x838x229	
	Weight	kg	10	10	
	Air Volume (SLo-Lo-Mid-Hi-Shi ^(*) (Dry/Wet))	Cooling	m ³ /min	3.9 - 5.9 - 8.2 - 10.4 - 12.3	
		Heating	m ³ /min	3.9 - 6.3 - 9.0 - 12.0 - 13.2	
	Sound Level (SPL) (SLo-Lo-Mid-Hi-SHi ^(*))	Cooling	dB(A)	19 - 27 - 36 - 41 - 46	
		Heating	dB(A)	19 - 31 - 39 - 46 - 49	
	Sound Level (PWL)	Cooling	dB(A)	60	
	Outdoor Unit	Dimensions	HxWxD	mm	550x800x285
		Weight	kg	34	
		Air Volume	Cooling	m ³ /min	30.4
			Heating	m ³ /min	30.4
Sound Level (SPL)		Cooling	dB(A)	46	
		Heating	dB(A)	49	
Sound Level (PWL)		Cooling	dB(A)	60	
Operating Current (Max)		A	9.6		
Breaker Size		A	12		
Ext.Piping		Diameter	Liquid/Gas	mm	6.35 / 9.52
	Max.Length	Out-In	m	20	
	Max.Height	Out-In	m	12	
Guaranteed Operating Range (Outdoor)	Cooling	°C	-10 ~ +46		
	Heating	°C	-25 ~ +24		

(*) Energy consumption based on standard test results. Actual energy consumption will depend on how the appliance is used and where it is located.

(*) SHi: Super High.

(*) For products in 2020 are 16A.

Indoor Unit			MSZ-AY25VGK(P)	MSZ-AY25VGK(P)	MSZ-AY35VGK(P)	MSZ-AY35VGK(P)	
Outdoor Unit			MUZ-AY25VG	MUZ-AY25VGH	MUZ-AY35VG	MUZ-AY35VGH	
Refrigerant			R32	R32	R32	R32	
Power Supply	Source		Outdoor Power supply	Outdoor Power supply	Outdoor Power supply	Outdoor Power supply	
	Outdoor (V/Phase/Hz)		230/SinglePhase/50Hz	230/SinglePhase/50Hz	230/SinglePhase/50Hz	230/SinglePhase/50Hz	
Cooling	Design load	kW	2.5	2.5	3.5	3.5	
	Annual electricity consumption ^(*)	kWh/a	100	100	141	141	
	SEER		8.7	8.7	8.7	8.7	
	Energy efficiency class			A+++	A+++	A+++	A+++
	Capacity	Rated	kW	2.5	2.5	3.5	3.5
		Min-Max	kW	0.9-3.4	0.9-3.4	1.1-3.8	1.1-3.8
	SHF		0.92	0.92	0.88	0.88	
	Total Input	Rated	kW	0.600	0.600	0.990	0.990
	EER		4.17	4.17	3.54	3.54	
	EEL Rank			A	A	A	A
Heating (Average Season)	Design load	kW	2.4(-10°C)	2.4(-10°C)	2.9(-10°C)	2.9(-10°C)	
	Declared Capacity	at reference design temperature	kW	2.4(-10°C)	2.4(-10°C)	2.9(-10°C)	2.9(-10°C)
		at bivalent temperature	kW	2.4(-10°C)	2.4(-10°C)	2.9(-10°C)	2.9(-10°C)
		at operation limit temperature	kW	1.9(-20°C)	1.9(-20°C)	2.0(-20°C)	2.0(-20°C)
	Back up heating capacity	kW	0.0(-10°C)	0.0(-10°C)	0.0(-10°C)	0.0(-10°C)	
	Annual electricity consumption ^(*)	kWh/a	697	709	863	880	
	SCOP		4.8	4.7	4.7	4.6	
	Energy efficiency class			A++	A++	A++	A++
	Capacity	Rated	kW	3.2	3.2	4.0	4.0
		Min-Max	kW	1.0-4.1	1.0-4.1	1.3-4.6	1.3-4.6
Total Input	Rated	kW	0.780	0.780	1.030	1.030	
COP		4.10	4.10	3.88	3.88		
EEL Rank			A	A	A	A	
Operating Current (Max)		A	7.6	7.6	7.6	7.6	
Indoor Unit	Input	Rated	kW	0.026	0.026	0.026	0.026
	Operating Current (Max)		A	0.3	0.3	0.3	0.3
	Dimensions	H x W x D	mm	299 x 798 x 245	299 x 798 x 245	299 x 798 x 245	299 x 798 x 245
	Weight		kg	VGKP: 11, VGK: 10.5	VGKP: 11, VGK: 10.5	VGKP: 11, VGK: 10.5	VGKP: 11, VGK: 10.5
	Air Volume (SLo-Lo-Mid-Hi-Shi ^(*) (Dry/Wet))	Cooling	m ³ /min	3.6- 5.0 - 6.3 - 7.8- 10.5	3.6- 5.0 - 6.3 - 7.8- 10.5	3.6- 5.0 - 6.3 - 7.8 - 11.1	3.6- 5.0 - 6.3 - 7.8 - 11.1
		Heating	m ³ /min	4.0 - 5.0 - 6.6 - 8.0 - 11.8	4.0 - 5.0 - 6.6 - 8.0 - 11.8	4.0 - 5.0 - 6.6 - 8.0 - 11.8	4.0 - 5.0 - 6.6 - 8.0 - 11.8
	Sound Level (SPL) (SLo-Lo-Mid-Hi-Shi) ^(*)	Cooling	dB(A)	18 - 24 - 30 - 36 - 42	18 - 24 - 30 - 36 - 42	18 - 24 - 30 - 36 - 42	18 - 24 - 30 - 36 - 42
		Heating	dB(A)	18 - 24 - 30 - 36 - 42	18 - 24 - 30 - 36 - 42	18 - 24 - 30 - 36 - 42	18 - 24 - 30 - 36 - 42
	Sound Level (PWL)	Cooling	dB(A)	57	57	57	57
	Outdoor Unit	Dimensions	H x W x D	mm	550 x 800 x 285	550 x 800 x 285	550 x 800 x 285
Weight			kg	27	27	28.5	28.5
Air Volume		Cooling	m ³ /min	32.2	32.2	32.2	32.2
		Heating	m ³ /min	29.8	29.8	29.8	29.8
Sound Level (SPL)		Cooling	dB(A)	47	47	49	49
		Heating	dB(A)	48	48	50	50
Sound Level (PWL)		Cooling	dB(A)	59	59	61	61
Operating Current (Max)			A	7.3	7.3	7.3	7.3
Breaker Size			A	10	10	10	10
Ext.Piping		Diameter	Liquid/Gas	mm	6.35 / 9.52	6.35 / 9.52	6.35 / 9.52
	Max.Length	Out-In	m	20	20	20	20
	Max.Height	Out-In	m	12	12	12	12
Guaranteed Operating Range (Outdoor)	Cooling	°C	-10 ~ +46	-10 ~ +46	-10 ~ +46	-10 ~ +46	
	Heating	°C	-20 ~ +24	-20 ~ +24	-20 ~ +24	-20 ~ +24	

(*) Energy consumption based on standard test results. Actual energy consumption will depend on how the appliance is used and where it is located.

(*) SHi: Super High.

Indoor Unit			MSZ-AY42VGK(P)	MSZ-AY42VGH	MSZ-AY50VGK(P)	MSZ-AY50VGH	
Outdoor Unit			MUZ-AY42VG		MUZ-AY50VG		
Refrigerant			R32		R32		
Power Supply	Source		Outdoor Power supply	Outdoor Power supply	Outdoor Power supply	Outdoor Power supply	
	Outdoor (V/Phase/Hz)		230/SinglePhase/50Hz	230/SinglePhase/50Hz	230/SinglePhase/50Hz	230/SinglePhase/50Hz	
Cooling	Design load	kW	4.2	4.2	5.0	5.0	
	Annual electricity consumption ^(*)	kWh/a	186	186	232	232	
	SEER		7.9	7.9	7.5	7.5	
		Energy efficiency class	A++	A++	A++	A++	
	Capacity	Rated	kW	4.2	4.2	5.0	5.0
		Min-Max	kW	0.9-4.5	0.9-4.5	1.4-5.4	1.4-5.4
	SHF		0.77	0.77	0.74	0.74	
	Total Input	Rated	kW	1.300	1.300	1.540	1.540
	EER			3.23	3.23	3.24	3.24
	EEL Rank			A	A	A	A
Heating (Average Season)	Design load	kW	3.8(-10°C)	3.8(-10°C)	4.2(-10°C)	4.2(-10°C)	
	Declared Capacity	at reference design temperature	kW	3.8(-10°C)	3.8(-10°C)	4.2(-10°C)	4.2(-10°C)
		at bivalent temperature	kW	3.8(-10°C)	3.8(-10°C)	4.2(-10°C)	4.2(-10°C)
		at operation limit temperature	kW	2.7(-20°C)	2.7(-20°C)	3.0(-20°C)	3.0(-20°C)
	Back up heating capacity	kW	0.0(-10°C)	0.0(-10°C)	0.0(-10°C)	0.0(-10°C)	
	Annual electricity consumption ^(*)	kWh/a	1131	1146	1248	1265	
	SCOP		4.7	4.6	4.7	4.6	
		Energy efficiency class	A++	A++	A++	A++	
	Capacity	Rated	kW	5.2	5.2	5.5	5.5
		Min-Max	kW	1.3-6.0	1.3-6.0	1.4-7.3	1.4-7.3
Total Input	Rated	kW	1.390	1.390	1.470	1.470	
COP			3.74	3.74	3.74	3.74	
EEL Rank			A	A	A	A	
Operating Current(Max)		A	9.9	9.9	13.8	13.8	
Indoor Unit	Input	Rated	kW	0.032	0.032	0.032	0.032
	Operating Current (Max)		A	0.3	0.3	0.3	0.3
	Dimensions	H x W x D	mm	299 x 798 x 245	299 x 798 x 245	299 x 798 x 245	299 x 798 x 245
	Weight		kg	VGKP:11, VGK:10.5	VGKP:11, VGK:10.5	VGKP:11, VGK:10.5	VGKP:11, VGK:10.5
	Air Volume (SLo-Lo-Mid-Hi-Shi ^(*) (Dry/Wet))	Cooling	m ³ /min	4.5 - 5.7 - 7.0 - 8.4 - 10.5	4.5 - 5.7 - 7.0 - 8.4 - 10.5	5.2 - 6.4 - 7.5 - 9.1 - 11.7	5.2 - 6.4 - 7.5 - 9.1 - 11.7
		Heating	m ³ /min	4.4 - 5.4 - 7.0 - 8.6 - 12.9	4.4 - 5.4 - 7.0 - 8.6 - 12.9	4.8 - 5.7 - 7.3 - 9.1 - 12.9	4.8 - 5.7 - 7.3 - 9.1 - 12.9
	Sound Level (SPL) (SLo-Lo-Mid-Hi-Shi) ^(*)	Cooling	dB(A)	21 - 29 - 34 - 38 - 42	21 - 29 - 34 - 38 - 42	28 - 33 - 36 - 40 - 44	28 - 33 - 36 - 40 - 44
		Heating	dB(A)	21 - 29 - 35 - 40 - 45	21 - 29 - 35 - 40 - 45	28 - 33 - 38 - 43 - 48	28 - 33 - 38 - 43 - 48
	Sound Level (PWL)	Cooling	dB(A)	57	57	58	58
	Outdoor Unit	Dimensions	H x W x D	mm	550 x 800 x 285	550 x 800 x 285	714 x 800 x 285
Weight			kg	34	34	41	41
Air Volume		Cooling	m ³ /min	32.0	32.0	40.5	40.5
		Heating	m ³ /min	28.1	28.1	37.4	37.4
Sound Level (SPL)		Cooling	dB(A)	50	50	52	52
		Heating	dB(A)	51	51	52	52
Sound Level (PWL)		Cooling	dB(A)	61	61	64	64
Operating Current (Max)			A	9.6	9.6	13.5	13.5
Breaker Size			A	10	10	16	16
Ext.Piping		Diameter	Liquid/Gas	mm	6.35 / 9.52	6.35 / 9.52	6.35 / 9.52
	Max.Length	Out-In	m	20	20	20	20
	Max.Height	Out-In	m	12	12	12	12
Guaranteed Operating Range (Outdoor)	Cooling	°C	-10 ~ +46	-10 ~ +46	-10 ~ +46	-10 ~ +46	
	Heating	°C	-20 ~ +24	-20 ~ +24	-20 ~ +24	-20 ~ +24	

(*) Energy consumption based on standard test results. Actual energy consumption will depend on how the appliance is used and where it is located.

(*) SHi: Super High.

Indoor Unit			MSZ-AP15VG/K	MSZ-AP20VG/K	
Outdoor Unit			MUZ-AP15VG	MUZ-AP20VG	
Refrigerant			R32	R32	
Power Source			Outdoor Power supply	Outdoor Power supply	
Supply (V/Phase/Hz)			230V/Single/50Hz	230V/Single/50Hz	
Cooling	Design Load	kW	1.5	2.0	
	Annual Electricity Consumption ^(*)	kWh/a	72	81	
	SEER		7.2	8.6	
	Energy Efficiency Class		A++	A+++	
	Capacity	Rated	kW	1.5	2.0
		Min-Max	kW	0.5-2.2	0.6-2.7
	SHF		0.86	0.8	
	Total Input	Rated	kW	0.370	0.460
	EER		4.05	4.35	
	EEL Rank		A	A	
Heating (Average Season)	Design Load	kW	1.6(-10°C)	2.3(-10°C)	
	Declared Capacity	at reference design temperature	kW	1.6(-10°C)	2.3(-10°C)
		at bivalent temperature	kW	1.6(-10°C)	2.3(-10°C)
		at operation limit temperature	kW	1.6(-15°C)	2.2(-15°C)
	Back up heating capacity	kW	0.0(-10°C)	0.0(-10°C)	
	Annual Electricity Consumption ^(*)	kWh/a	559	766	
	SCOP		4.0	4.2	
	Energy Efficiency Class		A+	A+	
	Capacity	Rated	kW	2.0	2.5
		Min-Max	kW	0.5-3.1	0.5-3.5
Total Input	Rated	kW	0.500	0.600	
COP		4.00	4.17		
EEL Rank		A	A		
Operating Current (Max)			A	5.5	7.0
Indoor Unit	Input	Rated	kW	0.017	0.019
	Operating Current (Max)		A	0.17	0.2
	Dimensions	HxWxD	mm	250x760x178	250x760x178
	Weight		kg	8.2	8.2
	Air Volume (SLo-Lo-Mid-Hi-Shi ^(*) (Dry/Wet))	Cooling	m ³ /min	3.5 - 3.9 - 4.6 - 5.5 - 6.4	3.5 - 3.9 - 4.6 - 5.5 - 6.9
		Heating	m ³ /min	3.7 - 4.4 - 5.0 - 6.0 - 6.8	3.7 - 4.4 - 5.0 - 6.0 - 7.3
	Sound Level (SPL) (SLo-Lo-Mid-Hi-Shi ^(*))	Cooling	dB(A)	21 - 26 - 30 - 35 - 40	21 - 26 - 30 - 35 - 42
		Heating	dB(A)	21 - 26 - 30 - 35 - 40	21 - 26 - 30 - 35 - 42
	Sound Level (PWL)	Cooling	dB(A)	59	60
	Outdoor Unit	Dimensions	HxWxD	mm	538x699x249
Weight			kg	23	31
Air Volume		Cooling	m ³ /min	26	32.2
		Heating	m ³ /min	21	29.8
Sound Level (SPL)		Cooling	dB(A)	50	47
		Heating	dB(A)	50	48
Sound Level (PWL)		Cooling	dB(A)	63	59
Operating Current (Max)			A	5.3	6.8
Breaker Size			A	10	10
Ext.Piping		Diameter	Liquid/Gas	mm	6.35 / 9.52
	Max.Length	Out-In	m	20	20
	Max.Height	Out-In	m	12	12
Guaranteed Operating Range (Outdoor)	Cooling	°C	-10 ~ +46	-10 ~ +46	
	Heating	°C	-15 ~ +24	-15 ~ +24	

(*) Energy consumption based on standard test results. Actual energy consumption will depend on how the appliance is used and where it is located.

(*)2 SHi: Super High.

Indoor Unit			MSZ-AP60VG/K	MSZ-AP71VG/K		
Outdoor Unit			MUZ-AP60VG	MUZ-AP71VG		
Refrigerant			R32	R32		
Power Supply			Outdoor Power supply 230V/SinglePhase/50Hz	Outdoor Power supply 230V/SinglePhase/50Hz		
Cooling	Source					
	Outdoor (V/Phase/Hz)					
	Design load	kW	6.1	7.1		
	Annual electricity consumption ^(*)	kWh/a	288	345		
	SEER		7.4	7.2		
	Energy efficiency class		A++	A++		
	Capacity	Rated	kW	6.1	7.1	
		Min-Max	kW	1.4-7.3	2.0-8.7	
	SHF			0.83	0.77	
	Total Input	Rated	kW	1.590	2.010	
EER			3.84	3.53		
EEL Rank			A	A		
Heating (Average Season)	Design load		kW	4.6(-10°C)	6.7(-10°C)	
	Declared Capacity	at reference design temperature	kW	4.6(-10°C)	6.7(-10°C)	
		at bivalent temperature	kW	4.6(-10°C)	6.7(-10°C)	
		at operation limit temperature	kW	3.7(-15°C)	5.4(-15°C)	
	Back up heating capacity		kW	0.0(-10°C)	0.0(-10°C)	
	Annual electricity consumption ^(*)		kWh/a	1398	2132	
	SCOP			4.6	4.4	
	Energy efficiency class			A++	A+	
	Capacity	Rated	kW	6.8	8.1	
		Min-Max	kW	2.0-8.6	2.2-10.3	
Total Input	Rated	kW	1.670	2.120		
COP			4.07	3.82		
EEL Rank			A	A		
Operating Current (Max)			A	14.1	16.4	
Indoor Unit	Input		Rated	kW	0.049	0.045
	Operating Current (Max)		A	0.5	0.4	
	Dimensions		H x W x D	mm	325 x 1100 x 257	325 x 1100 x 257
	Weight		kg	16	17	
	Air Volume (SLo-Lo-Mid-Hi-Shi ^(*) (Dry/Wet))	Cooling	m³/min	9.4 - 11.0 - 13.2 - 16.0 - 18.9	9.6 - 11.5 - 13.2 - 15.3 - 18.6	
		Heating	m³/min	10.8 - 13.4 - 15.4 - 17.4 - 20.3	10.2 - 11.5 - 13.2 - 15.3 - 19.2	
	Sound Level (SPL) (SLo-Lo-Mid-Hi-Shi ^(*))	Cooling	dB(A)	29 - 37 - 41 - 45 - 48	30 - 37 - 41 - 45 - 49	
		Heating	dB(A)	30 - 37 - 41 - 45 - 48	30 - 37 - 41 - 45 - 51	
	Sound Level (PWL)		Cooling	dB(A)	65	65
	Outdoor Unit	Dimensions		H x W x D	mm	714 x 800 x 285
Weight		kg	40	55		
Air Volume		Cooling	m³/min	52.1	54.1	
		Heating	m³/min	52.1	47.9	
Sound Level (SPL)		Cooling	dB(A)	56	56	
		Heating	dB(A)	57	55	
Sound Level (PWL)		Cooling	dB(A)	69	69	
Operating Current (Max)		A	13.6	16.0		
Breaker Size		A	16	20		
Ext.Piping		Diameter	Liquid/Gas	mm	6.35 / 12.7	6.35 / 12.7
	Max.Length	Out-In	m	30	30	
	Max.Height	Out-In	m	15	15	
Guaranteed Operating Range (Outdoor)	Cooling		°C	-10~+46	-10~+46	
	Heating		°C	-15~+24	-15~+24	

(*) Energy consumption based on standard test results. Actual energy consumption will depend on how the appliance is used and where it is located.

(*) SHi: Super High.

Indoor Unit				MSZ-HR25VF MSZ-HR25VFK	MSZ-HR35VF MSZ-HR35VFK	MSZ-HR42VF MSZ-HR42VFK	MSZ-HR50VF MSZ-HR50VFK
Outdoor Unit				MUZ-HR25VF	MUZ-HR35VF	MUZ-HR42VF	MUZ-HR50VF
Refrigerant				R32			
Power Supply	Source	Outdoor Power supply					
	Outdoor(V/Phase/Hz)	230V/Single/50Hz					
Cooling	Design load	kW	2.5	3.4	4.2	5.0	
	Annual electricity consumption (*)	kWh/a	141	191	226	269	
	SEER		6.2	6.2	6.5	6.5	
		Energy efficiency class		A++	A++	A++	A++
	Capacity	Rated	kW	2.5	3.4	4.2	5.0
		Min-Max	kW	0.5-2.9	0.9-3.4	1.1-4.6	1.3-5.0
	SHF		0.78	0.78	0.74	0.73	
	Total Input	Rated	kW	0.800	1.210	1.340	2.050
	EER		3.13	2.81	3.13	2.44	
	EEL Rank		B	C	B	D or less	
Heating (Average Season)	Design load	kW	1.9(-10°C)	2.4(-10°C)	2.9(-10°C)	3.8(-10°C)	
	Declared Capacity	at reference design temperature	kW	1.9(-10°C)	2.4(-10°C)	2.9(-10°C)	3.8(-10°C)
		at bivalent temperature	kW	1.9(-10°C)	2.4(-10°C)	2.9(-10°C)	3.8(-10°C)
		at operation limit temperature	kW	1.9(-10°C)	2.4(-10°C)	2.9(-10°C)	3.8(-10°C)
	Back up heating capacity	kW	0.0(-10°C)	0.0(-10°C)	0.0(-10°C)	0.0(-10°C)	
	Annual electricity consumption (*)	kWh/a	614	781	928	1224	
	SCOP		4.3	4.3	4.3	4.3	
		Energy efficiency class		A+	A+	A+	A+
	Capacity	Rated	kW	3.15	3.6	4.7	5.4
		Min-Max	kW	0.7-3.5	0.9-3.7	0.9-5.4	1.4-6.5
Total Input	Rated	kW	0.850	0.975	1.300	1.550	
COP		3.71	3.69	3.62	3.48		
EEL Rank		A	A	A	B		
Heating (Warmer Season)	Design load	kW	1.1(2°C)	1.3(2°C)	1.6(2°C)	2.1(2°C)	
	Declared Capacity	at reference design temperature	kW	1.1(2°C)	1.3(2°C)	1.6(2°C)	2.1(2°C)
		at bivalent temperature	kW	1.1(2°C)	1.3(2°C)	1.6(2°C)	2.1(2°C)
		at operation limit temperature	kW	1.9(-10°C)	2.4(-10°C)	2.9(-10°C)	3.8(-10°C)
	Back up heating capacity	kW	0.0(2°C)	0.0(2°C)	0.0(2°C)	0.0(2°C)	
	Annual electricity consumption (*)	kWh/a	289	344	427	558	
	SCOP		5.3	5.2	5.2	5.2	
Energy efficiency class		A+++	A+++	A+++	A+++		
Operating Current(Max)		A	5.0	6.7	8.5	10.0	
Indoor Unit	Input	Rated	kW	0.020	0.028	0.032	0.039
	Operating Current(Max)		A	0.2	0.27	0.3	0.36
	Dimensions	H x W x D	mm	280 x 838 x 228	280 x 838 x 228	280 x 838 x 228	280 x 838 x 228
	Weight		kg	8.5	8.5	9	9
	Air Volume	Cooling	m ³ /min	3.6 - 5.4 - 7.2 - 9.7	3.6 - 5.6 - 7.8 - 11.7	6.0 - 8.7 - 10.8 - 13.1	6.4 - 9.2 - 11.2 - 13.1
		Heating	m ³ /min	3.3 - 5.4 - 7.4 - 10.1	3.3 - 5.4 - 7.4 - 10.5	5.6 - 7.9 - 10.8 - 13.4	6.1 - 8.3 - 11.2 - 14.5
	Sound Level (SPL)	Cooling	dB(A)	21 - 30 - 37 - 43	22 - 31 - 38 - 46	24 - 34 - 39 - 45	28 - 36 - 40 - 45
		Heating	dB(A)	21 - 30 - 37 - 43	21 - 30 - 37 - 44	24 - 32 - 40 - 46	27 - 34 - 41 - 47
Sound Level (PWL)	Cooling	dB(A)	57	60	60	60	
Outdoor Unit	Dimensions	H x W x D	mm	538 x 699 x 249	538 x 699 x 249	550 x 800 x 285	550 x 800 x 285
	Weight		kg	23	22	32.5	34
	Air Volume	Cooling	m ³ /min	30.3	32.2	30.4	30.4
		Heating	m ³ /min	30.3	32.2	32.7	32.7
	Sound Level (SPL)	Cooling	dB(A)	50	51	50	50
		Heating	dB(A)	50	51	51	51
	Sound Level (PWL)	Cooling	dB(A)	63	64	64	64
	Operating Current(Max)		A	4.8	6.4	8.2	9.6
Breaker Size		A	10	10	10	12	
Ext.Piping	Diameter	Liquid/Gas	mm	6.35/9.52	6.35/9.52	6.35/9.52	6.35/9.52
	Max.Length	Out-In	m	20	20	20	20
	Max.Height	Out-In	m	12	12	12	12
Guaranteed Operating Range(Outdoor)	Cooling	°C	-10 ~ +46	-10 ~ +46	-10 ~ +46	-10 ~ +46	
	Heating	°C	-10 ~ +24	-10 ~ +24	-10 ~ +24	-10 ~ +24	

(*) Energy consumption based on standard test results. Actual energy consumption will depend on how the appliance is used and where it is located.

(*) SHi: Super High.

SPECIFICATIONS

WALL-MOUNTED

Indoor Unit				MSZ-HR60VF MSZ-HR60VFK	MSZ-HR71VF MSZ-HR71VFK	
Outdoor Unit				MUZ-HR60VF	MUZ-HR71VF	
Refrigerant				R32	R32	
Power Supply	Source			Outdoor Power supply	Outdoor Power supply	
	Outdoor(V/Phase/Hz)			230/Single/50	230/Single/50	
Cooling	Design load		kW	6.1	7.1	
	Annual electricity consumption (*1)		kWh/a	296	355	
	SEER			7.2	7.0	
	Energy efficiency class			A++	A++	
	Capacity	Rated	kW	6.1	7.1	
		Min-Max	kW	1.7-7.1	1.8-7.3	
	SHF			0.79	0.74	
	Total Input	Rated	kW	1.810	2.330	
	EER			3.37	3.05	
	EEL Rank			A	B	
Heating (Average Season)	Design load		kW	4.6(-10°C)	5.4(-10°C)	
	Declared Capacity	at reference design temperature	kW	4.6(-10°C)	5.4(-10°C)	
		at bivalent temperature	kW	4.6(-10°C)	5.4(-10°C)	
		at operation limit temperature	kW	4.6(-10°C)	5.4(-10°C)	
	Back up heating capacity		kW	0.0(-10°C)	0.0(-10°C)	
	Annual electricity consumption (*1)		kWh/a	1430	1755	
	SCOP			4.5	4.3	
	Energy efficiency class			A+	A+	
	Capacity	Rated	kW	6.8	8.1	
		Min-Max	kW	1.5-8.5	1.5-9.0	
Total Input	Rated	kW	1.810	2.440		
COP			3.76	3.32		
EEL Rank			A	C		
Heating (Warmer Season)	Design load		kW	2.5(2°C)	3.0(2°C)	
	Declared Capacity	at reference design temperature	kW	2.5(2°C)	3.0(2°C)	
		at bivalent temperature	kW	2.5(2°C)	3.0(2°C)	
		at operation limit temperature	kW	4.6(-10°C)	5.4(-10°C)	
	Back up heating capacity		kW	0.0(2°C)	0.0(2°C)	
	Annual electricity consumption (*1)		kWh/a	640	802	
	SCOP			5.4	5.2	
	Energy efficiency class			A+++	A+++	
	Operating Current(Max)			A	14.1	
	Indoor Unit	Input	Rated	kW	0.055	0.055
Operating Current(Max)		A	0.5	0.5		
Dimensions		H x W x D	mm	305 x 923 x 262	305 x 923 x 262	
Weight		kg	12.5	12.5		
Air Volume		Cooling	m ³ /min	10.4-12.6-15.4-19.6	10.4-12.6-15.4-19.6	
		(SLo-Lo-Mid-Hi-SHi(*2) (Dry/Wet)) Heating	m ³ /min	10.7-13.1-16.7-19.6	10.7-13.1-16.7-19.6	
Sound Level (SPL)		Cooling	dB(A)	33 - 38 - 44 - 50	33 - 38 - 44 - 50	
		(SLo-Lo-Mid-Hi-SHi(*2)) Heating	dB(A)	33 - 38 - 44 - 50	33 - 38 - 44 - 50	
Sound Level (PWL)		Cooling	dB(A)	65	65	
Outdoor Unit		Dimensions		H x W x D	mm	714 x 800 x 285
	Weight		kg	40	40	
	Air Volume	Cooling	m ³ /min	42.8	42.8	
		Heating	m ³ /min	48.3	48.3	
	Sound Level (SPL)	Cooling	dB(A)	53	53	
		Heating	dB(A)	57	57	
	Sound Level (PWL)	Cooling	dB(A)	65	66	
	Operating Current(Max)		A	13.6	13.6	
	Breaker Size		A	16	16	
	Ext.Piping	Diameter	Liquid/Gas	mm	6.35/12.7	6.35/12.7
Max.Length		Out-In	m	30	30	
Max.Height		Out-In	m	15	15	
Guaranteed Operating Range(Outdoor)	Cooling	°C	-10 ~ +46	-10 ~ +46		
	Heating	°C	-10 ~ +24	-10 ~ +24		

(*1) Energy consumption based on standard test results. Actual energy consumption will depend on how the appliance is used and where it is located.

(*2) SHi: Super High.

Indoor Unit			MSY-TP35VF	MSY-TP50VF			
Outdoor Unit			MUY-TP35VF	MUY-TP50VF			
Refrigerant			R32	R32			
Power Supply	Source		Indoor Power supply	Indoor Power supply			
	Outdoor(V/Phase/Hz)		230V/SinglePhase/50Hz	230V/SinglePhase/50Hz			
Cooling	Design load		kW	3.5	5.0		
	Annual electricity consumption ^(*)		kWh/a	136	218		
	SEER			9.0	8.0		
	Energy efficiency class			A+++	A++		
	Capacity	Rated		kW	3.5	5.0	
		Min-Max		kW	1.5 - 4.0	1.5 - 5.7	
	SHF			0.98	0.82		
	Total Input		Rated	kW	0.760	1.450	
	EER			4.61	3.45		
	EEL Rank			A	A		
Operating Current(Max)			A	9.6	9.6		
Indoor Unit	Input		Rated	kW	0.033	0.034	
	Operating Current(Max)			A	0.4	0.4	
	Dimensions		H x W x D	mm	305 x 923 x 250	305 x 923 x 250	
	Weight			kg	12.5	12.5	
	Air Volume (Lo-Mid-Hi-Shi ^(*) (Dry/Wet))		Cooling	m ³ /min	10.1 - 11.6 - 13.7 - 16.4	10.1 - 11.6 - 13.7 - 16.4	
	Sound Level (SPL) (Lo-Mid-Hi-Shi ^(*))		Cooling	dB(A)	31 - 36 - 40 - 45	31 - 36 - 40 - 45	
	Sound Level (PWL)		Cooling	dB(A)	60	60	
	Breaker Size			A	10	10	
	Outdoor Unit	Dimensions		H x W x D	mm	550 x 800 x 285	550 x 800 x 285
		Weight			kg	33	33
Air Volume		Cooling	m ³ /min	29.3	29.3		
Sound Level (SPL)		Cooling	dB(A)	45	47		
Sound Level (PWL)		Cooling	dB(A)	58	61		
Operating Current(Max)			A	9.2	9.2		
Ext.Piping	Diameter		Liquid/Gas	mm	6.35/9.52	6.35/9.52	
	Max.Length		Out-In	m	20	20	
	Max.Height		Out-In	m	12	12	
Guaranteed Operating Range(Outdoor)			Cooling	°C	-25 ~ +46	-25 ~ +46	

(*) Energy consumption based on standard test results. Actual energy consumption will depend on how the appliance is used and where it is located.

(*) SHi: Super High.

Indoor Unit				MSZ-FH25VE2	MSZ-FH35VE2	MSZ-FH50VE2	
Outdoor Unit				MUZ-FH25VE	MUZ-FH35VE	MUZ-FH50VE	
Refrigerant				R410A	R410A	R410A	
Power Supply				Outdoor Power supply	Outdoor Power supply	Outdoor Power supply	
Source				230V/Single/50Hz	230V/Single/50Hz	230V/Single/50Hz	
Outdoor (V/Phase/Hz)				230V/Single/50Hz	230V/Single/50Hz	230V/Single/50Hz	
Cooling	Design load		kW	2.5	3.5	5	
	Annual electricity consumption ^(*)		kWh/a	96	138	244	
	SEER			9.1	8.9	7.2	
		Energy efficiency class		A+++	A+++	A++	
	Capacity	Rated		kW	2.5	3.5	5.0
		Min - Max		kW	1.4 - 3.5	0.8 - 4.0	1.9 - 6.0
	SHF				0.95	0.84	0.73
	Total Input	Rated		kW	0.485	0.820	1.38
	EER				5.15	4.27	3.62
		EEL Rank			A	A	A
Heating (Average Season)	Design load		kW	3.0(-10°C)	3.6(-10°C)	4.5(-10°C)	
	Declared Capacity	at reference design temperature		kW	3.0(-10°C)	3.6(-10°C)	4.5(-10°C)
		at bivalent temperature		kW	3.0(-10°C)	3.6(-10°C)	4.5(-10°C)
		at operation limit temperature		kW	2.5(-15°C)	3.2(-15°C)	5.2(-15°C)
	Back up heating capacity		kW	0.0(-10°C)	0.0(-10°C)	0.0(-10°C)	
	Annual electricity consumption ^(*)		kWh/a	819	986	1372	
	SCOP			5.1	5.1	4.6	
		Energy efficiency class		A+++	A+++	A++	
	Capacity	Rated		kW	3.2	4.0	6.0
		Min - Max		kW	1.8 - 5.5	1.0 - 6.3	1.7 - 8.7
	Total Input	Rated		kW	0.580	0.800	1.48
	COP				5.52	5.00	4.05
		EEL Rank			A	A	A
Operating Current (Max)			A	10.0	10.0	14.0	
Indoor Unit	Input	Rated	kW	0.029	0.029	0.031	
	Operating Current (Max)		A	0.4	0.4	0.4	
	Dimensions	H x W x D	mm	305(+17) x 925 x 234	305(+17) x 925 x 234	305(+17) x 925 x 234	
	Weight		kg	13.5	13.5	13.5	
	Air Volume (Silent-Lo-Mid-Hi-SHi ^(*) (Dry/Wet))	Cooling		m ³ /min	3.9 - 4.7 - 6.3 - 8.6 - 11.6(10.5)	3.9 - 4.7 - 6.3 - 8.6 - 11.6(10.5)	6.4 - 7.4 - 8.6 - 10.1 - 12.4
		Heating		m ³ /min	4.0 - 4.7 - 6.4 - 9.2 - 13.2	4.0 - 4.7 - 6.4 - 9.2 - 13.2	5.7 - 7.2 - 9.0 - 11.2 - 14.6
	Sound Level (SPL) (Silent-Lo-Mid-Hi-SHi ^(*))	Cooling		dB(A)	20 - 23 - 29 - 36 - 42	21 - 24 - 29 - 36 - 42	27 - 31 - 35 - 39 - 44
		Heating		dB(A)	20 - 24 - 29 - 36 - 44	21 - 24 - 29 - 36 - 44	25 - 29 - 34 - 39 - 46
Sound Level (PWL)	Cooling		dB(A)	58	58	60	
Outdoor Unit	Dimensions	H x W x D	mm	550 x 800 x 285	550 x 800 x 285	880 x 840 x 330	
	Weight		kg	37	37	55	
	Air Volume	Cooling		m ³ /min	31.3	33.6	48.8
		Heating		m ³ /min	31.3	33.6	51.3
	Sound Level (SPL)	Cooling		dB(A)	46	49	51
		Heating		dB(A)	49	50	54
	Sound Level (PWL)	Cooling		dB(A)	60	61	64
		Heating		dB(A)	60	61	64
	Operating Current (Max)		A	9.6	9.6	13.6	
	Breaker Size		A	10	10	16	
Ext.Piping	Diameter	Liquid/Gas	mm	6.35/9.52	6.35/9.52	6.35/12.7	
	Max.Length	Out-In	m	20	20	30	
	Max.Height	Out-In	m	12	12	15	
Guaranteed Operating Range (Outdoor)	Cooling		°C	-10 ~ +46	-10 ~ +46	-10 ~ +46	
	Heating		°C	-15 ~ +24	-15 ~ +24	-15 ~ +24	

(*) Energy consumption based on standard test results. Actual energy consumption will depend on how the appliance is used and where it is located.

(*) SHi: Super High.

Indoor Unit				MSZ-FH25VE2	MSZ-FH35VE2	MSZ-FH50VE2	
Outdoor Unit				MUZ-FH25VEHZ	MUZ-FH35VEHZ	MUZ-FH50VEHZ	
Refrigerant				R410A	R410A	R410A	
Power Supply				Outdoor Power supply	Outdoor Power supply	Outdoor Power supply	
Outdoor (V/Phase/Hz)				230V/Single/50Hz	230V/Single/50Hz	230V/Single/50Hz	
Cooling	Design load		kW	2.5	3.5	5.0	
	Annual electricity consumption (*1)		kWh/a	96	138	244	
	SEER			9.1	8.9	7.2	
	Energy efficiency class			A+++	A+++	A++	
	Capacity	Rated	kW	2.5	3.5	5.0	
		Min. - Max.	kW	0.8 - 3.5	0.8 - 4.0	1.9 - 6.0	
	SHF			0.95	0.84	0.73	
	Total Input		Rated	kW	0.485	0.820	1.38
	EER			5.15	4.27	3.62	
	EEL Rank			A	A	A	
Heating (Average Season)	Design load		kW	3.2(-10°C)	4.0(-10°C)	6.0(-10°C)	
	Declared Capacity	at reference design temperature	kW	3.2(-10°C)	4.0(-10°C)	6.0(-10°C)	
		at bivalent temperature	kW	3.2(-10°C)	4.0(-10°C)	6.0(-10°C)	
		at operation limit temperature	kW	1.7(-25°C)	2.6(-25°C)	3.8(-25°C)	
	Back up heating capacity		kW	0.0(-10°C)	0.0(-10°C)	0.0(-10°C)	
	Annual electricity consumption (*1)		kWh/a	924	1173	2006	
	SCOP			4.9	4.8	4.2	
	Energy efficiency class			A++	A++	A+	
	Capacity	Rated	kW	3.2	4.0	6.0	
		Min. - Max.	kW	1.0 - 6.3	1.0 - 6.6	1.7 - 8.7	
	Total Input		Rated	kW	0.580	0.800	1.48
	COP			5.52	5.00	4.05	
	EEL Rank			A	A	A	
Operating Current (Max)			A	10.0	10.5	14.0	
Indoor Unit	Input		Rated	kW	0.029	0.029	0.031
	Operating Current (Max)			A	0.4	0.4	0.4
	Dimensions		H x W x D	mm	305(+17) x 925 x 234	305(+17) x 925 x 234	305(+17) x 925 x 234
	Weight			kg	13.5	13.5	13.5
	Air Volume (SLo-Lo-Mid-Hi-SHi (*2) (Dry/Wet))	Cooling	m³/min.	3.9 - 4.7 - 6.3 - 8.6 - 11.6(10.5)	3.9 - 4.7 - 6.3 - 8.6 - 11.6(10.5)	6.4 - 7.4 - 8.6 - 10.1 - 12.4	
		Heating	m³/min.	4.0 - 4.7 - 6.4 - 9.2 - 13.2	4.0 - 4.7 - 6.4 - 9.2 - 13.2	5.7 - 7.2 - 9.0 - 11.2 - 14.6	
	Sound Level (SPL) (SLo-Lo-Mid-Hi-SHi (*2))	Cooling	dB(A)	20 - 23 - 29 - 36 - 42	21 - 24 - 29 - 36 - 42	27 - 31 - 35 - 39 - 44	
		Heating	dB(A)	20 - 24 - 29 - 36 - 44	21 - 24 - 29 - 36 - 44	25 - 29 - 34 - 39 - 46	
Sound Level (PWL)		Cooling	dB(A)	58	58	60	
Outdoor Unit	Dimensions		H x W x D	mm	550 x 800 x 285	550 x 800 x 285	880 x 840 x 330
	Weight			kg	37	37	55
	Air Volume	Cooling	m³/min.	31.3	33.6	48.8	
		Heating	m³/min.	31.3	33.6	51.3	
	Sound Level (SPL)	Cooling	dB(A)	46	49	51	
		Heating	dB(A)	49	50	54	
	Sound Level (PWL)		Cooling	dB(A)	60	61	64
	Operating Current (Max)			A	9.2	10.1	13.6
	Breaker Size			A	10	12	16
	Ext.Piping	Diameter		Liquid/Gas	mm	6.35/9.52	6.35/9.52
Max.Length		Out-In	m	20	20	30	
Max.Height		Out-In	m	12	12	15	
Guaranteed Operating Range (Outdoor)		Cooling	°C	-10 ~ +46	-10 ~ +46	-10 ~ +46	
		Heating	°C	-25 ~ +24	-25 ~ +24	-25 ~ +24	

(*1) Energy consumption based on standard test results. Actual energy consumption will depend on how the appliance is used and where it is located.

(*2) SHi: Super High.

SPECIFICATIONS

WALL-MOUNTED

Indoor Unit			MSZ-EF18VG/K	MSZ-EF22VG/K	MSZ-EF25VG/K	MSZ-EF25VG/K	
Outdoor Unit			for Multi connection	for Multi connection	MUZ-EF25VG	MUZ-EF25VGH	
Refrigerant			R32	R32	R32	R32	
Power Supply	Source		Outdoor Power supply	Outdoor Power supply	Outdoor Power supply	Outdoor Power supply	
	Outdoor(V/Phase/Hz)		230/Single/50	230/Single/50	230/Single/50	230/Single/50	
Cooling	Design load	kW	-	-	2.5	2.5	
	Annual electricity consumption (*1)	kWh/a	-	-	96	96	
	SEER		-	-	9.1	9.1	
	Energy efficiency class				A+++	A+++	
	Capacity	Rated	kW	-	-	2.5	2.5
		Min-Max	kW	-	-	0.9-3.4	0.9-3.4
	SHF				0.97	0.97	
	Total Input	Rated	kW	-	-	0.540	0.540
	EER				4.63	4.63	
	EEL Rank				A	A	
Heating (Average Season)	Design load	kW	-	-	2.4(-10°C)	2.4(-10°C)	
	Declared Capacity	at reference design temperature	kW	-	-	2.4(-10°C)	2.4(-10°C)
		at bivalent temperature	kW	-	-	2.4(-10°C)	2.4(-10°C)
		at operation limit temperature	kW	-	-	2.0(-15°C)	1.6(-20°C)
		Back up heating capacity	kW	-	-	0.0(-10°C)	0.0(-10°C)
	Annual electricity consumption (*1)	kWh/a	-	-	713	727	
	SCOP				4.7	4.6	
	Energy efficiency class				A++	A++	
	Capacity	Rated	kW	-	-	3.2	3.2
		Min-Max	kW	-	-	1.0-4.2	1.0-4.2
Total Input	Rated	kW	-	-	0.700	0.700	
COP				4.57	4.57		
EEL Rank				A	A		
Heating (Warmer Season)	Design load	kW	-	-	1.3(2°C)	1.3(2°C)	
	Declared Capacity	at reference design temperature	kW	-	-	1.3(2°C)	1.3(2°C)
		at bivalent temperature	kW	-	-	1.3(2°C)	1.3(2°C)
		at operation limit temperature	kW	-	-	2.0(-15°C)	2.0(-15°C)
		Back up heating capacity	kW	-	-	0.0(2°C)	0.0(2°C)
	Annual electricity consumption (*1)	kWh/a	-	-	311	311	
	SCOP				5.9	5.9	
Energy efficiency class				A+++	A+++		
Operating Current(Max)		A	-	-	7.1	7.1	
Indoor Unit	Input	Rated	kW	0.026	0.026	0.026	
	Operating Current(Max)		A	0.3	0.3	0.3	
	Dimensions	H x W x D	mm	299 x 885 x 195	299 x 885 x 195	299 x 885 x 195	
	Weight		kg	11.5	11.5	11.5	
	Air Volume (SLo-Lo-Mid-Hi-SHi(*2)(Dry/Wet))	Cooling	m ³ /min	4.0 - 4.6 - 6.3 - 8.3 - 10.5	4.0 - 4.6 - 6.3 - 8.3 - 10.5	4.0 - 4.6 - 6.3 - 8.3 - 10.5	
		Heating	m ³ /min	4.0 - 4.6 - 6.2 - 8.9 - 11.9	4.0 - 4.6 - 6.2 - 8.9 - 11.9	4.0 - 4.6 - 6.2 - 8.9 - 11.9	
	Sound Level (SPL) (SLo-Lo-Mid-Hi-SHi(*2))	Cooling	dB(A)	19 - 23 - 29 - 36 - 42	19 - 23 - 29 - 36 - 42	19 - 23 - 29 - 36 - 42	
		Heating	dB(A)	21 - 24 - 29 - 37 - 45	21 - 24 - 29 - 37 - 45	21 - 24 - 29 - 37 - 45	
Sound Level (PWL)	Cooling	dB(A)	60	60	60		
Outdoor Unit	Dimensions	H x W x D	mm	-	550 x 800 x 285	550 x 800 x 285	
	Weight		kg	-	31	31	
	Air Volume	Cooling	m ³ /min	-	-	27.8	
		Heating	m ³ /min	-	-	29.8	
	Sound Level (SPL)	Cooling	dB(A)	-	-	47	
		Heating	dB(A)	-	-	48	
	Sound Level (PWL)	Cooling	dB(A)	-	-	58	
	Operating Current(Max)		A	-	-	6.8	
Breaker Size		A	-	-	10		
Ext.Piping	Diameter	Liquid/Gas	mm	-	6.35 / 9.52	6.35 / 9.52	
	Max.Length	Out-In	m	-	20	20	
	Max.Height	Out-In	m	-	12	12	
Guaranteed Operating Range(Outdoor)	Cooling	°C	-	-	-10 ~ +46	-10 ~ +46	
	Heating	°C	-	-	-15 ~ +24	-20 ~ +24	

(*1) Energy consumption based on standard test results. Actual energy consumption will depend on how the appliance is used and where it is located.

(*2) SHi: Super High.

Indoor Unit			MSZ-EF35VG/K	MSZ-EF35VG/K	MSZ-EF42VG/K	MSZ-EF50VG/K	
Outdoor Unit			MUZ-EF35VG	MUZ-EF35VGH	MUZ-EF42VG	MUZ-EF50VG	
Refrigerant			R32	R32	R32	R32	
Power Supply	Source		Outdoor Power supply	Outdoor Power supply	Outdoor Power supply	Outdoor Power supply	
	Outdoor(V/Phase/Hz)		230/Single/50	230/Single/50	230/Single/50	230/Single/50	
Cooling	Design load	kW	3.5	3.5	4.2	5.0	
	Annual electricity consumption ^(*)	kWh/a	139	139	186	233	
	SEER		8.8	8.8	7.9	7.5	
	Energy efficiency class			A+++	A+++	A++	A++
	Capacity	Rated	kW	3.5	3.5	4.2	5.0
		Min-Max	kW	1.1-4.0	1.1-4.0	0.9-4.6	1.4-5.4
	SHF			0.8	0.74	0.7	
	Total Input	Rated	kW	0.910	0.910	1.200	1.540
	EER			3.85	3.85	3.50	3.25
	EEL Rank			A	A	A	A
Heating (Average Season)	Design load	kW	2.9(-10°C)	2.9(-10°C)	3.8(-10°C)	4.2(-10°C)	
	Declared Capacity	at reference design temperature	kW	2.9(-10°C)	2.9(-10°C)	3.8(-10°C)	4.2(-10°C)
		at bivalent temperature	kW	2.9(-10°C)	2.9(-10°C)	3.8(-10°C)	4.2(-10°C)
		at operation limit temperature	kW	2.4(-15°C)	1.7(-20°C)	3.4(-15°C)	3.5(-15°C)
	Back up heating capacity	kW	0.0(-10°C)	0.0(-10°C)	0.0(-10°C)	0.0(-10°C)	
	Annual electricity consumption ^(*)	kWh/a	882	900	1151	1304	
	SCOP		4.6	4.5	4.6	4.5	
	Energy efficiency class			A++	A+	A++	A+
	Capacity	Rated	kW	4.0	4.0	5.4	5.8
		Min-Max	kW	1.3-5.1	1.3-5.1	1.3-6.3	1.4-7.5
Total Input	Rated	kW	0.950	0.950	1.455	1.560	
COP			4.21	4.21	3.71	3.72	
EEL Rank			A	A	A	A	
Heating (Warmer Season)	Design load	kW	1.6(2°C)	1.6(2°C)	2.1(2°C)	2.3(2°C)	
	Declared Capacity	at reference design temperature	kW	1.6(2°C)	1.6(2°C)	2.1(2°C)	2.3(2°C)
		at bivalent temperature	kW	1.6(2°C)	1.6(2°C)	2.1(2°C)	2.3(2°C)
		at operation limit temperature	kW	2.4(-15°C)	2.4(-15°C)	3.4(-15°C)	3.5(-15°C)
	Back up heating capacity	kW	0.0(2°C)	0.0(2°C)	0.0(2°C)	0.0(2°C)	
	Annual electricity consumption ^(*)	kWh/a	398	398	489	595	
	SCOP		5.6	5.6	6.0	5.4	
	Energy efficiency class			A+++	A+++	A+++	A+++
Operating Current(Max)		A	7.1	7.1	10.0	14	
Indoor Unit	Input	Rated	kW	0.030	0.030	0.033	0.043
	Operating Current(Max)		A	0.3	0.3	0.4	0.4
	Dimensions	H x W x D	mm	299 x 885 x 195	299 x 885 x 195	299 x 885 x 195	299 x 885 x 195
	Weight		kg	11.5	11.5	11.5	11.5
	Air Volume (SLo-Lo-Mid-Hi-SHi ^(*) (Dry/Wet))	Cooling	m ³ /min	4.0 - 4.6 - 6.3 - 8.3 - 10.5	4.0 - 4.6 - 6.3 - 8.3 - 10.5	5.8 - 6.6 - 7.7 - 8.9 - 11.2	5.8 - 6.8 - 7.9 - 9.2 - 11.3
		Heating	m ³ /min	4.0 - 4.6 - 6.2 - 8.9 - 12.7	4.0 - 4.6 - 6.2 - 8.9 - 12.7	5.5 - 6.3 - 7.8 - 9.9 - 13.2	6.4 - 7.2 - 9.0 - 11.1 - 14.6
	Sound Level (SPL) (SLo-Lo-Mid-Hi-SHi ^(*))	Cooling	dB(A)	21 - 24 - 30 - 36 - 42	21 - 24 - 30 - 36 - 42	28 - 31 - 35 - 39 - 43	30 - 33 - 36 - 40 - 43
		Heating	dB(A)	21 - 24 - 30 - 38 - 46	21 - 24 - 30 - 38 - 46	28 - 30 - 35 - 41 - 48	30 - 33 - 37 - 43 - 49
Sound Level (PWL)	Cooling	dB(A)	60	60	60	60	
Outdoor Unit	Dimensions	H x W x D	mm	550 x 800 x 285	550 x 800 x 285	550 x 800 x 285	714 x 800 x 285
	Weight		kg	34	34	35	40
	Air Volume	Cooling	m ³ /min	34.3	34.3	32.0	40.2
		Heating	m ³ /min	32.7	32.7	32.7	40.2
	Sound Level (SPL)	Cooling	dB(A)	49	49	50	52
		Heating	dB(A)	50	50	51	52
	Sound Level (PWL)	Cooling	dB(A)	62	62	62	65
	Operating Current(Max)		A	6.8	6.8	9.6	13.6
Breaker Size		A	10	10	12	16	
Ext.Piping	Diameter	Liquid/Gas	mm	6.35 / 9.52	6.35 / 9.52	6.35 / 9.52	6.35 / 9.52
	Max.Length	Out-In	m	20	20	20	30
	Max.Height	Out-In	m	12	12	12	15
Guaranteed Operating Range(Outdoor)	Cooling	°C	-10 ~ +46	-10 ~ +46	-10 ~ +46	-10 ~ +46	
	Heating	°C	-15 ~ +24	-20 ~ +24	-15 ~ +24	-15 ~ +24	

(*) Energy consumption based on standard test results. Actual energy consumption will depend on how the appliance is used and where it is located.
 (**) SHi: Super High.

SPECIFICATIONS

WALL-MOUNTED

Indoor Unit		MSZ-BT20VG/K	MSZ-BT25VG/K	MSZ-BT35VG/K	MSZ-BT50VG/K		
Outdoor Unit		MUZ-BT20VG	MUZ-BT25VG	MUZ-BT35VG	MUZ-BT50VG		
Refrigerant		R32	R32	R32	R32		
Power Supply		Outdoor Power supply 230/Single/50	Outdoor Power supply 230/Single/50	Outdoor Power supply 230/Single/50	Outdoor Power supply 230/Single/50		
Cooling	Design load	kW	2.0	2.5	3.5	5.0	
	Annual electricity consumption ^(*)	kWh/a	86	108	180	265	
	SEER		8.1	8.1	6.8	6.6	
	Energy efficiency class		A++	A++	A++	A++	
	Capacity	Rated	kW	2.0	2.5	3.5	5.0
		Min-Max	kW	0.5-2.9	0.5-3.0	0.9-3.5	1.3-5.0
	SHF			0.99	0.92	0.84	0.73
	Total Input	Rated	kW	0.450	0.700	1.240	2.050
	EER			4.44	3.57	2.82	2.44
		EEL Rank		A	A	C	E
Heating (Average Season)	Design load	kW	1.5(-10°C)	1.9(-10°C)	2.4(-10°C)	3.8(-10°C)	
	Declared Capacity	at reference design temperature	kW	1.5(-10°C)	1.9(-10°C)	2.4(-10°C)	3.8(-10°C)
		at bivalent temperature	kW	1.5(-10°C)	1.9(-10°C)	2.4(-10°C)	3.8(-10°C)
		at operation limit temperature	kW	1.3(-15°C)	1.7(-15°C)	2.1(-15°C)	3.4(-15°C)
	Back up heating capacity	kW	0.0(-10°C)	0.0(-10°C)	0.0(-10°C)	0.0(-10°C)	
	Annual electricity consumption ^(*)	kWh/a	487	577	727	1209	
	SCOP		4.3	4.6	4.6	4.4	
	Energy efficiency class			A+	A++	A++	A+
	Capacity	Rated	kW	2.5	3.15	3.6	5.4
		Min-Max	kW	0.7-3.2	0.7-3.5	0.9-4.1	1.4-6.5
Total Input	Rated	kW	0.550	0.750	0.930	1.550	
COP			4.55	4.20	3.87	3.48	
	EEL Rank		A	A	A	B	
Heating (Warmer Season)	Design load	kW	0.9(2°C)	1.1(2°C)	1.3(2°C)	2.1(2°C)	
	Declared Capacity	at reference design temperature	kW	0.9(2°C)	1.1(2°C)	1.3(2°C)	2.1(2°C)
		at bivalent temperature	kW	0.9(2°C)	1.1(2°C)	1.3(2°C)	2.1(2°C)
		at operation limit temperature	kW	1.3(-15°C)	1.7(-15°C)	2.1(-15°C)	3.4(-15°C)
	Back up heating capacity	kW	0.0(2°C)	0.0(2°C)	0.0(2°C)	0.0(2°C)	
	Annual electricity consumption ^(*)	kWh/a	234	268	304	543	
	SCOP		5.3	5.7	5.9	5.4	
Energy efficiency class			A+++	A+++	A+++	A+++	
Operating Current(Max)		A	5.6	7.0	7.0	10.0	
Indoor Unit	Input	Rated	kW	0.024	0.024	0.031	0.037
	Operating Current(Max)		A	0.25	0.25	0.31	0.35
	Dimensions	H x W x D	mm	280 x 838 x 235	280 x 838 x 235	280 x 838 x 235	280 x 838 x 235
	Weight		kg	9	9	9	9
	Air Volume (SLo-Lo-Mid-Hi-SHi ^(*) (Dry/Wet))	Cooling	m ³ /min	4.2 - 5.2 - 6.8 - 8.7 - 10.9	4.2 - 5.2 - 6.8 - 8.7 - 10.9	4.2 - 5.2 - 6.8 - 8.7 - 13.2	6.3 - 7.6 - 9.0 - 11.0 - 13.2
		Heating	m ³ /min	4.2 - 5.0 - 6.8 - 9.0 - 11.9	4.2 - 5.0 - 6.8 - 9.0 - 11.9	4.2 - 5.0 - 6.8 - 9.0 - 11.9	6.0 - 7.8 - 9.9 - 11.9 - 14.1
	Sound Level (SPL) (SLo-Lo-Mid-Hi-SHi ^(*))	Cooling	dB(A)	19 - 22 - 30 - 37 - 43	19 - 22 - 30 - 37 - 43	19 - 22 - 31 - 38 - 46	29 - 33 - 36 - 40 - 46
		Heating	dB(A)	20 - 23 - 30 - 37 - 43	20 - 23 - 30 - 37 - 43	20 - 23 - 30 - 37 - 44	29 - 33 - 38 - 43 - 48
	Sound Level (PWL)	Cooling	dB(A)	57	57	60	60
	Outdoor Unit	Dimensions	H x W x D	mm	538 x 699 x 249	538 x 699 x 249	538 x 699 x 249
Weight			kg	23	24	24	35
Air Volume		Cooling	m ³ /min	30.3	32.2	32.2	30.4
		Heating	m ³ /min	30.3	32.2	34.6	32.7
Sound Level (SPL)		Cooling	dB(A)	50	50	52	50
		Heating	dB(A)	50	50	52	51
Sound Level (PWL)		Cooling	dB(A)	63	63	64	64
Operating Current(Max)			A	5.3	6.7	6.7	9.6
Breaker Size			A	10	10	10	12
Ext.Piping		Diameter	Liquid/Gas	mm	6.35 / 9.52	6.35 / 9.52	6.35 / 9.52
	Max.Length	Out-In	m	20	20	20	20
	Max.Height	Out-In	m	12	12	12	12
Guaranteed Operating Range(Outdoor)	Cooling	°C	-10 ~ +46	-10 ~ +46	-10 ~ +46	-10 ~ +46	
	Heating	°C	-15 ~ +24	-15 ~ +24	-15 ~ +24	-15 ~ +24	

(*1) Energy consumption based on standard test results. Actual energy consumption will depend on how the appliance is used and where it is located.

(*2) SHi: Super High.

Indoor Unit			MSZ-DW25VF	MSZ-DW35VF	MSZ-DW50VF	
Outdoor Unit			MUZ-DW25VF	MUZ-DW35VF	MUZ-DW50VF	
Refrigerant			R32	R32	R32	
Power Supply			Outdoor Power supply 230V / SinglePhase / 50Hz	Outdoor Power supply 230V / SinglePhase / 50Hz	Outdoor Power supply 230V / SinglePhase / 50Hz	
Cooling	Source					
	Outdoor(V/Phase/Hz)					
	Design load	kW	2.5	3.4	5.0	
	Annual electricity consumption ^(*)	kWh/a	135	184	261	
	SEER		6.2	6.2	6.5	
	Energy efficiency class		A++	A++	A++	
	Capacity	Rated	kW	2.5	3.4	5.0
		Min-Max	kW	0.5 - 2.9	0.9 - 3.4	1.3 - 5.0
	SHF		0.86	0.78	0.7	
	Total Input	Rated	kW	0.800	1.210	2.050
EER		3.13	2.81	2.44		
EEL Rank			B	C	E	
Heating (Average Season)	Design load		kW	1.9 (-10°C)	2.4 (-10°C)	3.8 (-10°C)
	Declared Capacity	at reference design temperature	kW	1.9 (-10°C)	2.4 (-10°C)	3.8 (-10°C)
		at bivalent temperature	kW	1.9 (-10°C)	2.4 (-10°C)	3.8 (-10°C)
		at operation limit temperature	kW	1.9 (-10°C)	2.4 (-10°C)	3.8 (-10°C)
	Back up heating capacity	kW	0.0 (-10°C)	0.0 (-10°C)	0.0 (-10°C)	
	Annual electricity consumption ^(*)	kWh/a	618	781	1174	
	SCOP		4.3	4.3	4.3	
	Energy efficiency class		A+	A+	A+	
	Capacity	Rated	kW	3.15	3.6	5.4
		Min-Max	kW	0.7 - 3.5	0.9 - 3.7	1.4 - 6.5
Total Input	Rated	kW	0.850	0.975	1.550	
COP		3.7	3.7	3.5		
EEL Rank			A	A	B	
Heating (Warmer Season)	Design load		kW	0.9 (2°C)	0.9 (2°C)	0.9 (2°C)
	Declared Capacity	at reference design temperature	kW	0.9 (2°C)	0.9 (2°C)	0.9 (2°C)
		at bivalent temperature	kW	0.9 (2°C)	0.9 (2°C)	0.9 (2°C)
		at operation limit temperature	kW	1.6 (-15°C)	1.6 (-40°C)	1.6 (-41°C)
	Back up heating capacity	kW	0.0 (2°C)	0.0 (27°C)	0.0 (28°C)	
	Annual electricity consumption ^(*)	kWh/a	287	351	508	
	SCOP		5.3	5.1	5.3	
	Energy efficiency class		A+++	A+++	A+++	
	Operating Current (Max)	A	5.0	6.7	10.0	
	Indoor Unit	Input	Rated	kW	0.023	0.028
Operating Current (Max)		A	0.24	0.28	0.29	
Dimensions		HxWxD	mm	290 x 799 x 232	290 x 799 x 232	290 x 799 x 232
Weight			kg	9	9	10
Air Volume (SLo-Lo-Mid-Hi-Shi ^(*) (Dry/Wet))		Cooling	m ³ /min	3.6 - 5.6 - 7.5 - 9.9	3.6 - 5.8 - 8.1 - 11.3	5.9 - 7.7 - 9.7 - 12.3
		Heating	m ³ /min	3.4 - 5.6 - 7.7 - 10.3	3.4 - 5.6 - 7.7 - 10.7	6.0 - 7.7 - 9.7 - 12.6
Sound Level (SPL) (SLo-Lo-Mid-Hi-Shi ^(*))		Cooling	dB(A)	21 - 30 - 37 - 43	22 - 31 - 38 - 46	28 - 36 - 40 - 45
		Heating	dB(A)	21 - 30 - 37 - 43	21 - 30 - 37 - 44	27 - 34 - 41 - 47
Sound Level (PWL)		Cooling	dB(A)	57	60	60
Outdoor Unit		Dimensions	HxWxD	mm	538 x 699 x 249	538 x 699 x 249
	Weight		kg	23	24	35
	Air Volume	Cooling	m ³ /min	30.3	32.2	33.5
		Heating	m ³ /min	30.3	32.2	32.7
	Sound Level (SPL)	Cooling	dB(A)	50	51	50
		Heating	dB(A)	50	51	51
	Sound Level (PWL)	Cooling	dB(A)	63	64	64
	Operating Current (Max)	A	5.3	7.0	9.2	
	Breaker Size	A	10	10	12	
	Ext.Piping	Diameter	Liquid/Gas	mm	6.35 / 9.52	6.35 / 9.52
Max.Length		Out-In	m	20	20	20
Max.Height		Out-In	m	12	12	12
Guaranteed Operating Range (Outdoor)	Cooling	°C	-10 ~ +46	-10 ~ +46	-10 ~ +46	
	Heating	°C	-10 ~ +24	-10 ~ +24	-10 ~ +24	

(*) Energy consumption based on standard test results. Actual energy consumption will depend on how the appliance is used and where it is located

(*) SHi: Super High.

Indoor Unit				MSZ-SF15VA	MSZ-SF20VA	
Outdoor Unit				for Multi connection	for Multi connection	
Refrigerant				R410A	R410A	
Power Supply		Source		Outdoor Power supply	Outdoor Power supply	
		Outdoor (V/Phase/Hz)		230V/Single/50Hz	230V/Single/50Hz	
Cooling	Design load		kW	-	-	
	Annual electricity consumption ^(*)		kWh/a	-	-	
	SEER			-	-	
	Energy efficiency class			-	-	
	Capacity	Rated	kW	-	-	
		Min - Max	kW	-	-	
	SHF			-	-	
	Total Input	Rated	kW	-	-	
	EER			-	-	
	EEL Rank			-	-	
Heating	Design load		kW	-	-	
	Declared Capacity	at reference design temperature	kW	-	-	
		at bivalent temperature	kW	-	-	
		at operation limit temperature	kW	-	-	
	Back up heating capacity		kW	-	-	
	Annual electricity consumption ^(*)		kWh/a	-	-	
	SCOP			-	-	
	Energy efficiency class			-	-	
	Capacity	Rated	kW	-	-	
		Min - Max	kW	-	-	
	Total Input	Rated	kW	-	-	
	COP			-	-	
	EEL Rank			-	-	
Operating Current (Max)			A	-	-	
Indoor Unit	Input	Rated	kW	0.017	0.019	
	Operating Current (Max)		A	0.17	0.19	
	Dimensions		H x W x D	mm	250 x 760 x 168	250 x 760 x 168
	Weight			kg	7.7	7.7
	Air Volume (Silent-Lo-Mid-Hi-SHi ^(*) (Dry/Wet))	Cooling	m ³ /min	3.5 - 3.9 - 4.6 - 5.5 - 6.4	3.5 - 3.9 - 4.6 - 5.5 - 6.9	
		Heating	m ³ /min	3.7 - 4.4 - 5.0 - 6.0 - 6.8	3.7 - 4.4 - 5.0 - 6.0 - 7.3	
	Sound Level (SPL) (Silent-Lo-Mid-Hi-SHi ^(*))	Cooling	dB(A)	21 - 26 - 30 - 35 - 40	21 - 26 - 30 - 35 - 42	
		Heating	dB(A)	21 - 26 - 30 - 35 - 40	21 - 26 - 30 - 35 - 42	
Sound Level (PWL)		Cooling	dB(A)	59	60	
Outdoor Unit	Dimensions		H x W x D	mm	-	
	Weight			kg	-	
	Air Volume	Cooling	m ³ /min	-	-	
		Heating	m ³ /min	-	-	
	Sound Level (SPL)	Cooling	dB(A)	-	-	
		Heating	dB(A)	-	-	
	Sound Level (PWL)		Cooling	dB(A)	-	
	Operating Current (Max)			A	-	
Breaker Size			A	-		
Ext.Piping	Diameter	Liquid/Gas	mm	-	-	
	Max.Length	Out-In	m	-	-	
	Max.Height	Out-In	m	-	-	
Guaranteed Operating Range (Outdoor)			Cooling	°C	-	
			Heating	°C	-	

(*1) Energy consumption based on standard test results. Actual energy consumption will depend on how the appliance is used and where it is located.

(*2) SHi: Super High.

Indoor Unit			MSZ-SF25VE3	MSZ-SF25VE3	MSZ-SF35VE3	MSZ-SF35VE3	
Outdoor Unit			MUZ-SF25VE	MUZ-SF25VEH	MUZ-SF35VE	MUZ-SF35VEH	
Refrigerant			R410A	R410A	R410A	R410A	
Power Supply	Source		Outdoor Power supply	Outdoor Power supply	Outdoor Power supply	Outdoor Power supply	
	Outdoor (V/Phase/Hz)		230V/Single/50Hz	230V/Single/50Hz	230V/Single/50Hz	230V/Single/50Hz	
Cooling	Design load	kW	2.5	2.5	3.5	3.5	
	Annual electricity consumption ^(*)	kWh/a	116	116	171	171	
	SEER		7.6	7.6	7.2	7.2	
	Capacity	Rated	kW	2.5	2.5	3.5	3.5
		Min - Max	kW	0.9 - 3.4	0.9 - 3.4	1.1 - 3.8	1.1 - 3.8
	SHF		0.92	0.92	0.8	0.8	
	Total Input	Rated	kW	0.600	0.600	1.080	1.080
	EER			4.17	4.17	3.24	3.24
	EEL Rank			A	A	A	A
	Heating	Design load	kW	2.4(-10°C)	2.4(-10°C)	2.9(-10°C)	2.9(-10°C)
Declared Capacity		at reference design temperature	kW	2.4(-10°C)	2.4(-10°C)	2.9(-10°C)	2.9(-10°C)
		at bivalent temperature	kW	2.4(-10°C)	2.4(-10°C)	2.9(-10°C)	2.9(-10°C)
		at operation limit temperature	kW	2.0(-15°C)	1.6(-20°C)	2.2(-15°C)	1.6(-20°C)
Back up heating capacity		kW	0.0(-10°C)	0.0(-10°C)	0.0(-10°C)	0.0(-10°C)	
Annual electricity consumption ^(*)		kWh/a	764	790	923	948	
SCOP			4.4	4.3	4.4	4.3	
Capacity		Rated	kW	3.2	3.2	4.0	4.0
		Min - Max	kW	1.0 - 4.1	1.0 - 4.1	1.3 - 4.6	1.3 - 4.6
Total Input		Rated	kW	0.780	0.780	1.030	1.030
COP			4.10	4.10	3.88	3.88	
EEL Rank				A	A	A	A
Operating Current (Max)		A	8.4	8.4	8.5	8.5	
Indoor Unit	Input	Rated	kW	0.024	0.024	0.027	0.027
	Operating Current (Max)	A	0.2	0.2	0.3	0.3	
	Dimensions	H x W x D	mm	299 x 798 x 195	299 x 798 x 195	299 x 798 x 195	299 x 798 x 195
	Weight	kg	10	10	10	10	
	Air Volume (Silent-Lo-Mid-Hi-SHi ^(*) (Dry/Wet))	Cooling	m ³ /min	3.2 - 4.1 - 5.6 - 7.2 - 9.1	3.2 - 4.1 - 5.6 - 7.2 - 9.1	3.2 - 4.1 - 5.6 - 7.2 - 9.1	3.2 - 4.1 - 5.6 - 7.2 - 9.1
		Heating	m ³ /min	3.0 - 4.1 - 6.7 - 8.2 - 10.3	3.0 - 4.1 - 6.7 - 8.2 - 10.3	3.0 - 4.1 - 6.7 - 8.3 - 11.0	3.0 - 4.1 - 6.7 - 8.3 - 11.0
	Sound Level (SPL) (Silent-Lo-Mid-Hi-SHi ^(*))	Cooling	dB(A)	19 ^(*) - 24 - 30 - 36 - 42	19 ^(*) - 24 - 30 - 36 - 42	19 ^(*) - 24 - 30 - 36 - 42	19 ^(*) - 24 - 30 - 36 - 42
		Heating	dB(A)	19 ^(*) - 24 - 34 - 39 - 45	19 ^(*) - 24 - 34 - 39 - 45	19 ^(*) - 24 - 34 - 40 - 46	19 ^(*) - 24 - 34 - 40 - 46
	Sound Level (PWL)	Cooling	dB(A)	57	57	57	57
Outdoor Unit	Dimensions	H x W x D	mm	550 x 800 x 285	550 x 800 x 285	550 x 800 x 285	550 x 800 x 285
	Weight	kg	31	31	31	31	
	Air Volume	Cooling	m ³ /min	31.1	31.1	35.9	35.9
		Heating	m ³ /min	30.7	30.7	35.9	35.9
	Sound Level (SPL)	Cooling	dB(A)	47	47	49	49
		Heating	dB(A)	48	48	50	50
	Sound Level (PWL)	Cooling	dB(A)	58	58	62	62
	Operating Current (Max)	A	8.2	8.2	8.2	8.2	
	Breaker Size	A	10	10	10	10	
Ext.Piping	Diameter	Liquid/Gas	mm	6.35/9.52	6.35/9.52	6.35/9.52	6.35/9.52
	Max.Length	Out-In	m	20	20	20	20
	Max.Height	Out-In	m	12	12	12	12
Guaranteed Operating Range (Outdoor)	Cooling	°C	-10 ~ +46	-10 ~ +46	-10 ~ +46	-10 ~ +46	
	Heating	°C	-15 ~ +24	-20 ~ +24	-15 ~ +24	-20 ~ +24	

(*) Energy consumption based on standard test results. Actual energy consumption will depend on how the appliance is used and where it is located.

(*) SHi: Super High.

(*) SF25 - 35 For single use: only 19dB(A). For multi use (MXZ): 21dB(A)

SPECIFICATIONS

WALL-MOUNTED

Indoor Unit			MSZ-SF42VE3	MSZ-SF42VEH	MSZ-SF50VE3	MSZ-SF50VEH	
Outdoor Unit			MUZ-SF42VE	MUZ-SF42VEH	MUZ-SF50VE	MUZ-SF50VEH	
Refrigerant			R410A	R410A	R410A	R410A	
Power Supply	Source		Outdoor Power supply	Outdoor Power supply	Outdoor Power supply	Outdoor Power supply	
	Outdoor (V/Phase/Hz)		230V/Single/50Hz	230V/Single/50Hz	230V/Single/50Hz	230V/Single/50Hz	
Cooling	Design load	kW	4.2	4.2	5.0	5.0	
	Annual electricity consumption ^(*)	kWh/a	196	196	246	246	
	SEER		7.5	7.5	7.2	7.2	
		Energy efficiency class	A++	A++	A++	A++	
	Capacity	Rated	kW	4.2	4.2	5.0	5.0
		Min - Max	kW	0.8 - 4.5	0.8 - 4.5	1.4 - 5.4	1.4 - 5.4
	SHF		0.72	0.72	0.7	0.7	
	Total Input	Rated	kW	1.340	1.340	1.660	1.660
	EER			3.13	3.13	3.01	3.01
		EEL Rank		B	B	B	B
Heating	Design load	kW	3.8(-10°C)	3.8(-10°C)	4.2(-10°C)	4.2(-10°C)	
	Declared Capacity	at reference design temperature	kW	3.8(-10°C)	3.8(-10°C)	4.2(-10°C)	4.2(-10°C)
		at bivalent temperature	kW	3.8(-10°C)	3.8(-10°C)	4.2(-10°C)	4.2(-10°C)
		at operation limit temperature	kW	3.4(-15°C)	2.2(-20°C)	3.4(-15°C)	2.3(-20°C)
	Back up heating capacity	kW	0.0(-10°C)	0.0(-10°C)	0.0(-10°C)	0.0(-10°C)	
	Annual electricity consumption ^(*)	kWh/a	1215	1242	1351	1380	
	SCOP		4.4	4.3	4.4	4.3	
		Energy efficiency class		A+	A+	A+	A+
	Capacity	Rated	kW	5.4	5.4	5.8	5.8
		Min - Max	kW	1.3 - 6.0	1.3 - 6.0	1.4 - 7.3	1.4 - 7.3
	Total Input	Rated	kW	1.580	1.580	1.700	1.700
	COP			3.42	3.42	3.41	3.41
		EEL Rank		B	B	B	B
Operating Current (Max)	A		9.5	9.5	12.3	12.3	
Indoor Unit	Input	Rated	kW	0.027	0.027	0.035	0.035
	Operating Current (Max)	A		0.3	0.3	0.3	0.3
	Dimensions	H x W x D	mm	299 x 798 x 195	299 x 798 x 195	299 x 798 x 195	299 x 798 x 195
	Weight	kg		10	10	10	10
	Air Volume (Silent-Lo-Mid-Hi-SHi ^(*) (Dry/Wet))	Cooling	m ³ /min	4.7 - 5.8 - 6.7 - 7.9 - 9.1	4.7 - 5.8 - 6.7 - 7.9 - 9.1	5.1 - 6.2 - 7.0 - 8.2 - 9.9	5.1 - 6.2 - 7.0 - 8.2 - 9.9
		Heating	m ³ /min	4.7 - 5.8 - 7.2 - 9.1 - 11.4	4.7 - 5.8 - 7.2 - 9.1 - 11.4	5.1 - 6.4 - 8.0 - 9.8 - 12.0	5.1 - 6.4 - 8.0 - 9.8 - 12.0
	Sound Level (SPL) (Silent-Lo-Mid-Hi-SHi ^(*))	Cooling	dB(A)	26 ^(*) - 31 - 34 - 38 - 42	26 ^(*) - 31 - 34 - 38 - 42	28 ^(*) - 33 - 36 - 40 - 45	28 ^(*) - 33 - 36 - 40 - 45
		Heating	dB(A)	26 ^(*) - 31 - 36 - 42 - 47	26 ^(*) - 31 - 36 - 42 - 47	28 ^(*) - 33 - 38 - 43 - 49	28 ^(*) - 33 - 38 - 43 - 49
	Sound Level (PWL)	Cooling	dB(A)	57	57	58	58
Outdoor Unit	Dimensions	H x W x D	mm	550 x 800 x 285	550 x 800 x 285	880 x 840 x 330	880 x 840 x 330
	Weight	kg		35	35	55	55
	Air Volume	Cooling	m ³ /min	35.2	35.2	44.6	44.6
		Heating	m ³ /min	33.6	33.6	44.6	44.6
	Sound Level (SPL)	Cooling	dB(A)	50	50	52	52
		Heating	dB(A)	51	51	52	52
	Sound Level (PWL)	Cooling	dB(A)	63	63	65	65
	Operating Current (Max)	A		9.2	9.2	12.0	12.0
	Breaker Size	A		10	10	16	16
Ext.Piping	Diameter	Liquid/Gas	mm	6.35/9.52	6.35/9.52	6.35/12.7	6.35/12.7
	Max.Length	Out-In	m	20	20	30	30
	Max.Height	Out-In	m	12	12	15	15
Guaranteed Operating Range (Outdoor)	Cooling	°C	-10 ~ +46	-10 ~ +46	-10 ~ +46	-10 ~ +46	
	Heating	°C	-15 ~ +24	-20 ~ +24	-15 ~ +24	-20 ~ +24	

(*) Energy consumption based on standard test results. Actual energy consumption will depend on how the appliance is used and where it is located.

(*) SHi: Super High.

(*) SF42 For single use: only 26dB(A). For multi use (MXZ): 28dB(A)

(*) SF50 For single use: only 28dB(A). For multi use (MXZ): 30dB(A)

Indoor Unit				MSZ-GF60VE2	MSZ-GF71VE2	
Outdoor Unit				MUZ-GF60VE	MUZ-GF71VE	
Refrigerant				R410A	R410A	
Power Supply	Source			Outdoor Power supply	Outdoor Power supply	
	Outdoor (V/Phase/Hz)			230V/Single/50Hz	230V/Single/50Hz	
Cooling	Design load	kW		6.1	7.1	
	Annual electricity consumption ^(*)	kWh/a		311	364	
	SEER			6.8	6.8	
	Capacity	Energy efficiency class		A++	A++	
		Rated	kW		6.1	7.1
		Min - Max	kW	1.4 - 7.5	2.0 - 8.7	
	SHF			0.79	0.78	
	Total Input	Rated	kW	1.79	2.13	
	EER			3.41	3.33	
		EEL Rank		A	A	
Heating	Design load	kW		4.6(-10°C)	6.7(-10°C)	
	Declared Capacity	at reference design temperature	kW	4.6(-10°C)	6.7(-10°C)	
		at bivalent temperature	kW	4.6(-10°C)	6.7(-10°C)	
		at operation limit temperature	kW	3.7(-15°C)	5.4(-15°C)	
	Back up heating capacity	kW		0.0(-10°C)	0.0(-10°C)	
	Annual electricity consumption ^(*)	kWh/a		1489	2204	
	SCOP			4.3	4.2	
	Capacity	Energy efficiency class		A+	A+	
		Rated	kW		6.8	8.1
		Min - Max	kW	2.0 - 9.3	2.2 - 9.9	
	Total Input	Rated	kW	1.81	2.23	
	COP			3.76	3.63	
		EEL Rank		A	A	
Operating Current (Max)			A	14.5	16.6	
Indoor Unit	Input	Rated	kW	0.062	0.058	
	Operating Current (Max)			A	0.5	
	Dimensions	H x W x D	mm	325 x 1100 x 238	325 x 1100 x 238	
	Weight			kg	16	
	Air Volume (Silent-Lo-Mid-Hi-SHi ^(*) (Dry/Wet))	Cooling	m ³ /min		9.8 - 11.3 - 13.4 - 15.6 - 18.3	9.7 - 11.5 - 13.3 - 15.4 - 17.8
		Heating	m ³ /min		9.8 - 11.3 - 13.4 - 15.6 - 18.3	10.2 - 11.5 - 13.3 - 15.4 - 17.8
	Sound Level (SPL) (Silent-Lo-Mid-Hi-SHi ^(*))	Cooling	dB(A)		29-37-41-45-49	30-37-41-45-49
		Heating	dB(A)		29-37-41-45-49	30-37-41-45-49
Sound Level (PWL)	Cooling	dB(A)		65	65	
Outdoor Unit	Dimensions	H x W x D	mm	880 x 840 x 330	880 x 840 x 330	
	Weight			kg	50	
	Air Volume	Cooling	m ³ /min		49.2	50.1
		Heating	m ³ /min		49.2	48.2
	Sound Level (SPL)	Cooling	dB(A)		55	55
		Heating	dB(A)		55	55
	Sound Level (PWL)	Cooling	dB(A)		65	65
	Operating Current (Max)			A	14.0	16.1
Breaker Size			A	20	20	
Ext.Piping	Diameter	Liquid/Gas	mm	6.35/15.88	9.52/15.88	
	Max.Length	Out-In	m	30	30	
	Max.Height	Out-In	m	15	15	
Guaranteed Operating Range (Outdoor)	Cooling	°C		-10~+46	-10~+46	
	Heating	°C		-15~+24	-15~+24	

(*1) Energy consumption based on standard test results. Actual energy consumption will depend on how the appliance is used and where it is located.

(*2) SHi: Super High.

SPECIFICATIONS

WALL-MOUNTED

Indoor Unit				MSZ-WN25VA	MSZ-WN35VA	
Outdoor Unit				MUZ-WN25VA	MUZ-WN35VA	
Refrigerant				R410A	R410A	
Power Supply	Source			Indoor Power supply	Indoor Power supply	
	Outdoor (V/Phase/Hz)			230V/SinglePhase/50Hz	230V/SinglePhase/50Hz	
Cooling	Design load		kW	2.5	3.1	
	Annual electricity consumption (*1)		kWh/a	141	173	
	SEER			6.2	6.2	
	Energy efficiency class			A++	A++	
	Capacity	Rated		kW	2.5	3.15
		Min - Max		kW	1.3 - 3.0	1.4 - 3.5
	SHF			0.89	0.87	
	Total Input		Rated	kW	0.710	1.020
	EER			3.52	3.09	
	EEL Rank			A	B	
Heating (Average Season)	Design load		kW	1.9(-10°C)	2.4(-10°C)	
	Declared Capacity	at reference design temperature		kW	1.9(-10°C)	2.4(-10°C)
		at bivalent temperature		kW	1.9(-10°C)	2.4(-10°C)
		at operation limit temperature		kW	1.6(-15°C)	2.0(-15°C)
				kW	1.6(-15°C)	2.0(-15°C)
	Back up heating capacity		kW	0.0(-10°C)	0.0(-10°C)	
	Annual electricity consumption (*1)		kWh/a	628	793	
	SCOP			4.2	4.3	
	Energy efficiency class			A+	A+	
	Capacity	Rated		kW	3.15	3.6
		Min - Max		kW	0.9 - 3.5	1.1 - 4.1
	Total Input		Rated	kW	0.850	0.975
COP			3.71	3.69		
EEL Rank			A	A		
Operating Current (Max)			A	5.8	6.5	
Indoor Unit	Input		Rated	kW	0.020	0.026
	Operating Current (Max)			A	0.3	0.3
	Dimensions		H x W x D	mm	290 x 799 x 232	290 x 799 x 232
	Weight			kg	9	9
	Air Volume (SLo-Lo-Mid-Hi-SHi (*2) (Dry/Wet))	Cooling		m ³ /min	3.8 - 5.5 - 7.3 - 9.5	3.8 - 5.7 - 7.8 - 11.4
		Heating		m ³ /min	3.5 - 5.5 - 7.5 - 10.0	3.5 - 5.5 - 7.5 - 10.3
	Sound Level (SPL) (SLo-Lo-Mid-Hi-SHi (*2))	Cooling		dB(A)	22 - 30 - 37 - 43	22 - 31 - 38 - 46
		Heating		dB(A)	23 - 30 - 37 - 43	23 - 30 - 37 - 44
Sound Level (PWL)		Cooling	dB(A)	57	60	
Outdoor Unit	Dimensions		H x W x D	mm	538 x 699 x 249	538 x 699 x 249
	Weight			kg	24	25
	Air Volume	Cooling		m ³ /min	31.5	31.5
		Heating		m ³ /min	31.5	31.5
	Sound Level (SPL)	Cooling		dB(A)	50	52
		Heating		dB(A)	50	52
	Sound Level (PWL)		Cooling	dB(A)	63	64
	Operating Current (Max)			A	5.5	6.2
Breaker Size			A	10	10	
Ext.Piping	Diameter		Liquid/Gas	mm	6.35/9.52	6.35/9.52
	Max.Length		Out-In	m	20	20
	Max.Height		Out-In	m	12	12
Guaranteed Operating Range (Outdoor)			Cooling	°C	-10 ~ +46	-10 ~ +46
			Heating	°C	-15 ~ +24	-15 ~ +24

(*1) Energy consumption based on standard test results. Actual energy consumption will depend on how the appliance is used and where it is located.

(*2) SHi: Super High.

Indoor Unit				MSZ-DM25VA	MSZ-DM35VA	
Outdoor Unit				MUZ-DM25VA	MUZ-DM35VA	
Refrigerant				R410A	R410A	
Power Supply	Source			Indoor Power supply	Indoor Power supply	
	Outdoor(V/Phase/Hz)			230V/SinglePhase/50Hz	230V/SinglePhase/50Hz	
Cooling	Design load		kW	2.5	3.1	
	Annual electricity consumption ^(*)		kWh/a	149	190	
	SEER			5.8	5.7	
	Energy efficiency class			A+	A+	
	Capacity	Rated		kW	2.5	3.15
		Min-Max		kW	1.3 - 3.0	1.4 - 3.5
	SHF			0.89	0.87	
	Total Input		Rated	kW	0.710	1.020
	EER			3.52	3.09	
	EEL Rank			A	B	
Heating (Average Season)	Design load		kW	1.9(-10°C)	2.4(-10°C)	
	Declared Capacity	at reference design temperature		kW	1.9(-10°C)	2.4(-10°C)
		at bivalent temperature		kW	1.9(-10°C)	2.4(-10°C)
		at operation limit temperature		kW	1.9(-10°C)	2.4(-10°C)
		Back up heating capacity		kW	0.0(-10°C)	0.0(-10°C)
	Annual electricity consumption ^(*)		kWh/a	647	809	
	SCOP			4.1	4.1	
	Energy efficiency class			A+	A+	
	Capacity	Rated		kW	3.15	3.6
		Min-Max		kW	0.9 - 3.5	1.1 - 4.1
Total Input		Rated	kW	0.850	0.975	
COP			3.71	3.69		
EEL Rank			A	A		
Operating Current(Max)			A	5.8	6.5	
Indoor Unit	Input		Rated	kW	0.020	0.021
	Operating Current(Max)			A	0.3	0.3
	Dimensions		H x W x D	mm	290 x 799 x 232	290 x 799 x 232
	Weight			kg	9	9
	Air Volume (SLo-Lo-Mid-Hi-SHi ^(*) (Dry/Wet))	Cooling		m ³ /min	3.8 - 5.5 - 7.3 - 9.5	3.8 - 5.7 - 7.8 - 10.9
		Heating		m ³ /min	3.5 - 5.5 - 7.5 - 10.0	3.5 - 5.5 - 7.5 - 10.3
	Sound Level (SPL) (SLo-Lo-Mid-Hi-SHi ^(*))	Cooling		dB(A)	22 - 30 - 37 - 43	22 - 31 - 38 - 45
		Heating		dB(A)	23 - 30 - 37 - 43	23 - 30 - 37 - 44
Sound Level (PWL)		Cooling	dB(A)	57	60	
Outdoor Unit	Dimensions		H x W x D	mm	538 x 699 x 249	538 x 699 x 249
	Weight			kg	24	25
	Air Volume	Cooling		m ³ /min	31.5	31.5
		Heating		m ³ /min	31.5	31.5
	Sound Level (SPL)	Cooling		dB(A)	50	51
		Heating		dB(A)	50	51
	Sound Level (PWL)		Cooling	dB(A)	63	64
	Operating Current(Max)			A	5.5	6.2
Breaker Size			A	10	10	
Ext.Piping	Diameter		Liquid/Gas	mm	6.35/9.52	6.35/9.52
	Max.Length		Out-In	m	20	20
	Max.Height		Out-In	m	12	12
Guaranteed Operating Range(Outdoor)			Cooling	°C	-10 ~ +46	-10 ~ +46
			Heating	°C	-10 ~ +24	-10 ~ +24

(*) Energy consumption based on standard test results. Actual energy consumption will depend on how the appliance is used and where it is located.

(*)2 SHi: Super High.

SPECIFICATIONS

WALL-MOUNTED

Indoor Unit			MSZ-HJ25VA	MSZHJ35VA	MSZ-HJ50VA	MSZ-HJ60VA	MSZ-HJ71VA	
Outdoor Unit			MUZ-HJ25VA	MUZ-HJ35VA	MUZ-HJ50VA	MUZ-HJ60VA	MUZ-HJ71VA	
Refrigerant			R410A	R410A	R410A	R410A	R410A	
Power Supply	Source		Indoor Power supply	Indoor Power supply	Indoor Power supply	Indoor Power supply	Indoor Power supply	
	Outdoor(V/Phase/Hz)		230V/SinglePhase/50Hz	230V/SinglePhase/50Hz	230V/SinglePhase/50Hz	230 V/SinglePhase/50Hz	230V/SinglePhase/50Hz	
Cooling	Design load	kW	2.5	3.1	5.0	6.1	7.1	
	Annual electricity consumption (**)	SEER	kWh/a	171	212	292	354	441
		Energy efficiency class		A	A	A+	A+	A+
	Capacity	Rated	kW	2.5	3.15	5.0	6.1	7.1
		Min - Max	kW	1.3 - 3.0	1.4 - 3.5	1.3 - 5.0	1.7 - 7.1	1.8 - 7.1
	SHF		0.89	0.87	0.70	0.82	0.77	
	Total Input	Rated	kW	0.730	1.040	2.050	1.900	2.330
		EER		3.42	3.03	2.44	3.21	3.05
	EEL Rank		A	B	E	A	B	
	Heating (Average Season)	Design load	kW	1.9(-10°C)	2.4(-10°C)	3.8(-10°C)	4.6(-10°C)	5.4(-10°C)
Declared Capacity		at reference design temperature	kW	1.9(-10°C)	2.4(-10°C)	3.8(-10°C)	4.6(-10°C)	5.4(-10°C)
		at bivalent temperature	kW	1.9(-10°C)	2.4(-10°C)	3.8(-10°C)	4.6(-10°C)	5.4(-10°C)
		at operation limit temperature	kW	1.9(-10°C)	2.4(-10°C)	3.8(-10°C)	4.6(-10°C)	5.4(-10°C)
Back up heating capacity		kW	0.0(-10°C)	0.0(-10°C)	0.0(-10°C)	0.0(-10°C)	0.0(-10°C)	
Annual electricity consumption (**)		SCOP	kWh/a	698	885	1267	1544	1854
		Energy efficiency class		A	A	A+	A+	A+
Capacity		Rated	kW	3.15	3.6	5.4	6.8	8.1
		Min - Max	kW	0.9 - 3.5	1.1 - 4.1	1.4 - 6.5	1.5 - 8.4	1.5 - 8.5
Total Input		Rated	kW	0.870	0.995	1.480	1.970	2.440
		COP		3.62	3.62	3.65	3.45	3.32
EEL Rank			A	A	A	B	C	
Operating Current (Max)			A	5.8	6.5	9.8	12.5	
Indoor Unit		Input	Rated	kW	0.020	0.021	0.037	0.055
		Operating Current (Max)			A	0.3	0.3	0.4
	Dimensions			H x W x D	mm	290 x 799 x 232	290 x 799 x 232	290 x 799 x 232
	Weight			kg	9	9	9	
	Air Volume (Lo-Mid-Hi-SHi (**2) (Dry/Wet))	Cooling	m³/min	3.8 - 5.5 - 7.3 - 9.5	3.8 - 5.7 - 7.8 - 10.9	6.3 - 9.1 - 11.1 - 12.9	9.3 - 12.2 - 15.0 - 19.9	10.0 - 12.2 - 15.0 - 19.9
		Heating	m³/min	3.5 - 5.5 - 7.5 - 10.0	3.5 - 5.5 - 7.5 - 10.3	6.1 - 8.3 - 11.1 - 14.3	9.4 - 12.5 - 16.0 - 19.9	10.3 - 12.7 - 16.4 - 19.9
	Sound Level (SPL) (Lo-Mid-Hi-SHi (**2))	Cooling	dB(A)	22 - 30 - 37 - 43	22 - 31 - 38 - 45	28 - 36 - 40 - 45	31 - 38 - 44 - 50	33 - 38 - 44 - 50
		Heating	dB(A)	23 - 30 - 37 - 43	23 - 30 - 37 - 44	27 - 34 - 41 - 47	31 - 38 - 44 - 49	33 - 38 - 44 - 49
	Sound Level (PWL)	Cooling	dB(A)	57	60	60	65	65
	Outdoor Unit	Dimensions			H x W x D	mm	538 x 699 x 249	538 x 699 x 249
Weight			kg	24	25	36	55	
Air Volume		Cooling	m³/min	31.5	31.5	36.3	47.9	49.3
		Heating	m³/min	31.5	31.5	34.8	47.9	47.9
Sound Level (SPL)		Cooling	dB(A)	50	50	50	55	55
		Heating	dB(A)	50	50	51	55	55
Sound Level (PWL)		Cooling	dB(A)	63	64	64	65	66
Operating Current (Max)			A	5.5	6.2	9.4	12	
Breaker Size			A	10	10	12	16	
Ext.Piping		Diameter	Liquid/Gas	mm	6.35/9.52	6.35/9.52	6.35/12.7	6.35/15.88
	Max.Length	Out-In	m	20	20	20	30	
	Max.Height	Out-In	m	12	12	12	15	
Guaranteed Operating Range (Outdoor)			Cooling	°C	+15~+46	+15~+46	+15~+46	
			Heating	°C	-10~+24	-10~+24	-10~+24	-10~+24

(*1) Energy consumption based on standard test results. Actual energy consumption will depend on how the appliance is used and where it is located.

(*2) SHi: Super High.

C.1.2 OUTLINES AND DIMENSIONS

C.1.2.1 Indoor Unit

MSZ-RW25VG MSZ-RW35VG MSZ-RW50VG

Unit: mm

INDOOR UNIT

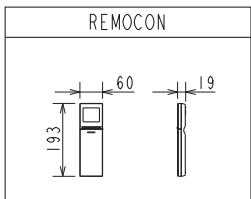
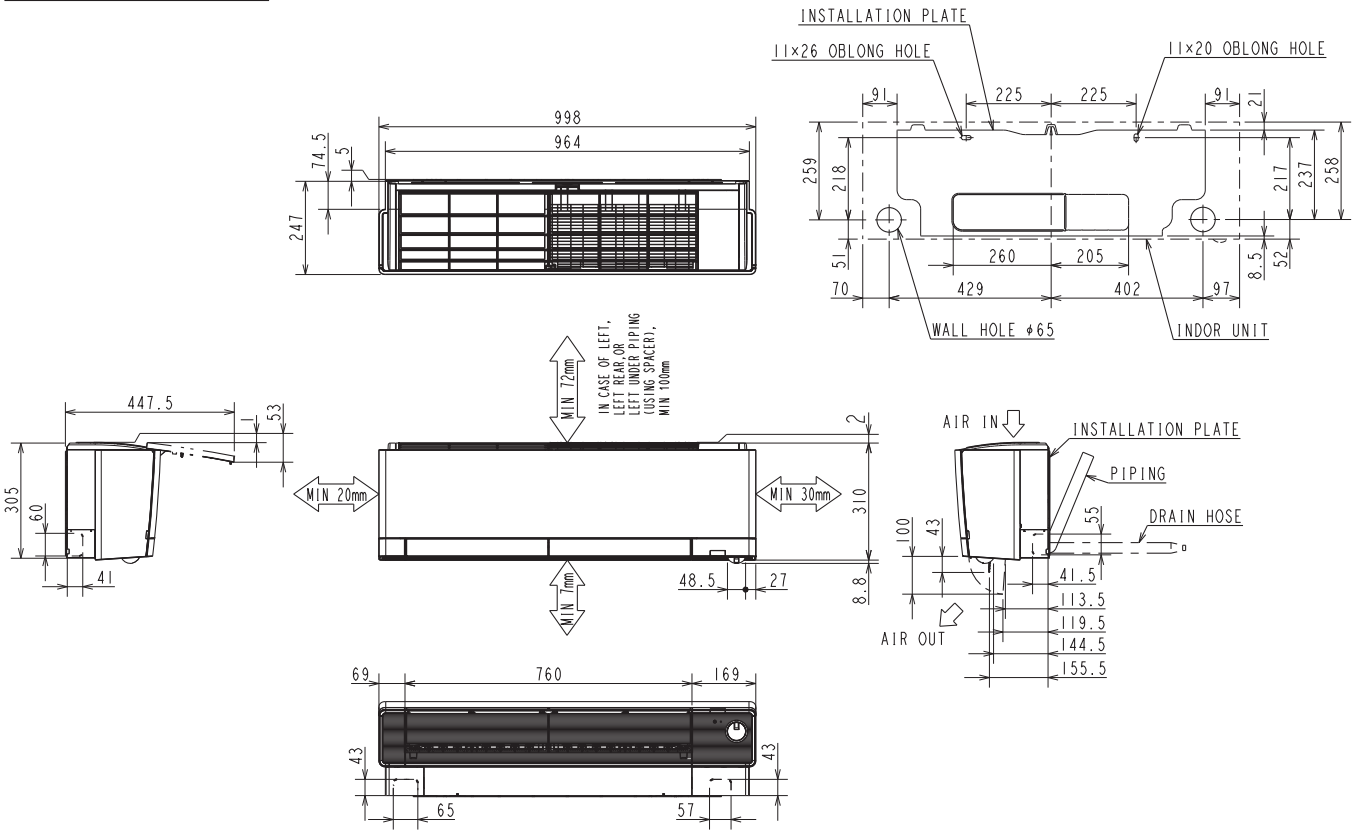

MSZ-RW25/35/50VG - [E1]

PIPING	INSULATION	ø37 O.D
	LIQUID LINE	ø6.35 - 0.5m (FLARED CONNECTION ø6.35)
	GAS LINE	ø9.52 - 0.45m (FLARED CONNECTION ø9.52)
DRAIN HOSE		INSULATION ø29 CONNECTED PART ø16 O.D

MSZ-RW25/35/50VG - [SC1]

PIPING	INSULATION	ø37 O.D
	LIQUID LINE	ø6.35 - 0.64m (FLARED CONNECTION ø6.35)
	GAS LINE	ø9.52 - 0.59m (FLARED CONNECTION ø9.52)
DRAIN HOSE		INSULATION ø29 CONNECTED PART ø16 O.D

OUTLINES AND DIMENSIONS

WALL-MOUNTED

Unit: mm

MSZ-LN18VG2W/V/B/R - [EN1]

MSZ-LN25VG2W/V/B/R - [EN2]

MSZ-LN35VG2W/V/B/R - [EN2]

MSZ-LN50VG2W/V/B/R - [EN2]

INDOOR UNIT

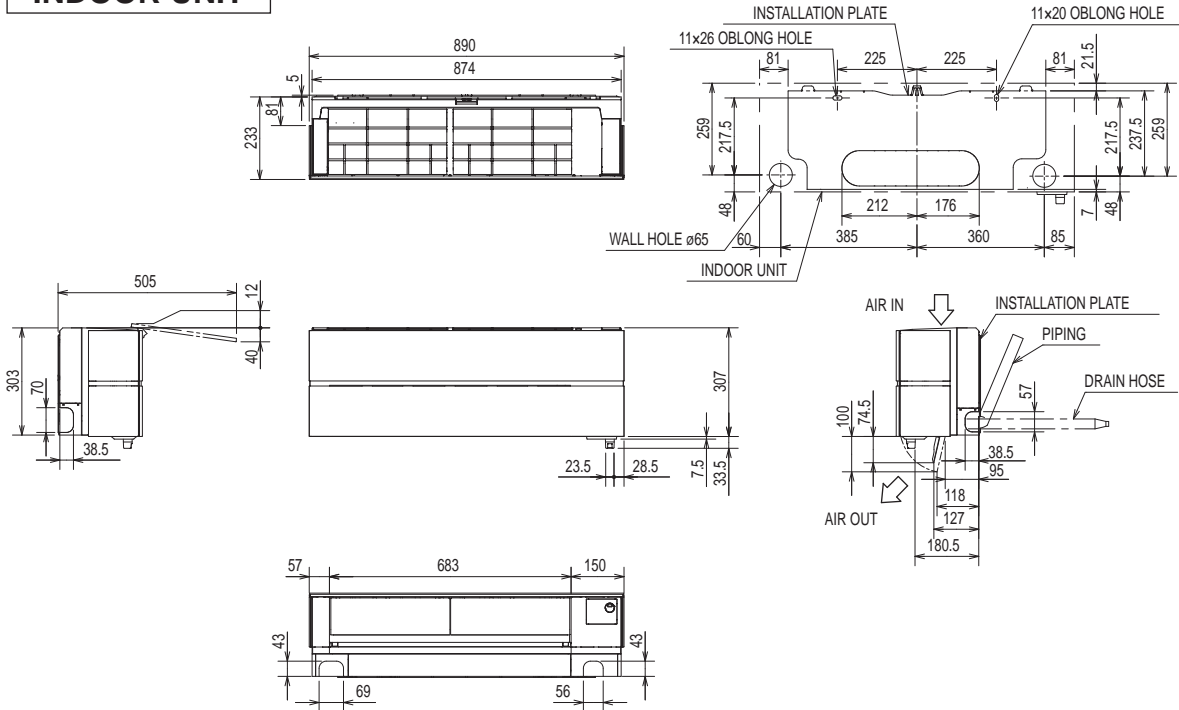

REMOTE CONTROLLER	
MSZ-LN18/25/35/50VG2W	
	60
	19
	193
MSZ-LN18/25/35/50VG2V/B/R	
	60
	21.4
	193

MSZ-LN18VG2W/V/B/R - [EN1]

MSZ-LN/25/35/50VG2W/V/B/R - [EN2]

PIPING	INSULATION	ø37 O.D
	LIQUID LINE	ø6.35 - 0.64m (FLARED CONNECTION ø6.35)
	GAS LINE	ø9.52 - 0.59m (FLARED CONNECTION ø9.52)
DRAIN HOSE		INSULATION ø29 CONNECTED PART ø16 O.D

WALL-MOUNTED OUTLINES AND DIMENSIONS

Unit: mm

- MSZ-LN18VG2W - [SC1], [E3]**
- MSZ-LN18VG2V/B/R - [E3]**
- MSZ-LN25VG2W/V/B/R - [SC1], [E3]**
- MSZ-LN35VG2W/V/B/R - [SC1], [E3]**
- MSZ-LN50VG2W/V/B/R - [SC1], [E3]**
- MSZ-LN60VG2W/V/B/R - [E3]**

INDOOR UNIT

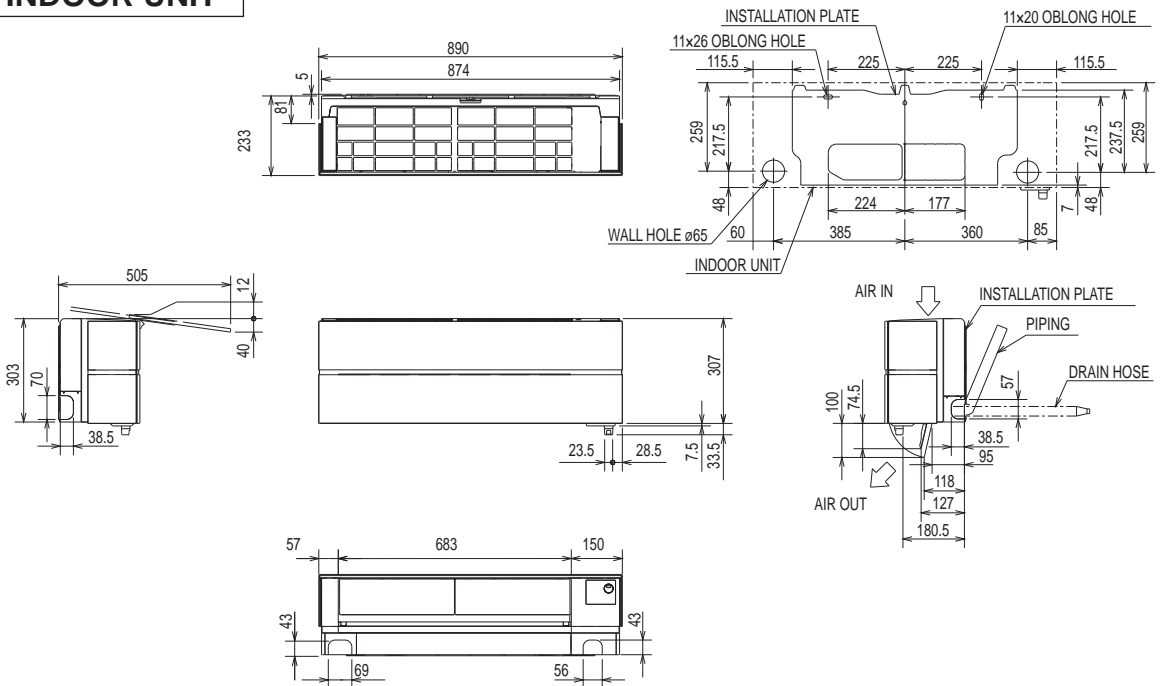

OUTLINES AND DIMENSIONS

WALL-MOUNTED

REMOTE CONTROLLER	
MSZ-LN18/25/35/50/60VG2W	
	60
	19
	183
MSZ-LN18/25/35/50/60VG2V/B/R	
	60
	21.4
	183

MSZ-LN18/25/35/50VG2W/V/B/R - [E3]

PIPING	INSULATION	ø37 O.D
	LIQUID LINE	ø6.35 - 0.5m (FLARED CONNECTION ø6.35)
	GAS LINE	ø9.52 - 0.45m (FLARED CONNECTION ø9.52)
DRAIN HOSE		INSULATION ø29 CONNECTED PART ø16 O.D

MSZ-LN18/25/35/50VG2W/V/B/R - [SC1]

PIPING	INSULATION	ø37 O.D
	LIQUID LINE	ø6.35 - 0.64m (FLARED CONNECTION ø6.35)
	GAS LINE	ø9.52 - 0.59m (FLARED CONNECTION ø9.52)
DRAIN HOSE		INSULATION ø29 CONNECTED PART ø16 O.D

MSZ-LN60VG2W/V/B/R - [E3]

PIPING	INSULATION	ø37 O.D
	LIQUID LINE	ø6.35 - 0.5m (FLARED CONNECTION ø6.35)
	GAS LINE	ø9.52 - 0.45m (FLARED CONNECTION ø12.7)
DRAIN HOSE		INSULATION ø29 CONNECTED PART ø16 O.D

Unit: mm

MSZ-FT25VG MSZ-FT35VG MSZ-FT50VG
MSZ-FT25VGK MSZ-FT35VGK MSZ-FT50VGK

INDOOR UNIT

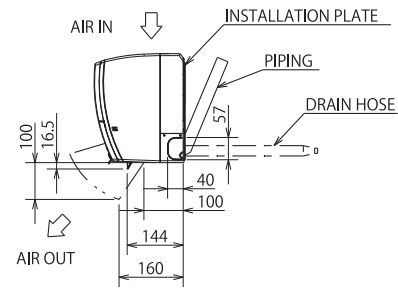
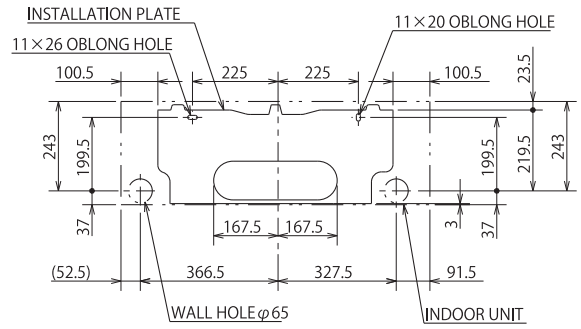
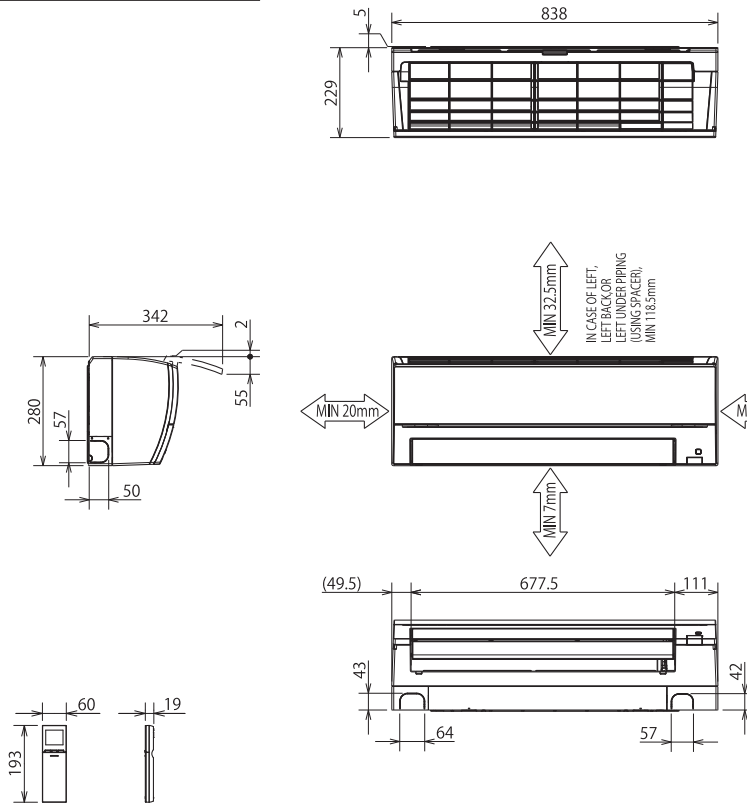

MSZ-FT25/35/50VG-[E1]
 MSZ-FT25/35/50VGK-[E2]

PIPING	INSULATION	φ 37 O.D
	LIQUID LINE	φ 7 - 0.39m (FLARED CONNECTION φ 6.35)
	GAS LINE	φ 9.52 - 0.34m (FLARED CONNECTION φ 9.52)
	DRAIN HOSE	INSULATION φ 29 CONNECTED PART φ 16 O.D

MSZ-FT25/35/50VGK-[SC2]

PIPING	INSULATION	φ 37 O.D
	LIQUID LINE	φ 7 - 0.59m (FLARED CONNECTION φ 6.35)
	GAS LINE	φ 9.52 - 0.54m (FLARED CONNECTION φ 9.52)
	DRAIN HOSE	INSULATION φ 29 CONNECTED PART φ 16 O.D

Unit: mm

MSZ-AY25VG MSZ-AY35VG MSZ-AY42VG MSZ-AY50VG
MSZ-AY25VGK MSZ-AY35VGK MSZ-AY42VGK MSZ-AY50VGK
MSZ-AY25VGKP MSZ-AY35VGKP MSZ-AY42VGKP MSZ-AY50VGKP

INDOOR UNIT

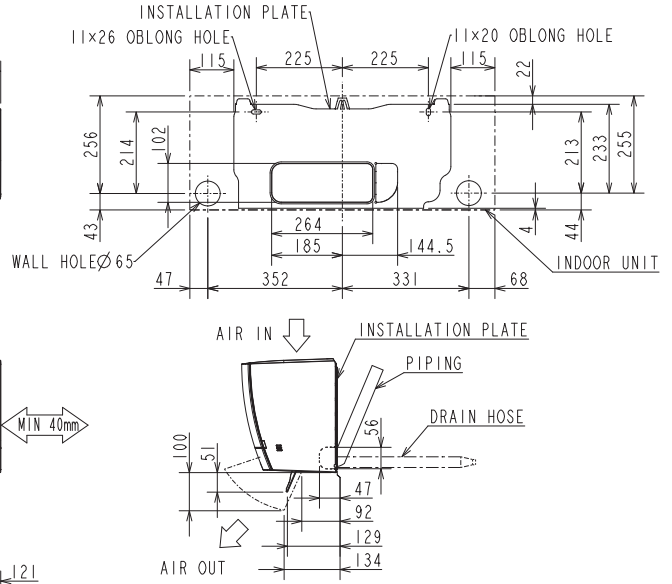
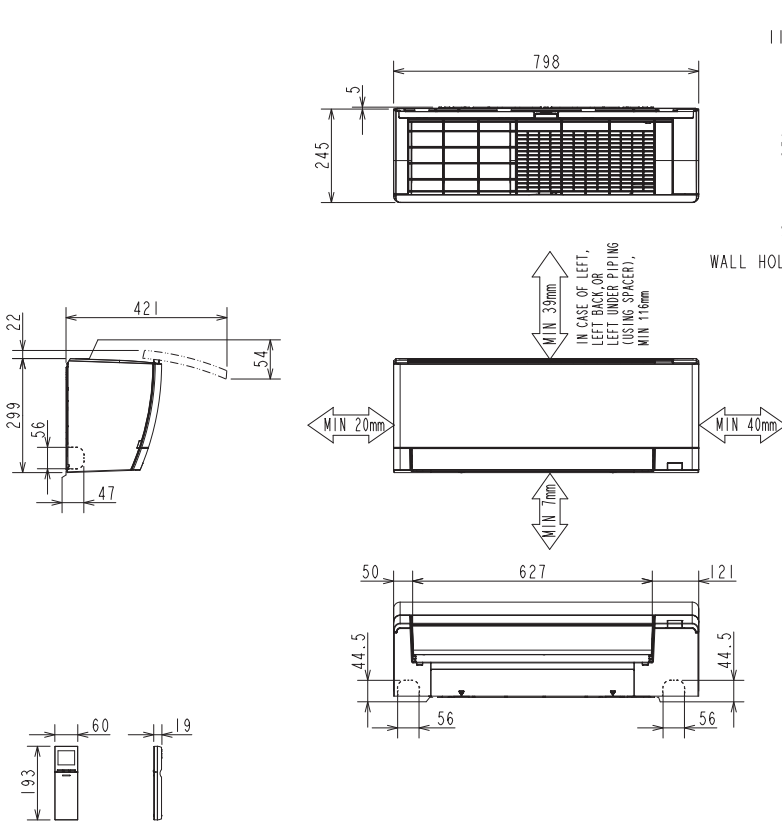

E1, ET1, ER1	
Piping	Insulation ø37 O.D
	Liquid line ø6.35 - 0.39m (Flared connection ø6.35)
	Gas line ø9.52 - 0.34m (Flared connection ø9.52)
	Drain hose Insulation ø29 Connected part ø16 O.D

SC1	
Piping	Insulation ø37 O.D
	Liquid line ø6.35 - 0.57m (Flared connection ø6.35)
	Gas line ø9.52 - 0.52m (Flared connection ø9.52)
	Drain hose Insulation ø29 Connected part ø16 O.D

Unit: mm

MSZ-AP15VG MSZ-AP15VGK MSZ-AP20VG MSZ-AP20VGK

INDOOR UNIT

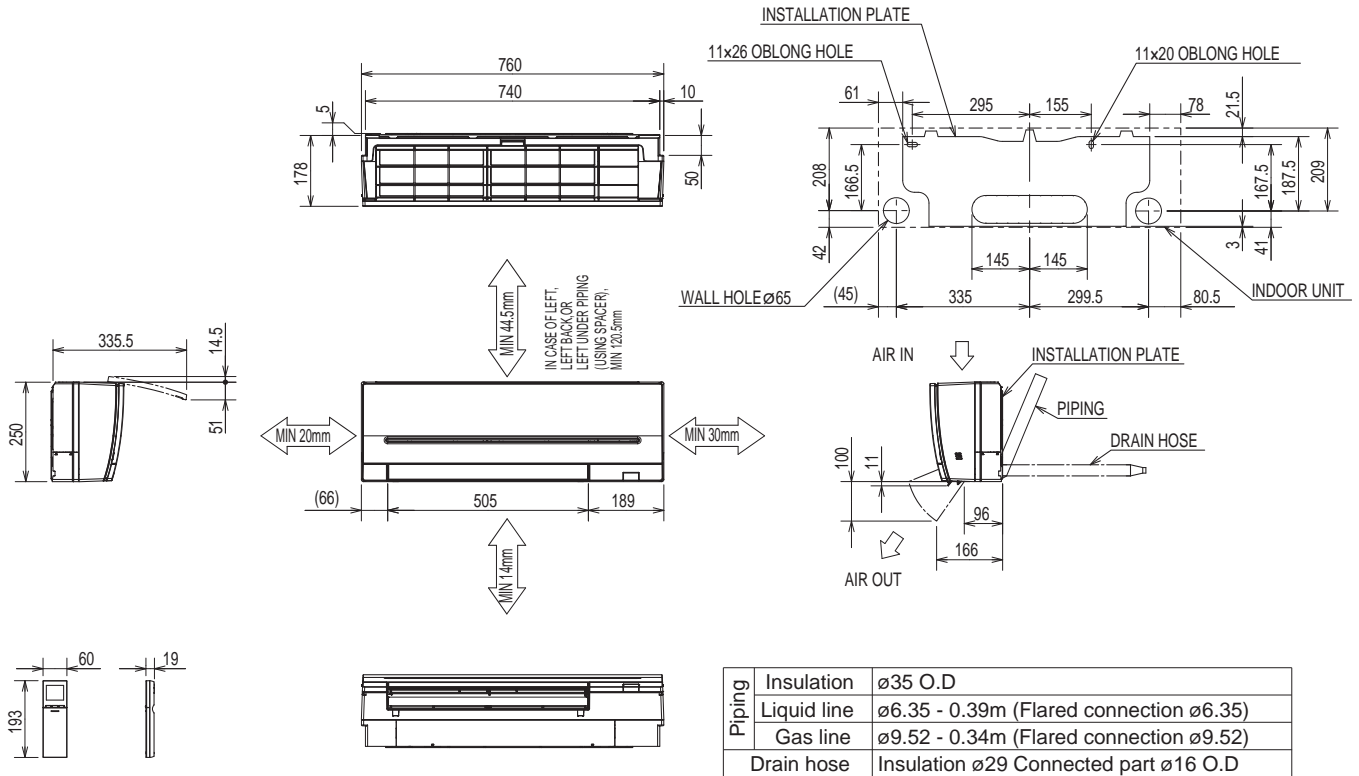

**MSZ-AP60VG MSZ-AP71VG
MSZ-AP60VGK MSZ-AP71VGK**

INDOOR UNIT

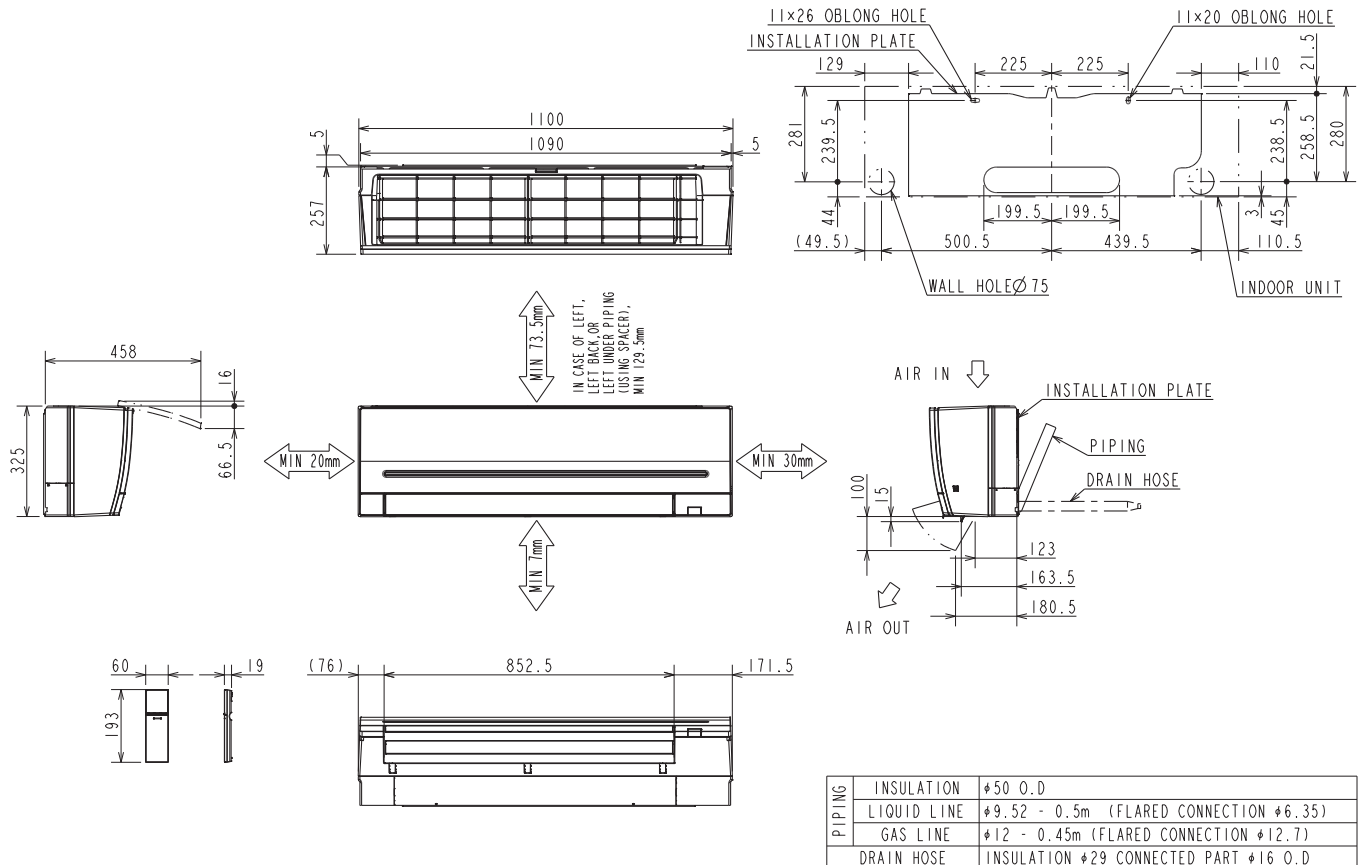

WALL-MOUNTED OUTLINES AND DIMENSIONS

Unit: mm

MSZ-HR25VF MSZ-HR35VF MSZ-HR42VF MSZ-HR50VF
MSZ-HR25VFK MSZ-HR35VFK MSZ-HR42VFK MSZ-HR50VFK

INDOOR UNIT

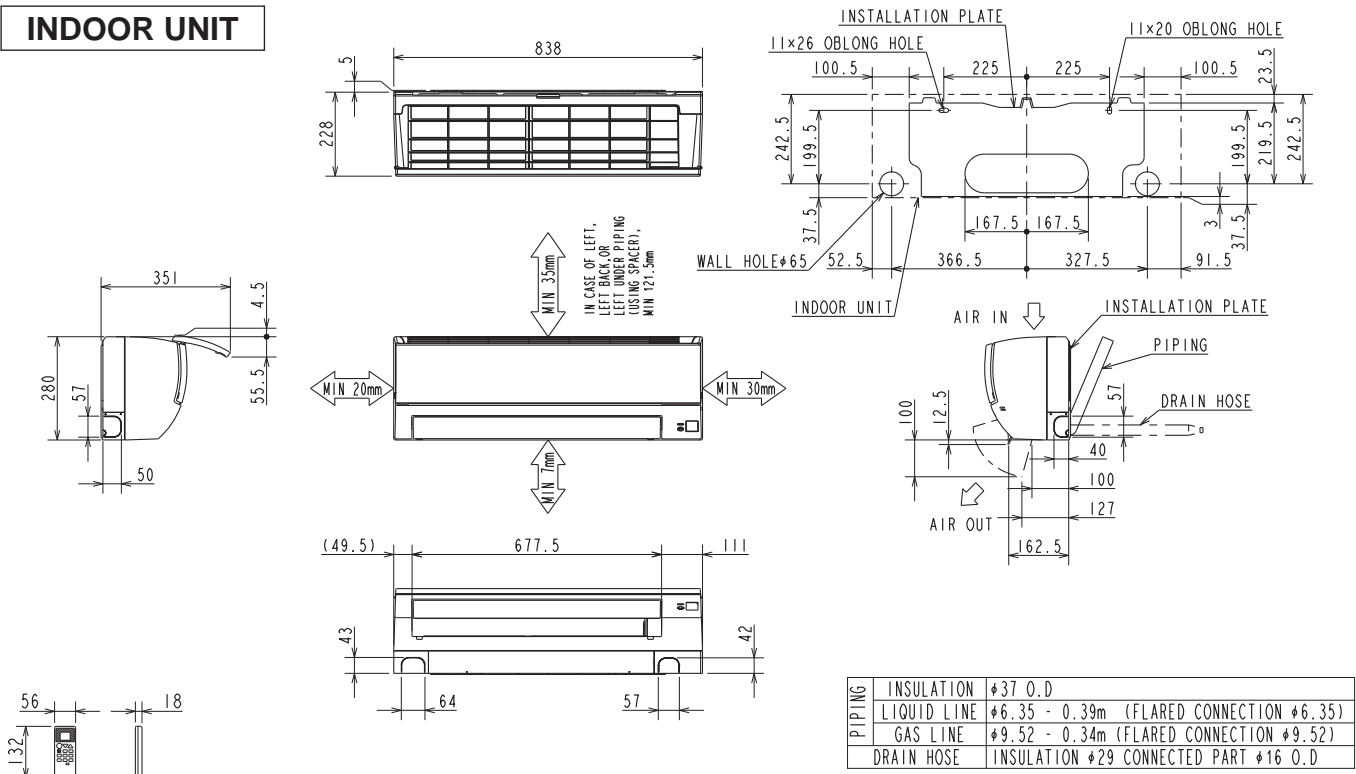

MSZ-HR60VF MSZ-HR71VF
MSZ-HR60VFK MSZ-HR71VFK

INDOOR UNIT

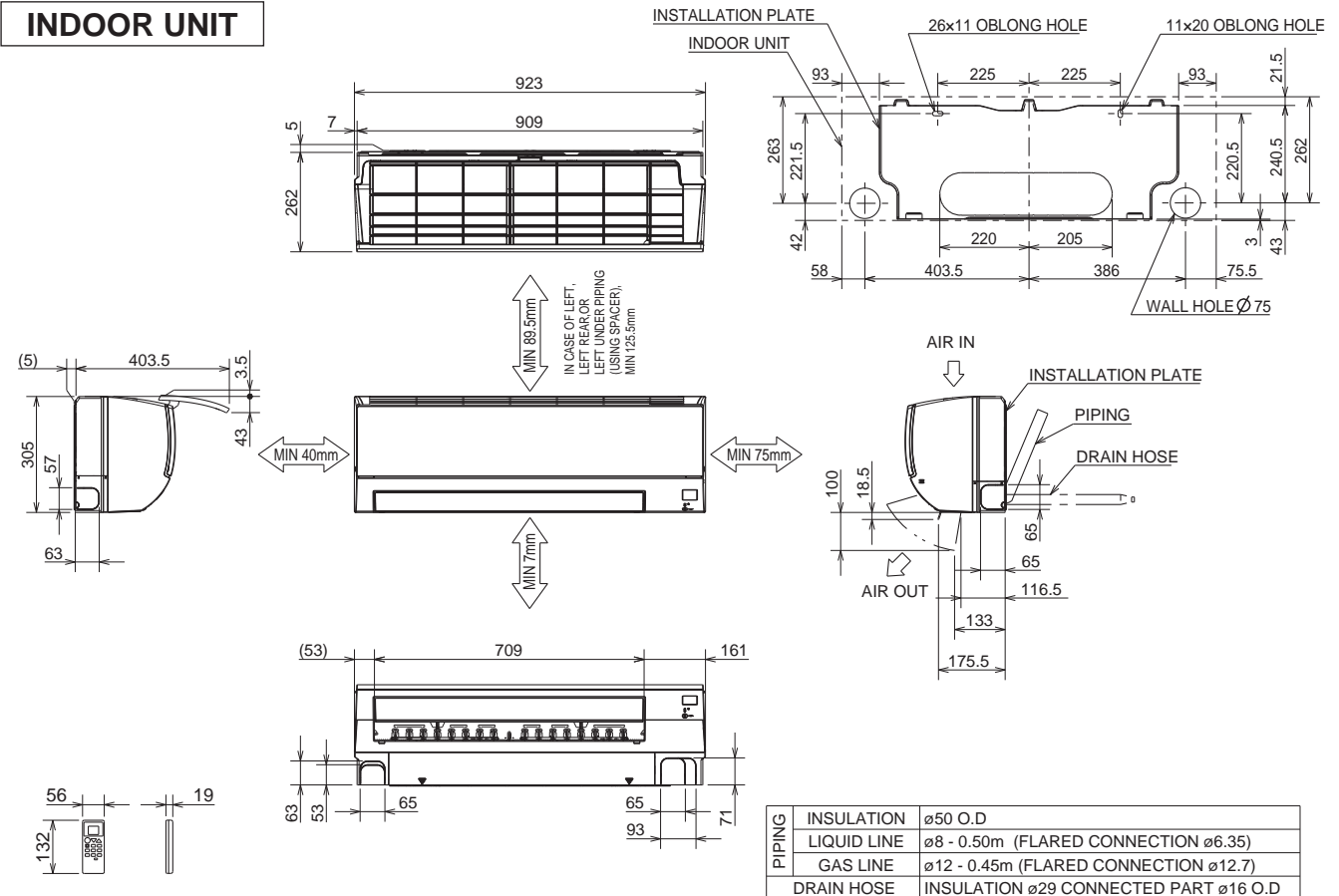

OUTLINES AND DIMENSIONS

WALL-MOUNTED

Unit: mm

MSY-TP35VF MSY-TP50VF

INDOOR UNIT

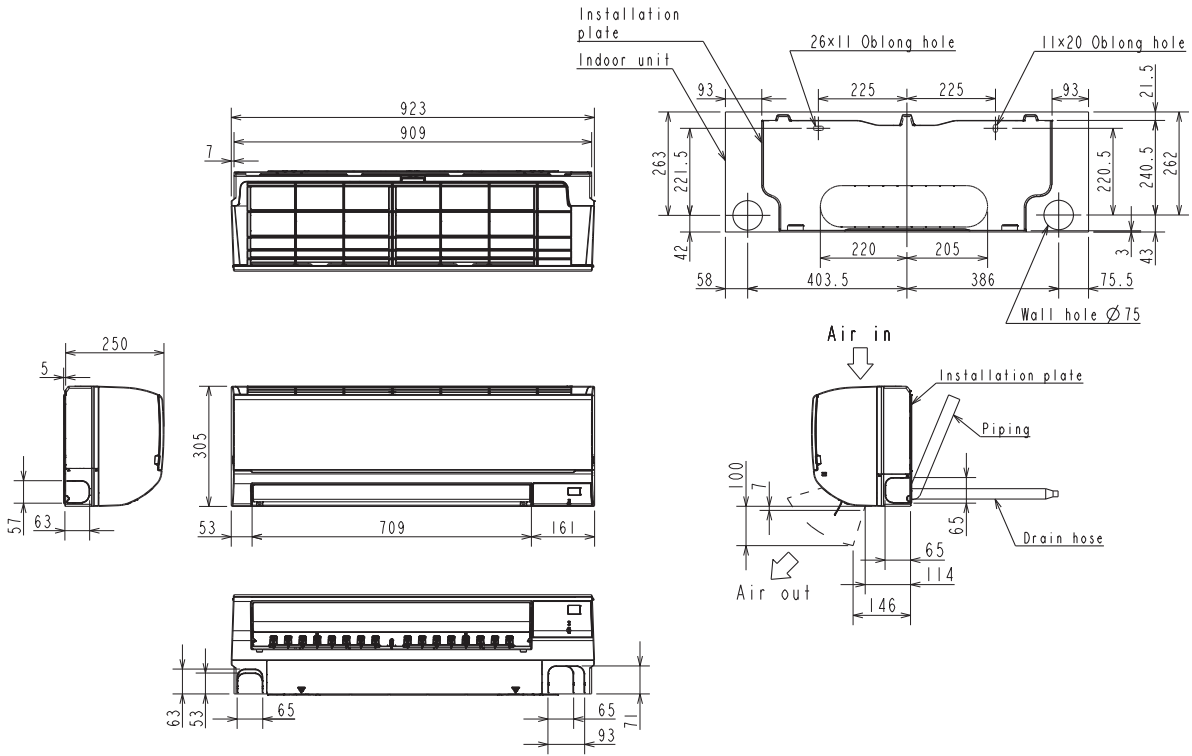

Piping	Insulation	ø50 O.D
	Liquid line	ø8 - 0.5m (Flared connection ø6.35)
	Gas line	ø12 - 0.45m (Flared connection ø9.52)
	Drain hose	Insulation ø29 Connected part ø16 O.D

WALL-MOUNTED OUTLINES AND DIMENSIONS

Unit: mm

- MSZ-EF18VGW MSZ-EF22VGW MSZ-EF25VGW MSZ-EF35VGW MSZ-EF42VGW MSZ-EF50VGW
 MSZ-EF18VGB MSZ-EF22VGB MSZ-EF25VGB MSZ-EF35VGB MSZ-EF42VGB MSZ-EF50VGB
 MSZ-EF18VGS MSZ-EF22VGS MSZ-EF25VGS MSZ-EF35VGS MSZ-EF42VGS MSZ-EF50VGS
 MSZ-EF18VGKW MSZ-EF22VGKW MSZ-EF25VGKW MSZ-EF35VGKW MSZ-EF42VGKW MSZ-EF50VGKW
 MSZ-EF18VGKB MSZ-EF22VGKB MSZ-EF25VGKB MSZ-EF35VGKB MSZ-EF42VGKB MSZ-EF50VGKB
 MSZ-EF18VGKS MSZ-EF22VGKS MSZ-EF25VGKS MSZ-EF35VGKS MSZ-EF42VGKS MSZ-EF50VGKS

INDOOR UNIT

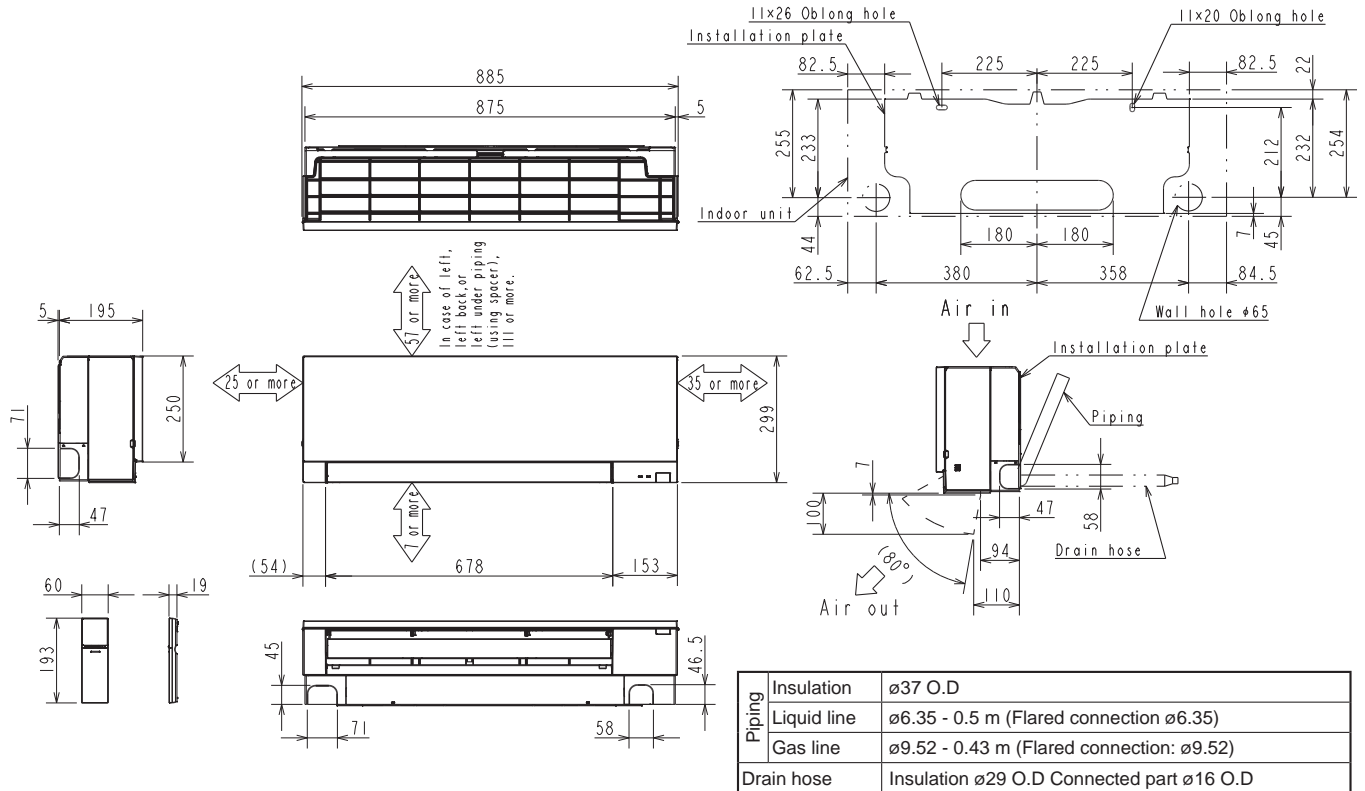

Unit: mm

MSZ-BT20VG MSZ-BT25VG MSZ-BT35VG MSZ-BT50VG
MSZ-BT20VGK MSZ-BT25VGK MSZ-BT35VGK MSZ-BT50VGK

INDOOR UNIT

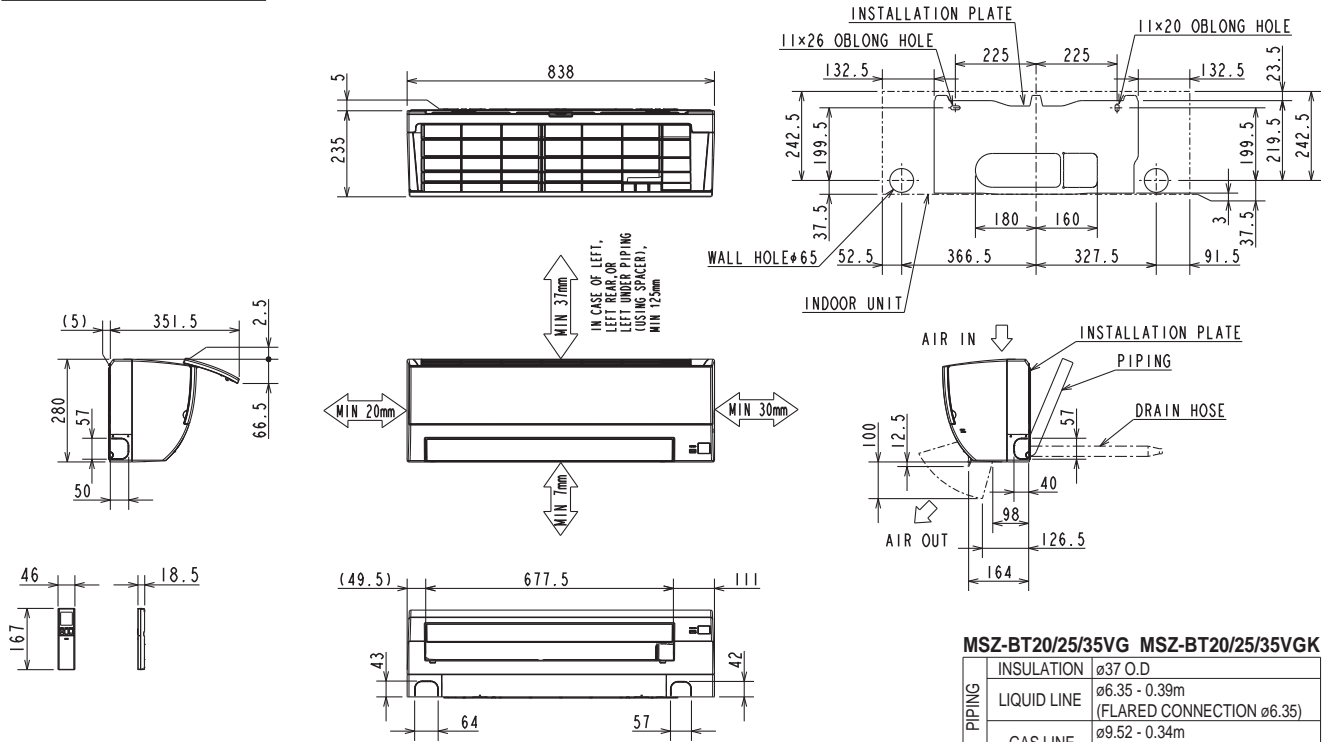

MSZ-BT20/25/35VG MSZ-BT20/25/35VGK

PIPING	INSULATION	ø37 O.D
	LIQUID LINE	ø6.35 - 0.39m (FLARED CONNECTION ø6.35)
	GAS LINE	ø9.52 - 0.34m (FLARED CONNECTION ø9.52)
DRAIN HOSE		INSULATION ø29 CONNECTED PART ø16 O.D

MSZ-BT50VG MSZ-BT50VGK

PIPING	INSULATION	ø37 O.D
	LIQUID LINE	ø6.35 - 0.39m (FLARED CONNECTION ø6.35)
	GAS LINE	ø9.52 - 0.34m (FLARED CONNECTION ø12.7)
DRAIN HOSE		INSULATION ø29 CONNECTED PART ø16 O.D

OUTLINES AND DIMENSIONS

WALL-MOUNTED

Unit: mm

MSZ-SF25VE3 MSZ-SF35VE3 MSZ-SF42VE3 MSZ-SF50VE3

INDOOR UNIT

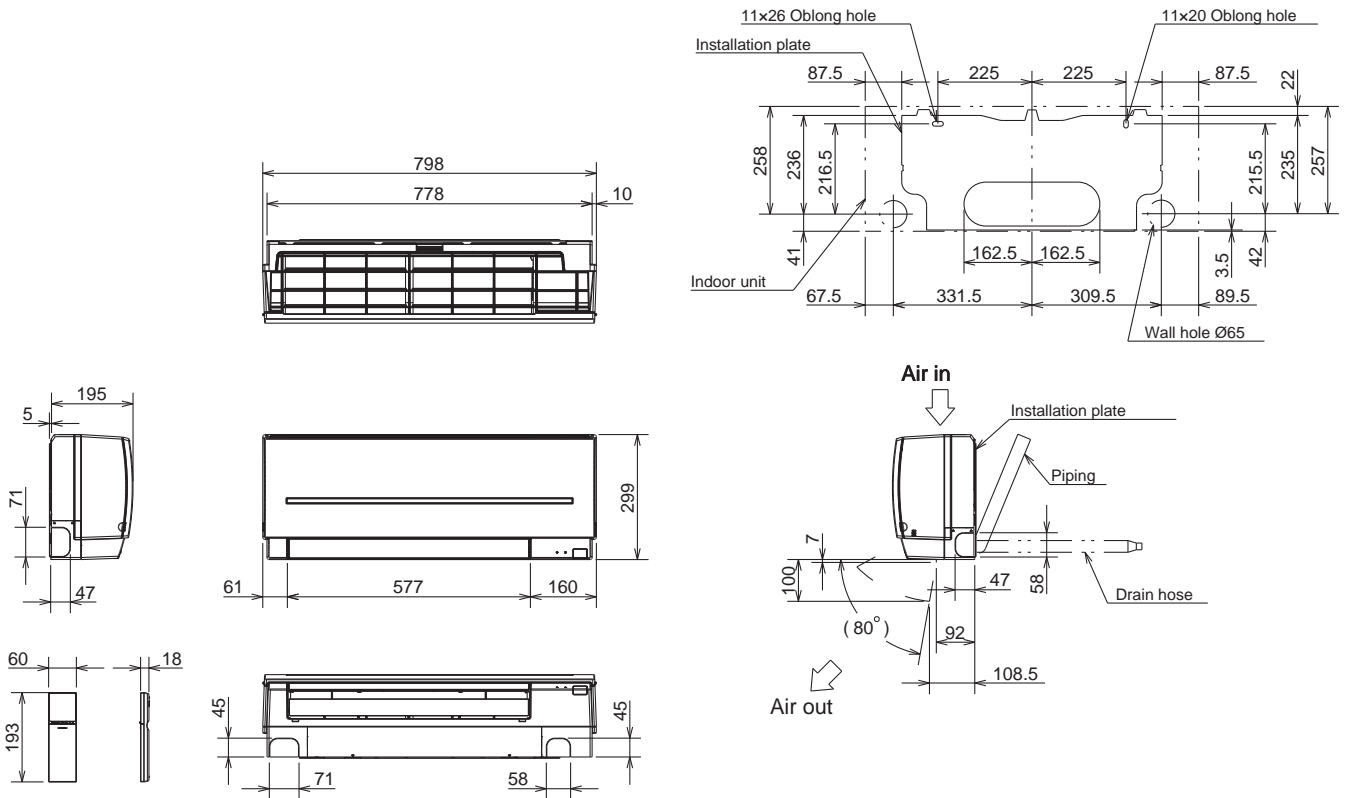

(MSZ-SF25/35/42/50VE3- [E1])

Piping	Insulation	ø37 O.D
	Liquid line	ø6.35 - 0.39m (Flared connection ø6.35)
	Gas line	ø9.52 - 0.34m [Flared connection ø9.52 (MSZ-SF25/35/42VE(2/3)), ø12.7 (MSZ-SF50VE(2/3))]
Drain hose	Insulation ø29 Connected part ø16 O.D	

(MSZ-SF25/35/42/50VE3- [EN1])

Piping	Insulation	ø37 O.D
	Liquid line	ø6.35 - 0.5m (Flared connection ø6.35)
	Gas line	ø9.52 - 0.43m [Flared connection ø9.52 (MSZ-SF25/35/42VE(2/3)), ø12.7 (MSZ-SF50VE(2/3))]
Drain hose	Insulation ø29 Connected part ø16 O.D	

WALL-MOUNTED OUTLINES AND DIMENSIONS

Unit: mm

MSZ-GF60VE2 MSZ-GF71VE2

INDOOR UNIT

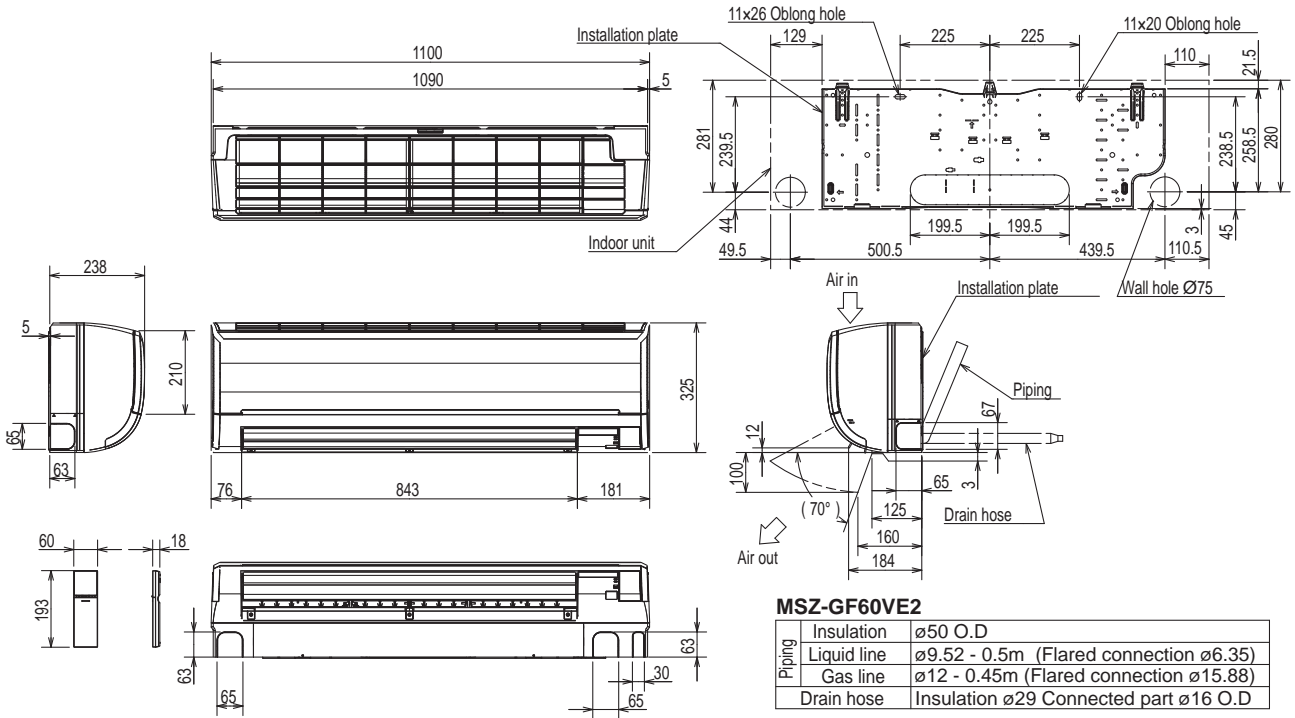

MSZ-GF71VE2	
Insulation	ø50 O.D
Liquid line	ø9.52 - 0.5m (Flared connection ø9.52)
Gas line	A1 - 0.45m (Flared connection ø15.88)
Drain hose	Insulation ø29 Connected part ø16 O.D

MSZ-WN25VA MSZ-WN35VA

INDOOR UNIT

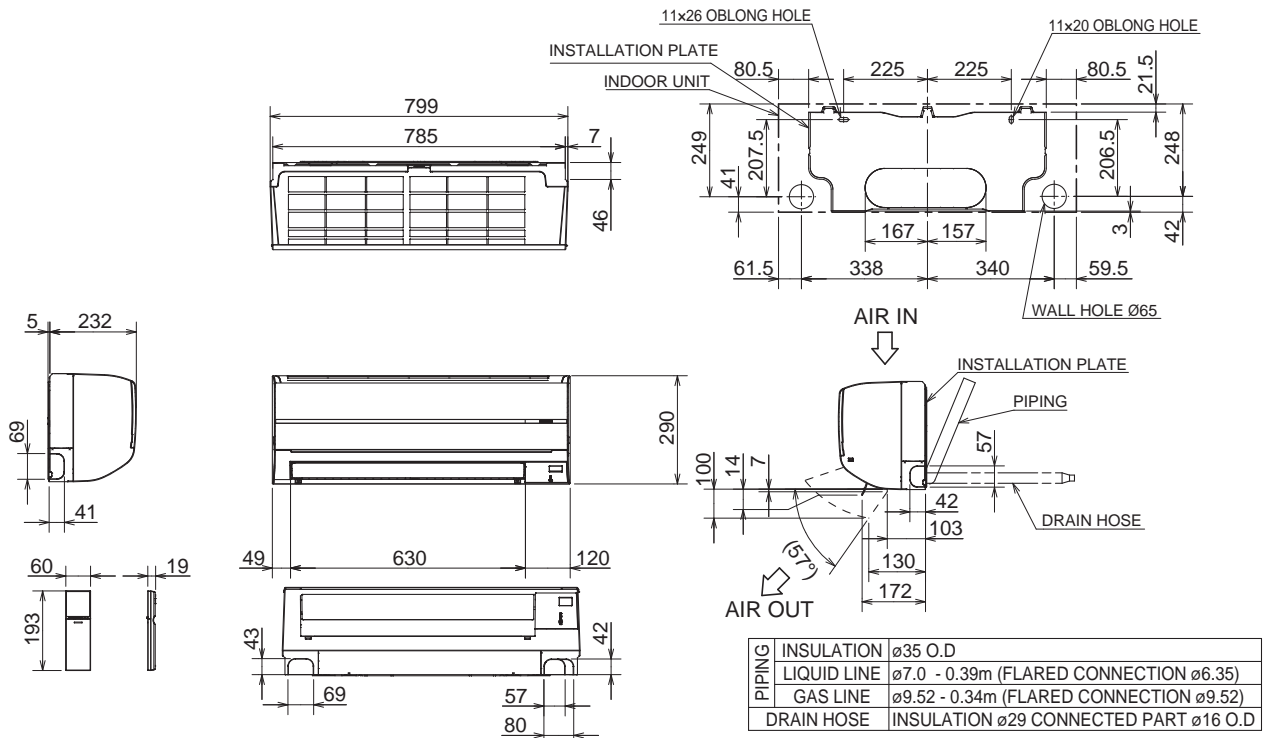

OUTLINES AND DIMENSIONS

WALL-MOUNTED

Unit: mm

MSZ-DM25VA MSZ-DM35VA
MSZ-HJ25VA MSZ-HJ35VA MSZ-HJ50VA

INDOOR UNIT

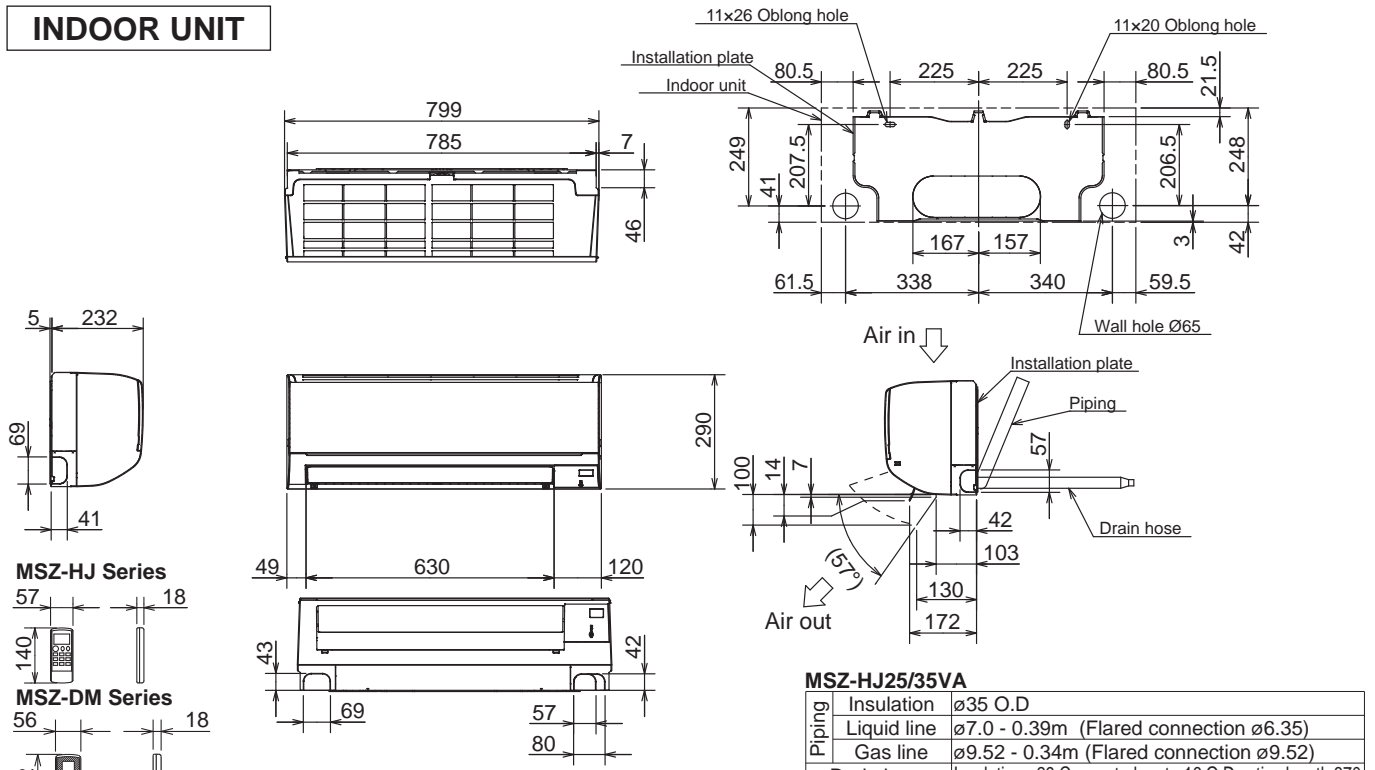

MSZ-DM25/35VA

Piping	Insulation	ø35 O.D
	Liquid line	ø7.0 - 0.39m (Flared connection ø6.35)
	Gas line	ø9.52 - 0.34m (Flared connection ø9.52)
Drain hose	Insulation	ø29 Connected part ø16 O.D

MSZ-HJ25/35VA

Piping	Insulation	ø35 O.D
	Liquid line	ø7.0 - 0.39m (Flared connection ø6.35)
	Gas line	ø9.52 - 0.34m (Flared connection ø9.52)
Drain hose	Insulation	ø29 Connected part ø16 O.D active length 370

MSZ-HJ50VA

Piping	Insulation	ø37 O.D
	Liquid line	ø7.0 - 0.39m (Flared connection ø6.35)
	Gas line	ø9.52 - 0.34m (Flared connection ø12.7)
Drain hose	Insulation	ø29 Connected part ø16 O.D active length 370

MSZ-HJ60VA MSZ-HJ71VA

INDOOR UNIT

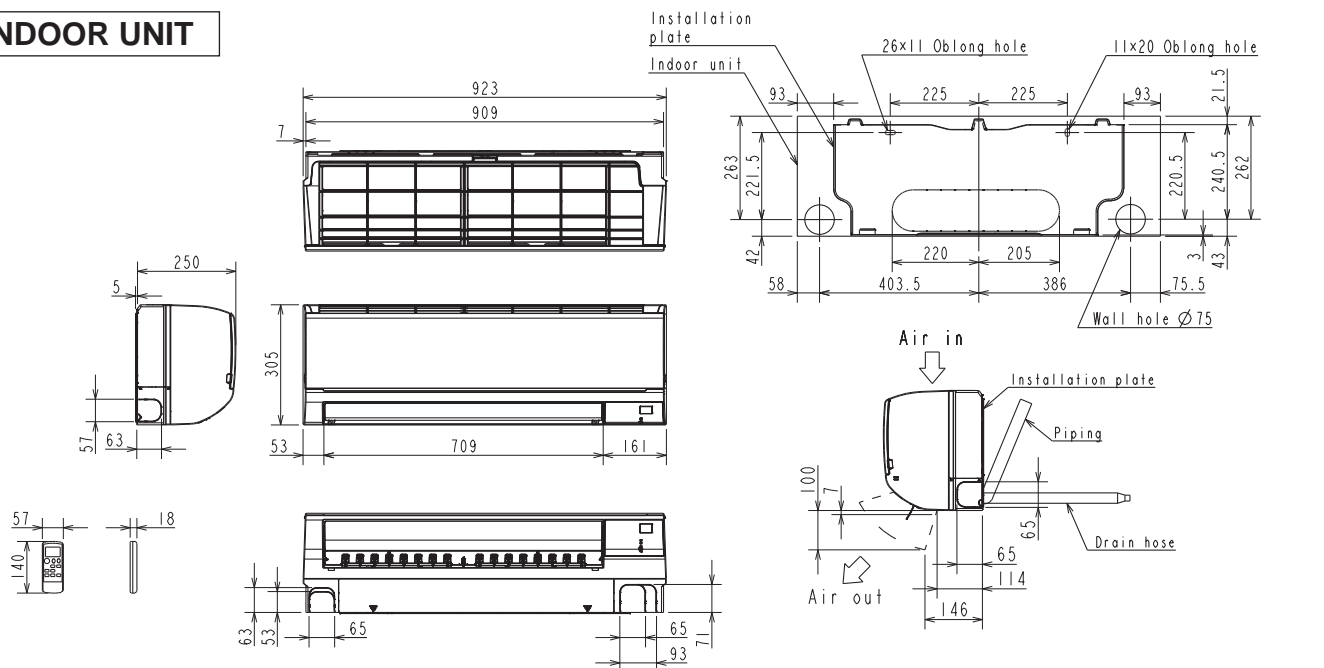

MSZ-HJ60VA

Piping	Insulation	ø50 O.D
	Liquid line	ø8 - 0.39m (Flared connection ø6.35)
	Gas line	ø12 - 0.34m (Flared connection ø15.88)
Drain hose	Insulation	ø29 Connected part ø16 O.D

MSZ-HJ71VA

Piping	Insulation	ø50 O.D
	Liquid line	ø8 - 0.39m (Flared connection ø9.52)
	Gas line	ø12 - 0.34m (Flared connection ø15.88)
Drain hose	Insulation	ø29 Connected part ø16 O.D

WALL-MOUNTED OUTLINES AND DIMENSIONS

C.1.2.2 Outdoor Unit
 MUZ-RW25VGHZ MUZ-RW35VGHZ

Unit: mm

OUTDOOR UNIT

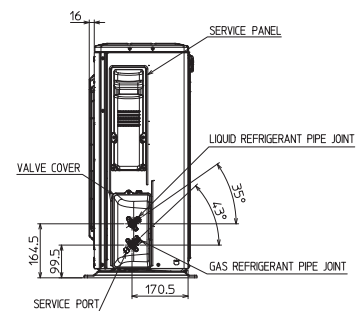
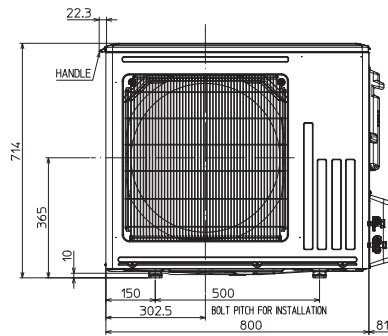
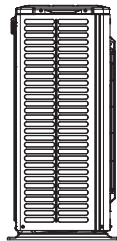
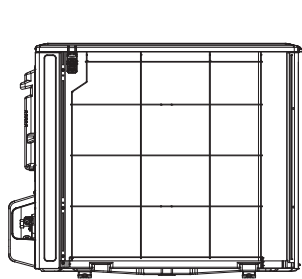
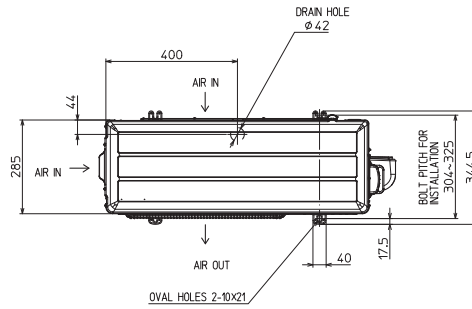
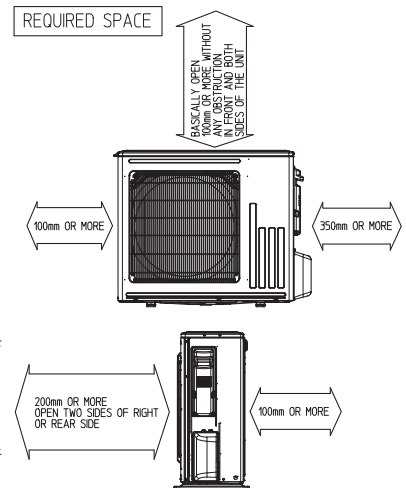

REFRIGERANT PIPE JOINT	LIQUID REFRIGERANT PIPE	FLARED 6.35(1/4")
	GAS REFRIGERANT PIPE	FLARED 9.52(3/8")

OUTLINES AND DIMENSIONS

WALL-MOUNTED

Unit: mm

MUZ-RW50VGHZ
OUTDOOR UNIT

REQUIRED SPACE

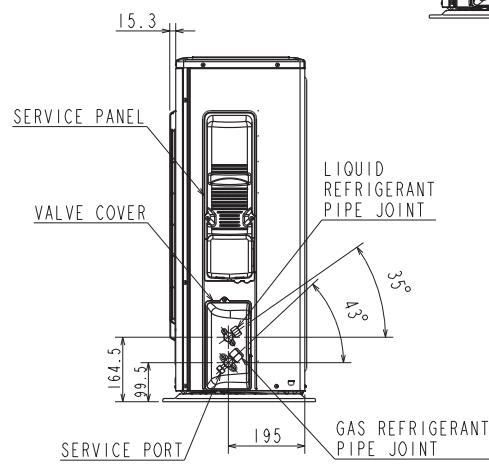
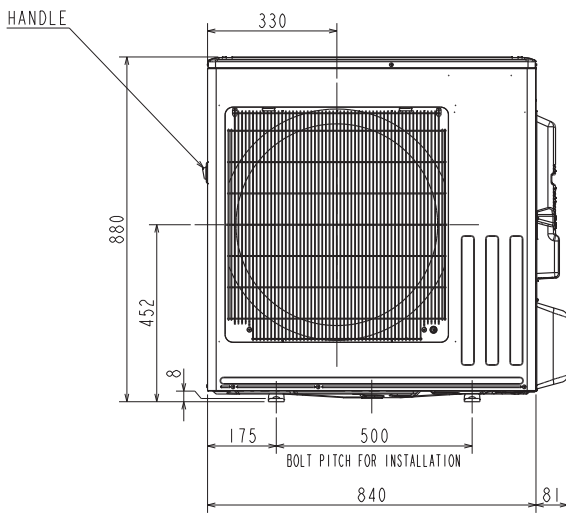
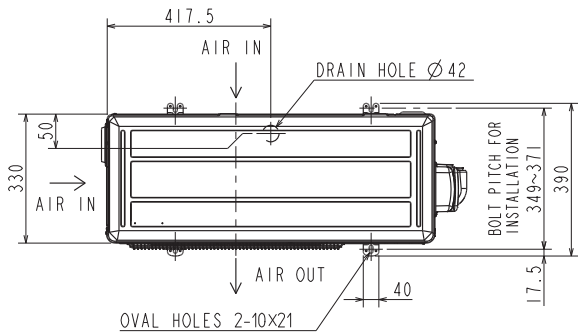
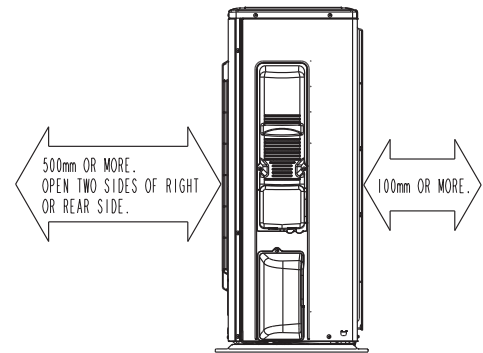
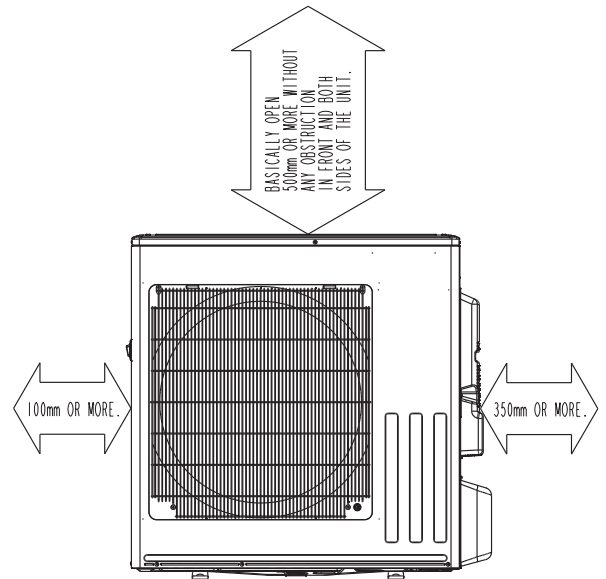

REFRIGERANT PIPE JOINT	LIQUID REFRIGERANT PIPE	FLARED ø6.35 (1/4")
	GAS REFRIGERANT PIPE	FLARED ø9.52 (3/8")

WALL-MOUNTED OUTLINES AND DIMENSIONS

MUZ-LN25VG2 MUZ-LN35VG2
OUTDOOR UNIT

Unit: mm

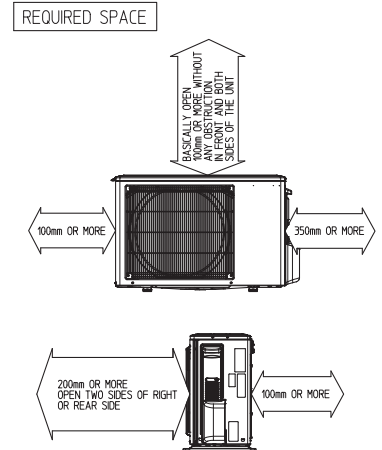
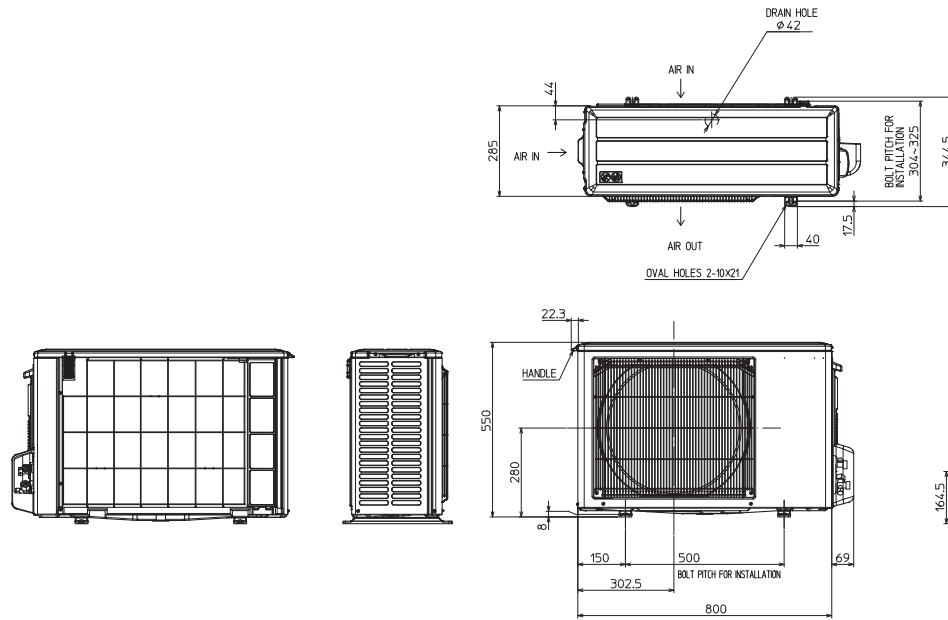

REFRIGERANT PIPE JOINT	LIQUID REFRIGERANT PIPE	FLARED 6.35(1/4")
	GAS REFRIGERANT PIPE	FLARED 9.52(3/8")

MUZ-LN25VGHZ2 MUZ-LN35VGHZ2
OUTDOOR UNIT

REQUIRED SPACE

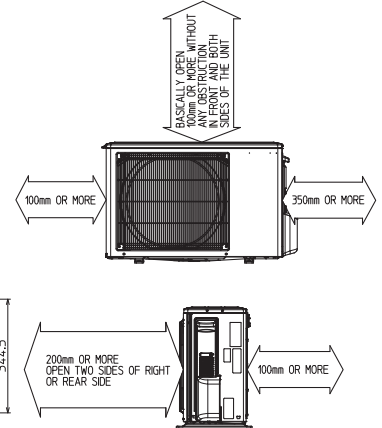
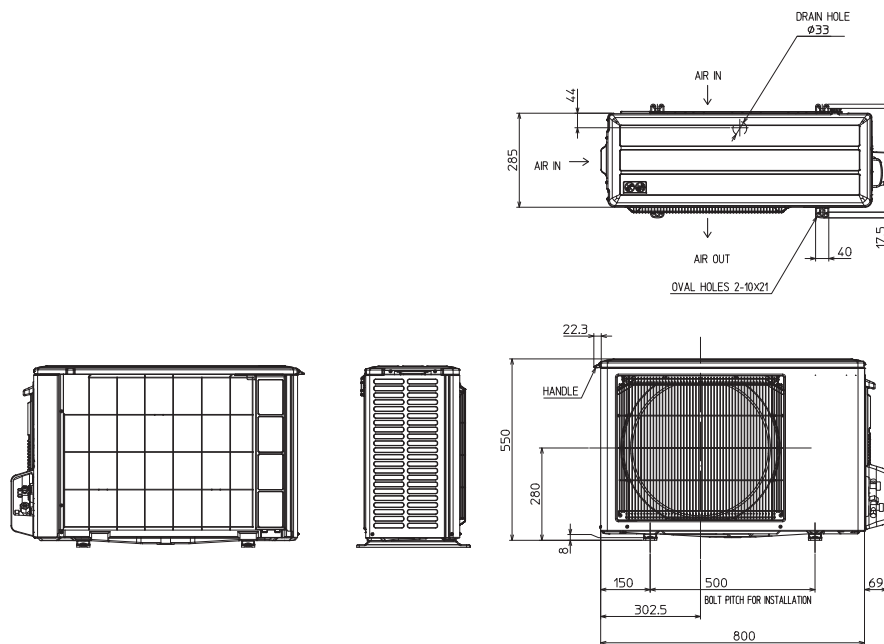

REFRIGERANT PIPE JOINT	LIQUID REFRIGERANT PIPE	FLARED 6.35(1/4")
	GAS REFRIGERANT PIPE	FLARED 9.52(3/8")

OUTLINES AND DIMENSIONS

WALL-MOUNTED

MUZ-LN50VG2
OUTDOOR UNIT

Unit: mm

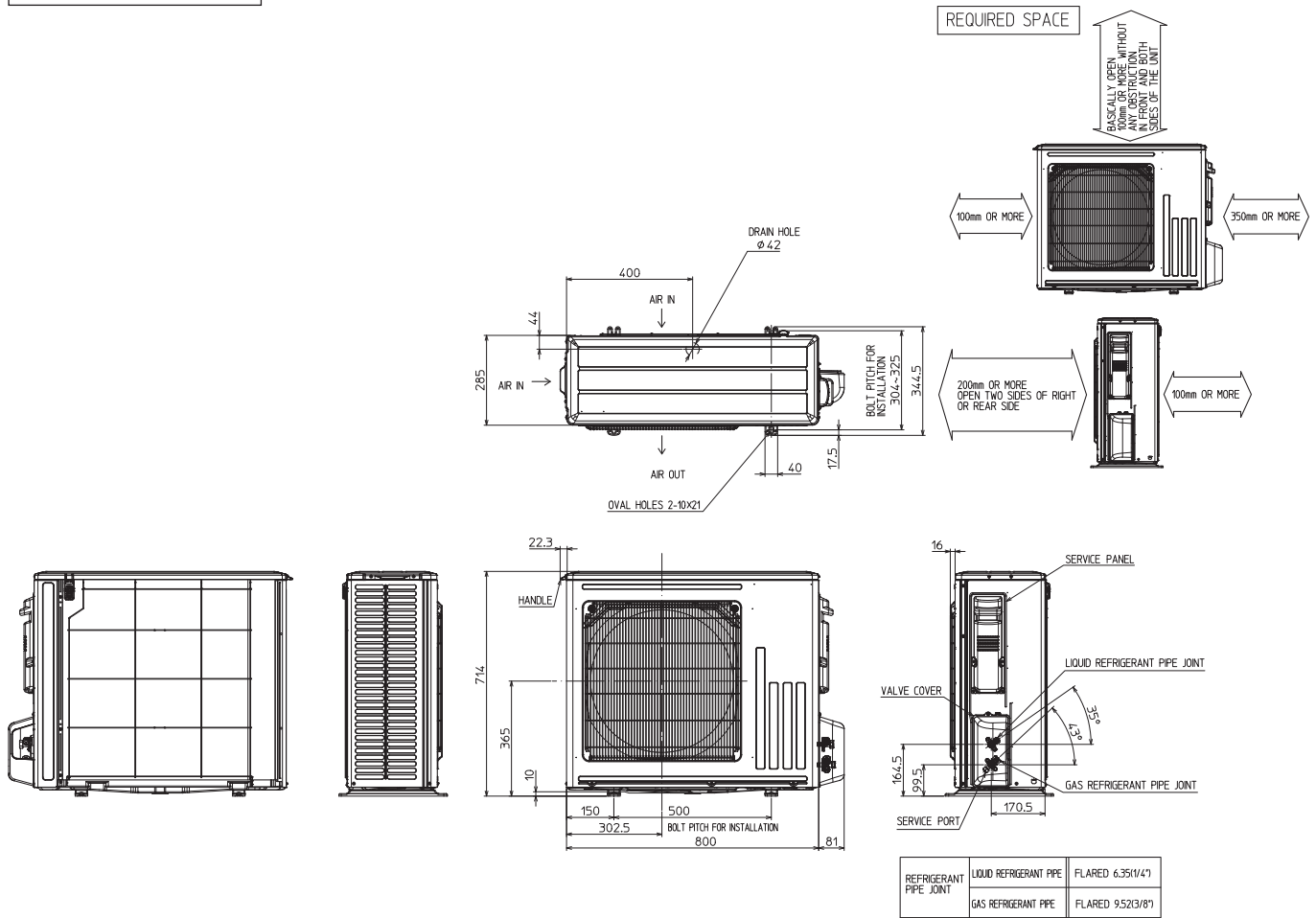

WALL-MOUNTED OUTLINES AND DIMENSIONS

Unit: mm

MUZ-LN50VGHZ2
MUZ-LN60VG2
OUTDOOR UNIT

REQUIRED SPACE

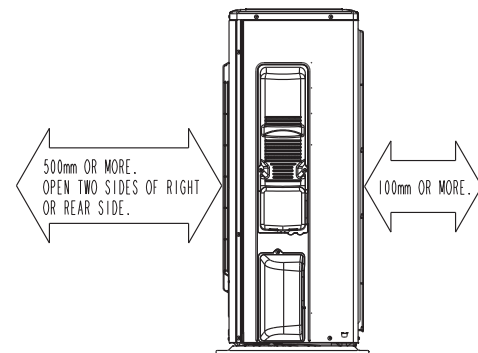
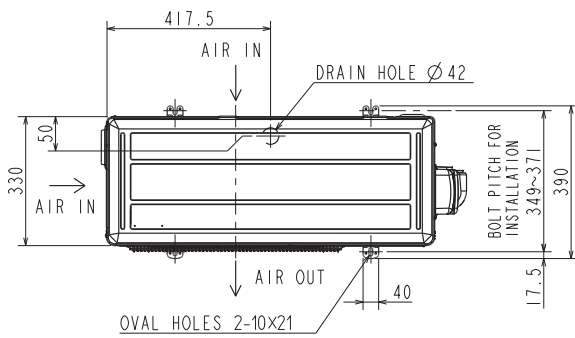
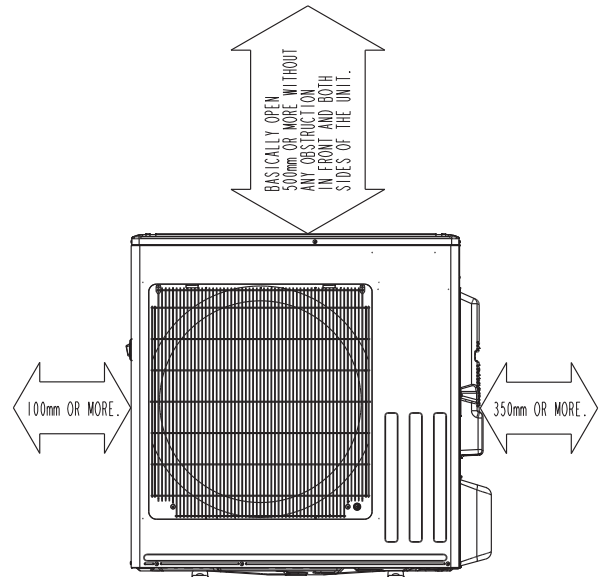

OUTLINES AND DIMENSIONS

WALL-MOUNTED

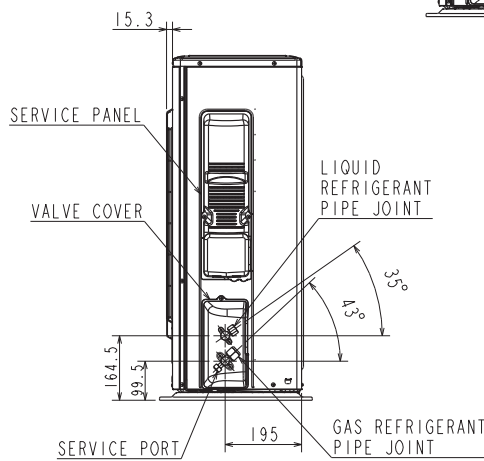
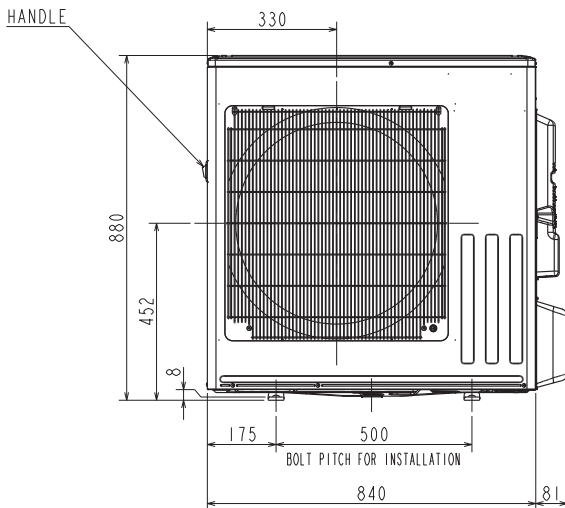

REFRIGERANT PIPE JOINT	LIQUID REFRIGERANT PIPE	FLARED $\phi 6.35$ (1/4")
	GAS REFRIGERANT PIPE	FLARED $\phi 9.52$ (3/8") (MUZ-LN50VGHZ2) FLARED $\phi 12.7$ (1/2") (MUZ-LN60VG2)

Unit: mm

MUZ-FT25VGHZ
OUTDOOR UNIT

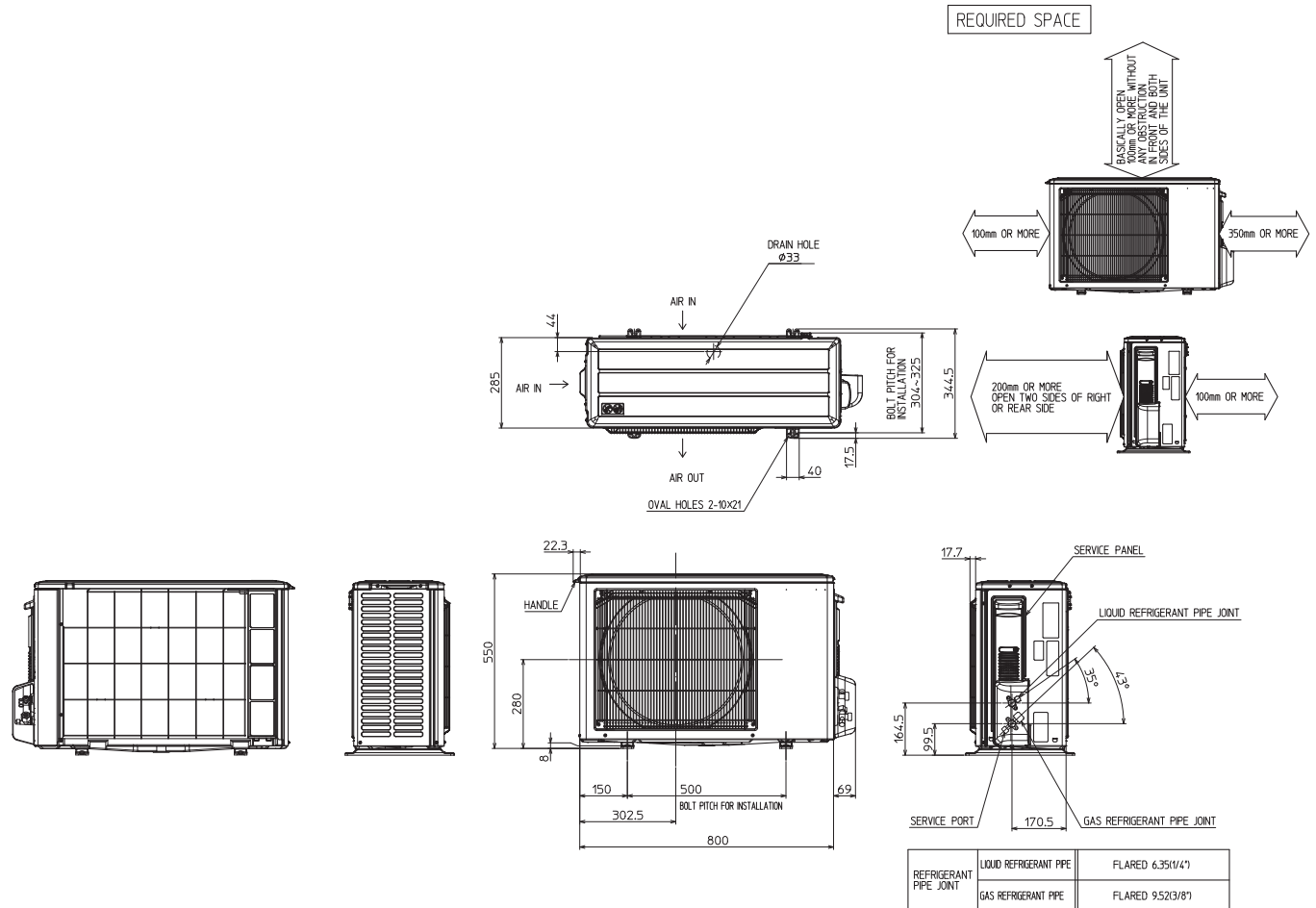

OUTLINES AND DIMENSIONS

WALL-MOUNTED

Unit: mm

MUZ-FT35VGHZ MUZ-FT50VGHZ

OUTDOOR UNIT

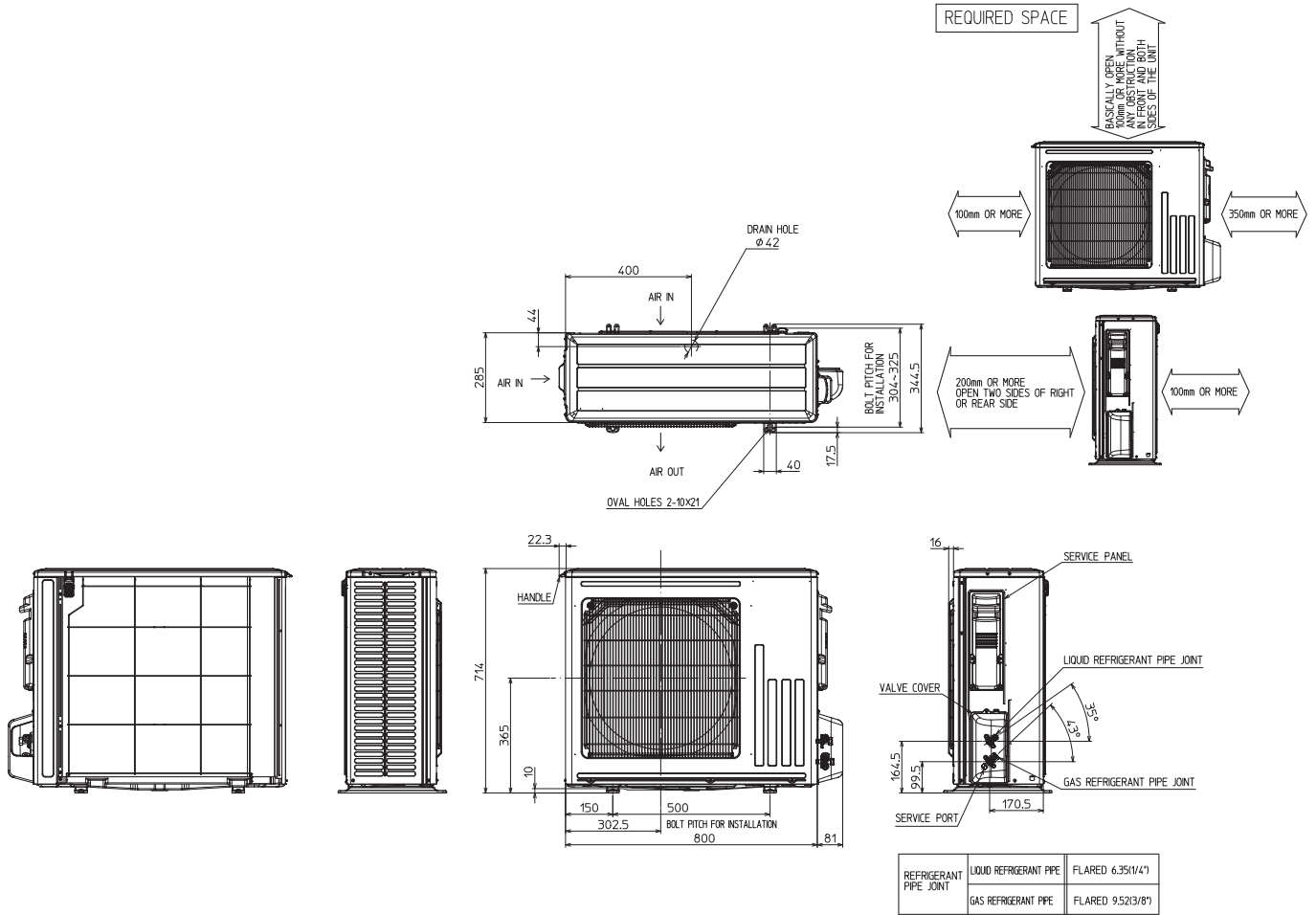

OUTLINES AND DIMENSIONS

WALL-MOUNTED

Unit: mm

- MUZ-AY25VG**
- MUZ-AY35VG**
- MUZ-AY42VG**
- MUZ-AY25VGH**
- MUZ-AY35VGH**
- MUZ-AY42VGH**
- MUZ-EF25VG**
- MUZ-EF35VG**
- MUZ-EF42VG**
- MUZ-EF25VGH**
- MUZ-EF35VGH**

OUTDOOR UNIT

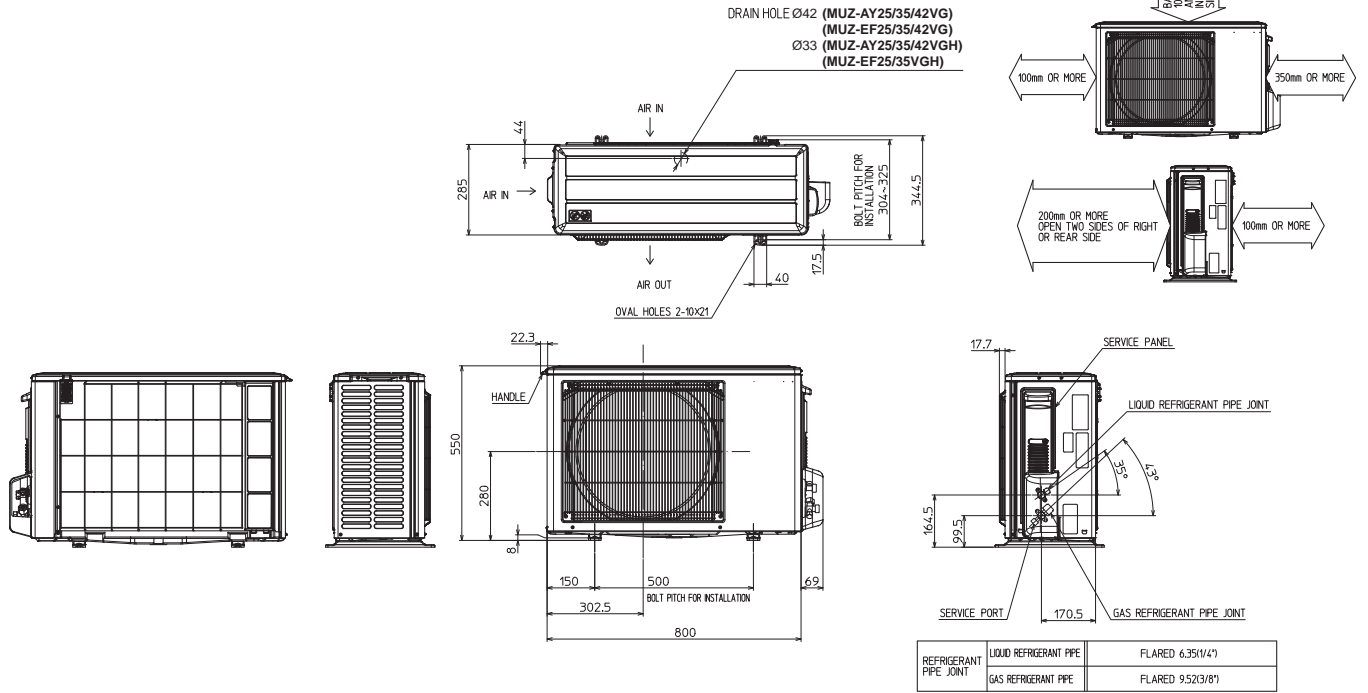

- MUZ-AY50VG**
- MUZ-AY50VGH**
- MUZ-AP60VG**
- MUZ-EF50VG**

OUTDOOR UNIT

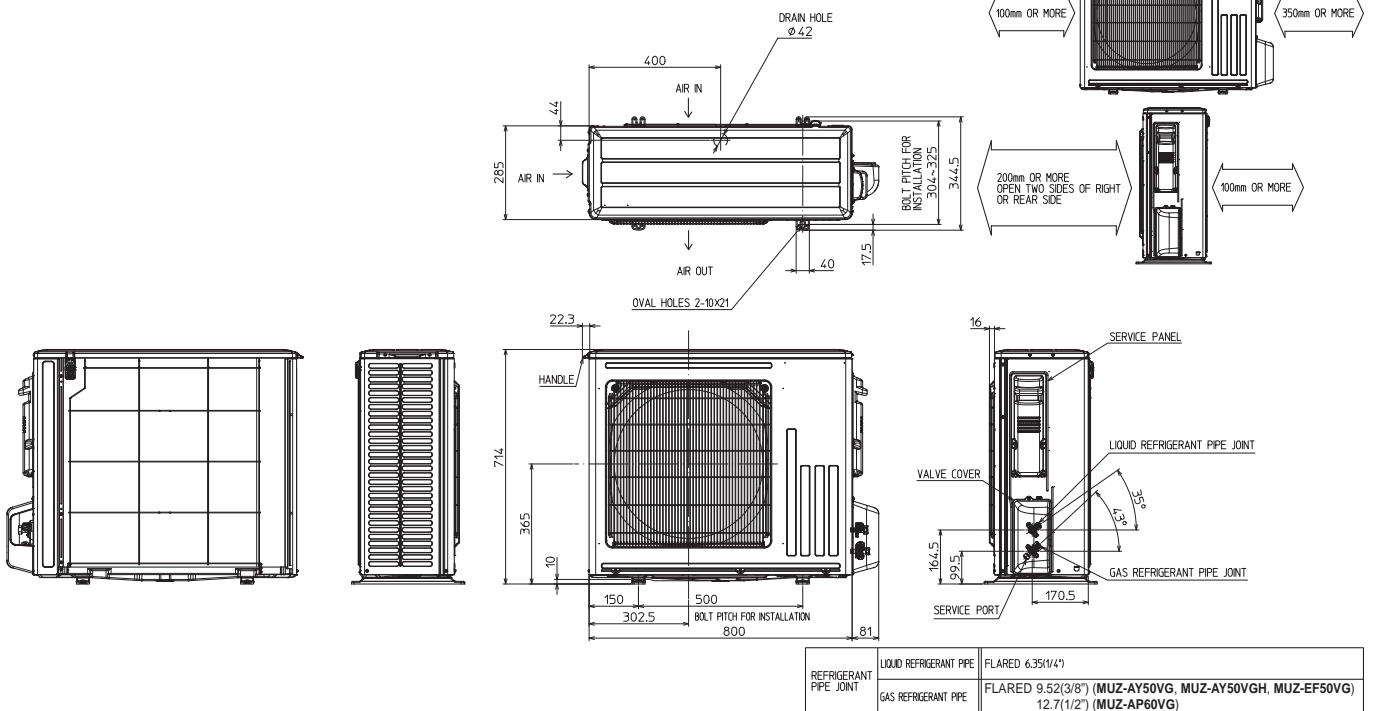

WALL-MOUNTED OUTLINES AND DIMENSIONS

Unit: mm

MUZ-AP15VG
OUTDOOR UNIT

REQUIRED SPACE

Open in principle
If there is no obstacle in front/
on both sides, ensure 100mm or more

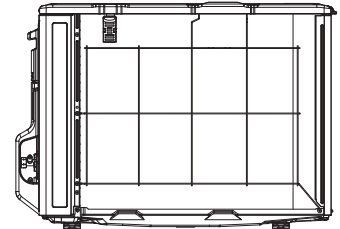
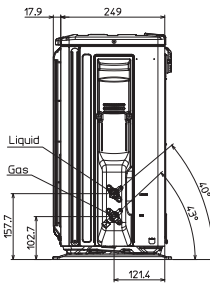
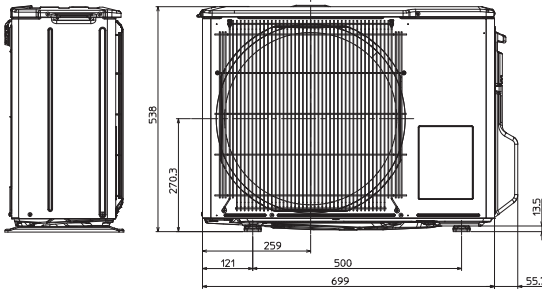
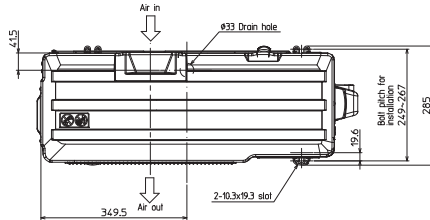
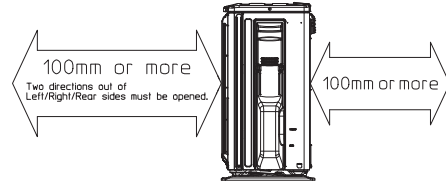

REFRIGERANT PIPE JOINT	LIQUID REFRIGERANT PIPE	FLARED 6.35(1/4")
	GAS REFRIGERANT PIPE	FLARED 9.52(3/8")

MUZ-AP20VG
OUTDOOR UNIT

REQUIRED SPACE

BASICALLY OPEN
WITHOUT
ANY OBSTRUCTION
IN FRONT AND BOTH
SIDES OF THE UNIT.

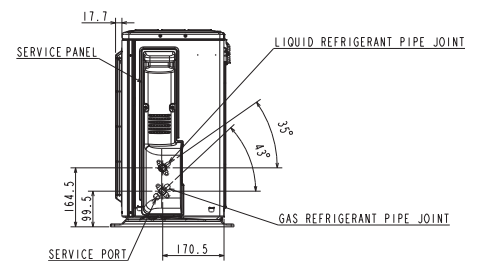
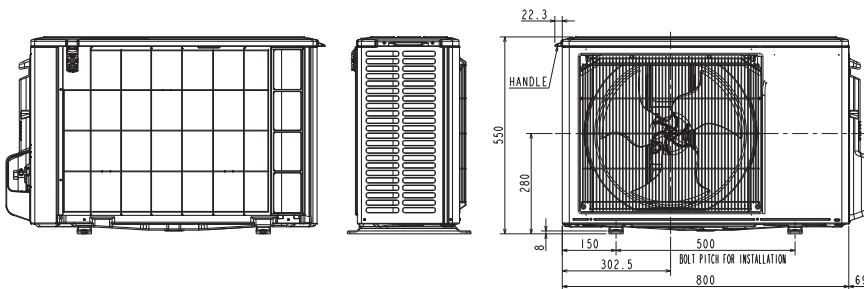
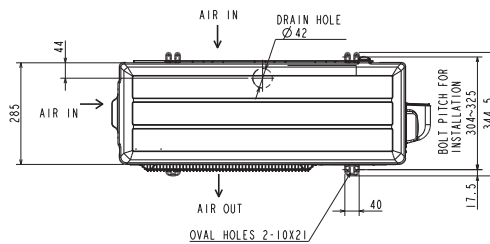
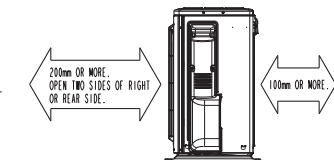
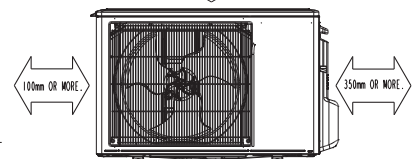

MODEL NAME	MUZ-AP20VG	
REFRIGERANT PIPE JOINT	LIQUID REFRIGERANT PIPE	FLARED 6.35(1/4")
	GAS REFRIGERANT PIPE	FLARED 9.52(3/8")
DRAIN HOLE DIAMETER	Ø42	

OUTLINES AND DIMENSIONS

WALL-MOUNTED

Unit: mm

- MUZ-AP71VG
- MUZ-FH50VE MUZ-FH50VEHZ
- MUZ-SF50VE MUZ-SF50VEH
- MUZ-GF60VE MUZ-GF71VE
- MUZ-HJ60VA MUZ-HJ71VA

OUTDOOR UNIT

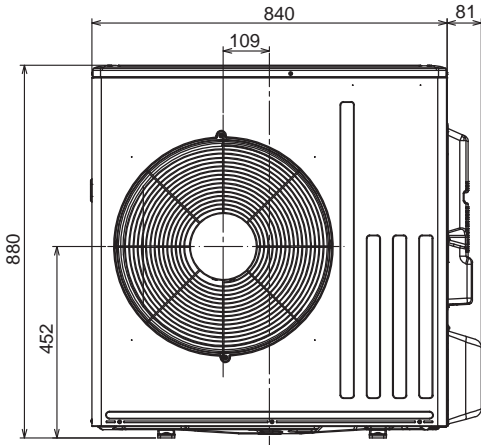
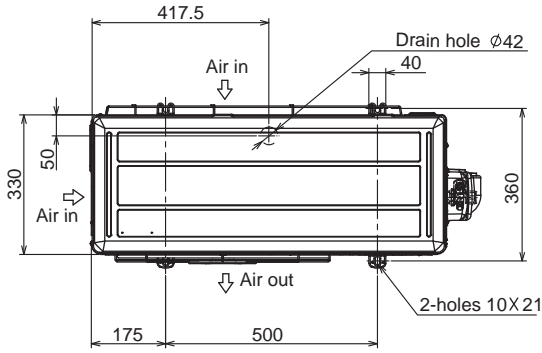

REQUIRED SPACE

*1 500 mm or more when front and sides of the unit are clear

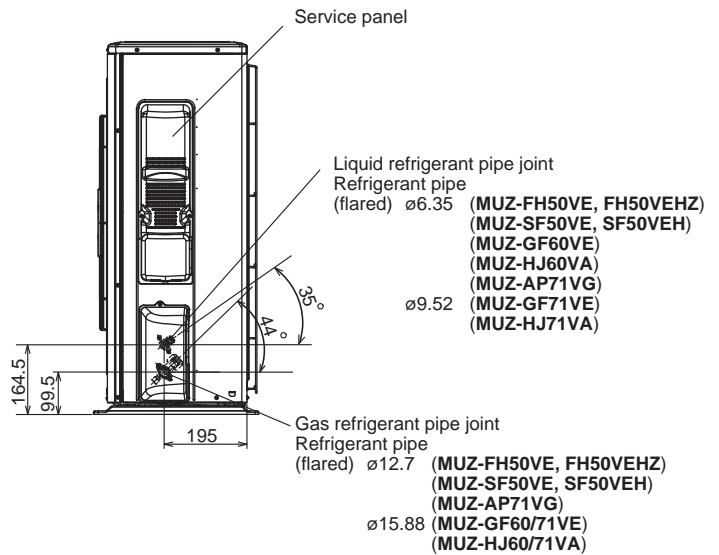
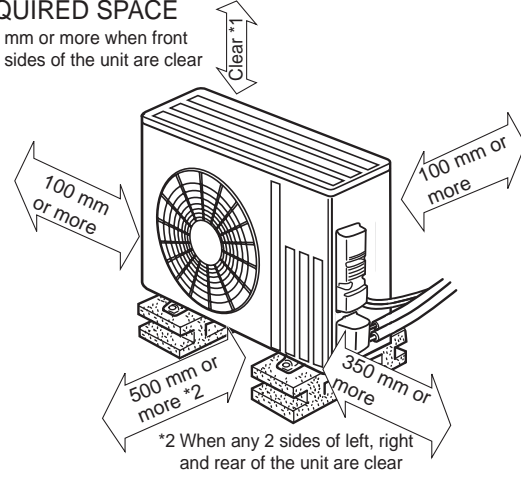

WALL-MOUNTED OUTLINES AND DIMENSIONS

Unit: mm

MUZ-HR25VF MUZ-HR35VF
OUTDOOR UNIT

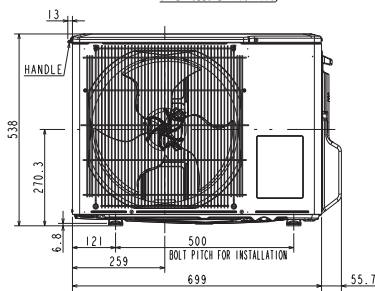
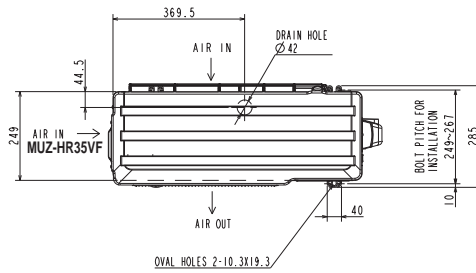
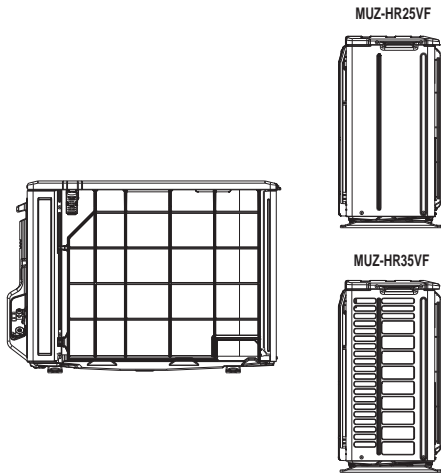

REQUIRED SPACE

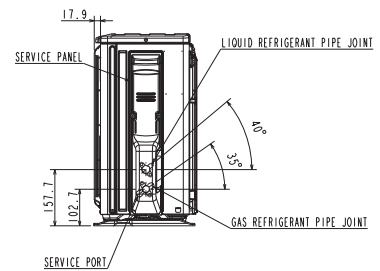
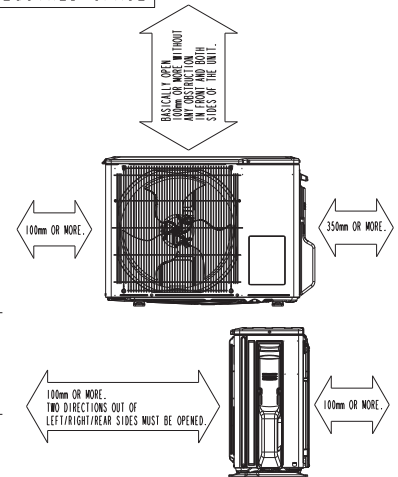

REFRIGERANT PIPE JOINT	LIQUID REFRIGERANT PIPE	FLARED 6.35(1/4")
	GAS REFRIGERANT PIPE	FLARED 9.52(3/8")

MUZ-HR42VF MUZ-HR50VF
OUTDOOR UNIT

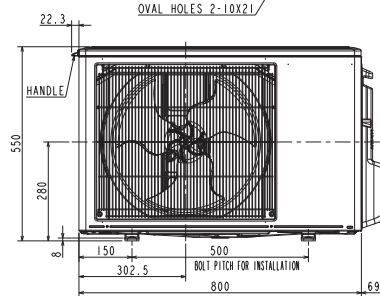
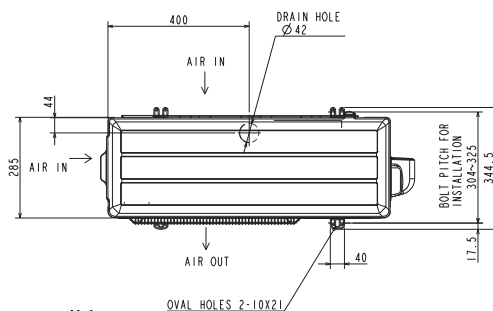
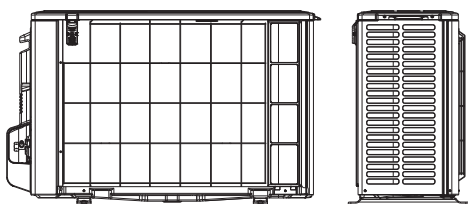

REQUIRED SPACE

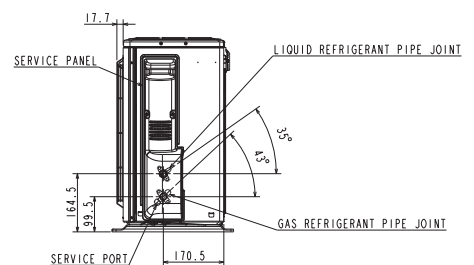
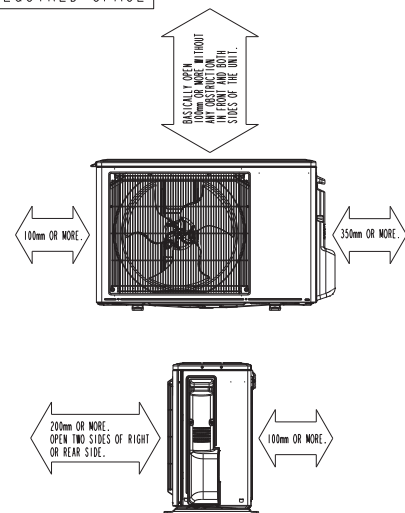

REFRIGERANT PIPE JOINT	LIQUID REFRIGERANT PIPE	FLARED 6.35(1/4")
	GAS REFRIGERANT PIPE	FLARED 9.52(3/8")

MUZ-HR60VF MUZ-HR71VF
OUTDOOR UNIT

Unit: mm

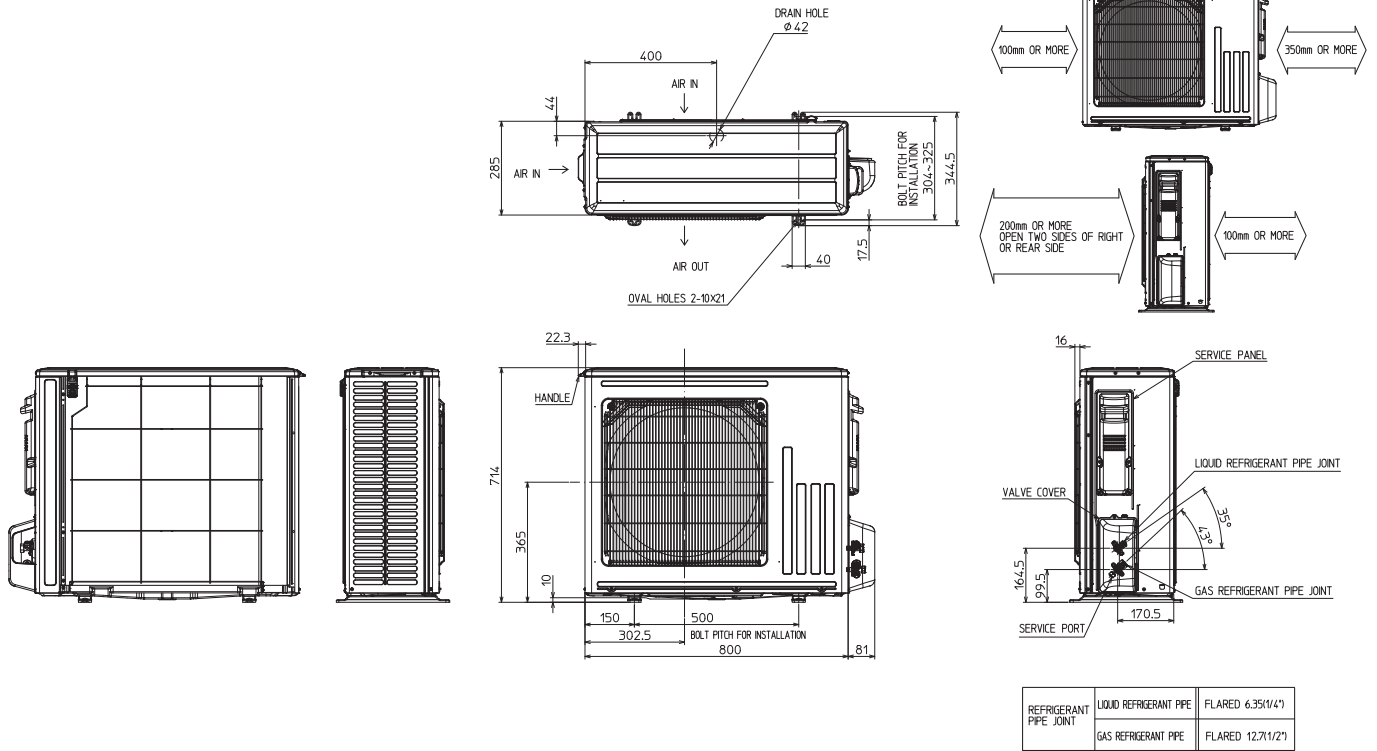

MUY-TP35VF MUY-TP50VF
OUTDOOR UNIT

Unit: mm

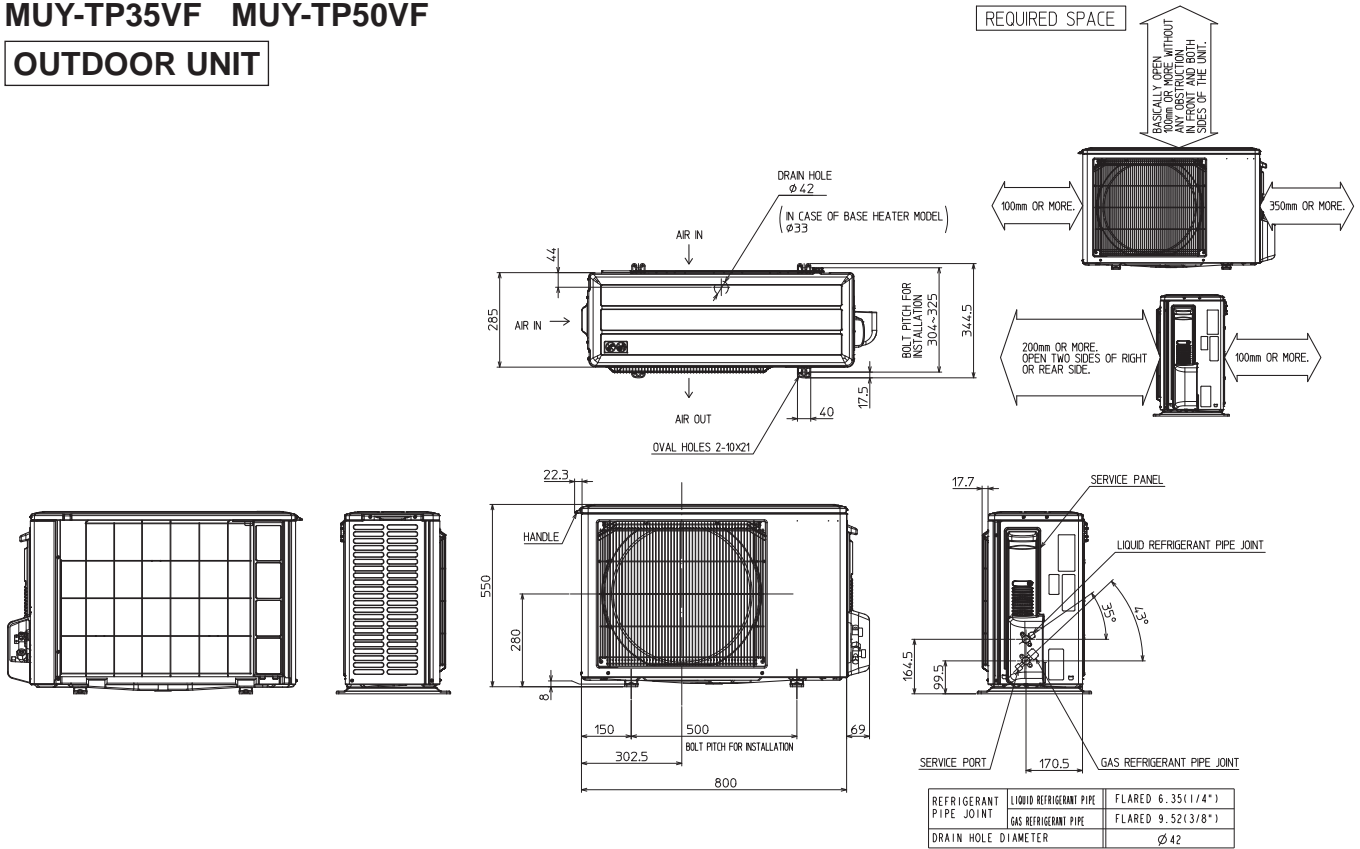

MUZ-FH25VE MUZ-FH35VE
MUZ-FH25VEHZ MUZ-FH35VEHZ
MUZ-SF25VE MUZ-SF35VE MUZ-SF42VE
MUZ-SF25VEH MUZ-SF35VEH MUZ-SF42VEH
MUZ-HJ50VA
OUTDOOR UNIT

OUTLINES AND DIMENSIONS

WALL-MOUNTED

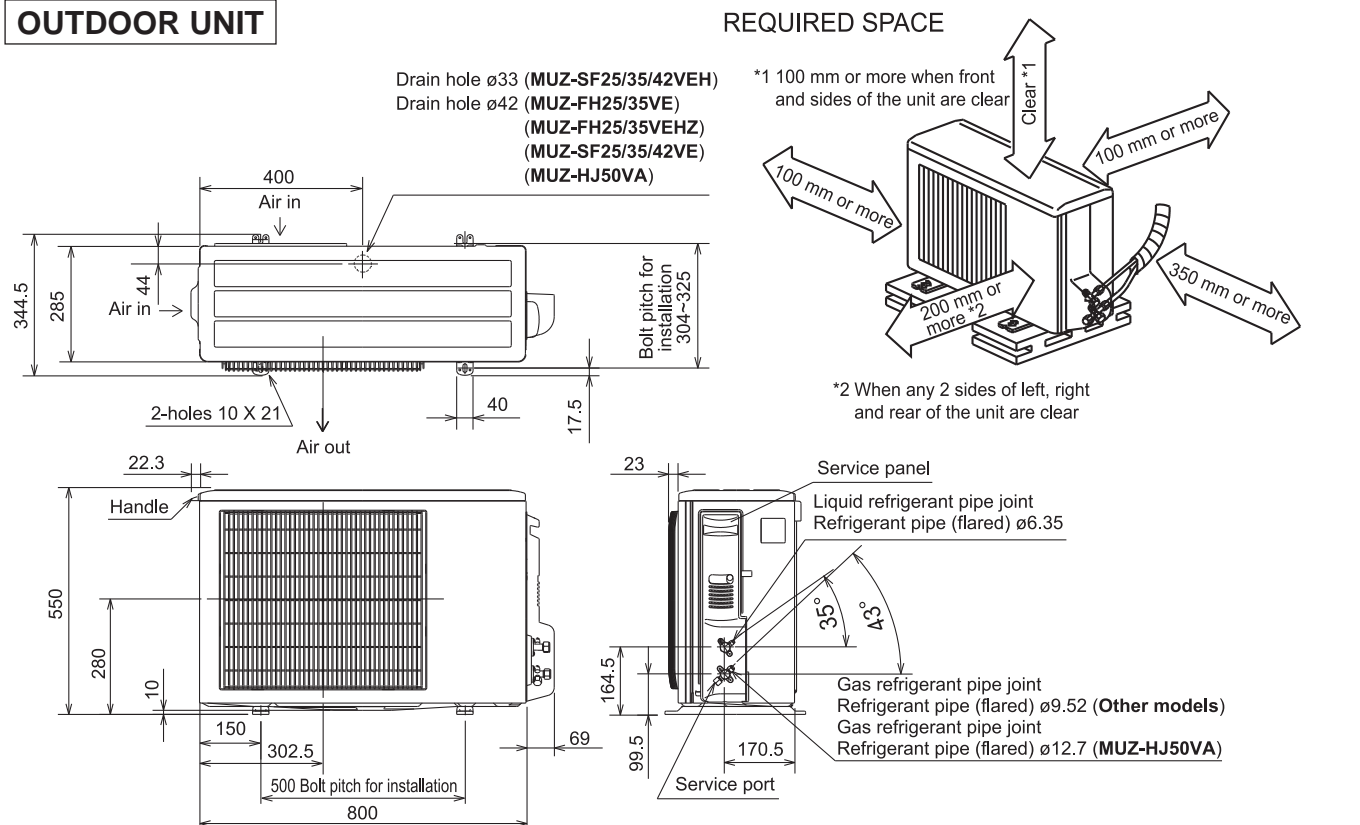

Unit: mm

MUZ-BT20VG MUZ-BT25VG MUZ-BT35VG
OUTDOOR UNIT

MUZ-BT20VG

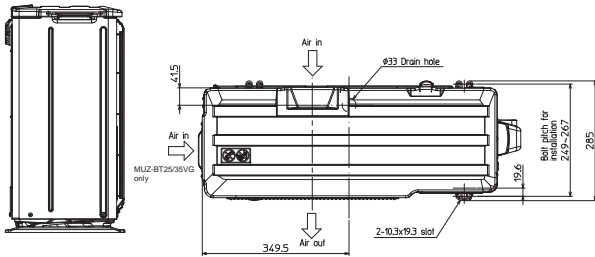

REQUIRED SPACE

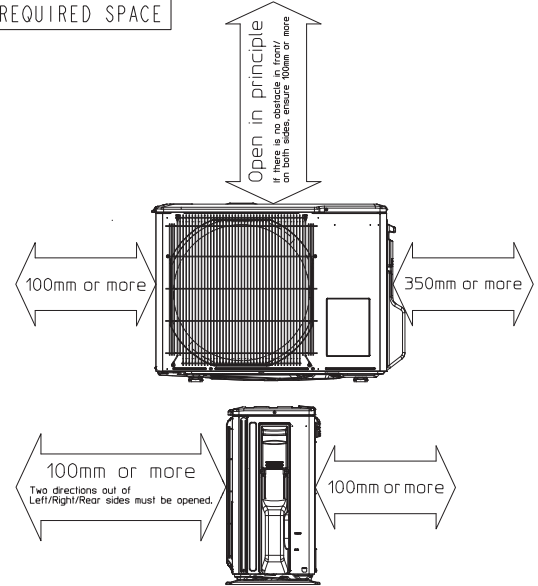

MUZ-BT25VG MUZ-BT35VG

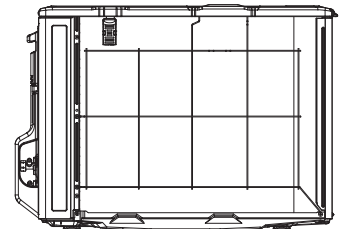
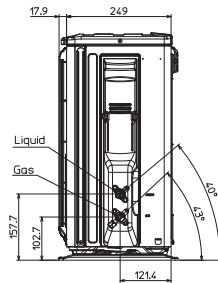
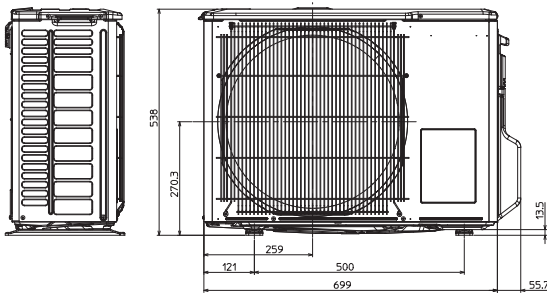

REFRIGERANT PIPE JOINT	LIQUID REFRIGERANT PIPE	FLARED 6.35(1/4")
	GAS REFRIGERANT PIPE	FLARED 9.52(3/8")

MUZ-BT50VG
OUTDOOR UNIT

REQUIRED SPACE

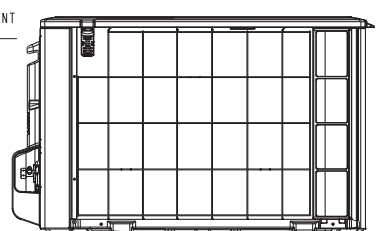
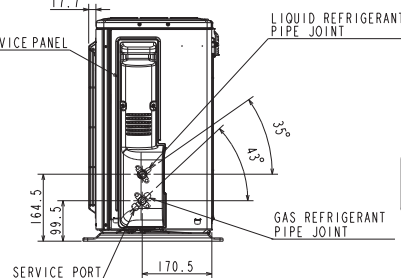
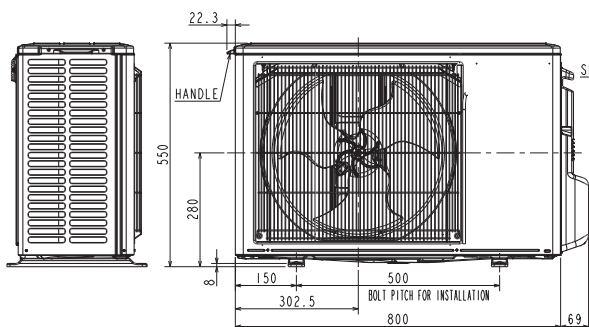
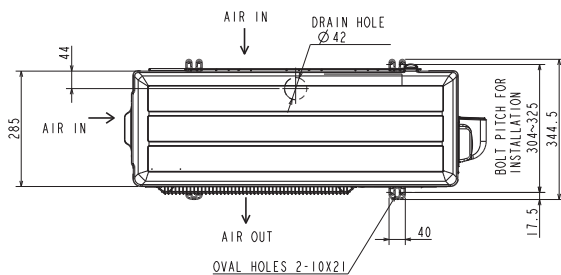
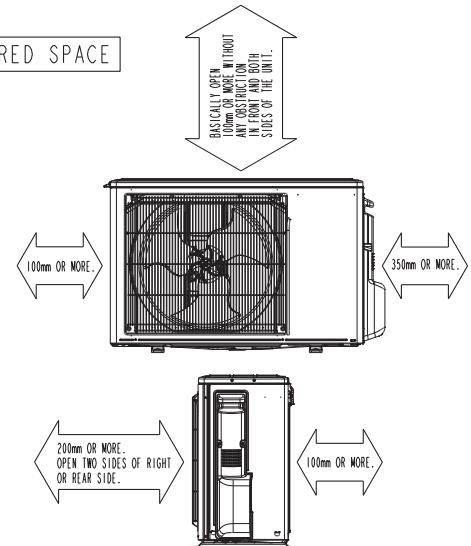

REFRIGERANT PIPE JOINT	LIQUID REFRIGERANT PIPE	FLARED 6.35(1/4")
	GAS REFRIGERANT PIPE	FLARED 12.7(1/2")

WALL-MOUNTED OUTLINES AND DIMENSIONS

Unit: mm

MUZ-DW25VF MUZ-DW35VF
OUTDOOR UNIT

MUZ-DW25VF

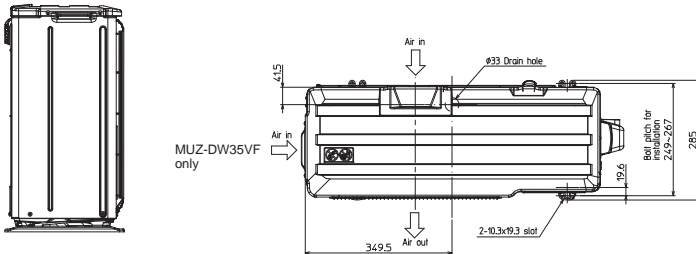

REQUIRED SPACE

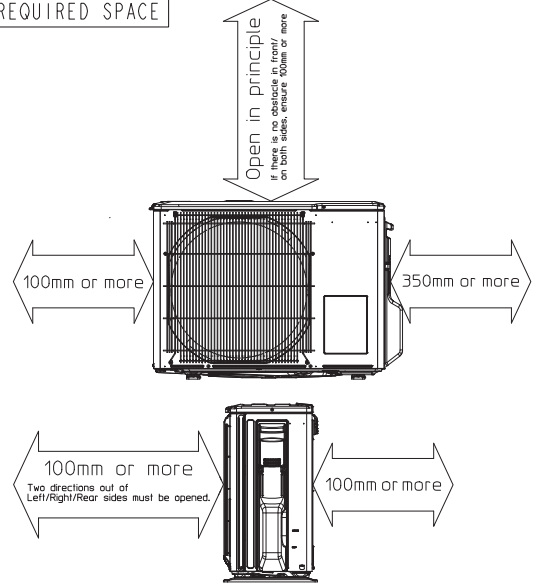

MUZ-DW35VF

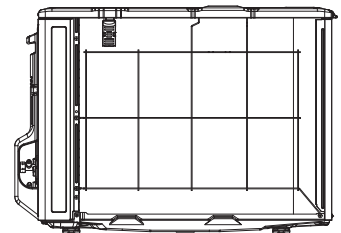
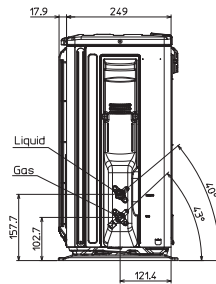
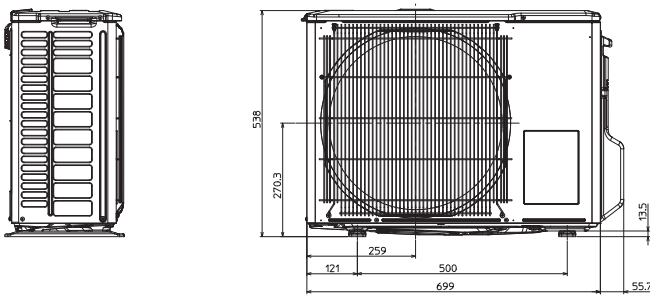

REFRIGERANT PIPE JOINT	LIQUID REFRIGERANT PIPE	FLARED 6.35(1/4")
	GAS REFRIGERANT PIPE	FLARED 9.52(3/8")

MUZ-DW50VF
OUTDOOR UNIT

REQUIRED SPACE

BASICALLY OPEN 100mm OR MORE WITHOUT ANY OBSTRUCTION IN FRONT AND BOTH SIDES OF THE UNIT

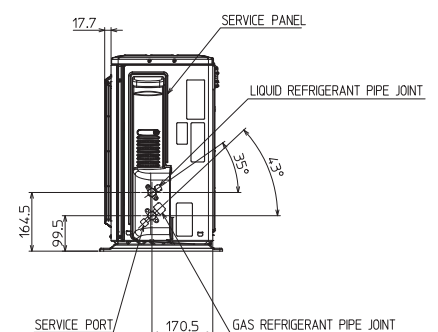
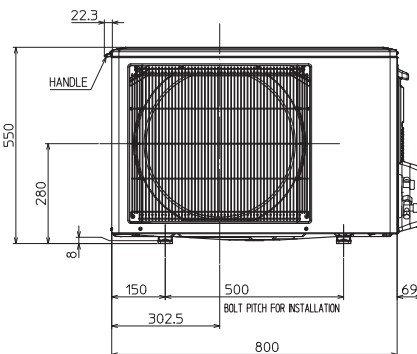
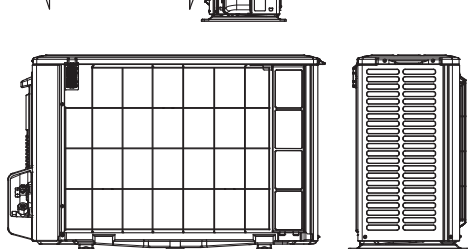
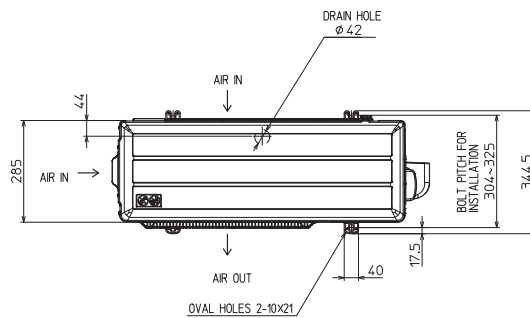
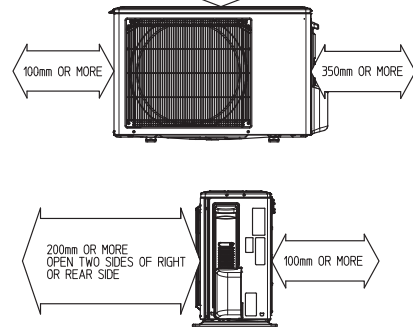

REFRIGERANT PIPE JOINT	LIQUID REFRIGERANT PIPE	FLARED 6.35(1/4")
	GAS REFRIGERANT PIPE	FLARED 9.52(3/8")

OUTLINES AND DIMENSIONS

WALL-MOUNTED

Unit: mm

MUZ-WN25VA MUZ-WN35VA

OUTDOOR UNIT

Necessary space of around the outdoor unit (Basic)

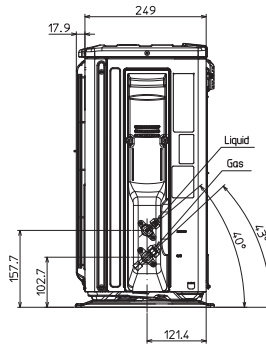
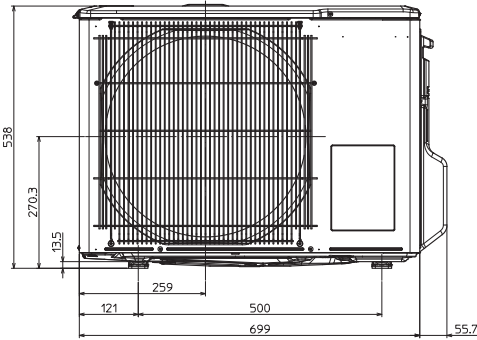
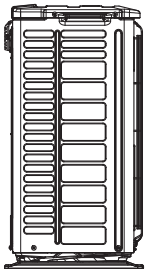
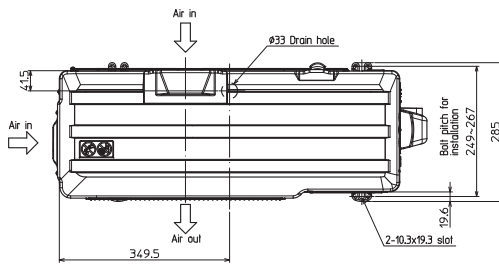
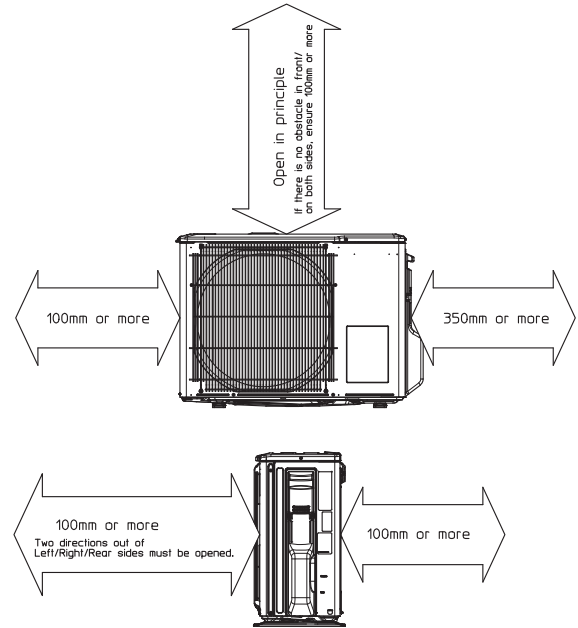

Rear view

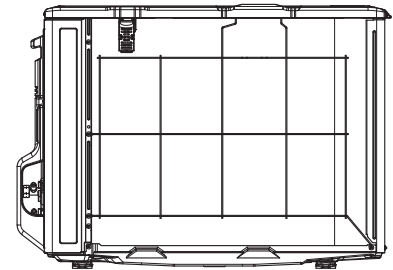

Refrigerant pipe joint	Liquid	Flared 6.35 (1/4")
	Gas	Flared 9.52 (3/8")

MUZ-DM25VA MUZ-DM35VA
 MUZ-HJ25VA MUZ-HJ35VA

OUTDOOR UNIT

Unit: mm

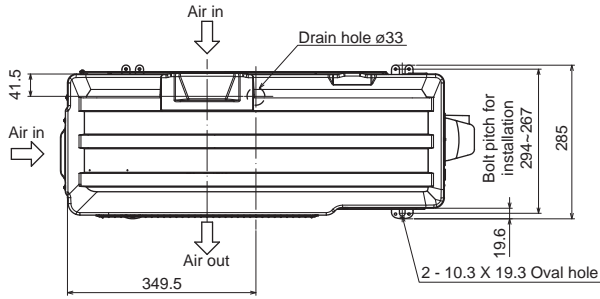

REQUIRED SPACE

*1 100 mm or more when front and sides of the unit are clear

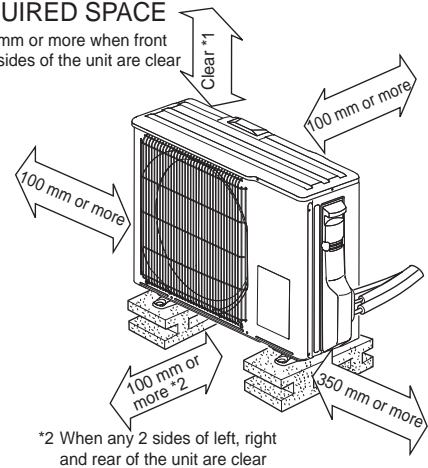

*2 When any 2 sides of left, right and rear of the unit are clear

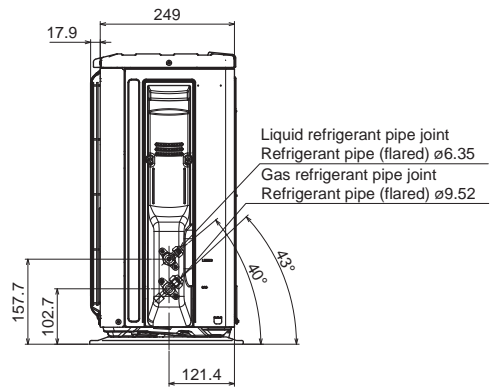
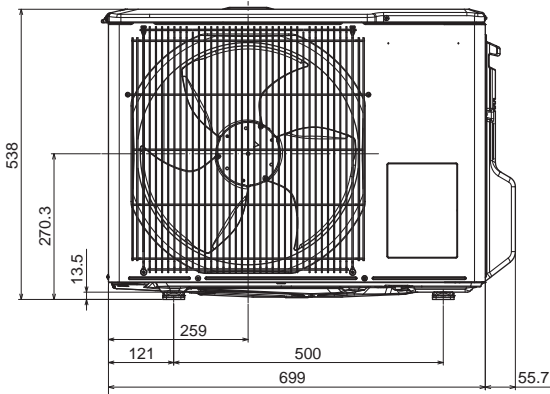

C.1.3 WIRING DIAGRAM

C.1.3.1 Indoor Unit

MSZ-RW25VG MSZ-RW35VG MSZ-RW50VG

INDOOR UNIT

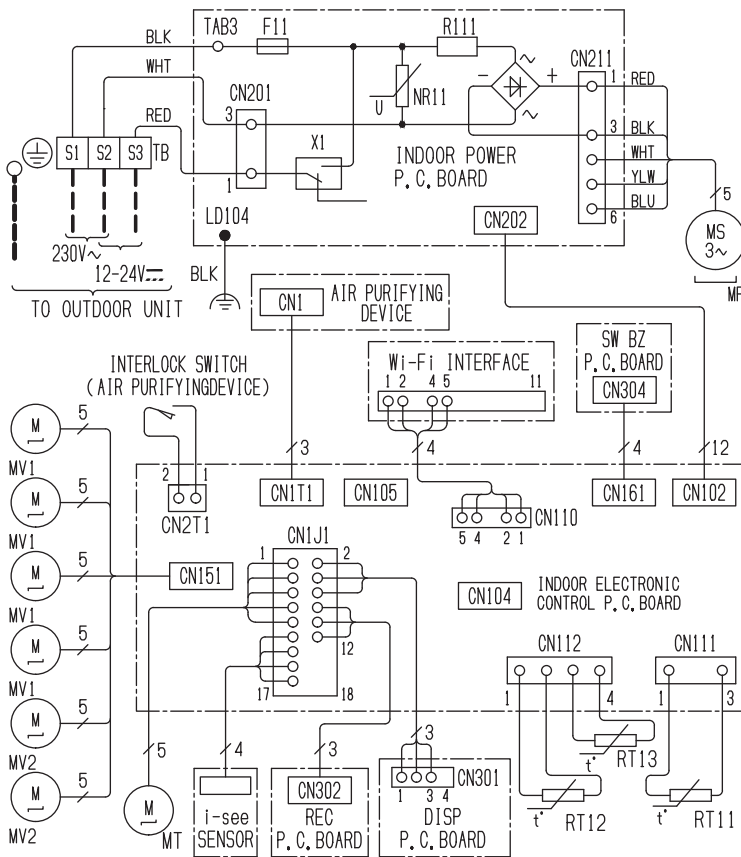

SYMBOL	NAME
F11	FUSE (T3, 15AL250V)
MF	FAN MOTOR
MV1	VANE MOTOR (HORIZONTAL)
MV2	VANE MOTOR (VERTICAL)
MT	i-see SENSOR MOTOR
NR11	VARISTOR
R111	RESISTOR
RT11	ROOM TEMP. THERMISTOR
RT12	COIL TEMP. THERMISTOR (MAIN)
RT13	COIL TEMP. THERMISTOR (SUB)
TB	TERMINAL BLOCK
X1	RELAY

NOTES: 1, About the outdoor side electronic wiring refer to the outdoor unit electronic wiring diagram for servicing.
 2, Use copper supply wires.
 3, Symbols indicate, : Terminal block : Connector

WALL-MOUNTED WIRING DIAGRAM

- | | | | |
|---------------------|---------------------|---------------------|---------------------|
| MSZ-LN18VG2W | MSZ-LN25VG2W | MSZ-LN35VG2W | MSZ-LN60VG2W |
| MSZ-LN18VG2V | MSZ-LN25VG2V | MSZ-LN35VG2V | MSZ-LN60VG2V |
| MSZ-LN18VG2B | MSZ-LN25VG2B | MSZ-LN35VG2B | MSZ-LN60VG2B |
| MSZ-LN18VG2R | MSZ-LN25VG2R | MSZ-LN35VG2R | MSZ-LN60VG2R |

INDOOR UNIT

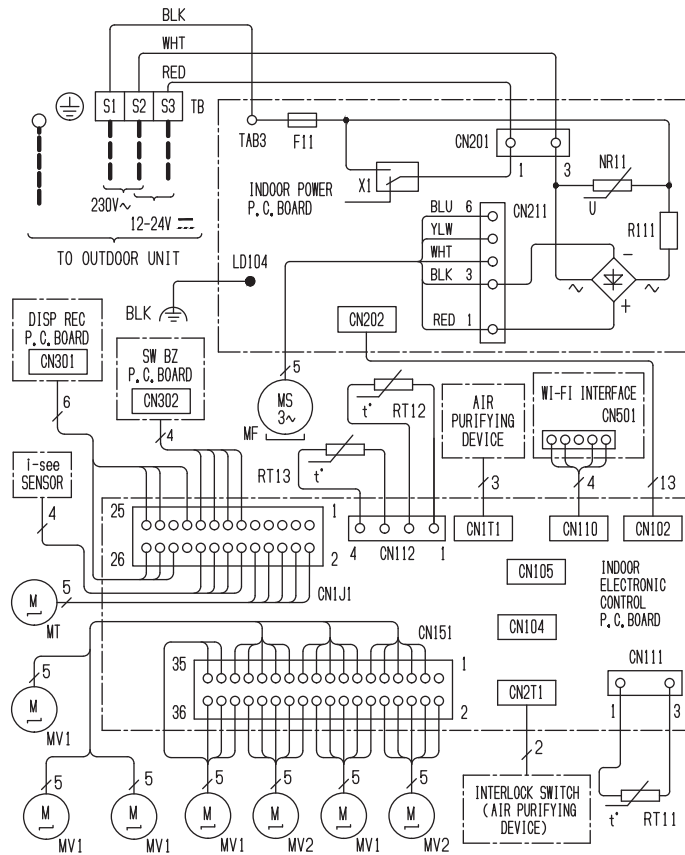

SYMBOL	NAME
F11	FUSE (T3, 15A/250V)
MF	FAN MOTOR
MV1	VANE MOTOR (HORIZONTAL)
MV2	VANE MOTOR (VERTICAL)
MT	i-see SENSOR MOTOR
NR11	VARISTOR
R111	RESISTOR
RT11	ROOM TEMP. THERMISTOR
RT12	COIL TEMP. THERMISTOR (MAIN)
RT13	COIL TEMP. THERMISTOR (SUB)
TB	TERMINAL BLOCK
X1	RELAY

NOTES: 1. About the outdoor side electronic wiring refer to the outdoor unit electronic wiring diagram for servicing.
 2. Use copper supply wires.
 3. Symbols indicate, : Terminal block : Connector

WIRING DIAGRAM

WALL-MOUNTED

MSZ-LN50VG2W
MSZ-LN50VG2V
MSZ-LN50VG2B
MSZ-LN50VG2R

INDOOR UNIT

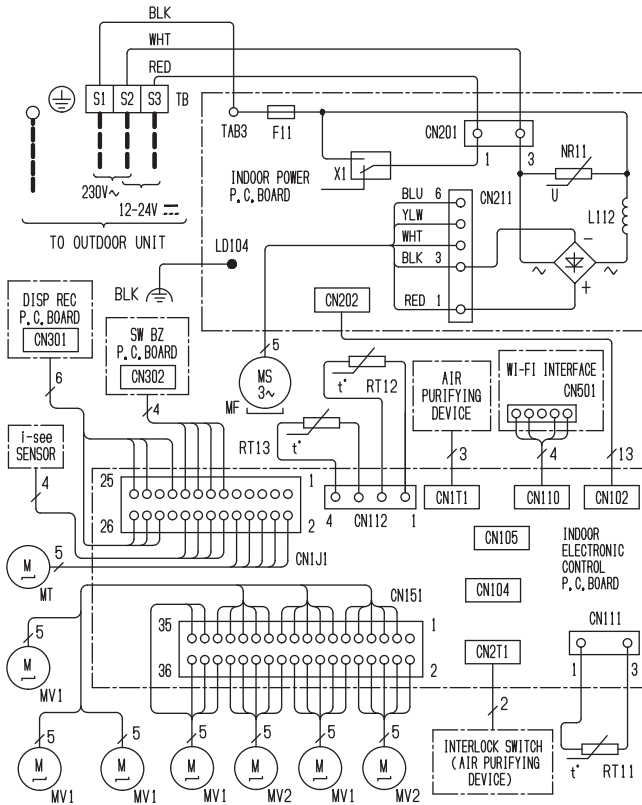

SYMBOL	NAME
F11	FUSE (T3, 15A/250V)
MF	FAN MOTOR
MV1	VANE MOTOR (HORIZONTAL)
MV2	VANE MOTOR (VERTICAL)
MT	i-see SENSOR MOTOR
NR11	VARISTOR
L112	REACTOR
RT11	ROOM TEMP. THERMISTOR
RT12	COIL TEMP. THERMISTOR (MAIN)
RT13	COIL TEMP. THERMISTOR (SUB)
TB	TERMINAL BLOCK
X1	RELAY

NOTES: 1. About the outdoor side electronic wiring refer to the outdoor unit electronic wiring diagram for servicing.
 2. Use copper supply wires.
 3. Symbols indicate, : Terminal block : Connector

WALL-MOUNTED WIRING DIAGRAM

MSZ-FT25VG
INDOOR UNIT

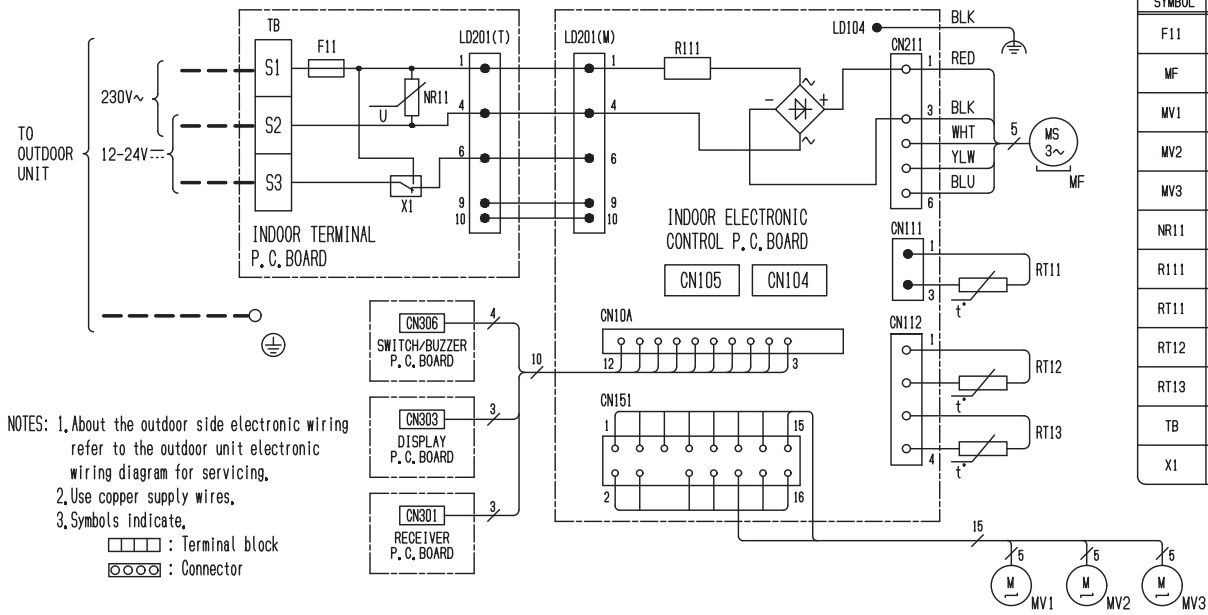

NOTES: 1, About the outdoor side electronic wiring refer to the outdoor unit electronic wiring diagram for servicing.
2, Use copper supply wires.
3, Symbols indicate,
□ : Terminal block
○ : Connector

MSZ-FT35VG MSZ-FT50VG
INDOOR UNIT

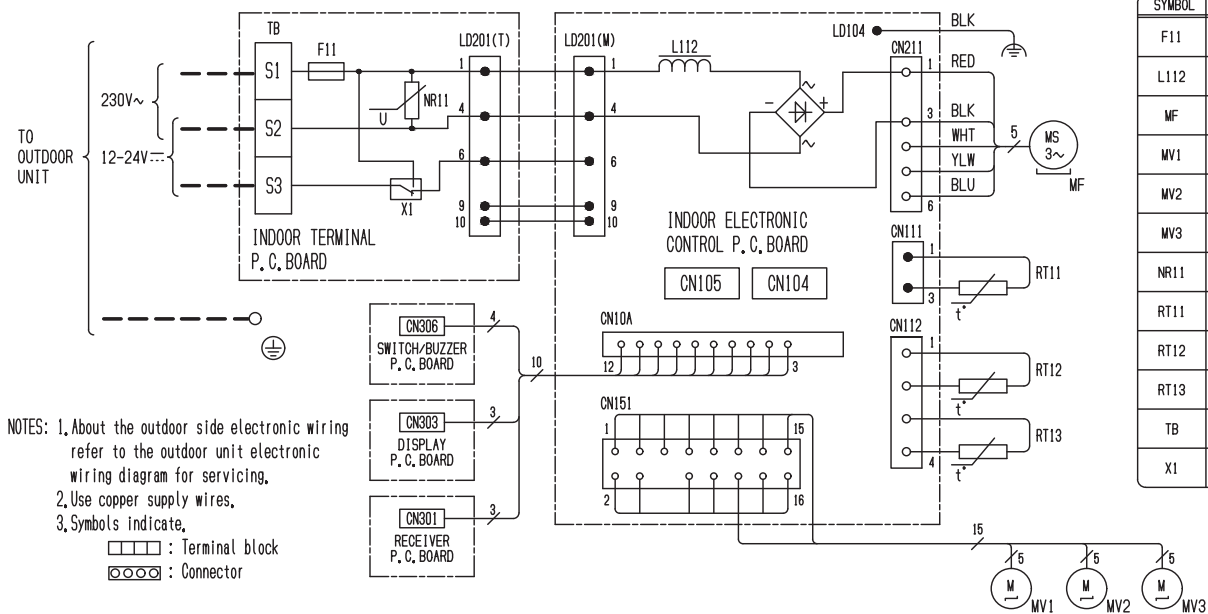

NOTES: 1, About the outdoor side electronic wiring refer to the outdoor unit electronic wiring diagram for servicing.
2, Use copper supply wires.
3, Symbols indicate,
□ : Terminal block
○ : Connector

WALL-MOUNTED WIRING DIAGRAM

MSZ-FT25VGK

INDOOR UNIT

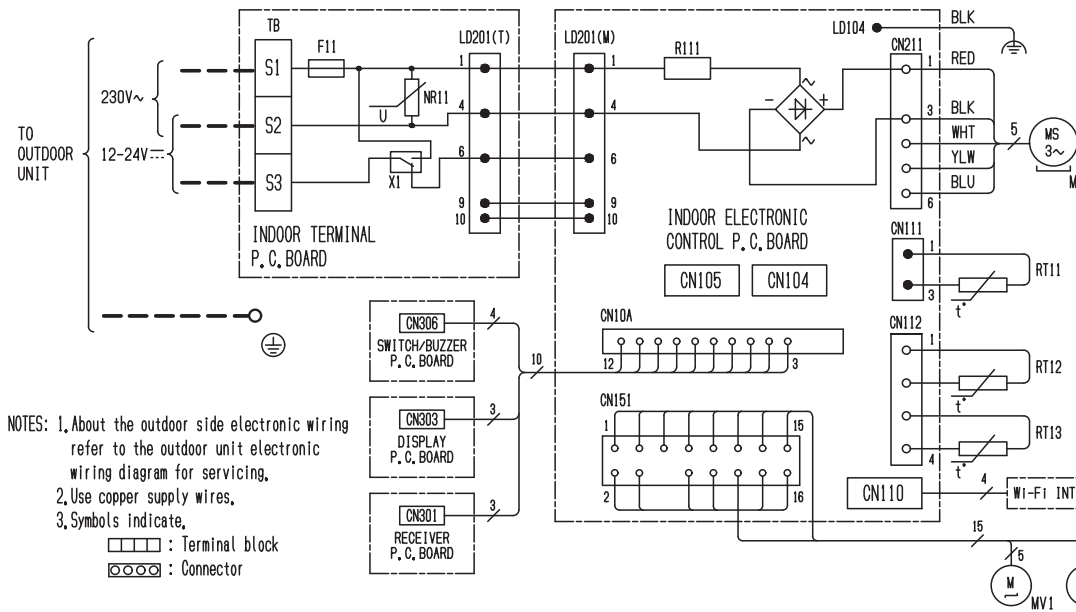

SYMBOL	NAME
F11	FUSE (T3, 15A/250V)
MF	FAN MOTOR
MV1	VANE MOTOR (HORIZONTAL UPPER)
MV2	VANE MOTOR (HORIZONTAL LOWER)
MV3	VANE MOTOR (VERTICAL)
NR11	VARISTOR
R111	RESISTOR
RT11	ROOM TEMP. THERMISTOR
RT12	COIL TEMP. THERMISTOR (MAIN)
RT13	COIL TEMP. THERMISTOR (SUB)
TB	TERMINAL BLOCK
X1	RELAY

MSZ-FT35VGK MSZ-FT50VGK

INDOOR UNIT

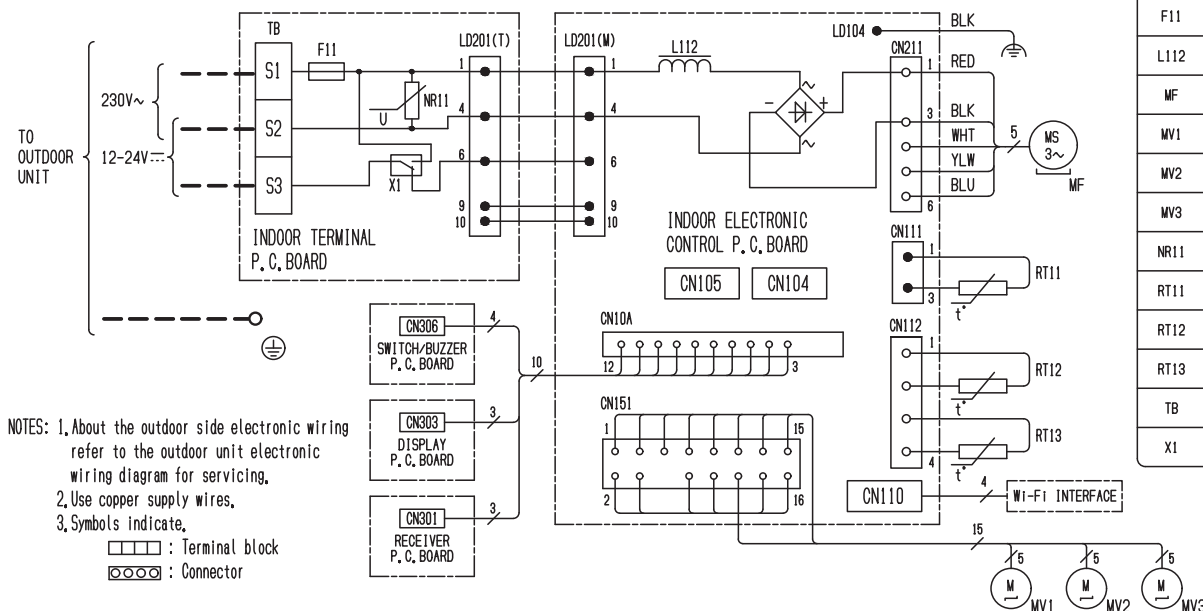

SYMBOL	NAME
F11	FUSE (T3, 15A/250V)
L112	REACTOR
MF	FAN MOTOR
MV1	VANE MOTOR (HORIZONTAL UPPER)
MV2	VANE MOTOR (HORIZONTAL LOWER)
MV3	VANE MOTOR (VERTICAL)
NR11	VARISTOR
RT11	ROOM TEMP. THERMISTOR
RT12	COIL TEMP. THERMISTOR (MAIN)
RT13	COIL TEMP. THERMISTOR (SUB)
TB	TERMINAL BLOCK
X1	RELAY

WALL-MOUNTED WIRING DIAGRAM

MSZ-AY25VG MSZ-AY35VG MSZ-AY42VG
MSZ-AY25VGK MSZ-AY35VGK MSZ-AY42VGK

INDOOR UNIT

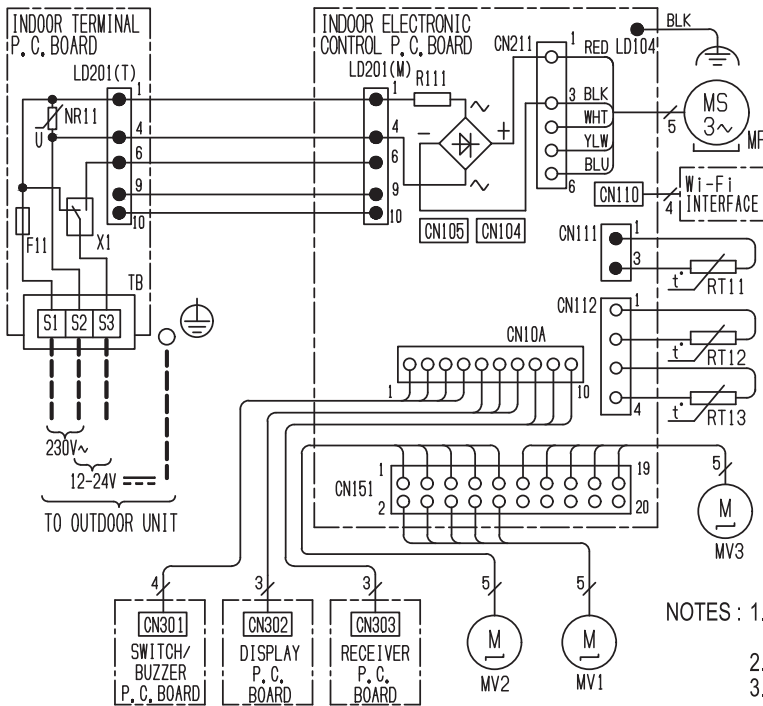

SYMBOL	NAME
F11	FUSE (T3, 15A/250V)
MF	FAN MOTOR
MV1	VANE MOTOR (HORIZONTAL UPPER)
MV2	VANE MOTOR (HORIZONTAL LOWER)
MV3	VANE MOTOR (VERTICAL)
NR11	VARISTOR
R111	RESISTOR
RT11	ROOM TEMP. THERMISTOR
RT12	COIL TEMP. THERMISTOR (MAIN)
RT13	COIL TEMP. THERMISTOR (SUB)
TB	TERMINAL BLOCK
X1	RELAY

Wi-Fi INTERFACE: **VGK** only

NOTES : 1. About the outdoor side electronic wiring refer to the outdoor unit electronic wiring diagram for servicing.
 2. Use copper supply wires.

3. Symbols indicate. □□□□ : Terminal block ○○○○ : Connector

MSZ-AY25VGKP MSZ-AY35VGKP MSZ-AY42VGKP

INDOOR UNIT

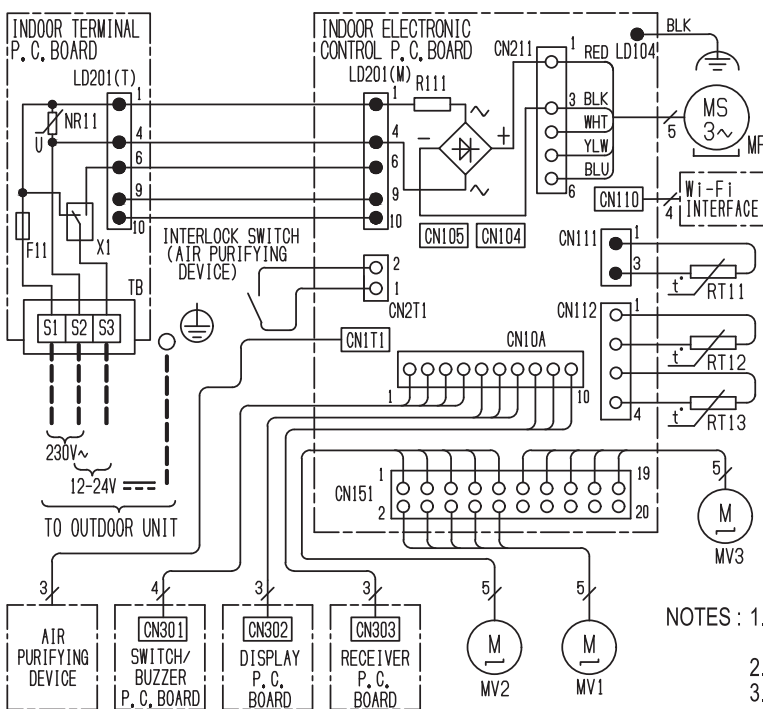

SYMBOL	NAME
F11	FUSE (T3, 15A/250V)
MF	FAN MOTOR
MV1	VANE MOTOR (HORIZONTAL UPPER)
MV2	VANE MOTOR (HORIZONTAL LOWER)
MV3	VANE MOTOR (VERTICAL)
NR11	VARISTOR
R111	RESISTOR
RT11	ROOM TEMP. THERMISTOR
RT12	COIL TEMP. THERMISTOR (MAIN)
RT13	COIL TEMP. THERMISTOR (SUB)
TB	TERMINAL BLOCK
X1	RELAY

NOTES : 1. About the outdoor side electronic wiring refer to the outdoor unit electronic wiring diagram for servicing.
 2. Use copper supply wires.

3. Symbols indicate. □□□□ : Terminal block ○○○○ : Connector

WIRING DIAGRAM

WALL-MOUNTED

**MSZ-AY50VG
MSZ-AY50VGK**

INDOOR UNIT

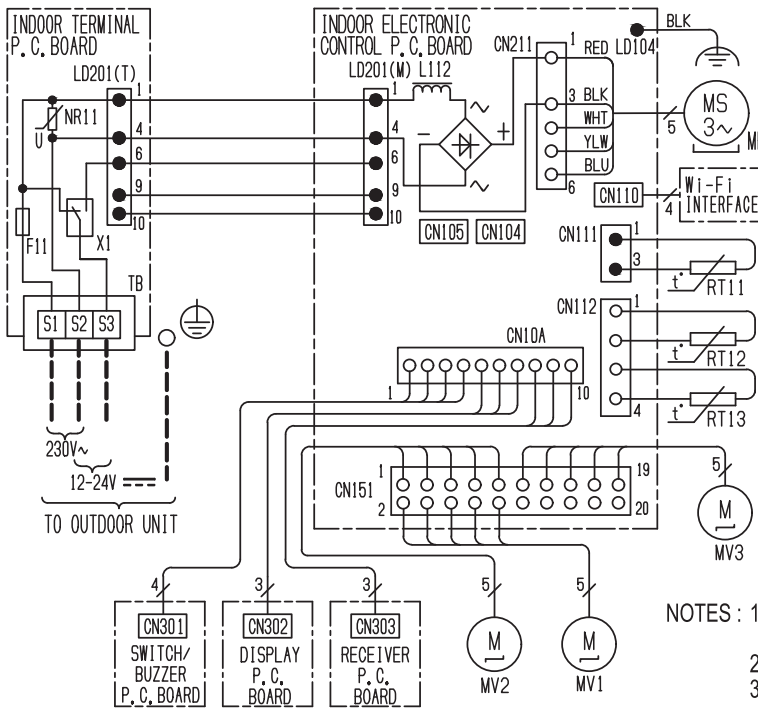

SYMBOL	NAME
F11	FUSE (T3, 15AL250V)
MF	FAN MOTOR
MV1	VANE MOTOR (HORIZONTAL UPPER)
MV2	VANE MOTOR (HORIZONTAL LOWER)
MV3	VANE MOTOR (VERTICAL)
NR11	VARISTOR
L112	REACTOR
RT11	ROOM TEMP. THERMISTOR
RT12	COIL TEMP. THERMISTOR (MAIN)
RT13	COIL TEMP. THERMISTOR (SUB)
TB	TERMINAL BLOCK
X1	RELAY

Wi-Fi INTERFACE: **VGK** only

- NOTES : 1. About the outdoor side electronic wiring refer to the outdoor unit electronic wiring diagram for servicing.
 2. Use copper supply wires.
 3. Symbols indicate. □□□□ : Terminal block ○ : Connector

MSZ-AY50VGKP
INDOOR UNIT

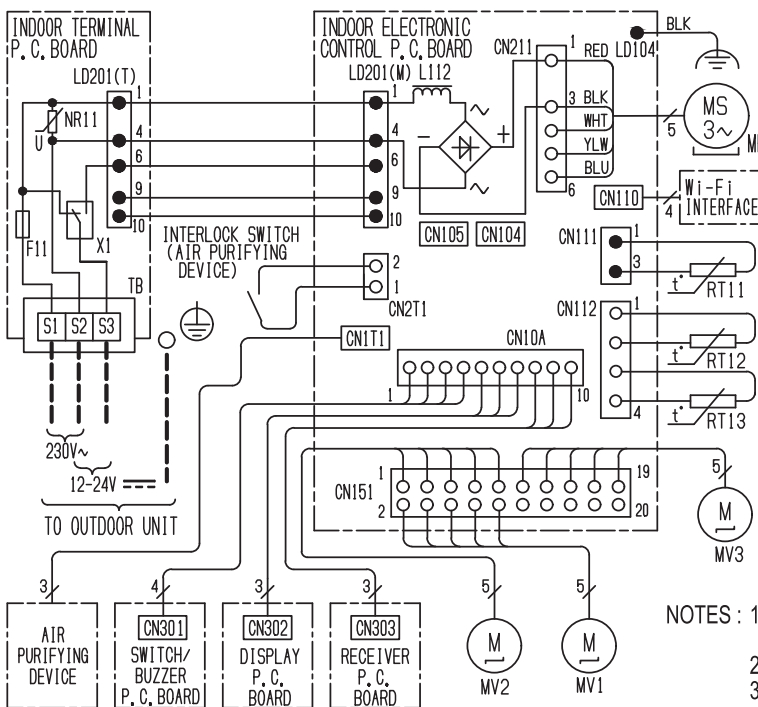

SYMBOL	NAME
F11	FUSE (T3, 15AL250V)
MF	FAN MOTOR
MV1	VANE MOTOR (HORIZONTAL UPPER)
MV2	VANE MOTOR (HORIZONTAL LOWER)
MV3	VANE MOTOR (VERTICAL)
NR11	VARISTOR
L112	REACTOR
RT11	ROOM TEMP. THERMISTOR
RT12	COIL TEMP. THERMISTOR (MAIN)
RT13	COIL TEMP. THERMISTOR (SUB)
TB	TERMINAL BLOCK
X1	RELAY

- NOTES : 1. About the outdoor side electronic wiring refer to the outdoor unit electronic wiring diagram for servicing.
 2. Use copper supply wires.
 3. Symbols indicate. □□□□ : Terminal block ○ : Connector

WALL-MOUNTED WIRING DIAGRAM

MSZ-AP15VG MSZ-AP20VG

INDOOR UNIT

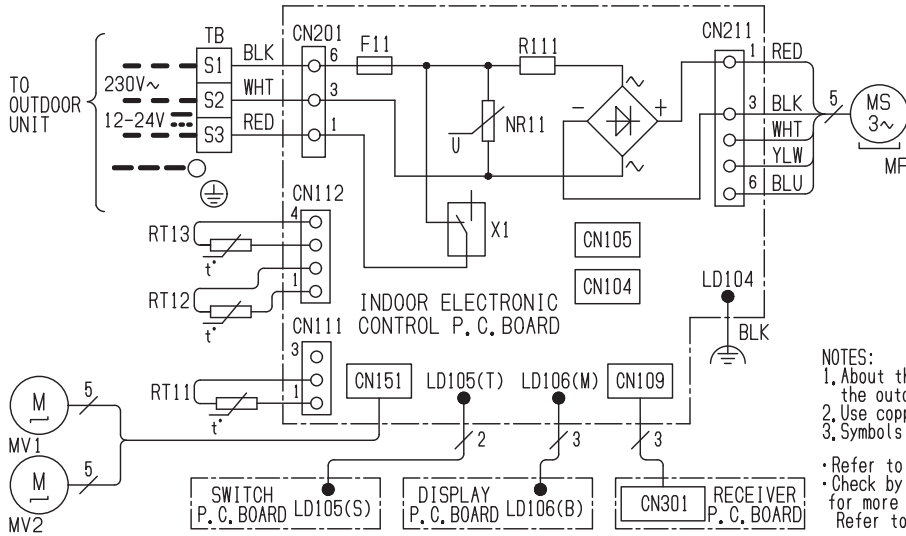

SYMBOL	NAME	SYMBOL	NAME
F11	FUSE (T3, 15AL250V)	RT11	ROOM TEMP. THERMISTOR
MF	FAN MOTOR	RT12	COIL TEMP. THERMISTOR (MAIN)
MV1	VANE MOTOR (HORIZONTAL UPPER)	RT13	COIL TEMP. THERMISTOR (SUB)
MV2	VANE MOTOR (HORIZONTAL LOWER)	TB	TERMINAL BLOCK
NR11	VARISTOR	X1	RELAY
R11	RESISTOR		

NOTES:
 1. About the outdoor side electronic wiring refer to the outdoor unit electronic wiring diagram for servicing.
 2. Use copper supply wires. □□□□: Terminal block
 3. Symbols indicate. ○○○○: Connector
 • Refer to SERVICE MANUAL for details.
 • Check by failure mode recall function for more confirmation of abnormality in detail. Refer to SERVICE MANUAL as for failure mode recall function.

MSZ-AP15VGK MSZ-AP20VGK

INDOOR UNIT

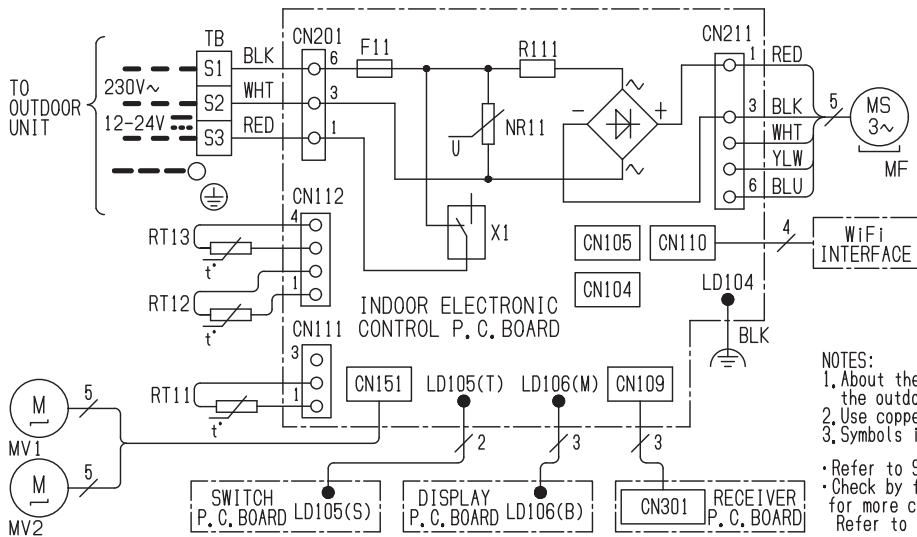

SYMBOL	NAME	SYMBOL	NAME
F11	FUSE (T3, 15AL250V)	RT11	ROOM TEMP. THERMISTOR
MF	FAN MOTOR	RT12	COIL TEMP. THERMISTOR (MAIN)
MV1	VANE MOTOR (HORIZONTAL UPPER)	RT13	COIL TEMP. THERMISTOR (SUB)
MV2	VANE MOTOR (HORIZONTAL LOWER)	TB	TERMINAL BLOCK
NR11	VARISTOR	X1	RELAY
R11	RESISTOR		

NOTES:
 1. About the outdoor side electronic wiring refer to the outdoor unit electronic wiring diagram for servicing.
 2. Use copper supply wires. □□□□: Terminal block
 3. Symbols indicate. ○○○○: Connector
 • Refer to SERVICE MANUAL for details.
 • Check by failure mode recall function for more confirmation of abnormality in detail. Refer to SERVICE MANUAL as for failure mode recall function.

WIRING DIAGRAM

WALL-MOUNTED

MSZ-AP60VG

INDOOR UNIT

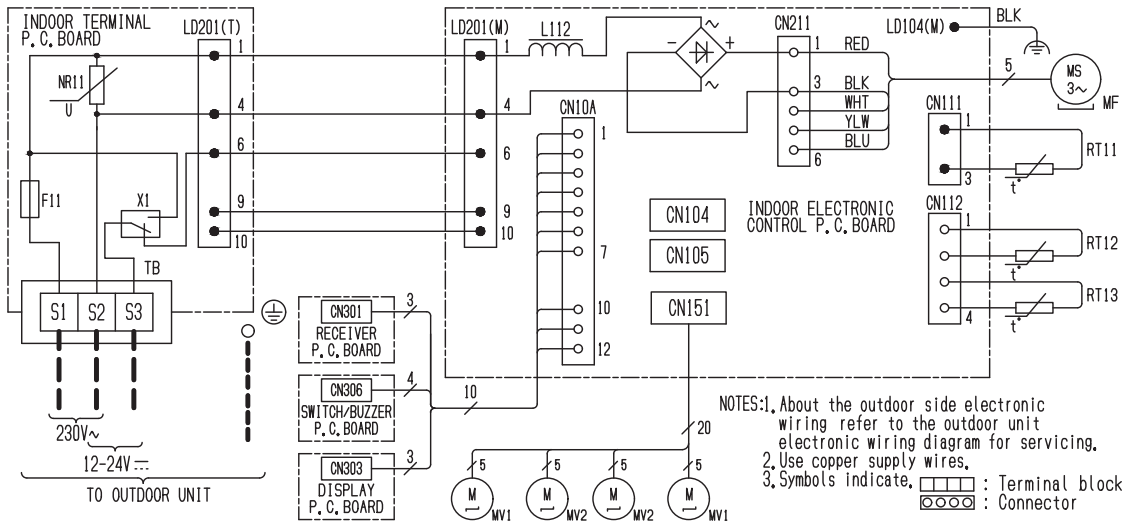

SYMBOL	NAME
F11	FUSE (T3, 15A/250V)
L112	REACTOR
MF	FAN MOTOR
MV1	VANE MOTOR (HORIZONTAL)
MV2	VANE MOTOR (VERTICAL)
NR11	VARIATOR
RT11	ROOM TEMP. THERMISTOR
RT12	COIL TEMP. THERMISTOR (MAIN)
RT13	COIL TEMP. THERMISTOR (SUB)
TB	TERMINAL BLOCK
X1	RELAY

NOTES: 1. About the outdoor side electronic wiring refer to the outdoor unit electronic wiring diagram for servicing.
 2. Use copper supply wires.
 3. Symbols indicate, : Terminal block
 : Connector

MSZ-AP60VGK

INDOOR UNIT

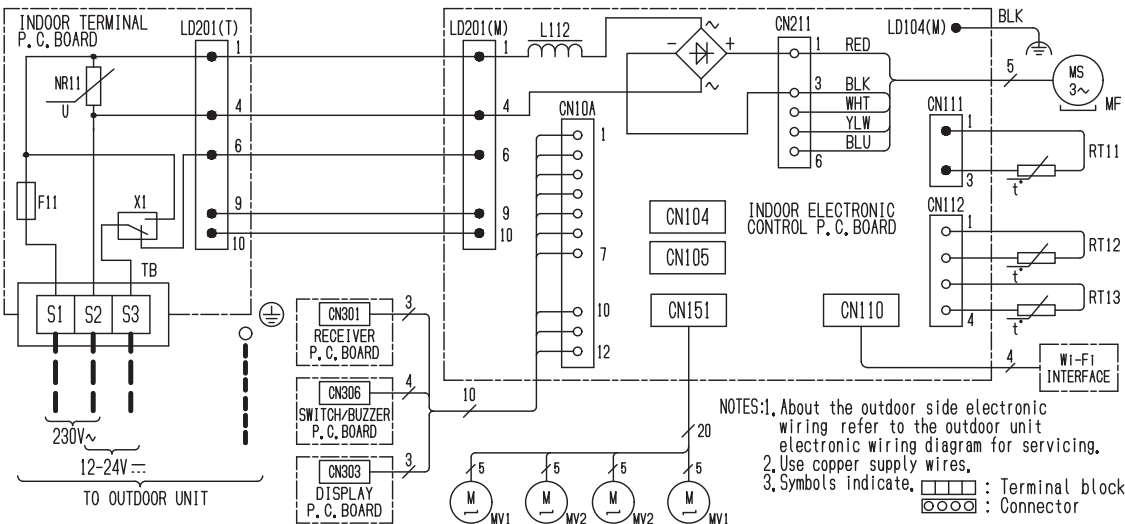

SYMBOL	NAME
F11	FUSE (T3, 15A/250V)
L112	REACTOR
MF	FAN MOTOR
MV1	VANE MOTOR (HORIZONTAL)
MV2	VANE MOTOR (VERTICAL)
NR11	VARIATOR
RT11	ROOM TEMP. THERMISTOR
RT12	COIL TEMP. THERMISTOR (MAIN)
RT13	COIL TEMP. THERMISTOR (SUB)
TB	TERMINAL BLOCK
X1	RELAY

NOTES: 1. About the outdoor side electronic wiring refer to the outdoor unit electronic wiring diagram for servicing.
 2. Use copper supply wires.
 3. Symbols indicate, : Terminal block
 : Connector

WALL-MOUNTED WIRING DIAGRAM

MSZ-AP71VG

INDOOR UNIT

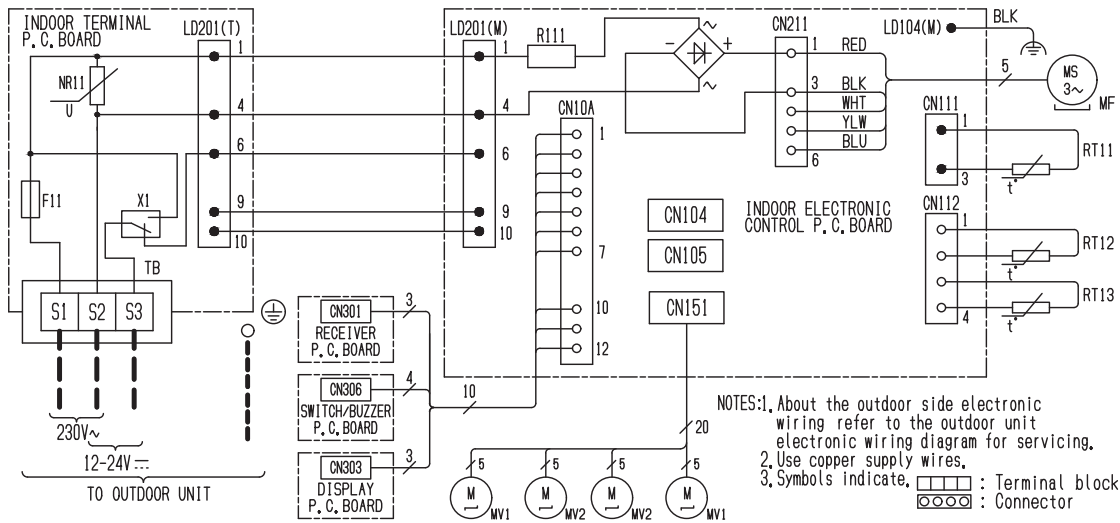

SYMBOL	NAME
F11	FUSE (T3, 15AL250V)
MF	FAN MOTOR
MV1	VANE MOTOR (HORIZONTAL)
MV2	VANE MOTOR (VERTICAL)
NR11	VARISTOR
R111	RESISTOR
RT11	ROOM TEMP. THERMISTOR
RT12	COIL TEMP. THERMISTOR (MAIN)
RT13	COIL TEMP. THERMISTOR (SUB)
TB	TERMINAL BLOCK
X1	RELAY

MSZ-AP71VGK

INDOOR UNIT

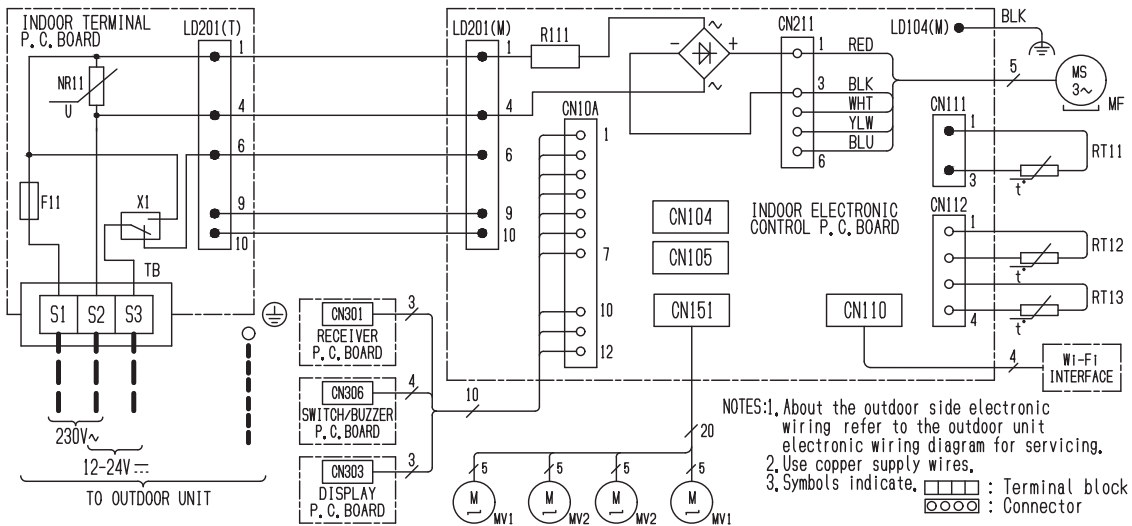

SYMBOL	NAME
F11	FUSE (T3, 15AL250V)
MF	FAN MOTOR
MV1	VANE MOTOR (HORIZONTAL)
MV2	VANE MOTOR (VERTICAL)
NR11	VARISTOR
R111	RESISTOR
RT11	ROOM TEMP. THERMISTOR
RT12	COIL TEMP. THERMISTOR (MAIN)
RT13	COIL TEMP. THERMISTOR (SUB)
TB	TERMINAL BLOCK
X1	RELAY

WIRING DIAGRAM

WALL-MOUNTED

MSZ-HR25VF MSZ-HR35VF MSZ-HR42VF MSZ-HR50VF

INDOOR UNIT

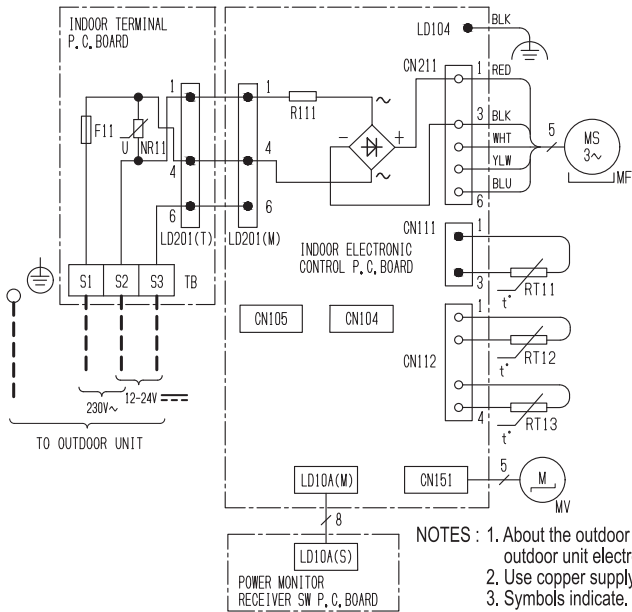

SYMBOL	NAME
F11	FUSE (T3, 15A/250V)
MF	FAN MOTOR
MV	VANE MOTOR (HORIZONTAL)
NR11	VARISTOR
R111	RESISTOR
RT11	ROOM TEMP. THERMISTOR
RT12	COIL TEMP. THERMISTOR (MAIN)
RT13	COIL TEMP. THERMISTOR (SUB)
TB	TERMINAL BLOCK

NOTES : 1. About the outdoor side electronic wiring refer to the outdoor unit electronic wiring diagram for servicing.
 2. Use copper supply wires.
 3. Symbols indicate. □□□□ : Terminal block ○○○○ : Connector

MSZ-HR25VFK MSZ-HR35VFK MSZ-HR42VFK MSZ-HR50VFK

INDOOR UNIT

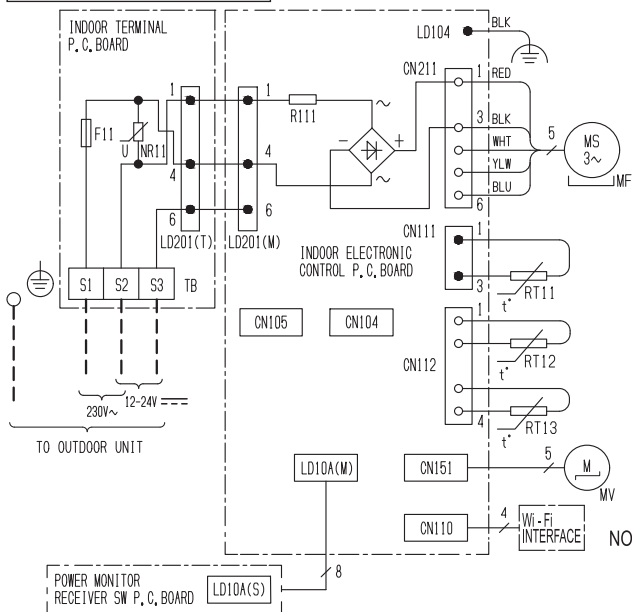

SYMBOL	NAME
F11	FUSE (T3, 15A/250V)
MF	FAN MOTOR
MV	VANE MOTOR (HORIZONTAL)
NR11	VARISTOR
R111	RESISTOR
RT11	ROOM TEMP. THERMISTOR
RT12	COIL TEMP. THERMISTOR (MAIN)
RT13	COIL TEMP. THERMISTOR (SUB)
TB	TERMINAL BLOCK

NOTES : 1. About the outdoor side electronic wiring refer to the outdoor unit electronic wiring diagram for servicing.
 2. Use copper supply wires.
 3. Symbols indicate. □□□□ : Terminal block ○○○○ : Connector

WALL-MOUNTED WIRING DIAGRAM

MSZ-HR60VF MSZ-HR71VF

INDOOR UNIT

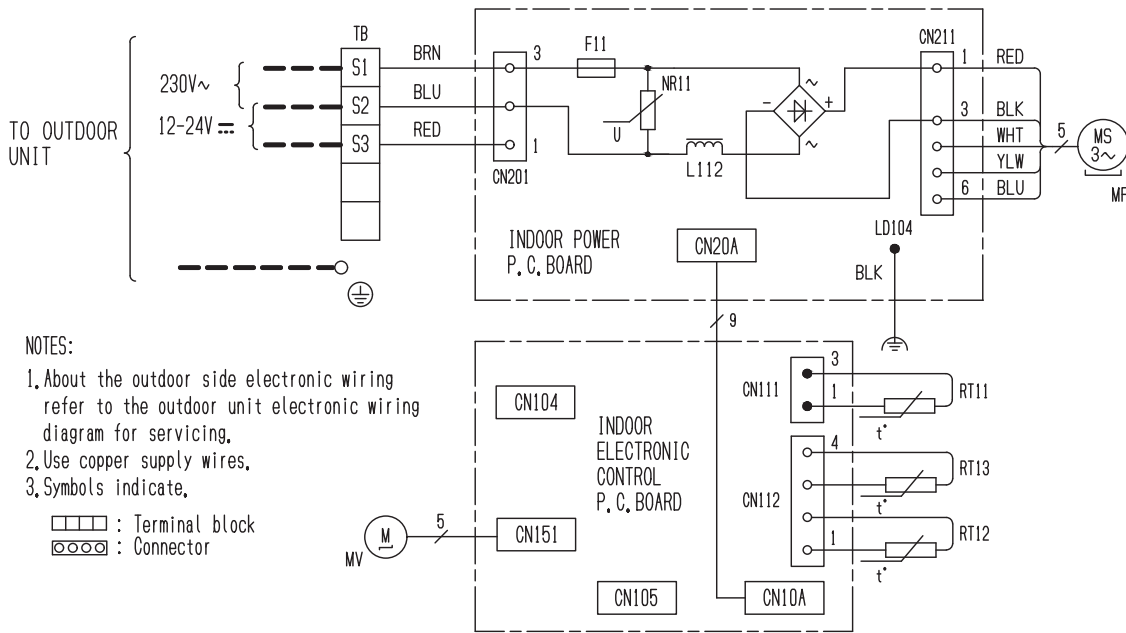

SYMBOL	NAME
F11	FUSE (T3, 15AL250V)
L112	REACTOR
MF	FAN MOTOR
MV	VANE MOTOR (HORIZONTAL)
NR11	VARISTOR
RT11	ROOM TEMP. THERMISTOR
RT12	COIL TEMP. THERMISTOR (MAIN)
RT13	COIL TEMP. THERMISTOR (SUB)
TB	TERMINAL BLOCK

NOTES:

- About the outdoor side electronic wiring refer to the outdoor unit electronic wiring diagram for servicing.
- Use copper supply wires.
- Symbols indicate.

□ : Terminal block
○ : Connector

MSZ-HR60VFK MSZ-HR71VFK

INDOOR UNIT

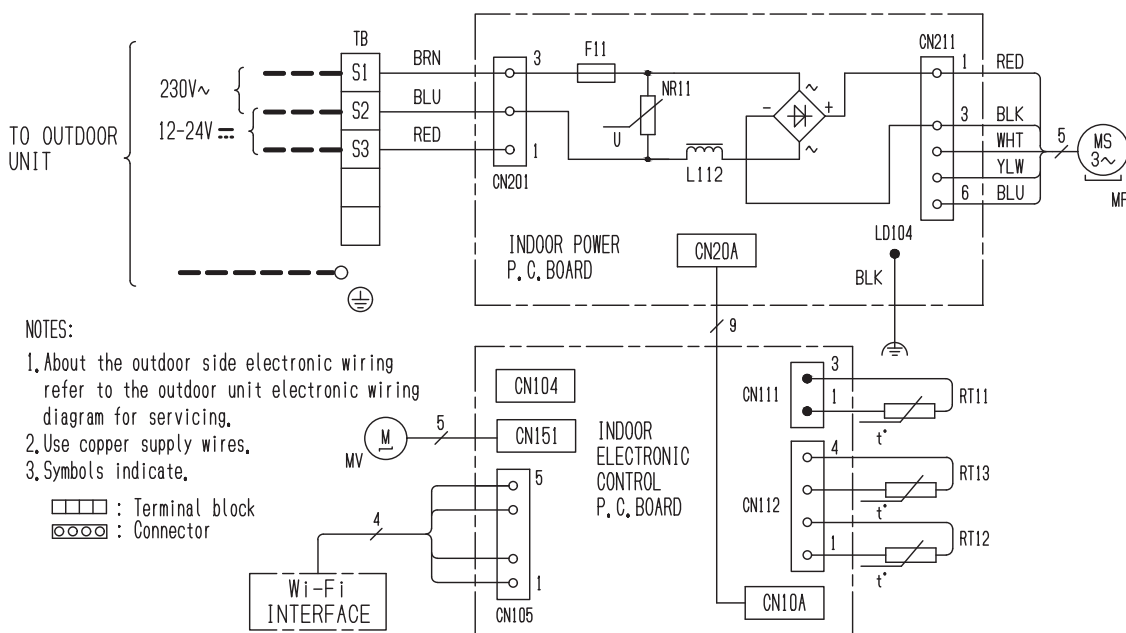

SYMBOL	NAME
F11	FUSE (T3, 15AL250V)
L112	REACTOR
MF	FAN MOTOR
MV	VANE MOTOR (HORIZONTAL)
NR11	VARISTOR
RT11	ROOM TEMP. THERMISTOR
RT12	COIL TEMP. THERMISTOR (MAIN)
RT13	COIL TEMP. THERMISTOR (SUB)
TB	TERMINAL BLOCK

NOTES:

- About the outdoor side electronic wiring refer to the outdoor unit electronic wiring diagram for servicing.
- Use copper supply wires.
- Symbols indicate.

□ : Terminal block
○ : Connector

MSY-TP35VF MSY-TP50VF

INDOOR UNIT

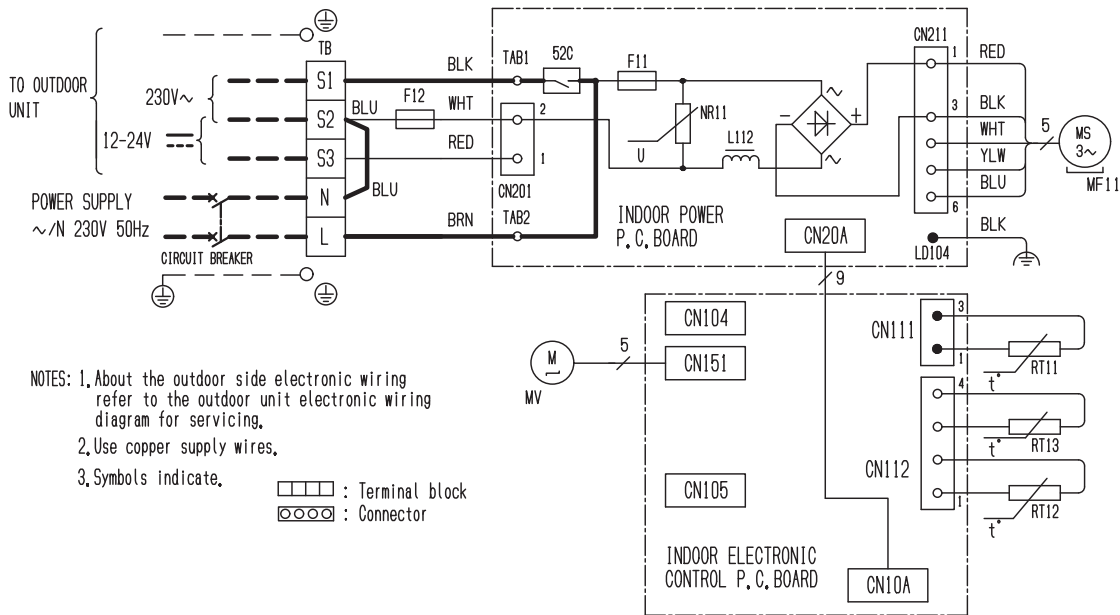

- NOTES: 1. About the outdoor side electronic wiring refer to the outdoor unit electronic wiring diagram for servicing.
 2. Use copper supply wires.
 3. Symbols indicate.

Terminal block symbol: : Terminal block
 Connector symbol: : Connector

SYMBOL	NAME
F11	FUSE (T3, 15AL250V)
F12	THERMAL FUSE (102°C 4.5A)
MF11	FAN MOTOR
MV	VANE MOTOR (HORIZONTAL)
NR11	VARISTOR
L112	REACTOR
RT11	ROOM TEMP. THERMISTOR
RT12	COIL TEMP. THERMISTOR (MAIN)
RT13	COIL TEMP. THERMISTOR (SUB)
TB	TERMINAL BLOCK
TAB1, TAB2	TAB
52C	RELAY

MSZ-FH25VE2 MSZ-FH35VE2 MSZ-FH50VE2

INDOOR UNIT

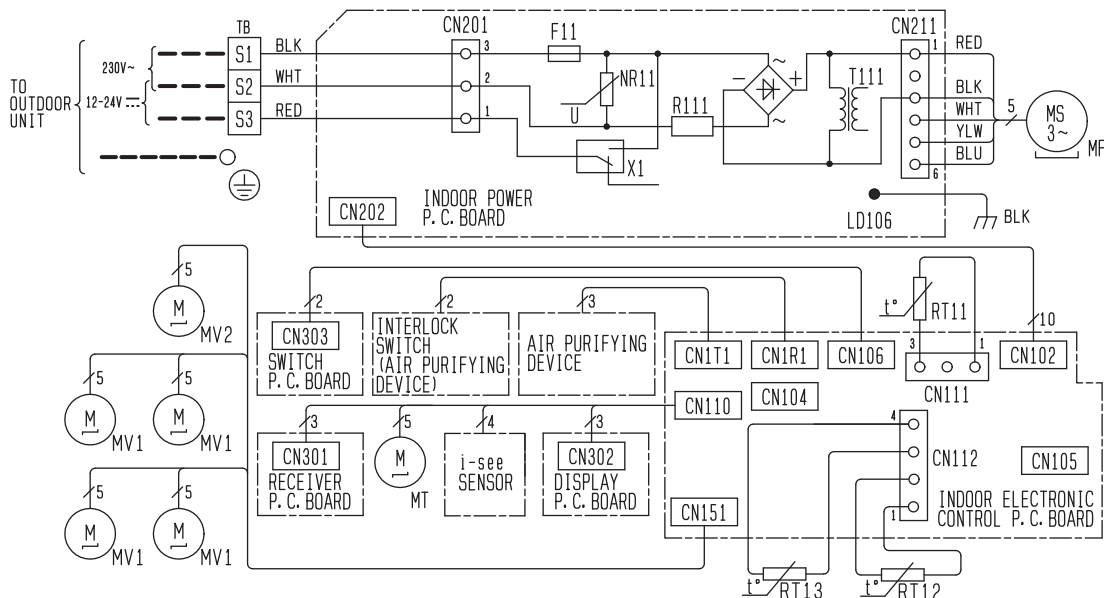

- NOTES: 1. About the outdoor side electronic wiring refer to the outdoor unit electronic wiring diagram for servicing.
 2. Use copper conductors only.
 (For field wiring) Terminal block symbol: : Terminal block
 Connector symbol: : Connector

SYMBOL	NAME
F11	FUSE (T3, 15AL250V)
MF	FAN MOTOR
MV1	VANE MOTOR (HORIZONTAL)
MV2	VANE MOTOR (VERTICAL)
MT	i-see SENSOR MOTOR
NR11	VARISTOR
R111	RESISTOR
RT11	ROOM TEMP. THERMISTOR
RT12	COIL TEMP. THERMISTOR (MAIN)
RT13	COIL TEMP. THERMISTOR (SUB)
T111	TRANSFORMER
TB	TERMINAL BLOCK
X1	RELAY

WALL-MOUNTED WIRING DIAGRAM

MSZ-EF18VGW MSZ-EF22VGW MSZ-EF25VGW MSZ-EF35VGW MSZ-EF42VGW
MSZ-EF18VGB MSZ-EF22VGB MSZ-EF25VGB MSZ-EF35VGB MSZ-EF42VGB
MSZ-EF18VGS MSZ-EF22VGS MSZ-EF25VGS MSZ-EF35VGS MSZ-EF42VGS

INDOOR UNIT

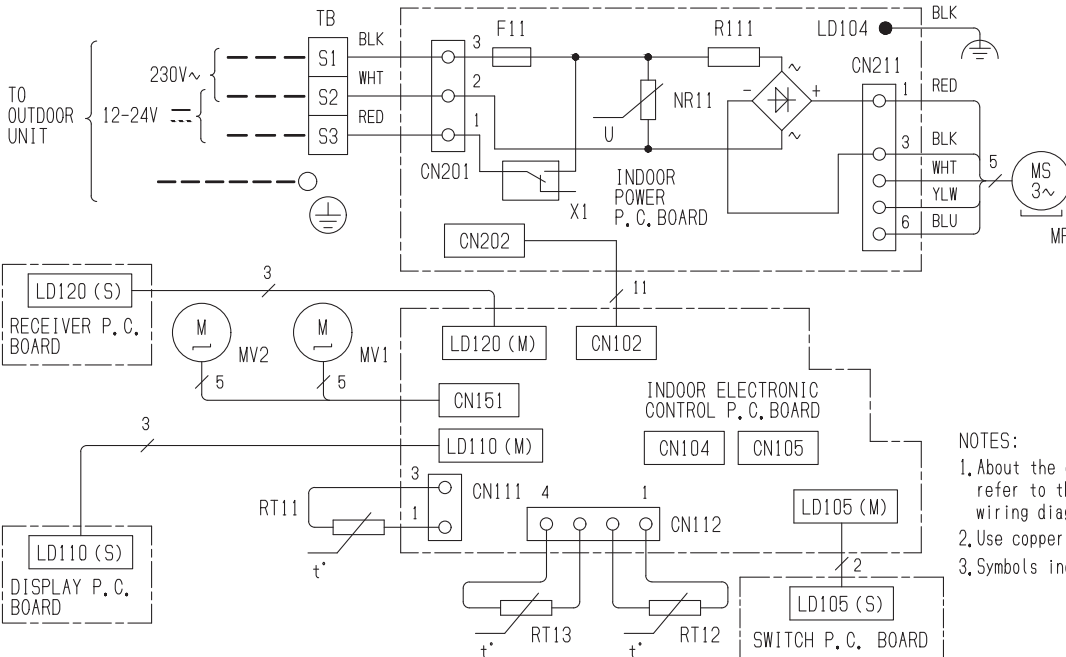

SYMBOL	NAME
F11	FUSE (T3, 15A/250V)
MF	FAN MOTOR
MV1	VANE MOTOR (HORIZONTAL UPPER)
MV2	VANE MOTOR (HORIZONTAL LOWER)
NR11	VARISTOR
R11	RESISTOR
RT11	ROOM TEMP. THERMISTOR
RT12	COIL TEMP. THERMISTOR (MAIN)
RT13	COIL TEMP. THERMISTOR (SUB)
TB	TERMINAL BLOCK
X1	RELAY

NOTES:
 1. About the outdoor side electronic wiring refer to the outdoor unit electronic wiring diagram for servicing.
 2. Use copper supply wires.
 3. Symbols indicate.

□ : Terminal block
 ○ : Connector

MSZ-EF18VGKW MSZ-EF22VGKW MSZ-EF25VGKW MSZ-EF35VGKW MSZ-EF42VGKW
MSZ-EF18VGBK MSZ-EF22VGBK MSZ-EF25VGBK MSZ-EF35VGBK MSZ-EF42VGBK
MSZ-EF18VGKS MSZ-EF22VGKS MSZ-EF25VGKS MSZ-EF35VGKS MSZ-EF42VGKS

INDOOR UNIT

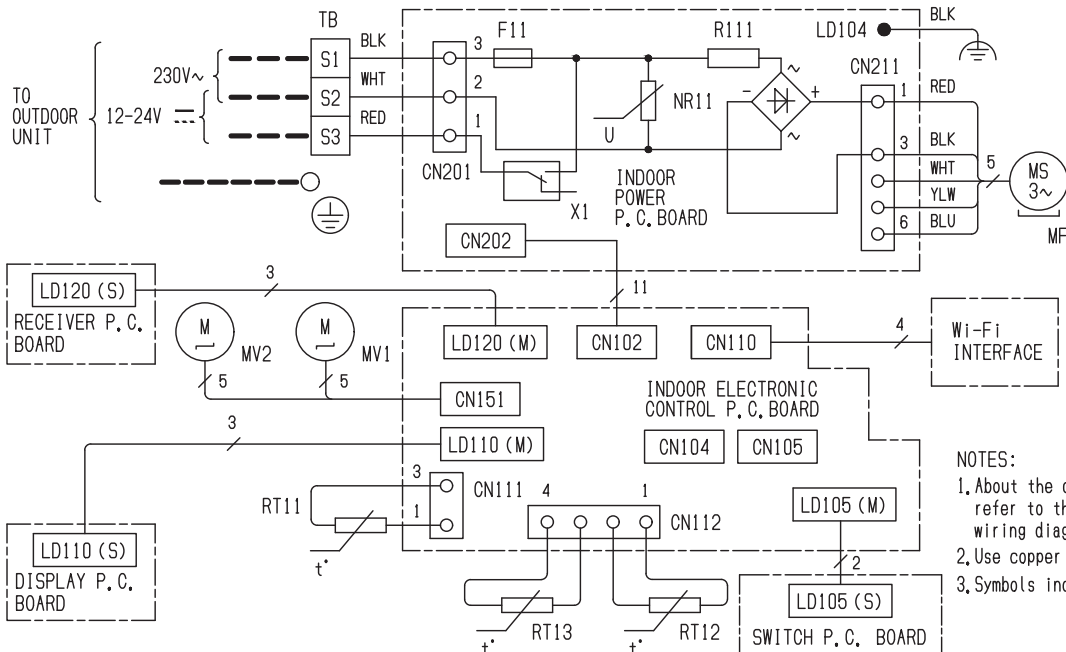

SYMBOL	NAME
F11	FUSE (T3, 15A/250V)
MF	FAN MOTOR
MV1	VANE MOTOR (HORIZONTAL UPPER)
MV2	VANE MOTOR (HORIZONTAL LOWER)
NR11	VARISTOR
R11	RESISTOR
RT11	ROOM TEMP. THERMISTOR
RT12	COIL TEMP. THERMISTOR (MAIN)
RT13	COIL TEMP. THERMISTOR (SUB)
TB	TERMINAL BLOCK
X1	RELAY

NOTES:
 1. About the outdoor side electronic wiring refer to the outdoor unit electronic wiring diagram for servicing.
 2. Use copper supply wires.
 3. Symbols indicate.

□ : Terminal block
 ○ : Connector

WIRING DIAGRAM

WALL-MOUNTED

**MSZ-EF50VGW
MSZ-EF50VGB
MSZ-EF50VGS**

INDOOR UNIT

SYMBOL	NAME
F11	FUSE (T3, 15A/250V)
L112	REACTOR
MF	FAN MOTOR
MV1	VANE MOTOR (HORIZONTAL UPPER)
MV2	VANE MOTOR (HORIZONTAL LOWER)
NR11	VARISTOR
RT11	ROOM TEMP. THERMISTOR
RT12	COIL TEMP. THERMISTOR (MAIN)
RT13	COIL TEMP. THERMISTOR (SUB)
TB	TERMINAL BLOCK
X1	RELAY

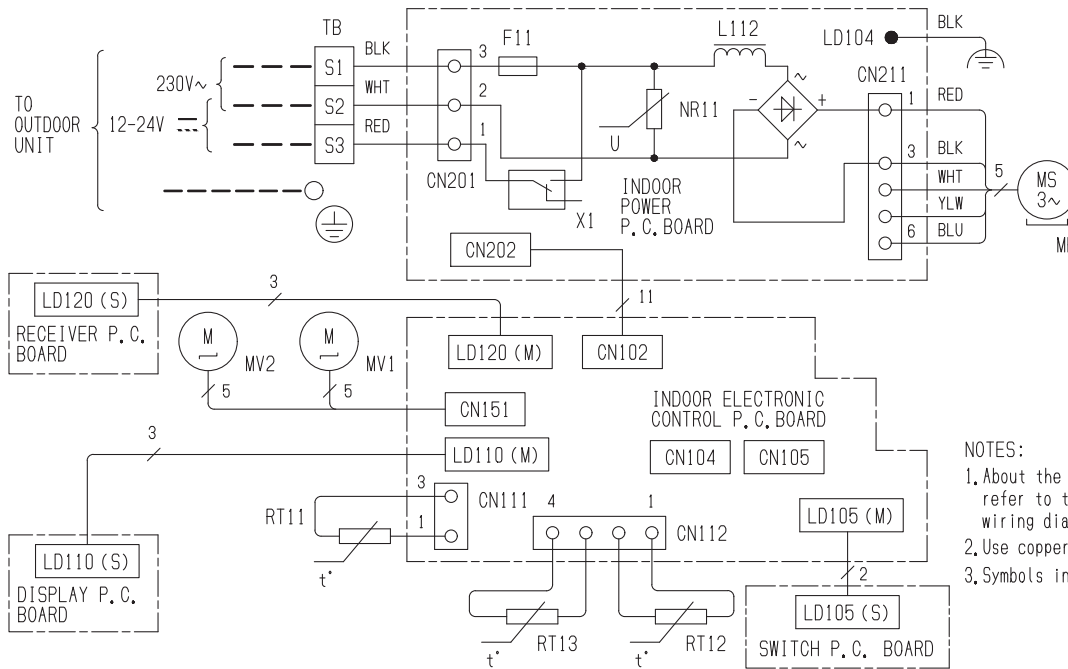

- NOTES:
- About the outdoor side electronic wiring refer to the outdoor unit electronic wiring diagram for servicing.
 - Use copper supply wires.
 - Symbols indicate.
- : Terminal block
 : Connector

**MSZ-EF50VGKW
MSZ-EF50VGKB
MSZ-EF50VGKS**

INDOOR UNIT

SYMBOL	NAME
F11	FUSE (T3, 15A/250V)
L112	REACTOR
MF	FAN MOTOR
MV1	VANE MOTOR (HORIZONTAL UPPER)
MV2	VANE MOTOR (HORIZONTAL LOWER)
NR11	VARISTOR
RT11	ROOM TEMP. THERMISTOR
RT12	COIL TEMP. THERMISTOR (MAIN)
RT13	COIL TEMP. THERMISTOR (SUB)
TB	TERMINAL BLOCK
X1	RELAY

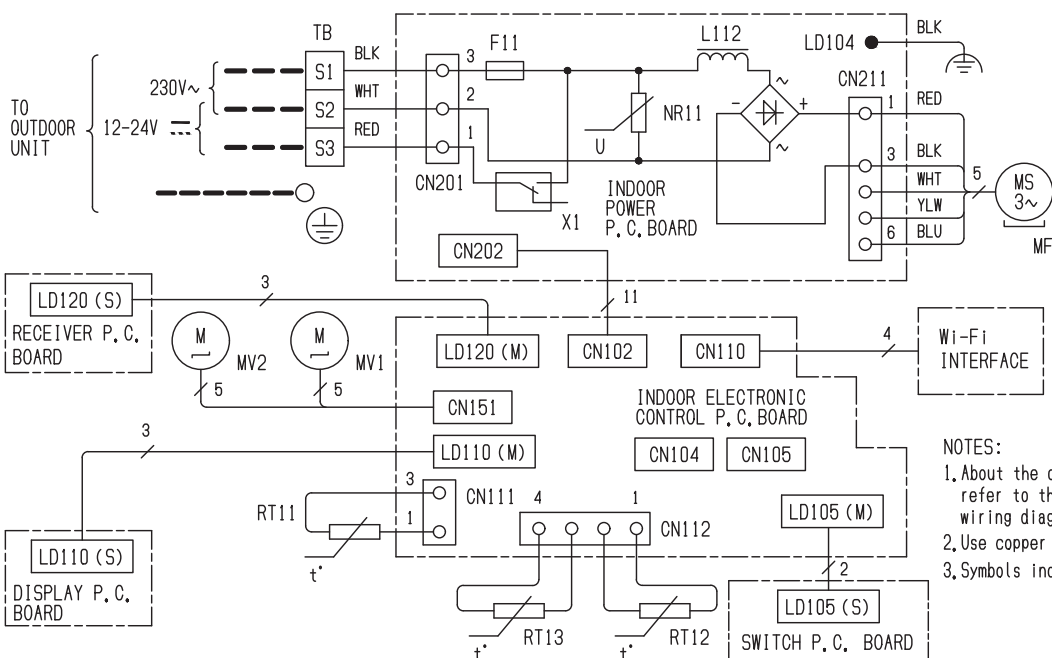

- NOTES:
- About the outdoor side electronic wiring refer to the outdoor unit electronic wiring diagram for servicing.
 - Use copper supply wires.
 - Symbols indicate.
- : Terminal block
 : Connector

WALL-MOUNTED WIRING DIAGRAM

MSZ-BT20VG MSZ-BT25VG MSZ-BT35VG MSZ-BT50VG

INDOOR UNIT

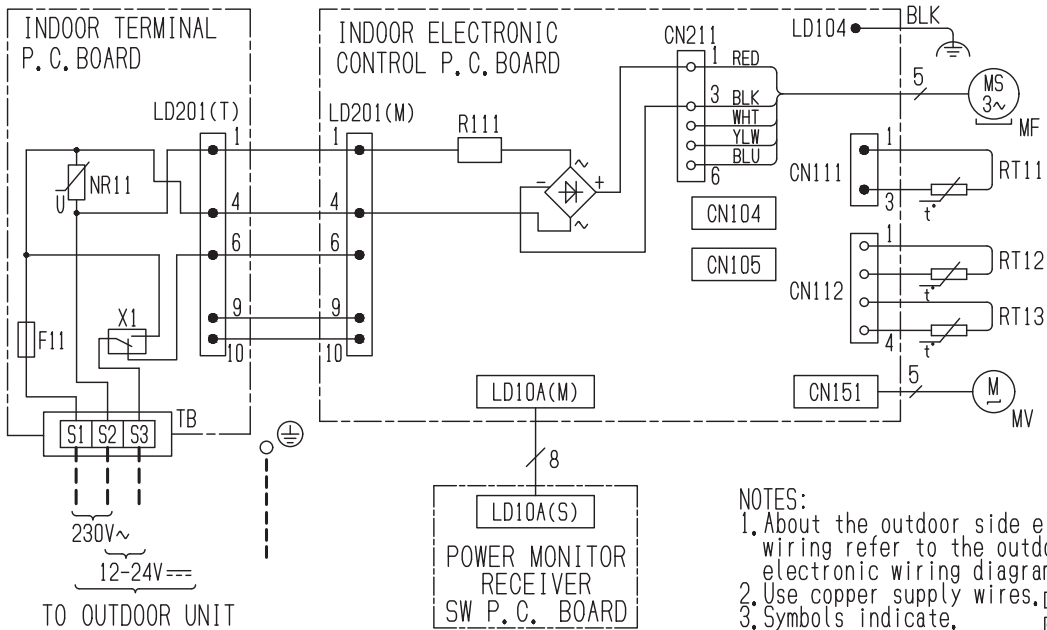

SYMBOL	NAME
F11	FUSE (T3, 15AL250V)
MF	FAN MOTOR
MV	VANE MOTOR (HORIZONTAL)
NR11	VARISTOR
R111	RESISTOR
RT11	ROOM TEMP. THERMISTOR
RT12	COIL TEMP. THERMISTOR (MAIN)
RT13	COIL TEMP. THERMISTOR (SUB)
TB	TERMINAL BLOCK
X1	RELAY

NOTES:
 1. About the outdoor side electronic wiring refer to the outdoor unit electronic wiring diagram for servicing.
 2. Use copper supply wires. : Terminal block
 3. Symbols indicate. : Connector

MSZ-BT20VGK MSZ-BT25VGK MSZ-BT35VGK MSZ-BT50VGK

INDOOR UNIT

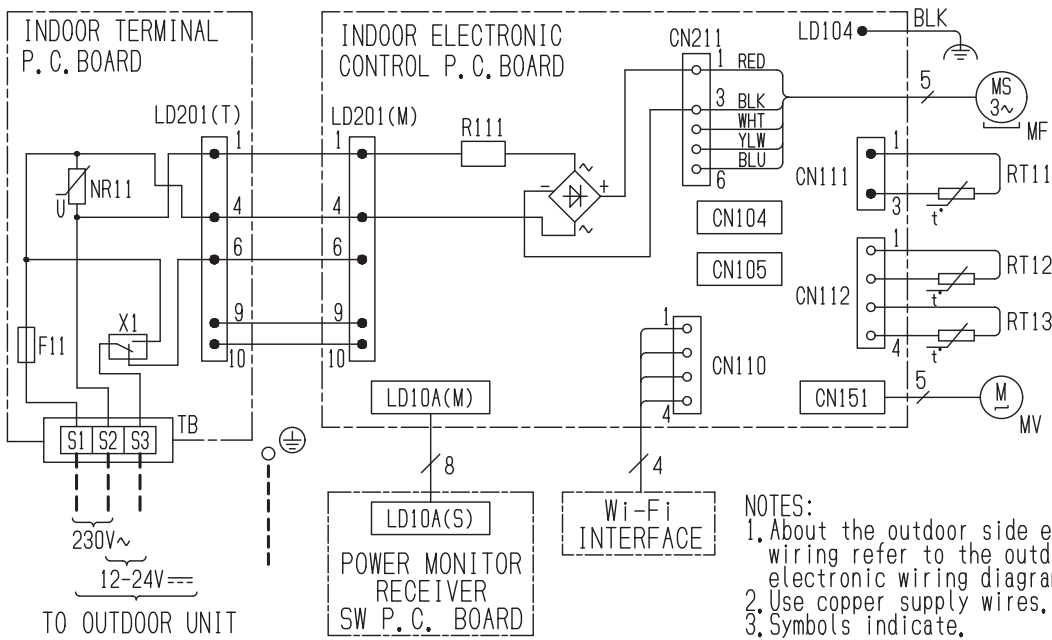

SYMBOL	NAME
F11	FUSE (T3, 15AL250V)
MF	FAN MOTOR
MV	VANE MOTOR (HORIZONTAL)
NR11	VARISTOR
R111	RESISTOR
RT11	ROOM TEMP. THERMISTOR
RT12	COIL TEMP. THERMISTOR (MAIN)
RT13	COIL TEMP. THERMISTOR (SUB)
TB	TERMINAL BLOCK
X1	RELAY

NOTES:
 1. About the outdoor side electronic wiring refer to the outdoor unit electronic wiring diagram for servicing.
 2. Use copper supply wires. : Terminal block
 3. Symbols indicate. : Connector

WIRING DIAGRAM

WALL-MOUNTED

MSZ-DW25VF MSZ-DW35VF MSZ-DW50VF

INDOOR UNIT

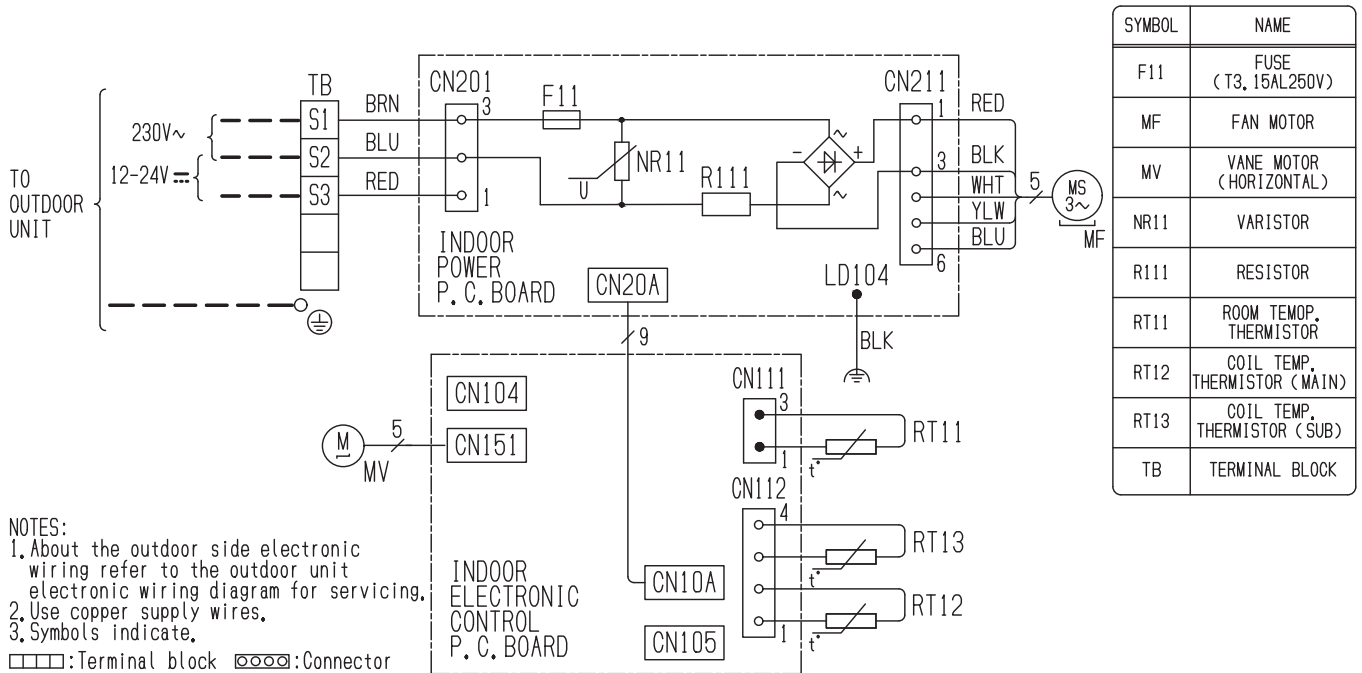

NOTES:
 1. About the outdoor side electronic wiring refer to the outdoor unit electronic wiring diagram for servicing.
 2. Use copper supply wires.
 3. Symbols indicate.
 □□□□: Terminal block ○○○○: Connector

MSZ-SF15VA MSZ-SF20VA

INDOOR UNIT

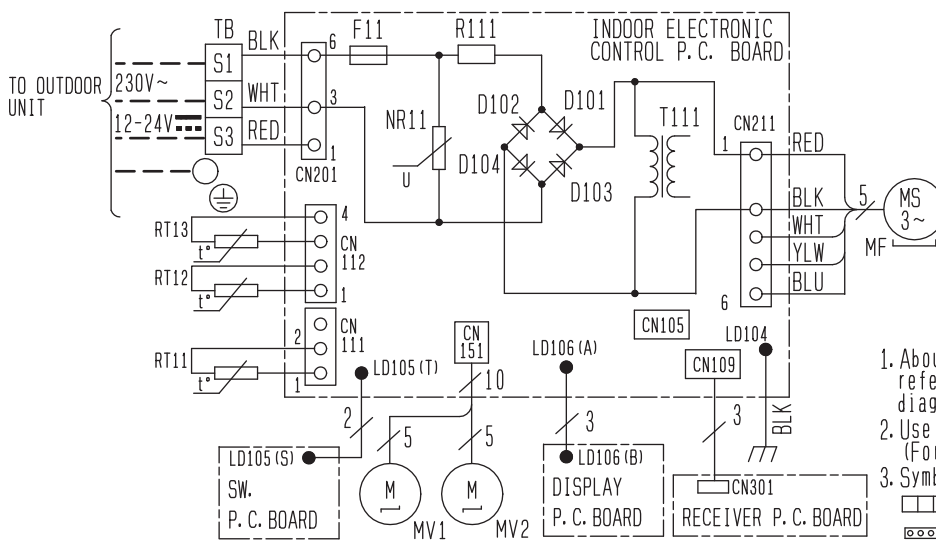

SYMBOL	NAME	SYMBOL	NAME
D101~D104	DIODE	RT11	ROOM TEMP. THERMISTOR
F11	FUSE (T3. 15A/250V)	RT12	COIL TEMP. THERMISTOR (MAIN)
MF	FAN MOTOR	RT13	COIL TEMP. THERMISTOR (SUB)
MV1	VANE MOTOR (HORIZONTAL)	T111	TRANSFORMER
MV2	VANE MOTOR (HORIZONTAL)	TB	TERMINAL BLOCK
NR11	VARISTOR	R111	RESISTOR

- About the outdoor side electric wiring refer to the outdoor unit electric wiring diagram for servicing.
- Use copper conductors only. (For field wiring)
- Symbols below indicate.
 : Terminal block
 : Connector

MSZ-SF25VE3 MSZ-SF42VE3

INDOOR UNIT

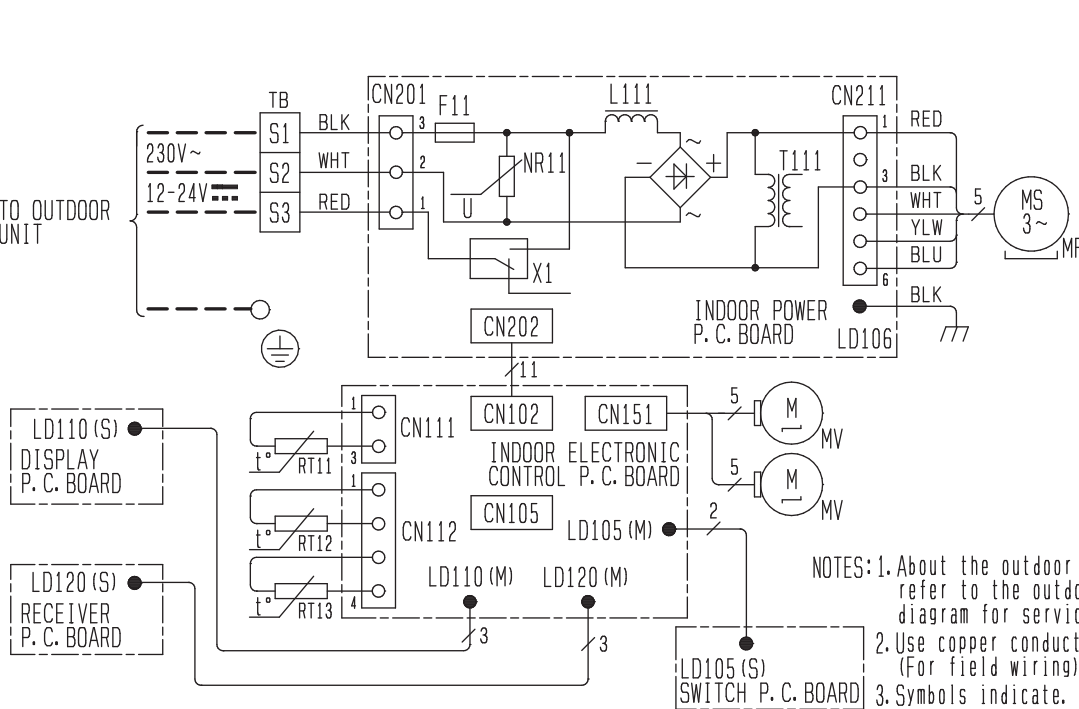

SYMBOL	NAME
F11	FUSE (T3. 15A/250V)
L111	REACTOR
MF	FAN MOTOR
MV	VANE MOTOR (HORIZONTAL)
NR11	VARISTOR
RT11	ROOM TEMP. THERMISTOR
RT12	COIL TEMP. THERMISTOR (MAIN)
RT13	COIL TEMP. THERMISTOR (SUB)
T111	TRANSFORMER
TB	TERMINAL BLOCK
X1	RELAY

- NOTES: 1. About the outdoor side electric wiring refer to the outdoor unit electronic wiring diagram for servicing.
2. Use copper conductors only. (For field wiring)
3. Symbols indicate.
 : Terminal block
 : Connector

WIRING DIAGRAM

WALL-MOUNTED

MSZ-SF35VE3 MSZ-SF50VE3

INDOOR UNIT

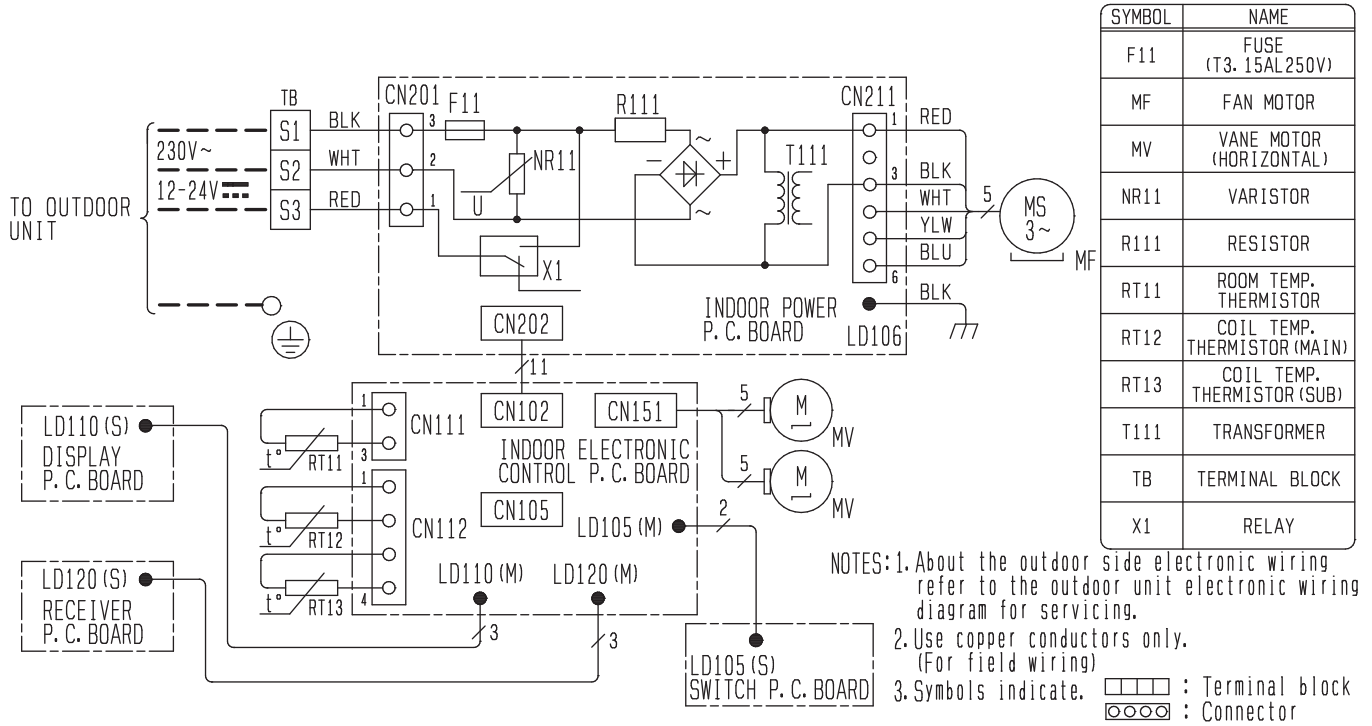

MSZ-GF60VE2 MSZ-GF71VE2

INDOOR UNIT

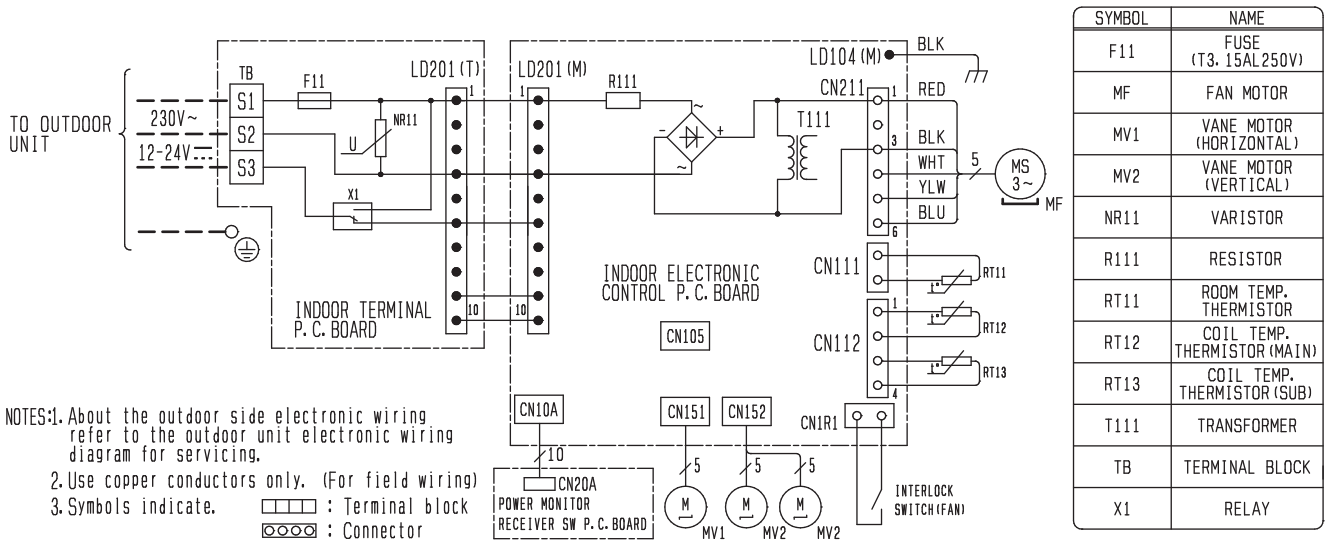

WALL-MOUNTED WIRING DIAGRAM

MSZ-WN25VA MSZ-WN35VA

INDOOR UNIT

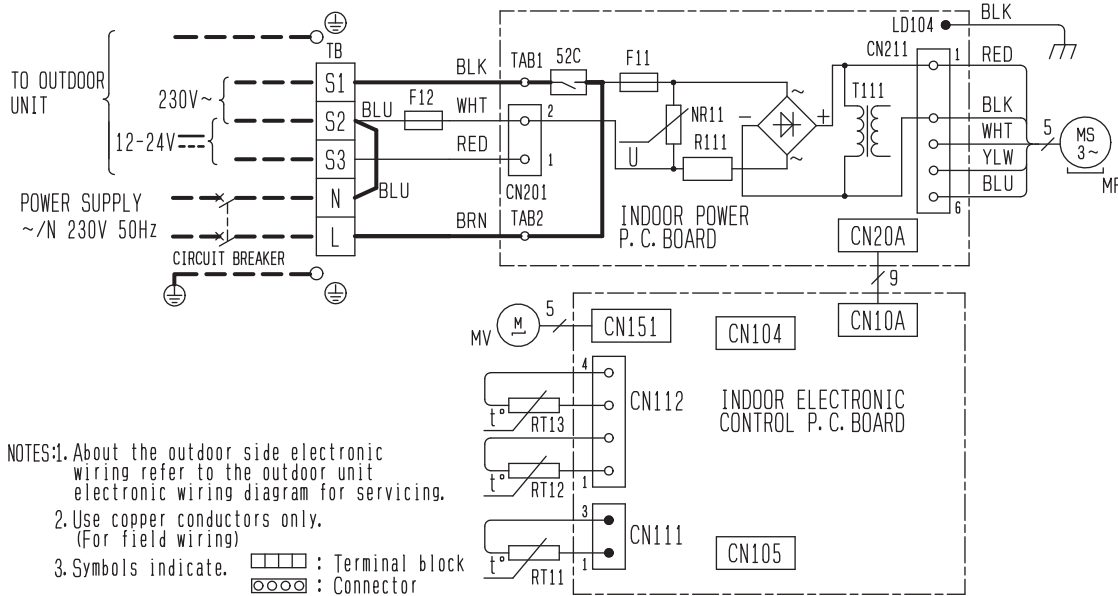

SYMBOL	NAME
F11	FUSE (T3. 15AL250V)
F12	THERMAL FUSE (102°C 5A)
MF	FAN MOTOR
MV	VANE MOTOR (HORIZONTAL)
NR11	VARISTOR
R111	RESISTOR
RT11	ROOM TEMP. THERMISTOR
RT12	COIL TEMP. THERMISTOR (MAIN)
RT13	COIL TEMP. THERMISTOR (SUB)
T111	TRANSFORMER
TB	TERMINAL BLOCK
52C	CONTACTOR
TAB1, TAB2	TAB

- NOTES: 1. About the outdoor side electronic wiring refer to the outdoor unit electronic wiring diagram for servicing.
 2. Use copper conductors only. (For field wiring)
 3. Symbols indicate. □□□□ : Terminal block
○○○○ : Connector

MSZ-DM25VA MSZ-DM35VA

INDOOR UNIT

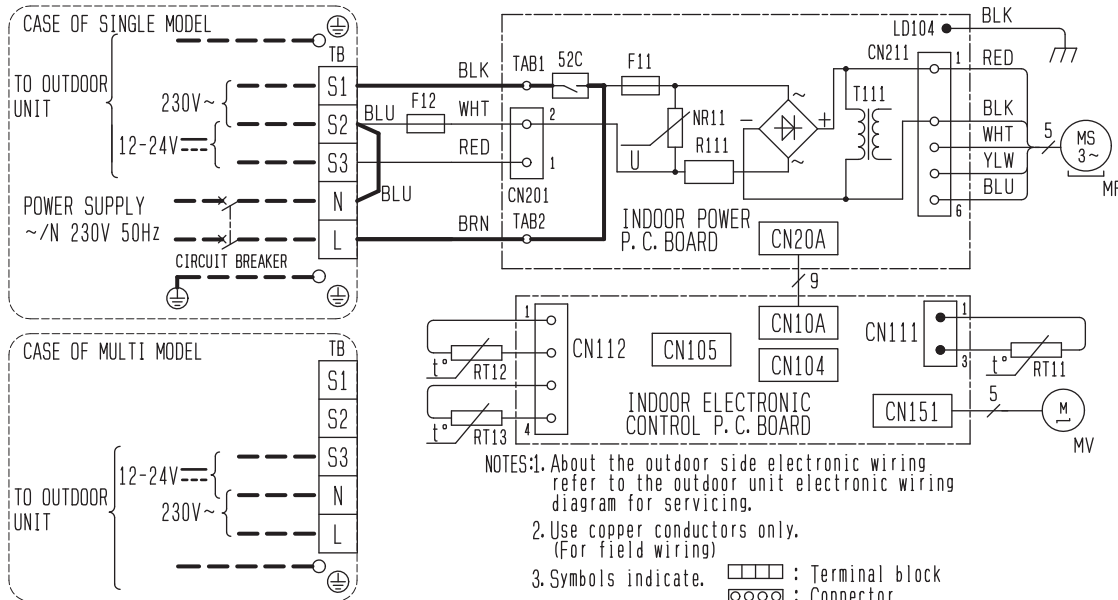

SYMBOL	NAME
F11	FUSE (T3. 15AL250V)
F12	THERMAL FUSE (102°C 5A)
MF	FAN MOTOR
MV	VANE MOTOR (HORIZONTAL)
NR11	VARISTOR
R111	RESISTOR
RT11	ROOM TEMP. THERMISTOR
RT12	COIL TEMP. THERMISTOR (MAIN)
RT13	COIL TEMP. THERMISTOR (SUB)
T111	TRANSFORMER
TB	TERMINAL BLOCK
52C	CONTACTOR
TAB1, TAB2	TAB

- NOTES: 1. About the outdoor side electronic wiring refer to the outdoor unit electronic wiring diagram for servicing.
 2. Use copper conductors only. (For field wiring)
 3. Symbols indicate. □□□□ : Terminal block
○○○○ : Connector

MSZ-HJ25VA MSZ-HJ35VA MSZ-HJ50VA

INDOOR UNIT

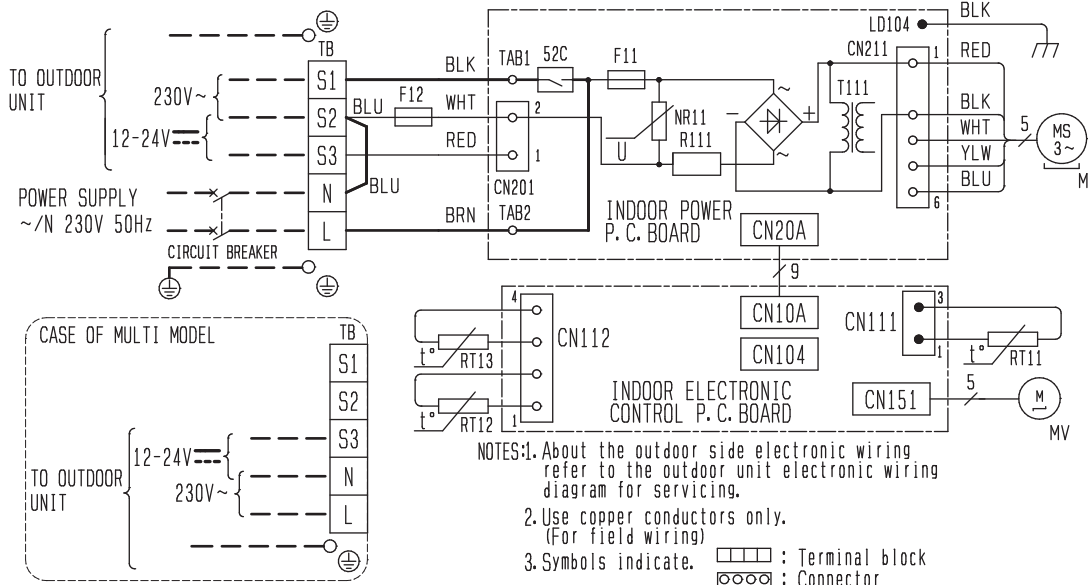

SYMBOL	NAME
F11	FUSE (T3. 15AL 250V)
F12	THERMAL FUSE (102°C 5A)
MF	FAN MOTOR
MV	VANE MOTOR (HORIZONTAL)
NR11	VARISTOR
R111	RESISTOR
RT11	ROOM TEMP. THERMISTOR
RT12	COIL TEMP. THERMISTOR (MAIN)
RT13	COIL TEMP. THERMISTOR (SUB)
T111	TRANSFORMER
TB	TERMINAL BLOCK
52C	CONTACTOR
TAB1, TAB2	TAB

NOTES: 1. About the outdoor side electronic wiring refer to the outdoor unit electronic wiring diagram for servicing.
 2. Use copper conductors only. (For field wiring)
 3. Symbols indicate. □ : Terminal block
○ : Connector

MSZ-HJ60VA MSZ-HJ71VA

INDOOR UNIT

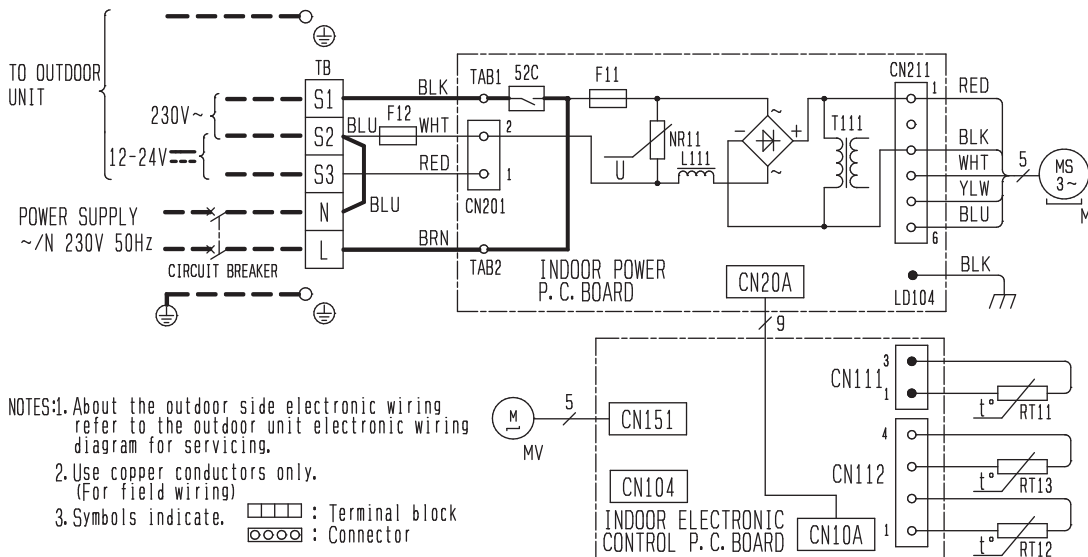

SYMBOL	NAME
F11	FUSE (T3. 15AL 250V)
F12	THERMAL FUSE (102°C 4.5A)
MF	FAN MOTOR
MV	VANE MOTOR (HORIZONTAL)
NR11	VARISTOR
L111	REACTOR
RT11	ROOM TEMP. THERMISTOR
RT12	COIL TEMP. THERMISTOR (MAIN)
RT13	COIL TEMP. THERMISTOR (SUB)
T111	TRANSFORMER
TB	TERMINAL BLOCK
TAB1, TAB2	TAB
52C	CONTACTOR

NOTES: 1. About the outdoor side electronic wiring refer to the outdoor unit electronic wiring diagram for servicing.
 2. Use copper conductors only. (For field wiring)
 3. Symbols indicate. □ : Terminal block
○ : Connector

WALL-MOUNTED WIRING DIAGRAM

C.1.3.2 Outdoor Unit
MUZ-RW25VGHZ MUZ-RW35VGHZ

OUTDOOR UNIT

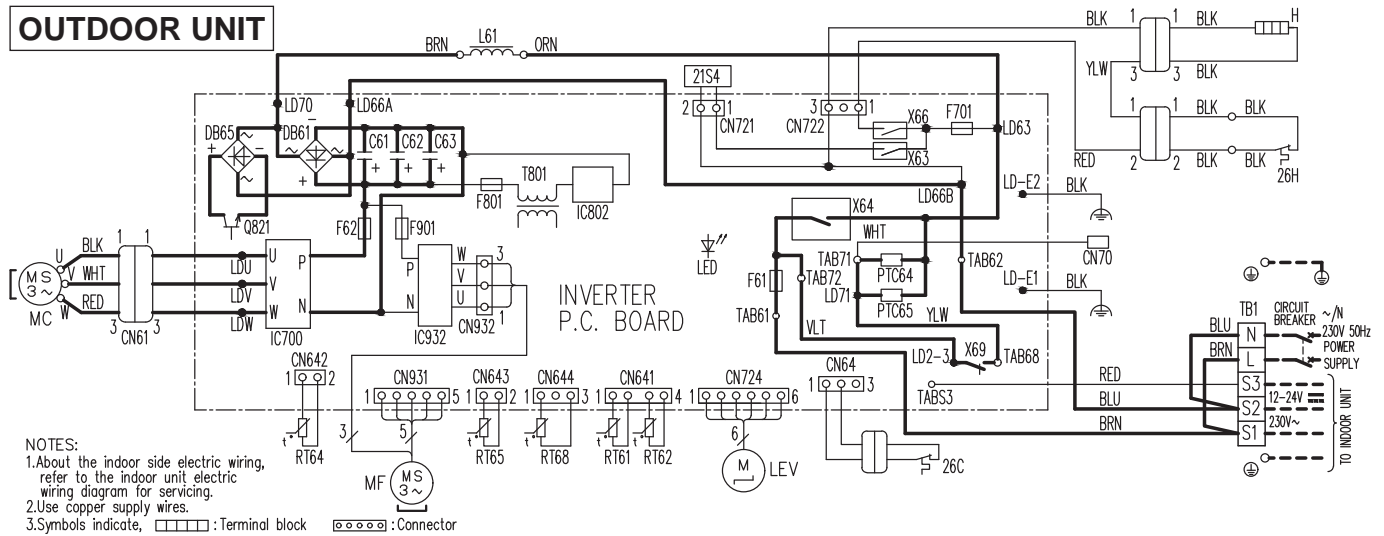

- NOTES:
 1.About the indoor side electric wiring, refer to the indoor unit electric wiring diagram for servicing.
 2.Use copper supply wires.
 3.Symbols indicate, : Terminal block : Connector

SYMBOL	NAME	SYMBOL	NAME	SYMBOL	NAME
CN61	CONNECTOR	LEV	EXPANSION VALVE COIL	RT68	OUTDOOR HEAT EXCHANGER TEMP. THERMISTOR
C61,C62,C63	SMOOTHING CAPACITOR	L61	REACTOR	TB1	TERMINAL BLOCK
DB61,DB65	DIODE MODULE	MC	COMPRESSOR	T801	TRANSFORMER
F61	FUSE (25A 250V)	MF	FAN MOTOR	21S4	REVERSING VALVE COIL
F62	FUSE (15A 250V)	PTC64,PTC65	CIRCUIT PROTECTION	26C	COMPRESSOR PROTECTOR
F701,F801,F901	FUSE (T3.15AL250V)	Q821	SWITCHING POWER TRANSISTOR	26H	HEATER PROTECTOR
H	DEFROST HEATER	RT61	DEFROST THERMISTOR		
IC700,IC932	POWER MODULE	RT62	DISCHARGE TEMP. THERMISTOR		
IC802	POWER DEVICE	RT64	FIN TEMP. THERMISTOR		
LED	LED	RT65	AMBIENT TEMP. THERMISTOR		

MUZ-RW50VGHZ

OUTDOOR UNIT

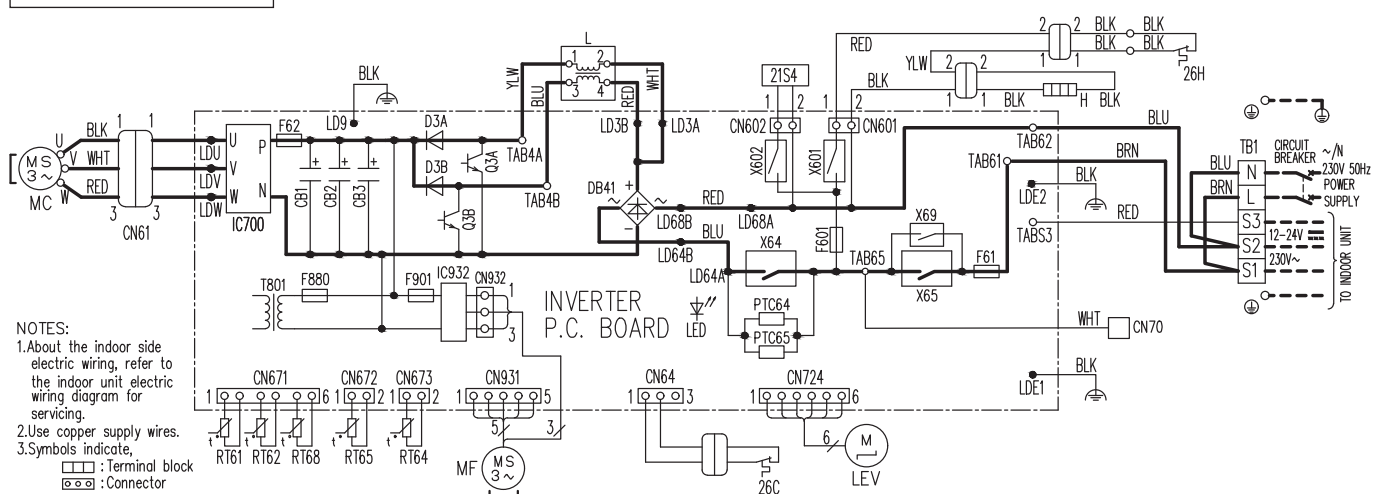

- NOTES:
 1.About the indoor side electric wiring, refer to the indoor unit electric wiring diagram for servicing.
 2.Use copper supply wires.
 3.Symbols indicate, : Terminal block : Connector

SYMBOL	NAME	SYMBOL	NAME	SYMBOL	NAME
CB1,CB2,CB3	SMOOTHING CAPACITOR	L	REACTOR	RT65	AMBIENT TEMP. THERMISTOR
CN61	CONNECTOR	LED	LED	RT68	OUTDOOR HEAT EXCHANGER TEMP. THERMISTOR
DB41	DIODE MODULE	LEV	EXPANSION VALVE COIL	TB1	TERMINAL BLOCK
D3A,D3B	DIODE	MC	COMPRESSOR	T801	TRANSFORMER
F601	FUSE (T3.15AL250V)	MF	FAN MOTOR	21S4,26C	REVERSING VALVE COIL COMPRESSOR PROTECTOR
F61	FUSE (25A 250V)	PTC64,PTC65	CIRCUIT PROTECTION	26H	HEATER PROTECTOR
F62	FUSE (15A 250V)	Q3A,Q3B	SWITCHING POWER TRANSISTOR		
F880,F901	FUSE (T3.15AL250V)	RT61	DEFROST THERMISTOR		
H	DEFROST HEATER	RT62	DISCHARGE TEMP. THERMISTOR		
IC700,IC932	POWER MODULE	RT64	FIN TEMP. THERMISTOR		

WIRING DIAGRAM

WALL-MOUNTED

MUZ-LN25VG2 MUZ-LN35VG2

OUTDOOR UNIT

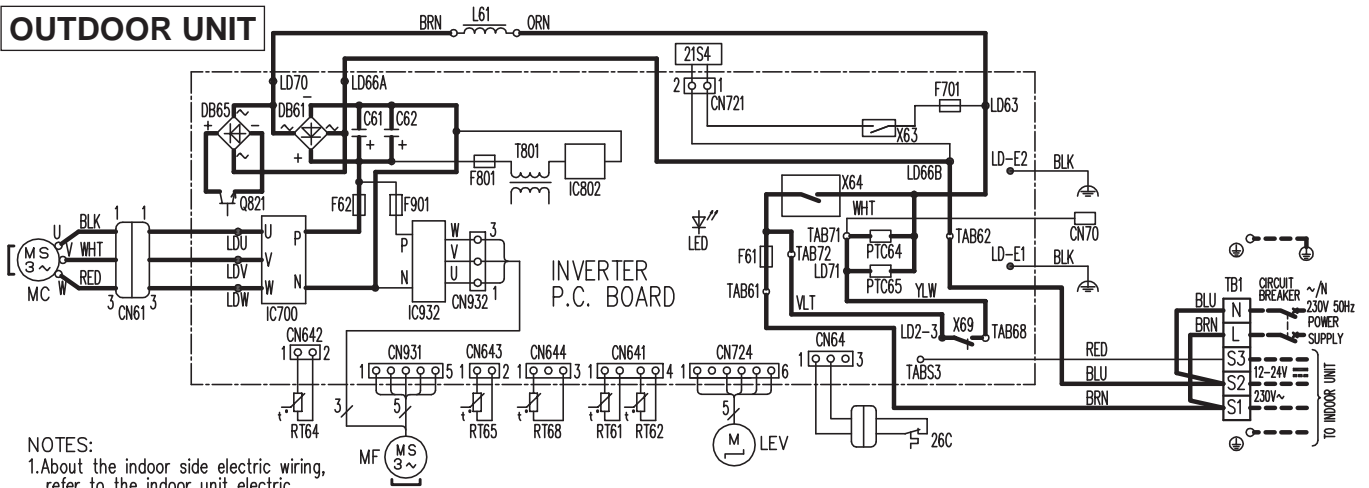

- NOTES:
- About the indoor side electric wiring, refer to the indoor unit electric wiring diagram for servicing.
 - Use copper supply wires.
 - Symbols indicate, □□□□ : Terminal block ○●○●○● : Connector

SYMBOL	NAME	SYMBOL	NAME	SYMBOL	NAME
CN61	CONNECTOR	LEV	EXPANSION VALVE COIL	RT65	AMBIENT TEMP. THERMISTOR
C61, C62	SMOOTHING CAPACITOR	L61	REACTOR	RT68	OUTDOOR HEAT EXCHANGER TEMP. THERMISTOR
DB61, DB65	DIODE MODULE	MC	COMPRESSOR	TB1	TERMINAL BLOCK
F61	FUSE (25A 250V)	MF	FAN MOTOR	T801	TRANSFORMER
F62	FUSE (15A 250V)	PTC64, PTC65	CIRCUIT PROTECTION	X63, X64, X69	RELAY
F701, F801, F901	FUSE (T3.15AL250V)	Q821	SWITCHING POWER TRANSISTOR	21S4	REVERSING VALVE COIL
IC700, IC932	POWER MODULE	RT61	DEFROST THERMISTOR	26C	COMPRESSOR PROTECTOR
IC802	POWER DEVICE	RT62	DISCHARGE TEMP. THERMISTOR		
LED	LED	RT64	FIN TEMP. THERMISTOR		

MUZ-LN25VGHZ2

OUTDOOR UNIT

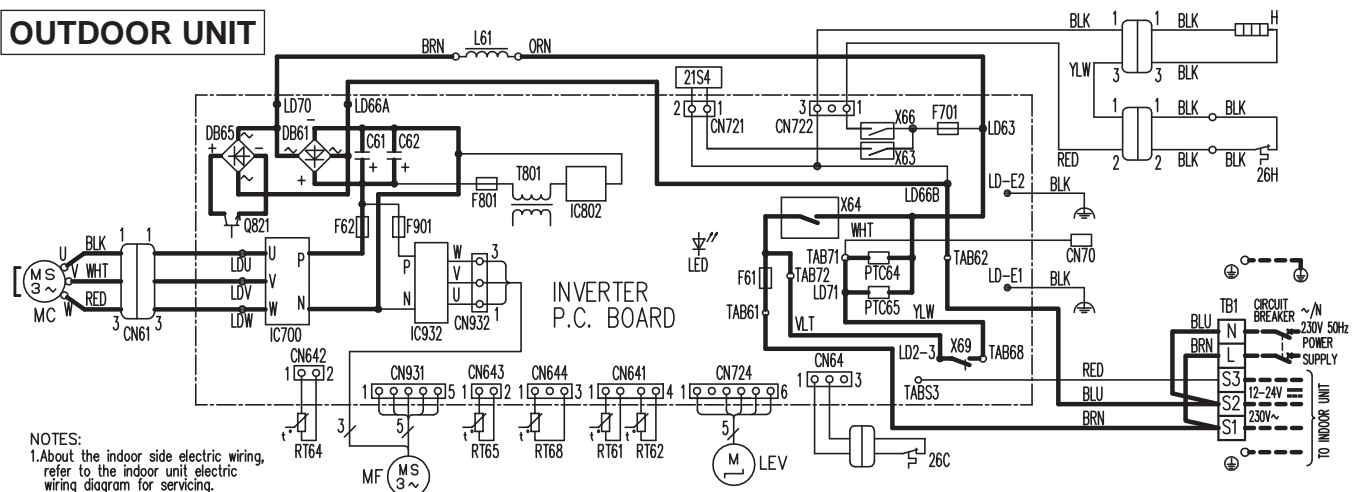

- NOTES:
- About the indoor side electric wiring, refer to the indoor unit electric wiring diagram for servicing.
 - Use copper supply wires.
 - Symbols indicate, □□□□ : Terminal block ○●○●○● : Connector

SYMBOL	NAME	SYMBOL	NAME	SYMBOL	NAME
CN61	CONNECTOR	LEV	EXPANSION VALVE COIL	RT68	OUTDOOR HEAT EXCHANGER TEMP. THERMISTOR
C61, C62	SMOOTHING CAPACITOR	L61	REACTOR	TB1	TERMINAL BLOCK
DB61, DB65	DIODE MODULE	MC	COMPRESSOR	T801	TRANSFORMER
F61	FUSE (25A 250V)	MF	FAN MOTOR	X63, X64, X66, X69	RELAY
F62	FUSE (15A 250V)	PTC64, PTC65	CIRCUIT PROTECTION	21S4	REVERSING VALVE COIL
F701, F801, F901	FUSE (T3.15AL250V)	Q821	SWITCHING POWER TRANSISTOR	26C	COMPRESSOR PROTECTOR
H	DEFROST HEATER	RT61	DEFROST THERMISTOR	26H	HEATER PROTECTOR
IC700, IC932	POWER MODULE	RT62	DISCHARGE TEMP. THERMISTOR		
IC802	POWER DEVICE	RT64	FIN TEMP. THERMISTOR		
LED	LED	RT65	AMBIENT TEMP. THERMISTOR		

WALL-MOUNTED WIRING DIAGRAM

MUZ-LN35VGHZ2

OUTDOOR UNIT

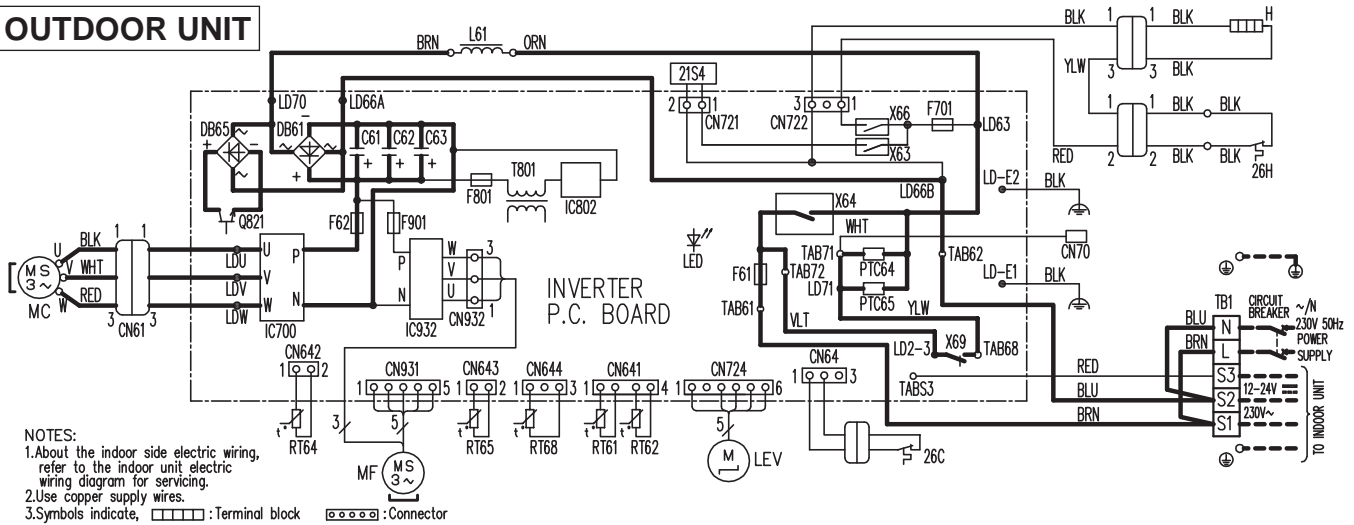

- NOTES:
 1.About the indoor side electric wiring, refer to the indoor unit electric wiring diagram for servicing.
 2.Use copper supply wires.
 3.Symbols indicate, □ : Terminal block ○ : Connector

SYMBOL	NAME	SYMBOL	NAME	SYMBOL	NAME
CN61	CONNECTOR	LEV	EXPANSION VALVE COIL	RT68	OUTDOOR HEAT EXCHANGER TEMP. THERMISTOR
C61, C62, C63	SMOOTHING CAPACITOR	L61	REACTOR	TB1	TERMINAL BLOCK
DB61, DB65	DIODE MODULE	MC	COMPRESSOR	T801	TRANSFORMER
F61	FUSE (25A 250V)	MF	FAN MOTOR	PTC64, PTC65	CIRCUIT PROTECTION
F62	FUSE (15A 250V)	Q821	SWITCHING POWER TRANSISTOR	X63, X64, X66, X69	RELAY
F701, F801, F901	FUSE (T3.15A 250V)	21S4	REVERSING VALVE COIL	26C	COMPRESSOR PROTECTOR
H	DEFROST HEATER	26H	HEATER PROTECTOR		
IC700, IC932	POWER MODULE				
IC802	POWER DEVICE				
LED	LED				

MUZ-LN50VG2

OUTDOOR UNIT

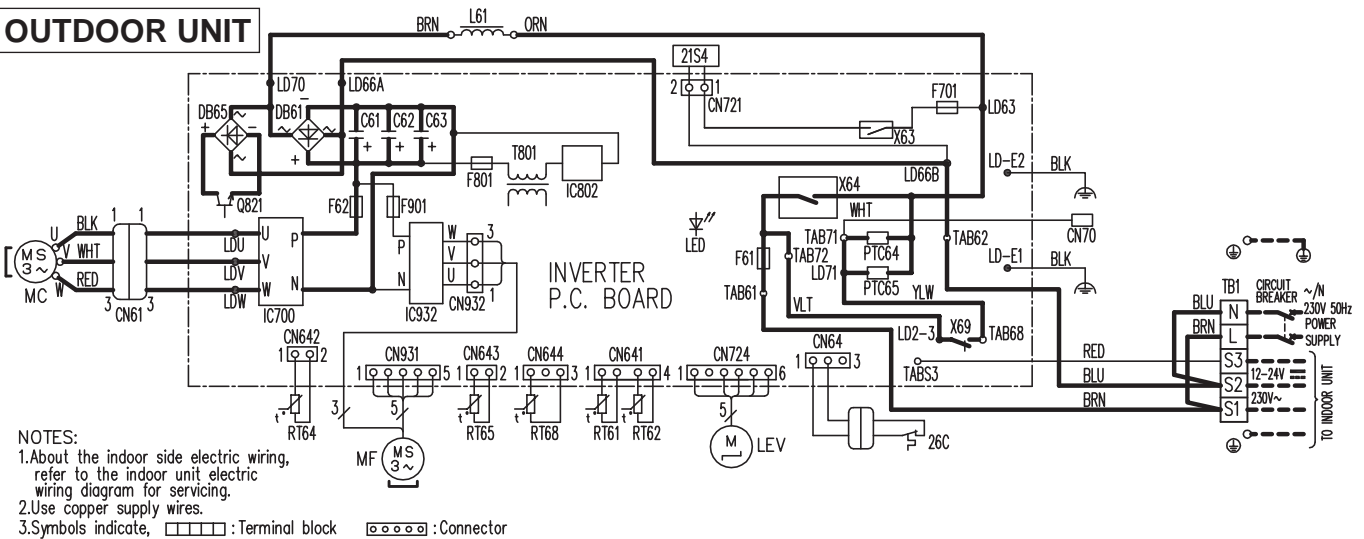

- NOTES:
 1.About the indoor side electric wiring, refer to the indoor unit electric wiring diagram for servicing.
 2.Use copper supply wires.
 3.Symbols indicate, □ : Terminal block ○ : Connector

SYMBOL	NAME	SYMBOL	NAME	SYMBOL	NAME
CN61	CONNECTOR	LEV	EXPANSION VALVE COIL	RT65	AMBIENT TEMP. THERMISTOR
C61, C62, C63	SMOOTHING CAPACITOR	L61	REACTOR	RT68	OUTDOOR HEAT EXCHANGER TEMP. THERMISTOR
DB61, DB65	DIODE MODULE	MC	COMPRESSOR	TB1	TERMINAL BLOCK
F61	FUSE (25A 250V)	MF	FAN MOTOR	T801	TRANSFORMER
F62	FUSE (15A 250V)	PTC64, PTC65	CIRCUIT PROTECTION	X63, X64, X69	RELAY
F701, F801, F901	FUSE (T3.15A 250V)	Q821	SWITCHING POWER TRANSISTOR	21S4	REVERSING VALVE COIL
IC700, IC932	POWER MODULE	RT61	DEFROST THERMISTOR	26C	COMPRESSOR PROTECTOR
IC802	POWER DEVICE	RT62	DISCHARGE TEMP. THERMISTOR		
LED	LED	RT64	FIN TEMP. THERMISTOR		

WIRING DIAGRAM

WALL-MOUNTED

MUZ-LN50VGHZ2

OUTDOOR UNIT

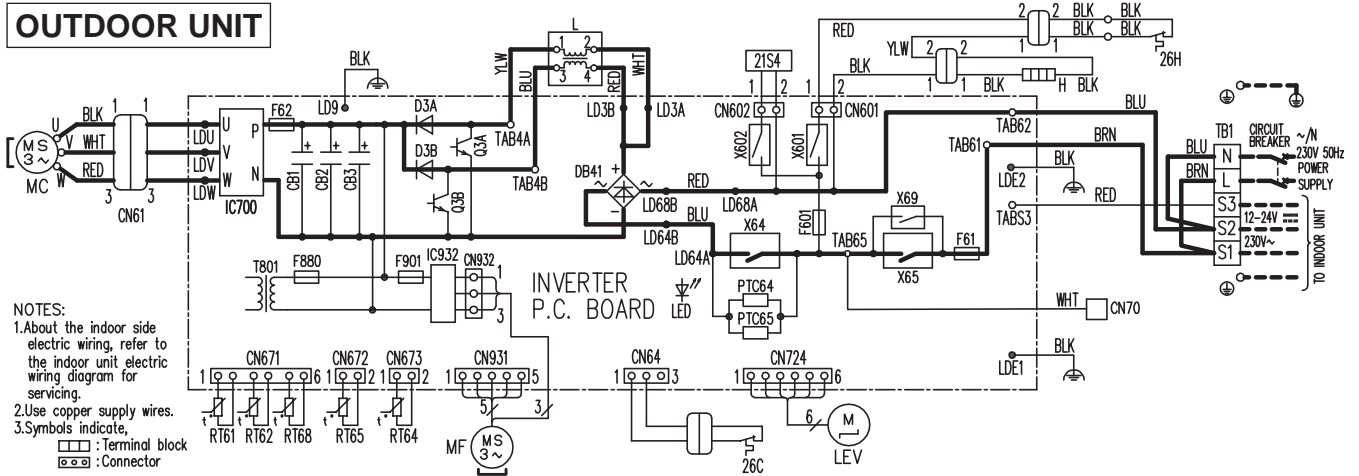

- NOTES:
- About the indoor side electric wiring, refer to the indoor unit electric wiring diagram for servicing.
 - Use copper supply wires.
 - Symbols indicate,
 - Terminal block
 - Connector

SYMBOL	NAME	SYMBOL	NAME	SYMBOL	NAME
CB1, CB2, CB3	SMOOTHING CAPACITOR	L	REACTOR	RT65	AMBIENT TEMP. THERMISTOR
CN61	CONNECTOR	LED	LED	RT68	OUTDOOR HEAT EXCHANGER TEMP. THERMISTOR
DB41	DIODE MODULE	LEV	EXPANSION VALVE COIL	TB1	TERMINAL BLOCK
D3A, D3B	DIODE	MC	COMPRESSOR	T801	TRANSFORMER
F601	FUSE (T3.15A/250V)	MF	FAN MOTOR	X601, X602	RELAY
F61	FUSE (25A 250V)	PTC64, PTC65	CIRCUIT PROTECTION	X64, X65, X69	RELAY
F62	FUSE (15A 250V)	Q3A, Q3B	SWITCHING POWER TRANSISTOR	21S4	REVERSING VALVE COIL
F880, F901	FUSE (T3.15A/250V)	RT61	DEFROST THERMISTOR	26C	COMPRESSOR PROTECTOR
H	DEFROST HEATER	RT62	DISCHARGE TEMP. THERMISTOR	26H	HEATER PROTECTOR
IC700, IC932	POWER MODULE	RT64	FIN TEMP. THERMISTOR		

MUZ-LN60VG2

OUTDOOR UNIT

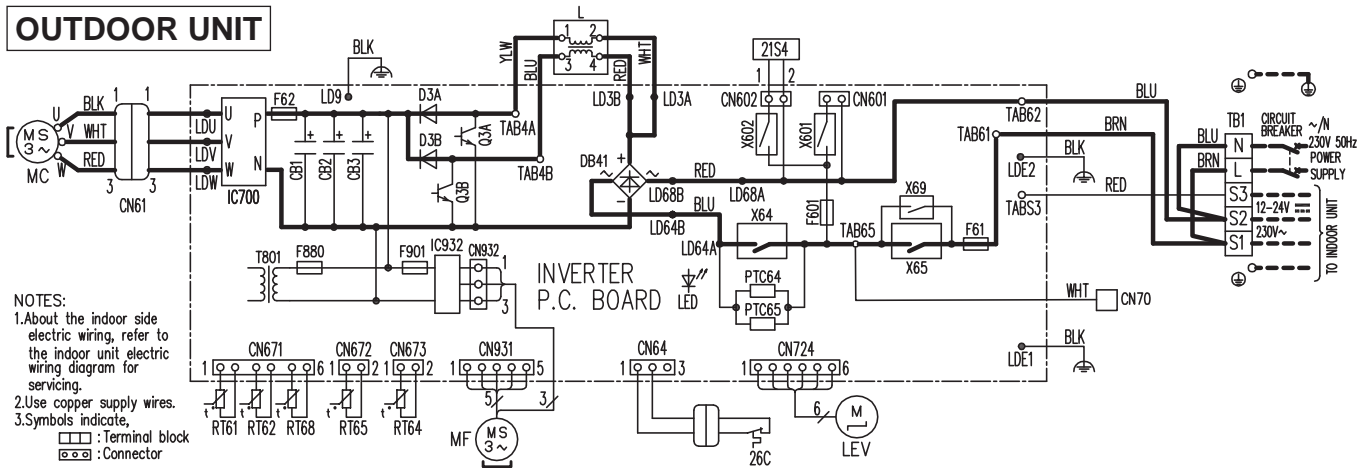

- NOTES:
- About the indoor side electric wiring, refer to the indoor unit electric wiring diagram for servicing.
 - Use copper supply wires.
 - Symbols indicate,
 - Terminal block
 - Connector

SYMBOL	NAME	SYMBOL	NAME	SYMBOL	NAME
CB1, CB2, CB3	SMOOTHING CAPACITOR	LED	LED	RT68	OUTDOOR HEAT EXCHANGER TEMP. THERMISTOR
CN61	CONNECTOR	LEV	EXPANSION VALVE COIL	TB1	TERMINAL BLOCK
DB41	DIODE MODULE	MC	COMPRESSOR	T801	TRANSFORMER
D3A, D3B	DIODE	MF	FAN MOTOR	X601, X602	RELAY
F601	FUSE (T3.15A/250V)	PTC64, PTC65	CIRCUIT PROTECTION	X64, X65, X69	RELAY
F61	FUSE (25A 250V)	Q3A, Q3B	SWITCHING POWER TRANSISTOR	21S4	REVERSING VALVE COIL
F62	FUSE (15A 250V)	RT61	DEFROST THERMISTOR	26C	COMPRESSOR PROTECTOR
F880, F901	FUSE (T3.15A/250V)	RT62	DISCHARGE TEMP. THERMISTOR		
IC700, IC932	POWER MODULE	RT64	FIN TEMP. THERMISTOR		
L	REACTOR	RT65	AMBIENT TEMP. THERMISTOR		

WALL-MOUNTED WIRING DIAGRAM

MUZ-FT25VGHZ MUZ-FT35VGHZ

OUTDOOR UNIT

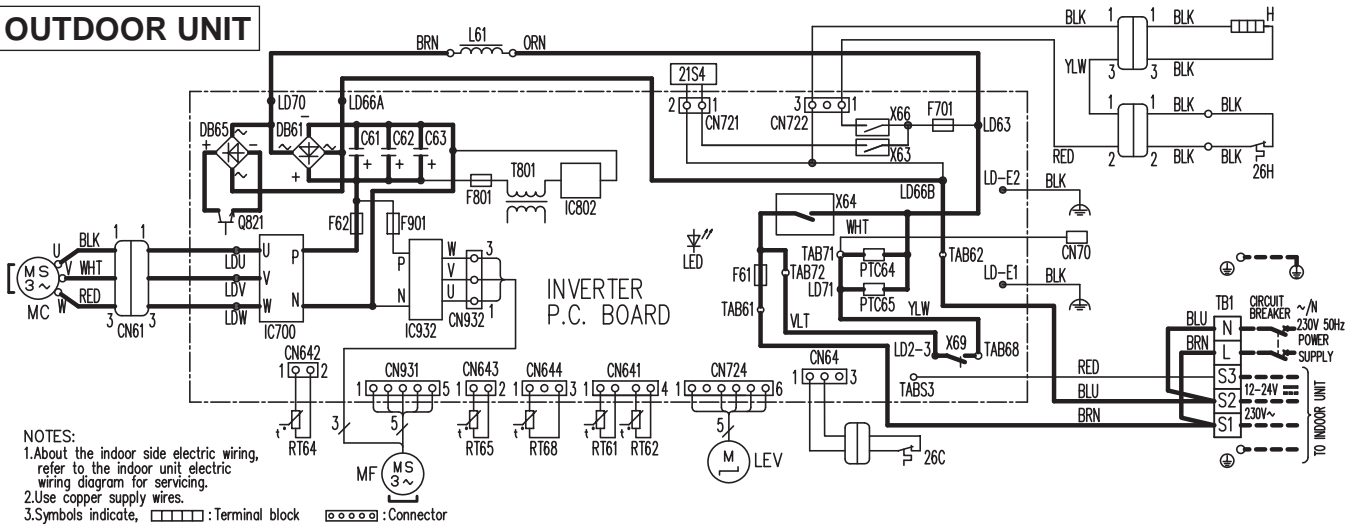

NOTES:
 1.About the indoor side electric wiring, refer to the indoor unit electric wiring diagram for servicing.
 2.Use copper supply wires.
 3.Symbols indicate, □□□□: Terminal block ○○○○○: Connector

SYMBOL	NAME	SYMBOL	NAME	SYMBOL	NAME
CN61	CONNECTOR	LEV	EXPANSION VALVE COIL	RT68	OUTDOOR HEAT EXCHANGER TEMP. THERMISTOR
C61,C62,C63	SMOOTHING CAPACITOR	L61	REACTOR	TB1	TERMINAL BLOCK
DB61,DB65	DIODE MODULE	MC	COMPRESSOR	T801	TRANSFORMER
F61	FUSE (25A 250V)	MF	FAN MOTOR	X63,X64,X66,X69	RELAY
F62	FUSE (15A 250V)	PTC64,PTC65	CIRCUIT PROTECTION	21S4	REVERSING VALVE COIL
F701,F801,F901	FUSE (T3.15A/250V)	Q821	SWITCHING POWER TRANSISTOR	26C	COMPRESSOR PROTECTOR
H	DEFROST HEATER	RT61	DEFROST THERMISTOR	26H	HEATER PROTECTOR
IC700,IC932	POWER MODULE	RT62	DISCHARGE TEMP. THERMISTOR		
IC802	POWER DEVICE	RT64	FIN TEMP. THERMISTOR		
LED	LED	RT65	AMBIENT TEMP. THERMISTOR		

MUZ-FT50VGHZ

OUTDOOR UNIT

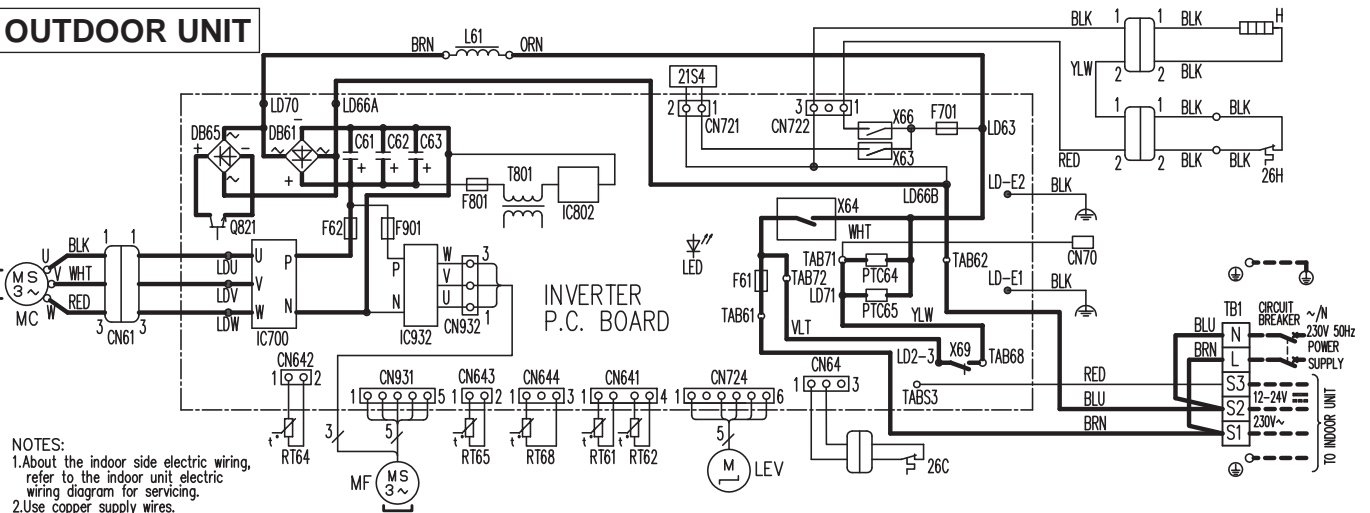

NOTES:
 1.About the indoor side electric wiring, refer to the indoor unit electric wiring diagram for servicing.
 2.Use copper supply wires.
 3.Symbols indicate, □□□□: Terminal block ○○○○○: Connector

SYMBOL	NAME	SYMBOL	NAME	SYMBOL	NAME
CN61	CONNECTOR	LEV	EXPANSION VALVE COIL	RT68	OUTDOOR HEAT EXCHANGER TEMP. THERMISTOR
C61,C62,C63	SMOOTHING CAPACITOR	L61	REACTOR	TB1	TERMINAL BLOCK
DB61,DB65	DIODE MODULE	MC	COMPRESSOR	T801	TRANSFORMER
F61	FUSE (25A 250V)	MF	FAN MOTOR	X63,X64,X66,X69	RELAY
F62	FUSE (15A 250V)	PTC64,PTC65	CIRCUIT PROTECTION	21S4	REVERSING VALVE COIL
F701,F801,F901	FUSE (T3.15A/250V)	Q821	SWITCHING POWER TRANSISTOR	26C	COMPRESSOR PROTECTOR
H	DEFROST HEATER	RT61	DEFROST THERMISTOR	26H	HEATER PROTECTOR
IC700,IC932	POWER MODULE	RT62	DISCHARGE TEMP. THERMISTOR		
IC802	POWER DEVICE	RT64	FIN TEMP. THERMISTOR		
LED	LED	RT65	AMBIENT TEMP. THERMISTOR		

WIRING DIAGRAM

WALL-MOUNTED

MUZ-AY25VG MUZ-AY35VG

OUTDOOR UNIT

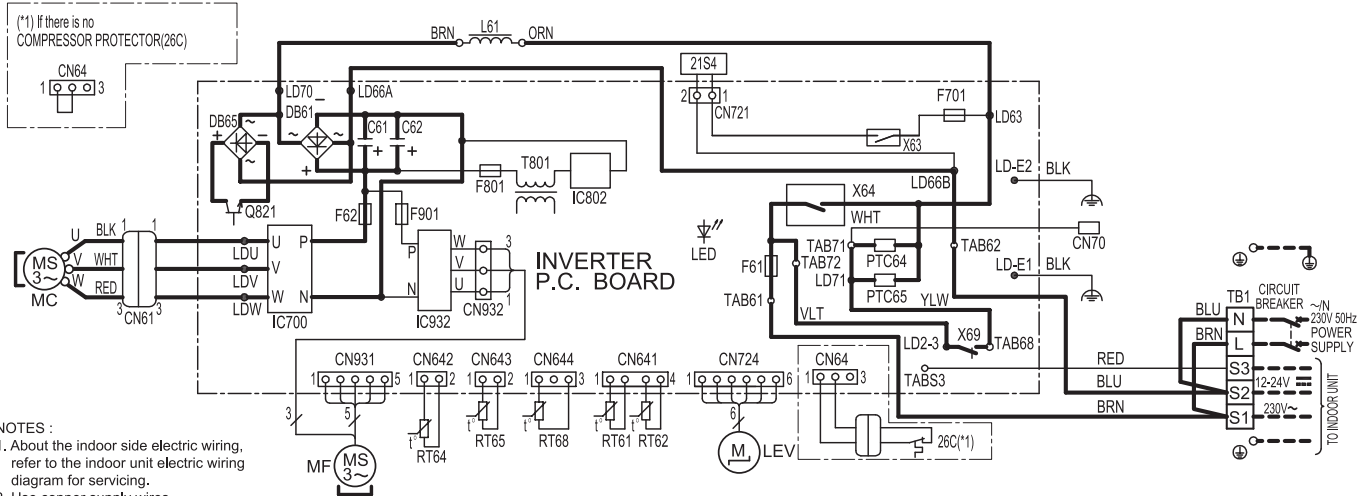

- NOTES :
- About the indoor side electric wiring, refer to the indoor unit electric wiring diagram for servicing.
 - Use copper supply wires.
 - Symbols indicate, □□□□ : Terminal block
○ : Connector

SYMBOL	NAME	SYMBOL	NAME	SYMBOL	NAME
CN61	CONNECTOR	LEV	EXPANSION VALVE COIL	RT65	AMBIENT TEMP. THERMISTOR
C61,C62	SMOOTHING CAPACITOR	L61	REACTOR	RT68	OUTDOOR HEAT EXCHANGER TEMP. THERMISTOR
DB61,DB65	DIODE MODULE	MC	COMPRESSOR	TB1	TERMINAL BLOCK
F61	FUSE (25A 250V)	MF	FAN MOTOR	T801	TRANSFORMER
F62	FUSE (15A 250V)	PTC64,PTC65	CIRCUIT PROTECTION	X63,X64,X69	RELAY
F701,F801,F901	FUSE (T3. 15AL250V)	Q821	SWITCHING POWER TRANSISTOR	21S4	REVERSING VALVE COIL
IC700,IC932	POWER MODULE	RT61	DEFROST THERMISTOR	26C	COMPRESSOR PROTECTOR
IC802	POWER DEVICE	RT62	DISCHARGE TEMP. THERMISTOR		
LED	LED	RT64	FIN TEMP. THERMISTOR		

MUZ-AY25VGH MUZ-AY35VGH

OUTDOOR UNIT

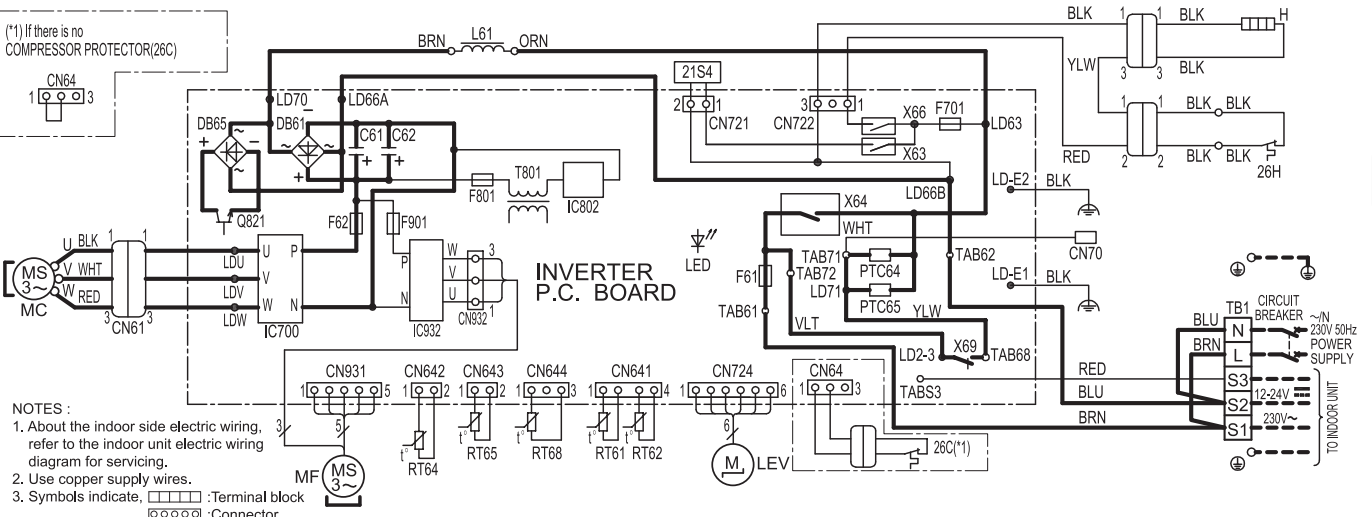

- NOTES :
- About the indoor side electric wiring, refer to the indoor unit electric wiring diagram for servicing.
 - Use copper supply wires.
 - Symbols indicate, □□□□ : Terminal block
○ : Connector

SYMBOL	NAME	SYMBOL	NAME	SYMBOL	NAME
CN61	CONNECTOR	LEV	EXPANSION VALVE COIL	RT68	OUTDOOR HEAT EXCHANGER TEMP. THERMISTOR
C61,C62	SMOOTHING CAPACITOR	L61	REACTOR	TB1	TERMINAL BLOCK
DB61,DB65	DIODE MODULE	MC	COMPRESSOR	T801	TRANSFORMER
F61	FUSE (25A 250V)	MF	FAN MOTOR	X63,X64,X66,X69	RELAY
F62	FUSE (15A 250V)	PTC64,PTC65	CIRCUIT PROTECTION	21S4	REVERSING VALVE COIL
F701,F801,F901	FUSE (T3. 15AL250V)	Q821	SWITCHING POWER TRANSISTOR	26C	COMPRESSOR PROTECTOR
H	DEFROST HEATER	RT61	DEFROST THERMISTOR	26H	HEATER PROTECTOR
IC700,IC932	POWER MODULE	RT62	DISCHARGE TEMP. THERMISTOR		
IC802	POWER DEVICE	RT64	FIN TEMP. THERMISTOR		
LED	LED	RT65	AMBIENT TEMP. THERMISTOR		

WALL-MOUNTED WIRING DIAGRAM

MUZ-AY42VG

OUTDOOR UNIT

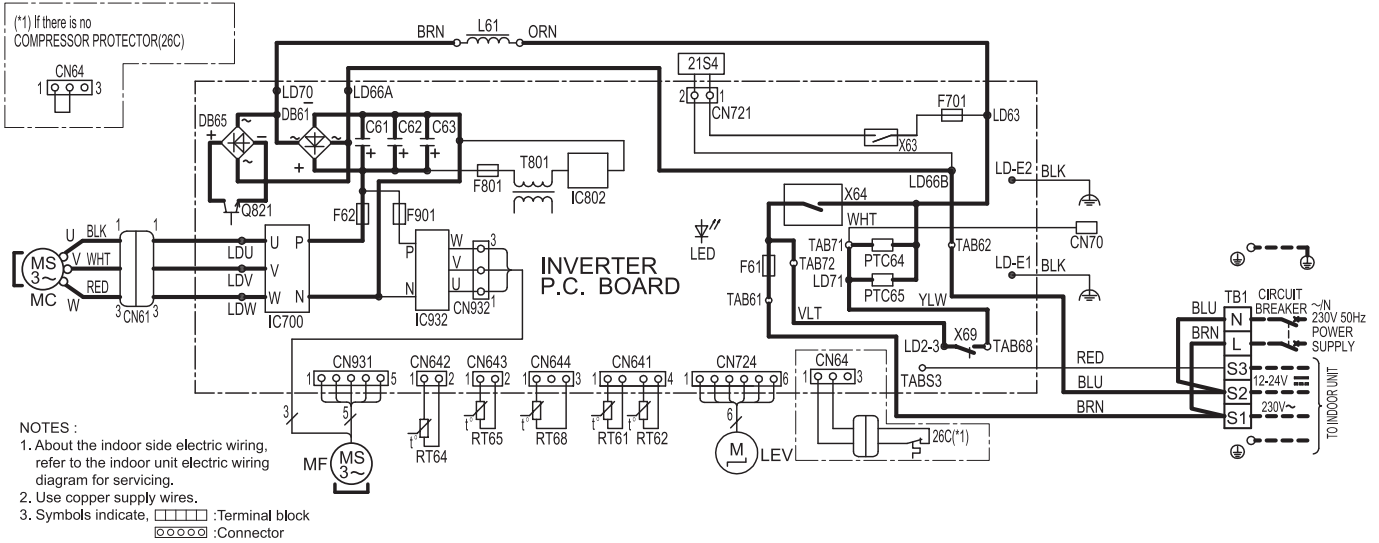

SYMBOL	NAME	SYMBOL	NAME	SYMBOL	NAME
CN61	CONNECTOR	LEV	EXPANSION VALVE COIL	RT65	AMBIENT TEMP. THERMISTOR
C61,C62,C63	SMOOTHING CAPACITOR	L61	REACTOR	RT68	OUTDOOR HEAT EXCHANGER TEMP. THERMISTOR
DB61,DB65	DIODE MODULE	MC	COMPRESSOR	TB1	TERMINAL BLOCK
F61	FUSE (25A 250V)	MF	FAN MOTOR	T801	TRANSFORMER
F62	FUSE (15A 250V)	PTC64,PTC65	CIRCUIT PROTECTION	X63,X64,X69	RELAY
F701,F801,F901	FUSE (T3. 15AL250V)	Q821	SWITCHING POWER TRANSISTOR	21S4	REVERSING VALVE COIL
IC700,IC932	POWER MODULE	RT61	DEFROST THERMISTOR	26C	COMPRESSOR PROTECTOR
IC802	POWER DEVICE	RT62	DISCHARGE TEMP. THERMISTOR		
LED	LED	RT64	FIN TEMP. THERMISTOR		

MUZ-AY42VGH

OUTDOOR UNIT

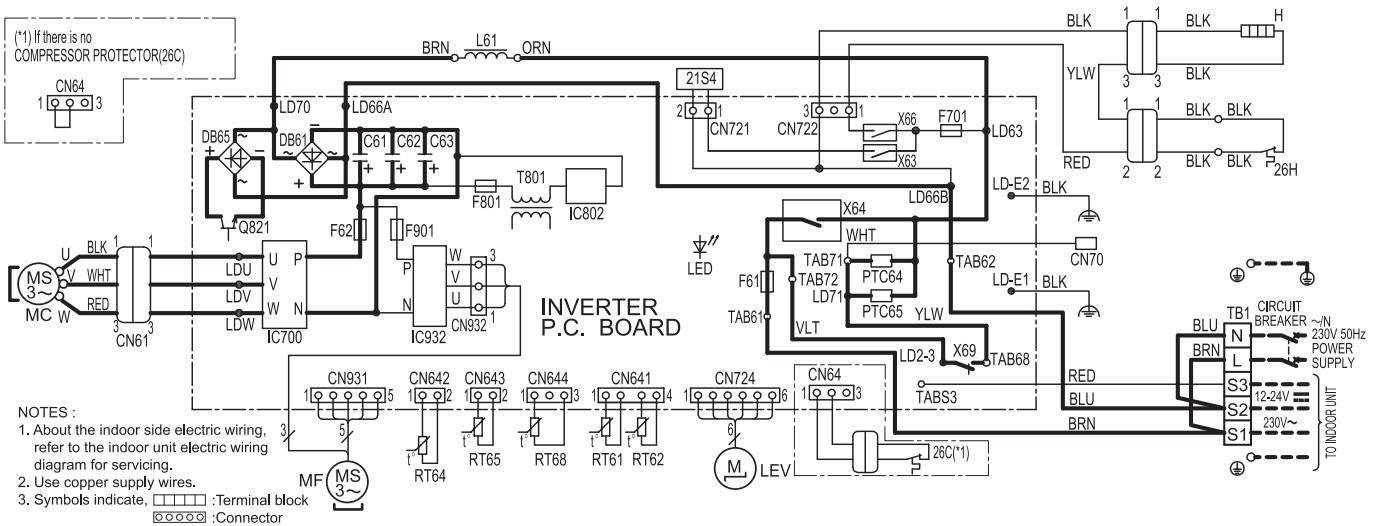

SYMBOL	NAME	SYMBOL	NAME	SYMBOL	NAME
CN61	CONNECTOR	LEV	EXPANSION VALVE COIL	RT68	OUTDOOR HEAT EXCHANGER TEMP. THERMISTOR
C61,C62,C63	SMOOTHING CAPACITOR	L61	REACTOR	TB1	TERMINAL BLOCK
DB61,DB65	DIODE MODULE	MC	COMPRESSOR	T801	TRANSFORMER
F61	FUSE (25A 250V)	MF	FAN MOTOR	X63,X64,X66,X69	RELAY
F62	FUSE (15A 250V)	PTC64,PTC65	CIRCUIT PROTECTION	21S4	REVERSING VALVE COIL
F701,F801,F901	FUSE (T3. 15AL250V)	Q821	SWITCHING POWER TRANSISTOR	26C	COMPRESSOR PROTECTOR
H	DEFROST HEATER	RT61	DEFROST THERMISTOR	26H	HEATER PROTECTOR
IC700,IC932	POWER MODULE	RT62	DISCHARGE TEMP. THERMISTOR		
IC802	POWER DEVICE	RT64	FIN TEMP. THERMISTOR		
LED	LED	RT65	AMBIENT TEMP. THERMISTOR		

WIRING DIAGRAM

WALL-MOUNTED

MUZ-AY50VG

OUTDOOR UNIT

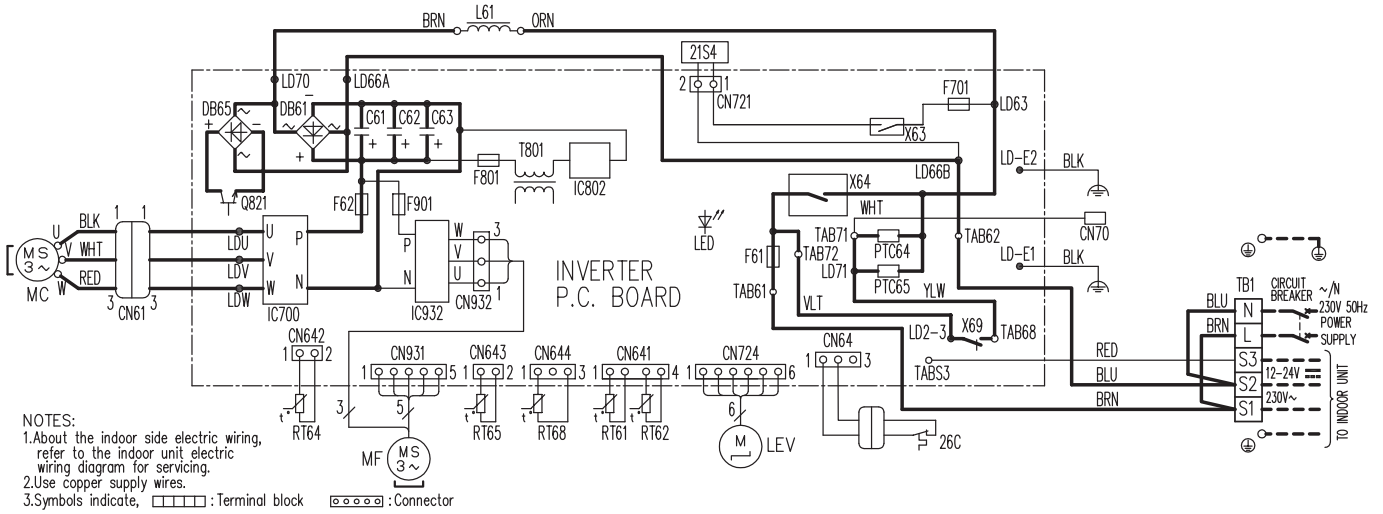

NOTES:
 1.About the indoor side electric wiring, refer to the indoor unit electric wiring diagram for servicing.
 2.Use copper supply wires.
 3.Symbols indicate, : Terminal block : Connector

SYMBOL	NAME	SYMBOL	NAME	SYMBOL	NAME
CN61	CONNECTOR	LEV	EXPANSION VALVE COIL	RT65	AMBIENT TEMP. THERMISTOR
C61, C62, C63	SMOOTHING CAPACITOR	L61	REACTOR	RT68	OUTDOOR HEAT EXCHANGER TEMP. THERMISTOR
DB61, DB65	DIODE MODULE	MC	COMPRESSOR	TB1	TERMINAL BLOCK
F61	FUSE (25A 250V)	MF	FAN MOTOR	T801	TRANSFORMER
F62	FUSE (15A 250V)	PTC64, PTC65	CIRCUIT PROTECTION	X63, X64, X69	RELAY
F701, F801, F901	FUSE (T3.15A/250V)	Q821	SWITCHING POWER TRANSISTOR	21S4	REVERSING VALVE COIL
IC700, IC932	POWER MODULE	RT61	DEFROST THERMISTOR	26C	COMPRESSOR PROTECTOR
IC802	POWER DEVICE	RT62	DISCHARGE TEMP. THERMISTOR		
LED	LED	RT64	FIN TEMP. THERMISTOR		

MUZ-AY50VGH

OUTDOOR UNIT

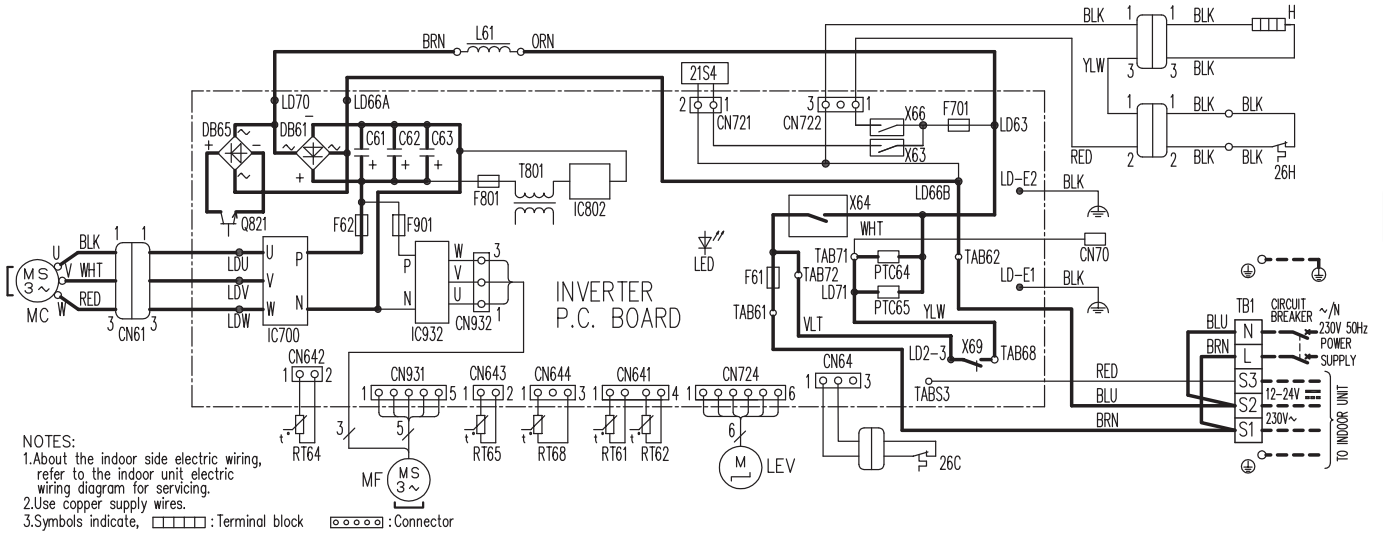

NOTES:
 1.About the indoor side electric wiring, refer to the indoor unit electric wiring diagram for servicing.
 2.Use copper supply wires.
 3.Symbols indicate, : Terminal block : Connector

SYMBOL	NAME	SYMBOL	NAME	SYMBOL	NAME
CN61	CONNECTOR	LEV	EXPANSION VALVE COIL	RT68	OUTDOOR HEAT EXCHANGER TEMP. THERMISTOR
C61, C62, C63	SMOOTHING CAPACITOR	L61	REACTOR	TB1	TERMINAL BLOCK
DB61, DB65	DIODE MODULE	MC	COMPRESSOR	T801	TRANSFORMER
F61	FUSE (25A 250V)	MF	FAN MOTOR	X63, X64, X66, X69	RELAY
F62	FUSE (15A 250V)	PTC64, PTC65	CIRCUIT PROTECTION	21S4	REVERSING VALVE COIL
F701, F801, F901	FUSE (T3.15A/250V)	Q821	SWITCHING POWER TRANSISTOR	26C	COMPRESSOR PROTECTOR
H	DEFROST HEATER	RT61	DEFROST THERMISTOR	26H	HEATER PROTECTOR
IC700, IC932	POWER MODULE	RT62	DISCHARGE TEMP. THERMISTOR		
IC802	POWER DEVICE	RT64	FIN TEMP. THERMISTOR		
LED	LED	RT65	AMBIENT TEMP. THERMISTOR		

WALL-MOUNTED WIRING DIAGRAM

MUZ-AP15VG

OUTDOOR UNIT

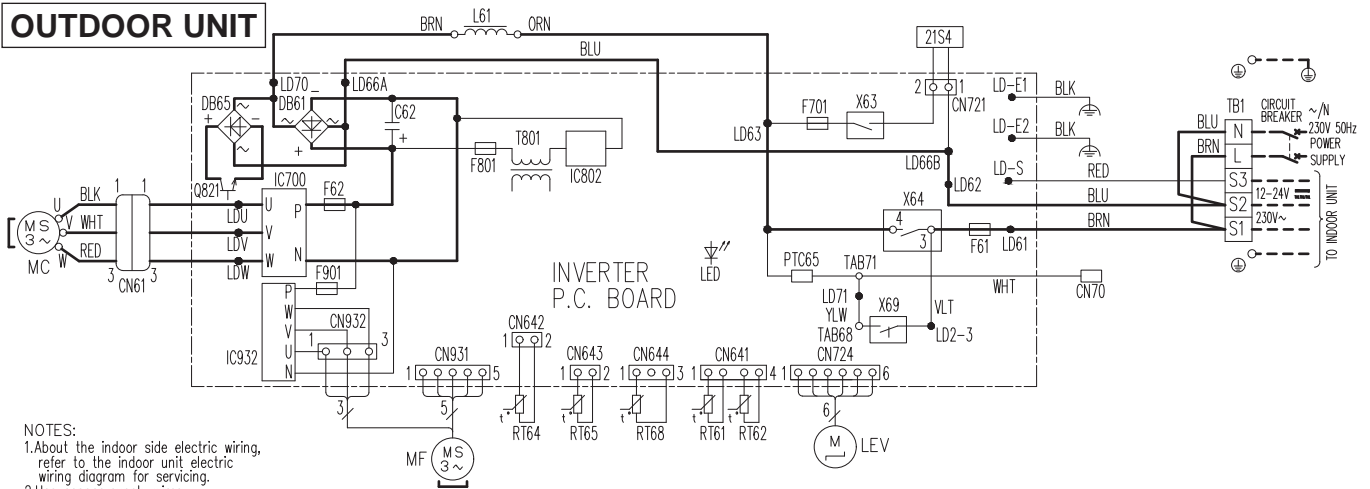

- NOTES:
 1.About the indoor side electric wiring, refer to the indoor unit electric wiring diagram for servicing.
 2.Use copper supply wires.
 3.Symbols indicate, : Terminal block
 : Connector

SYMBOL	NAME	SYMBOL	NAME	SYMBOL	NAME
CN61	CONNECTOR	LEV	EXPANSION VALVE COIL	RT64	FIN TEMP. THERMISTOR
C62	SMOOTHING CAPACITOR	L61	REACTOR	RT65	AMBIENT TEMP. THERMISTOR
DB61, DB65	DIODE MODULE	MC	COMPRESSOR	RT68	OUTDOOR HEAT EXCHANGER TEMP. THERMISTOR
F61, F62	FUSE (15A 250V)	MF	FAN MOTOR	TB1	TERMINAL BLOCK
F701, F801, F901	FUSE (T3.15AL250V)	PTC65	CIRCUIT PROTECTION	T801	TRANSFORMER
IC700, IC932	POWER MODULE	Q821	SWITCHING POWER TRANSISTOR	X63, X64, X69	RELAY
IC802	POWER DEVICE	RT61	DEFROST THERMISTOR	21S4	REVERSING VALVE COIL
LED	LED	RT62	DISCHARGE TEMP. THERMISTOR		

MUZ-AP20VG

OUTDOOR UNIT

WIRING DIAGRAM

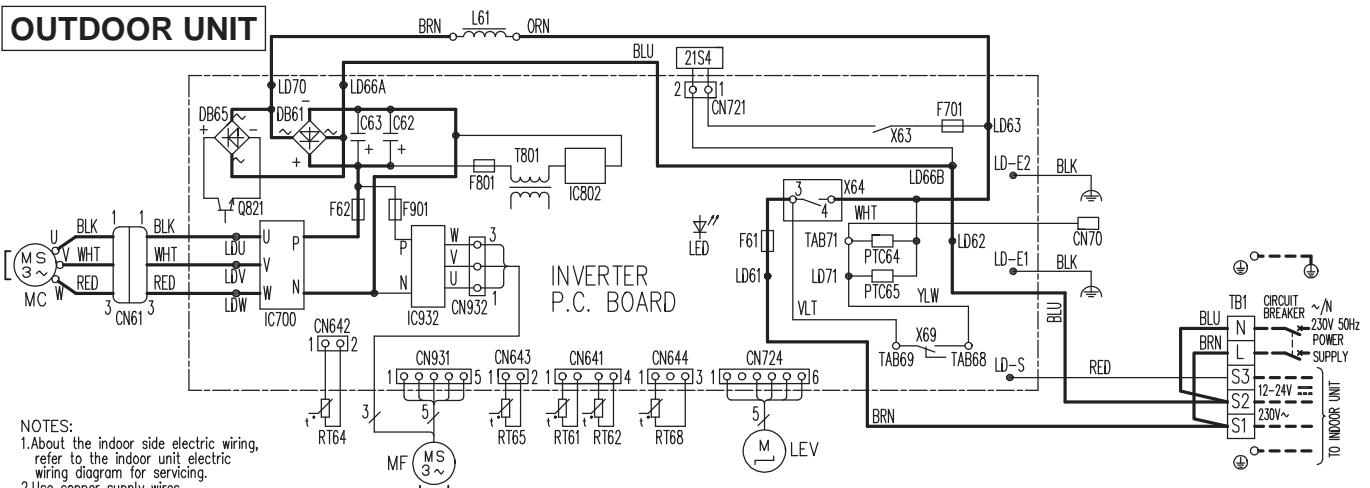

- NOTES:
 1.About the indoor side electric wiring, refer to the indoor unit electric wiring diagram for servicing.
 2.Use copper supply wires.
 3.Symbols indicate, : Terminal block
 : Connector

SYMBOL	NAME	SYMBOL	NAME	SYMBOL	NAME
CN61	CONNECTOR	LEV	EXPANSION VALVE COIL	RT65	AMBIENT TEMP. THERMISTOR
C62, C63	SMOOTHING CAPACITOR	L61	REACTOR	RT68	OUTDOOR HEAT EXCHANGER TEMP. THERMISTOR
DB61, DB65	DIODE MODULE	MC	COMPRESSOR	TB1	TERMINAL BLOCK
F61	FUSE (25A 250V)	MF	FAN MOTOR	T801	TRANSFORMER
F62	FUSE (15A 250V)	PTC64, PTC65	CIRCUIT PROTECTION	X63, X64, X69	RELAY
F701, F801, F901	FUSE (T3.15AL250V)	Q821	SWITCHING POWER TRANSISTOR	21S4	REVERSING VALVE COIL
IC700, IC932	POWER MODULE	RT61	DEFROST THERMISTOR		
IC802	POWER DEVICE	RT62	DISCHARGE TEMP. THERMISTOR		
LED	LED	RT64	FIN TEMP. THERMISTOR		

MUZ-AP60VG

OUTDOOR UNIT

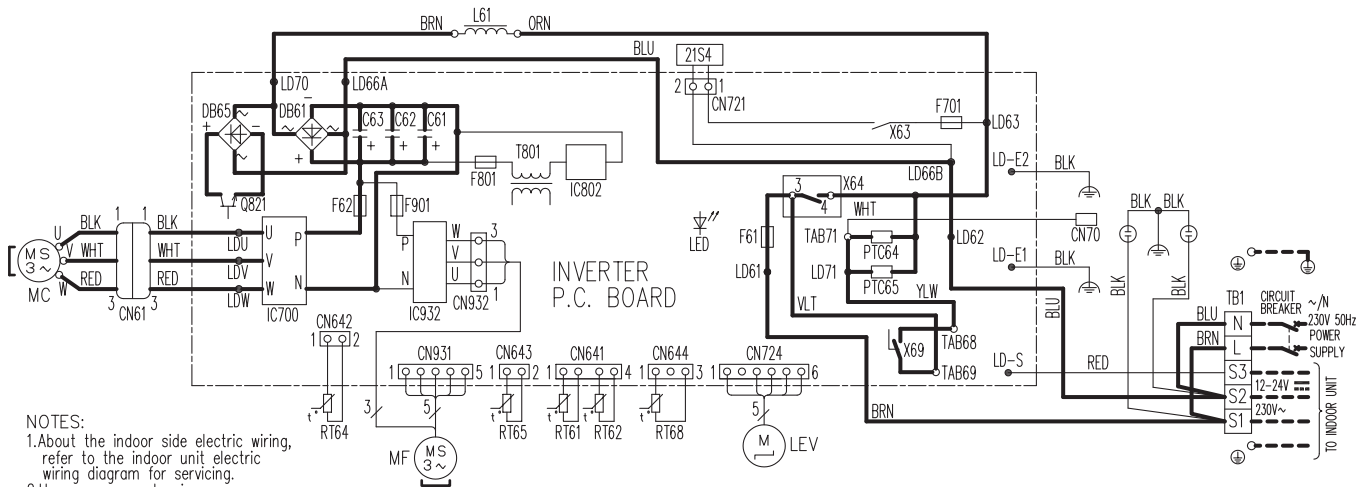

- NOTES:
 1.About the indoor side electric wiring, refer to the indoor unit electric wiring diagram for servicing.
 2.Use copper supply wires.
 3.Symbols indicate, □: Terminal block ○: Connector

SYMBOL	NAME	SYMBOL	NAME	SYMBOL	NAME
CN61	CONNECTOR	LEV	EXPANSION VALVE COIL	RT65	AMBIENT TEMP. THERMISTOR
C61, C62, C63	SMOOTHING CAPACITOR	L61	REACTOR	RT68	OUTDOOR HEAT EXCHANGER TEMP. THERMISTOR
DB61, DB65	DIODE MODULE	MC	COMPRESSOR	TB1	TERMINAL BLOCK
F61	FUSE (25A 250V)	MF	FAN MOTOR	T801	TRANSFORMER
F62	FUSE (15A 250V)	PTC64, PTC65	CIRCUIT PROTECTION	X63, X64, X69	RELAY
F701, F801, F901	FUSE (T3.15AL250V)	Q821	SWITCHING POWER TRANSISTOR	21S4	REVERSING VALVE COIL
IC700, IC932	POWER MODULE	RT61	DEFROST THERMISTOR		
IC802	POWER DEVICE	RT62	DISCHARGE TEMP. THERMISTOR		
LED	LED	RT64	FIN TEMP. THERMISTOR		

MUZ-AP71VG

OUTDOOR UNIT

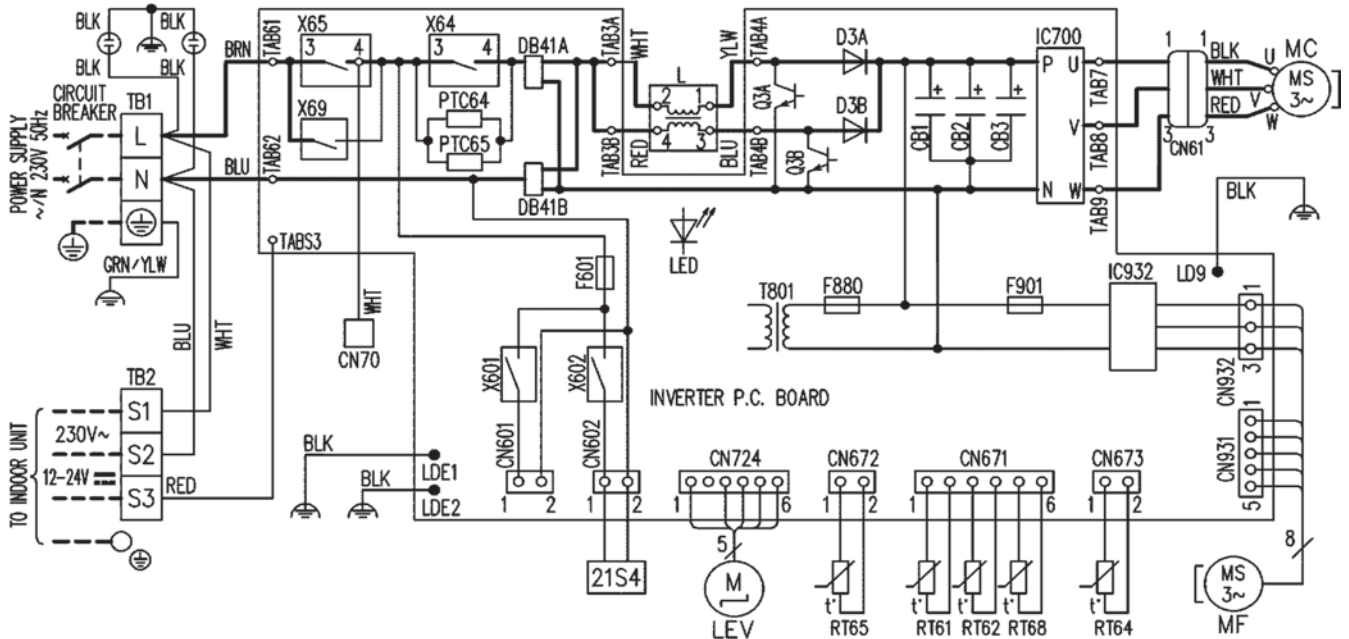

SYMBOL	NAME	SYMBOL	NAME	SYMBOL	NAME	SYMBOL	NAME
CN61	CONNECTOR	L	REACTOR	RT61	DEFROST THERMISTOR	T801	TRANSFORMER
CB1, CB2, CB3	SMOOTHING CAPACITOR	LED	LED	RT62	DISCHARGE TEMP.THERMISTOR	X64, X65, X69	RELAY
DB41A, DB41B	DIODE MODULE	LEV	EXPANSION VALVE COIL	RT64	FIN TEMP.THERMISTOR	X601, X602	RELAY
D3A, D3B	DIODE	MC	COMPRESSOR	RT65	AMBIENT TEMP.THERMISTOR	21S4	REVERSING VALVE COIL
F601	FUSE (T3.15AL250V)	MF	FAN MOTOR	RT68	OUTDOOR HEAT EXCHANGER TEMP.THERMISTOR	TB1, TB2	TERMINAL BLOCK
F880	FUSE (T3.15AL250V)	PTC64, PTC65	CIRCUIT PROTECTION	Q3A, Q3B	SWITCHING POWER TRANSISTOR		
F901	FUSE (T3.15AL250V)	IC700, IC932	POWER MODULE				

- NOTES 1.About the indoor side electric wiring, refer to the indoor unit electric wiring diagram for servicing.
 2.Use copper supply wires. 3.Symbols indicate, □: Terminal block ○: Connector

WALL-MOUNTED WIRING DIAGRAM

MUZ-HR25VF MUZ-HR35VF

OUTDOOR UNIT

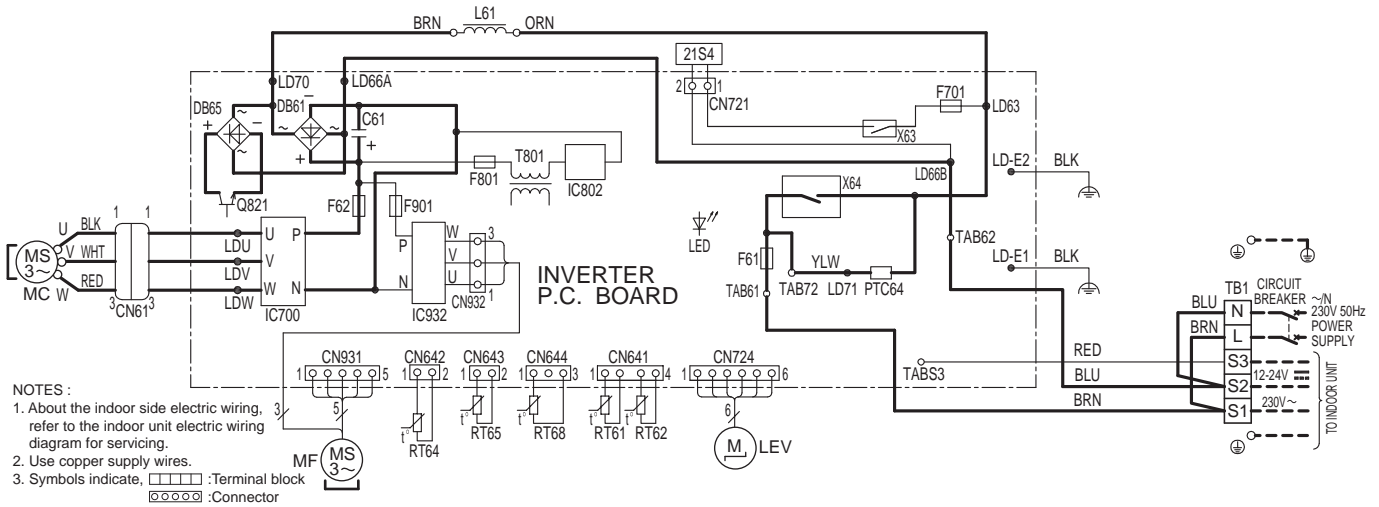

SYMBOL	NAME	SYMBOL	NAME	SYMBOL	NAME
CN61	CONNECTOR	LEV	EXPANSION VALVE COIL	RT64	FIN TEMP. THERMISTOR
C61	SMOOTHING CAPACITOR	L61	REACTOR	RT65	AMBIENT TEMP. THERMISTOR
DB61, DB65	DIODE MODULE	MC	COMPRESSOR	RT68	OUTDOOR HEAT EXCHANGER TEMP. THERMISTOR
F61, F62	FUSE (15A 250V)	MF	FAN MOTOR	TB1	TERMINAL BLOCK
F701, F801, F901	FUSE (T3. 15AL250V)	PTC64	CIRCUIT PROTECTION	T801	TRANSFORMER
IC700, IC932	POWER MODULE	Q821	SWITCHING POWER TRANSISTOR	X63, X64	RELAY
IC802	POWER DEVICE	RT61	DEFROST THERMISTOR	21S4	REVERSING VALVE COIL
LED	LED	RT62	DISCHARGE TEMP. THERMISTOR		

MUZ-HR42VF MUZ-HR50VF

OUTDOOR UNIT

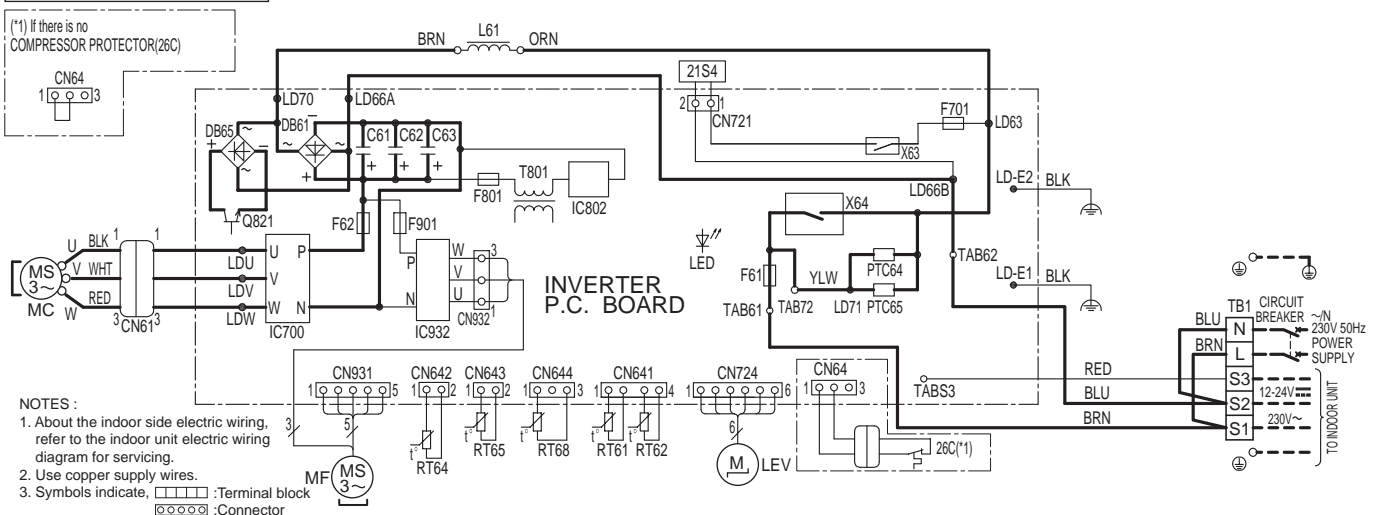

SYMBOL	NAME	SYMBOL	NAME	SYMBOL	NAME
CN61	CONNECTOR	LEV	EXPANSION VALVE COIL	RT65	AMBIENT TEMP. THERMISTOR
C61, C62, C63	SMOOTHING CAPACITOR	L61	REACTOR	RT68	OUTDOOR HEAT EXCHANGER TEMP. THERMISTOR
DB61, DB65	DIODE MODULE	MC	COMPRESSOR	TB1	TERMINAL BLOCK
F61	FUSE (25A 250V)	MF	FAN MOTOR	T801	TRANSFORMER
F62	FUSE (15A 250V)	PTC64, PTC65	CIRCUIT PROTECTION	X63, X64	RELAY
F701, F801, F901	FUSE (T3. 15AL250V)	Q821	SWITCHING POWER TRANSISTOR	21S4	REVERSING VALVE COIL
IC700, IC932	POWER MODULE	RT61	DEFROST THERMISTOR	26C	COMPRESSOR PROTECTOR
IC802	POWER DEVICE	RT62	DISCHARGE TEMP. THERMISTOR		
LED	LED	RT64	FIN TEMP. THERMISTOR		

WIRING DIAGRAM

WALL-MOUNTED

MUZ-HR60VF MUZ-HR71VF

OUTDOOR UNIT

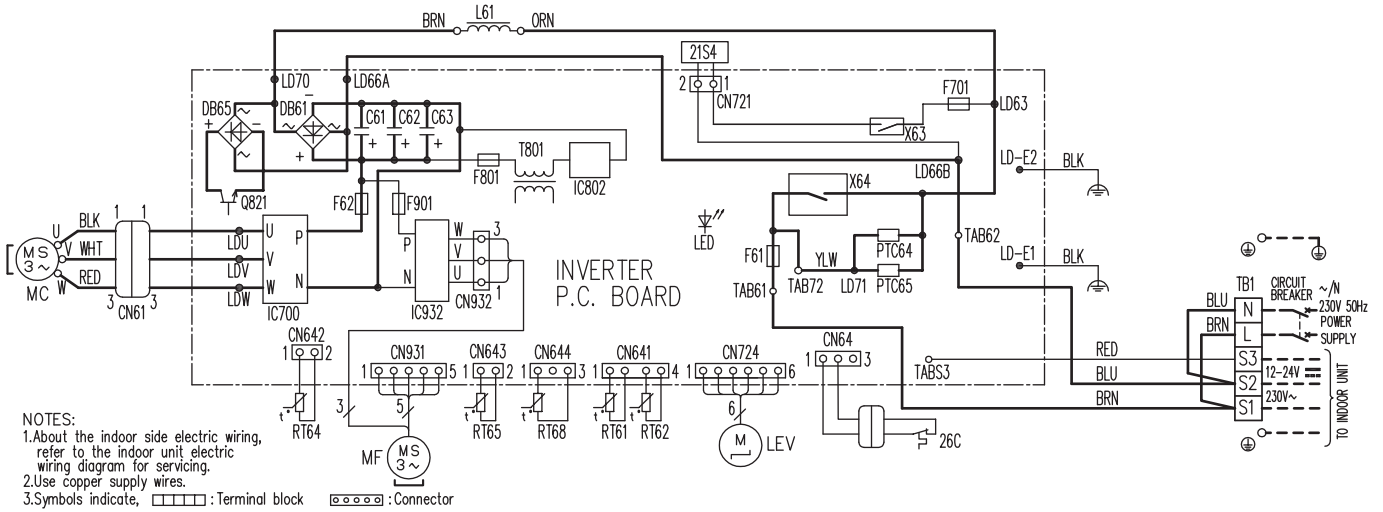

SYMBOL	NAME	SYMBOL	NAME	SYMBOL	NAME
CN61	CONNECTOR	LEV	EXPANSION VALVE COIL	RT65	AMBIENT TEMP. THERMISTOR
C61, C62, C63	SMOOTHING CAPACITOR	L61	REACTOR	RT68	OUTDOOR HEAT EXCHANGER TEMP. THERMISTOR
DB61, DB65	DIODE MODULE	MC	COMPRESSOR	TB1	TERMINAL BLOCK
F61	FUSE (25A 250V)	MF	FAN MOTOR	T801	TRANSFORMER
F62	FUSE (15A 250V)	PTC64, PTC65	CIRCUIT PROTECTION	X63, X64	RELAY
F701, F801, F901	FUSE (T3.15A/250V)	Q821	SWITCHING POWER TRANSISTOR	21S4	REVERSING VALVE COIL
IC700, IC932	POWER MODULE	RT61	DEFROST THERMISTOR	26C	COMPRESSOR PROTECTOR
IC802	POWER DEVICE	RT62	DISCHARGE TEMP. THERMISTOR		
LED	LED	RT64	FIN TEMP. THERMISTOR		

MUY-TP35VF MUY-TP50VF

OUTDOOR UNIT

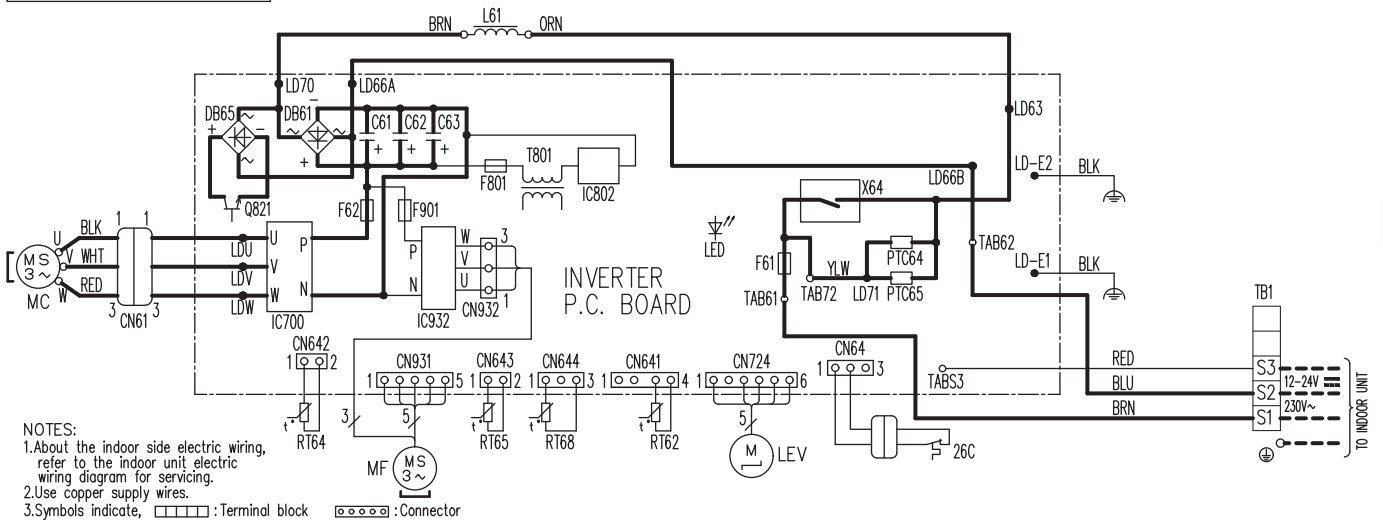

SYMBOL	NAME	SYMBOL	NAME	SYMBOL	NAME
CN61	CONNECTOR	L61	REACTOR	TB1	TERMINAL BLOCK
C61, C62, C63	SMOOTHING CAPACITOR	MC	COMPRESSOR	T801	TRANSFORMER
DB61, DB65	DIODE MODULE	MF	FAN MOTOR	X64	RELAY
F61	FUSE (25A 250V)	PTC64, PTC65	CIRCUIT PROTECTION	26C	COMPRESSOR PROTECTOR
F62	FUSE (15A 250V)	Q821	SWITCHING POWER TRANSISTOR		
F701, F801, F901	FUSE (T3.15A/250V)	RT62	DISCHARGE TEMP. THERMISTOR		
IC700, IC932	POWER MODULE	RT64	FIN TEMP. THERMISTOR		
IC802	POWER DEVICE	RT65	AMBIENT TEMP. THERMISTOR		
LED	LED	RT68	OUTDOOR HEAT EXCHANGER TEMP. THERMISTOR		
LEV	EXPANSION VALVE COIL				

WALL-MOUNTED WIRING DIAGRAM

MUZ-FH25VE MUZ-FH35VE

OUTDOOR UNIT

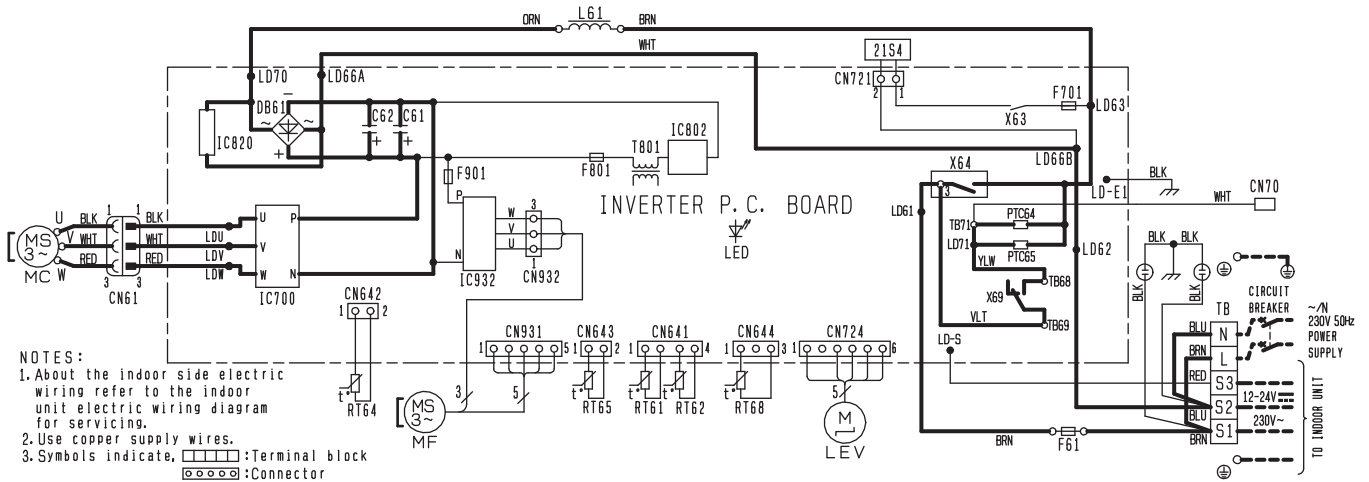

- NOTES:
1. About the indoor side electric wiring refer to the indoor unit electric wiring diagram for servicing.
 2. Use copper supply wires.
 3. Symbols indicate,

SYMBOL	NAME	SYMBOL	NAME	SYMBOL	NAME
CN70	CONNECTOR	LEV	EXPANSION VALVE COIL	RT65	AMBIENT TEMP. THERMISTOR
C61, C62	SMOOTHING CAPACITOR	L61	REACTOR	RT68	OUTDOOR HEAT EXCHANGER TEMP. THERMISTOR.
DB61	DIODE MODULE	MC	COMPRESSOR	TB	TERMINAL BLOCK
F61	FUSE (T20AL250V)	MF	FAN MOTOR	T801	TRANSFORMER
F701, F801, F901	FUSE (T3. 15AL250V)	PTC64, PTC65	CIRCUIT PROTECTION	X63, X64, X69	RELAY
IC700, IC820, IC932	POWER MODULE	RT61	DEFROST THERMISTOR	21S4	REVERSING VALVE COIL
IC802	POWER DEVICE	RT62	DISCHARGE TEMP. THERMISTOR		
LED	LED	RT64	FIN TEMP. THERMISTOR		

MUZ-FH25VEHZ MUZ-FH35VEHZ

OUTDOOR UNIT

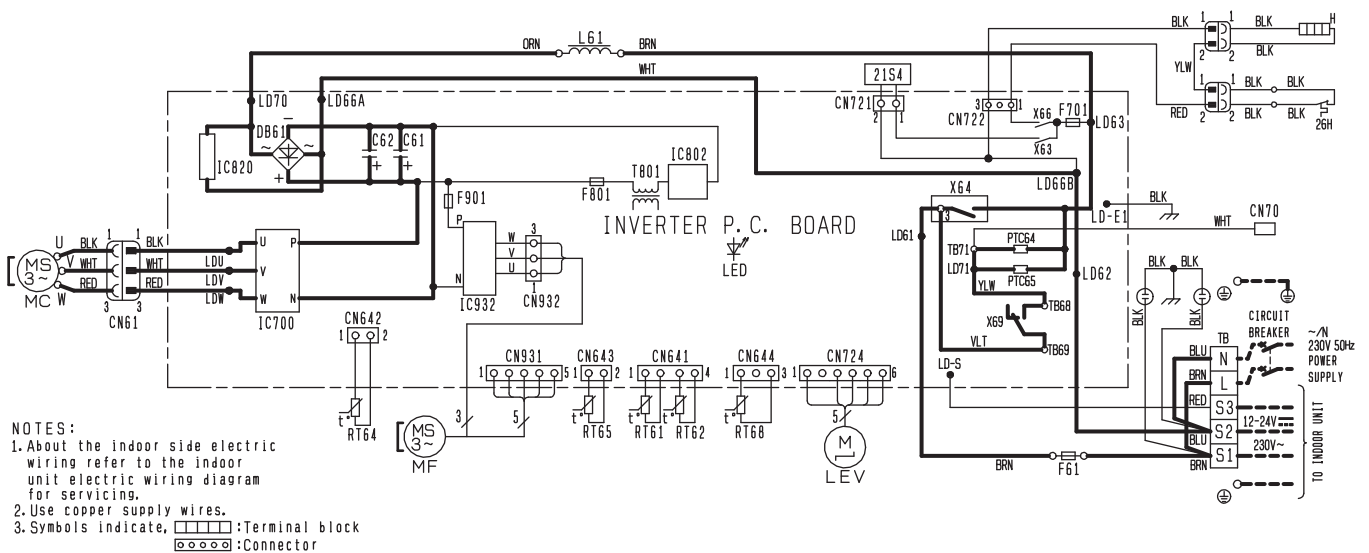

- NOTES:
1. About the indoor side electric wiring refer to the indoor unit electric wiring diagram for servicing.
 2. Use copper supply wires.
 3. Symbols indicate,

SYMBOL	NAME	SYMBOL	NAME	SYMBOL	NAME
CN70	CONNECTOR	LEV	EXPANSION VALVE COIL	RT68	OUTDOOR HEAT EXCHANGER TEMP. THERMISTOR.
C61, C62	SMOOTHING CAPACITOR	L61	REACTOR	TB	TERMINAL BLOCK
DB61	DIODE MODULE	MC	COMPRESSOR	T801	TRANSFORMER
F61	FUSE (T20AL250V)	MF	FAN MOTOR	X63, X64	RELAY
F701, F801, F901	FUSE (T3. 15AL250V)	PTC64, PTC65	CIRCUIT PROTECTION	X66, X69	RELAY
H	DEFROST HEATER	RT61	DEFROST THERMISTOR	21S4	REVERSING VALVE COIL
IC700, IC820, IC932	POWER MODULE	RT62	DISCHARGE TEMP. THERMISTOR	26H	HEATER PROTECTOR
IC802	POWER DEVICE	RT64	FIN TEMP. THERMISTOR		
LED	LED	RT65	AMBIENT TEMP. THERMISTOR		

WIRING DIAGRAM WALL-MOUNTED

MUZ-FH50VE
OUTDOOR UNIT

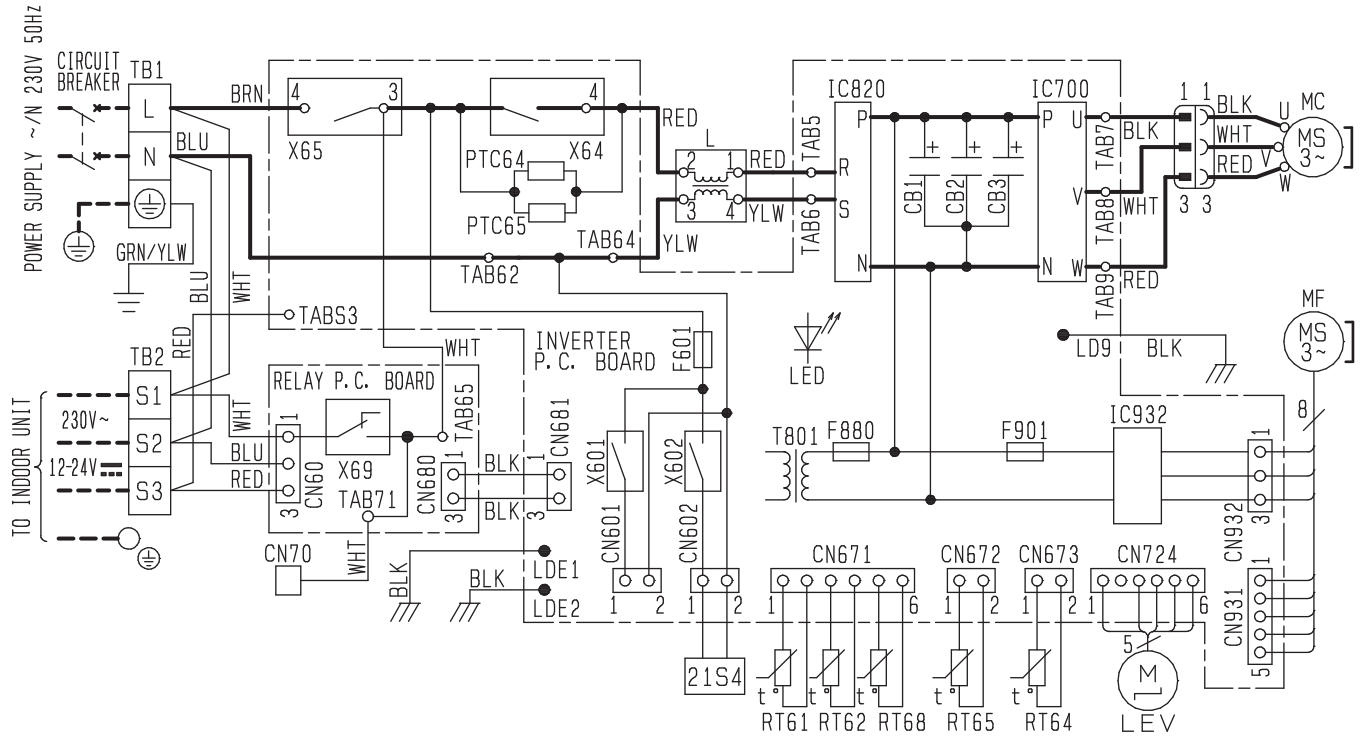

SYMBOL	NAME	SYMBOL	NAME	SYMBOL	NAME	SYMBOL	NAME
CB1 ~ 3	SMOOTHING CAPACITOR	L	REACTOR	RT62	DISCHARGE TEMP. THERMISTOR	X602	RELAY
CN70	CONNECTOR	LED	LED	RT64	FIN TEMP. THERMISTOR	X64	RELAY
F601	FUSE (T3. 15AL250V)	LEV	EXPANSION VALVE COIL	RT65	AMBIENT TEMP. THERMISTOR	X65	RELAY
F880	FUSE (T3. 15AL250V)	MC	COMPRESSOR	RT68	OUTDOOR HEAT EXCHANGER TEMP. THERMISTOR	X69	RELAY
F901	FUSE (T3. 15AL250V)	MF	FAN MOTOR	21S4	REVERSING VALVE COIL		
IC700	IGBT Module	PTC64	CIRCUIT PROTECTION	TB1, TB2	TERMINAL BLOCK		
IC820	DIODE Module	PTC65	CIRCUIT PROTECTION	T801	TRANSFORMER		
IC932	IGBT Module	RT61	DEFROST THERMISTOR	X601	RELAY		

NOTES 1. About the indoor side electric wiring, refer to the indoor unit electric wiring diagram for servicing.
2. Use copper conductors only (for field wiring). 3. Symbols indicate, : Terminal block

WIRING DIAGRAM

WALL-MOUNTED

MUZ-FH50VEHZ
OUTDOOR UNIT

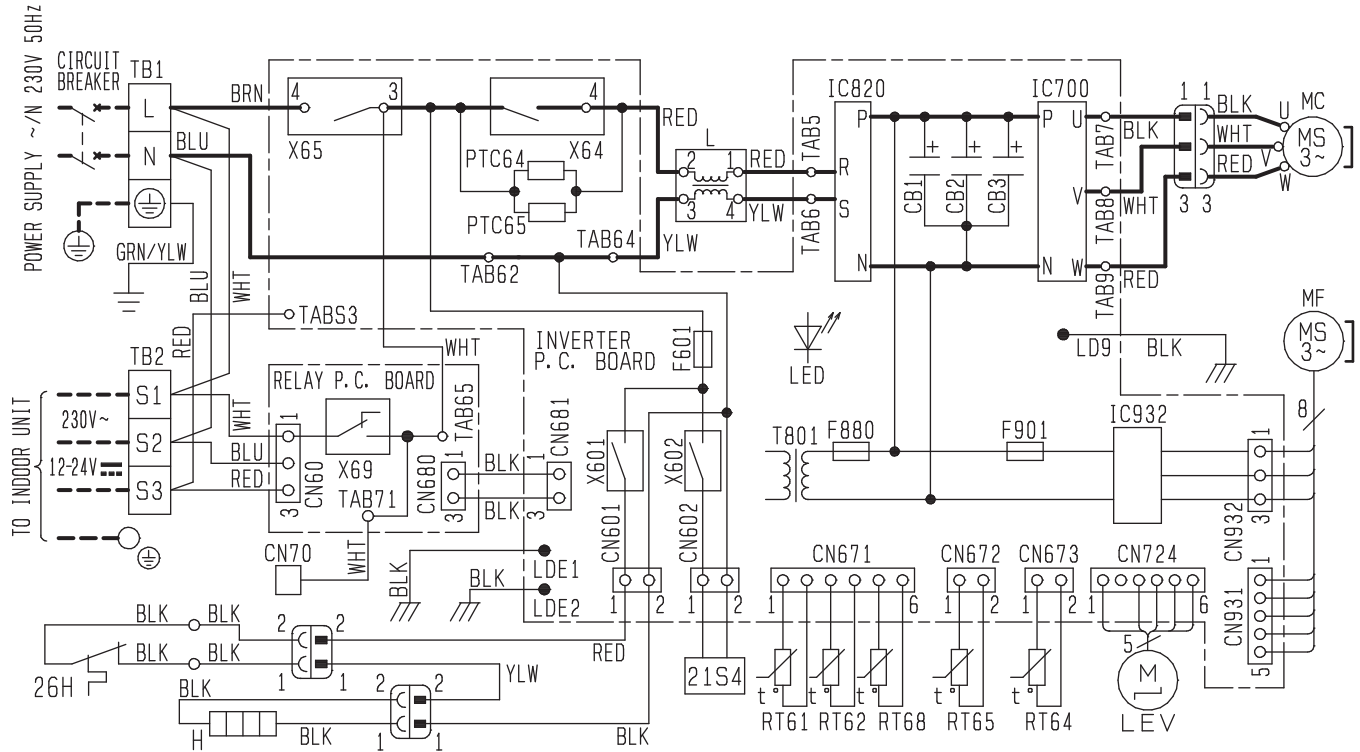

SYMBOL	NAME	SYMBOL	NAME	SYMBOL	NAME	SYMBOL	NAME
CB1~3	SMOOTHING CAPACITOR	IC932	IGBT Module	RT61	DEFROST THERMISTOR	X601	RELAY
CN70	CONNECTOR	L	REACTOR	RT62	DISCHARGE TEMP. THERMISTOR	X602	RELAY
F601	FUSE (T3. 15AL250V)	LED	LED	RT64	FIN TEMP. THERMISTOR	X64	RELAY
F880	FUSE (T3. 15AL250V)	LEV	EXPANSION VALVE COIL	RT65	AMBIENT TEMP. THERMISTOR	X65	RELAY
F901	FUSE (T3. 15AL250V)	MC	COMPRESSOR	RT68	OUTDOOR HEAT EXCHANGER TEMP. THERMISTOR	X69	RELAY
H	DEFROST HEATER	MF	FAN MOTOR	21S4	REVERSING VALVE COIL		
IC700	IGBT Module	PTC64	CIRCUIT PROTECTION	TB1, TB2	TERMINAL BLOCK	26H	HEATER PROTECTOR
IC820	DIODE Module	PTC65	CIRCUIT PROTECTION	T801	TRANSFORMER		

NOTES 1. About the indoor side electric wiring, refer to the indoor unit electric wiring diagram for servicing.
2. Use copper conductors only (for field wiring). 3. Symbols indicate, : terminal block

WIRING DIAGRAM

WALL-MOUNTED

MUZ-EF25VG MUZ-EF35VG

OUTDOOR UNIT

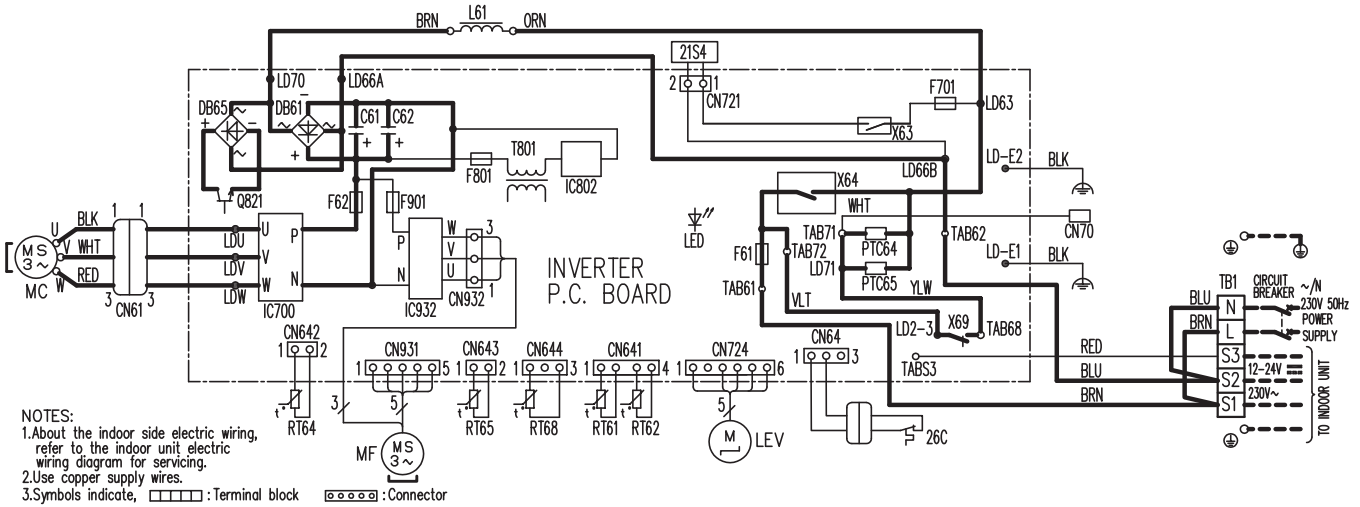

NOTES:
 1.About the indoor side electric wiring, refer to the indoor unit electric wiring diagram for servicing.
 2.Use copper supply wires.
 3.Symbols indicate, : Terminal block : Connector

SYMBOL	NAME	SYMBOL	NAME	SYMBOL	NAME
CN61	CONNECTOR	LEV	EXPANSION VALVE COIL	RT65	AMBIENT TEMP. THERMISTOR
C61, C62	SMOOTHING CAPACITOR	L61	REACTOR	RT68	OUTDOOR HEAT EXCHANGER TEMP. THERMISTOR
DB61, DB65	DIODE MODULE	MC	COMPRESSOR	TB1	TERMINAL BLOCK
F61	FUSE (25A 250V)	MF	FAN MOTOR	T801	TRANSFORMER
F62	FUSE (15A 250V)	PTC64, PTC65	CIRCUIT PROTECTION	X63, X64, X69	RELAY
F701, F801, F901	FUSE (T3.15A/250V)	Q821	SWITCHING POWER TRANSISTOR	21S4	REVERSING VALVE COIL
IC700, IC932	POWER MODULE	RT61	DEFROST THERMISTOR	26C	COMPRESSOR PROTECTOR
IC802	POWER DEVICE	RT62	DISCHARGE TEMP. THERMISTOR		
LED	LED	RT64	FIN TEMP. THERMISTOR		

MUZ-EF25VGH MUZ-EF35VGH

OUTDOOR UNIT

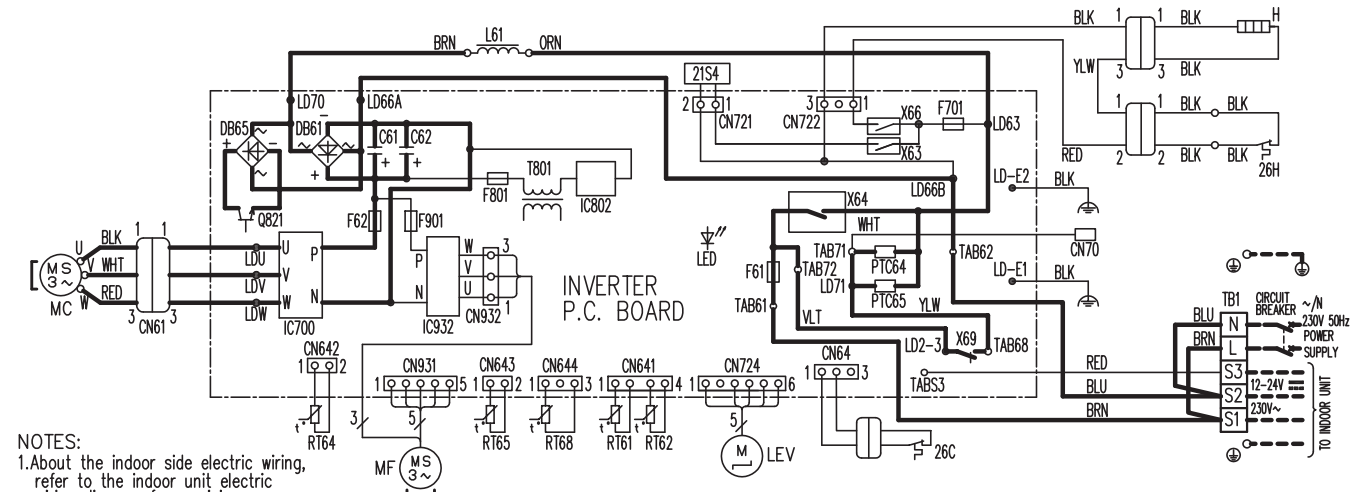

NOTES:
 1.About the indoor side electric wiring, refer to the indoor unit electric wiring diagram for servicing.
 2.Use copper supply wires.
 3.Symbols indicate, : Terminal block : Connector

SYMBOL	NAME	SYMBOL	NAME	SYMBOL	NAME
CN61	CONNECTOR	LEV	EXPANSION VALVE COIL	RT68	OUTDOOR HEAT EXCHANGER TEMP. THERMISTOR
C61, C62	SMOOTHING CAPACITOR	L61	REACTOR	TB1	TERMINAL BLOCK
DB61, DB65	DIODE MODULE	MC	COMPRESSOR	T801	TRANSFORMER
F61	FUSE (25A 250V)	MF	FAN MOTOR	X63, X64, X66, X69	RELAY
F62	FUSE (15A 250V)	PTC64, PTC65	CIRCUIT PROTECTION	21S4	REVERSING VALVE COIL
F701, F801, F901	FUSE (T3.15A/250V)	Q821	SWITCHING POWER TRANSISTOR	26C	COMPRESSOR PROTECTOR
H	DEFROST HEATER	RT61	DEFROST THERMISTOR	26H	HEATER PROTECTOR
IC700, IC932	POWER MODULE	RT62	DISCHARGE TEMP. THERMISTOR		
IC802	POWER DEVICE	RT64	FIN TEMP. THERMISTOR		
LED	LED	RT65	AMBIENT TEMP. THERMISTOR		

WALL-MOUNTED WIRING DIAGRAM

MUZ-EF42VG MUZ-EF50VG

OUTDOOR UNIT

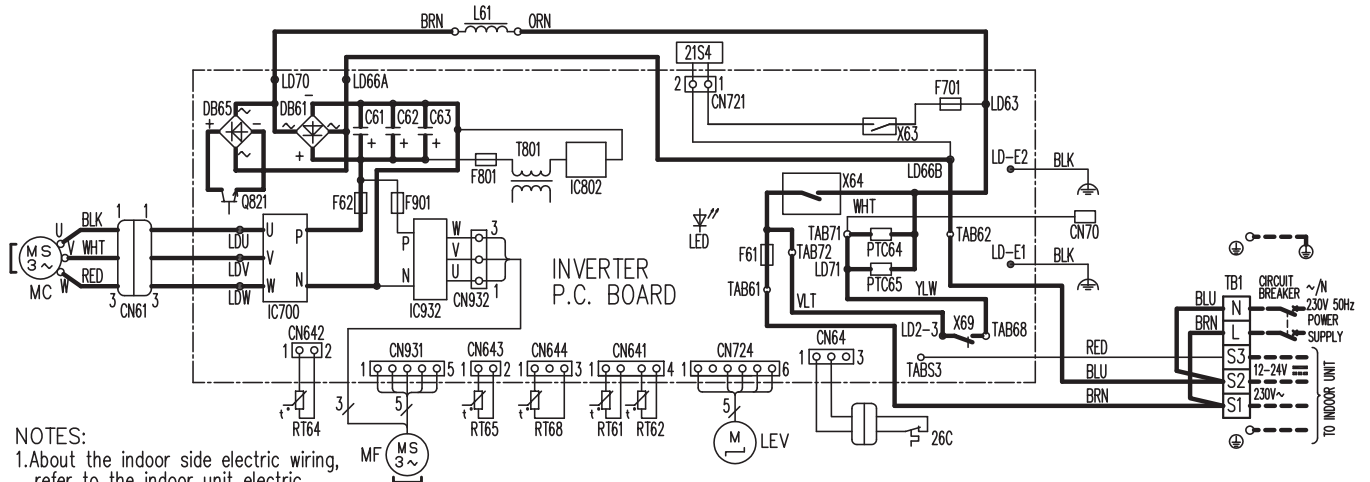

NOTES:

- About the indoor side electric wiring, refer to the indoor unit electric wiring diagram for servicing.
- Use copper supply wires.
- Symbols indicate, : Terminal block : Connector

SYMBOL	NAME	SYMBOL	NAME	SYMBOL	NAME
CN61	CONNECTOR	LEV	EXPANSION VALVE COIL	RT65	AMBIENT TEMP. THERMISTOR
C61,C62,C63	SMOOTHING CAPACITOR	L61	REACTOR	RT68	OUTDOOR HEAT EXCHANGER TEMP. THERMISTOR
DB61,DB65	DIODE MODULE	MC	COMPRESSOR	TB1	TERMINAL BLOCK
F61	FUSE (25A 250V)	MF	FAN MOTOR	T801	TRANSFORMER
F62	FUSE (15A 250V)	PTC64,PTC65	CIRCUIT PROTECTION	X63,X64,X69	RELAY
F701,F801,F901	FUSE (T3.15A/250V)	Q821	SWITCHING POWER TRANSISTOR	21S4	REVERSING VALVE COIL
IC700,IC932	POWER MODULE	RT61	DEFROST THERMISTOR	26C	COMPRESSOR PROTECTOR
IC802	POWER DEVICE	RT62	DISCHARGE TEMP. THERMISTOR		
LED	LED	RT64	FIN TEMP. THERMISTOR		

MUZ-BT20VG MUZ-BT25VG MUZ-BT35VG

OUTDOOR UNIT

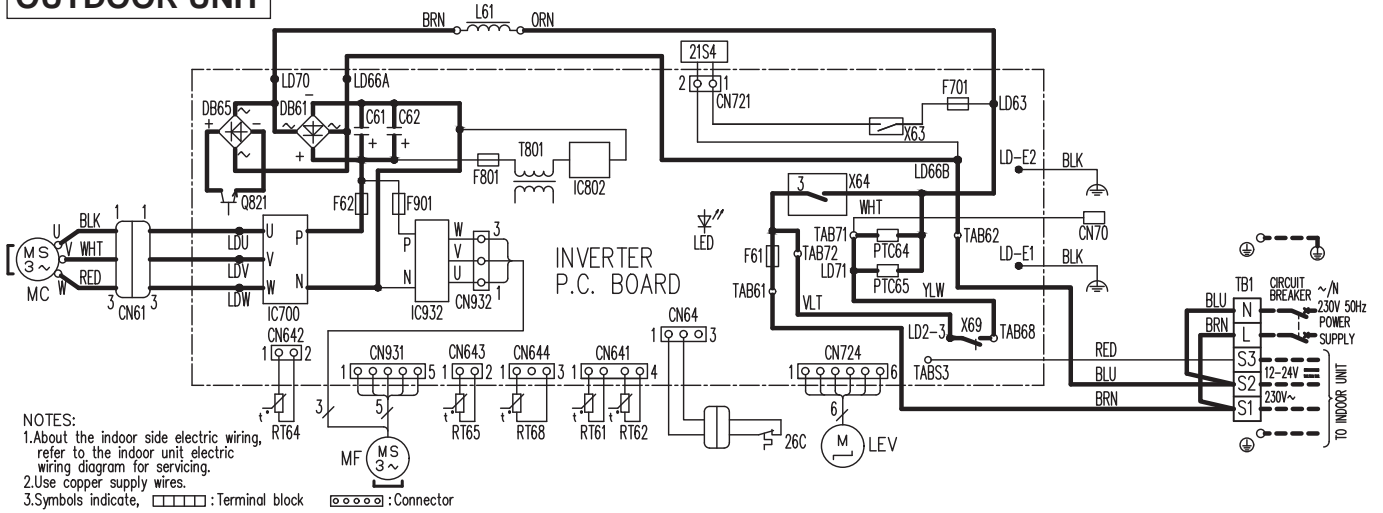

SYMBOL	NAME	SYMBOL	NAME	SYMBOL	NAME
CN61	CONNECTOR	L61	REACTOR	RT65	AMBIENT TEMP. THERMISTOR
C61,C62	SMOOTHING CAPACITOR	MC	COMPRESSOR	RT68	OUTDOOR HEAT EXCHANGER TEMP. THERMISTOR
DB61,DB65	DIODE MODULE	MF	FAN MOTOR	TB1	TERMINAL BLOCK
F61,F62	FUSE (15A 250V)	PTC64,PTC65	CIRCUIT PROTECTION	T801	TRANSFORMER
F701,F801,F901	FUSE (T3.15AL250V)	Q821	SWITCHING POWER TRANSISTOR	X63,X64,X69	RELAY
IC700,IC932	POWER MODULE	RT61	DEFROST THERMISTOR	21S4	REVERSING VALVE COIL
IC802	POWER DEVICE	RT62	DISCHARGE TEMP. THERMISTOR	26C	COMPRESSOR PROTECTOR
LED	LED	RT64	FIN TEMP. THERMISTOR		
LEV	EXPANSION VALVE COIL				

MUZ-BT50VG

OUTDOOR UNIT

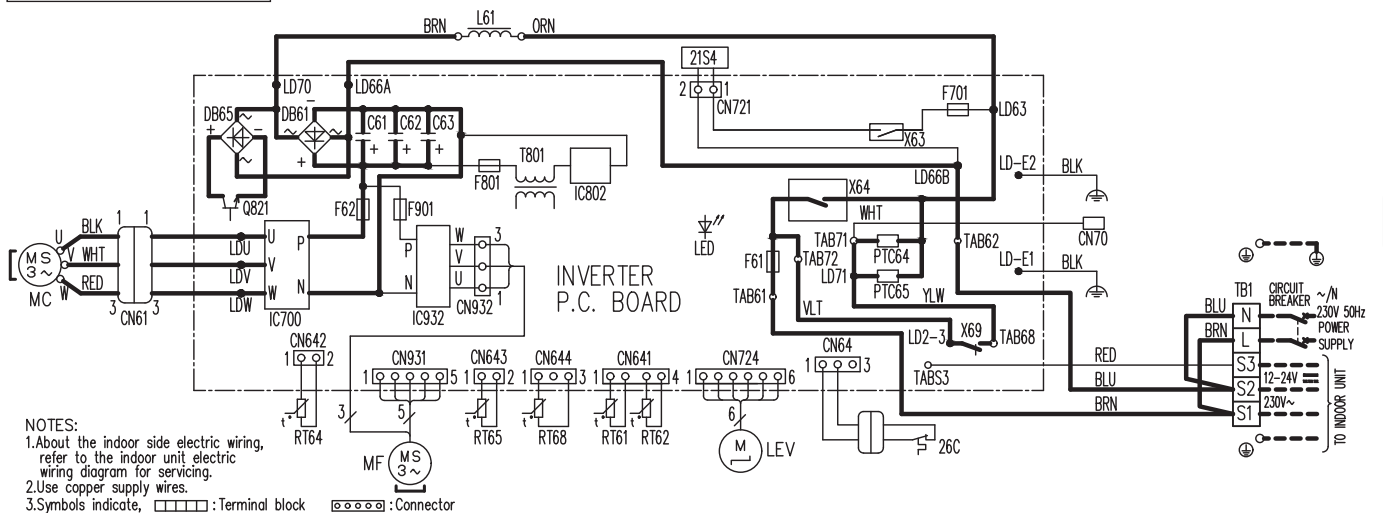

SYMBOL	NAME	SYMBOL	NAME	SYMBOL	NAME
CN61	CONNECTOR	LEV	EXPANSION VALVE COIL	RT65	AMBIENT TEMP. THERMISTOR
C61,C62,C63	SMOOTHING CAPACITOR	L61	REACTOR	RT68	OUTDOOR HEAT EXCHANGER TEMP. THERMISTOR
DB61,DB65	DIODE MODULE	MC	COMPRESSOR	TB1	TERMINAL BLOCK
F61	FUSE (25A 250V)	MF	FAN MOTOR	T801	TRANSFORMER
F62	FUSE (15A 250V)	PTC64,PTC65	CIRCUIT PROTECTION	X63,X64,X69	RELAY
F701,F801,F901	FUSE (T3.15AL250V)	Q821	SWITCHING POWER TRANSISTOR	21S4	REVERSING VALVE COIL
IC700,IC932	POWER MODULE	RT61	DEFROST THERMISTOR	26C	COMPRESSOR PROTECTOR
IC802	POWER DEVICE	RT62	DISCHARGE TEMP. THERMISTOR		
LED	LED	RT64	FIN TEMP. THERMISTOR		

WALL-MOUNTED WIRING DIAGRAM

MUZ-DW25VF MUZ-DW35VF

OUTDOOR UNIT

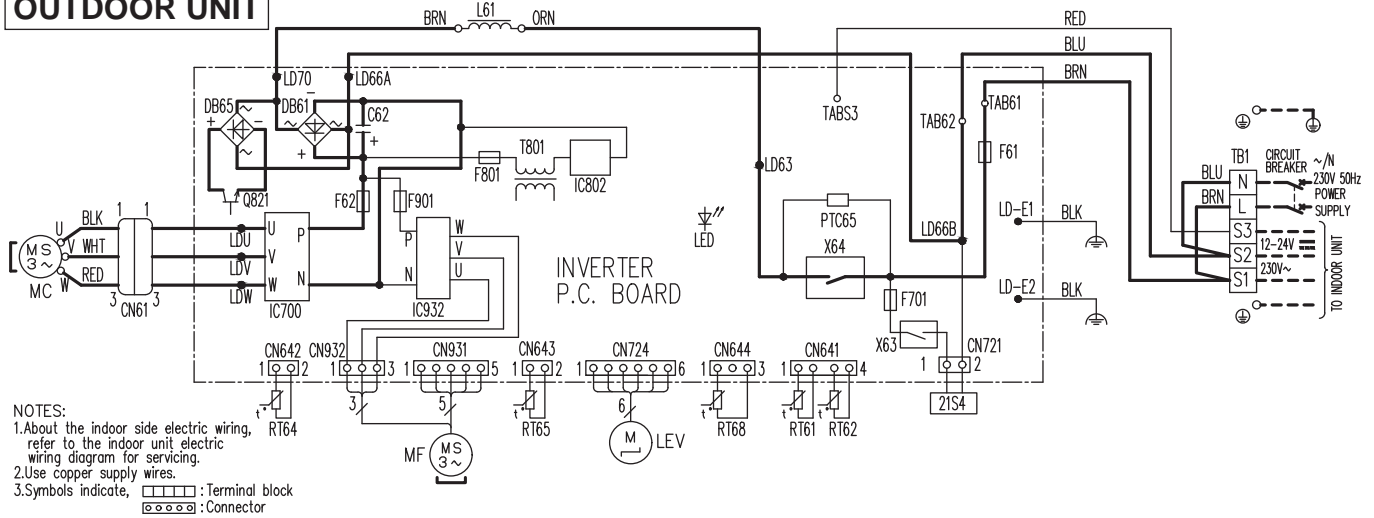

- NOTES:
 1.About the indoor side electric wiring, refer to the indoor unit electric wiring diagram for servicing.
 2.Use copper supply wires.
 3.Symbols indicate, □: Terminal block
○: Connector

SYMBOL	NAME	SYMBOL	NAME	SYMBOL	NAME
CN61	CONNECTOR	LEV	EXPANSION VALVE COIL	RT64	FIN TEMP. THERMISTOR
C62	SMOOTHING CAPACITOR	L61	REACTOR	RT65	AMBIENT TEMP. THERMISTOR
DB61, DB65	DIODE MODULE	MC	COMPRESSOR	RT68	OUTDOOR HEAT EXCHANGER TEMP. THERMISTOR
F61	FUSE (25A 250V)	MF	FAN MOTOR	TB1	TERMINAL BLOCK
F62	FUSE (15A 250V)	PTC65	CIRCUIT PROTECTION	T801	TRANSFORMER
F701, F801, F901	FUSE (T3.15A/250V)	Q821	SWITCHING POWER TRANSISTOR	X63, X64	RELAY
IC700, IC932	POWER MODULE	RT61	DEFROST THERMISTOR	21S4	REVERSING VALVE COIL
IC802	POWER DEVICE	RT62	DISCHARGE TEMP. THERMISTOR		
LED	LED				

MUZ-DW50VF

OUTDOOR UNIT

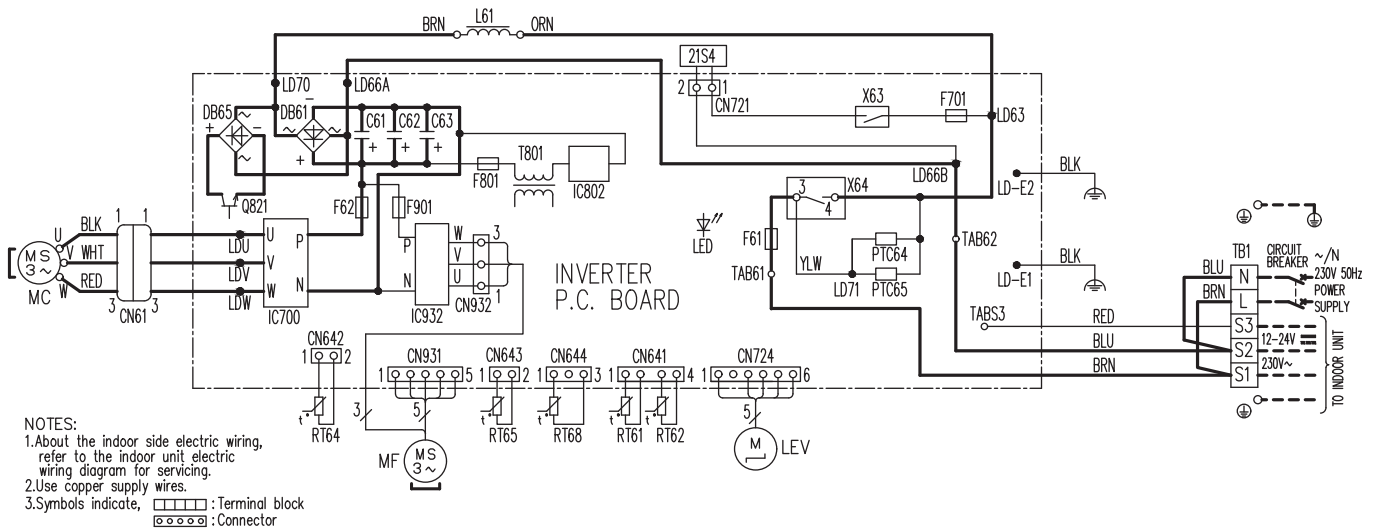

- NOTES:
 1.About the indoor side electric wiring, refer to the indoor unit electric wiring diagram for servicing.
 2.Use copper supply wires.
 3.Symbols indicate, □: Terminal block
○: Connector

SYMBOL	NAME	SYMBOL	NAME	SYMBOL	NAME
CN61	CONNECTOR	LEV	EXPANSION VALVE COIL	RT65	AMBIENT TEMP. THERMISTOR
C61, C62, C63	SMOOTHING CAPACITOR	L61	REACTOR	RT68	OUTDOOR HEAT EXCHANGER TEMP. THERMISTOR
DB61, DB65	DIODE MODULE	MC	COMPRESSOR	TB1	TERMINAL BLOCK
F61	FUSE (25A 250V)	MF	FAN MOTOR	T801	TRANSFORMER
F62	FUSE (15A 250V)	PTC64, PTC65	CIRCUIT PROTECTION	X63, X64	RELAY
F701, F801, F901	FUSE (T3.15A/250V)	Q821	SWITCHING POWER TRANSISTOR	21S4	REVERSING VALVE COIL
IC700, IC932	POWER MODULE	RT61	DEFROST THERMISTOR		
IC802	POWER DEVICE	RT62	DISCHARGE TEMP. THERMISTOR		
LED	LED	RT64	FIN TEMP. THERMISTOR		

WIRING DIAGRAM

WALL-MOUNTED

MUZ-SF25VE MUZ-SF35VE

OUTDOOR UNIT

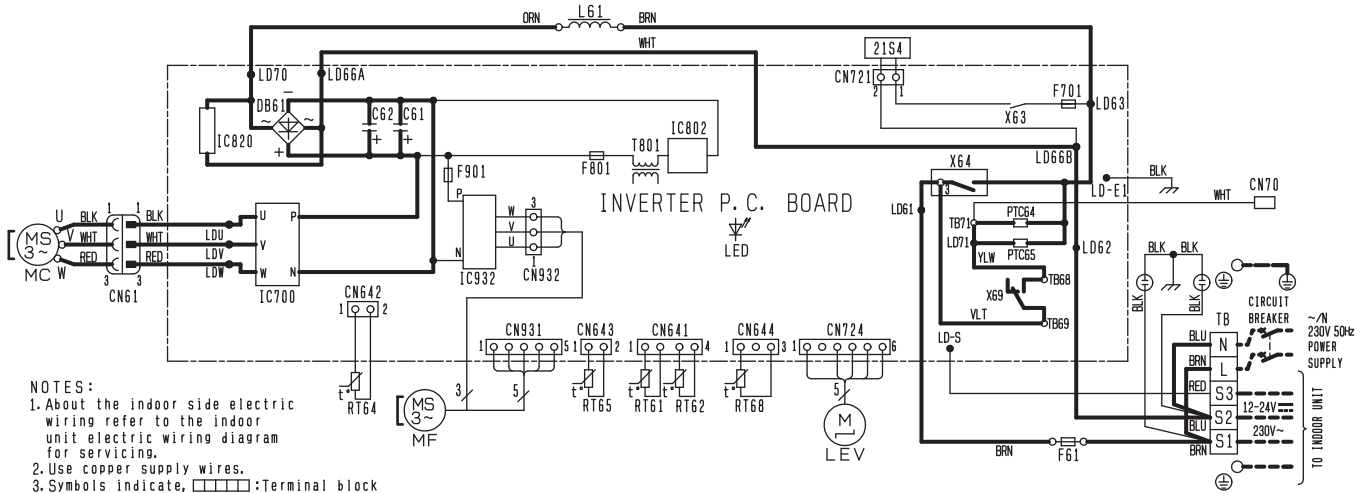

- NOTES:
- About the indoor side electric wiring refer to the indoor unit electric wiring diagram for servicing.
 - Use copper supply wires.
 - Symbols indicate, :Terminal block
:Connector

SYMBOL	NAME	SYMBOL	NAME	SYMBOL	NAME
CN70	CONNECTOR	LEV	EXPANSION VALVE COIL	RT65	AMBIENT TEMP. THERMISTOR
C61, C62	SMOOTHING CAPACITOR	L61	REACTOR	RT68	OUTDOOR HEAT EXCHANGER TEMP. THERMISTOR.
DB61	DIODE MODULE	MC	COMPRESSOR	TB	TERMINAL BLOCK
F61	FUSE (T20AL250V)	MF	FAN MOTOR	T801	TRANSFORMER
F701, F801, F901	FUSE (T3. 15AL250V)	PTC64, PTC65	CIRCUIT PROTECTION	X63, X64, X69	RELAY
IC700, IC820, IC932	POWER MODULE	RT61	DEFROST THERMISTOR	21S4	REVERSING VALVE COIL
IC802	POWER DEVICE	RT62	DISCHARGE TEMP. THERMISTOR		
LED	LED	RT64	FIN TEMP. THERMISTOR		

MUZ-SF25VEH MUZ-SF35VEH

OUTDOOR UNIT

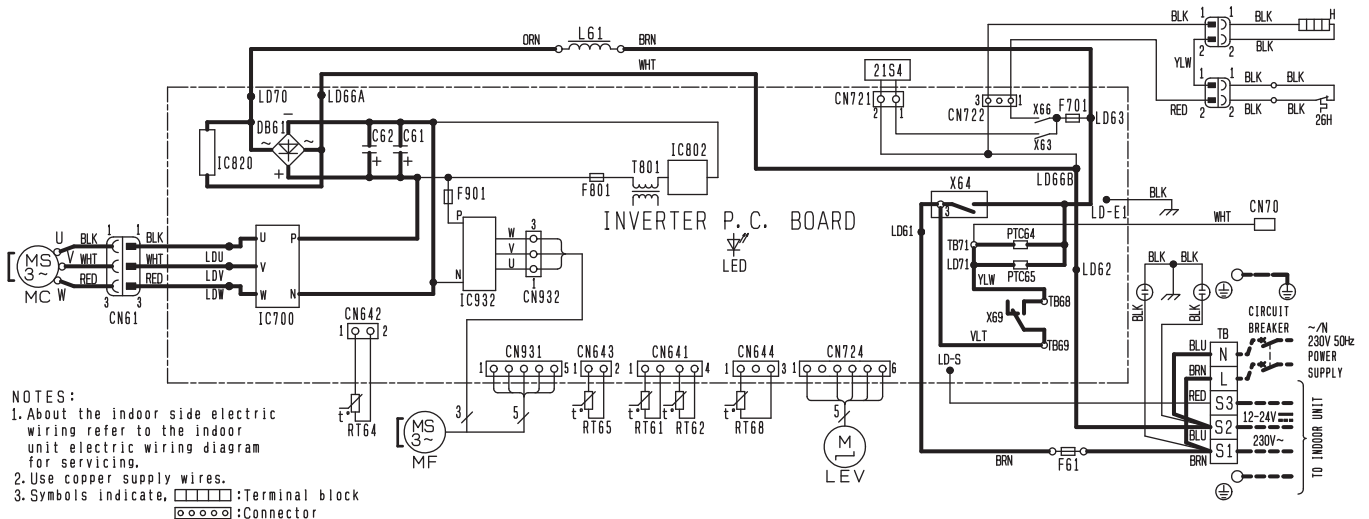

- NOTES:
- About the indoor side electric wiring refer to the indoor unit electric wiring diagram for servicing.
 - Use copper supply wires.
 - Symbols indicate, :Terminal block
:Connector

SYMBOL	NAME	SYMBOL	NAME	SYMBOL	NAME
CN70	CONNECTOR	LEV	EXPANSION VALVE COIL	RT68	OUTDOOR HEAT EXCHANGER TEMP. THERMISTOR.
C61, C62	SMOOTHING CAPACITOR	L61	REACTOR	TB	TERMINAL BLOCK
DB61	DIODE MODULE	MC	COMPRESSOR	T801	TRANSFORMER
F61	FUSE (T20AL250V)	MF	FAN MOTOR	X63, X64	RELAY
F701, F801, F901	FUSE (T3. 15AL250V)	PTC64, PTC65	CIRCUIT PROTECTION	X66, X69	RELAY
H	DEFROST HEATER	RT61	DEFROST THERMISTOR	21S4	REVERSING VALVE COIL
IC700, IC820, IC932	POWER MODULE	RT62	DISCHARGE TEMP. THERMISTOR	26H	HEATER PROTECTOR
IC802	POWER DEVICE	RT64	FIN TEMP. THERMISTOR		
LED	LED	RT65	AMBIENT TEMP. THERMISTOR		

WALL-MOUNTED WIRING DIAGRAM

MUZ-SF42VE MUZ-SF50VE

OUTDOOR UNIT

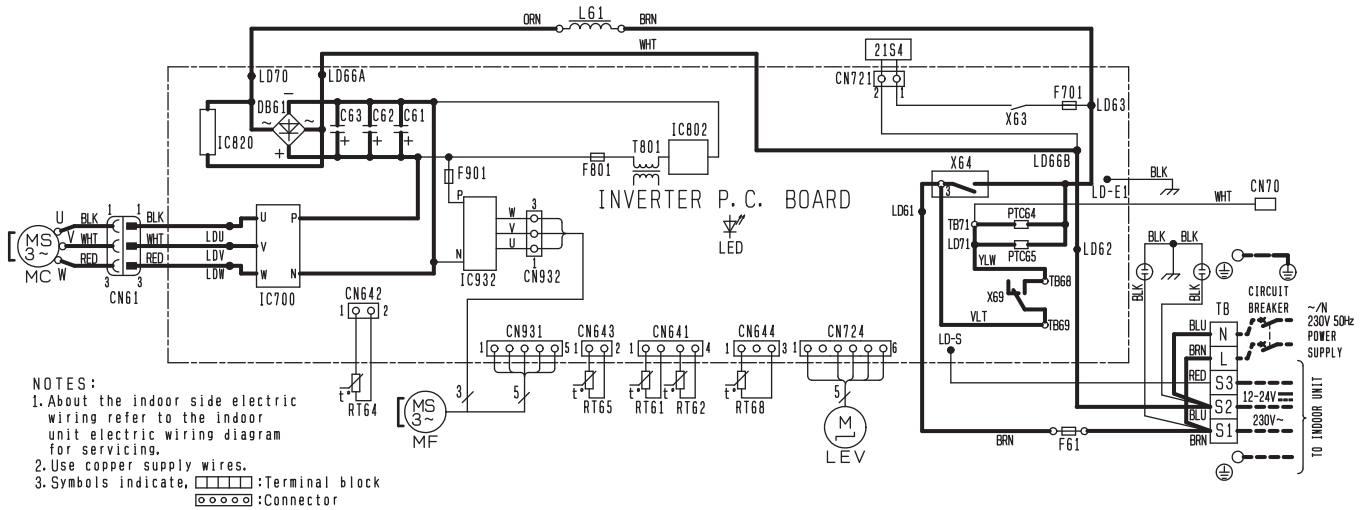

- NOTES:
- About the indoor side electric wiring refer to the indoor unit electric wiring diagram for servicing.
 - Use copper supply wires.
 - Symbols indicate, :Terminal block
:Connector

SYMBOL	NAME	SYMBOL	NAME	SYMBOL	NAME
CN70	CONNECTOR	LEV	EXPANSION VALVE COIL	RT65	AMBIENT TEMP. THERMISTOR
C61, C62, C63	SMOOTHING CAPACITOR	L61	REACTOR	RT68	OUTDOOR HEAT EXCHANGER TEMP. THERMISTOR.
DB61	DIODE MODULE	MC	COMPRESSOR	TB	TERMINAL BLOCK
F61	FUSE (T20AL250V)	MF	FAN MOTOR	T801	TRANSFORMER
F701, F801, F901	FUSE (T3. 15AL250V)	PTC64, PTC65	CIRCUIT PROTECTION	X63, X64, X69	RELAY
IC700, IC820, IC932	POWER MODULE	RT61	DEFROST THERMISTOR	21S4	REVERSING VALVE COIL
IC802	POWER DEVICE	RT62	DISCHARGE TEMP. THERMISTOR		
LED	LED	RT64	FIN TEMP. THERMISTOR		

MUZ-SF42VEH MUZ-SF50VEH

OUTDOOR UNIT

WIRING DIAGRAM

WALL-MOUNTED

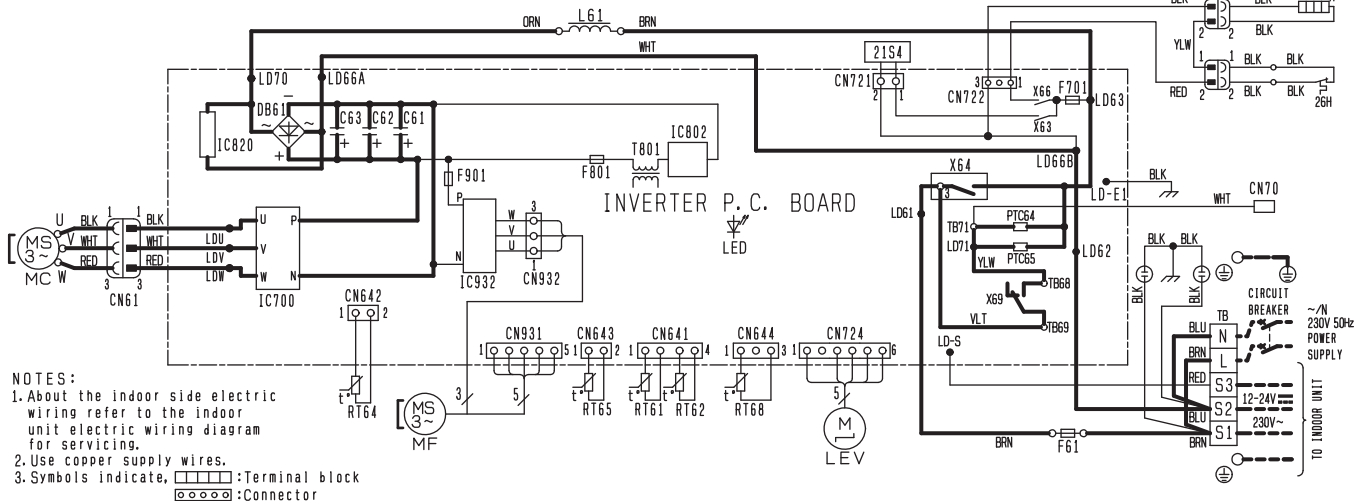

- NOTES:
- About the indoor side electric wiring refer to the indoor unit electric wiring diagram for servicing.
 - Use copper supply wires.
 - Symbols indicate, :Terminal block
:Connector

SYMBOL	NAME	SYMBOL	NAME	SYMBOL	NAME
CN70	CONNECTOR	LEV	EXPANSION VALVE COIL	RT68	OUTDOOR HEAT EXCHANGER TEMP. THERMISTOR.
C61, C62, C63	SMOOTHING CAPACITOR	L61	REACTOR	TB	TERMINAL BLOCK
DB61	DIODE MODULE	MC	COMPRESSOR	T801	TRANSFORMER
F61	FUSE (T20AL250V)	MF	FAN MOTOR	X63, X64	RELAY
F701, F801, F901	FUSE (T3. 15AL250V)	PTC64, PTC65	CIRCUIT PROTECTION	X66, X69	RELAY
H	DEFROST HEATER	RT61	DEFROST THERMISTOR	21S4	REVERSING VALVE COIL
IC700, IC820, IC932	POWER MODULE	RT62	DISCHARGE TEMP. THERMISTOR	26H	HEATER PROTECTOR
IC802	POWER DEVICE	RT64	FIN TEMP. THERMISTOR		
LED	LED	RT65	AMBIENT TEMP. THERMISTOR		

MUZ-GF60VE MUZ-GF71VE

OUTDOOR UNIT

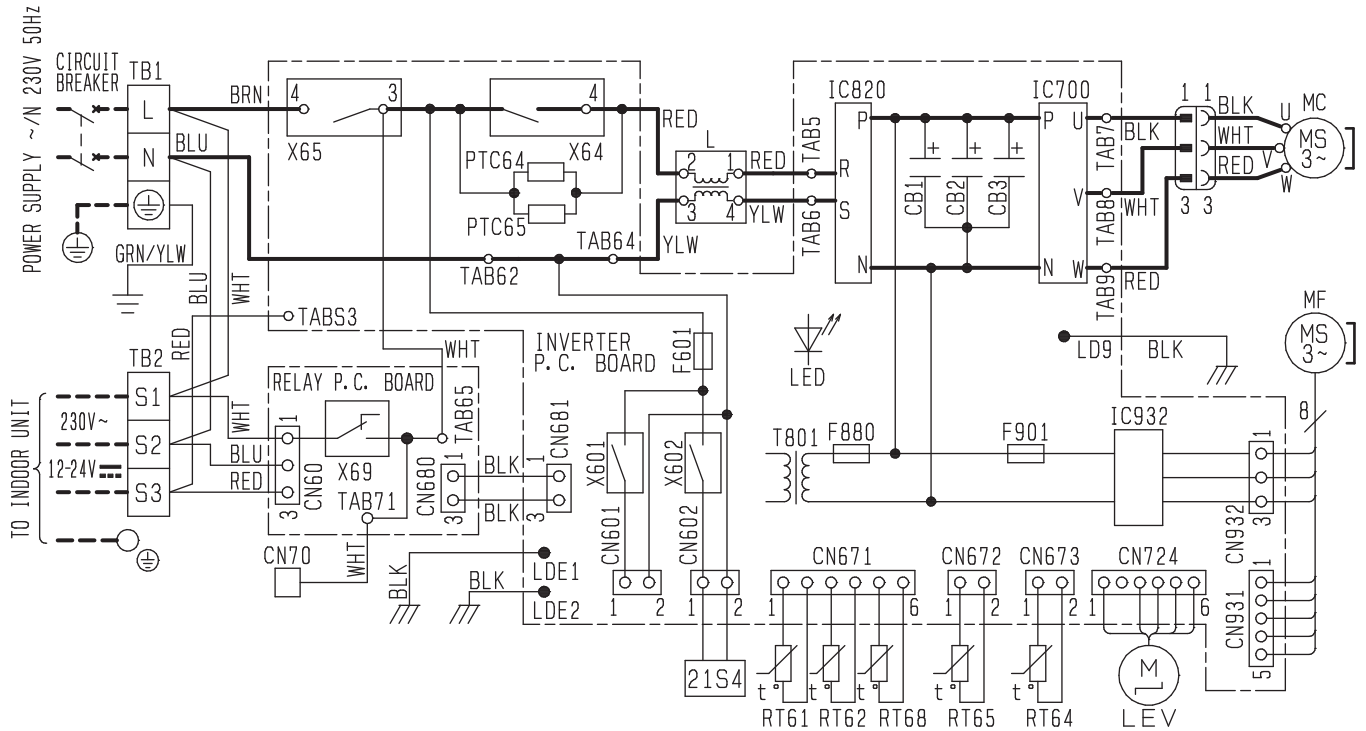

SYMBOL	NAME	SYMBOL	NAME	SYMBOL	NAME	SYMBOL	NAME
CB1 ~ 3	SMOOTHING CAPACITOR	L	REACTOR	RT62	DISCHARGE TEMP. THERMISTOR	X602	RELAY
CN70	CONNECTOR	LED	LED	RT64	FIN TEMP. THERMISTOR	X64	RELAY
F601	FUSE (T3. 15A/250V)	LEV	EXPANSION VALVE COIL	RT65	AMBIENT TEMP. THERMISTOR	X65	RELAY
F880	FUSE (T3. 15A/250V)	MC	COMPRESSOR	RT68	OUTDOOR HEAT EXCHANGER TEMP. THERMISTOR	X69	RELAY
F901	FUSE (T3. 15A/250V)	MF	FAN MOTOR			21S4	REVERSING VALVE SOLENOID COIL
IC700	IGBT Module	PTC64	CIRCUIT PROTECTION	TB1, TB2	TERMINAL BLOCK		
IC820	DIODE Module	PTC65	CIRCUIT PROTECTION	T801	TRANSFORMER		
IC932	IGBT Module	RT61	DEFROST THERMISTOR	X601	RELAY		

NOTES 1. About the indoor side electric wiring, refer to the indoor unit electric wiring diagram for servicing.
 2. Use copper conductors only (for field wiring). 3. Symbols indicate, : Terminal block

WIRING DIAGRAM

WALL-MOUNTED

MUZ-WN25VA MUZ-WN35VA

OUTDOOR UNIT

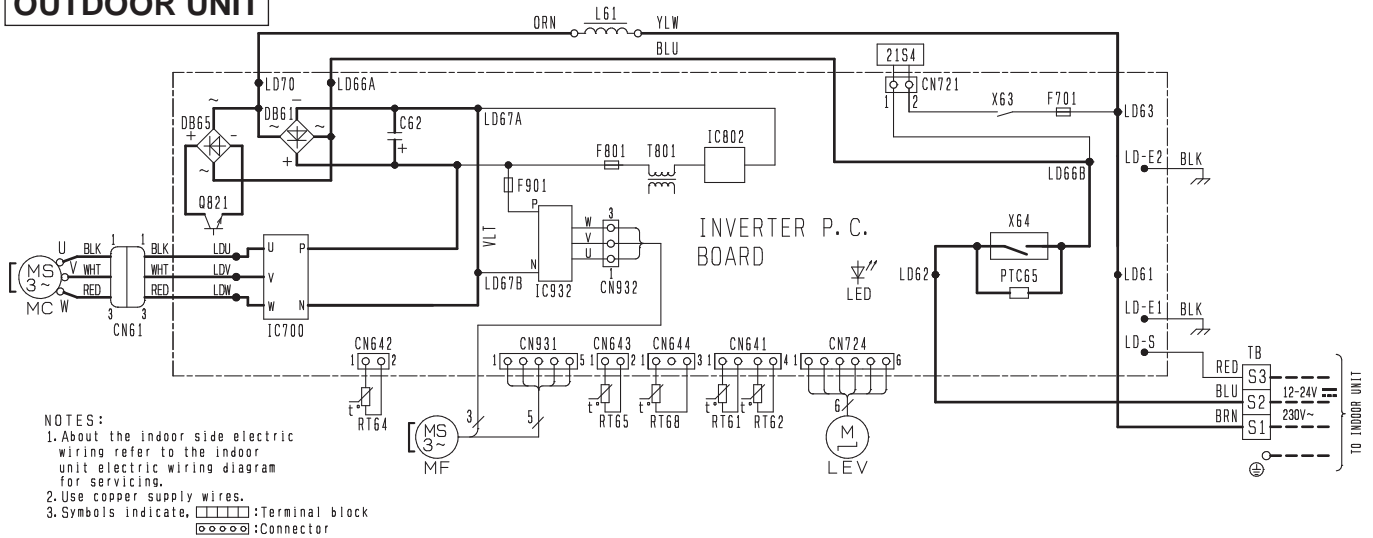

SYMBOL	NAME	SYMBOL	NAME	SYMBOL	NAME
CN61	CONNECTOR	L61	REACTOR	RT65	AMBIENT TEMP. THERMISTOR
C62	SMOOTHING CAPACITOR	MC	COMPRESSOR	RT68	OUTDOOR HEAT EXCHANGER TEMP. THERMISTOR
DB61, DB65	DIODE MODULE	MF	FAN MOTOR	TB	TERMINAL BLOCK
F701, F801, F901	FUSE (T3. 15A/250V)	PTC65	CIRCUIT PROTECTION	T801	TRANSFORMER
IC700, IC932	POWER MODULE	Q821	SWITCHING POWER TRANSISTOR	XG3, XG4	RELAY
IC802	POWER DEVICE	RT61	DEFROST THERMISTOR	21S4	REVERSING VALVE COIL
LED	LED	RT62	DISCHARGE TEMP. THERMISTOR		
LEV	EXPANSION VALVE COIL	RT64	FIN TEMP. THERMISTOR		

MUZ-DM25VA MUZ-DM35VA

OUTDOOR UNIT

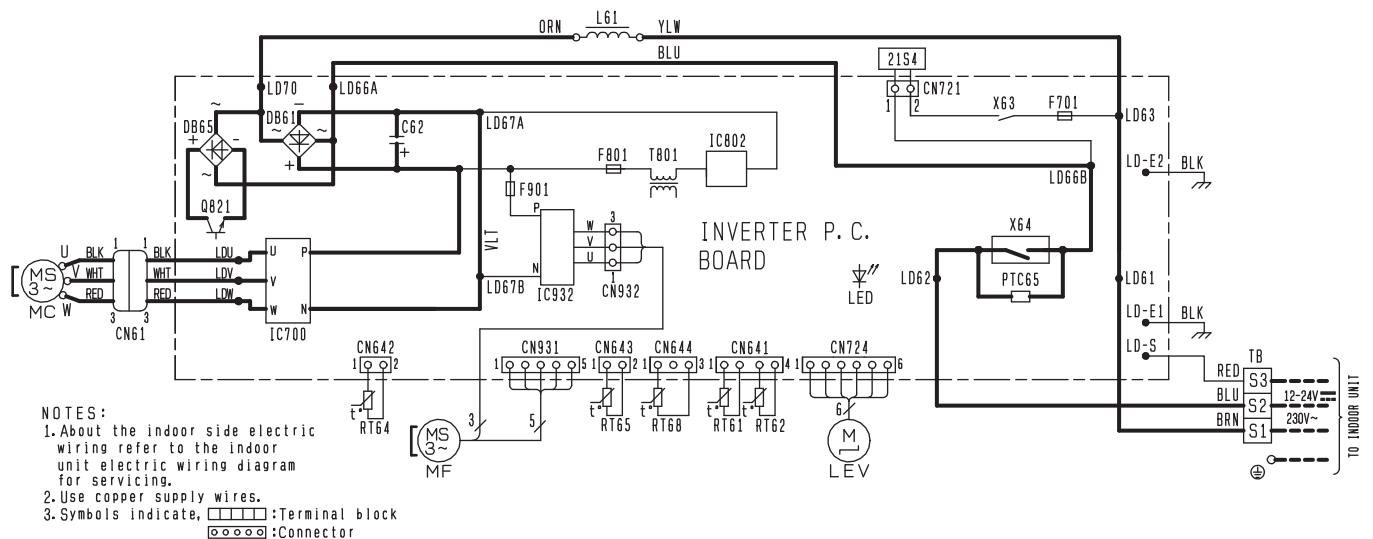

SYMBOL	NAME	SYMBOL	NAME	SYMBOL	NAME
CN61	CONNECTOR	L61	REACTOR	RT65	AMBIENT TEMP. THERMISTOR
C62	SMOOTHING CAPACITOR	MC	COMPRESSOR	RT68	OUTDOOR HEAT EXCHANGER TEMP. THERMISTOR
DB61, DB65	DIODE MODULE	MF	FAN MOTOR	TB	TERMINAL BLOCK
F701, F801, F901	FUSE (T3. 15A/250V)	PTC65	CIRCUIT PROTECTION	T801	TRANSFORMER
IC700, IC932	POWER MODULE	Q821	SWITCHING POWER TRANSISTOR	XG3, XG4	RELAY
IC802	POWER DEVICE	RT61	DEFROST THERMISTOR	21S4	REVERSING VALVE COIL
LED	LED	RT62	DISCHARGE TEMP. THERMISTOR		
LEV	EXPANSION VALVE COIL	RT64	FIN TEMP. THERMISTOR		

WIRING DIAGRAM

WALL-MOUNTED

MUZ-HJ25VA
OUTDOOR UNIT

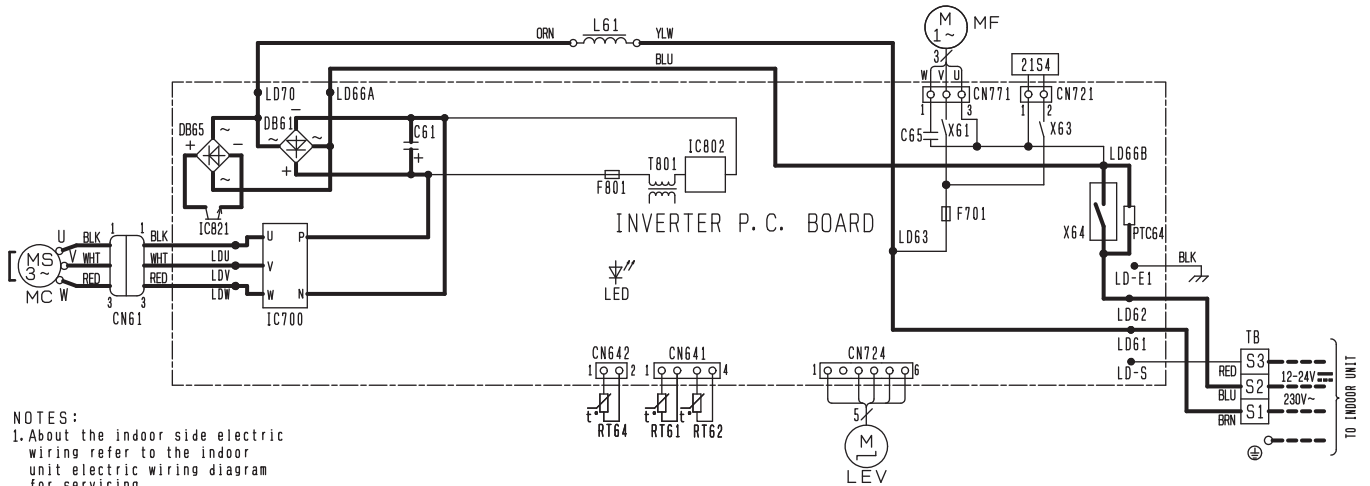

- NOTES:
- About the indoor side electric wiring refer to the indoor unit electric wiring diagram for servicing.
 - Use copper supply wires.
 - Symbols indicate, :Terminal block
 :Connector

SYMBOL	NAME	SYMBOL	NAME	SYMBOL	NAME
CN61	CONNECTOR	IC821	SWITCHING POWER TRANSISTOR	RT61	DEFROST THERMISTOR
C61	SMOOTHING CAPACITOR	LED	LED	RT62	DISCHARGE TEMP. THERMISTOR
C65	FAN MOTOR CAPACITOR	LEV	EXPANSION VALVE COIL	RT64	FIN TEMP. THERMISTOR
DB61, DB65	DIODE MODULE	L61	REACTOR	TB	TERMINAL BLOCK
F701, F801	FUSE (T3. 15A/250V)	MC	COMPRESSOR	T801	TRANSFORMER
IC700	POWER MODULE	MF	FAN MOTOR (INNER FUSE)	X61, X63, X64	RELAY
IC802	POWER DEVICE	PTC64	CIRCUIT PROTECTION	21S4	REVERSING VALVE COIL

MUZ-HJ35VA
OUTDOOR UNIT

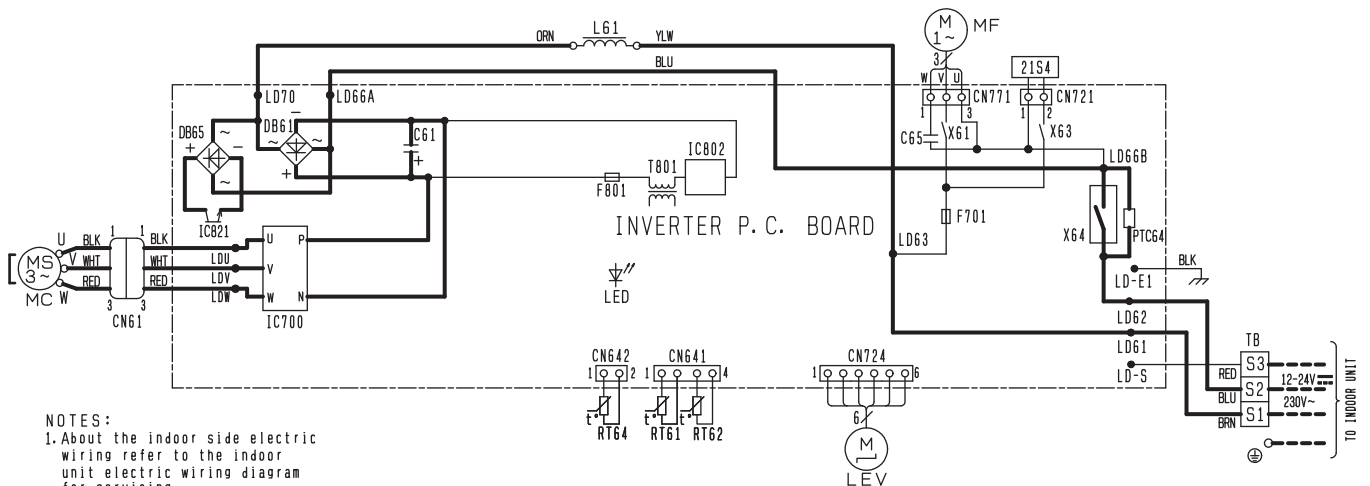

- NOTES:
- About the indoor side electric wiring refer to the indoor unit electric wiring diagram for servicing.
 - Use copper supply wires.
 - Symbols indicate, :Terminal block
 :Connector

SYMBOL	NAME	SYMBOL	NAME	SYMBOL	NAME
CN61	CONNECTOR	IC821	SWITCHING POWER TRANSISTOR	RT61	DEFROST THERMISTOR
C61	SMOOTHING CAPACITOR	LED	LED	RT62	DISCHARGE TEMP. THERMISTOR
C65	FAN MOTOR CAPACITOR	LEV	EXPANSION VALVE COIL	RT64	FIN TEMP. THERMISTOR
DB61, DB65	DIODE MODULE	L61	REACTOR	TB	TERMINAL BLOCK
F701, F801	FUSE (T3. 15A/250V)	MC	COMPRESSOR	T801	TRANSFORMER
IC700	POWER MODULE	MF	FAN MOTOR (INNER FUSE)	X61, X63, X64	RELAY
IC802	POWER DEVICE	PTC64	CIRCUIT PROTECTION	21S4	REVERSING VALVE COIL

WALL-MOUNTED WIRING DIAGRAM

MUZ-HJ50VA MUZ-HJ60VA MUZ-HJ71VA

OUTDOOR UNIT

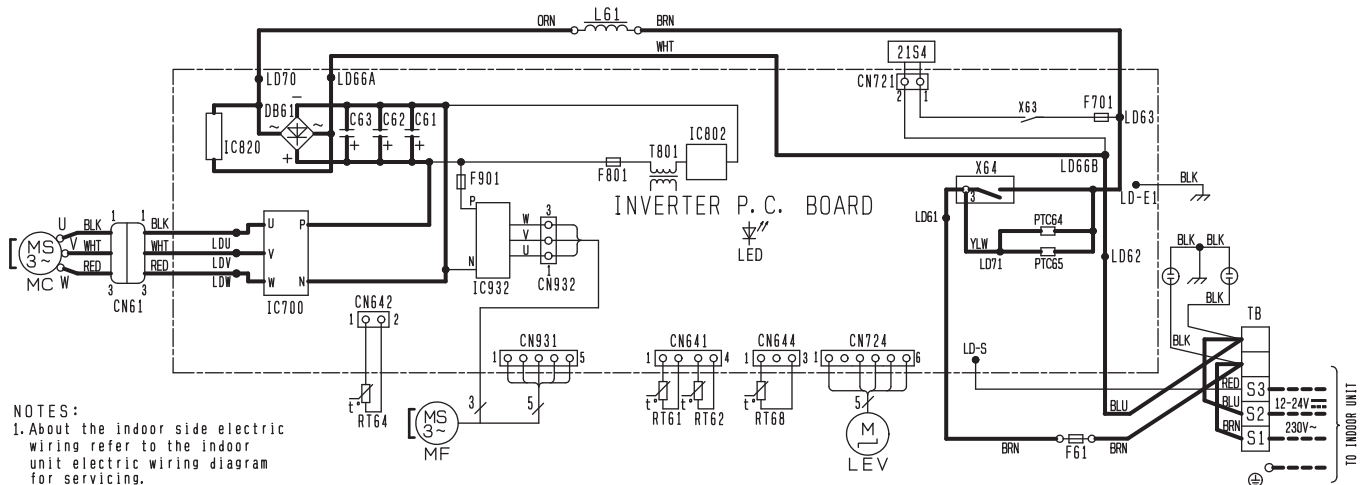

- NOTES:
- About the indoor side electric wiring refer to the indoor unit electric wiring diagram for servicing.
 - Use copper supply wires.
 - Symbols indicate, :Terminal block
 :Connector

SYMBOL	NAME	SYMBOL	NAME	SYMBOL	NAME
CN61	CONNECTOR	LEV	EXPANSION VALVE COIL	RT68	OUTDOOR HEAT EXCHANGER TEMP. THERMISTOR.
C61, C62, C63	SMOOTHING CAPACITOR	L61	REACTOR	TB	TERMINAL BLOCK
DB61	DIODE MODULE	MC	COMPRESSOR	T801	TRANSFORMER
F61	FUSE (T20AL250V)	MF	FAN MOTOR	X63, X64	RELAY
F701, F801, F901	FUSE (T3.15AL250V)	PTC64, PTC65	CIRCUIT PROTECTION	21S4	REVERSING VALVE COIL
IC700, IC820, IC932	POWER MODULE	RT61	DEFROST THERMISTOR		
IC802	POWER DEVICE	RT62	DISCHARGE TEMP. THERMISTOR		
LED	LED	RT64	FIN TEMP. THERMISTOR		

C.1.4 REFRIGERANT SYSTEM DIAGRAM

C.1.4.1 Inverter
MSZ-RW25VG
MSZ-RW35VG

Unit: mm
MUZ-RW25VGHZ
MUZ-RW35VGHZ

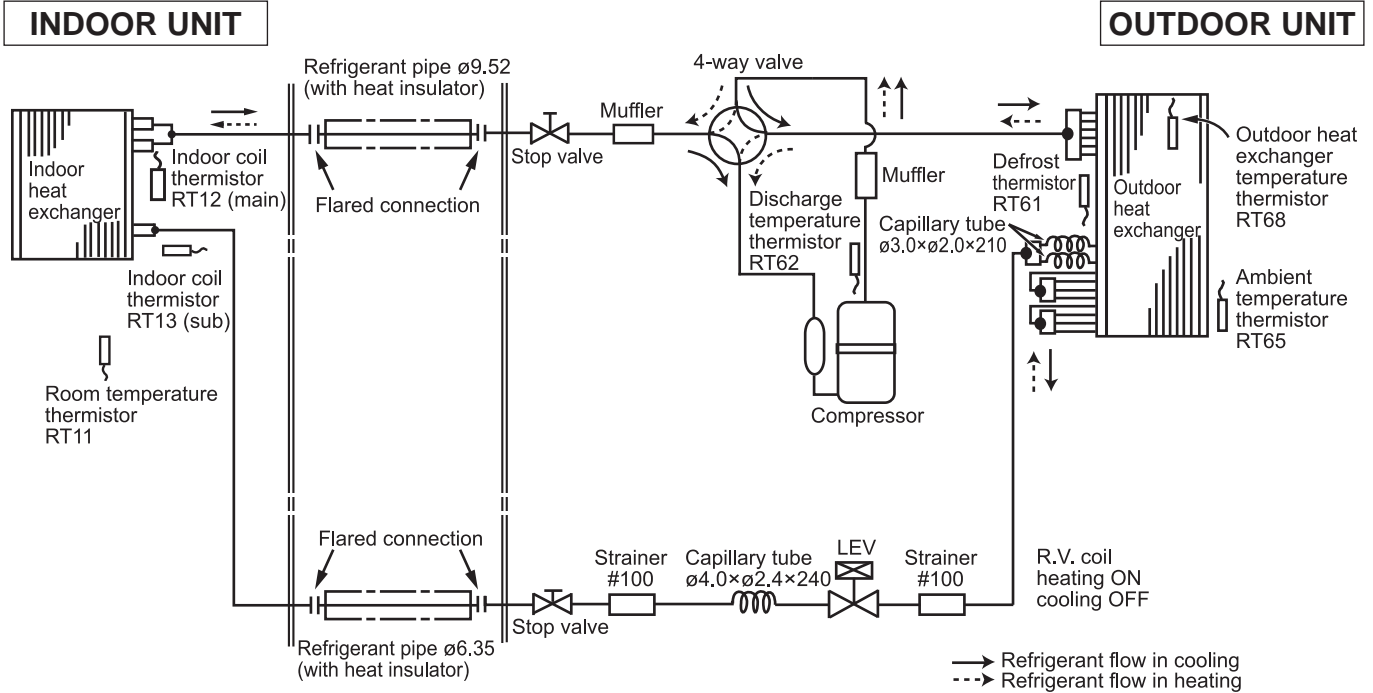

MSZ-RW50VG
INDOOR UNIT

MUZ-RW50VGHZ
OUTDOOR UNIT

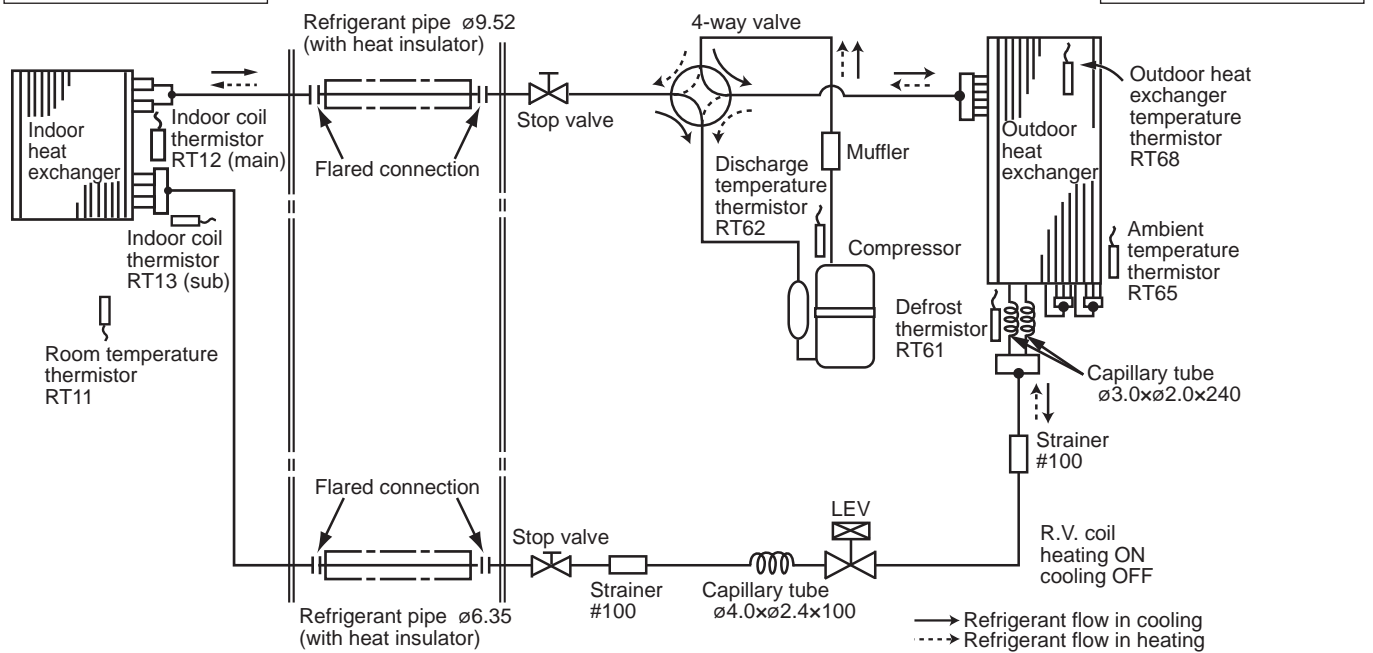

WALL-MOUNTED REFRIGERANT SYSTEM DIAGRAM

Unit: mm

MSZ-LN18VG2W
MSZ-LN18VG2V
MSZ-LN18VG2B
MSZ-LN18VG2R

OUTDOOR UNIT

INDOOR UNIT

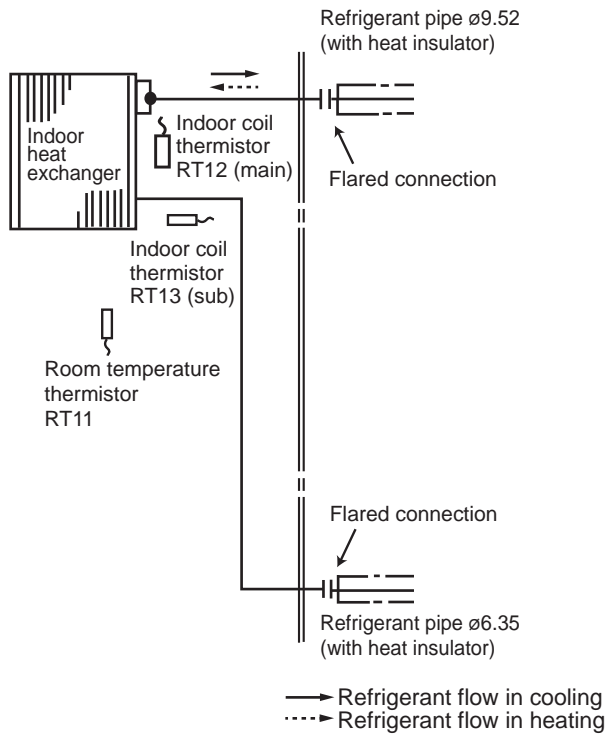

For Multi connection

MSZ-LN25VG2W
MSZ-LN25VG2V
MSZ-LN25VG2B
MSZ-LN25VG2R

MSZ-LN35VG2W
MSZ-LN35VG2V
MSZ-LN35VG2B
MSZ-LN35VG2R

MUZ-LN25VG2
MUZ-LN25VGHZ2
MUZ-LN35VG2
MUZ-LN35VGHZ2

INDOOR UNIT

OUTDOOR UNIT

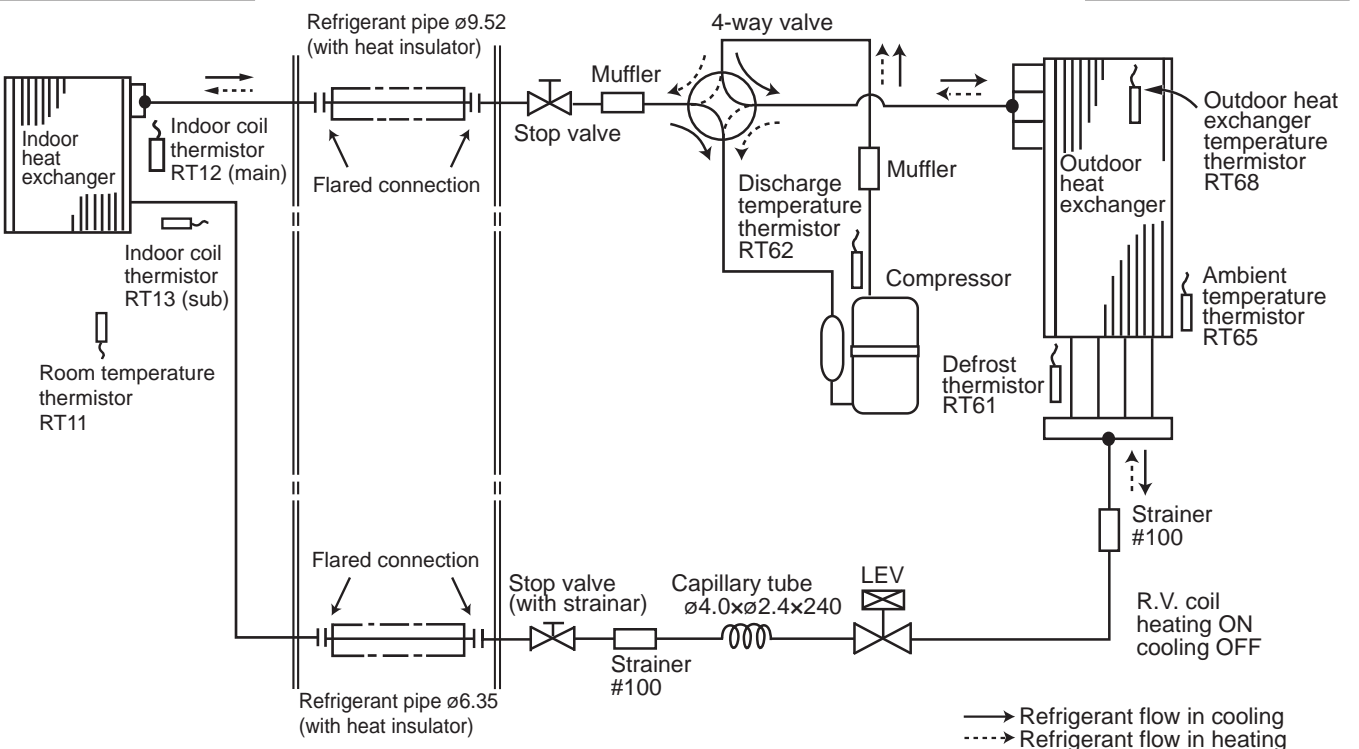

REFRIGERANT SYSTEM DIAGRAM

WALL-MOUNTED

Unit: mm

MSZ-LN50VG2W
MSZ-LN50VG2V
MSZ-LN50VG2B
MSZ-LN50VG2R

MUZ-LN50VG2

INDOOR UNIT

OUTDOOR UNIT

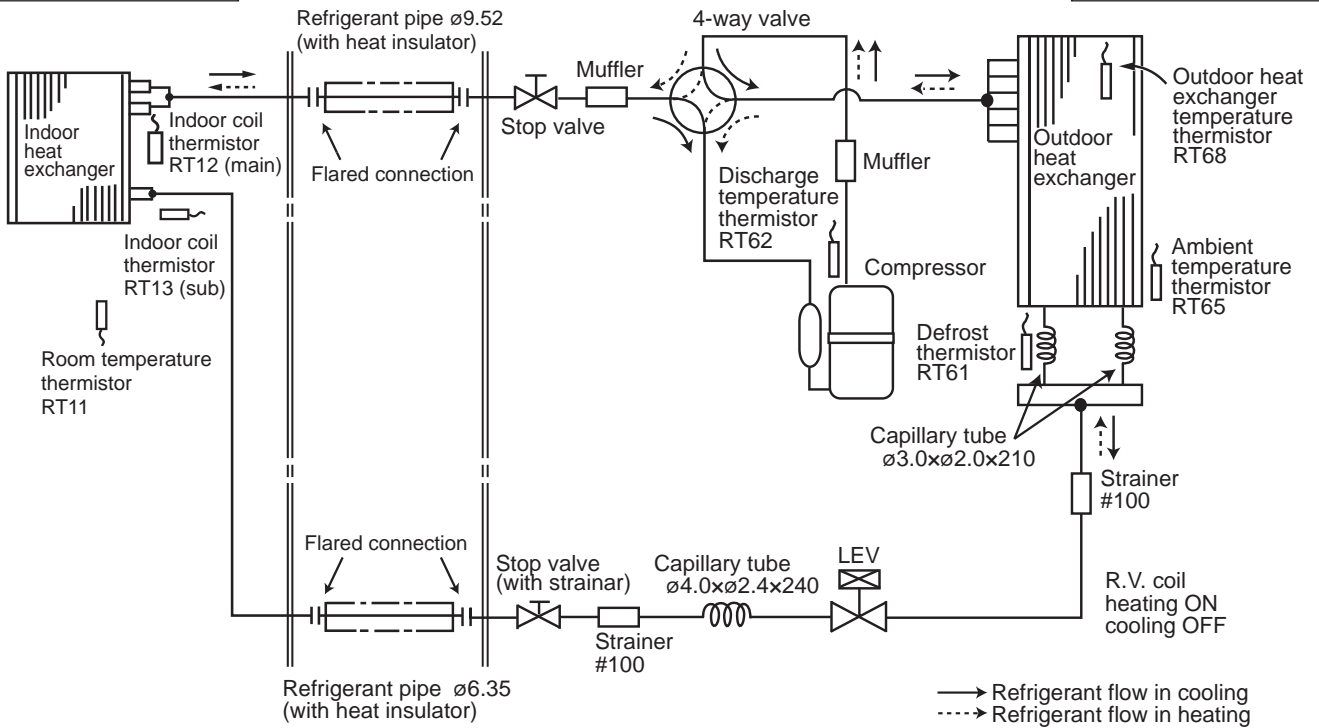

MSZ-LN50VG2W
MSZ-LN50VG2V
MSZ-LN50VG2B
MSZ-LN50VG2R

MUZ-LN50VGHZ2

INDOOR UNIT

OUTDOOR UNIT

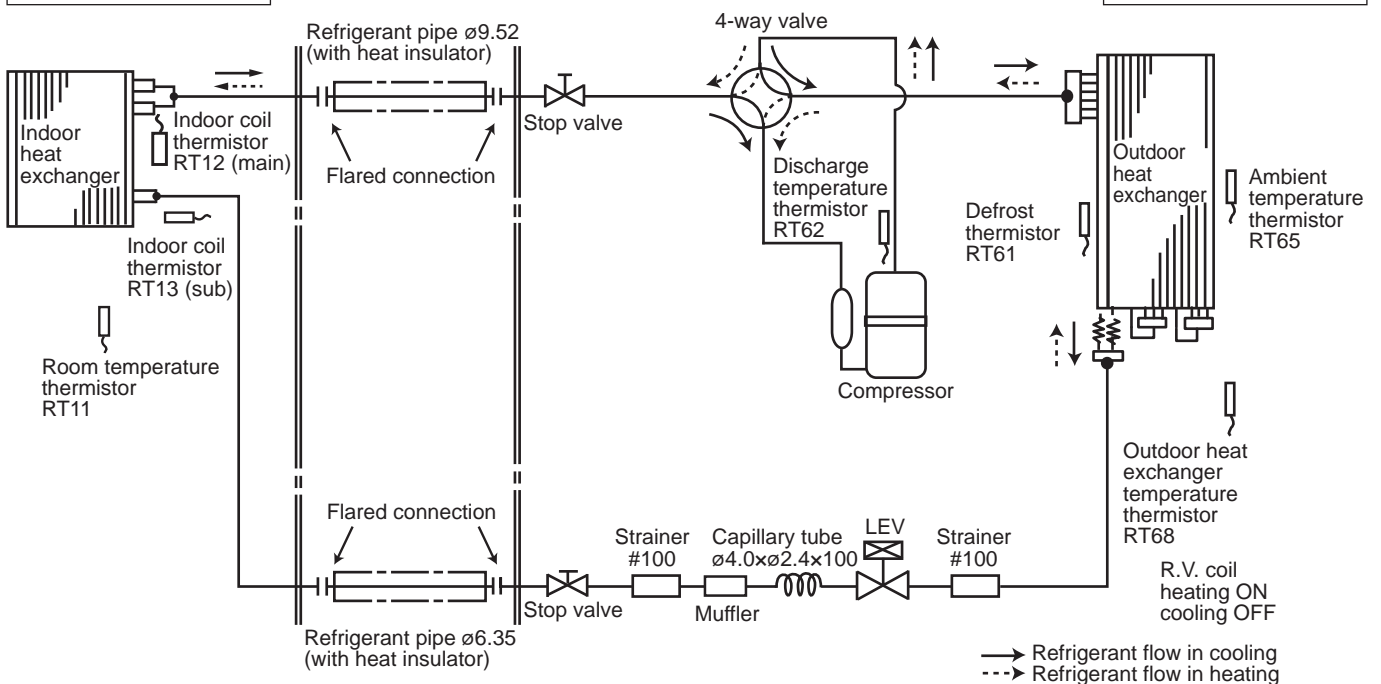

REFRIGERANT SYSTEM DIAGRAM

WALL-MOUNTED

Unit: mm

MSZ-LN60VG2W
MSZ-LN60VG2V
MSZ-LN60VG2B
MSZ-LN60VG2R

MUZ-LN60VG2

INDOOR UNIT

OUTDOOR UNIT

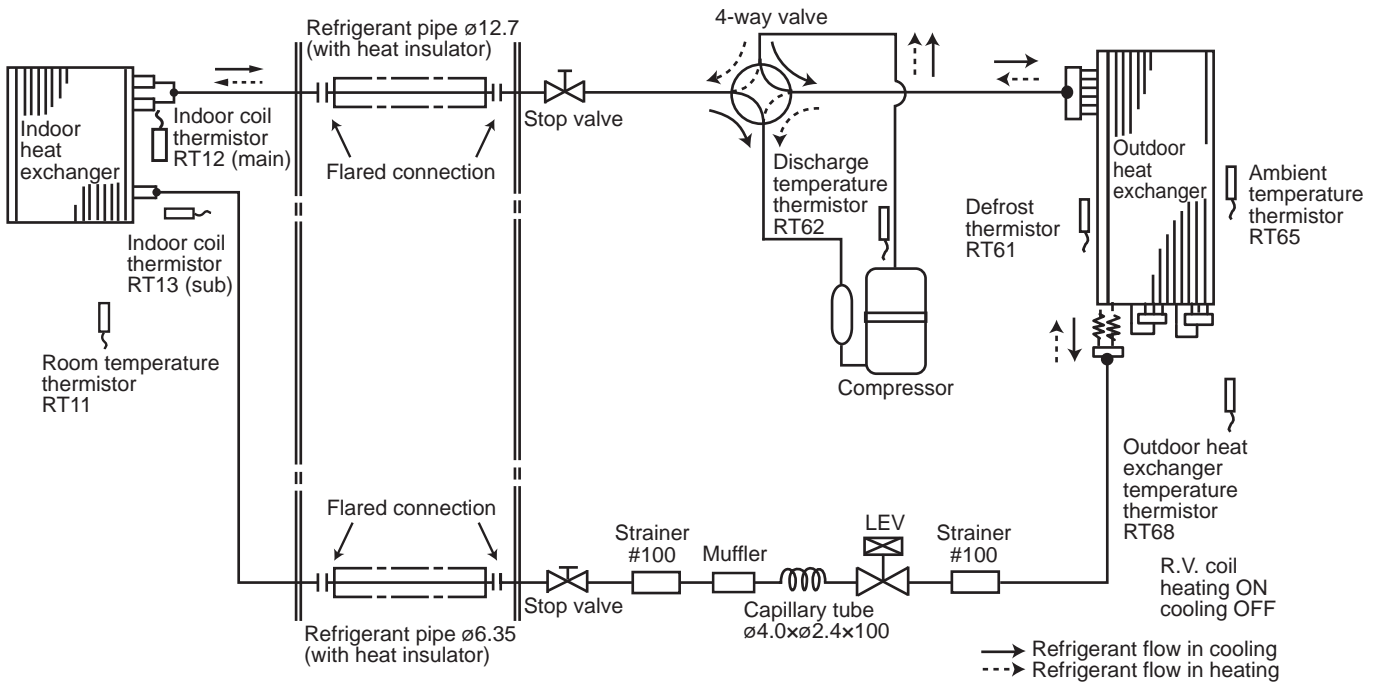

REFRIGERANT SYSTEM DIAGRAM

WALL-MOUNTED

Unit: mm

**MSZ-FT25VG
MSZ-FT25VGK**

MUZ-FT25VGHZ

INDOOR UNIT

OUTDOOR UNIT

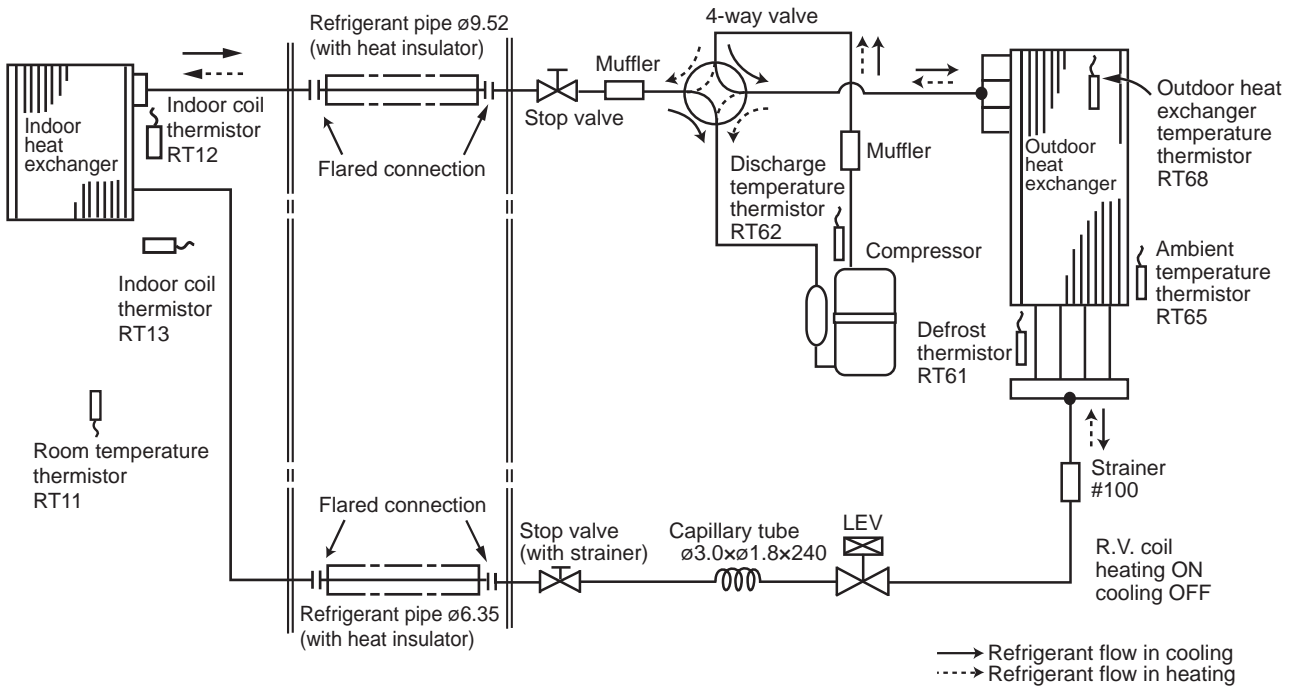

**MSZ-FT35VG
MSZ-FT35VGK
MSZ-FT50VG
MSZ-FT50VGK**

**MUZ-FT35VGHZ
MUZ-FT50VGHZ**

INDOOR UNIT

OUTDOOR UNIT

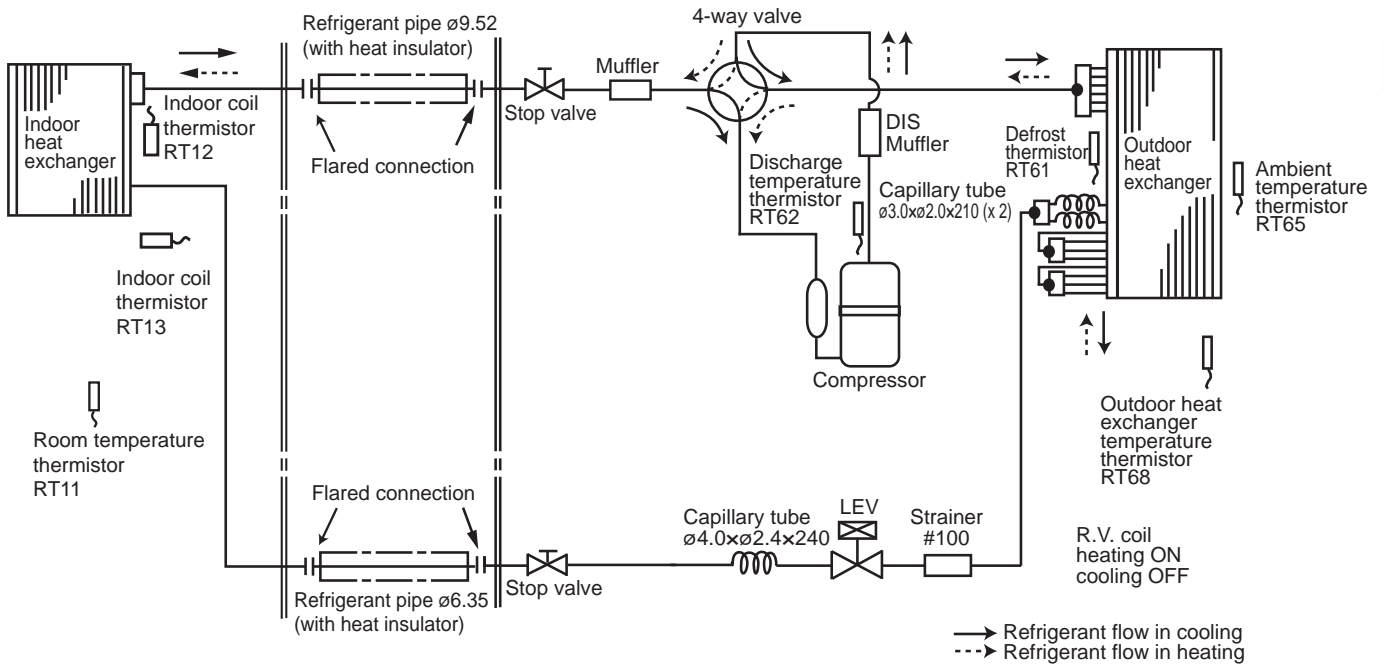

REFRIGERANT SYSTEM DIAGRAM

WALL-MOUNTED

Unit: mm

MSZ-AY25VG MSZ-AY35VG
MSZ-AY25VGK MSZ-AY35VGK
MSZ-AY25VGKP MSZ-AY35VGKP

MUZ-AY25VG MUZ-AY25VGH
MUZ-AY35VG MUZ-AY35VGH

INDOOR UNIT

OUTDOOR UNIT

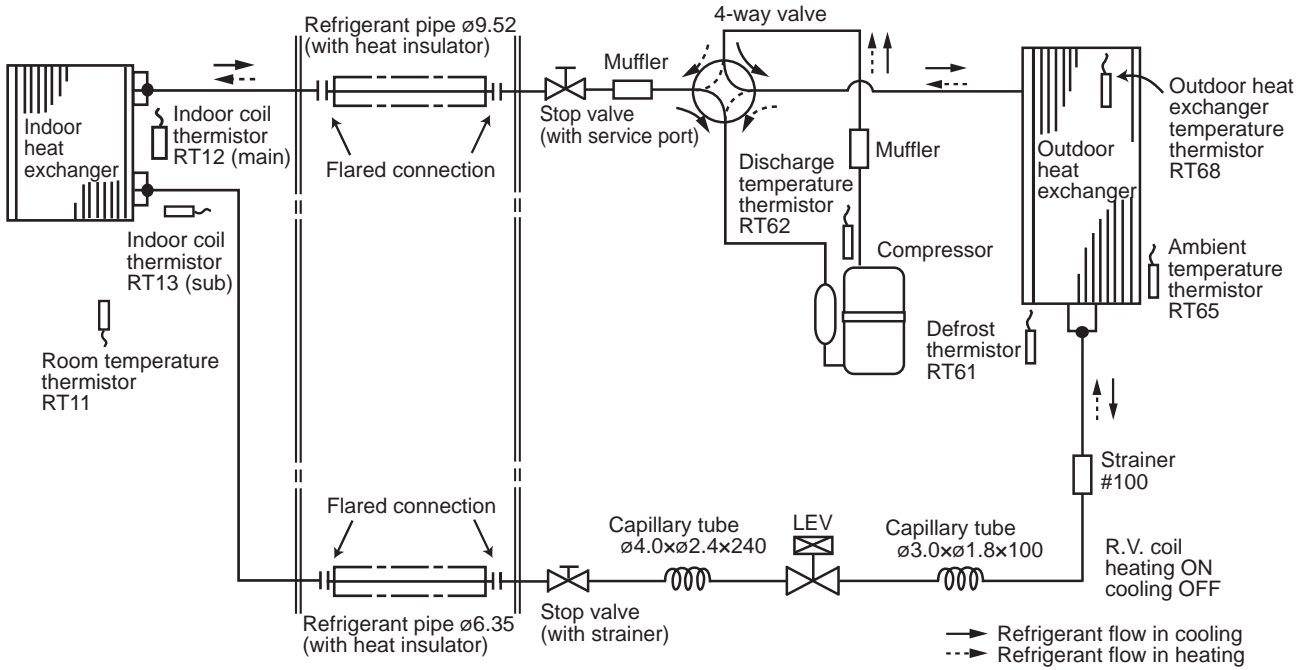

MSZ-AY42VG MSZ-AY42VGK

MUZ-AY42VG MUZ-AY42VGH

INDOOR UNIT

OUTDOOR UNIT

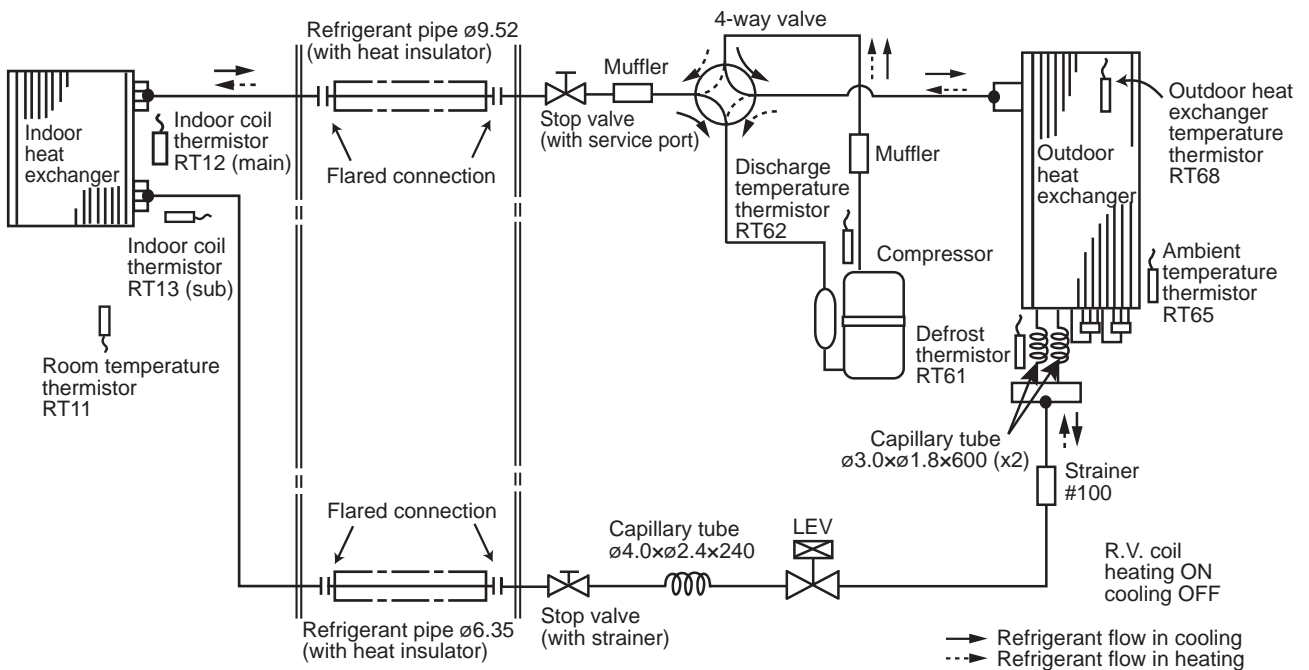

REFRIGERANT SYSTEM DIAGRAM

WALL-MOUNTED

Unit: mm

MSZ-AY50VG
MSZ-AY50VGK

MUZ-AY50VG
MUZ-AY50VGH

INDOOR UNIT

OUTDOOR UNIT

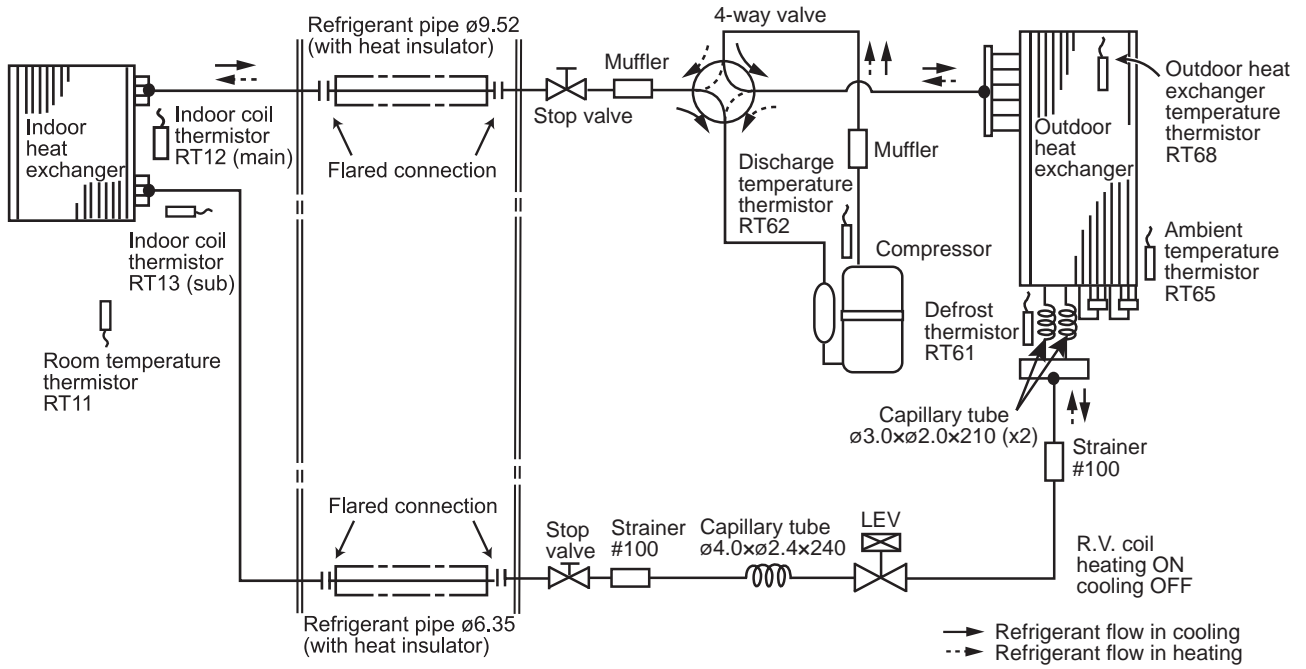

REFRIGERANT SYSTEM DIAGRAM

WALL-MOUNTED

Unit: mm

MSZ-AP15VG
MSZ-AP15VGK

MUZ-AP15VG

INDOOR UNIT

OUTDOOR UNIT

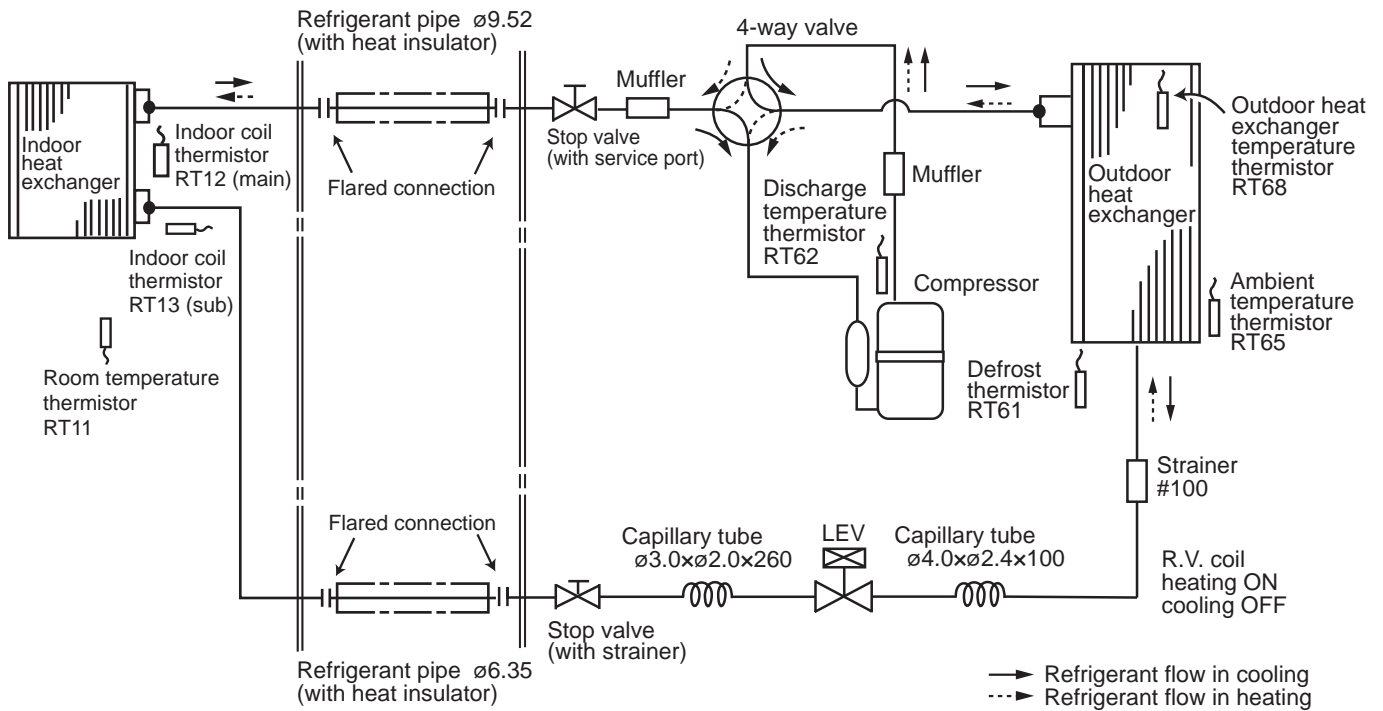

MSZ-AP20VG
MSZ-AP20VGK

MUZ-AP20VG

INDOOR UNIT

OUTDOOR UNIT

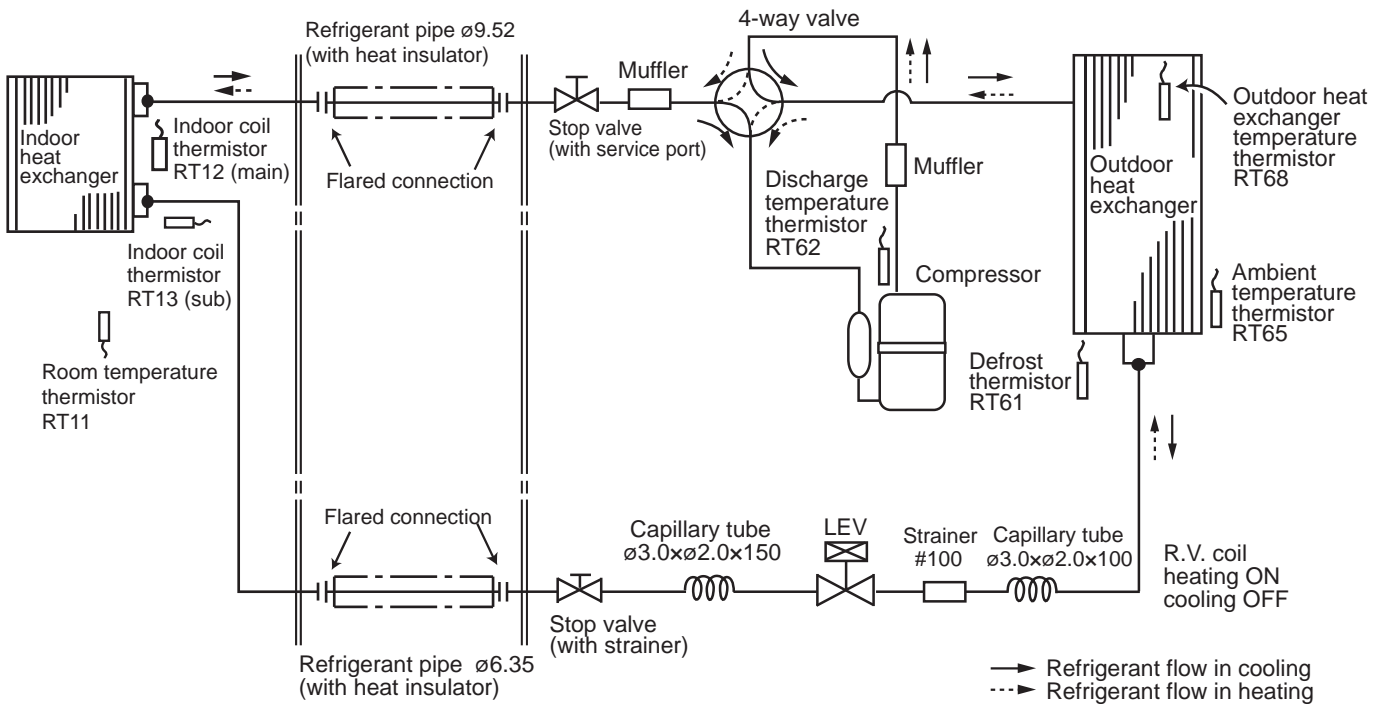

REFRIGERANT SYSTEM DIAGRAM

WALL-MOUNTED

Unit: mm

**MSZ-AP60VG
MSZ-AP60VGK**

MUZ-AP60VG

INDOOR UNIT

OUTDOOR UNIT

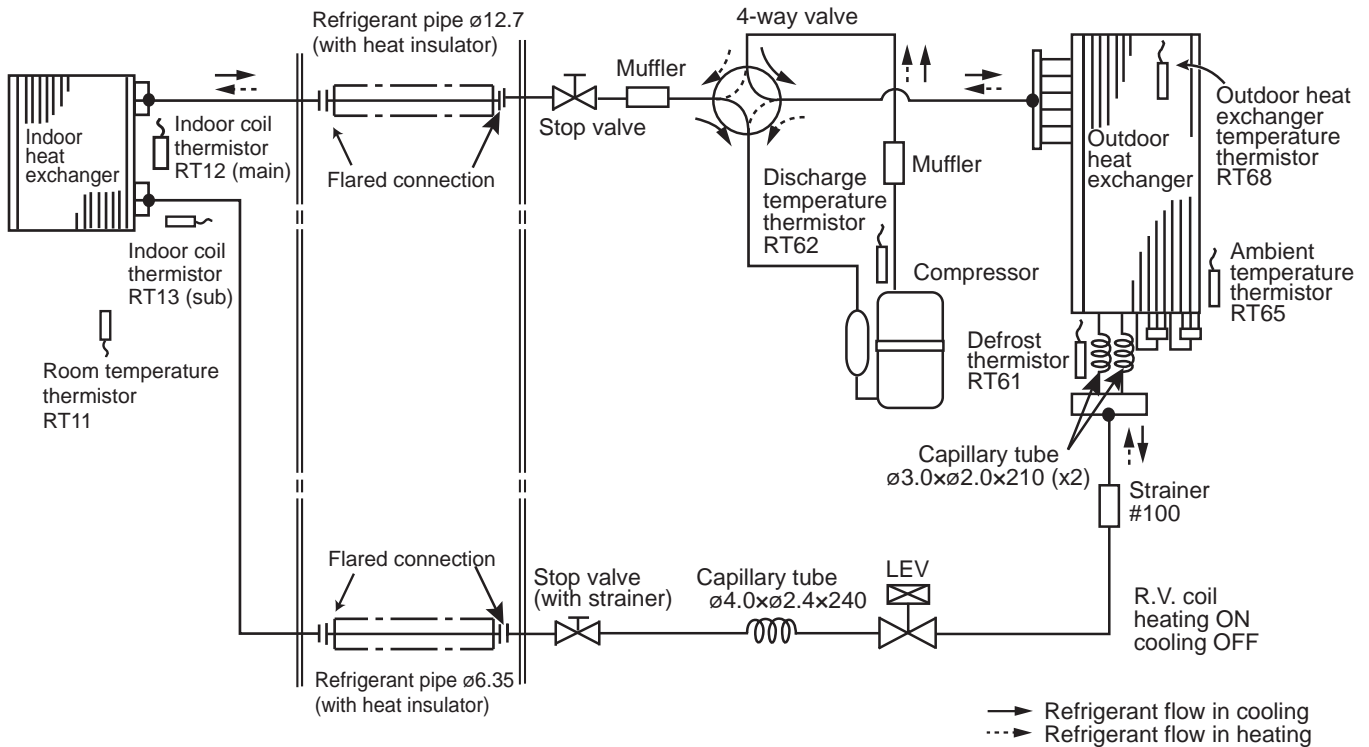

**MSZ-AP71VG
MSZ-AP71VGK**

MUZ-AP71VG

INDOOR UNIT

OUTDOOR UNIT

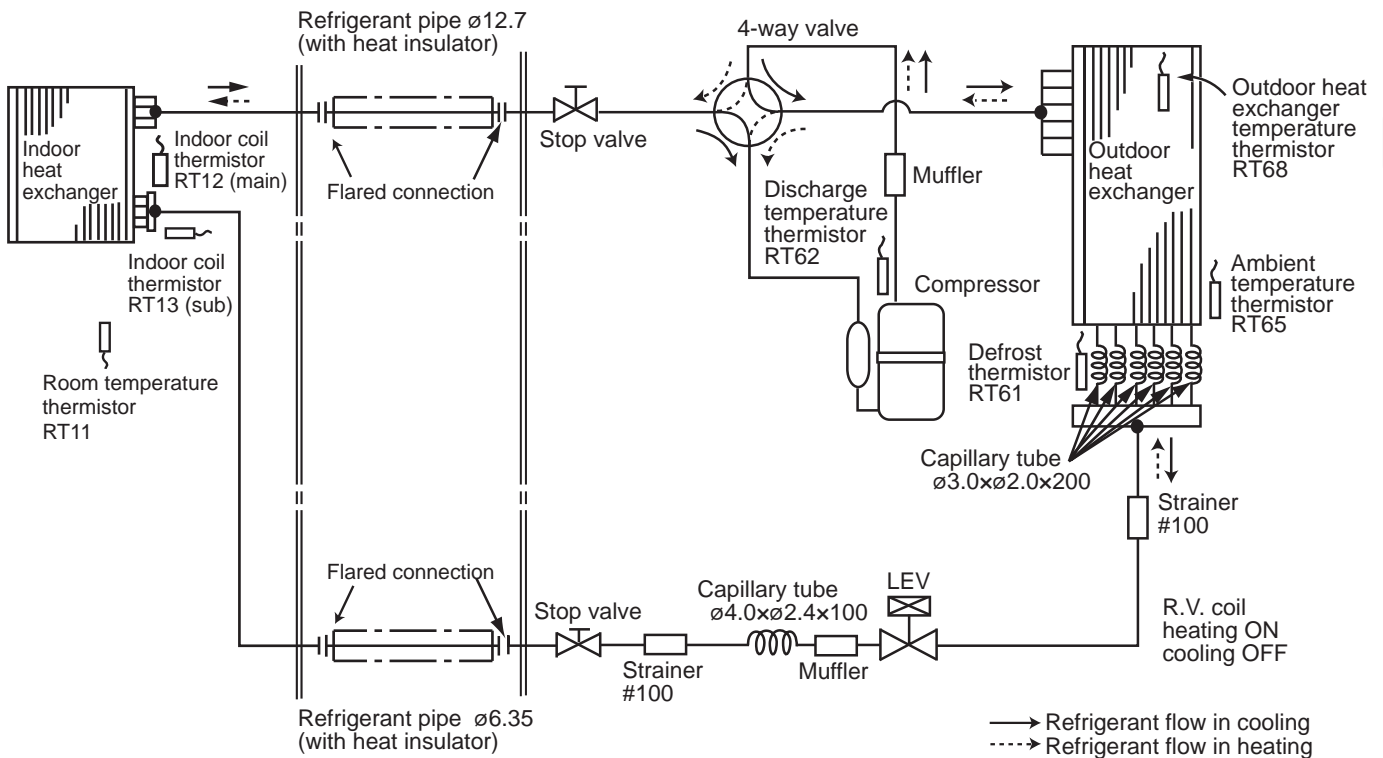

WALL-MOUNTED REFRIGERANT SYSTEM DIAGRAM

Unit: mm

MSZ-HR25VF
MSZ-HR25VFK

MUZ-HR25VF

INDOOR UNIT

OUTDOOR UNIT

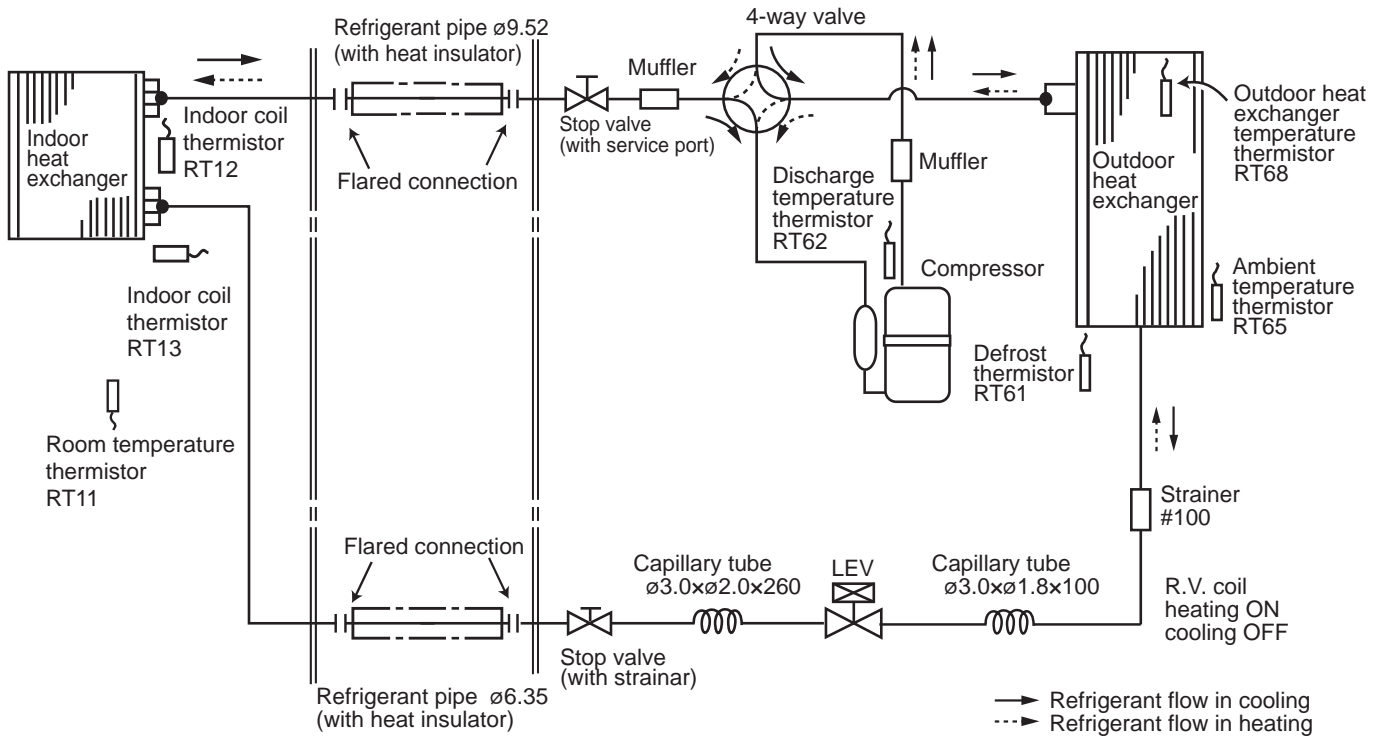

MSZ-HR35VF
MSZ-HR35VFK

MUZ-HR35VF

INDOOR UNIT

OUTDOOR UNIT

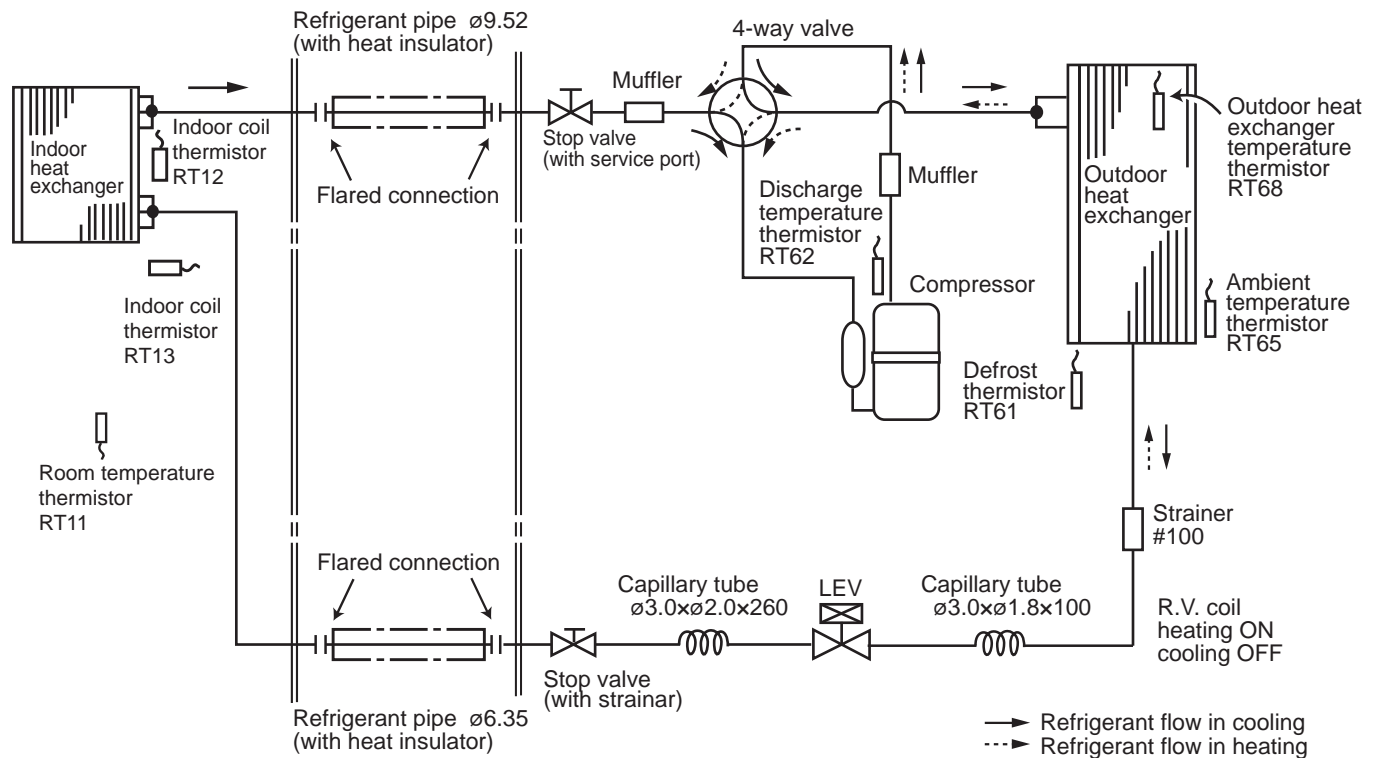

REFRIGERANT SYSTEM DIAGRAM

WALL-MOUNTED

Unit: mm

MSZ-HR42VF
MSZ-HR50VF

MSZ-HR42VFK
MSZ-HR50VFK

MUZ-HR42VF
MUZ-HR50VF

INDOOR UNIT

OUTDOOR UNIT

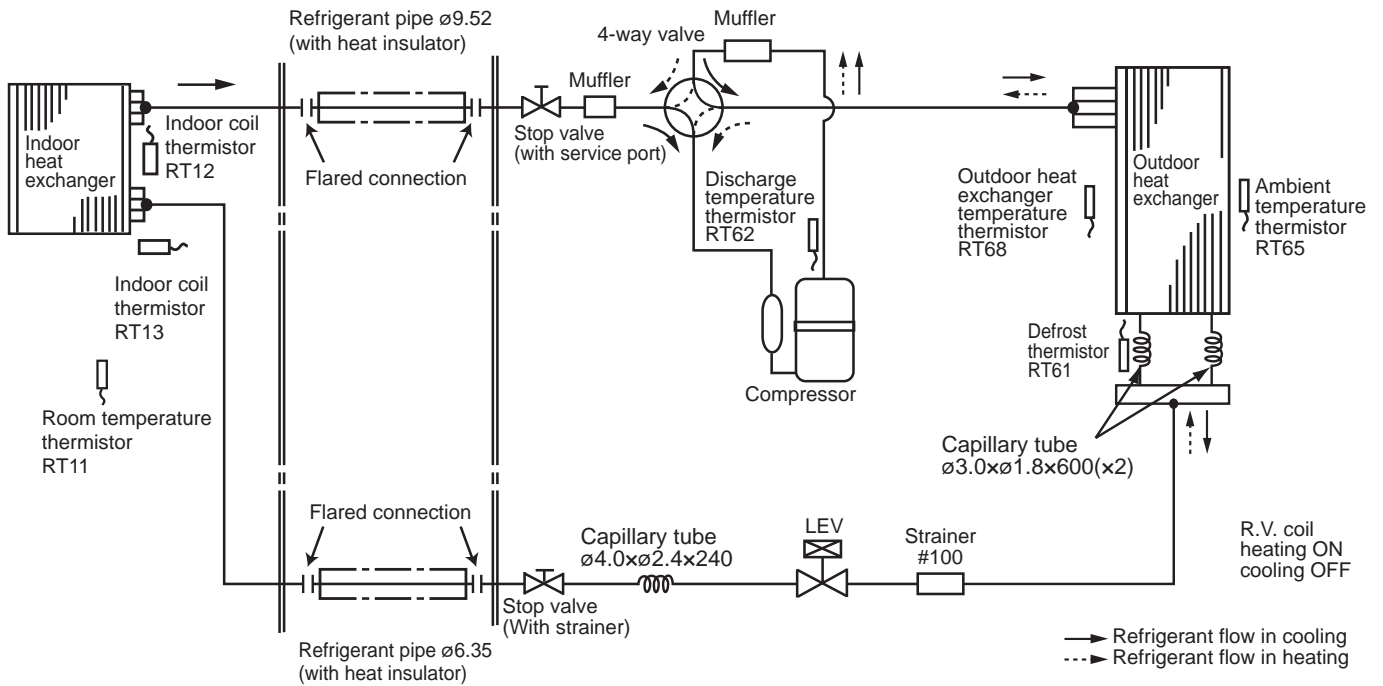

MSZ-HR60VF
MSZ-HR71VF

MSZ-HR60VFK
MSZ-HR71VFK

MUZ-HR60VF
MUZ-HR71VF

INDOOR UNIT

OUTDOOR UNIT

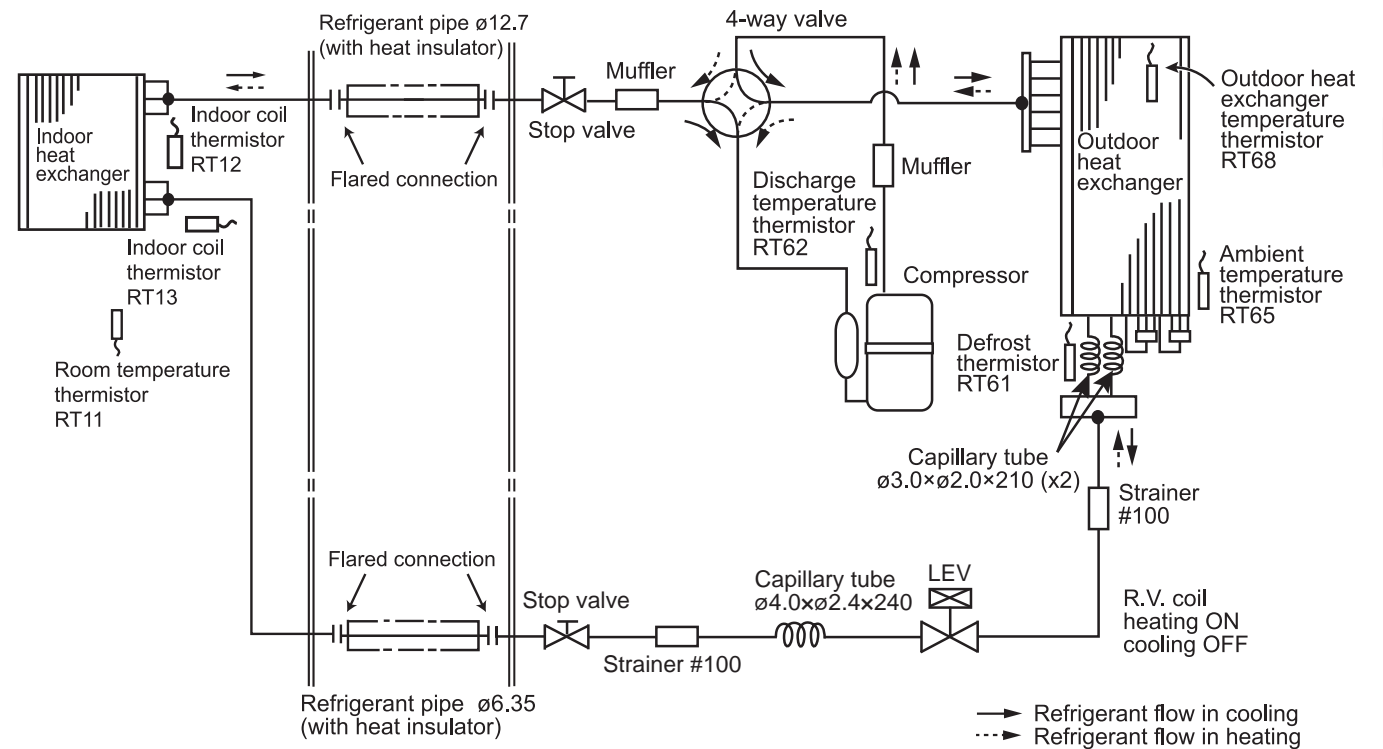

WALL-MOUNTED REFRIGERANT SYSTEM DIAGRAM

Unit: mm

MSY-TP35VF
MSY-TP50VF

MUY-TP35VF
MUY-TP50VF

INDOOR UNIT

OUTDOOR UNIT

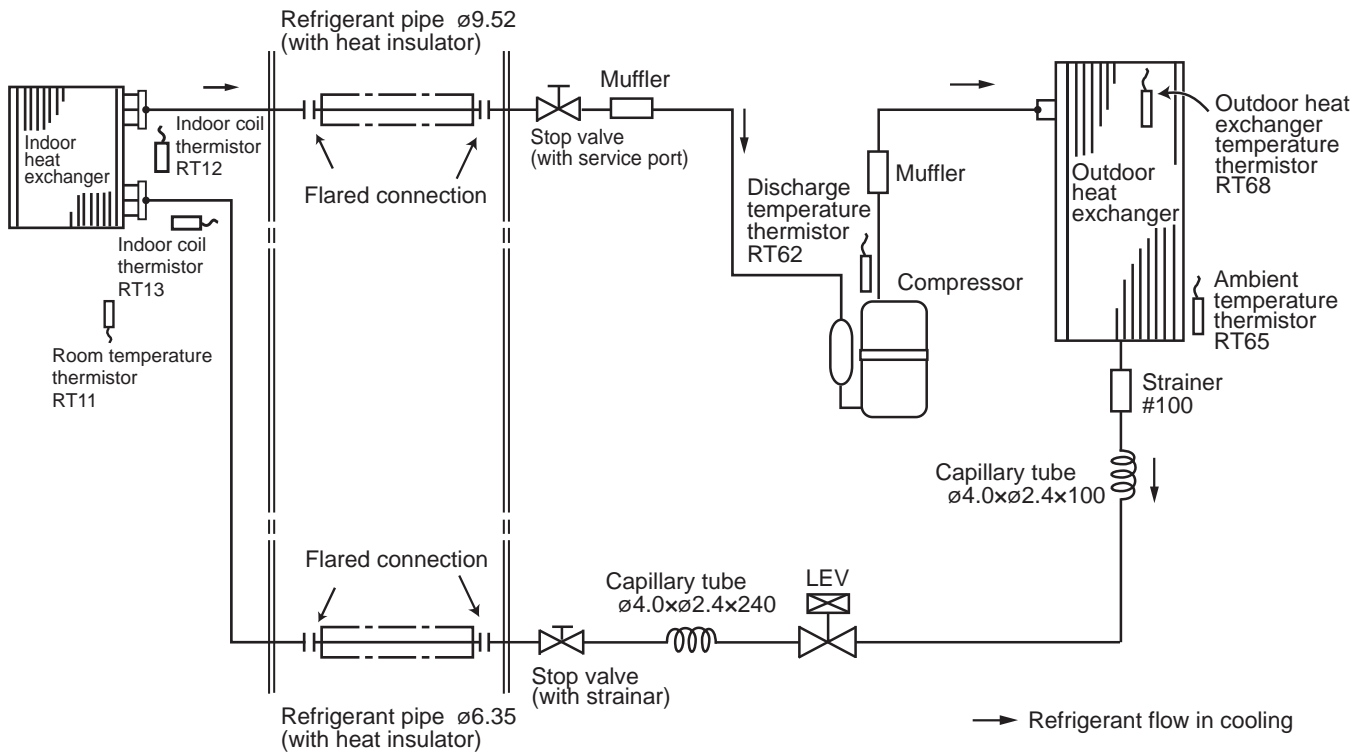

REFRIGERANT SYSTEM DIAGRAM

WALL-MOUNTED

Unit: mm

MSZ-FH25VE2
MSZ-FH35VE2

INDOOR UNIT

MUZ-FH25VE
MUZ-FH25VEHZ
MUZ-FH35VE
MUZ-FH35VEHZ
OUTDOOR UNIT

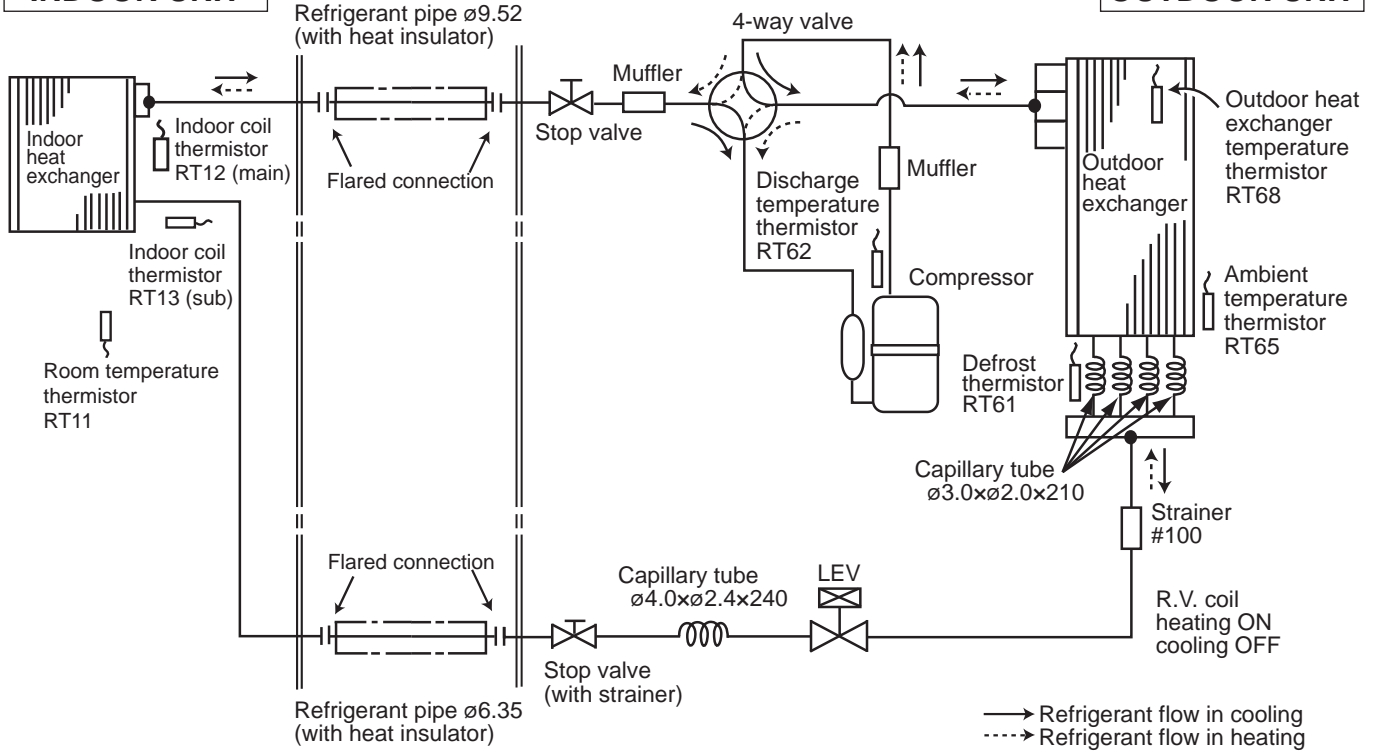

MSZ-FH50VE2

INDOOR UNIT

MUZ-FH50VE
MUZ-FH50VEHZ
OUTDOOR UNIT

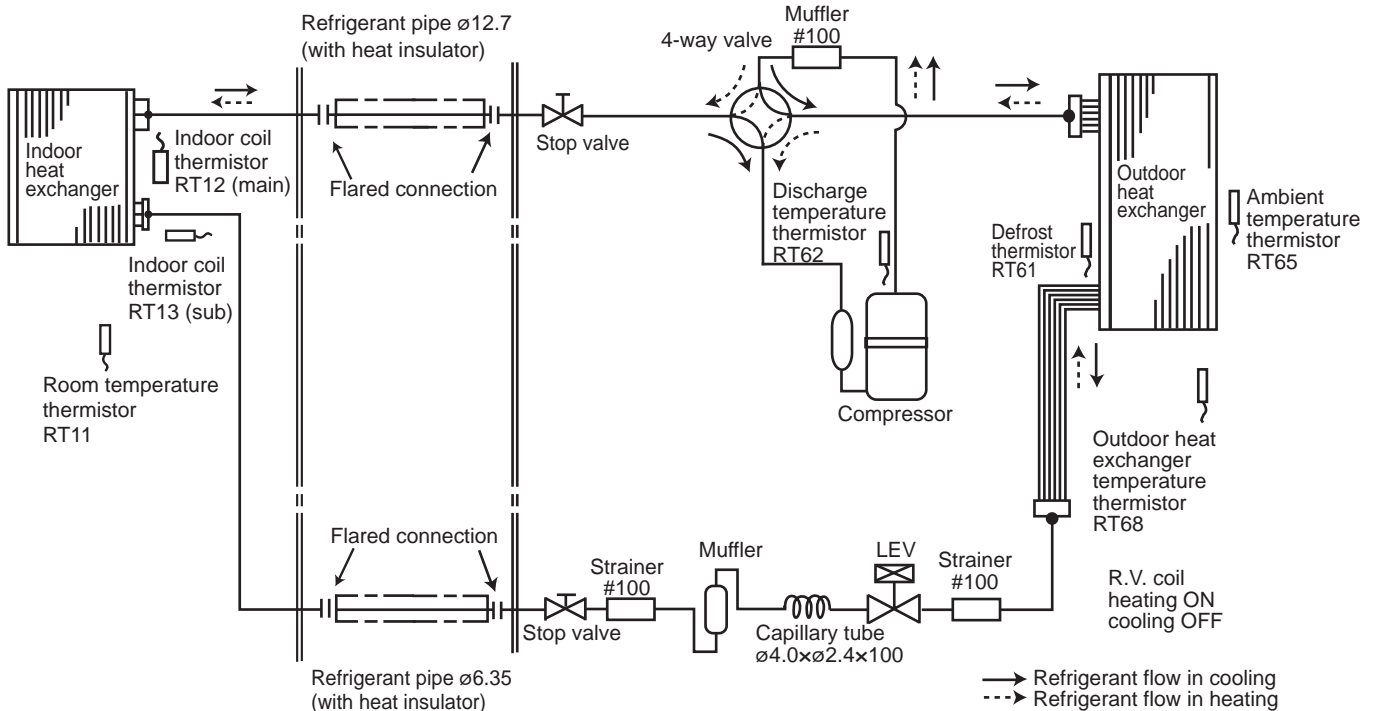

REFRIGERANT SYSTEM DIAGRAM

WALL-MOUNTED

Unit: mm

- | | | |
|---------------------|---------------------|---------------------|
| MSZ-EF18VGW | MSZ-EF18VGB | MSZ-EF18VGS |
| MSZ-EF18VGKW | MSZ-EF18VGKB | MSZ-EF18VGKS |
| MSZ-EF22VGW | MSZ-EF22VGB | MSZ-EF22VGS |
| MSZ-EF22VGKW | MSZ-EF22VGKB | MSZ-EF22VGKS |

INDOOR UNIT

OUTDOOR UNIT

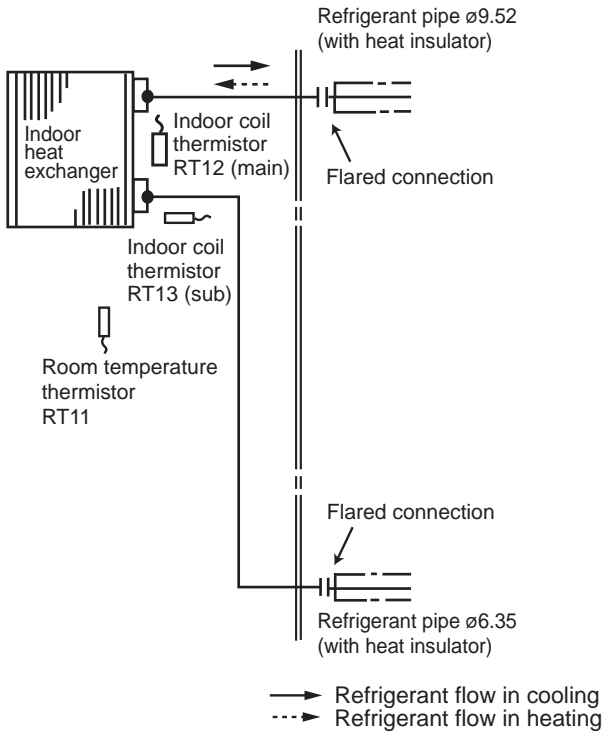

For Multi connection

- | | | |
|---------------------|---------------------|---------------------|
| MSZ-EF25VGW | MSZ-EF25VGB | MSZ-EF25VGS |
| MSZ-EF25VGKW | MSZ-EF25VGKB | MSZ-EF25VGKS |

- | |
|--------------------|
| MUZ-EF25VG |
| MUZ-EF25VGH |

INDOOR UNIT

OUTDOOR UNIT

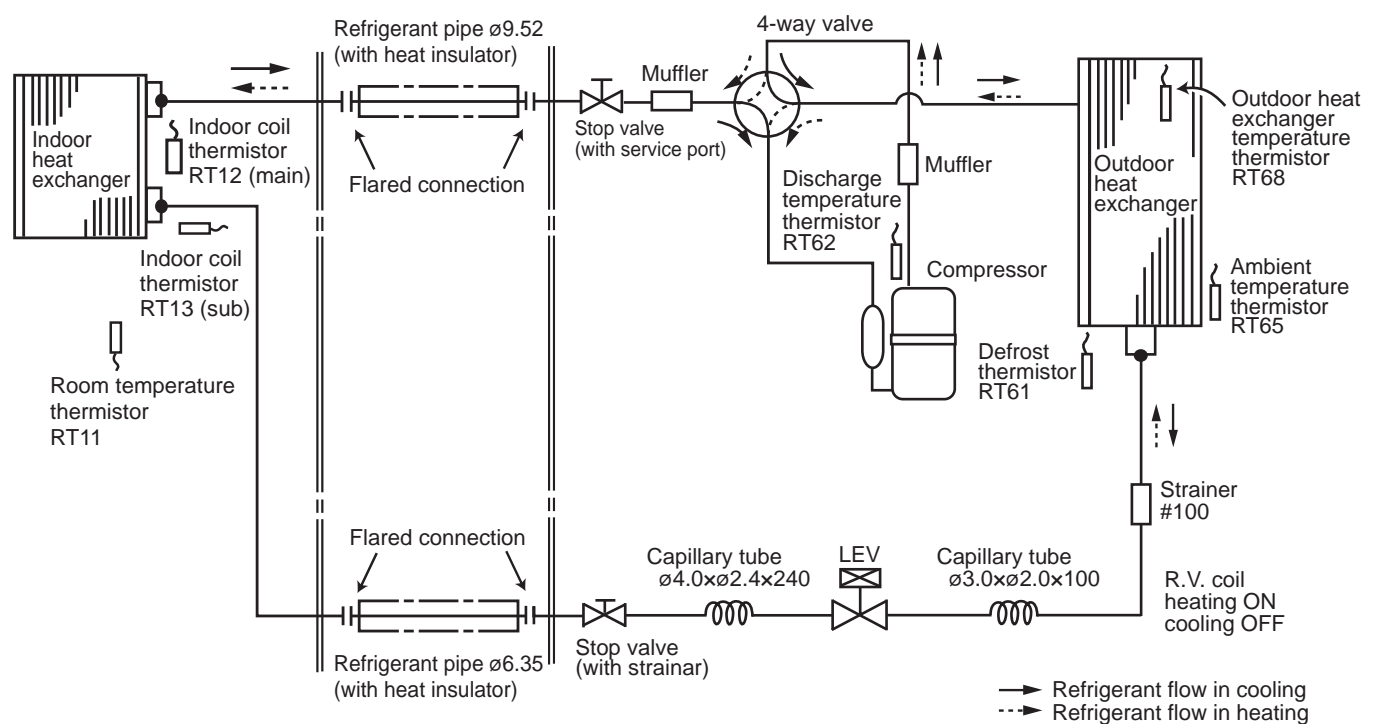

REFRIGERANT SYSTEM DIAGRAM

WALL-MOUNTED

Unit: mm

MSZ-EF35VGW MSZ-EF35VGB MSZ-EF35VGS
MSZ-EF35VGKW MSZ-EF35VGKB MSZ-EF35VGKS
MSZ-EF42VGW MSZ-EF42VGB MSZ-EF42VGS
MSZ-EF42VGKW MSZ-EF42VGKB MSZ-EF42VGKS

MUZ-EF35VG
MUZ-EF35VGH
MUZ-EF42VG

INDOOR UNIT

OUTDOOR UNIT

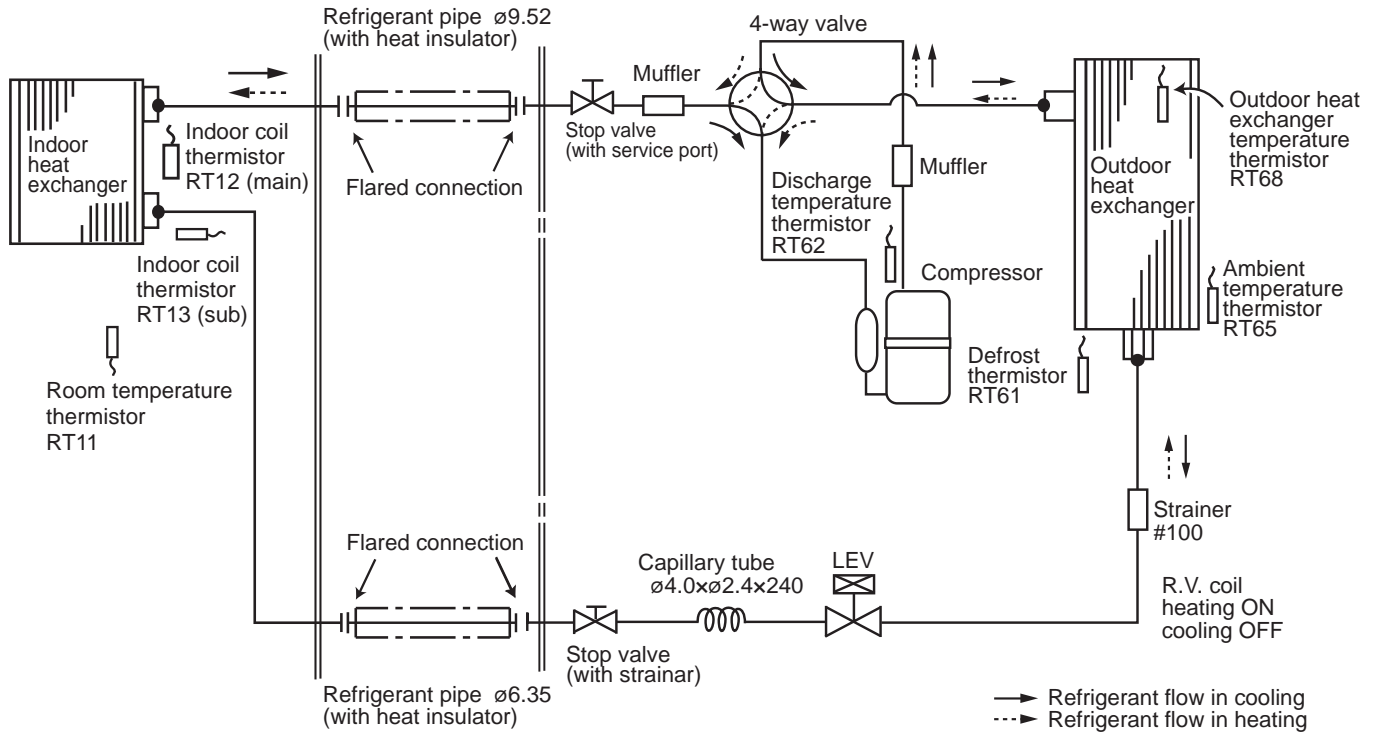

MSZ-EF50VGW MSZ-EF50VGB MSZ-EF50VGS
MSZ-EF50VGKW MSZ-EF50VGKB MSZ-EF50VGKS

MUZ-EF50VG

INDOOR UNIT

OUTDOOR UNIT

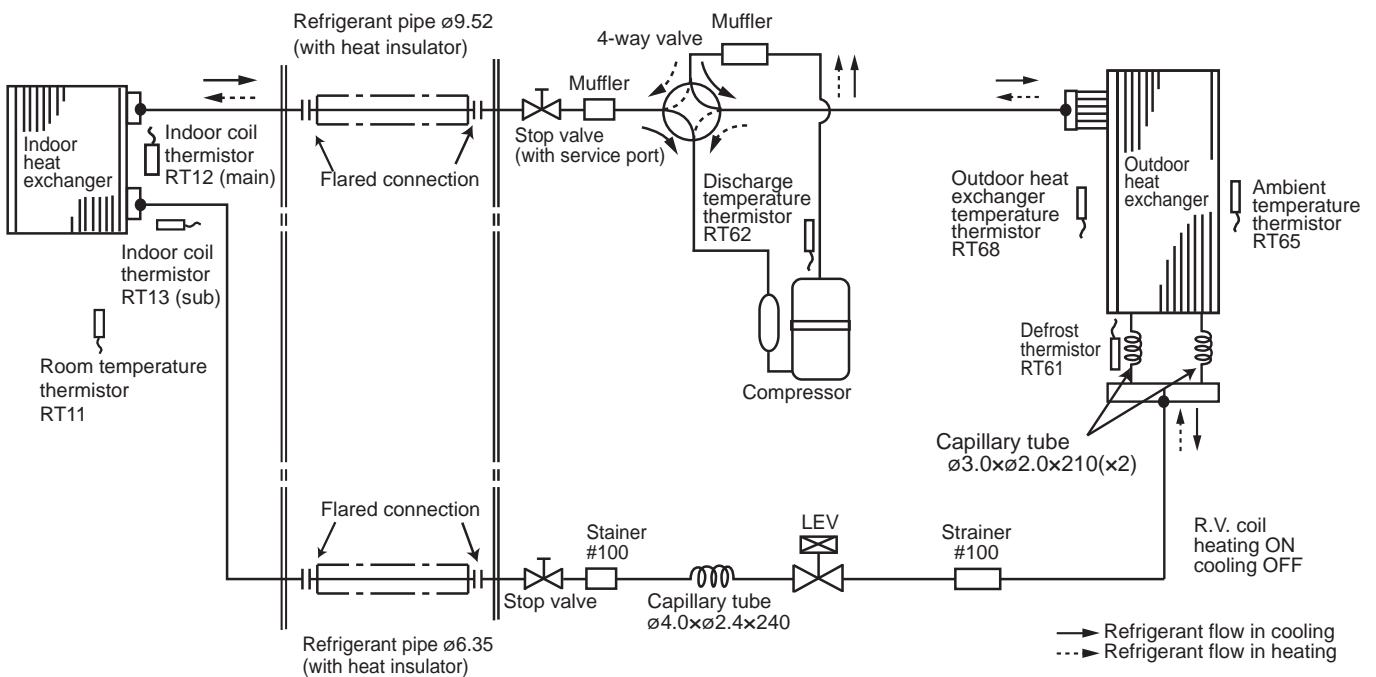

REFRIGERANT SYSTEM DIAGRAM

WALL-MOUNTED

Unit: mm

MSZ-BT20VG **MSZ-BT20VGK**
MSZ-BT25VG **MSZ-BT25VGK**

MUZ-BT20VG
MUZ-BT25VG

INDOOR UNIT

OUTDOOR UNIT

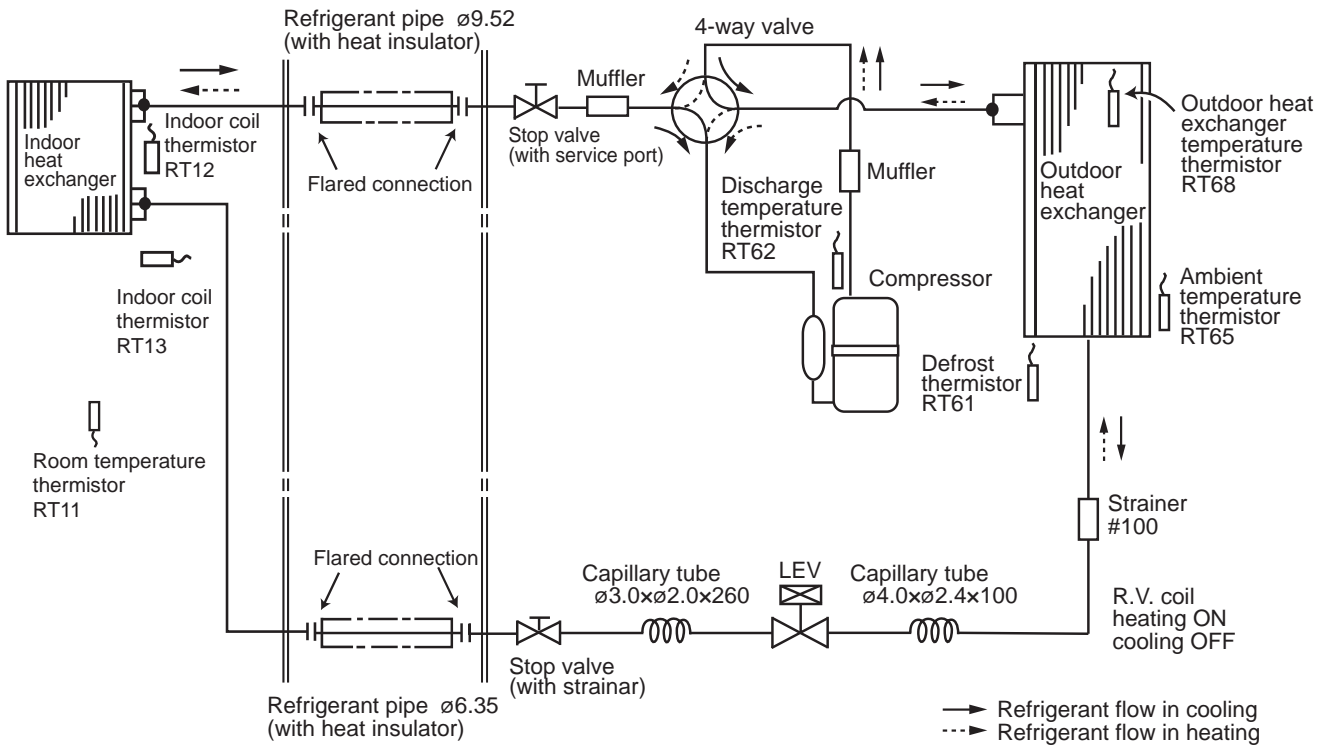

MSZ-BT35VG
MSZ-BT35VGK

MUZ-BT35VG

INDOOR UNIT

OUTDOOR UNIT

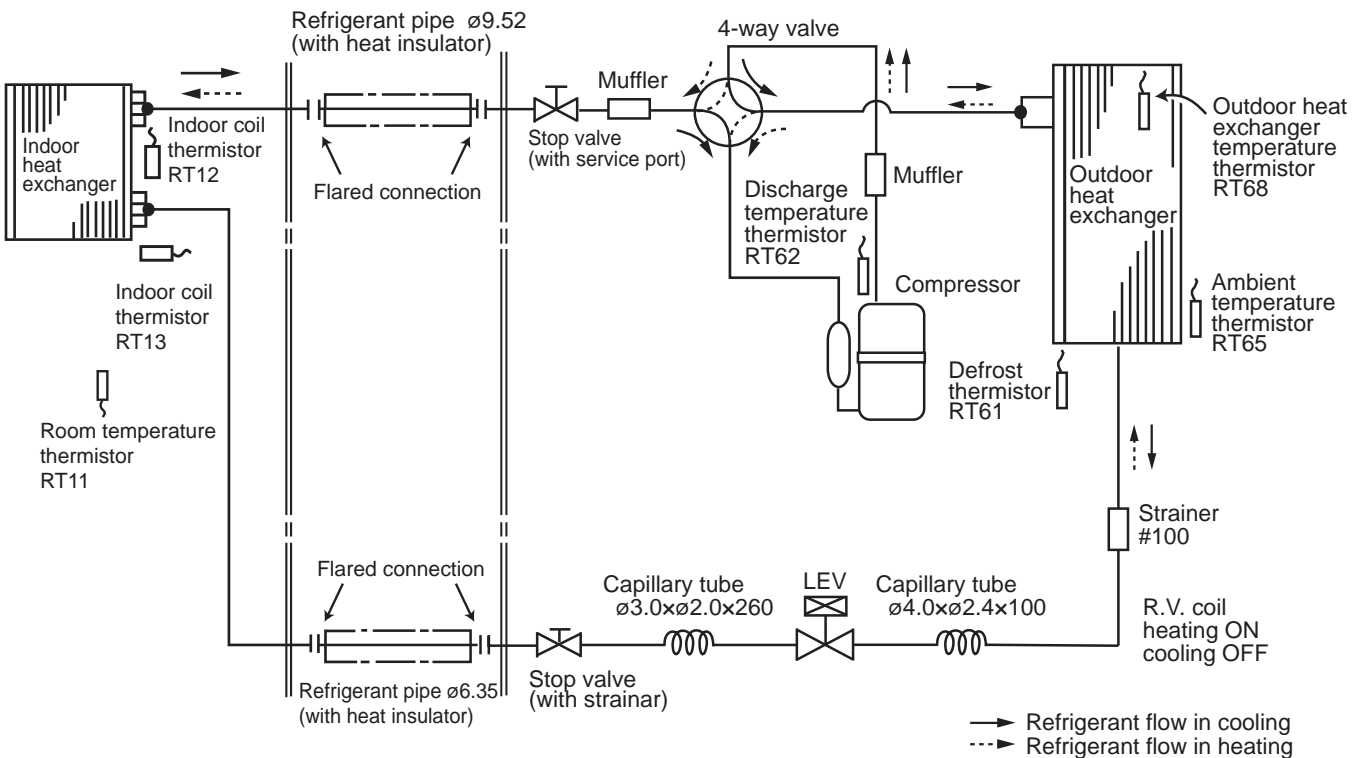

REFRIGERANT SYSTEM DIAGRAM

WALL-MOUNTED

Unit: mm

**MSZ-BT50VG
MSZ-BT50VGK**

MUZ-BT50VG

INDOOR UNIT

OUTDOOR UNIT

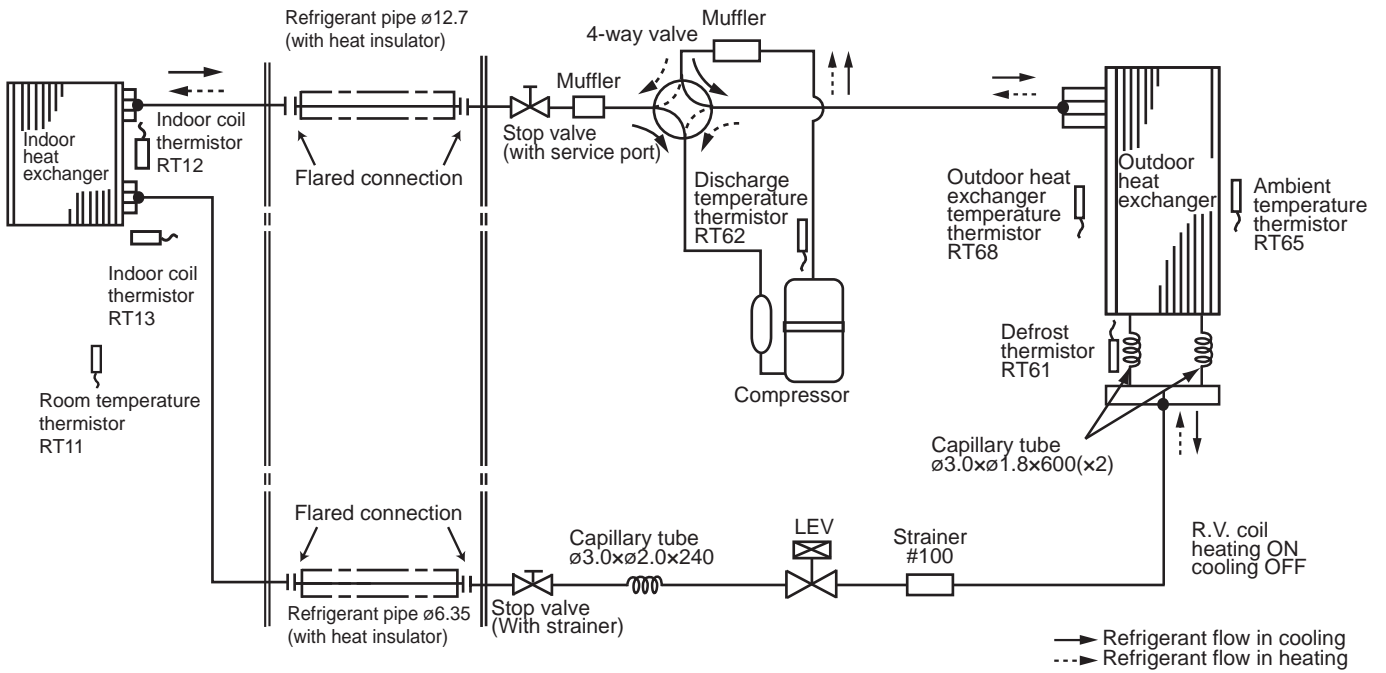

REFRIGERANT SYSTEM DIAGRAM

WALL-MOUNTED

Unit: mm

MSZ-DW25VF
MSZ-DW35VF

MUZ-DW25VF
MUZ-DW35VF

INDOOR UNIT

OUTDOOR UNIT

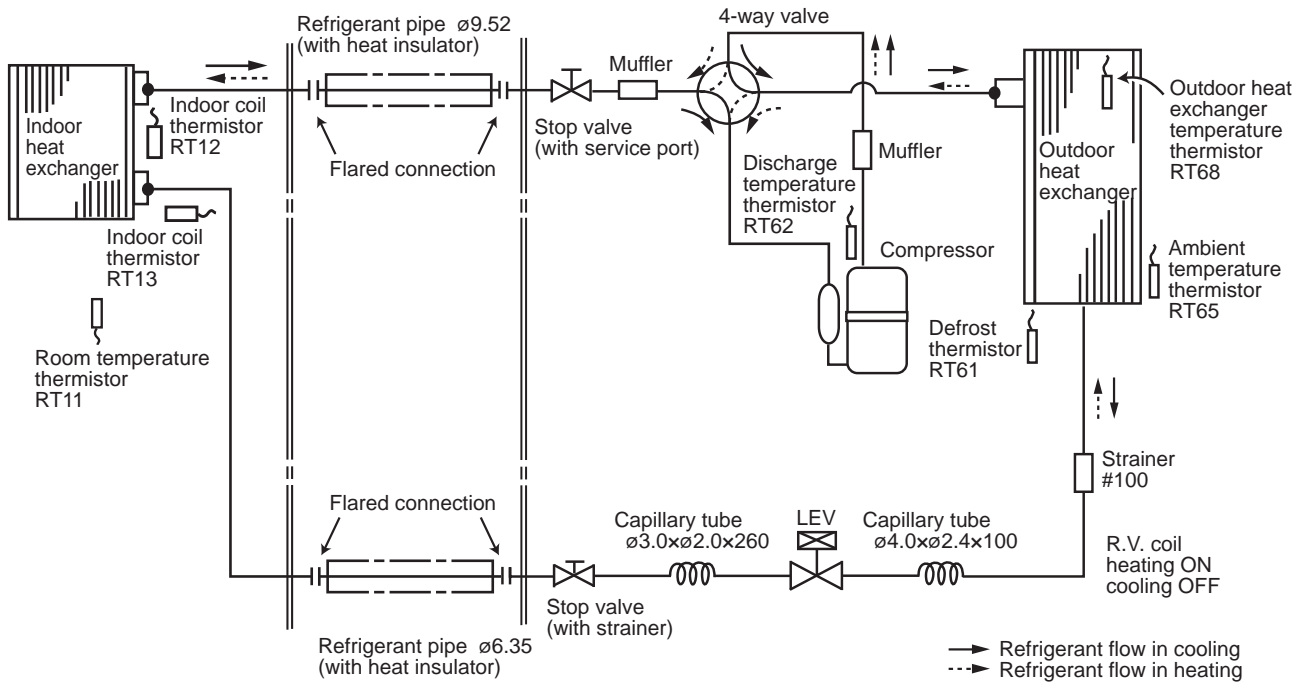

MSZ-DW50VF

MUZ-DW50VF

INDOOR UNIT

OUTDOOR UNIT

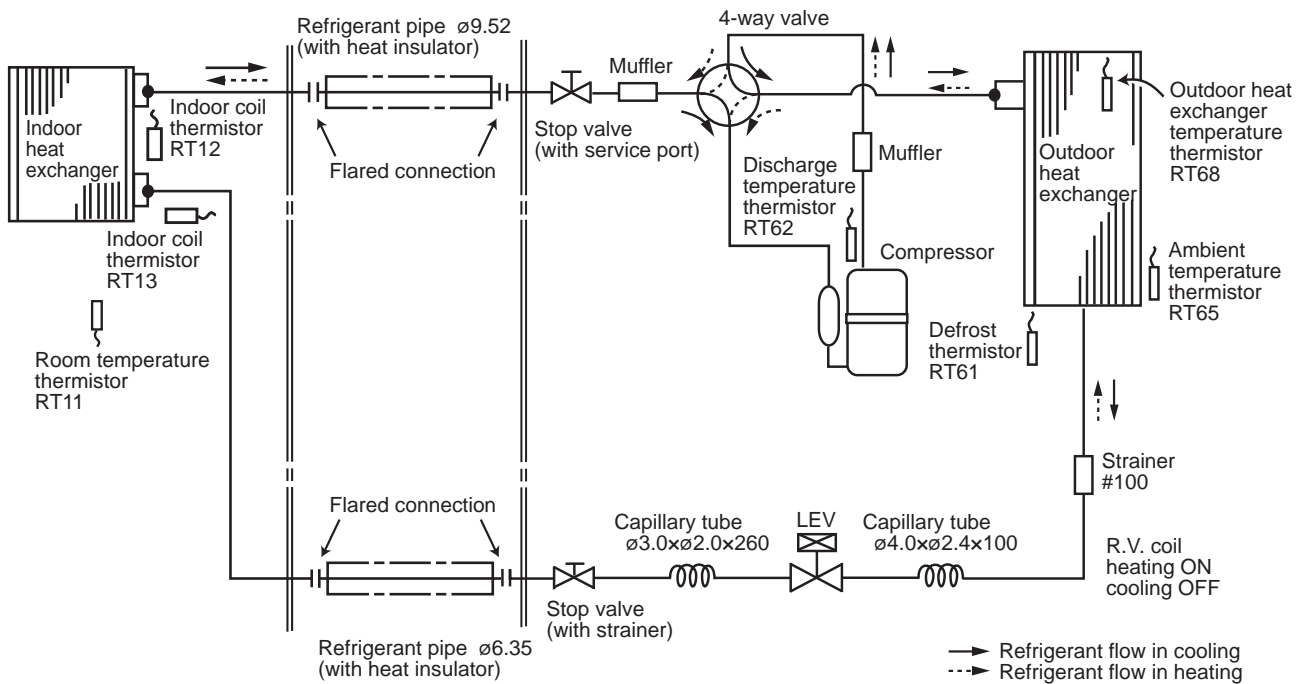

REFRIGERANT SYSTEM DIAGRAM

WALL-MOUNTED

Unit: mm

**MSZ-SF15VA
MSZ-SF20VA**

INDOOR UNIT

OUTDOOR UNIT

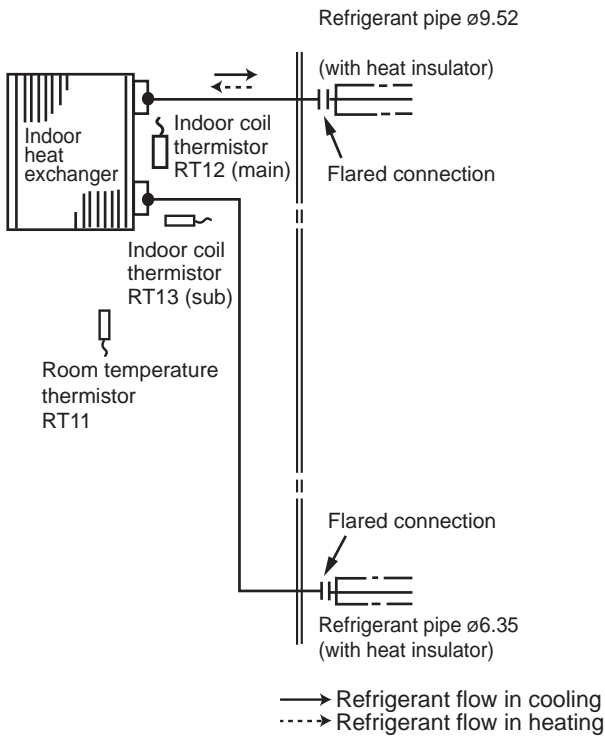

For Multi connection

**MSZ-SF25VE3
MSZ-SF35VE3**

INDOOR UNIT

**MUZ-SF25VE MUZ-SF25VEH
MUZ-SF35VE MUZ-SF35VEH**

OUTDOOR UNIT

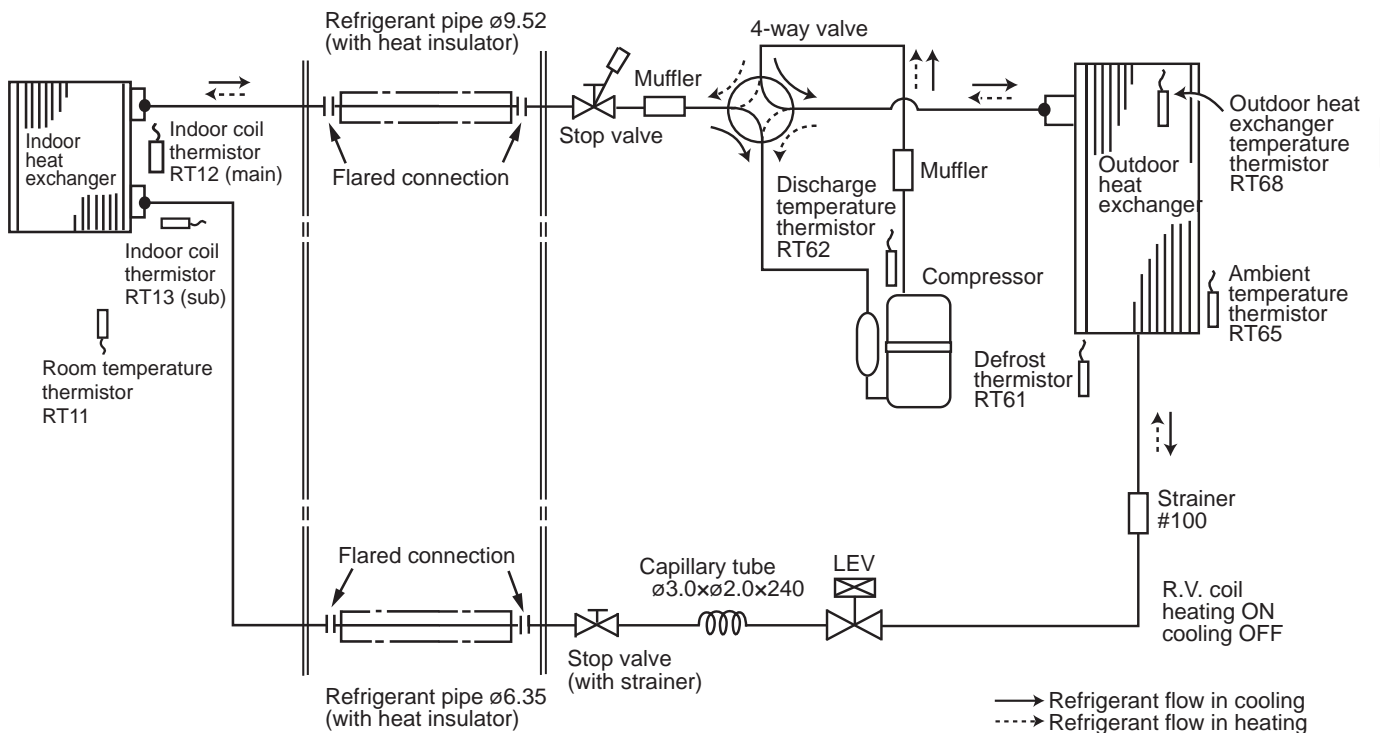

WALL-MOUNTED REFRIGERANT SYSTEM DIAGRAM

Unit: mm

**MUZ-SF42VE
MUZ-SF42VEH**

OUTDOOR UNIT

MSZ-SF42VE3

INDOOR UNIT

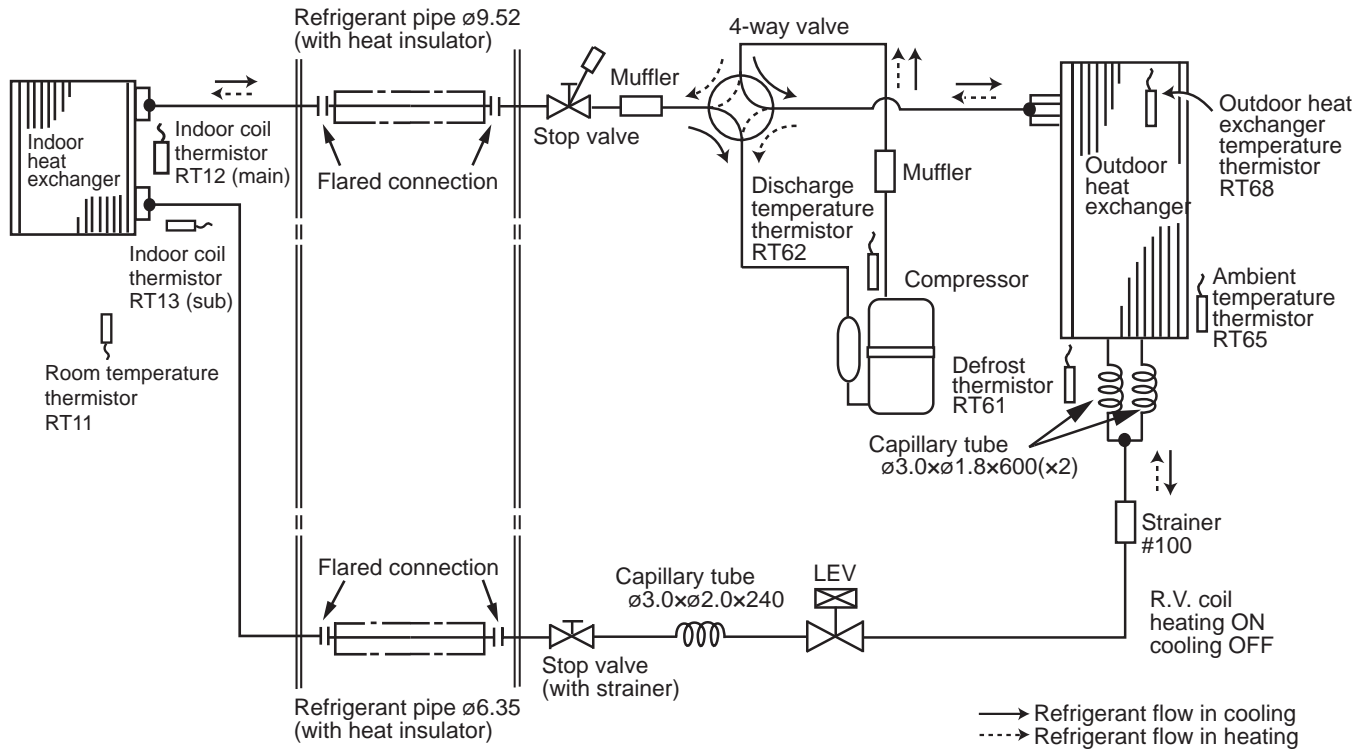

REFRIGERANT SYSTEM DIAGRAM

WALL-MOUNTED

**MUZ-SF50VE
MUZ-SF50VEH**

OUTDOOR UNIT

MSZ-SF50VE3

INDOOR UNIT

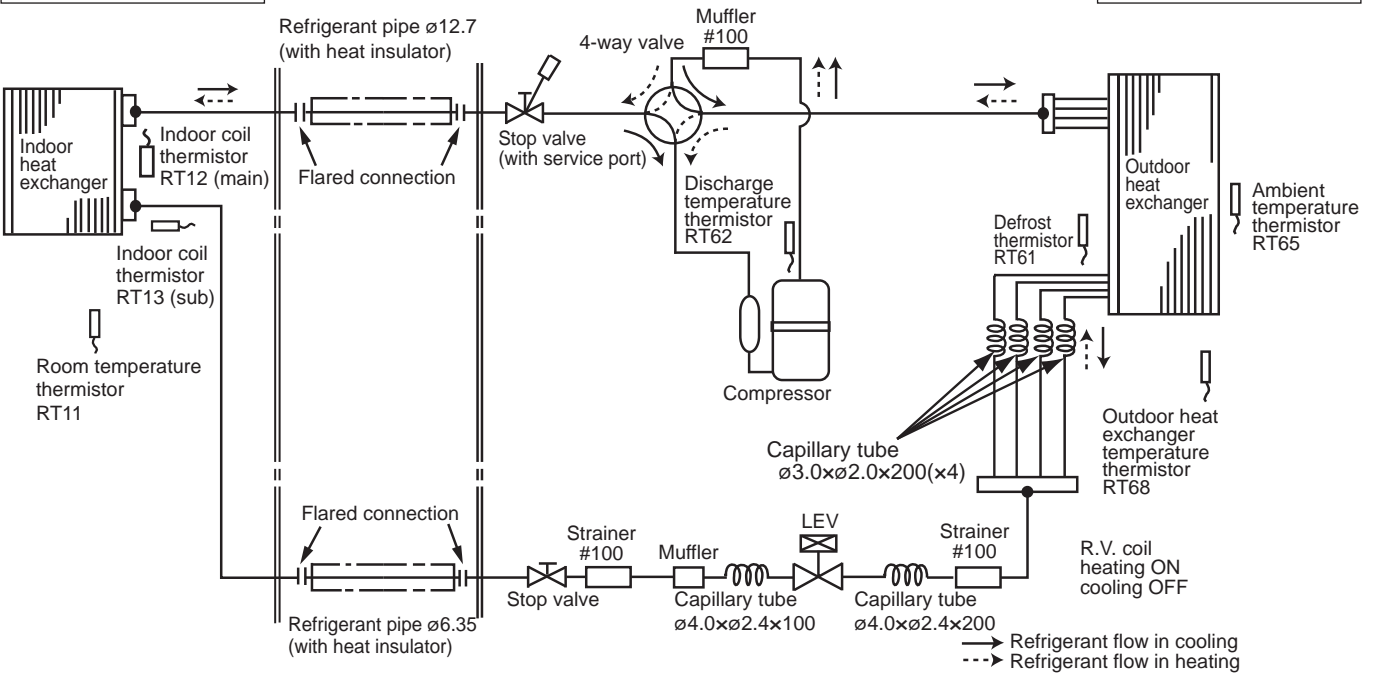

Unit: mm

MSZ-GF60VE2

MUZ-GF60VE

INDOOR UNIT

OUTDOOR UNIT

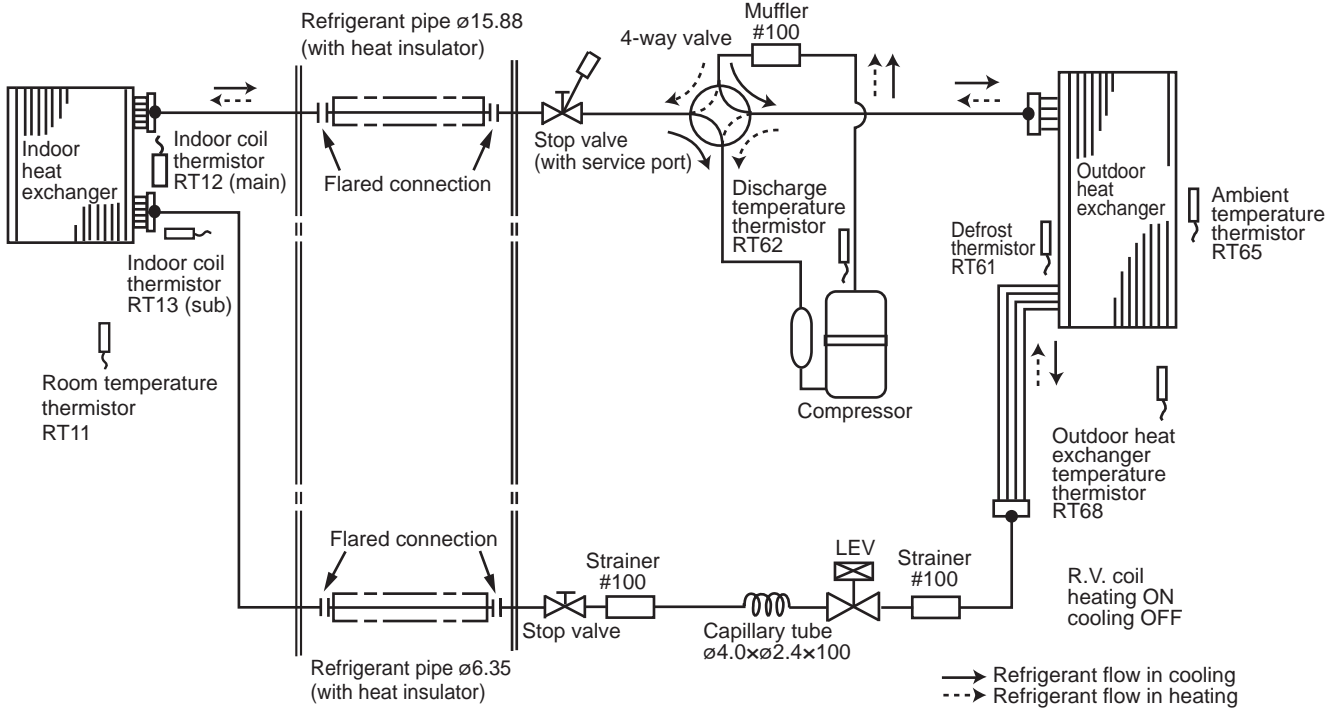

MSZ-GF71VE2

MUZ-GF71VE

INDOOR UNIT

OUTDOOR UNIT

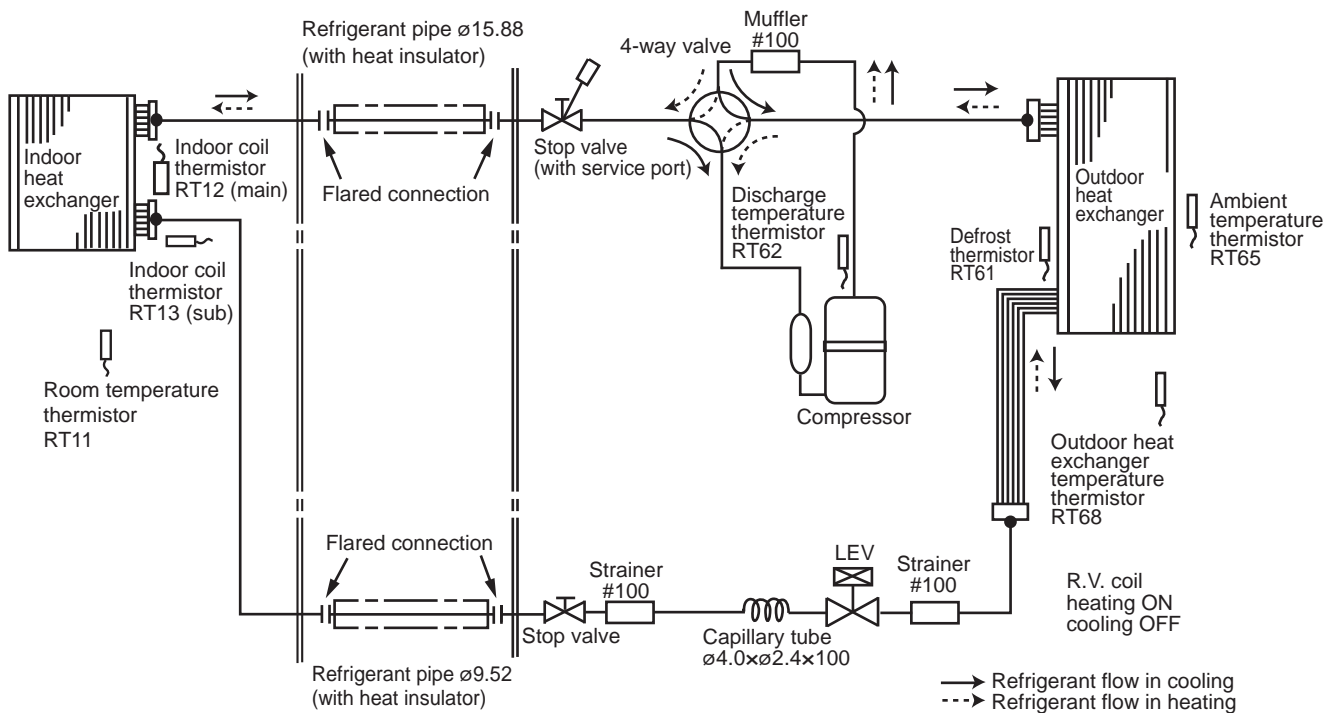

WALL-MOUNTED REFRIGERANT SYSTEM DIAGRAM

Unit: mm

**MSZ-WN25VA
MSZ-WN35VA**

**MUZ-WN25VA
MUZ-WN35VA**

INDOOR UNIT

OUTDOOR UNIT

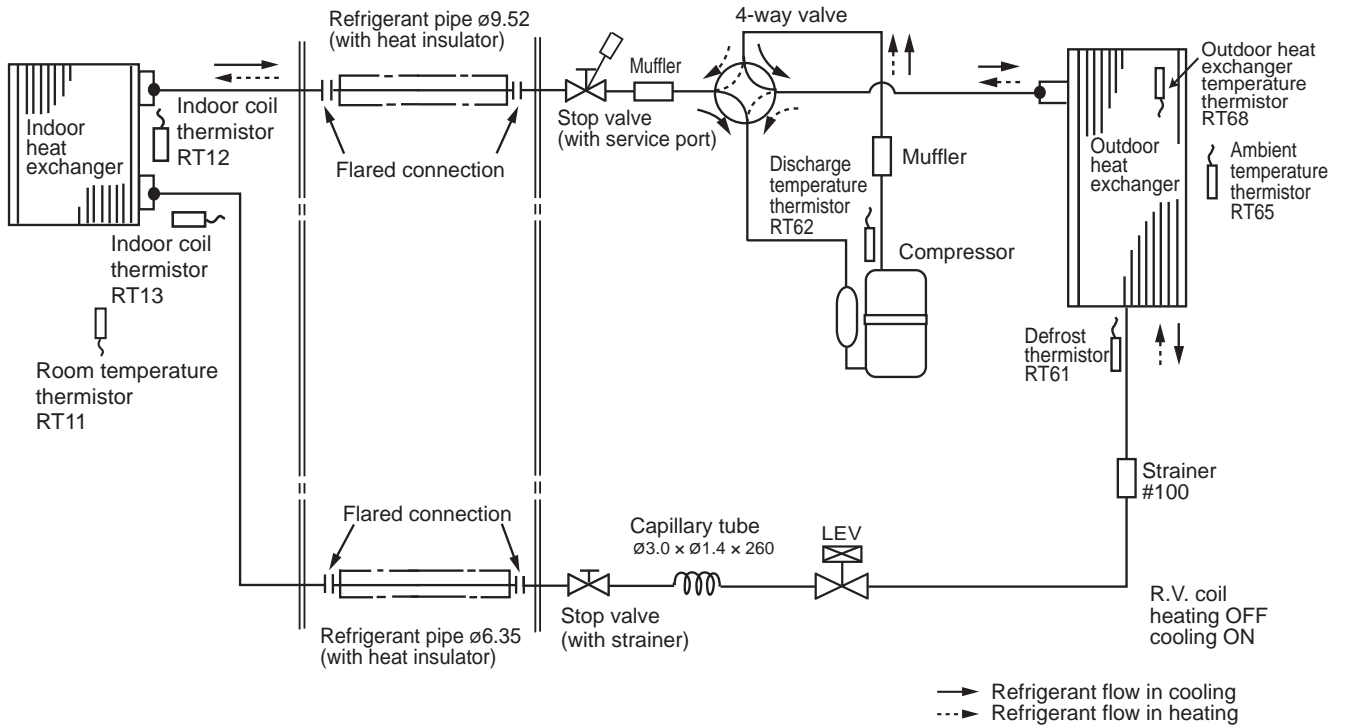

→ Refrigerant flow in cooling
 - - - - - Refrigerant flow in heating

**MSZ-DM25VA MSZ-HJ25VA
MSZ-DM35VA MSZ-HJ35VA**

**MUZ-DM25VA MUZ-HJ25VA
MUZ-DM35VA MUZ-HJ35VA**

INDOOR UNIT

OUTDOOR UNIT

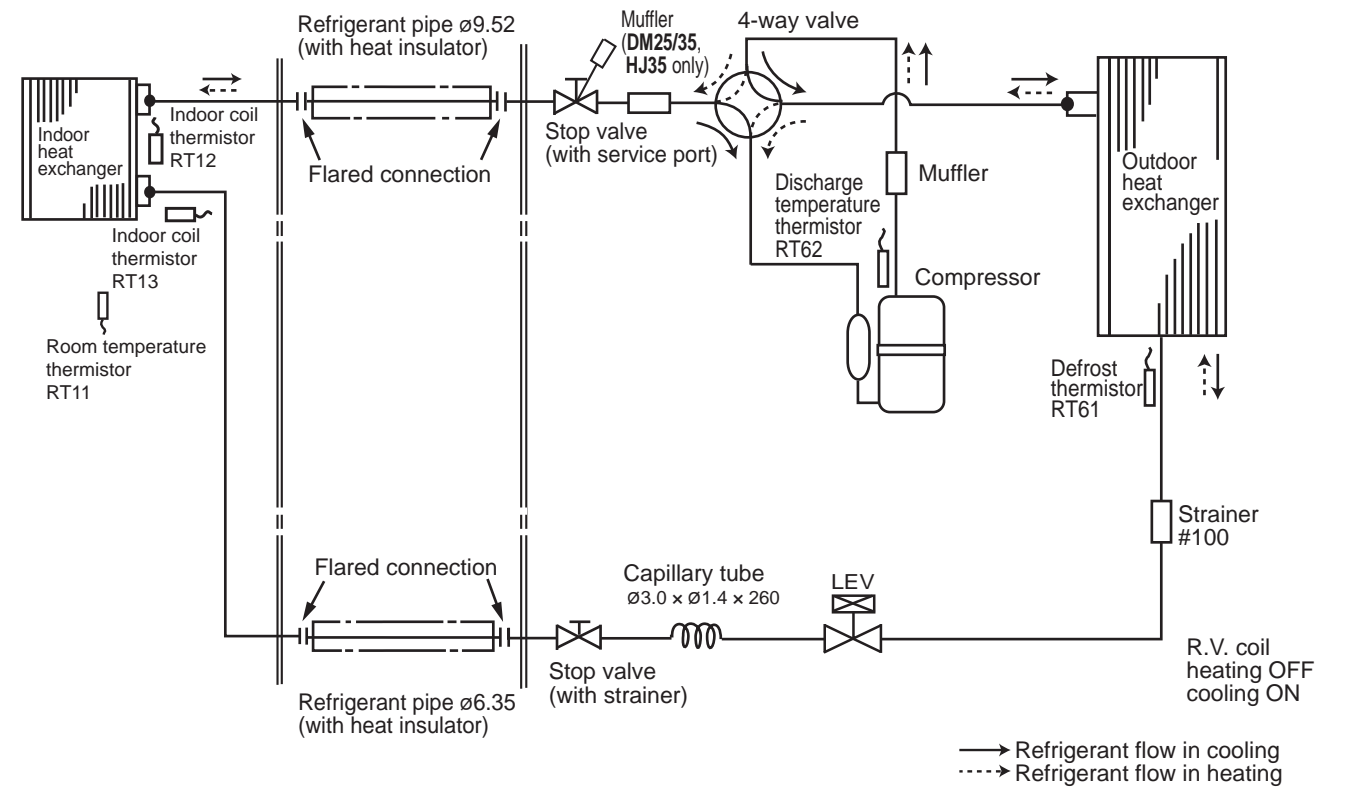

→ Refrigerant flow in cooling
 - - - - - Refrigerant flow in heating

REFRIGERANT SYSTEM DIAGRAM

WALL-MOUNTED

Unit: mm

MSZ-HJ50VA

MUZ-HJ50VA

INDOOR UNIT

OUTDOOR UNIT

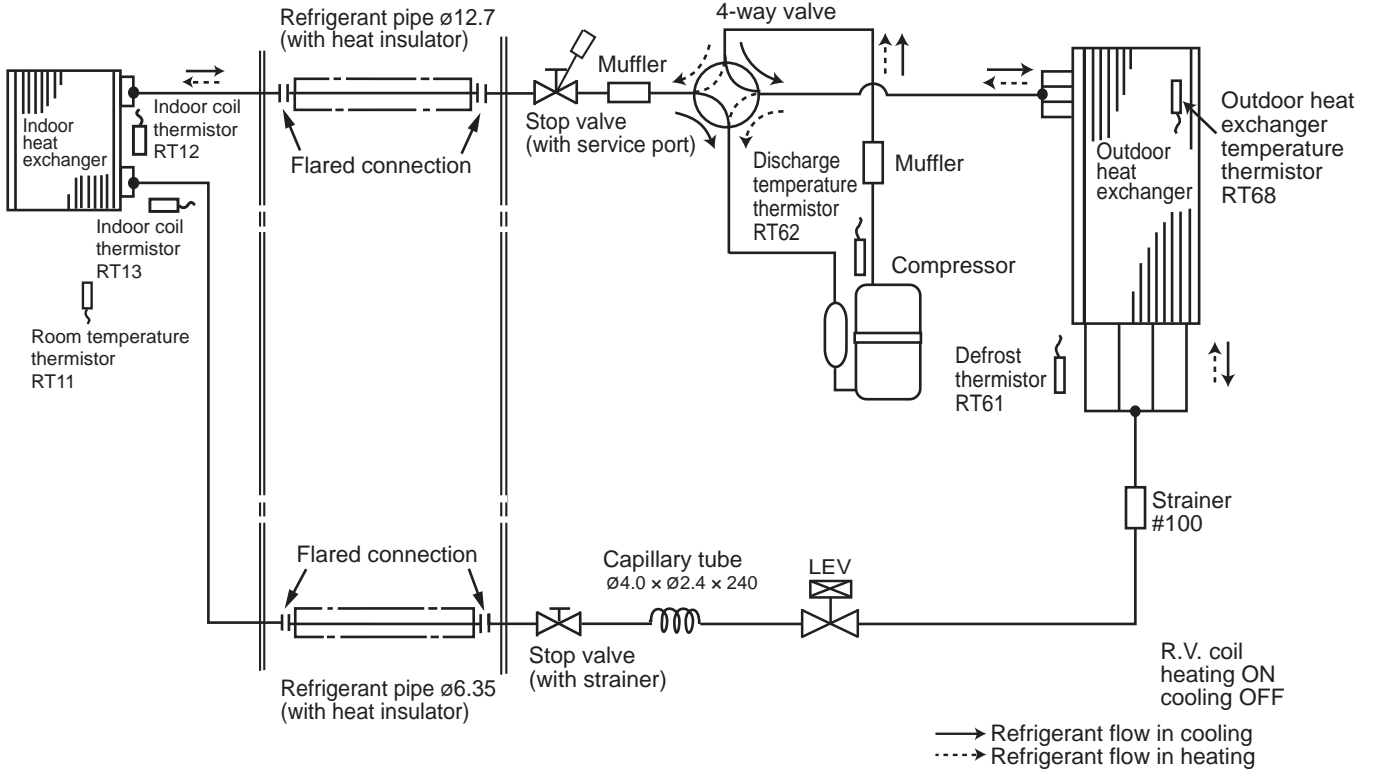

MSZ-HJ60VA

MUZ-HJ60VA

INDOOR UNIT

OUTDOOR UNIT

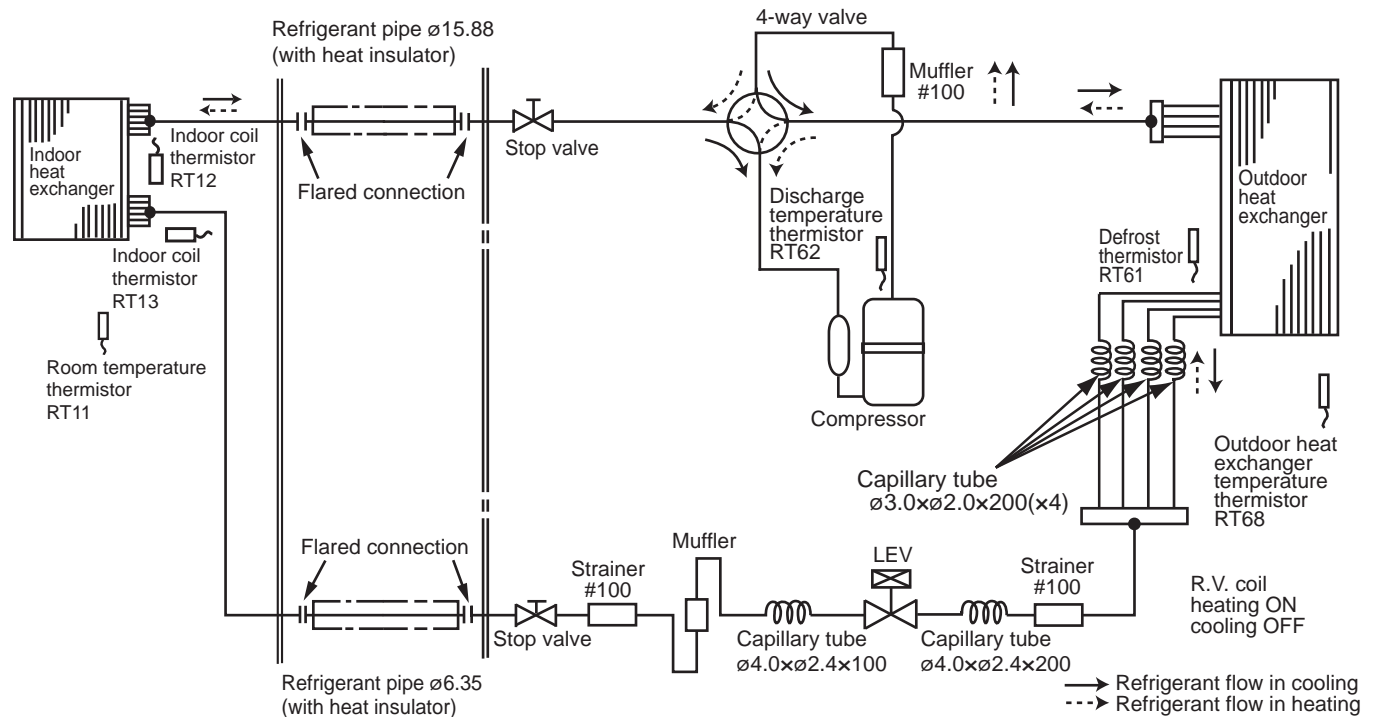

WALL-MOUNTED REFRIGERANT SYSTEM DIAGRAM

Unit: mm

MSZ-HJ71VA
INDOOR UNIT

MUZ-HJ71VA
OUTDOOR UNIT

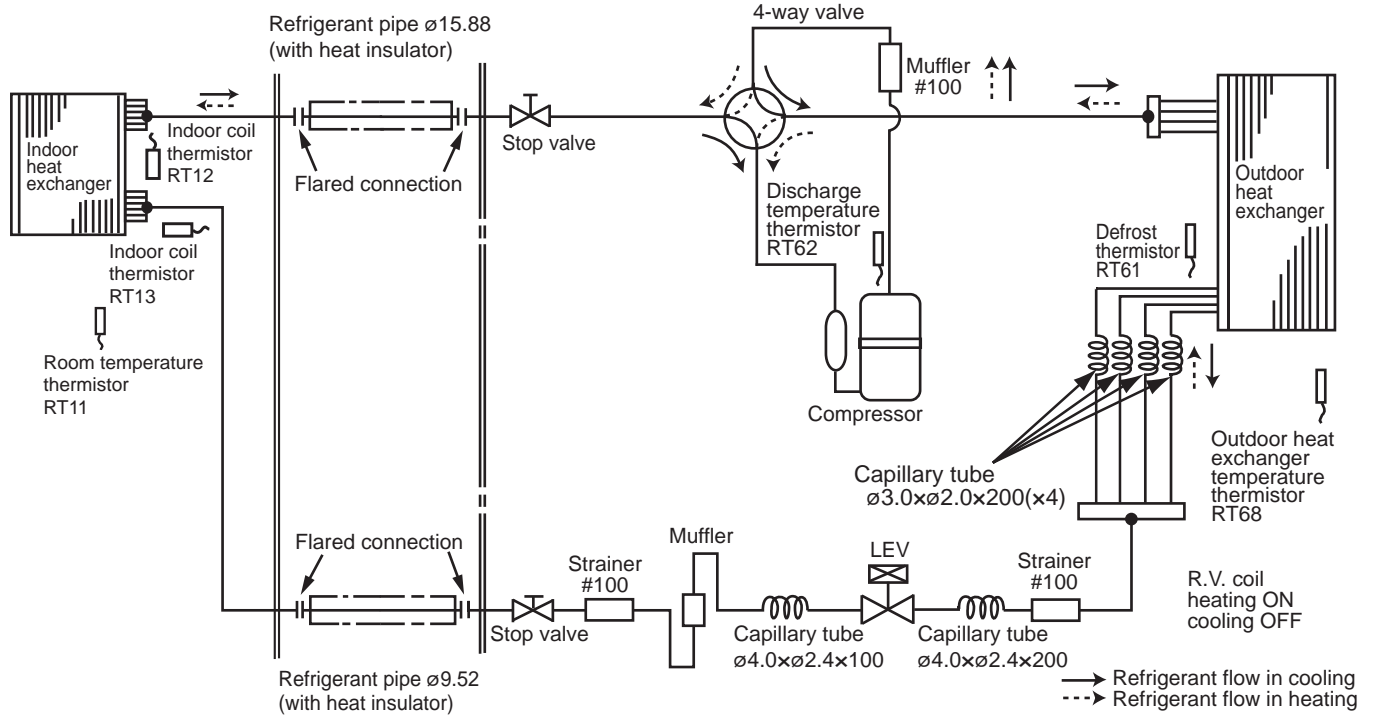

REFRIGERANT SYSTEM DIAGRAM

WALL-MOUNTED

C.1.5 PERFORMANCE CURVES

The standard specifications apply only to the operation of the air conditioner under normal conditions. Since operating conditions vary according to the areas where these units are installed, the following information has been provided to clarify the operating characteristics of the air conditioner under the conditions indicated by the performance curve.

(1) GUARANTEED VOLTAGE

198 ~ 264 V, 50 Hz

(2) AIR FLOW

Airflow should be set at MAX.

(3) MAIN READINGS

- | | | |
|--|---------|-----------|
| (1) Indoor intake air wet-bulb temperature: | °C [WB] | } Cooling |
| (2) Indoor outlet air wet-bulb temperature: | °C [WB] | |
| (3) Outdoor intake air dry-bulb temperature: | °C [DB] | |
| (4) Total input: | W | |
| (5) Indoor intake air dry-bulb temperature: | °C [DB] | } Heating |
| (6) Outdoor intake air wet-bulb temperature: | °C [WB] | |
| (7) Total input: | W | |

Indoor air wet and dry bulb temperature difference on the left side of the following chart shows the difference between the indoor intake air wet and dry bulb temperature and the indoor outlet air wet and dry bulb temperature for your reference at service.

How to measure the indoor air wet and dry bulb temperature difference

1. Attach at least 2 sets of wet and dry bulb thermometers to the indoor air intake as shown in the figure, and at least 2 sets of wet and dry bulb thermometers to the indoor air outlet. The thermometers must be attached to the position where air speed is high.
2. Attach at least 2 sets of wet and dry bulb thermometers to the outdoor air intake. Cover the thermometers to prevent direct rays of the sun.
3. Check that the air filter is cleaned.
4. Open windows and doors of room.
5. Press the emergency operation switch once (twice) to start the EMERGENCY COOL (HEAT) MODE.
6. When system stabilizes after more than 15 minutes, measure temperature and take an average temperature.
7. 10 minutes later, measure temperature again and check that the temperature does not change.

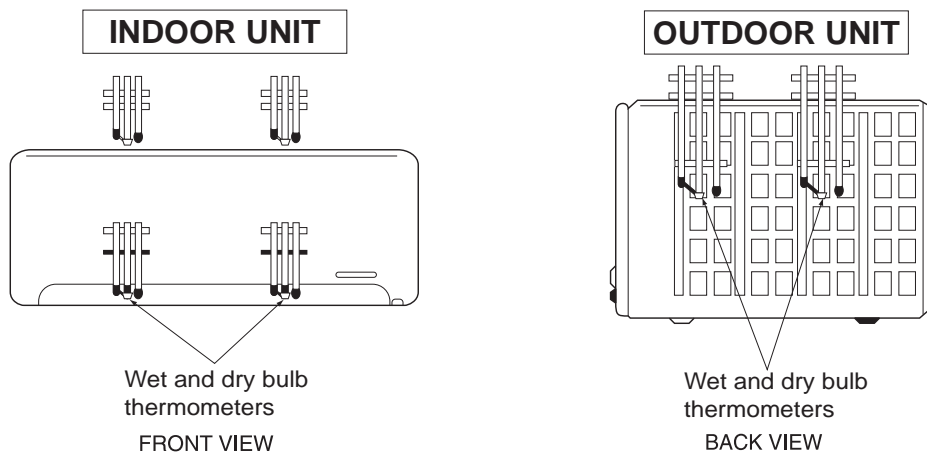

WALL-MOUNTED PERFORMANCE CURVES

C.1.5.1 Inverter

CAPACITY AND THE INPUT CURVES

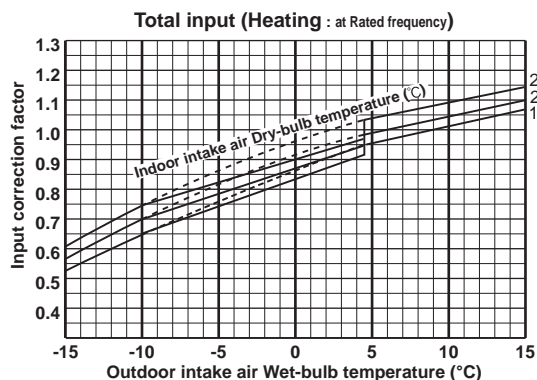
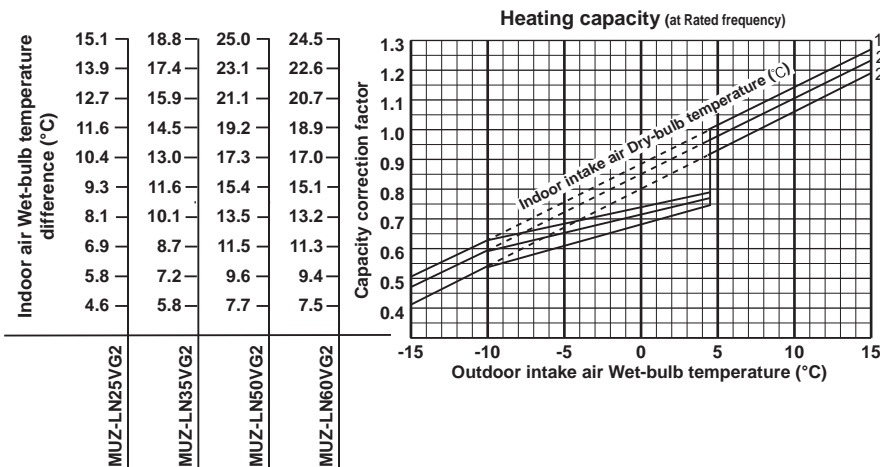
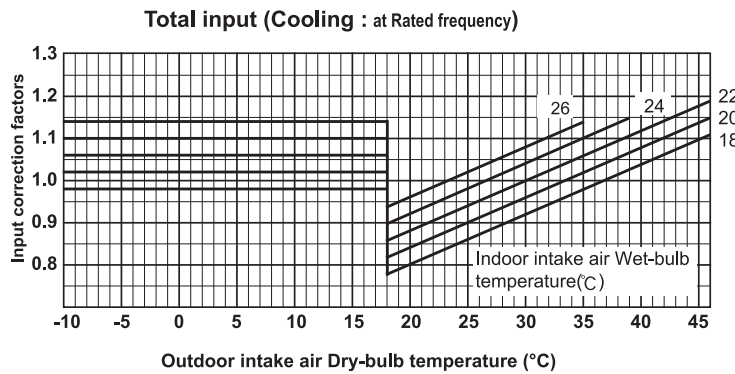
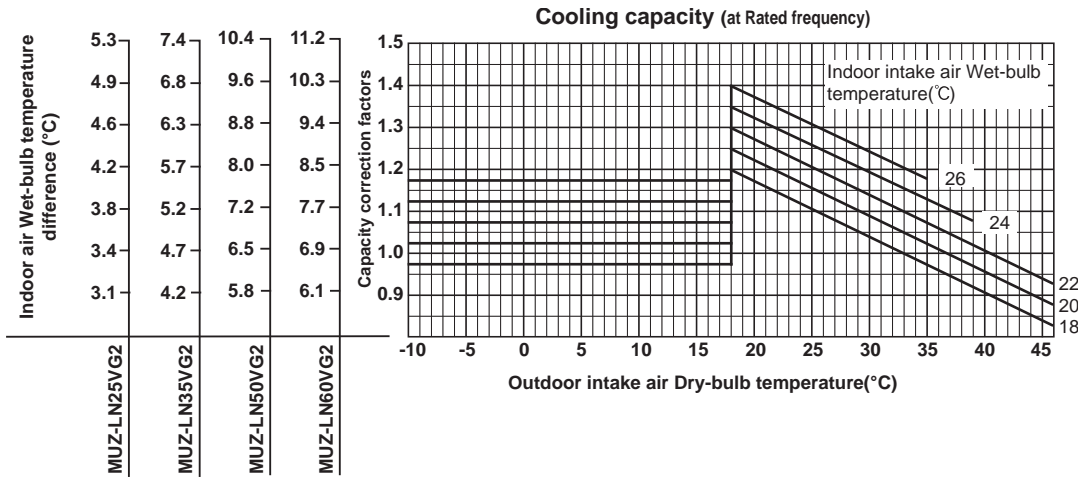

NOTE: The above broken lines are for the heating operation without any frost and defrost operation.

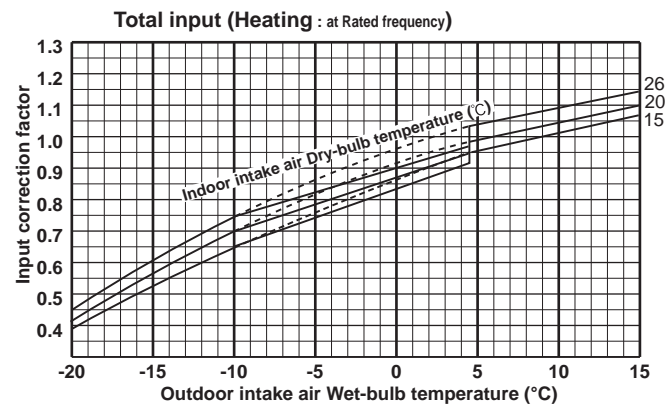
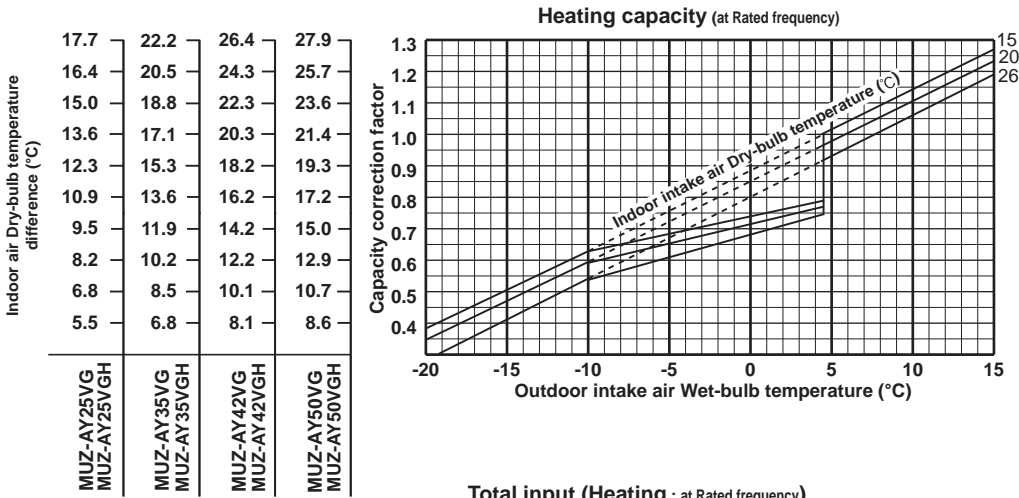
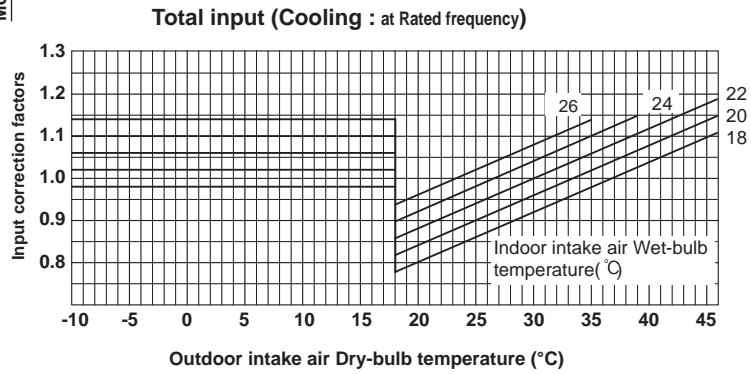
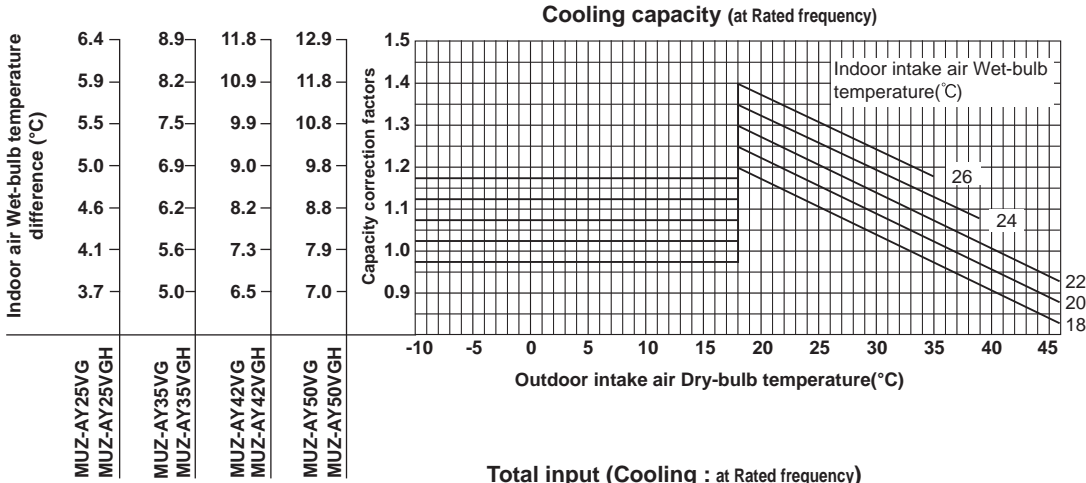

Lower limit of guaranteed operating range in heating
 MUZ-AY25/35/42/50VG: -15°C
 MUZ-AY25/35/42/50VGH: -20°C

NOTE: The above broken lines are for the heating operation without any frost and defrost operation.

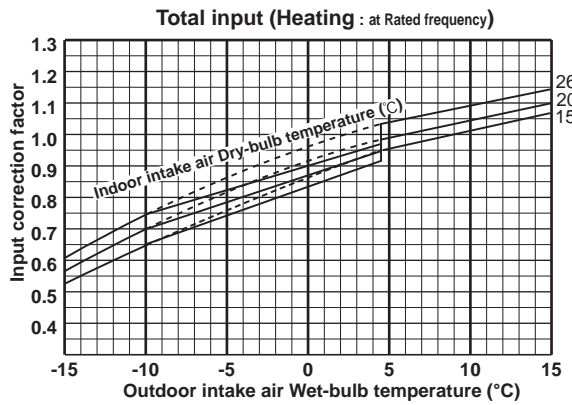
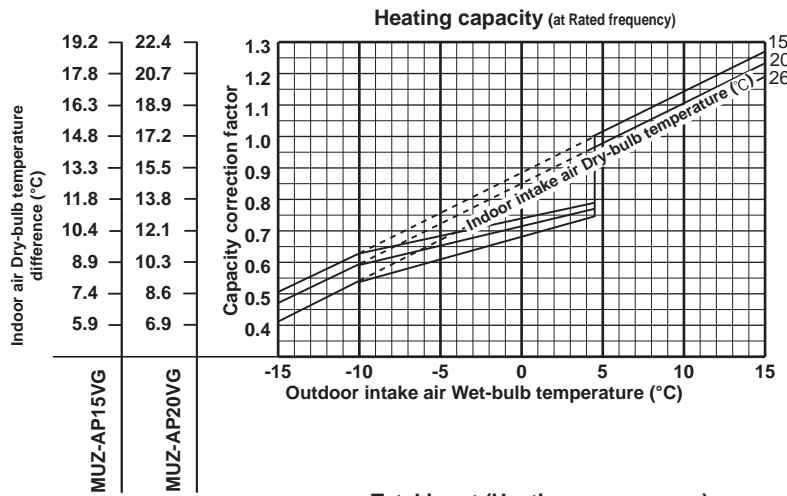
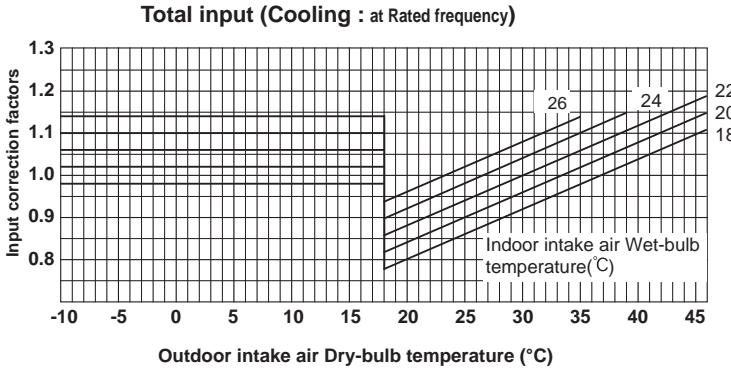
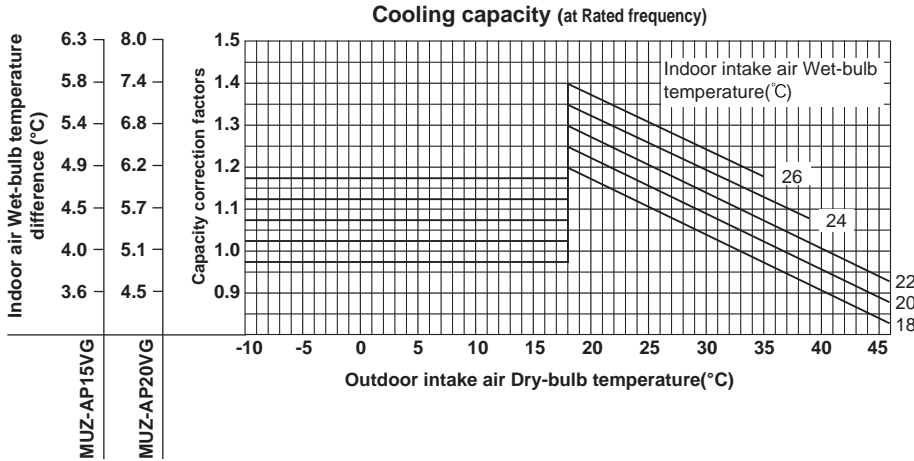

Lower limit of guaranteed operating range in heating
MUZ-AP15/20VG: -15°C

NOTE: The above broken lines are for the heating operation without any frost and defrost operation.

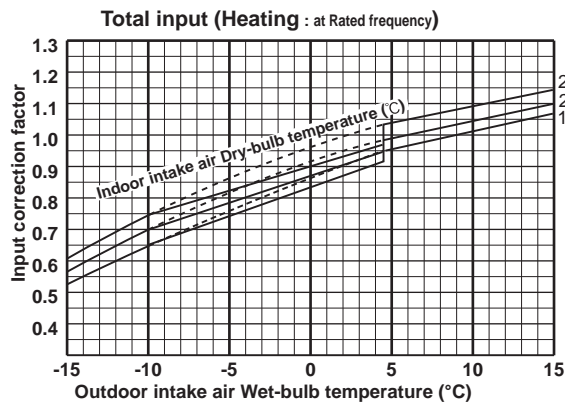
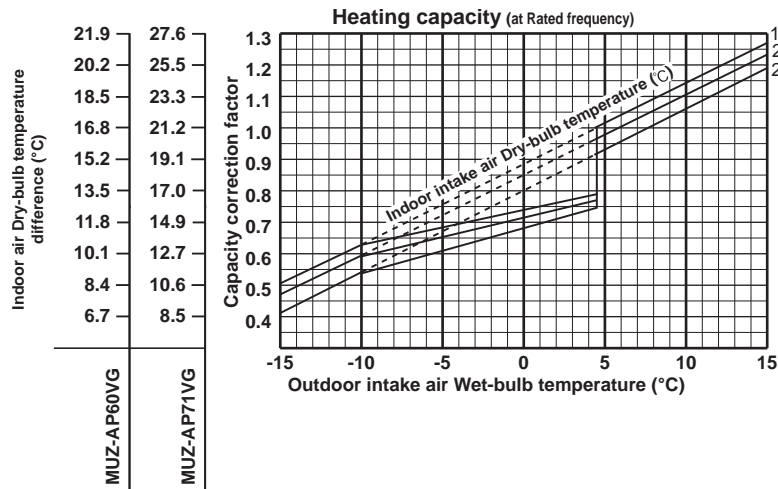
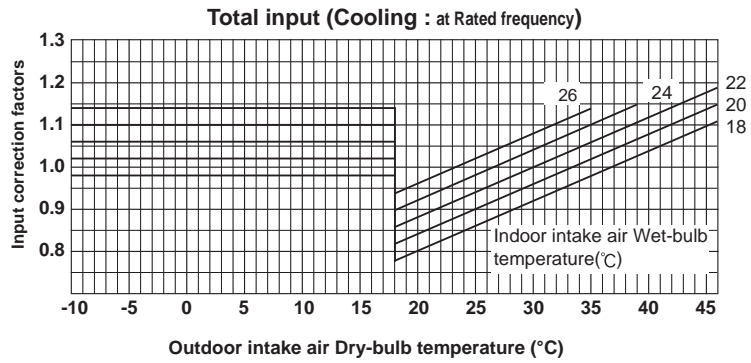
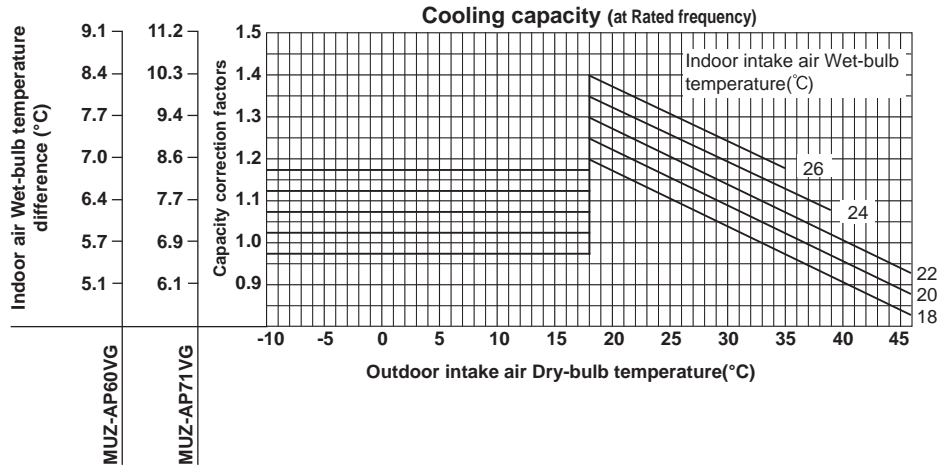

Lower limit of guaranteed operating range in heating
 MUZ-AP60/71VG: -15°C

NOTE: The above broken lines are for the heating operation without any frost and defrost operation.

Indoor air Wet-bulb temperature difference (°C)	7.0	8.1	9.1	11.2	8.7	10.5
	6.5	7.5	8.4	10.3	8.1	9.7
	6.0	6.8	7.7	9.4	7.4	8.8
	5.5	6.3	7.0	8.6	6.8	8.0
	5.0	5.7	6.3	7.7	6.1	7.3
	4.5	5.1	5.7	6.9	5.5	6.5
	4.0	4.5	5.1	6.1	4.9	5.8
	MUZ-HR25VF	MUZ-HR35VF	MUZ-HR42VF	MUZ-HR50VF	MUZ-HR60VF	MUZ-HR71VF

Cooling capacity (at Rated frequency)

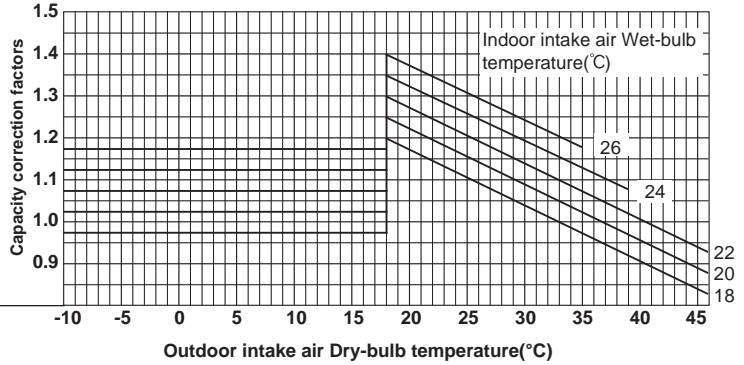

Total input (Cooling : at Rated frequency)

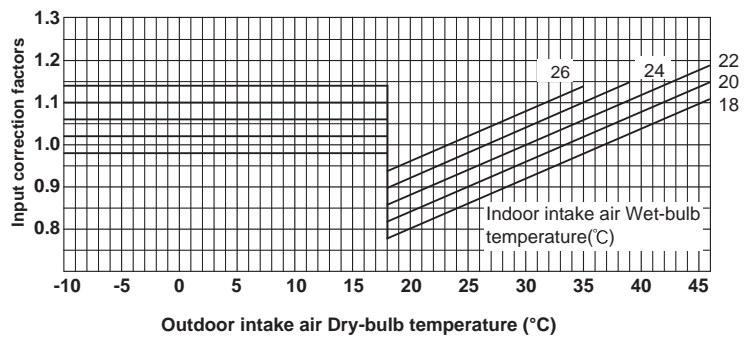

Indoor air Dry-bulb temperature difference (°C)	20.4	22.4	22.9	24.4	22.7	27.0
	18.8	20.7	21.2	22.5	20.9	24.9
	17.3	19.0	19.4	20.6	19.2	22.9
	15.7	17.2	17.6	18.7	17.5	20.8
	14.1	15.5	15.9	16.9	15.7	18.7
	12.6	13.8	14.1	15.0	14.0	16.6
	11.0	12.1	12.3	13.1	12.2	14.6
	9.4	10.3	10.6	11.2	10.5	12.5
	7.8	8.6	8.8	9.4	8.7	10.4
	6.3	6.9	7.1	7.5	7.0	8.3
	MUZ-HR25VF	MUZ-HR35VF	MUZ-HR42VF	MUZ-HR50VF	MUZ-HR60VF	MUZ-HR71VF

Heating capacity (at Rated frequency)

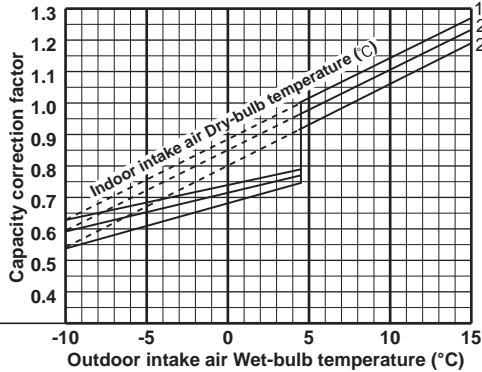

Total input (Heating : at Rated frequency)

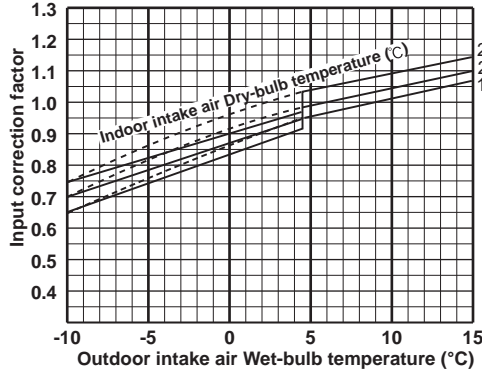

Lower limit of guaranteed operating range in heating
 MUZ-HR25/35/42/50VF: -10°C

NOTE: The above broken lines are for the heating operation without any frost and defrost operation.

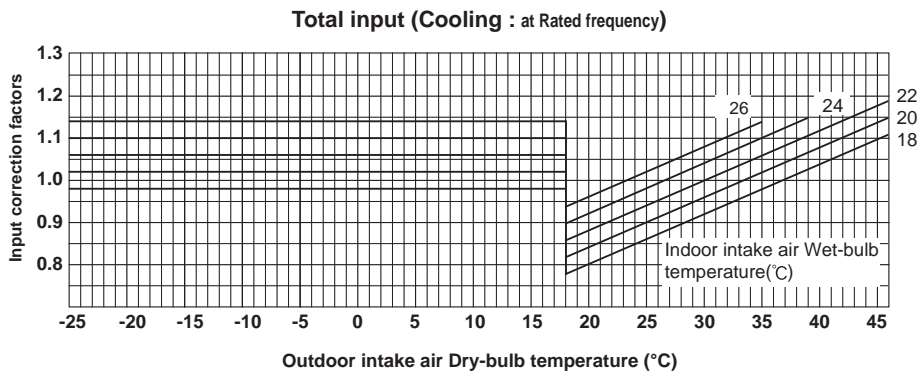
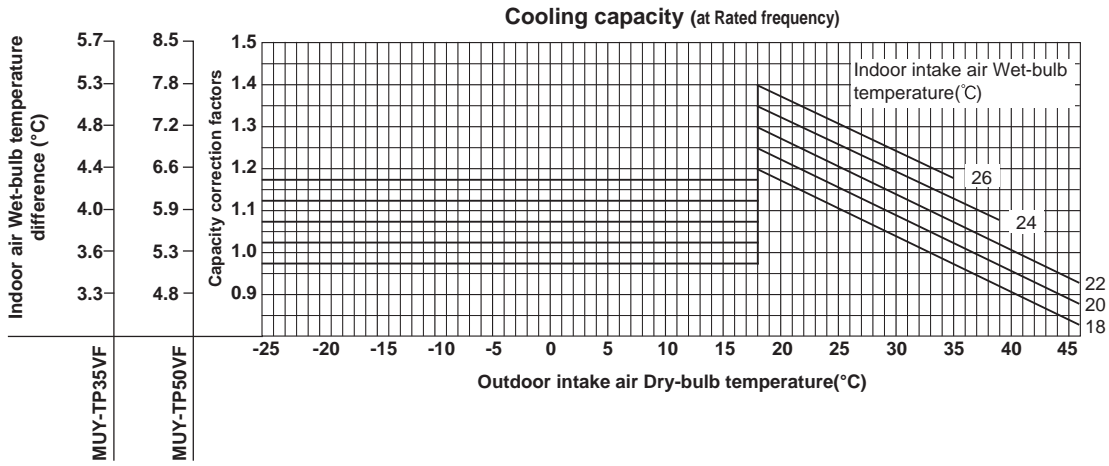

Indoor air Wet-bulb temperature difference (°C)	6.4	9.5	13.6
	5.9	8.7	12.5
	5.5	8.0	11.4
	5.0	7.3	10.3
	4.6	6.6	9.3
	4.1	5.9	8.3
	3.7	5.3	7.3
	MUZ-FH25VE	MUZ-FH35VE	MUZ-FH50VE

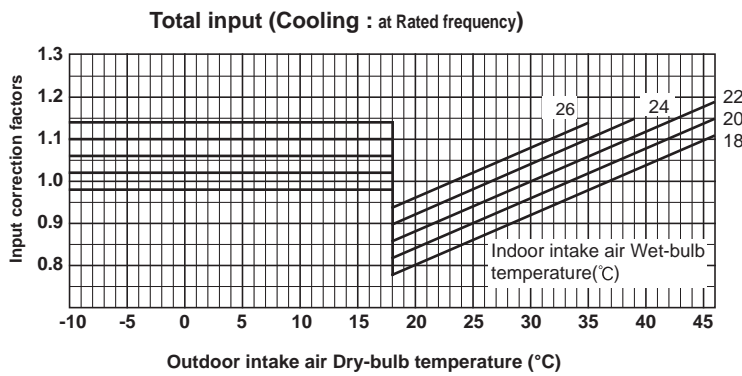
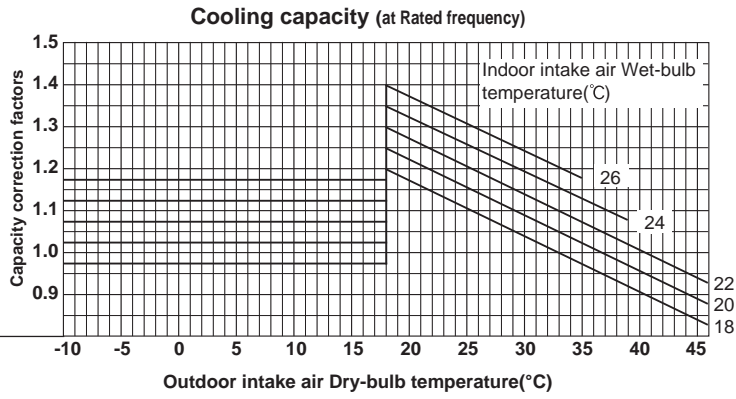

Indoor air Dry-bulb temperature difference (°C)	15.9	19.8	26.9
	14.6	18.3	24.8
	13.4	16.8	22.7
	12.2	15.2	20.7
	11.0	13.7	18.6
	9.8	12.2	16.5
	8.5	10.7	14.5
	7.3	9.1	12.4
	6.1	7.6	10.3
	4.9	6.1	8.3
	MUZ-FH25VE	MUZ-FH35VE	MUZ-FH50VE

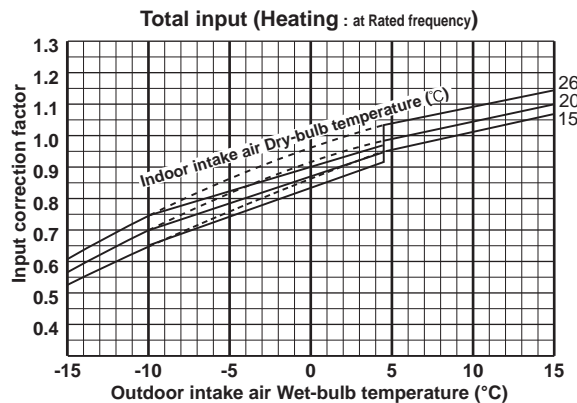
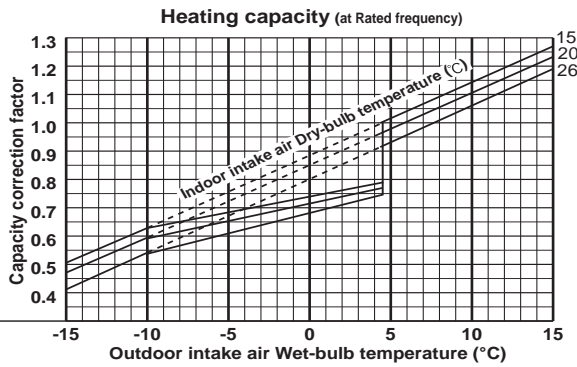

NOTE: The above broken lines are for the heating operation without any frost and defrost operation.

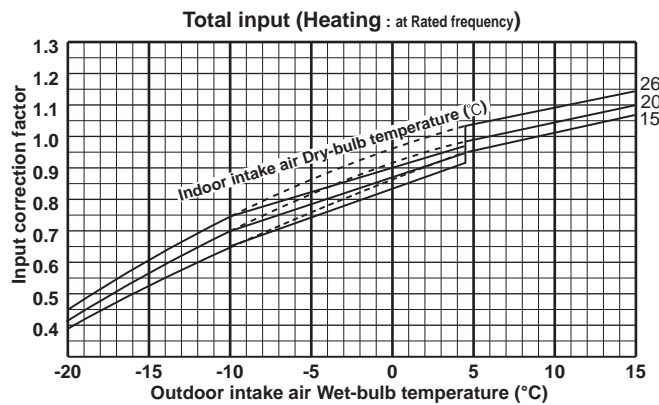
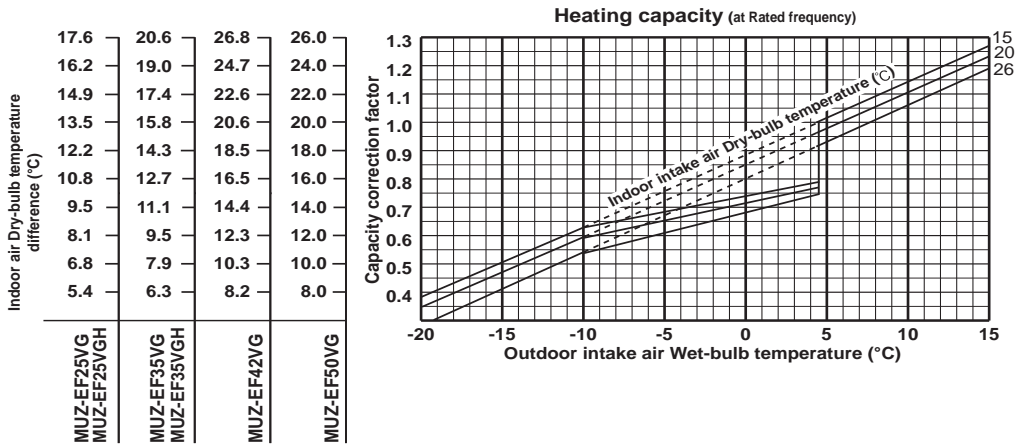
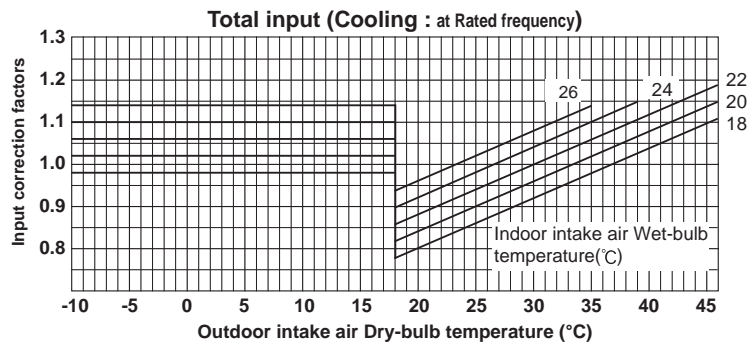
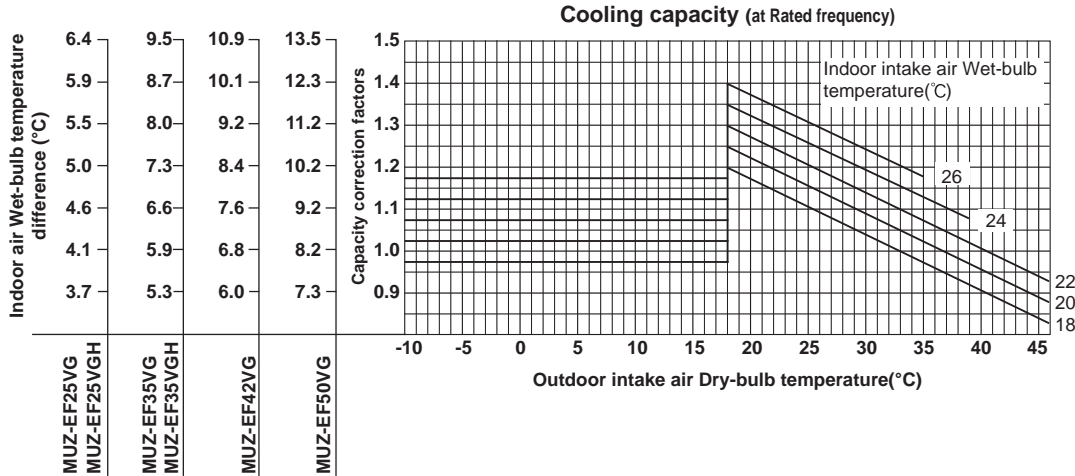

Lower limit of guaranteed operating range in heating
 MUZ-EF25/35/42/50VG : -15°C
 MUZ-EF25/35VGH : -20°C

NOTE: The above broken lines are for the heating operation without any frost and defrost operation.

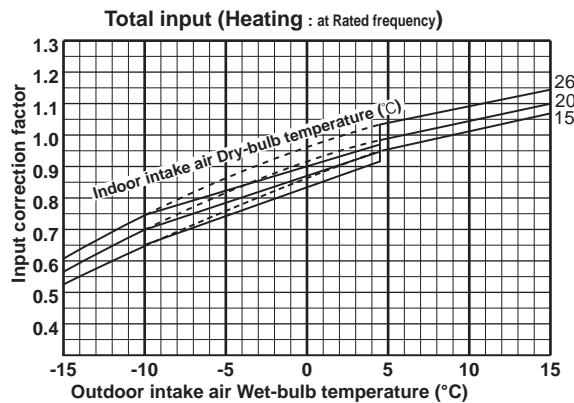
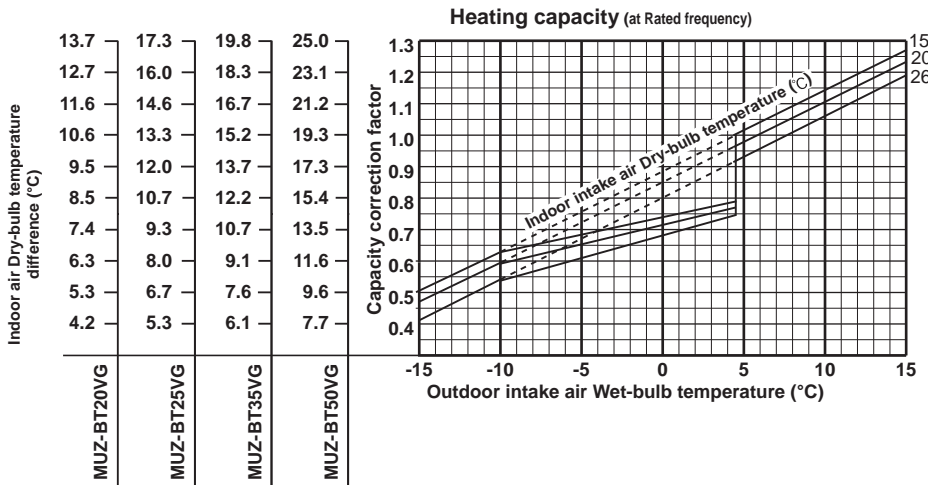
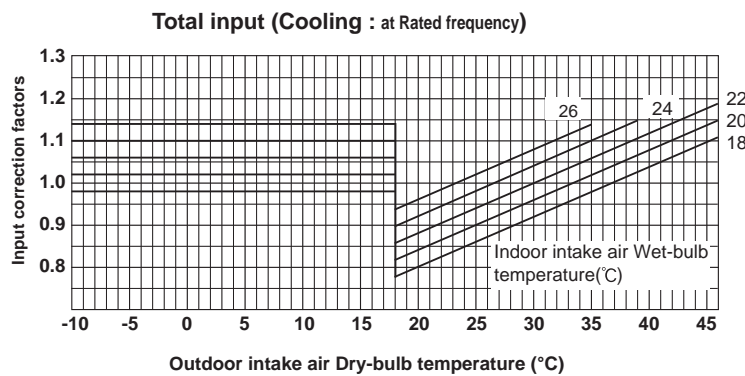
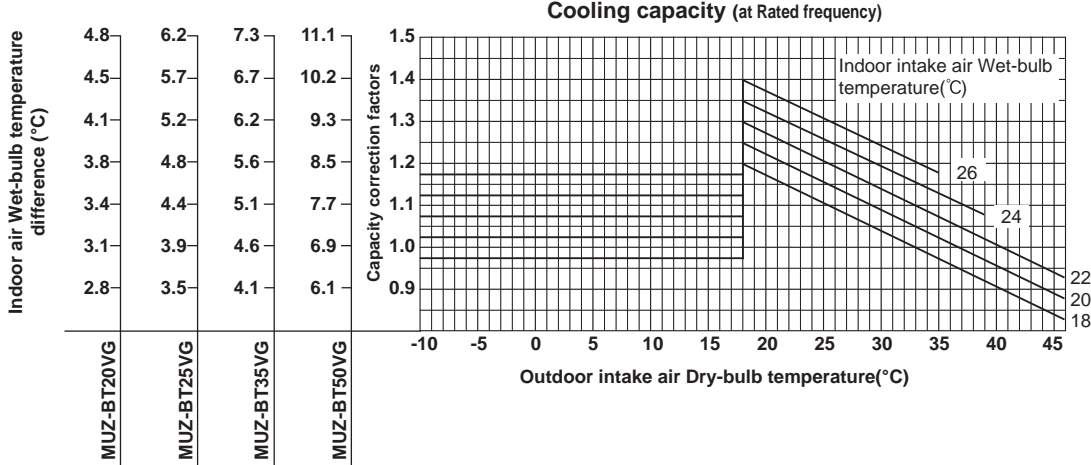

NOTE: The above broken lines are for the heating operation without any frost and defrost operation.

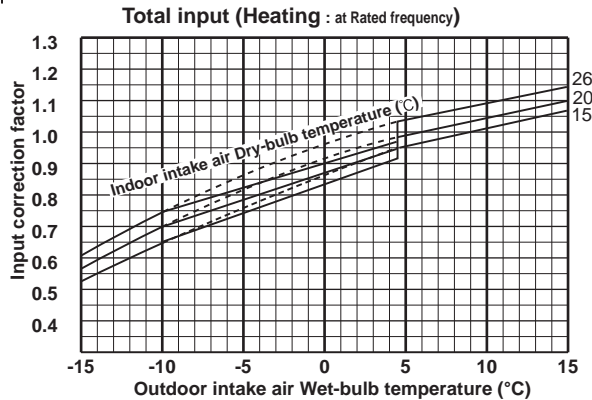
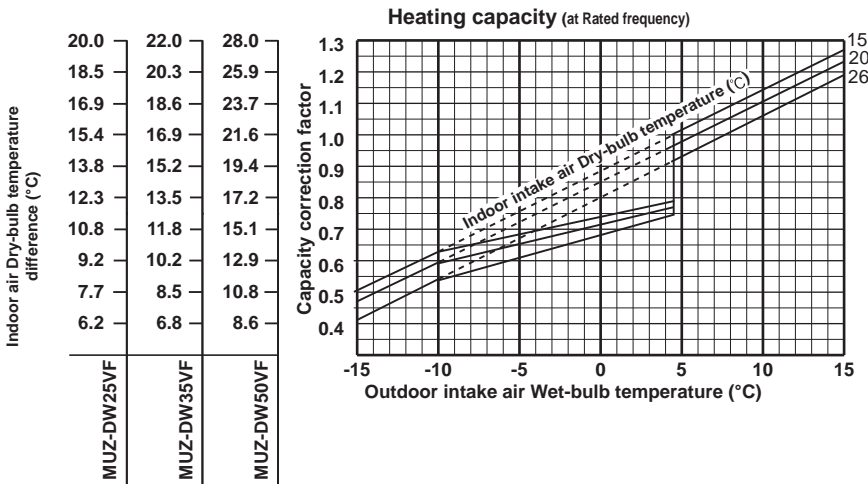
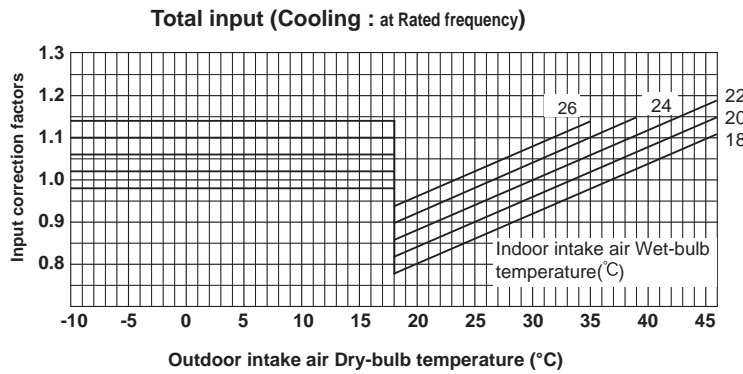
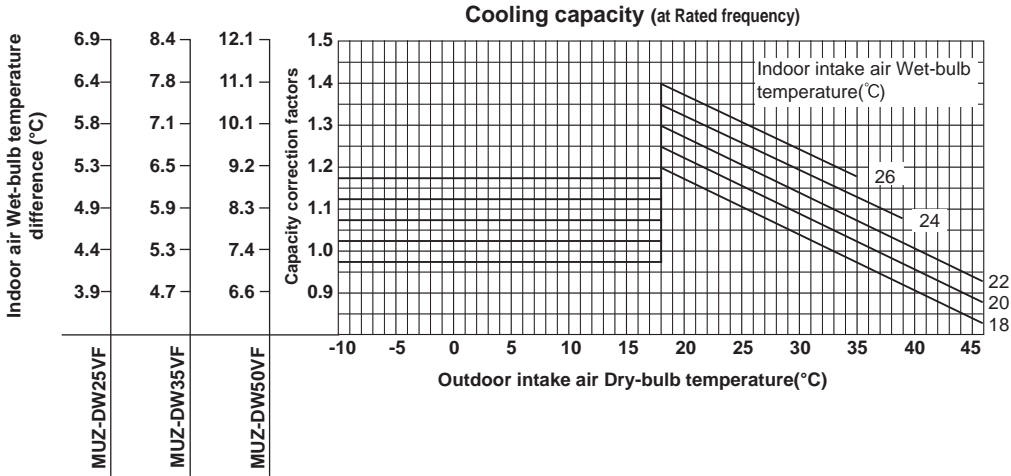

NOTE: The above broken lines are for the heating operation without any frost and defrost operation.

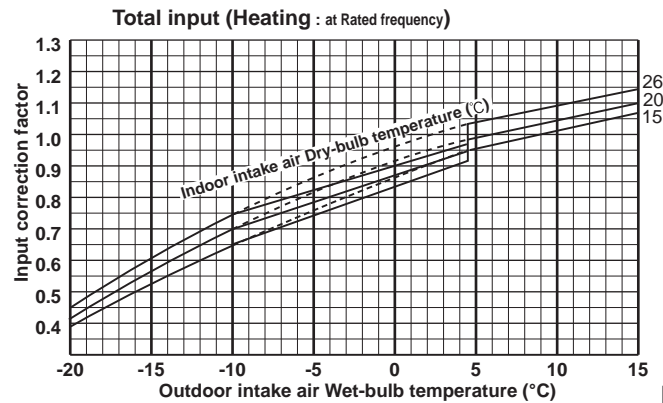
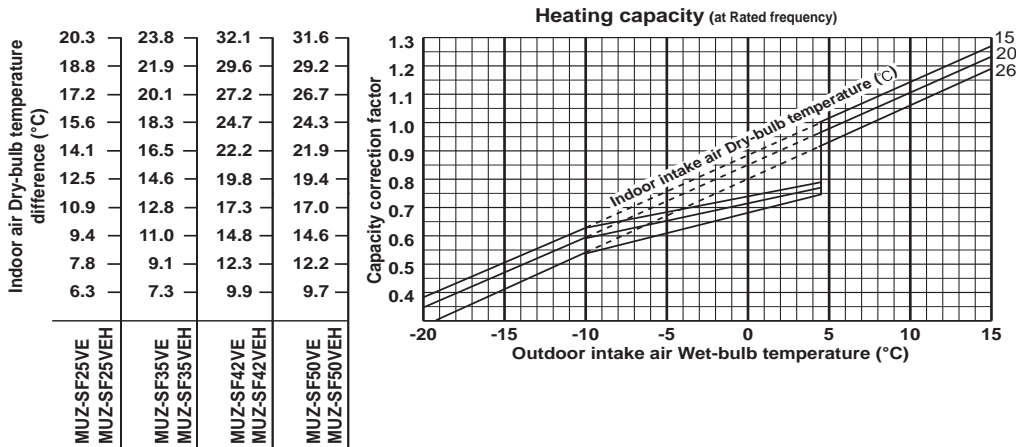
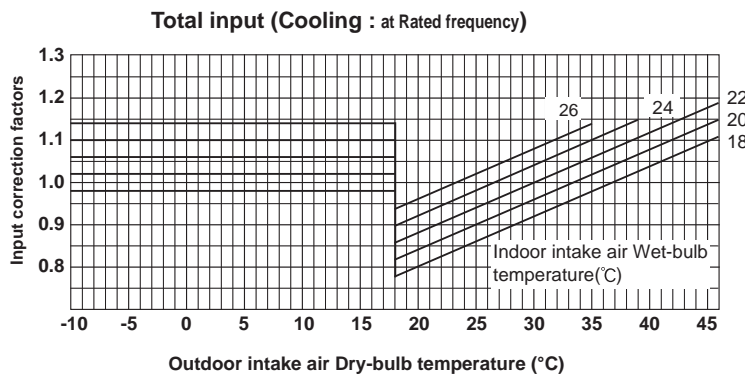
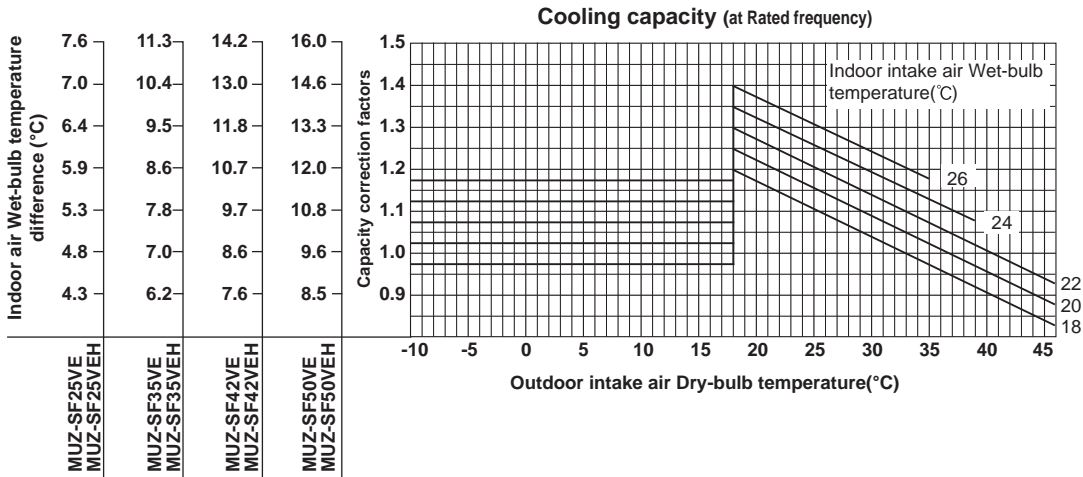

Lower limit of guaranteed operating range in heating
 MUZ-SF25/35/42/50VE: -15°C
 MUZ-SF25/35/42/50VEH: -20°C

NOTE: The above broken lines are for the heating operation without any frost and defrost operation.

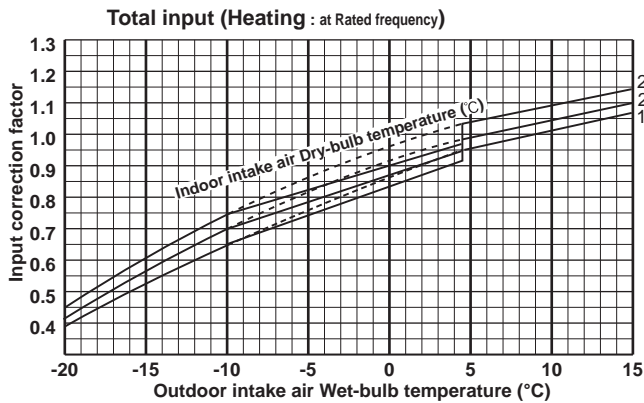
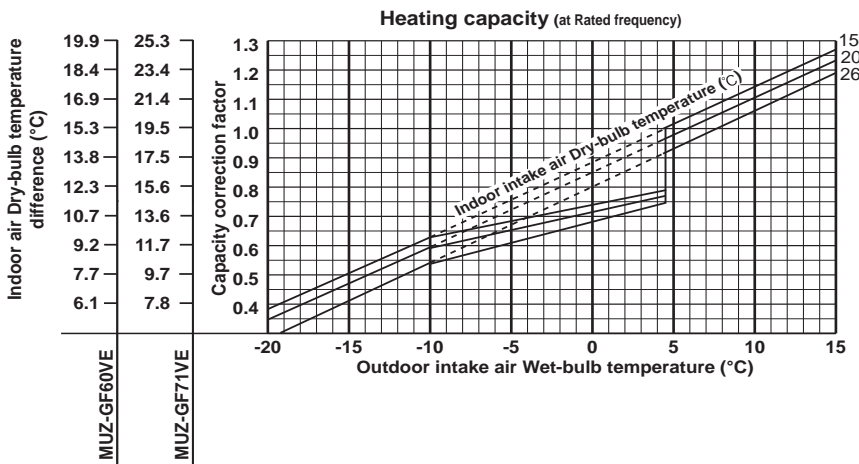
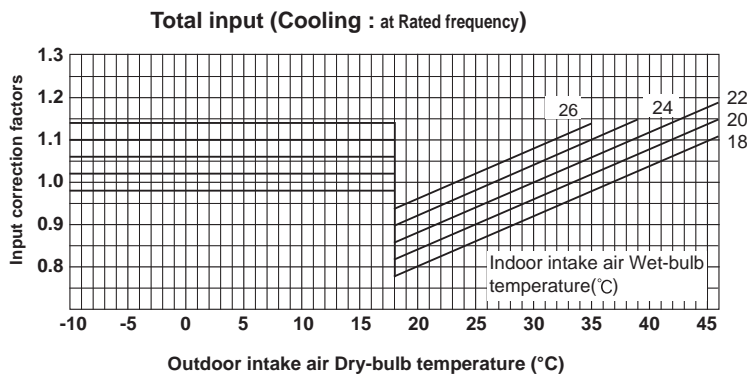
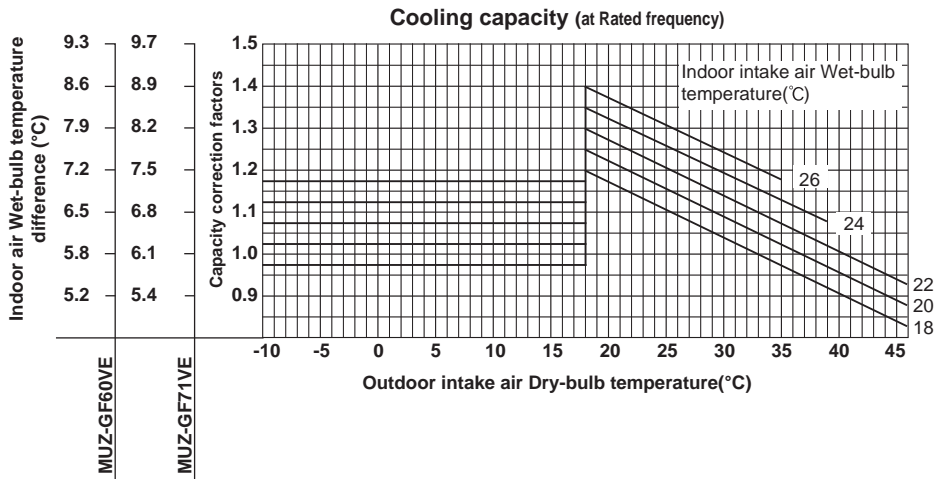

NOTE: The above broken lines are for the heating operation without any frost and defrost operation.

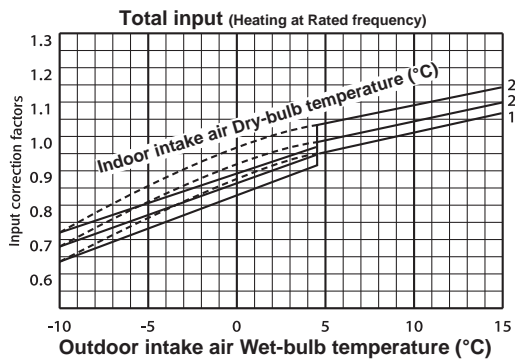
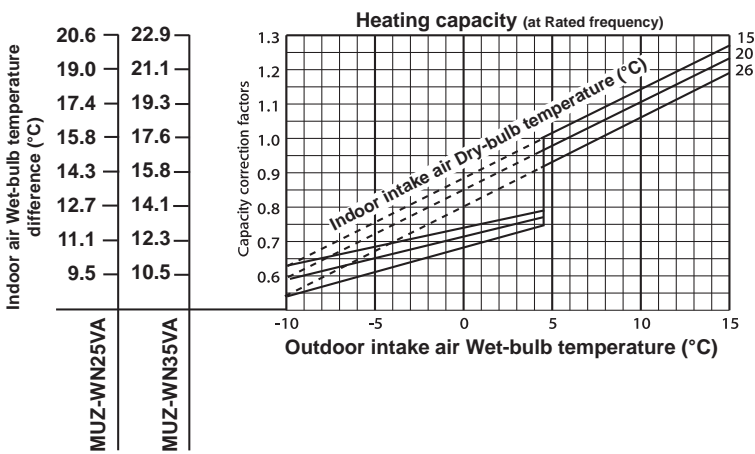
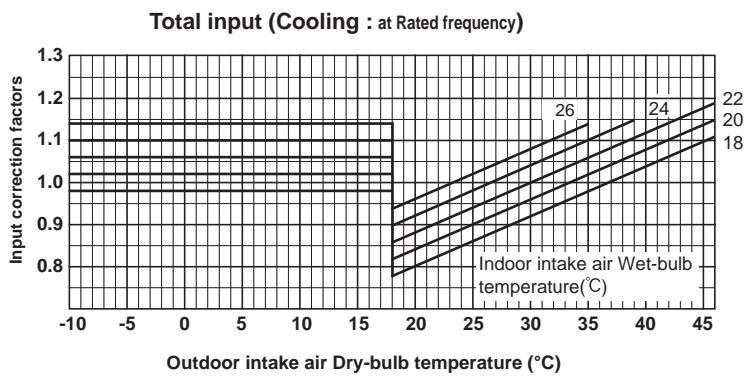
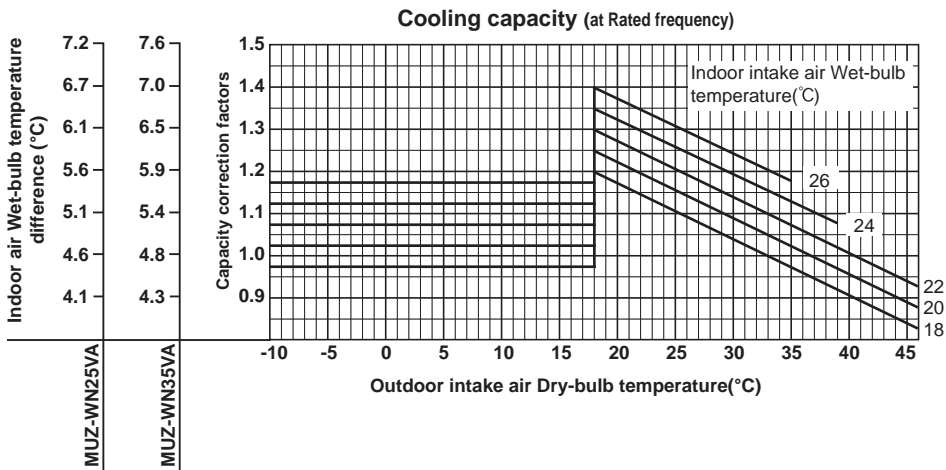

NOTE: The above broken lines are for the heating operation without any frost and defrost operation.

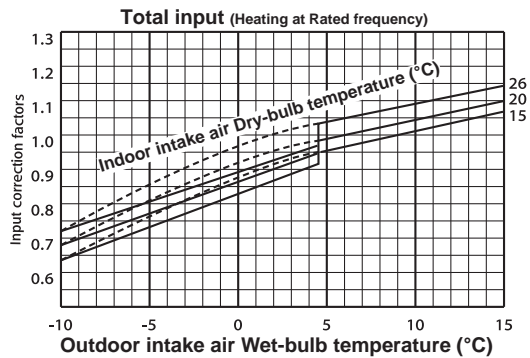
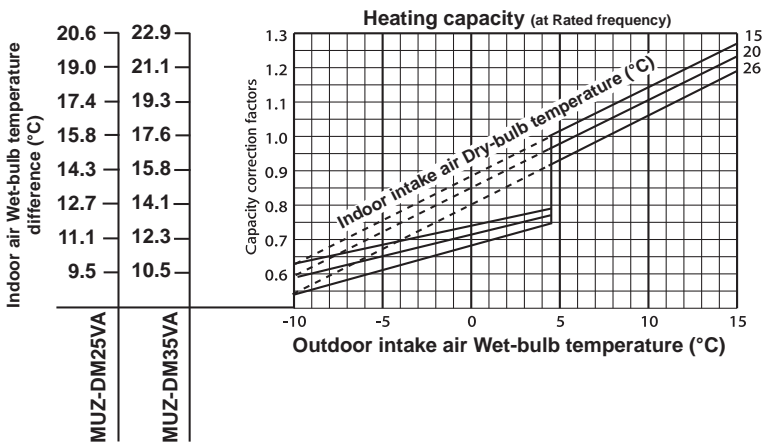
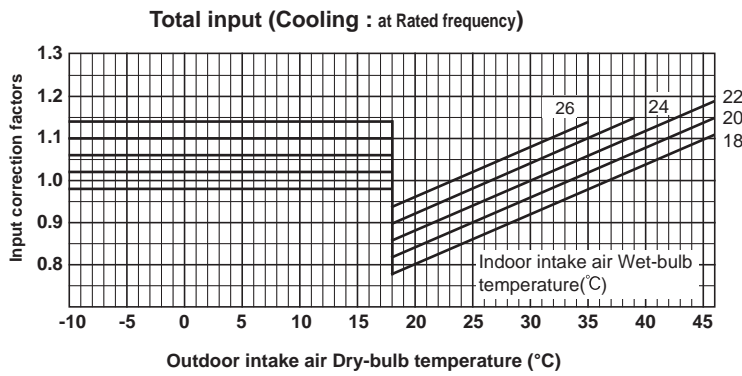
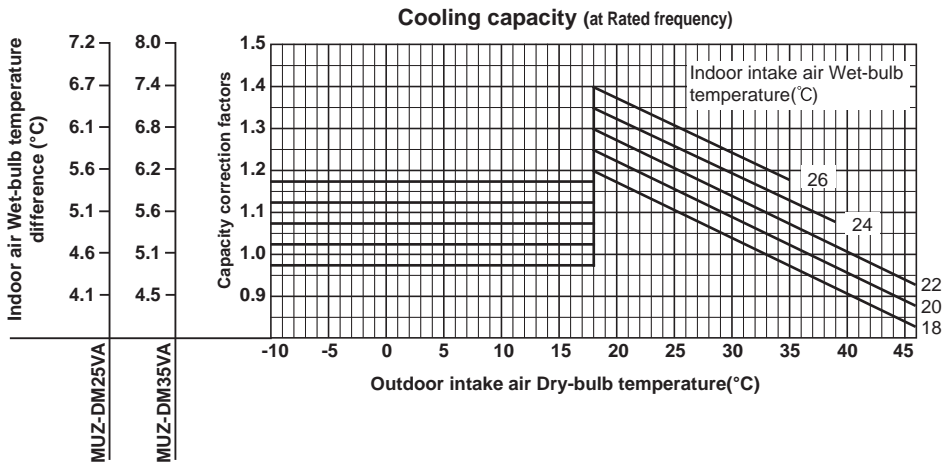

NOTE: The above broken lines are for the heating operation without any frost and defrost operation.

7.2	8.0	11.4	8.7	10.4
6.7	7.4	10.5	8.0	9.6
6.1	6.8	9.6	7.4	8.8
5.6	6.2	8.7	6.7	8.0
5.1	5.6	7.9	6.1	7.2
4.6	5.1	7.1	5.5	6.5
4.1	4.5	6.3	4.9	5.8
MUZ-HJ25VA	MUZ-HJ35VA	MUZ-HJ50VA	MUZ-HJ60VA	MUZ-HJ71VA

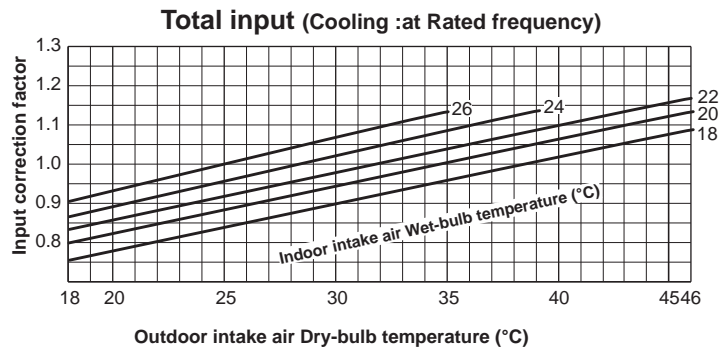
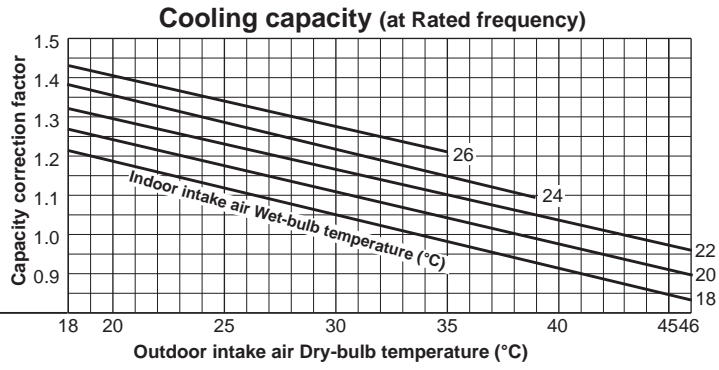

20.6	22.9	24.7	22.6	26.9
19.0	21.1	22.8	20.8	24.8
17.4	19.3	20.9	19.1	22.7
15.8	17.6	19.0	17.4	20.7
14.3	15.8	17.1	15.6	18.6
12.7	14.1	15.2	13.9	16.5
11.1	12.3	13.3	12.2	14.5
9.5	10.5	11.4	10.4	12.4
MUZ-HJ25VA	MUZ-HJ35VA	MUZ-HJ50VA	MUZ-HJ60VA	MUZ-HJ71VA

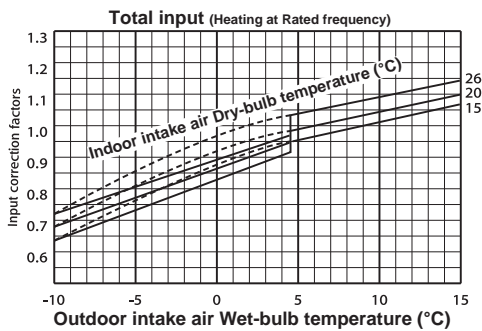
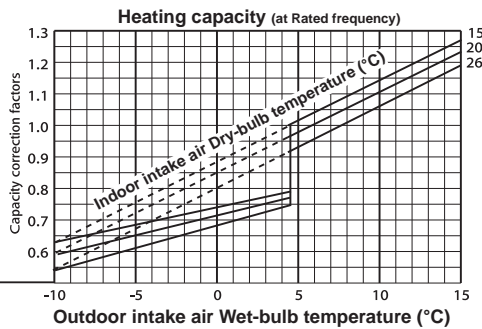

PERFORMANCE CURVES

WALL-MOUNTED

NOTE: The above broken lines are for the heating operation without any frost and defrost operation.

CAPACITY AND INPUT CORRECTION BY OPERATIONAL FREQUENCY OF COMPRESSOR

MUZ-LN25VG2

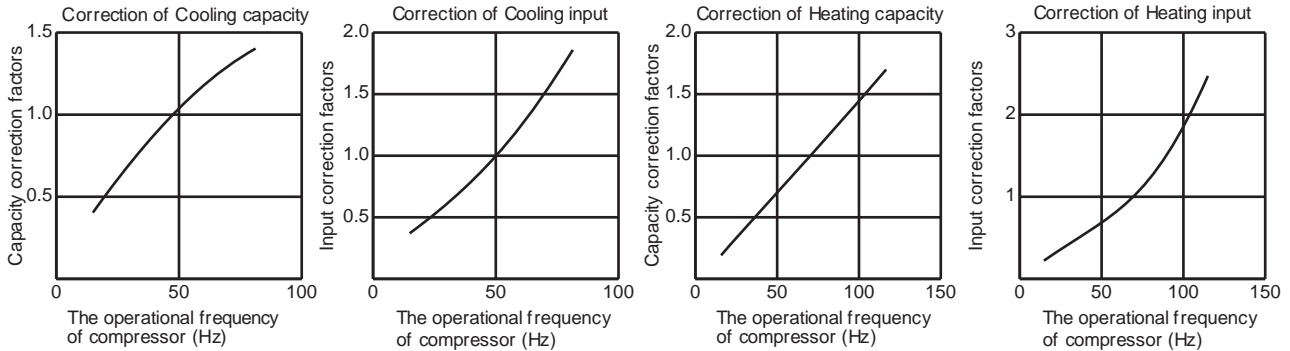

MUZ-LN35VG2

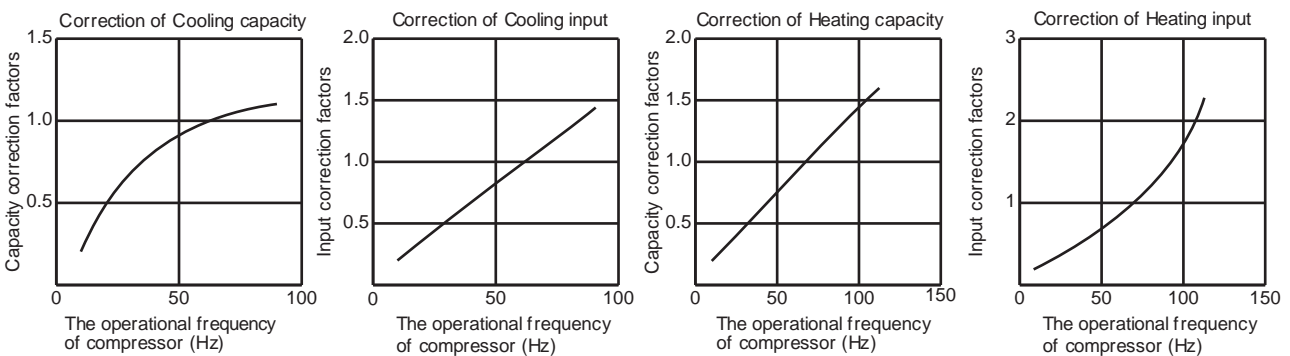

MUZ-LN50VG2

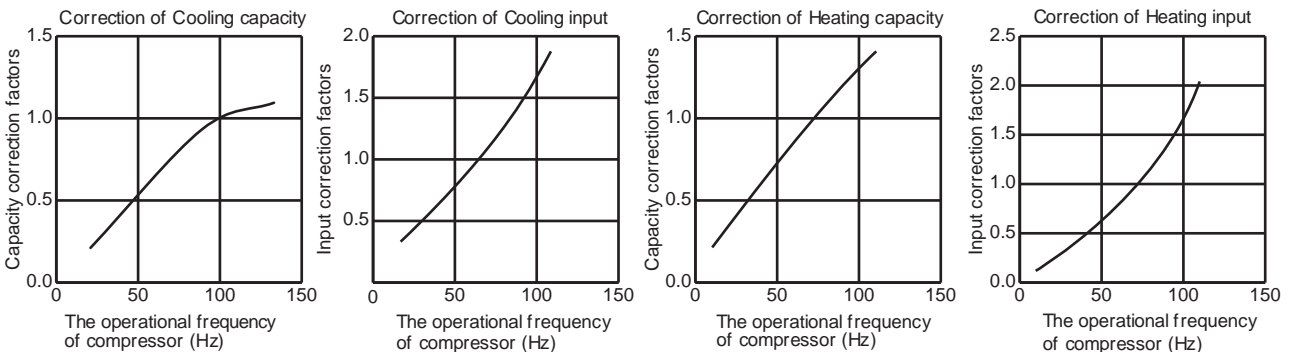

MUZ-LN60VG2

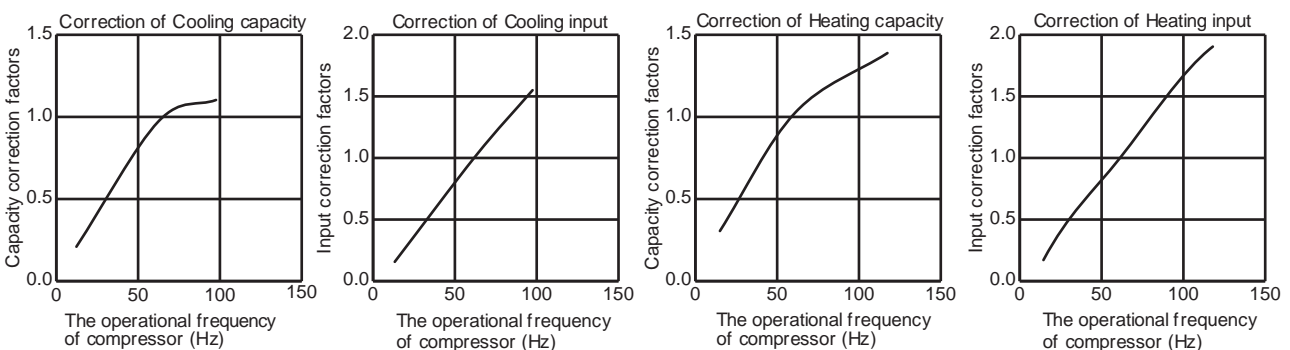

WALL-MOUNTED PERFORMANCE CURVES

**MUZ-AY25VG
MUZ-AY25VGH**

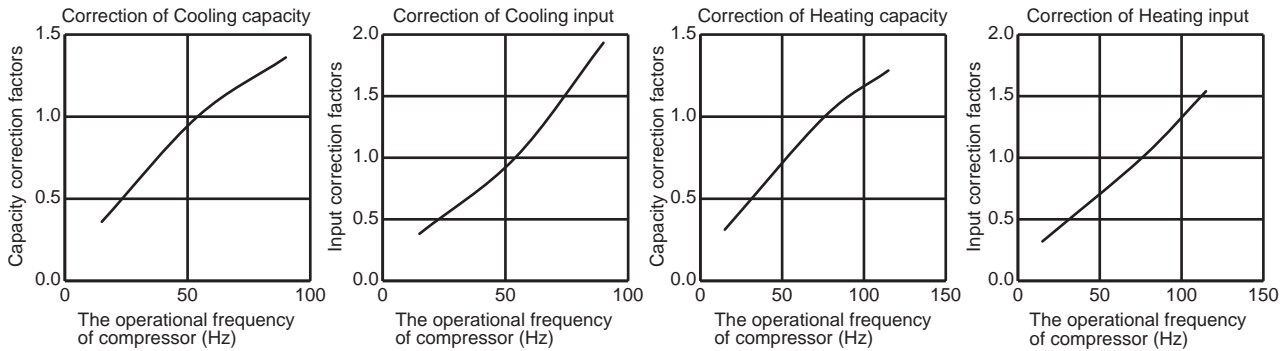

**MUZ-AY35VG
MUZ-AY35VGH**

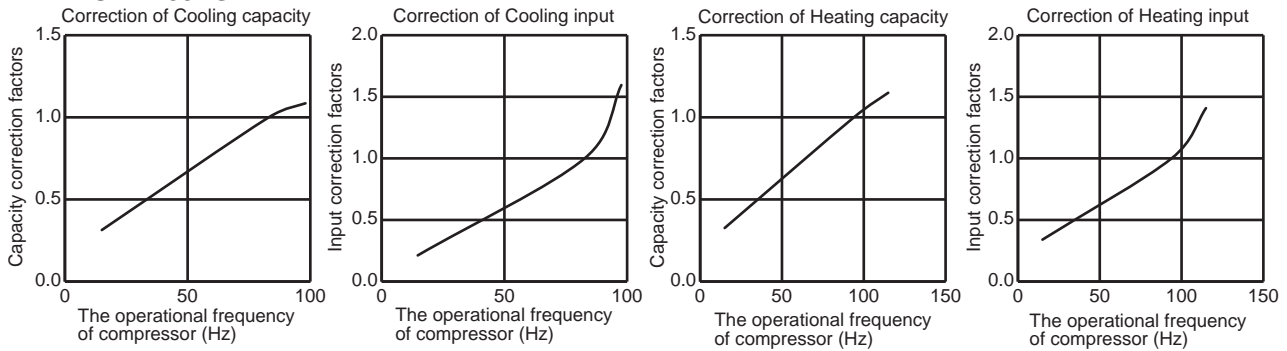

**MUZ-AY42VG
MUZ-AY42VGH**

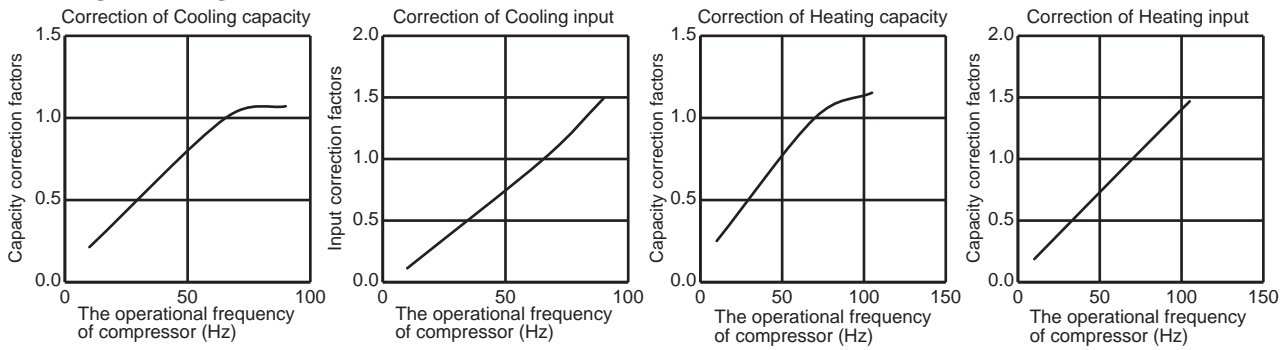

**MUZ-AY50VG
MUZ-AY50VGH**

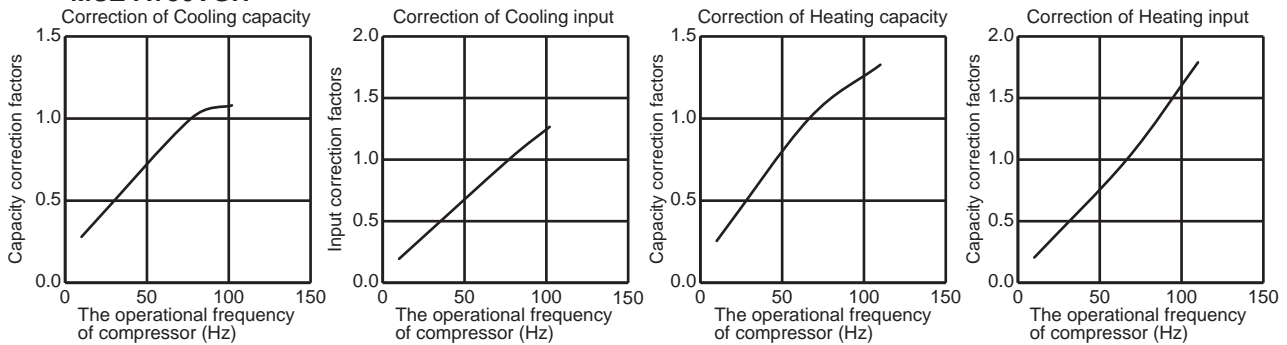

PERFORMANCE CURVES

WALL-MOUNTED

MUZ-AP15VG

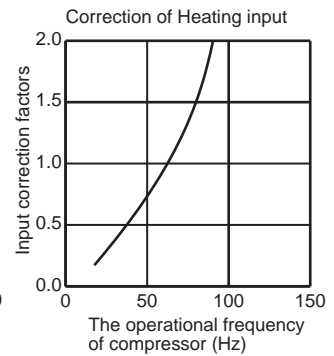
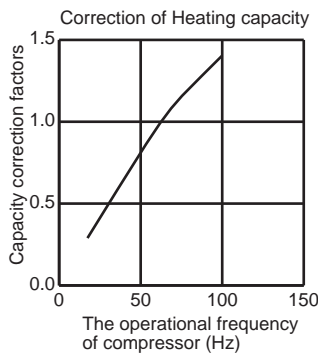
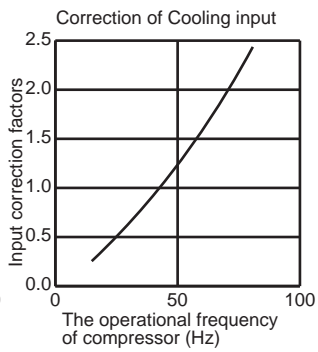
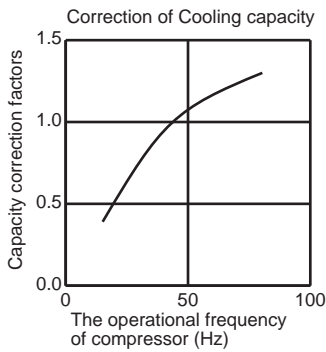

MUZ-AP20VG

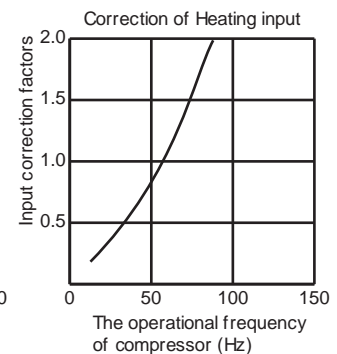
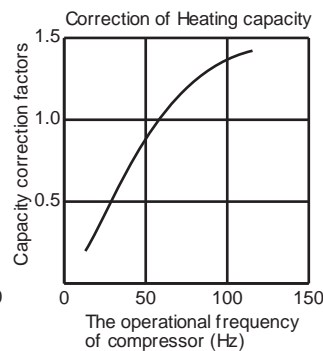
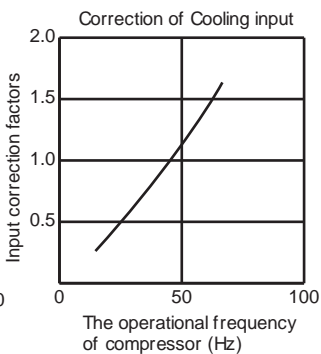
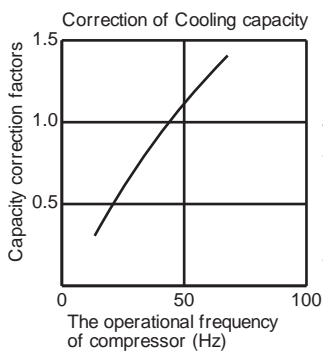

MUZ-AP60VG

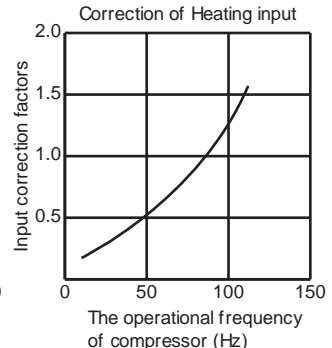
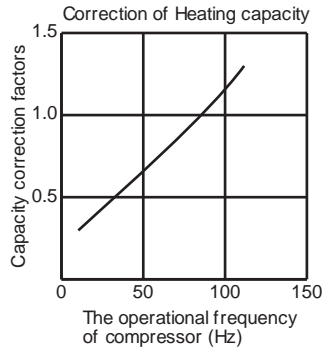
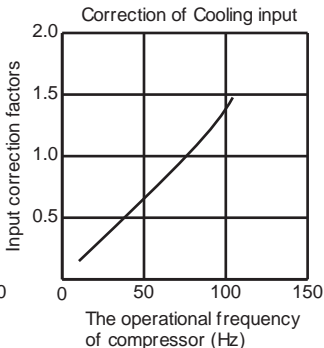
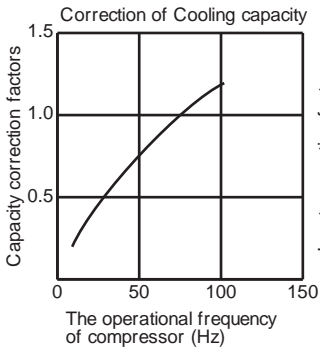

MUZ-AP71VG

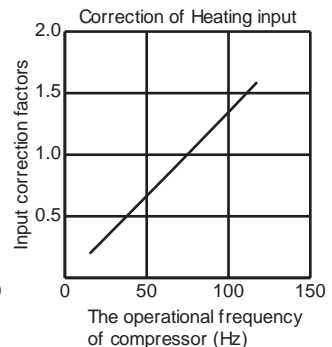
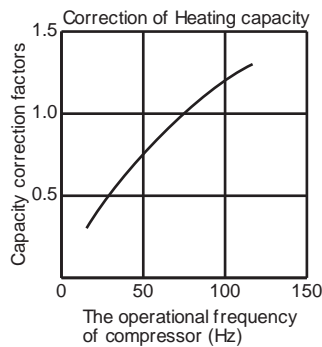
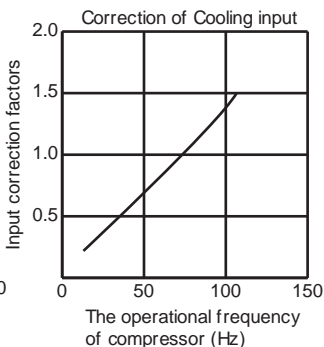
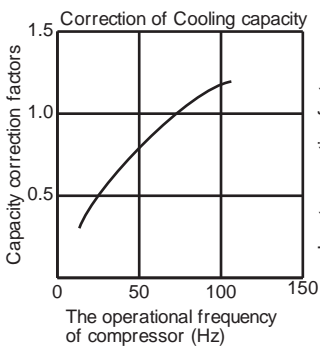

MUZ-HR25VF

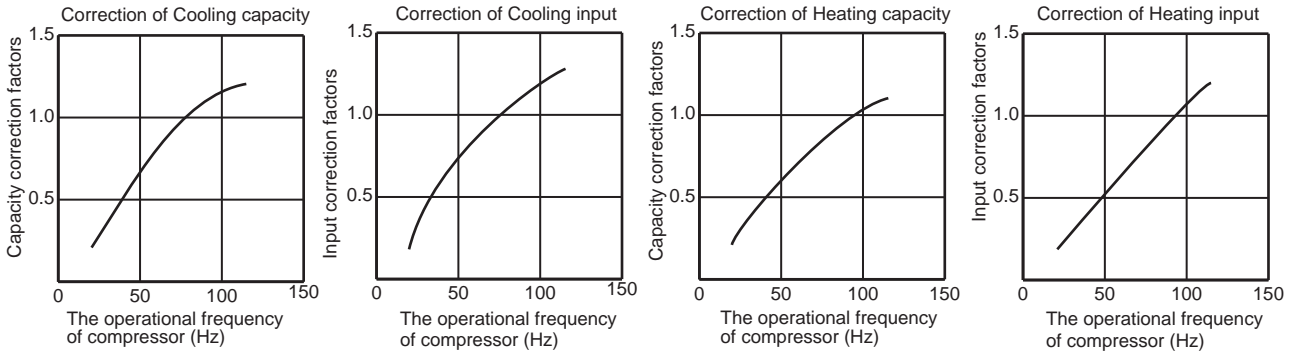

MUZ-HR35VF

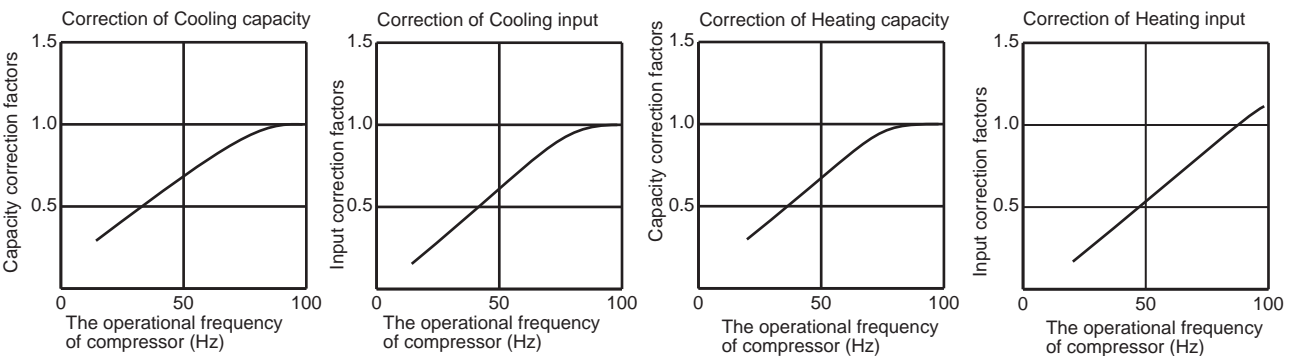

MUZ-HR42VF

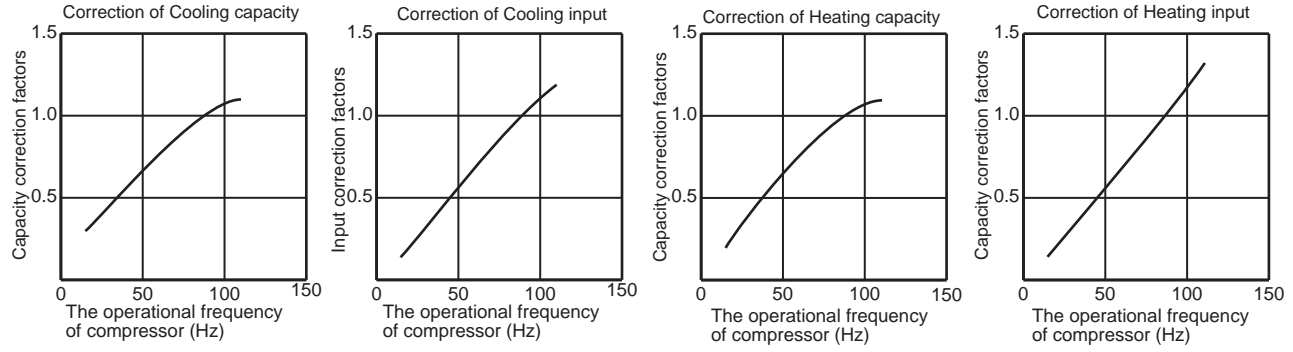

MUZ-HR50VF

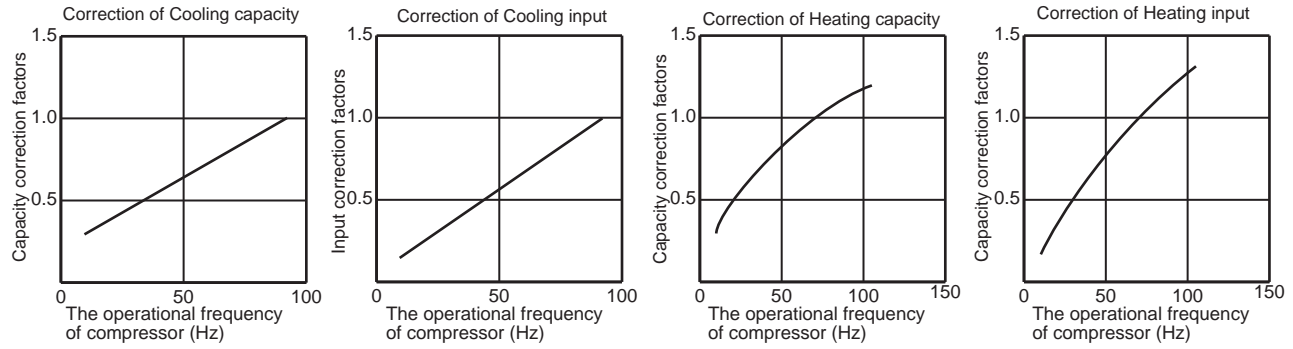

PERFORMANCE CURVES

WALL-MOUNTED

MUZ-HR60VF

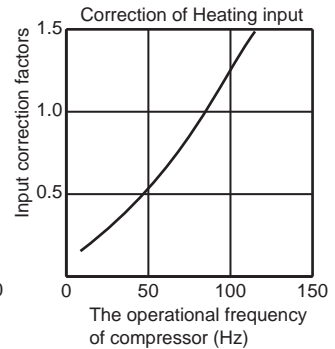
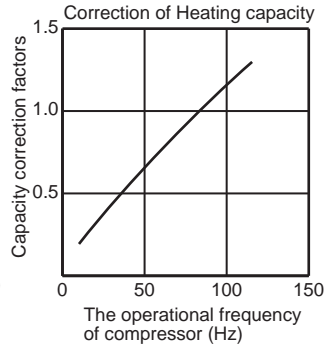
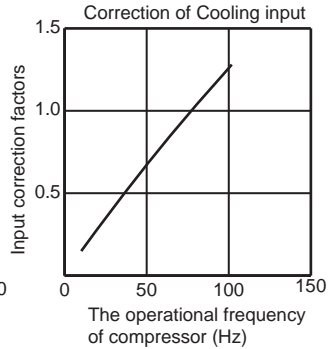
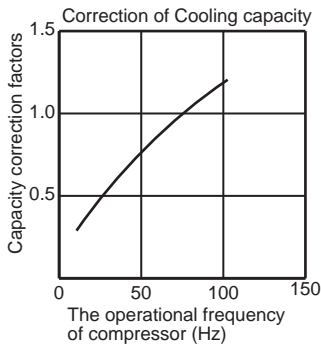

MUZ-HR71VF

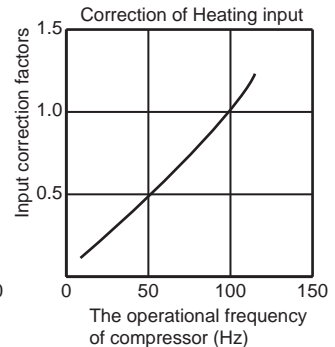
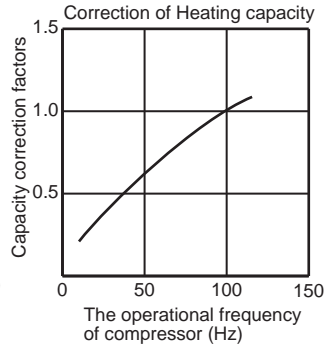
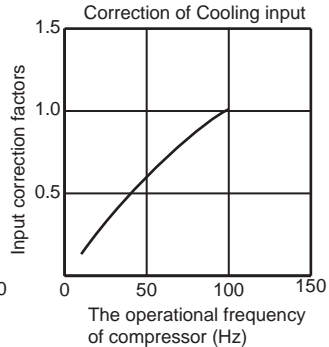
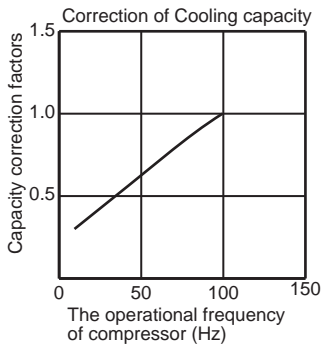

MUY-TP35VF

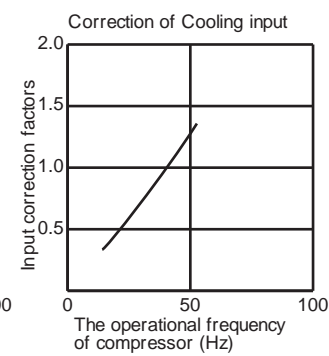
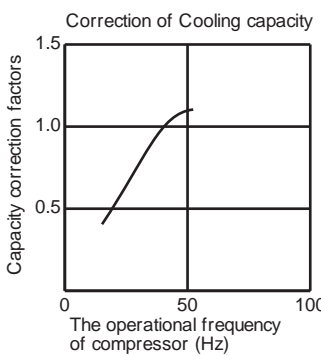

MUY-TP50VF

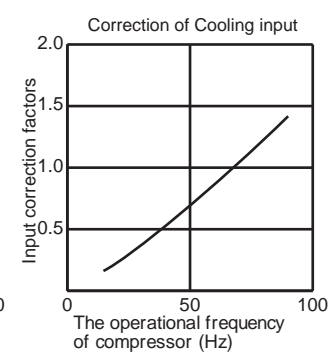
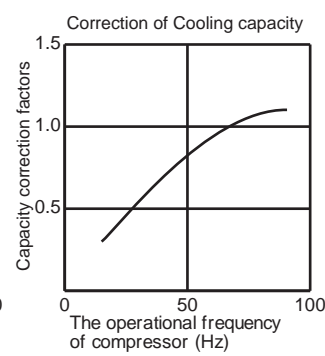

WALL-MOUNTED PERFORMANCE CURVES

MUZ-FH25VE

Correction of Cooling capacity

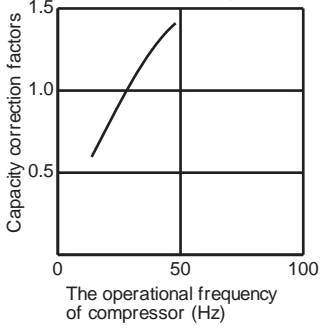

Correction of Cooling input

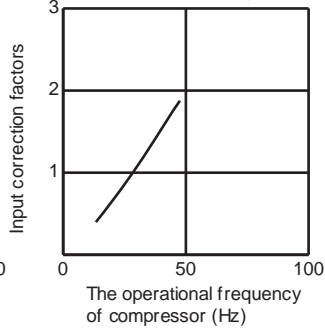

Correction of Heating capacity

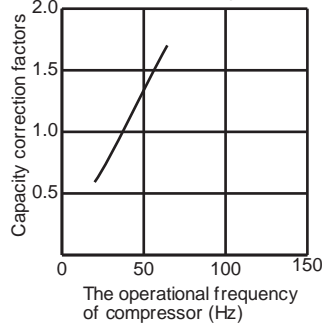

Correction of Heating input

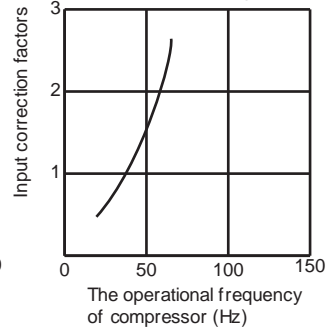

MUZ-FH35VE

Correction of Cooling capacity

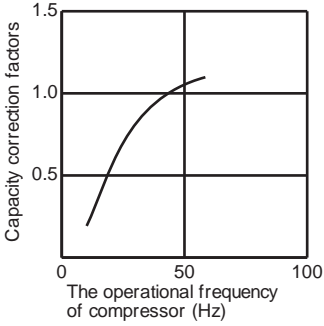

Correction of Cooling input

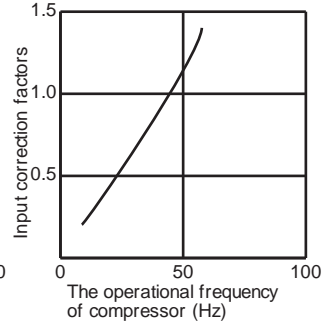

Correction of Heating capacity

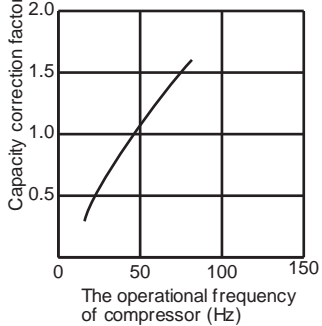

Correction of Heating input

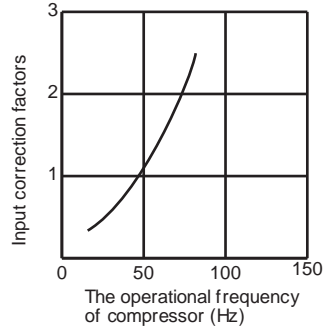

MUZ-FH50VE

Correction of Cooling capacity

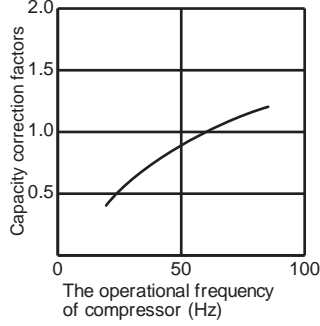

Correction of Cooling input

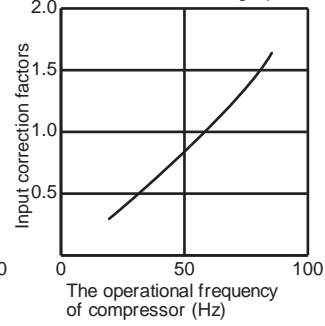

Correction of Heating capacity

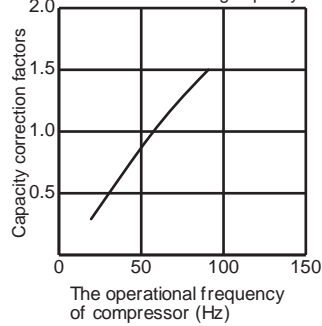

Correction of Heating input

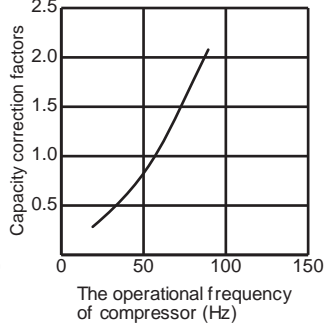

PERFORMANCE CURVES

WALL-MOUNTED

MUZ-EF25VG
MUZ-EF25VGH

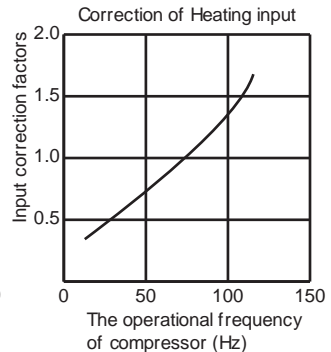
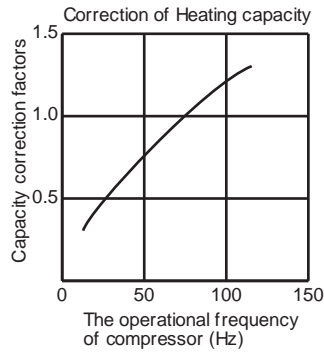
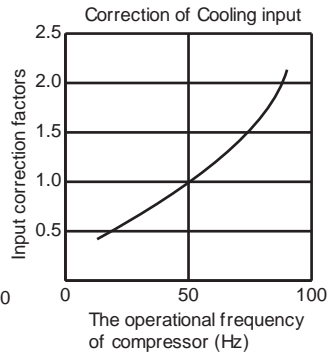
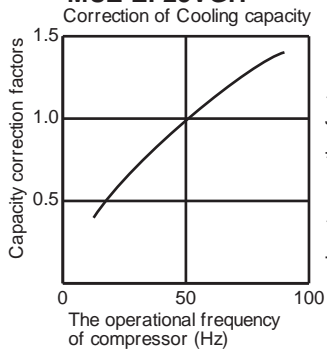

MUZ-EF35VG
MUZ-EF35VGH

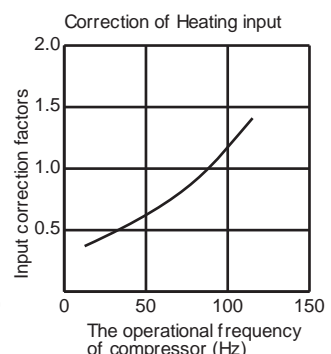
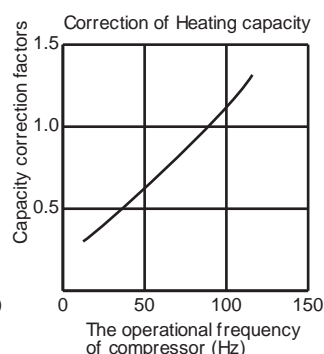
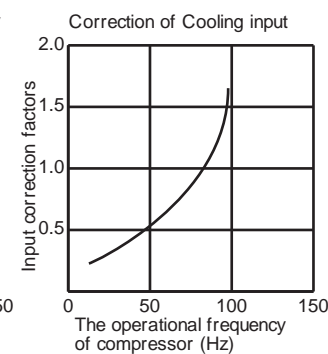
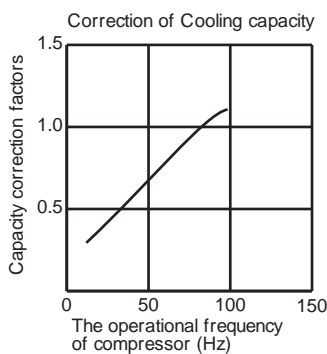

MUZ-EF42VG

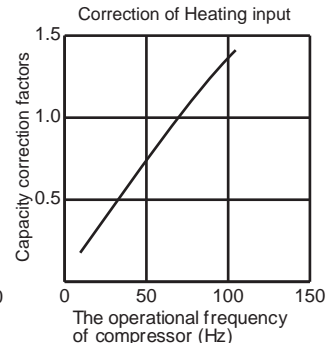
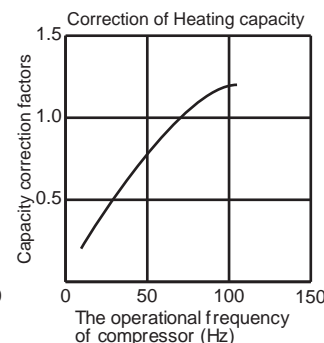
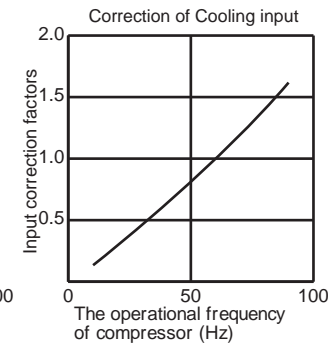
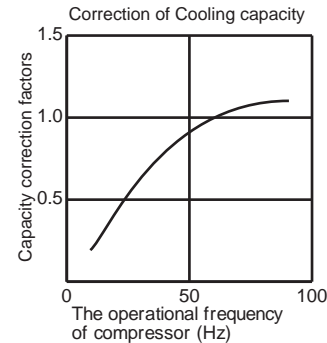

MUZ-EF50VG

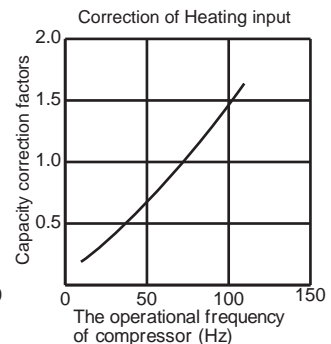
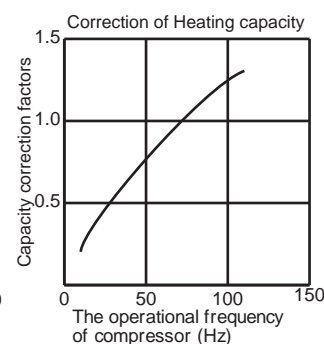
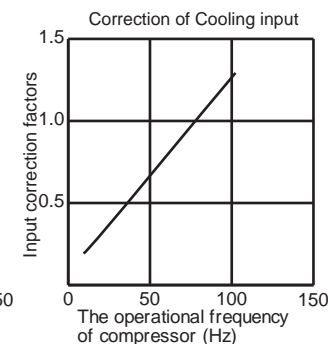
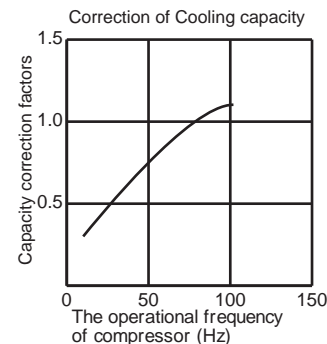

WALL-MOUNTED PERFORMANCE CURVES

MUZ-BT20VG

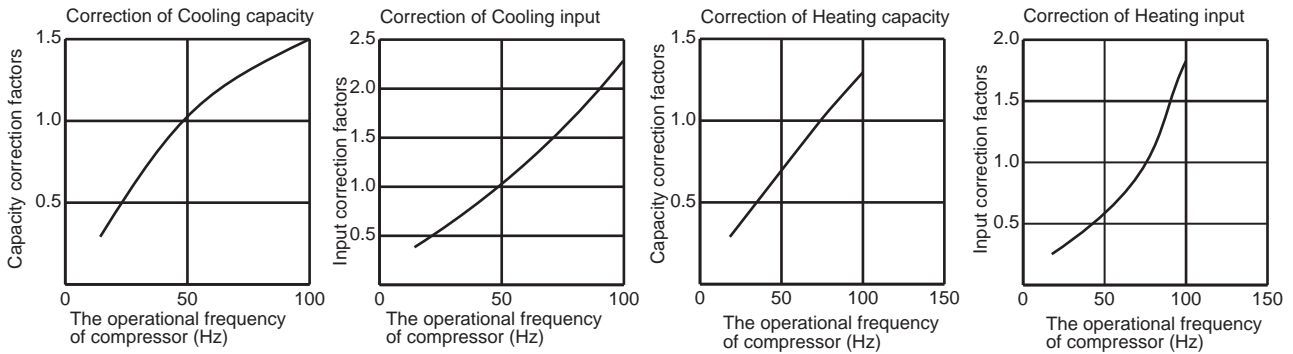

MUZ-BT25VG

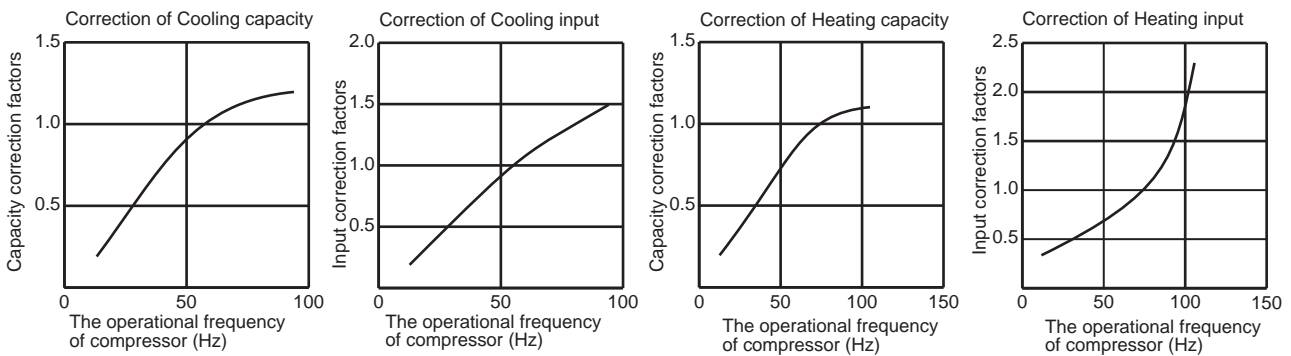

MUZ-BT35VG

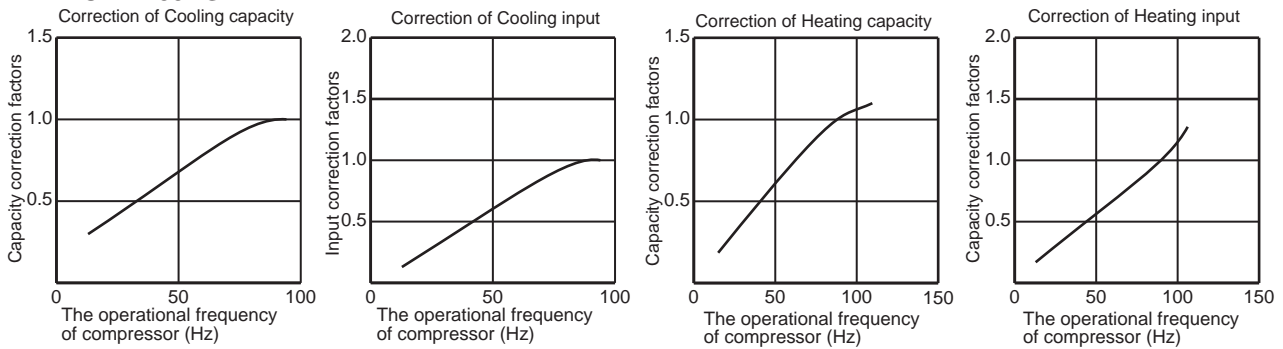

MUZ-BT50VG

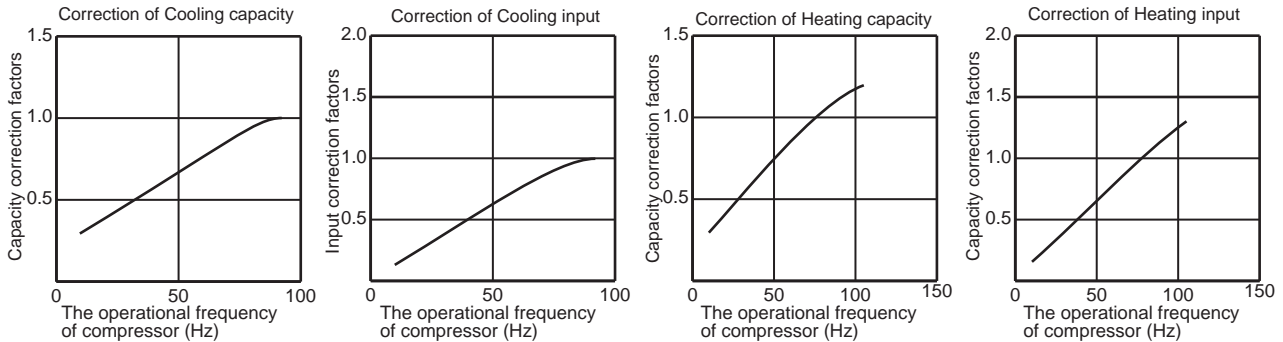

PERFORMANCE CURVES

WALL-MOUNTED

MUZ-DW25VF

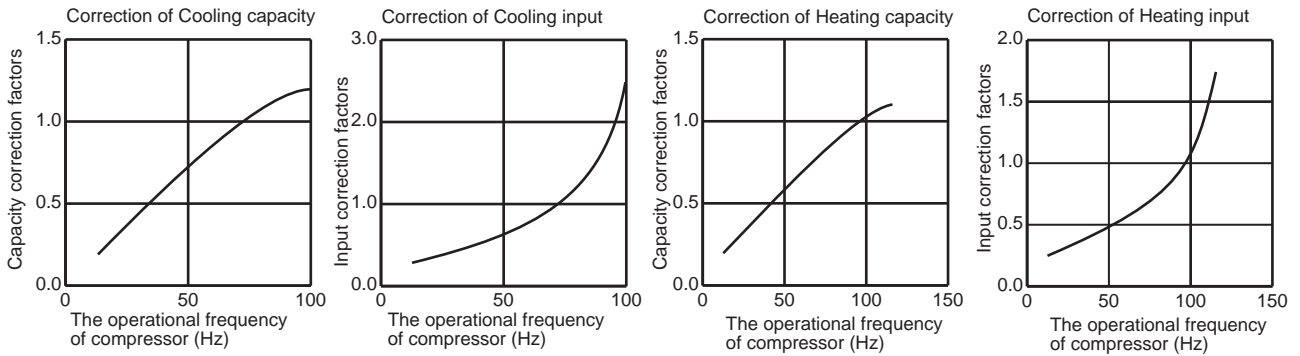

MUZ-DW35VF

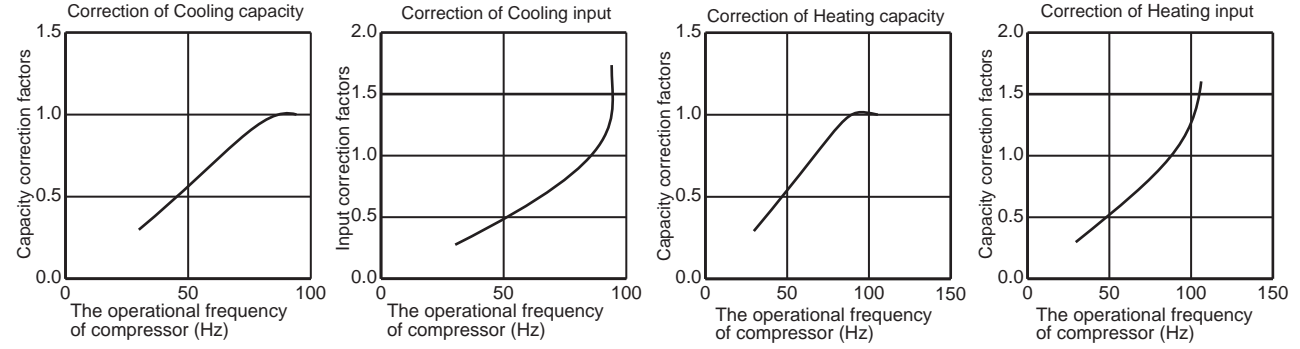

MUZ-DW50VF

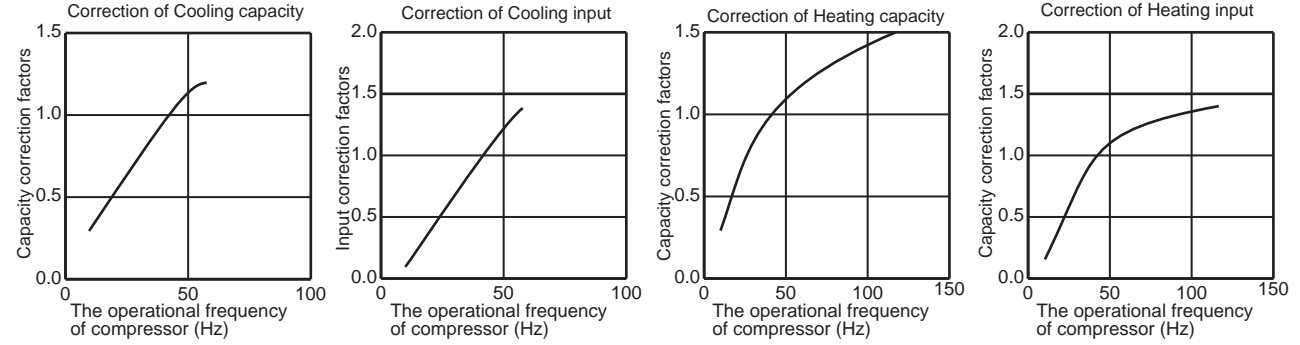

WALL-MOUNTED PERFORMANCE CURVES

MUZ-SF25VE
MUZ-SF25VEH

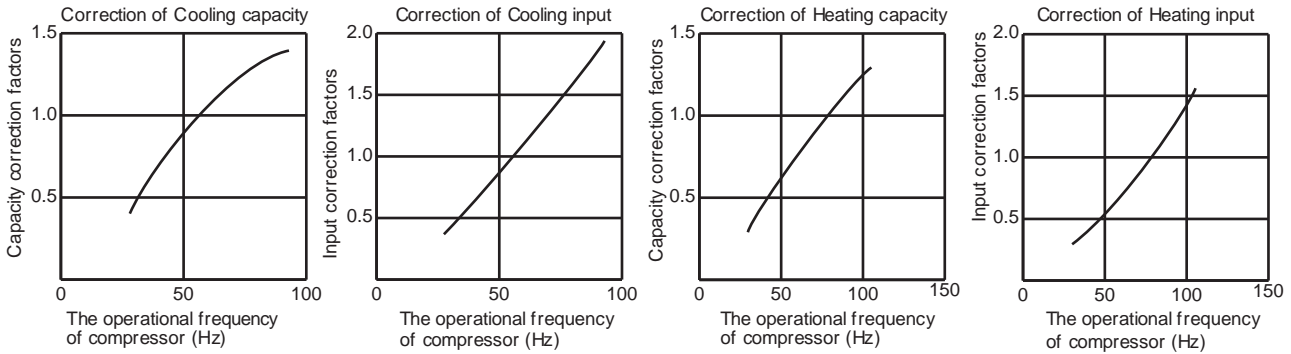

MUZ-SF35VE
MUZ-SF35VEH

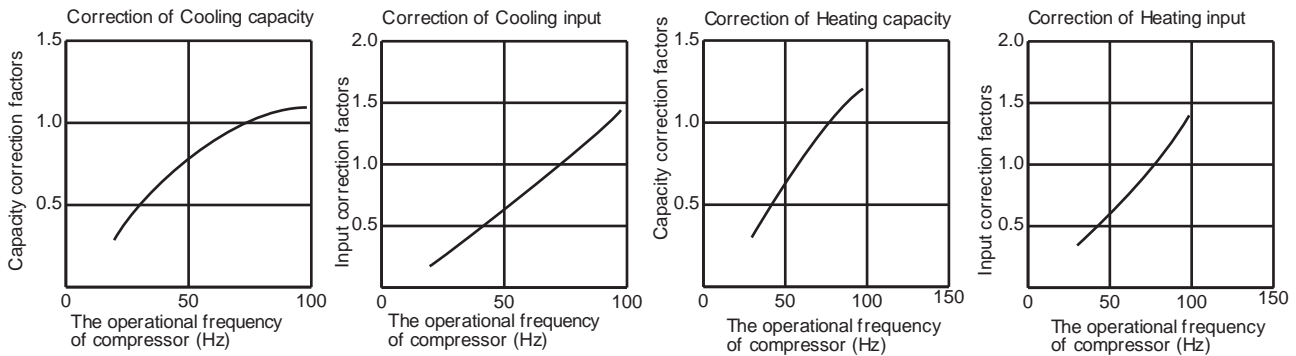

MUZ-SF42VE
MUZ-SF42VEH

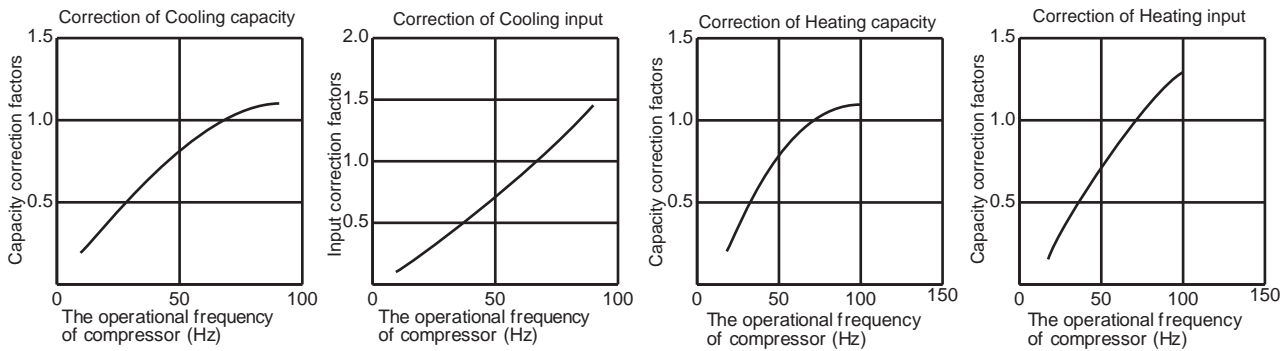

MUZ-SF50VE
MUZ-SF50VEH

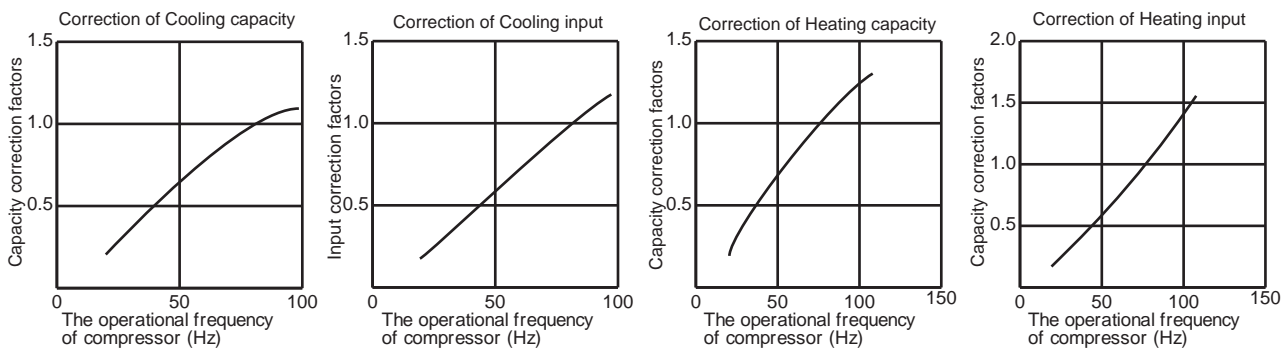

MUZ-GF60VE

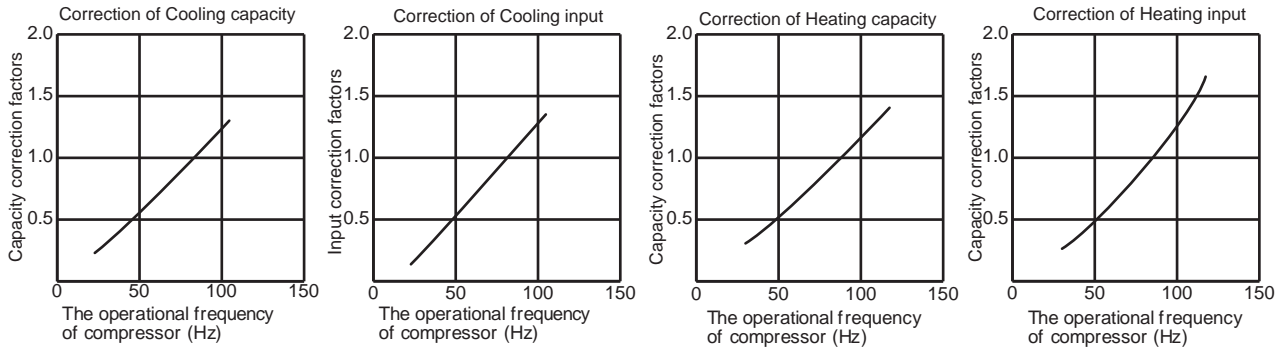

MUZ-GF71VE

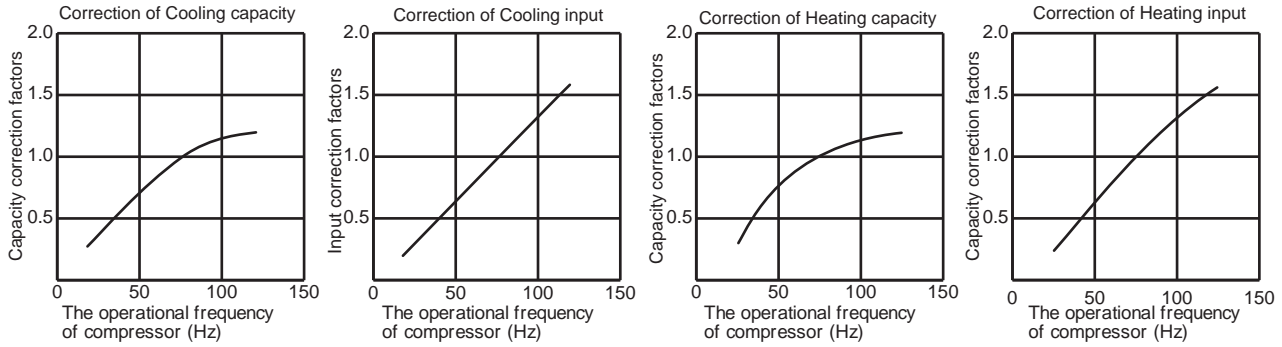

MUZ-WN25VA

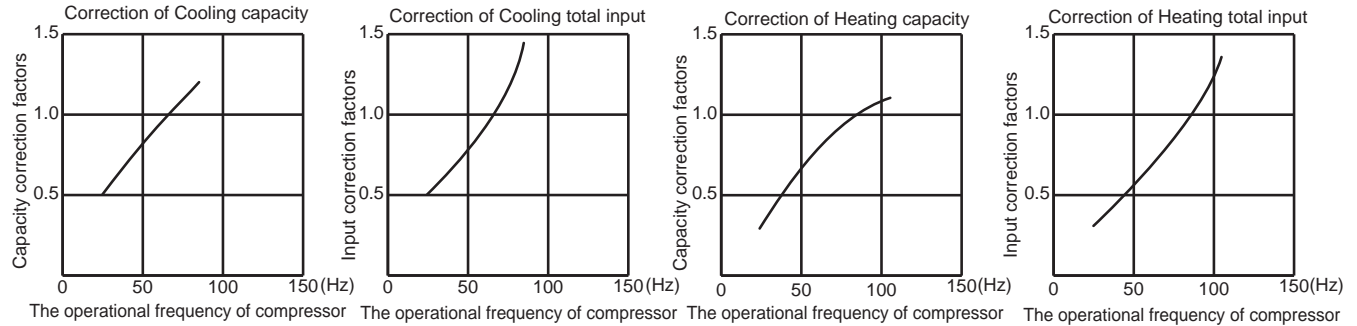

MUZ-WN35VA

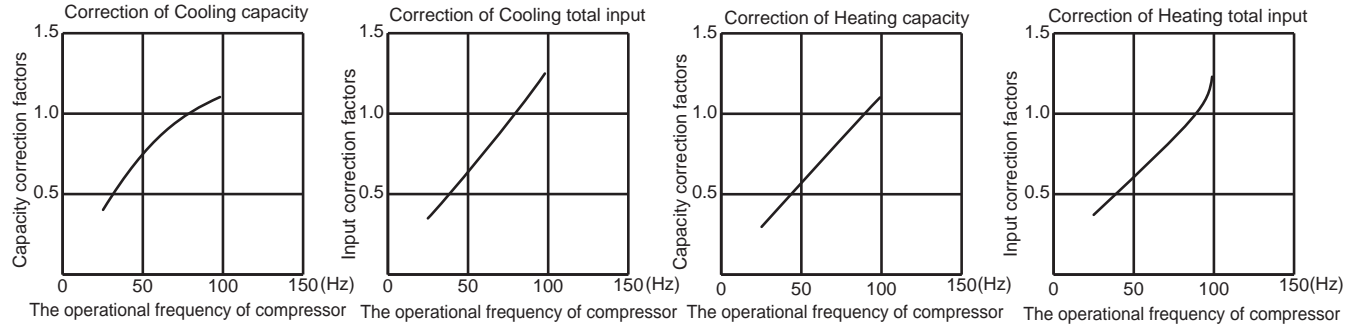

WALL-MOUNTED PERFORMANCE CURVES

MUZ-DM25VA

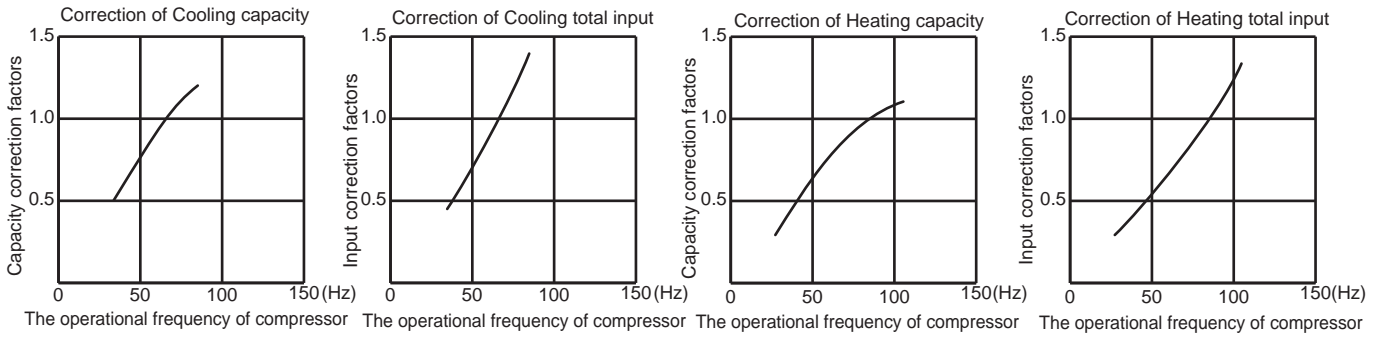

MUZ-DM35VA

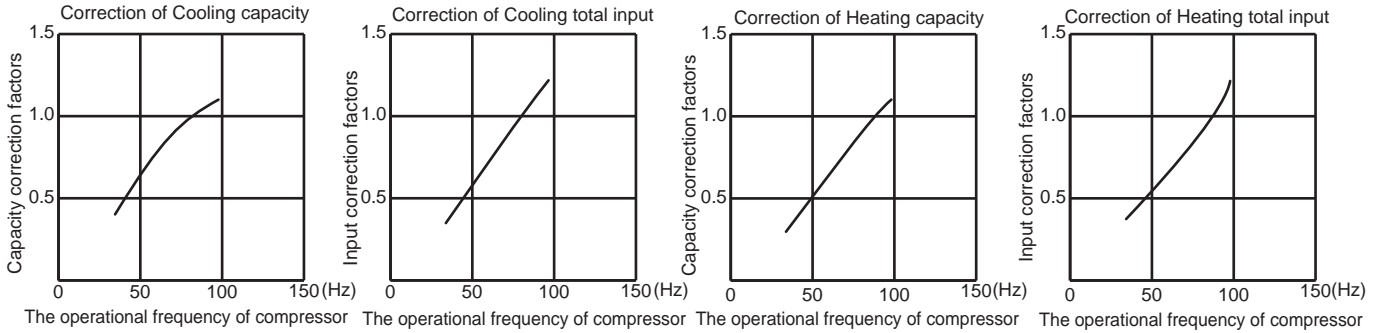

MUZ-HJ25VA

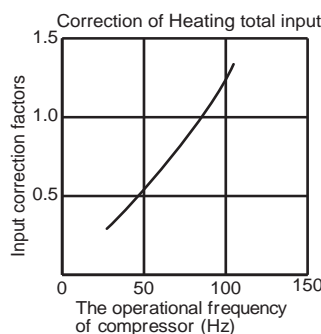
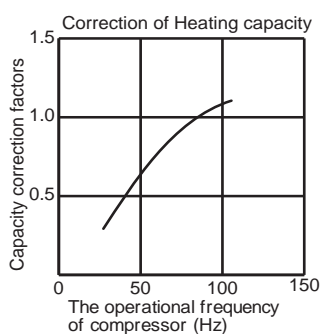
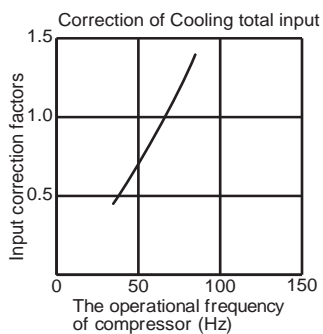
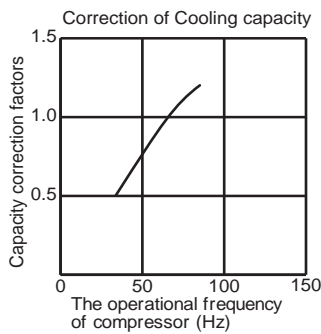

MUZ-HJ35VA

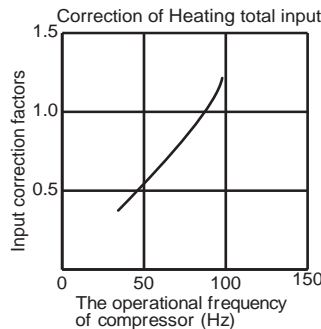
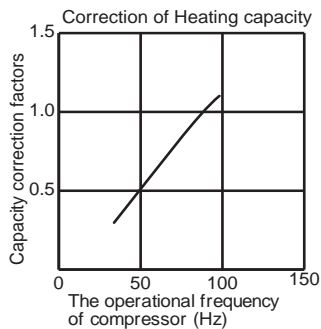
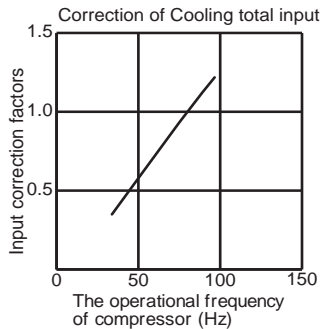
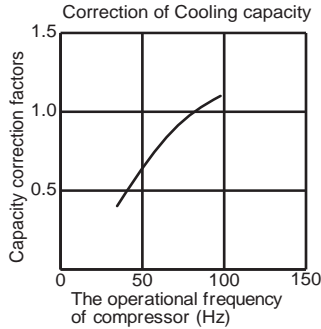

MUZ-HJ50VA

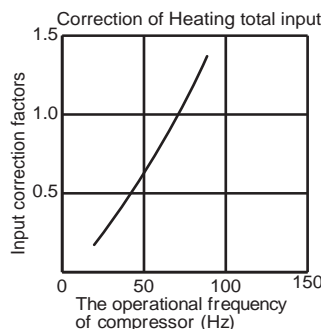
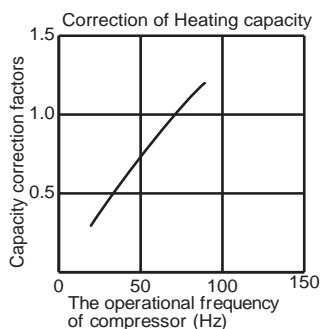
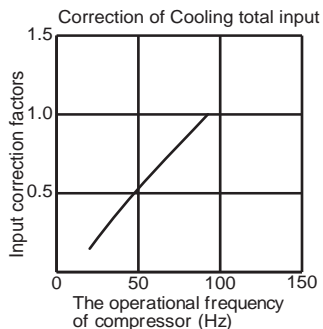
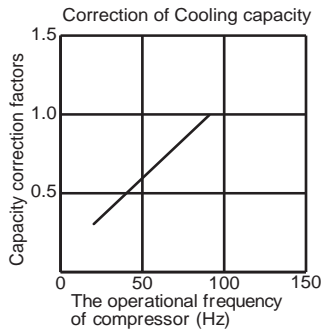

MUZ-HJ60VA

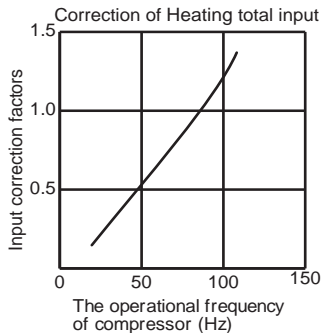
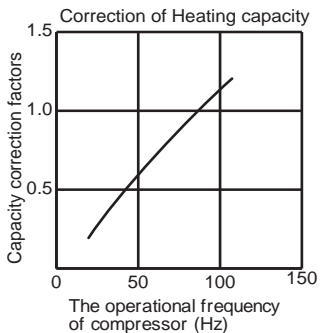
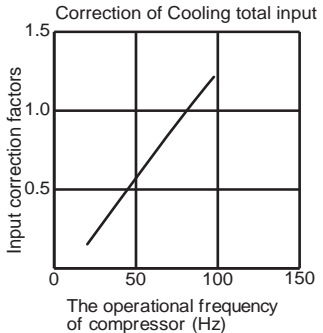
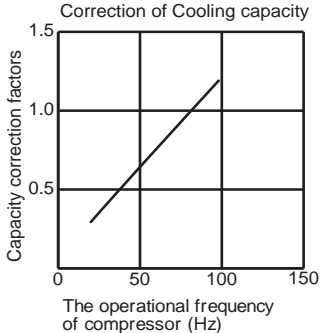

MUZ-HJ71VA

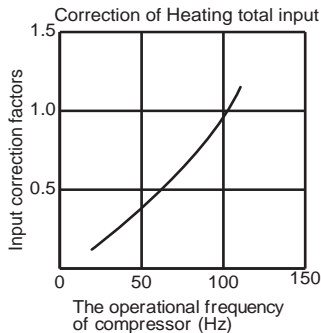
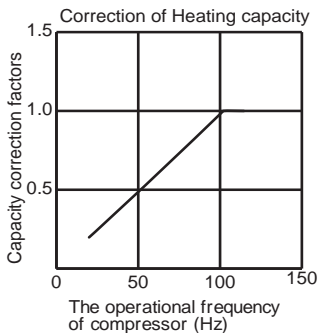
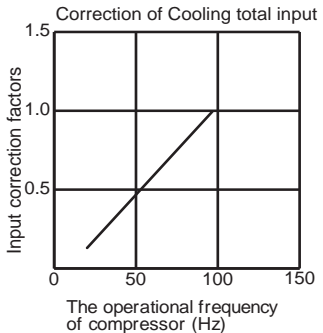
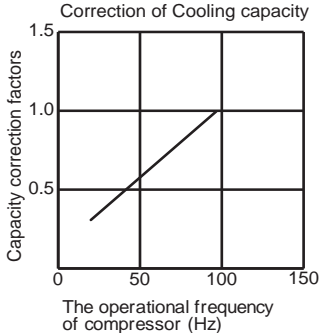

**C.1.5.2 Powerful Heating Heat Pump
CAPACITY AND THE INPUT CURVES**

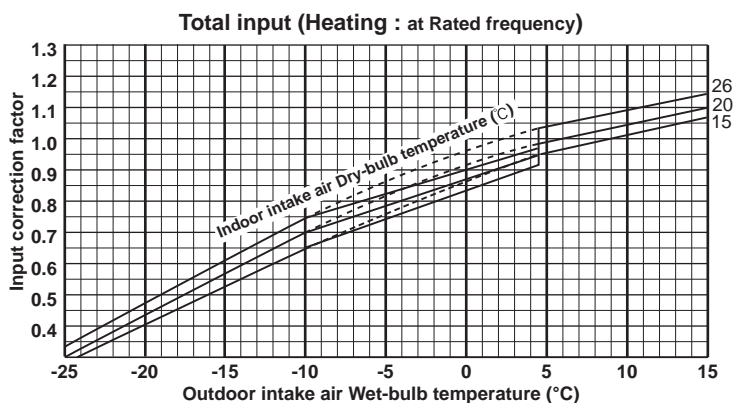
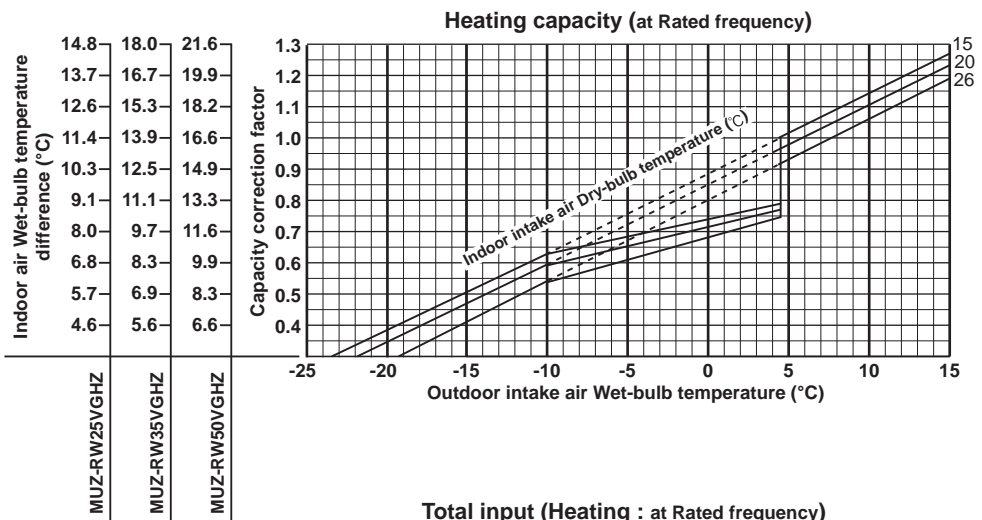
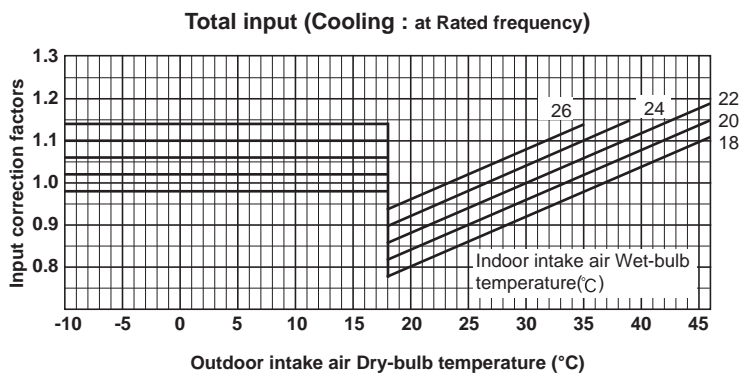
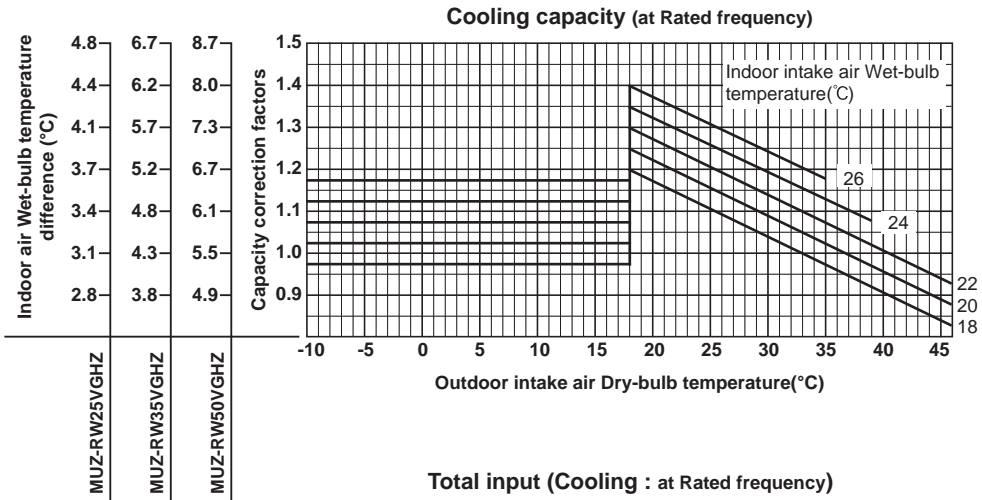

NOTE: The above broken lines are for the heating operation without any frost and defrost operation.

Indoor air Wet-bulb temperature difference (°C)	5.3	7.4	10.1
	4.9	6.8	9.3
	4.6	6.3	8.5
	4.2	5.7	7.8
	3.8	5.2	7.0
	3.4	4.7	6.3
	3.1	4.2	5.6
	MUZ-LN25VGHZ2	MUZ-LN35VGHZ2	MUZ-LN50VGHZ2

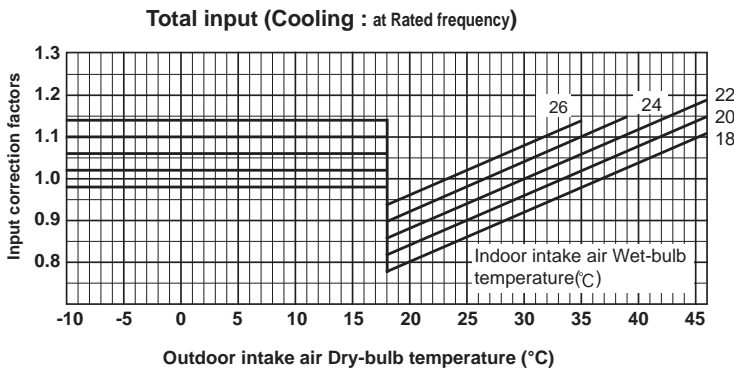
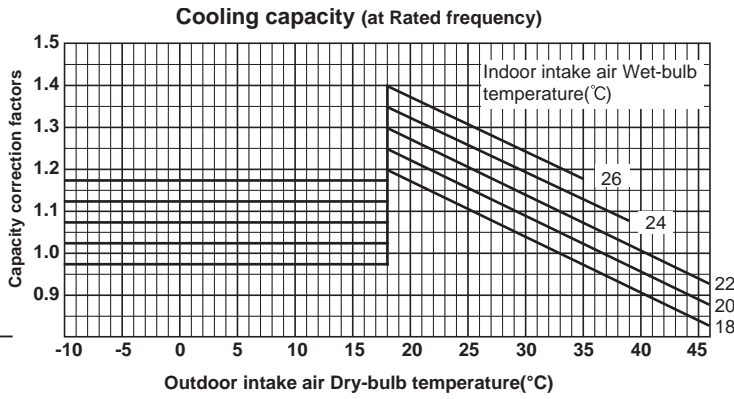

Indoor air Dry-bulb temperature difference (°C)	15.1	18.8	24.5
	13.9	17.4	22.6
	12.7	15.9	20.7
	11.6	14.5	18.9
	10.4	13.0	17.0
	9.3	11.6	15.1
	8.1	10.1	13.2
6.9	8.7	11.3	
5.8	7.2	9.4	
4.6	5.8	7.5	
	MUZ-LN25VGHZ2	MUZ-LN35VGHZ2	MUZ-LN50VGHZ2

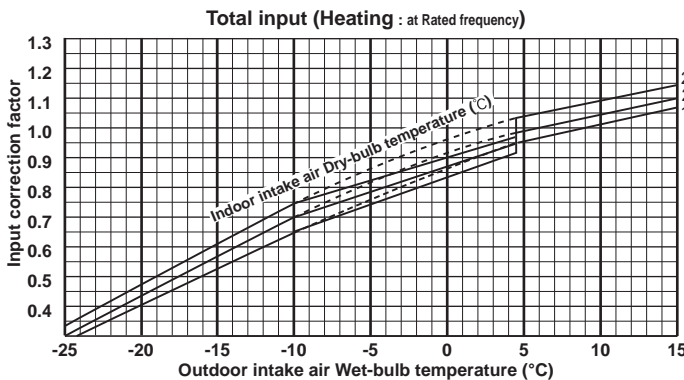
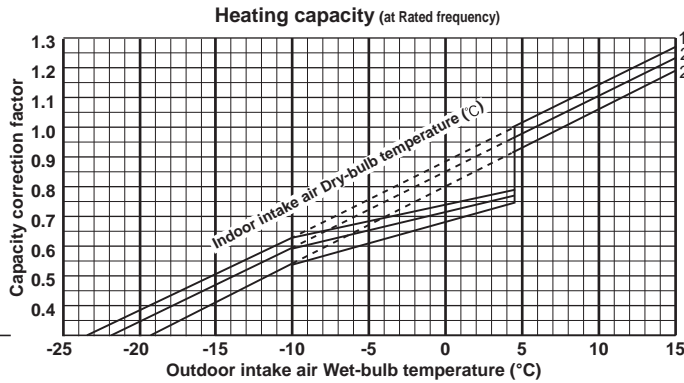

NOTE: The above broken lines are for the heating operation without any frost and defrost operation.

Indoor air Wet-bulb temperature difference (°C)	5.4	7.3	11.2
	5.0	6.8	10.3
	4.6	6.2	9.4
	4.2	5.7	8.6
	3.8	5.2	7.7
	3.5	4.7	6.9
	3.1	4.1	6.1
	MUZ-FT25VGHZ	MUZ-FT35VGHZ	MUZ-FT50VGHZ

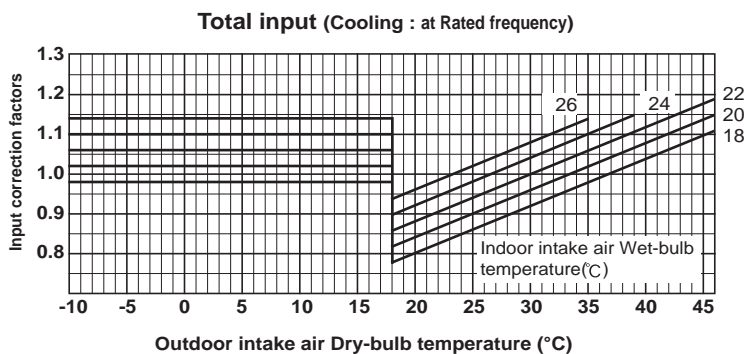
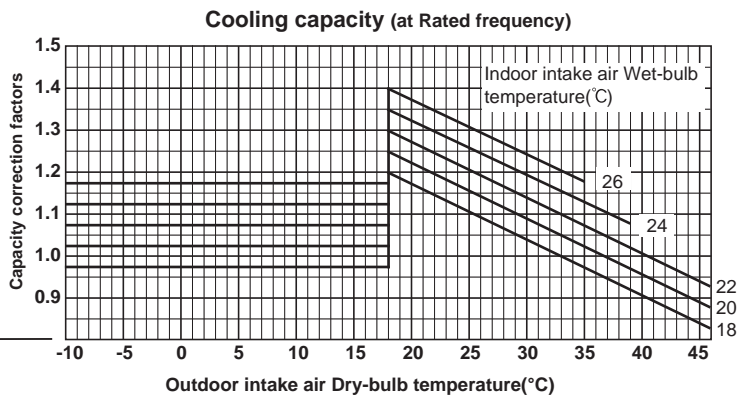

Indoor air Dry-bulb temperature difference (°C)	15.9	17.8	21.1
	14.6	16.4	19.5
	13.4	15.1	17.8
	12.2	13.7	16.2
	11.0	12.3	14.6
	9.8	10.9	13.0
	8.5	9.6	11.4
	7.3	8.2	9.7
	6.1	6.8	8.1
	4.9	5.5	6.5
	MUZ-FT25VGHZ	MUZ-FT35VGHZ	MUZ-FT50VGHZ

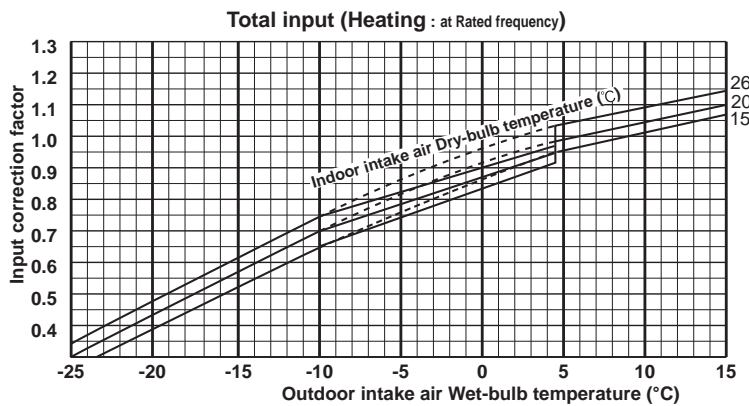
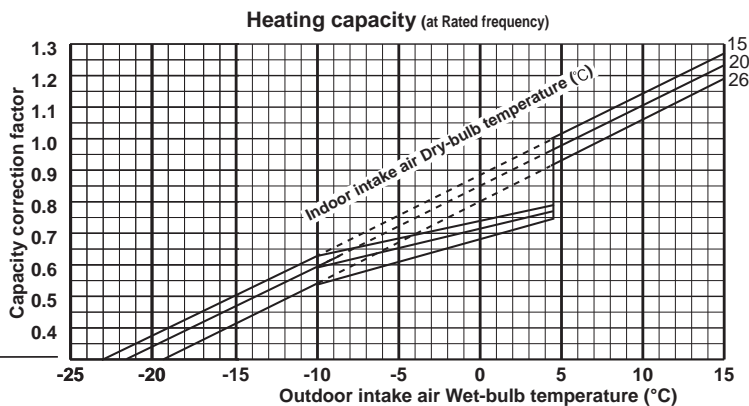

NOTE: The above broken lines are for the heating operation without any frost and defrost operation.

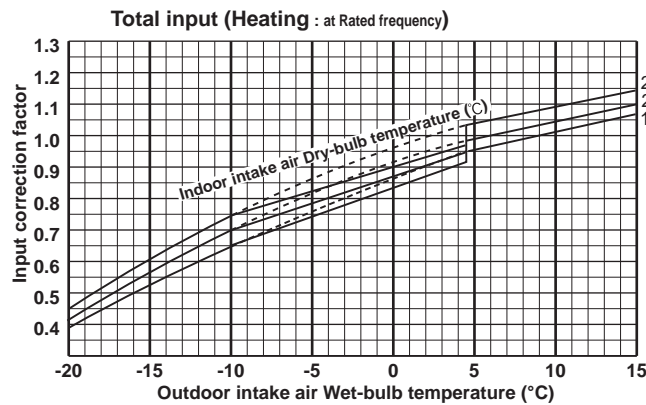
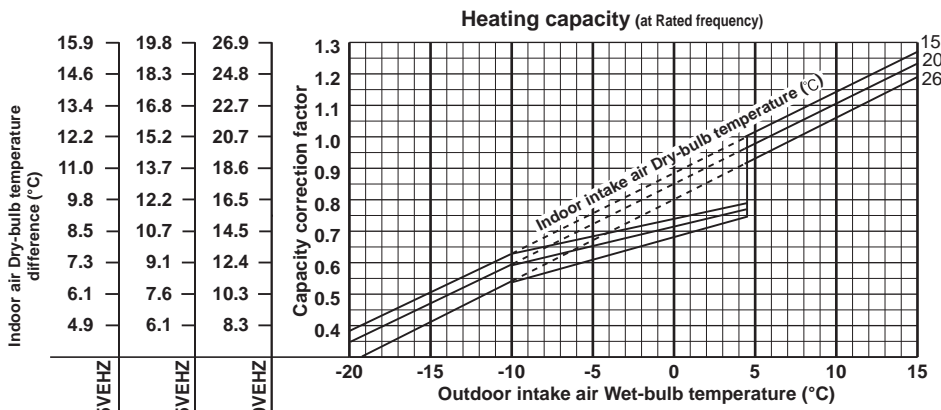
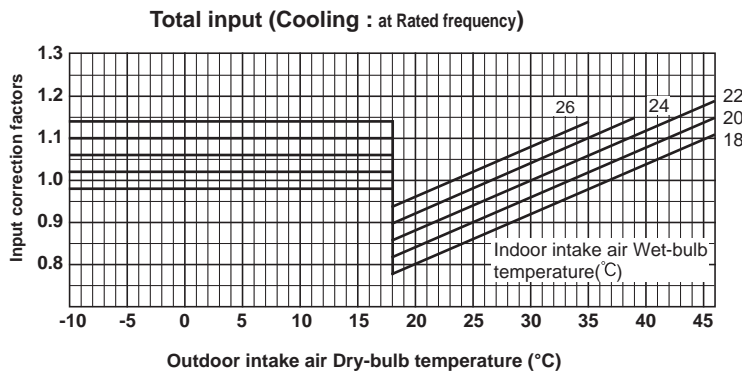
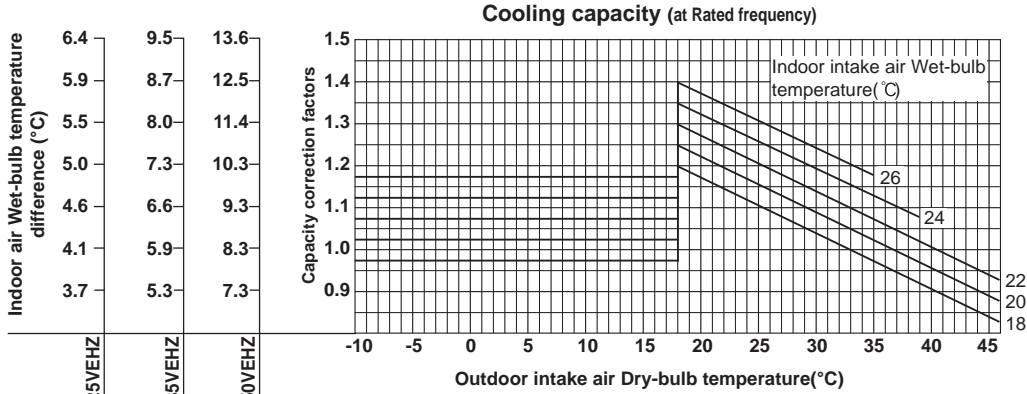

NOTE: The above broken lines are for the heating operation without any frost and defrost operation.

CAPACITY AND INPUT CORRECTION BY OPERATIONAL FREQUENCY OF COMPRESSOR

MUZ-RW25VGHZ

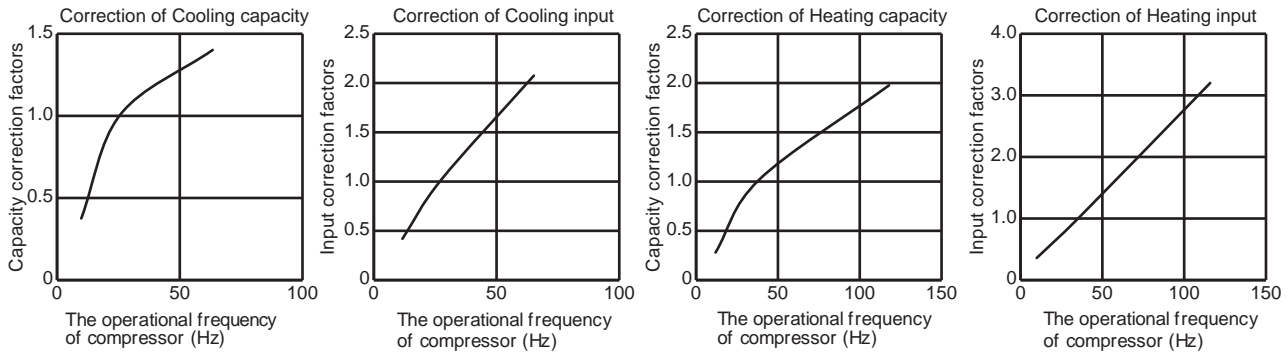

MUZ-RW35VGHZ

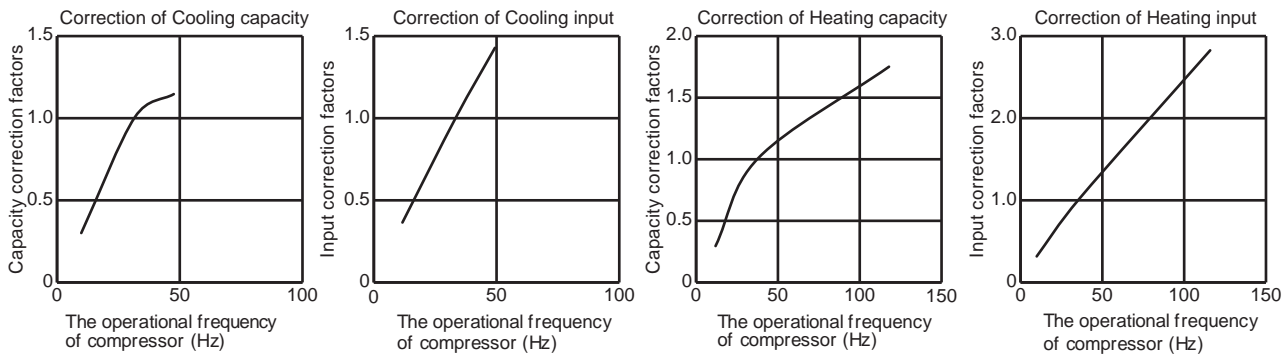

MUZ-RW50VGHZ

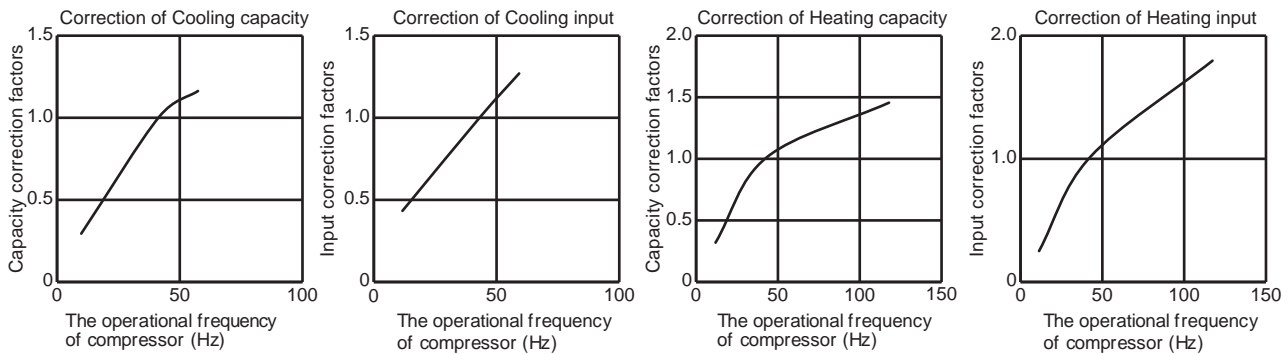

PERFORMANCE CURVES

WALL-MOUNTED

MUZ-LN25VGHZ2

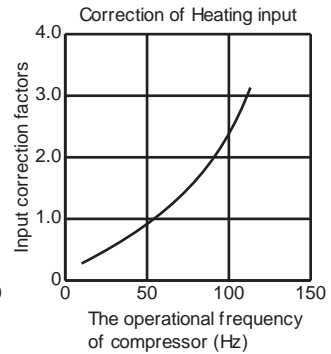
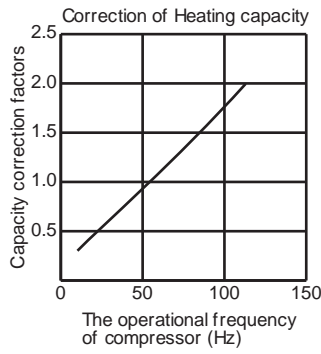
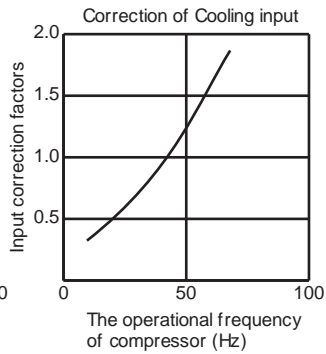
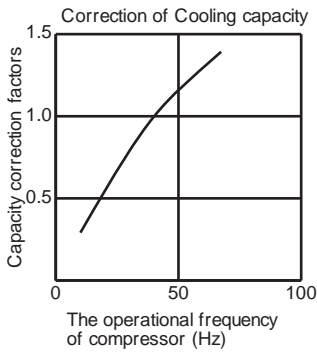

MUZ-LN35VGHZ2

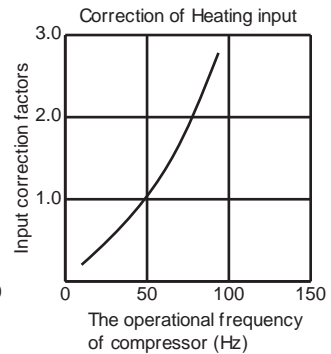
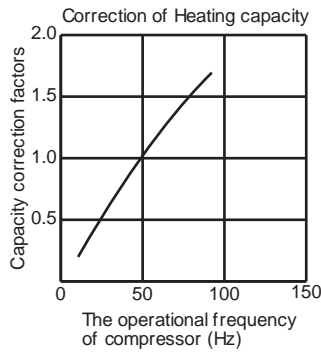
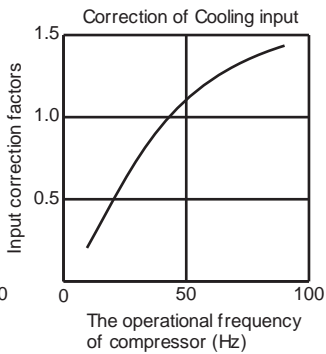
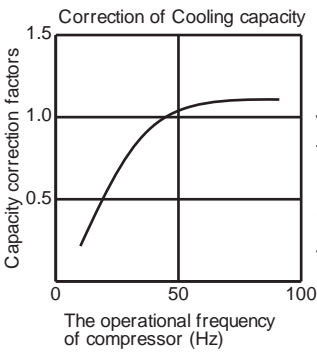

MUZ-LN50VGHZ2

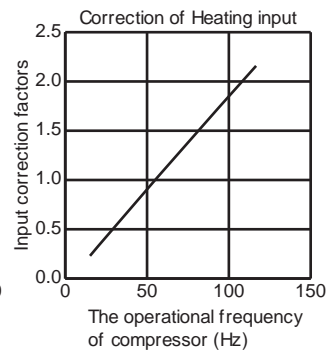
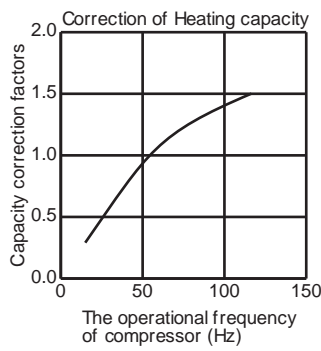
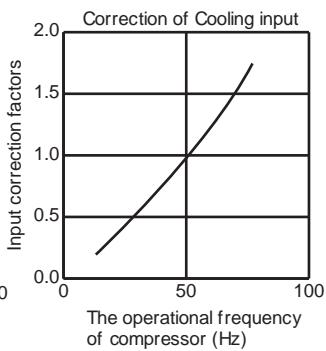
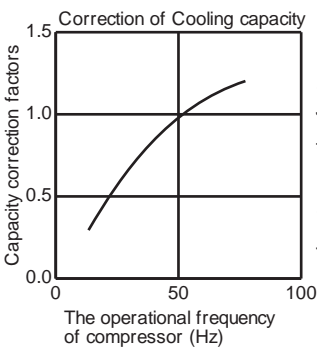

MUZ-FT25VGHZ

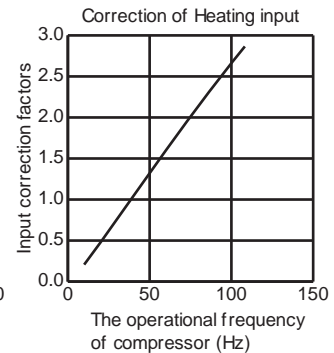
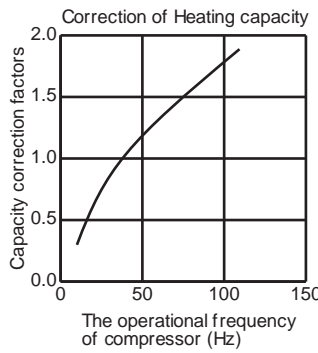
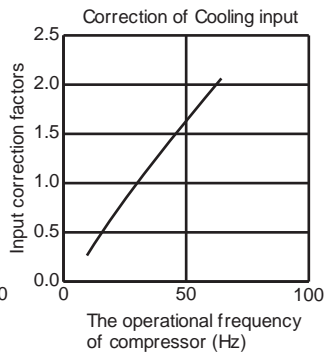
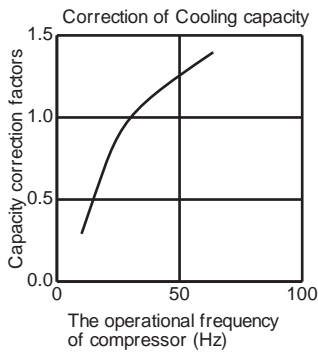

MUZ-FT35VGHZ

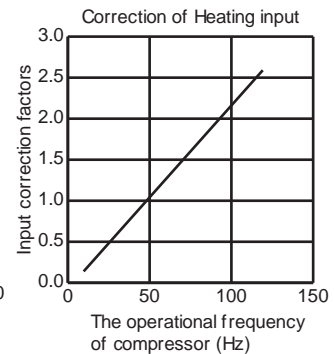
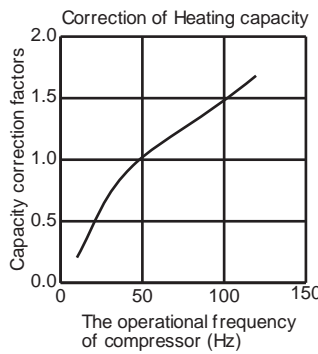
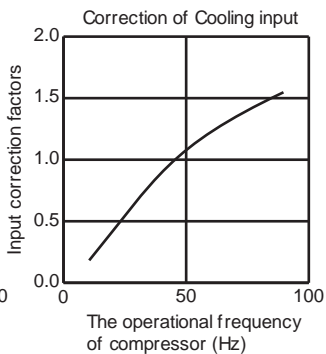
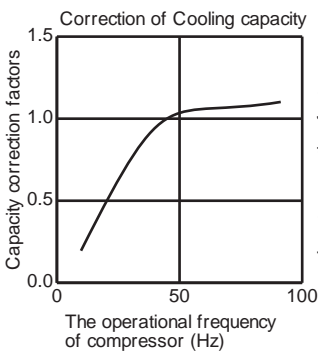

MUZ-FT50VGHZ

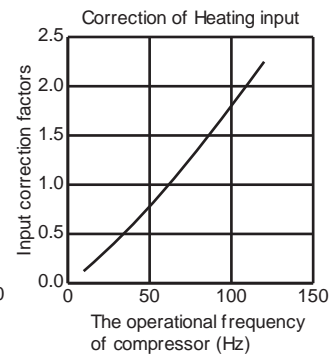
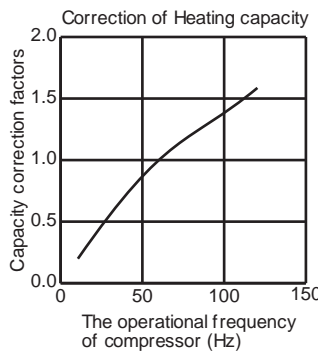
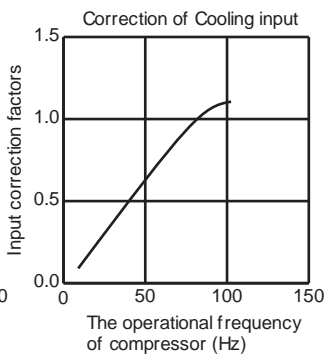
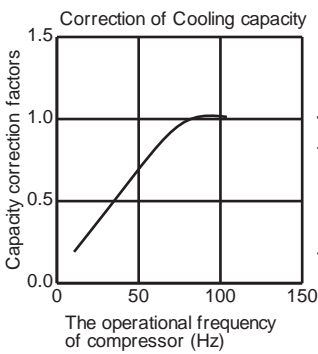

PERFORMANCE CURVES

WALL-MOUNTED

MUZ-FH25VEHZ

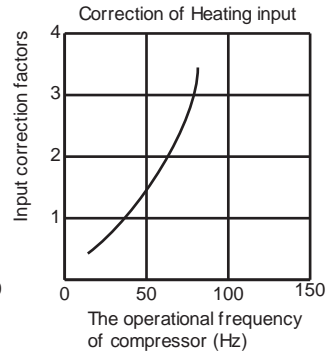
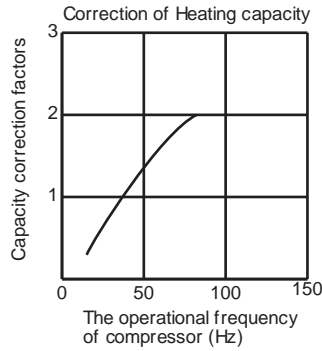
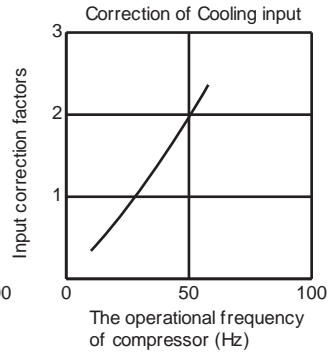
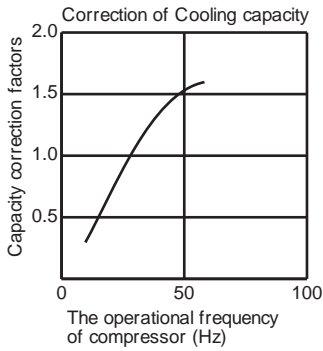

MUZ-FH35VEHZ

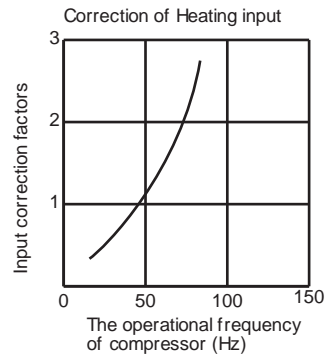
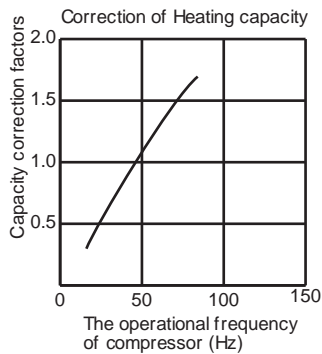
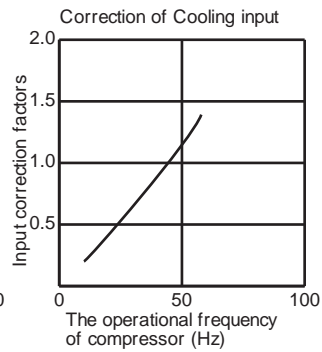
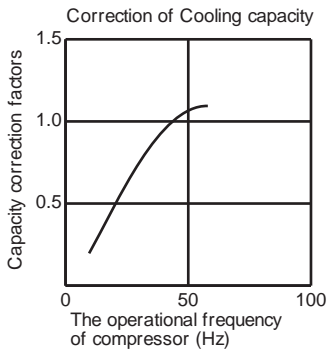

MUZ-FH50VEHZ

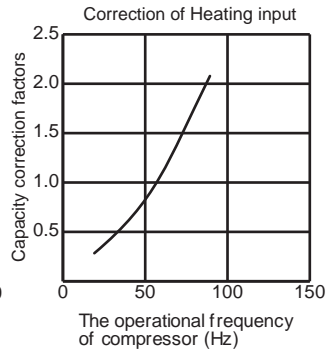
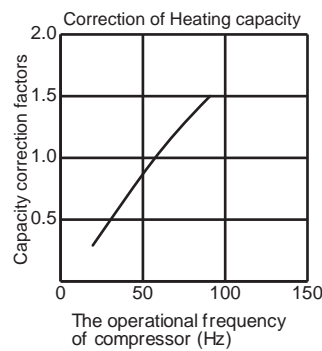
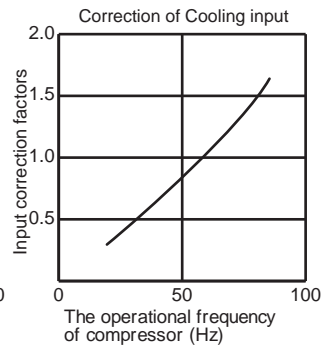
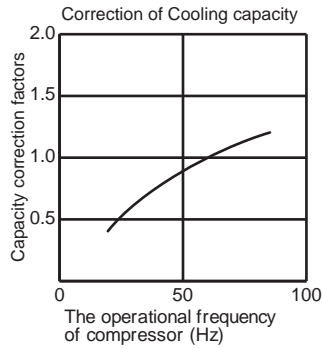

WALL-MOUNTED PERFORMANCE CURVES

C.1.5.3 Inverter/Powerful Heating Heat Pump
HOW TO OPERATE FIXED-FREQUENCY OPERATION

<Test run operation>

1. Press the emergency operation switch to start COOL or HEAT mode (COOL: Press once, HEAT: Press twice).
2. Test run operation starts and continues to operate for 30 minutes.
3. Compressor operates at rated frequency in COOL mode or 58 Hz in HEAT mode.
4. Indoor fan operates at High speed.
5. After 30 minutes, test run operation finishes and EMERGENCY OPERATION starts (operation frequency of compressor varies).
6. To cancel test run operation (EMERGENCY OPERATION), press the emergency operation switch or any button on remote controller.

OUTDOOR LOW PRESSURE AND OUTDOOR UNIT CURRENT

COOL operation

- ① Both indoor and outdoor unit are under the same temperature/humidity condition.
- ② Operation : TEST RUN OPERATION
- ③ The unit of pressure has been changed to MPa on the international system of units (SI unit system)
 The conversion factor is: **1 (MPa [Gauge]) = 10.2 (kgf/cm² [Gauge])**

Dry-bulb temperature (°C)	Relative humidity (%)
20	50
25	60
30	70

Outdoor low pressure

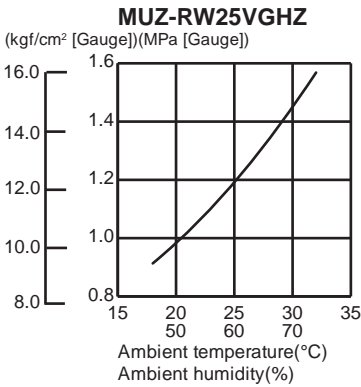

Outdoor unit current

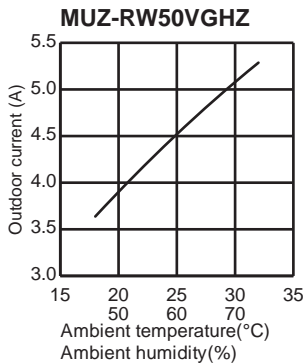
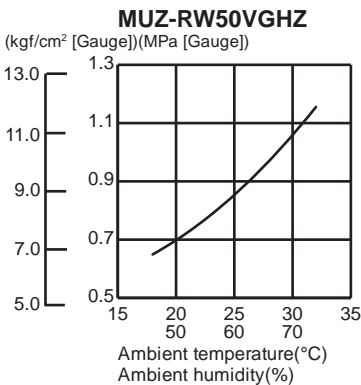
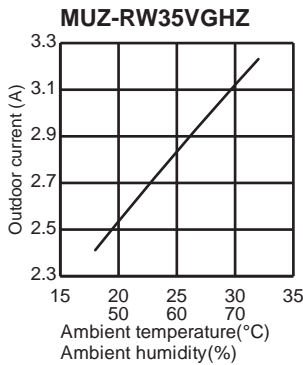
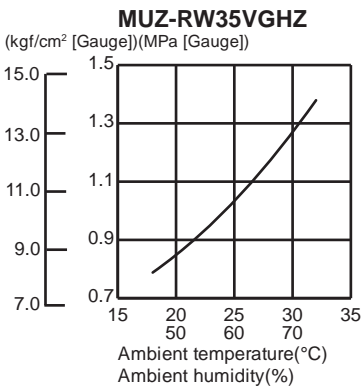
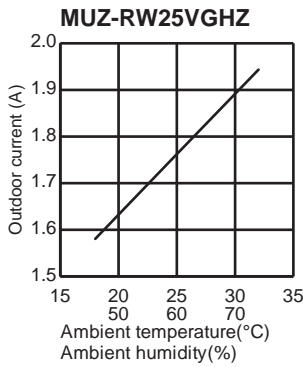

PERFORMANCE CURVES

WALL-MOUNTED

MUZ-LN25VG2

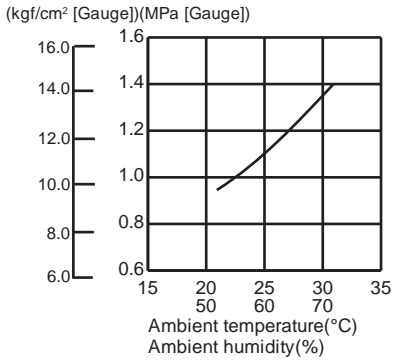

MUZ-LN25VG2

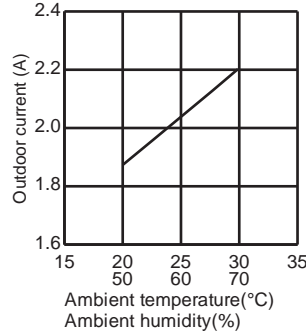

MUZ-LN25VGHZ2

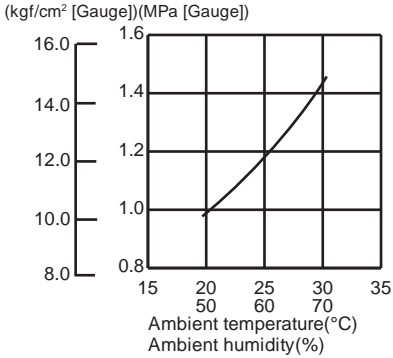

MUZ-LN25VGHZ2

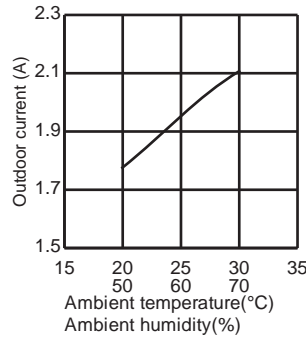

MUZ-LN35VG2

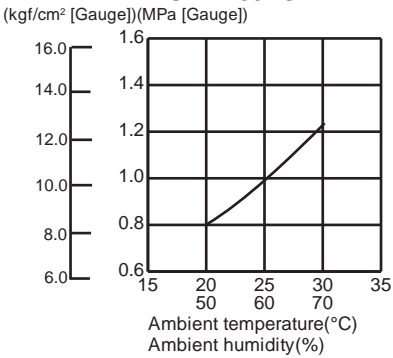

MUZ-LN35VG2

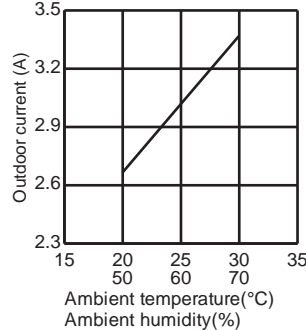

MUZ-LN35VGHZ2

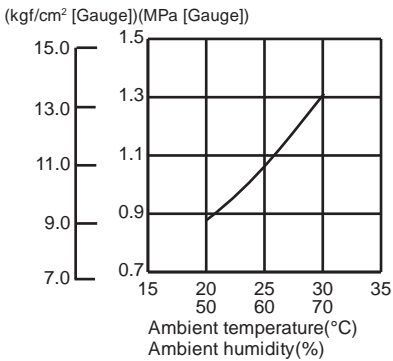

MUZ-LN35VGHZ2

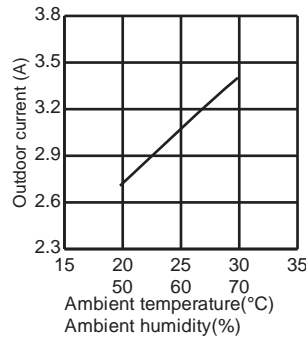

WALL-MOUNTED PERFORMANCE CURVES

MUZ-LN50VG2

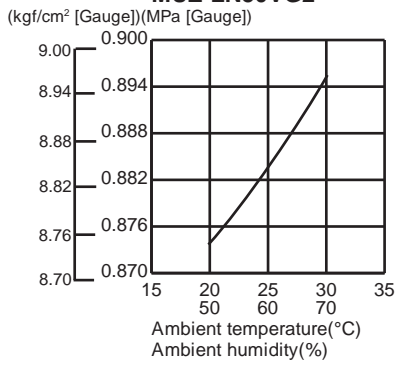

MUZ-LN50VG2

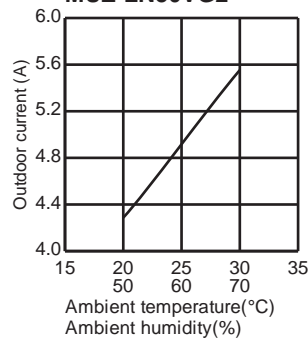

MUZ-LN50VGHZ2

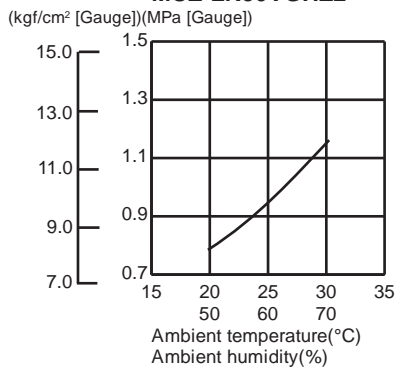

MUZ-LN50VGHZ2

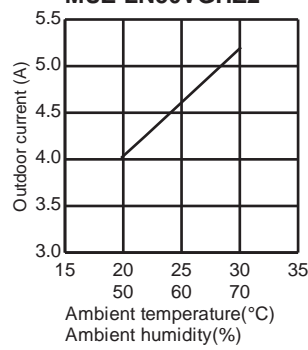

MUZ-LN60VG2

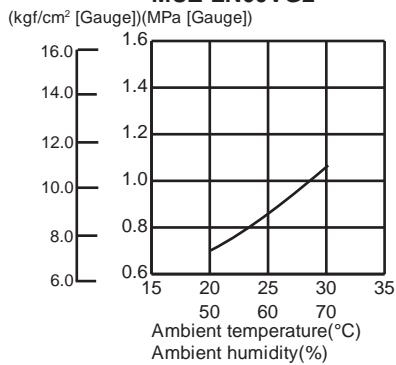

MUZ-LN60VG2

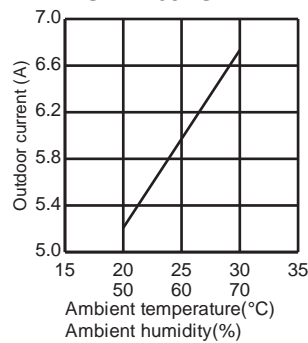

PERFORMANCE CURVES

WALL-MOUNTED

MUZ-FT25VGHZ

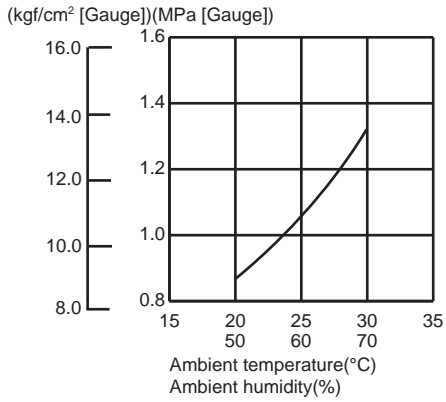

MUZ-FT25VGHZ

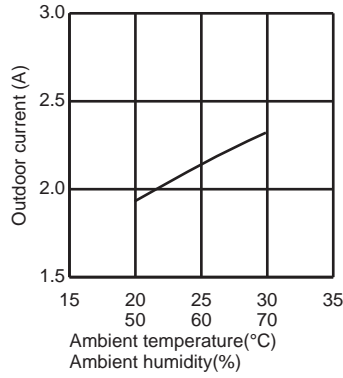

MUZ-FT35VGHZ

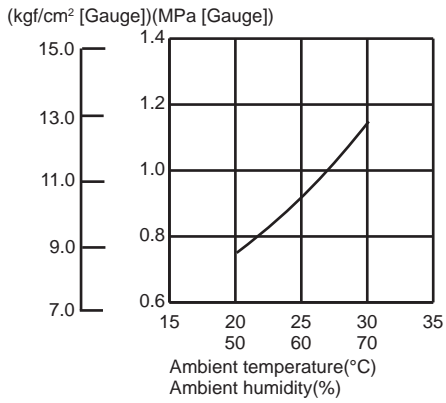

MUZ-FT35VGHZ

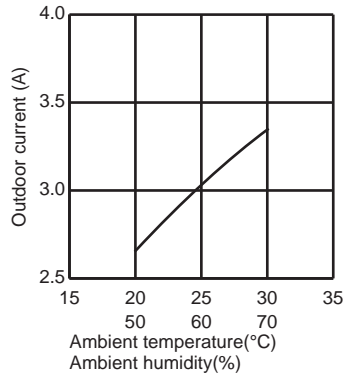

MUZ-FT50VGHZ

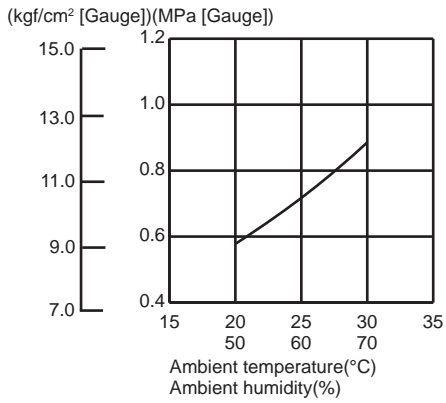

MUZ-FT50VGHZ

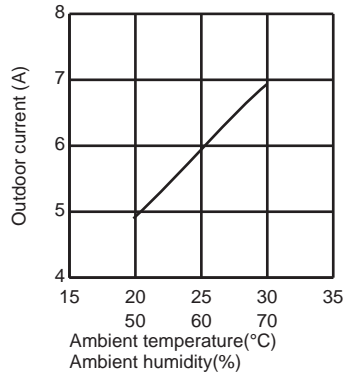

WALL-MOUNTED PERFORMANCE CURVES

**MUZ-AY25VG
MUZ-AY25VGH**

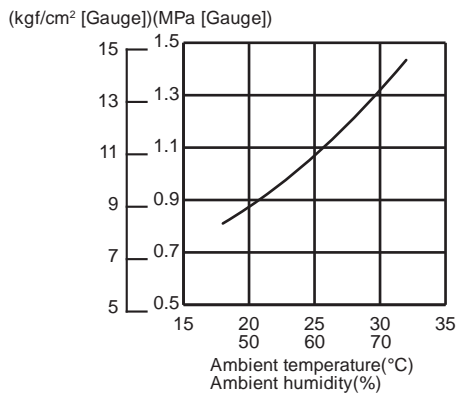

**MUZ-AY25VG
MUZ-AY25VGH**

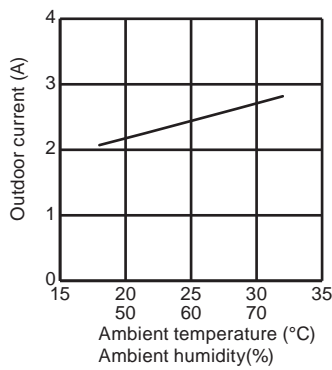

**MUZ-AY35VG
MUZ-AY35VGH**

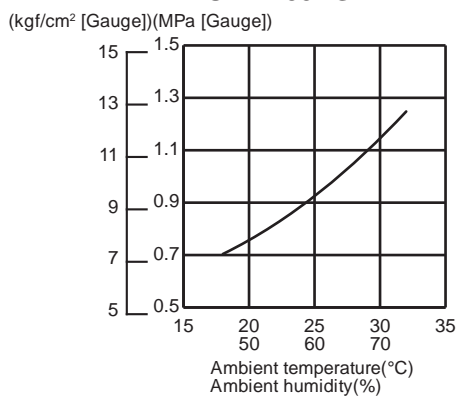

**MUZ-AY35VG
MUZ-AY35VGH**

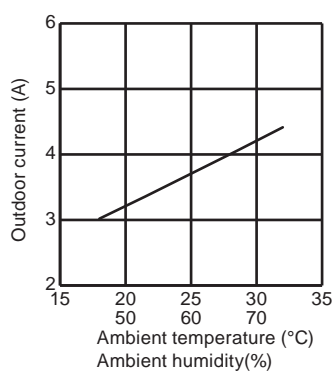

**MUZ-AY42VG
MUZ-AY42VGH**

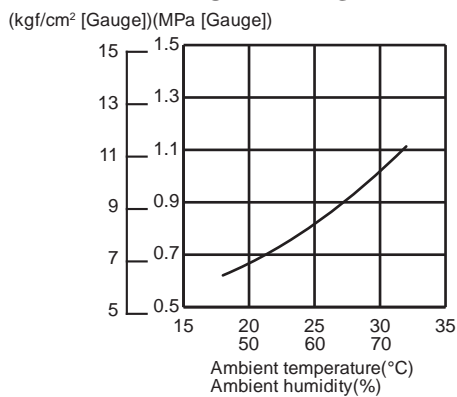

**MUZ-AY42VG
MUZ-AY42VGH**

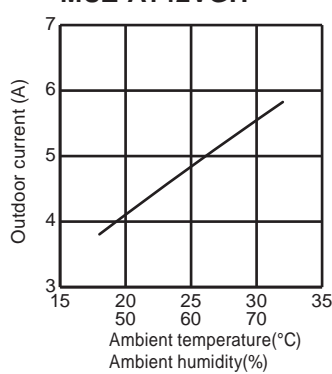

**MUZ-AY50VG
MUZ-AY50VGH**

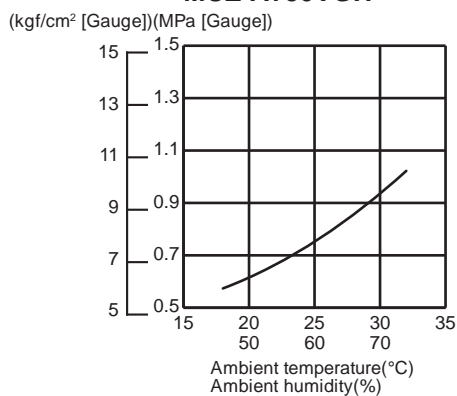

**MUZ-AY50VG
MUZ-AY50VGH**

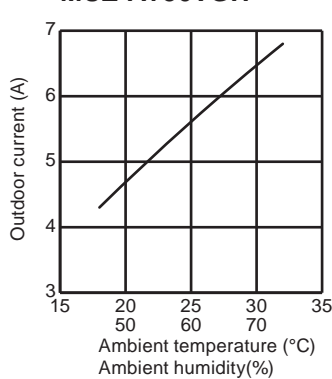

PERFORMANCE CURVES

WALL-MOUNTED

MUZ-AP15VG

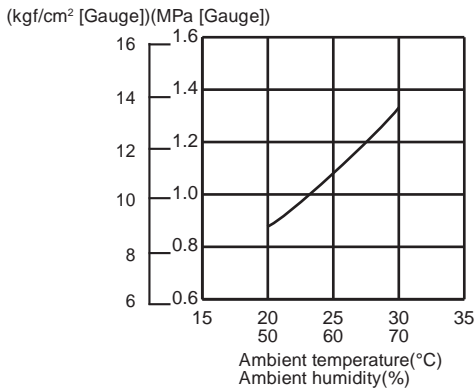

MUZ-AP15VG

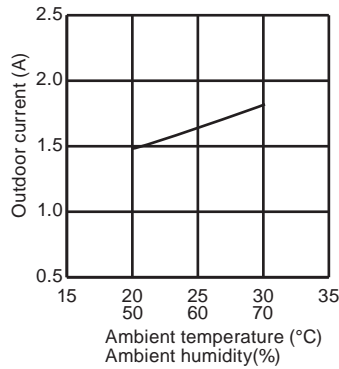

MUZ-AP20VG

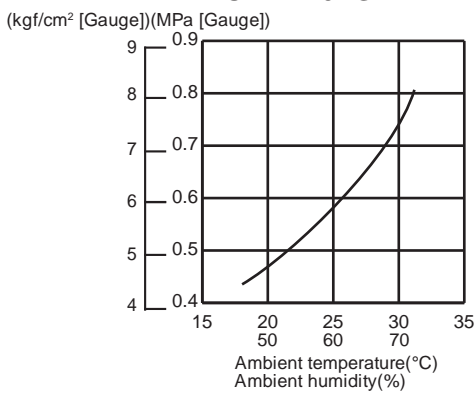

MUZ-AP20VG

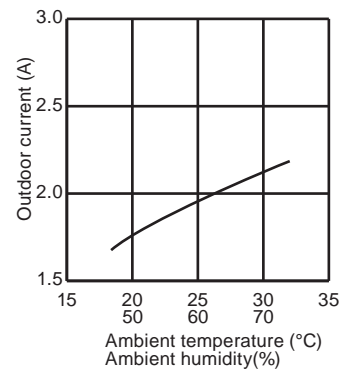

MUZ-AP60VG

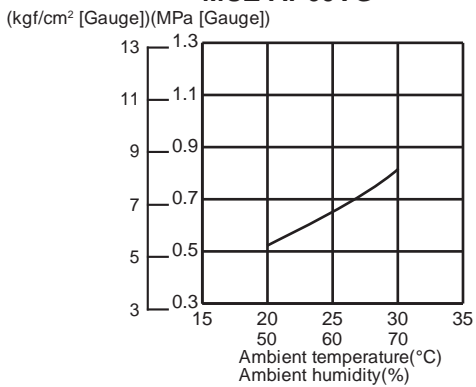

MUZ-AP60VG

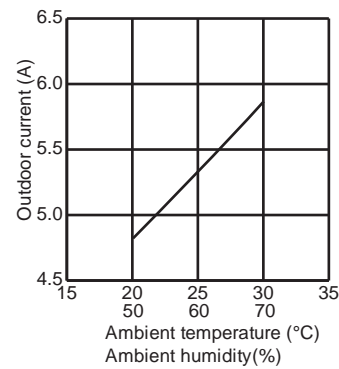

MUZ-AP71VG

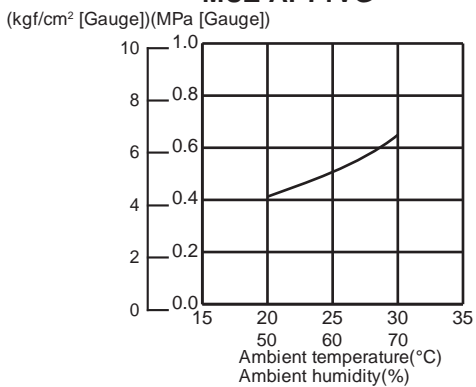

MUZ-AP71VG

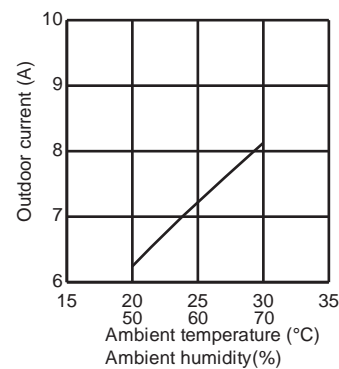

WALL-MOUNTED PERFORMANCE CURVES

MUZ-HR25VF

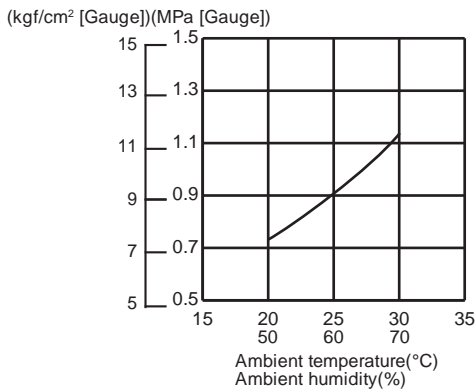

MUZ-HR25VF

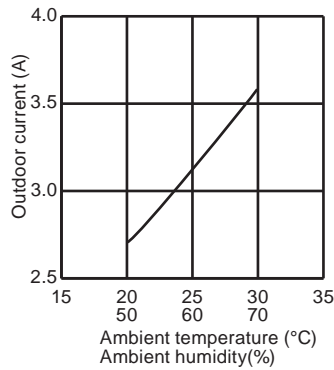

MUZ-HR35VF

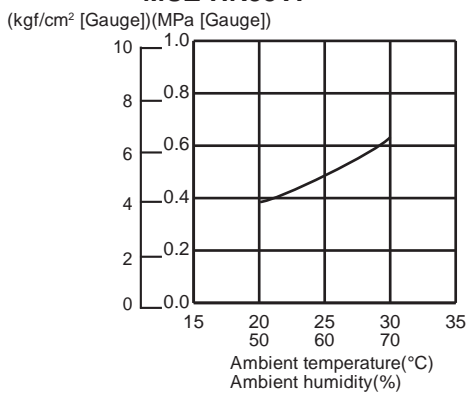

MUZ-HR35VF

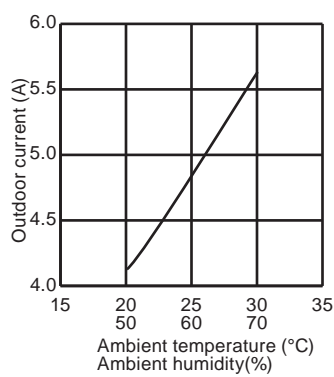

MUZ-HR42VF

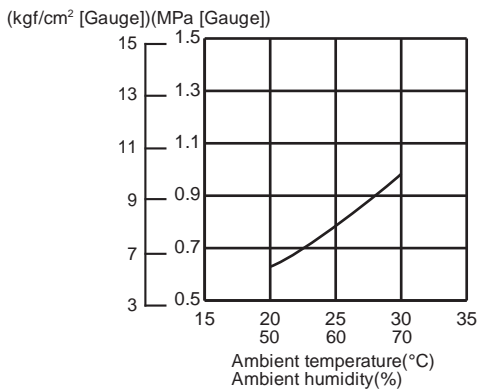

MUZ-HR42VF

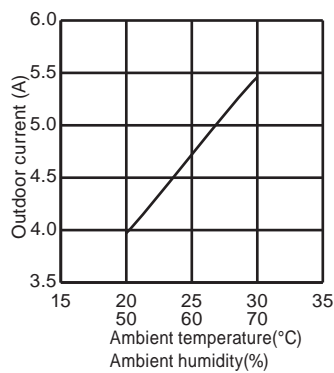

MUZ-HR50VF

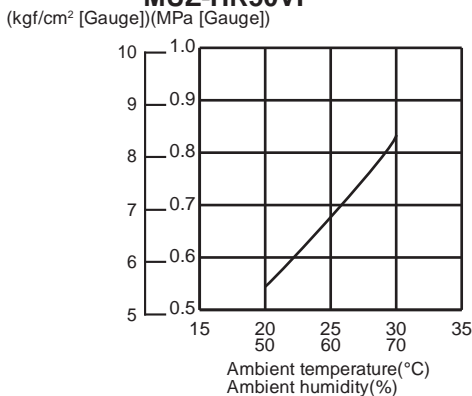

MUZ-HR50VF

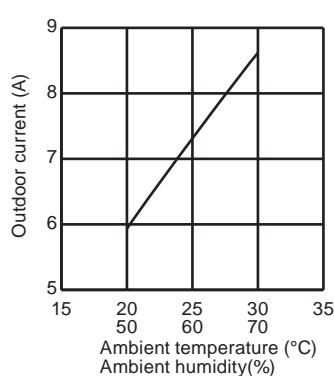

MUZ-HR60VF

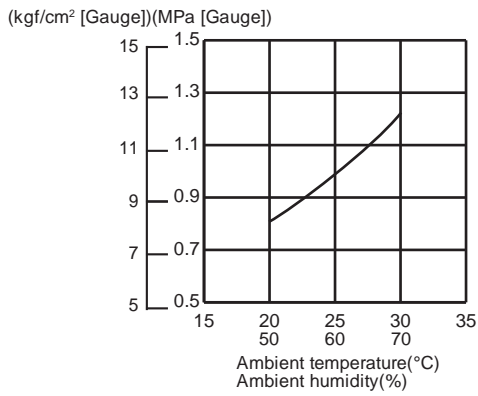

MUZ-HR60VF

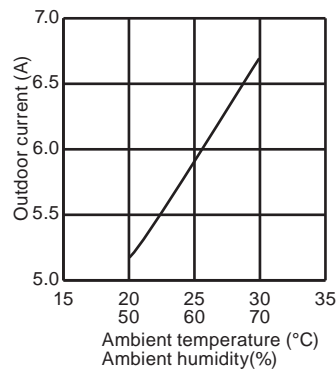

MUZ-HR71VF

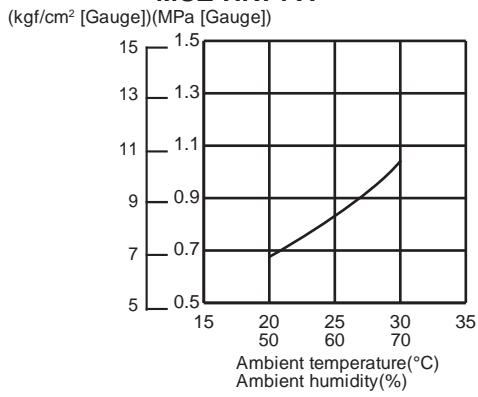

MUZ-HR71VF

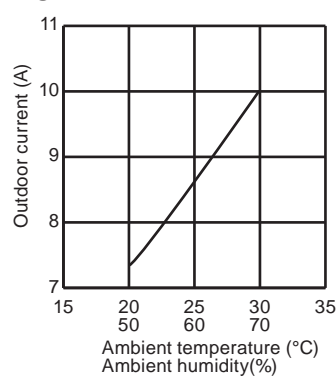

MUY-TP35VF

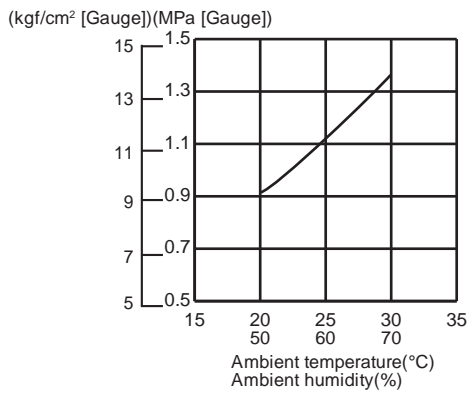

MUY-TP35VF

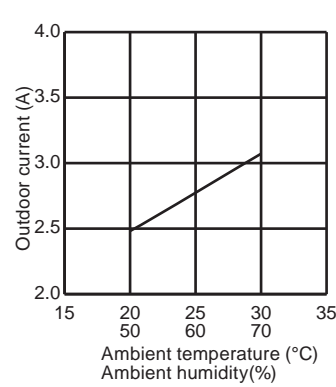

MUY-TP50VF

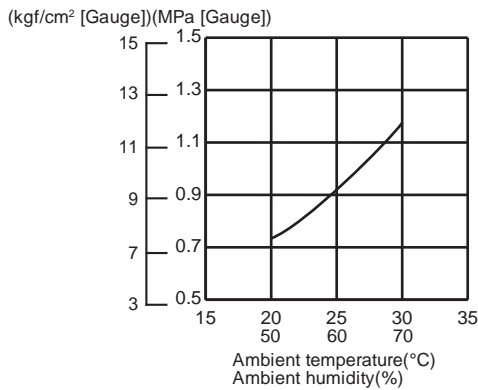

MUY-TP50VF

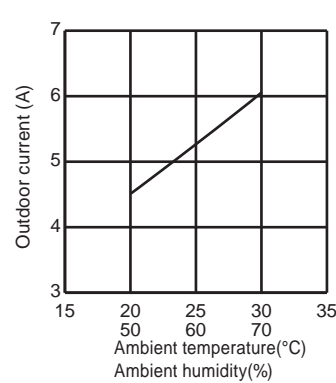

WALL-MOUNTED PERFORMANCE CURVES

MUZ-FH25VE

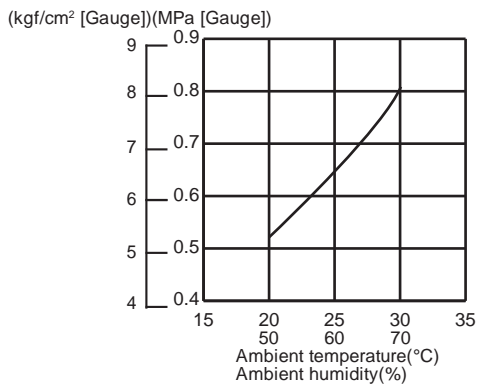

MUZ-FH25VE

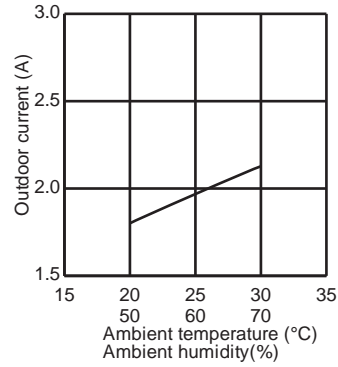

MUZ-FH35VE

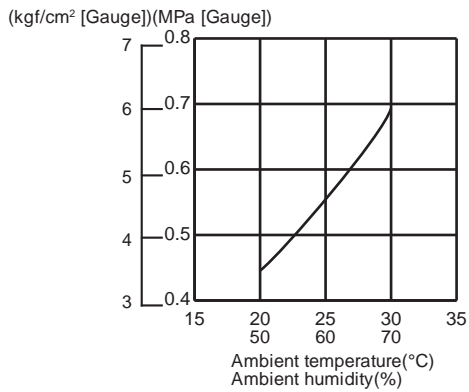

MUZ-FH35VE

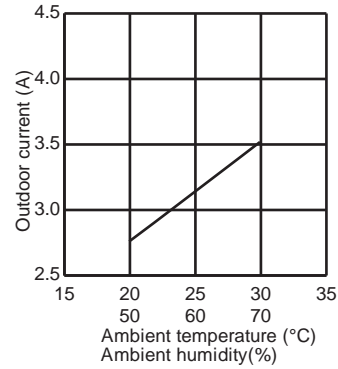

MUZ-FH50VE

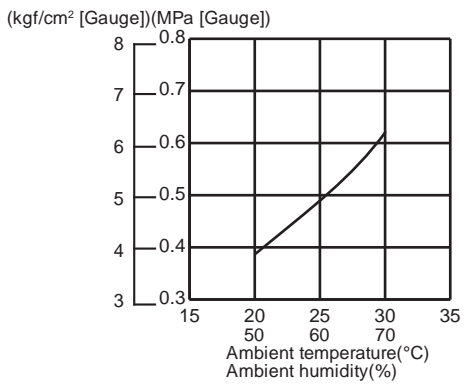

MUZ-FH50VE

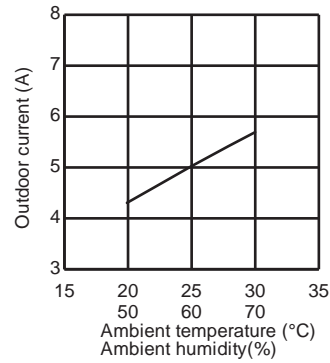

MUZ-FH25VEHZ

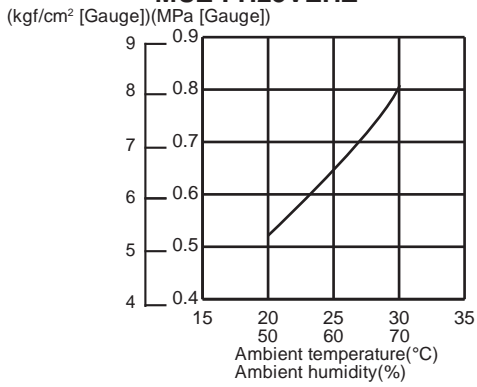

MUZ-FH25VEHZ

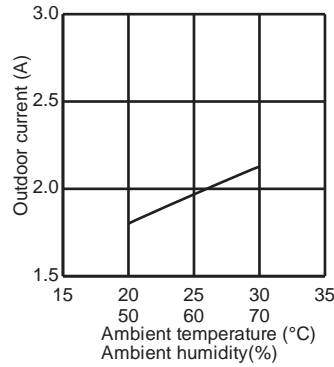

MUZ-FH35VEHZ

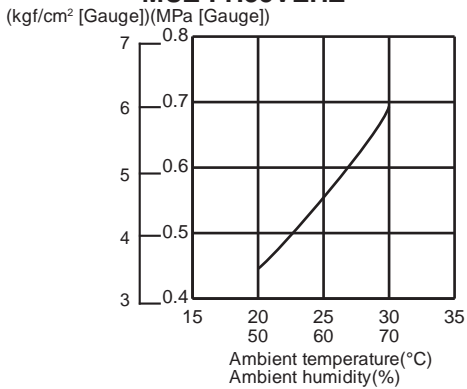

MUZ-FH35VEHZ

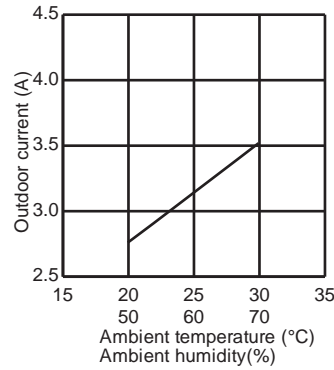

MUZ-FH50VEHZ

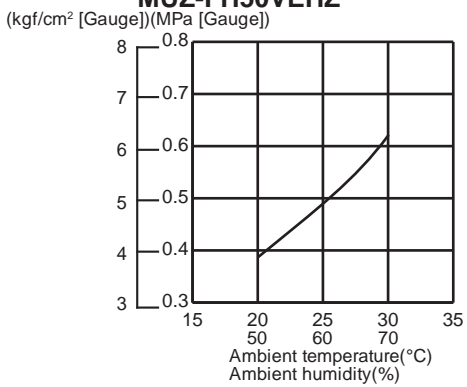

MUZ-FH50VEHZ

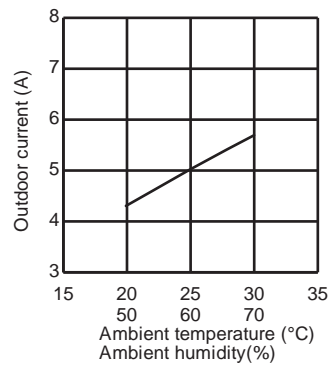

MUZ-EF25VG
MUZ-EF25VGH

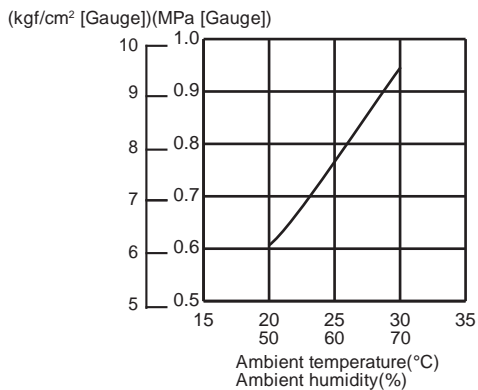

MUZ-EF25VG
MUZ-EF25VGH

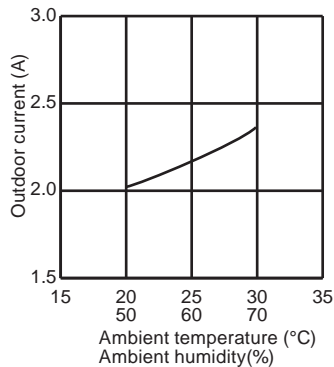

MUZ-EF35VG
MUZ-EF35VGH

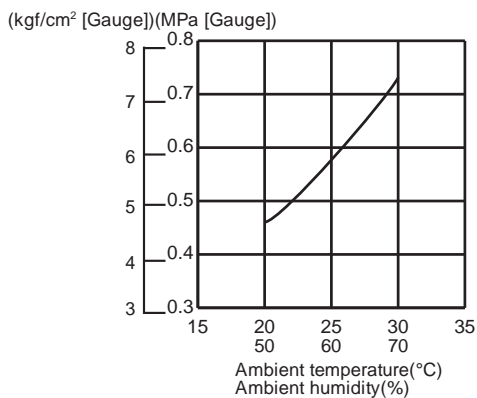

MUZ-EF35VG
MUZ-EF35VGH

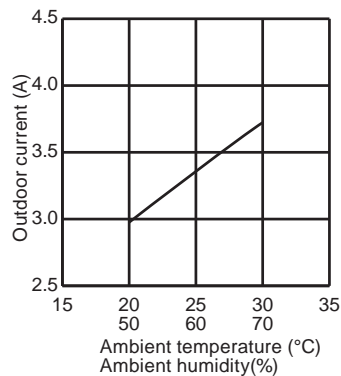

MUZ-EF42VG

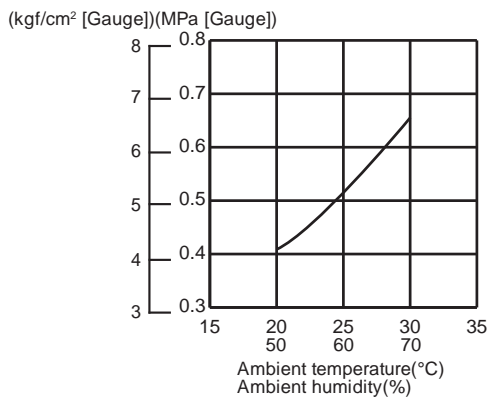

MUZ-EF42VG

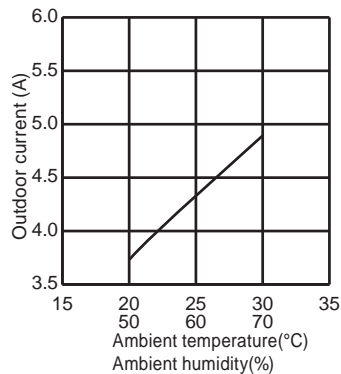

MUZ-EF50VG

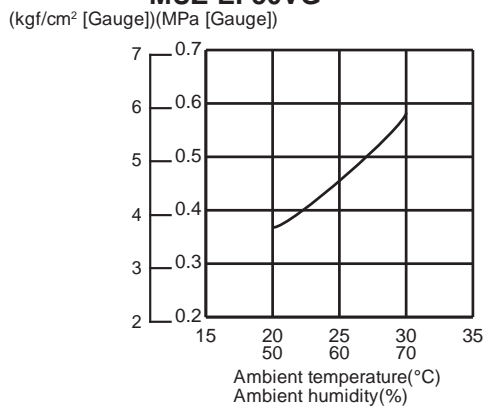

MUZ-EF50VG

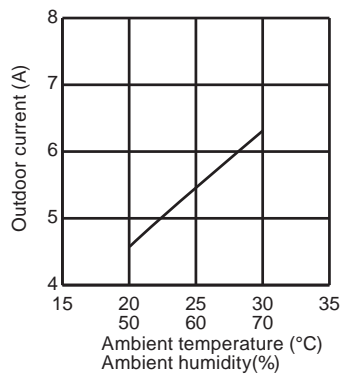

PERFORMANCE CURVES

WALL-MOUNTED

MUZ-BT20VG

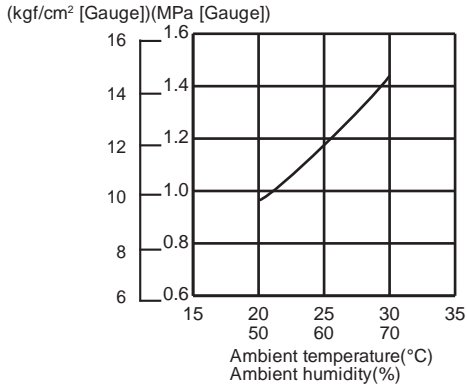

MUZ-BT20VG

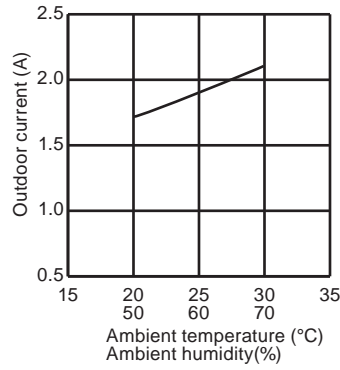

MUZ-BT25VG

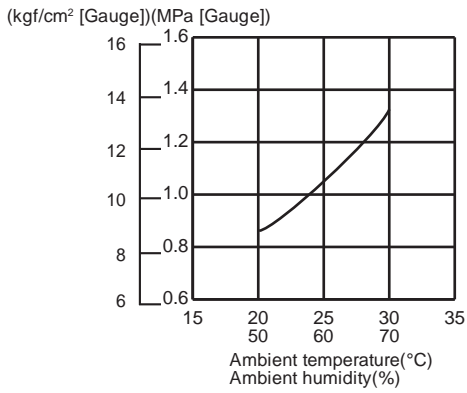

MUZ-BT25VG

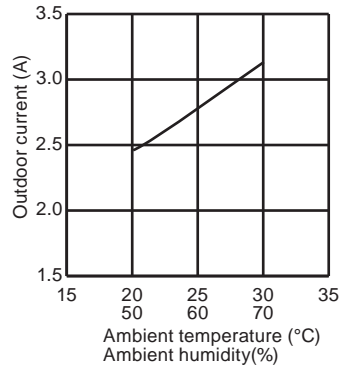

MUZ-BT35VG

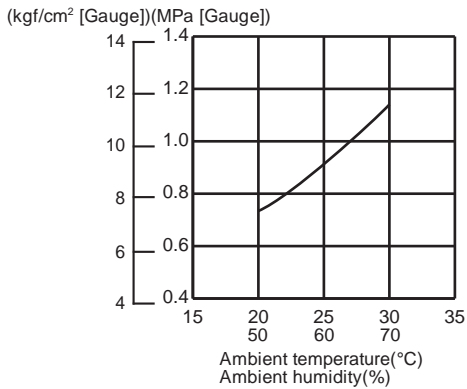

MUZ-BT35VG

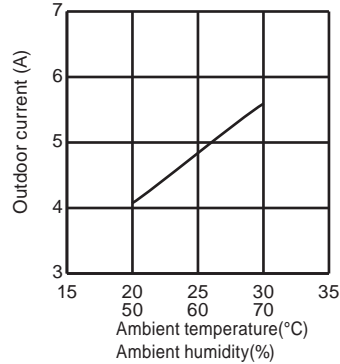

MUZ-BT50VG

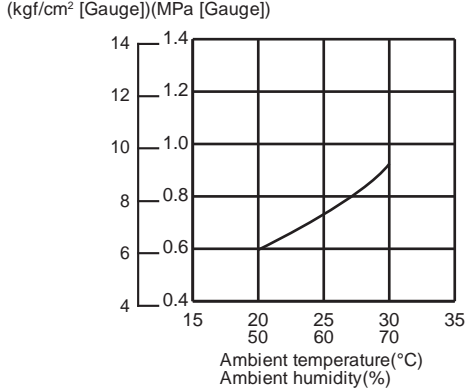

MUZ-BT50VG

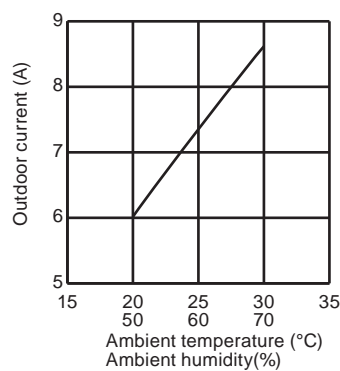

WALL-MOUNTED PERFORMANCE CURVES

MUZ-DW25VF

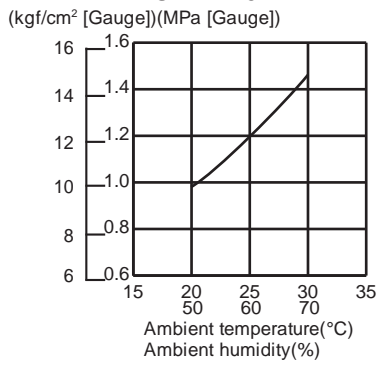

MUZ-DW25VF

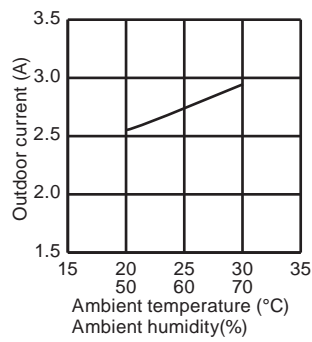

MUZ-DW35VF

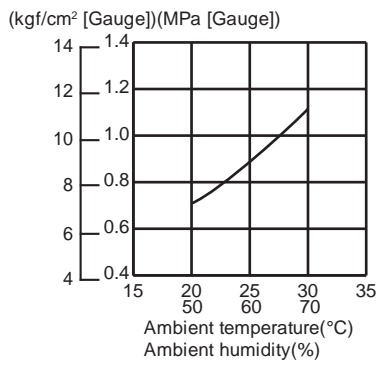

MUZ-DW35VF

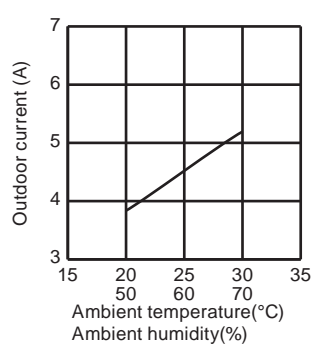

MUZ-DW50VF

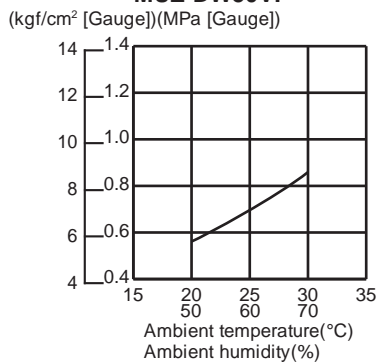

MUZ-DW50VF

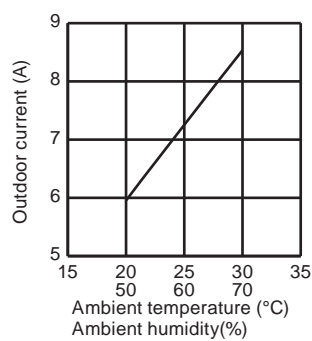

PERFORMANCE CURVES

WALL-MOUNTED

MUZ-SF25VE
MUZ-SF25VEH

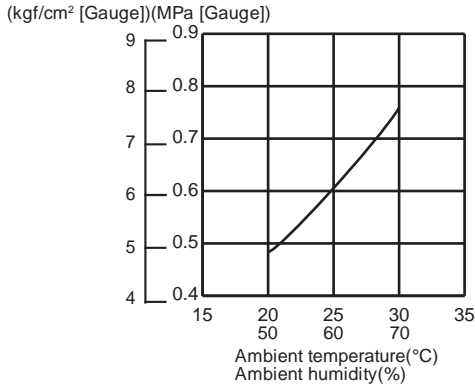

MUZ-SF25VE
MUZ-SF25VEH

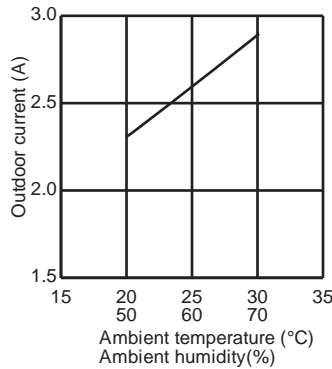

MUZ-SF35VE
MUZ-SF35VEH

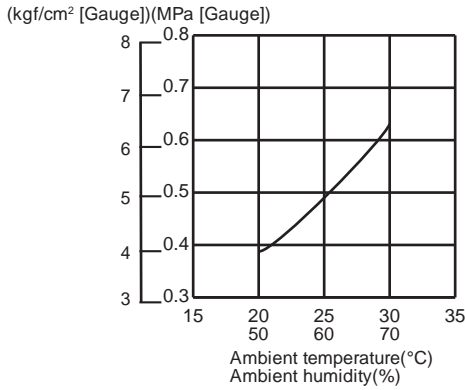

MUZ-SF35VE
MUZ-SF35VEH

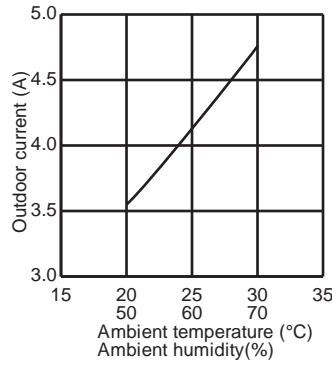

MUZ-SF42VE
MUZ-SF42VEH

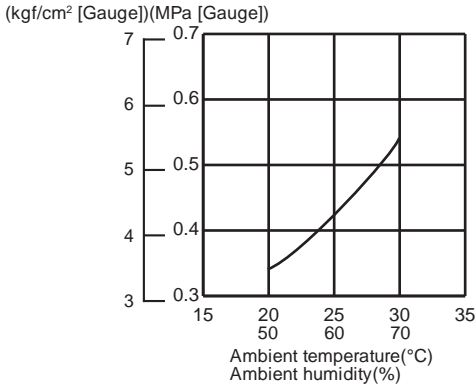

MUZ-SF42VE
MUZ-SF42VEH

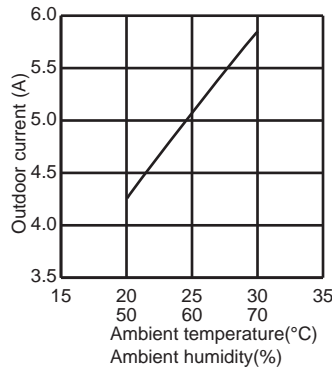

MUZ-SF50VE
MUZ-SF50VEH

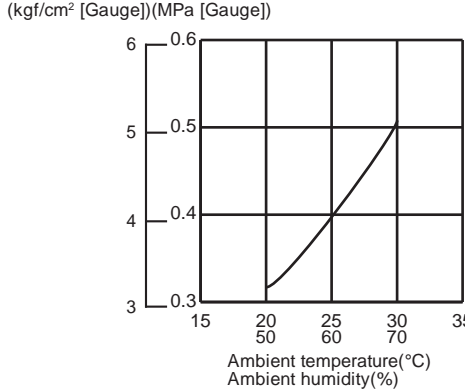

MUZ-SF50VE
MUZ-SF50VEH

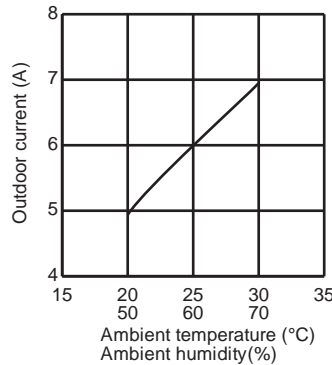

WALL-MOUNTED PERFORMANCE CURVES

MUZ-GF60VE

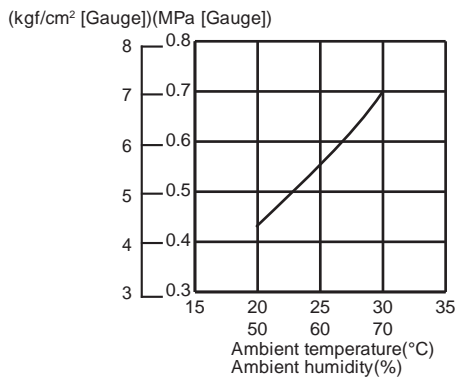

MUZ-GF60VE

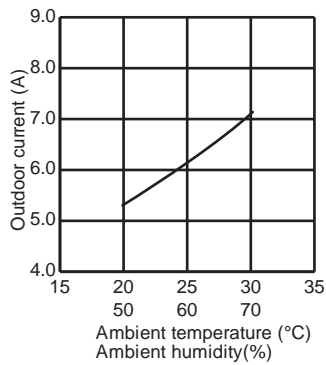

MUZ-GF71VE

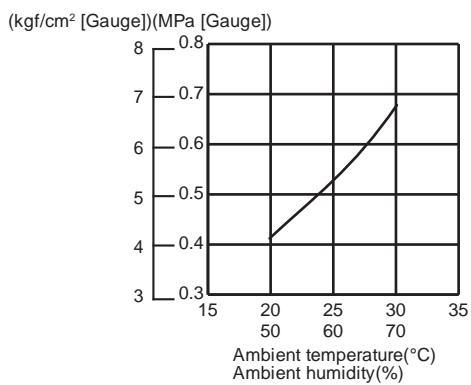

MUZ-GF71VE

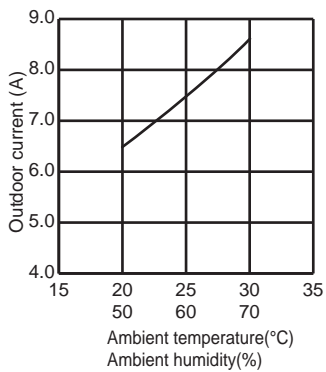

MUZ-WN25VA

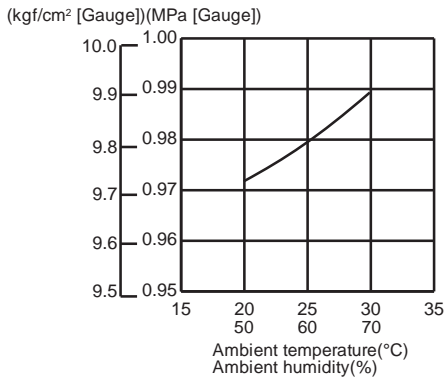

MUZ-WN25VA

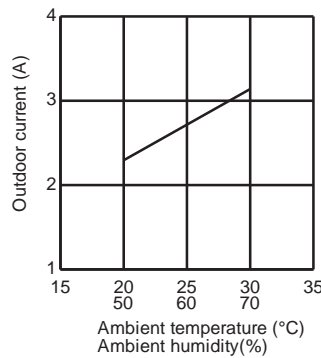

MUZ-WN35VA

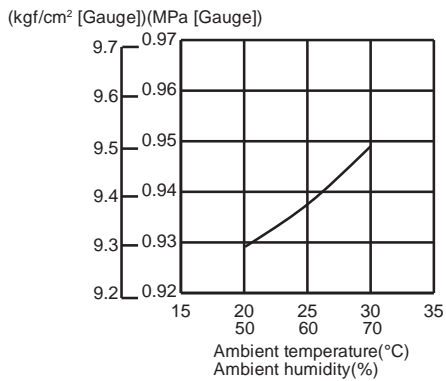

MUZ-WN35VA

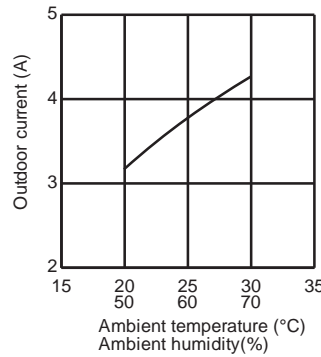

MUZ-DM25VA

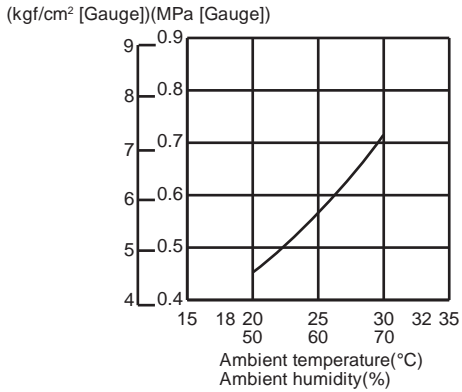

MUZ-DM25VA

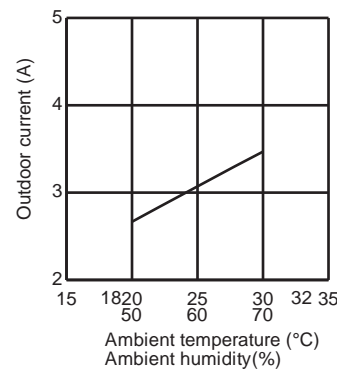

MUZ-DM35VA

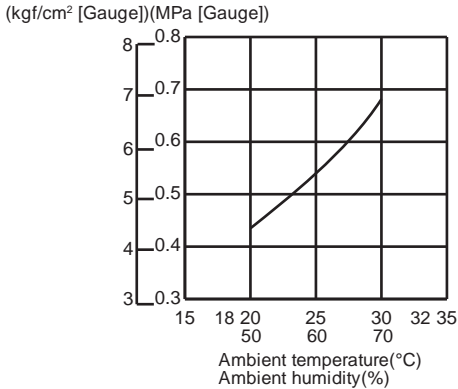

MUZ-DM35VA

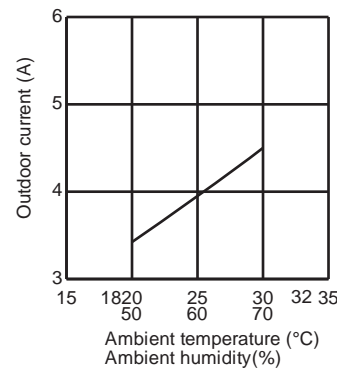

WALL-MOUNTED PERFORMANCE CURVES

MUZ-HJ25VA

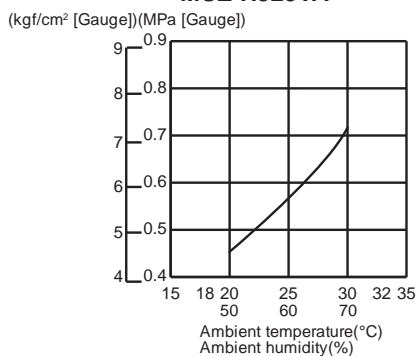

MUZ-HJ25VA

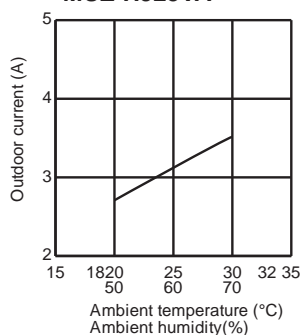

MUZ-HJ35VA

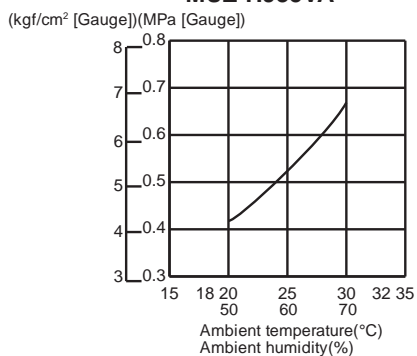

MUZ-HJ35VA

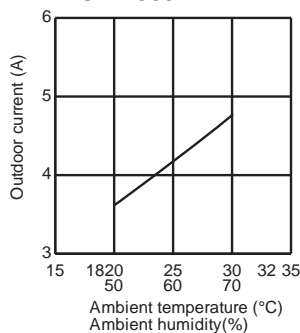

MUZ-HJ50VA

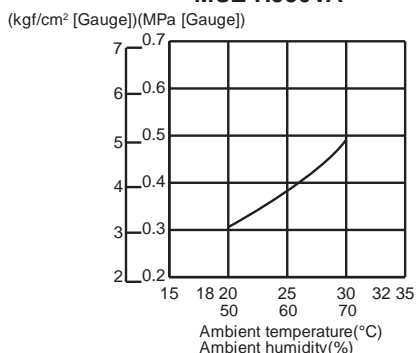

MUZ-HJ50VA

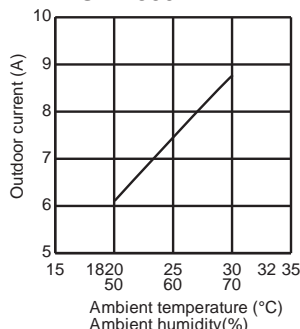

MUZ-HJ60VA

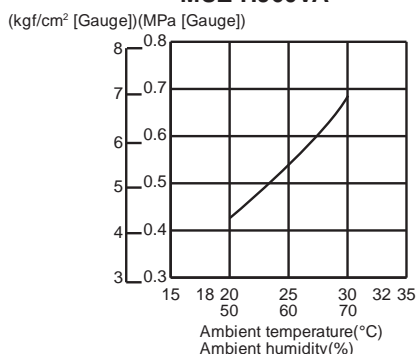

MUZ-HJ60VA

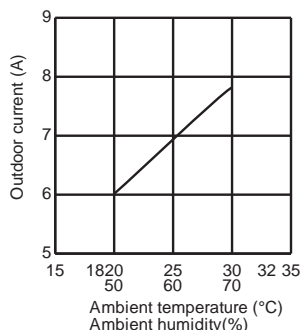

MUZ-HJ71VA

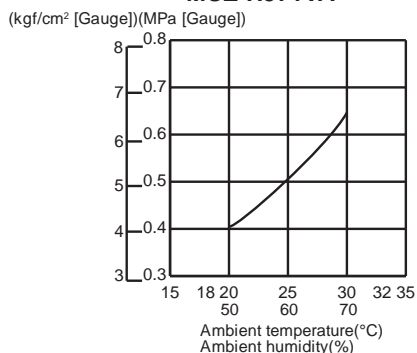

MUZ-HJ71VA

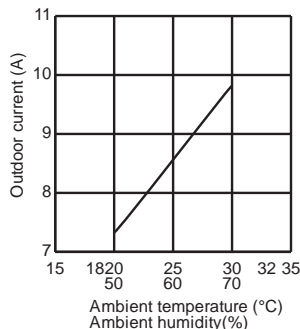

HEAT operation

① Condition :

	Indoor	Outdoor			
Dry bulb temperature (°C)	20.0	2	7	15	20.0
Wet bulb temperature (°C)	14.5	1	6	12	14.5

② Operation : TEST RUN OPERATION

Outdoor unit current

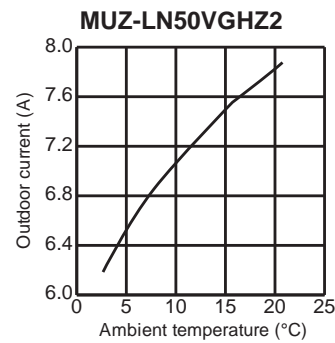
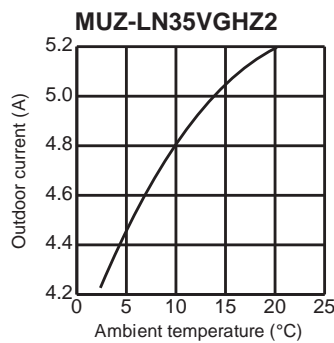
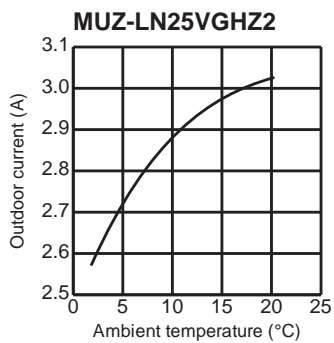
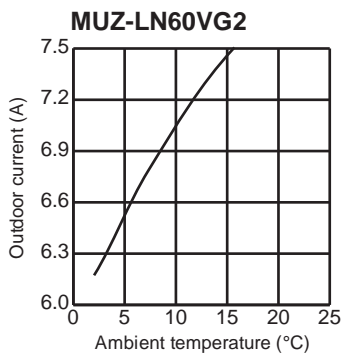
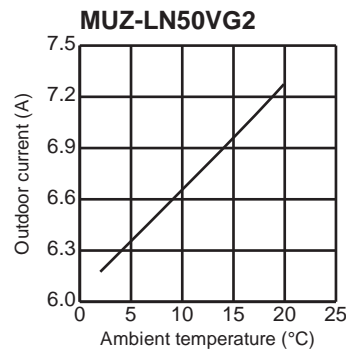
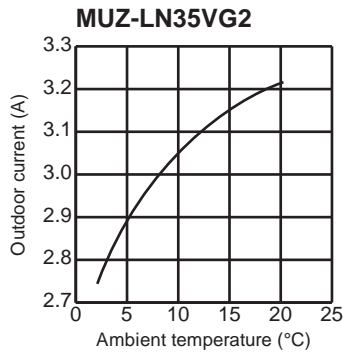
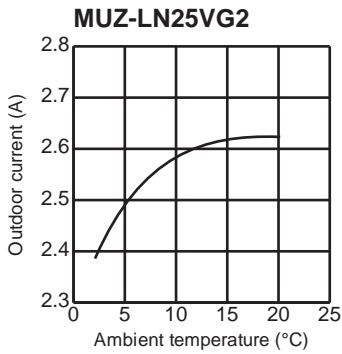
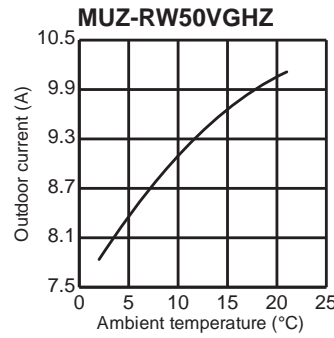
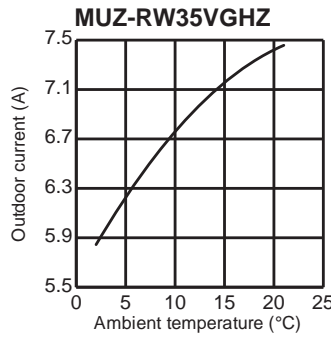
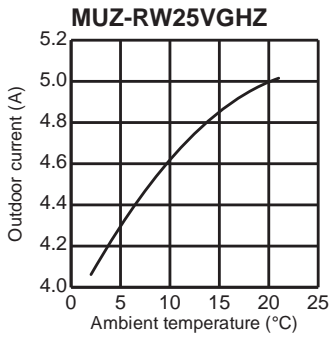

WALL-MOUNTED PERFORMANCE CURVES

MUZ-FT25VGHZ

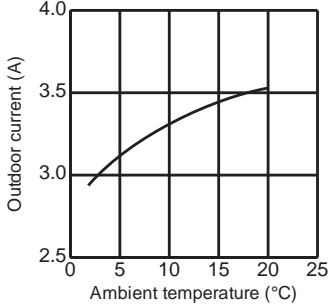

MUZ-FT35VGHZ

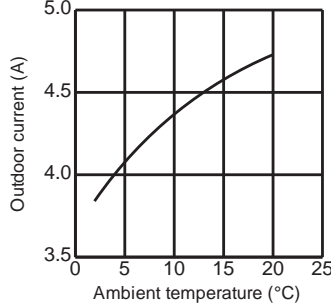

MUZ-FT50VGHZ

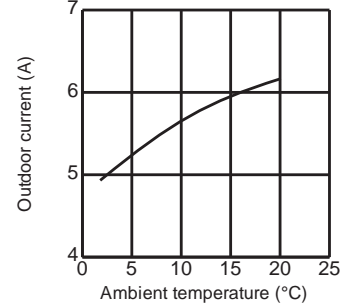

**MUZ-AY25VG
MUZ-AY25VGH**

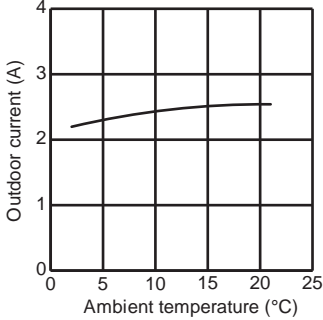

**MUZ-AY35VG
MUZ-AY35VGH**

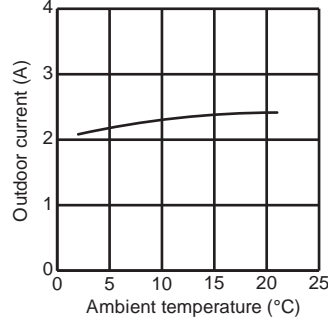

**MUZ-AY42VG
MUZ-AY42VGH**

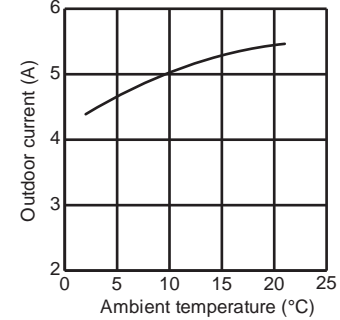

**MUZ-AY50VG
MUZ-AY50VGH**

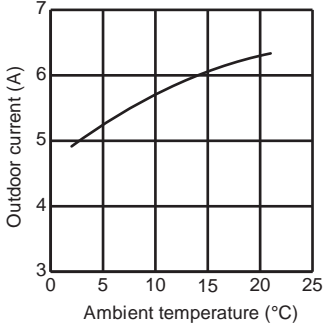

MUZ-AP15VG

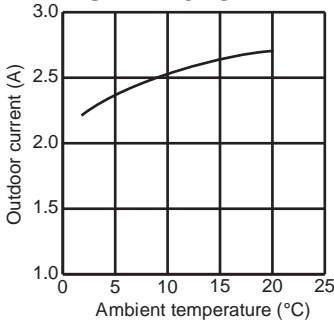

MUZ-AP20VG

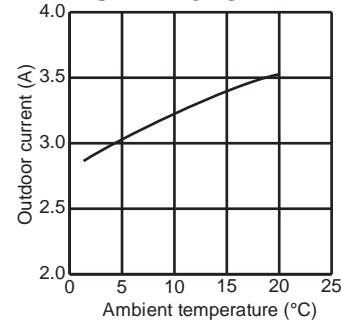

MUZ-AP60VG

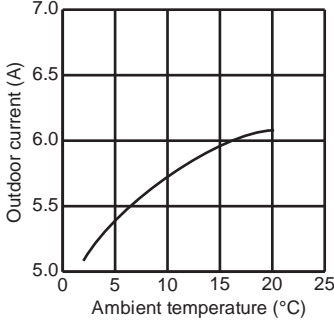

MUZ-AP71VG

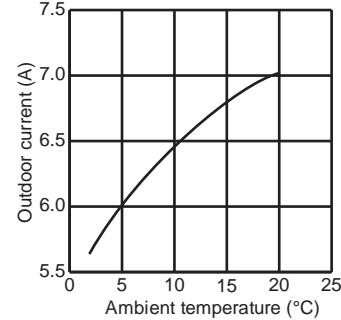

PERFORMANCE CURVES

WALL-MOUNTED

MUZ-HR25VF

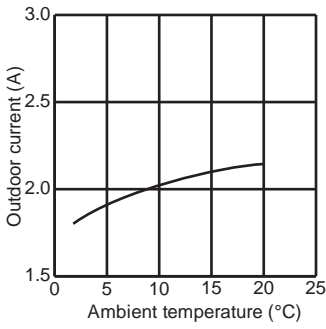

MUZ-HR35VF

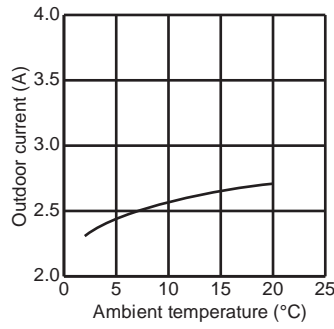

MUZ-HR42VF

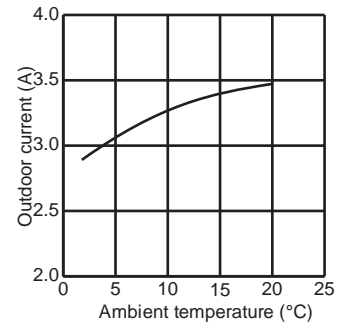

MUZ-HR50VF

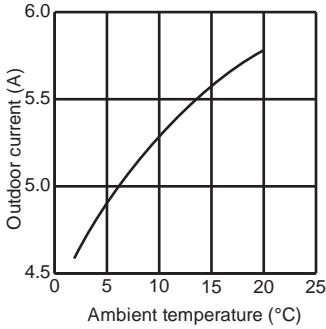

MUZ-HR60VF

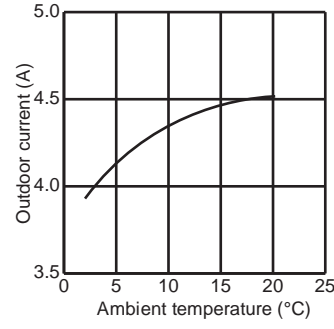

MUZ-HR71VF

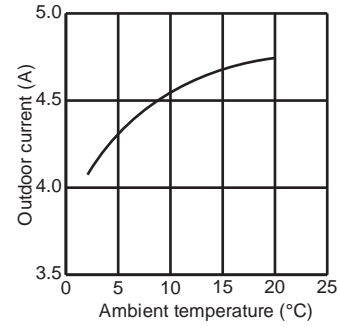

MUZ-FH25VE

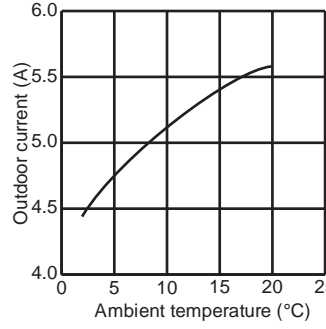

MUZ-FH35VE

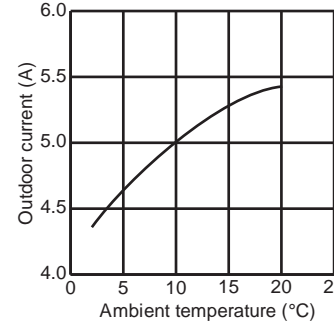

MUZ-FH50VE

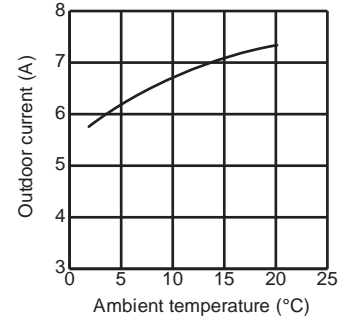

MUZ-FH25VEHZ

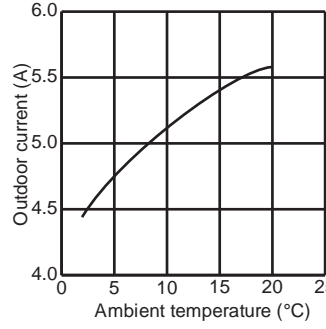

MUZ-FH35VEHZ

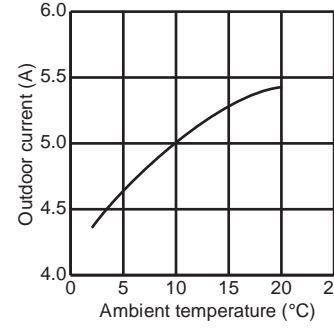

MUZ-FH50VEHZ

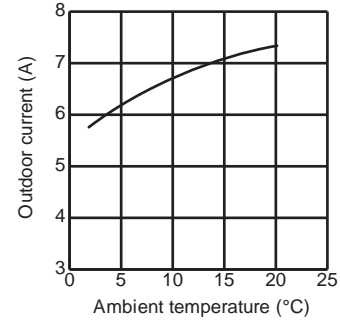

WALL-MOUNTED PERFORMANCE CURVES

MUZ-EF25VG
MUZ-EF25VGH

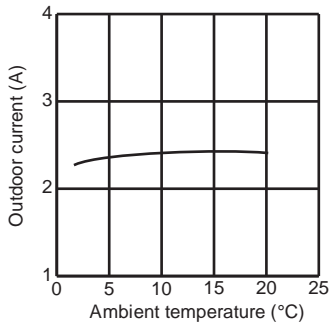

MUZ-EF35VG
MUZ-EF35VGH

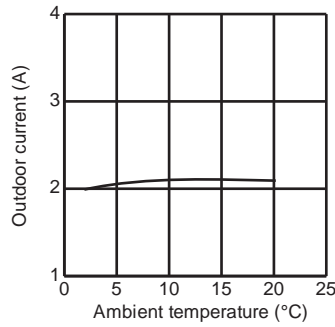

MUZ-EF42VG

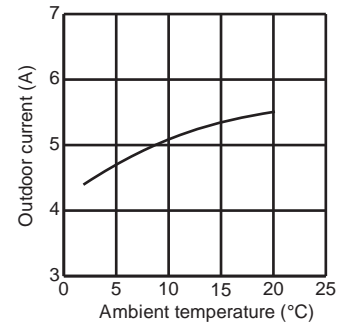

MUZ-EF50VG

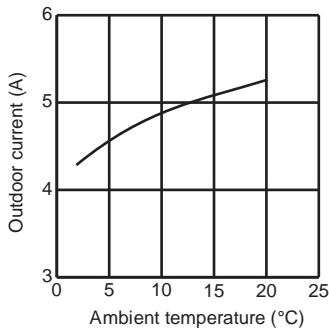

MUZ-BT20VG

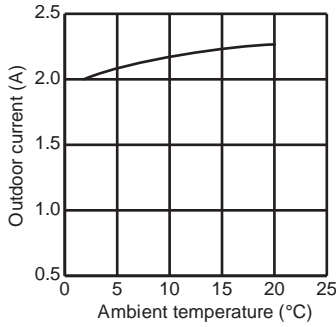

MUZ-BT25VG

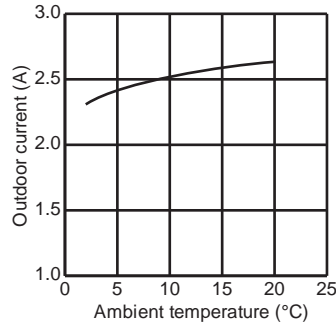

MUZ-BT35VG

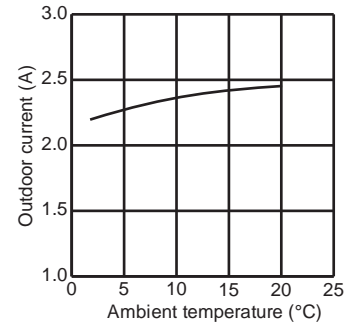

MUZ-BT50VG

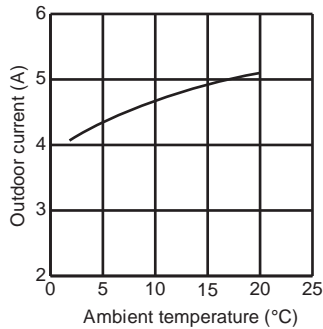

MUZ-DW25VF

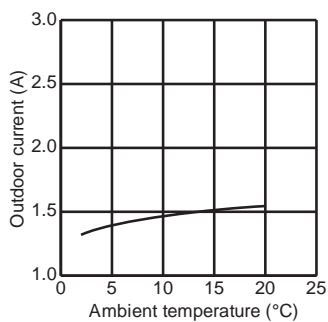

MUZ-DW35VF

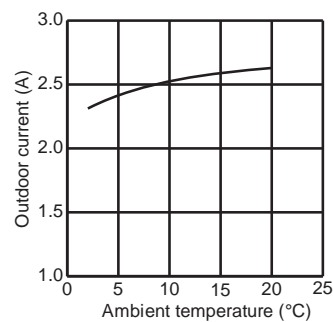

MUZ-DW50VF

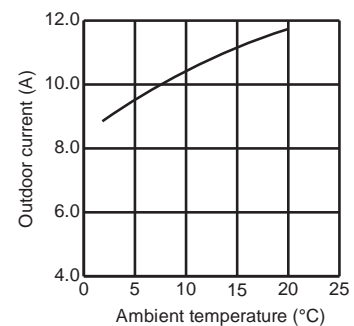

PERFORMANCE CURVES

WALL-MOUNTED

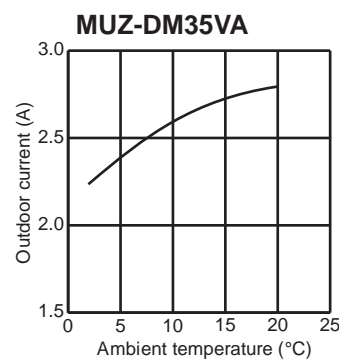
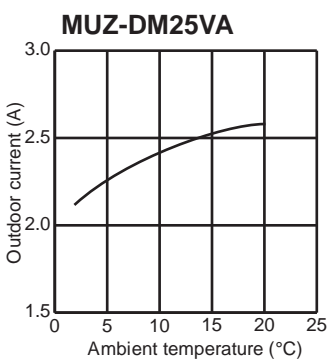
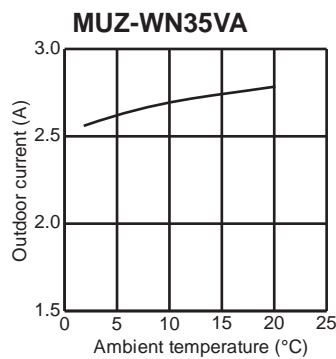
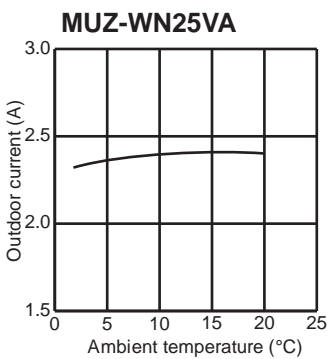
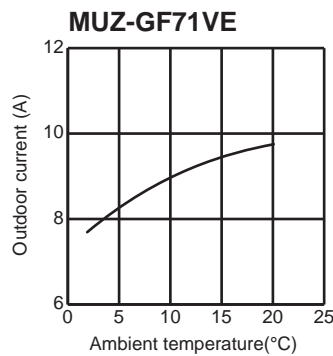
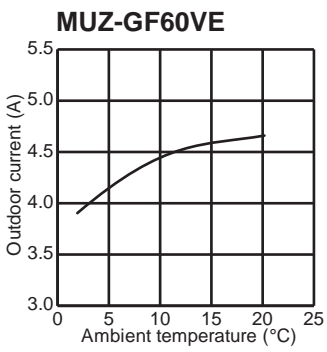
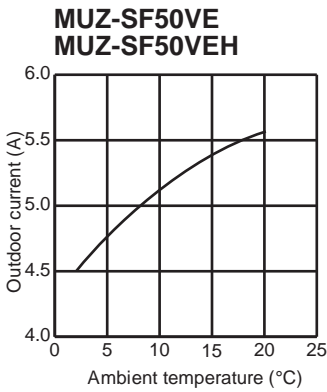
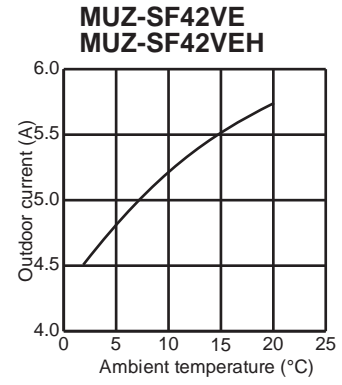
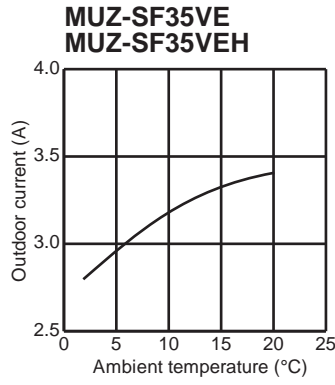
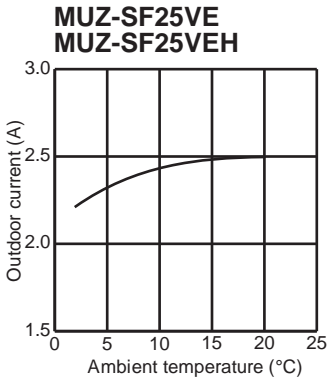

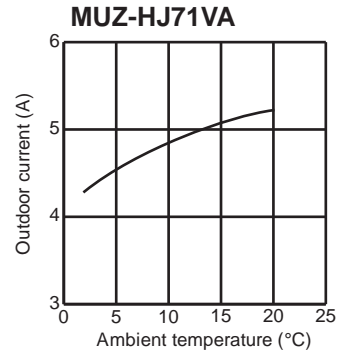
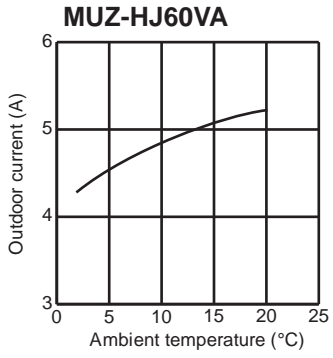
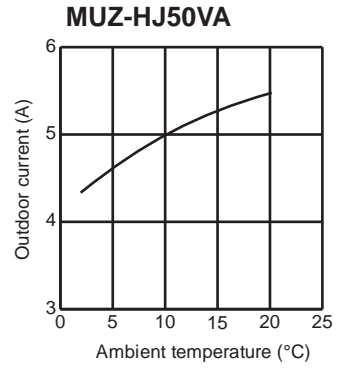
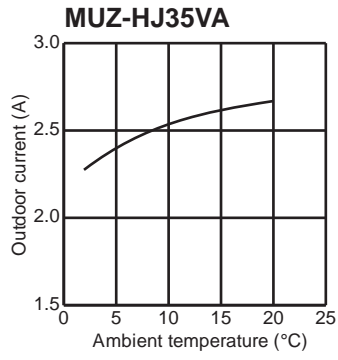
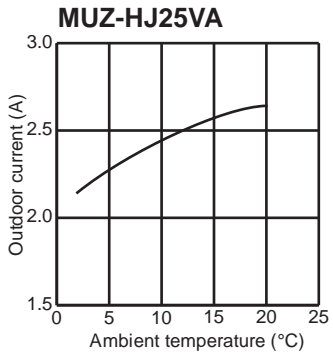

PERFORMANCE CURVES

WALL-MOUNTED

C.1.6 PERFORMANCE DATA

C.1.6.1 Inverter

Cooling performance data

MSZ-RW25VG: MUZ-RW25VGHZ

	Ambient temperature (°C)	INDOOR (°C)									
		DB	21		27			32			
		WB	15	19	15	19	23	15	19	23	
Max frequency	46	Capacity	2.57	3.01	2.57	3.01	3.45	2.57	3.01	3.45	
		SHF	0.77	0.53	1.00	0.77	0.53	1.00	0.96	0.73	
		EER	2.81	3.03	2.81	3.03	3.25	2.81	3.03	3.25	
	40	Capacity	2.84	3.26	2.84	3.26	3.68	2.84	3.26	3.68	
		SHF	0.77	0.53	1.00	0.77	0.53	1.00	0.96	0.73	
		EER	3.26	3.43	3.26	3.43	3.60	3.26	3.43	3.60	
	35	Capacity	3.12	3.52	3.12	3.52	3.92	3.12	3.52	3.92	
		SHF	0.77	0.53	1.00	0.77	0.53	1.00	0.96	0.73	
		EER	3.78	3.91	3.78	3.91	4.03	3.78	3.91	4.03	
	30	Capacity	3.34	3.75	3.34	3.75	4.15	3.34	3.75	4.15	
		SHF	0.77	0.53	1.00	0.77	0.53	1.00	0.96	0.73	
		EER	4.36	4.45	4.36	4.45	4.54	4.36	4.45	4.54	
	25	Capacity	3.64	4.03	3.64	4.03	4.41	3.64	4.03	4.41	
		SHF	0.77	0.53	1.00	0.77	0.53	1.00	0.96	0.73	
		EER	5.14	5.17	5.14	5.17	5.20	5.14	5.17	5.20	
	20	Capacity	3.94	4.31	3.94	4.31	4.67	3.94	4.31	4.67	
		SHF	0.77	0.53	1.00	0.77	0.53	1.00	0.96	0.73	
		EER	5.93	5.89	5.93	5.89	5.86	5.93	5.89	5.86	
	Rated frequency	46	Capacity	1.84	2.15	1.84	2.15	2.46	1.84	2.15	2.46
			SHF	0.99	0.75	1.00	0.97	0.75	1.00	1.00	0.95
			EER	4.15	4.47	4.15	4.47	4.80	4.15	4.47	4.80
		40	Capacity	2.03	2.33	2.03	2.33	2.63	2.03	2.33	2.63
			SHF	0.99	0.75	1.00	0.97	0.75	1.00	1.00	0.95
			EER	4.81	5.06	4.81	5.06	5.32	4.81	5.06	5.32
35		Capacity	2.23	2.51	2.23	2.51	2.80	2.23	2.51	2.80	
		SHF	0.99	0.75	1.00	0.97	0.75	1.00	1.00	0.95	
		EER	5.59	5.78	5.59	5.78	5.96	5.59	5.78	5.96	
30		Capacity	2.39	2.68	2.39	2.68	2.96	2.39	2.68	2.96	
		SHF	0.99	0.75	1.00	0.97	0.75	1.00	1.00	0.95	
		EER	6.44	6.58	6.44	6.58	6.71	6.44	6.58	6.71	
25		Capacity	2.60	2.88	2.60	2.88	3.15	2.60	2.88	3.15	
		SHF	0.99	0.75	1.00	0.97	0.75	1.00	1.00	0.95	
		EER	7.60	7.64	7.60	7.64	7.68	7.60	7.64	7.68	
20		Capacity	2.81	3.08	2.81	3.08	3.34	2.81	3.08	3.34	
		SHF	0.99	0.75	1.00	0.97	0.75	1.00	1.00	0.95	
		EER	8.76	8.71	8.76	8.71	8.66	8.76	8.71	8.66	
Minimum Frequency		46	Capacity	0.66	0.77	0.66	0.77	0.89	0.66	0.77	0.89
			EER	3.82	4.12	3.82	4.12	4.42	3.82	4.12	4.42
		40	Capacity	0.73	0.84	0.73	0.84	0.95	0.73	0.84	0.95
			EER	4.43	4.67	4.43	4.67	4.90	4.43	4.67	4.90
		35	Capacity	0.80	0.90	0.80	0.90	1.01	0.80	0.90	1.01
			EER	5.15	5.32	5.15	5.32	5.49	5.15	5.32	5.49
	30	Capacity	0.86	0.96	0.86	0.96	1.07	0.86	0.96	1.07	
		EER	5.93	6.06	5.93	6.06	6.18	5.93	6.06	6.18	
	25	Capacity	0.94	1.04	0.94	1.04	1.13	0.94	1.04	1.13	
		EER	7.00	7.04	7.00	7.04	7.08	7.00	7.04	7.08	
	20	Capacity	1.01	1.11	1.01	1.11	1.20	1.01	1.11	1.20	
		EER	8.07	8.02	8.07	8.02	7.97	8.07	8.02	7.97	

Cooling performance data (Low ambient Condition)

	Ambient temperature (°C)	INDOOR (°C)								
		DB	21		27			32		
		WB	15	19	15	19	23	15	19	23
Max Frequency	15 -10	Capacity	2.23	2.51	2.23	2.51	2.80	2.23	2.51	2.80
		SHF	0.99	0.75	1.00	0.97	0.75	1.00	1.00	0.95
		EER	5.59	5.78	5.59	5.78	5.96	5.59	5.78	5.96

* The low ambient condition requires a special control and all the performance is equal to or less than the rated operation.

Cooling performance data
MSZ-RW35VG: MUZ-RW35VGHZ

	Ambient temperature (°C)	INDOOR (°C)									
		DB	21		27			32			
		WB	15	19	15	19	23	15	19	23	
Max frequency	46	Capacity	2.94	3.44	2.94	3.44	3.94	2.94	3.44	3.94	
		SHF	0.79	0.55	1.00	0.79	0.55	1.00	0.97	0.75	
		EER	2.62	2.83	2.62	2.83	3.03	2.62	2.83	3.03	
	40	Capacity	3.24	3.72	3.24	3.72	4.20	3.24	3.72	4.20	
		SHF	0.79	0.55	1.00	0.79	0.55	1.00	0.97	0.75	
		EER	3.05	3.20	3.05	3.20	3.36	3.05	3.20	3.36	
	35	Capacity	3.56	4.02	3.56	4.02	4.48	3.56	4.02	4.48	
		SHF	0.79	0.55	1.00	0.79	0.55	1.00	0.97	0.75	
		EER	3.54	3.65	3.54	3.65	3.77	3.54	3.65	3.77	
	30	Capacity	3.82	4.28	3.82	4.28	4.74	3.82	4.28	4.74	
		SHF	0.79	0.55	1.00	0.79	0.55	1.00	0.97	0.75	
		EER	4.08	4.16	4.08	4.16	4.24	4.08	4.16	4.24	
	25	Capacity	4.16	4.60	4.16	4.60	5.04	4.16	4.60	5.04	
		SHF	0.79	0.55	1.00	0.79	0.55	1.00	0.97	0.75	
		EER	4.81	4.84	4.81	4.84	4.86	4.81	4.84	4.86	
	20	Capacity	4.50	4.92	4.50	4.92	5.34	4.50	4.92	5.34	
		SHF	0.79	0.55	1.00	0.79	0.55	1.00	0.97	0.75	
		EER	5.54	5.51	5.54	5.51	5.48	5.54	5.51	5.48	
	Rated frequency	46	Capacity	2.57	3.01	2.57	3.01	3.45	2.57	3.01	3.45
			SHF	0.94	0.70	1.00	0.94	0.70	1.00	1.00	0.90
			EER	3.28	3.54	3.28	3.54	3.79	3.28	3.54	3.79
		40	Capacity	2.84	3.26	2.84	3.26	3.68	2.84	3.26	3.68
			SHF	0.94	0.70	1.00	0.94	0.70	1.00	1.00	0.90
			EER	3.81	4.01	3.81	4.01	4.20	3.81	4.01	4.20
35		Capacity	3.12	3.52	3.12	3.52	3.92	3.12	3.52	3.92	
		SHF	0.94	0.70	1.00	0.94	0.70	1.00	1.00	0.90	
		EER	4.42	4.57	4.42	4.57	4.71	4.42	4.57	4.71	
30		Capacity	3.34	3.75	3.34	3.75	4.15	3.34	3.75	4.15	
		SHF	0.94	0.70	1.00	0.94	0.70	1.00	1.00	0.90	
		EER	5.10	5.20	5.10	5.20	5.31	5.10	5.20	5.31	
25		Capacity	3.64	4.03	3.64	4.03	4.41	3.64	4.03	4.41	
		SHF	0.94	0.70	1.00	0.94	0.70	1.00	1.00	0.90	
		EER	6.01	6.04	6.01	6.04	6.08	6.01	6.04	6.08	
20		Capacity	3.94	4.31	3.94	4.31	4.67	3.94	4.31	4.67	
		SHF	0.94	0.70	1.00	0.94	0.70	1.00	1.00	0.90	
		EER	6.93	6.89	6.93	6.89	6.85	6.93	6.89	6.85	
Minimum Frequency		46	Capacity	0.74	0.86	0.74	0.86	0.99	0.74	0.86	0.99
			EER	2.67	2.88	2.67	2.88	3.09	2.67	2.88	3.09
		40	Capacity	0.81	0.93	0.81	0.93	1.05	0.81	0.93	1.05
			EER	3.10	3.26	3.10	3.26	3.43	3.10	3.26	3.43
		35	Capacity	0.89	1.01	0.89	1.01	1.12	0.89	1.01	1.12
			EER	3.60	3.72	3.60	3.72	3.84	3.60	3.72	3.84
	30	Capacity	0.96	1.07	0.96	1.07	1.19	0.96	1.07	1.19	
		EER	4.15	4.24	4.15	4.24	4.32	4.15	4.24	4.32	
	25	Capacity	1.04	1.15	1.04	1.15	1.26	1.04	1.15	1.26	
		EER	4.90	4.93	4.90	4.93	4.95	4.90	4.93	4.95	
	20	Capacity	1.13	1.23	1.13	1.23	1.34	1.13	1.23	1.34	
		EER	5.65	5.61	5.65	5.61	5.58	5.65	5.61	5.58	

PERFORMANCE DATA

WALL-MOUNTED

Cooling performance data (Low ambient Condition)

	Ambient temperature (°C)	INDOOR (°C)								
		DB	21		27			32		
		WB	15	19	15	19	23	15	19	23
Max Frequency	15 -10	Capacity	3.12	3.52	3.12	3.52	3.92	3.12	3.52	3.92
		SHF	0.94	0.70	1.00	0.94	0.70	1.00	1.00	0.90
		EER	4.42	4.57	4.42	4.57	4.71	4.42	4.57	4.71

* The low ambient condition requires a special control and all the performance is equal to or less than the rated operation.

Cooling performance data
MSZ-RW50VG: MUZ-RW50VGHZ

	Ambient temperature (°C)	INDOOR (°C)									
		DB	21		27			32			
		WB	15	19	15	19	23	15	19	23	
Max frequency	46	Capacity	4.26	4.99	4.26	4.99	5.71	4.26	4.99	5.71	
		SHF	0.75	0.51	0.99	0.75	0.51	1.00	0.95	0.71	
		EER	2.39	2.58	2.39	2.58	2.77	2.39	2.58	2.77	
	40	Capacity	4.70	5.39	4.70	5.39	6.09	4.70	5.39	6.09	
		SHF	0.75	0.51	0.99	0.75	0.51	1.00	0.95	0.71	
		EER	2.78	2.92	2.78	2.92	3.07	2.78	2.92	3.07	
	35	Capacity	5.16	5.83	5.16	5.83	6.50	5.16	5.83	6.50	
		SHF	0.75	0.51	0.99	0.75	0.51	1.00	0.95	0.71	
		EER	3.22	3.33	3.22	3.33	3.44	3.22	3.33	3.44	
	30	Capacity	5.54	6.21	5.54	6.21	6.87	5.54	6.21	6.87	
		SHF	0.75	0.51	0.99	0.75	0.51	1.00	0.95	0.71	
		EER	3.72	3.79	3.72	3.79	3.87	3.72	3.79	3.87	
	25	Capacity	6.03	6.67	6.03	6.67	7.31	6.03	6.67	7.31	
		SHF	0.75	0.51	0.99	0.75	0.51	1.00	0.95	0.71	
		EER	4.38	4.41	4.38	4.41	4.43	4.38	4.41	4.43	
	20	Capacity	6.53	7.13	6.53	7.13	7.74	6.53	7.13	7.74	
		SHF	0.75	0.51	0.99	0.75	0.51	1.00	0.95	0.71	
		EER	5.05	5.02	5.05	5.02	4.99	5.05	5.02	4.99	
	Rated frequency	46	Capacity	3.68	4.30	3.68	4.30	4.93	3.68	4.30	4.93
			SHF	0.82	0.58	1.00	0.82	0.58	1.00	0.98	0.78
			EER	2.61	2.82	2.61	2.82	3.02	2.61	2.82	3.02
		40	Capacity	4.05	4.65	4.05	4.65	5.25	4.05	4.65	5.25
			SHF	0.82	0.58	1.00	0.82	0.58	1.00	0.98	0.78
			EER	3.03	3.19	3.03	3.19	3.35	3.03	3.19	3.35
35		Capacity	4.45	5.03	4.45	5.03	5.60	4.45	5.03	5.60	
		SHF	0.82	0.58	1.00	0.82	0.58	1.00	0.98	0.78	
		EER	3.53	3.64	3.53	3.64	3.76	3.53	3.64	3.76	
30		Capacity	4.78	5.35	4.78	5.35	5.93	4.78	5.35	5.93	
		SHF	0.82	0.58	1.00	0.82	0.58	1.00	0.98	0.78	
		EER	4.06	4.15	4.06	4.15	4.23	4.06	4.15	4.23	
25		Capacity	5.20	5.75	5.20	5.75	6.30	5.20	5.75	6.30	
		SHF	0.82	0.58	1.00	0.82	0.58	1.00	0.98	0.78	
		EER	4.79	4.82	4.79	4.82	4.84	4.79	4.82	4.84	
20		Capacity	5.63	6.15	5.63	6.15	6.68	5.63	6.15	6.68	
		SHF	0.82	0.58	1.00	0.82	0.58	1.00	0.98	0.78	
		EER	5.52	5.49	5.52	5.49	5.46	5.52	5.49	5.46	
Minimum Frequency		46	Capacity	1.03	1.20	1.03	1.20	1.38	1.03	1.20	1.38
			EER	1741.91	1878.09	1741.91	1878.09	2014.27	1741.91	1878.09	2014.27
		40	Capacity	1.13	1.30	1.13	1.30	1.47	1.13	1.30	1.47
			EER	2021.93	2127.25	2021.93	2127.25	2232.57	2021.93	2127.25	2232.57
		35	Capacity	1.25	1.41	1.25	1.41	1.57	1.25	1.41	1.57
			EER	2348.44	2425.63	2348.44	2425.63	2502.81	2348.44	2425.63	2502.81
	30	Capacity	1.34	1.50	1.34	1.50	1.66	1.34	1.50	1.66	
		EER	2705.82	2761.78	2705.82	2761.78	2817.73	2705.82	2761.78	2817.73	
	25	Capacity	1.46	1.61	1.46	1.61	1.76	1.46	1.61	1.76	
		EER	3192.89	3209.75	3192.89	3209.75	3226.61	3192.89	3209.75	3226.61	
	20	Capacity	1.58	1.72	1.58	1.72	1.87	1.58	1.72	1.87	
		EER	3679.97	3657.73	3679.97	3657.73	3635.49	3679.97	3657.73	3635.49	

Cooling performance data (Low ambient Condition)

	Ambient temperature (°C)	INDOOR (°C)								
		DB	21		27			32		
		WB	15	19	15	19	23	15	19	23
Max Frequency	15 -10	Capacity	4.45	5.03	4.45	5.03	5.60	4.45	5.03	5.60
		SHF	0.82	0.58	1.00	0.82	0.58	1.00	0.98	0.78
		EER	3.53	3.64	3.53	3.64	3.76	3.53	3.64	3.76

* The low ambient condition requires a special control and all the performance is equal to or less than the rated operation.

Cooling performance data

MSZ-LN25VG2W/V/B/R: MUZ-LN25VG2

	Ambient temperature (°C)	INDOOR (°C)									
		DB	21		27			32			
		WB	15	19	15	19	23	15	19	23	
Max frequency	46	Capacity	2.57	3.01	2.57	3.01	3.45	2.57	3.01	3.45	
		SHF	0.79	0.55	1.00	0.79	0.55	1.00	0.97	0.75	
		EER	2.81	3.03	2.81	3.03	3.25	2.81	3.03	3.25	
	40	Capacity	2.84	3.26	2.84	3.26	3.68	2.84	3.26	3.68	
		SHF	0.79	0.55	1.00	0.79	0.55	1.00	0.97	0.75	
		EER	3.26	3.43	3.26	3.43	3.60	3.26	3.43	3.60	
	35	Capacity	3.12	3.52	3.12	3.52	3.92	3.12	3.52	3.92	
		SHF	0.79	0.55	1.00	0.79	0.55	1.00	0.97	0.75	
		EER	3.78	3.91	3.78	3.91	4.03	3.78	3.91	4.03	
	30	Capacity	3.34	3.75	3.34	3.75	4.15	3.34	3.75	4.15	
		SHF	0.79	0.55	1.00	0.79	0.55	1.00	0.97	0.75	
		EER	4.36	4.45	4.36	4.45	4.54	4.36	4.45	4.54	
	25	Capacity	3.64	4.03	3.64	4.03	4.41	3.64	4.03	4.41	
		SHF	0.79	0.55	1.00	0.79	0.55	1.00	0.97	0.75	
		EER	5.14	5.17	5.14	5.17	5.20	5.14	5.17	5.20	
	20	Capacity	3.94	4.31	3.94	4.31	4.67	3.94	4.31	4.67	
		SHF	0.79	0.55	1.00	0.79	0.55	1.00	0.97	0.75	
		EER	5.93	5.89	5.93	5.89	5.86	5.93	5.89	5.86	
	Rated frequency	46	Capacity	1.84	2.15	1.84	2.15	2.46	1.84	2.15	2.46
			SHF	0.97	0.73	1.00	0.96	0.73	1.00	1.00	0.93
			EER	3.72	4.01	3.72	4.01	4.30	3.72	4.01	4.30
		40	Capacity	2.03	2.33	2.03	2.33	2.63	2.03	2.33	2.63
			SHF	0.97	0.73	1.00	0.96	0.73	1.00	1.00	0.93
			EER	4.32	4.54	4.32	4.54	4.77	4.32	4.54	4.77
35		Capacity	2.23	2.51	2.23	2.51	2.80	2.23	2.51	2.80	
		SHF	0.97	0.73	1.00	0.96	0.73	1.00	1.00	0.93	
		EER	5.02	5.18	5.02	5.18	5.34	5.02	5.18	5.34	
30		Capacity	2.39	2.68	2.39	2.68	2.96	2.39	2.68	2.96	
		SHF	0.97	0.73	1.00	0.96	0.73	1.00	1.00	0.93	
		EER	5.78	5.90	5.78	5.90	6.02	5.78	5.90	6.02	
25		Capacity	2.60	2.88	2.60	2.88	3.15	2.60	2.88	3.15	
		SHF	0.97	0.73	1.00	0.96	0.73	1.00	1.00	0.93	
		EER	6.82	6.85	6.82	6.85	6.89	6.82	6.85	6.89	
20		Capacity	2.81	3.08	2.81	3.08	3.34	2.81	3.08	3.34	
		SHF	0.97	0.73	1.00	0.96	0.73	1.00	1.00	0.93	
		EER	7.86	7.81	7.86	7.81	7.76	7.86	7.81	7.76	
Minimum Frequency		46	Capacity	0.74	0.86	0.74	0.86	0.99	0.74	0.86	0.99
			EER	4.01	4.32	4.01	4.32	4.64	4.01	4.32	4.64
		40	Capacity	0.81	0.93	0.81	0.93	1.05	0.81	0.93	1.05
			EER	4.65	4.90	4.65	4.90	5.14	4.65	4.90	5.14
		35	Capacity	0.89	1.01	0.89	1.01	1.12	0.89	1.01	1.12
			EER	5.41	5.58	5.41	5.58	5.76	5.41	5.58	5.76
	30	Capacity	0.96	1.07	0.96	1.07	1.19	0.96	1.07	1.19	
		EER	6.23	6.36	6.23	6.36	6.49	6.23	6.36	6.49	
	25	Capacity	1.04	1.15	1.04	1.15	1.26	1.04	1.15	1.26	
		EER	7.35	7.39	7.35	7.39	7.43	7.35	7.39	7.43	
	20	Capacity	1.13	1.23	1.13	1.23	1.34	1.13	1.23	1.34	
		EER	8.47	8.42	8.47	8.42	8.37	8.47	8.42	8.37	

Cooling performance data (Low ambient Condition)

	Ambient temperature (°C)	INDOOR (°C)								
		DB	21		27			32		
		WB	15	19	15	19	23	15	19	23
Max Frequency	15 -10	Capacity	2.23	2.51	2.23	2.51	2.80	2.23	2.51	2.80
		SHF	0.97	0.73	1.00	0.96	0.73	1.00	1.00	0.93
		EER	5.02	5.18	5.02	5.18	5.34	5.02	5.18	5.34

* The low ambient condition requires a special control and all the performance is equal to or less than the rated operation.

Cooling performance data

MSZ-LN25VG2W/V/B/R: MUZ-LN25VGHZ2

	Ambient temperature (°C)	INDOOR (°C)									
		DB	21		27			32			
		WB	15	19	15	19	23	15	19	23	
Max frequency	46	Capacity	2.57	3.01	2.57	3.01	3.45	2.57	3.01	3.45	
		SHF	0.75	0.51	0.99	0.75	0.51	1.00	0.95	0.71	
		EER	2.81	3.03	2.81	3.03	3.25	2.81	3.03	3.25	
	40	Capacity	2.84	3.26	2.84	3.26	3.68	2.84	3.26	3.68	
		SHF	0.75	0.51	0.99	0.75	0.51	1.00	0.95	0.71	
		EER	3.26	3.43	3.26	3.43	3.60	3.26	3.43	3.60	
	35	Capacity	3.12	3.52	3.12	3.52	3.92	3.12	3.52	3.92	
		SHF	0.75	0.51	0.99	0.75	0.51	1.00	0.95	0.71	
		EER	3.78	3.91	3.78	3.91	4.03	3.78	3.91	4.03	
	30	Capacity	3.34	3.75	3.34	3.75	4.15	3.34	3.75	4.15	
		SHF	0.75	0.51	0.99	0.75	0.51	1.00	0.95	0.71	
		EER	4.36	4.45	4.36	4.45	4.54	4.36	4.45	4.54	
	25	Capacity	3.64	4.03	3.64	4.03	4.41	3.64	4.03	4.41	
		SHF	0.75	0.51	0.99	0.75	0.51	1.00	0.95	0.71	
		EER	5.14	5.17	5.14	5.17	5.20	5.14	5.17	5.20	
	20	Capacity	3.94	4.31	3.94	4.31	4.67	3.94	4.31	4.67	
		SHF	0.75	0.51	0.99	0.75	0.51	1.00	0.95	0.71	
		EER	5.93	5.89	5.93	5.89	5.86	5.93	5.89	5.86	
	Rated frequency	46	Capacity	1.84	2.15	1.84	2.15	2.46	1.84	2.15	2.46
			SHF	0.97	0.73	1.00	0.96	0.73	1.00	1.00	0.93
			EER	3.72	4.01	3.72	4.01	4.30	3.72	4.01	4.30
		40	Capacity	2.03	2.33	2.03	2.33	2.63	2.03	2.33	2.63
			SHF	0.97	0.73	1.00	0.96	0.73	1.00	1.00	0.93
			EER	4.32	4.54	4.32	4.54	4.77	4.32	4.54	4.77
35		Capacity	2.23	2.51	2.23	2.51	2.80	2.23	2.51	2.80	
		SHF	0.97	0.73	1.00	0.96	0.73	1.00	1.00	0.93	
		EER	5.02	5.18	5.02	5.18	5.34	5.02	5.18	5.34	
30		Capacity	2.39	2.68	2.39	2.68	2.96	2.39	2.68	2.96	
		SHF	0.97	0.73	1.00	0.96	0.73	1.00	1.00	0.93	
		EER	5.78	5.90	5.78	5.90	6.02	5.78	5.90	6.02	
25		Capacity	2.60	2.88	2.60	2.88	3.15	2.60	2.88	3.15	
		SHF	0.97	0.73	1.00	0.96	0.73	1.00	1.00	0.93	
		EER	6.82	6.85	6.82	6.85	6.89	6.82	6.85	6.89	
20		Capacity	2.81	3.08	2.81	3.08	3.34	2.81	3.08	3.34	
		SHF	0.97	0.73	1.00	0.96	0.73	1.00	1.00	0.93	
		EER	7.86	7.81	7.86	7.81	7.76	7.86	7.81	7.76	
Minimum Frequency		46	Capacity	0.59	0.69	0.59	0.69	0.79	0.59	0.69	0.79
			EER	3.61	3.89	3.61	3.89	4.17	3.61	3.89	4.17
		40	Capacity	0.65	0.74	0.65	0.74	0.84	0.65	0.74	0.84
			EER	4.19	4.41	4.19	4.41	4.62	4.19	4.41	4.62
		35	Capacity	0.71	0.80	0.71	0.80	0.90	0.71	0.80	0.90
			EER	4.86	5.02	4.86	5.02	5.18	4.86	5.02	5.18
	30	Capacity	0.76	0.86	0.76	0.86	0.95	0.76	0.86	0.95	
		EER	5.60	5.72	5.60	5.72	5.84	5.60	5.72	5.84	
	25	Capacity	0.83	0.92	0.83	0.92	1.01	0.83	0.92	1.01	
		EER	6.61	6.65	6.61	6.65	6.68	6.61	6.65	6.68	
	20	Capacity	0.90	0.98	0.90	0.98	1.07	0.90	0.98	1.07	
		EER	7.62	7.58	7.62	7.58	7.53	7.62	7.58	7.53	

Cooling performance data (Low ambient Condition)

	Ambient temperature (°C)	INDOOR (°C)								
		DB	21		27			32		
		WB	15	19	15	19	23	15	19	23
Max Frequency	15 -10	Capacity	2.23	2.51	2.23	2.51	2.80	2.23	2.51	2.80
		SHF	0.97	0.73	1.00	0.96	0.73	1.00	1.00	0.93
		EER	5.02	5.18	5.02	5.18	5.34	5.02	5.18	5.34

* The low ambient condition requires a special control and all the performance is equal to or less than the rated operation.

Cooling performance data
MSZ-LN35VG2W/V/B/R: MUZ-LN35VG2

	Ambient temperature (°C)	INDOOR (°C)									
		DB	21		27			32			
		WB	15	19	15	19	23	15	19	23	
Max frequency	46	Capacity	2.94	3.44	2.94	3.44	3.94	2.94	3.44	3.94	
		SHF	0.75	0.51	0.99	0.75	0.51	1.00	0.95	0.71	
		EER	2.45	2.64	2.45	2.64	2.83	2.45	2.64	2.83	
	40	Capacity	3.24	3.72	3.24	3.72	4.20	3.24	3.72	4.20	
		SHF	0.75	0.51	0.99	0.75	0.51	1.00	0.95	0.71	
		EER	2.84	2.99	2.84	2.99	3.14	2.84	2.99	3.14	
	35	Capacity	3.56	4.02	3.56	4.02	4.48	3.56	4.02	4.48	
		SHF	0.75	0.51	0.99	0.75	0.51	1.00	0.95	0.71	
		EER	3.30	3.41	3.30	3.41	3.51	3.30	3.41	3.51	
	30	Capacity	3.82	4.28	3.82	4.28	4.74	3.82	4.28	4.74	
		SHF	0.75	0.51	0.99	0.75	0.51	1.00	0.95	0.71	
		EER	3.80	3.88	3.80	3.88	3.96	3.80	3.88	3.96	
	25	Capacity	4.16	4.60	4.16	4.60	5.04	4.16	4.60	5.04	
		SHF	0.75	0.51	0.99	0.75	0.51	1.00	0.95	0.71	
		EER	4.48	4.51	4.48	4.51	4.53	4.48	4.51	4.53	
	20	Capacity	4.50	4.92	4.50	4.92	5.34	4.50	4.92	5.34	
		SHF	0.75	0.51	0.99	0.75	0.51	1.00	0.95	0.71	
		EER	5.17	5.14	5.17	5.14	5.11	5.17	5.14	5.11	
	Rated frequency	46	Capacity	2.57	3.01	2.57	3.01	3.45	2.57	3.01	3.45
			SHF	0.90	0.66	1.00	0.90	0.66	1.00	1.00	0.86
			EER	3.08	3.32	3.08	3.32	3.56	3.08	3.32	3.56
		40	Capacity	2.84	3.26	2.84	3.26	3.68	2.84	3.26	3.68
			SHF	0.90	0.66	1.00	0.90	0.66	1.00	1.00	0.86
			EER	3.58	3.76	3.58	3.76	3.95	3.58	3.76	3.95
35		Capacity	3.12	3.52	3.12	3.52	3.92	3.12	3.52	3.92	
		SHF	0.90	0.66	1.00	0.90	0.66	1.00	1.00	0.86	
		EER	4.15	4.29	4.15	4.29	4.43	4.15	4.29	4.43	
30		Capacity	3.34	3.75	3.34	3.75	4.15	3.34	3.75	4.15	
		SHF	0.90	0.66	1.00	0.90	0.66	1.00	1.00	0.86	
		EER	4.78	4.88	4.78	4.88	4.98	4.78	4.88	4.98	
25		Capacity	3.64	4.03	3.64	4.03	4.41	3.64	4.03	4.41	
		SHF	0.90	0.66	1.00	0.90	0.66	1.00	1.00	0.86	
		EER	5.65	5.68	5.65	5.68	5.71	5.65	5.68	5.71	
20		Capacity	3.94	4.31	3.94	4.31	4.67	3.94	4.31	4.67	
		SHF	0.90	0.66	1.00	0.90	0.66	1.00	1.00	0.86	
		EER	6.51	6.47	6.51	6.47	6.43	6.51	6.47	6.43	
Minimum Frequency		46	Capacity	0.59	0.69	0.59	0.69	0.79	0.59	0.69	0.79
			EER	3.61	3.89	3.61	3.89	4.17	3.61	3.89	4.17
		40	Capacity	0.65	0.74	0.65	0.74	0.84	0.65	0.74	0.84
			EER	4.19	4.41	4.19	4.41	4.62	4.19	4.41	4.62
		35	Capacity	0.71	0.80	0.71	0.80	0.90	0.71	0.80	0.90
			EER	4.86	5.02	4.86	5.02	5.18	4.86	5.02	5.18
	30	Capacity	0.76	0.86	0.76	0.86	0.95	0.76	0.86	0.95	
		EER	5.60	5.72	5.60	5.72	5.84	5.60	5.72	5.84	
	25	Capacity	0.83	0.92	0.83	0.92	1.01	0.83	0.92	1.01	
		EER	6.61	6.65	6.61	6.65	6.68	6.61	6.65	6.68	
	20	Capacity	0.90	0.98	0.90	0.98	1.07	0.90	0.98	1.07	
		EER	7.62	7.58	7.62	7.58	7.53	7.62	7.58	7.53	

Cooling performance data (Low ambient Condition)

	Ambient temperature (°C)	INDOOR (°C)								
		DB	21		27			32		
		WB	15	19	15	19	23	15	19	23
Max Frequency	15 -10	Capacity	3.12	3.52	3.12	3.52	3.92	3.12	3.52	3.92
		SHF	0.90	0.66	1.00	0.90	0.66	1.00	1.00	0.86
		EER	4.15	4.29	4.15	4.29	4.43	4.15	4.29	4.43

* The low ambient condition requires a special control and all the performance is equal to or less than the rated operation.

Cooling performance data

MSZ-LN35VG2W/V/B/R: MUZ-LN35VGHZ2

	Ambient temperature (°C)	INDOOR (°C)									
		DB	21		27			32			
		WB	15	19	15	19	23	15	19	23	
Max frequency	46	Capacity	2.94	3.44	2.94	3.44	3.94	2.94	3.44	3.94	
		SHF	0.71	0.47	0.95	0.71	0.47	1.00	0.91	0.67	
		EER	2.45	2.64	2.45	2.64	2.83	2.45	2.64	2.83	
	40	Capacity	3.24	3.72	3.24	3.72	4.20	3.24	3.72	4.20	
		SHF	0.71	0.47	0.95	0.71	0.47	1.00	0.91	0.67	
		EER	2.84	2.99	2.84	2.99	3.14	2.84	2.99	3.14	
	35	Capacity	3.56	4.02	3.56	4.02	4.48	3.56	4.02	4.48	
		SHF	0.71	0.47	0.95	0.71	0.47	1.00	0.91	0.67	
		EER	3.30	3.41	3.30	3.41	3.51	3.30	3.41	3.51	
	30	Capacity	3.82	4.28	3.82	4.28	4.74	3.82	4.28	4.74	
		SHF	0.71	0.47	0.95	0.71	0.47	1.00	0.91	0.67	
		EER	3.80	3.88	3.80	3.88	3.96	3.80	3.88	3.96	
	25	Capacity	4.16	4.60	4.16	4.60	5.04	4.16	4.60	5.04	
		SHF	0.71	0.47	0.95	0.71	0.47	1.00	0.91	0.67	
		EER	4.48	4.51	4.48	4.51	4.53	4.48	4.51	4.53	
	20	Capacity	4.50	4.92	4.50	4.92	5.34	4.50	4.92	5.34	
		SHF	0.71	0.47	0.95	0.71	0.47	1.00	0.91	0.67	
		EER	5.17	5.14	5.17	5.14	5.11	5.17	5.14	5.11	
	Rated frequency	46	Capacity	2.57	3.01	2.57	3.01	3.45	2.57	3.01	3.45
			SHF	0.90	0.66	1.00	0.90	0.66	1.00	1.00	0.86
			EER	3.08	3.32	3.08	3.32	3.56	3.08	3.32	3.56
		40	Capacity	2.84	3.26	2.84	3.26	3.68	2.84	3.26	3.68
			SHF	0.90	0.66	1.00	0.90	0.66	1.00	1.00	0.86
			EER	3.58	3.76	3.58	3.76	3.95	3.58	3.76	3.95
35		Capacity	3.12	3.52	3.12	3.52	3.92	3.12	3.52	3.92	
		SHF	0.90	0.66	1.00	0.90	0.66	1.00	1.00	0.86	
		EER	4.15	4.29	4.15	4.29	4.43	4.15	4.29	4.43	
30		Capacity	3.34	3.75	3.34	3.75	4.15	3.34	3.75	4.15	
		SHF	0.90	0.66	1.00	0.90	0.66	1.00	1.00	0.86	
		EER	4.78	4.88	4.78	4.88	4.98	4.78	4.88	4.98	
25		Capacity	3.64	4.03	3.64	4.03	4.41	3.64	4.03	4.41	
		SHF	0.90	0.66	1.00	0.90	0.66	1.00	1.00	0.86	
		EER	5.65	5.68	5.65	5.68	5.71	5.65	5.68	5.71	
20		Capacity	3.94	4.31	3.94	4.31	4.67	3.94	4.31	4.67	
		SHF	0.90	0.66	1.00	0.90	0.66	1.00	1.00	0.86	
		EER	6.51	6.47	6.51	6.47	6.43	6.51	6.47	6.43	
Minimum Frequency		46	Capacity	0.59	0.69	0.59	0.69	0.79	0.59	0.69	0.79
			EER	3.61	3.89	3.61	3.89	4.17	3.61	3.89	4.17
		40	Capacity	0.65	0.74	0.65	0.74	0.84	0.65	0.74	0.84
			EER	4.19	4.41	4.19	4.41	4.62	4.19	4.41	4.62
		35	Capacity	0.71	0.80	0.71	0.80	0.90	0.71	0.80	0.90
			EER	4.86	5.02	4.86	5.02	5.18	4.86	5.02	5.18
	30	Capacity	0.76	0.86	0.76	0.86	0.95	0.76	0.86	0.95	
		EER	5.60	5.72	5.60	5.72	5.84	5.60	5.72	5.84	
	25	Capacity	0.83	0.92	0.83	0.92	1.01	0.83	0.92	1.01	
		EER	6.61	6.65	6.61	6.65	6.68	6.61	6.65	6.68	
	20	Capacity	0.90	0.98	0.90	0.98	1.07	0.90	0.98	1.07	
		EER	7.62	7.58	7.62	7.58	7.53	7.62	7.58	7.53	

Cooling performance data (Low ambient Condition)

	Ambient temperature (°C)	INDOOR (°C)								
		DB	21		27			32		
		WB	15	19	15	19	23	15	19	23
Max Frequency	15 -10	Capacity	3.12	3.52	3.12	3.52	3.92	3.12	3.52	3.92
		SHF	0.90	0.66	1.00	0.90	0.66	1.00	1.00	0.86
		EER	4.15	4.29	4.15	4.29	4.43	4.15	4.29	4.43

* The low ambient condition requires a special control and all the performance is equal to or less than the rated operation.

Cooling performance data

MSZ-LN50VG2W/V/B/R: MUZ-LN50VG2

	Ambient temperature (°C)	INDOOR (°C)									
		DB	21		27			32			
		WB	15	19	15	19	23	15	19	23	
Max frequency	46	Capacity	4.41	5.16	4.41	5.16	5.91	4.41	5.16	5.91	
		SHF	0.70	0.46	0.94	0.70	0.46	1.00	0.90	0.66	
		EER	1.86	2.00	1.86	2.00	2.15	1.86	2.00	2.15	
	40	Capacity	4.86	5.58	4.86	5.58	6.30	4.86	5.58	6.30	
		SHF	0.70	0.46	0.94	0.70	0.46	1.00	0.90	0.66	
		EER	2.16	2.27	2.16	2.27	2.38	2.16	2.27	2.38	
	35	Capacity	5.34	6.03	5.34	6.03	6.72	5.34	6.03	6.72	
		SHF	0.70	0.46	0.94	0.70	0.46	1.00	0.90	0.66	
		EER	2.51	2.59	2.51	2.59	2.67	2.51	2.59	2.67	
	30	Capacity	5.73	6.42	5.73	6.42	7.11	5.73	6.42	7.11	
		SHF	0.70	0.46	0.94	0.70	0.46	1.00	0.90	0.66	
		EER	2.89	2.95	2.89	2.95	3.01	2.89	2.95	3.01	
	25	Capacity	6.24	6.90	6.24	6.90	7.56	6.24	6.90	7.56	
		SHF	0.70	0.46	0.94	0.70	0.46	1.00	0.90	0.66	
		EER	3.41	3.42	3.41	3.42	3.44	3.41	3.42	3.44	
	20	Capacity	6.75	7.38	6.75	7.38	8.01	6.75	7.38	8.01	
		SHF	0.70	0.46	0.94	0.70	0.46	1.00	0.90	0.66	
		EER	3.93	3.90	3.93	3.90	3.88	3.93	3.90	3.88	
	Rated frequency	46	Capacity	3.68	4.30	3.68	4.30	4.93	3.68	4.30	4.93
			SHF	0.77	0.53	1.00	0.77	0.53	1.00	0.96	0.73
			EER	2.61	2.82	2.61	2.82	3.02	2.61	2.82	3.02
		40	Capacity	4.05	4.65	4.05	4.65	5.25	4.05	4.65	5.25
			SHF	0.77	0.53	1.00	0.77	0.53	1.00	0.96	0.73
			EER	3.03	3.19	3.03	3.19	3.35	3.03	3.19	3.35
35		Capacity	4.45	5.03	4.45	5.03	5.60	4.45	5.03	5.60	
		SHF	0.77	0.53	1.00	0.77	0.53	1.00	0.96	0.73	
		EER	3.53	3.64	3.53	3.64	3.76	3.53	3.64	3.76	
30		Capacity	4.78	5.35	4.78	5.35	5.93	4.78	5.35	5.93	
		SHF	0.77	0.53	1.00	0.77	0.53	1.00	0.96	0.73	
		EER	4.06	4.15	4.06	4.15	4.23	4.06	4.15	4.23	
25		Capacity	5.20	5.75	5.20	5.75	6.30	5.20	5.75	6.30	
		SHF	0.77	0.53	1.00	0.77	0.53	1.00	0.96	0.73	
		EER	4.79	4.82	4.79	4.82	4.84	4.79	4.82	4.84	
20		Capacity	5.63	6.15	5.63	6.15	6.68	5.63	6.15	6.68	
		SHF	0.77	0.53	1.00	0.77	0.53	1.00	0.96	0.73	
		EER	5.52	5.49	5.52	5.49	5.46	5.52	5.49	5.46	
Minimum Frequency		46	Capacity	0.74	0.86	0.74	0.86	0.99	0.74	0.86	0.99
			EER	3.80	4.10	3.80	4.10	4.39	3.80	4.10	4.39
		40	Capacity	0.81	0.93	0.81	0.93	1.05	0.81	0.93	1.05
			EER	4.41	4.64	4.41	4.64	4.87	4.41	4.64	4.87
		35	Capacity	0.89	1.01	0.89	1.01	1.12	0.89	1.01	1.12
			EER	5.12	5.29	5.12	5.29	5.46	5.12	5.29	5.46
	30	Capacity	0.96	1.07	0.96	1.07	1.19	0.96	1.07	1.19	
		EER	5.90	6.02	5.90	6.02	6.14	5.90	6.02	6.14	
	25	Capacity	1.04	1.15	1.04	1.15	1.26	1.04	1.15	1.26	
		EER	6.96	7.00	6.96	7.00	7.04	6.96	7.00	7.04	
	20	Capacity	1.13	1.23	1.13	1.23	1.34	1.13	1.23	1.34	
		EER	8.02	7.98	8.02	7.98	7.93	8.02	7.98	7.93	

Cooling performance data (Low ambient Condition)

	Ambient temperature (°C)	INDOOR (°C)								
		DB	21		27			32		
		WB	15	19	15	19	23	15	19	23
Max Frequency	15 -10	Capacity	4.45	5.03	4.45	5.03	5.60	4.45	5.03	5.60
		SHF	0.77	0.53	1.00	0.77	0.53	1.00	0.96	0.73
		EER	3.53	3.64	3.53	3.64	3.76	3.53	3.64	3.76

* The low ambient condition requires a special control and all the performance is equal to or less than the rated operation.

Cooling performance data

MSZ-LN50VG2W/V/B/R: MUZ-LN50VGHZ2

	Ambient temperature (°C)	INDOOR (°C)									
		DB	21		27			32			
		WB	15	19	15	19	23	15	19	23	
Max frequency	46	Capacity	4.26	4.99	4.26	4.99	5.71	4.26	4.99	5.71	
		SHF	0.68	0.44	0.92	0.68	0.44	1.00	0.88	0.64	
		EER	1.73	1.86	1.73	1.86	2.00	1.73	1.86	2.00	
	40	Capacity	4.70	5.39	4.70	5.39	6.09	4.70	5.39	6.09	
		SHF	0.68	0.44	0.92	0.68	0.44	1.00	0.88	0.64	
		EER	2.01	2.11	2.01	2.11	2.22	2.01	2.11	2.22	
	35	Capacity	5.16	5.83	5.16	5.83	6.50	5.16	5.83	6.50	
		SHF	0.68	0.44	0.92	0.68	0.44	1.00	0.88	0.64	
		EER	2.33	2.41	2.33	2.41	2.49	2.33	2.41	2.49	
	30	Capacity	5.54	6.21	5.54	6.21	6.87	5.54	6.21	6.87	
		SHF	0.68	0.44	0.92	0.68	0.44	1.00	0.88	0.64	
		EER	2.69	2.74	2.69	2.74	2.80	2.69	2.74	2.80	
	25	Capacity	6.03	6.67	6.03	6.67	7.31	6.03	6.67	7.31	
		SHF	0.68	0.44	0.92	0.68	0.44	1.00	0.88	0.64	
		EER	3.17	3.19	3.17	3.19	3.20	3.17	3.19	3.20	
	20	Capacity	6.53	7.13	6.53	7.13	7.74	6.53	7.13	7.74	
		SHF	0.68	0.44	0.92	0.68	0.44	1.00	0.88	0.64	
		EER	3.65	3.63	3.65	3.63	3.61	3.65	3.63	3.61	
	Rated frequency	46	Capacity	3.68	4.30	3.68	4.30	4.93	3.68	4.30	4.93
			SHF	0.77	0.53	1.00	0.77	0.53	1.00	0.96	0.73
			EER	2.61	2.82	2.61	2.82	3.02	2.61	2.82	3.02
		40	Capacity	4.05	4.65	4.05	4.65	5.25	4.05	4.65	5.25
			SHF	0.77	0.53	1.00	0.77	0.53	1.00	0.96	0.73
			EER	3.03	3.19	3.03	3.19	3.35	3.03	3.19	3.35
35		Capacity	4.45	5.03	4.45	5.03	5.60	4.45	5.03	5.60	
		SHF	0.77	0.53	1.00	0.77	0.53	1.00	0.96	0.73	
		EER	3.53	3.64	3.53	3.64	3.76	3.53	3.64	3.76	
30		Capacity	4.78	5.35	4.78	5.35	5.93	4.78	5.35	5.93	
		SHF	0.77	0.53	1.00	0.77	0.53	1.00	0.96	0.73	
		EER	4.06	4.15	4.06	4.15	4.23	4.06	4.15	4.23	
25		Capacity	5.20	5.75	5.20	5.75	6.30	5.20	5.75	6.30	
		SHF	0.77	0.53	1.00	0.77	0.53	1.00	0.96	0.73	
		EER	4.79	4.82	4.79	4.82	4.84	4.79	4.82	4.84	
20		Capacity	5.63	6.15	5.63	6.15	6.68	5.63	6.15	6.68	
		SHF	0.77	0.53	1.00	0.77	0.53	1.00	0.96	0.73	
		EER	5.52	5.49	5.52	5.49	5.46	5.52	5.49	5.46	
Minimum Frequency		46	Capacity	1.03	1.20	1.03	1.20	1.38	1.03	1.20	1.38
			EER	3.74	4.03	3.74	4.03	4.33	3.74	4.03	4.33
		40	Capacity	1.13	1.30	1.13	1.30	1.47	1.13	1.30	1.47
			EER	4.34	4.57	4.34	4.57	4.80	4.34	4.57	4.80
		35	Capacity	1.25	1.41	1.25	1.41	1.57	1.25	1.41	1.57
			EER	5.04	5.21	5.04	5.21	5.38	5.04	5.21	5.38
	30	Capacity	1.34	1.50	1.34	1.50	1.66	1.34	1.50	1.66	
		EER	5.81	5.93	5.81	5.93	6.05	5.81	5.93	6.05	
	25	Capacity	1.46	1.61	1.46	1.61	1.76	1.46	1.61	1.76	
		EER	6.86	6.90	6.86	6.90	6.93	6.86	6.90	6.93	
	20	Capacity	1.58	1.72	1.58	1.72	1.87	1.58	1.72	1.87	
		EER	7.91	7.86	7.91	7.86	7.81	7.91	7.86	7.81	

Cooling performance data (Low ambient Condition)

	Ambient temperature (°C)	INDOOR (°C)								
		DB	21		27			32		
		WB	15	19	15	19	23	15	19	23
Max Frequency	15 -10	Capacity	4.45	5.03	4.45	5.03	5.60	4.45	5.03	5.60
		SHF	0.77	0.53	1.00	0.77	0.53	1.00	0.96	0.73
		EER	3.53	3.64	3.53	3.64	3.76	3.53	3.64	3.76

* The low ambient condition requires a special control and all the performance is equal to or less than the rated operation.

Cooling performance data

MSZ-LN60VG2W/V/B/R: MUZ-LN60VG2

	Ambient temperature (°C)	INDOOR (°C)									
		DB	21		27			32			
		WB	15	19	15	19	23	15	19	23	
Max frequency	46	Capacity	5.07	5.93	5.07	5.93	6.80	5.07	5.93	6.80	
		SHF	0.68	0.44	0.92	0.68	0.44	1.00	0.88	0.64	
		EER	1.82	1.97	1.82	1.97	2.11	1.82	1.97	2.11	
	40	Capacity	5.59	6.42	5.59	6.42	7.25	5.59	6.42	7.25	
		SHF	0.68	0.44	0.92	0.68	0.44	1.00	0.88	0.64	
		EER	2.12	2.23	2.12	2.23	2.34	2.12	2.23	2.34	
	35	Capacity	6.14	6.93	6.14	6.93	7.73	6.14	6.93	7.73	
		SHF	0.68	0.44	0.92	0.68	0.44	1.00	0.88	0.64	
		EER	2.46	2.54	2.46	2.54	2.62	2.46	2.54	2.62	
	30	Capacity	6.59	7.38	6.59	7.38	8.18	6.59	7.38	8.18	
		SHF	0.68	0.44	0.92	0.68	0.44	1.00	0.88	0.64	
		EER	2.83	2.89	2.83	2.89	2.95	2.83	2.89	2.95	
	25	Capacity	7.18	7.94	7.18	7.94	8.69	7.18	7.94	8.69	
		SHF	0.68	0.44	0.92	0.68	0.44	1.00	0.88	0.64	
		EER	3.34	3.36	3.34	3.36	3.38	3.34	3.36	3.38	
	20	Capacity	7.76	8.49	7.76	8.49	9.21	7.76	8.49	9.21	
		SHF	0.68	0.44	0.92	0.68	0.44	1.00	0.88	0.64	
		EER	3.85	3.83	3.85	3.83	3.81	3.85	3.83	3.81	
	Rated frequency	46	Capacity	4.48	5.25	4.48	5.25	6.01	4.48	5.25	6.01
			SHF	0.75	0.51	0.99	0.75	0.51	1.00	0.95	0.71
			EER	2.46	2.65	2.46	2.65	2.84	2.46	2.65	2.84
		40	Capacity	4.94	5.67	4.94	5.67	6.41	4.94	5.67	6.41
			SHF	0.75	0.51	0.99	0.75	0.51	1.00	0.95	0.71
			EER	2.85	3.00	2.85	3.00	3.15	2.85	3.00	3.15
35		Capacity	5.43	6.13	5.43	6.13	6.83	5.43	6.13	6.83	
		SHF	0.75	0.51	0.99	0.75	0.51	1.00	0.95	0.71	
		EER	3.32	3.42	3.32	3.42	3.53	3.32	3.42	3.53	
30		Capacity	5.83	6.53	5.83	6.53	7.23	5.83	6.53	7.23	
		SHF	0.75	0.51	0.99	0.75	0.51	1.00	0.95	0.71	
		EER	3.82	3.90	3.82	3.90	3.98	3.82	3.90	3.98	
25		Capacity	6.34	7.02	6.34	7.02	7.69	6.34	7.02	7.69	
		SHF	0.75	0.51	0.99	0.75	0.51	1.00	0.95	0.71	
		EER	4.51	4.53	4.51	4.53	4.56	4.51	4.53	4.56	
20		Capacity	6.86	7.50	6.86	7.50	8.14	6.86	7.50	8.14	
		SHF	0.75	0.51	0.99	0.75	0.51	1.00	0.95	0.71	
		EER	5.20	5.16	5.20	5.16	5.13	5.20	5.16	5.13	
Minimum Frequency		46	Capacity	1.03	1.20	1.03	1.20	1.38	1.03	1.20	1.38
			EER	3.74	4.03	3.74	4.03	4.33	3.74	4.03	4.33
		40	Capacity	1.13	1.30	1.13	1.30	1.47	1.13	1.30	1.47
			EER	4.34	4.57	4.34	4.57	4.80	4.34	4.57	4.80
		35	Capacity	1.25	1.41	1.25	1.41	1.57	1.25	1.41	1.57
			EER	5.04	5.21	5.04	5.21	5.38	5.04	5.21	5.38
	30	Capacity	1.34	1.50	1.34	1.50	1.66	1.34	1.50	1.66	
		EER	5.81	5.93	5.81	5.93	6.05	5.81	5.93	6.05	
	25	Capacity	1.46	1.61	1.46	1.61	1.76	1.46	1.61	1.76	
		EER	6.86	6.90	6.86	6.90	6.93	6.86	6.90	6.93	
	20	Capacity	1.58	1.72	1.58	1.72	1.87	1.58	1.72	1.87	
		EER	7.91	7.86	7.91	7.86	7.81	7.91	7.86	7.81	

Cooling performance data (Low ambient Condition)

	Ambient temperature (°C)	INDOOR (°C)								
		DB	21		27			32		
		WB	15	19	15	19	23	15	19	23
Max Frequency	15 -10	Capacity	5.43	6.13	5.43	6.13	6.83	5.43	6.13	6.83
		SHF	0.75	0.51	0.99	0.75	0.51	1.00	0.95	0.71
		EER	3.32	3.42	3.32	3.42	3.53	3.32	3.42	3.53

* The low ambient condition requires a special control and all the performance is equal to or less than the rated operation.

Cooling performance data
MSZ-FT25VG, MSZ-FT25VGK: MUZ-FT25VGHZ

	Ambient temperature (°C)	INDOOR (°C)									
		DB	21		27			32			
		WB	15	19	15	19	23	15	19	23	
Max frequency	46	Capacity	2.57	3.01	2.57	3.01	3.45	2.57	3.01	3.45	
		SHF	0.84	0.60	1.00	0.84	0.60	1.00	0.99	0.80	
		EER	2.10	2.27	2.10	2.27	2.43	2.10	2.27	2.43	
	40	Capacity	2.84	3.26	2.84	3.26	3.68	2.84	3.26	3.68	
		SHF	0.84	0.60	1.00	0.84	0.60	1.00	0.99	0.80	
		EER	2.44	2.57	2.44	2.57	2.70	2.44	2.57	2.70	
	35	Capacity	3.12	3.52	3.12	3.52	3.92	3.12	3.52	3.92	
		SHF	0.84	0.60	1.00	0.84	0.60	1.00	0.99	0.80	
		EER	2.84	2.93	2.84	2.93	3.02	2.84	2.93	3.02	
	30	Capacity	3.34	3.75	3.34	3.75	4.15	3.34	3.75	4.15	
		SHF	0.84	0.60	1.00	0.84	0.60	1.00	0.99	0.80	
		EER	3.27	3.34	3.27	3.34	3.40	3.27	3.34	3.40	
	25	Capacity	3.64	4.03	3.64	4.03	4.41	3.64	4.03	4.41	
		SHF	0.84	0.60	1.00	0.84	0.60	1.00	0.99	0.80	
		EER	3.86	3.88	3.86	3.88	3.90	3.86	3.88	3.90	
	20	Capacity	3.94	4.31	3.94	4.31	4.67	3.94	4.31	4.67	
		SHF	0.84	0.60	1.00	0.84	0.60	1.00	0.99	0.80	
		EER	4.45	4.42	4.45	4.42	4.39	4.45	4.42	4.39	
	Rated frequency	46	Capacity	1.84	2.15	1.84	2.15	2.46	1.84	2.15	2.46
			SHF	0.95	0.71	1.00	0.95	0.71	1.00	1.00	0.91
			EER	3.11	3.35	3.11	3.35	3.60	3.11	3.35	3.60
		40	Capacity	2.03	2.33	2.03	2.33	2.63	2.03	2.33	2.63
			SHF	0.95	0.71	1.00	0.95	0.71	1.00	1.00	0.91
			EER	3.61	3.80	3.61	3.80	3.99	3.61	3.80	3.99
35		Capacity	2.23	2.51	2.23	2.51	2.80	2.23	2.51	2.80	
		SHF	0.95	0.71	1.00	0.95	0.71	1.00	1.00	0.91	
		EER	4.19	4.33	4.19	4.33	4.47	4.19	4.33	4.47	
30		Capacity	2.39	2.68	2.39	2.68	2.96	2.39	2.68	2.96	
		SHF	0.95	0.71	1.00	0.95	0.71	1.00	1.00	0.91	
		EER	4.83	4.93	4.83	4.93	5.03	4.83	4.93	5.03	
25		Capacity	2.60	2.88	2.60	2.88	3.15	2.60	2.88	3.15	
		SHF	0.95	0.71	1.00	0.95	0.71	1.00	1.00	0.91	
		EER	5.70	5.73	5.70	5.73	5.76	5.70	5.73	5.76	
20		Capacity	2.81	3.08	2.81	3.08	3.34	2.81	3.08	3.34	
		SHF	0.95	0.71	1.00	0.95	0.71	1.00	1.00	0.91	
		EER	6.57	6.53	6.57	6.53	6.49	6.57	6.53	6.49	
Minimum Frequency		46	Capacity	0.59	0.69	0.59	0.69	0.79	0.59	0.69	0.79
			EER	3.61	3.89	3.61	3.89	4.17	3.61	3.89	4.17
		40	Capacity	0.65	0.74	0.65	0.74	0.84	0.65	0.74	0.84
			EER	4.19	4.41	4.19	4.41	4.62	4.19	4.41	4.62
		35	Capacity	0.71	0.80	0.71	0.80	0.90	0.71	0.80	0.90
			EER	4.86	5.02	4.86	5.02	5.18	4.86	5.02	5.18
	30	Capacity	0.76	0.86	0.76	0.86	0.95	0.76	0.86	0.95	
		EER	5.60	5.72	5.60	5.72	5.84	5.60	5.72	5.84	
	25	Capacity	0.83	0.92	0.83	0.92	1.01	0.83	0.92	1.01	
		EER	6.61	6.65	6.61	6.65	6.68	6.61	6.65	6.68	
	20	Capacity	0.90	0.98	0.90	0.98	1.07	0.90	0.98	1.07	
		EER	7.62	7.58	7.62	7.58	7.53	7.62	7.58	7.53	

Cooling performance data (Low ambient Condition)

	Ambient temperature (°C)	INDOOR (°C)								
		DB	21		27			32		
		WB	15	19	15	19	23	15	19	23
Max Frequency	15 -10	Capacity	2.23	2.51	2.23	2.51	2.80	2.23	2.51	2.80
		SHF	0.95	0.71	1.00	0.95	0.71	1.00	1.00	0.91
		EER	4.19	4.33	4.19	4.33	4.47	4.19	4.33	4.47

* The low ambient condition requires a special control and all the performance is equal to or less than the rated operation.

WALL-MOUNTED PERFORMANCE DATA

Cooling performance data

MSZ-FT35VG, MSZ-FT35VGK: MUZ-FT35VGHZ

	Ambient temperature (°C)	INDOOR (°C)									
		DB	21		27			32			
		WB	15	19	15	19	23	15	19	23	
Max frequency	46	Capacity	2.94	3.44	2.94	3.44	3.94	2.94	3.44	3.94	
		SHF	0.77	0.53	1.00	0.77	0.53	1.00	0.95	0.73	
		EER	2.06	2.22	2.06	2.22	2.38	2.06	2.22	2.38	
	40	Capacity	3.24	3.72	3.24	3.72	4.20	3.24	3.72	4.20	
		SHF	0.77	0.53	1.00	0.77	0.53	1.00	0.95	0.73	
		EER	2.39	2.52	2.39	2.52	2.64	2.39	2.52	2.64	
	35	Capacity	3.56	4.02	3.56	4.02	4.48	3.56	4.02	4.48	
		SHF	0.77	0.53	1.00	0.77	0.53	1.00	0.95	0.73	
		EER	2.78	2.87	2.78	2.87	2.96	2.78	2.87	2.96	
	30	Capacity	3.82	4.28	3.82	4.28	4.74	3.82	4.28	4.74	
		SHF	0.77	0.53	1.00	0.77	0.53	1.00	0.95	0.73	
		EER	3.20	3.27	3.20	3.27	3.34	3.20	3.27	3.34	
	25	Capacity	4.16	4.60	4.16	4.60	5.04	4.16	4.60	5.04	
		SHF	0.77	0.53	1.00	0.77	0.53	1.00	0.95	0.73	
		EER	3.78	3.80	3.78	3.80	3.82	3.78	3.80	3.82	
	20	Capacity	4.50	4.92	4.50	4.92	5.34	4.50	4.92	5.34	
		SHF	0.77	0.53	1.00	0.77	0.53	1.00	0.95	0.73	
		EER	4.36	4.33	4.36	4.33	4.30	4.36	4.33	4.30	
	Rated frequency	46	Capacity	2.57	3.01	2.57	3.01	3.45	2.57	3.01	3.45
			SHF	0.80	0.56	1.00	0.80	0.56	1.00	0.97	0.76
			EER	2.78	2.99	2.78	2.99	3.21	2.78	2.99	3.21
		40	Capacity	2.84	3.26	2.84	3.26	3.68	2.84	3.26	3.68
			SHF	0.80	0.56	1.00	0.80	0.56	1.00	0.97	0.76
			EER	3.22	3.39	3.22	3.39	3.56	3.22	3.39	3.56
35		Capacity	3.12	3.52	3.12	3.52	3.92	3.12	3.52	3.92	
		SHF	0.80	0.56	1.00	0.80	0.56	1.00	0.97	0.76	
		EER	3.74	3.87	3.74	3.87	3.99	3.74	3.87	3.99	
30		Capacity	3.34	3.75	3.34	3.75	4.15	3.34	3.75	4.15	
		SHF	0.80	0.56	1.00	0.80	0.56	1.00	0.97	0.76	
		EER	4.31	4.40	4.31	4.40	4.49	4.31	4.40	4.49	
25		Capacity	3.64	4.03	3.64	4.03	4.41	3.64	4.03	4.41	
		SHF	0.80	0.56	1.00	0.80	0.56	1.00	0.97	0.76	
		EER	5.09	5.11	5.09	5.11	5.14	5.09	5.11	5.14	
20		Capacity	3.94	4.31	3.94	4.31	4.67	3.94	4.31	4.67	
		SHF	0.80	0.56	1.00	0.80	0.56	1.00	0.97	0.76	
		EER	5.86	5.83	5.86	5.83	5.79	5.86	5.83	5.79	
Minimum Frequency		46	Capacity	0.59	0.69	0.59	0.69	0.79	0.59	0.69	0.79
			EER	3.61	3.89	3.61	3.89	4.17	3.61	3.89	4.17
		40	Capacity	0.65	0.74	0.65	0.74	0.84	0.65	0.74	0.84
			EER	4.19	4.41	4.19	4.41	4.62	4.19	4.41	4.62
		35	Capacity	0.71	0.80	0.71	0.80	0.90	0.71	0.80	0.90
			EER	4.86	5.02	4.86	5.02	5.18	4.86	5.02	5.18
	30	Capacity	0.76	0.86	0.76	0.86	0.95	0.76	0.86	0.95	
		EER	5.60	5.72	5.60	5.72	5.84	5.60	5.72	5.84	
	25	Capacity	0.83	0.92	0.83	0.92	1.01	0.83	0.92	1.01	
		EER	6.61	6.65	6.61	6.65	6.68	6.61	6.65	6.68	
	20	Capacity	0.90	0.98	0.90	0.98	1.07	0.90	0.98	1.07	
		EER	7.62	7.58	7.62	7.58	7.53	7.62	7.58	7.53	

Cooling performance data (Low ambient Condition)

	Ambient temperature (°C)	INDOOR (°C)								
		DB	21		27			32		
		WB	15	19	15	19	23	15	19	23
Max Frequency	15 -10	Capacity	3.12	3.52	3.12	3.52	3.92	3.12	3.52	3.92
		SHF	0.80	0.56	1.00	0.80	0.56	1.00	0.97	0.76
		EER	3.74	3.87	3.74	3.87	3.99	3.74	3.87	3.99

* The low ambient condition requires a special control and all the performance is equal to or less than the rated operation.

Cooling performance data

MSZ-FT50VG, MSZ-FT50VGK: MUZ-FT50VGHZ

	Ambient temperature (°C)	INDOOR (°C)									
		DB	21		27			32			
		WB	15	19	15	19	23	15	19	23	
Max frequency	46	Capacity	3.82	4.47	3.82	4.47	5.12	3.82	4.47	5.12	
		SHF	0.68	0.44	0.92	0.68	0.44	1.00	0.88	0.64	
		EER	2.06	2.22	2.06	2.22	2.38	2.06	2.22	2.38	
	40	Capacity	4.21	4.84	4.21	4.84	5.46	4.21	4.84	5.46	
		SHF	0.68	0.44	0.92	0.68	0.44	1.00	0.88	0.64	
		EER	2.39	2.52	2.39	2.52	2.64	2.39	2.52	2.64	
	35	Capacity	4.63	5.23	4.63	5.23	5.82	4.63	5.23	5.82	
		SHF	0.68	0.44	0.92	0.68	0.44	1.00	0.88	0.64	
		EER	2.78	2.87	2.78	2.87	2.96	2.78	2.87	2.96	
	30	Capacity	4.97	5.56	4.97	5.56	6.16	4.97	5.56	6.16	
		SHF	0.68	0.44	0.92	0.68	0.44	1.00	0.88	0.64	
		EER	3.20	3.27	3.20	3.27	3.34	3.20	3.27	3.34	
	25	Capacity	5.41	5.98	5.41	5.98	6.55	5.41	5.98	6.55	
		SHF	0.68	0.44	0.92	0.68	0.44	1.00	0.88	0.64	
		EER	3.78	3.80	3.78	3.80	3.82	3.78	3.80	3.82	
	20	Capacity	5.85	6.40	5.85	6.40	6.94	5.85	6.40	6.94	
		SHF	0.68	0.44	0.92	0.68	0.44	1.00	0.88	0.64	
		EER	4.36	4.33	4.36	4.33	4.30	4.36	4.33	4.30	
	Rated frequency	46	Capacity	3.68	4.30	3.68	4.30	4.93	3.68	4.30	4.93
			SHF	0.69	0.45	0.93	0.69	0.45	1.00	0.89	0.65
			EER	2.21	2.39	2.21	2.39	2.56	2.21	2.39	2.56
		40	Capacity	4.05	4.65	4.05	4.65	5.25	4.05	4.65	5.25
			SHF	0.69	0.45	0.93	0.69	0.45	1.00	0.89	0.65
			EER	2.57	2.70	2.57	2.70	2.84	2.57	2.70	2.84
35		Capacity	4.45	5.03	4.45	5.03	5.60	4.45	5.03	5.60	
		SHF	0.69	0.45	0.93	0.69	0.45	1.00	0.89	0.65	
		EER	2.98	3.08	2.98	3.08	3.18	2.98	3.08	3.18	
30		Capacity	4.78	5.35	4.78	5.35	5.93	4.78	5.35	5.93	
		SHF	0.69	0.45	0.93	0.69	0.45	1.00	0.89	0.65	
		EER	3.44	3.51	3.44	3.51	3.58	3.44	3.51	3.58	
25		Capacity	5.20	5.75	5.20	5.75	6.30	5.20	5.75	6.30	
		SHF	0.69	0.45	0.93	0.69	0.45	1.00	0.89	0.65	
		EER	4.06	4.08	4.06	4.08	4.10	4.06	4.08	4.10	
20		Capacity	5.63	6.15	5.63	6.15	6.68	5.63	6.15	6.68	
		SHF	0.69	0.45	0.93	0.69	0.45	1.00	0.89	0.65	
		EER	4.68	4.65	4.68	4.65	4.62	4.68	4.65	4.62	
Minimum Frequency		46	Capacity	0.59	0.69	0.59	0.69	0.79	0.59	0.69	0.79
			EER	3.61	3.89	3.61	3.89	4.17	3.61	3.89	4.17
		40	Capacity	0.65	0.74	0.65	0.74	0.84	0.65	0.74	0.84
			EER	4.19	4.41	4.19	4.41	4.62	4.19	4.41	4.62
		35	Capacity	0.71	0.80	0.71	0.80	0.90	0.71	0.80	0.90
			EER	4.86	5.02	4.86	5.02	5.18	4.86	5.02	5.18
	30	Capacity	0.76	0.86	0.76	0.86	0.95	0.76	0.86	0.95	
		EER	5.60	5.72	5.60	5.72	5.84	5.60	5.72	5.84	
	25	Capacity	0.83	0.92	0.83	0.92	1.01	0.83	0.92	1.01	
		EER	6.61	6.65	6.61	6.65	6.68	6.61	6.65	6.68	
	20	Capacity	0.90	0.98	0.90	0.98	1.07	0.90	0.98	1.07	
		EER	7.62	7.58	7.62	7.58	7.53	7.62	7.58	7.53	

Cooling performance data (Low ambient Condition)

	Ambient temperature (°C)	INDOOR (°C)								
		DB	21		27			32		
		WB	15	19	15	19	23	15	19	23
Max Frequency	15 -10	Capacity	4.45	5.03	4.45	5.03	5.60	4.45	5.03	5.60
		SHF	0.69	0.45	0.93	0.69	0.45	1.00	0.89	0.65
		EER	2.98	3.08	2.98	3.08	3.18	2.98	3.08	3.18

* The low ambient condition requires a special control and all the performance is equal to or less than the rated operation.

Cooling performance data

MSZ-AY25VGK, MSZ-AY25VGKP: MUZ-AY25VG

	Ambient temperature (°C)	INDOOR (°C)									
		DB	21		27			32			
		WB	15	19	15	19	23	15	19	23	
Max frequency	46	Capacity	2.50	2.92	2.50	2.92	3.35	2.50	2.92	3.35	
		SHF	0.74	0.50	0.98	0.74	0.50	1.00	0.94	0.70	
		EER	2.12	2.28	2.12	2.28	2.45	2.12	2.28	2.45	
	40	Capacity	2.75	3.16	2.75	3.16	3.57	2.75	3.16	3.57	
		SHF	0.74	0.50	0.98	0.74	0.50	1.00	0.94	0.70	
		EER	2.46	2.58	2.46	2.58	2.71	2.46	2.58	2.71	
	35	Capacity	3.03	3.42	3.03	3.42	3.81	3.03	3.42	3.81	
		SHF	0.74	0.50	0.98	0.74	0.50	1.00	0.94	0.70	
		EER	2.85	2.95	2.85	2.95	3.04	2.85	2.95	3.04	
	30	Capacity	3.25	3.64	3.25	3.64	4.03	3.25	3.64	4.03	
		SHF	0.74	0.50	0.98	0.74	0.50	1.00	0.94	0.70	
		EER	3.29	3.35	3.29	3.35	3.42	3.29	3.35	3.42	
	25	Capacity	3.54	3.91	3.54	3.91	4.28	3.54	3.91	4.28	
		SHF	0.74	0.50	0.98	0.74	0.50	1.00	0.94	0.70	
		EER	3.88	3.90	3.88	3.90	3.92	3.88	3.90	3.92	
	20	Capacity	3.83	4.18	3.83	4.18	4.54	3.83	4.18	4.54	
		SHF	0.74	0.50	0.98	0.74	0.50	1.00	0.94	0.70	
		EER	4.47	4.44	4.47	4.44	4.41	4.47	4.44	4.41	
	Rated frequency	46	Capacity	1.84	2.15	1.84	2.15	2.46	1.84	2.15	2.46
			SHF	0.92	0.68	1.00	0.92	0.68	1.00	1.00	0.88
			EER	3.01	3.24	3.01	3.24	3.48	3.01	3.24	3.48
		40	Capacity	2.03	2.33	2.03	2.33	2.63	2.03	2.33	2.63
			SHF	0.92	0.68	1.00	0.92	0.68	1.00	1.00	0.88
			EER	3.49	3.67	3.49	3.67	3.85	3.49	3.67	3.85
35		Capacity	2.23	2.51	2.23	2.51	2.80	2.23	2.51	2.80	
		SHF	0.92	0.68	1.00	0.92	0.68	1.00	1.00	0.88	
		EER	4.05	4.19	4.05	4.19	4.32	4.05	4.19	4.32	
30		Capacity	2.39	2.68	2.39	2.68	2.96	2.39	2.68	2.96	
		SHF	0.92	0.68	1.00	0.92	0.68	1.00	1.00	0.88	
		EER	4.67	4.77	4.67	4.77	4.86	4.67	4.77	4.86	
25		Capacity	2.60	2.88	2.60	2.88	3.15	2.60	2.88	3.15	
		SHF	0.92	0.68	1.00	0.92	0.68	1.00	1.00	0.88	
		EER	5.51	5.54	5.51	5.54	5.57	5.51	5.54	5.57	
20		Capacity	2.81	3.08	2.81	3.08	3.34	2.81	3.08	3.34	
		SHF	0.92	0.68	1.00	0.92	0.68	1.00	1.00	0.88	
		EER	6.35	6.31	6.35	6.31	6.28	6.35	6.31	6.28	
Minimum Frequency		46	Capacity	0.66	0.77	0.66	0.77	0.89	0.66	0.77	0.89
			EER	2.82	3.04	2.82	3.04	3.27	2.82	3.04	3.27
		40	Capacity	0.73	0.84	0.73	0.84	0.95	0.73	0.84	0.95
			EER	3.28	3.45	3.28	3.45	3.62	3.28	3.45	3.62
		35	Capacity	0.80	0.90	0.80	0.90	1.01	0.80	0.90	1.01
			EER	3.81	3.93	3.81	3.93	4.06	3.81	3.93	4.06
	30	Capacity	0.86	0.96	0.86	0.96	1.07	0.86	0.96	1.07	
		EER	4.39	4.48	4.39	4.48	4.57	4.39	4.48	4.57	
	25	Capacity	0.94	1.04	0.94	1.04	1.13	0.94	1.04	1.13	
		EER	5.18	5.20	5.18	5.20	5.23	5.18	5.20	5.23	
	20	Capacity	1.01	1.11	1.01	1.11	1.20	1.01	1.11	1.20	
		EER	5.97	5.93	5.97	5.93	5.89	5.97	5.93	5.89	

Cooling performance data (Low ambient Condition)

	Ambient temperature (°C)	INDOOR (°C)								
		DB	21		27			32		
		WB	15	19	15	19	23	15	19	23
Max Frequency	15 -10	Capacity	2.23	2.51	2.23	2.51	2.80	2.23	2.51	2.80
		SHF	0.92	0.68	1.00	0.92	0.68	1.00	1.00	0.88
		EER	4.05	4.19	4.05	4.19	4.32	4.05	4.19	4.32

* The low ambient condition requires a special control and all the performance is equal to or less than the rated operation.

Cooling performance data

MSZ-AY35VGK, MSZ-AY35VGKP: MUZ-AY35VG

	Ambient temperature (°C)	INDOOR (°C)									
		DB	21		27			32			
		WB	15	19	15	19	23	15	19	23	
Max frequency	46	Capacity	2.77	3.11	2.77	3.11	3.45	2.77	3.11	3.45	
		SHF	0.71	0.47	0.95	0.71	0.47	1.00	0.91	0.67	
		EER	1.74	1.87	1.74	1.87	2.01	1.74	1.87	2.01	
	40	Capacity	3.31	3.50	3.31	3.50	3.70	3.31	3.50	3.70	
		SHF	0.71	0.47	0.95	0.71	0.47	1.00	0.91	0.67	
		EER	2.01	2.12	2.01	2.12	2.22	2.01	2.12	2.22	
	35	Capacity	3.49	3.82	3.49	3.82	4.15	3.49	3.82	4.15	
		SHF	0.71	0.47	0.95	0.71	0.47	1.00	0.91	0.67	
		EER	2.34	2.42	2.34	2.42	2.49	2.34	2.42	2.49	
	30	Capacity	3.63	4.07	3.63	4.07	4.50	3.63	4.07	4.50	
		SHF	0.71	0.47	0.95	0.71	0.47	1.00	0.91	0.67	
		EER	2.70	2.75	2.70	2.75	2.81	2.70	2.75	2.81	
	25	Capacity	3.95	4.37	3.95	4.37	4.79	3.95	4.37	4.79	
		SHF	0.71	0.47	0.95	0.71	0.47	1.00	0.91	0.67	
		EER	3.18	3.20	3.18	3.20	3.21	3.18	3.20	3.21	
	20	Capacity	4.28	4.67	4.28	4.67	5.07	4.28	4.67	5.07	
		SHF	0.71	0.47	0.95	0.71	0.47	1.00	0.91	0.67	
		EER	3.67	3.64	3.67	3.64	3.62	3.67	3.64	3.62	
	Rated frequency	46	Capacity	2.57	3.01	2.57	3.01	3.45	2.57	3.01	3.45
			SHF	0.88	0.64	1.00	0.88	0.64	1.00	1.00	0.84
			EER	2.55	2.75	2.55	2.75	2.95	2.55	2.75	2.95
		40	Capacity	2.84	3.26	2.84	3.26	3.68	2.84	3.26	3.68
			SHF	0.88	0.64	1.00	0.88	0.64	1.00	1.00	0.84
			EER	2.96	3.12	2.96	3.12	3.27	2.96	3.12	3.27
35		Capacity	3.12	3.52	3.12	3.52	3.92	3.12	3.52	3.92	
		SHF	0.88	0.64	1.00	0.88	0.64	1.00	1.00	0.84	
		EER	3.44	3.55	3.44	3.55	3.67	3.44	3.55	3.67	
30		Capacity	3.34	3.75	3.34	3.75	4.15	3.34	3.75	4.15	
		SHF	0.88	0.64	1.00	0.88	0.64	1.00	1.00	0.84	
		EER	3.96	4.05	3.96	4.05	4.13	3.96	4.05	4.13	
25		Capacity	3.64	4.03	3.64	4.03	4.41	3.64	4.03	4.41	
		SHF	0.88	0.64	1.00	0.88	0.64	1.00	1.00	0.84	
		EER	4.68	4.70	4.68	4.70	4.73	4.68	4.70	4.73	
20		Capacity	3.94	4.31	3.94	4.31	4.67	3.94	4.31	4.67	
		SHF	0.88	0.64	1.00	0.88	0.64	1.00	1.00	0.84	
		EER	5.39	5.36	5.39	5.36	5.32	5.39	5.36	5.32	
Minimum Frequency		46	Capacity	0.81	0.95	0.81	0.95	1.08	0.81	0.95	1.08
			EER	3.78	4.08	3.78	4.08	4.37	3.78	4.08	4.37
		40	Capacity	0.89	1.02	0.89	1.02	1.16	0.89	1.02	1.16
			EER	4.39	4.62	4.39	4.62	4.84	4.39	4.62	4.84
		35	Capacity	0.98	1.11	0.98	1.11	1.23	0.98	1.11	1.23
			EER	5.10	5.26	5.10	5.26	5.43	5.10	5.26	5.43
	30	Capacity	1.05	1.18	1.05	1.18	1.30	1.05	1.18	1.30	
		EER	5.87	5.99	5.87	5.99	6.11	5.87	5.99	6.11	
	25	Capacity	1.14	1.27	1.14	1.27	1.39	1.14	1.27	1.39	
		EER	6.93	6.97	6.93	6.97	7.00	6.93	6.97	7.00	
	20	Capacity	1.24	1.35	1.24	1.35	1.47	1.24	1.35	1.47	
		EER	7.99	7.94	7.99	7.94	7.89	7.99	7.94	7.89	

Cooling performance data (Low ambient Condition)

	Ambient temperature (°C)	INDOOR (°C)								
		DB	21		27			32		
		WB	15	19	15	19	23	15	19	23
Max Frequency	15 -10	Capacity	3.12	3.52	3.12	3.52	3.92	3.12	3.52	3.92
		SHF	0.88	0.64	1.00	0.88	0.64	1.00	1.00	0.84
		EER	3.44	3.55	3.44	3.55	3.67	3.44	3.55	3.67

* The low ambient condition requires a special control and all the performance is equal to or less than the rated operation.

Cooling performance data

MSZ-AY42VGK, MSZ-AY42VGKP: MUZ-AY42VG

	Ambient temperature (°C)	INDOOR (°C)									
		DB	21		27			32			
		WB	15	19	15	19	23	15	19	23	
Max frequency	46	Capacity	3.50	3.82	3.50	3.82	4.14	3.50	3.82	4.14	
		SHF	0.69	0.45	0.93	0.69	0.45	1.00	0.89	0.65	
		EER	1.67	1.80	1.67	1.80	1.94	1.67	1.80	1.94	
	40	Capacity	3.78	4.19	3.78	4.19	4.59	3.78	4.19	4.59	
		SHF	0.69	0.45	0.93	0.69	0.45	1.00	0.89	0.65	
		EER	1.94	2.04	1.94	2.04	2.15	1.94	2.04	2.15	
	35	Capacity	4.01	4.52	4.01	4.52	5.04	4.01	4.52	5.04	
		SHF	0.69	0.45	0.93	0.69	0.45	1.00	0.89	0.65	
		EER	2.26	2.33	2.26	2.33	2.41	2.26	2.33	2.41	
	30	Capacity	4.30	4.82	4.30	4.82	5.33	4.30	4.82	5.33	
		SHF	0.69	0.45	0.93	0.69	0.45	1.00	0.89	0.65	
		EER	2.60	2.65	2.60	2.65	2.71	2.60	2.65	2.71	
	25	Capacity	4.68	5.18	4.68	5.18	5.67	4.68	5.18	5.67	
		SHF	0.69	0.45	0.93	0.69	0.45	1.00	0.89	0.65	
		EER	3.07	3.08	3.07	3.08	3.10	3.07	3.08	3.10	
	20	Capacity	5.06	5.54	5.06	5.54	6.01	5.06	5.54	6.01	
		SHF	0.69	0.45	0.93	0.69	0.45	1.00	0.89	0.65	
		EER	3.54	3.51	3.54	3.51	3.49	3.54	3.51	3.49	
	Rated frequency	46	Capacity	3.09	3.61	3.09	3.61	4.14	3.09	3.61	4.14
			SHF	0.77	0.53	1.00	0.77	0.53	1.00	0.96	0.73
			EER	2.33	2.51	2.33	2.51	2.70	2.33	2.51	2.70
		40	Capacity	3.40	3.91	3.40	3.91	4.41	3.40	3.91	4.41
			SHF	0.77	0.53	1.00	0.77	0.53	1.00	0.96	0.73
			EER	2.71	2.85	2.71	2.85	2.99	2.71	2.85	2.99
35		Capacity	3.74	4.22	3.74	4.22	4.70	3.74	4.22	4.70	
		SHF	0.77	0.53	1.00	0.77	0.53	1.00	0.96	0.73	
		EER	3.14	3.25	3.14	3.25	3.35	3.14	3.25	3.35	
30		Capacity	4.01	4.49	4.01	4.49	4.98	4.01	4.49	4.98	
		SHF	0.77	0.53	1.00	0.77	0.53	1.00	0.96	0.73	
		EER	3.62	3.70	3.62	3.70	3.77	3.62	3.70	3.77	
25		Capacity	4.37	4.83	4.37	4.83	5.29	4.37	4.83	5.29	
		SHF	0.77	0.53	1.00	0.77	0.53	1.00	0.96	0.73	
		EER	4.27	4.30	4.27	4.30	4.32	4.27	4.30	4.32	
20		Capacity	4.73	5.17	4.73	5.17	5.61	4.73	5.17	5.61	
		SHF	0.77	0.53	1.00	0.77	0.53	1.00	0.96	0.73	
		EER	4.93	4.90	4.93	4.90	4.87	4.93	4.90	4.87	
Minimum Frequency		46	Capacity	0.66	0.77	0.66	0.77	0.89	0.66	0.77	0.89
			EER	4.33	4.67	4.33	4.67	5.01	4.33	4.67	5.01
		40	Capacity	0.73	0.84	0.73	0.84	0.95	0.73	0.84	0.95
			EER	5.03	5.29	5.03	5.29	5.55	5.03	5.29	5.55
		35	Capacity	0.80	0.90	0.80	0.90	1.01	0.80	0.90	1.01
			EER	5.84	6.03	5.84	6.03	6.22	5.84	6.03	6.22
	30	Capacity	0.86	0.96	0.86	0.96	1.07	0.86	0.96	1.07	
		EER	6.73	6.86	6.73	6.86	7.00	6.73	6.86	7.00	
	25	Capacity	0.94	1.04	0.94	1.04	1.13	0.94	1.04	1.13	
		EER	7.94	7.98	7.94	7.98	8.02	7.94	7.98	8.02	
	20	Capacity	1.01	1.11	1.01	1.11	1.20	1.01	1.11	1.20	
		EER	9.15	9.09	9.15	9.09	9.04	9.15	9.09	9.04	

Cooling performance data (Low ambient Condition)

	Ambient temperature (°C)	INDOOR (°C)								
		DB	21		27			32		
		WB	15	19	15	19	23	15	19	23
Max Frequency	15 -10	Capacity	3.74	4.22	3.74	4.22	4.70	3.74	4.22	4.70
		SHF	0.77	0.53	1.00	0.77	0.53	1.00	0.96	0.73
		EER	3.14	3.25	3.14	3.25	3.35	3.14	3.25	3.35

* The low ambient condition requires a special control and all the performance is equal to or less than the rated operation.

Cooling performance data

MSZ-AY50VGK, MSZ-AY50VGKP: MUZ-AY50VG

	Ambient temperature (°C)	INDOOR (°C)									
		DB	21		27			32			
		WB	15	19	15	19	23	15	19	23	
Max frequency	46	Capacity	3.97	4.64	3.97	4.64	5.32	3.97	4.64	5.32	
		SHF	0.69	0.45	0.93	0.69	0.45	1.00	0.89	0.65	
		EER	2.00	2.15	2.00	2.15	2.31	2.00	2.15	2.31	
	40	Capacity	4.37	5.02	4.37	5.02	5.67	4.37	5.02	5.67	
		SHF	0.69	0.45	0.93	0.69	0.45	1.00	0.89	0.65	
		EER	2.32	2.44	2.32	2.44	2.56	2.32	2.44	2.56	
	35	Capacity	4.81	5.43	4.81	5.43	6.05	4.81	5.43	6.05	
		SHF	0.69	0.45	0.93	0.69	0.45	1.00	0.89	0.65	
		EER	2.69	2.78	2.69	2.78	2.87	2.69	2.78	2.87	
	30	Capacity	5.16	5.78	5.16	5.78	6.40	5.16	5.78	6.40	
		SHF	0.69	0.45	0.93	0.69	0.45	1.00	0.89	0.65	
		EER	3.10	3.17	3.10	3.17	3.23	3.10	3.17	3.23	
	25	Capacity	5.62	6.21	5.62	6.21	6.80	5.62	6.21	6.80	
		SHF	0.69	0.45	0.93	0.69	0.45	1.00	0.89	0.65	
		EER	3.66	3.68	3.66	3.68	3.70	3.66	3.68	3.70	
	20	Capacity	6.08	6.64	6.08	6.64	7.21	6.08	6.64	7.21	
		SHF	0.69	0.45	0.93	0.69	0.45	1.00	0.89	0.65	
		EER	4.22	4.20	4.22	4.20	4.17	4.22	4.20	4.17	
	Rated frequency	46	Capacity	3.68	4.30	3.68	4.30	4.93	3.68	4.30	4.93
			SHF	0.74	0.50	0.98	0.74	0.50	1.00	0.94	0.70
			EER	2.34	2.53	2.34	2.53	2.71	2.34	2.53	2.71
		40	Capacity	4.05	4.65	4.05	4.65	5.25	4.05	4.65	5.25
			SHF	0.74	0.50	0.98	0.74	0.50	1.00	0.94	0.70
			EER	2.72	2.86	2.72	2.86	3.00	2.72	2.86	3.00
35		Capacity	4.45	5.03	4.45	5.03	5.60	4.45	5.03	5.60	
		SHF	0.74	0.50	0.98	0.74	0.50	1.00	0.94	0.70	
		EER	3.16	3.26	3.16	3.26	3.37	3.16	3.26	3.37	
30		Capacity	4.78	5.35	4.78	5.35	5.93	4.78	5.35	5.93	
		SHF	0.74	0.50	0.98	0.74	0.50	1.00	0.94	0.70	
		EER	3.64	3.71	3.64	3.71	3.79	3.64	3.71	3.79	
25		Capacity	5.20	5.75	5.20	5.75	6.30	5.20	5.75	6.30	
		SHF	0.74	0.50	0.98	0.74	0.50	1.00	0.94	0.70	
		EER	4.29	4.32	4.29	4.32	4.34	4.29	4.32	4.34	
20		Capacity	5.63	6.15	5.63	6.15	6.68	5.63	6.15	6.68	
		SHF	0.74	0.50	0.98	0.74	0.50	1.00	0.94	0.70	
		EER	4.95	4.92	4.95	4.92	4.89	4.95	4.92	4.89	
Minimum Frequency		46	Capacity	1.03	1.20	1.03	1.20	1.38	1.03	1.20	1.38
			EER	3.37	3.63	3.37	3.63	3.89	3.37	3.63	3.89
		40	Capacity	1.13	1.30	1.13	1.30	1.47	1.13	1.30	1.47
			EER	3.91	4.11	3.91	4.11	4.32	3.91	4.11	4.32
		35	Capacity	1.25	1.41	1.25	1.41	1.57	1.25	1.41	1.57
			EER	4.54	4.69	4.54	4.69	4.84	4.54	4.69	4.84
	30	Capacity	1.34	1.50	1.34	1.50	1.66	1.34	1.50	1.66	
		EER	5.23	5.34	5.23	5.34	5.45	5.23	5.34	5.45	
	25	Capacity	1.46	1.61	1.46	1.61	1.76	1.46	1.61	1.76	
		EER	6.17	6.21	6.17	6.21	6.24	6.17	6.21	6.24	
	20	Capacity	1.58	1.72	1.58	1.72	1.87	1.58	1.72	1.87	
		EER	7.11	7.07	7.11	7.07	7.03	7.11	7.07	7.03	

Cooling performance data (Low ambient Condition)

	Ambient temperature (°C)	INDOOR (°C)								
		DB	21		27			32		
		WB	15	19	15	19	23	15	19	23
Max Frequency	15 -10	Capacity	4.45	5.03	4.45	5.03	5.60	4.45	5.03	5.60
		SHF	0.74	0.50	0.98	0.74	0.50	1.00	0.94	0.70
		EER	3.16	3.26	3.16	3.26	3.37	3.16	3.26	3.37

* The low ambient condition requires a special control and all the performance is equal to or less than the rated operation.

Cooling performance data
MSZ-AP15VG, MSZ-AP15VGK: MUZ-AP15VG

	Ambient temperature (°C)	INDOOR (°C)									
		DB	21		27			32			
		WB	15	19	15	19	23	15	19	23	
Max frequency	46	Capacity	1.47	1.72	1.47	1.72	1.97	1.47	1.72	1.97	
		SHF	0.69	0.45	0.93	0.69	0.45	1.00	0.89	0.65	
		EER	1.60	1.73	1.60	1.73	1.85	1.60	1.73	1.85	
	40	Capacity	1.62	1.86	1.62	1.86	2.10	1.62	1.86	2.10	
		SHF	0.69	0.45	0.93	0.69	0.45	1.00	0.89	0.65	
		EER	1.86	1.96	1.86	1.96	2.06	1.86	1.96	2.06	
	35	Capacity	1.78	2.01	1.78	2.01	2.24	1.78	2.01	2.24	
		SHF	0.69	0.45	0.93	0.69	0.45	1.00	0.89	0.65	
		EER	2.16	2.23	2.16	2.23	2.30	2.16	2.23	2.30	
	30	Capacity	1.91	2.14	1.91	2.14	2.37	1.91	2.14	2.37	
		SHF	0.69	0.45	0.93	0.69	0.45	1.00	0.89	0.65	
		EER	2.49	2.54	2.49	2.54	2.59	2.49	2.54	2.59	
	25	Capacity	2.08	2.30	2.08	2.30	2.52	2.08	2.30	2.52	
		SHF	0.69	0.45	0.93	0.69	0.45	1.00	0.89	0.65	
		EER	2.94	2.96	2.94	2.96	2.97	2.94	2.96	2.97	
	20	Capacity	2.25	2.46	2.25	2.46	2.67	2.25	2.46	2.67	
		SHF	0.69	0.45	0.93	0.69	0.45	1.00	0.89	0.65	
		EER	3.39	3.37	3.39	3.37	3.35	3.39	3.37	3.35	
	Rated frequency	46	Capacity	1.10	1.29	1.10	1.29	1.48	1.10	1.29	1.48
			SHF	0.86	0.62	1.00	0.86	0.62	1.00	1.00	0.82
			EER	2.93	3.15	2.93	3.15	3.38	2.93	3.15	3.38
		40	Capacity	1.22	1.40	1.22	1.40	1.58	1.22	1.40	1.58
			SHF	0.86	0.62	1.00	0.86	0.62	1.00	1.00	0.82
			EER	3.40	3.57	3.40	3.57	3.75	3.40	3.57	3.75
35		Capacity	1.34	1.51	1.34	1.51	1.68	1.34	1.51	1.68	
		SHF	0.86	0.62	1.00	0.86	0.62	1.00	1.00	0.82	
		EER	3.94	4.07	3.94	4.07	4.20	3.94	4.07	4.20	
30		Capacity	1.43	1.61	1.43	1.61	1.78	1.43	1.61	1.78	
		SHF	0.86	0.62	1.00	0.86	0.62	1.00	1.00	0.82	
		EER	4.54	4.64	4.54	4.64	4.73	4.54	4.64	4.73	
25		Capacity	1.56	1.73	1.56	1.73	1.89	1.56	1.73	1.89	
		SHF	0.86	0.62	1.00	0.86	0.62	1.00	1.00	0.82	
		EER	5.36	5.39	5.36	5.39	5.42	5.36	5.39	5.42	
20		Capacity	1.69	1.85	1.69	1.85	2.00	1.69	1.85	2.00	
		SHF	0.86	0.62	1.00	0.86	0.62	1.00	1.00	0.82	
		EER	6.18	6.14	6.18	6.14	6.11	6.18	6.14	6.11	
Minimum Frequency		46	Capacity	0.44	0.52	0.44	0.52	0.59	0.44	0.52	0.59
			EER	4.33	4.67	4.33	4.67	5.01	4.33	4.67	5.01
		40	Capacity	0.49	0.56	0.49	0.56	0.63	0.49	0.56	0.63
			EER	5.03	5.29	5.03	5.29	5.55	5.03	5.29	5.55
		35	Capacity	0.53	0.60	0.53	0.60	0.67	0.53	0.60	0.67
			EER	5.84	6.03	5.84	6.03	6.22	5.84	6.03	6.22
	30	Capacity	0.57	0.64	0.57	0.64	0.71	0.57	0.64	0.71	
		EER	6.73	6.86	6.73	6.86	7.00	6.73	6.86	7.00	
	25	Capacity	0.62	0.69	0.62	0.69	0.76	0.62	0.69	0.76	
		EER	7.94	7.98	7.94	7.98	8.02	7.94	7.98	8.02	
	20	Capacity	0.68	0.74	0.68	0.74	0.80	0.68	0.74	0.80	
		EER	9.15	9.09	9.15	9.09	9.04	9.15	9.09	9.04	

PERFORMANCE DATA

WALL-MOUNTED

Cooling performance data (Low ambient Condition)

	Ambient temperature (°C)	INDOOR (°C)								
		DB	21		27			32		
		WB	15	19	15	19	23	15	19	23
Max Frequency	15 -10	Capacity	1.34	1.51	1.34	1.51	1.68	1.34	1.51	1.68
		SHF	0.86	0.62	1.00	0.86	0.62	1.00	1.00	0.82
		EER	3.94	4.07	3.94	4.07	4.20	3.94	4.07	4.20

* The low ambient condition requires a special control and all the performance is equal to or less than the rated operation.

Cooling performance data
MSZ-AP20VG, MSZ-AP20VGK: MUZ-AP20VG

	Ambient temperature (°C)	INDOOR (°C)									
		DB	21		27			32			
		WB	15	19	15	19	23	15	19	23	
Max frequency	46	Capacity	1.98	2.32	1.98	2.32	2.66	1.98	2.32	2.66	
		SHF	0.70	0.46	0.94	0.70	0.46	1.00	0.90	0.66	
		EER	2.60	2.80	2.60	2.80	3.00	2.60	2.80	3.00	
	40	Capacity	2.19	2.51	2.19	2.51	2.84	2.19	2.51	2.84	
		SHF	0.70	0.46	0.94	0.70	0.46	1.00	0.90	0.66	
		EER	3.02	3.17	3.02	3.17	3.33	3.02	3.17	3.33	
	35	Capacity	2.40	2.71	2.40	2.71	3.02	2.40	2.71	3.02	
		SHF	0.70	0.46	0.94	0.70	0.46	1.00	0.90	0.66	
		EER	3.50	3.62	3.50	3.62	3.73	3.50	3.62	3.73	
	30	Capacity	2.58	2.89	2.58	2.89	3.20	2.58	2.89	3.20	
		SHF	0.70	0.46	0.94	0.70	0.46	1.00	0.90	0.66	
		EER	4.04	4.12	4.04	4.12	4.20	4.04	4.12	4.20	
	25	Capacity	2.81	3.11	2.81	3.11	3.40	2.81	3.11	3.40	
		SHF	0.70	0.46	0.94	0.70	0.46	1.00	0.90	0.66	
		EER	4.76	4.79	4.76	4.79	4.81	4.76	4.79	4.81	
	20	Capacity	3.04	3.32	3.04	3.32	3.60	3.04	3.32	3.60	
		SHF	0.70	0.46	0.94	0.70	0.46	1.00	0.90	0.66	
		EER	5.49	5.46	5.49	5.46	5.42	5.49	5.46	5.42	
	Rated frequency	46	Capacity	1.47	1.72	1.47	1.72	1.97	1.47	1.72	1.97
			SHF	0.80	0.56	1.00	0.80	0.56	1.00	0.97	0.76
			EER	3.14	3.38	3.14	3.38	3.63	3.14	3.38	3.63
		40	Capacity	1.62	1.86	1.62	1.86	2.10	1.62	1.86	2.10
			SHF	0.80	0.56	1.00	0.80	0.56	1.00	0.97	0.76
			EER	3.64	3.83	3.64	3.83	4.02	3.64	3.83	4.02
35		Capacity	1.78	2.01	1.78	2.01	2.24	1.78	2.01	2.24	
		SHF	0.80	0.56	1.00	0.80	0.56	1.00	0.97	0.76	
		EER	4.23	4.37	4.23	4.37	4.51	4.23	4.37	4.51	
30		Capacity	1.91	2.14	1.91	2.14	2.37	1.91	2.14	2.37	
		SHF	0.80	0.56	1.00	0.80	0.56	1.00	0.97	0.76	
		EER	4.87	4.97	4.87	4.97	5.08	4.87	4.97	5.08	
25		Capacity	2.08	2.30	2.08	2.30	2.52	2.08	2.30	2.52	
		SHF	0.80	0.56	1.00	0.80	0.56	1.00	0.97	0.76	
		EER	5.75	5.78	5.75	5.78	5.81	5.75	5.78	5.81	
20		Capacity	2.25	2.46	2.25	2.46	2.67	2.25	2.46	2.67	
		SHF	0.80	0.56	1.00	0.80	0.56	1.00	0.97	0.76	
		EER	6.63	6.59	6.63	6.59	6.55	6.63	6.59	6.55	
Minimum Frequency		46	Capacity	0.44	0.52	0.44	0.52	0.59	0.44	0.52	0.59
			EER	3.61	3.89	3.61	3.89	4.17	3.61	3.89	4.17
		40	Capacity	0.49	0.56	0.49	0.56	0.63	0.49	0.56	0.63
			EER	4.19	4.41	4.19	4.41	4.62	4.19	4.41	4.62
		35	Capacity	0.53	0.60	0.53	0.60	0.67	0.53	0.60	0.67
			EER	4.86	5.02	4.86	5.02	5.18	4.86	5.02	5.18
	30	Capacity	0.57	0.64	0.57	0.64	0.71	0.57	0.64	0.71	
		EER	5.60	5.72	5.60	5.72	5.84	5.60	5.72	5.84	
	25	Capacity	0.62	0.69	0.62	0.69	0.76	0.62	0.69	0.76	
		EER	6.61	6.65	6.61	6.65	6.68	6.61	6.65	6.68	
	20	Capacity	0.68	0.74	0.68	0.74	0.80	0.68	0.74	0.80	
		EER	7.62	7.58	7.62	7.58	7.53	7.62	7.58	7.53	

WALL-MOUNTED PERFORMANCE DATA

Cooling performance data (Low ambient Condition)

	Ambient temperature (°C)	INDOOR (°C)								
		DB	21		27			32		
		WB	15	19	15	19	23	15	19	23
Max Frequency	15 -10	Capacity	1.78	2.01	1.78	2.01	2.24	1.78	2.01	2.24
		SHF	0.80	0.56	1.00	0.80	0.56	1.00	0.97	0.76
		EER	4.23	4.37	4.23	4.37	4.51	4.23	4.37	4.51

* The low ambient condition requires a special control and all the performance is equal to or less than the rated operation.

Cooling performance data
MSZ-AP60VG, MSZ-AP60VGK: MUZ-AP60VG

	Ambient temperature (°C)	INDOOR (°C)									
		DB	21		27			32			
		WB	15	19	15	19	23	15	19	23	
Max frequency	46	Capacity	5.37	6.28	5.37	6.28	7.19	5.37	6.28	7.19	
		SHF	0.77	0.53	1.00	0.77	0.53	1.00	0.96	0.73	
		EER	2.24	2.42	2.24	2.42	2.59	2.24	2.42	2.59	
	40	Capacity	5.91	6.79	5.91	6.79	7.67	5.91	6.79	7.67	
		SHF	0.77	0.53	1.00	0.77	0.53	1.00	0.96	0.73	
		EER	2.60	2.74	2.60	2.74	2.87	2.60	2.74	2.87	
	35	Capacity	6.50	7.34	6.50	7.34	8.18	6.50	7.34	8.18	
		SHF	0.77	0.53	1.00	0.77	0.53	1.00	0.96	0.73	
		EER	3.02	3.12	3.02	3.12	3.22	3.02	3.12	3.22	
	30	Capacity	6.97	7.81	6.97	7.81	8.65	6.97	7.81	8.65	
		SHF	0.77	0.53	1.00	0.77	0.53	1.00	0.96	0.73	
		EER	3.48	3.55	3.48	3.55	3.63	3.48	3.55	3.63	
	25	Capacity	7.59	8.40	7.59	8.40	9.20	7.59	8.40	9.20	
		SHF	0.77	0.53	1.00	0.77	0.53	1.00	0.96	0.73	
		EER	4.11	4.13	4.11	4.13	4.15	4.11	4.13	4.15	
	20	Capacity	8.21	8.98	8.21	8.98	9.75	8.21	8.98	9.75	
		SHF	0.77	0.53	1.00	0.77	0.53	1.00	0.96	0.73	
		EER	4.74	4.71	4.74	4.71	4.68	4.74	4.71	4.68	
	Rated frequency	46	Capacity	4.48	5.25	4.48	5.25	6.01	4.48	5.25	6.01
			SHF	0.83	0.59	1.00	0.83	0.59	1.00	0.99	0.79
			EER	2.77	2.99	2.77	2.99	3.20	2.77	2.99	3.20
		40	Capacity	4.94	5.67	4.94	5.67	6.41	4.94	5.67	6.41
			SHF	0.83	0.59	1.00	0.83	0.59	1.00	0.99	0.79
			EER	3.21	3.38	3.21	3.38	3.55	3.21	3.38	3.55
35		Capacity	5.43	6.13	5.43	6.13	6.83	5.43	6.13	6.83	
		SHF	0.83	0.59	1.00	0.83	0.59	1.00	0.99	0.79	
		EER	3.73	3.86	3.73	3.86	3.98	3.73	3.86	3.98	
30		Capacity	5.83	6.53	5.83	6.53	7.23	5.83	6.53	7.23	
		SHF	0.83	0.59	1.00	0.83	0.59	1.00	0.99	0.79	
		EER	4.30	4.39	4.30	4.39	4.48	4.30	4.39	4.48	
25		Capacity	6.34	7.02	6.34	7.02	7.69	6.34	7.02	7.69	
		SHF	0.83	0.59	1.00	0.83	0.59	1.00	0.99	0.79	
		EER	5.07	5.10	5.07	5.10	5.13	5.07	5.10	5.13	
20		Capacity	6.86	7.50	6.86	7.50	8.14	6.86	7.50	8.14	
		SHF	0.83	0.59	1.00	0.83	0.59	1.00	0.99	0.79	
		EER	5.85	5.81	5.85	5.81	5.78	5.85	5.81	5.78	
Minimum Frequency		46	Capacity	1.03	1.20	1.03	1.20	1.38	1.03	1.20	1.38
			EER	4.21	4.54	4.21	4.54	4.87	4.21	4.54	4.87
		40	Capacity	1.13	1.30	1.13	1.30	1.47	1.13	1.30	1.47
			EER	4.89	5.14	4.89	5.14	5.40	4.89	5.14	5.40
		35	Capacity	1.25	1.41	1.25	1.41	1.57	1.25	1.41	1.57
			EER	5.68	5.86	5.68	5.86	6.05	5.68	5.86	6.05
	30	Capacity	1.34	1.50	1.34	1.50	1.66	1.34	1.50	1.66	
		EER	6.54	6.67	6.54	6.67	6.81	6.54	6.67	6.81	
	25	Capacity	1.46	1.61	1.46	1.61	1.76	1.46	1.61	1.76	
		EER	7.72	7.76	7.72	7.76	7.80	7.72	7.76	7.80	
	20	Capacity	1.58	1.72	1.58	1.72	1.87	1.58	1.72	1.87	
		EER	8.89	8.84	8.89	8.84	8.79	8.89	8.84	8.79	

PERFORMANCE DATA

WALL-MOUNTED

Cooling performance data (Low ambient Condition)

	Ambient temperature (°C)	INDOOR (°C)								
		DB	21		27			32		
		WB	15	19	15	19	23	15	19	23
Max Frequency	15 -10	Capacity	5.43	6.13	5.43	6.13	6.83	5.43	6.13	6.83
		SHF	0.83	0.59	1.00	0.83	0.59	1.00	0.99	0.79
		EER	3.73	3.86	3.73	3.86	3.98	3.73	3.86	3.98

* The low ambient condition requires a special control and all the performance is equal to or less than the rated operation.

Cooling performance data

MSZ-AP71VG, MSZ-AP71VGK: MUZ-AP71VG

	Ambient temperature (°C)	INDOOR (°C)									
		DB	21		27			32			
		WB	15	19	15	19	23	15	19	23	
Max frequency	46	Capacity	6.39	7.48	6.39	7.48	8.57	6.39	7.48	8.57	
		SHF	0.67	0.43	0.91	0.67	0.43	1.00	0.87	0.63	
		EER	2.07	2.23	2.07	2.23	2.40	2.07	2.23	2.40	
	40	Capacity	7.05	8.09	7.05	8.09	9.14	7.05	8.09	9.14	
		SHF	0.67	0.43	0.91	0.67	0.43	1.00	0.87	0.63	
		EER	2.41	2.53	2.41	2.53	2.66	2.41	2.53	2.66	
	35	Capacity	7.74	8.74	7.74	8.74	9.74	7.74	8.74	9.74	
		SHF	0.67	0.43	0.91	0.67	0.43	1.00	0.87	0.63	
		EER	2.79	2.89	2.79	2.89	2.98	2.79	2.89	2.98	
	30	Capacity	8.31	9.31	8.31	9.31	10.31	8.31	9.31	10.31	
		SHF	0.67	0.43	0.91	0.67	0.43	1.00	0.87	0.63	
		EER	3.22	3.29	3.22	3.29	3.35	3.22	3.29	3.35	
	25	Capacity	9.05	10.01	9.05	10.01	10.96	9.05	10.01	10.96	
		SHF	0.67	0.43	0.91	0.67	0.43	1.00	0.87	0.63	
		EER	3.80	3.82	3.80	3.82	3.84	3.80	3.82	3.84	
	20	Capacity	9.79	10.70	9.79	10.70	11.61	9.79	10.70	11.61	
		SHF	0.67	0.43	0.91	0.67	0.43	1.00	0.87	0.63	
		EER	4.38	4.35	4.38	4.35	4.32	4.38	4.35	4.32	
	Rated frequency	46	Capacity	5.22	6.11	5.22	6.11	6.99	5.22	6.11	6.99
			SHF	0.77	0.53	1.00	0.77	0.53	1.00	0.96	0.73
			EER	2.55	2.75	2.55	2.75	2.95	2.55	2.75	2.95
		40	Capacity	5.75	6.60	5.75	6.60	7.46	5.75	6.60	7.46
			SHF	0.77	0.53	1.00	0.77	0.53	1.00	0.96	0.73
			EER	2.96	3.11	2.96	3.11	3.27	2.96	3.11	3.27
35		Capacity	6.32	7.14	6.32	7.14	7.95	6.32	7.14	7.95	
		SHF	0.77	0.53	1.00	0.77	0.53	1.00	0.96	0.73	
		EER	3.44	3.55	3.44	3.55	3.66	3.44	3.55	3.66	
30		Capacity	6.78	7.60	6.78	7.60	8.41	6.78	7.60	8.41	
		SHF	0.77	0.53	1.00	0.77	0.53	1.00	0.96	0.73	
		EER	3.96	4.04	3.96	4.04	4.12	3.96	4.04	4.12	
25		Capacity	7.38	8.17	7.38	8.17	8.95	7.38	8.17	8.95	
		SHF	0.77	0.53	1.00	0.77	0.53	1.00	0.96	0.73	
		EER	4.67	4.70	4.67	4.70	4.72	4.67	4.70	4.72	
20		Capacity	7.99	8.73	7.99	8.73	9.48	7.99	8.73	9.48	
		SHF	0.77	0.53	1.00	0.77	0.53	1.00	0.96	0.73	
		EER	5.39	5.35	5.39	5.35	5.32	5.39	5.35	5.32	
Minimum Frequency		46	Capacity	1.47	1.72	1.47	1.72	1.97	1.47	1.72	1.97
			EER	3.36	3.62	3.36	3.62	3.88	3.36	3.62	3.88
		40	Capacity	1.62	1.86	1.62	1.86	2.10	1.62	1.86	2.10
			EER	3.90	4.10	3.90	4.10	4.30	3.90	4.10	4.30
		35	Capacity	1.78	2.01	1.78	2.01	2.24	1.78	2.01	2.24
			EER	4.53	4.67	4.53	4.67	4.82	4.53	4.67	4.82
	30	Capacity	1.91	2.14	1.91	2.14	2.37	1.91	2.14	2.37	
		EER	5.21	5.32	5.21	5.32	5.43	5.21	5.32	5.43	
	25	Capacity	2.08	2.30	2.08	2.30	2.52	2.08	2.30	2.52	
		EER	6.15	6.18	6.15	6.18	6.22	6.15	6.18	6.22	
	20	Capacity	2.25	2.46	2.25	2.46	2.67	2.25	2.46	2.67	
		EER	7.09	7.05	7.09	7.05	7.01	7.09	7.05	7.01	

Cooling performance data (Low ambient Condition)

	Ambient temperature (°C)	INDOOR (°C)								
		DB	21		27			32		
		WB	15	19	15	19	23	15	19	23
Max Frequency	15 -10	Capacity	6.32	7.14	6.32	7.14	7.95	6.32	7.14	7.95
		SHF	0.77	0.53	1.00	0.77	0.53	1.00	0.96	0.73
		EER	3.44	3.55	3.44	3.55	3.66	3.44	3.55	3.66

* The low ambient condition requires a special control and all the performance is equal to or less than the rated operation.

Cooling performance data
MSZ-HR25VF, MSZ-HR25VFK: MUZ-HR25VF

	Ambient temperature (°C)	INDOOR (°C)									
		DB	21		27			32			
		WB	15	19	15	19	23	15	19	23	
Max frequency	46	Capacity	2.26	2.48	2.26	2.48	2.70	2.26	2.48	2.70	
		SHF	0.75	0.51	0.99	0.75	0.51	1.00	0.95	0.71	
		EER	2.05	2.21	2.05	2.21	2.37	2.05	2.21	2.37	
	40	Capacity	2.40	2.70	2.40	2.70	2.99	2.40	2.70	2.99	
		SHF	0.75	0.51	0.99	0.75	0.51	1.00	0.95	0.71	
		EER	2.38	2.51	2.38	2.51	2.63	2.38	2.51	2.63	
	35	Capacity	2.58	2.91	2.58	2.91	3.25	2.58	2.91	3.25	
		SHF	0.75	0.51	0.99	0.75	0.51	1.00	0.95	0.71	
		EER	2.77	2.86	2.77	2.86	2.95	2.77	2.86	2.95	
	30	Capacity	2.77	3.10	2.77	3.10	3.44	2.77	3.10	3.44	
		SHF	0.75	0.51	0.99	0.75	0.51	1.00	0.95	0.71	
		EER	3.19	3.25	3.19	3.25	3.32	3.19	3.25	3.32	
	25	Capacity	3.02	3.34	3.02	3.34	3.65	3.02	3.34	3.65	
		SHF	0.75	0.51	0.99	0.75	0.51	1.00	0.95	0.71	
		EER	3.76	3.78	3.76	3.78	3.80	3.76	3.78	3.80	
	20	Capacity	3.26	3.57	3.26	3.57	3.87	3.26	3.57	3.87	
		SHF	0.75	0.51	0.99	0.75	0.51	1.00	0.95	0.71	
		EER	4.33	4.31	4.33	4.31	4.28	4.33	4.31	4.28	
	Rated frequency	46	Capacity	1.84	2.15	1.84	2.15	2.46	1.84	2.15	2.46
			SHF	0.78	0.54	1.00	0.78	0.54	1.00	0.96	0.74
			EER	2.26	2.43	2.26	2.43	2.61	2.26	2.43	2.61
		40	Capacity	2.03	2.33	2.03	2.33	2.63	2.03	2.33	2.63
			SHF	0.78	0.54	1.00	0.78	0.54	1.00	0.96	0.74
			EER	2.62	2.75	2.62	2.75	2.89	2.62	2.75	2.89
35		Capacity	2.23	2.51	2.23	2.51	2.80	2.23	2.51	2.80	
		SHF	0.78	0.54	1.00	0.78	0.54	1.00	0.96	0.74	
		EER	3.04	3.14	3.04	3.14	3.24	3.04	3.14	3.24	
30		Capacity	2.39	2.68	2.39	2.68	2.96	2.39	2.68	2.96	
		SHF	0.78	0.54	1.00	0.78	0.54	1.00	0.96	0.74	
		EER	3.50	3.58	3.50	3.58	3.65	3.50	3.58	3.65	
25		Capacity	2.60	2.88	2.60	2.88	3.15	2.60	2.88	3.15	
		SHF	0.78	0.54	1.00	0.78	0.54	1.00	0.96	0.74	
		EER	4.13	4.16	4.13	4.16	4.18	4.13	4.16	4.18	
20		Capacity	2.81	3.08	2.81	3.08	3.34	2.81	3.08	3.34	
		SHF	0.78	0.54	1.00	0.78	0.54	1.00	0.96	0.74	
		EER	4.76	4.74	4.76	4.74	4.71	4.76	4.74	4.71	
Minimum Frequency		46	Capacity	0.37	0.43	0.37	0.43	0.49	0.37	0.43	0.49
			EER	2.41	2.59	2.41	2.59	2.78	2.41	2.59	2.78
		40	Capacity	0.41	0.47	0.41	0.47	0.53	0.41	0.47	0.53
			EER	2.79	2.94	2.79	2.94	3.08	2.79	2.94	3.08
		35	Capacity	0.45	0.50	0.45	0.50	0.56	0.45	0.50	0.56
			EER	3.24	3.35	3.24	3.35	3.46	3.24	3.35	3.46
	30	Capacity	0.48	0.54	0.48	0.54	0.59	0.48	0.54	0.59	
		EER	3.74	3.81	3.74	3.81	3.89	3.74	3.81	3.89	
	25	Capacity	0.52	0.58	0.52	0.58	0.63	0.52	0.58	0.63	
		EER	4.41	4.43	4.41	4.43	4.46	4.41	4.43	4.46	
	20	Capacity	0.56	0.62	0.56	0.62	0.67	0.56	0.62	0.67	
		EER	5.08	5.05	5.08	5.05	5.02	5.08	5.05	5.02	

Cooling performance data (Low ambient Condition)

	Ambient temperature (°C)	INDOOR (°C)								
		DB	21		27			32		
		WB	15	19	15	19	23	15	19	23
Max Frequency	15 -10	Capacity	2.23	2.51	2.23	2.51	2.80	2.23	2.51	2.80
		SHF	0.78	0.54	1.00	0.78	0.54	1.00	0.96	0.74
		EER	3.04	3.14	3.04	3.14	3.24	3.04	3.14	3.24

* The low ambient condition requires a special control and all the performance is equal to or less than the rated operation.

Cooling performance data
MSZ-HR35VF, MSZ-HR35VFK: MUZ-HR35VF

	Ambient temperature (°C)	INDOOR (°C)									
		DB	21		27			32			
		WB	15	19	15	19	23	15	19	23	
Max frequency	46	Capacity	2.50	2.92	2.50	2.92	3.35	2.50	2.92	3.35	
		SHF	0.78	0.54	1.00	0.78	0.54	1.00	0.96	0.74	
		EER	2.03	2.19	2.03	2.19	2.34	2.03	2.19	2.34	
	40	Capacity	2.75	3.16	2.75	3.16	3.57	2.75	3.16	3.57	
		SHF	0.78	0.54	1.00	0.78	0.54	1.00	0.96	0.74	
		EER	2.35	2.48	2.35	2.48	2.60	2.35	2.48	2.60	
	35	Capacity	3.03	3.42	3.03	3.42	3.81	3.03	3.42	3.81	
		SHF	0.78	0.54	1.00	0.78	0.54	1.00	0.96	0.74	
		EER	2.73	2.82	2.73	2.82	2.91	2.73	2.82	2.91	
	30	Capacity	3.25	3.64	3.25	3.64	4.03	3.25	3.64	4.03	
		SHF	0.78	0.54	1.00	0.78	0.54	1.00	0.96	0.74	
		EER	3.15	3.22	3.15	3.22	3.28	3.15	3.22	3.28	
	25	Capacity	3.54	3.91	3.54	3.91	4.28	3.54	3.91	4.28	
		SHF	0.78	0.54	1.00	0.78	0.54	1.00	0.96	0.74	
		EER	3.72	3.74	3.72	3.74	3.76	3.72	3.74	3.76	
	20	Capacity	3.83	4.18	3.83	4.18	4.54	3.83	4.18	4.54	
		SHF	0.78	0.54	1.00	0.78	0.54	1.00	0.96	0.74	
		EER	4.28	4.26	4.28	4.26	4.23	4.28	4.26	4.23	
	Rated frequency	46	Capacity	2.50	2.92	2.50	2.92	3.35	2.50	2.92	3.35
			SHF	0.78	0.54	1.00	0.78	0.54	1.00	0.96	0.74
			EER	2.03	2.19	2.03	2.19	2.34	2.03	2.19	2.34
		40	Capacity	2.75	3.16	2.75	3.16	3.57	2.75	3.16	3.57
			SHF	0.78	0.54	1.00	0.78	0.54	1.00	0.96	0.74
			EER	2.35	2.48	2.35	2.48	2.60	2.35	2.48	2.60
35		Capacity	3.03	3.42	3.03	3.42	3.81	3.03	3.42	3.81	
		SHF	0.78	0.54	1.00	0.78	0.54	1.00	0.96	0.74	
		EER	2.73	2.82	2.73	2.82	2.91	2.73	2.82	2.91	
30		Capacity	3.25	3.64	3.25	3.64	4.03	3.25	3.64	4.03	
		SHF	0.78	0.54	1.00	0.78	0.54	1.00	0.96	0.74	
		EER	3.15	3.22	3.15	3.22	3.28	3.15	3.22	3.28	
25		Capacity	3.54	3.91	3.54	3.91	4.28	3.54	3.91	4.28	
		SHF	0.78	0.54	1.00	0.78	0.54	1.00	0.96	0.74	
		EER	3.72	3.74	3.72	3.74	3.76	3.72	3.74	3.76	
20		Capacity	3.83	4.18	3.83	4.18	4.54	3.83	4.18	4.54	
		SHF	0.78	0.54	1.00	0.78	0.54	1.00	0.96	0.74	
		EER	4.28	4.26	4.28	4.26	4.23	4.28	4.26	4.23	
Minimum Frequency		46	Capacity	0.66	0.77	0.66	0.77	0.89	0.66	0.77	0.89
			EER	3.42	3.69	3.42	3.69	3.95	3.42	3.69	3.95
		40	Capacity	0.73	0.84	0.73	0.84	0.95	0.73	0.84	0.95
			EER	3.97	4.17	3.97	4.17	4.38	3.97	4.17	4.38
		35	Capacity	0.80	0.90	0.80	0.90	1.01	0.80	0.90	1.01
			EER	4.61	4.76	4.61	4.76	4.91	4.61	4.76	4.91
	30	Capacity	0.86	0.96	0.86	0.96	1.07	0.86	0.96	1.07	
		EER	5.31	5.42	5.31	5.42	5.53	5.31	5.42	5.53	
	25	Capacity	0.94	1.04	0.94	1.04	1.13	0.94	1.04	1.13	
		EER	6.27	6.30	6.27	6.30	6.33	6.27	6.30	6.33	
	20	Capacity	1.01	1.11	1.01	1.11	1.20	1.01	1.11	1.20	
		EER	7.22	7.18	7.22	7.18	7.13	7.22	7.18	7.13	

Cooling performance data (Low ambient Condition)

	Ambient temperature (°C)	INDOOR (°C)								
		DB	21		27			32		
		WB	15	19	15	19	23	15	19	23
Max Frequency	15 -10	Capacity	3.03	3.42	3.03	3.42	3.81	3.03	3.42	3.81
		SHF	0.78	0.54	1.00	0.78	0.54	1.00	0.96	0.74
		EER	2.73	2.82	2.73	2.82	2.91	2.73	2.82	2.91

* The low ambient condition requires a special control and all the performance is equal to or less than the rated operation.

Cooling performance data
MSZ-HR42VF, MSZ-HR42VFK: MUZ-HR42VF

	Ambient temperature (°C)	INDOOR (°C)									
		DB	21		27			32			
		WB	15	19	15	19	23	15	19	23	
Max frequency	46	Capacity	3.31	3.87	3.31	3.87	4.43	3.31	3.87	4.43	
		SHF	0.71	0.47	0.95	0.71	0.47	1.00	0.91	0.67	
		EER	2.03	2.19	2.03	2.19	2.35	2.03	2.19	2.35	
	40	Capacity	3.65	4.19	3.65	4.19	4.73	3.65	4.19	4.73	
		SHF	0.71	0.47	0.95	0.71	0.47	1.00	0.91	0.67	
		EER	2.36	2.48	2.36	2.48	2.60	2.36	2.48	2.60	
	35	Capacity	4.01	4.52	4.01	4.52	5.04	4.01	4.52	5.04	
		SHF	0.71	0.47	0.95	0.71	0.47	1.00	0.91	0.67	
		EER	2.74	2.83	2.74	2.83	2.92	2.74	2.83	2.92	
	30	Capacity	4.30	4.82	4.30	4.82	5.33	4.30	4.82	5.33	
		SHF	0.71	0.47	0.95	0.71	0.47	1.00	0.91	0.67	
		EER	3.15	3.22	3.15	3.22	3.28	3.15	3.22	3.28	
	25	Capacity	4.68	5.18	4.68	5.18	5.67	4.68	5.18	5.67	
		SHF	0.71	0.47	0.95	0.71	0.47	1.00	0.91	0.67	
		EER	3.72	3.74	3.72	3.74	3.76	3.72	3.74	3.76	
	20	Capacity	5.06	5.54	5.06	5.54	6.01	5.06	5.54	6.01	
		SHF	0.71	0.47	0.95	0.71	0.47	1.00	0.91	0.67	
		EER	4.29	4.26	4.29	4.26	4.24	4.29	4.26	4.24	
	Rated frequency	46	Capacity	3.09	3.61	3.09	3.61	4.14	3.09	3.61	4.14
			SHF	0.74	0.50	0.98	0.74	0.50	1.00	0.94	0.70
			EER	2.26	2.44	2.26	2.44	2.62	2.26	2.44	2.62
		40	Capacity	3.40	3.91	3.40	3.91	4.41	3.40	3.91	4.41
			SHF	0.74	0.50	0.98	0.74	0.50	1.00	0.94	0.70
			EER	2.63	2.76	2.63	2.76	2.90	2.63	2.76	2.90
35		Capacity	3.74	4.22	3.74	4.22	4.70	3.74	4.22	4.70	
		SHF	0.74	0.50	0.98	0.74	0.50	1.00	0.94	0.70	
		EER	3.05	3.15	3.05	3.15	3.25	3.05	3.15	3.25	
30		Capacity	4.01	4.49	4.01	4.49	4.98	4.01	4.49	4.98	
		SHF	0.74	0.50	0.98	0.74	0.50	1.00	0.94	0.70	
		EER	3.51	3.59	3.51	3.59	3.66	3.51	3.59	3.66	
25		Capacity	4.37	4.83	4.37	4.83	5.29	4.37	4.83	5.29	
		SHF	0.74	0.50	0.98	0.74	0.50	1.00	0.94	0.70	
		EER	4.15	4.17	4.15	4.17	4.19	4.15	4.17	4.19	
20		Capacity	4.73	5.17	4.73	5.17	5.61	4.73	5.17	5.61	
		SHF	0.74	0.50	0.98	0.74	0.50	1.00	0.94	0.70	
		EER	4.78	4.75	4.78	4.75	4.72	4.78	4.75	4.72	
Minimum Frequency		46	Capacity	0.81	0.95	0.81	0.95	1.08	0.81	0.95	1.08
			EER	4.18	4.50	4.18	4.50	4.83	4.18	4.50	4.83
		40	Capacity	0.89	1.02	0.89	1.02	1.16	0.89	1.02	1.16
			EER	4.85	5.10	4.85	5.10	5.35	4.85	5.10	5.35
		35	Capacity	0.98	1.11	0.98	1.11	1.23	0.98	1.11	1.23
			EER	5.63	5.82	5.63	5.82	6.00	5.63	5.82	6.00
	30	Capacity	1.05	1.18	1.05	1.18	1.30	1.05	1.18	1.30	
		EER	6.49	6.62	6.49	6.62	6.76	6.49	6.62	6.76	
	25	Capacity	1.14	1.27	1.14	1.27	1.39	1.14	1.27	1.39	
		EER	7.66	7.70	7.66	7.70	7.74	7.66	7.70	7.74	
	20	Capacity	1.24	1.35	1.24	1.35	1.47	1.24	1.35	1.47	
		EER	8.83	8.77	8.83	8.77	8.72	8.83	8.77	8.72	

PERFORMANCE DATA

WALL-MOUNTED

Cooling performance data (Low ambient Condition)

	Ambient temperature (°C)	INDOOR (°C)								
		DB	21		27			32		
		WB	15	19	15	19	23	15	19	23
Max Frequency	15 -10	Capacity	3.74	4.22	3.74	4.22	4.70	3.74	4.22	4.70
		SHF	0.74	0.50	0.98	0.74	0.50	1.00	0.94	0.70
		EER	3.05	3.15	3.05	3.15	3.25	3.05	3.15	3.25

* The low ambient condition requires a special control and all the performance is equal to or less than the rated operation.

Cooling performance data
MSZ-HR50VF, MSZ-HR50VFK: MUZ-HR50VF

	Ambient temperature (°C)	INDOOR (°C)									
		DB	21		27			32			
		WB	15	19	15	19	23	15	19	23	
Max frequency	46	Capacity	3.89	4.19	3.89	4.19	4.50	3.89	4.19	4.50	
		SHF	0.70	0.46	0.94	0.70	0.46	1.00	0.90	0.66	
		EER	1.76	1.90	1.76	1.90	2.04	1.76	1.90	2.04	
	40	Capacity	4.32	4.65	4.32	4.65	4.98	4.32	4.65	4.98	
		SHF	0.70	0.46	0.94	0.70	0.46	1.00	0.90	0.66	
		EER	2.04	2.15	2.04	2.15	2.26	2.04	2.15	2.26	
	35	Capacity	4.51	5.03	4.51	5.03	5.54	4.51	5.03	5.54	
		SHF	0.70	0.46	0.94	0.70	0.46	1.00	0.90	0.66	
		EER	2.37	2.45	2.37	2.45	2.53	2.37	2.45	2.53	
	30	Capacity	4.78	5.35	4.78	5.35	5.93	4.78	5.35	5.93	
		SHF	0.70	0.46	0.94	0.70	0.46	1.00	0.90	0.66	
		EER	2.73	2.79	2.73	2.79	2.85	2.73	2.79	2.85	
	25	Capacity	5.20	5.75	5.20	5.75	6.30	5.20	5.75	6.30	
		SHF	0.70	0.46	0.94	0.70	0.46	1.00	0.90	0.66	
		EER	3.23	3.24	3.23	3.24	3.26	3.23	3.24	3.26	
	20	Capacity	5.63	6.15	5.63	6.15	6.68	5.63	6.15	6.68	
		SHF	0.70	0.46	0.94	0.70	0.46	1.00	0.90	0.66	
		EER	3.72	3.70	3.72	3.70	3.67	3.72	3.70	3.67	
	Rated frequency	46	Capacity	3.89	4.19	3.89	4.19	4.50	3.89	4.19	4.50
			SHF	0.73	0.49	0.97	0.73	0.49	1.00	0.93	0.69
			EER	1.76	1.90	1.76	1.90	2.04	1.76	1.90	2.04
		40	Capacity	4.32	4.65	4.32	4.65	4.98	4.32	4.65	4.98
			SHF	0.73	0.49	0.97	0.73	0.49	1.00	0.93	0.69
			EER	2.04	2.15	2.04	2.15	2.26	2.04	2.15	2.26
35		Capacity	4.51	5.03	4.51	5.03	5.54	4.51	5.03	5.54	
		SHF	0.73	0.49	0.97	0.73	0.49	1.00	0.93	0.69	
		EER	2.37	2.45	2.37	2.45	2.53	2.37	2.45	2.53	
30		Capacity	4.78	5.35	4.78	5.35	5.93	4.78	5.35	5.93	
		SHF	0.73	0.49	0.97	0.73	0.49	1.00	0.93	0.69	
		EER	2.73	2.79	2.73	2.79	2.85	2.73	2.79	2.85	
25		Capacity	5.20	5.75	5.20	5.75	6.30	5.20	5.75	6.30	
		SHF	0.73	0.49	0.97	0.73	0.49	1.00	0.93	0.69	
		EER	3.23	3.24	3.23	3.24	3.26	3.23	3.24	3.26	
20		Capacity	5.63	6.15	5.63	6.15	6.68	5.63	6.15	6.68	
		SHF	0.73	0.49	0.97	0.73	0.49	1.00	0.93	0.69	
		EER	3.72	3.70	3.72	3.70	3.67	3.72	3.70	3.67	
Minimum Frequency		46	Capacity	0.96	1.12	0.96	1.12	1.28	0.96	1.12	1.28
			EER	3.13	3.37	3.13	3.37	3.62	3.13	3.37	3.62
		40	Capacity	1.05	1.21	1.05	1.21	1.37	1.05	1.21	1.37
			EER	3.63	3.82	3.63	3.82	4.01	3.63	3.82	4.01
		35	Capacity	1.16	1.31	1.16	1.31	1.46	1.16	1.31	1.46
			EER	4.22	4.35	4.22	4.35	4.49	4.22	4.35	4.49
	30	Capacity	1.24	1.39	1.24	1.39	1.54	1.24	1.39	1.54	
		EER	4.86	4.96	4.86	4.96	5.06	4.86	4.96	5.06	
	25	Capacity	1.35	1.50	1.35	1.50	1.64	1.35	1.50	1.64	
		EER	5.73	5.76	5.73	5.76	5.79	5.73	5.76	5.79	
	20	Capacity	1.46	1.60	1.46	1.60	1.74	1.46	1.60	1.74	
		EER	6.61	6.57	6.61	6.57	6.53	6.61	6.57	6.53	

Cooling performance data (Low ambient Condition)

	Ambient temperature (°C)	INDOOR (°C)								
		DB	21		27			32		
		WB	15	19	15	19	23	15	19	23
Max Frequency	15 -10	Capacity	4.51	5.03	4.51	5.03	5.54	4.51	5.03	5.54
		SHF	0.73	0.49	0.97	0.73	0.49	1.00	0.93	0.69
		EER	2.37	2.45	2.37	2.45	2.53	2.37	2.45	2.53

* The low ambient condition requires a special control and all the performance is equal to or less than the rated operation.

Cooling performance data
MSZ-HR60VF, MSZ-HR60VFK: MUZ-HR60VF

	Ambient temperature (°C)	INDOOR (°C)									
		DB	21		27			32			
		WB	15	19	15	19	23	15	19	23	
Max frequency	46	Capacity	5.22	6.11	5.22	6.11	6.99	5.22	6.11	6.99	
		SHF	0.75	0.51	0.99	0.75	0.51	1.00	0.95	0.71	
		EER	2.18	2.35	2.18	2.35	2.52	2.18	2.35	2.52	
	40	Capacity	5.75	6.60	5.75	6.60	7.46	5.75	6.60	7.46	
		SHF	0.75	0.51	0.99	0.75	0.51	1.00	0.95	0.71	
		EER	2.53	2.66	2.53	2.66	2.79	2.53	2.66	2.79	
	35	Capacity	6.32	7.14	6.32	7.14	7.95	6.32	7.14	7.95	
		SHF	0.75	0.51	0.99	0.75	0.51	1.00	0.95	0.71	
		EER	2.94	3.04	2.94	3.04	3.13	2.94	3.04	3.13	
	30	Capacity	6.78	7.60	6.78	7.60	8.41	6.78	7.60	8.41	
		SHF	0.75	0.51	0.99	0.75	0.51	1.00	0.95	0.71	
		EER	3.39	3.46	3.39	3.46	3.53	3.39	3.46	3.53	
	25	Capacity	7.38	8.17	7.38	8.17	8.95	7.38	8.17	8.95	
		SHF	0.75	0.51	0.99	0.75	0.51	1.00	0.95	0.71	
		EER	4.00	4.02	4.00	4.02	4.04	4.00	4.02	4.04	
	20	Capacity	7.99	8.73	7.99	8.73	9.48	7.99	8.73	9.48	
		SHF	0.75	0.51	0.99	0.75	0.51	1.00	0.95	0.71	
		EER	4.61	4.58	4.61	4.58	4.55	4.61	4.58	4.55	
	Rated frequency	46	Capacity	4.48	5.25	4.48	5.25	6.01	4.48	5.25	6.01
			SHF	0.79	0.55	1.00	0.79	0.55	1.00	0.97	0.75
			EER	2.43	2.62	2.43	2.62	2.81	2.43	2.62	2.81
		40	Capacity	4.94	5.67	4.94	5.67	6.41	4.94	5.67	6.41
			SHF	0.79	0.55	1.00	0.79	0.55	1.00	0.97	0.75
			EER	2.82	2.97	2.82	2.97	3.12	2.82	2.97	3.12
35		Capacity	5.43	6.13	5.43	6.13	6.83	5.43	6.13	6.83	
		SHF	0.79	0.55	1.00	0.79	0.55	1.00	0.97	0.75	
		EER	3.28	3.39	3.28	3.39	3.49	3.28	3.39	3.49	
30		Capacity	5.83	6.53	5.83	6.53	7.23	5.83	6.53	7.23	
		SHF	0.79	0.55	1.00	0.79	0.55	1.00	0.97	0.75	
		EER	3.78	3.86	3.78	3.86	3.93	3.78	3.86	3.93	
25		Capacity	6.34	7.02	6.34	7.02	7.69	6.34	7.02	7.69	
		SHF	0.79	0.55	1.00	0.79	0.55	1.00	0.97	0.75	
		EER	4.46	4.48	4.46	4.48	4.51	4.46	4.48	4.51	
20		Capacity	6.86	7.50	6.86	7.50	8.14	6.86	7.50	8.14	
		SHF	0.79	0.55	1.00	0.79	0.55	1.00	0.97	0.75	
		EER	5.14	5.11	5.14	5.11	5.08	5.14	5.11	5.08	
Minimum Frequency		46	Capacity	1.25	1.46	1.25	1.46	1.67	1.25	1.46	1.67
			EER	3.51	3.78	3.51	3.78	4.05	3.51	3.78	4.05
		40	Capacity	1.38	1.58	1.38	1.58	1.79	1.38	1.58	1.79
			EER	4.07	4.28	4.07	4.28	4.49	4.07	4.28	4.49
		35	Capacity	1.51	1.71	1.51	1.71	1.90	1.51	1.71	1.90
			EER	4.73	4.88	4.73	4.88	5.04	4.73	4.88	5.04
	30	Capacity	1.62	1.82	1.62	1.82	2.01	1.62	1.82	2.01	
		EER	5.44	5.56	5.44	5.56	5.67	5.44	5.56	5.67	
	25	Capacity	1.77	1.96	1.77	1.96	2.14	1.77	1.96	2.14	
		EER	6.42	6.46	6.42	6.46	6.49	6.42	6.46	6.49	
	20	Capacity	1.91	2.09	1.91	2.09	2.27	1.91	2.09	2.27	
		EER	7.40	7.36	7.40	7.36	7.32	7.40	7.36	7.32	

Cooling performance data (Low ambient Condition)

	Ambient temperature (°C)	INDOOR (°C)								
		DB	21		27			32		
		WB	15	19	15	19	23	15	19	23
Max Frequency	15 -10	Capacity	5.43	6.13	5.43	6.13	6.83	5.43	6.13	6.83
		SHF	0.79	0.55	1.00	0.79	0.55	1.00	0.97	0.75
		EER	3.28	3.39	3.28	3.39	3.49	3.28	3.39	3.49

* The low ambient condition requires a special control and all the performance is equal to or less than the rated operation.

Cooling performance data

MSZ-HR71VF, MSZ-HR71VFK: MUZ-HR71VF

	Ambient temperature (°C)	INDOOR (°C)									
		DB	21		27			32			
		WB	15	19	15	19	23	15	19	23	
Max frequency	46	Capacity	5.37	6.28	5.37	6.28	7.19	5.37	6.28	7.19	
		SHF	0.74	0.50	0.98	0.74	0.50	1.00	0.94	0.70	
		EER	2.15	2.32	2.15	2.32	2.49	2.15	2.32	2.49	
	40	Capacity	5.91	6.79	5.91	6.79	7.67	5.91	6.79	7.67	
		SHF	0.74	0.50	0.98	0.74	0.50	1.00	0.94	0.70	
		EER	2.50	2.63	2.50	2.63	2.76	2.50	2.63	2.76	
	35	Capacity	6.50	7.34	6.50	7.34	8.18	6.50	7.34	8.18	
		SHF	0.74	0.50	0.98	0.74	0.50	1.00	0.94	0.70	
		EER	2.90	2.99	2.90	2.99	3.09	2.90	2.99	3.09	
	30	Capacity	6.97	7.81	6.97	7.81	8.65	6.97	7.81	8.65	
		SHF	0.74	0.50	0.98	0.74	0.50	1.00	0.94	0.70	
		EER	3.34	3.41	3.34	3.41	3.48	3.34	3.41	3.48	
	25	Capacity	7.59	8.40	7.59	8.40	9.20	7.59	8.40	9.20	
		SHF	0.74	0.50	0.98	0.74	0.50	1.00	0.94	0.70	
		EER	3.94	3.96	3.94	3.96	3.98	3.94	3.96	3.98	
	20	Capacity	8.21	8.98	8.21	8.98	9.75	8.21	8.98	9.75	
		SHF	0.74	0.50	0.98	0.74	0.50	1.00	0.94	0.70	
		EER	4.54	4.52	4.54	4.52	4.49	4.54	4.52	4.49	
	Rated frequency	46	Capacity	5.22	6.11	5.22	6.11	6.99	5.22	6.11	6.99
			SHF	0.74	0.50	0.98	0.74	0.50	1.00	0.94	0.70
			EER	2.20	2.37	2.20	2.37	2.54	2.20	2.37	2.54
		40	Capacity	5.75	6.60	5.75	6.60	7.46	5.75	6.60	7.46
			SHF	0.74	0.50	0.98	0.74	0.50	1.00	0.94	0.70
			EER	2.55	2.69	2.55	2.69	2.82	2.55	2.69	2.82
35		Capacity	6.32	7.14	6.32	7.14	7.95	6.32	7.14	7.95	
		SHF	0.74	0.50	0.98	0.74	0.50	1.00	0.94	0.70	
		EER	2.96	3.06	2.96	3.06	3.16	2.96	3.06	3.16	
30		Capacity	6.78	7.60	6.78	7.60	8.41	6.78	7.60	8.41	
		SHF	0.74	0.50	0.98	0.74	0.50	1.00	0.94	0.70	
		EER	3.42	3.49	3.42	3.49	3.56	3.42	3.49	3.56	
25		Capacity	7.38	8.17	7.38	8.17	8.95	7.38	8.17	8.95	
		SHF	0.74	0.50	0.98	0.74	0.50	1.00	0.94	0.70	
		EER	4.03	4.05	4.03	4.05	4.07	4.03	4.05	4.07	
20		Capacity	7.99	8.73	7.99	8.73	9.48	7.99	8.73	9.48	
		SHF	0.74	0.50	0.98	0.74	0.50	1.00	0.94	0.70	
		EER	4.65	4.62	4.65	4.62	4.59	4.65	4.62	4.59	
Minimum Frequency		46	Capacity	1.32	1.55	1.32	1.55	1.77	1.32	1.55	1.77
			EER	5.41	5.84	5.41	5.84	6.26	5.41	5.84	6.26
		40	Capacity	1.46	1.67	1.46	1.67	1.89	1.46	1.67	1.89
			EER	6.28	6.61	6.28	6.61	6.94	6.28	6.61	6.94
		35	Capacity	1.60	1.81	1.60	1.81	2.02	1.60	1.81	2.02
			EER	7.30	7.54	7.30	7.54	7.78	7.30	7.54	7.78
	30	Capacity	1.72	1.93	1.72	1.93	2.13	1.72	1.93	2.13	
		EER	8.41	8.58	8.41	8.58	8.76	8.41	8.58	8.76	
	25	Capacity	1.87	2.07	1.87	2.07	2.27	1.87	2.07	2.27	
		EER	9.92	9.97	9.92	9.97	10.03	9.92	9.97	10.03	
	20	Capacity	2.03	2.21	2.03	2.21	2.40	2.03	2.21	2.40	
		EER	11.43	11.37	11.43	11.37	11.30	11.43	11.37	11.30	

Cooling performance data (Low ambient Condition)

	Ambient temperature (°C)	INDOOR (°C)								
		DB	21		27			32		
		WB	15	19	15	19	23	15	19	23
Max Frequency	15 -10	Capacity	6.32	7.14	6.32	7.14	7.95	6.32	7.14	7.95
		SHF	0.74	0.50	0.98	0.74	0.50	1.00	0.94	0.70
		EER	2.96	3.06	2.96	3.06	3.16	2.96	3.06	3.16

* The low ambient condition requires a special control and all the performance is equal to or less than the rated operation.

Cooling performance data
MSY-TP35VF: MUY-TP35VF

	Ambient temperature (°C)	INDOOR (°C)									
		DB	21		27			32			
		WB	15	19	15	19	23	15	19	23	
Max frequency	46	Capacity	2.94	3.44	2.94	3.44	3.94	2.94	3.44	3.94	
		SHF	0.93	0.69	1.00	0.93	0.69	1.00	1.00	0.89	
		EER	2.92	3.14	2.92	3.14	3.37	2.92	3.14	3.37	
	40	Capacity	3.24	3.72	3.24	3.72	4.20	3.24	3.72	4.20	
		SHF	0.93	0.69	1.00	0.93	0.69	1.00	1.00	0.89	
		EER	3.38	3.56	3.38	3.56	3.74	3.38	3.56	3.74	
	35	Capacity	3.56	4.02	3.56	4.02	4.48	3.56	4.02	4.48	
		SHF	0.93	0.69	1.00	0.93	0.69	1.00	1.00	0.89	
		EER	3.93	4.06	3.93	4.06	4.19	3.93	4.06	4.19	
	30	Capacity	3.82	4.28	3.82	4.28	4.74	3.82	4.28	4.74	
		SHF	0.93	0.69	1.00	0.93	0.69	1.00	1.00	0.89	
		EER	4.53	4.62	4.53	4.62	4.72	4.53	4.62	4.72	
	25	Capacity	4.16	4.60	4.16	4.60	5.04	4.16	4.60	5.04	
		SHF	0.93	0.69	1.00	0.93	0.69	1.00	1.00	0.89	
		EER	5.34	5.37	5.34	5.37	5.40	5.34	5.37	5.40	
	20	Capacity	4.50	4.92	4.50	4.92	5.34	4.50	4.92	5.34	
		SHF	0.93	0.69	1.00	0.93	0.69	1.00	1.00	0.89	
		EER	6.16	6.12	6.16	6.12	6.09	6.16	6.12	6.09	
	Rated frequency	46	Capacity	2.57	3.01	2.57	3.01	3.45	2.57	3.01	3.45
			SHF	0.98	0.74	1.00	0.96	0.74	1.00	1.00	0.94
			EER	3.32	3.58	3.32	3.58	3.84	3.32	3.58	3.84
		40	Capacity	2.84	3.26	2.84	3.26	3.68	2.84	3.26	3.68
			SHF	0.98	0.74	1.00	0.96	0.74	1.00	1.00	0.94
			EER	3.86	4.06	3.86	4.06	4.26	3.86	4.06	4.26
35		Capacity	3.12	3.52	3.12	3.52	3.92	3.12	3.52	3.92	
		SHF	0.98	0.74	1.00	0.96	0.74	1.00	1.00	0.94	
		EER	4.48	4.63	4.48	4.63	4.78	4.48	4.63	4.78	
30		Capacity	3.34	3.75	3.34	3.75	4.15	3.34	3.75	4.15	
		SHF	0.98	0.74	1.00	0.96	0.74	1.00	1.00	0.94	
		EER	5.16	5.27	5.16	5.27	5.38	5.16	5.27	5.38	
25		Capacity	3.64	4.03	3.64	4.03	4.41	3.64	4.03	4.41	
		SHF	0.98	0.74	1.00	0.96	0.74	1.00	1.00	0.94	
		EER	6.09	6.12	6.09	6.12	6.16	6.09	6.12	6.16	
20		Capacity	3.94	4.31	3.94	4.31	4.67	3.94	4.31	4.67	
		SHF	0.98	0.74	1.00	0.96	0.74	1.00	1.00	0.94	
		EER	7.02	6.98	7.02	6.98	6.94	7.02	6.98	6.94	
Minimum Frequency		46	Capacity	1.10	1.29	1.10	1.29	1.48	1.10	1.29	1.48
			EER	3.61	3.89	3.61	3.89	4.17	3.61	3.89	4.17
		40	Capacity	1.22	1.40	1.22	1.40	1.58	1.22	1.40	1.58
			EER	4.19	4.41	4.19	4.41	4.62	4.19	4.41	4.62
		35	Capacity	1.34	1.51	1.34	1.51	1.68	1.34	1.51	1.68
			EER	4.86	5.02	4.86	5.02	5.18	4.86	5.02	5.18
	30	Capacity	1.43	1.61	1.43	1.61	1.78	1.43	1.61	1.78	
		EER	5.60	5.72	5.60	5.72	5.84	5.60	5.72	5.84	
	25	Capacity	1.56	1.73	1.56	1.73	1.89	1.56	1.73	1.89	
		EER	6.61	6.65	6.61	6.65	6.68	6.61	6.65	6.68	
	20	Capacity	1.69	1.85	1.69	1.85	2.00	1.69	1.85	2.00	
		EER	7.62	7.58	7.62	7.58	7.53	7.62	7.58	7.53	

PERFORMANCE DATA

WALL-MOUNTED

Cooling performance data (Low ambient Condition)

	Ambient temperature (°C)	INDOOR (°C)								
		DB	21		27			32		
		WB	15	19	15	19	23	15	19	23
Max Frequency	15 -10	Capacity	3.12	3.52	3.12	3.52	3.92	3.12	3.52	3.92
		SHF	0.98	0.74	1.00	0.96	0.74	1.00	1.00	0.94
		EER	4.48	4.63	4.48	4.63	4.78	4.48	4.63	4.78

* The low ambient condition requires a special control and all the performance is equal to or less than the rated operation.

Cooling performance data
MSY-TP50VF: MUY-TP50VF

	Ambient temperature (°C)	INDOOR (°C)									
		DB	21		27			32			
		WB	15	19	15	19	23	15	19	23	
Max frequency	46	Capacity	4.34	4.68	4.34	4.68	5.02	4.34	4.68	5.02	
		SHF	0.77	0.53	1.00	0.77	0.53	1.00	0.96	0.73	
		EER	1.99	2.14	1.99	2.14	2.30	1.99	2.14	2.30	
	40	Capacity	4.96	5.27	4.96	5.27	5.57	4.96	5.27	5.57	
		SHF	0.77	0.53	1.00	0.77	0.53	1.00	0.96	0.73	
		EER	2.31	2.43	2.31	2.43	2.55	2.31	2.43	2.55	
	35	Capacity	5.22	5.73	5.22	5.73	6.24	5.22	5.73	6.24	
		SHF	0.77	0.53	1.00	0.77	0.53	1.00	0.96	0.73	
		EER	2.68	2.77	2.68	2.77	2.86	2.68	2.77	2.86	
	30	Capacity	5.44	6.10	5.44	6.10	6.75	5.44	6.10	6.75	
		SHF	0.77	0.53	1.00	0.77	0.53	1.00	0.96	0.73	
		EER	3.09	3.15	3.09	3.15	3.21	3.09	3.15	3.21	
	25	Capacity	5.93	6.56	5.93	6.56	7.18	5.93	6.56	7.18	
		SHF	0.77	0.53	1.00	0.77	0.53	1.00	0.96	0.73	
		EER	3.64	3.66	3.64	3.66	3.68	3.64	3.66	3.68	
	20	Capacity	6.41	7.01	6.41	7.01	7.61	6.41	7.01	7.61	
		SHF	0.77	0.53	1.00	0.77	0.53	1.00	0.96	0.73	
		EER	4.20	4.17	4.20	4.17	4.15	4.20	4.17	4.15	
	Rated frequency	46	Capacity	3.68	4.30	3.68	4.30	4.93	3.68	4.30	4.93
			SHF	0.82	0.58	1.00	0.82	0.58	1.00	0.98	0.78
			EER	2.49	2.68	2.49	2.68	2.88	2.49	2.68	2.88
		40	Capacity	4.05	4.65	4.05	4.65	5.25	4.05	4.65	5.25
			SHF	0.82	0.58	1.00	0.82	0.58	1.00	0.98	0.78
			EER	2.89	3.04	2.89	3.04	3.19	2.89	3.04	3.19
35		Capacity	4.45	5.03	4.45	5.03	5.60	4.45	5.03	5.60	
		SHF	0.82	0.58	1.00	0.82	0.58	1.00	0.98	0.78	
		EER	3.35	3.47	3.35	3.47	3.58	3.35	3.47	3.58	
30		Capacity	4.78	5.35	4.78	5.35	5.93	4.78	5.35	5.93	
		SHF	0.82	0.58	1.00	0.82	0.58	1.00	0.98	0.78	
		EER	3.87	3.95	3.87	3.95	4.03	3.87	3.95	4.03	
25		Capacity	5.20	5.75	5.20	5.75	6.30	5.20	5.75	6.30	
		SHF	0.82	0.58	1.00	0.82	0.58	1.00	0.98	0.78	
		EER	4.56	4.59	4.56	4.59	4.61	4.56	4.59	4.61	
20		Capacity	5.63	6.15	5.63	6.15	6.68	5.63	6.15	6.68	
		SHF	0.82	0.58	1.00	0.82	0.58	1.00	0.98	0.78	
		EER	5.26	5.23	5.26	5.23	5.19	5.26	5.23	5.19	
Minimum Frequency		46	Capacity	1.10	1.29	1.10	1.29	1.48	1.10	1.29	1.48
			EER	3.73	4.02	3.73	4.02	4.32	3.73	4.02	4.32
		40	Capacity	1.22	1.40	1.22	1.40	1.58	1.22	1.40	1.58
			EER	4.33	4.56	4.33	4.56	4.78	4.33	4.56	4.78
		35	Capacity	1.34	1.51	1.34	1.51	1.68	1.34	1.51	1.68
			EER	5.03	5.20	5.03	5.20	5.36	5.03	5.20	5.36
	30	Capacity	1.43	1.61	1.43	1.61	1.78	1.43	1.61	1.78	
		EER	5.80	5.92	5.80	5.92	6.04	5.80	5.92	6.04	
	25	Capacity	1.56	1.73	1.56	1.73	1.89	1.56	1.73	1.89	
		EER	6.84	6.88	6.84	6.88	6.91	6.84	6.88	6.91	
	20	Capacity	1.69	1.85	1.69	1.85	2.00	1.69	1.85	2.00	
		EER	7.89	7.84	7.89	7.84	7.79	7.89	7.84	7.79	

WALL-MOUNTED PERFORMANCE DATA

Cooling performance data (Low ambient Condition)

	Ambient temperature (°C)	INDOOR (°C)								
		DB	21		27			32		
		WB	15	19	15	19	23	15	19	23
Max Frequency	15 -10	Capacity	4.45	5.03	4.45	5.03	5.60	4.45	5.03	5.60
		SHF	0.82	0.58	1.00	0.82	0.58	1.00	0.98	0.78
		EER	3.35	3.47	3.35	3.47	3.58	3.35	3.47	3.58

* The low ambient condition requires a special control and all the performance is equal to or less than the rated operation.

Cooling performance data
MSZ-FH25VE2: MUZ-FH25VE

	Ambient temperature (°C)	INDOOR (°C)									
		DB	21		27			32			
		WB	15	19	15	19	23	15	19	23	
Max frequency	46	Capacity	2.57	3.01	2.57	3.01	3.45	2.57	3.01	3.45	
		SHF	0.95	0.71	1.00	0.95	0.71	1.00	1.00	0.91	
		EER	2.81	3.03	2.81	3.03	3.25	2.81	3.03	3.25	
	40	Capacity	2.84	3.26	2.84	3.26	3.68	2.84	3.26	3.68	
		SHF	0.95	0.71	1.00	0.95	0.71	1.00	1.00	0.91	
		EER	3.26	3.43	3.26	3.43	3.60	3.26	3.43	3.60	
	35	Capacity	3.12	3.52	3.12	3.52	3.92	3.12	3.52	3.92	
		SHF	0.95	0.71	1.00	0.95	0.71	1.00	1.00	0.91	
		EER	3.78	3.91	3.78	3.91	4.03	3.78	3.91	4.03	
	30	Capacity	3.34	3.75	3.34	3.75	4.15	3.34	3.75	4.15	
		SHF	0.95	0.71	1.00	0.95	0.71	1.00	1.00	0.91	
		EER	4.36	4.45	4.36	4.45	4.54	4.36	4.45	4.54	
	25	Capacity	3.64	4.03	3.64	4.03	4.41	3.64	4.03	4.41	
		SHF	0.95	0.71	1.00	0.95	0.71	1.00	1.00	0.91	
		EER	5.14	5.17	5.14	5.17	5.20	5.14	5.17	5.20	
	20	Capacity	3.94	4.31	3.94	4.31	4.67	3.94	4.31	4.67	
		SHF	0.95	0.71	1.00	0.95	0.71	1.00	1.00	0.91	
		EER	5.93	5.89	5.93	5.89	5.86	5.93	5.89	5.86	
	Rated frequency	46	Capacity	1.84	2.15	1.84	2.15	2.46	1.84	2.15	2.46
			SHF	0.95	0.71	1.00	0.95	0.71	1.00	1.00	0.91
			EER	3.72	4.01	3.72	4.01	4.30	3.72	4.01	4.30
		40	Capacity	2.03	2.33	2.03	2.33	2.63	2.03	2.33	2.63
			SHF	0.95	0.71	1.00	0.95	0.71	1.00	1.00	0.91
			EER	4.32	4.54	4.32	4.54	4.77	4.32	4.54	4.77
35		Capacity	2.23	2.51	2.23	2.51	2.80	2.23	2.51	2.80	
		SHF	0.95	0.71	1.00	0.95	0.71	1.00	1.00	0.91	
		EER	5.02	5.18	5.02	5.18	5.34	5.02	5.18	5.34	
30		Capacity	2.39	2.68	2.39	2.68	2.96	2.39	2.68	2.96	
		SHF	0.95	0.71	1.00	0.95	0.71	1.00	1.00	0.91	
		EER	5.78	5.90	5.78	5.90	6.02	5.78	5.90	6.02	
25		Capacity	2.60	2.88	2.60	2.88	3.15	2.60	2.88	3.15	
		SHF	0.95	0.71	1.00	0.95	0.71	1.00	1.00	0.91	
		EER	6.82	6.85	6.82	6.85	6.89	6.82	6.85	6.89	
20		Capacity	2.81	3.08	2.81	3.08	3.34	2.81	3.08	3.34	
		SHF	0.95	0.71	1.00	0.95	0.71	1.00	1.00	0.91	
		EER	7.86	7.81	7.86	7.81	7.76	7.86	7.81	7.76	
Minimum Frequency		46	Capacity	1.03	1.20	1.03	1.20	1.38	1.03	1.20	1.38
			EER	4.81	5.19	4.81	5.19	5.56	4.81	5.19	5.56
		40	Capacity	1.13	1.30	1.13	1.30	1.47	1.13	1.30	1.47
			EER	5.58	5.88	5.58	5.88	6.17	5.58	5.88	6.17
		35	Capacity	1.25	1.41	1.25	1.41	1.57	1.25	1.41	1.57
			EER	6.49	6.70	6.49	6.70	6.91	6.49	6.70	6.91
	30	Capacity	1.34	1.50	1.34	1.50	1.66	1.34	1.50	1.66	
		EER	7.47	7.63	7.47	7.63	7.78	7.47	7.63	7.78	
	25	Capacity	1.46	1.61	1.46	1.61	1.76	1.46	1.61	1.76	
		EER	8.82	8.87	8.82	8.87	8.91	8.82	8.87	8.91	
	20	Capacity	1.58	1.72	1.58	1.72	1.87	1.58	1.72	1.87	
		EER	10.16	10.10	10.16	10.10	10.04	10.16	10.10	10.04	

Cooling performance data (Low ambient Condition)

	Ambient temperature (°C)	INDOOR (°C)								
		DB	21		27			32		
		WB	15	19	15	19	23	15	19	23
Max Frequency	15 -10	Capacity	2.23	2.51	2.23	2.51	2.80	2.23	2.51	2.80
		SHF	0.95	0.71	1.00	0.95	0.71	1.00	1.00	0.91
		EER	5.02	5.18	5.02	5.18	5.34	5.02	5.18	5.34

* The low ambient condition requires a special control and all the performance is equal to or less than the rated operation.

Cooling performance data
MSZ-FH25VE2: MUZ-FH25VEHZ

	Ambient temperature (°C)	INDOOR (°C)									
		DB	21		27			32			
		WB	15	19	15	19	23	15	19	23	
Max frequency	46	Capacity	2.94	3.44	2.94	3.44	3.94	2.94	3.44	3.94	
		SHF	0.95	0.71	1.00	0.95	0.71	1.00	1.00	0.91	
		EER	2.51	2.71	2.51	2.71	2.90	2.51	2.71	2.90	
	40	Capacity	3.24	3.72	3.24	3.72	4.20	3.24	3.72	4.20	
		SHF	0.95	0.71	1.00	0.95	0.71	1.00	1.00	0.91	
		EER	2.91	3.07	2.91	3.07	3.22	2.91	3.07	3.22	
	35	Capacity	3.56	4.02	3.56	4.02	4.48	3.56	4.02	4.48	
		SHF	0.95	0.71	1.00	0.95	0.71	1.00	1.00	0.91	
		EER	3.38	3.50	3.38	3.50	3.61	3.38	3.50	3.61	
	30	Capacity	3.82	4.28	3.82	4.28	4.74	3.82	4.28	4.74	
		SHF	0.95	0.71	1.00	0.95	0.71	1.00	1.00	0.91	
		EER	3.90	3.98	3.90	3.98	4.06	3.90	3.98	4.06	
	25	Capacity	4.16	4.60	4.16	4.60	5.04	4.16	4.60	5.04	
		SHF	0.95	0.71	1.00	0.95	0.71	1.00	1.00	0.91	
		EER	4.60	4.63	4.60	4.63	4.65	4.60	4.63	4.65	
	20	Capacity	4.50	4.92	4.50	4.92	5.34	4.50	4.92	5.34	
		SHF	0.95	0.71	1.00	0.95	0.71	1.00	1.00	0.91	
		EER	5.30	5.27	5.30	5.27	5.24	5.30	5.27	5.24	
	Rated frequency	46	Capacity	1.84	2.15	1.84	2.15	2.46	1.84	2.15	2.46
			SHF	0.95	0.71	1.00	0.95	0.71	1.00	1.00	0.91
			EER	3.72	4.01	3.72	4.01	4.30	3.72	4.01	4.30
		40	Capacity	2.03	2.33	2.03	2.33	2.63	2.03	2.33	2.63
			SHF	0.95	0.71	1.00	0.95	0.71	1.00	1.00	0.91
			EER	4.32	4.54	4.32	4.54	4.77	4.32	4.54	4.77
35		Capacity	2.23	2.51	2.23	2.51	2.80	2.23	2.51	2.80	
		SHF	0.95	0.71	1.00	0.95	0.71	1.00	1.00	0.91	
		EER	5.02	5.18	5.02	5.18	5.34	5.02	5.18	5.34	
30		Capacity	2.39	2.68	2.39	2.68	2.96	2.39	2.68	2.96	
		SHF	0.95	0.71	1.00	0.95	0.71	1.00	1.00	0.91	
		EER	5.78	5.90	5.78	5.90	6.02	5.78	5.90	6.02	
25		Capacity	2.60	2.88	2.60	2.88	3.15	2.60	2.88	3.15	
		SHF	0.95	0.71	1.00	0.95	0.71	1.00	1.00	0.91	
		EER	6.82	6.85	6.82	6.85	6.89	6.82	6.85	6.89	
20		Capacity	2.81	3.08	2.81	3.08	3.34	2.81	3.08	3.34	
		SHF	0.95	0.71	1.00	0.95	0.71	1.00	1.00	0.91	
		EER	7.86	7.81	7.86	7.81	7.76	7.86	7.81	7.76	
Minimum Frequency		46	Capacity	0.59	0.69	0.59	0.69	0.79	0.59	0.69	0.79
			EER	3.40	3.66	3.40	3.66	3.93	3.40	3.66	3.93
		40	Capacity	0.65	0.74	0.65	0.74	0.84	0.65	0.74	0.84
			EER	3.94	4.15	3.94	4.15	4.35	3.94	4.15	4.35
		35	Capacity	0.71	0.80	0.71	0.80	0.90	0.71	0.80	0.90
			EER	4.58	4.73	4.58	4.73	4.88	4.58	4.73	4.88
	30	Capacity	0.76	0.86	0.76	0.86	0.95	0.76	0.86	0.95	
		EER	5.28	5.38	5.28	5.38	5.49	5.28	5.38	5.49	
	25	Capacity	0.83	0.92	0.83	0.92	1.01	0.83	0.92	1.01	
		EER	6.22	6.26	6.22	6.26	6.29	6.22	6.26	6.29	
	20	Capacity	0.90	0.98	0.90	0.98	1.07	0.90	0.98	1.07	
		EER	7.17	7.13	7.17	7.13	7.09	7.17	7.13	7.09	

Cooling performance data (Low ambient Condition)

	Ambient temperature (°C)	INDOOR (°C)								
		DB	21		27			32		
		WB	15	19	15	19	23	15	19	23
Max Frequency	15 -10	Capacity	2.23	2.51	2.23	2.51	2.80	2.23	2.51	2.80
		SHF	0.95	0.71	1.00	0.95	0.71	1.00	1.00	0.91
		EER	5.02	5.18	5.02	5.18	5.34	5.02	5.18	5.34

* The low ambient condition requires a special control and all the performance is equal to or less than the rated operation.

Cooling performance data
MSZ-FH35VE2: MUZ-FH35VE

	Ambient temperature (°C)	INDOOR (°C)									
		DB	21		27			32			
		WB	15	19	15	19	23	15	19	23	
Max frequency	46	Capacity	2.94	3.44	2.94	3.44	3.94	2.94	3.44	3.94	
		SHF	0.84	0.60	1.00	0.84	0.60	1.00	0.99	0.80	
		EER	2.51	2.71	2.51	2.71	2.90	2.51	2.71	2.90	
	40	Capacity	3.24	3.72	3.24	3.72	4.20	3.24	3.72	4.20	
		SHF	0.84	0.60	1.00	0.84	0.60	1.00	0.99	0.80	
		EER	2.91	3.07	2.91	3.07	3.22	2.91	3.07	3.22	
	35	Capacity	3.56	4.02	3.56	4.02	4.48	3.56	4.02	4.48	
		SHF	0.84	0.60	1.00	0.84	0.60	1.00	0.99	0.80	
		EER	3.38	3.50	3.38	3.50	3.61	3.38	3.50	3.61	
	30	Capacity	3.82	4.28	3.82	4.28	4.74	3.82	4.28	4.74	
		SHF	0.84	0.60	1.00	0.84	0.60	1.00	0.99	0.80	
		EER	3.90	3.98	3.90	3.98	4.06	3.90	3.98	4.06	
	25	Capacity	4.16	4.60	4.16	4.60	5.04	4.16	4.60	5.04	
		SHF	0.84	0.60	1.00	0.84	0.60	1.00	0.99	0.80	
		EER	4.60	4.63	4.60	4.63	4.65	4.60	4.63	4.65	
	20	Capacity	4.50	4.92	4.50	4.92	5.34	4.50	4.92	5.34	
		SHF	0.84	0.60	1.00	0.84	0.60	1.00	0.99	0.80	
		EER	5.30	5.27	5.30	5.27	5.24	5.30	5.27	5.24	
	Rated frequency	46	Capacity	2.57	3.01	2.57	3.01	3.45	2.57	3.01	3.45
			SHF	0.84	0.60	1.00	0.84	0.60	1.00	0.99	0.80
			EER	3.08	3.32	3.08	3.32	3.56	3.08	3.32	3.56
		40	Capacity	2.84	3.26	2.84	3.26	3.68	2.84	3.26	3.68
			SHF	0.84	0.60	1.00	0.84	0.60	1.00	0.99	0.80
			EER	3.58	3.76	3.58	3.76	3.95	3.58	3.76	3.95
35		Capacity	3.12	3.52	3.12	3.52	3.92	3.12	3.52	3.92	
		SHF	0.84	0.60	1.00	0.84	0.60	1.00	0.99	0.80	
		EER	4.15	4.29	4.15	4.29	4.43	4.15	4.29	4.43	
30		Capacity	3.34	3.75	3.34	3.75	4.15	3.34	3.75	4.15	
		SHF	0.84	0.60	1.00	0.84	0.60	1.00	0.99	0.80	
		EER	4.78	4.88	4.78	4.88	4.98	4.78	4.88	4.98	
25		Capacity	3.64	4.03	3.64	4.03	4.41	3.64	4.03	4.41	
		SHF	0.84	0.60	1.00	0.84	0.60	1.00	0.99	0.80	
		EER	5.65	5.68	5.65	5.68	5.71	5.65	5.68	5.71	
20		Capacity	3.94	4.31	3.94	4.31	4.67	3.94	4.31	4.67	
		SHF	0.84	0.60	1.00	0.84	0.60	1.00	0.99	0.80	
		EER	6.51	6.47	6.51	6.47	6.43	6.51	6.47	6.43	
Minimum Frequency		46	Capacity	0.59	0.69	0.59	0.69	0.79	0.59	0.69	0.79
			EER	3.40	3.66	3.40	3.66	3.93	3.40	3.66	3.93
		40	Capacity	0.65	0.74	0.65	0.74	0.84	0.65	0.74	0.84
			EER	3.94	4.15	3.94	4.15	4.35	3.94	4.15	4.35
		35	Capacity	0.71	0.80	0.71	0.80	0.90	0.71	0.80	0.90
			EER	4.58	4.73	4.58	4.73	4.88	4.58	4.73	4.88
	30	Capacity	0.76	0.86	0.76	0.86	0.95	0.76	0.86	0.95	
		EER	5.28	5.38	5.28	5.38	5.49	5.28	5.38	5.49	
	25	Capacity	0.83	0.92	0.83	0.92	1.01	0.83	0.92	1.01	
		EER	6.22	6.26	6.22	6.26	6.29	6.22	6.26	6.29	
	20	Capacity	0.90	0.98	0.90	0.98	1.07	0.90	0.98	1.07	
		EER	7.17	7.13	7.17	7.13	7.09	7.17	7.13	7.09	

Cooling performance data (Low ambient Condition)

	Ambient temperature (°C)	INDOOR (°C)								
		DB	21		27			32		
		WB	15	19	15	19	23	15	19	23
Max Frequency	15 -10	Capacity	3.12	3.52	3.12	3.52	3.92	3.12	3.52	3.92
		SHF	0.84	0.60	1.00	0.84	0.60	1.00	0.99	0.80
		EER	4.15	4.29	4.15	4.29	4.43	4.15	4.29	4.43

* The low ambient condition requires a special control and all the performance is equal to or less than the rated operation.

Cooling performance data
MSZ-FH35VE2: MUZ-FH35VEHZ

	Ambient temperature (°C)	INDOOR (°C)									
		DB	21		27			32			
		WB	15	19	15	19	23	15	19	23	
Max frequency	46	Capacity	2.94	3.44	2.94	3.44	3.94	2.94	3.44	3.94	
		SHF	0.84	0.60	1.00	0.84	0.60	1.00	0.99	0.80	
		EER	2.51	2.71	2.51	2.71	2.90	2.51	2.71	2.90	
	40	Capacity	3.24	3.72	3.24	3.72	4.20	3.24	3.72	4.20	
		SHF	0.84	0.60	1.00	0.84	0.60	1.00	0.99	0.80	
		EER	2.91	3.07	2.91	3.07	3.22	2.91	3.07	3.22	
	35	Capacity	3.56	4.02	3.56	4.02	4.48	3.56	4.02	4.48	
		SHF	0.84	0.60	1.00	0.84	0.60	1.00	0.99	0.80	
		EER	3.38	3.50	3.38	3.50	3.61	3.38	3.50	3.61	
	30	Capacity	3.82	4.28	3.82	4.28	4.74	3.82	4.28	4.74	
		SHF	0.84	0.60	1.00	0.84	0.60	1.00	0.99	0.80	
		EER	3.90	3.98	3.90	3.98	4.06	3.90	3.98	4.06	
	25	Capacity	4.16	4.60	4.16	4.60	5.04	4.16	4.60	5.04	
		SHF	0.84	0.60	1.00	0.84	0.60	1.00	0.99	0.80	
		EER	4.60	4.63	4.60	4.63	4.65	4.60	4.63	4.65	
	20	Capacity	4.50	4.92	4.50	4.92	5.34	4.50	4.92	5.34	
		SHF	0.84	0.60	1.00	0.84	0.60	1.00	0.99	0.80	
		EER	5.30	5.27	5.30	5.27	5.24	5.30	5.27	5.24	
	Rated frequency	46	Capacity	2.57	3.01	2.57	3.01	3.45	2.57	3.01	3.45
			SHF	0.84	0.60	1.00	0.84	0.60	1.00	0.99	0.80
			EER	3.08	3.32	3.08	3.32	3.56	3.08	3.32	3.56
		40	Capacity	2.84	3.26	2.84	3.26	3.68	2.84	3.26	3.68
			SHF	0.84	0.60	1.00	0.84	0.60	1.00	0.99	0.80
			EER	3.58	3.76	3.58	3.76	3.95	3.58	3.76	3.95
35		Capacity	3.12	3.52	3.12	3.52	3.92	3.12	3.52	3.92	
		SHF	0.84	0.60	1.00	0.84	0.60	1.00	0.99	0.80	
		EER	4.15	4.29	4.15	4.29	4.43	4.15	4.29	4.43	
30		Capacity	3.34	3.75	3.34	3.75	4.15	3.34	3.75	4.15	
		SHF	0.84	0.60	1.00	0.84	0.60	1.00	0.99	0.80	
		EER	4.78	4.88	4.78	4.88	4.98	4.78	4.88	4.98	
25		Capacity	3.64	4.03	3.64	4.03	4.41	3.64	4.03	4.41	
		SHF	0.84	0.60	1.00	0.84	0.60	1.00	0.99	0.80	
		EER	5.65	5.68	5.65	5.68	5.71	5.65	5.68	5.71	
20		Capacity	3.94	4.31	3.94	4.31	4.67	3.94	4.31	4.67	
		SHF	0.84	0.60	1.00	0.84	0.60	1.00	0.99	0.80	
		EER	6.51	6.47	6.51	6.47	6.43	6.51	6.47	6.43	
Minimum Frequency		46	Capacity	0.59	0.69	0.59	0.69	0.79	0.59	0.69	0.79
			EER	3.40	3.66	3.40	3.66	3.93	3.40	3.66	3.93
		40	Capacity	0.65	0.74	0.65	0.74	0.84	0.65	0.74	0.84
			EER	3.94	4.15	3.94	4.15	4.35	3.94	4.15	4.35
		35	Capacity	0.71	0.80	0.71	0.80	0.90	0.71	0.80	0.90
			EER	4.58	4.73	4.58	4.73	4.88	4.58	4.73	4.88
	30	Capacity	0.76	0.86	0.76	0.86	0.95	0.76	0.86	0.95	
		EER	5.28	5.38	5.28	5.38	5.49	5.28	5.38	5.49	
	25	Capacity	0.83	0.92	0.83	0.92	1.01	0.83	0.92	1.01	
		EER	6.22	6.26	6.22	6.26	6.29	6.22	6.26	6.29	
	20	Capacity	0.90	0.98	0.90	0.98	1.07	0.90	0.98	1.07	
		EER	7.17	7.13	7.17	7.13	7.09	7.17	7.13	7.09	

Cooling performance data (Low ambient Condition)

	Ambient temperature (°C)	INDOOR (°C)								
		DB	21		27			32		
		WB	15	19	15	19	23	15	19	23
Max Frequency	15 -10	Capacity	3.12	3.52	3.12	3.52	3.92	3.12	3.52	3.92
		SHF	0.84	0.60	1.00	0.84	0.60	1.00	0.99	0.80
		EER	4.15	4.29	4.15	4.29	4.43	4.15	4.29	4.43

* The low ambient condition requires a special control and all the performance is equal to or less than the rated operation.

Cooling performance data
MSZ-FH50VE2: MUZ-FH50VE

	Ambient temperature (°C)	INDOOR (°C)									
		DB	21		27			32			
		WB	15	19	15	19	23	15	19	23	
Max frequency	46	Capacity	4.41	5.16	4.41	5.16	5.91	4.41	5.16	5.91	
		SHF	0.73	0.49	0.97	0.73	0.49	1.00	0.93	0.69	
		EER	1.92	2.07	1.92	2.07	2.23	1.92	2.07	2.23	
	40	Capacity	4.86	5.58	4.86	5.58	6.30	4.86	5.58	6.30	
		SHF	0.73	0.49	0.97	0.73	0.49	1.00	0.93	0.69	
		EER	2.23	2.35	2.23	2.35	2.47	2.23	2.35	2.47	
	35	Capacity	5.34	6.03	5.34	6.03	6.72	5.34	6.03	6.72	
		SHF	0.73	0.49	0.97	0.73	0.49	1.00	0.93	0.69	
		EER	2.59	2.68	2.59	2.68	2.77	2.59	2.68	2.77	
	30	Capacity	5.73	6.42	5.73	6.42	7.11	5.73	6.42	7.11	
		SHF	0.73	0.49	0.97	0.73	0.49	1.00	0.93	0.69	
		EER	2.99	3.05	2.99	3.05	3.11	2.99	3.05	3.11	
	25	Capacity	6.24	6.90	6.24	6.90	7.56	6.24	6.90	7.56	
		SHF	0.73	0.49	0.97	0.73	0.49	1.00	0.93	0.69	
		EER	3.53	3.55	3.53	3.55	3.56	3.53	3.55	3.56	
	20	Capacity	6.75	7.38	6.75	7.38	8.01	6.75	7.38	8.01	
		SHF	0.73	0.49	0.97	0.73	0.49	1.00	0.93	0.69	
		EER	4.07	4.04	4.07	4.04	4.02	4.07	4.04	4.02	
	Rated frequency	46	Capacity	3.68	4.30	3.68	4.30	4.93	3.68	4.30	4.93
			SHF	0.73	0.49	0.97	0.73	0.49	1.00	0.93	0.69
			EER	2.61	2.82	2.61	2.82	3.02	2.61	2.82	3.02
		40	Capacity	4.05	4.65	4.05	4.65	5.25	4.05	4.65	5.25
			SHF	0.73	0.49	0.97	0.73	0.49	1.00	0.93	0.69
			EER	3.03	3.19	3.03	3.19	3.35	3.03	3.19	3.35
35		Capacity	4.45	5.03	4.45	5.03	5.60	4.45	5.03	5.60	
		SHF	0.73	0.49	0.97	0.73	0.49	1.00	0.93	0.69	
		EER	3.53	3.64	3.53	3.64	3.76	3.53	3.64	3.76	
30		Capacity	4.78	5.35	4.78	5.35	5.93	4.78	5.35	5.93	
		SHF	0.73	0.49	0.97	0.73	0.49	1.00	0.93	0.69	
		EER	4.06	4.15	4.06	4.15	4.23	4.06	4.15	4.23	
25		Capacity	5.20	5.75	5.20	5.75	6.30	5.20	5.75	6.30	
		SHF	0.73	0.49	0.97	0.73	0.49	1.00	0.93	0.69	
		EER	4.79	4.82	4.79	4.82	4.84	4.79	4.82	4.84	
20		Capacity	5.63	6.15	5.63	6.15	6.68	5.63	6.15	6.68	
		SHF	0.73	0.49	0.97	0.73	0.49	1.00	0.93	0.69	
		EER	5.52	5.49	5.52	5.49	5.46	5.52	5.49	5.46	
Minimum Frequency		46	Capacity	1.40	1.63	1.40	1.63	1.87	1.40	1.63	1.87
			EER	3.34	3.61	3.34	3.61	3.87	3.34	3.61	3.87
		40	Capacity	1.54	1.77	1.54	1.77	2.00	1.54	1.77	2.00
			EER	3.88	4.08	3.88	4.08	4.29	3.88	4.08	4.29
		35	Capacity	1.69	1.91	1.69	1.91	2.13	1.69	1.91	2.13
			EER	4.51	4.66	4.51	4.66	4.81	4.51	4.66	4.81
	30	Capacity	1.81	2.03	1.81	2.03	2.25	1.81	2.03	2.25	
		EER	5.19	5.30	5.19	5.30	5.41	5.19	5.30	5.41	
	25	Capacity	1.98	2.19	1.98	2.19	2.39	1.98	2.19	2.39	
		EER	6.13	6.16	6.13	6.16	6.19	6.13	6.16	6.19	
	20	Capacity	2.14	2.34	2.14	2.34	2.54	2.14	2.34	2.54	
		EER	7.07	7.02	7.07	7.02	6.98	7.07	7.02	6.98	

Cooling performance data (Low ambient Condition)

	Ambient temperature (°C)	INDOOR (°C)								
		DB	21		27			32		
		WB	15	19	15	19	23	15	19	23
Max Frequency	15 -10	Capacity	4.45	5.03	4.45	5.03	5.60	4.45	5.03	5.60
		SHF	0.73	0.49	0.97	0.73	0.49	1.00	0.93	0.69
		EER	3.53	3.64	3.53	3.64	3.76	3.53	3.64	3.76

* The low ambient condition requires a special control and all the performance is equal to or less than the rated operation.

Cooling performance data
MSZ-FH50VE2: MUZ-FH50VEHZ

	Ambient temperature (°C)	INDOOR (°C)									
		DB	21		27			32			
		WB	15	19	15	19	23	15	19	23	
Max frequency	46	Capacity	4.41	5.16	4.41	5.16	5.91	4.41	5.16	5.91	
		SHF	0.73	0.49	0.97	0.73	0.49	1.00	0.93	0.69	
		EER	1.92	2.07	1.92	2.07	2.23	1.92	2.07	2.23	
	40	Capacity	4.86	5.58	4.86	5.58	6.30	4.86	5.58	6.30	
		SHF	0.73	0.49	0.97	0.73	0.49	1.00	0.93	0.69	
		EER	2.23	2.35	2.23	2.35	2.47	2.23	2.35	2.47	
	35	Capacity	5.34	6.03	5.34	6.03	6.72	5.34	6.03	6.72	
		SHF	0.73	0.49	0.97	0.73	0.49	1.00	0.93	0.69	
		EER	2.59	2.68	2.59	2.68	2.77	2.59	2.68	2.77	
	30	Capacity	5.73	6.42	5.73	6.42	7.11	5.73	6.42	7.11	
		SHF	0.73	0.49	0.97	0.73	0.49	1.00	0.93	0.69	
		EER	2.99	3.05	2.99	3.05	3.11	2.99	3.05	3.11	
	25	Capacity	6.24	6.90	6.24	6.90	7.56	6.24	6.90	7.56	
		SHF	0.73	0.49	0.97	0.73	0.49	1.00	0.93	0.69	
		EER	3.53	3.55	3.53	3.55	3.56	3.53	3.55	3.56	
	20	Capacity	6.75	7.38	6.75	7.38	8.01	6.75	7.38	8.01	
		SHF	0.73	0.49	0.97	0.73	0.49	1.00	0.93	0.69	
		EER	4.07	4.04	4.07	4.04	4.02	4.07	4.04	4.02	
	Rated frequency	46	Capacity	3.68	4.30	3.68	4.30	4.93	3.68	4.30	4.93
			SHF	0.73	0.49	0.97	0.73	0.49	1.00	0.93	0.69
			EER	2.61	2.82	2.61	2.82	3.02	2.61	2.82	3.02
		40	Capacity	4.05	4.65	4.05	4.65	5.25	4.05	4.65	5.25
			SHF	0.73	0.49	0.97	0.73	0.49	1.00	0.93	0.69
			EER	3.03	3.19	3.03	3.19	3.35	3.03	3.19	3.35
35		Capacity	4.45	5.03	4.45	5.03	5.60	4.45	5.03	5.60	
		SHF	0.73	0.49	0.97	0.73	0.49	1.00	0.93	0.69	
		EER	3.53	3.64	3.53	3.64	3.76	3.53	3.64	3.76	
30		Capacity	4.78	5.35	4.78	5.35	5.93	4.78	5.35	5.93	
		SHF	0.73	0.49	0.97	0.73	0.49	1.00	0.93	0.69	
		EER	4.06	4.15	4.06	4.15	4.23	4.06	4.15	4.23	
25		Capacity	5.20	5.75	5.20	5.75	6.30	5.20	5.75	6.30	
		SHF	0.73	0.49	0.97	0.73	0.49	1.00	0.93	0.69	
		EER	4.79	4.82	4.79	4.82	4.84	4.79	4.82	4.84	
20		Capacity	5.63	6.15	5.63	6.15	6.68	5.63	6.15	6.68	
		SHF	0.73	0.49	0.97	0.73	0.49	1.00	0.93	0.69	
		EER	5.52	5.49	5.52	5.49	5.46	5.52	5.49	5.46	
Minimum Frequency		46	Capacity	1.40	1.63	1.40	1.63	1.87	1.40	1.63	1.87
			EER	3.34	3.61	3.34	3.61	3.87	3.34	3.61	3.87
		40	Capacity	1.54	1.77	1.54	1.77	2.00	1.54	1.77	2.00
			EER	3.88	4.08	3.88	4.08	4.29	3.88	4.08	4.29
		35	Capacity	1.69	1.91	1.69	1.91	2.13	1.69	1.91	2.13
			EER	4.51	4.66	4.51	4.66	4.81	4.51	4.66	4.81
	30	Capacity	1.81	2.03	1.81	2.03	2.25	1.81	2.03	2.25	
		EER	5.19	5.30	5.19	5.30	5.41	5.19	5.30	5.41	
	25	Capacity	1.98	2.19	1.98	2.19	2.39	1.98	2.19	2.39	
		EER	6.13	6.16	6.13	6.16	6.19	6.13	6.16	6.19	
	20	Capacity	2.14	2.34	2.14	2.34	2.54	2.14	2.34	2.54	
		EER	7.07	7.02	7.07	7.02	6.98	7.07	7.02	6.98	

WALL-MOUNTED PERFORMANCE DATA

Cooling performance data (Low ambient Condition)

	Ambient temperature (°C)	INDOOR (°C)								
		DB	21		27			32		
		WB	15	19	15	19	23	15	19	23
Max Frequency	15 -10	Capacity	4.45	5.03	4.45	5.03	5.60	4.45	5.03	5.60
		SHF	0.73	0.49	0.97	0.73	0.49	1.00	0.93	0.69
		EER	3.53	3.64	3.53	3.64	3.76	3.53	3.64	3.76

* The low ambient condition requires a special control and all the performance is equal to or less than the rated operation.

Cooling performance data

MSZ-EF25VGW/B/S, MSZ-EF25VGKW/B/S: MUZ-EF25VG, MUZ-EF25VGH

	Ambient temperature (°C)	INDOOR (°C)									
		DB	21		27			32			
		WB	15	19	15	19	23	15	19	23	
Max frequency	46	Capacity	2.50	2.92	2.50	2.92	3.35	2.50	2.92	3.35	
		SHF	0.80	0.56	1.00	0.80	0.56	1.00	0.97	0.76	
		EER	2.13	2.30	2.13	2.30	2.47	2.13	2.30	2.47	
	40	Capacity	2.75	3.16	2.75	3.16	3.57	2.75	3.16	3.57	
		SHF	0.80	0.56	1.00	0.80	0.56	1.00	0.97	0.76	
		EER	2.48	2.61	2.48	2.61	2.73	2.48	2.61	2.73	
	35	Capacity	3.03	3.42	3.03	3.42	3.81	3.03	3.42	3.81	
		SHF	0.80	0.56	1.00	0.80	0.56	1.00	0.97	0.76	
		EER	2.88	2.97	2.88	2.97	3.07	2.88	2.97	3.07	
	30	Capacity	3.25	3.64	3.25	3.64	4.03	3.25	3.64	4.03	
		SHF	0.80	0.56	1.00	0.80	0.56	1.00	0.97	0.76	
		EER	3.31	3.38	3.31	3.38	3.45	3.31	3.38	3.45	
	25	Capacity	3.54	3.91	3.54	3.91	4.28	3.54	3.91	4.28	
		SHF	0.80	0.56	1.00	0.80	0.56	1.00	0.97	0.76	
		EER	3.91	3.93	3.91	3.93	3.95	3.91	3.93	3.95	
	20	Capacity	3.83	4.18	3.83	4.18	4.54	3.83	4.18	4.54	
		SHF	0.80	0.56	1.00	0.80	0.56	1.00	0.97	0.76	
		EER	4.51	4.48	4.51	4.48	4.45	4.51	4.48	4.45	
	Rated frequency	46	Capacity	1.84	2.15	1.84	2.15	2.46	1.84	2.15	2.46
			SHF	0.97	0.73	1.00	0.96	0.73	1.00	1.00	0.93
			EER	3.34	3.60	3.34	3.60	3.86	3.34	3.60	3.86
		40	Capacity	2.03	2.33	2.03	2.33	2.63	2.03	2.33	2.63
			SHF	0.97	0.73	1.00	0.96	0.73	1.00	1.00	0.93
			EER	3.88	4.08	3.88	4.08	4.28	3.88	4.08	4.28
35		Capacity	2.23	2.51	2.23	2.51	2.80	2.23	2.51	2.80	
		SHF	0.97	0.73	1.00	0.96	0.73	1.00	1.00	0.93	
		EER	4.50	4.65	4.50	4.65	4.80	4.50	4.65	4.80	
30		Capacity	2.39	2.68	2.39	2.68	2.96	2.39	2.68	2.96	
		SHF	0.97	0.73	1.00	0.96	0.73	1.00	1.00	0.93	
		EER	5.19	5.30	5.19	5.30	5.40	5.19	5.30	5.40	
25		Capacity	2.60	2.88	2.60	2.88	3.15	2.60	2.88	3.15	
		SHF	0.97	0.73	1.00	0.96	0.73	1.00	1.00	0.93	
		EER	6.12	6.16	6.12	6.16	6.19	6.12	6.16	6.19	
20		Capacity	2.81	3.08	2.81	3.08	3.34	2.81	3.08	3.34	
		SHF	0.97	0.73	1.00	0.96	0.73	1.00	1.00	0.93	
		EER	7.06	7.02	7.06	7.02	6.97	7.06	7.02	6.97	
Minimum Frequency		46	Capacity	0.66	0.77	0.66	0.77	0.89	0.66	0.77	0.89
			EER	2.82	3.04	2.82	3.04	3.27	2.82	3.04	3.27
		40	Capacity	0.73	0.84	0.73	0.84	0.95	0.73	0.84	0.95
			EER	3.28	3.45	3.28	3.45	3.62	3.28	3.45	3.62
		35	Capacity	0.80	0.90	0.80	0.90	1.01	0.80	0.90	1.01
			EER	3.81	3.93	3.81	3.93	4.06	3.81	3.93	4.06
	30	Capacity	0.86	0.96	0.86	0.96	1.07	0.86	0.96	1.07	
		EER	4.39	4.48	4.39	4.48	4.57	4.39	4.48	4.57	
	25	Capacity	0.94	1.04	0.94	1.04	1.13	0.94	1.04	1.13	
		EER	5.18	5.20	5.18	5.20	5.23	5.18	5.20	5.23	
	20	Capacity	1.01	1.11	1.01	1.11	1.20	1.01	1.11	1.20	
		EER	5.97	5.93	5.97	5.93	5.89	5.97	5.93	5.89	

PERFORMANCE DATA

WALL-MOUNTED

Cooling performance data (Low ambient Condition)

	Ambient temperature (°C)	INDOOR (°C)								
		DB	21		27			32		
		WB	15	19	15	19	23	15	19	23
Max Frequency	15 -10	Capacity	2.23	2.51	2.23	2.51	2.80	2.23	2.51	2.80
		SHF	0.97	0.73	1.00	0.96	0.73	1.00	1.00	0.93
		EER	4.50	4.65	4.50	4.65	4.80	4.50	4.65	4.80

* The low ambient condition requires a special control and all the performance is equal to or less than the rated operation.

Cooling performance data

MSZ-EF35VGW/B/S, MSZ-EF35VGKW/B/S: MUZ-EF35VG, MUZ-EF35VGH

	Ambient temperature (°C)	INDOOR (°C)									
		DB	21		27			32			
		WB	15	19	15	19	23	15	19	23	
Max frequency	46	Capacity	3.11	3.35	3.11	3.35	3.60	3.11	3.35	3.60	
		SHF	0.79	0.55	1.00	0.79	0.55	1.00	0.97	0.75	
		EER	1.92	2.07	1.92	2.07	2.23	1.92	2.07	2.23	
	40	Capacity	3.45	3.72	3.45	3.72	3.99	3.45	3.72	3.99	
		SHF	0.79	0.55	1.00	0.79	0.55	1.00	0.97	0.75	
		EER	2.23	2.35	2.23	2.35	2.47	2.23	2.35	2.47	
	35	Capacity	3.61	4.02	3.61	4.02	4.43	3.61	4.02	4.43	
		SHF	0.79	0.55	1.00	0.79	0.55	1.00	0.97	0.75	
		EER	2.59	2.68	2.59	2.68	2.77	2.59	2.68	2.77	
	30	Capacity	3.82	4.28	3.82	4.28	4.74	3.82	4.28	4.74	
		SHF	0.79	0.55	1.00	0.79	0.55	1.00	0.97	0.75	
		EER	2.99	3.05	2.99	3.05	3.11	2.99	3.05	3.11	
	25	Capacity	4.16	4.60	4.16	4.60	5.04	4.16	4.60	5.04	
		SHF	0.79	0.55	1.00	0.79	0.55	1.00	0.97	0.75	
		EER	3.53	3.55	3.53	3.55	3.56	3.53	3.55	3.56	
	20	Capacity	4.50	4.92	4.50	4.92	5.34	4.50	4.92	5.34	
		SHF	0.79	0.55	1.00	0.79	0.55	1.00	0.97	0.75	
		EER	4.07	4.04	4.07	4.04	4.02	4.07	4.04	4.02	
	Rated frequency	46	Capacity	2.57	3.01	2.57	3.01	3.45	2.57	3.01	3.45
			SHF	0.80	0.56	1.00	0.80	0.56	1.00	0.97	0.76
			EER	2.78	2.99	2.78	2.99	3.21	2.78	2.99	3.21
		40	Capacity	2.84	3.26	2.84	3.26	3.68	2.84	3.26	3.68
			SHF	0.80	0.56	1.00	0.80	0.56	1.00	0.97	0.76
			EER	3.22	3.39	3.22	3.39	3.56	3.22	3.39	3.56
35		Capacity	3.12	3.52	3.12	3.52	3.92	3.12	3.52	3.92	
		SHF	0.80	0.56	1.00	0.80	0.56	1.00	0.97	0.76	
		EER	3.74	3.87	3.74	3.87	3.99	3.74	3.87	3.99	
30		Capacity	3.34	3.75	3.34	3.75	4.15	3.34	3.75	4.15	
		SHF	0.80	0.56	1.00	0.80	0.56	1.00	0.97	0.76	
		EER	4.31	4.40	4.31	4.40	4.49	4.31	4.40	4.49	
25		Capacity	3.64	4.03	3.64	4.03	4.41	3.64	4.03	4.41	
		SHF	0.80	0.56	1.00	0.80	0.56	1.00	0.97	0.76	
		EER	5.09	5.11	5.09	5.11	5.14	5.09	5.11	5.14	
20		Capacity	3.94	4.31	3.94	4.31	4.67	3.94	4.31	4.67	
		SHF	0.80	0.56	1.00	0.80	0.56	1.00	0.97	0.76	
		EER	5.86	5.83	5.86	5.83	5.79	5.86	5.83	5.79	
Minimum Frequency		46	Capacity	0.81	0.95	0.81	0.95	1.08	0.81	0.95	1.08
			EER	3.78	4.08	3.78	4.08	4.37	3.78	4.08	4.37
		40	Capacity	0.89	1.02	0.89	1.02	1.16	0.89	1.02	1.16
			EER	4.39	4.62	4.39	4.62	4.84	4.39	4.62	4.84
		35	Capacity	0.98	1.11	0.98	1.11	1.23	0.98	1.11	1.23
			EER	5.10	5.26	5.10	5.26	5.43	5.10	5.26	5.43
	30	Capacity	1.05	1.18	1.05	1.18	1.30	1.05	1.18	1.30	
		EER	5.87	5.99	5.87	5.99	6.11	5.87	5.99	6.11	
	25	Capacity	1.14	1.27	1.14	1.27	1.39	1.14	1.27	1.39	
		EER	6.93	6.97	6.93	6.97	7.00	6.93	6.97	7.00	
	20	Capacity	1.24	1.35	1.24	1.35	1.47	1.24	1.35	1.47	
		EER	7.99	7.94	7.99	7.94	7.89	7.99	7.94	7.89	

Cooling performance data (Low ambient Condition)

	Ambient temperature (°C)	INDOOR (°C)								
		DB	21		27			32		
		WB	15	19	15	19	23	15	19	23
Max Frequency	15 -10	Capacity	3.12	3.52	3.12	3.52	3.92	3.12	3.52	3.92
		SHF	0.80	0.56	1.00	0.80	0.56	1.00	0.97	0.76
		EER	3.74	3.87	3.74	3.87	3.99	3.74	3.87	3.99

* The low ambient condition requires a special control and all the performance is equal to or less than the rated operation.

Cooling performance data

MSZ-EF42VGW/B/S, MSZ-EF42VGKW/B/S: MUZ-EF42VG

	Ambient temperature (°C)	INDOOR (°C)									
		DB	21		27			32			
		WB	15	19	15	19	23	15	19	23	
Max frequency	46	Capacity	3.42	3.96	3.42	3.96	4.49	3.42	3.96	4.49	
		SHF	0.71	0.47	0.95	0.71	0.47	1.00	0.91	0.67	
		EER	1.72	1.85	1.72	1.85	1.99	1.72	1.85	1.99	
	40	Capacity	3.73	4.28	3.73	4.28	4.83	3.73	4.28	4.83	
		SHF	0.71	0.47	0.95	0.71	0.47	1.00	0.91	0.67	
		EER	2.00	2.10	2.00	2.10	2.20	2.00	2.10	2.20	
	35	Capacity	4.09	4.62	4.09	4.62	5.15	4.09	4.62	5.15	
		SHF	0.71	0.47	0.95	0.71	0.47	1.00	0.91	0.67	
		EER	2.32	2.40	2.32	2.40	2.47	2.32	2.40	2.47	
	30	Capacity	4.39	4.92	4.39	4.92	5.45	4.39	4.92	5.45	
		SHF	0.71	0.47	0.95	0.71	0.47	1.00	0.91	0.67	
		EER	2.67	2.73	2.67	2.73	2.78	2.67	2.73	2.78	
	25	Capacity	4.78	5.29	4.78	5.29	5.80	4.78	5.29	5.80	
		SHF	0.71	0.47	0.95	0.71	0.47	1.00	0.91	0.67	
		EER	3.15	3.17	3.15	3.17	3.19	3.15	3.17	3.19	
	20	Capacity	5.18	5.66	5.18	5.66	6.14	5.18	5.66	6.14	
		SHF	0.71	0.47	0.95	0.71	0.47	1.00	0.91	0.67	
		EER	3.63	3.61	3.63	3.61	3.59	3.63	3.61	3.59	
	Rated frequency	46	Capacity	3.09	3.61	3.09	3.61	4.14	3.09	3.61	4.14
			SHF	0.74	0.50	0.98	0.74	0.50	1.00	0.94	0.70
			EER	2.53	2.72	2.53	2.72	2.92	2.53	2.72	2.92
		40	Capacity	3.40	3.91	3.40	3.91	4.41	3.40	3.91	4.41
			SHF	0.74	0.50	0.98	0.74	0.50	1.00	0.94	0.70
			EER	2.93	3.08	2.93	3.08	3.24	2.93	3.08	3.24
35		Capacity	3.74	4.22	3.74	4.22	4.70	3.74	4.22	4.70	
		SHF	0.74	0.50	0.98	0.74	0.50	1.00	0.94	0.70	
		EER	3.41	3.52	3.41	3.52	3.63	3.41	3.52	3.63	
30		Capacity	4.01	4.49	4.01	4.49	4.98	4.01	4.49	4.98	
		SHF	0.74	0.50	0.98	0.74	0.50	1.00	0.94	0.70	
		EER	3.92	4.00	3.92	4.00	4.09	3.92	4.00	4.09	
25		Capacity	4.37	4.83	4.37	4.83	5.29	4.37	4.83	5.29	
		SHF	0.74	0.50	0.98	0.74	0.50	1.00	0.94	0.70	
		EER	4.63	4.65	4.63	4.65	4.68	4.63	4.65	4.68	
20		Capacity	4.73	5.17	4.73	5.17	5.61	4.73	5.17	5.61	
		SHF	0.74	0.50	0.98	0.74	0.50	1.00	0.94	0.70	
		EER	5.34	5.30	5.34	5.30	5.27	5.34	5.30	5.27	
Minimum Frequency		46	Capacity	0.66	0.77	0.66	0.77	0.89	0.66	0.77	0.89
			EER	4.33	4.67	4.33	4.67	5.01	4.33	4.67	5.01
		40	Capacity	0.73	0.84	0.73	0.84	0.95	0.73	0.84	0.95
			EER	5.03	5.29	5.03	5.29	5.55	5.03	5.29	5.55
		35	Capacity	0.80	0.90	0.80	0.90	1.01	0.80	0.90	1.01
			EER	5.84	6.03	5.84	6.03	6.22	5.84	6.03	6.22
	30	Capacity	0.86	0.96	0.86	0.96	1.07	0.86	0.96	1.07	
		EER	6.73	6.86	6.73	6.86	7.00	6.73	6.86	7.00	
	25	Capacity	0.94	1.04	0.94	1.04	1.13	0.94	1.04	1.13	
		EER	7.94	7.98	7.94	7.98	8.02	7.94	7.98	8.02	
	20	Capacity	1.01	1.11	1.01	1.11	1.20	1.01	1.11	1.20	
		EER	9.15	9.09	9.15	9.09	9.04	9.15	9.09	9.04	

Cooling performance data (Low ambient Condition)

	Ambient temperature (°C)	INDOOR (°C)								
		DB	21		27			32		
		WB	15	19	15	19	23	15	19	23
Max Frequency	15 -10	Capacity	3.74	4.22	3.74	4.22	4.70	3.74	4.22	4.70
		SHF	0.74	0.50	0.98	0.74	0.50	1.00	0.94	0.70
		EER	3.41	3.52	3.41	3.52	3.63	3.41	3.52	3.63

* The low ambient condition requires a special control and all the performance is equal to or less than the rated operation.

Cooling performance data

MSZ-EF50VGW/B/S, MSZ-EF50VGKW/B/S: MUZ-EF50VG

	Ambient temperature (°C)	INDOOR (°C)									
		DB	21		27			32			
		WB	15	19	15	19	23	15	19	23	
Max frequency	46	Capacity	3.97	4.64	3.97	4.64	5.32	3.97	4.64	5.32	
		SHF	0.70	0.46	0.94	0.70	0.46	1.00	0.90	0.66	
		EER	1.97	2.12	1.97	2.12	2.28	1.97	2.12	2.28	
	40	Capacity	4.37	5.02	4.37	5.02	5.67	4.37	5.02	5.67	
		SHF	0.70	0.46	0.94	0.70	0.46	1.00	0.90	0.66	
		EER	2.28	2.40	2.28	2.40	2.52	2.28	2.40	2.52	
	35	Capacity	4.81	5.43	4.81	5.43	6.05	4.81	5.43	6.05	
		SHF	0.70	0.46	0.94	0.70	0.46	1.00	0.90	0.66	
		EER	2.65	2.74	2.65	2.74	2.83	2.65	2.74	2.83	
	30	Capacity	5.16	5.78	5.16	5.78	6.40	5.16	5.78	6.40	
		SHF	0.70	0.46	0.94	0.70	0.46	1.00	0.90	0.66	
		EER	3.06	3.12	3.06	3.12	3.18	3.06	3.12	3.18	
	25	Capacity	5.62	6.21	5.62	6.21	6.80	5.62	6.21	6.80	
		SHF	0.70	0.46	0.94	0.70	0.46	1.00	0.90	0.66	
		EER	3.61	3.63	3.61	3.63	3.65	3.61	3.63	3.65	
	20	Capacity	6.08	6.64	6.08	6.64	7.21	6.08	6.64	7.21	
		SHF	0.70	0.46	0.94	0.70	0.46	1.00	0.90	0.66	
		EER	4.16	4.13	4.16	4.13	4.11	4.16	4.13	4.11	
	Rated frequency	46	Capacity	3.68	4.30	3.68	4.30	4.93	3.68	4.30	4.93
			SHF	0.70	0.46	0.94	0.70	0.46	1.00	0.90	0.66
			EER	2.34	2.53	2.34	2.53	2.71	2.34	2.53	2.71
		40	Capacity	4.05	4.65	4.05	4.65	5.25	4.05	4.65	5.25
			SHF	0.70	0.46	0.94	0.70	0.46	1.00	0.90	0.66
			EER	2.72	2.86	2.72	2.86	3.00	2.72	2.86	3.00
35		Capacity	4.45	5.03	4.45	5.03	5.60	4.45	5.03	5.60	
		SHF	0.70	0.46	0.94	0.70	0.46	1.00	0.90	0.66	
		EER	3.16	3.26	3.16	3.26	3.37	3.16	3.26	3.37	
30		Capacity	4.78	5.35	4.78	5.35	5.93	4.78	5.35	5.93	
		SHF	0.70	0.46	0.94	0.70	0.46	1.00	0.90	0.66	
		EER	3.64	3.71	3.64	3.71	3.79	3.64	3.71	3.79	
25		Capacity	5.20	5.75	5.20	5.75	6.30	5.20	5.75	6.30	
		SHF	0.70	0.46	0.94	0.70	0.46	1.00	0.90	0.66	
		EER	4.29	4.32	4.29	4.32	4.34	4.29	4.32	4.34	
20		Capacity	5.63	6.15	5.63	6.15	6.68	5.63	6.15	6.68	
		SHF	0.70	0.46	0.94	0.70	0.46	1.00	0.90	0.66	
		EER	4.95	4.92	4.95	4.92	4.89	4.95	4.92	4.89	
Minimum Frequency		46	Capacity	1.03	1.20	1.03	1.20	1.38	1.03	1.20	1.38
			EER	3.37	3.63	3.37	3.63	3.89	3.37	3.63	3.89
		40	Capacity	1.13	1.30	1.13	1.30	1.47	1.13	1.30	1.47
			EER	3.91	4.11	3.91	4.11	4.32	3.91	4.11	4.32
		35	Capacity	1.25	1.41	1.25	1.41	1.57	1.25	1.41	1.57
			EER	4.54	4.69	4.54	4.69	4.84	4.54	4.69	4.84
	30	Capacity	1.34	1.50	1.34	1.50	1.66	1.34	1.50	1.66	
		EER	5.23	5.34	5.23	5.34	5.45	5.23	5.34	5.45	
	25	Capacity	1.46	1.61	1.46	1.61	1.76	1.46	1.61	1.76	
		EER	6.17	6.21	6.17	6.21	6.24	6.17	6.21	6.24	
	20	Capacity	1.58	1.72	1.58	1.72	1.87	1.58	1.72	1.87	
		EER	7.11	7.07	7.11	7.07	7.03	7.11	7.07	7.03	

Cooling performance data (Low ambient Condition)

	Ambient temperature (°C)	INDOOR (°C)								
		DB	21		27			32		
		WB	15	19	15	19	23	15	19	23
Max Frequency	15 -10	Capacity	4.45	5.03	4.45	5.03	5.60	4.45	5.03	5.60
		SHF	0.70	0.46	0.94	0.70	0.46	1.00	0.90	0.66
		EER	3.16	3.26	3.16	3.26	3.37	3.16	3.26	3.37

* The low ambient condition requires a special control and all the performance is equal to or less than the rated operation.

Cooling performance data
MSZ-BT20VG, MSZ-BT20VGK: MUZ-BT20VG

	Ambient temperature (°C)	INDOOR (°C)									
		DB	21		27			32			
		WB	15	19	15	19	23	15	19	23	
Max frequency	46	Capacity	2.13	2.49	2.13	2.49	2.86	2.13	2.49	2.86	
		SHF	0.99	0.75	1.00	0.97	0.75	1.00	1.00	0.95	
		EER	2.05	2.21	2.05	2.21	2.37	2.05	2.21	2.37	
	40	Capacity	2.35	2.70	2.35	2.70	3.05	2.35	2.70	3.05	
		SHF	0.99	0.75	1.00	0.97	0.75	1.00	1.00	0.95	
		EER	2.38	2.51	2.38	2.51	2.63	2.38	2.51	2.63	
	35	Capacity	2.58	2.91	2.58	2.91	3.25	2.58	2.91	3.25	
		SHF	0.99	0.75	1.00	0.97	0.75	1.00	1.00	0.95	
		EER	2.77	2.86	2.77	2.86	2.95	2.77	2.86	2.95	
	30	Capacity	2.77	3.10	2.77	3.10	3.44	2.77	3.10	3.44	
		SHF	0.99	0.75	1.00	0.97	0.75	1.00	1.00	0.95	
		EER	3.19	3.25	3.19	3.25	3.32	3.19	3.25	3.32	
	25	Capacity	3.02	3.34	3.02	3.34	3.65	3.02	3.34	3.65	
		SHF	0.99	0.75	1.00	0.97	0.75	1.00	1.00	0.95	
		EER	3.76	3.78	3.76	3.78	3.80	3.76	3.78	3.80	
	20	Capacity	3.26	3.57	3.26	3.57	3.87	3.26	3.57	3.87	
		SHF	0.99	0.75	1.00	0.97	0.75	1.00	1.00	0.95	
		EER	4.33	4.31	4.33	4.31	4.28	4.33	4.31	4.28	
	Rated frequency	46	Capacity	1.47	1.72	1.47	1.72	1.97	1.47	1.72	1.97
			SHF	0.99	0.75	1.00	0.97	0.75	1.00	1.00	0.95
			EER	3.21	3.46	3.21	3.46	3.71	3.21	3.46	3.71
		40	Capacity	1.62	1.86	1.62	1.86	2.10	1.62	1.86	2.10
			SHF	0.99	0.75	1.00	0.97	0.75	1.00	1.00	0.95
			EER	3.72	3.92	3.72	3.92	4.11	3.72	3.92	4.11
35		Capacity	1.78	2.01	1.78	2.01	2.24	1.78	2.01	2.24	
		SHF	0.99	0.75	1.00	0.97	0.75	1.00	1.00	0.95	
		EER	4.32	4.47	4.32	4.47	4.61	4.32	4.47	4.61	
30		Capacity	1.91	2.14	1.91	2.14	2.37	1.91	2.14	2.37	
		SHF	0.99	0.75	1.00	0.97	0.75	1.00	1.00	0.95	
		EER	4.98	5.09	4.98	5.09	5.19	4.98	5.09	5.19	
25		Capacity	2.08	2.30	2.08	2.30	2.52	2.08	2.30	2.52	
		SHF	0.99	0.75	1.00	0.97	0.75	1.00	1.00	0.95	
		EER	5.88	5.91	5.88	5.91	5.94	5.88	5.91	5.94	
20		Capacity	2.25	2.46	2.25	2.46	2.67	2.25	2.46	2.67	
		SHF	0.99	0.75	1.00	0.97	0.75	1.00	1.00	0.95	
		EER	6.78	6.73	6.78	6.73	6.69	6.78	6.73	6.69	
Minimum Frequency		46	Capacity	0.37	0.43	0.37	0.43	0.49	0.37	0.43	0.49
			EER	2.41	2.59	2.41	2.59	2.78	2.41	2.59	2.78
		40	Capacity	0.41	0.47	0.41	0.47	0.53	0.41	0.47	0.53
			EER	2.79	2.94	2.79	2.94	3.08	2.79	2.94	3.08
		35	Capacity	0.45	0.50	0.45	0.50	0.56	0.45	0.50	0.56
			EER	3.24	3.35	3.24	3.35	3.46	3.24	3.35	3.46
	30	Capacity	0.48	0.54	0.48	0.54	0.59	0.48	0.54	0.59	
		EER	3.74	3.81	3.74	3.81	3.89	3.74	3.81	3.89	
	25	Capacity	0.52	0.58	0.52	0.58	0.63	0.52	0.58	0.63	
		EER	4.41	4.43	4.41	4.43	4.46	4.41	4.43	4.46	
	20	Capacity	0.56	0.62	0.56	0.62	0.67	0.56	0.62	0.67	
		EER	5.08	5.05	5.08	5.05	5.02	5.08	5.05	5.02	

Cooling performance data (Low ambient Condition)

	Ambient temperature (°C)	INDOOR (°C)								
		DB	21		27			32		
		WB	15	19	15	19	23	15	19	23
Max Frequency	15 -10	Capacity	1.78	2.01	1.78	2.01	2.24	1.78	2.01	2.24
		SHF	0.99	0.75	1.00	0.97	0.75	1.00	1.00	0.95
		EER	4.32	4.47	4.32	4.47	4.61	4.32	4.47	4.61

* The low ambient condition requires a special control and all the performance is equal to or less than the rated operation.

Cooling performance data
MSZ-BT25VG, MSZ-BT25VGK: MUZ-BT25VG

	Ambient temperature (°C)	INDOOR (°C)									
		DB	21		27			32			
		WB	15	19	15	19	23	15	19	23	
Max frequency	46	Capacity	2.21	2.58	2.21	2.58	2.96	2.21	2.58	2.96	
		SHF	0.74	0.50	0.98	0.74	0.50	1.00	0.94	0.70	
		EER	2.08	2.24	2.08	2.24	2.41	2.08	2.24	2.41	
	40	Capacity	2.43	2.79	2.43	2.79	3.15	2.43	2.79	3.15	
		SHF	0.74	0.50	0.98	0.74	0.50	1.00	0.94	0.70	
		EER	2.42	2.54	2.42	2.54	2.67	2.42	2.54	2.67	
	35	Capacity	2.67	3.02	2.67	3.02	3.36	2.67	3.02	3.36	
		SHF	0.74	0.50	0.98	0.74	0.50	1.00	0.94	0.70	
		EER	2.81	2.90	2.81	2.90	2.99	2.81	2.90	2.99	
	30	Capacity	2.87	3.21	2.87	3.21	3.56	2.87	3.21	3.56	
		SHF	0.74	0.50	0.98	0.74	0.50	1.00	0.94	0.70	
		EER	3.23	3.30	3.23	3.30	3.37	3.23	3.30	3.37	
	25	Capacity	3.12	3.45	3.12	3.45	3.78	3.12	3.45	3.78	
		SHF	0.74	0.50	0.98	0.74	0.50	1.00	0.94	0.70	
		EER	3.82	3.84	3.82	3.84	3.86	3.82	3.84	3.86	
	20	Capacity	3.38	3.69	3.38	3.69	4.01	3.38	3.69	4.01	
		SHF	0.74	0.50	0.98	0.74	0.50	1.00	0.94	0.70	
		EER	4.40	4.37	4.40	4.37	4.34	4.40	4.37	4.34	
	Rated frequency	46	Capacity	1.84	2.15	1.84	2.15	2.46	1.84	2.15	2.46
			SHF	0.92	0.68	1.00	0.92	0.68	1.00	1.00	0.88
			EER	2.58	2.78	2.58	2.78	2.98	2.58	2.78	2.98
		40	Capacity	2.03	2.33	2.03	2.33	2.63	2.03	2.33	2.63
			SHF	0.92	0.68	1.00	0.92	0.68	1.00	1.00	0.88
			EER	2.99	3.15	2.99	3.15	3.30	2.99	3.15	3.30
35		Capacity	2.23	2.51	2.23	2.51	2.80	2.23	2.51	2.80	
		SHF	0.92	0.68	1.00	0.92	0.68	1.00	1.00	0.88	
		EER	3.47	3.59	3.47	3.59	3.70	3.47	3.59	3.70	
30		Capacity	2.39	2.68	2.39	2.68	2.96	2.39	2.68	2.96	
		SHF	0.92	0.68	1.00	0.92	0.68	1.00	1.00	0.88	
		EER	4.00	4.09	4.00	4.09	4.17	4.00	4.09	4.17	
25		Capacity	2.60	2.88	2.60	2.88	3.15	2.60	2.88	3.15	
		SHF	0.92	0.68	1.00	0.92	0.68	1.00	1.00	0.88	
		EER	4.72	4.75	4.72	4.75	4.77	4.72	4.75	4.77	
20		Capacity	2.81	3.08	2.81	3.08	3.34	2.81	3.08	3.34	
		SHF	0.92	0.68	1.00	0.92	0.68	1.00	1.00	0.88	
		EER	5.44	5.41	5.44	5.41	5.38	5.44	5.41	5.38	
Minimum Frequency		46	Capacity	0.37	0.43	0.37	0.43	0.49	0.37	0.43	0.49
			EER	2.41	2.59	2.41	2.59	2.78	2.41	2.59	2.78
		40	Capacity	0.41	0.47	0.41	0.47	0.53	0.41	0.47	0.53
			EER	2.79	2.94	2.79	2.94	3.08	2.79	2.94	3.08
		35	Capacity	0.45	0.50	0.45	0.50	0.56	0.45	0.50	0.56
			EER	3.24	3.35	3.24	3.35	3.46	3.24	3.35	3.46
	30	Capacity	0.48	0.54	0.48	0.54	0.59	0.48	0.54	0.59	
		EER	3.74	3.81	3.74	3.81	3.89	3.74	3.81	3.89	
	25	Capacity	0.52	0.58	0.52	0.58	0.63	0.52	0.58	0.63	
		EER	4.41	4.43	4.41	4.43	4.46	4.41	4.43	4.46	
	20	Capacity	0.56	0.62	0.56	0.62	0.67	0.56	0.62	0.67	
		EER	5.08	5.05	5.08	5.05	5.02	5.08	5.05	5.02	

Cooling performance data (Low ambient Condition)

	Ambient temperature (°C)	INDOOR (°C)								
		DB	21		27			32		
		WB	15	19	15	19	23	15	19	23
Max Frequency	15 -10	Capacity	2.23	2.51	2.23	2.51	2.80	2.23	2.51	2.80
		SHF	0.92	0.68	1.00	0.92	0.68	1.00	1.00	0.88
		EER	3.47	3.59	3.47	3.59	3.70	3.47	3.59	3.70

* The low ambient condition requires a special control and all the performance is equal to or less than the rated operation.

Cooling performance data
MSZ-BT35VG, MSZ-BT35VGK: MUZ-BT35VG

	Ambient temperature (°C)	INDOOR (°C)									
		DB	21		27			32			
		WB	15	19	15	19	23	15	19	23	
Max frequency	46	Capacity	2.57	3.01	2.57	3.01	3.45	2.57	3.01	3.45	
		SHF	0.82	0.58	1.00	0.82	0.58	1.00	0.98	0.78	
		EER	2.04	2.20	2.04	2.20	2.36	2.04	2.20	2.36	
	40	Capacity	2.84	3.26	2.84	3.26	3.68	2.84	3.26	3.68	
		SHF	0.82	0.58	1.00	0.82	0.58	1.00	0.98	0.78	
		EER	2.36	2.49	2.36	2.49	2.61	2.36	2.49	2.61	
	35	Capacity	3.12	3.52	3.12	3.52	3.92	3.12	3.52	3.92	
		SHF	0.82	0.58	1.00	0.82	0.58	1.00	0.98	0.78	
		EER	2.75	2.84	2.75	2.84	2.93	2.75	2.84	2.93	
	30	Capacity	3.34	3.75	3.34	3.75	4.15	3.34	3.75	4.15	
		SHF	0.82	0.58	1.00	0.82	0.58	1.00	0.98	0.78	
		EER	3.16	3.23	3.16	3.23	3.29	3.16	3.23	3.29	
	25	Capacity	3.64	4.03	3.64	4.03	4.41	3.64	4.03	4.41	
		SHF	0.82	0.58	1.00	0.82	0.58	1.00	0.98	0.78	
		EER	3.73	3.75	3.73	3.75	3.77	3.73	3.75	3.77	
	20	Capacity	3.94	4.31	3.94	4.31	4.67	3.94	4.31	4.67	
		SHF	0.82	0.58	1.00	0.82	0.58	1.00	0.98	0.78	
		EER	4.30	4.28	4.30	4.28	4.25	4.30	4.28	4.25	
	Rated frequency	46	Capacity	2.57	3.01	2.57	3.01	3.45	2.57	3.01	3.45
			SHF	0.84	0.60	1.00	0.84	0.60	1.00	0.99	0.80
			EER	2.04	2.20	2.04	2.20	2.36	2.04	2.20	2.36
		40	Capacity	2.84	3.26	2.84	3.26	3.68	2.84	3.26	3.68
			SHF	0.84	0.60	1.00	0.84	0.60	1.00	0.99	0.80
			EER	2.36	2.49	2.36	2.49	2.61	2.36	2.49	2.61
35		Capacity	3.12	3.52	3.12	3.52	3.92	3.12	3.52	3.92	
		SHF	0.84	0.60	1.00	0.84	0.60	1.00	0.99	0.80	
		EER	2.75	2.84	2.75	2.84	2.93	2.75	2.84	2.93	
30		Capacity	3.34	3.75	3.34	3.75	4.15	3.34	3.75	4.15	
		SHF	0.84	0.60	1.00	0.84	0.60	1.00	0.99	0.80	
		EER	3.16	3.23	3.16	3.23	3.29	3.16	3.23	3.29	
25		Capacity	3.64	4.03	3.64	4.03	4.41	3.64	4.03	4.41	
		SHF	0.84	0.60	1.00	0.84	0.60	1.00	0.99	0.80	
		EER	3.73	3.75	3.73	3.75	3.77	3.73	3.75	3.77	
20		Capacity	3.94	4.31	3.94	4.31	4.67	3.94	4.31	4.67	
		SHF	0.84	0.60	1.00	0.84	0.60	1.00	0.99	0.80	
		EER	4.30	4.28	4.30	4.28	4.25	4.30	4.28	4.25	
Minimum Frequency		46	Capacity	0.66	0.77	0.66	0.77	0.89	0.66	0.77	0.89
			EER	3.42	3.69	3.42	3.69	3.95	3.42	3.69	3.95
		40	Capacity	0.73	0.84	0.73	0.84	0.95	0.73	0.84	0.95
			EER	3.97	4.17	3.97	4.17	4.38	3.97	4.17	4.38
		35	Capacity	0.80	0.90	0.80	0.90	1.01	0.80	0.90	1.01
			EER	4.61	4.76	4.61	4.76	4.91	4.61	4.76	4.91
	30	Capacity	0.86	0.96	0.86	0.96	1.07	0.86	0.96	1.07	
		EER	5.31	5.42	5.31	5.42	5.53	5.31	5.42	5.53	
	25	Capacity	0.94	1.04	0.94	1.04	1.13	0.94	1.04	1.13	
		EER	6.27	6.30	6.27	6.30	6.33	6.27	6.30	6.33	
	20	Capacity	1.01	1.11	1.01	1.11	1.20	1.01	1.11	1.20	
		EER	7.22	7.18	7.22	7.18	7.13	7.22	7.18	7.13	

Cooling performance data (Low ambient Condition)

	Ambient temperature (°C)	INDOOR (°C)								
		DB	21		27			32		
		WB	15	19	15	19	23	15	19	23
Max Frequency	15 -10	Capacity	3.12	3.52	3.12	3.52	3.92	3.12	3.52	3.92
		SHF	0.84	0.60	1.00	0.84	0.60	1.00	0.99	0.80
		EER	2.75	2.84	2.75	2.84	2.93	2.75	2.84	2.93

* The low ambient condition requires a special control and all the performance is equal to or less than the rated operation.

Cooling performance data
MSZ-BT50VG, MSZ-BT50VGK: MUZ-BT50VG

	Ambient temperature (°C)	INDOOR (°C)									
		DB	21		27			32			
		WB	15	19	15	19	23	15	19	23	
Max frequency	46	Capacity	3.89	4.20	3.89	4.20	4.50	3.89	4.20	4.50	
		SHF	0.73	0.49	0.97	0.73	0.49	1.00	0.93	0.69	
		EER	1.76	1.90	1.76	1.90	2.04	1.76	1.90	2.04	
	40	Capacity	4.31	4.65	4.31	4.65	4.99	4.31	4.65	4.99	
		SHF	0.73	0.49	0.97	0.73	0.49	1.00	0.93	0.69	
		EER	2.04	2.15	2.04	2.15	2.26	2.04	2.15	2.26	
	35	Capacity	4.51	5.03	4.51	5.03	5.54	4.51	5.03	5.54	
		SHF	0.73	0.49	0.97	0.73	0.49	1.00	0.93	0.69	
		EER	2.37	2.45	2.37	2.45	2.53	2.37	2.45	2.53	
	30	Capacity	4.78	5.35	4.78	5.35	5.93	4.78	5.35	5.93	
		SHF	0.73	0.49	0.97	0.73	0.49	1.00	0.93	0.69	
		EER	2.73	2.79	2.73	2.79	2.85	2.73	2.79	2.85	
	25	Capacity	5.20	5.75	5.20	5.75	6.30	5.20	5.75	6.30	
		SHF	0.73	0.49	0.97	0.73	0.49	1.00	0.93	0.69	
		EER	3.23	3.24	3.23	3.24	3.26	3.23	3.24	3.26	
	20	Capacity	5.63	6.15	5.63	6.15	6.68	5.63	6.15	6.68	
		SHF	0.73	0.49	0.97	0.73	0.49	1.00	0.93	0.69	
		EER	3.72	3.70	3.72	3.70	3.67	3.72	3.70	3.67	
	Rated frequency	46	Capacity	3.89	4.20	3.89	4.20	4.50	3.89	4.20	4.50
			SHF	0.73	0.49	0.97	0.73	0.49	1.00	0.93	0.69
			EER	1.76	1.90	1.76	1.90	2.04	1.76	1.90	2.04
		40	Capacity	4.31	4.65	4.31	4.65	4.99	4.31	4.65	4.99
			SHF	0.73	0.49	0.97	0.73	0.49	1.00	0.93	0.69
			EER	2.04	2.15	2.04	2.15	2.26	2.04	2.15	2.26
35		Capacity	4.51	5.03	4.51	5.03	5.54	4.51	5.03	5.54	
		SHF	0.73	0.49	0.97	0.73	0.49	1.00	0.93	0.69	
		EER	2.37	2.45	2.37	2.45	2.53	2.37	2.45	2.53	
30		Capacity	4.78	5.35	4.78	5.35	5.93	4.78	5.35	5.93	
		SHF	0.73	0.49	0.97	0.73	0.49	1.00	0.93	0.69	
		EER	2.73	2.79	2.73	2.79	2.85	2.73	2.79	2.85	
25		Capacity	5.20	5.75	5.20	5.75	6.30	5.20	5.75	6.30	
		SHF	0.73	0.49	0.97	0.73	0.49	1.00	0.93	0.69	
		EER	3.23	3.24	3.23	3.24	3.26	3.23	3.24	3.26	
20		Capacity	5.63	6.15	5.63	6.15	6.68	5.63	6.15	6.68	
		SHF	0.73	0.49	0.97	0.73	0.49	1.00	0.93	0.69	
		EER	3.72	3.70	3.72	3.70	3.67	3.72	3.70	3.67	
Minimum Frequency		46	Capacity	0.96	1.12	0.96	1.12	1.28	0.96	1.12	1.28
			EER	3.13	3.37	3.13	3.37	3.62	3.13	3.37	3.62
		40	Capacity	1.05	1.21	1.05	1.21	1.37	1.05	1.21	1.37
			EER	3.63	3.82	3.63	3.82	4.01	3.63	3.82	4.01
		35	Capacity	1.16	1.31	1.16	1.31	1.46	1.16	1.31	1.46
			EER	4.22	4.35	4.22	4.35	4.49	4.22	4.35	4.49
	30	Capacity	1.24	1.39	1.24	1.39	1.54	1.24	1.39	1.54	
		EER	4.86	4.96	4.86	4.96	5.06	4.86	4.96	5.06	
	25	Capacity	1.35	1.50	1.35	1.50	1.64	1.35	1.50	1.64	
		EER	5.73	5.76	5.73	5.76	5.79	5.73	5.76	5.79	
	20	Capacity	1.46	1.60	1.46	1.60	1.74	1.46	1.60	1.74	
		EER	6.61	6.57	6.61	6.57	6.53	6.61	6.57	6.53	

Cooling performance data (Low ambient Condition)

	Ambient temperature (°C)	INDOOR (°C)								
		DB	21		27			32		
		WB	15	19	15	19	23	15	19	23
Max Frequency	15 -10	Capacity	4.51	5.03	4.51	5.03	5.54	4.51	5.03	5.54
		SHF	0.73	0.49	0.97	0.73	0.49	1.00	0.93	0.69
		EER	2.37	2.45	2.37	2.45	2.53	2.37	2.45	2.53

* The low ambient condition requires a special control and all the performance is equal to or less than the rated operation.

Cooling performance data
MSZ-DW25VF: MUZ-DW25VF

	Ambient temperature (°C)	INDOOR (°C)									
		DB	21		27			32			
		WB	15	19	15	19	23	15	19	23	
Max frequency	46	Capacity	2.26	2.48	2.26	2.48	2.70	2.26	2.48	2.70	
		SHF	0.76	0.52	1.00	0.76	0.52	1.00	0.95	0.72	
		EER	1.94	2.09	1.94	2.09	2.24	1.94	2.09	2.24	
	40	Capacity	2.40	2.70	2.40	2.70	3.00	2.40	2.70	3.00	
		SHF	0.76	0.52	1.00	0.76	0.52	1.00	0.95	0.72	
		EER	2.25	2.37	2.25	2.37	2.48	2.25	2.37	2.48	
	35	Capacity	2.58	2.91	2.58	2.91	3.25	2.58	2.91	3.25	
		SHF	0.76	0.52	1.00	0.76	0.52	1.00	0.95	0.72	
		EER	2.61	2.70	2.61	2.70	2.78	2.61	2.70	2.78	
	30	Capacity	2.77	3.10	2.77	3.10	3.44	2.77	3.10	3.44	
		SHF	0.76	0.52	1.00	0.76	0.52	1.00	0.95	0.72	
		EER	3.01	3.07	3.01	3.07	3.13	3.01	3.07	3.13	
	25	Capacity	3.02	3.34	3.02	3.34	3.65	3.02	3.34	3.65	
		SHF	0.76	0.52	1.00	0.76	0.52	1.00	0.95	0.72	
		EER	3.55	3.57	3.55	3.57	3.59	3.55	3.57	3.59	
	20	Capacity	3.26	3.57	3.26	3.57	3.87	3.26	3.57	3.87	
		SHF	0.76	0.52	1.00	0.76	0.52	1.00	0.95	0.72	
		EER	4.09	4.07	4.09	4.07	4.04	4.09	4.07	4.04	
	Rated frequency	46	Capacity	1.84	2.15	1.84	2.15	2.46	1.84	2.15	2.46
			SHF	0.86	0.62	1.00	0.86	0.62	1.00	1.00	0.82
			EER	2.26	2.43	2.26	2.43	2.61	2.26	2.43	2.61
		40	Capacity	2.03	2.33	2.03	2.33	2.63	2.03	2.33	2.63
			SHF	0.86	0.62	1.00	0.86	0.62	1.00	1.00	0.82
			EER	2.62	2.75	2.62	2.75	2.89	2.62	2.75	2.89
35		Capacity	2.23	2.51	2.23	2.51	2.80	2.23	2.51	2.80	
		SHF	0.86	0.62	1.00	0.86	0.62	1.00	1.00	0.82	
		EER	3.04	3.14	3.04	3.14	3.24	3.04	3.14	3.24	
30		Capacity	2.39	2.68	2.39	2.68	2.96	2.39	2.68	2.96	
		SHF	0.86	0.62	1.00	0.86	0.62	1.00	1.00	0.82	
		EER	3.50	3.58	3.50	3.58	3.65	3.50	3.58	3.65	
25		Capacity	2.60	2.88	2.60	2.88	3.15	2.60	2.88	3.15	
		SHF	0.86	0.62	1.00	0.86	0.62	1.00	1.00	0.82	
		EER	4.13	4.16	4.13	4.16	4.18	4.13	4.16	4.18	
20		Capacity	2.81	3.08	2.81	3.08	3.34	2.81	3.08	3.34	
		SHF	0.86	0.62	1.00	0.86	0.62	1.00	1.00	0.82	
		EER	4.76	4.74	4.76	4.74	4.71	4.76	4.74	4.71	
Minimum Frequency		46	Capacity	0.37	0.43	0.37	0.43	0.49	0.37	0.43	0.49
			EER	3.01	3.24	3.01	3.24	3.48	3.01	3.24	3.48
		40	Capacity	0.41	0.47	0.41	0.47	0.53	0.41	0.47	0.53
			EER	3.49	3.67	3.49	3.67	3.85	3.49	3.67	3.85
		35	Capacity	0.45	0.50	0.45	0.50	0.56	0.45	0.50	0.56
			EER	4.05	4.19	4.05	4.19	4.32	4.05	4.19	4.32
	30	Capacity	0.48	0.54	0.48	0.54	0.59	0.48	0.54	0.59	
		EER	4.67	4.77	4.67	4.77	4.86	4.67	4.77	4.86	
	25	Capacity	0.52	0.58	0.52	0.58	0.63	0.52	0.58	0.63	
		EER	5.51	5.54	5.51	5.54	5.57	5.51	5.54	5.57	
	20	Capacity	0.56	0.62	0.56	0.62	0.67	0.56	0.62	0.67	
		EER	6.35	6.31	6.35	6.31	6.28	6.35	6.31	6.28	

Cooling performance data (Low ambient Condition)

	Ambient temperature (°C)	INDOOR (°C)								
		DB	21		27			32		
		WB	15	19	15	19	23	15	19	23
Max Frequency	15 -10	Capacity	2.23	2.51	2.23	2.51	2.80	2.23	2.51	2.80
		SHF	0.86	0.62	1.00	0.86	0.62	1.00	1.00	0.82
		EER	3.04	3.14	3.04	3.14	3.24	3.04	3.14	3.24

* The low ambient condition requires a special control and all the performance is equal to or less than the rated operation.

Cooling performance data
MSZ-DW35VF: MUZ-DW35VF

	Ambient temperature (°C)	INDOOR (°C)									
		DB	21		27			32			
		WB	15	19	15	19	23	15	19	23	
Max frequency	46	Capacity	2.50	2.92	2.50	2.92	3.35	2.50	2.92	3.35	
		SHF	0.74	0.50	0.98	0.74	0.50	1.00	0.94	0.70	
		EER	1.84	1.99	1.84	1.99	2.13	1.84	1.99	2.13	
	40	Capacity	2.75	3.16	2.75	3.16	3.57	2.75	3.16	3.57	
		SHF	0.74	0.50	0.98	0.74	0.50	1.00	0.94	0.70	
		EER	2.14	2.25	2.14	2.25	2.36	2.14	2.25	2.36	
	35	Capacity	3.03	3.42	3.03	3.42	3.81	3.03	3.42	3.81	
		SHF	0.74	0.50	0.98	0.74	0.50	1.00	0.94	0.70	
		EER	2.49	2.57	2.49	2.57	2.65	2.49	2.57	2.65	
	30	Capacity	3.25	3.64	3.25	3.64	4.03	3.25	3.64	4.03	
		SHF	0.74	0.50	0.98	0.74	0.50	1.00	0.94	0.70	
		EER	2.87	2.92	2.87	2.92	2.98	2.87	2.92	2.98	
	25	Capacity	3.54	3.91	3.54	3.91	4.28	3.54	3.91	4.28	
		SHF	0.74	0.50	0.98	0.74	0.50	1.00	0.94	0.70	
		EER	3.38	3.40	3.38	3.40	3.42	3.38	3.40	3.42	
	20	Capacity	3.83	4.18	3.83	4.18	4.54	3.83	4.18	4.54	
		SHF	0.74	0.50	0.98	0.74	0.50	1.00	0.94	0.70	
		EER	3.90	3.87	3.90	3.87	3.85	3.90	3.87	3.85	
	Rated frequency	46	Capacity	2.50	2.92	2.50	2.92	3.35	2.50	2.92	3.35
			SHF	0.78	0.54	1.00	0.78	0.54	1.00	0.96	0.74
			EER	2.03	2.19	2.03	2.19	2.34	2.03	2.19	2.34
		40	Capacity	2.75	3.16	2.75	3.16	3.57	2.75	3.16	3.57
			SHF	0.78	0.54	1.00	0.78	0.54	1.00	0.96	0.74
			EER	2.35	2.48	2.35	2.48	2.60	2.35	2.48	2.60
35		Capacity	3.03	3.42	3.03	3.42	3.81	3.03	3.42	3.81	
		SHF	0.78	0.54	1.00	0.78	0.54	1.00	0.96	0.74	
		EER	2.73	2.82	2.73	2.82	2.91	2.73	2.82	2.91	
30		Capacity	3.25	3.64	3.25	3.64	4.03	3.25	3.64	4.03	
		SHF	0.78	0.54	1.00	0.78	0.54	1.00	0.96	0.74	
		EER	3.15	3.22	3.15	3.22	3.28	3.15	3.22	3.28	
25		Capacity	3.54	3.91	3.54	3.91	4.28	3.54	3.91	4.28	
		SHF	0.78	0.54	1.00	0.78	0.54	1.00	0.96	0.74	
		EER	3.72	3.74	3.72	3.74	3.76	3.72	3.74	3.76	
20		Capacity	3.83	4.18	3.83	4.18	4.54	3.83	4.18	4.54	
		SHF	0.78	0.54	1.00	0.78	0.54	1.00	0.96	0.74	
		EER	4.28	4.26	4.28	4.26	4.23	4.28	4.26	4.23	
Minimum Frequency		46	Capacity	0.66	0.77	0.66	0.77	0.89	0.66	0.77	0.89
			EER	2.95	3.18	2.95	3.18	3.41	2.95	3.18	3.41
		40	Capacity	0.73	0.84	0.73	0.84	0.95	0.73	0.84	0.95
			EER	3.43	3.61	3.43	3.61	3.78	3.43	3.61	3.78
		35	Capacity	0.80	0.90	0.80	0.90	1.01	0.80	0.90	1.01
			EER	3.98	4.11	3.98	4.11	4.24	3.98	4.11	4.24
	30	Capacity	0.86	0.96	0.86	0.96	1.07	0.86	0.96	1.07	
		EER	4.59	4.68	4.59	4.68	4.78	4.59	4.68	4.78	
	25	Capacity	0.94	1.04	0.94	1.04	1.13	0.94	1.04	1.13	
		EER	5.41	5.44	5.41	5.44	5.47	5.41	5.44	5.47	
	20	Capacity	1.01	1.11	1.01	1.11	1.20	1.01	1.11	1.20	
		EER	6.24	6.20	6.24	6.20	6.16	6.24	6.20	6.16	

Cooling performance data (Low ambient Condition)

	Ambient temperature (°C)	INDOOR (°C)								
		DB	21		27			32		
		WB	15	19	15	19	23	15	19	23
Max Frequency	15 -10	Capacity	3.03	3.42	3.03	3.42	3.81	3.03	3.42	3.81
		SHF	0.78	0.54	1.00	0.78	0.54	1.00	0.96	0.74
		EER	2.73	2.82	2.73	2.82	2.91	2.73	2.82	2.91

* The low ambient condition requires a special control and all the performance is equal to or less than the rated operation.

Cooling performance data
MSZ-DW50VF: MUZ-DW50VF

	Ambient temperature (°C)	INDOOR (°C)									
		DB	21		27			32			
		WB	15	19	15	19	23	15	19	23	
Max frequency	46	Capacity	3.63	3.92	3.63	3.92	4.20	3.63	3.92	4.20	
		SHF	0.67	0.43	0.91	0.67	0.43	1.00	0.87	0.63	
		EER	1.90	2.05	1.90	2.05	2.20	1.90	2.05	2.20	
	40	Capacity	4.22	4.44	4.22	4.44	4.66	4.22	4.44	4.66	
		SHF	0.67	0.43	0.91	0.67	0.43	1.00	0.87	0.63	
		EER	2.20	2.32	2.20	2.32	2.43	2.20	2.32	2.43	
	35	Capacity	4.76	4.99	4.76	4.99	5.22	4.76	4.99	5.22	
		SHF	0.67	0.43	0.91	0.67	0.43	1.00	0.87	0.63	
		EER	2.56	2.64	2.56	2.64	2.73	2.56	2.64	2.73	
	30	Capacity	4.87	5.35	4.87	5.35	5.83	4.87	5.35	5.83	
		SHF	0.67	0.43	0.91	0.67	0.43	1.00	0.87	0.63	
		EER	2.95	3.01	2.95	3.01	3.07	2.95	3.01	3.07	
	25	Capacity	5.20	5.75	5.20	5.75	6.30	5.20	5.75	6.30	
		SHF	0.67	0.43	0.91	0.67	0.43	1.00	0.87	0.63	
		EER	3.48	3.50	3.48	3.50	3.52	3.48	3.50	3.52	
	20	Capacity	5.53	6.15	5.53	6.15	6.77	5.53	6.15	6.77	
		SHF	0.67	0.43	0.91	0.67	0.43	1.00	0.87	0.63	
		EER	4.01	3.99	4.01	3.99	3.96	4.01	3.99	3.96	
	Rated frequency	46	Capacity	3.37	3.63	3.37	3.63	3.89	3.37	3.63	3.89
			SHF	0.70	0.46	0.94	0.70	0.46	1.00	0.90	0.66
			EER	1.76	1.90	1.76	1.90	2.04	1.76	1.90	2.04
		40	Capacity	3.91	4.11	3.91	4.11	4.31	3.91	4.11	4.31
			SHF	0.70	0.46	0.94	0.70	0.46	1.00	0.90	0.66
			EER	2.04	2.15	2.04	2.15	2.26	2.04	2.15	2.26
35		Capacity	4.54	4.69	4.54	4.69	4.84	4.54	4.69	4.84	
		SHF	0.70	0.46	0.94	0.70	0.46	1.00	0.90	0.66	
		EER	2.37	2.45	2.37	2.45	2.53	2.37	2.45	2.53	
30		Capacity	5.16	5.30	5.16	5.30	5.45	5.16	5.30	5.45	
		SHF	0.70	0.46	0.94	0.70	0.46	1.00	0.90	0.66	
		EER	2.73	2.79	2.73	2.79	2.85	2.73	2.79	2.85	
25		Capacity	5.29	5.75	5.29	5.75	6.21	5.29	5.75	6.21	
		SHF	0.70	0.46	0.94	0.70	0.46	1.00	0.90	0.66	
		EER	3.23	3.24	3.23	3.24	3.26	3.23	3.24	3.26	
20		Capacity	5.43	6.20	5.43	6.20	6.97	5.43	6.20	6.97	
		SHF	0.70	0.46	0.94	0.70	0.46	1.00	0.90	0.66	
		EER	3.72	3.70	3.72	3.70	3.67	3.72	3.70	3.67	
Minimum Frequency		46	Capacity	0.96	1.12	0.96	1.12	1.28	0.96	1.12	1.28
			EER	6.25	6.74	6.25	6.74	7.23	6.25	6.74	7.23
		40	Capacity	1.05	1.21	1.05	1.21	1.37	1.05	1.21	1.37
			EER	7.26	7.64	7.26	7.64	8.02	7.26	7.64	8.02
		35	Capacity	1.16	1.31	1.16	1.31	1.46	1.16	1.31	1.46
			EER	8.43	8.71	8.43	8.71	8.99	8.43	8.71	8.99
	30	Capacity	1.24	1.39	1.24	1.39	1.54	1.24	1.39	1.54	
		EER	9.72	9.92	9.72	9.92	10.12	9.72	9.92	10.12	
	25	Capacity	1.35	1.50	1.35	1.50	1.64	1.35	1.50	1.64	
		EER	11.46	11.52	11.46	11.52	11.59	11.46	11.52	11.59	
	20	Capacity	1.46	1.60	1.46	1.60	1.74	1.46	1.60	1.74	
		EER	13.21	13.13	13.21	13.13	13.05	13.21	13.13	13.05	

Cooling performance data (Low ambient Condition)

	Ambient temperature (°C)	INDOOR (°C)								
		DB	21		27			32		
		WB	15	19	15	19	23	15	19	23
Max Frequency	15 -10	Capacity	4.54	4.69	4.54	4.69	4.84	4.54	4.69	4.84
		SHF	0.70	0.46	0.94	0.70	0.46	1.00	0.90	0.66
		EER	2.37	2.45	2.37	2.45	2.53	2.37	2.45	2.53

* The low ambient condition requires a special control and all the performance is equal to or less than the rated operation.

PERFORMANCE DATA COOL operation at Rated frequency

MSZ-SF25VE3: MUZ-SF25VE, MUZ-SF25VEH

CAPACITY: 2.5 kW SHF: 0.92 INPUT: 600 W

INDOOR DB (°C)	INDOOR WB (°C)	OUTDOOR DB (°C)															
		21				25				27				30			
		Q	SHC	SHF	INPUT	Q	SHC	SHF	INPUT	Q	SHC	SHF	INPUT	Q	SHC	SHF	INPUT
21	18	2.94	2.17	0.74	480	2.81	2.08	0.74	504	2.70	2.00	0.74	528	2.60	1.92	0.74	552
21	20	3.06	1.90	0.62	504	2.94	1.82	0.62	534	2.85	1.77	0.62	546	2.75	1.71	0.62	570
22	18	2.94	2.29	0.78	480	2.81	2.19	0.78	504	2.70	2.11	0.78	528	2.60	2.03	0.78	552
22	20	3.06	2.02	0.66	504	2.94	1.94	0.66	534	2.85	1.88	0.66	546	2.75	1.82	0.66	570
22	22	3.19	1.72	0.54	522	3.08	1.66	0.54	555	3.00	1.62	0.54	570	2.88	1.55	0.54	594
23	18	2.94	2.41	0.82	480	2.81	2.31	0.82	504	2.70	2.21	0.82	528	2.60	2.13	0.82	552
23	20	3.06	2.14	0.70	504	2.94	2.06	0.70	534	2.85	2.00	0.70	546	2.75	1.93	0.70	570
23	22	3.19	1.85	0.58	522	3.08	1.78	0.58	555	3.00	1.74	0.58	570	2.88	1.67	0.58	594
24	18	2.94	2.53	0.86	480	2.81	2.42	0.86	504	2.70	2.32	0.86	528	2.60	2.24	0.86	552
24	20	3.06	2.27	0.74	504	2.94	2.17	0.74	534	2.85	2.11	0.74	546	2.75	2.04	0.74	570
24	22	3.19	1.98	0.62	522	3.08	1.91	0.62	555	3.00	1.86	0.62	570	2.88	1.78	0.62	594
24	24	3.35	1.68	0.50	546	3.23	1.61	0.50	576	3.15	1.58	0.50	594	3.05	1.53	0.50	624
25	18	2.94	2.64	0.90	480	2.81	2.53	0.90	504	2.70	2.43	0.90	528	2.60	2.34	0.90	552
25	20	3.06	2.39	0.78	504	2.94	2.29	0.78	534	2.85	2.22	0.78	546	2.75	2.15	0.78	570
25	22	3.19	2.10	0.66	522	3.08	2.03	0.66	555	3.00	1.98	0.66	570	2.88	1.90	0.66	594
25	24	3.35	1.81	0.54	546	3.23	1.74	0.54	576	3.15	1.70	0.54	594	3.05	1.65	0.54	624
26	18	2.94	2.76	0.94	480	2.81	2.64	0.94	504	2.70	2.54	0.94	528	2.60	2.44	0.94	552
26	20	3.06	2.51	0.82	504	2.94	2.41	0.82	534	2.85	2.34	0.82	546	2.75	2.26	0.82	570
26	22	3.19	2.23	0.70	522	3.08	2.15	0.70	555	3.00	2.10	0.70	570	2.88	2.01	0.70	594
26	24	3.35	1.94	0.58	546	3.23	1.87	0.58	576	3.15	1.83	0.58	594	3.05	1.77	0.58	624
26	26	3.45	1.59	0.46	576	3.35	1.54	0.46	606	3.30	1.52	0.46	624	3.20	1.47	0.46	642
27	18	2.94	2.88	0.98	480	2.81	2.76	0.98	504	2.70	2.65	0.98	528	2.60	2.55	0.98	552
27	20	3.06	2.63	0.86	504	2.94	2.53	0.86	534	2.85	2.45	0.86	546	2.75	2.37	0.86	570
27	22	3.19	2.36	0.74	522	3.08	2.28	0.74	555	3.00	2.22	0.74	570	2.88	2.13	0.74	594
27	24	3.35	2.08	0.62	546	3.23	2.00	0.62	576	3.15	1.95	0.62	594	3.05	1.89	0.62	624
27	26	3.45	1.73	0.50	576	3.35	1.68	0.50	606	3.30	1.65	0.50	624	3.20	1.60	0.50	642
28	18	2.94	2.94	1.00	480	2.81	2.81	1.00	504	2.70	2.70	1.00	528	2.60	2.60	1.00	552
28	20	3.06	2.76	0.90	504	2.94	2.64	0.90	534	2.85	2.57	0.90	546	2.75	2.48	0.90	570
28	22	3.19	2.49	0.78	522	3.08	2.40	0.78	555	3.00	2.34	0.78	570	2.88	2.24	0.78	594
28	24	3.35	2.21	0.66	546	3.23	2.13	0.66	576	3.15	2.08	0.66	594	3.05	2.01	0.66	624
28	26	3.45	1.86	0.54	576	3.35	1.81	0.54	606	3.30	1.78	0.54	624	3.20	1.73	0.54	642
29	18	2.94	2.94	1.00	480	2.81	2.81	1.00	504	2.70	2.70	1.00	528	2.60	2.60	1.00	552
29	20	3.06	2.88	0.94	504	2.94	2.76	0.94	534	2.85	2.68	0.94	546	2.75	2.59	0.94	570
29	22	3.19	2.61	0.82	522	3.08	2.52	0.82	555	3.00	2.46	0.82	570	2.88	2.36	0.82	594
29	24	3.35	2.35	0.70	546	3.23	2.26	0.70	576	3.15	2.21	0.70	594	3.05	2.14	0.70	624
29	26	3.45	2.00	0.58	576	3.35	1.94	0.58	606	3.30	1.91	0.58	624	3.20	1.86	0.58	642
30	18	2.94	2.94	1.00	480	2.81	2.81	1.00	504	2.70	2.70	1.00	528	2.60	2.60	1.00	552
30	20	3.06	3.00	0.98	504	2.94	2.88	0.98	534	2.85	2.79	0.98	546	2.75	2.70	0.98	570
30	22	3.19	2.74	0.86	522	3.08	2.64	0.86	555	3.00	2.58	0.86	570	2.88	2.47	0.86	594
30	24	3.35	2.48	0.74	546	3.23	2.39	0.74	576	3.15	2.33	0.74	594	3.05	2.26	0.74	624
30	26	3.45	2.14	0.62	576	3.35	2.08	0.62	606	3.30	2.05	0.62	624	3.20	1.98	0.62	642
31	18	2.94	2.94	1.00	480	2.81	2.81	1.00	504	2.70	2.70	1.00	528	2.60	2.60	1.00	552
31	20	3.06	3.06	1.00	504	2.94	2.94	1.00	534	2.85	2.85	1.00	546	2.75	2.75	1.00	570
31	22	3.19	2.87	0.90	522	3.08	2.77	0.90	555	3.00	2.70	0.90	570	2.88	2.59	0.90	594
31	24	3.35	2.61	0.78	546	3.23	2.52	0.78	576	3.15	2.46	0.78	594	3.05	2.38	0.78	624
31	26	3.45	2.28	0.66	576	3.35	2.21	0.66	606	3.30	2.18	0.66	624	3.20	2.11	0.66	642
32	18	2.94	2.94	1.00	480	2.81	2.81	1.00	504	2.70	2.70	1.00	528	2.60	2.60	1.00	552
32	20	3.06	3.06	1.00	504	2.94	2.94	1.00	534	2.85	2.85	1.00	546	2.75	2.75	1.00	570
32	22	3.19	3.00	0.94	522	3.08	2.89	0.94	555	3.00	2.82	0.94	570	2.88	2.70	0.94	594
32	24	3.35	2.75	0.82	546	3.23	2.64	0.82	576	3.15	2.58	0.82	594	3.05	2.50	0.82	624
32	26	3.45	2.42	0.70	576	3.35	2.35	0.70	606	3.30	2.31	0.70	624	3.20	2.24	0.70	642

WALL-MOUNTED PERFORMANCE DATA

NOTE Q : Total capacity (kW) SHF : Sensible heat factor DB : Dry-bulb temperature
 SHC : Sensible heat capacity (kW) INPUT : Total power input (W) WB : Wet-bulb temperature

PERFORMANCE DATA COOL operation at Rated frequency

MSZ-SF25VE3: MUZ-SF25VE, MUZ-SF25VEH

CAPACITY: 2.5 kW SHF: 0.92 INPUT: 600 W

INDOOR DB (°C)	INDOOR WB (°C)	OUTDOOR DB (°C)											
		35				40				46			
		Q	SHC	SHF	INPUT	Q	SHC	SHF	INPUT	Q	SHC	SHF	INPUT
21	18	2.45	1.81	0.74	588	2.25	1.67	0.74	624	2.08	1.54	0.74	648
21	20	2.58	1.60	0.62	612	2.40	1.49	0.62	642	2.23	1.38	0.62	678
22	18	2.45	1.91	0.78	588	2.25	1.76	0.78	624	2.08	1.62	0.78	648
22	20	2.58	1.70	0.66	612	2.40	1.58	0.66	642	2.23	1.47	0.66	678
22	22	2.73	1.47	0.54	636	2.55	1.38	0.54	672	2.38	1.28	0.54	696
23	18	2.45	2.01	0.82	588	2.25	1.85	0.82	624	2.08	1.70	0.82	648
23	20	2.58	1.80	0.70	612	2.40	1.68	0.70	642	2.23	1.56	0.70	678
23	22	2.73	1.58	0.58	636	2.55	1.48	0.58	672	2.38	1.38	0.58	696
24	18	2.45	2.11	0.86	588	2.25	1.94	0.86	624	2.08	1.78	0.86	648
24	20	2.58	1.91	0.74	612	2.40	1.78	0.74	642	2.23	1.65	0.74	678
24	22	2.73	1.69	0.62	636	2.55	1.58	0.62	672	2.38	1.47	0.62	696
24	24	2.88	1.44	0.50	660	2.70	1.35	0.50	690	2.55	1.28	0.50	720
25	18	2.45	2.21	0.90	588	2.25	2.03	0.90	624	2.08	1.87	0.9	648
25	20	2.58	2.01	0.78	612	2.40	1.87	0.78	642	2.23	1.74	0.78	678
25	22	2.73	1.80	0.66	636	2.55	1.68	0.66	672	2.38	1.57	0.66	696
25	24	2.88	1.55	0.54	660	2.70	1.46	0.54	690	2.55	1.38	0.54	720
26	18	2.45	2.30	0.94	588	2.25	2.12	0.94	624	2.08	1.95	0.94	648
26	20	2.58	2.11	0.82	612	2.40	1.97	0.82	642	2.23	1.82	0.82	678
26	22	2.73	1.91	0.70	636	2.55	1.79	0.70	672	2.38	1.66	0.70	696
26	24	2.88	1.67	0.58	660	2.70	1.57	0.58	690	2.55	1.48	0.58	720
26	26	3.03	1.39	0.46	684	2.85	1.31	0.46	714	2.68	1.23	0.46	744
27	18	2.45	2.40	0.98	588	2.25	2.21	0.98	624	2.08	2.03	0.98	648
27	20	2.58	2.21	0.86	612	2.40	2.06	0.86	642	2.23	1.91	0.86	678
27	22	2.73	2.02	0.74	636	2.55	1.89	0.74	672	2.38	1.76	0.74	696
27	24	2.88	1.78	0.62	660	2.70	1.67	0.62	690	2.55	1.58	0.62	720
27	26	3.03	1.51	0.50	684	2.85	1.43	0.50	714	2.68	1.34	0.50	744
28	18	2.45	2.45	1.00	588	2.25	2.25	1.00	624	2.08	2.08	1.00	648
28	20	2.58	2.32	0.90	612	2.40	2.16	0.90	642	2.23	2.00	0.90	678
28	22	2.73	2.13	0.78	636	2.55	1.99	0.78	672	2.38	1.85	0.78	696
28	24	2.88	1.90	0.66	660	2.70	1.78	0.66	690	2.55	1.68	0.66	720
28	26	3.03	1.63	0.54	684	2.85	1.54	0.54	714	2.68	1.44	0.54	744
29	18	2.45	2.45	1.00	588	2.25	2.25	1.00	624	2.08	2.08	1.00	648
29	20	2.58	2.42	0.94	612	2.40	2.26	0.94	642	2.23	2.09	0.94	678
29	22	2.73	2.23	0.82	636	2.55	2.09	0.82	672	2.38	1.95	0.82	696
29	24	2.88	2.01	0.70	660	2.70	1.89	0.70	690	2.55	1.79	0.70	720
29	26	3.03	1.75	0.58	684	2.85	1.65	0.58	714	2.68	1.55	0.58	744
30	18	2.45	2.45	1.00	588	2.25	2.25	1.00	624	2.08	2.08	1.00	648
30	20	2.58	2.52	0.98	612	2.40	2.35	0.98	642	2.23	2.18	0.98	678
30	22	2.73	2.34	0.86	636	2.55	2.19	0.86	672	2.38	2.04	0.86	696
30	24	2.88	2.13	0.74	660	2.70	2.00	0.74	690	2.55	1.89	0.74	720
30	26	3.03	1.88	0.62	684	2.85	1.77	0.62	714	2.68	1.66	0.62	744
31	18	2.45	2.45	1.00	588	2.25	2.25	1.00	624	2.08	2.08	1.00	648
31	20	2.58	2.58	1.00	612	2.40	2.40	1.00	642	2.23	2.23	1.00	678
31	22	2.73	2.45	0.90	636	2.55	2.30	0.90	672	2.38	2.14	0.90	696
31	24	2.88	2.24	0.78	660	2.70	2.11	0.78	690	2.55	1.99	0.78	720
31	26	3.03	2.00	0.66	684	2.85	1.88	0.66	714	2.68	1.77	0.66	744
32	18	2.45	2.45	1.00	588	2.25	2.25	1.00	624	2.08	2.08	1.00	648
32	20	2.58	2.58	1.00	612	2.40	2.40	1.00	642	2.23	2.23	1.00	678
32	22	2.73	2.56	0.94	636	2.55	2.40	0.94	672	2.38	2.23	0.94	696
32	24	2.88	2.36	0.82	660	2.70	2.21	0.82	690	2.55	2.09	0.82	720
32	26	3.03	2.12	0.70	684	2.85	2.00	0.70	714	2.68	1.87	0.70	744

NOTE Q : Total capacity (kW) SHF : Sensible heat factor DB : Dry-bulb temperature
 SHC : Sensible heat capacity (kW) INPUT : Total power input (W) WB : Wet-bulb temperature

PERFORMANCE DATA COOL operation at Rated frequency

MSZ-SF35VE3: MUZ-SF35VE, MUZ-SF35VEH

CAPACITY: 3.5 kW SHF: 0.80 INPUT: 1080 W

INDOOR DB (°C)	INDOOR WB (°C)	OUTDOOR DB (°C)															
		21				25				27				30			
		Q	SHC	SHF	INPUT	Q	SHC	SHF	INPUT	Q	SHC	SHF	INPUT	Q	SHC	SHF	INPUT
21	18	4.11	2.55	0.62	864	3.94	2.44	0.62	907	3.78	2.34	0.62	950	3.64	2.26	0.62	994
21	20	4.29	2.14	0.50	907	4.11	2.06	0.50	961	3.99	2.00	0.50	983	3.85	1.93	0.50	1026
22	18	4.11	2.71	0.66	864	3.94	2.60	0.66	907	3.78	2.49	0.66	950	3.64	2.40	0.66	994
22	20	4.29	2.32	0.54	907	4.11	2.22	0.54	961	3.99	2.15	0.54	983	3.85	2.08	0.54	1026
22	22	4.46	1.87	0.42	940	4.31	1.81	0.42	999	4.20	1.76	0.42	1026	4.03	1.69	0.42	1069
23	18	4.11	2.88	0.70	864	3.94	2.76	0.70	907	3.78	2.65	0.70	950	3.64	2.55	0.70	994
23	20	4.29	2.49	0.58	907	4.11	2.39	0.58	961	3.99	2.31	0.58	983	3.85	2.23	0.58	1026
23	22	4.46	2.05	0.46	940	4.31	1.98	0.46	999	4.20	1.93	0.46	1026	4.03	1.85	0.46	1069
24	18	4.11	3.04	0.74	864	3.94	2.91	0.74	907	3.78	2.80	0.74	950	3.64	2.69	0.74	994
24	20	4.29	2.66	0.62	907	4.11	2.55	0.62	961	3.99	2.47	0.62	983	3.85	2.39	0.62	1026
24	22	4.46	2.23	0.50	940	4.31	2.15	0.50	999	4.20	2.10	0.50	1026	4.03	2.01	0.50	1069
24	24	4.69	1.78	0.38	983	4.52	1.72	0.38	1037	4.41	1.68	0.38	1069	4.27	1.62	0.38	1123
25	18	4.11	3.21	0.78	864	3.94	3.07	0.78	907	3.78	2.95	0.78	950	3.64	2.84	0.78	994
25	20	4.29	2.83	0.66	907	4.11	2.71	0.66	961	3.99	2.63	0.66	983	3.85	2.54	0.66	1026
25	22	4.46	2.41	0.54	940	4.31	2.32	0.54	999	4.20	2.27	0.54	1026	4.03	2.17	0.54	1069
25	24	4.69	1.97	0.42	983	4.52	1.90	0.42	1037	4.41	1.85	0.42	1069	4.27	1.79	0.42	1123
26	18	4.11	3.37	0.82	864	3.94	3.23	0.82	907	3.78	3.10	0.82	950	3.64	2.98	0.82	994
26	20	4.29	3.00	0.70	907	4.11	2.88	0.70	961	3.99	2.79	0.70	983	3.85	2.70	0.70	1026
26	22	4.46	2.59	0.58	940	4.31	2.50	0.58	999	4.20	2.44	0.58	1026	4.03	2.33	0.58	1069
26	24	4.69	2.16	0.46	983	4.52	2.08	0.46	1037	4.41	2.03	0.46	1069	4.27	1.96	0.46	1123
26	26	4.83	1.64	0.34	1037	4.69	1.59	0.34	1091	4.62	1.57	0.34	1123	4.48	1.52	0.34	1156
27	18	4.11	3.54	0.86	864	3.94	3.39	0.86	907	3.78	3.25	0.86	950	3.64	3.13	0.86	994
27	20	4.29	3.17	0.74	907	4.11	3.04	0.74	961	3.99	2.95	0.74	983	3.85	2.85	0.74	1026
27	22	4.46	2.77	0.62	940	4.31	2.67	0.62	999	4.20	2.60	0.62	1026	4.03	2.50	0.62	1069
27	24	4.69	2.35	0.50	983	4.52	2.26	0.50	1037	4.41	2.21	0.50	1069	4.27	2.14	0.50	1123
27	26	4.83	1.84	0.38	1037	4.69	1.78	0.38	1091	4.62	1.76	0.38	1123	4.48	1.70	0.38	1156
28	18	4.11	3.70	0.90	864	3.94	3.54	0.90	907	3.78	3.40	0.90	950	3.64	3.28	0.90	994
28	20	4.29	3.34	0.78	907	4.11	3.21	0.78	961	3.99	3.11	0.78	983	3.85	3.00	0.78	1026
28	22	4.46	2.95	0.66	940	4.31	2.84	0.66	999	4.20	2.77	0.66	1026	4.03	2.66	0.66	1069
28	24	4.69	2.53	0.54	983	4.52	2.44	0.54	1037	4.41	2.38	0.54	1069	4.27	2.31	0.54	1123
28	26	4.83	2.03	0.42	1037	4.69	1.97	0.42	1091	4.62	1.94	0.42	1123	4.48	1.88	0.42	1156
29	18	4.11	3.87	0.94	864	3.94	3.70	0.94	907	3.78	3.55	0.94	950	3.64	3.42	0.94	994
29	20	4.29	3.52	0.82	907	4.11	3.37	0.82	961	3.99	3.27	0.82	983	3.85	3.16	0.82	1026
29	22	4.46	3.12	0.70	940	4.31	3.01	0.70	999	4.20	2.94	0.70	1026	4.03	2.82	0.70	1069
29	24	4.69	2.72	0.58	983	4.52	2.62	0.58	1037	4.41	2.56	0.58	1069	4.27	2.48	0.58	1123
29	26	4.83	2.22	0.46	1037	4.69	2.16	0.46	1091	4.62	2.13	0.46	1123	4.48	2.06	0.46	1156
30	18	4.11	4.03	0.98	864	3.94	3.86	0.98	907	3.78	3.70	0.98	950	3.64	3.57	0.98	994
30	20	4.29	3.69	0.86	907	4.11	3.54	0.86	961	3.99	3.43	0.86	983	3.85	3.31	0.86	1026
30	22	4.46	3.30	0.74	940	4.31	3.19	0.74	999	4.20	3.11	0.74	1026	4.03	2.98	0.74	1069
30	24	4.69	2.91	0.62	983	4.52	2.80	0.62	1037	4.41	2.73	0.62	1069	4.27	2.65	0.62	1123
30	26	4.83	2.42	0.50	1037	4.69	2.35	0.50	1091	4.62	2.31	0.50	1123	4.48	2.24	0.50	1156
31	18	4.11	4.11	1.00	864	3.94	3.94	1.00	907	3.78	3.78	1.00	950	3.64	3.64	1.00	994
31	20	4.29	3.86	0.90	907	4.11	3.70	0.90	961	3.99	3.59	0.90	983	3.85	3.47	0.90	1026
31	22	4.46	3.48	0.78	940	4.31	3.36	0.78	999	4.20	3.28	0.78	1026	4.03	3.14	0.78	1069
31	24	4.69	3.10	0.66	983	4.52	2.98	0.66	1037	4.41	2.91	0.66	1069	4.27	2.82	0.66	1123
31	26	4.83	2.61	0.54	1037	4.69	2.53	0.54	1091	4.62	2.49	0.54	1123	4.48	2.42	0.54	1156
32	18	4.11	4.11	1.00	864	3.94	3.94	1.00	907	3.78	3.78	1.00	950	3.64	3.64	1.00	994
32	20	4.29	4.03	0.94	907	4.11	3.87	0.94	961	3.99	3.75	0.94	983	3.85	3.62	0.94	1026
32	22	4.46	3.66	0.82	940	4.31	3.53	0.82	999	4.20	3.44	0.82	1026	4.03	3.30	0.82	1069
32	24	4.69	3.28	0.70	983	4.52	3.16	0.70	1037	4.41	3.09	0.70	1069	4.27	2.99	0.70	1123
32	26	4.83	2.80	0.58	1037	4.69	2.72	0.58	1091	4.62	2.68	0.58	1123	4.48	2.60	0.58	1156

WALL-MOUNTED PERFORMANCE DATA

NOTE Q : Total capacity (kW) SHF : Sensible heat factor DB : Dry-bulb temperature
 SHC : Sensible heat capacity (kW) INPUT : Total power input (W) WB : Wet-bulb temperature

PERFORMANCE DATA COOL operation at Rated frequency

MSZ-SF35VE3: MUZ-SF35VE, MUZ-SF35VEH

CAPACITY: 3.5 kW SHF: 0.80 INPUT: 1080 W

INDOOR DB (°C)	INDOOR WB (°C)	OUTDOOR DB (°C)											
		35				40				46			
		Q	SHC	SHF	INPUT	Q	SHC	SHF	INPUT	Q	SHC	SHF	INPUT
21	18	3.43	2.13	0.62	1058	3.15	1.95	0.62	1123	2.91	1.80	0.62	1166
21	20	3.61	1.80	0.50	1102	3.36	1.68	0.50	1156	3.12	1.56	0.50	1220
22	18	3.43	2.26	0.66	1058	3.15	2.08	0.66	1123	2.91	1.92	0.66	1166
22	20	3.61	1.95	0.54	1102	3.36	1.81	0.54	1156	3.12	1.68	0.54	1220
22	22	3.82	1.60	0.42	1145	3.57	1.50	0.42	1210	3.33	1.40	0.42	1253
23	18	3.43	2.40	0.70	1058	3.15	2.21	0.70	1123	2.91	2.03	0.70	1166
23	20	3.61	2.09	0.58	1102	3.36	1.95	0.58	1156	3.12	1.81	0.58	1220
23	22	3.82	1.75	0.46	1145	3.57	1.64	0.46	1210	3.33	1.53	0.46	1253
24	18	3.43	2.54	0.74	1058	3.15	2.33	0.74	1123	2.91	2.15	0.74	1166
24	20	3.61	2.24	0.62	1102	3.36	2.08	0.62	1156	3.12	1.93	0.62	1220
24	22	3.82	1.91	0.50	1145	3.57	1.79	0.50	1210	3.33	1.66	0.50	1253
24	24	4.03	1.53	0.38	1188	3.78	1.44	0.38	1242	3.57	1.36	0.38	1296
25	18	3.43	2.68	0.78	1058	3.15	2.46	0.78	1123	2.91	2.27	0.78	1166
25	20	3.61	2.38	0.66	1102	3.36	2.22	0.66	1156	3.12	2.06	0.66	1220
25	22	3.82	2.06	0.54	1145	3.57	1.93	0.54	1210	3.33	1.80	0.54	1253
25	24	4.03	1.69	0.42	1188	3.78	1.59	0.42	1242	3.57	1.50	0.42	1296
26	18	3.43	2.81	0.82	1058	3.15	2.58	0.82	1123	2.91	2.38	0.82	1166
26	20	3.61	2.52	0.70	1102	3.36	2.35	0.70	1156	3.12	2.18	0.70	1220
26	22	3.82	2.21	0.58	1145	3.57	2.07	0.58	1210	3.33	1.93	0.58	1253
26	24	4.03	1.85	0.46	1188	3.78	1.74	0.46	1242	3.57	1.64	0.46	1296
26	26	4.24	1.44	0.34	1231	3.99	1.36	0.34	1285	3.75	1.27	0.34	1339
27	18	3.43	2.95	0.86	1058	3.15	2.71	0.86	1123	2.91	2.50	0.86	1166
27	20	3.61	2.67	0.74	1102	3.36	2.49	0.74	1156	3.12	2.31	0.74	1220
27	22	3.82	2.37	0.62	1145	3.57	2.21	0.62	1210	3.33	2.06	0.62	1253
27	24	4.03	2.01	0.50	1188	3.78	1.89	0.50	1242	3.57	1.79	0.50	1296
27	26	4.24	1.61	0.38	1231	3.99	1.52	0.38	1285	3.75	1.42	0.38	1339
28	18	3.43	3.09	0.90	1058	3.15	2.84	0.90	1123	2.91	2.61	0.90	1166
28	20	3.61	2.81	0.78	1102	3.36	2.62	0.78	1156	3.12	2.43	0.78	1220
28	22	3.82	2.52	0.66	1145	3.57	2.36	0.66	1210	3.33	2.19	0.66	1253
28	24	4.03	2.17	0.54	1188	3.78	2.04	0.54	1242	3.57	1.93	0.54	1296
28	26	4.24	1.78	0.42	1231	3.99	1.68	0.42	1285	3.75	1.57	0.42	1339
29	18	3.43	3.22	0.94	1058	3.15	2.96	0.94	1123	2.91	2.73	0.94	1166
29	20	3.61	2.96	0.82	1102	3.36	2.76	0.82	1156	3.12	2.55	0.82	1220
29	22	3.82	2.67	0.70	1145	3.57	2.50	0.70	1210	3.33	2.33	0.70	1253
29	24	4.03	2.33	0.58	1188	3.78	2.19	0.58	1242	3.57	2.07	0.58	1296
29	26	4.24	1.95	0.46	1231	3.99	1.84	0.46	1285	3.75	1.72	0.46	1339
30	18	3.43	3.36	0.98	1058	3.15	3.09	0.98	1123	2.91	2.85	0.98	1166
30	20	3.61	3.10	0.86	1102	3.36	2.89	0.86	1156	3.12	2.68	0.86	1220
30	22	3.82	2.82	0.74	1145	3.57	2.64	0.74	1210	3.33	2.46	0.74	1253
30	24	4.03	2.50	0.62	1188	3.78	2.34	0.62	1242	3.57	2.21	0.62	1296
30	26	4.24	2.12	0.50	1231	3.99	2.00	0.50	1285	3.75	1.87	0.50	1339
31	18	3.43	3.43	1.00	1058	3.15	3.15	1.00	1123	2.91	2.91	1.00	1166
31	20	3.61	3.24	0.90	1102	3.36	3.02	0.90	1156	3.12	2.80	0.90	1220
31	22	3.82	2.98	0.78	1145	3.57	2.78	0.78	1210	3.33	2.59	0.78	1253
31	24	4.03	2.66	0.66	1188	3.78	2.49	0.66	1242	3.57	2.36	0.66	1296
31	26	4.24	2.29	0.54	1231	3.99	2.15	0.54	1285	3.75	2.02	0.54	1339
32	18	3.43	3.43	1.00	1058	3.15	3.15	1.00	1123	2.91	2.91	1.00	1166
32	20	3.61	3.39	0.94	1102	3.36	3.16	0.94	1156	3.12	2.93	0.94	1220
32	22	3.82	3.13	0.82	1145	3.57	2.93	0.82	1210	3.33	2.73	0.82	1253
32	24	4.03	2.82	0.70	1188	3.78	2.65	0.70	1242	3.57	2.50	0.70	1296
32	26	4.24	2.46	0.58	1231	3.99	2.31	0.58	1285	3.75	2.17	0.58	1339

NOTE Q : Total capacity (kW) SHF : Sensible heat factor DB : Dry-bulb temperature
 SHC : Sensible heat capacity (kW) INPUT : Total power input (W) WB : Wet-bulb temperature

PERFORMANCE DATA COOL operation at Rated frequency

MSZ-SF42VE3: MUZ-SF42VE, MUZ-SF42VEH

CAPACITY: 4.2 kW

SHF: 0.72

INPUT: 1340 W

INDOOR DB (°C)	INDOOR WB (°C)	OUTDOOR DB (°C)															
		21				25				27				30			
		Q	SHC	SHF	INPUT	Q	SHC	SHF	INPUT	Q	SHC	SHF	INPUT	Q	SHC	SHF	INPUT
21	18	4.94	2.66	0.54	1072	4.73	2.55	0.54	1126	4.54	2.45	0.54	1179	4.37	2.36	0.54	1233
21	20	5.15	2.16	0.42	1126	4.94	2.07	0.42	1193	4.79	2.01	0.42	1219	4.62	1.94	0.42	1273
22	18	4.94	2.86	0.58	1072	4.73	2.74	0.58	1126	4.54	2.63	0.58	1179	4.37	2.53	0.58	1233
22	20	5.15	2.37	0.46	1126	4.94	2.27	0.46	1193	4.79	2.20	0.46	1219	4.62	2.13	0.46	1273
22	22	5.36	1.82	0.34	1166	5.17	1.76	0.34	1240	5.04	1.71	0.34	1273	4.83	1.64	0.34	1327
23	18	4.94	3.06	0.62	1072	4.73	2.93	0.62	1126	4.54	2.81	0.62	1179	4.37	2.71	0.62	1233
23	20	5.15	2.57	0.50	1126	4.94	2.47	0.50	1193	4.79	2.39	0.50	1219	4.62	2.31	0.50	1273
23	22	5.36	2.03	0.38	1166	5.17	1.96	0.38	1240	5.04	1.92	0.38	1273	4.83	1.84	0.38	1327
24	18	4.94	3.26	0.66	1072	4.73	3.12	0.66	1126	4.54	2.99	0.66	1179	4.37	2.88	0.66	1233
24	20	5.15	2.78	0.54	1126	4.94	2.66	0.54	1193	4.79	2.59	0.54	1219	4.62	2.49	0.54	1273
24	22	5.36	2.25	0.42	1166	5.17	2.17	0.42	1240	5.04	2.12	0.42	1273	4.83	2.03	0.42	1327
24	24	5.63	1.69	0.30	1219	5.42	1.63	0.30	1286	5.29	1.59	0.30	1327	5.12	1.54	0.30	1394
25	18	4.94	3.45	0.70	1072	4.73	3.31	0.70	1126	4.54	3.18	0.70	1179	4.37	3.06	0.70	1233
25	20	5.15	2.98	0.58	1126	4.94	2.86	0.58	1193	4.79	2.78	0.58	1219	4.62	2.68	0.58	1273
25	22	5.36	2.46	0.46	1166	5.17	2.38	0.46	1240	5.04	2.32	0.46	1273	4.83	2.22	0.46	1327
25	24	5.63	1.91	0.34	1219	5.42	1.84	0.34	1286	5.29	1.80	0.34	1327	5.12	1.74	0.34	1394
26	18	4.94	3.65	0.74	1072	4.73	3.50	0.74	1126	4.54	3.36	0.74	1179	4.37	3.23	0.74	1233
26	20	5.15	3.19	0.62	1126	4.94	3.06	0.62	1193	4.79	2.97	0.62	1219	4.62	2.86	0.62	1273
26	22	5.36	2.68	0.50	1166	5.17	2.58	0.50	1240	5.04	2.52	0.50	1273	4.83	2.42	0.50	1327
26	24	5.63	2.14	0.38	1219	5.42	2.06	0.38	1286	5.29	2.01	0.38	1327	5.12	1.95	0.38	1394
26	26	5.80	1.51	0.26	1286	5.63	1.46	0.26	1353	5.54	1.44	0.26	1394	5.38	1.40	0.26	1434
27	18	4.94	3.85	0.78	1072	4.73	3.69	0.78	1126	4.54	3.54	0.78	1179	4.37	3.41	0.78	1233
27	20	5.15	3.40	0.66	1126	4.94	3.26	0.66	1193	4.79	3.16	0.66	1219	4.62	3.05	0.66	1273
27	22	5.36	2.89	0.54	1166	5.17	2.79	0.54	1240	5.04	2.72	0.54	1273	4.83	2.61	0.54	1327
27	24	5.63	2.36	0.42	1219	5.42	2.28	0.42	1286	5.29	2.22	0.42	1327	5.12	2.15	0.42	1394
27	26	5.80	1.74	0.30	1286	5.63	1.69	0.30	1353	5.54	1.66	0.30	1394	5.38	1.61	0.30	1434
28	18	4.94	4.05	0.82	1072	4.73	3.87	0.82	1126	4.54	3.72	0.82	1179	4.37	3.58	0.82	1233
28	20	5.15	3.60	0.70	1126	4.94	3.45	0.70	1193	4.79	3.35	0.70	1219	4.62	3.23	0.70	1273
28	22	5.36	3.11	0.58	1166	5.17	3.00	0.58	1240	5.04	2.92	0.58	1273	4.83	2.80	0.58	1327
28	24	5.63	2.59	0.46	1219	5.42	2.49	0.46	1286	5.29	2.43	0.46	1327	5.12	2.36	0.46	1394
28	26	5.80	1.97	0.34	1286	5.63	1.91	0.34	1353	5.54	1.88	0.34	1394	5.38	1.83	0.34	1434
29	18	4.94	4.24	0.86	1072	4.73	4.06	0.86	1126	4.54	3.90	0.86	1179	4.37	3.76	0.86	1233
29	20	5.15	3.81	0.74	1126	4.94	3.65	0.74	1193	4.79	3.54	0.74	1219	4.62	3.42	0.74	1273
29	22	5.36	3.32	0.62	1166	5.17	3.20	0.62	1240	5.04	3.12	0.62	1273	4.83	2.99	0.62	1327
29	24	5.63	2.81	0.50	1219	5.42	2.71	0.50	1286	5.29	2.65	0.50	1327	5.12	2.56	0.50	1394
29	26	5.80	2.20	0.38	1286	5.63	2.14	0.38	1353	5.54	2.11	0.38	1394	5.38	2.04	0.38	1434
30	18	4.94	4.44	0.90	1072	4.73	4.25	0.90	1126	4.54	4.08	0.90	1179	4.37	3.93	0.90	1233
30	20	5.15	4.01	0.78	1126	4.94	3.85	0.78	1193	4.79	3.73	0.78	1219	4.62	3.60	0.78	1273
30	22	5.36	3.53	0.66	1166	5.17	3.41	0.66	1240	5.04	3.33	0.66	1273	4.83	3.19	0.66	1327
30	24	5.63	3.04	0.54	1219	5.42	2.93	0.54	1286	5.29	2.86	0.54	1327	5.12	2.77	0.54	1394
30	26	5.80	2.43	0.42	1286	5.63	2.36	0.42	1353	5.54	2.33	0.42	1394	5.38	2.26	0.42	1434
31	18	4.94	4.64	0.94	1072	4.73	4.44	0.94	1126	4.54	4.26	0.94	1179	4.37	4.11	0.94	1233
31	20	5.15	4.22	0.82	1126	4.94	4.05	0.82	1193	4.79	3.93	0.82	1219	4.62	3.79	0.82	1273
31	22	5.36	3.75	0.70	1166	5.17	3.62	0.70	1240	5.04	3.53	0.70	1273	4.83	3.38	0.70	1327
31	24	5.63	3.26	0.58	1219	5.42	3.14	0.58	1286	5.29	3.07	0.58	1327	5.12	2.97	0.58	1394
31	26	5.80	2.67	0.46	1286	5.63	2.59	0.46	1353	5.54	2.55	0.46	1394	5.38	2.47	0.46	1434
32	18	4.94	4.84	0.98	1072	4.73	4.63	0.98	1126	4.54	4.45	0.98	1179	4.37	4.28	0.98	1233
32	20	5.15	4.42	0.86	1126	4.94	4.24	0.86	1193	4.79	4.12	0.86	1219	4.62	3.97	0.86	1273
32	22	5.36	3.96	0.74	1166	5.17	3.82	0.74	1240	5.04	3.73	0.74	1273	4.83	3.57	0.74	1327
32	24	5.63	3.49	0.62	1219	5.42	3.36	0.62	1286	5.29	3.28	0.62	1327	5.12	3.18	0.62	1394
32	26	5.80	2.90	0.50	1286	5.63	2.81	0.50	1353	5.54	2.77	0.50	1394	5.38	2.69	0.50	1434

NOTE Q : Total capacity (kW) SHF : Sensible heat factor DB : Dry-bulb temperature
 SHC : Sensible heat capacity (kW) INPUT : Total power input (W) WB : Wet-bulb temperature

WALL-MOUNTED PERFORMANCE DATA

PERFORMANCE DATA COOL operation at Rated frequency

MSZ-SF42VE3: MUZ-SF42VE, MUZ-SF42VEH

CAPACITY: 4.2 kW SHF: 0.72 INPUT: 1340 W

INDOOR DB (°C)	INDOOR WB (°C)	OUTDOOR DB (°C)											
		35				40				46			
		Q	SHC	SHF	INPUT	Q	SHC	SHF	INPUT	Q	SHC	SHF	INPUT
21	18	4.12	2.22	0.54	1313	3.78	2.04	0.54	1394	3.49	1.88	0.54	1447
21	20	4.33	1.82	0.42	1367	4.03	1.69	0.42	1434	3.74	1.57	0.42	1514
22	18	4.12	2.39	0.58	1313	3.78	2.19	0.58	1394	3.49	2.02	0.58	1447
22	20	4.33	1.99	0.46	1367	4.03	1.85	0.46	1434	3.74	1.72	0.46	1514
22	22	4.58	1.56	0.34	1420	4.28	1.46	0.34	1501	3.99	1.36	0.34	1554
23	18	4.12	2.55	0.62	1313	3.78	2.34	0.62	1394	3.49	2.16	0.62	1447
23	20	4.33	2.16	0.50	1367	4.03	2.02	0.50	1434	3.74	1.87	0.50	1514
23	22	4.58	1.74	0.38	1420	4.28	1.63	0.38	1501	3.99	1.52	0.38	1554
24	18	4.12	2.72	0.66	1313	3.78	2.49	0.66	1394	3.49	2.30	0.66	1447
24	20	4.33	2.34	0.54	1367	4.03	2.18	0.54	1434	3.74	2.02	0.54	1514
24	22	4.58	1.92	0.42	1420	4.28	1.80	0.42	1501	3.99	1.68	0.42	1554
24	24	4.83	1.45	0.30	1474	4.54	1.36	0.30	1541	4.28	1.29	0.30	1608
25	18	4.12	2.88	0.70	1313	3.78	2.65	0.70	1394	3.49	2.44	0.7	1447
25	20	4.33	2.51	0.58	1367	4.03	2.34	0.58	1434	3.74	2.17	0.58	1514
25	22	4.58	2.11	0.46	1420	4.28	1.97	0.46	1501	3.99	1.84	0.46	1554
25	24	4.83	1.64	0.34	1474	4.54	1.54	0.34	1541	4.28	1.46	0.34	1608
26	18	4.12	3.05	0.74	1313	3.78	2.80	0.74	1394	3.49	2.58	0.74	1447
26	20	4.33	2.68	0.62	1367	4.03	2.50	0.62	1434	3.74	2.32	0.62	1514
26	22	4.58	2.29	0.50	1420	4.28	2.14	0.50	1501	3.99	2.00	0.50	1554
26	24	4.83	1.84	0.38	1474	4.54	1.72	0.38	1541	4.28	1.63	0.38	1608
26	26	5.08	1.32	0.26	1528	4.79	1.24	0.26	1595	4.49	1.17	0.26	1662
27	18	4.12	3.21	0.78	1313	3.78	2.95	0.78	1394	3.49	2.72	0.78	1447
27	20	4.33	2.86	0.66	1367	4.03	2.66	0.66	1434	3.74	2.47	0.66	1514
27	22	4.58	2.47	0.54	1420	4.28	2.31	0.54	1501	3.99	2.15	0.54	1554
27	24	4.83	2.03	0.42	1474	4.54	1.91	0.42	1541	4.28	1.80	0.42	1608
27	26	5.08	1.52	0.30	1528	4.79	1.44	0.30	1595	4.49	1.35	0.30	1662
28	18	4.12	3.38	0.82	1313	3.78	3.10	0.82	1394	3.49	2.86	0.82	1447
28	20	4.33	3.03	0.70	1367	4.03	2.82	0.70	1434	3.74	2.62	0.70	1514
28	22	4.58	2.66	0.58	1420	4.28	2.48	0.58	1501	3.99	2.31	0.58	1554
28	24	4.83	2.22	0.46	1474	4.54	2.09	0.46	1541	4.28	1.97	0.46	1608
28	26	5.08	1.73	0.34	1528	4.79	1.63	0.34	1595	4.49	1.53	0.34	1662
29	18	4.12	3.54	0.86	1313	3.78	3.25	0.86	1394	3.49	3.00	0.86	1447
29	20	4.33	3.20	0.74	1367	4.03	2.98	0.74	1434	3.74	2.77	0.74	1514
29	22	4.58	2.84	0.62	1420	4.28	2.66	0.62	1501	3.99	2.47	0.62	1554
29	24	4.83	2.42	0.50	1474	4.54	2.27	0.50	1541	4.28	2.14	0.50	1608
29	26	5.08	1.93	0.38	1528	4.79	1.82	0.38	1595	4.49	1.71	0.38	1662
30	18	4.12	3.70	0.90	1313	3.78	3.40	0.90	1394	3.49	3.14	0.90	1447
30	20	4.33	3.37	0.78	1367	4.03	3.14	0.78	1434	3.74	2.92	0.78	1514
30	22	4.58	3.02	0.66	1420	4.28	2.83	0.66	1501	3.99	2.63	0.66	1554
30	24	4.83	2.61	0.54	1474	4.54	2.45	0.54	1541	4.28	2.31	0.54	1608
30	26	5.08	2.13	0.42	1528	4.79	2.01	0.42	1595	4.49	1.89	0.42	1662
31	18	4.12	3.87	0.94	1313	3.78	3.55	0.94	1394	3.49	3.28	0.94	1447
31	20	4.33	3.55	0.82	1367	4.03	3.31	0.82	1434	3.74	3.07	0.82	1514
31	22	4.58	3.20	0.70	1420	4.28	3.00	0.70	1501	3.99	2.79	0.70	1554
31	24	4.83	2.80	0.58	1474	4.54	2.63	0.58	1541	4.28	2.48	0.58	1608
31	26	5.08	2.34	0.46	1528	4.79	2.20	0.46	1595	4.49	2.07	0.46	1662
32	18	4.12	4.03	0.98	1313	3.78	3.70	0.98	1394	3.49	3.42	0.98	1447
32	20	4.33	3.72	0.86	1367	4.03	3.47	0.86	1434	3.74	3.21	0.86	1514
32	22	4.58	3.39	0.74	1420	4.28	3.17	0.74	1501	3.99	2.95	0.74	1554
32	24	4.83	2.99	0.62	1474	4.54	2.81	0.62	1541	4.28	2.66	0.62	1608
32	26	5.08	2.54	0.50	1528	4.79	2.39	0.50	1595	4.49	2.25	0.50	1662

NOTE Q : Total capacity (kW) SHF : Sensible heat factor DB : Dry-bulb temperature
 SHC : Sensible heat capacity (kW) INPUT : Total power input (W) WB : Wet-bulb temperature

PERFORMANCE DATA COOL operation at Rated frequency

MSZ-SF50VE3: MUZ-SF50VE, MUZ-SF50VEH

CAPACITY: 5.0 kW SHF: 0.70 INPUT: 1660 W

INDOOR DB (°C)	INDOOR WB (°C)	OUTDOOR DB (°C)															
		21				25				27				30			
		Q	SHC	SHF	INPUT	Q	SHC	SHF	INPUT	Q	SHC	SHF	INPUT	Q	SHC	SHF	INPUT
21	18	5.88	3.06	0.52	1328	5.63	2.93	0.52	1394	5.40	2.81	0.52	1461	5.20	2.70	0.52	1527
21	20	6.13	2.45	0.40	1394	5.88	2.35	0.40	1477	5.70	2.28	0.40	1511	5.50	2.20	0.40	1577
22	18	5.88	3.29	0.56	1328	5.63	3.15	0.56	1394	5.40	3.02	0.56	1461	5.20	2.91	0.56	1527
22	20	6.13	2.70	0.44	1394	5.88	2.59	0.44	1477	5.70	2.51	0.44	1511	5.50	2.42	0.44	1577
22	22	6.38	2.04	0.32	1444	6.15	1.97	0.32	1536	6.00	1.92	0.32	1577	5.75	1.84	0.32	1643
23	18	5.88	3.53	0.60	1328	5.63	3.38	0.60	1394	5.40	3.24	0.60	1461	5.20	3.12	0.60	1527
23	20	6.13	2.94	0.48	1394	5.88	2.82	0.48	1477	5.70	2.74	0.48	1511	5.50	2.64	0.48	1577
23	22	6.38	2.30	0.36	1444	6.15	2.21	0.36	1536	6.00	2.16	0.36	1577	5.75	2.07	0.36	1643
24	18	5.88	3.76	0.64	1328	5.63	3.60	0.64	1394	5.40	3.46	0.64	1461	5.20	3.33	0.64	1527
24	20	6.13	3.19	0.52	1394	5.88	3.06	0.52	1477	5.70	2.96	0.52	1511	5.50	2.86	0.52	1577
24	22	6.38	2.55	0.40	1444	6.15	2.46	0.40	1536	6.00	2.40	0.40	1577	5.75	2.30	0.40	1643
24	24	6.70	1.88	0.28	1511	6.45	1.81	0.28	1594	6.30	1.76	0.28	1643	6.10	1.71	0.28	1726
25	18	5.88	4.00	0.68	1328	5.63	3.83	0.68	1394	5.40	3.67	0.68	1461	5.20	3.54	0.68	1527
25	20	6.13	3.43	0.56	1394	5.88	3.29	0.56	1477	5.70	3.19	0.56	1511	5.50	3.08	0.56	1577
25	22	6.38	2.81	0.44	1444	6.15	2.71	0.44	1536	6.00	2.64	0.44	1577	5.75	2.53	0.44	1643
25	24	6.70	2.14	0.32	1511	6.45	2.06	0.32	1594	6.30	2.02	0.32	1643	6.10	1.95	0.32	1726
26	18	5.88	4.23	0.72	1328	5.63	4.05	0.72	1394	5.40	3.89	0.72	1461	5.20	3.74	0.72	1527
26	20	6.13	3.68	0.60	1394	5.88	3.53	0.60	1477	5.70	3.42	0.60	1511	5.50	3.30	0.60	1577
26	22	6.38	3.06	0.48	1444	6.15	2.95	0.48	1536	6.00	2.88	0.48	1577	5.75	2.76	0.48	1643
26	24	6.70	2.41	0.36	1511	6.45	2.32	0.36	1594	6.30	2.27	0.36	1643	6.10	2.20	0.36	1726
26	26	6.90	1.66	0.24	1594	6.70	1.61	0.24	1677	6.60	1.58	0.24	1726	6.40	1.54	0.24	1776
27	18	5.88	4.47	0.76	1328	5.63	4.28	0.76	1394	5.40	4.10	0.76	1461	5.20	3.95	0.76	1527
27	20	6.13	3.92	0.64	1394	5.88	3.76	0.64	1477	5.70	3.65	0.64	1511	5.50	3.52	0.64	1577
27	22	6.38	3.32	0.52	1444	6.15	3.20	0.52	1536	6.00	3.12	0.52	1577	5.75	2.99	0.52	1643
27	24	6.70	2.68	0.40	1511	6.45	2.58	0.40	1594	6.30	2.52	0.40	1643	6.10	2.44	0.40	1726
27	26	6.90	1.93	0.28	1594	6.70	1.88	0.28	1677	6.60	1.85	0.28	1726	6.40	1.79	0.28	1776
28	18	5.88	4.70	0.80	1328	5.63	4.50	0.80	1394	5.40	4.32	0.80	1461	5.20	4.16	0.80	1527
28	20	6.13	4.17	0.68	1394	5.88	4.00	0.68	1477	5.70	3.88	0.68	1511	5.50	3.74	0.68	1577
28	22	6.38	3.57	0.56	1444	6.15	3.44	0.56	1536	6.00	3.36	0.56	1577	5.75	3.22	0.56	1643
28	24	6.70	2.95	0.44	1511	6.45	2.84	0.44	1594	6.30	2.77	0.44	1643	6.10	2.68	0.44	1726
28	26	6.90	2.21	0.32	1594	6.70	2.14	0.32	1677	6.60	2.11	0.32	1726	6.40	2.05	0.32	1776
29	18	5.88	4.94	0.84	1328	5.63	4.73	0.84	1394	5.40	4.54	0.84	1461	5.20	4.37	0.84	1527
29	20	6.13	4.41	0.72	1394	5.88	4.23	0.72	1477	5.70	4.10	0.72	1511	5.50	3.96	0.72	1577
29	22	6.38	3.83	0.60	1444	6.15	3.69	0.60	1536	6.00	3.60	0.60	1577	5.75	3.45	0.60	1643
29	24	6.70	3.22	0.48	1511	6.45	3.10	0.48	1594	6.30	3.02	0.48	1643	6.10	2.93	0.48	1726
29	26	6.90	2.48	0.36	1594	6.70	2.41	0.36	1677	6.60	2.38	0.36	1726	6.40	2.30	0.36	1776
30	18	5.88	5.17	0.88	1328	5.63	4.95	0.88	1394	5.40	4.75	0.88	1461	5.20	4.58	0.88	1527
30	20	6.13	4.66	0.76	1394	5.88	4.47	0.76	1477	5.70	4.33	0.76	1511	5.50	4.18	0.76	1577
30	22	6.38	4.08	0.64	1444	6.15	3.94	0.64	1536	6.00	3.84	0.64	1577	5.75	3.68	0.64	1643
30	24	6.70	3.48	0.52	1511	6.45	3.35	0.52	1594	6.30	3.28	0.52	1643	6.10	3.17	0.52	1726
30	26	6.90	2.76	0.40	1594	6.70	2.68	0.40	1677	6.60	2.64	0.40	1726	6.40	2.56	0.40	1776
31	18	5.88	5.41	0.92	1328	5.63	5.18	0.92	1394	5.40	4.97	0.92	1461	5.20	4.78	0.92	1527
31	20	6.13	4.90	0.80	1394	5.88	4.70	0.80	1477	5.70	4.56	0.80	1511	5.50	4.40	0.80	1577
31	22	6.38	4.34	0.68	1444	6.15	4.18	0.68	1536	6.00	4.08	0.68	1577	5.75	3.91	0.68	1643
31	24	6.70	3.75	0.56	1511	6.45	3.61	0.56	1594	6.30	3.53	0.56	1643	6.10	3.42	0.56	1726
31	26	6.90	3.04	0.44	1594	6.70	2.95	0.44	1677	6.60	2.90	0.44	1726	6.40	2.82	0.44	1776
32	18	5.88	5.64	0.96	1328	5.63	5.40	0.96	1394	5.40	5.18	0.96	1461	5.20	4.99	0.96	1527
32	20	6.13	5.15	0.84	1394	5.88	4.94	0.84	1477	5.70	4.79	0.84	1511	5.50	4.62	0.84	1577
32	22	6.38	4.59	0.72	1444	6.15	4.43	0.72	1536	6.00	4.32	0.72	1577	5.75	4.14	0.72	1643
32	24	6.70	4.02	0.60	1511	6.45	3.87	0.60	1594	6.30	3.78	0.60	1643	6.10	3.66	0.60	1726
32	26	6.90	3.31	0.48	1594	6.70	3.22	0.48	1677	6.60	3.17	0.48	1726	6.40	3.07	0.48	1776

WALL-MOUNTED PERFORMANCE DATA

NOTE Q : Total capacity (kW) SHF : Sensible heat factor DB : Dry-bulb temperature
 SHC : Sensible heat capacity (kW) INPUT : Total power input (W) WB : Wet-bulb temperature

PERFORMANCE DATA COOL operation at Rated frequency

MSZ-SF50VE3: MUZ-SF50VE, MUZ-SF50VEH

CAPACITY: 5.0 kW SHF: 0.70 INPUT: 1660 W

INDOOR DB (°C)	INDOOR WB (°C)	OUTDOOR DB (°C)											
		35				40				46			
		Q	SHC	SHF	INPUT	Q	SHC	SHF	INPUT	Q	SHC	SHF	INPUT
21	18	4.90	2.55	0.52	1627	4.50	2.34	0.52	1726	4.15	2.16	0.52	1793
21	20	5.15	2.06	0.40	1693	4.80	1.92	0.40	1776	4.45	1.78	0.40	1876
22	18	4.90	2.74	0.56	1627	4.50	2.52	0.56	1726	4.15	2.32	0.56	1793
22	20	5.15	2.27	0.44	1693	4.80	2.11	0.44	1776	4.45	1.96	0.44	1876
22	22	5.45	1.74	0.32	1760	5.10	1.63	0.32	1859	4.75	1.52	0.32	1926
23	18	4.90	2.94	0.60	1627	4.50	2.70	0.60	1726	4.15	2.49	0.60	1793
23	20	5.15	2.47	0.48	1693	4.80	2.30	0.48	1776	4.45	2.14	0.48	1876
23	22	5.45	1.96	0.36	1760	5.10	1.84	0.36	1859	4.75	1.71	0.36	1926
24	18	4.90	3.14	0.64	1627	4.50	2.88	0.64	1726	4.15	2.66	0.64	1793
24	20	5.15	2.68	0.52	1693	4.80	2.50	0.52	1776	4.45	2.31	0.52	1876
24	22	5.45	2.18	0.40	1760	5.10	2.04	0.40	1859	4.75	1.90	0.40	1926
24	24	5.75	1.61	0.28	1826	5.40	1.51	0.28	1909	5.10	1.43	0.28	1992
25	18	4.90	3.33	0.68	1627	4.50	3.06	0.68	1726	4.15	2.82	0.68	1793
25	20	5.15	2.88	0.56	1693	4.80	2.69	0.56	1776	4.45	2.49	0.56	1876
25	22	5.45	2.40	0.44	1760	5.10	2.24	0.44	1859	4.75	2.09	0.44	1926
25	24	5.75	1.84	0.32	1826	5.40	1.73	0.32	1909	5.10	1.63	0.32	1992
26	18	4.90	3.53	0.72	1627	4.50	3.24	0.72	1726	4.15	2.99	0.72	1793
26	20	5.15	3.09	0.60	1693	4.80	2.88	0.60	1776	4.45	2.67	0.60	1876
26	22	5.45	2.62	0.48	1760	5.10	2.45	0.48	1859	4.75	2.28	0.48	1926
26	24	5.75	2.07	0.36	1826	5.40	1.94	0.36	1909	5.10	1.84	0.36	1992
26	26	6.05	1.45	0.24	1892	5.70	1.37	0.24	1975	5.35	1.28	0.24	2058
27	18	4.90	3.72	0.76	1627	4.50	3.42	0.76	1726	4.15	3.15	0.76	1793
27	20	5.15	3.30	0.64	1693	4.80	3.07	0.64	1776	4.45	2.85	0.64	1876
27	22	5.45	2.83	0.52	1760	5.10	2.65	0.52	1859	4.75	2.47	0.52	1926
27	24	5.75	2.30	0.40	1826	5.40	2.16	0.40	1909	5.10	2.04	0.40	1992
27	26	6.05	1.69	0.28	1892	5.70	1.60	0.28	1975	5.35	1.50	0.28	2058
28	18	4.90	3.92	0.80	1627	4.50	3.60	0.80	1726	4.15	3.32	0.80	1793
28	20	5.15	3.50	0.68	1693	4.80	3.26	0.68	1776	4.45	3.03	0.68	1876
28	22	5.45	3.05	0.56	1760	5.10	2.86	0.56	1859	4.75	2.66	0.56	1926
28	24	5.75	2.53	0.44	1826	5.40	2.38	0.44	1909	5.10	2.24	0.44	1992
28	26	6.05	1.94	0.32	1892	5.70	1.82	0.32	1975	5.35	1.71	0.32	2058
29	18	4.90	4.12	0.84	1627	4.50	3.78	0.84	1726	4.15	3.49	0.84	1793
29	20	5.15	3.71	0.72	1693	4.80	3.46	0.72	1776	4.45	3.20	0.72	1876
29	22	5.45	3.27	0.60	1760	5.10	3.06	0.60	1859	4.75	2.85	0.60	1926
29	24	5.75	2.76	0.48	1826	5.40	2.59	0.48	1909	5.10	2.45	0.48	1992
29	26	6.05	2.18	0.36	1892	5.70	2.05	0.36	1975	5.35	1.93	0.36	2058
30	18	4.90	4.31	0.88	1627	4.50	3.96	0.88	1726	4.15	3.65	0.88	1793
30	20	5.15	3.91	0.76	1693	4.80	3.65	0.76	1776	4.45	3.38	0.76	1876
30	22	5.45	3.49	0.64	1760	5.10	3.26	0.64	1859	4.75	3.04	0.64	1926
30	24	5.75	2.99	0.52	1826	5.40	2.81	0.52	1909	5.10	2.65	0.52	1992
30	26	6.05	2.42	0.40	1892	5.70	2.28	0.40	1975	5.35	2.14	0.40	2058
31	18	4.90	4.51	0.92	1627	4.50	4.14	0.92	1726	4.15	3.82	0.92	1793
31	20	5.15	4.12	0.80	1693	4.80	3.84	0.80	1776	4.45	3.56	0.80	1876
31	22	5.45	3.71	0.68	1760	5.10	3.47	0.68	1859	4.75	3.23	0.68	1926
31	24	5.75	3.22	0.56	1826	5.40	3.02	0.56	1909	5.10	2.86	0.56	1992
31	26	6.05	2.66	0.44	1892	5.70	2.51	0.44	1975	5.35	2.35	0.44	2058
32	18	4.90	4.70	0.96	1627	4.50	4.32	0.96	1726	4.15	3.98	0.96	1793
32	20	5.15	4.33	0.84	1693	4.80	4.03	0.84	1776	4.45	3.74	0.84	1876
32	22	5.45	3.92	0.72	1760	5.10	3.67	0.72	1859	4.75	3.42	0.72	1926
32	24	5.75	3.45	0.60	1826	5.40	3.24	0.60	1909	5.10	3.06	0.60	1992
32	26	6.05	2.90	0.48	1892	5.70	2.74	0.48	1975	5.35	2.57	0.48	2058

NOTE Q : Total capacity (kW) SHF : Sensible heat factor DB : Dry-bulb temperature
 SHC : Sensible heat capacity (kW) INPUT : Total power input (W) WB : Wet-bulb temperature

PERFORMANCE DATA COOL operation at Rated frequency

MSZ-GF60VE2: MUZ-GF60VE

CAPACITY: 6.1 kW

SHF: 0.79

INPUT: 1790 W

INDOOR DB (°C)	INDOOR WB (°C)	OUTDOOR DB (°C)															
		21				25				27				30			
		Q	SHC	SHF	INPUT	Q	SHC	SHF	INPUT	Q	SHC	SHF	INPUT	Q	SHC	SHF	INPUT
21	18	7.17	4.37	0.61	1432	6.86	4.19	0.61	1504	6.59	4.02	0.61	1575	6.34	3.87	0.61	1647
21	20	7.47	3.66	0.49	1504	7.17	3.51	0.49	1593	6.95	3.41	0.49	1629	6.71	3.29	0.49	1701
22	18	7.17	4.66	0.65	1432	6.86	4.46	0.65	1504	6.59	4.28	0.65	1575	6.34	4.12	0.65	1647
22	20	7.47	3.96	0.53	1504	7.17	3.80	0.53	1593	6.95	3.69	0.53	1629	6.71	3.56	0.53	1701
22	22	7.78	3.19	0.41	1557	7.50	3.08	0.41	1656	7.32	3.00	0.41	1701	7.01	2.88	0.41	1772
23	18	7.17	4.95	0.69	1432	6.86	4.74	0.69	1504	6.59	4.55	0.69	1575	6.34	4.38	0.69	1647
23	20	7.47	4.26	0.57	1504	7.17	4.09	0.57	1593	6.95	3.96	0.57	1629	6.71	3.82	0.57	1701
23	22	7.78	3.50	0.45	1557	7.50	3.38	0.45	1656	7.32	3.29	0.45	1701	7.01	3.16	0.45	1772
24	18	7.17	5.23	0.73	1432	6.86	5.01	0.73	1504	6.59	4.81	0.73	1575	6.34	4.63	0.73	1647
24	20	7.47	4.56	0.61	1504	7.17	4.37	0.61	1593	6.95	4.24	0.61	1629	6.71	4.09	0.61	1701
24	22	7.78	3.81	0.49	1557	7.50	3.68	0.49	1656	7.32	3.59	0.49	1701	7.01	3.44	0.49	1772
24	24	8.17	3.02	0.37	1629	7.87	2.91	0.37	1718	7.69	2.84	0.37	1772	7.44	2.75	0.37	1862
25	18	7.17	5.52	0.77	1432	6.86	5.28	0.77	1504	6.59	5.07	0.77	1575	6.34	4.88	0.77	1647
25	20	7.47	4.86	0.65	1504	7.17	4.66	0.65	1593	6.95	4.52	0.65	1629	6.71	4.36	0.65	1701
25	22	7.78	4.12	0.53	1557	7.50	3.98	0.53	1656	7.32	3.88	0.53	1701	7.01	3.72	0.53	1772
25	24	8.17	3.35	0.41	1629	7.87	3.23	0.41	1718	7.69	3.15	0.41	1772	7.44	3.05	0.41	1862
26	18	7.17	5.81	0.81	1432	6.86	5.56	0.81	1504	6.59	5.34	0.81	1575	6.34	5.14	0.81	1647
26	20	7.47	5.16	0.69	1504	7.17	4.95	0.69	1593	6.95	4.80	0.69	1629	6.71	4.63	0.69	1701
26	22	7.78	4.43	0.57	1557	7.50	4.28	0.57	1656	7.32	4.17	0.57	1701	7.01	4.00	0.57	1772
26	24	8.17	3.68	0.45	1629	7.87	3.54	0.45	1718	7.69	3.46	0.45	1772	7.44	3.35	0.45	1862
26	26	8.42	2.78	0.33	1718	8.17	2.70	0.33	1808	8.05	2.66	0.33	1862	7.81	2.58	0.33	1915
27	18	7.17	6.09	0.85	1432	6.86	5.83	0.85	1504	6.59	5.60	0.85	1575	6.34	5.39	0.85	1647
27	20	7.47	5.45	0.73	1504	7.17	5.23	0.73	1593	6.95	5.08	0.73	1629	6.71	4.90	0.73	1701
27	22	7.78	4.74	0.61	1557	7.50	4.58	0.61	1656	7.32	4.47	0.61	1701	7.01	4.28	0.61	1772
27	24	8.17	4.01	0.49	1629	7.87	3.86	0.49	1718	7.69	3.77	0.49	1772	7.44	3.65	0.49	1862
27	26	8.42	3.11	0.37	1718	8.17	3.02	0.37	1808	8.05	2.98	0.37	1862	7.81	2.89	0.37	1915
28	18	7.17	6.38	0.89	1432	6.86	6.11	0.89	1504	6.59	5.86	0.89	1575	6.34	5.65	0.89	1647
28	20	7.47	5.75	0.77	1504	7.17	5.52	0.77	1593	6.95	5.35	0.77	1629	6.71	5.17	0.77	1701
28	22	7.78	5.06	0.65	1557	7.50	4.88	0.65	1656	7.32	4.76	0.65	1701	7.01	4.56	0.65	1772
28	24	8.17	4.33	0.53	1629	7.87	4.17	0.53	1718	7.69	4.07	0.53	1772	7.44	3.94	0.53	1862
28	26	8.42	3.45	0.41	1718	8.17	3.35	0.41	1808	8.05	3.30	0.41	1862	7.81	3.20	0.41	1915
29	18	7.17	6.67	0.93	1432	6.86	6.38	0.93	1504	6.59	6.13	0.93	1575	6.34	5.90	0.93	1647
29	20	7.47	6.05	0.81	1504	7.17	5.81	0.81	1593	6.95	5.63	0.81	1629	6.71	5.44	0.81	1701
29	22	7.78	5.37	0.69	1557	7.50	5.18	0.69	1656	7.32	5.05	0.69	1701	7.01	4.84	0.69	1772
29	24	8.17	4.66	0.57	1629	7.87	4.49	0.57	1718	7.69	4.38	0.57	1772	7.44	4.24	0.57	1862
29	26	8.42	3.79	0.45	1718	8.17	3.68	0.45	1808	8.05	3.62	0.45	1862	7.81	3.51	0.45	1915
30	18	7.17	6.95	0.97	1432	6.86	6.66	0.97	1504	6.59	6.39	0.97	1575	6.34	6.15	0.97	1647
30	20	7.47	6.35	0.85	1504	7.17	6.09	0.85	1593	6.95	5.91	0.85	1629	6.71	5.70	0.85	1701
30	22	7.78	5.68	0.73	1557	7.50	5.48	0.73	1656	7.32	5.34	0.73	1701	7.01	5.12	0.73	1772
30	24	8.17	4.99	0.61	1629	7.87	4.80	0.61	1718	7.69	4.69	0.61	1772	7.44	4.54	0.61	1862
30	26	8.42	4.12	0.49	1718	8.17	4.01	0.49	1808	8.05	3.95	0.49	1862	7.81	3.83	0.49	1915
31	18	7.17	7.17	1.00	1432	6.86	6.86	1.00	1504	6.59	6.59	1.00	1575	6.34	6.34	1.00	1647
31	20	7.47	6.65	0.89	1504	7.17	6.38	0.89	1593	6.95	6.19	0.89	1629	6.71	5.97	0.89	1701
31	22	7.78	5.99	0.77	1557	7.50	5.78	0.77	1656	7.32	5.64	0.77	1701	7.01	5.40	0.77	1772
31	24	8.17	5.31	0.65	1629	7.87	5.11	0.65	1718	7.69	5.00	0.65	1772	7.44	4.84	0.65	1862
31	26	8.42	4.46	0.53	1718	8.17	4.33	0.53	1808	8.05	4.27	0.53	1862	7.81	4.14	0.53	1915
32	18	7.17	7.17	1.00	1432	6.86	6.86	1.00	1504	6.59	6.59	1.00	1575	6.34	6.34	1.00	1647
32	20	7.47	6.95	0.93	1504	7.17	6.67	0.93	1593	6.95	6.47	0.93	1629	6.71	6.24	0.93	1701
32	22	7.78	6.30	0.81	1557	7.50	6.08	0.81	1656	7.32	5.93	0.81	1701	7.01	5.68	0.81	1772
32	24	8.17	5.64	0.69	1629	7.87	5.43	0.69	1718	7.69	5.30	0.69	1772	7.44	5.13	0.69	1862
32	26	8.42	4.80	0.57	1718	8.17	4.66	0.57	1808	8.05	4.59	0.57	1862	7.81	4.45	0.57	1915

WALL-MOUNTED PERFORMANCE DATA

NOTE Q : Total capacity (kW) SHF : Sensible heat factor DB : Dry-bulb temperature
 SHC : Sensible heat capacity (kW) INPUT : Total power input (W) WB : Wet-bulb temperature

PERFORMANCE DATA COOL operation at Rated frequency

MSZ-GF60VE2: MUZ-GF60VE

CAPACITY: 6.1 kW SHF: 0.79 INPUT: 1790 W

INDOOR DB (°C)	INDOOR WB (°C)	OUTDOOR DB (°C)											
		35				40				46			
		Q	SHC	SHF	INPUT	Q	SHC	SHF	INPUT	Q	SHC	SHF	INPUT
21	18	5.98	3.65	0.61	1754	5.49	3.35	0.61	1862	5.06	3.09	0.61	1933
21	20	6.28	3.08	0.49	1826	5.86	2.87	0.49	1915	5.43	2.66	0.49	2023
22	18	5.98	3.89	0.65	1754	5.49	3.57	0.65	1862	5.06	3.29	0.65	1933
22	20	6.28	3.33	0.53	1826	5.86	3.10	0.53	1915	5.43	2.88	0.53	2023
22	22	6.65	2.73	0.41	1897	6.22	2.55	0.41	2005	5.79	2.38	0.41	2076
23	18	5.98	4.12	0.69	1754	5.49	3.79	0.69	1862	5.06	3.49	0.69	1933
23	20	6.28	3.58	0.57	1826	5.86	3.34	0.57	1915	5.43	3.09	0.57	2023
23	22	6.65	2.99	0.45	1897	6.22	2.80	0.45	2005	5.79	2.61	0.45	2076
24	18	5.98	4.36	0.73	1754	5.49	4.01	0.73	1862	5.06	3.70	0.73	1933
24	20	6.28	3.83	0.61	1826	5.86	3.57	0.61	1915	5.43	3.31	0.61	2023
24	22	6.65	3.26	0.49	1897	6.22	3.05	0.49	2005	5.79	2.84	0.49	2076
24	24	7.01	2.60	0.37	1969	6.59	2.44	0.37	2059	6.22	2.30	0.37	2148
25	18	5.98	4.60	0.77	1754	5.49	4.23	0.77	1862	5.06	3.90	0.77	1933
25	20	6.28	4.08	0.65	1826	5.86	3.81	0.65	1915	5.43	3.53	0.65	2023
25	22	6.65	3.52	0.53	1897	6.22	3.30	0.53	2005	5.79	3.07	0.53	2076
25	24	7.01	2.88	0.41	1969	6.59	2.70	0.41	2059	6.22	2.55	0.41	2148
26	18	5.98	4.84	0.81	1754	5.49	4.45	0.81	1862	5.06	4.10	0.81	1933
26	20	6.28	4.34	0.69	1826	5.86	4.04	0.69	1915	5.43	3.75	0.69	2023
26	22	6.65	3.79	0.57	1897	6.22	3.55	0.57	2005	5.79	3.30	0.57	2076
26	24	7.01	3.16	0.45	1969	6.59	2.96	0.45	2059	6.22	2.80	0.45	2148
26	26	7.38	2.44	0.33	2041	6.95	2.29	0.33	2130	6.53	2.15	0.33	2220
27	18	5.98	5.08	0.85	1754	5.49	4.67	0.85	1862	5.06	4.30	0.85	1933
27	20	6.28	4.59	0.73	1826	5.86	4.27	0.73	1915	5.43	3.96	0.73	2023
27	22	6.65	4.06	0.61	1897	6.22	3.80	0.61	2005	5.79	3.53	0.61	2076
27	24	7.01	3.44	0.49	1969	6.59	3.23	0.49	2059	6.22	3.05	0.49	2148
27	26	7.38	2.73	0.37	2041	6.95	2.57	0.37	2130	6.53	2.41	0.37	2220
28	18	5.98	5.32	0.89	1754	5.49	4.89	0.89	1862	5.06	4.51	0.89	1933
28	20	6.28	4.84	0.77	1826	5.86	4.51	0.77	1915	5.43	4.18	0.77	2023
28	22	6.65	4.32	0.65	1897	6.22	4.04	0.65	2005	5.79	3.77	0.65	2076
28	24	7.01	3.72	0.53	1969	6.59	3.49	0.53	2059	6.22	3.30	0.53	2148
28	26	7.38	3.03	0.41	2041	6.95	2.85	0.41	2130	6.53	2.68	0.41	2220
29	18	5.98	5.56	0.93	1754	5.49	5.11	0.93	1862	5.06	4.71	0.93	1933
29	20	6.28	5.09	0.81	1826	5.86	4.74	0.81	1915	5.43	4.40	0.81	2023
29	22	6.65	4.59	0.69	1897	6.22	4.29	0.69	2005	5.79	4.00	0.69	2076
29	24	7.01	4.00	0.57	1969	6.59	3.76	0.57	2059	6.22	3.55	0.57	2148
29	26	7.38	3.32	0.45	2041	6.95	3.13	0.45	2130	6.53	2.94	0.45	2220
30	18	5.98	5.80	0.97	1754	5.49	5.33	0.97	1862	5.06	4.91	0.97	1933
30	20	6.28	5.34	0.85	1826	5.86	4.98	0.85	1915	5.43	4.61	0.85	2023
30	22	6.65	4.85	0.73	1897	6.22	4.54	0.73	2005	5.79	4.23	0.73	2076
30	24	7.01	4.28	0.61	1969	6.59	4.02	0.61	2059	6.22	3.80	0.61	2148
30	26	7.38	3.62	0.49	2041	6.95	3.41	0.49	2130	6.53	3.20	0.49	2220
31	18	5.98	5.98	1.00	1754	5.49	5.49	1.00	1862	5.06	5.06	1.00	1933
31	20	6.28	5.59	0.89	1826	5.86	5.21	0.89	1915	5.43	4.83	0.89	2023
31	22	6.65	5.12	0.77	1897	6.22	4.79	0.77	2005	5.79	4.46	0.77	2076
31	24	7.01	4.56	0.65	1969	6.59	4.28	0.65	2059	6.22	4.04	0.65	2148
31	26	7.38	3.91	0.53	2041	6.95	3.69	0.53	2130	6.53	3.46	0.53	2220
32	18	5.98	5.98	1.00	1754	5.49	5.49	1.00	1862	5.06	5.06	1.00	1933
32	20	6.28	5.84	0.93	1826	5.86	5.45	0.93	1915	5.43	5.05	0.93	2023
32	22	6.65	5.39	0.81	1897	6.22	5.04	0.81	2005	5.79	4.69	0.81	2076
32	24	7.01	4.84	0.69	1969	6.59	4.55	0.69	2059	6.22	4.29	0.69	2148
32	26	7.38	4.21	0.57	2041	6.95	3.96	0.57	2130	6.53	3.72	0.57	2220

PERFORMANCE DATA

WALL-MOUNTED

NOTE Q : Total capacity (kW) SHF : Sensible heat factor DB : Dry-bulb temperature
 SHC : Sensible heat capacity (kW) INPUT : Total power input (W) WB : Wet-bulb temperature

PERFORMANCE DATA COOL operation at Rated frequency**MSZ-GF71VE2: MUZ-GF71VE**

CAPACITY: 7.1 kW

SHF: 0.78

INPUT: 2130 W

INDOOR DB (°C)	INDOOR WB (°C)	OUTDOOR DB (°C)															
		21				25				27				30			
		Q	SHC	SHF	INPUT	Q	SHC	SHF	INPUT	Q	SHC	SHF	INPUT	Q	SHC	SHF	INPUT
21	18	8.34	5.01	0.60	1704	7.99	4.79	0.60	1789	7.67	4.60	0.60	1874	7.38	4.43	0.60	1960
21	20	8.70	4.17	0.48	1789	8.34	4.00	0.48	1896	8.09	3.89	0.48	1938	7.81	3.75	0.48	2024
22	18	8.34	5.34	0.64	1704	7.99	5.11	0.64	1789	7.67	4.91	0.64	1874	7.38	4.73	0.64	1960
22	20	8.70	4.52	0.52	1789	8.34	4.34	0.52	1896	8.09	4.21	0.52	1938	7.81	4.06	0.52	2024
22	22	9.05	3.62	0.40	1853	8.73	3.49	0.40	1970	8.52	3.41	0.40	2024	8.17	3.27	0.40	2109
23	18	8.34	5.67	0.68	1704	7.99	5.43	0.68	1789	7.67	5.21	0.68	1874	7.38	5.02	0.68	1960
23	20	8.70	4.87	0.56	1789	8.34	4.67	0.56	1896	8.09	4.53	0.56	1938	7.81	4.37	0.56	2024
23	22	9.05	3.98	0.44	1853	8.73	3.84	0.44	1970	8.52	3.75	0.44	2024	8.17	3.59	0.44	2109
24	18	8.34	6.01	0.72	1704	7.99	5.75	0.72	1789	7.67	5.52	0.72	1874	7.38	5.32	0.72	1960
24	20	8.70	5.22	0.60	1789	8.34	5.01	0.60	1896	8.09	4.86	0.60	1938	7.81	4.69	0.60	2024
24	22	9.05	4.35	0.48	1853	8.73	4.19	0.48	1970	8.52	4.09	0.48	2024	8.17	3.92	0.48	2109
24	24	9.51	3.43	0.36	1938	9.16	3.30	0.36	2045	8.95	3.22	0.36	2109	8.66	3.12	0.36	2215
25	18	8.34	6.34	0.76	1704	7.99	6.07	0.76	1789	7.67	5.83	0.76	1874	7.38	5.61	0.76	1960
25	20	8.70	5.57	0.64	1789	8.34	5.34	0.64	1896	8.09	5.18	0.64	1938	7.81	5.00	0.64	2024
25	22	9.05	4.71	0.52	1853	8.73	4.54	0.52	1970	8.52	4.43	0.52	2024	8.17	4.25	0.52	2109
25	24	9.51	3.81	0.40	1938	9.16	3.66	0.40	2045	8.95	3.58	0.40	2109	8.66	3.46	0.40	2215
26	18	8.34	6.67	0.80	1704	7.99	6.39	0.80	1789	7.67	6.13	0.80	1874	7.38	5.91	0.80	1960
26	20	8.70	5.91	0.68	1789	8.34	5.67	0.68	1896	8.09	5.50	0.68	1938	7.81	5.31	0.68	2024
26	22	9.05	5.07	0.56	1853	8.73	4.89	0.56	1970	8.52	4.77	0.56	2024	8.17	4.57	0.56	2109
26	24	9.51	4.19	0.44	1938	9.16	4.03	0.44	2045	8.95	3.94	0.44	2109	8.66	3.81	0.44	2215
26	26	9.80	3.14	0.32	2045	9.51	3.04	0.32	2151	9.37	3.00	0.32	2215	9.09	2.91	0.32	2279
27	18	8.34	7.01	0.84	1704	7.99	6.71	0.84	1789	7.67	6.44	0.84	1874	7.38	6.20	0.84	1960
27	20	8.70	6.26	0.72	1789	8.34	6.01	0.72	1896	8.09	5.83	0.72	1938	7.81	5.62	0.72	2024
27	22	9.05	5.43	0.60	1853	8.73	5.24	0.60	1970	8.52	5.11	0.60	2024	8.17	4.90	0.60	2109
27	24	9.51	4.57	0.48	1938	9.16	4.40	0.48	2045	8.95	4.29	0.48	2109	8.66	4.16	0.48	2215
27	26	9.80	3.53	0.36	2045	9.51	3.43	0.36	2151	9.37	3.37	0.36	2215	9.09	3.27	0.36	2279
28	18	8.34	7.34	0.88	1704	7.99	7.03	0.88	1789	7.67	6.75	0.88	1874	7.38	6.50	0.88	1960
28	20	8.70	6.61	0.76	1789	8.34	6.34	0.76	1896	8.09	6.15	0.76	1938	7.81	5.94	0.76	2024
28	22	9.05	5.79	0.64	1853	8.73	5.59	0.64	1970	8.52	5.45	0.64	2024	8.17	5.23	0.64	2109
28	24	9.51	4.95	0.52	1938	9.16	4.76	0.52	2045	8.95	4.65	0.52	2109	8.66	4.50	0.52	2215
28	26	9.80	3.92	0.40	2045	9.51	3.81	0.40	2151	9.37	3.75	0.40	2215	9.09	3.64	0.40	2279
29	18	8.34	7.68	0.92	1704	7.99	7.35	0.92	1789	7.67	7.05	0.92	1874	7.38	6.79	0.92	1960
29	20	8.70	6.96	0.80	1789	8.34	6.67	0.80	1896	8.09	6.48	0.80	1938	7.81	6.25	0.80	2024
29	22	9.05	6.16	0.68	1853	8.73	5.94	0.68	1970	8.52	5.79	0.68	2024	8.17	5.55	0.68	2109
29	24	9.51	5.33	0.56	1938	9.16	5.13	0.56	2045	8.95	5.01	0.56	2109	8.66	4.85	0.56	2215
29	26	9.80	4.31	0.44	2045	9.51	4.19	0.44	2151	9.37	4.12	0.44	2215	9.09	4.00	0.44	2279
30	18	8.34	8.01	0.96	1704	7.99	7.67	0.96	1789	7.67	7.36	0.96	1874	7.38	7.09	0.96	1960
30	20	8.70	7.31	0.84	1789	8.34	7.01	0.84	1896	8.09	6.80	0.84	1938	7.81	6.56	0.84	2024
30	22	9.05	6.52	0.72	1853	8.73	6.29	0.72	1970	8.52	6.13	0.72	2024	8.17	5.88	0.72	2109
30	24	9.51	5.71	0.60	1938	9.16	5.50	0.60	2045	8.95	5.37	0.60	2109	8.66	5.20	0.60	2215
30	26	9.80	4.70	0.48	2045	9.51	4.57	0.48	2151	9.37	4.50	0.48	2215	9.09	4.36	0.48	2279
31	18	8.34	8.34	1.00	1704	7.99	7.99	1.00	1789	7.67	7.67	1.00	1874	7.38	7.38	1.00	1960
31	20	8.70	7.65	0.88	1789	8.34	7.34	0.88	1896	8.09	7.12	0.88	1938	7.81	6.87	0.88	2024
31	22	9.05	6.88	0.76	1853	8.73	6.64	0.76	1970	8.52	6.48	0.76	2024	8.17	6.21	0.76	2109
31	24	9.51	6.09	0.64	1938	9.16	5.86	0.64	2045	8.95	5.73	0.64	2109	8.66	5.54	0.64	2215
31	26	9.80	5.09	0.52	2045	9.51	4.95	0.52	2151	9.37	4.87	0.52	2215	9.09	4.73	0.52	2279
32	18	8.34	8.34	1.00	1704	7.99	7.99	1.00	1789	7.67	7.67	1.00	1874	7.38	7.38	1.00	1960
32	20	8.70	8.00	0.92	1789	8.34	7.68	0.92	1896	8.09	7.45	0.92	1938	7.81	7.19	0.92	2024
32	22	9.05	7.24	0.80	1853	8.73	6.99	0.80	1970	8.52	6.82	0.80	2024	8.17	6.53	0.80	2109
32	24	9.51	6.47	0.68	1938	9.16	6.23	0.68	2045	8.95	6.08	0.68	2109	8.66	5.89	0.68	2215
32	26	9.80	5.49	0.56	2045	9.51	5.33	0.56	2151	9.37	5.25	0.56	2215	9.09	5.09	0.56	2279

NOTE Q : Total capacity (kW) SHF : Sensible heat factor DB : Dry-bulb temperature
SHC : Sensible heat capacity (kW) INPUT : Total power input (W) WB : Wet-bulb temperature

PERFORMANCE DATA COOL operation at Rated frequency**MSZ-GF71VE2: MUZ-GF71VE**

CAPACITY: 7.1 kW

SHF: 0.78

INPUT: 2130 W

INDOOR DB (°C)	INDOOR WB (°C)	OUTDOOR DB (°C)											
		35				40				46			
		Q	SHC	SHF	INPUT	Q	SHC	SHF	INPUT	Q	SHC	SHF	INPUT
21	18	6.96	4.17	0.60	2087	6.39	3.83	0.60	2215	5.89	3.54	0.60	2300
21	20	7.31	3.51	0.48	2173	6.82	3.27	0.48	2279	6.32	3.03	0.48	2407
22	18	6.96	4.45	0.64	2087	6.39	4.09	0.64	2215	5.89	3.77	0.64	2300
22	20	7.31	3.80	0.52	2173	6.82	3.54	0.52	2279	6.32	3.29	0.52	2407
22	22	7.74	3.10	0.40	2258	7.24	2.90	0.40	2386	6.75	2.70	0.40	2471
23	18	6.96	4.73	0.68	2087	6.39	4.35	0.68	2215	5.89	4.01	0.68	2300
23	20	7.31	4.10	0.56	2173	6.82	3.82	0.56	2279	6.32	3.54	0.56	2407
23	22	7.74	3.41	0.44	2258	7.24	3.19	0.44	2386	6.75	2.97	0.44	2471
24	18	6.96	5.01	0.72	2087	6.39	4.60	0.72	2215	5.89	4.24	0.72	2300
24	20	7.31	4.39	0.60	2173	6.82	4.09	0.60	2279	6.32	3.79	0.60	2407
24	22	7.74	3.71	0.48	2258	7.24	3.48	0.48	2386	6.75	3.24	0.48	2471
24	24	8.17	2.94	0.36	2343	7.67	2.76	0.36	2450	7.24	2.61	0.36	2556
25	18	6.96	5.29	0.76	2087	6.39	4.86	0.76	2215	5.89	4.48	0.76	2300
25	20	7.31	4.68	0.64	2173	6.82	4.36	0.64	2279	6.32	4.04	0.64	2407
25	22	7.74	4.02	0.52	2258	7.24	3.77	0.52	2386	6.75	3.51	0.52	2471
25	24	8.17	3.27	0.40	2343	7.67	3.07	0.40	2450	7.24	2.90	0.40	2556
26	18	6.96	5.57	0.80	2087	6.39	5.11	0.80	2215	5.89	4.71	0.80	2300
26	20	7.31	4.97	0.68	2173	6.82	4.63	0.68	2279	6.32	4.30	0.68	2407
26	22	7.74	4.33	0.56	2258	7.24	4.06	0.56	2386	6.75	3.78	0.56	2471
26	24	8.17	3.59	0.44	2343	7.67	3.37	0.44	2450	7.24	3.19	0.44	2556
26	26	8.59	2.75	0.32	2428	8.09	2.59	0.32	2535	7.60	2.43	0.32	2641
27	18	6.96	5.84	0.84	2087	6.39	5.37	0.84	2215	5.89	4.95	0.84	2300
27	20	7.31	5.27	0.72	2173	6.82	4.91	0.72	2279	6.32	4.55	0.72	2407
27	22	7.74	4.64	0.60	2258	7.24	4.35	0.60	2386	6.75	4.05	0.60	2471
27	24	8.17	3.92	0.48	2343	7.67	3.68	0.48	2450	7.24	3.48	0.48	2556
27	26	8.59	3.09	0.36	2428	8.09	2.91	0.36	2535	7.60	2.73	0.36	2641
28	18	6.96	6.12	0.88	2087	6.39	5.62	0.88	2215	5.89	5.19	0.88	2300
28	20	7.31	5.56	0.76	2173	6.82	5.18	0.76	2279	6.32	4.80	0.76	2407
28	22	7.74	4.95	0.64	2258	7.24	4.63	0.64	2386	6.75	4.32	0.64	2471
28	24	8.17	4.25	0.52	2343	7.67	3.99	0.52	2450	7.24	3.77	0.52	2556
28	26	8.59	3.44	0.40	2428	8.09	3.24	0.40	2535	7.60	3.04	0.40	2641
29	18	6.96	6.40	0.92	2087	6.39	5.88	0.92	2215	5.89	5.42	0.92	2300
29	20	7.31	5.85	0.80	2173	6.82	5.45	0.80	2279	6.32	5.06	0.80	2407
29	22	7.74	5.26	0.68	2258	7.24	4.92	0.68	2386	6.75	4.59	0.68	2471
29	24	8.17	4.57	0.56	2343	7.67	4.29	0.56	2450	7.24	4.06	0.56	2556
29	26	8.59	3.78	0.44	2428	8.09	3.56	0.44	2535	7.60	3.34	0.44	2641
30	18	6.96	6.68	0.96	2087	6.39	6.13	0.96	2215	5.89	5.66	0.96	2300
30	20	7.31	6.14	0.84	2173	6.82	5.73	0.84	2279	6.32	5.31	0.84	2407
30	22	7.74	5.57	0.72	2258	7.24	5.21	0.72	2386	6.75	4.86	0.72	2471
30	24	8.17	4.90	0.60	2343	7.67	4.60	0.60	2450	7.24	4.35	0.60	2556
30	26	8.59	4.12	0.48	2428	8.09	3.89	0.48	2535	7.60	3.65	0.48	2641
31	18	6.96	6.96	1.00	2087	6.39	6.39	1.00	2215	5.89	5.89	1.00	2300
31	20	7.31	6.44	0.88	2173	6.82	6.00	0.88	2279	6.32	5.56	0.88	2407
31	22	7.74	5.88	0.76	2258	7.24	5.50	0.76	2386	6.75	5.13	0.76	2471
31	24	8.17	5.23	0.64	2343	7.67	4.91	0.64	2450	7.24	4.63	0.64	2556
31	26	8.59	4.47	0.52	2428	8.09	4.21	0.52	2535	7.60	3.95	0.52	2641
32	18	6.96	6.96	1.00	2087	6.39	6.39	1.00	2215	5.89	5.89	1.00	2300
32	20	7.31	6.73	0.92	2173	6.82	6.27	0.92	2279	6.32	5.81	0.92	2407
32	22	7.74	6.19	0.80	2258	7.24	5.79	0.80	2386	6.75	5.40	0.80	2471
32	24	8.17	5.55	0.68	2343	7.67	5.21	0.68	2450	7.24	4.92	0.68	2556
32	26	8.59	4.81	0.56	2428	8.09	4.53	0.56	2535	7.60	4.25	0.56	2641

NOTE Q : Total capacity (kW) SHF : Sensible heat factor DB : Dry-bulb temperature
SHC : Sensible heat capacity (kW) INPUT : Total power input (W) WB : Wet-bulb temperature

PERFORMANCE DATA COOL operation at Rated frequency

MSZ-WN25VA: MUZ-WN25VA

CAPACITY: 2.5 kW

SHF: 0.89

INPUT: 710 W

INDOOR DB (°C)	INDOOR WB (°C)	OUTDOOR DB (°C)															
		21				25				27				30			
		Q	SHC	SHF	INPUT	Q	SHC	SHF	INPUT	Q	SHC	SHF	INPUT	Q	SHC	SHF	INPUT
21	18	2.94	2.09	0.71	568	2.81	2.00	0.71	596	2.70	1.92	0.71	625	2.60	1.85	0.71	653
21	20	3.06	1.81	0.59	596	2.94	1.73	0.59	632	2.85	1.68	0.59	646	2.75	1.62	0.59	675
22	18	2.94	2.20	0.75	568	2.81	2.11	0.75	596	2.70	2.03	0.75	625	2.60	1.95	0.75	653
22	20	3.06	1.93	0.63	596	2.94	1.85	0.63	632	2.85	1.80	0.63	646	2.75	1.73	0.63	675
22	22	3.19	1.63	0.51	618	3.08	1.57	0.51	657	3.00	1.53	0.51	675	2.88	1.47	0.51	703
23	18	2.94	2.32	0.79	568	2.81	2.22	0.79	596	2.70	2.13	0.79	625	2.60	2.05	0.79	653
23	20	3.06	2.05	0.67	596	2.94	1.97	0.67	632	2.85	1.91	0.67	646	2.75	1.84	0.67	675
23	22	3.19	1.75	0.55	618	3.08	1.69	0.55	657	3.00	1.65	0.55	675	2.88	1.58	0.55	703
24	18	2.94	2.44	0.83	568	2.81	2.33	0.83	596	2.70	2.24	0.83	625	2.60	2.16	0.83	653
24	20	3.06	2.17	0.71	596	2.94	2.09	0.71	632	2.85	2.02	0.71	646	2.75	1.95	0.71	675
24	22	3.19	1.88	0.59	618	3.08	1.81	0.59	657	3.00	1.77	0.59	675	2.88	1.70	0.59	703
24	24	3.35	1.57	0.47	646	3.23	1.52	0.47	682	3.15	1.48	0.47	703	3.05	1.43	0.47	738
25	18	2.94	2.56	0.87	568	2.81	2.45	0.87	596	2.70	2.35	0.87	625	2.60	2.26	0.87	653
25	20	3.06	2.30	0.75	596	2.94	2.20	0.75	632	2.85	2.14	0.75	646	2.75	2.06	0.75	675
25	22	3.19	2.01	0.63	618	3.08	1.94	0.63	657	3.00	1.89	0.63	675	2.88	1.81	0.63	703
25	24	3.35	1.71	0.51	646	3.23	1.64	0.51	682	3.15	1.61	0.51	703	3.05	1.56	0.51	738
26	18	2.94	2.67	0.91	568	2.81	2.56	0.91	596	2.70	2.46	0.91	625	2.60	2.37	0.91	653
26	20	3.06	2.42	0.79	596	2.94	2.32	0.79	632	2.85	2.25	0.79	646	2.75	2.17	0.79	675
26	22	3.19	2.14	0.67	618	3.08	2.06	0.67	657	3.00	2.01	0.67	675	2.88	1.93	0.67	703
26	24	3.35	1.84	0.55	646	3.23	1.77	0.55	682	3.15	1.73	0.55	703	3.05	1.68	0.55	738
26	26	3.45	1.48	0.43	682	3.35	1.44	0.43	717	3.30	1.42	0.43	738	3.20	1.38	0.43	760
27	18	2.94	2.79	0.95	568	2.81	2.67	0.95	596	2.70	2.57	0.95	625	2.60	2.47	0.95	653
27	20	3.06	2.54	0.83	596	2.94	2.44	0.83	632	2.85	2.37	0.83	646	2.75	2.28	0.83	675
27	22	3.19	2.26	0.71	618	3.08	2.18	0.71	657	3.00	2.13	0.71	675	2.88	2.04	0.71	703
27	24	3.35	1.98	0.59	646	3.23	1.90	0.59	682	3.15	1.86	0.59	703	3.05	1.80	0.59	738
27	26	3.45	1.62	0.47	682	3.35	1.57	0.47	717	3.30	1.55	0.47	738	3.20	1.50	0.47	760
28	18	2.94	2.91	0.99	568	2.81	2.78	0.99	596	2.70	2.67	0.99	625	2.60	2.57	0.99	653
28	20	3.06	2.66	0.87	596	2.94	2.56	0.87	632	2.85	2.48	0.87	646	2.75	2.39	0.87	675
28	22	3.19	2.39	0.75	618	3.08	2.31	0.75	657	3.00	2.25	0.75	675	2.88	2.16	0.75	703
28	24	3.35	2.11	0.63	646	3.23	2.03	0.63	682	3.15	1.98	0.63	703	3.05	1.92	0.63	738
28	26	3.45	1.76	0.51	682	3.35	1.71	0.51	717	3.30	1.68	0.51	738	3.20	1.63	0.51	760
29	18	2.94	2.94	1.00	568	2.81	2.81	1.00	596	2.70	2.70	1.00	625	2.60	2.60	1.00	653
29	20	3.06	2.79	0.91	596	2.94	2.67	0.91	632	2.85	2.59	0.91	646	2.75	2.50	0.91	675
29	22	3.19	2.52	0.79	618	3.08	2.43	0.79	657	3.00	2.37	0.79	675	2.88	2.27	0.79	703
29	24	3.35	2.24	0.67	646	3.23	2.16	0.67	682	3.15	2.11	0.67	703	3.05	2.04	0.67	738
29	26	3.45	1.90	0.55	682	3.35	1.84	0.55	717	3.30	1.82	0.55	738	3.20	1.76	0.55	760
30	18	2.94	2.94	1.00	568	2.81	2.81	1.00	596	2.70	2.70	1.00	625	2.60	2.60	1.00	653
30	20	3.06	2.91	0.95	596	2.94	2.79	0.95	632	2.85	2.71	0.95	646	2.75	2.61	0.95	675
30	22	3.19	2.65	0.83	618	3.08	2.55	0.83	657	3.00	2.49	0.83	675	2.88	2.39	0.83	703
30	24	3.35	2.38	0.71	646	3.23	2.29	0.71	682	3.15	2.24	0.71	703	3.05	2.17	0.71	738
30	26	3.45	2.04	0.59	682	3.35	1.98	0.59	717	3.30	1.95	0.59	738	3.20	1.89	0.59	760
31	18	2.94	2.94	1.00	568	2.81	2.81	1.00	596	2.70	2.70	1.00	625	2.60	2.60	1.00	653
31	20	3.06	3.03	0.99	596	2.94	2.91	0.99	632	2.85	2.82	0.99	646	2.75	2.72	0.99	675
31	22	3.19	2.77	0.87	618	3.08	2.68	0.87	657	3.00	2.61	0.87	675	2.88	2.50	0.87	703
31	24	3.35	2.51	0.75	646	3.23	2.42	0.75	682	3.15	2.36	0.75	703	3.05	2.29	0.75	738
31	26	3.45	2.17	0.63	682	3.35	2.11	0.63	717	3.30	2.08	0.63	738	3.20	2.02	0.63	760
32	18	2.94	2.94	1.00	568	2.81	2.81	1.00	596	2.70	2.70	1.00	625	2.60	2.60	1.00	653
32	20	3.06	3.06	1.00	596	2.94	2.94	1.00	632	2.85	2.85	1.00	646	2.75	2.75	1.00	675
32	22	3.19	2.90	0.91	618	3.08	2.80	0.91	657	3.00	2.73	0.91	675	2.88	2.62	0.91	703
32	24	3.35	2.65	0.79	646	3.23	2.55	0.79	682	3.15	2.49	0.79	703	3.05	2.41	0.79	738
32	26	3.45	2.31	0.67	682	3.35	2.24	0.67	717	3.30	2.21	0.67	738	3.20	2.14	0.67	760

NOTE Q : Total capacity (kW) SHF : Sensible heat factor DB : Dry-bulb temperature
 SHC : Sensible heat capacity (kW) INPUT : Total power input (W) WB : Wet-bulb temperature

WALL-MOUNTED PERFORMANCE DATA

PERFORMANCE DATA COOL operation at Rated frequency

MSZ-WN25VA: MUZ-WN25VA

CAPACITY: 2.5 kW SHF: 0.89 INPUT: 710 W

INDOOR DB (°C)	INDOOR WB (°C)	OUTDOOR DB (°C)											
		35				40				46			
		Q	SHC	SHF	INPUT	Q	SHC	SHF	INPUT	Q	SHC	SHF	INPUT
21	18	2.45	1.74	0.71	696	2.25	1.60	0.71	738	2.08	1.47	0.71	767
21	20	2.58	1.52	0.59	724	2.40	1.42	0.59	760	2.23	1.31	0.59	802
22	18	2.45	1.84	0.75	696	2.25	1.69	0.75	738	2.08	1.56	0.75	767
22	20	2.58	1.62	0.63	724	2.40	1.51	0.63	760	2.23	1.40	0.63	802
22	22	2.73	1.39	0.51	753	2.55	1.30	0.51	795	2.38	1.21	0.51	824
23	18	2.45	1.94	0.79	696	2.25	1.78	0.79	738	2.08	1.64	0.79	767
23	20	2.58	1.73	0.67	724	2.40	1.61	0.67	760	2.23	1.49	0.67	802
23	22	2.73	1.50	0.55	753	2.55	1.40	0.55	795	2.38	1.31	0.55	824
24	18	2.45	2.03	0.83	696	2.25	1.87	0.83	738	2.08	1.72	0.83	767
24	20	2.58	1.83	0.71	724	2.40	1.70	0.71	760	2.23	1.58	0.71	802
24	22	2.73	1.61	0.59	753	2.55	1.50	0.59	795	2.38	1.40	0.59	824
24	24	2.88	1.35	0.47	781	2.70	1.27	0.47	817	2.55	1.20	0.47	852
25	18	2.45	2.13	0.87	696	2.25	1.96	0.87	738	2.08	1.81	0.87	767
25	20	2.58	1.93	0.75	724	2.40	1.80	0.75	760	2.23	1.67	0.75	802
25	22	2.73	1.72	0.63	753	2.55	1.61	0.63	795	2.38	1.50	0.63	824
25	24	2.88	1.47	0.51	781	2.70	1.38	0.51	817	2.55	1.30	0.51	852
26	18	2.45	2.23	0.91	696	2.25	2.05	0.91	738	2.08	1.89	0.91	767
26	20	2.58	2.03	0.79	724	2.40	1.90	0.79	760	2.23	1.76	0.79	802
26	22	2.73	1.83	0.67	753	2.55	1.71	0.67	795	2.38	1.59	0.67	824
26	24	2.88	1.58	0.55	781	2.70	1.49	0.55	817	2.55	1.40	0.55	852
26	26	3.03	1.30	0.43	809	2.85	1.23	0.43	845	2.68	1.15	0.43	880
27	18	2.45	2.33	0.95	696	2.25	2.14	0.95	738	2.08	1.97	0.95	767
27	20	2.58	2.14	0.83	724	2.40	1.99	0.83	760	2.23	1.85	0.83	802
27	22	2.73	1.93	0.71	753	2.55	1.81	0.71	795	2.38	1.69	0.71	824
27	24	2.88	1.70	0.59	781	2.70	1.59	0.59	817	2.55	1.50	0.59	852
27	26	3.03	1.42	0.47	809	2.85	1.34	0.47	845	2.68	1.26	0.47	880
28	18	2.45	2.43	0.99	696	2.25	2.23	0.99	738	2.08	2.05	0.99	767
28	20	2.58	2.24	0.87	724	2.40	2.09	0.87	760	2.23	1.94	0.87	802
28	22	2.73	2.04	0.75	753	2.55	1.91	0.75	795	2.38	1.78	0.75	824
28	24	2.88	1.81	0.63	781	2.70	1.70	0.63	817	2.55	1.61	0.63	852
28	26	3.03	1.54	0.51	809	2.85	1.45	0.51	845	2.68	1.36	0.51	880
29	18	2.45	2.45	1.00	696	2.25	2.25	1.00	738	2.08	2.08	1.00	767
29	20	2.58	2.34	0.91	724	2.40	2.18	0.91	760	2.23	2.02	0.91	802
29	22	2.73	2.15	0.79	753	2.55	2.01	0.79	795	2.38	1.88	0.79	824
29	24	2.88	1.93	0.67	781	2.70	1.81	0.67	817	2.55	1.71	0.67	852
29	26	3.03	1.66	0.55	809	2.85	1.57	0.55	845	2.68	1.47	0.55	880
30	18	2.45	2.45	1.00	696	2.25	2.25	1.00	738	2.08	2.08	1.00	767
30	20	2.58	2.45	0.95	724	2.40	2.28	0.95	760	2.23	2.11	0.95	802
30	22	2.73	2.26	0.83	753	2.55	2.12	0.83	795	2.38	1.97	0.83	824
30	24	2.88	2.04	0.71	781	2.70	1.92	0.71	817	2.55	1.81	0.71	852
30	26	3.03	1.78	0.59	809	2.85	1.68	0.59	845	2.68	1.58	0.59	880
31	18	2.45	2.45	1.00	696	2.25	2.25	1.00	738	2.08	2.08	1.00	767
31	20	2.58	2.55	0.99	724	2.40	2.38	0.99	760	2.23	2.20	0.99	802
31	22	2.73	2.37	0.87	753	2.55	2.22	0.87	795	2.38	2.07	0.87	824
31	24	2.88	2.16	0.75	781	2.70	2.03	0.75	817	2.55	1.91	0.75	852
31	26	3.03	1.91	0.63	809	2.85	1.80	0.63	845	2.68	1.69	0.63	880
32	18	2.45	2.45	1.00	696	2.25	2.25	1.00	738	2.08	2.08	1.00	767
32	20	2.58	2.58	1.00	724	2.40	2.40	1.00	760	2.23	2.23	1.00	802
32	22	2.73	2.48	0.91	753	2.55	2.32	0.91	795	2.38	2.16	0.91	824
32	24	2.88	2.27	0.79	781	2.70	2.13	0.79	817	2.55	2.01	0.79	852
32	26	3.03	2.03	0.67	809	2.85	1.91	0.67	845	2.68	1.79	0.67	880

NOTE Q : Total capacity (kW) SHF : Sensible heat factor DB : Dry-bulb temperature
 SHC : Sensible heat capacity (kW) INPUT : Total power input (W) WB : Wet-bulb temperature

PERFORMANCE DATA COOL operation at Rated frequency

MSZ-WN35VA: MUZ-WN35VA

CAPACITY: 3.15 kW SHF: 0.87 INPUT: 1020 W

INDOOR DB (°C)	INDOOR WB (°C)	OUTDOOR DB (°C)															
		21				25				27				30			
		Q	SHC	SHF	INPUT	Q	SHC	SHF	INPUT	Q	SHC	SHF	INPUT	Q	SHC	SHF	INPUT
21	18	3.70	2.55	0.69	816	3.54	2.45	0.69	857	3.40	2.35	0.69	898	3.28	2.26	0.69	938
21	20	3.86	2.20	0.57	857	3.70	2.11	0.57	908	3.59	2.05	0.57	928	3.47	1.98	0.57	969
22	18	3.70	2.70	0.73	816	3.54	2.59	0.73	857	3.40	2.48	0.73	898	3.28	2.39	0.73	938
22	20	3.86	2.35	0.61	857	3.70	2.26	0.61	908	3.59	2.19	0.61	928	3.47	2.11	0.61	969
22	22	4.02	1.97	0.49	887	3.87	1.90	0.49	944	3.78	1.85	0.49	969	3.62	1.78	0.49	1010
23	18	3.70	2.85	0.77	816	3.54	2.73	0.77	857	3.40	2.62	0.77	898	3.28	2.52	0.77	938
23	20	3.86	2.51	0.65	857	3.70	2.41	0.65	908	3.59	2.33	0.65	928	3.47	2.25	0.65	969
23	22	4.02	2.13	0.53	887	3.87	2.05	0.53	944	3.78	2.00	0.53	969	3.62	1.92	0.53	1010
24	18	3.70	3.00	0.81	816	3.54	2.87	0.81	857	3.40	2.76	0.81	898	3.28	2.65	0.81	938
24	20	3.86	2.66	0.69	857	3.70	2.55	0.69	908	3.59	2.48	0.69	928	3.47	2.39	0.69	969
24	22	4.02	2.29	0.57	887	3.87	2.21	0.57	944	3.78	2.15	0.57	969	3.62	2.06	0.57	1010
24	24	4.22	1.90	0.45	928	4.06	1.83	0.45	979	3.97	1.79	0.45	1010	3.84	1.73	0.45	1061
25	18	3.70	3.15	0.85	816	3.54	3.01	0.85	857	3.40	2.89	0.85	898	3.28	2.78	0.85	938
25	20	3.86	2.82	0.73	857	3.70	2.70	0.73	908	3.59	2.62	0.73	928	3.47	2.53	0.73	969
25	22	4.02	2.45	0.61	887	3.87	2.36	0.61	944	3.78	2.31	0.61	969	3.62	2.21	0.61	1010
25	24	4.22	2.07	0.49	928	4.06	1.99	0.49	979	3.97	1.94	0.49	1010	3.84	1.88	0.49	1061
26	18	3.70	3.29	0.89	816	3.54	3.15	0.89	857	3.40	3.03	0.89	898	3.28	2.92	0.89	938
26	20	3.86	2.97	0.77	857	3.70	2.85	0.77	908	3.59	2.77	0.77	928	3.47	2.67	0.77	969
26	22	4.02	2.61	0.65	887	3.87	2.52	0.65	944	3.78	2.46	0.65	969	3.62	2.35	0.65	1010
26	24	4.22	2.24	0.53	928	4.06	2.15	0.53	979	3.97	2.10	0.53	1010	3.84	2.04	0.53	1061
26	26	4.35	1.78	0.41	979	4.22	1.73	0.41	1030	4.16	1.70	0.41	1061	4.03	1.65	0.41	1091
27	18	3.70	3.44	0.93	816	3.54	3.30	0.93	857	3.40	3.16	0.93	898	3.28	3.05	0.93	938
27	20	3.86	3.13	0.81	857	3.70	3.00	0.81	908	3.59	2.91	0.81	928	3.47	2.81	0.81	969
27	22	4.02	2.77	0.69	887	3.87	2.67	0.69	944	3.78	2.61	0.69	969	3.62	2.50	0.69	1010
27	24	4.22	2.41	0.57	928	4.06	2.32	0.57	979	3.97	2.26	0.57	1010	3.84	2.19	0.57	1061
27	26	4.35	1.96	0.45	979	4.22	1.90	0.45	1030	4.16	1.87	0.45	1061	4.03	1.81	0.45	1091
28	18	3.70	3.59	0.97	816	3.54	3.44	0.97	857	3.40	3.30	0.97	898	3.28	3.18	0.97	938
28	20	3.86	3.28	0.85	857	3.70	3.15	0.85	908	3.59	3.05	0.85	928	3.47	2.95	0.85	969
28	22	4.02	2.93	0.73	887	3.87	2.83	0.73	944	3.78	2.76	0.73	969	3.62	2.64	0.73	1010
28	24	4.22	2.57	0.61	928	4.06	2.48	0.61	979	3.97	2.42	0.61	1010	3.84	2.34	0.61	1061
28	26	4.35	2.13	0.49	979	4.22	2.07	0.49	1030	4.16	2.04	0.49	1061	4.03	1.98	0.49	1091
29	18	3.70	3.70	1.00	816	3.54	3.54	1.00	857	3.40	3.40	1.00	898	3.28	3.28	1.00	938
29	20	3.86	3.43	0.89	857	3.70	3.29	0.89	908	3.59	3.20	0.89	928	3.47	3.08	0.89	969
29	22	4.02	3.09	0.77	887	3.87	2.98	0.77	944	3.78	2.91	0.77	969	3.62	2.79	0.77	1010
29	24	4.22	2.74	0.65	928	4.06	2.64	0.65	979	3.97	2.58	0.65	1010	3.84	2.50	0.65	1061
29	26	4.35	2.30	0.53	979	4.22	2.24	0.53	1030	4.16	2.20	0.53	1061	4.03	2.14	0.53	1091
30	18	3.70	3.70	1.00	816	3.54	3.54	1.00	857	3.40	3.40	1.00	898	3.28	3.28	1.00	938
30	20	3.86	3.59	0.93	857	3.70	3.44	0.93	908	3.59	3.34	0.93	928	3.47	3.22	0.93	969
30	22	4.02	3.25	0.81	887	3.87	3.14	0.81	944	3.78	3.06	0.81	969	3.62	2.93	0.81	1010
30	24	4.22	2.91	0.69	928	4.06	2.80	0.69	979	3.97	2.74	0.69	1010	3.84	2.65	0.69	1061
30	26	4.35	2.48	0.57	979	4.22	2.41	0.57	1030	4.16	2.37	0.57	1061	4.03	2.30	0.57	1091
31	18	3.70	3.70	1.00	816	3.54	3.54	1.00	857	3.40	3.40	1.00	898	3.28	3.28	1.00	938
31	20	3.86	3.74	0.97	857	3.70	3.59	0.97	908	3.59	3.48	0.97	928	3.47	3.36	0.97	969
31	22	4.02	3.41	0.85	887	3.87	3.29	0.85	944	3.78	3.21	0.85	969	3.62	3.08	0.85	1010
31	24	4.22	3.08	0.73	928	4.06	2.97	0.73	979	3.97	2.90	0.73	1010	3.84	2.81	0.73	1061
31	26	4.35	2.65	0.61	979	4.22	2.57	0.61	1030	4.16	2.54	0.61	1061	4.03	2.46	0.61	1091
32	18	3.70	3.70	1.00	816	3.54	3.54	1.00	857	3.40	3.40	1.00	898	3.28	3.28	1.00	938
32	20	3.86	3.86	1.00	857	3.70	3.70	1.00	908	3.59	3.59	1.00	928	3.47	3.47	1.00	969
32	22	4.02	3.57	0.89	887	3.87	3.45	0.89	944	3.78	3.36	0.89	969	3.62	3.22	0.89	1010
32	24	4.22	3.25	0.77	928	4.06	3.13	0.77	979	3.97	3.06	0.77	1010	3.84	2.96	0.77	1061
32	26	4.35	2.83	0.65	979	4.22	2.74	0.65	1030	4.16	2.70	0.65	1061	4.03	2.62	0.65	1091

WALL-MOUNTED PERFORMANCE DATA

NOTE Q : Total capacity (kW) SHF : Sensible heat factor DB : Dry-bulb temperature
 SHC : Sensible heat capacity (kW) INPUT : Total power input (W) WB : Wet-bulb temperature

PERFORMANCE DATA COOL operation at Rated frequency**MSZ-WN35VA: MUZ-WN35VA**

CAPACITY: 3.15 kW

SHF: 0.87

INPUT: 1020 W

INDOOR DB (°C)	INDOOR WB (°C)	OUTDOOR DB (°C)											
		35				40				46			
		Q	SHC	SHF	INPUT	Q	SHC	SHF	INPUT	Q	SHC	SHF	INPUT
21	18	3.09	2.13	0.69	1000	2.84	1.96	0.69	1061	2.61	1.80	0.69	1102
21	20	3.24	1.85	0.57	1040	3.02	1.72	0.57	1091	2.80	1.60	0.57	1153
22	18	3.09	2.25	0.73	1000	2.84	2.07	0.73	1061	2.61	1.91	0.73	1102
22	20	3.24	1.98	0.61	1040	3.02	1.84	0.61	1091	2.80	1.71	0.61	1153
22	22	3.43	1.68	0.49	1081	3.21	1.57	0.49	1142	2.99	1.47	0.49	1183
23	18	3.09	2.38	0.77	1000	2.84	2.18	0.77	1061	2.61	2.01	0.77	1102
23	20	3.24	2.11	0.65	1040	3.02	1.97	0.65	1091	2.80	1.82	0.65	1153
23	22	3.43	1.82	0.53	1081	3.21	1.70	0.53	1142	2.99	1.59	0.53	1183
24	18	3.09	2.50	0.81	1000	2.84	2.30	0.81	1061	2.61	2.12	0.81	1102
24	20	3.24	2.24	0.69	1040	3.02	2.09	0.69	1091	2.80	1.93	0.69	1153
24	22	3.43	1.96	0.57	1081	3.21	1.83	0.57	1142	2.99	1.71	0.57	1183
24	24	3.62	1.63	0.45	1122	3.40	1.53	0.45	1173	3.21	1.45	0.45	1224
25	18	3.09	2.62	0.85	1000	2.84	2.41	0.85	1061	2.61	2.22	0.85	1102
25	20	3.24	2.37	0.73	1040	3.02	2.21	0.73	1091	2.80	2.05	0.73	1153
25	22	3.43	2.09	0.61	1081	3.21	1.96	0.61	1142	2.99	1.83	0.61	1183
25	24	3.62	1.78	0.49	1122	3.40	1.67	0.49	1173	3.21	1.57	0.49	1224
26	18	3.09	2.75	0.89	1000	2.84	2.52	0.89	1061	2.61	2.33	0.89	1102
26	20	3.24	2.50	0.77	1040	3.02	2.33	0.77	1091	2.80	2.16	0.77	1153
26	22	3.43	2.23	0.65	1081	3.21	2.09	0.65	1142	2.99	1.95	0.65	1183
26	24	3.62	1.92	0.53	1122	3.40	1.80	0.53	1173	3.21	1.70	0.53	1224
26	26	3.81	1.56	0.41	1163	3.59	1.47	0.41	1214	3.37	1.38	0.41	1265
27	18	3.09	2.87	0.93	1000	2.84	2.64	0.93	1061	2.61	2.43	0.93	1102
27	20	3.24	2.63	0.81	1040	3.02	2.45	0.81	1091	2.80	2.27	0.81	1153
27	22	3.43	2.37	0.69	1081	3.21	2.22	0.69	1142	2.99	2.06	0.69	1183
27	24	3.62	2.06	0.57	1122	3.40	1.94	0.57	1173	3.21	1.83	0.57	1224
27	26	3.81	1.72	0.45	1163	3.59	1.62	0.45	1214	3.37	1.52	0.45	1265
28	18	3.09	2.99	0.97	1000	2.84	2.75	0.97	1061	2.61	2.54	0.97	1102
28	20	3.24	2.76	0.85	1040	3.02	2.57	0.85	1091	2.80	2.38	0.85	1153
28	22	3.43	2.51	0.73	1081	3.21	2.35	0.73	1142	2.99	2.18	0.73	1183
28	24	3.62	2.21	0.61	1122	3.40	2.08	0.61	1173	3.21	1.96	0.61	1224
28	26	3.81	1.87	0.49	1163	3.59	1.76	0.49	1214	3.37	1.65	0.49	1265
29	18	3.09	3.09	1.00	1000	2.84	2.84	1.00	1061	2.61	2.61	1.00	1102
29	20	3.24	2.89	0.89	1040	3.02	2.69	0.89	1091	2.80	2.50	0.89	1153
29	22	3.43	2.64	0.77	1081	3.21	2.47	0.77	1142	2.99	2.30	0.77	1183
29	24	3.62	2.35	0.65	1122	3.40	2.21	0.65	1173	3.21	2.09	0.65	1224
29	26	3.81	2.02	0.53	1163	3.59	1.90	0.53	1214	3.37	1.79	0.53	1265
30	18	3.09	3.09	1.00	1000	2.84	2.84	1.00	1061	2.61	2.61	1.00	1102
30	20	3.24	3.02	0.93	1040	3.02	2.81	0.93	1091	2.80	2.61	0.93	1153
30	22	3.43	2.78	0.81	1081	3.21	2.60	0.81	1142	2.99	2.42	0.81	1183
30	24	3.62	2.50	0.69	1122	3.40	2.35	0.69	1173	3.21	2.22	0.69	1224
30	26	3.81	2.17	0.57	1163	3.59	2.05	0.57	1214	3.37	1.92	0.57	1265
31	18	3.09	3.09	1.00	1000	2.84	2.84	1.00	1061	2.61	2.61	1.00	1102
31	20	3.24	3.15	0.97	1040	3.02	2.93	0.97	1091	2.80	2.72	0.97	1153
31	22	3.43	2.92	0.85	1081	3.21	2.73	0.85	1142	2.99	2.54	0.85	1183
31	24	3.62	2.64	0.73	1122	3.40	2.48	0.73	1173	3.21	2.35	0.73	1224
31	26	3.81	2.33	0.61	1163	3.59	2.19	0.61	1214	3.37	2.06	0.61	1265
32	18	3.09	3.09	1.00	1000	2.84	2.84	1.00	1061	2.61	2.61	1.00	1102
32	20	3.24	3.24	1.00	1040	3.02	3.02	1.00	1091	2.80	2.80	1.00	1153
32	22	3.43	3.06	0.89	1081	3.21	2.86	0.89	1142	2.99	2.66	0.89	1183
32	24	3.62	2.79	0.77	1122	3.40	2.62	0.77	1173	3.21	2.47	0.77	1224
32	26	3.81	2.48	0.65	1163	3.59	2.33	0.65	1214	3.37	2.19	0.65	1265

NOTE Q : Total capacity (kW) SHF : Sensible heat factor DB : Dry-bulb temperature
 SHC : Sensible heat capacity (kW) INPUT : Total power input (W) WB : Wet-bulb temperature

PERFORMANCE DATA COOL operation at Rated frequency

MSZ-DM25VA: MUZ-DM25VA

CAPACITY: 2.5 kW

SHF: 0.89

INPUT: 710 W

INDOOR DB (°C)	INDOOR WB (°C)	OUTDOOR DB (°C)															
		21				25				27				30			
		Q	SHC	SHF	INPUT	Q	SHC	SHF	INPUT	Q	SHC	SHF	INPUT	Q	SHC	SHF	INPUT
21	18	2.94	2.09	0.71	568	2.81	2.00	0.71	596	2.70	1.92	0.71	625	2.60	1.85	0.71	653
21	20	3.06	1.81	0.59	596	2.94	1.73	0.59	632	2.85	1.68	0.59	646	2.75	1.62	0.59	675
22	18	2.94	2.20	0.75	568	2.81	2.11	0.75	596	2.70	2.03	0.75	625	2.60	1.95	0.75	653
22	20	3.06	1.93	0.63	596	2.94	1.85	0.63	632	2.85	1.80	0.63	646	2.75	1.73	0.63	675
22	22	3.19	1.63	0.51	618	3.08	1.57	0.51	657	3.00	1.53	0.51	675	2.88	1.47	0.51	703
23	18	2.94	2.32	0.79	568	2.81	2.22	0.79	596	2.70	2.13	0.79	625	2.60	2.05	0.79	653
23	20	3.06	2.05	0.67	596	2.94	1.97	0.67	632	2.85	1.91	0.67	646	2.75	1.84	0.67	675
23	22	3.19	1.75	0.55	618	3.08	1.69	0.55	657	3.00	1.65	0.55	675	2.88	1.58	0.55	703
24	18	2.94	2.44	0.83	568	2.81	2.33	0.83	596	2.70	2.24	0.83	625	2.60	2.16	0.83	653
24	20	3.06	2.17	0.71	596	2.94	2.09	0.71	632	2.85	2.02	0.71	646	2.75	1.95	0.71	675
24	22	3.19	1.88	0.59	618	3.08	1.81	0.59	657	3.00	1.77	0.59	675	2.88	1.70	0.59	703
24	24	3.35	1.57	0.47	646	3.23	1.52	0.47	682	3.15	1.48	0.47	703	3.05	1.43	0.47	738
25	18	2.94	2.56	0.87	568	2.81	2.45	0.87	596	2.70	2.35	0.87	625	2.60	2.26	0.87	653
25	20	3.06	2.30	0.75	596	2.94	2.20	0.75	632	2.85	2.14	0.75	646	2.75	2.06	0.75	675
25	22	3.19	2.01	0.63	618	3.08	1.94	0.63	657	3.00	1.89	0.63	675	2.88	1.81	0.63	703
25	24	3.35	1.71	0.51	646	3.23	1.64	0.51	682	3.15	1.61	0.51	703	3.05	1.56	0.51	738
26	18	2.94	2.67	0.91	568	2.81	2.56	0.91	596	2.70	2.46	0.91	625	2.60	2.37	0.91	653
26	20	3.06	2.42	0.79	596	2.94	2.32	0.79	632	2.85	2.25	0.79	646	2.75	2.17	0.79	675
26	22	3.19	2.14	0.67	618	3.08	2.06	0.67	657	3.00	2.01	0.67	675	2.88	1.93	0.67	703
26	24	3.35	1.84	0.55	646	3.23	1.77	0.55	682	3.15	1.73	0.55	703	3.05	1.68	0.55	738
26	26	3.45	1.48	0.43	682	3.35	1.44	0.43	717	3.30	1.42	0.43	738	3.20	1.38	0.43	760
27	18	2.94	2.79	0.95	568	2.81	2.67	0.95	596	2.70	2.57	0.95	625	2.60	2.47	0.95	653
27	20	3.06	2.54	0.83	596	2.94	2.44	0.83	632	2.85	2.37	0.83	646	2.75	2.28	0.83	675
27	22	3.19	2.26	0.71	618	3.08	2.18	0.71	657	3.00	2.13	0.71	675	2.88	2.04	0.71	703
27	24	3.35	1.98	0.59	646	3.23	1.90	0.59	682	3.15	1.86	0.59	703	3.05	1.80	0.59	738
27	26	3.45	1.62	0.47	682	3.35	1.57	0.47	717	3.30	1.55	0.47	738	3.20	1.50	0.47	760
28	18	2.94	2.91	0.99	568	2.81	2.78	0.99	596	2.70	2.67	0.99	625	2.60	2.57	0.99	653
28	20	3.06	2.66	0.87	596	2.94	2.56	0.87	632	2.85	2.48	0.87	646	2.75	2.39	0.87	675
28	22	3.19	2.39	0.75	618	3.08	2.31	0.75	657	3.00	2.25	0.75	675	2.88	2.16	0.75	703
28	24	3.35	2.11	0.63	646	3.23	2.03	0.63	682	3.15	1.98	0.63	703	3.05	1.92	0.63	738
28	26	3.45	1.76	0.51	682	3.35	1.71	0.51	717	3.30	1.68	0.51	738	3.20	1.63	0.51	760
29	18	2.94	2.94	1.00	568	2.81	2.81	1.00	596	2.70	2.70	1.00	625	2.60	2.60	1.00	653
29	20	3.06	2.79	0.91	596	2.94	2.67	0.91	632	2.85	2.59	0.91	646	2.75	2.50	0.91	675
29	22	3.19	2.52	0.79	618	3.08	2.43	0.79	657	3.00	2.37	0.79	675	2.88	2.27	0.79	703
29	24	3.35	2.24	0.67	646	3.23	2.16	0.67	682	3.15	2.11	0.67	703	3.05	2.04	0.67	738
29	26	3.45	1.90	0.55	682	3.35	1.84	0.55	717	3.30	1.82	0.55	738	3.20	1.76	0.55	760
30	18	2.94	2.94	1.00	568	2.81	2.81	1.00	596	2.70	2.70	1.00	625	2.60	2.60	1.00	653
30	20	3.06	2.91	0.95	596	2.94	2.79	0.95	632	2.85	2.71	0.95	646	2.75	2.61	0.95	675
30	22	3.19	2.65	0.83	618	3.08	2.55	0.83	657	3.00	2.49	0.83	675	2.88	2.39	0.83	703
30	24	3.35	2.38	0.71	646	3.23	2.29	0.71	682	3.15	2.24	0.71	703	3.05	2.17	0.71	738
30	26	3.45	2.04	0.59	682	3.35	1.98	0.59	717	3.30	1.95	0.59	738	3.20	1.89	0.59	760
31	18	2.94	2.94	1.00	568	2.81	2.81	1.00	596	2.70	2.70	1.00	625	2.60	2.60	1.00	653
31	20	3.06	3.03	0.99	596	2.94	2.91	0.99	632	2.85	2.82	0.99	646	2.75	2.72	0.99	675
31	22	3.19	2.77	0.87	618	3.08	2.68	0.87	657	3.00	2.61	0.87	675	2.88	2.50	0.87	703
31	24	3.35	2.51	0.75	646	3.23	2.42	0.75	682	3.15	2.36	0.75	703	3.05	2.29	0.75	738
31	26	3.45	2.17	0.63	682	3.35	2.11	0.63	717	3.30	2.08	0.63	738	3.20	2.02	0.63	760
32	18	2.94	2.94	1.00	568	2.81	2.81	1.00	596	2.70	2.70	1.00	625	2.60	2.60	1.00	653
32	20	3.06	3.06	1.00	596	2.94	2.94	1.00	632	2.85	2.85	1.00	646	2.75	2.75	1.00	675
32	22	3.19	2.90	0.91	618	3.08	2.80	0.91	657	3.00	2.73	0.91	675	2.88	2.62	0.91	703
32	24	3.35	2.65	0.79	646	3.23	2.55	0.79	682	3.15	2.49	0.79	703	3.05	2.41	0.79	738
32	26	3.45	2.31	0.67	682	3.35	2.24	0.67	717	3.30	2.21	0.67	738	3.20	2.14	0.67	760

PERFORMANCE DATA
WALL-MOUNTED

NOTE Q : Total capacity (kW) SHF : Sensible heat factor DB : Dry-bulb temperature
SHC : Sensible heat capacity (kW) INPUT : Total power input (W) WB : Wet-bulb temperature

PERFORMANCE DATA COOL operation at Rated frequency

MSZ-DM25VA: MUZ-DM25VA

CAPACITY: 2.5 kW

SHF: 0.89

INPUT: 710 W

INDOOR DB (°C)	INDOOR WB (°C)	OUTDOOR DB (°C)											
		35				40				46			
		Q	SHC	SHF	INPUT	Q	SHC	SHF	INPUT	Q	SHC	SHF	INPUT
21	18	2.45	1.74	0.71	696	2.25	1.60	0.71	738	2.08	1.47	0.71	767
21	20	2.58	1.52	0.59	724	2.40	1.42	0.59	760	2.23	1.31	0.59	802
22	18	2.45	1.84	0.75	696	2.25	1.69	0.75	738	2.08	1.56	0.75	767
22	20	2.58	1.62	0.63	724	2.40	1.51	0.63	760	2.23	1.40	0.63	802
22	22	2.73	1.39	0.51	753	2.55	1.30	0.51	795	2.38	1.21	0.51	824
23	18	2.45	1.94	0.79	696	2.25	1.78	0.79	738	2.08	1.64	0.79	767
23	20	2.58	1.73	0.67	724	2.40	1.61	0.67	760	2.23	1.49	0.67	802
23	22	2.73	1.50	0.55	753	2.55	1.40	0.55	795	2.38	1.31	0.55	824
24	18	2.45	2.03	0.83	696	2.25	1.87	0.83	738	2.08	1.72	0.83	767
24	20	2.58	1.83	0.71	724	2.40	1.70	0.71	760	2.23	1.58	0.71	802
24	22	2.73	1.61	0.59	753	2.55	1.50	0.59	795	2.38	1.40	0.59	824
24	24	2.88	1.35	0.47	781	2.70	1.27	0.47	817	2.55	1.20	0.47	852
25	18	2.45	2.13	0.87	696	2.25	1.96	0.87	738	2.08	1.81	0.87	767
25	20	2.58	1.93	0.75	724	2.40	1.80	0.75	760	2.23	1.67	0.75	802
25	22	2.73	1.72	0.63	753	2.55	1.61	0.63	795	2.38	1.50	0.63	824
25	24	2.88	1.47	0.51	781	2.70	1.38	0.51	817	2.55	1.30	0.51	852
26	18	2.45	2.23	0.91	696	2.25	2.05	0.91	738	2.08	1.89	0.91	767
26	20	2.58	2.03	0.79	724	2.40	1.90	0.79	760	2.23	1.76	0.79	802
26	22	2.73	1.83	0.67	753	2.55	1.71	0.67	795	2.38	1.59	0.67	824
26	24	2.88	1.58	0.55	781	2.70	1.49	0.55	817	2.55	1.40	0.55	852
26	26	3.03	1.30	0.43	809	2.85	1.23	0.43	845	2.68	1.15	0.43	880
27	18	2.45	2.33	0.95	696	2.25	2.14	0.95	738	2.08	1.97	0.95	767
27	20	2.58	2.14	0.83	724	2.40	1.99	0.83	760	2.23	1.85	0.83	802
27	22	2.73	1.93	0.71	753	2.55	1.81	0.71	795	2.38	1.69	0.71	824
27	24	2.88	1.70	0.59	781	2.70	1.59	0.59	817	2.55	1.50	0.59	852
27	26	3.03	1.42	0.47	809	2.85	1.34	0.47	845	2.68	1.26	0.47	880
28	18	2.45	2.43	0.99	696	2.25	2.23	0.99	738	2.08	2.05	0.99	767
28	20	2.58	2.24	0.87	724	2.40	2.09	0.87	760	2.23	1.94	0.87	802
28	22	2.73	2.04	0.75	753	2.55	1.91	0.75	795	2.38	1.78	0.75	824
28	24	2.88	1.81	0.63	781	2.70	1.70	0.63	817	2.55	1.61	0.63	852
28	26	3.03	1.54	0.51	809	2.85	1.45	0.51	845	2.68	1.36	0.51	880
29	18	2.45	2.45	1.00	696	2.25	2.25	1.00	738	2.08	2.08	1.00	767
29	20	2.58	2.34	0.91	724	2.40	2.18	0.91	760	2.23	2.02	0.91	802
29	22	2.73	2.15	0.79	753	2.55	2.01	0.79	795	2.38	1.88	0.79	824
29	24	2.88	1.93	0.67	781	2.70	1.81	0.67	817	2.55	1.71	0.67	852
29	26	3.03	1.66	0.55	809	2.85	1.57	0.55	845	2.68	1.47	0.55	880
30	18	2.45	2.45	1.00	696	2.25	2.25	1.00	738	2.08	2.08	1.00	767
30	20	2.58	2.45	0.95	724	2.40	2.28	0.95	760	2.23	2.11	0.95	802
30	22	2.73	2.26	0.83	753	2.55	2.12	0.83	795	2.38	1.97	0.83	824
30	24	2.88	2.04	0.71	781	2.70	1.92	0.71	817	2.55	1.81	0.71	852
30	26	3.03	1.78	0.59	809	2.85	1.68	0.59	845	2.68	1.58	0.59	880
31	18	2.45	2.45	1.00	696	2.25	2.25	1.00	738	2.08	2.08	1.00	767
31	20	2.58	2.55	0.99	724	2.40	2.38	0.99	760	2.23	2.20	0.99	802
31	22	2.73	2.37	0.87	753	2.55	2.22	0.87	795	2.38	2.07	0.87	824
31	24	2.88	2.16	0.75	781	2.70	2.03	0.75	817	2.55	1.91	0.75	852
31	26	3.03	1.91	0.63	809	2.85	1.80	0.63	845	2.68	1.69	0.63	880
32	18	2.45	2.45	1.00	696	2.25	2.25	1.00	738	2.08	2.08	1.00	767
32	20	2.58	2.58	1.00	724	2.40	2.40	1.00	760	2.23	2.23	1.00	802
32	22	2.73	2.48	0.91	753	2.55	2.32	0.91	795	2.38	2.16	0.91	824
32	24	2.88	2.27	0.79	781	2.70	2.13	0.79	817	2.55	2.01	0.79	852
32	26	3.03	2.03	0.67	809	2.85	1.91	0.67	845	2.68	1.79	0.67	880

PERFORMANCE DATA

WALL-MOUNTED

NOTE Q : Total capacity (kW) SHF : Sensible heat factor DB : Dry-bulb temperature
 SHC : Sensible heat capacity (kW) INPUT : Total power input (W) WB : Wet-bulb temperature

PERFORMANCE DATA COOL operation at Rated frequency

MSZ-DM35VA: MUZ-DM35VA

CAPACITY: 3.15 kW

SHF: 0.87

INPUT: 1020 W

INDOOR DB (°C)	INDOOR WB (°C)	OUTDOOR DB (°C)															
		21				25				27				30			
		Q	SHC	SHF	INPUT	Q	SHC	SHF	INPUT	Q	SHC	SHF	INPUT	Q	SHC	SHF	INPUT
21	18	3.70	2.55	0.69	816	3.54	2.45	0.69	857	3.40	2.35	0.69	898	3.28	2.26	0.69	938
21	20	3.86	2.20	0.57	857	3.70	2.11	0.57	908	3.59	2.05	0.57	928	3.47	1.98	0.57	969
22	18	3.70	2.70	0.73	816	3.54	2.59	0.73	857	3.40	2.48	0.73	898	3.28	2.39	0.73	938
22	20	3.86	2.35	0.61	857	3.70	2.26	0.61	908	3.59	2.19	0.61	928	3.47	2.11	0.61	969
22	22	4.02	1.97	0.49	887	3.87	1.90	0.49	944	3.78	1.85	0.49	969	3.62	1.78	0.49	1010
23	18	3.70	2.85	0.77	816	3.54	2.73	0.77	857	3.40	2.62	0.77	898	3.28	2.52	0.77	938
23	20	3.86	2.51	0.65	857	3.70	2.41	0.65	908	3.59	2.33	0.65	928	3.47	2.25	0.65	969
23	22	4.02	2.13	0.53	887	3.87	2.05	0.53	944	3.78	2.00	0.53	969	3.62	1.92	0.53	1010
24	18	3.70	3.00	0.81	816	3.54	2.87	0.81	857	3.40	2.76	0.81	898	3.28	2.65	0.81	938
24	20	3.86	2.66	0.69	857	3.70	2.55	0.69	908	3.59	2.48	0.69	928	3.47	2.39	0.69	969
24	22	4.02	2.29	0.57	887	3.87	2.21	0.57	944	3.78	2.15	0.57	969	3.62	2.06	0.57	1010
24	24	4.22	1.90	0.45	928	4.06	1.83	0.45	979	3.97	1.79	0.45	1010	3.84	1.73	0.45	1061
25	18	3.70	3.15	0.85	816	3.54	3.01	0.85	857	3.40	2.89	0.85	898	3.28	2.78	0.85	938
25	20	3.86	2.82	0.73	857	3.70	2.70	0.73	908	3.59	2.62	0.73	928	3.47	2.53	0.73	969
25	22	4.02	2.45	0.61	887	3.87	2.36	0.61	944	3.78	2.31	0.61	969	3.62	2.21	0.61	1010
25	24	4.22	2.07	0.49	928	4.06	1.99	0.49	979	3.97	1.94	0.49	1010	3.84	1.88	0.49	1061
26	18	3.70	3.29	0.89	816	3.54	3.15	0.89	857	3.40	3.03	0.89	898	3.28	2.92	0.89	938
26	20	3.86	2.97	0.77	857	3.70	2.85	0.77	908	3.59	2.77	0.77	928	3.47	2.67	0.77	969
26	22	4.02	2.61	0.65	887	3.87	2.52	0.65	944	3.78	2.46	0.65	969	3.62	2.35	0.65	1010
26	24	4.22	2.24	0.53	928	4.06	2.15	0.53	979	3.97	2.10	0.53	1010	3.84	2.04	0.53	1061
26	26	4.35	1.78	0.41	979	4.22	1.73	0.41	1030	4.16	1.70	0.41	1061	4.03	1.65	0.41	1091
27	18	3.70	3.44	0.93	816	3.54	3.30	0.93	857	3.40	3.16	0.93	898	3.28	3.05	0.93	938
27	20	3.86	3.13	0.81	857	3.70	3.00	0.81	908	3.59	2.91	0.81	928	3.47	2.81	0.81	969
27	22	4.02	2.77	0.69	887	3.87	2.67	0.69	944	3.78	2.61	0.69	969	3.62	2.50	0.69	1010
27	24	4.22	2.41	0.57	928	4.06	2.32	0.57	979	3.97	2.26	0.57	1010	3.84	2.19	0.57	1061
27	26	4.35	1.96	0.45	979	4.22	1.90	0.45	1030	4.16	1.87	0.45	1061	4.03	1.81	0.45	1091
28	18	3.70	3.59	0.97	816	3.54	3.44	0.97	857	3.40	3.30	0.97	898	3.28	3.18	0.97	938
28	20	3.86	3.28	0.85	857	3.70	3.15	0.85	908	3.59	3.05	0.85	928	3.47	2.95	0.85	969
28	22	4.02	2.93	0.73	887	3.87	2.83	0.73	944	3.78	2.76	0.73	969	3.62	2.64	0.73	1010
28	24	4.22	2.57	0.61	928	4.06	2.48	0.61	979	3.97	2.42	0.61	1010	3.84	2.34	0.61	1061
28	26	4.35	2.13	0.49	979	4.22	2.07	0.49	1030	4.16	2.04	0.49	1061	4.03	1.98	0.49	1091
29	18	3.70	3.70	1.00	816	3.54	3.54	1.00	857	3.40	3.40	1.00	898	3.28	3.28	1.00	938
29	20	3.86	3.43	0.89	857	3.70	3.29	0.89	908	3.59	3.20	0.89	928	3.47	3.08	0.89	969
29	22	4.02	3.09	0.77	887	3.87	2.98	0.77	944	3.78	2.91	0.77	969	3.62	2.79	0.77	1010
29	24	4.22	2.74	0.65	928	4.06	2.64	0.65	979	3.97	2.58	0.65	1010	3.84	2.50	0.65	1061
29	26	4.35	2.30	0.53	979	4.22	2.24	0.53	1030	4.16	2.20	0.53	1061	4.03	2.14	0.53	1091
30	18	3.70	3.70	1.00	816	3.54	3.54	1.00	857	3.40	3.40	1.00	898	3.28	3.28	1.00	938
30	20	3.86	3.59	0.93	857	3.70	3.44	0.93	908	3.59	3.34	0.93	928	3.47	3.22	0.93	969
30	22	4.02	3.25	0.81	887	3.87	3.14	0.81	944	3.78	3.06	0.81	969	3.62	2.93	0.81	1010
30	24	4.22	2.91	0.69	928	4.06	2.80	0.69	979	3.97	2.74	0.69	1010	3.84	2.65	0.69	1061
30	26	4.35	2.48	0.57	979	4.22	2.41	0.57	1030	4.16	2.37	0.57	1061	4.03	2.30	0.57	1091
31	18	3.70	3.70	1.00	816	3.54	3.54	1.00	857	3.40	3.40	1.00	898	3.28	3.28	1.00	938
31	20	3.86	3.74	0.97	857	3.70	3.59	0.97	908	3.59	3.48	0.97	928	3.47	3.36	0.97	969
31	22	4.02	3.41	0.85	887	3.87	3.29	0.85	944	3.78	3.21	0.85	969	3.62	3.08	0.85	1010
31	24	4.22	3.08	0.73	928	4.06	2.97	0.73	979	3.97	2.90	0.73	1010	3.84	2.81	0.73	1061
31	26	4.35	2.65	0.61	979	4.22	2.57	0.61	1030	4.16	2.54	0.61	1061	4.03	2.46	0.61	1091
32	18	3.70	3.70	1.00	816	3.54	3.54	1.00	857	3.40	3.40	1.00	898	3.28	3.28	1.00	938
32	20	3.86	3.86	1.00	857	3.70	3.70	1.00	908	3.59	3.59	1.00	928	3.47	3.47	1.00	969
32	22	4.02	3.57	0.89	887	3.87	3.45	0.89	944	3.78	3.36	0.89	969	3.62	3.22	0.89	1010
32	24	4.22	3.25	0.77	928	4.06	3.13	0.77	979	3.97	3.06	0.77	1010	3.84	2.96	0.77	1061
32	26	4.35	2.83	0.65	979	4.22	2.74	0.65	1030	4.16	2.70	0.65	1061	4.03	2.62	0.65	1091

WALL-MOUNTED PERFORMANCE DATA

NOTE Q : Total capacity (kW) SHF : Sensible heat factor DB : Dry-bulb temperature
SHC : Sensible heat capacity (kW) INPUT : Total power input (W) WB : Wet-bulb temperature

PERFORMANCE DATA COOL operation at Rated frequency

MSZ-DM35VA: MUZ-DM35VA

CAPACITY: 3.15 kW

SHF: 0.87

INPUT: 1020 W

INDOOR DB (°C)	INDOOR WB (°C)	OUTDOOR DB (°C)											
		35				40				46			
		Q	SHC	SHF	INPUT	Q	SHC	SHF	INPUT	Q	SHC	SHF	INPUT
21	18	3.09	2.13	0.69	1000	2.84	1.96	0.69	1061	2.61	1.80	0.69	1102
21	20	3.24	1.85	0.57	1040	3.02	1.72	0.57	1091	2.80	1.60	0.57	1153
22	18	3.09	2.25	0.73	1000	2.84	2.07	0.73	1061	2.61	1.91	0.73	1102
22	20	3.24	1.98	0.61	1040	3.02	1.84	0.61	1091	2.80	1.71	0.61	1153
22	22	3.43	1.68	0.49	1081	3.21	1.57	0.49	1142	2.99	1.47	0.49	1183
23	18	3.09	2.38	0.77	1000	2.84	2.18	0.77	1061	2.61	2.01	0.77	1102
23	20	3.24	2.11	0.65	1040	3.02	1.97	0.65	1091	2.80	1.82	0.65	1153
23	22	3.43	1.82	0.53	1081	3.21	1.70	0.53	1142	2.99	1.59	0.53	1183
24	18	3.09	2.50	0.81	1000	2.84	2.30	0.81	1061	2.61	2.12	0.81	1102
24	20	3.24	2.24	0.69	1040	3.02	2.09	0.69	1091	2.80	1.93	0.69	1153
24	22	3.43	1.96	0.57	1081	3.21	1.83	0.57	1142	2.99	1.71	0.57	1183
24	24	3.62	1.63	0.45	1122	3.40	1.53	0.45	1173	3.21	1.45	0.45	1224
25	18	3.09	2.62	0.85	1000	2.84	2.41	0.85	1061	2.61	2.22	0.85	1102
25	20	3.24	2.37	0.73	1040	3.02	2.21	0.73	1091	2.80	2.05	0.73	1153
25	22	3.43	2.09	0.61	1081	3.21	1.96	0.61	1142	2.99	1.83	0.61	1183
25	24	3.62	1.78	0.49	1122	3.40	1.67	0.49	1173	3.21	1.57	0.49	1224
26	18	3.09	2.75	0.89	1000	2.84	2.52	0.89	1061	2.61	2.33	0.89	1102
26	20	3.24	2.50	0.77	1040	3.02	2.33	0.77	1091	2.80	2.16	0.77	1153
26	22	3.43	2.23	0.65	1081	3.21	2.09	0.65	1142	2.99	1.95	0.65	1183
26	24	3.62	1.92	0.53	1122	3.40	1.80	0.53	1173	3.21	1.70	0.53	1224
26	26	3.81	1.56	0.41	1163	3.59	1.47	0.41	1214	3.37	1.38	0.41	1265
27	18	3.09	2.87	0.93	1000	2.84	2.64	0.93	1061	2.61	2.43	0.93	1102
27	20	3.24	2.63	0.81	1040	3.02	2.45	0.81	1091	2.80	2.27	0.81	1153
27	22	3.43	2.37	0.69	1081	3.21	2.22	0.69	1142	2.99	2.06	0.69	1183
27	24	3.62	2.06	0.57	1122	3.40	1.94	0.57	1173	3.21	1.83	0.57	1224
27	26	3.81	1.72	0.45	1163	3.59	1.62	0.45	1214	3.37	1.52	0.45	1265
28	18	3.09	2.99	0.97	1000	2.84	2.75	0.97	1061	2.61	2.54	0.97	1102
28	20	3.24	2.76	0.85	1040	3.02	2.57	0.85	1091	2.80	2.38	0.85	1153
28	22	3.43	2.51	0.73	1081	3.21	2.35	0.73	1142	2.99	2.18	0.73	1183
28	24	3.62	2.21	0.61	1122	3.40	2.08	0.61	1173	3.21	1.96	0.61	1224
28	26	3.81	1.87	0.49	1163	3.59	1.76	0.49	1214	3.37	1.65	0.49	1265
29	18	3.09	3.09	1.00	1000	2.84	2.84	1.00	1061	2.61	2.61	1.00	1102
29	20	3.24	2.89	0.89	1040	3.02	2.69	0.89	1091	2.80	2.50	0.89	1153
29	22	3.43	2.64	0.77	1081	3.21	2.47	0.77	1142	2.99	2.30	0.77	1183
29	24	3.62	2.35	0.65	1122	3.40	2.21	0.65	1173	3.21	2.09	0.65	1224
29	26	3.81	2.02	0.53	1163	3.59	1.90	0.53	1214	3.37	1.79	0.53	1265
30	18	3.09	3.09	1.00	1000	2.84	2.84	1.00	1061	2.61	2.61	1.00	1102
30	20	3.24	3.02	0.93	1040	3.02	2.81	0.93	1091	2.80	2.61	0.93	1153
30	22	3.43	2.78	0.81	1081	3.21	2.60	0.81	1142	2.99	2.42	0.81	1183
30	24	3.62	2.50	0.69	1122	3.40	2.35	0.69	1173	3.21	2.22	0.69	1224
30	26	3.81	2.17	0.57	1163	3.59	2.05	0.57	1214	3.37	1.92	0.57	1265
31	18	3.09	3.09	1.00	1000	2.84	2.84	1.00	1061	2.61	2.61	1.00	1102
31	20	3.24	3.15	0.97	1040	3.02	2.93	0.97	1091	2.80	2.72	0.97	1153
31	22	3.43	2.92	0.85	1081	3.21	2.73	0.85	1142	2.99	2.54	0.85	1183
31	24	3.62	2.64	0.73	1122	3.40	2.48	0.73	1173	3.21	2.35	0.73	1224
31	26	3.81	2.33	0.61	1163	3.59	2.19	0.61	1214	3.37	2.06	0.61	1265
32	18	3.09	3.09	1.00	1000	2.84	2.84	1.00	1061	2.61	2.61	1.00	1102
32	20	3.24	3.24	1.00	1040	3.02	3.02	1.00	1091	2.80	2.80	1.00	1153
32	22	3.43	3.06	0.89	1081	3.21	2.86	0.89	1142	2.99	2.66	0.89	1183
32	24	3.62	2.79	0.77	1122	3.40	2.62	0.77	1173	3.21	2.47	0.77	1224
32	26	3.81	2.48	0.65	1163	3.59	2.33	0.65	1214	3.37	2.19	0.65	1265

NOTE Q : Total capacity (kW) SHF : Sensible heat factor DB : Dry-bulb temperature
 SHC : Sensible heat capacity (kW) INPUT : Total power input (W) WB : Wet-bulb temperature

PERFORMANCE DATA COOL operation at Rated frequency

MSZ-HJ25VA: MUZ-HJ25VA

CAPACITY: 2.5 kW

SHF: 0.89

INPUT: 730 W

INDOOR DB (°C)	INDOOR WB (°C)	OUTDOOR DB (°C)															
		21				25				27				30			
		Q	SHC	SHF	INPUT	Q	SHC	SHF	INPUT	Q	SHC	SHF	INPUT	Q	SHC	SHF	INPUT
21	18	2.94	2.09	0.71	584	2.81	2.00	0.71	613	2.70	1.92	0.71	642	2.60	1.85	0.71	672
21	20	3.06	1.81	0.59	613	2.94	1.73	0.59	650	2.85	1.68	0.59	664	2.75	1.62	0.59	694
22	18	2.94	2.20	0.75	584	2.81	2.11	0.75	613	2.70	2.03	0.75	642	2.60	1.95	0.75	672
22	20	3.06	1.93	0.63	613	2.94	1.85	0.63	650	2.85	1.80	0.63	664	2.75	1.73	0.63	694
22	22	3.19	1.63	0.51	635	3.08	1.57	0.51	675	3.00	1.53	0.51	694	2.88	1.47	0.51	723
23	18	2.94	2.32	0.79	584	2.81	2.22	0.79	613	2.70	2.13	0.79	642	2.60	2.05	0.79	672
23	20	3.06	2.05	0.67	613	2.94	1.97	0.67	650	2.85	1.91	0.67	664	2.75	1.84	0.67	694
23	22	3.19	1.75	0.55	635	3.08	1.69	0.55	675	3.00	1.65	0.55	694	2.88	1.58	0.55	723
24	18	2.94	2.44	0.83	584	2.81	2.33	0.83	613	2.70	2.24	0.83	642	2.60	2.16	0.83	672
24	20	3.06	2.17	0.71	613	2.94	2.09	0.71	650	2.85	2.02	0.71	664	2.75	1.95	0.71	694
24	22	3.19	1.88	0.59	635	3.08	1.81	0.59	675	3.00	1.77	0.59	694	2.88	1.70	0.59	723
24	24	3.35	1.57	0.47	664	3.23	1.52	0.47	701	3.15	1.48	0.47	723	3.05	1.43	0.47	759
25	18	2.94	2.56	0.87	584	2.81	2.45	0.87	613	2.70	2.35	0.87	642	2.60	2.26	0.87	672
25	20	3.06	2.30	0.75	613	2.94	2.20	0.75	650	2.85	2.14	0.75	664	2.75	2.06	0.75	694
25	22	3.19	2.01	0.63	635	3.08	1.94	0.63	675	3.00	1.89	0.63	694	2.88	1.81	0.63	723
25	24	3.35	1.71	0.51	664	3.23	1.64	0.51	701	3.15	1.61	0.51	723	3.05	1.56	0.51	759
26	18	2.94	2.67	0.91	584	2.81	2.56	0.91	613	2.70	2.46	0.91	642	2.60	2.37	0.91	672
26	20	3.06	2.42	0.79	613	2.94	2.32	0.79	650	2.85	2.25	0.79	664	2.75	2.17	0.79	694
26	22	3.19	2.14	0.67	635	3.08	2.06	0.67	675	3.00	2.01	0.67	694	2.88	1.93	0.67	723
26	24	3.35	1.84	0.55	664	3.23	1.77	0.55	701	3.15	1.73	0.55	723	3.05	1.68	0.55	759
26	26	3.45	1.48	0.43	701	3.35	1.44	0.43	737	3.30	1.42	0.43	759	3.20	1.38	0.43	781
27	18	2.94	2.79	0.95	584	2.81	2.67	0.95	613	2.70	2.57	0.95	642	2.60	2.47	0.95	672
27	20	3.06	2.54	0.83	613	2.94	2.44	0.83	650	2.85	2.37	0.83	664	2.75	2.28	0.83	694
27	22	3.19	2.26	0.71	635	3.08	2.18	0.71	675	3.00	2.13	0.71	694	2.88	2.04	0.71	723
27	24	3.35	1.98	0.59	664	3.23	1.90	0.59	701	3.15	1.86	0.59	723	3.05	1.80	0.59	759
27	26	3.45	1.62	0.47	701	3.35	1.57	0.47	737	3.30	1.55	0.47	759	3.20	1.50	0.47	781
28	18	2.94	2.91	0.99	584	2.81	2.78	0.99	613	2.70	2.67	0.99	642	2.60	2.57	0.99	672
28	20	3.06	2.66	0.87	613	2.94	2.56	0.87	650	2.85	2.48	0.87	664	2.75	2.39	0.87	694
28	22	3.19	2.39	0.75	635	3.08	2.31	0.75	675	3.00	2.25	0.75	694	2.88	2.16	0.75	723
28	24	3.35	2.11	0.63	664	3.23	2.03	0.63	701	3.15	1.98	0.63	723	3.05	1.92	0.63	759
28	26	3.45	1.76	0.51	701	3.35	1.71	0.51	737	3.30	1.68	0.51	759	3.20	1.63	0.51	781
29	18	2.94	2.94	1.00	584	2.81	2.81	1.00	613	2.70	2.70	1.00	642	2.60	2.60	1.00	672
29	20	3.06	2.79	0.91	613	2.94	2.67	0.91	650	2.85	2.59	0.91	664	2.75	2.50	0.91	694
29	22	3.19	2.52	0.79	635	3.08	2.43	0.79	675	3.00	2.37	0.79	694	2.88	2.27	0.79	723
29	24	3.35	2.24	0.67	664	3.23	2.16	0.67	701	3.15	2.11	0.67	723	3.05	2.04	0.67	759
29	26	3.45	1.90	0.55	701	3.35	1.84	0.55	737	3.30	1.82	0.55	759	3.20	1.76	0.55	781
30	18	2.94	2.94	1.00	584	2.81	2.81	1.00	613	2.70	2.70	1.00	642	2.60	2.60	1.00	672
30	20	3.06	2.91	0.95	613	2.94	2.79	0.95	650	2.85	2.71	0.95	664	2.75	2.61	0.95	694
30	22	3.19	2.65	0.83	635	3.08	2.55	0.83	675	3.00	2.49	0.83	694	2.88	2.39	0.83	723
30	24	3.35	2.38	0.71	664	3.23	2.29	0.71	701	3.15	2.24	0.71	723	3.05	2.17	0.71	759
30	26	3.45	2.04	0.59	701	3.35	1.98	0.59	737	3.30	1.95	0.59	759	3.20	1.89	0.59	781
31	18	2.94	2.94	1.00	584	2.81	2.81	1.00	613	2.70	2.70	1.00	642	2.60	2.60	1.00	672
31	20	3.06	3.03	0.99	613	2.94	2.91	0.99	650	2.85	2.82	0.99	664	2.75	2.72	0.99	694
31	22	3.19	2.77	0.87	635	3.08	2.68	0.87	675	3.00	2.61	0.87	694	2.88	2.50	0.87	723
31	24	3.35	2.51	0.75	664	3.23	2.42	0.75	701	3.15	2.36	0.75	723	3.05	2.29	0.75	759
31	26	3.45	2.17	0.63	701	3.35	2.11	0.63	737	3.30	2.08	0.63	759	3.20	2.02	0.63	781
32	18	2.94	2.94	1.00	584	2.81	2.81	1.00	613	2.70	2.70	1.00	642	2.60	2.60	1.00	672
32	20	3.06	3.06	1.00	613	2.94	2.94	1.00	650	2.85	2.85	1.00	664	2.75	2.75	1.00	694
32	22	3.19	2.90	0.91	635	3.08	2.80	0.91	675	3.00	2.73	0.91	694	2.88	2.62	0.91	723
32	24	3.35	2.65	0.79	664	3.23	2.55	0.79	701	3.15	2.49	0.79	723	3.05	2.41	0.79	759
32	26	3.45	2.31	0.67	701	3.35	2.24	0.67	737	3.30	2.21	0.67	759	3.20	2.14	0.67	781

NOTE Q : Total capacity (kW) SHF : Sensible heat factor DB : Dry-bulb temperature
SHC : Sensible heat capacity (kW) INPUT : Total power input (W) WB : Wet-bulb temperature

WALL-MOUNTED PERFORMANCE DATA

PERFORMANCE DATA COOL operation at Rated frequency

MSZ-HJ25VA: MUZ-HJ25VA

CAPACITY: 2.5 kW SHF: 0.89 INPUT: 730 W

INDOOR DB (°C)	INDOOR WB (°C)	OUTDOOR DB (°C)											
		35				40				46			
		Q	SHC	SHF	INPUT	Q	SHC	SHF	INPUT	Q	SHC	SHF	INPUT
21	18	2.45	1.74	0.71	715	2.25	1.60	0.71	759	2.08	1.47	0.71	788
21	20	2.58	1.52	0.59	745	2.40	1.42	0.59	781	2.23	1.31	0.59	825
22	18	2.45	1.84	0.75	715	2.25	1.69	0.75	759	2.08	1.56	0.75	788
22	20	2.58	1.62	0.63	745	2.40	1.51	0.63	781	2.23	1.40	0.63	825
22	22	2.73	1.39	0.51	774	2.55	1.30	0.51	818	2.38	1.21	0.51	847
23	18	2.45	1.94	0.79	715	2.25	1.78	0.79	759	2.08	1.64	0.79	788
23	20	2.58	1.73	0.67	745	2.40	1.61	0.67	781	2.23	1.49	0.67	825
23	22	2.73	1.50	0.55	774	2.55	1.40	0.55	818	2.38	1.31	0.55	847
24	18	2.45	2.03	0.83	715	2.25	1.87	0.83	759	2.08	1.72	0.83	788
24	20	2.58	1.83	0.71	745	2.40	1.70	0.71	781	2.23	1.58	0.71	825
24	22	2.73	1.61	0.59	774	2.55	1.50	0.59	818	2.38	1.40	0.59	847
24	24	2.88	1.35	0.47	803	2.70	1.27	0.47	839	2.55	1.20	0.47	876
25	18	2.45	2.13	0.87	715	2.25	1.96	0.87	759	2.08	1.81	0.87	788
25	20	2.58	1.93	0.75	745	2.40	1.80	0.75	781	2.23	1.67	0.75	825
25	22	2.73	1.72	0.63	774	2.55	1.61	0.63	818	2.38	1.50	0.63	847
25	24	2.88	1.47	0.51	803	2.70	1.38	0.51	839	2.55	1.30	0.51	876
26	18	2.45	2.23	0.91	715	2.25	2.05	0.91	759	2.08	1.89	0.91	788
26	20	2.58	2.03	0.79	745	2.40	1.90	0.79	781	2.23	1.76	0.79	825
26	22	2.73	1.83	0.67	774	2.55	1.71	0.67	818	2.38	1.59	0.67	847
26	24	2.88	1.58	0.55	803	2.70	1.49	0.55	839	2.55	1.40	0.55	876
26	26	3.03	1.30	0.43	832	2.85	1.23	0.43	869	2.68	1.15	0.43	905
27	18	2.45	2.33	0.95	715	2.25	2.14	0.95	759	2.08	1.97	0.95	788
27	20	2.58	2.14	0.83	745	2.40	1.99	0.83	781	2.23	1.85	0.83	825
27	22	2.73	1.93	0.71	774	2.55	1.81	0.71	818	2.38	1.69	0.71	847
27	24	2.88	1.70	0.59	803	2.70	1.59	0.59	839	2.55	1.50	0.59	876
27	26	3.03	1.42	0.47	832	2.85	1.34	0.47	869	2.68	1.26	0.47	905
28	18	2.45	2.43	0.99	715	2.25	2.23	0.99	759	2.08	2.05	0.99	788
28	20	2.58	2.24	0.87	745	2.40	2.09	0.87	781	2.23	1.94	0.87	825
28	22	2.73	2.04	0.75	774	2.55	1.91	0.75	818	2.38	1.78	0.75	847
28	24	2.88	1.81	0.63	803	2.70	1.70	0.63	839	2.55	1.61	0.63	876
28	26	3.03	1.54	0.51	832	2.85	1.45	0.51	869	2.68	1.36	0.51	905
29	18	2.45	2.45	1.00	715	2.25	2.25	1.00	759	2.08	2.08	1.00	788
29	20	2.58	2.34	0.91	745	2.40	2.18	0.91	781	2.23	2.02	0.91	825
29	22	2.73	2.15	0.79	774	2.55	2.01	0.79	818	2.38	1.88	0.79	847
29	24	2.88	1.93	0.67	803	2.70	1.81	0.67	839	2.55	1.71	0.67	876
29	26	3.03	1.66	0.55	832	2.85	1.57	0.55	869	2.68	1.47	0.55	905
30	18	2.45	2.45	1.00	715	2.25	2.25	1.00	759	2.08	2.08	1.00	788
30	20	2.58	2.45	0.95	745	2.40	2.28	0.95	781	2.23	2.11	0.95	825
30	22	2.73	2.26	0.83	774	2.55	2.12	0.83	818	2.38	1.97	0.83	847
30	24	2.88	2.04	0.71	803	2.70	1.92	0.71	839	2.55	1.81	0.71	876
30	26	3.03	1.78	0.59	832	2.85	1.68	0.59	869	2.68	1.58	0.59	905
31	18	2.45	2.45	1.00	715	2.25	2.25	1.00	759	2.08	2.08	1.00	788
31	20	2.58	2.55	0.99	745	2.40	2.38	0.99	781	2.23	2.20	0.99	825
31	22	2.73	2.37	0.87	774	2.55	2.22	0.87	818	2.38	2.07	0.87	847
31	24	2.88	2.16	0.75	803	2.70	2.03	0.75	839	2.55	1.91	0.75	876
31	26	3.03	1.91	0.63	832	2.85	1.80	0.63	869	2.68	1.69	0.63	905
32	18	2.45	2.45	1.00	715	2.25	2.25	1.00	759	2.08	2.08	1.00	788
32	20	2.58	2.58	1.00	745	2.40	2.40	1.00	781	2.23	2.23	1.00	825
32	22	2.73	2.48	0.91	774	2.55	2.32	0.91	818	2.38	2.16	0.91	847
32	24	2.88	2.27	0.79	803	2.70	2.13	0.79	839	2.55	2.01	0.79	876
32	26	3.03	2.03	0.67	832	2.85	1.91	0.67	869	2.68	1.79	0.67	905

PERFORMANCE DATA

WALL-MOUNTED

NOTE Q : Total capacity (kW) SHF : Sensible heat factor DB : Dry-bulb temperature
 SHC : Sensible heat capacity (kW) INPUT : Total power input (W) WB : Wet-bulb temperature

PERFORMANCE DATA COOL operation at Rated frequency**MSZ-HJ35VA: MUZ-HJ35VA**

CAPACITY: 3.15 kW

SHF: 0.87

INPUT: 1040 W

INDOOR DB (°C)	INDOOR WB (°C)	OUTDOOR DB (°C)															
		21				25				27				30			
		Q	SHC	SHF	INPUT	Q	SHC	SHF	INPUT	Q	SHC	SHF	INPUT	Q	SHC	SHF	INPUT
21	18	3.70	2.55	0.69	832	3.54	2.45	0.69	874	3.40	2.35	0.69	915	3.28	2.26	0.69	957
21	20	3.86	2.20	0.57	874	3.70	2.11	0.57	926	3.59	2.05	0.57	946	3.47	1.98	0.57	988
22	18	3.70	2.70	0.73	832	3.54	2.59	0.73	874	3.40	2.48	0.73	915	3.28	2.39	0.73	957
22	20	3.86	2.35	0.61	874	3.70	2.26	0.61	926	3.59	2.19	0.61	946	3.47	2.11	0.61	988
22	22	4.02	1.97	0.49	905	3.87	1.90	0.49	962	3.78	1.85	0.49	988	3.62	1.78	0.49	1030
23	18	3.70	2.85	0.77	832	3.54	2.73	0.77	874	3.40	2.62	0.77	915	3.28	2.52	0.77	957
23	20	3.86	2.51	0.65	874	3.70	2.41	0.65	926	3.59	2.33	0.65	946	3.47	2.25	0.65	988
23	22	4.02	2.13	0.53	905	3.87	2.05	0.53	962	3.78	2.00	0.53	988	3.62	1.92	0.53	1030
24	18	3.70	3.00	0.81	832	3.54	2.87	0.81	874	3.40	2.76	0.81	915	3.28	2.65	0.81	957
24	20	3.86	2.66	0.69	874	3.70	2.55	0.69	926	3.59	2.48	0.69	946	3.47	2.39	0.69	988
24	22	4.02	2.29	0.57	905	3.87	2.21	0.57	962	3.78	2.15	0.57	988	3.62	2.06	0.57	1030
24	24	4.22	1.90	0.45	946	4.06	1.83	0.45	998	3.97	1.79	0.45	1030	3.84	1.73	0.45	1082
25	18	3.70	3.15	0.85	832	3.54	3.01	0.85	874	3.40	2.89	0.85	915	3.28	2.78	0.85	957
25	20	3.86	2.82	0.73	874	3.70	2.70	0.73	926	3.59	2.62	0.73	946	3.47	2.53	0.73	988
25	22	4.02	2.45	0.61	905	3.87	2.36	0.61	962	3.78	2.31	0.61	988	3.62	2.21	0.61	1030
25	24	4.22	2.07	0.49	946	4.06	1.99	0.49	998	3.97	1.94	0.49	1030	3.84	1.88	0.49	1082
26	18	3.70	3.29	0.89	832	3.54	3.15	0.89	874	3.40	3.03	0.89	915	3.28	2.92	0.89	957
26	20	3.86	2.97	0.77	874	3.70	2.85	0.77	926	3.59	2.77	0.77	946	3.47	2.67	0.77	988
26	22	4.02	2.61	0.65	905	3.87	2.52	0.65	962	3.78	2.46	0.65	988	3.62	2.35	0.65	1030
26	24	4.22	2.24	0.53	946	4.06	2.15	0.53	998	3.97	2.10	0.53	1030	3.84	2.04	0.53	1082
26	26	4.35	1.78	0.41	998	4.22	1.73	0.41	1050	4.16	1.70	0.41	1082	4.03	1.65	0.41	1113
27	18	3.70	3.44	0.93	832	3.54	3.30	0.93	874	3.40	3.16	0.93	915	3.28	3.05	0.93	957
27	20	3.86	3.13	0.81	874	3.70	3.00	0.81	926	3.59	2.91	0.81	946	3.47	2.81	0.81	988
27	22	4.02	2.77	0.69	905	3.87	2.67	0.69	962	3.78	2.61	0.69	988	3.62	2.50	0.69	1030
27	24	4.22	2.41	0.57	946	4.06	2.32	0.57	998	3.97	2.26	0.57	1030	3.84	2.19	0.57	1082
27	26	4.35	1.96	0.45	998	4.22	1.90	0.45	1050	4.16	1.87	0.45	1082	4.03	1.81	0.45	1113
28	18	3.70	3.59	0.97	832	3.54	3.44	0.97	874	3.40	3.30	0.97	915	3.28	3.18	0.97	957
28	20	3.86	3.28	0.85	874	3.70	3.15	0.85	926	3.59	3.05	0.85	946	3.47	2.95	0.85	988
28	22	4.02	2.93	0.73	905	3.87	2.83	0.73	962	3.78	2.76	0.73	988	3.62	2.64	0.73	1030
28	24	4.22	2.57	0.61	946	4.06	2.48	0.61	998	3.97	2.42	0.61	1030	3.84	2.34	0.61	1082
28	26	4.35	2.13	0.49	998	4.22	2.07	0.49	1050	4.16	2.04	0.49	1082	4.03	1.98	0.49	1113
29	18	3.70	3.70	1.00	832	3.54	3.54	1.00	874	3.40	3.40	1.00	915	3.28	3.28	1.00	957
29	20	3.86	3.43	0.89	874	3.70	3.29	0.89	926	3.59	3.20	0.89	946	3.47	3.08	0.89	988
29	22	4.02	3.09	0.77	905	3.87	2.98	0.77	962	3.78	2.91	0.77	988	3.62	2.79	0.77	1030
29	24	4.22	2.74	0.65	946	4.06	2.64	0.65	998	3.97	2.58	0.65	1030	3.84	2.50	0.65	1082
29	26	4.35	2.30	0.53	998	4.22	2.24	0.53	1050	4.16	2.20	0.53	1082	4.03	2.14	0.53	1113
30	18	3.70	3.70	1.00	832	3.54	3.54	1.00	874	3.40	3.40	1.00	915	3.28	3.28	1.00	957
30	20	3.86	3.59	0.93	874	3.70	3.44	0.93	926	3.59	3.34	0.93	946	3.47	3.22	0.93	988
30	22	4.02	3.25	0.81	905	3.87	3.14	0.81	962	3.78	3.06	0.81	988	3.62	2.93	0.81	1030
30	24	4.22	2.91	0.69	946	4.06	2.80	0.69	998	3.97	2.74	0.69	1030	3.84	2.65	0.69	1082
30	26	4.35	2.48	0.57	998	4.22	2.41	0.57	1050	4.16	2.37	0.57	1082	4.03	2.30	0.57	1113
31	18	3.70	3.70	1.00	832	3.54	3.54	1.00	874	3.40	3.40	1.00	915	3.28	3.28	1.00	957
31	20	3.86	3.74	0.97	874	3.70	3.59	0.97	926	3.59	3.48	0.97	946	3.47	3.36	0.97	988
31	22	4.02	3.41	0.85	905	3.87	3.29	0.85	962	3.78	3.21	0.85	988	3.62	3.08	0.85	1030
31	24	4.22	3.08	0.73	946	4.06	2.97	0.73	998	3.97	2.90	0.73	1030	3.84	2.81	0.73	1082
31	26	4.35	2.65	0.61	998	4.22	2.57	0.61	1050	4.16	2.54	0.61	1082	4.03	2.46	0.61	1113
32	18	3.70	3.70	1.00	832	3.54	3.54	1.00	874	3.40	3.40	1.00	915	3.28	3.28	1.00	957
32	20	3.86	3.86	1.00	874	3.70	3.70	1.00	926	3.59	3.59	1.00	946	3.47	3.47	1.00	988
32	22	4.02	3.57	0.89	905	3.87	3.45	0.89	962	3.78	3.36	0.89	988	3.62	3.22	0.89	1030
32	24	4.22	3.25	0.77	946	4.06	3.13	0.77	998	3.97	3.06	0.77	1030	3.84	2.96	0.77	1082
32	26	4.35	2.83	0.65	998	4.22	2.74	0.65	1050	4.16	2.70	0.65	1082	4.03	2.62	0.65	1113

NOTE Q : Total capacity (kW)

SHF : Sensible heat factor

DB : Dry-bulb temperature

SHC : Sensible heat capacity (kW)

INPUT : Total power input (W)

WB : Wet-bulb temperature

PERFORMANCE DATA COOL operation at Rated frequency

MSZ-HJ35VA: MUZ-HJ35VA

CAPACITY: 3.15 kW SHF: 0.87 INPUT: 1040 W

INDOOR DB (°C)	INDOOR WB (°C)	OUTDOOR DB (°C)											
		35				40				46			
		Q	SHC	SHF	INPUT	Q	SHC	SHF	INPUT	Q	SHC	SHF	INPUT
21	18	3.09	2.13	0.69	1019	2.84	1.96	0.69	1082	2.61	1.80	0.69	1123
21	20	3.24	1.85	0.57	1061	3.02	1.72	0.57	1113	2.80	1.60	0.57	1175
22	18	3.09	2.25	0.73	1019	2.84	2.07	0.73	1082	2.61	1.91	0.73	1123
22	20	3.24	1.98	0.61	1061	3.02	1.84	0.61	1113	2.80	1.71	0.61	1175
22	22	3.43	1.68	0.49	1102	3.21	1.57	0.49	1165	2.99	1.47	0.49	1206
23	18	3.09	2.38	0.77	1019	2.84	2.18	0.77	1082	2.61	2.01	0.77	1123
23	20	3.24	2.11	0.65	1061	3.02	1.97	0.65	1113	2.80	1.82	0.65	1175
23	22	3.43	1.82	0.53	1102	3.21	1.70	0.53	1165	2.99	1.59	0.53	1206
24	18	3.09	2.50	0.81	1019	2.84	2.30	0.81	1082	2.61	2.12	0.81	1123
24	20	3.24	2.24	0.69	1061	3.02	2.09	0.69	1113	2.80	1.93	0.69	1175
24	22	3.43	1.96	0.57	1102	3.21	1.83	0.57	1165	2.99	1.71	0.57	1206
24	24	3.62	1.63	0.45	1144	3.40	1.53	0.45	1196	3.21	1.45	0.45	1248
25	18	3.09	2.62	0.85	1019	2.84	2.41	0.85	1082	2.61	2.22	0.85	1123
25	20	3.24	2.37	0.73	1061	3.02	2.21	0.73	1113	2.80	2.05	0.73	1175
25	22	3.43	2.09	0.61	1102	3.21	1.96	0.61	1165	2.99	1.83	0.61	1206
25	24	3.62	1.78	0.49	1144	3.40	1.67	0.49	1196	3.21	1.57	0.49	1248
26	18	3.09	2.75	0.89	1019	2.84	2.52	0.89	1082	2.61	2.33	0.89	1123
26	20	3.24	2.50	0.77	1061	3.02	2.33	0.77	1113	2.80	2.16	0.77	1175
26	22	3.43	2.23	0.65	1102	3.21	2.09	0.65	1165	2.99	1.95	0.65	1206
26	24	3.62	1.92	0.53	1144	3.40	1.80	0.53	1196	3.21	1.70	0.53	1248
26	26	3.81	1.56	0.41	1186	3.59	1.47	0.41	1238	3.37	1.38	0.41	1290
27	18	3.09	2.87	0.93	1019	2.84	2.64	0.93	1082	2.61	2.43	0.93	1123
27	20	3.24	2.63	0.81	1061	3.02	2.45	0.81	1113	2.80	2.27	0.81	1175
27	22	3.43	2.37	0.69	1102	3.21	2.22	0.69	1165	2.99	2.06	0.69	1206
27	24	3.62	2.06	0.57	1144	3.40	1.94	0.57	1196	3.21	1.83	0.57	1248
27	26	3.81	1.72	0.45	1186	3.59	1.62	0.45	1238	3.37	1.52	0.45	1290
28	18	3.09	2.99	0.97	1019	2.84	2.75	0.97	1082	2.61	2.54	0.97	1123
28	20	3.24	2.76	0.85	1061	3.02	2.57	0.85	1113	2.80	2.38	0.85	1175
28	22	3.43	2.51	0.73	1102	3.21	2.35	0.73	1165	2.99	2.18	0.73	1206
28	24	3.62	2.21	0.61	1144	3.40	2.08	0.61	1196	3.21	1.96	0.61	1248
28	26	3.81	1.87	0.49	1186	3.59	1.76	0.49	1238	3.37	1.65	0.49	1290
29	18	3.09	3.09	1.00	1019	2.84	2.84	1.00	1082	2.61	2.61	1.00	1123
29	20	3.24	2.89	0.89	1061	3.02	2.69	0.89	1113	2.80	2.50	0.89	1175
29	22	3.43	2.64	0.77	1102	3.21	2.47	0.77	1165	2.99	2.30	0.77	1206
29	24	3.62	2.35	0.65	1144	3.40	2.21	0.65	1196	3.21	2.09	0.65	1248
29	26	3.81	2.02	0.53	1186	3.59	1.90	0.53	1238	3.37	1.79	0.53	1290
30	18	3.09	3.09	1.00	1019	2.84	2.84	1.00	1082	2.61	2.61	1.00	1123
30	20	3.24	3.02	0.93	1061	3.02	2.81	0.93	1113	2.80	2.61	0.93	1175
30	22	3.43	2.78	0.81	1102	3.21	2.60	0.81	1165	2.99	2.42	0.81	1206
30	24	3.62	2.50	0.69	1144	3.40	2.35	0.69	1196	3.21	2.22	0.69	1248
30	26	3.81	2.17	0.57	1186	3.59	2.05	0.57	1238	3.37	1.92	0.57	1290
31	18	3.09	3.09	1.00	1019	2.84	2.84	1.00	1082	2.61	2.61	1.00	1123
31	20	3.24	3.15	0.97	1061	3.02	2.93	0.97	1113	2.80	2.72	0.97	1175
31	22	3.43	2.92	0.85	1102	3.21	2.73	0.85	1165	2.99	2.54	0.85	1206
31	24	3.62	2.64	0.73	1144	3.40	2.48	0.73	1196	3.21	2.35	0.73	1248
31	26	3.81	2.33	0.61	1186	3.59	2.19	0.61	1238	3.37	2.06	0.61	1290
32	18	3.09	3.09	1.00	1019	2.84	2.84	1.00	1082	2.61	2.61	1.00	1123
32	20	3.24	3.24	1.00	1061	3.02	3.02	1.00	1113	2.80	2.80	1.00	1175
32	22	3.43	3.06	0.89	1102	3.21	2.86	0.89	1165	2.99	2.66	0.89	1206
32	24	3.62	2.79	0.77	1144	3.40	2.62	0.77	1196	3.21	2.47	0.77	1248
32	26	3.81	2.48	0.65	1186	3.59	2.33	0.65	1238	3.37	2.19	0.65	1290

PERFORMANCE DATA

WALL-MOUNTED

NOTE Q : Total capacity (kW) SHF : Sensible heat factor DB : Dry-bulb temperature
 SHC : Sensible heat capacity (kW) INPUT : Total power input (W) WB : Wet-bulb temperature

PERFORMANCE DATA COOL operation at Rated frequency

MSZ-HJ50VA: MUZ-HJ50VA

CAPACITY: 5.0 kW

SHF: 0.70

INPUT: 2050 W

INDOOR DB (°C)	INDOOR WB (°C)	OUTDOOR DB (°C)															
		21				25				27				30			
		Q	SHC	SHF	INPUT	Q	SHC	SHF	INPUT	Q	SHC	SHF	INPUT	Q	SHC	SHF	INPUT
21	18	5.88	3.06	0.52	1640	5.63	2.93	0.52	1722	5.40	2.81	0.52	1804	5.20	2.70	0.52	1886
21	20	6.13	2.45	0.40	1722	5.88	2.35	0.40	1825	5.70	2.28	0.40	1866	5.50	2.20	0.40	1948
22	18	5.88	3.29	0.56	1640	5.63	3.15	0.56	1722	5.40	3.02	0.56	1804	5.20	2.91	0.56	1886
22	20	6.13	2.70	0.44	1722	5.88	2.59	0.44	1825	5.70	2.51	0.44	1866	5.50	2.42	0.44	1948
22	22	6.38	2.04	0.32	1784	6.15	1.97	0.32	1896	6.00	1.92	0.32	1948	5.75	1.84	0.32	2030
23	18	5.88	3.53	0.60	1640	5.63	3.38	0.60	1722	5.40	3.24	0.60	1804	5.20	3.12	0.60	1886
23	20	6.13	2.94	0.48	1722	5.88	2.82	0.48	1825	5.70	2.74	0.48	1866	5.50	2.64	0.48	1948
23	22	6.38	2.30	0.36	1784	6.15	2.21	0.36	1896	6.00	2.16	0.36	1948	5.75	2.07	0.36	2030
24	18	5.88	3.76	0.64	1640	5.63	3.60	0.64	1722	5.40	3.46	0.64	1804	5.20	3.33	0.64	1886
24	20	6.13	3.19	0.52	1722	5.88	3.06	0.52	1825	5.70	2.96	0.52	1866	5.50	2.86	0.52	1948
24	22	6.38	2.55	0.40	1784	6.15	2.46	0.40	1896	6.00	2.40	0.40	1948	5.75	2.30	0.40	2030
24	24	6.70	1.88	0.28	1866	6.45	1.81	0.28	1968	6.30	1.76	0.28	2030	6.10	1.71	0.28	2132
25	18	5.88	4.00	0.68	1640	5.63	3.83	0.68	1722	5.40	3.67	0.68	1804	5.20	3.54	0.68	1886
25	20	6.13	3.43	0.56	1722	5.88	3.29	0.56	1825	5.70	3.19	0.56	1866	5.50	3.08	0.56	1948
25	22	6.38	2.81	0.44	1784	6.15	2.71	0.44	1896	6.00	2.64	0.44	1948	5.75	2.53	0.44	2030
25	24	6.70	2.14	0.32	1866	6.45	2.06	0.32	1968	6.30	2.02	0.32	2030	6.10	1.95	0.32	2132
26	18	5.88	4.23	0.72	1640	5.63	4.05	0.72	1722	5.40	3.89	0.72	1804	5.20	3.74	0.72	1886
26	20	6.13	3.68	0.60	1722	5.88	3.53	0.60	1825	5.70	3.42	0.60	1866	5.50	3.30	0.60	1948
26	22	6.38	3.06	0.48	1784	6.15	2.95	0.48	1896	6.00	2.88	0.48	1948	5.75	2.76	0.48	2030
26	24	6.70	2.41	0.36	1866	6.45	2.32	0.36	1968	6.30	2.27	0.36	2030	6.10	2.20	0.36	2132
26	26	6.90	1.66	0.24	1968	6.70	1.61	0.24	2071	6.60	1.58	0.24	2132	6.40	1.54	0.24	2194
27	18	5.88	4.47	0.76	1640	5.63	4.28	0.76	1722	5.40	4.10	0.76	1804	5.20	3.95	0.76	1886
27	20	6.13	3.92	0.64	1722	5.88	3.76	0.64	1825	5.70	3.65	0.64	1866	5.50	3.52	0.64	1948
27	22	6.38	3.32	0.52	1784	6.15	3.20	0.52	1896	6.00	3.12	0.52	1948	5.75	2.99	0.52	2030
27	24	6.70	2.68	0.40	1866	6.45	2.58	0.40	1968	6.30	2.52	0.40	2030	6.10	2.44	0.40	2132
27	26	6.90	1.93	0.28	1968	6.70	1.88	0.28	2071	6.60	1.85	0.28	2132	6.40	1.79	0.28	2194
28	18	5.88	4.70	0.80	1640	5.63	4.50	0.80	1722	5.40	4.32	0.80	1804	5.20	4.16	0.80	1886
28	20	6.13	4.17	0.68	1722	5.88	4.00	0.68	1825	5.70	3.88	0.68	1866	5.50	3.74	0.68	1948
28	22	6.38	3.57	0.56	1784	6.15	3.44	0.56	1896	6.00	3.36	0.56	1948	5.75	3.22	0.56	2030
28	24	6.70	2.95	0.44	1866	6.45	2.84	0.44	1968	6.30	2.77	0.44	2030	6.10	2.68	0.44	2132
28	26	6.90	2.21	0.32	1968	6.70	2.14	0.32	2071	6.60	2.11	0.32	2132	6.40	2.05	0.32	2194
29	18	5.88	4.94	0.84	1640	5.63	4.73	0.84	1722	5.40	4.54	0.84	1804	5.20	4.37	0.84	1886
29	20	6.13	4.41	0.72	1722	5.88	4.23	0.72	1825	5.70	4.10	0.72	1866	5.50	3.96	0.72	1948
29	22	6.38	3.83	0.60	1784	6.15	3.69	0.60	1896	6.00	3.60	0.60	1948	5.75	3.45	0.60	2030
29	24	6.70	3.22	0.48	1866	6.45	3.10	0.48	1968	6.30	3.02	0.48	2030	6.10	2.93	0.48	2132
29	26	6.90	2.48	0.36	1968	6.70	2.41	0.36	2071	6.60	2.38	0.36	2132	6.40	2.30	0.36	2194
30	18	5.88	5.17	0.88	1640	5.63	4.95	0.88	1722	5.40	4.75	0.88	1804	5.20	4.58	0.88	1886
30	20	6.13	4.66	0.76	1722	5.88	4.47	0.76	1825	5.70	4.33	0.76	1866	5.50	4.18	0.76	1948
30	22	6.38	4.08	0.64	1784	6.15	3.94	0.64	1896	6.00	3.84	0.64	1948	5.75	3.68	0.64	2030
30	24	6.70	3.48	0.52	1866	6.45	3.35	0.52	1968	6.30	3.28	0.52	2030	6.10	3.17	0.52	2132
30	26	6.90	2.76	0.40	1968	6.70	2.68	0.40	2071	6.60	2.64	0.40	2132	6.40	2.56	0.40	2194
31	18	5.88	5.41	0.92	1640	5.63	5.18	0.92	1722	5.40	4.97	0.92	1804	5.20	4.78	0.92	1886
31	20	6.13	4.90	0.80	1722	5.88	4.70	0.80	1825	5.70	4.56	0.80	1866	5.50	4.40	0.80	1948
31	22	6.38	4.34	0.68	1784	6.15	4.18	0.68	1896	6.00	4.08	0.68	1948	5.75	3.91	0.68	2030
31	24	6.70	3.75	0.56	1866	6.45	3.61	0.56	1968	6.30	3.53	0.56	2030	6.10	3.42	0.56	2132
31	26	6.90	3.04	0.44	1968	6.70	2.95	0.44	2071	6.60	2.90	0.44	2132	6.40	2.82	0.44	2194
32	18	5.88	5.64	0.96	1640	5.63	5.40	0.96	1722	5.40	5.18	0.96	1804	5.20	4.99	0.96	1886
32	20	6.13	5.15	0.84	1722	5.88	4.94	0.84	1825	5.70	4.79	0.84	1866	5.50	4.62	0.84	1948
32	22	6.38	4.59	0.72	1784	6.15	4.43	0.72	1896	6.00	4.32	0.72	1948	5.75	4.14	0.72	2030
32	24	6.70	4.02	0.60	1866	6.45	3.87	0.60	1968	6.30	3.78	0.60	2030	6.10	3.66	0.60	2132
32	26	6.90	3.31	0.48	1968	6.70	3.22	0.48	2071	6.60	3.17	0.48	2132	6.40	3.07	0.48	2194

NOTE Q : Total capacity (kW) SHF : Sensible heat factor DB : Dry-bulb temperature
SHC : Sensible heat capacity (kW) INPUT : Total power input (W) WB : Wet-bulb temperature

WALL-MOUNTED PERFORMANCE DATA

PERFORMANCE DATA COOL operation at Rated frequency
MSZ-HJ50VA: MUZ-HJ50VA

CAPACITY: 5.0 kW SHF: 0.70 INPUT: 2050 W

INDOOR DB (°C)	INDOOR WB (°C)	OUTDOOR DB (°C)											
		35				40				46			
		Q	SHC	SHF	INPUT	Q	SHC	SHF	INPUT	Q	SHC	SHF	INPUT
21	18	4.90	2.55	0.52	2009	4.50	2.34	0.52	2132	4.15	2.16	0.52	2214
21	20	5.15	2.06	0.40	2091	4.80	1.92	0.40	2194	4.45	1.78	0.40	2317
22	18	4.90	2.74	0.56	2009	4.50	2.52	0.56	2132	4.15	2.32	0.56	2214
22	20	5.15	2.27	0.44	2091	4.80	2.11	0.44	2194	4.45	1.96	0.44	2317
22	22	5.45	1.74	0.32	2173	5.10	1.63	0.32	2296	4.75	1.52	0.32	2378
23	18	4.90	2.94	0.60	2009	4.50	2.70	0.60	2132	4.15	2.49	0.60	2214
23	20	5.15	2.47	0.48	2091	4.80	2.30	0.48	2194	4.45	2.14	0.48	2317
23	22	5.45	1.96	0.36	2173	5.10	1.84	0.36	2296	4.75	1.71	0.36	2378
24	18	4.90	3.14	0.64	2009	4.50	2.88	0.64	2132	4.15	2.66	0.64	2214
24	20	5.15	2.68	0.52	2091	4.80	2.50	0.52	2194	4.45	2.31	0.52	2317
24	22	5.45	2.18	0.40	2173	5.10	2.04	0.40	2296	4.75	1.90	0.40	2378
24	24	5.75	1.61	0.28	2255	5.40	1.51	0.28	2358	5.10	1.43	0.28	2460
25	18	4.90	3.33	0.68	2009	4.50	3.06	0.68	2132	4.15	2.82	0.68	2214
25	20	5.15	2.88	0.56	2091	4.80	2.69	0.56	2194	4.45	2.49	0.56	2317
25	22	5.45	2.40	0.44	2173	5.10	2.24	0.44	2296	4.75	2.09	0.44	2378
25	24	5.75	1.84	0.32	2255	5.40	1.73	0.32	2358	5.10	1.63	0.32	2460
26	18	4.90	3.53	0.72	2009	4.50	3.24	0.72	2132	4.15	2.99	0.72	2214
26	20	5.15	3.09	0.60	2091	4.80	2.88	0.60	2194	4.45	2.67	0.60	2317
26	22	5.45	2.62	0.48	2173	5.10	2.45	0.48	2296	4.75	2.28	0.48	2378
26	24	5.75	2.07	0.36	2255	5.40	1.94	0.36	2358	5.10	1.84	0.36	2460
26	26	6.05	1.45	0.24	2337	5.70	1.37	0.24	2440	5.35	1.28	0.24	2542
27	18	4.90	3.72	0.76	2009	4.50	3.42	0.76	2132	4.15	3.15	0.76	2214
27	20	5.15	3.30	0.64	2091	4.80	3.07	0.64	2194	4.45	2.85	0.64	2317
27	22	5.45	2.83	0.52	2173	5.10	2.65	0.52	2296	4.75	2.47	0.52	2378
27	24	5.75	2.30	0.40	2255	5.40	2.16	0.40	2358	5.10	2.04	0.40	2460
27	26	6.05	1.69	0.28	2337	5.70	1.60	0.28	2440	5.35	1.50	0.28	2542
28	18	4.90	3.92	0.80	2009	4.50	3.60	0.80	2132	4.15	3.32	0.80	2214
28	20	5.15	3.50	0.68	2091	4.80	3.26	0.68	2194	4.45	3.03	0.68	2317
28	22	5.45	3.05	0.56	2173	5.10	2.86	0.56	2296	4.75	2.66	0.56	2378
28	24	5.75	2.53	0.44	2255	5.40	2.38	0.44	2358	5.10	2.24	0.44	2460
28	26	6.05	1.94	0.32	2337	5.70	1.82	0.32	2440	5.35	1.71	0.32	2542
29	18	4.90	4.12	0.84	2009	4.50	3.78	0.84	2132	4.15	3.49	0.84	2214
29	20	5.15	3.71	0.72	2091	4.80	3.46	0.72	2194	4.45	3.20	0.72	2317
29	22	5.45	3.27	0.60	2173	5.10	3.06	0.60	2296	4.75	2.85	0.60	2378
29	24	5.75	2.76	0.48	2255	5.40	2.59	0.48	2358	5.10	2.45	0.48	2460
29	26	6.05	2.18	0.36	2337	5.70	2.05	0.36	2440	5.35	1.93	0.36	2542
30	18	4.90	4.31	0.88	2009	4.50	3.96	0.88	2132	4.15	3.65	0.88	2214
30	20	5.15	3.91	0.76	2091	4.80	3.65	0.76	2194	4.45	3.38	0.76	2317
30	22	5.45	3.49	0.64	2173	5.10	3.26	0.64	2296	4.75	3.04	0.64	2378
30	24	5.75	2.99	0.52	2255	5.40	2.81	0.52	2358	5.10	2.65	0.52	2460
30	26	6.05	2.42	0.40	2337	5.70	2.28	0.40	2440	5.35	2.14	0.40	2542
31	18	4.90	4.51	0.92	2009	4.50	4.14	0.92	2132	4.15	3.82	0.92	2214
31	20	5.15	4.12	0.80	2091	4.80	3.84	0.80	2194	4.45	3.56	0.80	2317
31	22	5.45	3.71	0.68	2173	5.10	3.47	0.68	2296	4.75	3.23	0.68	2378
31	24	5.75	3.22	0.56	2255	5.40	3.02	0.56	2358	5.10	2.86	0.56	2460
31	26	6.05	2.66	0.44	2337	5.70	2.51	0.44	2440	5.35	2.35	0.44	2542
32	18	4.90	4.70	0.96	2009	4.50	4.32	0.96	2132	4.15	3.98	0.96	2214
32	20	5.15	4.33	0.84	2091	4.80	4.03	0.84	2194	4.45	3.74	0.84	2317
32	22	5.45	3.92	0.72	2173	5.10	3.67	0.72	2296	4.75	3.42	0.72	2378
32	24	5.75	3.45	0.60	2255	5.40	3.24	0.60	2358	5.10	3.06	0.60	2460
32	26	6.05	2.90	0.48	2337	5.70	2.74	0.48	2440	5.35	2.57	0.48	2542

NOTE Q : Total capacity (kW) SHF : Sensible heat factor DB : Dry-bulb temperature
 SHC : Sensible heat capacity (kW) INPUT : Total power input (W) WB : Wet-bulb temperature

PERFORMANCE DATA COOL operation at Rated frequency

MSZ-HJ60VA: MUZ-HJ60VA

CAPACITY: 6.1 kW

SHF: 0.82

INPUT: 1900 W

INDOOR DB (°C)	INDOOR WB (°C)	OUTDOOR DB (°C)															
		21				25				27				30			
		Q	SHC	SHF	INPUT	Q	SHC	SHF	INPUT	Q	SHC	SHF	INPUT	Q	SHC	SHF	INPUT
21	18	7.17	4.59	0.64	1520	6.86	4.39	0.64	1596	6.59	4.22	0.64	1672	6.34	4.06	0.64	1748
21	20	7.47	3.89	0.52	1596	7.17	3.73	0.52	1691	6.95	3.62	0.52	1729	6.71	3.49	0.52	1805
22	18	7.17	4.87	0.68	1520	6.86	4.67	0.68	1596	6.59	4.48	0.68	1672	6.34	4.31	0.68	1748
22	20	7.47	4.18	0.56	1596	7.17	4.01	0.56	1691	6.95	3.89	0.56	1729	6.71	3.76	0.56	1805
22	22	7.78	3.42	0.44	1653	7.50	3.30	0.44	1758	7.32	3.22	0.44	1805	7.01	3.09	0.44	1881
23	18	7.17	5.16	0.72	1520	6.86	4.94	0.72	1596	6.59	4.74	0.72	1672	6.34	4.57	0.72	1748
23	20	7.47	4.48	0.60	1596	7.17	4.30	0.60	1691	6.95	4.17	0.60	1729	6.71	4.03	0.60	1805
23	22	7.78	3.73	0.48	1653	7.50	3.60	0.48	1758	7.32	3.51	0.48	1805	7.01	3.37	0.48	1881
24	18	7.17	5.45	0.76	1520	6.86	5.22	0.76	1596	6.59	5.01	0.76	1672	6.34	4.82	0.76	1748
24	20	7.47	4.78	0.64	1596	7.17	4.59	0.64	1691	6.95	4.45	0.64	1729	6.71	4.29	0.64	1805
24	22	7.78	4.04	0.52	1653	7.50	3.90	0.52	1758	7.32	3.81	0.52	1805	7.01	3.65	0.52	1881
24	24	8.17	3.27	0.40	1729	7.87	3.15	0.40	1824	7.69	3.07	0.40	1881	7.44	2.98	0.40	1976
25	18	7.17	5.73	0.80	1520	6.86	5.49	0.80	1596	6.59	5.27	0.80	1672	6.34	5.08	0.80	1748
25	20	7.47	5.08	0.68	1596	7.17	4.87	0.68	1691	6.95	4.73	0.68	1729	6.71	4.56	0.68	1805
25	22	7.78	4.36	0.56	1653	7.50	4.20	0.56	1758	7.32	4.10	0.56	1805	7.01	3.93	0.56	1881
25	24	8.17	3.60	0.44	1729	7.87	3.46	0.44	1824	7.69	3.38	0.44	1881	7.44	3.27	0.44	1976
26	18	7.17	6.02	0.84	1520	6.86	5.76	0.84	1596	6.59	5.53	0.84	1672	6.34	5.33	0.84	1748
26	20	7.47	5.38	0.72	1596	7.17	5.16	0.72	1691	6.95	5.01	0.72	1729	6.71	4.83	0.72	1805
26	22	7.78	4.67	0.60	1653	7.50	4.50	0.60	1758	7.32	4.39	0.60	1805	7.01	4.21	0.60	1881
26	24	8.17	3.92	0.48	1729	7.87	3.78	0.48	1824	7.69	3.69	0.48	1881	7.44	3.57	0.48	1976
26	26	8.42	3.03	0.36	1824	8.17	2.94	0.36	1919	8.05	2.90	0.36	1976	7.81	2.81	0.36	2033
27	18	7.17	6.31	0.88	1520	6.86	6.04	0.88	1596	6.59	5.80	0.88	1672	6.34	5.58	0.88	1748
27	20	7.47	5.68	0.76	1596	7.17	5.45	0.76	1691	6.95	5.29	0.76	1729	6.71	5.10	0.76	1805
27	22	7.78	4.98	0.64	1653	7.50	4.80	0.64	1758	7.32	4.68	0.64	1805	7.01	4.49	0.64	1881
27	24	8.17	4.25	0.52	1729	7.87	4.09	0.52	1824	7.69	4.00	0.52	1881	7.44	3.87	0.52	1976
27	26	8.42	3.37	0.40	1824	8.17	3.27	0.40	1919	8.05	3.22	0.40	1976	7.81	3.12	0.40	2033
28	18	7.17	6.59	0.92	1520	6.86	6.31	0.92	1596	6.59	6.06	0.92	1672	6.34	5.84	0.92	1748
28	20	7.47	5.98	0.80	1596	7.17	5.73	0.80	1691	6.95	5.56	0.80	1729	6.71	5.37	0.80	1805
28	22	7.78	5.29	0.68	1653	7.50	5.10	0.68	1758	7.32	4.98	0.68	1805	7.01	4.77	0.68	1881
28	24	8.17	4.58	0.56	1729	7.87	4.41	0.56	1824	7.69	4.30	0.56	1881	7.44	4.17	0.56	1976
28	26	8.42	3.70	0.44	1824	8.17	3.60	0.44	1919	8.05	3.54	0.44	1976	7.81	3.44	0.44	2033
29	18	7.17	6.88	0.96	1520	6.86	6.59	0.96	1596	6.59	6.32	0.96	1672	6.34	6.09	0.96	1748
29	20	7.47	6.28	0.84	1596	7.17	6.02	0.84	1691	6.95	5.84	0.84	1729	6.71	5.64	0.84	1805
29	22	7.78	5.60	0.72	1653	7.50	5.40	0.72	1758	7.32	5.27	0.72	1805	7.01	5.05	0.72	1881
29	24	8.17	4.90	0.60	1729	7.87	4.72	0.60	1824	7.69	4.61	0.60	1881	7.44	4.47	0.60	1976
29	26	8.42	4.04	0.48	1824	8.17	3.92	0.48	1919	8.05	3.86	0.48	1976	7.81	3.75	0.48	2033
30	18	7.17	7.17	1.00	1520	6.86	6.86	1.00	1596	6.59	6.59	1.00	1672	6.34	6.34	1.00	1748
30	20	7.47	6.58	0.88	1596	7.17	6.31	0.88	1691	6.95	6.12	0.88	1729	6.71	5.90	0.88	1805
30	22	7.78	5.91	0.76	1653	7.50	5.70	0.76	1758	7.32	5.56	0.76	1805	7.01	5.33	0.76	1881
30	24	8.17	5.23	0.64	1729	7.87	5.04	0.64	1824	7.69	4.92	0.64	1881	7.44	4.76	0.64	1976
30	26	8.42	4.38	0.52	1824	8.17	4.25	0.52	1919	8.05	4.19	0.52	1976	7.81	4.06	0.52	2033
31	18	7.17	7.17	1.00	1520	6.86	6.86	1.00	1596	6.59	6.59	1.00	1672	6.34	6.34	1.00	1748
31	20	7.47	6.87	0.92	1596	7.17	6.59	0.92	1691	6.95	6.40	0.92	1729	6.71	6.17	0.92	1805
31	22	7.78	6.22	0.80	1653	7.50	6.00	0.80	1758	7.32	5.86	0.80	1805	7.01	5.61	0.80	1881
31	24	8.17	5.56	0.68	1729	7.87	5.35	0.68	1824	7.69	5.23	0.68	1881	7.44	5.06	0.68	1976
31	26	8.42	4.71	0.56	1824	8.17	4.58	0.56	1919	8.05	4.51	0.56	1976	7.81	4.37	0.56	2033
32	18	7.17	7.17	1.00	1520	6.86	6.86	1.00	1596	6.59	6.59	1.00	1672	6.34	6.34	1.00	1748
32	20	7.47	7.17	0.96	1596	7.17	6.88	0.96	1691	6.95	6.68	0.96	1729	6.71	6.44	0.96	1805
32	22	7.78	6.53	0.84	1653	7.50	6.30	0.84	1758	7.32	6.15	0.84	1805	7.01	5.89	0.84	1881
32	24	8.17	5.89	0.72	1729	7.87	5.67	0.72	1824	7.69	5.53	0.72	1881	7.44	5.36	0.72	1976
32	26	8.42	5.05	0.60	1824	8.17	4.90	0.60	1919	8.05	4.83	0.60	1976	7.81	4.68	0.60	2033

WALL-MOUNTED PERFORMANCE DATA

NOTE Q : Total capacity (kW) SHF : Sensible heat factor DB : Dry-bulb temperature
SHC : Sensible heat capacity (kW) INPUT : Total power input (W) WB : Wet-bulb temperature

PERFORMANCE DATA COOL operation at Rated frequency

MSZ-HJ60VA: MUZ-HJ60VA

CAPACITY: 6.1 kW SHF: 0.82 INPUT: 1900 W

INDOOR DB (°C)	INDOOR WB (°C)	OUTDOOR DB (°C)											
		35				40				46			
		Q	SHC	SHF	INPUT	Q	SHC	SHF	INPUT	Q	SHC	SHF	INPUT
21	18	5.98	3.83	0.64	1862	5.49	3.51	0.64	1976	5.06	3.24	0.64	2052
21	20	6.28	3.27	0.52	1938	5.86	3.05	0.52	2033	5.43	2.82	0.52	2147
22	18	5.98	4.07	0.68	1862	5.49	3.73	0.68	1976	5.06	3.44	0.68	2052
22	20	6.28	3.52	0.56	1938	5.86	3.28	0.56	2033	5.43	3.04	0.56	2147
22	22	6.65	2.93	0.44	2014	6.22	2.74	0.44	2128	5.79	2.55	0.44	2204
23	18	5.98	4.30	0.72	1862	5.49	3.95	0.72	1976	5.06	3.65	0.72	2052
23	20	6.28	3.77	0.60	1938	5.86	3.51	0.60	2033	5.43	3.26	0.60	2147
23	22	6.65	3.19	0.48	2014	6.22	2.99	0.48	2128	5.79	2.78	0.48	2204
24	18	5.98	4.54	0.76	1862	5.49	4.17	0.76	1976	5.06	3.85	0.76	2052
24	20	6.28	4.02	0.64	1938	5.86	3.75	0.64	2033	5.43	3.47	0.64	2147
24	22	6.65	3.46	0.52	2014	6.22	3.24	0.52	2128	5.79	3.01	0.52	2204
24	24	7.01	2.81	0.40	2090	6.59	2.64	0.40	2185	6.22	2.49	0.40	2280
25	18	5.98	4.78	0.80	1862	5.49	4.39	0.80	1976	5.06	4.05	0.8	2052
25	20	6.28	4.27	0.68	1938	5.86	3.98	0.68	2033	5.43	3.69	0.68	2147
25	22	6.65	3.72	0.56	2014	6.22	3.48	0.56	2128	5.79	3.25	0.56	2204
25	24	7.01	3.09	0.44	2090	6.59	2.90	0.44	2185	6.22	2.74	0.44	2280
26	18	5.98	5.02	0.84	1862	5.49	4.61	0.84	1976	5.06	4.25	0.84	2052
26	20	6.28	4.52	0.72	1938	5.86	4.22	0.72	2033	5.43	3.91	0.72	2147
26	22	6.65	3.99	0.60	2014	6.22	3.73	0.60	2128	5.79	3.48	0.60	2204
26	24	7.01	3.37	0.48	2090	6.59	3.16	0.48	2185	6.22	2.99	0.48	2280
26	26	7.38	2.66	0.36	2166	6.95	2.50	0.36	2261	6.53	2.35	0.36	2356
27	18	5.98	5.26	0.88	1862	5.49	4.83	0.88	1976	5.06	4.46	0.88	2052
27	20	6.28	4.78	0.76	1938	5.86	4.45	0.76	2033	5.43	4.13	0.76	2147
27	22	6.65	4.26	0.64	2014	6.22	3.98	0.64	2128	5.79	3.71	0.64	2204
27	24	7.01	3.65	0.52	2090	6.59	3.43	0.52	2185	6.22	3.24	0.52	2280
27	26	7.38	2.95	0.40	2166	6.95	2.78	0.40	2261	6.53	2.61	0.40	2356
28	18	5.98	5.50	0.92	1862	5.49	5.05	0.92	1976	5.06	4.66	0.92	2052
28	20	6.28	5.03	0.80	1938	5.86	4.68	0.80	2033	5.43	4.34	0.80	2147
28	22	6.65	4.52	0.68	2014	6.22	4.23	0.68	2128	5.79	3.94	0.68	2204
28	24	7.01	3.93	0.56	2090	6.59	3.69	0.56	2185	6.22	3.48	0.56	2280
28	26	7.38	3.25	0.44	2166	6.95	3.06	0.44	2261	6.53	2.87	0.44	2356
29	18	5.98	5.74	0.96	1862	5.49	5.27	0.96	1976	5.06	4.86	0.96	2052
29	20	6.28	5.28	0.84	1938	5.86	4.92	0.84	2033	5.43	4.56	0.84	2147
29	22	6.65	4.79	0.72	2014	6.22	4.48	0.72	2128	5.79	4.17	0.72	2204
29	24	7.01	4.21	0.60	2090	6.59	3.95	0.60	2185	6.22	3.73	0.60	2280
29	26	7.38	3.54	0.48	2166	6.95	3.34	0.48	2261	6.53	3.13	0.48	2356
30	18	5.98	5.98	1.00	1862	5.49	5.49	1.00	1976	5.06	5.06	1.00	2052
30	20	6.28	5.53	0.88	1938	5.86	5.15	0.88	2033	5.43	4.78	0.88	2147
30	22	6.65	5.05	0.76	2014	6.22	4.73	0.76	2128	5.79	4.40	0.76	2204
30	24	7.01	4.49	0.64	2090	6.59	4.22	0.64	2185	6.22	3.98	0.64	2280
30	26	7.38	3.84	0.52	2166	6.95	3.62	0.52	2261	6.53	3.39	0.52	2356
31	18	5.98	5.98	1.00	1862	5.49	5.49	1.00	1976	5.06	5.06	1.00	2052
31	20	6.28	5.78	0.92	1938	5.86	5.39	0.92	2033	5.43	4.99	0.92	2147
31	22	6.65	5.32	0.80	2014	6.22	4.98	0.80	2128	5.79	4.64	0.80	2204
31	24	7.01	4.77	0.68	2090	6.59	4.48	0.68	2185	6.22	4.23	0.68	2280
31	26	7.38	4.13	0.56	2166	6.95	3.89	0.56	2261	6.53	3.66	0.56	2356
32	18	5.98	5.98	1.00	1862	5.49	5.49	1.00	1976	5.06	5.06	1.00	2052
32	20	6.28	6.03	0.96	1938	5.86	5.62	0.96	2033	5.43	5.21	0.96	2147
32	22	6.65	5.59	0.84	2014	6.22	5.23	0.84	2128	5.79	4.87	0.84	2204
32	24	7.01	5.05	0.72	2090	6.59	4.74	0.72	2185	6.22	4.48	0.72	2280
32	26	7.38	4.43	0.60	2166	6.95	4.17	0.60	2261	6.53	3.92	0.60	2356

PERFORMANCE DATA

WALL-MOUNTED

NOTE Q : Total capacity (kW) SHF : Sensible heat factor DB : Dry-bulb temperature
 SHC : Sensible heat capacity (kW) INPUT : Total power input (W) WB : Wet-bulb temperature

PERFORMANCE DATA COOL operation at Rated frequency**MSZ-HJ71VA: MUZ-HJ71VA**

CAPACITY: 7.1 kW SHF: 0.77 INPUT: 2330 W

INDOOR DB (°C)	INDOOR WB (°C)	OUTDOOR DB (°C)															
		21				25				27				30			
		Q	SHC	SHF	INPUT	Q	SHC	SHF	INPUT	Q	SHC	SHF	INPUT	Q	SHC	SHF	INPUT
21	18	8.34	4.92	0.59	1864	7.99	4.71	0.59	1957	7.67	4.52	0.59	2050	7.38	4.36	0.59	2144
21	20	8.70	4.09	0.47	1957	8.34	3.92	0.47	2074	8.09	3.80	0.47	2120	7.81	3.67	0.47	2214
22	18	8.34	5.26	0.63	1864	7.99	5.03	0.63	1957	7.67	4.83	0.63	2050	7.38	4.65	0.63	2144
22	20	8.70	4.44	0.51	1957	8.34	4.25	0.51	2074	8.09	4.13	0.51	2120	7.81	3.98	0.51	2214
22	22	9.05	3.53	0.39	2027	8.73	3.41	0.39	2155	8.52	3.32	0.39	2214	8.17	3.18	0.39	2307
23	18	8.34	5.59	0.67	1864	7.99	5.35	0.67	1957	7.67	5.14	0.67	2050	7.38	4.95	0.67	2144
23	20	8.70	4.78	0.55	1957	8.34	4.59	0.55	2074	8.09	4.45	0.55	2120	7.81	4.30	0.55	2214
23	22	9.05	3.89	0.43	2027	8.73	3.76	0.43	2155	8.52	3.66	0.43	2214	8.17	3.51	0.43	2307
24	18	8.34	5.92	0.71	1864	7.99	5.67	0.71	1957	7.67	5.44	0.71	2050	7.38	5.24	0.71	2144
24	20	8.70	5.13	0.59	1957	8.34	4.92	0.59	2074	8.09	4.78	0.59	2120	7.81	4.61	0.59	2214
24	22	9.05	4.25	0.47	2027	8.73	4.10	0.47	2155	8.52	4.00	0.47	2214	8.17	3.84	0.47	2307
24	24	9.51	3.33	0.35	2120	9.16	3.21	0.35	2237	8.95	3.13	0.35	2307	8.66	3.03	0.35	2423
25	18	8.34	6.26	0.75	1864	7.99	5.99	0.75	1957	7.67	5.75	0.75	2050	7.38	5.54	0.75	2144
25	20	8.70	5.48	0.63	1957	8.34	5.26	0.63	2074	8.09	5.10	0.63	2120	7.81	4.92	0.63	2214
25	22	9.05	4.62	0.51	2027	8.73	4.45	0.51	2155	8.52	4.35	0.51	2214	8.17	4.16	0.51	2307
25	24	9.51	3.71	0.39	2120	9.16	3.57	0.39	2237	8.95	3.49	0.39	2307	8.66	3.38	0.39	2423
26	18	8.34	6.59	0.79	1864	7.99	6.31	0.79	1957	7.67	6.06	0.79	2050	7.38	5.83	0.79	2144
26	20	8.70	5.83	0.67	1957	8.34	5.59	0.67	2074	8.09	5.42	0.67	2120	7.81	5.23	0.67	2214
26	22	9.05	4.98	0.55	2027	8.73	4.80	0.55	2155	8.52	4.69	0.55	2214	8.17	4.49	0.55	2307
26	24	9.51	4.09	0.43	2120	9.16	3.94	0.43	2237	8.95	3.85	0.43	2307	8.66	3.72	0.43	2423
26	26	9.80	3.04	0.31	2237	9.51	2.95	0.31	2353	9.37	2.91	0.31	2423	9.09	2.82	0.31	2493
27	18	8.34	6.92	0.83	1864	7.99	6.63	0.83	1957	7.67	6.36	0.83	2050	7.38	6.13	0.83	2144
27	20	8.70	6.18	0.71	1957	8.34	5.92	0.71	2074	8.09	5.75	0.71	2120	7.81	5.55	0.71	2214
27	22	9.05	5.34	0.59	2027	8.73	5.15	0.59	2155	8.52	5.03	0.59	2214	8.17	4.82	0.59	2307
27	24	9.51	4.47	0.47	2120	9.16	4.30	0.47	2237	8.95	4.20	0.47	2307	8.66	4.07	0.47	2423
27	26	9.80	3.43	0.35	2237	9.51	3.33	0.35	2353	9.37	3.28	0.35	2423	9.09	3.18	0.35	2493
28	18	8.34	7.26	0.87	1864	7.99	6.95	0.87	1957	7.67	6.67	0.87	2050	7.38	6.42	0.87	2144
28	20	8.70	6.52	0.75	1957	8.34	6.26	0.75	2074	8.09	6.07	0.75	2120	7.81	5.86	0.75	2214
28	22	9.05	5.70	0.63	2027	8.73	5.50	0.63	2155	8.52	5.37	0.63	2214	8.17	5.14	0.63	2307
28	24	9.51	4.85	0.51	2120	9.16	4.67	0.51	2237	8.95	4.56	0.51	2307	8.66	4.42	0.51	2423
28	26	9.80	3.82	0.39	2237	9.51	3.71	0.39	2353	9.37	3.66	0.39	2423	9.09	3.54	0.39	2493
29	18	8.34	7.59	0.91	1864	7.99	7.27	0.91	1957	7.67	6.98	0.91	2050	7.38	6.72	0.91	2144
29	20	8.70	6.87	0.79	1957	8.34	6.59	0.79	2074	8.09	6.39	0.79	2120	7.81	6.17	0.79	2214
29	22	9.05	6.07	0.67	2027	8.73	5.85	0.67	2155	8.52	5.71	0.67	2214	8.17	5.47	0.67	2307
29	24	9.51	5.23	0.55	2120	9.16	5.04	0.55	2237	8.95	4.92	0.55	2307	8.66	4.76	0.55	2423
29	26	9.80	4.21	0.43	2237	9.51	4.09	0.43	2353	9.37	4.03	0.43	2423	9.09	3.91	0.43	2493
30	18	8.34	7.93	0.95	1864	7.99	7.59	0.95	1957	7.67	7.28	0.95	2050	7.38	7.01	0.95	2144
30	20	8.70	7.22	0.83	1957	8.34	6.92	0.83	2074	8.09	6.72	0.83	2120	7.81	6.48	0.83	2214
30	22	9.05	6.43	0.71	2027	8.73	6.20	0.71	2155	8.52	6.05	0.71	2214	8.17	5.80	0.71	2307
30	24	9.51	5.61	0.59	2120	9.16	5.40	0.59	2237	8.95	5.28	0.59	2307	8.66	5.11	0.59	2423
30	26	9.80	4.61	0.47	2237	9.51	4.47	0.47	2353	9.37	4.40	0.47	2423	9.09	4.27	0.47	2493
31	18	8.34	8.26	0.99	1864	7.99	7.91	0.99	1957	7.67	7.59	0.99	2050	7.38	7.31	0.99	2144
31	20	8.70	7.57	0.87	1957	8.34	7.26	0.87	2074	8.09	7.04	0.87	2120	7.81	6.79	0.87	2214
31	22	9.05	6.79	0.75	2027	8.73	6.55	0.75	2155	8.52	6.39	0.75	2214	8.17	6.12	0.75	2307
31	24	9.51	5.99	0.63	2120	9.16	5.77	0.63	2237	8.95	5.64	0.63	2307	8.66	5.46	0.63	2423
31	26	9.80	5.00	0.51	2237	9.51	4.85	0.51	2353	9.37	4.78	0.51	2423	9.09	4.63	0.51	2493
32	18	8.34	8.34	1.00	1864	7.99	7.99	1.00	1957	7.67	7.67	1.00	2050	7.38	7.38	1.00	2144
32	20	8.70	7.91	0.91	1957	8.34	7.59	0.91	2074	8.09	7.37	0.91	2120	7.81	7.11	0.91	2214
32	22	9.05	7.15	0.79	2027	8.73	6.90	0.79	2155	8.52	6.73	0.79	2214	8.17	6.45	0.79	2307
32	24	9.51	6.37	0.67	2120	9.16	6.14	0.67	2237	8.95	5.99	0.67	2307	8.66	5.80	0.67	2423
32	26	9.80	5.39	0.55	2237	9.51	5.23	0.55	2353	9.37	5.15	0.55	2423	9.09	5.00	0.55	2493

NOTE Q : Total capacity (kW) SHF : Sensible heat factor DB : Dry-bulb temperature
SHC : Sensible heat capacity (kW) INPUT : Total power input (W) WB : Wet-bulb temperature

WALL-MOUNTED PERFORMANCE DATA

PERFORMANCE DATA COOL operation at Rated frequency

MSZ-HJ71VA: MUZ-HJ71VA

CAPACITY: 7.1 kW SHF: 0.77 INPUT: 2330 W

INDOOR DB (°C)	INDOOR WB (°C)	OUTDOOR DB (°C)											
		35				40				46			
		Q	SHC	SHF	INPUT	Q	SHC	SHF	INPUT	Q	SHC	SHF	INPUT
21	18	6.96	4.11	0.59	2283	6.39	3.77	0.59	2423	5.89	3.48	0.59	2516
21	20	7.31	3.44	0.47	2377	6.82	3.20	0.47	2493	6.32	2.97	0.47	2633
22	18	6.96	4.38	0.63	2283	6.39	4.03	0.63	2423	5.89	3.71	0.63	2516
22	20	7.31	3.73	0.51	2377	6.82	3.48	0.51	2493	6.32	3.22	0.51	2633
22	22	7.74	3.02	0.39	2470	7.24	2.82	0.39	2610	6.75	2.63	0.39	2703
23	18	6.96	4.66	0.67	2283	6.39	4.28	0.67	2423	5.89	3.95	0.67	2516
23	20	7.31	4.02	0.55	2377	6.82	3.75	0.55	2493	6.32	3.48	0.55	2633
23	22	7.74	3.33	0.43	2470	7.24	3.11	0.43	2610	6.75	2.90	0.43	2703
24	18	6.96	4.94	0.71	2283	6.39	4.54	0.71	2423	5.89	4.18	0.71	2516
24	20	7.31	4.31	0.59	2377	6.82	4.02	0.59	2493	6.32	3.73	0.59	2633
24	22	7.74	3.64	0.47	2470	7.24	3.40	0.47	2610	6.75	3.17	0.47	2703
24	24	8.17	2.86	0.35	2563	7.67	2.68	0.35	2680	7.24	2.53	0.35	2796
25	18	6.96	5.22	0.75	2283	6.39	4.79	0.75	2423	5.89	4.42	0.75	2516
25	20	7.31	4.61	0.63	2377	6.82	4.29	0.63	2493	6.32	3.98	0.63	2633
25	22	7.74	3.95	0.51	2470	7.24	3.69	0.51	2610	6.75	3.44	0.51	2703
25	24	8.17	3.18	0.39	2563	7.67	2.99	0.39	2680	7.24	2.82	0.39	2796
26	18	6.96	5.50	0.79	2283	6.39	5.05	0.79	2423	5.89	4.66	0.79	2516
26	20	7.31	4.90	0.67	2377	6.82	4.57	0.67	2493	6.32	4.23	0.67	2633
26	22	7.74	4.26	0.55	2470	7.24	3.98	0.55	2610	6.75	3.71	0.55	2703
26	24	8.17	3.51	0.43	2563	7.67	3.30	0.43	2680	7.24	3.11	0.43	2796
26	26	8.59	2.66	0.31	2656	8.09	2.51	0.31	2773	7.60	2.36	0.31	2889
27	18	6.96	5.78	0.83	2283	6.39	5.30	0.83	2423	5.89	4.89	0.83	2516
27	20	7.31	5.19	0.71	2377	6.82	4.84	0.71	2493	6.32	4.49	0.71	2633
27	22	7.74	4.57	0.59	2470	7.24	4.27	0.59	2610	6.75	3.98	0.59	2703
27	24	8.17	3.84	0.47	2563	7.67	3.60	0.47	2680	7.24	3.40	0.47	2796
27	26	8.59	3.01	0.35	2656	8.09	2.83	0.35	2773	7.60	2.66	0.35	2889
28	18	6.96	6.05	0.87	2283	6.39	5.56	0.87	2423	5.89	5.13	0.87	2516
28	20	7.31	5.48	0.75	2377	6.82	5.11	0.75	2493	6.32	4.74	0.75	2633
28	22	7.74	4.88	0.63	2470	7.24	4.56	0.63	2610	6.75	4.25	0.63	2703
28	24	8.17	4.16	0.51	2563	7.67	3.91	0.51	2680	7.24	3.69	0.51	2796
28	26	8.59	3.35	0.39	2656	8.09	3.16	0.39	2773	7.60	2.96	0.39	2889
29	18	6.96	6.33	0.91	2283	6.39	5.81	0.91	2423	5.89	5.36	0.91	2516
29	20	7.31	5.78	0.79	2377	6.82	5.38	0.79	2493	6.32	4.99	0.79	2633
29	22	7.74	5.19	0.67	2470	7.24	4.85	0.67	2610	6.75	4.52	0.67	2703
29	24	8.17	4.49	0.55	2563	7.67	4.22	0.55	2680	7.24	3.98	0.55	2796
29	26	8.59	3.69	0.43	2656	8.09	3.48	0.43	2773	7.60	3.27	0.43	2889
30	18	6.96	6.61	0.95	2283	6.39	6.07	0.95	2423	5.89	5.60	0.95	2516
30	20	7.31	6.07	0.83	2377	6.82	5.66	0.83	2493	6.32	5.24	0.83	2633
30	22	7.74	5.49	0.71	2470	7.24	5.14	0.71	2610	6.75	4.79	0.71	2703
30	24	8.17	4.82	0.59	2563	7.67	4.52	0.59	2680	7.24	4.27	0.59	2796
30	26	8.59	4.04	0.47	2656	8.09	3.80	0.47	2773	7.60	3.57	0.47	2889
31	18	6.96	6.89	0.99	2283	6.39	6.33	0.99	2423	5.89	5.83	0.99	2516
31	20	7.31	6.36	0.87	2377	6.82	5.93	0.87	2493	6.32	5.50	0.87	2633
31	22	7.74	5.80	0.75	2470	7.24	5.43	0.75	2610	6.75	5.06	0.75	2703
31	24	8.17	5.14	0.63	2563	7.67	4.83	0.63	2680	7.24	4.56	0.63	2796
31	26	8.59	4.38	0.51	2656	8.09	4.13	0.51	2773	7.60	3.87	0.51	2889
32	18	6.96	6.96	1.00	2283	6.39	6.39	1.00	2423	5.89	5.89	1.00	2516
32	20	7.31	6.65	0.91	2377	6.82	6.20	0.91	2493	6.32	5.75	0.91	2633
32	22	7.74	6.11	0.79	2470	7.24	5.72	0.79	2610	6.75	5.33	0.79	2703
32	24	8.17	5.47	0.67	2563	7.67	5.14	0.67	2680	7.24	4.85	0.67	2796
32	26	8.59	4.73	0.55	2656	8.09	4.45	0.55	2773	7.60	4.18	0.55	2889

PERFORMANCE DATA

WALL-MOUNTED

NOTE Q : Total capacity (kW) SHF : Sensible heat factor DB : Dry-bulb temperature
 SHC : Sensible heat capacity (kW) INPUT : Total power input (W) WB : Wet-bulb temperature

Heating performance data

MSZ-RW25VG: MUZ-RW25VGHZ

	Ambient temperature (°C)	Indoor DB (°C)									
		5		10		15		20		25	
		Capacity	COP	Capacity	COP	Capacity	COP	Capacity	COP	Capacity	COP
Max frequency	20	9.62	4.93	9.25	4.55	8.89	4.20	8.55	3.88	7.92	3.54
	15	8.95	4.75	8.61	4.38	8.27	4.05	7.96	3.73	7.59	3.41
	12	8.55	4.63	8.22	4.28	7.90	3.95	7.60	3.64	7.25	3.33
	7	7.88	4.43	7.58	4.09	7.29	3.77	6.90	3.48	6.68	3.19
	2	7.21	4.21	6.93	3.89	6.67	3.59	6.41	3.31	6.12	3.03
	-7	6.01	3.64	5.78	3.36	5.55	3.11	5.34	2.87	5.09	2.63
	-10	5.61	3.48	5.39	3.22	5.18	2.98	4.98	2.75	4.75	2.52
	-15	5.40	2.84	5.19	2.62	4.99	2.42	4.80	2.24	4.58	2.05
	-20	4.27	2.89	4.10	2.67	3.95	2.47	3.79	2.29	3.62	2.09
	-25	3.60	2.56	3.46	2.36	3.33	2.18	3.20	2.02	3.05	1.85
-30	2.93	2.22	2.82	2.05	2.71	1.90	2.61	1.75	2.49	1.61	
Rated frequency	20	4.85	8.55	4.66	7.89	4.48	7.29	4.31	6.73	4.19	6.32
	15	4.31	7.80	4.15	7.20	3.99	6.65	3.83	6.14	3.70	5.78
	12	4.06	7.48	3.91	6.90	3.76	6.37	3.61	5.88	3.47	5.51
	7	3.62	7.04	3.48	6.49	3.35	6.00	3.22	5.53	3.06	5.07
	2	3.17	6.63	3.05	6.12	2.93	5.65	2.82	5.21	2.65	4.68
	-7	2.36	5.42	2.27	5.03	2.18	4.67	2.10	4.33	1.93	3.71
	-10	2.09	5.31	2.01	4.93	1.93	4.58	1.86	4.25	1.68	3.56
	-15	1.65	5.06	1.58	4.70	1.52	4.37	1.46	4.06	1.27	3.28
	-20	1.23	4.69	1.18	4.37	1.13	4.07	1.09	3.79	0.86	2.83
	-25	0.78	4.12	0.75	3.85	0.72	3.60	0.69	3.36	0.48	2.17
-30	0.33	3.55	0.31	3.33	0.30	3.13	0.29	2.93	0.10	1.50	
Minimum frequency	20	1.19	6.78	1.14	6.26	1.10	5.78	1.06	5.34	1.03	5.02
	15	1.08	6.28	1.04	5.80	1.00	5.35	0.96	4.94	0.92	4.65
	12	1.02	6.02	0.98	5.56	0.94	5.13	0.90	4.74	0.87	4.43
	7	0.91	5.67	0.87	5.23	0.84	4.83	0.80	4.46	0.76	4.08
	2	0.79	5.34	0.76	4.93	0.73	4.55	0.70	4.20	0.66	3.77
	-7	0.59	3.34	0.57	3.12	0.55	2.92	0.52	2.73	0.48	2.38
	-10	0.52	3.19	0.50	2.99	0.48	2.80	0.46	2.62	0.42	2.23
	-15	0.41	2.89	0.40	2.71	0.38	2.54	0.37	2.39	0.32	1.96
	-20	0.31	2.49	0.29	2.35	0.28	2.21	0.27	2.08	0.22	1.58
	-25	0.19	1.96	0.19	1.85	0.18	1.75	0.17	1.65	0.12	1.10
-30	0.08	1.42	0.08	1.35	0.08	1.29	0.07	1.23	0.02	0.61	

* The changes in capacity and efficiency due to the defrosting operation are not considered.

* Ambient temperature condition is DB 20°C/WB 19°C, DB 15°C/WB 14°C, DB 12°C/WB 11°C, DB 7°C/WB 6°C, DB 2°C/WB 1°C, DB -7°C/WB -8°C, DB -10°C/WB -11°C, DB -20°C/WB -21°C, DB -25°C/WB -26°C

Heating performance data

MSZ-RW35VG: MUZ-RW35VGHZ

	Ambient temperature (°C)	Indoor DB (°C)									
		5		10		15		20		25	
		Capacity	COP	Capacity	COP	Capacity	COP	Capacity	COP	Capacity	COP
Max frequency	20	10.00	5.04	9.61	4.65	9.24	4.29	8.89	3.96	8.48	3.62
	15	9.39	4.78	9.02	4.41	8.68	4.07	8.34	3.76	7.96	3.44
	12	9.02	4.62	8.67	4.26	8.34	3.93	8.02	3.63	7.65	3.32
	7	8.41	4.35	8.08	4.01	7.77	3.70	7.40	3.42	7.13	3.13
	2	7.80	4.07	7.50	3.76	7.21	3.47	6.93	3.20	6.61	2.93
	-7	6.70	3.45	6.44	3.19	6.19	2.95	5.95	2.73	5.68	2.50
	-10	6.26	3.19	6.02	2.95	5.79	2.73	5.56	2.52	5.31	2.31
	-15	5.96	2.84	5.73	2.62	5.51	2.42	5.30	2.24	5.06	2.05
	-20	5.11	2.71	4.91	2.50	4.72	2.31	4.54	2.14	4.33	1.96
	-25	4.50	2.41	4.33	2.22	4.16	2.06	4.00	1.90	3.82	1.74
-30	3.89	2.11	3.74	1.95	3.60	1.80	3.46	1.66	3.30	1.52	
Rated frequency	20	6.06	7.65	5.82	7.07	5.60	6.52	5.38	6.02	5.24	5.66
	15	5.49	7.08	5.28	6.53	5.08	6.03	4.88	5.57	4.72	5.25
	12	5.18	6.79	4.98	6.27	4.79	5.79	4.61	5.34	4.43	5.01
	7	4.64	6.37	4.46	5.88	4.29	5.43	4.12	5.01	3.93	4.61
	2	4.08	6.01	3.92	5.54	3.77	5.12	3.62	4.72	3.41	4.26
	-7	3.06	5.07	2.95	4.70	2.83	4.36	2.72	4.04	2.52	3.47
	-10	2.73	5.00	2.62	4.63	2.52	4.30	2.42	3.98	2.21	3.35
	-15	2.16	4.83	2.08	4.48	2.00	4.16	1.92	3.86	1.69	3.14
	-20	1.64	4.58	1.58	4.26	1.52	3.96	1.46	3.68	1.18	2.80
	-25	1.08	4.14	1.04	3.85	1.00	3.59	0.96	3.34	0.70	2.21
-30	0.52	3.69	0.50	3.44	0.48	3.22	0.46	3.00	0.22	1.63	
Minimum frequency	20	1.67	7.41	1.60	6.84	1.54	6.32	1.48	5.83	1.44	5.48
	15	1.51	6.85	1.45	6.33	1.40	5.84	1.34	5.39	1.30	5.08
	12	1.43	6.58	1.37	6.07	1.32	5.60	1.27	5.17	1.22	4.85
	7	1.28	6.17	1.23	5.70	1.18	5.26	1.13	4.85	1.08	4.47
	2	1.12	5.82	1.08	5.37	1.04	4.96	1.00	4.58	0.94	4.12
	-7	0.84	3.92	0.81	3.66	0.78	3.42	0.75	3.19	0.69	2.78
	-10	0.75	3.79	0.72	3.54	0.69	3.31	0.67	3.09	0.61	2.64
	-15	0.59	3.49	0.57	3.27	0.55	3.06	0.53	2.87	0.46	2.37
	-20	0.45	3.12	0.43	2.93	0.42	2.75	0.40	2.58	0.32	1.99
	-25	0.30	2.54	0.29	2.39	0.28	2.25	0.26	2.12	0.19	1.45
-30	0.14	1.95	0.14	1.85	0.13	1.75	0.13	1.66	0.06	0.90	

* The changes in capacity and efficiency due to the defrosting operation are not considered.

* Ambient temperature condition is DB 20°C/WB 19°C, DB 15°C/WB 14°C, DB 12°C/WB 11°C, DB 7°C/WB 6°C, DB 2°C/WB 1°C, DB -7°C/WB -8°C, DB -10°C/WB -11°C, DB -20°C/WB -21°C, DB -25°C/WB -26°C

Heating performance data

MSZ-RW50VG: MUZ-RW50VGHZ

	Ambient temperature (°C)	Indoor DB (°C)									
		5		10		15		20		25	
		Capacity	COP	Capacity	COP	Capacity	COP	Capacity	COP	Capacity	COP
Max frequency	20	12.35	5.53	11.87	5.11	11.42	4.72	10.98	4.35	10.47	3.98
	15	11.72	5.09	11.27	4.70	10.84	4.34	10.42	4.00	9.94	3.66
	12	11.35	4.84	10.91	4.46	10.50	4.12	10.09	3.80	9.63	3.48
	7	10.73	4.43	10.32	4.09	9.92	3.78	9.50	3.49	9.10	3.19
	2	10.11	4.05	9.72	3.74	9.35	3.45	8.99	3.19	8.57	2.92
	-7	8.99	3.27	8.64	3.03	8.31	2.80	7.99	2.59	7.62	2.37
	-10	8.61	3.09	8.28	2.85	7.97	2.64	7.66	2.44	7.31	2.23
	-15	7.99	2.70	7.69	2.49	7.39	2.31	7.11	2.13	6.78	1.95
	-20	7.37	2.51	7.09	2.32	6.82	2.14	6.55	1.98	6.25	1.82
	-25	6.75	2.24	6.49	2.07	6.24	1.91	6.00	1.77	5.72	1.62
-30	6.13	1.97	5.89	1.82	5.67	1.69	5.45	1.56	5.20	1.43	
Rated frequency	20	9.09	6.41	8.74	5.92	8.40	5.47	8.08	5.04	7.85	4.74
	15	8.24	5.93	7.92	5.47	7.62	5.05	7.33	4.66	7.08	4.40
	12	7.77	5.69	7.48	5.25	7.19	4.85	6.91	4.48	6.65	4.20
	7	6.96	5.34	6.69	4.93	6.43	4.55	6.18	4.20	5.89	3.87
	2	6.11	5.03	5.88	4.65	5.65	4.29	5.43	3.96	5.12	3.57
	-7	4.59	4.20	4.42	3.89	4.25	3.61	4.08	3.35	3.77	2.88
	-10	4.09	4.14	3.93	3.84	3.78	3.56	3.63	3.30	3.31	2.78
	-15	3.24	3.98	3.12	3.70	3.00	3.43	2.88	3.19	2.53	2.60
	-20	2.47	3.77	2.37	3.50	2.28	3.26	2.19	3.03	1.76	2.31
	-25	1.62	3.37	1.56	3.15	1.50	2.93	1.44	2.73	1.04	1.81
-30	0.78	2.98	0.75	2.79	0.72	2.61	0.69	2.44	0.32	1.32	
Minimum frequency	20	2.73	8.45	2.62	7.80	2.52	7.20	2.42	6.65	2.36	6.25
	15	2.47	7.82	2.38	7.22	2.29	6.66	2.20	6.15	2.12	5.80
	12	2.33	7.50	2.24	6.92	2.16	6.39	2.07	5.90	1.99	5.53
	7	2.09	7.04	2.01	6.50	1.93	6.00	1.86	5.54	1.77	5.10
	2	1.83	6.63	1.76	6.12	1.70	5.65	1.63	5.22	1.54	4.70
	-7	1.38	4.03	1.33	3.77	1.27	3.53	1.23	3.30	1.13	2.90
	-10	1.23	3.86	1.18	3.62	1.13	3.39	1.09	3.17	0.99	2.73
	-15	0.97	3.50	0.94	3.29	0.90	3.09	0.87	2.90	0.76	2.41
	-20	0.74	3.06	0.71	2.88	0.68	2.71	0.66	2.55	0.53	1.99
	-25	0.49	2.41	0.47	2.28	0.45	2.15	0.43	2.03	0.31	1.40
-30	0.23	1.75	0.22	1.67	0.22	1.59	0.21	1.51	0.10	0.82	

* The changes in capacity and efficiency due to the defrosting operation are not considered.

* Ambient temperature condition is DB 20°C/WB 19°C, DB 15°C/WB 14°C, DB 12°C/WB 11°C, DB 7°C/WB 6°C, DB 2°C/WB 1°C, DB -7°C/WB -8°C, DB -10°C/WB -11°C, DB -20°C/WB -21°C, DB -25°C/WB -26°C

Heating performance data

MSZ-LN25VG2W/V/B/R: MUZ-LN25VG2

	Ambient temperature (°C)	Indoor DB (°C)									
		5		10		15		20		25	
		Capacity	COP	Capacity	COP	Capacity	COP	Capacity	COP	Capacity	COP
Max frequency	20	8.16	5.45	7.75	5.03	7.20	4.65	6.64	4.29	6.08	3.92
	15	7.37	5.15	7.09	4.76	6.75	4.39	6.28	4.05	5.74	3.71
	12	6.90	4.96	6.64	4.58	6.36	4.22	6.04	3.90	5.52	3.57
	7	6.11	4.61	5.88	4.25	5.65	3.93	5.40	3.62	5.13	3.31
	2	5.33	4.22	5.12	3.90	4.93	3.60	4.74	3.32	4.52	3.04
	-7	3.91	3.41	3.76	3.15	3.62	2.91	3.48	2.68	3.32	2.46
	-10	3.44	3.11	3.31	2.87	3.18	2.65	3.06	2.44	2.92	2.24
	-15	2.65	2.55	2.55	2.35	2.45	2.17	2.36	2.00	2.25	1.83
Rated frequency	20	4.76	8.14	4.57	7.52	4.40	6.94	4.23	6.40	4.11	6.02
	15	4.31	7.54	4.15	6.96	3.99	6.42	3.83	5.93	3.70	5.58
	12	4.06	7.23	3.91	6.67	3.76	6.16	3.61	5.69	3.47	5.32
	7	3.62	6.80	3.48	6.28	3.35	5.80	3.22	5.35	3.06	4.90
	2	3.17	6.41	3.05	5.92	2.93	5.46	2.82	5.04	2.65	4.53
	-7	2.36	6.08	2.27	5.61	2.18	5.18	2.10	4.78	1.93	4.05
	-10	2.09	6.06	2.01	5.59	1.93	5.16	1.86	4.76	1.68	3.95
	-15	1.65	6.00	1.58	5.54	1.52	5.12	1.46	4.72	1.27	3.76
Minimum frequency	20	1.04	7.12	1.00	6.58	0.96	6.07	0.92	5.60	0.90	5.27
	15	0.94	6.60	0.91	6.09	0.87	5.62	0.84	5.19	0.81	4.88
	12	0.89	6.33	0.85	5.84	0.82	5.39	0.79	4.98	0.76	4.66
	7	0.79	5.95	0.76	5.49	0.73	5.07	0.70	4.68	0.67	4.29
	2	0.69	5.61	0.67	5.18	0.64	4.78	0.62	4.41	0.58	3.96
	-7	0.52	5.32	0.50	4.91	0.48	4.53	0.46	4.18	0.42	3.55
	-10	0.46	5.30	0.44	4.89	0.42	4.52	0.41	4.17	0.37	3.45
	-15	0.36	5.25	0.35	4.85	0.33	4.48	0.32	4.13	0.28	3.29

* The changes in capacity and efficiency due to the defrosting operation are not considered.

* Ambient temperature condition is DB 20°C/WB 19°C, DB 15°C/WB 14°C, DB 12°C/WB 11°C, DB 7°C/WB 6°C, DB 2°C/WB 1°C, DB -7°C/WB -8°C, DB -10°C/WB -11°C, DB -20°C/WB -21°C, DB -25°C/WB -26°C

Heating performance data

MSZ-LN25VG2W/V/B/R: MUZ-LN25VGHZ2

	Ambient temperature (°C)	Indoor DB (°C)									
		5		10		15		20		25	
		Capacity	COP	Capacity	COP	Capacity	COP	Capacity	COP	Capacity	COP
Max frequency	20	8.99	4.57	8.64	4.22	8.31	3.90	7.82	3.60	7.19	3.29
	15	8.26	4.46	7.94	4.12	7.64	3.80	7.34	3.51	6.95	3.21
	12	7.82	4.39	7.52	4.05	7.23	3.74	6.95	3.45	6.62	3.16
	7	7.10	4.25	6.82	3.92	6.56	3.62	6.30	3.34	6.02	3.06
	2	6.37	4.09	6.12	3.78	5.89	3.49	5.66	3.22	5.40	2.94
	-7	5.06	3.58	4.87	3.31	4.68	3.06	4.50	2.83	4.29	2.59
	-10	4.62	3.44	4.45	3.18	4.27	2.94	4.11	2.72	3.92	2.49
	-15	3.90	3.17	3.75	2.93	3.60	2.71	3.46	2.50	3.30	2.29
	-20	3.17	2.83	3.05	2.62	2.93	2.43	2.82	2.24	2.69	2.06
-25	2.44	2.45	2.35	2.27	2.26	2.10	2.17	1.94	2.07	1.78	
Rated frequency	20	4.76	8.14	4.57	7.52	4.40	6.94	4.23	6.40	4.11	6.02
	15	4.31	7.54	4.15	6.96	3.99	6.42	3.83	5.93	3.70	5.58
	12	4.06	7.23	3.91	6.67	3.76	6.16	3.61	5.69	3.47	5.32
	7	3.62	6.80	3.48	6.28	3.35	5.80	3.22	5.35	3.06	4.90
	2	3.17	6.41	3.05	5.92	2.93	5.46	2.82	5.04	2.65	4.53
	-7	2.36	5.26	2.27	4.88	2.18	4.53	2.10	4.20	1.93	3.60
	-10	2.09	5.15	2.01	4.79	1.93	4.44	1.86	4.13	1.68	3.46
	-15	1.65	4.92	1.58	4.57	1.52	4.25	1.46	3.95	1.27	3.19
	-20	1.23	4.57	1.18	4.26	1.13	3.96	1.09	3.69	0.86	2.75
-25	0.78	4.03	0.75	3.76	0.72	3.51	0.69	3.28	0.48	2.11	
Minimum frequency	20	1.19	7.18	1.14	6.63	1.10	6.12	1.06	5.65	1.03	5.32
	15	1.08	6.65	1.04	6.14	1.00	5.67	0.96	5.23	0.92	4.93
	12	1.02	6.38	0.98	5.89	0.94	5.44	0.90	5.02	0.87	4.70
	7	0.91	6.00	0.87	5.54	0.84	5.11	0.80	4.72	0.76	4.32
	2	0.79	5.65	0.76	5.22	0.73	4.82	0.70	4.45	0.66	3.99
	-7	0.59	3.46	0.57	3.24	0.55	3.04	0.52	2.84	0.48	2.47
	-10	0.52	3.31	0.50	3.10	0.48	2.90	0.46	2.72	0.42	2.32
	-15	0.41	2.98	0.40	2.80	0.38	2.63	0.37	2.47	0.32	2.03
	-20	0.31	2.57	0.29	2.42	0.28	2.28	0.27	2.14	0.22	1.63
-25	0.19	2.00	0.19	1.89	0.18	1.79	0.17	1.69	0.12	1.13	

* The changes in capacity and efficiency due to the defrosting operation are not considered.

* Ambient temperature condition is DB 20°C/WB 19°C, DB 15°C/WB 14°C, DB 12°C/WB 11°C, DB 7°C/WB 6°C, DB 2°C/WB 1°C, DB -7°C/WB -8°C, DB -10°C/WB -11°C, DB -20°C/WB -21°C, DB -25°C/WB -26°C

Heating performance data

MSZ-LN35VG2W/V/B/R: MUZ-LN35VG2

	Ambient temperature (°C)	Indoor DB (°C)									
		5		10		15		20		25	
		Capacity	COP	Capacity	COP	Capacity	COP	Capacity	COP	Capacity	COP
Max frequency	20	9.30	4.63	8.94	4.28	8.54	3.95	7.94	3.64	7.29	3.33
	15	8.46	4.50	8.13	4.16	7.82	3.84	7.52	3.54	7.02	3.24
	12	7.96	4.42	7.65	4.08	7.36	3.76	7.07	3.48	6.71	3.18
	7	7.12	4.26	6.84	3.93	6.58	3.63	6.30	3.35	6.04	3.06
	2	6.28	4.07	6.04	3.75	5.81	3.47	5.58	3.20	5.33	2.93
	-7	4.77	3.63	4.59	3.35	4.41	3.09	4.24	2.86	4.05	2.61
	-10	4.27	3.45	4.11	3.19	3.95	2.94	3.80	2.71	3.62	2.48
	-15	3.43	3.09	3.30	2.85	3.17	2.64	3.05	2.43	2.91	2.22
Rated frequency	20	5.94	7.45	5.72	6.87	5.50	6.35	5.28	5.86	5.13	5.51
	15	5.39	6.90	5.18	6.37	4.98	5.88	4.79	5.42	4.62	5.11
	12	5.08	6.61	4.88	6.10	4.70	5.63	4.52	5.20	4.34	4.87
	7	4.53	6.22	4.35	5.74	4.18	5.30	4.02	4.89	3.82	4.48
	2	3.96	5.86	3.81	5.41	3.66	4.99	3.52	4.61	3.31	4.14
	-7	2.95	5.56	2.84	5.13	2.73	4.74	2.62	4.37	2.41	3.71
	-10	2.61	5.54	2.51	5.11	2.42	4.72	2.32	4.36	2.10	3.61
	-15	2.06	5.49	1.98	5.07	1.90	4.68	1.83	4.32	1.59	3.44
Minimum frequency	20	1.34	8.08	1.29	7.46	1.24	6.89	1.19	6.36	1.15	5.98
	15	1.21	7.48	1.17	6.91	1.12	6.38	1.08	5.89	1.04	5.54
	12	1.14	7.18	1.10	6.62	1.06	6.12	1.02	5.65	0.98	5.28
	7	1.02	6.75	0.98	6.23	0.94	5.75	0.91	5.31	0.86	4.86
	2	0.89	6.36	0.86	5.87	0.82	5.42	0.79	5.00	0.74	4.49
	-7	0.66	6.03	0.64	5.57	0.61	5.14	0.59	4.75	0.54	4.02
	-10	0.59	6.01	0.57	5.55	0.54	5.12	0.52	4.73	0.47	3.92
	-15	0.46	5.96	0.45	5.50	0.43	5.08	0.41	4.69	0.36	3.73

* The changes in capacity and efficiency due to the defrosting operation are not considered.

* Ambient temperature condition is DB 20°C/WB 19°C, DB 15°C/WB 14°C, DB 12°C/WB 11°C, DB 7°C/WB 6°C, DB 2°C/WB 1°C, DB -7°C/WB -8°C, DB -10°C/WB -11°C, DB -20°C/WB -21°C, DB -25°C/WB -26°C

Heating performance data

MSZ-LN35VG2W/V/B/R: MUZ-LN35VGHZ2

	Ambient temperature (°C)	Indoor DB (°C)									
		5		10		15		20		25	
		Capacity	COP	Capacity	COP	Capacity	COP	Capacity	COP	Capacity	COP
Max frequency	20	8.97	3.89	8.34	3.59	7.70	3.32	7.11	3.06	6.50	2.80
	15	8.42	3.81	8.08	3.51	7.52	3.24	6.96	2.99	6.36	2.74
	12	8.04	3.75	7.73	3.46	7.37	3.20	6.85	2.95	6.27	2.70
	7	7.41	3.65	7.12	3.37	6.85	3.11	6.60	2.87	6.10	2.63
	2	6.78	3.54	6.51	3.27	6.26	3.02	6.02	2.78	5.72	2.55
	-7	5.64	3.19	5.42	2.95	5.21	2.72	5.01	2.52	4.78	2.30
	-10	5.26	3.09	5.06	2.86	4.86	2.64	4.67	2.44	4.46	2.24
	-15	4.63	2.92	4.45	2.70	4.28	2.49	4.11	2.30	3.92	2.11
	-20	3.99	2.71	3.84	2.51	3.69	2.32	3.55	2.14	3.39	1.96
-25	3.36	2.48	3.23	2.30	3.11	2.12	2.99	1.96	2.85	1.80	
Rated frequency	20	5.94	7.45	5.72	6.87	5.50	6.35	5.28	5.86	5.13	5.51
	15	5.39	6.90	5.18	6.37	4.98	5.88	4.79	5.42	4.62	5.11
	12	5.08	6.61	4.88	6.10	4.70	5.63	4.52	5.20	4.34	4.87
	7	4.53	6.22	4.35	5.74	4.18	5.30	4.02	4.89	3.82	4.48
	2	3.96	5.86	3.81	5.41	3.66	4.99	3.52	4.61	3.31	4.14
	-7	2.95	4.99	2.84	4.63	2.73	4.29	2.62	3.97	2.41	3.39
	-10	2.61	4.91	2.51	4.55	2.42	4.22	2.32	3.91	2.10	3.27
	-15	2.06	4.73	1.98	4.39	1.90	4.07	1.83	3.78	1.59	3.04
	-20	1.53	4.45	1.47	4.14	1.42	3.84	1.36	3.57	1.08	2.66
-25	0.97	4.01	0.93	3.74	0.90	3.48	0.86	3.24	0.60	2.08	
Minimum frequency	20	1.34	8.08	1.29	7.46	1.24	6.89	1.19	6.36	1.15	5.98
	15	1.21	7.48	1.17	6.91	1.12	6.38	1.08	5.89	1.04	5.54
	12	1.14	7.18	1.10	6.62	1.06	6.12	1.02	5.65	0.98	5.28
	7	1.02	6.75	0.98	6.23	0.94	5.75	0.91	5.31	0.86	4.86
	2	0.89	6.36	0.86	5.87	0.82	5.42	0.79	5.00	0.74	4.49
	-7	0.66	3.90	0.64	3.65	0.61	3.42	0.59	3.20	0.54	2.78
	-10	0.59	3.72	0.57	3.49	0.54	3.27	0.52	3.06	0.47	2.61
	-15	0.46	3.36	0.45	3.15	0.43	2.96	0.41	2.78	0.36	2.29
	-20	0.34	2.89	0.33	2.72	0.32	2.56	0.31	2.41	0.24	1.84
-25	0.22	2.25	0.21	2.13	0.20	2.02	0.19	1.91	0.14	1.27	

* The changes in capacity and efficiency due to the defrosting operation are not considered.

* Ambient temperature condition is DB 20°C/WB 19°C, DB 15°C/WB 14°C, DB 12°C/WB 11°C, DB 7°C/WB 6°C, DB 2°C/WB 1°C, DB -7°C/WB -8°C, DB -10°C/WB -11°C, DB -20°C/WB -21°C, DB -25°C/WB -26°C

Heating performance data

MSZ-LN50VG2W/V/B/R: MUZ-LN50VG2

	Ambient temperature (°C)	Indoor DB (°C)									
		5		10		15		20		25	
		Capacity	COP	Capacity	COP	Capacity	COP	Capacity	COP	Capacity	COP
Max frequency	20	11.95	3.81	11.12	3.52	10.28	3.25	9.49	3.00	8.68	2.74
	15	10.99	3.70	10.57	3.41	9.90	3.15	9.20	2.91	8.42	2.66
	12	10.34	3.62	9.95	3.34	9.50	3.08	9.01	2.85	8.24	2.60
	7	9.26	3.47	8.91	3.21	8.56	2.96	8.20	2.73	7.77	2.50
	2	8.18	3.31	7.87	3.05	7.56	2.82	7.27	2.60	6.94	2.38
	-7	6.24	2.93	6.00	2.70	5.77	2.49	5.54	2.30	5.29	2.11
	-10	5.59	2.77	5.37	2.56	5.17	2.36	4.97	2.18	4.74	2.00
	-15	4.51	2.47	4.33	2.28	4.17	2.11	4.01	1.94	3.82	1.78
Rated frequency	20	8.92	6.19	8.57	5.71	8.24	5.27	7.93	4.87	7.70	4.58
	15	8.09	5.73	7.78	5.29	7.48	4.88	7.19	4.51	6.94	4.24
	12	7.62	5.50	7.33	5.07	7.04	4.68	6.77	4.32	6.50	4.05
	7	6.79	5.17	6.53	4.77	6.28	4.41	6.03	4.07	5.74	3.72
	2	5.94	4.87	5.72	4.50	5.50	4.15	5.28	3.83	4.97	3.44
	-7	4.43	4.62	4.26	4.27	4.09	3.94	3.93	3.63	3.62	3.08
	-10	3.92	4.60	3.77	4.25	3.62	3.92	3.48	3.62	3.16	3.00
	-15	3.09	4.56	2.97	4.21	2.86	3.89	2.75	3.59	2.38	2.86
Minimum frequency	20	1.49	8.98	1.43	8.29	1.37	7.65	1.32	7.06	1.28	6.64
	15	1.35	8.32	1.30	7.68	1.25	7.09	1.20	6.54	1.16	6.16
	12	1.27	7.97	1.22	7.36	1.17	6.79	1.13	6.27	1.08	5.87
	7	1.13	7.50	1.09	6.92	1.05	6.39	1.01	5.90	0.96	5.40
	2	0.99	7.07	0.95	6.52	0.92	6.02	0.88	5.56	0.83	4.99
	-7	0.74	6.70	0.71	6.19	0.68	5.71	0.66	5.27	0.60	4.47
	-10	0.65	6.68	0.63	6.17	0.60	5.69	0.58	5.25	0.53	4.35
	-15	0.51	6.62	0.50	6.11	0.48	5.64	0.46	5.21	0.40	4.14

* The changes in capacity and efficiency due to the defrosting operation are not considered.

* Ambient temperature condition is DB 20°C/WB 19°C, DB 15°C/WB 14°C, DB 12°C/WB 11°C, DB 7°C/WB 6°C, DB 2°C/WB 1°C, DB -7°C/WB -8°C, DB -10°C/WB -11°C, DB -20°C/WB -21°C, DB -25°C/WB -26°C

Heating performance data

MSZ-LN50VG2W/V/B/R: MUZ-LN50VGHZ2

	Ambient temperature (°C)	Indoor DB (°C)									
		5		10		15		20		25	
		Capacity	COP	Capacity	COP	Capacity	COP	Capacity	COP	Capacity	COP
Max frequency	20	11.61	3.77	11.16	3.48	10.73	3.21	10.22	2.96	9.38	2.71
	15	10.89	3.65	10.47	3.37	10.07	3.11	9.68	2.87	9.07	2.63
	12	10.46	3.58	10.06	3.30	9.67	3.05	9.30	2.82	8.83	2.58
	7	9.74	3.45	9.37	3.19	9.01	2.94	8.70	2.72	8.26	2.48
	2	9.02	3.31	8.68	3.06	8.34	2.82	8.02	2.61	7.65	2.38
	-7	7.73	2.90	7.43	2.68	7.15	2.48	6.87	2.29	6.56	2.10
	-10	7.30	2.80	7.02	2.59	6.75	2.40	6.49	2.22	6.19	2.03
	-15	6.58	2.63	6.33	2.43	6.08	2.25	5.85	2.08	5.58	1.90
	-20	5.86	2.44	5.64	2.25	5.42	2.08	5.21	1.93	4.97	1.77
-25	5.14	2.23	4.95	2.07	4.76	1.91	4.57	1.77	4.36	1.62	
Rated frequency	20	8.92	6.19	8.57	5.71	8.24	5.27	7.93	4.87	7.70	4.58
	15	8.09	5.73	7.78	5.29	7.48	4.88	7.19	4.51	6.94	4.24
	12	7.62	5.50	7.33	5.07	7.04	4.68	6.77	4.32	6.50	4.05
	7	6.79	5.17	6.53	4.77	6.28	4.41	6.03	4.07	5.74	3.72
	2	5.94	4.87	5.72	4.50	5.50	4.15	5.28	3.83	4.97	3.44
	-7	4.43	4.10	4.26	3.80	4.09	3.53	3.93	3.27	3.62	2.79
	-10	3.92	4.03	3.77	3.74	3.62	3.47	3.48	3.22	3.16	2.69
	-15	3.09	3.87	2.97	3.60	2.86	3.34	2.75	3.10	2.38	2.49
	-20	2.30	3.63	2.21	3.38	2.12	3.14	2.04	2.92	1.62	2.17
-25	1.45	3.25	1.40	3.03	1.34	2.82	1.29	2.63	0.90	1.69	
Minimum frequency	20	2.68	8.33	2.57	7.69	2.47	7.10	2.38	6.55	2.31	6.16
	15	2.43	7.71	2.33	7.12	2.24	6.57	2.16	6.07	2.08	5.71
	12	2.29	7.39	2.20	6.83	2.11	6.30	2.03	5.82	1.95	5.44
	7	2.04	6.96	1.96	6.42	1.88	5.93	1.81	5.47	1.72	5.01
	2	1.78	6.55	1.71	6.05	1.65	5.58	1.59	5.16	1.49	4.63
	-7	1.33	3.97	1.28	3.72	1.23	3.48	1.18	3.26	1.09	2.84
	-10	1.18	3.79	1.13	3.55	1.09	3.33	1.05	3.12	0.95	2.67
	-15	0.93	3.41	0.89	3.21	0.86	3.01	0.82	2.83	0.71	2.33
	-20	0.69	2.93	0.66	2.76	0.64	2.60	0.61	2.45	0.49	1.87
-25	0.44	2.28	0.42	2.16	0.40	2.04	0.39	1.93	0.27	1.28	

* The changes in capacity and efficiency due to the defrosting operation are not considered.

* Ambient temperature condition is DB 20°C/WB 19°C, DB 15°C/WB 14°C, DB 12°C/WB 11°C, DB 7°C/WB 6°C, DB 2°C/WB 1°C, DB -7°C/WB -8°C, DB -10°C/WB -11°C, DB -20°C/WB -21°C, DB -25°C/WB -26°C

Heating performance data

MSZ-LN60VG2W/V/B/R: MUZ-LN60VG2

	Ambient temperature (°C)	Indoor DB (°C)									
		5		10		15		20		25	
		Capacity	COP	Capacity	COP	Capacity	COP	Capacity	COP	Capacity	COP
Max frequency	20	12.72	3.72	11.87	3.44	10.98	3.17	10.13	2.93	9.27	2.68
	15	11.84	3.62	11.38	3.34	10.65	3.09	9.86	2.85	9.02	2.61
	12	11.31	3.56	10.88	3.28	10.39	3.03	9.68	2.80	8.86	2.56
	7	10.44	3.44	10.03	3.18	9.65	2.93	9.30	2.71	8.57	2.47
	2	9.56	3.31	9.19	3.06	8.84	2.82	8.50	2.60	8.07	2.38
	-7	7.98	3.04	7.67	2.81	7.38	2.59	7.09	2.39	6.77	2.19
	-10	7.45	2.94	7.16	2.72	6.89	2.51	6.62	2.31	6.32	2.12
	-15	6.57	2.76	6.32	2.54	6.08	2.35	5.84	2.17	5.58	1.98
Rated frequency	20	10.11	5.74	9.72	5.29	9.34	4.89	8.98	4.51	8.73	4.24
	15	9.16	5.31	8.81	4.90	8.47	4.53	8.15	4.18	7.86	3.93
	12	8.63	5.09	8.30	4.70	7.98	4.34	7.68	4.01	7.37	3.75
	7	7.69	4.79	7.40	4.42	7.11	4.08	6.84	3.77	6.50	3.45
	2	6.74	4.51	6.48	4.17	6.23	3.85	5.99	3.55	5.63	3.19
	-7	5.02	4.28	4.82	3.95	4.64	3.65	4.46	3.37	4.10	2.86
	-10	4.44	4.27	4.27	3.94	4.11	3.64	3.95	3.36	3.58	2.78
	-15	3.50	4.23	3.37	3.90	3.24	3.60	3.11	3.33	2.70	2.65
Minimum frequency	20	2.68	8.33	2.57	7.69	2.47	7.10	2.38	6.55	2.31	6.16
	15	2.43	7.71	2.33	7.12	2.24	6.57	2.16	6.07	2.08	5.71
	12	2.29	7.39	2.20	6.83	2.11	6.30	2.03	5.82	1.95	5.44
	7	2.04	6.96	1.96	6.42	1.88	5.93	1.81	5.47	1.72	5.01
	2	1.78	6.55	1.71	6.05	1.65	5.58	1.59	5.16	1.49	4.63
	-7	1.33	6.22	1.28	5.74	1.23	5.30	1.18	4.89	1.09	4.15
	-10	1.18	6.19	1.13	5.72	1.09	5.28	1.05	4.87	0.95	4.04
	-15	0.93	6.14	0.89	5.67	0.86	5.23	0.82	4.83	0.71	3.84

* The changes in capacity and efficiency due to the defrosting operation are not considered.

* Ambient temperature condition is DB 20°C/WB 19°C, DB 15°C/WB 14°C, DB 12°C/WB 11°C, DB 7°C/WB 6°C, DB 2°C/WB 1°C, DB -7°C/WB -8°C, DB -10°C/WB -11°C, DB -20°C/WB -21°C, DB -25°C/WB -26°C

Heating performance data

MSZ-FT25VG, MSZ-FT25VGK: MUZ-FT25VGHZ

	Ambient temperature (°C)	Indoor DB (°C)									
		5		10		15		20		25	
		Capacity	COP	Capacity	COP	Capacity	COP	Capacity	COP	Capacity	COP
Max frequency	20	8.46	3.91	7.89	3.61	7.29	3.33	6.73	3.08	6.15	2.81
	15	7.88	3.79	7.58	3.50	7.06	3.23	6.52	2.98	5.96	2.73
	12	7.53	3.72	7.24	3.43	6.91	3.17	6.39	2.92	5.84	2.67
	7	6.96	3.58	6.69	3.30	6.43	3.05	6.20	2.81	5.63	2.57
	2	6.38	3.43	6.13	3.17	5.90	2.92	5.67	2.70	5.37	2.47
	-7	5.34	3.02	5.13	2.79	4.94	2.58	4.75	2.38	4.53	2.18
	-10	4.99	2.91	4.80	2.69	4.62	2.48	4.44	2.29	4.23	2.10
	-15	4.41	2.70	4.24	2.50	4.08	2.31	3.92	2.13	3.74	1.95
	-20	3.84	2.47	3.69	2.29	3.55	2.12	3.41	1.96	3.25	1.79
-25	3.26	2.23	3.13	2.06	3.01	1.90	2.90	1.76	2.76	1.61	
Rated frequency	20	4.76	6.43	4.57	5.93	4.40	5.48	4.23	5.06	4.11	4.76
	15	4.31	5.95	4.15	5.49	3.99	5.07	3.83	4.68	3.70	4.41
	12	4.06	5.71	3.91	5.27	3.76	4.86	3.61	4.49	3.47	4.20
	7	3.62	5.37	3.48	4.96	3.35	4.58	3.22	4.22	3.06	3.87
	2	3.17	5.06	3.05	4.67	2.93	4.31	2.82	3.98	2.65	3.57
	-7	2.36	4.27	2.27	3.96	2.18	3.67	2.10	3.40	1.93	2.91
	-10	2.09	4.20	2.01	3.90	1.93	3.61	1.86	3.35	1.68	2.80
	-15	1.65	4.04	1.58	3.75	1.52	3.48	1.46	3.23	1.27	2.60
	-20	1.23	3.79	1.18	3.52	1.13	3.28	1.09	3.05	0.86	2.27
-25	0.78	3.39	0.75	3.17	0.72	2.95	0.69	2.75	0.48	1.76	
Minimum frequency	20	1.34	8.59	1.29	7.93	1.24	7.32	1.19	6.75	1.15	6.35
	15	1.21	7.95	1.17	7.34	1.12	6.78	1.08	6.26	1.04	5.89
	12	1.14	7.63	1.10	7.04	1.06	6.50	1.02	6.00	0.98	5.61
	7	1.02	7.17	0.98	6.62	0.94	6.11	0.91	5.64	0.86	5.17
	2	0.89	6.76	0.86	6.24	0.82	5.76	0.79	5.32	0.74	4.78
	-7	0.66	4.05	0.64	3.80	0.61	3.55	0.59	3.33	0.54	2.90
	-10	0.59	3.86	0.57	3.62	0.54	3.39	0.52	3.18	0.47	2.72
	-15	0.46	3.47	0.45	3.26	0.43	3.07	0.41	2.88	0.36	2.37
	-20	0.34	2.97	0.33	2.80	0.32	2.64	0.31	2.49	0.24	1.90
-25	0.22	2.30	0.21	2.18	0.20	2.06	0.19	1.95	0.14	1.30	

* The changes in capacity and efficiency due to the defrosting operation are not considered.

* Ambient temperature condition is DB 20°C/WB 19°C, DB 15°C/WB 14°C, DB 12°C/WB 11°C, DB 7°C/WB 6°C, DB 2°C/WB 1°C, DB -7°C/WB -8°C, DB -10°C/WB -11°C, DB -20°C/WB -21°C, DB -25°C/WB -26°C

Heating performance data

MSZ-FT35VG, MSZ-FT35VGK: MUZ-FT35VGHZ

	Ambient temperature (°C)	Indoor DB (°C)									
		5		10		15		20		25	
		Capacity	COP	Capacity	COP	Capacity	COP	Capacity	COP	Capacity	COP
Max frequency	20	8.89	4.05	8.55	3.73	8.22	3.45	7.91	3.18	7.41	2.91
	15	8.32	3.90	8.00	3.60	7.69	3.32	7.40	3.07	7.06	2.81
	12	7.97	3.81	7.67	3.52	7.37	3.25	7.09	3.00	6.76	2.74
	7	7.40	3.65	7.11	3.37	6.84	3.11	6.60	2.87	6.27	2.62
	2	6.82	3.48	6.56	3.21	6.31	2.96	6.06	2.73	5.78	2.50
	-7	5.78	3.04	5.56	2.81	5.35	2.60	5.14	2.40	4.91	2.20
	-10	5.44	2.92	5.23	2.70	5.03	2.49	4.83	2.30	4.61	2.11
	-15	4.86	2.70	4.67	2.50	4.49	2.31	4.32	2.14	4.12	1.96
	-20	4.29	2.47	4.12	2.29	3.96	2.11	3.81	1.95	3.63	1.79
-25	3.71	2.23	3.57	2.06	3.43	1.91	3.30	1.76	3.15	1.61	
Rated frequency	20	5.94	5.99	5.72	5.53	5.50	5.10	5.28	4.71	5.13	4.43
	15	5.39	5.54	5.18	5.12	4.98	4.72	4.79	4.36	4.62	4.10
	12	5.08	5.32	4.88	4.91	4.70	4.53	4.52	4.18	4.34	3.91
	7	4.53	5.00	4.35	4.62	4.18	4.26	4.02	3.93	3.82	3.60
	2	3.96	4.71	3.81	4.35	3.66	4.02	3.52	3.71	3.31	3.33
	-7	2.95	4.09	2.84	3.79	2.73	3.51	2.62	3.25	2.41	2.77
	-10	2.61	4.04	2.51	3.74	2.42	3.47	2.32	3.21	2.10	2.68
	-15	2.06	3.91	1.98	3.62	1.90	3.36	1.83	3.11	1.59	2.50
	-20	1.53	3.71	1.47	3.44	1.42	3.19	1.36	2.97	1.08	2.20
-25	0.97	3.38	0.93	3.15	0.90	2.93	0.86	2.72	0.60	1.74	
Minimum frequency	20	1.34	8.59	1.29	7.93	1.24	7.32	1.19	6.75	1.15	6.35
	15	1.21	7.95	1.17	7.34	1.12	6.78	1.08	6.26	1.04	5.89
	12	1.14	7.63	1.10	7.04	1.06	6.50	1.02	6.00	0.98	5.61
	7	1.02	7.17	0.98	6.62	0.94	6.11	0.91	5.64	0.86	5.17
	2	0.89	6.76	0.86	6.24	0.82	5.76	0.79	5.32	0.74	4.78
	-7	0.66	4.05	0.64	3.80	0.61	3.55	0.59	3.33	0.54	2.90
	-10	0.59	3.86	0.57	3.62	0.54	3.39	0.52	3.18	0.47	2.72
	-15	0.46	3.47	0.45	3.26	0.43	3.07	0.41	2.88	0.36	2.37
	-20	0.34	2.97	0.33	2.80	0.32	2.64	0.31	2.49	0.24	1.90
-25	0.22	2.30	0.21	2.18	0.20	2.06	0.19	1.95	0.14	1.30	

* The changes in capacity and efficiency due to the defrosting operation are not considered.

* Ambient temperature condition is DB 20°C/WB 19°C, DB 15°C/WB 14°C, DB 12°C/WB 11°C, DB 7°C/WB 6°C, DB 2°C/WB 1°C, DB -7°C/WB -8°C, DB -10°C/WB -11°C, DB -20°C/WB -21°C, DB -25°C/WB -26°C

Heating performance data

MSZ-FT50VG, MSZ-FT50VGK: MUZ-FT50VGHZ

	Ambient temperature (°C)	Indoor DB (°C)									
		5		10		15		20		25	
		Capacity	COP	Capacity	COP	Capacity	COP	Capacity	COP	Capacity	COP
Max frequency	20	10.73	3.81	10.32	3.51	9.89	3.24	9.20	2.99	8.42	2.74
	15	9.97	3.71	9.59	3.42	9.22	3.16	8.87	2.92	8.19	2.67
	12	9.52	3.65	9.15	3.37	8.80	3.11	8.46	2.87	8.00	2.62
	7	8.76	3.53	8.42	3.26	8.10	3.01	7.80	2.78	7.43	2.54
	2	8.00	3.41	7.69	3.15	7.39	2.90	7.11	2.68	6.78	2.45
	-7	6.63	2.97	6.38	2.75	6.13	2.54	5.90	2.35	5.62	2.15
	-10	6.18	2.87	5.94	2.65	5.71	2.46	5.49	2.27	5.24	2.08
	-15	5.42	2.68	5.21	2.48	5.01	2.29	4.82	2.12	4.59	1.94
	-20	4.66	2.46	4.48	2.28	4.31	2.11	4.14	1.95	3.95	1.79
-25	3.90	2.22	3.75	2.06	3.60	1.90	3.47	1.76	3.31	1.62	
Rated frequency	20	7.43	5.87	7.14	5.42	6.87	5.00	6.61	4.62	6.42	4.34
	15	6.74	5.44	6.48	5.02	6.23	4.63	5.99	4.28	5.78	4.03
	12	6.35	5.21	6.10	4.81	5.87	4.44	5.64	4.10	5.42	3.84
	7	5.66	4.90	5.44	4.53	5.23	4.18	5.03	3.86	4.78	3.53
	2	4.95	4.62	4.76	4.27	4.58	3.94	4.40	3.64	4.14	3.27
	-7	3.69	3.83	3.55	3.56	3.41	3.30	3.28	3.06	3.02	2.62
	-10	3.27	3.76	3.14	3.49	3.02	3.24	2.90	3.01	2.63	2.52
	-15	2.57	3.60	2.48	3.34	2.38	3.11	2.29	2.89	1.98	2.32
	-20	1.91	3.35	1.84	3.12	1.77	2.91	1.70	2.70	1.35	2.02
-25	1.21	2.97	1.16	2.78	1.12	2.59	1.08	2.42	0.75	1.55	
Minimum frequency	20	1.34	8.59	1.29	7.93	1.24	7.32	1.19	6.75	1.15	6.35
	15	1.21	7.95	1.17	7.34	1.12	6.78	1.08	6.26	1.04	5.89
	12	1.14	7.63	1.10	7.04	1.06	6.50	1.02	6.00	0.98	5.61
	7	1.02	7.17	0.98	6.62	0.94	6.11	0.91	5.64	0.86	5.17
	2	0.89	6.76	0.86	6.24	0.82	5.76	0.79	5.32	0.74	4.78
	-7	0.66	2.96	0.64	2.80	0.61	2.64	0.59	2.48	0.54	2.19
	-10	0.59	2.77	0.57	2.61	0.54	2.47	0.52	2.33	0.47	2.02
	-15	0.46	2.39	0.45	2.27	0.43	2.14	0.41	2.03	0.36	1.69
	-20	0.34	1.96	0.33	1.86	0.32	1.76	0.31	1.67	0.24	1.29
-25	0.22	1.41	0.21	1.35	0.20	1.28	0.19	1.22	0.14	0.83	

* The changes in capacity and efficiency due to the defrosting operation are not considered.

* Ambient temperature condition is DB 20°C/WB 19°C, DB 15°C/WB 14°C, DB 12°C/WB 11°C, DB 7°C/WB 6°C, DB 2°C/WB 1°C, DB -7°C/WB -8°C, DB -10°C/WB -11°C, DB -20°C/WB -21°C, DB -25°C/WB -26°C

Heating performance data

MSZ-AY25VGK, MSZ-AY25VGKP: MUZ-AY25VG

	Ambient temperature (°C)	Indoor DB (°C)									
		5		10		15		20		25	
		Capacity	COP	Capacity	COP	Capacity	COP	Capacity	COP	Capacity	COP
Max frequency	20	5.86	4.92	5.63	4.54	5.42	4.19	5.21	3.87	4.97	3.54
	15	5.38	4.72	5.18	4.35	4.98	4.02	4.78	3.71	4.56	3.39
	12	5.10	4.59	4.90	4.23	4.71	3.91	4.53	3.61	4.32	3.30
	7	4.62	4.35	4.44	4.02	4.27	3.71	4.10	3.42	3.92	3.13
	2	4.14	4.10	3.98	3.78	3.83	3.49	3.68	3.22	3.51	2.95
	-7	3.28	3.56	3.16	3.29	3.03	3.03	2.92	2.80	2.78	2.56
	-10	3.00	3.36	2.88	3.10	2.77	2.86	2.66	2.64	2.54	2.42
	-15	2.52	2.99	2.42	2.76	2.33	2.55	2.24	2.35	2.14	2.15
Rated frequency	20	4.76	6.26	4.57	5.78	4.40	5.34	4.23	4.93	4.11	4.63
	15	4.31	5.80	4.15	5.35	3.99	4.94	3.83	4.56	3.70	4.29
	12	4.06	5.56	3.91	5.13	3.76	4.74	3.61	4.37	3.47	4.09
	7	3.62	5.23	3.48	4.83	3.35	4.46	3.22	4.12	3.06	3.77
	2	3.17	4.93	3.05	4.55	2.93	4.20	2.82	3.88	2.65	3.48
	-7	2.36	4.68	2.27	4.32	2.18	3.98	2.10	3.68	1.93	3.12
	-10	2.09	4.66	2.01	4.30	1.93	3.97	1.86	3.66	1.68	3.04
	-15	1.65	4.62	1.58	4.26	1.52	3.94	1.46	3.63	1.27	2.89
Minimum frequency	20	1.49	6.11	1.43	5.64	1.37	5.20	1.32	4.80	1.28	4.52
	15	1.35	5.65	1.30	5.22	1.25	4.82	1.20	4.45	1.16	4.19
	12	1.27	5.42	1.22	5.01	1.17	4.62	1.13	4.27	1.08	3.99
	7	1.13	5.10	1.09	4.71	1.05	4.35	1.01	4.01	0.96	3.67
	2	0.99	4.81	0.95	4.44	0.92	4.10	0.88	3.78	0.83	3.40
	-7	0.74	4.56	0.71	4.21	0.68	3.89	0.66	3.59	0.60	3.04
	-10	0.65	4.54	0.63	4.19	0.60	3.87	0.58	3.57	0.53	2.96
	-15	0.51	4.50	0.50	4.16	0.48	3.84	0.46	3.54	0.40	2.82
	-20	0.38	4.44	0.37	4.10	0.35	3.78	0.34	3.49	0.27	2.56

* The changes in capacity and efficiency due to the defrosting operation are not considered.

* Ambient temperature condition is DB 20°C/WB 19°C, DB 15°C/WB 14°C, DB 12°C/WB 11°C, DB 7°C/WB 6°C, DB 2°C/WB 1°C, DB -7°C/WB -8°C, DB -10°C/WB -11°C, DB -20°C/WB -21°C, DB -25°C/WB -26°C

Heating performance data

MSZ-AY25VGK, MSZ-AY25VGKP: MUZ-AY25VGH

	Ambient temperature (°C)	Indoor DB (°C)									
		5		10		15		20		25	
		Capacity	COP	Capacity	COP	Capacity	COP	Capacity	COP	Capacity	COP
Max frequency	20	5.86	4.99	5.63	4.61	5.42	4.25	5.21	3.93	4.97	3.59
	15	5.38	4.76	5.18	4.40	4.98	4.06	4.78	3.75	4.56	3.43
	12	5.10	4.62	4.90	4.26	4.71	3.93	4.53	3.63	4.32	3.32
	7	4.62	4.36	4.44	4.02	4.27	3.71	4.10	3.43	3.92	3.13
	2	4.14	4.08	3.98	3.76	3.83	3.47	3.68	3.21	3.51	2.93
	-7	3.28	3.29	3.16	3.04	3.03	2.82	2.92	2.61	2.78	2.39
	-10	3.00	3.08	2.88	2.85	2.77	2.64	2.66	2.44	2.54	2.24
	-15	2.52	2.72	2.42	2.51	2.33	2.33	2.24	2.15	2.14	1.97
Rated frequency	20	4.76	6.26	4.57	5.78	4.40	5.34	4.23	4.93	4.11	4.63
	15	4.31	5.80	4.15	5.35	3.99	4.94	3.83	4.56	3.70	4.29
	12	4.06	5.56	3.91	5.13	3.76	4.74	3.61	4.37	3.47	4.09
	7	3.62	5.23	3.48	4.83	3.35	4.46	3.22	4.12	3.06	3.77
	2	3.17	4.93	3.05	4.55	2.93	4.20	2.82	3.88	2.65	3.48
	-7	2.36	4.18	2.27	3.87	2.18	3.59	2.10	3.33	1.93	2.84
	-10	2.09	4.11	2.01	3.81	1.93	3.53	1.86	3.27	1.68	2.74
	-15	1.65	3.95	1.58	3.67	1.52	3.40	1.46	3.16	1.27	2.54
Minimum frequency	20	1.23	3.71	1.18	3.45	1.13	3.21	1.09	2.98	0.86	2.22
	20	1.49	6.11	1.43	5.64	1.37	5.20	1.32	4.80	1.28	4.52
	15	1.35	5.65	1.30	5.22	1.25	4.82	1.20	4.45	1.16	4.19
	12	1.27	5.42	1.22	5.01	1.17	4.62	1.13	4.27	1.08	3.99
	7	1.13	5.10	1.09	4.71	1.05	4.35	1.01	4.01	0.96	3.67
	2	0.99	4.81	0.95	4.44	0.92	4.10	0.88	3.78	0.83	3.40
	-7	0.74	3.32	0.71	3.10	0.68	2.89	0.66	2.70	0.60	2.33
	-10	0.65	3.20	0.63	2.99	0.60	2.79	0.58	2.61	0.53	2.21
-15	0.51	2.95	0.50	2.76	0.48	2.58	0.46	2.41	0.40	1.97	
-20	0.38	2.60	0.37	2.44	0.35	2.29	0.34	2.15	0.27	1.63	

* The changes in capacity and efficiency due to the defrosting operation are not considered.

* Ambient temperature condition is DB 20°C/WB 19°C, DB 15°C/WB 14°C, DB 12°C/WB 11°C, DB 7°C/WB 6°C, DB 2°C/WB 1°C, DB -7°C/WB -8°C, DB -10°C/WB -11°C, DB -20°C/WB -21°C, DB -25°C/WB -26°C

Heating performance data

MSZ-AY35VGK, MSZ-AY35VGKP: MUZ-AY35VG

	Ambient temperature (°C)	Indoor DB (°C)									
		5		10		15		20		25	
		Capacity	COP	Capacity	COP	Capacity	COP	Capacity	COP	Capacity	COP
Max frequency	20	6.66	4.41	6.40	4.07	6.15	3.76	5.74	3.47	5.27	3.17
	15	6.09	4.28	5.86	3.95	5.63	3.65	5.42	3.37	5.08	3.08
	12	5.75	4.19	5.53	3.87	5.32	3.57	5.11	3.30	4.86	3.02
	7	5.19	4.03	4.99	3.72	4.80	3.43	4.60	3.17	4.40	2.90
	2	4.62	3.85	4.45	3.55	4.27	3.28	4.11	3.03	3.92	2.77
	-7	3.61	3.44	3.47	3.17	3.33	2.93	3.21	2.70	3.06	2.47
	-10	3.27	3.27	3.14	3.02	3.02	2.79	2.90	2.58	2.77	2.36
	-15	2.70	2.96	2.60	2.73	2.50	2.52	2.40	2.33	2.29	2.13
Rated frequency	20	2.14	2.58	2.05	2.38	1.98	2.20	1.90	2.03	1.81	1.86
	15	5.94	5.93	5.72	5.47	5.50	5.05	5.28	4.66	5.13	4.39
	12	5.39	5.49	5.18	5.07	4.98	4.68	4.79	4.32	4.62	4.07
	7	5.08	5.26	4.88	4.86	4.70	4.49	4.52	4.14	4.34	3.87
	2	4.53	4.95	4.35	4.57	4.18	4.22	4.02	3.90	3.82	3.57
	-7	3.96	4.67	3.81	4.31	3.66	3.98	3.52	3.67	3.31	3.30
	-10	2.95	4.43	2.84	4.09	2.73	3.77	2.62	3.48	2.41	2.95
	-15	2.61	4.41	2.51	4.07	2.42	3.76	2.32	3.47	2.10	2.87
Minimum frequency	20	2.06	4.37	1.98	4.04	1.90	3.73	1.83	3.44	1.59	2.74
	15	1.53	4.31	1.47	3.98	1.42	3.67	1.36	3.39	1.08	2.49
	12	1.93	5.67	1.86	5.23	1.79	4.83	1.72	4.46	1.67	4.20
	7	1.75	5.25	1.68	4.85	1.62	4.47	1.56	4.13	1.50	3.89
	2	1.65	5.04	1.59	4.65	1.53	4.29	1.47	3.96	1.41	3.71
	-7	1.47	4.74	1.41	4.37	1.36	4.04	1.31	3.73	1.24	3.41
	-10	1.29	4.46	1.24	4.12	1.19	3.80	1.15	3.51	1.08	3.15
	-15	0.96	4.23	0.92	3.91	0.89	3.61	0.85	3.33	0.78	2.82
	20	0.85	4.22	0.82	3.89	0.79	3.59	0.76	3.32	0.68	2.75
	15	0.67	4.18	0.64	3.86	0.62	3.56	0.60	3.29	0.52	2.62
	-20	0.50	4.12	0.48	3.80	0.46	3.51	0.44	3.24	0.35	2.38

* The changes in capacity and efficiency due to the defrosting operation are not considered.

* Ambient temperature condition is DB 20°C/WB 19°C, DB 15°C/WB 14°C, DB 12°C/WB 11°C, DB 7°C/WB 6°C, DB 2°C/WB 1°C, DB -7°C/WB -8°C, DB -10°C/WB -11°C, DB -20°C/WB -21°C, DB -25°C/WB -26°C

Heating performance data

MSZ-AY35VGK, MSZ-AY35VGKP: MUZ-AY35VGH

	Ambient temperature (°C)	Indoor DB (°C)									
		5		10		15		20		25	
		Capacity	COP	Capacity	COP	Capacity	COP	Capacity	COP	Capacity	COP
Max frequency	20	6.66	4.39	6.40	4.06	6.15	3.74	5.72	3.46	5.25	3.16
	15	6.09	4.27	5.86	3.94	5.63	3.64	5.42	3.36	5.07	3.07
	12	5.75	4.18	5.53	3.86	5.32	3.56	5.11	3.29	4.85	3.01
	7	5.19	4.03	4.99	3.72	4.80	3.43	4.60	3.17	4.40	2.90
	2	4.62	3.85	4.45	3.56	4.27	3.28	4.11	3.03	3.92	2.77
	-7	3.61	3.27	3.47	3.02	3.33	2.80	3.21	2.59	3.06	2.37
	-10	3.27	3.11	3.14	2.88	3.02	2.66	2.90	2.46	2.77	2.26
	-15	2.70	2.80	2.60	2.59	2.50	2.40	2.40	2.22	2.29	2.04
Rated frequency	20	5.94	5.93	5.72	5.47	5.50	5.05	5.28	4.66	5.13	4.39
	15	5.39	5.49	5.18	5.07	4.98	4.68	4.79	4.32	4.62	4.07
	12	5.08	5.26	4.88	4.86	4.70	4.49	4.52	4.14	4.34	3.87
	7	4.53	4.95	4.35	4.57	4.18	4.22	4.02	3.90	3.82	3.57
	2	3.96	4.67	3.81	4.31	3.66	3.98	3.52	3.67	3.31	3.30
	-7	2.95	4.06	2.84	3.76	2.73	3.48	2.62	3.22	2.41	2.75
	-10	2.61	4.00	2.51	3.71	2.42	3.44	2.32	3.18	2.10	2.65
	-15	2.06	3.87	1.98	3.59	1.90	3.33	1.83	3.09	1.59	2.48
Minimum frequency	20	1.93	5.67	1.86	5.23	1.79	4.83	1.72	4.46	1.67	4.20
	15	1.75	5.25	1.68	4.85	1.62	4.47	1.56	4.13	1.50	3.89
	12	1.65	5.04	1.59	4.65	1.53	4.29	1.47	3.96	1.41	3.71
	7	1.47	4.74	1.41	4.37	1.36	4.04	1.31	3.73	1.24	3.41
	2	1.29	4.46	1.24	4.12	1.19	3.80	1.15	3.51	1.08	3.15
	-7	0.96	3.34	0.92	3.11	0.89	2.90	0.85	2.69	0.78	2.32
	-10	0.85	3.25	0.82	3.02	0.79	2.82	0.76	2.62	0.68	2.21
	-15	0.67	3.03	0.64	2.83	0.62	2.64	0.60	2.46	0.52	2.00
	-20	0.50	2.74	0.48	2.56	0.46	2.40	0.44	2.24	0.35	1.69

* The changes in capacity and efficiency due to the defrosting operation are not considered.

* Ambient temperature condition is DB 20°C/WB 19°C, DB 15°C/WB 14°C, DB 12°C/WB 11°C, DB 7°C/WB 6°C, DB 2°C/WB 1°C, DB -7°C/WB -8°C, DB -10°C/WB -11°C, DB -20°C/WB -21°C, DB -25°C/WB -26°C

Heating performance data

MSZ-AY42VGK, MSZ-AY42VGKP: MUZ-AY42VG

	Ambient temperature (°C)	Indoor DB (°C)									
		5		10		15		20		25	
		Capacity	COP	Capacity	COP	Capacity	COP	Capacity	COP	Capacity	COP
Max frequency	20	9.12	4.17	8.42	3.85	7.77	3.55	7.17	3.28	6.56	3.00
	15	8.80	4.08	8.19	3.77	7.60	3.48	7.02	3.21	6.42	2.94
	12	8.30	4.02	7.91	3.71	7.49	3.43	6.92	3.16	6.33	2.89
	7	7.45	3.91	7.16	3.61	6.88	3.33	6.60	3.08	6.15	2.81
	2	6.60	3.78	6.35	3.49	6.10	3.22	5.87	2.97	5.59	2.72
	-7	5.07	3.46	4.88	3.19	4.69	2.95	4.51	2.72	4.30	2.49
	-10	4.57	3.33	4.39	3.07	4.22	2.84	4.06	2.62	3.87	2.39
	-15	3.72	3.06	3.57	2.82	3.44	2.61	3.30	2.41	3.15	2.20
Rated frequency	20	7.58	5.68	7.29	5.25	7.01	4.84	6.74	4.47	6.54	4.21
	15	6.87	5.26	6.61	4.86	6.35	4.48	6.11	4.14	5.90	3.90
	12	6.48	5.05	6.23	4.66	5.99	4.30	5.76	3.97	5.53	3.71
	7	5.77	4.75	5.55	4.38	5.33	4.05	5.13	3.73	4.88	3.42
	2	5.05	4.47	4.86	4.13	4.67	3.81	4.49	3.52	4.22	3.16
	-7	3.76	4.24	3.62	3.92	3.48	3.62	3.34	3.34	3.08	2.83
	-10	3.33	4.23	3.20	3.90	3.08	3.60	2.96	3.33	2.68	2.75
	-15	2.63	4.19	2.52	3.87	2.43	3.57	2.33	3.30	2.02	2.62
Minimum frequency	20	1.93	7.63	1.86	7.05	1.79	6.50	1.72	6.00	1.67	5.65
	15	1.75	7.07	1.68	6.52	1.62	6.02	1.56	5.56	1.50	5.23
	12	1.65	6.78	1.59	6.26	1.53	5.78	1.47	5.33	1.41	4.99
	7	1.47	6.38	1.41	5.89	1.36	5.43	1.31	5.02	1.24	4.59
	2	1.29	6.01	1.24	5.55	1.19	5.12	1.15	4.73	1.08	4.24
	-7	0.96	5.70	0.92	5.26	0.89	4.86	0.85	4.48	0.78	3.80
	-10	0.85	5.68	0.82	5.24	0.79	4.84	0.76	4.47	0.68	3.70
	-15	0.67	5.63	0.64	5.20	0.62	4.80	0.60	4.43	0.52	3.52
	-20	0.50	5.55	0.48	5.12	0.46	4.73	0.44	4.36	0.35	3.20

* The changes in capacity and efficiency due to the defrosting operation are not considered.

* Ambient temperature condition is DB 20°C/WB 19°C, DB 15°C/WB 14°C, DB 12°C/WB 11°C, DB 7°C/WB 6°C, DB 2°C/WB 1°C, DB -7°C/WB -8°C, DB -10°C/WB -11°C, DB -20°C/WB -21°C, DB -25°C/WB -26°C

Heating performance data

MSZ-AY42VGK, MSZ-AY42VGKP: MUZ-AY42VGH

	Ambient temperature (°C)	Indoor DB (°C)									
		5		10		15		20		25	
		Capacity	COP	Capacity	COP	Capacity	COP	Capacity	COP	Capacity	COP
Max frequency	20	9.11	4.17	8.41	3.85	7.77	3.55	7.17	3.28	6.56	3.00
	15	8.80	4.08	8.18	3.77	7.60	3.48	7.02	3.21	6.42	2.94
	12	8.30	4.02	7.91	3.71	7.49	3.43	6.92	3.16	6.32	2.89
	7	7.45	3.91	7.16	3.61	6.88	3.33	6.60	3.07	6.15	2.81
	2	6.60	3.78	6.35	3.49	6.10	3.22	5.87	2.97	5.59	2.72
	-7	5.07	3.33	4.88	3.07	4.69	2.84	4.51	2.63	4.30	2.41
	-10	4.57	3.19	4.39	2.95	4.22	2.73	4.06	2.52	3.87	2.31
	-15	3.72	2.92	3.57	2.70	3.44	2.50	3.30	2.31	3.15	2.11
Rated frequency	20	7.58	5.68	7.29	5.25	7.01	4.84	6.74	4.47	6.54	4.21
	15	6.87	5.26	6.61	4.86	6.35	4.48	6.11	4.14	5.90	3.90
	12	6.48	5.05	6.23	4.66	5.99	4.30	5.76	3.97	5.53	3.71
	7	5.77	4.75	5.55	4.38	5.33	4.05	5.13	3.73	4.88	3.42
	2	5.05	4.47	4.86	4.13	4.67	3.81	4.49	3.52	4.22	3.16
	-7	3.76	3.97	3.62	3.68	3.48	3.40	3.34	3.15	3.08	2.68
	-10	3.33	3.93	3.20	3.63	3.08	3.36	2.96	3.11	2.68	2.59
	-15	2.63	3.82	2.52	3.54	2.43	3.28	2.33	3.04	2.02	2.43
Minimum frequency	20	1.93	7.63	1.86	7.05	1.79	6.50	1.72	6.00	1.67	5.65
	15	1.75	7.07	1.68	6.52	1.62	6.02	1.56	5.56	1.50	5.23
	12	1.65	6.78	1.59	6.26	1.53	5.78	1.47	5.33	1.41	4.99
	7	1.47	6.38	1.41	5.89	1.36	5.43	1.31	5.02	1.24	4.59
	2	1.29	6.01	1.24	5.55	1.19	5.12	1.15	4.73	1.08	4.24
	-7	0.96	4.19	0.92	3.91	0.89	3.65	0.85	3.40	0.78	2.94
	-10	0.85	4.05	0.82	3.78	0.79	3.53	0.76	3.29	0.68	2.79
	-15	0.67	3.73	0.64	3.49	0.62	3.27	0.60	3.05	0.52	2.49
	-20	0.50	3.31	0.48	3.10	0.46	2.91	0.44	2.73	0.35	2.06

* The changes in capacity and efficiency due to the defrosting operation are not considered.

* Ambient temperature condition is DB 20°C/WB 19°C, DB 15°C/WB 14°C, DB 12°C/WB 11°C, DB 7°C/WB 6°C, DB 2°C/WB 1°C, DB -7°C/WB -8°C, DB -10°C/WB -11°C, DB -20°C/WB -21°C, DB -25°C/WB -26°C

Heating performance data

MSZ-AY50VGK, MSZ-AY50VGKP: MUZ-AY50VG

	Ambient temperature (°C)	Indoor DB (°C)									
		5		10		15		20		25	
		Capacity	COP	Capacity	COP	Capacity	COP	Capacity	COP	Capacity	COP
Max frequency	20	10.67	3.86	10.26	3.56	9.87	3.29	9.27	3.03	8.53	2.77
	15	9.74	3.74	9.36	3.46	9.00	3.19	8.66	2.94	8.19	2.69
	12	9.18	3.67	8.82	3.39	8.48	3.12	8.16	2.88	7.77	2.64
	7	8.24	3.53	7.92	3.26	7.62	3.00	7.30	2.77	6.99	2.54
	2	7.30	3.36	7.02	3.11	6.75	2.87	6.49	2.65	6.20	2.42
	-7	5.62	3.00	5.40	2.77	5.20	2.55	5.00	2.36	4.77	2.16
	-10	5.06	2.85	4.86	2.63	4.68	2.43	4.50	2.24	4.29	2.05
	-15	4.12	2.56	3.96	2.36	3.81	2.18	3.67	2.01	3.50	1.84
Rated frequency	20	8.17	5.71	7.86	5.27	7.56	4.87	7.27	4.49	7.06	4.23
	15	7.41	5.29	7.13	4.88	6.85	4.51	6.59	4.16	6.36	3.92
	12	6.98	5.07	6.72	4.68	6.46	4.32	6.21	3.99	5.96	3.73
	7	6.22	4.77	5.98	4.40	5.75	4.07	5.53	3.75	5.26	3.44
	2	5.45	4.50	5.24	4.15	5.04	3.83	4.84	3.54	4.55	3.18
	-7	4.06	4.26	3.90	3.94	3.75	3.63	3.61	3.35	3.32	2.84
	-10	3.59	4.25	3.45	3.92	3.32	3.62	3.19	3.34	2.89	2.77
	-15	2.83	4.21	2.72	3.89	2.62	3.59	2.52	3.31	2.18	2.64
Minimum frequency	20	2.08	7.12	2.00	6.58	1.92	6.07	1.85	5.60	1.80	5.27
	15	1.89	6.60	1.81	6.09	1.74	5.62	1.68	5.19	1.62	4.88
	12	1.78	6.33	1.71	5.84	1.64	5.39	1.58	4.98	1.52	4.66
	7	1.58	5.95	1.52	5.49	1.46	5.07	1.41	4.68	1.34	4.29
	2	1.39	5.61	1.33	5.18	1.28	4.78	1.23	4.41	1.16	3.96
	-7	1.03	5.32	0.99	4.91	0.95	4.53	0.92	4.18	0.84	3.55
	-10	0.91	5.30	0.88	4.89	0.85	4.52	0.81	4.17	0.74	3.45
	-15	0.72	5.25	0.69	4.85	0.67	4.48	0.64	4.13	0.55	3.29
	-20	0.54	5.18	0.52	4.78	0.50	4.41	0.48	4.07	0.38	2.99

* The changes in capacity and efficiency due to the defrosting operation are not considered.

* Ambient temperature condition is DB 20°C/WB 19°C, DB 15°C/WB 14°C, DB 12°C/WB 11°C, DB 7°C/WB 6°C, DB 2°C/WB 1°C, DB -7°C/WB -8°C, DB -10°C/WB -11°C, DB -20°C/WB -21°C, DB -25°C/WB -26°C

Heating performance data

MSZ-AY50VGK, MSZ-AY50VGKP: MUZ-AY50VGH

	Ambient temperature (°C)	Indoor DB (°C)									
		5		10		15		20		25	
		Capacity	COP	Capacity	COP	Capacity	COP	Capacity	COP	Capacity	COP
Max frequency	20	10.67	3.88	10.26	3.59	9.87	3.31	9.32	3.05	8.59	2.79
	15	9.74	3.76	9.36	3.47	9.00	3.20	8.66	2.96	8.23	2.71
	12	9.18	3.68	8.82	3.40	8.48	3.13	8.16	2.89	7.77	2.65
	7	8.24	3.53	7.92	3.26	7.62	3.01	7.30	2.78	6.99	2.54
	2	7.30	3.36	7.02	3.10	6.75	2.86	6.49	2.64	6.20	2.41
	-7	5.62	2.88	5.40	2.66	5.20	2.46	5.00	2.27	4.77	2.08
	-10	5.06	2.72	4.86	2.52	4.68	2.33	4.50	2.15	4.29	1.97
	-15	4.12	2.43	3.96	2.24	3.81	2.07	3.67	1.92	3.50	1.76
Rated frequency	20	8.17	5.71	7.86	5.27	7.56	4.87	7.27	4.49	7.06	4.23
	15	7.41	5.29	7.13	4.88	6.85	4.51	6.59	4.16	6.36	3.92
	12	6.98	5.07	6.72	4.68	6.46	4.32	6.21	3.99	5.96	3.73
	7	6.22	4.77	5.98	4.40	5.75	4.07	5.53	3.75	5.26	3.44
	2	5.45	4.50	5.24	4.15	5.04	3.83	4.84	3.54	4.55	3.18
	-7	4.06	4.01	3.90	3.71	3.75	3.43	3.61	3.18	3.32	2.70
	-10	3.59	3.97	3.45	3.67	3.32	3.40	3.19	3.14	2.89	2.62
	-15	2.83	3.86	2.72	3.58	2.62	3.31	2.52	3.07	2.18	2.46
Minimum frequency	20	2.08	7.12	2.00	6.58	1.92	6.07	1.85	5.60	1.80	5.27
	15	1.89	6.60	1.81	6.09	1.74	5.62	1.68	5.19	1.62	4.88
	12	1.78	6.33	1.71	5.84	1.64	5.39	1.58	4.98	1.52	4.66
	7	1.58	5.95	1.52	5.49	1.46	5.07	1.41	4.68	1.34	4.29
	2	1.39	5.61	1.33	5.18	1.28	4.78	1.23	4.41	1.16	3.96
	-7	1.03	4.06	0.99	3.78	0.95	3.52	0.92	3.28	0.84	2.83
	-10	0.91	3.93	0.88	3.66	0.85	3.42	0.81	3.18	0.74	2.69
	-15	0.72	3.65	0.69	3.41	0.67	3.18	0.64	2.97	0.55	2.42
	-20	0.54	3.26	0.52	3.05	0.50	2.86	0.48	2.68	0.38	2.02

* The changes in capacity and efficiency due to the defrosting operation are not considered.

* Ambient temperature condition is DB 20°C/WB 19°C, DB 15°C/WB 14°C, DB 12°C/WB 11°C, DB 7°C/WB 6°C, DB 2°C/WB 1°C, DB -7°C/WB -8°C, DB -10°C/WB -11°C, DB -20°C/WB -21°C, DB -25°C/WB -26°C

Heating performance data

MSZ-AP15VG, MSZ-AP15VGK: MUZ-AP15VG

	Ambient temperature (°C)	Indoor DB (°C)									
		5		10		15		20		25	
		Capacity	COP	Capacity	COP	Capacity	COP	Capacity	COP	Capacity	COP
Max frequency	20	3.80	3.20	3.55	2.96	3.30	2.73	3.04	2.52	2.78	2.31
	15	3.51	3.17	3.37	2.93	3.22	2.70	3.00	2.49	2.75	2.28
	12	3.33	3.15	3.20	2.90	3.07	2.68	2.93	2.47	2.73	2.26
	7	3.04	3.10	2.92	2.86	2.81	2.64	2.70	2.44	2.57	2.23
	2	2.74	3.05	2.64	2.82	2.54	2.60	2.44	2.40	2.33	2.19
	-7	2.21	2.93	2.13	2.70	2.05	2.49	1.97	2.30	1.88	2.11
	-10	2.04	2.88	1.96	2.65	1.88	2.45	1.81	2.26	1.73	2.07
	-15	1.74	2.77	1.67	2.56	1.61	2.36	1.55	2.18	1.48	1.99
Rated frequency	20	2.97	6.11	2.86	5.64	2.75	5.20	2.64	4.80	2.57	4.52
	15	2.70	5.65	2.59	5.22	2.49	4.82	2.40	4.45	2.31	4.19
	12	2.54	5.42	2.44	5.01	2.35	4.62	2.26	4.27	2.17	3.99
	7	2.26	5.10	2.18	4.71	2.09	4.35	2.01	4.01	1.91	3.67
	2	1.98	4.81	1.91	4.44	1.83	4.10	1.76	3.78	1.66	3.40
	-7	1.48	4.56	1.42	4.21	1.36	3.89	1.31	3.59	1.21	3.04
	-10	1.31	4.54	1.26	4.19	1.21	3.87	1.16	3.57	1.05	2.96
	-15	1.03	4.50	0.99	4.16	0.95	3.84	0.92	3.54	0.79	2.82
Minimum frequency	20	0.74	7.63	0.71	7.05	0.69	6.50	0.66	6.00	0.64	5.65
	15	0.67	7.07	0.65	6.52	0.62	6.02	0.60	5.56	0.58	5.23
	12	0.63	6.78	0.61	6.26	0.59	5.78	0.56	5.33	0.54	4.99
	7	0.57	6.38	0.54	5.89	0.52	5.43	0.50	5.02	0.48	4.59
	2	0.50	6.01	0.48	5.55	0.46	5.12	0.44	4.73	0.41	4.24
	-7	0.37	5.70	0.35	5.26	0.34	4.86	0.33	4.48	0.30	3.80
	-10	0.33	5.68	0.31	5.24	0.30	4.84	0.29	4.47	0.26	3.70
	-15	0.26	5.63	0.25	5.20	0.24	4.80	0.23	4.43	0.20	3.52

* The changes in capacity and efficiency due to the defrosting operation are not considered.

* Ambient temperature condition is DB 20°C/WB 19°C, DB 15°C/WB 14°C, DB 12°C/WB 11°C, DB 7°C/WB 6°C, DB 2°C/WB 1°C, DB -7°C/WB -8°C, DB -10°C/WB -11°C, DB -20°C/WB -21°C, DB -25°C/WB -26°C

Heating performance data

MSZ-AP20VG, MSZ-AP20VGK: MUZ-AP20VG

	Ambient temperature (°C)	Indoor DB (°C)									
		5		10		15		20		25	
		Capacity	COP	Capacity	COP	Capacity	COP	Capacity	COP	Capacity	COP
Max frequency	20	4.62	2.99	4.28	2.76	3.95	2.55	3.65	2.36	3.34	2.15
	15	4.49	2.98	4.22	2.75	3.93	2.54	3.63	2.34	3.32	2.14
	12	4.28	2.97	4.09	2.74	3.90	2.53	3.61	2.33	3.30	2.13
	7	3.93	2.94	3.78	2.72	3.63	2.51	3.50	2.32	3.28	2.12
	2	3.58	2.92	3.45	2.69	3.31	2.49	3.19	2.30	3.04	2.10
	-7	2.96	2.86	2.85	2.64	2.74	2.44	2.63	2.25	2.51	2.06
	-10	2.75	2.83	2.65	2.62	2.54	2.42	2.45	2.23	2.33	2.04
	-15	2.41	2.78	2.31	2.57	2.22	2.37	2.14	2.19	2.04	2.00
Rated frequency	20	3.72	6.36	3.57	5.87	3.44	5.42	3.30	5.00	3.21	4.71
	15	3.37	5.89	3.24	5.44	3.12	5.02	3.00	4.63	2.89	4.36
	12	3.17	5.65	3.05	5.21	2.94	4.81	2.82	4.44	2.71	4.16
	7	2.83	5.31	2.72	4.90	2.62	4.53	2.51	4.18	2.39	3.83
	2	2.48	5.01	2.38	4.62	2.29	4.27	2.20	3.94	2.07	3.54
	-7	1.84	4.75	1.77	4.38	1.71	4.05	1.64	3.74	1.51	3.17
	-10	1.63	4.73	1.57	4.37	1.51	4.03	1.45	3.72	1.32	3.08
	-15	1.29	4.69	1.24	4.33	1.19	4.00	1.14	3.69	0.99	2.94
Minimum frequency	20	0.74	6.36	0.71	5.87	0.69	5.42	0.66	5.00	0.64	4.71
	15	0.67	5.89	0.65	5.44	0.62	5.02	0.60	4.63	0.58	4.36
	12	0.63	5.65	0.61	5.21	0.59	4.81	0.56	4.44	0.54	4.16
	7	0.57	5.31	0.54	4.90	0.52	4.53	0.50	4.18	0.48	3.83
	2	0.50	5.01	0.48	4.62	0.46	4.27	0.44	3.94	0.41	3.54
	-7	0.37	4.75	0.35	4.38	0.34	4.05	0.33	3.74	0.30	3.17
	-10	0.33	4.73	0.31	4.37	0.30	4.03	0.29	3.72	0.26	3.08
	-15	0.26	4.69	0.25	4.33	0.24	4.00	0.23	3.69	0.20	2.94

* The changes in capacity and efficiency due to the defrosting operation are not considered.

* Ambient temperature condition is DB 20°C/WB 19°C, DB 15°C/WB 14°C, DB 12°C/WB 11°C, DB 7°C/WB 6°C, DB 2°C/WB 1°C, DB -7°C/WB -8°C, DB -10°C/WB -11°C, DB -20°C/WB -21°C, DB -25°C/WB -26°C

Heating performance data

MSZ-AP60VG, MSZ-AP60VGK: MUZ-AP60VG

	Ambient temperature (°C)	Indoor DB (°C)									
		5		10		15		20		25	
		Capacity	COP	Capacity	COP	Capacity	COP	Capacity	COP	Capacity	COP
Max frequency	20	13.22	4.60	12.71	4.24	12.01	3.92	11.17	3.62	10.24	3.31
	15	11.88	4.47	11.43	4.12	10.99	3.80	10.57	3.51	9.85	3.21
	12	11.09	4.38	10.66	4.04	10.25	3.73	9.86	3.44	9.34	3.15
	7	9.75	4.20	9.38	3.88	9.02	3.58	8.60	3.31	8.27	3.02
	2	8.42	4.00	8.10	3.69	7.79	3.41	7.49	3.14	7.14	2.87
	-7	6.03	3.49	5.79	3.22	5.57	2.97	5.36	2.74	5.11	2.51
	-10	5.23	3.27	5.03	3.02	4.83	2.79	4.65	2.57	4.43	2.35
	-15	3.90	2.81	3.75	2.59	3.60	2.39	3.46	2.21	3.30	2.02
Rated frequency	20	10.11	6.22	9.72	5.74	9.34	5.30	8.98	4.89	8.73	4.60
	15	9.16	5.76	8.81	5.31	8.47	4.91	8.15	4.53	7.86	4.26
	12	8.63	5.52	8.30	5.10	7.98	4.70	7.68	4.34	7.37	4.06
	7	7.69	5.19	7.40	4.79	7.11	4.42	6.84	4.08	6.50	3.74
	2	6.74	4.89	6.48	4.52	6.23	4.17	5.99	3.85	5.63	3.46
	-7	5.02	4.64	4.82	4.28	4.64	3.95	4.46	3.65	4.10	3.10
	-10	4.44	4.62	4.27	4.27	4.11	3.94	3.95	3.64	3.58	3.01
	-15	3.50	4.58	3.37	4.23	3.24	3.91	3.11	3.61	2.70	2.87
Minimum frequency	20	2.97	10.18	2.86	9.39	2.75	8.67	2.64	8.01	2.57	7.53
	15	2.70	9.42	2.59	8.70	2.49	8.03	2.40	7.41	2.31	6.98
	12	2.54	9.04	2.44	8.34	2.35	7.70	2.26	7.11	2.17	6.65
	7	2.26	8.50	2.18	7.85	2.09	7.24	2.01	6.69	1.91	6.12
	2	1.98	8.01	1.91	7.39	1.83	6.83	1.76	6.30	1.66	5.66
	-7	1.48	7.60	1.42	7.01	1.36	6.48	1.31	5.98	1.21	5.07
	-10	1.31	7.57	1.26	6.99	1.21	6.45	1.16	5.96	1.05	4.93
	-15	1.03	7.50	0.99	6.93	0.95	6.39	0.92	5.90	0.79	4.70

* The changes in capacity and efficiency due to the defrosting operation are not considered.

* Ambient temperature condition is DB 20°C/WB 19°C, DB 15°C/WB 14°C, DB 12°C/WB 11°C, DB 7°C/WB 6°C, DB 2°C/WB 1°C, DB -7°C/WB -8°C, DB -10°C/WB -11°C, DB -20°C/WB -21°C, DB -25°C/WB -26°C

Heating performance data

MSZ-AP71VG, MSZ-AP71VGK: MUZ-AP71VG

	Ambient temperature (°C)	Indoor DB (°C)									
		5		10		15		20		25	
		Capacity	COP	Capacity	COP	Capacity	COP	Capacity	COP	Capacity	COP
Max frequency	20	14.93	4.52	14.36	4.18	13.81	3.85	12.95	3.56	11.86	3.25
	15	13.66	4.29	13.13	3.96	12.63	3.65	12.14	3.37	11.24	3.08
	12	12.89	4.14	12.40	3.82	11.92	3.53	11.46	3.25	10.84	2.98
	7	11.62	3.87	11.17	3.57	10.74	3.30	10.30	3.04	9.85	2.78
	2	10.34	3.58	9.95	3.31	9.56	3.05	9.19	2.82	8.77	2.58
	-7	8.05	3.00	7.74	2.77	7.44	2.56	7.15	2.36	6.82	2.16
	-10	7.24	2.78	6.97	2.56	6.70	2.36	6.44	2.18	6.14	2.00
	-15	5.86	2.35	5.63	2.17	5.41	2.00	5.21	1.85	4.97	1.69
Rated frequency	20	12.04	5.83	11.57	5.38	11.13	4.97	10.70	4.59	10.39	4.32
	15	10.92	5.40	10.50	4.99	10.09	4.60	9.70	4.25	9.36	4.00
	12	10.29	5.18	9.89	4.78	9.51	4.41	9.14	4.07	8.78	3.81
	7	9.16	4.87	8.81	4.50	8.47	4.15	8.15	3.83	7.74	3.51
	2	8.03	4.59	7.72	4.24	7.42	3.91	7.13	3.61	6.70	3.24
	-7	5.97	4.36	5.75	4.02	5.52	3.71	5.31	3.43	4.89	2.90
	-10	5.29	4.34	5.09	4.01	4.89	3.70	4.70	3.41	4.26	2.83
	-15	4.17	4.30	4.01	3.97	3.86	3.66	3.71	3.38	3.21	2.69
Minimum frequency	20	3.27	8.00	3.14	7.38	3.02	6.81	2.91	6.29	2.82	5.92
	15	2.96	7.41	2.85	6.84	2.74	6.31	2.64	5.82	2.54	5.48
	12	2.79	7.10	2.69	6.55	2.58	6.05	2.48	5.59	2.38	5.23
	7	2.49	6.68	2.39	6.17	2.30	5.69	2.21	5.25	2.10	4.81
	2	2.18	6.29	2.10	5.81	2.02	5.36	1.94	4.95	1.82	4.45
	-7	1.62	5.97	1.56	5.51	1.50	5.09	1.44	4.70	1.33	3.98
	-10	1.44	5.95	1.38	5.49	1.33	5.07	1.28	4.68	1.16	3.88
	-15	1.13	5.90	1.09	5.44	1.05	5.02	1.01	4.64	0.87	3.69

* The changes in capacity and efficiency due to the defrosting operation are not considered.

* Ambient temperature condition is DB 20°C/WB 19°C, DB 15°C/WB 14°C, DB 12°C/WB 11°C, DB 7°C/WB 6°C, DB 2°C/WB 1°C, DB -7°C/WB -8°C, DB -10°C/WB -11°C, DB -20°C/WB -21°C, DB -25°C/WB -26°C

Heating performance data

MSZ-HR25VF, MSZ-HR25VFK: MUZ-HR25VF

	Ambient temperature (°C)	Indoor DB (°C)									
		5		10		15		20		25	
		Capacity	COP	Capacity	COP	Capacity	COP	Capacity	COP	Capacity	COP
Max frequency	20	5.47	4.96	5.16	4.58	4.80	4.22	4.44	3.90	4.06	3.57
	15	4.90	4.80	4.71	4.43	4.53	4.09	4.25	3.77	3.92	3.45
	12	4.55	4.69	4.38	4.33	4.21	3.99	4.02	3.69	3.80	3.37
	7	3.98	4.48	3.82	4.13	3.68	3.81	3.50	3.52	3.37	3.22
	2	3.40	4.22	3.27	3.90	3.14	3.60	3.02	3.32	2.89	3.04
	-7	2.37	3.60	2.28	3.32	2.19	3.07	2.10	2.83	2.01	2.59
Rated frequency	-10	2.02	3.32	1.94	3.07	1.87	2.83	1.80	2.62	1.72	2.39
	20	4.68	5.66	4.50	5.22	4.33	4.82	4.16	4.45	4.04	4.19
	15	4.25	5.24	4.08	4.84	3.92	4.46	3.77	4.12	3.64	3.88
	12	4.00	5.02	3.85	4.64	3.70	4.28	3.56	3.95	3.41	3.70
	7	3.56	4.73	3.43	4.36	3.29	4.03	3.17	3.72	3.01	3.40
	2	3.12	4.45	3.00	4.11	2.89	3.79	2.77	3.50	2.61	3.15
Minimum frequency	-7	2.32	4.22	2.23	3.90	2.15	3.60	2.07	3.32	1.90	2.82
	-10	2.06	4.21	1.98	3.88	1.90	3.59	1.83	3.31	1.66	2.74
	20	1.04	7.12	1.00	6.58	0.96	6.07	0.92	5.60	0.90	5.27
	15	0.94	6.60	0.91	6.09	0.87	5.62	0.84	5.19	0.81	4.88
	12	0.89	6.33	0.85	5.84	0.82	5.39	0.79	4.98	0.76	4.66
	7	0.79	5.95	0.76	5.49	0.73	5.07	0.70	4.68	0.67	4.29
	2	0.69	5.61	0.67	5.18	0.64	4.78	0.62	4.41	0.58	3.96
	-7	0.52	5.32	0.50	4.91	0.48	4.53	0.46	4.18	0.42	3.55
	-10	0.46	5.30	0.44	4.89	0.42	4.52	0.41	4.17	0.37	3.45

* The changes in capacity and efficiency due to the defrosting operation are not considered.

* Ambient temperature condition is DB 20°C/WB 19°C, DB 15°C/WB 14°C, DB 12°C/WB 11°C, DB 7°C/WB 6°C, DB 2°C/WB 1°C, DB -7°C/WB -8°C, DB -10°C/WB -11°C, DB -20°C/WB -21°C, DB -25°C/WB -26°C

Heating performance data

MSZ-HR35VF, MSZ-HR35VFK: MUZ-HR35VF

	Ambient temperature (°C)	Indoor DB (°C)									
		5		10		15		20		25	
		Capacity	COP	Capacity	COP	Capacity	COP	Capacity	COP	Capacity	COP
Max frequency	20	5.59	5.24	5.37	4.84	5.16	4.46	4.97	4.12	4.74	3.77
	15	5.09	4.97	4.89	4.59	4.70	4.24	4.52	3.91	4.32	3.58
	12	4.79	4.80	4.61	4.43	4.43	4.09	4.26	3.78	4.06	3.45
	7	4.29	4.50	4.13	4.15	3.97	3.83	3.80	3.54	3.64	3.23
	2	3.79	4.16	3.65	3.84	3.51	3.55	3.37	3.27	3.22	2.99
	-7	2.90	3.47	2.79	3.20	2.68	2.96	2.58	2.73	2.46	2.50
Rated frequency	-10	2.60	3.21	2.50	2.97	2.40	2.74	2.31	2.53	2.21	2.31
	20	5.35	5.64	5.14	5.20	4.95	4.80	4.76	4.43	4.62	4.17
	15	4.85	5.22	4.67	4.82	4.49	4.45	4.31	4.11	4.16	3.86
	12	4.57	5.01	4.40	4.62	4.23	4.27	4.06	3.94	3.90	3.68
	7	4.07	4.71	3.92	4.35	3.77	4.01	3.62	3.70	3.44	3.39
	2	3.57	4.44	3.43	4.10	3.30	3.78	3.17	3.49	2.98	3.13
Minimum frequency	-7	2.66	4.21	2.55	3.89	2.46	3.59	2.36	3.31	2.17	2.81
	-10	2.35	4.19	2.26	3.87	2.17	3.57	2.09	3.30	1.89	2.73
	20	1.34	8.08	1.29	7.46	1.24	6.89	1.19	6.36	1.15	5.98
	15	1.21	7.48	1.17	6.91	1.12	6.38	1.08	5.89	1.04	5.54
	12	1.14	7.18	1.10	6.62	1.06	6.12	1.02	5.65	0.98	5.28
	7	1.02	6.75	0.98	6.23	0.94	5.75	0.91	5.31	0.86	4.86
	2	0.89	6.36	0.86	5.87	0.82	5.42	0.79	5.00	0.74	4.49
	-7	0.66	6.03	0.64	5.57	0.61	5.14	0.59	4.75	0.54	4.02
	-10	0.59	6.01	0.57	5.55	0.54	5.12	0.52	4.73	0.47	3.92

* The changes in capacity and efficiency due to the defrosting operation are not considered.

* Ambient temperature condition is DB 20°C/WB 19°C, DB 15°C/WB 14°C, DB 12°C/WB 11°C, DB 7°C/WB 6°C, DB 2°C/WB 1°C, DB -7°C/WB -8°C, DB -10°C/WB -11°C, DB -20°C/WB -21°C, DB -25°C/WB -26°C

Heating performance data

MSZ-HR42VF, MSZ-HR42VFK: MUZ-HR42VF

	Ambient temperature (°C)	Indoor DB (°C)									
		5		10		15		20		25	
		Capacity	COP	Capacity	COP	Capacity	COP	Capacity	COP	Capacity	COP
Max frequency	20	8.47	4.57	8.05	4.22	7.49	3.90	6.96	3.60	6.36	3.29
	15	7.57	4.48	7.28	4.13	7.00	3.81	6.70	3.52	6.17	3.22
	12	7.04	4.41	6.76	4.07	6.50	3.76	6.25	3.47	5.90	3.17
	7	6.14	4.28	5.90	3.95	5.67	3.65	5.40	3.37	5.21	3.08
	2	5.24	4.12	5.04	3.80	4.84	3.51	4.66	3.24	4.44	2.96
	-7	3.62	3.68	3.48	3.40	3.35	3.14	3.22	2.89	3.07	2.65
Rated frequency	-10	3.08	3.47	2.96	3.21	2.85	2.96	2.74	2.73	2.61	2.50
	20	6.98	5.52	6.72	5.09	6.46	4.70	6.21	4.34	6.03	4.08
	15	6.33	5.11	6.09	4.72	5.86	4.36	5.63	4.02	5.43	3.78
	12	5.97	4.90	5.74	4.52	5.52	4.18	5.31	3.86	5.09	3.61
	7	5.32	4.61	5.11	4.26	4.92	3.93	4.73	3.63	4.49	3.32
	2	4.66	4.34	4.48	4.01	4.31	3.70	4.14	3.42	3.89	3.07
Minimum frequency	-7	3.47	4.12	3.33	3.80	3.21	3.51	3.08	3.24	2.84	2.75
	-10	3.07	4.11	2.95	3.79	2.84	3.50	2.73	3.23	2.47	2.67
	20	1.34	7.63	1.29	7.05	1.24	6.50	1.19	6.00	1.15	5.65
	15	1.21	7.07	1.17	6.52	1.12	6.02	1.08	5.56	1.04	5.23
	12	1.14	6.78	1.10	6.26	1.06	5.78	1.02	5.33	0.98	4.99
	7	1.02	6.38	0.98	5.89	0.94	5.43	0.91	5.02	0.86	4.59
	2	0.89	6.01	0.86	5.55	0.82	5.12	0.79	4.73	0.74	4.24
	-7	0.66	5.70	0.64	5.26	0.61	4.86	0.59	4.48	0.54	3.80
	-10	0.59	5.68	0.57	5.24	0.54	4.84	0.52	4.47	0.47	3.70

* The changes in capacity and efficiency due to the defrosting operation are not considered.

* Ambient temperature condition is DB 20°C/WB 19°C, DB 15°C/WB 14°C, DB 12°C/WB 11°C, DB 7°C/WB 6°C, DB 2°C/WB 1°C, DB -7°C/WB -8°C, DB -10°C/WB -11°C, DB -20°C/WB -21°C, DB -25°C/WB -26°C

Heating performance data

MSZ-HR50VF, MSZ-HR50VFK: MUZ-HR50VF

	Ambient temperature (°C)	Indoor DB (°C)									
		5		10		15		20		25	
		Capacity	COP	Capacity	COP	Capacity	COP	Capacity	COP	Capacity	COP
Max frequency	20	9.87	4.43	9.24	4.09	8.59	3.77	7.93	3.48	7.25	3.19
	15	8.91	4.31	8.57	3.98	8.23	3.67	7.66	3.39	7.05	3.10
	12	8.33	4.22	8.01	3.90	7.70	3.60	7.34	3.32	6.92	3.04
	7	7.36	4.07	7.08	3.75	6.81	3.47	6.50	3.20	6.24	2.93
	2	6.40	3.88	6.15	3.58	5.92	3.31	5.69	3.05	5.43	2.79
	-7	4.66	3.42	4.48	3.16	4.31	2.92	4.14	2.69	3.95	2.46
Rated frequency	-10	4.08	3.23	3.92	2.98	3.77	2.75	3.63	2.54	3.46	2.32
	20	8.03	5.32	7.72	4.91	7.42	4.53	7.13	4.18	6.93	3.94
	15	7.28	4.93	7.00	4.55	6.73	4.20	6.47	3.87	6.24	3.65
	12	6.86	4.72	6.59	4.36	6.34	4.02	6.10	3.71	5.85	3.48
	7	6.11	4.44	5.87	4.10	5.65	3.79	5.43	3.49	5.16	3.20
	2	5.35	4.19	5.14	3.86	4.95	3.57	4.76	3.29	4.47	2.96
Minimum frequency	-7	3.98	3.97	3.83	3.67	3.68	3.38	3.54	3.12	3.26	2.65
	-10	3.53	3.96	3.39	3.65	3.26	3.37	3.14	3.11	2.84	2.58
	20	2.08	7.92	2.00	7.31	1.92	6.75	1.85	6.23	1.80	5.86
	15	1.89	7.33	1.81	6.77	1.74	6.25	1.68	5.77	1.62	5.43
	12	1.78	7.03	1.71	6.49	1.64	5.99	1.58	5.53	1.52	5.17
	7	1.58	6.61	1.52	6.10	1.46	5.63	1.41	5.20	1.34	4.76
	2	1.39	6.23	1.33	5.75	1.28	5.31	1.23	4.90	1.16	4.40
	-7	1.03	5.91	0.99	5.46	0.95	5.04	0.92	4.65	0.84	3.94
	-10	0.91	5.89	0.88	5.44	0.85	5.02	0.81	4.63	0.74	3.84

* The changes in capacity and efficiency due to the defrosting operation are not considered.

* Ambient temperature condition is DB 20°C/WB 19°C, DB 15°C/WB 14°C, DB 12°C/WB 11°C, DB 7°C/WB 6°C, DB 2°C/WB 1°C, DB -7°C/WB -8°C, DB -10°C/WB -11°C, DB -20°C/WB -21°C, DB -25°C/WB -26°C

Heating performance data

MSZ-HR60VF, MSZ-HR60VFK: MUZ-HR60VF

	Ambient temperature (°C)	Indoor DB (°C)									
		5		10		15		20		25	
		Capacity	COP	Capacity	COP	Capacity	COP	Capacity	COP	Capacity	COP
Max frequency	20	13.15	4.16	12.23	3.84	11.38	3.54	10.50	3.27	9.61	2.99
	15	11.90	4.09	11.44	3.78	10.99	3.49	10.22	3.22	9.42	2.94
	12	11.06	4.05	10.63	3.74	10.22	3.45	9.74	3.18	9.21	2.91
	7	9.66	3.96	9.29	3.65	8.93	3.37	8.50	3.11	8.19	2.85
	2	8.26	3.84	7.94	3.55	7.63	3.27	7.34	3.02	7.00	2.76
	-7	5.73	3.52	5.51	3.25	5.30	3.00	5.10	2.77	4.86	2.53
Rated frequency	-10	4.89	3.37	4.71	3.11	4.52	2.87	4.35	2.65	4.15	2.42
	20	10.11	5.74	9.72	5.29	9.34	4.89	8.98	4.51	8.73	4.24
	15	9.16	5.31	8.81	4.90	8.47	4.53	8.15	4.18	7.86	3.93
	12	8.63	5.09	8.30	4.70	7.98	4.34	7.68	4.01	7.37	3.75
	7	7.69	4.79	7.40	4.42	7.11	4.08	6.84	3.77	6.50	3.45
	2	6.74	4.51	6.48	4.17	6.23	3.85	5.99	3.55	5.63	3.19
Minimum frequency	-7	5.02	4.28	4.82	3.95	4.64	3.65	4.46	3.37	4.10	2.86
	-10	4.44	4.27	4.27	3.94	4.11	3.64	3.95	3.36	3.58	2.78
	20	2.23	8.48	2.14	7.83	2.06	7.23	1.98	6.67	1.92	6.28
	15	2.02	7.85	1.94	7.25	1.87	6.69	1.80	6.18	1.73	5.82
	12	1.90	7.53	1.83	6.95	1.76	6.42	1.69	5.92	1.63	5.54
	7	1.70	7.08	1.63	6.54	1.57	6.04	1.51	5.57	1.43	5.10
	2	1.49	6.68	1.43	6.16	1.37	5.69	1.32	5.25	1.24	4.72
	-7	1.11	6.33	1.06	5.85	1.02	5.40	0.98	4.98	0.90	4.22
	-10	0.98	6.31	0.94	5.82	0.91	5.38	0.87	4.96	0.79	4.11

* The changes in capacity and efficiency due to the defrosting operation are not considered.

* Ambient temperature condition is DB 20°C/WB 19°C, DB 15°C/WB 14°C, DB 12°C/WB 11°C, DB 7°C/WB 6°C, DB 2°C/WB 1°C, DB -7°C/WB -8°C, DB -10°C/WB -11°C, DB -20°C/WB -21°C, DB -25°C/WB -26°C

Heating performance data

MSZ-HR71VF, MSZ-HR71VFK: MUZ-HR71VF

	Ambient temperature (°C)	Indoor DB (°C)									
		5		10		15		20		25	
		Capacity	COP	Capacity	COP	Capacity	COP	Capacity	COP	Capacity	COP
Max frequency	20	13.53	4.71	13.01	4.35	12.51	4.01	11.81	3.70	10.88	3.39
	15	12.24	4.52	11.77	4.17	11.32	3.85	10.88	3.56	10.33	3.25
	12	11.47	4.40	11.03	4.06	10.61	3.75	10.20	3.46	9.72	3.16
	7	10.19	4.17	9.79	3.85	9.42	3.55	9.00	3.28	8.64	3.00
	2	8.90	3.91	8.56	3.61	8.23	3.33	7.91	3.07	7.55	2.81
	-7	6.59	3.32	6.33	3.07	6.09	2.83	5.86	2.61	5.59	2.39
Rated frequency	-10	5.82	3.09	5.59	2.85	5.38	2.63	5.17	2.43	4.93	2.22
	20	12.04	5.07	11.57	4.68	11.13	4.32	10.70	3.99	10.39	3.75
	15	10.92	4.69	10.50	4.33	10.09	4.00	9.70	3.69	9.36	3.47
	12	10.29	4.50	9.89	4.15	9.51	3.83	9.14	3.54	8.78	3.31
	7	9.16	4.23	8.81	3.91	8.47	3.61	8.15	3.33	7.74	3.05
	2	8.03	3.99	7.72	3.68	7.42	3.40	7.13	3.14	6.70	2.82
Minimum frequency	-7	5.97	3.78	5.75	3.49	5.52	3.22	5.31	2.98	4.89	2.52
	-10	5.29	3.77	5.09	3.48	4.89	3.21	4.70	2.97	4.26	2.46
	20	2.23	9.54	2.14	8.81	2.06	8.13	1.98	7.51	1.92	7.06
	15	2.02	8.84	1.94	8.16	1.87	7.53	1.80	6.95	1.73	6.54
	12	1.90	8.47	1.83	7.82	1.76	7.22	1.69	6.66	1.63	6.24
	7	1.70	7.97	1.63	7.36	1.57	6.79	1.51	6.27	1.43	5.74
	2	1.49	7.51	1.43	6.93	1.37	6.40	1.32	5.91	1.24	5.31
	-7	1.11	7.12	1.06	6.58	1.02	6.07	0.98	5.60	0.90	4.75
	-10	0.98	7.10	0.94	6.55	0.91	6.05	0.87	5.58	0.79	4.62

* The changes in capacity and efficiency due to the defrosting operation are not considered.

* Ambient temperature condition is DB 20°C/WB 19°C, DB 15°C/WB 14°C, DB 12°C/WB 11°C, DB 7°C/WB 6°C, DB 2°C/WB 1°C, DB -7°C/WB -8°C, DB -10°C/WB -11°C, DB -20°C/WB -21°C, DB -25°C/WB -26°C

Heating performance data

MSZ-FH25VE2: MUZ-FH25VE

	Ambient temperature (°C)	Indoor DB (°C)									
		5		10		15		20		25	
		Capacity	COP	Capacity	COP	Capacity	COP	Capacity	COP	Capacity	COP
Max frequency	20	8.35	4.84	8.03	4.47	7.72	4.12	7.42	3.81	7.08	3.48
	15	7.53	4.75	7.24	4.38	6.96	4.04	6.70	3.73	6.39	3.41
	12	7.04	4.68	6.77	4.32	6.51	3.99	6.26	3.68	5.97	3.37
	7	6.23	4.56	5.99	4.21	5.76	3.88	5.50	3.58	5.28	3.28
	2	5.42	4.40	5.21	4.06	5.01	3.75	4.82	3.46	4.59	3.17
	-7	3.95	4.01	3.80	3.71	3.65	3.42	3.51	3.16	3.35	2.89
	-10	3.46	3.84	3.33	3.54	3.20	3.27	3.08	3.02	2.94	2.76
	-15	2.65	3.46	2.55	3.19	2.45	2.95	2.36	2.72	2.25	2.49
Rated frequency	20	4.76	8.42	4.57	7.77	4.40	7.18	4.23	6.63	4.11	6.23
	15	4.31	7.80	4.15	7.20	3.99	6.65	3.83	6.14	3.70	5.78
	12	4.06	7.48	3.91	6.90	3.76	6.37	3.61	5.88	3.47	5.51
	7	3.62	7.04	3.48	6.49	3.35	6.00	3.22	5.53	3.06	5.07
	2	3.17	6.63	3.05	6.12	2.93	5.65	2.82	5.21	2.65	4.68
	-7	2.36	6.29	2.27	5.81	2.18	5.36	2.10	4.95	1.93	4.19
	-10	2.09	6.27	2.01	5.78	1.93	5.34	1.86	4.93	1.68	4.08
	-15	1.65	6.21	1.58	5.73	1.52	5.29	1.46	4.89	1.27	3.89
Minimum frequency	20	2.68	9.81	2.57	9.06	2.47	8.36	2.38	7.72	2.31	7.26
	15	2.43	9.09	2.33	8.39	2.24	7.74	2.16	7.15	2.08	6.73
	12	2.29	8.71	2.20	8.04	2.11	7.43	2.03	6.85	1.95	6.41
	7	2.04	8.20	1.96	7.57	1.88	6.99	1.81	6.45	1.72	5.91
	2	1.78	7.72	1.71	7.13	1.65	6.58	1.59	6.08	1.49	5.46
	-7	1.33	7.33	1.28	6.76	1.23	6.24	1.18	5.76	1.09	4.89
	-10	1.18	7.30	1.13	6.74	1.09	6.22	1.05	5.74	0.95	4.76
	-15	0.93	7.24	0.89	6.68	0.86	6.17	0.82	5.69	0.71	4.53

* The changes in capacity and efficiency due to the defrosting operation are not considered.

* Ambient temperature condition is DB 20°C/WB 19°C, DB 15°C/WB 14°C, DB 12°C/WB 11°C, DB 7°C/WB 6°C, DB 2°C/WB 1°C, DB -7°C/WB -8°C, DB -10°C/WB -11°C, DB -20°C/WB -21°C, DB -25°C/WB -26°C

Heating performance data

MSZ-FH25VE2: MUZ-FH25VEHZ

	Ambient temperature (°C)	Indoor DB (°C)									
		5		10		15		20		25	
		Capacity	COP	Capacity	COP	Capacity	COP	Capacity	COP	Capacity	COP
Max frequency	20	9.12	4.38	8.48	4.05	7.83	3.74	7.23	3.45	6.61	3.15
	15	8.46	4.25	8.12	3.93	7.56	3.62	7.01	3.35	6.41	3.06
	12	7.96	4.17	7.65	3.85	7.29	3.55	6.86	3.28	6.28	3.00
	7	7.12	4.00	6.84	3.69	6.58	3.41	6.30	3.15	5.96	2.88
	2	6.28	3.81	6.04	3.52	5.80	3.25	5.58	3.00	5.33	2.74
	-7	4.77	3.09	4.58	2.87	4.41	2.65	4.24	2.46	4.04	2.25
	-10	4.26	2.92	4.10	2.70	3.94	2.50	3.79	2.32	3.62	2.13
	-15	3.42	2.57	3.29	2.39	3.17	2.21	3.04	2.05	2.90	1.88
	-20	2.58	2.15	2.48	2.00	2.39	1.85	2.30	1.72	2.19	1.58
-25	1.74	1.66	1.68	1.54	1.61	1.42	1.55	1.32	1.48	1.21	
Rated frequency	20	4.76	8.42	4.57	7.77	4.40	7.18	4.23	6.63	4.11	6.23
	15	4.31	7.80	4.15	7.20	3.99	6.65	3.83	6.14	3.70	5.78
	12	4.06	7.48	3.91	6.90	3.76	6.37	3.61	5.88	3.47	5.51
	7	3.62	7.04	3.48	6.49	3.35	6.00	3.22	5.53	3.06	5.07
	2	3.17	6.63	3.05	6.12	2.93	5.65	2.82	5.21	2.65	4.68
	-7	2.36	4.66	2.27	4.35	2.18	4.06	2.10	3.78	1.93	3.27
	-10	2.09	4.50	2.01	4.20	1.93	3.92	1.86	3.66	1.68	3.10
	-15	1.65	4.16	1.58	3.89	1.52	3.64	1.46	3.40	1.27	2.77
	-20	1.23	3.69	1.18	3.46	1.13	3.25	1.09	3.04	0.86	2.30
-25	0.78	3.02	0.75	2.84	0.72	2.68	0.69	2.52	0.48	1.66	
Minimum frequency	20	1.49	5.65	1.43	5.22	1.37	4.82	1.32	4.45	1.28	4.18
	15	1.35	5.24	1.30	4.83	1.25	4.46	1.20	4.12	1.16	3.88
	12	1.27	5.02	1.22	4.63	1.17	4.28	1.13	3.95	1.08	3.70
	7	1.13	4.72	1.09	4.36	1.05	4.02	1.01	3.72	0.96	3.40
	2	0.99	4.45	0.95	4.11	0.92	3.79	0.88	3.50	0.83	3.14
	-7	0.74	2.42	0.71	2.27	0.68	2.13	0.66	2.00	0.60	1.75
	-10	0.65	2.29	0.63	2.15	0.60	2.02	0.58	1.90	0.53	1.63
	-15	0.51	2.03	0.50	1.91	0.48	1.80	0.46	1.69	0.40	1.40
	-20	0.38	1.71	0.37	1.61	0.35	1.52	0.34	1.44	0.27	1.10
-25	0.24	1.29	0.23	1.22	0.22	1.16	0.22	1.10	0.15	0.74	

* The changes in capacity and efficiency due to the defrosting operation are not considered.

* Ambient temperature condition is DB 20°C/WB 19°C, DB 15°C/WB 14°C, DB 12°C/WB 11°C, DB 7°C/WB 6°C, DB 2°C/WB 1°C, DB -7°C/WB -8°C, DB -10°C/WB -11°C, DB -20°C/WB -21°C, DB -25°C/WB -26°C

Heating performance data

MSZ-FH35VE2: MUZ-FH35VE

	Ambient temperature (°C)	Indoor DB (°C)									
		5		10		15		20		25	
		Capacity	COP	Capacity	COP	Capacity	COP	Capacity	COP	Capacity	COP
Max frequency	20	9.09	4.20	8.46	3.87	7.82	3.58	7.22	3.30	6.60	3.02
	15	8.46	4.13	8.13	3.81	7.61	3.52	7.08	3.25	6.49	2.97
	12	7.96	4.08	7.65	3.77	7.30	3.48	6.96	3.21	6.41	2.93
	7	7.12	3.99	6.84	3.68	6.58	3.40	6.30	3.14	5.99	2.87
	2	6.28	3.88	6.04	3.58	5.81	3.30	5.58	3.05	5.33	2.79
	-7	4.77	3.61	4.59	3.33	4.41	3.07	4.24	2.84	4.05	2.60
	-10	4.27	3.49	4.11	3.22	3.95	2.97	3.80	2.75	3.62	2.51
	-15	3.43	3.24	3.30	2.99	3.17	2.76	3.05	2.55	2.91	2.33
Rated frequency	20	5.94	7.63	5.72	7.05	5.50	6.50	5.28	6.00	5.13	5.65
	15	5.39	7.07	5.18	6.52	4.98	6.02	4.79	5.56	4.62	5.23
	12	5.08	6.78	4.88	6.26	4.70	5.78	4.52	5.33	4.34	4.99
	7	4.53	6.38	4.35	5.89	4.18	5.43	4.02	5.02	3.82	4.59
	2	3.96	6.01	3.81	5.55	3.66	5.12	3.52	4.73	3.31	4.24
	-7	2.95	5.70	2.84	5.26	2.73	4.86	2.62	4.48	2.41	3.80
	-10	2.61	5.68	2.51	5.24	2.42	4.84	2.32	4.47	2.10	3.70
	-15	2.06	5.63	1.98	5.20	1.90	4.80	1.83	4.43	1.59	3.52
Minimum frequency	20	1.49	5.65	1.43	5.22	1.37	4.82	1.32	4.45	1.28	4.18
	15	1.35	5.24	1.30	4.83	1.25	4.46	1.20	4.12	1.16	3.88
	12	1.27	5.02	1.22	4.63	1.17	4.28	1.13	3.95	1.08	3.70
	7	1.13	4.72	1.09	4.36	1.05	4.02	1.01	3.72	0.96	3.40
	2	0.99	4.45	0.95	4.11	0.92	3.79	0.88	3.50	0.83	3.14
	-7	0.74	4.22	0.71	3.90	0.68	3.60	0.66	3.32	0.60	2.82
	-10	0.65	4.21	0.63	3.88	0.60	3.58	0.58	3.31	0.53	2.74
	-15	0.51	4.17	0.50	3.85	0.48	3.55	0.46	3.28	0.40	2.61

* The changes in capacity and efficiency due to the defrosting operation are not considered.

* Ambient temperature condition is DB 20°C/WB 19°C, DB 15°C/WB 14°C, DB 12°C/WB 11°C, DB 7°C/WB 6°C, DB 2°C/WB 1°C, DB -7°C/WB -8°C, DB -10°C/WB -11°C, DB -20°C/WB -21°C, DB -25°C/WB -26°C

Heating performance data

MSZ-FH35VE2: MUZ-FH35VEHZ

	Ambient temperature (°C)	Indoor DB (°C)									
		5		10		15		20		25	
		Capacity	COP	Capacity	COP	Capacity	COP	Capacity	COP	Capacity	COP
Max frequency	20	9.17	4.22	8.51	3.89	7.86	3.59	7.25	3.32	6.63	3.03
	15	8.59	4.07	8.17	3.76	7.59	3.47	7.01	3.20	6.41	2.93
	12	8.15	3.98	7.82	3.68	7.42	3.39	6.85	3.13	6.26	2.86
	7	7.43	3.81	7.14	3.52	6.86	3.25	6.60	3.00	6.00	2.74
	2	6.70	3.63	6.44	3.35	6.19	3.09	5.96	2.85	5.64	2.61
	-7	5.39	3.00	5.19	2.78	4.99	2.57	4.79	2.38	4.57	2.18
	-10	4.96	2.86	4.77	2.64	4.58	2.45	4.41	2.27	4.20	2.08
	-15	4.23	2.59	4.07	2.40	3.91	2.22	3.76	2.05	3.59	1.88
	-20	3.51	2.28	3.37	2.11	3.24	1.96	3.12	1.81	2.97	1.66
-25	2.78	1.95	2.67	1.80	2.57	1.67	2.47	1.55	2.36	1.42	
Rated frequency	20	5.94	7.63	5.72	7.05	5.50	6.50	5.28	6.00	5.13	5.65
	15	5.39	7.07	5.18	6.52	4.98	6.02	4.79	5.56	4.62	5.23
	12	5.08	6.78	4.88	6.26	4.70	5.78	4.52	5.33	4.34	4.99
	7	4.53	6.38	4.35	5.89	4.18	5.43	4.02	5.02	3.82	4.59
	2	3.96	6.01	3.81	5.55	3.66	5.12	3.52	4.73	3.31	4.24
	-7	2.95	4.55	2.84	4.23	2.73	3.94	2.62	3.66	2.41	3.15
	-10	2.61	4.42	2.51	4.12	2.42	3.83	2.32	3.57	2.10	3.01
	-15	2.06	4.14	1.98	3.87	1.90	3.61	1.83	3.36	1.59	2.73
	-20	1.53	3.75	1.47	3.51	1.42	3.28	1.36	3.07	1.08	2.30
-25	0.97	3.17	0.93	2.98	0.90	2.79	0.86	2.62	0.60	1.71	
Minimum frequency	20	1.49	5.65	1.43	5.22	1.37	4.82	1.32	4.45	1.28	4.18
	15	1.35	5.24	1.30	4.83	1.25	4.46	1.20	4.12	1.16	3.88
	12	1.27	5.02	1.22	4.63	1.17	4.28	1.13	3.95	1.08	3.70
	7	1.13	4.72	1.09	4.36	1.05	4.02	1.01	3.72	0.96	3.40
	2	0.99	4.45	0.95	4.11	0.92	3.79	0.88	3.50	0.83	3.14
	-7	0.74	2.42	0.71	2.27	0.68	2.13	0.66	2.00	0.60	1.75
	-10	0.65	2.29	0.63	2.15	0.60	2.02	0.58	1.90	0.53	1.63
	-15	0.51	2.03	0.50	1.91	0.48	1.80	0.46	1.69	0.40	1.40
	-20	0.38	1.71	0.37	1.61	0.35	1.52	0.34	1.44	0.27	1.10
-25	0.24	1.29	0.23	1.22	0.22	1.16	0.22	1.10	0.15	0.74	

* The changes in capacity and efficiency due to the defrosting operation are not considered.

* Ambient temperature condition is DB 20°C/WB 19°C, DB 15°C/WB 14°C, DB 12°C/WB 11°C, DB 7°C/WB 6°C, DB 2°C/WB 1°C, DB -7°C/WB -8°C, DB -10°C/WB -11°C, DB -20°C/WB -21°C, DB -25°C/WB -26°C

Heating performance data

MSZ-FH50VE2: MUZ-FH50VE

	Ambient temperature (°C)	Indoor DB (°C)									
		5		10		15		20		25	
		Capacity	COP	Capacity	COP	Capacity	COP	Capacity	COP	Capacity	COP
Max frequency	20	12.22	4.42	11.75	4.08	11.30	3.77	10.76	3.48	9.84	3.18
	15	11.29	4.13	10.85	3.81	10.43	3.52	10.03	3.25	9.19	2.97
	12	10.72	3.95	10.31	3.64	9.91	3.36	9.53	3.10	8.79	2.84
	7	9.79	3.64	9.41	3.36	9.05	3.10	8.70	2.87	8.12	2.62
	2	8.85	3.33	8.51	3.08	8.18	2.84	7.87	2.62	7.42	2.40
	-7	7.16	2.75	6.89	2.54	6.62	2.35	6.37	2.17	6.07	1.98
	-10	6.60	2.56	6.35	2.36	6.10	2.18	5.87	2.01	5.60	1.84
	-15	5.66	2.22	5.44	2.05	5.23	1.89	5.03	1.75	4.80	1.60
Rated frequency	20	8.92	6.19	8.57	5.71	8.24	5.27	7.93	4.87	7.70	4.58
	15	8.09	5.73	7.78	5.29	7.48	4.88	7.19	4.51	6.94	4.24
	12	7.62	5.50	7.33	5.07	7.04	4.68	6.77	4.32	6.50	4.05
	7	6.79	5.17	6.53	4.77	6.28	4.41	6.03	4.07	5.74	3.72
	2	5.94	4.87	5.72	4.50	5.50	4.15	5.28	3.83	4.97	3.44
	-7	4.43	4.62	4.26	4.27	4.09	3.94	3.93	3.63	3.62	3.08
	-10	3.92	4.60	3.77	4.25	3.62	3.92	3.48	3.62	3.16	3.00
	-15	3.09	4.56	2.97	4.21	2.86	3.89	2.75	3.59	2.38	2.86
Minimum frequency	20	2.53	6.04	2.43	5.57	2.34	5.14	2.25	4.75	2.18	4.47
	15	2.29	5.59	2.20	5.16	2.12	4.76	2.04	4.40	1.97	4.14
	12	2.16	5.36	2.08	4.95	2.00	4.57	1.92	4.22	1.84	3.94
	7	1.92	5.04	1.85	4.65	1.78	4.30	1.71	3.97	1.63	3.63
	2	1.68	4.75	1.62	4.38	1.56	4.05	1.50	3.74	1.41	3.36
	-7	1.25	4.51	1.21	4.16	1.16	3.84	1.11	3.54	1.03	3.01
	-10	1.11	4.49	1.07	4.14	1.03	3.83	0.99	3.53	0.89	2.92
	-15	0.88	4.45	0.84	4.11	0.81	3.79	0.78	3.50	0.67	2.79

* The changes in capacity and efficiency due to the defrosting operation are not considered.

* Ambient temperature condition is DB 20°C/WB 19°C, DB 15°C/WB 14°C, DB 12°C/WB 11°C, DB 7°C/WB 6°C, DB 2°C/WB 1°C, DB -7°C/WB -8°C, DB -10°C/WB -11°C, DB -20°C/WB -21°C, DB -25°C/WB -26°C

Heating performance data

MSZ-FH50VE2: MUZ-FH50VEHZ

	Ambient temperature (°C)	Indoor DB (°C)									
		5		10		15		20		25	
		Capacity	COP	Capacity	COP	Capacity	COP	Capacity	COP	Capacity	COP
Max frequency	20	12.08	4.23	11.62	3.90	11.12	3.60	10.29	3.32	9.41	3.04
	15	11.20	4.01	10.76	3.70	10.35	3.41	9.76	3.15	8.92	2.88
	12	10.66	3.87	10.25	3.57	9.86	3.30	9.42	3.04	8.62	2.78
	7	9.78	3.63	9.40	3.35	9.04	3.09	8.70	2.86	8.09	2.61
	2	8.89	3.38	8.55	3.12	8.22	2.88	7.90	2.66	7.51	2.43
	-7	7.29	2.77	7.01	2.56	6.74	2.37	6.48	2.19	6.18	2.00
	-10	6.76	2.60	6.50	2.41	6.25	2.23	6.01	2.06	5.73	1.89
	-15	5.87	2.32	5.65	2.14	5.43	1.98	5.22	1.83	4.98	1.68
	-20	4.98	2.02	4.79	1.87	4.61	1.73	4.43	1.60	4.23	1.46
-25	4.10	1.71	3.94	1.58	3.79	1.46	3.64	1.35	3.47	1.24	
Rated frequency	20	8.92	6.19	8.57	5.71	8.24	5.27	7.93	4.87	7.70	4.58
	15	8.09	5.73	7.78	5.29	7.48	4.88	7.19	4.51	6.94	4.24
	12	7.62	5.50	7.33	5.07	7.04	4.68	6.77	4.32	6.50	4.05
	7	6.79	5.17	6.53	4.77	6.28	4.41	6.03	4.07	5.74	3.72
	2	5.94	4.87	5.72	4.50	5.50	4.15	5.28	3.83	4.97	3.44
	-7	4.43	4.10	4.26	3.80	4.09	3.53	3.93	3.27	3.62	2.79
	-10	3.92	4.03	3.77	3.74	3.62	3.47	3.48	3.22	3.16	2.69
	-15	3.09	3.87	2.97	3.60	2.86	3.34	2.75	3.10	2.38	2.49
	-20	2.30	3.63	2.21	3.38	2.12	3.14	2.04	2.92	1.62	2.17
-25	1.45	3.25	1.40	3.03	1.34	2.82	1.29	2.63	0.90	1.69	
Minimum frequency	20	2.53	6.04	2.43	5.57	2.34	5.14	2.25	4.75	2.18	4.47
	15	2.29	5.59	2.20	5.16	2.12	4.76	2.04	4.40	1.97	4.14
	12	2.16	5.36	2.08	4.95	2.00	4.57	1.92	4.22	1.84	3.94
	7	1.92	5.04	1.85	4.65	1.78	4.30	1.71	3.97	1.63	3.63
	2	1.68	4.75	1.62	4.38	1.56	4.05	1.50	3.74	1.41	3.36
	-7	1.25	3.14	1.21	2.94	1.16	2.74	1.11	2.56	1.03	2.22
	-10	1.11	3.02	1.07	2.82	1.03	2.64	0.99	2.47	0.89	2.10
	-15	0.88	2.76	0.84	2.58	0.81	2.42	0.78	2.27	0.67	1.86
	-20	0.65	2.41	0.63	2.27	0.60	2.13	0.58	2.00	0.46	1.52
-25	0.41	1.93	0.40	1.82	0.38	1.72	0.37	1.62	0.26	1.07	

* The changes in capacity and efficiency due to the defrosting operation are not considered.

* Ambient temperature condition is DB 20°C/WB 19°C, DB 15°C/WB 14°C, DB 12°C/WB 11°C, DB 7°C/WB 6°C, DB 2°C/WB 1°C, DB -7°C/WB -8°C, DB -10°C/WB -11°C, DB -20°C/WB -21°C, DB -25°C/WB -26°C

Heating performance data

MSZ-EF25VGW/B/S, MSZ-EF25VGKW/B/S: MUZ-EF25VG

	Ambient temperature (°C)	Indoor DB (°C)									
		5		10		15		20		25	
		Capacity	COP	Capacity	COP	Capacity	COP	Capacity	COP	Capacity	COP
Max frequency	20	6.30	5.35	6.06	4.93	5.83	4.56	5.60	4.21	5.35	3.85
	15	5.71	5.08	5.49	4.69	5.28	4.33	5.07	3.99	4.84	3.65
	12	5.35	4.90	5.14	4.53	4.95	4.18	4.76	3.86	4.54	3.53
	7	4.75	4.59	4.57	4.23	4.39	3.91	4.20	3.61	4.03	3.30
	2	4.16	4.24	4.00	3.91	3.84	3.61	3.70	3.33	3.53	3.05
	-7	3.08	3.49	2.97	3.22	2.85	2.98	2.74	2.75	2.62	2.51
	-10	2.73	3.21	2.62	2.96	2.52	2.73	2.42	2.52	2.31	2.31
	-15	2.13	2.68	2.05	2.47	1.97	2.28	1.89	2.11	1.81	1.93
Rated frequency	20	4.76	6.98	4.57	6.44	4.40	5.95	4.23	5.49	4.11	5.16
	15	4.31	6.46	4.15	5.97	3.99	5.51	3.83	5.08	3.70	4.79
	12	4.06	6.20	3.91	5.72	3.76	5.28	3.61	4.87	3.47	4.56
	7	3.62	5.83	3.48	5.38	3.35	4.97	3.22	4.59	3.06	4.20
	2	3.17	5.49	3.05	5.07	2.93	4.68	2.82	4.32	2.65	3.88
	-7	2.36	5.21	2.27	4.81	2.18	4.44	2.10	4.10	1.93	3.48
	-10	2.09	5.19	2.01	4.79	1.93	4.42	1.86	4.08	1.68	3.38
	-15	1.65	5.15	1.58	4.75	1.52	4.39	1.46	4.05	1.27	3.22
Minimum frequency	20	1.49	6.11	1.43	5.64	1.37	5.20	1.32	4.80	1.28	4.52
	15	1.35	5.65	1.30	5.22	1.25	4.82	1.20	4.45	1.16	4.19
	12	1.27	5.42	1.22	5.01	1.17	4.62	1.13	4.27	1.08	3.99
	7	1.13	5.10	1.09	4.71	1.05	4.35	1.01	4.01	0.96	3.67
	2	0.99	4.81	0.95	4.44	0.92	4.10	0.88	3.78	0.83	3.40
	-7	0.74	4.56	0.71	4.21	0.68	3.89	0.66	3.59	0.60	3.04
	-10	0.65	4.54	0.63	4.19	0.60	3.87	0.58	3.57	0.53	2.96
	-15	0.51	4.50	0.50	4.16	0.48	3.84	0.46	3.54	0.40	2.82

* The changes in capacity and efficiency due to the defrosting operation are not considered.

* Ambient temperature condition is DB 20°C/WB 19°C, DB 15°C/WB 14°C, DB 12°C/WB 11°C, DB 7°C/WB 6°C, DB 2°C/WB 1°C, DB -7°C/WB -8°C, DB -10°C/WB -11°C, DB -20°C/WB -21°C, DB -25°C/WB -26°C

Heating performance data

MSZ-EF25VGW/B/S, MSZ-EF25VGKW/B/S: MUZ-EF25VGH

	Ambient temperature (°C)	Indoor DB (°C)									
		5		10		15		20		25	
		Capacity	COP	Capacity	COP	Capacity	COP	Capacity	COP	Capacity	COP
Max frequency	20	6.22	5.48	5.98	5.06	5.75	4.67	5.53	4.31	5.28	3.94
	15	5.65	5.16	5.44	4.77	5.23	4.40	5.03	4.06	4.80	3.71
	12	5.31	4.96	5.11	4.58	4.91	4.22	4.72	3.90	4.51	3.57
	7	4.75	4.60	4.56	4.24	4.39	3.92	4.20	3.62	4.03	3.31
	2	4.18	4.21	4.02	3.88	3.86	3.58	3.72	3.31	3.55	3.03
	-7	3.16	3.00	3.04	2.78	2.92	2.58	2.81	2.39	2.68	2.20
	-10	2.82	2.74	2.71	2.54	2.61	2.36	2.51	2.18	2.39	2.01
	-15	2.25	2.27	2.17	2.11	2.08	1.96	2.00	1.82	1.91	1.67
Rated frequency	20	4.76	6.98	4.57	6.44	4.40	5.95	4.23	5.49	4.11	5.16
	15	4.31	6.46	4.15	5.97	3.99	5.51	3.83	5.08	3.70	4.79
	12	4.06	6.20	3.91	5.72	3.76	5.28	3.61	4.87	3.47	4.56
	7	3.62	5.83	3.48	5.38	3.35	4.97	3.22	4.59	3.06	4.20
	2	3.17	5.49	3.05	5.07	2.93	4.68	2.82	4.32	2.65	3.88
	-7	2.36	4.04	2.27	3.77	2.18	3.51	2.10	3.26	1.93	2.81
	-10	2.09	3.92	2.01	3.65	1.93	3.40	1.86	3.17	1.68	2.68
	-15	1.65	3.65	1.58	3.41	1.52	3.18	1.46	2.97	1.27	2.42
Minimum frequency	20	1.49	6.11	1.43	5.64	1.37	5.20	1.32	4.80	1.28	4.52
	15	1.35	5.65	1.30	5.22	1.25	4.82	1.20	4.45	1.16	4.19
	12	1.27	5.42	1.22	5.01	1.17	4.62	1.13	4.27	1.08	3.99
	7	1.13	5.10	1.09	4.71	1.05	4.35	1.01	4.01	0.96	3.67
	2	0.99	4.81	0.95	4.44	0.92	4.10	0.88	3.78	0.83	3.40
	-7	0.74	2.52	0.71	2.37	0.68	2.23	0.66	2.09	0.60	1.83
	-10	0.65	2.38	0.63	2.24	0.60	2.11	0.58	1.98	0.53	1.71
	-15	0.51	2.10	0.50	1.98	0.48	1.87	0.46	1.76	0.40	1.46
	-20	0.38	1.76	0.37	1.67	0.35	1.57	0.34	1.49	0.27	1.14

* The changes in capacity and efficiency due to the defrosting operation are not considered.

* Ambient temperature condition is DB 20°C/WB 19°C, DB 15°C/WB 14°C, DB 12°C/WB 11°C, DB 7°C/WB 6°C, DB 2°C/WB 1°C, DB -7°C/WB -8°C, DB -10°C/WB -11°C, DB -20°C/WB -21°C, DB -25°C/WB -26°C

Heating performance data

MSZ-EF35VGW/B/S, MSZ-EF35VGKW/B/S: MUZ-EF35VG

	Ambient temperature (°C)	Indoor DB (°C)									
		5		10		15		20		25	
		Capacity	COP	Capacity	COP	Capacity	COP	Capacity	COP	Capacity	COP
Max frequency	20	7.68	5.93	7.38	5.48	7.10	5.05	6.82	4.67	6.51	4.27
	15	6.94	5.56	6.68	5.14	6.42	4.74	6.17	4.38	5.89	4.00
	12	6.50	5.33	6.25	4.92	6.01	4.54	5.78	4.19	5.52	3.83
	7	5.77	4.92	5.55	4.54	5.34	4.19	5.10	3.87	4.90	3.54
	2	5.04	4.47	4.85	4.12	4.66	3.81	4.48	3.51	4.28	3.21
	-7	3.72	3.56	3.58	3.29	3.44	3.03	3.31	2.80	3.16	2.56
	-10	3.29	3.23	3.16	2.99	3.04	2.76	2.92	2.54	2.79	2.33
	-15	2.55	2.66	2.46	2.45	2.36	2.27	2.27	2.09	2.17	1.91
Rated frequency	20	5.94	6.43	5.72	5.93	5.50	5.48	5.28	5.06	5.13	4.76
	15	5.39	5.95	5.18	5.49	4.98	5.07	4.79	4.68	4.62	4.41
	12	5.08	5.71	4.88	5.27	4.70	4.86	4.52	4.49	4.34	4.20
	7	4.53	5.37	4.35	4.96	4.18	4.58	4.02	4.22	3.82	3.87
	2	3.96	5.06	3.81	4.67	3.66	4.31	3.52	3.98	3.31	3.57
	-7	2.95	4.80	2.84	4.43	2.73	4.09	2.62	3.78	2.41	3.20
	-10	2.61	4.78	2.51	4.41	2.42	4.07	2.32	3.76	2.10	3.11
	-15	2.06	4.74	1.98	4.38	1.90	4.04	1.83	3.73	1.59	2.97
Minimum frequency	20	1.93	5.67	1.86	5.23	1.79	4.83	1.72	4.46	1.67	4.20
	15	1.75	5.25	1.68	4.85	1.62	4.47	1.56	4.13	1.50	3.89
	12	1.65	5.04	1.59	4.65	1.53	4.29	1.47	3.96	1.41	3.71
	7	1.47	4.74	1.41	4.37	1.36	4.04	1.31	3.73	1.24	3.41
	2	1.29	4.46	1.24	4.12	1.19	3.80	1.15	3.51	1.08	3.15
	-7	0.96	4.23	0.92	3.91	0.89	3.61	0.85	3.33	0.78	2.82
	-10	0.85	4.22	0.82	3.89	0.79	3.59	0.76	3.32	0.68	2.75
	-15	0.67	4.18	0.64	3.86	0.62	3.56	0.60	3.29	0.52	2.62

* The changes in capacity and efficiency due to the defrosting operation are not considered.

* Ambient temperature condition is DB 20°C/WB 19°C, DB 15°C/WB 14°C, DB 12°C/WB 11°C, DB 7°C/WB 6°C, DB 2°C/WB 1°C, DB -7°C/WB -8°C, DB -10°C/WB -11°C, DB -20°C/WB -21°C, DB -25°C/WB -26°C

Heating performance data

MSZ-EF35VGW/B/S, MSZ-EF35VGKW/B/S: MUZ-EF35VGH

	Ambient temperature (°C)	Indoor DB (°C)									
		5		10		15		20		25	
		Capacity	COP	Capacity	COP	Capacity	COP	Capacity	COP	Capacity	COP
Max frequency	20	7.71	6.02	7.41	5.56	7.13	5.13	6.85	4.74	6.54	4.33
	15	6.96	5.62	6.70	5.19	6.44	4.79	6.19	4.42	5.91	4.04
	12	6.52	5.37	6.27	4.96	6.03	4.57	5.79	4.22	5.53	3.86
	7	5.78	4.92	5.55	4.54	5.34	4.19	5.10	3.87	4.90	3.54
	2	5.03	4.44	4.84	4.10	4.65	3.79	4.47	3.50	4.27	3.20
	-7	3.70	3.11	3.55	2.88	3.42	2.67	3.28	2.47	3.13	2.27
	-10	3.25	2.79	3.12	2.59	3.00	2.40	2.89	2.22	2.76	2.04
	-15	2.51	2.23	2.41	2.07	2.32	1.92	2.23	1.78	2.13	1.63
Rated frequency	20	5.94	6.43	5.72	5.93	5.50	5.48	5.28	5.06	5.13	4.76
	15	5.39	5.95	5.18	5.49	4.98	5.07	4.79	4.68	4.62	4.41
	12	5.08	5.71	4.88	5.27	4.70	4.86	4.52	4.49	4.34	4.20
	7	4.53	5.37	4.35	4.96	4.18	4.58	4.02	4.22	3.82	3.87
	2	3.96	5.06	3.81	4.67	3.66	4.31	3.52	3.98	3.31	3.57
	-7	2.95	3.96	2.84	3.68	2.73	3.42	2.62	3.18	2.41	2.73
	-10	2.61	3.86	2.51	3.59	2.42	3.34	2.32	3.10	2.10	2.61
	-15	2.06	3.64	1.98	3.39	1.90	3.16	1.83	2.94	1.59	2.38
Minimum frequency	20	1.93	5.67	1.86	5.23	1.79	4.83	1.72	4.46	1.67	4.20
	15	1.75	5.25	1.68	4.85	1.62	4.47	1.56	4.13	1.50	3.89
	12	1.65	5.04	1.59	4.65	1.53	4.29	1.47	3.96	1.41	3.71
	7	1.47	4.74	1.41	4.37	1.36	4.04	1.31	3.73	1.24	3.41
	2	1.29	4.46	1.24	4.12	1.19	3.80	1.15	3.51	1.08	3.15
	-7	0.96	2.68	0.92	2.52	0.89	2.36	0.85	2.20	0.78	1.92
	-10	0.85	2.56	0.82	2.40	0.79	2.25	0.76	2.11	0.68	1.80
	-15	0.67	2.30	0.64	2.16	0.62	2.03	0.60	1.91	0.52	1.57
	-20	0.50	1.97	0.48	1.86	0.46	1.75	0.44	1.65	0.35	1.26

* The changes in capacity and efficiency due to the defrosting operation are not considered.

* Ambient temperature condition is DB 20°C/WB 19°C, DB 15°C/WB 14°C, DB 12°C/WB 11°C, DB 7°C/WB 6°C, DB 2°C/WB 1°C, DB -7°C/WB -8°C, DB -10°C/WB -11°C, DB -20°C/WB -21°C, DB -25°C/WB -26°C

Heating performance data

MSZ-EF42VGW/B/S, MSZ-EF42VGKW/B/S: MUZ-EF42VG

	Ambient temperature (°C)	Indoor DB (°C)									
		5		10		15		20		25	
		Capacity	COP	Capacity	COP	Capacity	COP	Capacity	COP	Capacity	COP
Max frequency	20	9.14	4.46	8.79	4.12	8.45	3.80	7.96	3.51	7.30	3.21
	15	8.36	4.27	8.04	3.94	7.73	3.64	7.43	3.36	6.96	3.07
	12	7.89	4.14	7.58	3.82	7.29	3.53	7.01	3.26	6.66	2.98
	7	7.11	3.92	6.83	3.62	6.57	3.34	6.30	3.08	6.03	2.82
	2	6.33	3.67	6.08	3.39	5.85	3.13	5.62	2.89	5.36	2.64
	-7	4.92	3.15	4.73	2.91	4.55	2.68	4.37	2.48	4.17	2.27
	-10	4.45	2.95	4.28	2.73	4.11	2.52	3.96	2.32	3.77	2.12
	-15	3.67	2.59	3.53	2.39	3.39	2.21	3.26	2.04	3.11	1.86
Rated frequency	20	8.03	5.67	7.72	5.23	7.42	4.83	7.13	4.46	6.93	4.19
	15	7.28	5.25	7.00	4.84	6.73	4.47	6.47	4.13	6.24	3.88
	12	6.86	5.03	6.59	4.64	6.34	4.29	6.10	3.96	5.85	3.70
	7	6.11	4.73	5.87	4.37	5.65	4.03	5.43	3.72	5.16	3.41
	2	5.35	4.46	5.14	4.12	4.95	3.80	4.76	3.51	4.47	3.15
	-7	3.98	4.23	3.83	3.91	3.68	3.60	3.54	3.33	3.26	2.82
	-10	3.53	4.21	3.39	3.89	3.26	3.59	3.14	3.32	2.84	2.75
	-15	2.78	4.18	2.67	3.86	2.57	3.56	2.47	3.29	2.14	2.62
Minimum frequency	20	1.93	7.63	1.86	7.05	1.79	6.50	1.72	6.00	1.67	5.65
	15	1.75	7.07	1.68	6.52	1.62	6.02	1.56	5.56	1.50	5.23
	12	1.65	6.78	1.59	6.26	1.53	5.78	1.47	5.33	1.41	4.99
	7	1.47	6.38	1.41	5.89	1.36	5.43	1.31	5.02	1.24	4.59
	2	1.29	6.01	1.24	5.55	1.19	5.12	1.15	4.73	1.08	4.24
	-7	0.96	5.70	0.92	5.26	0.89	4.86	0.85	4.48	0.78	3.80
	-10	0.85	5.68	0.82	5.24	0.79	4.84	0.76	4.47	0.68	3.70
	-15	0.67	5.63	0.64	5.20	0.62	4.80	0.60	4.43	0.52	3.52

* The changes in capacity and efficiency due to the defrosting operation are not considered.

* Ambient temperature condition is DB 20°C/WB 19°C, DB 15°C/WB 14°C, DB 12°C/WB 11°C, DB 7°C/WB 6°C, DB 2°C/WB 1°C, DB -7°C/WB -8°C, DB -10°C/WB -11°C, DB -20°C/WB -21°C, DB -25°C/WB -26°C

Heating performance data

MSZ-EF50VGW/B/S, MSZ-EF50VGKW/B/S: MUZ-EF50VG

	Ambient temperature (°C)	Indoor DB (°C)									
		5		10		15		20		25	
		Capacity	COP	Capacity	COP	Capacity	COP	Capacity	COP	Capacity	COP
Max frequency	20	11.31	4.05	10.88	3.74	10.46	3.45	10.05	3.19	9.26	2.92
	15	10.23	3.90	9.83	3.60	9.45	3.33	9.09	3.07	8.67	2.81
	12	9.58	3.80	9.21	3.51	8.85	3.24	8.51	2.99	8.12	2.74
	7	8.49	3.62	8.16	3.34	7.85	3.08	7.50	2.85	7.20	2.60
	2	7.41	3.40	7.12	3.14	6.85	2.90	6.58	2.68	6.28	2.45
	-7	5.46	2.91	5.25	2.69	5.04	2.48	4.85	2.29	4.63	2.10
	-10	4.80	2.71	4.62	2.51	4.44	2.31	4.27	2.14	4.07	1.95
	-15	3.72	2.32	3.58	2.14	3.44	1.98	3.31	1.83	3.16	1.67
Rated frequency	20	8.62	5.68	8.29	5.24	7.97	4.84	7.66	4.46	7.44	4.20
	15	7.82	5.26	7.52	4.85	7.23	4.48	6.95	4.13	6.70	3.89
	12	7.36	5.04	7.08	4.65	6.81	4.29	6.55	3.96	6.29	3.71
	7	6.56	4.74	6.31	4.38	6.07	4.04	5.83	3.73	5.54	3.42
	2	5.75	4.47	5.53	4.12	5.31	3.81	5.11	3.51	4.80	3.16
	-7	4.28	4.24	4.11	3.91	3.96	3.61	3.80	3.33	3.50	2.83
	-10	3.79	4.22	3.64	3.90	3.50	3.60	3.37	3.32	3.05	2.75
	-15	2.99	4.19	2.87	3.86	2.76	3.57	2.65	3.29	2.30	2.62
Minimum frequency	20	2.08	7.12	2.00	6.58	1.92	6.07	1.85	5.60	1.80	5.27
	15	1.89	6.60	1.81	6.09	1.74	5.62	1.68	5.19	1.62	4.88
	12	1.78	6.33	1.71	5.84	1.64	5.39	1.58	4.98	1.52	4.66
	7	1.58	5.95	1.52	5.49	1.46	5.07	1.41	4.68	1.34	4.29
	2	1.39	5.61	1.33	5.18	1.28	4.78	1.23	4.41	1.16	3.96
	-7	1.03	5.32	0.99	4.91	0.95	4.53	0.92	4.18	0.84	3.55
	-10	0.91	5.30	0.88	4.89	0.85	4.52	0.81	4.17	0.74	3.45
	-15	0.72	5.25	0.69	4.85	0.67	4.48	0.64	4.13	0.55	3.29

* The changes in capacity and efficiency due to the defrosting operation are not considered.

* Ambient temperature condition is DB 20°C/WB 19°C, DB 15°C/WB 14°C, DB 12°C/WB 11°C, DB 7°C/WB 6°C, DB 2°C/WB 1°C, DB -7°C/WB -8°C, DB -10°C/WB -11°C, DB -20°C/WB -21°C, DB -25°C/WB -26°C

Heating performance data

MSZ-BT20VG, MSZ-BT20VGK: MUZ-BT20VG

	Ambient temperature (°C)	Indoor DB (°C)									
		5		10		15		20		25	
		Capacity	COP	Capacity	COP	Capacity	COP	Capacity	COP	Capacity	COP
Max frequency	20	4.98	4.27	4.79	3.94	4.53	3.64	4.22	3.36	3.88	3.07
	15	4.46	4.20	4.29	3.87	4.12	3.58	3.97	3.30	3.75	3.02
	12	4.15	4.15	3.99	3.83	3.84	3.54	3.69	3.26	3.51	2.98
	7	3.63	4.05	3.49	3.74	3.36	3.45	3.20	3.19	3.08	2.91
	2	3.12	3.93	3.00	3.63	2.88	3.35	2.77	3.09	2.64	2.83
	-7	2.19	3.60	2.10	3.32	2.02	3.07	1.94	2.83	1.85	2.59
	-10	1.88	3.44	1.80	3.18	1.73	2.93	1.67	2.71	1.59	2.48
	-15	1.36	3.07	1.31	2.84	1.26	2.62	1.21	2.42	1.15	2.21
Rated frequency	20	3.72	6.94	3.57	6.41	3.44	5.91	3.30	5.46	3.21	5.13
	15	3.37	6.43	3.24	5.93	3.12	5.48	3.00	5.05	2.89	4.76
	12	3.17	6.16	3.05	5.69	2.94	5.25	2.82	4.85	2.71	4.54
	7	2.83	5.80	2.72	5.35	2.62	4.94	2.51	4.56	2.39	4.18
	2	2.48	5.46	2.38	5.04	2.29	4.65	2.20	4.30	2.07	3.86
	-7	1.84	5.18	1.77	4.78	1.71	4.41	1.64	4.08	1.51	3.46
	-10	1.63	5.16	1.57	4.77	1.51	4.40	1.45	4.06	1.32	3.36
	-15	1.29	5.12	1.24	4.72	1.19	4.36	1.14	4.02	0.99	3.20
Minimum frequency	20	1.04	7.12	1.00	6.58	0.96	6.07	0.92	5.60	0.90	5.27
	15	0.94	6.60	0.91	6.09	0.87	5.62	0.84	5.19	0.81	4.88
	12	0.89	6.33	0.85	5.84	0.82	5.39	0.79	4.98	0.76	4.66
	7	0.79	5.95	0.76	5.49	0.73	5.07	0.70	4.68	0.67	4.29
	2	0.69	5.61	0.67	5.18	0.64	4.78	0.62	4.41	0.58	3.96
	-7	0.52	5.32	0.50	4.91	0.48	4.53	0.46	4.18	0.42	3.55
	-10	0.46	5.30	0.44	4.89	0.42	4.52	0.41	4.17	0.37	3.45
	-15	0.36	5.25	0.35	4.85	0.33	4.48	0.32	4.13	0.28	3.29

* The changes in capacity and efficiency due to the defrosting operation are not considered.

* Ambient temperature condition is DB 20°C/WB 19°C, DB 15°C/WB 14°C, DB 12°C/WB 11°C, DB 7°C/WB 6°C, DB 2°C/WB 1°C, DB -7°C/WB -8°C, DB -10°C/WB -11°C, DB -20°C/WB -21°C, DB -25°C/WB -26°C

Heating performance data

MSZ-BT25VG, MSZ-BT25VGK: MUZ-BT25VG

	Ambient temperature (°C)	Indoor DB (°C)									
		5		10		15		20		25	
		Capacity	COP	Capacity	COP	Capacity	COP	Capacity	COP	Capacity	COP
Max frequency	20	5.23	4.64	5.02	4.28	4.83	3.95	4.65	3.65	4.43	3.34
	15	4.74	4.51	4.56	4.17	4.38	3.85	4.21	3.55	4.02	3.25
	12	4.45	4.43	4.28	4.09	4.11	3.77	3.95	3.48	3.77	3.19
	7	3.96	4.27	3.81	3.94	3.66	3.64	3.50	3.36	3.36	3.07
	2	3.47	4.09	3.34	3.77	3.21	3.48	3.09	3.21	2.94	2.94
	-7	2.59	3.65	2.49	3.37	2.40	3.11	2.31	2.87	2.20	2.62
	-10	2.30	3.46	2.21	3.20	2.13	2.95	2.05	2.72	1.95	2.49
	-15	1.81	3.09	1.75	2.85	1.68	2.63	1.61	2.43	1.54	2.22
Rated frequency	20	4.68	6.41	4.50	5.92	4.33	5.46	4.16	5.04	4.04	4.74
	15	4.25	5.94	4.08	5.48	3.92	5.06	3.77	4.67	3.64	4.40
	12	4.00	5.69	3.85	5.26	3.70	4.85	3.56	4.48	3.41	4.19
	7	3.56	5.36	3.43	4.94	3.29	4.56	3.17	4.21	3.01	3.86
	2	3.12	5.05	3.00	4.66	2.89	4.30	2.77	3.97	2.61	3.57
	-7	2.32	4.79	2.23	4.42	2.15	4.08	2.07	3.77	1.90	3.19
	-10	2.06	4.77	1.98	4.40	1.90	4.06	1.83	3.75	1.66	3.11
	-15	1.62	4.73	1.56	4.36	1.50	4.03	1.44	3.72	1.25	2.96
Minimum frequency	20	1.04	7.12	1.00	6.58	0.96	6.07	0.92	5.60	0.90	5.27
	15	0.94	6.60	0.91	6.09	0.87	5.62	0.84	5.19	0.81	4.88
	12	0.89	6.33	0.85	5.84	0.82	5.39	0.79	4.98	0.76	4.66
	7	0.79	5.95	0.76	5.49	0.73	5.07	0.70	4.68	0.67	4.29
	2	0.69	5.61	0.67	5.18	0.64	4.78	0.62	4.41	0.58	3.96
	-7	0.52	5.32	0.50	4.91	0.48	4.53	0.46	4.18	0.42	3.55
	-10	0.46	5.30	0.44	4.89	0.42	4.52	0.41	4.17	0.37	3.45
	-15	0.36	5.25	0.35	4.85	0.33	4.48	0.32	4.13	0.28	3.29

* The changes in capacity and efficiency due to the defrosting operation are not considered.

* Ambient temperature condition is DB 20°C/WB 19°C, DB 15°C/WB 14°C, DB 12°C/WB 11°C, DB 7°C/WB 6°C, DB 2°C/WB 1°C, DB -7°C/WB -8°C, DB -10°C/WB -11°C, DB -20°C/WB -21°C, DB -25°C/WB -26°C

Heating performance data

MSZ-BT35VG, MSZ-BT35VGK: MUZ-BT35VG

	Ambient temperature (°C)	Indoor DB (°C)									
		5		10		15		20		25	
		Capacity	COP	Capacity	COP	Capacity	COP	Capacity	COP	Capacity	COP
Max frequency	20	6.04	4.82	5.80	4.45	5.58	4.11	5.37	3.79	5.12	3.47
	15	5.50	4.67	5.28	4.31	5.08	3.98	4.89	3.67	4.66	3.36
	12	5.17	4.57	4.97	4.22	4.78	3.89	4.60	3.59	4.39	3.29
	7	4.63	4.38	4.45	4.04	4.28	3.73	4.10	3.45	3.93	3.15
	2	4.09	4.16	3.93	3.84	3.78	3.55	3.64	3.27	3.47	2.99
	-7	3.12	3.67	3.00	3.39	2.88	3.13	2.77	2.89	2.64	2.64
	-10	2.79	3.47	2.69	3.21	2.58	2.96	2.48	2.73	2.37	2.50
	-15	2.25	3.09	2.17	2.85	2.08	2.63	2.00	2.43	1.91	2.22
Rated frequency	20	5.35	5.91	5.14	5.45	4.95	5.04	4.76	4.65	4.62	4.37
	15	4.85	5.47	4.67	5.05	4.49	4.66	4.31	4.30	4.16	4.05
	12	4.57	5.25	4.40	4.84	4.23	4.47	4.06	4.13	3.90	3.86
	7	4.07	4.94	3.92	4.56	3.77	4.21	3.62	3.88	3.44	3.56
	2	3.57	4.65	3.43	4.29	3.30	3.96	3.17	3.66	2.98	3.29
	-7	2.66	4.41	2.55	4.07	2.46	3.76	2.36	3.47	2.17	2.94
	-10	2.35	4.40	2.26	4.06	2.17	3.75	2.09	3.46	1.89	2.86
	-15	1.85	4.36	1.78	4.02	1.71	3.71	1.65	3.43	1.43	2.73
Minimum frequency	20	1.34	7.63	1.29	7.05	1.24	6.50	1.19	6.00	1.15	5.65
	15	1.21	7.07	1.17	6.52	1.12	6.02	1.08	5.56	1.04	5.23
	12	1.14	6.78	1.10	6.26	1.06	5.78	1.02	5.33	0.98	4.99
	7	1.02	6.38	0.98	5.89	0.94	5.43	0.91	5.02	0.86	4.59
	2	0.89	6.01	0.86	5.55	0.82	5.12	0.79	4.73	0.74	4.24
	-7	0.66	5.70	0.64	5.26	0.61	4.86	0.59	4.48	0.54	3.80
	-10	0.59	5.68	0.57	5.24	0.54	4.84	0.52	4.47	0.47	3.70
	-15	0.46	5.63	0.45	5.20	0.43	4.80	0.41	4.43	0.36	3.52

* The changes in capacity and efficiency due to the defrosting operation are not considered.

* Ambient temperature condition is DB 20°C/WB 19°C, DB 15°C/WB 14°C, DB 12°C/WB 11°C, DB 7°C/WB 6°C, DB 2°C/WB 1°C, DB -7°C/WB -8°C, DB -10°C/WB -11°C, DB -20°C/WB -21°C, DB -25°C/WB -26°C

Heating performance data

MSZ-BT50VG, MSZ-BT50VGK: MUZ-BT50VG

	Ambient temperature (°C)	Indoor DB (°C)									
		5		10		15		20		25	
		Capacity	COP	Capacity	COP	Capacity	COP	Capacity	COP	Capacity	COP
Max frequency	20	9.51	4.44	9.15	4.09	8.52	3.78	7.91	3.49	7.23	3.19
	15	8.68	4.31	8.34	3.98	8.02	3.67	7.61	3.39	7.01	3.10
	12	8.17	4.22	7.86	3.90	7.56	3.60	7.24	3.32	6.85	3.04
	7	7.34	4.07	7.06	3.75	6.78	3.47	6.50	3.20	6.22	2.93
	2	6.50	3.88	6.25	3.59	6.01	3.31	5.78	3.06	5.51	2.79
	-7	5.00	3.47	4.80	3.20	4.62	2.96	4.44	2.73	4.24	2.50
	-10	4.49	3.30	4.32	3.05	4.15	2.82	4.00	2.60	3.81	2.38
	-15	3.66	2.97	3.52	2.74	3.38	2.53	3.25	2.34	3.10	2.14
Rated frequency	20	8.03	5.32	7.72	4.91	7.42	4.53	7.13	4.18	6.93	3.94
	15	7.28	4.93	7.00	4.55	6.73	4.20	6.47	3.87	6.24	3.65
	12	6.86	4.72	6.59	4.36	6.34	4.02	6.10	3.71	5.85	3.48
	7	6.11	4.44	5.87	4.10	5.65	3.79	5.43	3.49	5.16	3.20
	2	5.35	4.19	5.14	3.86	4.95	3.57	4.76	3.29	4.47	2.96
	-7	3.98	3.97	3.83	3.67	3.68	3.38	3.54	3.12	3.26	2.65
	-10	3.53	3.96	3.39	3.65	3.26	3.37	3.14	3.11	2.84	2.58
	-15	2.78	3.92	2.67	3.62	2.57	3.34	2.47	3.08	2.14	2.45
Minimum frequency	20	2.08	7.92	2.00	7.31	1.92	6.75	1.85	6.23	1.80	5.86
	15	1.89	7.33	1.81	6.77	1.74	6.25	1.68	5.77	1.62	5.43
	12	1.78	7.03	1.71	6.49	1.64	5.99	1.58	5.53	1.52	5.17
	7	1.58	6.61	1.52	6.10	1.46	5.63	1.41	5.20	1.34	4.76
	2	1.39	6.23	1.33	5.75	1.28	5.31	1.23	4.90	1.16	4.40
	-7	1.03	5.91	0.99	5.46	0.95	5.04	0.92	4.65	0.84	3.94
	-10	0.91	5.89	0.88	5.44	0.85	5.02	0.81	4.63	0.74	3.84
	-15	0.72	5.84	0.69	5.39	0.67	4.97	0.64	4.59	0.55	3.65

* The changes in capacity and efficiency due to the defrosting operation are not considered.

* Ambient temperature condition is DB 20°C/WB 19°C, DB 15°C/WB 14°C, DB 12°C/WB 11°C, DB 7°C/WB 6°C, DB 2°C/WB 1°C, DB -7°C/WB -8°C, DB -10°C/WB -11°C, DB -20°C/WB -21°C, DB -25°C/WB -26°C

Heating performance data

MSZ-DW25VF: MUZ-DW25VF

	Ambient temperature (°C)	Indoor DB (°C)									
		5		10		15		20		25	
		Capacity	COP	Capacity	COP	Capacity	COP	Capacity	COP	Capacity	COP
Max frequency	20	5.47	4.92	5.26	4.54	5.00	4.19	4.65	3.87	4.27	3.54
	15	4.90	4.76	4.71	4.40	4.53	4.06	4.35	3.75	4.09	3.43
	12	4.55	4.66	4.38	4.30	4.21	3.97	4.05	3.66	3.84	3.35
	7	3.98	4.45	3.82	4.11	3.68	3.79	3.50	3.50	3.37	3.20
	2	3.40	4.20	3.27	3.88	3.14	3.58	3.02	3.31	2.89	3.02
	-7	2.37	3.59	2.28	3.32	2.19	3.06	2.10	2.83	2.01	2.59
Rated frequency	-10	2.02	3.33	1.94	3.07	1.87	2.83	1.80	2.62	1.72	2.39
	20	4.68	5.66	4.50	5.22	4.33	4.82	4.16	4.45	4.04	4.19
	15	4.25	5.24	4.08	4.84	3.92	4.46	3.77	4.12	3.64	3.88
	12	4.00	5.02	3.85	4.64	3.70	4.28	3.56	3.95	3.41	3.70
	7	3.56	4.73	3.43	4.36	3.29	4.03	3.17	3.72	3.01	3.40
	2	3.12	4.45	3.00	4.11	2.89	3.79	2.77	3.50	2.61	3.15
Minimum frequency	-7	2.32	4.22	2.23	3.90	2.15	3.60	2.07	3.32	1.90	2.82
	-10	2.06	4.21	1.98	3.88	1.90	3.59	1.83	3.31	1.66	2.74
	20	1.04	7.12	1.00	6.58	0.96	6.07	0.92	5.60	0.90	5.27
	15	0.94	6.60	0.91	6.09	0.87	5.62	0.84	5.19	0.81	4.88
	12	0.89	6.33	0.85	5.84	0.82	5.39	0.79	4.98	0.76	4.66
	7	0.79	5.95	0.76	5.49	0.73	5.07	0.70	4.68	0.67	4.29
	2	0.69	5.61	0.67	5.18	0.64	4.78	0.62	4.41	0.58	3.96
	-7	0.52	5.32	0.50	4.91	0.48	4.53	0.46	4.18	0.42	3.55
	-10	0.46	5.30	0.44	4.89	0.42	4.52	0.41	4.17	0.37	3.45

* The changes in capacity and efficiency due to the defrosting operation are not considered.

* Ambient temperature condition is DB 20°C/WB 19°C, DB 15°C/WB 14°C, DB 12°C/WB 11°C, DB 7°C/WB 6°C, DB 2°C/WB 1°C, DB -7°C/WB -8°C, DB -10°C/WB -11°C, DB -20°C/WB -21°C, DB -25°C/WB -26°C

Heating performance data

MSZ-DW35VF: MUZ-DW35VF

	Ambient temperature (°C)	Indoor DB (°C)									
		5		10		15		20		25	
		Capacity	COP	Capacity	COP	Capacity	COP	Capacity	COP	Capacity	COP
Max frequency	20	5.37	3.82	5.17	3.53	4.97	3.26	4.63	3.01	4.26	2.75
	15	4.91	3.77	4.72	3.48	4.54	3.21	4.37	2.96	4.14	2.71
	12	4.63	3.73	4.46	3.44	4.29	3.18	4.12	2.93	3.92	2.68
	7	4.17	3.66	4.01	3.38	3.86	3.12	3.70	2.88	3.54	2.63
	2	3.71	3.57	3.57	3.30	3.43	3.04	3.30	2.81	3.15	2.57
	-7	2.88	3.36	2.77	3.10	2.67	2.86	2.56	2.64	2.45	2.42
Rated frequency	-10	2.61	3.27	2.51	3.02	2.41	2.79	2.32	2.57	2.21	2.35
	20	5.35	5.64	5.14	5.20	4.95	4.80	4.63	4.43	4.26	4.17
	15	4.85	5.22	4.67	4.82	4.49	4.45	4.31	4.11	4.14	3.86
	12	4.57	5.01	4.40	4.62	4.23	4.27	4.06	3.94	3.90	3.68
	7	4.07	4.71	3.92	4.35	3.77	4.01	3.62	3.70	3.44	3.39
	2	3.57	4.44	3.43	4.10	3.30	3.78	3.17	3.49	2.98	3.13
Minimum frequency	-7	2.66	4.21	2.55	3.89	2.46	3.59	2.36	3.31	2.17	2.81
	-10	2.35	4.19	2.26	3.87	2.17	3.57	2.09	3.30	1.89	2.73
	20	1.34	5.28	1.29	4.88	1.24	4.50	1.19	4.16	1.15	3.91
	15	1.21	4.89	1.17	4.52	1.12	4.17	1.08	3.85	1.04	3.62
	12	1.14	4.69	1.10	4.33	1.06	4.00	1.02	3.69	0.98	3.45
	7	1.02	4.41	0.98	4.07	0.94	3.76	0.91	3.47	0.86	3.18
	2	0.89	4.16	0.86	3.84	0.82	3.54	0.79	3.27	0.74	2.94
	-7	0.66	3.95	0.64	3.64	0.61	3.36	0.59	3.10	0.54	2.63
	-10	0.59	3.93	0.57	3.63	0.54	3.35	0.52	3.09	0.47	2.56

* The changes in capacity and efficiency due to the defrosting operation are not considered.

* Ambient temperature condition is DB 20°C/WB 19°C, DB 15°C/WB 14°C, DB 12°C/WB 11°C, DB 7°C/WB 6°C, DB 2°C/WB 1°C, DB -7°C/WB -8°C, DB -10°C/WB -11°C, DB -20°C/WB -21°C, DB -25°C/WB -26°C

Heating performance data

MSZ-DW50VF: MUZ-DW50VF

	Ambient temperature (°C)	Indoor DB (°C)									
		5		10		15		20		25	
		Capacity	COP	Capacity	COP	Capacity	COP	Capacity	COP	Capacity	COP
Max frequency	20	9.40	4.50	8.69	4.15	8.03	3.83	7.41	3.54	6.78	3.23
	15	8.91	4.37	8.36	4.03	7.78	3.72	7.19	3.43	6.58	3.14
	12	8.33	4.28	7.96	3.95	7.59	3.64	7.05	3.36	6.45	3.08
	7	7.36	4.11	7.08	3.79	6.81	3.50	6.50	3.23	6.15	2.96
	2	6.40	3.91	6.15	3.61	5.92	3.33	5.69	3.08	5.43	2.81
	-7	4.66	3.43	4.48	3.17	4.31	2.92	4.14	2.70	3.95	2.47
Rated frequency	-10	4.08	3.23	3.92	2.98	3.77	2.75	3.63	2.54	3.46	2.32
	20	8.03	5.32	7.72	4.91	7.42	4.53	7.13	4.18	6.78	3.94
	15	7.28	4.93	7.00	4.55	6.73	4.20	6.47	3.87	6.24	3.65
	12	6.86	4.72	6.59	4.36	6.34	4.02	6.10	3.71	5.85	3.48
	7	6.11	4.44	5.87	4.10	5.65	3.79	5.43	3.49	5.16	3.20
	2	5.35	4.19	5.14	3.86	4.95	3.57	4.76	3.29	4.47	2.96
Minimum frequency	-7	3.98	3.97	3.83	3.67	3.68	3.38	3.54	3.12	3.26	2.65
	-10	3.53	3.96	3.39	3.65	3.26	3.37	3.14	3.11	2.84	2.58
	20	2.08	9.71	2.00	8.97	1.92	8.28	1.85	7.64	1.80	7.19
	15	1.89	9.00	1.81	8.30	1.74	7.67	1.68	7.08	1.62	6.66
	12	1.78	8.63	1.71	7.96	1.64	7.35	1.58	6.79	1.52	6.35
	7	1.58	8.12	1.52	7.49	1.46	6.92	1.41	6.38	1.34	5.85
	2	1.39	7.65	1.33	7.06	1.28	6.52	1.23	6.01	1.16	5.40
	-7	1.03	7.25	0.99	6.70	0.95	6.18	0.92	5.71	0.84	4.84
	-10	0.91	7.23	0.88	6.67	0.85	6.16	0.81	5.68	0.74	4.71

* The changes in capacity and efficiency due to the defrosting operation are not considered.

* Ambient temperature condition is DB 20°C/WB 19°C, DB 15°C/WB 14°C, DB 12°C/WB 11°C, DB 7°C/WB 6°C, DB 2°C/WB 1°C, DB -7°C/WB -8°C, DB -10°C/WB -11°C, DB -20°C/WB -21°C, DB -25°C/WB -26°C

PERFORMANCE DATA HEAT operation at Rated frequency**MSZ-SF25VE3: MUZ-SF25VE, MUZ-SF25VEH**

CAPACITY: 3.2 kW INPUT: 780 W

INDOOR DB (°C)	OUTDOOR WB (°C)													
	-10		-5		0		5		10		15		20	
	Q	INPUT	Q	INPUT	Q	INPUT	Q	INPUT	Q	INPUT	Q	INPUT	Q	INPUT
15	2.02	507	2.43	608	2.85	686	3.26	741	3.68	788	4.06	811	4.48	827
21	1.92	546	2.30	647	2.72	718	3.10	772	3.52	811	3.90	835	4.30	866
26	1.73	585	2.14	686	2.53	757	2.94	811	3.36	850	3.74	874	4.16	897

MSZ-SF35VE3: MUZ-SF35VE, MUZ-SF35VEH

CAPACITY: 4.0 kW INPUT: 1030 W

INDOOR DB (°C)	OUTDOOR WB (°C)													
	-10		-5		0		5		10		15		20	
	Q	INPUT	Q	INPUT	Q	INPUT	Q	INPUT	Q	INPUT	Q	INPUT	Q	INPUT
15	2.52	670	3.04	803	3.56	906	4.08	979	4.60	1040	5.08	1071	5.60	1092
21	2.40	721	2.88	855	3.40	948	3.88	1020	4.40	1071	4.88	1102	5.38	1143
26	2.16	773	2.68	906	3.16	999	3.68	1071	4.20	1123	4.68	1154	5.20	1185

MSZ-SF42VE3: MUZ-SF42VE, MUZ-SF42VEH

CAPACITY: 5.4 kW INPUT: 1580 W

INDOOR DB (°C)	OUTDOOR WB (°C)													
	-10		-5		0		5		10		15		20	
	Q	INPUT	Q	INPUT	Q	INPUT	Q	INPUT	Q	INPUT	Q	INPUT	Q	INPUT
15	3.40	1027	4.10	1232	4.81	1390	5.51	1501	6.21	1596	6.86	1643	7.56	1675
21	3.24	1106	3.89	1311	4.59	1454	5.24	1564	5.94	1643	6.59	1691	7.26	1754
26	2.92	1185	3.62	1390	4.27	1533	4.97	1643	5.67	1722	6.32	1770	7.02	1817

MSZ-SF50VE3: MUZ-SF50VE, MUZ-SF50VEH

CAPACITY: 5.8 kW INPUT: 1700 W

INDOOR DB (°C)	OUTDOOR WB (°C)													
	-10		-5		0		5		10		15		20	
	Q	INPUT	Q	INPUT	Q	INPUT	Q	INPUT	Q	INPUT	Q	INPUT	Q	INPUT
15	3.65	1105	4.41	1326	5.16	1496	5.92	1615	6.67	1717	7.37	1768	8.12	1802
21	3.48	1190	4.18	1411	4.93	1564	5.63	1683	6.38	1768	7.08	1819	7.80	1887
26	3.13	1275	3.89	1496	4.58	1649	5.34	1768	6.09	1853	6.79	1904	7.54	1955

MSZ-GF60VE2: MUZ-GF60VE

CAPACITY: 6.8 kW INPUT: 1810 W

INDOOR DB (°C)	OUTDOOR WB (°C)													
	-10		-5		0		5		10		15		20	
	Q	INPUT	Q	INPUT	Q	INPUT	Q	INPUT	Q	INPUT	Q	INPUT	Q	INPUT
15	4.28	1177	5.17	1412	6.05	1593	6.94	1720	7.82	1828	8.64	1882	9.52	1919
21	4.08	1267	4.90	1502	5.78	1665	6.60	1792	7.48	1882	8.30	1937	9.15	2009
26	3.67	1358	4.56	1593	5.37	1756	6.26	1882	7.14	1973	7.96	2027	8.84	2082

MSZ-GF71VE2: MUZ-GF71VE

CAPACITY: 8.1 kW INPUT: 2230 W

INDOOR DB (°C)	OUTDOOR WB (°C)													
	-10		-5		0		5		10		15		20	
	Q	INPUT	Q	INPUT	Q	INPUT	Q	INPUT	Q	INPUT	Q	INPUT	Q	INPUT
15	5.10	1450	6.16	1739	7.21	1962	8.26	2119	9.32	2252	10.29	2319	11.34	2364
21	4.86	1561	5.83	1851	6.89	2052	7.86	2208	8.91	2319	9.88	2386	10.89	2475
26	4.37	1673	5.43	1962	6.40	2163	7.45	2319	8.51	2431	9.48	2498	10.53	2565

NOTE: Q: Total capacity (kW) INPUT : Total power input (W) DB: Dry-bulb temperature WB: Wet-bulb temperature

PERFORMANCE DATA HEAT operation at Rated frequency**MUZ-WN25VA: MUZ-WN25VA**

CAPACITY: 3.15 kW INPUT: 850 W

INDOOR DB (°C)	OUTDOOR WB (°C)													
	-10		-5		0		5		10		15		20	
	Q	INPUT	Q	INPUT	Q	INPUT	Q	INPUT	Q	INPUT	Q	INPUT	Q	INPUT
15	1.98	553	2.39	663	2.80	748	3.21	808	3.62	859	4.00	884	4.41	901
21	1.89	595	2.27	706	2.68	782	3.06	842	3.47	884	3.84	910	4.24	944
26	1.70	638	2.11	748	2.49	825	2.90	884	3.31	927	3.69	952	4.10	978

MUZ-WN35VA: MUZ-WN35VA

CAPACITY: 3.6 kW INPUT: 975 W

INDOOR DB (°C)	OUTDOOR WB (°C)													
	-10		-5		0		5		10		15		20	
	Q	INPUT	Q	INPUT	Q	INPUT	Q	INPUT	Q	INPUT	Q	INPUT	Q	INPUT
15	2.27	634	2.74	761	3.20	858	3.67	926	4.14	985	4.57	1014	5.04	1034
21	2.16	683	2.59	809	3.06	897	3.49	965	3.96	1014	4.39	1043	4.84	1082
26	1.94	731	2.41	858	2.84	946	3.31	1014	3.78	1063	4.21	1092	4.68	1121

MSZ-DM25VA: MUZ-DM25VA

CAPACITY: 3.15 kW INPUT: 850 W

INDOOR DB (°C)	OUTDOOR WB (°C)													
	-10		-5		0		5		10		15		20	
	Q	INPUT	Q	INPUT	Q	INPUT	Q	INPUT	Q	INPUT	Q	INPUT	Q	INPUT
15	1.98	553	2.39	663	2.80	748	3.21	808	3.62	859	4.00	884	4.41	901
21	1.89	595	2.27	706	2.68	782	3.06	842	3.47	884	3.84	910	4.24	944
26	1.70	638	2.11	748	2.49	825	2.90	884	3.31	927	3.69	952	4.10	978

MSZ-DM35VA: MUZ-DM35VA

CAPACITY: 3.6 kW INPUT: 975 W

INDOOR DB (°C)	OUTDOOR WB (°C)													
	-10		-5		0		5		10		15		20	
	Q	INPUT	Q	INPUT	Q	INPUT	Q	INPUT	Q	INPUT	Q	INPUT	Q	INPUT
15	2.27	634	2.74	761	3.20	858	3.67	926	4.14	985	4.57	1014	5.04	1034
21	2.16	683	2.59	809	3.06	897	3.49	965	3.96	1014	4.39	1043	4.84	1082
26	1.94	731	2.41	858	2.84	946	3.31	1014	3.78	1063	4.21	1092	4.68	1121

NOTE: Q: Total capacity (kW) INPUT : Total power input (W) DB: Dry-bulb temperature WB: Wet-bulb temperature

PERFORMANCE DATA HEAT operation at Rated frequency**MSZ-HJ25VA: MUZ-HJ25VA**

CAPACITY: 3.15 kW INPUT: 870 W

INDOOR DB (°C)	OUTDOOR WB (°C)													
	-10		-5		0		5		10		15		20	
	Q	INPUT	Q	INPUT	Q	INPUT	Q	INPUT	Q	INPUT	Q	INPUT	Q	INPUT
15	1.98	566	2.39	679	2.80	766	3.21	827	3.62	879	4.00	905	4.41	922
21	1.89	609	2.27	722	2.68	800	3.06	861	3.47	905	3.84	931	4.24	966
26	1.70	653	2.11	766	2.49	844	2.90	905	3.31	948	3.69	974	4.10	1001

MSZ-HJ35VA: MUZ-HJ35VA

CAPACITY: 3.6 kW INPUT: 995 W

INDOOR DB (°C)	OUTDOOR WB (°C)													
	-10		-5		0		5		10		15		20	
	Q	INPUT	Q	INPUT	Q	INPUT	Q	INPUT	Q	INPUT	Q	INPUT	Q	INPUT
15	2.27	647	2.74	776	3.20	876	3.67	945	4.14	1005	4.57	1035	5.04	1055
21	2.16	697	2.59	826	3.06	915	3.49	985	3.96	1035	4.39	1065	4.84	1104
26	1.94	746	2.41	876	2.84	965	3.31	1035	3.78	1085	4.21	1114	4.68	1144

MSZ-HJ50VA: MUZ-HJ50VA

CAPACITY: 5.4 kW INPUT: 1480 W

INDOOR DB (°C)	OUTDOOR WB (°C)													
	-10		-5		0		5		10		15		20	
	Q	INPUT	Q	INPUT	Q	INPUT	Q	INPUT	Q	INPUT	Q	INPUT	Q	INPUT
15	3.40	962	4.10	1154	4.81	1302	5.51	1406	6.21	1495	6.86	1539	7.56	1569
21	3.24	1036	3.89	1228	4.59	1362	5.24	1465	5.94	1539	6.59	1584	7.26	1643
26	2.92	1110	3.62	1302	4.27	1436	4.97	1539	5.67	1613	6.32	1658	7.02	1702

MSZ-HJ60VA: MUZ-HJ60VA

CAPACITY: 6.8 kW INPUT: 1970 W

INDOOR DB (°C)	OUTDOOR WB (°C)													
	-10		-5		0		5		10		15		20	
	Q	INPUT	Q	INPUT	Q	INPUT	Q	INPUT	Q	INPUT	Q	INPUT	Q	INPUT
15	4.28	1281	5.17	1537	6.05	1734	6.94	1872	7.82	1990	8.64	2049	9.52	2088
21	4.08	1379	4.90	1635	5.78	1812	6.60	1950	7.48	2049	8.30	2108	9.15	2187
26	3.67	1478	4.56	1734	5.37	1911	6.26	2049	7.14	2147	7.96	2206	8.84	2266

MSZ-HJ71VA: MUZ-HJ71VA

CAPACITY: 8.1 kW INPUT: 2440 W

INDOOR DB (°C)	OUTDOOR WB (°C)													
	-10		-5		0		5		10		15		20	
	Q	INPUT	Q	INPUT	Q	INPUT	Q	INPUT	Q	INPUT	Q	INPUT	Q	INPUT
15	5.10	1586	6.16	1903	7.21	2147	8.26	2318	9.32	2464	10.29	2538	11.34	2586
21	4.86	1708	5.83	2025	6.89	2245	7.86	2416	8.91	2538	9.88	2611	10.89	2708
26	4.37	1830	5.43	2147	6.40	2367	7.45	2538	8.51	2660	9.48	2733	10.53	2806

NOTE: Q: Total capacity (kW) INPUT : Total power input (W) DB: Dry-bulb temperature WB: Wet-bulb temperature

C.1.7 NOISE CRITERIA CURVES

C.1.7.1 Indoor Unit

MSZ-RW25VG

INDOOR UNIT

FAN SPEED	FUNCTION	SPL(dB(A))	LINE
Super High	COOLING	42	●—●
	HEATING	41	○—○

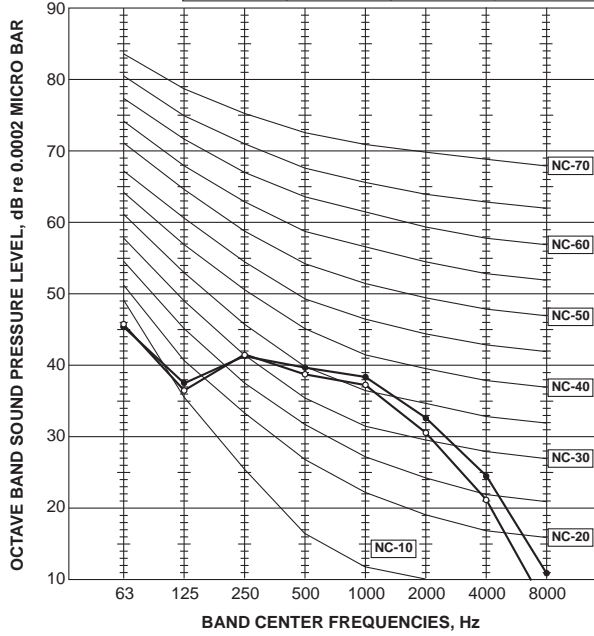

MSZ-RW35VG

INDOOR UNIT

FAN SPEED	FUNCTION	SPL(dB(A))	LINE
Super High	COOLING	43	●—●
	HEATING	42	○—○

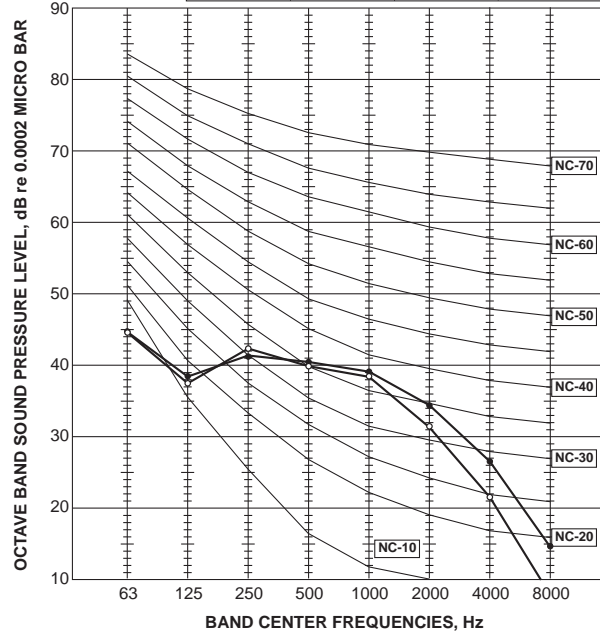

MSZ-RW50VG

INDOOR UNIT

FAN SPEED	FUNCTION	SPL(dB(A))	LINE
Super High	COOLING	45	●—●
	HEATING	46	○—○

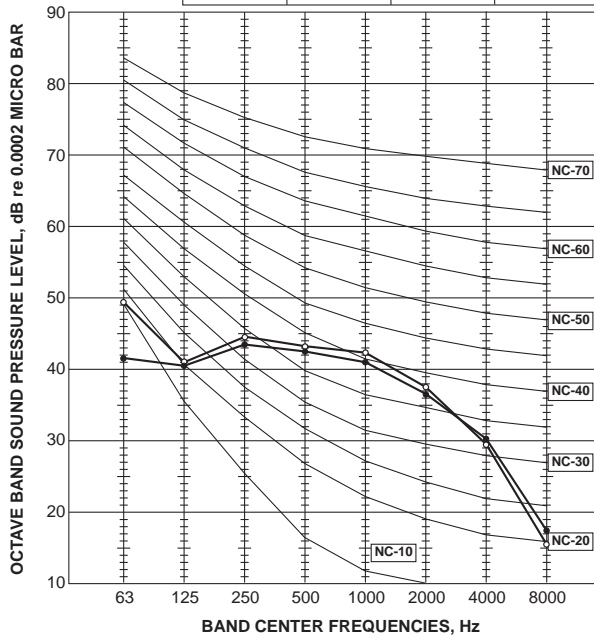

NOISE CRITERIA CURVES

WALL-MOUNTED

MSZ-LN18VG2W MSZ-LN25VG2W
MSZ-LN18VG2V MSZ-LN25VG2V
MSZ-LN18VG2B MSZ-LN25VG2B
MSZ-LN18VG2R MSZ-LN25VG2R

INDOOR UNIT

FAN SPEED	FUNCTION	SPL(dB(A))	LINE
Super High	COOLING	42	●—●
	HEATING	45	○—○

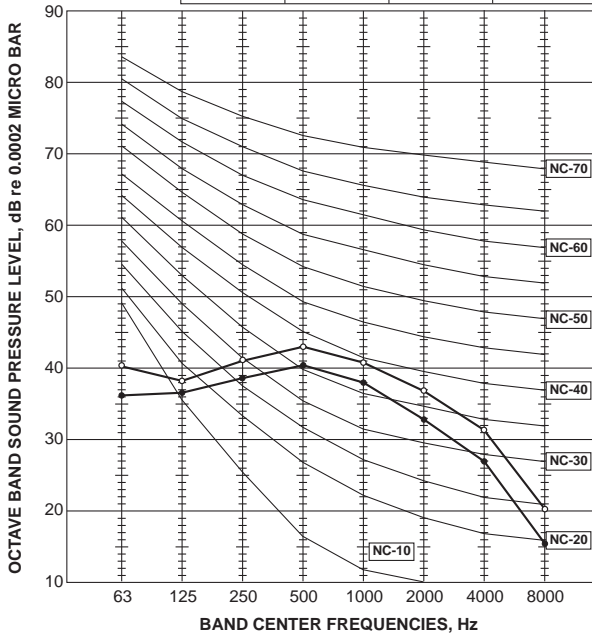

MSZ-LN35VG2W MSZ-LN35VG2V
MSZ-LN35VG2B MSZ-LN35VG2B
MSZ-LN35VG2R MSZ-LN35VG2R

INDOOR UNIT

FAN SPEED	FUNCTION	SPL(dB(A))	LINE
Super High	COOLING	43	●—●
	HEATING	45	○—○

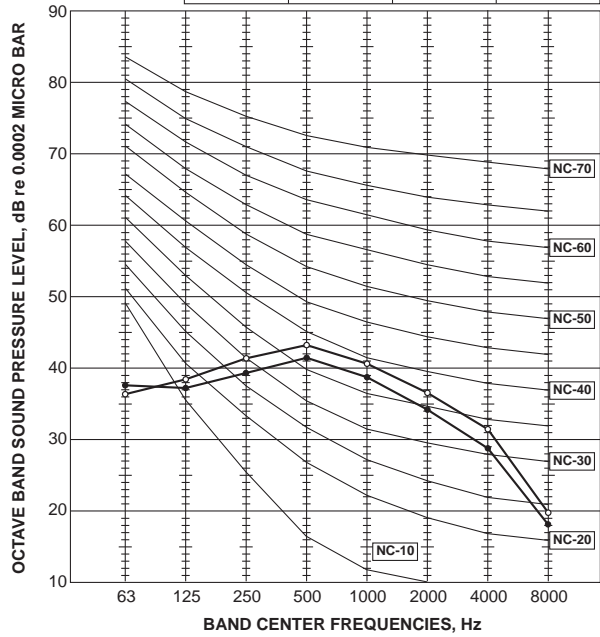

MSZ-LN50VG2W MSZ-LN50VG2V
MSZ-LN50VG2B MSZ-LN50VG2B
MSZ-LN50VG2R MSZ-LN50VG2R

INDOOR UNIT

FAN SPEED	FUNCTION	SPL(dB(A))	LINE
Super High	COOLING	46	●—●
	HEATING	47	○—○

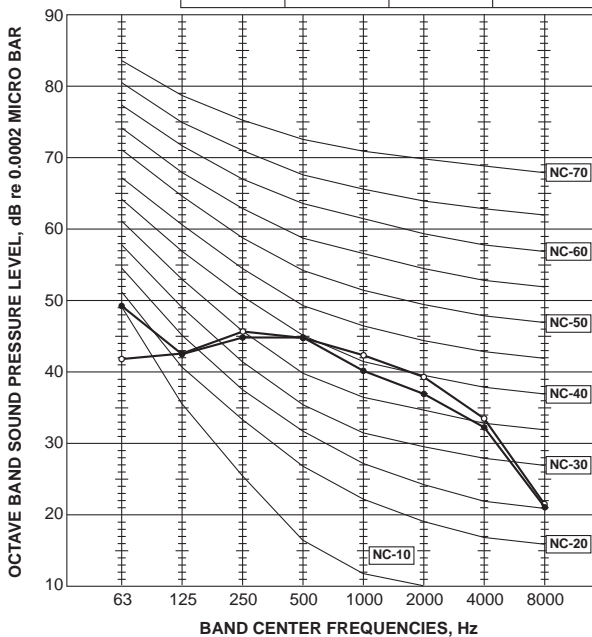

MSZ-LN60VG2W MSZ-LN60VG2V
MSZ-LN60VG2B MSZ-LN60VG2B
MSZ-LN60VG2R MSZ-LN60VG2R

INDOOR UNIT

FAN SPEED	FUNCTION	SPL(dB(A))	LINE
Super High	COOLING	49	●—●
	HEATING	49	○—○

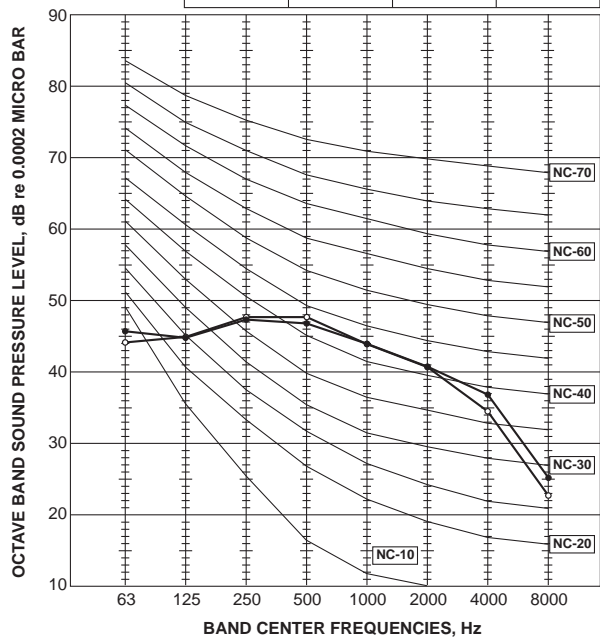

WALL-MOUNTED NOISE CRITERIA CURVES

**MSZ-FT25VG
MSZ-FT25VGK**

INDOOR UNIT

FUNCTION	SPL(dB(A))	LINE
COOLING	46	● — ●
HEATING	49	□ - - □

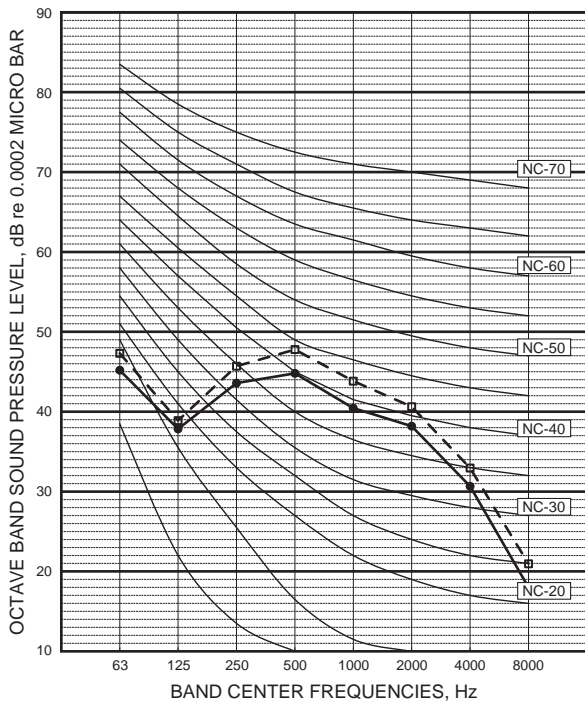

**MSZ-FT35VG
MSZ-FT35VGK**

INDOOR UNIT

FUNCTION	SPL(dB(A))	LINE
COOLING	47	● — ●
HEATING	52	□ - - □

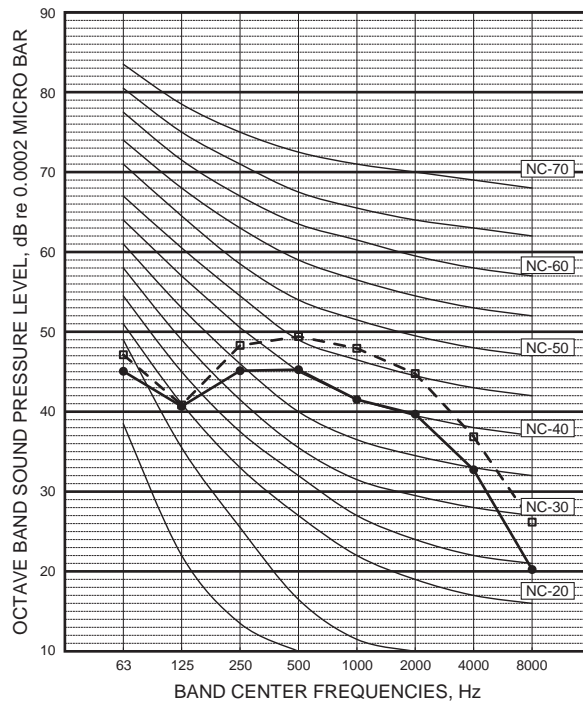

**MSZ-FT50VG
MSZ-FT50VGK**

INDOOR UNIT

FUNCTION	SPL(dB(A))	LINE
COOLING	48	● — ●
HEATING	54	□ - - □

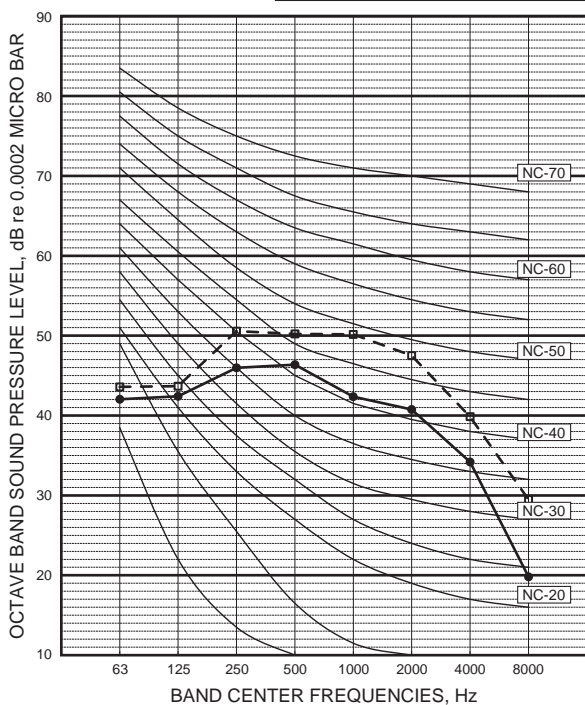

NOISE CRITERIA CURVES

WALL-MOUNTED

**MSZ-AY25VG
MSZ-AY25VGK
MSZ-AY25VGKP**

INDOOR UNIT

FAN SPEED	FUNCTION	SPL(dB(A))	LINE
Super High	COOLING	42	●—●
	HEATING	45	○—○

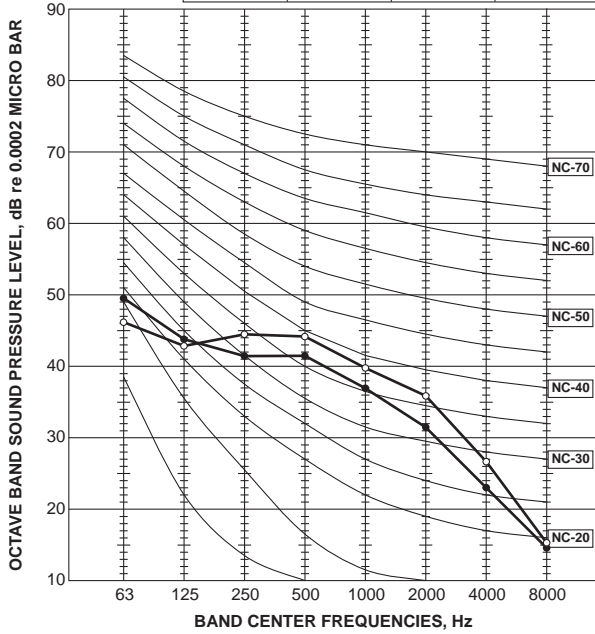

**MSZ-AY35VG
MSZ-AY35VGK
MSZ-AY35VGKP**

INDOOR UNIT

FAN SPEED	FUNCTION	SPL(dB(A))	LINE
Super High	COOLING	42	●—●
	HEATING	45	○—○

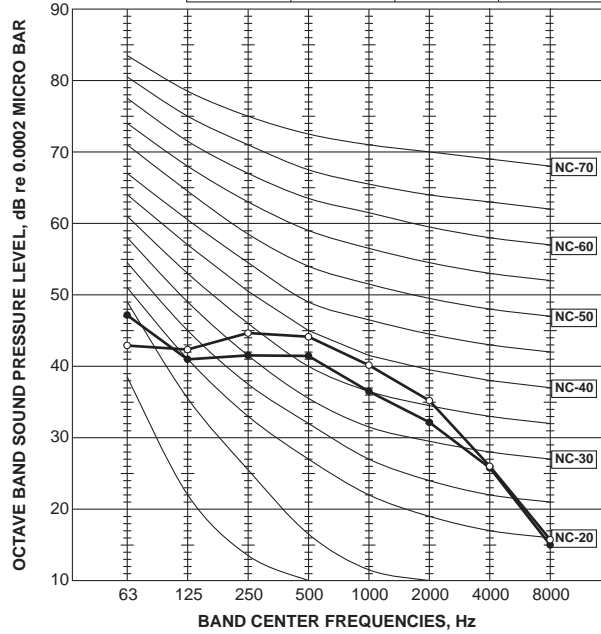

**MSZ-AY42VG
MSZ-AY42VGK
MSZ-AY42VGKP**

INDOOR UNIT

FAN SPEED	FUNCTION	SPL(dB(A))	LINE
Super High	COOLING	42	●—●
	HEATING	45	○—○

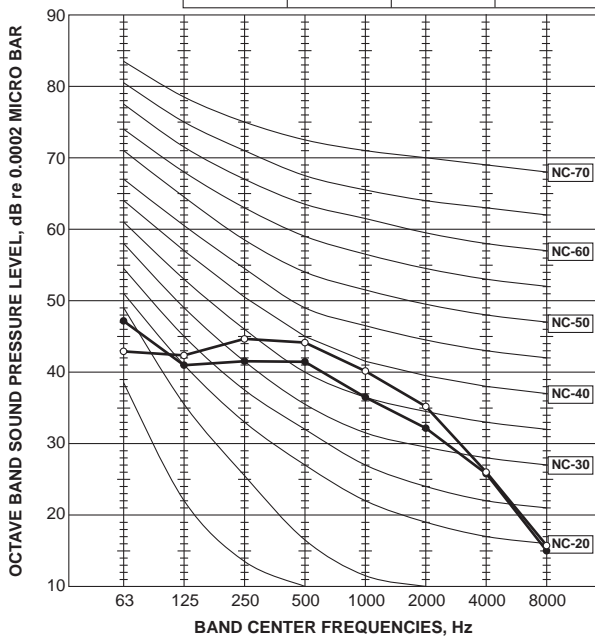

**MSZ-AY50VG
MSZ-AY50VGK
MSZ-AY50VGKP**

INDOOR UNIT

FAN SPEED	FUNCTION	SPL(dB(A))	LINE
Super High	COOLING	44	●—●
	HEATING	48	○—○

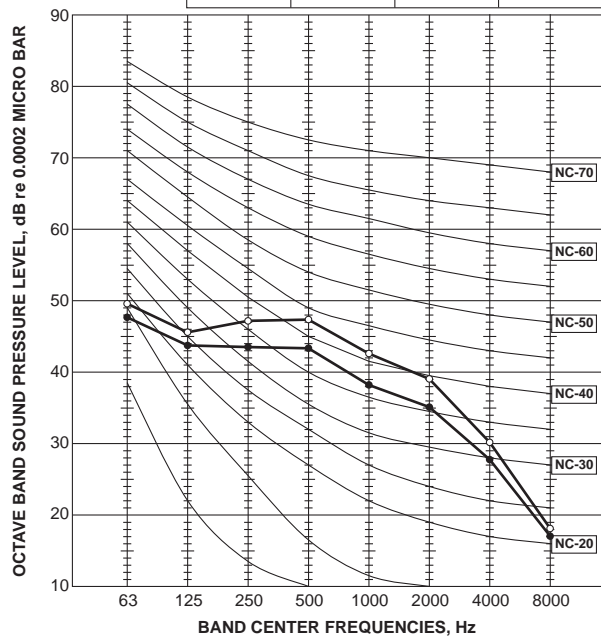

WALL-MOUNTED NOISE CRITERIA CURVES

**MSZ-AP15VG
MSZ-AP15VGK**

INDOOR UNIT

FAN SPEED	FUNCTION	SPL(dB(A))	LINE
Super High	COOLING	40	●—●
	HEATING	40	○—○

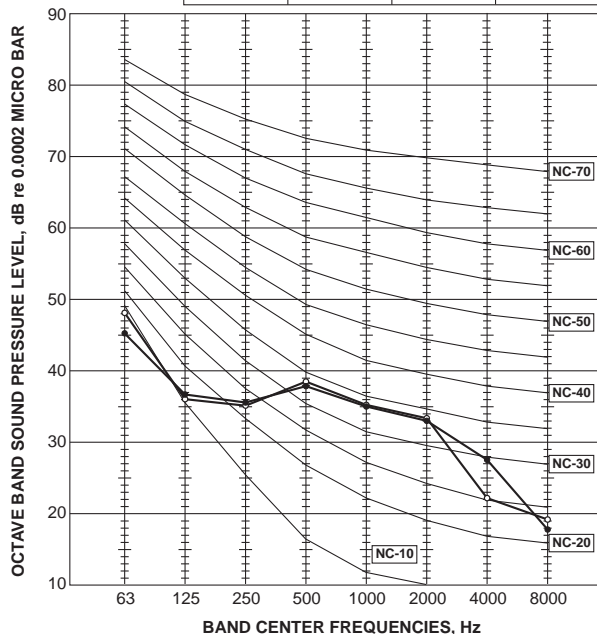

**MSZ-AP20VG
MSZ-AP20VGK**

INDOOR UNIT

FAN SPEED	FUNCTION	SPL(dB(A))	LINE
Super High	COOLING	42	●—●
	HEATING	42	○—○

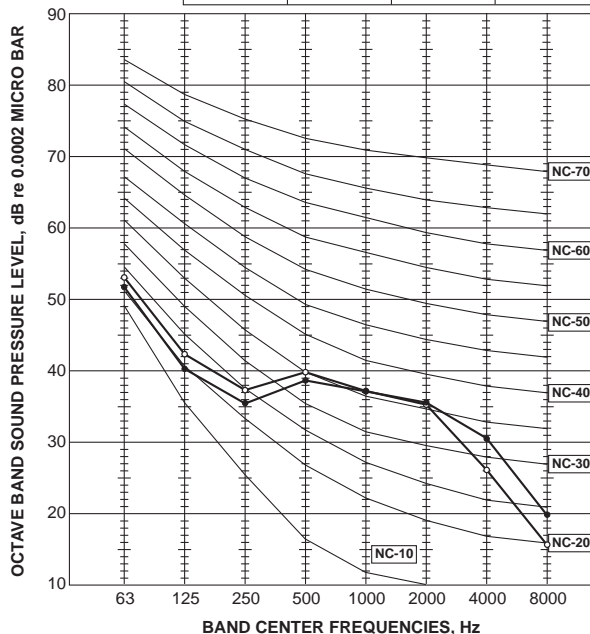

**MSZ-AP60VG
MSZ-AP60VGK**

INDOOR UNIT

FAN SPEED	FUNCTION	SPL(dB(A))	LINE
Super High	COOLING	48	●—●
	HEATING	48	○—○

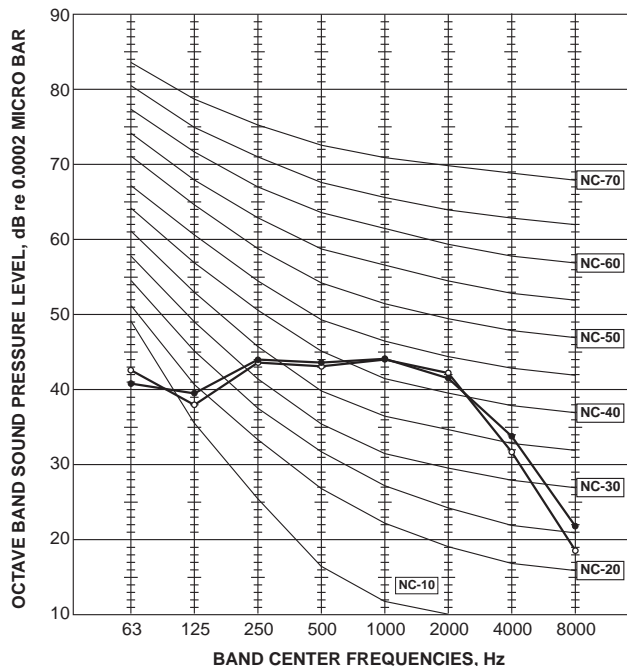

**MSZ-AP71VG
MSZ-AP71VGK**

INDOOR UNIT

FAN SPEED	FUNCTION	SPL(dB(A))	LINE
Super High	COOLING	49	●—●
	HEATING	51	○—○

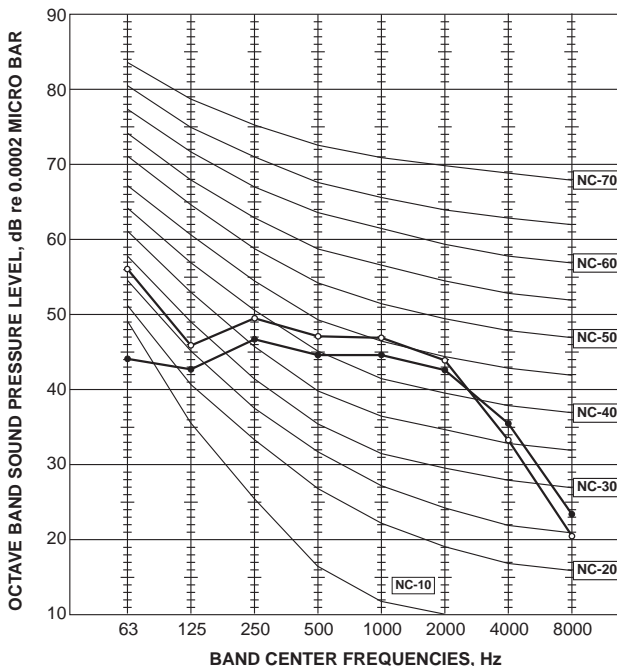

NOISE CRITERIA CURVES

WALL-MOUNTED

**MSZ-HR25VF
MSZ-HR25VFK**

INDOOR UNIT

FUNCTION	SPL(dB(A))	LINE
COOLING	43	●—●
HEATING	43	○—○

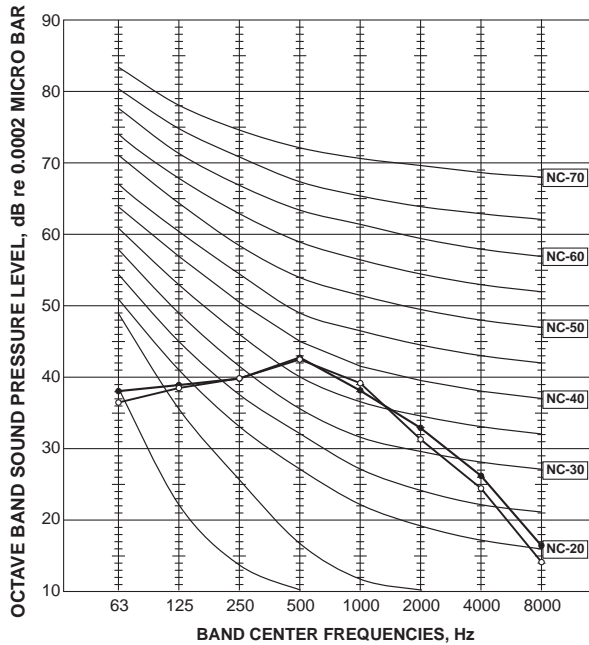

**MSZ-HR35VF
MSZ-HR35VFK**

INDOOR UNIT

FUNCTION	SPL(dB(A))	LINE
COOLING	46	●—●
HEATING	44	○—○

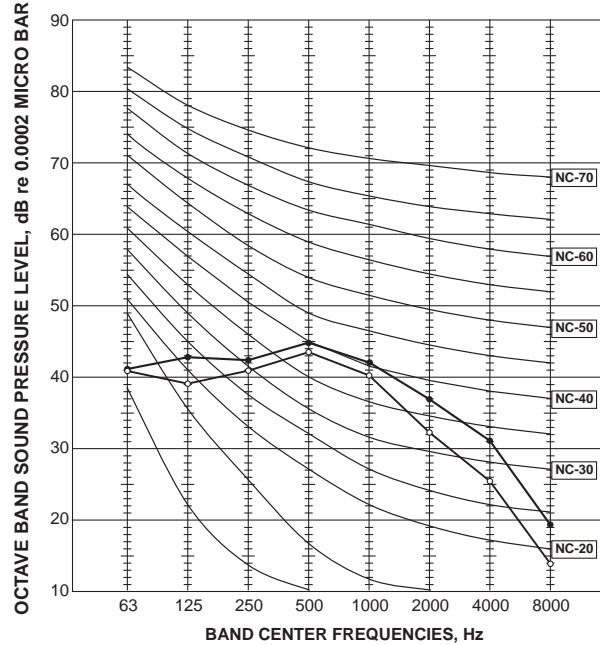

**MSZ-HR42VF
MSZ-HR42VFK**

INDOOR UNIT

FUNCTION	SPL(dB(A))	LINE
COOLING	45	●—●
HEATING	46	○—○

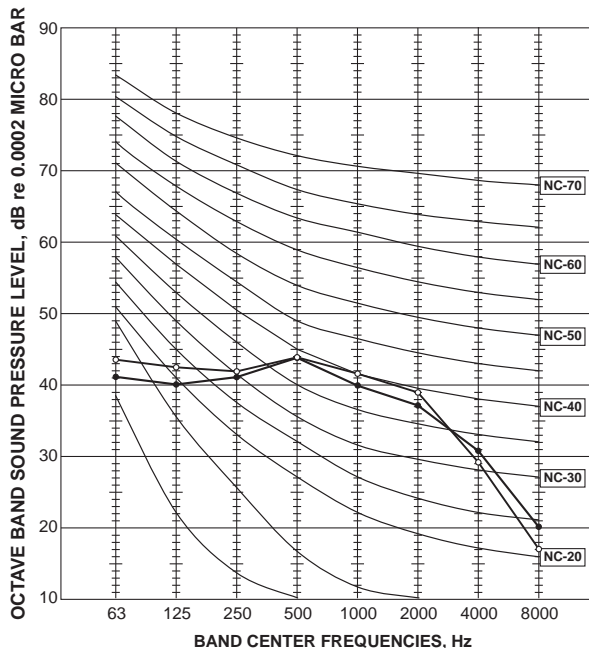

**MSZ-HR50VF
MSZ-HR50VFK**

INDOOR UNIT

FUNCTION	SPL(dB(A))	LINE
COOLING	45	●—●
HEATING	47	○—○

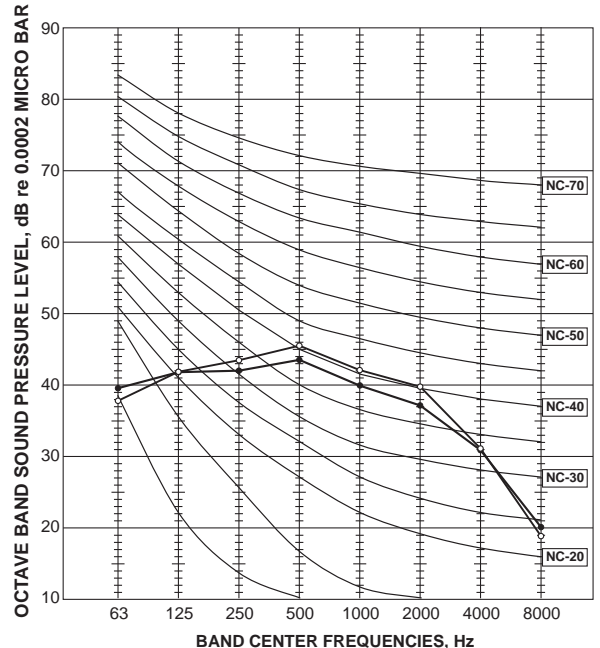

WALL-MOUNTED NOISE CRITERIA CURVES

**MSZ-HR60VF
MSZ-HR60VFK**

INDOOR UNIT

FAN SPEED	FUNCTION	SPL(dB(A))	LINE
Super High	COOLING	50	●—●
	HEATING	50	○—○

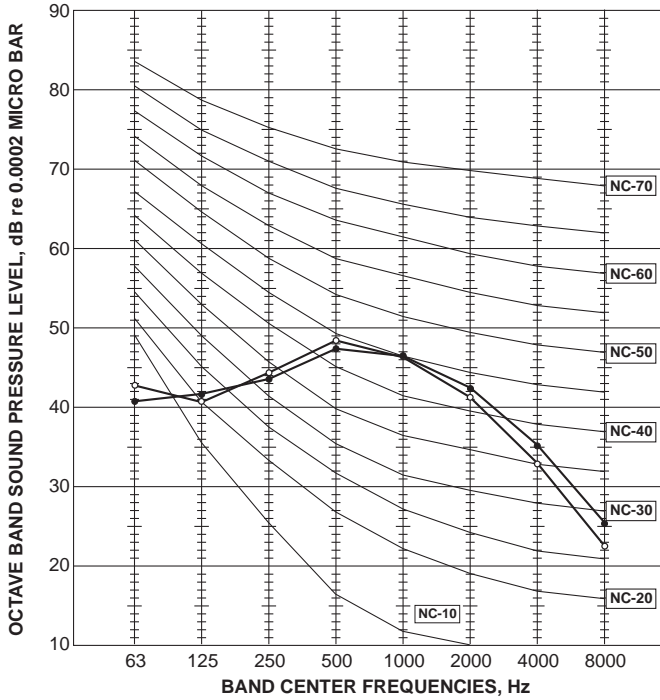

**MSZ-HR71VF
MSZ-HR71VFK**

INDOOR UNIT

FAN SPEED	FUNCTION	SPL(dB(A))	LINE
Super High	COOLING	50	●—●
	HEATING	50	○—○

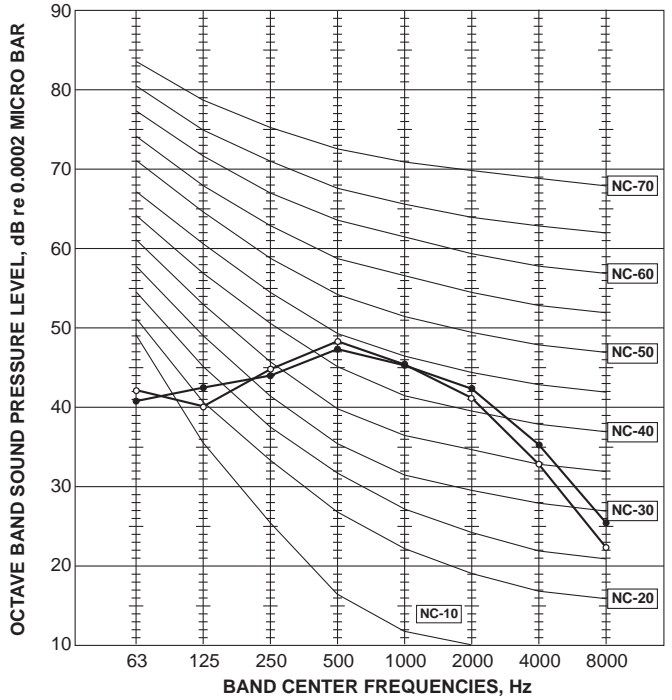

MSY-TP35VF

INDOOR UNIT

FAN SPEED	FUNCTION	SPL(dB(A))	LINE
Super High	COOLING	45	●—●

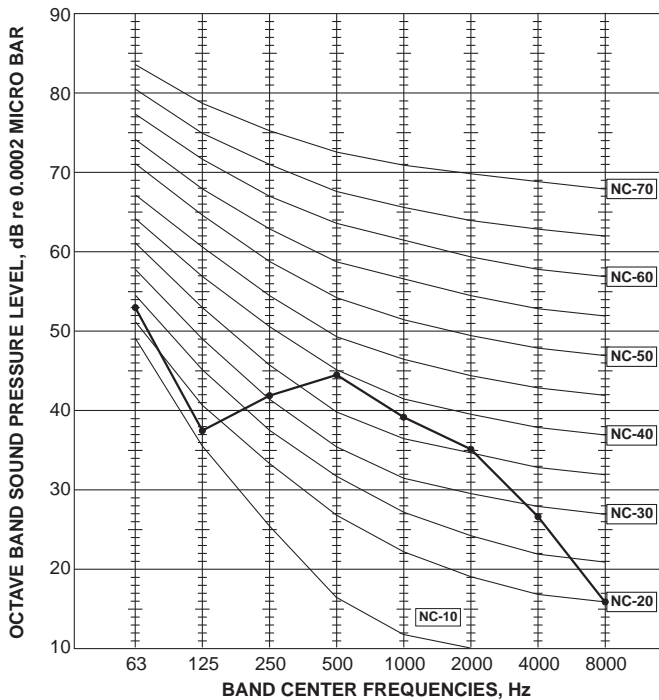

MSY-TP50VF

INDOOR UNIT

FAN SPEED	FUNCTION	SPL(dB(A))	LINE
Super High	COOLING	45	●—●

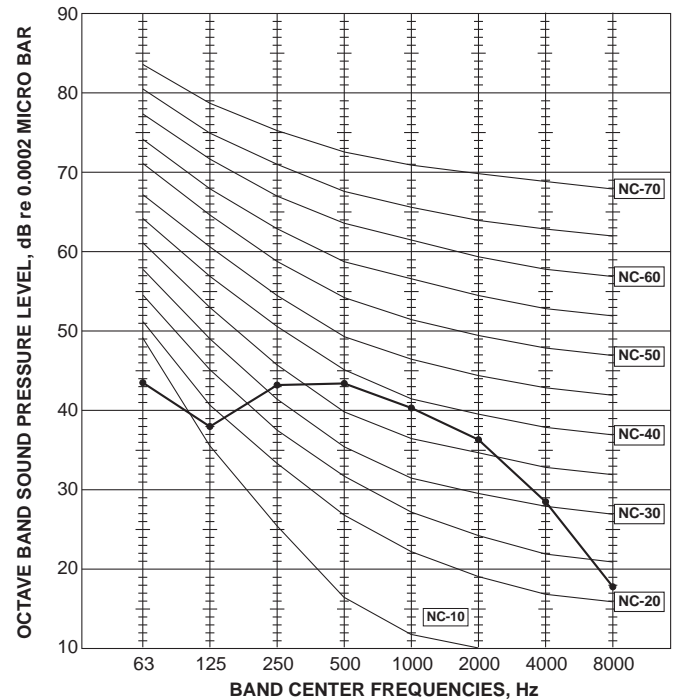

NOISE CRITERIA CURVES

WALL-MOUNTED

MSZ-FH25VE2 MSZ-FH35VE2

INDOOR UNIT

FAN SPEED	FUNCTION	SPL(dB(A))	LINE
Super High	COOLING	42	●—●
	HEATING	44	○—○

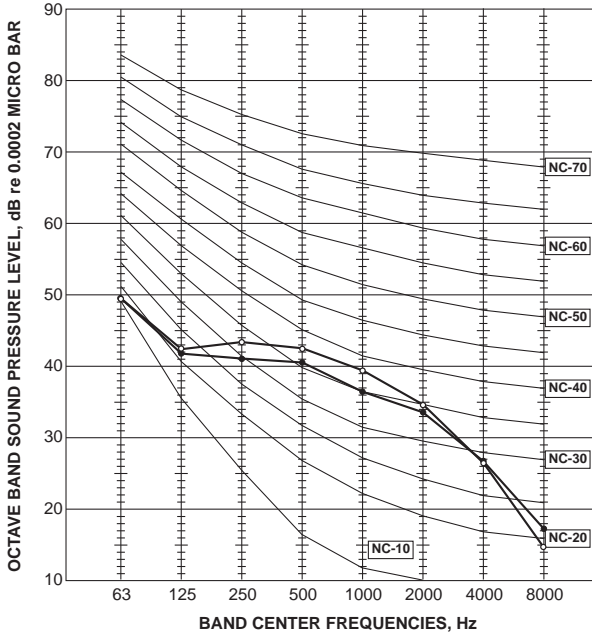

MSZ-FH50VE2

INDOOR UNIT

FAN SPEED	FUNCTION	SPL(dB(A))	LINE
Super High	COOLING	44	●—●
	HEATING	46	○—○

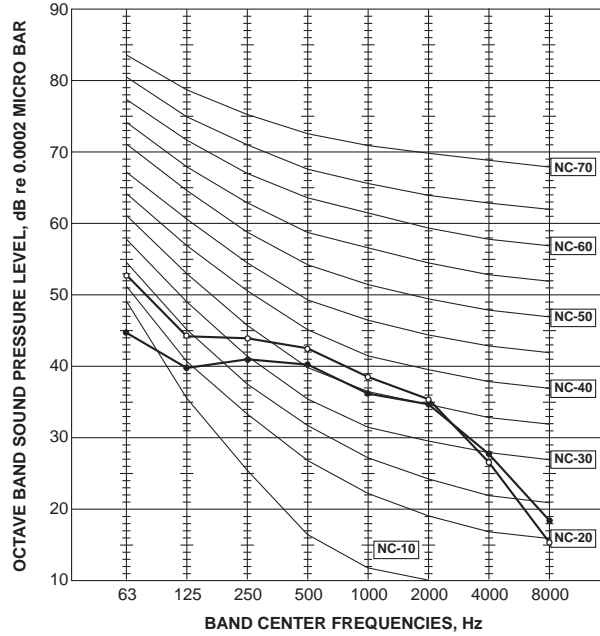

- MSZ-EF18VGW MSZ-EF22VGW MSZ-EF25VGW
- MSZ-EF18VGB MSZ-EF22VGB MSZ-EF25VGB
- MSZ-EF18VGS MSZ-EF22VGS MSZ-EF25VGS
- MSZ-EF18VGKW MSZ-EF22VGKW MSZ-EF25VGKW
- MSZ-EF18VGKB MSZ-EF22VGKB MSZ-EF25VGKB
- MSZ-EF18VGKS MSZ-EF22VGKS MSZ-EF25VGKS

INDOOR UNIT

FAN SPEED	FUNCTION	SPL(dB(A))	LINE
Super High	COOLING	42	●—●
	HEATING	45	○—○

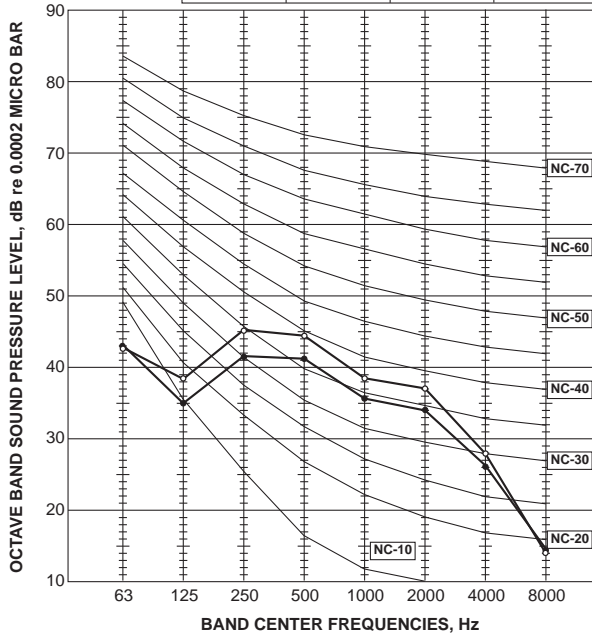

WALL-MOUNTED NOISE CRITERIA CURVES

MSZ-EF35VGW MSZ-EF35VGKB
MSZ-EF35VGB MSZ-EF35VGKS
MSZ-EF35VGS MSZ-EF35VGKW

INDOOR UNIT

FAN SPEED	FUNCTION	SPL(dB(A))	LINE
Super High	COOLING	42	●—●
	HEATING	46	○—○

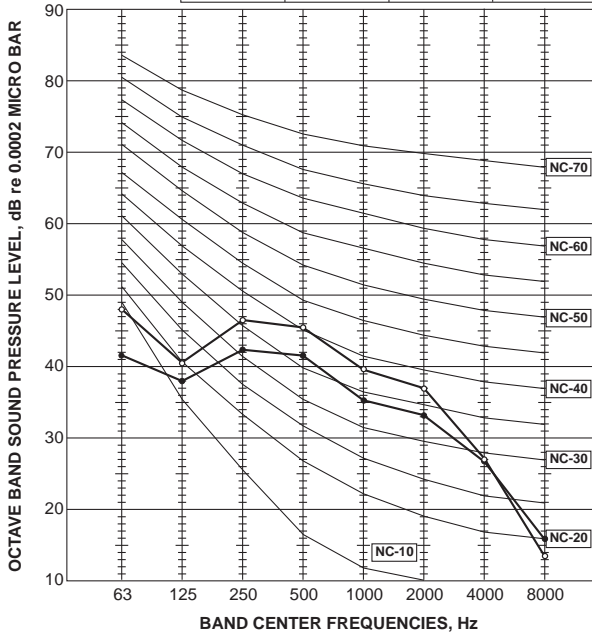

MSZ-EF42VGW MSZ-EF42VGKW
MSZ-EF42VGB MSZ-EF42VGKB
MSZ-EF42VGS MSZ-EF42VGKS

INDOOR UNIT

FAN SPEED	FUNCTION	SPL(dB(A))	LINE
Super High	COOLING	43	●—●
	HEATING	48	○—○

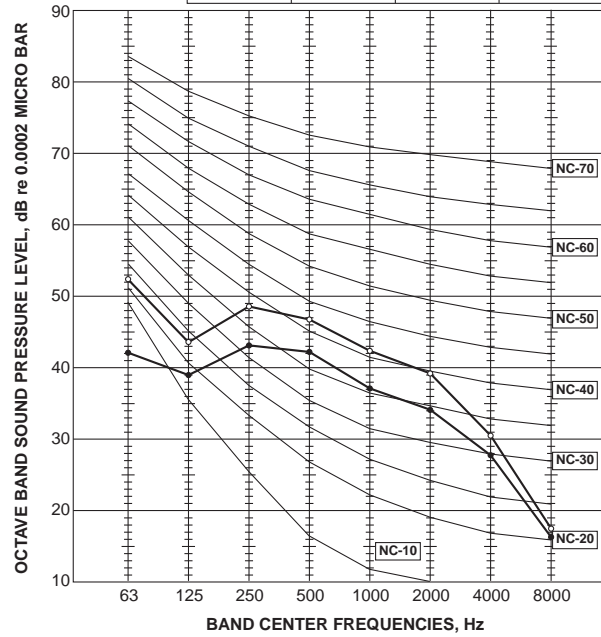

MSZ-EF50VGW MSZ-EF50VGKW
MSZ-EF50VGB MSZ-EF50VGKB
MSZ-EF50VGS MSZ-EF50VGKS

INDOOR UNIT

FAN SPEED	FUNCTION	SPL(dB(A))	LINE
Super High	COOLING	43	●—●
	HEATING	49	○—○

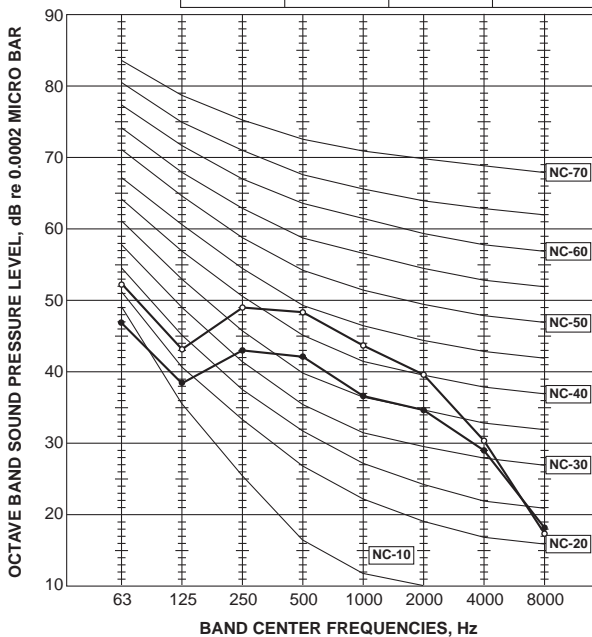

NOISE CRITERIA CURVES

WALL-MOUNTED

**MSZ-BT20VG
MSZ-BT20VGK**

INDOOR UNIT

FUNCTION	SPL(dB(A))	LINE
COOLING	43	● — ●
HEATING	43	□ - - □

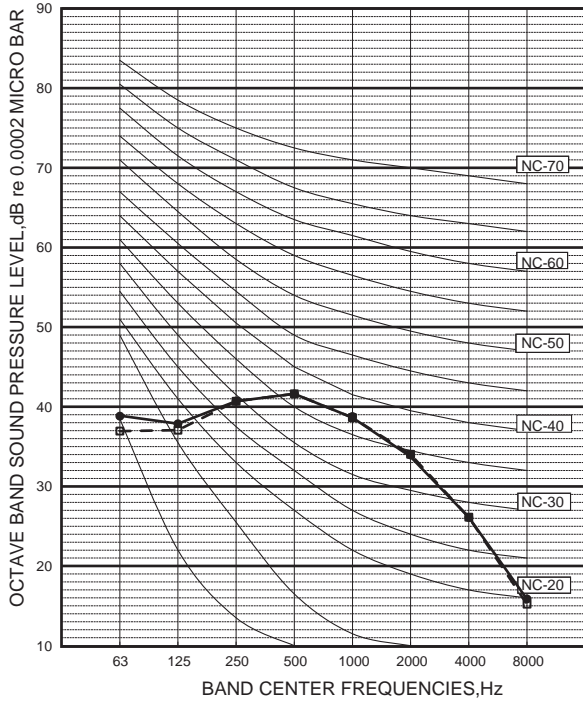

**MSZ-BT25VG
MSZ-BT25VGK**

INDOOR UNIT

FUNCTION	SPL(dB(A))	LINE
COOLING	43	● — ●
HEATING	43	□ - - □

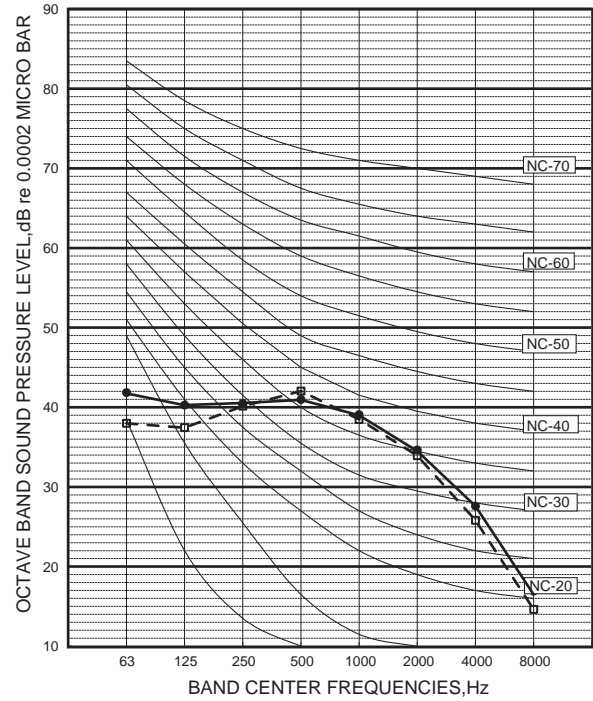

**MSZ-BT35VG
MSZ-BT35VGK**

INDOOR UNIT

FUNCTION	SPL(dB(A))	LINE
COOLING	46	● — ●
HEATING	44	□ - - □

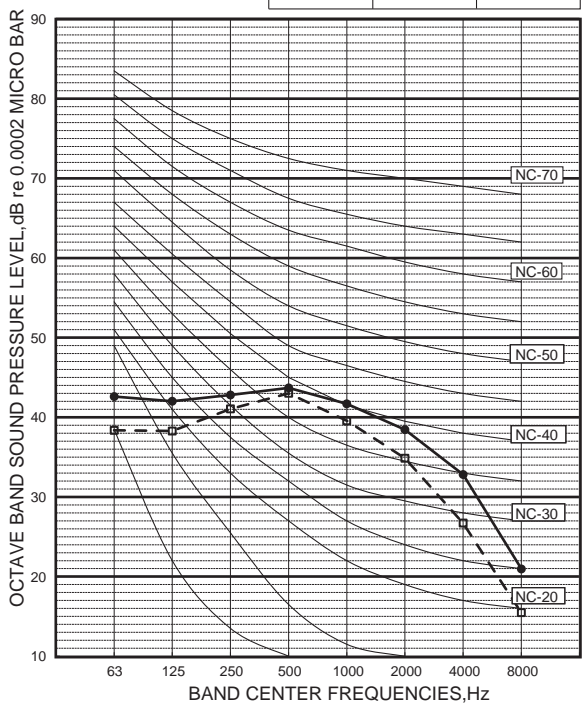

**MSZ-BT50VG
MSZ-BT50VGK**

INDOOR UNIT

FUNCTION	SPL(dB(A))	LINE
COOLING	46	● — ●
HEATING	48	□ - - □

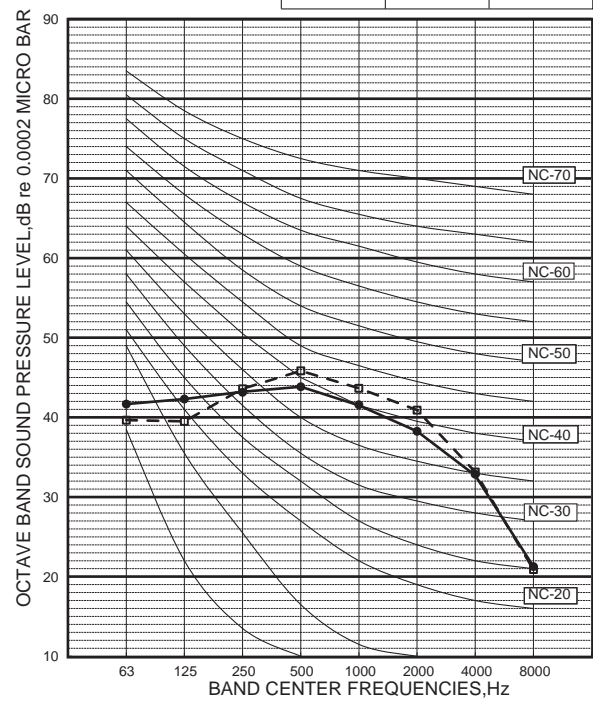

WALL-MOUNTED NOISE CRITERIA CURVES

MSZ-DW25VF

INDOOR UNIT

FAN SPEED	FUNCTION	SPL(dB(A))	LINE
Super High	COOLING	43	●—●
	HEATING	44	○—○

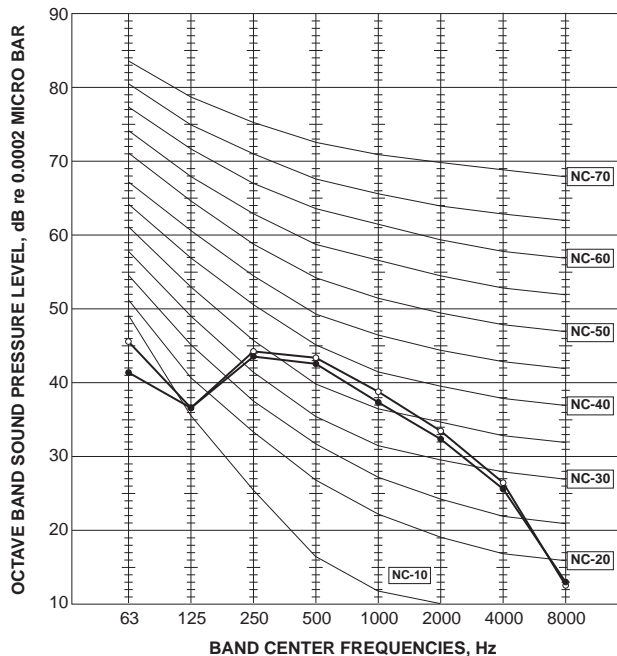

MSZ-DW35VF

INDOOR UNIT

FAN SPEED	FUNCTION	SPL(dB(A))	LINE
Super High	COOLING	47	●—●
	HEATING	45	○—○

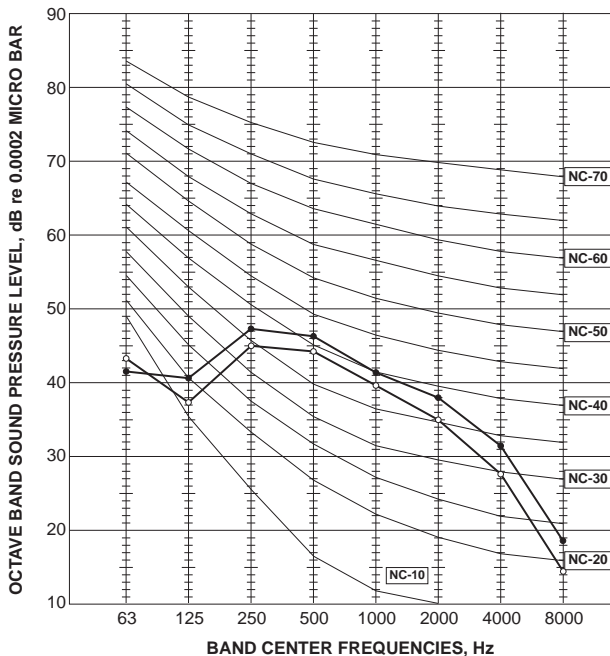

MSZ-DW50VF

INDOOR UNIT

FAN SPEED	FUNCTION	SPL(dB(A))	LINE
Super High	COOLING	46	●—●
	HEATING	47	○—○

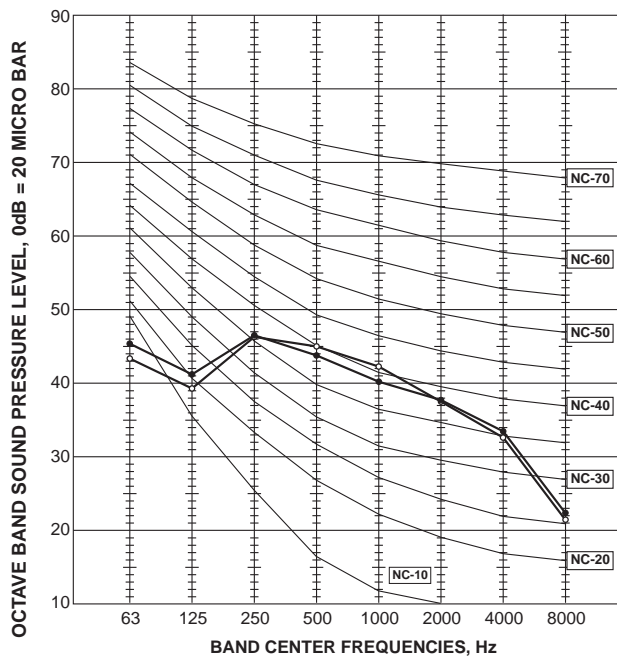

NOISE CRITERIA CURVES

WALL-MOUNTED

MSZ-SF15VA
INDOOR UNIT

FAN SPEED	FUNCTION	SPL(dB(A))	LINE
Super High	COOLING	40	●—●
	HEATING	40	○—○

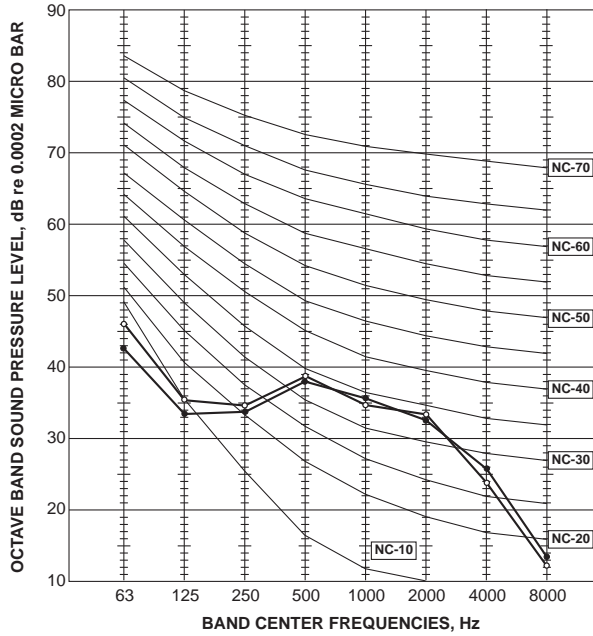

MSZ-SF20VA
INDOOR UNIT

FAN SPEED	FUNCTION	SPL(dB(A))	LINE
Super High	COOLING	42	●—●
	HEATING	42	○—○

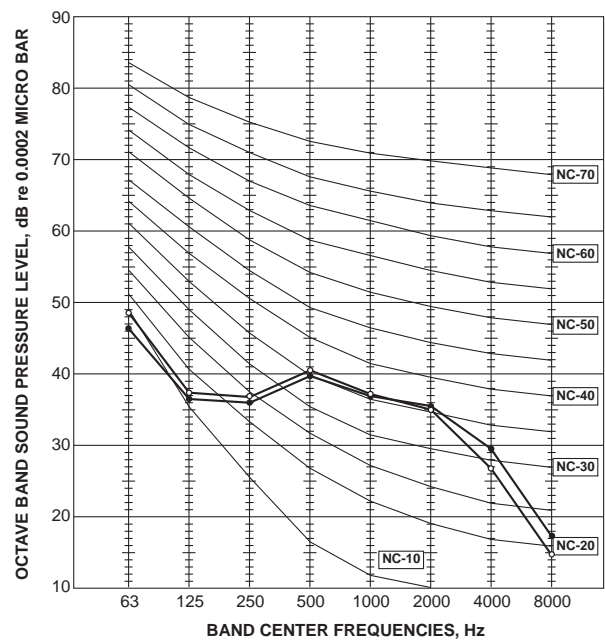

MSZ-SF25VE3
INDOOR UNIT

FAN SPEED	FUNCTION	SPL(dB(A))	LINE
Super High	COOLING	42	●—●
	HEATING	45	○—○

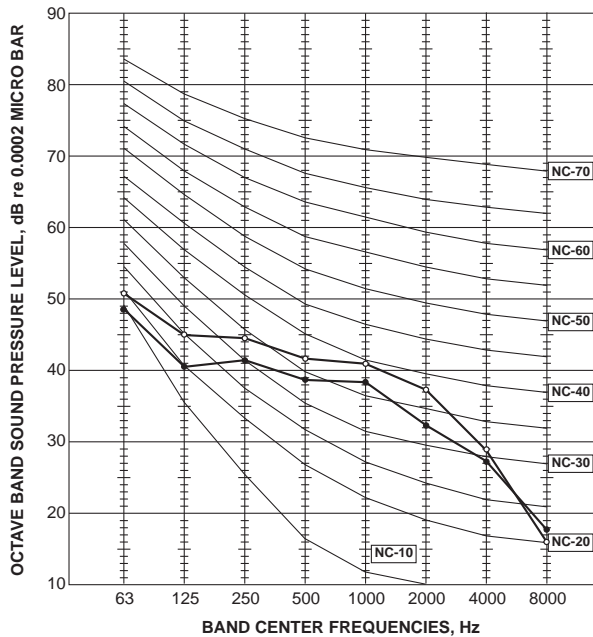

MSZ-SF35VE3
INDOOR UNIT

FAN SPEED	FUNCTION	SPL(dB(A))	LINE
Super High	COOLING	42	●—●
	HEATING	46	○—○

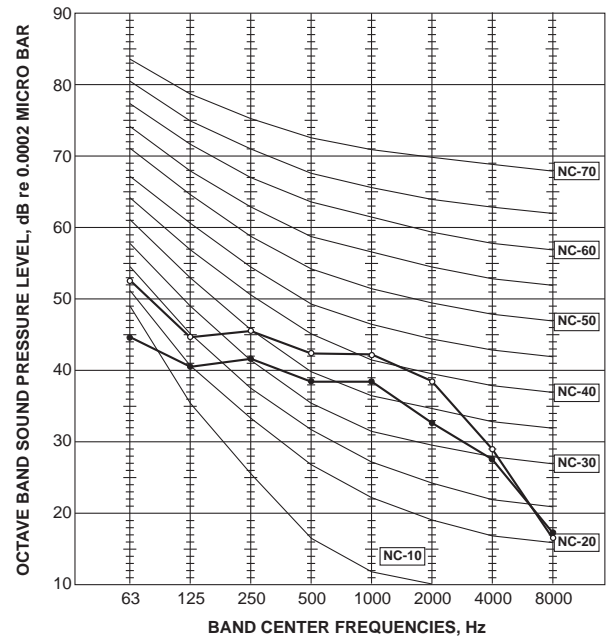

WALL-MOUNTED NOISE CRITERIA CURVES

MSZ-SF42VE3

INDOOR UNIT

FAN SPEED	FUNCTION	SPL(dB(A))	LINE
Super High	COOLING	42	●—●
	HEATING	47	○—○

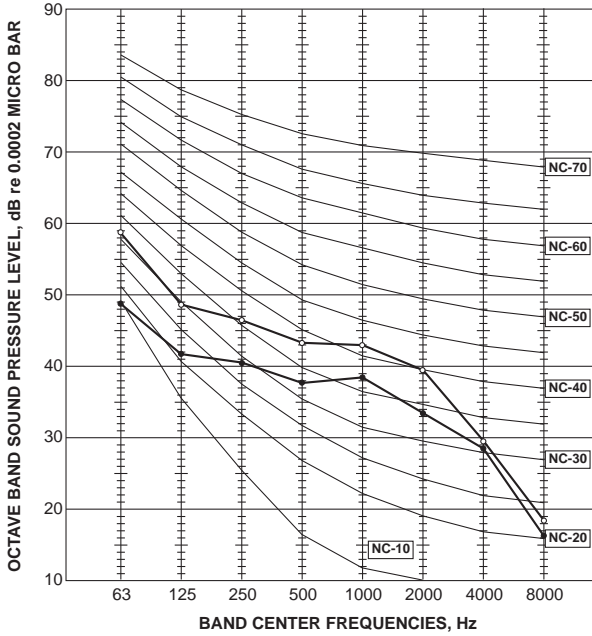

MSZ-SF50VE3

INDOOR UNIT

FAN SPEED	FUNCTION	SPL(dB(A))	LINE
Super High	COOLING	45	●—●
	HEATING	49	○—○

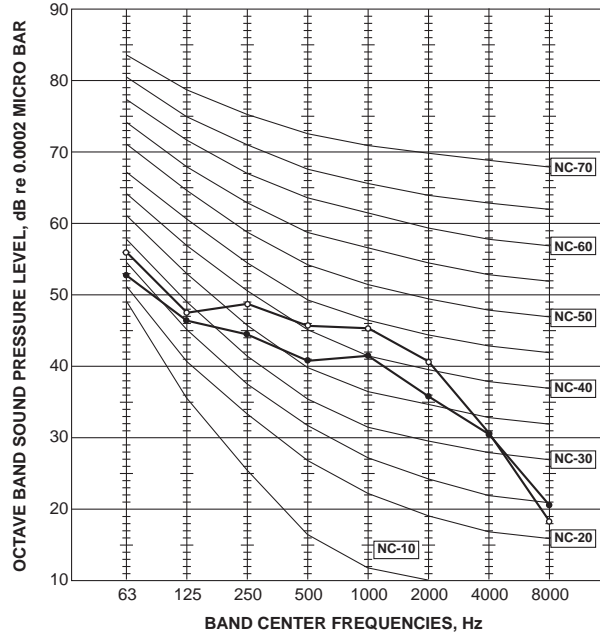

MSZ-GF60VE2

INDOOR UNIT

FAN SPEED	FUNCTION	SPL(dB(A))	LINE
Super High	COOLING	49	●—●
	HEATING	49	○—○

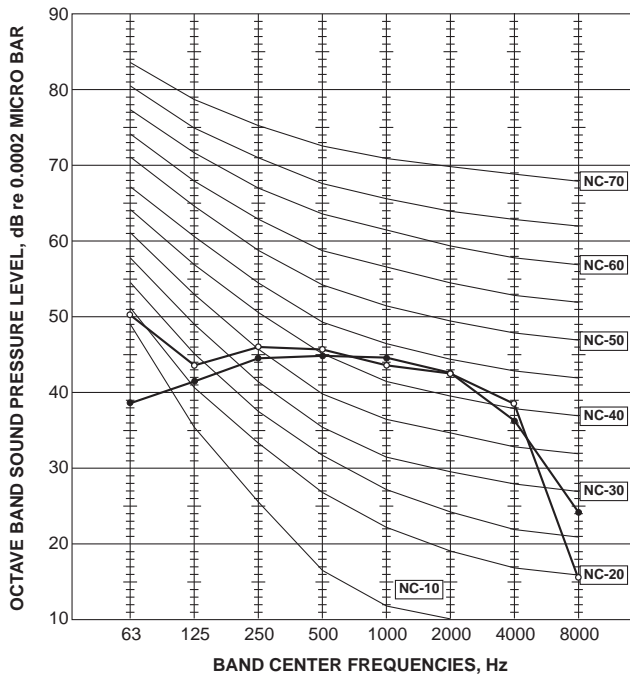

MSZ-GF71VE2

INDOOR UNIT

FAN SPEED	FUNCTION	SPL(dB(A))	LINE
Super High	COOLING	49	●—●
	HEATING	49	○—○

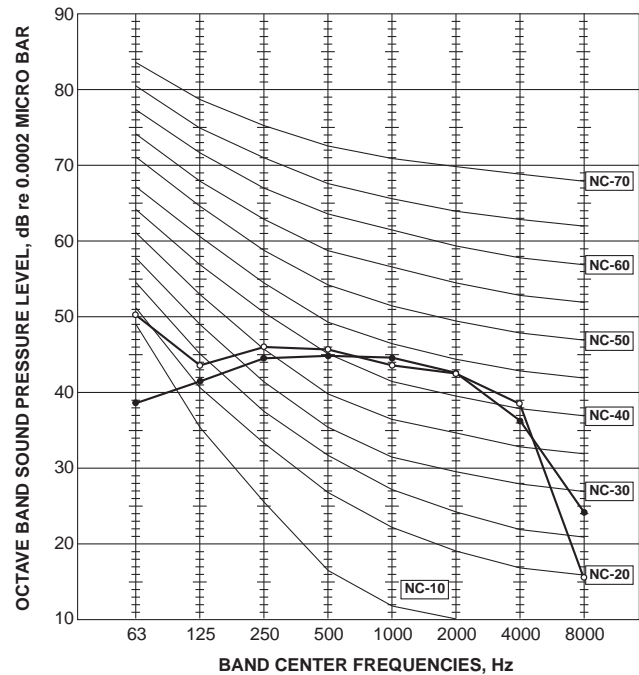

NOISE CRITERIA CURVES

WALL-MOUNTED

MSZ-WN25VA

INDOOR UNIT

FAN SPEED	FUNCTION	SPL(dB(A))	LINE
Super High	COOLING	43	●—●
	HEATING	43	○—○

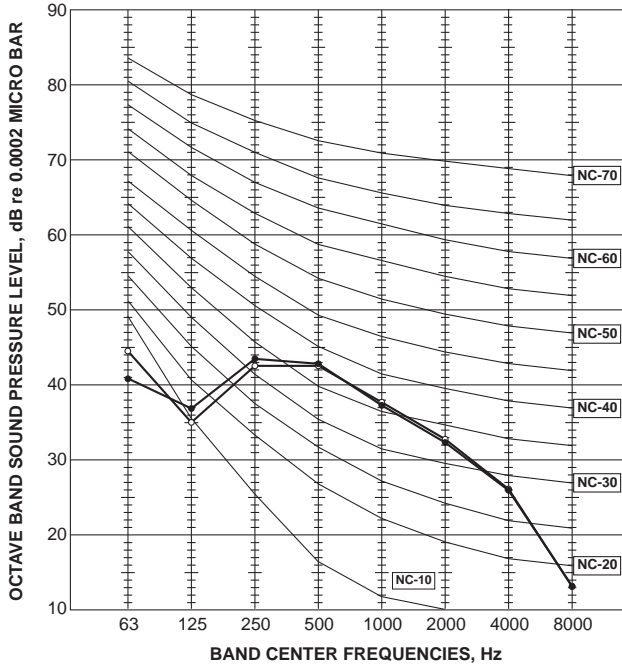

MSZ-WN35VA

INDOOR UNIT

FAN SPEED	FUNCTION	SPL(dB(A))	LINE
Super High	COOLING	46	●—●
	HEATING	44	○—○

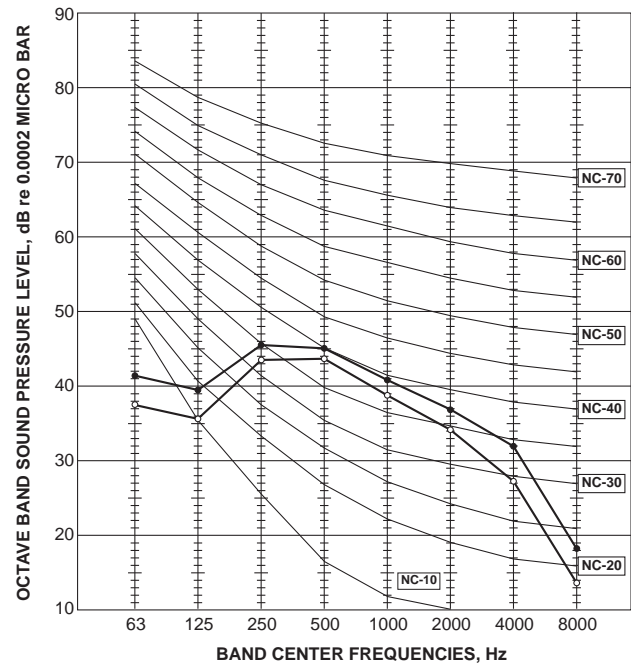

MSZ-DM25VA

INDOOR UNIT

FAN SPEED	FUNCTION	SPL(dB(A))	LINE
Super High	COOLING	43	●—●
	HEATING	43	○—○

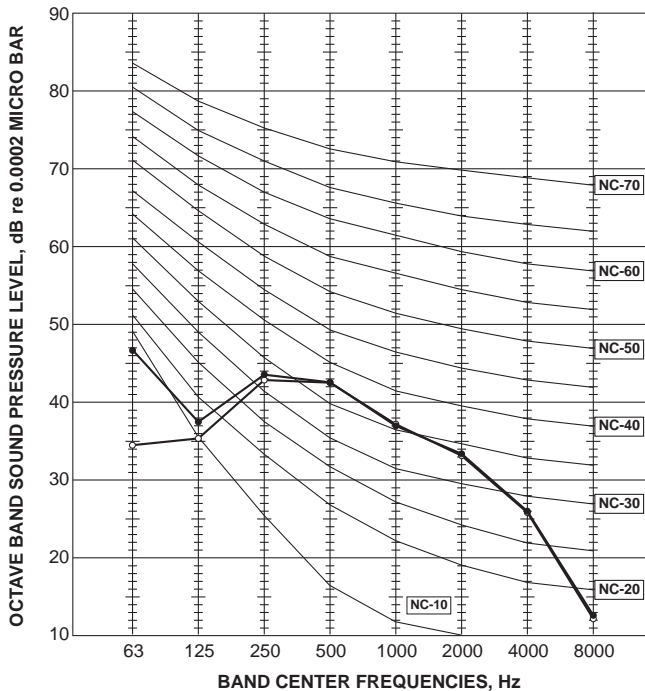

MSZ-DM35VA

INDOOR UNIT

FAN SPEED	FUNCTION	SPL(dB(A))	LINE
Super High	COOLING	45	●—●
	HEATING	44	○—○

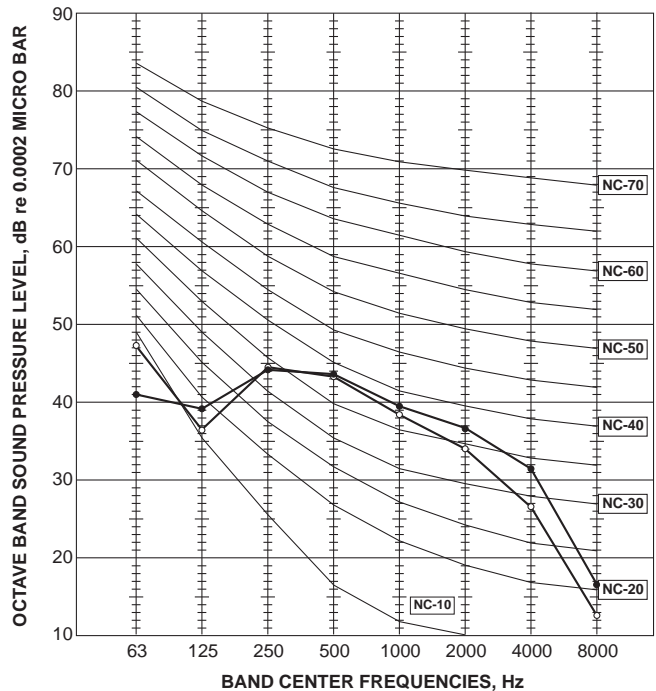

WALL-MOUNTED NOISE CRITERIA CURVES

MSZ-HJ25VA

INDOOR UNIT

FAN SPEED	FUNCTION	SPL(dB(A))	LINE
Super High	COOLING	43	●—●
	HEATING	43	○—○

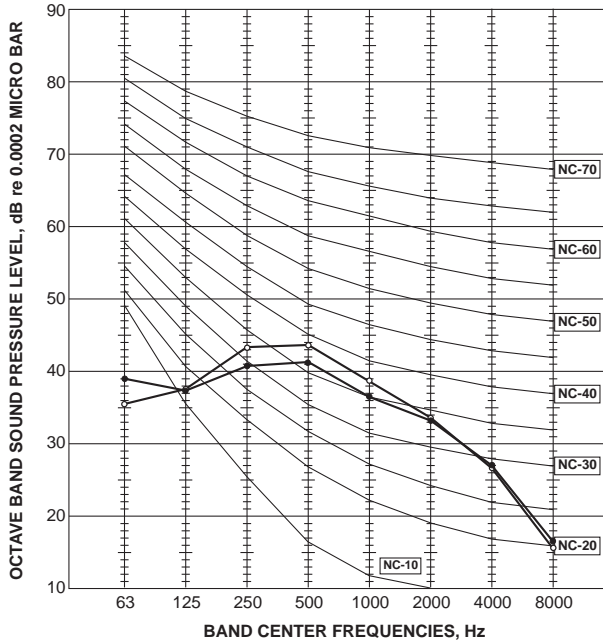

MSZ-HJ35VA

INDOOR UNIT

FAN SPEED	FUNCTION	SPL(dB(A))	LINE
Super High	COOLING	45	●—●
	HEATING	44	○—○

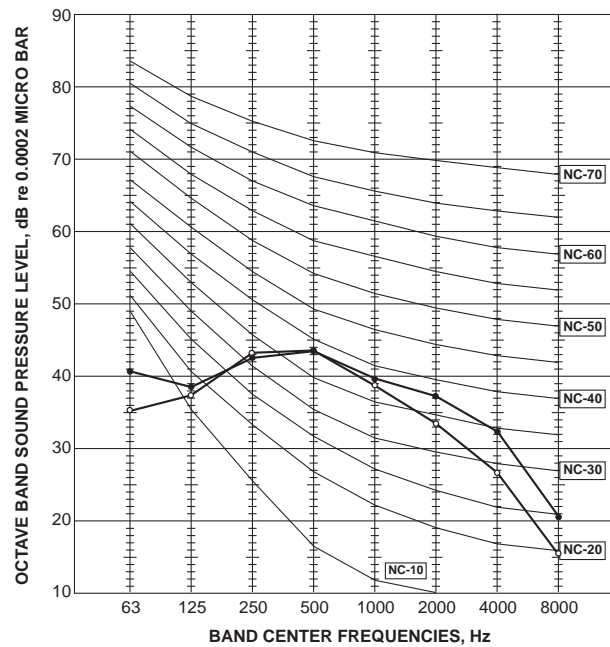

MSZ-HJ50VA

INDOOR UNIT

FAN SPEED	FUNCTION	SPL(dB(A))	LINE
Super High	COOLING	45	●—●
	HEATING	47	○—○

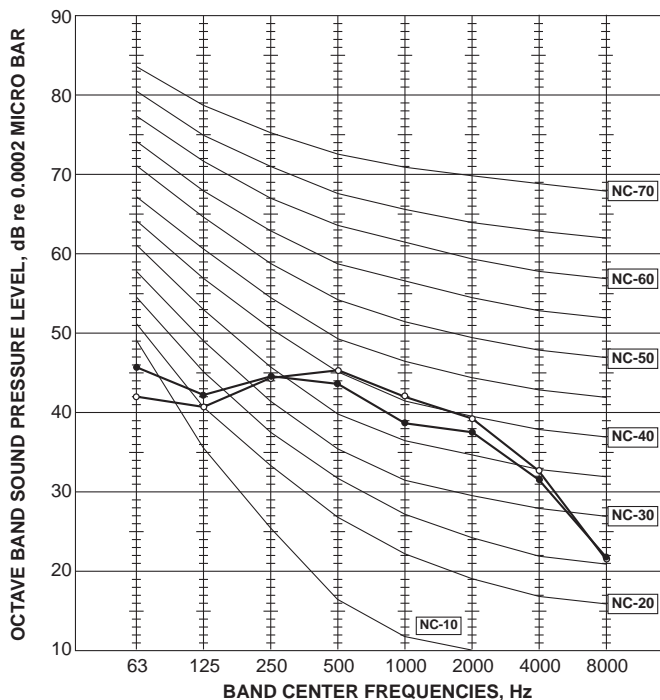

MSZ-HJ60VA

INDOOR UNIT

FAN SPEED	FUNCTION	SPL(dB(A))	LINE
Super High	COOLING	50	●—●
	HEATING	49	○—○

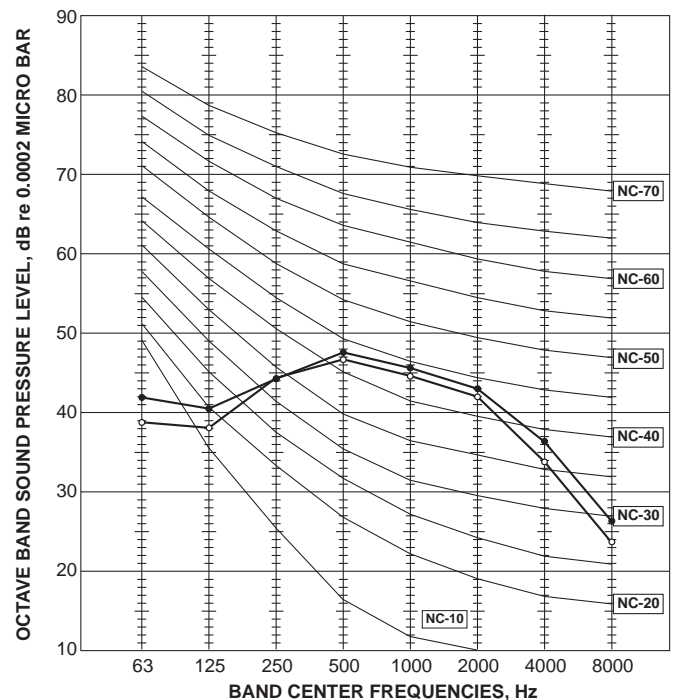

NOISE CRITERIA CURVES

WALL-MOUNTED

MSZ-HJ71VA

INDOOR UNIT

FAN SPEED	FUNCTION	SPL(dB(A))	LINE
Super High	COOLING	50	●—●
	HEATING	49	○—○

Test conditions

Cooling: Dry-bulb temperature 27 °C Wet-bulb temperature 19 °C
 Heating: Dry-bulb temperature 20 °C (MSZ)

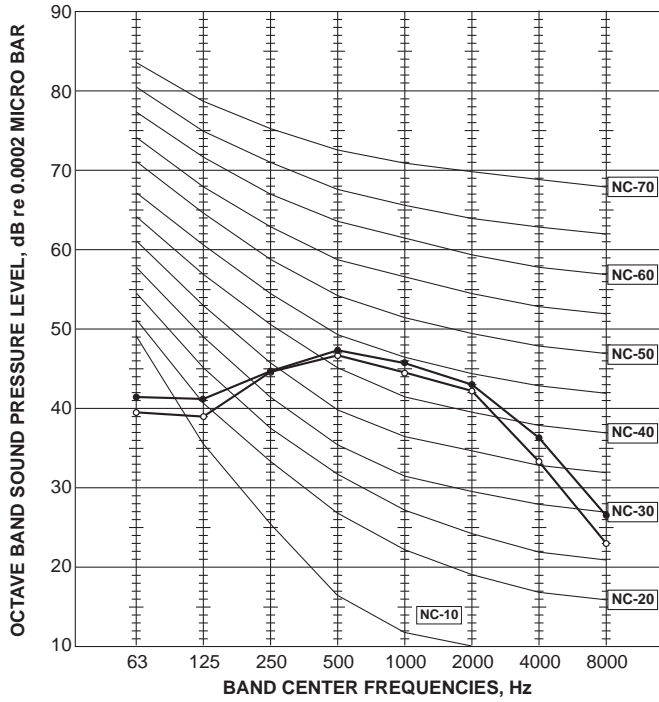
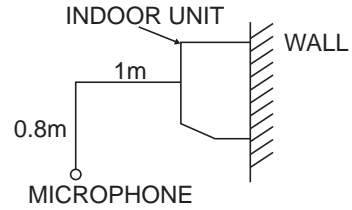

WALL-MOUNTED NOISE CRITERIA CURVES

**C.1.7.2 Outdoor Unit
MUZ-RW25VGHZ**

OUTDOOR UNIT

FUNCTION	SPL(dB(A))	LINE
COOLING	46	●—●
HEATING	49	○—○

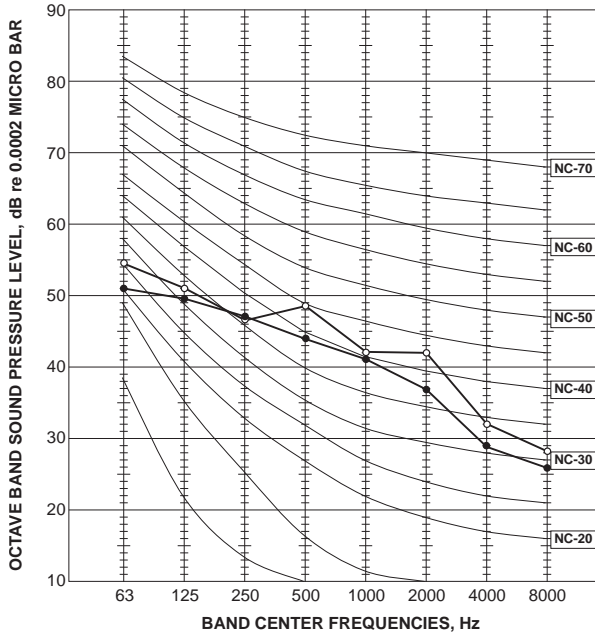

MUZ-RW35VGHZ

OUTDOOR UNIT

FUNCTION	SPL(dB(A))	LINE
COOLING	49	●—●
HEATING	50	○—○

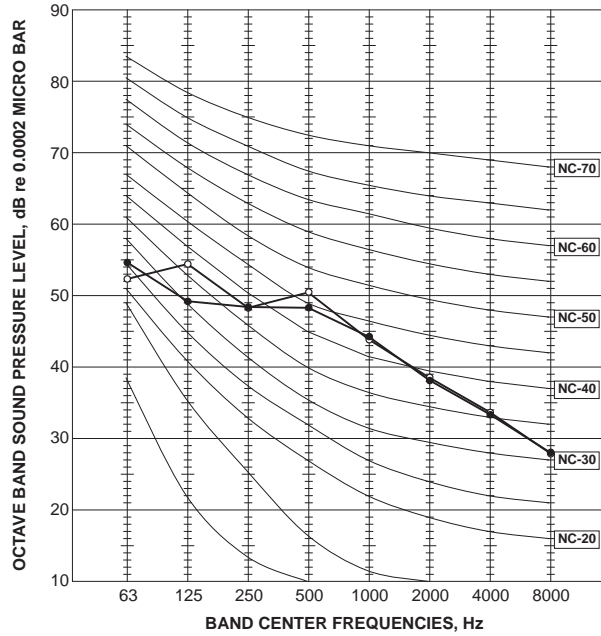

MUZ-RW50VGHZ

OUTDOOR UNIT

FUNCTION	SPL(dB(A))	LINE
COOLING	51	●—●
HEATING	54	○—○

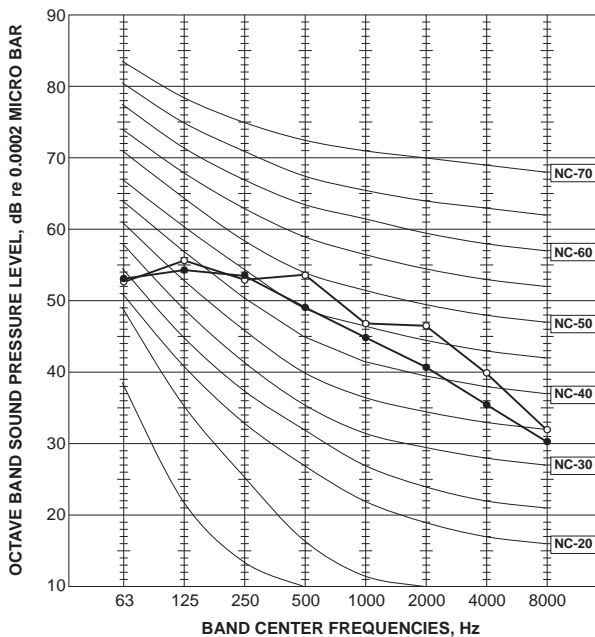

<Notes>

- 1) Sound data is taken when the system is running stably.
- 2) Relatively large noise could be heard transiently in the case 4-way valve, or LEV operates.

MUZ-LN25VG2

OUTDOOR UNIT

FUNCTION	SPL(dB(A))	LINE
COOLING	46	●—●
HEATING	49	○—○

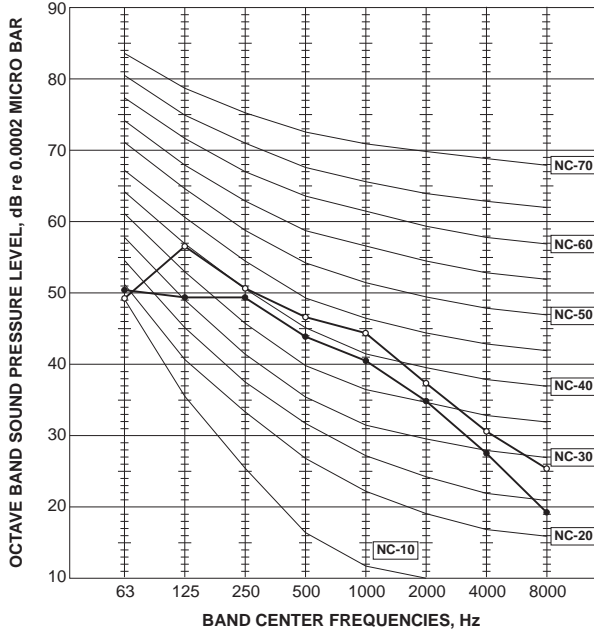

MUZ-LN25VGHZ2

OUTDOOR UNIT

FUNCTION	SPL(dB(A))	LINE
COOLING	46	●—●
HEATING	49	○—○

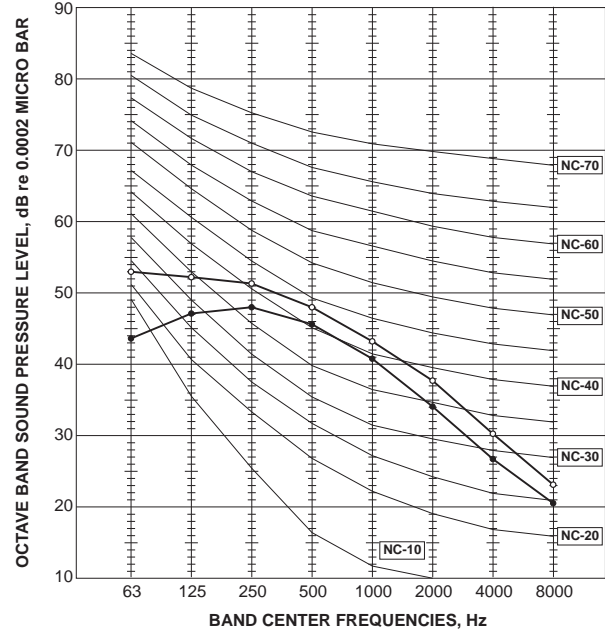

MUZ-LN35VG2

OUTDOOR UNIT

FUNCTION	SPL(dB(A))	LINE
COOLING	49	●—●
HEATING	50	○—○

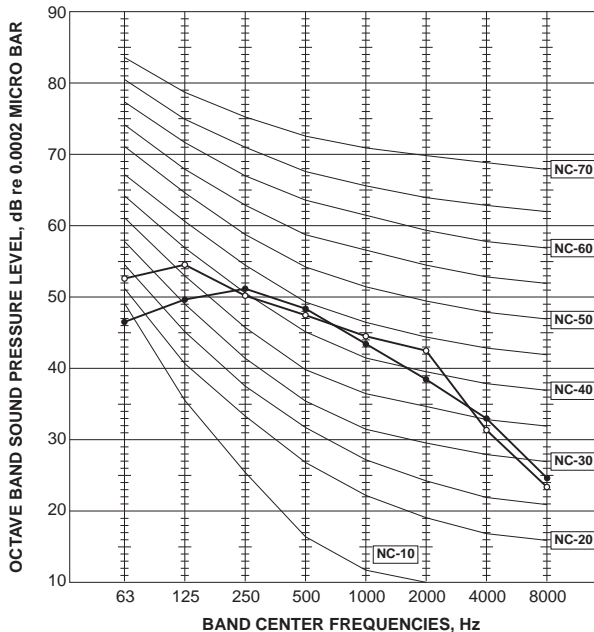

MUZ-LN35VGHZ2

OUTDOOR UNIT

FUNCTION	SPL(dB(A))	LINE
COOLING	49	●—●
HEATING	50	○—○

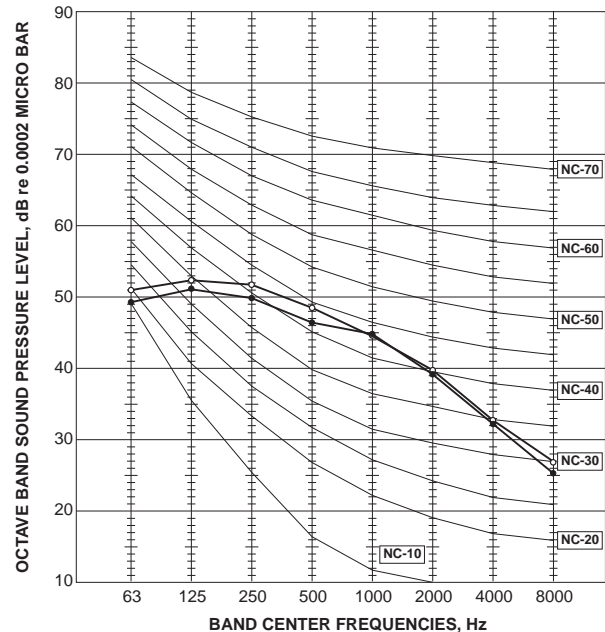

<Notes>

- 1) Sound data is taken when the system is running stably.
- 2) Relatively large noise could be heard transiently in the case 4-way valve, or LEV operates.

MUZ-LN50VG2

OUTDOOR UNIT

FUNCTION	SPL(dB(A))	LINE
COOLING	51	●—●
HEATING	54	○—○

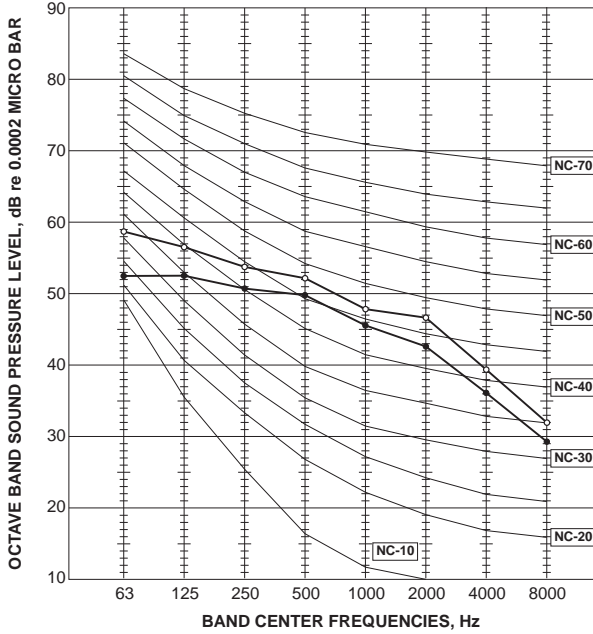

MUZ-LN50VGHZ2

OUTDOOR UNIT

FUNCTION	SPL(dB(A))	LINE
COOLING	51	●—●
HEATING	54	○—○

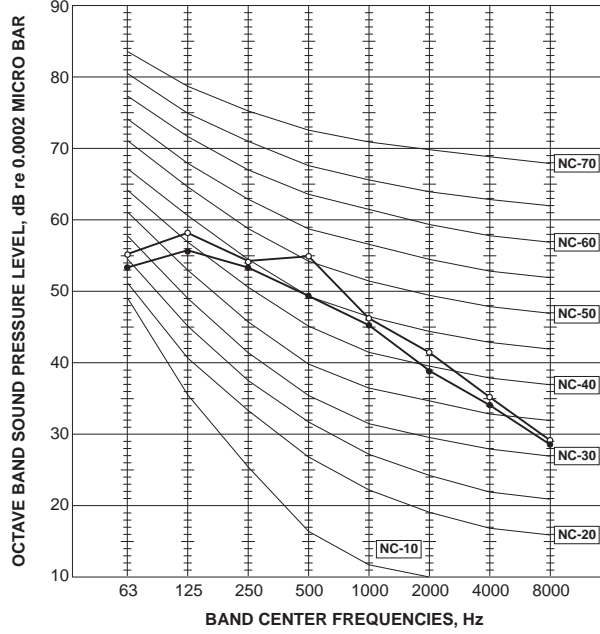

MUZ-LN60VG2

OUTDOOR UNIT

FUNCTION	SPL(dB(A))	LINE
COOLING	55	●—●
HEATING	55	○—○

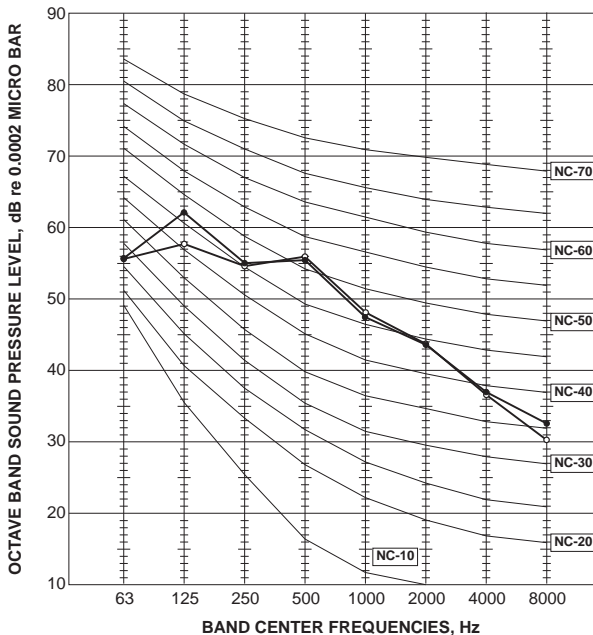

<Notes>

- 1) Sound data is taken when the system is running stably.
- 2) Relatively large noise could be heard transiently in the case 4-way valve, or LEV operates.

MUZ-FT25VGHZ

OUTDOOR UNIT

FUNCTION	SPL(dB(A))	LINE
COOLING	46	●—●
HEATING	49	□—□

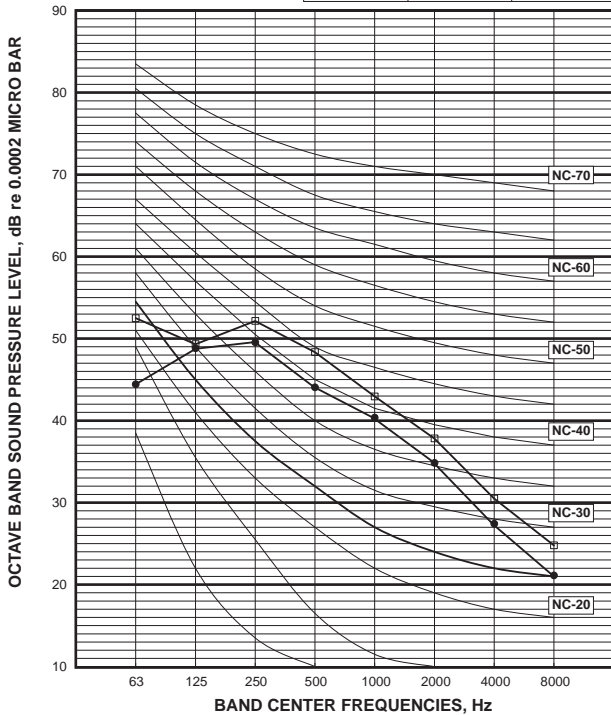

MUZ-FT35VGHZ

OUTDOOR UNIT

FUNCTION	SPL(dB(A))	LINE
COOLING	49	●—●
HEATING	50	□—□

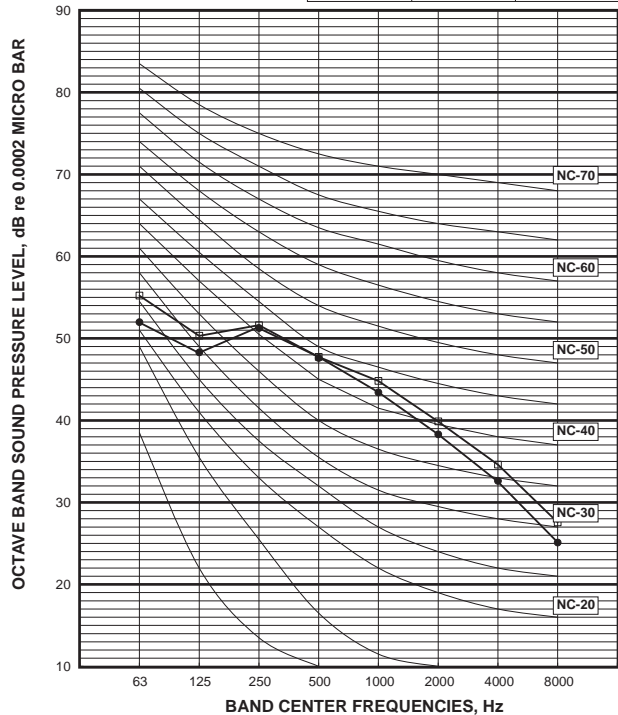

MUZ-FT50VGHZ

OUTDOOR UNIT

FUNCTION	SPL(dB(A))	LINE
COOLING	51	●—●
HEATING	54	□—□

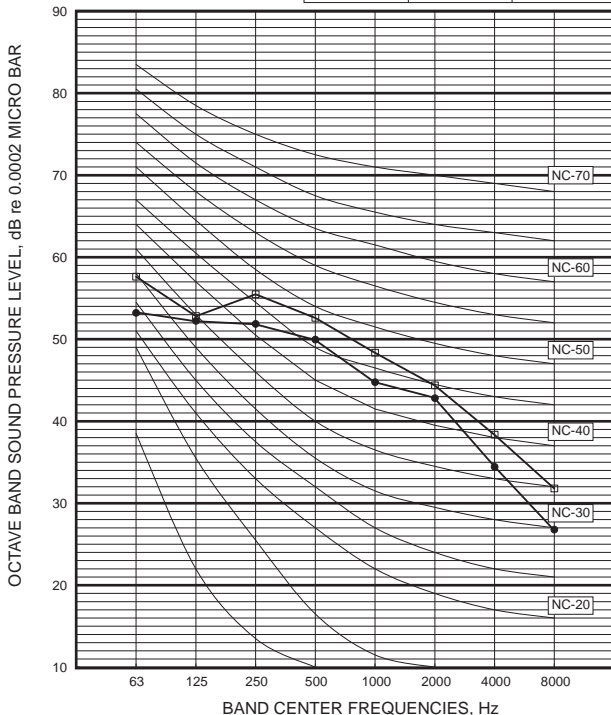

<Notes>

- 1) Sound data is taken when the system is running stably.
- 2) Relatively large noise could be heard transiently in the case 4-way valve, or LEV operates.

WALL-MOUNTED NOISE CRITERIA CURVES

**MUZ-AY25VG
MUZ-AY25VGH**

OUTDOOR UNIT

FUNCTION	SPL(dB(A))	LINE
COOLING	47	●—●
HEATING	48	○—○

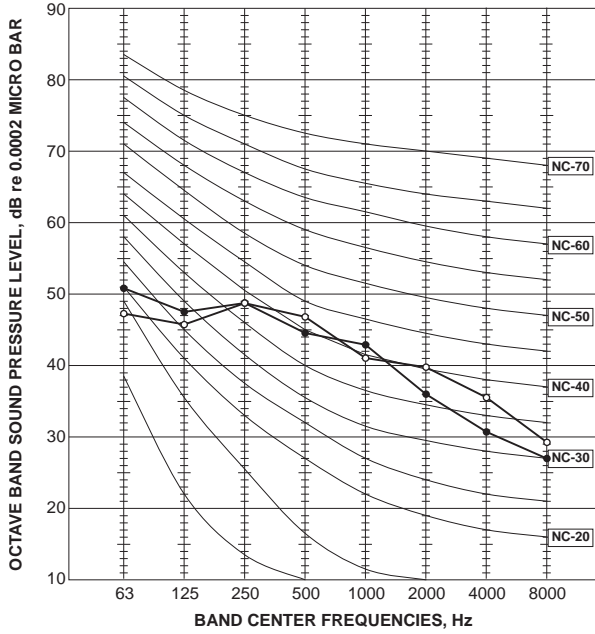

**MUZ-AY35VG
MUZ-AY35VGH**

OUTDOOR UNIT

FUNCTION	SPL(dB(A))	LINE
COOLING	49	●—●
HEATING	50	○—○

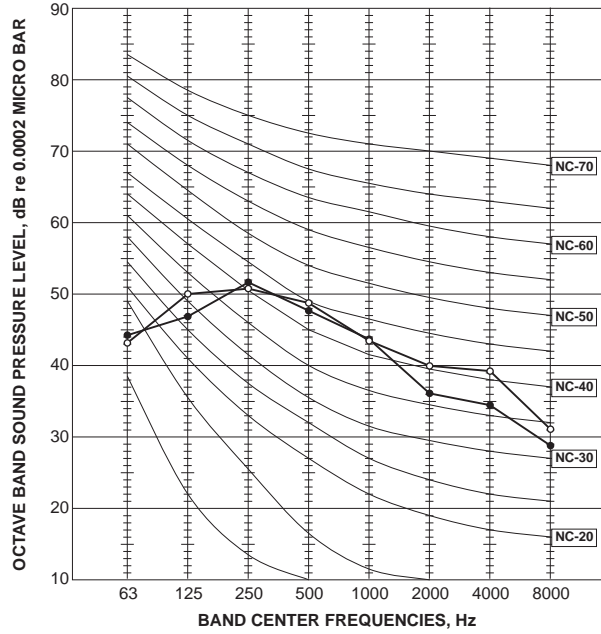

**MUZ-AY42VG
MUZ-AY42VGH**

OUTDOOR UNIT

FUNCTION	SPL(dB(A))	LINE
COOLING	50	●—●
HEATING	51	○—○

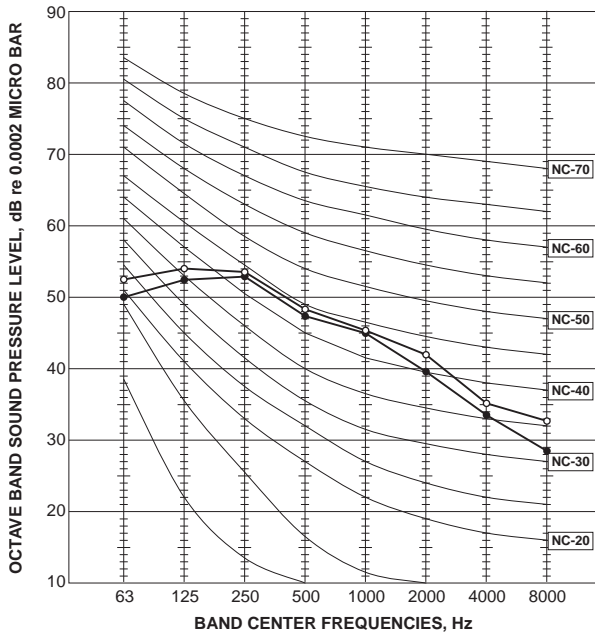

**MUZ-AY50VG
MUZ-AY50VGH**

OUTDOOR UNIT

FUNCTION	SPL(dB(A))	LINE
COOLING	52	●—●
HEATING	52	○—○

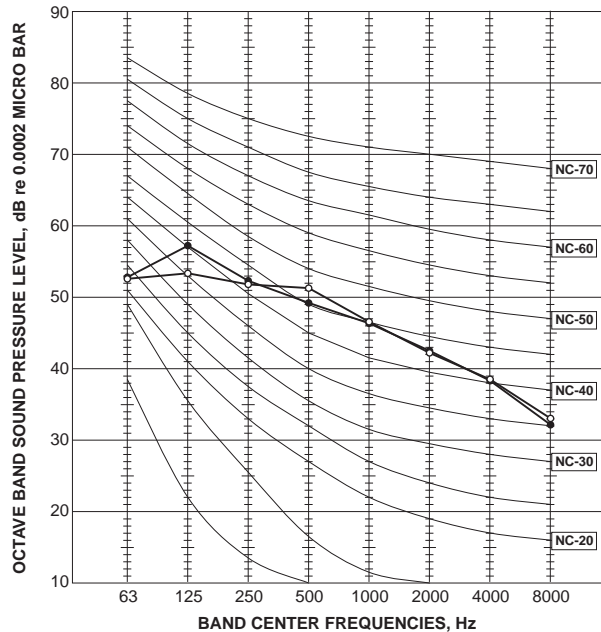

<Notes>

- 1) Sound data is taken when the system is running stably.
- 2) Relatively large noise could be heard transiently in the case 4-way valve, or LEV operates.

MUZ-AP15VG

OUTDOOR UNIT

FAN SPEED	FUNCTION	SPL(dB(A))	LINE
Super High	COOLING	50	●—●
	HEATING	50	○—○

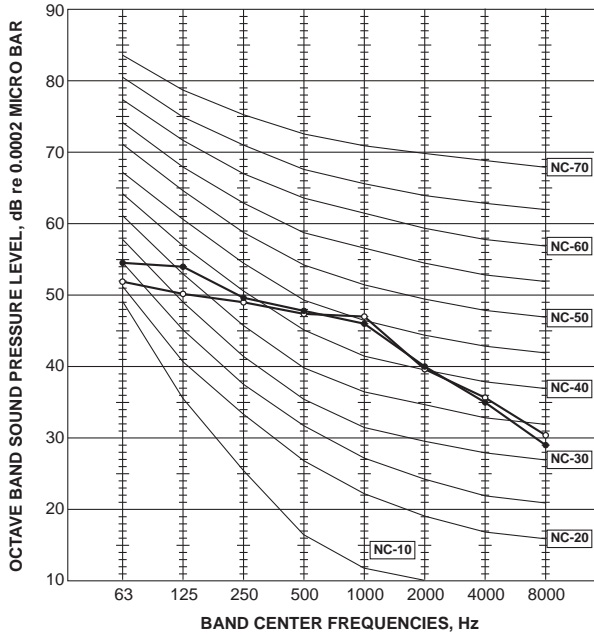

MUZ-AP20VG

OUTDOOR UNIT

FAN SPEED	FUNCTION	SPL(dB(A))	LINE
Super High	COOLING	47	●—●
	HEATING	48	○—○

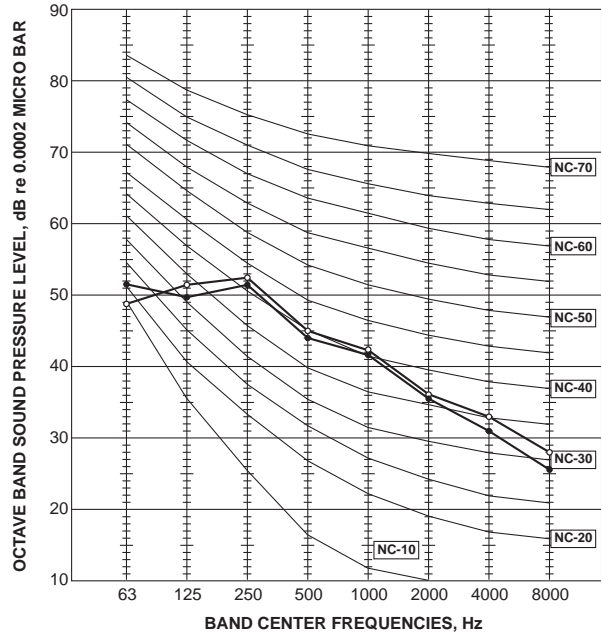

MUZ-AP60VG

OUTDOOR UNIT

FUNCTION	SPL(dB(A))	LINE
COOLING	56	●—●
HEATING	57	○—○

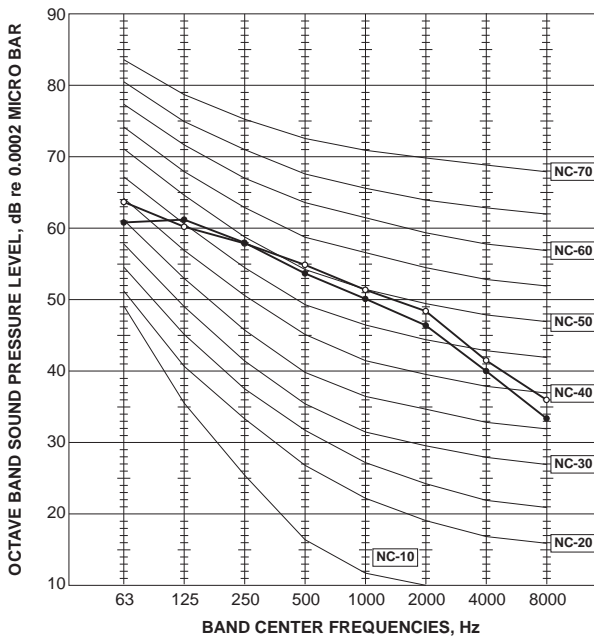

MUZ-AP71VG

OUTDOOR UNIT

FUNCTION	SPL(dB(A))	LINE
COOLING	56	●—●
HEATING	55	○—○

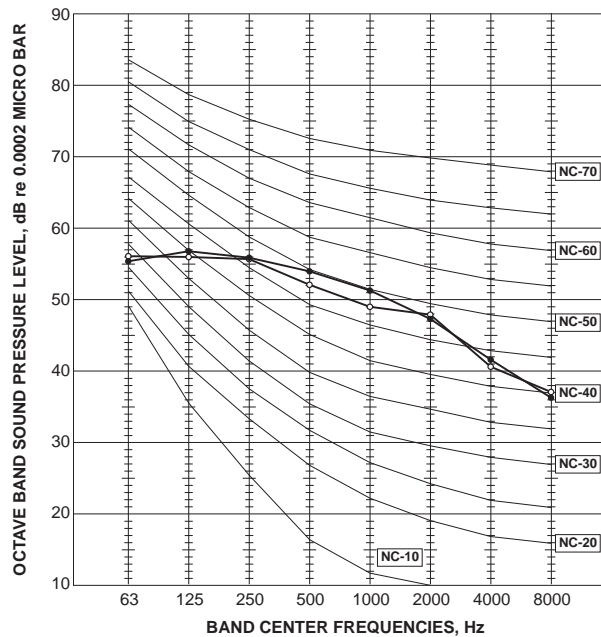

<Notes>

- 1) Sound data is taken when the system is running stably.
- 2) Relatively large noise could be heard transiently in the case 4-way valve, or LEV operates.

MUZ-HR25VF

OUTDOOR UNIT

FUNCTION	SPL(dB(A))	LINE
COOLING	50	●—●
HEATING	50	○—○

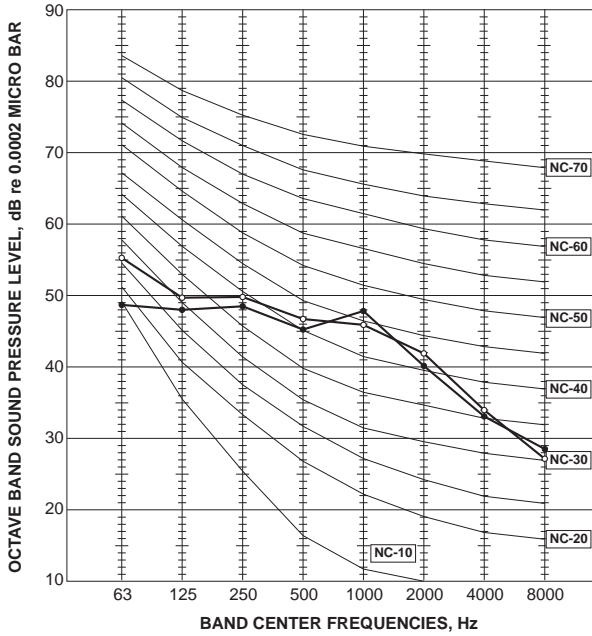

MUZ-HR35VF

OUTDOOR UNIT

FUNCTION	SPL(dB(A))	LINE
COOLING	51	●—●
HEATING	51	○—○

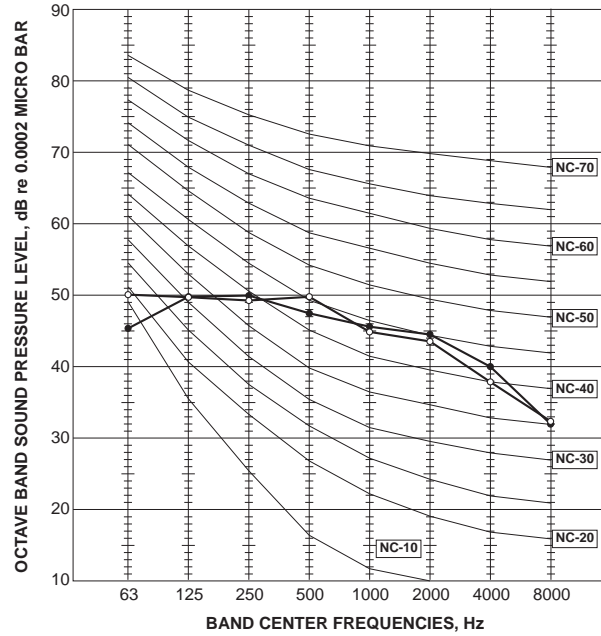

MUZ-HR42VF

OUTDOOR UNIT

FUNCTION	SPL(dB(A))	LINE
COOLING	50	●—●
HEATING	51	○—○

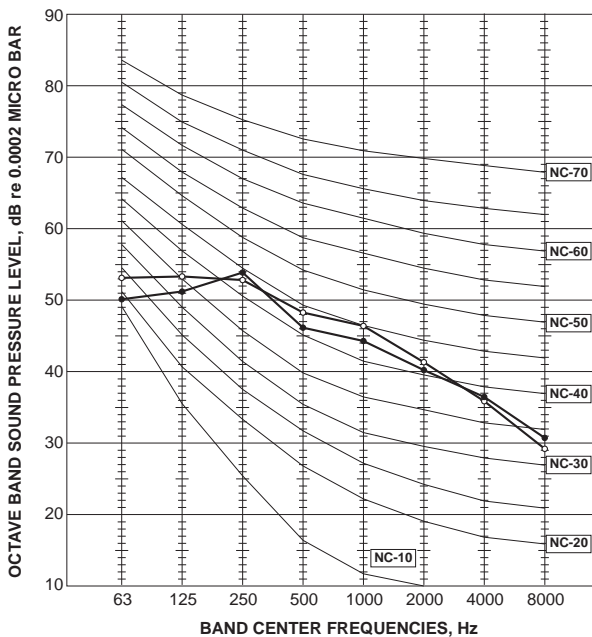

MUZ-HR50VF

OUTDOOR UNIT

FUNCTION	SPL(dB(A))	LINE
COOLING	50	●—●
HEATING	51	○—○

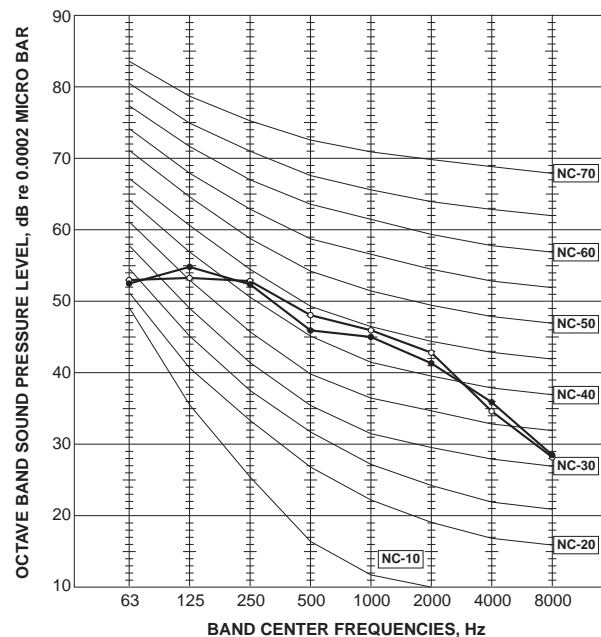

<Notes>

- 1) Sound data is taken when the system is running stably.
- 2) Relatively large noise could be heard transiently in the case 4-way valve, or LEV operates.

MUZ-HR60VF

OUTDOOR UNIT

FUNCTION	SPL(dB(A))	LINE
COOLING	53	●—●
HEATING	57	○—○

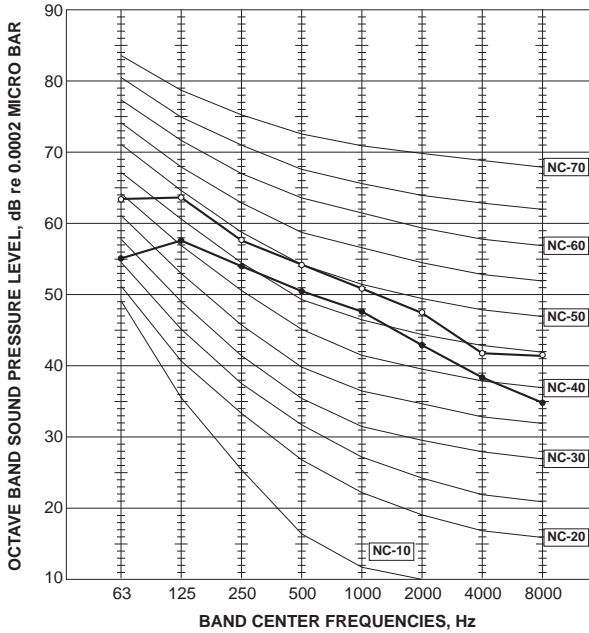

MUZ-HR71VF

OUTDOOR UNIT

FUNCTION	SPL(dB(A))	LINE
COOLING	53	●—●
HEATING	57	○—○

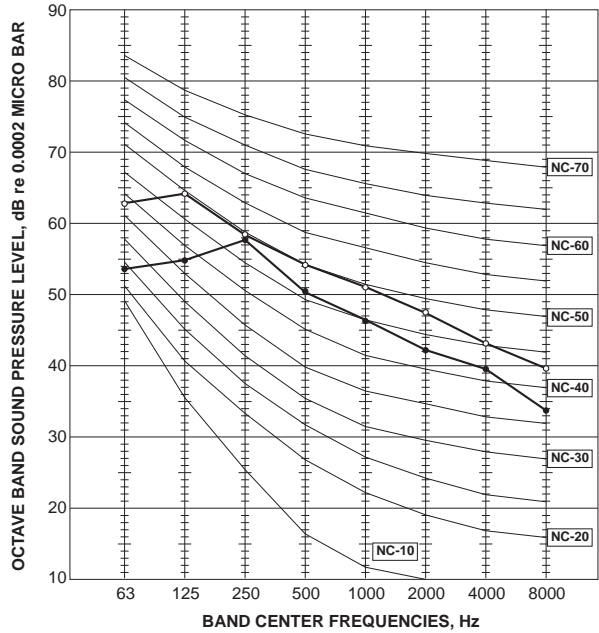

MUY-TP35VF

OUTDOOR UNIT

FUNCTION	SPL(dB(A))	LINE
COOLING	45	●—●

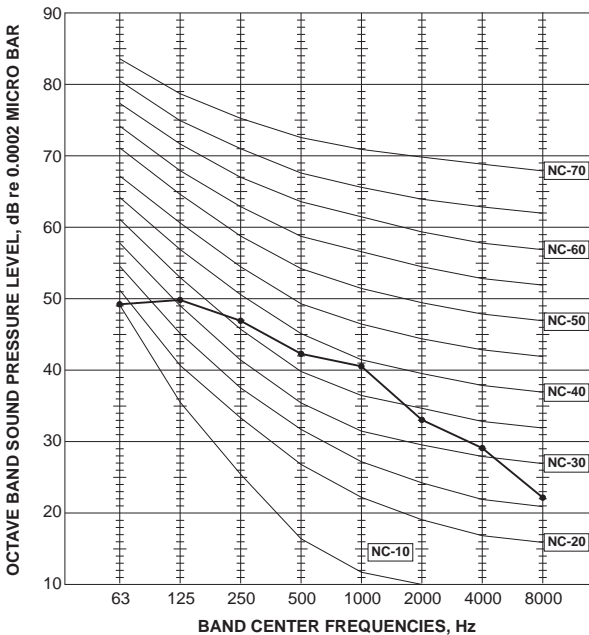

MUY-TP50VF

OUTDOOR UNIT

FUNCTION	SPL(dB(A))	LINE
COOLING	47	●—●

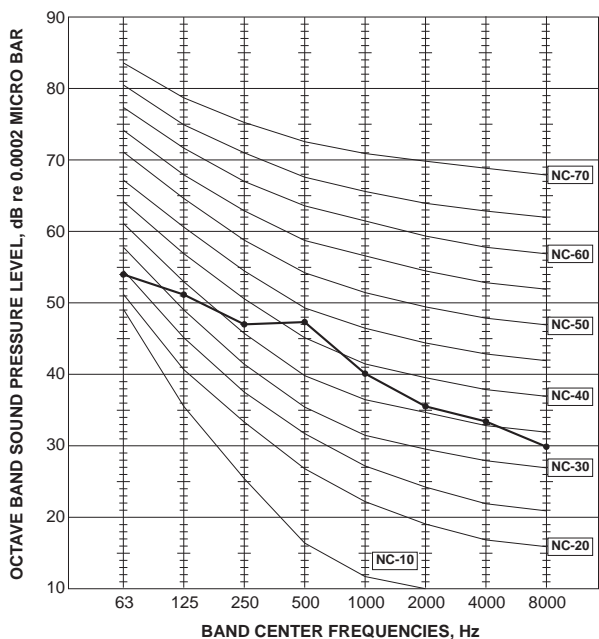

<Notes>

- 1) Sound data is taken when the system is running stably.
- 2) Relatively large noise could be heard transiently in the case 4-way valve, or LEV operates.

MUZ-FH25VE

OUTDOOR UNIT

FUNCTION	SPL(dB(A))	LINE
COOLING	46	●—●
HEATING	49	○—○

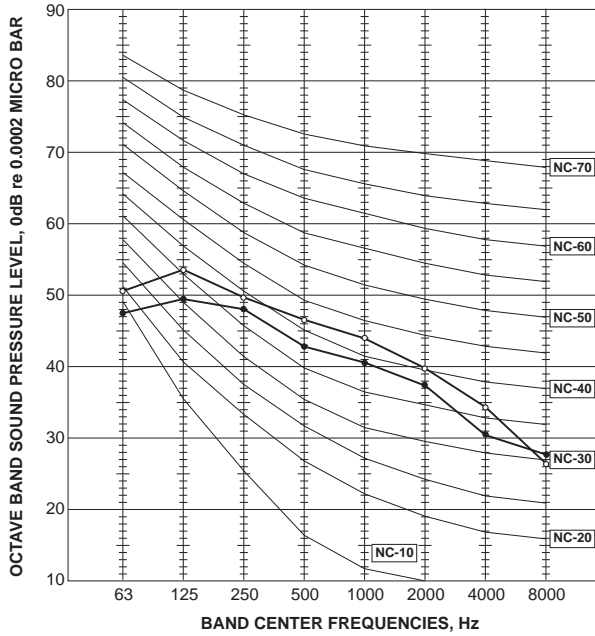

MUZ-FH25VEHZ

OUTDOOR UNIT

FUNCTION	SPL(dB(A))	LINE
COOLING	46	●—●
HEATING	49	○—○

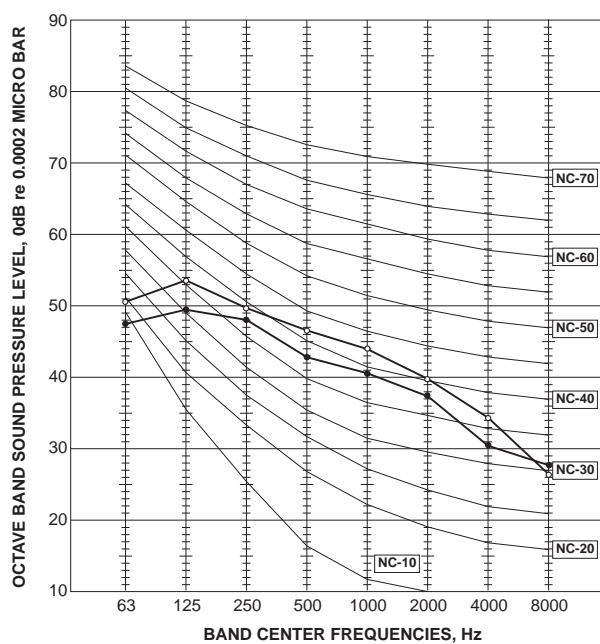

MUZ-FH35VE

OUTDOOR UNIT

FUNCTION	SPL(dB(A))	LINE
COOLING	49	●—●
HEATING	50	○—○

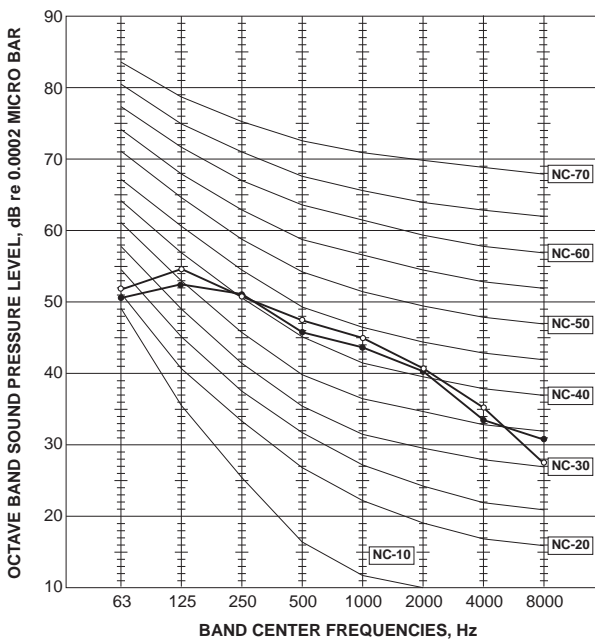

MUZ-FH35VEHZ

OUTDOOR UNIT

FUNCTION	SPL(dB(A))	LINE
COOLING	49	●—●
HEATING	50	○—○

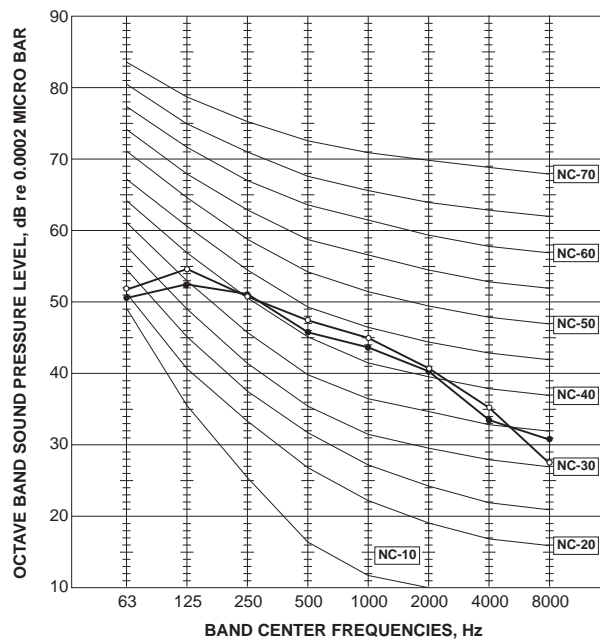

<Notes>

- 1) Sound data is taken when the system is running stably.
- 2) Relatively large noise could be heard transiently in the case 4-way valve, or LEV operates.

MUZ-FH50VE

OUTDOOR UNIT

FUNCTION	SPL(dB(A))	LINE
COOLING	51	●—●
HEATING	54	○—○

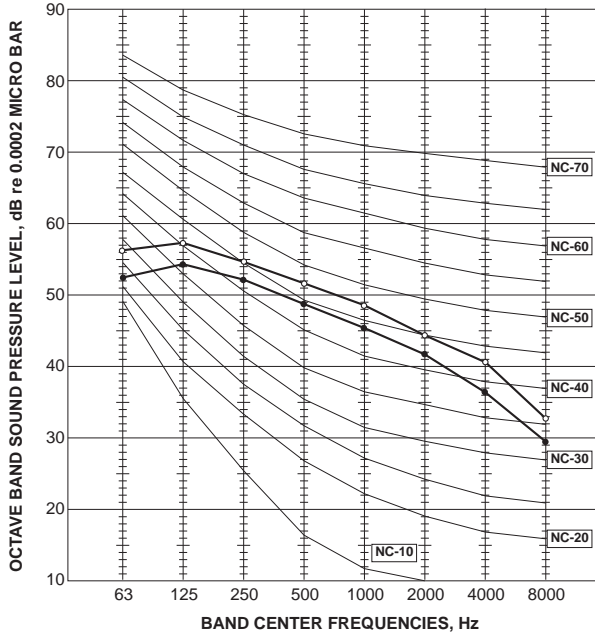

MUZ-FH50VEHZ

OUTDOOR UNIT

FUNCTION	SPL(dB(A))	LINE
COOLING	51	●—●
HEATING	54	○—○

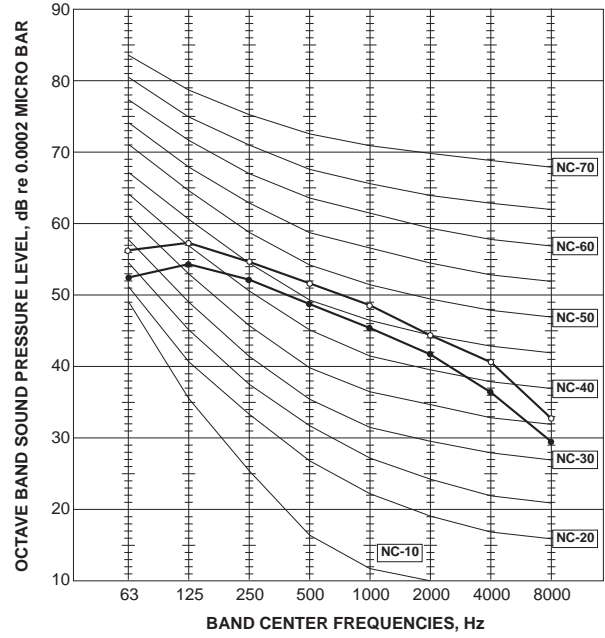

<Notes>

- 1) Sound data is taken when the system is running stably.
- 2) Relatively large noise could be heard transiently in the case 4-way valve, or LEV operates.

**MUZ-EF25VG
MUZ-EF25VGH**

OUTDOOR UNIT

FUNCTION	SPL(dB(A))	LINE
COOLING	47	●—●
HEATING	48	○—○

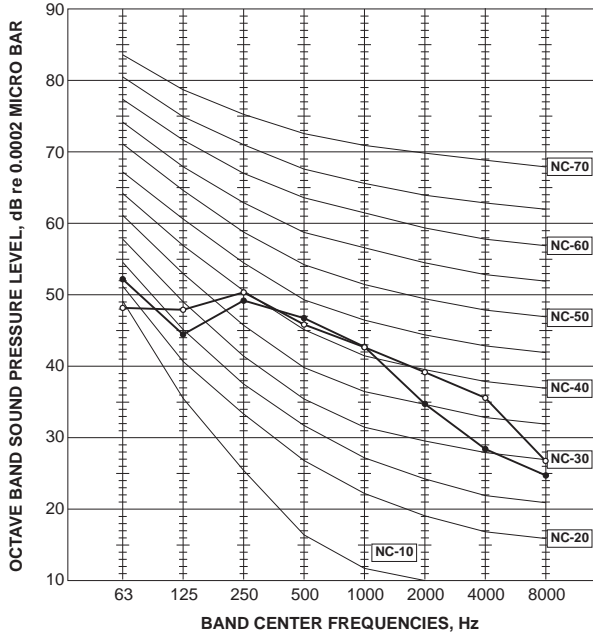

**MUZ-EF35VG
MUZ-EF35VGH**

OUTDOOR UNIT

FUNCTION	SPL(dB(A))	LINE
COOLING	49	●—●
HEATING	50	○—○

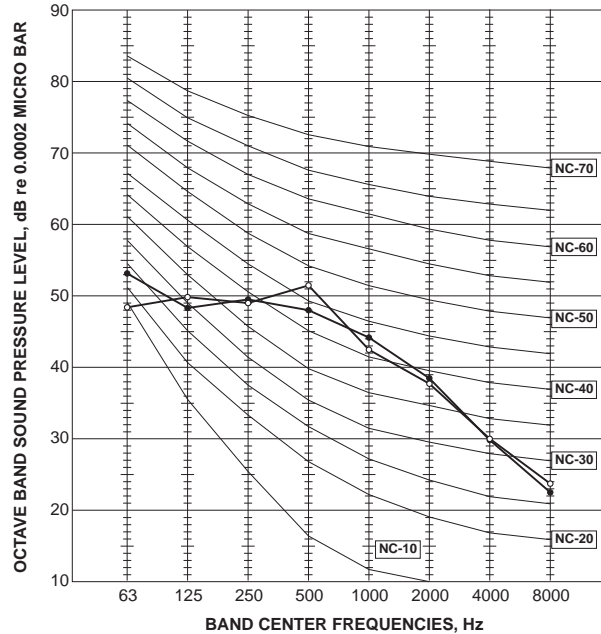

MUZ-EF42VG

OUTDOOR UNIT

FUNCTION	SPL(dB(A))	LINE
COOLING	50	●—●
HEATING	51	○—○

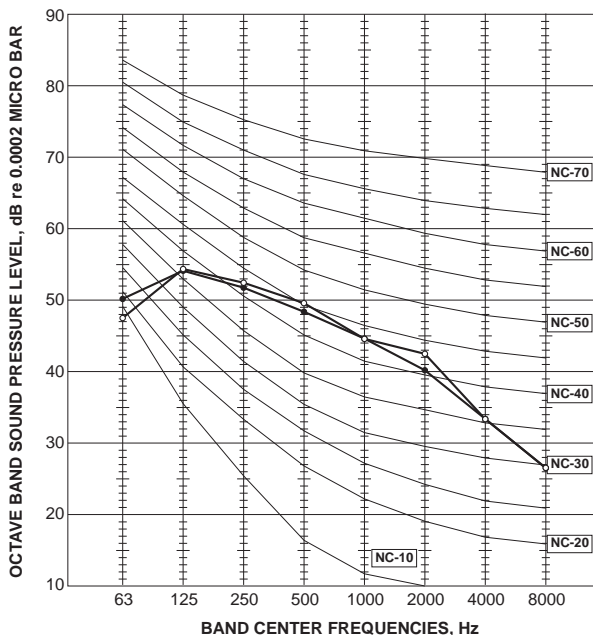

MUZ-EF50VG

OUTDOOR UNIT

FUNCTION	SPL(dB(A))	LINE
COOLING	52	●—●
HEATING	52	○—○

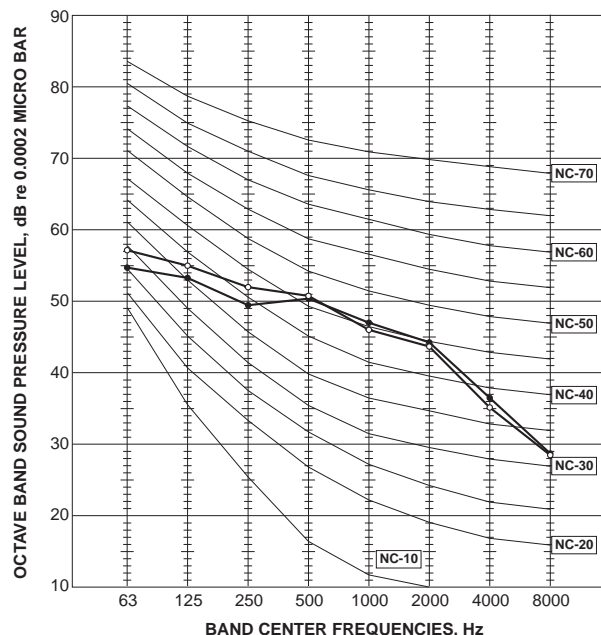

<Notes>

- 1) Sound data is taken when the system is running stably.
- 2) Relatively large noise could be heard transiently in the case 4-way valve, or LEV operates.

MUZ-BT20VG

OUTDOOR UNIT

FUNCTION	SPL(dB(A))	LINE
COOLING	50	● — ●
HEATING	50	□ - - □

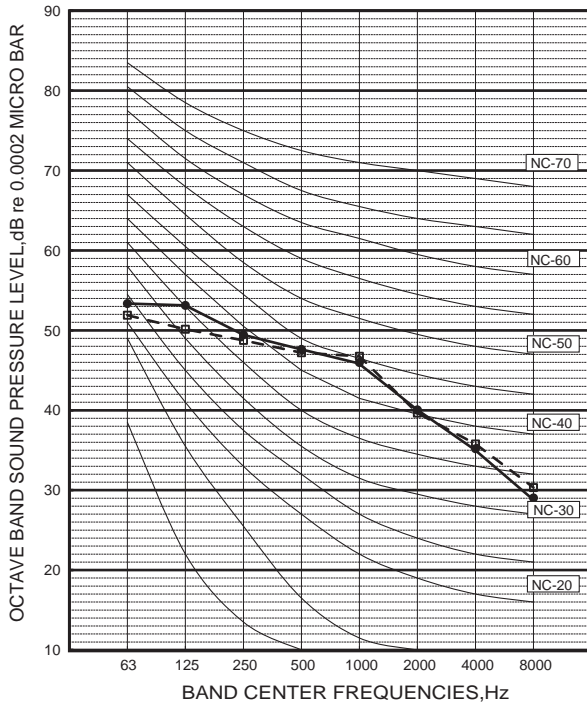

MUZ-BT25VG

OUTDOOR UNIT

FUNCTION	SPL(dB(A))	LINE
COOLING	50	● — ●
HEATING	50	□ - - □

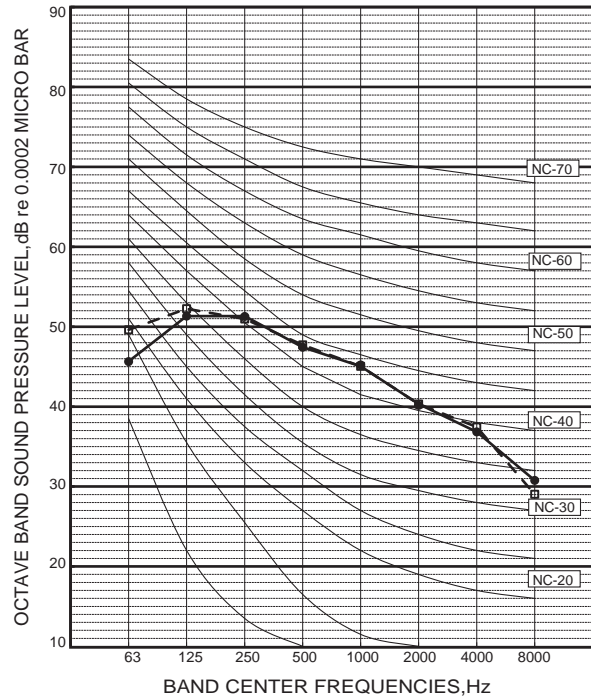

MUZ-BT35VG

OUTDOOR UNIT

FUNCTION	SPL(dB(A))	LINE
COOLING	52	● — ●
HEATING	52	□ - - □

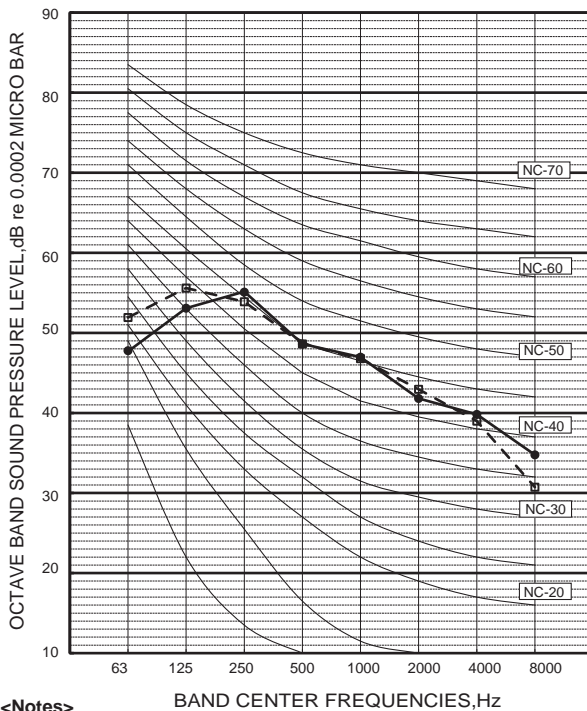

MUZ-BT50VG

OUTDOOR UNIT

FUNCTION	SPL(dB(A))	LINE
COOLING	50	● — ●
HEATING	51	□ - - □

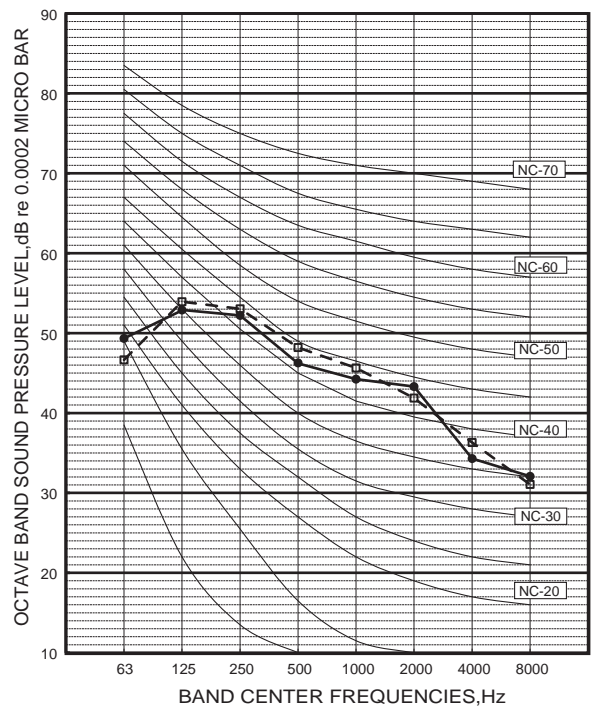

<Notes>

- 1) Sound data is taken when the system is running stably.
- 2) Relatively large noise could be heard transiently in the case 4-way valve, or LEV operates.

MUZ-DW25VF

OUTDOOR UNIT

FUNCTION	SPL(dB(A))	LINE
COOLING	50	●—●
HEATING	50	○—○

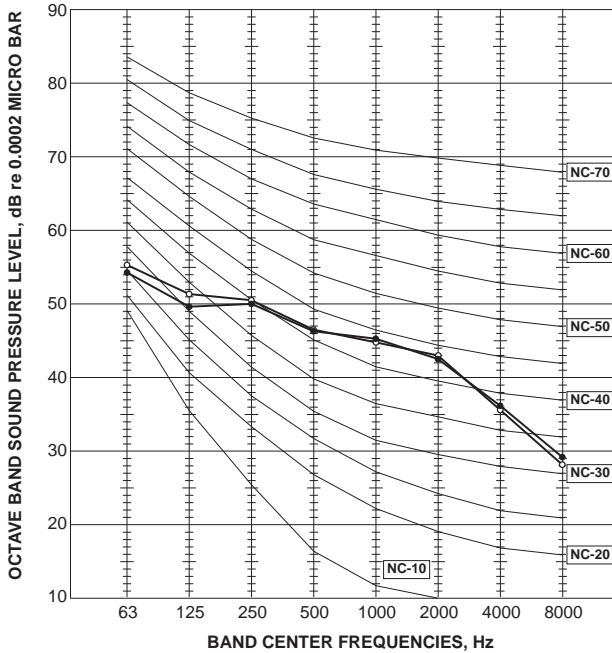

MUZ-DW35VF

OUTDOOR UNIT

FUNCTION	SPL(dB(A))	LINE
COOLING	51	●—●
HEATING	51	○—○

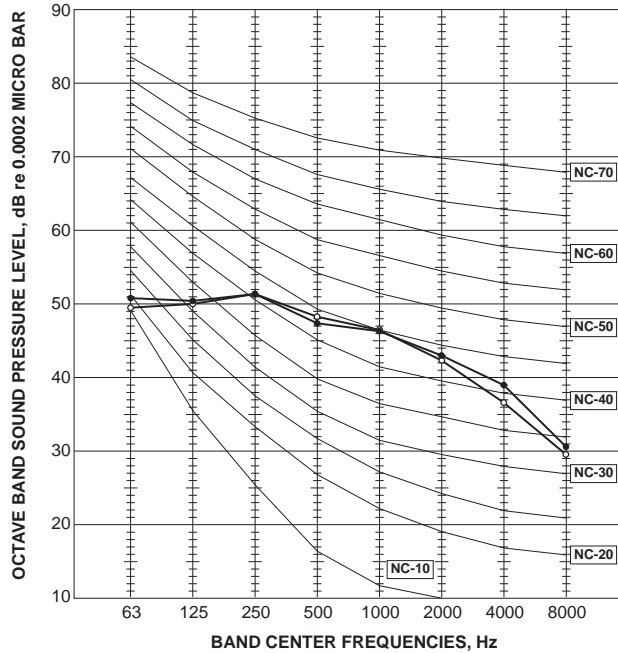

MUZ-DW50VF

OUTDOOR UNIT

FUNCTION	SPL(dB(A))	LINE
COOLING	50	●—●
HEATING	51	○—○

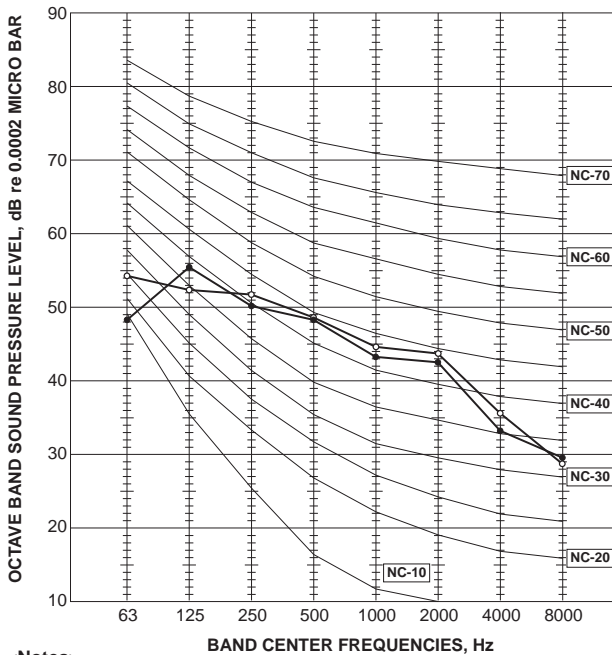

<Notes>

- 1) Sound data is taken when the system is running stably.
- 2) Relatively large noise could be heard transiently in the case 4-way valve, or LEV operates.

**MUZ-SF25VE
MUZ-SF25VEH**

OUTDOOR UNIT

FUNCTION	SPL(dB(A))	LINE
COOLING	47	●—●
HEATING	48	○—○

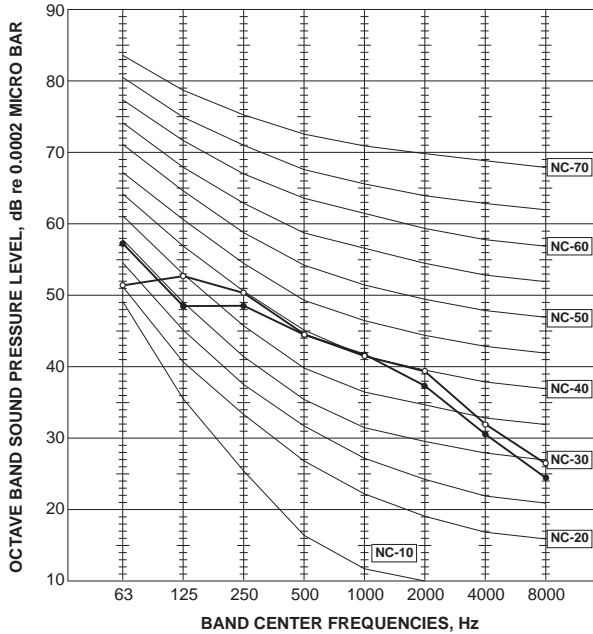

**MUZ-SF35VE
MUZ-SF35VEH**

OUTDOOR UNIT

FUNCTION	SPL(dB(A))	LINE
COOLING	49	●—●
HEATING	50	○—○

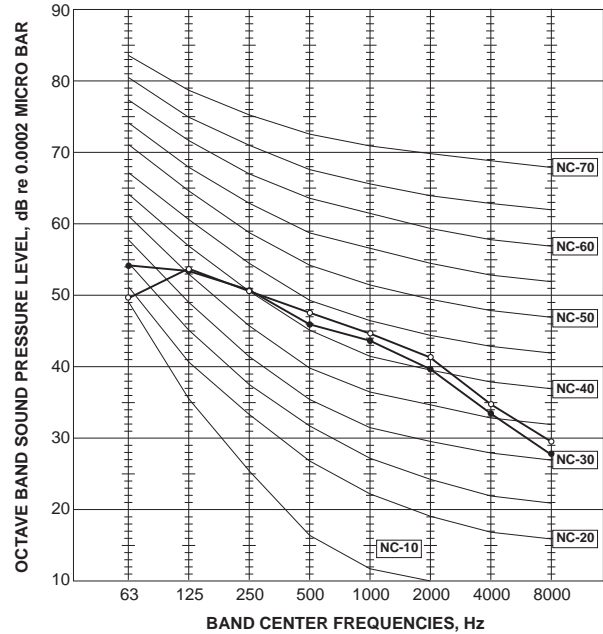

**MUZ-SF42VE
MUZ-SF42VEH**

OUTDOOR UNIT

FUNCTION	SPL(dB(A))	LINE
COOLING	50	●—●
HEATING	51	○—○

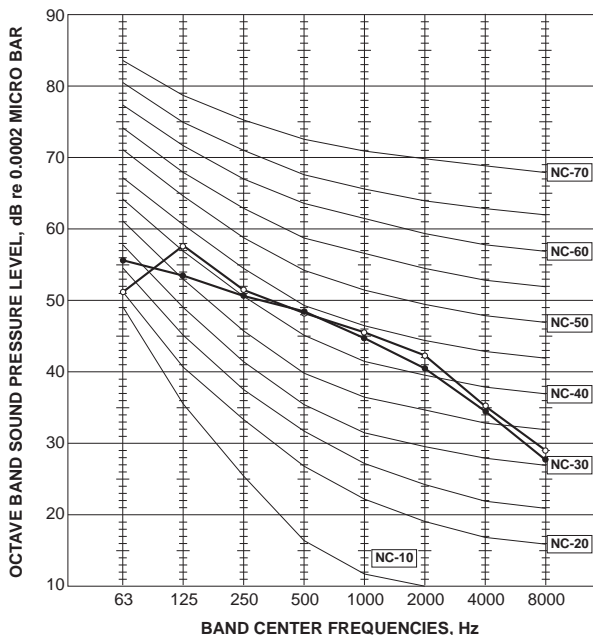

**MUZ-SF50VE
MUZ-SF50VEH**

OUTDOOR UNIT

FUNCTION	SPL(dB(A))	LINE
COOLING	52	●—●
HEATING	52	○—○

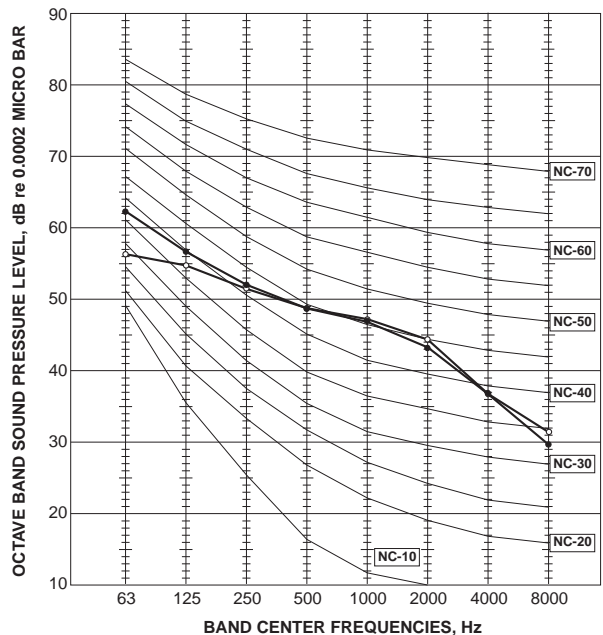

<Notes>

- 1) Sound data is taken when the system is running stably.
- 2) Relatively large noise could be heard transiently in the case 4-way valve, or LEV operates.

MUZ-GF60VE

OUTDOOR UNIT

FUNCTION	SPL(dB(A))	LINE
COOLING	55	●—●
HEATING	55	○—○

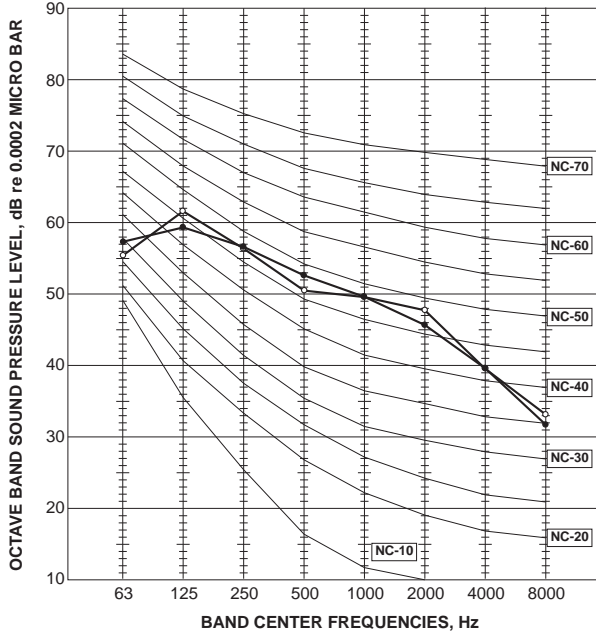

MUZ-GF71VE

OUTDOOR UNIT

FUNCTION	SPL(dB(A))	LINE
COOLING	55	●—●
HEATING	55	○—○

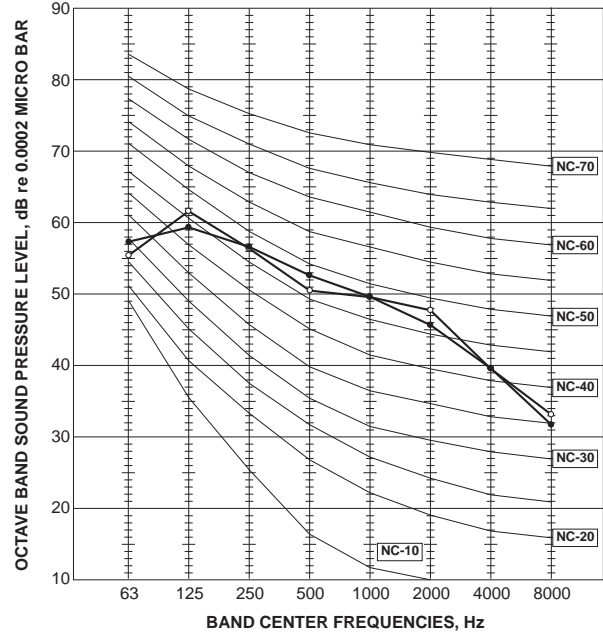

MUZ-WN25VA

OUTDOOR UNIT

FUNCTION	SPL(dB(A))	LINE
COOLING	50	●—●
HEATING	50	○—○

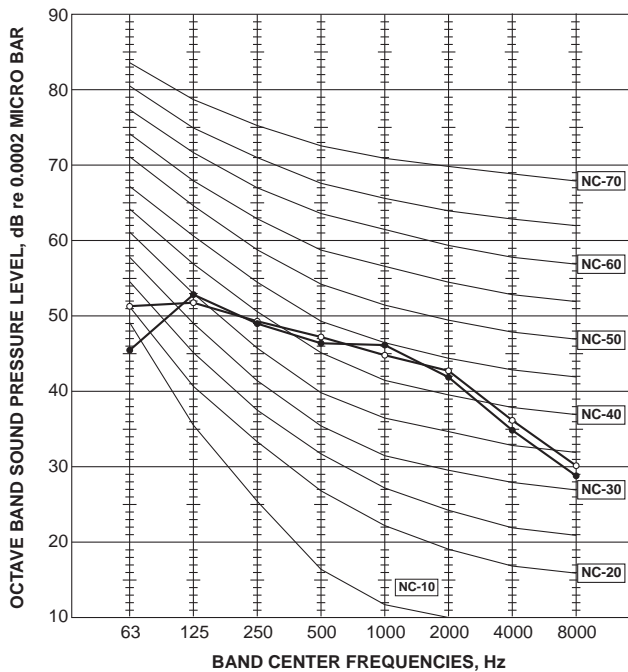

MUZ-WN35VA

OUTDOOR UNIT

FUNCTION	SPL(dB(A))	LINE
COOLING	52	●—●
HEATING	52	○—○

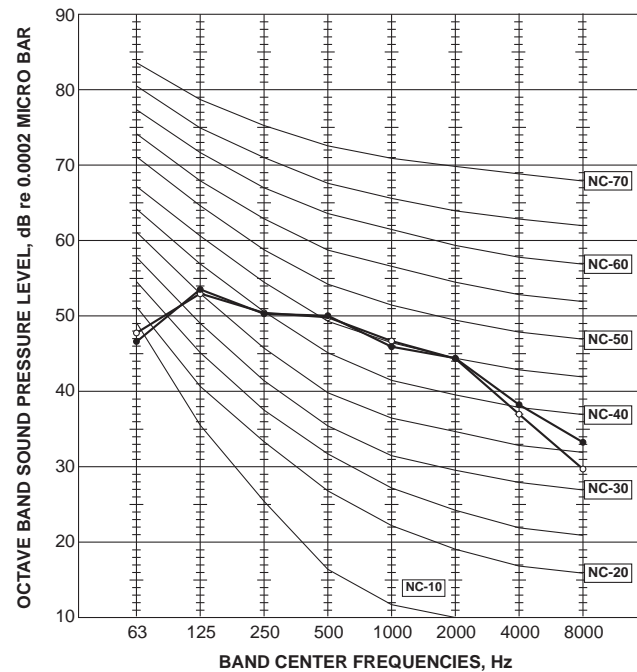

<Notes>

- 1) Sound data is taken when the system is running stably.
- 2) Relatively large noise could be heard transiently in the case 4-way valve, or LEV operates.

MUZ-DM25VA

OUTDOOR UNIT

FUNCTION	SPL(dB(A))	LINE
COOLING	50	●—●
HEATING	50	○—○

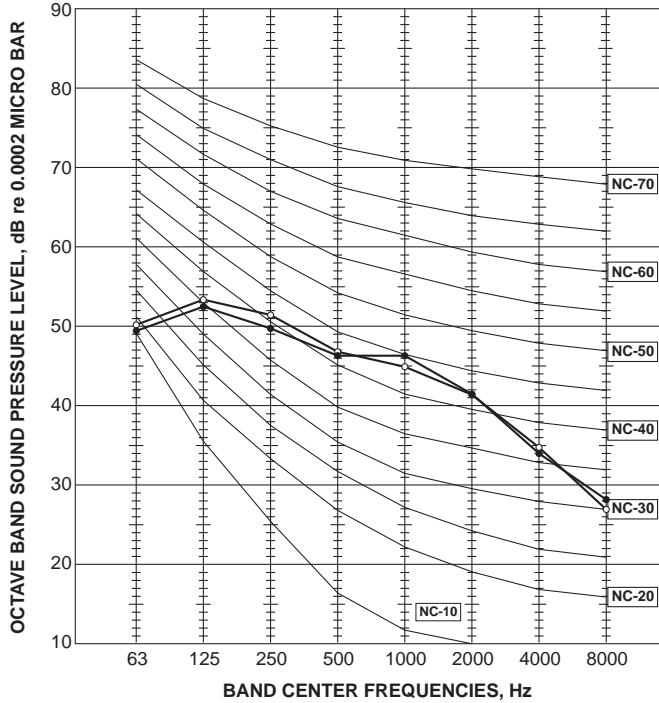

MUZ-DM35VA

OUTDOOR UNIT

FUNCTION	SPL(dB(A))	LINE
COOLING	51	●—●
HEATING	51	○—○

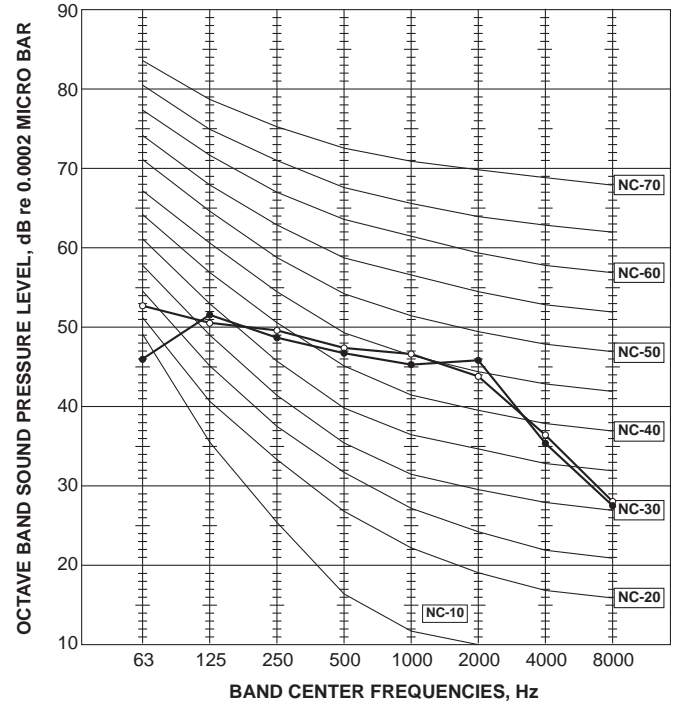

MUZ-HJ25VA

OUTDOOR UNIT

FUNCTION	SPL(dB(A))	LINE
COOLING	50	●—●
HEATING	50	○—○

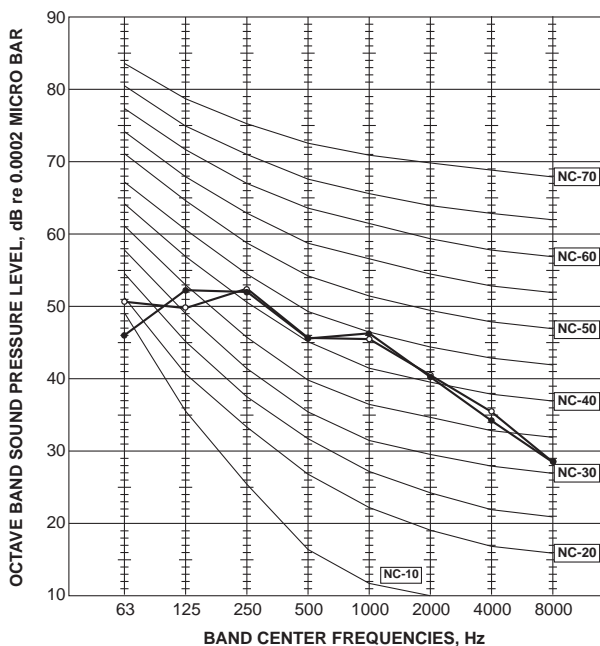

MUZ-HJ35VA

OUTDOOR UNIT

FUNCTION	SPL(dB(A))	LINE
COOLING	50	●—●
HEATING	50	○—○

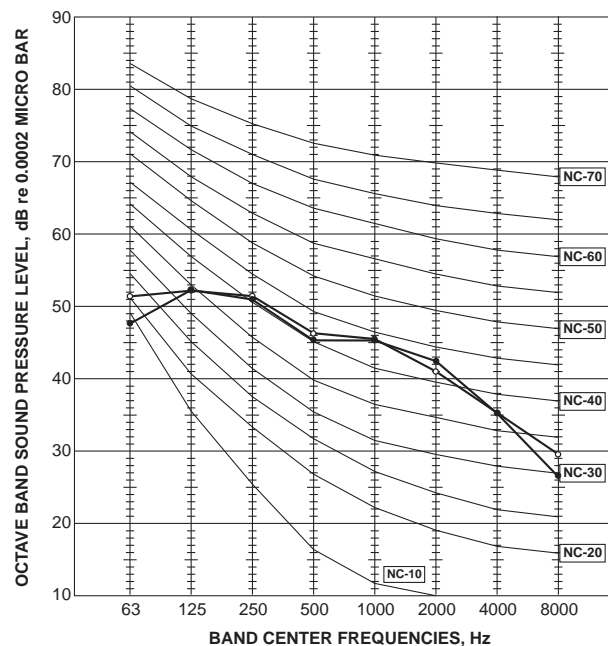

<Notes>

- 1) Sound data is taken when the system is running stably.
- 2) Relatively large noise could be heard transiently in the case 4-way valve, or LEV operates.

MUZ-HJ50VE

OUTDOOR UNIT

FUNCTION	SPL(dB(A))	LINE
COOLING	50	●—●
HEATING	51	○—○

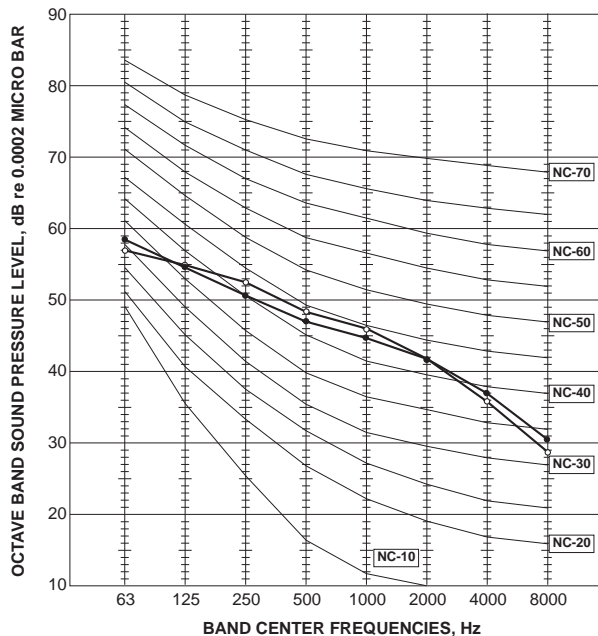

MUZ-HJ60VA

OUTDOOR UNIT

FUNCTION	SPL(dB(A))	LINE
COOLING	55	●—●
HEATING	55	○—○

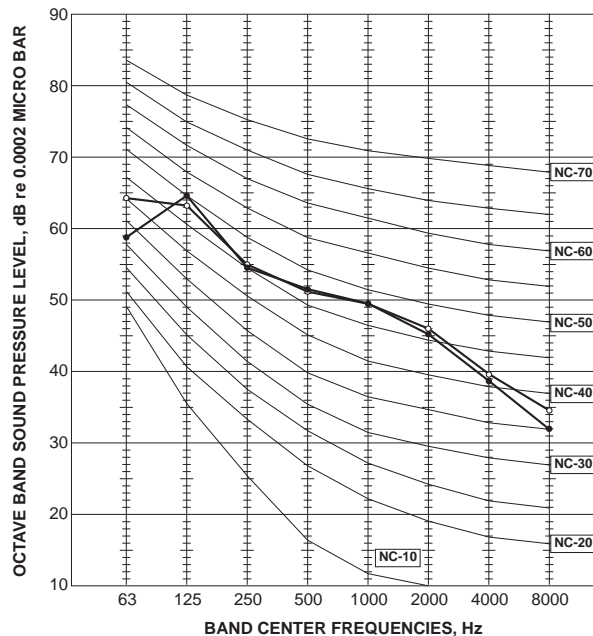

MUZ-HJ71VA

OUTDOOR UNIT

FUNCTION	SPL(dB(A))	LINE
COOLING	55	●—●
HEATING	55	○—○

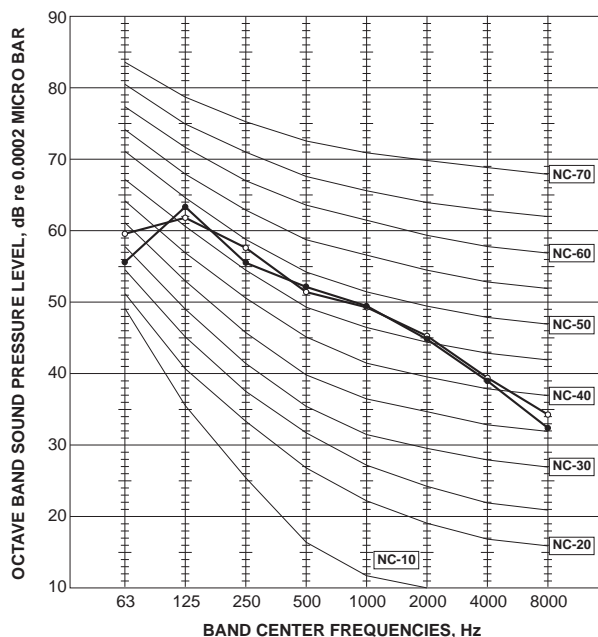

Test conditions

Cooling: Dry-bulb temperature 35°C Wet-bulb temperature 24°C
 Heating: Dry-bulb temperature 7°C Wet-bulb temperature 6°C (MUZ)

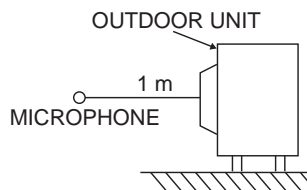

<Notes>

- 1) Sound data is taken when the system is running stably.
- 2) Relatively large noise could be heard transiently in the case 4-way valve, or LEV operates.

C.1.8 TEMPERATURE AND AIR FLOW DISTRIBUTIONS

MSZ-RW25VG

Temperature distribution

<Cooling mode>

Air volume: high
Air direction: auto (upward air flow)

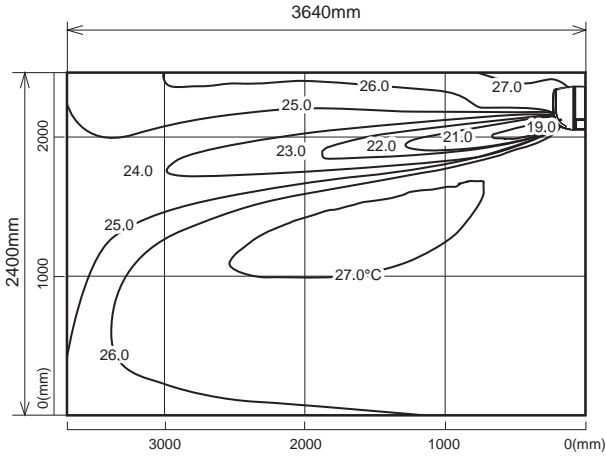

<Heating mode>

Air volume: high
Air direction: auto (downward air flow)

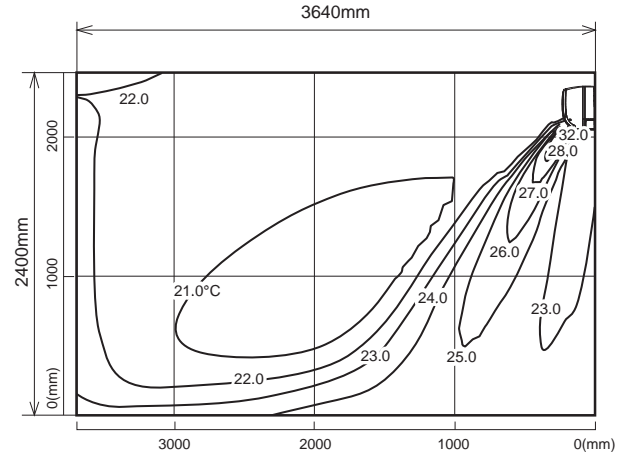

Airflow distribution

<Cooling mode>

Air volume: high
Air direction: auto (upward air flow)

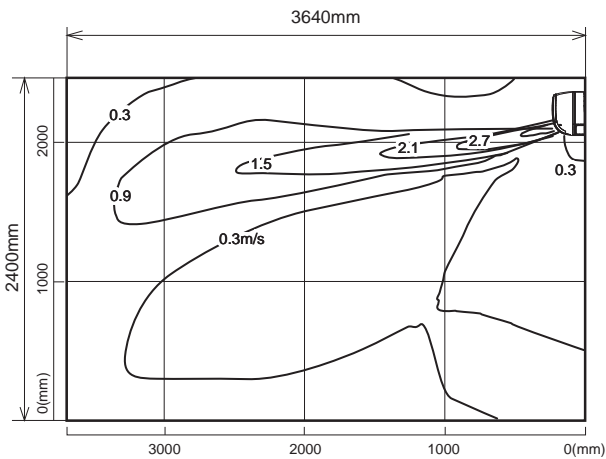

<Heating mode>

Air volume: high
Air direction: auto (downward air flow)

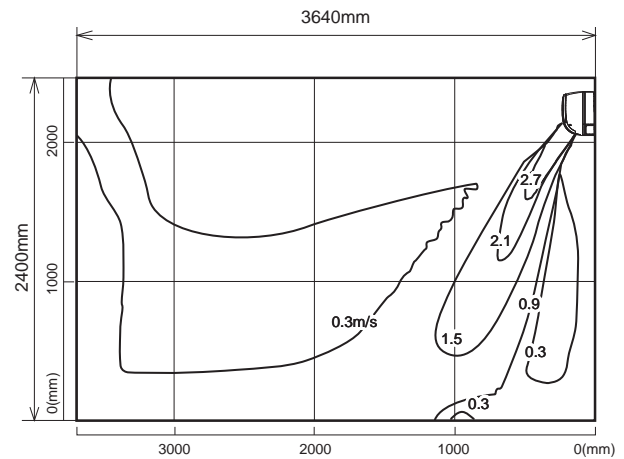

Note : These figures show typical airflow distributions in the conditions above. In the actual installation, they may differ from these figures under the influence of air temperature conditions, ceiling height, cooling/heating load, obstacles, etc.

WALL-MOUNTED TEMPERATURE AND AIR FLOW DISTRIBUTIONS

MSZ-RW35VG

Temperature distribution

<Cooling mode>

Air volume: high
Air direction: auto (upward air flow)

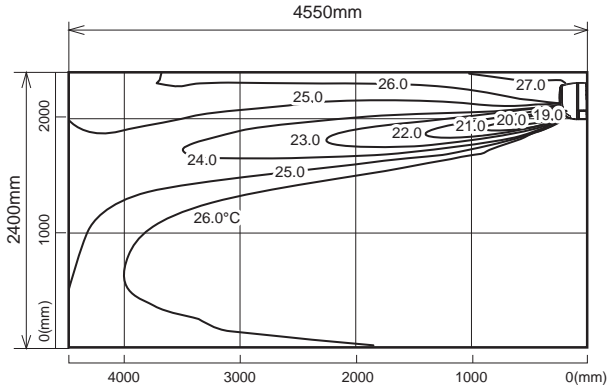

<Heating mode>

Air volume: high
Air direction: auto (downward air flow)

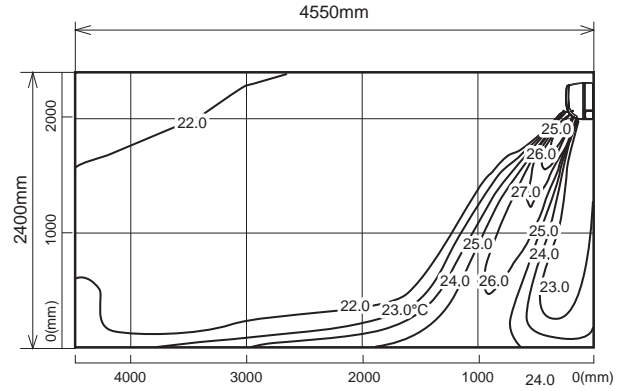

Airflow distribution

<Cooling mode>

Air volume: high
Air direction: auto (upward air flow)

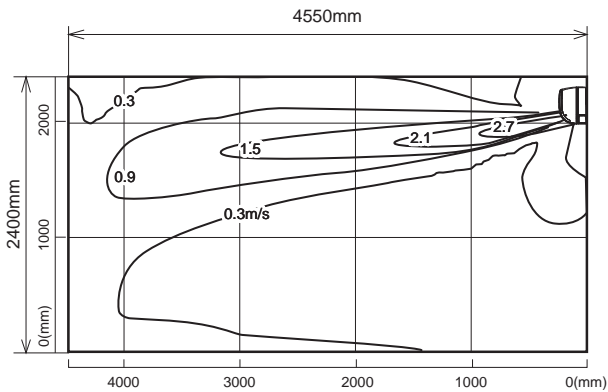

<Heating mode>

Air volume: high
Air direction: auto (downward air flow)

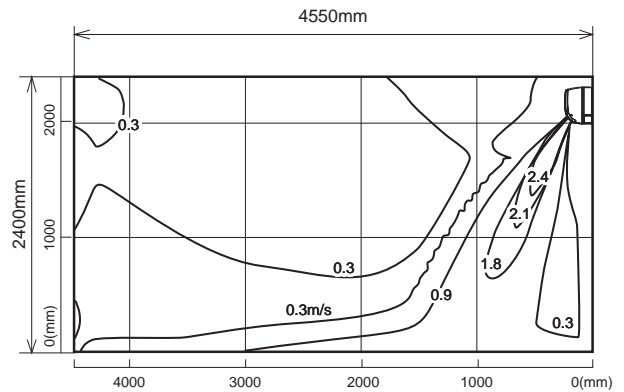

Note : These figures show typical airflow distributions in the conditions above. In the actual installation, they may differ from these figures under the influence of air temperature conditions, ceiling height, cooling/heating load, obstacles, etc.

TEMPERATURE AND AIR FLOW DISTRIBUTIONS

WALL-MOUNTED

MSZ-RW50VG

Temperature distribution

<Cooling mode>

Air volume: high
Air direction: auto (upward air flow)

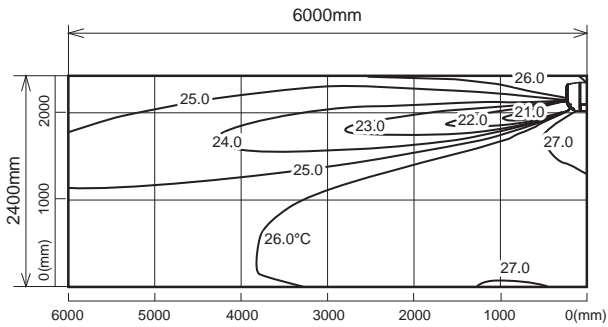

<Heating mode>

Air volume: high
Air direction: auto (downward air flow)

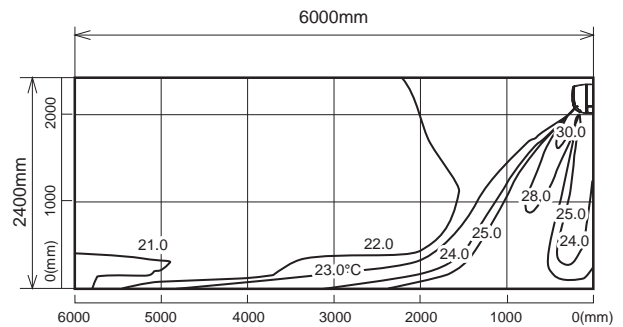

Airflow distribution

<Cooling mode>

Air volume: high
Air direction: auto (upward air flow)

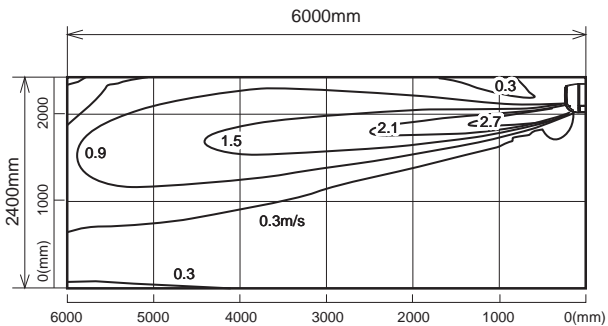

<Heating mode>

Air volume: high
Air direction: auto (downward air flow)

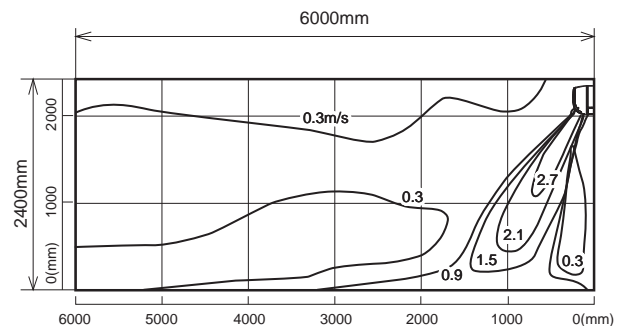

Note : These figures show typical airflow distributions in the conditions above. In the actual installation, they may differ from these figures under the influence of air temperature conditions, ceiling height, cooling/heating load, obstacles, etc.

WALL-MOUNTED TEMPERATURE AND AIR FLOW DISTRIBUTIONS

MSZ-LN18VG2W MSZ-LN18VG2V MSZ-LN18VG2B MSZ-LN18VG2R

Temperature distribution

<Cooling mode>

Air volume: high
Air direction: auto (upward air flow)

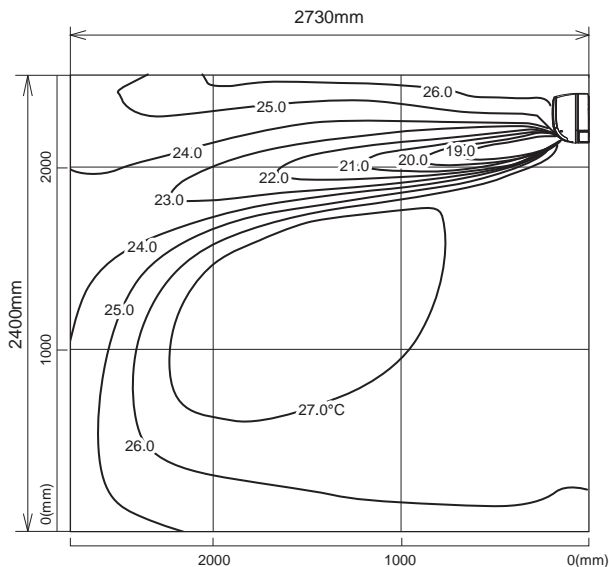

<Heating mode>

Air volume: high
Air direction: auto (downward air flow)

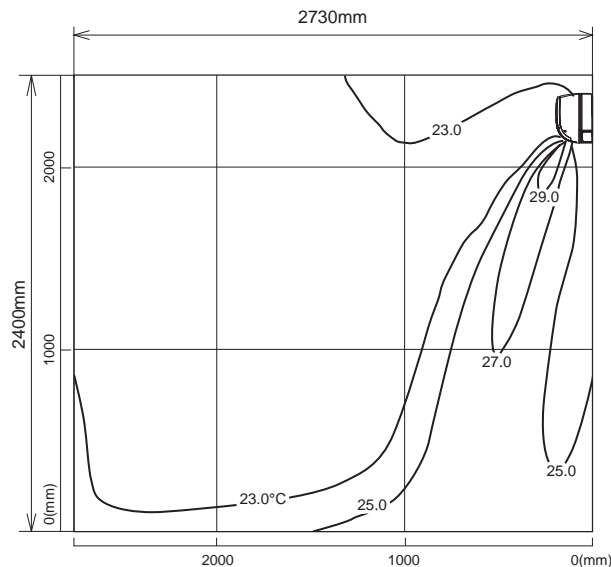

Airflow distribution

<Cooling mode>

Air volume: high
Air direction: auto (upward air flow)

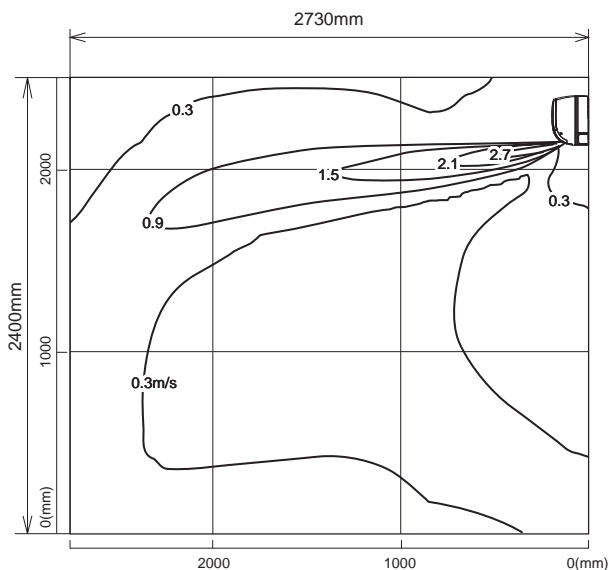

<Heating mode>

Air volume: high
Air direction: auto (downward air flow)

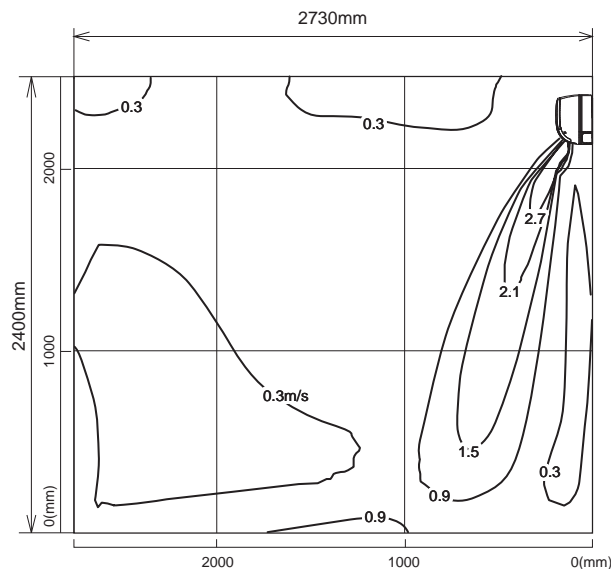

Note : These figures show typical airflow distributions in the conditions above. In the actual installation, they may differ from these figures under the influence of air temperature conditions, ceiling height, cooling/heating load, obstacles, etc.

TEMPERATURE AND AIR FLOW DISTRIBUTIONS

WALL-MOUNTED

MSZ-LN25VG2W MSZ-LN25VG2V MSZ-LN25VG2B MSZ-LN25VG2R

Temperature distribution

<Cooling mode>

Air volume: high
Air direction: auto (upward air flow)

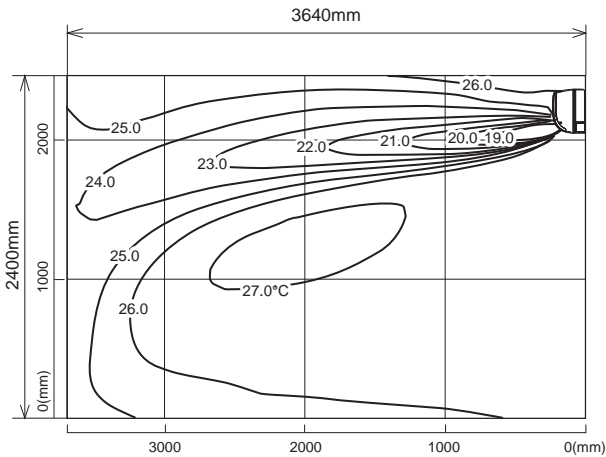

<Heating mode>

Air volume: high
Air direction: auto (downward air flow)

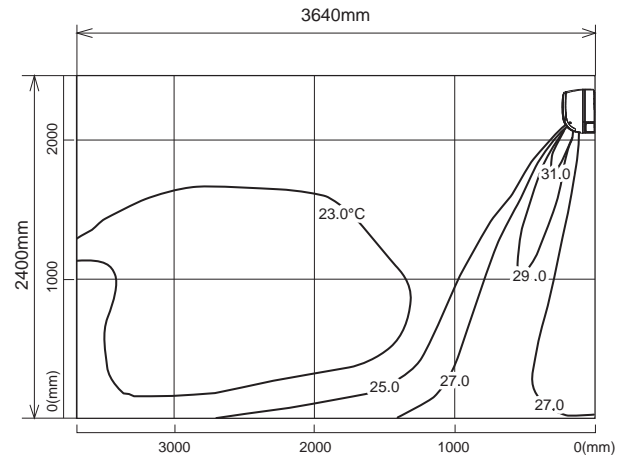

Airflow distribution

<Cooling mode>

Air volume: high
Air direction: auto (upward air flow)

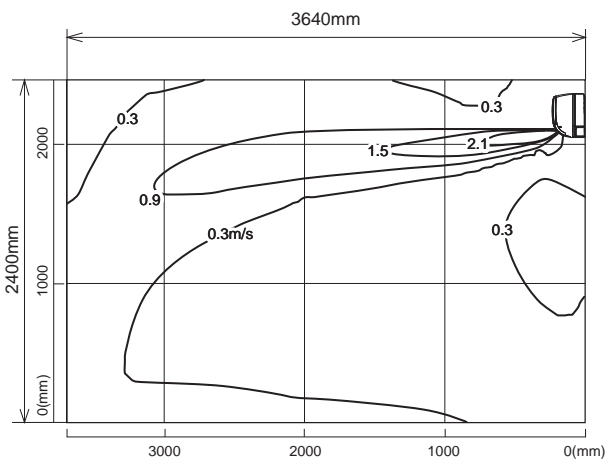

<Heating mode>

Air volume: high
Air direction: auto (downward air flow)

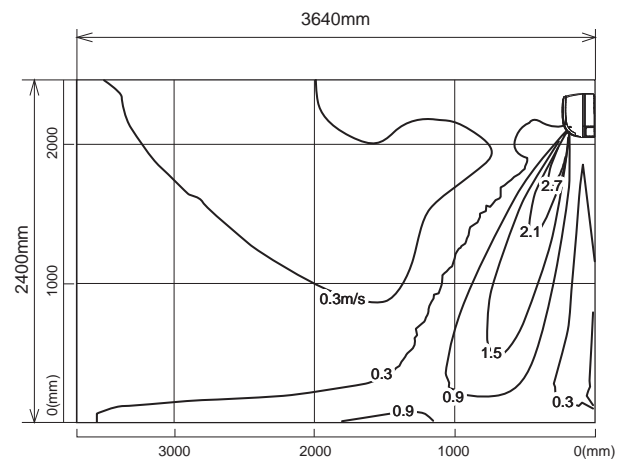

Note : These figures show typical airflow distributions in the conditions above. In the actual installation, they may differ from these figures under the influence of air temperature conditions, ceiling height, cooling/heating load, obstacles, etc.

WALL-MOUNTED TEMPERATURE AND AIR FLOW DISTRIBUTIONS

MSZ-LN35VG2W MSZ-LN35VG2V MSZ-LN35VG2B MSZ-LN35VG2R

Temperature distribution

<Cooling mode>

Air volume: high
Air direction: auto (upward air flow)

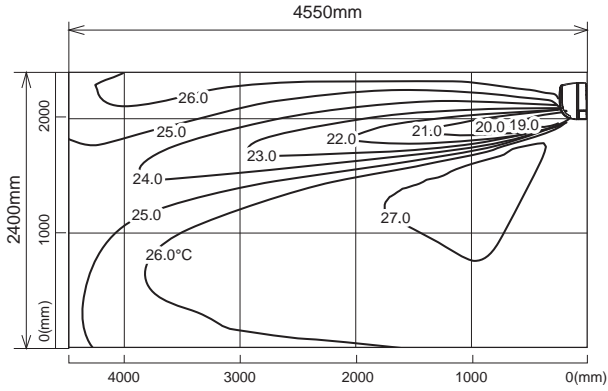

<Heating mode>

Air volume: high
Air direction: auto (downward air flow)

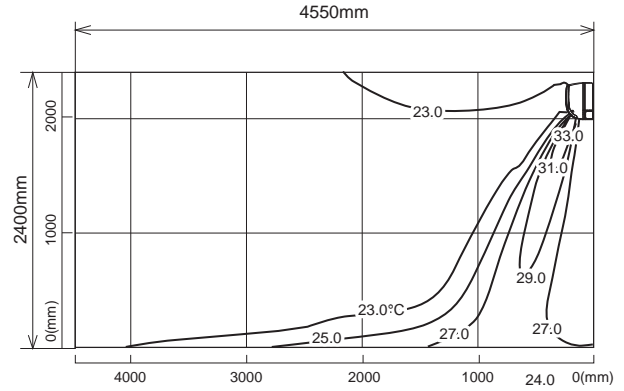

Airflow distribution

<Cooling mode>

Air volume: high
Air direction: auto (upward air flow)

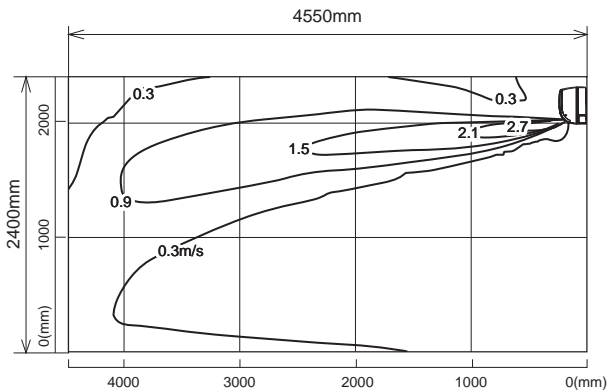

<Heating mode>

Air volume: high
Air direction: auto (downward air flow)

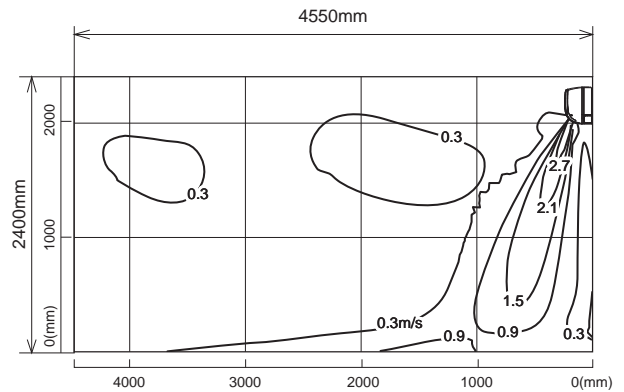

Note : These figures show typical airflow distributions in the conditions above. In the actual installation, they may differ from these figures under the influence of air temperature conditions, ceiling height, cooling/heating load, obstacles, etc.

TEMPERATURE AND AIR FLOW DISTRIBUTIONS

WALL-MOUNTED

MSZ-LN50VG2W MSZ-LN50VG2V MSZ-LN50VG2B MSZ-LN50VG2R

Temperature distribution

<Cooling mode>

Air volume: high
Air direction: auto (upward air flow)

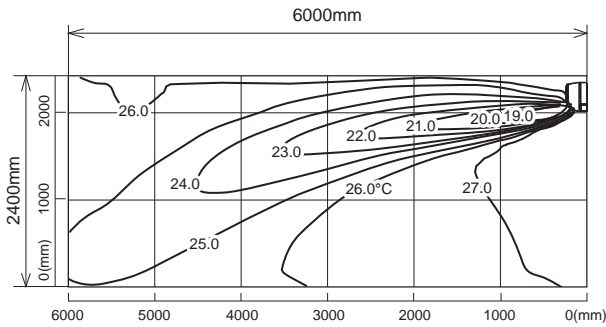

<Heating mode>

Air volume: high
Air direction: auto (downward air flow)

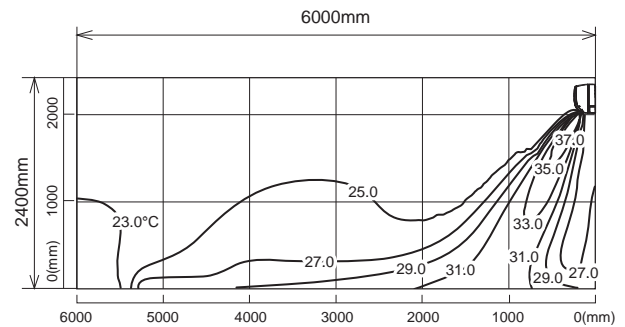

Airflow distribution

<Cooling mode>

Air volume: high
Air direction: auto (upward air flow)

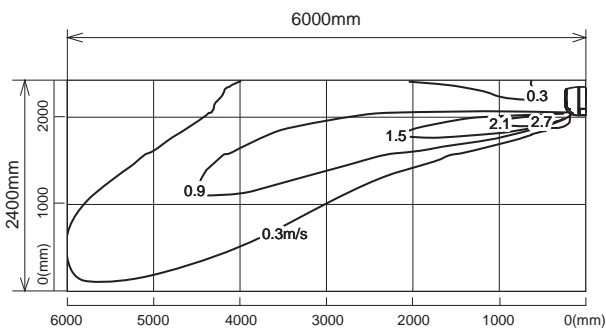

<Heating mode>

Air volume: high
Air direction: auto (downward air flow)

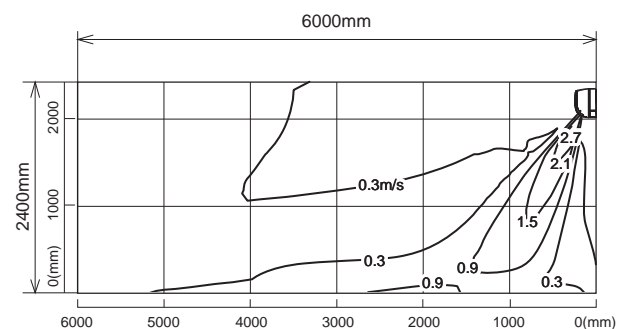

Note : These figures show typical airflow distributions in the conditions above. In the actual installation, they may differ from these figures under the influence of air temperature conditions, ceiling height, cooling/heating load, obstacles, etc.

WALL-MOUNTED TEMPERATURE AND AIR FLOW DISTRIBUTIONS

MSZ-LN60VG2W MSZ-LN60VG2V MSZ-LN60VG2B MSZ-LN60VG2R

Temperature distribution

<Cooling mode>

Air volume: high
Air direction: auto (upward air flow)

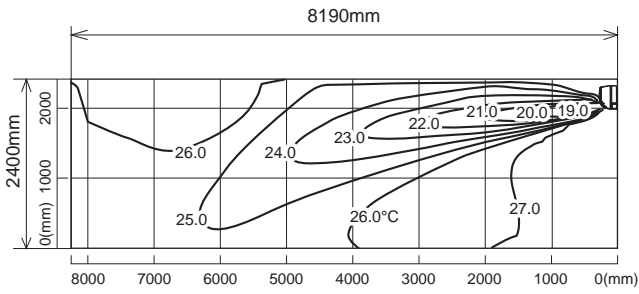

<Heating mode>

Air volume: high
Air direction: auto (downward air flow)

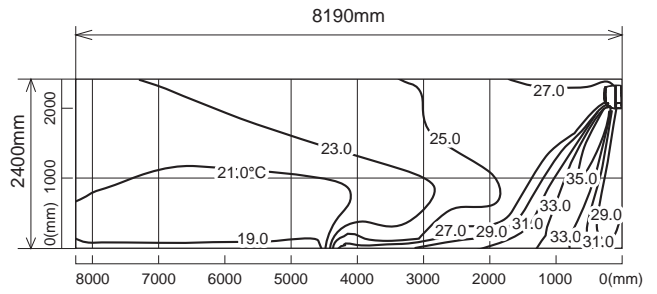

Airflow distribution

<Cooling mode>

Air volume: high
Air direction: auto (upward air flow)

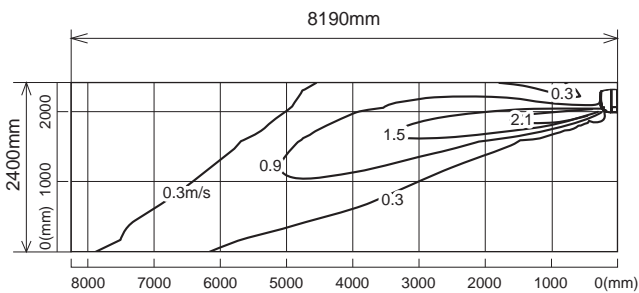

<Heating mode>

Air volume: high
Air direction: auto (downward air flow)

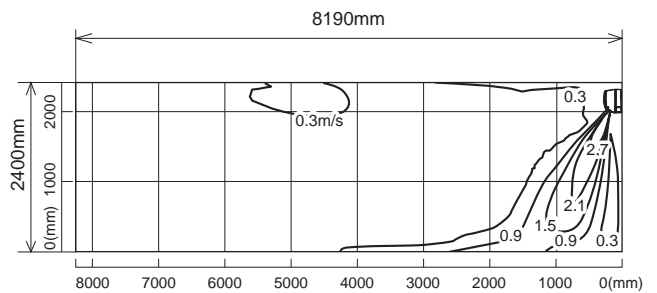

Note : These figures show typical airflow distributions in the conditions above. In the actual installation, they may differ from these figures under the influence of air temperature conditions, ceiling height, cooling/heating load, obstacles, etc.

TEMPERATURE AND AIR FLOW DISTRIBUTIONS

WALL-MOUNTED

MSZ-FT25VG MSZ-FT25VGK

Temperature distribution

<Cooling mode>

Air volume: high
Air direction: auto (upward air flow)

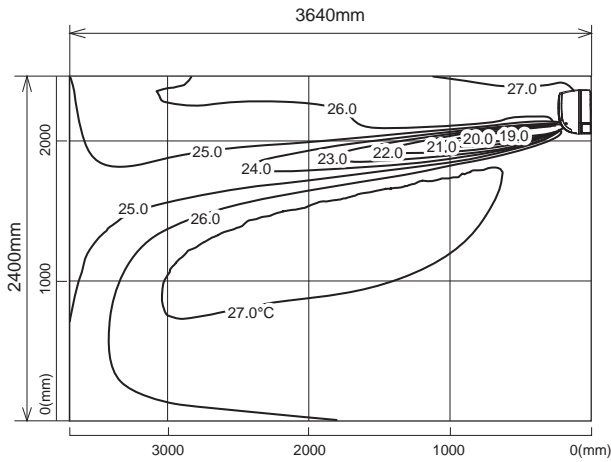

<Heating mode>

Air volume: high
Air direction: auto (downward air flow)

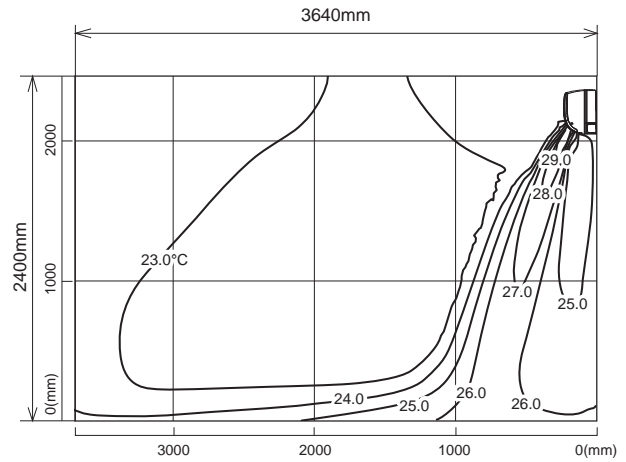

Airflow distribution

<Cooling mode>

Air volume: high
Air direction: auto (upward air flow)

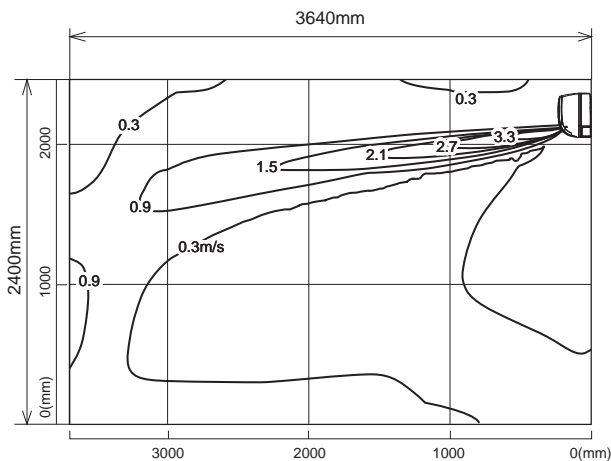

<Heating mode>

Air volume: high
Air direction: auto (downward air flow)

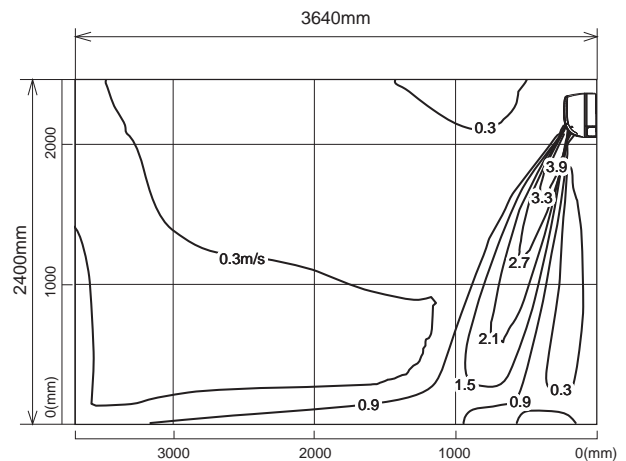

Note : These figures show typical airflow distributions in the conditions above. In the actual installation, they may differ from these figures under the influence of air temperature conditions, ceiling height, cooling/heating load, obstacles, etc.

WALL-MOUNTED TEMPERATURE AND AIR FLOW DISTRIBUTIONS

MSZ-FT35VG MSZ-FT35VGK

Temperature distribution

<Cooling mode>

Air volume: high
Air direction: auto (upward air flow)

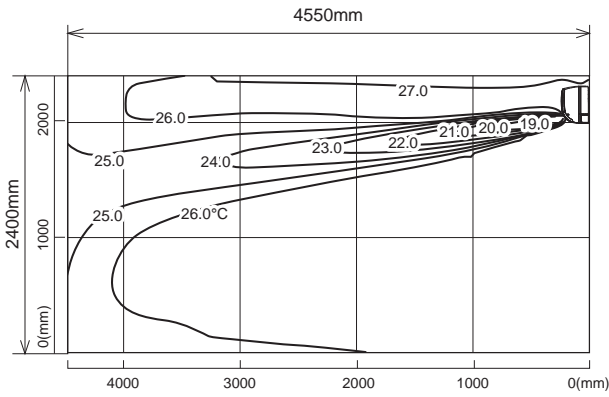

<Heating mode>

Air volume: high
Air direction: auto (downward air flow)

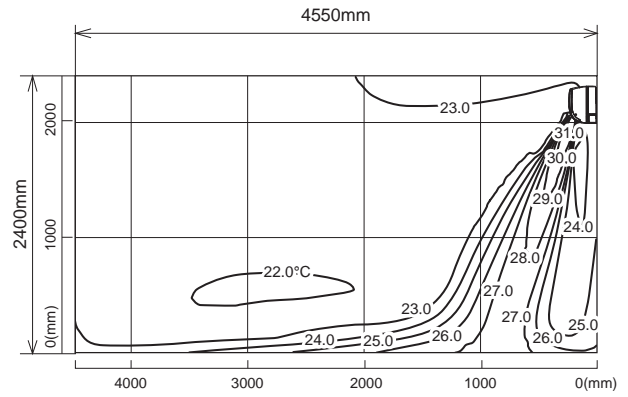

Airflow distribution

<Cooling mode>

Air volume: high
Air direction: auto (upward air flow)

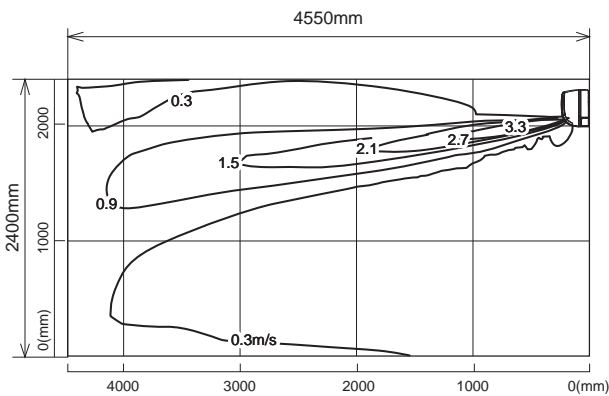

<Heating mode>

Air volume: high
Air direction: auto (downward air flow)

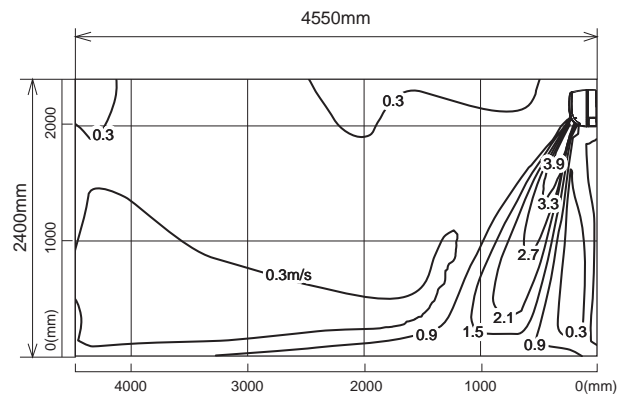

Note : These figures show typical airflow distributions in the conditions above. In the actual installation, they may differ from these figures under the influence of air temperature conditions, ceiling height, cooling/heating load, obstacles, etc.

TEMPERATURE AND AIR FLOW DISTRIBUTIONS

WALL-MOUNTED

MSZ-FT50VG MSZ-FT50VGK

Temperature distribution

<Cooling mode>

Air volume: high
Air direction: auto (upward air flow)

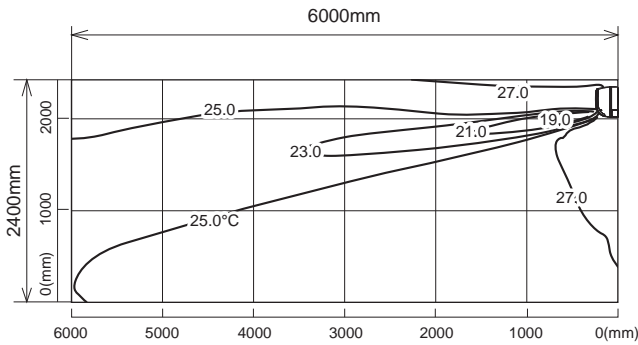

<Heating mode>

Air volume: high
Air direction: auto (downward air flow)

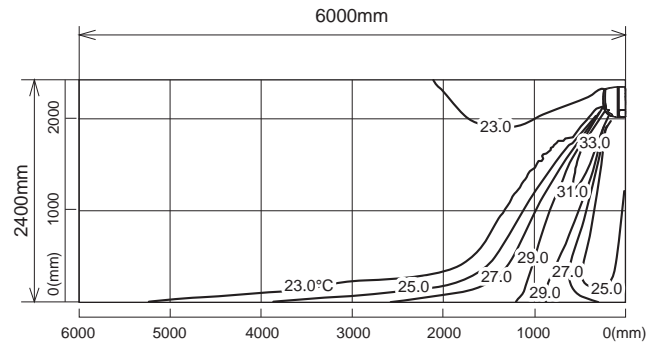

Airflow distribution

<Cooling mode>

Air volume: high
Air direction: auto (upward air flow)

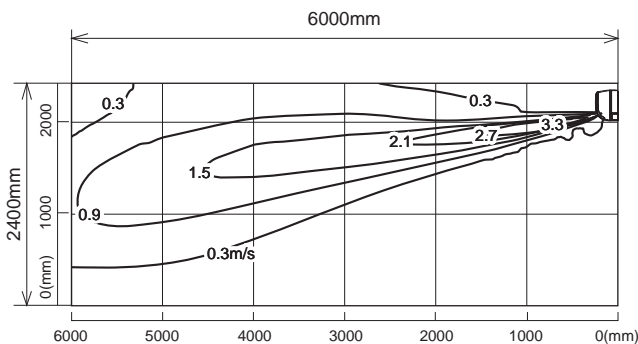

<Heating mode>

Air volume: high
Air direction: auto (downward air flow)

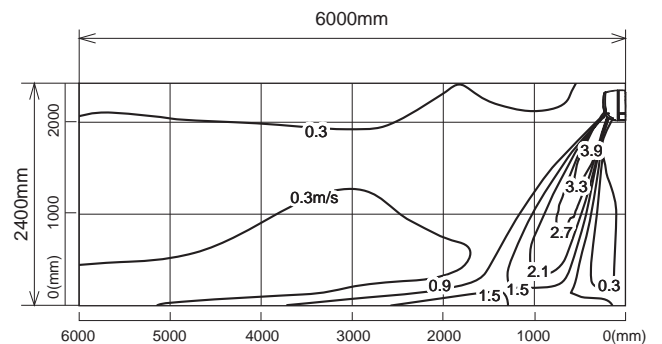

Note : These figures show typical airflow distributions in the conditions above. In the actual installation, they may differ from these figures under the influence of air temperature conditions, ceiling height, cooling/heating load, obstacles, etc.

WALL-MOUNTED TEMPERATURE AND AIR FLOW DISTRIBUTIONS

MSZ-AY25VG MSZ-AY25VGK MSZ-AY25VGKP

Temperature distribution

<Cooling mode>

Air volume: high
Air direction: auto (upward air flow)

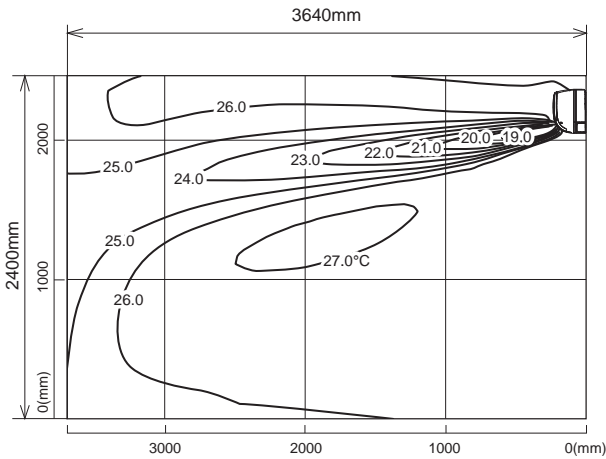

<Heating mode>

Air volume: high
Air direction: auto (downward air flow)

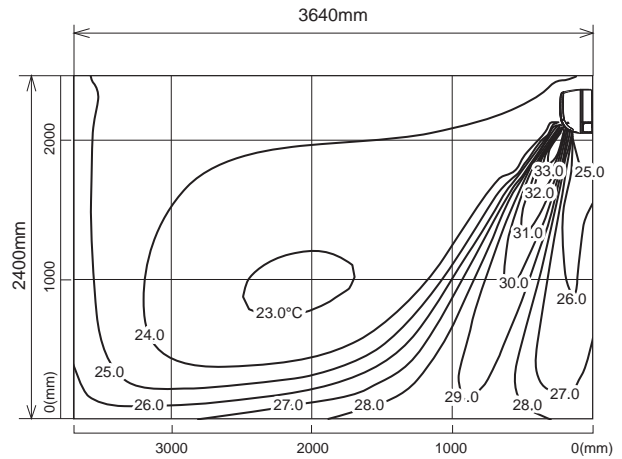

Airflow distribution

<Cooling mode>

Air volume: high
Air direction: auto (upward air flow)

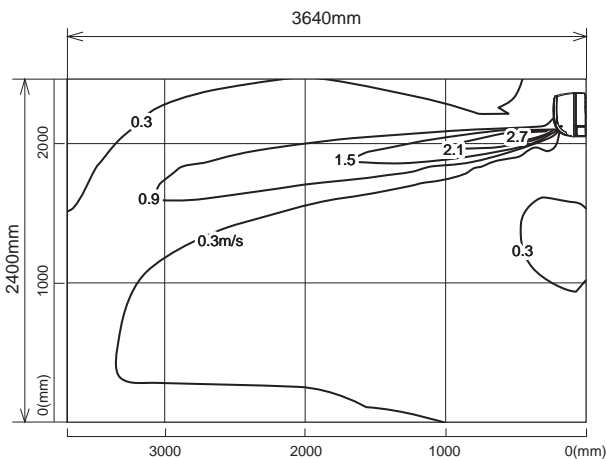

<Heating mode>

Air volume: high
Air direction: auto (downward air flow)

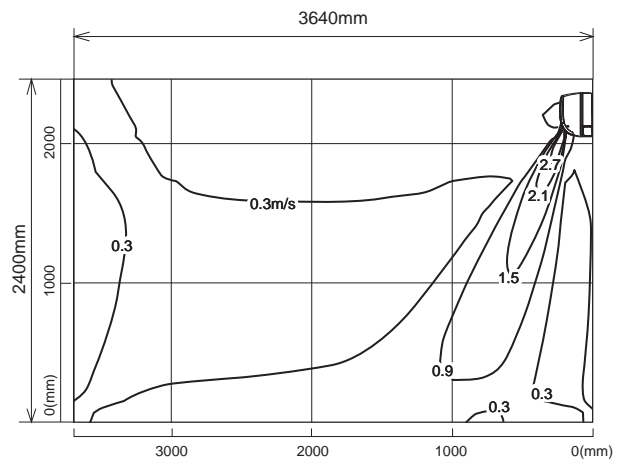

Note : These figures show typical airflow distributions in the conditions above. In the actual installation, they may differ from these figures under the influence of air temperature conditions, ceiling height, cooling/heating load, obstacles, etc.

TEMPERATURE AND AIR FLOW DISTRIBUTIONS

WALL-MOUNTED

MSZ-AY35VG MSZ-AY35VGK MSZ-AY35VGKP

Temperature distribution

<Cooling mode>

Air volume: high
Air direction: auto (upward air flow)

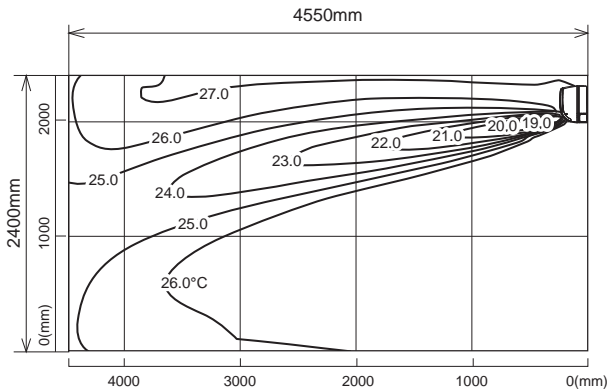

<Heating mode>

Air volume: high
Air direction: auto (downward air flow)

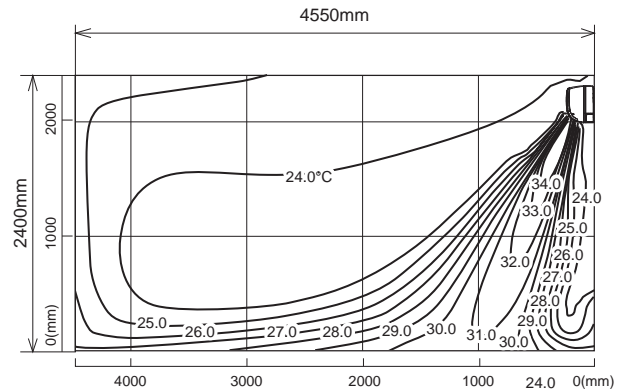

Airflow distribution

<Cooling mode>

Air volume: high
Air direction: auto (upward air flow)

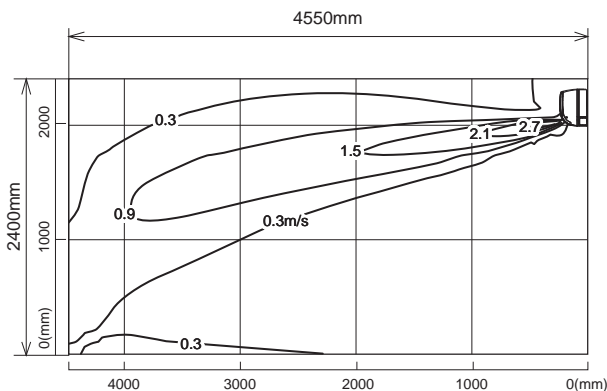

<Heating mode>

Air volume: high
Air direction: auto (downward air flow)

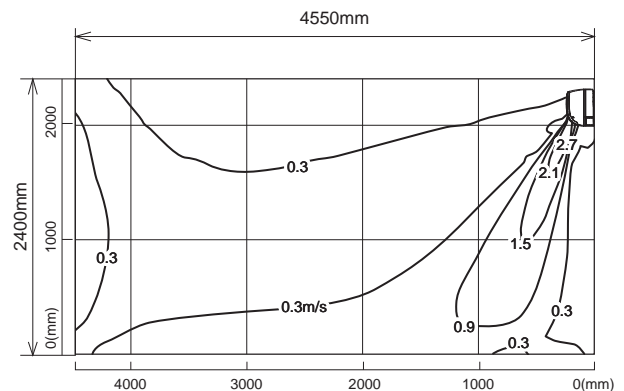

Note : These figures show typical airflow distributions in the conditions above. In the actual installation, they may differ from these figures under the influence of air temperature conditions, ceiling height, cooling/heating load, obstacles, etc.

WALL-MOUNTED TEMPERATURE AND AIR FLOW DISTRIBUTIONS

MSZ-AY42VG MSZ-AY42VGK MSZ-AY42VGKP

Temperature distribution

<Cooling mode>

Air volume: high
Air direction: auto (upward air flow)

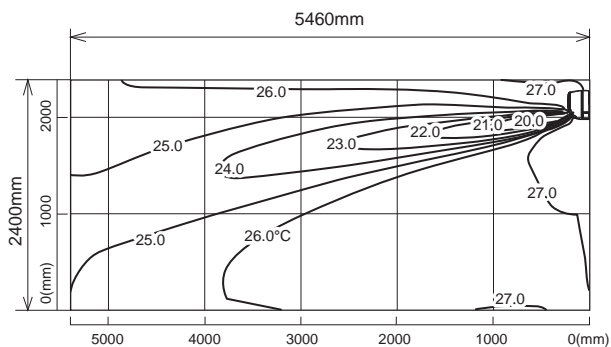

<Heating mode>

Air volume: high
Air direction: auto (downward air flow)

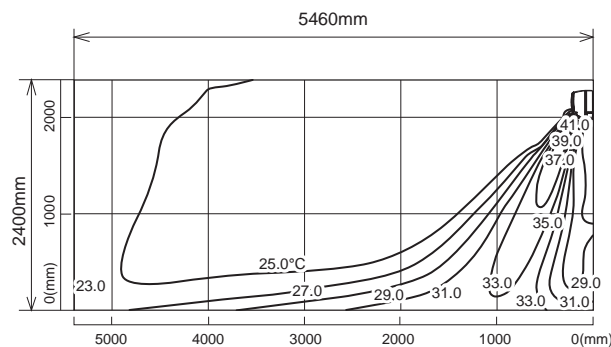

Airflow distribution

<Cooling mode>

Air volume: high
Air direction: auto (upward air flow)

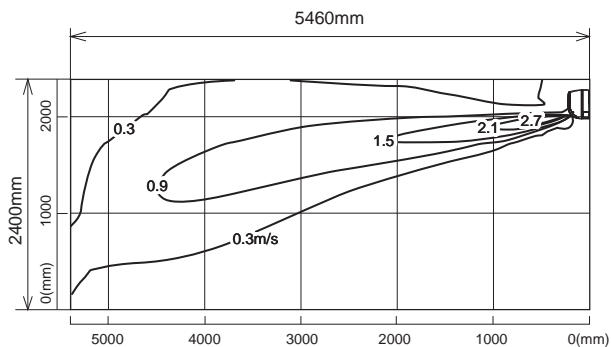

<Heating mode>

Air volume: high
Air direction: auto (downward air flow)

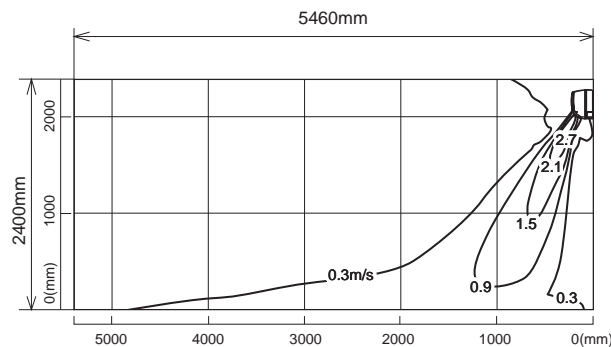

Note : These figures show typical airflow distributions in the conditions above. In the actual installation, they may differ from these figures under the influence of air temperature conditions, ceiling height, cooling/heating load, obstacles, etc.

TEMPERATURE AND AIR FLOW DISTRIBUTIONS

WALL-MOUNTED

MSZ-AY50VG MSZ-AY50VGK MSZ-AY50VGKP

Temperature distribution

<Cooling mode>

Air volume: high
Air direction: auto (upward air flow)

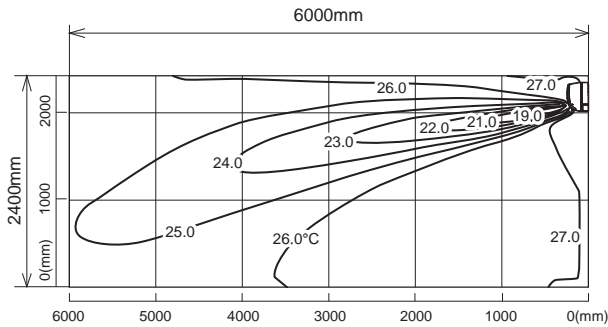

<Heating mode>

Air volume: high
Air direction: auto (downward air flow)

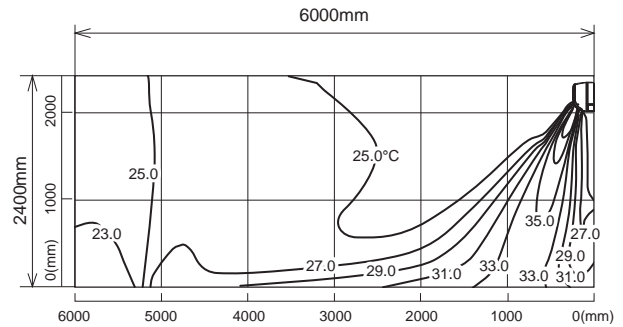

Airflow distribution

<Cooling mode>

Air volume: high
Air direction: auto (upward air flow)

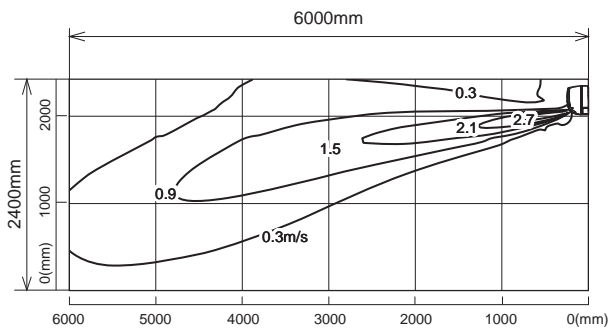

<Heating mode>

Air volume: high
Air direction: auto (downward air flow)

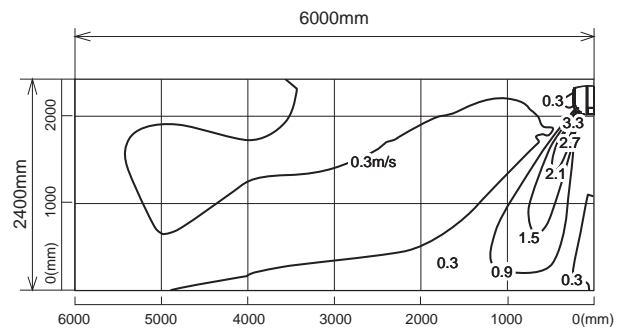

Note : These figures show typical airflow distributions in the conditions above. In the actual installation, they may differ from these figures under the influence of air temperature conditions, ceiling height, cooling/heating load, obstacles, etc.

WALL-MOUNTED TEMPERATURE AND AIR FLOW DISTRIBUTIONS

MSZ-AP15VG MSZ-AP15VGK

Temperature distribution

<Cooling mode>

Air volume: high
Air direction: auto (upward air flow)

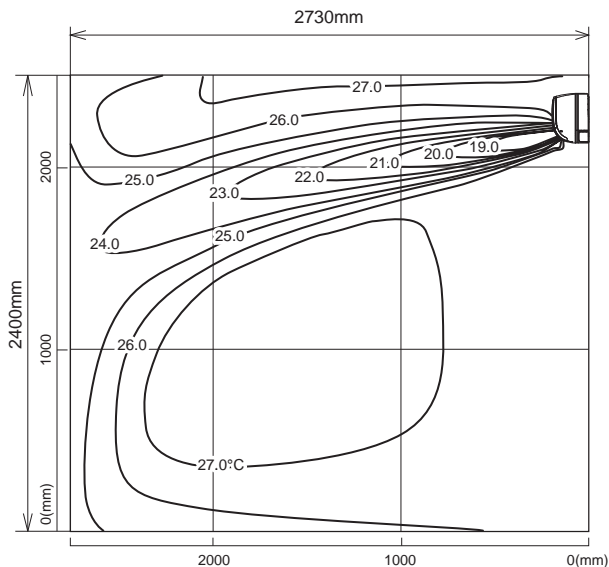

<Heating mode>

Air volume: high
Air direction: auto (downward air flow)

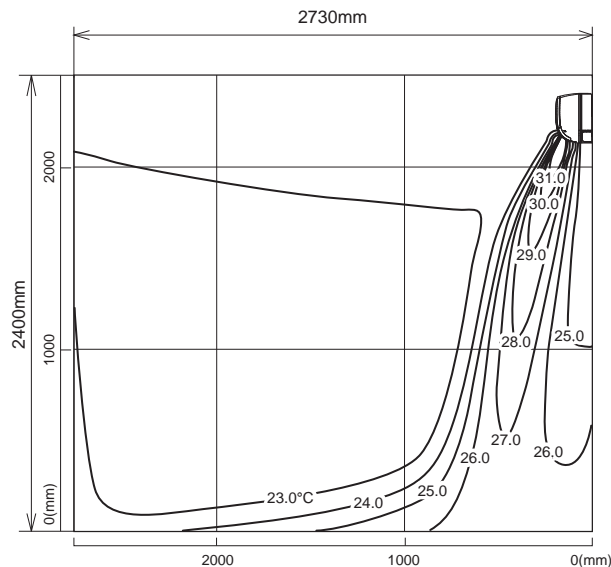

Airflow distribution

<Cooling mode>

Air volume: high
Air direction: auto (upward air flow)

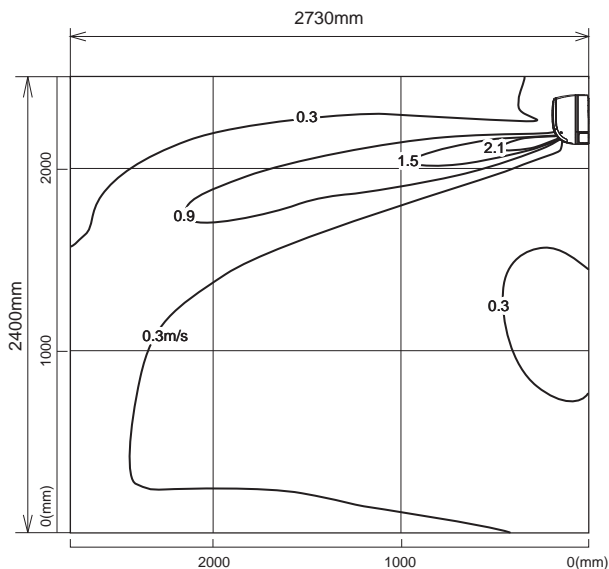

<Heating mode>

Air volume: high
Air direction: auto (downward air flow)

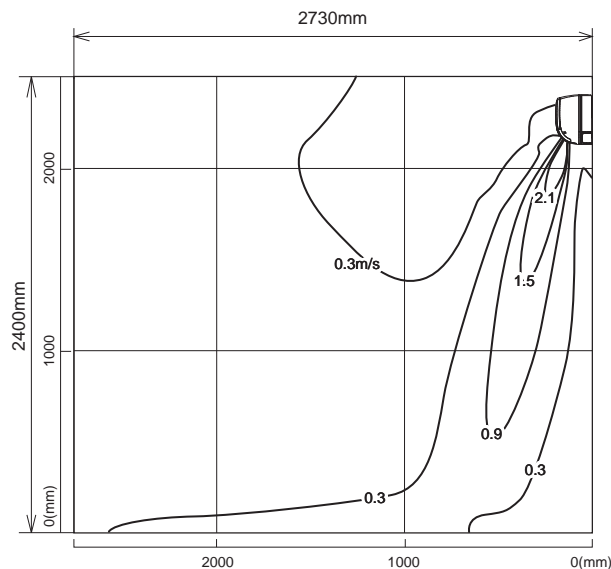

Note : These figures show typical airflow distributions in the conditions above. In the actual installation, they may differ from these figures under the influence of air temperature conditions, ceiling height, cooling/heating load, obstacles, etc.

TEMPERATURE AND AIR FLOW DISTRIBUTIONS

WALL-MOUNTED

MSZ-AP20VG MSZ-AP20VGK

Temperature distribution

<Cooling mode>

Air volume: high
Air direction: auto (upward air flow)

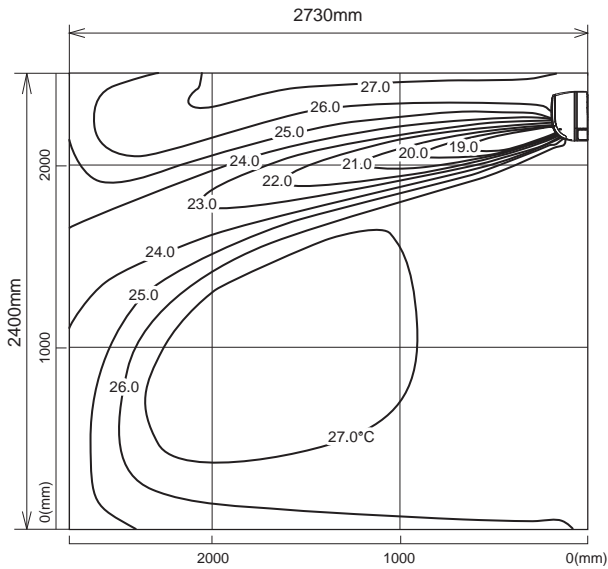

<Heating mode>

Air volume: high
Air direction: auto (downward air flow)

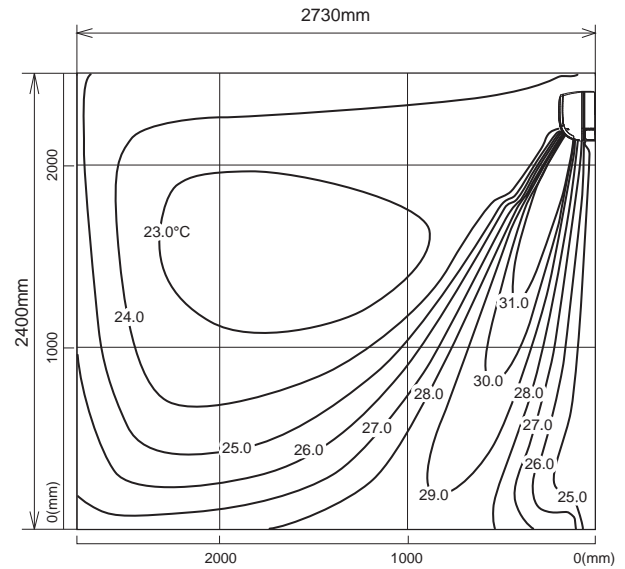

Airflow distribution

<Cooling mode>

Air volume: high
Air direction: auto (upward air flow)

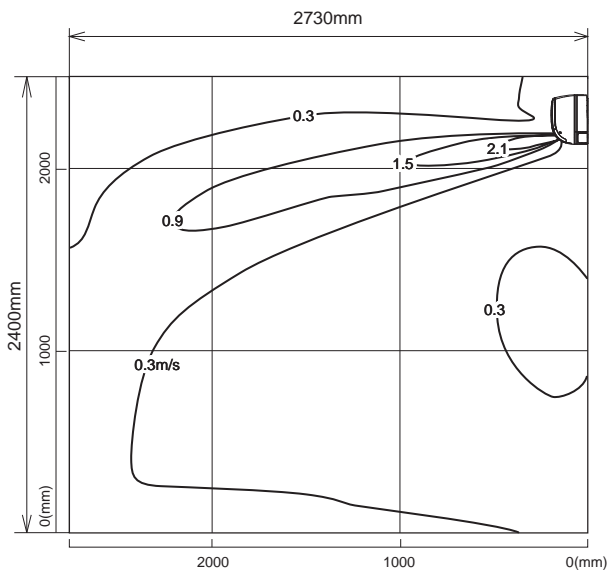

<Heating mode>

Air volume: high
Air direction: auto (downward air flow)

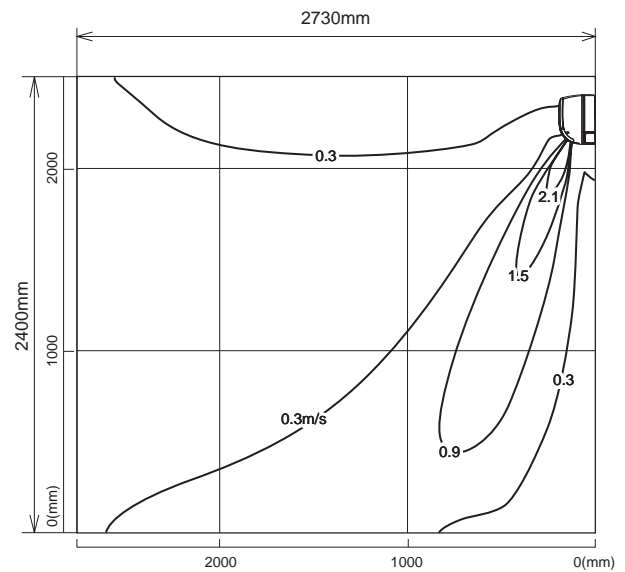

Note : These figures show typical airflow distributions in the conditions above. In the actual installation, they may differ from these figures under the influence of air temperature conditions, ceiling height, cooling/heating load, obstacles, etc.

WALL-MOUNTED TEMPERATURE AND AIR FLOW DISTRIBUTIONS

MSZ-AP60VG MSZ-AP60VGK

Temperature distribution

<Cooling mode>

Air volume: high
Air direction: auto (upward air flow)

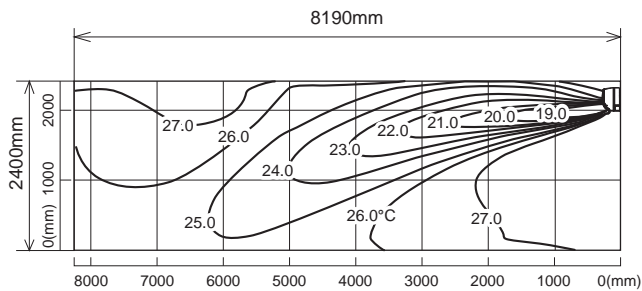

<Heating mode>

Air volume: high
Air direction: auto (downward air flow)

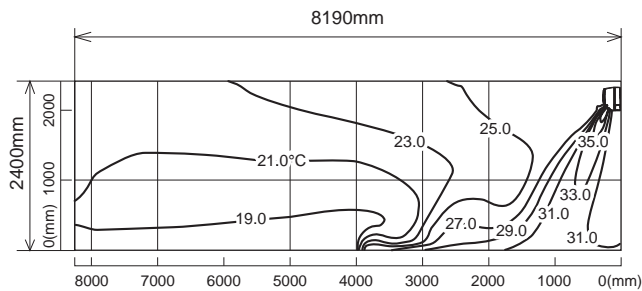

Airflow distribution

<Cooling mode>

Air volume: high
Air direction: auto (upward air flow)

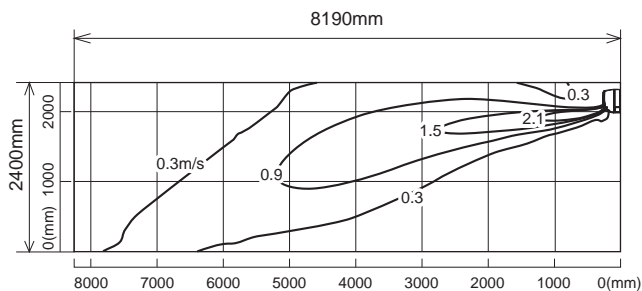

<Heating mode>

Air volume: high
Air direction: auto (downward air flow)

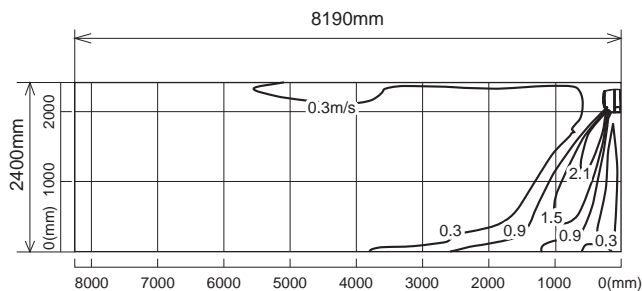

Note : These figures show typical airflow distributions in the conditions above. In the actual installation, they may differ from these figures under the influence of air temperature conditions, ceiling height, cooling/heating load, obstacles, etc.

TEMPERATURE AND AIR FLOW DISTRIBUTIONS

WALL-MOUNTED

MSZ-AP71VG MSZ-AP71VGK

Temperature distribution

<Cooling mode>

Air volume: high
Air direction: auto (upward air flow)

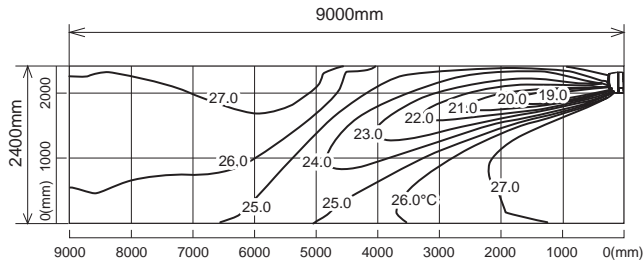

<Heating mode>

Air volume: high
Air direction: auto (downward air flow)

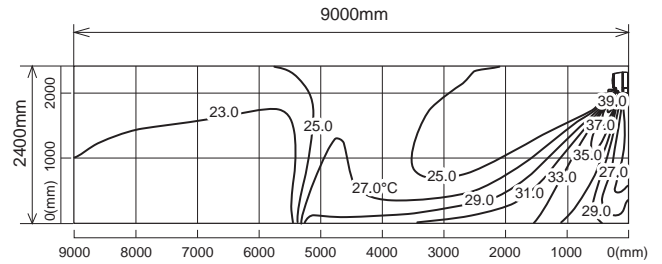

Airflow distribution

<Cooling mode>

Air volume: high
Air direction: auto (upward air flow)

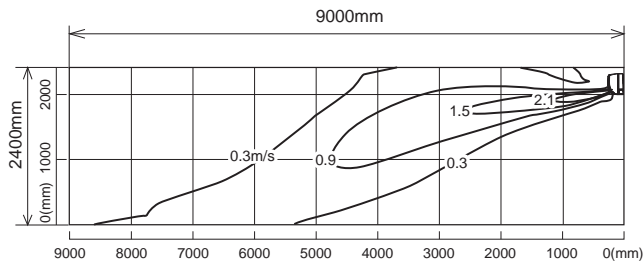

<Heating mode>

Air volume: high
Air direction: auto (downward air flow)

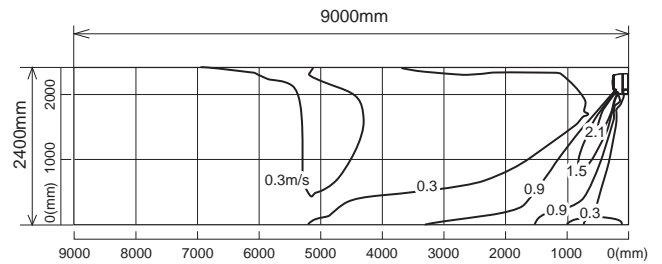

Note : These figures show typical airflow distributions in the conditions above. In the actual installation, they may differ from these figures under the influence of air temperature conditions, ceiling height, cooling/heating load, obstacles, etc.

WALL-MOUNTED TEMPERATURE AND AIR FLOW DISTRIBUTIONS

MSZ-HR25VF MSZ-HR25VFK

Temperature distribution

<Cooling mode>

Air volume: high
Air direction: auto (upward air flow)

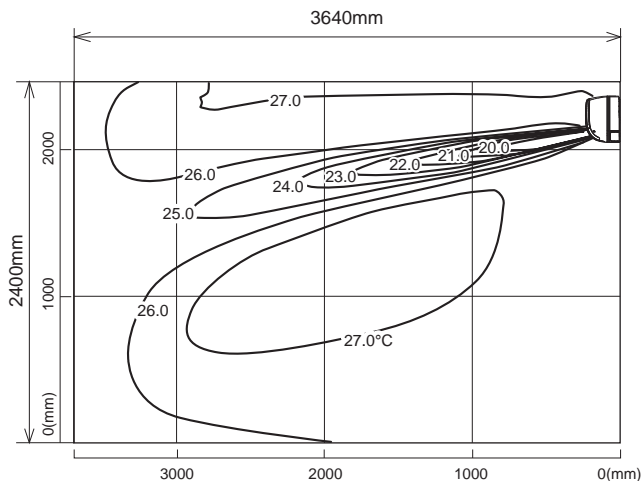

<Heating mode>

Air volume: high
Air direction: auto (downward air flow)

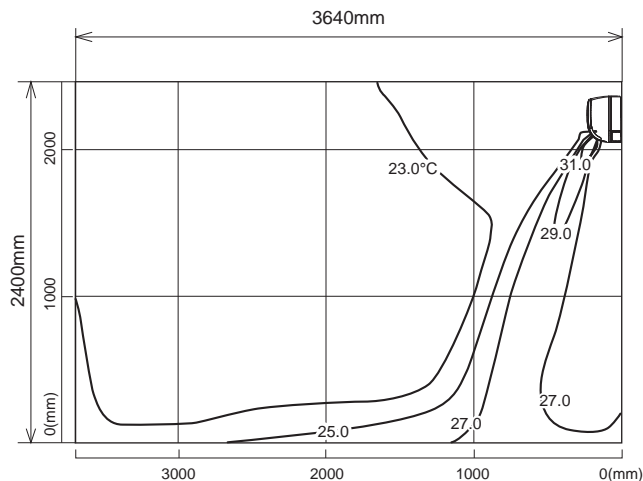

Airflow distribution

<Cooling mode>

Air volume: high
Air direction: auto (upward air flow)

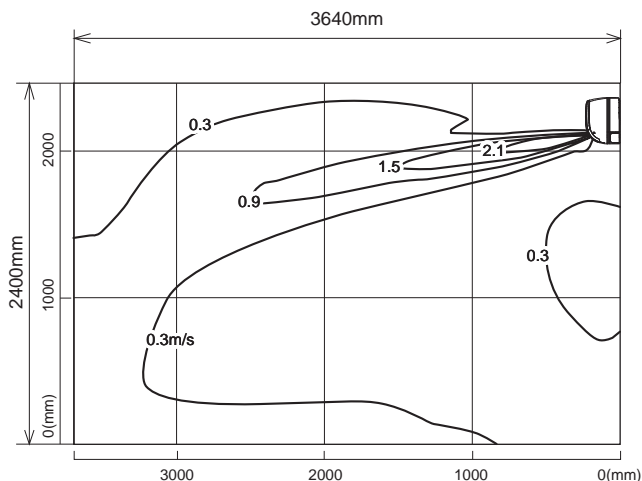

<Heating mode>

Air volume: high
Air direction: auto (downward air flow)

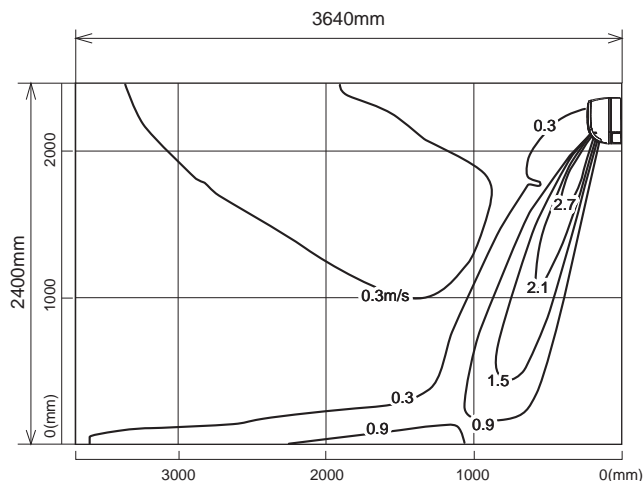

Note : These figures show typical airflow distributions in the conditions above. In the actual installation, they may differ from these figures under the influence of air temperature conditions, ceiling height, cooling/heating load, obstacles, etc.

TEMPERATURE AND AIR FLOW DISTRIBUTIONS

WALL-MOUNTED

MSZ-HR35VF MSZ-HR35VFK

Temperature distribution

<Cooling mode>

Air volume: high
Air direction: auto (upward air flow)

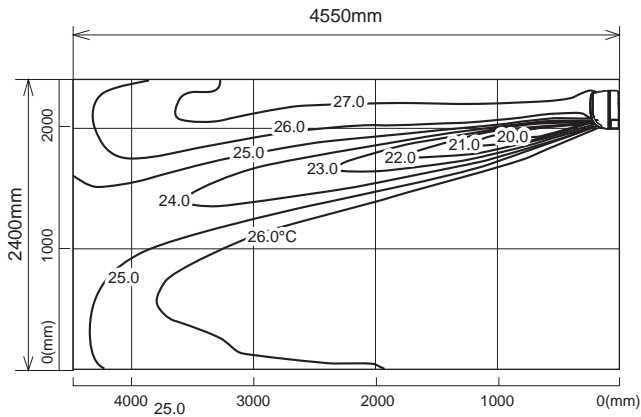

<Heating mode>

Air volume: high
Air direction: auto (downward air flow)

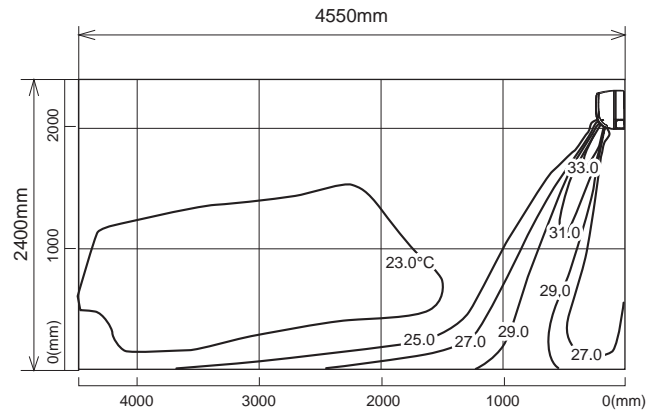

Airflow distribution

<Cooling mode>

Air volume: high
Air direction: auto (upward air flow)

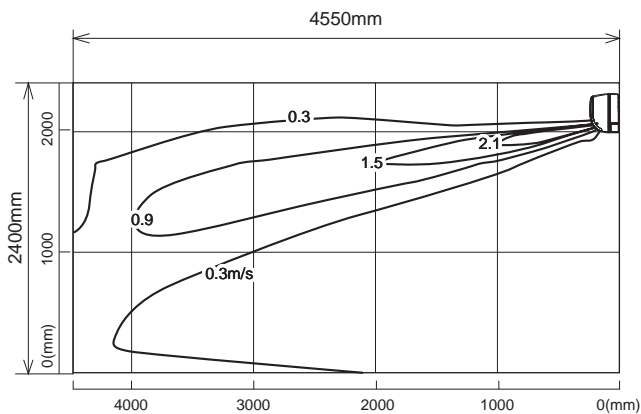

<Heating mode>

Air volume: high
Air direction: auto (downward air flow)

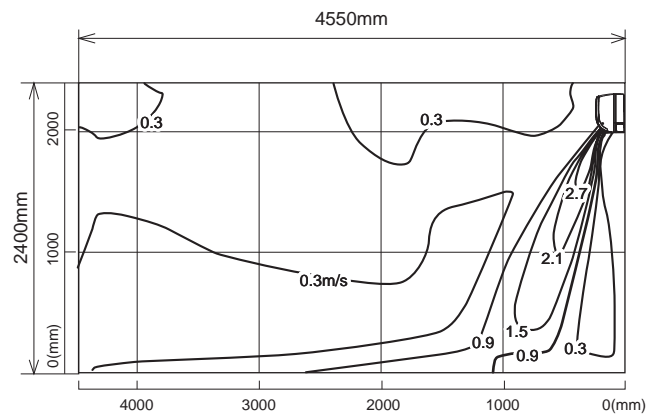

Note : These figures show typical airflow distributions in the conditions above. In the actual installation, they may differ from these figures under the influence of air temperature conditions, ceiling height, cooling/heating load, obstacles, etc.

WALL-MOUNTED TEMPERATURE AND AIR FLOW DISTRIBUTIONS

MSZ-HR42VF MSZ-HR42VFK

Temperature distribution

<Cooling mode>

Air volume: high
Air direction: auto (upward air flow)

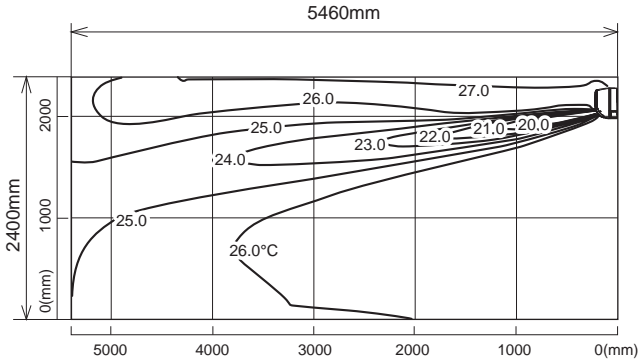

<Heating mode>

Air volume: high
Air direction: auto (downward air flow)

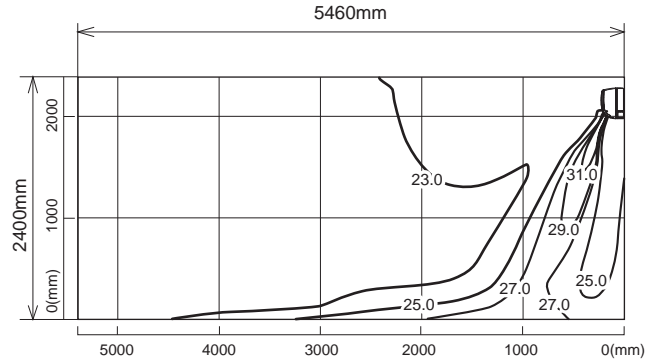

Airflow distribution

<Cooling mode>

Air volume: high
Air direction: auto (upward air flow)

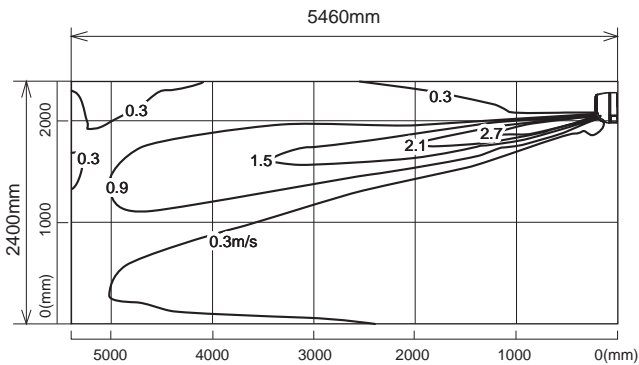

<Heating mode>

Air volume: high
Air direction: auto (downward air flow)

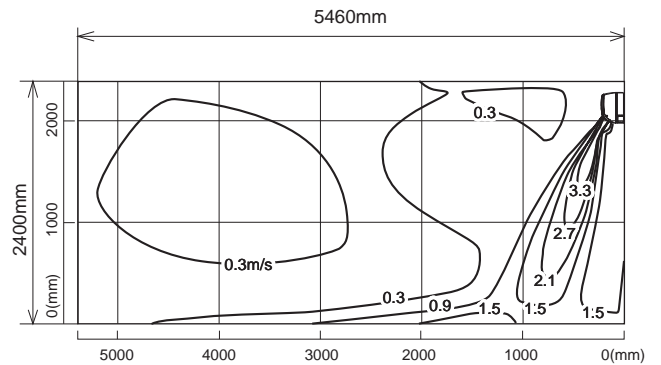

Note : These figures show typical airflow distributions in the conditions above. In the actual installation, they may differ from these figures under the influence of air temperature conditions, ceiling height, cooling/heating load, obstacles, etc.

TEMPERATURE AND AIR FLOW DISTRIBUTIONS

WALL-MOUNTED

MSZ-HR50VF MSZ-HR50VFK

Temperature distribution

<Cooling mode>

Air volume: high
Air direction: auto (upward air flow)

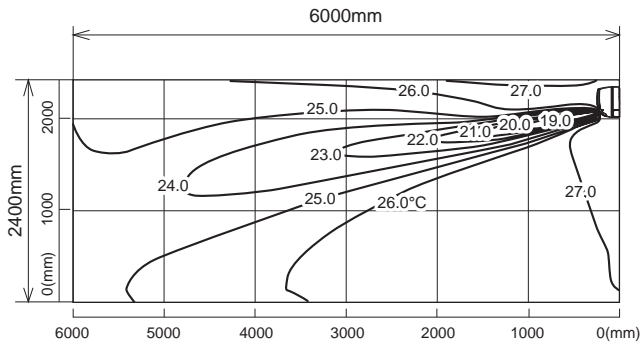

<Heating mode>

Air volume: high
Air direction: auto (downward air flow)

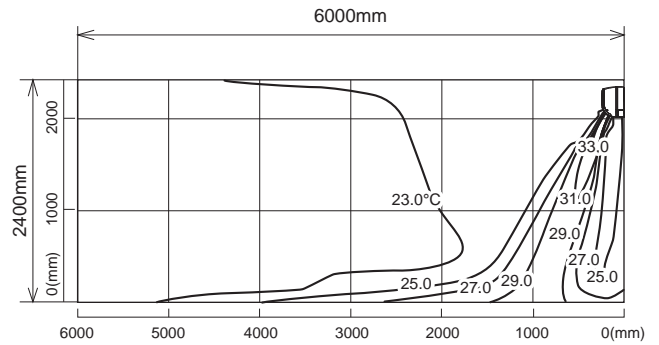

Airflow distribution

<Cooling mode>

Air volume: high
Air direction: auto (upward air flow)

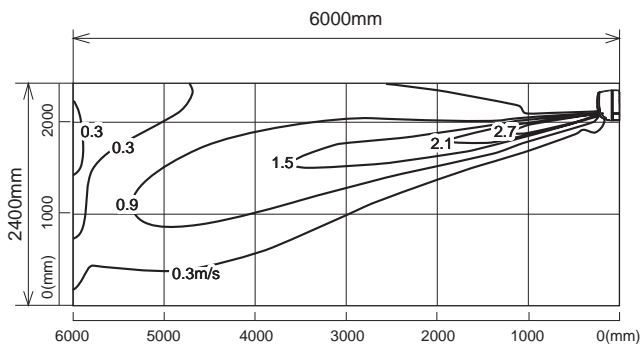

<Heating mode>

Air volume: high
Air direction: auto (downward air flow)

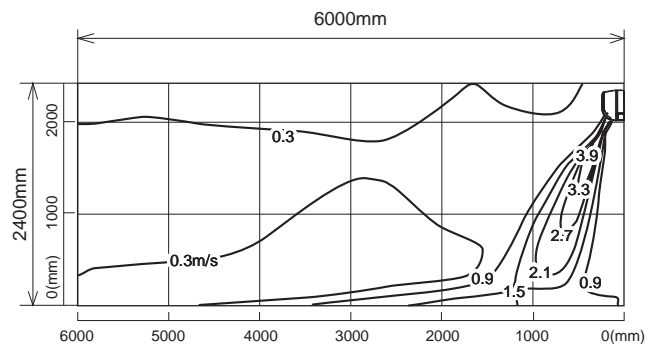

Note : These figures show typical airflow distributions in the conditions above. In the actual installation, they may differ from these figures under the influence of air temperature conditions, ceiling height, cooling/heating load, obstacles, etc.

WALL-MOUNTED TEMPERATURE AND AIR FLOW DISTRIBUTIONS

MSZ-HR60VF MSZ-HR60VFK

Temperature distribution

<Cooling mode>

Air volume: high
Air direction: auto (upward air flow)

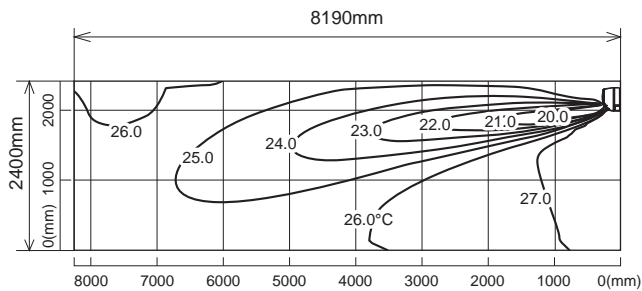

<Heating mode>

Air volume: high
Air direction: auto (downward air flow)

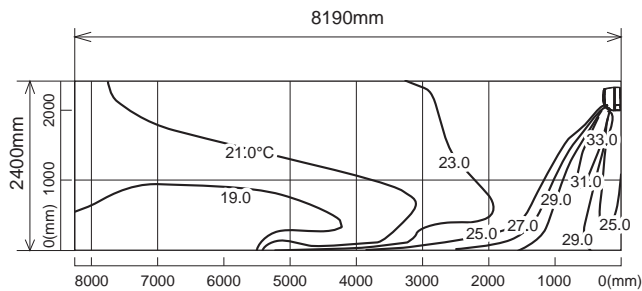

Airflow distribution

<Cooling mode>

Air volume: high
Air direction: auto (upward air flow)

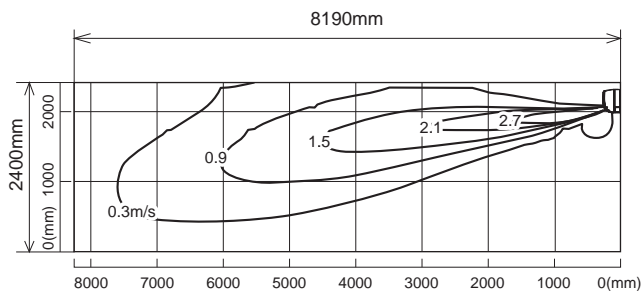

<Heating mode>

Air volume: high
Air direction: auto (downward air flow)

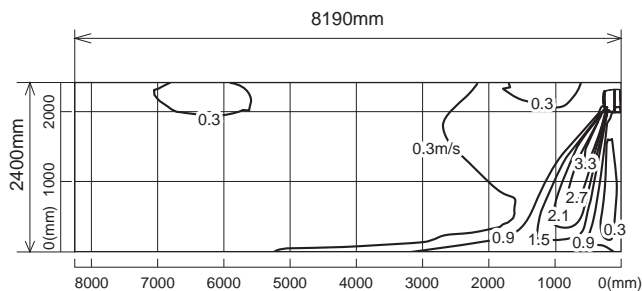

Note : These figures show typical airflow distributions in the conditions above. In the actual installation, they may differ from these figures under the influence of air temperature conditions, ceiling height, cooling/heating load, obstacles, etc.

TEMPERATURE AND AIR FLOW DISTRIBUTIONS

WALL-MOUNTED

MSZ-HR71VF MSZ-HR71VFK

Temperature distribution

<Cooling mode>

Air volume: high
Air direction: auto (upward air flow)

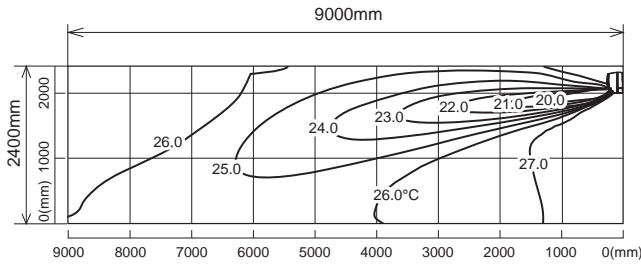

<Heating mode>

Air volume: high
Air direction: auto (downward air flow)

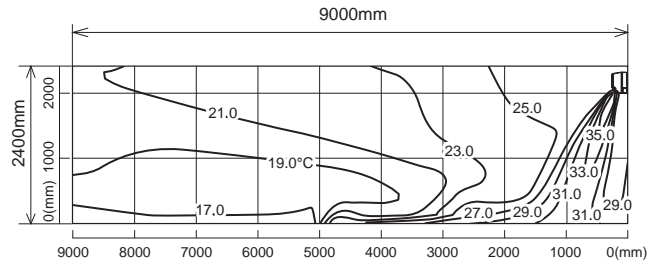

Airflow distribution

<Cooling mode>

Air volume: high
Air direction: auto (upward air flow)

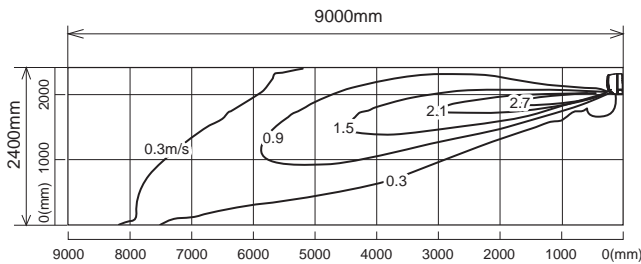

<Heating mode>

Air volume: high
Air direction: auto (downward air flow)

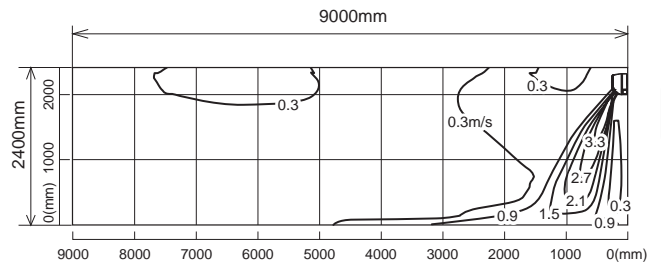

Note : These figures show typical airflow distributions in the conditions above. In the actual installation, they may differ from these figures under the influence of air temperature conditions, ceiling height, cooling/heating load, obstacles, etc.

WALL-MOUNTED TEMPERATURE AND AIR FLOW DISTRIBUTIONS

MST-TP35VF

Temperature distribution

<Cooling mode>

Air volume: high

Air direction: auto (upward air flow)

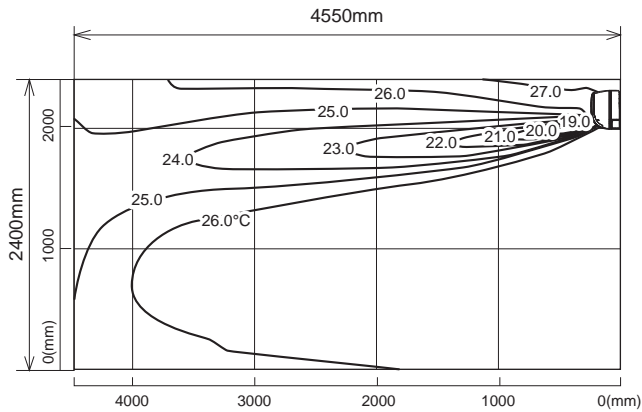

Airflow distribution

<Cooling mode>

Air volume: high

Air direction: auto (upward air flow)

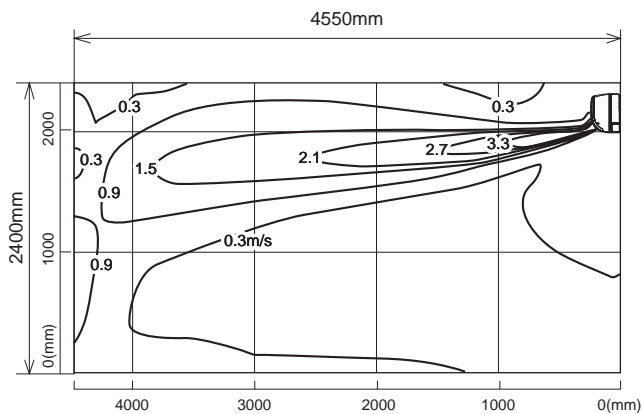

TEMPERATURE AND AIR FLOW DISTRIBUTIONS

WALL-MOUNTED

MST-TP50VF

Temperature distribution

<Cooling mode>

Air volume: high

Air direction: auto (upward air flow)

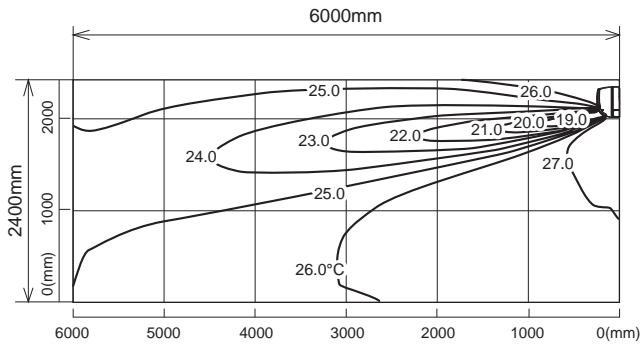

Airflow distribution

<Cooling mode>

Air volume: high

Air direction: auto (upward air flow)

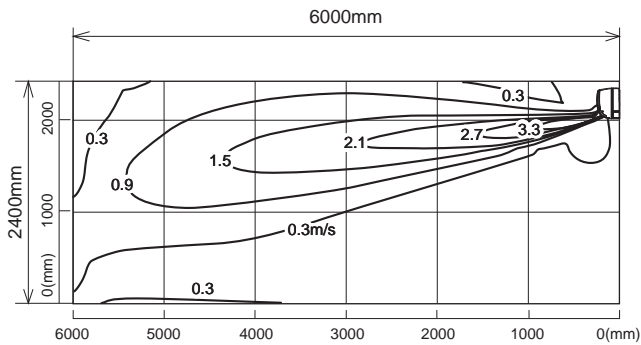

WALL-MOUNTED TEMPERATURE AND AIR FLOW DISTRIBUTIONS

MSZ-FH25VE2

Temperature distribution

<Cooling mode>

Air volume: high
Air direction: auto (upward air flow)

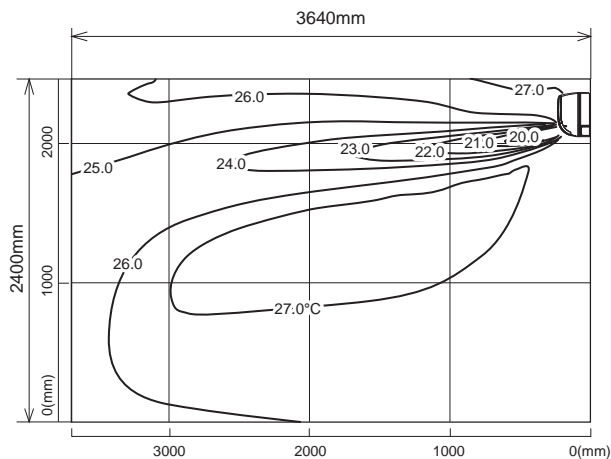

<Heating mode>

Air volume: high
Air direction: auto (downward air flow)

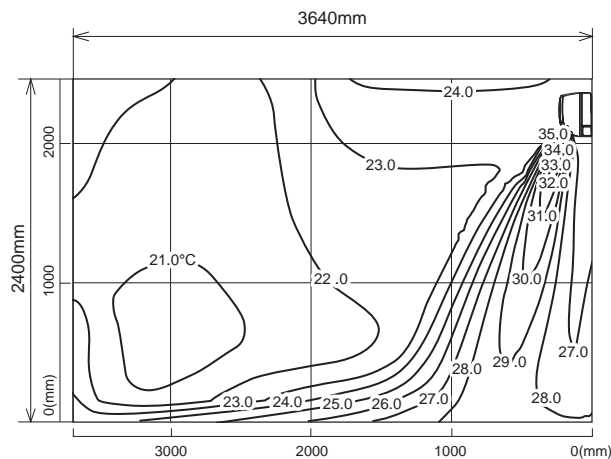

Airflow distribution

<Cooling mode>

Air volume: high
Air direction: auto (upward air flow)

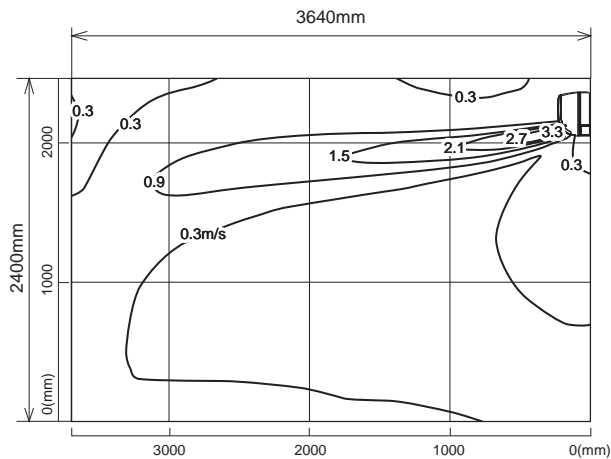

<Heating mode>

Air volume: high
Air direction: auto (downward air flow)

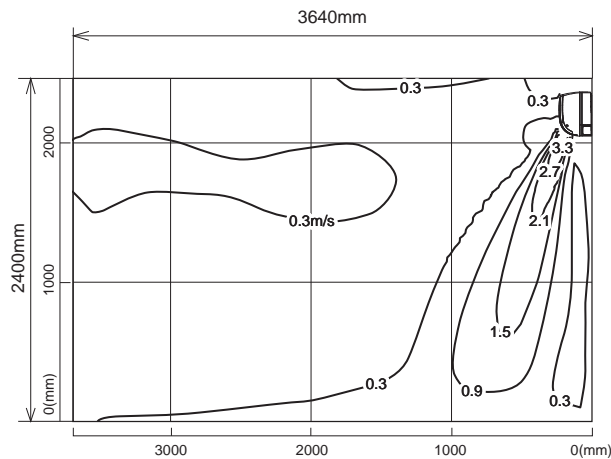

Note : These figures show typical airflow distributions in the conditions above. In the actual installation, they may differ from these figures under the influence of air temperature conditions, ceiling height, cooling/heating load, obstacles, etc.

TEMPERATURE AND AIR FLOW DISTRIBUTIONS

WALL-MOUNTED

MSZ-FH35VE2

Temperature distribution

<Cooling mode>

Air volume: high
Air direction: auto (upward air flow)

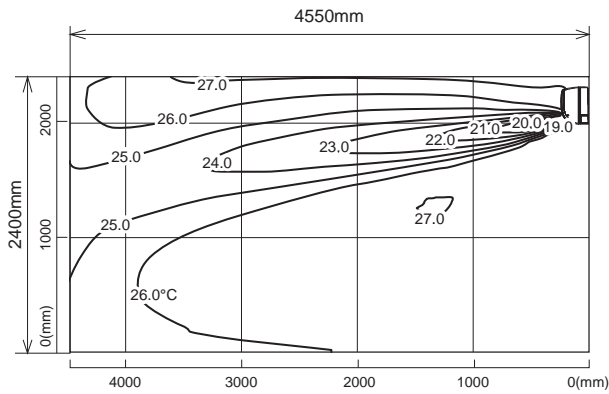

<Heating mode>

Air volume: high
Air direction: auto (downward air flow)

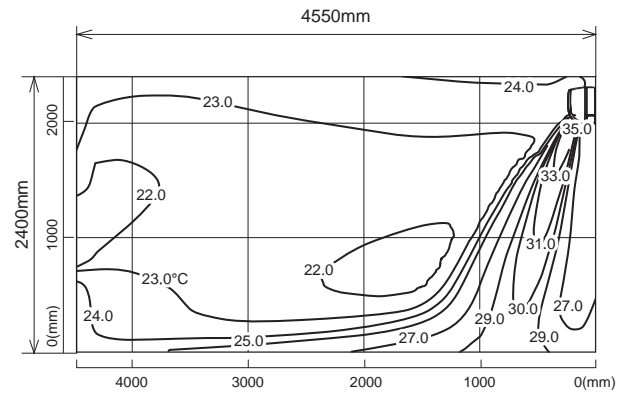

Airflow distribution

<Cooling mode>

Air volume: high
Air direction: auto (upward air flow)

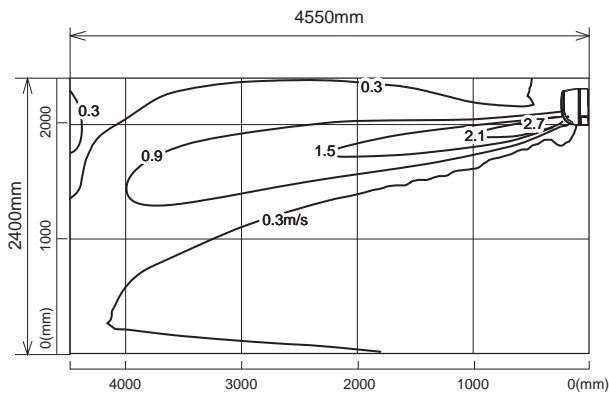

<Heating mode>

Air volume: high
Air direction: auto (downward air flow)

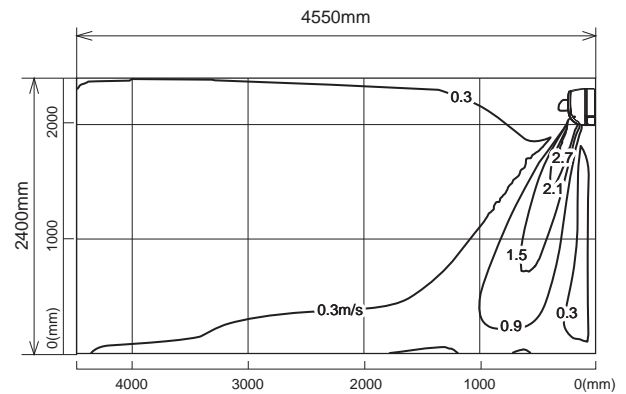

Note : These figures show typical airflow distributions in the conditions above. In the actual installation, they may differ from these figures under the influence of air temperature conditions, ceiling height, cooling/heating load, obstacles, etc.

WALL-MOUNTED TEMPERATURE AND AIR FLOW DISTRIBUTIONS

MSZ-FH50VE2

Temperature distribution

<Cooling mode>

Air volume: high
Air direction: auto (upward air flow)

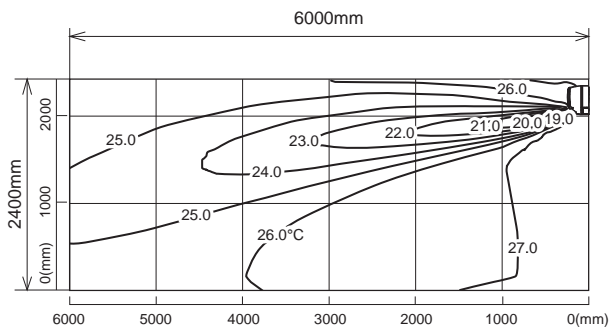

<Heating mode>

Air volume: high
Air direction: auto (downward air flow)

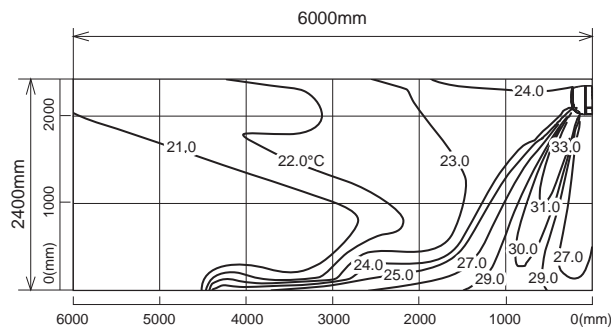

Airflow distribution

<Cooling mode>

Air volume: high
Air direction: auto (upward air flow)

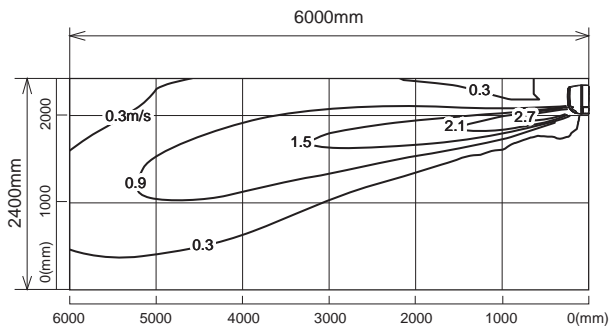

<Heating mode>

Air volume: high
Air direction: auto (downward air flow)

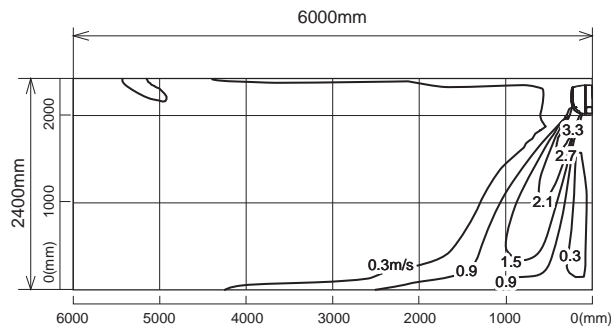

Note : These figures show typical airflow distributions in the conditions above. In the actual installation, they may differ from these figures under the influence of air temperature conditions, ceiling height, cooling/heating load, obstacles, etc.

TEMPERATURE AND AIR FLOW DISTRIBUTIONS

WALL-MOUNTED

**MSZ-EF18VGW MSZ-EF18VGB MSZ-EF18VGS
MSZ-EF18VGKW MSZ-EF18VGKB MSZ-EF18VGKS**

Temperature distribution

<Cooling mode>

Air volume: high
Air direction: auto (upward air flow)

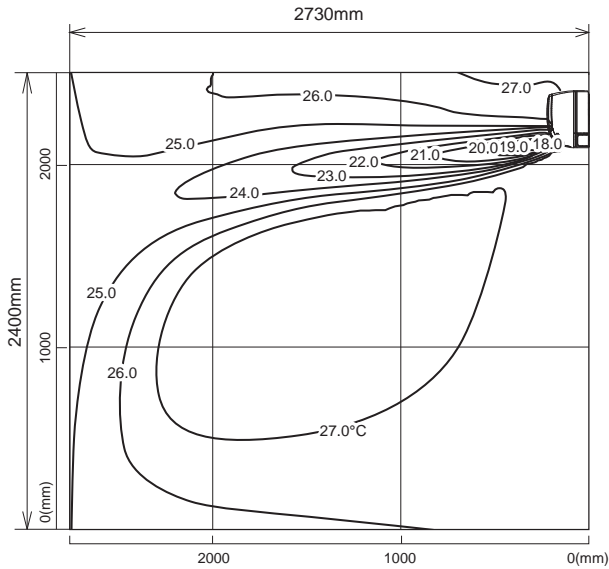

<Heating mode>

Air volume: high
Air direction: auto (downward air flow)

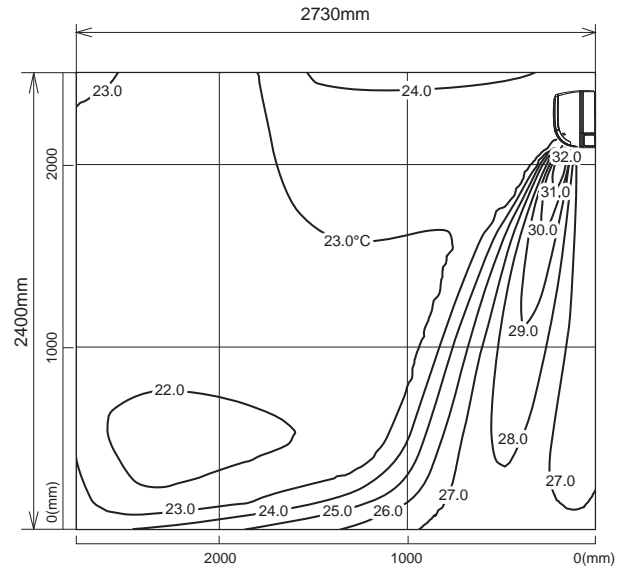

Airflow distribution

<Cooling mode>

Air volume: high
Air direction: auto (upward air flow)

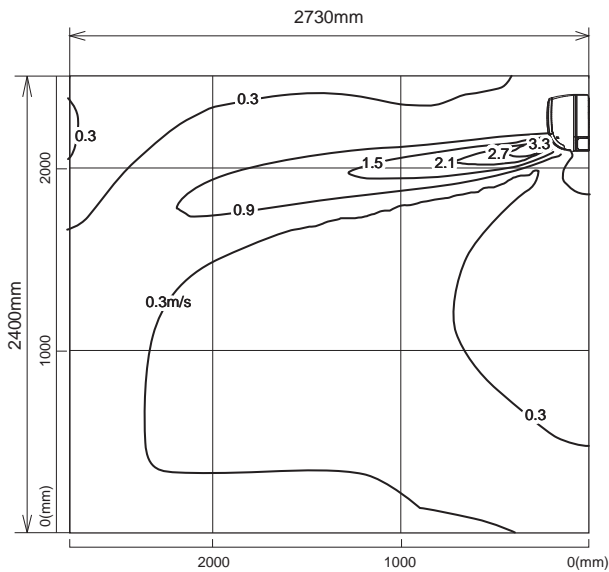

<Heating mode>

Air volume: high
Air direction: auto (downward air flow)

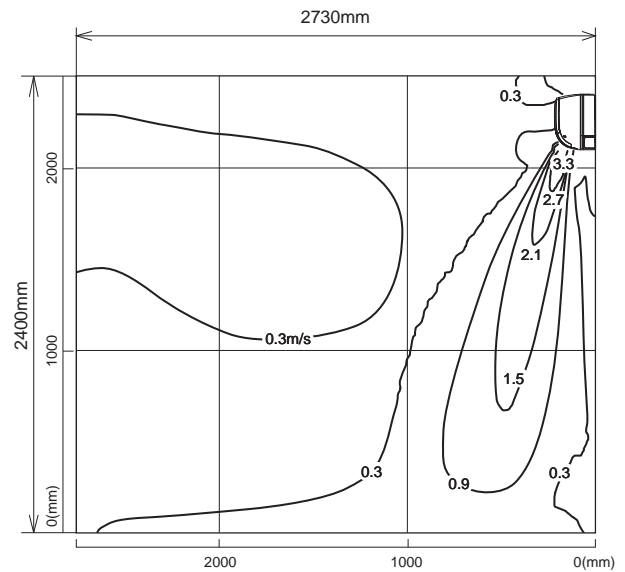

Note : These figures show typical airflow distributions in the conditions above. In the actual installation, they may differ from these figures under the influence of air temperature conditions, ceiling height, cooling/heating load, obstacles, etc.

WALL-MOUNTED TEMPERATURE AND AIR FLOW DISTRIBUTIONS

**MSZ-EF22VGW MSZ-EF22VGB MSZ-EF22VGS
MSZ-EF22VGKW MSZ-EF22VGKB MSZ-EF22VGKS**

Temperature distribution

<Cooling mode>

Air volume: high
Air direction: auto (upward air flow)

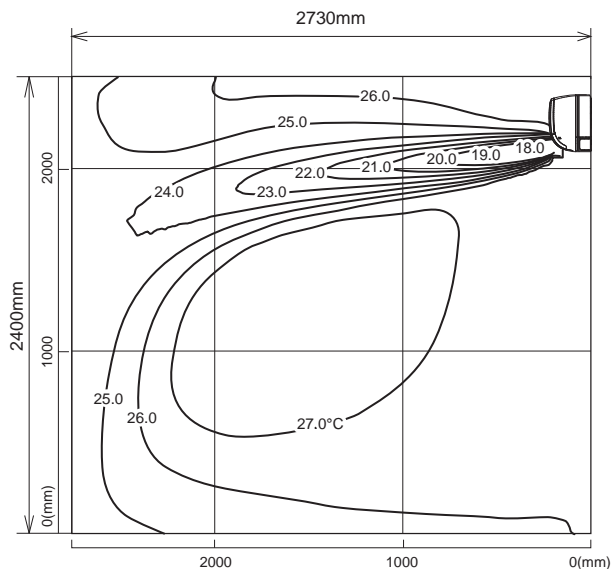

<Heating mode>

Air volume: high
Air direction: auto (downward air flow)

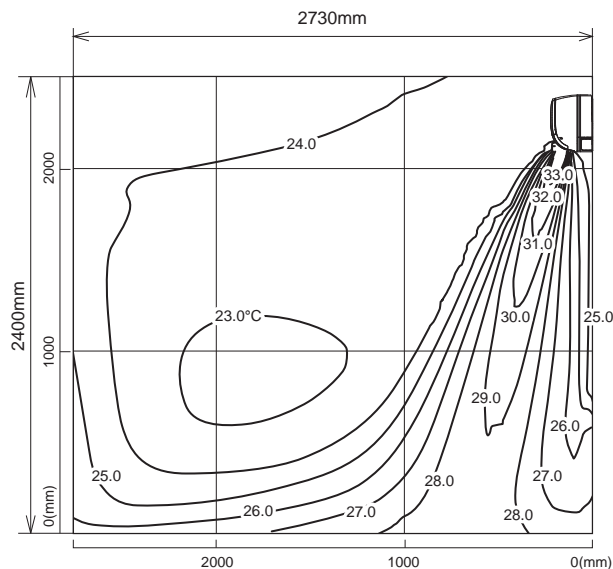

Airflow distribution

<Cooling mode>

Air volume: high
Air direction: auto (upward air flow)

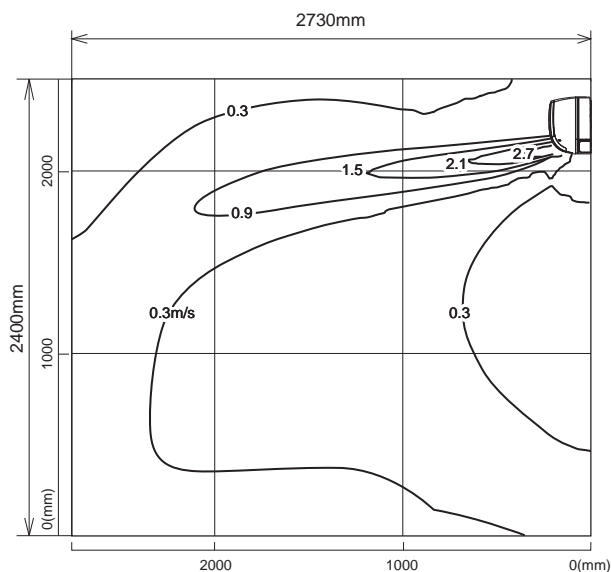

<Heating mode>

Air volume: high
Air direction: auto (downward air flow)

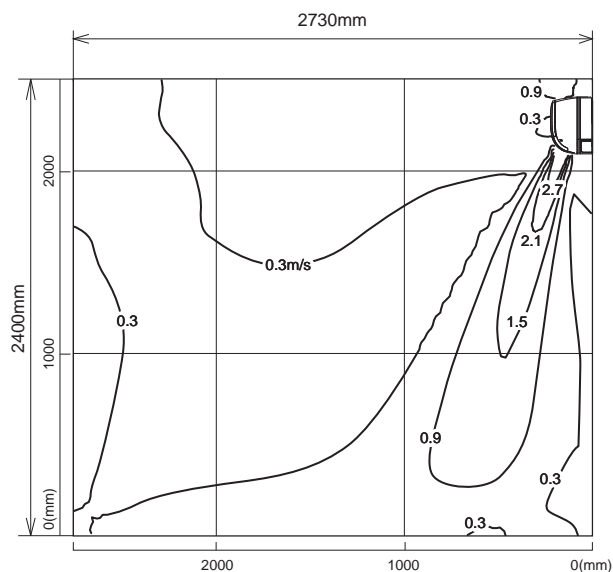

Note : These figures show typical airflow distributions in the conditions above. In the actual installation, they may differ from these figures under the influence of air temperature conditions, ceiling height, cooling/heating load, obstacles, etc.

TEMPERATURE AND AIR FLOW DISTRIBUTIONS

WALL-MOUNTED

**MSZ-EF25VGW MSZ-EF25VGB MSZ-EF25VGS
MSZ-EF25VGKW MSZ-EF25VGKB MSZ-EF25VGKS**

Temperature distribution

<Cooling mode>

Air volume: high
Air direction: auto (upward air flow)

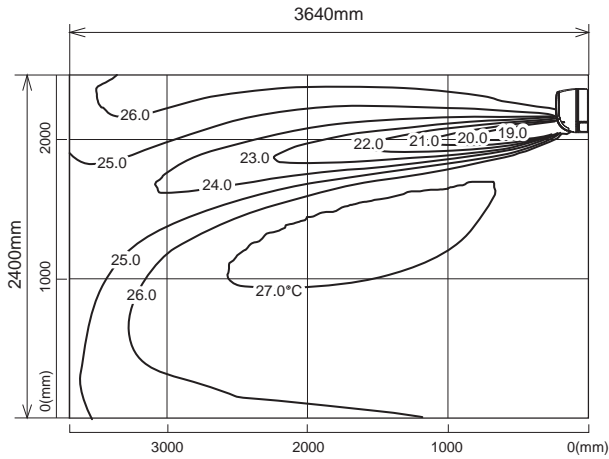

<Heating mode>

Air volume: high
Air direction: auto (downward air flow)

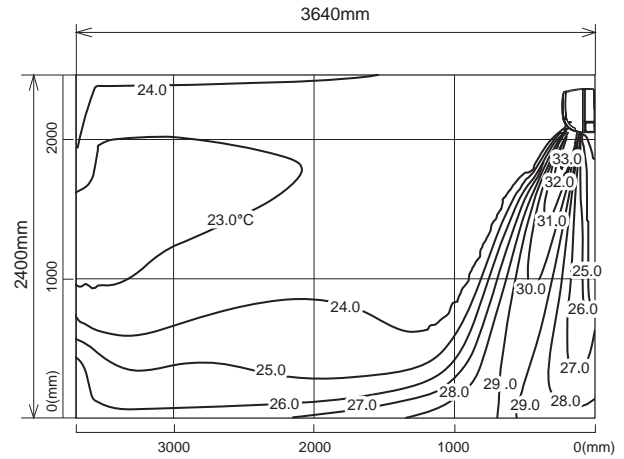

Airflow distribution

<Cooling mode>

Air volume: high
Air direction: auto (upward air flow)

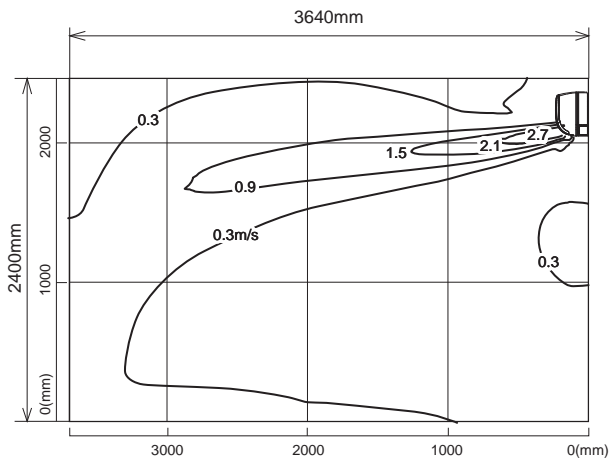

<Heating mode>

Air volume: high
Air direction: auto (downward air flow)

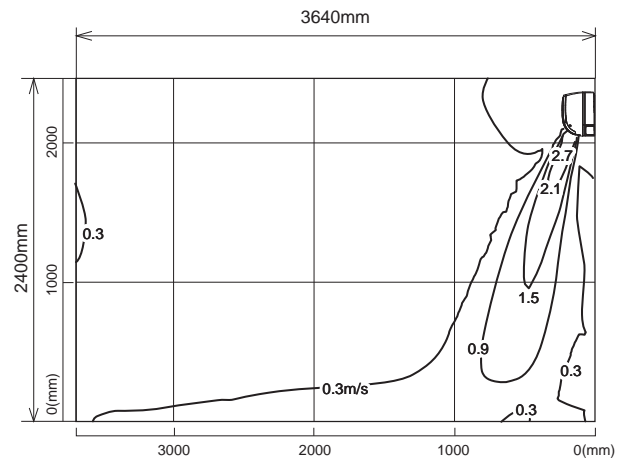

Note : These figures show typical airflow distributions in the conditions above. In the actual installation, they may differ from these figures under the influence of air temperature conditions, ceiling height, cooling/heating load, obstacles, etc.

WALL-MOUNTED TEMPERATURE AND AIR FLOW DISTRIBUTIONS

**MSZ-EF35VGW MSZ-EF35VGB MSZ-EF35VGS
MSZ-EF35VGKW MSZ-EF35VGKB MSZ-EF35VGKS**

Temperature distribution

<Cooling mode>

Air volume: high
Air direction: auto (upward air flow)

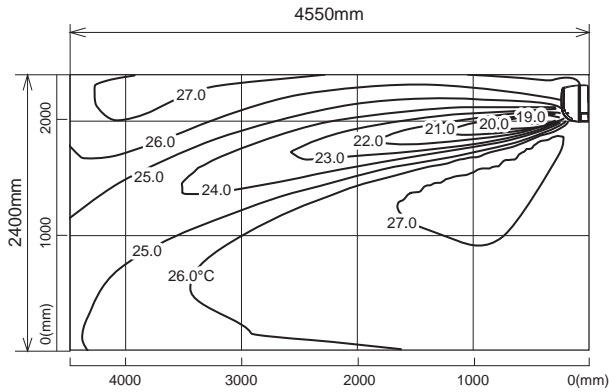

<Heating mode>

Air volume: high
Air direction: auto (downward air flow)

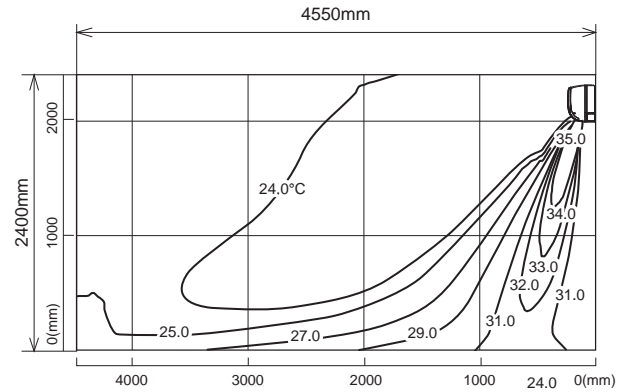

Airflow distribution

<Cooling mode>

Air volume: high
Air direction: auto (upward air flow)

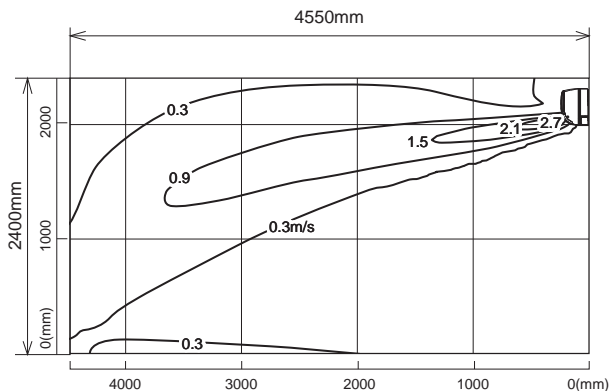

<Heating mode>

Air volume: high
Air direction: auto (downward air flow)

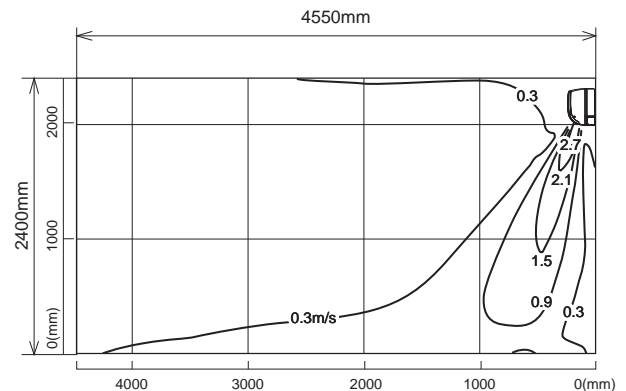

Note : These figures show typical airflow distributions in the conditions above. In the actual installation, they may differ from these figures under the influence of air temperature conditions, ceiling height, cooling/heating load, obstacles, etc.

TEMPERATURE AND AIR FLOW DISTRIBUTIONS

WALL-MOUNTED

**MSZ-EF42VGW MSZ-EF42VGB MSZ-EF42VGS
MSZ-EF42VGKW MSZ-EF42VGKB MSZ-EF42VGKS**

Temperature distribution

<Cooling mode>

Air volume: high
Air direction: auto (upward air flow)

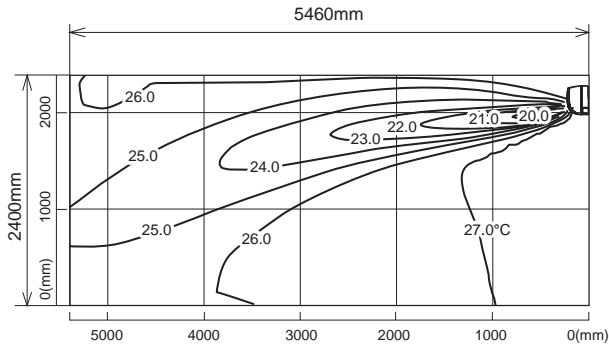

<Heating mode>

Air volume: high
Air direction: auto (downward air flow)

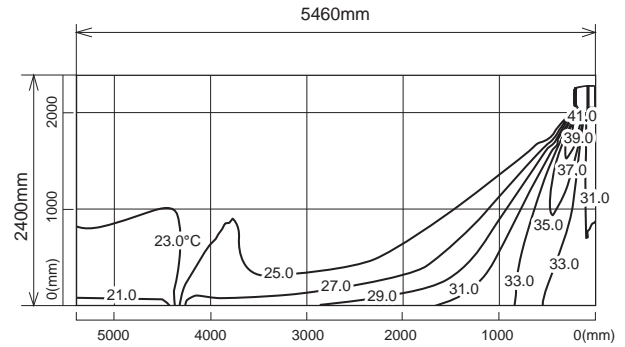

Airflow distribution

<Cooling mode>

Air volume: high
Air direction: auto (upward air flow)

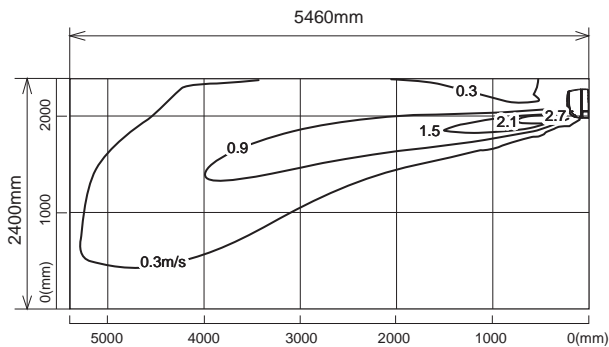

<Heating mode>

Air volume: high
Air direction: auto (downward air flow)

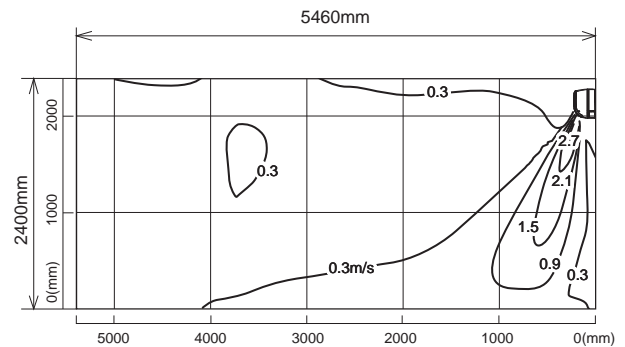

Note : These figures show typical airflow distributions in the conditions above. In the actual installation, they may differ from these figures under the influence of air temperature conditions, ceiling height, cooling/heating load, obstacles, etc.

WALL-MOUNTED TEMPERATURE AND AIR FLOW DISTRIBUTIONS

**MSZ-EF50VGW MSZ-EF50VGB MSZ-EF50VGS
MSZ-EF50VGKW MSZ-EF50VGKB MSZ-EF50VGKS**

Temperature distribution

<Cooling mode>

Air volume: high
Air direction: auto (upward air flow)

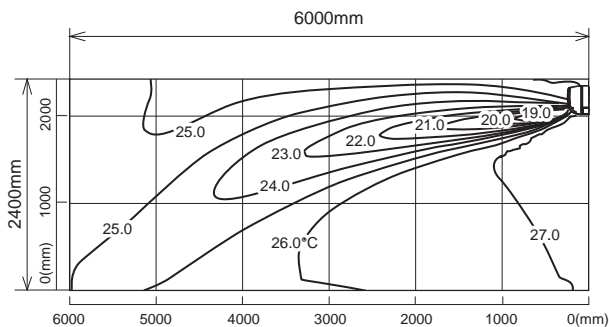

<Heating mode>

Air volume: high
Air direction: auto (downward air flow)

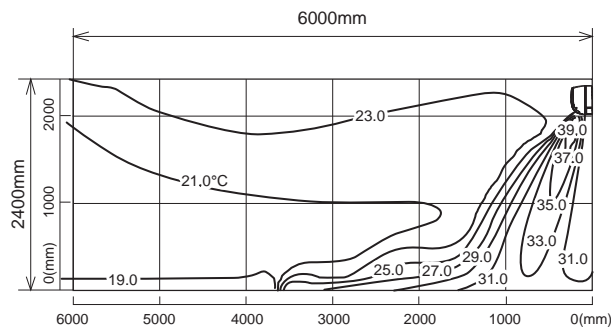

Airflow distribution

<Cooling mode>

Air volume: high
Air direction: auto (upward air flow)

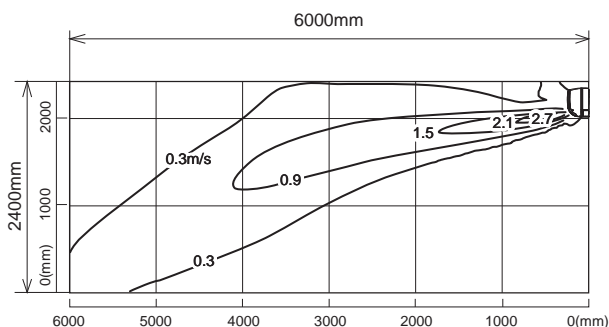

<Heating mode>

Air volume: high
Air direction: auto (downward air flow)

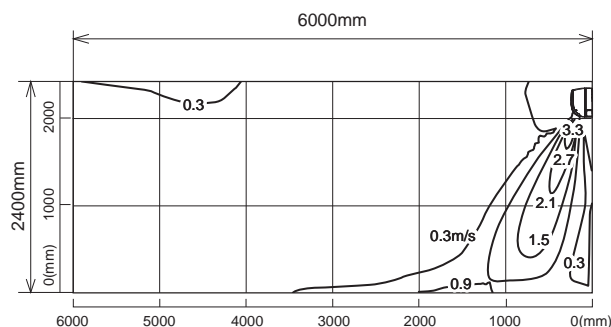

Note : These figures show typical airflow distributions in the conditions above. In the actual installation, they may differ from these figures under the influence of air temperature conditions, ceiling height, cooling/heating load, obstacles, etc.

TEMPERATURE AND AIR FLOW DISTRIBUTIONS

WALL-MOUNTED

MSZ-BT20VG MSZ-BT20VGK

Temperature distribution

<Cooling mode>

Air volume: high
Air direction: auto (upward air flow)

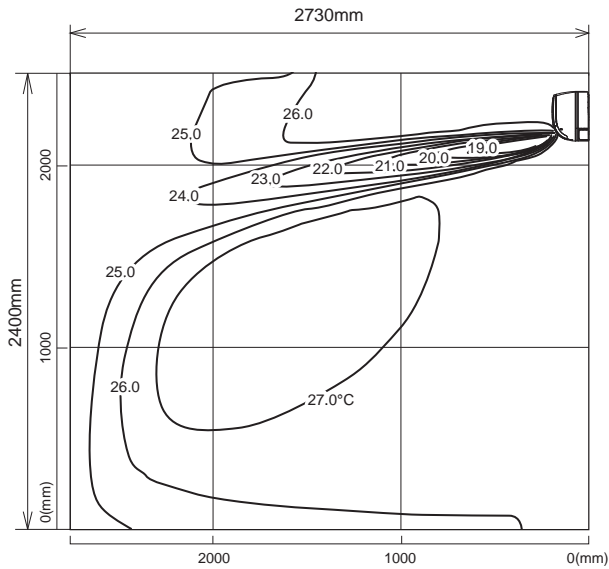

<Heating mode>

Air volume: high
Air direction: auto (downward air flow)

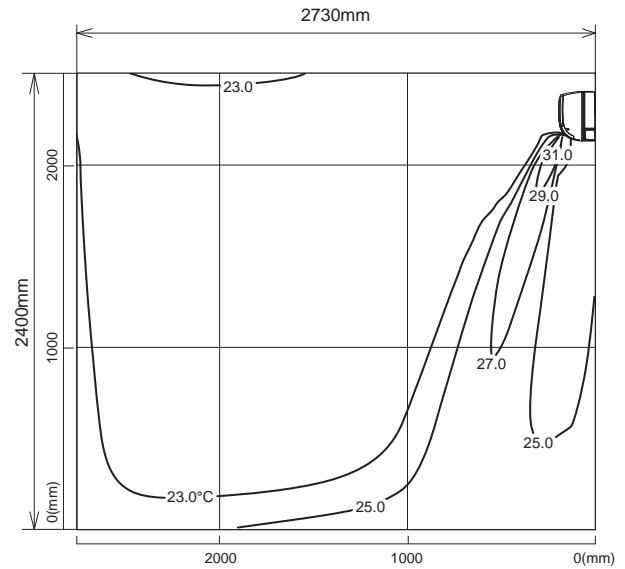

Airflow distribution

<Cooling mode>

Air volume: high
Air direction: auto (upward air flow)

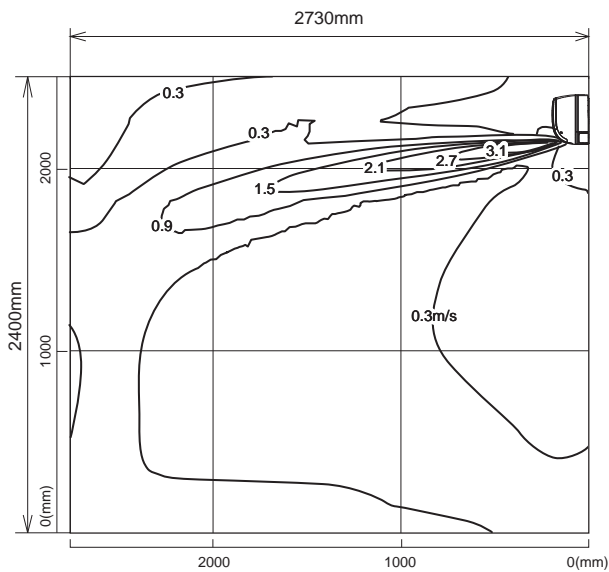

<Heating mode>

Air volume: high
Air direction: auto (downward air flow)

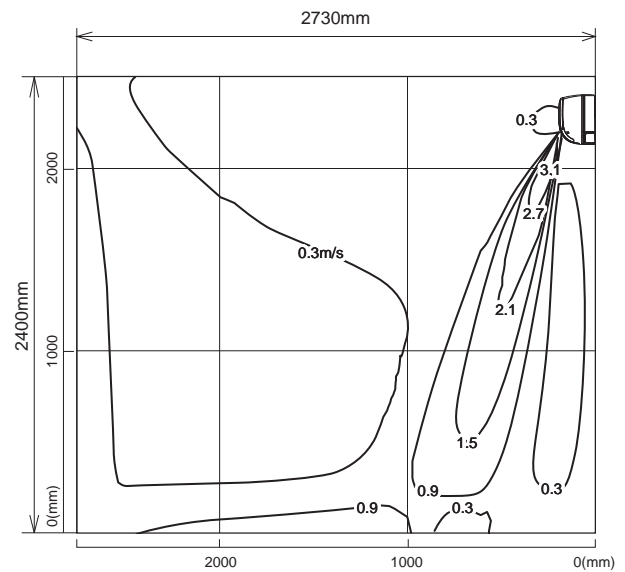

Note : These figures show typical airflow distributions in the conditions above. In the actual installation, they may differ from these figures under the influence of air temperature conditions, ceiling height, cooling/heating load, obstacles, etc.

WALL-MOUNTED TEMPERATURE AND AIR FLOW DISTRIBUTIONS

MSZ-BT25VG MSZ-BT25VGK

Temperature distribution

<Cooling mode>

Air volume: high
Air direction: auto (upward air flow)

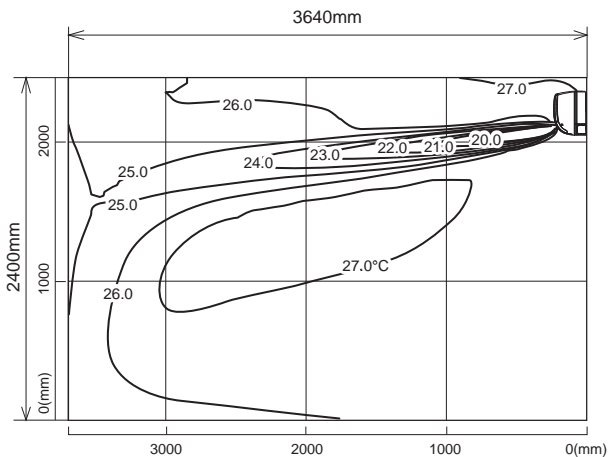

<Heating mode>

Air volume: high
Air direction: auto (downward air flow)

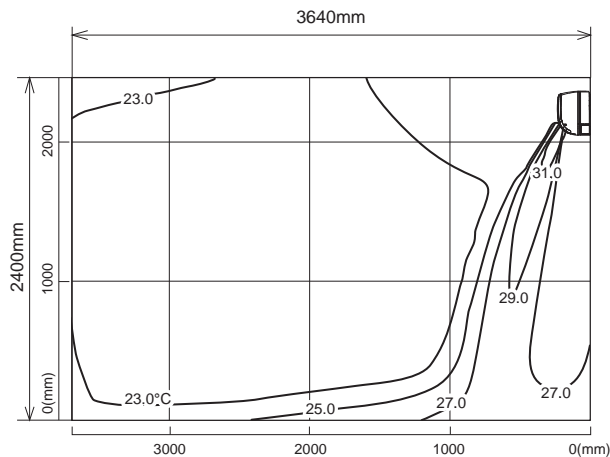

Airflow distribution

<Cooling mode>

Air volume: high
Air direction: auto (upward air flow)

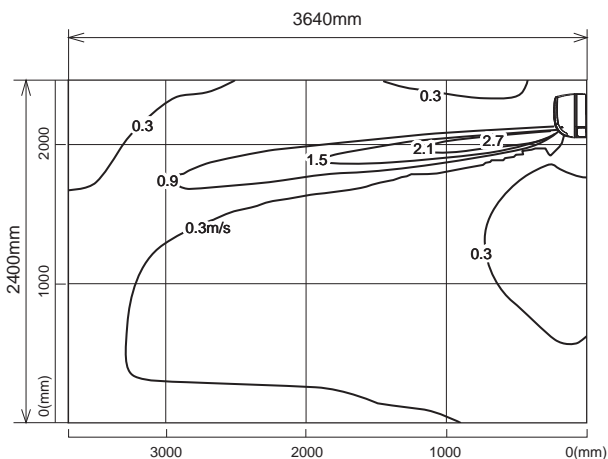

<Heating mode>

Air volume: high
Air direction: auto (downward air flow)

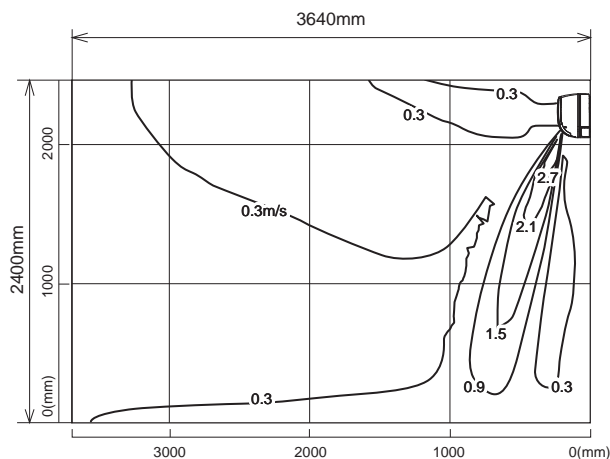

Note : These figures show typical airflow distributions in the conditions above. In the actual installation, they may differ from these figures under the influence of air temperature conditions, ceiling height, cooling/heating load, obstacles, etc.

TEMPERATURE AND AIR FLOW DISTRIBUTIONS

WALL-MOUNTED

MSZ-BT35VG MSZ-BT35VGK

Temperature distribution

<Cooling mode>

Air volume: high
Air direction: auto (upward air flow)

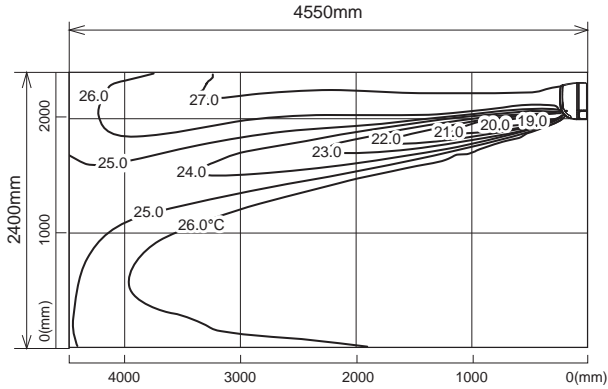

<Heating mode>

Air volume: high
Air direction: auto (downward air flow)

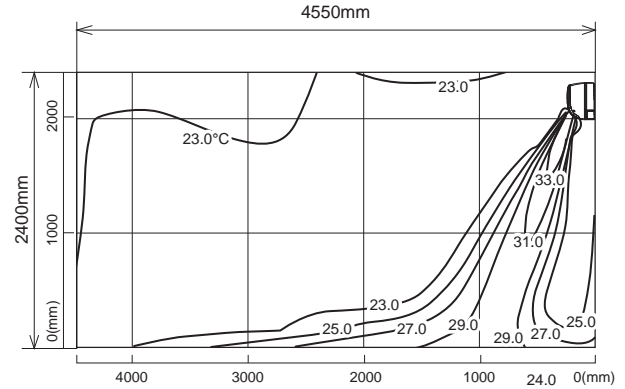

Airflow distribution

<Cooling mode>

Air volume: high
Air direction: auto (upward air flow)

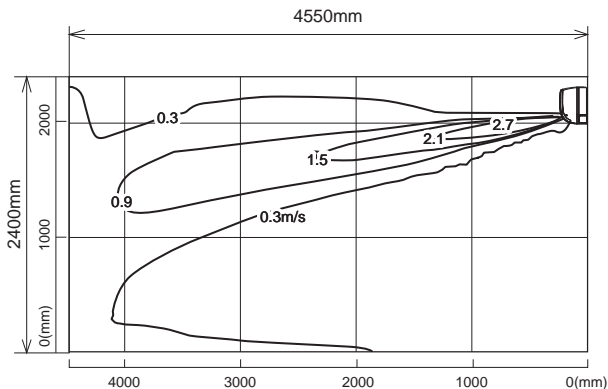

<Heating mode>

Air volume: high
Air direction: auto (downward air flow)

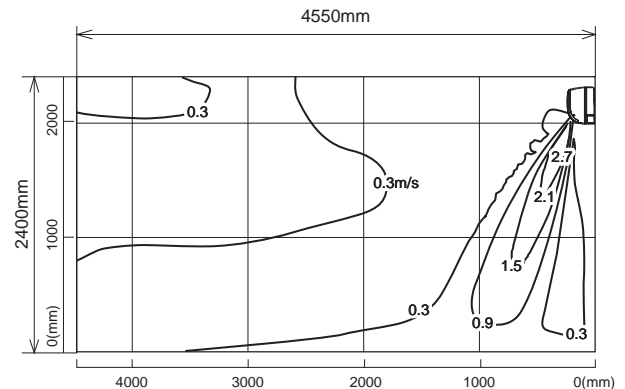

Note : These figures show typical airflow distributions in the conditions above. In the actual installation, they may differ from these figures under the influence of air temperature conditions, ceiling height, cooling/heating load, obstacles, etc.

WALL-MOUNTED TEMPERATURE AND AIR FLOW DISTRIBUTIONS

MSZ-BT50VG MSZ-BT50VGK

Temperature distribution

<Cooling mode>

Air volume: high
Air direction: auto (upward air flow)

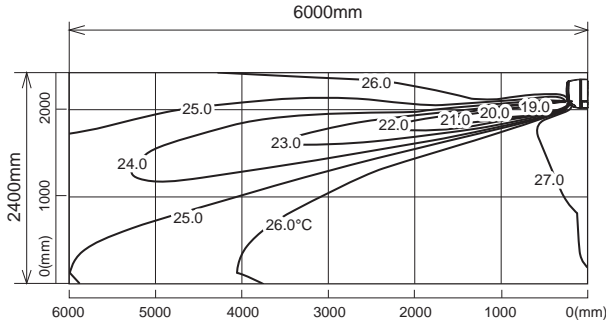

<Heating mode>

Air volume: high
Air direction: auto (downward air flow)

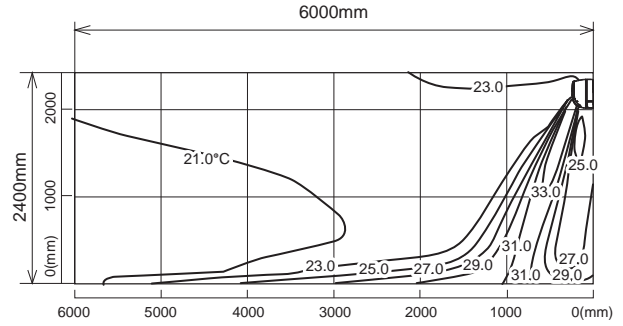

Airflow distribution

<Cooling mode>

Air volume: high
Air direction: auto (upward air flow)

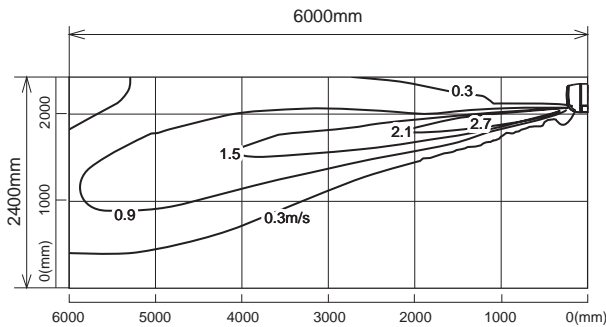

<Heating mode>

Air volume: high
Air direction: auto (downward air flow)

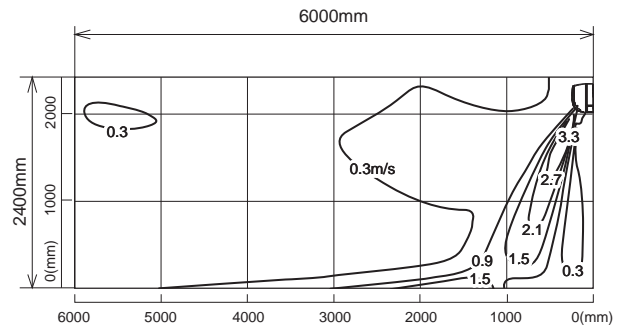

Note : These figures show typical airflow distributions in the conditions above. In the actual installation, they may differ from these figures under the influence of air temperature conditions, ceiling height, cooling/heating load, obstacles, etc.

TEMPERATURE AND AIR FLOW DISTRIBUTIONS

WALL-MOUNTED

MSZ-DW25VF

Temperature distribution

<Cooling mode>

Air volume: high
Air direction: auto (upward air flow)

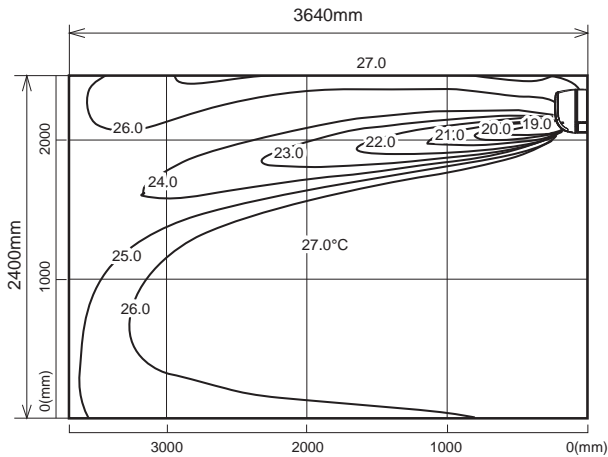

<Heating mode>

Air volume: high
Air direction: auto (downward air flow)

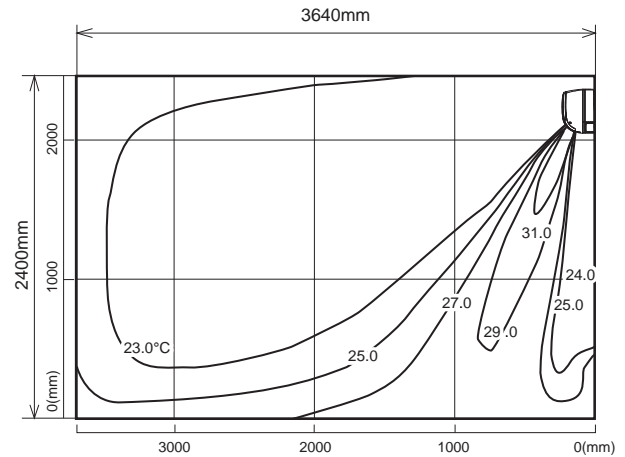

Airflow distribution

<Cooling mode>

Air volume: high
Air direction: auto (upward air flow)

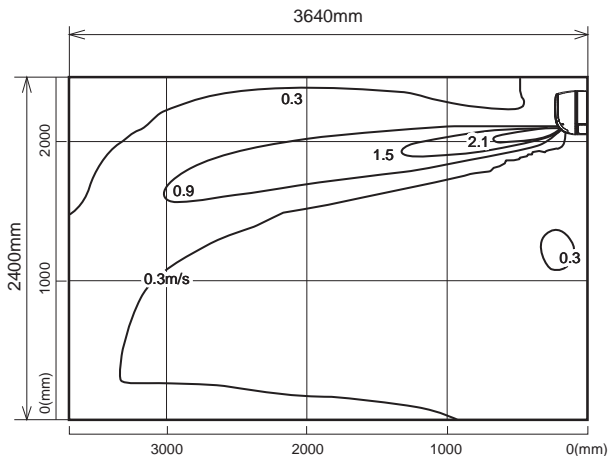

<Heating mode>

Air volume: high
Air direction: auto (downward air flow)

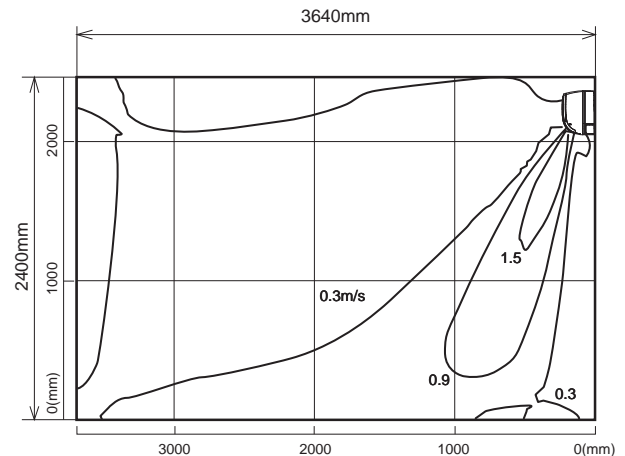

Note : These figures show typical airflow distributions in the conditions above. In the actual installation, they may differ from these figures under the influence of air temperature conditions, ceiling height, cooling/heating load, obstacles, etc.

WALL-MOUNTED TEMPERATURE AND AIR FLOW DISTRIBUTIONS

MSZ-DW35VF

Temperature distribution

<Cooling mode>

Air volume: high
Air direction: auto (upward air flow)

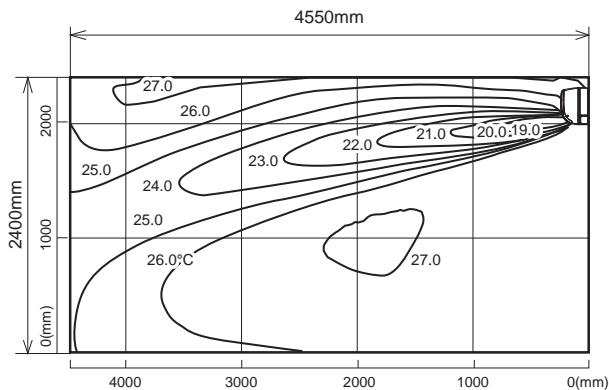

<Heating mode>

Air volume: high
Air direction: auto (downward air flow)

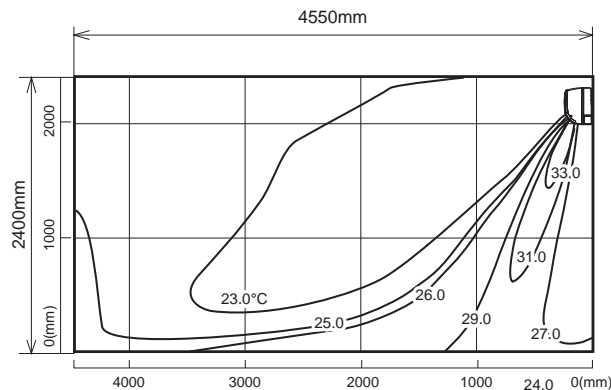

Airflow distribution

<Cooling mode>

Air volume: high
Air direction: auto (upward air flow)

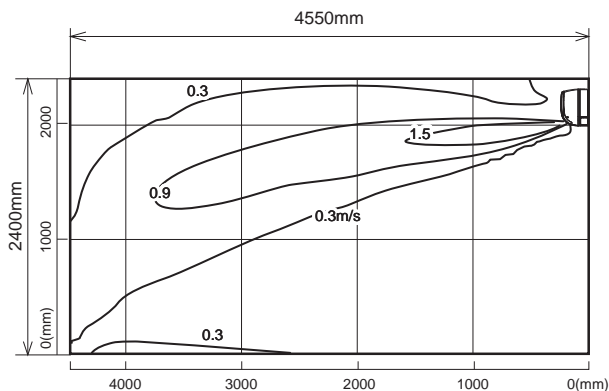

<Heating mode>

Air volume: high
Air direction: auto (downward air flow)

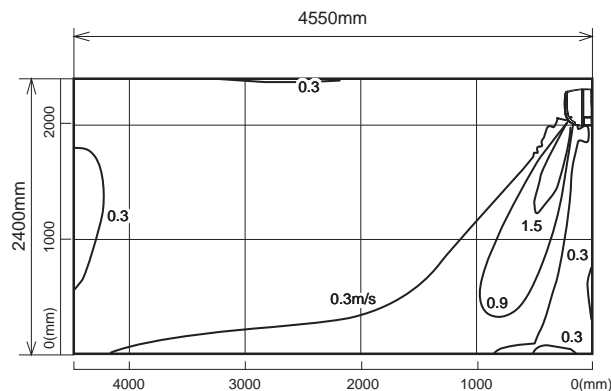

Note : These figures show typical airflow distributions in the conditions above. In the actual installation, they may differ from these figures under the influence of air temperature conditions, ceiling height, cooling/heating load, obstacles, etc.

TEMPERATURE AND AIR FLOW DISTRIBUTIONS

WALL-MOUNTED

MSZ-DW50VF

Temperature distribution

<Cooling mode>

Air volume: high
Air direction: auto (upward air flow)

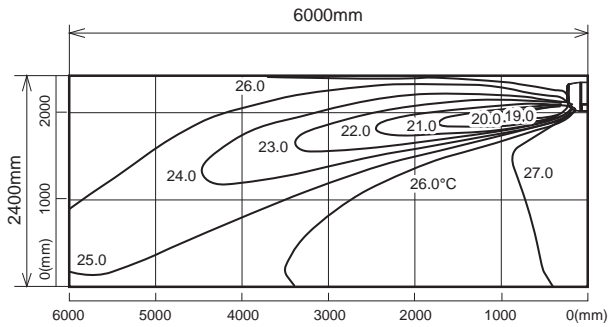

<Heating mode>

Air volume: high
Air direction: auto (downward air flow)

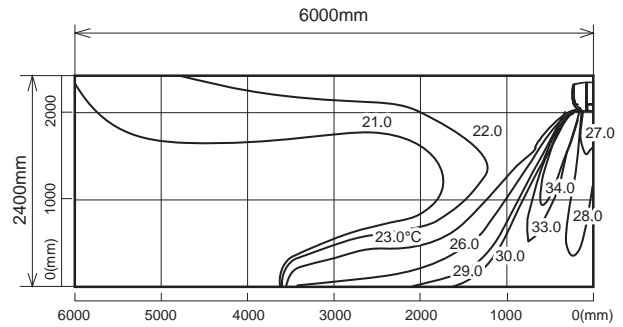

Airflow distribution

<Cooling mode>

Air volume: high
Air direction: auto (upward air flow)

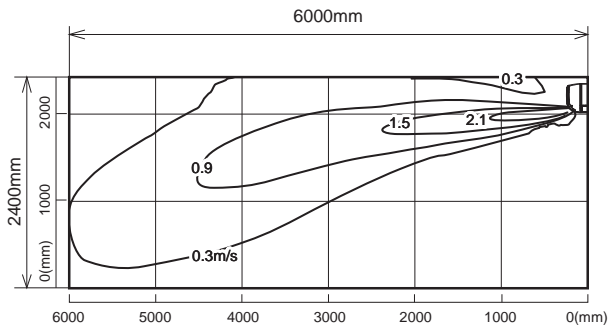

<Heating mode>

Air volume: high
Air direction: auto (downward air flow)

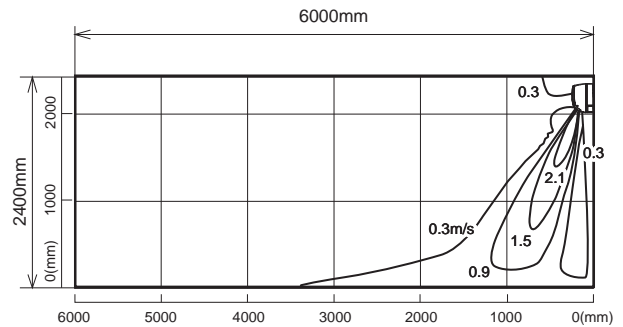

Note : These figures show typical airflow distributions in the conditions above. In the actual installation, they may differ from these figures under the influence of air temperature conditions, ceiling height, cooling/heating load, obstacles, etc.

WALL-MOUNTED TEMPERATURE AND AIR FLOW DISTRIBUTIONS

MSZ-SF15VA

Temperature distribution

<Cooling mode>

Air volume: high
Air direction: auto (upward air flow)

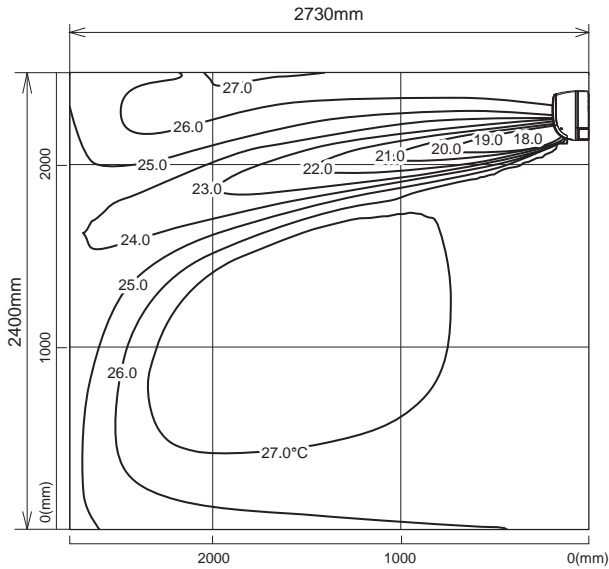

<Heating mode>

Air volume: high
Air direction: auto (downward air flow)

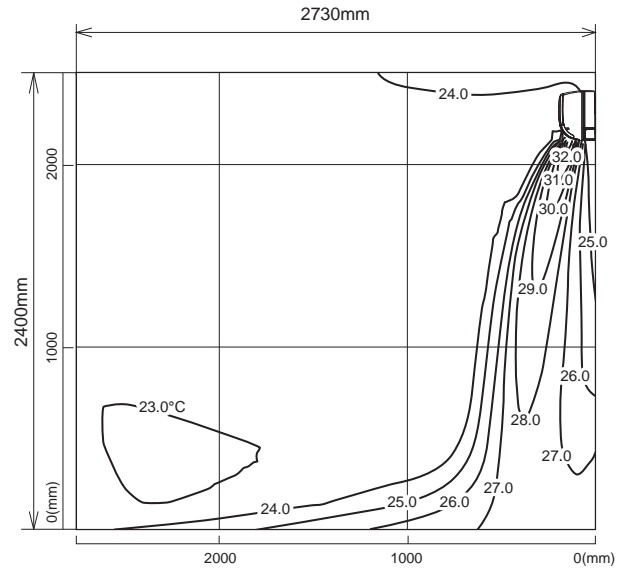

Airflow distribution

<Cooling mode>

Air volume: high
Air direction: auto (upward air flow)

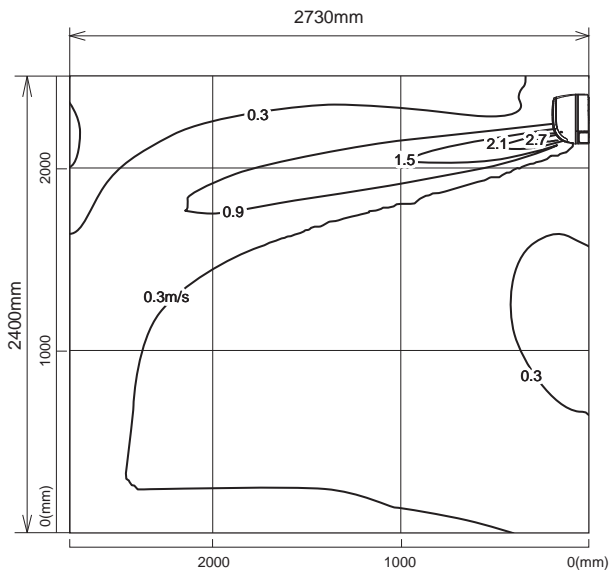

<Heating mode>

Air volume: high
Air direction: auto (downward air flow)

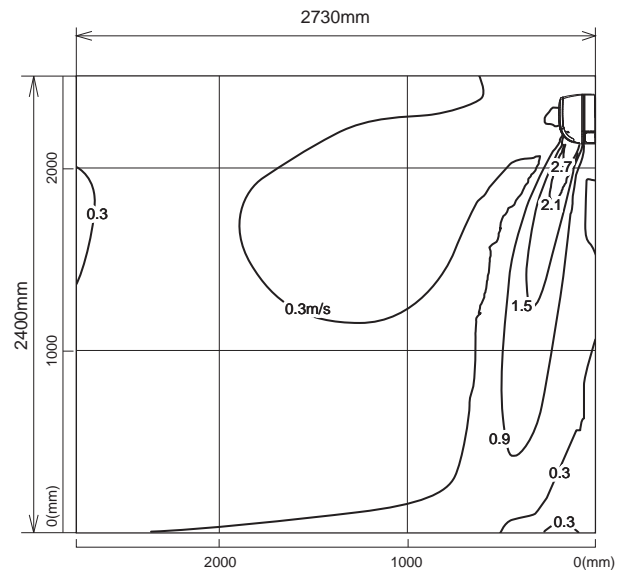

Note : These figures show typical airflow distributions in the conditions above. In the actual installation, they may differ from these figures under the influence of air temperature conditions, ceiling height, cooling/heating load, obstacles, etc.

TEMPERATURE AND AIR FLOW DISTRIBUTIONS

WALL-MOUNTED

MSZ-SF20VA

Temperature distribution

<Cooling mode>

Air volume: high
Air direction: auto (upward air flow)

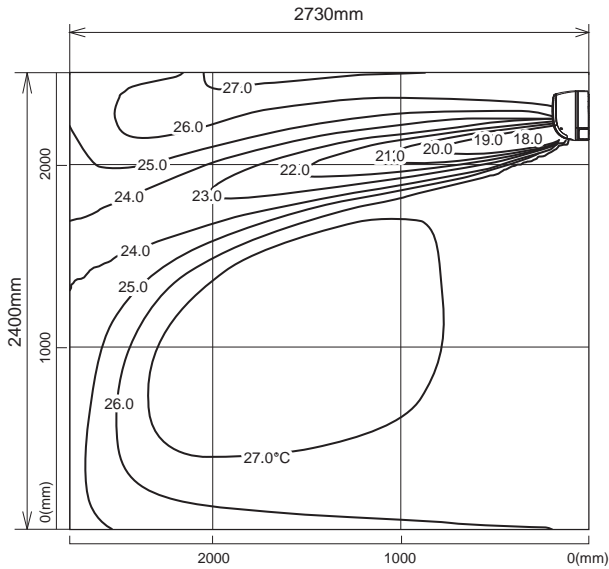

<Heating mode>

Air volume: high
Air direction: auto (downward air flow)

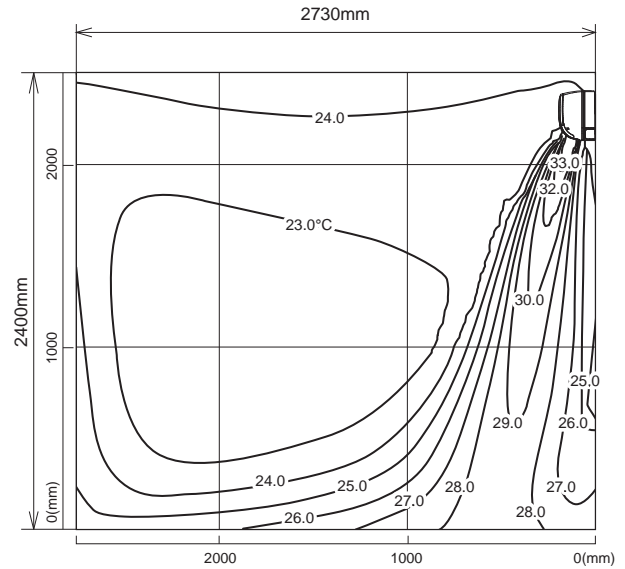

Airflow distribution

<Cooling mode>

Air volume: high
Air direction: auto (upward air flow)

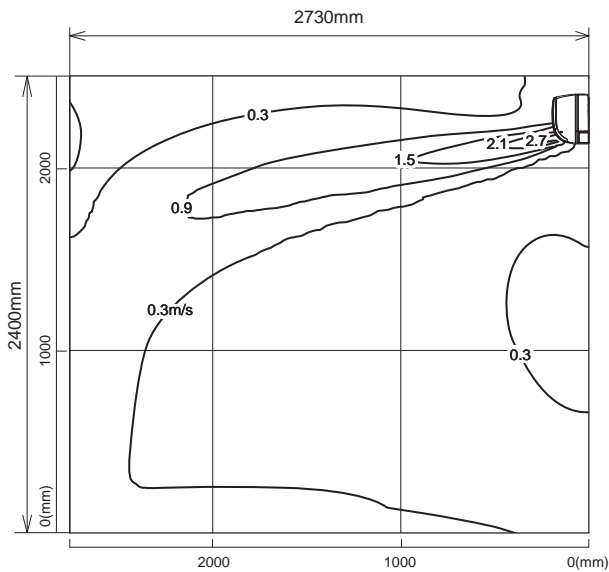

<Heating mode>

Air volume: high
Air direction: auto (downward air flow)

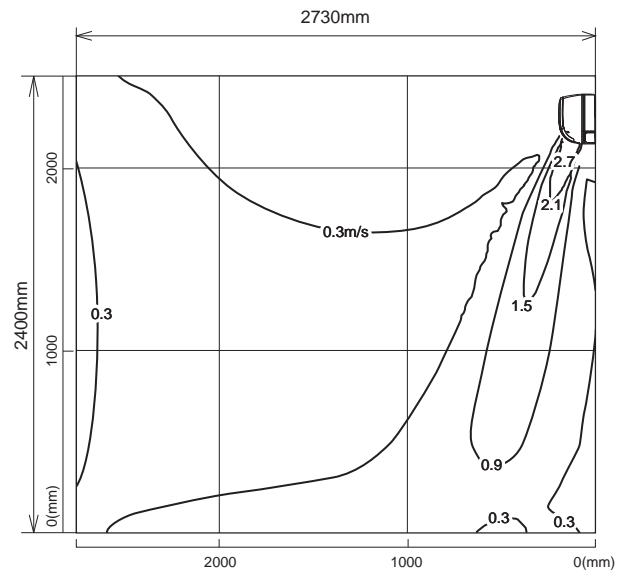

Note : These figures show typical airflow distributions in the conditions above. In the actual installation, they may differ from these figures under the influence of air temperature conditions, ceiling height, cooling/heating load, obstacles, etc.

WALL-MOUNTED TEMPERATURE AND AIR FLOW DISTRIBUTIONS

MSZ-SF25VE3

Temperature distribution

<Cooling mode>

Air volume: high
Air direction: auto (upward air flow)

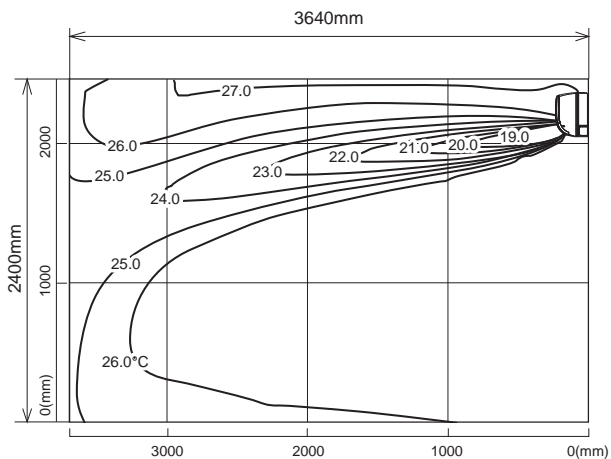

<Heating mode>

Air volume: high
Air direction: auto (downward air flow)

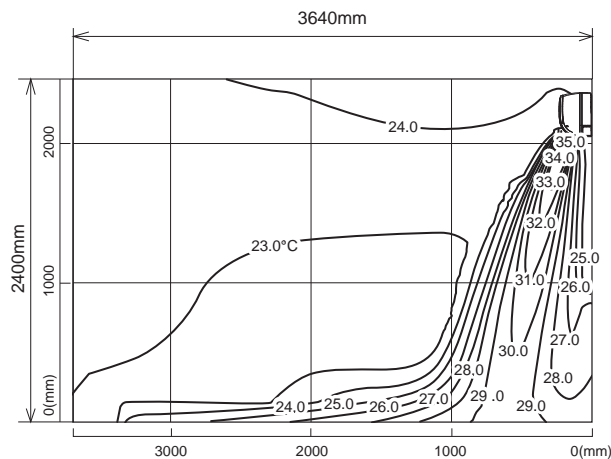

Airflow distribution

<Cooling mode>

Air volume: high
Air direction: auto (upward air flow)

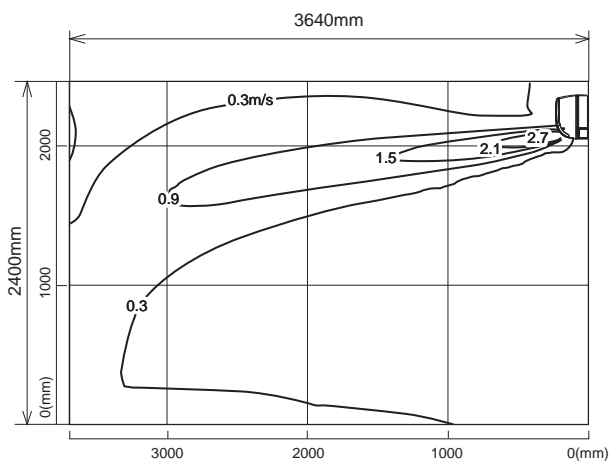

<Heating mode>

Air volume: high
Air direction: auto (downward air flow)

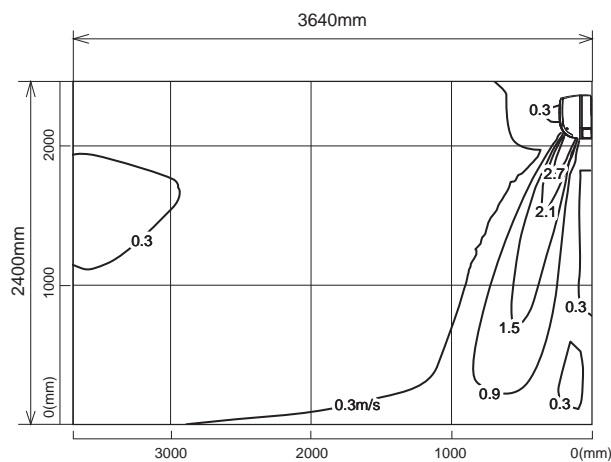

Note : These figures show typical airflow distributions in the conditions above. In the actual installation, they may differ from these figures under the influence of air temperature conditions, ceiling height, cooling/heating load, obstacles, etc.

TEMPERATURE AND AIR FLOW DISTRIBUTIONS

WALL-MOUNTED

MSZ-SF35VE3

Temperature distribution

<Cooling mode>

Air volume: high
Air direction: auto (upward air flow)

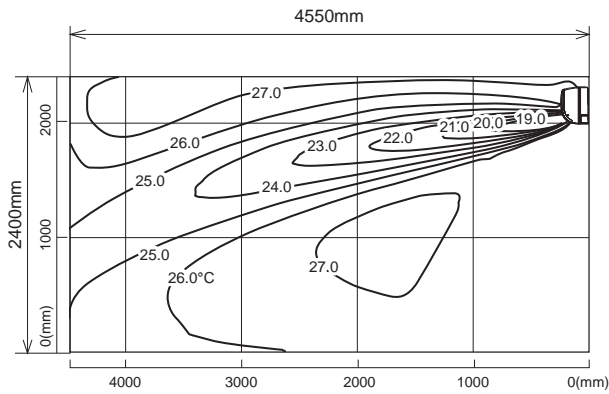

<Heating mode>

Air volume: high
Air direction: auto (downward air flow)

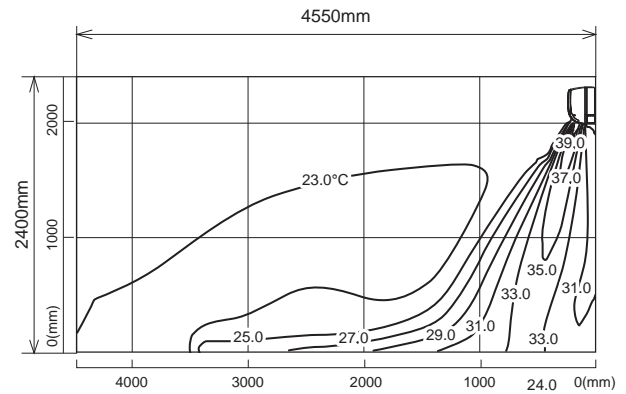

Airflow distribution

<Cooling mode>

Air volume: high
Air direction: auto (upward air flow)

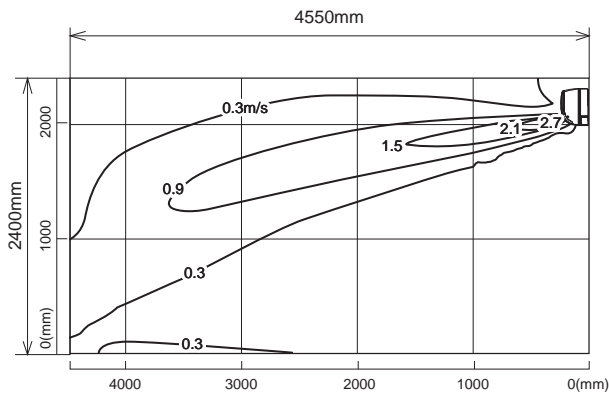

<Heating mode>

Air volume: high
Air direction: auto (downward air flow)

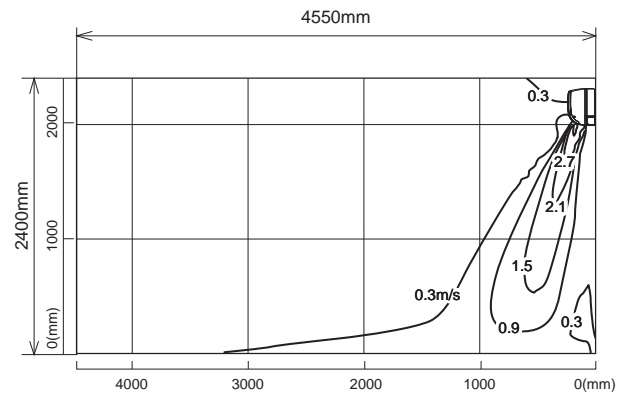

Note : These figures show typical airflow distributions in the conditions above. In the actual installation, they may differ from these figures under the influence of air temperature conditions, ceiling height, cooling/heating load, obstacles, etc.

WALL-MOUNTED TEMPERATURE AND AIR FLOW DISTRIBUTIONS

MSZ-SF42VE3

Temperature distribution

<Cooling mode>

Air volume: high
Air direction: auto (upward air flow)

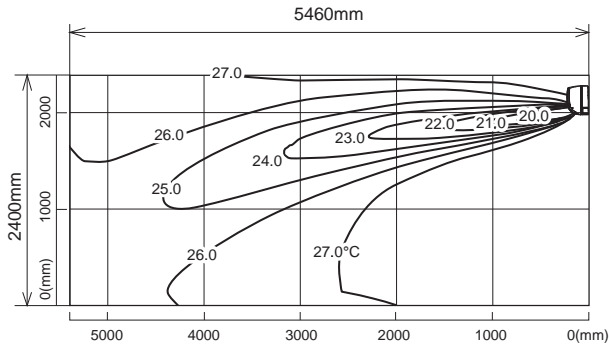

<Heating mode>

Air volume: high
Air direction: auto (downward air flow)

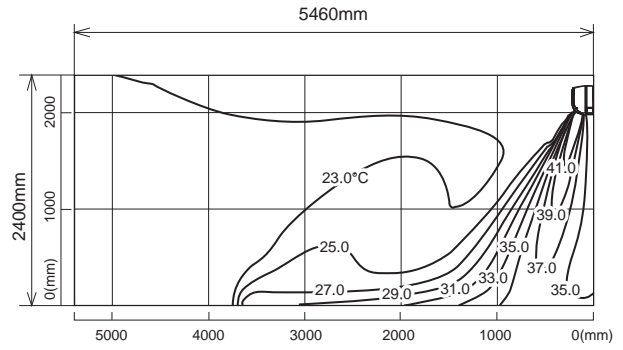

Airflow distribution

<Cooling mode>

Air volume: high
Air direction: auto (upward air flow)

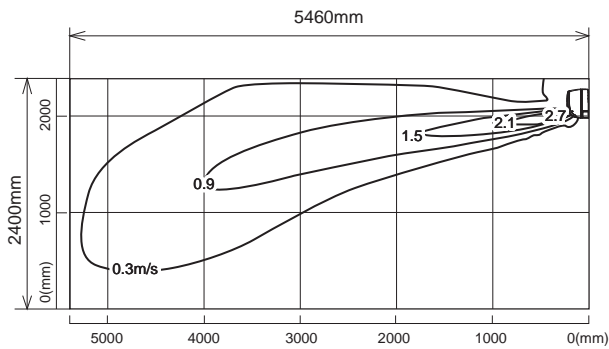

<Heating mode>

Air volume: high
Air direction: auto (downward air flow)

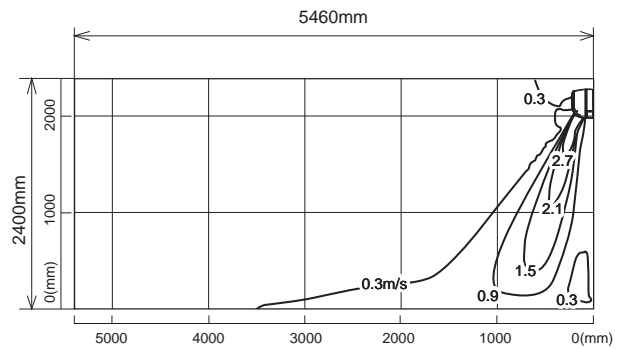

Note : These figures show typical airflow distributions in the conditions above. In the actual installation, they may differ from these figures under the influence of air temperature conditions, ceiling height, cooling/heating load, obstacles, etc.

TEMPERATURE AND AIR FLOW DISTRIBUTIONS

WALL-MOUNTED

MSZ-SF50VE3

Temperature distribution

<Cooling mode>

Air volume: high
Air direction: auto (upward air flow)

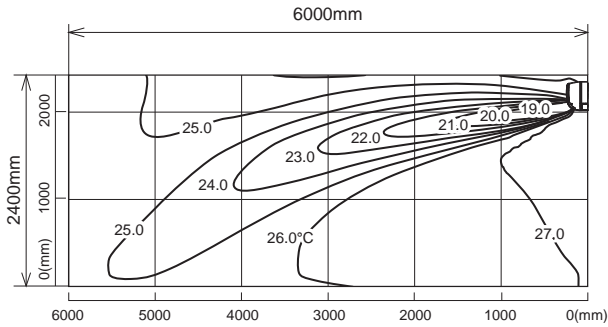

<Heating mode>

Air volume: high
Air direction: auto (downward air flow)

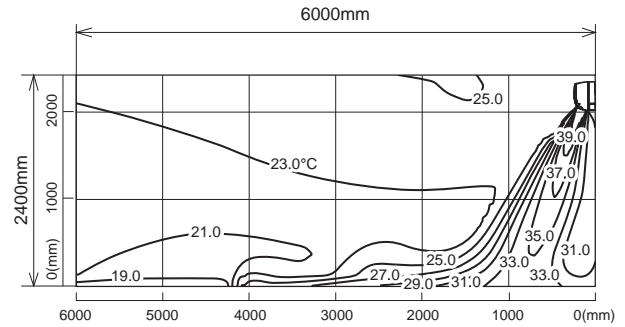

Airflow distribution

<Cooling mode>

Air volume: high
Air direction: auto (upward air flow)

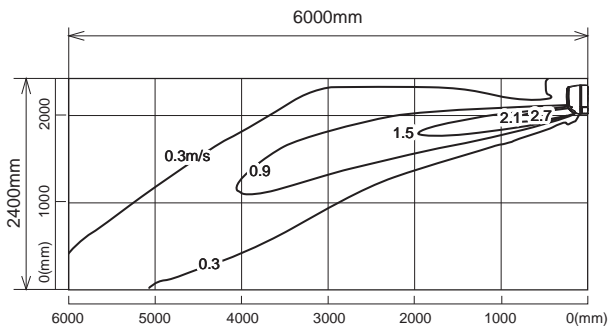

<Heating mode>

Air volume: high
Air direction: auto (downward air flow)

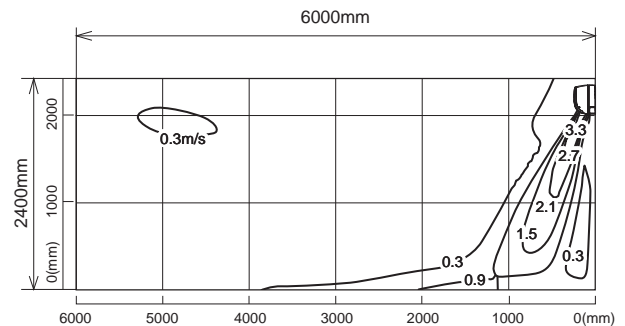

Note : These figures show typical airflow distributions in the conditions above. In the actual installation, they may differ from these figures under the influence of air temperature conditions, ceiling height, cooling/heating load, obstacles, etc.

WALL-MOUNTED TEMPERATURE AND AIR FLOW DISTRIBUTIONS

MSZ-GF60VE2

Temperature distribution

<Cooling mode>

Air volume: high
Air direction: auto (upward air flow)

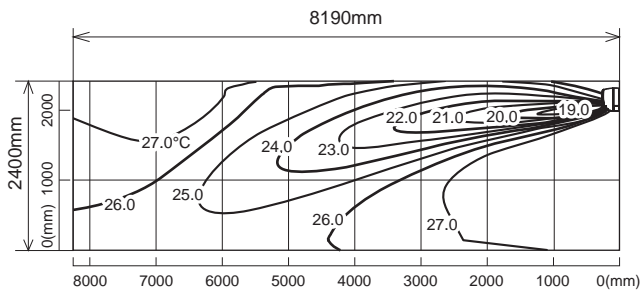

<Heating mode>

Air volume: high
Air direction: auto (downward air flow)

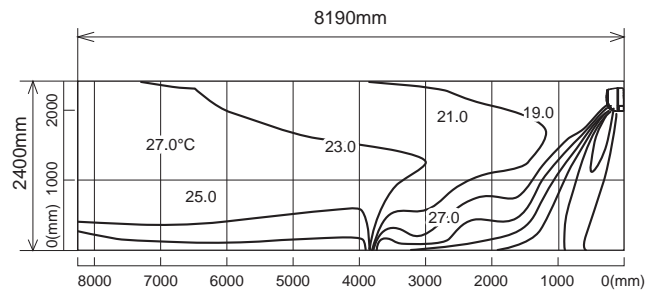

Airflow distribution

<Cooling mode>

Air volume: high
Air direction: auto (upward air flow)

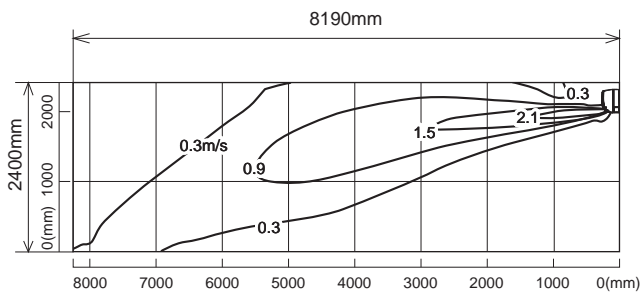

<Heating mode>

Air volume: high
Air direction: auto (downward air flow)

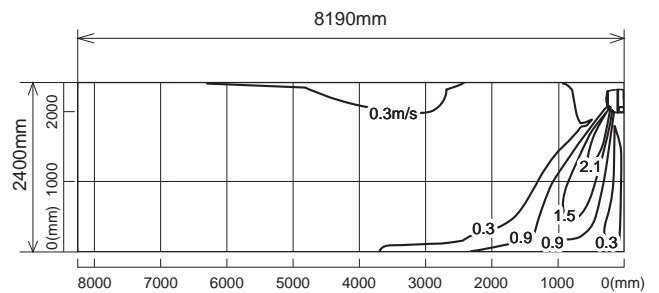

Note : These figures show typical airflow distributions in the conditions above. In the actual installation, they may differ from these figures under the influence of air temperature conditions, ceiling height, cooling/heating load, obstacles, etc.

TEMPERATURE AND AIR FLOW DISTRIBUTIONS

WALL-MOUNTED

MSZ-GF71VE2

Temperature distribution

<Cooling mode>

Air volume: high
Air direction: auto (upward air flow)

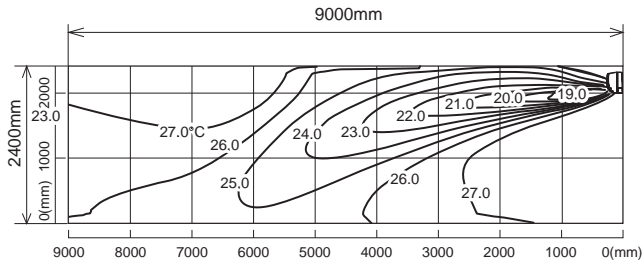

<Heating mode>

Air volume: high
Air direction: auto (downward air flow)

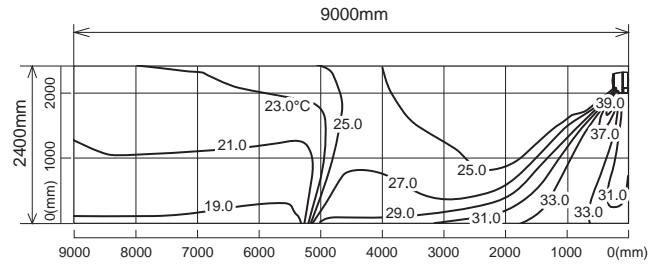

Airflow distribution

<Cooling mode>

Air volume: high
Air direction: auto (upward air flow)

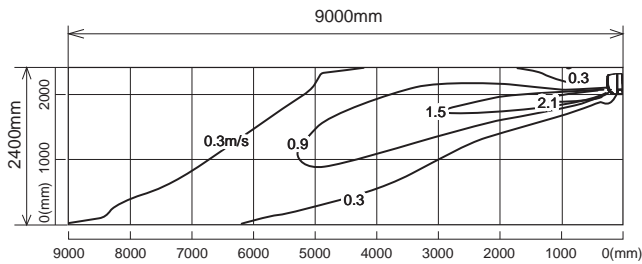

<Heating mode>

Air volume: high
Air direction: auto (downward air flow)

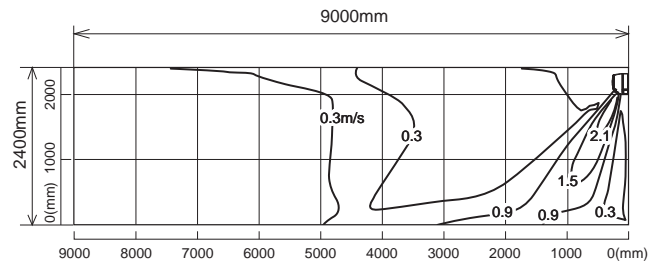

Note : These figures show typical airflow distributions in the conditions above. In the actual installation, they may differ from these figures under the influence of air temperature conditions, ceiling height, cooling/heating load, obstacles, etc.

WALL-MOUNTED TEMPERATURE AND AIR FLOW DISTRIBUTIONS

MSZ-WN25VA

Temperature distribution

<Cooling mode>

Air volume: high
Air direction: auto (upward air flow)

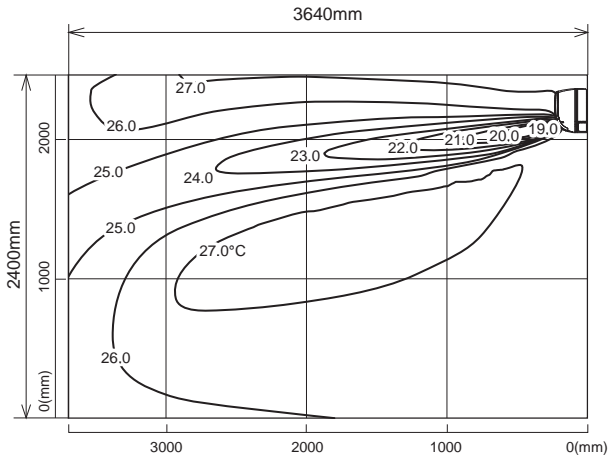

<Heating mode>

Air volume: high
Air direction: auto (downward air flow)

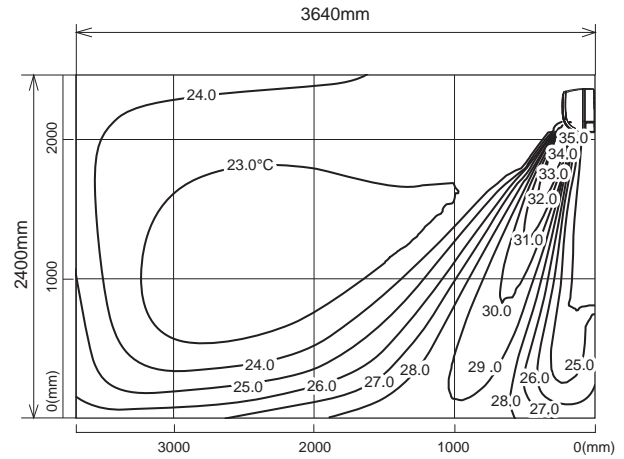

Airflow distribution

<Cooling mode>

Air volume: high
Air direction: auto (upward air flow)

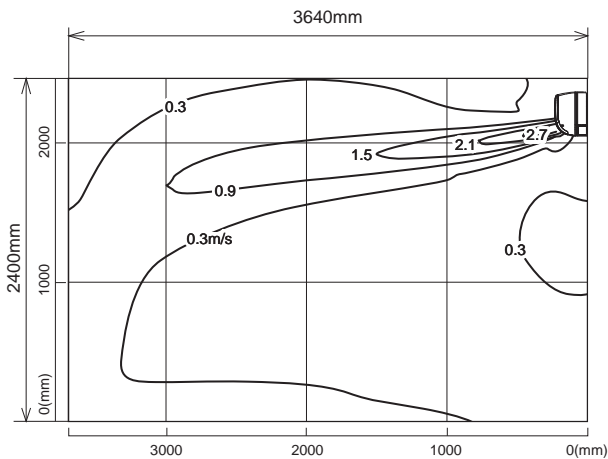

<Heating mode>

Air volume: high
Air direction: auto (downward air flow)

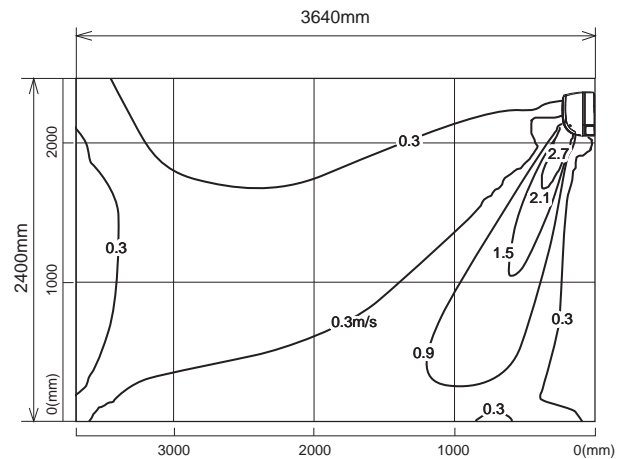

Note : These figures show typical airflow distributions in the conditions above. In the actual installation, they may differ from these figures under the influence of air temperature conditions, ceiling height, cooling/heating load, obstacles, etc.

TEMPERATURE AND AIR FLOW DISTRIBUTIONS

WALL-MOUNTED

MSZ-WN35VA

Temperature distribution

<Cooling mode>

Air volume: high
Air direction: auto (upward air flow)

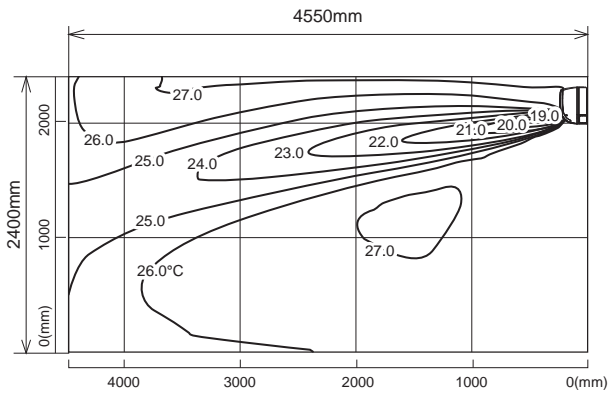

<Heating mode>

Air volume: high
Air direction: auto (downward air flow)

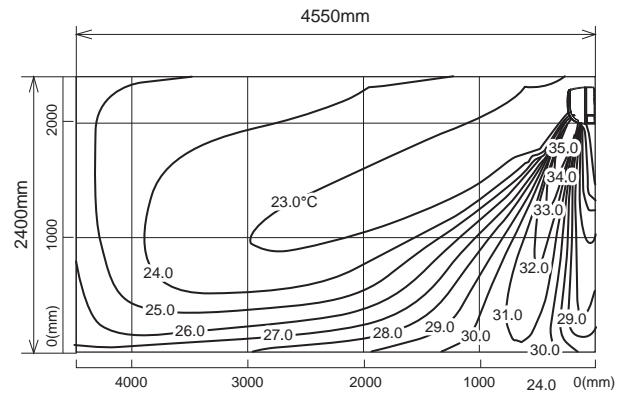

Airflow distribution

<Cooling mode>

Air volume: high
Air direction: auto (upward air flow)

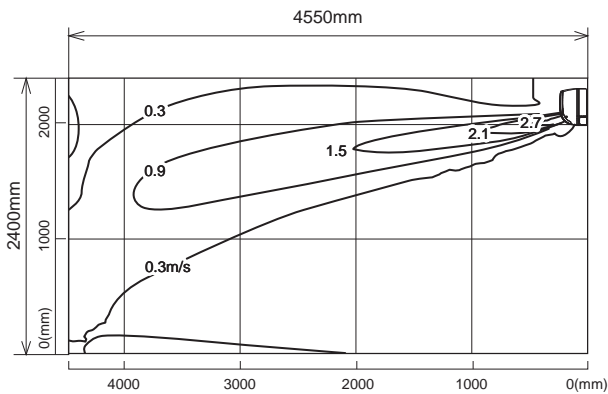

<Heating mode>

Air volume: high
Air direction: auto (downward air flow)

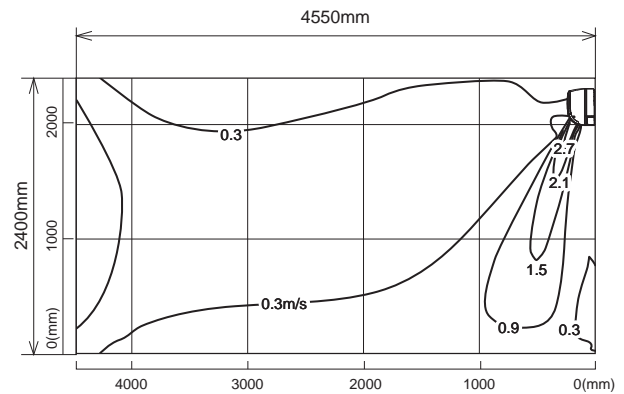

Note : These figures show typical airflow distributions in the conditions above. In the actual installation, they may differ from these figures under the influence of air temperature conditions, ceiling height, cooling/heating load, obstacles, etc.

WALL-MOUNTED TEMPERATURE AND AIR FLOW DISTRIBUTIONS

MSZ-DM25VA

Temperature distribution

<Cooling mode>

Air volume: high
Air direction: auto (upward air flow)

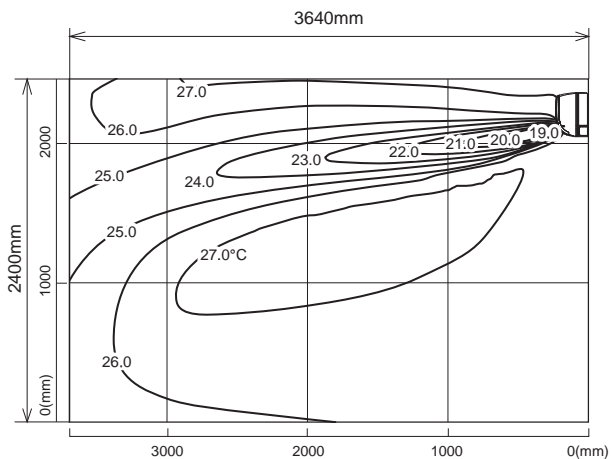

<Heating mode>

Air volume: high
Air direction: auto (downward air flow)

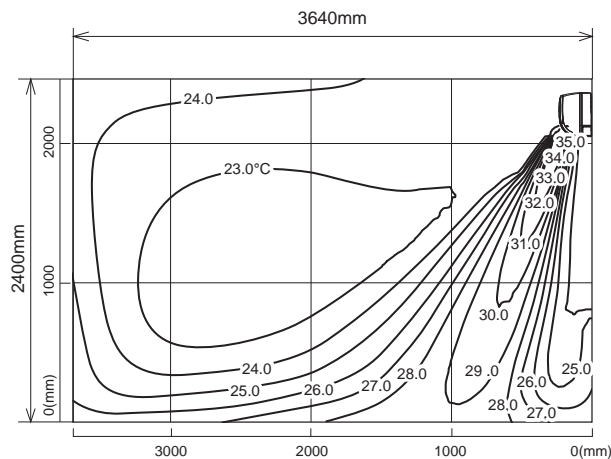

Airflow distribution

<Cooling mode>

Air volume: high
Air direction: auto (upward air flow)

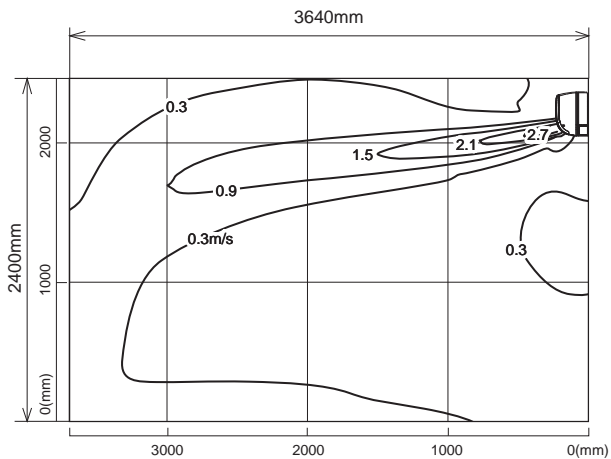

<Heating mode>

Air volume: high
Air direction: auto (downward air flow)

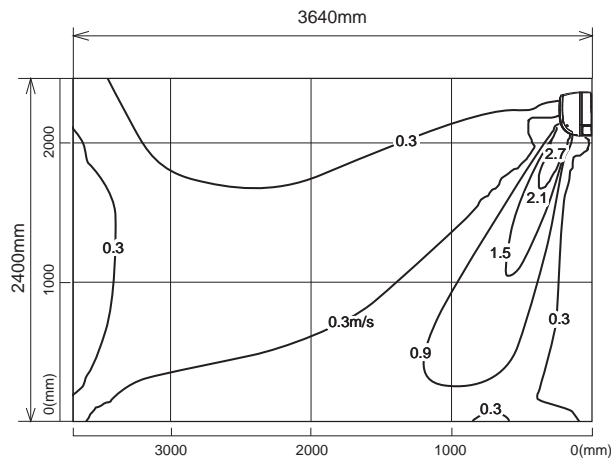

Note : These figures show typical airflow distributions in the conditions above. In the actual installation, they may differ from these figures under the influence of air temperature conditions, ceiling height, cooling/heating load, obstacles, etc.

TEMPERATURE AND AIR FLOW DISTRIBUTIONS

WALL-MOUNTED

MSZ-DM35VA

Temperature distribution

<Cooling mode>

Air volume: high
Air direction: auto (upward air flow)

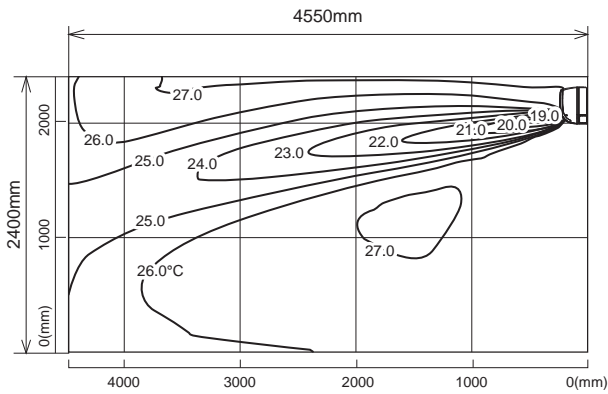

<Heating mode>

Air volume: high
Air direction: auto (downward air flow)

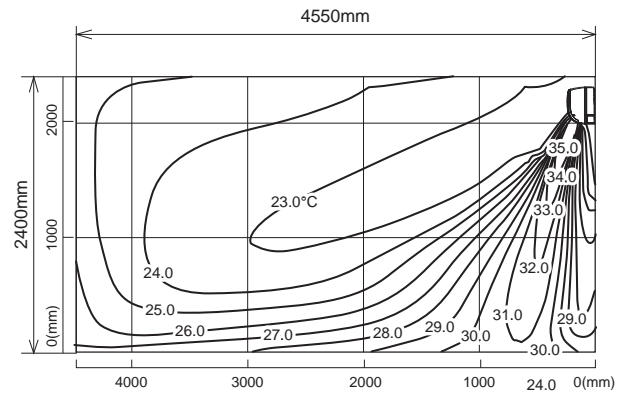

Airflow distribution

<Cooling mode>

Air volume: high
Air direction: auto (upward air flow)

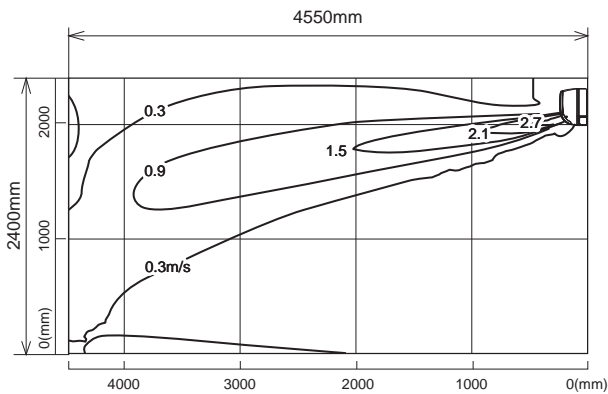

<Heating mode>

Air volume: high
Air direction: auto (downward air flow)

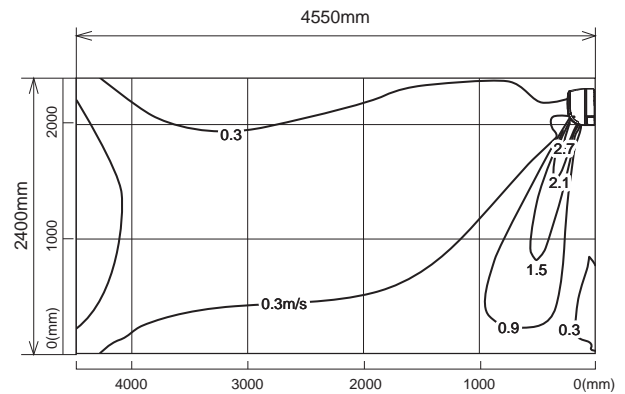

Note : These figures show typical airflow distributions in the conditions above. In the actual installation, they may differ from these figures under the influence of air temperature conditions, ceiling height, cooling/heating load, obstacles, etc.

WALL-MOUNTED TEMPERATURE AND AIR FLOW DISTRIBUTIONS

MSZ-HJ25VA

Temperature distribution

<Cooling mode>

Air volume: high
Air direction: auto (upward air flow)

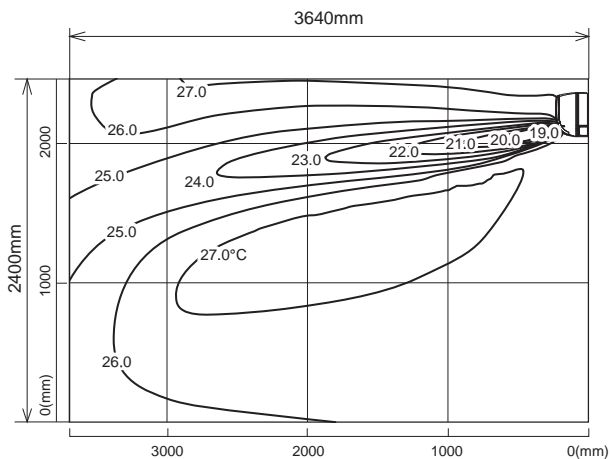

<Heating mode>

Air volume: high
Air direction: auto (downward air flow)

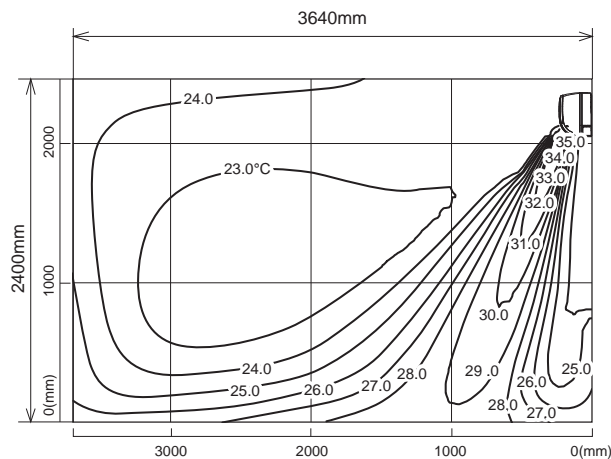

Airflow distribution

<Cooling mode>

Air volume: high
Air direction: auto (upward air flow)

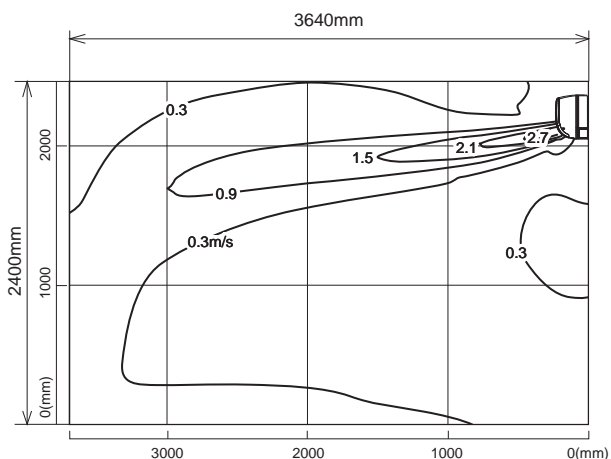

<Heating mode>

Air volume: high
Air direction: auto (downward air flow)

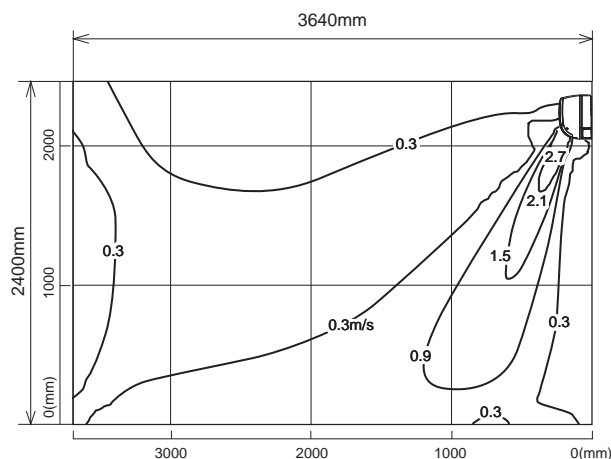

Note : These figures show typical airflow distributions in the conditions above. In the actual installation, they may differ from these figures under the influence of air temperature conditions, ceiling height, cooling/heating load, obstacles, etc.

TEMPERATURE AND AIR FLOW DISTRIBUTIONS

WALL-MOUNTED

MSZ-HJ35VA

Temperature distribution

<Cooling mode>

Air volume: high
Air direction: auto (upward air flow)

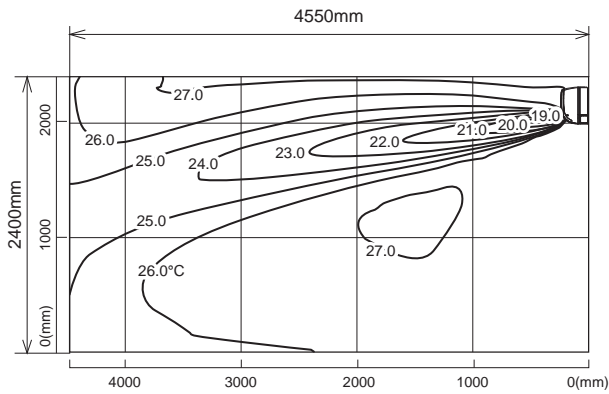

<Heating mode>

Air volume: high
Air direction: auto (downward air flow)

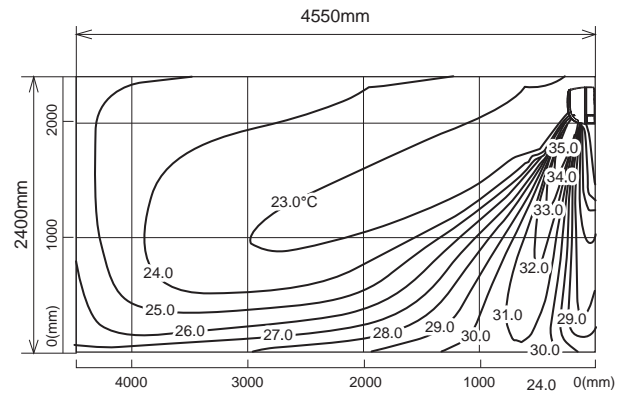

Airflow distribution

<Cooling mode>

Air volume: high
Air direction: auto (upward air flow)

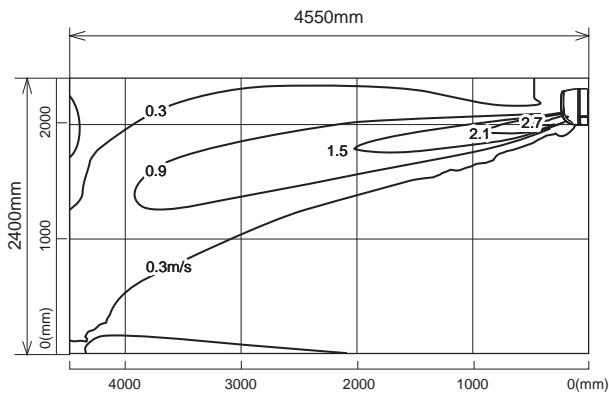

<Heating mode>

Air volume: high
Air direction: auto (downward air flow)

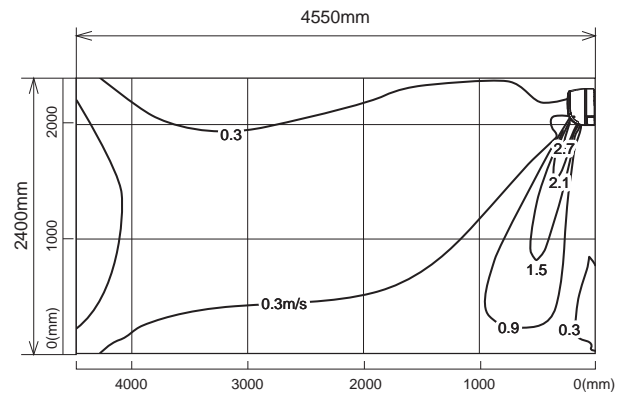

Note : These figures show typical airflow distributions in the conditions above. In the actual installation, they may differ from these figures under the influence of air temperature conditions, ceiling height, cooling/heating load, obstacles, etc.

WALL-MOUNTED TEMPERATURE AND AIR FLOW DISTRIBUTIONS

MSZ-HJ50VA

Temperature distribution

<Cooling mode>

Air volume: high
Air direction: auto (upward air flow)

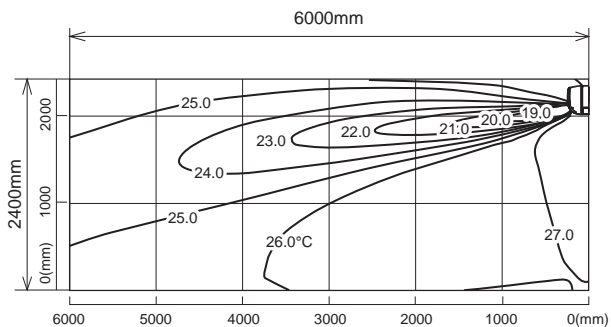

<Heating mode>

Air volume: high
Air direction: auto (downward air flow)

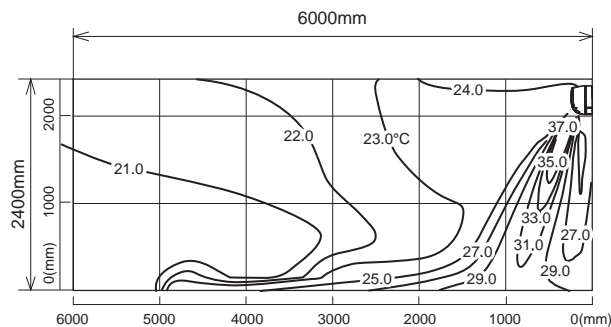

Airflow distribution

<Cooling mode>

Air volume: high
Air direction: auto (upward air flow)

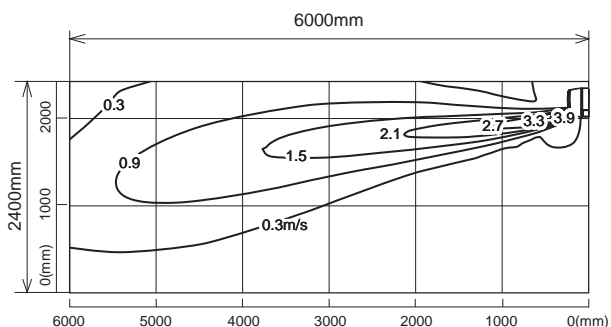

<Heating mode>

Air volume: high
Air direction: auto (downward air flow)

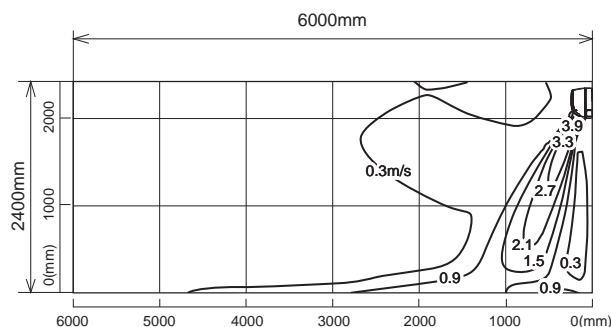

Note : These figures show typical airflow distributions in the conditions above. In the actual installation, they may differ from these figures under the influence of air temperature conditions, ceiling height, cooling/heating load, obstacles, etc.

TEMPERATURE AND AIR FLOW DISTRIBUTIONS

WALL-MOUNTED

MSZ-HJ60VA

Temperature distribution

<Cooling mode>

Air volume: high
Air direction: auto (upward air flow)

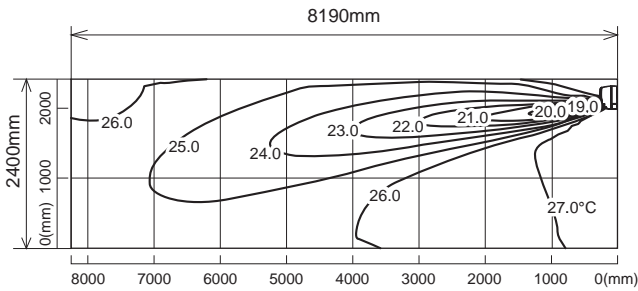

<Heating mode>

Air volume: high
Air direction: auto (downward air flow)

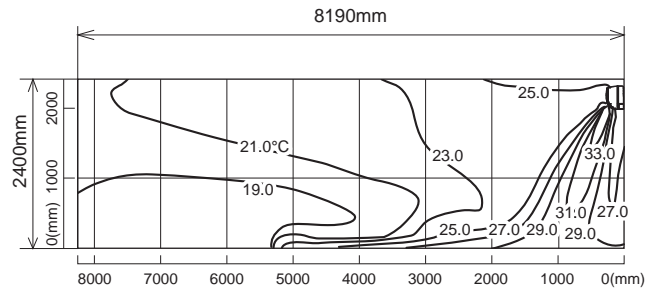

Airflow distribution

<Cooling mode>

Air volume: high
Air direction: auto (upward air flow)

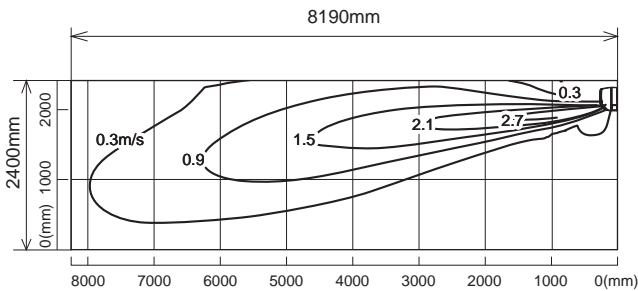

<Heating mode>

Air volume: high
Air direction: auto (downward air flow)

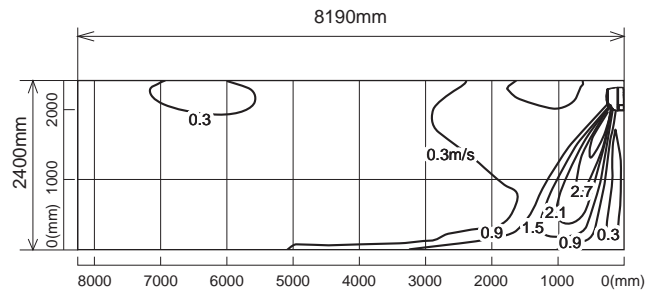

WALL-MOUNTED TEMPERATURE AND AIR FLOW DISTRIBUTIONS

Note : These figures show typical airflow distributions in the conditions above. In the actual installation, they may differ from these figures under the influence of air temperature conditions, ceiling height, cooling/heating load, obstacles, etc.

MSZ-HJ71VA

Temperature distribution

<Cooling mode>

Air volume: high
Air direction: auto (upward air flow)

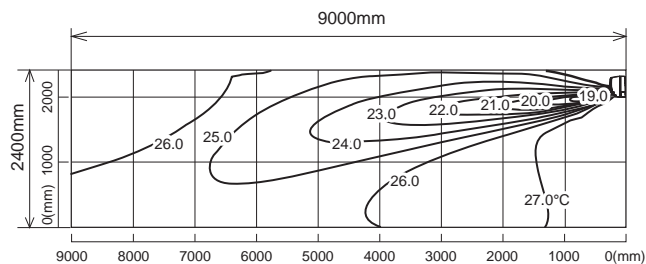

<Heating mode>

Air volume: high
Air direction: auto (downward air flow)

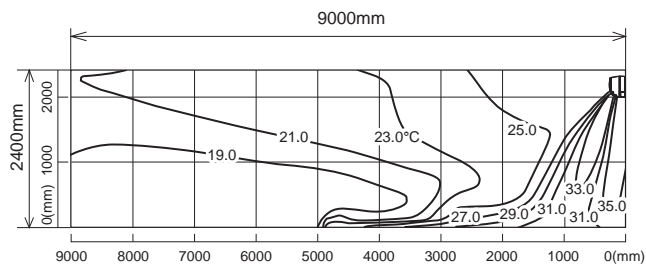

Airflow distribution

<Cooling mode>

Air volume: high
Air direction: auto (upward air flow)

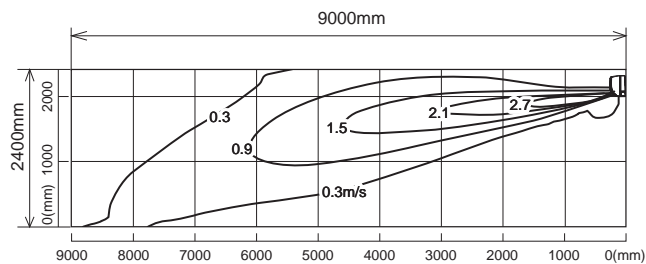

<Heating mode>

Air volume: high
Air direction: auto (downward air flow)

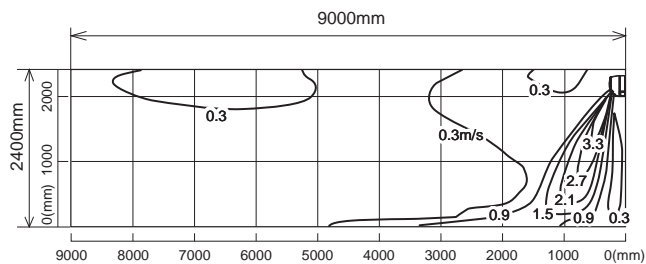

Note : These figures show typical airflow distributions in the conditions above. In the actual installation, they may differ from these figures under the influence of air temperature conditions, ceiling height, cooling/heating load, obstacles, etc.

TEMPERATURE AND AIR FLOW DISTRIBUTIONS

WALL-MOUNTED

C.1.9 OPERATION AND ACTUATOR CONTROL

C.1.9.1 MSZ-RW•VG Series

MSZ-RW25VG MSZ-RW35VG MSZ-RW50VG
 MUZ-RW25VGHZ MUZ-RW35VGHZ MUZ-RW50VGHZ
 MSZ-RW25VG-[E1] MSZ-RW35VG-[E1] MSZ-RW50VG-[E1]
 MUZ-RW25VGHZ MUZ-RW35VGHZ MUZ-RW50VGHZ

WIRELESS REMOTE CONTROLLER

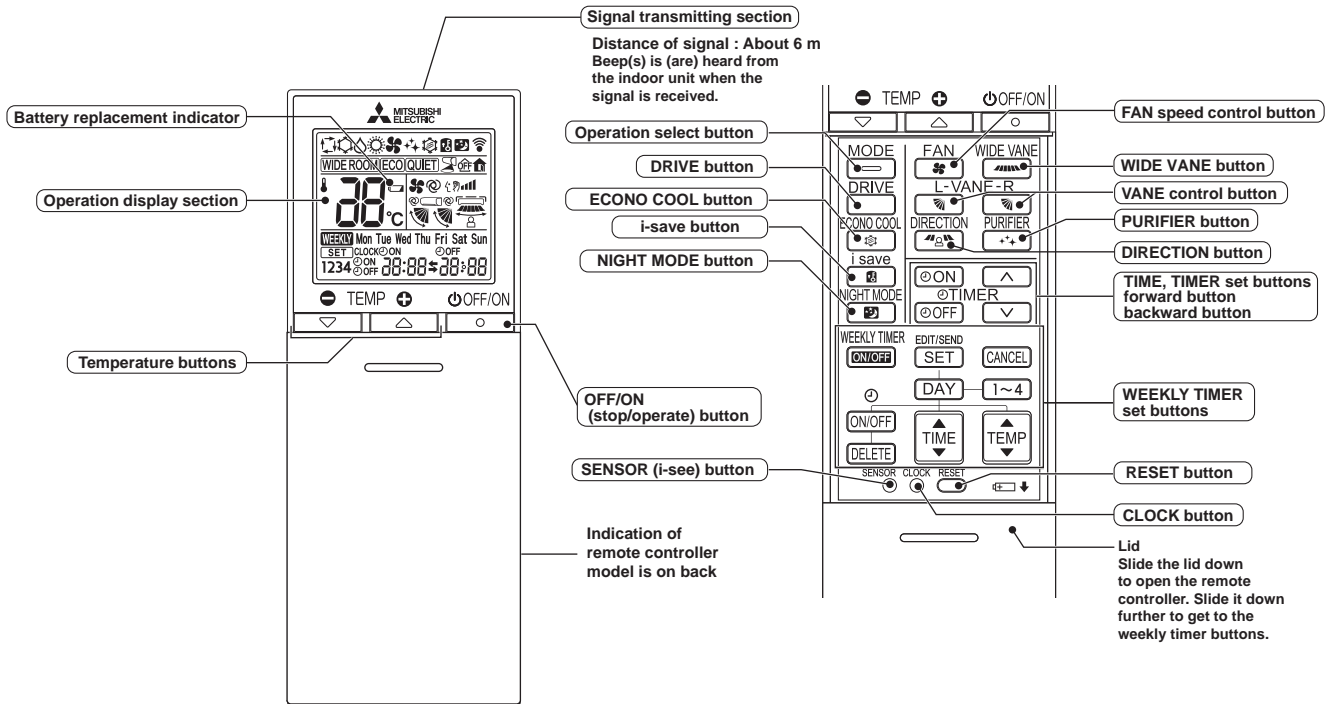



NOTE: Last setting will be stored after the unit is turned OFF with the remote controller. Indoor unit receives the signal of the remote controller with beeps.

INDOOR UNIT DISPLAY SECTION

Operation Indicator lamp

The operation indicator at the right side of the indoor unit indicates the operation state.

- The following indication applies regardless of shape of the indication.

Indication	Operation state	Room temperature
 	Standby mode (Only during multi system operation)	—

-  Lit
-  Blinking
-  Not lit

MSZ-RW25VG - [SC1] MSZ-RW35VG - [SC1] MSZ-RW50VG - [SC1]
 MUZ-RW25VGHZ MUZ-RW35VGHZ MUZ-RW50VGHZ

WIRELESS REMOTE CONTROLLER

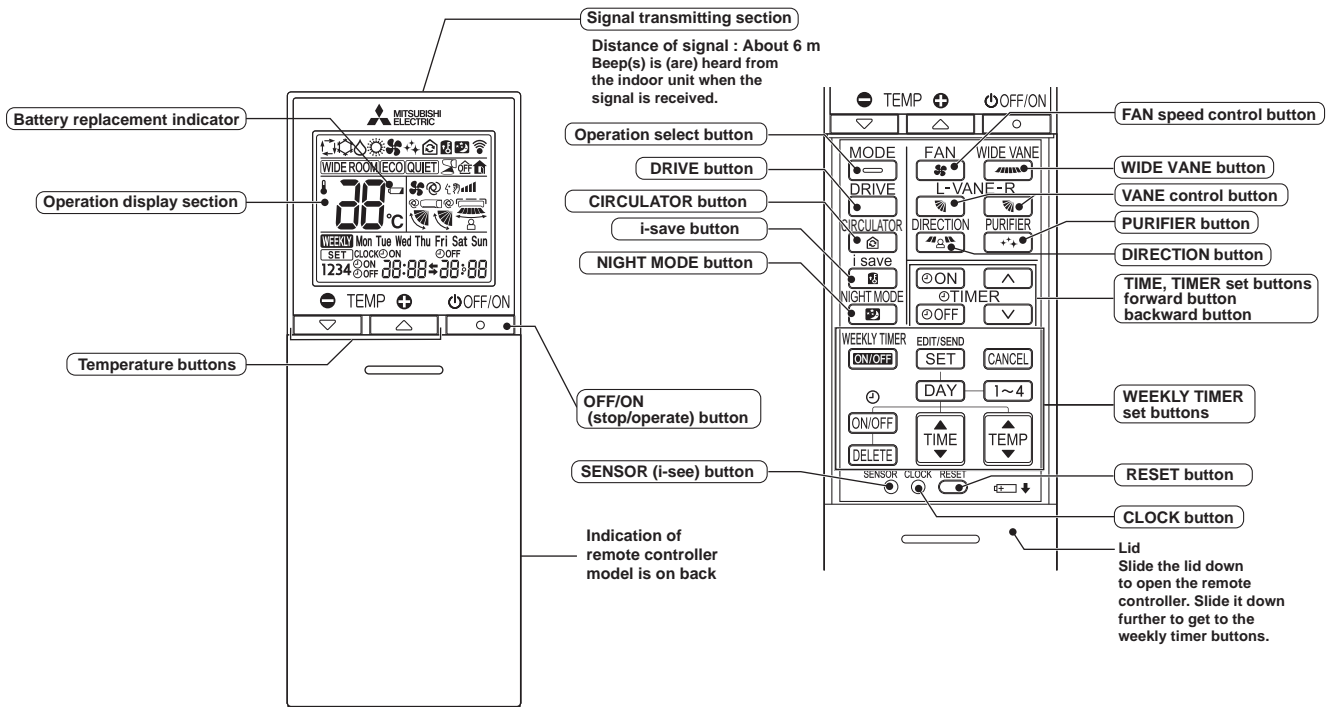



NOTE: Last setting will be stored after the unit is turned OFF with the remote controller. Indoor unit receives the signal of the remote controller with beeps.

INDOOR UNIT DISPLAY SECTION

Operation Indicator lamp

The operation indicator at the right side of the indoor unit indicates the operation state.

- The following indication applies regardless of shape of the indication.

Indication	Operation state	Room temperature
 	Standby mode (Only during multi system operation)	—

-  Lit
-  Blinking
-  Not lit

a. COOL (❄️) OPERATION

- (1) Press OFF/ON (stop/operate) button.

OPERATION INDICATOR lamp of the indoor unit turns on with a beep tone.

- (2) Select COOL mode with Operation select button.

- (3) Press Temperature buttons TEMP \ominus or \oplus button to select the desired temperature. The setting range is 16 - 31°C.

1. Coil frost prevention

The compressor operational frequency is controlled by the temperature of the indoor heat exchanger to prevent the coil from frosting.

When the temperature of indoor heat exchanger becomes too low, the coil frost prevention mode works.

The indoor fan operates at the set speed and the compressor stops. This mode continues until the temperature of indoor heat exchanger rises.

2. Low outside temperature operation

When the outside temperature is lower, low outside temperature operation starts, and the outdoor fan slows or stops.

3. Indoor fan speed control

When the thermostat turns OFF, the indoor fan operates very Low to reduce power consumption.

When the room temperature rises and the thermostat is ON, the indoor fan operates according to the settings on the remote controller.

b. DRY (☀️) OPERATION

- (1) Press OFF/ON (stop/operate) button.

OPERATION INDICATOR lamp of the indoor unit turns on with a beep tone.

- (2) Select DRY mode with Operation select button.

- (3) The set temperature is determined from the initial room temperature.

1. Coil frost prevention

Coil frost prevention works the same way as that in COOL mode. (a.1.)

2. Low outside temperature operation

Low outside temperature operation works the same way as that in COOL mode. (a.2.)

3. Indoor fan speed control

Indoor fan speed control works the same way as that in COOL mode. (a.3.)

c. FAN (🌀) OPERATION

- (1) OPERATION INDICATOR lamp of the indoor unit turns on with a beep tone.

- (2) Select FAN mode with Operation select button.

- (3) Select the desired fan speed. When AUTO, it becomes Low.

Only indoor fan operates.

Outdoor unit does not operate.

d. HEAT (🔥) OPERATION

- (1) Press OFF/ON (stop/operate) button.

OPERATION INDICATOR lamp of the indoor unit turns on with a beep tone.

- (2) Select HEAT mode with Operation select button.

- (3) Press Temperature buttons TEMP \ominus or \oplus button to select the desired temperature. The setting range is 10 - 31°C.

1. Cold air prevention control

When the compressor is not operating or is starting, and the temperature of indoor heat exchanger and/or the room temperature is low or when defrosting is being done, the indoor fan will stop or rotate in Very Low speed.

2. High pressure protection

The compressor operational frequency is controlled by the temperature of the indoor heat exchanger to prevent the condensing pressure from increasing excessively.

When the temperature of indoor heat exchanger becomes too high, the high pressure protection works.

The indoor fan operates following the cold air prevention control. This mode continues until the temperature of indoor heat exchanger falls.

3. Defrosting

Defrosting starts when the temperature of outdoor heat exchanger becomes too low.

The compressor stops once, the indoor/outdoor fans stop, the 4-way valve reverses, and the compressor re-starts.

This mode continues until the temperature of outdoor heat exchanger rises or the fixed time passes.

e. AUTO CHANGE OVER ... AUTO MODE OPERATION

Once desired temperature is set, unit operation is switched automatically between COOL and HEAT operation.

Mode selection

- (1) Initial mode

When unit starts the operation with AUTO operation from OFF:

- If the room temperature is higher than the set temperature, operation starts in COOL mode.
- If the room temperature is equal to or lower than the set temperature, operation starts in HEAT mode.

- (2) Mode change

COOL mode changes to HEAT mode when about 15 minutes have passed with the room temperature 1°C below the set temperature.

HEAT mode changes to COOL mode when about 15 minutes have passed with the room temperature 1°C above the set temperature.

NOTE 1:

If 2 or more indoor units are operating in multi system, there might be a case that the indoor unit, which is operating in □ (AUTO), cannot change over to the other operating mode (COOL ↔ HEAT) and becomes a state of standby. Refer to **NOTE 2 “FOR MULTI SYSTEM AIR CONDITIONER”**.

NOTE 2:

**FOR MULTI SYSTEM AIR CONDITIONER
OUTDOOR UNIT: MXZ series**

Multi system air conditioner can connect 2 or more indoor units with one outdoor unit.

- When you try to operate 2 or more indoor units with one outdoor unit simultaneously, one for the cooling and the others for heating, the operation mode of the indoor unit that operates first is selected. Other indoor units cannot operate, and operation indicator lamp blinks as shown in the figure below. In this case, please set all the indoor units to the same operation mode.

OPERATION INDICATOR

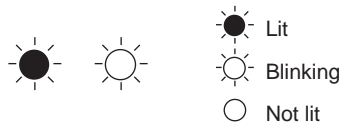

- When indoor unit starts the operation while the defrosting of outdoor unit is being done, it takes a few minutes (max. 10 minutes) to blow out the warm air.
- In the heating operation, though indoor unit that does not operate may get warm or the sound of refrigerant flowing may be heard, they are not malfunction. The reason is that the refrigerant continuously flows into it.

f. AUTO VANE OPERATION

1. Horizontal vane

(1) Vane motor drive

These models are equipped with stepping motors for the horizontal vanes. The rotating direction, speed, and angle of the motor are controlled by pulse signals (approximately 12 V) transmitted from indoor microprocessor.

(2) The horizontal vane angle and mode change as follows by pressing VANE CONTROL () button.

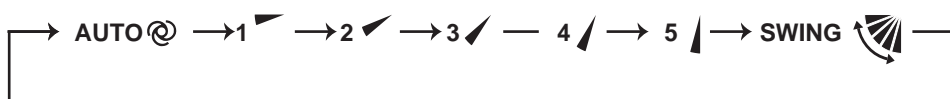

NOTE: The right and left horizontal vanes set to the same level may not align perfectly.

(3) Positioning

To confirm the standard position, the vane moves until it touches the vane stopper. Then the vane is set to the selected angle.

Confirmation of standard position is performed in the following cases:

- (a) When the operation starts or finishes (including timer operation).
- (b) When the test run starts.
- (c) When standby mode (only during multi system operation) starts or finishes.

(4) VANE AUTO (@) mode

In VANE AUTO mode, the microprocessor automatically determines the vane angle to make the optimum room temperature distribution.

In COOL and DRY operation

Vane angle is fixed to Horizontal position.



In HEAT operation

Vane angle is fixed to Angle 4.



(5) STOP (operation OFF) and ON TIMER standby

In the following cases, the horizontal vane returns to the closed position.

- (a) When OFF/ON (stop/operate) button is pressed (POWER OFF).
- (b) When the operation is stopped by the emergency operation.
- (c) When ON TIMER is ON standby.

(6) Dew prevention

During COOL or DRY operation with the lower position when the compressor cumulative operation time exceeds 1 hour, the vane angle automatically changes to Angle 1 for dew prevention.

(7) SWING (🌀) mode

By selecting SWING mode with VANE control button, the horizontal vanes swing vertically.

When COOL, DRY or FAN mode is selected, only the upper vane swings.

(8) Cold air prevention in HEAT operation

The horizontal vane position is set to Upward.

NOTE: When 2 or more indoor units are operated with multi outdoor unit, even if any indoor unit turns thermostat off, this control does not work in the indoor unit.

(9) ECONO COOL (🌡️) operation (ECONOMical operation) (MSZ-RW25/35/50VG-E1 only)

When ECONO COOL button is pressed in COOL mode, set temperature is automatically set 2°C higher by the microprocessor. However, the temperature on the LCD screen on the remote controller is not changed. Also the horizontal vane swings in various cycle.

SWING operation makes you feel cooler than set temperature. So, even though the set temperature is higher, the air conditioner can keep comfort. As a result, energy can be saved.

To cancel this operation, select a different mode or press one of the following buttons in ECONO COOL operation: ECONO COOL or VANE control button.

2. Vertical vane

(1) Vane motor drive

These models are equipped with a stepping motor for the vertical vane. The rotating direction, speed, and angle of the motor are controlled by pulse signals (approximately 12 V) transmitted from microprocessor.

(2) The vertical vane angle and mode change as follows by pressing WIDE VANE button.

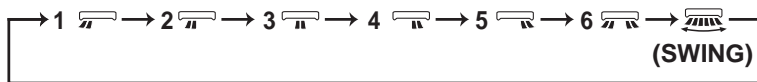

(3) Positioning

To confirm the standard position, the vane moves until it touches the vane stopper. Then the vane is set to the selected angle.

Confirmation of standard position is performed in the following cases:

(a) OFF/ON (stop/operate) button is pressed (POWER ON).

(4) SWING (🌀) MODE

By selecting SWING mode with WIDE VANE button, the vertical vane swings horizontally. The remote controller displays "🌀". Swing mode is cancelled when WIDE VANE button is pressed once again.

g. TIMER OPERATION

1. How to set the time

(1) Check that the current time is set correctly.

NOTE: Timer operation will not work without setting the current time. Initially “0:00” blinks at the current time display of TIME MONITOR, so set the current time correctly with CLOCK button.

How to set the current time

- (a) Press the CLOCK button.
 - (b) Press the TIME set buttons (▲ and ▼) to set the current time.
 - Each time forward button (▲) is pressed, the set time increases by 1 minute, and each time backward button (▼) is pressed, the set time decreases by 1 minute.
 - Pressing those buttons longer, the set time increases/decreases by 10 minutes.
 - (c) Press the CLOCK set button.
- (2) Press OFF/ON (stop/operate) button to start the air conditioner.
- (3) Set the time of timer.

ON timer setting

- (a) Press ON TIMER button (⊙ON) during operation.
- (b) Set the time of the timer using TIME set buttons (▲ and ▼). *

OFF timer setting

- (a) Press OFF TIMER button (⊙OFF) during operation.
 - (b) Set the time of the timer using TIME set buttons (▲ and ▼). *
- * Each time forward button (▲) is pressed, the set time increases by 10 minutes: each time backward button (▼) is pressed, the set time decreases by 10 minutes.

2. To release the timer

To release ON timer, press ON TIMER button (⊙ON).
 To release OFF timer, press OFF TIMER button (⊙OFF).
 TIMER is cancelled and the display of set time disappears.

PROGRAM TIMER

- OFF timer and ON timer can be used in combination. The set time that is reached first will operate first.
- “→” and “←” display shows the order of OFF timer and ON timer operation.

(Example 1) The current time is 8:00 PM.
 The unit turns off at 11:00 PM, and on at 6:00 AM.

(Example 2) The current time is 11:00 AM.
 The unit turns on at 5:00 PM, and off at 9:00 PM.

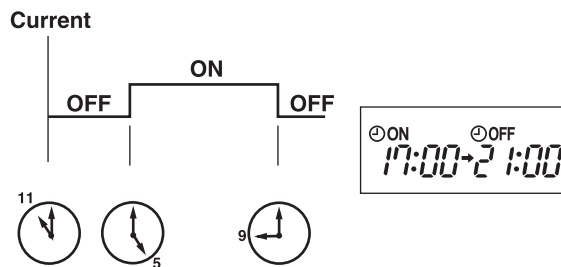
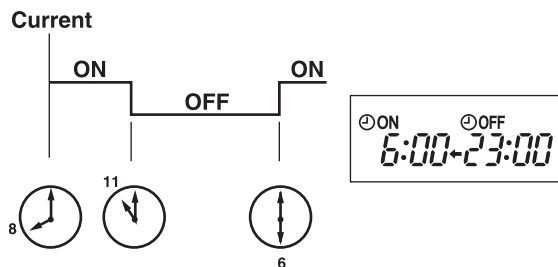

NOTE: If the main power is turned OFF or a power failure occurs while ON/OFF timer is active, the timer setting is cancelled. As these models are equipped with an auto restart function, the air conditioner starts operating with timer cancelled when power is restored.

h. WEEKLY TIMER OPERATION

- A maximum of 4 ON or OFF timers can be set for individual days of the week.
- A maximum of 28 ON or OFF timers can be set for a week.

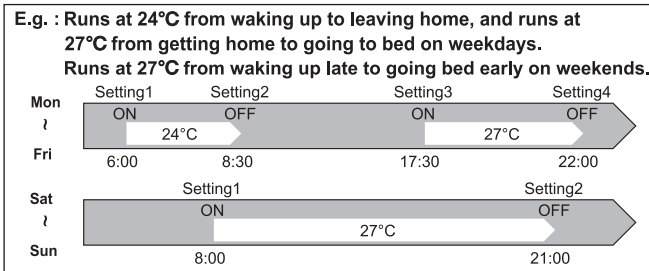

NOTE:

- The simple ON/OFF timer setting is available while the weekly timer is on. In this case, the ON/OFF timer has priority over the weekly timer; the weekly timer operation will start again after the simple ON/OFF timer is complete.

1. How to set the weekly timer

* Make sure that the current time and day are set correctly.

(1) Press **EDIT/SEND SET** button to enter the weekly timer setting mode.

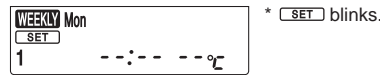

(2) Press **DAY** and **1~4** buttons to select setting day and number.

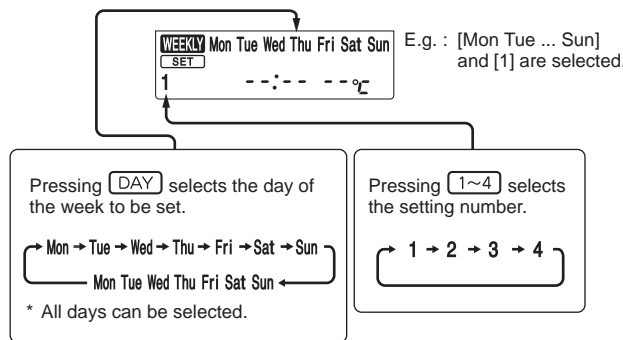

(3) Press **ON/OFF**, **TIME**, and **TEMP** buttons to set ON/OFF, time, and temperature.

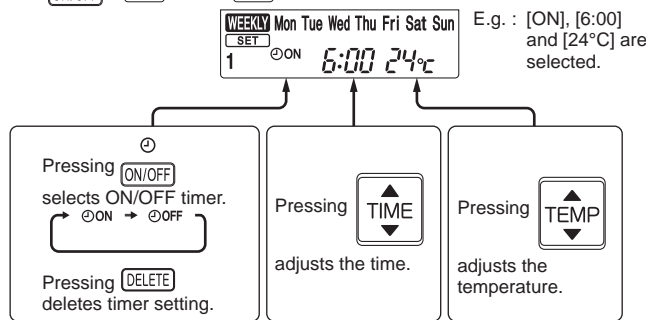

- * Hold down the button to change the time quickly.
- * The temperature can be set between 16°C and 31°C at COOL operation.
- * The temperature can be set between 10°C and 31°C at HEAT operation.

Press **DAY** and **1~4** buttons to continue setting the timer for other days and/or numbers.

(4) Press button to complete and transmit the weekly timer setting.



* which was blinking goes out, and the current time will be displayed.

NOTE:

- Press button to transmit the setting information of weekly timer to the indoor unit. Point the remote controller toward the indoor unit for 3 seconds.
- When setting the timer for more than one day of the week or one number, button does not have to be pressed per each setting. Press button once after all the settings are completed. All the weekly timer settings will be saved.
- Press button to enter the weekly timer setting mode, and press and hold button for 5 seconds to erase all weekly timer settings. Point the remote controller toward the indoor unit.

(5) Press button to turn the weekly timer ON. (lights.)

- When the timer is ON, the day of the week whose timer setting is completed, will light.

Press button again to turn the weekly timer OFF. (goes out.)

NOTE:

The saved settings will not be cleared when the weekly timer is turned OFF.

2. Checking weekly timer setting

(1) Press button to enter the weekly timer setting mode.

* blinks.

(2) Press or buttons to view the setting of the particular day or number.

(3) Press button to exit the weekly timer setting.

NOTE:

When all days of the week are selected to view the settings and a different setting is included among them, --:-- --:~ will be displayed.

i. i-see CONTROL () MODE AND ABSENCE DETECTION

In the i-see control mode, the room temperature is controlled based on the sensible temperature.

(1) Press SENSOR button with a thin instrument during COOL, DRY, HEAT and AUTO mode to activate i-see control mode ().

The default setting is “active”.

(2) Press SENSOR button several times to cancel i-see control mode.

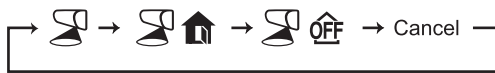

NOTE:

How to detect human presence

- When the air conditioner starts to operate, the i-see Sensor analyzes the temperature of a room by rotating clockwise and counterclockwise.
- Then, it detects human presence by their motion based on their heat signatures.

Detection range

The i-see Sensor does not analyze the temperature in the following range.

- The wall surface on which the air conditioner is installed
- The spot beneath the air conditioner
- Where there is an object (such as furniture) between the place and the air conditioner

It might not detect human and objects properly on the following conditions

- When the temperature of the floor and the wall is high (such as when the air conditioner starts to operate in summer)
- When occupants are in blanket or wear heavily
- When there is an object whose temperature changes rapidly in a short time
- When windows and doors are small or they are far from the air conditioner
- When the sensor cannot detect the heat source such as of small kids or pets
- When using a floor heating or an electric carpet
- When occupants do not move after the air conditioner starts to operate

Refer to the following “Absence Detection” for and .

ABSENCE DETECTION (🏠)

This function automatically changes the operation to No occupancy energy-saving mode or No occupancy Auto-OFF mode when nobody is in the room.

- (1) To activate this No occupancy energy-saving mode, press SENSOR button until 🏠 appears on the operation display of the remote controller.
- (2) To activate this No occupancy Auto-OFF mode, press SENSOR button until OFF appears on the operation display of the remote controller.
- (3) Press SENSOR button again to cancel the ABSENCE DETECTION.

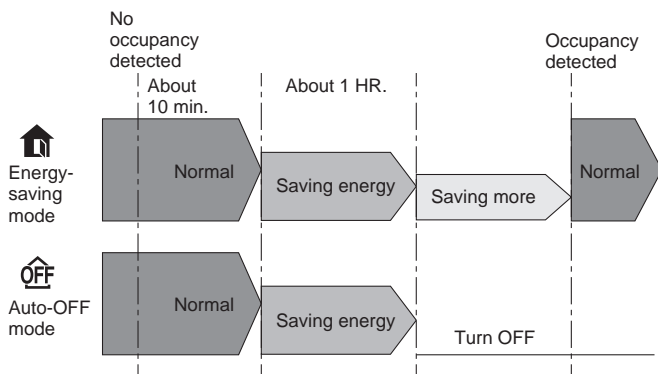
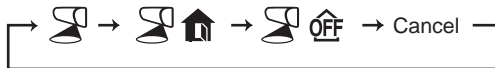

- Even if the unit is turned OFF due to No occupancy Auto-OFF mode, the display of the remote controller remains to indicate the unit is in operation. Press STOP/OPERATE(OFF/ON) button then press STOP/OPERATE(OFF/ON) button again to restart operation.
- When OFF timer is set, a priority is given to OFF timer.
- The unit will not be turned off if no one is detected during normal operation mode, even though No occupancy Auto-OFF mode is activated.

j. AIRFLOW CONTROL MODE

AIRFLOW CONTROL mode offers air conditioning according to a location of an occupant in a room detected by i-see SENSOR.

- (1) Press DIRECTION button during COOL, DRY, HEAT or AUTO mode to activate the AIRFLOW CONTROL mode. This mode is only available when the i-see control mode is effective.
- (2) Each press of DIRECTION button changes AIRFLOW CONTROL in the following order:

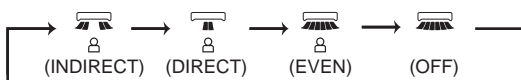

(INDIRECT) : An occupant will be less exposed to direct airflow.

(DIRECT) : Mainly the vicinity of an occupant will be air-conditioned.

(EVEN) : The unit learns the area where an occupant spend most of the time, and evens out the temperature of that area.

NOTE:

- Horizontal and vertical airflow directions will be automatically selected.
- When more than a couple of people are in a room, the AIRFLOW CONTROL mode may work less effectively.
- If you still feel uncomfortable with the air direction determined by the INDIRECT mode, adjust the air direction manually.

- (3) Cancelling the i-see control mode automatically cancels the AIRFLOW CONTROL mode.
 - The AIRFLOW CONTROL mode is also cancelled when the VANE control or WIDE VANE buttons is pressed.

WALL-MOUNTED OPERATION AND ACTUATOR CONTROL

k. NIGHT MODE (🌙) OPERATION

NIGHT MODE changes the brightness of the operation indicator, disables the beep sound and limits the noise level of the outdoor unit.

(1) Press NIGHT MODE button during operation to activate NIGHT mode (🌙).

- The operation indicator lamp dims.
- The beep sound will be disabled except that emitted when the operation is started or stopped.
- Noise level of the outdoor unit will be lower than that mentioned in SPECIFICATIONS.(Except the connection to MXZ.)

(2) Press NIGHT MODE button to cancel NIGHT mode (🌙).

NOTE:

- Noise level of the outdoor unit may not change after startup of the unit, during the protection operation, or depending on other operating conditions.
- The fan speed of the indoor unit will not change.
- The operation indicator lamp will be hard to be seen in a bright room.
- Noise level of the outdoor unit will not decrease during Multi system operation.

l. AIR PURIFYING (🌿) OPERATION

In the AIR PURIFYING operation, the indoor unit built-in device reduces airborne fungi, viruses, mold, and allergens.

(1) Press PURIFIER button to start AIR PURIFYING operation.

- AIR PURIFYING lamp turns on. (Display section)

(2) Press PURIFIER button again to cancel AIR PURIFYING operation.

- AIR PURIFYING lamp turns off. (Display section)

NOTE:

- Never touch the air purifying device during operation. Although the air purifying device is safety-conscious design, touching this device could be the cause of trouble as this device discharge high voltage electricity.
- A "hissing" sound may be heard during the air purifying operation. This sound is produced when plasma is being discharged. This is not a malfunction.
- AIR PURIFYING lamp does not turn on if the front panel is not closed completely.

m. i-save (🌙) OPERATION**1. How to set i-save operation**

- (1) Press OFF/ON (stop/operate) button.
- (2) Select COOL, CIRCULATOR, HEAT, ECONO COOL, or NIGHT mode.
- (3) Press i-save button.
- (4) Set the temperature, fan speed, and airflow direction for i-save operation.

NOTE:



- i-save operation cannot be selected during DRY, FAN or AUTO mode operation.
- The setting range of HEAT mode i-save operation is 10 - 31°C.
- 2 groups of setting can be saved. (One for COOL/ECONO COOL/CIRCULATOR, one for HEAT)

2. How to cancel operation



- Press i-save button again.
- i-save operation can also be cancelled by pressing Operation select button to change the operation mode. The preferred setting can be saved for the next time with a single press of i-save button.



n. OPERATION LOCK

This function locks operation mode only. Other functions, such as OFF/ON, temperature setting, or airflow direction adjustment, are available.

(1) Hold down  button and  button simultaneously for 2 seconds while the unit is not operating to enable OPERATION LOCK.

The icon for the locked operation mode blinks.

(2) Hold down  button and  button simultaneously for 2 seconds again while the unit is not operating to disable OPERATION LOCK.

- The icon for the locked operation mode blinks when  button and  button are held down to enable or disable OPERATION LOCK or  button is pressed during operation while OPERATION LOCK is enabled.
- AIR PURIFYING operation is not available when OPERATION LOCK is enabled in a mode other than FAN mode.

o. CIRCULATOR OPERATION (MSZ-RW25/35/50VG - [SC1] only)

In case the indoor temperature reaches the setting temperature, the outdoor unit stops and the indoor unit starts FAN operation to circulate the indoor air.

The setting of fan speed and airflow direction can be changed.

The outdoor unit starts operation automatically when the indoor temperature drops below the setting temperature.

(1) Press CIRCULATOR button during HEAT mode to enable CIRCULATOR operation.

The unit performs FAN operation in case the indoor temperature reaches the setting temperature.

(2) Set the fan speed and airflow direction.

- The setting of fan speed and airflow direction is common for HEAT and CIRCULATOR operation.
- Ventilation starts at Low fan speed in case AUTO fan speed is selected.

(3) Press CIRCULATOR button again to cancel CIRCULATOR operation.

NOTE:

CIRCULATOR operation doesn't work in the following situation.

- AUTO mode (Auto change over) is selected.
- Defrosting is being done.
- Indoor unit is connected to multi type outdoor unit.

Although received sound will be heard from the indoor unit and mark is displayed on remote controller when is pushed, CIRCULATOR operation doesn't work in multi connection.

- FAN operation may make you feel cold wind.

Reduce the FAN speed or adjust the airflow direction to avoid the wind.

p. DRIVE MODE SELECTOR**1. How to set DRIVE mode selector**

(1) Select a desired mode from WIDE ROOM, ECO, or QUIET.

(2) Press DRIVE button during COOL and HEAT mode to activate the DRIVE mode.

(3) Press DRIVE button several times to cancel the DRIVE MODE.



The details of each mode are as follows:

WIDE ROOM

Increases air volume and delivers airflow to a longer distance, reducing temperature unevenness in the room.

QUIET

- Decreases air volume and lowers the operating sound level of the unit.

ECO

- Suppresses a maximum capacity and operates efficiently without an excessive power consumption even when a room temperature suddenly changes.

NOTE:

- WIDE ROOM mode increases operating sound level due to the air volume increase.
- QUIET mode and ECO mode can affect heating and cooling performance.
- ECO mode cannot be activated when connected to a multi-system outdoor unit.
- Cancel the mode if you feel uncomfortable after setting.

q. EMERGENCY/TEST OPERATION

In the case of test run operation or emergency operation, use the emergency operation switch on the right side of the indoor unit. Emergency operation is available when the remote controller is missing or has failed, or when the batteries in the remote controller are running down. The unit will start and OPERATION INDICATOR lamp will light up.

The first 30 minutes of operation is the test run operation. This operation is for servicing. The indoor fan runs at High speed and the temperature control does not work.

After 30 minutes of test run operation, the system shifts to EMERGENCY COOL/HEAT MODE with a set temperature of 24°C. The fan speed shifts to Med.

The coil frost prevention works even in the test run or the emergency operation.

In the test run or emergency operation, the horizontal vane operates in VANE AUTO (@) mode.

Emergency operation continues until the emergency operation switch is pressed once or twice or the unit receives any signal from the remote controller. In the latter case, normal operation will start.

NOTE: Do not press the emergency operation switch during normal operation.

Operation mode	COOL/HEAT
Set temperature	24°C
Fan speed	Med.
Horizontal vane	Auto

The operation mode is indicated by the Operation Indicator lamp as following

Operation indicator lamp

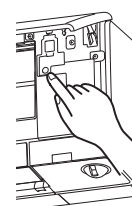
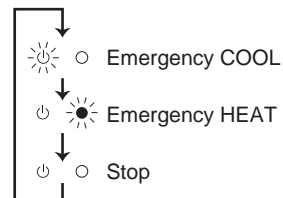

Emergency operation switch (E.O. SW)

r. 3-MINUTE TIME DELAY OPERATION

When the system turns OFF, compressor will not restart for 3 minutes as 3-minute time delay function operates to protect compressor from overload.

s. ACTUATOR CONTROL

s-1. OUTDOOR FAN MOTOR CONTROL

The fan motor turns ON/OFF, interlocking with the compressor.

[ON] The fan motor turns ON 5 seconds before the compressor starts up.

[OFF] The fan motor turns OFF 15 seconds after the compressor has stopped running.

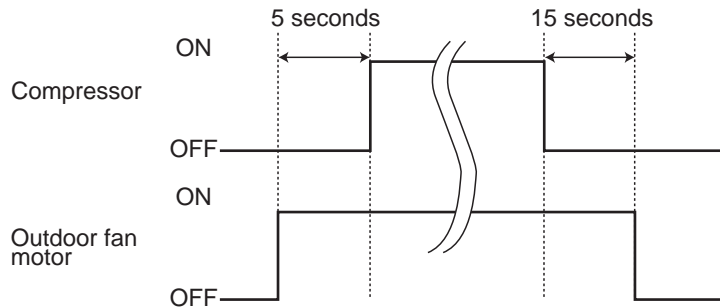

s-2. R.V. COIL CONTROL

Heating ON

Cooling OFF

Dry OFF

NOTE: The 4-way valve reverses for 5 seconds right before startup of the compressor.

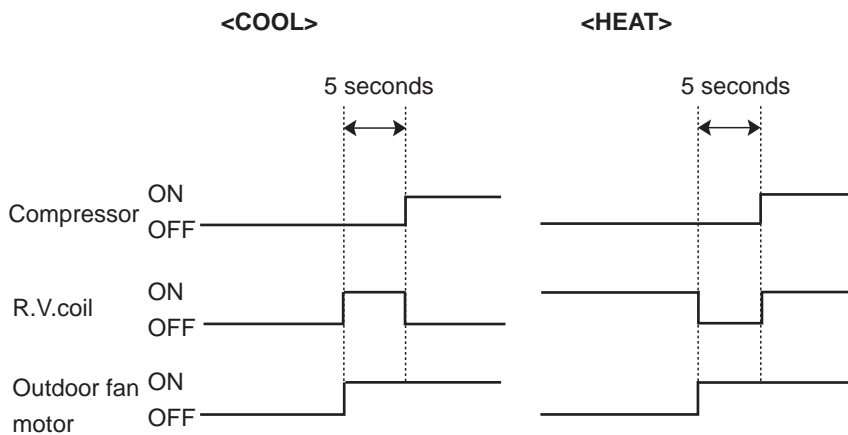

s-3. RELATION BETWEEN MAIN SENSOR AND ACTUATOR

Sensor	Purpose	Actuator					
		Compressor	LEV	Outdoor fan motor	R.V. coil	Indoor fan motor	Defrost heater
Discharge temperature thermistor	Protection	○	○				
Indoor coil temperature thermistor	Cooling: Coil frost prevention	○					
	Heating: High pressure protection	○	○				
Defrost thermistor	Heating: Defrosting	○	○	○	○	○	
Fin temperature thermistor	Protection	○		○			
Ambient temperature thermistor	Cooling: Low ambient temperature operation	○	○	○			
	Heating: Defrosting (Heater)						○
Outdoor heat exchanger temperature thermistor	Cooling: Low ambient temperature operation	○	○	○			
	Cooling: High pressure protection	○	○	○			

WALL-MOUNTED OPERATION AND ACTUATOR CONTROL

C.1.9.2 MSZ-LN•VG2 Series

MSZ-LN18VG2W	MSZ-LN25VG2W	MSZ-LN35VG2W	MSZ-LN50VG2W	MSZ-LN60VG2W
MSZ-LN18VG2V	MSZ-LN25VG2V	MSZ-LN35VG2V	MSZ-LN50VG2V	MSZ-LN60VG2V
MSZ-LN18VG2B	MSZ-LN25VG2B	MSZ-LN35VG2B	MSZ-LN50VG2B	MSZ-LN60VG2B
MSZ-LN18VG2R	MSZ-LN25VG2R	MSZ-LN35VG2R	MSZ-LN50VG2R	MSZ-LN60VG2R
MUZ-LN25VG2	MUZ-LN35VG2	MUZ-LN50VG2	MUZ-LN60VG2	
MUZ-LN25VGHZ2	MUZ-LN35VGHZ2	MUZ-LN50VGHZ2		

WIRELESS REMOTE CONTROLLER

MSZ-LN18VG2W- E3	MSZ-LN25VG2W- E3	MSZ-LN35VG2W- E3	MSZ-LN50VG2W- E3	MSZ-LN60VG2W- E3
MSZ-LN18VG2V- E3	MSZ-LN25VG2V- E3	MSZ-LN35VG2V- E3	MSZ-LN50VG2V- E3	MSZ-LN60VG2V- E3
MSZ-LN18VG2B- E3	MSZ-LN25VG2B- E3	MSZ-LN35VG2B- E3	MSZ-LN50VG2B- E3	MSZ-LN60VG2B- E3
MSZ-LN18VG2R- E3	MSZ-LN25VG2R- E3	MSZ-LN35VG2R- E3	MSZ-LN50VG2R- E3	MSZ-LN60VG2R- E3
MUZ-LN25VG2	MUZ-LN35VG2	MUZ-LN50VG2	MUZ-LN60VG2	
MUZ-LN25VGHZ2	MUZ-LN35VGHZ2	MUZ-LN50VGHZ2		

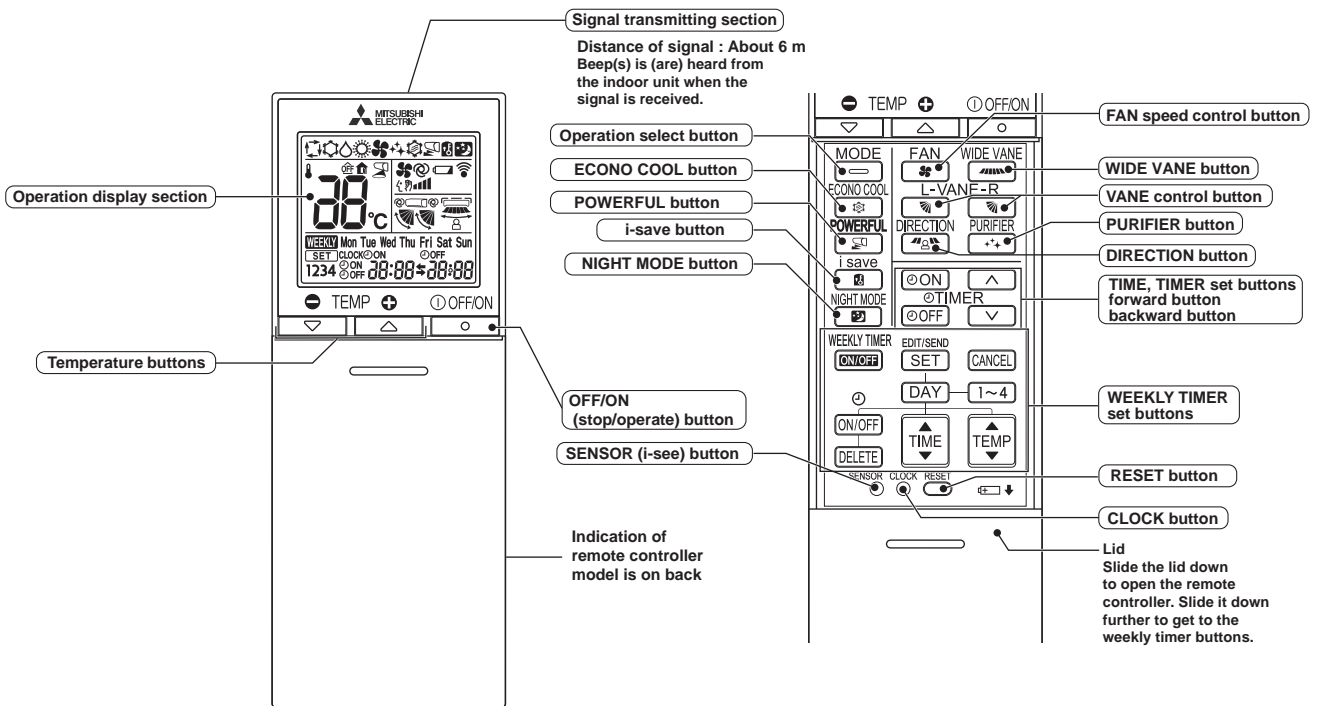

OPERATION AND ACTUATOR CONTROL

WALL-MOUNTED

- | | | | |
|--------------------------------------|--------------------------------------|--------------------------------------|--------------------------------------|
| MSZ-LN18VG2W- ^{[EN1],[SC1]} | MSZ-LN25VG2W- ^{[EN2],[SC1]} | MSZ-LN35VG2W- ^{[EN2],[SC1]} | MSZ-LN50VG2W- ^{[EN2],[SC1]} |
| MSZ-LN18VG2V- ^[EN1] | MSZ-LN25VG2V- ^{[EN2],[SC1]} | MSZ-LN35VG2V- ^{[EN2],[SC1]} | MSZ-LN50VG2V- ^{[EN2],[SC1]} |
| MSZ-LN18VG2B- ^[EN1] | MSZ-LN25VG2B- ^{[EN2],[SC1]} | MSZ-LN35VG2B- ^{[EN2],[SC1]} | MSZ-LN50VG2B- ^{[EN2],[SC1]} |
| MSZ-LN18VG2R- ^[EN1] | MSZ-LN25VG2R- ^{[EN2],[SC1]} | MSZ-LN35VG2R- ^{[EN2],[SC1]} | MSZ-LN50VG2R- ^{[EN2],[SC1]} |
| MUZ-LN25VG2 | MUZ-LN35VG2 | MUZ-LN50VG2 | |
| MUZ-LN25VGHZ2 | MUZ-LN35VGHZ2 | MUZ-LN50VGHZ2 | |

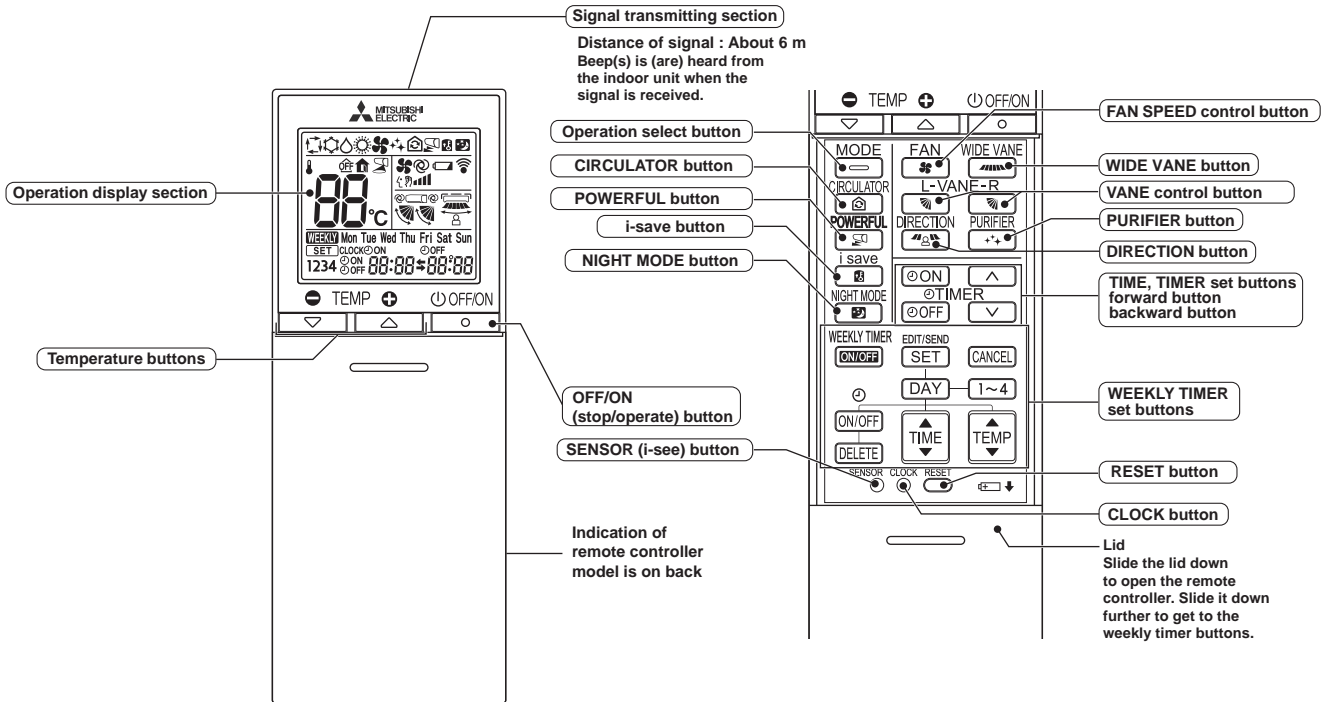

NOTE: Last setting will be stored after the unit is turned OFF with the remote controller. Indoor unit receives the signal of the remote controller with beeps.

INDOOR UNIT DISPLAY SECTION

Operation Indicator lamp

The operation indicator at the right side of the indoor unit indicates the operation state.

- The following indication applies regardless of shape of the indication.

Indication	Operation state	Room temperature	
	Standby mode (Only during multi system operation)	—	Lit Blinking Not lit

a. COOL (❄️) OPERATION

- (1) Press OFF/ON (stop/operate) button.
OPERATION INDICATOR lamp of the indoor unit turns on with a beep tone.
- (2) Select COOL mode with Operation select button.
- (3) Press Temperature buttons TEMP \ominus or \oplus button to select the desired temperature. The setting range is 16 - 31°C.

1. Coil frost prevention

The compressor operational frequency is controlled by the temperature of the indoor heat exchanger to prevent the coil from frosting.

When the temperature of indoor heat exchanger becomes too low, the coil frost prevention mode works.

The indoor fan operates at the set speed and the compressor stops. This mode continues until the temperature of indoor heat exchanger rises.

2. Low outside temperature operation

When the outside temperature is lower, low outside temperature operation starts, and the outdoor fan slows or stops.

3. Indoor fan speed control

When the thermostat turns OFF, the indoor fan operates very Low to reduce power consumption.

When the room temperature rises and the thermostat is ON, the indoor fan operates according to the settings on the remote controller.

b. DRY (△) OPERATION

- (1) Press OFF/ON (stop/operate) button.
OPERATION INDICATOR lamp of the indoor unit turns on with a beep tone.
- (2) Select DRY mode with Operation select button.
- (3) The set temperature is determined from the initial room temperature.

1. Coil frost prevention

Coil frost prevention works the same way as that in COOL mode. (a.1.)

2. Low outside temperature operation

Low outside temperature operation works the same way as that in COOL mode. (a.2.)

3. Indoor fan speed control

Indoor fan speed control works the same way as that in COOL mode. (a.3.)

c. FAN (⚙️) OPERATION

- (1) OPERATION INDICATOR lamp of the indoor unit turns on with a beep tone.
- (2) Select FAN mode with Operation select button.
- (3) Select the desired fan speed. When AUTO, it becomes Low.
Only indoor fan operates.
Outdoor unit does not operate.

d. HEAT (🔥) OPERATION

- (1) Press OFF/ON (stop/operate) button.
OPERATION INDICATOR lamp of the indoor unit turns on with a beep tone.
- (2) Select HEAT mode with Operation select button.
- (3) Press Temperature buttons TEMP \ominus or \oplus button to select the desired temperature. The setting range is 10 - 31°C.

1. Cold air prevention control

When the compressor is not operating or is starting, and the temperature of indoor heat exchanger and/or the room temperature is low or when defrosting is being done, the indoor fan will stop or rotate in Very Low speed.

2. High pressure protection

The compressor operational frequency is controlled by the temperature of the indoor heat exchanger to prevent the condensing pressure from increasing excessively.

When the temperature of indoor heat exchanger becomes too high, the high pressure protection works.

The indoor fan operates following the cold air prevention control. This mode continues until the temperature of indoor heat exchanger falls.

3. Defrosting

Defrosting starts when the temperature of outdoor heat exchanger becomes too low.

The compressor stops once, the indoor/outdoor fans stop, the 4-way valve reverses, and the compressor re-starts.

This mode continues until the temperature of outdoor heat exchanger rises or the fixed time passes.

e. AUTO CHANGE OVER ... AUTO MODE OPERATION

Once desired temperature is set, unit operation is switched automatically between COOL and HEAT operation.

Mode selection**(1) Initial mode**

When unit starts the operation with AUTO operation from OFF:

- If the room temperature is higher than the set temperature, operation starts in COOL mode.
- If the room temperature is equal to or lower than the set temperature, operation starts in HEAT mode.

(2) Mode change

COOL mode changes to HEAT mode when about 15 minutes have passed with the room temperature 1°C below the set temperature.

HEAT mode changes to COOL mode when about 15 minutes have passed with the room temperature 1°C above the set temperature.

NOTE 1:

If 2 or more indoor units are operating in multi system, there might be a case that the indoor unit, which is operating in □ (AUTO), cannot change over to the other operating mode (COOL ↔ HEAT) and becomes a state of standby.

Refer to **NOTE 2 “FOR MULTI SYSTEM AIR CONDITIONER”**.

NOTE 2:

FOR MULTI SYSTEM AIR CONDITIONER

OUTDOOR UNIT: MXZ series

Multi system air conditioner can connect 2 or more indoor units with one outdoor unit.

- When you try to operate 2 or more indoor units with one outdoor unit simultaneously, one for the cooling and the others for heating, the operation mode of the indoor unit that operates first is selected. Other indoor units cannot operate, and operation indicator lamp blinks as shown in the figure below. In this case, please set all the indoor units to the same operation mode.

OPERATION INDICATOR

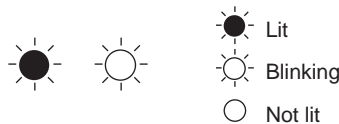

- When indoor unit starts the operation while the defrosting of outdoor unit is being done, it takes a few minutes (max. 10 minutes) to blow out the warm air.
- In the heating operation, though indoor unit that does not operate may get warm or the sound of refrigerant flowing may be heard, they are not malfunction. The reason is that the refrigerant continuously flows into it.

f. AUTO VANE OPERATION

1. Horizontal vane

(1) Vane motor drive

These models are equipped with stepping motors for the horizontal vanes. The rotating direction, speed, and angle of the motor are controlled by pulse signals (approximately 12 V) transmitted from indoor microprocessor.

(2) The horizontal vane angle and mode change as follows by pressing VANE CONTROL () button.

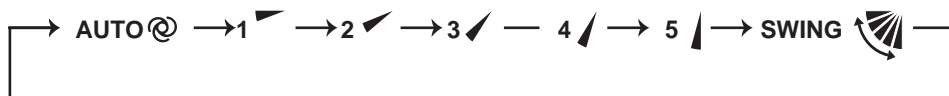

NOTE: The right and left horizontal vanes set to the same level may not align perfectly.

(3) Positioning

To confirm the standard position, the vane moves until it touches the vane stopper. Then the vane is set to the selected angle.

Confirmation of standard position is performed in the following cases:

- (a) When the operation starts or finishes (including timer operation).
- (b) When the test run starts.
- (c) When standby mode (only during multi system operation) starts or finishes.

(4) VANE AUTO (@) mode

In VANE AUTO mode, the microprocessor automatically determines the vane angle to make the optimum room temperature distribution.

In COOL and DRY operation

Vane angle is fixed to Horizontal position.



In HEAT operation

Vane angle is fixed to Angle 4.



(5) STOP (operation OFF) and ON TIMER standby

In the following cases, the horizontal vane returns to the closed position.

- (a) When OFF/ON (stop/operate) button is pressed (POWER OFF).
- (b) When the operation is stopped by the emergency operation.
- (c) When ON TIMER is ON standby.

(6) Dew prevention

During COOL or DRY operation with the lower position when the compressor cumulative operation time exceeds 1 hour, the vane angle automatically changes to Angle 1 for dew prevention.

- (7) SWING (🌀) mode
By selecting SWING mode with VANE control button, the horizontal vanes swing vertically.
When COOL, DRY or FAN mode is selected, only the upper vane swings.
- (8) Cold air prevention in HEAT operation
The horizontal vane position is set to Upward.
NOTE: When 2 or more indoor units are operated with multi outdoor unit, even if any indoor unit turns thermostat off, this control does not work in the indoor unit.
- (9) ECONO COOL (🌀) operation (ECONOMical operation)
When ECONO COOL button is pressed in COOL mode, set temperature is automatically set 2°C higher by the micro-processor. However, the temperature on the LCD screen on the remote controller is not changed. Also the horizontal vane swings in various cycle.
SWING operation makes you feel cooler than set temperature. So, even though the set temperature is higher, the air conditioner can keep comfort. As a result, energy can be saved.
To cancel this operation, select a different mode or press one of the following buttons in ECONO COOL operation: ECONO COOL, VANE control, LONG or POWERFUL button.
- (10) POWERFUL (🌀) operation
The air conditioner automatically adjusts the fan speed and the set temperature, and operates the POWERFUL mode. The POWERFUL mode is cancelled automatically 15 minutes after operation starts, or when POWERFUL button is pressed once again within 15 minutes after operation starts. The operation mode returns to the mode prior to POWERFUL operation. To cancel this operation manually, select a different mode or press one of the following buttons within 15 minutes after operation starts: OFF/ON (stop/operate), ECONO COOL, FAN SPEED control, CIRCULATOR, or i-save button.

2. Vertical vane

- (1) Vane motor drive
These models are equipped with a stepping motor for the vertical vane. The rotating direction, speed, and angle of the motor are controlled by pulse signals (approximately 12 V) transmitted from microprocessor.
- (2) The vertical vane angle and mode change as follows by pressing WIDE VANE button.

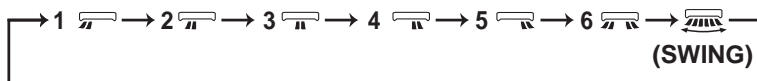

- (3) Positioning
To confirm the standard position, the vane moves until it touches the vane stopper. Then the vane is set to the selected angle.
Confirmation of standard position is performed in the following cases:
(a) OFF/ON (stop/operate) button is pressed (POWER ON).
- (4) SWING (🌀) MODE
By selecting SWING mode with WIDE VANE button, the vertical vane swings horizontally. The remote controller displays "🌀". Swing mode is cancelled when WIDE VANE button is pressed once again.

g. TIMER OPERATION

1. How to set the time

(1) Check that the current time is set correctly.

NOTE: Timer operation will not work without setting the current time. Initially “0:00” blinks at the current time display of TIME MONITOR, so set the current time correctly with CLOCK button.

How to set the current time

- (a) Press the CLOCK button.
 - (b) Press the TIME set buttons (▲ and ▼) to set the current time.
 - Each time forward button (▲) is pressed, the set time increases by 1 minute, and each time backward button (▼) is pressed, the set time decreases by 1 minute.
 - Pressing those buttons longer, the set time increases/decreases by 10 minutes.
 - (c) Press the CLOCK set button.
- (2) Press OFF/ON (stop/operate) button to start the air conditioner.
- (3) Set the time of timer.

ON timer setting

- (a) Press ON TIMER button (ⓄON) during operation.
- (b) Set the time of the timer using TIME set buttons (▲ and ▼).*

OFF timer setting

- (a) Press OFF TIMER button (ⓄOFF) during operation.
 - (b) Set the time of the timer using TIME set buttons (▲ and ▼).*
- * Each time forward button (▲) is pressed, the set time increases by 10 minutes: each time backward button (▼) is pressed, the set time decreases by 10 minutes.

2. To release the timer

To release ON timer, press ON TIMER button (ⓄON).
 To release OFF timer, press OFF TIMER button (ⓄOFF).
 TIMER is cancelled and the display of set time disappears.

PROGRAM TIMER

- OFF timer and ON timer can be used in combination. The set time that is reached first will operate first.
- “→” and “←” display shows the order of OFF timer and ON timer operation.

(Example 1) The current time is 8:00 PM.
 The unit turns off at 11:00 PM, and on at 6:00 AM.

(Example 2) The current time is 11:00 AM.
 The unit turns on at 5:00 PM, and off at 9:00 PM.

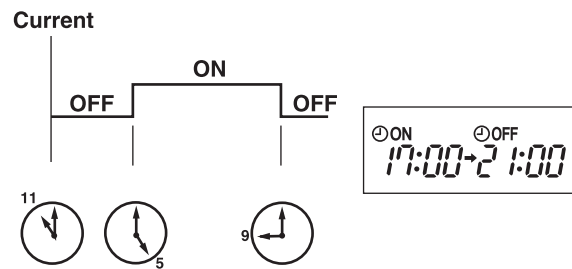
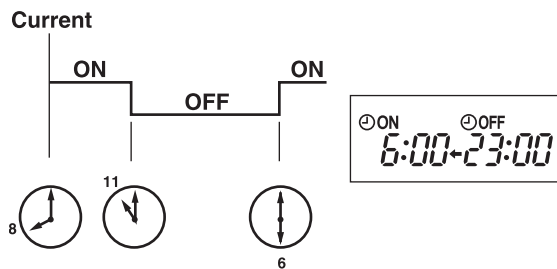

NOTE: If the main power is turned OFF or a power failure occurs while ON/OFF timer is active, the timer setting is cancelled. As these models are equipped with an auto restart function, the air conditioner starts operating with timer cancelled when power is restored.

h. WEEKLY TIMER OPERATION

- A maximum of 4 ON or OFF timers can be set for individual days of the week.
- A maximum of 28 ON or OFF timers can be set for a week.

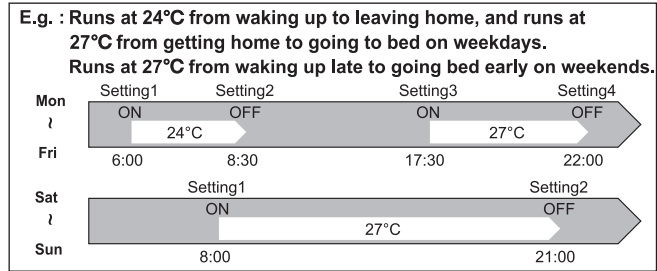

NOTE:

- The simple ON/OFF timer setting is available while the weekly timer is on. In this case, the ON/OFF timer has priority over the weekly timer; the weekly timer operation will start again after the simple ON/OFF timer is complete.

1. How to set the weekly timer

* Make sure that the current time and day are set correctly.

(1) Press **EDIT/SEND SET** button to enter the weekly timer setting mode.

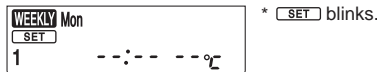

(2) Press **DAY** and **1~4** buttons to select setting day and number.

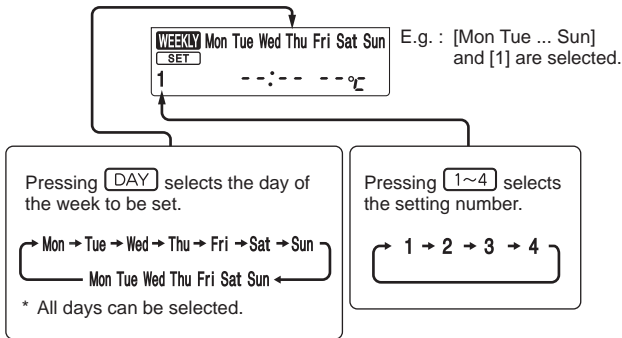

(3) Press **ON/OFF**, **TIME**, and **TEMP** buttons to set ON/OFF, time, and temperature.

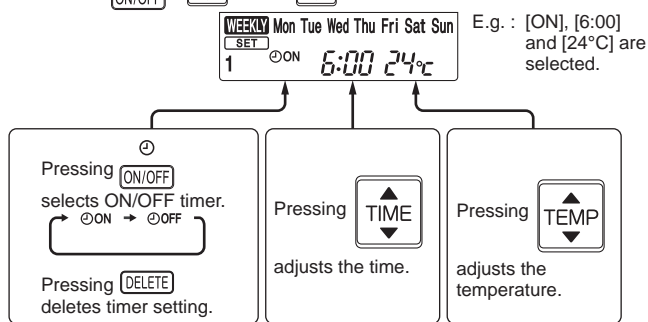

- * Hold down the button to change the time quickly.
- * The temperature can be set between 16°C and 31°C at COOL operation.
- * The temperature can be set between 10°C and 31°C at HEAT operation.





Press **DAY** and **1~4** buttons to continue setting the timer for other days and/or numbers.



(4) Press  button to complete and transmit the weekly timer setting.





*  which was blinking goes out, and the current time will be displayed.

NOTE:

- Press  button to transmit the setting information of weekly timer to the indoor unit. Point the remote controller toward the indoor unit for 3 seconds.
- When setting the timer for more than one day of the week or one number,  button does not have to be pressed per each setting. Press  button once after all the settings are completed. All the weekly timer settings will be saved.
- Press  button to enter the weekly timer setting mode, and press and hold  button for 5 seconds to erase all weekly timer settings. Point the remote controller toward the indoor unit.

(5) Press  button to turn the weekly timer ON. ( lights.)

•When the weekly timer is ON, the day of the week whose timer setting is completed, will light.

Press  button again to turn the weekly timer OFF. ( goes out.)



NOTE:

The saved settings will not be cleared when the weekly timer is turned OFF.

2. Checking weekly timer setting

(1) Press  button to enter the weekly timer setting mode.

*  blinks.

(2) Press  or  buttons to view the setting of the particular day or number.

(3) Press  button to exit the weekly timer setting.

NOTE:

When all days of the week are selected to view the settings and a different setting is included among them, --:-- °C will be displayed.

i. i-see CONTROL () MODE AND ABSENCE DETECTION

In the i-see control mode, the room temperature is controlled based on the sensible temperature.

(1) Press SENSOR button with a thin instrument during COOL, DRY, HEAT and AUTO mode to activate i-see control mode ().
The default setting is “active”.

(2) Press SENSOR button several times to cancel i-see control mode.

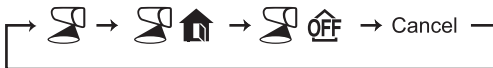

NOTE:

How to detect human presence

- When the air conditioner starts to operate, the i-see Sensor analyzes the temperature of a room by rotating clockwise and counterclockwise.
- Then, it detects human presence by their motion based on their heat signatures.



Detection range

The i-see Sensor does not analyze the temperature in the following range.

- The wall surface on which the air conditioner is installed
- The spot beneath the air conditioner
- Where there is an object (such as furniture) between the place and the air conditioner

It might not detect human and objects properly on the following conditions

- When the temperature of the floor and the wall is high (such as when the air conditioner starts to operate in summer)
- When occupants are in blanket or wear heavily
- When there is an object whose temperature changes rapidly in a short time
- When windows and doors are small or they are far from the air conditioner
- When the sensor cannot detect the heat source such as of small kids or pets
- When using a floor heating or an electric carpet
- When occupants do not move after the air conditioner starts to operate

Refer to the following “Absence Detection” for  and .

ABSENCE DETECTION (🏠)

This function automatically changes the operation to No occupancy energy-saving mode or No occupancy Auto-OFF mode when nobody is in the room.

- (1) To activate this No occupancy energy-saving mode, press SENSOR button until 🏠 appears on the operation display of the remote controller.
- (2) To activate this No occupancy Auto-OFF mode, press SENSOR button until OFF appears on the operation display of the remote controller.
- (3) Press SENSOR button again to cancel the ABSENCE DETECTION.

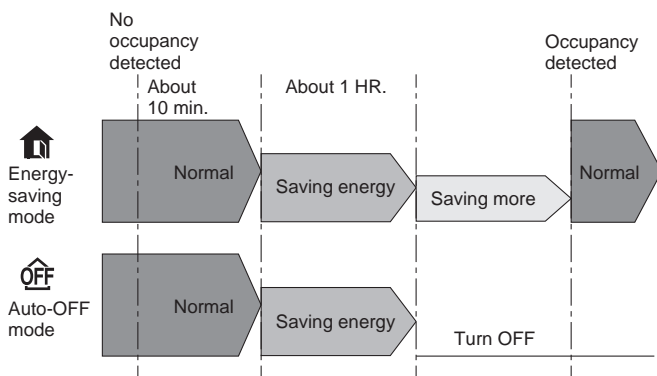
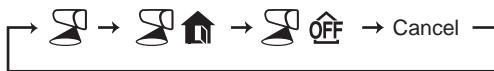

- Even if the unit is turned OFF due to No occupancy Auto-OFF mode, the display of the remote controller remains to indicate the unit is in operation. Press STOP/OPERATE(OFF/ON) button then press STOP/OPERATE(OFF/ON) button again to restart operation.
- When OFF timer is set, a priority is given to OFF timer.
- No occupancy energy saving mode or No occupancy Auto-OFF mode are not available during POWERFUL operation.
- The unit will not be turned off if no one is detected during normal operation mode, even though No occupancy Auto-OFF mode is activated.

j. AIRFLOW CONTROL MODE

AIRFLOW CONTROL mode offers air conditioning according to a location of an occupant in a room detected by i-see SENSOR.

- (1) Press DIRECTION button during COOL, DRY, HEAT or AUTO mode to activate the AIRFLOW CONTROL mode. This mode is only available when the i-see control mode is effective.
- (2) Each press of DIRECTION button changes AIRFLOW CONTROL in the following order:

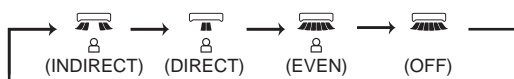

- 🏠 (INDIRECT) : An occupant will be less exposed to direct airflow.
- 🏠 (DIRECT) : Mainly the vicinity of an occupant will be air-conditioned.
- 🏠 (EVEN) : The unit learns the area where an occupant spend most of the time, and evens out the temperature of that area.

NOTE:

- Horizontal and vertical airflow directions will be automatically selected.
- When more than a couple of people are in a room, the AIRFLOW CONTROL mode may work less effectively.
- If you still feel uncomfortable with the air direction determined by the INDIRECT mode, adjust the air direction manually.

- (3) Cancelling the i-see control mode automatically cancels the AIRFLOW CONTROL mode.
 - The AIRFLOW CONTROL mode is also cancelled when the VANE control or WIDE VANE buttons is pressed.

k. NIGHT MODE (🌙) OPERATION

NIGHT MODE changes the brightness of the operation indicator, disables the beep sound and limits the noise level of the outdoor unit.

(1) Press NIGHT MODE button during operation to activate NIGHT mode (🌙).

- The operation indicator lamp dims.
- The beep sound will be disabled except that emitted when the operation is started or stopped.
- Noise level of the outdoor unit will be lower than that mentioned in SPECIFICATIONS. (Except the connection to **MXZ**.)

(2) Press NIGHT MODE button to cancel NIGHT mode (🌙).

NOTE:

- Noise level of the outdoor unit may not change after startup of the unit, during the protection operation, or depending on other operating conditions.
- The fan speed of the indoor unit will not change.
- The operation indicator lamp will be hard to be seen in a bright room.
- Operating POWERFUL operation during NIGHT mode will increase the noise level of the outdoor unit.
- Noise level of the outdoor unit will not decrease during Multi system operation.

l. AIR PURIFYING (🌿) OPERATION

In the AIR PURIFYING operation, the indoor unit built-in device reduces airborne fungi, viruses, mold, and allergens.

(1) Press PURIFIER button to start AIR PURIFYING operation.

- AIR PURIFYING lamp turns on. (Display section)

(2) Press PURIFIER button again to cancel AIR PURIFYING operation.

- AIR PURIFYING lamp turns off. (Display section)

NOTE:

- Never touch the air purifying device during operation. Although the air purifying device is safety-conscious design, touching this device could be the cause of trouble as this device discharge high voltage electricity.
- A "hissing" sound may be heard during the air purifying operation. This sound is produced when plasma is being discharged. This is not a malfunction.
- AIR PURIFYING lamp does not turn on if the front panel is not closed completely.

m. i-save (🔒) OPERATION**1. How to set i-save operation**

(1) Press OFF/ON (stop/operate) button.

(2) Select COOL, CIRCULATOR, HEAT, ECONO COOL, or NIGHT mode.

(3) Press i-save button.

(4) Set the temperature, fan speed, and airflow direction for i-save operation.

NOTE:

- i-save operation cannot be selected during DRY, FAN or AUTO mode operation.
- The setting range of HEAT mode i-save operation is 10 - 31°C.
- 2 groups of setting can be saved. (One for COOL/ECONO COOL/CIRCULATOR, one for HEAT)

2. How to cancel operation







• Press i-save button again.

• i-save operation can also be cancelled by pressing POWERFUL button or Operation select button to change the operation mode.

The preferred setting can be saved for the next time with a single press of i-save button.

n. OPERATION LOCK

This function locks operation mode only. Other functions, such as OFF/ON, temperature setting, or airflow direction adjustment, are available.

- (1) Hold down  button and  button simultaneously for 2 seconds while the unit is not operating to enable OPERATION LOCK.
The icon for the locked operation mode blinks.
- (2) Hold down  button and  button simultaneously for 2 seconds again while the unit is not operating to disable OPERATION LOCK.
 - The icon for the locked operation mode blinks when  button and  button are held down to enable or disable OPERATION LOCK or  button is pressed during operation while OPERATION LOCK is enabled.
 - AIR PURIFYING operation is not available when OPERATION LOCK is enabled in a mode other than FAN mode.

o. CIRCULATOR OPERATION

In case the indoor temperature reaches the setting temperature, the outdoor unit stops and the indoor unit starts FAN operation to circulate the indoor air.
The setting of fan speed and airflow direction can be changed.
The outdoor unit starts operation automatically when the indoor temperature drops below the setting temperature.

- (1) Press CIRCULATOR button during HEAT mode to enable CIRCULATOR operation.
The unit performs FAN operation in case the indoor temperature reaches the setting temperature.
- (2) Set the fan speed and airflow direction.
 - The setting of fan speed and airflow direction is common for HEAT and CIRCULATOR operation.
 - Ventilation starts at Low fan speed in case AUTO fan speed is selected.
- (3) Press CIRCULATOR button again to cancel CIRCULATOR operation.

NOTE:

CIRCULATOR operation doesn't work in the following situation.

- AUTO mode (Auto change over) is selected.
- Defrosting is being done.
- Indoor unit is connected to multi type outdoor unit.
Although received sound will be heard from the indoor unit and mark is displayed on remote controller when is pushed, CIRCULATOR operation doesn't work in multi connection.
- FAN operation may make you feel cold wind.
Reduce the FAN speed or adjust the airflow direction to avoid the wind.

p. EMERGENCY/TEST OPERATION

In the case of test run operation or emergency operation, use the emergency operation switch on the right side of the indoor unit. Emergency operation is available when the remote controller is missing or has failed, or when the batteries in the remote controller are running down. The unit will start and OPERATION INDICATOR lamp will light up.

The first 30 minutes of operation is the test run operation. This operation is for servicing. The indoor fan runs at High speed and the temperature control does not work.

After 30 minutes of test run operation, the system shifts to EMERGENCY COOL/HEAT MODE with a set temperature of 24°C. The fan speed shifts to Med.

The coil frost prevention works even in the test run or the emergency operation.

In the test run or emergency operation, the horizontal vane operates in VANE AUTO (@) mode.

Emergency operation continues until the emergency operation switch is pressed once or twice or the unit receives any signal from the remote controller. In the latter case, normal operation will start.

NOTE: Do not press the emergency operation switch during normal operation.

Operation mode	COOL/HEAT
Set temperature	24°C
Fan speed	Med.
Horizontal vane	Auto

The operation mode is indicated by the Operation Indicator lamp as following

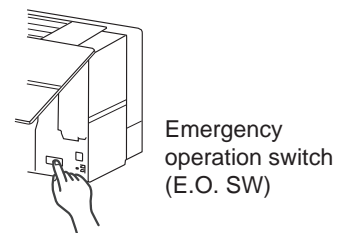
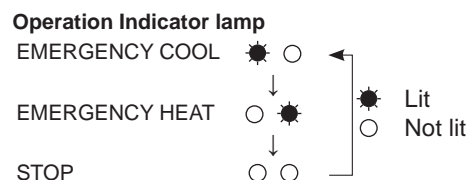

q. 3-MINUTE TIME DELAY OPERATION

When the system turns OFF, compressor will not restart for 3 minutes as 3-minute time delay function operates to protect compressor from overload.

r. ACTUATOR CONTROL

r-1. OUTDOOR FAN MOTOR CONTROL

The fan motor turns ON/OFF, interlocking with the compressor.

[ON] The fan motor turns ON 5 seconds before the compressor starts up.

[OFF] The fan motor turns OFF 15 seconds after the compressor has stopped running.

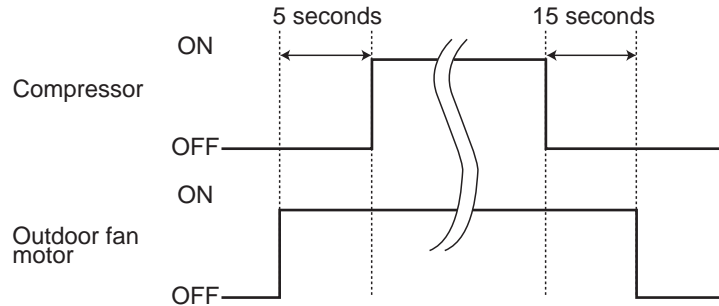

r-2. R.V. COIL CONTROL

Heating..... ON

Cooling..... OFF

Dry..... OFF

NOTE: The 4-way valve reverses for 5 seconds right before startup of the compressor.

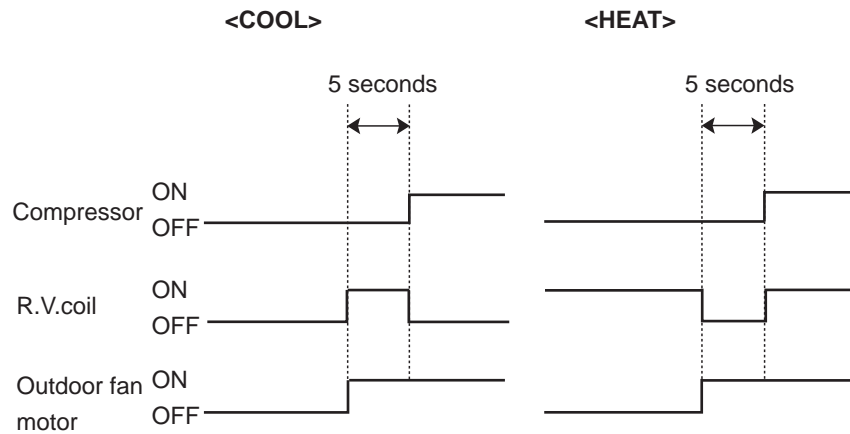

r-3. RELATION BETWEEN MAIN SENSOR AND ACTUATOR

Sensor	Purpose	Actuator					
		Compressor	LEV	Outdoor fan motor	R.V. coil	Indoor fan motor	Defrost heater
Discharge temperature thermistor	Protection	○	○				
Indoor coil temperature thermistor	Cooling: Coil frost prevention	○					
	Heating: High pressure protection	○	○				
Defrost thermistor	Heating: Defrosting	○	○	○	○	○	
Fin temperature thermistor	Protection	○		○			
Ambient temperature thermistor	Cooling: Low ambient temperature operation	○	○	○			
	Heating: Defrosting (Heater)						○
Outdoor heat exchanger temperature thermistor	Cooling: Low ambient temperature operation	○	○	○			
	Cooling: High pressure protection	○	○	○			

C.1.9.3 MSZ-FT•VG/K Series

- MSZ-FT25VG MSZ-FT35VG MSZ-FT50VG
- MSZ-FT25VGK MSZ-FT35VGK MSZ-FT50VGK
- MUZ-FT25VGHZ MUZ-FT35VGHZ MUZ-FT50VGHZ

WIRELESS REMOTE CONTROLLER

- MSZ-FT25VG- [E1] MSZ-FT35VG- [E1] MSZ-FT50VG- [E1]
- MSZ-FT25VGK- [E2] MSZ-FT35VGK- [E2] MSZ-FT50VGK- [E2]
- MUZ-FT25VGHZ MUZ-FT35VGHZ MUZ-FT50VGHZ

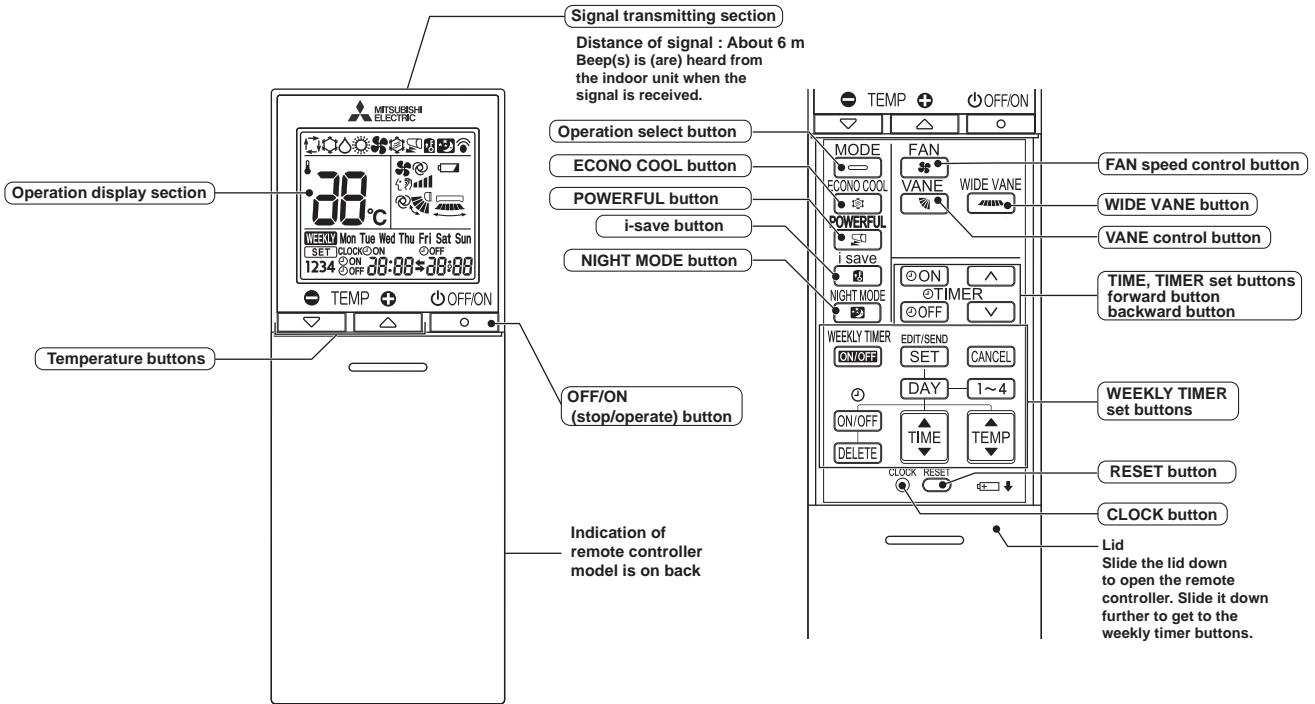

- MSZ-FT25VGK- [SC1], [SC2] MSZ-FT35VGK- [SC1], [SC2] MSZ-FT50VGK- [SC1], [SC2]
- MUZ-FT25VGHZ MUZ-FT35VGHZ MUZ-FT50VGHZ

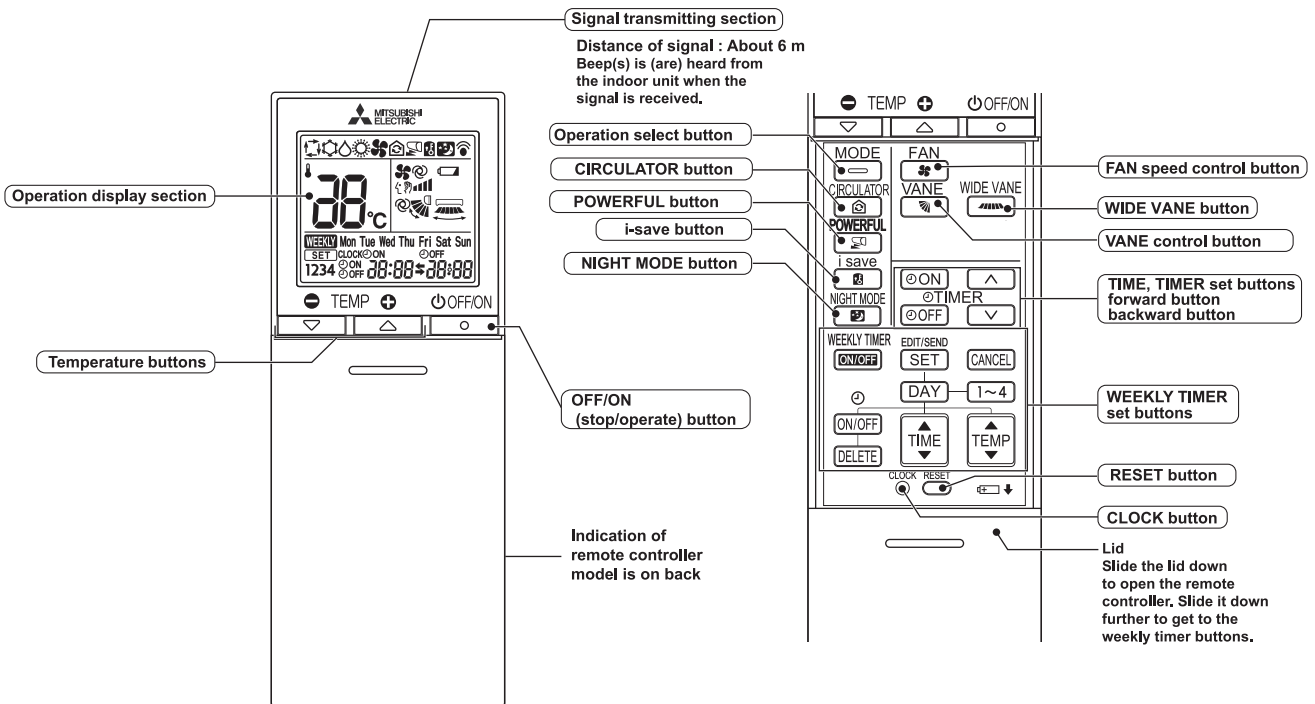

NOTE: Last setting will be stored after the unit is turned OFF with the remote controller. Indoor unit receives the signal of the remote controller with beeps.

OPERATION AND ACTUATOR CONTROL



WALL-MOUNTED

INDOOR UNIT DISPLAY SECTION

Operation Indicator lamp



The operation indicator at the right side of the indoor unit indicates the operation state.

- The following indication applies regardless of shape of the indication.

Indication	Operation state	Room temperature
	The unit is operating to reach the set temperature	About 2°C or more away from set temperature
	The room temperature is approaching the set temperature	About 1 to 2°C from set temperature
	Standby mode (Only during multi system operation)	—

-  Lit
-  Blinking
-  Not lit

a. COOL (❄️) OPERATION

- Press OFF/ON (stop/operate) button.
OPERATION INDICATOR lamp of the indoor unit turns on with a beep tone.
- Select COOL mode with Operation select button.
- Press Temperature buttons TEMP  or  button to select the desired temperature. The setting range is 16 - 31°C.

1. Coil frost prevention

The compressor operational frequency is controlled by the temperature of the indoor heat exchanger to prevent the coil from frosting.

When the temperature of indoor heat exchanger becomes too low, the coil frost prevention mode works.

The indoor fan operates at the set speed and the compressor stops. This mode continues until the temperature of indoor heat exchanger rises.

2. Low outside temperature operation

When the outside temperature is lower, low outside temperature operation starts, and the outdoor fan slows or stops.

3. Indoor fan speed control

When the thermostat turns OFF, the indoor fan operates very Low to reduce power consumption.

When the room temperature rises and the thermostat is ON, the indoor fan operates according to the settings on the remote controller.

b. DRY (☀️) OPERATION

- Press OFF/ON (stop/operate) button.
OPERATION INDICATOR lamp of the indoor unit turns on with a beep tone.
- Select DRY mode with Operation select button.
- The set temperature is determined from the initial room temperature.

1. Coil frost prevention

Coil frost prevention works the same way as that in COOL mode. (a.1.)

2. Low outside temperature operation

Low outside temperature operation works the same way as that in COOL mode. (a.2.)

3. Indoor fan speed control

Indoor fan speed control works the same way as that in COOL mode. (a.3.)

c. FAN (🌀) OPERATION

- OPERATION INDICATOR lamp of the indoor unit turns on with a beep tone.
- Select FAN mode with Operation select button.
- Select the desired fan speed. When AUTO, it becomes Low.
Only indoor fan operates.
Outdoor unit does not operate.

d. HEAT (☀) OPERATION

(1) Press OFF/ON (stop/operate) button.

OPERATION INDICATOR lamp of the indoor unit turns on with a beep tone.

(2) Select HEAT mode with Operation select button.

(3) Press Temperature buttons TEMP \ominus or \oplus button to select the desired temperature. The setting range is 10 - 31°C.

1. Cold air prevention control

When the compressor is not operating or is starting, and the temperature of indoor heat exchanger and/or the room temperature is low or when defrosting is being done, the indoor fan will stop or rotate in Very Low speed.

2. High pressure protection

The compressor operational frequency is controlled by the temperature of the indoor heat exchanger to prevent the condensing pressure from increasing excessively.

When the temperature of indoor heat exchanger becomes too high, the high pressure protection works.

The indoor fan operates following the cold air prevention control. This mode continues until the temperature of indoor heat exchanger falls.

3. Defrosting

Defrosting starts when the temperature of outdoor heat exchanger becomes too low.

The compressor stops once, the indoor/outdoor fans stop, the 4-way valve reverses, and the compressor re-starts.

This mode continues until the temperature of outdoor heat exchanger rises or the fixed time passes.

e. AUTO CHANGE OVER ... AUTO MODE OPERATION

Once desired temperature is set, unit operation is switched automatically between COOL and HEAT operation.

Mode selection

(1) Initial mode

When unit starts the operation with AUTO operation from OFF:

- If the room temperature is higher than the set temperature, operation starts in COOL mode.
- If the room temperature is equal to or lower than the set temperature, operation starts in HEAT mode.

(2) Mode change

COOL mode changes to HEAT mode when about 15 minutes have passed with the room temperature 1°C below the set temperature.

HEAT mode changes to COOL mode when about 15 minutes have passed with the room temperature 1°C above the set temperature.

NOTE 1:

If 2 or more indoor units are operating in multi system, there might be a case that the indoor unit, which is operating in \square (AUTO), cannot change over to the other operating mode (COOL \leftrightarrow HEAT) and becomes a state of standby.

Refer to **NOTE 2 "FOR MULTI SYSTEM AIR CONDITIONER"**.

NOTE 2**FOR MULTI SYSTEM AIR CONDITIONER****OUTDOOR UNIT: MXZ series**

Multi system air conditioner can connect 2 or more indoor units with 1 outdoor unit.

- When you try to operate 2 or more indoor units with 1 outdoor unit simultaneously, one for the cooling and the others for heating, the operation mode of the indoor unit that operates first is selected. Other indoor units cannot operate, and operation indicator lamp blinks as shown in the figure below. In this case, please set all the indoor units to the same operation mode.

OPERATION INDICATOR

- Lit
- Blinking
- Not lit

- When indoor unit starts the operation during defrosting of outdoor unit, it takes a few minutes (max. 10 minutes) to blow out warm air.
- In the heating operation, though indoor unit is not operating, it may get warm or the sound of refrigerant flow may be heard. It is not malfunction. The reason is that the refrigerant continuously flows into it.

f. AUTO VANE OPERATION

1. Horizontal vane

(1) Vane motor drive

These models are equipped with a stepping motor for the horizontal vane. The rotating direction, speed, and angle of the motor are controlled by pulse signals (approximately 12 V) transmitted from indoor microprocessor.

(2) The horizontal vane angle and mode change as follows by pressing VANE control button.



(3) Positioning

To confirm the standard position, the vane moves until it touches the vane stopper. Then the vane is set to the selected angle.

Confirmation of standard position is performed in the following cases:

- When the operation starts or finishes (including timer operation).
- When the test run starts.
- When standby mode (only during multi system operation) starts or finishes.

(4) VANE AUTO (⊙) mode

In VANE AUTO mode, the microprocessor automatically determines the vane angle to make the optimum room temperature distribution.

In COOL and DRY operation

Vane angle is fixed to Horizontal position.



In HEAT operation

Vane angle is fixed to Downward position.

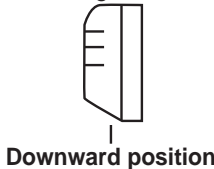

(5) STOP (operation OFF) and ON TIMER standby

In the following cases, the horizontal vane returns to the closed position.

- When OFF/ON (stop/operate) button is pressed (POWER OFF).
- When the operation is stopped by the emergency operation.
- When ON TIMER is ON standby.

(6) Dew prevention

If the lower position is selected during COOL/DRY, the vane automatically moves to the upward position after 0.5 to 1 hour to prevent any condensation from dripping.

(7) SWING (🌀) mode

By selecting SWING mode with VANE control button, the horizontal vane swings vertically.

(8) ECONO COOL (🌀) operation (ECONOMICAL operation)

When ECONO COOL button is pressed in COOL mode, set temperature and the air flow direction is automatically changed by the microprocessor. However, the temperature on the LCD screen on the remote controller is not changed. Also the horizontal vane swings in various cycle.

SWING operation makes you feel cooler than set temperature. So, even though the set temperature is higher, the air conditioner can keep comfort. As a result, energy can be saved.

To cancel this operation, select a different mode or press one of the following buttons in ECONO COOL operation:

ECONO COOL, VANE control or POWERFUL button.

(9) POWERFUL (🌀) operation

The air conditioner automatically adjusts the fan speed and the set temperature, and operates the POWERFUL mode.

The POWERFUL mode is cancelled automatically 15 minutes after operation starts, or when POWERFUL button is pressed once again within 15 minutes after operation starts. The operation mode returns to the mode prior to POWERFUL operation. To cancel this operation manually, select a different mode or press one of the following buttons within 15 minutes after operation starts: OFF/ON (stop/operate), ECONO COOL, FAN speed control, CIRCULATOR, or i-save button.

2. Vertical vane

(1) Vane motor drive

These models are equipped with a stepping motor for the vertical vane. The rotating direction, speed, and angle of the motor are controlled by pulse signals (approximately 12 V) transmitted from microprocessor.

(2) The vertical vane angle and mode change as follows by pressing WIDE VANE button.

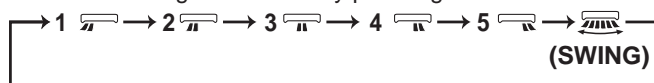

(3) Positioning

To confirm the standard position, the vane moves until it touches the vane stopper. Then the vane is set to the selected angle.

Confirmation of standard position is performed in the following cases:

(a) OFF/ON (stop/operate) button is pressed (POWER ON).

(4) SWING (SWING) MODE

By selecting SWING mode with WIDE VANE button, the vertical vane swings horizontally. The remote controller displays "SWING". Swing mode is cancelled when WIDE VANE button is pressed once again.

g. TIMER OPERATION

1. How to set the time

(1) Check that the current time is set correctly.

NOTE: Timer operation will not work without setting the current time. Initially "0:00" blinks at the current time display of TIME MONITOR, so set the current time correctly with CLOCK button.

How to set the current time

(a) Press the CLOCK button.

(b) Press the TIME SET buttons (▲ and ▼) to set the current time.

- Each time forward button (▲) is pressed, the set time increases by 1 minute, and each time backward button (▼) is pressed, the set time decreases by 1 minute.
- Pressing those buttons longer, the set time increases/decreases by 10 minutes.

(c) Press the CLOCK set button.

(2) Press OFF/ON (stop/operate) button to start the air conditioner.

(3) Set the time of timer.

ON timer setting

(a) Press ON TIMER button (ⓄON) during operation.

(b) Set the time of the timer using TIME SET buttons (▲ and ▼).*

OFF timer setting

(a) Press OFF TIMER button (ⓄOFF) during operation.

(b) Set the time of the timer using TIME SET buttons (▲ and ▼).*

* Each time forward button (▲) is pressed, the set time increases by 10 minutes: each time backward button (▼) is pressed, the set time decreases by 10 minutes.

2. To release the timer

To release ON timer, press ON TIMER button (ⓄON).

To release OFF timer, press OFF TIMER button (ⓄOFF).

TIMER is cancelled and the display of set time disappears.

PROGRAM TIMER

- OFF timer and ON timer can be used in combination. The set time that is reached first will operate first.
- “→” and “←” display shows the order of OFF timer and ON timer operation.

(Example 1) The current time is 8:00 PM.
The unit turns off at 11:00 PM, and on at 6:00 AM.

(Example 2) The current time is 11:00 AM.
The unit turns on at 5:00 PM, and off at 9:00 PM.

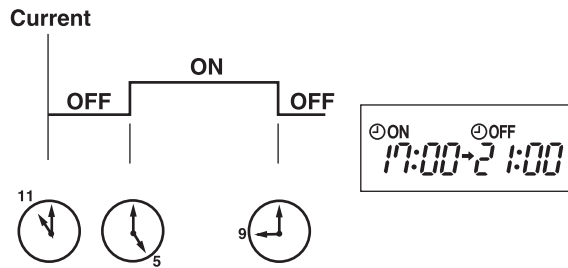
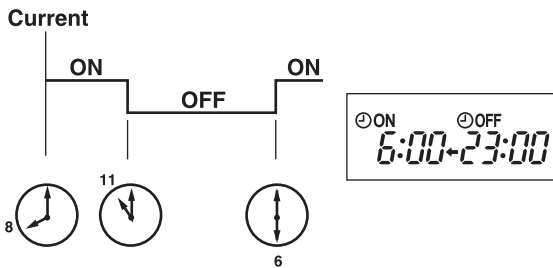

NOTE: If the main power is turned OFF or a power failure occurs while ON/OFF timer is active, the timer setting is cancelled. As these models are equipped with an auto restart function, the air conditioner starts operating with timer cancelled when power is restored.

h. WEEKLY TIMER OPERATION

- A maximum of 4 ON or OFF timers can be set for individual days of the week.
- A maximum of 28 ON or OFF timers can be set for a week.

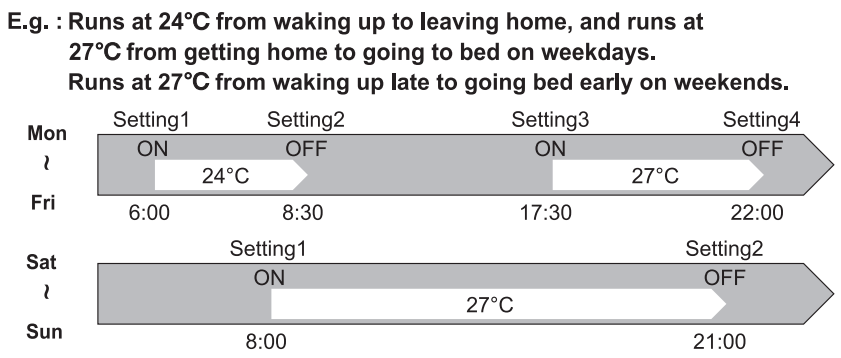

NOTE:

- The simple ON/OFF timer setting is available while the weekly timer is on. In this case, the ON/OFF timer has priority over the weekly timer; the weekly timer operation will start again after the simple ON/OFF timer is complete.

1. How to set the weekly timer

* Make sure that the current time and day are set correctly.

(1) Press **EDIT/SEND SET** button to enter the weekly timer setting mode.

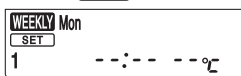

* **SET** blinks.

(2) Press **DAY** and **1~4** buttons to select setting day and number.

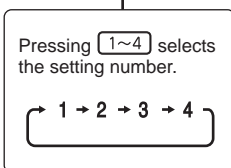
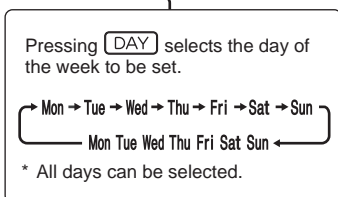
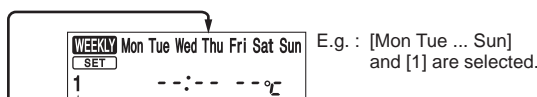

(3) Press , , and buttons to set ON/OFF, time, and temperature.

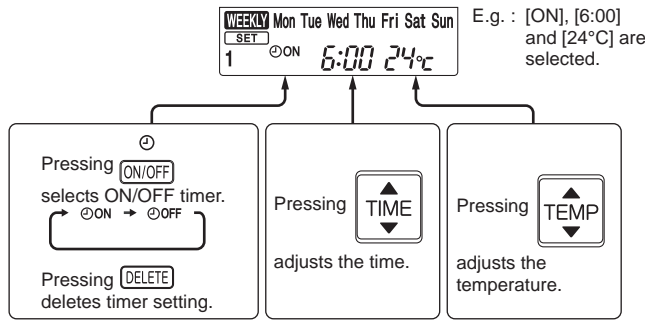

- * Hold down the button to change the time quickly.
- * The temperature can be set between 16°C and 31°C at COOL operation.
- * The temperature can be set between 10°C and 31°C at HEAT operation.

Press and to continue setting the timer for other days and/or numbers.

(4) Press button to complete and transmit the weekly timer setting.



NOTE:

- Press button to transmit the setting information of weekly timer to the indoor unit. Point the remote controller toward the indoor unit for 3 seconds.
- When setting the timer for more than one day of the week or one number, button does not have to be pressed per each setting. Press button once after all the settings are completed. All the weekly timer settings will be saved.
- Press button to enter the weekly timer setting mode, and press and hold button for 5 seconds to erase all weekly timer settings. Point the remote controller toward the indoor unit.

(5) Press button to turn the weekly timer ON. (**WEEKLY** lights.)

- When the weekly timer is ON, the day of the week whose timer setting is completed, will light.

Press button again to turn the weekly timer OFF. (**WEEKLY** goes out.)

NOTE:

The saved settings will not be cleared when the weekly timer is turned OFF.

2. Checking weekly timer setting

(1) Press button to enter the weekly timer setting mode.

* blinks.

(2) Press or buttons to view the setting of the particular day or number.

(3) Press button to exit the weekly timer setting.

NOTE:

When all days of the week are selected to view the settings and a different setting is included among them, --:-- °C will be displayed.

i. NIGHT MODE (🌙) OPERATION

NIGHT MODE changes the brightness of the operation indicator, disables the beep sound and limits the noise level of the outdoor unit.

(1) Press NIGHT MODE button during operation to activate NIGHT mode (🌙).

- The operation indicator lamp dims.
- The beep sound will be disabled except that emitted when the operation is started or stopped.
- Noise level of the outdoor unit will be lower than that mentioned in SPECIFICATIONS. (Except the connection to MXZ.)

(2) Press NIGHT MODE button to cancel NIGHT mode (🌙).

NOTE:

- Noise level of the outdoor unit may not change after startup of the unit, during the protection operation, or depending on other operating conditions.
- The fan speed of the indoor unit will not change.
- The operation indicator lamp will be hard to be seen in a bright room.
- Operating POWERFUL operation during NIGHT mode will increase the noise level of the outdoor unit.
- Noise level of the outdoor unit will not decrease during Multi system operation.

j. i-save (🌙) OPERATION**1. How to set i-save operation**

- (1) Press OFF/ON (stop/operate) button.
- (2) Select COOL, CIRCULATOR, HEAT, ECONO COOL, or NIGHT mode.
- (3) Press i-save button.
- (4) Set the temperature, fan speed, and airflow direction for i-save operation.

NOTE:

- i-save operation cannot be selected during DRY, FAN or AUTO mode operation.
- The setting range of HEAT mode i-save operation is 10 - 31°C.
- 2 groups of setting can be saved. (One for COOL/ECONO COOL/CIRCULATOR, one for HEAT)

2. How to cancel operation

- Press i-save button again.
- i-save operation can also be cancelled by pressing POWERFUL button or Operation select button to change the operation mode.

The preferred setting can be saved for the next time with a single press of i-save button.

k. CIRCULATOR OPERATION

In case the indoor temperature reaches the setting temperature, the outdoor unit stops and the indoor unit starts FAN operation to circulate the indoor air.

The setting of fan speed and airflow direction can be changed.

The outdoor unit starts operation automatically when the indoor temperature drops below the setting temperature.

(1) Press CIRCULATOR button during HEAT mode to enable CIRCULATOR operation.

The unit performs FAN operation in case the indoor temperature reaches the setting temperature.

(2) Set the fan speed and airflow direction.

- The setting of fan speed and airflow direction is common for HEAT and CIRCULATOR operation.
- Ventilation starts at Low fan speed in case AUTO fan speed is selected.

(3) Press CIRCULATOR button again to cancel CIRCULATOR operation.

NOTE:

1. FAN operation may make you feel cold wind.
Reduce the FAN speed or adjust the airflow direction to avoid the wind.
2. CIRCULATOR operation doesn't work in the following situation.
 - AUTO mode (Auto change over) is selected.
 - Defrosting is being done.
 - Indoor unit is connected to multi type outdoor unit.
Although received sound is heard from the indoor unit and mark is displayed on remote controller when the button is pushed, CIRCULATOR operation will not work in multi connection.

I. EMERGENCY/TEST OPERATION

In the case of test run operation or the emergency operation, use the emergency operation switch in the right side of the indoor unit. The emergency operation is available when the remote controller is missing or has failed, or when the batteries in the remote controller are running down. The unit will start and OPERATION INDICATOR lamp will light up.

The first 30 minutes of operation is the test run operation. This operation is for servicing. The indoor fan runs at High speed and the temperature control does not work.

After 30 minutes of test run operation, the system shifts to EMERGENCY COOL/HEAT MODE with a set temperature of 24°C. The fan speed shifts to Med.

The coil frost prevention works even in the test run or the emergency operation.

In the test run or the emergency operation, the horizontal vane operates in VANE AUTO (Ⓢ) mode.

The emergency operation continues until the emergency operation switch is pressed once or twice or the unit receives any signal from the remote controller. In the latter case, normal operation will start.

NOTE: Do not press the emergency operation switch during normal operation.

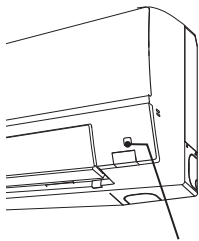

Emergency operation switch (E.O. SW)

Operation mode	COOL/HEAT
Set temperature	24°C
Fan speed	Med.
Horizontal vane	Auto

The operation mode is indicated by the Operation Indicator lamp as following

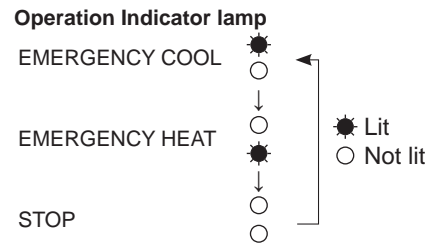

m. 3-MINUTE TIME DELAY OPERATION

When the system turns OFF, compressor will not restart for 3 minutes as 3-minute time delay function operates to protect compressor from overload.

n. ACTUATOR CONTROL

n-1. OUTDOOR FAN MOTOR CONTROL

The fan motor turns ON/OFF, interlocking with the compressor.

[ON] The fan motor turns ON 5 seconds before the compressor starts up.

[OFF] The fan motor turns OFF 15 seconds after the compressor has stopped running.

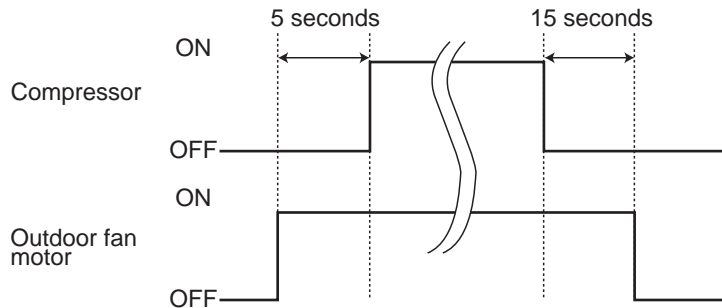

n-2. R.V. COIL CONTROL

Heating ON

Cooling OFF

Dry OFF

NOTE: The 4-way valve reverses for 5 seconds right before startup of the compressor.

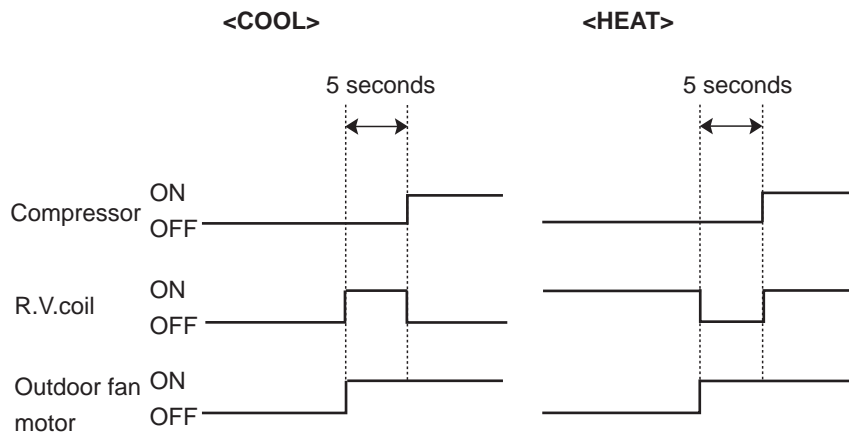

n-3. RELATION BETWEEN MAIN SENSOR AND ACTUATOR

Sensor	Purpose	Actuator					
		Compressor	LEV	Outdoor fan motor	R.V. coil	Indoor fan motor	Defrost heater
Discharge temperature thermistor	Protection	○	○				
Indoor coil temperature thermistor	Cooling: Coil frost prevention	○					
	Heating: High pressure protection	○	○				
Defrost thermistor	Heating: Defrosting	○	○	○	○	○	
Fin temperature thermistor	Protection	○		○			
Ambient temperature thermistor	Cooling: Low ambient temperature operation	○	○	○			
	Heating: Defrosting (Heater)						○
Outdoor heat exchanger temperature thermistor	Cooling: Low ambient temperature operation	○	○	○			
	Cooling: High pressure protection	○	○	○			

C.1.9.4 MSZ-AY•VG/K/KP Series

- | | | | |
|---------------------|---------------------|---------------------|---------------------|
| MSZ-AY25VG | MSZ-AY35VG | MSZ-AY42VG | MSZ-AY50VG |
| MSZ-AY25VGK | MSZ-AY35VGK | MSZ-AY42VGK | MSZ-AY50VGK |
| MSZ-AY25VGKP | MSZ-AY35VGKP | MSZ-AY42VGKP | MSZ-AY50VGKP |
| MUZ-AY25VG | MUZ-AY35VG | MUZ-AY42VG | MUZ-AY50VG |
| MUZ-AY25VGH | MUZ-AY35VGH | MUZ-AY42VGH | MUZ-AY50VGH |

WIRELESS REMOTE CONTROLLER

- | | | | |
|----------------------------|----------------------------|----------------------------|----------------------------|
| MSZ-AY25VG - [ET1] | MSZ-AY35VG - [ET1] | MSZ-AY42VG - [ET1] | MSZ-AY50VG - [ET1] |
| MSZ-AY25VGK - [E1] | MSZ-AY35VGK - [E1] | MSZ-AY42VGK - [E1] | MSZ-AY50VGK - [E1] |
| MSZ-AY25VGKP - [E1] | MSZ-AY35VGKP - [E1] | MSZ-AY42VGKP - [E1] | MSZ-AY50VGKP - [E1] |
| MUZ-AY25VG | MUZ-AY35VG | MUZ-AY42VG | MUZ-AY50VG |
| MUZ-AY25VGH | MUZ-AY35VGH | MUZ-AY42VGH | MUZ-AY50VGH |

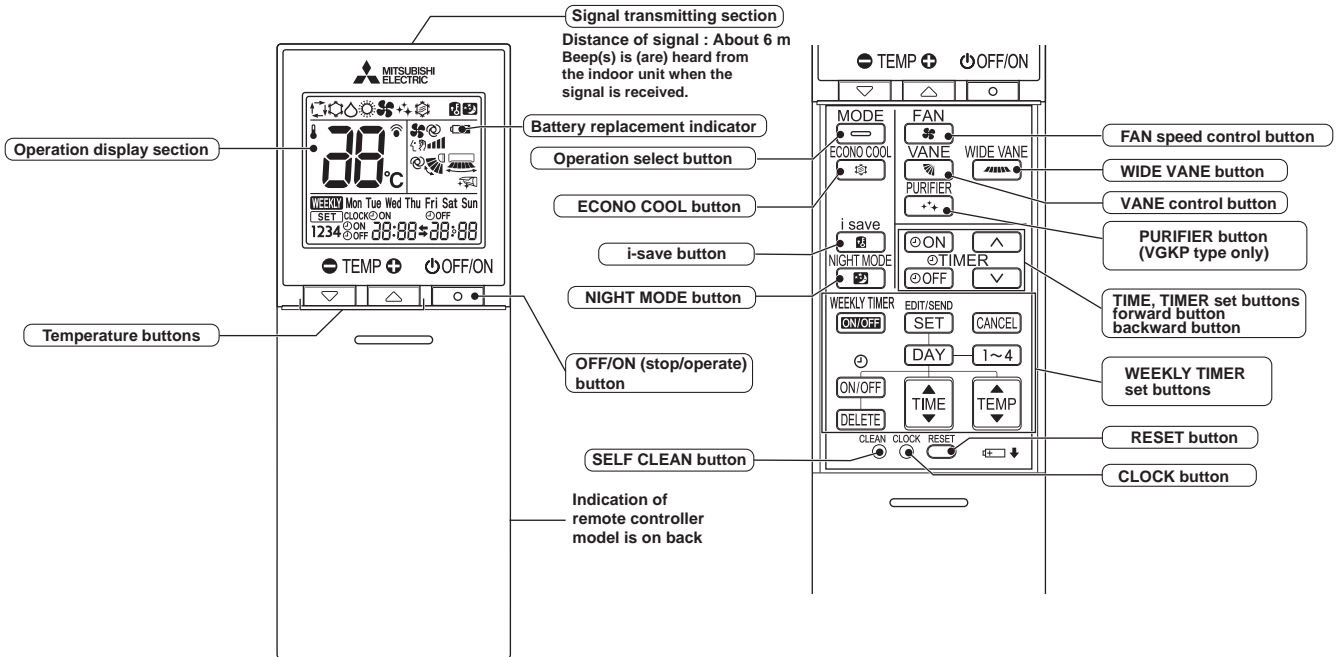

- | | | | |
|-----------------------------|-----------------------------|-----------------------------|-----------------------------|
| MSZ-AY25VGK - [SC1] | MSZ-AY35VGK - [SC1] | MSZ-AY42VGK - [SC1] | MSZ-AY50VGK - [SC1] |
| MSZ-AY25VGKP - [SC1] | MSZ-AY35VGKP - [SC1] | MSZ-AY42VGKP - [SC1] | MSZ-AY50VGKP - [SC1] |
| MUZ-AY25VG | MUZ-AY35VG | MUZ-AY42VG | MUZ-AY50VG |
| MUZ-AY25VGH | MUZ-AY35VGH | MUZ-AY42VGH | MUZ-AY50VGH |

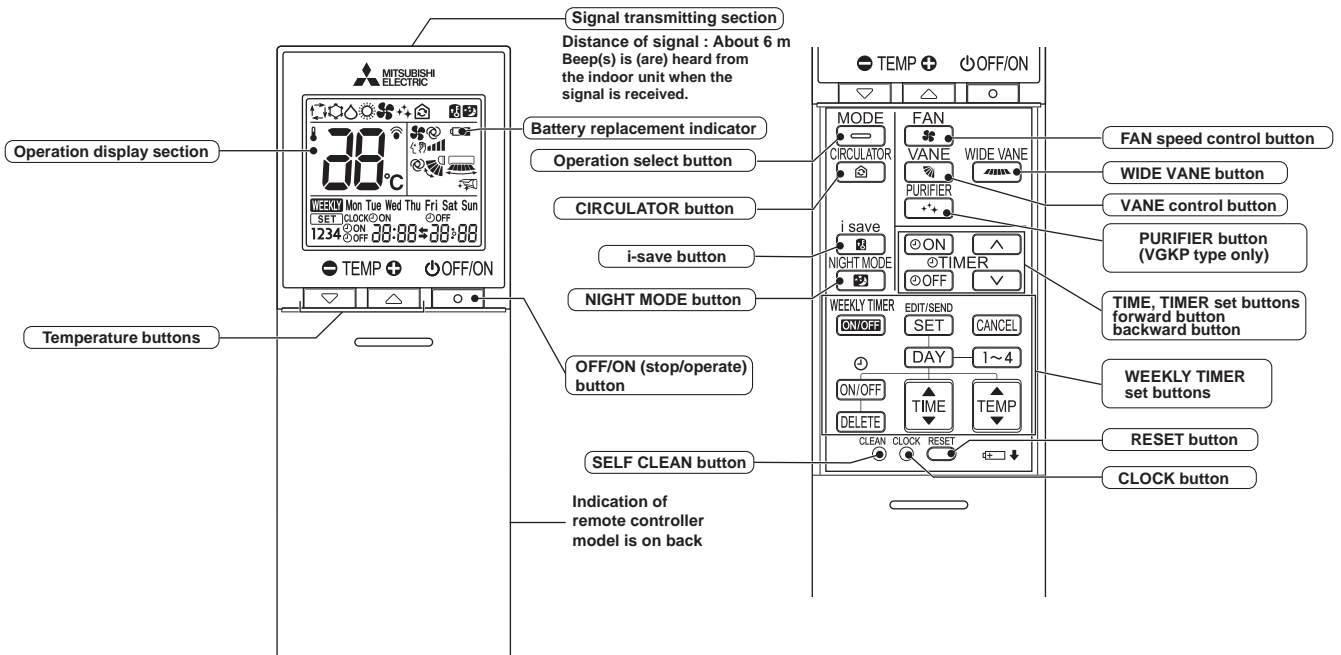





NOTE: Last setting will be stored after the unit is turned OFF with the remote controller. Indoor unit receives the signal of the remote controller with beeps.

INDOOR UNIT DISPLAY SECTION

Operation Indicator lamp



The operation indicator at the right side of the indoor unit indicates the operation state.

• The following indication applies regardless of shape of the indication.

Indication	Operation state	Room temperature
	The unit is operating to reach the set temperature (VG, VGK only)	About 2°C or more away from set temperature
	The room temperature is approaching the set temperature (VG, VGK only)	About 1 to 2°C from set temperature
	Lower lamp lights during clean operation. Refer to m. SELF CLEAN OPERATION	—
	Standby mode (Only during multi system operation)	—

-  Lit
-  Blinking
-  Not lit

a. COOL (❄️) OPERATION

- (1) Press OFF/ON (stop/operate) button.
OPERATION INDICATOR lamp of the indoor unit turns on with a beep tone.
- (2) Select COOL mode with Operation select button.
- (3) Press Temperature buttons TEMP  or  button to select the desired temperature. The setting range is 16 - 31°C.

1. Coil frost prevention

The compressor operational frequency is controlled by the temperature of the indoor heat exchanger to prevent the coil from frosting.

When the temperature of indoor heat exchanger becomes too low, the coil frost prevention mode works.

The indoor fan operates at the set speed and the compressor stops. This mode continues until the temperature of indoor heat exchanger rises.

2. Low outside temperature operation

When the outside temperature is lower, low outside temperature operation starts, and the outdoor fan slows or stops.

3. Indoor fan speed control

When the thermostat turns OFF, the indoor fan operates very Low to reduce power consumption.

When the room temperature rises and the thermostat is ON, the indoor fan operates according to the settings on the remote controller.

b. DRY (☀️) OPERATION

- (1) Press OFF/ON (stop/operate) button.
OPERATION INDICATOR lamp of the indoor unit turns on with a beep tone.
- (2) Select DRY mode with Operation select button.
- (3) The set temperature is determined from the initial room temperature.

1. Coil frost prevention

Coil frost prevention works the same way as that in COOL mode. (a.1.)

2. Low outside temperature operation

Low outside temperature operation works the same way as that in COOL mode. (a.2.)

3. Indoor fan speed control

Indoor fan speed control works the same way as that in COOL mode. (a.3.)

c. FAN (🌀) OPERATION

- (1) OPERATION INDICATOR lamp of the indoor unit turns on with a beep tone.
- (2) Select FAN mode with Operation select button.
- (3) Select the desired fan speed. When AUTO, it becomes Low.
Only indoor fan operates.
Outdoor unit does not operate.

d. HEAT (☀) OPERATION

(1) Press OFF/ON (stop/operate) button.

OPERATION INDICATOR lamp of the indoor unit turns on with a beep tone.

(2) Select HEAT mode with Operation select button.

(3) Press Temperature buttons TEMP \ominus or \oplus button to select the desired temperature. The setting range is 10 - 31°C.

1. Cold air prevention control

When the compressor is not operating or is starting, and the temperature of indoor heat exchanger and/or the room temperature is low or when defrosting is being done, the indoor fan will stop or rotate in Very Low speed.

2. High pressure protection

The compressor operational frequency is controlled by the temperature of the indoor heat exchanger to prevent the condensing pressure from increasing excessively.

When the temperature of indoor heat exchanger becomes too high, the high pressure protection works.

The indoor fan operates following the cold air prevention control. This mode continues until the temperature of indoor heat exchanger falls.

3. Defrosting

Defrosting starts when the temperature of outdoor heat exchanger becomes too low.

The compressor stops once, the indoor/outdoor fans stop, the 4-way valve reverses, and the compressor re-starts.

This mode continues until the temperature of outdoor heat exchanger rises or the fixed time passes.

e. AUTO CHANGE OVER ... AUTO MODE OPERATION

Once desired temperature is set, unit operation is switched automatically between COOL and HEAT operation.

Mode selection

(1) Initial mode

When unit starts the operation with AUTO operation from OFF:

- If the room temperature is higher than the set temperature, operation starts in COOL mode.
- If the room temperature is equal to or lower than the set temperature, operation starts in HEAT mode.

(2) Mode change

COOL mode changes to HEAT mode when about 15 minutes have passed with the room temperature 1°C below the set temperature.

HEAT mode changes to COOL mode when about 15 minutes have passed with the room temperature 1°C above the set temperature.

NOTE 1

If 2 or more indoor units are operating in multi system, there might be a case that the indoor unit, which is operating in \square (AUTO), cannot change over to the other operating mode (COOL \leftrightarrow HEAT) and becomes a state of standby.

Refer to **NOTE 2 "FOR MULTI SYSTEM AIR CONDITIONER"**.

NOTE 2**FOR MULTI SYSTEM AIR CONDITIONER****OUTDOOR UNIT: MXZ series**

Multi system air conditioner can connect 2 or more indoor units with 1 outdoor unit.

- When you try to operate 2 or more indoor units with 1 outdoor unit simultaneously, one for the cooling and the others for heating, the operation mode of the indoor unit that operates first is selected. Other indoor units cannot operate, and operation indicator lamp blinks as shown in the figure below. In this case, please set all the indoor units to the same operation mode.

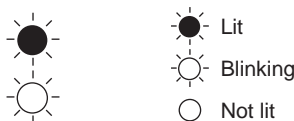
OPERATION INDICATOR

- When indoor unit starts the operation while the defrosting of outdoor unit is being done, it takes a few minutes (max. 10 minutes) to blow out the warm air.
- In the heating operation, though indoor unit is not operating, it may get warm or the sound of refrigerant flow may be heard. It is not malfunction. The reason is that the refrigerant continuously flows into it.

f. AUTO VANE OPERATION

1. Horizontal vane

(1) Vane motor drive

These models are equipped with a stepping motor for the horizontal vane. The rotating direction, speed, and angle of the motor are controlled by pulse signals (approximately 12 V) transmitted from indoor microprocessor.

(2) The horizontal vane angle and mode change as follows by pressing Up-down airflow control button.

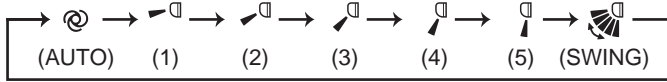

(3) Positioning

To confirm the standard position, the vane moves until it touches the vane stopper. Then the vane is set to the selected angle.

Confirming of standard position is performed in the following cases:

- When the operation starts or finishes (including timer operation).
- When the test run starts.
- When standby mode (only during multi system operation) starts or finishes.

(4) VANE AUTO (Ⓐ) mode

In VANE AUTO mode, the microprocessor automatically determines the vane angle to make the optimum room temperature distribution.

In COOL and DRY operation

Vane angle is fixed to Horizontal position.



In HEAT operation

Vane angle is fixed to Angle 4.



(5) STOP (operation OFF) and ON TIMER standby

In the following cases, the horizontal vane returns to the closed position.

- When OFF/ON (stop/operate) button is pressed (POWER OFF).
- When the operation is stopped by the emergency operation.
- When ON TIMER is ON standby.

(6) Dew prevention

During COOL or DRY operation with the vane angle at Angle 5 when the compressor cumulative operation time exceeds 1 hour, the vane angle automatically changes to Angle 4 for dew prevention.

(7) SWING (🌀) mode

By selecting SWING mode with Up-down airflow control button, the horizontal vanes swing vertically.

When COOL, DRY or FAN mode is selected, only the upper vane swings.

(8) Cold air prevention in HEAT operation

The horizontal vane position is set to upward.

NOTE: When 2 or more indoor units are operated with multi outdoor unit, even if any indoor unit turns thermostat off, this control does not work in the indoor unit.

(9) ECONO COOL (🌡️) operation (ECONOMical operation)

When ECONO COOL button is pressed in COOL mode, set temperature is automatically set 2°C higher by the microprocessor. (However, the temperature on the LCD screen on the remote controller is not changed.)

Also the horizontal vane swings in various cycle.

SWING operation makes you feel cooler than set temperature. So, even though the set temperature is higher, the air conditioner can keep comfort. As a result, energy can be saved.

To cancel this operation, select a different mode or press one of the following buttons in ECONO COOL operation: ECONO COOL, or Up-down airflow control button.

2. Vertical vane

(1) Vane motor drive

These models are equipped with a stepping motor for the vertical vane. The rotating direction, speed, and angle of the motor are controlled by pulse signals (approximately 12 V) transmitted from microprocessor.

(2) The vertical vane angle and mode change as follows by pressing Left-right airflow control button.

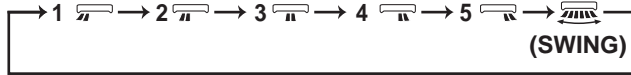

(3) Positioning

To confirm the standard position, the vane moves until it touches the vane stopper. Then the vane is set to the selected angle.

Confirmation of standard position is performed in the following cases:

(a) OFF/ON (stop/operate) button is pressed (POWER ON).

(4) SWING (SWING) MODE

By selecting SWING mode with Left-right airflow control button, the vertical vane swings horizontally. The remote controller displays "SWING". Swing mode is cancelled when Left-right airflow control button is pressed once again.

g. TIMER OPERATION

1. How to set the time

(1) Check that the current time is set correctly.

NOTE: Timer operation will not work without setting the current time. Initially "0:00" blinks at the current time display of TIME MONITOR, so set the current time correctly with CLOCK button.

How to set the current time

(a) Press the CLOCK button.

(b) Press the TIME SET buttons (▲ and ▼) to set the current time.

- Each time FORWARD button (▲) is pressed, the set time increases by 1 minute, and each time BACKWARD button (▼) is pressed, the set time decreases by 1 minute.
- Pressing those buttons longer, the set time increases/decreases by 10 minutes.

(c) Press the CLOCK button.

(2) Press OFF/ON (stop/operate) button to start the air conditioner.

(3) Set the time of timer.

ON timer setting

(a) Press ON TIMER button (ⓄON) during operation.

(b) Set the time of the timer using TIME SET buttons (▲ and ▼). *

OFF timer setting

(a) Press OFF TIMER button (ⓄOFF) during operation.

(b) Set the time of the timer using TIME SET buttons (▲ and ▼). *

* Each time FORWARD button (▲) is pressed, the set time increases by 10 minutes; each time BACKWARD button (▼) is pressed, the set time decreases by 10 minutes.

2. To release the timer

To release ON timer, press ON TIMER button (ⓄON).

To release OFF timer, press OFF TIMER button (ⓄOFF).

TIMER is cancelled and the display of set time disappears.

PROGRAM TIMER

- OFF timer and ON timer can be used in combination. The set time that is reached first will operate first.
- "←" and "→" display shows the order of OFF timer and ON timer operation.

(Example 1) The current time is 8:00 PM.

The unit turns off at 11:00 PM, and on at 6:00 AM.

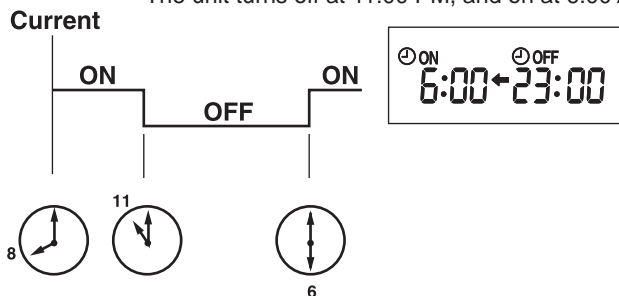

(Example 2) The current time is 11:00 AM.

The unit turns on at 5:00 PM, and off at 9:00 PM.

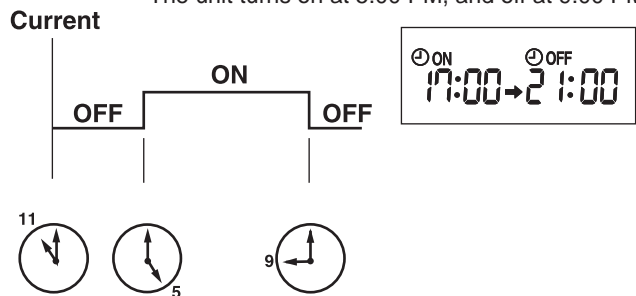

NOTE: If the main power is turned OFF or a power failure occurs while ON/OFF timer is active, the timer setting is cancelled. As these models are equipped with an auto restart function, the air conditioner starts operating with timer cancelled when power is restored.

h. WEEKLY TIMER OPERATION

- A maximum of 4 ON or OFF timers can be set for individual days of the week.
- A maximum of 28 ON or OFF timers can be set for a week.

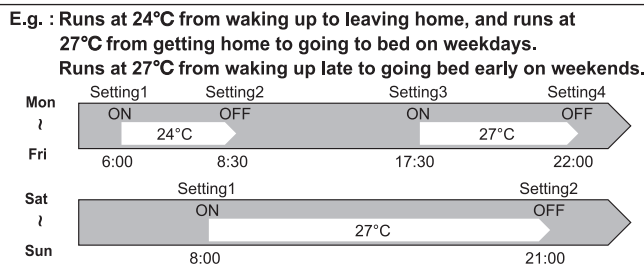

NOTE:

- The simple ON/OFF timer setting is available while the weekly timer is on. In this case, the ON/OFF timer has priority over the weekly timer; the weekly timer operation will start again after the simple ON/OFF timer is complete.

1. How to set the weekly timer

* Make sure that the current time and day are set correctly.

(1) Press **EDIT/SEND SET** button to enter the weekly timer setting mode.

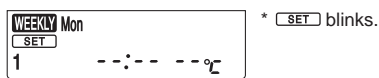

(2) Press **DAY** and **1~4** buttons to select setting day and number.

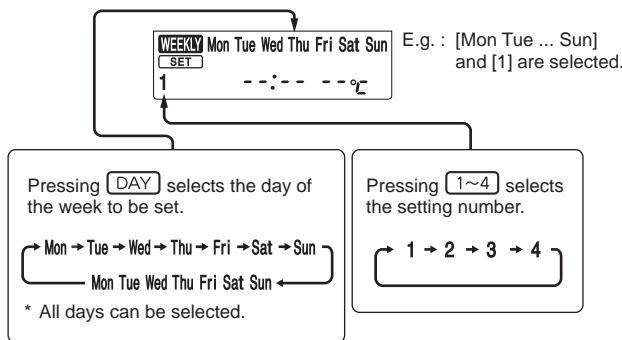

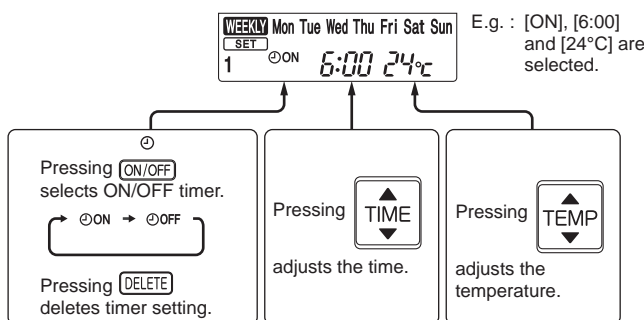

(3) Press **ON/OFF**, **TIME**, and **TEMP** buttons to set ON/OFF, time, and temperature.





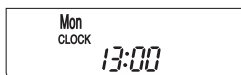

- * Hold down the button to change the time quickly.
 - * The temperature can be set between 16°C and 31°C at cool operation.
 - * The temperature can be set between 10°C and 31°C at heat operation.
- Press **DAY** and **1~4** buttons to continue setting the timer for other days and/or numbers.



- (4) Press  button to complete and transmit the weekly timer setting.





*  which was blinking goes out, and the current time will be displayed.

NOTE:

- Press  button to transmit the setting information of weekly timer to the indoor unit. Point the remote controller toward the indoor unit for 3 seconds.
- When setting the timer for more than one day of the week or one number,  button does not have to be pressed per each setting. Press  button once after all the settings are complete. All the weekly timer settings will be saved.
- Press  button to enter the weekly timer setting mode, and press and hold  button for 5 seconds to erase all weekly timer settings. Point the remote controller toward the indoor unit.

- (5) Press  button to turn the weekly timer ON. ( lights.)

- When the weekly timer is ON, the day of the week whose timer setting is complete, will light.

Press  button again to turn the weekly timer OFF. ( goes out.)



NOTE:

The saved settings will not be cleared when the weekly timer is turned OFF.

2. Checking weekly timer setting

- (1) Press  button to enter the weekly timer setting mode.

*  blinks.

- (2) Press  or  buttons to view the setting of the particular day or number.

- (3) Press  button to exit the weekly timer setting.

NOTE:

When all days of the week are selected to view the settings and a different setting is included among them,  will be displayed.

i. NIGHT MODE (🌙) OPERATION

NIGHT MODE changes the brightness of the operation indicator, disables the beep sound and limits the noise level of the outdoor unit.

- (1) Press NIGHT MODE button during operation to activate NIGHT MODE (🌙).

- The operation indicator lamp dims.
- The beep sound will be disabled except that emitted when the operation is started or stopped.
- Noise level of the outdoor unit will be lower than that mentioned in SPECIFICATIONS. (Except the connection to **MXZ**.)

- (2) Press NIGHT MODE button to cancel NIGHT MODE (🌙).

NOTE:

- Noise level of the outdoor unit may not change after startup of the unit, during the protection operation, or depending on other operating conditions.
- The fan speed of the indoor unit will not change.
- The operation indicator lamp will be hard to be seen in a bright room.
- Noise level of the outdoor unit will not decrease during Multi system operation.

j. i-save (i) OPERATION**1. How to set i-save operation**

- (1) Press OFF/ON (stop/operate) button.
- (2) Select COOL, HEAT or ECONO COOL mode.
- (3) Press i-save button.
- (4) Set the temperature, fan speed, and airflow direction for i-save operation.

NOTE:



- i-save operation cannot be selected during DRY or AUTO mode operation.
- The setting range of HEAT mode i-save operation is 10 - 31°C.
- 2 groups of setting can be saved. (One for COOL/ECONO COOL, one for HEAT)

2. How to cancel operation



- Press i-save button again.
- i-save operation can also be cancelled by pressing Operation select button to change the operation mode. The preferred setting can be saved for the next time with a single press of i-save button.

k. OPERATION LOCK

This function locks operation mode only. Other functions, such as OFF/ON, temperature setting, or airflow direction adjustment, are available.

- (1) Hold down  button and  button simultaneously for 2 seconds while the unit is not operating to enable OPERATION LOCK.

The icon for the locked operation mode blinks.

- (2) Hold down  button and  button simultaneously for 2 seconds again while the unit is not operating to disable OPERATION LOCK.

- The icon for the locked operation mode blinks when  button and  button are held down to enable or disable OPERATION LOCK or  button is pressed during operation while OPERATION LOCK is enabled.
- AIR PURIFYING operation is not available when OPERATION LOCK is enabled in a mode other than FAN mode.

l. AIR PURIFYING (✦) OPERATION (MSZ-AY-VGKP)

In the AIR PURIFYING operation, the indoor unit built-in device reduces airborne fungi, viruses, mold, and allergens.

- (1) Press PURIFIER button to start AIR PURIFYING operation.
 - AIR PURIFYING lamp turns on. (Display section)
- (2) Press PURIFIER button again to cancel AIR PURIFYING operation.
 - AIR PURIFYING lamp turns off. (Display section)

NOTE:

- Never touch the air purifying device during operation. Although the air purifying device is safety-conscious design, touching this device could be the cause of trouble as this device discharge high voltage electricity.
- A "hissing" sound may be heard during the air purifying operation. This sound is produced when plasma is being discharged. This is not a malfunction.
- AIR PURIFYING lamp does not turn on if the front panel is not closed completely.

m. SELF CLEAN (✦) OPERATION

- When SELF CLEAN operation is set, it performs for 25 minutes when unit is stopped after COOL/DRY operation. SELF CLEAN operation performs when: COOL/DRY is operated more than 3 minutes.
- The fan is stopped for the first 3 minutes. Then, the horizontal vane is set to higher than angle 1 and the fan is operated for 25 minutes.

n. EMERGENCY/TEST OPERATION

In the case of test run operation or the emergency operation, use the emergency operation switch on the right side of the indoor unit. The emergency operation is available when the remote controller is missing or has failed, or the batteries in the remote controller are running down. The unit will start and OPERATION INDICATOR lamp will light up.

The first 30 minutes of operation is the test run operation. This operation is for servicing. The indoor fan runs at High speed and the temperature control does not work.

After 30 minutes of test run operation, the system shifts to EMERGENCY COOL/HEAT MODE with a set temperature of 24°C. The fan speed shifts to Med.

The coil frost prevention works even in the test run or the emergency operation.

In the test run or the emergency operation, the horizontal vane operates in VANE AUTO (Ⓜ) mode.

The emergency operation continues until the emergency operation switch is pressed once or twice or the unit receives any signal from the remote controller. In the latter case, normal operation will start.

NOTE: Do not press the emergency operation switch during normal operation.

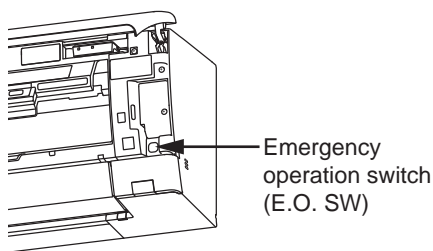

Operation mode	COOL/HEAT
Set temperature	24°C
Fan speed	Med.
Horizontal vane	Auto

The operation mode is indicated by the Operation Indicator lamp as following

Operation Indicator lamp

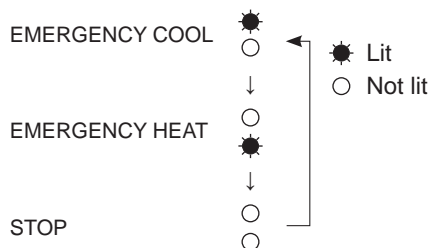

o. 3-MINUTE TIME DELAY OPERATION

When the system turns OFF, compressor will not restart for 3 minutes as 3-minute time delay function operates to protect compressor from overload.

OPERATION AND ACTUATOR CONTROL

WALL-MOUNTED

p. ACTUATOR CONTROL

p-1. OUTDOOR FAN MOTOR CONTROL

The fan motor turns ON/OFF, interlocking with the compressor.

[ON] The fan motor turns ON 5 seconds before the compressor starts up.

[OFF] The fan motor turns OFF 15 seconds after the compressor has stopped running.

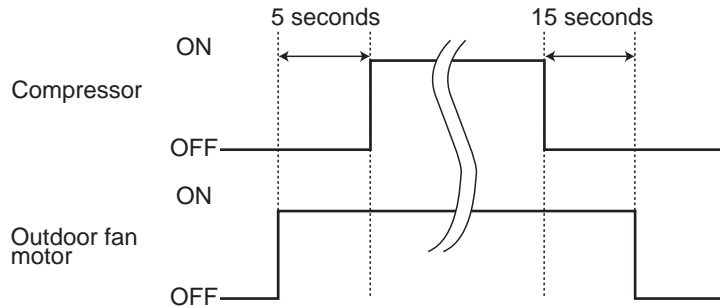

p-2. R.V. COIL CONTROL

Heating ······ ON

Cooling ······ OFF

Dry ······ OFF

NOTE: The 4-way valve reverses for 5 seconds right before startup of the compressor.

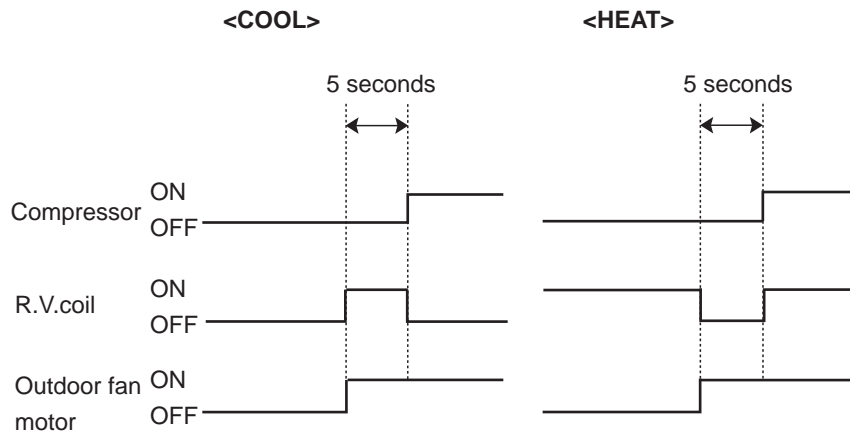

p-3. RELATION BETWEEN MAIN SENSOR AND ACTUATOR

Sensor	Purpose	Actuator					
		Compressor	LEV	Outdoor fan motor	R.V. coil	Indoor fan motor	Defrost heater
Discharge temperature thermistor	Protection	○	○				
Indoor coil temperature thermistor	Cooling: Coil frost prevention	○					
	Heating: High pressure protection	○	○				
Defrost thermistor	Heating: Defrosting	○	○	○	○	○	
Fin temperature thermistor	Protection	○		○			
Ambient temperature thermistor	Cooling: Low ambient temperature operation	○	○	○			
	Heating: Defrosting (Heater)						○
Outdoor heat exchanger temperature thermistor	Cooling: Low ambient temperature operation	○	○	○			
	Cooling: High pressure protection	○	○	○			

C.1.9.5 MSZ-AP•VG/K Series

MSZ-AP15VG MSZ-AP15VGK MSZ-AP20VG MSZ-AP20VGK
 MUZ-AP15VG MUZ-AP20VG

WIRELESS REMOTE CONTROLLER

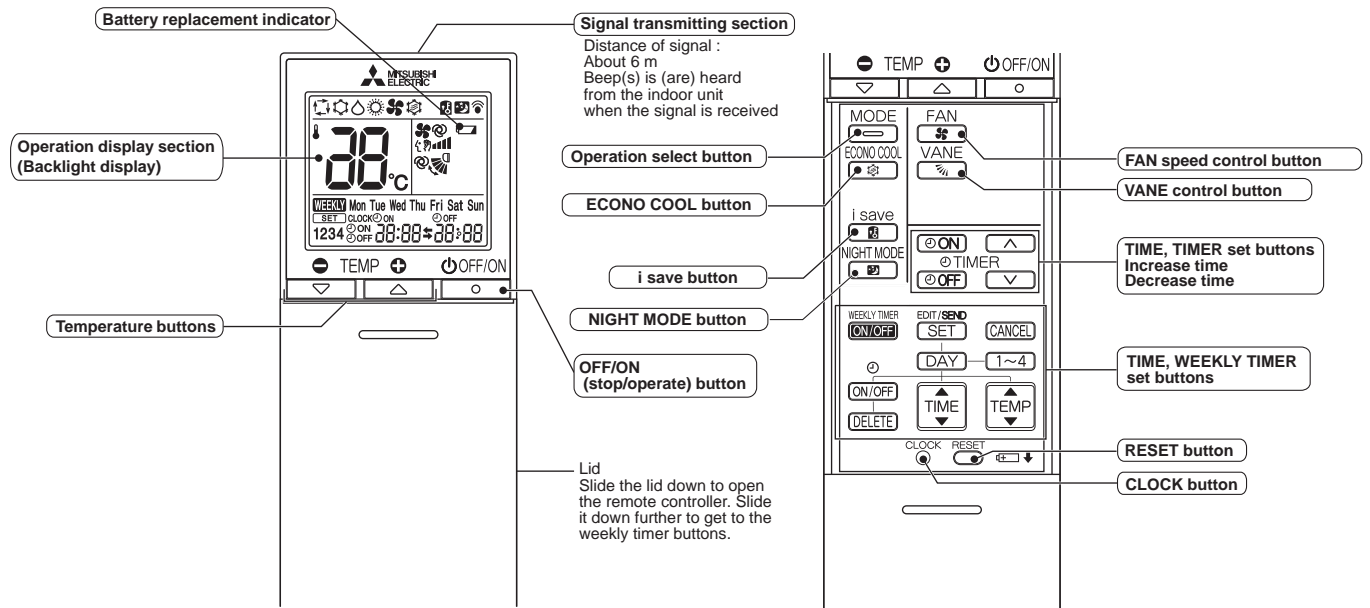

NOTE: Last setting will be stored after the unit is turned OFF with the remote controller. Indoor unit receives the signal of the remote controller with beeps.

INDOOR UNIT DISPLAY SECTION

Operation Indicator lamp

The operation indicator at the right side of the indoor unit indicates the operation state.

•The following indication applies regardless of shape of the indication.

Indication	Operation state	Room temperature
● ●	The unit is operating to reach the set temperature	About 2°C or more away from set temperature
● ○	The room temperature is approaching the set temperature	About 1 to 2°C from set temperature
● ☉	Standby mode (Only during multi system operation)	—

- Lit
- ☉ Blinking
- Not lit

a. COOL (❄️) OPERATION

- (1) Press OFF/ON(stop/operate) button.
OPERATION INDICATOR lamp of the indoor unit turns on with a beep tone.
- (2) Select COOL mode with Operation select button.
- (3) Press Temperature buttons (TEMP \ominus or \oplus button) to select the desired temperature. The setting range is 16 - 31°C.

1. Coil frost prevention

The compressor operational frequency is controlled by the temperature of the indoor heat exchanger to prevent the coil from frosting.

When the temperature of indoor heat exchanger becomes too low, the coil frost prevention mode works.

The indoor fan operates at the set speed and the compressor stops. This mode continues until the temperature of indoor heat exchanger rises.

2. Low outside temperature operation

When the outside temperature is lower, low outside temperature operation starts, and the outdoor fan slows or stops.

b. DRY (☀️) OPERATION

- (1) Press OFF/ON(stop/operate) button.
OPERATION INDICATOR lamp of the indoor unit turns on with a beep tone.
- (2) Select DRY mode with Operation select button.
- (3) The set temperature is determined from the initial room temperature.

1. Coil frost prevention

Coil frost prevention works the same way as that in COOL mode. (a.1.)

2. Low outside temperature operation

Low outside temperature operation works the same way as that in COOL mode. (a.2.)

c. FAN (🌀) OPERATION

- (1) OPERATION INDICATOR lamp of the indoor unit turns on with a beep tone.
- (2) Select FAN mode with Operation select button.
- (3) Select the desired fan speed. When AUTO, it becomes Low.
Only indoor fan operates.
Outdoor unit does not operate.

d. HEAT (🔥) OPERATION

- (1) Press OFF/ON(stop/operate) button.
OPERATION INDICATOR lamp of the indoor unit turns on with a beep tone.
- (2) Select HEAT mode with Operation select button.
- (3) Press Temperature buttons (TEMP \ominus or \oplus button) to select the desired temperature. The setting range is 10 - 31°C.

1. Cold air prevention control

When the compressor is not operating or is starting, and the temperature of indoor heat exchanger and/or the room temperature is low or when defrosting is being done, the indoor fan will stop or rotate in Very Low speed.

2. High pressure protection

The compressor operational frequency is controlled by the temperature of the indoor heat exchanger to prevent the condensing pressure from increasing excessively.

When the temperature of indoor heat exchanger becomes too high, the high pressure protection works.

The indoor fan operates following the cold air prevention control. This mode continues until the temperature of indoor heat exchanger falls.

3. Defrosting

Defrosting starts when the temperature of outdoor heat exchanger becomes too low.

The compressor stops once, the indoor/outdoor fans stop, the 4-way valve reverses, and the compressor re-starts.

This mode continues until the temperature of outdoor heat exchanger rises or the fixed time passes.

e. AUTO CHANGE OVER ... AUTO MODE OPERATION

Once desired temperature is set, unit operation is switched automatically between COOL and HEAT operation.

Mode selection

(1) Initial mode

When unit starts the operation with AUTO operation from OFF:

- If the room temperature is higher than the set temperature, operation starts in COOL mode.
- If the room temperature is equal to or lower than the set temperature, operation starts in HEAT mode.

(2) Mode change

COOL mode changes to HEAT mode when about 15 minutes has passed with the room temperature 1°C below the set temperature.

HEAT mode changes to COOL mode when about 15 minutes has passed with the room temperature 1°C above the set temperature.

NOTE 1

If 2 or more indoor units are operating in multi system, there might be a case that the indoor unit, which is operating in □ (AUTO), cannot change over to the other operating mode (COOL ↔ HEAT) and becomes a state of standby.

Refer to **NOTE 2 "FOR MULTI SYSTEM AIR CONDITIONER"**.

NOTE 2

FOR MULTI SYSTEM AIR CONDITIONER OUTDOOR UNIT: MXZ series

Multi system air conditioner can connect 2 or more indoor units with one outdoor unit.

- When you try to operate 2 or more indoor units with one outdoor unit simultaneously, one for the cooling and the others for heating, the operation mode of the indoor unit that operates first is selected. Other indoor units cannot operate, and operation indicator lamp blinks as shown in the figure below. In this case, please set all the indoor units to the same operation mode.

OPERATION INDICATOR

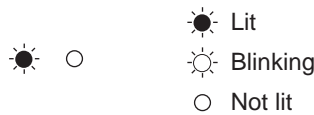

- When indoor unit starts the operation while the defrosting of outdoor unit is being done, it takes a few minutes (max. 10 minutes) to blow out the warm air.
- In HEAT operation, though indoor unit that does not operate may get warm or the sound of refrigerant flowing may be heard, they are not malfunction. The reason is that the refrigerant continuously flows into it.

f. AUTO VANE OPERATION

1. Horizontal vane

(1) Vane motor drive

These models are equipped with a stepping motor for the horizontal vane. The rotating direction, speed, and angle of the motor are controlled by pulse signals (approximately 12 V) transmitted from indoor microprocessor.

(2) The horizontal vane angle and mode change as follows by pressing VANE control button.

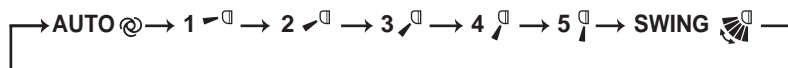

(3) Positioning

To confirm the standard position, the vane moves until it touches the vane stopper. Then the vane is set to the selected angle.

Confirming of standard position is performed in the following cases:

- (a) When the operation starts or finishes (including timer operation).
- (b) When the test run starts.
- (c) When standby mode (only during multi system operation) starts or finishes.

(4) VANE AUTO (Ⓢ) mode

In VANE AUTO mode, the microprocessor automatically determines the vane angle to make the optimum room temperature distribution.

In COOL and DRY operation
Vane angle is fixed to Horizontal position.

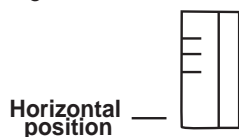

In HEAT operation
Vane angle is fixed to Angle 4.



- (5) STOP (operation OFF) and ON TIMER standby
In the following cases, the horizontal vane returns to the closed position.
- (a) When OFF/ON(stop/operate) button is pressed (POWER OFF).
 - (b) When the operation is stopped by the emergency operation.
 - (c) When ON TIMER is ON standby.
- (6) Dew prevention
During COOL or DRY operation with the vane angle at Angle 4 or 5 when the compressor cumulative operation time exceeds 1 hour, the vane angle automatically changes to Angle 1 for dew prevention.
- (7) SWING (🌀) mode
By selecting SWING mode with VANE control button, the horizontal vane swings vertically.
- (8) Cold air prevention in HEAT operation
The horizontal vane position is set to Upward.
NOTE: When 2 or more indoor units are operated with multi outdoor unit, even if any indoor unit turns thermostat off, this control does not work in the indoor unit.
- (9) ECONO COOL (🌀) operation (ECONOMical operation)
When ECONO COOL button is pressed in COOL mode, set temperature is automatically set 2°C higher by the micro-processor. However, the temperature on the LCD screen on the remote controller is not changed.
Also the horizontal vane swings in various cycle.
SWING operation makes you feel cooler than set temperature. So, even though the set temperature is higher, the air conditioner can keep comfort. As a result, energy can be saved.
To cancel this operation, select a different mode or press one of the following buttons in ECONO COOL operation:
ECONO COOL, VANE control button.

g. TIMER OPERATION

1. How to set the time

- (1) Check that the current time is set correctly.
NOTE: Timer operation will not work without setting the current time. Initially "0:00" blinks at the current time display of TIME MONITOR, so set the current time correctly with CLOCK button.

How to set the current time

- (a) Press the CLOCK button.
 - (b) Press the TIME set buttons (▲) and (▼) to set the current time.
 - Each time Increase time button (▲) is pressed, the set time increases by 1 minute, and each time Decrease time button (▼) is pressed, the set time decreases by 1 minute.
 - Pressing those buttons longer, the set time increases/decreases by 10 minutes.
 - (c) Press the CLOCK button.
- (2) Press OFF/ON(stop/operate) button to start the air conditioner.
- (3) Set the time of timer.

ON timer setting

- (a) Press ON TIMER button (ⓄON) during operation.
- (b) Set the time of the timer using TIME set buttons (▲) and (▼).*

OFF timer setting

- (a) Press OFF TIMER button (ⓄOFF) during operation.
 - (b) Set the time of the timer using TIME set buttons (▲) and (▼).*
- * Each time Increase time button (▲) is pressed, the set time increases by 10 minutes: each time Decrease time button (▼) is pressed, the set time decreases by 10 minutes.

2. To release the timer

- To release ON timer, press ON TIMER button (ⓄON).
To release OFF timer, press OFF TIMER button (ⓄOFF).
TIMER is cancelled and the display of set time disappears.

PROGRAM TIMER

- OFF timer and ON timer can be used in combination. The set time that is reached first will operate first.
- “←” and “→” display shows the order of OFF timer and ON timer operation.

(Example 1) The current time is 8:00 PM.
The unit turns off at 11:00 PM, and on at 6:00 AM.

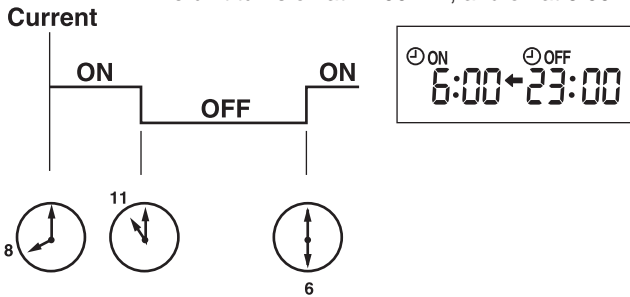

(Example 2) The current time is 11:00 AM.
The unit turns on at 5:00 PM, and off at 9:00 PM.

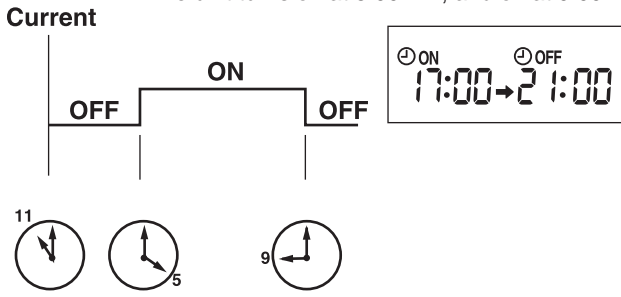

NOTE: If the main power is turned OFF or a power failure occurs while ON/OFF timer is active, the timer setting is cancelled. As these models are equipped with an auto restart function, the air conditioner starts operating with timer cancelled when power is restored.

h. WEEKLY TIMER OPERATION

- A maximum of 4 ON or OFF timers can be set for individual days of the week.
- A maximum of 28 ON or OFF timers can be set for a week.

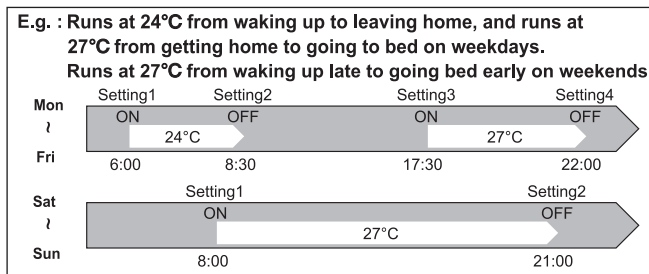

NOTE:

- The simple ON/OFF timer setting is available while the weekly timer is on. In this case, the ON/OFF timer has priority over the weekly timer; the weekly timer operation will start again after the simple ON/OFF timer is complete.
- When the weekly timer is set, temperature cannot be set to 10°C.
- The weekly timer operation and i-save operation cannot be used together.

1. How to set the weekly timer

* Make sure that the current time and day are set correctly.

(1) Press **EDIT/SEND** **SET** button to enter the weekly timer setting mode.

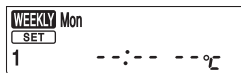

* **SET** blinks.

(2) Press **DAY** and **1~4** buttons to select setting day and number.

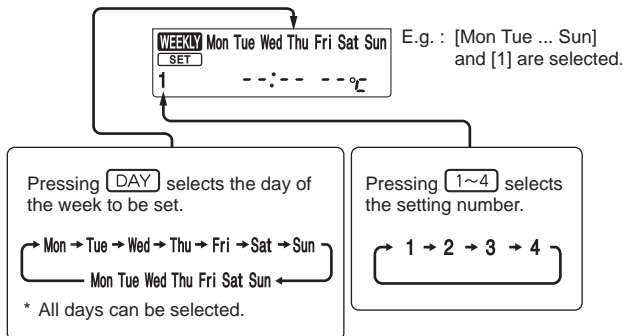

(3) Press , , and buttons to set ON/OFF, time, and temperature.

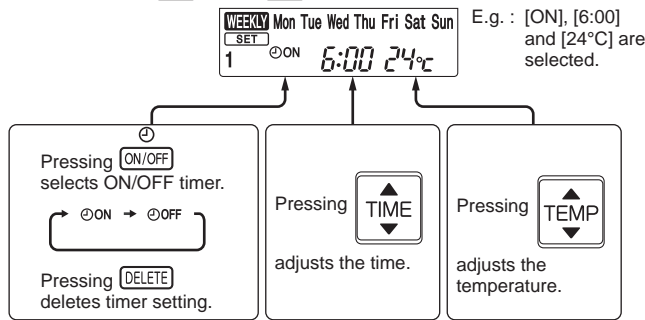

* Hold down the button to change the time quickly.

Press and buttons to continue setting the timer for other days and/or numbers.

(4) Press button to complete and transmit the weekly timer setting.



NOTE:

- Press button to transmit the setting information of weekly timer to the indoor unit. Point the remote controller toward the indoor unit for 3 seconds.
- When setting the timer for more than one day of the week or one number, button does not have to be pressed per each setting. Press button once after all the settings are complete. All the weekly timer settings will be saved.
- Press button to enter the weekly timer setting mode, and press and hold for 5 seconds to erase all weekly timer settings. Point the remote controller toward the indoor unit.

(5) Press button to turn the weekly timer ON. (lights.)

• When the weekly timer is ON, the day of the week whose timer setting is complete, will light.

Press button again to turn the weekly timer OFF. (goes out.)

NOTE:

The saved settings will not be cleared when the weekly timer is turned OFF.

2. Checking weekly timer setting

(1) Press button to enter the weekly timer setting mode.

* blinks.

(2) Press or buttons to view the setting of the particular day or number.

(3) Press button to exit the weekly timer setting.

NOTE:

When all days of the week are selected to view the settings and a different setting is included among them, --:-- °C will be displayed.

i. NIGHT MODE (🌙) OPERATION

NIGHT MODE changes the brightness of the operation indicator, disables the beep sound and limits the noise level of the outdoor unit.

(1) Press NIGHT MODE button during operation to activate NIGHT MODE (🌙).

- The operation indicator lamp dims.
- The beep sound will be disabled except that emitted when the operation is started or stopped.
- Noise level of the outdoor unit will be lower than that mentioned in SPECIFICATIONS.(Except the connection to MXZ.)

(2) Press NIGHT MODE button to cancel NIGHT MODE (🌙).

NOTE:

- The cooling / heating capacity may drop.
- Noise level of the outdoor unit may not change after startup of the unit, during the protection operation, or depending on other operating conditions.
- The fan speed of the indoor unit will not change.
- The operation indicator lamp will be hard to be seen in a bright room.
- Noise level of the outdoor unit will not decrease during Multi system operation.
- Operating POWERFUL operation during NIGHT MODE operation will increase the noise level of the outdoor unit.
- Noise level of the outdoor unit will not decrease during Multi system operation.

j. i-save (i) OPERATION

1. How to set i-save operation

- (1) Press OFF/ON(stop/operate) button.
- (2) Select COOL, HEAT, ECONO COOL or NIGHT MODE.
- (3) Press i-save button.
- (4) Set the temperature, fan speed, and airflow direction for i-save operation.

NOTE:

- i-save operation cannot be selected during DRY or AUTO mode operation.
- The setting range of HEAT mode i-save operation is 10°C and 16 - 31°C.
- 2 groups of setting can be saved. (One for COOL/ECONO COOL, one for HEAT)
- i-save operation and the weekly timer operation cannot be used together.

2. How to cancel operation

- Press i-save button again.
- i-save operation can also be cancelled by pressing Operation select button to change the operation mode. The preferred setting can be saved for the next time with a single press of i-save button.

k. EMERGENCY/TEST OPERATION

In the case of test run operation or emergency operation, use the emergency operation switch on the right side of the indoor unit. Emergency operation is available when the remote controller is missing or has failed, or when the batteries in the remote controller are running down. The unit will start and OPERATION INDICATOR lamp will light up. The first 30 minutes of operation is the test run operation. This operation is for servicing. The indoor fan runs at High speed and the temperature control does not work. After 30 minutes of test run operation, the system shifts to EMERGENCY COOL/HEAT MODE with a set temperature of 24°C. The fan speed shifts to Med. The coil frost prevention works even in the test run or the emergency operation. In the test run or emergency operation, the horizontal vane operates in VANE AUTO (Ⓢ) mode. Emergency operation continues until the emergency operation switch is pressed once or twice or the unit receives any signal from the remote controller. In the latter case, normal operation will start.

Operation mode	COOL/HEAT
Set temperature	24°C
Fan speed	Medium
Horizontal vane	Auto

The operation mode is indicated by the Operation Indicator lamp as following

Operation Indicator lamp

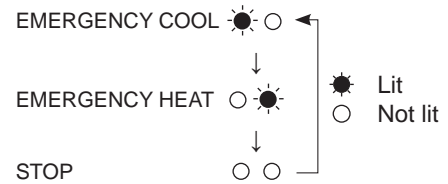

NOTE: Do not press the emergency operation switch during normal operation.

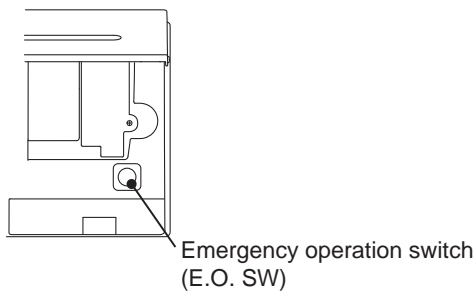

l. 3-MINUTE TIME DELAY OPERATION

When the system turns OFF, compressor will not restart for 3 minutes as 3-minute time delay function operates to protect compressor from overload.

m. ACTUATOR CONTROL

m-1. OUTDOOR FAN MOTOR CONTROL

The fan motor turns ON/OFF, interlocking with the compressor.

[ON] The fan motor turns ON 5 seconds before the compressor starts up.

[OFF] The fan motor turns OFF 15 seconds after the compressor has stopped running.

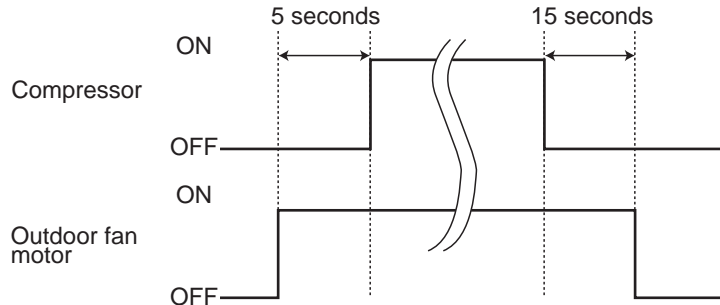

m-2. R.V. COIL CONTROL

Heating ON

Cooling OFF

Dry OFF

NOTE: The 4-way valve reverses for 5 seconds right before startup of the compressor.

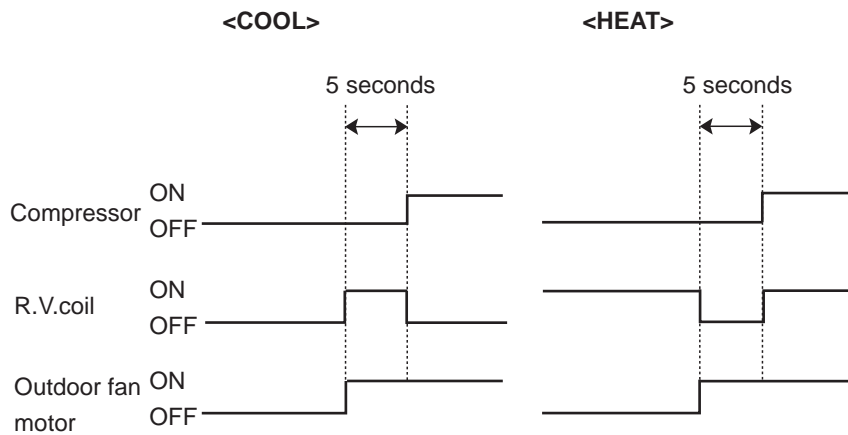

m-3. RELATION BETWEEN MAIN SENSOR AND ACTUATOR

Sensor	Purpose	Actuator				
		Compressor	LEV	Outdoor fan motor	R.V. coil	Indoor fan motor
Discharge temperature thermistor	Protection	○	○			
Indoor coil temperature thermistor	Cooling: Coil frost prevention	○				
	Heating: High pressure protection	○	○			
Defrost thermistor	Heating: Defrosting	○	○	○	○	○
Fin temperature thermistor	Protection	○		○		
Ambient temperature thermistor	Cooling: Low ambient temperature operation	○	○	○		
Outdoor heat exchanger temperature thermistor	Cooling: Low ambient temperature operation	○	○	○		
	Cooling: High pressure protection	○	○	○		

MSZ-AP60VG MSZ-AP71VG
MSZ-AP60VGK MSZ-AP71VGK
MUZ-AP60VG MUZ-AP71VG

WIRELESS REMOTE CONTROLLER

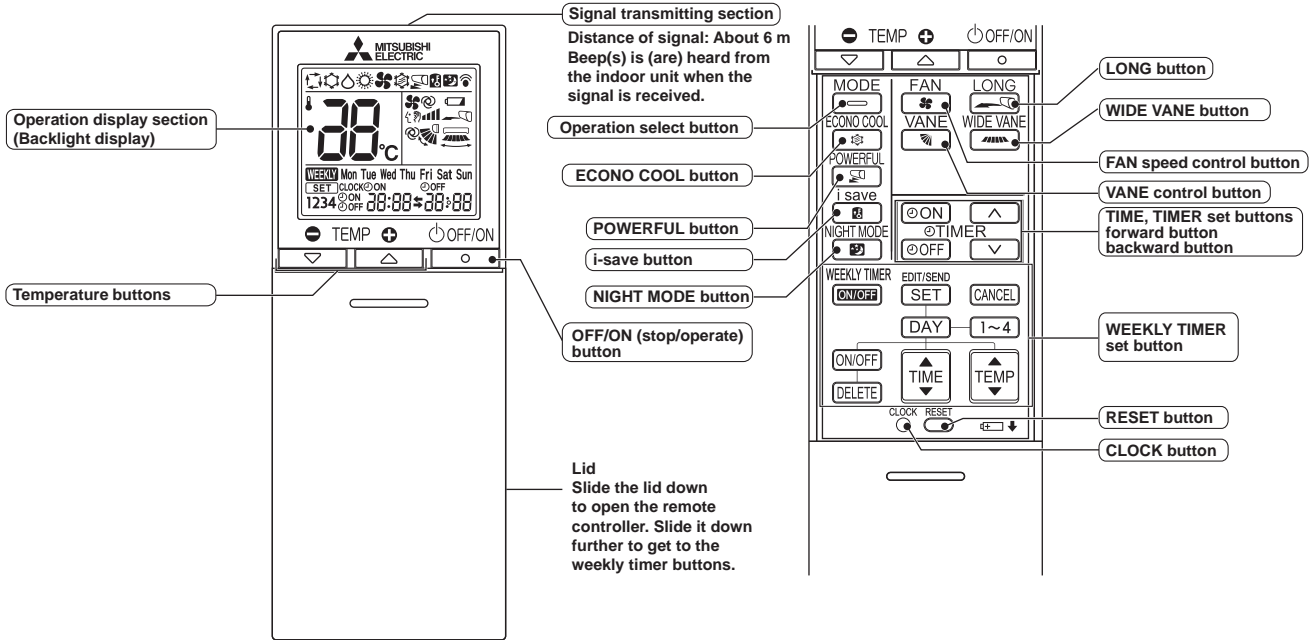

NOTE: Last setting will be stored after the unit is turned OFF with the remote controller. Indoor unit receives the signal of the remote controller with beeps.

INDOOR UNIT DISPLAY SECTION

Operation Indicator lamp

The operation indicator at the right side of the indoor unit indicates the operation state.

- The following indication applies regardless of shape of the indication.

Indication	Operation state	Room temperature
● ●	The unit is operating to reach the set temperature	About 2°C or more away from set temperature
● ○	The room temperature is approaching the set temperature	About 1 to 2°C from set temperature
● ●	Standby mode (Only during multi system operation)	—

- Lit
- Blinking
- Not lit

a. COOL (❄️) OPERATION

(1) Press OFF/ON (stop/operate) button.

OPERATION INDICATOR lamp of the indoor unit turns on with a beep tone.

(2) Select COOL mode with Operation select button.

(3) Press Temperature buttons TEMP \ominus or \oplus button to select the desired temperature. The setting range is 16 - 31°C.

1. Coil frost prevention

The compressor operational frequency is controlled by the temperature of the indoor heat exchanger to prevent the coil from frosting.

When the temperature of indoor heat exchanger becomes too low, the coil frost prevention mode works.

The indoor fan operates at the set speed and the compressor stops. This mode continues until the temperature of indoor heat exchanger rises.

2. Low outside temperature operation

When the outside temperature is lower, low outside temperature operation starts, and the outdoor fan slows or stops.

3. Indoor fan speed control

When the thermostat turns OFF, the indoor fan operates very Low to reduce power consumption.

When the room temperature rises and the thermostat is ON, the indoor fan operates according to the settings on the remote controller.

b. DRY (☀️) OPERATION

(1) Press OFF/ON (stop/operate) button.

OPERATION INDICATOR lamp of the indoor unit turns on with a beep tone.

(2) Select DRY mode with Operation select button.

(3) The set temperature is determined from the initial room temperature.

1. Coil frost prevention

Coil frost prevention works the same way as that in COOL mode. (a.1.)

2. Low outside temperature operation

Low outside temperature operation works the same way as that in COOL mode. (a.2.)

3. Indoor fan speed control

Indoor fan speed control works the same way as that in COOL mode. (a.3.)

c. FAN (🌀) OPERATION

(1) OPERATION INDICATOR lamp of the indoor unit turns on with a beep tone.

(2) Select FAN mode with Operation select button.

(3) Select the desired fan speed. When AUTO, it becomes Low.

Only indoor fan operates.

Outdoor unit does not operate.

d. HEAT (🔥) OPERATION

(1) Press OFF/ON (stop/operate) button.

OPERATION INDICATOR lamp of the indoor unit turns on with a beep tone.

(2) Select HEAT mode with Operation select button.

(3) Press Temperature buttons TEMP \ominus or \oplus button to select the desired temperature. The setting range is 10 - 31°C.

1. Cold air prevention control

When the compressor is not operating or is starting, and the temperature of indoor heat exchanger and/or the room temperature is low or when defrosting is being done, the indoor fan will stop or rotate in Very Low speed.

2. High pressure protection

The compressor operational frequency is controlled by the temperature of the indoor heat exchanger to prevent the condensing pressure from increasing excessively.

When the temperature of indoor heat exchanger becomes too high, the high pressure protection works.

The indoor fan operates following the cold air prevention control. This mode continues until the temperature of indoor heat exchanger falls.

3. Defrosting

Defrosting starts when the temperature of outdoor heat exchanger becomes too low.

The compressor stops once, the indoor/outdoor fans stop, the 4-way valve reverses, and the compressor re-starts.

This mode continues until the temperature of outdoor heat exchanger rises or the fixed time passes.

e. AUTO CHANGE OVER ... AUTO MODE OPERATION

Once desired temperature is set, unit operation is switched automatically between COOL and HEAT operation.

Mode selection**(1) Initial mode**

When unit starts the operation with AUTO operation from OFF:

- If the room temperature is higher than the set temperature, operation starts in COOL mode.
- If the room temperature is equal to or lower than the set temperature, operation starts in HEAT mode.

(2) Mode change

COOL mode changes to HEAT mode when about 15 minutes have passed with the room temperature 1°C below the set temperature.

HEAT mode changes to COOL mode when about 15 minutes have passed with the room temperature 1°C above the set temperature.

NOTE 1

If 2 or more indoor units are operating in multi system, there might be a case that the indoor unit, which is operating in □ (AUTO), cannot change over to the other operating mode (COOL ↔ HEAT) and becomes a state of standby.

Refer to **NOTE 2 "FOR MULTI SYSTEM AIR CONDITIONER"**.

NOTE 2**FOR MULTI SYSTEM AIR CONDITIONER OUTDOOR UNIT: MXZ series**

Multi system air conditioner can connect 2 or more indoor units with 1 outdoor unit.

- When you try to operate 2 or more indoor units with 1 outdoor unit simultaneously, one for the cooling and the others for heating, the operation mode of the indoor unit that operates first is selected. Other indoor units cannot operate, and operation indicator lamp blinks as shown in the figure below. In this case, please set all the indoor units to the same operation mode.

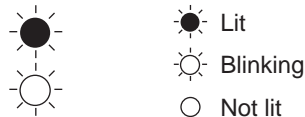
OPERATION INDICATOR

- When indoor unit starts the operation during defrosting of outdoor unit, it takes a few minutes (max. 10 minutes) to blow out warm air.
- In the heating operation, though indoor unit is not operating, it may get warm or the sound of refrigerant flow may be heard. It is not malfunction. The reason is that the refrigerant continuously flows into it.

f. AUTO VANE OPERATION

1. Horizontal vane

(1) Vane motor drive

These models are equipped with a stepping motor for the horizontal vane. The rotating direction, speed, and angle of the motor are controlled by pulse signals (approximately 12 V) transmitted from indoor microprocessor.

(2) The horizontal vane angle and mode change as follows by pressing VANE control button.

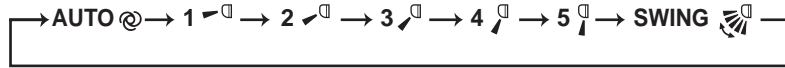

(3) Positioning

To confirm the standard position, the vane moves until it touches the vane stopper. Then the vane is set to the selected angle.

Confirming of standard position is performed in the following cases:

- When the operation starts or finishes (including timer operation).
- When the test run starts.
- When standby mode (only during multi system operation) starts or finishes.

(4) VANE AUTO (Ⓐ) mode

In VANE AUTO mode, the microprocessor automatically determines the vane angle to make the optimum room temperature distribution.

In COOL and DRY operation

Vane angle is fixed to Horizontal position.



In HEAT operation

Vane angle is fixed to Angle 4.



(5) STOP (operation OFF) and ON TIMER standby

In the following cases, the horizontal vane returns to the closed position.

- When OFF/ON (stop/operate) button is pressed (POWER OFF).
- When the operation is stopped by the emergency operation.
- When ON TIMER is ON standby.

(6) Dew prevention

During COOL or DRY operation with the vane angle at Angle 4 or 5 when the compressor cumulative operation time exceeds 1 hour, the vane angle automatically changes to Angle 3 for dew prevention.

(7) SWING (🌀) mode

By selecting SWING mode with VANE control button, the horizontal vanes swing vertically.

When COOL, DRY or FAN mode is selected, only the upper vane swings.

(8) Cold air prevention in HEAT operation

The horizontal vane position is set to upward.

NOTE: When 2 or more indoor units are operated with multi outdoor unit, even if any indoor unit turns thermostat off, this control does not work in the indoor unit.

(9) ECONO COOL (🌡️) operation (ECONOMICAL operation)

When ECONO COOL button is pressed in COOL mode, set temperature is automatically set 2°C higher by the microprocessor. However, the temperature on the LCD screen on the remote controller is not changed. Also the horizontal vane swings in various cycle.

SWING operation makes you feel cooler than set temperature. So, even though the set temperature is higher, the air conditioner can keep comfort. As a result, energy can be saved.

To cancel this operation, select a different mode or press one of the following buttons in ECONO COOL operation:



ECONO COOL, VANE control, LONG or POWERFUL button.

(10) POWERFUL (🔥) operation

The air conditioner automatically adjusts the fan speed and the set temperature, and operates the POWERFUL mode.

The POWERFUL mode is cancelled automatically 15 minutes after operation starts, or when POWERFUL button is pressed once again within 15 minutes after operation starts. The operation mode returns to the mode prior to POWERFUL operation. POWERFUL mode also is cancelled, when the OFF/ON (stop/operate), ECONO COOL, FAN speed control or i-save button is pressed within 15 minutes after operation starts, or operation mode is changed.

(11) LONG MODE ()

By pressing LONG button indoor fan speed becomes faster than setting fan speed on the remote controller, and the horizontal vane moves to the position for LONG mode. The remote controller displays “  ”. LONG mode is cancelled when OFF/ON (stop/operate), LONG, VANE control or ECONO COOL button is pressed. In the following example, the vertical vane is set to  (front.).

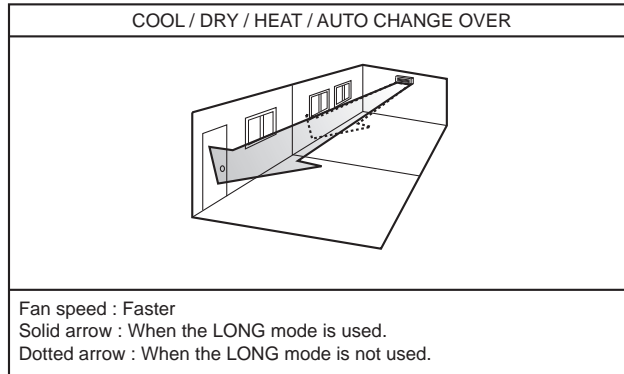

2. Vertical vane

(1) Vane motor drive

These models are equipped with a stepping motor for the vertical vane. The rotating direction, speed, and angle of the motor are controlled by pulse signals (approximately 12 V) transmitted from microprocessor.

(2) The vertical vane angle and mode change as follows by pressing WIDE VANE button.

(3) Positioning



To confirm the standard position, the vane moves until it touches the vane stopper. Then the vane is set to the selected angle.

Confirmation of standard position is performed in the following cases:

- (a) OFF/ON (stop/operate) button is pressed (POWER ON).

(4) SWING () MODE

By selecting SWING mode with WIDE VANE button, the vertical vane swings horizontally. The remote controller displays “  ”. Swing mode is cancelled when WIDE VANE button is pressed once again.





g. TIMER OPERATION

1. How to set the time



(1) Check that the current time is set correctly.

NOTE: Timer operation will not work without setting the current time. Initially “0:00” blinks at the current time display of TIME MONITOR, so set the current time correctly with CLOCK button.

How to set the current time



- (a) Press the CLOCK button.
 - (b) Press the TIME set buttons () and () to set the current time.
 - Each time forward button () is pressed, the set time increases by 1 minute, and each time backward button () is pressed, the set time decreases by 1 minute.
 - Pressing those buttons longer, the set time increases/decreases by 10 minutes.
 - (c) Press the CLOCK button.
- (2) Press OFF/ON (stop/operate) button to start the air conditioner.
- (3) Set the time of timer.

ON timer setting



- (a) Press ON TIMER button () during operation.
- (b) Set the time of the timer using TIME set buttons () and () . *

OFF timer setting

- (a) Press OFF TIMER button () during operation.
- (b) Set the time of the timer using TIME set buttons () and () . *

* Each time forward button () is pressed, the set time increases by 10 minutes: each time backward button () is pressed, the set time decreases by 10 minutes.

2. To release the timer

To release ON timer, press ON TIMER button ().
 To release OFF timer, press OFF TIMER button ().
 TIMER is cancelled and the display of set time disappears.

PROGRAM TIMER

- OFF timer and ON timer can be used in combination. The set time that is reached first will operate first.
- “←” and “→” display shows the order of OFF timer and ON timer operation.

(Example 1) The current time is 8:00 PM.
The unit turns off at 11:00 PM, and on at 6:00 AM.

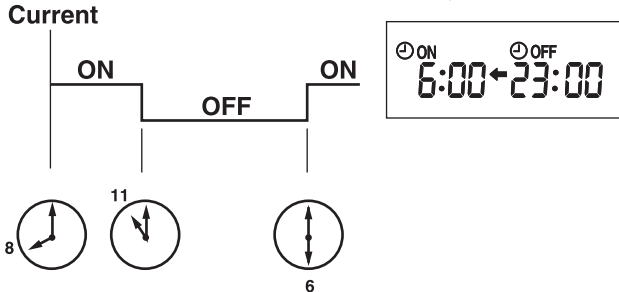

(Example 2) The current time is 11:00 AM.
The unit turns on at 5:00 PM, and off at 9:00 PM.

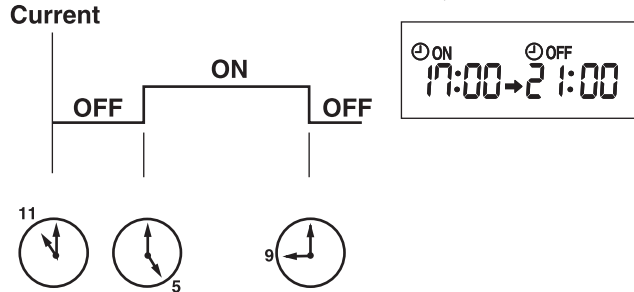

NOTE: If the main power is turned OFF or a power failure occurs while ON/OFF timer is active, the timer setting is cancelled. As these models are equipped with an auto restart function, the air conditioner starts operating with timer cancelled when power is restored.

h. WEEKLY TIMER OPERATION

- A maximum of 4 ON or OFF timers can be set for individual days of the week.
- A maximum of 28 ON or OFF timers can be set for a week.

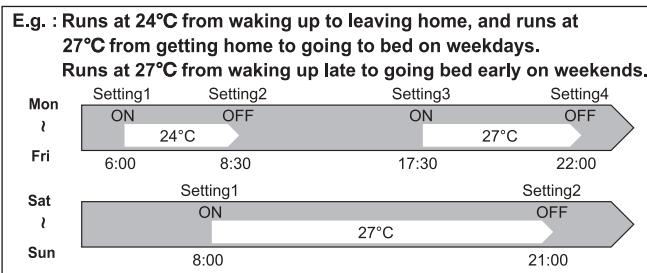

NOTE:

- The simple ON/OFF timer setting is available while the weekly timer is on. In this case, the ON/OFF timer has priority over the weekly timer; the weekly timer operation will start again after the simple ON/OFF timer is complete.

1. How to set the weekly timer

* Make sure that the current time and day are set correctly.

(1) Press **EDIT/SEND SET** button to enter the weekly timer setting mode.

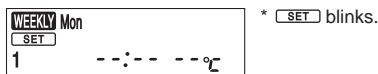

(2) Press **DAY** and **1~4** buttons to select setting day and number.

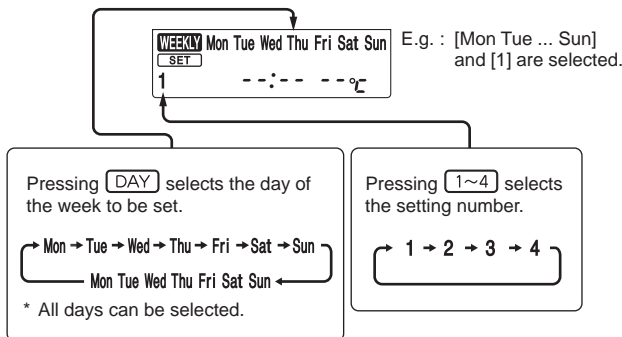

(3) Press , , and buttons to set ON/OFF, time, and temperature.

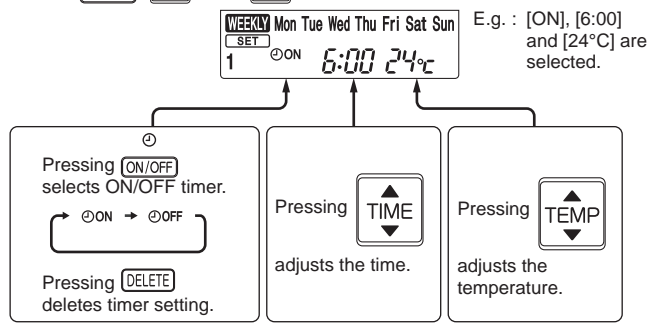

- * Hold down the button to change the time quickly.
 - * The temperature can be set between 16°C and 31°C at cool operation.
 - * The temperature can be set between 10°C and 31°C at HEAT operation.
- Press and buttons to continue setting the timer for other days and/or numbers.

(4) Press button to complete and transmit the weekly timer setting.



NOTE:

- Press button to transmit the setting information of weekly timer to the indoor unit. Point the remote controller toward the indoor unit for 3 seconds.
- When setting the timer for more than one day of the week or one number, button does not have to be pressed per each setting. Press button once after all the settings are complete. All the weekly timer settings will be saved.
- Press button to enter the weekly timer setting mode, and press and hold button for 5 seconds to erase all weekly timer settings. Point the remote controller toward the indoor unit.

(5) Press button to turn the weekly timer ON. (.)

- When the weekly timer is ON, the day of the week whose timer setting is complete, will light.

Press button again to turn the weekly timer OFF. (goes out.)

NOTE:

The saved settings will not be cleared when the weekly timer is turned OFF.

2. Checking weekly timer setting

(1) Press button to enter the weekly timer setting mode.

* blinks.

(2) Press or buttons to view the setting of the particular day or number.

(3) Press button to exit the weekly timer setting.

NOTE:

When all days of the week are selected to view the settings and a different setting is included among them, --:-- °C will be displayed.

i. NIGHT MODE (🌙) OPERATION

NIGHT MODE changes the brightness of the operation indicator, disables the beep sound and limits the noise level of the outdoor unit.

(1) Press NIGHT MODE button during operation to activate NIGHT MODE (🌙).

- The operation indicator lamp dims.
- The beep sound will be disabled except that emitted when the operation is started or stopped.
- Noise level of the outdoor unit will be lower than that mentioned in SPECIFICATIONS.(Except the connection to **MXZ**.)

(2) Press NIGHT MODE button to cancel NIGHT MODE (🌙).

NOTE:

- The cooling / heating capacity may drop.
- Noise level of the outdoor unit may not change after startup of the unit, during the protection operation, or depending on other operating conditions.
- The fan speed of the indoor unit will not change.
- The operation indicator lamp will be hard to be seen in a bright room.
- Noise level of the outdoor unit will not decrease during Multi system operation.

j. i-save (i) OPERATION

1. How to set i-save operation

- (1) Press OFF/ON (stop/operate) button.
- (2) Select COOL, ECONO COOL, HEAT or NIGHT mode.
- (3) Press i-save button.
- (4) Set the temperature, fan speed, and airflow direction for i-save operation.

NOTE:



- i-save operation cannot be selected during DRY or AUTO mode operation.
- The setting range of HEAT mode i-save operation is 10 - 31°C.
- 2 groups of setting can be saved. (One for COOL/ECONO COOL, one for HEAT)

2. How to cancel operation



- Press i-save button again.
 - i-save operation can also be cancelled by pressing Operation select button to change the operation mode.
- The preferred setting can be saved for the next time with a single press of i-save button.



k. OPERATION LOCK

This function locks operation mode only. Other functions, such as OFF/ON, temperature setting, or airflow direction adjustment, are available.

- (1) Hold down  button and  button simultaneously for 2 seconds while the unit is not operating to enable OPERATION LOCK.

The icon for the locked operation mode blinks.

- (2) Hold down  button and  button simultaneously for 2 seconds again while the unit is not operating to disable OPERATION LOCK.

- The icon for the locked operation mode blinks when  button and  button are held down to enable or disable OPERATION LOCK or  button is pressed during operation while OPERATION LOCK is enabled.

l. EMERGENCY/TEST OPERATION

In the case of test run operation or emergency operation, use EMERGENCY OPERATION switch on the right side of the indoor unit. Emergency operation is available when the remote controller is missing or has failed, or the batteries in the remote controller are running down. The unit will start and OPERATION INDICATOR lamp will light up.

The first 30 minutes of operation is the test run operation. This operation is for servicing. The indoor fan runs at High speed and the temperature control does not work.

After 30 minutes of test run operation, the system shifts to EMERGENCY COOL/HEAT MODE with a set temperature of 24°C.

The fan speed shifts to Med.

The coil frost prevention works even in the test run or the emergency operation.

In the test run or emergency operation, the horizontal vane operates in VANE AUTO (Ⓢ) mode.

Emergency operation continues until EMERGENCY OPERATION switch is pressed once or twice or the unit receives any signal from the remote controller. In the latter case, normal operation will start.

Operation mode	COOL/HEAT
Set temperature	24°C
Fan speed	Med.
Horizontal vane	Auto

The operation mode is indicated by the Operation Indicator lamp as following

Operation Indicator lamp

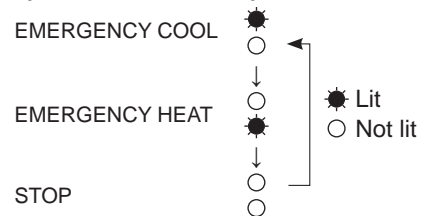

NOTE: Do not press EMERGENCY OPERATION switch during normal operation.

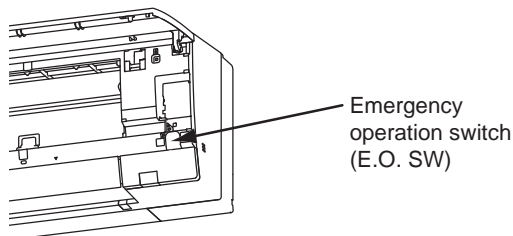

m. 3-MINUTE TIME DELAY OPERATION

When the system turns OFF, compressor will not restart for 3 minutes as 3-minute time delay function operates to protect compressor from overload.

n. ACTUATOR CONTROL

n-1. OUTDOOR FAN MOTOR CONTROL

The fan motor turns ON/OFF, interlocking with the compressor.

[ON] The fan motor turns ON 5 seconds before the compressor starts up.

[OFF] The fan motor turns OFF 15 seconds after the compressor has stopped running.

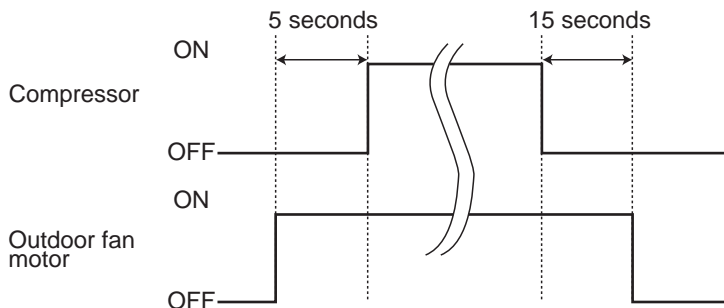

n-2. R.V. COIL CONTROL

Heating ON

Cooling OFF

Dry OFF

NOTE: The 4-way valve reverses for 5 seconds right before startup of the compressor.

<COOL>

<HEAT>

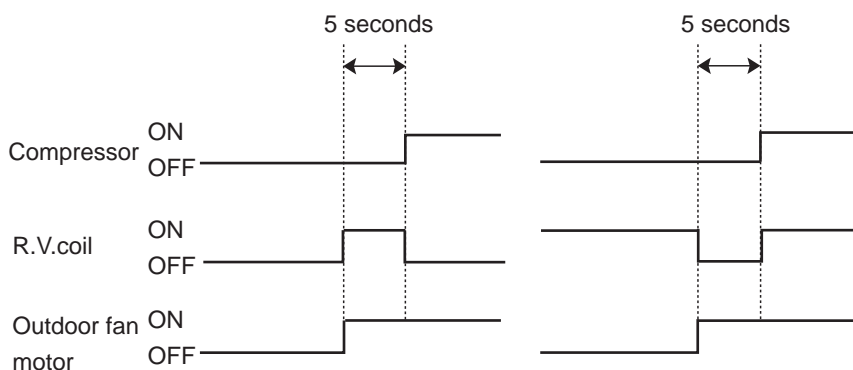

n-3. RELATION BETWEEN MAIN SENSOR AND ACTUATOR

Sensor	Purpose	Actuator					
		Compressor	LEV	Outdoor fan motor	R.V. coil	Indoor fan motor	Defrost heater
Discharge temperature thermistor	Protection	○	○				
Indoor coil temperature thermistor	Cooling: Coil frost prevention	○					
	Heating: High pressure protection	○	○				
Defrost thermistor	Heating: Defrosting	○	○	○	○	○	
Fin temperature thermistor	Protection	○		○			
Ambient temperature thermistor	Cooling: Low ambient temperature operation	○	○	○			
	Heating: Defrosting (Heater)						○
Outdoor heat exchanger temperature thermistor	Cooling: Low ambient temperature operation	○	○	○			
	Cooling: High pressure protection	○	○	○			

OPERATION AND ACTUATOR CONTROL

WALL-MOUNTED

C.1.9.6 MSZ-HR•VF Series

- MSZ-HR25VF MSZ-HR35VF MSZ-HR42VF MSZ-HR50VF MSZ-HR60VF MSZ-HR71VF
 MSZ-HR25VFK MSZ-HR35VFK MSZ-HR42VFK MSZ-HR50VFK MSZ-HR60VFK MSZ-HR71VFK
 MUZ-HR25VF MUZ-HR35VF MUZ-HR42VF MUZ-HR50VF MUZ-HR60VF MUZ-HR71VF

WIRELESS REMOTE CONTROLLER

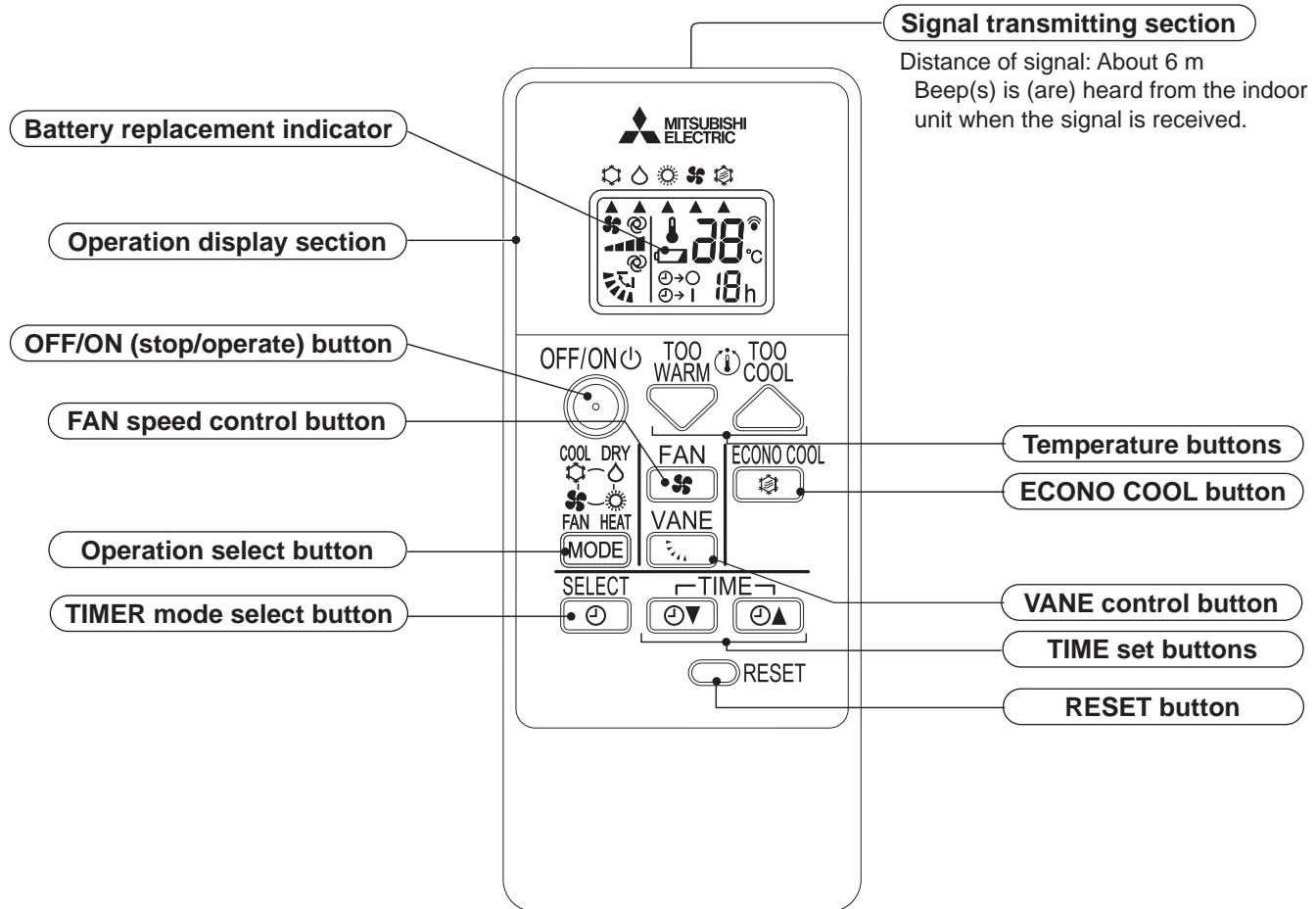

NOTE: Last setting will be stored after the unit is turned OFF with the remote controller. Indoor unit receives the signal of the remote controller with beeps.

INDOOR UNIT DISPLAY SECTION

Operation Indicator lamp

The operation indicator at the right side of the indoor unit indicates the operation state.

• The following indication applies regardless of shape of the indication.

Indication		Operation state	Room temperature
HR25/35/42/50VF	HR60/71VF		
● ●	● ●	The unit is operating to reach the set temperature	About 2°C or more away from set temperature
● ○	● ○	The room temperature is approaching the set temperature	About 1 to 2°C from set temperature
● ●	● ●	Standby mode (only during multi system operation)	—

- Lit
- Blinking
- Not lit

WALL-MOUNTED OPERATION AND ACTUATOR CONTROL

a. COOL (❄️) OPERATION

- (1) Press OFF/ON (stop/operate) button.
OPERATION INDICATOR lamp of the indoor unit turns on with a beep tone.
- (2) Select COOL mode with OPERATION SELECT button.
- (3) Press TEMPERATURE buttons (TOO WARM or TOO COOL button) to select the set temperature. The setting range is 16 - 31°C.

1. Coil frost prevention

The compressor operational frequency is controlled by the temperature of the indoor heat exchanger to prevent the coil from frosting.

When the temperature of indoor heat exchanger becomes too low, the coil frost prevention mode works.

The indoor fan operates at the set speed and the compressor stops. This mode continues until the temperature of indoor heat exchanger rises.

2. Low outside temperature operation

When the outside temperature is lower, low outside temperature operation starts, and the outdoor fan slows or stops.

b. DRY (☀️) OPERATION

- (1) Press OFF/ON (stop/operate) button.
OPERATION INDICATOR lamp of the indoor unit turns on with a beep tone.
- (2) Select DRY mode with OPERATION SELECT button.
- (3) The set temperature is determined from the initial room temperature.

1. Coil frost prevention

Coil frost prevention works the same way as that in COOL mode. (a.1.)

2. Low outside temperature operation

Low outside temperature operation works the same way as that in COOL mode. (a.2.)

c. FAN (🌀) OPERATION

- (1) Press OFF/ON (stop/operate) button.
OPERATION INDICATOR lamp of the indoor unit turns ON with a beep tone.
- (2) Select FAN mode with OPERATION SELECT button.
- (3) Select the desired fan speed. When AUTO, it becomes Low.
Only indoor fan operates. Outdoor unit does not operate.

d. HEAT (🔥) OPERATION

- (1) Press OFF/ON (stop/operate) button.
OPERATION INDICATOR lamp of the indoor unit turns on with a beep tone.
- (2) Select HEAT mode with OPERATION SELECT button.
- (3) Press TEMPERATURE buttons (TOO WARM or TOO COOL button) to select the set temperature.
The setting range is 16 to 31°C.

1. Cold air prevention control

When the compressor is not operating or is starting, and the temperature of indoor heat exchanger and/or the room temperature is low or when defrosting is being done, the indoor fan will stop or rotate in Very Low speed.

2. High pressure protection

The compressor operational frequency is controlled by the temperature of the indoor heat exchanger to prevent the condensing pressure from increasing excessively.

When the temperature of indoor heat exchanger becomes too high, the high pressure protection works.

The indoor fan operates following the cold air prevention control. This mode continues until the temperature of indoor heat exchanger falls.

3. Defrosting

Defrosting starts when the temperature of outdoor heat exchanger becomes too low.

The compressor stops once, the indoor/outdoor fans stop, the 4-way valve reverses, and the compressor restarts.

This mode continues until the temperature of outdoor heat exchanger rises or the fixed time passes.

**e. MULTI SYSTEM OPERATION
FOR MULTI SYSTEM AIR CONDITIONER
OUTDOOR UNIT: MXZ series**

Multi system air conditioner can connect 2 or more indoor units with 1 outdoor unit.

- When you try to operate 2 or more indoor units with 1 outdoor unit simultaneously, one for the cooling and the others for heating, the operation mode of the indoor unit that operates first is selected. Other indoor units cannot operate, and operation indicator lamp blinks as shown in the figure below. In this case, please set all the indoor units to the same operation mode.

HR25/35/42/50VF

OPERATION INDICATOR

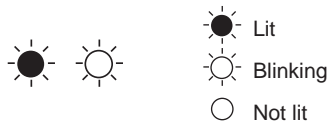

HR60/71VF

OPERATION INDICATOR

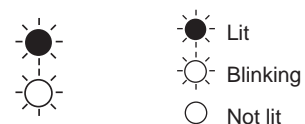

- When indoor unit starts the operation while the defrosting of outdoor unit is being done, it takes a few minutes (max. 10 minutes) to blow out the warm air.
- In the heating operation, though indoor unit is not operating, it may get warm or the sound of refrigerant flow may be heard. It is not malfunction. The reason is that the refrigerant continuously flows into it.

f. AUTO VANE OPERATION

1. Horizontal vane

(1) Vane motor drive

These models are equipped with a stepping motor for the horizontal vane. The rotating direction, speed, and angle of the motor are controlled by pulse signals (approximately 12 V) transmitted from indoor microprocessor.

(2) The horizontal vane angle and mode change as follows by pressing VANE CONTROL button.

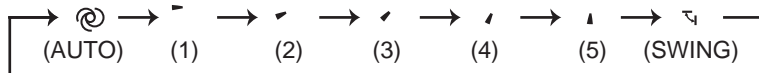

(3) Positioning

To confirm the standard position, the vane moves until it touches the vane stopper. Then the vane is set to the selected angle.

Confirmation of standard position is performed in the following cases:

- (a) When the operation starts or finishes (including timer operation).
- (b) When the test run starts.
- (c) When standby mode (only during multi system operation) starts or finishes.

(4) VANE AUTO (Ⓐ) mode

In VANE AUTO mode, the microprocessor automatically determines the vane angle to make the optimum room temperature distribution.

In COOL and DRY operation
Vane angle is fixed to Horizontal position.

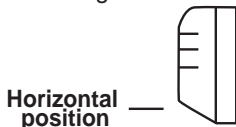

In HEAT operation
Vane angle is fixed to Angle 4.



(5) STOP (operation OFF) and ON TIMER standby

In the following cases, the horizontal vane returns to the closed position.

- (a) When OFF/ON (stop/operate) button is pressed (POWER OFF).
- (b) When the operation is stopped by the emergency operation.
- (c) When ON TIMER is ON standby.

(6) Dew prevention

During COOL or DRY operation with the vane angle at Angle 3 to 5 when the compressor cumulative operation time exceeds 1 hour, the vane angle automatically changes to Angle 2 for dew prevention.

(7) SWING () mode

By selecting SWING mode with VANE CONTROL button, the horizontal vane swings vertically.

(8) ECONO COOL () operation (ECONOMical operation)

When ECONO COOL button is pressed in COOL mode, set temperature and the airflow direction is automatically changed by the microprocessor. However, the temperature on the LCD screen on the remote controller is not changed. Also the horizontal vane swings in various cycle.



SWING operation makes you feel cooler than set temperature. So, even though the set temperature is higher, the air conditioner can keep comfort. As a result, energy can be saved.

To cancel this operation, select a different mode or press one of the following buttons in ECONO COOL operation: ECONO COOL, VANE CONTROL button.

WALL-MOUNTED OPERATION AND ACTUATOR CONTROL

g. TIMER OPERATION (ON/OFF TIMER)

1. How to set the timer

- (1) Press STOP/OPERATE/ (OFF/ON) button to start the air conditioner.
- (2) Select the timer mode by pressing the  button during operation.
Each time this button is pressed, the timer mode is changed in sequence:
☉→○ (OFF TIMER) → ☉→| (ON TIMER) → TIMER RELEASE
- (3) Set the time of the timer using the   button.
Each time this button is pressed, the set time increase or decrease by 1 hour to 12 hours.

2. To release the timer

Press the  button until ☉→○ (OFF TIMER) and ☉→| (ON TIMER) are not displayed.

NOTE :

- The OFF TIMER and the ON TIMER cannot be set at the same time.
- The displayed time is the time remaining and will decrease in 1-hour increments as time passes.

h. EMERGENCY/TEST OPERATION

In the case of test run operation or the emergency operation, use the emergency operation switch in the right side of the indoor unit. The emergency operation is available when the remote controller is missing or has failed, or when the batteries in the remote controller are running down. The unit will start and OPERATION INDICATOR lamp will light up. The first 30 minutes of operation is the test run operation. This operation is for servicing. The indoor fan runs at High speed and the temperature control does not work. After 30 minutes of test run operation, the system shifts to EMERGENCY COOL/HEAT MODE with a set temperature of 24°C. The fan speed shifts to Med. The coil frost prevention works even in the test run or the emergency operation. In the test run or the emergency operation, the horizontal vane operates in VANE AUTO (Ⓢ) mode. The emergency operation continues until the emergency operation switch is pressed once or twice or the unit receives any signal from the remote controller. In the latter case, normal operation will start.

NOTE: Do not press the emergency operation switch during normal operation.

Operation mode	COOL/HEAT
Set temperature	24°C
Fan speed	Med.
Horizontal vane	Auto

The operation mode is indicated by the Operation Indicator lamp as following Operation Indicator lamp

HR25/35/42/50VF

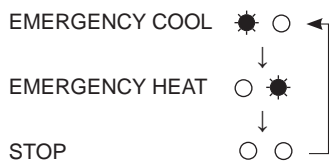

HR60/71VF

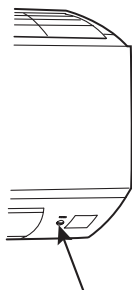
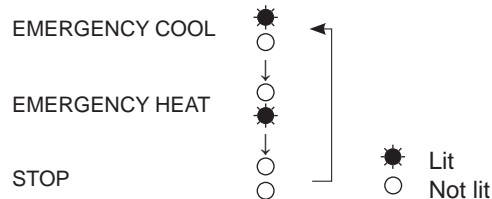

Emergency operation switch —  E.O.S.W



Emergency operation switch —  E.O.S.W

i. 3-MINUTE TIME DELAY OPERATION

When the system turns OFF, compressor will not restart for 3 minutes as 3-minute time delay function operates to protect compressor from overload.

j. ACTUATOR CONTROL

j-1. OUTDOOR FAN MOTOR CONTROL

The fan motor turns ON/OFF, interlocking with the compressor.

[ON] The fan motor turns ON 5 seconds before the compressor starts up.

[OFF] The fan motor turns OFF 15 seconds after the compressor has stopped running.

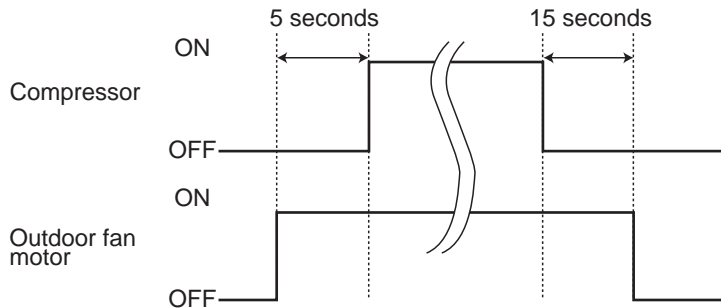

j-2. R.V. COIL CONTROL

Heating ON

Cooling OFF

Dry OFF

NOTE: The 4-way valve reverses for 5 seconds right before startup of the compressor.

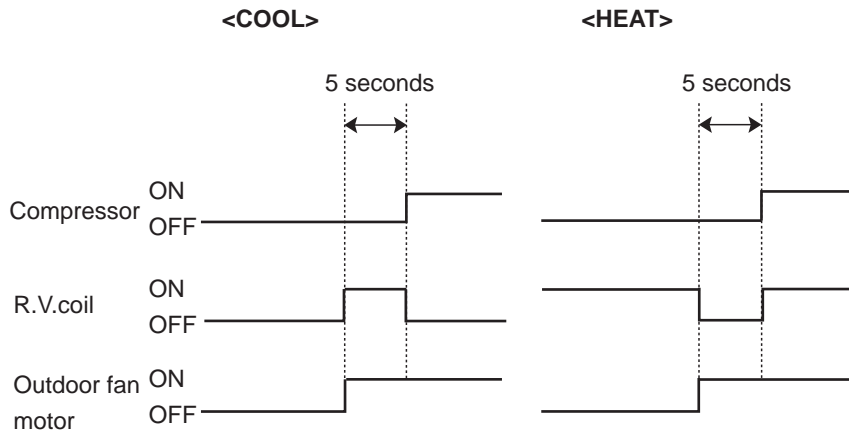

j-3. RELATION BETWEEN MAIN SENSOR AND ACTUATOR

Sensor	Purpose	Actuator				
		Compressor	LEV	Outdoor fan motor	R.V. coil	Indoor fan motor
Discharge temperature thermistor	Protection	○	○			
Indoor coil temperature thermistor	Cooling: Coil frost prevention	○				
	Heating: High pressure protection	○	○			
Defrost thermistor	Heating: Defrosting	○	○	○	○	○
Fin temperature thermistor	Protection	○		○		
Ambient temperature thermistor	Cooling: Low ambient temperature operation	○	○	○		
Outdoor heat exchanger temperature thermistor	Cooling: Low ambient temperature operation	○	○	○		
	Cooling: High pressure protection	○	○	○		

C.1.9.7 MSY-TP•VF Series
MSY-TP35VF MSY-TP50VF
MUY-TP35VF MUY-TP50VF

1 WIRED REMOTE CONTROLLER
(Option : Example) PAR-33MAA

NOTE: MAC-SL100M-E (option) may be used with this product.
(Refer to 2 WIRELESS REMOTE CONTROLLER.)

Display

The main display can be displayed in 2 different modes: "Full" and "Basic."
 The initial setting is "Full."

Full mode

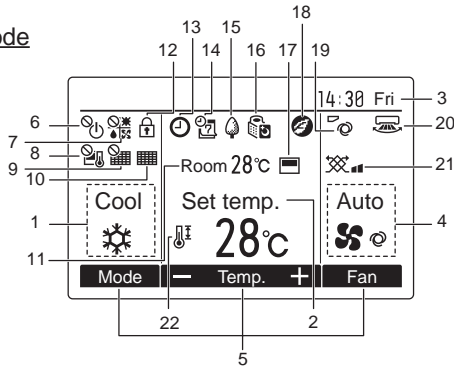

Basic mode

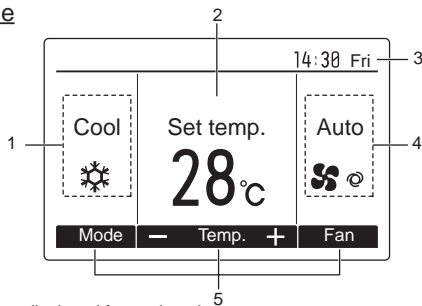

Note: All icons are displayed for explanation.

- 1 Operation mode**
Indoor unit operation mode appears here.
- 2 Preset temperature**
Preset temperature appears here.
- 3 Clock**
(See the Installation Manual.)
Current time appears here.
- 4 Fan speed**
Fan speed setting appears here.
- 5 Button function guide**
Functions of the corresponding buttons appear here.
- 6** Appears when the ON/OFF operation is centrally controlled.
- 7** Appears when the operation mode is centrally controlled.
- 8** Appears when the preset temperature is centrally controlled.
- 9** Appears when the filter reset function is centrally controlled.
- 10** Indicates when filter needs maintenance.
- 11 Room temperature**
(See the Installation Manual.)
Current room temperature appears here.
- 12** Appears when the buttons are locked.
- 13** Appears when the On/Off timer or Night setback function is enabled.
- 14** Appears when the Weekly timer is enabled.
- 15** Appears while the units are operated in the energy-saving mode.
- 16** Appears while the outdoor units are operated in the silent mode.
- 17** Appears when the built-in thermistor on the remote controller is activated to monitor the room temperature (a).
 appears when the thermistor on the indoor unit is activated to monitor the room temperature.
- 18** Appears when the units are operated in the energy-saving mode with 3D i-see Sensor.
- 19** Indicates the vane setting.
- 20** Indicates the louver setting.
- 21** Indicates the ventilation setting.
- 22** Appears when the preset temperature range is restricted.

Controller interface

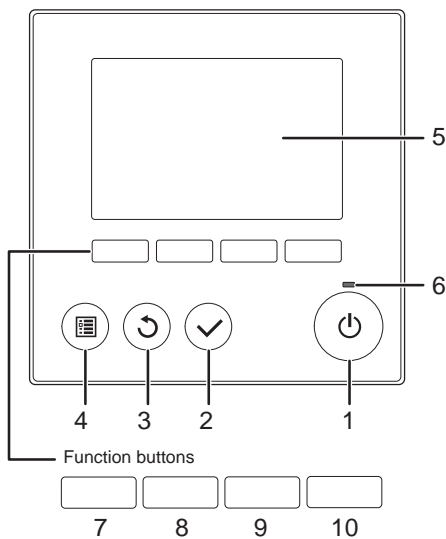

- When the backlight is off, pressing any button turns the backlight on and does not perform its function. (except for the OFF/ON button)
- Most settings (except OFF/ON, mode, fan speed, temperature) can be made from the Menu screen.

- 1 OFF/ON button**
Press to turn ON/OFF the indoor unit.
- 2 SELECT button**
Press to save the setting.
- 3 RETURN button**
Press to return to the previous screen.
- 4 MENU button**
Press to bring up the Main menu.
- 5 Backlit LCD**
Operation settings will appear. When the backlight is off, pressing any button turns the backlight on and it will stay lit for a certain period of time depending on the screen.
- 6 ON/OFF lamp**
This lamp lights up in green while the unit is in operation. It blinks while the remote controller is starting up or when there is an error.

The functions of the function buttons change depending on the screen. Refer to the button function guide that appears at the bottom of the LCD for the functions they serve on a given screen. When the system is centrally controlled, the button function guide that corresponds to the locked button will not appear.

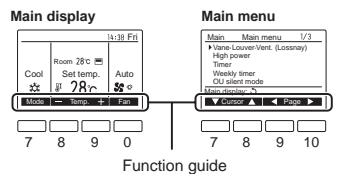

- 7 Function button [F1]**
Main display: Press to change the operation mode.
Main menu: Press to move the cursor down.
- 8 Function button [F2]**
Main display: Press to decrease temperature.
Main menu: Press to move the cursor up.
- 9 Function button [F3]**
Main display: Press to increase temperature.
Main menu: Press to go to the previous page.
- 10 Function button [F4]**
Main display: Press to change the fan speed.
Main menu: Press to go to the next page.

Menu structure

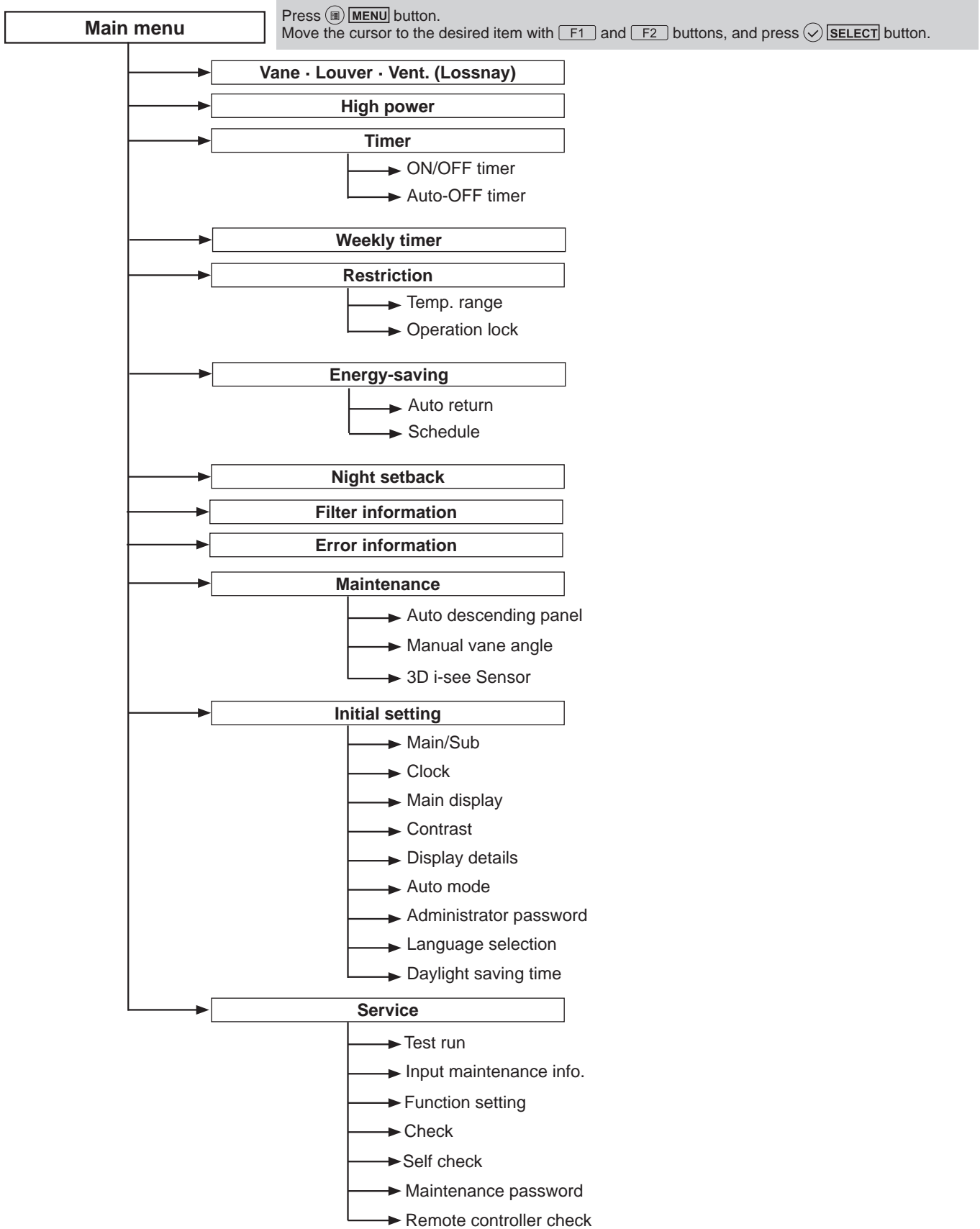

Not all functions are available on all models of indoor units.

Main menu list

Setting and display items		Setting details
Vane · Louver · Vent. (Lossnay)		<p>Use to set the vane angle.</p> <ul style="list-style-type: none"> Select a desired vane setting from 5 different settings. <p>Use to turn ON/OFF the louver. Not available</p> <p>Use to set the amount of ventilation. Not available</p>
High power		<p>Use to reach the comfortable room temperature quickly. Not available</p>
Timer	ON/OFF timer*	<p>Use to set the operation ON/OFF times.</p> <ul style="list-style-type: none"> Time can be set in 5-minute increments.
	Auto-Off timer	<p>Use to set the Auto-OFF time.</p> <ul style="list-style-type: none"> Time can be set to a value from 30 to 240 in 10-minute increments.
Filter information		<p>Use to check the filter status. Not available</p>
Error information		<p>Use to check error information when an error occurs.</p> <ul style="list-style-type: none"> Check code, error source, refrigerant address, unit model, manufacturing number, contact information (dealer's phone number) can be displayed. (The unit model, manufacturing number, and contact information need to be registered in advance to be displayed.)
Weekly timer*		<p>Use to set the weekly operation ON/OFF times.</p> <ul style="list-style-type: none"> Up to 8 operation patterns can be set for each day. (Not valid when the ON/OFF timer is enabled.)
Energy saving	Auto return	<p>Use to get the units to operate at the preset temperature after performing energy-saving operation for a specified time period.</p> <ul style="list-style-type: none"> Time can be set to a value from 30 and 120 in 10-minute increments. (This function will not be valid when the preset temperature ranges are restricted.)
	Schedule*	<p>Set the start/stop times to operate the units in the energy-saving mode for each day of the week, and set the energy-saving rate. Not available</p>
Night setback*		<p>Use to make Night setback settings.</p> <ul style="list-style-type: none"> Select "Yes" to enable the setting, and "No" to disable the setting. The temperature range and the start/stop times can be set.
Restriction	Temp. range	<p>Use to restrict the preset temperature range.</p> <ul style="list-style-type: none"> Different temperature ranges can be set for different operation modes.
	Operation lock	<p>Use to lock selected functions.</p> <ul style="list-style-type: none"> The locked functions cannot be operated.
Maintenance	Auto descending panel	Not available
	Manual vane angle	Not available
	3D i-see Sensor	Not available
Initial setting	Main/Sub	When connecting 2 remote controllers, one of them needs to be designated as a sub controller.
	Clock	Use to set the current time.
	Main display	Use to switch between "Full" and "Basic" modes for the Main display. • The initial setting is "Full."
	Contrast	Use to adjust screen contrast.
	Display details	<p>Make the settings for the remote controller related items as necessary.</p> <p>Clock: The initial settings are "Yes" and "24h" format. Temperature: Set either Celsius (°C) or Fahrenheit (°F). Room temp. : Set Show or Hide. Auto mode: Set the Auto mode display or Only Auto display.</p>
	Auto mode	Whether or not to use the AUTO mode can be selected by using the button. This setting is valid only when indoor units with the AUTO mode function are connected.
	Administrator password	<p>The administrator password is required to make the settings for the following items.</p> <ul style="list-style-type: none"> Timer setting • Energy-saving setting • Weekly timer setting Restriction setting • Outdoor unit silent mode setting • Night set back
	Language selection	Use to select the desired language.
	Daylight saving time	Sets the daylight saving time.
Service	Test run	Select "Test run" from the Service menu to bring up the Test run menu. Not available
	Input maintenance	Select "Input maintenance Info." from the Service menu to bring up the Maintenance information screen. The following settings can be made from the Maintenance Information screen. • Model name input • Serial No. input • Dealer information input
	Function setting	Not available
	Check	<p>Error history: Display the error history and delete the error history. Refrigerant leak check: Not available Smooth maintenance: Not available Request code: Not available</p>
	Self check	Error history of each unit can be checked via the remote controller.
	Maintenance password	Use to change the maintenance password.
Remote controller check	When the remote controller does not work properly, use the remote controller checking function to troubleshoot the problem.	



* Clock setting is required.

INDOOR UNIT DISPLAY SECTION

Operation Indicator lamp

The operation indicator at the right side of the indoor unit indicates the operation state.

- The following indication applies regardless of shape of the indication.

Indication	Operation state	Room temperature
	The unit is operating to reach the set temperature.	About 2°C or more away from set temperature
	The room temperature is approaching the set temperature.	About 1 to 2°C from set temperature

 Lit

 Blinking

 Not lit

Operation status memory

	Remote controller setting
Operation mode	Operation mode before the power was turned off
Preset temperature	Preset temperature before the power was turned off
Fan speed	Fan speed before the power was turned off

Settable preset temperature range

Operation mode	Preset temperature range
Cool/Dry	16 ~ 31°C
Fan/Ventilation	Not settable

Mode selection

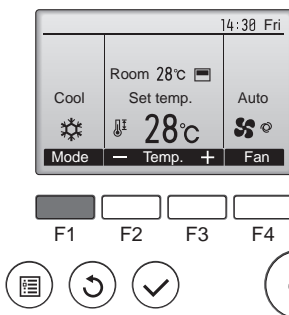

Press **[F1]** button to go through the operation modes in the order of “Cool”, “Dry”, and “Fan”. Select the desired operation mode.



a. COOL (❄️) OPERATION

- (1) Press **[OFF/ON]** button.
OFF/ON lamp will light up in green and the operation will start.
- (2) Select COOL mode with **[F1]** button.
- (3) Press **[F2]** button to decrease the preset temperature, and **[F3]** button to increase.
The setting range is 16 ~ 31°C.

1. Coil frost prevention

The compressor operational frequency is controlled by the temperature of the indoor heat exchanger to prevent the coil from frosting. When the temperature of indoor heat exchanger becomes too low, the coil frost prevention mode works. The indoor fan operates at the set speed and the compressor stops. This mode continues until the temperature of indoor heat exchanger rises.

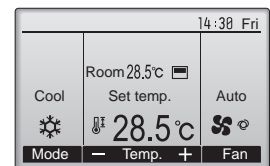
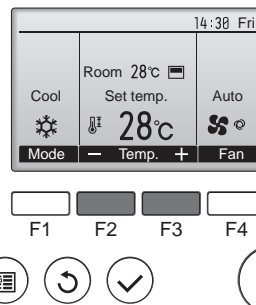

Example display (Centigrade in 0.5-degree increments)

b. DRY (💧) OPERATION

- (1) Press **[OFF/ON]** button.
OFF/ON lamp will light up in green and the operation will start.
- (2) Select DRY mode with **[F1]** button.
- (3) Press **[F2]** button to decrease the preset temperature, and **[F3]** button to increase.

- Preset temperature will be displayed either in Centigrade in 0.5- or 1-degree increments, or in Fahrenheit, depending on the display mode setting on the remote controller.

1. Coil frost prevention

Coil frost prevention works the same way as that in COOL mode. (a.1.)

c. FAN () OPERATION

- (1) Press **[OFF/ON]** button. OFF/ON lamp will light up in green and the operation will start.
 - (2) Select FAN mode with **[F1]** button.
 - (3) Press **[F4]** button to select the desired fan speed. When AUTO, it becomes Low.
- Only indoor fan operates. Outdoor unit does not operate.

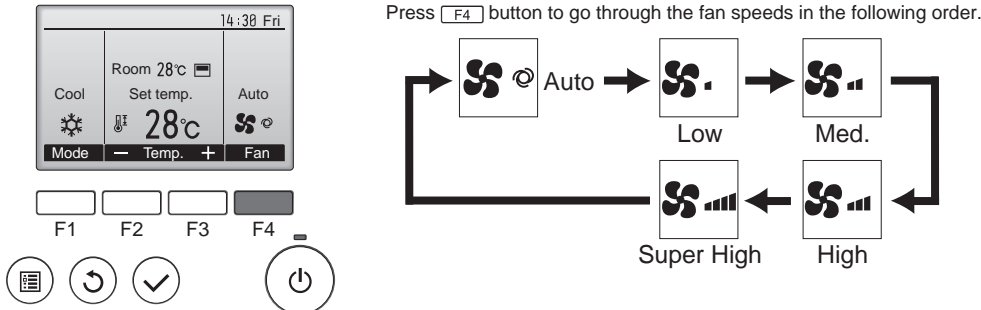

d. AUTO VANE OPERATION

1. Horizontal vane

- (1) Vane motor drive

These models are equipped with a stepping motor for the horizontal vane. The rotating direction, speed, and angle of the motor are controlled by pulse signals (approximately 12 V) transmitted from indoor microprocessor.
- (2) How to set the vane angle
 - ① Press the **[MENU]** button.
 - ② Select "Vane·Louver·Vent. (Lossnay)" with **[F1]** or **[F2]** button, and press **[SELECT]** button.

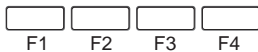
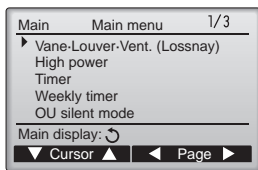

- ③ Press **[F1]** or **[F2]** button to go through the vane setting options: "Auto", "Step 1", "Step 2", "Step 3", "Step 4", "Step 5" and "Swing", and select the desired setting.

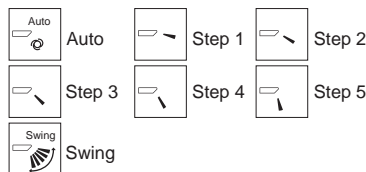
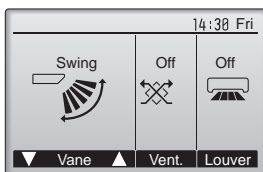

- ④ Press **[RETURN]** button to go back to the Main menu.

(3) Positioning

To confirm the standard position, the vane moves until it touches the vane stopper. Then the vane is set to the selected angle.

Confirmation of standard position is performed in the following cases:

- (a) When the operation starts or finishes (including timer operation).
- (b) When the test run starts.

(4) VANE AUTO (Auto) mode

In VANE AUTO mode, the microprocessor automatically determines the vane angle to make the optimum room temperature distribution.

In COOL and DRY operation
Vane angle is fixed to Horizontal position.



(5) STOP (operation OFF) and ON TIMER standby

In the following cases, the horizontal vane returns to the closed position.

- (a) When [OFF/ON] button is pressed (POWER OFF).
- (b) When the operation is stopped by the emergency operation.
- (c) When ON TIMER is ON standby.

(6) Dew prevention

During COOL or DRY operation with the vane angle at Angle 3 ~ 5 when the compressor cumulative operation time exceeds 1 hour, the vane angle automatically changes to Angle 2 for dew prevention.

(7) SWING mode

Select "Swing" to move the vanes up and down automatically.
When set to "Step 1" through "Step 5", the vane will be fixed at the selected angle.

e. TIMER OPERATION (ON/OFF TIMER)

The unit automatically turns on or off at the preset time.

Select "Timer" from the Main menu, and press [SELECT] button (Refer to the appropriate operation manual include with remote controller.).

f. EMERGENCY/TEST OPERATION

In the case of test run operation or emergency operation, use EMERGENCY OPERATION switch on the right side of the indoor unit. Emergency operation is available when the remote controller is missing or has failed, or when the batteries in the remote controller are running down. The unit will start and OPERATION INDICATOR lamp will light up. The first 30 minutes of operation is the test run operation. This operation is for servicing. The indoor fan runs at High speed and the temperature control does not work.

After 30 minutes of test run operation, the system shifts to EMERGENCY COOL MODE with a set temperature of 24°C. The fan speed shifts to Med.

The coil frost prevention works even in the test run or the emergency operation.

In the test run or emergency operation, the horizontal vane operates in VANE AUTO (Auto) mode.

Emergency operation continues until EMERGENCY OPERATION switch is pressed once or the unit receives any signal from the remote controller. In the latter case, normal operation will start.

NOTE: Do not press EMERGENCY OPERATION switch during normal operation.

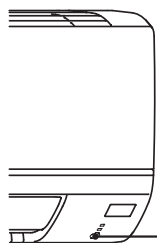

EMERGENCY OPERATION switch



Operation mode	COOL
Set temperature	24°C
Fan speed	Med.
Horizontal vane	Auto

The operation mode is indicated by the Operation Indicator lamp as follows:

Operation Indicator lamp

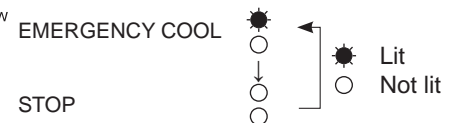

g. 3-MINUTE TIME DELAY OPERATION

When the system turns OFF, compressor will not restart for 3 minutes as 3-minute time delay function operates to protect compressor from overload.

2 WIRELESS REMOTE CONTROLLER (Option : Example) MAC-SL100M-E

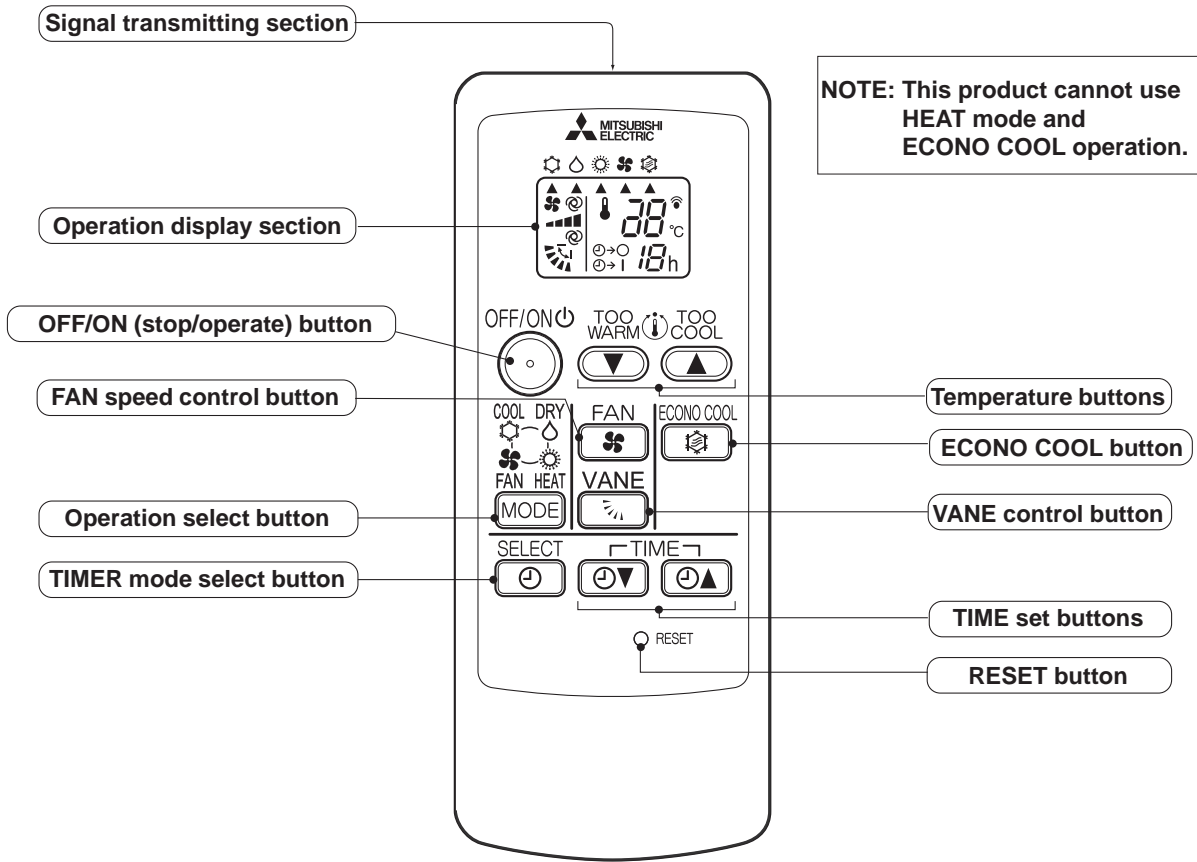

NOTE: Last setting will be stored after the unit is turned OFF with the remote controller. Indoor unit receives the signal of the remote controller with beeps.

OPERATION AND ACTUATOR CONTROL

WALL-MOUNTED

INDOOR UNIT DISPLAY SECTION

Operation Indicator lamp

The operation indicator at the right side of the indoor unit indicates the operation state.

• The following indication applies regardless of shape of the indication.

Indication	Operation state	Room temperature
●	The unit is operating to reach the set temperature	About 2°C or more away from set temperature
○		
●	The room temperature is approaching the set temperature	About 1 to 2°C from set temperature
○		

- Lit
- Blinking
- Not lit

h. COOL (❄️) OPERATION

- (1) Press OFF/ON (stop/operate) button.
OPERATION INDICATOR lamp of the indoor unit turns on with a beep tone.
- (2) Select COOL mode with Operation select button.
- (3) Press Temperature buttons (TOO WARM or TOO COOL button) to select the desired temperature.
The setting range is 16 - 31°C.

1. Coil frost prevention

The compressor operational frequency is controlled by the temperature of the indoor heat exchanger to prevent the coil from frosting.

When the temperature of indoor heat exchanger becomes too low, the coil frost prevention mode works. The indoor fan operates at the set speed and the compressor stops. This mode continues until the temperature of indoor heat exchanger rises.

2. Low outside temperature operation

When the outside temperature is lower, low outside temperature operation starts, and the outdoor fan slows or stops.

i. DRY (☁️) OPERATION

- (1) Press OFF/ON (stop/operate) button.
OPERATION INDICATOR lamp of the indoor unit turns on with a beep tone.
- (2) Select DRY mode with Operation select button.
- (3) The set temperature is determined from the initial room temperature.

1. Coil frost prevention

Coil frost prevention works the same way as that in COOL mode. (9-8.1.)

2. Low outside temperature operation

Low outside temperature operation works the same way as that in COOL mode. (9-8.2.)

j. FAN (🌀) OPERATION

- (1) Press OFF/ON (stop/operate) button.
OPERATION INDICATOR lamp of the indoor unit turns ON with a beep tone.
- (2) Select FAN mode with Operation select button.
- (3) Select the desired fan speed. When AUTO, it becomes Low.
Only indoor fan operates. Outdoor unit does not operate.

k. AUTO VANE OPERATION

1. Horizontal vane

- (1) Vane motor drive
These models are equipped with a stepping motor for the horizontal vane. The rotating direction, speed, and angle of the motor are controlled by pulse signals (approximately 12 V) transmitted from indoor microprocessor.
- (2) The horizontal vane angle and mode change as follows by pressing VANE control button.

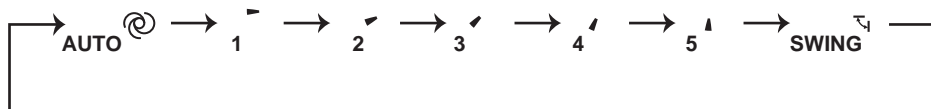

- (3) Positioning
To confirm the standard position, the vane moves until it touches the vane stopper. Then the vane is set to the selected angle.
Confirmation of standard position is performed in the following cases:
 - (a) When the operation starts or finishes (including timer operation).
 - (b) When the test run starts.
 - (c) When standby mode (only during multi system operation) starts or finishes.

(4) VANE AUTO (Ⓐ) mode

In VANE AUTO mode, the microprocessor automatically determines the vane angle to make the optimum room temperature distribution.



In COOL and DRY operation
Vane angle is fixed to Horizontal position.



- (5) STOP (operation OFF) and ON TIMER standby
 In the following cases, the horizontal vane returns to the closed position.
 - (a) When OFF/ON (stop/operate) button is pressed (POWER OFF).
 - (b) When the operation is stopped by the emergency operation.
 - (c) When ON TIMER is ON standby.
- (6) Dew prevention
 During COOL or DRY operation with the vane angle at Angle 3 ~ 5 when the compressor cumulative operation time exceeds 1 hour, the vane angle automatically changes to Angle 2 for dew prevention.
- (7) SWING (↔) mode
 By selecting SWING mode with VANE control button, the horizontal vane swings vertically.

I. TIMER OPERATION (ON/OFF TIMER)

1. How to set the timer

- (1) Press OFF/ON (stop/operate) button to start the air conditioner.
- (2) Select the timer mode by pressing the  button during operation.
 Each time this button is pressed, the timer mode is changed in sequence:
 ⊕→○ (OFF TIMER) → ⊕→| (ON TIMER) → TIMER RELEASE
- (3) Set the time of the timer using the   button.
 Each time this button is pressed, the set time increase or decrease by 1 hour to 12 hours.

2. To release the timer

Press the  button until ⊕→○ (OFF TIMER) and ⊕→| (ON TIMER) are not displayed.

NOTE :

- The OFF TIMER and the ON TIMER cannot be set at the same time.
- The displayed time is the time remaining and will decrease in 1-hour increments as time passes.

m. EMERGENCY/TEST OPERATION

In the case of test run operation or emergency operation, use the emergency operation switch on the right side of the indoor unit. Emergency operation is available when the remote controller is missing or has failed, or when the batteries in the remote controller are running down. The unit will start and OPERATION INDICATOR lamp will light up. The first 30 minutes of operation is the test run operation. This operation is for servicing. The indoor fan runs at High speed and the temperature control does not work. After 30 minutes of test run operation, the system shifts to EMERGENCY COOL with a set temperature of 24°C. The fan speed shifts to Med. The coil frost prevention works even in the test run or the emergency operation. In the test run or emergency operation, the horizontal vane operates in VANE AUTO (⊙) mode. Emergency operation continues until the emergency operation switch is pressed once or twice or the unit receives any signal from the remote controller. In the latter case, normal operation will start.

NOTE: Do not press the emergency operation switch during normal operation.

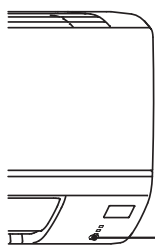

EMERGENCY OPERATION switch 

Operation mode	COOL
Set temperature	24°C
Fan speed	Med.
Horizontal vane	Auto

The operation mode is indicated by the Operation Indicator lamp as follows:

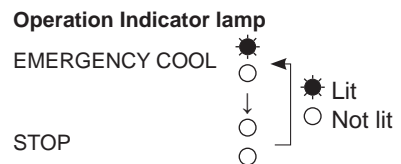

n. 3-MINUTE TIME DELAY OPERATION

When the system turns OFF, compressor will not restart for 3 minutes as 3-minute time delay function operates to protect compressor from overload.

o. ACTUATOR CONTROL

o-1. Outdoor fan motor control

The fan motor turns ON/OFF, interlocking with the compressor.

[ON] The fan motor turns ON 5 seconds before the compressor starts up.

[OFF] The fan motor turns OFF 15 seconds after the compressor has stopped running.

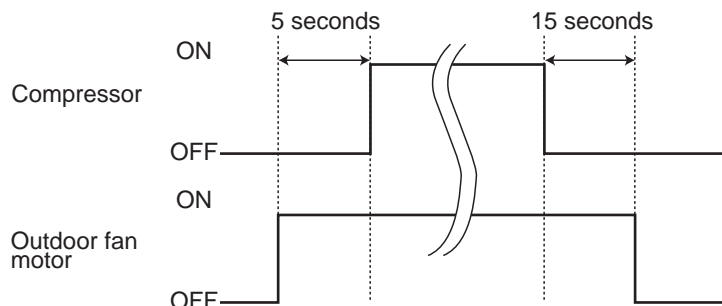

o-2. Relation between main sensor and actuator

Sensor	Purpose	Actuator		
		Compressor	LEV	Outdoor fan motor
Discharge temperature thermistor	Protection	○	○	
Indoor coil temperature thermistor	Cooling: Coil frost prevention	○		
Fin temperature thermistor	Protection	○		○
Ambient temperature thermistor	Cooling: Low ambient temperature operation	○	○	○
Outdoor heat exchanger temperature thermistor	Cooling: Low ambient temperature operation	○	○	○
	Cooling: High pressure protection	○	○	○

C.1.9.8 MSZ-FH•VE2 Series

- MSZ-FH25VE2 MSZ-FH35VE2 MSZ-FH50VE2
- MUZ-FH25VE MUZ-FH35VE MUZ-FH50VE
- MUZ-FH25VEHZ MUZ-FH35VEHZ MUZ-FH50VEHZ

WIRELESS REMOTE CONTROLLER

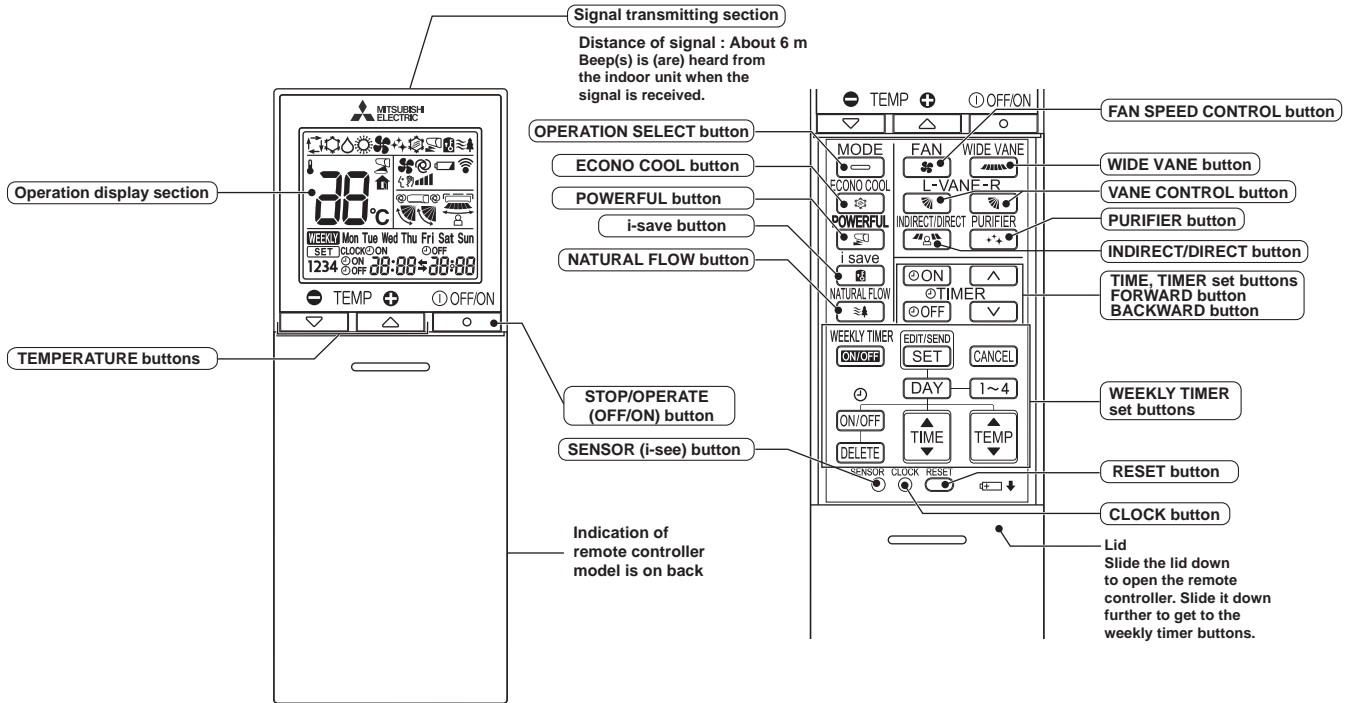

NOTE: Last setting will be stored after the unit is turned OFF with the remote controller. Indoor unit receives the signal of the remote controller with beeps.

INDOOR UNIT DISPLAY SECTION

Operation Indicator lamp

The operation indicator at the right side of the indoor unit indicates the operation state.

- The following indication applies regardless of shape of the indication.

Indication	Operation state	Room temperature
	Standby mode (Only during multi system operation)	—

- Lit
- Blinking
- Not lit

a. COOL (❄️) OPERATION

- (1) Press STOP/OPERATE (OFF/ON) button.
OPERATION INDICATOR lamp of the indoor unit turns on with a beep tone.
- (2) Select COOL mode with OPERATION SELECT button.
- (3) Press TEMPERATURE buttons TEMP \ominus or \oplus button to select the desired temperature. The setting range is 16 - 31°C.

1. Coil frost prevention

The compressor operational frequency is controlled by the temperature of the indoor heat exchanger to prevent the coil from frosting.

When the temperature of indoor heat exchanger becomes too low, the coil frost prevention mode works.

The indoor fan operates at the set speed and the compressor stops. This mode continues until the temperature of indoor heat exchanger rises.

2. Low outside temperature operation

When the outside temperature is lower, low outside temperature operation starts, and the outdoor fan slows or stops.

3. Indoor fan speed control

When the thermostat turns OFF, the indoor fan operates very Low to reduce power consumption.

When the room temperature rises and the thermostat is ON, the indoor fan operates according to the settings on the remote controller.

b. DRY (△) OPERATION

- (1) Press STOP/OPERATE (OFF/ON) button.
OPERATION INDICATOR lamp of the indoor unit turns on with a beep tone.
- (2) Select DRY mode with OPERATION SELECT button.
- (3) The set temperature is determined from the initial room temperature.
 1. **Coil frost prevention**
Coil frost prevention works the same way as that in COOL mode. (a.1.)
 2. **Low outside temperature operation**
Low outside temperature operation works the same way as that in COOL mode. (a.2.)
 3. **Indoor fan speed control**
Indoor fan speed control works the same way as that in COOL mode. (a.3.)

c. FAN (⚙️) OPERATION

- (1) OPERATION INDICATOR lamp of the indoor unit turns on with a beep tone.
- (2) Select FAN mode with OPERATION SELECT button.
- (3) Select the desired fan speed. When AUTO, it becomes Low.
Only indoor fan operates.
Outdoor unit does not operate.

d. HEAT (☀️) OPERATION

- (1) Press STOP/OPERATE (OFF/ON) button.
OPERATION INDICATOR lamp of the indoor unit turns on with a beep tone.
- (2) Select HEAT mode with OPERATION SELECT button.
- (3) Press TEMPERATURE buttons TEMP \ominus or \oplus button to select the desired temperature. The setting range is 16 - 31°C.
 1. **Cold air prevention control**
When the compressor is not operating or is starting, and the temperature of indoor heat exchanger and/or the room temperature is low or when defrosting is being done, the indoor fan will stop or rotate in Very Low speed.
 2. **High pressure protection**
The compressor operational frequency is controlled by the temperature of the indoor heat exchanger to prevent the condensing pressure from increasing excessively.
When the temperature of indoor heat exchanger becomes too high, the high pressure protection works.
The indoor fan operates following the cold air prevention control. This mode continues until the temperature of indoor heat exchanger falls.
 3. **Defrosting**
Defrosting starts when the temperature of outdoor heat exchanger becomes too low.
The compressor stops once, the indoor/outdoor fans stop, the 4-way valve reverses, and the compressor restarts.
This mode continues until the temperature of outdoor heat exchanger rises or the fixed time passes.

e. AUTO CHANGE OVER ... AUTO MODE OPERATION

Once desired temperature is set, unit operation is switched automatically between COOL and HEAT operation.

Mode selection

- (1) Initial mode
When unit starts the operation with AUTO operation from OFF:
 - If the room temperature is higher than the set temperature, operation starts in COOL mode.
 - If the room temperature is equal to or lower than the set temperature, operation starts in HEAT mode.
- (2) Mode change
COOL mode changes to HEAT mode when about 15 minutes have passed with the room temperature 1°C below the set temperature.
HEAT mode changes to COOL mode when about 15 minutes have passed with the room temperature 1°C above the set temperature.

NOTE 1

If two or more indoor units are operating in multi system, there might be a case that the indoor unit, which is operating in □ (AUTO), cannot change over to the other operating mode (COOL ↔ HEAT) and becomes a state of standby.
Refer to **NOTE 2 "FOR MULTI SYSTEM AIR CONDITIONER"**.

NOTE 2
FOR MULTI SYSTEM AIR CONDITIONER
OUTDOOR UNIT: MXZ series

Multi system air conditioner can connect two or more indoor units with one outdoor unit.

- When you try to operate two or more indoor units with one outdoor unit simultaneously, one for the cooling and the others for heating, the operation mode of the indoor unit that operates first is selected. Other indoor units cannot operate, and operation indicator lamp blinks as shown in the figure below. In this case, please set all the indoor units to the same operation mode.

OPERATION INDICATOR

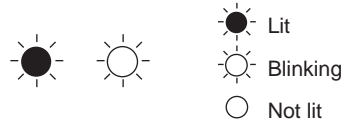

- When indoor unit starts the operation while the defrosting of outdoor unit is being done, it takes a few minutes (max. 10 minutes) to blow out the warm air.
- In the heating operation, though indoor unit that does not operate may get warm or the sound of refrigerant flowing may be heard, they are not malfunction. The reason is that the refrigerant continuously flows into it.

f. AUTO VANE OPERATION

1. Horizontal vane

(1) Vane motor drive

These models are equipped with stepping motors for the horizontal vanes. The rotating direction, speed, and angle of the motor are controlled by pulse signals (approximately 12 V) transmitted from indoor microprocessor.

- (2) The horizontal vane angle and mode change as follows by pressing VANE CONTROL () button.

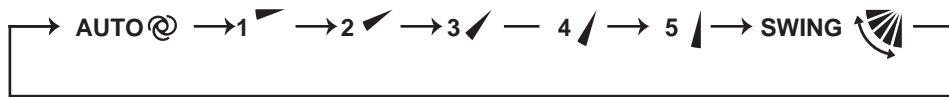

NOTE: The right and left horizontal vanes set to the same level may not align perfectly.

(3) Positioning

To confirm the standard position, the vane moves until it touches the vane stopper. Then the vane is set to the selected angle.

Confirmation of standard position is performed in the following cases:

- (a) When the operation starts or finishes (including timer operation).
- (b) When the test run starts.
- (c) When standby mode (only during multi system operation) starts or finishes.

(4) VANE AUTO (@) mode

In VANE AUTO mode, the microprocessor automatically determines the vane angle to make the optimum room temperature distribution.

In COOL and DRY operation

Vane angle is fixed to Horizontal position.



In HEAT operation

Vane angle is fixed to Angle 4.



(5) STOP (operation OFF) and ON TIMER standby

In the following cases, the horizontal vane returns to the closed position.

- (a) When STOP/OPERATE (OFF/ON) button is pressed (POWER OFF).
- (b) When the operation is stopped by the emergency operation.
- (c) When ON TIMER is ON standby.

(6) Dew prevention

During COOL or DRY operation with the vane angle at Angle 4 or 5 when the compressor cumulative operation time exceeds 1 hour, the vane angle automatically changes to Angle 3 for dew prevention.

(7) SWING (🌀) mode

By selecting SWING mode with VANE CONTROL button, the horizontal vanes swing vertically. When COOL, DRY or FAN mode is selected, only the upper vane swings.

(8) Cold air prevention in HEAT operation

The horizontal vane position is set to Upward.

NOTE: When 2 or more indoor units are operated with multi outdoor unit, even if any indoor unit turns thermostat off, this control does not work in the indoor unit.

(9) ECONO COOL (🌀) operation (ECONOMical operation)

When ECONO COOL button is pressed in COOL mode, set temperature is automatically set 2°C higher by the micro-processor. However, the temperature on the LCD screen on the remote controller is not changed. Also the horizontal vane swings in various cycle.

SWING operation makes you feel cooler than set temperature. So, even though the set temperature is higher, the air conditioner can keep comfort. As a result, energy can be saved.

To cancel this operation, select a different mode or press one of the following buttons in ECONO COOL operation:

ECONO COOL, VANE CONTROL, POWERFUL or NATURAL FLOW button.

(10) POWERFUL (🌀) operation

The air conditioner automatically adjusts the fan speed and the set temperature, and operates the POWERFUL mode.

The POWERFUL mode is cancelled automatically 15 minutes after operation starts, or when POWERFUL button is pressed once again within 15 minutes after operation starts. The operation mode returns to the mode prior to POWERFUL operation.

To cancel this operation manually, select a different mode or press one of the following buttons within 15 minutes after operation starts: STOP/OPERATE (OFF/ON), ECONO COOL, FAN SPEED CONTROL, NATURAL FLOW or i-save button.

2. Vertical vane

(1) Vane motor drive

These models are equipped with a stepping motor for the vertical vane. The rotating direction, speed, and angle of the motor are controlled by pulse signals (approximately 12 V) transmitted from microprocessor.

(2) The vertical vane angle and mode change as follows by pressing WIDE VANE CONTROL button.

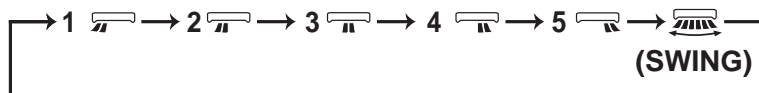

(3) Positioning

To confirm the standard position, the vane moves until it touches the vane stopper. Then the vane is set to the selected angle.

Confirmation of standard position is performed in the following cases:

(a) When STOP/OPERATE (OFF/ON) button is pressed (POWER ON).

(4) SWING (🌀) MODE

By selecting SWING mode with WIDE VANE CONTROL button, the vertical vane swings horizontally. The remote controller displays "🌀". Swing mode is cancelled when WIDE MODE CONTROL button is pressed once again.

g. TIMER OPERATION

1. How to set the time

(1) Check that the current time is set correctly.

NOTE: Timer operation will not work without setting the current time. Initially "0:00" blinks at the current time display of TIME MONITOR, so set the current time correctly with CLOCK button.

How to set the current time

(a) Press the CLOCK button.

(b) Press the TIME SET buttons (▲) and (▼) to set the current time.

- Each time FORWARD button (▲) is pressed, the set time increases by 1 minute, and each time BACKWARD button (▼) is pressed, the set time decreases by 1 minute.
- Pressing those buttons longer, the set time increases/decreases by 10 minutes.

(c) Press the CLOCK set button.

(2) Press STOP/OPERATE (OFF/ON) button to start the air conditioner.

(3) Set the time of timer.

ON timer setting

(a) Press ON TIMER button (ⓄON) during operation.

(b) Set the time of the timer using TIME SET buttons (▲) and (▼). *

OFF timer setting

(a) Press OFF TIMER button (ⓄOFF) during operation.

(b) Set the time of the timer using TIME SET buttons (▲) and (▼). *

* Each time FORWARD button (▲) is pressed, the set time increases by 10 minutes: each time BACKWARD button (▼) is pressed, the set time decreases by 10 minutes.

2. To release the timer

To release ON timer, press ON TIMER button (ⓄON).

To release OFF timer, press OFF TIMER button (ⓄOFF).

TIMER is cancelled and the display of set time disappears.

PROGRAM TIMER

- OFF timer and ON timer can be used in combination. The set time that is reached first will operate first.
- "←" and "→" display shows the order of OFF timer and ON timer operation.

(Example 1) The current time is 8:00 PM.
The unit turns off at 11:00 PM, and on at 6:00 AM.

(Example 2) The current time is 11:00 AM.
The unit turns on at 5:00 PM, and off at 9:00 PM.

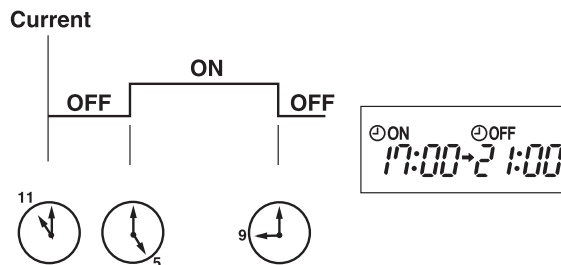
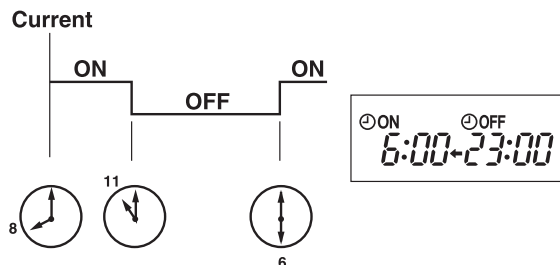

NOTE: If the main power is turned OFF or a power failure occurs while ON/OFF timer is active, the timer setting is cancelled. As these models are equipped with an auto restart function, the air conditioner starts operating with timer cancelled when power is restored.

h. WEEKLY TIMER OPERATION

- A maximum of 4 ON or OFF timers can be set for individual days of the week.
- A maximum of 28 ON or OFF timers can be set for a week.

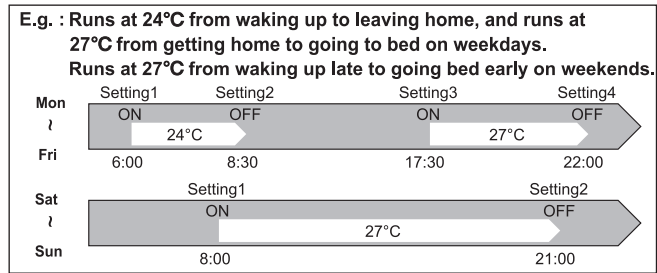

NOTE:

- The simple ON/OFF timer setting is available while the weekly timer is on. In this case, the ON/OFF timer has priority over the weekly timer; the weekly timer operation will start again after the simple ON/OFF timer is complete.
- When the weekly timer is set, temperature cannot be set to 10°C.
- The weekly timer operation and i-save operation cannot be used together.

1. How to set the weekly timer

* Make sure that the current time and day are set correctly.

(1) Press **EDIT/SEND SET** button to enter the weekly timer setting mode.

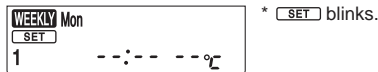

(2) Press **DAY** and **1~4** buttons to select setting day and number.

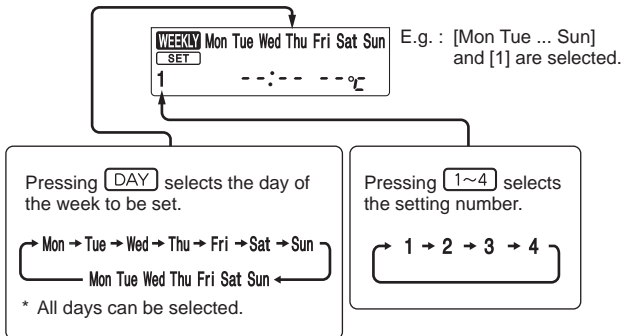

(3) Press **ON/OFF**, **TIME**, and **TEMP** buttons to set ON/OFF, time, and temperature.

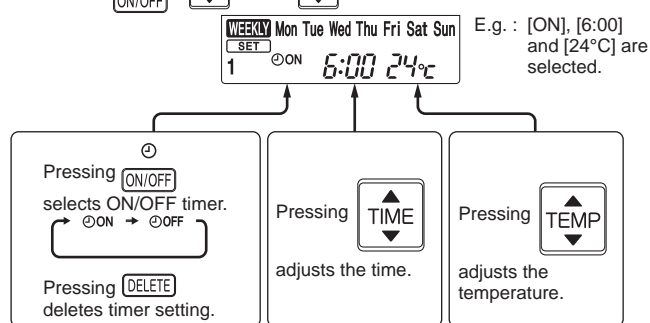

- * Hold down the button to change the time quickly.
- * The temperature can be set between 16°C and 31°C at weekly timer.

Press **DAY** and **1~4** buttons to continue setting the timer for other days and/or numbers.

(4) Press button to complete and transmit the weekly timer setting.



* which was blinking goes out, and the current time will be displayed.

NOTE:

- Press button to transmit the setting information of weekly timer to the indoor unit. Point the remote controller toward the indoor unit for 3 seconds.
- When setting the timer for more than one day of the week or one number, button does not have to be pressed per each setting. Press button once after all the settings are complete. All the weekly timer settings will be saved.
- Press button to enter the weekly timer setting mode, and press and hold button for 5 seconds to erase all weekly timer settings. Point the remote controller toward the indoor unit.

(5) Press button to turn the weekly timer ON. (lights.)

- When the weekly timer is ON, the day of the week whose timer setting is complete, will light.

Press button again to turn the weekly timer OFF. (goes out.)

NOTE:

The saved settings will not be cleared when the weekly timer is turned OFF.

2. Checking weekly timer setting

(1) Press button to enter the weekly timer setting mode.

* blinks.

(2) Press or buttons to view the setting of the particular day or number.

(3) Press button to exit the weekly timer setting.

NOTE:

When all days of the week are selected to view the settings and a different setting is included among them, --:-- --° will be displayed.

i. i-see CONTROL (👁) MODE

In the i-see control mode, the room temperature is controlled based on the sensible temperature.

- (1) Press SENSOR button with a thin instrument during COOL, DRY, HEAT and AUTO mode to activate i-see control mode (👁). The default setting is “active”.
- (2) Press SENSOR button again to activate ABSENCE DETECTION (🏠).
- (3) Press SENSOR button again to release i-see control mode.

ABSENCE DETECTION (🏠)

This function automatically changes the operation to energy-saving operation when nobody is in the room.

- (1) To activate this function, press SENSOR button until 🏠 appears on the operation display of the remote controller during the i-see control mode.
- (2) Press SENSOR button again to release ABSENCE DETECTION.

j. INDIRECT/DIRECT MODE

The INDIRECT/DIRECT mode offers finely-tuned operation by locating where an occupant is in the room.

- (1) Press INDIRECT/DIRECT button during COOL, DRY, HEAT or AUTO mode to activate INDIRECT/DIRECT mode. This mode is only available when the i-see control mode is effective.
- (2) Each press of INDIRECT/DIRECT button changes INDIRECT/DIRECT in the following order:



(INDIRECT): An occupant will be less exposed to direct airflow.

(DIRECT) : Mainly the vicinity of an occupant will be air-conditioned.

NOTE:

- Horizontal and vertical airflow directions will be automatically selected.
- If you still feel uncomfortable with the air direction determined by the INDIRECT mode, adjust the air direction manually.
- Cancelling the i-see control mode automatically cancels the INDIRECT/DIRECT mode. INDIRECT/DIRECT mode is also cancelled when the VANE or WIDE VANE buttons is pressed.
- Do not touch the i-see SENSOR. This may cause malfunction of the i-see SENSOR.

k. NATURAL FLOW (≅) OPERATION

In NATURAL FLOW operation, air flow will become more like natural wind. An occupant will not be directly exposed to the air flow and feel more comfortable.

- (1) Press NATURAL FLOW button during COOL or FAN mode to start NATURAL FLOW operation.
- (2) Press NATURAL FLOW button again to cancel NATURAL FLOW operation.

- NATURAL FLOW operation is also cancelled when the POWERFUL or ECONO COOL button is pressed.

NOTE: As the fan speed changes constantly during NATURAL FLOW operation, the sound of air flow, wind velocity and air flow temperature also change. This is not a malfunction.

l. AIR PURIFYING (+) OPERATION

In the AIR PURIFYING operation, the indoor unit built-in device reduces airborne fungi, viruses, mold, and allergens.

- (1) Press PURIFIER button to start AIR PURIFYING operation.
 - AIR PURIFYING lamp turns on. (Display section)
- (2) Press PURIFIER button again to cancel AIR PURIFYING operation.
 - AIR PURIFYING lamp turns off. (Display section)

NOTE:

- Never touch the air purifying device during operation. Although the air purifying device is safety-conscious design, touching this device could be the cause of trouble as this device discharge high voltage electricity.
- A “hissing” sound may be heard during the air purifying operation. This sound is produced when plasma is being discharged. This is not a malfunction.
- AIR PURIFYING lamp does not turn on if the front panel is not closed completely.

m. i-save (B) OPERATION

1. How to set i-save operation

- (1) Press STOP/OPERATE (OFF/ON) button.
- (2) Select COOL, HEAT or ECONO COOL mode.
- (3) Press i-save button.
- (4) Set the temperature, fan speed, and airflow direction for i-save operation.

NOTE:

- i-save operation cannot be selected during DRY or AUTO mode operation.
- The setting range of HEAT mode i-save operation is 10°C and 16 - 31°C.
- 2 groups of setting can be saved. (One for COOL/ECONO COOL, one for HEAT)
- i-save operation and the weekly timer operation cannot be used together.

2. How to cancel operation

- Press i-save button again.
 - i-save operation can also be cancelled by pressing POWERFUL button or OPERATION SELECT button to change the operation mode.
- The same setting is select from the next time by simply pressing i-save button.

n. EMERGENCY/TEST OPERATION

In the case of test run operation or emergency operation, use EMERGENCY OPERATION switch on the right side of the indoor unit. Emergency operation is available when the remote controller is missing or has failed, or when the batteries in the remote controller are running down. The unit will start and OPERATION INDICATOR lamp will light up.

The first 30 minutes of operation is the test run operation. This operation is for servicing. The indoor fan runs at High speed and the temperature control does not work.

After 30 minutes of test run operation, the system shifts to EMERGENCY COOL/HEAT MODE with a set temperature of 24°C. The fan speed shifts to Med.

The coil frost prevention works even in the test run or the emergency operation.

In the test run or emergency operation, the horizontal vane operates in VANE AUTO (Ⓜ) mode.

Emergency operation continues until EMERGENCY OPERATION switch is pressed once or twice or the unit receives any signal from the remote controller. In the latter case, normal operation will start.

NOTE: Do not press EMERGENCY OPERATION switch during normal operation.

Operation mode	COOL/HEAT
Set temperature	24°C
Fan speed	Med.
Horizontal vane	Auto

The operation mode is indicated by the Operation Indicator lamp as following

Operation Indicator lamp

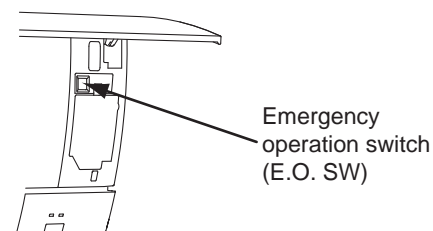
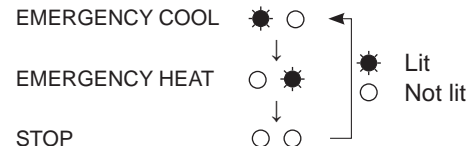

o. 3-MINUTE TIME DELAY OPERATION

When the system turns OFF, compressor will not restart for 3 minutes as 3-minute time delay function operates to protect compressor from overload.

p. ACTUATOR CONTROL

p-1. Outdoor fan motor control

The fan motor turns ON/OFF, interlocking with the compressor.

[ON] The fan motor turns ON 5 seconds before the compressor starts up.

[OFF] The fan motor turns OFF 15 seconds after the compressor has stopped running.

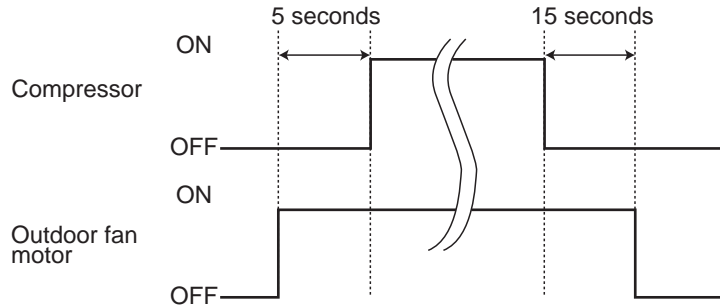

p-2. R.V. coil control

Heating ON

Cooling OFF

Dry OFF

NOTE: The 4-way valve reverses for 5 seconds right before start-up of the compressor.

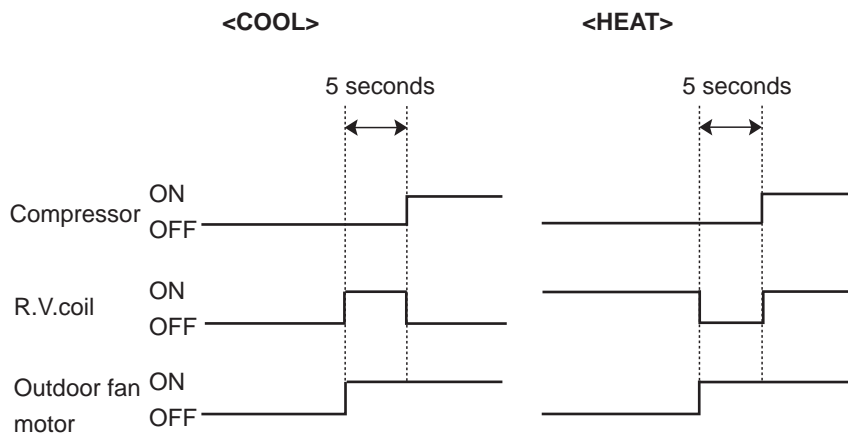

p-3. Relation between main sensor and actuator

Sensor	Purpose	Actuator					
		Compressor	LEV	Outdoor fan motor	R.V.coil	Indoor fan motor	Defrost heater
Discharge temperature thermistor	Protection	○	○				
Indoor coil temperature thermistor	Cooling: Coil frost prevention	○					
	Heating: High pressure protection	○	○				
Defrost thermistor	Heating: Defrosting	○	○	○	○	○	
Fin temperature thermistor	Protection	○		○			
Ambient temperature thermistor	Cooling: Low ambient temperature operation	○	○	○			
	Heating: Defrosting (Heater)						○
Outdoor heat exchanger temperature thermistor	Cooling: Low ambient temperature operation	○	○	○			
	Cooling: High pressure protection	○	○	○			

OPERATION AND ACTUATOR CONTROL

WALL-MOUNTED

C.1.9.9 MSZ-EF•VG/K, SF•VE3 Series

- | | | | | |
|--------------|--------------|--------------|------------|-------------|
| MSZ-EF18VGW | MSZ-EF18VGB | MSZ-EF18VGS | | |
| MSZ-EF18VGKW | MSZ-EF18VGKB | MSZ-EF18VGKS | | |
| MSZ-EF22VGW | MSZ-EF22VGB | MSZ-EF22VGS | | |
| MSZ-EF22VGKW | MSZ-EF22VGKB | MSZ-EF22VGKS | | |
| MSZ-EF25VGW | MSZ-EF25VGB | MSZ-EF25VGS | MUZ-EF25VG | MUZ-EF25VGH |
| MSZ-EF25VGKW | MSZ-EF25VGKB | MSZ-EF25VGKS | | |
| MSZ-EF35VGW | MSZ-EF35VGB | MSZ-EF35VGS | MUZ-EF35VG | MUZ-EF35VGH |
| MSZ-EF35VGKW | MSZ-EF35VGKB | MSZ-EF35VGKS | | |
| MSZ-EF42VGW | MSZ-EF42VGB | MSZ-EF42VGS | MUZ-EF42VG | |
| MSZ-EF42VGKW | MSZ-EF42VGKB | MSZ-EF42VGKS | | |
| MSZ-EF50VGW | MSZ-EF50VGB | MSZ-EF50VGS | MUZ-EF50VG | |
| MSZ-EF50VGKW | MSZ-EF50VGKB | MSZ-EF50VGKS | | |
| MSZ-SF25VE3 | MUZ-SF25VE | MUZ-SF25VEH | | |
| MSZ-SF35VE3 | MUZ-SF35VE | MUZ-SF35VEH | | |
| MSZ-SF42VE3 | MUZ-SF42VE | MUZ-SF42VEH | | |
| MSZ-SF50VE3 | MUZ-SF50VE | MUZ-SF50VEH | | |

WIRELESS REMOTE CONTROLLER

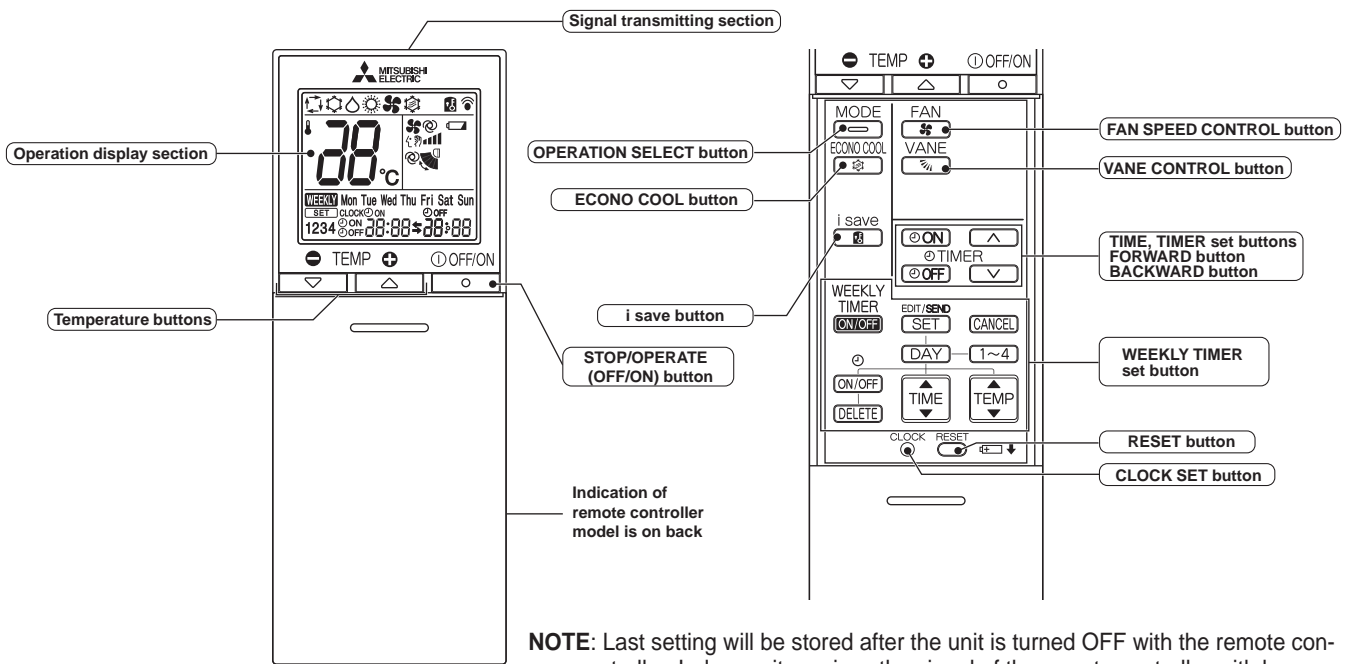

INDOOR UNIT DISPLAY SECTION

Operation Indicator lamp

The operation indicator at the right side of the indoor unit indicates the operation state.

•The following indication applies regardless of shape of the indication.

Indication	Operation state	Room temperature
● ●	The unit is operating to reach the set temperature	About 2°C or more away from set temperature
● ○	The room temperature is approaching the set temperature	About 1 to 2°C from set temperature
● ●	Standby mode (Only during multi system operation)	—

- Lit
- Blinking
- Not lit

OPERATION AND ACTUATOR CONTROL
WALL-MOUNTED

a. COOL (❄️) OPERATION

- (1) Press / STOP/OPERATE (OFF/ON) button.
OPERATION INDICATOR lamp of the indoor unit turns on with a beep tone.
- (2) Select COOL mode with OPERATION SELECT button.
- (3) Press TEMPERATURE buttons TEMP \ominus or \oplus button to select the desired temperature. The setting range is 16 - 31°C.

1. Coil frost prevention

The compressor operational frequency is controlled by the temperature of the indoor heat exchanger to prevent the coil from frosting.

When the temperature of indoor heat exchanger becomes too low, the coil frost prevention mode works.

The indoor fan operates at the set speed and the compressor stops. This mode continues until the temperature of indoor heat exchanger rises.

2. Low outside temperature operation

When the outside temperature is lower, low outside temperature operation starts, and the outdoor fan slows or stops.

3. Indoor fan speed control

When the thermostat turns OFF, the indoor fan operates very Low to reduce power consumption.

When the room temperature rises and the thermostat is ON, the indoor fan operates according to the settings on the remote controller.

b. DRY (☀️) OPERATION

- (1) Press STOP/OPERATE (OFF/ON) button.
OPERATION INDICATOR lamp of the indoor unit turns on with a beep tone.
- (2) Select DRY mode with OPERATION SELECT button.
- (3) The set temperature is determined from the initial room temperature.

1. Coil frost prevention

Coil frost prevention works the same way as that in COOL mode. (a.1.)

2. Low outside temperature operation

Low outside temperature operation works the same way as that in COOL mode. (a.2.)

3. Indoor fan speed control

Indoor fan speed control works the same way as that in COOL mode. (a.3.)

c. FAN (🌀) OPERATION

- (1) OPERATION INDICATOR lamp of the indoor unit turns on with a beep tone.
- (2) Select FAN mode with OPERATION SELECT button.
- (3) Select the desired fan speed. When AUTO, it becomes Low.
Only indoor fan operates.
Outdoor unit does not operate.

d. HEAT (🔥) OPERATION

- (1) Press STOP/OPERATE (OFF/ON) button.
OPERATION INDICATOR lamp of the indoor unit turns on with a beep tone.
- (2) Select HEAT mode with OPERATION SELECT button.
- (3) Press TEMPERATURE buttons TEMP \ominus or \oplus button to select the desired temperature. The setting range is 16 - 31°C.

1. Cold air prevention control

When the compressor is not operating or is starting, and the temperature of indoor heat exchanger and/or the room temperature is low or when defrosting is being done, the indoor fan will stop or rotate in Very Low speed.

2. High pressure protection

The compressor operational frequency is controlled by the temperature of the indoor heat exchanger to prevent the condensing pressure from increasing excessively.

When the temperature of indoor heat exchanger becomes too high, the high pressure protection works.

The indoor fan operates following the cold air prevention control. This mode continues until the temperature of indoor heat exchanger falls.

3. Defrosting

Defrosting starts when the temperature of outdoor heat exchanger becomes too low.

The compressor stops once, the indoor/outdoor fans stop, the 4-way valve reverses, and the compressor restarts.

This mode continues until the temperature of outdoor heat exchanger rises or the fixed time passes.

e. AUTO CHANGE OVER ... AUTO MODE OPERATION

Once desired temperature is set, unit operation is switched automatically between COOL and HEAT operation.

Mode selection

- (1) Initial mode
When unit starts the operation with AUTO operation from OFF:
 - If the room temperature is higher than the set temperature, operation starts in COOL mode.
 - If the room temperature is equal to or lower than the set temperature, operation starts in HEAT mode.
- (2) Mode change
COOL mode changes to HEAT mode when about 15 minutes have passed with the room temperature 1°C below the set temperature.
HEAT mode changes to COOL mode when about 15 minutes have passed with the room temperature 1°C above the set temperature.

NOTE 1

If 2 or more indoor units are operating in multi system, there might be a case that the indoor unit, which is operating in ☐ (AUTO), cannot change over to the other operating mode (COOL ↔ HEAT) and becomes a state of standby.

Refer to **NOTE 2 "FOR MULTI SYSTEM AIR CONDITIONER"**.

NOTE 2

FOR MULTI SYSTEM AIR CONDITIONER

OUTDOOR UNIT: MXZ series

Multi system air conditioner can connect 2 or more indoor units with one outdoor unit.

- When you try to operate 2 or more indoor units with one outdoor unit simultaneously, one for the cooling and the others for heating, the operation mode of the indoor unit that operates first is selected. Other indoor units cannot operate, and operation indicator lamp blinks as shown in the figure below. In this case, please set all the indoor units to the same operation mode.

OPERATION INDICATOR

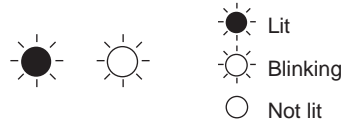

- When indoor unit starts the operation while the defrosting of outdoor unit is being done, it takes a few minutes (max. 10 minutes) to blow out the warm air.
- In the heating operation, though indoor unit that does not operate may get warm or the sound of refrigerant flowing may be heard, they are not malfunction. The reason is that the refrigerant continuously flows into it.

f. AUTO VANE OPERATION

1. Horizontal vane

(1) Vane motor drive

These models are equipped with a stepping motor for the horizontal vane. The rotating direction, speed, and angle of the motor are controlled by pulse signals (approximately 12 V) transmitted from indoor microprocessor.

(2) The horizontal vane angle and mode change as follows by pressing VANE CONTROL button.

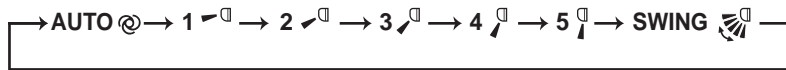

(3) Positioning

To confirm the standard position, the vane moves until it touches the vane stopper. Then the vane is set to the selected angle.

Confirming of standard position is performed in the following cases:

- When the operation starts or finishes (including timer operation).
- When the test run starts.
- When standby mode (only during multi system operation) starts or finishes.

(4) VANE AUTO (@) mode

In VANE AUTO mode, the microprocessor automatically determines the vane angle to make the optimum room temperature distribution.

In COOL and DRY operation

Vane angle is fixed to Horizontal position.



In HEAT operation

Vane angle is fixed to Angle 4.



(5) STOP (operation OFF) and ON TIMER standby

In the following cases, the horizontal vane returns to the closed position.

- When STOP/OPERATE (OFF/ON) button is pressed (POWER OFF).
- When the operation is stopped by the emergency operation.
- When ON TIMER is ON standby.

(6) Dew prevention

During COOL or DRY operation with the vane angle at Angle 4 or 5 when the compressor cumulative operation time exceeds 1 hour, the vane angle automatically changes to Angle 1 for dew prevention.

(7) SWING (with vane icon) mode

By selecting SWING mode with VANE CONTROL button, the horizontal vanes swing vertically.

When COOL, DRY or FAN mode is selected, only the upper vane swings.

(8) Cold air prevention in HEAT operation

The horizontal vane position is set to Upward.

NOTE: When 2 or more indoor units are operated with multi outdoor unit, even if any indoor unit turns thermostat off, this control does not work in the indoor unit.

(9) ECONO COOL (🌀) operation (ECONOmical operation)

When ECONO COOL button is pressed in COOL mode, set temperature is automatically set 2°C higher by microprocessor. However, the temperature on the LCD screen on the remote controller is not changed.

Also the horizontal vane swings in various cycle.

SWING operation makes you feel cooler than set temperature. So, even though the set temperature is higher, the air conditioner can keep comfort. As a result, energy can be saved.

To cancel this operation, select a different mode or press one of the following buttons in ECONO COOL operation: ECONO COOL, or VANE CONTROL button.

g. TIMER OPERATION

1. How to set the time

(1) Check that the current time is set correctly.

NOTE: Timer operation will not work without setting the current time. Initially “0:00” blinks at the current time display of TIME MONITOR, so set the current time correctly with CLOCK SET button.

How to set the current time

(a) Press the CLOCK set button.

(b) Press the TIME SET buttons (⏮ and ⏭) to set the current time.

- Each time FORWARD button (⏮) is pressed, the set time increases by 1 minute, and each time BACKWARD button (⏭) is pressed, the set time decreases by 1 minute.
- Pressing those buttons longer, the set time increases/decreases by 10 minutes.

(c) Press the CLOCK set button.

(2) Press STOP/OPERATE (OFF/ON) button to start the air conditioner.

(3) Set the time of timer.

ON timer setting

(a) Press ON TIMER button (🕒ON) during operation.

(b) Set the time of the timer using TIME SET buttons (⏮ and ⏭). *

OFF timer setting

(a) Press OFF TIMER button (🕒OFF) during operation.

(b) Set the time of the timer using TIME SET buttons (⏮ and ⏭). *

* Each time FORWARD button (⏮) is pressed, the set time increases by 10 minutes: each time BACKWARD button (⏭) is pressed, the set time decreases by 10 minutes.

2. To release the timer

To release ON timer, press ON TIMER button (🕒ON).

To release OFF timer, press OFF TIMER button (🕒OFF).

TIMER is cancelled and the display of set time disappears.

PROGRAM TIMER

- OFF timer and ON timer can be used in combination. The set time that is reached first will operate first.
- “←” and “→” display shows the order of OFF timer and ON timer operation.

(Example 1) The current time is 8:00 PM.

The unit turns off at 11:00 PM, and on at 6:00 AM.

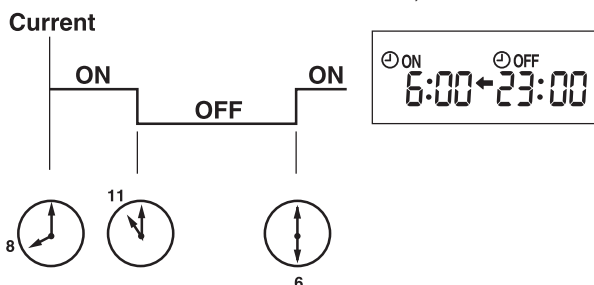

(Example 2) The current time is 11:00 AM.

The unit turns on at 5:00 PM, and off at 9:00 PM.

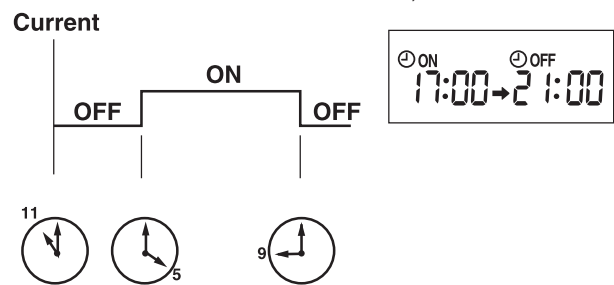

NOTE: If the main power is turned OFF or a power failure occurs while ON/OFF timer is active, the timer setting is cancelled. As these models are equipped with an auto restart function, the air conditioner starts operating with timer cancelled when power is restored.

h. WEEKLY TIMER OPERATION

- A maximum of 4 ON or OFF timers can be set for individual days of the week.
- A maximum of 28 ON or OFF timers can be set for a week.

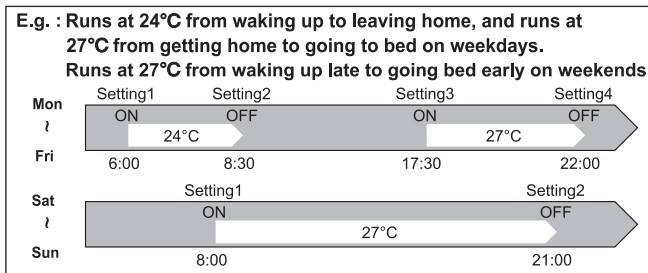

NOTE:

- The simple ON/OFF timer setting is available while the weekly timer is on. In this case, the ON/OFF timer has priority over the weekly timer; the weekly timer operation will start again after the simple ON/OFF timer is complete.
- When the weekly timer is set, temperature cannot be set to 10°C.
- The weekly timer operation and i-save operation cannot be used together.

1. How to set the weekly timer

* Make sure that the current time and day are set correctly.

(1) Press **EDIT/SEND SET** button to enter the weekly timer setting mode.

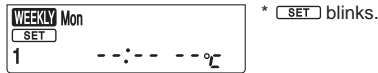

(2) Press **DAY** and **1~4** buttons to select setting day and number.

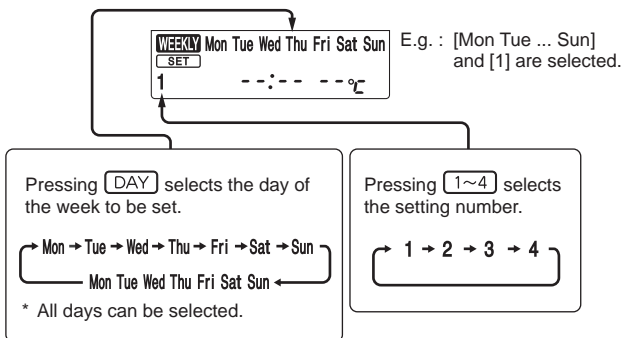

(3) Press **ON/OFF**, **TIME**, and **TEMP** buttons to set ON/OFF, time, and temperature.

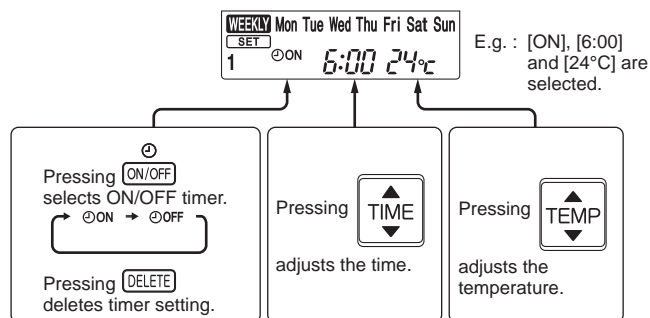

* Hold down the button to change the time quickly.





Press **DAY** and **1~4** buttons to continue setting the timer for other days and/or numbers.



(4) Press  button to complete and transmit the weekly timer setting.





*  which was blinking goes out, and the current time will be displayed.

NOTE:

- Press  button to transmit the setting information of weekly timer to the indoor unit. Point the remote controller toward the indoor unit for 3 seconds.
- When setting the timer for more than one day of the week or one number,  button does not have to be pressed per each setting. Press  button once after all the settings are complete. All the weekly timer settings will be saved.
- Press  button to enter the weekly timer setting mode, and press and hold  button for 5 seconds to erase all weekly timer settings. Point the remote controller toward the indoor unit.

(5) Press  button to turn the weekly timer ON. ()

- When the weekly timer is ON, the day of the week whose timer setting is complete, will light.

Press  button again to turn the weekly timer OFF. ()



NOTE:

The saved settings will not be cleared when the weekly timer is turned OFF.

2. Checking weekly timer setting

(1) Press  button to enter the weekly timer setting mode.

*  blinks.

(2) Press  or  buttons to view the setting of the particular day or number.

(3) Press  button to exit the weekly timer setting.

NOTE:

When all days of the week are selected to view the settings and a different setting is included among them, --:-- --° will be displayed.

i. i-save OPERATION

1. How to set i-save operation

- (1) Press STOP/OPERATE (OFF/ON) button.
- (2) Select COOL, HEAT or ECONO COOL mode.
- (3) Press i-save button.
- (4) Set the temperature, fan speed, and airflow direction for i-save operation.

NOTE:

- i-save operation cannot be selected during DRY or AUTO mode operation.
- The setting range of HEAT mode i-save operation is 10°C and 16 - 31°C.
- 2 groups of setting can be saved. (One for COOL/ECONO COOL, one for HEAT)
- i-save operation and the weekly timer operation cannot be used together.

2. How to cancel operation

- Press i-save button again.
- i-save operation can also be cancelled by pressing OPERATION SELECT button to change the operation mode. The preferred setting can be saved for the next time with a single press of i-save button.

j. EMERGENCY/TEST OPERATION

In the case of test run operation or the emergency operation, use the emergency operation switch on the right side of the indoor unit. The emergency operation is available when the remote controller is missing or has failed, or the batteries in the remote controller are running down. The unit will start and OPERATION INDICATOR lamp will light up.

The first 30 minutes of operation is the test run operation. This operation is for servicing. The indoor fan runs at High speed and the temperature control does not work.

After 30 minutes of test run operation, the system shifts to EMERGENCY COOL/HEAT MODE with a set temperature of 24°C. The fan speed shifts to Med. The coil frost prevention works even in the test run or the emergency operation.

In the test run or the emergency operation, the horizontal vane operates in VANE AUTO (Ⓢ) mode.

The emergency operation continues until the emergency operation switch is pressed once or twice or the unit receives any signal from the remote controller. In the latter case normal operation will start.

NOTE: Do not press the emergency operation switch during normal operation.

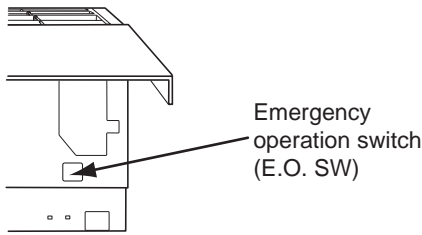

Operation mode	COOL/HEAT
Set temperature	24°C
Fan speed	Med.
Horizontal vane	Auto

The operation mode is indicated by the Operation Indicator lamp as following

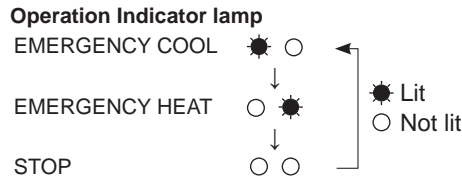

k. 3-MINUTE TIME DELAY OPERATION

When the system turns OFF, compressor will not restart for 3 minutes as 3-minute time delay function operates to protect compressor from overload.

I. ACTUATOR CONTROL

I-1. Outdoor fan motor control

The fan motor turns ON/OFF, interlocking with the compressor.

[ON] The fan motor turns ON 5 seconds before the compressor starts up.

[OFF] The fan motor turns OFF 15 seconds after the compressor has stopped running.

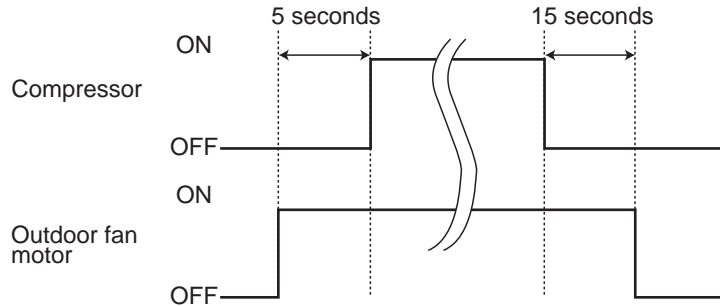

I-2. R.V. coil control

Heating ON

Cooling OFF

Dry OFF

NOTE: The 4-way valve reverses for 5 seconds right before start-up of the compressor.

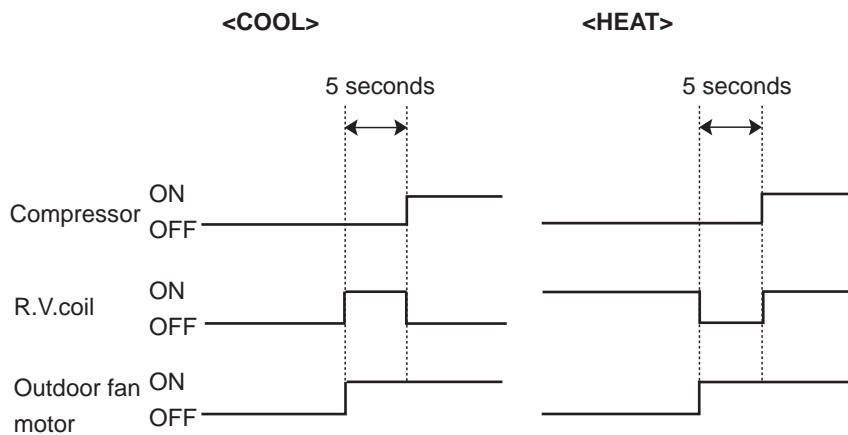

I-3. Relation between main sensor and actuator

Sensor	Purpose	Actuator					
		Compressor	LEV	Outdoor fan motor	R.V.coil	Indoor fan motor	Defrost heater
Discharge temperature thermistor	Protection	○	○				
Indoor coil temperature thermistor	Cooling: Coil frost prevention	○					
	Heating: High pressure protection	○	○				
Defrost thermistor	Heating: Defrosting	○	○	○	○	○	
Fin temperature thermistor	Protection	○		○			
Ambient temperature thermistor	Cooling: Low ambient temperature operation	○	○	○			
	Heating: Defrosting (Heater)						○
Outdoor heat exchanger temperature thermistor	Cooling: Low ambient temperature operation	○	○	○			
	Cooling: High pressure protection	○	○	○			

OPERATION AND ACTUATOR CONTROL

WALL-MOUNTED

C.1.9.10 MSZ-BT•VG/K Series

- MSZ-BT20VG MSZ-BT25VG MSZ-BT35VG MSZ-BT50VG
- MSZ-BT20VGK MSZ-BT25VGK MSZ-BT35VGK MSZ-BT50VGK
- MUZ-BT20VG MUZ-BT25VG MUZ-BT35VG MUZ-BT50VG

WIRELESS REMOTE CONTROLLER

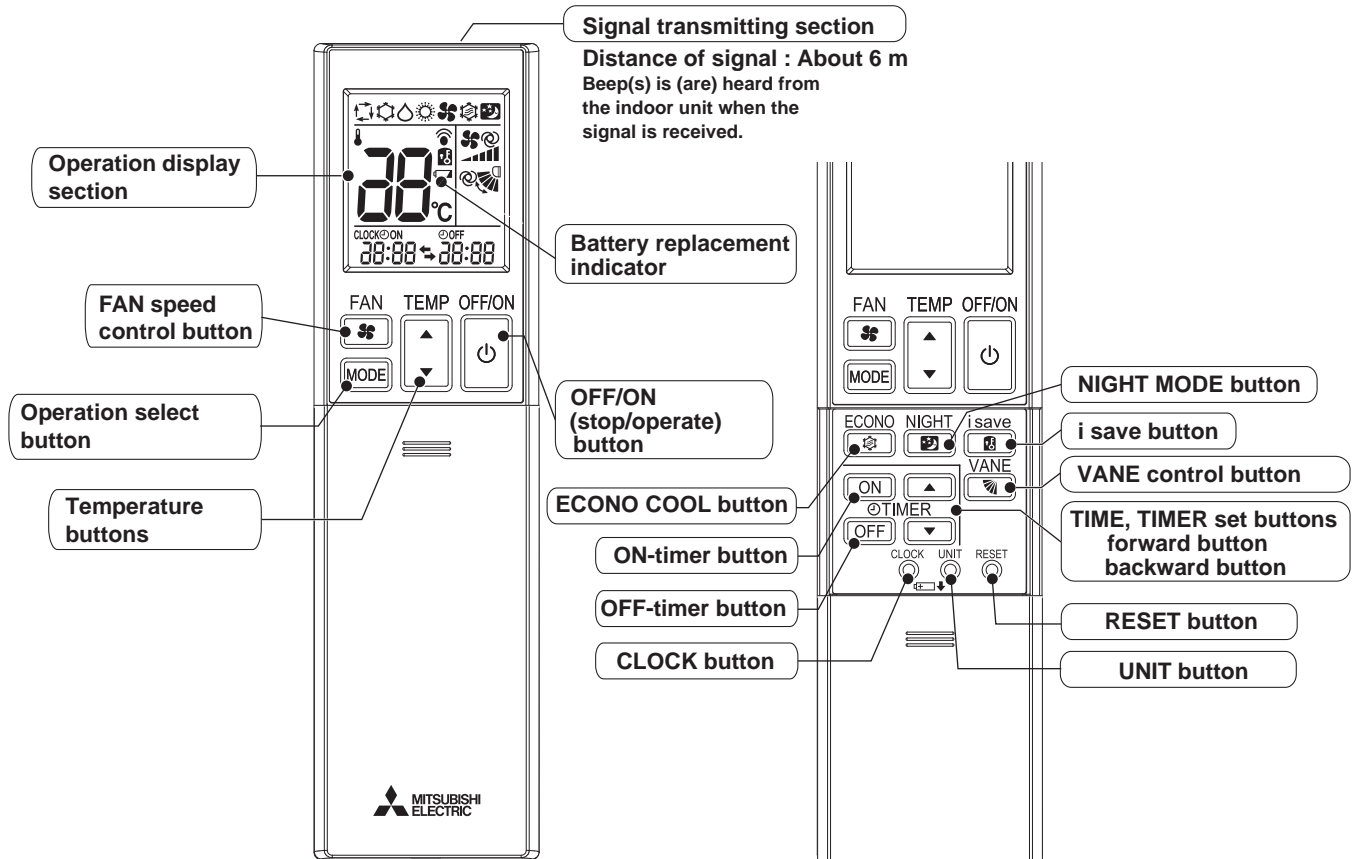

NOTE: Last setting will be stored after the unit is turned OFF with the remote controller. Indoor unit receives the signal of the remote controller with beeps.

INDOOR UNIT DISPLAY SECTION

Operation Indicator lamp

The operation indicator at the right side of the indoor unit indicates the operation state.

• The following indication applies regardless of shape of the indication.

Indication	Operation state	Room temperature
● ●	The unit is operating to reach the set temperature	About 2°C or more away from set temperature
● ○	The room temperature is approaching the set temperature	About 1 to 2°C from set temperature
● ☉	Standby mode (only during multi system operation)	—

- Lit
- ☉ Blinking
- Not lit

a. COOL (❄️) OPERATION

- (1) Press OFF/ON (stop/operate) button.

OPERATION INDICATOR lamp of the indoor unit turns on with a beep tone.

- (2) Select COOL mode with Operation select button.
- (3) Press Temperature buttons (TOO WARM or TOO COOL button) to select the desired temperature. The setting range is 16 - 31°C.

1. Coil frost prevention

The compressor operational frequency is controlled by the temperature of the indoor heat exchanger to prevent the coil from frosting.

When the temperature of indoor heat exchanger becomes too low, the coil frost prevention mode works.

The indoor fan operates at the set speed and the compressor stops. This mode continues until the temperature of indoor heat exchanger rises.

2. Low outside temperature operation

When the outside temperature is lower, low outside temperature operation starts, and the outdoor fan slows or stops.

b. DRY (☀️) OPERATION

- (1) Press OFF/ON (stop/operate) button.

OPERATION INDICATOR lamp of the indoor unit turns on with a beep tone.

- (2) Select DRY mode with Operation select button.
- (3) The set temperature is determined from the initial room temperature.

1. Coil frost prevention

Coil frost prevention works the same way as that in COOL mode. (a.1.)

2. Low outside temperature operation

Low outside temperature operation works the same way as that in COOL mode. (a.2.)

c. FAN (🌀) OPERATION

- (1) Press OFF/ON (stop/operate) button.

OPERATION INDICATOR lamp of the indoor unit turns ON with a beep tone.

- (2) Select FAN mode with Operation select button.
- (3) Select the desired fan speed. When AUTO, it becomes Low.
Only indoor fan operates. Outdoor unit does not operate.

d. HEAT (🔥) OPERATION

- (1) Press OFF/ON (stop/operate) button.

OPERATION INDICATOR lamp of the indoor unit turns on with a beep tone.

- (2) Select HEAT mode with Operation select button.
- (3) Press Temperature buttons (TOO WARM or TOO COOL button) to select the desired temperature.
The setting range is 10 ~ 31°C.

1. Cold air prevention control

When the compressor is not operating or is starting, and the temperature of indoor heat exchanger and/or the room temperature is low or when defrosting is being done, the indoor fan will stop or rotate in Very Low speed.

2. High pressure protection

The compressor operational frequency is controlled by the temperature of the indoor heat exchanger to prevent the condensing pressure from increasing excessively.

When the temperature of indoor heat exchanger becomes too high, the high pressure protection works.

The indoor fan operates following the cold air prevention control. This mode continues until the temperature of indoor heat exchanger falls.

3. Defrosting

Defrosting starts when the temperature of outdoor heat exchanger becomes too low.

The compressor stops once, the indoor/outdoor fans stop, the 4-way valve reverses, and the compressor re-starts.

This mode continues until the temperature of outdoor heat exchanger rises or the fixed time passes.

**e. MULTI SYSTEM OPERATION
FOR MULTI SYSTEM AIR CONDITIONER**

OUTDOOR UNIT: MXZ series

Multi system air conditioner can connect 2 or more indoor units with 1 outdoor unit.

- When you try to operate 2 or more indoor units with 1 outdoor unit simultaneously, one for the cooling and the others for heating, the operation mode of the indoor unit that operates first is selected. Other indoor units cannot operate, and operation indicator lamp blinks as shown in the figure below. In this case, please set all the indoor units to the same operation mode.

OPERATION INDICATOR



- When indoor unit starts the operation while the defrosting of outdoor unit is being done, it takes a few minutes (max. 10 minutes) to blow out the warm air.
- In the heating operation, though indoor unit is not operating, it may get warm or the sound of refrigerant flow may be heard. It is not malfunction. The reason is that the refrigerant continuously flows into it.

f. AUTO VANE OPERATION

1. Horizontal vane

(1) Vane motor drive

These models are equipped with a stepping motor for the horizontal vane. The rotating direction, speed, and angle of the motor are controlled by pulse signals (approximately 12 V) transmitted from indoor microprocessor.

(2) The horizontal vane angle and mode change as follows by pressing VANE control button.

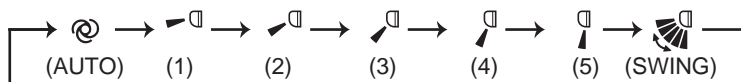

(3) Positioning

To confirm the standard position, the vane moves until it touches the vane stopper. Then the vane is set to the selected angle.

Confirmation of standard position is performed in the following cases:

- (a) When the operation starts or finishes (including timer operation).
- (b) When the test run starts.
- (c) When standby mode (only during multi system operation) starts or finishes.

(4) VANE AUTO (@) mode

In VANE AUTO mode, the microprocessor automatically determines the vane angle to make the optimum room temperature distribution.

In COOL and DRY operation

Vane angle is fixed to Horizontal position.

In HEAT operation

Vane angle is fixed to Angle 5.

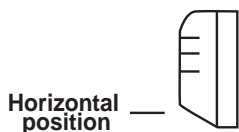

(5) STOP (operation OFF) and ON TIMER standby

In the following cases, the horizontal vane returns to the closed position.

- (a) When OFF/ON (stop/operate) button is pressed (POWER OFF).
- (b) When the operation is stopped by the emergency operation.
- (c) When ON TIMER is ON standby.

(6) Dew prevention

During COOL or DRY operation with the vane angle at Angle 3 to 5 when the compressor cumulative operation time exceeds 1 hour, the vane angle automatically changes to Angle 2 for dew prevention.

(7) SWING () mode

By selecting SWING mode with VANE control button, the horizontal vane swings vertically.

(8) ECONO COOL () operation (ECONOMical operation)

When ECONO COOL button is pressed in COOL mode, set temperature and the air flow direction is automatically changed by the microprocessor. However, the temperature on the LCD screen on the remote controller is not changed. Also the horizontal vane swings in various cycle.

SWING operation makes you feel cooler than set temperature. So, even though the set temperature is higher, the air conditioner can keep comfort. As a result, energy can be saved.

To cancel this operation, select a different mode or press one of the following buttons in ECONO COOL operation: ECONO COOL, VANE control button.

g. TIMER OPERATION (ON/OFF TIMER)

1. How to set the timer

- (1) Press **ON** or **OFF** during operation to set the timer.
- (2) **ON** (ON timer) : The unit turns ON at the set time.
OFF (OFF timer) : The unit turns OFF at the set time.
- (3) Press **▲** (forward) and **▼** (backward) to set the time of timer.

h. EMERGENCY/TEST OPERATION

In the case of test run operation or the emergency operation, use the the emergency operation switch in the right side of the indoor unit. The emergency operation is available when the remote controller is missing or has failed, or when the batteries in the remote controller are running down. The unit will start and OPERATION INDICATOR lamp will light up. The first 30 minutes of operation is the test run operation. This operation is for servicing. The indoor fan runs at High speed and the temperature control does not work. After 30 minutes of test run operation, the system shifts to EMERGENCY COOL/HEAT MODE with a set temperature of 24°C. The fan speed shifts to Medium. The coil frost prevention works even in the test run or the the emergency operation. In the test run or the emergency operation, the horizontal vane operates in VANE AUTO (@) mode. The emergency operation continues until the the emergency operation switch is pressed once or twice or the unit receives any signal from the remote controller. In the latter case, normal operation will start.

NOTE: Do not press the the emergency operation switch during normal operation.

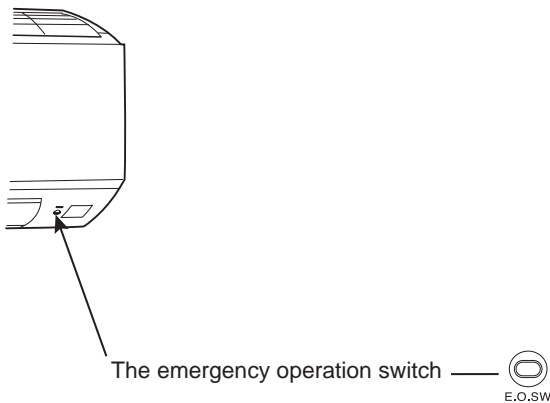

Operation mode	COOL/HEAT
Set temperature	24°C
Fan speed	Medium
Horizontal vane	Auto

The operation mode is indicated by the Operation Indicator lamp as following

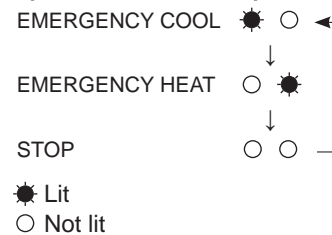

i. 3-MINUTE TIME DELAY OPERATION

When the system turns OFF, compressor will not restart for 3 minutes as 3-minute time delay function operates to protect compressor from overload.

OPERATION AND ACTUATOR CONTROL

WALL-MOUNTED

j. ACTUATOR CONTROL

j-1. OUTDOOR FAN MOTOR CONTROL

The fan motor turns ON/OFF, interlocking with the compressor.

[ON] The fan motor turns ON 5 seconds before the compressor starts up.

[OFF] The fan motor turns OFF 15 seconds after the compressor has stopped running.

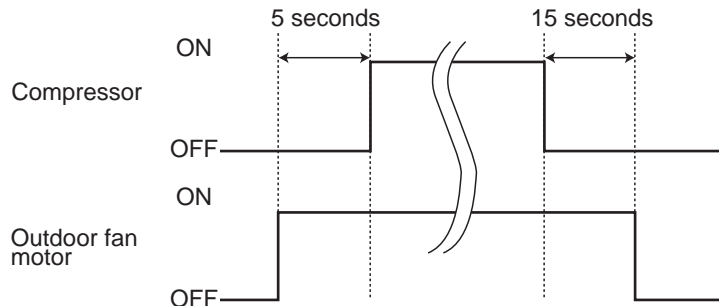

j-2. R.V. COIL CONTROL

Heating ON

Cooling OFF

Dry OFF

NOTE: The 4-way valve reverses for 5 seconds right before start-up of the compressor.

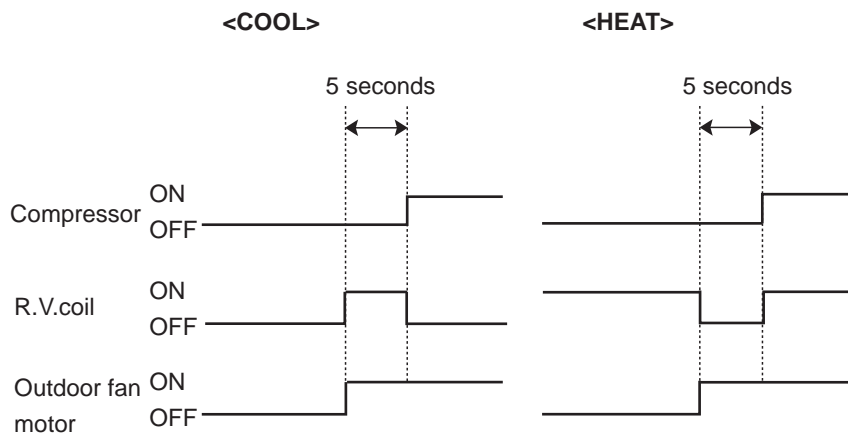

j-3. RELATION BETWEEN MAIN SENSOR AND ACTUATOR

Sensor	Purpose	Actuator					
		Compressor	LEV	Outdoor fan motor	R.V. coil	Indoor fan motor	Defrost heater
Discharge temperature thermistor	Protection	○	○				
Indoor coil temperature thermistor	Cooling: Coil frost prevention	○					
	Heating: High pressure protection	○	○				
Defrost thermistor	Heating: Defrosting	○	○	○	○	○	
Fin temperature thermistor	Protection	○		○			
Ambient temperature thermistor	Cooling: Low ambient temperature operation	○	○	○			
	Heating: Defrosting (Heater)						○
Outdoor heat exchanger temperature thermistor	Cooling: Low ambient temperature operation	○	○	○			
	Cooling: High pressure protection	○	○	○			

WALL-MOUNTED OPERATION AND ACTUATOR CONTROL

C.1.9.11 MSZ-DW•VF Series
MSZ-DW25VF MSZ-DW35VF MSZ-DW50VF
MUZ-DW25VF MUZ-DW35VF MUZ-DW50VF

WIRELESS REMOTE CONTROLLER

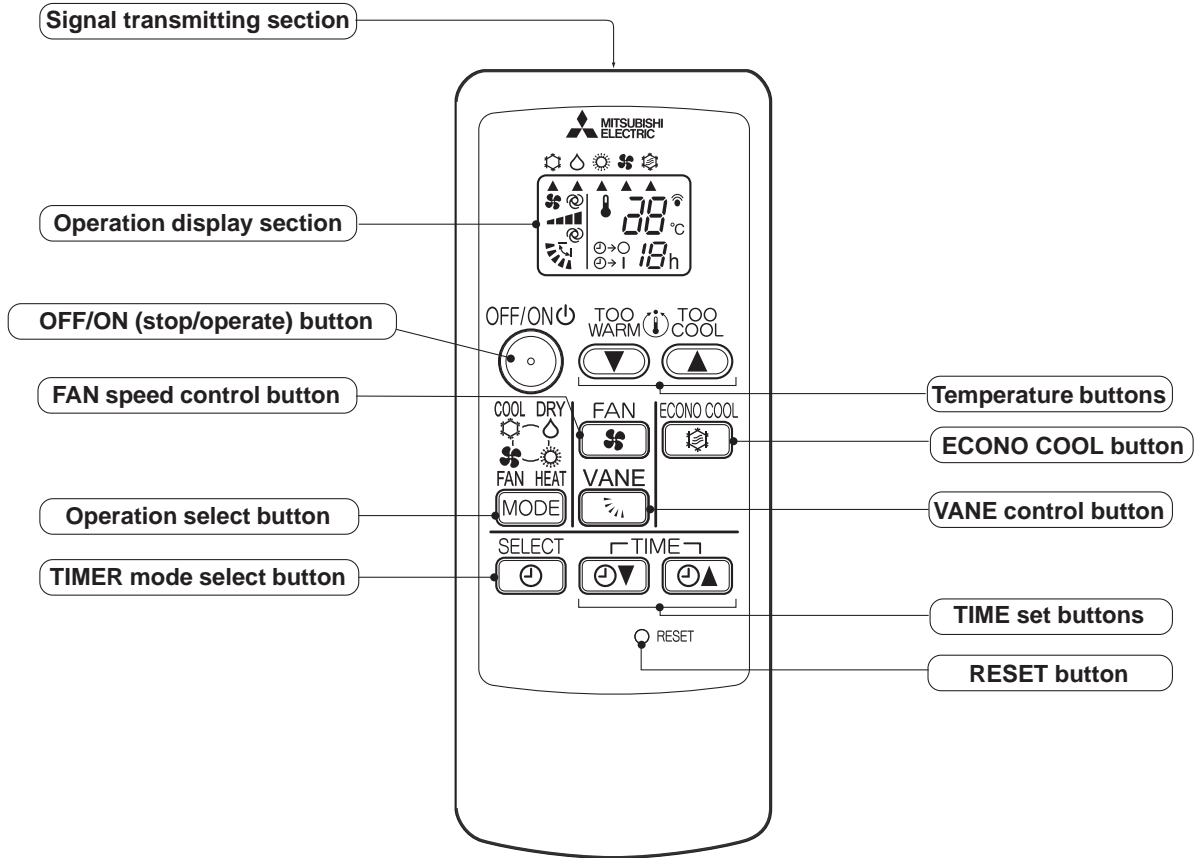

NOTE: Last setting will be stored after the unit is turned OFF with the remote controller. Indoor unit receives the signal of the remote controller with beeps.

OPERATION AND ACTUATOR CONTROL

WALL-MOUNTED

INDOOR UNIT DISPLAY SECTION

Operation Indicator lamp

The operation indicator at the right side of the indoor unit indicates the operation state.

- The following indication applies regardless of shape of the indication.

Indication	Operation state	Room temperature
● ●	The unit is operating to reach the set temperature	About 2°C or more away from set temperature
● ○	The room temperature is approaching the set temperature	About 1 to 2°C from set temperature
● ●	MSZ-DW25/35VF Standby mode (only during multi system operation)	—

- Lit
- Blinking
- Not lit

a. COOL (❄️) OPERATION

- (1) Press OFF/ON (stop/operate) button.
OPERATION INDICATOR lamp of the indoor unit turns on with a beep tone.
- (2) Select COOL mode with Operation select button.
- (3) Press Temperature buttons (TOO WARM or TOO COOL button) to select the desired temperature.
The setting range is 16 ~ 31°C.

1. Coil frost prevention

The compressor operational frequency is controlled by the temperature of the indoor heat exchanger to prevent the coil from frosting.

When the temperature of indoor heat exchanger becomes too low, the coil frost prevention mode works. The indoor fan operates at the set speed and the compressor stops. This mode continues until the temperature of indoor heat exchanger rises.

2. Low outside temperature operation

When the outside temperature is lower, low outside temperature operation starts, and the outdoor fan slows or stops.

b. DRY (☀️) OPERATION

- (1) Press OFF/ON (stop/operate) button.
OPERATION INDICATOR lamp of the indoor unit turns on with a beep tone.
- (2) Select DRY mode with Operation select button.
- (3) The set temperature is determined from the initial room temperature.

1. Coil frost prevention

Coil frost prevention works the same way as that in COOL mode. (a.1.)

2. Low outside temperature operation

Low outside temperature operation works the same way as that in COOL mode. (a.2.)

c. FAN (🌀) OPERATION

- (1) Press OFF/ON (stop/operate) button.
OPERATION INDICATOR lamp of the indoor unit turns ON with a beep tone.
- (2) Select FAN mode with Operation select button.
- (3) Select the desired fan speed. When AUTO, it becomes Low.
Only indoor fan operates. Outdoor unit does not operate.

d. HEAT (🔥) OPERATION

- (1) Press OFF/ON (stop/operate) button.
OPERATION INDICATOR lamp of the indoor unit turns on with a beep tone.
- (2) Select HEAT mode with Operation select button.
- (3) Press Temperature buttons (TOO WARM or TOO COOL button) to select the desired temperature.
The setting range is 16 ~ 31°C.

1. Cold air prevention control

When the compressor is not operating or is starting, and the temperature of indoor heat exchanger and/or the room temperature is low or when defrosting is being done, the indoor fan will stop or rotate in Very Low speed.

2. High pressure protection

The compressor operational frequency is controlled by the temperature of the indoor heat exchanger to prevent the condensing pressure from increasing excessively.

When the temperature of indoor heat exchanger becomes too high, the high pressure protection works.

The indoor fan operates following the cold air prevention control. This mode continues until the temperature of indoor heat exchanger falls.

3. Defrosting

Defrosting starts when the temperature of outdoor heat exchanger becomes too low.

The compressor stops once, the indoor/outdoor fans stop, the 4-way valve reverses, and the compressor re-starts.

This mode continues until the temperature of outdoor heat exchanger rises or the fixed time passes.

e. MULTI SYSTEM OPERATION (MSZ-DW25/35VF)**FOR MULTI SYSTEM AIR CONDITIONER****OUTDOOR UNIT: MXZ series**

Multi system air conditioner can connect 2 or more indoor units with 1 outdoor unit.

- When trying to operate 2 or more indoor units with 1 outdoor unit simultaneously, one for the cooling and the others for heating, the operation mode of the indoor unit that operates first is selected. Other indoor units cannot operate, and operation indicator lamp blinks as shown in the figure below. In this case, please set all the indoor units to the same operation mode.

OPERATION INDICATOR

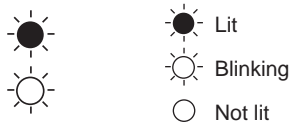

- When indoor unit starts the operation while the defrosting of outdoor unit is being done, it takes a few minutes (max. 10 minutes) to blow out the warm air.
- In the heating operation, though indoor unit is not operating, it may get warm or the sound of refrigerant flow may be heard. It is not malfunction. The reason is that the refrigerant continuously flows into it.

f. AUTO VANE OPERATION

1. Horizontal vane

(1) Vane motor drive

These models are equipped with a stepping motor for the horizontal vane. The rotating direction, speed, and angle of the motor are controlled by pulse signals (approximately 12 V) transmitted from indoor microprocessor.

(2) The horizontal vane angle and mode change as follows by pressing VANE control button.

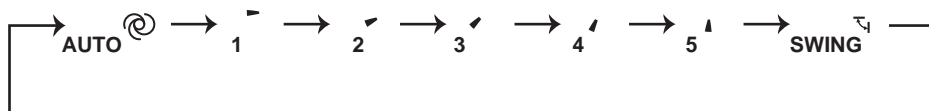

(3) Positioning

To confirm the standard position, the vane moves until it touches the vane stopper. Then the vane is set to the selected angle.

Confirmation of standard position is performed in the following cases:

- (a) When the operation starts or finishes (including timer operation).
- (b) When the test run starts.
- (c) When standby mode (only during multi system operation) starts or finishes.

(4) VANE AUTO (A) mode

In VANE AUTO mode, the microprocessor automatically determines the vane angle to make the optimum room temperature distribution.

In COOL and DRY operation
Vane angle is fixed to Horizontal position.



In HEAT operation
Vane angle is fixed to Angle 4.

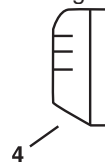

(5) STOP (operation OFF) and ON TIMER standby

In the following cases, the horizontal vane returns to the closed position.

- (a) When OFF/ON (stop/operate) button is pressed (POWER OFF).
- (b) When the operation is stopped by the emergency operation.
- (c) When ON TIMER is ON standby.

(6) Dew prevention

During COOL or DRY operation with the vane angle at Angle 3 ~ 5 when the compressor cumulative operation time exceeds 1 hour, the vane angle automatically changes to Angle 2 for dew prevention.

(7) SWING (V) mode

By selecting SWING mode with VANE control button, the horizontal vane swings vertically.

(8) ECONO COOL (E) operation (ECONOMical operation)

When ECONO COOL button is pressed in COOL mode, set temperature is automatically set 2°C higher.

Also the horizontal vane swings in various cycle.

SWING operation makes you feel cooler than set temperature. So, even though the set temperature is higher, the air conditioner can keep comfort. As a result, energy can be saved.

ECONO COOL operation is cancelled when ECONO COOL button is pressed once again or VANE control button is pressed or change to other operation mode.



g. TIMER OPERATION (ON/OFF TIMER)

1. How to set the timer

(1) Press OFF/ON (stop/operate) button to start the air conditioner.

(2) Select the timer mode by pressing the  button during operation.

Each time this button is pressed, the timer mode is changed in sequence:
 ☉→○ (OFF TIMER) → ☉→| (ON TIMER) → TIMER RELEASE

(3) Set the time of the timer using the   button.

Each time this button is pressed, the set time increase or decrease by 1 hour to 12 hours.

2. To release the timer

Press the  button until ☉→○ (OFF TIMER) and ☉→| (ON TIMER) are not displayed.

NOTE :

- The OFF TIMER and the ON TIMER cannot be set at the same time.
- The displayed time is the time remaining and will decrease in 1-hour increments as time passes.

h. EMERGENCY/TEST OPERATION

In the case of test run operation or emergency operation, use the emergency operation switch on the right side of the indoor unit. Emergency operation is available when the remote controller is missing or has failed, or when the batteries in the remote controller are running down. The unit will start and OPERATION INDICATOR lamp will light up.

The first 30 minutes of operation is the test run operation. This operation is for servicing. The indoor fan runs at High speed and the temperature control does not work.

After 30 minutes of test run operation, the system shifts to EMERGENCY COOL/HEAT MODE with a set temperature of 24°C. The fan speed shifts to Med.

The coil frost prevention works even in the test run or the emergency operation.

In the test run or emergency operation, the horizontal vane operates in VANE AUTO (@) mode.

Emergency operation continues until the emergency operation switch is pressed once or twice or the unit receives any signal from the remote controller. In the latter case, normal operation will start.

NOTE: Do not press the emergency operation switch during normal operation.

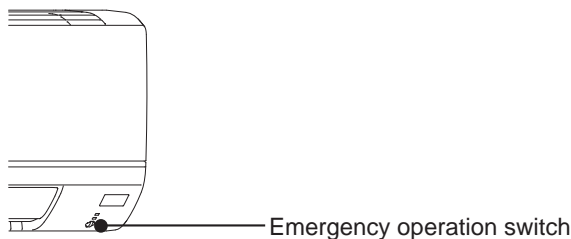

Operation mode	COOL	HEAT
Set temperature	24°C	24°C
Fan speed	Med.	Med.
Horizontal vane	Auto	Auto

The operation mode is indicated by the Operation Indicator lamp as follows:

Operation Indicator lamp

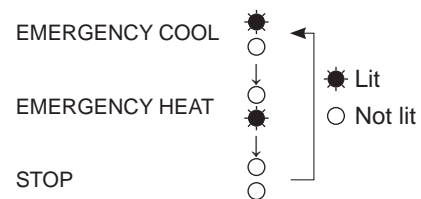

i. 3-MINUTE TIME DELAY OPERATION

When the system turns OFF, compressor will not restart for 3 minutes as 3-minute time delay function operates to protect compressor from overload.

j. ACTUATOR CONTROL

j-1. OUTDOOR FAN MOTOR CONTROL

The fan motor turns ON/OFF, interlocking with the compressor.

[ON] The fan motor turns ON 5 seconds before the compressor starts up.

[OFF] The fan motor turns OFF 15 seconds after the compressor has stopped running.

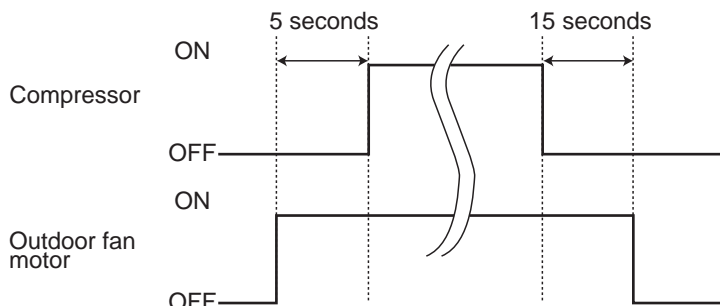

j-2. R.V. COIL CONTROL

Heating ON

Cooling OFF

Dry OFF

NOTE: The 4-way valve reverses for 5 seconds right before start-up of the compressor.

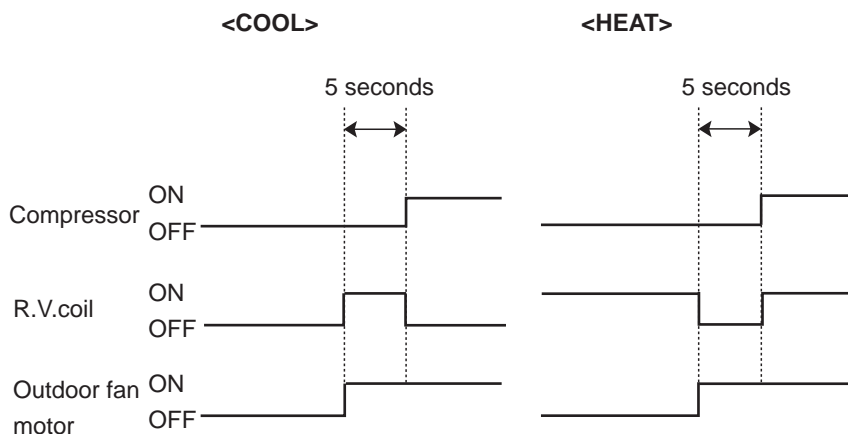

j-3. RELATION BETWEEN MAIN SENSOR AND ACTUATOR

Sensor	Purpose	Actuator				
		Compressor	LEV	Outdoor fan motor	R.V. coil	Indoor fan motor
Discharge temperature thermistor	Protection	○	○			
Indoor coil temperature thermistor	Cooling: Coil frost prevention	○				
	Heating: High pressure protection	○	○			
Defrost thermistor	Heating: Defrosting	○	○	○	○	○
Fin temperature thermistor	Protection	○		○		
Ambient temperature thermistor	Cooling: Low ambient temperature operation	○	○	○		
Outdoor heat exchanger temperature thermistor	Cooling: Low ambient temperature operation	○	○	○		
	Cooling: High pressure protection	○	○	○		

OPERATION AND ACTUATOR CONTROL

WALL-MOUNTED

C.1.9.12 MSZ-SF•VA Series

MSZ-SF15VA

MSZ-SF20VA

WIRELESS REMOTE CONTROLLER

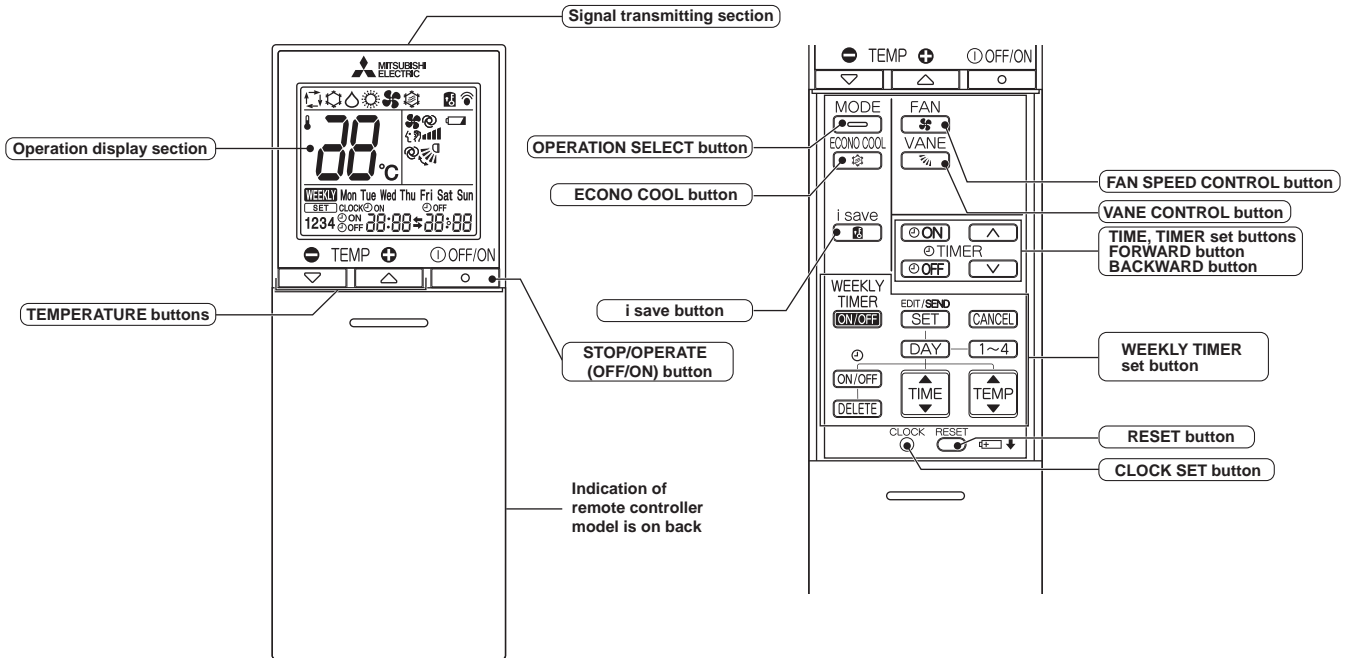

NOTE: Last setting will be stored after the unit is turned OFF with the remote controller. Indoor unit receives the signal of the remote controller with beeps.

INDOOR UNIT DISPLAY SECTION

Operation Indicator lamp

The operation indicator at the right side of the indoor unit indicates the operation state.

•The following indication applies regardless of shape of the indication.

Indication	Operation state	Room temperature
	The unit is operating to reach the set temperature	About 2°C or more away from set temperature
	The room temperature is approaching the set temperature	About 1 to 2°C from set temperature
	Standby mode (Only during multi system operation)	—

Lit
 Blinking
 Not lit

a. COOL (❄️) OPERATION

(1) Press STOP/OPERATE (OFF/ON) button.

OPERATION INDICATOR lamp of the indoor unit turns on with a beep tone.

(2) Select COOL mode with OPERATION SELECT button.

(3) Press TEMPERATURE buttons (TEMP or button) to select the desired temperature. The setting range is 16 - 31°C.

1. Coil frost prevention

The compressor operational frequency is controlled by the temperature of the indoor heat exchanger to prevent the coil from frosting.

When the temperature of indoor heat exchanger becomes too low, the coil frost prevention mode works.

The indoor fan operates at the set speed and the compressor stops. This mode continues until the temperature of indoor heat exchanger rises.

2. Low outside temperature operation

When the outside temperature is lower, low outside temperature operation starts, and the outdoor fan slows or stops.

WALL-MOUNTED OPERATION AND ACTUATOR CONTROL

b. DRY (△) OPERATION

- (1) Press STOP/OPERATE (OFF/ON) button.
OPERATION INDICATOR lamp of the indoor unit turns on with a beep tone.
- (2) Select DRY mode with OPERATION SELECT button.
- (3) The set temperature is determined from the initial room temperature.

1. Coil frost prevention

Coil frost prevention works the same way as that in COOL mode. (a.1.)

2. Low outside temperature operation

Low outside temperature operation works the same way as that in COOL mode. (a.2.)

c. FAN (✳) OPERATION

- (1) OPERATION INDICATOR lamp of the indoor unit turns on with a beep tone.
- (2) Select FAN mode with OPERATION SELECT button.
- (3) Select the desired fan speed. When AUTO, it becomes Low.
Only indoor fan operates.

Outdoor unit does not operate.

d. HEAT (☀) OPERATION

- (1) Press STOP/OPERATE (OFF/ON) button.
OPERATION INDICATOR lamp of the indoor unit turns on with a beep tone.
- (2) Select HEAT mode with OPERATION SELECT button.
- (3) Press TEMPERATURE buttons (TEMP \ominus or \oplus button) to select the desired temperature. The setting range is 16 - 31°C.

1. Cold air prevention control

When the compressor is not operating or is starting, and the temperature of indoor heat exchanger and/or the room temperature is low or when defrosting is being done, the indoor fan will stop or rotate in Very Low speed.

2. High pressure protection

The compressor operational frequency is controlled by the temperature of the indoor heat exchanger to prevent the condensing pressure from increasing excessively.

When the temperature of indoor heat exchanger becomes too high, the high pressure protection works.

The indoor fan operates following the cold air prevention control. This mode continues until the temperature of indoor heat exchanger falls.

3. Defrosting

Defrosting starts when the temperature of outdoor heat exchanger becomes too low.

The compressor stops once, the indoor/outdoor fans stop, the 4-way valve reverses, and the compressor restarts.

This mode continues until the temperature of outdoor heat exchanger rises or the fixed time passes.

e. AUTO CHANGE OVER ... AUTO MODE OPERATION

Once desired temperature is set, unit operation is switched automatically between COOL and HEAT operation.

Mode selection

(1) Initial mode

When unit starts the operation with AUTO operation from OFF:

- If the room temperature is higher than the set temperature, operation starts in COOL mode.
- If the room temperature is equal to or lower than the set temperature, operation starts in HEAT mode.

(2) Mode change

COOL mode changes to HEAT mode when about 15 minutes has passed with the room temperature 1°C below the set temperature.

HEAT mode changes to COOL mode when about 15 minutes has passed with the room temperature 1°C above the set temperature.

NOTE 1

If 2 or more indoor units are operating in multi system, there might be a case that the indoor unit, which is operating in □ (AUTO), cannot change over to the other operating mode (COOL ↔ HEAT) and becomes a state of standby.

Refer to **NOTE 2 “FOR MULTI SYSTEM AIR CONDITIONER”**.

NOTE 2

FOR MULTI SYSTEM AIR CONDITIONER OUTDOOR UNIT: MXZ series

Multi system air conditioner can connect 2 or more indoor units with one outdoor unit.

- When you try to operate 2 or more indoor units with one outdoor unit simultaneously, one for the cooling and the others for heating, the operation mode of the indoor unit that operates first is selected. Other indoor units cannot operate, and operation indicator lamp blinks as shown in the figure below. In this case, please set all the indoor units to the same operation mode.

OPERATION INDICATOR

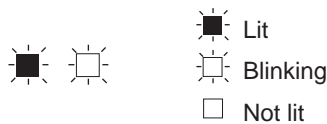

- When indoor unit starts the operation while the defrosting of outdoor unit is being done, it takes a few minutes (max. 10 minutes) to blow out the warm air.
- In the heating operation, though indoor unit that does not operate may get warm or the sound of refrigerant flowing may be heard, they are not malfunction. The reason is that the refrigerant continuously flows into it.

f. AUTO VANE OPERATION

1. Horizontal vane

(1) Vane motor drive

These models are equipped with a stepping motor for the horizontal vane. The rotating direction, speed, and angle of the motor are controlled by pulse signals (approximately 12 V) transmitted from indoor microprocessor.

(2) The horizontal vane angle and mode change as follows by pressing VANE CONTROL button.

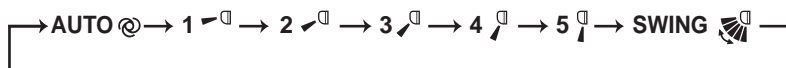

(3) Positioning

To confirm the standard position, the vane moves until it touches the vane stopper. Then the vane is set to the selected angle.

Confirming of standard position is performed in the following cases:

- (a) When the operation starts or finishes (including timer operation).
- (b) When the test run starts.
- (c) When standby mode (only during multi system operation) starts or finishes.

(4) VANE AUTO (@) mode

In VANE AUTO mode, the microprocessor automatically determines the vane angle to make the optimum room temperature distribution.

In COOL and DRY operation
Vane angle is fixed to Horizontal position.



In HEAT operation
Vane angle is fixed to Angle 4.



WALL-MOUNTED OPERATION AND ACTUATOR CONTROL

- (5) STOP (operation OFF) and ON TIMER standby
In the following cases, the horizontal vane returns to the closed position.
- (a) When STOP/OPERATE (OFF/ON) button is pressed (POWER OFF).
 - (b) When the operation is stopped by the emergency operation.
 - (c) When ON TIMER is ON standby.
- (6) Dew prevention
During COOL or DRY operation with the vane angle at Angle 4 or 5 when the compressor cumulative operation time exceeds 1 hour, the vane angle automatically changes to Angle 1 for dew prevention.
- (7) SWING (🌀) mode
By selecting SWING mode with VANE CONTROL button, the horizontal vane swings vertically.
- (8) Cold air prevention in HEAT operation
The horizontal vane position is set to Upward.
NOTE: When 2 or more indoor units are operated with multi outdoor unit, even if any indoor unit turns thermostat off, this control does not work in the indoor unit.
- (9) ECONO COOL (🌀) operation (ECONOMical operation)
When ECONO COOL button is pressed in COOL mode, set temperature is automatically set 2°C higher by the micro-processor. However, the temperature on the LCD screen on the remote controller is not changed.
Also the horizontal vane swings in various cycle.
SWING operation makes you feel cooler than set temperature. So, even though the set temperature is higher, the air conditioner can keep comfort. As a result, energy can be saved.
To cancel this operation, select a different mode or press one of the following buttons in ECONO COOL operation:
ECONO COOL, VANE CONTROL button.

g. TIMER OPERATION

1. How to set the time

- (1) Check that the current time is set correctly.

NOTE: Timer operation will not work without setting the current time. Initially "0:00" blinks at the current time display of TIME MONITOR, so set the current time correctly with CLOCK SET button.

How to set the current time

- (a) Press the CLOCK set button.
 - (b) Press the TIME SET buttons (⏮) and (⏭) to set the current time.
 - Each time FORWARD button (⏮) is pressed, the set time increases by 1 minute, and each time BACKWARD button (⏭) is pressed, the set time decreases by 1 minute.
 - Pressing those buttons longer, the set time increases/decreases by 10 minutes.
 - (c) Press the CLOCK set button.
- (2) Press STOP/OPERATE (OFF/ON) button to start the air conditioner.
- (3) Set the time of timer.

ON timer setting

- (a) Press ON TIMER button (⏻) during operation.
- (b) Set the time of the timer using TIME SET buttons (⏮) and (⏭). *

OFF timer setting

- (a) Press OFF TIMER button (⏻) during operation.
- (b) Set the time of the timer using TIME SET buttons (⏮) and (⏭). *
 - * Each time FORWARD button (⏮) is pressed, the set time increases by 10 minutes: each time BACKWARD button (⏭) is pressed, the set time decreases by 10 minutes.

2. To release the timer

- To release ON timer, press ON TIMER button (⏻).
- To release OFF timer, press OFF TIMER button (⏻).
- TIMER is cancelled and the display of set time disappears.

PROGRAM TIMER

- OFF timer and ON timer can be used in combination. The set time that is reached first will operate first.
- “←” and “→” display shows the order of OFF timer and ON timer operation.

(Example 1) The current time is 8:00 PM.
The unit turns off at 11:00 PM, and on at 6:00 AM.

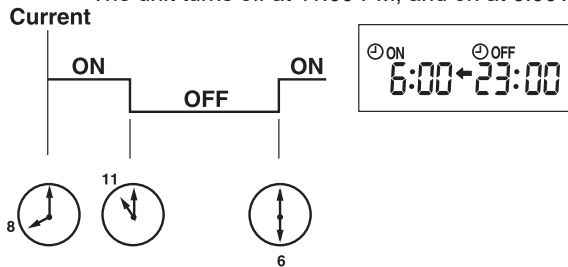

(Example 2) The current time is 11:00 AM.
The unit turns on at 5:00 PM, and off at 9:00 PM.

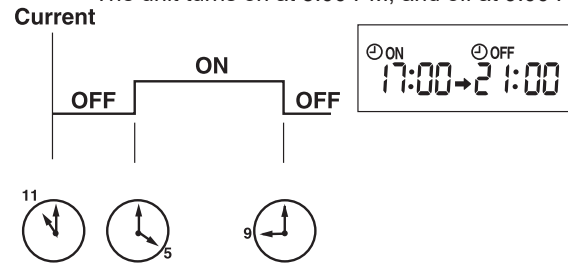

NOTE: If the main power is turned OFF or a power failure occurs while ON/OFF timer is active, the timer setting is cancelled. As these models are equipped with an auto restart function, the air conditioner starts operating with timer cancelled when power is restored.

h. WEEKLY TIMER OPERATION

- A maximum of 4 ON or OFF timers can be set for individual days of the week.
- A maximum of 28 ON or OFF timers can be set for a week.

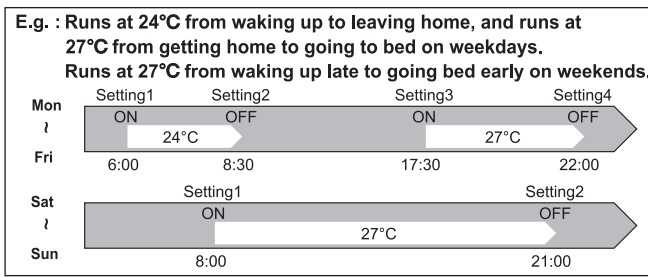

NOTE:

- The simple ON/OFF timer setting is available while the weekly timer is on. In this case, the ON/OFF timer has priority over the weekly timer; the weekly timer operation will start again after the simple ON/OFF timer is complete.
- When the weekly timer is set, temperature cannot be set to 10°C.
- The weekly timer operation and i-save operation cannot be used together.

1. How to set the weekly timer

* Make sure that the current time and day are set correctly.

(1) Press **ADJUST/SEND SET** button to enter the weekly timer setting mode.

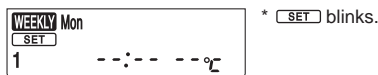

(2) Press **DAY** and **1~4** buttons to select setting day and number.

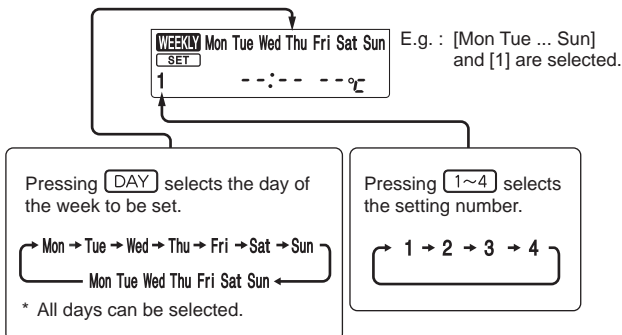

(3) Press **ON/OFF**, **TIME**, and **TEMP** buttons to set ON/OFF, time, and temperature.

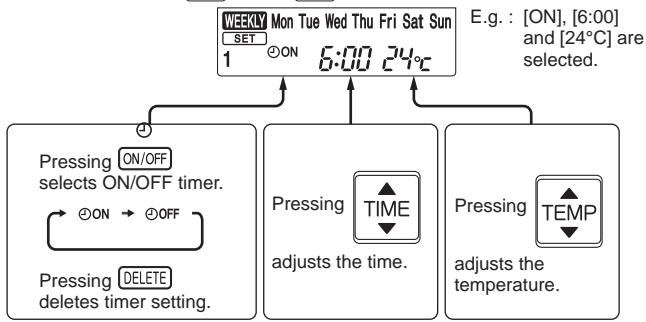

* Hold down the button to change the time quickly.

Press **DAY** and **1~4** buttons to continue setting the timer for other days and/or numbers.

(4) Press **EDIT/SEND SET** button to complete and transmit the weekly timer setting.



NOTE:

- Press **EDIT/SEND SET** button to transmit the setting information of weekly timer to the indoor unit. Point the remote controller toward the indoor unit for 3 seconds.
- When setting the timer for more than one day of the week or one number, **EDIT/SEND SET** button does not have to be pressed per each setting. Press **EDIT/SEND SET** button once after all the settings are complete. All the weekly timer settings will be saved.
- Press **EDIT/SEND SET** button to enter the weekly timer setting mode, and press and hold **DELETE** button for 5 seconds to erase all weekly timer settings. Point the remote controller toward the indoor unit.

(5) Press **WEEKLY TIMER ON/OFF** button to turn the weekly timer ON. (**WEEKLY** lights.)

•When the weekly timer is ON, the day of the week whose timer setting is complete, will light.

Press **WEEKLY TIMER ON/OFF** button again to turn the weekly timer OFF. (**WEEKLY** goes out.)

NOTE:

The saved settings will not be cleared when the weekly timer is turned OFF.

2. Checking weekly timer setting

(1) Press **EDIT/SEND SET** button to enter the weekly timer setting mode.

***SET** blinks.

(2) Press **DAY** or **1~4** buttons to view the setting of the particular day or number.

(3) Press **CANCEL** button to exit the weekly timer setting.

NOTE:

When all days of the week are selected to view the settings and a different setting is included among them, --:-- °C will be displayed.

i. i-save (i) OPERATION

1. How to set i-save operation

- (1) Press STOP/OPERATE (OFF/ON) button.
- (2) Select COOL, HEAT or ECONO COOL mode.
- (3) Press i-save button.
- (4) Set the temperature, fan speed, and airflow direction for i-save operation.

NOTE:

- i-save operation cannot be selected during DRY or AUTO mode operation.
- The setting range of HEAT mode i-save operation is 10°C and 16 - 31°C.
- 2 groups of setting can be saved. (One for COOL/ECONO COOL, one for HEAT)
- i-save operation and the weekly timer operation cannot be used together.

2. How to cancel operation

- Press i-save button again.
- i-save operation can also be cancelled by pressing OPERATION SELECT button to change the operation mode. The same setting is selected from the next time by simply pressing i-save button.

j. EMERGENCY/TEST OPERATION

In the case of test run operation or emergency operation, use EMERGENCY OPERATION switch on the right side of the indoor unit. Emergency operation is available when the remote controller is missing or has failed, or when the batteries in the remote controller are running down. The unit will start and OPERATION INDICATOR lamp will light up. The first 30 minutes of operation is the test run operation. This operation is for servicing. The indoor fan runs at High speed and the temperature control does not work. After 30 minutes of test run operation, the system shifts to EMERGENCY COOL/HEAT MODE with a set temperature of 24°C. The fan speed shifts to Med. The coil frost prevention works even in the test run or the emergency operation. In the test run or emergency operation, the horizontal vane operates in VANE AUTO (Ⓢ) mode. Emergency operation continues until EMERGENCY OPERATION switch is pressed once or twice or the unit receives any signal from the remote controller. In the latter case, normal operation will start.

NOTE: Do not press EMERGENCY OPERATION switch during normal operation.

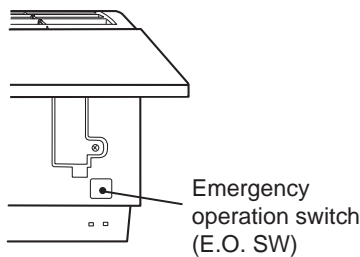

Operation mode	COOL/HEAT
Set temperature	24°C
Fan speed	Med.
Horizontal vane	Auto

The operation mode is indicated by the Operation Indicator lamp as following

Operation Indicator lamp

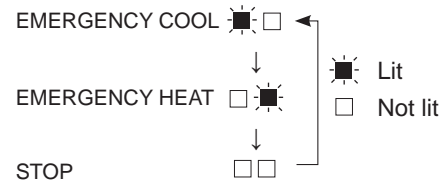

k. 3-MINUTE TIME DELAY OPERATION

When the system turns OFF, compressor will not restart for 3 minutes as 3-minute time delay function operates to protect compressor from overload.

C.1.9.13 MSZ-GF•VE2 Series

MSZ-GF60VE2 MSZ-GF71VE2
 MUZ-GF60VE MUZ-GF71VE

WIRELESS REMOTE CONTROLLER

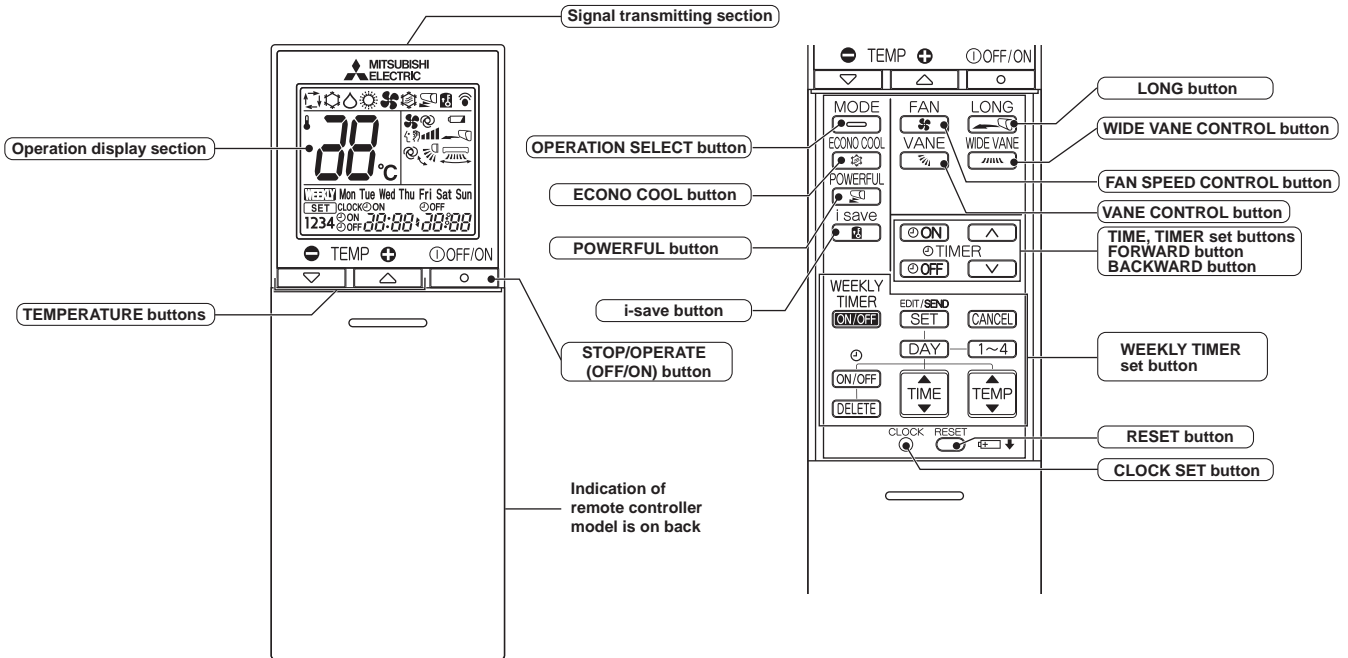

NOTE: Last setting will be stored after the unit is turned OFF with the remote controller. Indoor unit receives the signal of the remote controller with beeps.

INDOOR UNIT DISPLAY SECTION

Operation Indicator lamp

The operation indicator at the right side of the indoor unit indicates the operation state.

•The following indication applies regardless of shape of the indication.

Indication	Operation state	Room temperature
● ●	The unit is operating to reach the set temperature	About 2°C or more away from set temperature
● ○	The room temperature is approaching the set temperature	About 1 to 2°C from set temperature
● ○	Standby mode (Only during multi system operation)	—

- Lit
- Blinking
- Not lit

a. COOL (❄️) OPERATION

- (1) Press STOP/OPERATE (OFF/ON) button.
OPERATION INDICATOR lamp of the indoor unit turns on with a beep tone.
- (2) Select COOL mode with OPERATION SELECT button.
- (3) Press TEMPERATURE buttons (TEMP \ominus or \oplus button) to select the desired temperature. The setting range is 16 - 31°C.

1. Coil frost prevention

The compressor operational frequency is controlled by the temperature of the indoor heat exchanger to prevent the coil from frosting.

When the temperature of indoor heat exchanger becomes too low, the coil frost prevention mode works.

The indoor fan operates at the set speed and the compressor stops. This mode continues until the temperature of indoor heat exchanger rises.

2. Low outside temperature operation

When the outside temperature is lower, low outside temperature operation starts, and the outdoor fan slows or stops.

3. Indoor fan speed control

When the thermostat turns OFF, the indoor fan stops running to reduce power consumption.

After that, the indoor fan stops for 60 seconds and then operates at Very Low for 10 seconds to sense accurate room temperature. The indoor fan alternates ON and OFF at this interval while the thermostat is OFF.

When the room temperature rises and the thermostat is ON, the indoor fan starts running according to the settings on the remote controller.

b. DRY (☀️) OPERATION

- (1) Press STOP/OPERATE (OFF/ON) button.
OPERATION INDICATOR lamp of the indoor unit turns on with a beep tone.
- (2) Select DRY mode with OPERATION SELECT button.
- (3) The set temperature is determined from the initial room temperature.

1. Coil frost prevention

Coil frost prevention works the same way as that in COOL mode. (a.1.)

2. Low outside temperature operation

Low outside temperature operation works the same way as that in COOL mode. (a.2.)

3. Indoor fan speed control

Indoor fan speed control works the same way as that in COOL mode. (a.3.)

c. HEAT (🔥) OPERATION

- (1) Press STOP/OPERATE (OFF/ON) button.
OPERATION INDICATOR lamp of the indoor unit turns on with a beep tone.
- (2) Select HEAT mode with OPERATION SELECT button.
- (3) Press TEMPERATURE buttons (TEMP \ominus or \oplus button) to select the desired temperature. The setting range is 16 - 31°C.

1. Cold air prevention control

When the compressor is not operating or is starting, and the temperature of indoor heat exchanger and/or the room temperature is low or when defrosting is being done, the indoor fan will stop or rotate in Very Low speed.

2. High pressure protection

The compressor operational frequency is controlled by the temperature of the indoor heat exchanger to prevent the condensing pressure from increasing excessively.

When the temperature of indoor heat exchanger becomes too high, the high pressure protection works.

The indoor fan operates following the cold air prevention control. This mode continues until the temperature of indoor heat exchanger falls.

3. Defrosting

Defrosting starts when the temperature of outdoor heat exchanger becomes too low.

The compressor stops once, the indoor/outdoor fans stop, the 4-way valve reverses, and the compressor restarts.

This mode continues until the temperature of outdoor heat exchanger rises or the fixed time passes.

d. AUTO CHANGE OVER ... AUTO MODE OPERATION

Once desired temperature is set, unit operation is switched automatically between COOL and HEAT operation.

Mode selection

- (1) Initial mode
When unit starts the operation with AUTO operation from OFF:
 - If the room temperature is higher than the set temperature, operation starts in COOL mode.
 - If the room temperature is equal to or lower than the set temperature, operation starts in HEAT mode.
- (2) Mode change
COOL mode changes to HEAT mode when about 15 minutes have passed with the room temperature 1°C below the set temperature.
HEAT mode changes to COOL mode when about 15 minutes have passed with the room temperature 1°C above the set temperature.

NOTE 1

If 2 or more indoor units are operating in multi system, there might be a case that the indoor unit, which is operating in □ (AUTO), cannot change over to the other operating mode (COOL ↔ HEAT) and becomes a state of standby.

Refer to **NOTE 2 “FOR MULTI SYSTEM AIR CONDITIONER”**.

NOTE 2
FOR MULTI SYSTEM AIR CONDITIONER
OUTDOOR UNIT: MXZ series

Multi system air conditioner can connect 2 or more indoor units with one outdoor unit.

- When you try to operate 2 or more indoor units with one outdoor unit simultaneously, one for the cooling and the others for heating, the operation mode of the indoor unit that operates first is selected. Other indoor units cannot operate, and operation indicator lamp blinks as shown in the figure below. In this case, please set all the indoor units to the same operation mode.

OPERATION INDICATOR

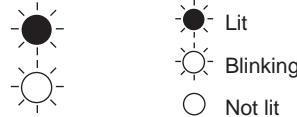

- When indoor unit starts the operation while the defrosting of outdoor unit is being done, it takes a few minutes (max. 10 minutes) to blow out the warm air.
- In the heating operation, though indoor unit that does not operate may get warm or the sound of refrigerant flowing may be heard, they are not malfunction. The reason is that the refrigerant continuously flows into it.

e. AUTO VANE OPERATION

1. Horizontal vane

(1) Vane motor drive

These models are equipped with a stepping motor for the horizontal vane. The rotating direction, speed, and angle of the motor are controlled by pulse signals (approximately 12 V) transmitted from indoor microprocessor.

(2) The horizontal vane angle and mode change as follows by pressing VANE CONTROL button.

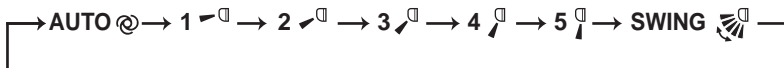

(3) Positioning

To confirm the standard position, the vane moves until it touches the vane stopper. Then the vane is set to the selected angle.

Confirming of standard position is performed in the following cases:

- (a) When the operation starts or finishes (including timer operation).
- (b) When the test run starts.
- (c) When standby mode (only during multi system operation) starts or finishes.

(4) VANE AUTO (@) mode

In VANE AUTO mode, the microprocessor automatically determines the vane angle to make the optimum room temperature distribution.

In COOL and DRY operation

Vane angle is fixed to Horizontal position.



In HEAT operation

Vane angle is fixed to Angle 5.









(5) STOP (operation OFF) and ON TIMER standby

In the following cases, the horizontal vane returns to the closed position.

- (a) When STOP/OPERATE (OFF/ON) button is pressed (POWER OFF).
- (b) When the operation is stopped by the emergency operation.
- (c) When ON TIMER is ON standby.

(6) Dew prevention

During COOL or DRY operation with the vane angle at Angle 4 or 5 when the compressor cumulative operation time exceeds 1 hour, the vane angle automatically changes to Angle 1 for dew prevention.

- (7) SWING () mode
By selecting SWING mode with VANE CONTROL button, the horizontal vane swings vertically.
- (8) Cold air prevention in HEAT operation
The horizontal vane position is set to Upward.
NOTE: When 2 or more indoor units are operated with multi outdoor unit, even if any indoor unit turns thermostat off, this control does not work in the indoor unit.
- (9) ECONO COOL () operation (ECONOMical operation)
When ECONO COOL button is pressed in COOL mode, set temperature is automatically set 2°C higher by the micro-processor. However, the temperature on the LCD screen on the remote controller is not changed. Also the horizontal vane swings in various cycle.
SWING operation makes you feel cooler than set temperature. So, even though the set temperature is higher, the air conditioner can keep comfort. As a result, energy can be saved.
To cancel this operation, select a different mode or press one of the following buttons in ECONO COOL operation: ECONO COOL, VANE CONTROL, LONG or POWERFUL button.
- (10) POWERFUL () operation
The air conditioner automatically adjusts the fan speed and the set temperature, and operates the POWERFUL mode. The POWERFUL mode is cancelled automatically 15 minutes after operation starts, or when POWERFUL button is pressed once again within 15 minutes after operation starts. The operation mode returns to the mode prior to POWERFUL operation. POWERFUL mode also is cancelled, when the STOP/OPERATE (OFF/ON), ECONO COOL, FAN SPEED CONTROL or i-save button is pressed within 15 minutes after operation starts, or operation mode is changed.
- (11) LONG MODE ()
By pressing LONG button indoor fan speed becomes faster than setting fan speed on the remote controller, and the horizontal vane moves to the position for LONG mode. The remote controller displays “  ”. LONG mode is cancelled when LONG button is pressed once again or STOP/OPERATE (OFF/ON) or VANE CONTROL button is pressed or ECONO COOL button is pressed in COOL mode. In the following example, the vertical vane is set to  (front.).

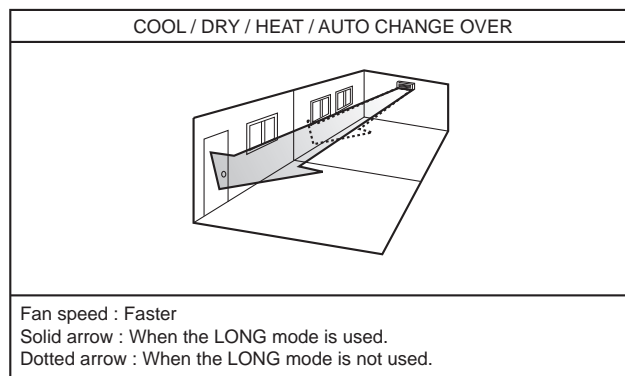

2. Vertical vane

- (1) Vane motor drive
These models are equipped with a stepping motor for the vertical vane. The rotating direction, speed, and angle of the motor are controlled by pulse signals (approximately 12 V) transmitted from microprocessor.
- (2) The vertical vane angle and mode change as follows by pressing WIDE VANE CONTROL button.
- (3) Positioning
To confirm the standard position, the vane moves until it touches the vane stopper. Then the vane is set to the selected angle.

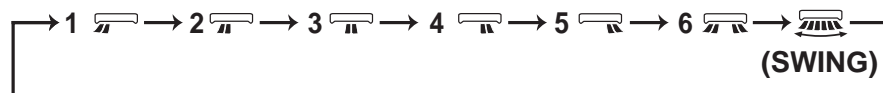

Confirmation of standard position is performed in the following cases:

- (a) When STOP/OPERATE (OFF/ON) button is pressed (POWER ON).
- (b) SWING is started.

(4) SWING () MODE

By selecting SWING mode with WIDE VANE CONTROL button, the vertical vane swings horizontally. The remote controller displays “  ”. Swing mode is cancelled when WIDE MODE CONTROL button is pressed once again.

f. TIMER OPERATION

1. How to set the time

(1) Check that the current time is set correctly.

NOTE: Timer operation will not work without setting the current time. Initially “0:00” blinks at the current time display of TIME MONITOR, so set the current time correctly with CLOCK SET button.

How to set the current time

(a) Press the CLOCK set button.

(b) Press the TIME SET buttons (▲) and (▼) to set the current time.

- Each time FORWARD button (▲) is pressed, the set time increases by 1 minute, and each time BACKWARD button (▼) is pressed, the set time decreases by 1 minute.
- Pressing those buttons longer, the set time increases/decreases by 10 minutes.

(c) Press the CLOCK set button.

(2) Press STOP/OPERATE (OFF/ON) button to start the air conditioner.

(3) Set the time of timer.

ON timer setting

(a) Press ON TIMER button (⊕ON) during operation.

(b) Set the time of the timer using TIME SET buttons (▲) and (▼). *

OFF timer setting

(a) Press OFF TIMER button (⊖OFF) during operation.

(b) Set the time of the timer using TIME SET buttons (▲) and (▼). *

* Each time FORWARD button (▲) is pressed, the set time increases by 10 minutes: each time BACKWARD button (▼) is pressed, the set time decreases by 10 minutes.

2. To release the timer

To release ON timer, press ON TIMER button (⊕ON).

To release OFF timer, press OFF TIMER button (⊖OFF).

TIMER is cancelled and the display of set time disappears.

PROGRAM TIMER

- OFF timer and ON timer can be used in combination. The timer of the set time that is reached first will operate first.
- “◀” and “▶” display shows the order of OFF timer and ON timer operation.

(Example 1) The current time is 8:00 PM.
The unit turns off at 11:00 PM, and on at 6:00 AM.

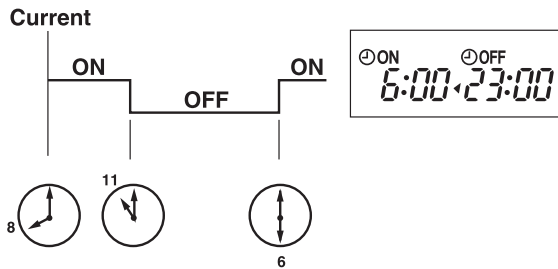

(Example 2) The current time is 11:00 AM.
The unit turns on at 5:00 PM, and off at 9:00 PM.

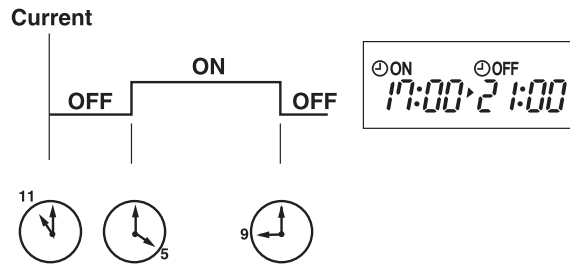

NOTE: If the main power is turned OFF or a power failure occurs while ON/OFF timer is active, the timer setting is cancelled. As these models are equipped with an auto restart function, the air conditioner starts operating with timer cancelled when power is restored.

g. WEEKLY TIMER OPERATION

- A maximum of 4 ON or OFF timers can be set for individual days of the week.
- A maximum of 28 ON or OFF timers can be set for a week.

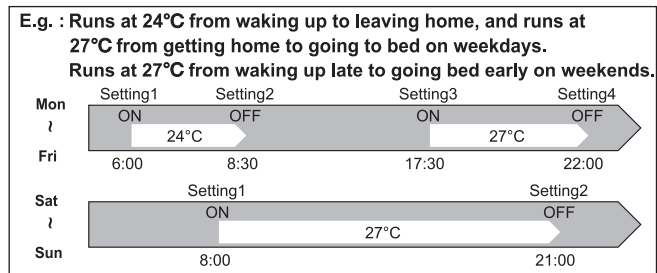

NOTE:

- The simple ON/OFF timer setting is available while the weekly timer is on. In this case, the ON/OFF timer has priority over the weekly timer; the weekly timer operation will start again after the simple ON/OFF timer is complete.
- When the weekly timer is set, temperature can not be set to 10°C.
- The weekly timer operation and i-save operation cannot be used together.

1. How to set the weekly timer

* Make sure that the current time and day are set correctly.

(1) Press **EDIT/SEND SET** button to enter the weekly timer setting mode.

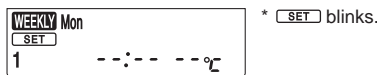

(2) Press **DAY** and **1~4** buttons to select setting day and number.

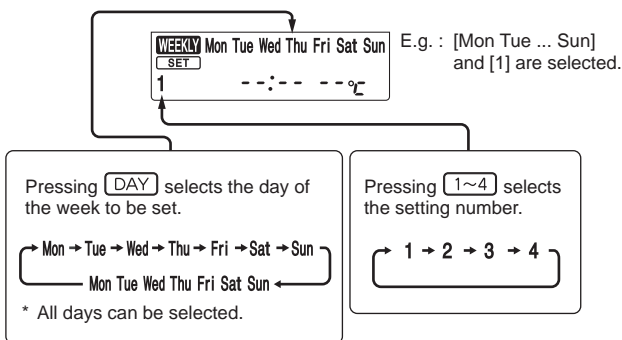

(3) Press **ON/OFF**, **TIME**, and **TEMP** buttons to set ON/OFF, time, and temperature.

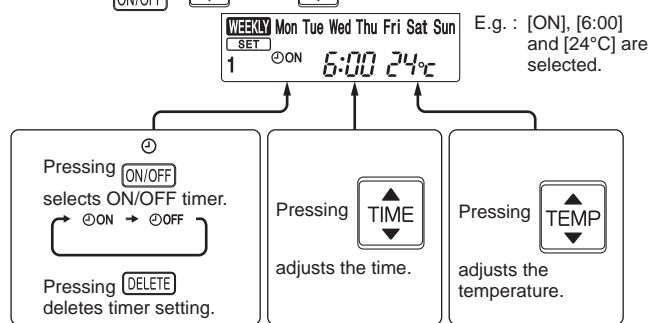

* Hold down the button to change the time quickly.

* The temperature can be set between 16°C and 31°C at weekly timer.

Press **DAY** and **1~4** buttons to continue setting the timer for other days and/or numbers.

(4) Press **EDIT/SEND SET** button to complete and transmit the weekly timer setting.



NOTE:

- Press **EDIT/SEND SET** button to transmit the setting information of weekly timer to the indoor unit. Point the remote controller toward the indoor unit for 3 seconds.
- When setting the timer for more than one day of the week or one number, **EDIT/SEND SET** button does not have to be pressed per each setting. Press **EDIT/SEND SET** button once after all the settings are complete. All the weekly timer settings will be saved.
- Press **EDIT/SEND SET** button to enter the weekly timer setting mode, and press and hold **DELETE** button for 5 seconds to erase all weekly timer settings. Point the remote controller toward the indoor unit.

(5) Press button to turn the weekly timer ON. ()

•When the weekly timer is ON, the day of the week whose timer setting is complete, will light.

Press button again to turn the weekly timer OFF. ()

NOTE:

The saved settings will not be cleared when the weekly timer is turned OFF.

2. Checking weekly timer setting

(1) Press button to enter the weekly timer setting mode.

* blinks.

(2) Press or buttons to view the setting of the particular day or number.

(3) Press button to exit the weekly timer setting.

NOTE:

When all days of the week are selected to view the settings and a different setting is included among them, will be displayed.

h. i-save (i) OPERATION

1. How to set i-save operation

- (1) Press STOP/OPERATE (OFF/ON) button.
- (2) Select COOL, HEAT or ECONO COOL mode.
- (3) Press i-save button.
- (4) Set the temperature, fan speed, and airflow direction for i-save operation.

NOTE:

- i-save operation cannot be selected during DRY or AUTO mode operation.
- The setting range of HEAT mode i-save operation is 10°C and 16 - 31°C.
- 2 groups of setting can be saved. (One for COOL/ECONO COOL, one for HEAT)
- i-save operation and the weekly timer operation cannot be used together.

2. How to cancel operation

- Press i-save button again.
 - i-save operation can also be cancelled by pressing OPERATION SELECT button to change the operation mode.
- The same setting is select from the next time by simply pressing i-save button.

i. EMERGENCY/TEST OPERATION

In the case of test run operation or emergency operation, use EMERGENCY OPERATION switch on the right side of the indoor unit. Emergency operation is available when the remote controller is missing or has failed, or when the batteries in the remote controller are running down. The unit will start and OPERATION INDICATOR lamp will light up. The first 30 minutes of operation is the test run operation. This operation is for servicing. The indoor fan runs at High speed and the temperature control does not work.

After 30 minutes of test run operation, the system shifts to EMERGENCY COOL/HEAT MODE with a set temperature of 24°C. The fan speed shifts to Med.

The coil frost prevention works even in the test run or the emergency operation.

In the test run or emergency operation, the horizontal vane operates in VANE AUTO (Ⓜ) mode.

Emergency operation continues until EMERGENCY OPERATION switch is pressed once or twice or the unit receives any signal from the remote controller. In the latter case, normal operation will start.

NOTE: Do not press EMERGENCY OPERATION switch during normal operation.

Operation mode	COOL/HEAT
Set temperature	24°C
Fan speed	Med.
Horizontal vane	Auto

The operation mode is indicated by the Operation Indicator lamp as follows:

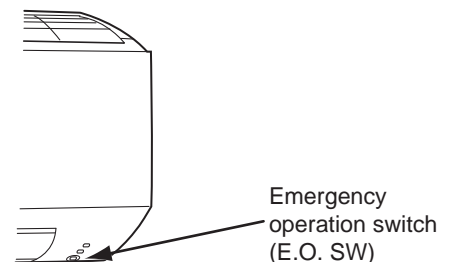
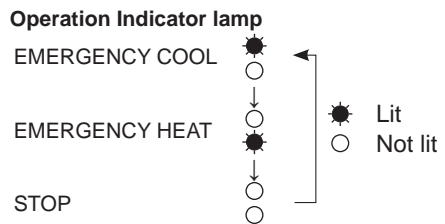

j. 3-MINUTE TIME DELAY OPERATION

When the system turns OFF, compressor will not restart for 3 minutes as 3-minute time delay function operates to protect compressor from overload.

k. ACTUATOR CONTROL

k-1. Outdoor fan motor control

The fan motor turns ON/OFF, interlocking with the compressor.

[ON] The fan motor turns ON 5 seconds before the compressor starts up.

[OFF] The fan motor turns OFF 15 seconds after the compressor has stopped running.

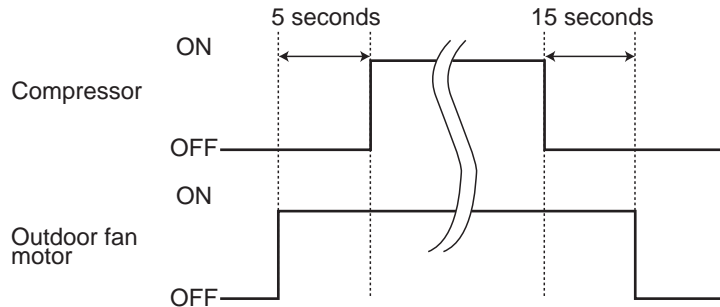

k-2. R.V. coil control

- Heating ON
- Cooling OFF
- Dry OFF

NOTE: The 4-way valve reverses for 5 seconds right before start-up of the compressor.

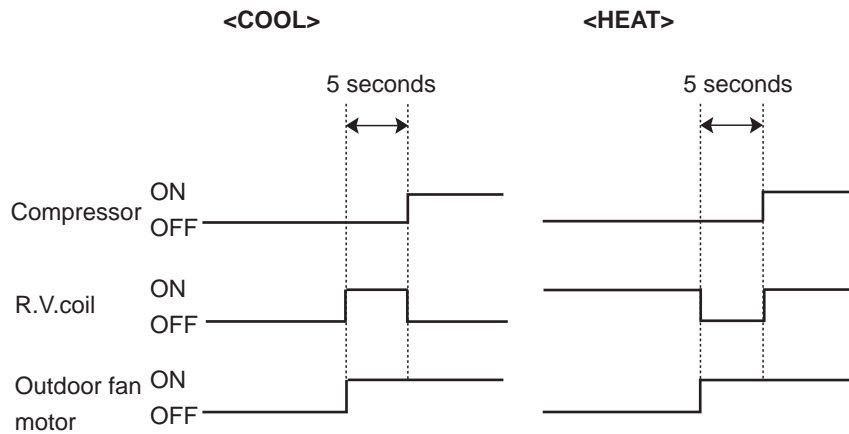

k-3. Relation between main sensor and actuator

Sensor	Purpose	Actuator				
		Compressor	LEV	Outdoor fan motor	R.V.coil	Indoor fan motor
Discharge temperature thermistor	Protection	○	○			
Indoor coil temperature thermistor	Cooling: Coil frost prevention	○				
	Heating: High pressure protection	○	○			
Defrost thermistor	Heating: Defrosting	○	○	○	○	○
Fin temperature thermistor	Protection	○		○		
Ambient temperature thermistor	Cooling: Low ambient temperature operation	○	○	○		
Outdoor heat exchanger temperature thermistor	Cooling: Low ambient temperature operation	○	○	○		
	Cooling: High pressure protection	○	○	○		

C.1.9.14 MSZ-WN•VA Series

MSZ-WN25VA MSZ-WN35VA
 MUZ-WN25VA MUZ-WN35VA

WIRELESS REMOTE CONTROLLER

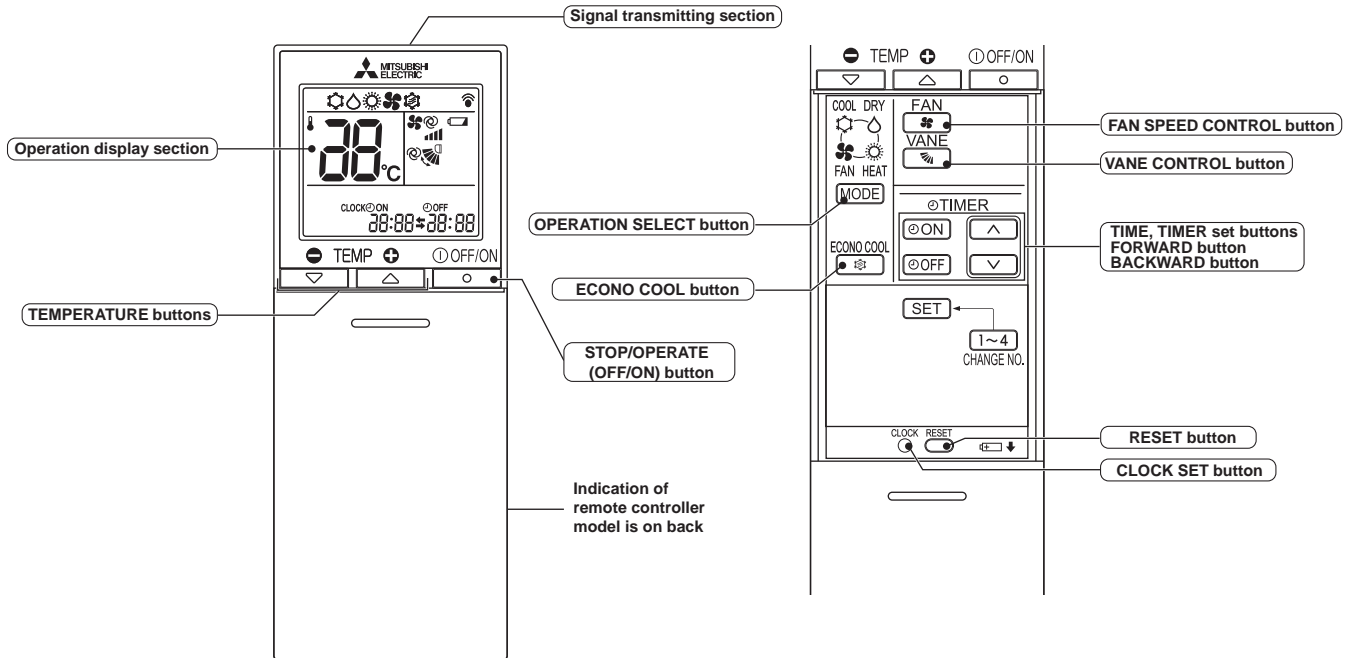

NOTE: Last setting will be stored after the unit is turned OFF with the remote controller. Indoor unit receives the signal of the remote controller with beeps.

INDOOR UNIT DISPLAY SECTION

Operation Indicator lamp

The operation indicator at the right side of the indoor unit indicates the operation state.

•The following indication applies regardless of shape of the indication.

Indication	Operation state	Room temperature
	The unit is operating to reach the set temperature	About 2°C or more away from set temperature
	The room temperature is approaching the set temperature	About 1 to 2°C from set temperature

Lit
 Blinking
 Not lit

a. COOL (❄️) OPERATION

- (1) Press STOP/OPERATE/ (OFF/ON) button.
 OPERATION INDICATOR lamp of the indoor unit turns on with a beep tone.
- (2) Select COOL mode with OPERATION SELECT button.
- (3) Press TEMPERATURE buttons (TOO WARM or TOO COOL button) to select the desired temperature.
 The setting range is 16 ~ 31°C.

1. Coil frost prevention

The compressor operational frequency is controlled by the temperature of the indoor heat exchanger to prevent the coil from frosting.

When the temperature of indoor heat exchanger becomes too low, the coil frost prevention mode works. The indoor fan operates at the set speed and the compressor stops. This mode continues until the temperature of indoor heat exchanger rises.

b. DRY (△) OPERATION

- (1) Press STOP/OPERATE/ (OFF/ON) button.
OPERATION INDICATOR lamp of the indoor unit turns on with a beep tone.
- (2) Select DRY mode with OPERATION SELECT button.
- (3) The set temperature is determined from the initial room temperature.

1. Coil frost prevention

Coil frost prevention works the same way as that in COOL mode. (a.1.)

c. HEAT (☀) OPERATION

- (1) Press STOP/OPERATE/ (OFF/ON) button.
OPERATION INDICATOR lamp of the indoor unit turns on with a beep tone.
- (2) Select HEAT mode with OPERATION SELECT button.
- (3) Press TEMPERATURE buttons (TOO WARM or TOO COOL button) to select the desired temperature.
The setting range is 16 ~ 31°C.

1. Cold air prevention control

When the compressor is not operating or is starting, and the temperature of indoor heat exchanger and/or the room temperature is low or when defrosting is being done, the indoor fan will stop or rotate in Very Low speed.

2. High pressure protection

The compressor operational frequency is controlled by the temperature of the indoor heat exchanger to prevent the condensing pressure from increasing excessively.

When the temperature of indoor heat exchanger becomes too high, the high pressure protection works.

The indoor fan operates following the cold air prevention control. This mode continues until the temperature of indoor heat exchanger falls.

3. Defrosting

Defrosting starts when the temperature of outdoor heat exchanger becomes too low.

The compressor stops once, the indoor/outdoor fans stop, the 4-way valve reverses, and the compressor restarts.

This mode continues until the temperature of outdoor heat exchanger rises or the fixed time passes.

d. AUTO VANE OPERATION

1. Horizontal vane

- (1) Vane motor drive
These models are equipped with a stepping motor for the horizontal vane. The rotating direction, speed, and angle of the motor are controlled by pulse signals (approximately 12 V) transmitted from indoor microprocessor.
- (2) The horizontal vane angle and mode change as follows by pressing VANE CONTROL button.

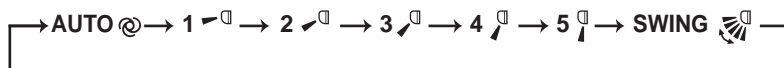

(3) Positioning

To confirm the standard position, the vane moves until it touches the vane stopper. Then the vane is set to the selected angle.

Confirmation of standard position is performed in the following cases:

- (a) When the operation starts or finishes (including timer operation).
- (b) When the test run starts.
- (c) When standby mode (only during multi system operation) starts or finishes.

(4) VANE AUTO (ⓐ) mode

In VANE AUTO mode, the microprocessor automatically determines the vane angle to make the optimum room temperature distribution.

In COOL and DRY operation
Vane angle is fixed to Horizontal position.



In HEAT operation
Vane angle is fixed to Angle 4.

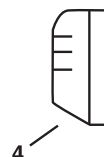

WALL-MOUNTED OPERATION AND ACTUATOR CONTROL

- (5) STOP (operation OFF) and ON TIMER standby
In the following cases, the horizontal vane returns to the closed position.
- When STOP/OPERATE/ (OFF/ON) button is pressed (POWER OFF).
 - When the operation is stopped by the emergency operation.
 - When ON TIMER is ON standby.
- (6) Dew prevention
During COOL or DRY operation with the vane angle at Angle 3 ~ 5 when the compressor cumulative operation time exceeds 1 hour, the vane angle automatically changes to Angle 2 for dew prevention.
- (7) SWING (🌀) mode
By selecting SWING mode with VANE CONTROL button, the horizontal vane swings vertically.
- (8) Cold air prevention in HEAT operation.
The horizontal vane position is set to Upward.
NOTE: When 2 or more indoor units are operated with multi outdoor unit, even if any indoor unit turns thermostat off, this control does not work in the indoor unit.
- (9) ECONO COOL (🌿) operation (ECONOMical operation)
When ECONO COOL button is pressed in COOL mode, set temperature is automatically set 2°C higher by the microprocessor. (However, the temperature on the LCD screen on the remote controller is not changed.)
Also the horizontal vane swings in various cycle.
SWING operation makes you feel cooler than set temperature. So, even though the set temperature is higher, the air conditioner can keep comfort. As a result, energy can be saved.
To cancel this operation, select a different mode or press one of the following buttons in ECONO COOL operation: ECONO COOL, or VANE CONTROL button.

e. TIMER OPERATION (ON/OFF TIMER)

1. How to set the time

- (1) Check that the current time is set correctly.

NOTE: Timer operation will not work without setting the current time. Initially "0:00" blinks at the current time display of TIME MONITOR, so set the current time correctly with CLOCK SET button.

How to set the current time

- Press the CLOCK set button.
 - Press the TIME SET buttons (▲) and (▼) to set the current time.
 - Each time FORWARD button (▲) is pressed, the set time increases by 1 minute, and each time BACKWARD button (▼) is pressed, the set time decreases by 1 minute.
 - Pressing those buttons longer, the set time increases/decreases by 10 minutes.
 - Press the CLOCK set button.
- (2) Press STOP/OPERATE (OFF/ON) button to start the air conditioner.
- (3) Set the time of timer.

ON timer setting

- Press ON TIMER button (ⓄON) during operation.
- Set the time of the timer using TIME SET buttons (▲) and (▼). *

OFF timer setting

- Press OFF TIMER button (ⓄOFF) during operation.
- Set the time of the timer using TIME SET buttons (▲) and (▼). *

* Each time FORWARD button (▲) is pressed, the set time increases by 10 minutes: each time BACKWARD button (▼) is pressed, the set time decreases by 10 minutes.

2. To release the timer

To release ON timer, press ON TIMER button (ⓄON).
To release OFF timer, press OFF TIMER button (ⓄOFF).
TIMER is cancelled and the display of set time disappears.

PROGRAM TIMER

- OFF timer and ON timer can be used in combination. The set time that is reached first will operate first.
- “←” and “→” display show the order of OFF timer and ON timer operation.

(Example 1) The current time is 8:00 PM.
The unit turns off at 11:00 PM, and on at 6:00 AM.

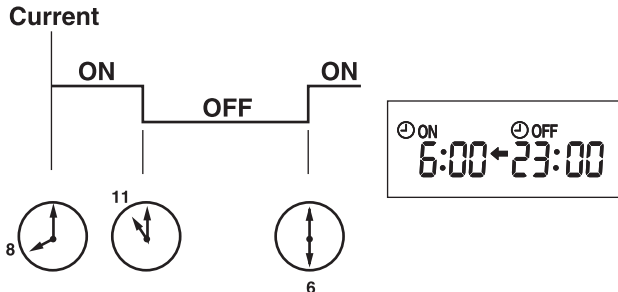

(Example 2) The current time is 11:00 AM.
The unit turns on at 5:00 PM, and off at 9:00 PM.

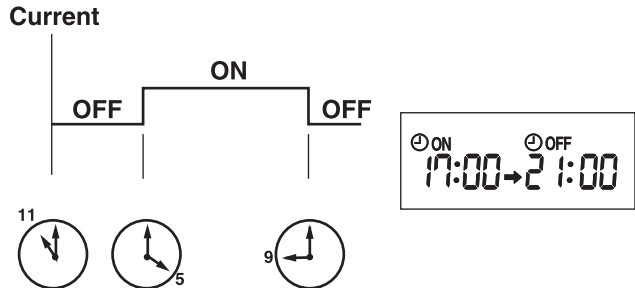

NOTE: If the main power is turned OFF or a power failure occurs while ON/OFF timer is active, the timer setting is cancelled. As these models are equipped with an auto restart function, the air conditioner starts operating with timer cancelled when power is restored.

f. EMERGENCY/TEST OPERATION

In the case of test run operation or emergency operation, use EMERGENCY OPERATION switch on the right side of the indoor unit. Emergency operation is available when the remote controller is missing or has failed, or when the batteries in the remote controller are running down. The unit will start and OPERATION INDICATOR lamp will light up. The first 30 minutes of operation is the test run operation. This operation is for servicing. The indoor fan runs at High speed and the temperature control does not work. After 30 minutes of test run operation, the system shifts to EMERGENCY COOL/HEAT MODE with a set temperature of 24°C. The fan speed shifts to Med. The coil frost prevention works even in the test run or the emergency operation. In the test run or emergency operation, the horizontal vane operates in VANE AUTO (Ⓜ) mode. Emergency operation continues until EMERGENCY OPERATION switch is pressed once or twice or the unit receives any signal from the remote controller. In the latter case, normal operation will start.

NOTE: Do not press EMERGENCY OPERATION switch during normal operation.



Operation mode	COOL	HEAT
Set temperature	24°C	24°C
Fan speed	Med.	Med.
Horizontal vane	Auto	Auto

The operation mode is indicated by the Operation Indicator lamp as follows:

Operation Indicator lamp

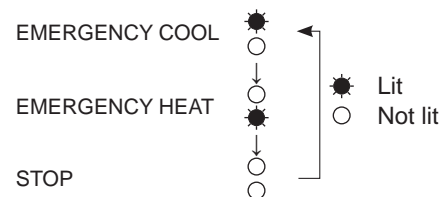

g. 3-MINUTE TIME DELAY OPERATION

When the system turns OFF, compressor will not restart for 3 minutes as 3-minute time delay function operates to protect compressor from overload.

h. ACTUATOR CONTROL

h-1. OUTDOOR FAN MOTOR CONTROL

The fan motor turns ON/OFF, interlocking with the compressor.

[ON] The fan motor turns ON 5 seconds before the compressor starts up.

[OFF] The fan motor turns OFF 15 seconds after the compressor has stopped running.

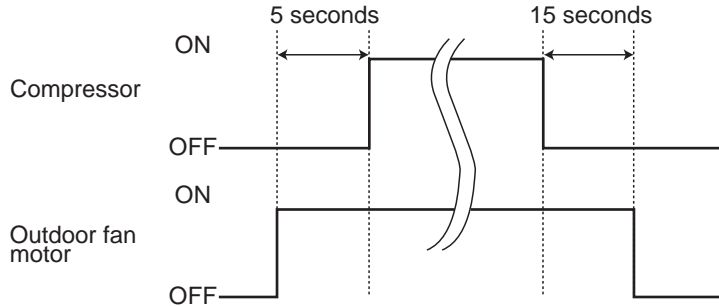

h-2. R.V. COIL CONTROL

Heating OFF

Cooling ON

Dry ON

NOTE: The 4-way valve reverses for 5 seconds right before start-up of the compressor.

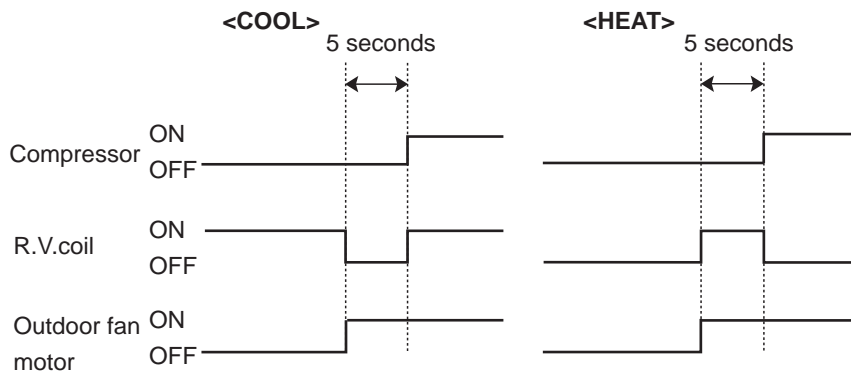

h-3. RELATION BETWEEN MAIN SENSOR AND ACTUATOR

Sensor	Purpose	Actuator				
		Compressor	LEV	Outdoor fan motor	R.V. coil	Indoor fan motor
Discharge temperature thermistor	Protection	○	○			
Indoor coil temperature thermistor	Cooling: Coil frost prevention	○				
	Heating: High pressure protection	○				
Defrost thermistor	Cooling: High pressure protection	○	○	○		
	Heating: Defrosting	○	○	○	○	○
Fin temperature thermistor	Protection	○		○		

OPERATION AND ACTUATOR CONTROL

WALL-MOUNTED

C.1.9.15 MSZ-DM•VA Series

MSZ-DM25VA MSZ-DM35VA
 MUZ-DM25VA MUZ-DM35VA

WIRELESS REMOTE CONTROLLER

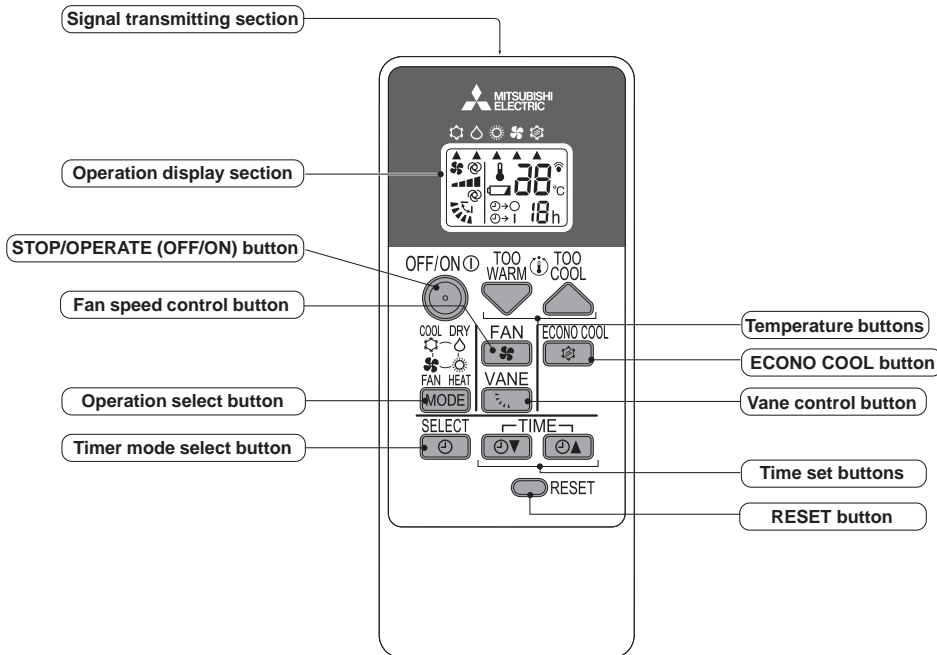

NOTE : Last setting will be stored after the unit is turned OFF with the remote controller. Indoor unit receives the signal of the remote controller with beeps.

INDOOR UNIT DISPLAY SECTION

Operation Indicator lamp

The operation indicator at the right side of the indoor unit indicates the operation state.

•The following indication applies regardless of shape of the indication.

Indication	Operation state	Room temperature
● ●	The unit is operating to reach the set temperature	About 2°C or more away from set temperature
● ○	The room temperature is approaching the set temperature	About 1 to 2°C from set temperature
● ●	Standby mode (Only during multi system operation)	—

● Lit
 ● Blinking
 ○ Not lit

a. COOL (❄️) OPERATION

- Press STOP/OPERATE (OFF/ON) button.
OPERATION INDICATOR lamp of the indoor unit turns on with a beep tone.
- Select COOL mode with OPERATION SELECT button.
- Press TEMPERATURE buttons (TOO WARM or TOO COOL button) to select the desired temperature.
The setting range is 16 ~ 31°C.

1. Coil frost prevention

The compressor operational frequency is controlled by the temperature of the indoor heat exchanger to prevent the coil from frosting.
 When the temperature of indoor heat exchanger becomes too low, the coil frost prevention mode works. The indoor fan operates at the set speed and the compressor stops. This mode continues until the temperature of indoor heat exchanger rises.

b. DRY (△) OPERATION

- (1) Press STOP/OPERATE (OFF/ON) button.
OPERATION INDICATOR lamp of the indoor unit turns on with a beep tone.
- (2) Select DRY mode with OPERATION SELECT button.
- (3) The set temperature is determined from the initial room temperature.

1. Coil frost prevention

Coil frost prevention works the same way as that in COOL mode. (a.1.)

c. HEAT (⊙) OPERATION

- (1) Press STOP/OPERATE (OFF/ON) button.
OPERATION INDICATOR lamp of the indoor unit turns on with a beep tone.
- (2) Select HEAT mode with OPERATION SELECT button.
- (3) Press TEMPERATURE buttons (TOO WARM or TOO COOL button) to select the desired temperature.
The setting range is 16 ~ 31°C.

1. Cold air prevention control

When the compressor is not operating or is starting, and the temperature of indoor heat exchanger and/or the room temperature is low or when defrosting is being done, the indoor fan will stop or rotate in Very Low speed.

2. High pressure protection

The compressor operational frequency is controlled by the temperature of the indoor heat exchanger to prevent the condensing pressure from increasing excessively.

When the temperature of indoor heat exchanger becomes too high, the high pressure protection works.

The indoor fan operates following the cold air prevention control. This mode continues until the temperature of indoor heat exchanger falls.

3. Defrosting

Defrosting starts when the temperature of outdoor heat exchanger becomes too low.

The compressor stops once, the indoor/outdoor fans stop, the 4-way valve reverses, and the compressor restarts.

This mode continues until the temperature of outdoor heat exchanger rises or the fixed time passes.

d. AUTO VANE OPERATION

1. Horizontal vane

- (1) Vane motor drive
These models are equipped with a stepping motor for the horizontal vane. The rotating direction, speed, and angle of the motor are controlled by pulse signals (approximately 12 V) transmitted from indoor microprocessor.
- (2) The horizontal vane angle and mode change as follows by pressing VANE CONTROL button.

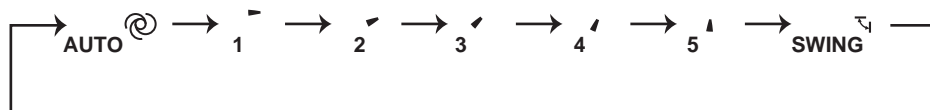

(3) Positioning

To confirm the standard position, the vane moves until it touches the vane stopper. Then the vane is set to the selected angle.

Confirmation of standard position is performed in the following cases:

- (a) When the operation starts or finishes (including timer operation).
- (b) When the test run starts.
- (c) When standby mode (only during multi system operation) starts or finishes.

(4) VANE AUTO (Ⓢ) mode

In VANE AUTO mode, the microprocessor automatically determines the vane angle to make the optimum room temperature distribution.

In COOL and DRY operation
Vane angle is fixed to Horizontal position.



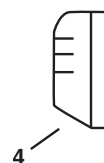

In HEAT operation
Vane angle is fixed to Angle 4.



- (5) STOP (operation OFF) and ON TIMER standby
 In the following cases, the horizontal vane returns to the closed position.
 (a) When STOP/OPERATE (OFF/ON) button is pressed (POWER OFF).
 (b) When the operation is stopped by the emergency operation.
 (c) When ON TIMER is ON standby.
- (6) Dew prevention
 During COOL or DRY operation with the vane angle at Angle 3 ~ 5 when the compressor cumulative operation time exceeds 1 hour, the vane angle automatically changes to Angle 2 for dew prevention.
- (7) SWING (↕) mode
 By selecting SWING mode with VANE CONTROL button, the horizontal vane swings vertically.
- (8) Cold air prevention in HEAT operation.
 The horizontal vane position is set to Upward.
NOTE: When 2 or more indoor units are operated with multi outdoor unit, even if any indoor unit turns thermostat off, this control does not work in the indoor unit.
- (9) ECONO COOL (🌡️) operation (ECONOMICAL operation)
 When ECONO COOL button is pressed in COOL mode, set temperature is automatically set 2°C higher.
 Also the horizontal vane swings in various cycle.
 SWING operation makes you feel cooler than set temperature. So, even though the set temperature is higher, the air conditioner can keep comfort. As a result, energy can be saved.
 ECONO COOL operation is cancelled when ECONO COOL button is pressed once again or VANE CONTROL button is pressed or change to other operation mode.

e. TIMER OPERATION (ON/OFF TIMER)

1. How to set the timer

- (1) Press STOP/OPERATE (OFF/ON) button to start the air conditioner.
- (2) Select the timer mode by pressing the  button during operation.
 Each time this button is pressed, the timer mode is changed in sequence:
 ☉→○ (OFF TIMER) → ☉→| (ON TIMER) → TIMER RELEASE
- (3) Set the time of the timer using the  button.
 Each time this button is pressed, the set time increase or decrease by 1 hour to 12 hours.

2. To release the timer

Press the  button until ☉→○ (OFF TIMER) and ☉→| (ON TIMER) are not displayed.

NOTE :

- The OFF TIMER and the ON TIMER cannot be set at the same time.
- The displayed time is the time remaining and will decrease in 1-hour increments as time passes.

f. EMERGENCY/TEST OPERATION

In the case of test run operation or emergency operation, use EMERGENCY OPERATION switch on the right side of the indoor unit. Emergency operation is available when the remote controller is missing or has failed, or when the batteries in the remote controller are running down. The unit will start and OPERATION INDICATOR lamp will light up.

The first 30 minutes of operation is the test run operation. This operation is for servicing. The indoor fan runs at High speed and the temperature control does not work.

After 30 minutes of test run operation, the system shifts to EMERGENCY COOL/HEAT MODE with a set temperature of 24°C. The fan speed shifts to Med.

The coil frost prevention works even in the test run or the emergency operation.

In the test run or emergency operation, the horizontal vane operates in VANE AUTO (@) mode.

Emergency operation continues until EMERGENCY OPERATION switch is pressed once or twice or the unit receives any signal from the remote controller. In the latter case, normal operation will start.

NOTE: Do not press EMERGENCY OPERATION switch during normal operation.



Operation mode	COOL	HEAT
Set temperature	24°C	24°C
Fan speed	Med.	Med.
Horizontal vane	Auto	Auto

The operation mode is indicated by the Operation Indicator lamp as follows:

Operation Indicator lamp

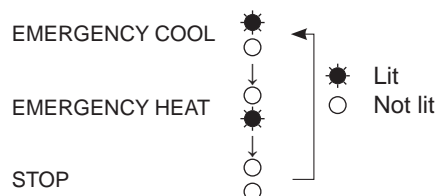

g. 3-MINUTE TIME DELAY OPERATION

When the system turns OFF, compressor will not restart for 3 minutes as 3-minute time delay function operates to protect compressor from overload.

OPERATION AND ACTUATOR CONTROL

WALL-MOUNTED

h. ACTUATOR CONTROL

h-1. Outdoor fan motor control

The fan motor turns ON/OFF, interlocking with the compressor.

[ON] The fan motor turns ON 5 seconds before the compressor starts up.

[OFF] The fan motor turns OFF 15 seconds after the compressor has stopped running.

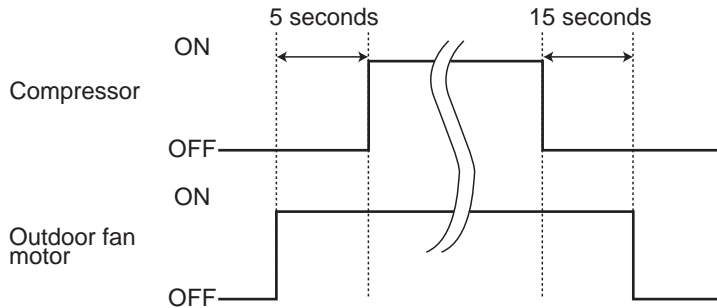

h-2. R.V. Coil control

Heating OFF

Cooling ON

Dry ON

NOTE: The 4-way valve reverses for 5 seconds right before start-up of the compressor.

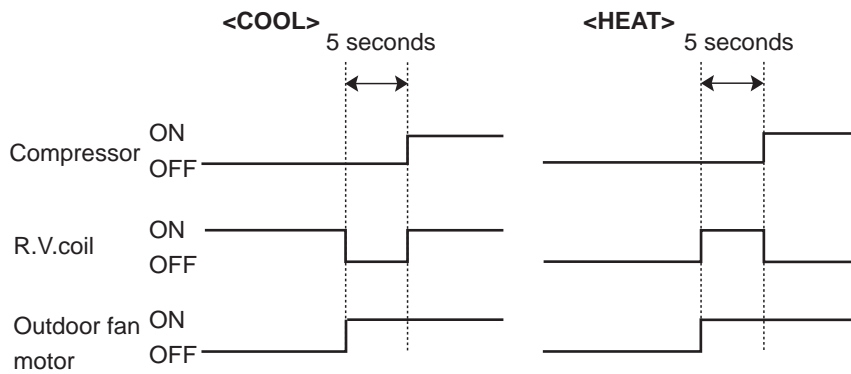

h-3. Relation between main sensor and actuator

Sensor	Purpose	Actuator				
		Compressor	LEV	Outdoor fan motor	R.V. coil	Indoor fan motor
Discharge temperature thermistor	Protection	○	○			
Indoor coil temperature thermistor	Cooling: Coil frost prevention	○				
	Heating: High pressure protection	○				
Defrost thermistor	Cooling: High pressure protection	○	○	○		
	Heating: Defrosting	○	○	○	○	○
Fin temperature thermistor	Protection	○		○		

C.1.9.16 MSZ-HJ•VA Series

MSZ-HJ25VA MSZ-HJ35VA MSZ-HJ50VA MSZ-HJ60VA MSZ-HJ71VA
 MUZ-HJ25VA MUZ-HJ35VA MUZ-HJ50VA MUZ-HJ60VA MUZ-HJ71VA

WIRELESS REMOTE CONTROLLER

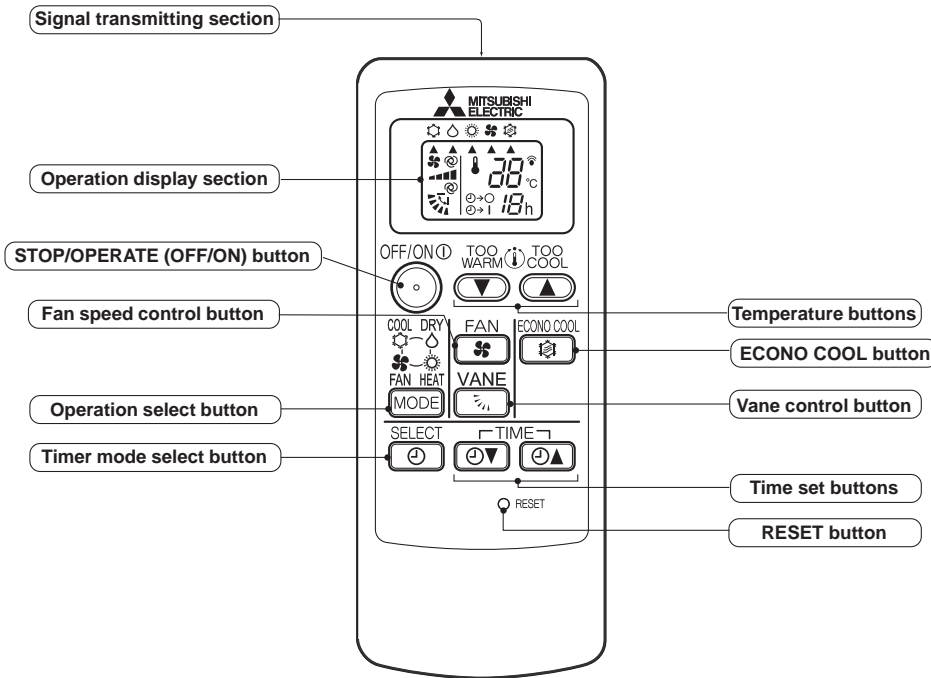

NOTE: Last setting will be stored after the unit is turned OFF with the remote controller. Indoor unit receives the signal of the remote controller with beeps.

INDOOR UNIT DISPLAY SECTION

Operation Indicator lamp

The operation indicator at the right side of the indoor unit indicates the operation state.

•The following indication applies regardless of shape of the indication.

Indication	Operation state	Room temperature
	The unit is operating to reach the set temperature.	About 2°C or more away from set temperature
	The room temperature is approaching the set temperature.	About 1 to 2°C from set temperature
	Standby mode (Only during multi system operation)	—

Lit
 Blinking
 Not lit

a. COOL (❄️) OPERATION

- (1) Press STOP/OPERATE (OFF/ON) button.
OPERATION INDICATOR lamp of the indoor unit turns on with a beep tone.
- (2) Select COOL mode with OPERATION SELECT button.
- (3) Press TEMPERATURE buttons (TOO WARM or TOO COOL button) to select the desired temperature.
The setting range is 16 ~ 31°C.

1. Coil frost prevention

The compressor operational frequency is controlled by the temperature of the indoor heat exchanger to prevent the coil from frosting.

When the temperature of indoor heat exchanger becomes too low, the coil frost prevention mode works. The indoor fan operates at the set speed and the compressor stops. This mode continues until the temperature of indoor heat exchanger rises.

b. DRY (△) OPERATION

- (1) Press STOP/OPERATE (OFF/ON) button.
OPERATION INDICATOR lamp of the indoor unit turns on with a beep tone.
- (2) Select DRY mode with OPERATION SELECT button.
- (3) The set temperature is determined from the initial room temperature.

1. Coil frost prevention

Coil frost prevention works the same way as that in COOL mode. (a.1.)

c. HEAT (⊙) OPERATION

- (1) Press STOP/OPERATE (OFF/ON) button.
OPERATION INDICATOR lamp of the indoor unit turns on with a beep tone.
- (2) Select HEAT mode with OPERATION SELECT button.
- (3) Press TEMPERATURE buttons (TOO WARM or TOO COOL button) to select the desired temperature.
The setting range is 16 ~ 31°C.

1. Cold air prevention control

When the compressor is not operating or is starting, and the temperature of indoor heat exchanger and/or the room temperature is low or when defrosting is being done, the indoor fan will stop or rotate in Very Low speed.

2. High pressure protection

The compressor operational frequency is controlled by the temperature of the indoor heat exchanger to prevent the condensing pressure from increasing excessively.

When the temperature of indoor heat exchanger becomes too high, the high pressure protection works.

The indoor fan operates following the cold air prevention control. This mode continues until the temperature of indoor heat exchanger falls.

3. Defrosting

Defrosting starts when the temperature of outdoor heat exchanger becomes too low.

The compressor stops once, the indoor/outdoor fans stop, the 4-way valve reverses, and the compressor restarts.

This mode continues until the temperature of outdoor heat exchanger rises or the fixed time passes.

d. AUTO VANE OPERATION

1. Horizontal vane

(1) Vane motor drive

These models are equipped with a stepping motor for the horizontal vane. The rotating direction, speed, and angle of the motor are controlled by pulse signals (approximately 12 V) transmitted from indoor microprocessor.

(2) The horizontal vane angle and mode change as follows by pressing VANE CONTROL button.

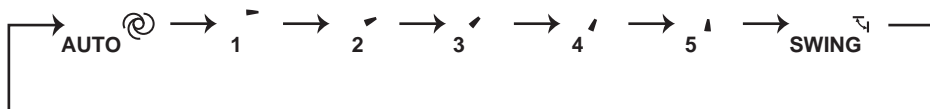

(3) Positioning

To confirm the standard position, the vane moves until it touches the vane stopper. Then the vane is set to the selected angle.

Confirmation of standard position is performed in the following cases:

- (a) When the operation starts or finishes (including timer operation).
- (b) When the test run starts.
- (c) When standby mode (only during multi system operation) starts or finishes.

(4) VANE AUTO (⊙) mode

In VANE AUTO mode, the microprocessor automatically determines the vane angle to make the optimum room temperature distribution.

In COOL and DRY operation
Vane angle is fixed to Horizontal position.



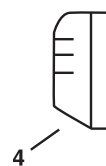

In HEAT operation
Vane angle is fixed to Angle 4.



- (5) STOP (operation OFF) and ON TIMER standby
 In the following cases, the horizontal vane returns to the closed position.
 (a) When STOP/OPERATE (OFF/ON) button is pressed (POWER OFF).
 (b) When the operation is stopped by the emergency operation.
 (c) When ON TIMER is ON standby.
- (6) Dew prevention
 During COOL or DRY operation with the vane angle at Angle 3 ~ 5 when the compressor cumulative operation time exceeds 1 hour, the vane angle automatically changes to Angle 2 for dew prevention.
- (7) SWING (↕) mode
 By selecting SWING mode with VANE CONTROL button, the horizontal vane swings vertically.
- (8) Cold air prevention in HEAT operation.
 The horizontal vane position is set to Upward.
NOTE: When 2 or more indoor units are operated with multi outdoor unit, even if any indoor unit turns thermostat off, this control does not work in the indoor unit.
- (9) ECONO COOL (🌿) operation (ECONOMical operation)
 When ECONO COOL button is pressed in COOL mode, set temperature is automatically set 2°C higher.
 Also the horizontal vane swings in various cycle.
 SWING operation makes you feel cooler than set temperature. So, even though the set temperature is higher, the air conditioner can keep comfort. As a result, energy can be saved.
 ECONO COOL operation is cancelled when ECONO COOL button is pressed once again or VANE CONTROL button is pressed or change to other operation mode.

e. TIMER OPERATION (ON/OFF TIMER)

1. How to set the timer

- (1) Press STOP/OPERATE (OFF/ON) button to start the air conditioner.
- (2) Select the timer mode by pressing the  button during operation.
 Each time this button is pressed, the timer mode is changed in sequence:
 ⓪→⓪ (OFF TIMER) → ⓪→| (ON TIMER) → TIMER RELEASE
- (3) Set the time of the timer using the   button.
 Each time this button is pressed, the set time increase or decrease by 1 hour to 12 hours.

2. To release the timer

Press the  button until ⓪→⓪ (OFF TIMER) and ⓪→| (ON TIMER) are not displayed.

NOTE :

- The OFF TIMER and the ON TIMER cannot be set at the same time.
- The displayed time is the time remaining and will decrease in 1-hour increments as time passes.

f. EMERGENCY/TEST OPERATION

In the case of test run operation or emergency operation, use EMERGENCY OPERATION switch on the right side of the indoor unit. Emergency operation is available when the remote controller is missing or has failed, or when the batteries in the remote controller are running down. The unit will start and OPERATION INDICATOR lamp will light up.

The first 30 minutes of operation is the test run operation. This operation is for servicing. The indoor fan runs at High speed and the temperature control does not work.

After 30 minutes of test run operation, the system shifts to EMERGENCY COOL/HEAT MODE with a set temperature of 24°C. The fan speed shifts to Med.

The coil frost prevention works even in the test run or the emergency operation.

In the test run or emergency operation, the horizontal vane operates in VANE AUTO (@) mode.

Emergency operation continues until EMERGENCY OPERATION switch is pressed once or twice or the unit receives any signal from the remote controller. In the latter case, normal operation will start.

NOTE: Do not press EMERGENCY OPERATION switch during normal operation.

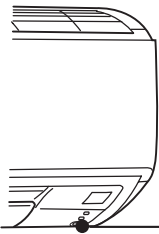



Operation mode	COOL	HEAT
Set temperature	24°C	24°C
Fan speed	Med.	Med.
Horizontal vane	Auto	Auto



The operation mode is indicated by the Operation Indicator lamp as follows:

Operation Indicator lamp

EMERGENCY COOL 

EMERGENCY HEAT 

STOP 

 Lit
 Not lit

g. 3-MINUTE TIME DELAY OPERATION

When the system turns OFF, compressor will not restart for 3 minutes as 3-minute time delay function operates to protect compressor from overload.

h. ACTUATOR CONTROL

h-1. Outdoor fan motor control

The fan motor turns ON/OFF, interlocking with the compressor.

[ON] The fan motor turns ON 5 seconds before the compressor starts up.

[OFF] The fan motor turns OFF 15 seconds after the compressor has stopped running.

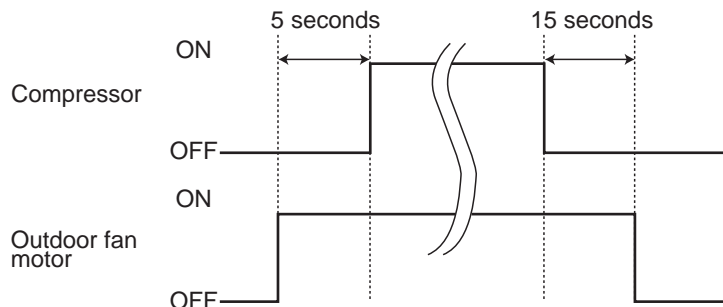

WALL-MOUNTED OPERATION AND ACTUATOR CONTROL

h-2. R.V. coil control

MUZ-HJ25VA MUZ-HJ35VA

Heating OFF

Cooling ON

Dry ON

NOTE: The 4-way valve reverses for 5 seconds right before start-up of the compressor.

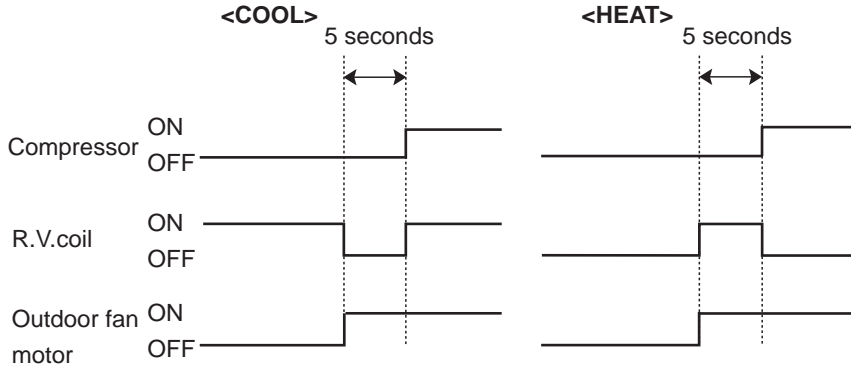

MUZ-HJ50VA MUZ-HJ60VA MUZ-HJ71VA

Heating ON

Cooling OFF

Dry OFF

NOTE: The 4-way valve reverses for 5 seconds right before start-up of the compressor.

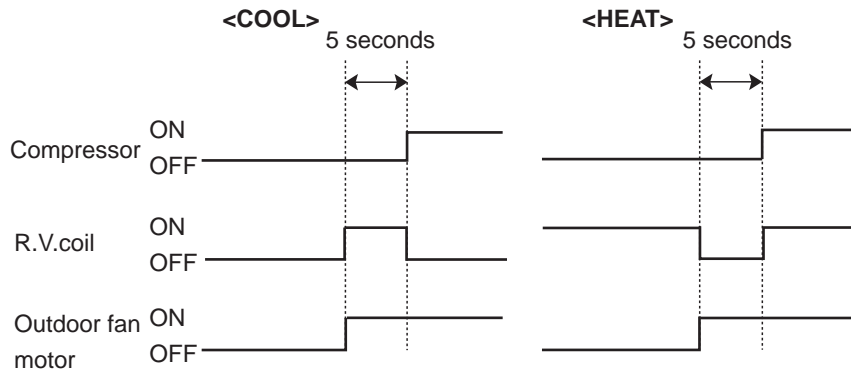

h-3. Relation between main sensor and actuator

Sensor	Purpose	Actuator				
		Compressor	LEV	Outdoor fan motor	R.V. coil	Indoor fan motor
Discharge temperature thermistor	Protection	○	○			
Indoor coil temperature thermistor	Cooling: Coil frost prevention	○				
	Heating: High pressure protection	○				
Defrost thermistor	Cooling: High pressure protection	○	○	○		
	Heating: Defrosting	○	○	○	○	○
Fin temperature thermistor	Protection	○		○		

OPERATION AND ACTUATOR CONTROL

WALL-MOUNTED

C.1.10 CAPACITY CORRECTION RATIO CURVE FOR PIPING LENGTH

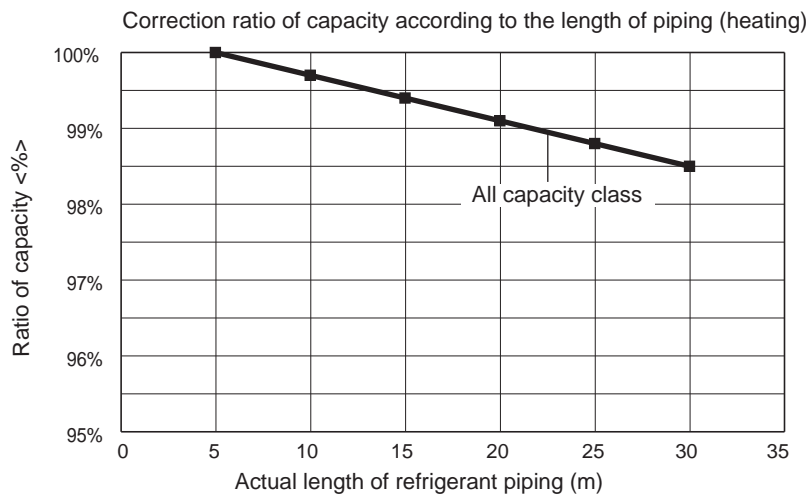
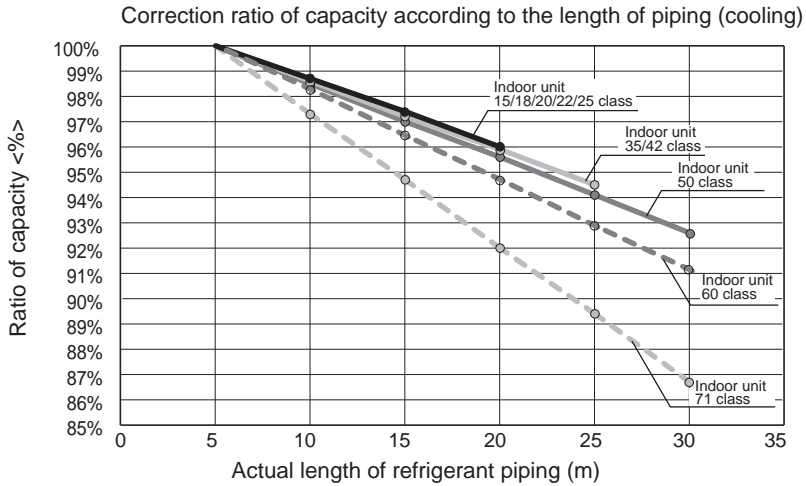

The length intended for the capacity calculation, which counts the length of refrigerant piping and the number of bends, is called actual length.

$$\text{Length of refrigerant piping (m)} + (\text{Number of bends} \times 0.3 \text{ m}) = \text{Actual length of refrigerant piping (m)}$$

C.2 FLOOR-STANDING

C.2.1	SPECIFICATIONS	C-552
	C.2.1.1 Inverter Heat Pump.....	C-552
C.2.2	OUTLINES AND DIMENSIONS.....	C-555
	C.2.2.1 Indoor Unit.....	C-555
	C.2.2.2 Outdoor Unit.....	C-556
C.2.3	WIRING DIAGRAM.....	C-558
	C.2.3.1 Indoor Unit.....	C-558
	C.2.3.2 Outdoor Unit.....	C-559
C.2.4	REFRIGERANT SYSTEM DIAGRAM	C-560
	C.2.4.1 Inverter Heat Pump.....	C-560
C.2.5	PERFORMANCE CURVES	C-563
	C.2.5.1 Inverter Heat Pump.....	C-563
C.2.6	PERFORMANCE DATA.....	C-570
	C.2.6.1 Inverter Heat Pump.....	C-570
C.2.7	NOISE CRITERIA CURVES	C-588
	C.2.7.1 Inverter Heat Pump.....	C-588
C.2.8	TEMPERATURE AND AIR FLOW DISTRIBUTIONS.....	C-592
C.2.9	OPERATION AND ACTUATOR CONTROL	C-608
	C.2.9.1 MFZ-KW•VG Series	C-608
	C.2.9.2 MFZ-KT•VG Series	C-616
C.2.10	CAPACITY CORRECTION RATIO CURVE FOR PIPING LENGTH.....	C-624

C.2.1 SPECIFICATIONS

C.2.1.1 Inverter Heat Pump

Indoor Unit				MFZ-KW25VG	MFZ-KW35VG	MFZ-KW50VG
Outdoor Unit				MUFZ-KW25VGHZ	MUFZ-KW35VGHZ	MUFZ-KW50VGHZ
Refrigerant				R32	R32	R32
Power	Source			Outdoor power supply	Outdoor power supply	Outdoor power supply
Supply	Outdoor(V/Phase/Hz)			230 / Single / 50	230 / Single / 50	230 / Single / 50
Cooling	Capacity	Rated	kW	2.5	3.5	5.0
		Min-Max	kW	0.7 - 3.6	0.7 - 4.3	1.0 - 5.8
	SHF	Rated		0.84	0.72	0.70
	Total Input	Rated	kW	0.57	0.90	1.36
	EER			4.38	3.88	3.67
	Design load		kW	2.5	3.5	5.0
	Annual electricity consumption ^(*)		kWh/a	103	151	255
	SEER			8.5	8.1	6.8
			Energy efficiency class	A+++	A++	A++
			ηsc	-	-	-
Heating (Average Season)	Capacity	Rated	kW	3.4	4.3	6.0
		Min-Max (7°C)	kW	0.2 - 5.1	0.2 - 6.0	1.2 - 8.4
	Total Input	Rated	kW	0.83	1.21	1.60
	COP			4.09	3.55	3.75
	Design load		kW	3.5	3.6	4.5
	Declared Capacity	at reference design temperature	kW	3.5 (-10°C)	3.6 (-10°C)	4.5 (-10°C)
		at bivalent temperature	kW	3.5 (-10°C)	3.6 (-10°C)	4.5 (-10°C)
		at operation limit temperature	kW	2.6 (-25°C)	2.6 (-25°C)	4.0 (-25°C)
	Back up heating capacity		kW	0.0 (-10°C)	0.0 (-10°C)	0.0 (-10°C)
	Annual electricity consumption ^(*)		kWh/a	1188	1211	1500
	SCOP			4.1	4.1	4.2
			Energy efficiency class	A+	A+	A+
			ηsh	-	-	-
Operating Current(Max)			A	9.9	10.3	15.3
Indoor Unit	Input [cooling / Heating]	Rated	kW	0.019 / 0.025	0.019 / 0.025	0.026 / 0.052
	Operating Current(Max)		A	0.22	0.22	0.47
	Dimensions	H x W x D	mm	600 x 750 x 215	600 x 750 x 215	600 x 750 x 215
	Weight		kg	15	15	15
	Air Volume (SLo-Lo-Mid-Hi-SHi)	Cooling	m ³ /min	3.9 - 4.9 - 5.9 - 7.1 - 8.2	3.9 - 4.9 - 5.9 - 7.1 - 8.2	5.6 - 6.7 - 8.0 - 9.3 - 10.6
	Air Volume (SLo-Lo-Mid-Hi-SHi)	Heating	m ³ /min	3.5 - 5.1 - 6.2 - 7.7 - 9.7	3.5 - 5.1 - 6.2 - 7.7 - 9.7	6.0 - 7.7 - 9.4 - 11.6 - 14.0
	Sound Level (SLo-Lo-Mid-Hi-SHi ^(*)) (SPL)	Cooling	dB(A)	20 - 25 - 30 - 35 - 39	20 - 25 - 30 - 35 - 39	27 - 31 - 35 - 39 - 44
	Sound Level (SLo-Lo-Mid-Hi-SHi ^(*)) (SPL)	Heating	dB(A)	18 - 25 - 30 - 35 - 41	18 - 25 - 30 - 35 - 41	29 - 35 - 40 - 45 - 50
	Sound Level (PWL)		dB(A)	49	50	56
	Outdoor Unit	Dimensions	H x W x D	mm	550 x 800 x 285	550 x 800 x 285
Weight			kg	35	35	54
Air Volume		Cooling	m ³ /min	32.7	32.7	43.8
		Heating	m ³ /min	27.3	27.3	46.3
Sound Level (SPL)		Cooling	dB(A)	47	47	50
		Heating	dB(A)	46	47	54
Sound Level (PWL)		Cooling	dB(A)	61	61	65
Operating Current (Max)			A	9.6	10.0	14.8
Breaker Size			A	10	12	16
Ext.Piping		Diameter	Liquid/Gas	mm	6.35 / 9.52	6.35 / 9.52
	Max.Length	Out-In	m	20	20	30
	Max.Height	Out-In	m	12	12	15
Guaranteed Operating Range (Outdoor)	Cooling		°C	-10 ~ +46	-10 ~ +46	-10 ~ +46
	Heating		°C	-25 ~ +24	-25 ~ +24	-25 ~ +24

(*) Energy consumption based on standard test results. Actual energy consumption will depend on how the appliance is used and where it is located.

(*)2 SHi: Super High

Indoor Unit				MFZ-KW60VG	
Outdoor Unit				MUFZ-KW60VGHZ	
Refrigerant				R32	
Power	Source			Outdoor power supply	
Supply	Outdoor(V/Phase/Hz)			230 / Single / 50	
Cooling	Capacity	Rated	kW	6.1	
		Min-Max	kW	1.0 - 6.5	
	SHF	Rated		0.74	
	Total Input	Rated	kW	1.73	
	EER			3.52	
	Design load		kW	6.1	
	Annual electricity consumption ^(*)		kWh/a	316	
	SEER			6.7	
			Energy efficiency class	A++	
		ηsc		-	
Heating (Average Season)	Capacity	Rated	kW	6.5	
		Min-Max (7°C)	kW	1.2 - 9.0	
	Total Input	Rated	kW	1.88	
	COP			3.45	
	Design load		kW	4.8	
	Declared Capacity	at reference design temperature	kW	4.8 (-10°C)	
		at bivalent temperature	kW	4.8 (-10°C)	
		at operation limit temperature	kW	4.0 (-25°C)	
	Back up heating capacity		kW	0.0 (-10°C)	
	Annual electricity consumption ^(*)		kWh/a	1624	
	SCOP			4.1	
			Energy efficiency class	A+	
		ηsh		-	
Operating Current(Max)			A	15.4	
Indoor Unit	Input [cooling / Heating]	Rated	kW	0.063 / 0.059	
	Operating Current(Max)			A	0.55
	Dimensions	H x W x D	mm	600 x 750 x 215	
	Weight			kg	15
	Air Volume (SLo-Lo-Mid-Hi-SHi)	Cooling	m ³ /min	5.6 - 8.0 - 9.6 - 12.3 - 15.0	
	Air Volume (SLo-Lo-Mid-Hi-SHi)	Heating	m ³ /min	6.0 - 7.7 - 9.7 - 12.5 - 14.6	
	Sound Level (SLo-Lo-Mid-Hi-SHi ^(*)) (SPL)	Cooling	dB(A)	27 - 35 - 39 - 46 - 53	
	Sound Level (SLo-Lo-Mid-Hi-SHi ^(*)) (SPL)	Heating	dB(A)	29 - 35 - 41 - 47 - 51	
	Sound Level (PWL)			dB(A)	65
	Outdoor Unit	Dimensions	H x W x D	mm	880 x 840 x 330
Weight			kg	54	
Air Volume		Cooling	m ³ /min	48.8	
		Heating	m ³ /min	51.3	
Sound Level (SPL)		Cooling	dB(A)	52	
		Heating	dB(A)	56	
Sound Level (PWL)		Cooling	dB(A)	66	
Operating Current (Max)			A	14.8	
Breaker Size			A	16	
Ext.Piping	Diameter	Liquid/Gas	mm	6.35 / 12.7	
	Max.Length	Out-In	m	30	
	Max.Height	Out-In	m	15	
Guaranteed Operating Range (Outdoor)	Cooling		°C	-10 ~ +46	
	Heating		°C	-25 ~ +24	

(*) Energy consumption based on standard test results. Actual energy consumption will depend on how the appliance is used and where it is located.

(*)2 SHi: Super High

Indoor Unit				MFZ-KT25VG	MFZ-KT35VG	MFZ-KT50VG	MFZ-KT60VG		
Outdoor Unit				SUZ-M25VA	SUZ-M35VA	SUZ-M50VA	SUZ-M60VA		
Refrigerant				R32	R32	R32	R32		
Power Supply	Source	Outdoor Power supply		Outdoor Power supply	Outdoor Power supply	Outdoor Power supply	Outdoor Power supply		
	Outdoor (V/Phase/Hz)	230V/SinglePhase/50Hz		230V/SinglePhase/50Hz	230V/SinglePhase/50Hz	230V/SinglePhase/50Hz	230V/SinglePhase/50Hz		
Cooling	Design load		kW	2.5	3.5	5.0	6.1		
		Annual electricity consumption ^(*)	kWh/a	134	185	257	343		
		SEER		6.5	6.6	6.8	6.2		
		Energy efficiency class		A++	A++	A++	A++		
	Capacity	Rated		kW	2.5	3.5	5.0	6.1	
		Min-Max.		kW	1.6-3.2	0.9-3.9	1.2-5.6	1.7-6.3	
	SHF			0.79	0.70	0.72	0.70		
	Total Input	Rated		kW	0.62	1.06	1.55	1.84	
	EER				4.00	3.30	3.21	3.30	
	Heating (Average Season)	Design load		kW	2.2	2.6	4.3	4.6	
Declared Capacity			at reference design temperature	kW	2.0(-10°C)	2.3(-10°C)	3.5(-10°C)	4.1(-10°C)	
			at bivalent temperature	kW	2.0(-7°C)	2.3(-7°C)	3.9(-7°C)	4.1(-7°C)	
			at operation limit temperature	kW	2.0(-10°C)	2.3(-10°C)	3.5(-10°C)	4.1(-10°C)	
Back up heating capacity			kW	0.2	0.3	0.8	0.5		
Annual electricity consumption ^(*)			kWh/a	732	825	1423	1568		
SCOP				4.2	4.4	4.2	4.1		
Energy efficiency class				A+	A+	A+	A+		
Capacity		Rated		kW	3.4	4.3	6.0	7.0	
		Min-Max.		kW	1.3-4.2	1.1-5.0	1.5-7.2	1.6-8.0	
Total Input		Rated		kW	0.91	1.26	1.86	2.18	
COP					3.71	3.41	3.21	3.21	
Operating Current (Max.)				A	7.0	8.7	14.0	15.4	
Indoor Unit		Input [Cooling / Heating]		Rated	kW	0.020/0.024	0.020/0.024	0.037/0.052	0.063/0.059
	Operating Current (Max.)			A	0.20	0.20	0.45	0.55	
	Dimensions		H x W x D	mm	600 x 750 x 215	600 x 750 x 215	600 x 750 x 215	600 x 750 x 215	
	Weight			kg	14.5	14.5	14.5	15.0	
	single	Air Volume (SLo-Lo-Mid-Hi-SHi ^(*))	Cooling	m ³ /min.	3.9 - 4.8 - 6.5 - 7.8 - 8.9	3.9 - 4.8 - 6.5 - 7.8 - 8.9	5.6 - 6.7 - 8.6 - 10.4 - 12.3	5.6 - 8.0 - 9.6 - 12.3 - 15.0	
			Heating	m ³ /min.	3.5 - 4.0 - 5.6 - 7.3 - 9.7	3.5 - 4.0 - 5.6 - 7.3 - 9.7	6.0 - 7.7 - 9.4 - 11.6 - 14.0	6.0 - 7.7 - 9.7 - 12.5 - 14.6	
		Sound Level (SPL) (SLo-Lo-Mid-Hi-SHi ^(*))	Cooling	dB(A)	19 - 24 - 31 - 37 - 41	19 - 24 - 31 - 37 - 41	28 - 32 - 37 - 42 - 48	28 - 36 - 40 - 46 - 53	
			Heating	dB(A)	19 - 23 - 30 - 37 - 44	19 - 23 - 30 - 37 - 44	29 - 35 - 40 - 44 - 49	29 - 35 - 41 - 47 - 51	
	Multi	Air Volume (SLo-Lo-Mid-Hi-SHi ^(*))	Cooling	m ³ /min.	4.2 - 4.8 - 6.5 - 7.8 - 9.0	4.2 - 4.8 - 6.5 - 7.8 - 9.0	5.6 - 6.7 - 8.6 - 10.4 - 12.3	-	
			Heating	m ³ /min.	4.2 - 4.9 - 6.3 - 7.8 - 9.7	4.2 - 4.9 - 6.3 - 7.8 - 9.7	6.0 - 7.7 - 9.4 - 11.6 - 14.0	-	
		Sound Level (SPL) (SLo-Lo-Mid-Hi-SHi ^(*))	Cooling	dB(A)	23 - 28 - 33 - 38 - 43	23 - 28 - 33 - 38 - 43	28 - 32 - 37 - 42 - 48	-	
			Heating	dB(A)	24 - 28 - 34 - 39 - 44	24 - 28 - 34 - 39 - 44	29 - 35 - 40 - 44 - 49	-	
	Outdoor Unit	Dimensions		H x W x D	mm	550 x 800 x 285	550 x 800 x 285	714 x 800 x 285	880 x 840 x 300
		Weight			kg	30	35	41	54
Air Volume		Cooling	m ³ /min.	36.3	34.3	45.8	50.1		
		Heating	m ³ /min.	34.6	32.7	43.7	50.1		
Sound Level (SPL)		Cooling	dB(A)	45	48	48	49		
		Heating	dB(A)	46	48	49	51		
Sound Level (PWL)		Cooling	dB(A)	59	59	64	65		
Operating Current (Max.)			A	6.8	8.5	13.5	14.8		
Breaker Size			A	10	10	20	20		
Ext.Piping		Diameter	Liquid/Gas	mm	6.35 / 9.52	6.35 / 9.52	6.35 / 12.7	6.35 / 15.88	
		Max.Length	Out-In	m	20	20	30	30	
		Max.Height	Out-In	m	12	12	30	30	
Guaranteed Operating Range (Outdoor)		Cooling	°C	-10~+46	-10~+46	-15~+46	-15~+46		
		Heating	°C	-10~+24	-10~+24	-10~+24	-10~+24		

(*1) Energy consumption based on standard test results. Actual energy consumption will depend on how the appliance is used and where it is located.

(*2) SHi: Super High.

C.2.2 OUTLINES AND DIMENSIONS

C.2.2.1 Indoor Unit

Unit: mm

MFZ-KW25VG MFZ-KW35VG MFZ-KW50VG MFZ-KW60VG

INDOOR UNIT

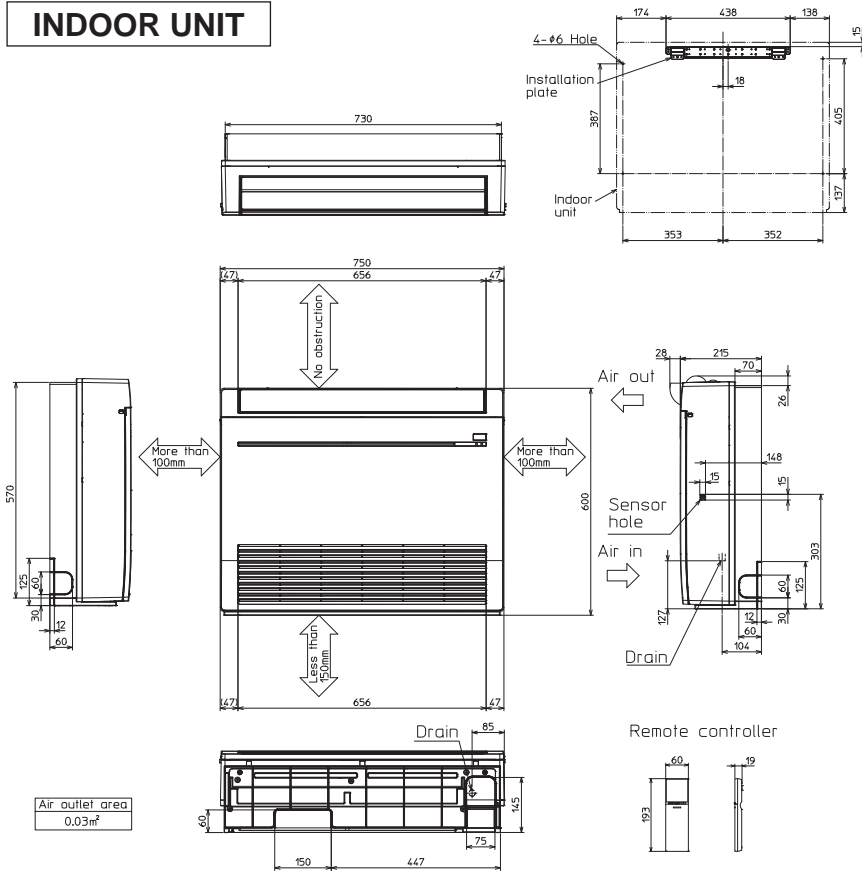

The position of gas pipe and liquid pipe

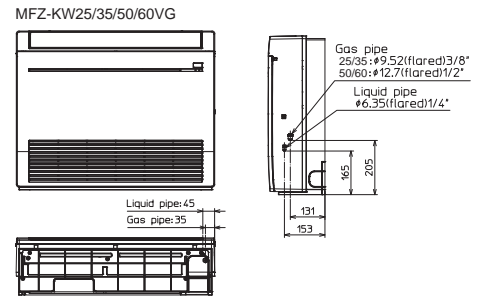

MFZ-KT25VG MFZ-KT35VG MFZ-KT50VG MFZ-KT60VG

INDOOR UNIT

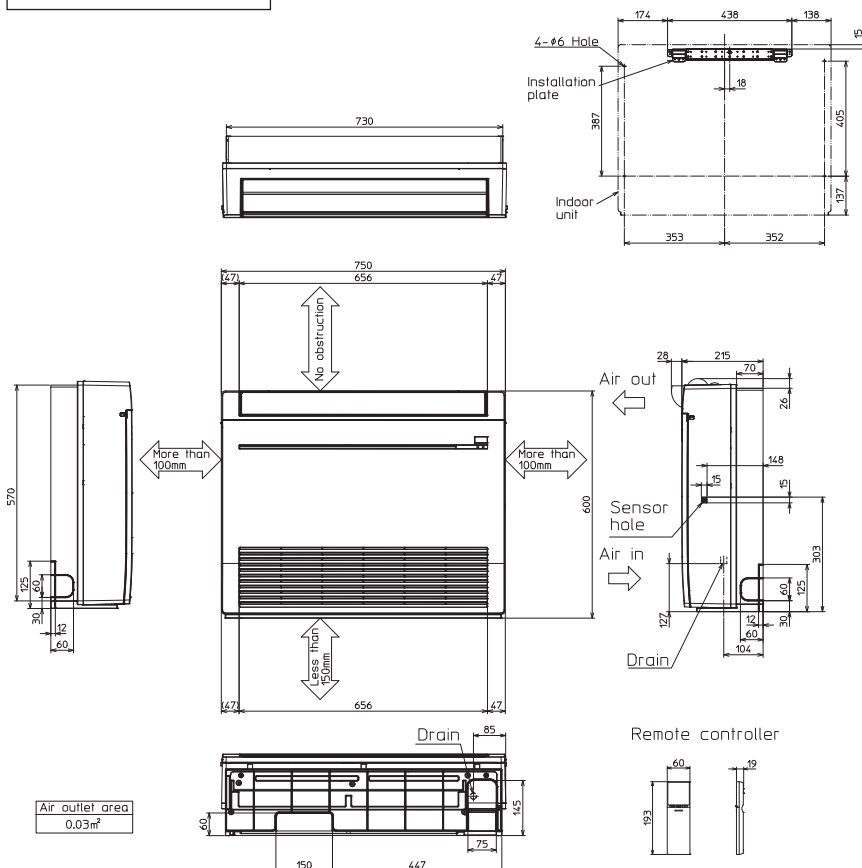

The position of gas pipe and liquid pipe

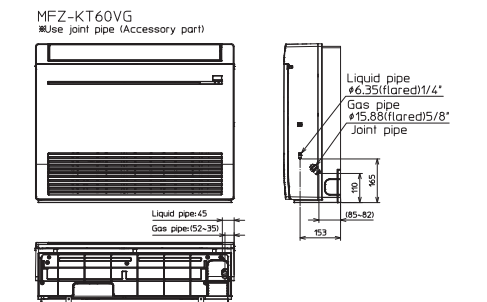
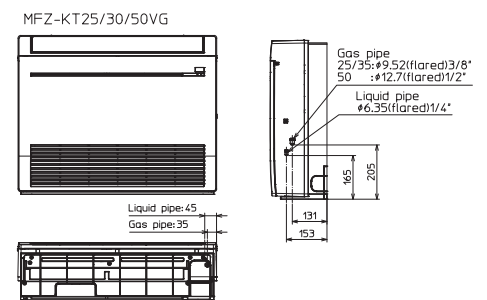

FLOOR-STANDING OUTLINES AND DIMENSIONS

C.2.2.2 Outdoor Unit
 MUFZ-KW25VGHZ
 MUFZ-KW35VGHZ

Unit: mm

OUTDOOR UNIT

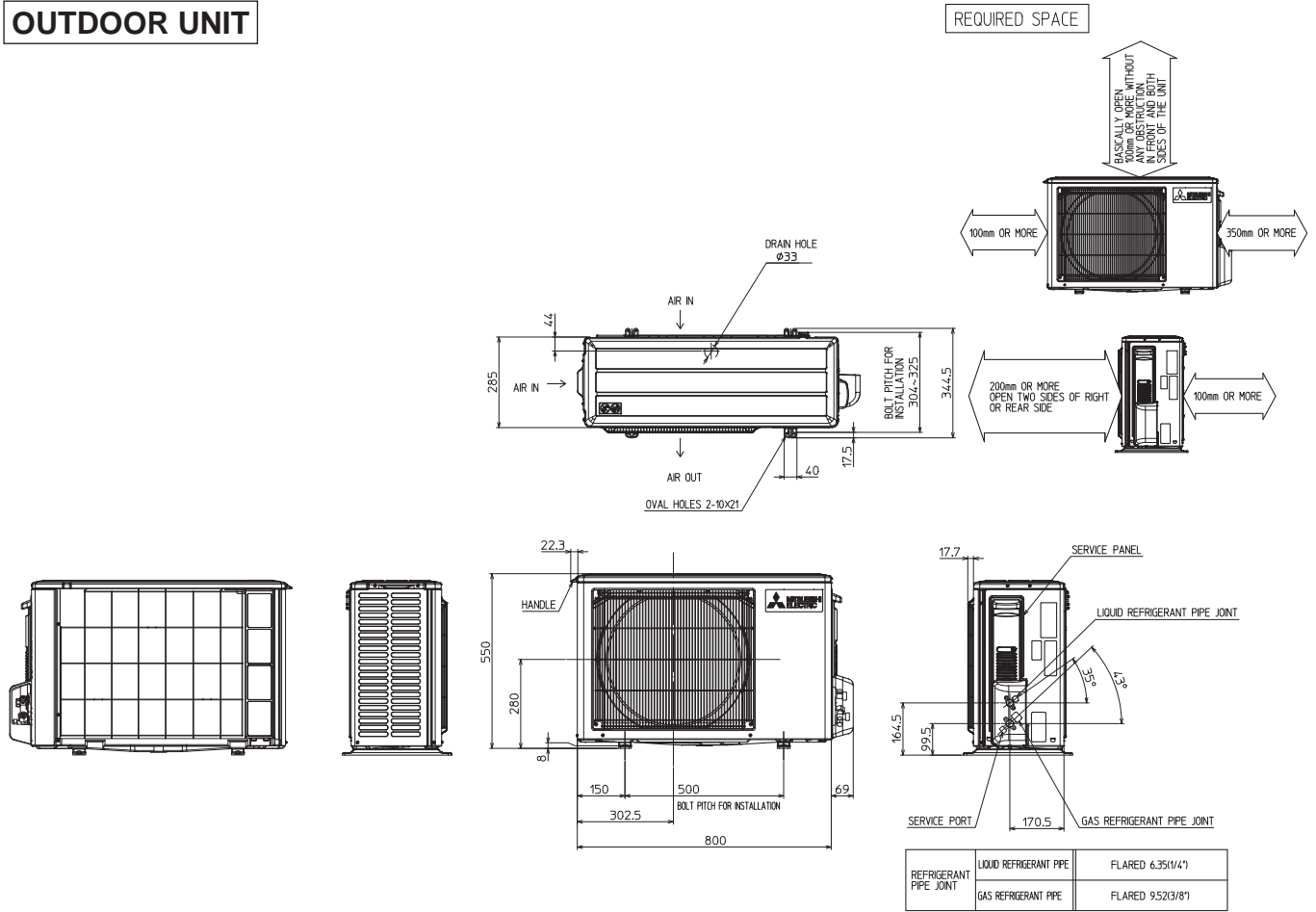

OUTLINES AND DIMENSIONS

FLOOR-STANDING

Unit: mm

MUFZ-KW50VGHZ
MUFZ-KW60VGHZ

OUTDOOR UNIT

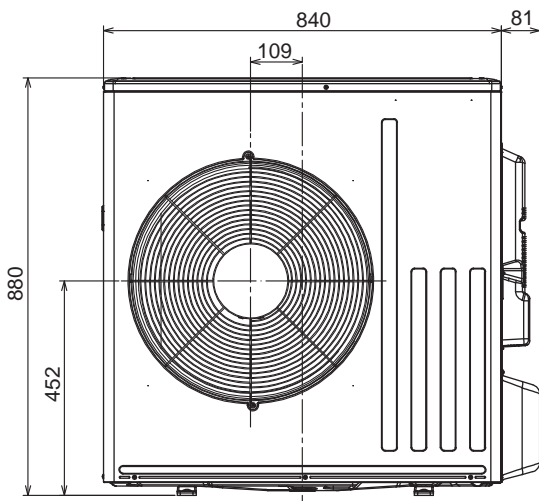
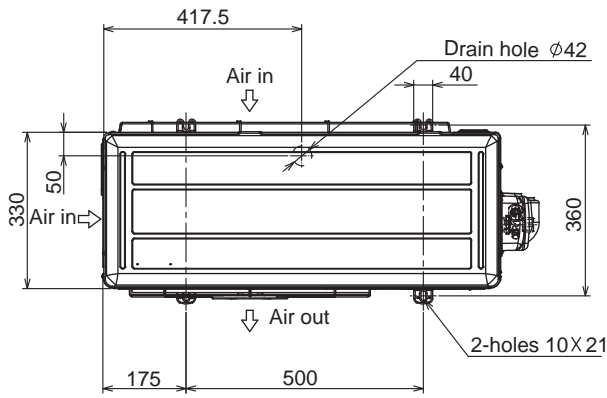

REQUIRED SPACE

*1. 500 mm or more when front and sides of the unit are clear

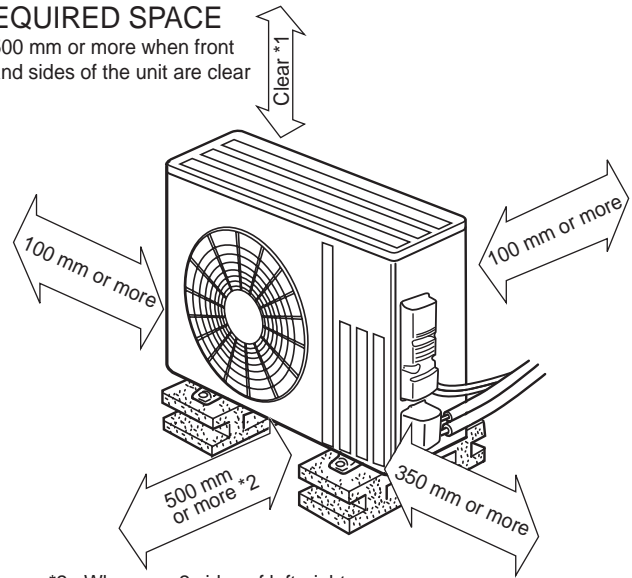

*2. When any 2 sides of left, right and rear of the unit are clear

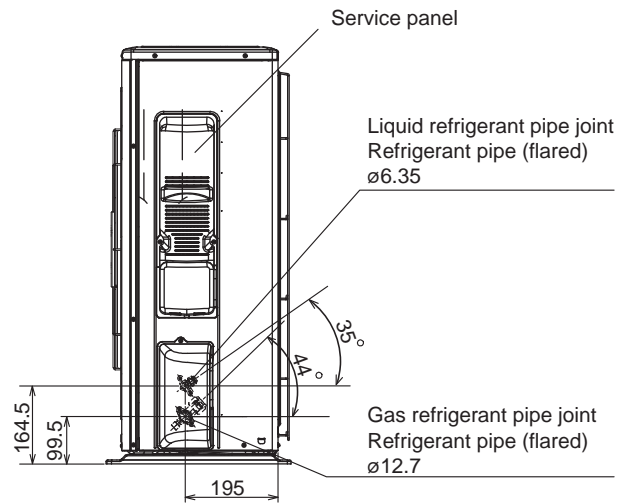

FLOOR-STANDING OUTLINES AND DIMENSIONS

C.2.3 WIRING DIAGRAM

C.2.3.1 Indoor Unit

MFZ-KW25VG MFZ-KW35VG MFZ-KW50VG MFZ-KW60VG

INDOOR UNIT

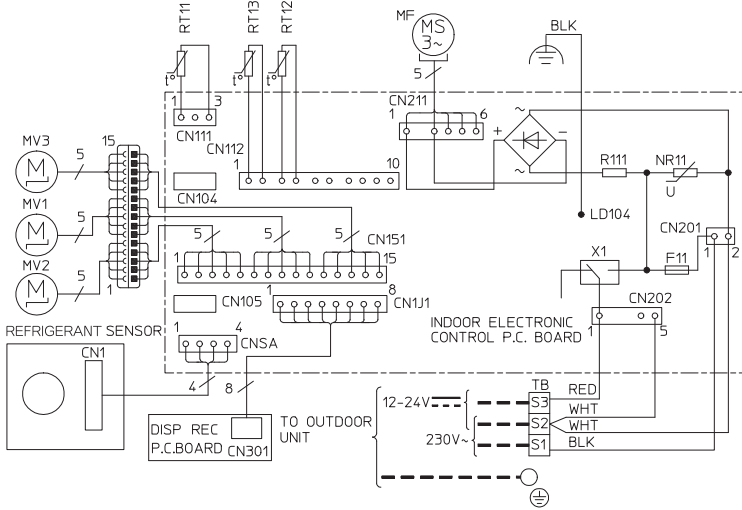

SYMBOL	NAME	SYMBOL	NAME
MF	FAN MOTOR	TB	TERMINAL BLOCK
MV1	HORIZONTAL VANE MOTOR (FRONT)	RT11	ROOM TEMP. THERMISTOR
MV2	HORIZONTAL VANE MOTOR (BACK)	RT12	COIL TEMP. THERMISTOR(MAIN1)
MV3	MULTI-FLOW VANE MOTOR	RT13	COIL TEMP. THERMISTOR(SUB)
F11	FUSE (T3,15AL250V)	NR11	VARISTOR
X1	RELAY	R111	RESISTOR

NOTES:

- About the outdoor side electric wiring refer to the outdoor unit electric wiring diagram for servicing.
- Use copper conductors only. (For field wiring)
- Symbols below indicate.

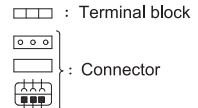

MFZ-KT25VG MFZ-KT35VG MFZ-KT50VG

INDOOR UNIT

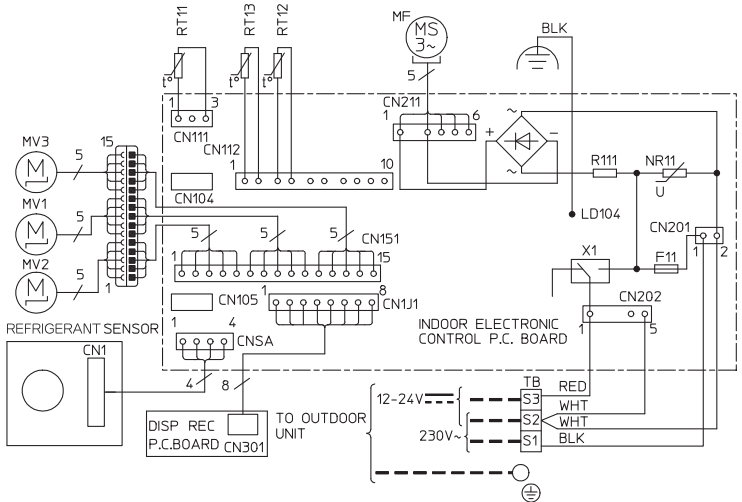

SYMBOL	NAME	SYMBOL	NAME
MF	FAN MOTOR	TB	TERMINAL BLOCK
MV1	HORIZONTAL VANE MOTOR (FRONT)	RT11	ROOM TEMP. THERMISTOR
MV2	HORIZONTAL VANE MOTOR (BACK)	RT12	COIL TEMP. THERMISTOR(MAIN1)
MV3	MULTI-FLOW VANE MOTOR	RT13	COIL TEMP. THERMISTOR(SUB)
F11	FUSE (T3,15AL250V)	NR11	VARISTOR
X1	RELAY	R111	RESISTOR

NOTES:

- About the outdoor side electric wiring refer to the outdoor unit electric wiring diagram for servicing.
- Use copper conductors only. (For field wiring)
- Symbols below indicate.

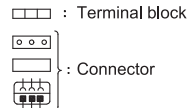

MFZ-KT60VG

INDOOR UNIT

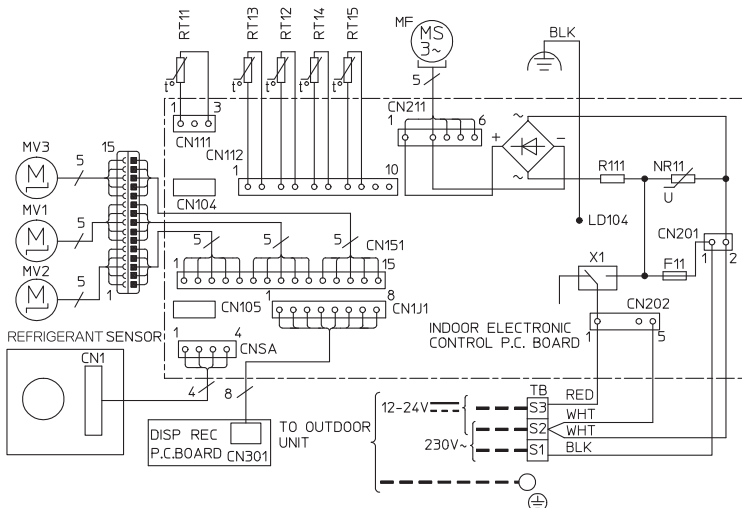

SYMBOL	NAME	SYMBOL	NAME
MF	FAN MOTOR	RT11	ROOM TEMP. THERMISTOR
MV1	HORIZONTAL VANE MOTOR (FRONT)	RT12	COIL TEMP. THERMISTOR(MAIN1)
MV2	HORIZONTAL VANE MOTOR (BACK)	RT13	COIL TEMP. THERMISTOR(SUB)
MV3	MULTI-FLOW VANE MOTOR	RT14	COIL TEMP. THERMISTOR(MAIN2)
F11	FUSE (T3,15AL250V)	RT15	COIL TEMP. THERMISTOR(MAIN3)
X1	RELAY	NR11	VARISTOR
TB	TERMINAL BLOCK	R111	RESISTOR

NOTES:

- About the outdoor side electric wiring refer to the outdoor unit electric wiring diagram for servicing.
- Use copper conductors only. (For field wiring)
- Symbols below indicate.

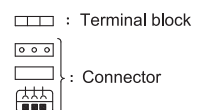

WIRING DIAGRAM

FLOOR-STANDING

C.2.3.2 Outdoor Unit
MUFZ-KW25VGHZ MUFZ-KW35VGHZ
OUTDOOR UNIT

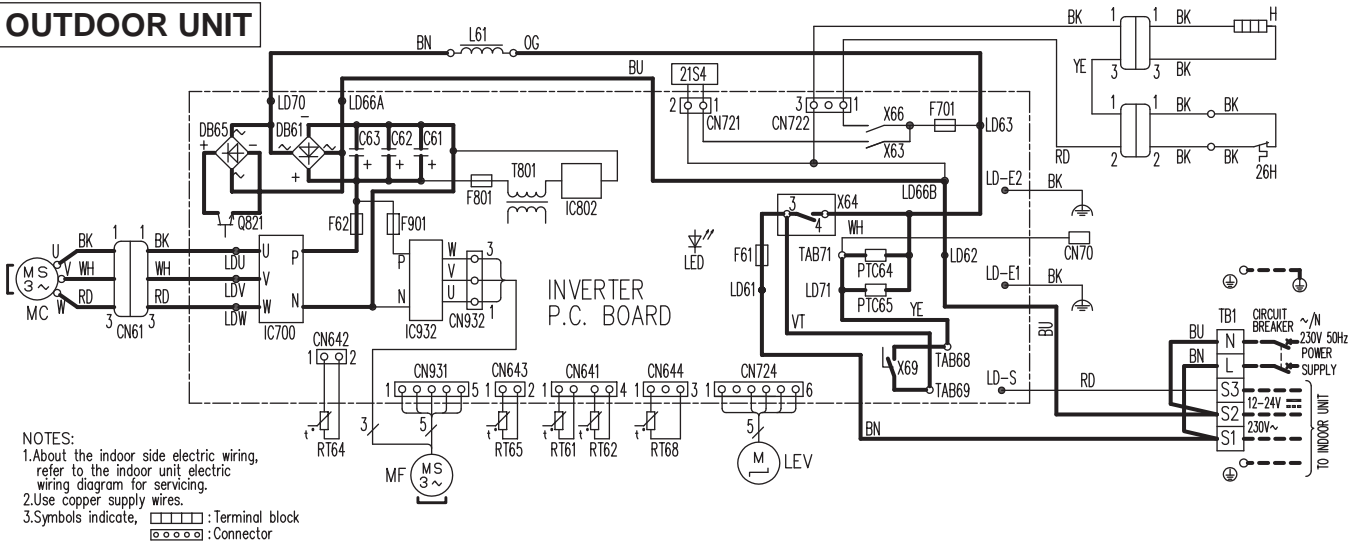

NOTES:
 1. About the indoor side electric wiring, refer to the indoor unit electric wiring diagram for servicing.
 2. Use copper supply wires.
 3. Symbols indicate, : Terminal block
 : Connector

SYMBOL	NAME	SYMBOL	NAME	SYMBOL	NAME
CN61	CONNECTOR	LED	LED	RT64	FIN TEMP. THERMISTOR
C61, C62, C63	SMOOTHING CAPACITOR	LEV	EXPANSION VALVE COIL	RT65	AMBIENT TEMP. THERMISTOR
DB61, DB65	DIODE MODULE	L61	REACTOR	RT68	OUTDOOR HEAT EXCHANGER TEMP. THERMISTOR
F61	FUSE (25A 250V)	MC	COMPRESSOR	TB1	TERMINAL BLOCK
F62	FUSE (15A 250V)	MF	FAN MOTOR	T801	TRANSFORMER
F701, F801, F901	FUSE (T3.15AL250V)	PTC64, PTC65	CIRCUIT PROTECTION	X63, X64, X66, X69	RELAY
H	DEFROST HEATER	Q821	SWITCHING POWER TRANSISTOR	21S4	REVERSING VALVE COIL
IC700, IC932	POWER MODULE	RT61	DEFROST THERMISTOR	26H	HEATER PROTECTOR
IC802	POWER DEVICE	RT62	DISCHARGE TEMP. THERMISTOR		

MUFZ-KW50VGHZ MUFZ-KW60VGHZ
OUTDOOR UNIT

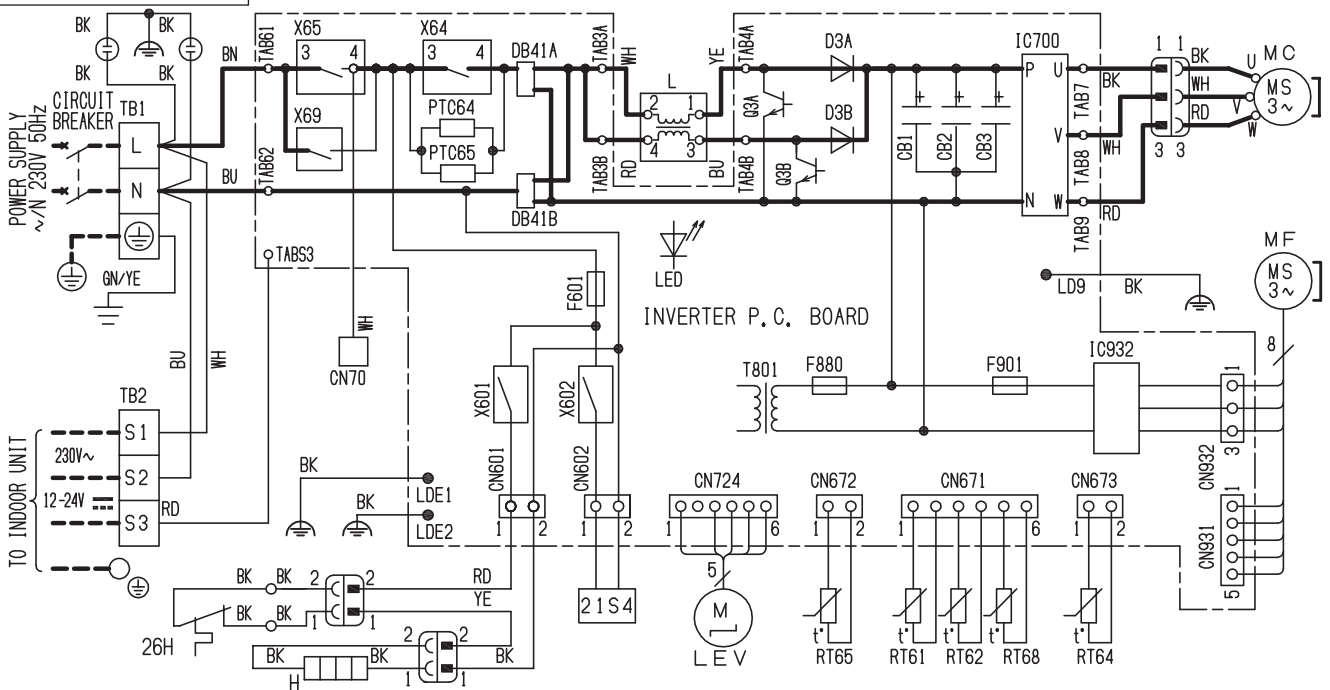

NOTES:
 1. About the indoor side electric wiring, refer to the indoor unit electric wiring diagram for servicing.
 2. Use copper supply wires.
 3. Symbols indicate, : Terminal block : Connector

SYMBOL	NAME	SYMBOL	NAME	SYMBOL	NAME	SYMBOL	NAME
CB1, CB2, CB3	SMOOTHING CAPACITOR	IC700, IC932	POWER MODULE	Q3A, Q3B	SWITCHING POWER TRANSISTOR	TB1, TB2	TERMINAL BLOCK
DB41A, DB41B	DIODE MODULE	L	REACTOR	RT61	DEFROST THERMISTOR	T801	TRANSFORMER
D3A, D3B	DIODE	LED	LED	RT62	DISCHARGE TEMP. THERMISTOR	X64, X65, X69	RELAY
F601	FUSE (T3, 15AL250V)	LEV	EXPANSION VALVE COIL	RT64	FIN TEMP. THERMISTOR	X601, X602	RELAY
F880	FUSE (T3, 15AL250V)	MC	COMPRESSOR	RT65	AMBIENT TEMP. THERMISTOR	21S4	REVERSING VALVE COIL
F901	FUSE (T3, 15AL250V)	MF	FAN MOTOR	RT68	OUTDOOR HEAT EXCHANGER TEMP. THERMISTOR	26H	HEATER PROTECTOR
H	DEFROST HEATER	PTC64, PTC65	CIRCUIT PROTECTION				

FLOOR-STANDING WIRING DIAGRAM

C.2.4 REFRIGERANT SYSTEM DIAGRAM

C.2.4.1 Inverter Heat Pump

MFZ-KW25VG
MFZ-KW35VG

Unit: mm
MUFZ-KW25VGHZ
MUFZ-KW35VGHZ

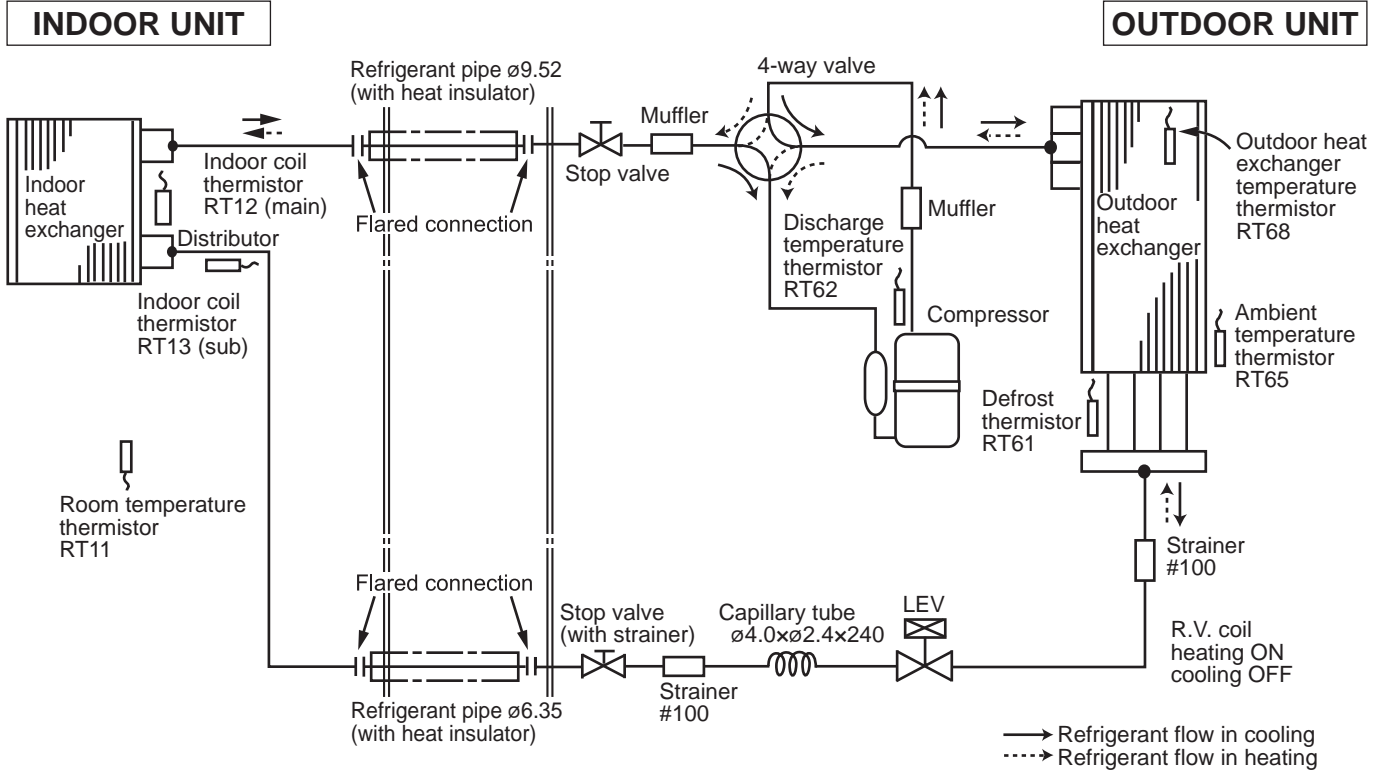

REFRIGERANT SYSTEM DIAGRAM

FLOOR-STANDING

MFZ-KW50VG
MFZ-KW60VG

MUFZ-KW50VGHZ
MUFZ-KW60VGHZ

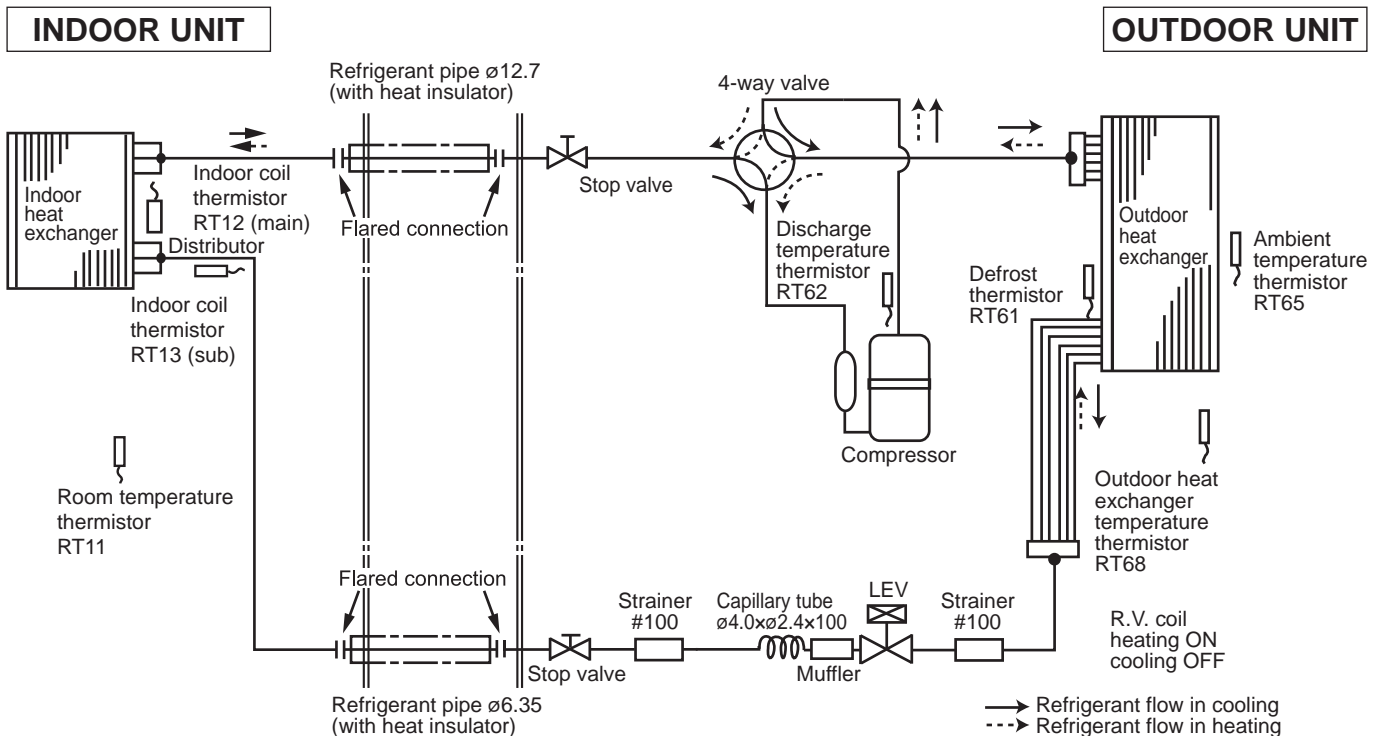

Unit: mm

MFZ-KT25VG
MFZ-KT35VG

INDOOR UNIT

OUTDOOR UNIT

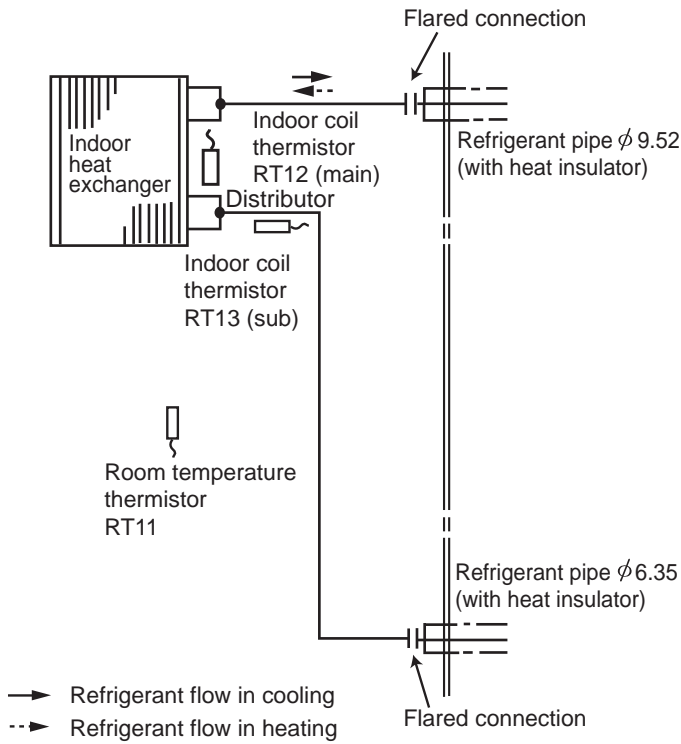

For SUZ-M25/35VA connection

MFZ-KT50VG

INDOOR UNIT

OUTDOOR UNIT

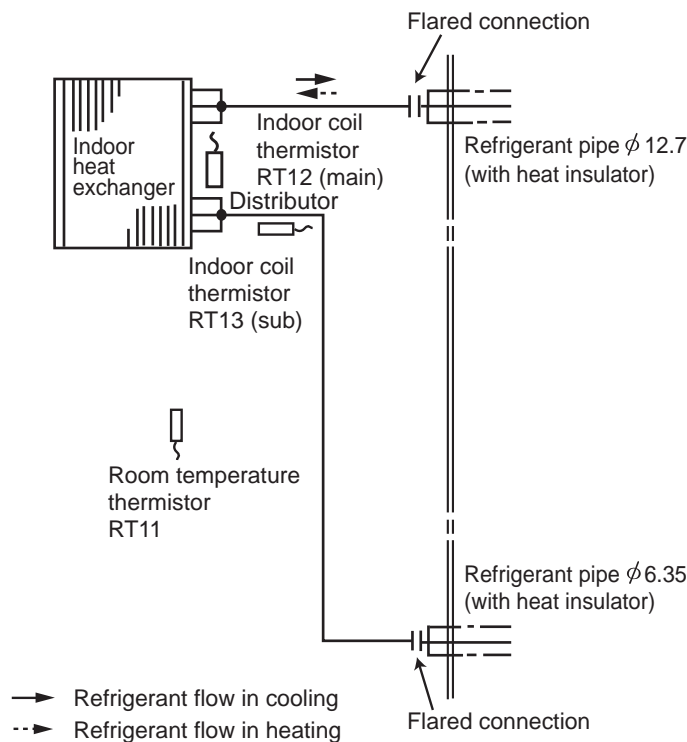

For SUZ-M50VA connection

Unit: mm

MFZ-KT60VG

INDOOR UNIT

OUTDOOR UNIT

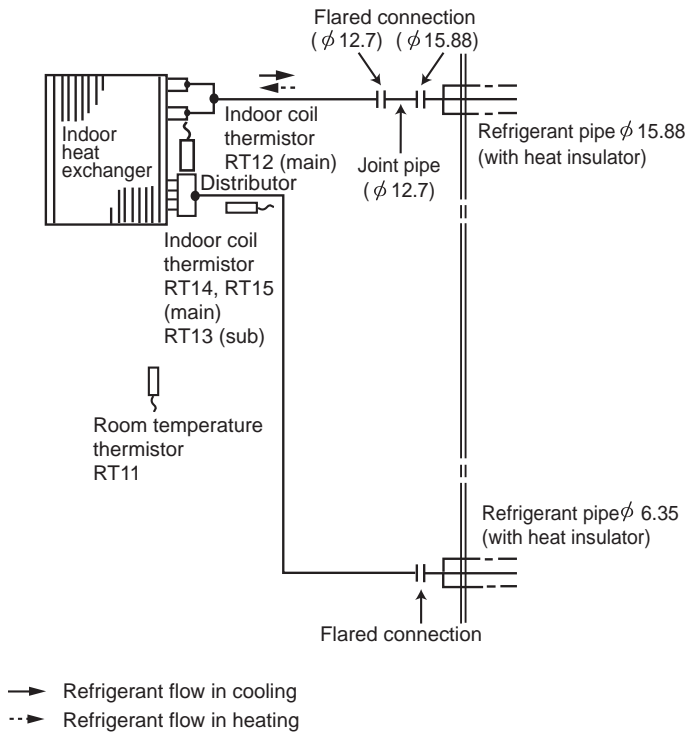

For SUZ-M60VA connection

C.2.5 PERFORMANCE CURVES

C.2.5.1 Inverter Heat Pump

MUFZ-KW25VGHZ MUFZ-KW35VGHZ MUFZ-KW50VGHZ MUFZ-KW60VGHZ

The standard specifications apply only to the operation of the air conditioner under normal conditions. Since operating conditions vary according to the areas where these units are installed, the following information has been provided to clarify the operating characteristics of the air conditioner under the conditions indicated by the performance curve.

(1) GUARANTEED VOLTAGE

198 ~ 264V, 50 Hz

(2) AIRFLOW

Airflow should be set at MAX.

(3) MAIN READINGS

(1) Indoor intake air wet-bulb temperature:	°C [WB]	} Cooling
(2) Indoor outlet air wet-bulb temperature:	°C [WB]	
(3) Outdoor intake air dry-bulb temperature:	°C [DB]	
(4) Total input:	W	} Heating
(5) Indoor intake air dry-bulb temperature:	°C [DB]	
(6) Outdoor intake air wet-bulb temperature:	°C [WB]	
(7) Total input:	W	

Indoor air wet and dry bulb temperature difference on the left side of the following chart shows the difference between the indoor intake air wet and dry bulb temperature and the indoor outlet air wet and dry bulb temperature for your reference at service.

(4) GUARANTEED OUTDOOR TEMPERATURE

COOLING (DB/WB): -10/ ~ ~ 46/ ~

HEATING (DB/WB): -25/ ~ ~ 24/18

How to measure the indoor air wet and dry bulb temperature difference

1. Attach at least 2 sets of wet and dry bulb thermometers to the indoor air intake as shown in the figure, and at least 2 sets of wet and dry bulb thermometers to the indoor air outlet. The thermometers must be attached to the position where air speed is high.
2. Attach at least 2 sets of wet and dry bulb thermometers to the outdoor air intake. Cover the thermometers to prevent direct rays of the sun.
3. Check that the air filter is cleaned.
4. Open windows and doors of room.
5. Press the emergency operation switch once (twice) to start the EMERGENCY COOL (HEAT) MODE.
6. When system stabilizes after more than 15 minutes, measure temperature and take an average temperature.
7. 10 minutes later, measure temperature again and check that the temperature does not change.

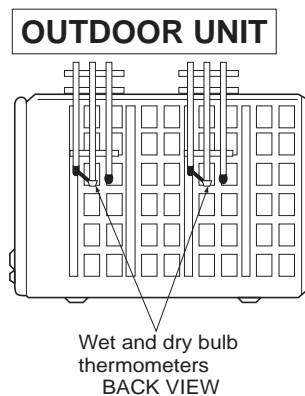
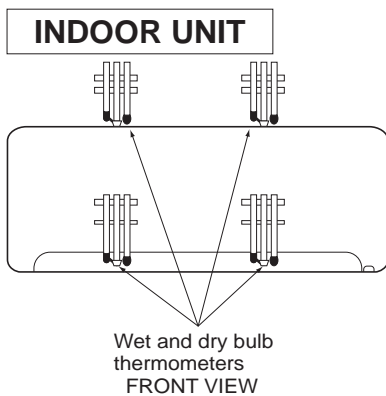

CAPACITY AND INPUT CURVES

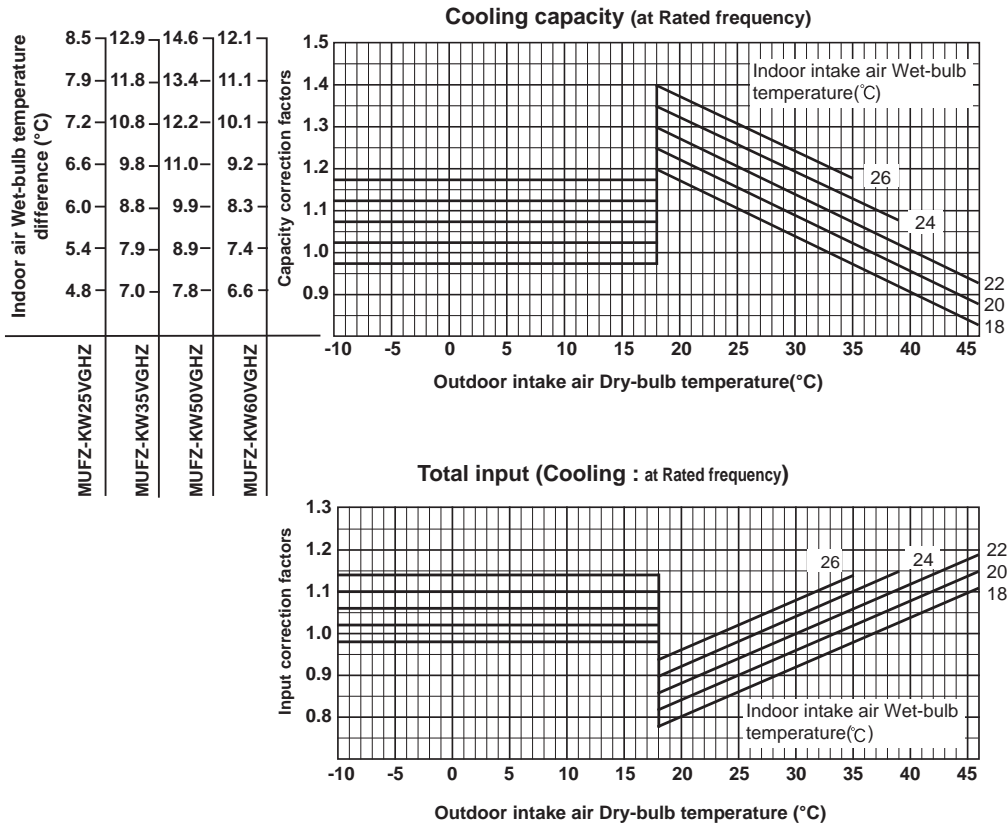

NOTE: The above broken lines are for the heating operation without any frost and defrost operation.

MUFZ-KW25VGHZ

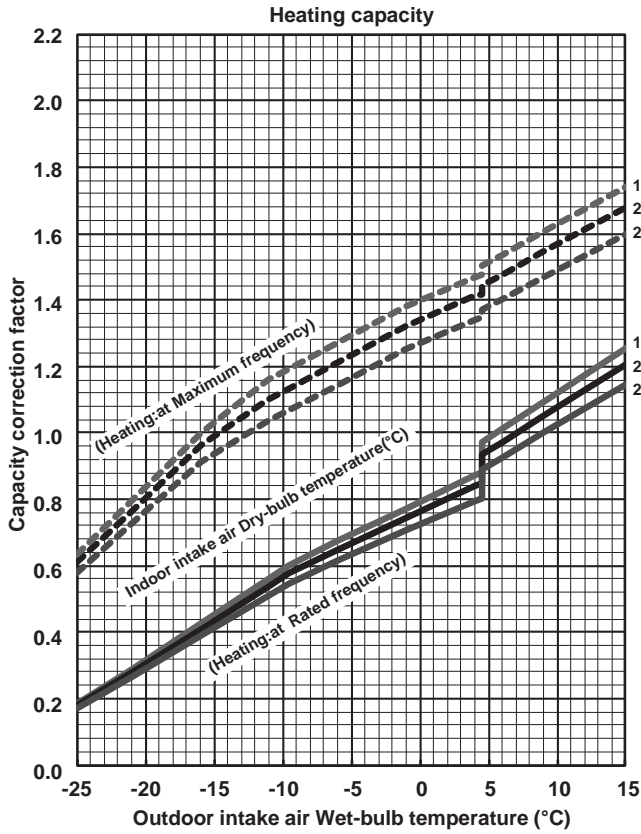

MUFZ-KW35VGHZ

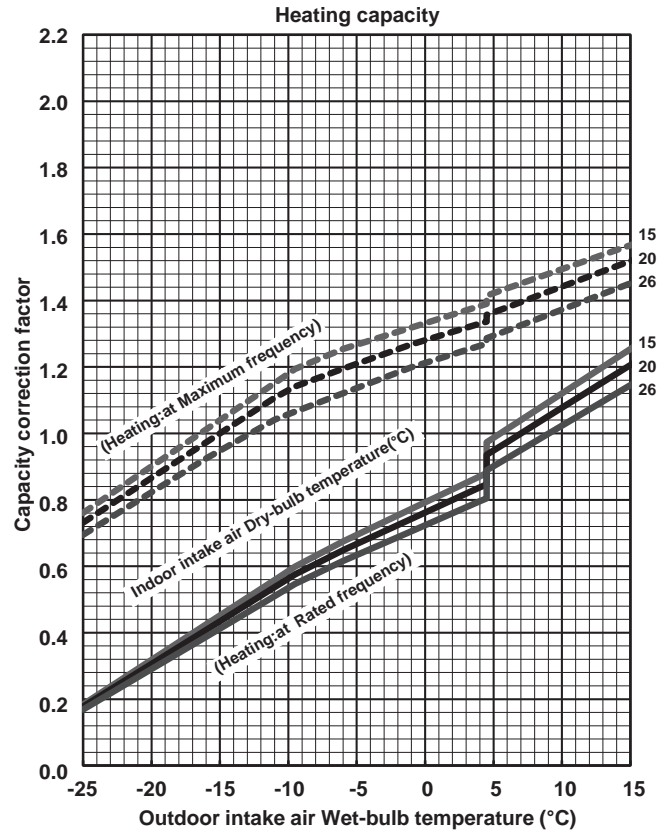

MUFZ-KW50VGHZ

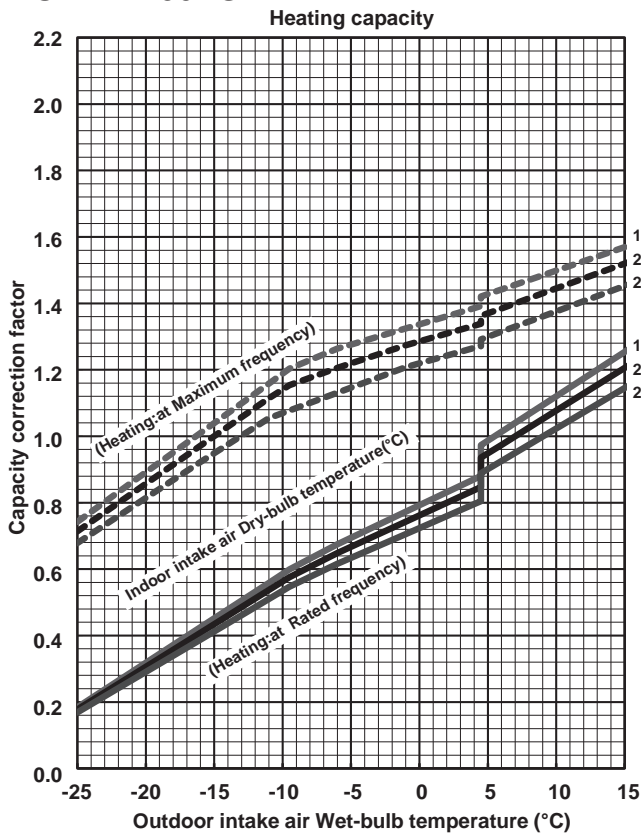

MUFZ-KW60VGHZ

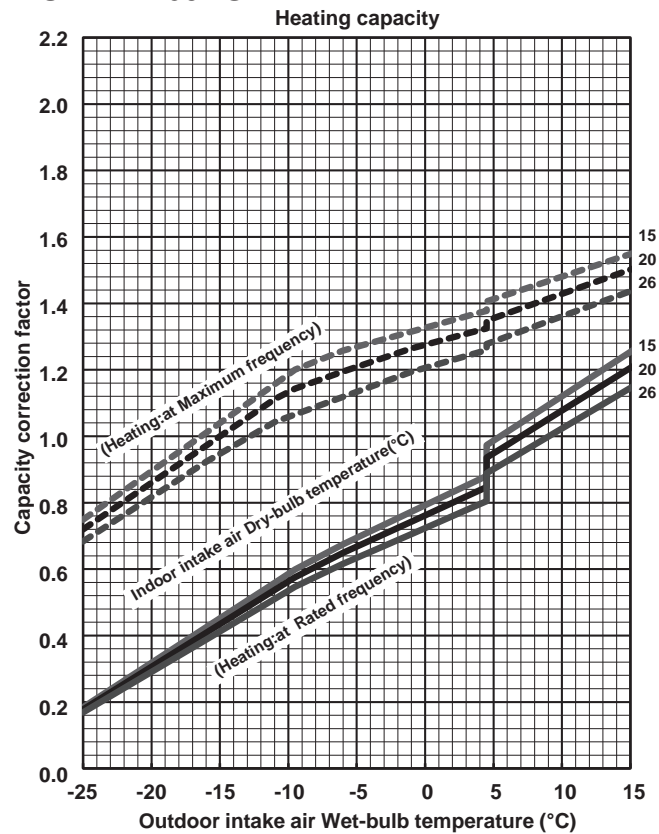

FLOOR-STANDING PERFORMANCE CURVES

NOTE: The above broken lines are for the heating operation without any frost and defrost operation.

MUFZ-KW25VEHZ

Total input (Heating)

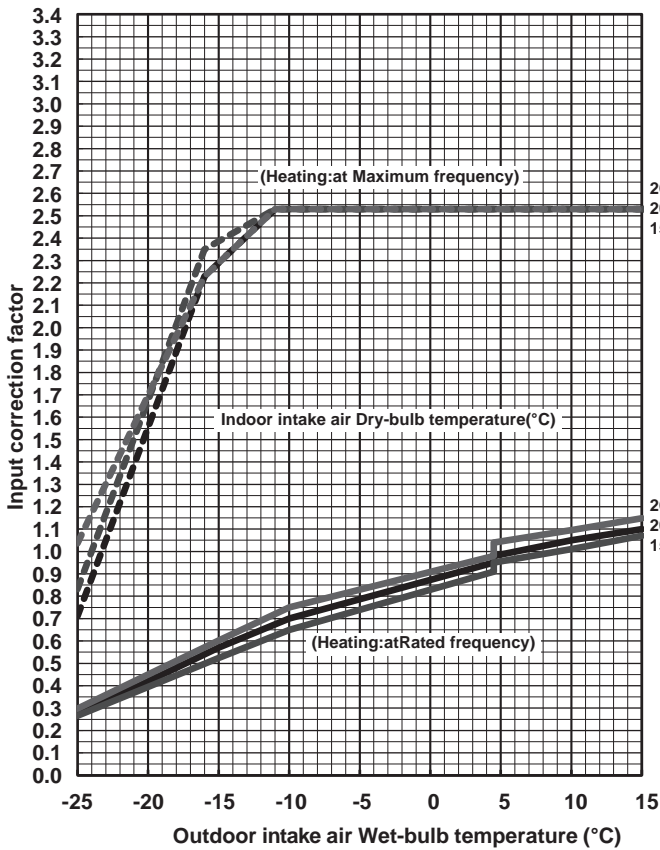

MUFZ-KW35VEHZ

Total input (Heating)

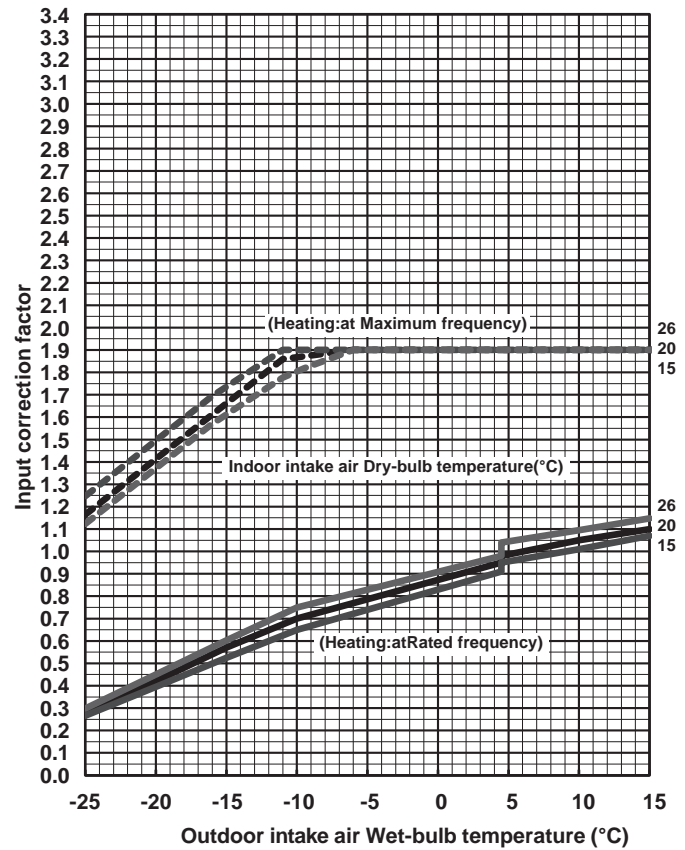

MUFZ-KW50VGHZ

Total input (Heating)

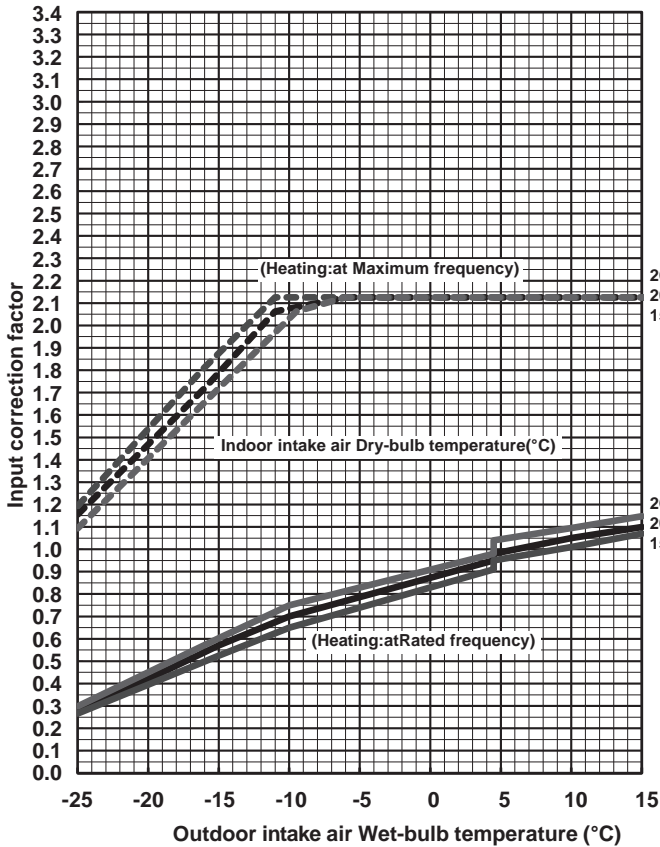

MUFZ-KW60VGHZ

Total input (Heating)

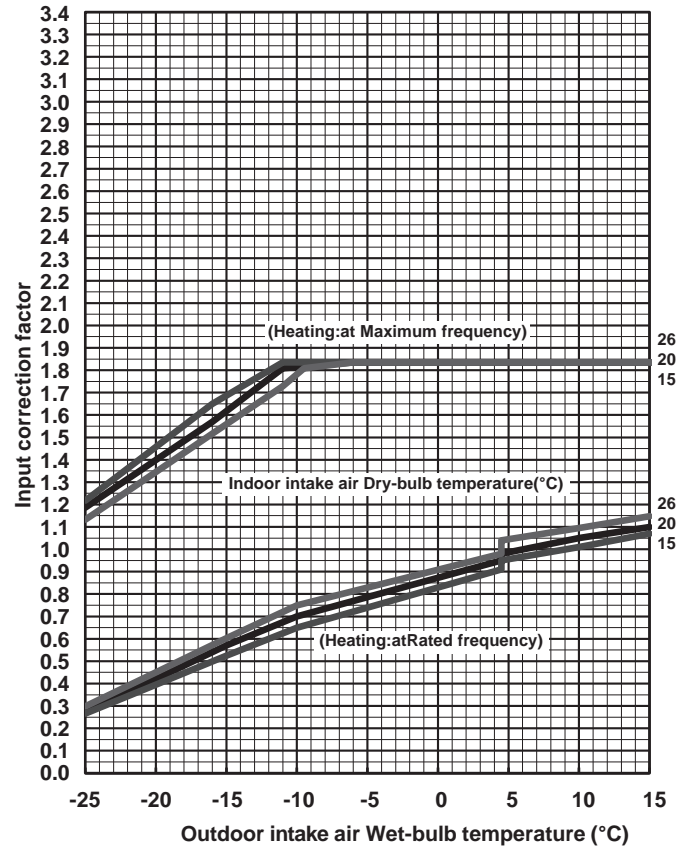

NOTE: The above broken lines are for the heating operation without any frost and defrost operation.

PERFORMANCE CURVES

FLOOR-STANDING

CAPACITY AND INPUT CORRECTION BY OPERATIONAL FREQUENCY OF COMPRESSOR

MUFZ-KW25VGHZ

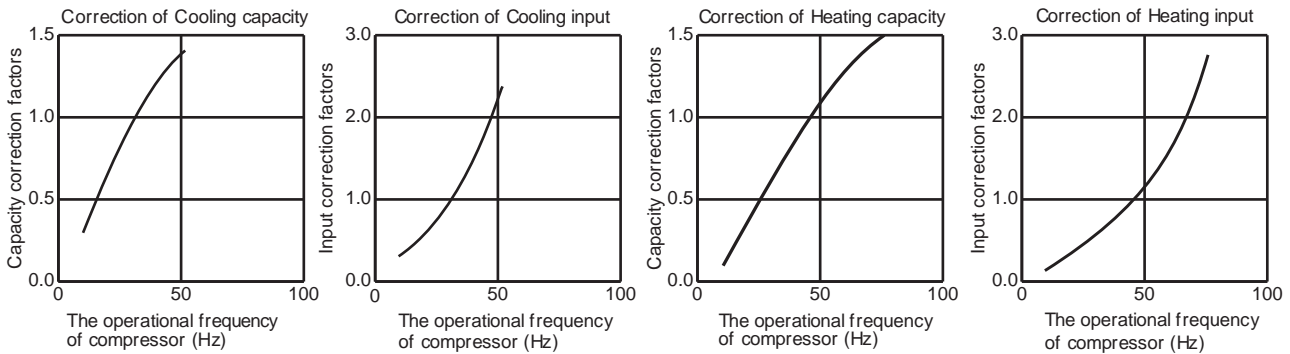

MUFZ-KW35VGHZ

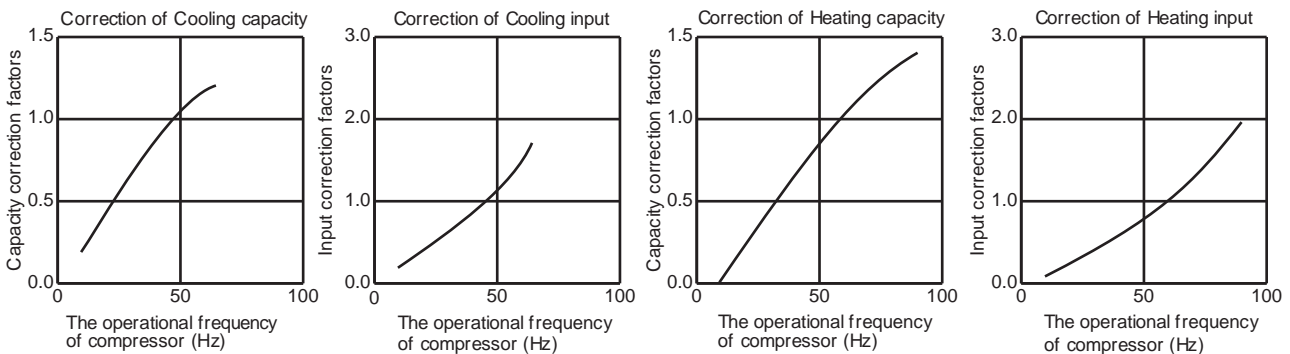

MUFZ-KW50VGHZ

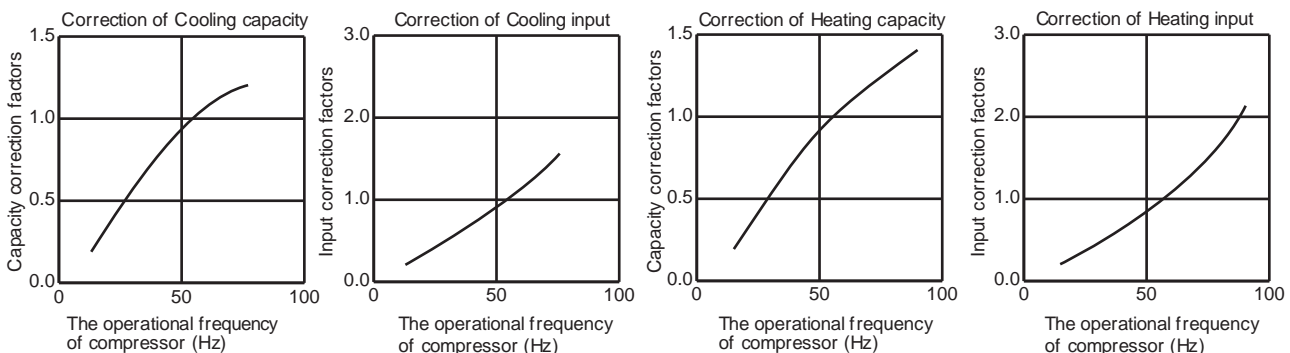

MUFZ-KW60VGHZ

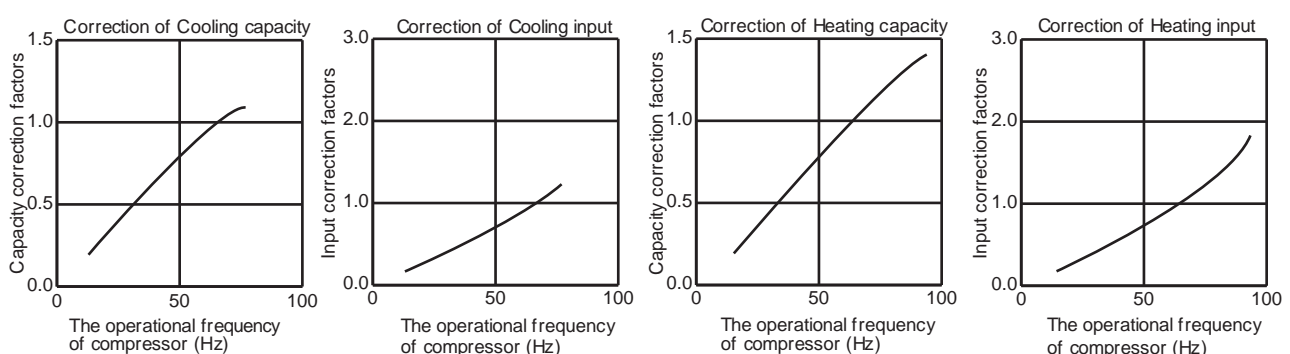

HOW TO OPERATE FIXED-FREQUENCY OPERATION

<Test run operation>

1. Press the emergency operation switch to start COOL or HEAT mode (COOL: Press once, HEAT: Press twice).
2. Test run operation starts and continues to operate for 30 minutes.
3. Compressor operates at rated frequency in COOL mode or 58 Hz in HEAT mode.
4. Indoor fan operates at High speed.
5. After 30 minutes, test run operation finishes and EMERGENCY OPERATION starts (operation frequency of compressor varies).
6. To cancel test run operation (EMERGENCY OPERATION), press the emergency operation switch or any button on remote controller.

OUTDOOR LOW PRESSURE AND OUTDOOR UNIT CURRENT
COOL operation

- ① Both indoor and outdoor unit are under the same temperature/humidity condition.
- ② Operation: Test run operation
 (Refer to HOW TO OPERATE FIXED-FREQUENCY OPERATION)

Dry-bulb temperature (°C)	Relative humidity (%)
20	50
25	60
30	70

Outdoor low pressure

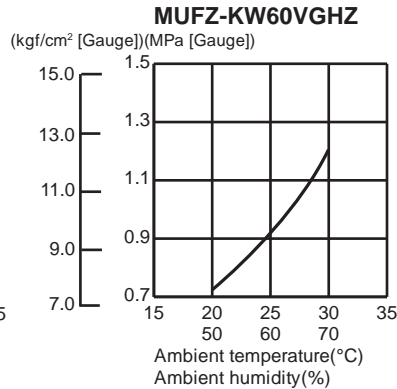
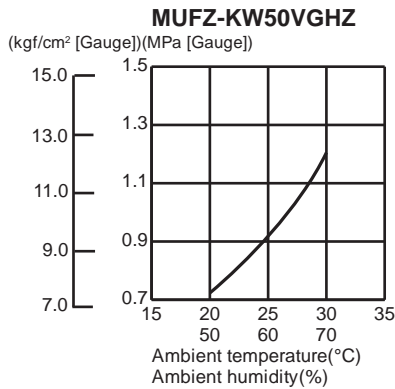
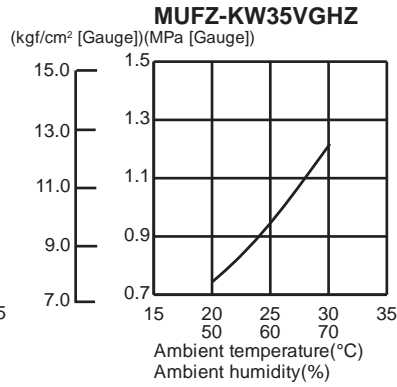
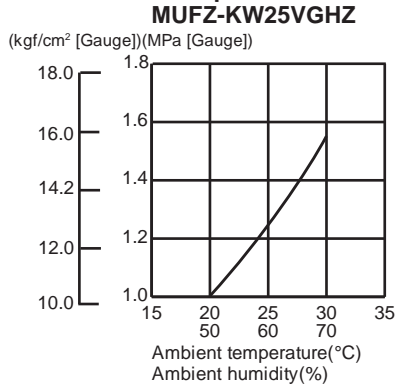

NOTE:

The unit of pressure has been changed to MPa on the international system of units (SI unit system)
 The conversion factor is: **1 (MPa [Gauge]) = 10.2 (kgf/cm² [Gauge])**

Outdoor unit current

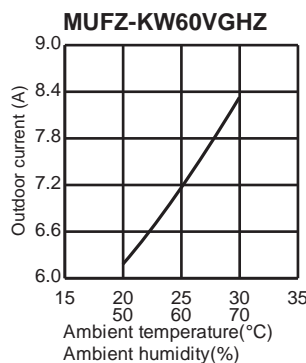
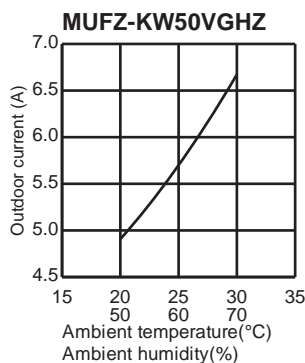
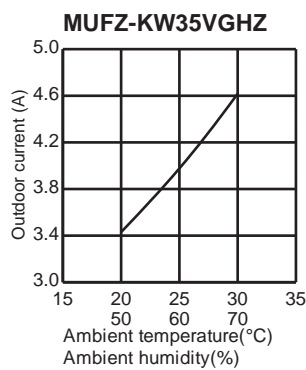
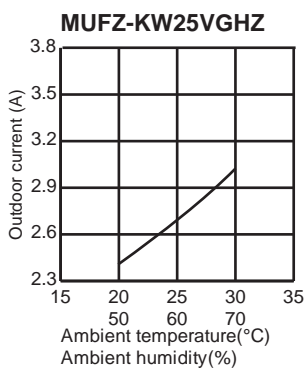

HEAT operation

① Condition:

	Indoor	Outdoor			
		2	7	15	20.0
Dry bulb temperature (°C)	20.0	2	7	15	20.0
Wet bulb temperature (°C)	14.5	1	6	12	14.5

② Operation: Test run operation (Refer to HOW TO OPERATE FIXED-FREQUENCY OPERATION)

Outdoor unit current

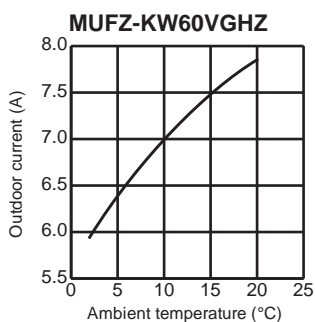
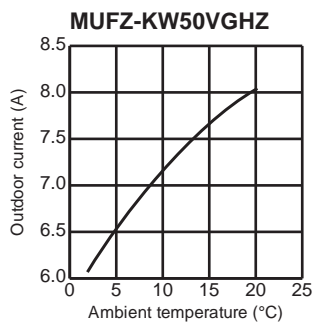
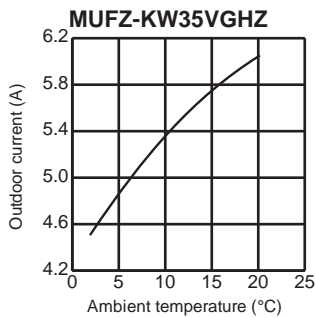
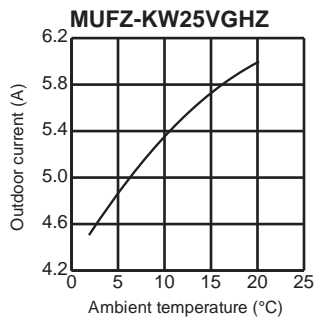

C.2.6 PERFORMANCE DATA

C.2.6.1 Inverter Heat Pump

PERFORMANCE DATA COOL operation at Rated frequency

MFZ-KW25VG: MUFZ-KW25VGHZ

CAPACITY: 2.5 kW

SHF: 0.84

INPUT: 570 W

INDOOR DB (°C)	INDOOR WB (°C)	OUTDOOR DB (°C)															
		21				25				27				30			
		Q	SHC	SHF	INPUT	Q	SHC	SHF	INPUT	Q	SHC	SHF	INPUT	Q	SHC	SHF	INPUT
21	18	2.94	1.94	0.66	456	2.81	1.86	0.66	479	2.70	1.78	0.66	502	2.60	1.72	0.66	524
21	20	3.06	1.65	0.54	479	2.94	1.59	0.54	507	2.85	1.54	0.54	519	2.75	1.49	0.54	542
22	18	2.94	2.06	0.70	456	2.81	1.97	0.70	479	2.70	1.89	0.70	502	2.60	1.82	0.70	524
22	20	3.06	1.78	0.58	479	2.94	1.70	0.58	507	2.85	1.65	0.58	519	2.75	1.60	0.58	542
22	22	3.19	1.47	0.46	496	3.08	1.41	0.46	527	3.00	1.38	0.46	542	2.88	1.32	0.46	564
23	18	2.94	2.17	0.74	456	2.81	2.08	0.74	479	2.70	2.00	0.74	502	2.60	1.92	0.74	524
23	20	3.06	1.90	0.62	479	2.94	1.82	0.62	507	2.85	1.77	0.62	519	2.75	1.71	0.62	542
23	22	3.19	1.59	0.50	496	3.08	1.54	0.50	527	3.00	1.50	0.50	542	2.88	1.44	0.50	564
24	18	2.94	2.29	0.78	456	2.81	2.19	0.78	479	2.70	2.11	0.78	502	2.60	2.03	0.78	524
24	20	3.06	2.02	0.66	479	2.94	1.94	0.66	507	2.85	1.88	0.66	519	2.75	1.82	0.66	542
24	22	3.19	1.72	0.54	496	3.08	1.66	0.54	527	3.00	1.62	0.54	542	2.88	1.55	0.54	564
24	24	3.35	1.41	0.42	519	3.23	1.35	0.42	547	3.15	1.32	0.42	564	3.05	1.28	0.42	593
25	18	2.94	2.41	0.82	456	2.81	2.31	0.82	479	2.70	2.21	0.82	502	2.60	2.13	0.82	524
25	20	3.06	2.14	0.70	479	2.94	2.06	0.70	507	2.85	2.00	0.70	519	2.75	1.93	0.70	542
25	22	3.19	1.85	0.58	496	3.08	1.78	0.58	527	3.00	1.74	0.58	542	2.88	1.67	0.58	564
25	24	3.35	1.54	0.46	519	3.23	1.48	0.46	547	3.15	1.45	0.46	564	3.05	1.40	0.46	593
26	18	2.94	2.53	0.86	456	2.81	2.42	0.86	479	2.70	2.32	0.86	502	2.60	2.24	0.86	524
26	20	3.06	2.27	0.74	479	2.94	2.17	0.74	507	2.85	2.11	0.74	519	2.75	2.04	0.74	542
26	22	3.19	1.98	0.62	496	3.08	1.91	0.62	527	3.00	1.86	0.62	542	2.88	1.78	0.62	564
26	24	3.35	1.68	0.50	519	3.23	1.61	0.50	547	3.15	1.58	0.50	564	3.05	1.53	0.50	593
26	26	3.45	1.31	0.38	547	3.35	1.27	0.38	576	3.30	1.25	0.38	593	3.20	1.22	0.38	610
27	18	2.94	2.64	0.90	456	2.81	2.53	0.90	479	2.70	2.43	0.90	502	2.60	2.34	0.90	524
27	20	3.06	2.39	0.78	479	2.94	2.29	0.78	507	2.85	2.22	0.78	519	2.75	2.15	0.78	542
27	22	3.19	2.10	0.66	496	3.08	2.03	0.66	527	3.00	1.98	0.66	542	2.88	1.90	0.66	564
27	24	3.35	1.81	0.54	519	3.23	1.74	0.54	547	3.15	1.70	0.54	564	3.05	1.65	0.54	593
27	26	3.45	1.45	0.42	547	3.35	1.41	0.42	576	3.30	1.39	0.42	593	3.20	1.34	0.42	610
28	18	2.94	2.76	0.94	456	2.81	2.64	0.94	479	2.70	2.54	0.94	502	2.60	2.44	0.94	524
28	20	3.06	2.51	0.82	479	2.94	2.41	0.82	507	2.85	2.34	0.82	519	2.75	2.26	0.82	542
28	22	3.19	2.23	0.70	496	3.08	2.15	0.70	527	3.00	2.10	0.70	542	2.88	2.01	0.70	564
28	24	3.35	1.94	0.58	519	3.23	1.87	0.58	547	3.15	1.83	0.58	564	3.05	1.77	0.58	593
28	26	3.45	1.59	0.46	547	3.35	1.54	0.46	576	3.30	1.52	0.46	593	3.20	1.47	0.46	610
29	18	2.94	2.88	0.98	456	2.81	2.76	0.98	479	2.70	2.65	0.98	502	2.60	2.55	0.98	524
29	20	3.06	2.63	0.86	479	2.94	2.53	0.86	507	2.85	2.45	0.86	519	2.75	2.37	0.86	542
29	22	3.19	2.36	0.74	496	3.08	2.28	0.74	527	3.00	2.22	0.74	542	2.88	2.13	0.74	564
29	24	3.35	2.08	0.62	519	3.23	2.00	0.62	547	3.15	1.95	0.62	564	3.05	1.89	0.62	593
29	26	3.45	1.73	0.50	547	3.35	1.68	0.50	576	3.30	1.65	0.50	593	3.20	1.60	0.50	610
30	18	2.94	2.94	1.00	456	2.81	2.81	1.00	479	2.70	2.70	1.00	502	2.60	2.60	1.00	524
30	20	3.06	2.76	0.90	479	2.94	2.64	0.90	507	2.85	2.57	0.90	519	2.75	2.48	0.90	542
30	22	3.19	2.49	0.78	496	3.08	2.40	0.78	527	3.00	2.34	0.78	542	2.88	2.24	0.78	564
30	24	3.35	2.21	0.66	519	3.23	2.13	0.66	547	3.15	2.08	0.66	564	3.05	2.01	0.66	593
30	26	3.45	1.86	0.54	547	3.35	1.81	0.54	576	3.30	1.78	0.54	593	3.20	1.73	0.54	610
31	18	2.94	2.94	1.00	456	2.81	2.81	1.00	479	2.70	2.70	1.00	502	2.60	2.60	1.00	524
31	20	3.06	2.88	0.94	479	2.94	2.76	0.94	507	2.85	2.68	0.94	519	2.75	2.59	0.94	542
31	22	3.19	2.61	0.82	496	3.08	2.52	0.82	527	3.00	2.46	0.82	542	2.88	2.36	0.82	564
31	24	3.35	2.35	0.70	519	3.23	2.26	0.70	547	3.15	2.21	0.70	564	3.05	2.14	0.70	593
31	26	3.45	2.00	0.58	547	3.35	1.94	0.58	576	3.30	1.91	0.58	593	3.20	1.86	0.58	610
32	18	2.94	2.94	1.00	456	2.81	2.81	1.00	479	2.70	2.70	1.00	502	2.60	2.60	1.00	524
32	20	3.06	3.00	0.98	479	2.94	2.88	0.98	507	2.85	2.79	0.98	519	2.75	2.70	0.98	542
32	22	3.19	2.74	0.86	496	3.08	2.64	0.86	527	3.00	2.58	0.86	542	2.88	2.47	0.86	564
32	24	3.35	2.48	0.74	519	3.23	2.39	0.74	547	3.15	2.33	0.74	564	3.05	2.26	0.74	593
32	26	3.45	2.14	0.62	547	3.35	2.08	0.62	576	3.30	2.05	0.62	593	3.20	1.98	0.62	610

NOTE Q : Total capacity (kW) SHF : Sensible heat factor DB : Dry-bulb temperature
 SHC : Sensible heat capacity (kW) INPUT : Total power input (W) WB : Wet-bulb temperature

PERFORMANCE DATA COOL operation at Rated frequency

MFZ-KW25VG: MUFZ-KW25VGHZ

CAPACITY: 2.5 kW SHF: 0.84 INPUT: 570 W

INDOOR DB (°C)	INDOOR WB (°C)	OUTDOOR DB (°C)											
		35				40				46			
		Q	SHC	SHF	INPUT	Q	SHC	SHF	INPUT	Q	SHC	SHF	INPUT
21	18	2.45	1.62	0.66	559	2.25	1.49	0.66	593	2.08	1.37	0.66	616
21	20	2.58	1.39	0.54	581	2.40	1.30	0.54	610	2.23	1.20	0.54	644
22	18	2.45	1.72	0.70	559	2.25	1.58	0.70	593	2.08	1.45	0.70	616
22	20	2.58	1.49	0.58	581	2.40	1.39	0.58	610	2.23	1.29	0.58	644
22	22	2.73	1.25	0.46	604	2.55	1.17	0.46	638	2.38	1.09	0.46	661
23	18	2.45	1.81	0.74	559	2.25	1.67	0.74	593	2.08	1.54	0.74	616
23	20	2.58	1.60	0.62	581	2.40	1.49	0.62	610	2.23	1.38	0.62	644
23	22	2.73	1.36	0.50	604	2.55	1.28	0.50	638	2.38	1.19	0.50	661
24	18	2.45	1.91	0.78	559	2.25	1.76	0.78	593	2.08	1.62	0.78	616
24	20	2.58	1.70	0.66	581	2.40	1.58	0.66	610	2.23	1.47	0.66	644
24	22	2.73	1.47	0.54	604	2.55	1.38	0.54	638	2.38	1.28	0.54	661
24	24	2.88	1.21	0.42	627	2.70	1.13	0.42	656	2.55	1.07	0.42	684
25	18	2.45	2.01	0.82	559	2.25	1.85	0.82	593	2.08	1.70	0.82	616
25	20	2.58	1.80	0.70	581	2.40	1.68	0.70	610	2.23	1.56	0.70	644
25	22	2.73	1.58	0.58	604	2.55	1.48	0.58	638	2.38	1.38	0.58	661
25	24	2.88	1.32	0.46	627	2.70	1.24	0.46	656	2.55	1.17	0.46	684
26	18	2.45	2.11	0.86	559	2.25	1.94	0.86	593	2.08	1.78	0.86	616
26	20	2.58	1.91	0.74	581	2.40	1.78	0.74	610	2.23	1.65	0.74	644
26	22	2.73	1.69	0.62	604	2.55	1.58	0.62	638	2.38	1.47	0.62	661
26	24	2.88	1.44	0.50	627	2.70	1.35	0.50	656	2.55	1.28	0.50	684
26	26	3.03	1.15	0.38	650	2.85	1.08	0.38	678	2.68	1.02	0.38	707
27	18	2.45	2.21	0.90	559	2.25	2.03	0.90	593	2.08	1.87	0.90	616
27	20	2.58	2.01	0.78	581	2.40	1.87	0.78	610	2.23	1.74	0.78	644
27	22	2.73	1.80	0.66	604	2.55	1.68	0.66	638	2.38	1.57	0.66	661
27	24	2.88	1.55	0.54	627	2.70	1.46	0.54	656	2.55	1.38	0.54	684
27	26	3.03	1.27	0.42	650	2.85	1.20	0.42	678	2.68	1.12	0.42	707
28	18	2.45	2.30	0.94	559	2.25	2.12	0.94	593	2.08	1.95	0.94	616
28	20	2.58	2.11	0.82	581	2.40	1.97	0.82	610	2.23	1.82	0.82	644
28	22	2.73	1.91	0.70	604	2.55	1.79	0.70	638	2.38	1.66	0.70	661
28	24	2.88	1.67	0.58	627	2.70	1.57	0.58	656	2.55	1.48	0.58	684
28	26	3.03	1.39	0.46	650	2.85	1.31	0.46	678	2.68	1.23	0.46	707
29	18	2.45	2.40	0.98	559	2.25	2.21	0.98	593	2.08	2.03	0.98	616
29	20	2.58	2.21	0.86	581	2.40	2.06	0.86	610	2.23	1.91	0.86	644
29	22	2.73	2.02	0.74	604	2.55	1.89	0.74	638	2.38	1.76	0.74	661
29	24	2.88	1.78	0.62	627	2.70	1.67	0.62	656	2.55	1.58	0.62	684
29	26	3.03	1.51	0.50	650	2.85	1.43	0.50	678	2.68	1.34	0.50	707
30	18	2.45	2.45	1.00	559	2.25	2.25	1.00	593	2.08	2.08	1.00	616
30	20	2.58	2.32	0.90	581	2.40	2.16	0.90	610	2.23	2.00	0.90	644
30	22	2.73	2.13	0.78	604	2.55	1.99	0.78	638	2.38	1.85	0.78	661
30	24	2.88	1.90	0.66	627	2.70	1.78	0.66	656	2.55	1.68	0.66	684
30	26	3.03	1.63	0.54	650	2.85	1.54	0.54	678	2.68	1.44	0.54	707
31	18	2.45	2.45	1.00	559	2.25	2.25	1.00	593	2.08	2.08	1.00	616
31	20	2.58	2.42	0.94	581	2.40	2.26	0.94	610	2.23	2.09	0.94	644
31	22	2.73	2.23	0.82	604	2.55	2.09	0.82	638	2.38	1.95	0.82	661
31	24	2.88	2.01	0.70	627	2.70	1.89	0.70	656	2.55	1.79	0.70	684
31	26	3.03	1.75	0.58	650	2.85	1.65	0.58	678	2.68	1.55	0.58	707
32	18	2.45	2.45	1.00	559	2.25	2.25	1.00	593	2.08	2.08	1.00	616
32	20	2.58	2.52	0.98	581	2.40	2.35	0.98	610	2.23	2.18	0.98	644
32	22	2.73	2.34	0.86	604	2.55	2.19	0.86	638	2.38	2.04	0.86	661
32	24	2.88	2.13	0.74	627	2.70	2.00	0.74	656	2.55	1.89	0.74	684
32	26	3.03	1.88	0.62	650	2.85	1.77	0.62	678	2.68	1.66	0.62	707

NOTE Q : Total capacity (kW) SHF : Sensible heat factor DB : Dry-bulb temperature
 SHC : Sensible heat capacity (kW) INPUT : Total power input (W) WB : Wet-bulb temperature

PERFORMANCE DATA COOL operation at Rated frequency

MFZ-KW35VG: MUFZ-KW35VGHZ

CAPACITY: 3.5 kW SHF: 0.72 INPUT: 900 W

INDOOR DB (°C)	INDOOR WB (°C)	OUTDOOR DB (°C)															
		21				25				27				30			
		Q	SHC	SHF	INPUT	Q	SHC	SHF	INPUT	Q	SHC	SHF	INPUT	Q	SHC	SHF	INPUT
21	18	4.11	2.22	0.54	720	3.94	2.13	0.54	756	3.78	2.04	0.54	792	3.64	1.97	0.54	828
21	20	4.29	1.80	0.42	756	4.11	1.73	0.42	801	3.99	1.68	0.42	819	3.85	1.62	0.42	855
22	18	4.11	2.39	0.58	720	3.94	2.28	0.58	756	3.78	2.19	0.58	792	3.64	2.11	0.58	828
22	20	4.29	1.97	0.46	756	4.11	1.89	0.46	801	3.99	1.84	0.46	819	3.85	1.77	0.46	855
22	22	4.46	1.52	0.34	783	4.31	1.46	0.34	833	4.20	1.43	0.34	855	4.03	1.37	0.34	891
23	18	4.11	2.55	0.62	720	3.94	2.44	0.62	756	3.78	2.34	0.62	792	3.64	2.26	0.62	828
23	20	4.29	2.14	0.50	756	4.11	2.06	0.50	801	3.99	1.99	0.50	819	3.85	1.92	0.50	855
23	22	4.46	1.70	0.38	783	4.31	1.64	0.38	833	4.20	1.60	0.38	855	4.03	1.53	0.38	891
24	18	4.11	2.71	0.66	720	3.94	2.60	0.66	756	3.78	2.49	0.66	792	3.64	2.40	0.66	828
24	20	4.29	2.32	0.54	756	4.11	2.22	0.54	801	3.99	2.15	0.54	819	3.85	2.08	0.54	855
24	22	4.46	1.87	0.42	783	4.31	1.81	0.42	833	4.20	1.76	0.42	855	4.03	1.69	0.42	891
24	24	4.69	1.41	0.30	819	4.52	1.35	0.30	864	4.41	1.32	0.30	891	4.27	1.28	0.30	936
25	18	4.11	2.88	0.70	720	3.94	2.76	0.70	756	3.78	2.65	0.70	792	3.64	2.55	0.70	828
25	20	4.29	2.49	0.58	756	4.11	2.39	0.58	801	3.99	2.31	0.58	819	3.85	2.23	0.58	855
25	22	4.46	2.05	0.46	783	4.31	1.98	0.46	833	4.20	1.93	0.46	855	4.03	1.85	0.46	891
25	24	4.69	1.59	0.34	819	4.52	1.53	0.34	864	4.41	1.50	0.34	891	4.27	1.45	0.34	936
26	18	4.11	3.04	0.74	720	3.94	2.91	0.74	756	3.78	2.80	0.74	792	3.64	2.69	0.74	828
26	20	4.29	2.66	0.62	756	4.11	2.55	0.62	801	3.99	2.47	0.62	819	3.85	2.39	0.62	855
26	22	4.46	2.23	0.50	783	4.31	2.15	0.50	833	4.20	2.10	0.50	855	4.03	2.01	0.50	891
26	24	4.69	1.78	0.38	819	4.52	1.72	0.38	864	4.41	1.68	0.38	891	4.27	1.62	0.38	936
26	26	4.83	1.26	0.26	864	4.69	1.22	0.26	909	4.62	1.20	0.26	936	4.48	1.16	0.26	963
27	18	4.11	3.21	0.78	720	3.94	3.07	0.78	756	3.78	2.95	0.78	792	3.64	2.84	0.78	828
27	20	4.29	2.83	0.66	756	4.11	2.71	0.66	801	3.99	2.63	0.66	819	3.85	2.54	0.66	855
27	22	4.46	2.41	0.54	783	4.31	2.32	0.54	833	4.20	2.27	0.54	855	4.03	2.17	0.54	891
27	24	4.69	1.97	0.42	819	4.52	1.90	0.42	864	4.41	1.85	0.42	891	4.27	1.79	0.42	936
27	26	4.83	1.45	0.30	864	4.69	1.41	0.30	909	4.62	1.39	0.30	936	4.48	1.34	0.30	963
28	18	4.11	3.37	0.82	720	3.94	3.23	0.82	756	3.78	3.10	0.82	792	3.64	2.98	0.82	828
28	20	4.29	3.00	0.70	756	4.11	2.88	0.70	801	3.99	2.79	0.70	819	3.85	2.69	0.70	855
28	22	4.46	2.59	0.58	783	4.31	2.50	0.58	833	4.20	2.44	0.58	855	4.03	2.33	0.58	891
28	24	4.69	2.16	0.46	819	4.52	2.08	0.46	864	4.41	2.03	0.46	891	4.27	1.96	0.46	936
28	26	4.83	1.64	0.34	864	4.69	1.59	0.34	909	4.62	1.57	0.34	936	4.48	1.52	0.34	963
29	18	4.11	3.54	0.86	720	3.94	3.39	0.86	756	3.78	3.25	0.86	792	3.64	3.13	0.86	828
29	20	4.29	3.17	0.74	756	4.11	3.04	0.74	801	3.99	2.95	0.74	819	3.85	2.85	0.74	855
29	22	4.46	2.77	0.62	783	4.31	2.67	0.62	833	4.20	2.60	0.62	855	4.03	2.50	0.62	891
29	24	4.69	2.34	0.50	819	4.52	2.26	0.50	864	4.41	2.20	0.50	891	4.27	2.13	0.50	936
29	26	4.83	1.84	0.38	864	4.69	1.78	0.38	909	4.62	1.76	0.38	936	4.48	1.70	0.38	963
30	18	4.11	3.70	0.90	720	3.94	3.54	0.90	756	3.78	3.40	0.90	792	3.64	3.28	0.90	828
30	20	4.29	3.34	0.78	756	4.11	3.21	0.78	801	3.99	3.11	0.78	819	3.85	3.00	0.78	855
30	22	4.46	2.95	0.66	783	4.31	2.84	0.66	833	4.20	2.77	0.66	855	4.03	2.66	0.66	891
30	24	4.69	2.53	0.54	819	4.52	2.44	0.54	864	4.41	2.38	0.54	891	4.27	2.31	0.54	936
30	26	4.83	2.03	0.42	864	4.69	1.97	0.42	909	4.62	1.94	0.42	936	4.48	1.88	0.42	963
31	18	4.11	3.87	0.94	720	3.94	3.70	0.94	756	3.78	3.55	0.94	792	3.64	3.42	0.94	828
31	20	4.29	3.52	0.82	756	4.11	3.37	0.82	801	3.99	3.27	0.82	819	3.85	3.16	0.82	855
31	22	4.46	3.12	0.70	783	4.31	3.01	0.70	833	4.20	2.94	0.70	855	4.03	2.82	0.70	891
31	24	4.69	2.72	0.58	819	4.52	2.62	0.58	864	4.41	2.56	0.58	891	4.27	2.48	0.58	936
31	26	4.83	2.22	0.46	864	4.69	2.16	0.46	909	4.62	2.13	0.46	936	4.48	2.06	0.46	963
32	18	4.11	4.03	0.98	720	3.94	3.86	0.98	756	3.78	3.70	0.98	792	3.64	3.57	0.98	828
32	20	4.29	3.69	0.86	756	4.11	3.54	0.86	801	3.99	3.43	0.86	819	3.85	3.31	0.86	855
32	22	4.46	3.30	0.74	783	4.31	3.19	0.74	833	4.20	3.11	0.74	855	4.03	2.98	0.74	891
32	24	4.69	2.91	0.62	819	4.52	2.80	0.62	864	4.41	2.73	0.62	891	4.27	2.65	0.62	936
32	26	4.83	2.41	0.50	864	4.69	2.34	0.50	909	4.62	2.31	0.50	936	4.48	2.24	0.50	963

NOTE Q : Total capacity (kW) SHF : Sensible heat factor DB : Dry-bulb temperature
 SHC : Sensible heat capacity (kW) INPUT : Total power input (W) WB : Wet-bulb temperature

PERFORMANCE DATA COOL operation at Rated frequency

MFZ-KW35VG: MUFZ-KW35VGHZ

CAPACITY: 3.5 kW SHF: 0.72 INPUT: 900 W

INDOOR DB (°C)	INDOOR WB (°C)	OUTDOOR DB (°C)											
		35				40				46			
		Q	SHC	SHF	INPUT	Q	SHC	SHF	INPUT	Q	SHC	SHF	INPUT
21	18	3.43	1.85	0.54	882	3.15	1.70	0.54	936	2.91	1.57	0.54	972
21	20	3.61	1.51	0.42	918	3.36	1.41	0.42	963	3.12	1.31	0.42	1017
22	18	3.43	1.99	0.58	882	3.15	1.83	0.58	936	2.91	1.68	0.58	972
22	20	3.61	1.66	0.46	918	3.36	1.55	0.46	963	3.12	1.43	0.46	1017
22	22	3.82	1.30	0.34	954	3.57	1.21	0.34	1008	3.33	1.13	0.34	1044
23	18	3.43	2.13	0.62	882	3.15	1.95	0.62	936	2.91	1.80	0.62	972
23	20	3.61	1.80	0.50	918	3.36	1.68	0.50	963	3.12	1.56	0.50	1017
23	22	3.82	1.45	0.38	954	3.57	1.36	0.38	1008	3.33	1.26	0.38	1044
24	18	3.43	2.26	0.66	882	3.15	2.08	0.66	936	2.91	1.92	0.66	972
24	20	3.61	1.95	0.54	918	3.36	1.81	0.54	963	3.12	1.68	0.54	1017
24	22	3.82	1.60	0.42	954	3.57	1.50	0.42	1008	3.33	1.40	0.42	1044
24	24	4.03	1.21	0.30	990	3.78	1.13	0.30	1035	3.57	1.07	0.30	1080
25	18	3.43	2.40	0.70	882	3.15	2.20	0.70	936	2.91	2.03	0.70	972
25	20	3.61	2.09	0.58	918	3.36	1.95	0.58	963	3.12	1.81	0.58	1017
25	22	3.82	1.75	0.46	954	3.57	1.64	0.46	1008	3.33	1.53	0.46	1044
25	24	4.03	1.37	0.34	990	3.78	1.29	0.34	1035	3.57	1.21	0.34	1080
26	18	3.43	2.54	0.74	882	3.15	2.33	0.74	936	2.91	2.15	0.74	972
26	20	3.61	2.23	0.62	918	3.36	2.08	0.62	963	3.12	1.93	0.62	1017
26	22	3.82	1.91	0.50	954	3.57	1.78	0.50	1008	3.33	1.66	0.50	1044
26	24	4.03	1.53	0.38	990	3.78	1.44	0.38	1035	3.57	1.36	0.38	1080
26	26	4.24	1.10	0.26	1026	3.99	1.04	0.26	1071	3.75	0.97	0.26	1116
27	18	3.43	2.68	0.78	882	3.15	2.46	0.78	936	2.91	2.27	0.78	972
27	20	3.61	2.38	0.66	918	3.36	2.22	0.66	963	3.12	2.06	0.66	1017
27	22	3.82	2.06	0.54	954	3.57	1.93	0.54	1008	3.33	1.80	0.54	1044
27	24	4.03	1.69	0.42	990	3.78	1.59	0.42	1035	3.57	1.50	0.42	1080
27	26	4.24	1.27	0.30	1026	3.99	1.20	0.30	1071	3.75	1.12	0.30	1116
28	18	3.43	2.81	0.82	882	3.15	2.58	0.82	936	2.91	2.38	0.82	972
28	20	3.61	2.52	0.70	918	3.36	2.35	0.70	963	3.12	2.18	0.70	1017
28	22	3.82	2.21	0.58	954	3.57	2.07	0.58	1008	3.33	1.93	0.58	1044
28	24	4.03	1.85	0.46	990	3.78	1.74	0.46	1035	3.57	1.64	0.46	1080
28	26	4.24	1.44	0.34	1026	3.99	1.36	0.34	1071	3.75	1.27	0.34	1116
29	18	3.43	2.95	0.86	882	3.15	2.71	0.86	936	2.91	2.50	0.86	972
29	20	3.61	2.67	0.74	918	3.36	2.49	0.74	963	3.12	2.30	0.74	1017
29	22	3.82	2.37	0.62	954	3.57	2.21	0.62	1008	3.33	2.06	0.62	1044
29	24	4.03	2.01	0.50	990	3.78	1.89	0.50	1035	3.57	1.78	0.50	1080
29	26	4.24	1.61	0.38	1026	3.99	1.52	0.38	1071	3.75	1.42	0.38	1116
30	18	3.43	3.09	0.90	882	3.15	2.83	0.90	936	2.91	2.61	0.90	972
30	20	3.61	2.81	0.78	918	3.36	2.62	0.78	963	3.12	2.43	0.78	1017
30	22	3.82	2.52	0.66	954	3.57	2.36	0.66	1008	3.33	2.19	0.66	1044
30	24	4.03	2.17	0.54	990	3.78	2.04	0.54	1035	3.57	1.93	0.54	1080
30	26	4.24	1.78	0.42	1026	3.99	1.68	0.42	1071	3.75	1.57	0.42	1116
31	18	3.43	3.22	0.94	882	3.15	2.96	0.94	936	2.91	2.73	0.94	972
31	20	3.61	2.96	0.82	918	3.36	2.76	0.82	963	3.12	2.55	0.82	1017
31	22	3.82	2.67	0.70	954	3.57	2.50	0.70	1008	3.33	2.33	0.70	1044
31	24	4.03	2.33	0.58	990	3.78	2.19	0.58	1035	3.57	2.07	0.58	1080
31	26	4.24	1.95	0.46	1026	3.99	1.84	0.46	1071	3.75	1.72	0.46	1116
32	18	3.43	3.36	0.98	882	3.15	3.09	0.98	936	2.91	2.85	0.98	972
32	20	3.61	3.10	0.86	918	3.36	2.89	0.86	963	3.12	2.68	0.86	1017
32	22	3.82	2.82	0.74	954	3.57	2.64	0.74	1008	3.33	2.46	0.74	1044
32	24	4.03	2.50	0.62	990	3.78	2.34	0.62	1035	3.57	2.21	0.62	1080
32	26	4.24	2.12	0.50	1026	3.99	1.99	0.50	1071	3.75	1.87	0.50	1116

NOTE Q : Total capacity (kW) SHF : Sensible heat factor DB : Dry-bulb temperature
 SHC : Sensible heat capacity (kW) INPUT : Total power input (W) WB : Wet-bulb temperature

PERFORMANCE DATA COOL operation at Rated frequency

MFZ-KW50VG: MUFZ-KW50VGHZ

CAPACITY: 5.0 kW SHF: 0.70 INPUT: 1360 W

INDOOR DB (°C)	INDOOR WB (°C)	OUTDOOR DB (°C)															
		21				25				27				30			
		Q	SHC	SHF	INPUT	Q	SHC	SHF	INPUT	Q	SHC	SHF	INPUT	Q	SHC	SHF	INPUT
21	18	5.88	3.05	0.52	1088	5.63	2.92	0.52	1142	5.40	2.81	0.52	1197	5.20	2.70	0.52	1251
21	20	6.13	2.45	0.40	1142	5.88	2.35	0.40	1210	5.70	2.28	0.40	1238	5.50	2.20	0.40	1292
22	18	5.88	3.29	0.56	1088	5.63	3.15	0.56	1142	5.40	3.02	0.56	1197	5.20	2.91	0.56	1251
22	20	6.13	2.69	0.44	1142	5.88	2.58	0.44	1210	5.70	2.51	0.44	1238	5.50	2.42	0.44	1292
22	22	6.38	2.04	0.32	1183	6.15	1.96	0.32	1258	6.00	1.92	0.32	1292	5.75	1.84	0.32	1346
23	18	5.88	3.52	0.60	1088	5.63	3.37	0.60	1142	5.40	3.24	0.60	1197	5.20	3.12	0.60	1251
23	20	6.13	2.94	0.48	1142	5.88	2.82	0.48	1210	5.70	2.73	0.48	1238	5.50	2.64	0.48	1292
23	22	6.38	2.29	0.36	1183	6.15	2.21	0.36	1258	6.00	2.16	0.36	1292	5.75	2.07	0.36	1346
24	18	5.88	3.76	0.64	1088	5.63	3.60	0.64	1142	5.40	3.45	0.64	1197	5.20	3.33	0.64	1251
24	20	6.13	3.18	0.52	1142	5.88	3.05	0.52	1210	5.70	2.96	0.52	1238	5.50	2.86	0.52	1292
24	22	6.38	2.55	0.40	1183	6.15	2.46	0.40	1258	6.00	2.40	0.40	1292	5.75	2.30	0.40	1346
24	24	6.70	1.87	0.28	1238	6.45	1.80	0.28	1306	6.30	1.76	0.28	1346	6.10	1.71	0.28	1414
25	18	5.88	3.99	0.68	1088	5.63	3.82	0.68	1142	5.40	3.67	0.68	1197	5.20	3.53	0.68	1251
25	20	6.13	3.43	0.56	1142	5.88	3.29	0.56	1210	5.70	3.19	0.56	1238	5.50	3.08	0.56	1292
25	22	6.38	2.80	0.44	1183	6.15	2.70	0.44	1258	6.00	2.64	0.44	1292	5.75	2.53	0.44	1346
25	24	6.70	2.14	0.32	1238	6.45	2.06	0.32	1306	6.30	2.01	0.32	1346	6.10	1.95	0.32	1414
26	18	5.88	4.23	0.72	1088	5.63	4.05	0.72	1142	5.40	3.89	0.72	1197	5.20	3.74	0.72	1251
26	20	6.13	3.67	0.60	1142	5.88	3.52	0.60	1210	5.70	3.42	0.60	1238	5.50	3.30	0.60	1292
26	22	6.38	3.06	0.48	1183	6.15	2.95	0.48	1258	6.00	2.88	0.48	1292	5.75	2.76	0.48	1346
26	24	6.70	2.41	0.36	1238	6.45	2.32	0.36	1306	6.30	2.26	0.36	1346	6.10	2.19	0.36	1414
26	26	6.90	1.65	0.24	1306	6.70	1.60	0.24	1374	6.60	1.58	0.24	1414	6.40	1.53	0.24	1455
27	18	5.88	4.46	0.76	1088	5.63	4.27	0.76	1142	5.40	4.10	0.76	1197	5.20	3.95	0.76	1251
27	20	6.13	3.92	0.64	1142	5.88	3.76	0.64	1210	5.70	3.65	0.64	1238	5.50	3.52	0.64	1292
27	22	6.38	3.31	0.52	1183	6.15	3.19	0.52	1258	6.00	3.12	0.52	1292	5.75	2.99	0.52	1346
27	24	6.70	2.68	0.40	1238	6.45	2.58	0.40	1306	6.30	2.52	0.40	1346	6.10	2.44	0.40	1414
27	26	6.90	1.93	0.28	1306	6.70	1.87	0.28	1374	6.60	1.84	0.28	1414	6.40	1.79	0.28	1455
28	18	5.88	4.70	0.80	1088	5.63	4.50	0.80	1142	5.40	4.32	0.80	1197	5.20	4.16	0.80	1251
28	20	6.13	4.16	0.68	1142	5.88	3.99	0.68	1210	5.70	3.87	0.68	1238	5.50	3.74	0.68	1292
28	22	6.38	3.57	0.56	1183	6.15	3.44	0.56	1258	6.00	3.36	0.56	1292	5.75	3.22	0.56	1346
28	24	6.70	2.94	0.44	1238	6.45	2.83	0.44	1306	6.30	2.77	0.44	1346	6.10	2.68	0.44	1414
28	26	6.90	2.20	0.32	1306	6.70	2.14	0.32	1374	6.60	2.11	0.32	1414	6.40	2.04	0.32	1455
29	18	5.88	4.93	0.84	1088	5.63	4.72	0.84	1142	5.40	4.53	0.84	1197	5.20	4.37	0.84	1251
29	20	6.13	4.41	0.72	1142	5.88	4.23	0.72	1210	5.70	4.10	0.72	1238	5.50	3.96	0.72	1292
29	22	6.38	3.82	0.60	1183	6.15	3.69	0.60	1258	6.00	3.60	0.60	1292	5.75	3.45	0.60	1346
29	24	6.70	3.21	0.48	1238	6.45	3.09	0.48	1306	6.30	3.02	0.48	1346	6.10	2.93	0.48	1414
29	26	6.90	2.48	0.36	1306	6.70	2.41	0.36	1374	6.60	2.37	0.36	1414	6.40	2.30	0.36	1455
30	18	5.88	5.17	0.88	1088	5.63	4.95	0.88	1142	5.40	4.75	0.88	1197	5.20	4.57	0.88	1251
30	20	6.13	4.65	0.76	1142	5.88	4.46	0.76	1210	5.70	4.33	0.76	1238	5.50	4.18	0.76	1292
30	22	6.38	4.08	0.64	1183	6.15	3.93	0.64	1258	6.00	3.84	0.64	1292	5.75	3.68	0.64	1346
30	24	6.70	3.48	0.52	1238	6.45	3.35	0.52	1306	6.30	3.27	0.52	1346	6.10	3.17	0.52	1414
30	26	6.90	2.76	0.40	1306	6.70	2.68	0.40	1374	6.60	2.64	0.40	1414	6.40	2.56	0.40	1455
31	18	5.88	5.40	0.92	1088	5.63	5.17	0.92	1142	5.40	4.97	0.92	1197	5.20	4.78	0.92	1251
31	20	6.13	4.90	0.80	1142	5.88	4.70	0.80	1210	5.70	4.56	0.80	1238	5.50	4.40	0.80	1292
31	22	6.38	4.33	0.68	1183	6.15	4.18	0.68	1258	6.00	4.08	0.68	1292	5.75	3.91	0.68	1346
31	24	6.70	3.75	0.56	1238	6.45	3.61	0.56	1306	6.30	3.52	0.56	1346	6.10	3.41	0.56	1414
31	26	6.90	3.03	0.44	1306	6.70	2.94	0.44	1374	6.60	2.90	0.44	1414	6.40	2.81	0.44	1455
32	18	5.88	5.64	0.96	1088	5.63	5.40	0.96	1142	5.40	5.18	0.96	1197	5.20	4.99	0.96	1251
32	20	6.13	5.14	0.84	1142	5.88	4.93	0.84	1210	5.70	4.79	0.84	1238	5.50	4.62	0.84	1292
32	22	6.38	4.59	0.72	1183	6.15	4.42	0.72	1258	6.00	4.32	0.72	1292	5.75	4.14	0.72	1346
32	24	6.70	4.02	0.60	1238	6.45	3.87	0.60	1306	6.30	3.78	0.60	1346	6.10	3.66	0.60	1414
32	26	6.90	3.31	0.48	1306	6.70	3.21	0.48	1374	6.60	3.16	0.48	1414	6.40	3.07	0.48	1455

NOTE Q : Total capacity (kW) SHF : Sensible heat factor DB : Dry-bulb temperature
 SHC : Sensible heat capacity (kW) INPUT : Total power input (W) WB : Wet-bulb temperature

PERFORMANCE DATA COOL operation at Rated frequency

MFZ-KW50VG: MUFZ-KW50VGHZ

CAPACITY: 5.0 kW SHF: 0.70 INPUT: 1360 W

INDOOR DB (°C)	INDOOR WB (°C)	OUTDOOR DB (°C)											
		35				40				46			
		Q	SHC	SHF	INPUT	Q	SHC	SHF	INPUT	Q	SHC	SHF	INPUT
21	18	4.90	2.55	0.52	1333	4.50	2.34	0.52	1414	4.15	2.16	0.52	1469
21	20	5.15	2.06	0.40	1387	4.80	1.92	0.40	1455	4.45	1.78	0.40	1537
22	18	4.90	2.74	0.56	1333	4.50	2.52	0.56	1414	4.15	2.32	0.56	1469
22	20	5.15	2.26	0.44	1387	4.80	2.11	0.44	1455	4.45	1.96	0.44	1537
22	22	5.45	1.74	0.32	1442	5.10	1.63	0.32	1523	4.75	1.52	0.32	1578
23	18	4.90	2.94	0.60	1333	4.50	2.70	0.60	1414	4.15	2.49	0.60	1469
23	20	5.15	2.47	0.48	1387	4.80	2.30	0.48	1455	4.45	2.13	0.48	1537
23	22	5.45	1.96	0.36	1442	5.10	1.83	0.36	1523	4.75	1.71	0.36	1578
24	18	4.90	3.13	0.64	1333	4.50	2.88	0.64	1414	4.15	2.65	0.64	1469
24	20	5.15	2.68	0.52	1387	4.80	2.49	0.52	1455	4.45	2.31	0.52	1537
24	22	5.45	2.18	0.40	1442	5.10	2.04	0.40	1523	4.75	1.90	0.40	1578
24	24	5.75	1.61	0.28	1496	5.40	1.51	0.28	1564	5.10	1.43	0.28	1632
25	18	4.90	3.33	0.68	1333	4.50	3.06	0.68	1414	4.15	2.82	0.68	1469
25	20	5.15	2.88	0.56	1387	4.80	2.69	0.56	1455	4.45	2.49	0.56	1537
25	22	5.45	2.40	0.44	1442	5.10	2.24	0.44	1523	4.75	2.09	0.44	1578
25	24	5.75	1.84	0.32	1496	5.40	1.73	0.32	1564	5.10	1.63	0.32	1632
26	18	4.90	3.53	0.72	1333	4.50	3.24	0.72	1414	4.15	2.99	0.72	1469
26	20	5.15	3.09	0.60	1387	4.80	2.88	0.60	1455	4.45	2.67	0.60	1537
26	22	5.45	2.61	0.48	1442	5.10	2.45	0.48	1523	4.75	2.28	0.48	1578
26	24	5.75	2.07	0.36	1496	5.40	1.94	0.36	1564	5.10	1.83	0.36	1632
26	26	6.05	1.45	0.24	1550	5.70	1.37	0.24	1618	5.35	1.28	0.24	1686
27	18	4.90	3.72	0.76	1333	4.50	3.42	0.76	1414	4.15	3.15	0.76	1469
27	20	5.15	3.29	0.64	1387	4.80	3.07	0.64	1455	4.45	2.85	0.64	1537
27	22	5.45	2.83	0.52	1442	5.10	2.65	0.52	1523	4.75	2.47	0.52	1578
27	24	5.75	2.30	0.40	1496	5.40	2.16	0.40	1564	5.10	2.04	0.40	1632
27	26	6.05	1.69	0.28	1550	5.70	1.59	0.28	1618	5.35	1.50	0.28	1686
28	18	4.90	3.92	0.80	1333	4.50	3.60	0.80	1414	4.15	3.32	0.80	1469
28	20	5.15	3.50	0.68	1387	4.80	3.26	0.68	1455	4.45	3.02	0.68	1537
28	22	5.45	3.05	0.56	1442	5.10	2.85	0.56	1523	4.75	2.66	0.56	1578
28	24	5.75	2.53	0.44	1496	5.40	2.37	0.44	1564	5.10	2.24	0.44	1632
28	26	6.05	1.93	0.32	1550	5.70	1.82	0.32	1618	5.35	1.71	0.32	1686
29	18	4.90	4.11	0.84	1333	4.50	3.78	0.84	1414	4.15	3.48	0.84	1469
29	20	5.15	3.71	0.72	1387	4.80	3.45	0.72	1455	4.45	3.20	0.72	1537
29	22	5.45	3.27	0.60	1442	5.10	3.06	0.60	1523	4.75	2.85	0.60	1578
29	24	5.75	2.76	0.48	1496	5.40	2.59	0.48	1564	5.10	2.45	0.48	1632
29	26	6.05	2.18	0.36	1550	5.70	2.05	0.36	1618	5.35	1.92	0.36	1686
30	18	4.90	4.31	0.88	1333	4.50	3.96	0.88	1414	4.15	3.65	0.88	1469
30	20	5.15	3.91	0.76	1387	4.80	3.65	0.76	1455	4.45	3.38	0.76	1537
30	22	5.45	3.49	0.64	1442	5.10	3.26	0.64	1523	4.75	3.04	0.64	1578
30	24	5.75	2.99	0.52	1496	5.40	2.81	0.52	1564	5.10	2.65	0.52	1632
30	26	6.05	2.42	0.40	1550	5.70	2.28	0.40	1618	5.35	2.14	0.40	1686
31	18	4.90	4.51	0.92	1333	4.50	4.14	0.92	1414	4.15	3.82	0.92	1469
31	20	5.15	4.12	0.80	1387	4.80	3.84	0.80	1455	4.45	3.56	0.80	1537
31	22	5.45	3.70	0.68	1442	5.10	3.47	0.68	1523	4.75	3.23	0.68	1578
31	24	5.75	3.22	0.56	1496	5.40	3.02	0.56	1564	5.10	2.85	0.56	1632
31	26	6.05	2.66	0.44	1550	5.70	2.51	0.44	1618	5.35	2.35	0.44	1686
32	18	4.90	4.70	0.96	1333	4.50	4.32	0.96	1414	4.15	3.98	0.96	1469
32	20	5.15	4.32	0.84	1387	4.80	4.03	0.84	1455	4.45	3.74	0.84	1537
32	22	5.45	3.92	0.72	1442	5.10	3.67	0.72	1523	4.75	3.42	0.72	1578
32	24	5.75	3.45	0.60	1496	5.40	3.24	0.60	1564	5.10	3.06	0.60	1632
32	26	6.05	2.90	0.48	1550	5.70	2.73	0.48	1618	5.35	2.57	0.48	1686

NOTE Q : Total capacity (kW) SHF : Sensible heat factor DB : Dry-bulb temperature
 SHC : Sensible heat capacity (kW) INPUT : Total power input (W) WB : Wet-bulb temperature

PERFORMANCE DATA COOL operation at Rated frequency

MFZ-KW60VG: MUFZ-KW60VGHZ

CAPACITY: 6.1 kW SHF: 0.74 INPUT: 1730 W

INDOOR DB (°C)	INDOOR WB (°C)	OUTDOOR DB (°C)															
		21				25				27				30			
		Q	SHC	SHF	INPUT	Q	SHC	SHF	INPUT	Q	SHC	SHF	INPUT	Q	SHC	SHF	INPUT
21	18	7.17	4.03	0.56	1384	6.86	3.86	0.56	1453	6.59	3.70	0.56	1522	6.34	3.57	0.56	1592
21	20	7.47	3.30	0.44	1453	7.17	3.17	0.44	1540	6.95	3.07	0.44	1574	6.71	2.97	0.44	1644
22	18	7.17	4.32	0.60	1384	6.86	4.13	0.60	1453	6.59	3.97	0.60	1522	6.34	3.82	0.60	1592
22	20	7.47	3.60	0.48	1453	7.17	3.46	0.48	1540	6.95	3.35	0.48	1574	6.71	3.23	0.48	1644
22	22	7.78	2.82	0.36	1505	7.50	2.72	0.36	1600	7.32	2.65	0.36	1644	7.02	2.54	0.36	1713
23	18	7.17	4.60	0.64	1384	6.86	4.41	0.64	1453	6.59	4.23	0.64	1522	6.34	4.07	0.64	1592
23	20	7.47	3.90	0.52	1453	7.17	3.74	0.52	1540	6.95	3.63	0.52	1574	6.71	3.50	0.52	1644
23	22	7.78	3.13	0.40	1505	7.50	3.02	0.40	1600	7.32	2.94	0.40	1644	7.02	2.82	0.40	1713
24	18	7.17	4.89	0.68	1384	6.86	4.68	0.68	1453	6.59	4.49	0.68	1522	6.34	4.33	0.68	1592
24	20	7.47	4.20	0.56	1453	7.17	4.03	0.56	1540	6.95	3.91	0.56	1574	6.71	3.77	0.56	1644
24	22	7.78	3.44	0.44	1505	7.50	3.32	0.44	1600	7.32	3.24	0.44	1644	7.02	3.10	0.44	1713
24	24	8.17	2.63	0.32	1574	7.87	2.53	0.32	1661	7.69	2.48	0.32	1713	7.44	2.40	0.32	1799
25	18	7.17	5.18	0.72	1384	6.86	4.96	0.72	1453	6.59	4.76	0.72	1522	6.34	4.58	0.72	1592
25	20	7.47	4.50	0.60	1453	7.17	4.32	0.60	1540	6.95	4.19	0.60	1574	6.71	4.04	0.60	1644
25	22	7.78	3.75	0.48	1505	7.50	3.62	0.48	1600	7.32	3.53	0.48	1644	7.02	3.38	0.48	1713
25	24	8.17	2.96	0.36	1574	7.87	2.85	0.36	1661	7.69	2.78	0.36	1713	7.44	2.69	0.36	1799
26	18	7.17	5.46	0.76	1384	6.86	5.23	0.76	1453	6.59	5.02	0.76	1522	6.34	4.83	0.76	1592
26	20	7.47	4.80	0.64	1453	7.17	4.60	0.64	1540	6.95	4.47	0.64	1574	6.71	4.31	0.64	1644
26	22	7.78	4.06	0.52	1505	7.50	3.92	0.52	1600	7.32	3.82	0.52	1644	7.02	3.66	0.52	1713
26	24	8.17	3.29	0.40	1574	7.87	3.16	0.40	1661	7.69	3.09	0.40	1713	7.44	2.99	0.40	1799
26	26	8.42	2.37	0.28	1661	8.17	2.31	0.28	1747	8.05	2.27	0.28	1799	7.81	2.20	0.28	1851
27	18	7.17	5.75	0.80	1384	6.86	5.50	0.80	1453	6.59	5.28	0.80	1522	6.34	5.09	0.80	1592
27	20	7.47	5.10	0.68	1453	7.17	4.89	0.68	1540	6.95	4.74	0.68	1574	6.71	4.58	0.68	1644
27	22	7.78	4.37	0.56	1505	7.50	4.22	0.56	1600	7.32	4.11	0.56	1644	7.02	3.94	0.56	1713
27	24	8.17	3.61	0.44	1574	7.87	3.48	0.44	1661	7.69	3.40	0.44	1713	7.44	3.29	0.44	1799
27	26	8.42	2.71	0.32	1661	8.17	2.63	0.32	1747	8.05	2.59	0.32	1799	7.81	2.51	0.32	1851
28	18	7.17	6.04	0.84	1384	6.86	5.78	0.84	1453	6.59	5.55	0.84	1522	6.34	5.34	0.84	1592
28	20	7.47	5.40	0.72	1453	7.17	5.18	0.72	1540	6.95	5.02	0.72	1574	6.71	4.85	0.72	1644
28	22	7.78	4.68	0.60	1505	7.50	4.52	0.60	1600	7.32	4.41	0.60	1644	7.02	4.22	0.60	1713
28	24	8.17	3.94	0.48	1574	7.87	3.79	0.48	1661	7.69	3.71	0.48	1713	7.44	3.59	0.48	1799
28	26	8.42	3.05	0.36	1661	8.17	2.96	0.36	1747	8.05	2.92	0.36	1799	7.81	2.83	0.36	1851
29	18	7.17	6.32	0.88	1384	6.86	6.05	0.88	1453	6.59	5.81	0.88	1522	6.34	5.60	0.88	1592
29	20	7.47	5.69	0.76	1453	7.17	5.46	0.76	1540	6.95	5.30	0.76	1574	6.71	5.11	0.76	1644
29	22	7.78	4.99	0.64	1505	7.50	4.82	0.64	1600	7.32	4.70	0.64	1644	7.02	4.50	0.64	1713
29	24	8.17	4.27	0.52	1574	7.87	4.11	0.52	1661	7.69	4.01	0.52	1713	7.44	3.89	0.52	1799
29	26	8.42	3.38	0.40	1661	8.17	3.29	0.40	1747	8.05	3.24	0.40	1799	7.81	3.14	0.40	1851
30	18	7.17	6.61	0.92	1384	6.86	6.33	0.92	1453	6.59	6.07	0.92	1522	6.34	5.85	0.92	1592
30	20	7.47	5.99	0.80	1453	7.17	5.75	0.80	1540	6.95	5.58	0.80	1574	6.71	5.38	0.80	1644
30	22	7.78	5.31	0.68	1505	7.50	5.12	0.68	1600	7.32	4.99	0.68	1644	7.02	4.78	0.68	1713
30	24	8.17	4.59	0.56	1574	7.87	4.42	0.56	1661	7.69	4.32	0.56	1713	7.44	4.18	0.56	1799
30	26	8.42	3.72	0.44	1661	8.17	3.61	0.44	1747	8.05	3.56	0.44	1799	7.81	3.45	0.44	1851
31	18	7.17	6.90	0.96	1384	6.86	6.60	0.96	1453	6.59	6.34	0.96	1522	6.34	6.10	0.96	1592
31	20	7.47	6.29	0.84	1453	7.17	6.04	0.84	1540	6.95	5.86	0.84	1574	6.71	5.65	0.84	1644
31	22	7.78	5.62	0.72	1505	7.50	5.42	0.72	1600	7.32	5.29	0.72	1644	7.02	5.07	0.72	1713
31	24	8.17	4.92	0.60	1574	7.87	4.74	0.60	1661	7.69	4.63	0.60	1713	7.44	4.48	0.60	1799
31	26	8.42	4.06	0.48	1661	8.17	3.94	0.48	1747	8.05	3.88	0.48	1799	7.81	3.76	0.48	1851
32	18	7.17	7.17	1.00	1384	6.86	6.86	1.00	1453	6.59	6.59	1.00	1522	6.34	6.34	1.00	1592
32	20	7.47	6.59	0.88	1453	7.17	6.32	0.88	1540	6.95	6.13	0.88	1574	6.71	5.92	0.88	1644
32	22	7.78	5.93	0.76	1505	7.50	5.72	0.76	1600	7.32	5.58	0.76	1644	7.02	5.35	0.76	1713
32	24	8.17	5.25	0.64	1574	7.87	5.05	0.64	1661	7.69	4.94	0.64	1713	7.44	4.78	0.64	1799
32	26	8.42	4.40	0.52	1661	8.17	4.27	0.52	1747	8.05	4.20	0.52	1799	7.81	4.08	0.52	1851

NOTE Q : Total capacity (kW) SHF : Sensible heat factor DB : Dry-bulb temperature
 SHC : Sensible heat capacity (kW) INPUT : Total power input (W) WB : Wet-bulb temperature

PERFORMANCE DATA COOL operation at Rated frequency

MFZ-KW60VG: MUFZ-KW60VGHZ

CAPACITY: 6.1 kW SHF: 0.74 INPUT: 1730 W

INDOOR DB (°C)	INDOOR WB (°C)	OUTDOOR DB (°C)											
		35				40				46			
		Q	SHC	SHF	INPUT	Q	SHC	SHF	INPUT	Q	SHC	SHF	INPUT
21	18	5.98	3.36	0.56	1695	5.49	3.09	0.56	1799	5.06	2.85	0.56	1868
21	20	6.28	2.78	0.44	1765	5.86	2.59	0.44	1851	5.43	2.40	0.44	1955
22	18	5.98	3.60	0.60	1695	5.49	3.31	0.60	1799	5.06	3.05	0.60	1868
22	20	6.28	3.03	0.48	1765	5.86	2.82	0.48	1851	5.43	2.62	0.48	1955
22	22	6.65	2.41	0.36	1834	6.22	2.25	0.36	1938	5.80	2.10	0.36	2007
23	18	5.98	3.84	0.64	1695	5.49	3.53	0.64	1799	5.06	3.25	0.64	1868
23	20	6.28	3.28	0.52	1765	5.86	3.06	0.52	1851	5.43	2.83	0.52	1955
23	22	6.65	2.67	0.40	1834	6.22	2.50	0.40	1938	5.80	2.33	0.40	2007
24	18	5.98	4.08	0.68	1695	5.49	3.74	0.68	1799	5.06	3.45	0.68	1868
24	20	6.28	3.53	0.56	1765	5.86	3.29	0.56	1851	5.43	3.05	0.56	1955
24	22	6.65	2.94	0.44	1834	6.22	2.75	0.44	1938	5.80	2.56	0.44	2007
24	24	7.02	2.26	0.32	1903	6.59	2.12	0.32	1990	6.22	2.00	0.32	2076
25	18	5.98	4.32	0.72	1695	5.49	3.96	0.72	1799	5.06	3.66	0.72	1868
25	20	6.28	3.78	0.60	1765	5.86	3.53	0.60	1851	5.43	3.27	0.60	1955
25	22	6.65	3.21	0.48	1834	6.22	3.00	0.48	1938	5.80	2.79	0.48	2007
25	24	7.02	2.54	0.36	1903	6.59	2.39	0.36	1990	6.22	2.25	0.36	2076
26	18	5.98	4.56	0.76	1695	5.49	4.18	0.76	1799	5.06	3.86	0.76	1868
26	20	6.28	4.03	0.64	1765	5.86	3.76	0.64	1851	5.43	3.49	0.64	1955
26	22	6.65	3.47	0.52	1834	6.22	3.25	0.52	1938	5.80	3.03	0.52	2007
26	24	7.02	2.82	0.40	1903	6.59	2.65	0.40	1990	6.22	2.50	0.40	2076
26	26	7.38	2.08	0.28	1972	6.95	1.96	0.28	2059	6.53	1.84	0.28	2145
27	18	5.98	4.79	0.80	1695	5.49	4.40	0.80	1799	5.06	4.06	0.80	1868
27	20	6.28	4.29	0.68	1765	5.86	3.99	0.68	1851	5.43	3.70	0.68	1955
27	22	6.65	3.74	0.56	1834	6.22	3.50	0.56	1938	5.80	3.26	0.56	2007
27	24	7.02	3.10	0.44	1903	6.59	2.91	0.44	1990	6.22	2.75	0.44	2076
27	26	7.38	2.38	0.32	1972	6.95	2.24	0.32	2059	6.53	2.10	0.32	2145
28	18	5.98	5.03	0.84	1695	5.49	4.62	0.84	1799	5.06	4.26	0.84	1868
28	20	6.28	4.54	0.72	1765	5.86	4.23	0.72	1851	5.43	3.92	0.72	1955
28	22	6.65	4.00	0.60	1834	6.22	3.75	0.60	1938	5.80	3.49	0.60	2007
28	24	7.02	3.38	0.48	1903	6.59	3.18	0.48	1990	6.22	3.00	0.48	2076
28	26	7.38	2.67	0.36	1972	6.95	2.52	0.36	2059	6.53	2.36	0.36	2145
29	18	5.98	5.27	0.88	1695	5.49	4.84	0.88	1799	5.06	4.47	0.88	1868
29	20	6.28	4.79	0.76	1765	5.86	4.46	0.76	1851	5.43	4.14	0.76	1955
29	22	6.65	4.27	0.64	1834	6.22	4.00	0.64	1938	5.80	3.72	0.64	2007
29	24	7.02	3.66	0.52	1903	6.59	3.44	0.52	1990	6.22	3.25	0.52	2076
29	26	7.38	2.97	0.40	1972	6.95	2.80	0.40	2059	6.53	2.62	0.40	2145
30	18	5.98	5.51	0.92	1695	5.49	5.06	0.92	1799	5.06	4.67	0.92	1868
30	20	6.28	5.04	0.80	1765	5.86	4.70	0.80	1851	5.43	4.35	0.80	1955
30	22	6.65	4.54	0.68	1834	6.22	4.24	0.68	1938	5.80	3.95	0.68	2007
30	24	7.02	3.94	0.56	1903	6.59	3.70	0.56	1990	6.22	3.50	0.56	2076
30	26	7.38	3.26	0.44	1972	6.95	3.07	0.44	2059	6.53	2.89	0.44	2145
31	18	5.98	5.75	0.96	1695	5.49	5.28	0.96	1799	5.06	4.87	0.96	1868
31	20	6.28	5.29	0.84	1765	5.86	4.93	0.84	1851	5.43	4.57	0.84	1955
31	22	6.65	4.80	0.72	1834	6.22	4.49	0.72	1938	5.80	4.18	0.72	2007
31	24	7.02	4.22	0.60	1903	6.59	3.97	0.60	1990	6.22	3.75	0.60	2076
31	26	7.38	3.56	0.48	1972	6.95	3.35	0.48	2059	6.53	3.15	0.48	2145
32	18	5.98	5.98	1.00	1695	5.49	5.49	1.00	1799	5.06	5.06	1.00	1868
32	20	6.28	5.54	0.88	1765	5.86	5.17	0.88	1851	5.43	4.79	0.88	1955
32	22	6.65	5.07	0.76	1834	6.22	4.74	0.76	1938	5.80	4.42	0.76	2007
32	24	7.02	4.50	0.64	1903	6.59	4.23	0.64	1990	6.22	4.00	0.64	2076
32	26	7.38	3.85	0.52	1972	6.95	3.63	0.52	2059	6.53	3.41	0.52	2145

NOTE Q : Total capacity (kW) SHF : Sensible heat factor DB : Dry-bulb temperature
 SHC : Sensible heat capacity (kW) INPUT : Total power input (W) WB : Wet-bulb temperature

PERFORMANCE DATA COOL operation at Rated frequency

MFZ-KT25VG: SUZ-M25VA

CAPACITY: 2.5 kW

SHF: 0.79

INPUT: 620 W

Indoor intake air DB (°C)	Indoor intake air WB (°C)	Outdoor intake air DB (°C)															
		21				25				27				30			
		CA	SHC (W)	SHF	P.C.	CA	SHC (W)	SHF	P.C.	CA	SHC (W)	SHF	P.C.	CA	SHC (W)	SHF	P.C.
21	18	2938	1792	0.61	0.50	2813	1716	0.61	0.52	2700	1647	0.61	0.55	2600	1586	0.61	0.57
21	20	3063	1501	0.49	0.52	2938	1439	0.49	0.55	2850	1397	0.49	0.56	2750	1348	0.49	0.59
22	18	2938	1909	0.65	0.50	2813	1828	0.65	0.52	2700	1755	0.65	0.55	2600	1690	0.65	0.57
22	20	3063	1623	0.53	0.52	2938	1557	0.53	0.55	2850	1511	0.53	0.56	2750	1458	0.53	0.59
22	22	3188	1307	0.41	0.54	3075	1261	0.41	0.57	3000	1230	0.41	0.59	2875	1179	0.41	0.61
23	18	2938	2027	0.69	0.50	2813	1941	0.69	0.52	2700	1863	0.69	0.55	2600	1794	0.69	0.57
23	20	3063	1746	0.57	0.52	2938	1674	0.57	0.55	2850	1625	0.57	0.56	2750	1568	0.57	0.59
23	22	3188	1434	0.45	0.54	3075	1384	0.45	0.57	3000	1350	0.45	0.59	2875	1294	0.45	0.61
24	18	2938	2144	0.73	0.50	2813	2053	0.73	0.52	2700	1971	0.73	0.55	2600	1898	0.73	0.57
24	20	3063	1868	0.61	0.52	2938	1792	0.61	0.55	2850	1739	0.61	0.56	2750	1678	0.61	0.59
24	22	3188	1562	0.49	0.54	3075	1507	0.49	0.57	3000	1470	0.49	0.59	2875	1409	0.49	0.61
24	24	3350	1240	0.37	0.56	3225	1193	0.37	0.60	3150	1166	0.37	0.61	3050	1129	0.37	0.64
25	20	3063	1991	0.65	0.52	2938	1909	0.65	0.55	2850	1853	0.65	0.56	2750	1788	0.65	0.59
25	22	3188	1689	0.53	0.54	3075	1630	0.53	0.57	3000	1590	0.53	0.59	2875	1524	0.53	0.61
25	24	3350	1374	0.41	0.56	3225	1322	0.41	0.60	3150	1292	0.41	0.61	3050	1251	0.41	0.64
26	18	2938	2379	0.81	0.50	2813	2278	0.81	0.52	2700	2187	0.81	0.55	2600	2106	0.81	0.57
26	20	3063	2113	0.69	0.52	2938	2027	0.69	0.55	2850	1967	0.69	0.56	2750	1898	0.69	0.59
26	22	3188	1817	0.57	0.54	3075	1753	0.57	0.57	3000	1710	0.57	0.59	2875	1639	0.57	0.61
26	24	3350	1508	0.45	0.56	3225	1451	0.45	0.60	3150	1418	0.45	0.61	3050	1373	0.45	0.64
26	26	3450	1139	0.33	0.60	3350	1106	0.33	0.63	3300	1089	0.33	0.64	3200	1056	0.33	0.66
27	18	2938	2497	0.85	0.50	2813	2391	0.85	0.52	2700	2295	0.85	0.55	2600	2210	0.85	0.57
27	20	3063	2236	0.73	0.52	2938	2144	0.73	0.55	2850	2081	0.73	0.56	2750	2008	0.73	0.59
27	22	3188	1944	0.61	0.54	3075	1876	0.61	0.57	3000	1830	0.61	0.59	2875	1754	0.61	0.61
27	24	3350	1642	0.49	0.56	3225	1580	0.49	0.60	3150	1544	0.49	0.61	3050	1495	0.49	0.64
27	26	3450	1277	0.37	0.60	3350	1240	0.37	0.63	3300	1221	0.37	0.64	3200	1184	0.37	0.66
28	18	2938	2614	0.89	0.50	2813	2503	0.89	0.52	2700	2403	0.89	0.55	2600	2314	0.89	0.57
28	20	3063	2358	0.77	0.52	2938	2262	0.77	0.55	2850	2195	0.77	0.56	2750	2118	0.77	0.59
28	22	3188	2072	0.65	0.54	3075	1999	0.65	0.57	3000	1950	0.65	0.59	2875	1869	0.65	0.61
28	24	3350	1776	0.53	0.56	3225	1709	0.53	0.60	3150	1670	0.53	0.61	3050	1617	0.53	0.64
28	26	3450	1415	0.41	0.60	3350	1374	0.41	0.63	3300	1353	0.41	0.64	3200	1312	0.41	0.66
29	18	2938	2732	0.93	0.50	2813	2616	0.93	0.52	2700	2511	0.93	0.55	2600	2418	0.93	0.57
29	20	3063	2481	0.81	0.52	2938	2379	0.81	0.55	2850	2309	0.81	0.56	2750	2228	0.81	0.59
29	22	3188	2199	0.69	0.54	3075	2122	0.69	0.57	3000	2070	0.69	0.59	2875	1984	0.69	0.61
29	24	3350	1910	0.57	0.56	3225	1838	0.57	0.60	3150	1796	0.57	0.61	3050	1739	0.57	0.64
29	26	3450	1553	0.45	0.60	3350	1508	0.45	0.63	3300	1485	0.45	0.64	3200	1440	0.45	0.66
30	18	2938	2849	0.97	0.50	2813	2728	0.97	0.52	2700	2619	0.97	0.55	2600	2522	0.97	0.57
30	20	3063	2603	0.85	0.52	2938	2497	0.85	0.55	2850	2423	0.85	0.56	2750	2338	0.85	0.59
30	22	3188	2327	0.73	0.54	3075	2245	0.73	0.57	3000	2190	0.73	0.59	2875	2099	0.73	0.61
30	24	3350	2044	0.61	0.56	3225	1967	0.61	0.60	3150	1922	0.61	0.61	3050	1861	0.61	0.64
30	26	3450	1691	0.49	0.60	3350	1642	0.49	0.63	3300	1617	0.49	0.64	3200	1568	0.49	0.66
31	18	2938	2938	1.00	0.50	2813	2813	1.00	0.52	2700	2700	1.00	0.55	2600	2600	1.00	0.57
31	20	3063	2726	0.89	0.52	2938	2614	0.89	0.55	2850	2537	0.89	0.56	2750	2448	0.89	0.59
31	22	3188	2454	0.77	0.54	3075	2368	0.77	0.57	3000	2310	0.77	0.59	2875	2214	0.77	0.61
31	24	3350	2178	0.65	0.56	3225	2096	0.65	0.60	3150	2048	0.65	0.61	3050	1983	0.65	0.64
31	26	3450	1829	0.53	0.60	3350	1776	0.53	0.63	3300	1749	0.53	0.64	3200	1696	0.53	0.66
32	18	2938	2938	1.00	0.50	2813	2813	1.00	0.52	2700	2700	1.00	0.55	2600	2600	1.00	0.57
32	20	3063	2848	0.93	0.52	2938	2732	0.93	0.55	2850	2651	0.93	0.56	2750	2558	0.93	0.59
32	22	3188	2582	0.81	0.54	3075	2491	0.81	0.57	3000	2430	0.81	0.59	2875	2329	0.81	0.61
32	24	3350	2312	0.69	0.56	3225	2225	0.69	0.60	3150	2174	0.69	0.61	3050	2105	0.69	0.64
32	26	3450	1967	0.57	0.60	3350	1910	0.57	0.63	3300	1881	0.57	0.64	3200	1824	0.57	0.66

NOTE C.A :Capacity (W) SHC :Sensible heat capacity (W) DB : Dry-bulb temperature
P.C. :Power consumption (kW) SHF :Sensible heat factor WB : Wet-bulb temperature

PERFORMANCE DATA COOL operation at Rated frequency

MFZ-KT25VG: SUZ-M25VA

CAPACITY: 2.5 kW SHF: 0.79 INPUT: 620 W

Indoor intake air DB (°C)	Indoor intake air WB (°C)	Outdoor intake air DB (°C)											
		35				40				46			
		CA	SHC (W)	SHF	P.C.	CA	SHC (W)	SHF	P.C.	CA	SHC (W)	SHF	P.C.
21	18	2450	1495	0.61	0.61	2250	1373	0.61	0.64	2075	1266	0.61	0.67
21	20	2575	1262	0.49	0.63	2400	1176	0.49	0.66	2225	1090	0.49	0.70
22	18	2450	1593	0.65	0.61	2250	1463	0.65	0.64	2075	1349	0.65	0.67
22	20	2575	1365	0.53	0.63	2400	1272	0.53	0.66	2225	1179	0.53	0.70
22	22	2725	1117	0.41	0.66	2550	1046	0.41	0.69	2375	974	0.41	0.72
23	18	2450	1691	0.69	0.61	2250	1553	0.69	0.64	2075	1432	0.69	0.67
23	20	2575	1468	0.57	0.63	2400	1368	0.57	0.66	2225	1268	0.57	0.70
23	22	2725	1226	0.45	0.66	2550	1148	0.45	0.69	2375	1069	0.45	0.72
24	18	2450	1789	0.73	0.61	2250	1643	0.73	0.64	2075	1515	0.73	0.67
24	20	2575	1571	0.61	0.63	2400	1464	0.61	0.66	2225	1357	0.61	0.70
24	22	2725	1335	0.49	0.66	2550	1250	0.49	0.69	2375	1164	0.49	0.72
24	24	2875	1064	0.37	0.68	2700	999	0.37	0.71	2550	944	0.37	0.74
25	20	2575	1674	0.65	0.63	2400	1560	0.65	0.66	2225	1446	0.65	0.70
25	22	2725	1444	0.53	0.66	2550	1352	0.53	0.69	2375	1259	0.53	0.72
25	24	2875	1179	0.41	0.68	2700	1107	0.41	0.71	2550	1046	0.41	0.74
26	18	2450	1985	0.81	0.61	2250	1823	0.81	0.64	2075	1681	0.81	0.67
26	20	2575	1777	0.69	0.63	2400	1656	0.69	0.66	2225	1535	0.69	0.70
26	22	2725	1553	0.57	0.66	2550	1454	0.57	0.69	2375	1354	0.57	0.72
26	24	2875	1294	0.45	0.68	2700	1215	0.45	0.71	2550	1148	0.45	0.74
26	26	3025	998	0.33	0.71	2850	941	0.33	0.74	2675	883	0.33	0.77
27	18	2450	2083	0.85	0.61	2250	1913	0.85	0.64	2075	1764	0.85	0.67
27	20	2575	1880	0.73	0.63	2400	1752	0.73	0.66	2225	1624	0.73	0.70
27	22	2725	1662	0.61	0.66	2550	1556	0.61	0.69	2375	1449	0.61	0.72
27	24	2875	1409	0.49	0.68	2700	1323	0.49	0.71	2550	1250	0.49	0.74
27	26	3025	1119	0.37	0.71	2850	1055	0.37	0.74	2675	990	0.37	0.77
28	18	2450	2181	0.89	0.61	2250	2003	0.89	0.64	2075	1847	0.89	0.67
28	20	2575	1983	0.77	0.63	2400	1848	0.77	0.66	2225	1713	0.77	0.70
28	22	2725	1771	0.65	0.66	2550	1658	0.65	0.69	2375	1544	0.65	0.72
28	24	2875	1524	0.53	0.68	2700	1431	0.53	0.71	2550	1352	0.53	0.74
28	26	3025	1240	0.41	0.71	2850	1169	0.41	0.74	2675	1097	0.41	0.77
29	18	2450	2279	0.93	0.61	2250	2093	0.93	0.64	2075	1930	0.93	0.67
29	20	2575	2086	0.81	0.63	2400	1944	0.81	0.66	2225	1802	0.81	0.70
29	22	2725	1880	0.69	0.66	2550	1760	0.69	0.69	2375	1639	0.69	0.72
29	24	2875	1639	0.57	0.68	2700	1539	0.57	0.71	2550	1454	0.57	0.74
29	26	3025	1361	0.45	0.71	2850	1283	0.45	0.74	2675	1204	0.45	0.77
30	18	2450	2377	0.97	0.61	2250	2183	0.97	0.64	2075	2013	0.97	0.67
30	20	2575	2189	0.85	0.63	2400	2040	0.85	0.66	2225	1891	0.85	0.70
30	22	2725	1989	0.73	0.66	2550	1862	0.73	0.69	2375	1734	0.73	0.72
30	24	2875	1754	0.61	0.68	2700	1647	0.61	0.71	2550	1556	0.61	0.74
30	26	3025	1482	0.49	0.71	2850	1397	0.49	0.74	2675	1311	0.49	0.77
31	18	2450	2450	1.00	0.61	2250	2250	1.00	0.64	2075	2075	1.00	0.67
31	20	2575	2292	0.89	0.63	2400	2136	0.89	0.66	2225	1980	0.89	0.70
31	22	2725	2098	0.77	0.66	2550	1964	0.77	0.69	2375	1829	0.77	0.72
31	24	2875	1869	0.65	0.68	2700	1755	0.65	0.71	2550	1658	0.65	0.74
31	26	3025	1603	0.53	0.71	2850	1511	0.53	0.74	2675	1418	0.53	0.77
32	18	2450	2450	1.00	0.61	2250	2250	1.00	0.64	2075	2075	1.00	0.67
32	20	2575	2395	0.93	0.63	2400	2232	0.93	0.66	2225	2069	0.93	0.70
32	22	2725	2207	0.81	0.66	2550	2066	0.81	0.69	2375	1924	0.81	0.72
32	24	2875	1984	0.69	0.68	2700	1863	0.69	0.71	2550	1760	0.69	0.74
32	26	3025	1724	0.57	0.71	2850	1625	0.57	0.74	2675	1525	0.57	0.77

NOTE C A :Capacity (W) SHC :Sensible heat capacity (W) DB : Dry-bulb temperature
P.C. :Power consumption (kW) SHF :Sensible heat factor WB : Wet-bulb temperature

PERFORMANCE DATA COOL operation at Rated frequency

MFZ-KT35VG: SUZ-M35VA

CAPACITY: 3.5 kW SHF: 0.70 INPUT: 1060 W

Indoor intake air DB (°C)	Indoor intake air WB (°C)	Outdoor intake air DB (°C)															
		21				25				27				30			
		CA	SHC (W)	SHF	P.C.	CA	SHC (W)	SHF	P.C.	CA	SHC (W)	SHF	P.C.	CA	SHC (W)	SHF	P.C.
21	18	4113	2139	0.52	0.85	3938	2048	0.52	0.89	3780	1966	0.52	0.93	3640	1893	0.52	0.98
21	20	4288	1715	0.40	0.89	4113	1645	0.40	0.94	3990	1596	0.40	0.96	3850	1540	0.40	1.01
22	18	4113	2303	0.56	0.85	3938	2205	0.56	0.89	3780	2117	0.56	0.93	3640	2038	0.56	0.98
22	20	4288	1887	0.44	0.89	4113	1810	0.44	0.94	3990	1756	0.44	0.96	3850	1694	0.44	1.01
22	22	4463	1428	0.32	0.92	4305	1378	0.32	0.98	4200	1344	0.32	1.01	4025	1288	0.32	1.05
23	18	4113	2468	0.60	0.85	3938	2363	0.60	0.89	3780	2268	0.60	0.93	3640	2184	0.60	0.98
23	20	4288	2058	0.48	0.89	4113	1974	0.48	0.94	3990	1915	0.48	0.96	3850	1848	0.48	1.01
23	22	4463	1607	0.36	0.92	4305	1550	0.36	0.98	4200	1512	0.36	1.01	4025	1449	0.36	1.05
24	18	4113	2632	0.64	0.85	3938	2520	0.64	0.89	3780	2419	0.64	0.93	3640	2330	0.64	0.98
24	20	4288	2230	0.52	0.89	4113	2139	0.52	0.94	3990	2075	0.52	0.96	3850	2002	0.52	1.01
24	22	4463	1785	0.40	0.92	4305	1722	0.40	0.98	4200	1680	0.40	1.01	4025	1610	0.40	1.05
24	24	4690	1313	0.28	0.96	4515	1264	0.28	1.02	4410	1235	0.28	1.05	4270	1196	0.28	1.10
25	20	4288	2401	0.56	0.89	4113	2303	0.56	0.94	3990	2234	0.56	0.96	3850	2156	0.56	1.01
25	22	4463	1964	0.44	0.92	4305	1894	0.44	0.98	4200	1848	0.44	1.01	4025	1771	0.44	1.05
25	24	4690	1501	0.32	0.96	4515	1445	0.32	1.02	4410	1411	0.32	1.05	4270	1366	0.32	1.10
26	18	4113	2961	0.72	0.85	3938	2835	0.72	0.89	3780	2722	0.72	0.93	3640	2621	0.72	0.98
26	20	4288	2573	0.60	0.89	4113	2468	0.60	0.94	3990	2394	0.60	0.96	3850	2310	0.60	1.01
26	22	4463	2142	0.48	0.92	4305	2066	0.48	0.98	4200	2016	0.48	1.01	4025	1932	0.48	1.05
26	24	4690	1688	0.36	0.96	4515	1625	0.36	1.02	4410	1588	0.36	1.05	4270	1537	0.36	1.10
26	26	4830	1159	0.24	1.02	4690	1126	0.24	1.07	4620	1109	0.24	1.10	4480	1075	0.24	1.13
27	18	4113	3126	0.76	0.85	3938	2993	0.76	0.89	3780	2873	0.76	0.93	3640	2766	0.76	0.98
27	20	4288	2744	0.64	0.89	4113	2632	0.64	0.94	3990	2554	0.64	0.96	3850	2464	0.64	1.01
27	22	4463	2321	0.52	0.92	4305	2239	0.52	0.98	4200	2184	0.52	1.01	4025	2093	0.52	1.05
27	24	4690	1876	0.40	0.96	4515	1806	0.40	1.02	4410	1764	0.40	1.05	4270	1708	0.40	1.10
27	26	4830	1352	0.28	1.02	4690	1313	0.28	1.07	4620	1294	0.28	1.10	4480	1254	0.28	1.13
28	18	4113	3290	0.80	0.85	3938	3150	0.80	0.89	3780	3024	0.80	0.93	3640	2912	0.80	0.98
28	20	4288	2916	0.68	0.89	4113	2797	0.68	0.94	3990	2713	0.68	0.96	3850	2618	0.68	1.01
28	22	4463	2499	0.56	0.92	4305	2411	0.56	0.98	4200	2352	0.56	1.01	4025	2254	0.56	1.05
28	24	4690	2064	0.44	0.96	4515	1987	0.44	1.02	4410	1940	0.44	1.05	4270	1879	0.44	1.10
28	26	4830	1546	0.32	1.02	4690	1501	0.32	1.07	4620	1478	0.32	1.10	4480	1434	0.32	1.13
29	18	4113	3455	0.84	0.85	3938	3308	0.84	0.89	3780	3175	0.84	0.93	3640	3058	0.84	0.98
29	20	4288	3087	0.72	0.89	4113	2961	0.72	0.94	3990	2873	0.72	0.96	3850	2772	0.72	1.01
29	22	4463	2678	0.60	0.92	4305	2583	0.60	0.98	4200	2520	0.60	1.01	4025	2415	0.60	1.05
29	24	4690	2251	0.48	0.96	4515	2167	0.48	1.02	4410	2117	0.48	1.05	4270	2050	0.48	1.10
29	26	4830	1739	0.36	1.02	4690	1688	0.36	1.07	4620	1663	0.36	1.10	4480	1613	0.36	1.13
30	18	4113	3619	0.88	0.85	3938	3465	0.88	0.89	3780	3326	0.88	0.93	3640	3203	0.88	0.98
30	20	4288	3259	0.76	0.89	4113	3126	0.76	0.94	3990	3032	0.76	0.96	3850	2926	0.76	1.01
30	22	4463	2856	0.64	0.92	4305	2755	0.64	0.98	4200	2688	0.64	1.01	4025	2576	0.64	1.05
30	24	4690	2439	0.52	0.96	4515	2348	0.52	1.02	4410	2293	0.52	1.05	4270	2220	0.52	1.10
30	26	4830	1932	0.40	1.02	4690	1876	0.40	1.07	4620	1848	0.40	1.10	4480	1792	0.40	1.13
31	18	4113	3784	0.92	0.85	3938	3623	0.92	0.89	3780	3478	0.92	0.93	3640	3349	0.92	0.98
31	20	4288	3430	0.80	0.89	4113	3290	0.80	0.94	3990	3192	0.80	0.96	3850	3080	0.80	1.01
31	22	4463	3035	0.68	0.92	4305	2927	0.68	0.98	4200	2856	0.68	1.01	4025	2737	0.68	1.05
31	24	4690	2626	0.56	0.96	4515	2528	0.56	1.02	4410	2470	0.56	1.05	4270	2391	0.56	1.10
31	26	4830	2125	0.44	1.02	4690	2064	0.44	1.07	4620	2033	0.44	1.10	4480	1971	0.44	1.13
32	18	4113	3948	0.96	0.85	3938	3780	0.96	0.89	3780	3629	0.96	0.93	3640	3494	0.96	0.98
32	20	4288	3602	0.84	0.89	4113	3455	0.84	0.94	3990	3352	0.84	0.96	3850	3234	0.84	1.01
32	22	4463	3213	0.72	0.92	4305	3100	0.72	0.98	4200	3024	0.72	1.01	4025	2898	0.72	1.05
32	24	4690	2814	0.60	0.96	4515	2709	0.60	1.02	4410	2646	0.60	1.05	4270	2562	0.60	1.10
32	26	4830	2318	0.48	1.02	4690	2251	0.48	1.07	4620	2218	0.48	1.10	4480	2150	0.48	1.13

NOTE C A :Capacity (W) SHC :Sensible heat capacity (W) DB : Dry-bulb temperature
 P.C. :Power consumption (kW) SHF :Sensible heat factor WB : Wet-bulb temperature

PERFORMANCE DATA COOL operation at Rated frequency

MFZ-KT35VG: SUZ-M35VA

CAPACITY: 3.5 kW

SHF: 0.70

INPUT: 1060 W

Indoor intake air DB (°C)	Indoor intake air WB (°C)	Outdoor intake air DB (°C)											
		35				40				46			
		CA	SHC (W)	SHF	P.C.	CA	SHC (W)	SHF	P.C.	CA	SHC (W)	SHF	P.C.
21	18	3430	1784	0.52	1.04	3150	1638	0.52	1.10	2905	1511	0.52	1.14
21	20	3605	1442	0.40	1.08	3360	1344	0.40	1.13	3115	1246	0.40	1.20
22	18	3430	1921	0.56	1.04	3150	1764	0.56	1.10	2905	1627	0.56	1.14
22	20	3605	1586	0.44	1.08	3360	1478	0.44	1.13	3115	1371	0.44	1.20
22	22	3815	1221	0.32	1.12	3570	1142	0.32	1.19	3325	1064	0.32	1.23
23	18	3430	2058	0.60	1.04	3150	1890	0.60	1.10	2905	1743	0.60	1.14
23	20	3605	1730	0.48	1.08	3360	1613	0.48	1.13	3115	1495	0.48	1.20
23	22	3815	1373	0.36	1.12	3570	1285	0.36	1.19	3325	1197	0.36	1.23
24	18	3430	2195	0.64	1.04	3150	2016	0.64	1.10	2905	1859	0.64	1.14
24	20	3605	1875	0.52	1.08	3360	1747	0.52	1.13	3115	1620	0.52	1.20
24	22	3815	1526	0.40	1.12	3570	1428	0.40	1.19	3325	1330	0.40	1.23
24	24	4025	1127	0.28	1.17	3780	1058	0.28	1.22	3570	1000	0.28	1.27
25	20	3605	2019	0.56	1.08	3360	1882	0.56	1.13	3115	1744	0.56	1.20
25	22	3815	1679	0.44	1.12	3570	1571	0.44	1.19	3325	1463	0.44	1.23
25	24	4025	1288	0.32	1.17	3780	1210	0.32	1.22	3570	1142	0.32	1.27
26	18	3430	2470	0.72	1.04	3150	2268	0.72	1.10	2905	2092	0.72	1.14
26	20	3605	2163	0.60	1.08	3360	2016	0.60	1.13	3115	1869	0.60	1.20
26	22	3815	1831	0.48	1.12	3570	1714	0.48	1.19	3325	1596	0.48	1.23
26	24	4025	1449	0.36	1.17	3780	1361	0.36	1.22	3570	1285	0.36	1.27
26	26	4235	1016	0.24	1.21	3990	958	0.24	1.26	3745	899	0.24	1.31
27	18	3430	2607	0.76	1.04	3150	2394	0.76	1.10	2905	2208	0.76	1.14
27	20	3605	2307	0.64	1.08	3360	2150	0.64	1.13	3115	1994	0.64	1.20
27	22	3815	1984	0.52	1.12	3570	1856	0.52	1.19	3325	1729	0.52	1.23
27	24	4025	1610	0.40	1.17	3780	1512	0.40	1.22	3570	1428	0.40	1.27
27	26	4235	1186	0.28	1.21	3990	1117	0.28	1.26	3745	1049	0.28	1.31
28	18	3430	2744	0.80	1.04	3150	2520	0.80	1.10	2905	2324	0.80	1.14
28	20	3605	2451	0.68	1.08	3360	2285	0.68	1.13	3115	2118	0.68	1.20
28	22	3815	2136	0.56	1.12	3570	1999	0.56	1.19	3325	1862	0.56	1.23
28	24	4025	1771	0.44	1.17	3780	1663	0.44	1.22	3570	1571	0.44	1.27
28	26	4235	1355	0.32	1.21	3990	1277	0.32	1.26	3745	1198	0.32	1.31
29	18	3430	2881	0.84	1.04	3150	2646	0.84	1.10	2905	2440	0.84	1.14
29	20	3605	2596	0.72	1.08	3360	2419	0.72	1.13	3115	2243	0.72	1.20
29	22	3815	2289	0.60	1.12	3570	2142	0.60	1.19	3325	1995	0.60	1.23
29	24	4025	1932	0.48	1.17	3780	1814	0.48	1.22	3570	1714	0.48	1.27
29	26	4235	1525	0.36	1.21	3990	1436	0.36	1.26	3745	1348	0.36	1.31
30	18	3430	3018	0.88	1.04	3150	2772	0.88	1.10	2905	2556	0.88	1.14
30	20	3605	2740	0.76	1.08	3360	2554	0.76	1.13	3115	2367	0.76	1.20
30	22	3815	2442	0.64	1.12	3570	2285	0.64	1.19	3325	2128	0.64	1.23
30	24	4025	2093	0.52	1.17	3780	1966	0.52	1.22	3570	1856	0.52	1.27
30	26	4235	1694	0.40	1.21	3990	1596	0.40	1.26	3745	1498	0.40	1.31
31	18	3430	3156	0.92	1.04	3150	2898	0.92	1.10	2905	2673	0.92	1.14
31	20	3605	2884	0.80	1.08	3360	2688	0.80	1.13	3115	2492	0.80	1.20
31	22	3815	2594	0.68	1.12	3570	2428	0.68	1.19	3325	2261	0.68	1.23
31	24	4025	2254	0.56	1.17	3780	2117	0.56	1.22	3570	1999	0.56	1.27
31	26	4235	1863	0.44	1.21	3990	1756	0.44	1.26	3745	1648	0.44	1.31
32	18	3430	3293	0.96	1.04	3150	3024	0.96	1.10	2905	2789	0.96	1.14
32	20	3605	3028	0.84	1.08	3360	2822	0.84	1.13	3115	2617	0.84	1.20
32	22	3815	2747	0.72	1.12	3570	2570	0.72	1.19	3325	2394	0.72	1.23
32	24	4025	2415	0.60	1.17	3780	2268	0.60	1.22	3570	2142	0.60	1.27
32	26	4235	2033	0.48	1.21	3990	1915	0.48	1.26	3745	1798	0.48	1.31

NOTE CA :Capacity (W) SHC :Sensible heat capacity (W) DB : Dry-bulb temperature
 P.C. :Power consumption (kW) SHF :Sensible heat factor WB : Wet-bulb temperature

FLOOR-STANDING PERFORMANCE DATA

PERFORMANCE DATA COOL operation at Rated frequency

MFZ-KT50VG: SUZ-M50VA

CAPACITY: 5.0 kW

SHF: 0.72

INPUT: 155 W

Indoor intake air DB (°C)	Indoor intake air WB (°C)	Outdoor intake air DB (°C)															
		21				25				27				30			
		CA	SHC (W)	SHF	P.C.	CA	SHC (W)	SHF	P.C.	CA	SHC (W)	SHF	P.C.	CA	SHC (W)	SHF	P.C.
21	18	5875	3173	0.54	1.24	5625	3038	0.54	1.30	5400	2916	0.54	1.36	5200	2808	0.54	1.43
21	20	6125	2573	0.42	1.30	5875	2468	0.42	1.38	5700	2394	0.42	1.41	5500	2310	0.42	1.47
22	18	5875	3408	0.58	1.24	5625	3263	0.58	1.30	5400	3132	0.58	1.36	5200	3016	0.58	1.43
22	20	6125	2818	0.46	1.30	5875	2703	0.46	1.38	5700	2622	0.46	1.41	5500	2530	0.46	1.47
22	22	6375	2168	0.34	1.35	6150	2091	0.34	1.43	6000	2040	0.34	1.47	5750	1955	0.34	1.53
23	18	5875	3643	0.62	1.24	5625	3488	0.62	1.30	5400	3348	0.62	1.36	5200	3224	0.62	1.43
23	20	6125	3063	0.50	1.30	5875	2938	0.50	1.38	5700	2850	0.50	1.41	5500	2750	0.50	1.47
23	22	6375	2423	0.38	1.35	6150	2337	0.38	1.43	6000	2280	0.38	1.47	5750	2185	0.38	1.53
24	18	5875	3878	0.66	1.24	5625	3713	0.66	1.30	5400	3564	0.66	1.36	5200	3432	0.66	1.43
24	20	6125	3308	0.54	1.30	5875	3173	0.54	1.38	5700	3078	0.54	1.41	5500	2970	0.54	1.47
24	22	6375	2678	0.42	1.35	6150	2583	0.42	1.43	6000	2520	0.42	1.47	5750	2415	0.42	1.53
24	24	6700	2010	0.30	1.41	6450	1935	0.30	1.49	6300	1890	0.30	1.53	6100	1830	0.30	1.61
25	20	6125	3553	0.58	1.30	5875	3408	0.58	1.38	5700	3306	0.58	1.41	5500	3190	0.58	1.47
25	22	6375	2933	0.46	1.35	6150	2829	0.46	1.43	6000	2760	0.46	1.47	5750	2645	0.46	1.53
25	24	6700	2278	0.34	1.41	6450	2193	0.34	1.49	6300	2142	0.34	1.53	6100	2074	0.34	1.61
26	18	5875	4348	0.74	1.24	5625	4163	0.74	1.30	5400	3996	0.74	1.36	5200	3848	0.74	1.43
26	20	6125	3798	0.62	1.30	5875	3643	0.62	1.38	5700	3534	0.62	1.41	5500	3410	0.62	1.47
26	22	6375	3188	0.50	1.35	6150	3075	0.50	1.43	6000	3000	0.50	1.47	5750	2875	0.50	1.53
26	24	6700	2546	0.38	1.41	6450	2451	0.38	1.49	6300	2394	0.38	1.53	6100	2318	0.38	1.61
26	26	6900	1794	0.26	1.49	6700	1742	0.26	1.57	6600	1716	0.26	1.61	6400	1664	0.26	1.66
27	18	5875	4583	0.78	1.24	5625	4388	0.78	1.30	5400	4212	0.78	1.36	5200	4056	0.78	1.43
27	20	6125	4043	0.66	1.30	5875	3878	0.66	1.38	5700	3762	0.66	1.41	5500	3630	0.66	1.47
27	22	6375	3443	0.54	1.35	6150	3321	0.54	1.43	6000	3240	0.54	1.47	5750	3105	0.54	1.53
27	24	6700	2814	0.42	1.41	6450	2709	0.42	1.49	6300	2646	0.42	1.53	6100	2562	0.42	1.61
27	26	6900	2070	0.30	1.49	6700	2010	0.30	1.57	6600	1980	0.30	1.61	6400	1920	0.30	1.66
28	18	5875	4818	0.82	1.24	5625	4613	0.82	1.30	5400	4428	0.82	1.36	5200	4264	0.82	1.43
28	20	6125	4288	0.70	1.30	5875	4113	0.70	1.38	5700	3990	0.70	1.41	5500	3850	0.70	1.47
28	22	6375	3698	0.58	1.35	6150	3567	0.58	1.43	6000	3480	0.58	1.47	5750	3335	0.58	1.53
28	24	6700	3082	0.46	1.41	6450	2967	0.46	1.49	6300	2898	0.46	1.53	6100	2806	0.46	1.61
28	26	6900	2346	0.34	1.49	6700	2278	0.34	1.57	6600	2244	0.34	1.61	6400	2176	0.34	1.66
29	18	5875	5053	0.86	1.24	5625	4838	0.86	1.30	5400	4644	0.86	1.36	5200	4472	0.86	1.43
29	20	6125	4533	0.74	1.30	5875	4348	0.74	1.38	5700	4218	0.74	1.41	5500	4070	0.74	1.47
29	22	6375	3953	0.62	1.35	6150	3813	0.62	1.43	6000	3720	0.62	1.47	5750	3565	0.62	1.53
29	24	6700	3350	0.50	1.41	6450	3225	0.50	1.49	6300	3150	0.50	1.53	6100	3050	0.50	1.61
29	26	6900	2622	0.38	1.49	6700	2546	0.38	1.57	6600	2508	0.38	1.61	6400	2432	0.38	1.66
30	18	5875	5288	0.90	1.24	5625	5063	0.90	1.30	5400	4860	0.90	1.36	5200	4680	0.90	1.43
30	20	6125	4778	0.78	1.30	5875	4583	0.78	1.38	5700	4446	0.78	1.41	5500	4290	0.78	1.47
30	22	6375	4208	0.66	1.35	6150	4059	0.66	1.43	6000	3960	0.66	1.47	5750	3795	0.66	1.53
30	24	6700	3618	0.54	1.41	6450	3483	0.54	1.49	6300	3402	0.54	1.53	6100	3294	0.54	1.61
30	26	6900	2898	0.42	1.49	6700	2814	0.42	1.57	6600	2772	0.42	1.61	6400	2688	0.42	1.66
31	18	5875	5523	0.94	1.24	5625	5288	0.94	1.30	5400	5076	0.94	1.36	5200	4888	0.94	1.43
31	20	6125	5023	0.82	1.30	5875	4818	0.82	1.38	5700	4674	0.82	1.41	5500	4510	0.82	1.47
31	22	6375	4463	0.70	1.35	6150	4305	0.70	1.43	6000	4200	0.70	1.47	5750	4025	0.70	1.53
31	24	6700	3886	0.58	1.41	6450	3741	0.58	1.49	6300	3654	0.58	1.53	6100	3538	0.58	1.61
31	26	6900	3174	0.46	1.49	6700	3082	0.46	1.57	6600	3036	0.46	1.61	6400	2944	0.46	1.66
32	18	5875	5758	0.98	1.24	5625	5513	0.98	1.30	5400	5292	0.98	1.36	5200	5096	0.98	1.43
32	20	6125	5268	0.86	1.30	5875	5053	0.86	1.38	5700	4902	0.86	1.41	5500	4730	0.86	1.47
32	22	6375	4718	0.74	1.35	6150	4551	0.74	1.43	6000	4440	0.74	1.47	5750	4255	0.74	1.53
32	24	6700	4154	0.62	1.41	6450	3999	0.62	1.49	6300	3906	0.62	1.53	6100	3782	0.62	1.61
32	26	6900	3450	0.50	1.49	6700	3350	0.50	1.57	6600	3300	0.50	1.61	6400	3200	0.50	1.66

NOTE C A :Capacity (W) SHC :Sensible heat capacity (W) DB : Dry-bulb temperature
 P.C. :Power consumption (kW) SHF :Sensible heat factor WB : Wet-bulb temperature

PERFORMANCE DATA COOL operation at Rated frequency

MFZ-KT50VG: SUZ-M50VA

CAPACITY: 5.0 kW

SHF: 0.72

INPUT: 155 W

Indoor intake air DB (°C)	Indoor intake air WB (°C)	Outdoor intake air DB (°C)											
		35				40				46			
		CA	SHC (W)	SHF	P.C.	CA	SHC (W)	SHF	P.C.	CA	SHC (W)	SHF	P.C.
21	18	4900	2646	0.54	1.52	4500	2430	0.54	1.61	4150	2241	0.54	1.67
21	20	5150	2163	0.42	1.58	4800	2016	0.42	1.66	4450	1869	0.42	1.75
22	18	4900	2842	0.58	1.52	4500	2610	0.58	1.61	4150	2407	0.58	1.67
22	20	5150	2369	0.46	1.58	4800	2208	0.46	1.66	4450	2047	0.46	1.75
22	22	5450	1853	0.34	1.64	5100	1734	0.34	1.74	4750	1615	0.34	1.80
23	18	4900	3038	0.62	1.52	4500	2790	0.62	1.61	4150	2573	0.62	1.67
23	20	5150	2575	0.50	1.58	4800	2400	0.50	1.66	4450	2225	0.50	1.75
23	22	5450	2071	0.38	1.64	5100	1938	0.38	1.74	4750	1805	0.38	1.80
24	18	4900	3234	0.66	1.52	4500	2970	0.66	1.61	4150	2739	0.66	1.67
24	20	5150	2781	0.54	1.58	4800	2592	0.54	1.66	4450	2403	0.54	1.75
24	22	5450	2289	0.42	1.64	5100	2142	0.42	1.74	4750	1995	0.42	1.80
24	24	5750	1725	0.30	1.71	5400	1620	0.30	1.78	5100	1530	0.30	1.86
25	20	5150	2987	0.58	1.58	4800	2784	0.58	1.66	4450	2581	0.58	1.75
25	22	5450	2507	0.46	1.64	5100	2346	0.46	1.74	4750	2185	0.46	1.80
25	24	5750	1955	0.34	1.71	5400	1836	0.34	1.78	5100	1734	0.34	1.86
26	18	4900	3626	0.74	1.52	4500	3330	0.74	1.61	4150	3071	0.74	1.67
26	20	5150	3193	0.62	1.58	4800	2976	0.62	1.66	4450	2759	0.62	1.75
26	22	5450	2725	0.50	1.64	5100	2550	0.50	1.74	4750	2375	0.50	1.80
26	24	5750	2185	0.38	1.71	5400	2052	0.38	1.78	5100	1938	0.38	1.86
26	26	6050	1573	0.26	1.77	5700	1482	0.26	1.84	5350	1391	0.26	1.92
27	18	4900	3822	0.78	1.52	4500	3510	0.78	1.61	4150	3237	0.78	1.67
27	20	5150	3399	0.66	1.58	4800	3168	0.66	1.66	4450	2937	0.66	1.75
27	22	5450	2943	0.54	1.64	5100	2754	0.54	1.74	4750	2565	0.54	1.80
27	24	5750	2415	0.42	1.71	5400	2268	0.42	1.78	5100	2142	0.42	1.86
27	26	6050	1815	0.30	1.77	5700	1710	0.30	1.84	5350	1605	0.30	1.92
28	18	4900	4018	0.82	1.52	4500	3690	0.82	1.61	4150	3403	0.82	1.67
28	20	5150	3605	0.70	1.58	4800	3360	0.70	1.66	4450	3115	0.70	1.75
28	22	5450	3161	0.58	1.64	5100	2958	0.58	1.74	4750	2755	0.58	1.80
28	24	5750	2645	0.46	1.71	5400	2484	0.46	1.78	5100	2346	0.46	1.86
28	26	6050	2057	0.34	1.77	5700	1938	0.34	1.84	5350	1819	0.34	1.92
29	18	4900	4214	0.86	1.52	4500	3870	0.86	1.61	4150	3569	0.86	1.67
29	20	5150	3811	0.74	1.58	4800	3552	0.74	1.66	4450	3293	0.74	1.75
29	22	5450	3379	0.62	1.64	5100	3162	0.62	1.74	4750	2945	0.62	1.80
29	24	5750	2875	0.50	1.71	5400	2700	0.50	1.78	5100	2550	0.50	1.86
29	26	6050	2299	0.38	1.77	5700	2166	0.38	1.84	5350	2033	0.38	1.92
30	18	4900	4410	0.90	1.52	4500	4050	0.90	1.61	4150	3735	0.90	1.67
30	20	5150	4017	0.78	1.58	4800	3744	0.78	1.66	4450	3471	0.78	1.75
30	22	5450	3597	0.66	1.64	5100	3366	0.66	1.74	4750	3135	0.66	1.80
30	24	5750	3105	0.54	1.71	5400	2916	0.54	1.78	5100	2754	0.54	1.86
30	26	6050	2541	0.42	1.77	5700	2394	0.42	1.84	5350	2247	0.42	1.92
31	18	4900	4606	0.94	1.52	4500	4230	0.94	1.61	4150	3901	0.94	1.67
31	20	5150	4223	0.82	1.58	4800	3936	0.82	1.66	4450	3649	0.82	1.75
31	22	5450	3815	0.70	1.64	5100	3570	0.70	1.74	4750	3325	0.70	1.80
31	24	5750	3335	0.58	1.71	5400	3132	0.58	1.78	5100	2958	0.58	1.86
31	26	6050	2783	0.46	1.77	5700	2622	0.46	1.84	5350	2461	0.46	1.92
32	18	4900	4802	0.98	1.52	4500	4410	0.98	1.61	4150	4067	0.98	1.67
32	20	5150	4429	0.86	1.58	4800	4128	0.86	1.66	4450	3827	0.86	1.75
32	22	5450	4033	0.74	1.64	5100	3774	0.74	1.74	4750	3515	0.74	1.80
32	24	5750	3565	0.62	1.71	5400	3348	0.62	1.78	5100	3162	0.62	1.86
32	26	6050	3025	0.50	1.77	5700	2850	0.50	1.84	5350	2675	0.50	1.92

NOTE CA :Capacity (W) SHC :Sensible heat capacity (W) DB : Dry-bulb temperature
 P.C. :Power consumption (kW) SHF :Sensible heat factor WB : Wet-bulb temperature

FLOOR-STANDING PERFORMANCE DATA

PERFORMANCE DATA COOL operation at Rated frequency

MFZ-KT60VG: SUZ-M60VA

CAPACITY: 6.1 kW

SHF: 0.70

INPUT: 184 W

Indoor intake air DB (°C)	Indoor intake air WB (°C)	Outdoor intake air DB (°C)															
		21				25				27				30			
		CA	SHC (W)	SHF	P.C.	CA	SHC (W)	SHF	P.C.	CA	SHC (W)	SHF	P.C.	CA	SHC (W)	SHF	P.C.
21	18	7168	3727	0.52	1.47	6863	3569	0.52	1.55	6588	3426	0.52	1.62	6344	3299	0.52	1.69
21	20	7473	2989	0.40	1.55	7168	2867	0.40	1.64	6954	2782	0.40	1.67	6710	2684	0.40	1.75
22	18	7168	4014	0.56	1.47	6863	3843	0.56	1.55	6588	3689	0.56	1.62	6344	3553	0.56	1.69
22	20	7473	3288	0.44	1.55	7168	3154	0.44	1.64	6954	3060	0.44	1.67	6710	2952	0.44	1.75
22	22	7778	2489	0.32	1.60	7503	2401	0.32	1.70	7320	2342	0.32	1.75	7015	2245	0.32	1.82
23	18	7168	4301	0.60	1.47	6863	4118	0.60	1.55	6588	3953	0.60	1.62	6344	3806	0.60	1.69
23	20	7473	3587	0.48	1.55	7168	3440	0.48	1.64	6954	3338	0.48	1.67	6710	3221	0.48	1.75
23	22	7778	2800	0.36	1.60	7503	2701	0.36	1.70	7320	2635	0.36	1.75	7015	2525	0.36	1.82
24	18	7168	4587	0.64	1.47	6863	4392	0.64	1.55	6588	4216	0.64	1.62	6344	4060	0.64	1.69
24	20	7473	3886	0.52	1.55	7168	3727	0.52	1.64	6954	3616	0.52	1.67	6710	3489	0.52	1.75
24	22	7778	3111	0.40	1.60	7503	3001	0.40	1.70	7320	2928	0.40	1.75	7015	2806	0.40	1.82
24	24	8174	2289	0.28	1.67	7869	2203	0.28	1.77	7686	2152	0.28	1.82	7442	2084	0.28	1.91
25	20	7473	4185	0.56	1.55	7168	4014	0.56	1.64	6954	3894	0.56	1.67	6710	3758	0.56	1.75
25	22	7778	3422	0.44	1.60	7503	3301	0.44	1.70	7320	3221	0.44	1.75	7015	3087	0.44	1.82
25	24	8174	2616	0.32	1.67	7869	2518	0.32	1.77	7686	2460	0.32	1.82	7442	2381	0.32	1.91
26	18	7168	5161	0.72	1.47	6863	4941	0.72	1.55	6588	4743	0.72	1.62	6344	4568	0.72	1.69
26	20	7473	4484	0.60	1.55	7168	4301	0.60	1.64	6954	4172	0.60	1.67	6710	4026	0.60	1.75
26	22	7778	3733	0.48	1.60	7503	3601	0.48	1.70	7320	3514	0.48	1.75	7015	3367	0.48	1.82
26	24	8174	2943	0.36	1.67	7869	2833	0.36	1.77	7686	2767	0.36	1.82	7442	2679	0.36	1.91
26	26	8418	2020	0.24	1.77	8174	1962	0.24	1.86	8052	1932	0.24	1.91	7808	1874	0.24	1.97
27	18	7168	5447	0.76	1.47	6863	5216	0.76	1.55	6588	5007	0.76	1.62	6344	4821	0.76	1.69
27	20	7473	4782	0.64	1.55	7168	4587	0.64	1.64	6954	4451	0.64	1.67	6710	4294	0.64	1.75
27	22	7778	4044	0.52	1.60	7503	3902	0.52	1.70	7320	3806	0.52	1.75	7015	3648	0.52	1.82
27	24	8174	3270	0.40	1.67	7869	3148	0.40	1.77	7686	3074	0.40	1.82	7442	2977	0.40	1.91
27	26	8418	2357	0.28	1.77	8174	2289	0.28	1.86	8052	2255	0.28	1.91	7808	2186	0.28	1.97
28	18	7168	5734	0.80	1.47	6863	5490	0.80	1.55	6588	5270	0.80	1.62	6344	5075	0.80	1.69
28	20	7473	5081	0.68	1.55	7168	4874	0.68	1.64	6954	4729	0.68	1.67	6710	4563	0.68	1.75
28	22	7778	4355	0.56	1.60	7503	4202	0.56	1.70	7320	4099	0.56	1.75	7015	3928	0.56	1.82
28	24	8174	3597	0.44	1.67	7869	3462	0.44	1.77	7686	3382	0.44	1.82	7442	3274	0.44	1.91
28	26	8418	2694	0.32	1.77	8174	2616	0.32	1.86	8052	2577	0.32	1.91	7808	2499	0.32	1.97
29	18	7168	6021	0.84	1.47	6863	5765	0.84	1.55	6588	5534	0.84	1.62	6344	5329	0.84	1.69
29	20	7473	5380	0.72	1.55	7168	5161	0.72	1.64	6954	5007	0.72	1.67	6710	4831	0.72	1.75
29	22	7778	4667	0.60	1.60	7503	4502	0.60	1.70	7320	4392	0.60	1.75	7015	4209	0.60	1.82
29	24	8174	3924	0.48	1.67	7869	3777	0.48	1.77	7686	3689	0.48	1.82	7442	3572	0.48	1.91
29	26	8418	3030	0.36	1.77	8174	2943	0.36	1.86	8052	2899	0.36	1.91	7808	2811	0.36	1.97
30	18	7168	6307	0.88	1.47	6863	6039	0.88	1.55	6588	5797	0.88	1.62	6344	5583	0.88	1.69
30	20	7473	5679	0.76	1.55	7168	5447	0.76	1.64	6954	5285	0.76	1.67	6710	5100	0.76	1.75
30	22	7778	4978	0.64	1.60	7503	4802	0.64	1.70	7320	4685	0.64	1.75	7015	4490	0.64	1.82
30	24	8174	4250	0.52	1.67	7869	4092	0.52	1.77	7686	3997	0.52	1.82	7442	3870	0.52	1.91
30	26	8418	3367	0.40	1.77	8174	3270	0.40	1.86	8052	3221	0.40	1.91	7808	3123	0.40	1.97
31	18	7168	6594	0.92	1.47	6863	6314	0.92	1.55	6588	6061	0.92	1.62	6344	5836	0.92	1.69
31	20	7473	5978	0.80	1.55	7168	5734	0.80	1.64	6954	5563	0.80	1.67	6710	5368	0.80	1.75
31	22	7778	5289	0.68	1.60	7503	5102	0.68	1.70	7320	4978	0.68	1.75	7015	4770	0.68	1.82
31	24	8174	4577	0.56	1.67	7869	4407	0.56	1.77	7686	4304	0.56	1.82	7442	4168	0.56	1.91
31	26	8418	3704	0.44	1.77	8174	3597	0.44	1.86	8052	3543	0.44	1.91	7808	3436	0.44	1.97
32	18	7168	6881	0.96	1.47	6863	6588	0.96	1.55	6588	6324	0.96	1.62	6344	6090	0.96	1.69
32	20	7473	6277	0.84	1.55	7168	6021	0.84	1.64	6954	5841	0.84	1.67	6710	5636	0.84	1.75
32	22	7778	5600	0.72	1.60	7503	5402	0.72	1.70	7320	5270	0.72	1.75	7015	5051	0.72	1.82
32	24	8174	4904	0.60	1.67	7869	4721	0.60	1.77	7686	4612	0.60	1.82	7442	4465	0.60	1.91
32	26	8418	4041	0.48	1.77	8174	3924	0.48	1.86	8052	3865	0.48	1.91	7808	3748	0.48	1.97

NOTE C.A :Capacity (W) SHC :Sensible heat capacity (W) DB : Dry-bulb temperature
 P.C. :Power consumption (kW) SHF :Sensible heat factor WB : Wet-bulb temperature

PERFORMANCE DATA COOL operation at Rated frequency

MFZ-KT60VG: SUZ-M60VA

CAPACITY: 6.1 kW

SHF: 0.70

INPUT: 184 W

Indoor intake air DB (°C)	Indoor intake air WB (°C)	Outdoor intake air DB (°C)											
		35				40				46			
		CA	SHC (W)	SHF	P.C.	CA	SHC (W)	SHF	P.C.	CA	SHC (W)	SHF	P.C.
21	18	5978	3109	0.52	1.80	5490	2855	0.52	1.91	5063	2633	0.52	1.99
21	20	6283	2513	0.40	1.88	5856	2342	0.40	1.97	5429	2172	0.40	2.08
22	18	5978	3348	0.56	1.80	5490	3074	0.56	1.91	5063	2835	0.56	1.99
22	20	6283	2765	0.44	1.88	5856	2577	0.44	1.97	5429	2389	0.44	2.08
22	22	6649	2128	0.32	1.95	6222	1991	0.32	2.06	5795	1854	0.32	2.13
23	18	5978	3587	0.60	1.80	5490	3294	0.60	1.91	5063	3038	0.60	1.99
23	20	6283	3016	0.48	1.88	5856	2811	0.48	1.97	5429	2606	0.48	2.08
23	22	6649	2394	0.36	1.95	6222	2240	0.36	2.06	5795	2086	0.36	2.13
24	18	5978	3826	0.64	1.80	5490	3514	0.64	1.91	5063	3240	0.64	1.99
24	20	6283	3267	0.52	1.88	5856	3045	0.52	1.97	5429	2823	0.52	2.08
24	22	6649	2660	0.40	1.95	6222	2489	0.40	2.06	5795	2318	0.40	2.13
24	24	7015	1964	0.28	2.02	6588	1845	0.28	2.12	6222	1742	0.28	2.21
25	20	6283	3518	0.56	1.88	5856	3279	0.56	1.97	5429	3040	0.56	2.08
25	22	6649	2926	0.44	1.95	6222	2738	0.44	2.06	5795	2550	0.44	2.13
25	24	7015	2245	0.32	2.02	6588	2108	0.32	2.12	6222	1991	0.32	2.21
26	18	5978	4304	0.72	1.80	5490	3953	0.72	1.91	5063	3645	0.72	1.99
26	20	6283	3770	0.60	1.88	5856	3514	0.60	1.97	5429	3257	0.60	2.08
26	22	6649	3192	0.48	1.95	6222	2987	0.48	2.06	5795	2782	0.48	2.13
26	24	7015	2525	0.36	2.02	6588	2372	0.36	2.12	6222	2240	0.36	2.21
26	26	7381	1771	0.24	2.10	6954	1669	0.24	2.19	6527	1566	0.24	2.28
27	18	5978	4543	0.76	1.80	5490	4172	0.76	1.91	5063	3848	0.76	1.99
27	20	6283	4021	0.64	1.88	5856	3748	0.64	1.97	5429	3475	0.64	2.08
27	22	6649	3457	0.52	1.95	6222	3235	0.52	2.06	5795	3013	0.52	2.13
27	24	7015	2806	0.40	2.02	6588	2635	0.40	2.12	6222	2489	0.40	2.21
27	26	7381	2067	0.28	2.10	6954	1947	0.28	2.19	6527	1828	0.28	2.28
28	18	5978	4782	0.80	1.80	5490	4392	0.80	1.91	5063	4050	0.80	1.99
28	20	6283	4272	0.68	1.88	5856	3982	0.68	1.97	5429	3692	0.68	2.08
28	22	6649	3723	0.56	1.95	6222	3484	0.56	2.06	5795	3245	0.56	2.13
28	24	7015	3087	0.44	2.02	6588	2899	0.44	2.12	6222	2738	0.44	2.21
28	26	7381	2362	0.32	2.10	6954	2225	0.32	2.19	6527	2089	0.32	2.28
29	18	5978	5022	0.84	1.80	5490	4612	0.84	1.91	5063	4253	0.84	1.99
29	20	6283	4524	0.72	1.88	5856	4216	0.72	1.97	5429	3909	0.72	2.08
29	22	6649	3989	0.60	1.95	6222	3733	0.60	2.06	5795	3477	0.60	2.13
29	24	7015	3367	0.48	2.02	6588	3162	0.48	2.12	6222	2987	0.48	2.21
29	26	7381	2657	0.36	2.10	6954	2503	0.36	2.19	6527	2350	0.36	2.28
30	18	5978	5261	0.88	1.80	5490	4831	0.88	1.91	5063	4455	0.88	1.99
30	20	6283	4775	0.76	1.88	5856	4451	0.76	1.97	5429	4126	0.76	2.08
30	22	6649	4255	0.64	1.95	6222	3982	0.64	2.06	5795	3709	0.64	2.13
30	24	7015	3648	0.52	2.02	6588	3426	0.52	2.12	6222	3235	0.52	2.21
30	26	7381	2952	0.40	2.10	6954	2782	0.40	2.19	6527	2611	0.40	2.28
31	18	5978	5500	0.92	1.80	5490	5051	0.92	1.91	5063	4658	0.92	1.99
31	20	6283	5026	0.80	1.88	5856	4685	0.80	1.97	5429	4343	0.80	2.08
31	22	6649	4521	0.68	1.95	6222	4231	0.68	2.06	5795	3941	0.68	2.13
31	24	7015	3928	0.56	2.02	6588	3689	0.56	2.12	6222	3484	0.56	2.21
31	26	7381	3248	0.44	2.10	6954	3060	0.44	2.19	6527	2872	0.44	2.28
32	18	5978	5739	0.96	1.80	5490	5270	0.96	1.91	5063	4860	0.96	1.99
32	20	6283	5278	0.84	1.88	5856	4919	0.84	1.97	5429	4560	0.84	2.08
32	22	6649	4787	0.72	1.95	6222	4480	0.72	2.06	5795	4172	0.72	2.13
32	24	7015	4209	0.60	2.02	6588	3953	0.60	2.12	6222	3733	0.60	2.21
32	26	7381	3543	0.48	2.10	6954	3338	0.48	2.19	6527	3133	0.48	2.28

NOTE CA :Capacity (W) SHC :Sensible heat capacity (W) DB : Dry-bulb temperature
 P.C. :Power consumption (kW) SHF :Sensible heat factor WB : Wet-bulb temperature

FLOOR-STANDING PERFORMANCE DATA

PERFORMANCE DATA HEAT operation at Rated frequency

MFZ-KW25VG: MUFZ-KW25VGHZ

CAPACITY: 3.4 kW INPUT: 830 W

INDOOR DB (°C)	OUTDOOR WB (°C)																			
	-25		-20		-15		-10		-5		0		5		10		15		20	
	Q	INPUT	Q	INPUT	Q	INPUT	Q	INPUT	Q	INPUT	Q	INPUT	Q	INPUT	Q	INPUT	Q	INPUT	Q	INPUT
15	0.85	224	1.29	332	1.70	432	2.14	540	2.58	647	3.03	730	3.47	789	3.91	838	4.32	863	4.76	880
21	0.78	241	1.19	349	1.60	457	2.04	581	2.45	689	2.89	764	3.30	822	3.74	863	4.15	888	4.57	921
26	0.54	266	0.95	374	1.39	498	1.84	623	2.28	730	2.69	805	3.13	863	3.57	905	3.98	930	4.42	955

MFZ-KW35VG: MUFZ-KW35VGHZ

CAPACITY: 4.3 kW INPUT: 1210 W

INDOOR DB (°C)	OUTDOOR WB (°C)																			
	-25		-20		-15		-10		-5		0		5		10		15		20	
	Q	INPUT	Q	INPUT	Q	INPUT	Q	INPUT	Q	INPUT	Q	INPUT	Q	INPUT	Q	INPUT	Q	INPUT	Q	INPUT
15	1.08	327	1.63	484	2.15	629	2.71	787	3.27	944	3.83	1065	4.39	1150	4.95	1222	5.46	1258	6.02	1283
21	0.99	351	1.51	508	2.02	666	2.58	847	3.10	1004	3.66	1113	4.17	1198	4.73	1258	5.25	1295	5.78	1343
26	0.69	387	1.20	545	1.76	726	2.32	908	2.88	1065	3.40	1174	3.96	1258	4.52	1319	5.03	1355	5.59	1392

MFZ-KW50VG: MUFZ-KW50VGHZ

CAPACITY: 6.0 kW INPUT: 1600 W

INDOOR DB (°C)	OUTDOOR WB (°C)																			
	-25		-20		-15		-10		-5		0		5		10		15		20	
	Q	INPUT	Q	INPUT	Q	INPUT	Q	INPUT	Q	INPUT	Q	INPUT	Q	INPUT	Q	INPUT	Q	INPUT	Q	INPUT
15	1.50	432	2.28	640	3.00	832	3.78	1040	4.56	1248	5.34	1408	6.12	1520	6.90	1616	7.62	1664	8.40	1696
21	1.38	464	2.10	672	2.82	880	3.60	1120	4.32	1328	5.10	1472	5.82	1584	6.60	1664	7.32	1712	8.07	1776
26	0.96	512	1.68	720	2.46	960	3.24	1200	4.02	1408	4.74	1552	5.52	1664	6.30	1744	7.02	1792	7.80	1840

MFZ-KW60VG: MUFZ-KW60VGHZ

CAPACITY: 6.5 kW INPUT: 1880 W

INDOOR DB (°C)	OUTDOOR WB (°C)																			
	-25		-20		-15		-10		-5		0		5		10		15		20	
	Q	INPUT	Q	INPUT	Q	INPUT	Q	INPUT	Q	INPUT	Q	INPUT	Q	INPUT	Q	INPUT	Q	INPUT	Q	INPUT
15	1.63	508	2.47	752	3.25	978	4.10	1222	4.94	1466	5.79	1654	6.63	1786	7.48	1899	8.26	1955	9.10	1993
21	1.50	545	2.28	790	3.06	1034	3.90	1316	4.68	1560	5.53	1730	6.31	1861	7.15	1955	7.93	2012	8.74	2087
26	1.04	602	1.82	846	2.67	1128	3.51	1410	4.36	1654	5.14	1824	5.98	1955	6.83	2049	7.61	2106	8.45	2162

NOTE: Q: Total capacity (kW) INPUT : Total power input (W) DB: Dry-bulb temperature WB: Wet-bulb temperature

PERFORMANCE DATA

FLOOR-STANDING

PERFORMANCE DATA HEAT operation at Rated frequency

MFZ-KT25VG: SUZ-M25VA

CAPACITY: 3.4 kW INPUT: 91 W

Indoor intake air DB (°C)	Outdoor intake air WB (°C)													
	-10		-5		0		5		10		15		20	
	CA	P.C.	CA	P.C.	CA	P.C.	CA	P.C.	CA	P.C.	CA	P.C.	CA	P.C.
15	2142	0.59	2584	0.71	3026	0.80	3468	0.86	3910	0.92	4318	0.95	4760	0.96
21	2040	0.64	2448	0.76	2890	0.84	3298	0.90	3740	0.95	4148	0.97	4573	1.01
26	1836	0.68	2278	0.80	2686	0.88	3128	0.95	3570	0.99	3978	1.02	4420	1.05

MFZ-KT35VG: SUZ-M35VA

CAPACITY: 4.3 kW INPUT: 126 W

Indoor intake air DB (°C)	Outdoor intake air WB (°C)													
	-10		-5		0		5		10		15		20	
	CA	P.C.	CA	P.C.	CA	P.C.	CA	P.C.	CA	P.C.	CA	P.C.	CA	P.C.
15	2709	0.82	3268	0.98	3827	1.11	4386	1.20	4945	1.27	5461	1.31	6020	1.34
21	2580	0.88	3096	1.05	3655	1.16	4171	1.25	4730	1.31	5246	1.35	5784	1.40
26	2322	0.95	2881	1.11	3397	1.22	3956	1.31	4515	1.37	5031	1.41	5590	1.45

MFZ-KT50VG: SUZ-M50VA

CAPACITY: 6.0 kW INPUT: 186 W

Indoor intake air DB (°C)	Outdoor intake air WB (°C)													
	-10		-5		0		5		10		15		20	
	CA	P.C.	CA	P.C.	CA	P.C.	CA	P.C.	CA	P.C.	CA	P.C.	CA	P.C.
15	3780	1.21	4560	1.45	5340	1.64	6120	1.77	6900	1.88	7620	1.93	8400	1.97
21	3600	1.30	4320	1.54	5100	1.71	5820	1.84	6600	1.93	7320	1.99	8070	2.06
26	3240	1.40	4020	1.64	4740	1.80	5520	1.93	6300	2.03	7020	2.08	7800	2.14

MFZ-KT60VG: SUZ-M60VA

CAPACITY: 7.0 kW INPUT: 218 W

Indoor intake air DB (°C)	Outdoor intake air WB (°C)													
	-10		-5		0		5		10		15		20	
	CA	P.C.	CA	P.C.	CA	P.C.	CA	P.C.	CA	P.C.	CA	P.C.	CA	P.C.
15	4410	1.42	5320	1.70	6230	1.92	7140	2.07	8050	2.20	8890	2.27	9800	2.31
21	4200	1.53	5040	1.81	5950	2.01	6790	2.16	7700	2.27	8540	2.33	9415	2.42
26	3780	1.64	4690	1.92	5530	2.11	6440	2.27	7350	2.38	8190	2.44	9100	2.51

NOTE: CA :Capacity (W) P.C. :Power consumption (kW) DB: Dry-bulb temperature WB: Wet-bulb temperature

C.2.7 NOISE CRITERIA CURVES

C.2.7.1 Inverter Heat Pump

MFZ-KW25VG

INDOOR UNIT

FAN SPEED	FUNCTION	SPL(dB(A))	LINE
Super High	COOLING	39	●—●
	HEATING	41	○—○

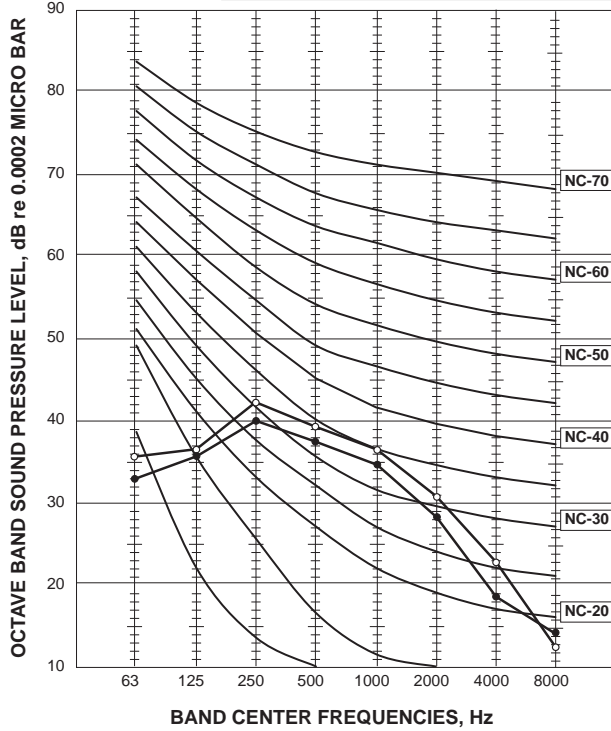

MFZ-KW35VG

INDOOR UNIT

FAN SPEED	FUNCTION	SPL(dB(A))	LINE
Super High	COOLING	39	●—●
	HEATING	41	○—○

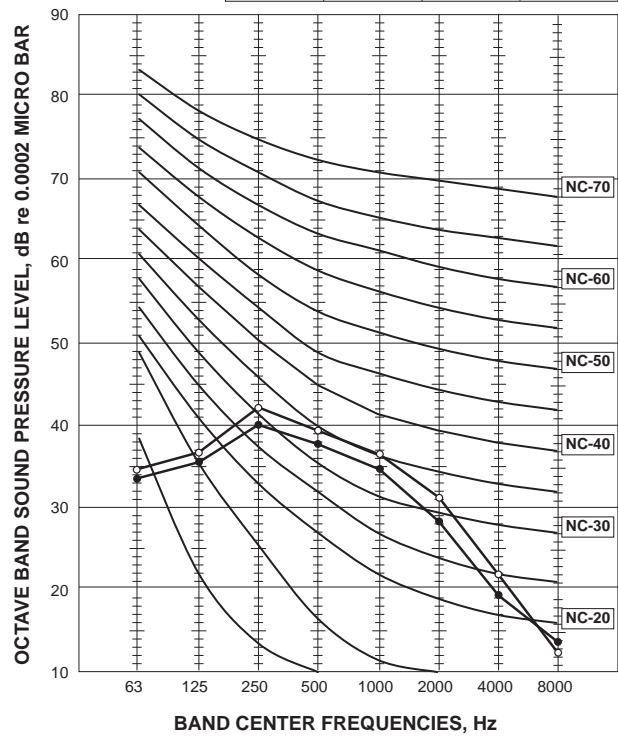

MFZ-KW50VG

INDOOR UNIT

FAN SPEED	FUNCTION	SPL(dB(A))	LINE
Super High	COOLING	44	●—●
	HEATING	50	○—○

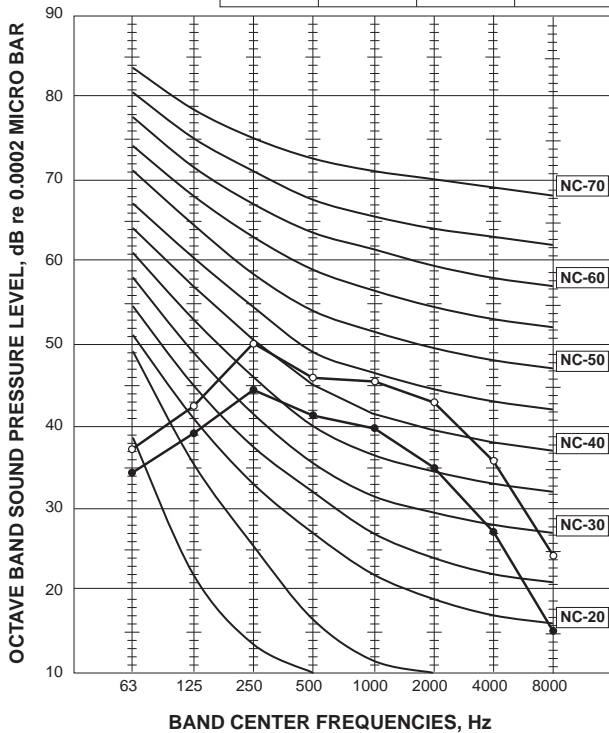

MFZ-KW60VG

INDOOR UNIT

FAN SPEED	FUNCTION	SPL(dB(A))	LINE
Super High	COOLING	53	●—●
	HEATING	51	○—○

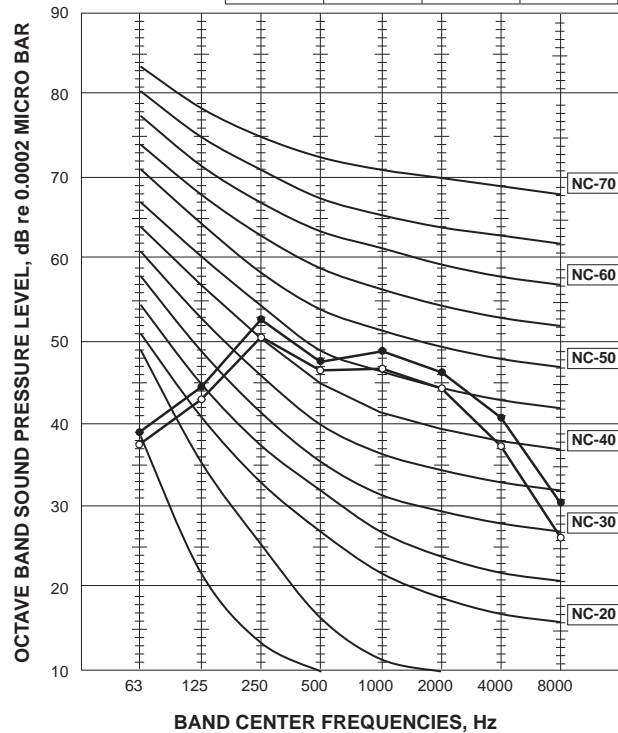

NOISE CRITERIA CURVES

FLOOR-STANDING

MFZ-KT25VG

INDOOR UNIT

FAN SPEED	FUNCTION	SPL(dB(A))	LINE
Super High	COOLING	41	●—●
	HEATING	44	○—○

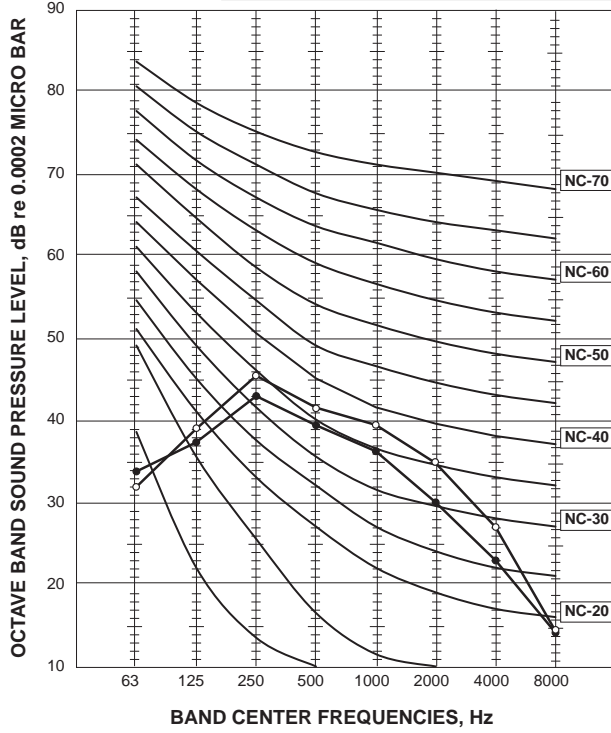

MFZ-KT35VG

INDOOR UNIT

FAN SPEED	FUNCTION	SPL(dB(A))	LINE
Super High	COOLING	41	●—●
	HEATING	44	○—○

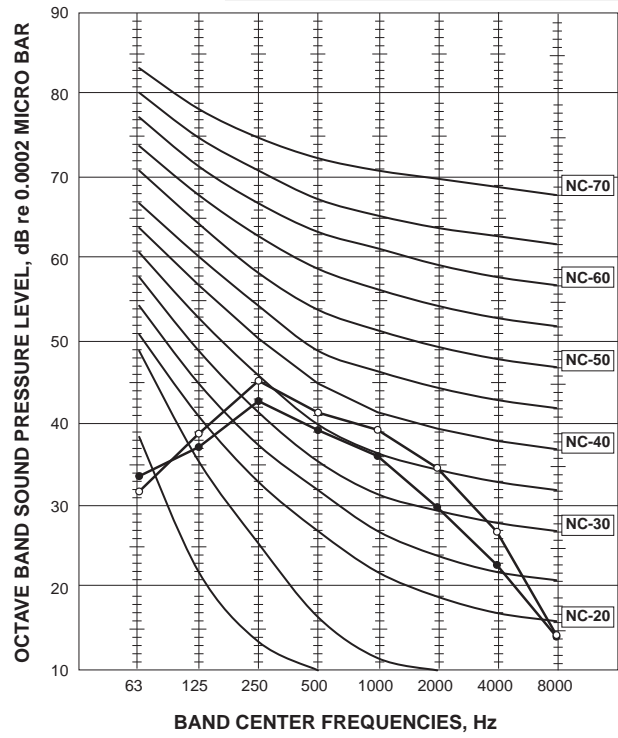

MFZ-KT50VG

INDOOR UNIT

FAN SPEED	FUNCTION	SPL(dB(A))	LINE
Super High	COOLING	48	●—●
	HEATING	49	○—○

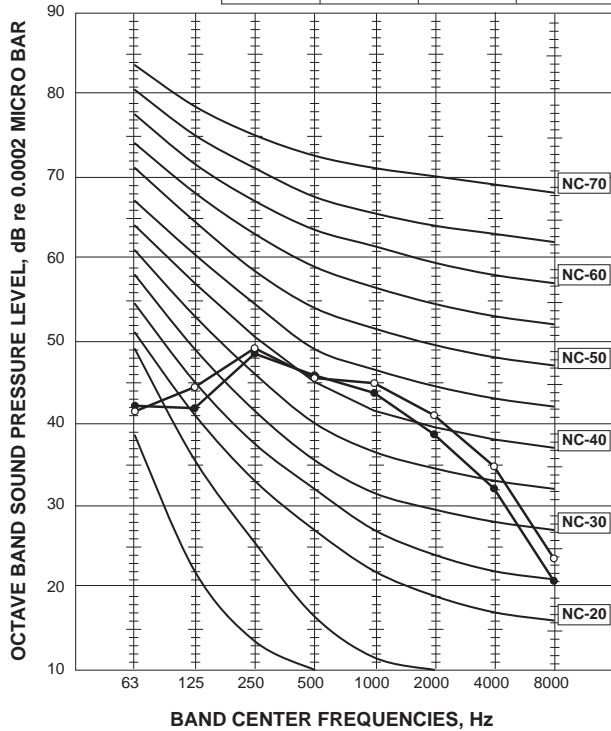

FLOOR-STANDING NOISE CRITERIA CURVES

MFZ-KT60VG

INDOOR UNIT

FAN SPEED	FUNCTION	SPL(dB(A))	LINE
Super High	COOLING	53	●—●
	HEATING	51	○—○

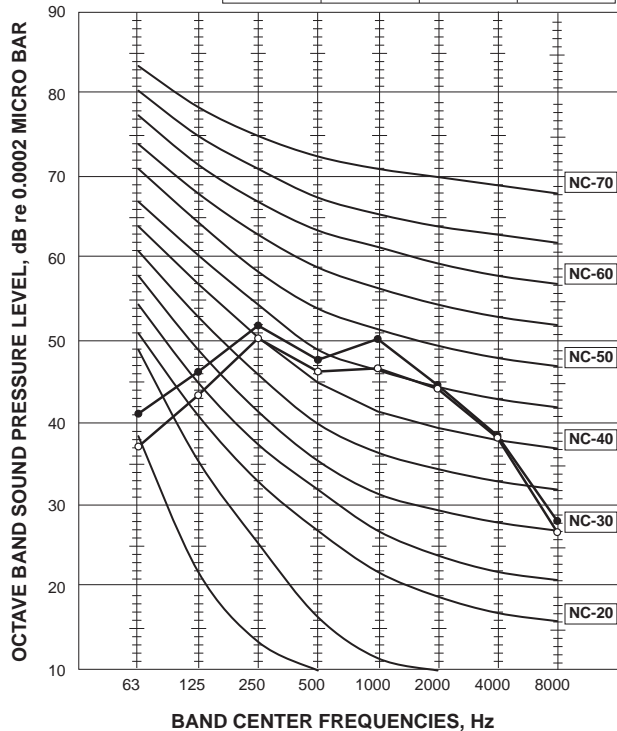

NOISE CRITERIA CURVES

Test conditions

Cooling : Dry-bulb temperature 27 °C Wet-bulb temperature 19 °C
 Heating : Dry-bulb temperature 20 °C

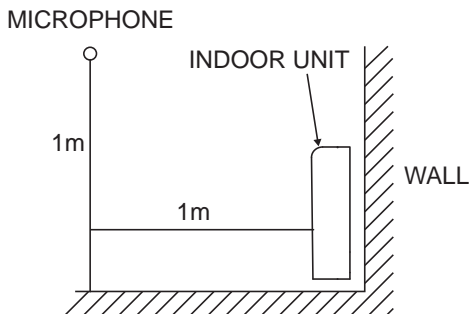

FLOOR-STANDING

MUFZ-KW25VGHZ

OUTDOOR UNIT

FUNCTION	SPL(dB(A))	LINE
COOLING	47	●—●
HEATING	46	○—○

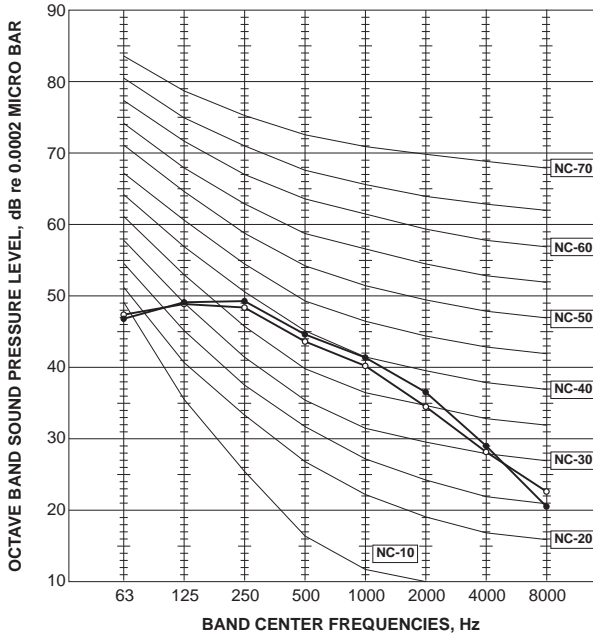

MUFZ-KW35VGHZ

OUTDOOR UNIT

FUNCTION	SPL(dB(A))	LINE
COOLING	47	●—●
HEATING	47	○—○

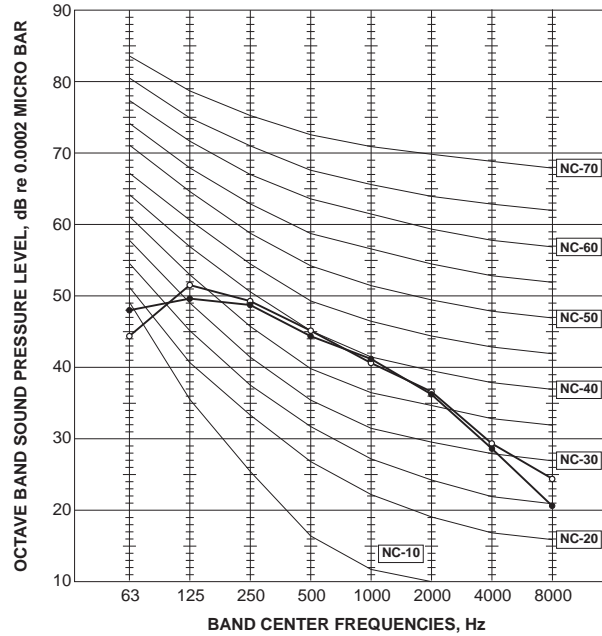

MUFZ-KW50VGHZ

OUTDOOR UNIT

FUNCTION	SPL(dB(A))	LINE
COOLING	50	●—●
HEATING	54	○—○

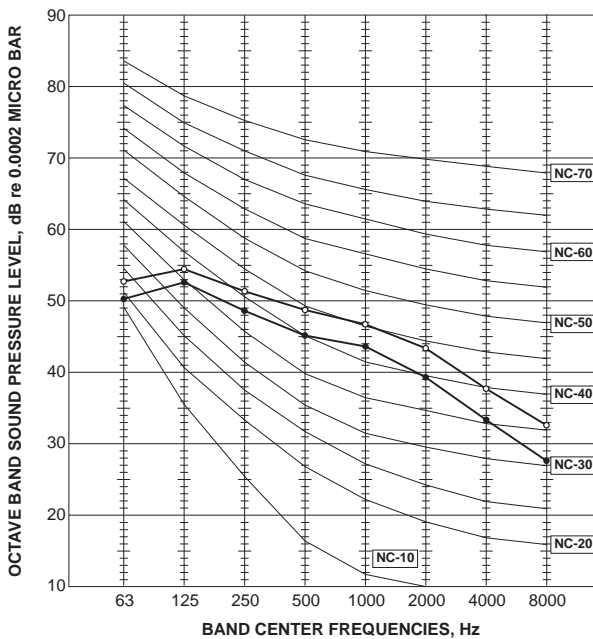

MUFZ-KW60VGHZ

OUTDOOR UNIT

FUNCTION	SPL(dB(A))	LINE
COOLING	52	●—●
HEATING	56	○—○

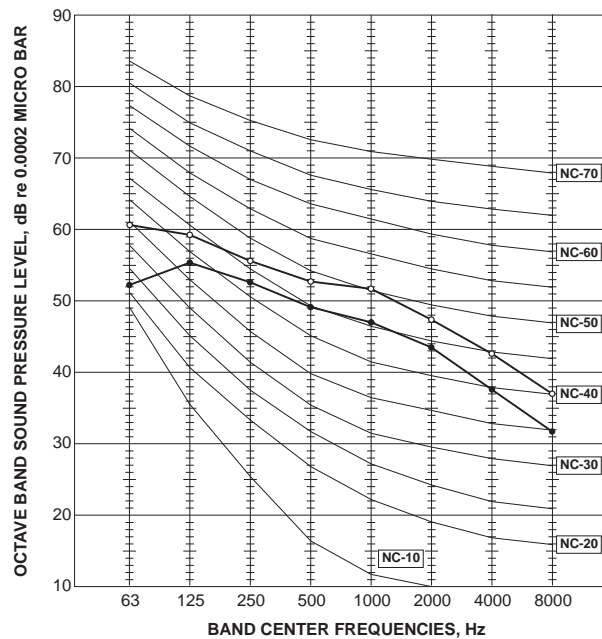

Test conditions
 Cooling: Dry-bulb temperature 35°C
 Heating: Dry-bulb temperature 7°C Wet-bulb temperature 6°C

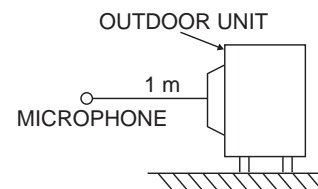

FLOOR-STANDING NOISE CRITERIA CURVES

C.2.8 TEMPERATURE AND AIR FLOW DISTRIBUTIONS

MFZ-KW25VG

Standard installation (One-direction air flow)

Temperature distribution

<Cooling mode>

Air volume: super high
Air direction: auto

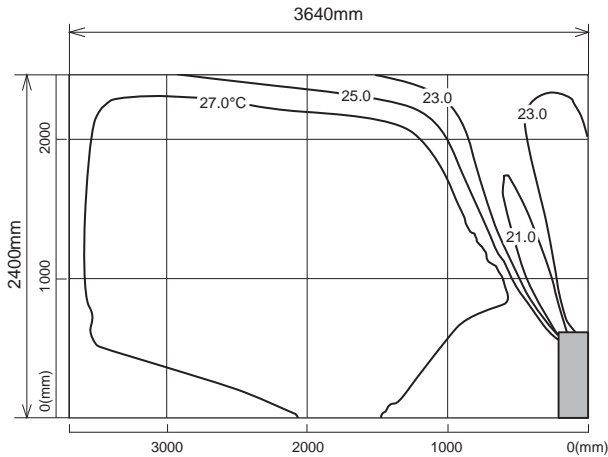

<Heating mode>

Air volume: super high
Air direction: auto

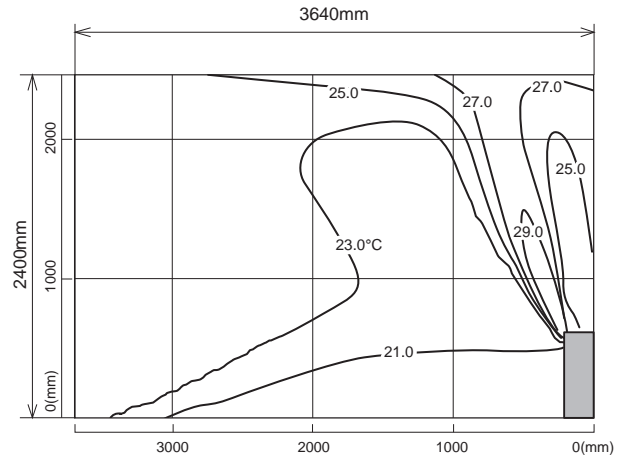

Airflow distribution

<Cooling mode>

Air volume: super high
Air direction: auto

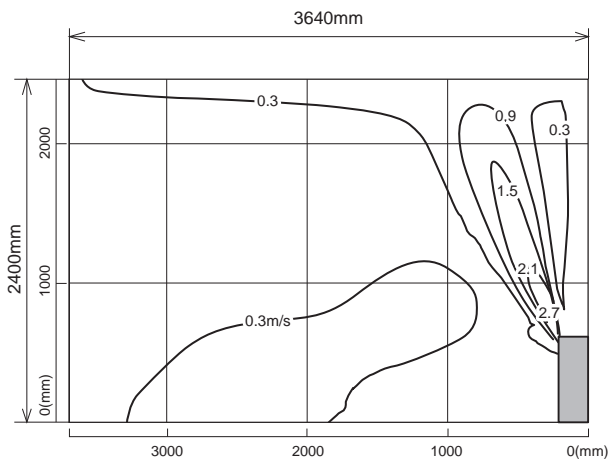

<Heating mode>

Air volume: super high
Air direction: auto

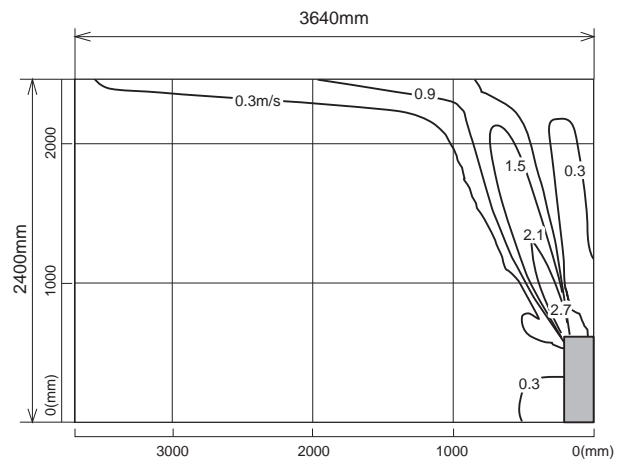

Note : These figures show typical airflow distributions in the conditions above. In the actual installation, they may differ from these figures under the influence of air temperature conditions, ceiling height, cooling/heating load, obstacles, etc.

TEMPERATURE AND AIR FLOW DISTRIBUTIONS

FLOOR-STANDING

MFZ-KW25VG

Standard installation (Two-direction air flow)

Temperature distribution

<Cooling mode>

Air volume: super high
Air direction: auto

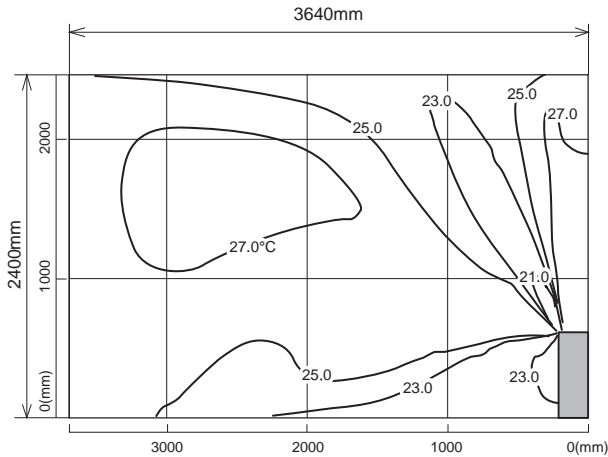

<Heating mode>

Air volume: super high
Air direction: auto

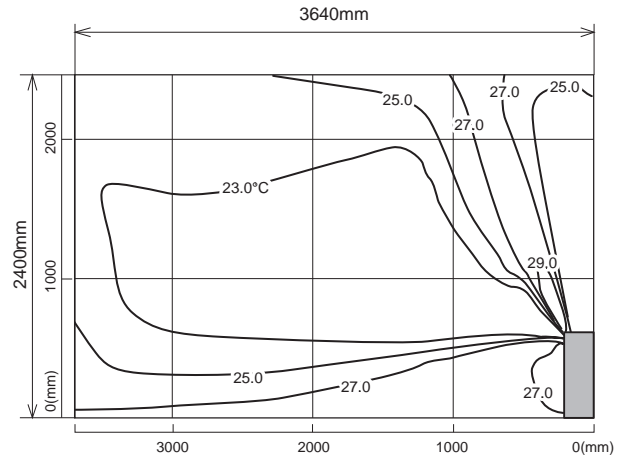

Airflow distribution

<Cooling mode>

Air volume: super high
Air direction: auto

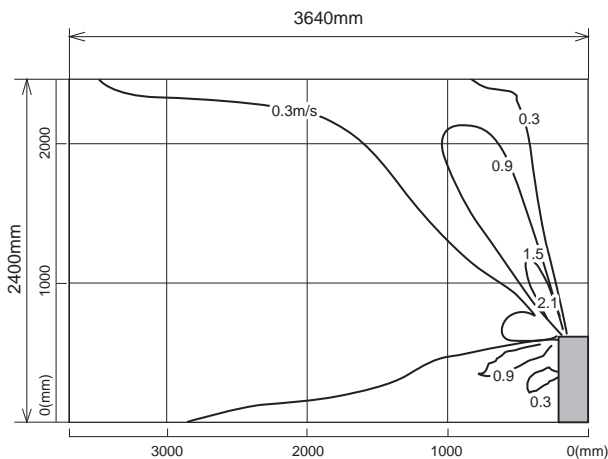

<Heating mode>

Air volume: super high
Air direction: auto

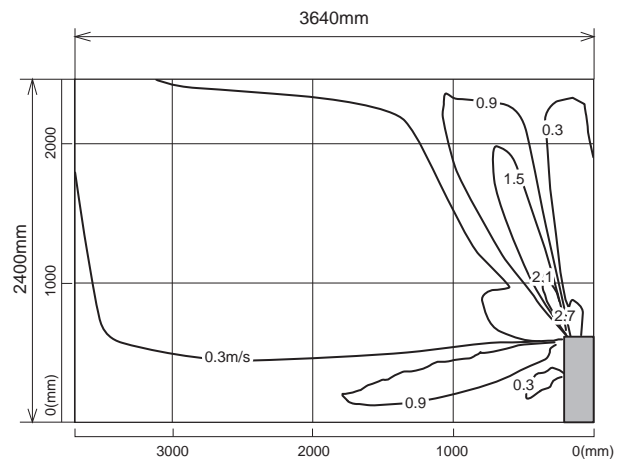

Note : These figures show typical airflow distributions in the conditions above. In the actual installation, they may differ from these figures under the influence of air temperature conditions, ceiling height, cooling/heating load, obstacles, etc.

FLOOR-STANDING TEMPERATURE AND AIR FLOW DISTRIBUTIONS

MFZ-KW35VG

Standard installation (One-direction air flow)

Temperature distribution

<Cooling mode>

Air volume: super high
Air direction: auto

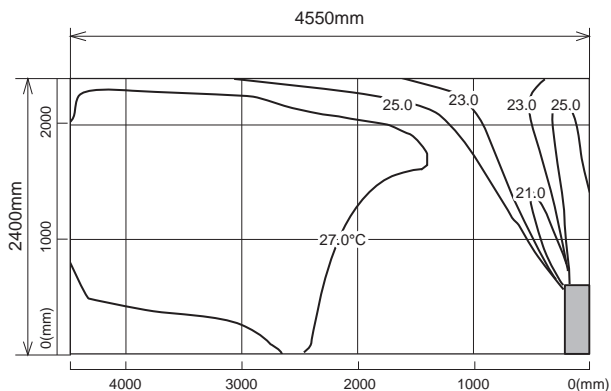

<Heating mode>

Air volume: super high
Air direction: auto

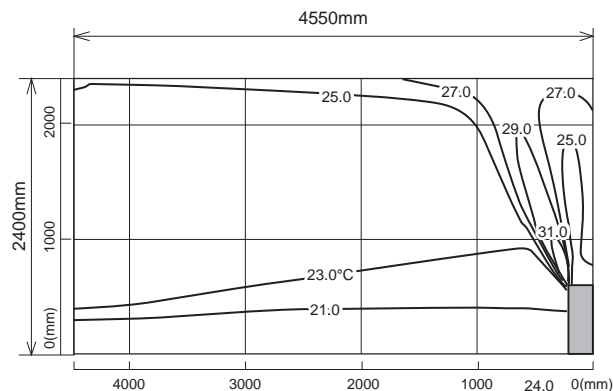

Airflow distribution

<Cooling mode>

Air volume: super high
Air direction: auto

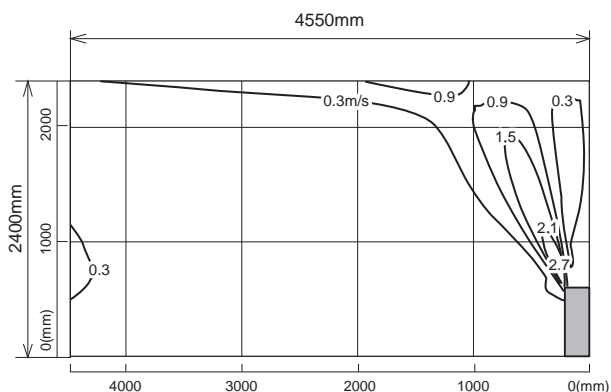

<Heating mode>

Air volume: super high
Air direction: auto

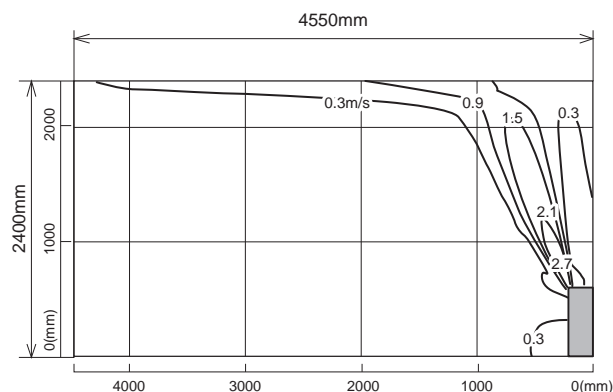

Note : These figures show typical airflow distributions in the conditions above. In the actual installation, they may differ from these figures under the influence of air temperature conditions, ceiling height, cooling/heating load, obstacles, etc.

TEMPERATURE AND AIR FLOW DISTRIBUTIONS

FLOOR-STANDING

MFZ-KW35VG

Standard installation (Two-direction air flow)

Temperature distribution

<Cooling mode>

Air volume: super high
Air direction: auto

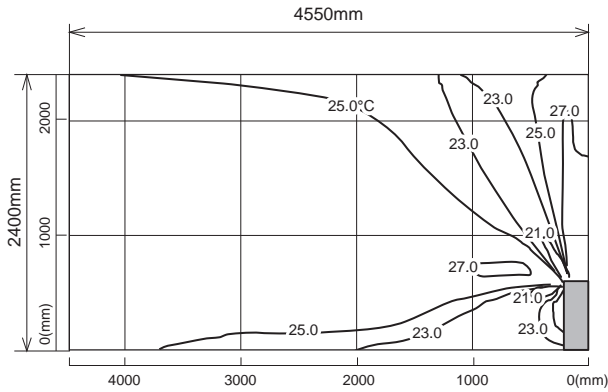

<Heating mode>

Air volume: super high
Air direction: auto

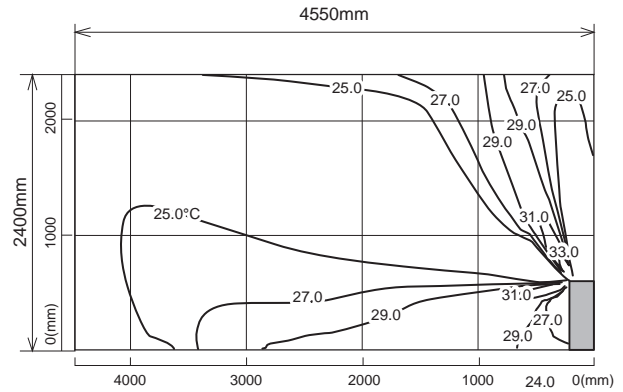

Airflow distribution

<Cooling mode>

Air volume: super high
Air direction: auto

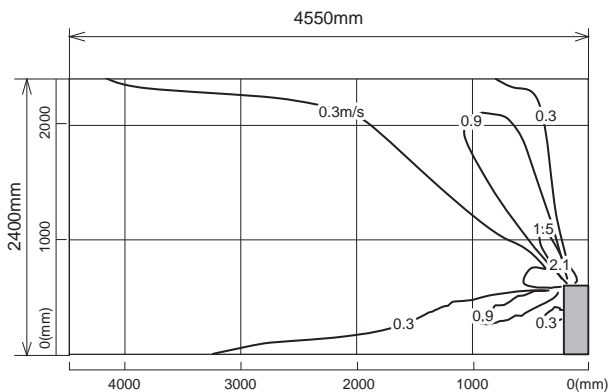

<Heating mode>

Air volume: super high
Air direction: auto

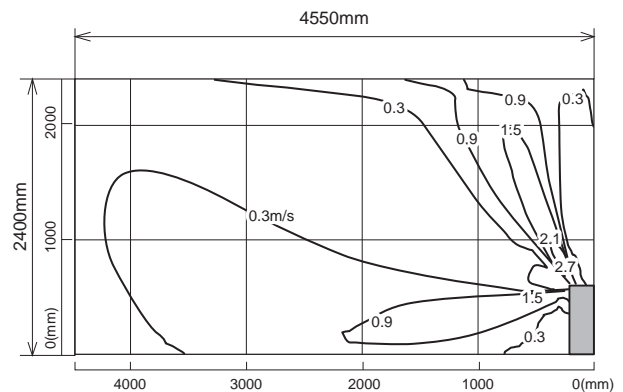

Note : These figures show typical airflow distributions in the conditions above. In the actual installation, they may differ from these figures under the influence of air temperature conditions, ceiling height, cooling/heating load, obstacles, etc.

FLOOR-STANDING TEMPERATURE AND AIR FLOW DISTRIBUTIONS

MFZ-KW50VG

Standard installation (One-direction air flow)

Temperature distribution

<Cooling mode>

Air volume: super high
Air direction: auto

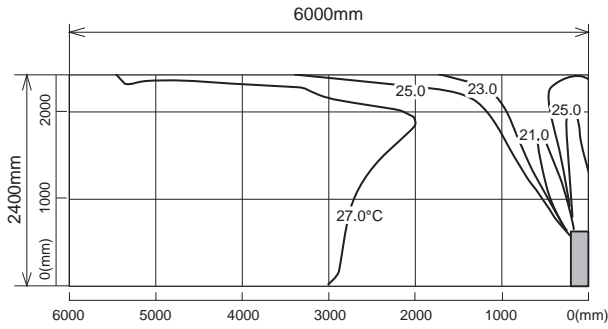

<Heating mode>

Air volume: super high
Air direction: auto

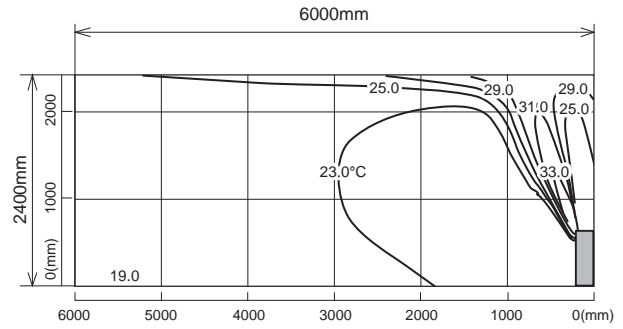

Airflow distribution

<Cooling mode>

Air volume: super high
Air direction: auto

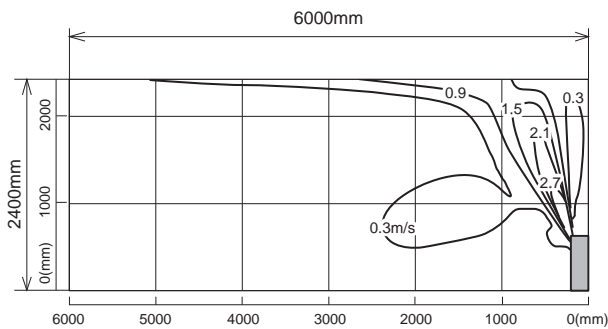

<Heating mode>

Air volume: super high
Air direction: auto

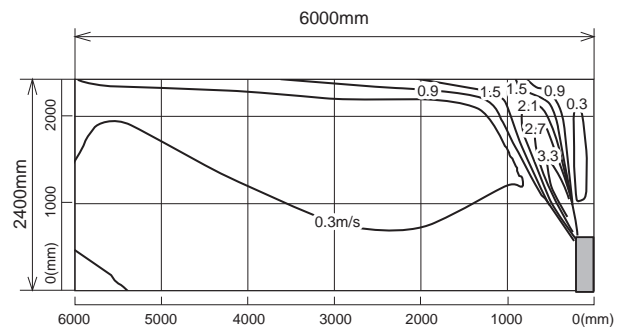

Note : These figures show typical airflow distributions in the conditions above. In the actual installation, they may differ from these figures under the influence of air temperature conditions, ceiling height, cooling/heating load, obstacles, etc.

TEMPERATURE AND AIR FLOW DISTRIBUTIONS

FLOOR-STANDING

MFZ-KW50VG

Standard installation (Two-direction air flow)

Temperature distribution

<Cooling mode>

Air volume: super high
Air direction: auto

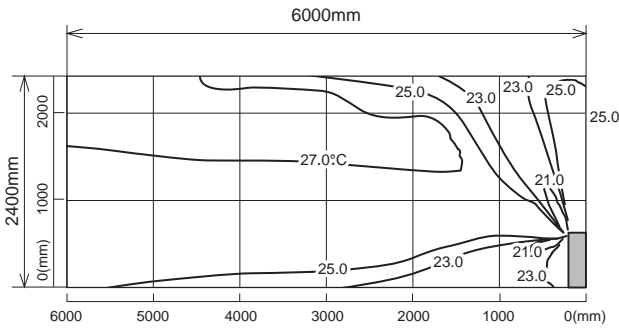

<Heating mode>

Air volume: super high
Air direction: auto

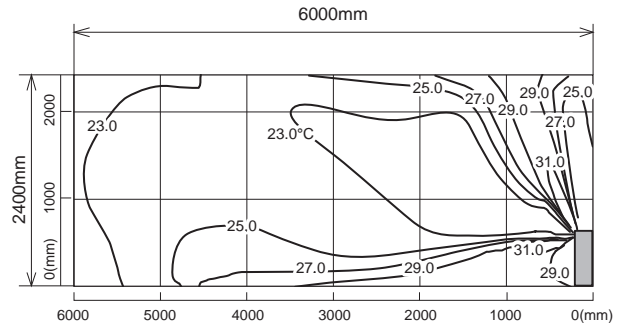

Airflow distribution

<Cooling mode>

Air volume: super high
Air direction: auto

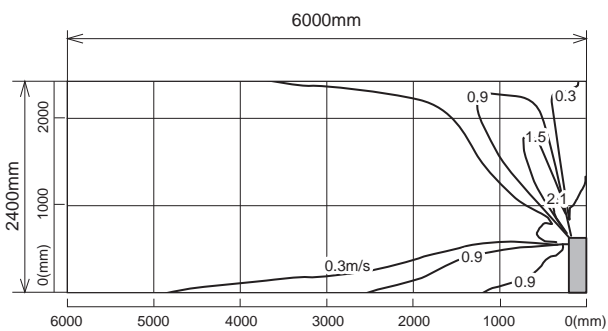

<Heating mode>

Air volume: super high
Air direction: auto

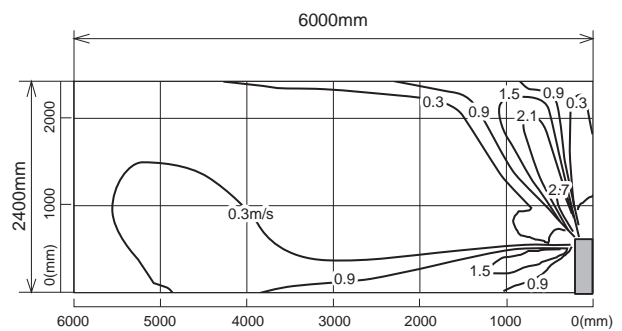

Note : These figures show typical airflow distributions in the conditions above. In the actual installation, they may differ from these figures under the influence of air temperature conditions, ceiling height, cooling/heating load, obstacles, etc.

FLOOR-STANDING TEMPERATURE AND AIR FLOW DISTRIBUTIONS

MFZ-KW60VG

Standard installation (One-direction air flow)

Temperature distribution

<Cooling mode>

Air volume: super high
Air direction: auto

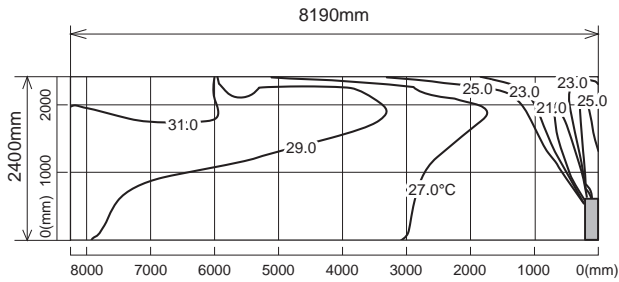

<Heating mode>

Air volume: super high
Air direction: auto

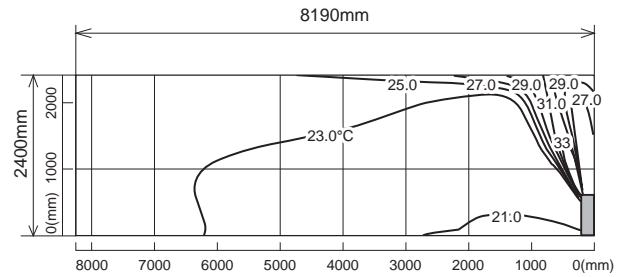

Airflow distribution

<Cooling mode>

Air volume: super high
Air direction: auto

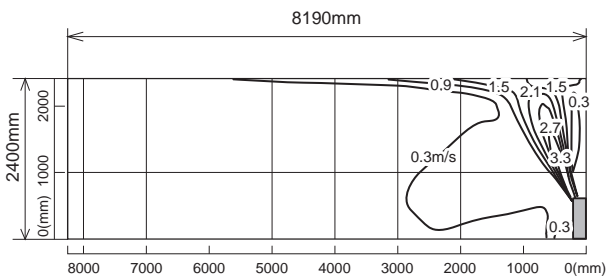

<Heating mode>

Air volume: super high
Air direction: auto

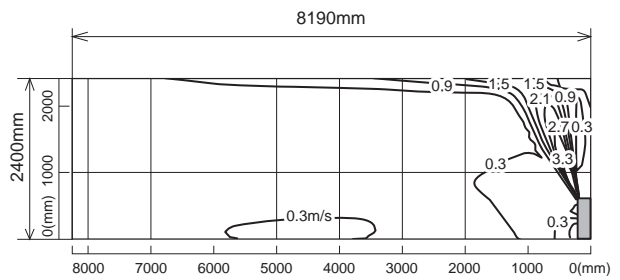

TEMPERATURE AND AIR FLOW DISTRIBUTIONS

FLOOR-STANDING

MFZ-KW60VG

Standard installation (Two-direction air flow)

Temperature distribution

<Cooling mode>

Air volume: super high
Air direction: auto

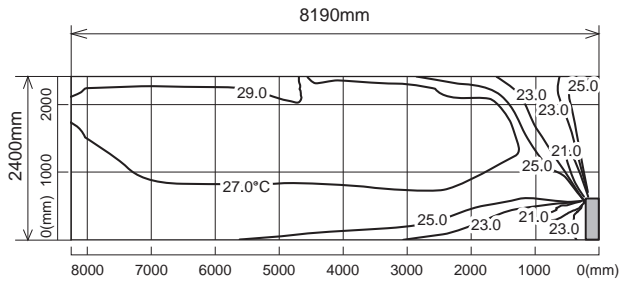

<Heating mode>

Air volume: super high
Air direction: auto

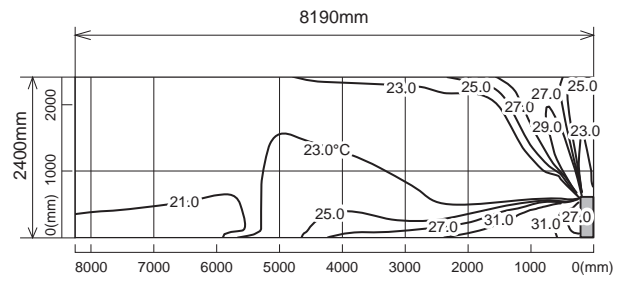

Airflow distribution

<Cooling mode>

Air volume: super high
Air direction: auto

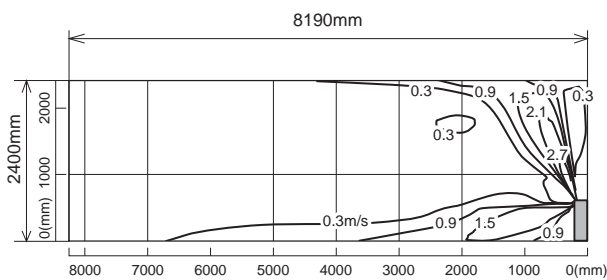

<Heating mode>

Air volume: super high
Air direction: auto

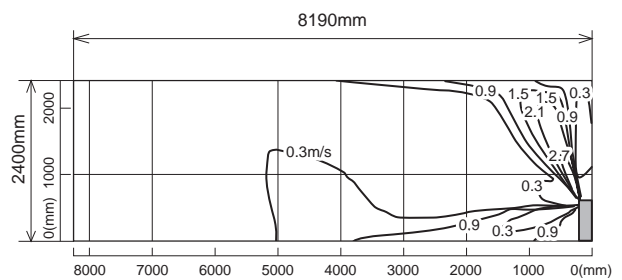

FLOOR-STANDING TEMPERATURE AND AIR FLOW DISTRIBUTIONS

MFZ- KT25VG

Standard installation (One-direction air flow)

Temperature distribution

<Cooling mode>

Air volume: super high
Air direction: auto

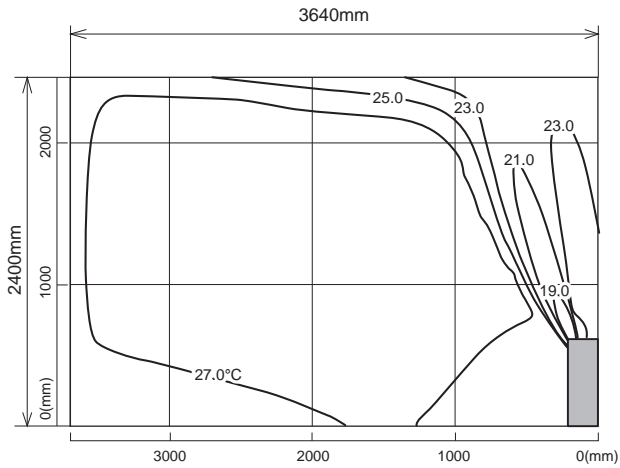

<Heating mode>

Air volume: super high
Air direction: auto

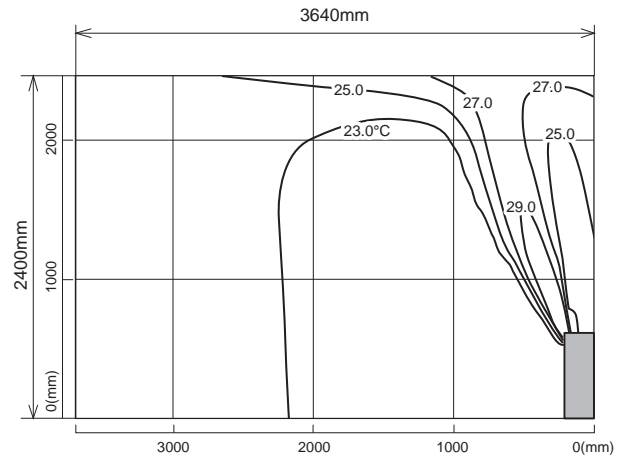

Airflow distribution

<Cooling mode>

Air volume: super high
Air direction: auto

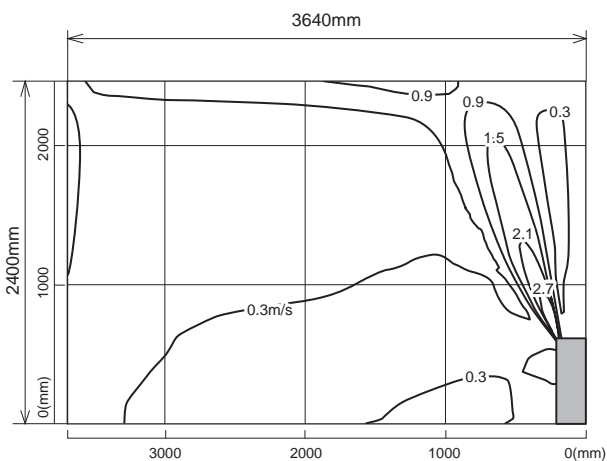

<Heating mode>

Air volume: super high
Air direction: auto

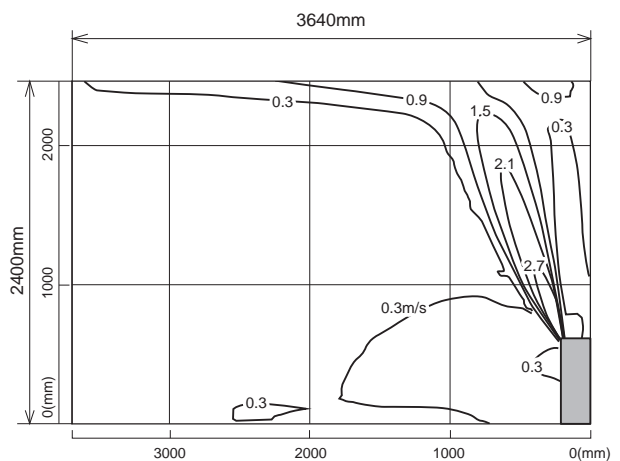

Note : These figures show typical airflow distributions in the conditions above. In the actual installation, they may differ from these figures under the influence of air temperature conditions, ceiling height, cooling/heating load, obstacles, etc.

TEMPERATURE AND AIR FLOW DISTRIBUTIONS

FLOOR-STANDING

MFZ- KT25VG

Standard installation (Two-direction air flow)

Temperature distribution

<Cooling mode>

Air volume: super high
Air direction: auto

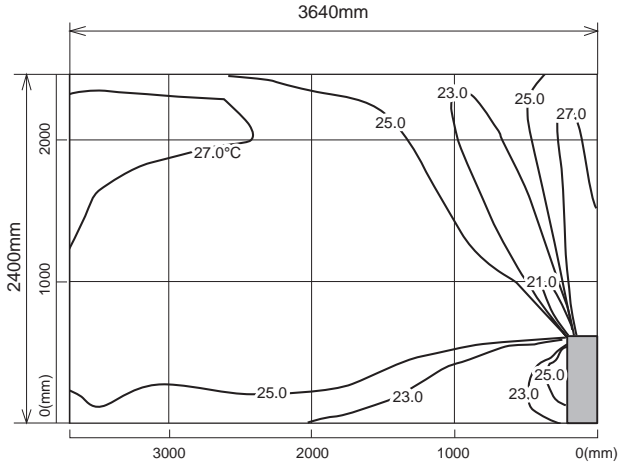

<Heating mode>

Air volume: super high
Air direction: auto

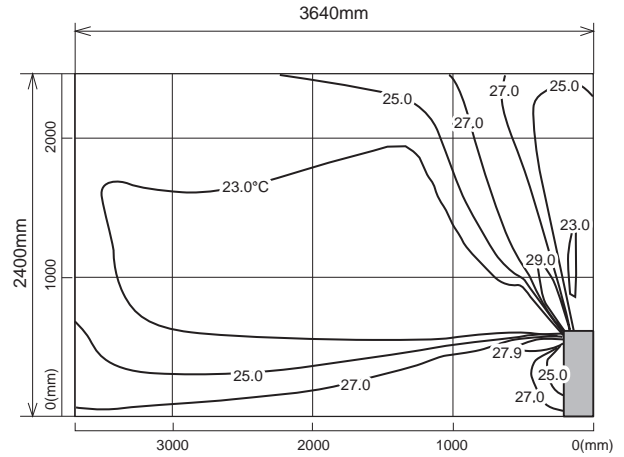

Airflow distribution

<Cooling mode>

Air volume: super high
Air direction: auto

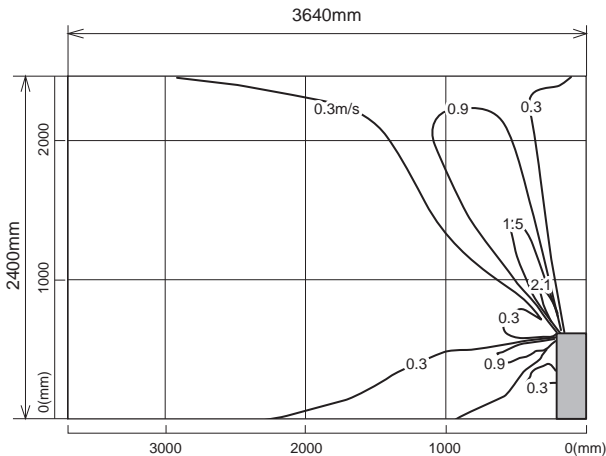

<Heating mode>

Air volume: super high
Air direction: auto

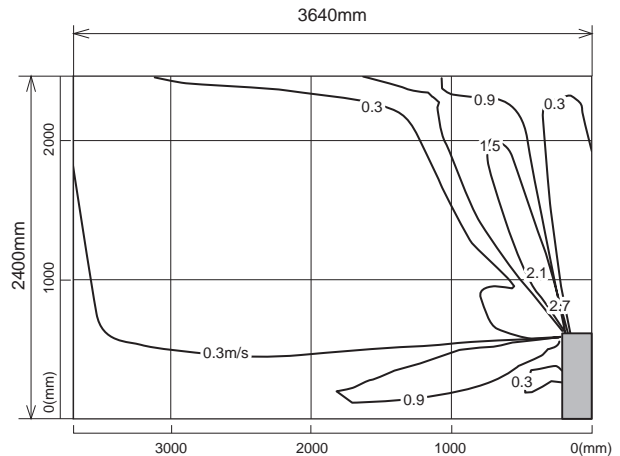

Note : These figures show typical airflow distributions in the conditions above. In the actual installation, they may differ from these figures under the influence of air temperature conditions, ceiling height, cooling/heating load, obstacles, etc.

FLOOR-STANDING TEMPERATURE AND AIR FLOW DISTRIBUTIONS

MFZ- KT35VG

Standard installation (One-direction air flow)

Temperature distribution

<Cooling mode>

Air volume: super high
Air direction: auto

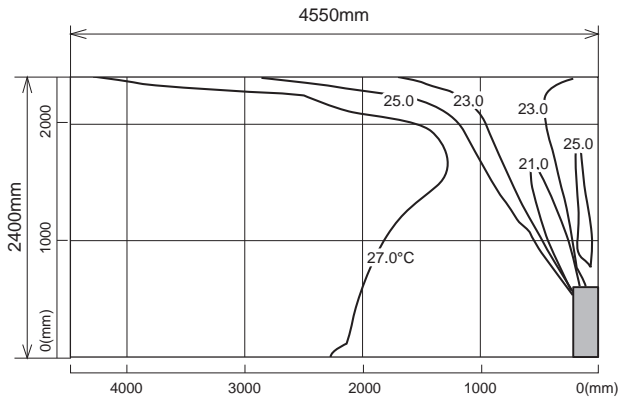

<Heating mode>

Air volume: super high
Air direction: auto

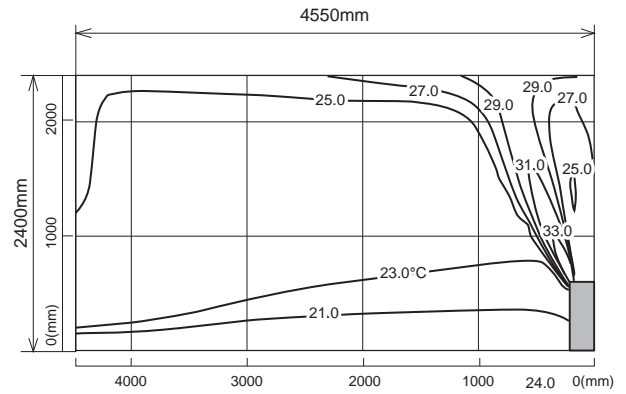

Airflow distribution

<Cooling mode>

Air volume: super high
Air direction: auto

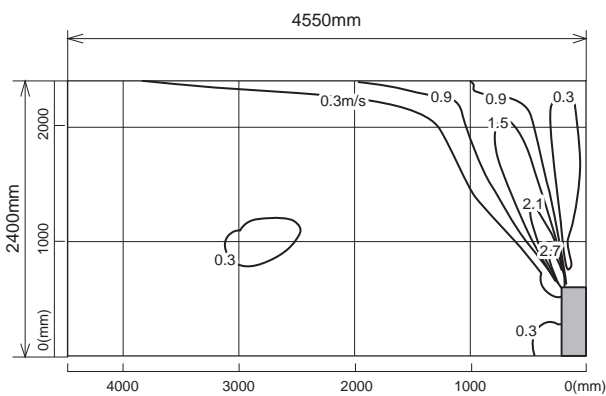

<Heating mode>

Air volume: super high
Air direction: auto

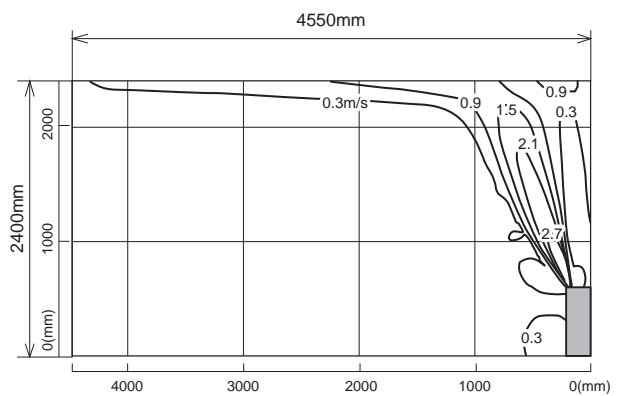

Note : These figures show typical airflow distributions in the conditions above. In the actual installation, they may differ from these figures under the influence of air temperature conditions, ceiling height, cooling/heating load, obstacles, etc.

TEMPERATURE AND AIR FLOW DISTRIBUTIONS

FLOOR-STANDING

MFZ- KT35VG

Standard installation (Two-direction air flow)

Temperature distribution

<Cooling mode>

Air volume: super high
Air direction: auto

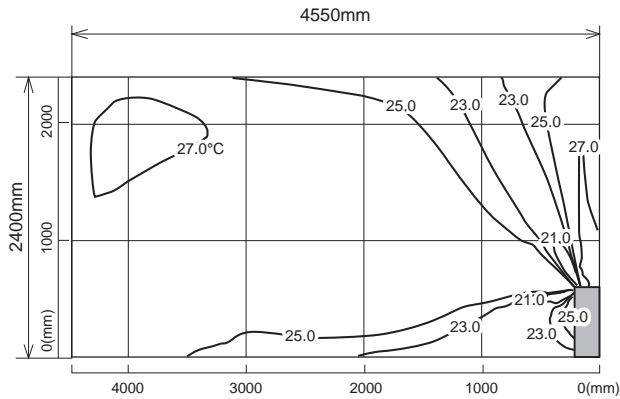

<Heating mode>

Air volume: super high
Air direction: auto

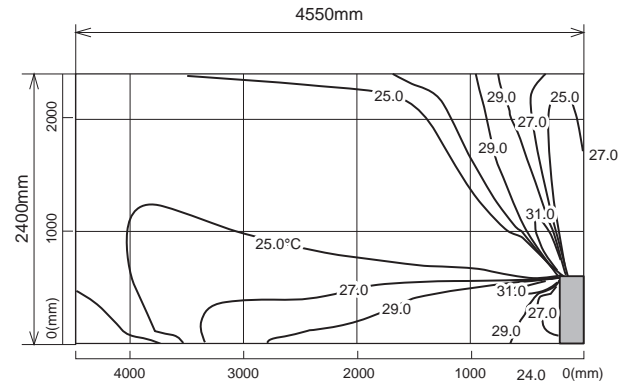

Airflow distribution

<Cooling mode>

Air volume: super high
Air direction: auto

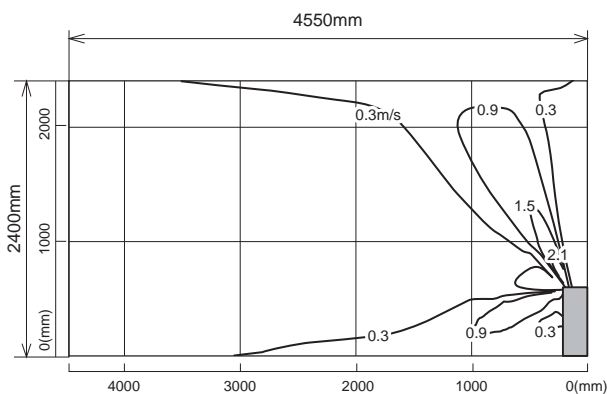

<Heating mode>

Air volume: super high
Air direction: auto

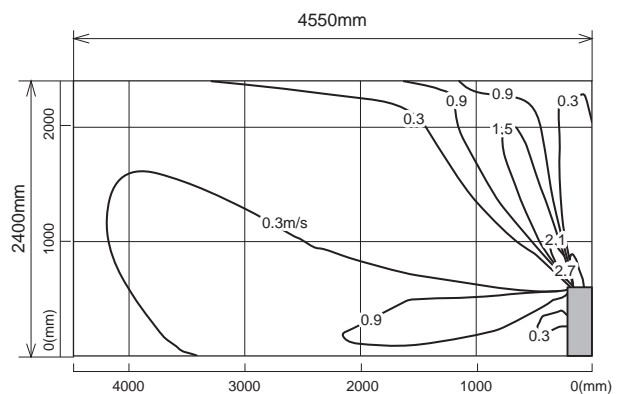

Note : These figures show typical airflow distributions in the conditions above. In the actual installation, they may differ from these figures under the influence of air temperature conditions, ceiling height, cooling/heating load, obstacles, etc.

FLOOR-STANDING TEMPERATURE AND AIR FLOW DISTRIBUTIONS

MFZ- KT50VG

Standard installation (One-direction air flow)

Temperature distribution

<Cooling mode>

Air volume: super high
Air direction: auto

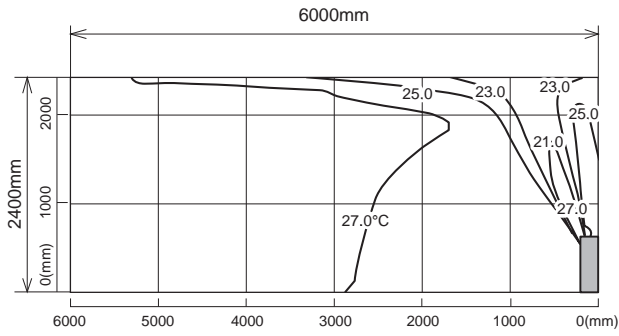

<Heating mode>

Air volume: super high
Air direction: auto

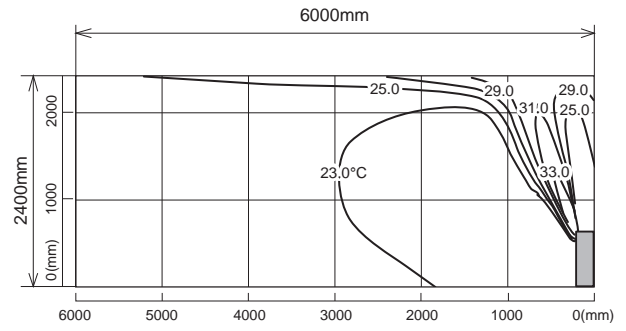

Airflow distribution

<Cooling mode>

Air volume: super high
Air direction: auto

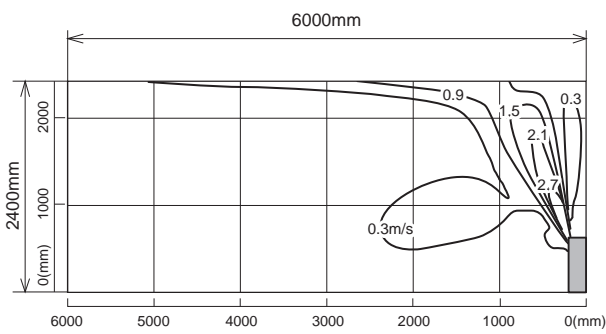

<Heating mode>

Air volume: super high
Air direction: auto

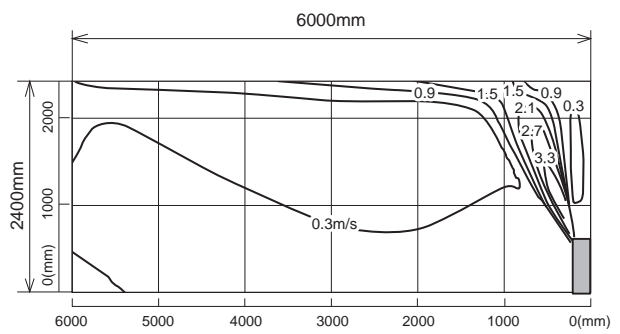

Note : These figures show typical airflow distributions in the conditions above. In the actual installation, they may differ from these figures under the influence of air temperature conditions, ceiling height, cooling/heating load, obstacles, etc.

TEMPERATURE AND AIR FLOW DISTRIBUTIONS

FLOOR-STANDING

MFZ- KT50VG

Standard installation (Two-direction air flow)

Temperature distribution

<Cooling mode>

Air volume: super high
Air direction: auto

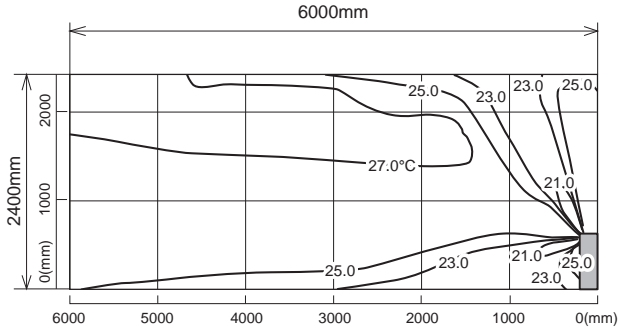

<Heating mode>

Air volume: super high
Air direction: auto

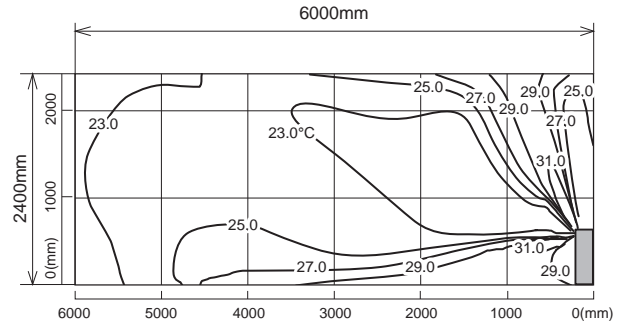

Airflow distribution

<Cooling mode>

Air volume: super high
Air direction: auto

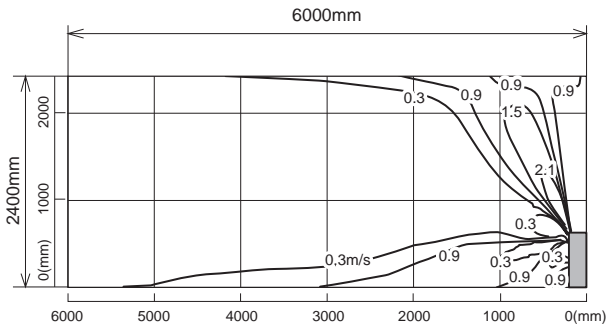

<Heating mode>

Air volume: super high
Air direction: auto

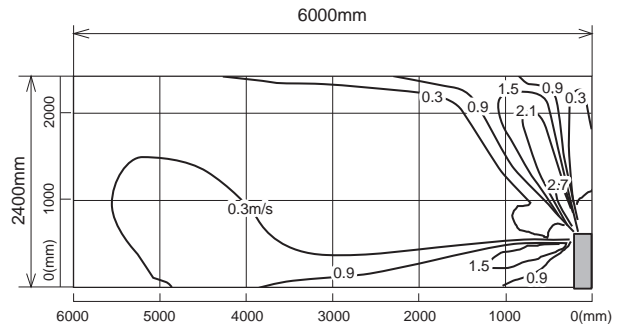

Note : These figures show typical airflow distributions in the conditions above. In the actual installation, they may differ from these figures under the influence of air temperature conditions, ceiling height, cooling/heating load, obstacles, etc.

FLOOR-STANDING TEMPERATURE AND AIR FLOW DISTRIBUTIONS

MFZ- KT60VG

Standard installation (One-direction air flow)

Temperature distribution

<Cooling mode>

Air volume: super high
Air direction: auto

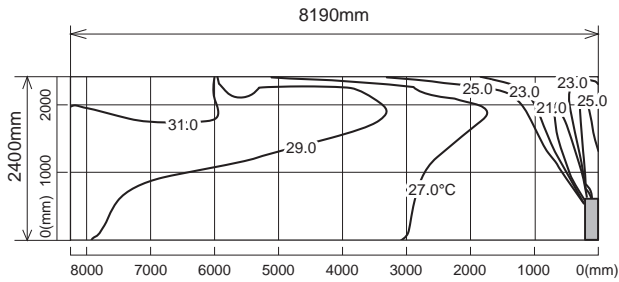

<Heating mode>

Air volume: super high
Air direction: auto

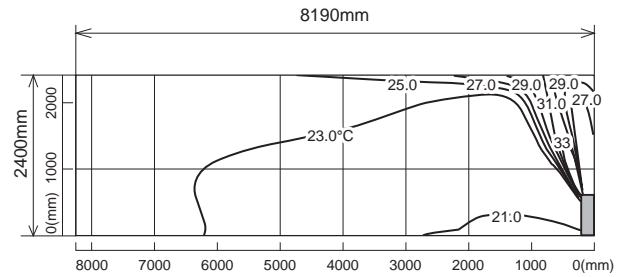

Airflow distribution

<Cooling mode>

Air volume: super high
Air direction: auto

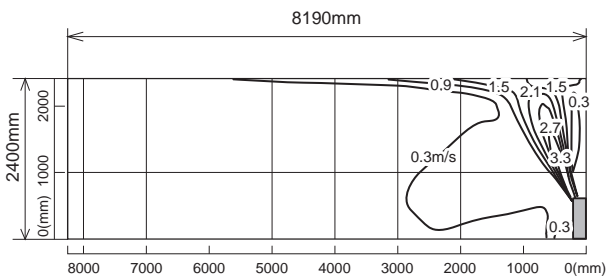

<Heating mode>

Air volume: super high
Air direction: auto

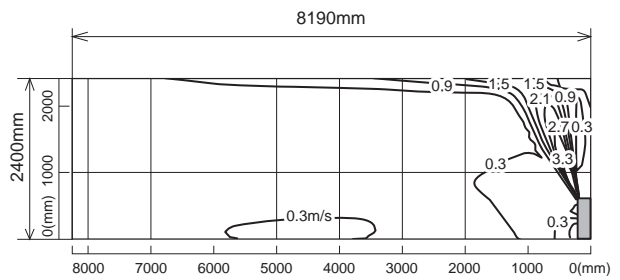

Note : These figures show typical airflow distributions in the conditions above. In the actual installation, they may differ from these figures under the influence of air temperature conditions, ceiling height, cooling/heating load, obstacles, etc.

TEMPERATURE AND AIR FLOW DISTRIBUTIONS

FLOOR-STANDING

MFZ- KT60VG

Standard installation (Two-direction air flow)

Temperature distribution

<Cooling mode>

Air volume: super high
Air direction: auto

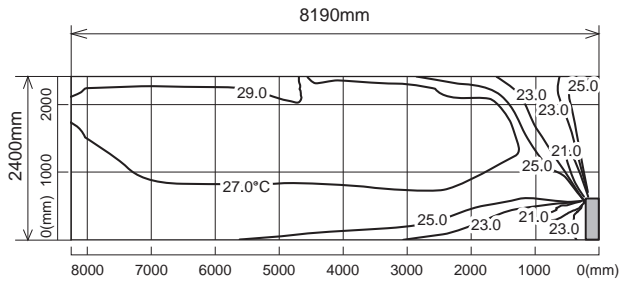

<Heating mode>

Air volume: super high
Air direction: auto

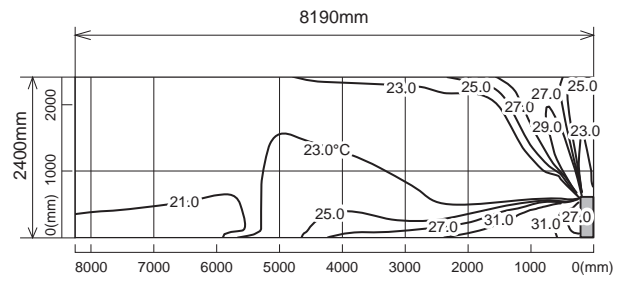

Airflow distribution

<Cooling mode>

Air volume: super high
Air direction: auto

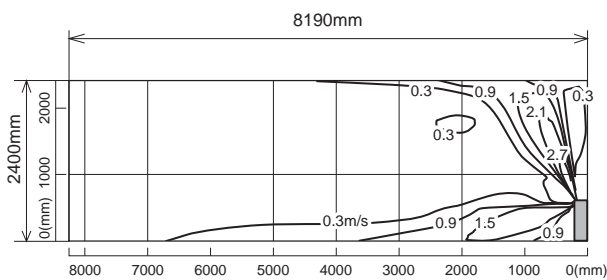

<Heating mode>

Air volume: super high
Air direction: auto

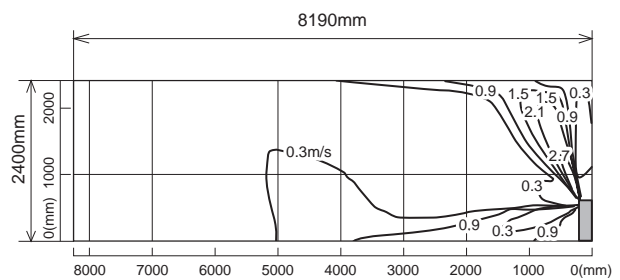

Note : These figures show typical airflow distributions in the conditions above. In the actual installation, they may differ from these figures under the influence of air temperature conditions, ceiling height, cooling/heating load, obstacles, etc.

FLOOR-STANDING TEMPERATURE AND AIR FLOW DISTRIBUTIONS

C.2.9 OPERATION AND ACTUATOR CONTROL

C.2.9.1 MFZ-KW•VG Series

MFZ-KW25VG MFZ-KW35VG MFZ-KW50VG MFZ-KW60VG

WIRELESS REMOTE CONTROLLER

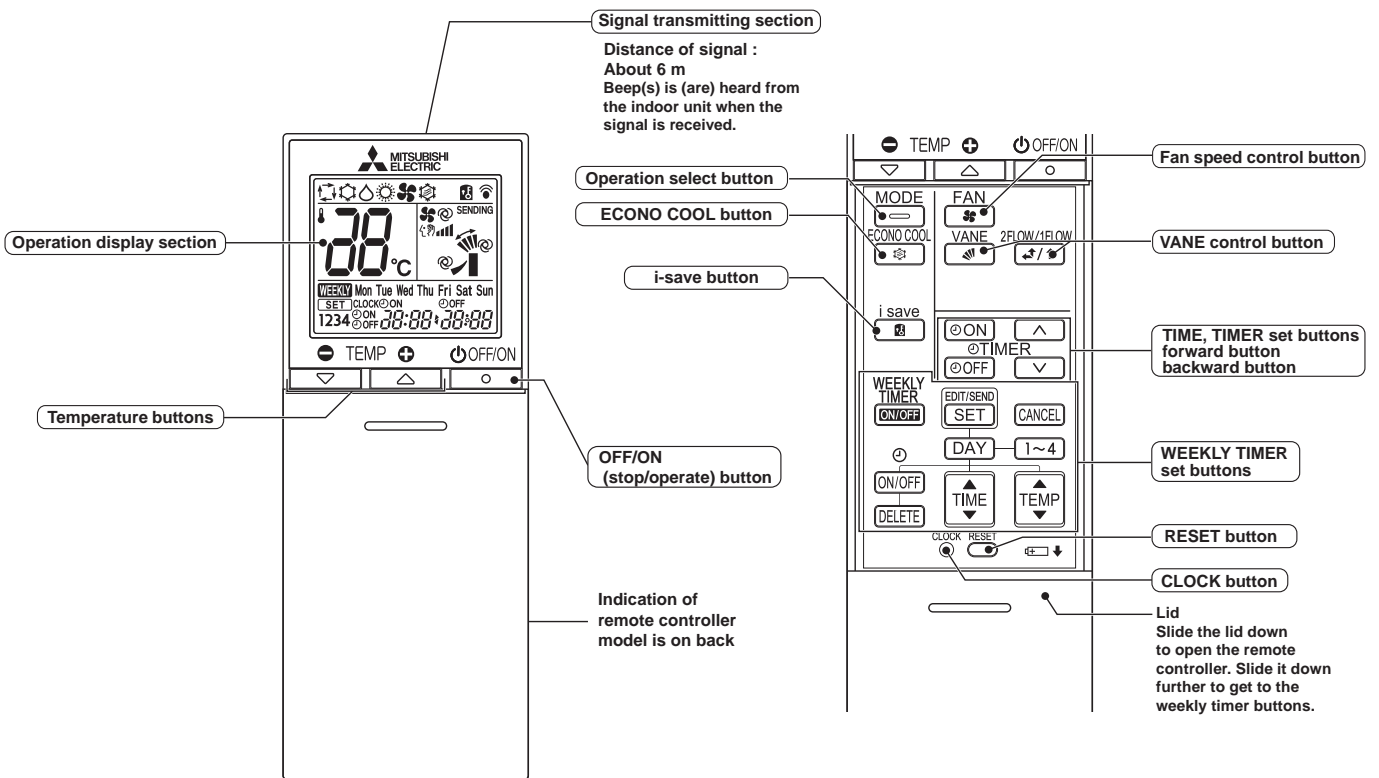

NOTE: Last setting will be stored after the unit is turned OFF with the remote controller. Indoor unit receives the signal of the remote controller with beeps.

INDOOR UNIT DISPLAY SECTION

Operation Indicator lamp

The operation indicator at the right side of the indoor unit indicates the operation state.

- The following indication applies regardless of shape of the indication.

Indication	Operation state	Room temperature
● ●	The unit is operating to reach the set temperature	About 2°C or more away from set temperature
● ○	The room temperature is approaching the set temperature	About 1 to 2°C from set temperature

- Lit
- Blinking
- Not lit

a. COOL (❄️) OPERATION

- Press OFF/ON (stop/operate) button.
OPERATION INDICATOR lamp of the indoor unit turns on with a beep tone.
- Select COOL mode with Operation select button.
- Press Temperature buttons TEMP (−) or (+) button to select the set temperature. The setting range is 16 - 31°C.

1. Coil frost prevention

The compressor operational frequency is controlled by the temperature of the indoor heat exchanger to prevent the coil from frosting.

When the temperature of indoor heat exchanger becomes too low, the coil frost prevention mode works.

The indoor fan operates at the set speed and the compressor stops. This mode continues until the temperature of indoor heat exchanger rises.

2. Low outside temperature operation

When the outside temperature is lower, low outside temperature operation starts, and the outdoor fan slows or stops.

3. Indoor fan speed control

When the thermostat turns OFF, the indoor fan operates at the setting fan speed.

b. DRY (△) OPERATION

- (1) Press OFF/ON (stop/operate) button.
OPERATION INDICATOR lamp of the indoor unit turns on with a beep tone.
- (2) Select DRY mode with Operation select button.
- (3) The set temperature is determined from the initial room temperature.
 - 1. Coil frost prevention**
Coil frost prevention works the same way as that in COOL mode. (a.1.)
 - 2. Low outside temperature operation**
Low outside temperature operation works the same way as that in COOL mode. (a.2.)
 - 3. Indoor fan speed control**
Indoor fan speed control works the same way as that in COOL mode. (a.3.)
However in AUTO setting, the fan speed changes.

c. FAN (⚙) OPERATION

- (1) Press OFF/ON (stop/operate) button.
OPERATION INDICATOR lamp of the indoor unit turns on with a beep tone.
- (2) Select FAN mode with Operation select button.
- (3) Select the desired fan speed. When AUTO, it becomes Low.
Only indoor fan operates.
Outdoor unit does not operate.
NOTE: Temperature cannot be set during FAN mode.

d. HEAT (☀) OPERATION

- (1) Press OFF/ON (stop/operate) button.
OPERATION INDICATOR lamp of the indoor unit turns on with a beep tone.
- (2) Select HEAT mode with Operation select button.
- (3) Press Temperature buttons TEMP \ominus or \oplus button to select the set temperature. The setting range is 16 - 31°C.
 - 1. Cold air prevention control**
When the compressor is not operating or is starting, and the temperature of indoor heat exchanger and/or the room temperature is low or when defrosting is being done, the indoor fan will stop or rotate in Very Low speed.
 - 2. High pressure protection**
The compressor operational frequency is controlled by the temperature of the indoor heat exchanger to prevent the condensing pressure from increasing excessively.
When the temperature of indoor heat exchanger becomes too high, the high pressure protection works.
This mode continues until the temperature of indoor heat exchanger falls.
 - 3. Defrosting**
Defrosting starts when the temperature of outdoor heat exchanger becomes too low.
The compressor stops once, the indoor/outdoor fans stop, the 4-way valve reverses, and the compressor re-starts.
This mode continues until the temperature of outdoor heat exchanger rises or the fixed time passes.

e. AUTO CHANGE OVER ... AUTO MODE OPERATION

Once set temperature is set, unit operation is switched automatically between COOL and HEAT operation.

1. Mode selection

- (1) Initial mode
At first indoor unit operates only indoor fan with outdoor unit OFF for 3 minutes to detect present room temperature.
Following the conditions below, operation mode is selected.
 - ① If the room temperature thermistor RT11 reads more than set temperature, COOL mode is selected.
 - ② If the room temperature thermistor RT11 reads set temperature or less, HEAT mode is selected.
- (2) Mode change
In case of the following conditions the operation mode is changed.
 - ① COOL mode changes to HEAT mode when 15 minutes have passed with the room temperature 2 degrees below the set temperature.
 - ② HEAT mode changes to COOL mode when 15 minutes have passed with the room temperature 2 degrees below the set temperature.

In the other cases than the above conditions, the present operation mode is continued.

NOTE 1: At the beginning of AUTO mode, the airflow direction and the fan speed are set to AUTO and the air outlet selection is set to 2 FLOW.

f. AUTO VANE OPERATION

1. Horizontal vane (Horizontal vane/Multi-flow vane)

(1) Vane motor drive

These models are equipped with a stepping motors for the horizontal vanes. The rotating direction, speed, and angle of the motor are controlled by pulse signals (approximately 12 V) transmitted from indoor microprocessor.

(2) The horizontal vane angle and mode change as follows by pressing VANE control () button.



(3) Positioning

The vane presses the vane stopper once to confirm the standard position and then moves to the set angle. Confirming of standard position is performed in case of the followings.

- (a) The power supply turns on.
- (b) The operation starts or finishes (including timer operation).
- (c) The test run starts.
- (d) The multi-standby starts or finishes.
- (e) Every time the vane has swung more than the specified numbers of times.
- (f) The horizontal vane automatically moves in certain intervals to determine its position, and then it returns to set position.
- (g) The vane operates for the dew prevention.

(4) Air outlet selection

The air outlet(s) can be selected by pressing to VANE control () button.

When 2 FLOW is selected, air blows from the top and the front of the unit. When 1 FLOW is selected, air blows only from the top of the unit.

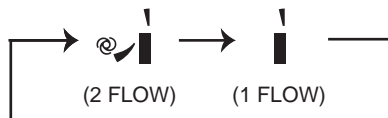

The multi-flow vane is automatically set to the appropriate position.

In HEAT, the multi-flow vane automatically changes its position according to the indoor fan speed.

Even if 2 FLOW is selected, air will blow only from the top of the unit in the following conditions:

- During COOL/DRY: The room temperature is close to set temperature.
The air conditioner has operated for 0.5 to 1 hour.
- During HEAT: The airflow temperature is low. (During defrosting operation, start of operation, etc.)

NOTE:

Movement at the start of the 2 FLOW operation

- COOL/DRY, HEAT: It takes 0.5 to 1 minute to start the 2 FLOW operation.
- HEAT: When cold air blows out from the air outlet, the multi-flow vane may stop moving for up to 10 minutes to make and blow out warm air.

(5) VANE AUTO (@) mode

In VANE AUTO mode, the microprocessor automatically determines the vane angle to make the optimum room temperature distribution.

In COOL, DRY and FAN operation

2 FLOW: Vane angle is fixed to position 2.

In HEAT operation

2 FLOW: Vane angle is fixed to position 2.

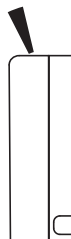

1 FLOW: Vane angle is fixed to position 1.

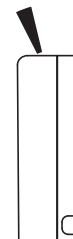

1 FLOW: Vane angle is fixed to position 3.



- (6) STOP (operation OFF) and ON TIMER standby
 In the following cases, the horizontal vane returns to the closed position.
 - (a) When OFF/ON (stop/operate) button is pressed (POWER OFF).
 - (b) When the operation is stopped by the emergency operation.
 - (c) When ON TIMER is ON standby.
- (7) Dew prevention
 During COOL or DRY operation with the vane angle at Angle 3 or 4 when the compressor cumulative operation time exceeds 1 hour, the vane angle automatically changes to Angle 1 for dew prevention.
- (8) SWING (扇) mode
 By selecting SWING mode with VANE control button, the horizontal vanes swing vertically.
 The remote controller displays "扇". SWING mode is cancelled when VANE control button is pressed once again.
- (9) Cold air prevention in HEAT operation
 The horizontal vane position is set to Upward.
- (10) ECONO COOL (扇) operation (ECONOMical operation)
 When ECONO COOL button is pressed in COOL mode, set temperature is automatically set 2°C higher by the micro-processor. However, the temperature on the LCD screen on the remote controller is not changed. Also the horizontal vane swings in various cycle.
 SWING operation makes you feel cooler than set temperature. So, even though the set temperature is higher, the air conditioner can keep comfort. As a result, energy can be saved.
 To cancel this operation, select a different mode or press one of the following buttons in ECONO COOL operation: ECONO COOL, VANE control button.

g. TIMER OPERATION

1. How to set the time

- (1) Check that the current time is set correctly.
NOTE: Timer operation will not work without setting the current time. Initially "0:00" blinks at the current time display of TIME MONITOR, so set the current time correctly with CLOCK button.

How to set the current time

- (a) Press the CLOCK button.
- (b) Press the TIME SET buttons (▲ and ▼) to set the current time.
 - Each time forward button (▲) is pressed, the set time increases by 1 minute, and each time backward button (▼) is pressed, the set time decreases by 1 minute.
 - Pressing those buttons longer, the set time increases/decreases by 10 minutes.
- (c) Press the CLOCK set button.
- (2) Press OFF/ON (stop/operate) button to start the air conditioner.
- (3) Set the time of timer.

ON timer setting

- (a) Press ON TIMER button (ON) during operation.
- (b) Set the time of the timer using TIME SET buttons (▲ and ▼). *

OFF timer setting

- (a) Press OFF TIMER button (OFF) during operation.
- (b) Set the time of the timer using TIME SET buttons (▲ and ▼). *
- * Each time forward button (▲) is pressed, the set time increases by 10 minutes: each time backward button (▼) is pressed, the set time decreases by 10 minutes.

2. To release the timer

To release ON timer, press ON TIMER button (ON).
 To release OFF timer, press OFF TIMER button (OFF).
 TIMER is cancelled and the display of set time disappears.

PROGRAM TIMER

- OFF timer and ON timer can be used in combination. The set time that is reached first will operate first.
 - "◀" and "▶" display shows the order of OFF timer and ON timer operation.
- (Example 1) The current time is 8:00 PM. The unit turns off at 11:00 PM, and on at 6:00 AM.
 (Example 2) The current time is 11:00 AM. The unit turns on at 5:00 PM, and off at 9:00 PM.

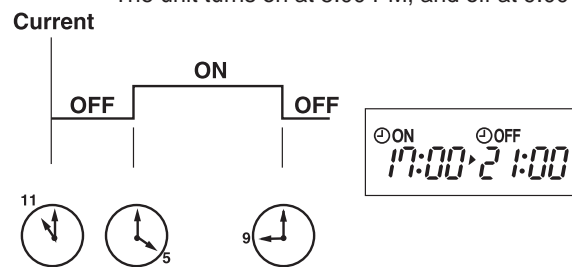
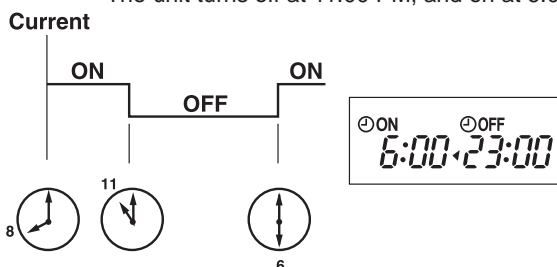

NOTE: If the main power is turned OFF or a power failure occurs while ON/OFF timer is active, the timer setting is cancelled. As these models are equipped with an auto restart function, the air conditioner starts operating with timer cancelled when power is restored.

h. WEEKLY TIMER OPERATION

- A maximum of 4 ON or OFF timers can be set for individual days of the week.
- A maximum of 28 ON or OFF timers can be set for a week.

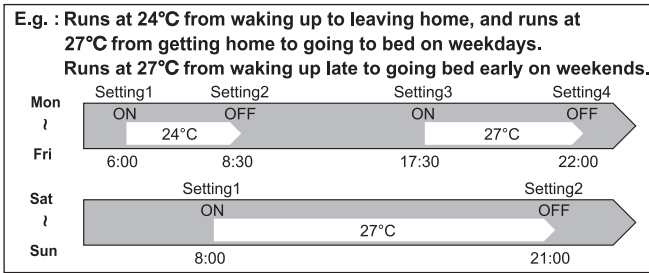

NOTE:

- The simple ON/OFF timer setting is available while the weekly timer is on. In this case, the ON/OFF timer has priority over the weekly timer; the weekly timer operation will start again after the simple ON/OFF timer is complete.
- When the weekly timer is set, temperature cannot be set to 10°C.
- The weekly timer operation and i-save operation cannot be used together.

1. How to set the weekly timer

* Make sure that the current time and day are set correctly.

(1) Press **EDIT/SEND SET** button to enter the weekly timer setting mode.

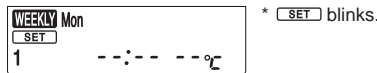

(2) Press **DAY** and **1~4** buttons to select setting day and number.

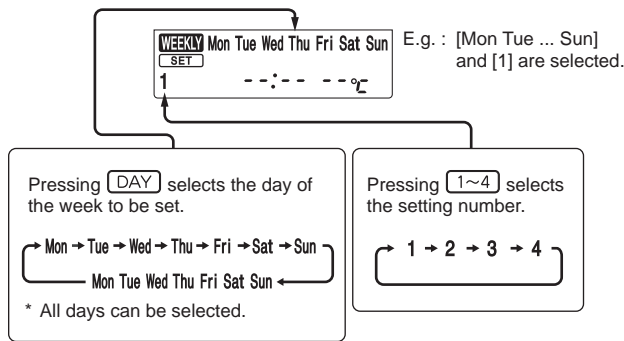

(3) Press **ON/OFF**, **TIME**, and **TEMP** buttons to set ON/OFF, time, and temperature.

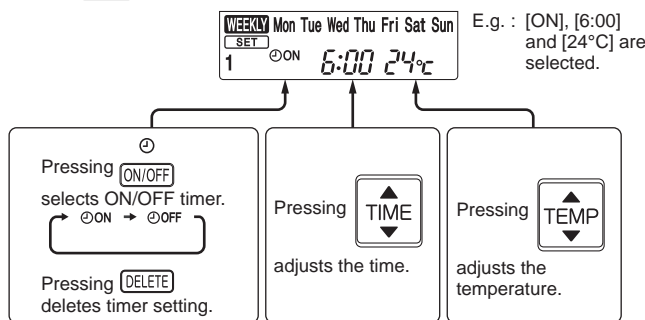

- * Hold down the button to change the time quickly.
- * The temperature can be set between 16 °C and 31 °C at weekly timer.





Press **DAY** and **1~4** buttons to continue setting the timer for other days and/or numbers.

- (4) Press  button to complete and transmit the weekly timer setting.



*  which was blinking goes out, and the current time will be displayed.

NOTE:

- Press  button to transmit the setting information of weekly timer to the indoor unit. Point the remote controller toward the indoor unit for 3 seconds.
- When setting the timer for more than one day of the week or one number,  button does not have to be pressed per each setting. Press  button once after all the settings are complete. All the weekly timer settings will be saved.
- Press  button to enter the weekly timer setting mode, and press and hold  button for 5 seconds to erase all weekly timer settings. Point the remote controller toward the indoor unit.

- (5) Press  button to turn the weekly timer ON. (**WEEKLY** lights.)

- When the weekly timer is ON, the day of the week whose timer setting is complete, will light.

Press  button again to turn the weekly timer OFF. (**WEEKLY** goes out.)



NOTE:

The saved settings will not be cleared when the weekly timer is turned OFF.

2. Checking weekly timer setting

- (1) Press  button to enter the weekly timer setting mode.

*  blinks.

- (2) Press  or  buttons to view the setting of the particular day or number.

- (3) Press  button to exit the weekly timer setting.

i. i-save OPERATION

1. How to set i-save operation

- (1) Press OFF/ON (stop/operate) button.
- (2) Select COOL or HEAT mode.
- (3) Press i-save button.
- (4) Set the temperature, fan speed, airflow direction, and 2 FLOW/1 FLOW for i-save operation.

NOTE:

- i-save operation cannot be selected during DRY, FAN or AUTO mode operation.
- The setting range of HEAT mode i-save operation is 10°C and 16 - 31°C.
- 2 groups of setting can be saved. (One for COOL, one for HEAT)
- i-save operation and the weekly timer operation cannot be used together.

2. How to cancel operation

- Press i-save button again.
- i-save operation can also be cancelled by pressing Operation select button to change the operation mode. The preferred setting can be saved for the next time with a single press of i-save button.

j. EMERGENCY/TEST OPERATION

In the case of test run operation or emergency operation, use the emergency operation switch on the right side of the indoor unit. Emergency operation is available when the remote controller is missing or has failed, or when the batteries in the remote controller are running down. The unit will start and OPERATION INDICATOR lamp will light up.

The first 30 minutes of operation is the test run operation. This operation is for servicing. The indoor fan runs at High speed and the temperature control does not work. In COOL MODE, the air outlet selection is set to 2 FLOW during the test run operation.

After 30 minutes of test run operation, the system shifts to EMERGENCY COOL/HEAT MODE with a set temperature of 24°C. The fan speed shifts to Med. The coil frost prevention works even in the test run or the emergency operation.

In the test run or emergency operation, the horizontal vane operates in VANE AUTO (Ⓢ) mode.

Emergency operation continues until the emergency operation switch is pressed once or twice or the unit receives any signal from the remote controller. In the latter case, normal operation will start.

NOTE: Do not press the emergency operation switch during normal operation.

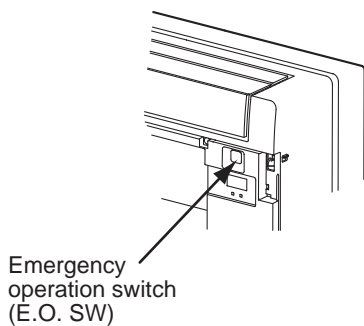

Operation mode	COOL/HEAT
Set temperature	24°C
Fan speed	Med.
Horizontal vane	Auto
Air outlet	2 FLOW

The operation mode is indicated by the Operation Indicator lamp as following

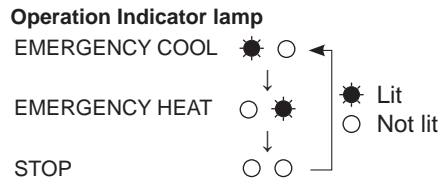

k. 3-MINUTE TIME DELAY OPERATION

When the system turns OFF, compressor will not restart for 3 minutes as 3-minute time delay function operates to protect compressor from overload.

I. ACTUATOR CONTROL

I-1. OUTDOOR FAN MOTOR CONTROL

The fan motor turns ON/OFF, interlocking with the compressor.

[ON] The fan motor turns ON 5 seconds before the compressor starts up.

[OFF] The fan motor turns OFF 15 seconds after the compressor has stopped running.

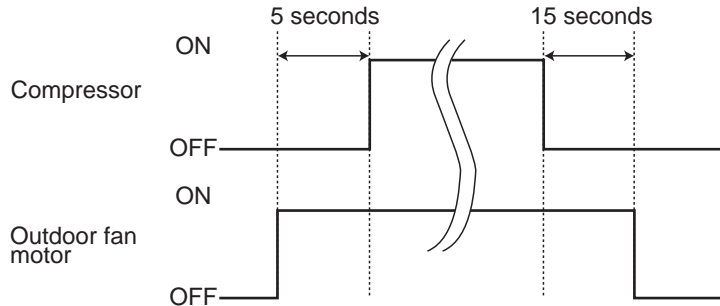

I-2. R.V. COIL CONTROL

Heating ON

Cooling OFF

Dry OFF

NOTE: The 4-way valve reverses for 5 seconds right before startup of the compressor.

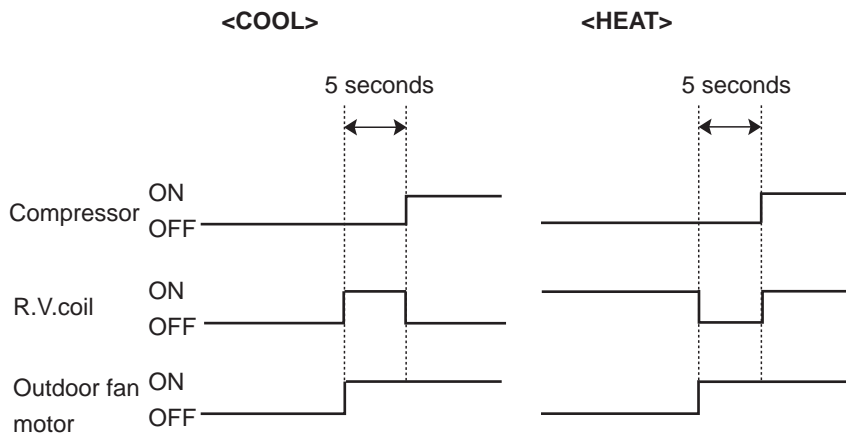

I-3. RELATION BETWEEN MAIN SENSOR AND ACTUATOR

Sensor	Purpose	Actuator					
		Compressor	LEV	Outdoor fan motor	R.V. coil	Indoor fan motor	Defrost heater
Discharge temperature thermistor	Protection	○	○				
Indoor coil temperature thermistor	Cooling: Coil frost prevention	○					
	Heating: High pressure protection	○	○				
Defrost thermistor	Heating: Defrosting	○	○	○	○	○	
Fin temperature thermistor	Protection	○		○			
Ambient temperature thermistor	Cooling: Low ambient temperature operation	○	○	○			
	Heating: Defrosting (Heater)						○
Outdoor heat exchanger temperature thermistor	Cooling: Low ambient temperature operation	○	○	○			
	Cooling: High pressure protection	○	○	○			

C.2.9.2 MFZ-KT•VG Series

MFZ-KT25VG MFZ-KT35VG MFZ-KT50VG MFZ-KT60VG

WIRELESS REMOTE CONTROLLER

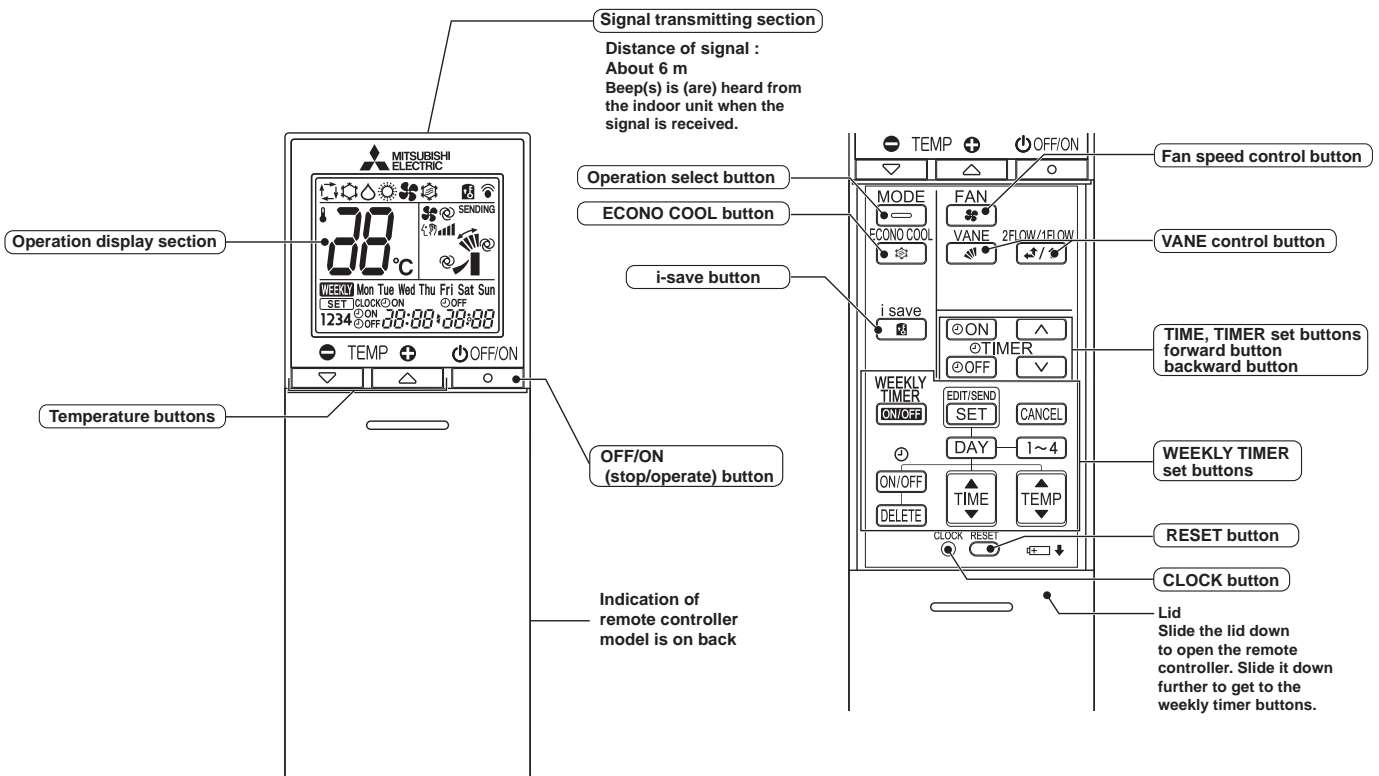

NOTE: Last setting will be stored after the unit is turned OFF with the remote controller. Indoor unit receives the signal of the remote controller with beeps.

INDOOR UNIT DISPLAY SECTION

Operation Indicator lamp

The operation indicator at the right side of the indoor unit indicates the operation state.

•The following indication applies regardless of shape of the indication.

Indication	Operation state	Room temperature
● ●	The unit is operating to reach the set temperature	About 2°C or more away from set temperature
● ○	The room temperature is approaching the set temperature	About 1 to 2°C from set temperature
● ●	Standby mode (only during multi system operation)	—

- Lit
- Blinking
- Not lit

a. COOL (❄️) OPERATION

- (1) Press OFF/ON (stop/operate) button.
OPERATION INDICATOR lamp of the indoor unit turns on with a beep tone.
- (2) Select COOL mode with Operation select button.
- (3) Press Temperature buttons TEMP (⊖) or (⊕) button to select the set temperature. The setting range is 16 - 31°C.

1. Coil frost prevention

The compressor operational frequency is controlled by the temperature of the indoor heat exchanger to prevent the coil from frosting.

When the temperature of indoor heat exchanger becomes too low, the coil frost prevention mode works.

The indoor fan operates at the set speed and the compressor stops. This mode continues until the temperature of indoor heat exchanger rises.

2. Low outside temperature operation

When the outside temperature is lower, low outside temperature operation starts, and the outdoor fan slows or stops.

3. Indoor fan speed control

When the thermostat turns OFF, the indoor fan operates at the setting fan speed.

b. DRY (△) OPERATION

- (1) Press OFF/ON (stop/operate) button.
OPERATION INDICATOR lamp of the indoor unit turns on with a beep tone.
- (2) Select DRY mode with Operation select button.
- (3) The set temperature is determined from the initial room temperature.
 1. **Coil frost prevention**
Coil frost prevention works the same way as that in COOL mode. (a.1.)
 2. **Low outside temperature operation**
Low outside temperature operation works the same way as that in COOL mode. (a.2.)
 3. **Indoor fan speed control**
Indoor fan speed control works the same way as that in COOL mode. (a.3.)
However in AUTO setting, the fan speed changes.

c. FAN (✳) OPERATION

- (1) Press OFF/ON (stop/operate) button.
OPERATION INDICATOR lamp of the indoor unit turns on with a beep tone.
- (2) Select FAN mode with Operation select button.
- (3) Select the desired fan speed. When AUTO, it becomes Low.
Only indoor fan operates.
Outdoor unit does not operate.
NOTE: Temperature cannot be set during FAN mode.

d. HEAT (☀) OPERATION

- (1) Press OFF/ON (stop/operate) button.
OPERATION INDICATOR lamp of the indoor unit turns on with a beep tone.
- (2) Select HEAT mode with Operation select button.
- (3) Press Temperature buttons TEMP (⊖) or (⊕) button to select the set temperature. The setting range is 16 - 31°C.
 1. **Cold air prevention control**
When the compressor is not operating or is starting, and the temperature of indoor heat exchanger and/or the room temperature is low or when defrosting is being done, the indoor fan will stop or rotate in Very Low speed.
 2. **High pressure protection**
The compressor operational frequency is controlled by the temperature of the indoor heat exchanger to prevent the condensing pressure from increasing excessively.
When the temperature of indoor heat exchanger becomes too high, the high pressure protection works.
This mode continues until the temperature of indoor heat exchanger falls.
 3. **Defrosting**
Defrosting starts when the temperature of outdoor heat exchanger becomes too low.
The compressor stops once, the indoor/outdoor fans stop, the 4-way valve reverses, and the compressor re-starts.
This mode continues until the temperature of outdoor heat exchanger rises or the fixed time passes.

e. AUTO CHANGE OVER ... AUTO MODE OPERATION

Once set temperature is set, unit operation is switched automatically between COOL and HEAT operation.

1. Mode selection

- (1) Initial mode
At first indoor unit operates only indoor fan with outdoor unit OFF for 3 minutes to detect present room temperature.
Following the conditions below, operation mode is selected.
 - ① If the room temperature thermistor RT11 reads more than set temperature, COOL mode is selected.
 - ② If the room temperature thermistor RT11 reads set temperature or less, HEAT mode is selected.
- (2) Mode change
In case of the following conditions the operation mode is changed.
 - ① COOL mode changes to HEAT mode when 15 minutes have passed with the room temperature 2 degrees below the set temperature.
 - ② HEAT mode changes to COOL mode when 15 minutes have passed with the room temperature 2 degrees below the set temperature.

In the other cases than the above conditions, the present operation mode is continued.

NOTE 1: Mode selection is performed when multi standby (refer to **NOTE 2**) is released and the unit starts operation with ON-timer.

NOTE 2: If 2 or more indoor units are operating in multi system, there might be a case that the indoor unit, which is operating in AUTO (□), cannot change over the other operating mode (COOL ↔ HEAT) and becomes a state of standby.

NOTE 3: At the beginning of AUTO mode, the airflow direction and the fan speed are set to AUTO and the air outlet selection is set to 2 FLOW.

f. AUTO VANE OPERATION

1. Horizontal vane (Horizontal vane/Multi-flow vane)

(1) Vane motor drive

These models are equipped with a stepping motors for the horizontal vanes. The rotating direction, speed, and angle of the motor are controlled by pulse signals (approximately 12 V) transmitted from indoor microprocessor.

(2) The horizontal vane angle and mode change as follows by pressing VANE control () button.



(3) Positioning

The vane presses the vane stopper once to confirm the standard position and then moves to the set angle. Confirming of standard position is performed in case of the followings.

- (a) The power supply turns on.
- (b) The operation starts or finishes (including timer operation).
- (c) The test run starts.
- (d) The multi-standby starts or finishes.
- (e) Every time the vane has swung more than the specified numbers of times.
- (f) The horizontal vane automatically moves in certain intervals to determine its position, and then it returns to set position.
- (g) The vane operates for the dew prevention.

(4) Air outlet selection

The air outlet(s) can be selected by pressing to VANE control () button.

When 2 FLOW is selected, air blows from the top and the front of the unit. When 1 FLOW is selected, air blows only from the top of the unit.

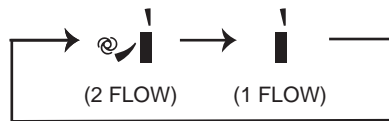

The multi-flow vane is automatically set to the appropriate position.

In HEAT, the multi-flow vane automatically changes its position according to the indoor fan speed.

Even if 2 FLOW is selected, air will blow only from the top of the unit in the following conditions:

- During COOL/DRY: The room temperature is close to set temperature.
The air conditioner has operated for 0.5 to 1 hour.
- During HEAT: The airflow temperature is low. (During defrosting operation, start of operation, etc.)

NOTE:

Movement at the start of the 2 FLOW operation

- COOL/DRY, HEAT: It takes 0.5 to 1 minute to start the 2 FLOW operation.
- HEAT: When cold air blows out from the air outlet, the multi-flow vane may stop moving for up to 10 minutes to make and blow out warm air.

(5) VANE AUTO (🌀) mode

In VANE AUTO mode, the microprocessor automatically determines the vane angle to make the optimum room temperature distribution.

In COOL, DRY and FAN operation

2 FLOW: Vane angle is fixed to position 2.



1 FLOW: Vane angle is fixed to position 1.



In HEAT operation

2 FLOW: Vane angle is fixed to position 2.

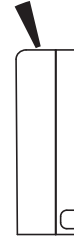

1 FLOW: Vane angle is fixed to position 3.



(6) STOP (operation OFF) and ON TIMER standby

In the following cases, the horizontal vane returns to the closed position.

(a) When OFF/ON (stop/operate) button is pressed (POWER OFF).

(b) When the operation is stopped by the emergency operation.

(c) When ON TIMER is ON standby.

(7) Dew prevention

During COOL or DRY operation with the vane angle at Angle 3 or 4 when the compressor cumulative operation time exceeds 1 hour, the vane angle automatically changes to Angle 1 for dew prevention.

(8) SWING (🌀) mode

By selecting SWING mode with VANE control button, the horizontal vanes swing vertically.

The remote controller displays "🌀". SWING mode is cancelled when VANE control button is pressed once again.

(9) Cold air prevention in HEAT operation

The horizontal vane position is set to Upward.

(10) ECONO COOL (🌀) operation (ECONOMical operation)

When ECONO COOL button is pressed in COOL mode, set temperature is automatically set 2°C higher by the microprocessor. However, the temperature on the LCD screen on the remote controller is not changed. Also the horizontal vane swings in various cycle.

SWING operation makes you feel cooler than set temperature. So, even though the set temperature is higher, the air conditioner can keep comfort. As a result, energy can be saved.

To cancel this operation, select a different mode or press one of the following buttons in ECONO COOL operation:

ECONO COOL, VANE control button.

g. TIMER OPERATION

1. How to set the time

(1) Check that the current time is set correctly.

NOTE: Timer operation will not work without setting the current time. Initially “0:00” blinks at the current time display of TIME MONITOR, so set the current time correctly with CLOCK button.

How to set the current time

(a) Press the CLOCK button.

(b) Press the TIME SET buttons (▲) and (▼) to set the current time.

- Each time forward button (▲) is pressed, the set time increases by 1 minute, and each time backward button (▼) is pressed, the set time decreases by 1 minute.
- Pressing those buttons longer, the set time increases/decreases by 10 minutes.

(c) Press the CLOCK set button.

(2) Press OFF/ON (stop/operate) button to start the air conditioner.

(3) Set the time of timer.

ON timer setting

(a) Press ON TIMER button (ⓄON) during operation.

(b) Set the time of the timer using TIME SET buttons (▲) and (▼). *

OFF timer setting

(a) Press OFF TIMER button (ⓄOFF) during operation.

(b) Set the time of the timer using TIME SET buttons (▲) and (▼). *

* Each time forward button (▲) is pressed, the set time increases by 10 minutes: each time backward button (▼) is pressed, the set time decreases by 10 minutes.

2. To release the timer

To release ON timer, press ON TIMER button (ⓄON).

To release OFF timer, press OFF TIMER button (ⓄOFF).

TIMER is cancelled and the display of set time disappears.

PROGRAM TIMER

• OFF timer and ON timer can be used in combination. The set time that is reached first will operate first.

• “◀” and “▶” display shows the order of OFF timer and ON timer operation.

(Example 1) The current time is 8:00 PM.

The unit turns off at 11:00 PM, and on at 6:00 AM.

(Example 2) The current time is 11:00 AM.

The unit turns on at 5:00 PM, and off at 9:00 PM.

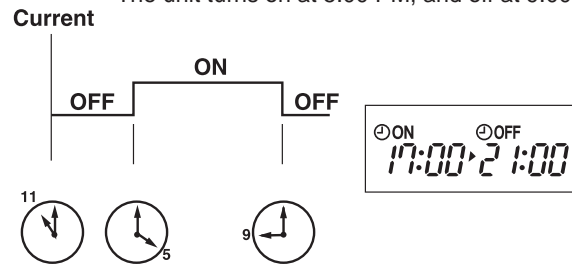
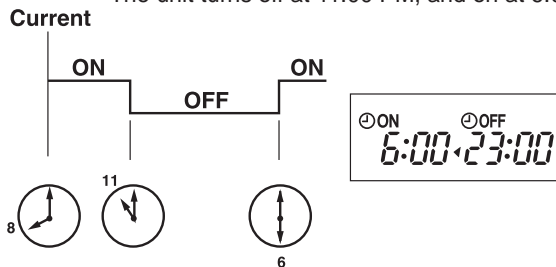

NOTE: If the main power is turned OFF or a power failure occurs while ON/OFF timer is active, the timer setting is cancelled. As these models are equipped with an auto restart function, the air conditioner starts operating with timer cancelled when power is restored.

h. WEEKLY TIMER OPERATION

- A maximum of 4 ON or OFF timers can be set for individual days of the week.
- A maximum of 28 ON or OFF timers can be set for a week.

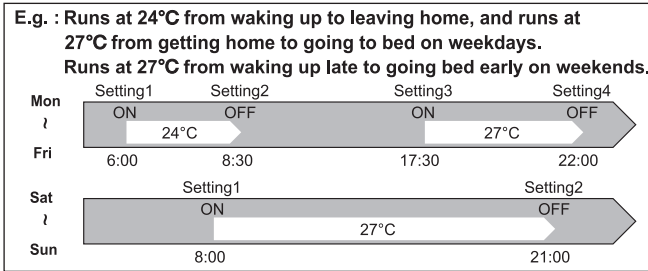

NOTE:

- The simple ON/OFF timer setting is available while the weekly timer is on. In this case, the ON/OFF timer has priority over the weekly timer; the weekly timer operation will start again after the simple ON/OFF timer is complete.
- When the weekly timer is set, temperature cannot be set to 10°C.
- The weekly timer operation and i-save operation cannot be used together.

1. How to set the weekly timer

* Make sure that the current time and day are set correctly.

(1) Press **EDIT/SEND SET** button to enter the weekly timer setting mode.

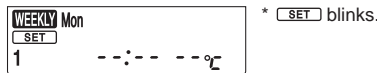

(2) Press **DAY** and **1~4** buttons to select setting day and number.

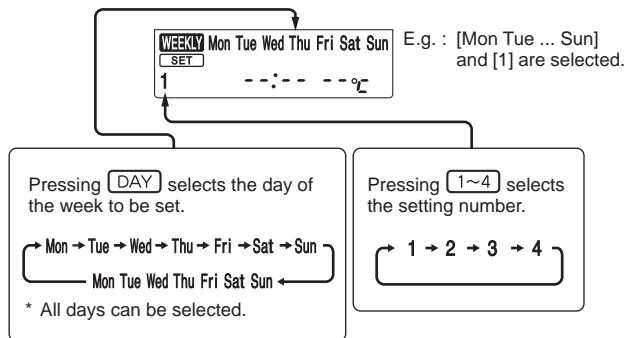

(3) Press **ON/OFF**, **TIME**, and **TEMP** buttons to set ON/OFF, time, and temperature.

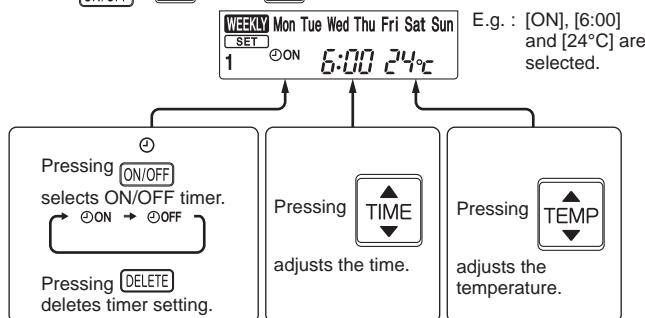

* Hold down the button to change the time quickly.

* The temperature can be set between 16 °C and 31 °C at weekly timer.





Press **DAY** and **1~4** buttons to continue setting the timer for other days and/or numbers.

(4) Press  button to complete and transmit the weekly timer setting.



*  which was blinking goes out, and the current time will be displayed.

NOTE:

- Press  button to transmit the setting information of weekly timer to the indoor unit. Point the remote controller toward the indoor unit for 3 seconds.
- When setting the timer for more than one day of the week or one number,  button does not have to be pressed per each setting. Press  button once after all the settings are complete. All the weekly timer settings will be saved.
- Press  button to enter the weekly timer setting mode, and press and hold  button for 5 seconds to erase all weekly timer settings. Point the remote controller toward the indoor unit.

(5) Press  button to turn the weekly timer ON. (**WEEKLY** lights.)

- When the weekly timer is ON, the day of the week whose timer setting is complete, will light.

Press  button again to turn the weekly timer OFF. (**WEEKLY** goes out.)



NOTE:

The saved settings will not be cleared when the weekly timer is turned OFF.

2. Checking weekly timer setting

(1) Press  button to enter the weekly timer setting mode.

*  blinks.

(2) Press  or  buttons to view the setting of the particular day or number.

(3) Press  button to exit the weekly timer setting.

i. i-save  OPERATION

1. How to set i-save operation

- (1) Press OFF/ON (stop/operate) button.
- (2) Select COOL or HEAT mode.
- (3) Press i-save button.
- (4) Set the temperature, fan speed, airflow direction, and 2 FLOW/1 FLOW for i-save operation.

NOTE:

- i-save operation cannot be selected during DRY, FAN or AUTO mode operation.
- The setting range of HEAT mode i-save operation is 10°C and 16 - 31°C.
- 2 groups of setting can be saved. (One for COOL, one for HEAT)
- i-save operation and the weekly timer operation cannot be used together.

2. How to cancel operation

- Press i-save button again.
- i-save operation can also be cancelled by pressing Operation select button to change the operation mode. The preferred setting can be saved for the next time with a single press of i-save button.

j. EMERGENCY/TEST OPERATION

In the case of test run operation or emergency operation, use the emergency operation switch on the right side of the indoor unit. Emergency operation is available when the remote controller is missing or has failed, or when the batteries in the remote controller are running down. The unit will start and OPERATION INDICATOR lamp will light up.

The first 30 minutes of operation is the test run operation. This operation is for servicing. The indoor fan runs at High speed and the temperature control does not work. In COOL MODE, the air outlet selection is set to 2 FLOW during the test run operation.

After 30 minutes of test run operation, the system shifts to EMERGENCY COOL/HEAT MODE with a set temperature of 24°C. The fan speed shifts to Med. The coil frost prevention works even in the test run or the emergency operation.

In the test run or emergency operation, the horizontal vane operates in VANE AUTO (Ⓢ) mode.

Emergency operation continues until the emergency operation switch is pressed once or twice or the unit receives any signal from the remote controller. In the latter case, normal operation will start.

NOTE: Do not press the emergency operation switch during normal operation.

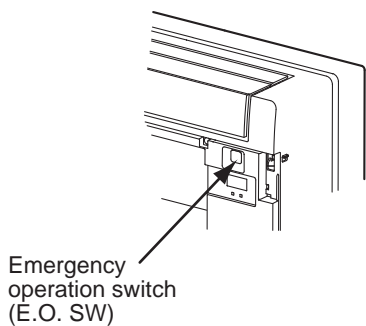

Operation mode	COOL/HEAT
Set temperature	24°C
Fan speed	Med.
Horizontal vane	Auto
Air outlet	2 FLOW

The operation mode is indicated by the Operation Indicator lamp as following

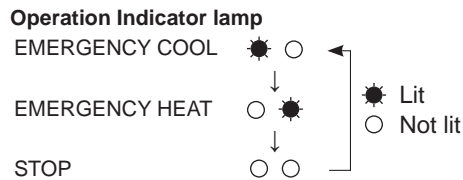

k. 3-MINUTE TIME DELAY OPERATION

When the system turns OFF, compressor will not restart for 3 minutes as 3-minute time delay function operates to protect compressor from overload.

C.2.10 CAPACITY CORRECTION RATIO CURVE FOR PIPING LENGTH

Correction ratio of capacity according to the length of piping (cooling)

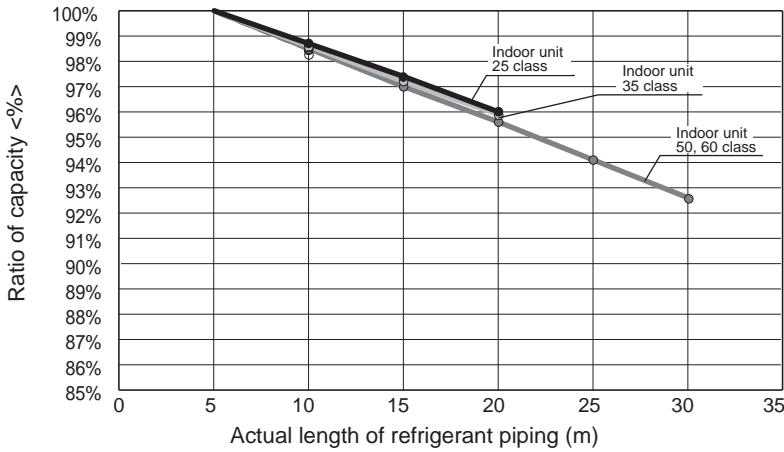

Correction ratio of capacity according to the length of piping (heating)

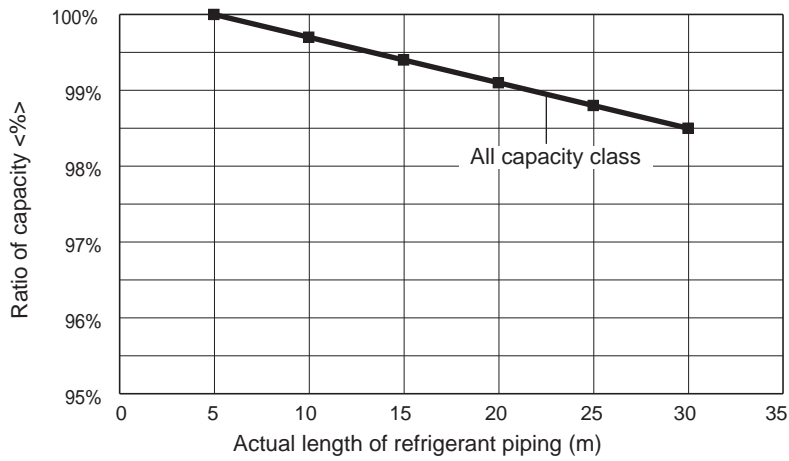

The length intended for the capacity calculation, which counts the length of refrigerant piping and the number of bends, is called actual length.

$$\text{Length of refrigerant piping (m)} + (\text{Number of bends} \times 0.3 \text{ m}) = \text{Actual length of refrigerant piping (m)}$$

CAPACITY CORRECTION RATIO CURVE FOR PIPING LENGTH

FLOOR-STANDING

C.3 CEILING CASSETTE

C.3.1	SPECIFICATIONS	C-626
	C.3.1.1 Inverter Heat Pump	C-626
C.3.2	OUTLINES AND DIMENSIONS.....	C-628
	C.3.2.1 Indoor Unit.....	C-628
C.3.3	WIRING DIAGRAM.....	C-630
	C.3.3.1 Indoor Unit.....	C-630
C.3.4	REFRIGERANT SYSTEM DIAGRAM	C-632
	C.3.4.1 Inverter Heat Pump	C-632
C.3.5	PERFORMANCE DATA.....	C-634
	C.3.5.1 Inverter Heat Pump	C-634
C.3.6	NOISE CRITERIA CURVES	C-641
	C.3.6.1 Inverter Heat Pump	C-641
C.3.7	TEMPERATURE AND AIR FLOW DISTRIBUTIONS.....	C-643
C.3.8	OPERATION	C-647
	C.3.8.1 MLZ-KP•VF Series.....	C-647
	C.3.8.2 MLZ-KY•VG Series	C-655

C.3.1 SPECIFICATIONS

C.3.1.1 Inverter Heat Pump

Indoor Unit				MLZ-KP25VF	MLZ-KP35VF	MLZ-KP50VF		
Outdoor Unit				SUZ-M25VA	SUZ-M35VA	SUZ-M50VA		
Refrigerant				R32	R32	R32		
Power Supply				Outdoor Power supply	Outdoor Power supply	Outdoor Power supply		
Outdoor (V/Phase/Hz)				230V/SinglePhase/50Hz	230V/SinglePhase/50Hz	230V/SinglePhase/50Hz		
Cooling	Design load		kW	2.5	3.5	5.0		
	Annual electricity consumption (*1)		kWh/a	141	175	260		
	SEER			6.2	7.0	6.7		
	Energy efficiency class			A++	A++	A++		
	Capacity	Rated	kW	2.5	3.5	5.0		
		Min-Max.	kW	1.4-3.2	0.8-3.9	1.7-5.6		
	SHF			0.87	0.74	0.72		
	Total Input	Rated	kW	0.59	0.94	1.38		
	EER			4.20	3.70	3.60		
	Heating (Average Season)	Design load		kW	2.2	2.6	4.3	
Declared Capacity		at reference design temperature	kW	2.0(-10°C)	2.3(-10°C)	3.8(-10°C)		
		at bivalent temperature	kW	2.0(-7°C)	2.3(-7°C)	3.8(-7°C)		
		at operation limit temperature	kW	2.0(-10°C)	2.3(-10°C)	3.8(-10°C)		
Back up heating capacity		kW	0.2	0.3	0.5			
Annual electricity consumption (*1)		kWh/a	697	791	1397			
SCOP			4.4	4.6	4.3			
Energy efficiency class			A+	A++	A+			
Capacity		Rated	kW	3.2	4.1	6.0		
		Min-Max.	kW	1.4-4.2	1.1-4.9	1.7-7.2		
Total Input	Rated	kW	0.80	1.10	1.86			
COP			4.00	3.71	3.21			
Operating Current (Max.)			A	7.2	8.9	13.9		
Indoor Unit	Input		Rated	kW	0.04	0.04	0.04	
	Operating Current (Max.)			A	0.40	0.40	0.40	
	Dimensions		H x W x D	mm	185 x 1102 x 360	185 x 1102 x 360	185 x 1102 x 360	
	Weight			kg	15.5	15.5	15.5	
	Air Volume (SLo-Lo-Mid-Hi-SHi (*2) (Dry))	Cooling	m³/min.	6.0 - 7.2 - 8.0 - 8.8	6.0 - 7.3 - 8.4 - 9.4	6.0 - 8.3 - 9.8 - 11.4		
		Heating	m³/min.	6.0 - 7.0 - 8.2 - 9.2	6.0 - 7.7 - 8.8 - 9.9	6.0 - 8.8 - 10.3 - 11.8		
	Sound Level (SPL) (SLo-Lo-Mid-Hi-SHi (*2))	Cooling	dB(A)	27 - 31 - 34 - 38	27 - 32 - 36 - 40	29 - 36 - 41 - 47		
		Heating	dB(A)	26 - 27 - 34 - 37	26 - 32 - 36 - 40	26 - 37 - 42 - 48		
	Sound Level (PWL)		Cooling	dB(A)	52	53	59	
	Panel	Dimensions		H x W x D	mm	24 x 1200 x 424	24 x 1200 x 424	
Weight			kg	3.5	3.5			
Outdoor Unit	Dimensions		H x W x D	mm	550 x 800 x 285	550 x 800 x 285	714 x 800 x 285	
	Weight			kg	30	35	41	
	Air Volume	Cooling	m³/min.	36.3	34.3	45.8		
		Heating	m³/min.	34.6	32.7	43.7		
	Sound Level (SPL)	Cooling	dB(A)	45	48	48		
		Heating	dB(A)	46	48	49		
	Sound Level (PWL)		Cooling	dB(A)	59	59	64	
	Operating Current (Max.)			A	6.8	8.5	13.5	
	Breaker Size			A	10	10	20	
	Ext.Piping	Diameter		Liquid/Gas	mm	6.35/9.52	6.35/9.52	6.35/12.7
Max.Length		Out-In	m	20	20	30		
Max.Height		Out-In	m	12	12	30		
Guaranteed Operating Range (Outdoor)				Cooling	°C	-10 ~ +46	-10 ~ +46	-15 ~ +46
				Heating	°C	-10 ~ +24	-10 ~ +24	-10 ~ +24

(*1) Energy consumption based on standard test results. Actual energy consumption will depend on how the appliance is used and where it is located.

(*2) SHi: Super High.

Indoor Unit		MLZ-KY20VG		
Outdoor Unit		For Multi connection		
		MLP-448W		
Refrigerant		R32		
Power Supply	Source	Outdoor Power supply		
	Outdoor (V/Phase/Hz)	230V/SinglePhase/50Hz		
Cooling	Design load	kW	-	
	Annual electricity consumption (*1)	kWh/a	-	
	SEER		-	
		Energy efficiency class		-
	Capacity	Rated	kW	-
		Min-Max.	kW	-
	SHF			-
	Total Input	Rated	kW	-
EER			-	
Heating (Average Season)	Design load	kW	-	
	Declared Capacity	at reference design temperature	kW	-
		at bivalent temperature	kW	-
		at operation limit temperature	kW	-
	Back up heating capacity	kW	-	
	Annual electricity consumption (*1)	kWh/a	-	
	SCOP			-
		Energy efficiency class		-
	Capacity	Rated	kW	-
		Min-Max.	kW	-
	Total Input	Rated	kW	-
COP			-	
Operating Current (Max.)		A	-	
Indoor Unit	Input	Rated	kW	0.01
	Operating Current (Max.)		A	0.12
	Dimensions	H x W x D	mm	194 x 842 x 301
	Weight		kg	14.0
	Air Volume (SLo-Lo-Mid-Hi-SHi (*2) (Dry))	Cooling	m ³ /min.	4.3 - 4.7 - 5.2 - 5.6
		Heating	m ³ /min.	4.3 - 4.9 - 5.5 - 6.0
	Sound Level (SPL) (SLo-Lo-Mid-Hi-SHi (*2))	Cooling	dB(A)	30 - 32 - 34 - 37
Heating		dB(A)	29 - 32 - 35 - 58	
Sound Level (PWL)	Cooling	dB(A)	40-42-44-50	
Panel	Dimensions	H x W x D	mm	34 x 915 x 370
	Weight		kg	3.8
Outdoor Unit	Dimensions	H x W x D	mm	-
	Weight		kg	-
	Air Volume	Cooling	m ³ /min.	-
		Heating	m ³ /min.	-
	Sound Level (SPL)	Cooling	dB(A)	-
		Heating	dB(A)	-
	Sound Level (PWL)	Cooling	dB(A)	-
Operating Current (Max.)		A	-	
Breaker Size		A	-	
Ext.Piping	Diameter	Liquid/Gas	mm	6.35/9.52
	Max.Length	Out-In	m	-
	Max.Height	Out-In	m	-
Guaranteed Operating Range (Outdoor)	Cooling	°C	-	
	Heating	°C	-	

(*1) Energy consumption based on standard test results. Actual energy consumption will depend on how the appliance is used and where it is located.

(*2) SHi: Super High.

C.3.2 OUTLINES AND DIMENSIONS

C.3.2.1 Indoor Unit

MLZ-KP25VF MLZ-KP35VF MLZ-KP50VF

Unit: mm

INDOOR UNIT

INDOOR UNIT OUTLINE DRAWING

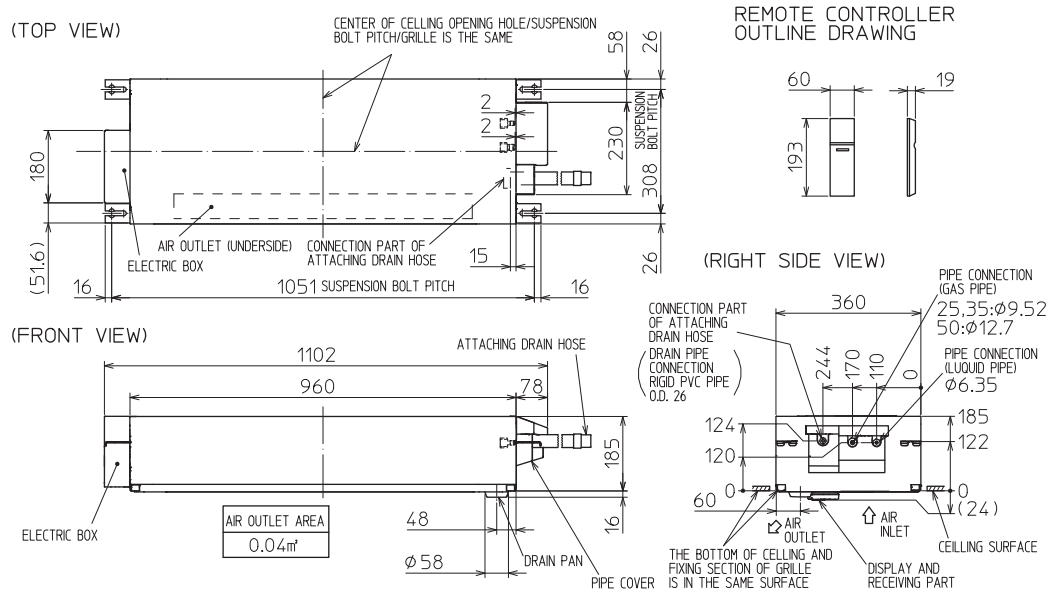

GRILLE OUTLINE DRAWING (MLP-444W)

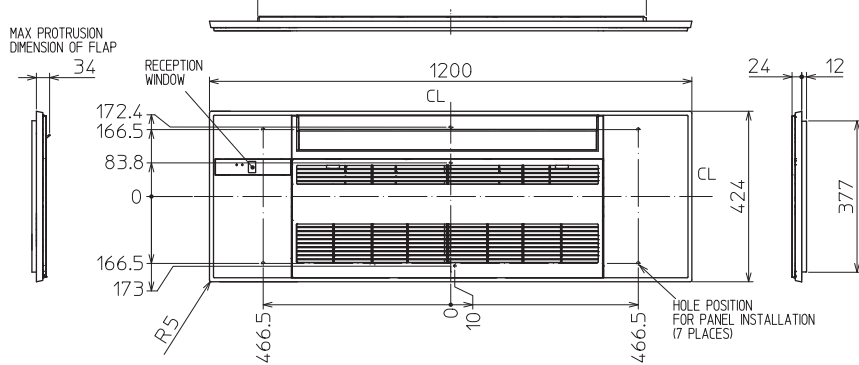

		KP25/35VF	KP50VF
EXTENSION PIPE	LIQUID PIPE O.D.	6.35	
	GAS PIPE O.D.	9.52	12.7
CONNECTION OF PIPE	LIQUID PIPE	FLARED CONNECTION 6.35	
	GAS PIPE	FLARED CONNECTION 9.52	FLARED CONNECTION 12.7
DRAIN HOSE	HEAT INSULATOR O.D.	CONNECTION I.D.	EFFECTIVE LENGTH
	32	25	480
DRAIN PIPE CONNECTION	RIGID PVC PIPE O.D. 26		

NOTE1. CUT THE DRAIN HOSE (ACCESSORY) FOR USE, IF NECESSARY.

INDOOR UNIT DETAIL VIEW (TOP VIEW)

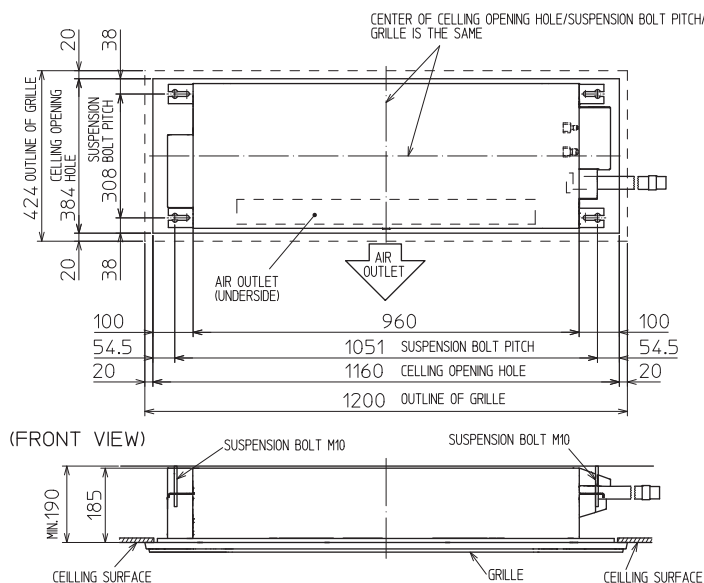

THE METHOD FOR STANDING DRAIN FROM INDOOR UNIT
 ※ CUT THE DRAIN HOSE (ACCESSORY) FOR USE, IF NECESSARY.

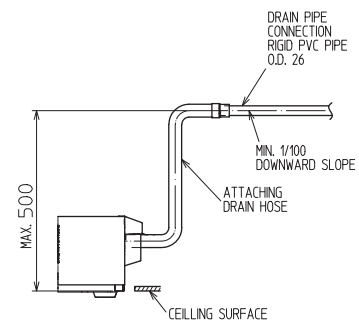

MLZ-KY20VG

Unit: mm

INDOOR UNIT

INDOOR UNIT OUTLINE DRAWING

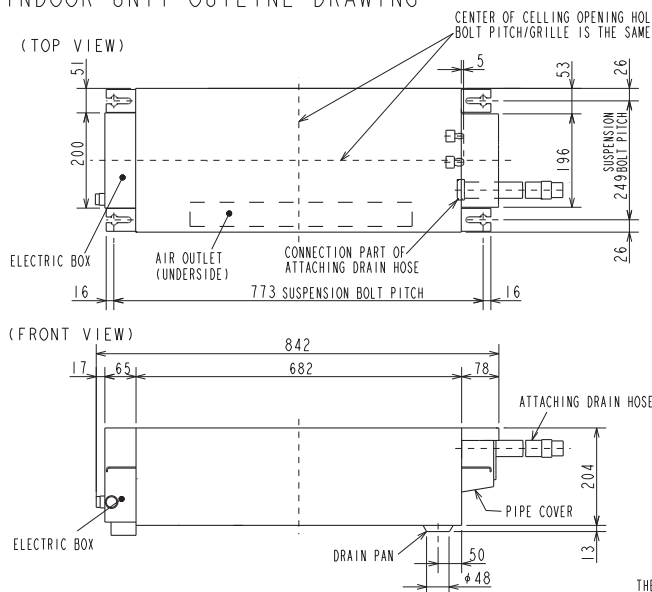

REMOTE CONTROLLER OUTLINE DRAWING

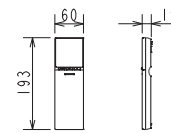

(RIGHT SIDE VIEW)

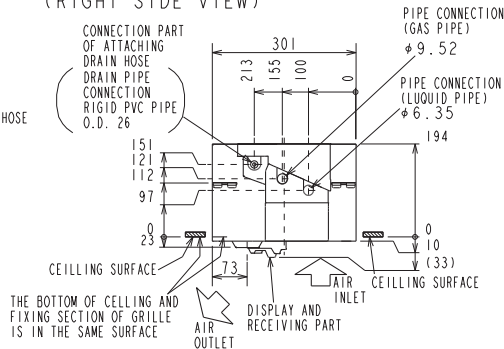

GRILLE OUTLINE DRAWING (MLP-448W)

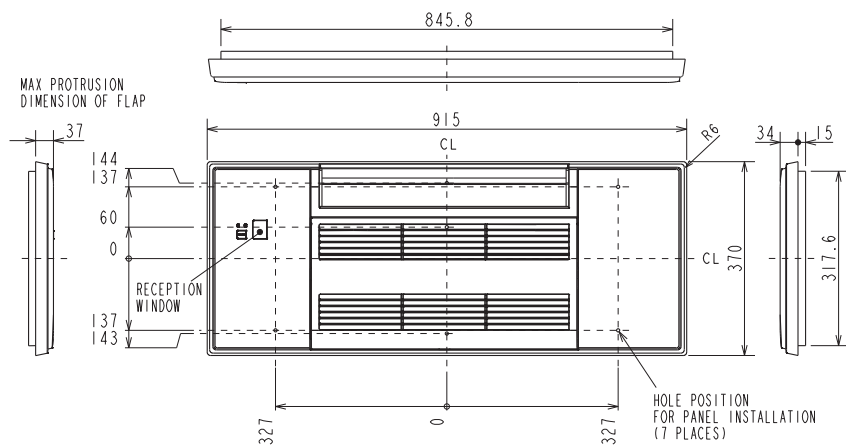

EXTENSION PIPE	LIQUID PIPE O.D.	φ6.35
	GAS PIPE O.D.	φ9.52
CONNECTION OF PIPE	LIQUID PIPE	FLARED CONNECTION φ6.35
	GAS PIPE	FLARED CONNECTION φ9.52
DRAIN HOSE	HEAT INSULATOR O.D.	φ32
	CONNECTION I.D.	φ25
	EFFECTIVE LENGTH	480
DRAIN PIPE CONNECTION	RIGID PVC PIPE O.D. φ26	

NOTE1. CUT THE DRAIN HOSE (ACCESSORY) FOR USE, IF NECESSARY.

INDOOR UNIT DETAIL VIEW

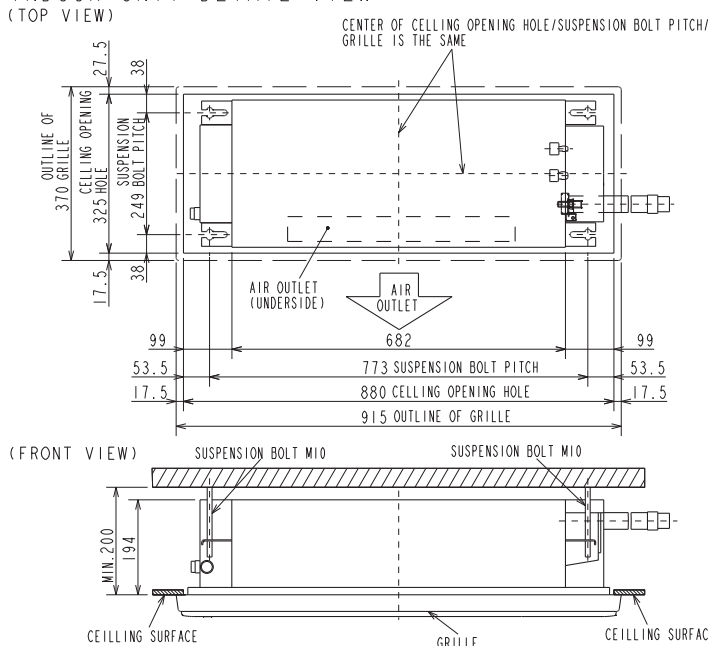

THE METHOD FOR STANDING DRAIN FROM INDOOR UNIT
 * CUT THE DRAIN HOSE (ACCESSORY) FOR USE, IF NECESSARY.

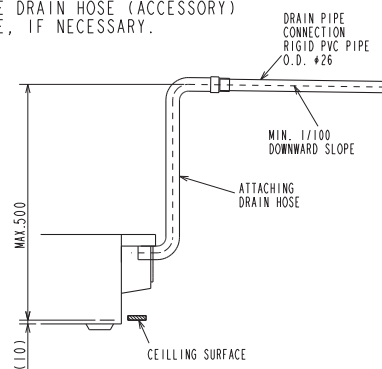

OUTLINES AND DIMENSIONS

CEILING CASSETTE

C.3.3 WIRING DIAGRAM

C.3.3.1 Indoor Unit

MLZ-KP25VF

MLZ-KP35VF

INDOOR UNIT

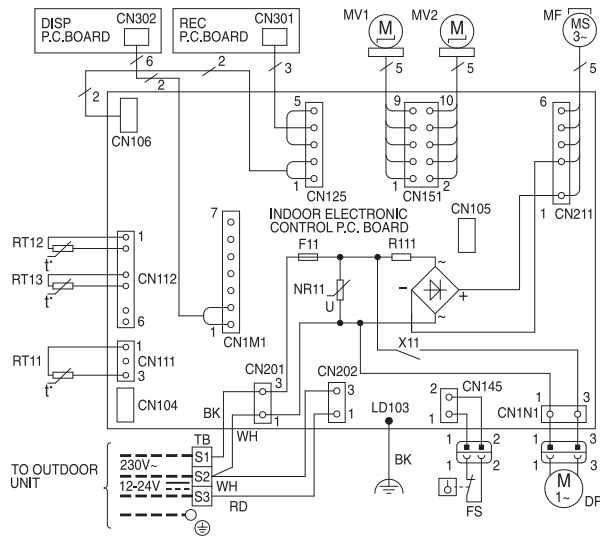

SYMBOL	NAME	SYMBOL	NAME
MF	FAN MOTOR	RT11	ROOM TEMP. THERMISTOR
MV1	HORIZONTAL VANE MOTOR	RT12	COIL TEMP. THERMISTOR(MAIN)
MV2	VERTICAL VANE MOTOR	RT13	COIL TEMP. THERMISTOR(SUB)
DP	DRAIN PUMP	NR11	VARISTOR
FS	FLOAT SENSOR	R111	RESISTOR
F11	FUSE (T3.15AL250V)		
X11	RELAY		
TB	TERMINAL BLOCK		

NOTES :

1. About the outdoor side electric wiring refer to the outdoor unit electric wiring diagram for servicing.
2. Use copper conductors only.
3. Symbols below indicate.

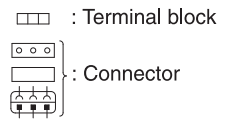

MLZ-KP50VF

INDOOR UNIT

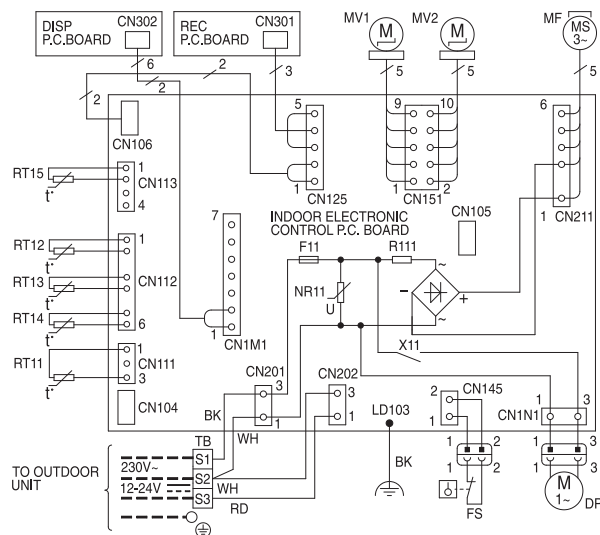

SYMBOL	NAME	SYMBOL	NAME
MF	FAN MOTOR	RT11	ROOM TEMP. THERMISTOR
MV1	HORIZONTAL VANE MOTOR	RT12	COIL TEMP. THERMISTOR(MAIN1)
MV2	VERTICAL VANE MOTOR	RT13	COIL TEMP. THERMISTOR(SUB)
DP	DRAIN PUMP	RT14	COIL TEMP. THERMISTOR(MAIN2)
FS	FLOAT SENSOR	RT15	COIL TEMP. THERMISTOR(MAIN3)
F11	FUSE (T3.15AL250V)	NR11	VARISTOR
X11	RELAY	R111	RESISTOR
TB	TERMINAL BLOCK		

NOTES :

1. About the outdoor side electric wiring refer to the outdoor unit electric wiring diagram for servicing.
2. Use copper conductors only.
3. Symbols below indicate.

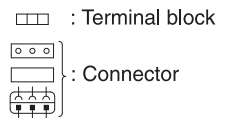

WIRING DIAGRAM

CEILING CASSETTE

MLZ-KY20VG

INDOOR UNIT

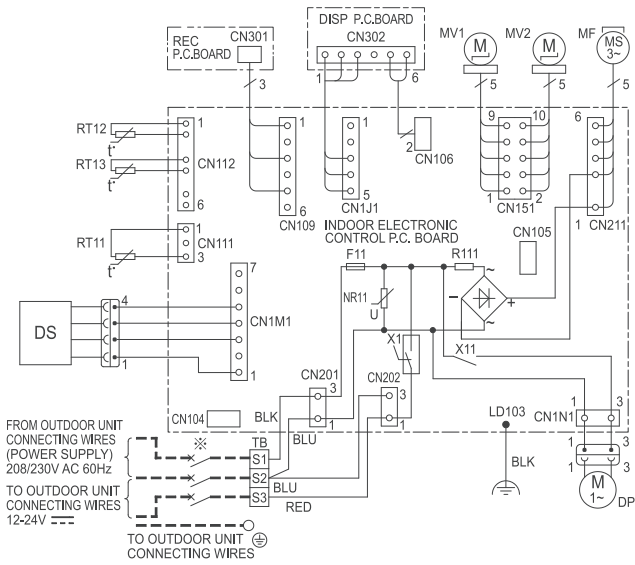

SYMBOL	NAME	SYMBOL	NAME
MF	FAN MOTOR	RT11	ROOM TEMP. THERMISTOR
MV1	HORIZONTAL VANE MOTOR	RT12	COIL TEMP. THERMISTOR(MAIN)
MV2	VERTICAL VANE MOTOR	RT13	COIL TEMP. THERMISTOR(SUB)
DP	DRAIN PUMP	NR11	VARISTOR
DS	DRAIN SENSOR	R111	RESISTOR
F11	FUSE (T3.15A/250V)	CN105	IT TERMINAL
X11	RELAY	X1	RELAY
TB	TERMINAL BLOCK		

NOTES :

1. About the outdoor side electric wiring refer to the outdoor unit electric wiring diagram for servicing.
2. Use copper conductors only.
3. Symbols below indicate.

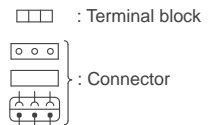

C.3.4 REFRIGERANT SYSTEM DIAGRAM

C.3.4.1 Inverter Heat Pump

Unit: mm

MLZ-KP25VF

MLZ-KP35VF

INDOOR UNIT

OUTDOOR UNIT

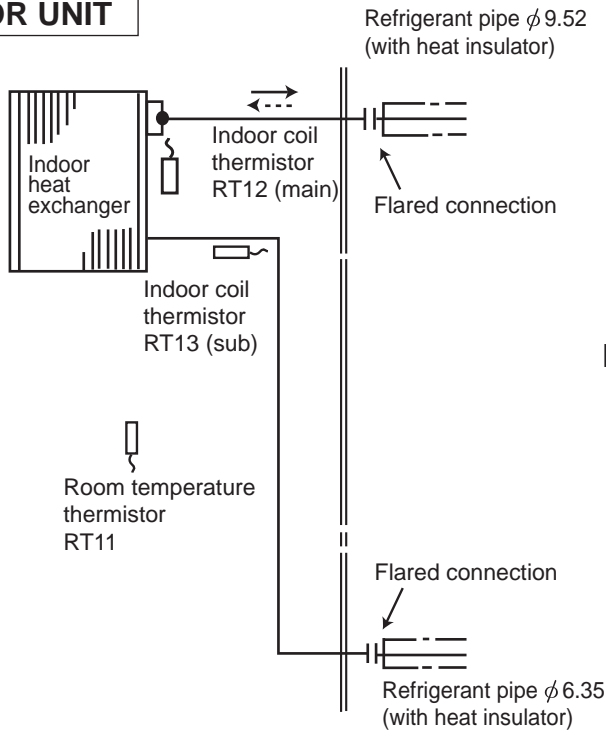

For SUZ-M25/35VA connection

→ Refrigerant flow in cooling
 ·····→ Refrigerant flow in heating

MLZ-KP50VF

INDOOR UNIT

OUTDOOR UNIT

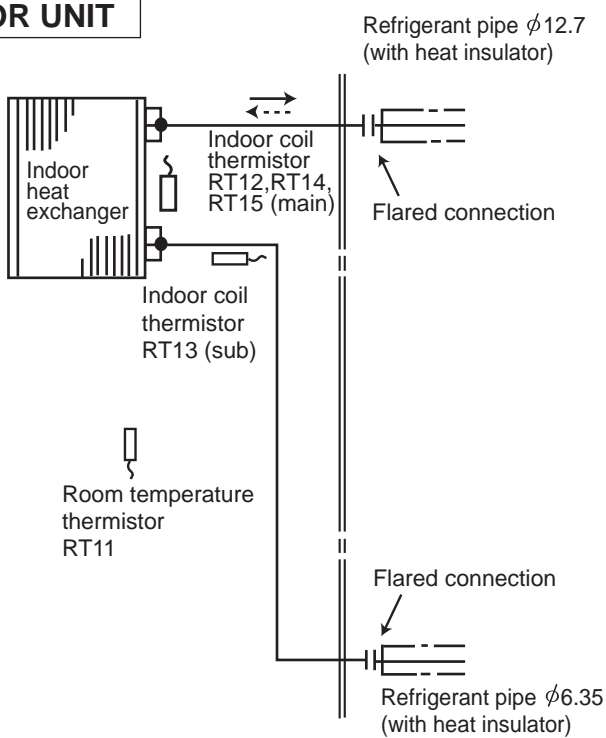

For SUZ-M50VA connection

→ Refrigerant flow in cooling
 ·····→ Refrigerant flow in heating

REFRIGERANT SYSTEM DIAGRAM

CEILING CASSETTE

MLZ-KY20VG

INDOOR UNIT

OUTDOOR UNIT

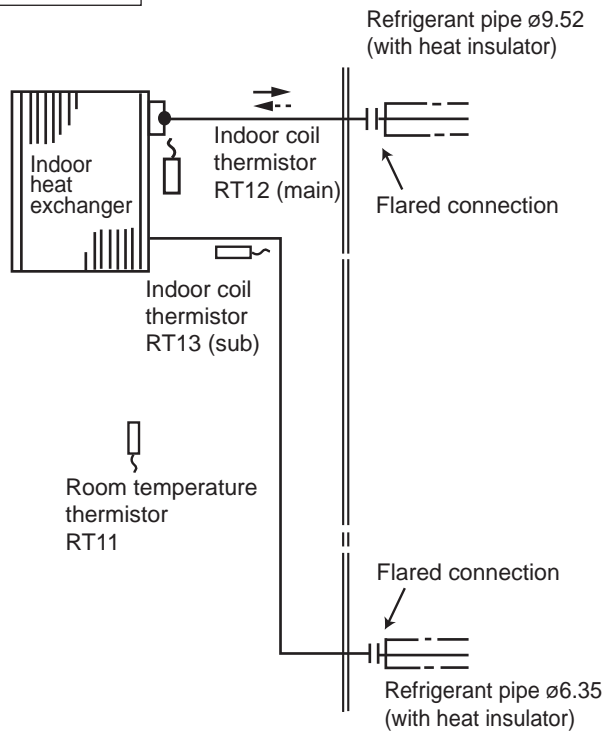

For Multi connection

- Refrigerant flow in cooling
- - → Refrigerant flow in heating

C.3.5 PERFORMANCE DATA

C.3.5.1 Inverter Heat Pump

PERFORMANCE DATA COOL operation at Rated frequency

MLZ-KP25VF: SUZ-M25VA

CAPACITY: 2.5 kW

SHF: 0.87

INPUT: 590 W

INDOOR DB (°C)	INDOOR WB (°C)	OUTDOOR DB (°C)															
		21				25				27				30			
		Q	SHC	SHF	INPUT	Q	SHC	SHF	INPUT	Q	SHC	SHF	INPUT	Q	SHC	SHF	INPUT
21	18	2.94	2.03	0.69	472	2.81	1.94	0.69	496	2.70	1.86	0.69	519	2.60	1.79	0.69	543
21	20	3.06	1.75	0.57	496	2.94	1.67	0.57	525	2.85	1.62	0.57	537	2.75	1.57	0.57	561
22	18	2.94	2.14	0.73	472	2.81	2.05	0.73	496	2.70	1.97	0.73	519	2.60	1.90	0.73	543
22	20	3.06	1.87	0.61	496	2.94	1.79	0.61	525	2.85	1.74	0.61	537	2.75	1.68	0.61	561
22	22	3.19	1.56	0.49	513	3.08	1.51	0.49	546	3.00	1.47	0.49	561	2.88	1.41	0.49	584
23	18	2.94	2.26	0.77	472	2.81	2.17	0.77	496	2.70	2.08	0.77	519	2.60	2.00	0.77	543
23	20	3.06	1.99	0.65	496	2.94	1.91	0.65	525	2.85	1.85	0.65	537	2.75	1.79	0.65	561
23	22	3.19	1.69	0.53	513	3.08	1.63	0.53	546	3.00	1.59	0.53	561	2.88	1.52	0.53	584
24	18	2.94	2.38	0.81	472	2.81	2.28	0.81	496	2.70	2.19	0.81	519	2.60	2.11	0.81	543
24	20	3.06	2.11	0.69	496	2.94	2.03	0.69	525	2.85	1.97	0.69	537	2.75	1.90	0.69	561
24	22	3.19	1.82	0.57	513	3.08	1.75	0.57	546	3.00	1.71	0.57	561	2.88	1.64	0.57	584
24	24	3.35	1.51	0.45	537	3.23	1.45	0.45	566	3.15	1.42	0.45	584	3.05	1.37	0.45	614
25	20	3.06	2.24	0.73	496	2.94	2.14	0.73	525	2.85	2.08	0.73	537	2.75	2.01	0.73	561
25	22	3.19	1.94	0.61	513	3.08	1.88	0.61	546	3.00	1.83	0.61	561	2.88	1.75	0.61	584
25	24	3.35	1.64	0.49	537	3.23	1.58	0.49	566	3.15	1.54	0.49	584	3.05	1.49	0.49	614
26	18	2.94	2.61	0.89	472	2.81	2.50	0.89	496	2.70	2.40	0.89	519	2.60	2.31	0.89	543
26	20	3.06	2.36	0.77	496	2.94	2.26	0.77	525	2.85	2.19	0.77	537	2.75	2.12	0.77	561
26	22	3.19	2.07	0.65	513	3.08	2.00	0.65	546	3.00	1.95	0.65	561	2.88	1.87	0.65	584
26	24	3.35	1.78	0.53	537	3.23	1.71	0.53	566	3.15	1.67	0.53	584	3.05	1.62	0.53	614
26	26	3.45	1.41	0.41	566	3.35	1.37	0.41	596	3.30	1.35	0.41	614	3.20	1.31	0.41	631
27	18	2.94	2.73	0.93	472	2.81	2.62	0.93	496	2.70	2.51	0.93	519	2.60	2.42	0.93	543
27	20	3.06	2.48	0.81	496	2.94	2.38	0.81	525	2.85	2.31	0.81	537	2.75	2.23	0.81	561
27	22	3.19	2.20	0.69	513	3.08	2.12	0.69	546	3.00	2.07	0.69	561	2.88	1.98	0.69	584
27	24	3.35	1.91	0.57	537	3.23	1.84	0.57	566	3.15	1.80	0.57	584	3.05	1.74	0.57	614
27	26	3.45	1.55	0.45	566	3.35	1.51	0.45	596	3.30	1.49	0.45	614	3.20	1.44	0.45	631
28	18	2.94	2.85	0.97	472	2.81	2.73	0.97	496	2.70	2.62	0.97	519	2.60	2.52	0.97	543
28	20	3.06	2.60	0.85	496	2.94	2.50	0.85	525	2.85	2.42	0.85	537	2.75	2.34	0.85	561
28	22	3.19	2.33	0.73	513	3.08	2.24	0.73	546	3.00	2.19	0.73	561	2.88	2.10	0.73	584
28	24	3.35	2.04	0.61	537	3.23	1.97	0.61	566	3.15	1.92	0.61	584	3.05	1.86	0.61	614
28	26	3.45	1.69	0.49	566	3.35	1.64	0.49	596	3.30	1.62	0.49	614	3.20	1.57	0.49	631
29	18	2.94	2.94	1.00	472	2.81	2.81	1.00	496	2.70	2.70	1.00	519	2.60	2.60	1.00	543
29	20	3.06	2.73	0.89	496	2.94	2.61	0.89	525	2.85	2.54	0.89	537	2.75	2.45	0.89	561
29	22	3.19	2.45	0.77	513	3.08	2.37	0.77	546	3.00	2.31	0.77	561	2.88	2.21	0.77	584
29	24	3.35	2.18	0.65	537	3.23	2.10	0.65	566	3.15	2.05	0.65	584	3.05	1.98	0.65	614
29	26	3.45	1.83	0.53	566	3.35	1.78	0.53	596	3.30	1.75	0.53	614	3.20	1.70	0.53	631
30	18	2.94	2.94	1.00	472	2.81	2.81	1.00	496	2.70	2.70	1.00	519	2.60	2.60	1.00	543
30	20	3.06	2.85	0.93	496	2.94	2.73	0.93	525	2.85	2.65	0.93	537	2.75	2.56	0.93	561
30	22	3.19	2.58	0.81	513	3.08	2.49	0.81	546	3.00	2.43	0.81	561	2.88	2.33	0.81	584
30	24	3.35	2.31	0.69	537	3.23	2.23	0.69	566	3.15	2.17	0.69	584	3.05	2.10	0.69	614
30	26	3.45	1.97	0.57	566	3.35	1.91	0.57	596	3.30	1.88	0.57	614	3.20	1.82	0.57	631
31	18	2.94	2.94	1.00	472	2.81	2.81	1.00	496	2.70	2.70	1.00	519	2.60	2.60	1.00	543
31	20	3.06	2.97	0.97	496	2.94	2.85	0.97	525	2.85	2.76	0.97	537	2.75	2.67	0.97	561
31	22	3.19	2.71	0.85	513	3.08	2.61	0.85	546	3.00	2.55	0.85	561	2.88	2.44	0.85	584
31	24	3.35	2.45	0.73	537	3.23	2.35	0.73	566	3.15	2.30	0.73	584	3.05	2.23	0.73	614
31	26	3.45	2.10	0.61	566	3.35	2.04	0.61	596	3.30	2.01	0.61	614	3.20	1.95	0.61	631
32	18	2.94	2.94	1.00	472	2.81	2.81	1.00	496	2.70	2.70	1.00	519	2.60	2.60	1.00	543
32	20	3.06	3.06	1.00	496	2.94	2.94	1.00	525	2.85	2.85	1.00	537	2.75	2.75	1.00	561
32	22	3.19	2.84	0.89	513	3.08	2.74	0.89	546	3.00	2.67	0.89	561	2.88	2.56	0.89	584
32	24	3.35	2.58	0.77	537	3.23	2.48	0.77	566	3.15	2.43	0.77	584	3.05	2.35	0.77	614
32	26	3.45	2.24	0.65	566	3.35	2.18	0.65	596	3.30	2.15	0.65	614	3.20	2.08	0.65	631

NOTE Q : Total capacity (kW) SHF : Sensible heat factor DB : Dry-bulb temperature
 SHC : Sensible heat capacity (kW) INPUT : Total power input (W) WB : Wet-bulb temperature

PERFORMANCE DATA

CEILING CASSETTE

PERFORMANCE DATA COOL operation at Rated frequency

MLZ-KP25VF: SUZ-M25VA

CAPACITY: 2.5 kW

SHF: 0.87

INPUT: 590 W

INDOOR DB (°C)	INDOOR WB (°C)	OUTDOOR DB (°C)											
		35				40				46			
		Q	SHC	SHF	INPUT	Q	SHC	SHF	INPUT	Q	SHC	SHF	INPUT
21	18	2.45	1.69	0.69	578	2.25	1.55	0.69	614	2.08	1.43	0.69	637
21	20	2.58	1.47	0.57	602	2.40	1.37	0.57	631	2.23	1.27	0.57	667
22	18	2.45	1.79	0.73	578	2.25	1.64	0.73	614	2.08	1.51	0.73	637
22	20	2.58	1.57	0.61	602	2.40	1.46	0.61	631	2.23	1.36	0.61	667
22	22	2.73	1.34	0.49	625	2.55	1.25	0.49	661	2.38	1.16	0.49	684
23	18	2.45	1.89	0.77	578	2.25	1.73	0.77	614	2.08	1.60	0.77	637
23	20	2.58	1.67	0.65	602	2.40	1.56	0.65	631	2.23	1.45	0.65	667
23	22	2.73	1.44	0.53	625	2.55	1.35	0.53	661	2.38	1.26	0.53	684
24	18	2.45	1.98	0.81	578	2.25	1.82	0.81	614	2.08	1.68	0.81	637
24	20	2.58	1.78	0.69	602	2.40	1.66	0.69	631	2.23	1.54	0.69	667
24	22	2.73	1.55	0.57	625	2.55	1.45	0.57	661	2.38	1.35	0.57	684
24	24	2.88	1.29	0.45	649	2.70	1.22	0.45	679	2.55	1.15	0.45	708
25	20	2.58	1.88	0.73	602	2.40	1.75	0.73	631	2.23	1.62	0.73	667
25	22	2.73	1.66	0.61	625	2.55	1.56	0.61	661	2.38	1.45	0.61	684
25	24	2.88	1.41	0.49	649	2.70	1.32	0.49	679	2.55	1.25	0.49	708
26	18	2.45	2.18	0.89	578	2.25	2.00	0.89	614	2.08	1.85	0.89	637
26	20	2.58	1.98	0.77	602	2.40	1.85	0.77	631	2.23	1.71	0.77	667
26	22	2.73	1.77	0.65	625	2.55	1.66	0.65	661	2.38	1.54	0.65	684
26	24	2.88	1.52	0.53	649	2.70	1.43	0.53	679	2.55	1.35	0.53	708
26	26	3.03	1.24	0.41	673	2.85	1.17	0.41	702	2.68	1.10	0.41	732
27	18	2.45	2.28	0.93	578	2.25	2.09	0.93	614	2.08	1.93	0.93	637
27	20	2.58	2.09	0.81	602	2.40	1.94	0.81	631	2.23	1.80	0.81	667
27	22	2.73	1.88	0.69	625	2.55	1.76	0.69	661	2.38	1.64	0.69	684
27	24	2.88	1.64	0.57	649	2.70	1.54	0.57	679	2.55	1.45	0.57	708
27	26	3.03	1.36	0.45	673	2.85	1.28	0.45	702	2.68	1.20	0.45	732
28	18	2.45	2.38	0.97	578	2.25	2.18	0.97	614	2.08	2.01	0.97	637
28	20	2.58	2.19	0.85	602	2.40	2.04	0.85	631	2.23	1.89	0.85	667
28	22	2.73	1.99	0.73	625	2.55	1.86	0.73	661	2.38	1.73	0.73	684
28	24	2.88	1.75	0.61	649	2.70	1.65	0.61	679	2.55	1.56	0.61	708
28	26	3.03	1.48	0.49	673	2.85	1.40	0.49	702	2.68	1.31	0.49	732
29	18	2.45	2.45	1.00	578	2.25	2.25	1.00	614	2.08	2.08	1.00	637
29	20	2.58	2.29	0.89	602	2.40	2.14	0.89	631	2.23	1.98	0.89	667
29	22	2.73	2.10	0.77	625	2.55	1.96	0.77	661	2.38	1.83	0.77	684
29	24	2.88	1.87	0.65	649	2.70	1.76	0.65	679	2.55	1.66	0.65	708
29	26	3.03	1.60	0.53	673	2.85	1.51	0.53	702	2.68	1.42	0.53	732
30	18	2.45	2.45	1.00	578	2.25	2.25	1.00	614	2.08	2.08	1.00	637
30	20	2.58	2.39	0.93	602	2.40	2.23	0.93	631	2.23	2.07	0.93	667
30	22	2.73	2.21	0.81	625	2.55	2.07	0.81	661	2.38	1.92	0.81	684
30	24	2.88	1.98	0.69	649	2.70	1.86	0.69	679	2.55	1.76	0.69	708
30	26	3.03	1.72	0.57	673	2.85	1.62	0.57	702	2.68	1.52	0.57	732
31	18	2.45	2.45	1.00	578	2.25	2.25	1.00	614	2.08	2.08	1.00	637
31	20	2.58	2.50	0.97	602	2.40	2.33	0.97	631	2.23	2.16	0.97	667
31	22	2.73	2.32	0.85	625	2.55	2.17	0.85	661	2.38	2.02	0.85	684
31	24	2.88	2.10	0.73	649	2.70	1.97	0.73	679	2.55	1.86	0.73	708
31	26	3.03	1.85	0.61	673	2.85	1.74	0.61	702	2.68	1.63	0.61	732
32	18	2.45	2.45	1.00	578	2.25	2.25	1.00	614	2.08	2.08	1.00	637
32	20	2.58	2.58	1.00	602	2.40	2.40	1.00	631	2.23	2.23	1.00	667
32	22	2.73	2.43	0.89	625	2.55	2.27	0.89	661	2.38	2.11	0.89	684
32	24	2.88	2.21	0.77	649	2.70	2.08	0.77	679	2.55	1.96	0.77	708
32	26	3.03	1.97	0.65	673	2.85	1.85	0.65	702	2.68	1.74	0.65	732

NOTE Q : Total capacity (kW) SHF : Sensible heat factor DB : Dry-bulb temperature
 SHC : Sensible heat capacity (kW) INPUT : Total power input (W) WB : Wet-bulb temperature

CEILING CASSETTE PERFORMANCE DATA

PERFORMANCE DATA COOL operation at Rated frequency

MLZ-KP35VF: SUZ-M35VA

CAPACITY: 3.5 kW SHF: 0.74 INPUT: 940 W

INDOOR DB (°C)	INDOOR WB (°C)	OUTDOOR DB (°C)															
		21				25				27				30			
		Q	SHC	SHF	INPUT	Q	SHC	SHF	INPUT	Q	SHC	SHF	INPUT	Q	SHC	SHF	INPUT
21	18	4.11	2.30	0.56	752	3.94	2.21	0.56	790	3.78	2.12	0.56	827	3.64	2.04	0.56	865
21	20	4.29	1.89	0.44	790	4.11	1.81	0.44	837	3.99	1.76	0.44	855	3.85	1.69	0.44	893
22	18	4.11	2.47	0.60	752	3.94	2.36	0.60	790	3.78	2.27	0.60	827	3.64	2.18	0.60	865
22	20	4.29	2.06	0.48	790	4.11	1.97	0.48	837	3.99	1.92	0.48	855	3.85	1.85	0.48	893
22	22	4.46	1.61	0.36	818	4.31	1.55	0.36	870	4.20	1.51	0.36	893	4.03	1.45	0.36	931
23	18	4.11	2.63	0.64	752	3.94	2.52	0.64	790	3.78	2.42	0.64	827	3.64	2.33	0.64	865
23	20	4.29	2.23	0.52	790	4.11	2.14	0.52	837	3.99	2.07	0.52	855	3.85	2.00	0.52	893
23	22	4.46	1.79	0.40	818	4.31	1.72	0.40	870	4.20	1.68	0.40	893	4.03	1.61	0.40	931
24	18	4.11	2.80	0.68	752	3.94	2.68	0.68	790	3.78	2.57	0.68	827	3.64	2.48	0.68	865
24	20	4.29	2.40	0.56	790	4.11	2.30	0.56	837	3.99	2.23	0.56	855	3.85	2.16	0.56	893
24	22	4.46	1.96	0.44	818	4.31	1.89	0.44	870	4.20	1.85	0.44	893	4.03	1.77	0.44	931
24	24	4.69	1.50	0.32	855	4.52	1.44	0.32	902	4.41	1.41	0.32	931	4.27	1.37	0.32	978
25	20	4.29	2.57	0.60	790	4.11	2.47	0.60	837	3.99	2.39	0.60	855	3.85	2.31	0.60	893
25	22	4.46	2.14	0.48	818	4.31	2.07	0.48	870	4.20	2.02	0.48	893	4.03	1.93	0.48	931
25	24	4.69	1.69	0.36	855	4.52	1.63	0.36	902	4.41	1.59	0.36	931	4.27	1.54	0.36	978
26	18	4.11	3.13	0.76	752	3.94	2.99	0.76	790	3.78	2.87	0.76	827	3.64	2.77	0.76	865
26	20	4.29	2.74	0.64	790	4.11	2.63	0.64	837	3.99	2.55	0.64	855	3.85	2.46	0.64	893
26	22	4.46	2.32	0.52	818	4.31	2.24	0.52	870	4.20	2.18	0.52	893	4.03	2.09	0.52	931
26	24	4.69	1.88	0.40	855	4.52	1.81	0.40	902	4.41	1.76	0.40	931	4.27	1.71	0.40	978
26	26	4.83	1.35	0.28	902	4.69	1.31	0.28	949	4.62	1.29	0.28	978	4.48	1.25	0.28	1,006
27	18	4.11	3.29	0.80	752	3.94	3.15	0.80	790	3.78	3.02	0.80	827	3.64	2.91	0.80	865
27	20	4.29	2.92	0.68	790	4.11	2.80	0.68	837	3.99	2.71	0.68	855	3.85	2.62	0.68	893
27	22	4.46	2.50	0.56	818	4.31	2.41	0.56	870	4.20	2.35	0.56	893	4.03	2.25	0.56	931
27	24	4.69	2.06	0.44	855	4.52	1.99	0.44	902	4.41	1.94	0.44	931	4.27	1.88	0.44	978
27	26	4.83	1.55	0.32	902	4.69	1.50	0.32	949	4.62	1.48	0.32	978	4.48	1.43	0.32	1,006
28	18	4.11	3.45	0.84	752	3.94	3.31	0.84	790	3.78	3.18	0.84	827	3.64	3.06	0.84	865
28	20	4.29	3.09	0.72	790	4.11	2.96	0.72	837	3.99	2.87	0.72	855	3.85	2.77	0.72	893
28	22	4.46	2.68	0.60	818	4.31	2.58	0.60	870	4.20	2.52	0.60	893	4.03	2.42	0.60	931
28	24	4.69	2.25	0.48	855	4.52	2.17	0.48	902	4.41	2.12	0.48	931	4.27	2.05	0.48	978
28	26	4.83	1.74	0.36	902	4.69	1.69	0.36	949	4.62	1.66	0.36	978	4.48	1.61	0.36	1,006
29	18	4.11	3.62	0.88	752	3.94	3.47	0.88	790	3.78	3.33	0.88	827	3.64	3.20	0.88	865
29	20	4.29	3.26	0.76	790	4.11	3.13	0.76	837	3.99	3.03	0.76	855	3.85	2.93	0.76	893
29	22	4.46	2.86	0.64	818	4.31	2.76	0.64	870	4.20	2.69	0.64	893	4.03	2.58	0.64	931
29	24	4.69	2.44	0.52	855	4.52	2.35	0.52	902	4.41	2.29	0.52	931	4.27	2.22	0.52	978
29	26	4.83	1.93	0.40	902	4.69	1.88	0.40	949	4.62	1.85	0.40	978	4.48	1.79	0.40	1,006
30	18	4.11	3.78	0.92	752	3.94	3.62	0.92	790	3.78	3.48	0.92	827	3.64	3.35	0.92	865
30	20	4.29	3.43	0.80	790	4.11	3.29	0.80	837	3.99	3.19	0.80	855	3.85	3.08	0.80	893
30	22	4.46	3.03	0.68	818	4.31	2.93	0.68	870	4.20	2.86	0.68	893	4.03	2.74	0.68	931
30	24	4.69	2.63	0.56	855	4.52	2.53	0.56	902	4.41	2.47	0.56	931	4.27	2.39	0.56	978
30	26	4.83	2.13	0.44	902	4.69	2.06	0.44	949	4.62	2.03	0.44	978	4.48	1.97	0.44	1,006
31	18	4.11	3.95	0.96	752	3.94	3.78	0.96	790	3.78	3.63	0.96	827	3.64	3.49	0.96	865
31	20	4.29	3.60	0.84	790	4.11	3.45	0.84	837	3.99	3.35	0.84	855	3.85	3.23	0.84	893
31	22	4.46	3.21	0.72	818	4.31	3.10	0.72	870	4.20	3.02	0.72	893	4.03	2.90	0.72	931
31	24	4.69	2.81	0.60	855	4.52	2.71	0.60	902	4.41	2.65	0.60	931	4.27	2.56	0.60	978
31	26	4.83	2.32	0.48	902	4.69	2.25	0.48	949	4.62	2.22	0.48	978	4.48	2.15	0.48	1,006
32	18	4.11	4.11	1.00	752	3.94	3.94	1.00	790	3.78	3.78	1.00	827	3.64	3.64	1.00	865
32	20	4.29	3.77	0.88	790	4.11	3.62	0.88	837	3.99	3.51	0.88	855	3.85	3.39	0.88	893
32	22	4.46	3.39	0.76	818	4.31	3.27	0.76	870	4.20	3.19	0.76	893	4.03	3.06	0.76	931
32	24	4.69	3.00	0.64	855	4.52	2.89	0.64	902	4.41	2.82	0.64	931	4.27	2.73	0.64	978
32	26	4.83	2.51	0.52	902	4.69	2.44	0.52	949	4.62	2.40	0.52	978	4.48	2.33	0.52	1,006

NOTE Q : Total capacity (kW) SHF : Sensible heat factor DB : Dry-bulb temperature
 SHC : Sensible heat capacity (kW) INPUT : Total power input (W) WB : Wet-bulb temperature

PERFORMANCE DATA

CEILING CASSETTE

PERFORMANCE DATA COOL operation at Rated frequency

MLZ-KP35VF: SUZ-M35VA

CAPACITY: 3.5 kW

SHF: 0.74

INPUT: 940 W

INDOOR DB (°C)	INDOOR WB (°C)	OUTDOOR DB (°C)											
		35				40				46			
		Q	SHC	SHF	INPUT	Q	SHC	SHF	INPUT	Q	SHC	SHF	INPUT
21	18	3.43	1.92	0.56	921	3.15	1.76	0.56	978	2.91	1.63	0.56	1,015
21	20	3.61	1.59	0.44	959	3.36	1.48	0.44	1,006	3.12	1.37	0.44	1,062
22	18	3.43	2.06	0.60	921	3.15	1.89	0.60	978	2.91	1.74	0.60	1,015
22	20	3.61	1.73	0.48	959	3.36	1.61	0.48	1,006	3.12	1.50	0.48	1,062
22	22	3.82	1.37	0.36	996	3.57	1.29	0.36	1,053	3.33	1.20	0.36	1,090
23	18	3.43	2.20	0.64	921	3.15	2.02	0.64	978	2.91	1.86	0.64	1,015
23	20	3.61	1.87	0.52	959	3.36	1.75	0.52	1,006	3.12	1.62	0.52	1,062
23	22	3.82	1.53	0.40	996	3.57	1.43	0.40	1,053	3.33	1.33	0.40	1,090
24	18	3.43	2.33	0.68	921	3.15	2.14	0.68	978	2.91	1.98	0.68	1,015
24	20	3.61	2.02	0.56	959	3.36	1.88	0.56	1,006	3.12	1.74	0.56	1,062
24	22	3.82	1.68	0.44	996	3.57	1.57	0.44	1,053	3.33	1.46	0.44	1,090
24	24	4.03	1.29	0.32	1,034	3.78	1.21	0.32	1,081	3.57	1.14	0.32	1,128
25	20	3.61	2.16	0.60	959	3.36	2.02	0.60	1,006	3.12	1.87	0.60	1,062
25	22	3.82	1.83	0.48	996	3.57	1.71	0.48	1,053	3.33	1.60	0.48	1,090
25	24	4.03	1.45	0.36	1,034	3.78	1.36	0.36	1,081	3.57	1.29	0.36	1,128
26	18	3.43	2.61	0.76	921	3.15	2.39	0.76	978	2.91	2.21	0.76	1,015
26	20	3.61	2.31	0.64	959	3.36	2.15	0.64	1,006	3.12	1.99	0.64	1,062
26	22	3.82	1.98	0.52	996	3.57	1.86	0.52	1,053	3.33	1.73	0.52	1,090
26	24	4.03	1.61	0.40	1,034	3.78	1.51	0.40	1,081	3.57	1.43	0.40	1,128
26	26	4.24	1.19	0.28	1,072	3.99	1.12	0.28	1,119	3.75	1.05	0.28	1,166
27	18	3.43	2.74	0.80	921	3.15	2.52	0.80	978	2.91	2.32	0.80	1,015
27	20	3.61	2.45	0.68	959	3.36	2.28	0.68	1,006	3.12	2.12	0.68	1,062
27	22	3.82	2.14	0.56	996	3.57	2.00	0.56	1,053	3.33	1.86	0.56	1,090
27	24	4.03	1.77	0.44	1,034	3.78	1.66	0.44	1,081	3.57	1.57	0.44	1,128
27	26	4.24	1.36	0.32	1,072	3.99	1.28	0.32	1,119	3.75	1.20	0.32	1,166
28	18	3.43	2.88	0.84	921	3.15	2.65	0.84	978	2.91	2.44	0.84	1,015
28	20	3.61	2.60	0.72	959	3.36	2.42	0.72	1,006	3.12	2.24	0.72	1,062
28	22	3.82	2.29	0.60	996	3.57	2.14	0.60	1,053	3.33	2.00	0.60	1,090
28	24	4.03	1.93	0.48	1,034	3.78	1.81	0.48	1,081	3.57	1.71	0.48	1,128
28	26	4.24	1.52	0.36	1,072	3.99	1.44	0.36	1,119	3.75	1.35	0.36	1,166
29	18	3.43	3.02	0.88	921	3.15	2.77	0.88	978	2.91	2.56	0.88	1,015
29	20	3.61	2.74	0.76	959	3.36	2.55	0.76	1,006	3.12	2.37	0.76	1,062
29	22	3.82	2.44	0.64	996	3.57	2.28	0.64	1,053	3.33	2.13	0.64	1,090
29	24	4.03	2.09	0.52	1,034	3.78	1.97	0.52	1,081	3.57	1.86	0.52	1,128
29	26	4.24	1.69	0.40	1,072	3.99	1.60	0.40	1,119	3.75	1.50	0.40	1,166
30	18	3.43	3.16	0.92	921	3.15	2.90	0.92	978	2.91	2.67	0.92	1,015
30	20	3.61	2.88	0.80	959	3.36	2.69	0.80	1,006	3.12	2.49	0.80	1,062
30	22	3.82	2.59	0.68	996	3.57	2.43	0.68	1,053	3.33	2.26	0.68	1,090
30	24	4.03	2.25	0.56	1,034	3.78	2.12	0.56	1,081	3.57	2.00	0.56	1,128
30	26	4.24	1.86	0.44	1,072	3.99	1.76	0.44	1,119	3.75	1.65	0.44	1,166
31	18	3.43	3.29	0.96	921	3.15	3.02	0.96	978	2.91	2.79	0.96	1,015
31	20	3.61	3.03	0.84	959	3.36	2.82	0.84	1,006	3.12	2.62	0.84	1,062
31	22	3.82	2.75	0.72	996	3.57	2.57	0.72	1,053	3.33	2.39	0.72	1,090
31	24	4.03	2.42	0.60	1,034	3.78	2.27	0.60	1,081	3.57	2.14	0.60	1,128
31	26	4.24	2.03	0.48	1,072	3.99	1.92	0.48	1,119	3.75	1.80	0.48	1,166
32	18	3.43	3.43	1.00	921	3.15	3.15	1.00	978	2.91	2.91	1.00	1,015
32	20	3.61	3.17	0.88	959	3.36	2.96	0.88	1,006	3.12	2.74	0.88	1,062
32	22	3.82	2.90	0.76	996	3.57	2.71	0.76	1,053	3.33	2.53	0.76	1,090
32	24	4.03	2.58	0.64	1,034	3.78	2.42	0.64	1,081	3.57	2.28	0.64	1,128
32	26	4.24	2.20	0.52	1,072	3.99	2.07	0.52	1,119	3.75	1.95	0.52	1,166

NOTE Q : Total capacity (kW) SHF : Sensible heat factor DB : Dry-bulb temperature
 SHC : Sensible heat capacity (kW) INPUT : Total power input (W) WB : Wet-bulb temperature

CEILING CASSETTE PERFORMANCE DATA

PERFORMANCE DATA COOL operation at Rated frequency

MLZ-KP50VF: SUZ-M50VA

CAPACITY: 5.0 kW

SHF: 0.72

INPUT: 1,380 W

INDOOR DB (°C)	INDOOR WB (°C)	OUTDOOR DB (°C)															
		21				25				27				30			
		Q	SHC	SHF	INPUT	Q	SHC	SHF	INPUT	Q	SHC	SHF	INPUT	Q	SHC	SHF	INPUT
21	18	5.88	3.17	0.54	1,104	5.63	3.04	0.54	1,159	5.40	2.92	0.54	1,214	5.20	2.81	0.54	1,270
21	20	6.13	2.57	0.42	1,159	5.88	2.47	0.42	1,228	5.70	2.39	0.42	1,256	5.50	2.31	0.42	1,311
22	18	5.88	3.41	0.58	1,104	5.63	3.26	0.58	1,159	5.40	3.13	0.58	1,214	5.20	3.02	0.58	1,270
22	20	6.13	2.82	0.46	1,159	5.88	2.70	0.46	1,228	5.70	2.62	0.46	1,256	5.50	2.53	0.46	1,311
22	22	6.38	2.17	0.34	1,201	6.15	2.09	0.34	1,277	6.00	2.04	0.34	1,311	5.75	1.96	0.34	1,366
23	18	5.88	3.64	0.62	1,104	5.63	3.49	0.62	1,159	5.40	3.35	0.62	1,214	5.20	3.22	0.62	1,270
23	20	6.13	3.06	0.50	1,159	5.88	2.94	0.50	1,228	5.70	2.85	0.50	1,256	5.50	2.75	0.50	1,311
23	22	6.38	2.42	0.38	1,201	6.15	2.34	0.38	1,277	6.00	2.28	0.38	1,311	5.75	2.19	0.38	1,366
24	18	5.88	3.88	0.66	1,104	5.63	3.71	0.66	1,159	5.40	3.56	0.66	1,214	5.20	3.43	0.66	1,270
24	20	6.13	3.31	0.54	1,159	5.88	3.17	0.54	1,228	5.70	3.08	0.54	1,256	5.50	2.97	0.54	1,311
24	22	6.38	2.68	0.42	1,201	6.15	2.58	0.42	1,277	6.00	2.52	0.42	1,311	5.75	2.42	0.42	1,366
24	24	6.70	2.01	0.30	1,256	6.45	1.94	0.30	1,325	6.30	1.89	0.30	1,366	6.10	1.83	0.30	1,435
25	20	6.13	3.55	0.58	1,159	5.88	3.41	0.58	1,228	5.70	3.31	0.58	1,256	5.50	3.19	0.58	1,311
25	22	6.38	2.93	0.46	1,201	6.15	2.83	0.46	1,277	6.00	2.76	0.46	1,311	5.75	2.65	0.46	1,366
25	24	6.70	2.28	0.34	1,256	6.45	2.19	0.34	1,325	6.30	2.14	0.34	1,366	6.10	2.07	0.34	1,435
26	18	5.88	4.35	0.74	1,104	5.63	4.16	0.74	1,159	5.40	4.00	0.74	1,214	5.20	3.85	0.74	1,270
26	20	6.13	3.80	0.62	1,159	5.88	3.64	0.62	1,228	5.70	3.53	0.62	1,256	5.50	3.41	0.62	1,311
26	22	6.38	3.19	0.50	1,201	6.15	3.08	0.50	1,277	6.00	3.00	0.50	1,311	5.75	2.88	0.50	1,366
26	24	6.70	2.55	0.38	1,256	6.45	2.45	0.38	1,325	6.30	2.39	0.38	1,366	6.10	2.32	0.38	1,435
26	26	6.90	1.79	0.26	1,325	6.70	1.74	0.26	1,394	6.60	1.72	0.26	1,435	6.40	1.66	0.26	1,477
27	18	5.88	4.58	0.78	1,104	5.63	4.39	0.78	1,159	5.40	4.21	0.78	1,214	5.20	4.06	0.78	1,270
27	20	6.13	4.04	0.66	1,159	5.88	3.88	0.66	1,228	5.70	3.76	0.66	1,256	5.50	3.63	0.66	1,311
27	22	6.38	3.44	0.54	1,201	6.15	3.32	0.54	1,277	6.00	3.24	0.54	1,311	5.75	3.11	0.54	1,366
27	24	6.70	2.81	0.42	1,256	6.45	2.71	0.42	1,325	6.30	2.65	0.42	1,366	6.10	2.56	0.42	1,435
27	26	6.90	2.07	0.30	1,325	6.70	2.01	0.30	1,394	6.60	1.98	0.30	1,435	6.40	1.92	0.30	1,477
28	18	5.88	4.82	0.82	1,104	5.63	4.61	0.82	1,159	5.40	4.43	0.82	1,214	5.20	4.26	0.82	1,270
28	20	6.13	4.29	0.70	1,159	5.88	4.11	0.70	1,228	5.70	3.99	0.70	1,256	5.50	3.85	0.70	1,311
28	22	6.38	3.70	0.58	1,201	6.15	3.57	0.58	1,277	6.00	3.48	0.58	1,311	5.75	3.34	0.58	1,366
28	24	6.70	3.08	0.46	1,256	6.45	2.97	0.46	1,325	6.30	2.90	0.46	1,366	6.10	2.81	0.46	1,435
28	26	6.90	2.35	0.34	1,325	6.70	2.28	0.34	1,394	6.60	2.24	0.34	1,435	6.40	2.18	0.34	1,477
29	18	5.88	5.05	0.86	1,104	5.63	4.84	0.86	1,159	5.40	4.64	0.86	1,214	5.20	4.47	0.86	1,270
29	20	6.13	4.53	0.74	1,159	5.88	4.35	0.74	1,228	5.70	4.22	0.74	1,256	5.50	4.07	0.74	1,311
29	22	6.38	3.95	0.62	1,201	6.15	3.81	0.62	1,277	6.00	3.72	0.62	1,311	5.75	3.57	0.62	1,366
29	24	6.70	3.35	0.50	1,256	6.45	3.23	0.50	1,325	6.30	3.15	0.50	1,366	6.10	3.05	0.50	1,435
29	26	6.90	2.62	0.38	1,325	6.70	2.55	0.38	1,394	6.60	2.51	0.38	1,435	6.40	2.43	0.38	1,477
30	18	5.88	5.29	0.90	1,104	5.63	5.06	0.90	1,159	5.40	4.86	0.90	1,214	5.20	4.68	0.90	1,270
30	20	6.13	4.78	0.78	1,159	5.88	4.58	0.78	1,228	5.70	4.45	0.78	1,256	5.50	4.29	0.78	1,311
30	22	6.38	4.21	0.66	1,201	6.15	4.06	0.66	1,277	6.00	3.96	0.66	1,311	5.75	3.80	0.66	1,366
30	24	6.70	3.62	0.54	1,256	6.45	3.48	0.54	1,325	6.30	3.40	0.54	1,366	6.10	3.29	0.54	1,435
30	26	6.90	2.90	0.42	1,325	6.70	2.81	0.42	1,394	6.60	2.77	0.42	1,435	6.40	2.69	0.42	1,477
31	18	5.88	5.52	0.94	1,104	5.63	5.29	0.94	1,159	5.40	5.08	0.94	1,214	5.20	4.89	0.94	1,270
31	20	6.13	5.02	0.82	1,159	5.88	4.82	0.82	1,228	5.70	4.67	0.82	1,256	5.50	4.51	0.82	1,311
31	22	6.38	4.46	0.70	1,201	6.15	4.31	0.70	1,277	6.00	4.20	0.70	1,311	5.75	4.03	0.70	1,366
31	24	6.70	3.89	0.58	1,256	6.45	3.74	0.58	1,325	6.30	3.65	0.58	1,366	6.10	3.54	0.58	1,435
31	26	6.90	3.17	0.46	1,325	6.70	3.08	0.46	1,394	6.60	3.04	0.46	1,435	6.40	2.94	0.46	1,477
32	18	5.88	5.76	0.98	1,104	5.63	5.51	0.98	1,159	5.40	5.29	0.98	1,214	5.20	5.10	0.98	1,270
32	20	6.13	5.27	0.86	1,159	5.88	5.05	0.86	1,228	5.70	4.90	0.86	1,256	5.50	4.73	0.86	1,311
32	22	6.38	4.72	0.74	1,201	6.15	4.55	0.74	1,277	6.00	4.44	0.74	1,311	5.75	4.26	0.74	1,366
32	24	6.70	4.15	0.62	1,256	6.45	4.00	0.62	1,325	6.30	3.91	0.62	1,366	6.10	3.78	0.62	1,435
32	26	6.90	3.45	0.50	1,325	6.70	3.35	0.50	1,394	6.60	3.30	0.50	1,435	6.40	3.20	0.50	1,477

NOTE Q : Total capacity (kW) SHF : Sensible heat factor DB : Dry-bulb temperature
 SHC : Sensible heat capacity (kW) INPUT : Total power input (W) WB : Wet-bulb temperature

PERFORMANCE DATA

CEILING CASSETTE

PERFORMANCE DATA COOL operation at Rated frequency

MLZ-KP50VF: SUZ-M50VA

CAPACITY: 5.0 kW

SHF: 0.72

INPUT: 1,380 W

INDOOR DB (°C)	INDOOR WB (°C)	OUTDOOR DB (°C)											
		35				40				46			
		Q	SHC	SHF	INPUT	Q	SHC	SHF	INPUT	Q	SHC	SHF	INPUT
21	18	4.90	2.65	0.54	1,352	4.50	2.43	0.54	1,435	4.15	2.24	0.54	1,490
21	20	5.15	2.16	0.42	1,408	4.80	2.02	0.42	1,477	4.45	1.87	0.42	1,559
22	18	4.90	2.84	0.58	1,352	4.50	2.61	0.58	1,435	4.15	2.41	0.58	1,490
22	20	5.15	2.37	0.46	1,408	4.80	2.21	0.46	1,477	4.45	2.05	0.46	1,559
22	22	5.45	1.85	0.34	1,463	5.10	1.73	0.34	1,546	4.75	1.62	0.34	1,601
23	18	4.90	3.04	0.62	1,352	4.50	2.79	0.62	1,435	4.15	2.57	0.62	1,490
23	20	5.15	2.58	0.50	1,408	4.80	2.40	0.50	1,477	4.45	2.23	0.50	1,559
23	22	5.45	2.07	0.38	1,463	5.10	1.94	0.38	1,546	4.75	1.81	0.38	1,601
24	18	4.90	3.23	0.66	1,352	4.50	2.97	0.66	1,435	4.15	2.74	0.66	1,490
24	20	5.15	2.78	0.54	1,408	4.80	2.59	0.54	1,477	4.45	2.40	0.54	1,559
24	22	5.45	2.29	0.42	1,463	5.10	2.14	0.42	1,546	4.75	2.00	0.42	1,601
24	24	5.75	1.73	0.30	1,518	5.40	1.62	0.30	1,587	5.10	1.53	0.30	1,656
25	20	5.15	2.99	0.58	1,408	4.80	2.78	0.58	1,477	4.45	2.58	0.58	1,559
25	22	5.45	2.51	0.46	1,463	5.10	2.35	0.46	1,546	4.75	2.19	0.46	1,601
25	24	5.75	1.96	0.34	1,518	5.40	1.84	0.34	1,587	5.10	1.73	0.34	1,656
26	18	4.90	3.63	0.74	1,352	4.50	3.33	0.74	1,435	4.15	3.07	0.74	1,490
26	20	5.15	3.19	0.62	1,408	4.80	2.98	0.62	1,477	4.45	2.76	0.62	1,559
26	22	5.45	2.73	0.50	1,463	5.10	2.55	0.50	1,546	4.75	2.38	0.50	1,601
26	24	5.75	2.19	0.38	1,518	5.40	2.05	0.38	1,587	5.10	1.94	0.38	1,656
26	26	6.05	1.57	0.26	1,573	5.70	1.48	0.26	1,642	5.35	1.39	0.26	1,711
27	18	4.90	3.82	0.78	1,352	4.50	3.51	0.78	1,435	4.15	3.24	0.78	1,490
27	20	5.15	3.40	0.66	1,408	4.80	3.17	0.66	1,477	4.45	2.94	0.66	1,559
27	22	5.45	2.94	0.54	1,463	5.10	2.75	0.54	1,546	4.75	2.57	0.54	1,601
27	24	5.75	2.42	0.42	1,518	5.40	2.27	0.42	1,587	5.10	2.14	0.42	1,656
27	26	6.05	1.82	0.30	1,573	5.70	1.71	0.30	1,642	5.35	1.61	0.30	1,711
28	18	4.90	4.02	0.82	1,352	4.50	3.69	0.82	1,435	4.15	3.40	0.82	1,490
28	20	5.15	3.61	0.70	1,408	4.80	3.36	0.70	1,477	4.45	3.12	0.70	1,559
28	22	5.45	3.16	0.58	1,463	5.10	2.96	0.58	1,546	4.75	2.76	0.58	1,601
28	24	5.75	2.65	0.46	1,518	5.40	2.48	0.46	1,587	5.10	2.35	0.46	1,656
28	26	6.05	2.06	0.34	1,573	5.70	1.94	0.34	1,642	5.35	1.82	0.34	1,711
29	18	4.90	4.21	0.86	1,352	4.50	3.87	0.86	1,435	4.15	3.57	0.86	1,490
29	20	5.15	3.81	0.74	1,408	4.80	3.55	0.74	1,477	4.45	3.29	0.74	1,559
29	22	5.45	3.38	0.62	1,463	5.10	3.16	0.62	1,546	4.75	2.95	0.62	1,601
29	24	5.75	2.88	0.50	1,518	5.40	2.70	0.50	1,587	5.10	2.55	0.50	1,656
29	26	6.05	2.30	0.38	1,573	5.70	2.17	0.38	1,642	5.35	2.03	0.38	1,711
30	18	4.90	4.41	0.90	1,352	4.50	4.05	0.90	1,435	4.15	3.74	0.90	1,490
30	20	5.15	4.02	0.78	1,408	4.80	3.74	0.78	1,477	4.45	3.47	0.78	1,559
30	22	5.45	3.60	0.66	1,463	5.10	3.37	0.66	1,546	4.75	3.14	0.66	1,601
30	24	5.75	3.11	0.54	1,518	5.40	2.92	0.54	1,587	5.10	2.75	0.54	1,656
30	26	6.05	2.54	0.42	1,573	5.70	2.39	0.42	1,642	5.35	2.25	0.42	1,711
31	18	4.90	4.61	0.94	1,352	4.50	4.23	0.94	1,435	4.15	3.90	0.94	1,490
31	20	5.15	4.22	0.82	1,408	4.80	3.94	0.82	1,477	4.45	3.65	0.82	1,559
31	22	5.45	3.82	0.70	1,463	5.10	3.57	0.70	1,546	4.75	3.33	0.70	1,601
31	24	5.75	3.34	0.58	1,518	5.40	3.13	0.58	1,587	5.10	2.96	0.58	1,656
31	26	6.05	2.78	0.46	1,573	5.70	2.62	0.46	1,642	5.35	2.46	0.46	1,711
32	18	4.90	4.80	0.98	1,352	4.50	4.41	0.98	1,435	4.15	4.07	0.98	1,490
32	20	5.15	4.43	0.86	1,408	4.80	4.13	0.86	1,477	4.45	3.83	0.86	1,559
32	22	5.45	4.03	0.74	1,463	5.10	3.77	0.74	1,546	4.75	3.52	0.74	1,601
32	24	5.75	3.57	0.62	1,518	5.40	3.35	0.62	1,587	5.10	3.16	0.62	1,656
32	26	6.05	3.03	0.50	1,573	5.70	2.85	0.50	1,642	5.35	2.68	0.50	1,711

NOTE Q : Total capacity (kW) SHF : Sensible heat factor DB : Dry-bulb temperature
 SHC : Sensible heat capacity (kW) INPUT : Total power input (W) WB : Wet-bulb temperature

PERFORMANCE DATA HEAT operation at Rated frequency

MLZ-KP25VF: SUZ-M25VA

CAPACITY: 3.2 kW INPUT: 800 W

INDOOR DB (°C)	OUTDOOR WB (°C)															
	-15		-10		-5		0		5		10		15		20	
	Q	INPUT	Q	INPUT	Q	INPUT	Q	INPUT	Q	INPUT	Q	INPUT	Q	INPUT	Q	INPUT
15	1.60	416	2.02	520	2.43	624	2.85	704	3.26	760	3.68	808	4.06	832	4.48	848
21	1.50	443	1.92	560	2.30	664	2.72	736	3.10	792	3.52	832	3.90	856	4.30	888
26	1.31	480	1.73	600	2.14	704	2.53	776	2.94	832	3.36	872	3.74	896	4.16	920

MLZ-KP35VF: SUZ-M35VA

CAPACITY: 4.1 kW INPUT: 1100 W

INDOOR DB (°C)	OUTDOOR WB (°C)															
	-15		-10		-5		0		5		10		15		20	
	Q	INPUT	Q	INPUT	Q	INPUT	Q	INPUT	Q	INPUT	Q	INPUT	Q	INPUT	Q	INPUT
15	2.05	572	2.58	715	3.12	858	3.65	968	4.18	1045	4.72	1111	5.21	1144	5.74	1166
21	1.93	609	2.46	770	2.95	913	3.49	1012	3.98	1089	4.51	1144	5.00	1177	5.51	1221
26	1.68	660	2.21	825	2.75	968	3.24	1067	3.77	1144	4.31	1199	4.80	1232	5.33	1265

MLZ-KP50VF: SUZ-M50VA

CAPACITY: 6.0 kW INPUT: 1860 W

INDOOR DB (°C)	OUTDOOR WB (°C)															
	-15		-10		-5		0		5		10		15		20	
	Q	INPUT	Q	INPUT	Q	INPUT	Q	INPUT	Q	INPUT	Q	INPUT	Q	INPUT	Q	INPUT
15	3.00	967	3.78	1209	4.56	1451	5.34	1637	6.12	1767	6.90	1879	7.62	1934	8.40	1972
21	2.82	1030	3.60	1302	4.32	1544	5.10	1711	5.82	1841	6.60	1934	7.32	1990	8.07	2065
26	2.46	1116	3.24	1395	4.02	1637	4.74	1804	5.52	1934	6.30	2027	7.02	2083	7.80	2139

NOTE: Q: Total capacity (kW) INPUT : Total power input (W) DB: Dry-bulb temperature WB: Wet-bulb temperature

C.3.6 NOISE CRITERIA CURVES

C.3.6.1 Inverter Heat Pump

MLZ-KP25VF

FAN SPEED	FUNCTION	SPL(dB(A))	LINE
High	COOLING	38	●—●
	HEATING	37	○—○

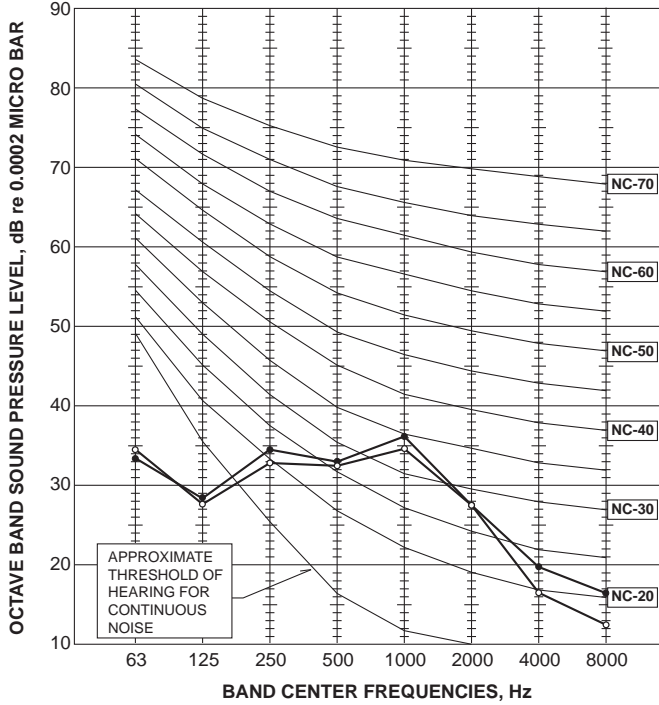

MLZ-KP35VF

FAN SPEED	FUNCTION	SPL(dB(A))	LINE
High	COOLING	40	●—●
	HEATING	40	○—○

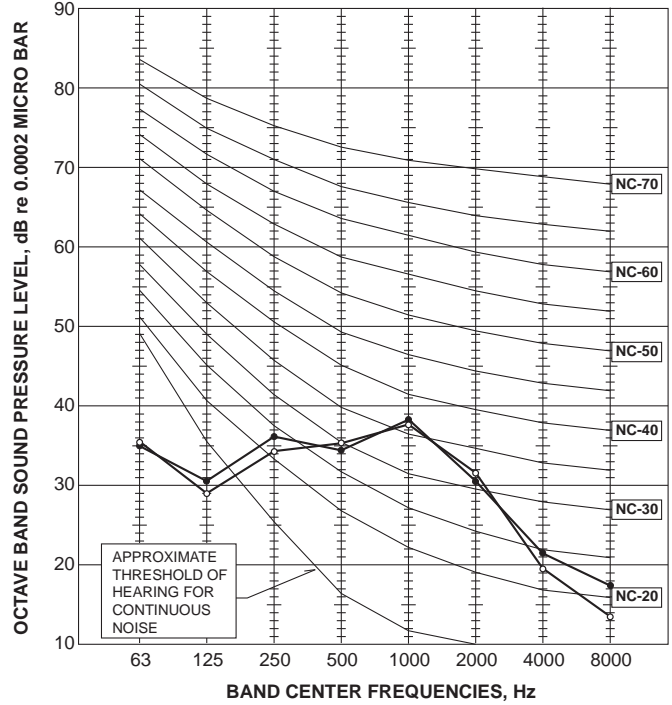

MLZ-KP50VF

FAN SPEED	FUNCTION	SPL(dB(A))	LINE
High	COOLING	47	●—●
	HEATING	48	○—○

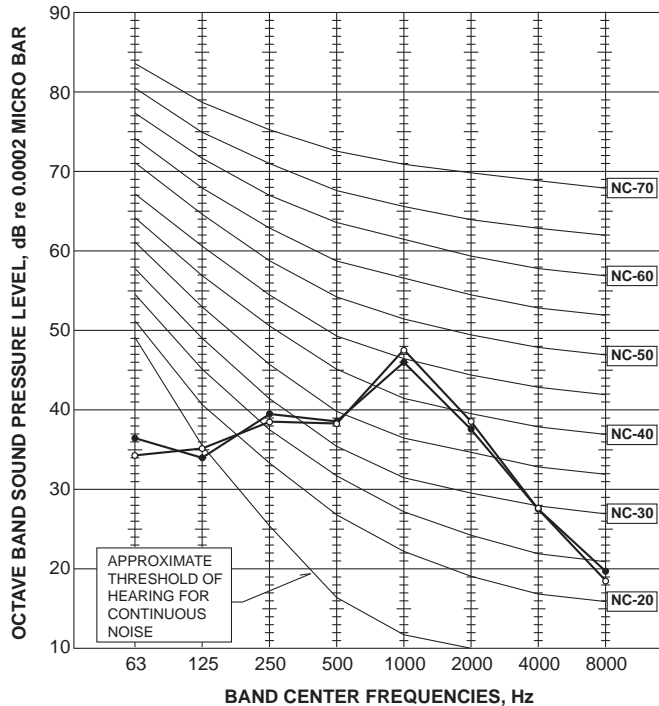

MLZ-KY20VG

FAN SPEED	FUNCTION	SPL(dB(A))	LINE
High	COOLING	37	●—●
	HEATING	38	○—○

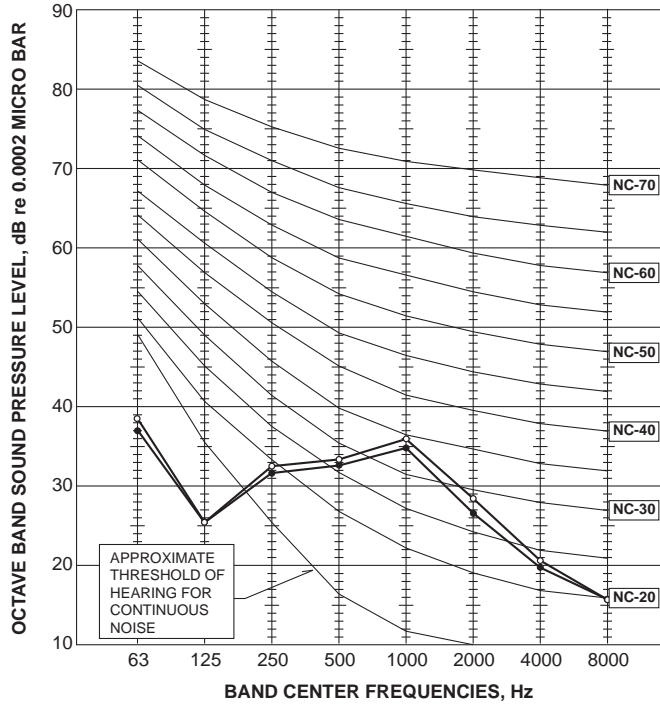

Test conditions
 Cooling : Dry-bulb temperature 27 °C Wet-bulb temperature 19 °C
 Heating : Dry-bulb temperature 20 °C

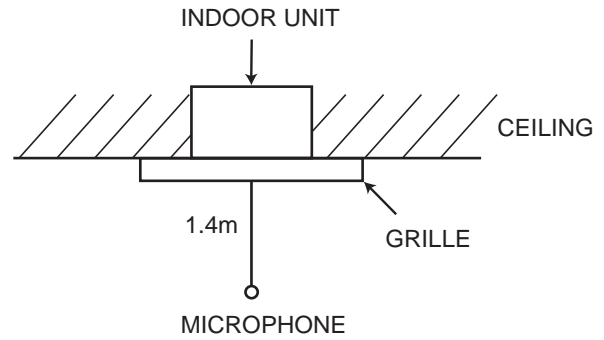

NOISE CRITERIA CURVES

CEILING CASSETTE

C.3.7 TEMPERATURE AND AIR FLOW DISTRIBUTIONS

MLZ-KP25VF

Temperature distribution

<Cooling mode>

Air volume: high
Air direction: auto (upward air flow)

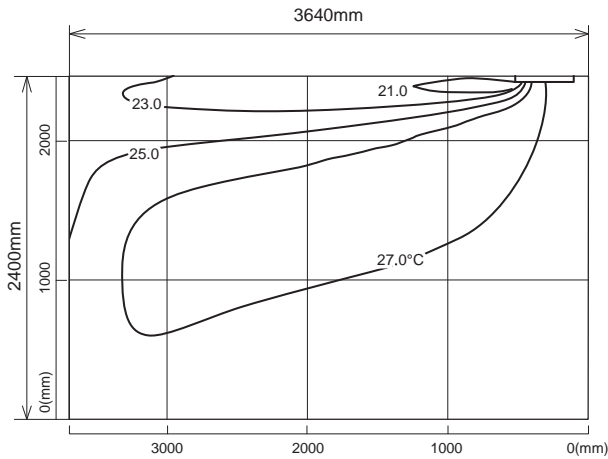

<Heating mode>

Air volume: high
Air direction: auto (downward air flow)

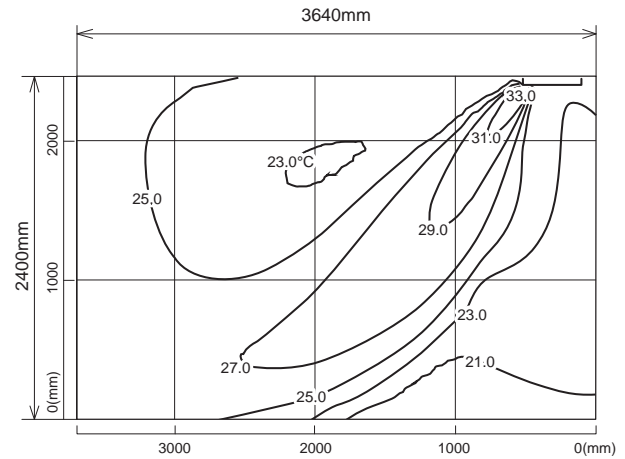

Airflow distribution

<Cooling mode>

Air volume: high
Air direction: auto (upward air flow)

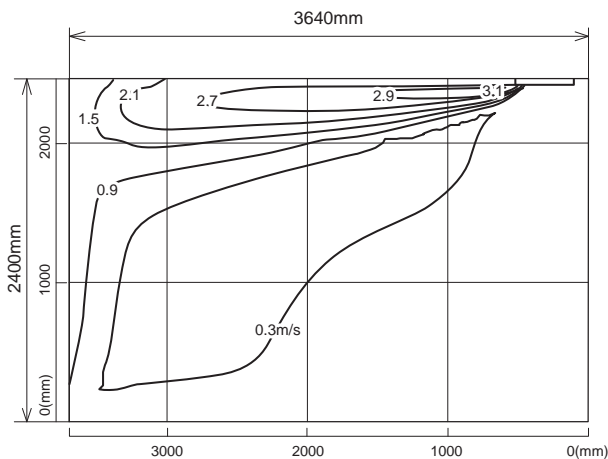

<Heating mode>

Air volume: high
Air direction: auto (downward air flow)

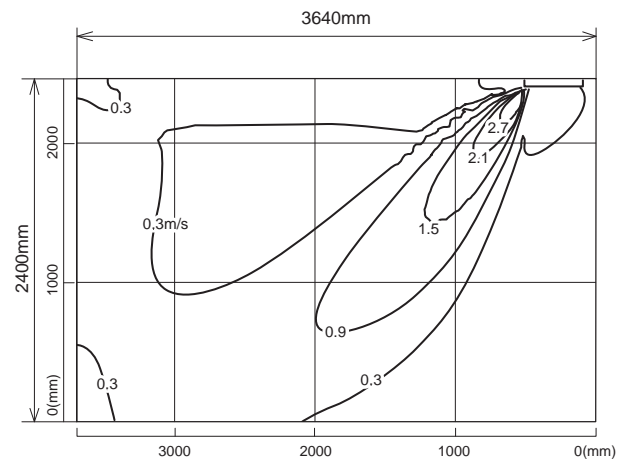

Note : These figures show typical airflow distributions in the conditions above. In the actual installation, they may differ from these figures under the influence of air temperature conditions, ceiling height, cooling/heating load, obstacles, etc.

CEILING CASSETTE TEMPERATURE AND AIR FLOW DISTRIBUTIONS

MLZ-KP35VF

Temperature distribution

<Cooling mode>

Air volume: high
Air direction: auto (upward air flow)

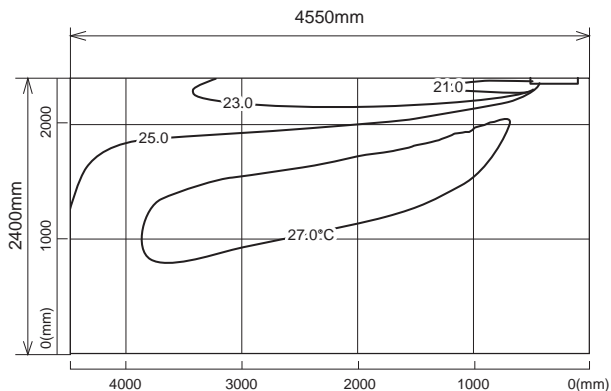

<Heating mode>

Air volume: high
Air direction: auto (downward air flow)

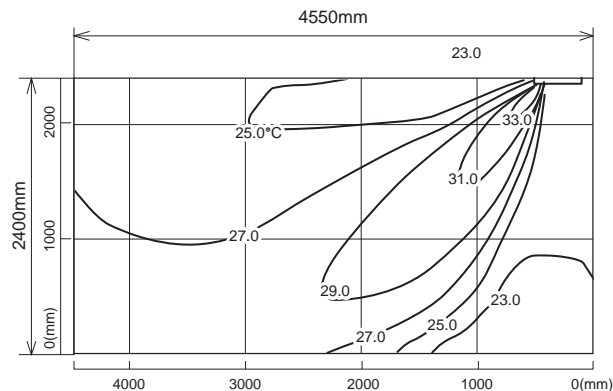

Airflow distribution

<Cooling mode>

Air volume: high
Air direction: auto (upward air flow)

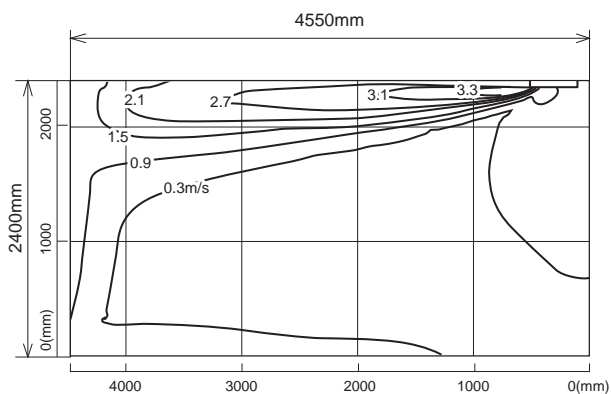

<Heating mode>

Air volume: high
Air direction: auto (downward air flow)

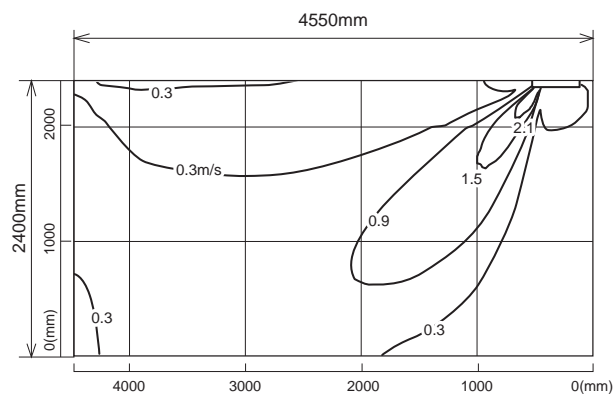

Note : These figures show typical airflow distributions in the conditions above. In the actual installation, they may differ from these figures under the influence of air temperature conditions, ceiling height, cooling/heating load, obstacles, etc.

TEMPERATURE AND AIR FLOW DISTRIBUTIONS

CEILING CASSETTE

MLZ-KP50VF

Temperature distribution

<Cooling mode>

Air volume: high
Air direction: auto (upward air flow)

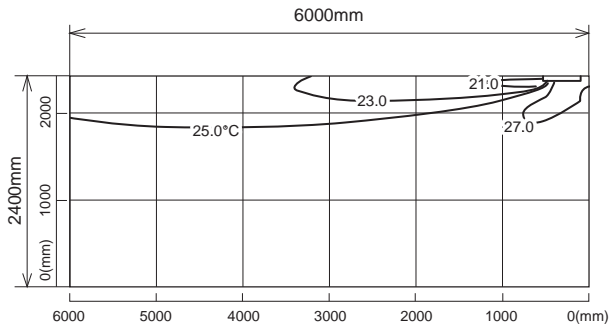

<Heating mode>

Air volume: high
Air direction: auto (downward air flow)

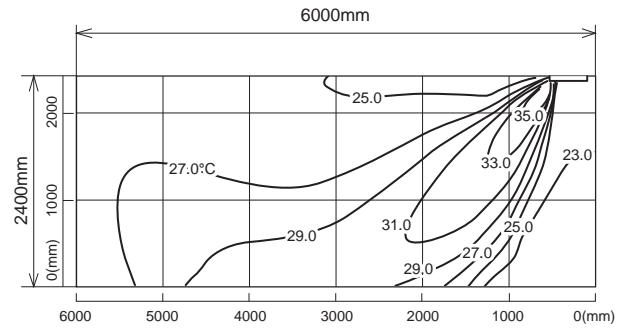

Airflow distribution

<Cooling mode>

Air volume: high
Air direction: auto (upward air flow)

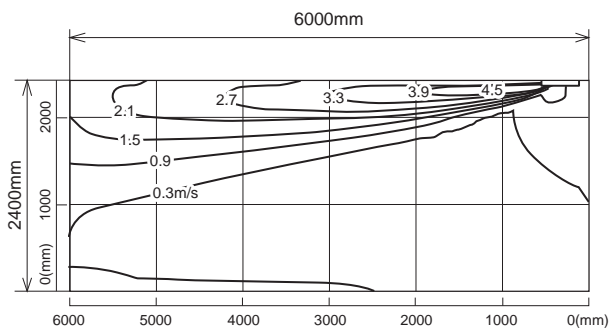

<Heating mode>

Air volume: high
Air direction: auto (downward air flow)

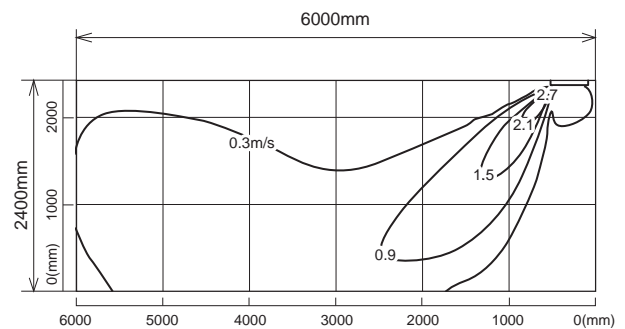

Note : These figures show typical airflow distributions in the conditions above. In the actual installation, they may differ from these figures under the influence of air temperature conditions, ceiling height, cooling/heating load, obstacles, etc.

TEMPERATURE AND AIR FLOW DISTRIBUTIONS
CEILING CASSETTE

MLZ-KY20VG

Temperature distribution

<Cooling mode>

Air volume: high
Air direction: auto (upward air flow)

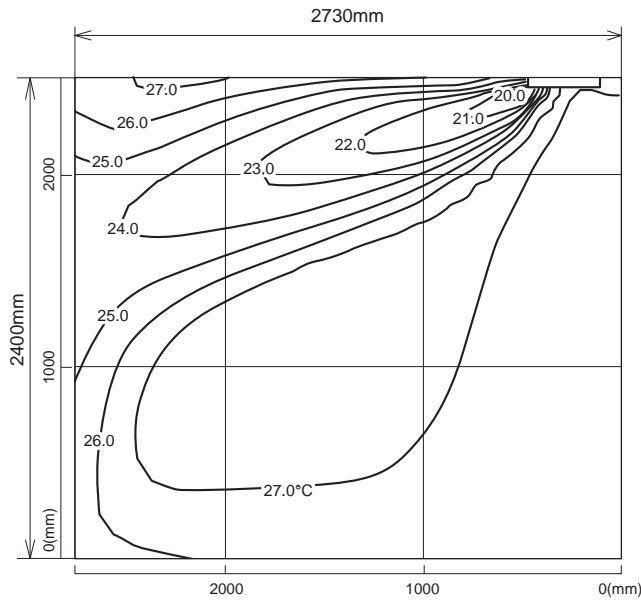

<Heating mode>

Air volume: high
Air direction: auto (downward air flow)

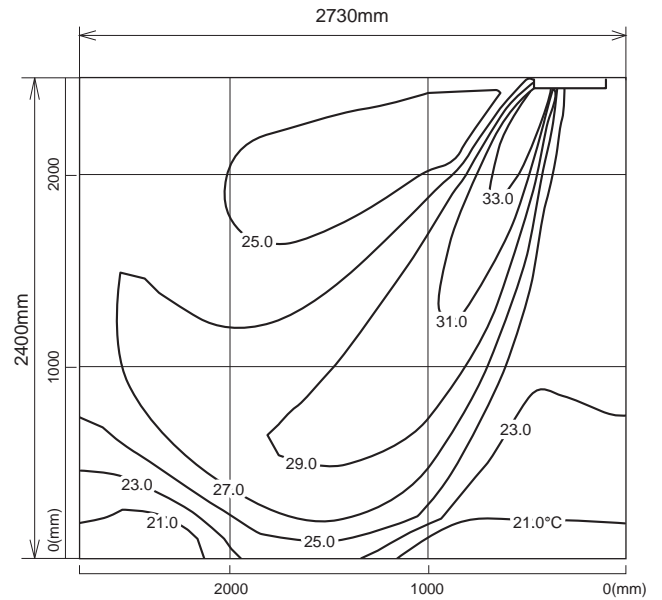

Airflow distribution

<Cooling mode>

Air volume: high
Air direction: auto (upward air flow)

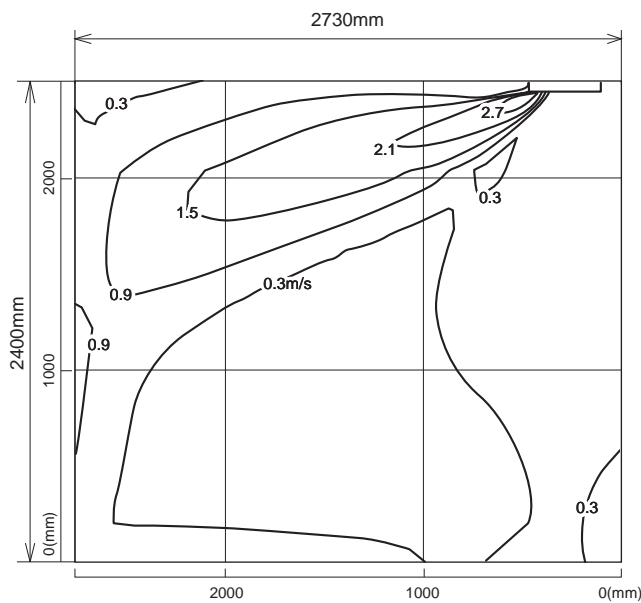

<Heating mode>

Air volume: high
Air direction: auto (downward air flow)

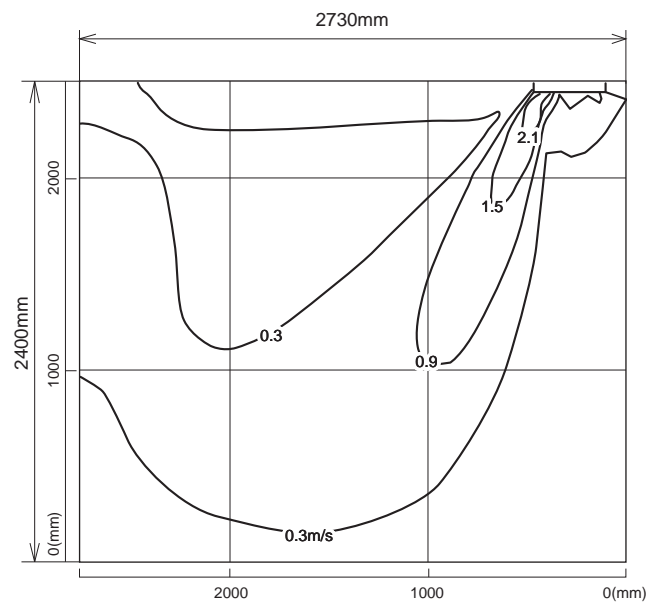

Note : These figures show typical airflow distributions in the conditions above. In the actual installation, they may differ from these figures under the influence of air temperature conditions, ceiling height, cooling/heating load, obstacles, etc.

TEMPERATURE AND AIR FLOW DISTRIBUTIONS

CEILING CASSETTE

C.3.8 OPERATION

C.3.8.1 MLZ-KP·VF Series

MLZ-KP25VF

MLZ-KP35VF

MLZ-KP50VF

WIRELESS REMOTE CONTROLLER

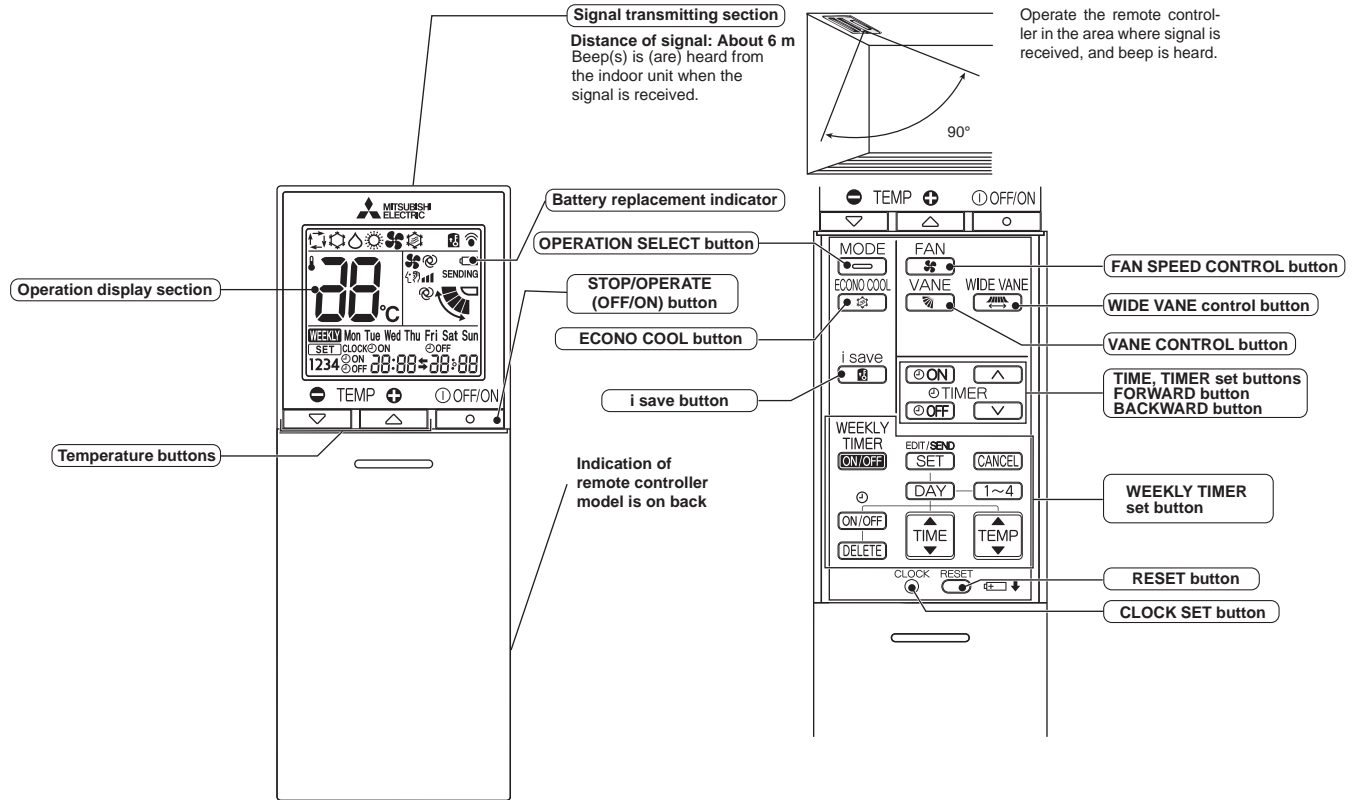

NOTE: Last setting will be stored after the unit is turned OFF with the remote controller. Indoor unit receives the signal of the remote controller with beeps.

INDOOR UNIT DISPLAY SECTION

Operation Indicator lamp

The operation indicator at the right side of the indoor unit indicates the operation state.

•The following indication applies regardless of shape of the indication.

Indication	Operation state	Room temperature
● ●	The unit is operating to reach the set temperature	About 2°C or more away from set temperature
● ○	The room temperature is approaching the set temperature	About 1 to 2°C from set temperature
● ●	Standby mode (Refer to multi system operation)	—

- Lit
- Blinking
- Not lit

a. COOL (❄️) OPERATION

- (1) Press STOP/OPERATE(OFF/ON) button.
OPERATION INDICATOR lamp of the indoor unit turns on with a beep tone.
- (2) Select COOL mode with OPERATION SELECT button.
- (3) Press TEMPERATURE buttons TEMP \ominus or \oplus button to select the desired temperature. The setting range is 16 - 31°C.

1. Coil frost prevention

The compressor operational frequency is controlled by the temperature of the indoor heat exchanger to prevent the coil from frosting.

When the temperature of indoor heat exchanger becomes too low, the coil frost prevention mode works.

The indoor fan operates at the set speed and the compressor stops. This mode continues until the temperature of indoor heat exchanger rises.

b. DRY (☀️) OPERATION

- (1) Press STOP/OPERATE(OFF/ON) button.
OPERATION INDICATOR lamp of the indoor unit turns on with a beep tone.
- (2) Select DRY mode with OPERATION SELECT button.
- (3) The set temperature is determined from the initial room temperature.

1. Coil frost prevention

Coil frost prevention works the same way as that in COOL mode. (a.1.)

c. FAN (🌀) OPERATION

- (1) OPERATION INDICATOR lamp of the indoor unit turns on with a beep tone.
- (2) Select FAN mode with OPERATION SELECT button.
- (3) Select the desired fan speed. When AUTO, it becomes Low.
Only indoor fan operates.
Outdoor unit does not operate.

d. HEAT (🔥) OPERATION

- (1) Press STOP/OPERATE(OFF/ON) button.
OPERATION INDICATOR lamp of the indoor unit turns on with a beep tone.
- (2) Select HEAT mode with OPERATION SELECT button.
- (3) Press TEMPERATURE buttons TEMP \ominus or \oplus button to select the desired temperature. The setting range is 10°C and 16 - 31°C.

1. Cold air prevention control

When the compressor is not operating or is starting, and the temperature of indoor heat exchanger and/or the room temperature is low or when defrosting is being done, the indoor fan will stop or rotate in Very Low speed.

2. Defrosting

Defrosting starts when the temperature of outdoor heat exchanger becomes too low.

The compressor stops once, the indoor/outdoor fans stop, the 4-way valve reverses, and the compressor re-starts.

This mode continues until the temperature of outdoor heat exchanger rises or the fixed time passes.

e. AUTO CHANGE OVER ... AUTO MODE OPERATION

Once desired temperature is set, unit operation is switched automatically between COOL and HEAT operation.

Mode selection

- (1) Initial mode
When unit starts the operation with AUTO operation from OFF:
 - If the room temperature is higher than the set temperature, operation starts in COOL mode.
 - If the room temperature is equal to or lower than the set temperature, operation starts in HEAT mode.
- (2) Mode change
COOL mode changes to HEAT mode when about 15 minutes have passed with the room temperature 2°C below the set temperature.
HEAT mode changes to COOL mode when about 15 minutes have passed with the room temperature 2°C above the set temperature.

NOTE 1

If 2 or more indoor units are operating in multi system, there might be a case that the indoor unit, which is operating in □ (AUTO), cannot change over to the other operating mode (COOL ↔ HEAT) and becomes a state of standby.

Refer to **NOTE 2 “FOR MULTI SYSTEM AIR CONDITIONER”**.

NOTE 2

FOR MULTI SYSTEM AIR CONDITIONER

OUTDOOR UNIT: MXZ series

Multi system air conditioner can connect 2 or more indoor units with one outdoor unit.

- When you try to operate 2 or more indoor units with one outdoor unit simultaneously, one for the cooling and the others for heating, the operation mode of the indoor unit that operates first is selected. Other indoor units cannot operate, and operation indicator lamp flashes as shown in the figure below. In this case, please set all the indoor units to the same operation mode.

OPERATION INDICATOR

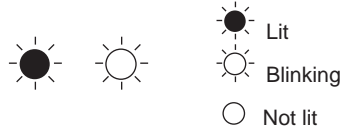

- When indoor unit starts the operation while the defrosting of outdoor unit is being done, it takes a few minutes (max. 10 minutes) to blow out the warm air.
- In the heating operation, though indoor unit that does not operate may get warm or the sound of refrigerant flowing may be heard, they are not malfunction. The reason is that the refrigerant continuously flows into it.

f. AUTO VANE OPERATION

1. Horizontal vane

(1) Vane motor drive

These models are equipped with a stepping motor for the horizontal vane. The rotating direction, speed, and angle of the motor are controlled by pulse signals (approximately 12 V) transmitted from indoor microprocessor.

(2) The horizontal vane angle and mode change as follows by pressing VANE CONTROL button.

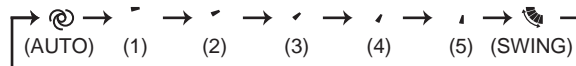

NOTE:

The setting when the lower airflow is preferred in the Airflow direction (1)

The angle of airflow direction (1) can be slightly lowered by changing SWV1 to normal when the lower airflow is preferred or the airflow causes the dirt on the ceiling.

Factory setting is up.

(3) Positioning

To confirm the standard position, the vane moves until it touches the vane stopper. Then the vane is set to the selected angle.

Confirming of standard position is performed in the following cases:

- (a) When the power supply turns on.
- (b) When the operation starts or finishes (including timer operation).
- (c) When the test run starts.
- (d) When multi-standby starts or finishes.
- (e) When the swing operation finishes.

(4) VANE AUTO (A) mode

In VANE AUTO mode, the microprocessor automatically determines the vane angle and operation to make the optimum room-temperature distribution.

(1) In COOL and DRY operation Vane angle is fixed to Angle 1.

(2) In HEAT operation Vane angle is fixed to Angle 4.

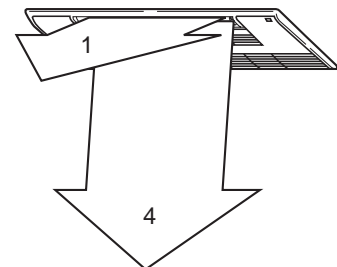

(5) STOP (operation OFF) and ON TIMER standby

In the following cases, the horizontal vane returns to the closed position.

- (a) When STOP/OPERATE(OFF/ON) button is pressed (POWER OFF).
- (b) When the operation is stopped by the emergency operation.
- (c) When ON TIMER is ON standby.

(6) SWING () mode

By selecting SWING mode with VANE CONTROL button, the horizontal vanes swing vertically.
When COOL, DRY or FAN mode is selected, only the upper vane swings.

(7) Cold air prevention in HEAT operation

The horizontal vane position is set to upward.

(8) ECONO COOL () operation (ECONOMical operation)

When ECONO COOL button is pressed in COOL mode, set temperature is automatically set 2°C higher by microprocessor. However, the temperature on the LCD screen on the remote controller is not changed.

Also the horizontal vane swings in various cycle.

SWING operation makes you feel cooler than set temperature. So, even though the set temperature is higher, the air conditioner can keep comfort. As a result, energy can be saved.

To cancel this operation, select a different mode or press one of the following buttons in ECONO COOL operation: ECONO COOL, WIDE VANE CONTROL or VANE CONTROL button.

2. Vertical vane

(1) Press WIDE VANE button to change horizontal airflow direction.

- The vertical vane moves for about 30 seconds.

(After 30 seconds, the vertical vane moves to its original position. In this case, press WIDE VANE button again.)

(2) Press WIDE VANE button again to set horizontal airflow direction.

- The vertical vane stops and the airflow direction is set.

(3) Positioning

To confirm the standard position, the vane moves until it touches the vane stopper. Then the vane set to the desired angle.

Confirming of standard position is performed in the following cases:

- (a) When STOP/OPERATE(OFF/ON) button is pressed (POWER ON).
- (b) When SWING is started.

g. DRAIN PUMP/ FLOAT SENSOR CONTROL

1. Drain pump

Operating condition:

1. During COOL, DRY, or emergency COOL operation
2. When float sensor detects water level above fixed point during:
 - (a) HEAT operation.
 - (b) emergency HEAT operation.
 - (c) standby when during multi system operation.
 - (d) standby when ON timer is set.
 - (e) operation STOP.

Drain pump operates in conditions 1 or 2.

2. Float sensor

Float moves with the up and down of water surface inside the drain pan, and judges water level.
(Fixed point differs at raised and lowered water levels.)

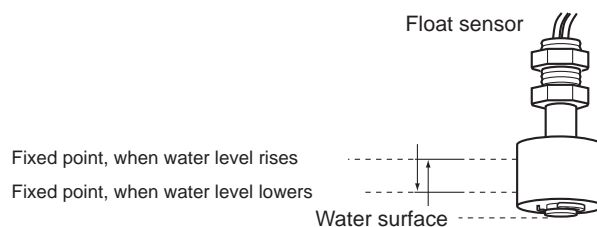

h. TIMER OPERATION

1. How to set the time

(1) Check that the current time is set correctly.

NOTE: Timer operation will not work without setting the current time. Initially “0:00” blinks at the current time display of TIME MONITOR, so set the current time correctly with CLOCK SET button.

How to set the current time

(a) Press the CLOCK set button.

(b) Press the TIME SET buttons (▲) and (▼) to set the current time.

- Each time FORWARD button (▲) is pressed, the set time increases by 1 minute, and each time BACKWARD button (▼) is pressed, the set time decreases by 1 minute.
- Pressing those buttons longer, the set time increases/decreases by 10 minutes.

(c) Press the CLOCK set button.

(2) Press STOP/OPERATE(OFF/ON) button to start the air conditioner.

(3) Set the time of timer.

ON timer setting

(a) Press ON TIMER button (ⓄON) during operation.

(b) Set the time of the timer using TIME SET buttons (▲) and (▼).*

OFF timer setting

(a) Press OFF TIMER button (ⓄOFF) during operation.

(b) Set the time of the timer using TIME SET buttons (▲) and (▼).*

* Each time FORWARD button (▲) is pressed, the set time increases by 10 minutes: each time BACKWARD button (▼) is pressed, the set time decreases by 10 minutes.

2. To release the timer

To release ON timer, press ON TIMER button (ⓄON).

To release OFF timer, press OFF TIMER button (ⓄOFF).

TIMER is cancelled and the display of set time disappears.

PROGRAM TIMER

- OFF timer and ON timer can be used in combination. The set time that is reached first will operate first.
- “←” and “→” display shows the order of OFF timer and ON timer operation.

(Example 1) The current time is 8:00 PM.
The unit turns off at 11:00 PM, and on at 6:00 AM.

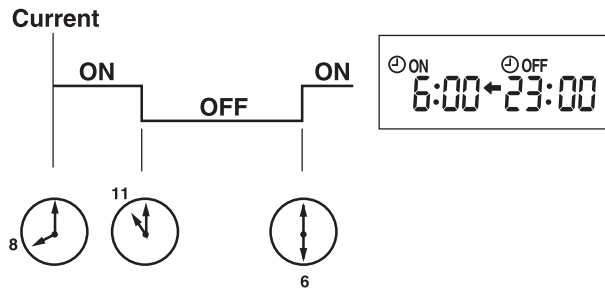

(Example 2) The current time is 11:00 AM.
The unit turns on at 5:00 PM, and off at 9:00 PM.

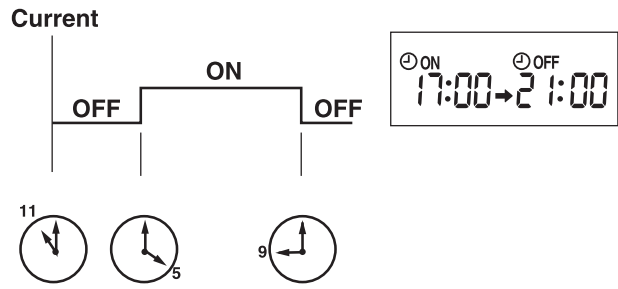

NOTE: If the main power is turned OFF or a power failure occurs while ON/OFF timer is active, the timer setting is cancelled. As these models are equipped with an auto restart function, the air conditioner starts operating with timer cancelled when power is restored.

i. WEEKLY TIMER OPERATION

- A maximum of 4 ON or OFF timers can be set for individual days of the week.
- A maximum of 28 ON or OFF timers can be set for a week.

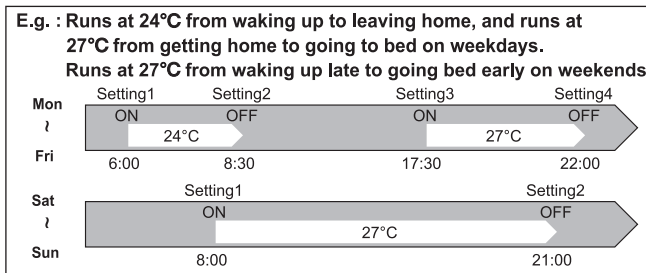

NOTE:

- The simple ON/OFF timer setting is available while the weekly timer is on. In this case, the ON/OFF timer has priority over the weekly timer; the weekly timer operation will start again after the simple ON/OFF timer is complete.
- When the weekly timer is set, temperature cannot be set to 10°C.
- The weekly timer operation and i-save operation cannot be used together.

1. How to set the weekly timer

* Make sure that the current time and day are set correctly.

(1) Press **EDIT/SEND SET** button to enter the weekly timer setting mode.

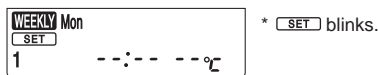

(2) Press **DAY** and **1~4** buttons to select setting days and/or numbers.

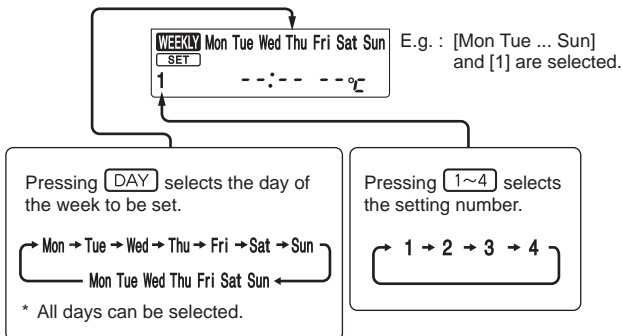

(3) Press **ON/OFF**, **TIME**, and **TEMP** buttons to set ON/OFF, time, and temperature.

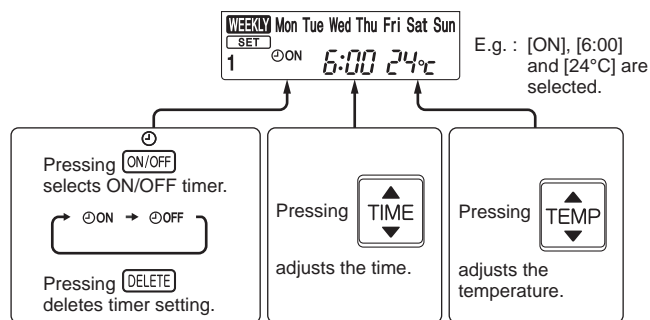

- * Hold down the button to change the time quickly.
- * The temperature can be set between 16°C and 31°C at weekly timer.





Press **DAY** and **1~4** buttons to continue setting the timer for other days and/or numbers.



(4) Press  button to complete and transmit the weekly timer setting.





*  which was blinking goes out, and the current time will be displayed.

NOTE:

- Press  button to transmit the setting information of weekly timer to the indoor unit. Point the remote controller toward the indoor unit for 3 seconds.
- When setting the timer for more than one day of the week or one number,  button does not have to be pressed per each setting. Press  button once after all the settings are complete. All the weekly timer settings will be saved.
- Press  button to enter the weekly timer setting mode, and press and hold  button for 5 seconds to erase all weekly timer settings. Point the remote controller toward the indoor unit.

(5) Press  button to turn the weekly timer ON. ()

- When the weekly timer is ON, the day of the week whose timer setting is complete, will light.

Press  button again to turn the weekly timer OFF. ()



NOTE:

The saved settings will not be cleared when the weekly timer is turned OFF.

2. Checking weekly timer setting

(1) Press  button to enter the weekly timer setting mode.

*  blinks.

(2) Press  or  buttons to view the setting of the particular day or number.

(3) Press  button to exit the weekly timer setting.

j. i-save OPERATION

1. How to set i-save operation

- (1) Press STOP/OPERATE(OFF/ON) button.
- (2) Select COOL or HEAT mode.
- (3) Press i-save button.
- (4) Set the temperature, fan speed, and airflow direction for i-save operation.

NOTE:

- i-save operation cannot be selected during DRY, FAN or AUTO mode operation.
- The setting range of HEAT mode i-save operation is 10°C and 16 - 31°C.
- 2 groups of setting can be saved. (One for COOL, one for HEAT)
- i-save operation and the weekly timer operation cannot be used together.

2. How to cancel operation

- Press i-save button again.
- i-save operation can also be cancelled by pressing OPERATION SELECT button to change the operation mode. The same setting is selected from the next time by simply pressing i-save button.

k. EMERGENCY/TEST OPERATION

In the case of test run operation or emergency operation, use EMERGENCY OPERATION switch on the right side of the indoor unit. Emergency operation is available when the remote controller is missing or has failed, or the batteries in the remote controller are running down. The unit will start and OPERATION INDICATOR lamp will light up. The first 30 minutes of operation is the test run operation. This operation is for servicing. The indoor fan runs at High speed and the temperature control does not work. After 30 minutes of test run operation, the system shifts to EMERGENCY COOL/HEAT MODE with a set temperature of 24°C. The fan speed shifts to Medium. The coil frost prevention works even in the test run or the emergency operation. In the test run or emergency operation, the horizontal vane operates in VANE AUTO (Ⓜ) mode. Emergency operation continues until EMERGENCY OPERATION switch is pressed once or twice or the unit receives any signal from the remote controller. In the latter case normal operation will start.

NOTE: Do not press EMERGENCY OPERATION switch during normal operation.

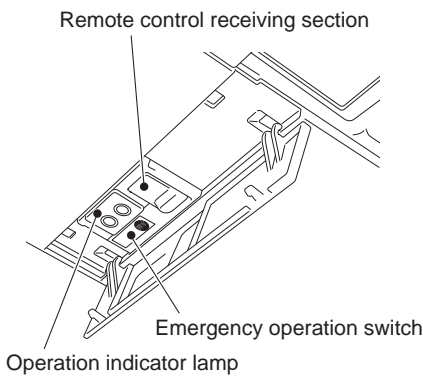

Operation mode	COOL/HEAT
Set temperature	24°C
Fan speed	Medium
Horizontal vane	Auto

The operation mode is indicated by the Operation Indicator lamp as following

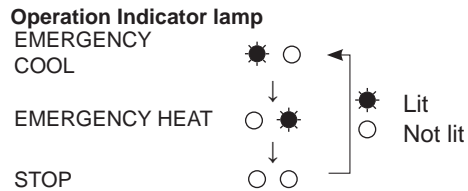

I. 3-MINUTE TIME DELAY OPERATION

When the system turns OFF, compressor will not restart for 3 minutes as 3-minute time delay function operates to protect compressor from overload.

C.3.8.2 MLZ-KY·VG Series

MLZ-KY20VG

WIRELESS REMOTE CONTROLLER

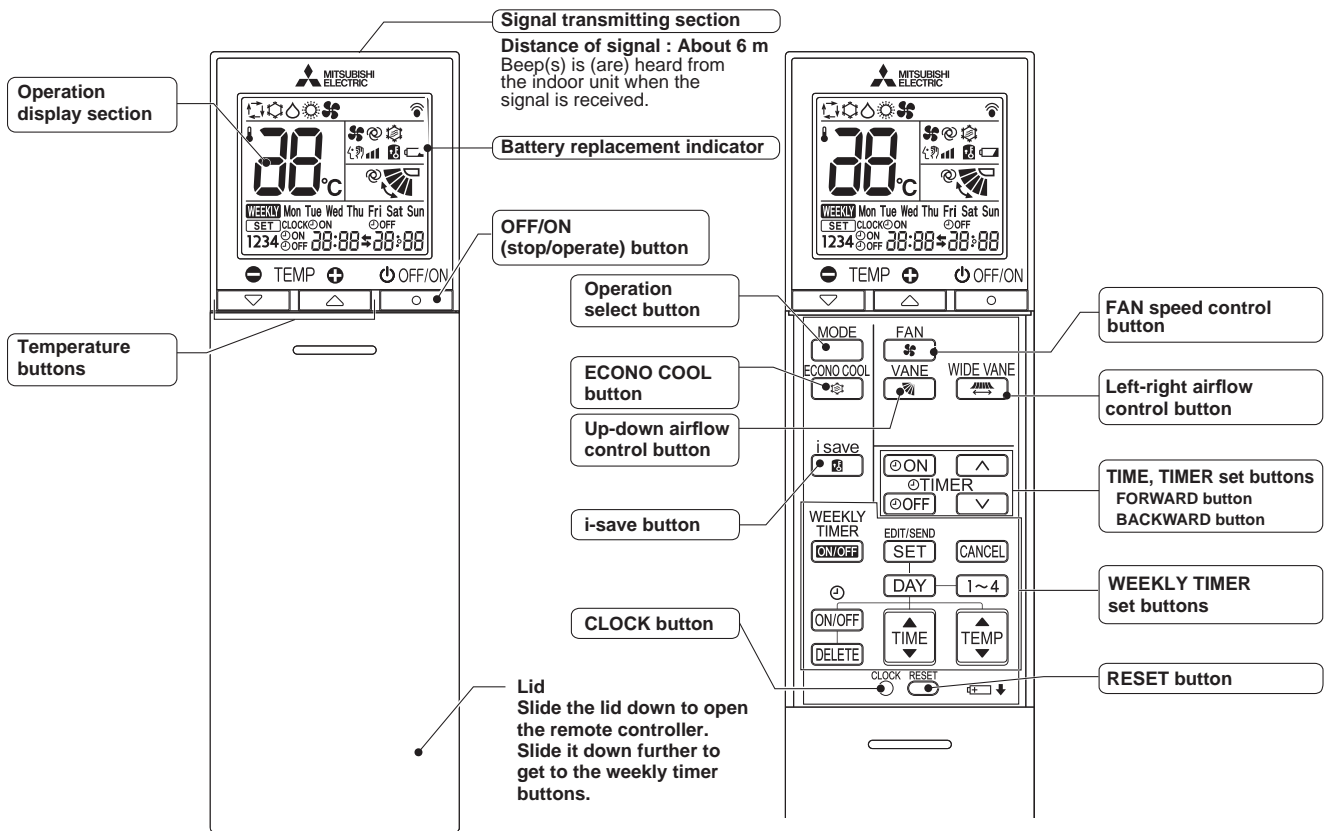

NOTE: Last setting will be stored after the unit is turned OFF with the remote controller. Indoor unit receives the signal of the remote controller with beeps.

INDOOR UNIT DISPLAY SECTION

Operation Indicator lamp

The operation indicator at the right side of the indoor unit indicates the operation state.

• The following indication applies regardless of shape of the indication.

Indication	Operation state	Room temperature
● ●	The unit is operating to reach the set temperature	About 2°C or more away from set temperature
● ○	The room temperature is approaching the set temperature	About 1 to 2°C from set temperature
● ☉	Standby mode (Refer to multi system operation)	—

- Lit
- Blinking
- Not lit

a. COOL (❄️) OPERATION

(1) Press OFF/ON (stop/operate) button.

OPERATION INDICATOR lamp of the indoor unit turns on with a beep tone.

(2) Select COOL mode with Operation select button.

(3) Press Temperature buttons TEMP \ominus or \oplus button to select the desired temperature. The setting range is 16 - 31°C.

1. Coil frost prevention

The compressor operational frequency is controlled by the temperature of the indoor heat exchanger to prevent the coil from frosting.

When the temperature of indoor heat exchanger becomes too low, the coil frost prevention mode works.

The indoor fan operates at the set speed and the compressor stops. This mode continues until the temperature of indoor heat exchanger rises.

b. DRY (☀️) OPERATION

(1) Press OFF/ON (stop/operate) button.

OPERATION INDICATOR lamp of the indoor unit turns on with a beep tone.

(2) Select DRY mode with Operation select button.

(3) The set temperature is determined from the initial room temperature.

1. Coil frost prevention

Coil frost prevention works the same way as that in COOL mode. (a.1.)

c. FAN (🌀) OPERATION

(1) OPERATION INDICATOR lamp of the indoor unit turns on with a beep tone.

(2) Select FAN mode with Operation select button.

(3) Select the desired fan speed. When AUTO, it becomes Low.

Only indoor fan operates.

Outdoor unit does not operate.

d. HEAT (🔥) OPERATION

(1) Press OFF/ON (stop/operate) button.

OPERATION INDICATOR lamp of the indoor unit turns on with a beep tone.

(2) Select HEAT mode with Operation select button.

(3) Press Temperature buttons TEMP \ominus or \oplus button to select the desired temperature. The setting range is 10°C and 16 - 31°C.

1. Cold air prevention control

When the compressor is not operating or is starting, and the temperature of indoor heat exchanger and/or the room temperature is low or when defrosting is being done, the indoor fan will stop or rotate in Very Low speed.

2. Defrosting

Defrosting starts when the temperature of outdoor heat exchanger becomes too low.

The compressor stops once, the indoor/outdoor fans stop, the 4-way valve reverses, and the compressor re-starts.

This mode continues until the temperature of outdoor heat exchanger rises or the fixed time passes.

e. AUTO CHANGE OVER ... AUTO MODE OPERATION

Once desired temperature is set, unit operation is switched automatically between COOL and HEAT operation.

Mode selection

(1) Initial mode

When unit starts the operation with AUTO operation from OFF:

- If the room temperature is higher than the set temperature, operation starts in COOL mode.
- If the room temperature is equal to or lower than the set temperature, operation starts in HEAT mode.

(2) Mode change

COOL mode changes to HEAT mode when about 15 minutes have passed with the room temperature 2°C below the set temperature.

HEAT mode changes to COOL mode when about 15 minutes have passed with the room temperature 2°C above the set temperature.

NOTE 1

If 2 or more indoor units are operating in multi system, there might be a case that the indoor unit, which is operating in □ (AUTO), cannot change over to the other operating mode (COOL ↔ HEAT) and becomes a state of standby.

Refer to **NOTE 2 "FOR MULTI SYSTEM AIR CONDITIONER"**.

NOTE 2
FOR MULTI SYSTEM AIR CONDITIONER
OUTDOOR UNIT: MXZ series

Multi system air conditioner can connect 2 or more indoor units with one outdoor unit.

- When you try to operate 2 or more indoor units with one outdoor unit simultaneously, one for the cooling and the others for heating, the operation mode of the indoor unit that operates first is selected. Other indoor units cannot operate, and operation indicator lamp blinks as shown in the figure below. In this case, please set all the indoor units to the same operation mode.

OPERATION INDICATOR

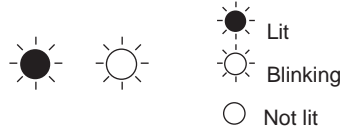

- When indoor unit starts the operation while the defrosting of outdoor unit is being done, it takes a few minutes (max. 10 minutes) to blow out the warm air.
- In the heating operation, though indoor unit that does not operate may get warm or the sound of refrigerant flowing may be heard, they are not malfunction. The reason is that the refrigerant continuously flows into it.

f. AUTO VANE OPERATION

1. Horizontal vane

(1) Vane motor drive

These models are equipped with a stepping motor for the horizontal vane. The rotating direction, speed, and angle of the motor are controlled by pulse signals (approximately 12 V) transmitted from indoor microprocessor.

(2) The horizontal vane angle and mode change as follows by pressing VANE CONTROL button.

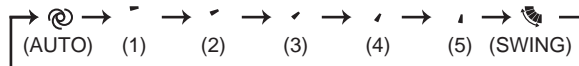

NOTE:

The setting when the lower airflow is preferred in the Airflow direction (1)

The angle of airflow direction (1) can be slightly lowered by changing SWV1 to normal when the lower airflow is preferred or the airflow causes the dirt on the ceiling.

(Refer to 9-5. P.C. BOARD MODIFICATION FOR CHANGING AIRFLOW DIRECTION ADJUSTMENT.)

Factory setting is up.

(3) Positioning

To confirm the standard position, the vane moves until it touches the vane stopper. Then the vane is set to the selected angle.

Confirming of standard position is performed in the following cases:

- (a) When the power supply turns on.
- (b) When the operation starts or finishes (including timer operation).
- (c) When the test run starts.
- (d) When multi-standby starts or finishes.
- (e) When the swing operation finishes.

(4) VANE AUTO (Ⓐ) mode

In VANE AUTO mode, the microprocessor automatically determines the vane angle and operation to make the optimum room-temperature distribution.

(1) In COOL and DRY operation Vane angle is fixed to Angle 1.

(2) In HEAT operation Vane angle is fixed to Angle 4.

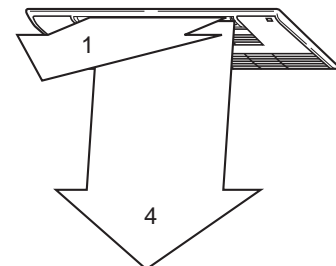

(5) STOP (operation OFF) and ON TIMER standby

In the following cases, the horizontal vane returns to the closed position.

- (a) When OFF/ON (stop/operate) button is pressed (POWER OFF).
- (b) When the operation is stopped by the emergency operation.
- (c) When ON TIMER is ON standby.

(6) SWING (🌀) mode

By selecting SWING mode with VANE CONTROL button, the horizontal vanes swing vertically.

When COOL, DRY or FAN mode is selected, only the upper vane swings.

(7) Cold air prevention in HEAT operation

The horizontal vane position is set to upward.

(8) ECONO COOL (🌀) operation (ECONOMICAL operation)

When ECONO COOL button is pressed in COOL mode, set temperature is automatically set 2°C higher by microprocessor. However, the temperature on the LCD screen on the remote controller is not changed.

Also the horizontal vane swings in various cycle.

SWING operation makes you feel cooler than set temperature. So, even though the set temperature is higher, the air conditioner can keep comfort. As a result, energy can be saved.

To cancel this operation, select a different mode or press one of the following buttons in ECONO COOL operation:

ECONO COOL, WIDE VANE CONTROL or VANE CONTROL button.

2. Vertical vane

(1) Press WIDE VANE CONTROL button to change horizontal airflow direction.

- The vertical vane moves for about 30 seconds.

(After 30 seconds, the vertical vane moves to its original position. In this case, press WIDE VANE CONTROL button again.)

(2) Press WIDE VANE CONTROL button again to set horizontal airflow direction.

- The vertical vane stops and the airflow direction is set.

(3) Positioning

To confirm the standard position, the vane moves until it touches the vane stopper. Then the vane set to the desired angle.

Confirming of standard position is performed in the following cases:

- When OFF/ON (stop/operate) button is pressed (POWER ON).
- When SWING is started.

g. DRAIN PUMP CONTROL**1. Drain pump**

Operating conditions:

- During COOL, DRY, or emergency COOL operation
 - When the drain sensor detects the water level above the fixed point during the following states:
 - Standby during multi system operation
 - Standby while the ON timer is set
 - Operation stop
 - When there is a failure on the drain sensor
- Drain pump operates in conditions 1,2 or 3.

Stop conditions:

States other than 1 or 2 indicated above

h. TIMER OPERATION

1. How to set the time

(1) Check that the current time is set correctly.

NOTE: Timer operation will not work without setting the current time. Initially "0:00" blinks at the current time display of TIME MONITOR, so set the current time correctly with CLOCK SET button.

How to set the current time

- (a) Press the CLOCK set button.
- (b) Press the TIME SET buttons (▲ and ▼) to set the current time.
 - Each time FORWARD button (▲) is pressed, the set time increases by 1 minute, and each time BACKWARD button (▼) is pressed, the set time decreases by 1 minute.
 - Pressing those buttons longer, the set time increases/decreases by 10 minutes.
- (c) Press the CLOCK set button.
- (2) Press OFF/ON (stop/operate) button to start the air conditioner.
- (3) Set the time of timer.

ON timer setting

- (a) Press ON TIMER button (ⓄON) during operation.
- (b) Set the time of the timer using TIME SET buttons (▲ and ▼). *

OFF timer setting

- (a) Press OFF TIMER button (ⓄOFF) during operation.
- (b) Set the time of the timer using TIME SET buttons (▲ and ▼). *

* Each time FORWARD button (▲) is pressed, the set time increases by 10 minutes: each time BACKWARD button (▼) is pressed, the set time decreases by 10 minutes.

2. To release the timer

To release ON timer, press ON TIMER button (ⓄON).
 To release OFF timer, press OFF TIMER button (ⓄOFF).
 TIMER is cancelled and the display of set time disappears.

PROGRAM TIMER

- OFF timer and ON timer can be used in combination. The set time that is reached first will operate first.
- "←" and "→" display shows the order of OFF timer and ON timer operation.

(Example 1) The current time is 8:00 PM.
 The unit turns off at 11:00 PM, and on at 6:00 AM.

(Example 2) The current time is 11:00 AM.
 The unit turns on at 5:00 PM, and off at 9:00 PM.

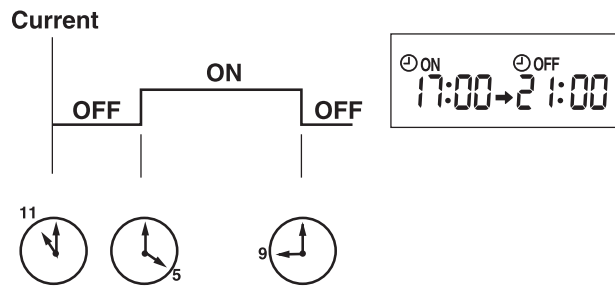
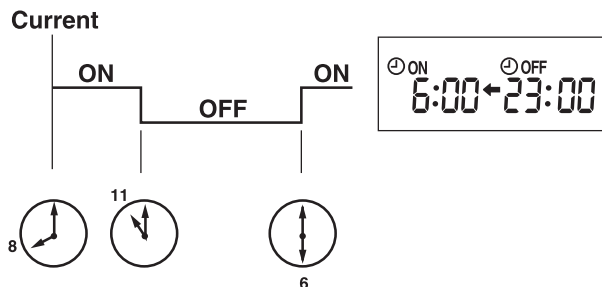

NOTE: If the main power is turned OFF or a power failure occurs while ON/OFF timer is active, the timer setting is cancelled. As these models are equipped with an auto restart function, the air conditioner starts operating with timer cancelled when power is restored.

i. WEEKLY TIMER OPERATION

- A maximum of 4 ON or OFF timers can be set for individual days of the week.
- A maximum of 28 ON or OFF timers can be set for a week.

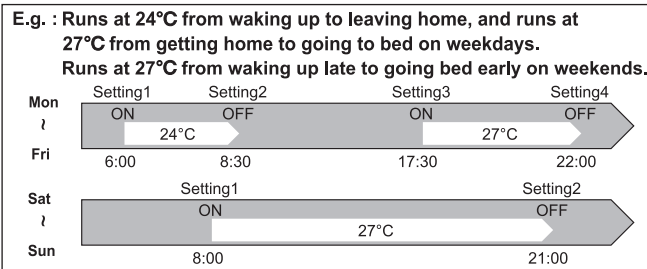

NOTE:

- The simple ON/OFF timer setting is available while the weekly timer is on. In this case, the ON/OFF timer has priority over the weekly timer; the weekly timer operation will start again after the simple ON/OFF timer is complete.
- When the weekly timer is set, temperature cannot be set to 10°C.
- The weekly timer operation and i-save operation cannot be used together.

1. How to set the weekly timer

* Make sure that the current time and day are set correctly.

(1) Press **EDIT/SEND SET** button to enter the weekly timer setting mode.

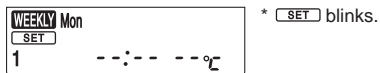

(2) Press **DAY** and **1~4** buttons to select setting days and/or numbers.

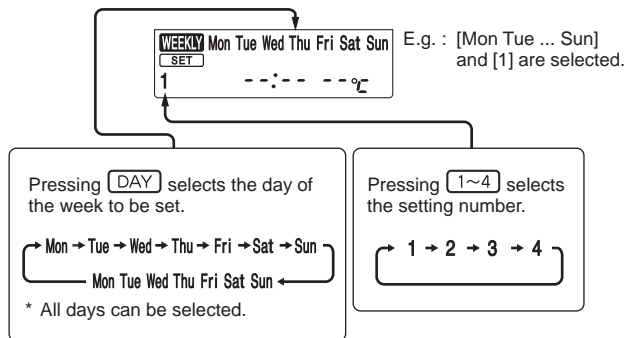

(3) Press **ON/OFF**, **TIME**, and **TEMP** buttons to set ON/OFF, time, and temperature.

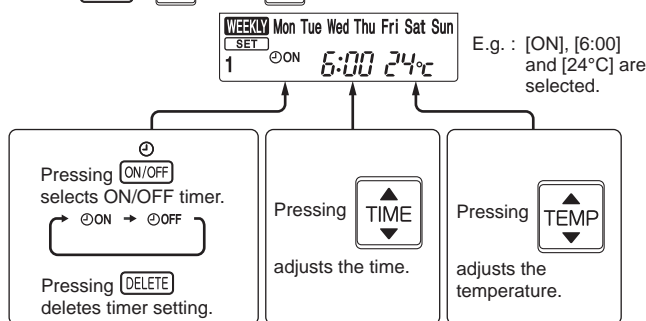

- * Hold down the button to change the time quickly.
- * The temperature can be set between 16°C and 31°C at weekly timer.









Press **DAY** and **1~4** buttons to continue setting the timer for other days and/or numbers.

- (4) Press  button to complete and transmit the weekly timer setting.



*  which was blinking goes out, and the current time will be displayed.





NOTE:

- Press  button to transmit the setting information of weekly timer to the indoor unit. Point the remote controller toward the indoor unit for 3 seconds.
 - When setting the timer for more than one day of the week or one number,  button does not have to be pressed per each setting. Press  button once after all the settings are complete. All the weekly timer settings will be saved.
 - Press  button to enter the weekly timer setting mode, and press and hold  button for 5 seconds to erase all weekly timer settings. Point the remote controller toward the indoor unit.
- (5) Press  button to turn the weekly timer ON. ( lights.)
- When the weekly timer is ON, the day of the week whose timer setting is complete, will light.
- Press  button again to turn the weekly timer OFF. ( goes out.)

NOTE:

The saved settings will not be cleared when the weekly timer is turned OFF.

2. Checking weekly timer setting

- (1) Press  button to enter the weekly timer setting mode.
- *  blinks.
- (2) Press  or  buttons to view the setting of the particular day or number.
- (3) Press  button to exit the weekly timer setting.

j. i-save OPERATION

1. How to set i-save operation

- (1) Press OFF/ON (stop/operate) button.
- (2) Select COOL or HEAT mode.
- (3) Press i-save button.
- (4) Set the temperature, fan speed, and airflow direction for i-save operation.

NOTE:

- i-save operation cannot be selected during DRY, FAN or AUTO mode operation.
- The setting range of HEAT mode i-save operation is 10°C and 16 - 31°C.
- 2 groups of setting can be saved. (One for COOL, one for HEAT)
- i-save operation and the weekly timer operation cannot be used together.

2. How to cancel operation

- Press i-save button again.
- i-save operation can also be cancelled by pressing Operation select button to change the operation mode. The same setting is selected from the next time by simply pressing i-save button.

k. EMERGENCY/TEST OPERATION

In the case of test run operation or emergency operation, use the emergency operation switch on the right side of the indoor unit. Emergency operation is available when the remote controller is missing or has failed, or the batteries in the remote controller are running down. The unit will start and OPERATION INDICATOR lamp will light up.

The first 30 minutes of operation is the test run operation. This operation is for servicing. The indoor fan runs at High speed and the temperature control does not work.

After 30 minutes of test run operation, the system shifts to EMERGENCY COOL/HEAT MODE with a set temperature of 24°C. The fan speed shifts to Medium.

The coil frost prevention works even in the test run or the emergency operation.

In the test run or emergency operation, the horizontal vane operates in VANE AUTO (Ⓢ) mode.

Emergency operation continues until the emergency operation switch is pressed once or twice or the unit receives any signal from the remote controller. In the latter case normal operation will start.

NOTE: Do not press the emergency operation switch during normal operation.

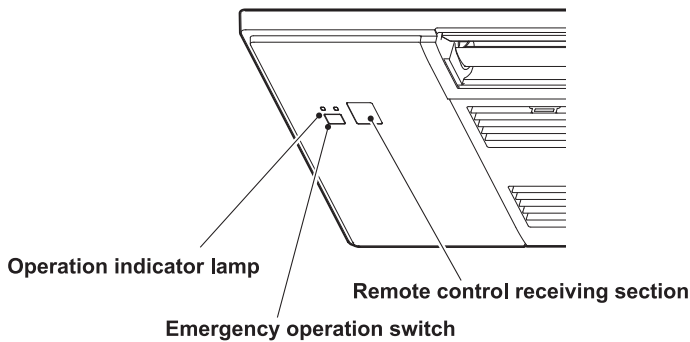

Operation mode	COOL/HEAT
Set temperature	24°C
Fan speed	Medium
Horizontal vane	Auto

The operation mode is indicated by the Operation Indicator lamp as following

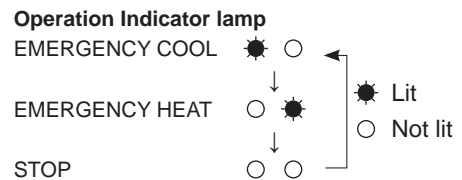

I. 3-MINUTE TIME DELAY OPERATION

When the system turns OFF, compressor will not restart for 3 minutes as 3-minute time delay function operates to protect compressor from overload.

C.4 MULTI SYSTEM

C.4.1	SPECIFICATIONS	C-664
	C.4.1.1 Inverter Heat Pump	C-664
C.4.2	OUTLINES AND DIMENSIONS.....	C-677
	C.4.2.1 Inverter Heat Pump	C-677
C.4.3	WIRING DIAGRAM.....	C-691
	C.4.3.1 Inverter Heat Pump	C-691
C.4.4	REFRIGERANT SYSTEM DIAGRAM	C-715
	C.4.4.1 Inverter Heat Pump	C-715
	C.4.4.2 Refrigerant Pipe Length and Pipe Size	C-726
C.4.5	PERFORMANCE CURVES	C-741
	C.4.5.1 Inverter Heat Pump	C-741
C.4.6	NOISE CRITERIA CURVES	C-854
	C.4.6.1 Inverter Heat Pump	C-854
C.4.7	ACTUATOR CONTROL.....	C-863
	C.4.7.1 MXZ Series.....	C-863
C.4.8	CAPACITY CORRECTION RATIO CURVE FOR PIPING LENGTH.....	C-864
	C.4.8.1 for MXZ R410A model.....	C-864
	C.4.8.2 for MXZ R32 model	C-865

C.4.1 SPECIFICATIONS

C.4.1.1 Inverter Heat Pump

Indoor Unit				Please refer to ^{(*)3}			
Outdoor Unit				MXZ-2F33VF4	MXZ-2F42VF4	MXZ-2F53VF4	MXZ-2F53VVFH4
Refrigerant				R32			
Power Supply				Outdoor power supply			
Outdoor (V/Phase/Hz)				220-230-240V/Single/50Hz			
Cooling	Capacity	Rated	kW	3.3	4.2	5.3	5.3
	Input	Rated	kW	0.85	0.98	1.40	1.40
	Design load		kW	3.3	4.2	5.3	5.3
	Annual electricity consumption ^{(*)1}		kWh/a	189	169	216	216
	SEER ^{(*)3}			6.1	8.7	8.6	8.6
		Energy efficiency class ^{(*)3}		A++	A+++	A+++	A+++
Heating	Capacity	Rated	kW	4.0	4.5	6.4	6.4
	Input	Rated	kW	0.91	0.88	1.56	1.56
	Design load		kW	2.7	3.5	3.5	3.5
	Declared Capacity	at reference design temperature	kW	2.2	2.7	2.7	2.7
		at bivalent temperature	kW	2.4	2.9	2.9	2.9
		at operation limit temperature	kW	1.6	2.3	2.3	2.1
	Back up heating capacity		kW	0.5	0.8	0.8	0.8
	Annual electricity consumption ^{(*)1}		kWh/a	944	1065	1065	1089
	SCOP ^{(*)3}			4.0	4.6	4.6	4.5
			Energy efficiency class ^{(*)3}		A+	A++	A++
Max. Operating Current (Indoor+Outdoor)			A	10.0	12.2	12.2	12.2
Outdoor Unit	Dimensions	H x W x D	mm	550 x 800 (+69) x 285 (+59.5)			
	Weight		kg	33	37	37	38
	Air Volume	Cooling	m ³ /min	30.8	28.4	32.7	32.7
		Heating	m ³ /min	32.3	33.5	34.7	34.7
	Sound Level (SPL)	Cooling	dB(A)	49	44	46	46
		Heating	dB(A)	50	50	51	51
	Sound Level (PWL)	Cooling	dB(A)	60	59	61	61
Breaker Size		A	15	15	15	15	
Ext.Piping	Port diameter	Liquid	mm	6.35x2	6.35x2	6.35x2	6.35x2
		Gas	mm	9.52x2	9.52x2	9.52x2	9.52x2
	Total piping length (Max.)		m	20	30	30	30
	Each indoor unit piping length (Max.)		m	15	20	20	20
	Max.Height		m	10	15(10) ^{(*)2}	15(10) ^{(*)2}	15(10) ^{(*)2}
Chargeless length		m	20	30	30	30	
Guaranteed Operating Range (Outdoor)	Cooling	°C	-10 ~ +46	-10 ~ +46	-10 ~ +46	-10 ~ +46	
	Heating	°C	-15 ~ +24	-15 ~ +24	-15 ~ +24	-20 ~ +24	
Refrigerant/GWP				R32/675 ^{(*)4}	R32/675 ^{(*)4}	R32/675 ^{(*)4}	R32/675 ^{(*)4}
Pre-Charged quantity	Weight	Kg	0.8	1.0	1.0	1.0	
	CO ₂ equivalent	t	0.54	0.68	0.68	0.68	
Max added quantity	Weight	Kg	0.8	1.0	1.0	1.0	
	CO ₂ equivalent	t	0.54	0.68	0.68	0.68	

(*1) Energy consumption based on standard test results.

Actual energy consumption will depend on how the appliance is used and where it is located.

(*2) If the outdoor unit is installed higher than the indoor unit, max. height is reduced to 10 m.

(*3) SEER/SCOP values and energy efficiency class are measured when connected to the indoor units listed below.

MXZ-2F33VF4 → MSZ-AP15VG + MSZ-LN18VG2

MXZ-2F42VF4 → MSZ-LN18VG2 + MSZ-LN25VG2

MXZ-2F53VF4/VFH4 → MSZ-LN18VG2 + MSZ-LN35VG2

(*4) This GWP value is based on Regulation(EU) No 517/2014 from IPCC 4th edition.

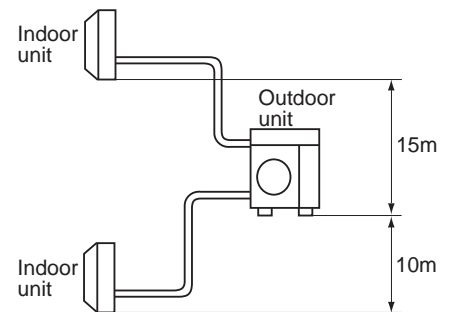

Indoor Unit				Please refer to ^{(*)3}				
Outdoor Unit				MXZ-3F54VF4	MXZ-3F68VF4	MXZ-4F72VF4	MXZ-4F80VF4	
Refrigerant				R32				
Power Supply				Outdoor power supply				
Outdoor (V/Phase/Hz)				220-230-240V/Single/50Hz				
Cooling	Capacity	Rated	kW	5.4	6.8	7.2	8.0	
	Input	Rated	kW	1.32	1.84	1.85	2.25	
	Design load		kW	5.4	6.8	7.2	8.0	
	Annual electricity consumption ^{(*)1}		kWh/a	222	301	311	368	
	SEER ^{(*)3}			8.5	7.9	8.1	7.6	
				Energy efficiency class ^{(*)3}				
				A+++	A++	A++	A++	
Heating	Capacity	Rated	kW	7.0	8.6	8.6	8.8	
	Input	Rated	kW	1.40	1.91	1.87	2.00	
	Design load		kW	5.2	6.8	7.0	7.0	
	Declared Capacity	at reference design temperature		kW	4.2	5.7	5.6	5.6
		at bivalent temperature		kW	4.8	6.4	6.2	6.2
		at operation limit temperature		kW	3.2	4.6	4.8	4.8
	Back up heating capacity		kW	1.0	1.1	1.4	1.4	
	Annual electricity consumption ^{(*)1}		kWh/a	1583	2321	2389	2389	
	SCOP ^{(*)3}			4.6	4.1	4.1	4.1	
					Energy efficiency class ^{(*)3}			
				A++	A+	A+	A+	
Max. Operating Current (Indoor+Outdoor)			A	18.0	18.0	18.0	18.0	
Outdoor Unit	Dimensions	H x W x D	mm	710 x 840 x 330 (+66)				
	Weight		kg	58	58	59	59	
	Air Volume	Cooling	m ³ /min	31	35.4	35.4	40.3	
		Heating	m ³ /min	31	39.6	42.7	44.1	
	Sound Level (SPL)	Cooling	dB(A)	46	48	48	50	
		Heating	dB(A)	50	53	54	55	
	Sound Level (PWL)	Cooling	dB(A)	60	63	63	65	
Breaker Size		A	25	25	25	25		
Ext.Piping	Port diameter	Liquid	mm	6.35x3	6.35x3	6.35x4	6.35x4	
		Gas	mm	9.52x3	9.52x3	12.7x1+9.52x3	12.7x1+9.52x3	
	Total piping length (Max.)		m	50	60	60	60	
	Each indoor unit piping length (Max.)		m	25	25	25	25	
	Max.Height		m	15(10) ^{(*)2}	15(10) ^{(*)2}	15(10) ^{(*)2}	15(10) ^{(*)2}	
Chargeless length		m	50	60	60	60		
Guaranteed Operating Range (Outdoor)	Cooling	°C	-10 ~ +46	-10 ~ +46	-10 ~ +46	-10 ~ +46		
	Heating	°C	-15 ~ +24	-15 ~ +24	-15 ~ +24	-15 ~ +24		
Refrigerant/GWP				R32/675 ^{(*)4}	R32/675 ^{(*)4}	R32/675 ^{(*)4}	R32/675 ^{(*)4}	
Pre-Charged quantity	Weight	Kg	2.4	2.4	2.4	2.4		
	CO ₂ equivalent	t	1.62	1.62	1.62	1.62		
Max added quantity	Weight	Kg	2.4	2.4	2.4	2.4		
	CO ₂ equivalent	t	1.62	1.62	1.62	1.62		

(*1) Energy consumption based on standard test results.

Actual energy consumption will depend on how the appliance is used and where it is located.

(*2) If the outdoor unit is installed higher than the indoor unit, max. height is reduced to 10 m.

(*3) SEER/SCOP values and energy efficiency class are measured when connected to the indoor units listed below.

MXZ-3F54VF4 → MSZ-LN18VG2 + MSZ-LN18VG2 + MSZ-LN18VG2

MXZ-3F68VF4 → MSZ-LN18VG2 + MSZ-LN25VG2 + MSZ-LN25VG2

MXZ-4F72VF4 → MSZ-LN18VG2 + MSZ-LN18VG2 + MSZ-LN18VG2 + MSZ-LN18VG2

MXZ-4F80VF4 → MSZ-LN18VG2 + MSZ-LN18VG2 + MSZ-LN18VG2 + MSZ-LN25VG2

(*4) This GWP value is based on Regulation(EU) No 517/2014 from IPCC 4th edition.

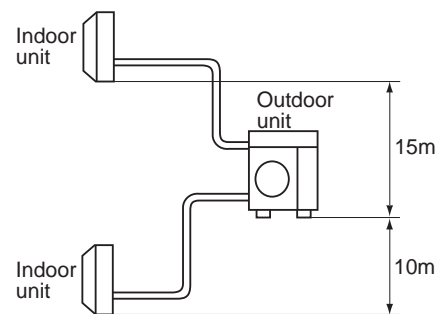

Indoor Unit				Please refer to ^{(*)2}		
Outdoor Unit				MXZ-4F83VF2	MXZ-5F102VF2	
Refrigerant				R32	R32	
Power Supply	Source			Outdoor power supply	Outdoor power supply	
	Outdoor(V/Phase/Hz)			220-230-240V/Single/50Hz	220-230-240V/Single/50Hz	
Cooling	Capacity	Rated	kW	8.3	10.2	
	Input	Rated	kW	1.97	2.80	
	Design load		kW	8.3	10.2	
	Annual electricity consumption ^{(*)1}		kWh/a	342	436	
	SEER ^{(*)2}			8.5	8.2	
		Energy efficiency class ^{(*)2}		A+++	A++	
Heating	Capacity	Rated	kW	9.3	10.5	
	Input	Rated	kW	2.00	2.28	
	Design load		kW	7.0	7.4	
	Declared Capacity	at reference design temperature	kW	5.8	5.9	
		at bivalent temperature	kW	6.2	6.4	
		at operation limit temperature	kW	4.9	4.9	
	Back up heating capacity		kW	1.2	1.5	
	Annual electricity consumption ^{(*)1}		kWh/a	2087	2205	
	SCOP ^{(*)2}			4.7	4.6	
			Energy efficiency class ^{(*)2}		A++	A++
Max. Operating Current (Indoor+Outdoor)			A	21.4	21.4	
Outdoor Unit	Dimensions	H x W x D	mm	796 x 950 x 330	796 x 950 x 330	
	Weight		kg	62	62	
	Air Volume	Cooling		m ³ /min	55	62
		Heating		m ³ /min	71	74
	Sound Level (SPL)	Cooling		dB(A)	49	52
		Heating		dB(A)	51	56
	Sound Level (PWL)	Cooling		dB(A)	61	65
Breaker Size			A	25	25	
Ext.Piping	Port diameter	Liquid	mm	6.35x4	6.35x5	
		Gas	mm	12.7x1+9.52x3	12.7x1+9.52x4	
	Total piping length (Max.)		m	70	80	
	Each indoor unit piping length (Max.)		m	25	25	
	Max.Height		m	15	15	
Chargeless length		m	70	80		
Guaranteed Operating Range (Outdoor)	Cooling		°C	-10 ~ +46	-10 ~ +46	
	Heating		°C	-15 ~ +24	-15 ~ +24	
Refrigerant/GWP				R32/675 ^{(*)3}	R32/675 ^{(*)3}	
Pre-Charged quantity	Weight		Kg	2.4	2.4	
	CO ₂ equivalent		t	1.62	1.62	
Max added quantity	Weight		Kg	2.4	2.4	
	CO ₂ equivalent		t	1.62	1.62	

(*1) Energy consumption based on standard test results.

Actual energy consumption will depend on how the appliance is used and where it is located.

(*2) SEER/SCOP values and energy efficiency class are measured when connected to the indoor units listed below.

MXZ-4F83VF2 → MSZ-LN18VG + MSZ-LN18VG + MSZ-LN25VG + MSZ-LN25VG

MXZ-5F102VF2 → MSZ-LN18VG2 + MSZ-LN18VG2 + MSZ-LN18VG2 + MSZ-LN25VG2 + MSZ-LN25VG2

(*3) This GWP value is based on Regulation(EU) No 517/2014 from IPCC 4th edition.

Indoor Unit				Please refer to ^{(*)2}	
Outdoor Unit				MXZ-6F120VF2	
Refrigerant				R32	
Power Supply	Source			Outdoor power supply	
	Outdoor (V/Phase/Hz)			220-230-240V/Single/50Hz	
Cooling	Capacity	Rated	kW	12.0	
	Input	Rated	kW	3.60	
	Design load			12.0	
	Annual electricity consumption ^{(*)1}			kWh/a 612	
	SEER ^{(*)2}			6.86	
			Energy efficiency class ^{(*)2}	A++	
Heating	Capacity	Rated	kW	14.0	
	Input	Rated	kW	3.31	
	Design load			8.10	
	Declared Capacity	at reference design temperature		kW	6.90
		at bivalent temperature		kW	7.60
		at operation limit temperature		kW	5.72
	Back up heating capacity			kW 1.20	
	Annual electricity consumption ^{(*)1}			kWh/a 2794	
	SCOP ^{(*)2}			4.06	
				Energy efficiency class ^{(*)2}	A+
Max. Operating Current (Indoor+Outdoor)			A	29.8	
Outdoor Unit	Dimensions		H x W x D	mm 1048 x 950 x 330	
	Weight			kg 87	
	Air Volume	Cooling		m ³ /min 63	
		Heating		m ³ /min 77	
	Sound Level (SPL)	Cooling		dB(A) 55	
		Heating		dB(A) 57	
	Sound Level (PWL)	Cooling		dB(A) 69	
Heating			dB(A) 74		
Breaker Size			A 32		
Ext.Piping	Port diameter	Liquid	mm	6.35x6	
		Gas	mm	12.7x1+9.52x5	
	Total piping length (Max.)		m	80	
	Each indoor unit piping length (Max.)		m	25	
	Max.Height		m	15	
Chargeless length		m	80		
Guaranteed Operating Range (Outdoor)		Cooling	°C	-10 ~ +46	
		Heating	°C	-15 ~ +24	
Refrigerant/GWP				R32/675 ^{(*)3}	
Pre-Charged quantity	Weight		Kg	2.4	
	CO ₂ equivalent		t	1.62	
Max added quantity	Weight		Kg	2.4	
	CO ₂ equivalent		t	1.62	

(*1) Energy consumption based on standard test results.

Actual energy consumption will depend on how the appliance is used and where it is located.

(*2) SEER/SCOP values and energy efficiency class are measured when connected to the indoor units listed below.

MXZ-6F120VF2 →

MSZ-LN18VG2 + MSZ-LN18VG2 + MSZ-LN18VG2 + MSZ-LN18VG2 + MSZ-LN25VG2 + MSZ-LN25VG2

(*3) This GWP value is based on Regulation(EU) No 517/2014 from IPCC 4th edition.

Indoor Unit				Please refer to ^{(*)2}		
Outdoor Unit				MXZ-2F53VFHZ2	MXZ-4F83VFHZ2	
Refrigerant				R32		
Power Supply				Outdoor power supply		
Outdoor (V/Phase/Hz)				220-230-240V/Single/50Hz		
Cooling	Capacity	Rated	kW	5.3	8.3	
	Input	Rated	kW	1.29	1.90	
	Design load		kW	5.3	8.3	
	Annual electricity consumption ^{(*)1}		kWh/a	274	398	
	SEER ^{(*)2}			6.8	7.3	
		Energy efficiency class ^{(*)2}		A++	A++	
Heating	Capacity	Rated	kW	6.4	9.0	
	Input	Rated	kW	1.36	1.70	
	Design load		kW	6.4	10.1	
	Declared Capacity	at reference design temperature	kW	6.9	10.6	
		at bivalent temperature	kW	7.4	11.5	
		at operation limit temperature	kW	4.1	5.7	
	Back up heating capacity		kW	0.0	0.0	
	Annual electricity consumption ^{(*)1}		kWh/a	2172	3286	
	SCOP ^{(*)2}			4.1	4.3	
			Energy efficiency class ^{(*)2}		A+	A+
Max. Operating Current (Indoor+Outdoor)			A	15.6	28.0	
Outdoor Unit	Dimensions	H x W x D	mm	796 x 950 x 330	1048 x 950 x 330	
	Weight		kg	61	86	
	Air Volume	Cooling		m ³ /min	43	63
		Heating		m ³ /min	41	77
	Sound Level (SPL)	Cooling		dB(A)	45	55
		Heating		dB(A)	47	57
	Sound Level (PWL)	Cooling		dB(A)	55	66
Breaker Size			A	16	30	
Ext.Piping	Port diameter	Liquid	mm	6.35x2	6.35x4	
		Gas	mm	9.52x2	12.7x1+9.52x3	
	Total piping length (Max.)		m	30	70	
	Each indoor unit piping length (Max.)		m	20	25	
	Max.Height		m	15	15	
Chargeless length		m	30	70		
Guaranteed Operating Range (Outdoor)	Cooling		°C	-10 ~ +46	-10 ~ +46	
	Heating		°C	-25 ~ +24	-25 ~ +24	
Refrigerant/GWP				R32/675 ^{(*)3}	R32/675 ^{(*)3}	
Pre-Charged quantity	Weight		Kg	2.4	2.4	
	CO ₂ equivalent		t	1.62	1.62	
Max added quantity	Weight		Kg	2.4	2.4	
	CO ₂ equivalent		t	1.62	1.62	

(*1) Energy consumption based on standard test results.

Actual energy consumption will depend on how the appliance is used and where it is located.

(*2) SEER/SCOP values and energy efficiency class are measured when connected to the indoor units listed below.

MXZ-2F53VFHZ2 → MSZ-LN18VG2 + MSZ-LN35VG2

MXZ-4F83VFHZ2 → MSZ-LN18VG2 + MSZ-LN18VG2 + MSZ-LN25VG2 + MSZ-LN25VG2

(*3) This GWP value is based on Regulation(EU) No 517/2014 from IPCC 4th edition.

Indoor Unit				Please refer to ^{(*)3}				
Outdoor Unit				MXZ-2D33VA	MXZ-2D42VA2	MXZ-2D53VA2	MXZ-2D53VAH2	
Refrigerant				R410A				
Power Supply		Source		Outdoor power supply				
		Outdoor(V/Phase/Hz)		220-230-240V/Single/50Hz				
Cooling	Capacity	Rated	kW	3.3	4.2	5.3	5.3	
	Input	Rated	kW	0.90	1.00	1.54	1.54	
	Design load		kW	3.3	4.2	5.3	5.3	
	Annual electricity consumption ^{(*)1}		kWh/a	211	216	262	262	
	SEER ^{(*)3}			5.5	6.8	7.1	7.1	
			Energy efficiency class ^{(*)3}	A	A++	A++	A++	
Heating	Capacity	Rated	kW	4.0	4.5	6.4	6.4	
	Input	Rated	kW	0.96	0.93	1.70	1.70	
	Design load		kW	2.7	3.2	4.5	4.5	
	Declared Capacity	at reference design temperature		kW	2.1	2.7	3.7	3.6
		at bivalent temperature		kW	2.4	3.0	4.0	4.0
		at operation limit temperature		kW	1.7	2.3	3.3	3.0
	Back up heating capacity		kW	0.6	0.5	0.8	0.9	
	Annual electricity consumption ^{(*)1}		kWh/a	926	1065	1507	1546	
	SCOP ^{(*)3}			4.1	4.2	4.2	4.1	
			Energy efficiency class ^{(*)3}	A+	A+	A+	A+	
Operating Current(Max)			A	10.0	12.2	12.2	12.2	
Outdoor Unit	Dimensions	H x W x D	mm	550 x 800(+69) x 285(+59.5)				
	Weight		kg	32	37	37	38	
	Air Volume	Cooling	m ³ /min	32.9	27.7	32.9	32.9	
		Heating	m ³ /min	33.7	33.3	33.3	33.3	
	Sound Level (SPL)	Cooling	dB(A)	49	46	50	50	
		Heating	dB(A)	50	51	53	53	
	Sound Level (PWL)	Cooling	dB(A)	63	60	64	64	
Breaker Size		A	10	15	15	15		
Ext.Piping	Port diameter	Liquid/Gas	mm	6.35 x 2 / 9.52 x 2	6.35 x 2 / 9.52 x 2	6.35 x 2 / 9.52 x 2	6.35 x 2 / 9.52 x 2	
	Total piping length (Max.)		m	20	30	30	30	
	Each indoor unit piping length (Max.)		m	15	20	20	20	
	Max.Height		m	10	15(10) ^{(*)2}	15(10) ^{(*)2}	15(10) ^{(*)2}	
	Chargeless length		m	20	20	20	20	
Guaranteed Operating Range(Outdoor)		Cooling	°C	-10 ~ +46				
		Heating	°C	-15 ~ +24		-20 ~ +24		

(*)1 Energy consumption based on standard test results.

Actual energy consumption will depend on how the appliance is used and where it is located.

(*)2 If the outdoor unit is installed higher than the indoor unit, max. height is reduced to 10 m.

(*)3 SEER/SCOP values and energy efficiency class are measured

- MXZ-2D33VA → MSZ-SF15VA + MSZ-EF18VE
- MXZ-2D42VA2 → MSZ-EF18VE + MSZ-EF25VE
- MXZ-2D53VA2 → MSZ-EF18VE + MSZ-EF35VE
- MXZ-2D53VAH2 → MSZ-EF18VE + MSZ-EF35VE

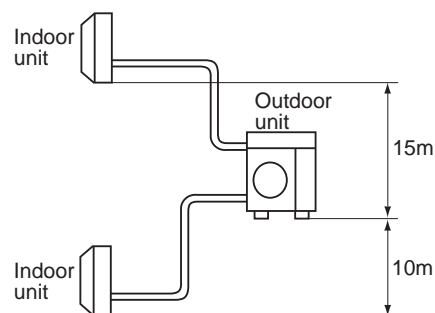

Indoor Unit				Please refer to ^{(*)2}	
Outdoor Unit				MXZ-2E53VAHZ	MXZ-4E83VAHZ
Refrigerant				R410A	
Power Supply	Source			Outdoor power supply	
	Outdoor(V/Phase/Hz)			220-230-240V/Single/50Hz	
Cooling	Capacity	Rated	kW	5.3	8.3
		Min. - Max.	kW	1.1-6.0	3.5-9.2
	Input	Rated	kW	1.29	2.25
	Design load		kW	5.3	8.3
	Annual electricity consumption ^{(*)3}		kWh/a	282	447
	SEER ^{(*)2}			6.5	6.5
			Energy efficiency class ^{(*)2}		A++
Heating	Capacity	Rated (7°C)	kW	6.4	9.0
		Min. - Max.	kW	1.0-7.0	3.5-11.6
	Input	Rated	kW	1.36	1.90
	Design load		kW	6.4	10.1
	Declared Capacity	at reference design temperature	kW	6.4	9.0
		at bivalent temperature	kW	6.4	9.0
		at operation limit temperature	kW	2.4	2.5
	Back up heating capacity		kW	0.0	1.1
	Annual electricity consumption ^{(*)3}		kWh/a	2165	3446
	SCOP ^{(*)2}			4.1	4.1
		Energy efficiency class ^{(*)2}		A+	A+
Max. Operating Current (Indoor+Outdoor)			A	15.6	28.0
Outdoor Unit	Dimensions	H x W x D	mm	796 x 950 x 330	1048 x 950 x 330
	Weight		kg	61	87
	Air Volume	Cooling	m ³ /min	47.0	63.0
		Heating	m ³ /min	47.0	77.0
	Sound Level (SPL)	Cooling	dB(A)	45	53
		Heating	dB(A)	47	57
	Sound Level (PWL)	Cooling	dB(A)	55	66
Breaker Size		A	16	30	
Ext.Piping	Port diameter	Liquid/Gas	mm	6.35x 2 / 9.52 x 2	6.35 x 4 / 12.7 x 1 + 9.52 x 3
	Total piping length (Max.)		m	30	70
	Each indoor unit piping length (Max.)		m	20	25
	Max.Height		m	15(10) ^{(*)1}	15(10) ^{(*)1}
	Chargeless length		m	20	25
Guaranteed Operating Range(Outdoor)	Cooling	°C		-10 ~ +46	
	Heating	°C		-25 ~ +24	

(*)1 If the outdoor unit is installed higher than the indoor unit, max. height is reduced to 10 m.

(*)2 SEER/SCOP values and energy efficiency class are measured when connected to the indoor units listed below.

MXZ-2E53VAHZ → MSZ-EF18VE + MSZ-EF35VE

MXZ-4E83VAHZ → MSZ-EF18VE + MSZ-EF18VE + MSZ-EF22VE + MSZ-EF25VE

(*)3 Energy consumption based on standard test results.

Actual energy consumption will depend on how the appliance is used and where it is located.

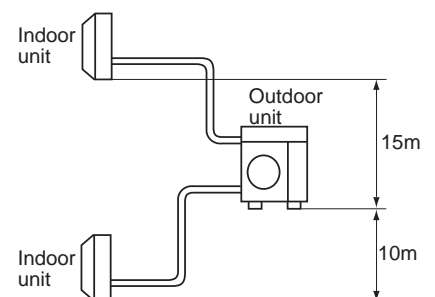

Indoor Unit				Please refer to ^{(*)3}		
Outdoor Unit				MXZ-3E54VA	MXZ-3E68VA	MXZ-4E72VA
Refrigerant				R410A		
Power Supply	Source			Outdoor power supply		
	Outdoor(V/Phase/Hz)			220-230-240V/Single/50Hz		
Cooling	Capacity	Rated	kW	5.4	6.8	7.2
	Input	Rated	kW	1.35	2.19	2.25
	Design load		kW	5.4	6.8	7.2
	Annual electricity consumption ^{(*)1}		kWh/a	295	425	443
	SEER ^{(*)3}			6.4	5.6	5.7
			Energy efficiency class ^{(*)3}	A++	A+	A+
Heating	Capacity	Rated	kW	7.0	8.6	8.6
	Input	Rated	kW	1.59	2.38	2.28
	Design load		kW	5.0	6.8	7.0
	Declared Capacity	at reference design temperature	kW	4.0	5.4	5.6
		at bivalent temperature	kW	4.5	6.0	6.2
		at operation limit temperature	kW	3.2	4.4	4.7
	Back up heating capacity		kW	1.0	1.4	1.4
	Annual electricity consumption ^{(*)1}		kWh/a	1751	2466	2516
	SCOP ^{(*)3}			4.0	3.9	3.9
			Energy efficiency class ^{(*)3}	A+	A	A
Operating Current(Max)			A	18.0	18.0	18.0
Outdoor Unit	Dimensions	H x W x D	mm	710 x 840(+30) x 330(+66)		
	Weight		kg	58	58	59
	Air Volume	Cooling	m ³ /min	42.1	42.1	42.1
		Heating	m ³ /min	43.0	43.0	43.0
	Sound Level (SPL)	Cooling	dB(A)	50	50	50
		Heating	dB(A)	53	53	53
	Sound Level (PWL)	Cooling	dB(A)	64	64	64
Breaker Size		A	25	25	25	
Ext.Piping	Port diameter	Liquid/Gas	mm	6.35 x 3 / 9.52 x 3	6.35 x 3 / 9.52 x 3	6.35 x 4 / 12.7 x 1+9.52 x 3
	Total piping length (Max.)		m	50	60	60
	Each indoor unit piping length (Max.)		m	25	25	25
	Max.Height		m	15(10) ^{(*)2}	15(10) ^{(*)2}	15(10) ^{(*)2}
	Chargeless length		m	40	40	40
Guaranteed Operating Range(Outdoor)	Cooling	°C	-10 ~ +46			
	Heating	°C	-15 ~ +24			

(*1) Energy consumption based on standard test results.

Actual energy consumption will depend on how the appliance is used and where it is located.

(*2) If the outdoor unit is installed higher than the indoor unit, max. height is reduced to 10 m.

- (*3) SEER/SCOP values and energy efficiency class are measured
 MXZ-3E54VA → MSZ-EF18VE + MSZ-EF18VE + MSZ-EF18VE
 MXZ-3E68VA → MSZ-EF18VE + MSZ-EF25VE + MSZ-EF25VE
 MXZ-4E72VA → MSZ-EF18VE + MSZ-EF18VE + MSZ-EF18VE + MSZ-EF18VE

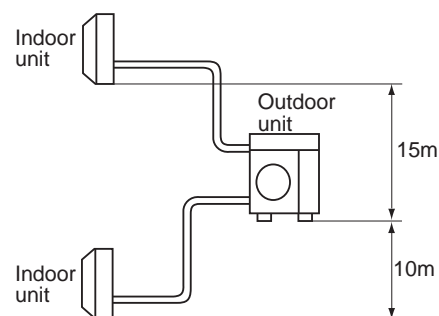

Indoor Unit				Please refer to ^{(*)3}		
Outdoor Unit				MXZ-4E83VA	MXZ-5E102VA	
Refrigerant				R410A		
Power Supply	Source			Outdoor power supply		
	Outdoor(V/Phase/Hz)			220-230-240V/Single/50Hz		
Cooling	Capacity	Rated	kW	8.3	10.2	
	Input	Rated	kW	2.44	3.15	
	Design load			kW	8.3	10.2
	Annual electricity consumption ^{(*)1}			kWh/a	460	537
	SEER ^{(*)3}				6.3	6.6
			Energy efficiency class ^{(*)3}	A++	A++	
Heating	Capacity	Rated	kW	9.3	10.5	
	Input	Rated	kW	2.00	2.34	
	Design load			kW	8.7	8.9
	Declared Capacity	at reference design temperature		kW	7.1	7.3
		at bivalent temperature		kW	7.8	7.9
		at operation limit temperature		kW	6.0	6.3
	Back up heating capacity			kW	1.6	1.6
	Annual electricity consumption ^{(*)1}			kWh/a	2889	2958
	SCOP ^{(*)3}				4.2	4.2
				Energy efficiency class ^{(*)3}	A+	A+
Operating Current(Max)			A	21.4	21.4	
Outdoor Unit	Dimensions	H x W x D		mm 796 x 950 x 330		
	Weight			kg	63	64
	Air Volume	Cooling		m ³ /min	55.6	65.1
		Heating		m ³ /min	55.6	68.0
	Sound Level (SPL)	Cooling		dB(A)	49	52
		Heating		dB(A)	51	56
	Sound Level (PWL)	Cooling		dB(A)	61	65
Breaker Size			A	25	25	
Ext.Piping	Port diameter	Liquid/Gas		mm	6.35 x 4 / 12.7 x 1+9.52 x 3	6.35 x 5 / 12.7 x 1+9.52 x 4
	Total piping length (Max.)			m	70	80
	Each indoor unit piping length (Max.)			m	25	25
	Max.Height			m	15 ^{(*)2}	15 ^{(*)2}
	Chargeless length			m	25	0
Guaranteed Operating Range(Outdoor)		Cooling	°C	-10 ~ +46		
		Heating	°C	-15 ~ +24		

(*1) Energy consumption based on standard test results.

Actual energy consumption will depend on how the appliance is used and where it is located.

(*2) If the outdoor unit is installed higher than the indoor unit, max. height is reduced to 10 m.

(*3) SEER/SCOP values and energy efficiency class are measured
 MXZ-4E83VA → MSZ-EF18VE + MSZ-EF18VE + MSZ-EF22VE + MSZ-EF25VE

MXZ-5E102VA → MSZ-EF18VE + MSZ-EF18VE + MSZ-EF22VE + MSZ-EF22VE + MSZ-EF22VE

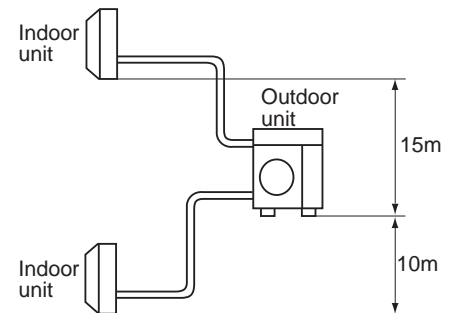

Indoor Unit				Please refer to ^{(*)2}	
Outdoor Unit				MXZ-6D122VA2	
Refrigerant				R410A	
Power Supply	Source			Outdoor power supply	
	Outdoor(V/Phase/Hz)			220-230-240V/Single/50Hz	
Cooling	Capacity	Rated	kW	12.2	
		Min. - Max.	kW	3.5 - 13.5	
	Input ^{(*)1}	Rated	kW	3.66	
	EER ^{(*)2}				3.33
		EEL Rank		A	
Heating	Capacity	Rated	kW	14.0	
		Min. - Max.	kW	3.5 - 16.5	
	Input ^{(*)1}	Rated	kW	3.31	
	COP ^{(*)2}				4.23
		EEL Rank		A	
Operating Current(Max) ^{(*)1}			A	26.8	
Total Capacity of all Indoor Units (max)			kW	Please refer to combination table	
Outdoor Unit	Dimensions	H x W x D		mm	1048 x 950 x 330
	Weight			kg	88
	Air Volume	Cooling	m ³ /min		63.0
		Heating	m ³ /min		77.0
	Sound Level (SPL)	Cooling	dB(A)		55
		Heating	dB(A)		57
	Sound Level (PWL)	Cooling	dB(A)		69
	Operating Current	Cooling	A		16.8 - 16.1 - 15.4
		Heating	A		15.2 - 14.5 - 13.9
Breaker Size			A	32	
Ext.Piping	Port diameter	Liquid/Gas	mm	6.35 x 6 / 12.7 x 1+9.52 x 5	
	Total piping length (Max.)			m	80
	Each indoor unit piping length (Max.)			m	25
	Max.Height			m	15(10) ^{(*)3}
	Chargeless length			m	30
Guaranteed Operating Range(Outdoor)		Cooling	°C	-10 ~ +46	
		Heating	°C	-15 ~ +24	

(*)1 Power input and operating current (max) figures are for outdoor unit only.

(*)2 EER/COP and EEL rank are measured when connected to the indoor units listed below.

MXZ-6D122VA2 → MSZ-EF18VE + MSZ-EF18VE + MSZ-EF18VE + MSZ-EF18VE + MSZ-EF25VE + MSZ-EF25VE

(*)3 If the outdoor unit is installed higher than the indoor unit, max. height is reduced to 10 m.

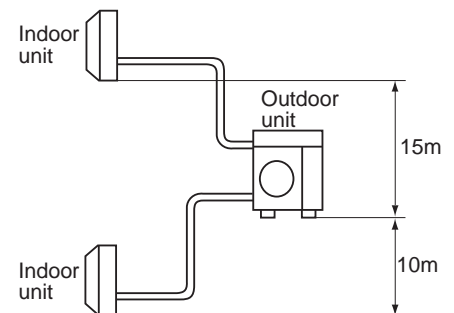

MULTI SYSTEM SPECIFICATIONS

Indoor Unit				Refer to ^{(*)2}		
Outdoor Unit				MXZ-2DM40VA	MXZ-3DM50VA	
Refrigerant				R410A		
Power Supply		Outdoor power supply				
Source		230V/Single/50Hz				
Outdoor (V/Phase/Hz)						
Cooling	Capacity	Rated	kW	4.0	5.0	
		Min. - Max.	kW	1.1-4.3	2.7-6.5	
	Input	Rated	kW	1.05	1.13	
		EER ^{(*)2}			3.81	4.42
	EEL Rank ^{(*)2}			A	A	
	Annual Electricity Consumption ^{(*)3}		kWh/a	226	283	
	SEER ^{(*)2}			6.1	6.1	
Energy efficiency class ^{(*)2}			A++	A++		
Heating (Average Season)	Capacity	Rated	kW	4.3	6.0	
		Min. - Max.	kW	1.0-4.7	2.4-7.5	
	Input	Rated	kW	1.16	1.31	
		COP ^{(*)2}			3.71	4.58
	EEL Rank ^{(*)2}			A	A	
	Annual Electricity Consumption ^{(*)3}		kWh/a	1105	1455	
	SCOP ^{(*)2}			4.0	3.8	
Energy efficiency class ^{(*)2}			A+	A		
Operating Current (Max.)			A	12.2	18.0	
Outdoor Unit	Dimensions		H x W x D	mm	550 x 800(+69) x 285(+59.5)	710 x 840(+30) x 330(+66)
	Weight			kg	32	57
	Air Volume	Cooling	m ³ /min	29.2	37.5	
		Heating	m ³ /min	31.9	39.6	
	Sound Level (SPL)	Cooling	dB(A)	48	50	
		Heating	dB(A)	52	53	
	Sound Level (PWL)	Cooling	dB(A)	63	64	
	Operating Current	Cooling	A	5.1	5.0	
		Heating	A	5.6	5.8	
Breaker Size		A	15	25		
Ext. Piping	Port diameter	Liquid/Gas	mm	6.35 x 2 / 9.52 x 2	6.35 x 3 / 9.52 x 3	
	Total piping length (Max.)		m	30	50	
	Each indoor unit piping length (Max.)		m	20	25	
	Max. Height		m	15(10) ^{(*)1}	15(10) ^{(*)1}	
	Chargeless length		m	20	40	
Guaranteed Operating Range (Outdoor)		Cooling	°C	-10 ~ +46		
		Heating	°C	-15 ~ +24		

(*1) If the outdoor unit is installed higher than the indoor unit, max. height is reduced to 10 m.

(*2) SEER/SCOP values and energy efficiency class are measured when connected to the indoor units listed below.

MXZ-2DM40VA → MSZ-DM25VA + MSZ-DM25VA

MXZ-3DM50VA → MSZ-DM25VA + MSZ-DM25VA + MSZ-DM25VA

(*3) Energy consumption based on standard test results.

Actual energy consumption will depend on how the appliance is used and where it is located.

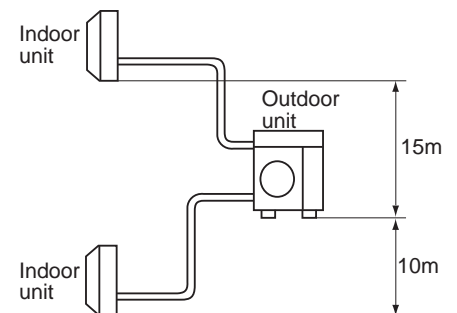

Indoor Unit				Please refer to ^{(*)3}		
Outdoor Unit				MXZ-2HA40VF2	MXZ-2HA50VF2	MXZ-3HA50VF2
Refrigerant				R32		
Power Supply				Outdoor power supply		
Outdoor (V/Phase/Hz)				220-230-240V/Single/50Hz		
Cooling	Capacity	Rated	kW	4.0	5.0	5.0
		Min-Max	kW	1.1 - 4.3	1.1 - 5.4	2.9 - 6.5
	Input	Rated	kW	1.05	1.52	1.26
	Design load		kW	4.0	5.0	5.0
	Annual electricity consumption ^{(*)1}		kWh/a	172	225	241
	SEER ^{(*)3}			8.12	7.78	7.26
Heating	Capacity	Rated	kW	4.3	6.0	6.0
		Min-Max	kW	1.0 - 4.7	1.0 - 6.4	2.6 - 7.5
	Input	Rated	kW	0.91	1.54	1.30
	Design load		kW	3.2	3.2	4.0
	Declared Capacity	at reference design temperature	kW	2.4	2.4	3.0
		at bivalent temperature	kW	2.9	2.9	3.6
		at operation limit temperature	kW	2.1	2.1	2.6
	Back up heating capacity		kW	0.8	0.8	1.0
	Annual electricity consumption ^{(*)1}		kWh/a	1043	1043	1394
	SCOP ^{(*)3}			4.30	4.30	4.02
	Energy efficiency class ^{(*)3}		A+	A+	A+	
Max. Operating Current (Indoor+Outdoor)			A	12.2	12.2	18.0
Outdoor Unit	Dimensions	H x W x D	mm	550 x 800 (+69) x 285 (+59.5)		710 x 840 x 330 (+66)
	Weight		kg	37	37	57
	Air Volume	Cooling	m ³ /min	28.4	32.7	31.0
		Heating	m ³ /min	33.5	34.7	29.1
	Sound Level (SPL)	Cooling	dB(A)	44	47	46
		Heating	dB(A)	50	51	50
	Sound Level (PWL)	Cooling	dB(A)	59	64	61
Breaker Size		A	15	15	25	
Ext.Piping	Port diameter	Liquid	mm	6.35 x 2	6.35 x 2	6.35 x 3
		Gas	mm	9.52 x 2	9.52 x 2	9.52 x 3
	Total piping length (Max.)	m	30	30	50	
	Each indoor unit piping length (Max.)	m	20	20	25	
	Max.Height	m	15(10) ^{(*)2}	15(10) ^{(*)2}	15(10) ^{(*)2}	
Chargeless length	m	30	30	40		
Guaranteed Operating Range (Outdoor)	Cooling	°C	-10 ~ +46			
	Heating	°C	-15 ~ +24			
Refrigerant/GWP				R32/675 ^{(*)4}	R32/675 ^{(*)4}	R32/675 ^{(*)4}
Pre-Charged quantity	Weight	Kg	0.9	0.9	1.4	
	CO ₂ equivalent	t	0.61	0.61	0.95	
Max added quantity	Weight	Kg	0.9	0.9	1.6	
	CO ₂ equivalent	t	0.61	0.61	1.08	

- (*1) Energy consumption based on standard test results.
Actual energy consumption will depend on how the appliance is used and where it is located.
- (*2) If the outdoor unit is installed higher than the indoor unit, max. height is reduced to 10 m.
- (*3) SEER/SCOP values and energy efficiency class are measured when connected to the indoor units listed below.
 MXZ-2HA40VF2 → MSZ-HR25VF + MSZ-HR25VF
 MXZ-2HA50VF2 → MSZ-HR25VF + MSZ-HR25VF
 MXZ-3HA50VF2 → MSZ-HR25VF + MSZ-HR25VF + MSZ-HR25VF
- (*4) This GWP value is based on Regulation(EU) No 517/2014 from IPCC 4th edition.

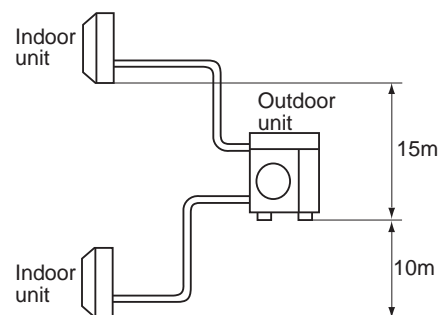

MODEL NAME				PXZ-4F75VG	PXZ-5F85VG
POWER SUPPLY(Phase, voltage, frequency)				1φ, 230V, 50Hz	1φ, 230V, 50Hz
Max. Current		A		18.0	21.4
Braker size		A		25.0	25.0
Outer casing				Galvanized plate	Galvanized plate
External finish				Munsell No. 3Y 7.8/1.1	Munsell No. 3Y 7.8/1.1
Refrigerant control				Linear expansion valve	Linear expansion valve
Compressor				Hermetic twin rotary	Hermetic twin rotary
Model				SVB172FPM1T	SVB220FUGMC-L1
Motor output		kW		2.0	2.2
Start type				Inverter	Inverter
Protection devices				HP switch Theraml Protector Comp. Surface thermo Over current detection	HP switch Theraml Protector Comp. Surface thermo Over current detection
Oil (Model)		L		0.6 (FW68CA)	0.6 (FW68CA)
Crankcase heater				-	-
Heat exchanger		Air		Plate fin coil	Plate fin coil
		Water		Plate heat exchanger	Plate heat exchanger
Fan				Propeller fan x1	Propeller fan x1
Fan(drive) x No.				0.064	0.088
Fan motor output		kW		42.7 (1508)	62.0 (2182)
Air flow		m ³ /min (CFM)			
Defrost method				Reverse cycle	Reverse cycle
ATA		Heating (Full Load)	dB	54	51
		Cooling	dB	48	49
Noise level (PWL)		ATA	Cooling	dB	63
				63	61
Dimensions					
		Width	mm(in)	840 (33-11/16)	950 (37-3/8)
		Depth	mm(in)	330 (13)	330 (13)
		Height	mm(in)	710 (27-15/16)	796 (31-5/16)
Weight				kg(lbs)	59 (130)
Refrigerant				R32	R32
		Chargeless	kg(lbs)	2.4 (5.3)	2.4 (5.3)
		MAX.	kg(lbs)	2.4 (5.3)	2.4 (5.3)
Pipe size O.D.					
		Liquid	mm(in)	6.35 (1/4)	6.35 (1/4)
		Gas	mm(in)	12.7 (1/2)	12.7 (1/2)
Connection method				Flared	Flared
Between the indoor & outdoor unit		Height difference	m	Max. 20	Max. 20
		Piping length	m	Max. 60m total Max. 30m for each	Max. 70m total Max. 30m for each
ATA		Heating	°C	-20 to +24	-20 to +24
		Cooling	°C	-10 to +46	-10 to +46

C.4.2 OUTLINES AND DIMENSIONS

C.4.2.1 Inverter Heat Pump

MXZ-2F33VF4	MXZ-2D33VA	MXZ-2DM40VA
MXZ-2F42VF4	MXZ-2D42VA2	MXZ-2HA40VF2
MXZ-2F53VF4	MXZ-2D53VA2	MXZ-2HA50VF2
MXZ-2F53VFH4	MXZ-2D53VAH2	

OUTDOOR UNIT

Unit: mm

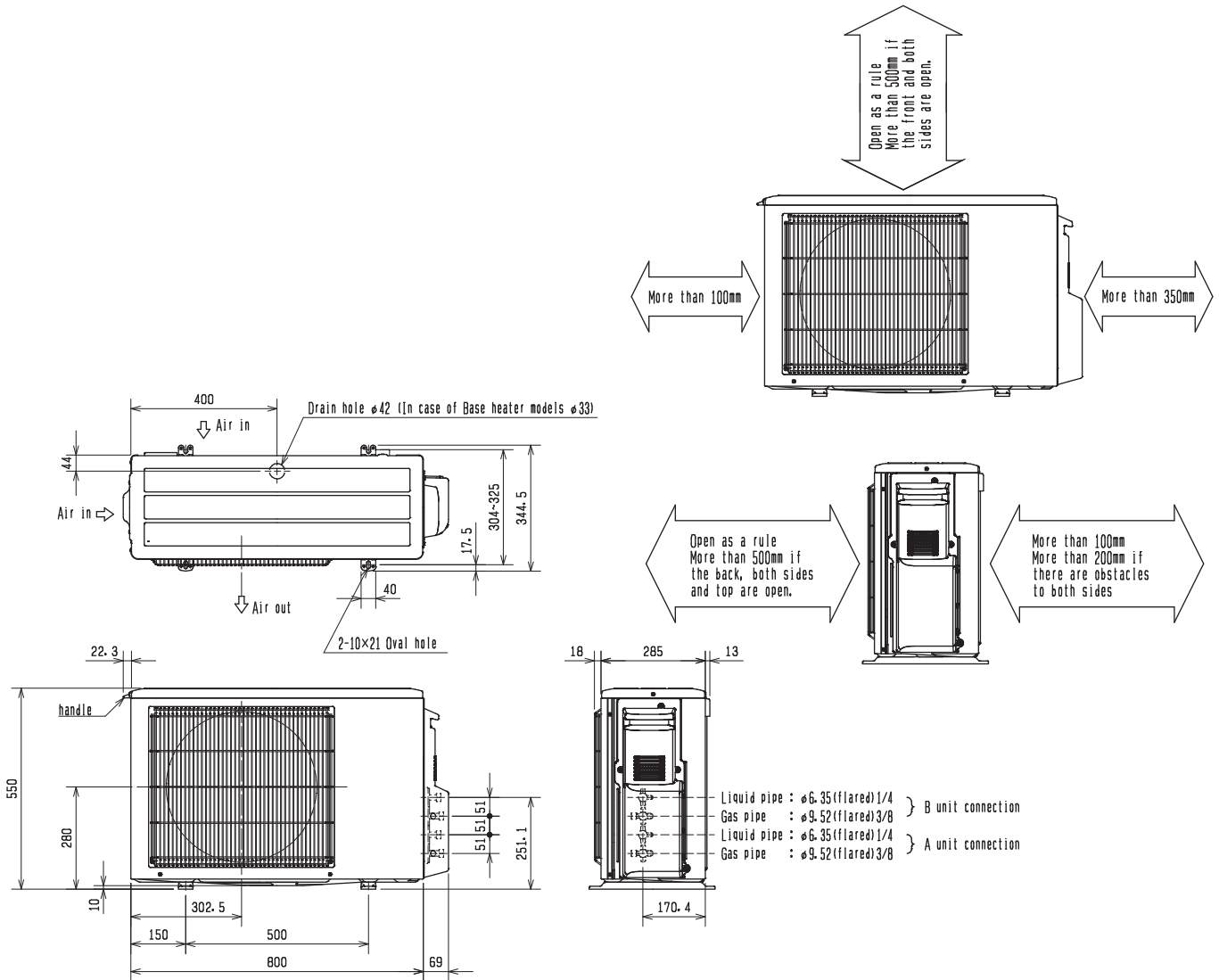

MXZ-3F54VF4
MXZ-3F68VF4

MXZ-3E54VA
MXZ-3E68VA

MXZ-3HA50VF2

OUTDOOR UNIT

Unit: mm

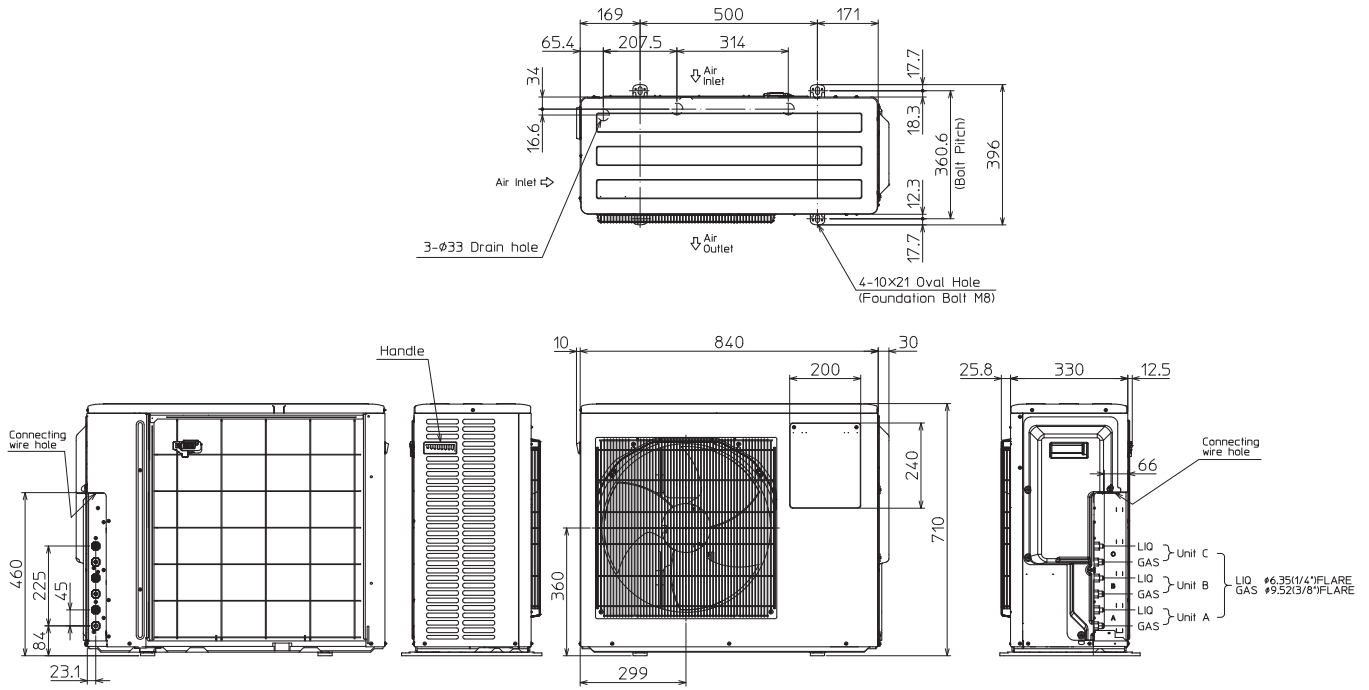

1. Installation space

Note : Leave front and both sides free of obstruction.

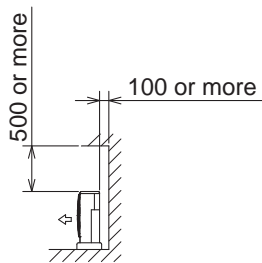

2. Service space

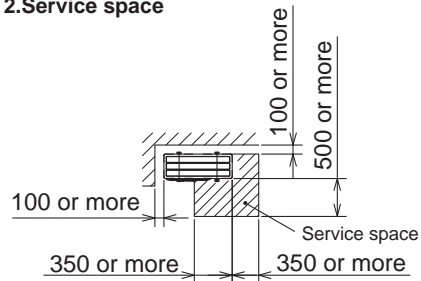

Note : Leave front and overhead free of obstruction.

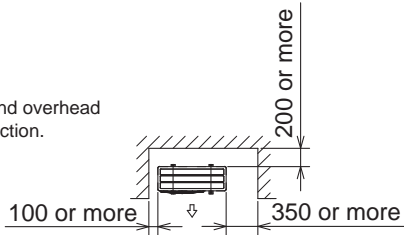

Note : Leave rear, overhead and both sides free of obstruction.

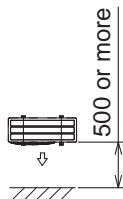

MXZ-4F72VF4

MXZ-4F80VF4

MXZ-4E72VA

PXZ-4F75VG

OUTDOOR UNIT

Unit: mm

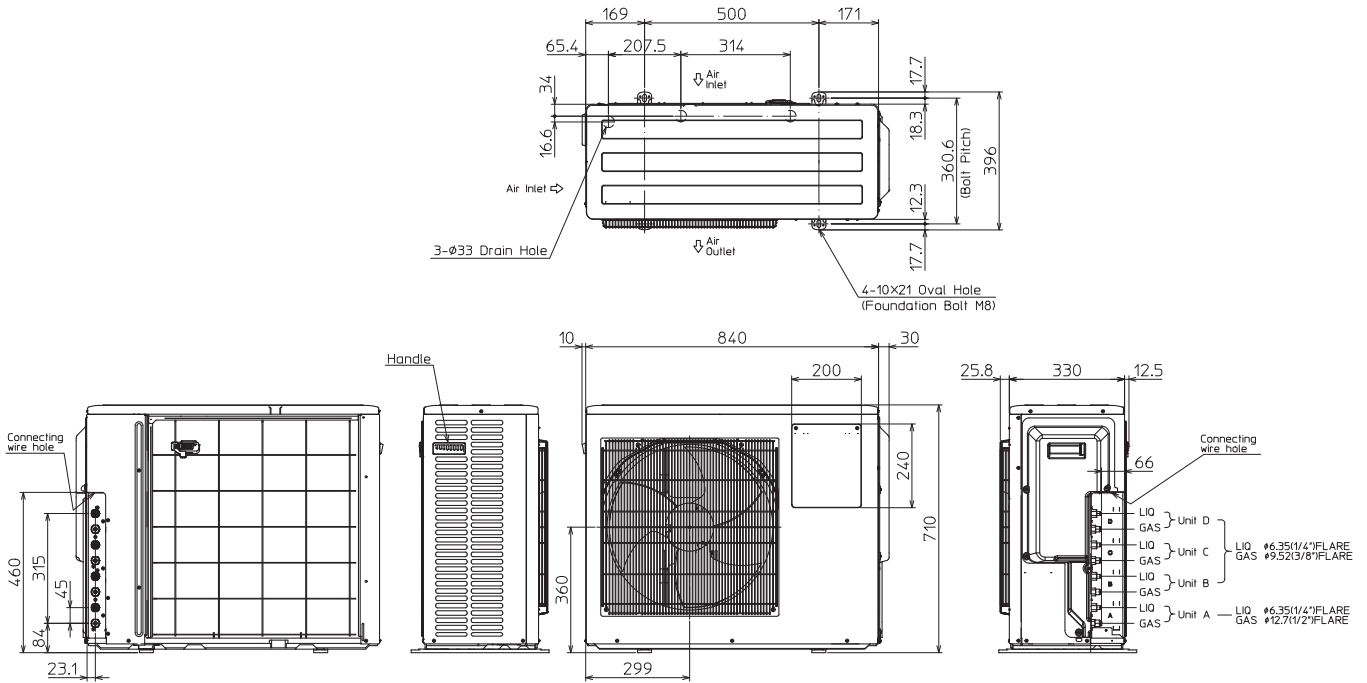

1. Installation space

Note : Leave front and both sides free of obstruction.

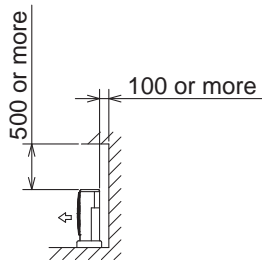

Note : Leave front and overhead free of obstruction.

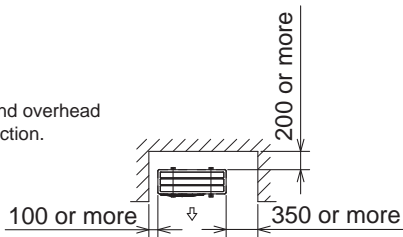

Note : Leave rear, overhead and both sides free of obstruction.

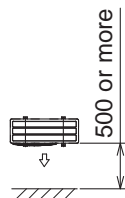

2. Service space

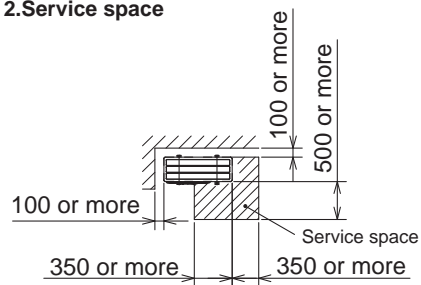

MXZ-4F83VF2

OUTDOOR UNIT

Unit: mm

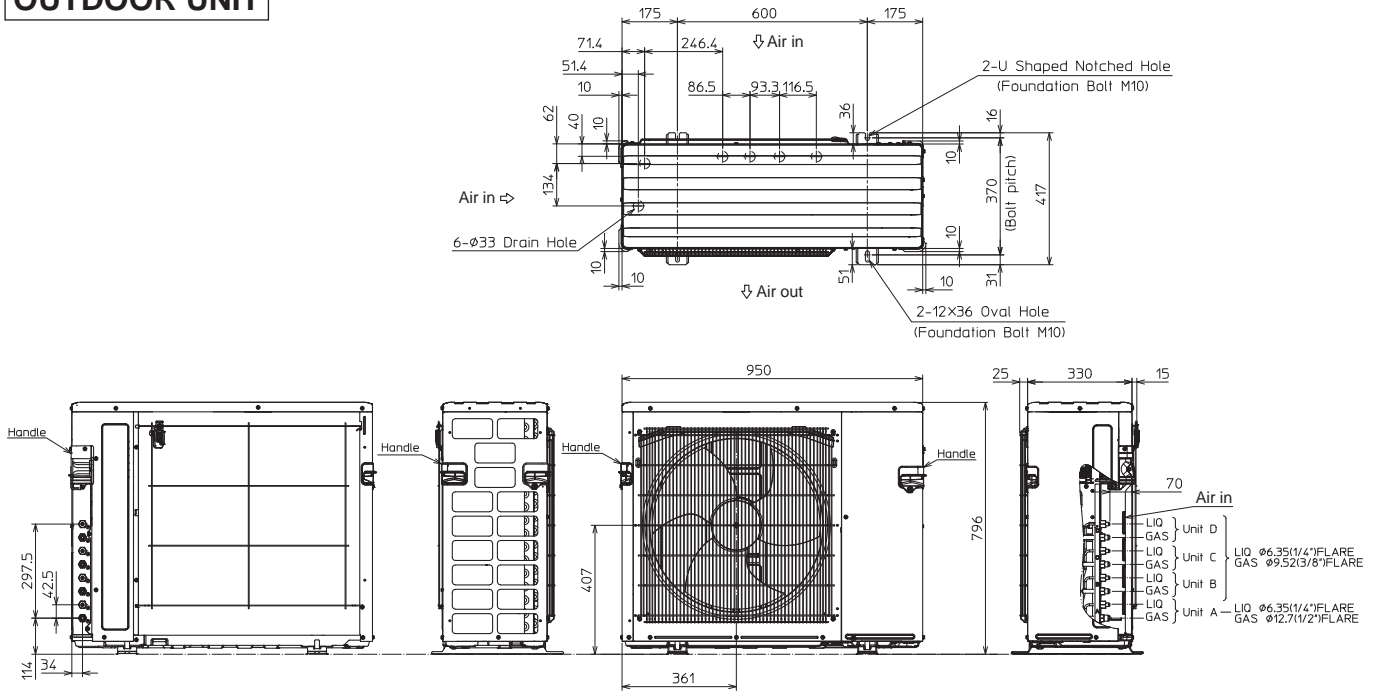

1.FREE SPACE

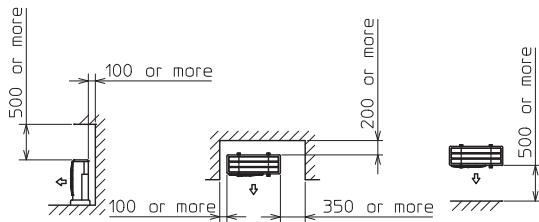

2.SERVICE SPACE

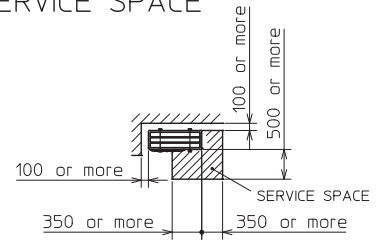

MXZ-5F102VF2 PXZ-5F85VG

OUTDOOR UNIT

Unit: mm

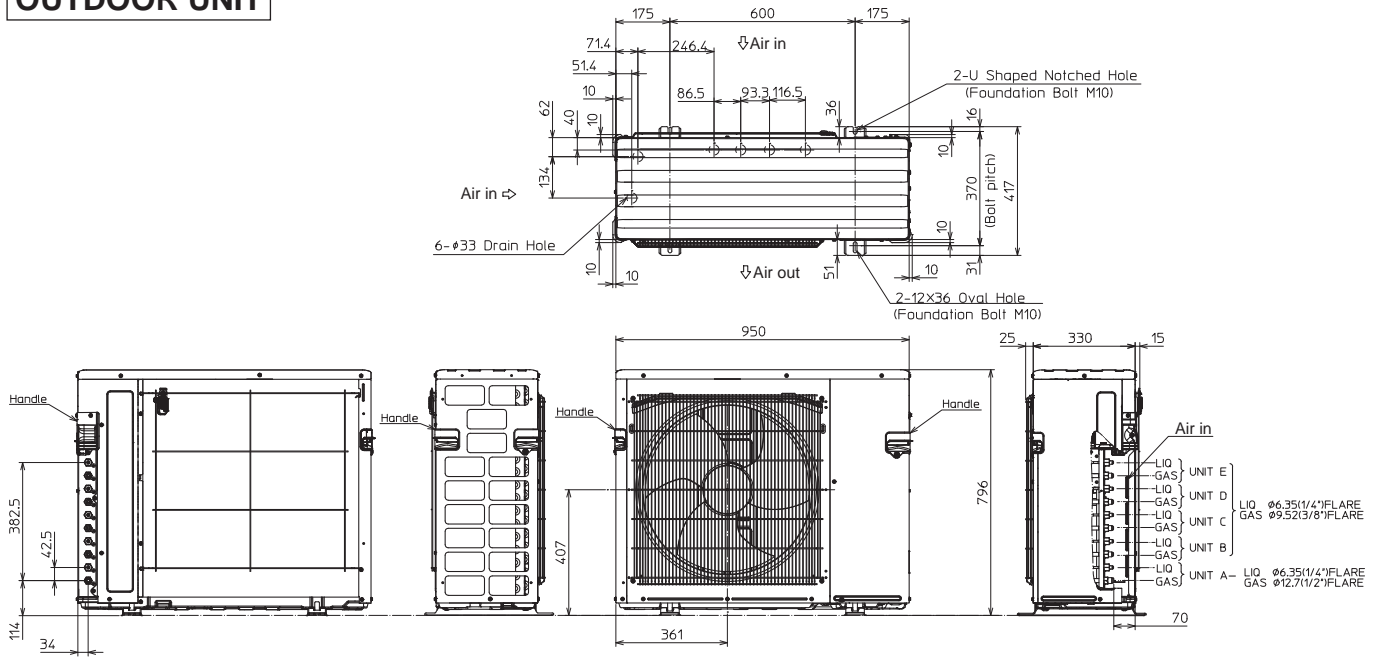

1.FREE SPACE

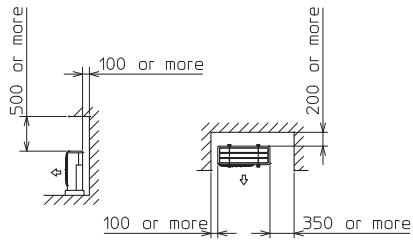

2.SERVICE SPACE

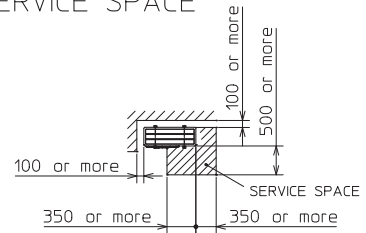

MXZ-6F120VF2

OUTDOOR UNIT

Unit: mm

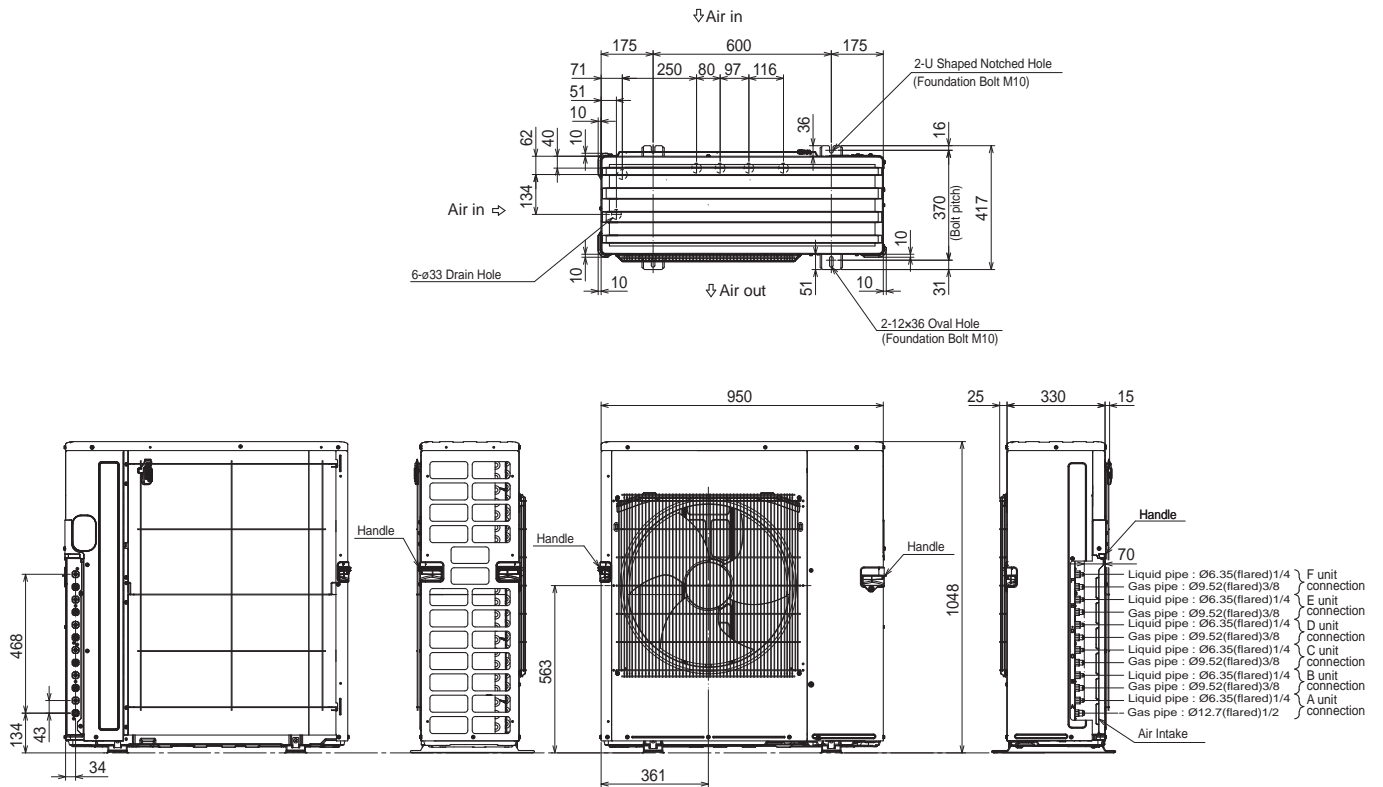

1.FREE SPACE

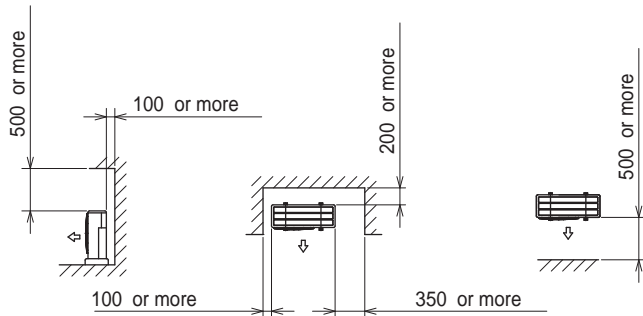

2.SERVICE SPACE

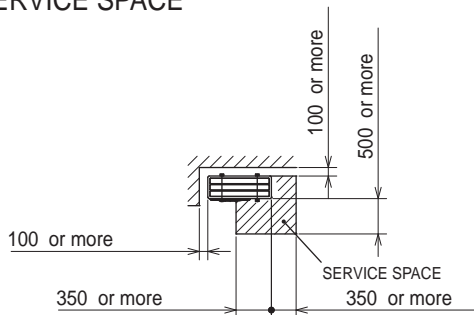

MXZ-2F53VFH2

OUTDOOR UNIT

Unit: mm

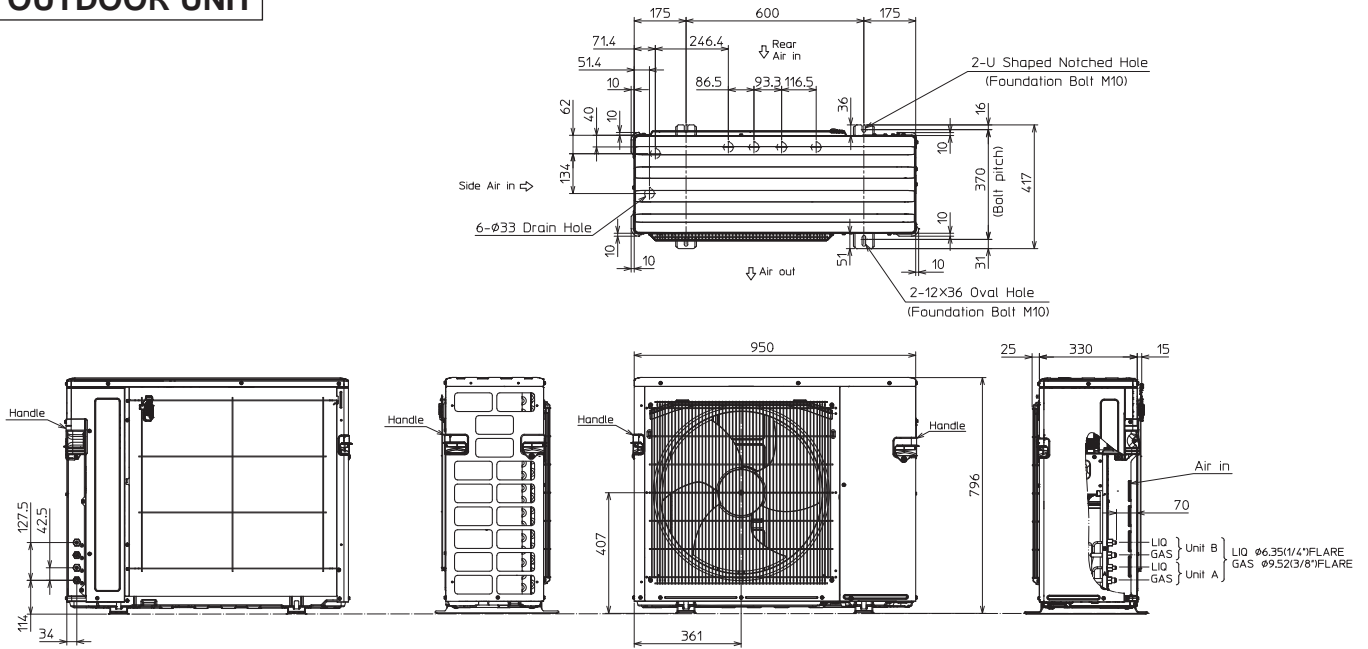

1. FREE SPACE

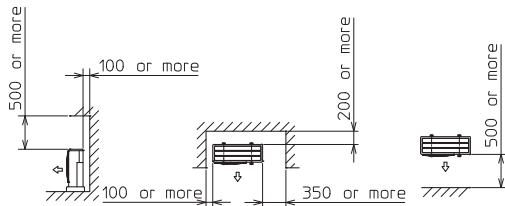

2. SERVICE SPACE

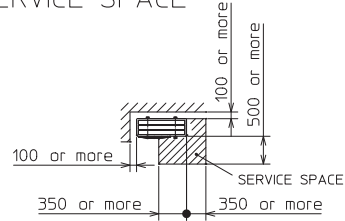

MXZ-4F83VFH2

OUTDOOR UNIT

Unit: mm

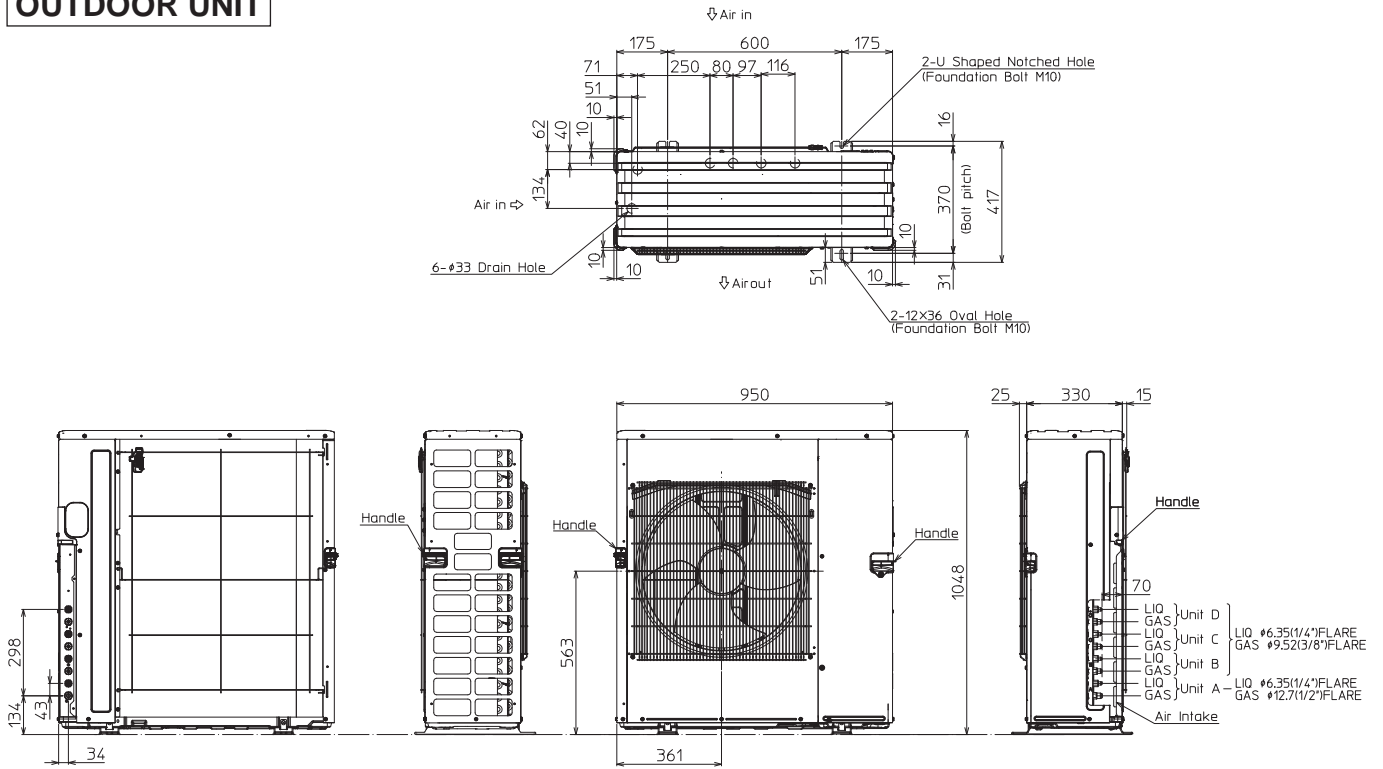

1.FREE SPACE

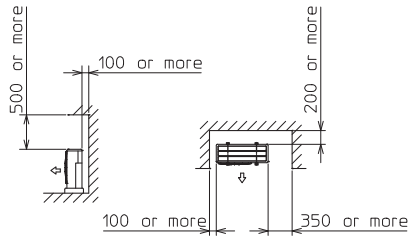

2.SERVICE SPACE

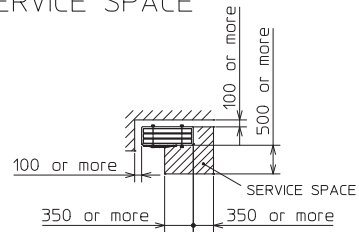

MXZ-2E53VAHZ

OUTDOOR UNIT

Unit: mm

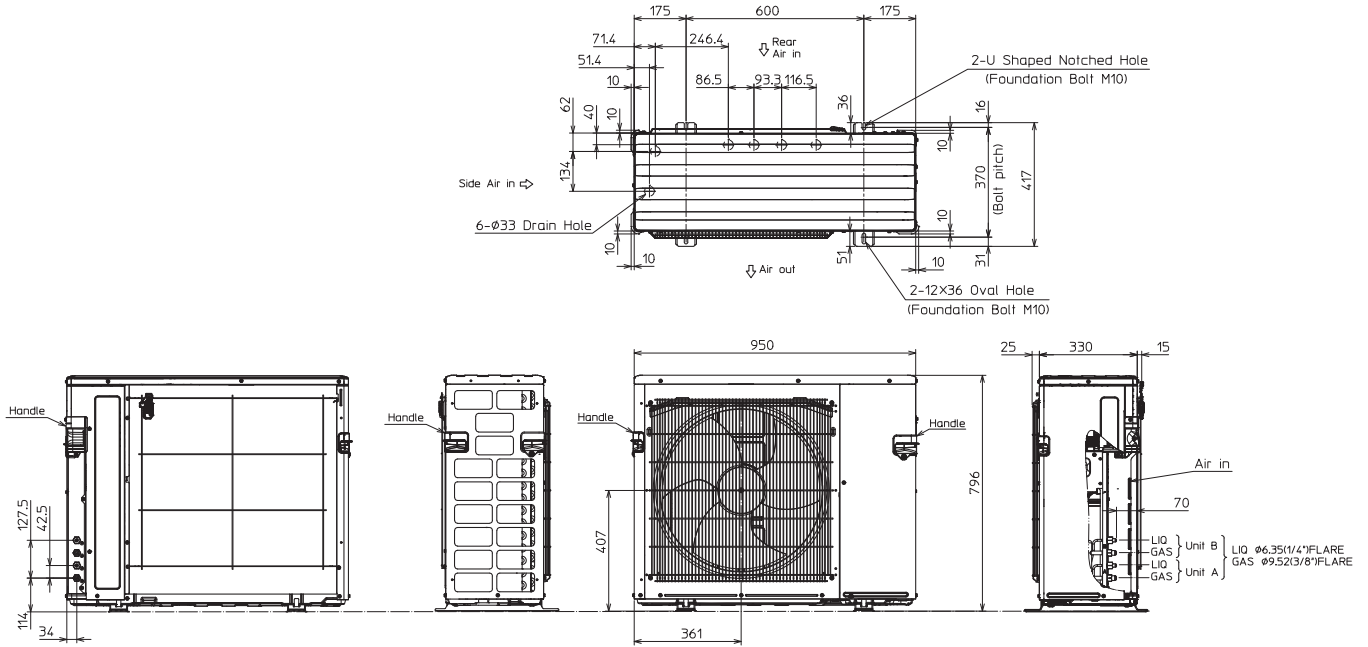

1.FREE SPACE

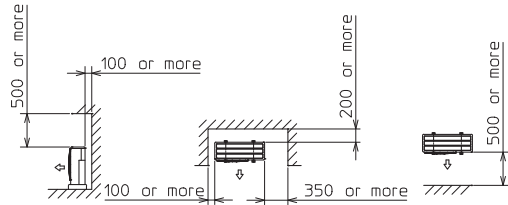

2.SERVICE SPACE

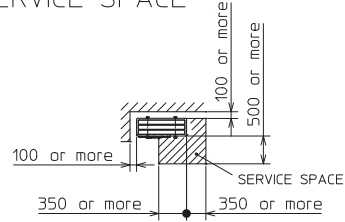

MXZ-4E83VA

OUTDOOR UNIT

Unit: mm

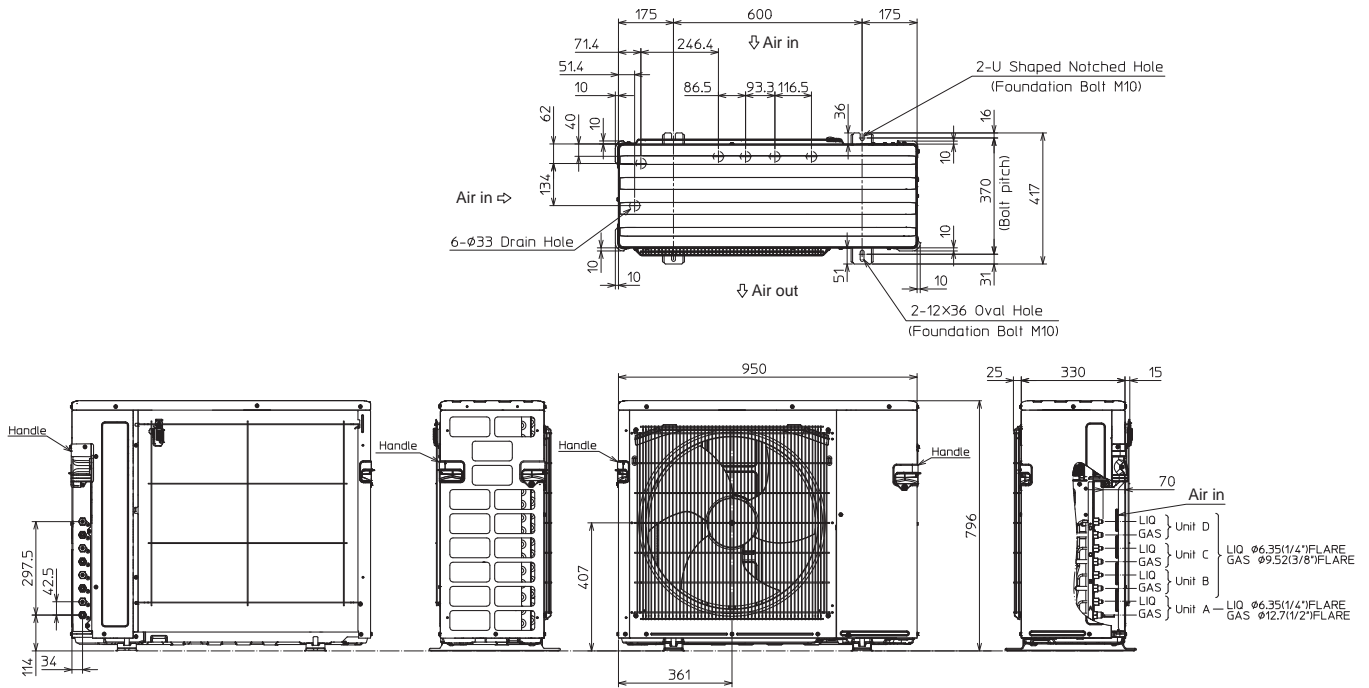

1.FREE SPACE

2.SERVICE SPACE

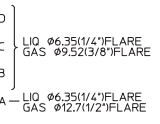
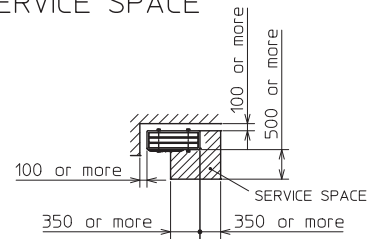
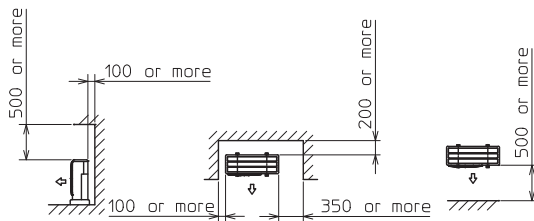

MXZ-4E83VAHZ

OUTDOOR UNIT

Unit: mm

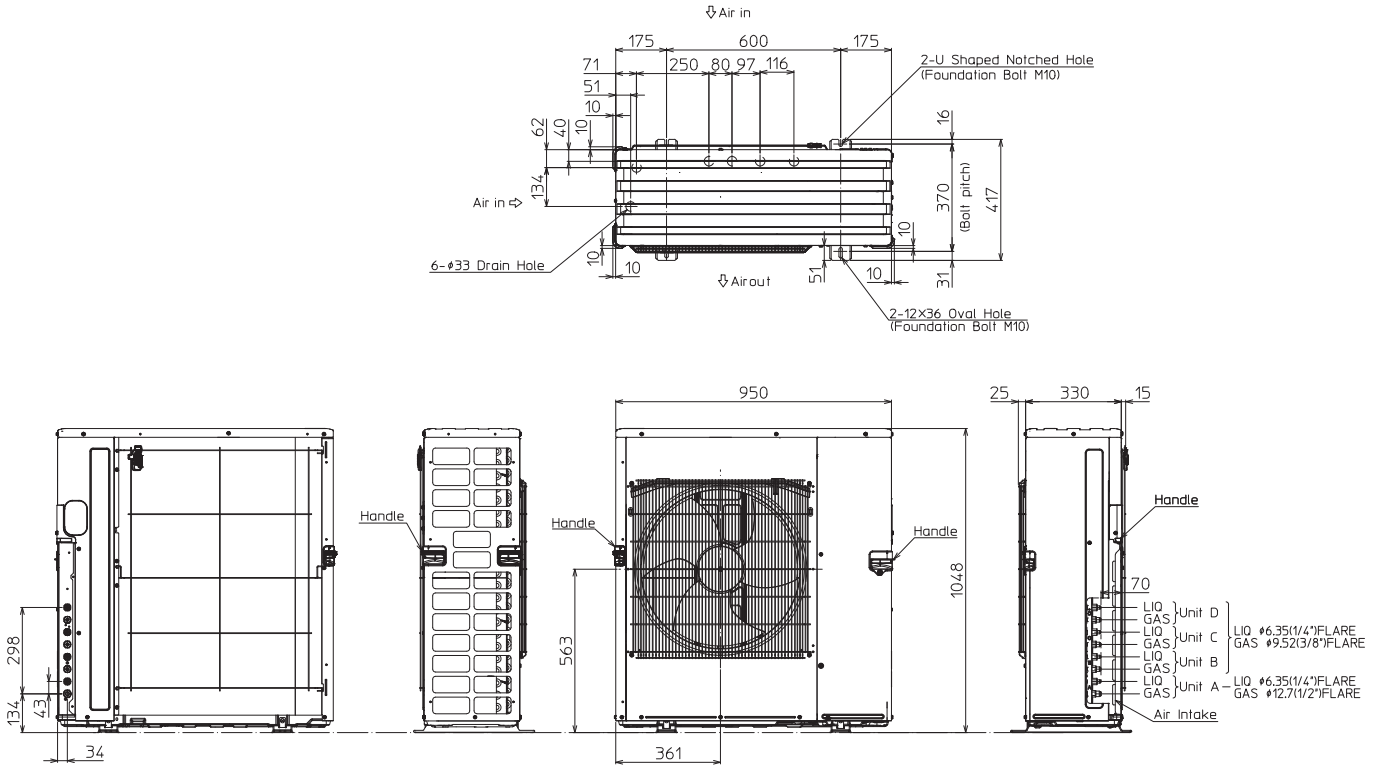

1.FREE SPACE

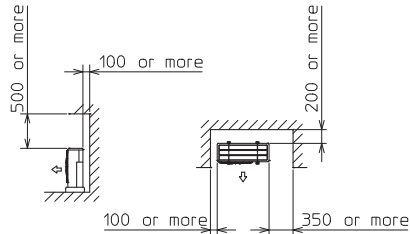

2.SERVICE SPACE

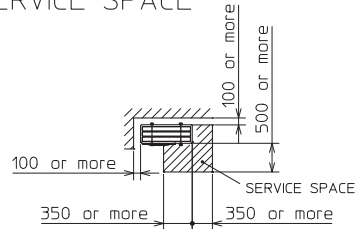

MXZ-5E102VA

OUTDOOR UNIT

Unit: mm

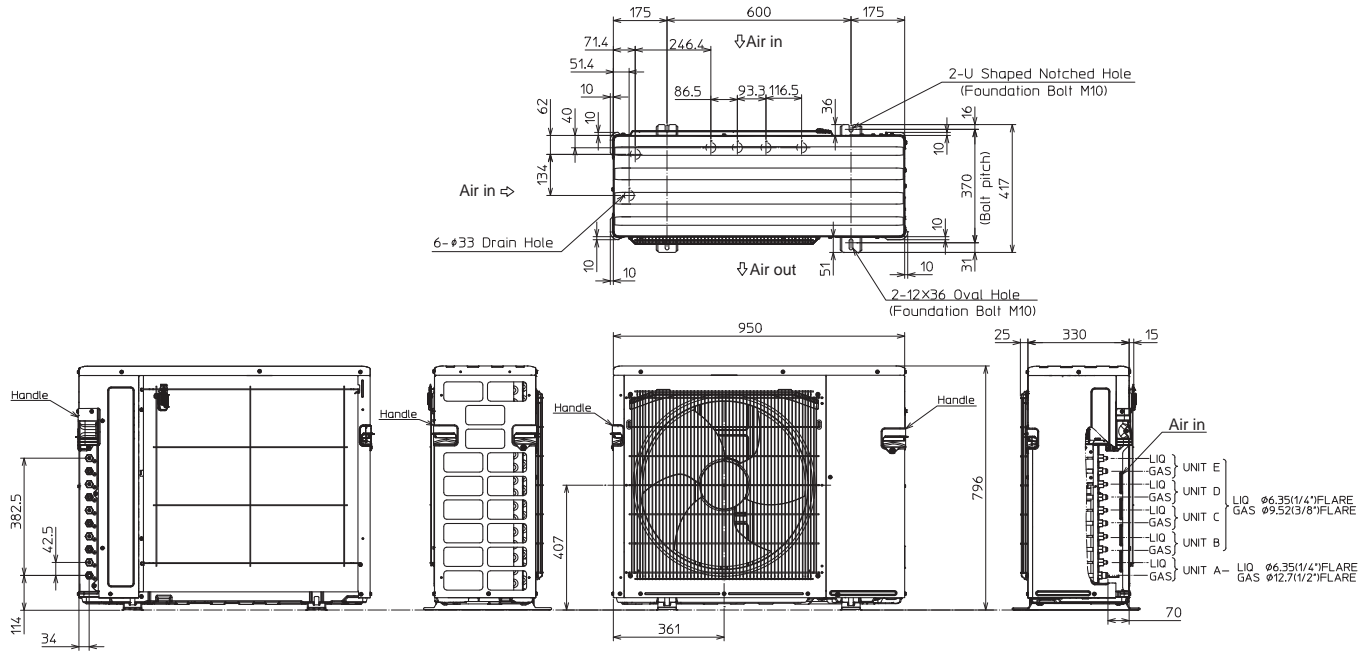

1. FREE SPACE

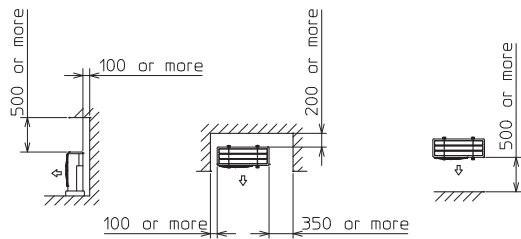

2. SERVICE SPACE

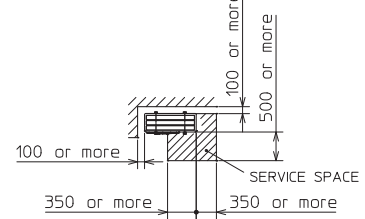

MXZ-6D122VA2

OUTDOOR UNIT

Unit: mm

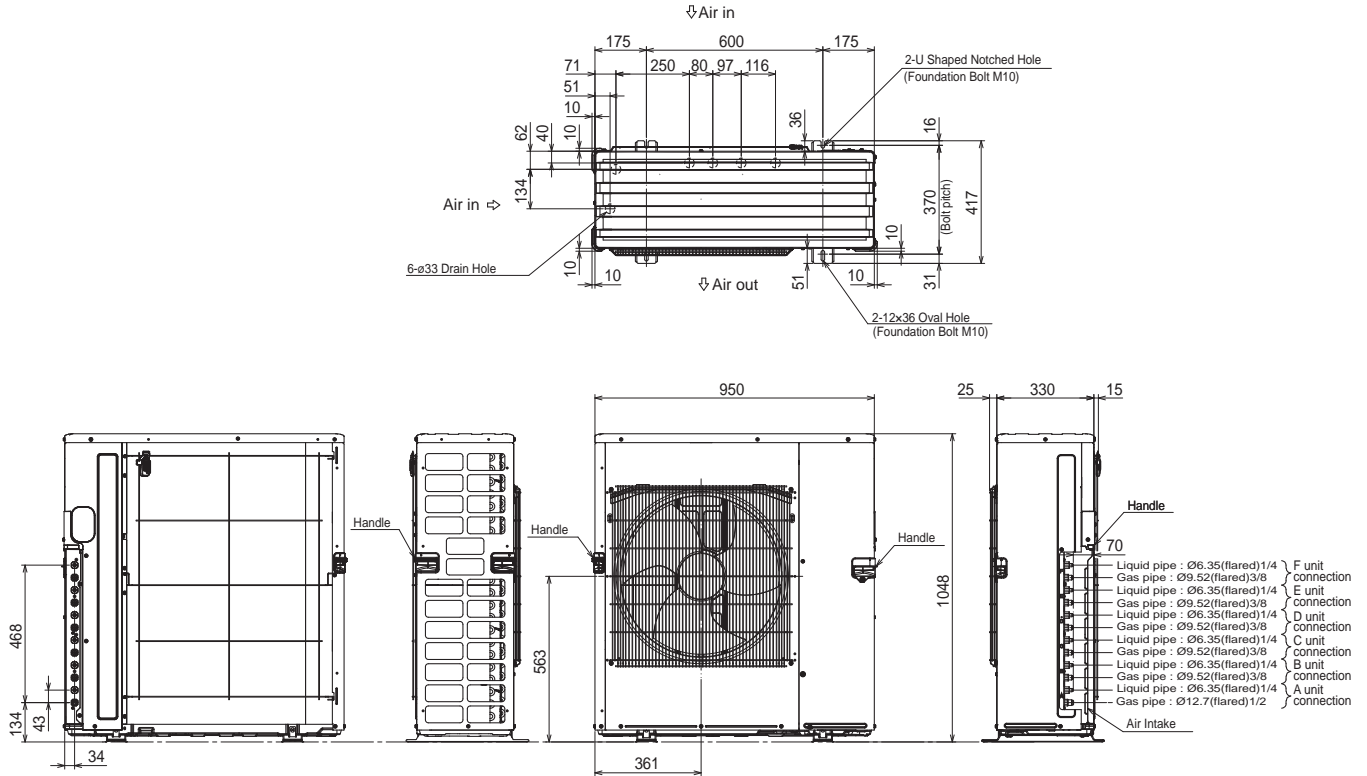

1. FREE SPACE

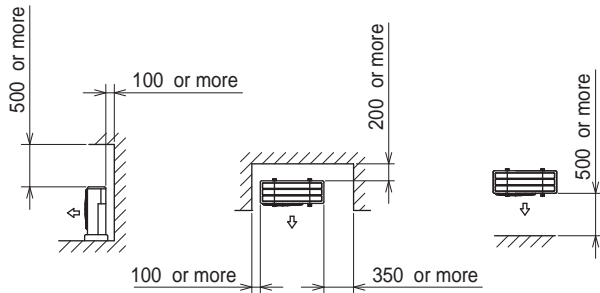

2. SERVICE SPACE

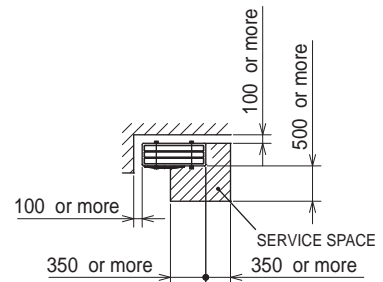

MXZ-3DM50VA

OUTDOOR UNIT

Unit: mm

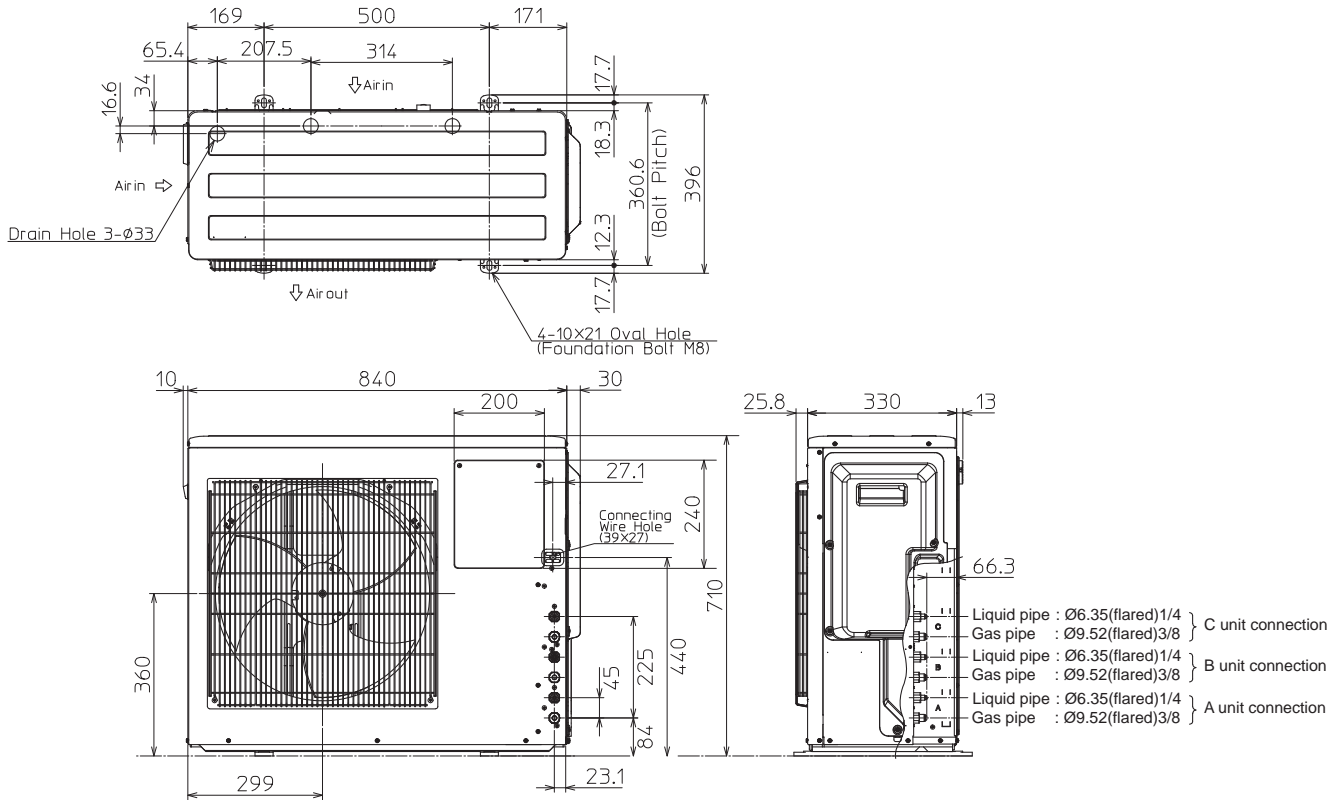

1. Installation space

Note : Leave front and both sides free of obstruction.

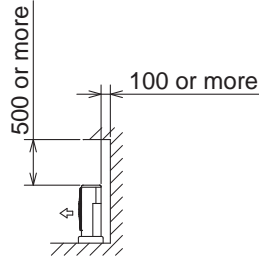

Note : Leave front and overhead free of obstruction.

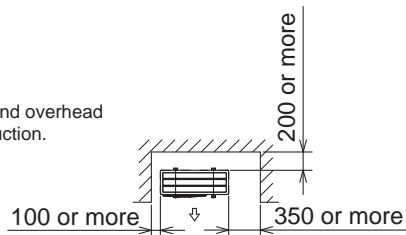

Note : Leave rear, overhead and both sides free of obstruction.

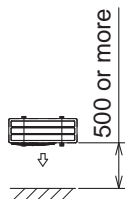

2. Service space

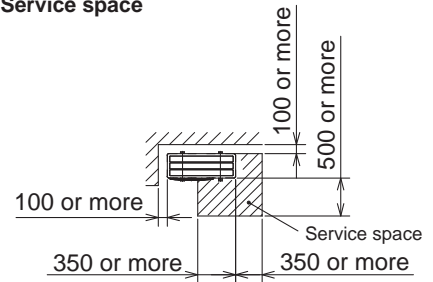

C.4.3 WIRING DIAGRAM

C.4.3.1 Inverter Heat Pump

MXZ-2F33VF4 MXZ-2F42VF4 MXZ-2F53VF4

OUTDOOR UNIT

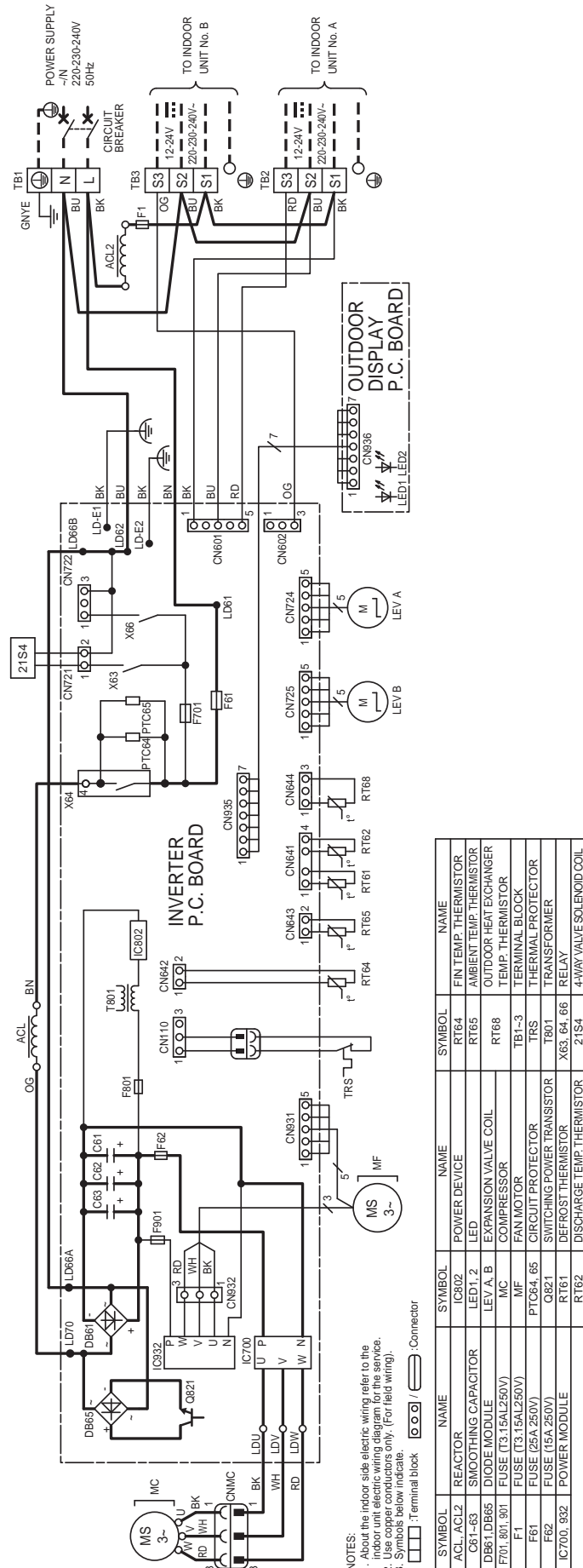

NOTES:
 1. About the indoor side electric wiring refer to the indoor unit electric wiring diagram for the service.
 2. Use copper conductors only. (For field wiring).
 3. Symbols below indicate.
 □ : terminal block
 ○ : Connector

SYMBOL	NAME	SYMBOL	NAME
ACL ACL2	REACTOR	IC802	POWER DEVICE
C61-63	SMOOTHING CAPACITOR	LED1, 2	LED
DB61, DB65	DIODE MODULE	LEV A, B	EXPANSION VALVE COIL
F701, 801, 901	FUSE (T3.15A/250V)	MC	COMPRESSOR
F1	FUSE (T3.15A/250V)	MF	FAN MOTOR
F61	FUSE (25A/250V)	PTC64, 65	CIRCUIT PROTECTOR
F62	FUSE (15A/250V)	TR801	SWITCHING POWER TRANSISTOR
IC700, 832	POWER MODULE	RT61	DEFROST THERMISTOR
		RT62	DISCHARGE TEMP. THERMISTOR
		21S4	4-WAY VALVE SOLENOID COIL

MXZ-2F53VFH4
OUTDOOR UNIT

WIRING DIAGRAM

MULTI
SYSTEM

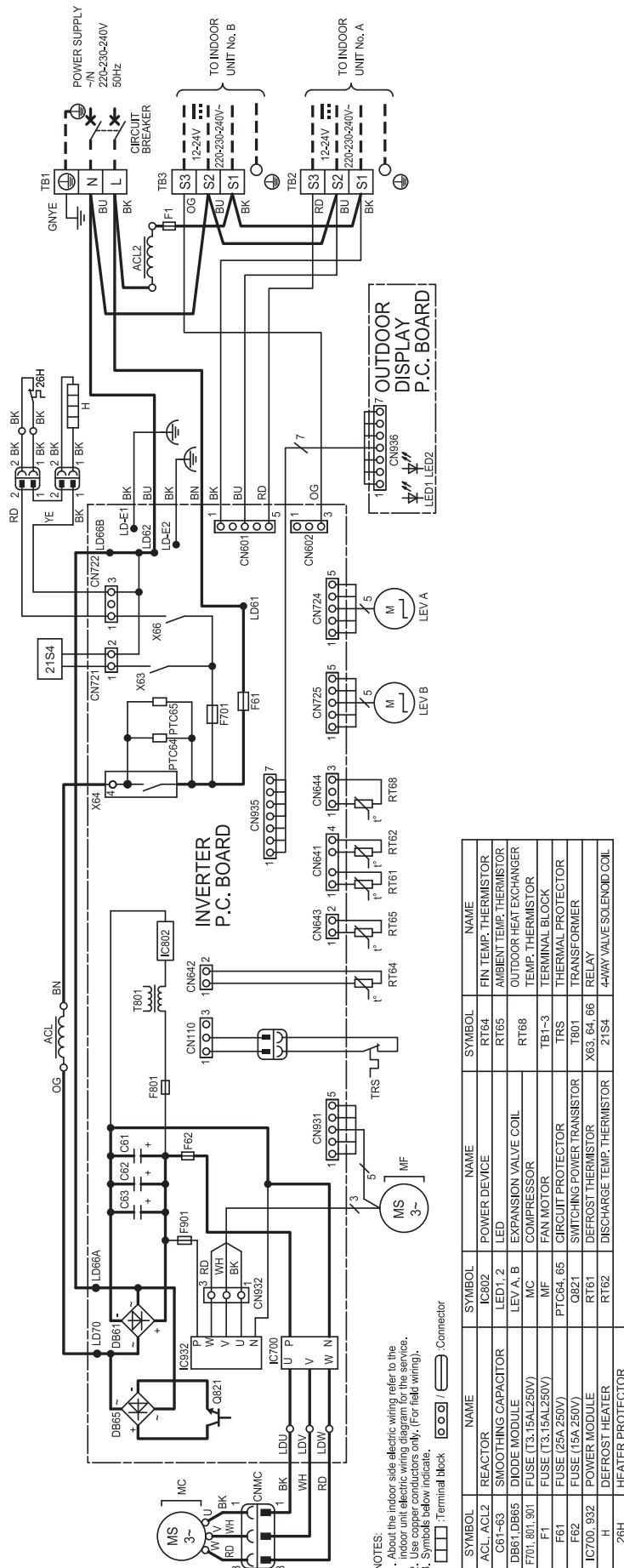

NOTES:

1. About the indoor side electric wiring refer to the indoor unit electric wiring diagram for the service.
2. The indoor unit electric wiring diagram is for field wiring only. (For field wiring).
3. Symbols below indicate:
 - □ □ □ : Terminal block
 - ○ ○ ○ / ○ ○ ○ ○ : Connector

SYMBOL	NAME	SYMBOL	NAME	SYMBOL	NAME
ACL ACL2	REACTOR	IC802	POWER DEVICE	RT64	FIN TEMP. THERMISTOR
C61-63	SMOOTHING CAPACITOR	LED1.2	LED	RT65	AMBIENT TEMP. THERMISTOR
DB61, DB65	DIODE MODULE	LEV. A, B	EXPANSION VALVE COIL	RT68	OUTDOOR HEAT EXCHANGER TEMP. THERMISTOR
F701, 801, 901	FUSE (T3.15A/250V)	MC	COMPRESSOR	TB1-3	TERMINAL BLOCK
F1	FUSE (T3.15A/250V)	MF	FAN MOTOR	TRS	TRANSFORMER
F61	FUSE (25A/250V)	PTC64, 65	CIRCUIT PROTECTOR	RT64	4-WAY VALVE SOLENOID COIL
F62	FUSE (15A/250V)	OB21	SWITCHING POWER TRANSISTOR	RT65	RELAY
IC700, 932	POWER MODULE	RT61	DEFROST THERMISTOR	X63, 64, 66	4-WAY VALVE SOLENOID COIL
H	DEFROST HEATER	RT62	DISCHARGE TEMP. THERMISTOR	21S4	26H
26H	HEATER PROTECTOR				

MXZ-3F54VF4 MXZ-3F68VF4

OUTDOOR UNIT

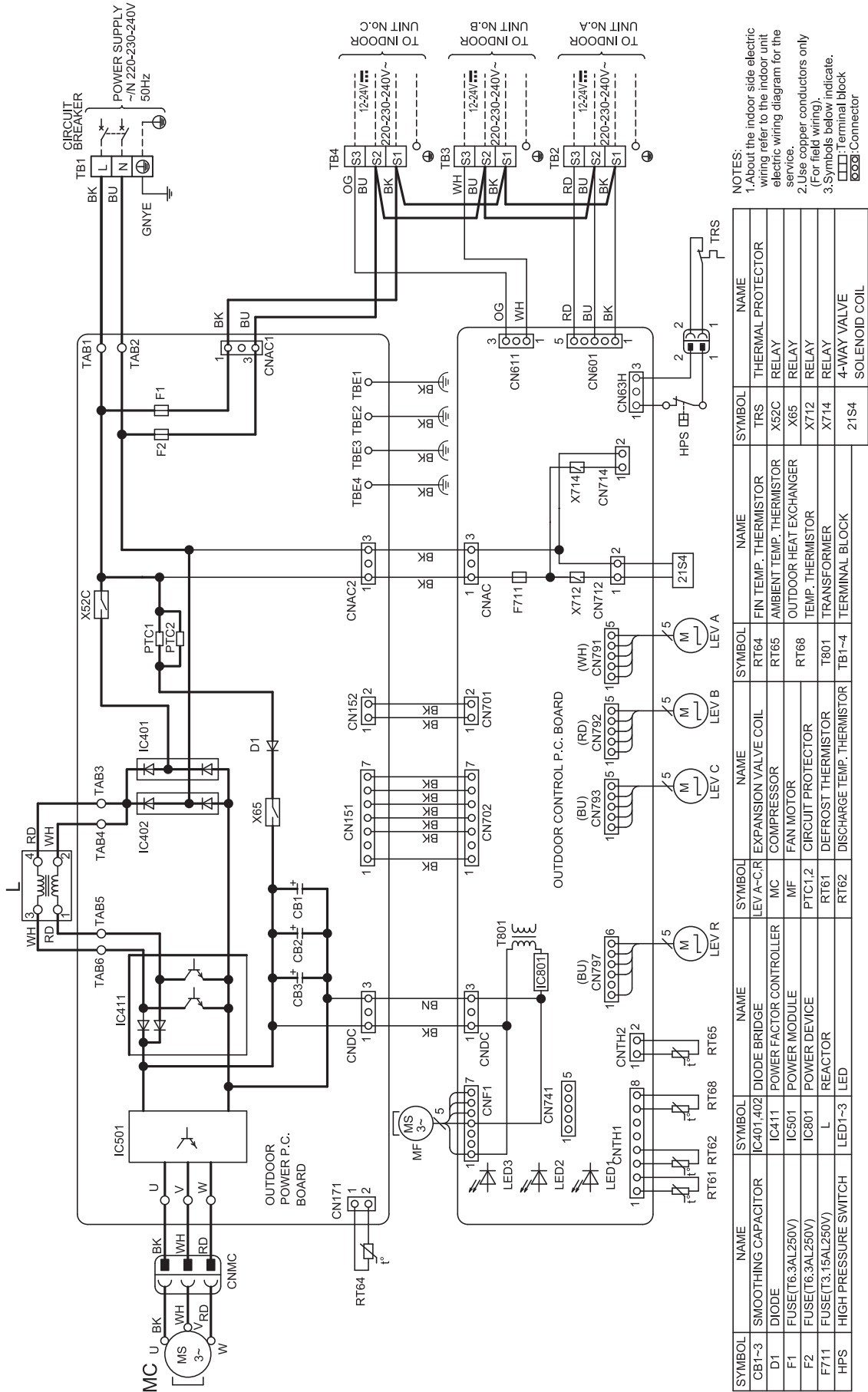

MXZ-4F72VF4 MXZ-4F80VF4

OUTDOOR UNIT

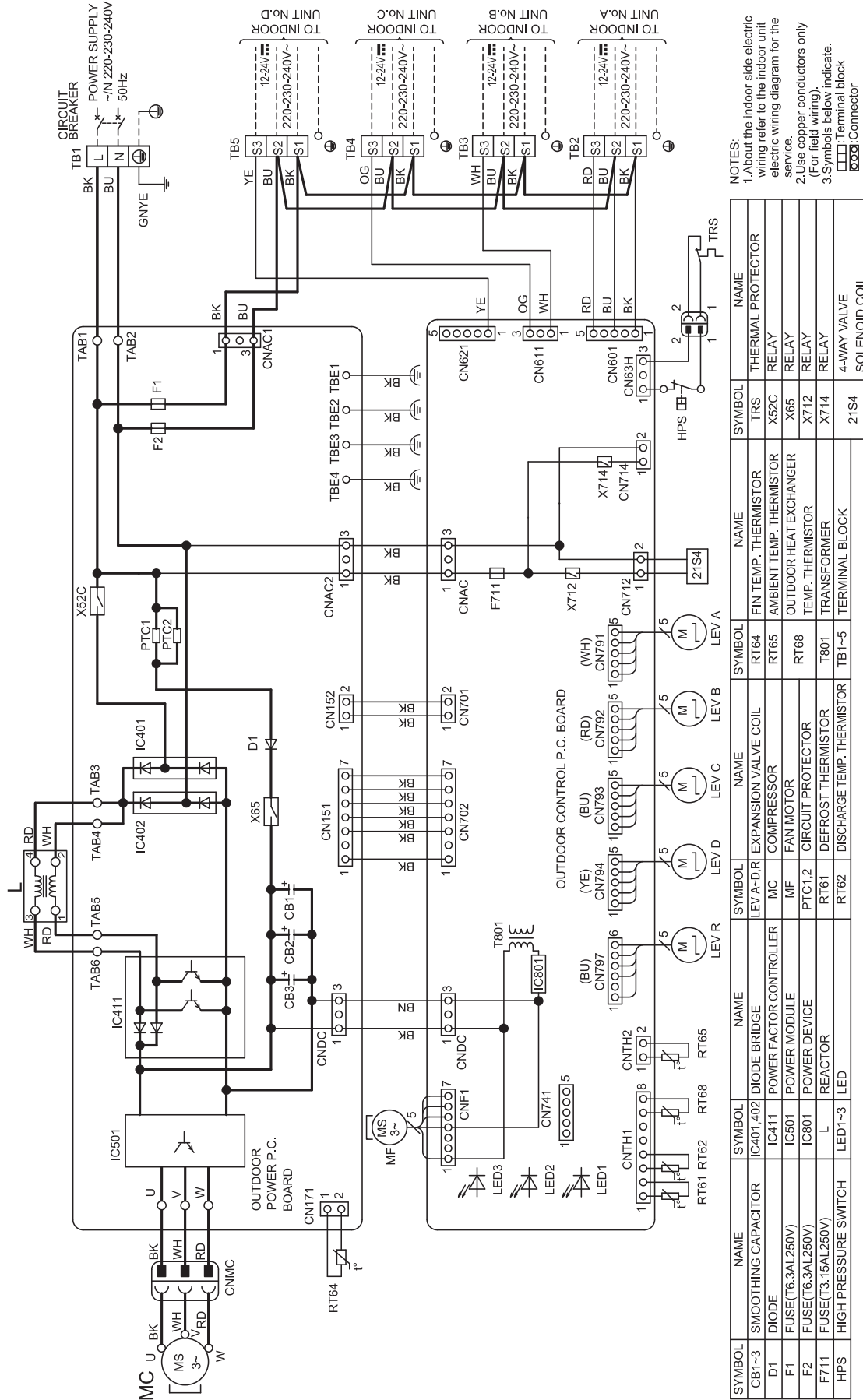

- NOTES:
- 1.About the indoor side electric wiring refer to the indoor unit electric wiring diagram for the service.
 - 2.Use copper conductors only (For field wiring).
 - 3.Symbols below indicate.
 - :Terminal block
 - :Connector

SYMBOL	NAME	SYMBOL	NAME	SYMBOL	NAME
CB1~3	SMOOTHING CAPACITOR	IC401,402	DIODE BRIDGE	TR1	THERMAL PROTECTOR
D1	DIODE	IC411	POWER FACTOR CONTROLLER	X52C	RELAY
F1	FUSE(T6.3AL250V)	IC501	POWER MODULE	X65	RELAY
F2	FUSE(T6.3AL250V)	IC801	POWER DEVICE	X712	RELAY
F71	FUSE(T3.15AL250V)	L	REACTOR	X714	RELAY
HPS	HIGH PRESSURE SWITCH	LED1~3	LED	21S4	SOLENOID COIL
LEV A-D	EXPANSION VALVE COIL	LEV A	LEV A		
MC	COMPRESSOR	LEV B	LEV B		
MF	FAN MOTOR	LEV C	LEV C		
PTC1.2	CIRCUIT PROTECTOR	LEV D	LEV D		
RT61	DEFROST THERMISTOR	T801	DEFROST THERMISTOR		
RT62	DISCHARGE TEMP. THERMISTOR	TB1~5	TERMINAL BLOCK		

WIRING DIAGRAM

MULTI SYSTEM

MXZ-5F102VF2

OUTDOOR UNIT

WIRING DIAGRAM

MULTI SYSTEM

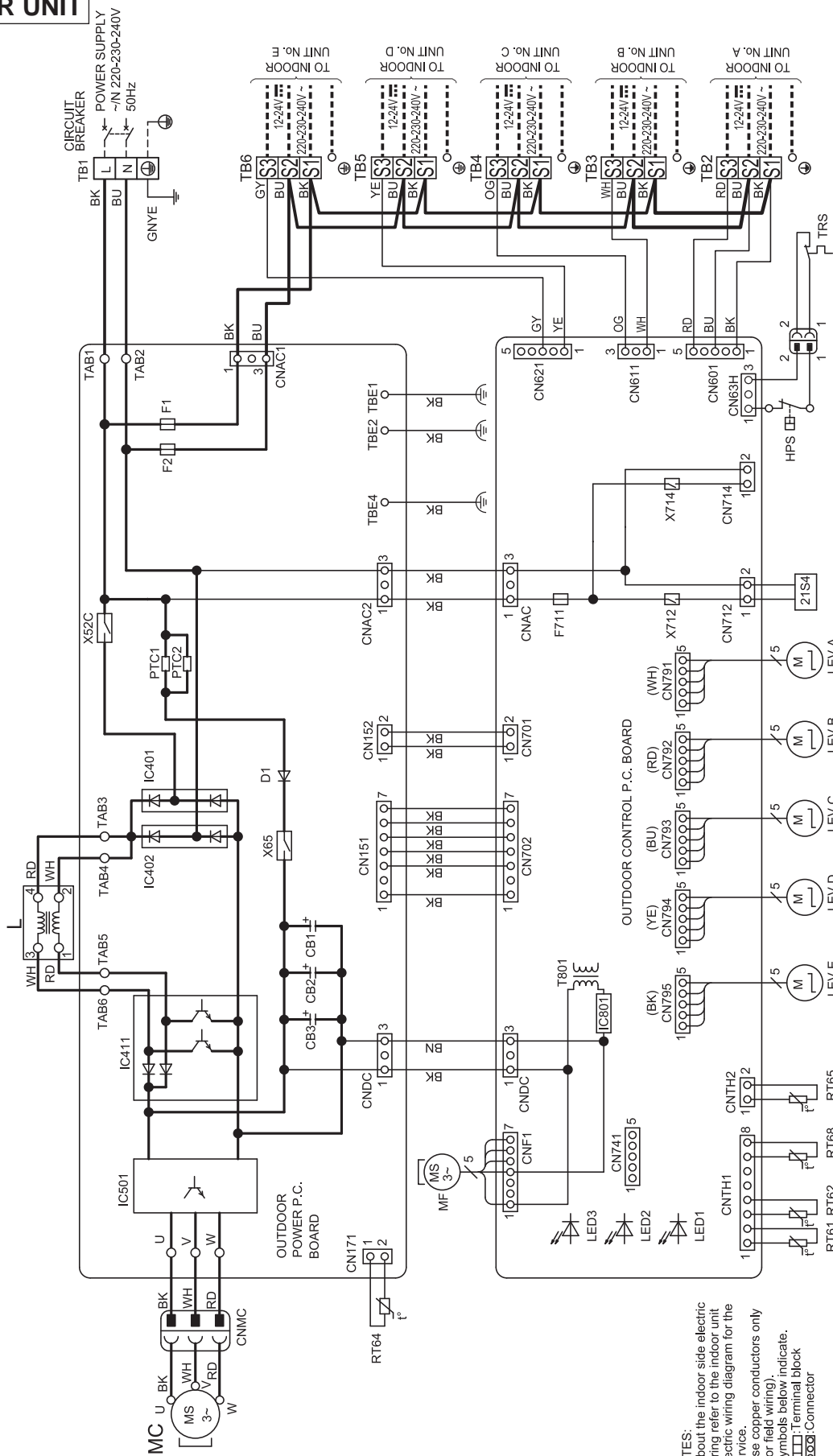

NOTES:
 1. About the indoor side electric wiring refer to the indoor unit electric wiring diagram for the service.
 2. Use copper conductors only (For field wiring).
 3. Symbols below indicate.
 □ Terminal block
 ○ Connector

SYMBOL	NAME	SYMBOL	NAME	SYMBOL	NAME	SYMBOL	NAME
CB1-3	SMOOTHING CAPACITOR	IC401, 402	DIODE BRIDGE	LEV A-E	EXPANSION VALVE COIL	RT64	FIN TEMP. THERMISTOR
D1	DIODE	IC411	POWER FACTOR CONTROLLER	MC	COMPRESSOR	RT65	AMBIENT TEMP. THERMISTOR
F1	FUSE (T6.3AL250V)	IC501	POWER MODULE	MF	FAN MOTOR	X65	OUTDOOR HEAT EXCHANGER
F2	FUSE (T6.3AL250V)	IC801	POWER DEVICE	PTC1, 2	CIRCUIT PROTECTOR	X712	TEMP. THERMISTOR
F711	FUSE (T3.15AL250V)	L	REACTOR	RT61	DEFROST THERMISTOR	X714	RELAY
HPS	HIGH PRESSURE SWITCH	LED1-3	LED	RT62	DISCHARGE TEMP. THERMISTOR	TR5	4-WAY VALVE SOLENOID COIL
				RT66	TERMINAL BLOCK		

MXZ-6F120VF2

OUTDOOR UNIT

POWER SUPPLY
~N 220-230-240V 50Hz

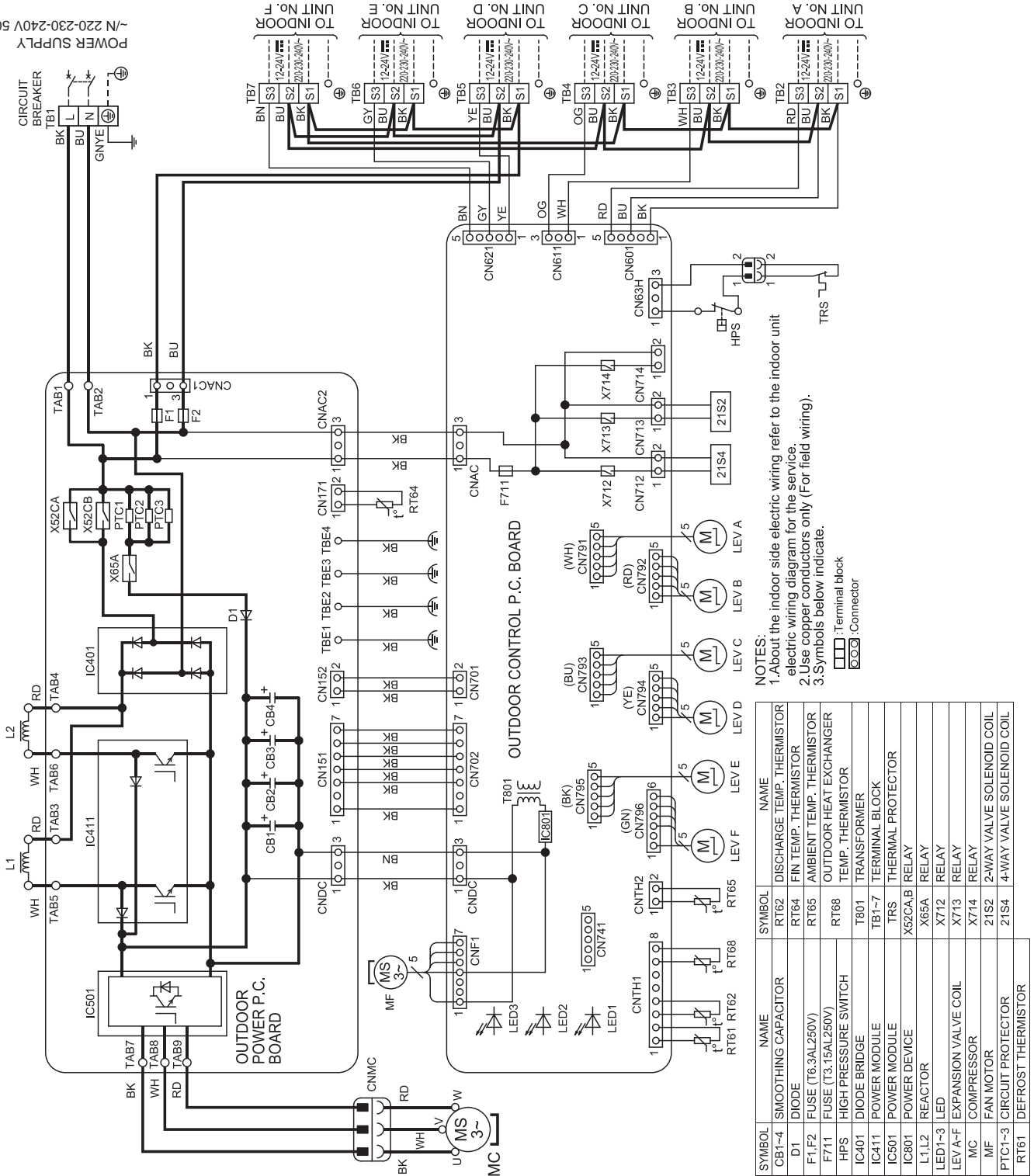

NOTES:
1. About the indoor side electric wiring refer to the indoor unit electric wiring diagram for the service.
2. Use copper conductors only (For field wiring).
3. Symbols below indicate.

⊠ : Terminal block
⊞ : Connector

SYMBOL	NAME	SYMBOL	NAME
CB1-4	SMOOTHING CAPACITOR	RT62	DISCHARGE TEMP. THERMISTOR
D1	DIODE	RT64	FAN TEMP. THERMISTOR
F1,F2	FUSE (T6.3AL250V)	RT65	AMBIENT TEMP. THERMISTOR
F711	FUSE (T3.15AL250V)	RT68	OUTDOOR HEAT EXCHANGER TEMP. THERMISTOR
HPS	HIGH PRESSURE SWITCH	T801	TRANSFORMER
IC401	DIODE BRIDGE	T801	TRANSFORMER
IC411	POWER MODULE	TB1-7	TERMINAL BLOCK
IC801	POWER MODULE	TR5	THERMAL PROTECTOR
L1,L2	REACTOR	X52CA,B	RELAY
LED1-3	LED	X65A	RELAY
LEV-A-F	EXPANSION VALVE COIL	X712	RELAY
MC	COMPRESSOR	X713	RELAY
MF	FAN MOTOR	X714	RELAY
PTC1-3	CIRCUIT PROTECTOR	21S2	2-WAY VALVE SOLENOID COIL
RT61	DEFROST THERMISTOR	21S4	4-WAY VALVE SOLENOID COIL

MXZ-2F53VFHZ2
OUTDOOR UNIT

WIRING DIAGRAM

MULTI SYSTEM

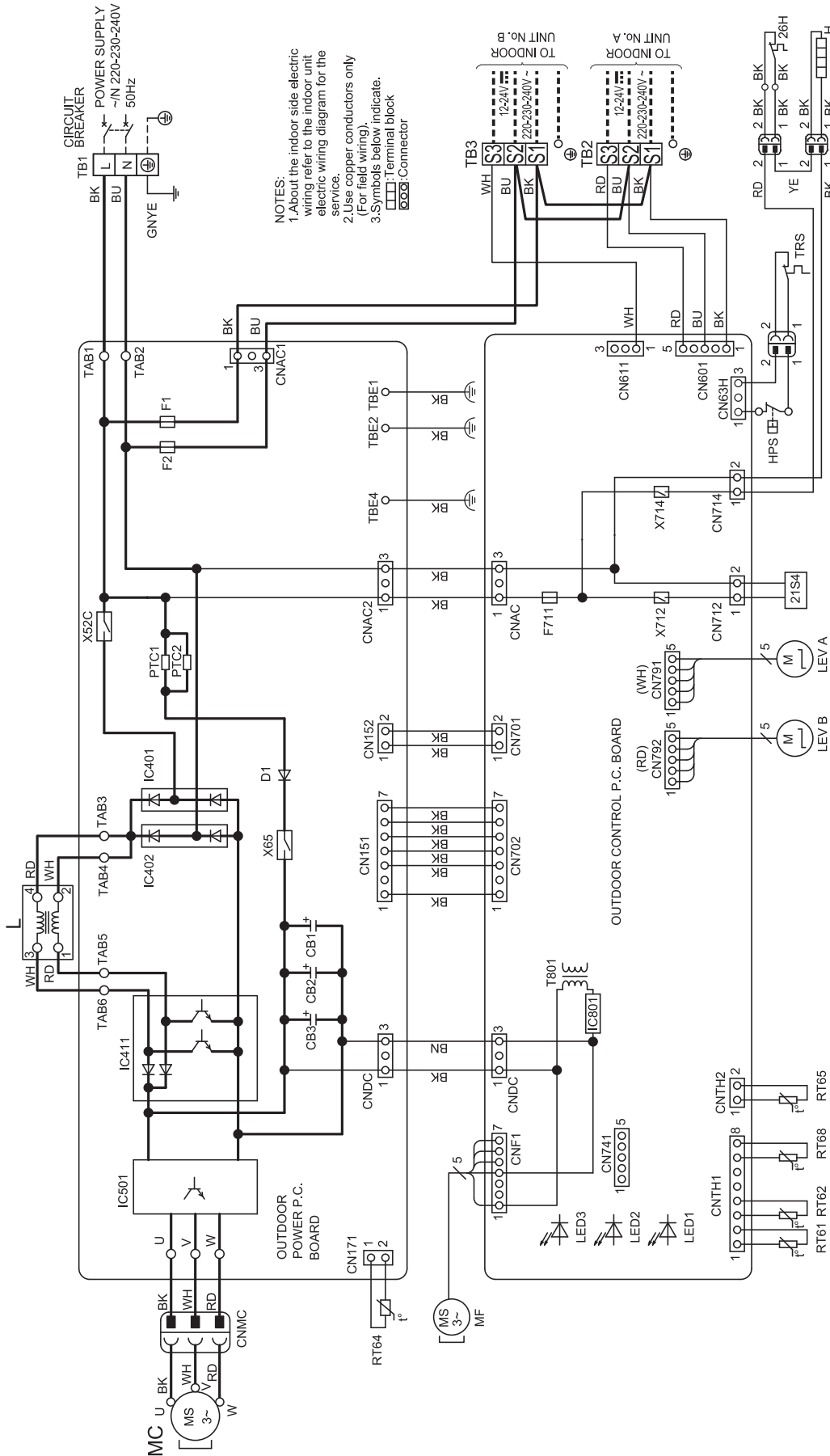

NOTES:
1. About the indoor side electric wiring refer to the indoor unit electric wiring diagram for the service.
2. Use copper conductors only.
3. (For field wiring).
□: Terminal block
○: Connector

SYMBOL	NAME	SYMBOL	NAME	SYMBOL	NAME	SYMBOL	NAME
CB1-3	SMOOTHING CAPACITOR	HPS	HIGH PRESSURE SWITCH	TB1-3	TERMINAL BLOCK	21S4	4-WAY VALVE SOLENOID COIL
D1	DIODE	IC401,402	DIODE BRIDGE	TRS	THERMAL PROTECTOR	26H	HEATER PROTECTOR
F1	FUSE (T6.3AL250V)	IC411	POWER FACTOR CONTROLLER	X52C	RELAY	X65	RELAY
F2	FUSE (T6.3AL250V)	IC501	POWER MODULE	X712	DEFROST THERMISTOR	X717	RELAY
F711	FUSE (T3.15AL250V)	IC801	CIRCUIT PROTECTOR	X714	TEMP. THERMISTOR	X712	RELAY
H	DEFROST HEATER	L	REACTOR	T801	TRANSFORMER	X714	RELAY

MXZ-4F83VFH2Z

OUTDOOR UNIT

POWER SUPPLY /N 220-230-240V 50Hz

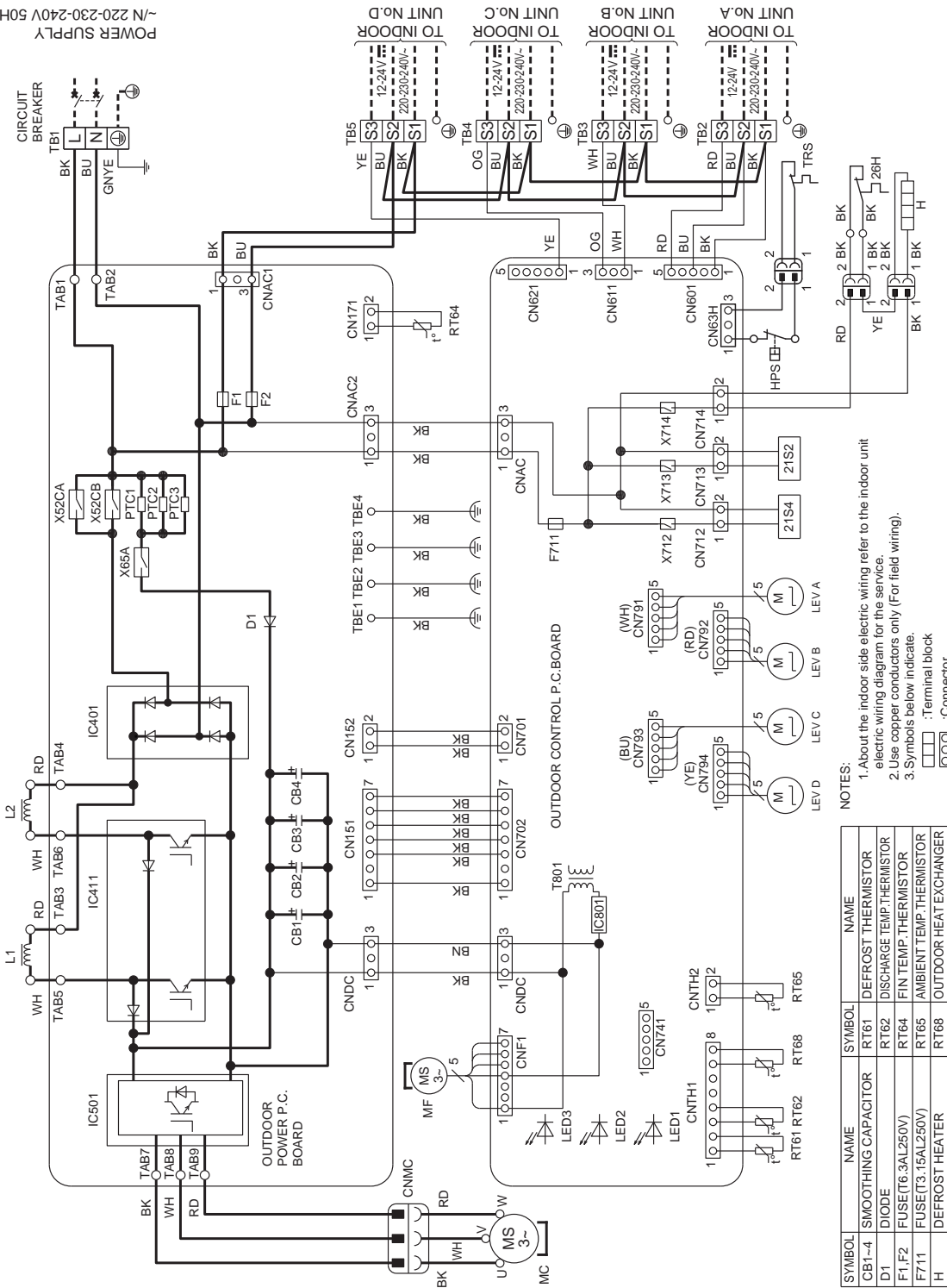

- NOTES:
1. About the indoor side electric wiring refer to the indoor unit electric wiring diagram for the service.
 2. Use copper conductors only (For field wiring).
 3. Symbols below indicate.
 - : Terminal block
 - : Connector

SYMBOL	NAME	SYMBOL	NAME
CBI-4	SMOOTHING CAPACITOR	RT61	DEFROST THERMISTOR
D1	DIODE	RT62	DISCHARGE TEMP.THERMISTOR
F1,F2	FUSE(T6.3AL250V)	RT64	FIN TEMP.THERMISTOR
F711	FUSE(T3.15AL250V)	RT65	AMBIENT TEMP.THERMISTOR
H	DEFROST HEATER	RT68	OUTDOOR HEAT EXCHANGER TEMP.THERMISTOR
IC401	DIODE BRIDGE	T801	TRANSFORMER
IC411	POWER MODULE	TBT-5	TERMINAL BLOCK
IC501	POWER MODULE	TRS	THERMAL PROTECTOR
IC801	POWER DEVICE	X62CAB	RELAY
L1,L2	REACTOR	X65A	RELAY
LED1-3	LED	X712	RELAY
LEV A-D	EXPANSION VALVE COIL	X713	RELAY
MC	COMPRESSOR	X714	RELAY
MF	FAN MOTOR	21S2	2-WAY VALVE SOLENOID COIL
PTC1-3	CIRCUIT PROTECTOR	21S4	4-WAY VALVE SOLENOID COIL
		26H	HEATER PROTECTOR

MXZ-2D33VA MXZ-2D42VA2 MXZ-2D53VA2

OUTDOOR UNIT

WIRING DIAGRAM

MULTI SYSTEM

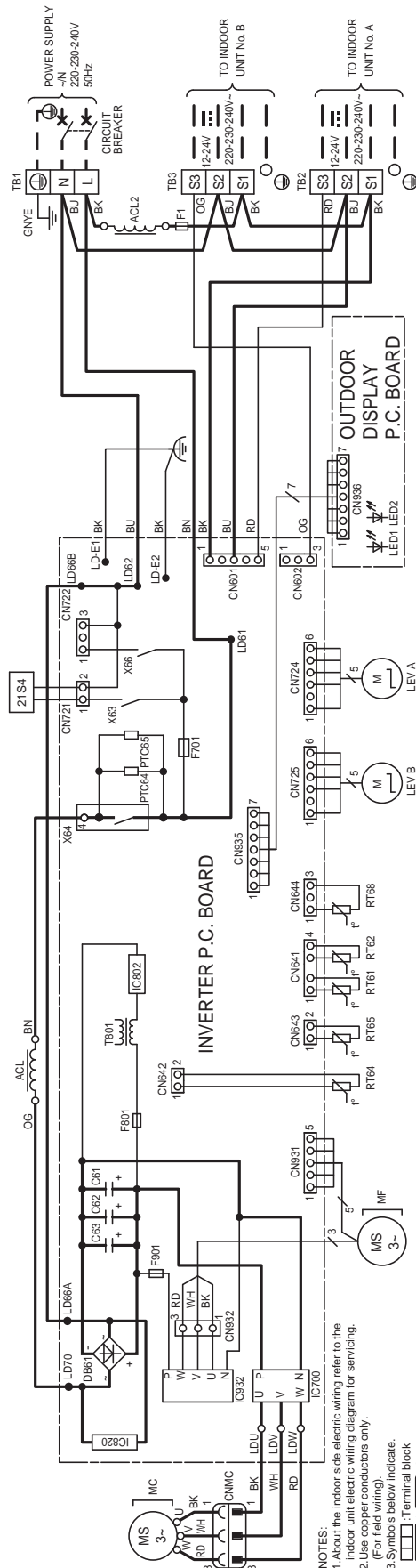

NOTES:
 1. About the indoor side electric wiring refer to the indoor unit electric wiring diagram for servicing.
 2. Use copper conductors only.
 3. Symbols below indicate.
 □: Terminal block
 ○: Connector

SYMBOL	NAME	SYMBOL	NAME	SYMBOL	NAME
ACL	ACL2	LEV A	B	LEV A	B
C61	L63	MC	COMPRESSOR	RT68	OUTDOOR HEAT EXCHANGER TEMP THERMISTOR
DB61	DIODE MODULE	MF	FAN MOTOR	TB1-3	TERMINAL BLOCK
F701	801_801	PTC64_65	CIRCUIT PROTECTOR	T801	SWITCHING TRANS RELAY
F1	FUSE (T3.15AL250V)	RT61	DEFROST THERMISTOR	X63_64_66	REVERSING VALVE COIL
IC700_820_932	POWER MODULE	RT62	DISCHARGE TEMP. THERMISTOR	Z1S4	FIN TEMP. THERMISTOR
IC802	POWER DEVICE	RT64	FIN TEMP. THERMISTOR		
LED1_2	LED	RT65	AMBIENT TEMP. THERMISTOR		

MXZ-2D53VAH2
OUTDOOR UNIT

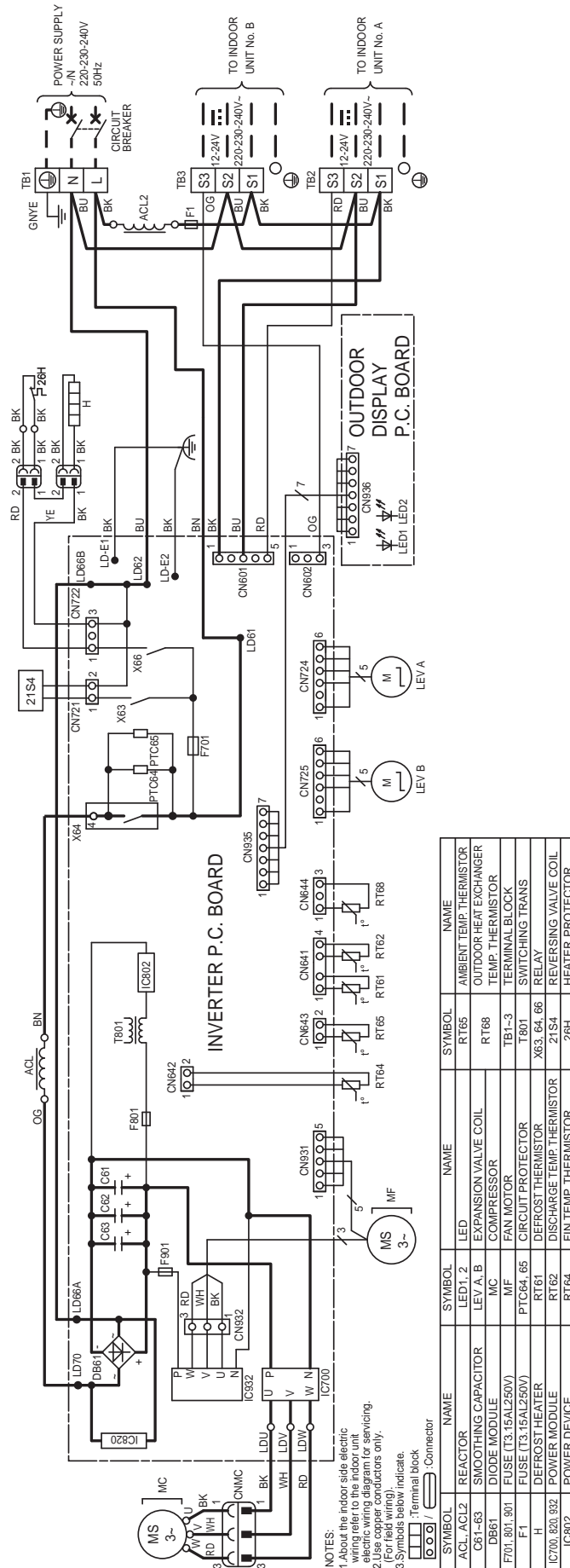

SYMBOL	NAME	SYMBOL	NAME
ACL, ACL2	REACTOR	RT65	AMBIENT TEMP. THERMISTOR
C61-63	SMOOTHING CAPACITOR	RT68	OUTDOOR HEAT EXCHANGER TEMP. THERMISTOR
DB61	DIODE MODULE	TB1-3	TERMINAL BLOCK
F701, 801, 801	FUSE (T3.15A/250V)	TC64, 65	CIRCUIT PROTECTOR
F1	FUSE (T3.15A/250V)	X63, 64, 66	SWITCHING TRANS RELAY
H	DEFROST HEATER	21S4	DISCHARGE TEMP. THERMISTOR
IC700, 820, 932	POWER MODULE	26H	FIN TEMP. THERMISTOR
IC802	POWER DEVICE		HEATER PROTECTOR

MXZ-2E53VAHZ
OUTDOOR UNIT

WIRING DIAGRAM

MULTI SYSTEM

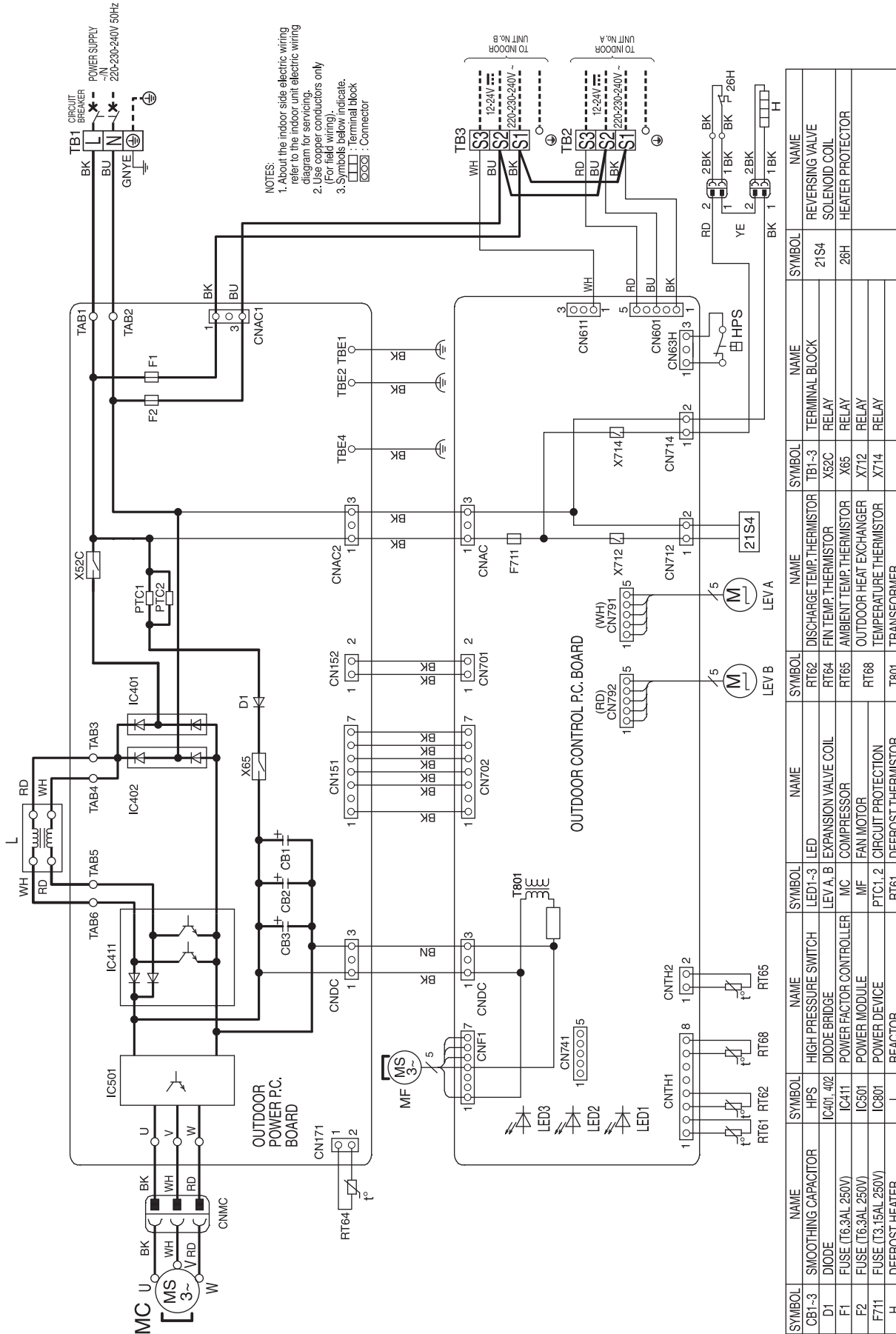

MXZ-3E54VA MXZ-3E68VA

OUTDOOR UNIT

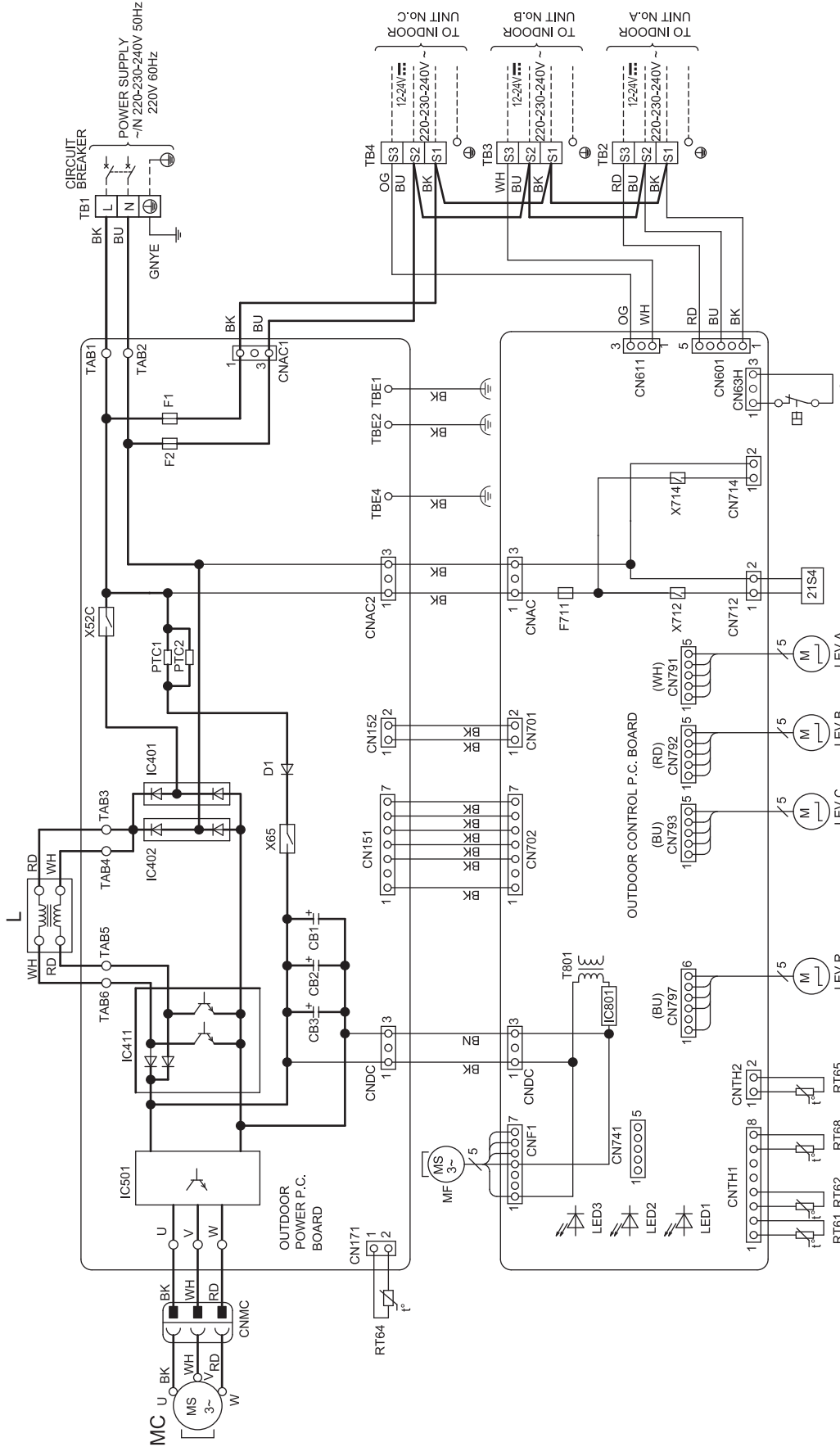

NOTES:
 1. About the indoor side electric wiring refer to the indoor unit electric wiring diagram for servicing.
 2. Use copper conductors only (For field wiring).
 3. Symbols below indicate.
 □: Terminal block
 ○: Connector

SYMBOL	NAME	SYMBOL	NAME	SYMBOL	NAME
CB1-3	SMOOTHING CAPACITOR	X52C	FIN TEMP. THERMISTOR	X52C	RELAY
D1	DIODE	X65	AMBIENT TEMP. THERMISTOR	X65	RELAY
F1	FUSE(T6.3AL250V)	X712	OUTDOOR HEAT EXCHANGER	X712	RELAY
F2	FUSE(T6.3AL250V)	X714	TEMPERATURE THERMISTOR	X714	RELAY
F71	FUSE(T3.15AL250V)	T801	TRANSFORMER	T801	REVERSING VALVE
HPS	HIGH PRESSURE SWITCH	TB1-4	TERMINAL BLOCK	21S4	SOLENOID COIL

MXZ-4E72VA

OUTDOOR UNIT

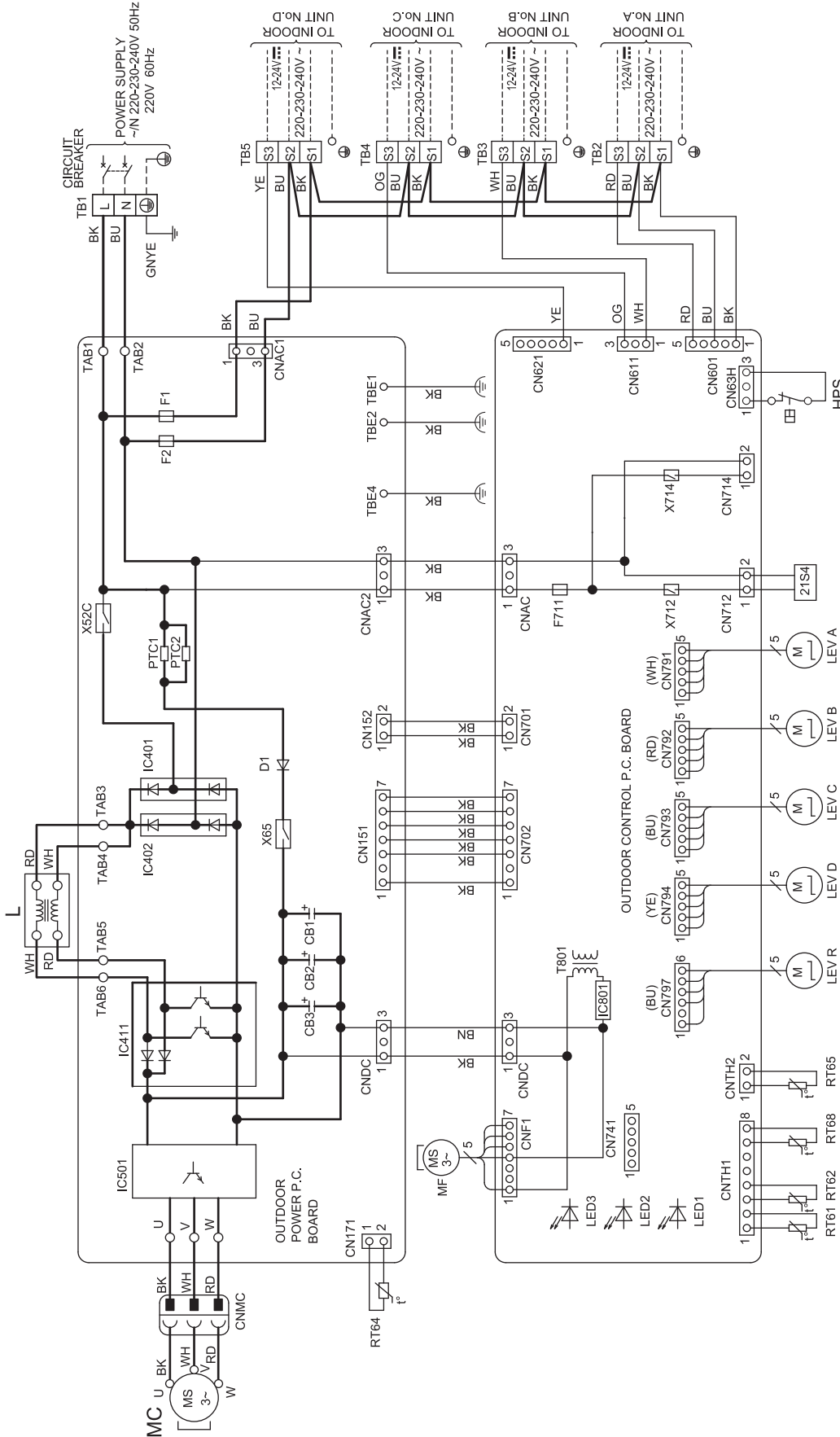

NOTES:
 1. About the indoor side electric wiring refer to the indoor unit electric wiring diagram for servicing.
 2. Use copper conductors only (For field wiring).
 3. Symbols below indicate.
 □: Terminal block
 ○: Connector

SYMBOL	NAME	SYMBOL	NAME	SYMBOL	NAME
CB1~3	SMOOTHING CAPACITOR	X52C	RELAY	RT64	FIN TEMP. THERMISTOR
D1	DIODE	X65	RELAY	RT65	AMBIENT TEMP. THERMISTOR
F1	FUSE(T6.3AL250V)	X712	RELAY	RT68	OUTDOOR HEAT EXCHANGER
F2	FUSE(T6.3AL250V)	X714	RELAY	RT61	TEMPERATURE THERMISTOR
F711	FUSE(T6.3AL250V)	21S4	TERMINAL BLOCK	T801	TRANSFORMER
HPS	HIGH PRESSURE SWITCH			TB1~5	DISCHARGE TEMP. THERMISTOR

MULTI SYSTEM WIRING DIAGRAM

MXZ-4E83VA

OUTDOOR UNIT

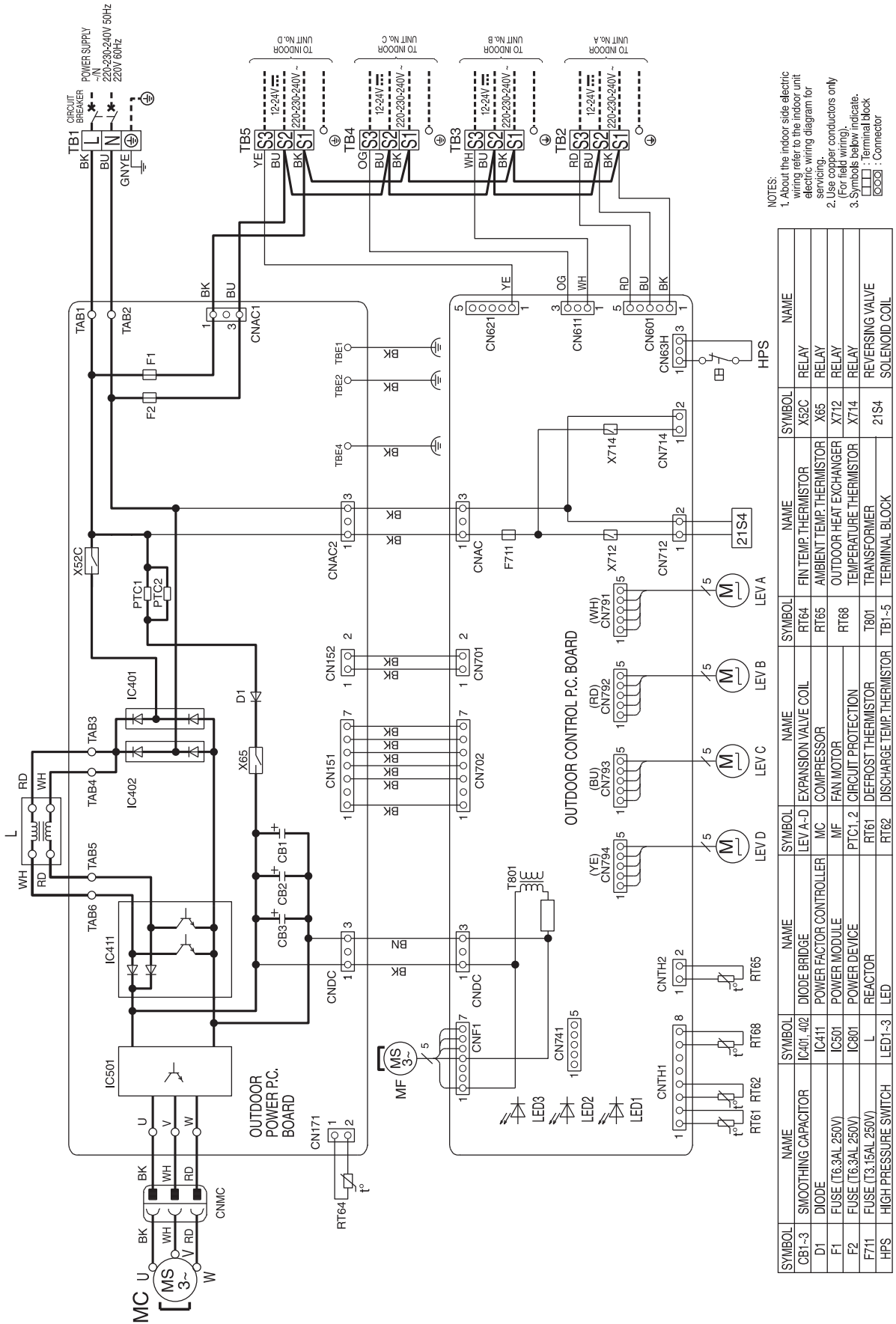

- NOTES:
- About the indoor side electric wiring, refer to the indoor unit electric wiring diagram for servicing.
 - Use copper conductors only for field wiring.
 - Symbols below indicate:
 - Terminal block
 - Connector

MXZ-4E83VAHZ

OUTDOOR UNIT

WIRING DIAGRAM

MULTI SYSTEM

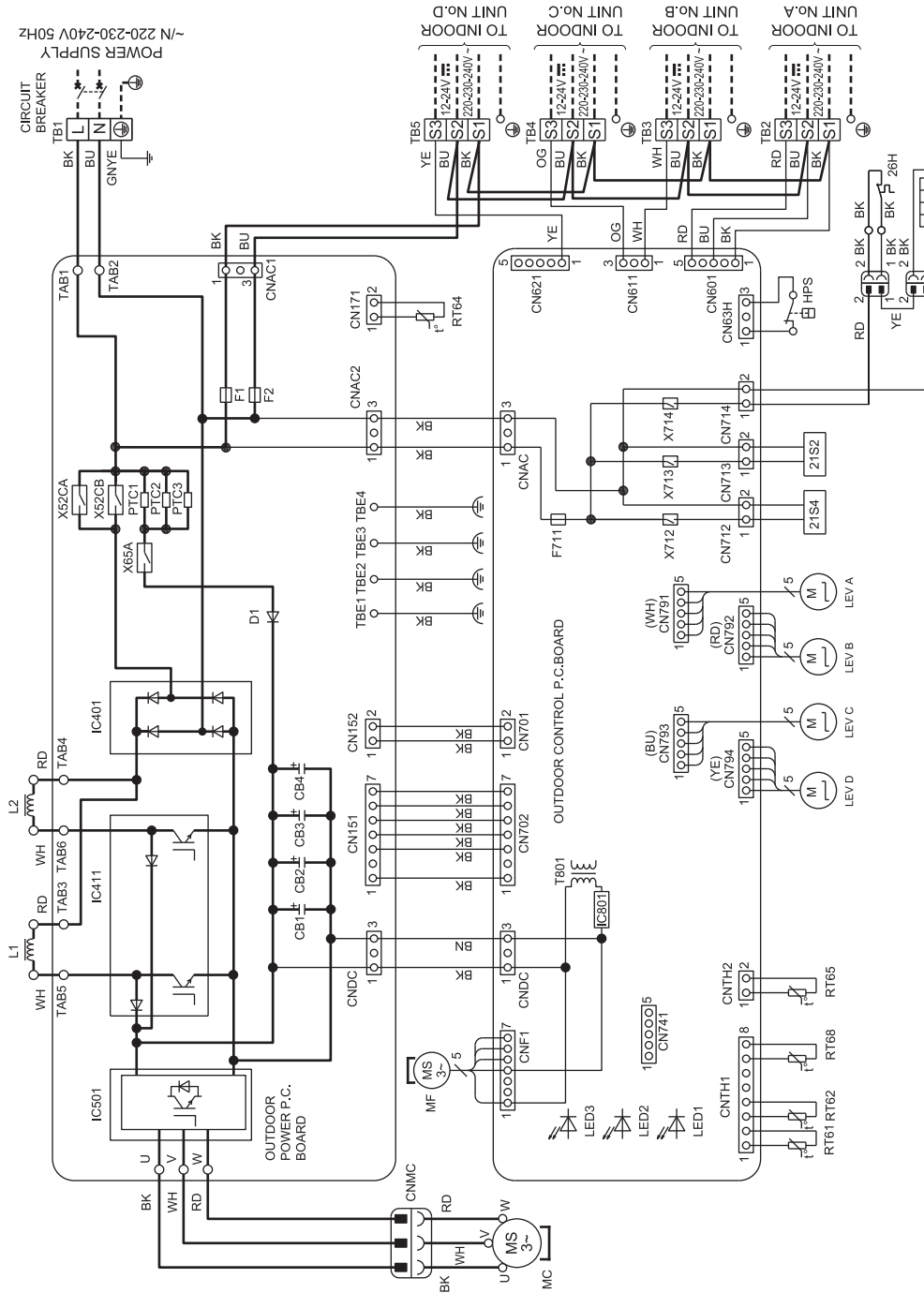

- NOTES:
1. About the indoor side electric wiring refer to the indoor unit electric wiring diagram for servicing.
 2. Use copper conductors only (For field wiring).
 3. Symbols below indicate.
 - : Terminal block
 - : Connector

SYMBOL	NAME	SYMBOL	NAME
CB1~4	SMOOTHING CAPACITOR	RT61	DEFROST THERMISTOR
D1	DIODE	RT62	DISCHARGE TEMP.THERMISTOR
F1,F2	FUSE(T6.3AL250V)	RT64	FIN TEMP.THERMISTOR
F711	FUSE(T3.15AL250V)	RT65	AMBIENT TEMP.THERMISTOR
H	DEFROST HEATER	RT68	OUTDOOR HEAT EXCHANGER
HPS	HIGH PRESSURE SWITCH		TEMPERATURE THERMISTOR
IC401	DIODE BRIDGE	T801	TRANSFORMER
IC411	POWER MODULE	TB1~5	TERMINAL BLOCK
IC501	POWER MODULE	X52CA	RELAY
IC801	POWER DEVICE	X65A	RELAY
L1,L2	REACTOR	X712	RELAY
LED1~3	LED	X713	RELAY
LEV A-D	EXPANSION VALVE COIL	X714	RELAY
MC	COMPRESSOR	21S2	2WAY VALVE SOLENOID COIL
MF	FAN MOTOR	21S4	REVERSING VALVE SOLENOID COIL
PTC1~3	CIRCUIT PROTECTION	26H	HEATER PROTECTOR

MXZ-5E102VA

OUTDOOR UNIT

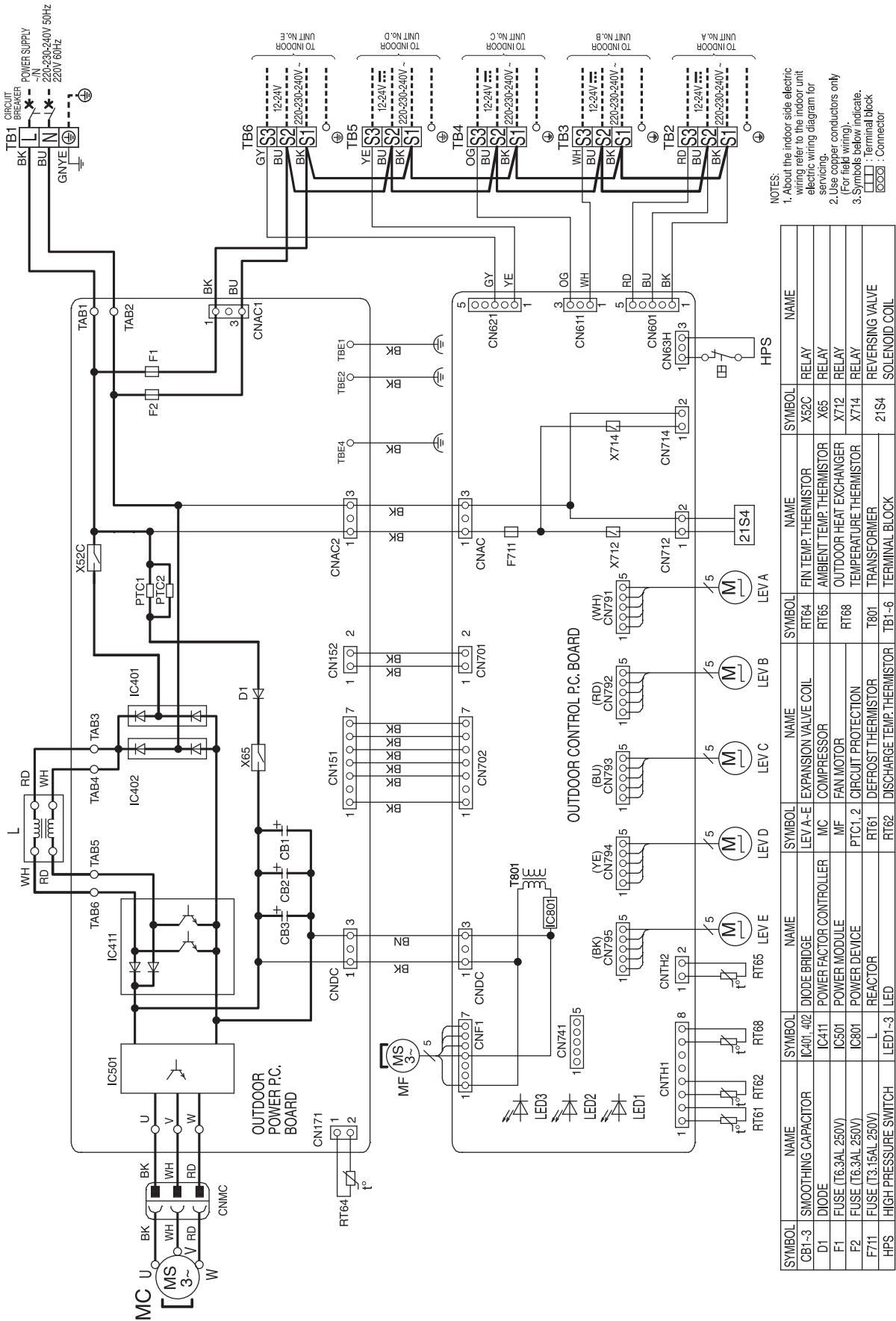

NOTES:
 1. About the indoor side electric wiring refer to the indoor unit electric wiring diagram for servicing.
 2. Use copper conductors only (For field wiring).
 3. Symbols below indicate.
 □□□□ : terminal block
 □□□□ : Connector

MXZ-6D122VA2

OUTDOOR UNIT

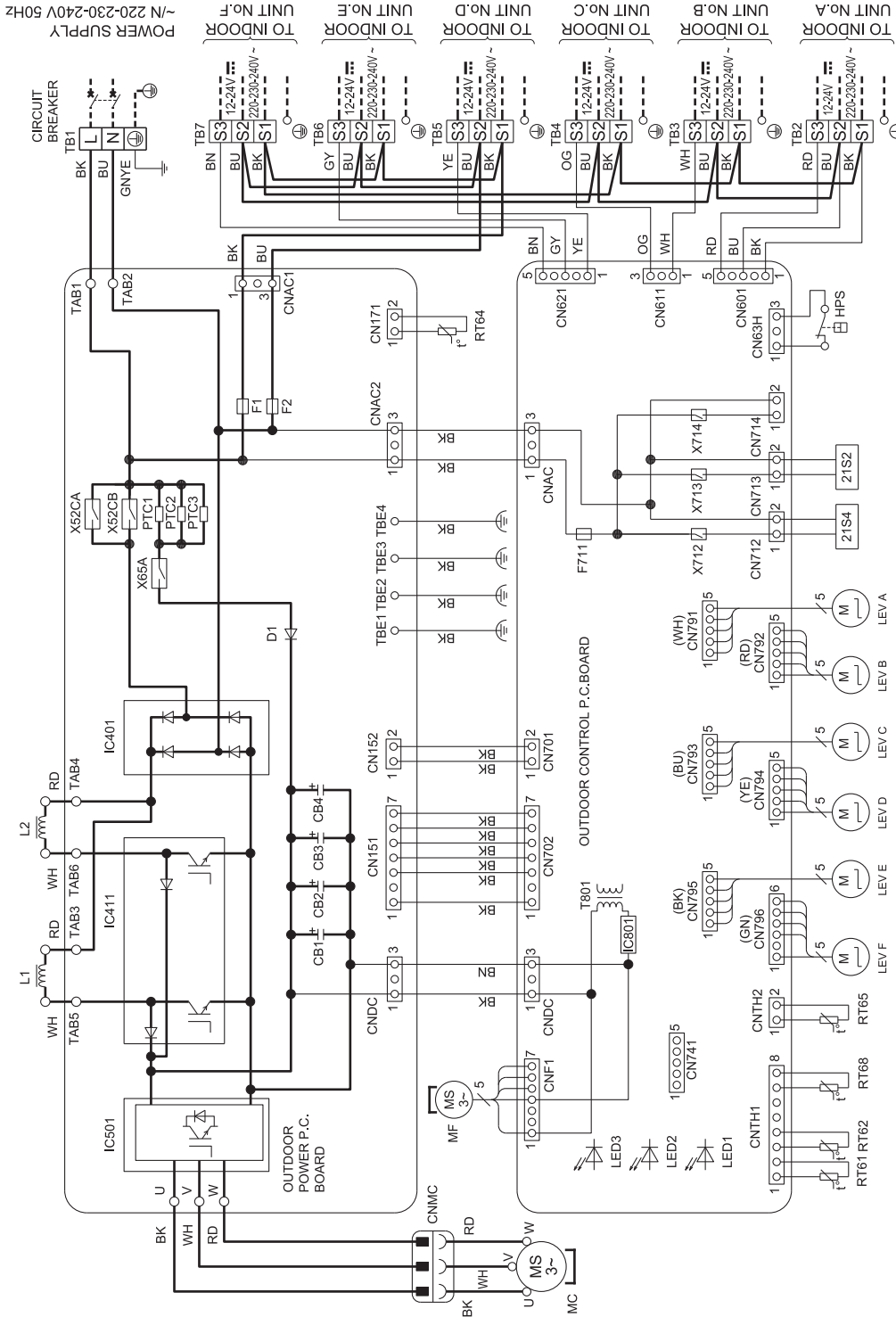

NOTES:
 1. About the indoor side electric wiring refer to the indoor unit electric wiring diagram for servicing.
 2. Use copper conductors only (For field wiring).
 3. Symbols below indicate:
 □ □ □ □ : Terminal block
 ○ ○ ○ ○ : Connector

SYMBOL	NAME	SYMBOL	NAME
CB1-4	SMOOTHING CAPACITOR	RT61	DEFROST THERMISTOR
D1	DIODE	RT62	DISCHARGE TEMP.THERMISTOR
F1,F2	FUSE(T6.3A/250V)	RT64	FIN TEMP.THERMISTOR
F711	FUSE(T3.15A/250V)	RT65	AMBIENT TEMP.THERMISTOR
HPS	HIGH PRESSURE SWITCH	RT68	OUTDOOR HEAT EXCHANGER TEMPERATURE THERMISTOR
IC401	DIODE BRIDGE	T801	TRANSFORMER
IC411	POWER MODULE	TB1-7	TERMINAL BLOCK
IC501	POWER DEVICE	X52CA B	RELAY
L1,L2	REACTOR	X65A	RELAY
LED1-3	LED	X712	RELAY
LEV-A-F	EXPANSION VALVE COIL	X713	RELAY
MC	COMPRESSOR	X714	RELAY
MF	FAN MOTOR	21S2	2WAY VALVE SOLENOID COIL
PTC1-3	CIRCUIT PROTECTION	21S4	REVERSING VALVE SOLENOID COIL

WIRING DIAGRAM

MULTI SYSTEM

MXZ-2DM40VA
OUTDOOR UNIT

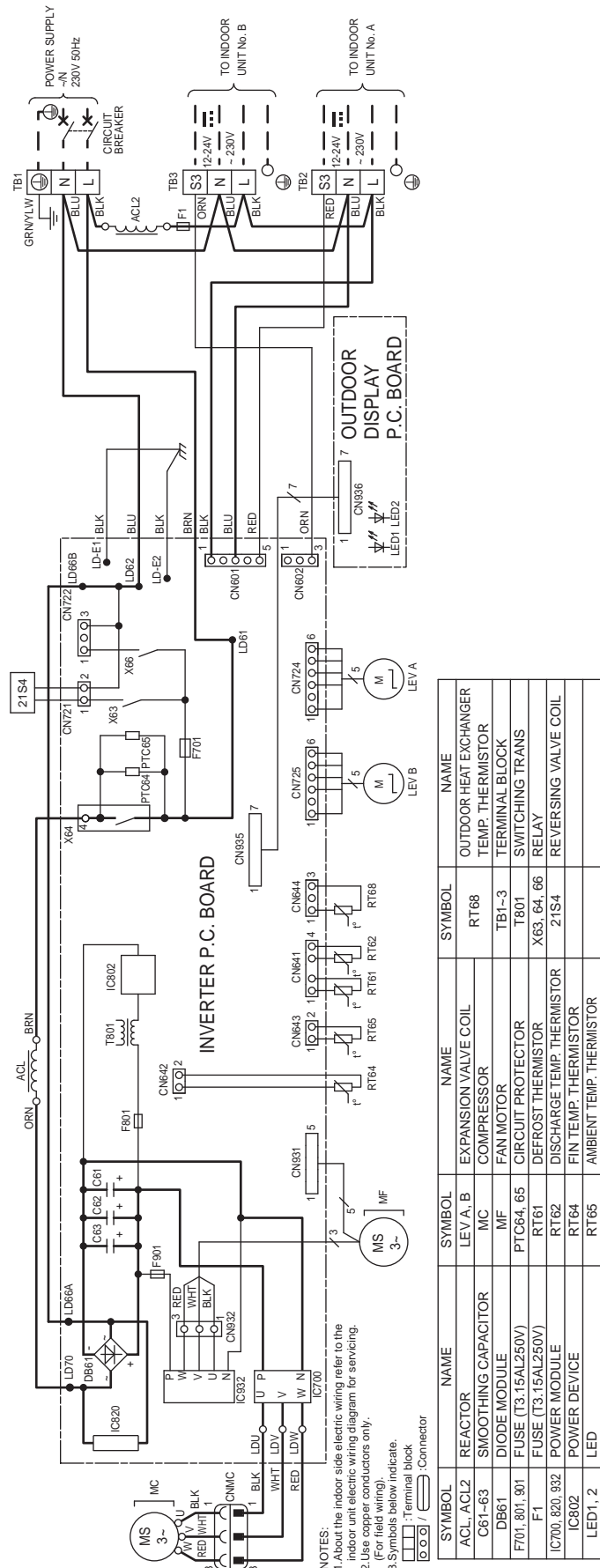

NOTES:
1. About the indoor side electric wiring refer to the indoor unit electric wiring diagram for servicing.
2. Use copper conductors only.
3. Symbols below indicate:
: Terminal block
: Connector

SYMBOL	NAME	SYMBOL	NAME	SYMBOL	NAME
ACL, ACL2	REACTOR	LEV A, B	EXPANSION VALVE COIL	RT68	OUTDOOR HEAT EXCHANGER TEMP. THERMISTOR
C61-63	SMOOTHING CAPACITOR	MC	COMPRESSOR	TB1-3	TERMINAL BLOCK
DB61	DIODE MODULE	MF	FAN MOTOR	T801	SWITCHING TRANS RELAY
F701, 801, 901	FUSE (T3.15AL250V)	PTC64, 65	CIRCUIT PROTECTOR	X63, 64, 66	REVERSING VALVE COIL
IC700, 820, 932	POWER MODULE	RT61	DEFROST THERMISTOR	21S4	
IC802	POWER DEVICE	RT62	DISCHARGE TEMP. THERMISTOR		
LED1, 2	LED	RT64	FIN TEMP. THERMISTOR		
		RT65	AMBIENT TEMP. THERMISTOR		

MXZ-2HA40VF2 MXZ-2HA50VF2

OUTDOOR UNIT

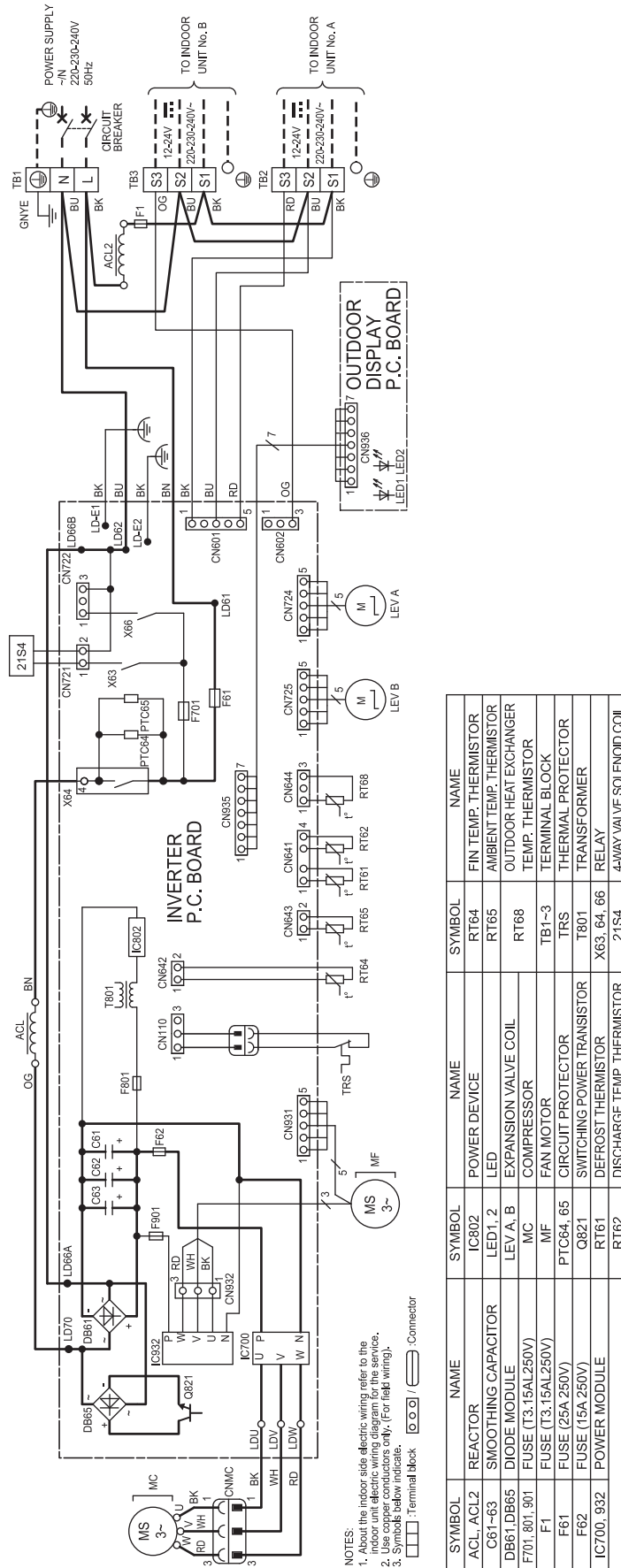

SYMBOL	NAME	SYMBOL	NAME	SYMBOL	NAME
ACL, ACL2	REACTOR	IC802	POWER DEVICE	RT64	FIN TEMP. THERMISTOR
C61~63	SMOOTHING CAPACITOR	LED1, 2	LED	RT65	AMBIENT TEMP. THERMISTOR
DB61, DB65	DIODE MODULE	LEV A, B	EXPANSION VALVE COIL	RT68	OUTDOOR HEAT EXCHANGER TEMP. THERMISTOR
F701, 801, 901	FUSE (T3.15A/250V)	MC	COMPRESSOR	TB1~3	TERMINAL BLOCK
F1	FUSE (T3.15A/250V)	MF	FAN MOTOR	TRS	THERMAL PROTECTOR
F61	FUSE (25A 250V)	PTC64, 65	CIRCUIT PROTECTOR	TR801	TRANSFORMER
F62	FUSE (15A 250V)	Q821	SWITCHING POWER TRANSISTOR	X63, 64, 66	RELAY
IC700, 932	POWER MODULE	RT61	DEFROST THERMISTOR	2TS4	4-WAY VALVE SOLENOID COIL

MXZ-3HA50VF2

OUTDOOR UNIT

WIRING DIAGRAM

MULTI SYSTEM

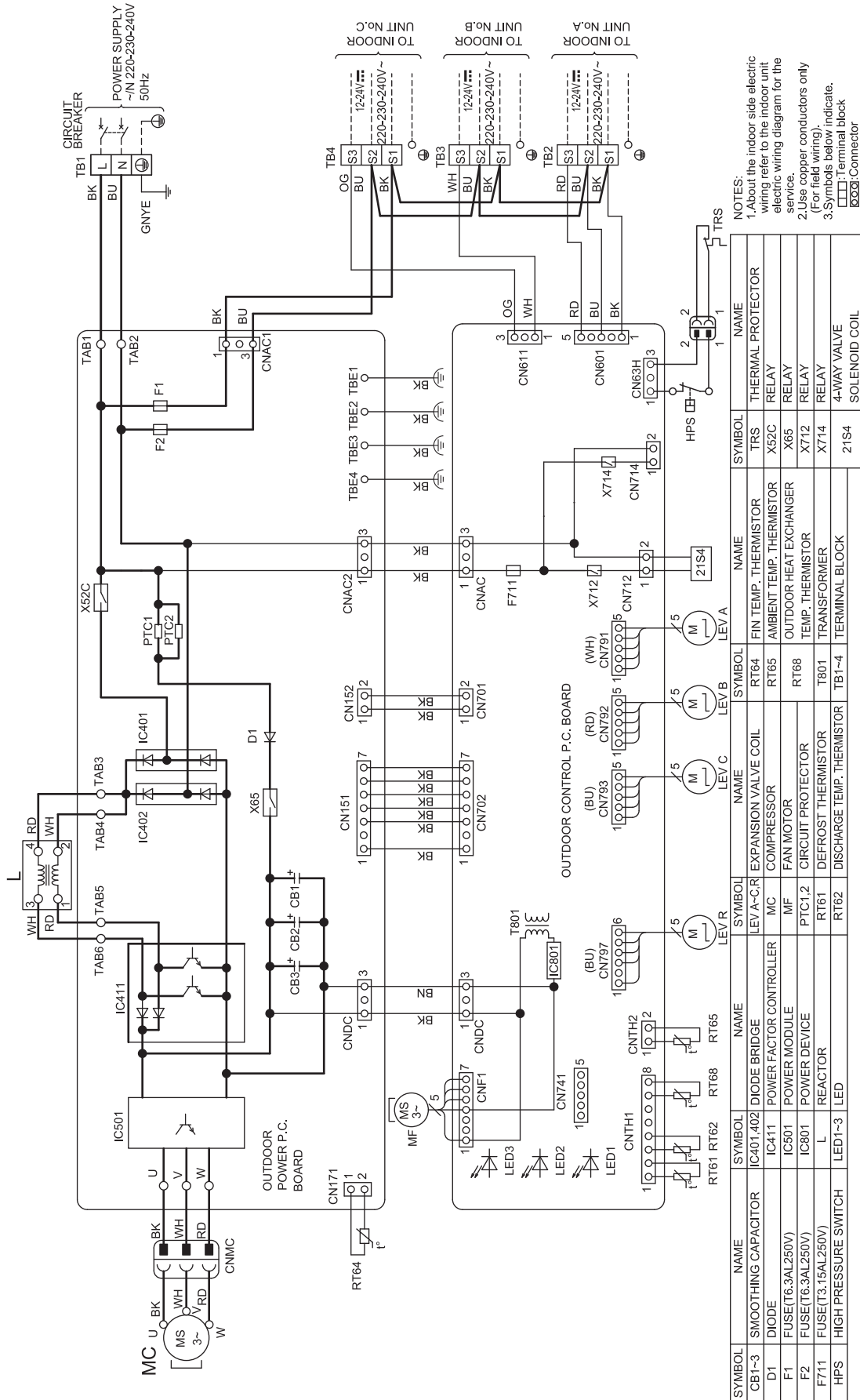

PXZ-4F75VG

OUTDOOR UNIT

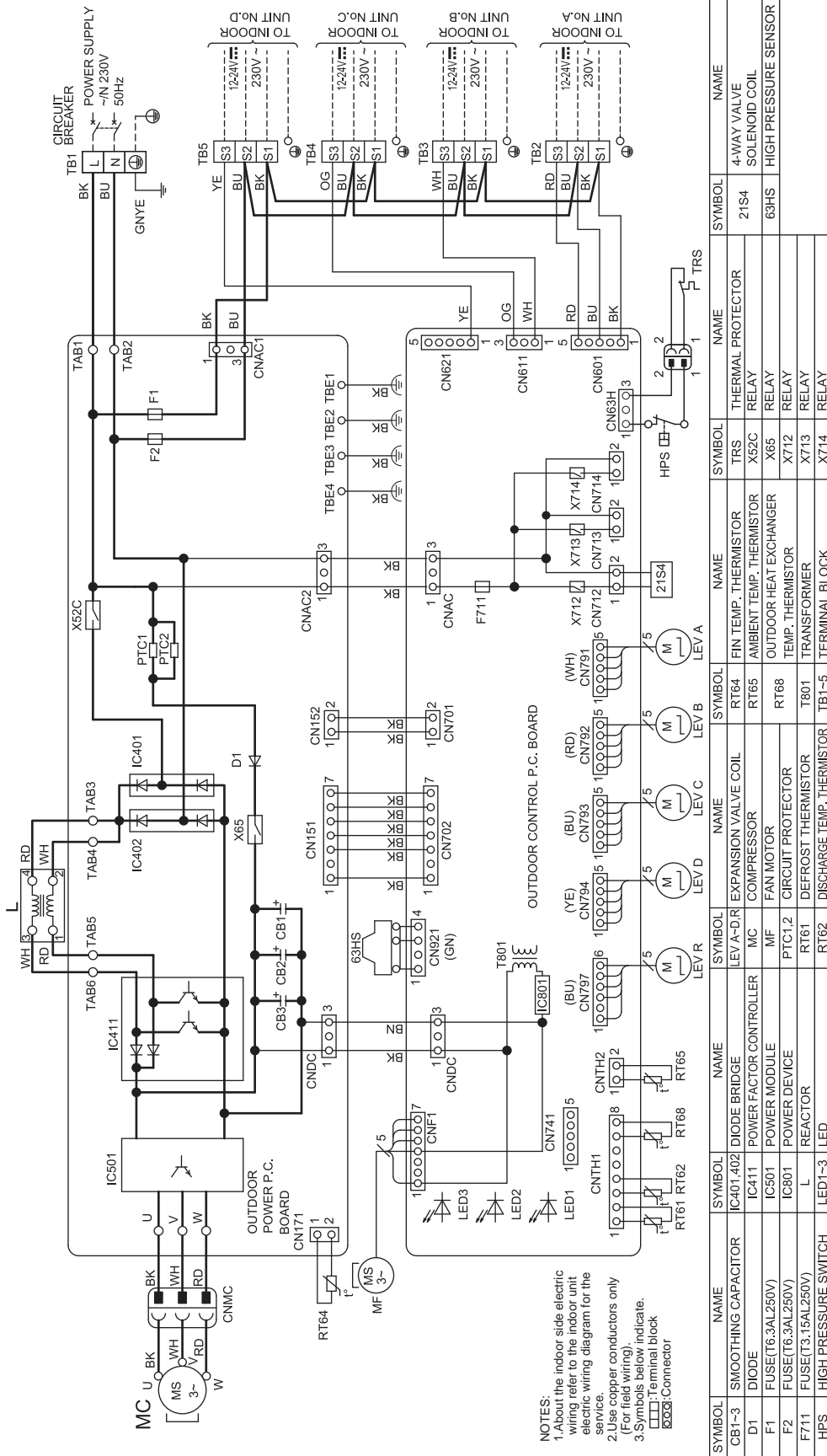

SYMBOL	NAME	SYMBOL	NAME	SYMBOL	NAME	SYMBOL	NAME
CB1-3	SMOOTHING CAPACITOR	IC401.402	DIODE BRIDGE	LEV A-D R	EXPANSION VALVE COIL	RT64	FIN TEMP. THERMISTOR
D1	DIODE	IC411	POWER FACTOR CONTROLLER	MC	COMPRESSOR	RT65	AMBIENT TEMP. THERMISTOR
F1	FUSE(T6.3AL250V)	IC501	POWER MODULE	MF	FAN MOTOR	X65	OUTDOOR HEAT EXCHANGER
F2	FUSE(T6.3AL250V)	IC801	POWER DEVICE	PTC1.2	CIRCUIT PROTECTOR	X712	TEMP. THERMISTOR
F711	FUSE(T3.15AL250V)	L	REACTOR	RT61	DEFROST THERMISTOR	X713	RELAY
HPS	HIGH PRESSURE SWITCH	LED1-3	LED	RT62	DISCHARGE TEMP. THERMISTOR	X714	RELAY
				TB1-5	TERMINAL BLOCK		
				TRS	THERMAL PROTECTOR		
				X52C	RELAY		
				X63HS	RELAY		
				X712	RELAY		
				X713	RELAY		
				X714	RELAY		
				21S4	4-WAY VALVE SOLENOID COIL		
				63HS	HIGH PRESSURE SENSOR		

PXZ-5F85VG

OUTDOOR UNIT

WIRING DIAGRAM

MULTI SYSTEM

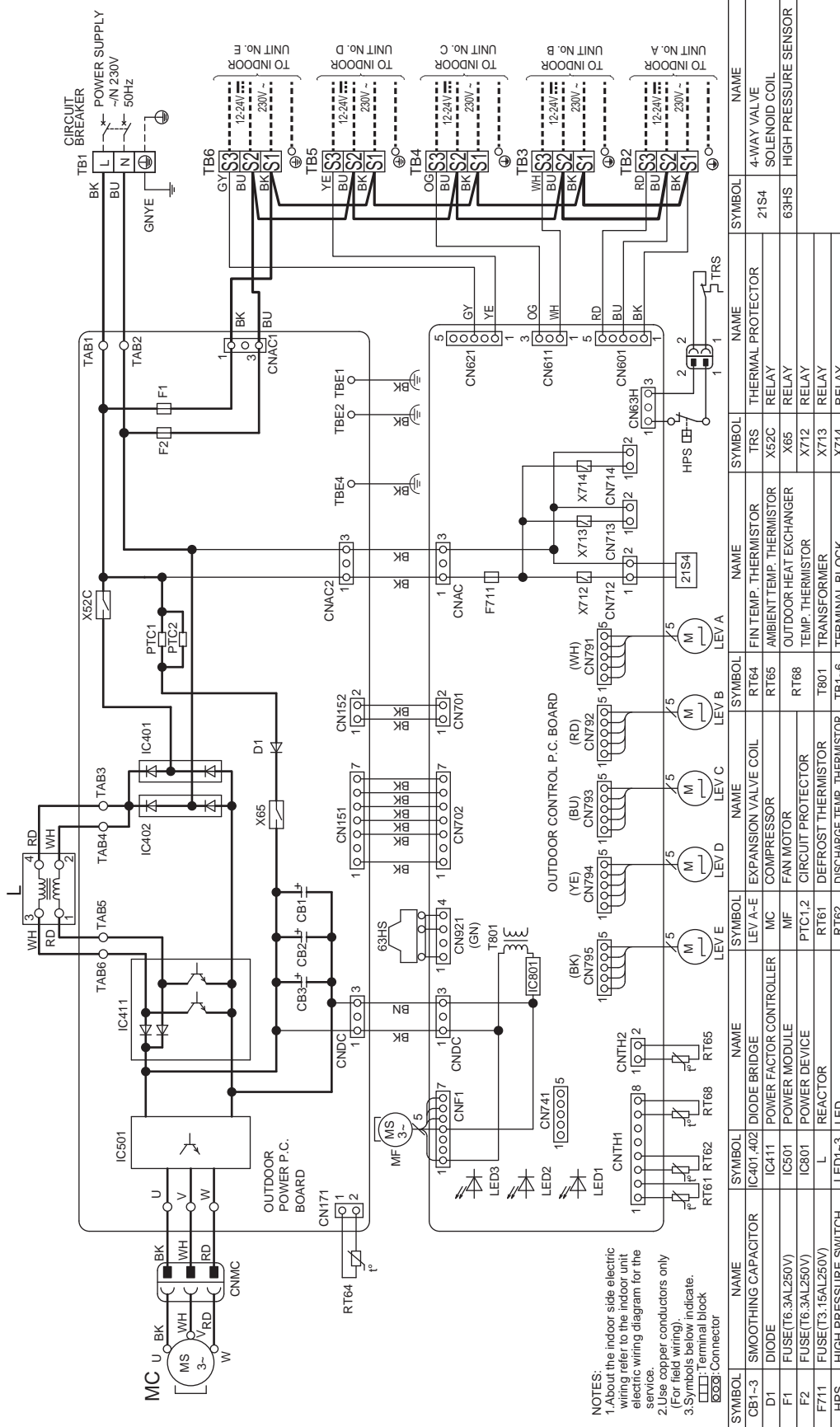

C.4.4 REFRIGERANT SYSTEM DIAGRAM

C.4.4.1 Inverter Heat Pump

MXZ-2F33VF4

Unit: mm

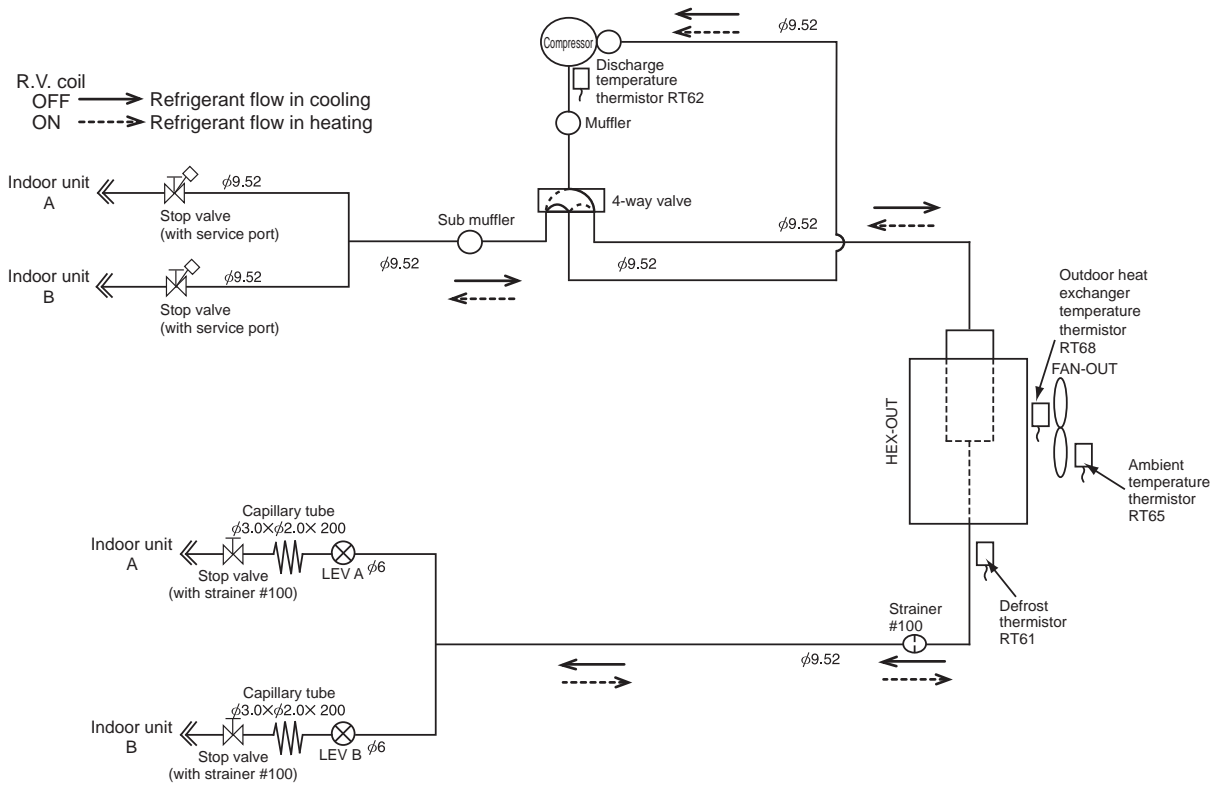

MXZ-2F42VF4 MXZ-2F53VF4 MXZ-2F53VFH4 MXZ-2HA40VF2 MXZ-2HA50VF2 Unit: mm

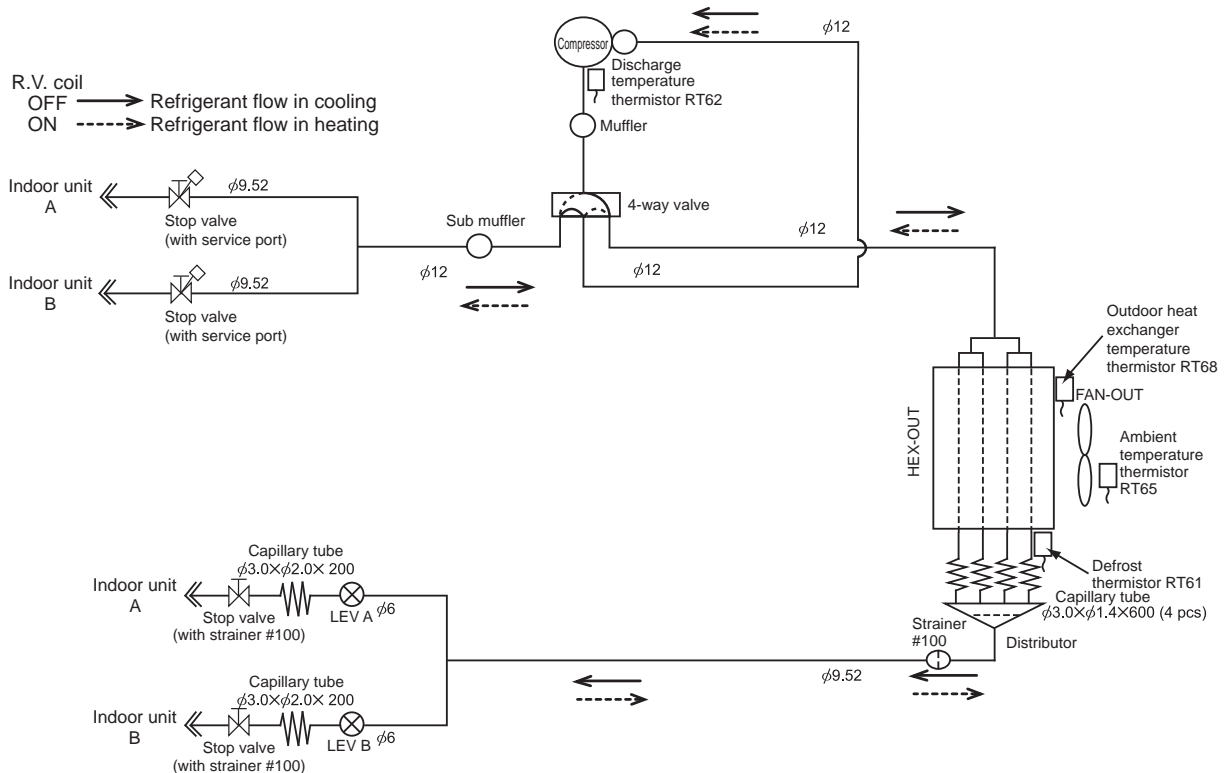

MULTI SYSTEM REFRIGERANT SYSTEM DIAGRAM

MXZ-3F54VF4 MXZ-3F68VF4 MXZ-3HA50VF2

Unit: mm

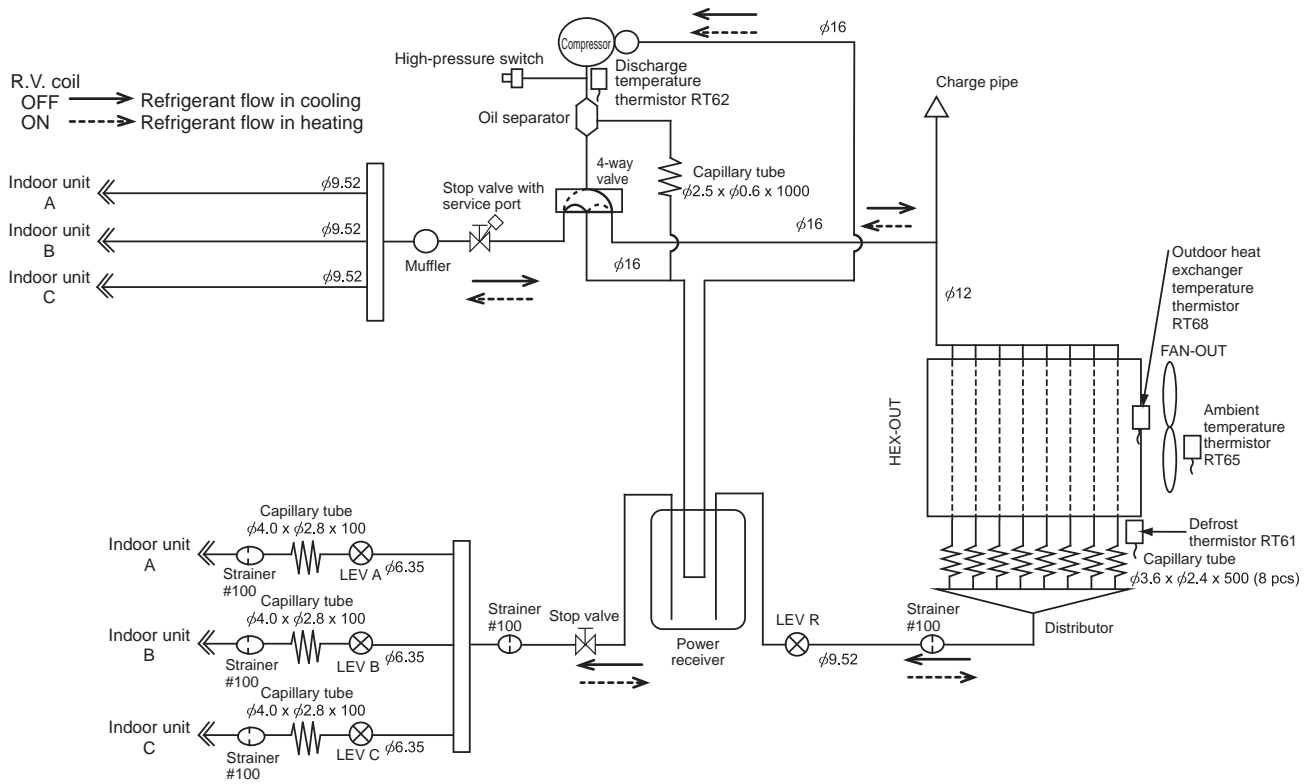

MXZ-4F72VF4 MXZ-4F80VF4

Unit: mm

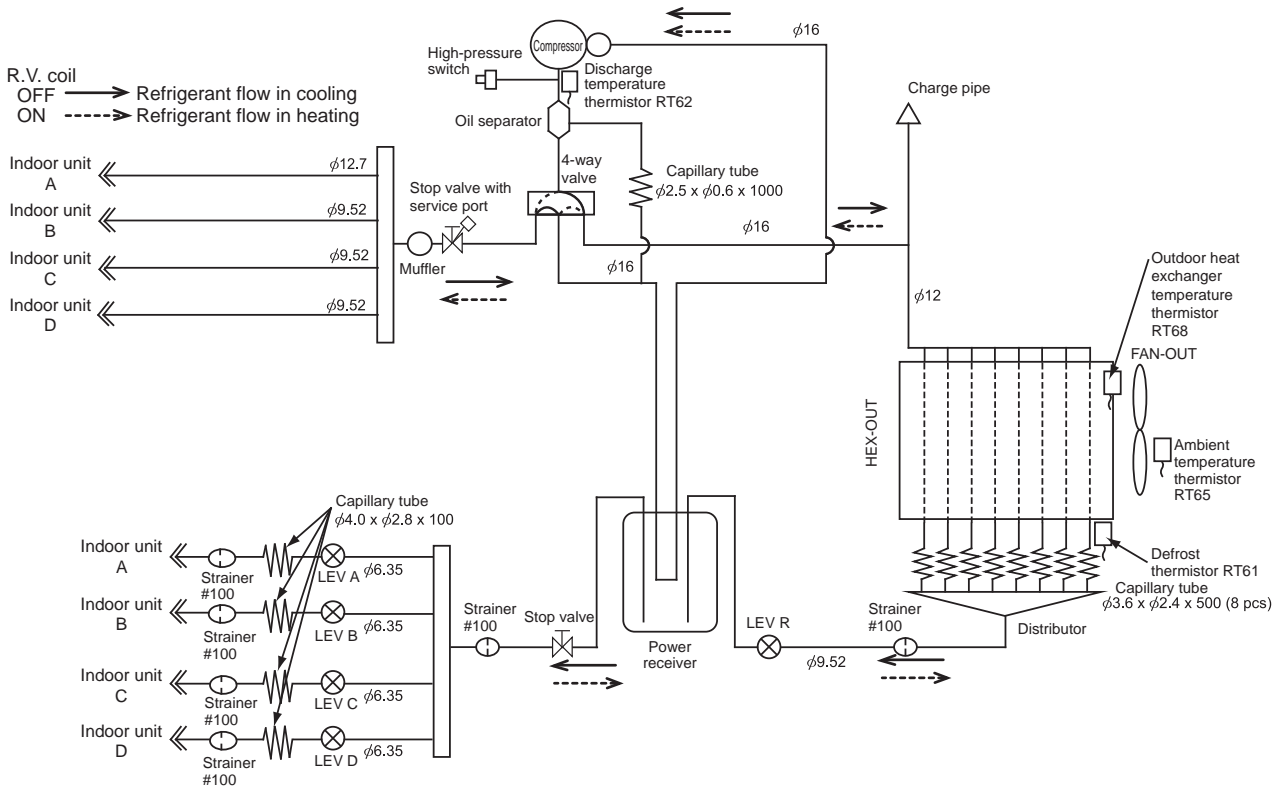

REFRIGERANT SYSTEM DIAGRAM

MULTI SYSTEM

MXZ-4F83VF2

Unit: mm

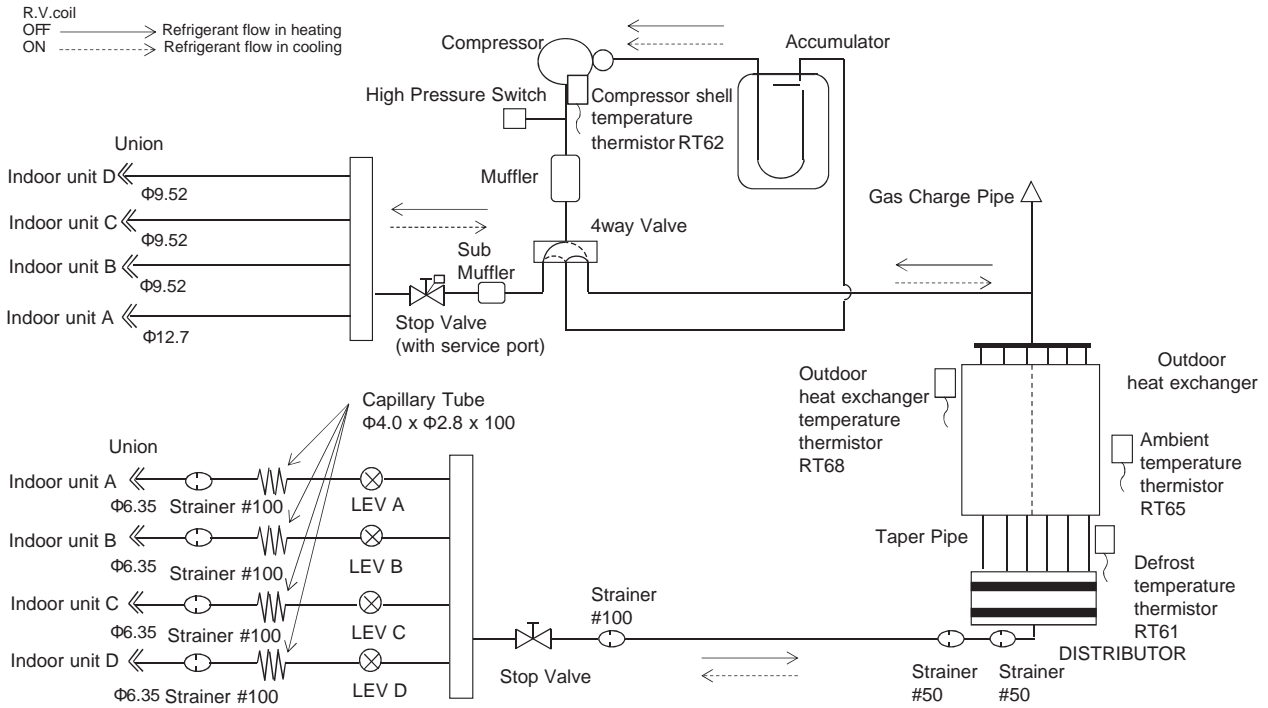

MXZ-5F102VF2

Unit: mm

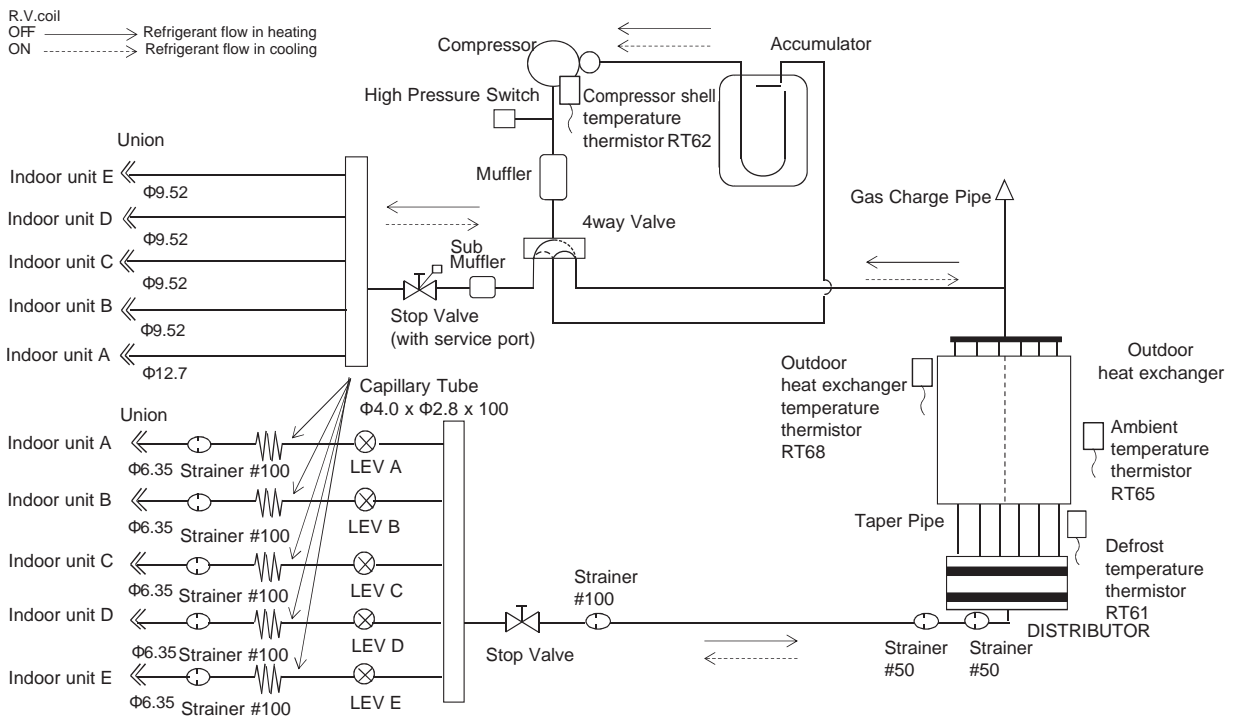

MULTI SYSTEM REFRIGERANT SYSTEM DIAGRAM

MXZ-6F120VF2

Unit: mm

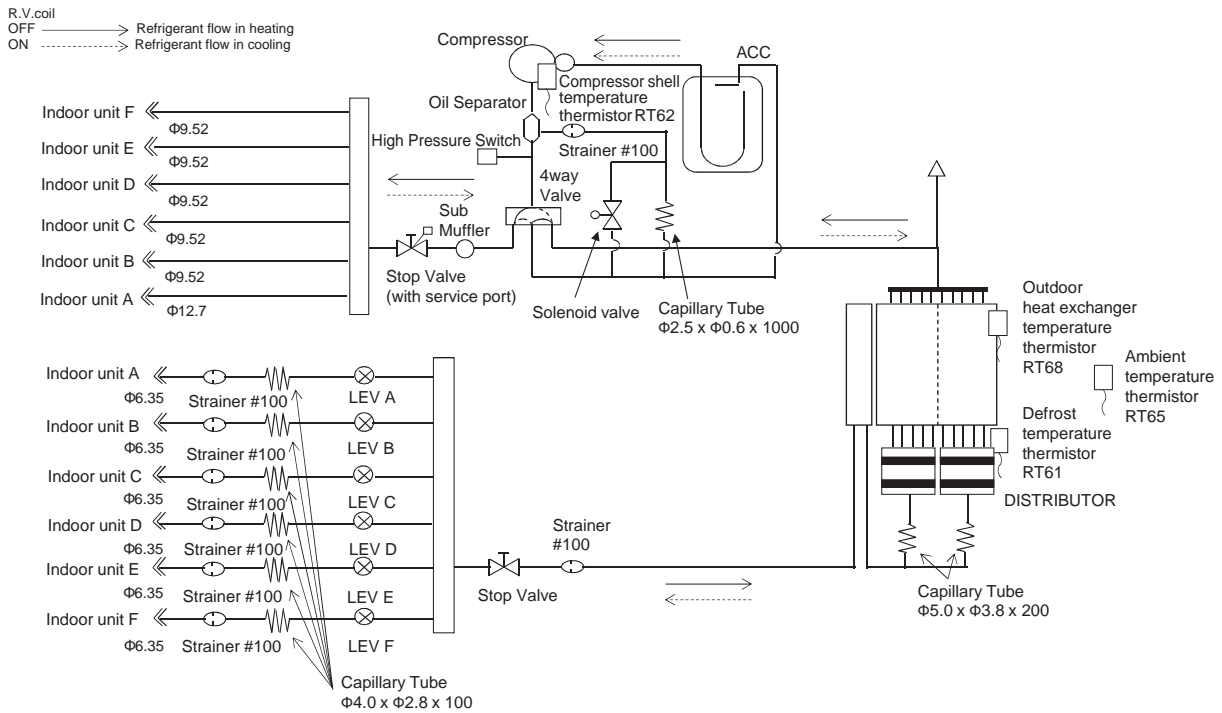

MXZ-2F53VFH2Z

Unit: mm

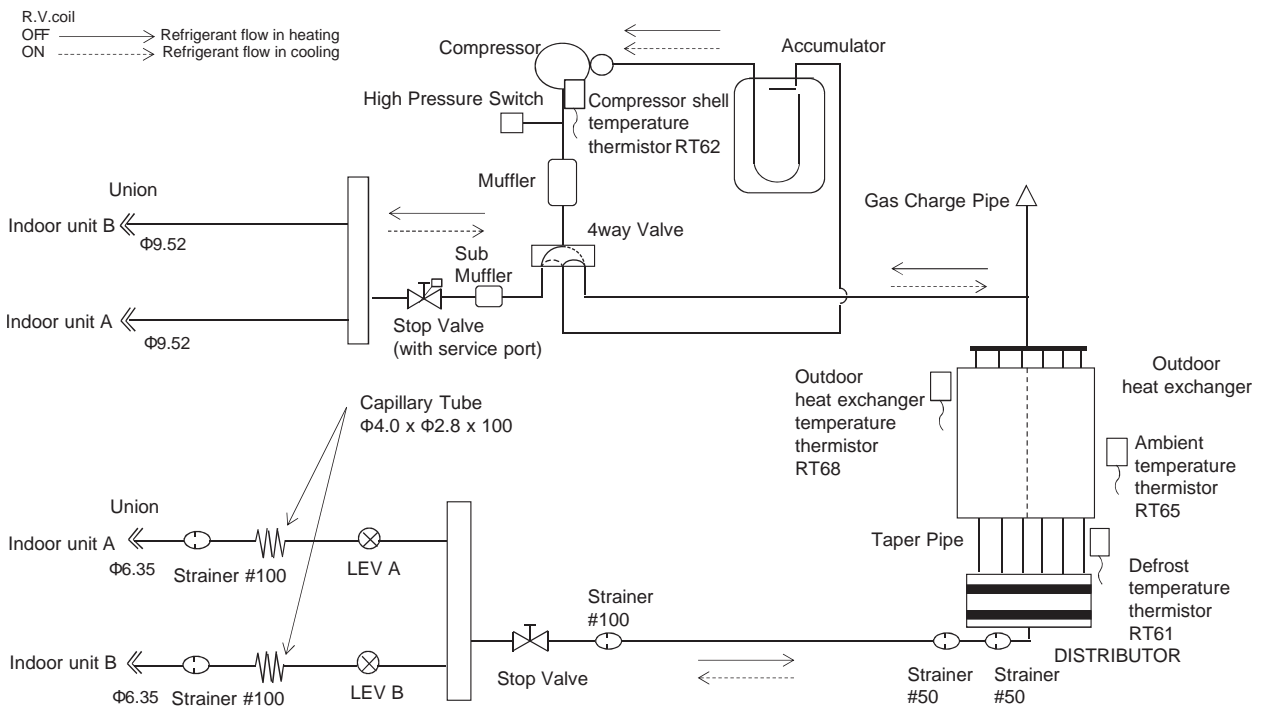

REFRIGERANT SYSTEM DIAGRAM

MULTI SYSTEM

MXZ-4F83VFH22

Unit: mm

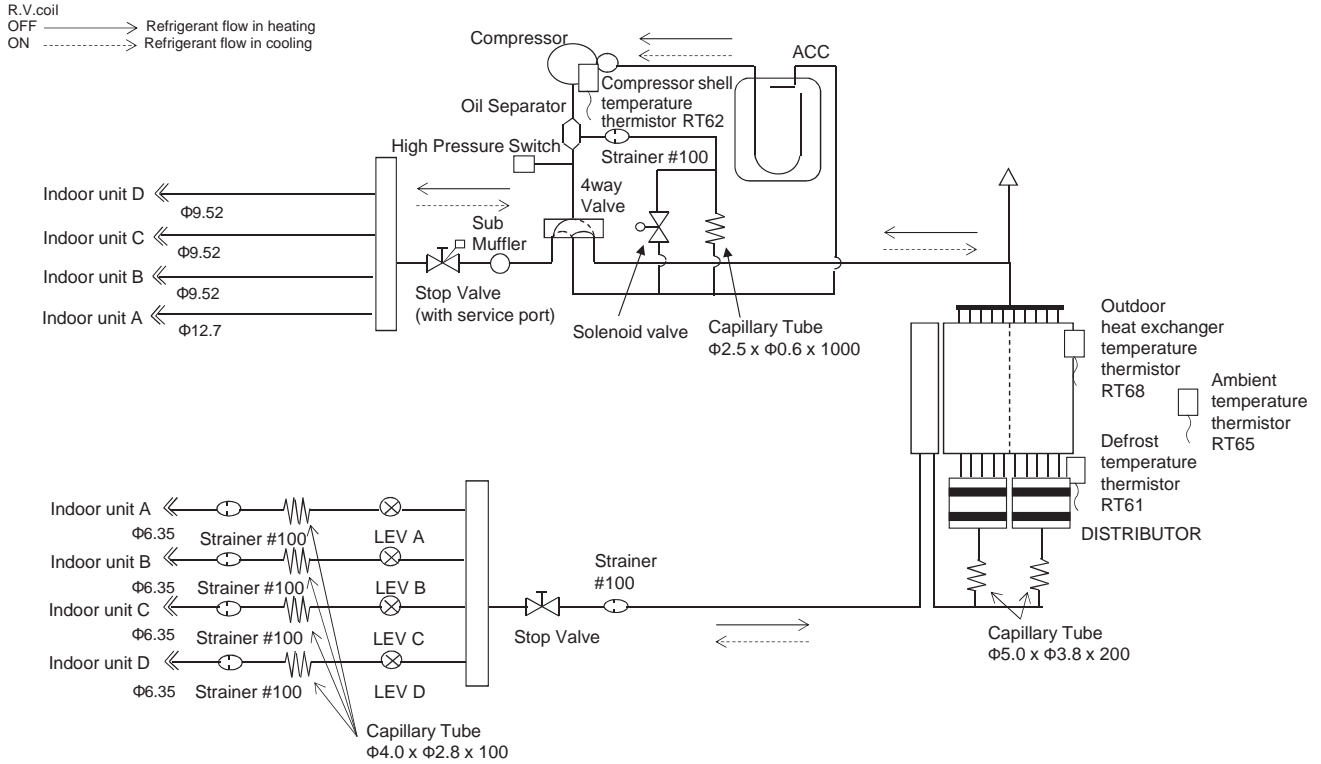

MXZ-2D33VA

Unit: mm

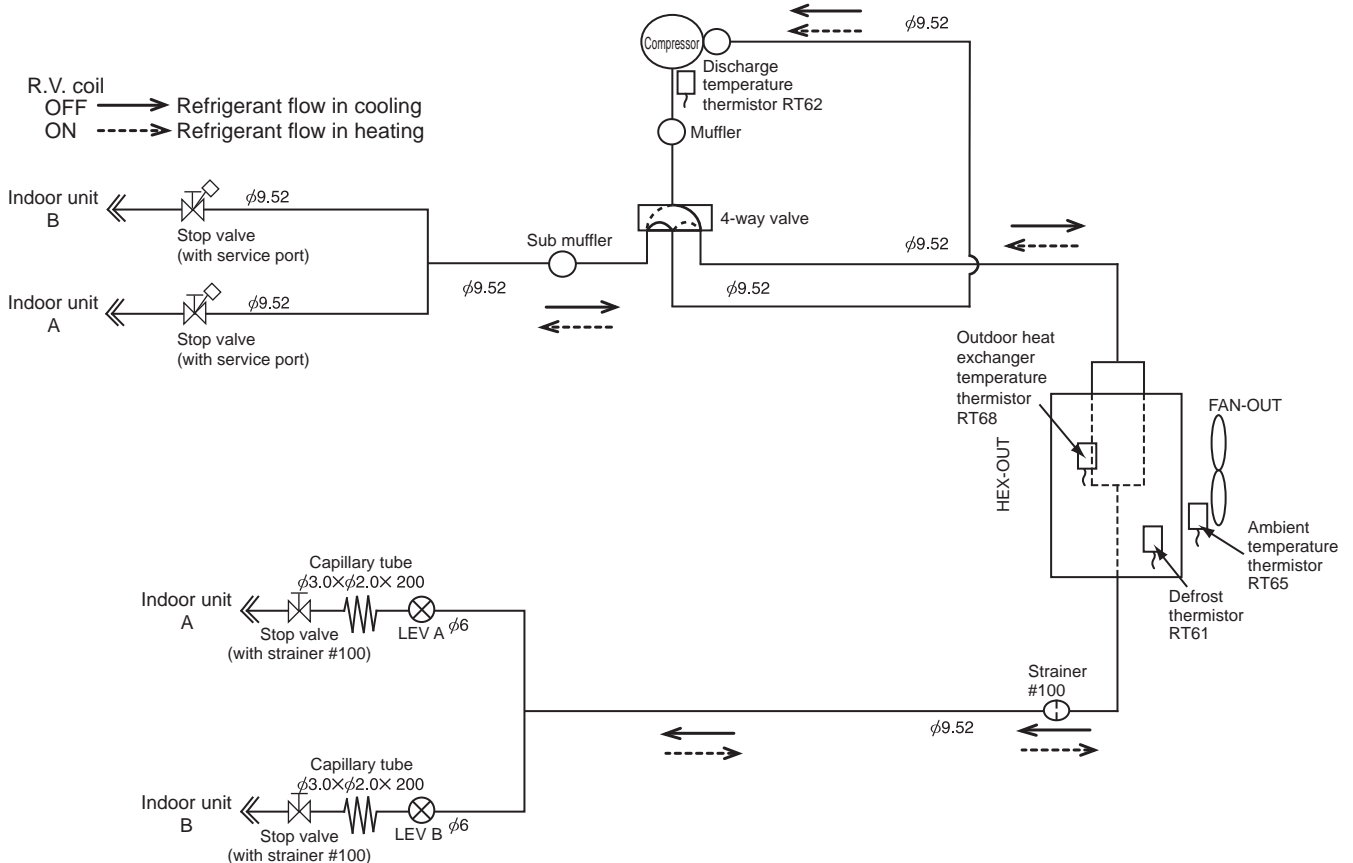

MULTI SYSTEM REFRIGERANT SYSTEM DIAGRAM

MXZ-2D42VA2 MXZ-2D53VA2 MXZ-2D53VAH2

Unit: mm

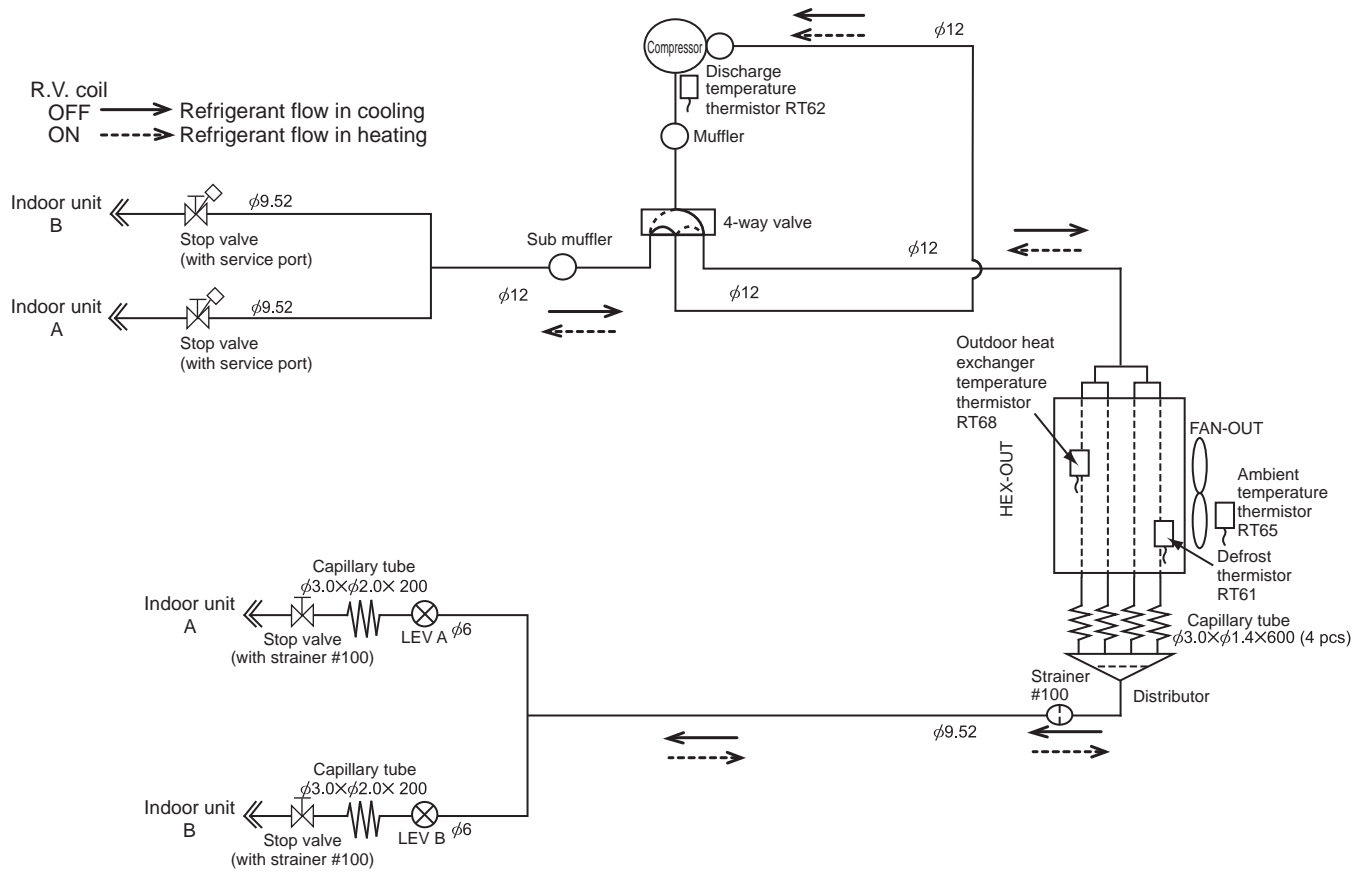

MXZ-2E53VAHZ

Unit: mm

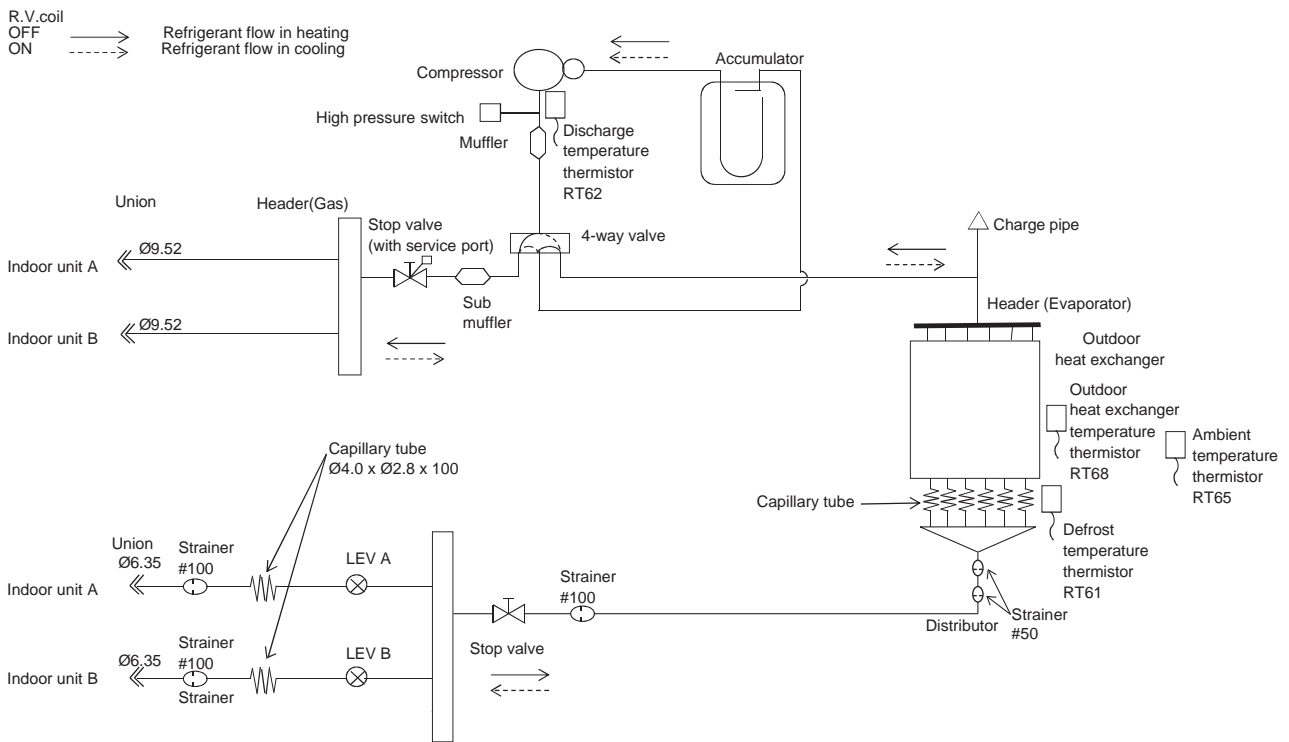

REFRIGERANT SYSTEM DIAGRAM

MULTI SYSTEM

MXZ-3E54VA MXZ-3E68VA

Unit: mm

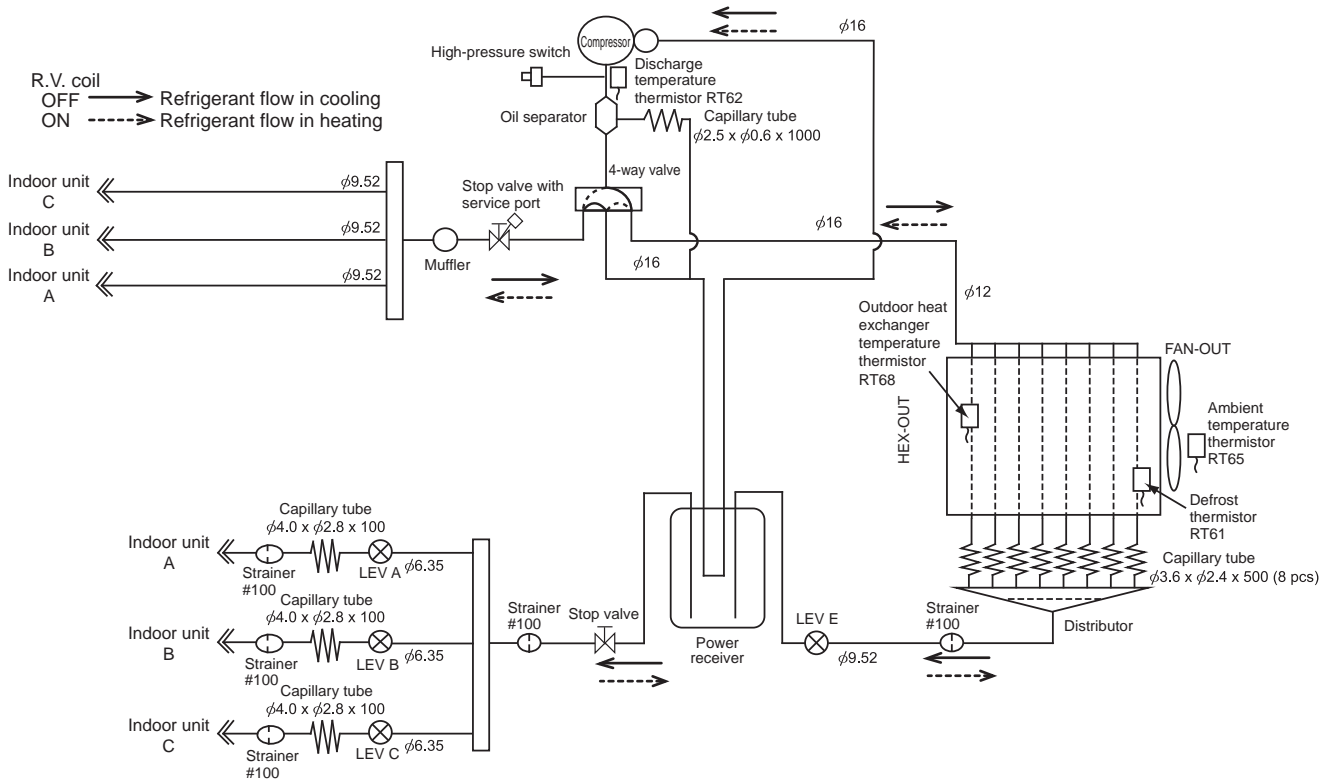

MXZ-4E72VA

Unit: mm

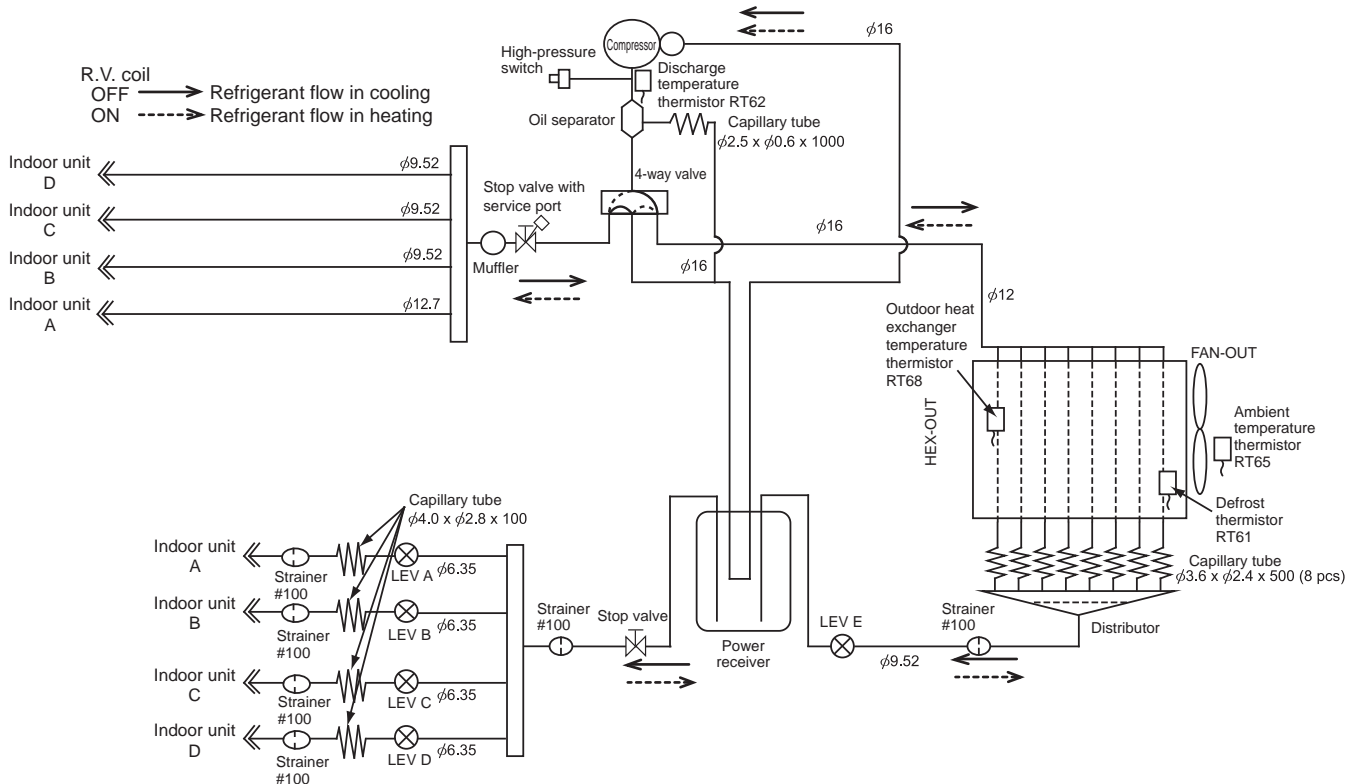

MULTI SYSTEM REFRIGERANT SYSTEM DIAGRAM

MXZ-4E83VA

Unit: mm

R.V.coil
 OFF → Refrigerant flow in heating
 ON - - - - - Refrigerant flow in cooling

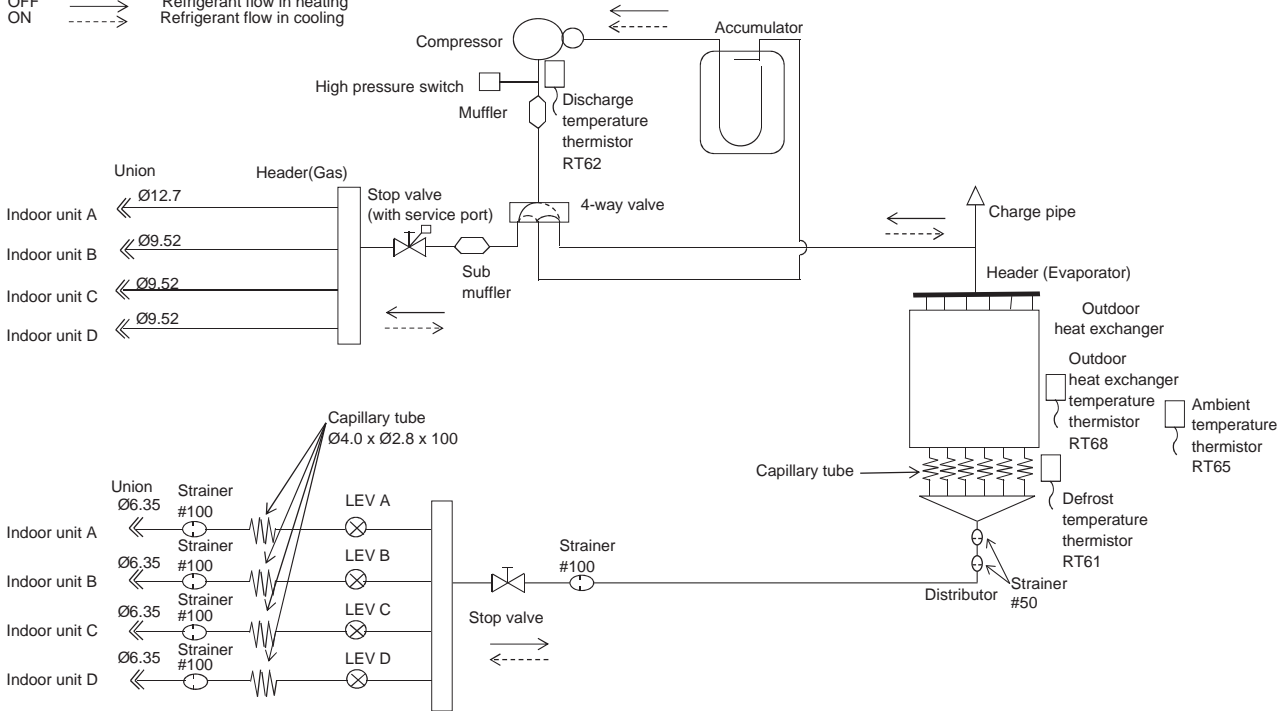

MXZ-4E83VAHZ

Unit: mm

R.V.coil
 OFF → Refrigerant flow in heating
 ON - - - - - Refrigerant flow in cooling

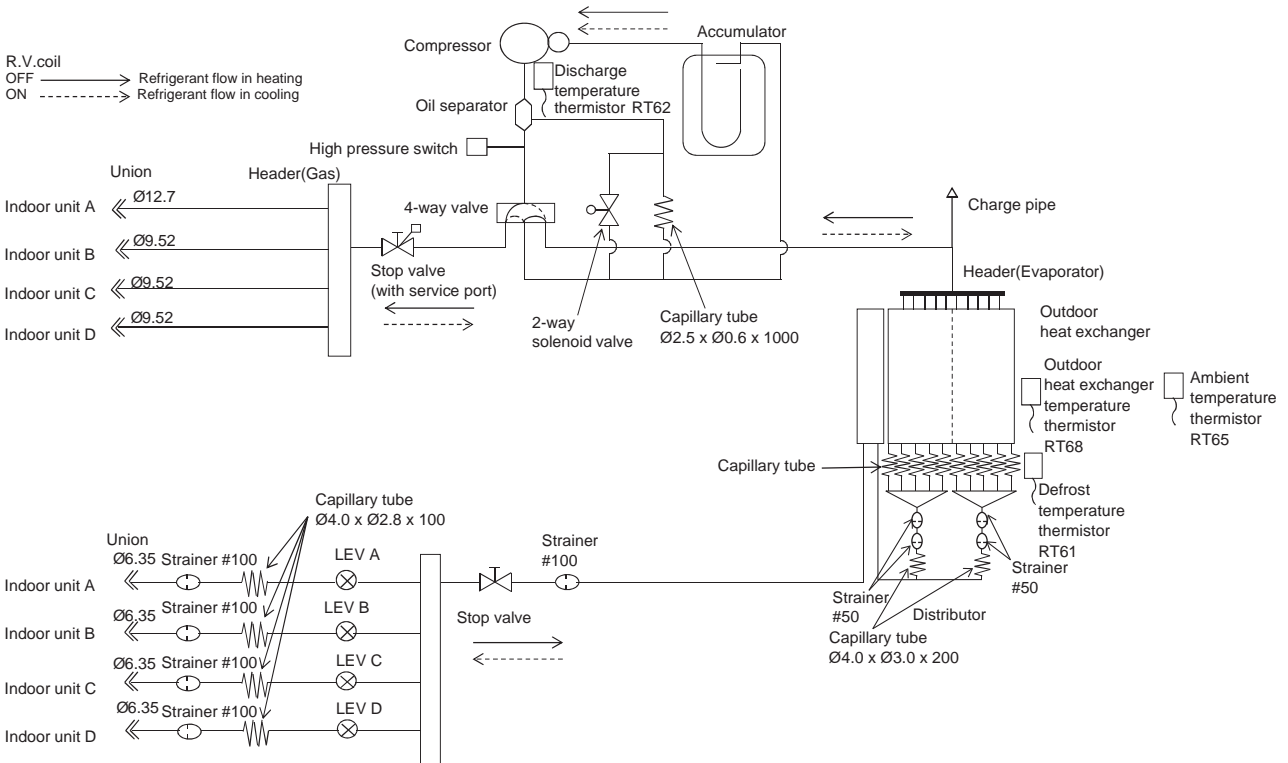

REFRIGERANT SYSTEM DIAGRAM

MULTI SYSTEM

MXZ-5E102VA

Unit: mm

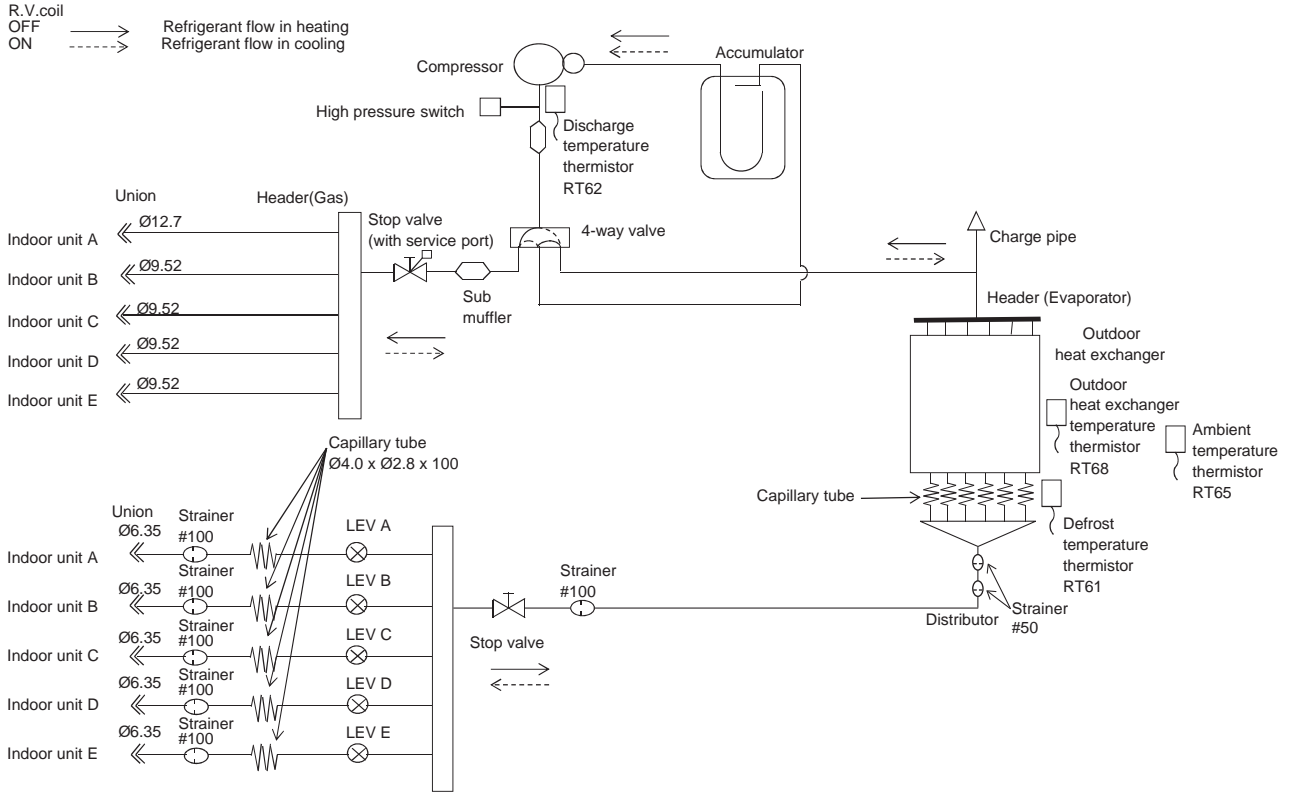

MXZ-6D122VA2

Unit: mm

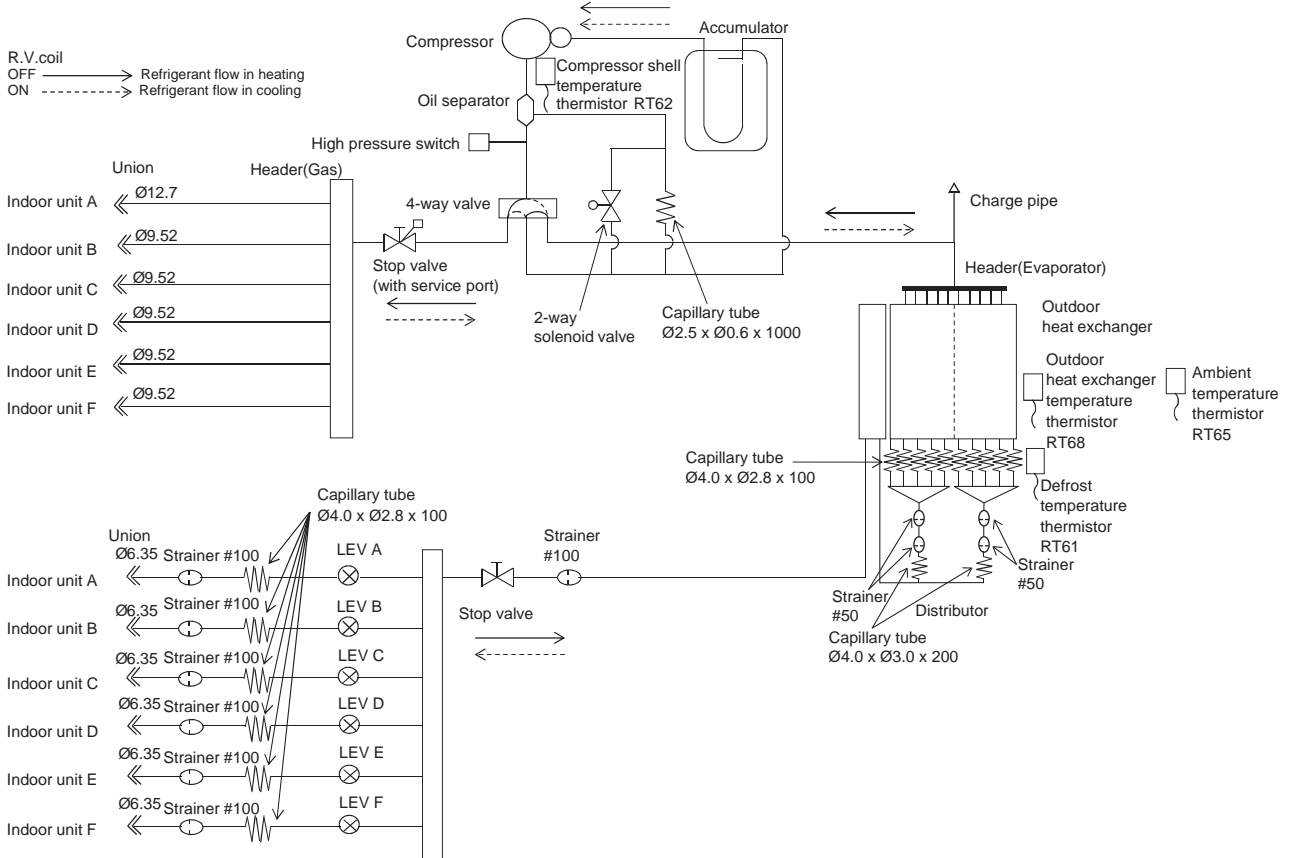

MULTI SYSTEM REFRIGERANT SYSTEM DIAGRAM

MXZ-2DM40VA

Unit: mm

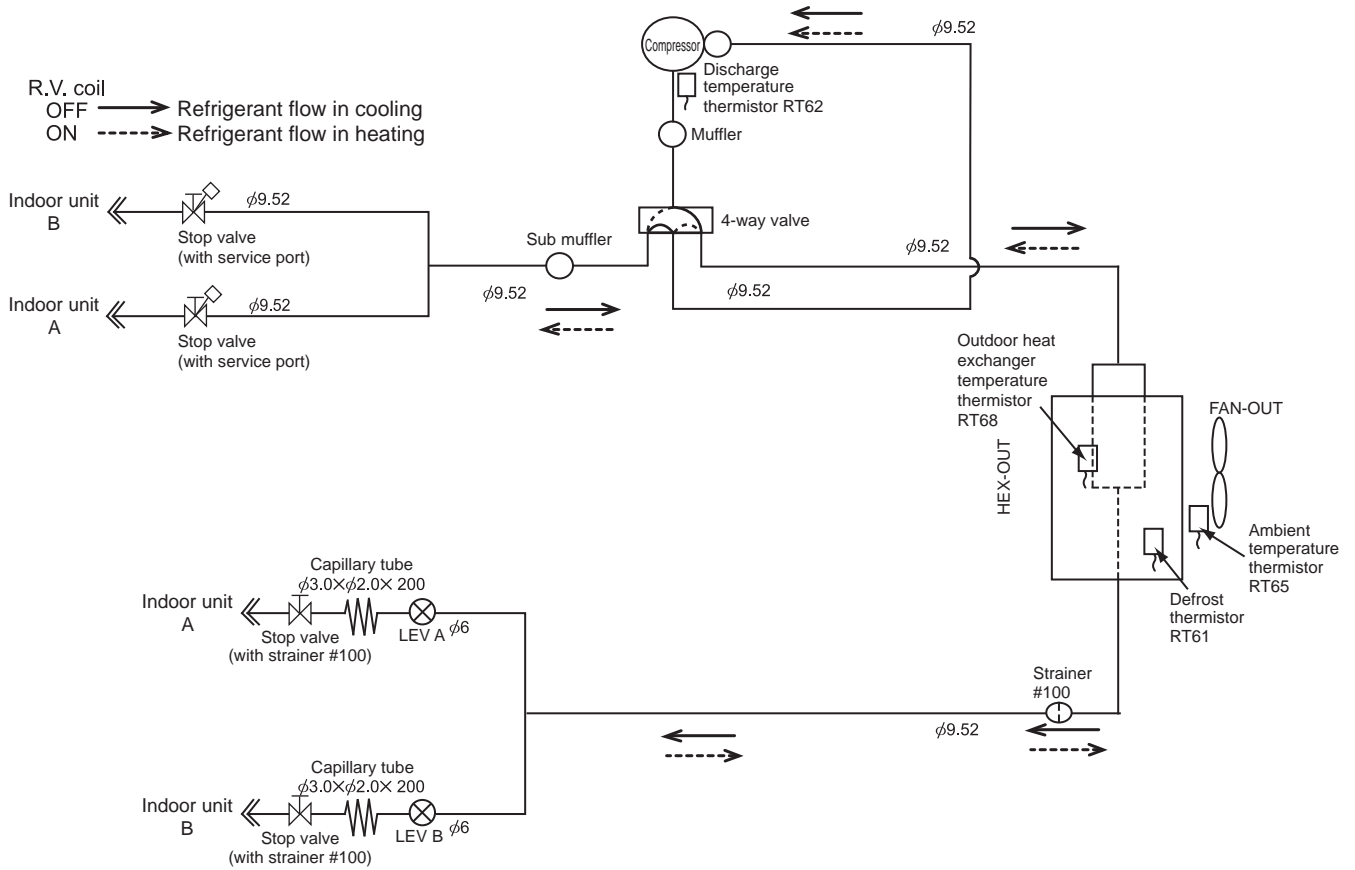

MXZ-3DM50VA

Unit: mm

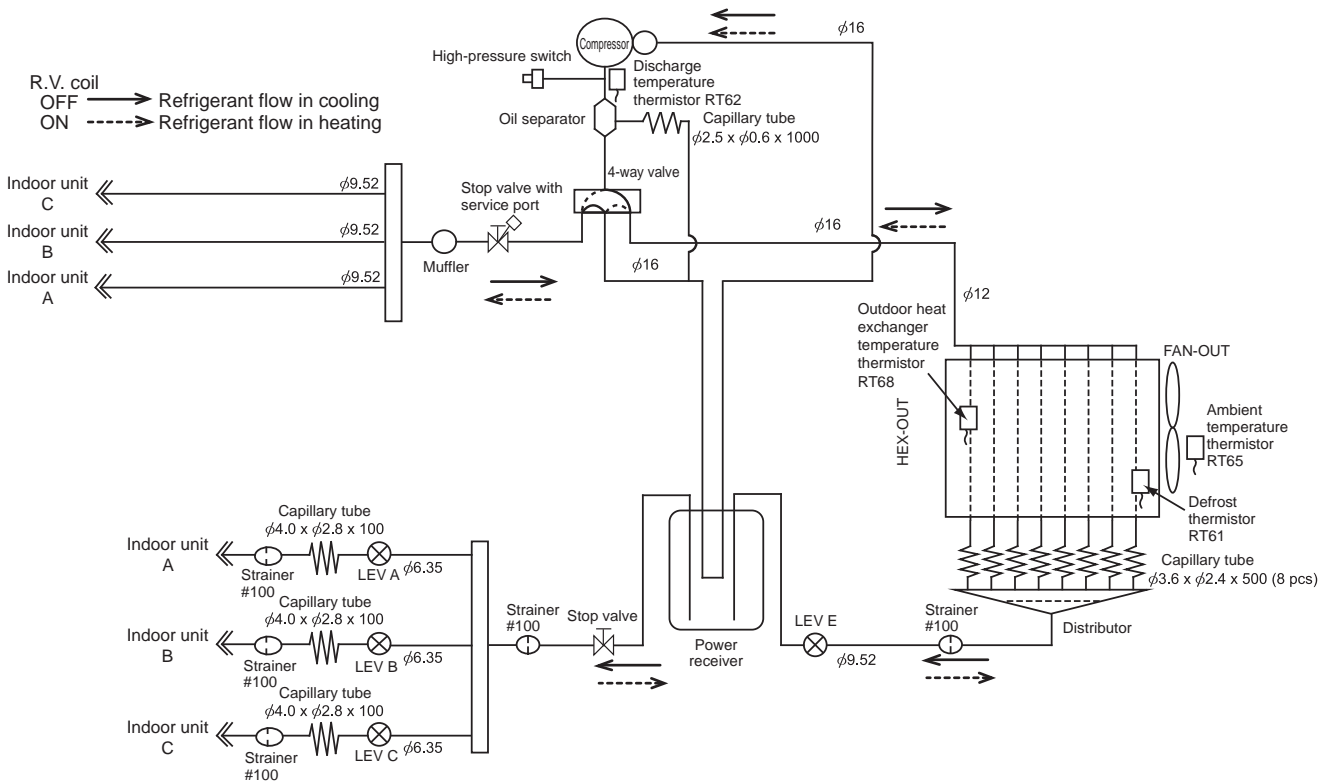

REFRIGERANT SYSTEM DIAGRAM

MULTI SYSTEM

PXZ-4F75VG

Unit: mm

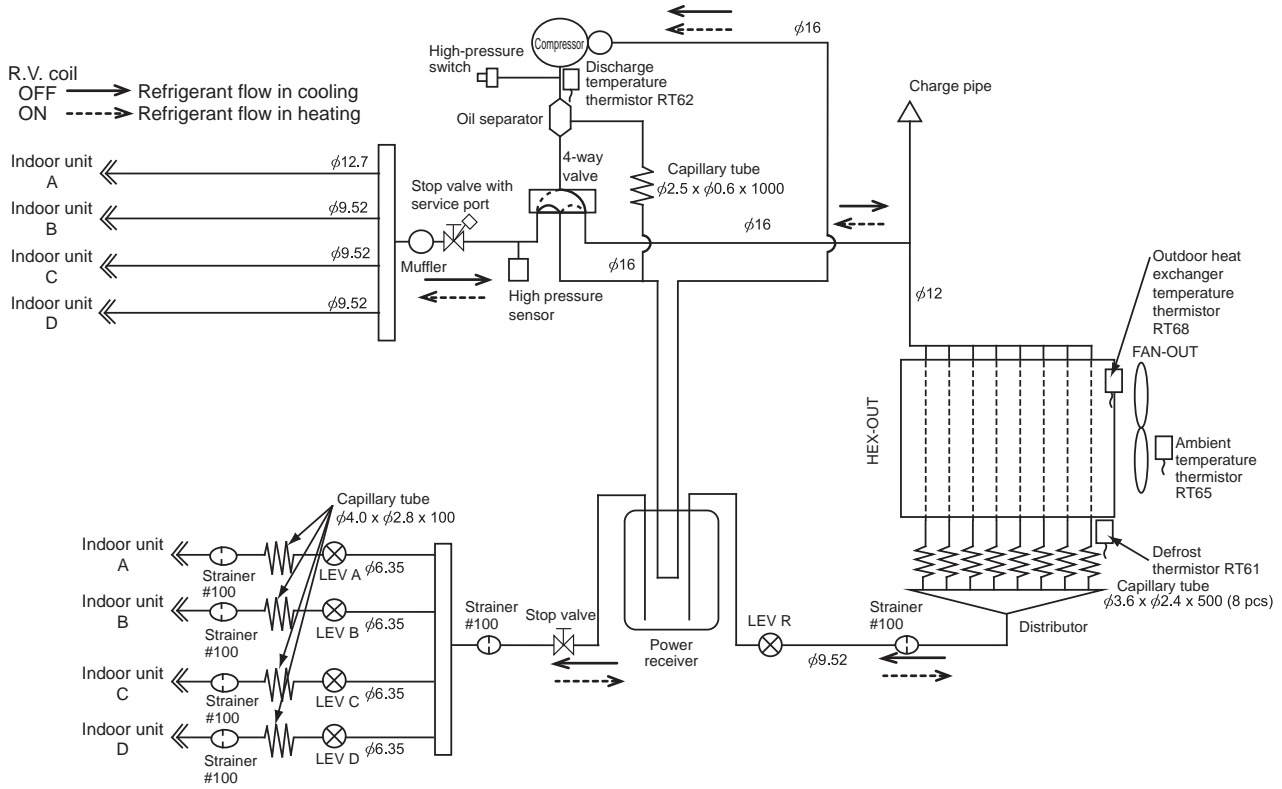

PXZ-5F85VG

Unit: mm

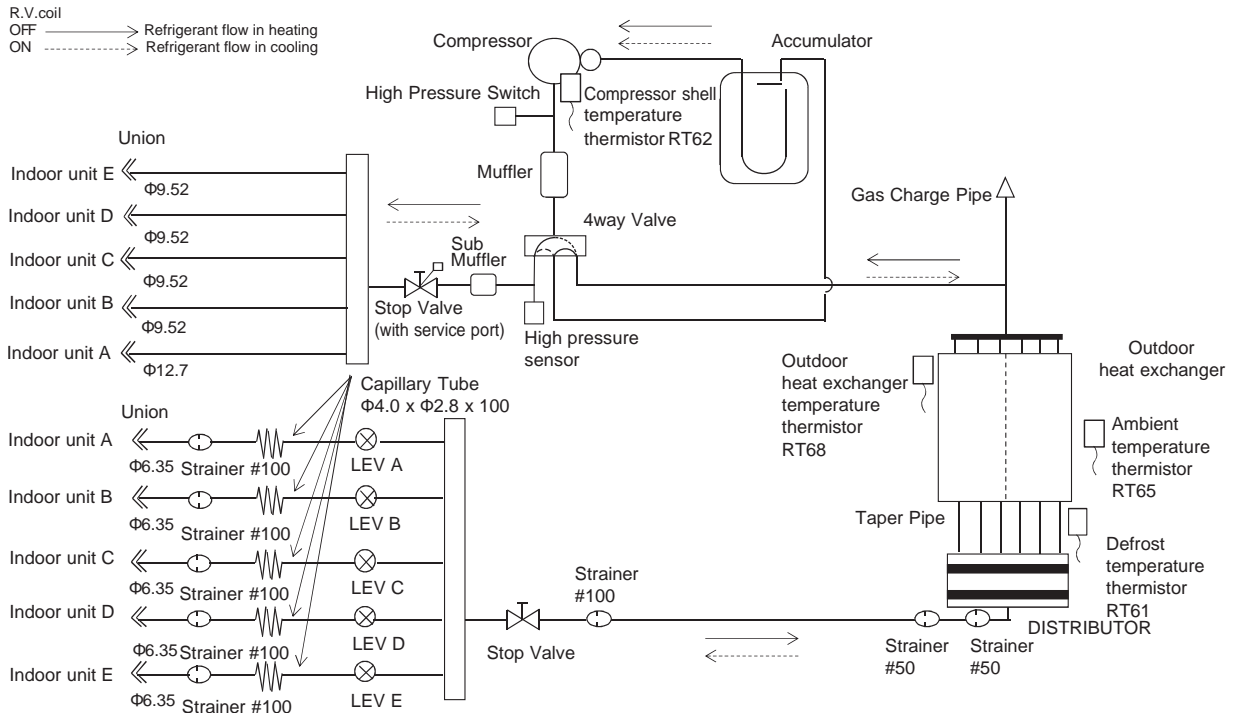

MULTI SYSTEM REFRIGERANT SYSTEM DIAGRAM

**C.4.4.2 Refrigerant Pipe Length and Pipe Size
MXZ-2F33VF4**

MAX REFRIGERANT PIPING LENGTH

Piping length each indoor unit (a, b)	15 m
Total piping length (a+b)	20 m
Bending point for each unit	15
Total bending point	20

*It is irrelevant which unit is higher.

ADDITIONAL REFRIGERANT CHARGE

Outdoor unit precharged (g)	Refrigerant piping length (one way, 2 unit total)
800	0

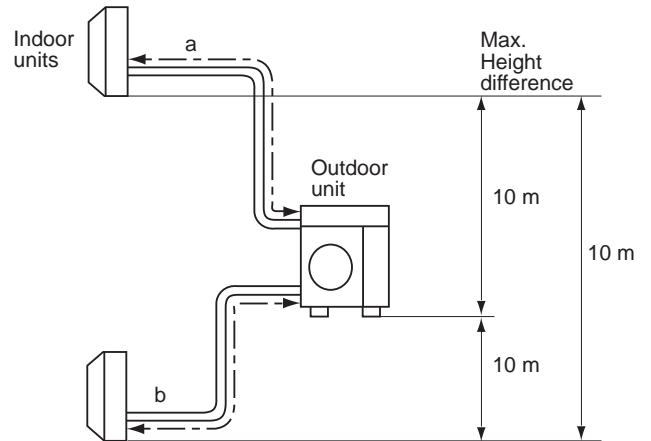

Unit: mm (inch)

- Refrigerant pipe diameter is different according to indoor unit to be connected. When using extension pipes, refer to the right table.

Outdoor unit union diameter		
For		
Indoor unit A	Liquid	6.35(1/4)
	Gas	9.52(3/8)
Indoor unit B	Liquid	6.35(1/4)
	Gas	9.52(3/8)

MXZ-2F42VF4 MXZ-2F53VF4 MXZ-2F53VFH4 MXZ-2HA40VF2 MXZ-2HA50VF2

MAX REFRIGERANT PIPING LENGTH

Piping length each indoor unit (a, b)	20 m
Total piping length (a+b)	30 m
Bending point for each unit	30
Total bending point	20

*It is irrelevant which unit is higher.

ADDITIONAL REFRIGERANT CHARGE

Model name	Outdoor unit precharged (g)	Refrigerant piping length (one way, 2 unit total)
		30 m
MXZ-2F42/53VF4 MXZ-2F53VFH4	1,000	0
MXZ-2HA40VF2 MXZ-2HA50VF2	900	0

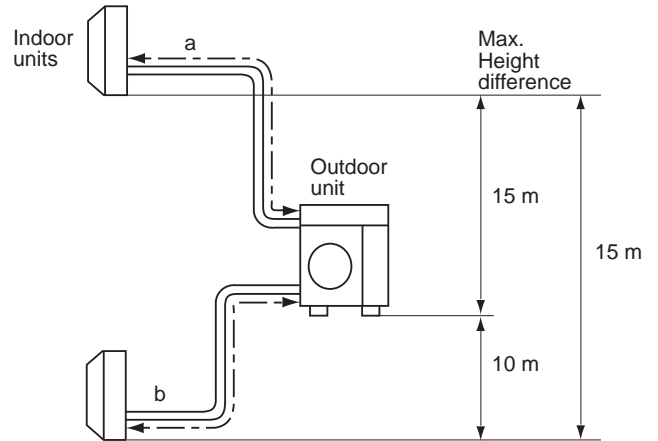

Unit: mm (inch)

- Refrigerant pipe diameter is different according to indoor unit to be connected. When using extension pipes, refer to the right table.
- For **MXZ-2F53VF4** and **MXZ-2F53VFH4** when diameter of refrigerant pipe is different from that of outdoor unit union, use optional Different-diameter pipe.

Outdoor unit union diameter		
For		
Indoor unit A	Liquid	6.35(1/4)
	Gas	9.52(3/8)
Indoor unit B	Liquid	6.35(1/4)
	Gas	9.52(3/8)

REFRIGERANT SYSTEM DIAGRAM

MULTI SYSTEM

MXZ-3F54VF4 MXZ-3HA50VF2

MAX REFRIGERANT PIPING LENGTH

Piping length each indoor unit (a, b, c)	25 m
Total piping length (a+b+c)	50 m
Bending point for each unit	25
Total bending point	50

*It is irrelevant which unit is higher.

ADDITIONAL REFRIGERANT CHARGE

MXZ-3F54VF4

Outdoor unit precharged (g)	Refrigerant piping length (one way, 3 unit total)	
	40 m	50 m
2,400	0	

MXZ-3HA50VF2

Outdoor unit precharged (g)	Refrigerant piping length (one way, 3 unit total)	
	40 m	50 m
1,400	0	200

Calculation: $Xg = 20 \text{ g/m} \times (\text{Refrigerant piping length (m)} - 40)$

- Refrigerant pipe diameter is different according to indoor unit to be connected. When using extension pipes, refer to the right table.
- When diameter of refrigerant pipe is different from that of outdoor unit union, use optional Different-diameter pipe.

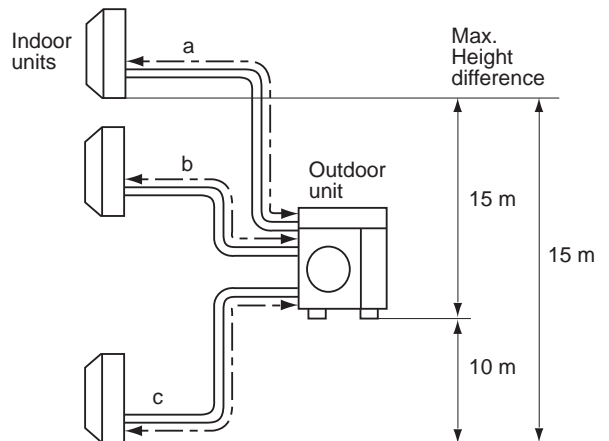

Unit: mm (inch)

Outdoor unit union diameter		
For		
Indoor unit A	Liquid	6.35(1/4)
	Gas	9.52(3/8)
Indoor unit B	Liquid	6.35(1/4)
	Gas	9.52(3/8)
Indoor unit C	Liquid	6.35(1/4)
	Gas	9.52(3/8)

MXZ-3F68VF4

MAX REFRIGERANT PIPING LENGTH

Piping length each indoor unit (a, b, c)	25 m
Total piping length (a+b+c)	60 m
Bending point for each unit	25
Total bending point	60

*It is irrelevant which unit is higher.

ADDITIONAL REFRIGERANT CHARGE

Outdoor unit precharged (g)	Refrigerant piping length (one way, 3 unit total)	
	40 m	60 m
2,400	0	

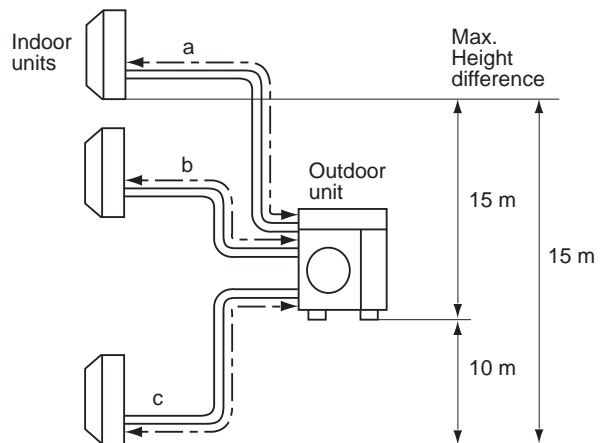

Unit: mm (inch)

Outdoor unit union diameter		
For		
Indoor unit A	Liquid	6.35(1/4)
	Gas	9.52(3/8)
Indoor unit B	Liquid	6.35(1/4)
	Gas	9.52(3/8)
Indoor unit C	Liquid	6.35(1/4)
	Gas	9.52(3/8)

- Refrigerant pipe diameter is different according to indoor unit to be connected. When using extension pipes, refer to the right table.
- When diameter of refrigerant pipe is different from that of outdoor unit union, use optional Different-diameter pipe.

MULTI SYSTEM REFRIGERANT SYSTEM DIAGRAM

MXZ-4F72VF4 MXZ-4F80VF4

MAX REFRIGERANT PIPING LENGTH

Piping length each indoor unit (a, b, c, d)	25 m
Total piping length (a+b+c+d)	60 m
Bending point for each unit	25
Total bending point	60

*It is irrelevant which unit is higher.

ADDITIONAL REFRIGERANT CHARGE

Outdoor unit precharged (g)	Refrigerant piping length (one way, 4 unit total)	
	60 m	
2,400	0	

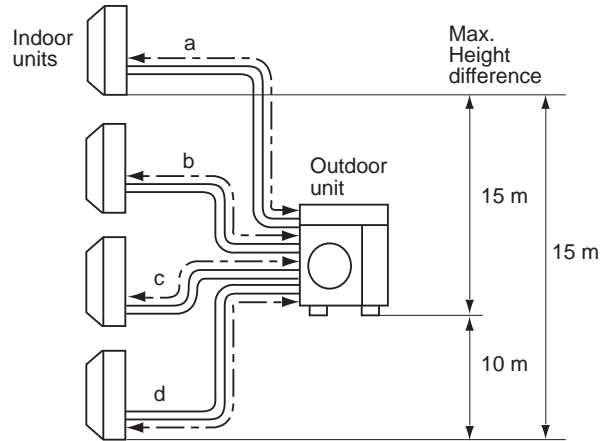

- Refrigerant pipe diameter is different according to indoor unit to be connected. When using extension pipes, refer to the right table.
- When diameter of refrigerant pipe is different from that of outdoor unit union, use optional Different-diameter pipe.

Unit: mm (inch)

Outdoor unit union diameter		
For		
Indoor unit A	Liquid	6.35(1/4)
	Gas	12.7(1/2)
Indoor unit B	Liquid	6.35(1/4)
	Gas	9.52(3/8)
Indoor unit C	Liquid	6.35(1/4)
	Gas	9.52(3/8)
Indoor unit D	Liquid	6.35(1/4)
	Gas	9.52(3/8)

MXZ-4F83VF2

MAX REFRIGERANT PIPING LENGTH

Piping length each indoor unit (a, b, c, d)	25 m
Total piping length (a+b+c+d)	70 m
Bending point for each unit	25
Total bending point	70

*It is irrelevant which unit is higher.

ADDITIONAL REFRIGERANT CHARGE

Outdoor unit precharged (g)	Refrigerant piping length (one way, 4 units total)	
	70 m	
2,400	0	

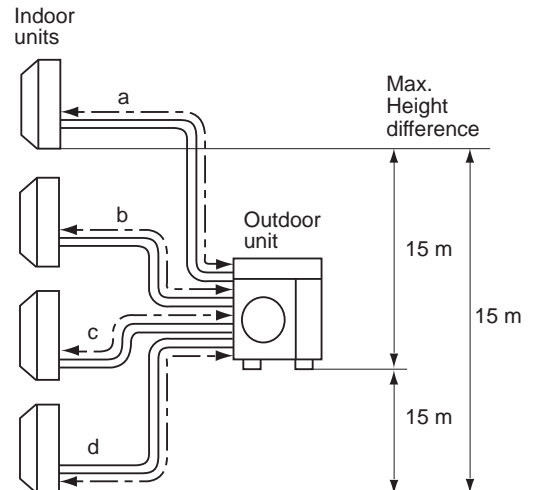

Unit: mm (inch)

Outdoor unit union diameter		
For		
Indoor unit A	Liquid	6.35(1/4)
	Gas	12.7(1/2)
Indoor unit B	Liquid	6.35(1/4)
	Gas	9.52(3/8)
Indoor unit C	Liquid	6.35(1/4)
	Gas	9.52(3/8)
Indoor unit D	Liquid	6.35(1/4)
	Gas	9.52(3/8)

- Refrigerant pipe diameter is different according to indoor unit to be connected. When using extension pipes, refer to the right table.
- When diameter of refrigerant pipe is different from that of outdoor unit union, use optional Different-diameter pipe.

REFRIGERANT SYSTEM DIAGRAM

MULTI SYSTEM

MXZ-5F102VF2

MAX REFRIGERANT PIPING LENGTH

Piping length each indoor unit (a, b, c, d, e)	25 m
Total piping length (a+b+c+d+e)	80 m
Bending point for each unit	25
Total bending point	80

*It is irrelevant which unit is higher.

ADDITIONAL REFRIGERANT CHARGE

Outdoor unit precharged (g)	Refrigerant piping length (one way, 5 units total)	
	80 m	
2,400	0	

- Refrigerant pipe diameter is different according to indoor unit to be connected. When using extension pipes, refer to the right table.
- When diameter of refrigerant pipe is different from that of outdoor unit union, use optional Different-diameter pipe.

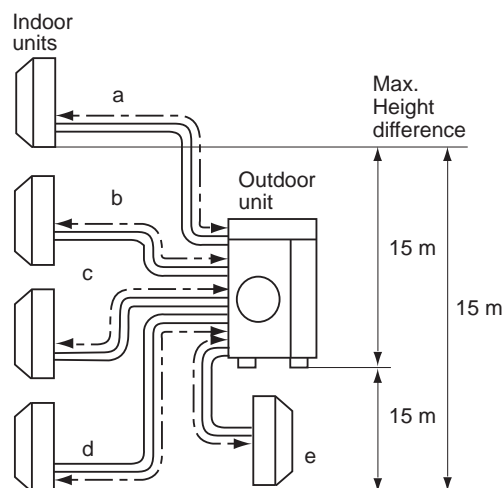

Unit: mm (inch)

Outdoor unit union diameter		
For		
Indoor unit A	Liquid	6.35(1/4)
	Gas	12.7(1/2)
Indoor unit B	Liquid	6.35(1/4)
	Gas	9.52(3/8)
Indoor unit C	Liquid	6.35(1/4)
	Gas	9.52(3/8)
Indoor unit D	Liquid	6.35(1/4)
	Gas	9.52(3/8)
Indoor unit E	Liquid	6.35(1/4)
	Gas	9.52(3/8)

MXZ-6F120VF2

MAX REFRIGERANT PIPING LENGTH

Piping length each indoor unit (a, b, c, d, e, f)	25 m
Total piping length (a+b+c+d+e+f)	80 m
Bending point for each unit	25
Total bending point	80

*It is irrelevant which unit is higher.

ADDITIONAL REFRIGERANT CHARGE

Outdoor unit precharged (g)	Refrigerant piping length (one way, 6 units total)	
	80 m	
2,400	0	

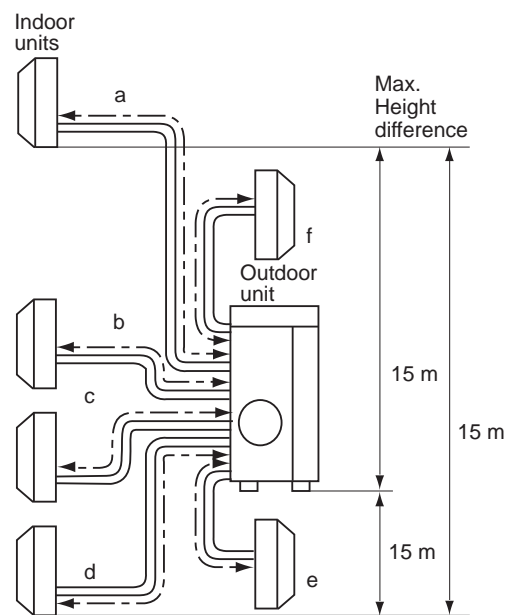

- Refrigerant pipe diameter is different according to indoor unit to be connected. When using extension pipes, refer to the tables below.
- When diameter of refrigerant pipe is different from that of outdoor unit union, use optional Different-diameter pipe.

Unit: mm (inch)

Outdoor unit union diameter			Outdoor unit union diameter		
For			For		
Indoor unit A	Liquid	6.35(1/4)	Indoor unit D	Liquid	6.35(1/4)
	Gas	12.7(1/2)		Gas	9.52(3/8)
Indoor unit B	Liquid	6.35(1/4)	Indoor unit E	Liquid	6.35(1/4)
	Gas	9.52(3/8)		Gas	9.52(3/8)
Indoor unit C	Liquid	6.35(1/4)	Indoor unit F	Liquid	6.35(1/4)
	Gas	9.52(3/8)		Gas	9.52(3/8)

MXZ-2F53VFH2

MAX REFRIGERANT PIPING LENGTH

Piping length each indoor unit (a, b)	20 m
Total piping length (a+b)	30 m
Bending point for each unit	20
Total bending point	30

*It is irrelevant which unit is higher.

ADDITIONAL REFRIGERANT CHARGE

Outdoor unit precharged (g)	Refrigerant piping length (one way, 2 units total)	
	30 m	
2,400	0	

- Refrigerant pipe diameter is different according to indoor unit to be connected. When using extension pipes, refer to the right table.
- When diameter of refrigerant pipe is different from that of outdoor unit union, use optional Different-diameter pipe.

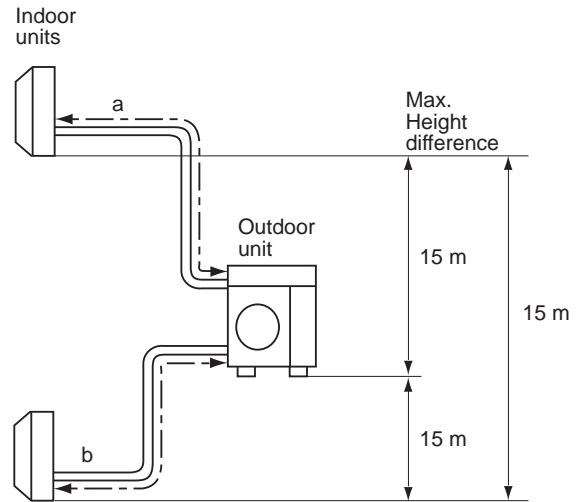

Unit: mm (inch)

Outdoor unit union diameter		
For		
Indoor unit A	Liquid	6.35(1/4)
	Gas	9.52(3/8)
Indoor unit B	Liquid	6.35(1/4)
	Gas	9.52(3/8)

MXZ-4F83VFH2

MAX REFRIGERANT PIPING LENGTH

Piping length each indoor unit (a, b, c, d)	25 m
Total piping length (a+b+c+d)	70 m
Bending point for each unit	25
Total bending point	70

*It is irrelevant which unit is higher.

ADDITIONAL REFRIGERANT CHARGE

Outdoor unit precharged (g)	Refrigerant piping length (one way, 4 units total)	
	70 m	
2,400	0	

- Refrigerant pipe diameter is different according to indoor unit to be connected. When using extension pipes, refer to the right table.
- When diameter of refrigerant pipe is different from that of outdoor unit union, use optional Different-diameter pipe.

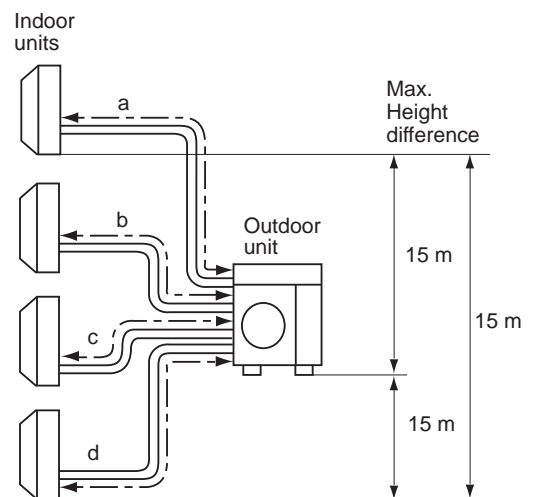

Unit: mm (inch)

Outdoor unit union diameter		
For		
Indoor unit A	Liquid	6.35(1/4)
	Gas	12.7(1/2)
Indoor unit B	Liquid	6.35(1/4)
	Gas	9.52(3/8)
Indoor unit C	Liquid	6.35(1/4)
	Gas	9.52(3/8)
Indoor unit D	Liquid	6.35(1/4)
	Gas	9.52(3/8)

MULTI SYSTEM REFRIGERANT SYSTEM DIAGRAM

MXZ-2D33VA

MAX REFRIGERANT PIPING LENGTH

Piping length each indoor unit (a, b)	15 m
Total piping length (a+b)	20 m
Bending point for each unit	15
Total bending point	20

*It is irrelevant which unit is higher.

ADDITIONAL REFRIGERANT CHARGE

Outdoor unit precharged (g)	Refrigerant piping length (one way, 2 unit total)	
	20 m	
1,150	0	

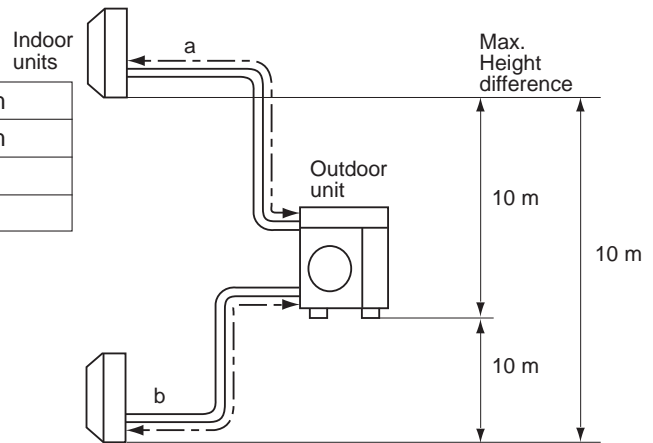

WHEN CONNECTING TO MFZ-KJ SERIES INDOOR UNIT

No. of MFZ-KJ indoor units	Refrigerant piping length (L)		Maximum amount of refrigerant
	~ 20 m		
None	Charge-less (1,150 g)		1,150 g
1 unit	100 g additional charge (1,250 g)		1,250 g
2 units	Not available		-

- Refrigerant pipe diameter is different according to indoor unit to be connected. When using extension pipes, refer to the right table.

Unit: mm (inch)

Outdoor unit union diameter		
For		
Indoor unit A	Liquid	6.35(1/4)
	Gas	9.52(3/8)
Indoor unit B	Liquid	6.35(1/4)
	Gas	9.52(3/8)

MXZ-2D42VA2 MXZ-2D53VA2 MXZ-2D53VAH2

MAX REFRIGERANT PIPING LENGTH

Piping length each indoor unit (a, b)	20 m
Total piping length (a+b)	30 m
Bending point for each unit	20
Total bending point	30

*It is irrelevant which unit is higher.

ADDITIONAL REFRIGERANT CHARGE

Outdoor unit precharged (g)	Refrigerant piping length (one way, 2 unit total)	
	20 m	30 m
1,300	0	200

Calculation : $Xg = 20 \text{ g/m} \times (\text{Refrigerant piping length(m)} - 20)$

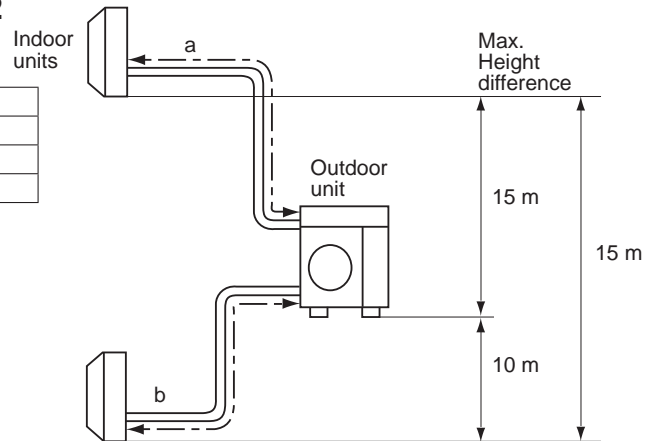

WHEN CONNECTING TO MFZ-KJ SERIES INDOOR UNIT

No. of MFZ-KJ indoor units	Refrigerant piping length (L)		Maximum amount of refrigerant
	~ 20 m	~ 30 m	
None	Charge-less (1,300 g)	$(L-20) \times 20 \text{ g/m}$	1,500 g
1 unit	100 g additional charge (1,400 g)	$100 \text{ g} + (L-20) \times 20 \text{ g/m}$	1,600 g
2 units	200 g additional charge (1,500 g)	$200 \text{ g} + (L-20) \times 20 \text{ g/m}$	1,700 g

- Refrigerant pipe diameter is different according to indoor unit to be connected. When using extension pipes, refer to the right table.
- When diameter of refrigerant pipe is different from that of outdoor unit union, use optional Different-diameter pipe.

Unit: mm (inch)

Outdoor unit union diameter		
For		
Indoor unit A	Liquid	6.35(1/4)
	Gas	9.52(3/8)
Indoor unit B	Liquid	6.35(1/4)
	Gas	9.52(3/8)

REFRIGERANT SYSTEM DIAGRAM

MULTI SYSTEM

MXZ-2E53VAHZ

MAX REFRIGERANT PIPING LENGTH

Piping length each indoor unit (a, b)	20 m
Total piping length (a+b)	30 m
Bending point for each unit	20
Total bending point	30

*It is irrelevant which unit is higher.

ADDITIONAL REFRIGERANT CHARGE

Outdoor unit precharged (g)	Refrigerant piping length (one way, 2 unit total)		
	20 m	25 m	30 m
2,000	0	100	200

Calculation : $Xg = 20 \text{ g/m} \times (\text{Refrigerant piping length (m)} - 20)$

- Refrigerant pipe diameter is different according to indoor unit to be connected. When using extension pipes, refer to the table below.
- When diameter of refrigerant pipe is different from that of outdoor unit union, use optional Different-diameter pipe.

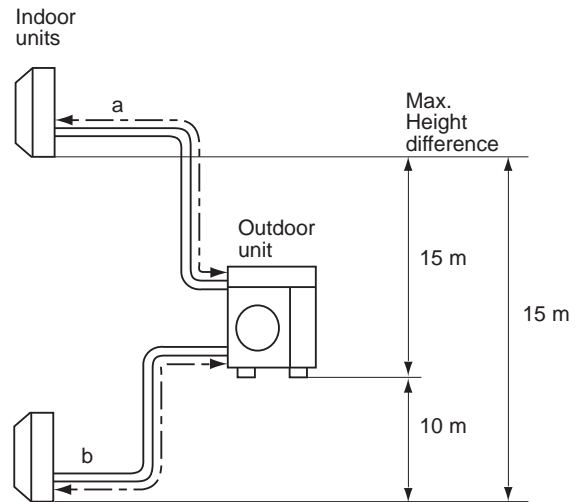

Unit: mm (inch)

Outdoor unit union diameter		
For		
Indoor unit A	Liquid	6.35(1/4)
	Gas	9.52(3/8)
Indoor unit B	Liquid	6.35(1/4)
	Gas	9.52(3/8)

MXZ-3E54VA MXZ-3E68VA

MAX REFRIGERANT PIPING LENGTH

	3E54	3E68
Piping length each indoor unit (a, b, c)	25 m	25 m
Total piping length (a+b+c)	50 m	60 m
Bending point for each unit	25	25
Total bending point	50	60

*It is irrelevant which unit is higher.

ADDITIONAL REFRIGERANT CHARGE

Outdoor unit precharged (g)	Refrigerant piping length (one way, 3 unit total)		
	40 m	50 m	60 m
2,700	0	200	400

Calculation : $Xg = 20 \text{ g/m} \times (\text{Refrigerant piping length (m)} - 40)$

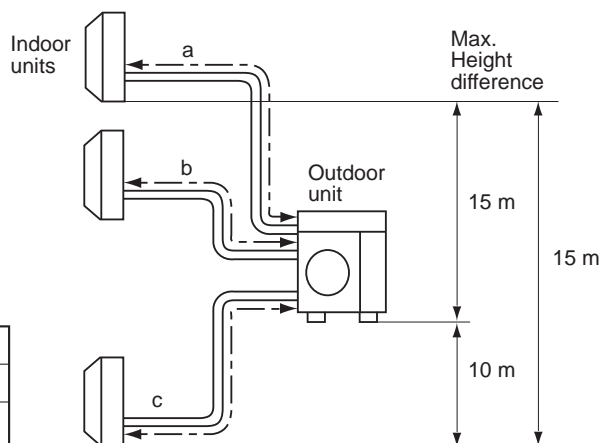

**WHEN CONNECTING TO MFZ-KJ SERIES INDOOR UNIT
MXZ-3E54VA**

No. of MFZ-KJ indoor units	Refrigerant piping length (L)		Maximum amount of refrigerant
	~ 40 m	~ 50 m	
None	Charge-less (2,700 g)	$(L-40) \times 20 \text{ g/m}$	2,900 g
1 unit	100 g additional charge (2,800 g)	$100 \text{ g} + (L-40) \times 20 \text{ g/m}$	3,000 g
2 units	200 g additional charge (2,900 g)	$200 \text{ g} + (L-40) \times 20 \text{ g/m}$	3,100 g
3 units	300 g additional charge (3,000 g)	$300 \text{ g} + (L-40) \times 20 \text{ g/m}$	3,200 g

**WHEN CONNECTING TO MFZ-KJ SERIES INDOOR UNIT
MXZ-3E68VA**

No. of MFZ-KJ indoor units	Refrigerant piping length (L)		Maximum amount of refrigerant
	~ 40 m	~ 60 m	
None	Charge-less (2,700 g)	$(L-40) \times 20 \text{ g/m}$	3,100 g
1 unit	100 g additional charge (2,800 g)	$100 \text{ g} + (L-40) \times 20 \text{ g/m}$	3,200 g
2 units	200 g additional charge (2,900 g)	$200 \text{ g} + (L-40) \times 20 \text{ g/m}$	3,300 g
3 units	300 g additional charge (3,000 g)	$300 \text{ g} + (L-40) \times 20 \text{ g/m}$	3,400 g

- Refrigerant pipe diameter is different according to indoor unit to be connected. When using extension pipes, refer to the table below.
- When diameter of refrigerant pipe is different from that of outdoor unit union, use optional Different-diameter pipe.

Unit: mm (inch)

Outdoor unit union diameter		
For		
Indoor unit A	Liquid	6.35(1/4)
	Gas	9.52(3/8)
Indoor unit B	Liquid	6.35(1/4)
	Gas	9.52(3/8)
Indoor unit C	Liquid	6.35(1/4)
	Gas	9.52(3/8)

REFRIGERANT SYSTEM DIAGRAM

MULTI SYSTEM

MXZ-4E72VA

MAX REFRIGERANT PIPING LENGTH

Piping length each indoor unit (a, b, c, d)	25 m
Total piping length (a+b+c+d)	60 m
Bending point for each unit	25
Total bending point	60

*It is irrelevant which unit is higher.

ADDITIONAL REFRIGERANT CHARGE

Outdoor unit precharged (g)	Refrigerant piping length (one way, 4 unit total)		
	40 m	50 m	60 m
2,700	0	200	400

Calculation : $Xg = 20 \text{ g/m} \times (\text{Refrigerant piping length (m)} - 40)$

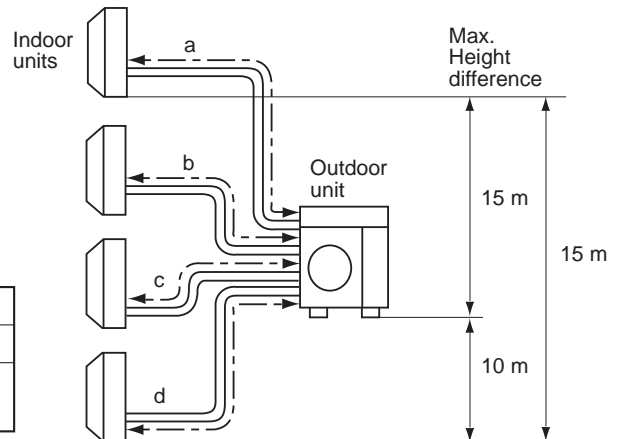

WHEN CONNECTING TO MFZ-KJ SERIES INDOOR UNIT

No. of MFZ-KJ indoor units	Refrigerant piping length (L)		Maximum amount of refrigerant
	~ 40 m	~ 60 m	
None	Charge-less (2,700 g)	$(L-40) \times 20 \text{ g/m}$	3,100 g
1 unit	100 g additional charge (2,800 g)	$100 \text{ g} + (L-40) \times 20 \text{ g/m}$	3,200 g
2 units	200 g additional charge (2,900 g)	$200 \text{ g} + (L-40) \times 20 \text{ g/m}$	3,300 g
3 units	300 g additional charge (3,000 g)	$300 \text{ g} + (L-40) \times 20 \text{ g/m}$	3,400 g
4 units	400 g additional charge (3,100 g)	$400 \text{ g} + (L-40) \times 20 \text{ g/m}$	3,500 g

- Refrigerant pipe diameter is different according to indoor unit to be connected. When using extension pipes, refer to the table below.
- When diameter of refrigerant pipe is different from that of outdoor unit union, use optional Different-diameter pipe.

Outdoor unit union diameter		Unit: mm (inch)			
		For		For	
Indoor unit A	Liquid	6.35(1/4)	Indoor unit C	Liquid	6.35(1/4)
	Gas	12.7(1/2)		Gas	9.52(3/8)
Indoor unit B	Liquid	6.35(1/4)	Indoor unit D	Liquid	6.35(1/4)
	Gas	9.52(3/8)		Gas	9.52(3/8)

MULTI SYSTEM REFRIGERANT SYSTEM DIAGRAM

MXZ-4E83VA

MAX REFRIGERANT PIPING LENGTH

Piping length each indoor unit (a, b, c, d)	25 m
Total piping length (a+b+c+d)	70 m
Bending point for each unit	25
Total bending point	70

*It is irrelevant which unit is higher.

ADDITIONAL REFRIGERANT CHARGE

Outdoor unit precharged (g)	Refrigerant piping length (one way, 4 unit total)			
	25 m	40 m	55 m	70 m
2,990	0	300	600	900

Calculation : $Xg = 20 \text{ g/m} \times (\text{Refrigerant piping length (m)} - 25)$

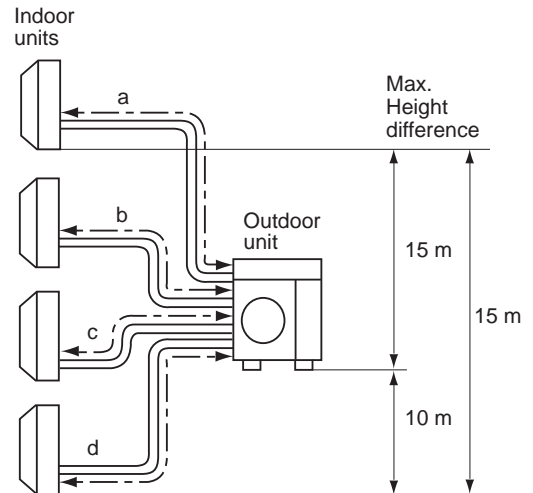

- Refrigerant pipe diameter is different according to indoor unit to be connected. When using extension pipes, refer to the table below.
- When diameter of refrigerant pipe is different from that of outdoor unit union, use optional Different-diameter pipe.

Unit: mm (inch)

Outdoor unit union diameter			Outdoor unit union diameter		
For			For		
Indoor unit A	Liquid	6.35(1/4)	Indoor unit C	Liquid	6.35(1/4)
	Gas	12.7(1/2)		Gas	9.52(3/8)
Indoor unit B	Liquid	6.35(1/4)	Indoor unit D	Liquid	6.35(1/4)
	Gas	9.52(3/8)		Gas	9.52(3/8)

MXZ-4E83VAHZ

MAX REFRIGERANT PIPING LENGTH

Piping length each indoor unit (a, b, c, d)	25 m
Total piping length (a+b+c+d)	70 m
Bending point for each unit	25
Total bending point	70

*It is irrelevant which unit is higher.

ADDITIONAL REFRIGERANT CHARGE

Outdoor unit precharged (g)	Refrigerant piping length (one way, 4 unit total)			
	25 m	40 m	55 m	70 m
3,900	0	300	600	900

Calculation : $Xg = 20 \text{ g/m} \times (\text{Refrigerant piping length (m)} - 25)$

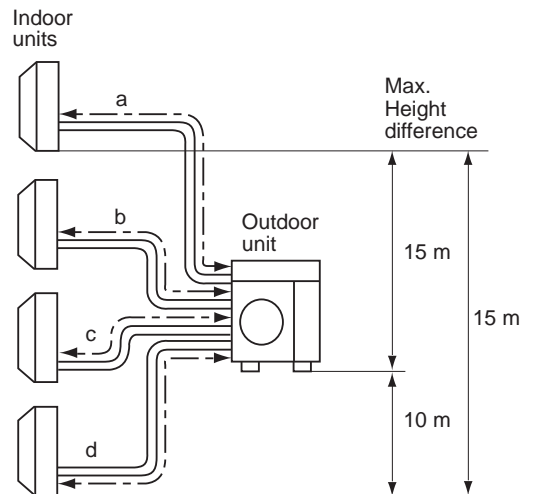

- Refrigerant pipe diameter is different according to indoor unit to be connected. When using extension pipes, refer to the table below.
- When diameter of refrigerant pipe is different from that of outdoor unit union, use optional Different-diameter pipe.

Unit: mm (inch)

Outdoor unit union diameter			Outdoor unit union diameter		
For			For		
Indoor unit A	Liquid	6.35(1/4)	Indoor unit C	Liquid	6.35(1/4)
	Gas	12.7(1/2)		Gas	9.52(3/8)
Indoor unit B	Liquid	6.35(1/4)	Indoor unit D	Liquid	6.35(1/4)
	Gas	9.52(3/8)		Gas	9.52(3/8)

REFRIGERANT SYSTEM DIAGRAM

MULTI SYSTEM

MXZ-5E102VA

MAX REFRIGERANT PIPING LENGTH

Piping length each indoor unit (a, b, c, d,e)	25 m
Total piping length (a+b+c+d+e)	80 m
Bending point for each unit	25
Total bending point	80

*It is irrelevant which unit is higher.

ADDITIONAL REFRIGERANT CHARGE

Outdoor unit precharged (g)	Refrigerant piping length (one way, 5 unit total)				
	0 m	20 m	40 m	60 m	80 m
2,990	0	400	800	1,200	1,600

Calculation : $Xg = 20 \text{ g/m} \times (\text{Refrigerant piping length (m)} - 0)$

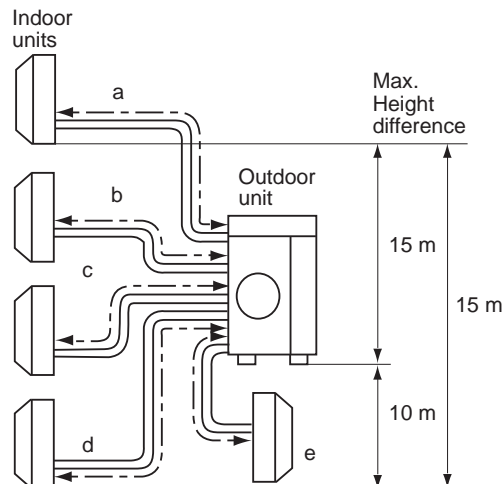

- Refrigerant pipe diameter is different according to indoor unit to be connected. When using extension pipes, refer to the table below.
- When diameter of refrigerant pipe is different from that of outdoor unit union, use optional Different-diameter pipe.

Unit: mm (inch)

Outdoor unit union diameter			Outdoor unit union diameter		
For			For		
Indoor unit A	Liquid	6.35(1/4)	Indoor unit D	Liquid	6.35(1/4)
	Gas	12.7(1/2)		Gas	9.52(3/8)
Indoor unit B	Liquid	6.35(1/4)	Indoor unit E	Liquid	6.35(1/4)
	Gas	9.52(3/8)		Gas	9.52(3/8)
Indoor unit C	Liquid	6.35(1/4)			
	Gas	9.52(3/8)			

MXZ-6D122VA2

MAX REFRIGERANT PIPING LENGTH

Piping length each indoor unit (a, b, c, d, e)	25 m
Total piping length (a+b+c+d+e)	80 m
Bending point for each unit	25
Total bending point	80

*It is irrelevant which unit is higher.

ADDITIONAL REFRIGERANT CHARGE

Outdoor unit precharged (g)	Refrigerant piping length (one way, 5 unit total)				
	40 m	50 m	60 m	70 m	80 m
4,000	200	400	600	800	1000

Calculation : $Xg = 20 \text{ g/m} \times (\text{Refrigerant piping length (m)} - 30)$

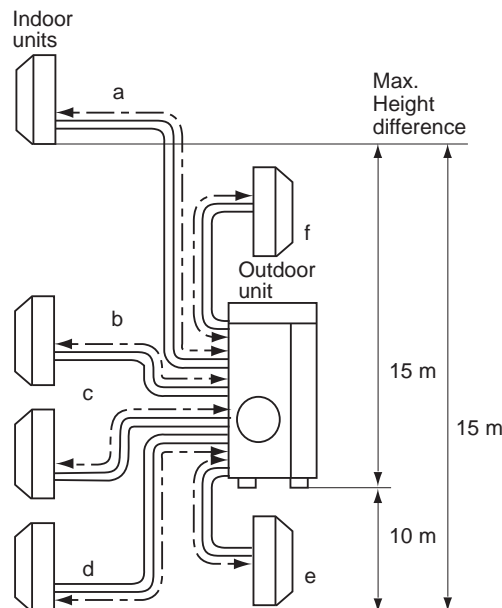

- Refrigerant pipe diameter is different according to indoor unit to be connected. When using extension pipes, refer to the table below.
- When diameter of refrigerant pipe is different from that of outdoor unit union, use optional Different-diameter pipe.

Unit: mm (inch)

Outdoor unit union diameter			Outdoor unit union diameter		
For			For		
Indoor unit A	Liquid	6.35(1/4)	Indoor unit D	Liquid	6.35(1/4)
	Gas	12.7(1/2)		Gas	9.52(3/8)
Indoor unit B	Liquid	6.35(1/4)	Indoor unit E	Liquid	6.35(1/4)
	Gas	9.52(3/8)		Gas	9.52(3/8)
Indoor unit C	Liquid	6.35(1/4)	Indoor unit F	Liquid	6.35(1/4)
	Gas	9.52(3/8)		Gas	9.52(3/8)

MXZ-2DM40VA

MAX REFRIGERANT PIPING LENGTH

Piping length each indoor unit (a, b)	20 m
Total piping length (a+b)	30 m
Bending point for each unit	20
Total bending point	30

*It is irrelevant which unit is higher.

ADDITIONAL REFRIGERANT CHARGE

Outdoor unit precharged (g)	Refrigerant piping length (one way, 2 unit total)	
	20 m	30 m
950	0	200

Calculation : $Xg = 20 \text{ g/m} \times (\text{Refrigerant piping length (m)} - 20)$

- Refrigerant pipe diameter is different according to indoor unit to be connected. When using extension pipes, refer to the right table.
- When diameter of refrigerant pipe is different from that of outdoor unit union, use optional Different-diameter pipe.

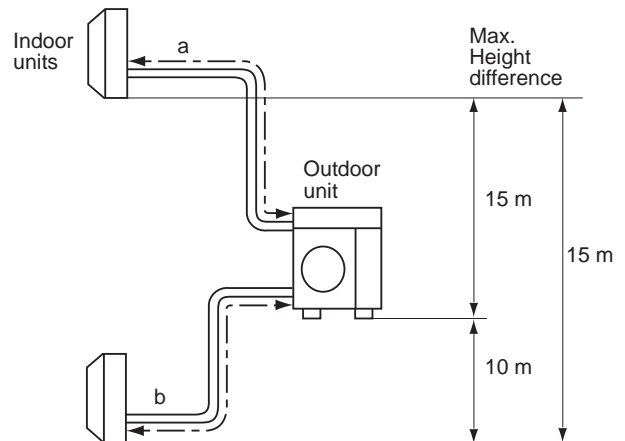

Unit: mm (inch)

Outdoor unit union diameter		
For		
Indoor unit A	Liquid	6.35(1/4)
	Gas	9.52(3/8)
Indoor unit B	Liquid	6.35(1/4)
	Gas	9.52(3/8)

MXZ-3DM50VA

MAX REFRIGERANT PIPING LENGTH

Piping length each indoor unit (a, b, c)	25 m
Total piping length (a+b+c)	50 m
Bending point for each unit	25
Total bending point	50

*It is irrelevant which unit is higher.

ADDITIONAL REFRIGERANT CHARGE

Outdoor unit precharged (g)	Refrigerant piping length (one way, 3 unit total)	
	40 m	50 m
2,700	0	200

Calculation : $Xg = 20 \text{ g/m} \times (\text{Refrigerant piping length (m)} - 40)$

- Refrigerant pipe diameter is different according to indoor unit to be connected. When using extension pipes, refer to the right table.
- When diameter of refrigerant pipe is different from that of outdoor unit union, use optional Different-diameter pipe.

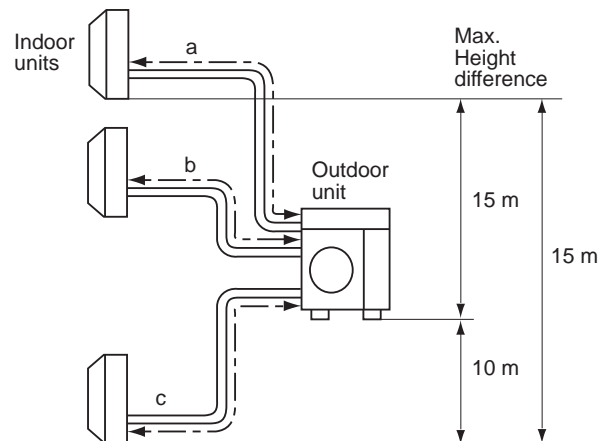

Unit: mm (inch)

Outdoor unit union diameter		
For		
Indoor unit A	Liquid	6.35(1/4)
	Gas	9.52(3/8)
Indoor unit B	Liquid	6.35(1/4)
	Gas	9.52(3/8)
Indoor unit C	Liquid	6.35(1/4)
	Gas	9.52(3/8)

MULTI SYSTEM REFRIGERANT SYSTEM DIAGRAM

PXZ-4F75VG

MAX REFRIGERANT PIPING LENGTH

Piping length each indoor unit (a, b, c, d)	30 m
Total piping length (a+b+c+d)	60 m
Bending point for each unit	25
Total bending point	60

*It is irrelevant which unit is higher.

ADDITIONAL REFRIGERANT CHARGE

Outdoor unit precharged (g)	Refrigerant piping length (one way, 4 unit total)
	60 m
2,400	0

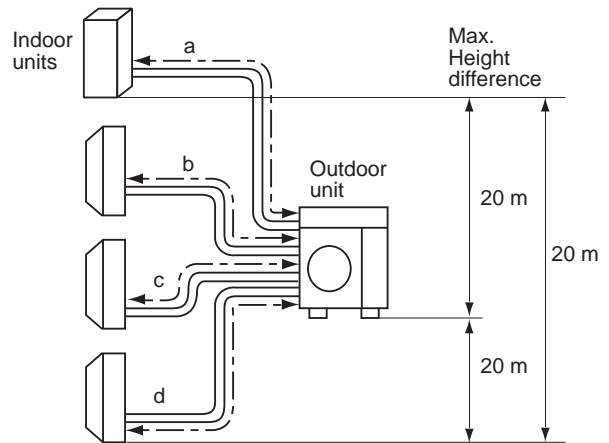

a: Cylinder unit / Hydrobox / DHW tank or ATA indoor unit
b/c/d: ATA indoor unit

- Refrigerant pipe diameter is different according to indoor unit to be connected. When using extension pipes, refer to the right table.
- When diameter of refrigerant pipe is different from that of outdoor unit union, use optional Different-diameter pipe.

Unit: mm (inch)

Outdoor unit union diameter		
For		
Indoor unit A	Liquid	6.35(1/4)
	Gas	12.7(1/2)
Indoor unit B	Liquid	6.35(1/4)
	Gas	9.52(3/8)
Indoor unit C	Liquid	6.35(1/4)
	Gas	9.52(3/8)
Indoor unit D	Liquid	6.35(1/4)
	Gas	9.52(3/8)

PXZ-5F85VG

MAX REFRIGERANT PIPING LENGTH

Piping length each indoor unit (a, b, c, d, e)	30 m
Total piping length (a+b+c+d+e)	70 m
Bending point for each unit	25
Total bending point	70

*It is irrelevant which unit is higher.

ADDITIONAL REFRIGERANT CHARGE

Outdoor unit precharged (g)	Refrigerant piping length (one way, 5 unit total)
	70 m
2,400	0

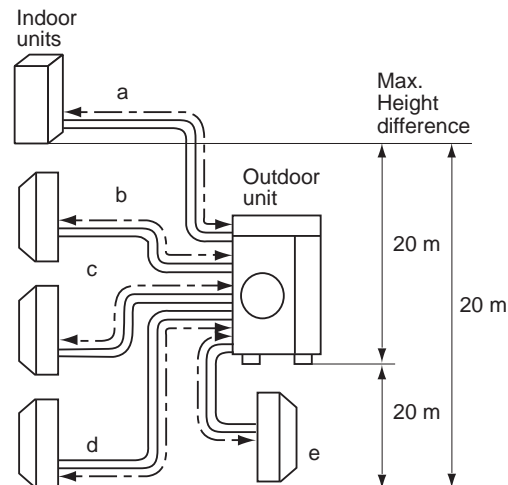

a: Cylinder unit / Hydrobox / DHW tank or ATA indoor unit
b/c/d: ATA indoor unit

Unit: mm (inch)

Outdoor unit union diameter		
For		
Indoor unit A	Liquid	6.35(1/4)
	Gas	12.7(1/2)
Indoor unit B	Liquid	6.35(1/4)
	Gas	9.52(3/8)
Indoor unit C	Liquid	6.35(1/4)
	Gas	9.52(3/8)
Indoor unit D	Liquid	6.35(1/4)
	Gas	9.52(3/8)
Indoor unit E	Liquid	6.35(1/4)
	Gas	9.52(3/8)

- Refrigerant pipe diameter is different according to indoor unit to be connected. When using extension pipes, refer to the right table.
- When diameter of refrigerant pipe is different from that of outdoor unit union, use optional Different-diameter pipe.

REFRIGERANT SYSTEM DIAGRAM

MULTI SYSTEM

C.4.5 PERFORMANCE CURVES

C.4.5.1 Inverter Heat Pump

CAPACITY AND THE INPUT CURVES

MXZ-2F33VF4 MXZ-2F42VF4 MXZ-2F53VF4 MXZ-2F53VFH4

5.8	4.1	7.4	5.2	5.9	8.7	11.1	12.8
5.4	3.8	6.8	4.8	5.5	8.0	10.2	11.6
4.9	3.5	6.2	4.4	5.0	7.3	9.3	10.5
4.5	3.2	5.7	4.0	4.6	6.6	8.3	9.5
4.0	2.9	5.1	3.6	4.1	5.9	7.5	8.5
3.6	2.6	4.5	3.2	3.7	5.3	6.6	7.5
3.2	2.3	4.0	2.8	3.2	4.6	5.8	6.6
2.8	2.0	3.5	2.4	2.8	4.0	5.0	5.6
15 class	18 class	20 class	22 class	25 class	35 class (MXZ-2F42F3)	42 class (MXZ-2F53)	50 class (MXZ-2F53)

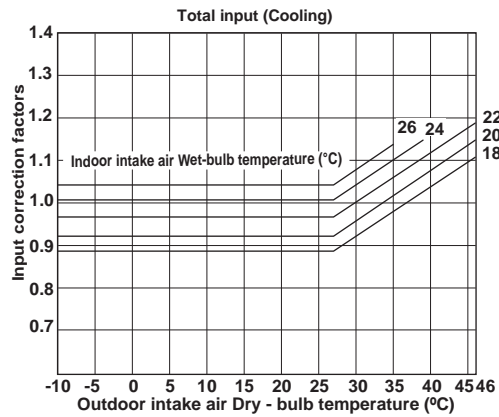
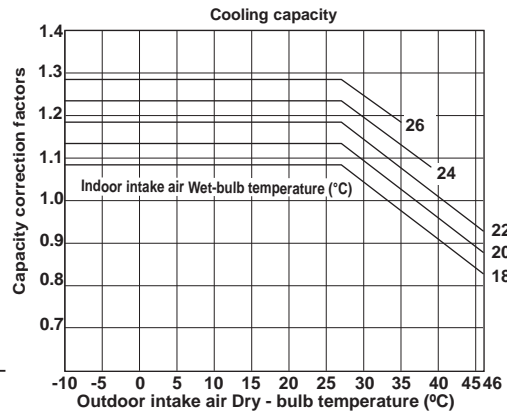

17.6	19.5	21.2	19.5	21.3	22.2	26.6	26.7
16.3	18.1	19.7	18.1	19.8	20.6	24.7	24.8
15.1	16.7	18.2	16.7	18.3	19.0	22.8	22.9
13.8	15.3	16.7	15.3	16.7	17.4	20.9	21.0
12.6	13.9	15.2	13.9	15.2	15.8	19.0	19.1
11.3	12.6	13.6	12.6	13.7	14.3	17.1	17.1
10.1	11.2	12.1	11.2	12.2	12.7	15.2	15.2
8.8	9.8	10.6	9.8	10.7	11.1	13.3	13.3
7.5	8.4	9.1	8.4	9.1	9.5	11.4	11.4
6.3	7.0	7.6	7.0	7.6	7.9	9.5	9.5
5.0	5.6	6.1	5.6	6.1	6.3	7.6	7.6
15 class	18 class	20 class	22 class	25 class	35 class (MXZ-2F42F3)	42 class (MXZ-2F53)	50 class (MXZ-2F53)

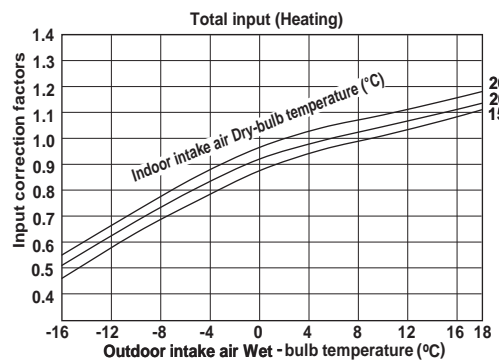
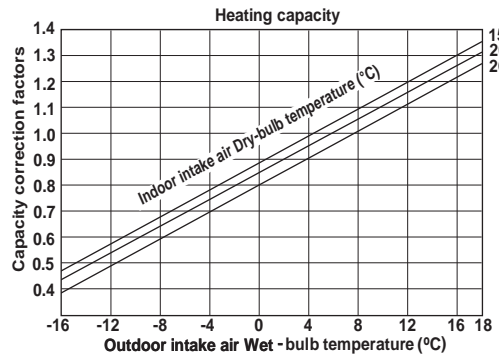

MXZ-3F54VF4 MXZ-3F68VF4 MXZ-4F72VF4 MXZ-4F80VF4

5.8	4.1	7.4	5.2	5.9	8.7	11.1	12.8	8.7
5.4	3.8	6.8	4.8	5.5	8.0	10.2	11.6	8.0
4.9	3.5	6.2	4.4	5.0	7.3	9.3	10.5	7.3
4.5	3.2	5.7	4.0	4.6	6.6	8.3	9.5	6.6
4.0	2.9	5.1	3.6	4.1	5.9	7.5	8.5	5.9
3.6	2.6	4.5	3.2	3.7	5.3	6.6	7.5	5.3
3.2	2.3	4.0	2.8	3.2	4.6	5.8	6.6	4.6
2.8	2.0	3.5	2.4	2.8	4.0	5.0	5.6	4.0
15 class	18 class	20 class	22 class	25 class	35 class	42 class	50 class	60 class

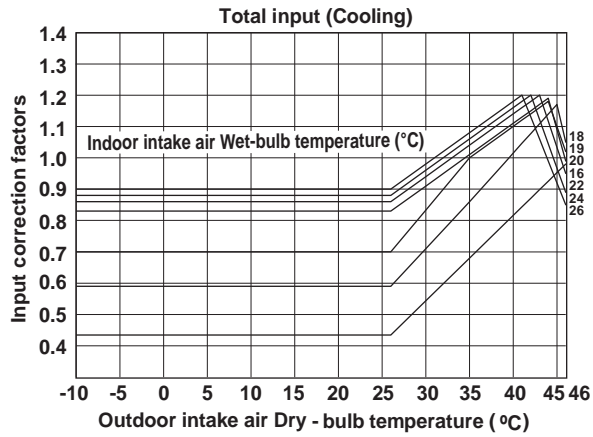
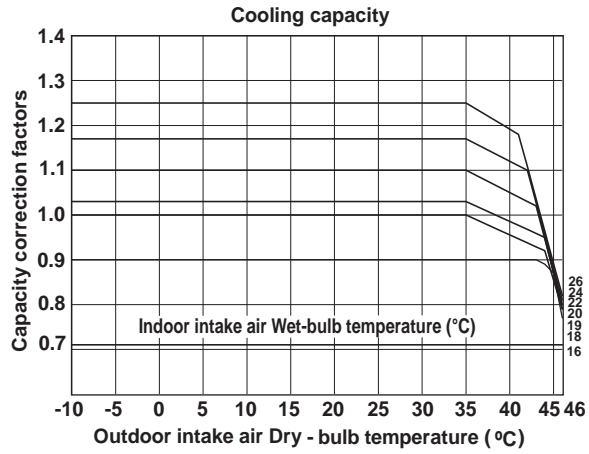

17.6	19.5	21.2	19.5	21.3	22.2	29.9	38.4	30.9
16.3	18.1	19.7	18.1	19.8	20.6	27.8	35.7	28.7
15.1	16.7	18.2	16.7	18.3	19.0	25.7	32.9	26.5
13.8	15.3	16.7	15.3	16.7	17.4	23.5	30.2	24.3
12.6	13.9	15.2	13.9	15.2	15.8	21.4	27.4	22.1
11.3	12.6	13.6	12.6	13.7	14.3	19.2	24.7	19.9
10.1	11.2	12.1	11.2	12.2	12.7	17.1	21.9	17.7
8.8	9.8	10.6	9.8	10.7	11.1	15.0	19.2	15.5
7.5	8.4	9.1	8.4	9.1	9.5	12.8	16.5	13.2
6.3	7.0	7.6	7.0	7.6	7.9	10.7	13.7	11.0
5.0	5.6	6.1	5.6	6.1	6.3	8.6	11.0	8.8
15 class	18 class	20 class	22 class	25 class	35 class	42 class	50 class	60 class

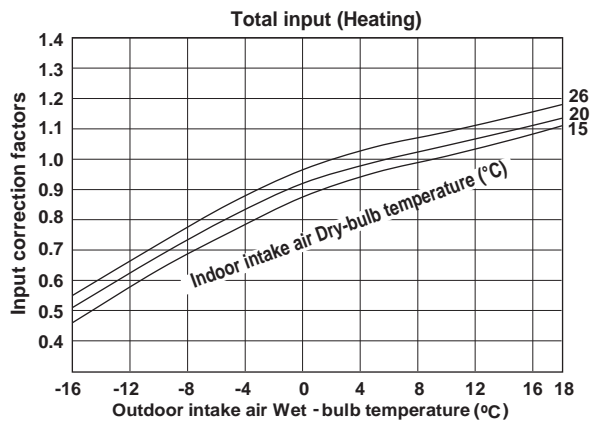
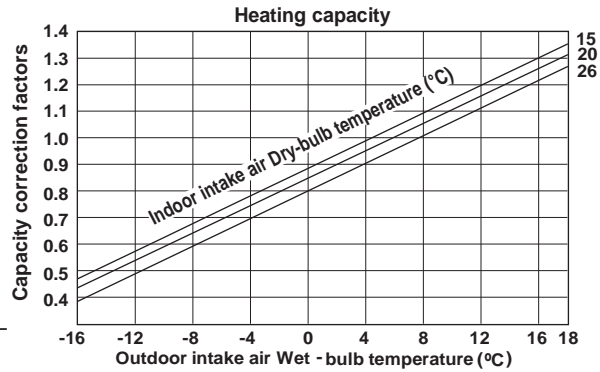

PERFORMANCE CURVES

MULTI SYSTEM

MXZ-4F83VF2 MXZ-5F102VF2

5.4	3.8	6.8	4.8	5.0	7.3	9.0	9.9	8.2	8.6
4.9	3.5	6.2	4.4	4.6	6.7	8.2	9.0	7.5	7.9
4.5	3.2	5.7	4.0	4.2	6.0	7.4	8.1	6.8	7.1
4.0	2.9	5.1	3.6	3.8	5.4	6.7	7.3	6.1	6.4
3.6	2.6	4.5	3.2	3.4	5.8	5.9	6.4	5.4	5.7
3.2	2.3	4.0	2.8	3.0	4.2	5.2	5.6	4.7	5.0
2.8	2.0	3.5	2.5	2.6	3.7	4.5	4.9	4.1	4.3
15 class	18 class	20 class	22 class	25 class	35 class	42 class	50 class	60 class	71 class

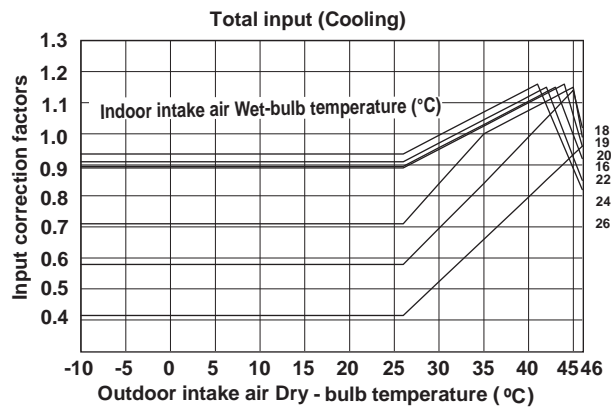
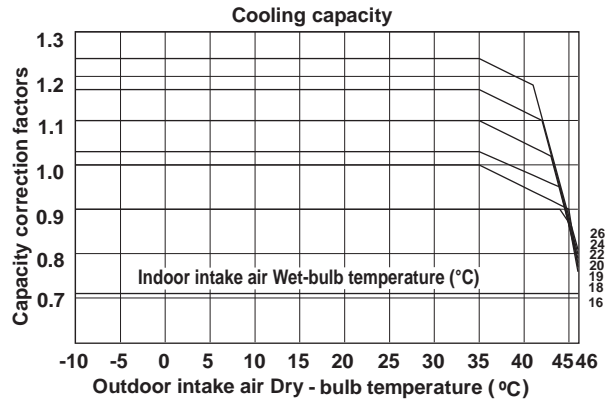

17.9	19.2	21.5	19.2	17.7	22.1	27.5	29.5	27.0	28.9
16.6	17.8	20.5	17.8	16.4	20.6	25.6	27.5	25.0	26.9
15.3	16.5	18.4	16.5	15.2	19.0	23.6	25.4	23.1	24.8
14.0	15.1	16.9	15.1	13.9	17.4	21.6	23.2	21.2	22.7
12.9	13.9	15.6	13.9	12.8	16.0	19.9	21.4	19.5	20.9
11.6	12.5	14.0	12.5	11.5	14.4	17.9	19.2	17.5	18.8
10.3	11.1	12.4	11.1	10.2	12.8	15.9	17.1	15.6	16.7
9.0	9.7	10.9	9.7	9.0	11.2	13.9	15.0	13.6	14.6
7.8	8.4	9.4	8.4	7.8	9.7	12.1	13.0	11.8	12.7
6.5	7.0	7.9	7.0	6.5	8.1	10.1	10.8	9.9	10.6
5.2	5.5	6.3	5.6	5.2	6.5	8.1	8.7	7.9	8.5
15 class	18 class	20 class	22 class	25 class	35 class	42 class	50 class	60 class	71 class

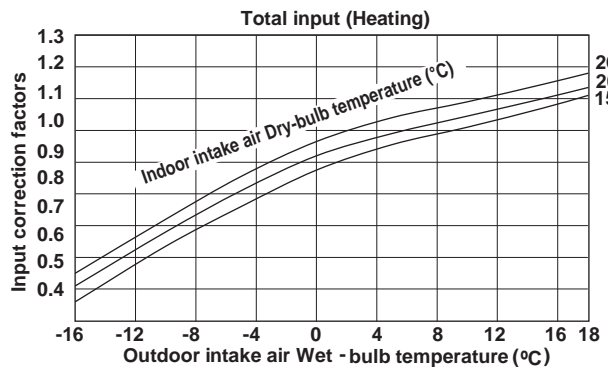
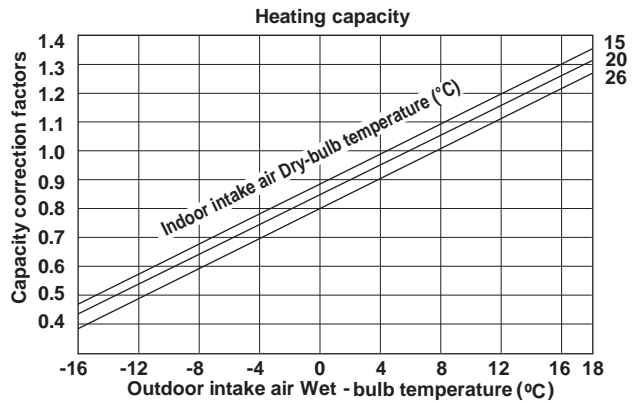

MULTI SYSTEM PERFORMANCE CURVES

MXZ-6F120VF2

5.4	3.8	6.8	4.8	5.0	7.3	9.0	9.9	8.2	8.6
4.9	3.5	6.2	4.4	4.6	6.7	8.2	9.0	7.5	7.9
4.5	3.2	5.7	4.0	4.2	6.0	7.4	8.1	6.8	7.1
4.0	2.9	5.1	3.6	3.8	5.4	6.7	7.3	6.1	6.4
3.6	2.6	4.5	3.2	3.4	5.8	5.9	6.4	5.4	5.7
3.2	2.3	4.0	2.8	3.0	4.2	5.2	5.6	4.7	5.0
2.8	2.0	3.5	2.5	2.6	3.7	4.5	4.9	4.1	4.3
15 class	18 class	20 class	22 class	25 class	35 class	42 class	50 class	60 class	71 class

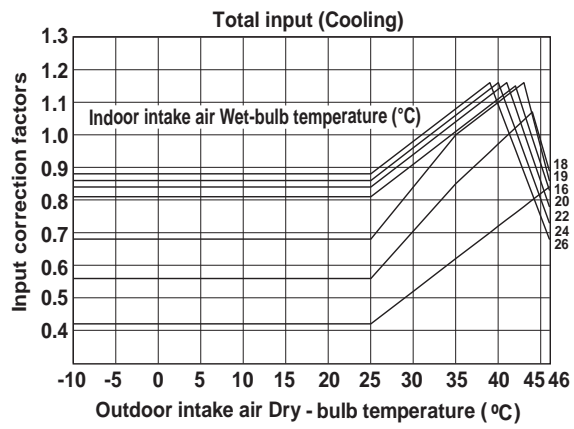
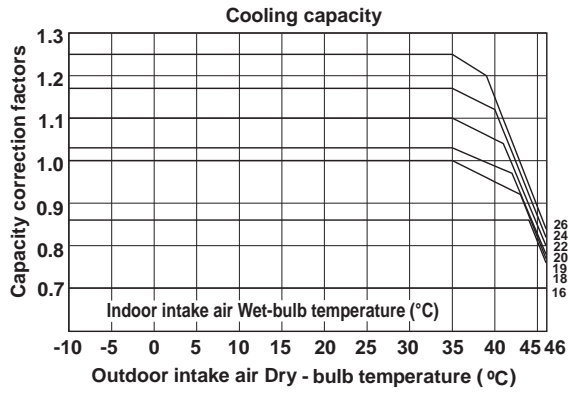

17.9	19.2	21.5	19.2	17.7	22.1	27.5	29.5	27.0	28.9
16.6	17.8	20.5	17.8	16.4	20.6	25.6	27.5	25.0	26.9
15.3	16.5	18.4	16.5	15.2	19.0	23.6	25.4	23.1	24.8
14.0	15.1	16.9	15.1	13.9	17.4	21.6	23.2	21.2	22.7
12.9	13.9	15.6	13.9	12.8	16.0	19.9	21.4	19.5	20.9
11.6	12.5	14.0	12.5	11.5	14.4	17.9	19.2	17.5	18.8
10.3	11.1	12.4	11.1	10.2	12.8	15.9	17.1	15.6	16.7
9.0	9.7	10.9	9.7	9.0	11.2	13.9	15.0	13.6	14.6
7.8	8.4	9.4	8.4	7.8	9.7	12.1	13.0	11.8	12.7
6.5	7.0	7.9	7.0	6.5	8.1	10.1	10.8	9.9	10.6
5.2	5.5	6.3	5.6	5.2	6.5	8.1	8.7	7.9	8.5
15 class	18 class	20 class	22 class	25 class	35 class	42 class	50 class	60 class	71 class

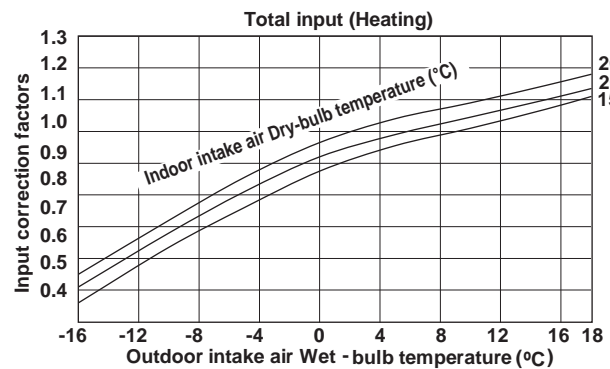
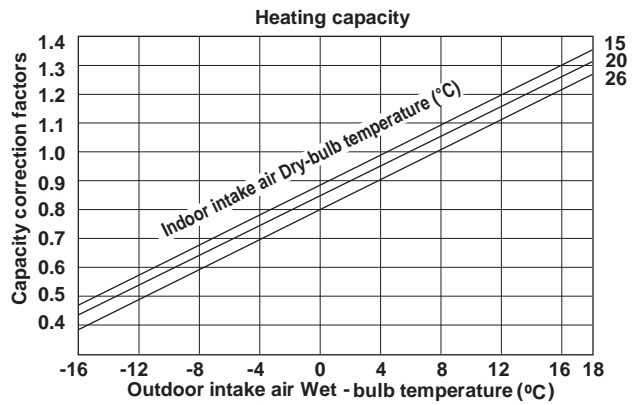

PERFORMANCE CURVES

MULTI SYSTEM

MXZ-2F53VFH22

5.4	3.8	6.8	4.8	5.0	7.3	9.0	9.9
4.9	3.5	6.2	4.4	4.6	6.7	8.2	9.0
4.5	3.2	5.7	4.0	4.2	6.0	7.4	8.1
4.0	2.9	5.1	3.6	3.8	5.4	6.7	7.3
3.6	2.6	4.5	3.2	3.4	4.8	5.9	6.4
3.2	2.3	4.0	2.8	3.0	4.2	5.2	5.6
2.8	2.0	3.5	2.5	2.6	3.7	4.5	4.9
15 class	18 class	20 class	22 class	25 class	35 class	42 class	50 class

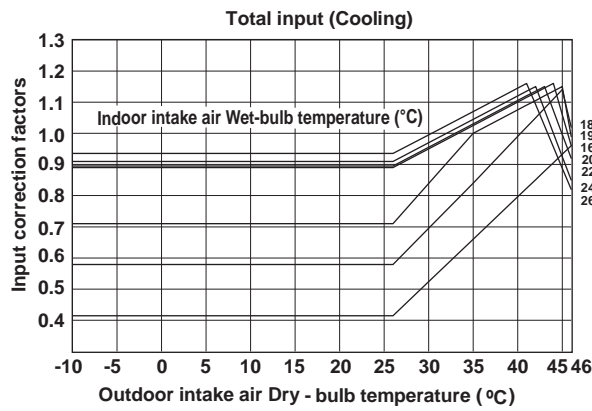
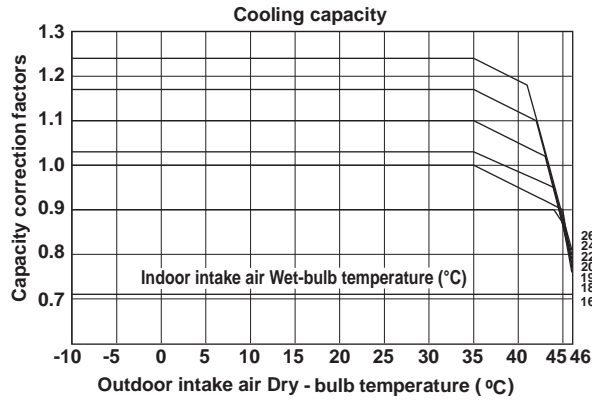

17.9	19.2	21.5	19.2	17.7	22.1	27.5	29.6
16.6	17.8	20.0	17.8	16.4	20.6	25.6	27.5
15.3	16.5	18.4	16.5	15.2	19.0	23.6	25.4
14.0	15.1	16.9	15.1	13.9	17.4	21.6	23.2
12.9	13.9	15.6	13.9	12.8	16.0	19.9	21.4
11.6	12.5	14.0	12.5	11.5	14.4	17.9	19.2
10.3	11.1	12.4	11.1	10.2	12.8	15.9	17.1
9.0	9.7	10.9	9.7	9.0	11.2	13.9	15.0
7.8	8.4	9.4	8.4	7.8	9.7	12.1	13.0
6.5	7.0	7.9	7.0	6.5	8.1	10.1	10.8
15 class	18 class	20 class	22 class	25 class	35 class	42 class	50 class

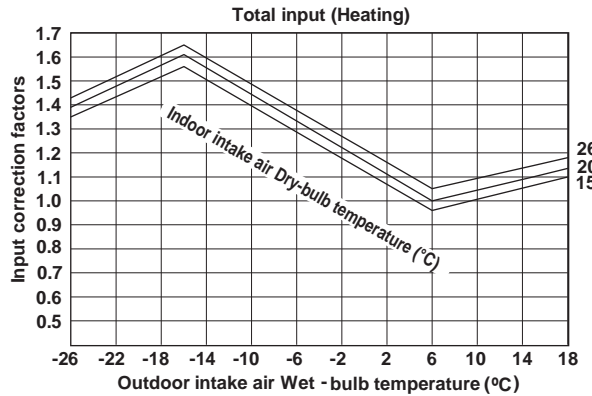
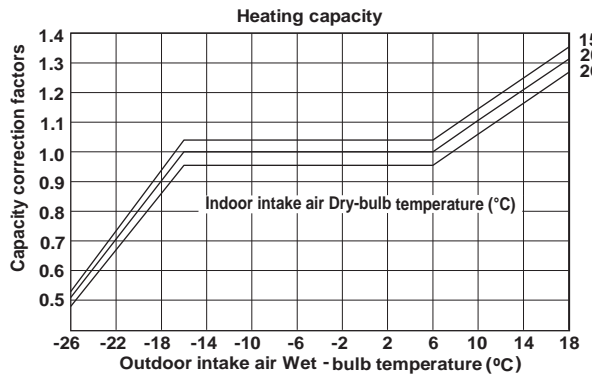

MXZ-4F83VFH22

5.4	3.8	6.8	4.8	5.0	7.3	9.0	9.9	8.2	8.6
4.9	3.5	6.2	4.4	4.6	6.7	8.2	9.0	7.5	7.9
4.5	3.2	5.7	4.0	4.2	6.0	7.4	8.1	6.8	7.1
4.0	2.9	5.1	3.6	3.8	5.4	6.7	7.3	6.1	6.4
3.6	2.6	4.5	3.2	3.4	5.8	5.9	6.4	5.4	5.7
3.2	2.3	4.0	2.8	3.0	4.2	5.2	5.6	4.7	5.0
2.8	2.0	3.5	2.5	2.6	3.7	4.5	4.9	4.1	4.3
15 class	18 class	20 class	22 class	25 class	35 class	42 class	50 class	60 class	71 class

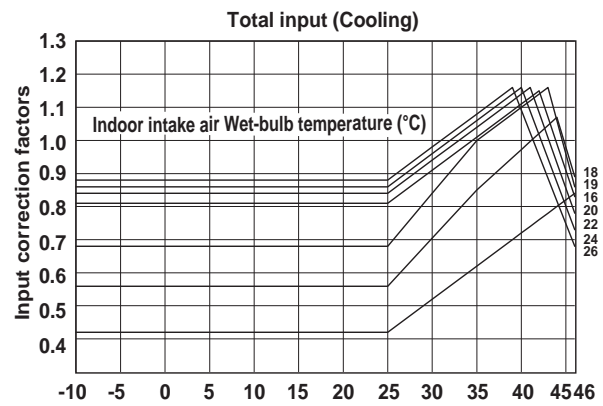
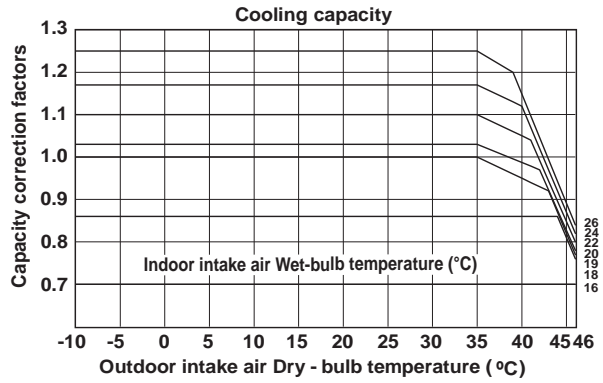

17.9	19.2	21.5	19.2	17.7	22.1	27.5	29.5	27.0	28.9
16.6	17.8	20.5	17.8	16.4	20.6	25.6	27.5	25.0	26.9
15.3	16.5	18.4	16.5	15.2	19.0	23.6	25.4	23.1	24.8
14.0	15.1	16.9	15.1	13.9	17.4	21.6	23.2	21.2	22.7
12.9	13.9	15.6	13.9	12.8	16.0	19.9	21.4	19.5	20.9
11.6	12.5	14.0	12.5	11.5	14.4	17.9	19.2	17.5	18.8
10.3	11.1	12.4	11.1	10.2	12.8	15.9	17.1	15.6	16.7
9.0	9.7	10.9	9.7	9.0	11.2	13.9	15.0	13.6	14.6
7.8	8.4	9.4	8.4	7.8	9.7	12.1	13.0	11.8	12.7
6.5	7.0	7.9	7.0	6.5	8.1	10.1	10.8	9.9	10.6
5.2	5.5	6.3	5.6	5.2	6.5	8.1	8.7	7.9	8.5
15 class	18 class	20 class	22 class	25 class	35 class	42 class	50 class	60 class	71 class

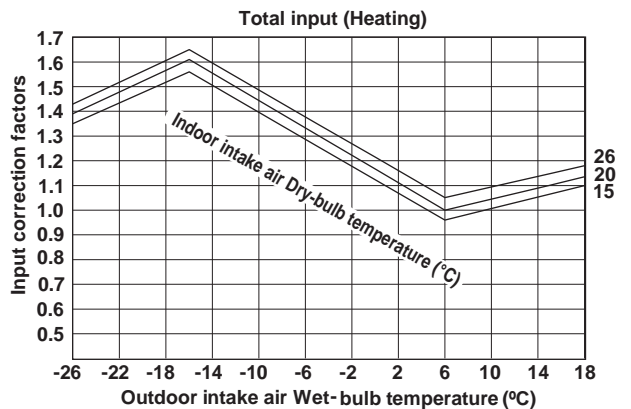
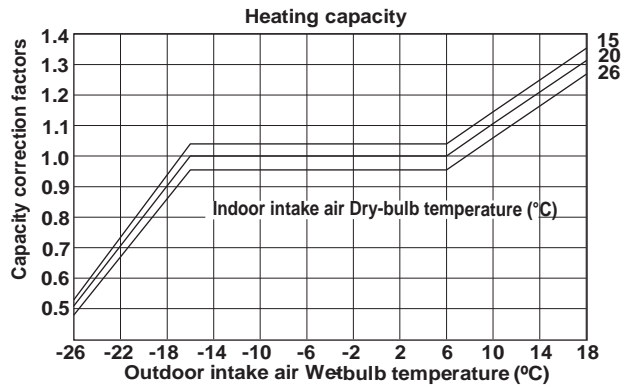

MXZ-2D33VA MXZ-2D42VA2
MXZ-2D53VA2 MXZ-2D53VAH2

Indoor air Wet-bulb temperature difference (°C)	15 class	18 class	20 class	22 class	25 class	35 class (MXZ-2D40S3)	42 class (MXZ-2D53)	50 class (MXZ-2D53)
5.8	4.1	7.4	5.2	6.0	8.8	10.9	11.2	
5.4	3.8	6.8	4.8	5.5	8.0	10.0	10.2	
4.9	3.5	6.2	4.4	5.0	7.3	9.1	9.3	
4.5	3.2	5.7	4.0	4.6	6.6	8.2	8.4	
4.0	2.9	5.1	3.6	4.1	6.0	7.3	7.5	
3.6	2.6	4.5	3.2	3.7	5.3	6.5	6.7	

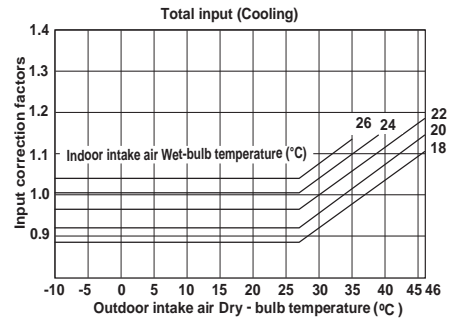
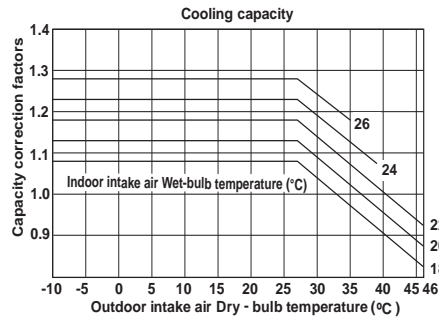

Indoor air Dry-bulb temperature difference (°C)	15 class	18 class	20 class	22 class	25 class	35 class (MXZ-2D40S3)	42 class (MXZ-2D53)	50 class (MXZ-2D53)
18.6	20.4	22.7	20.4	22.8	23.6	28.5	28.7	
17.2	19.0	20.9	19.0	21.0	21.9	26.5	26.6	
15.8	17.6	19.1	17.6	19.2	20.2	24.5	24.5	
14.4	16.1	17.5	16.1	17.6	18.3	22.2	22.3	
13.1	14.5	15.9	14.5	16.0	16.6	20.2	20.2	
11.7	13.0	14.2	13.0	14.2	14.8	18.0	18.0	
10.3	11.6	12.6	11.6	12.6	13.2	16.0	16.0	
9.0	10.0	11.0	10.0	11.1	11.5	13.8	13.8	
7.7	8.6	9.3	8.6	9.4	9.8	11.8	11.9	
6.4	7.2	7.6	7.2	7.7	8.1	9.8	10.0	
5.1	5.8	5.9	5.8	6.0	6.4	7.8	8.1	

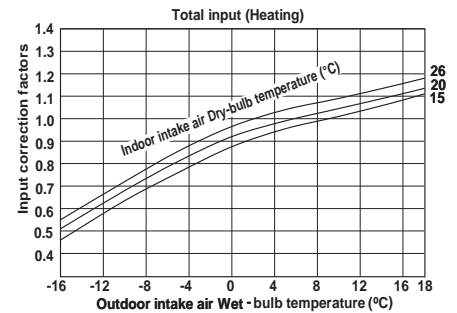
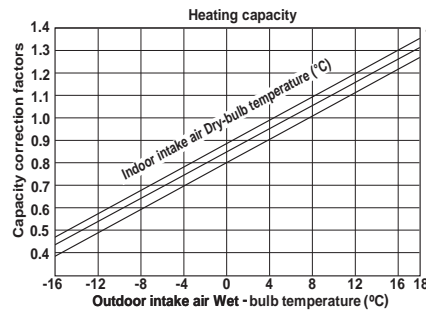

MXZ-2E53VAHZ

5.4	3.8	6.8	4.8	5.5	8.0	10.2	11.6
4.9	3.5	6.2	4.4	5.0	7.3	9.3	10.6
4.5	3.2	5.7	4.0	4.6	6.6	8.4	9.5
4.0	2.9	5.1	3.6	4.1	6.0	7.5	8.5
3.6	2.6	4.5	3.2	3.7	5.3	6.6	7.5
3.2	2.3	4.0	2.8	3.2	4.6	5.8	6.6
2.8	2.0	3.5	2.5	2.8	4.0	5.0	5.6
15 class	18 class	20 class	22 class	25 class	35 class	42 class	50 class

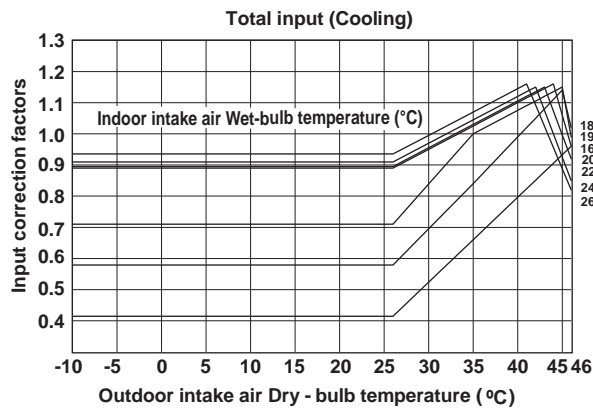
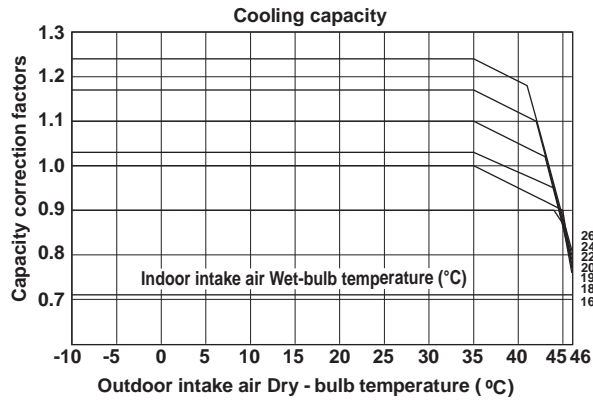

18.3	19.7	22.0	19.7	19.7	23.0	31.1	32.1
17.0	18.2	20.5	18.2	18.2	21.4	28.9	29.8
15.7	16.8	18.9	16.8	16.8	19.7	26.6	27.5
14.4	15.4	17.3	15.4	15.4	18.1	24.4	25.2
12.9	13.9	15.6	13.9	13.9	16.3	21.9	22.7
11.6	12.5	14.0	12.5	12.5	14.6	19.7	20.4
10.3	11.1	12.4	11.1	11.1	13.0	17.6	18.1
9.0	9.7	10.9	9.7	9.7	11.4	15.4	15.9
7.7	8.2	9.2	8.2	8.2	9.6	13.0	13.4
6.4	6.9	7.7	6.9	6.9	8.0	10.8	11.2
15 class	18 class	20 class	22 class	25 class	35 class	42 class	50 class

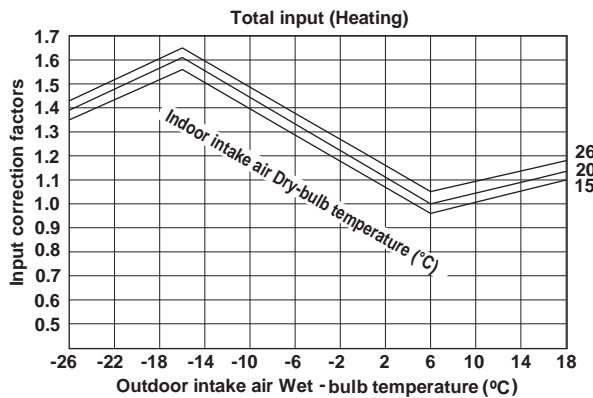
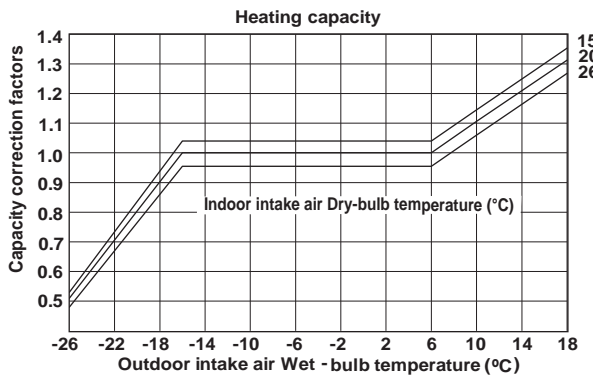

PERFORMANCE CURVES

MULTI SYSTEM

MXZ-3E54VA MXZ-3E68VA MXZ-4E72VA

5.8	3.8	7.3	7.8	8.5	9.7	8.7	11.9	12.4
5.3	3.5	6.7	7.1	7.8	8.8	8.0	10.8	11.3
4.8	3.2	6.0	6.4	7.0	7.9	7.2	9.7	10.1
4.3	2.9	5.4	5.8	6.3	7.1	6.5	8.7	9.0
3.9	2.6	4.8	5.1	5.6	6.3	5.7	7.7	8.0
3.5	2.3	4.2	4.4	4.9	5.5	4.9	6.7	7.0
3.1	2.0	3.6	3.7	4.2	4.7	4.1	5.7	6.0
15 class	18 class	20 class	22 class	25 class	35 class	42 class	50 class	60 class

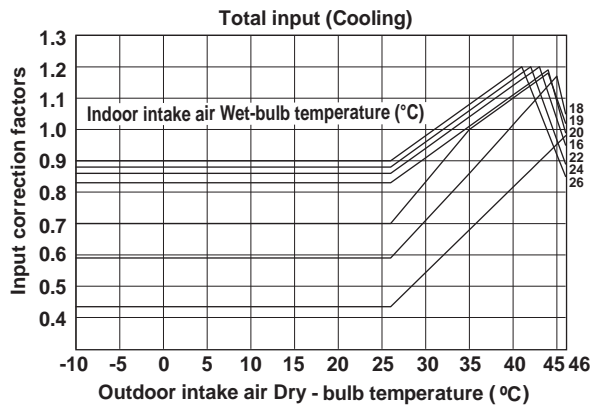
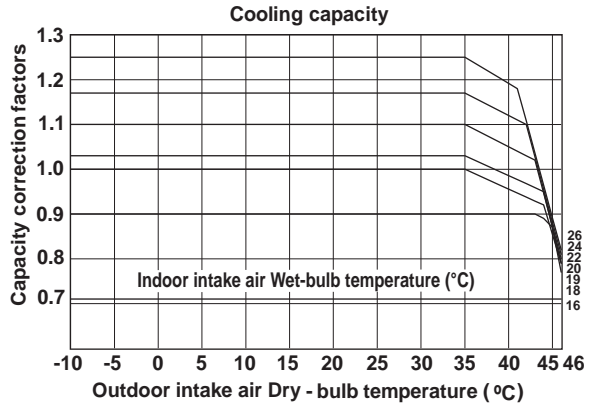

18.4	20.4	21.2	27.4	25.8	27.9	29.1	33.8	34.4
17.1	19.0	19.7	25.4	24.0	25.9	27.0	31.4	31.9
15.8	17.6	18.2	23.4	22.2	23.9	24.9	29.0	29.4
14.5	16.1	16.7	21.5	20.3	21.9	22.8	26.6	27.0
13.2	14.5	15.2	19.5	18.5	19.9	20.7	24.1	24.5
11.8	13.0	13.6	17.6	16.6	17.9	18.7	21.7	22.1
10.5	11.6	12.1	15.6	14.8	15.9	16.6	19.3	19.6
9.2	10.0	10.6	13.7	12.9	13.9	14.5	16.9	17.2
7.9	8.6	9.1	11.7	11.1	12.0	12.4	14.5	14.7
6.6	7.2	7.6	9.7	9.3	10.1	10.3	12.1	12.2
5.3	5.8	6.1	7.7	7.5	8.2	8.2	9.7	9.7
15 class	18 class	20 class	22 class	25 class	35 class	42 class	50 class	60 class

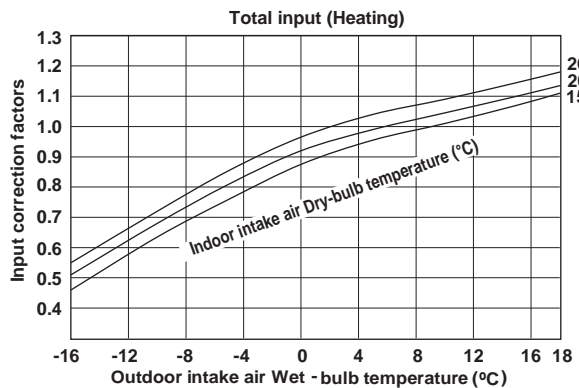
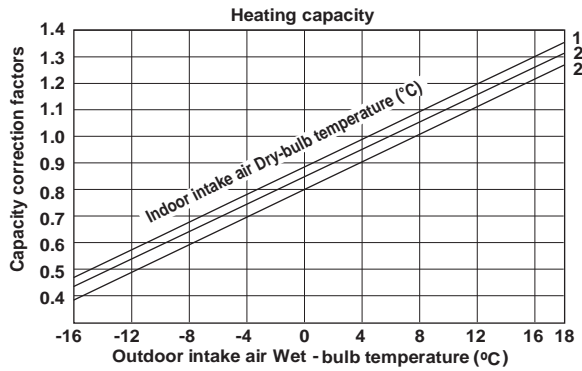

MXZ-4E83VA MXZ-5E102VA

5.4	3.8	6.8	4.8	5.5	8.0	10.2	11.6	8.0	8.2
4.9	3.5	6.2	4.4	5.0	7.3	9.3	10.6	7.3	7.5
4.5	3.2	5.7	4.0	4.6	6.6	8.4	9.5	6.6	6.8
4.0	2.9	5.1	3.6	4.1	6.0	7.5	8.5	6.0	6.1
3.6	2.6	4.5	3.2	3.7	5.3	6.6	7.5	5.3	5.4
3.2	2.3	4.0	2.8	3.2	4.6	5.8	6.6	4.6	4.7
2.8	2.0	3.5	2.5	2.8	4.0	5.0	5.6	4.0	4.1
15 class	18 class	20 class	22 class	25 class	35 class	42 class	50 class	60 class	71 class

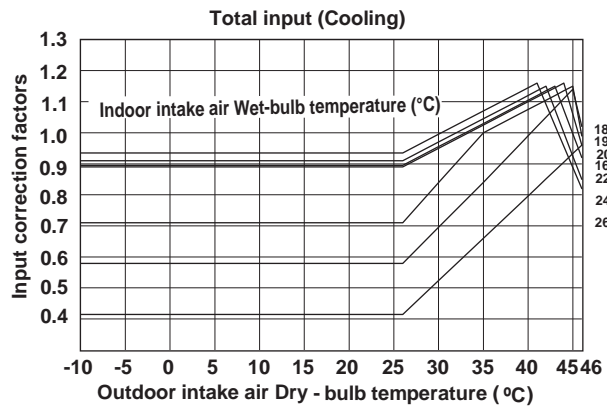
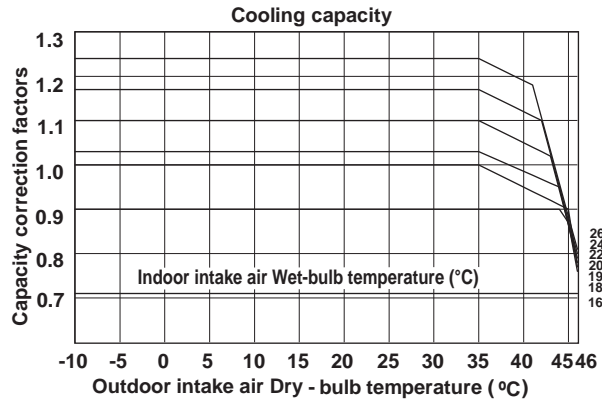

18.3	19.7	22.0	19.7	19.7	23.0	31.1	32.1	22.3	28.3
17.0	18.2	20.5	18.2	18.2	21.4	28.9	29.8	20.7	26.3
15.7	16.8	18.9	16.8	16.8	19.7	26.6	27.5	19.1	24.3
14.4	15.4	17.3	15.4	15.4	18.1	24.4	25.2	17.5	22.3
12.9	13.9	15.6	13.9	13.9	16.3	21.9	22.7	15.7	20.0
11.6	12.5	14.0	12.5	12.5	14.6	19.7	20.4	14.2	18.0
10.3	11.1	12.4	11.1	11.1	13.0	17.6	18.1	12.6	16.0
9.0	9.7	10.9	9.7	9.7	11.4	15.4	15.9	11.0	14.0
7.7	8.2	9.2	8.2	8.2	9.6	13.0	13.4	9.3	11.9
6.4	6.9	7.7	6.9	6.9	8.0	10.8	11.2	7.8	9.9
5.1	5.5	6.1	5.5	5.5	6.4	8.7	9.0	6.2	7.9
15 class	18 class	20 class	22 class	25 class	35 class	42 class	50 class	60 class	71 class

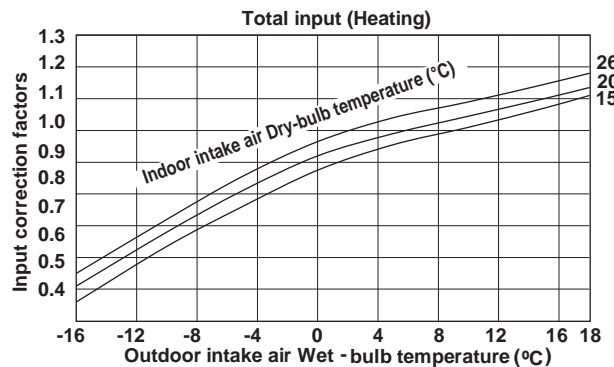
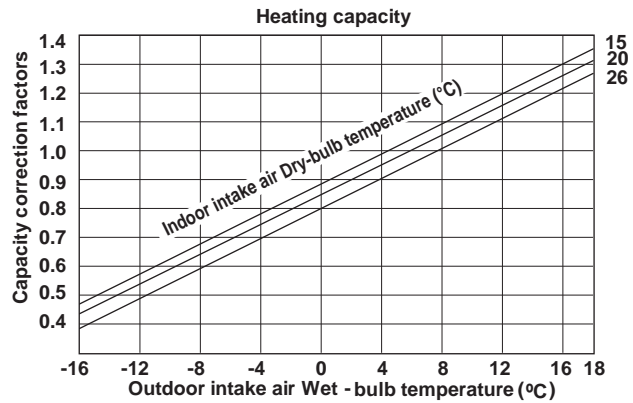

PERFORMANCE CURVES

MULTI SYSTEM

MXZ-4E83VAHZ

5.4	3.8	6.8	4.8	5.5	8.0	10.2	11.6	8.0	8.2
4.9	3.5	6.2	4.4	5.0	7.3	9.3	10.6	7.3	7.5
4.5	3.2	5.7	4.0	4.6	6.6	8.4	9.5	6.6	6.8
4.0	2.9	5.1	3.6	4.1	6.0	7.5	8.5	6.0	6.1
3.6	2.6	4.5	3.2	3.7	5.3	6.6	7.5	5.3	5.4
3.2	2.3	4.0	2.8	3.2	4.6	5.8	6.6	4.6	4.7
2.8	2.0	3.5	2.5	2.8	4.0	5.0	5.6	4.0	4.1
15 class	18 class	20 class	22 class	25 class	35 class	42 class	50 class	60 class	71 class

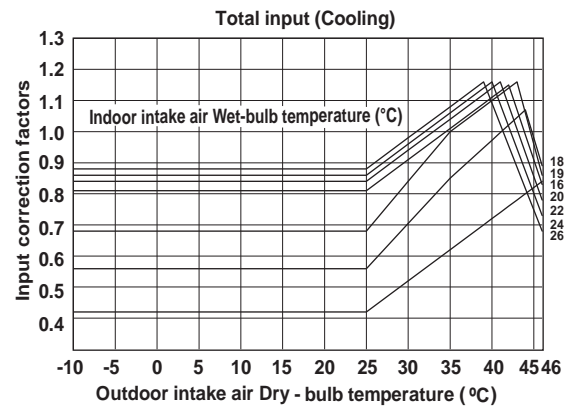
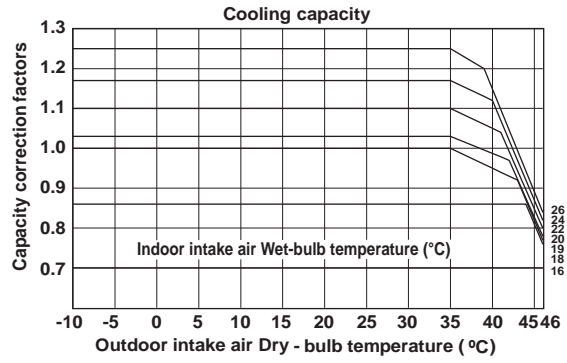

18.3	19.7	22.0	19.7	19.7	23.0	31.1	32.1	22.3	28.3
17.0	18.2	20.5	18.2	18.2	21.4	28.9	29.8	20.7	26.3
15.7	16.8	18.9	16.8	16.8	19.7	26.6	27.5	19.1	24.3
14.4	15.4	17.3	15.4	15.4	18.1	24.4	25.2	17.5	22.3
12.9	13.9	15.6	13.9	13.9	16.3	21.9	22.7	15.7	20.0
11.6	12.5	14.0	12.5	12.5	14.6	19.7	20.4	14.2	18.0
10.3	11.1	12.4	11.1	11.1	13.0	17.6	18.1	12.6	16.0
9.0	9.7	10.9	9.7	9.7	11.4	15.4	15.9	11.0	14.0
7.7	8.2	9.2	8.2	8.2	9.6	13.0	13.4	9.3	11.9
6.4	6.9	7.7	6.9	6.9	8.0	10.8	11.2	7.8	9.9
15 class	18 class	20 class	22 class	25 class	35 class	42 class	50 class	60 class	71 class

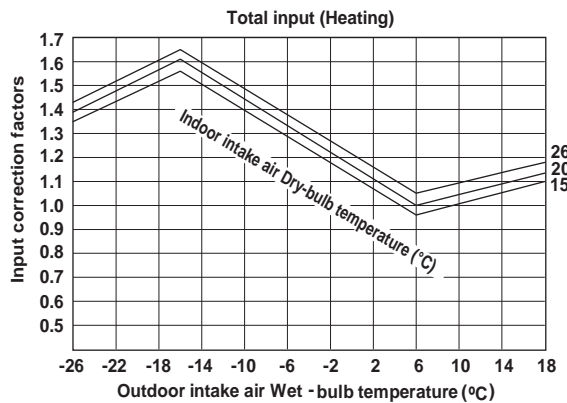
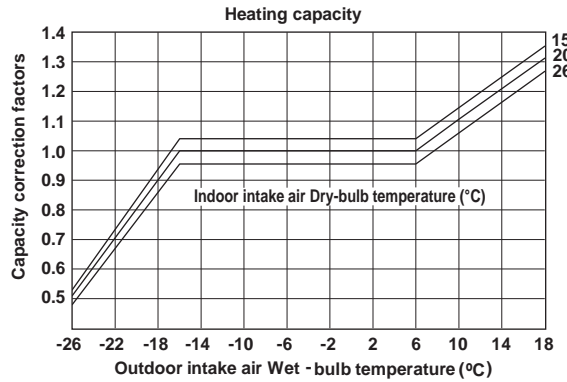

MULTI SYSTEM PERFORMANCE CURVES

MXZ-6D122VA2

5.4	3.8	6.8	4.8	5.5	8.0	10.2	11.6	8.0	8.2
4.9	3.5	6.2	4.4	5.0	7.3	9.3	10.6	7.3	7.5
4.5	3.2	5.7	4.0	4.6	6.6	8.4	9.5	6.6	6.8
4.0	2.9	5.1	3.6	4.1	6.0	7.5	8.5	6.0	6.1
3.6	2.6	4.5	3.2	3.7	5.3	6.6	7.5	5.3	5.4
3.2	2.3	4.0	2.8	3.2	4.6	5.8	6.6	4.6	4.7
2.8	2.0	3.5	2.5	2.8	4.0	5.0	5.6	4.0	4.1
15 class	18 class	20 class	22 class	25 class	35 class	42 class	50 class	60 class	71 class

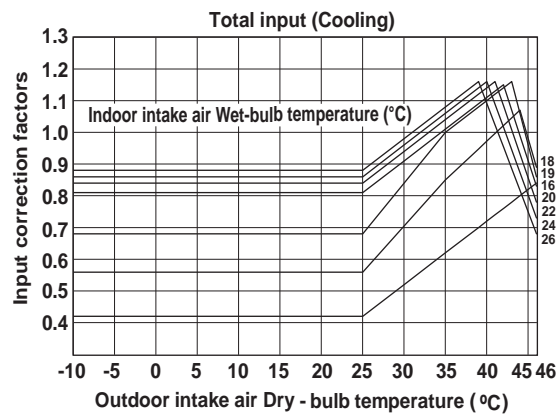
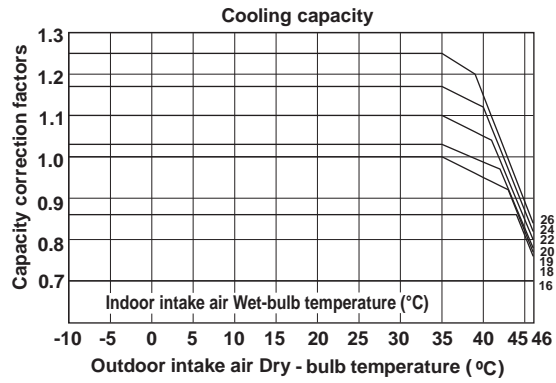

18.3	19.7	22.0	19.7	19.7	23.0	31.1	32.1	22.3	28.3
17.0	18.2	20.5	18.2	18.2	21.4	28.9	29.8	20.7	26.3
15.7	16.8	18.9	16.8	16.8	19.7	26.6	27.5	19.1	24.3
14.4	15.4	17.3	15.4	15.4	18.1	24.4	25.2	17.5	22.3
12.9	13.9	15.6	13.9	13.9	16.3	21.9	22.7	15.7	20.0
11.6	12.5	14.0	12.5	12.5	14.6	19.7	20.4	14.2	18.0
10.3	11.1	12.4	11.1	11.1	13.0	17.6	18.1	12.6	16.0
9.0	9.7	10.9	9.7	9.7	11.4	15.4	15.9	11.0	14.0
7.7	8.2	9.2	8.2	8.2	9.6	13.0	13.4	9.3	11.9
6.4	6.9	7.7	6.9	6.9	8.0	10.8	11.2	7.8	9.9
5.1	5.5	6.1	5.5	5.5	6.4	8.7	9.0	6.2	7.9
15 class	18 class	20 class	22 class	25 class	35 class	42 class	50 class	60 class	71 class

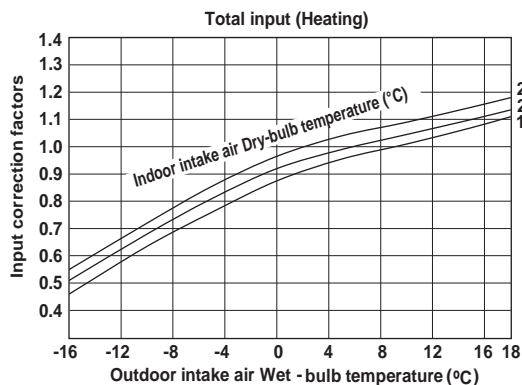
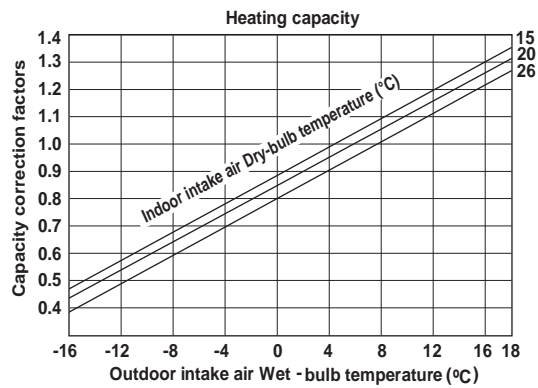

PERFORMANCE CURVES

MULTI SYSTEM

MXZ-2DM40VA

Indoor air Wet-bulb temperature difference (°C)	6.7	7.4
	6.1	6.8
	5.6	6.2
	5.1	5.6
	4.6	5.1
	4.1	4.5
25 class		35 class

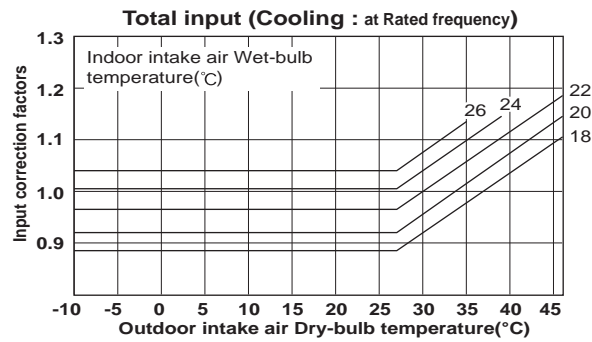
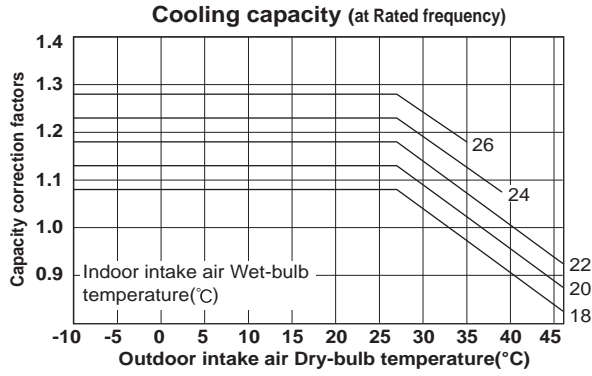

Indoor air Dry-bulb temperature difference (°C)	22.2	24.6
	20.6	22.9
	19.0	21.1
	17.4	19.3
	15.8	17.6
	14.3	15.8
	12.7	14.1
	11.1	12.3
	9.5	10.5
	7.9	8.8
	6.3	7.0
25 class		35 class

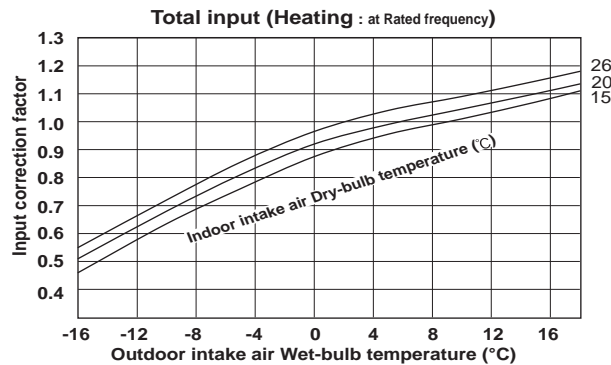
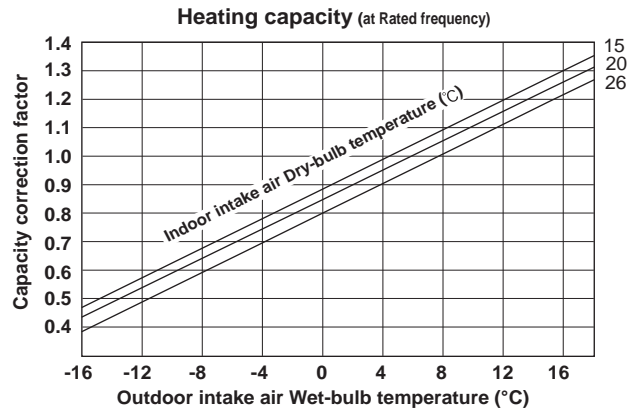

MXZ-3DM50VA

Indoor air Wet-bulb temperature difference (°C)	6.7	7.4	10.5
	6.1	6.8	9.6
	5.6	6.2	8.7
	5.1	5.6	7.9
	4.6	5.1	7.1
	4.1	4.5	6.3
	25 class	35 class	50 class

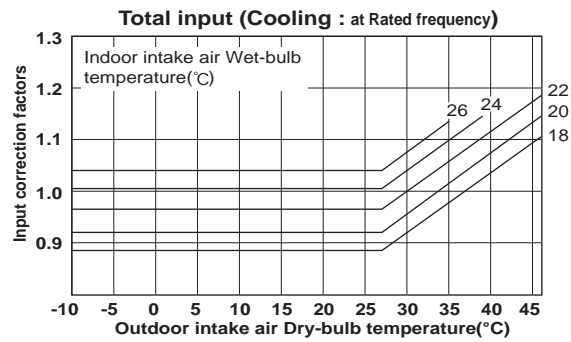
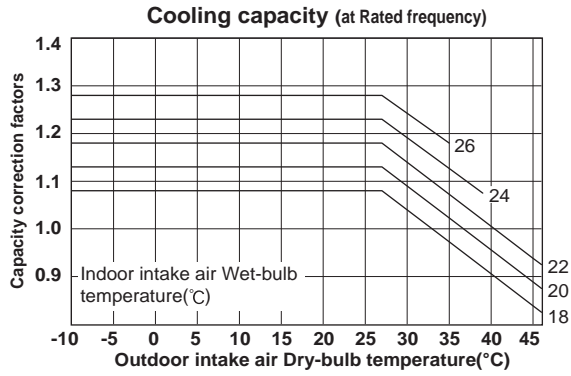

Indoor air Dry-bulb temperature difference (°C)	22.2	24.6	26.6
	20.6	22.9	24.7
	19.0	21.1	22.8
	17.4	19.3	20.9
	15.8	17.6	19.0
	14.3	15.8	17.1
	12.7	14.1	15.2
	11.1	12.3	13.3
	9.5	10.5	11.4
	7.9	8.8	9.5
	6.3	7.0	7.6
	25 class	35 class	50 class

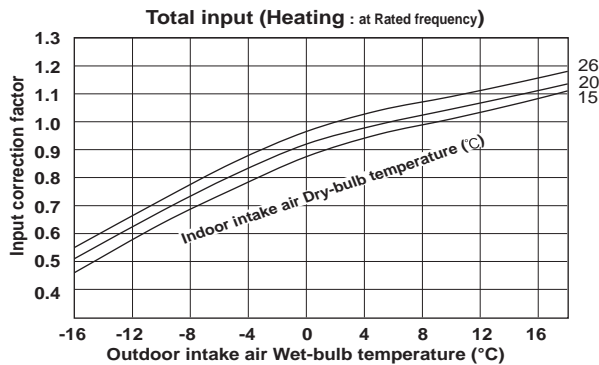
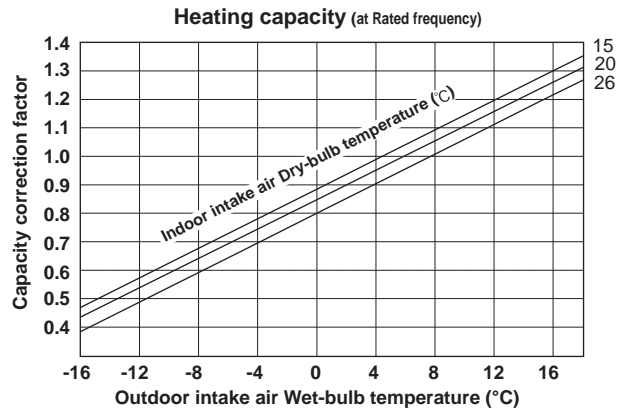

PERFORMANCE CURVES

MULTI SYSTEM

MXZ-2HA40VF2 MXZ-2HA50VF2

5.9	8.7	11.1
5.5	8.0	10.2
5.0	7.3	9.3
4.6	6.6	8.3
4.1	5.9	7.5
3.7	5.3	6.6
3.2	4.6	5.8
2.8	4.0	5.0
25 class	35 class	42 class (MXZ-2HA50VF2)

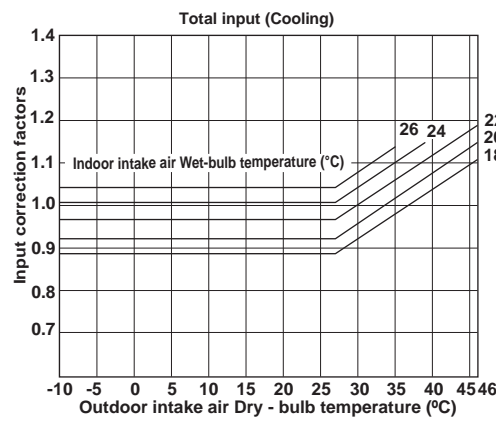
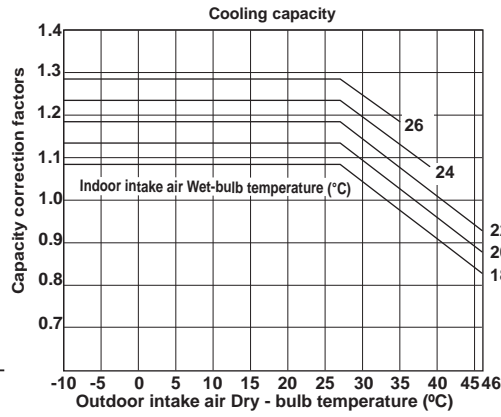

21.3	22.2	26.6
19.8	20.6	24.7
18.3	19.0	22.8
16.7	17.4	20.9
15.2	15.8	19.0
13.7	14.3	17.1
12.2	12.7	15.2
10.7	11.1	13.3
9.1	9.5	11.4
7.6	7.9	9.5
6.1	6.3	7.6
25 class	35 class	42 class (MXZ-2HA50VF2)

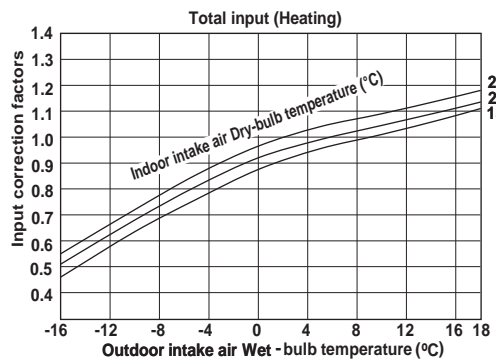
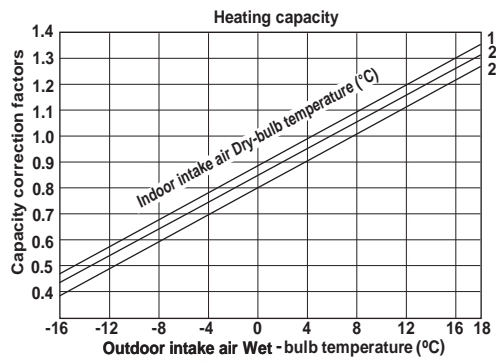

MXZ-3HA50VF2

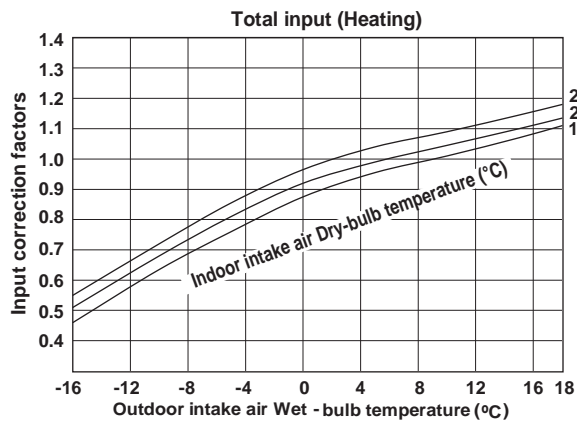
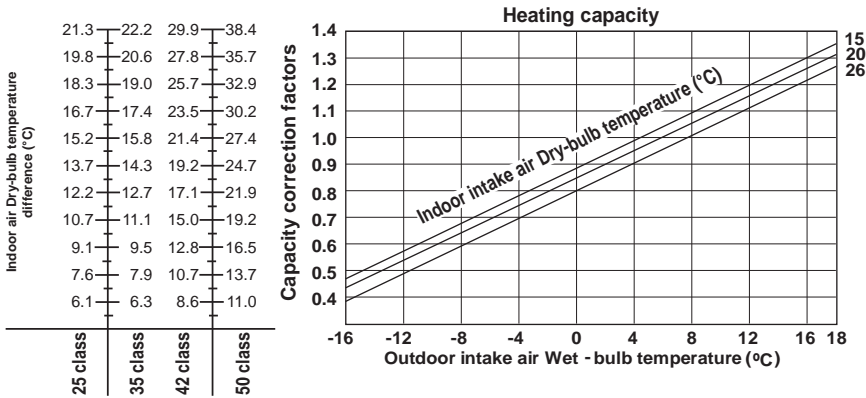
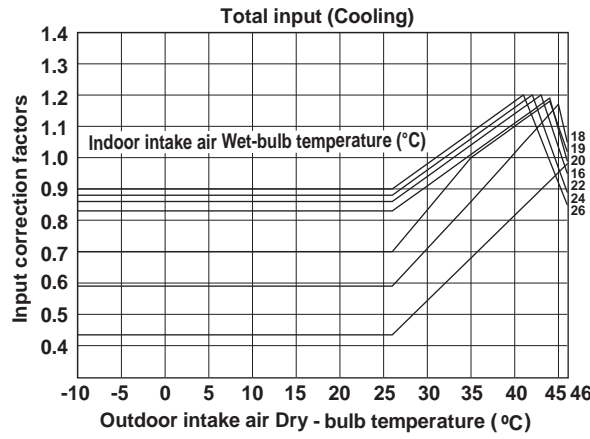
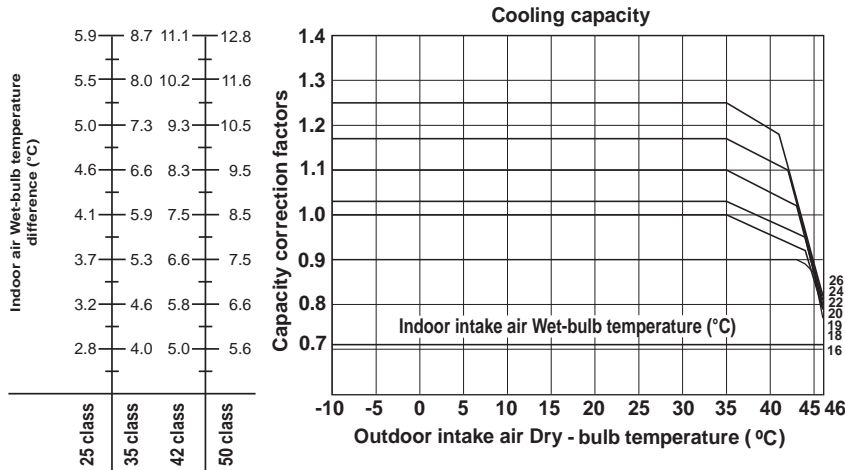

PXZ-4F75VG

5.8	4.1	7.4	5.2	5.9	8.7	11.1	12.8	8.7	9.3
5.4	3.8	6.8	4.8	5.5	8.0	10.2	11.6	8.0	8.6
4.9	3.5	6.2	4.4	5.0	7.3	9.3	10.5	7.3	7.9
4.5	3.2	5.7	4.0	4.6	6.6	8.3	9.5	6.6	7.1
4.0	2.9	5.1	3.6	4.1	5.9	7.5	8.5	5.9	6.4
3.6	2.6	4.5	3.2	3.7	5.3	6.6	7.5	5.3	5.7
3.2	2.3	4.0	2.8	3.2	4.6	5.8	6.6	4.6	5.0
2.8	2.0	3.5	2.4	2.8	4.0	5.0	5.6	4.0	4.3
15 class	18 class	20 class	22 class	25 class	35 class	42 class	50 class	60 class	71 class

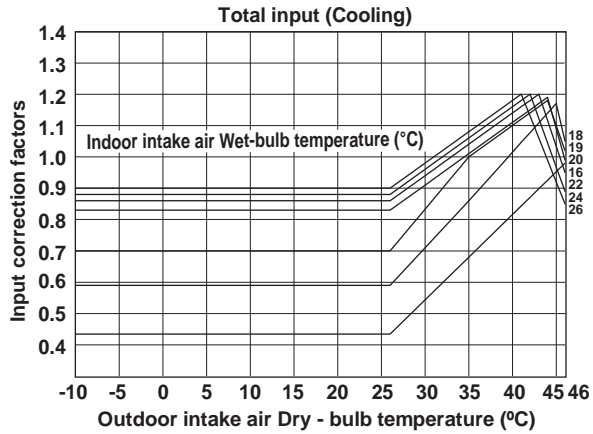
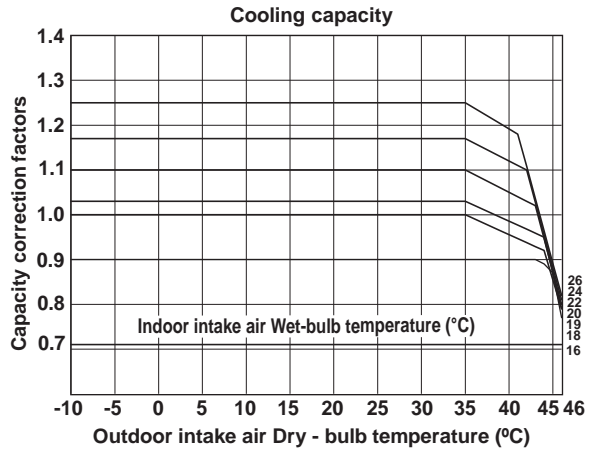

17.6	19.5	21.2	19.5	21.3	22.2	29.9	38.4	30.9	28.9
16.3	18.1	19.7	18.1	19.8	20.6	27.8	35.7	28.7	26.9
15.1	16.7	18.2	16.7	18.3	19.0	25.7	32.9	26.5	24.8
13.8	15.3	16.7	15.3	16.7	17.4	23.5	30.2	24.3	22.7
12.6	13.9	15.2	13.9	15.2	15.8	21.4	27.4	22.1	20.9
11.3	12.6	13.6	12.6	13.7	14.3	19.2	24.7	19.9	18.8
10.1	11.2	12.1	11.2	12.2	12.7	17.1	21.9	17.7	16.7
8.8	9.8	10.6	9.8	10.7	11.1	15.0	19.2	15.5	14.6
7.5	8.4	9.1	8.4	9.1	9.5	12.8	16.5	13.2	12.7
6.3	7.0	7.6	7.0	7.6	7.9	10.7	13.7	11.0	10.6
5.0	5.6	6.1	5.6	6.1	6.3	8.6	11.0	8.8	8.5
15 class	18 class	20 class	22 class	25 class	35 class	42 class	50 class	60 class	71 class

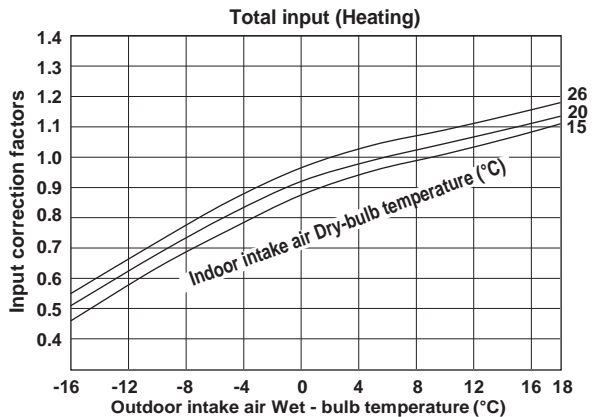
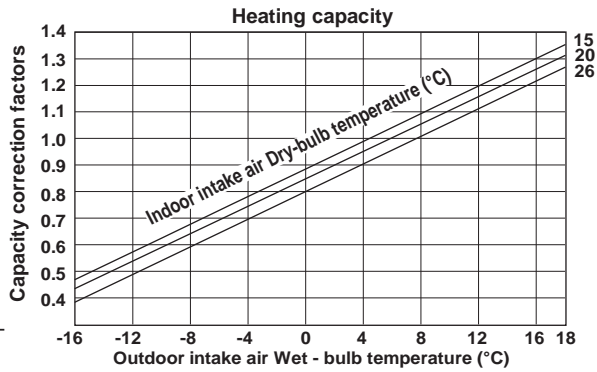

PXZ-5F85VG

Indoor air Wet-bulb temperature difference (°C)	5.4	3.8	6.8	4.8	5.0	7.3	9.0	9.9	8.2	8.6
	4.9	3.5	6.2	4.4	4.6	6.7	8.2	9.0	7.5	7.9
	4.5	3.2	5.7	4.0	4.2	6.0	7.4	8.1	6.8	7.1
	4.0	2.9	5.1	3.6	3.8	5.4	6.7	7.3	6.1	6.4
	3.6	2.6	4.5	3.2	3.4	5.8	5.9	6.4	5.4	5.7
	3.2	2.3	4.0	2.8	3.0	4.2	5.2	5.6	4.7	5.0
	2.8	2.0	3.5	2.5	2.6	3.7	4.5	4.9	4.1	4.3
	15 class	18 class	20 class	22 class	25 class	35 class	42 class	50 class	60 class	71 class

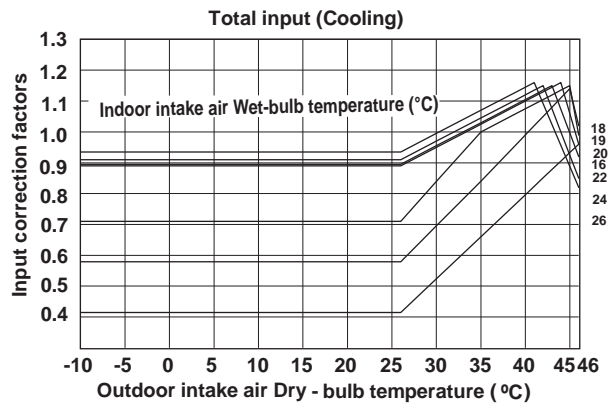
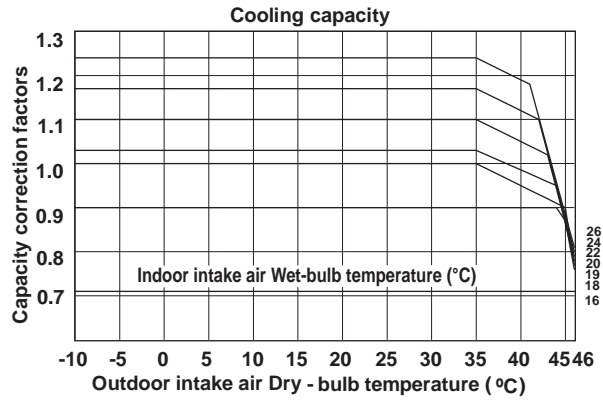

Indoor air Dry-bulb temperature difference (°C)	17.9	19.2	21.5	19.2	17.7	22.1	27.5	29.5	27.0	28.9
	16.6	17.8	20.5	17.8	16.4	20.6	25.6	27.5	25.0	26.9
	15.3	16.5	18.4	16.5	15.2	19.0	23.6	25.4	23.1	24.8
	14.0	15.1	16.9	15.1	13.9	17.4	21.6	23.2	21.2	22.7
	12.9	13.9	15.6	13.9	12.8	16.0	19.9	21.4	19.5	20.9
	11.6	12.5	14.0	12.5	11.5	14.4	17.9	19.2	17.5	18.8
	10.3	11.1	12.4	11.1	10.2	12.8	15.9	17.1	15.6	16.7
	9.0	9.7	10.9	9.7	9.0	11.2	13.9	15.0	13.6	14.6
	7.8	8.4	9.4	8.4	7.8	9.7	12.1	13.0	11.8	12.7
	6.5	7.0	7.9	7.0	6.5	8.1	10.1	10.8	9.9	10.6
	5.2	5.5	6.3	5.6	5.2	6.5	8.1	8.7	7.9	8.5
	15 class	18 class	20 class	22 class	25 class	35 class	42 class	50 class	60 class	71 class

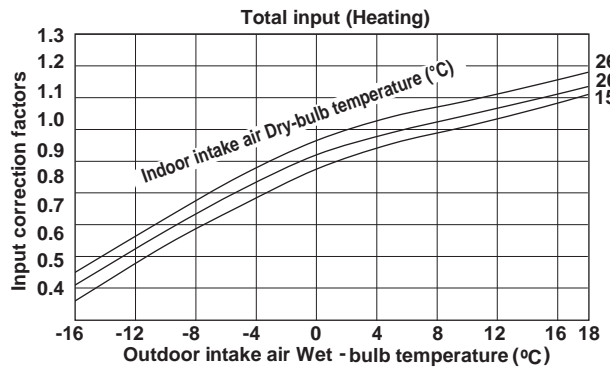
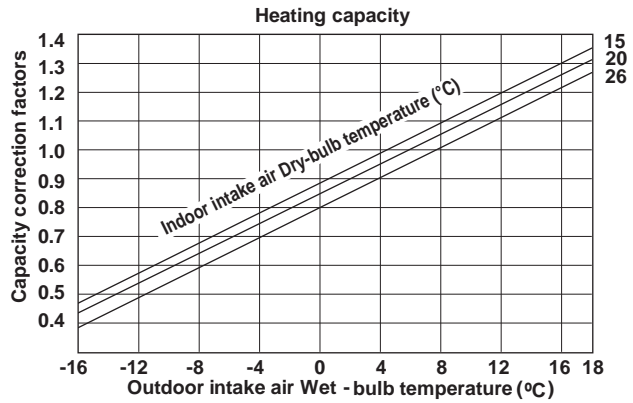

PERFORMANCE CURVES

MULTI SYSTEM

CAPACITY AND INPUT CORRECTION BY INVERTER OUTPUT FREQUENCY
MXZ-2F33VF4

1. 15-class unit in single operation

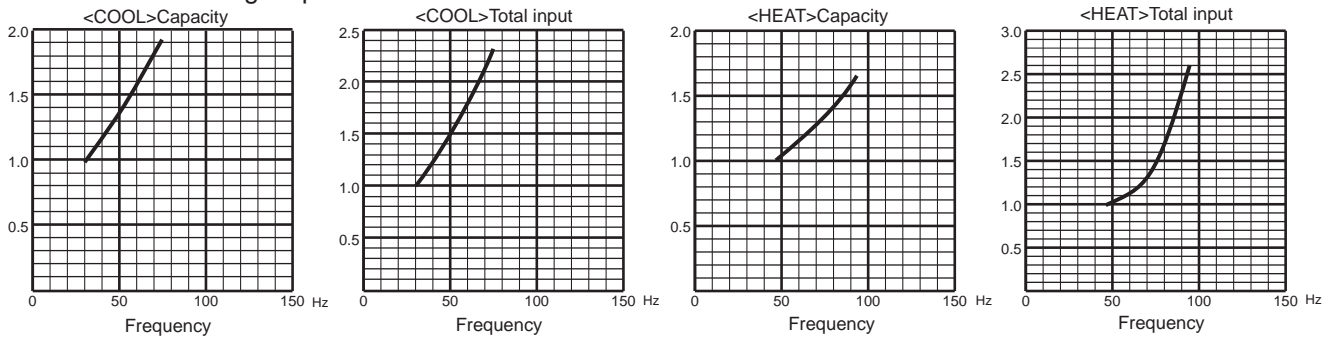

2. 18-class unit in single operation

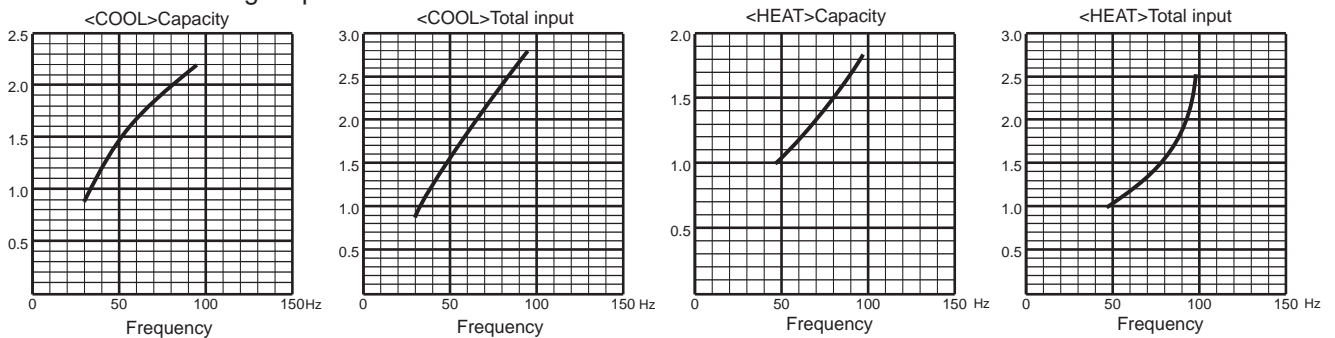

3. 20-class unit in single operation

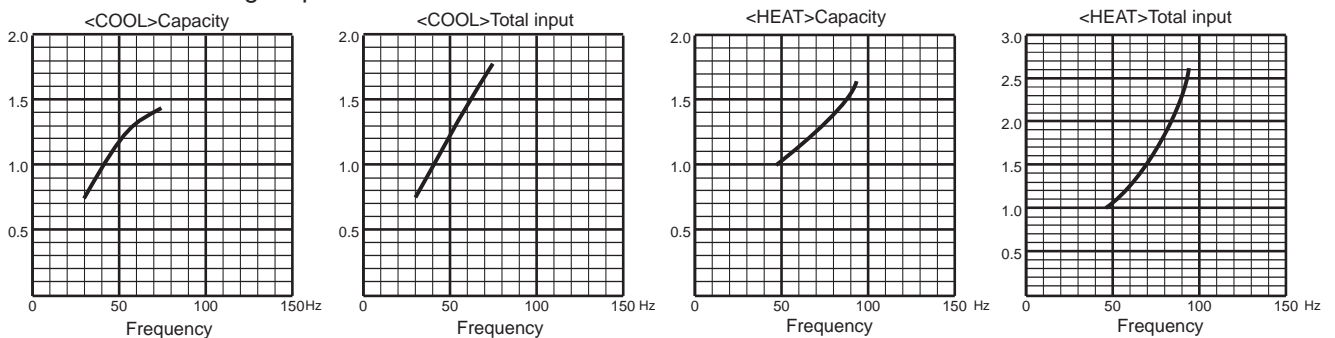

4. 22-class unit in single operation

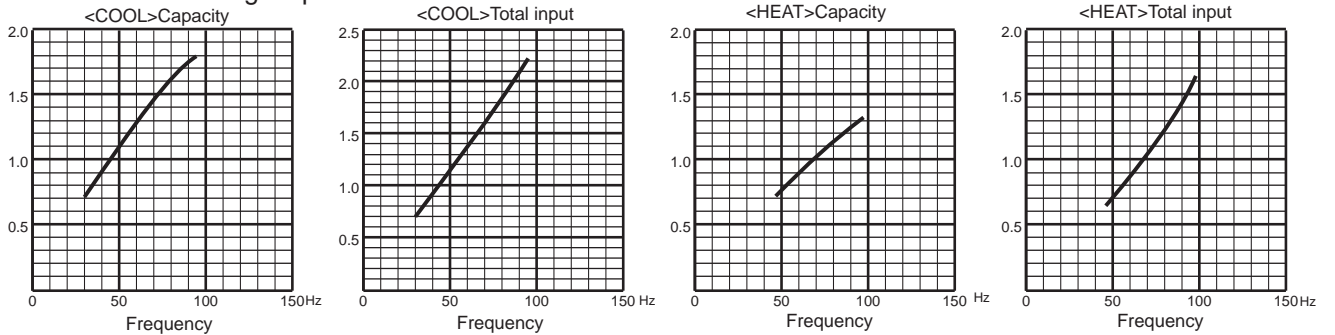

5. 25-class unit in single operation

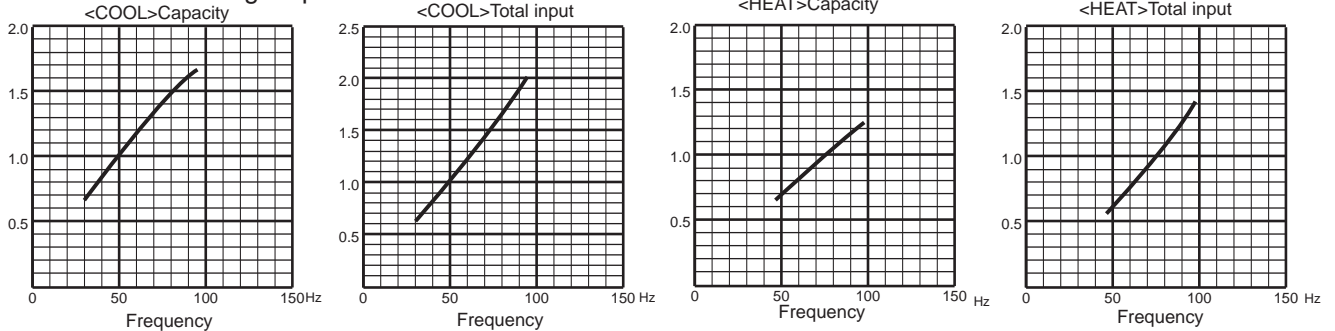

MXZ-2F42VF4

1. 15-class unit in single operation

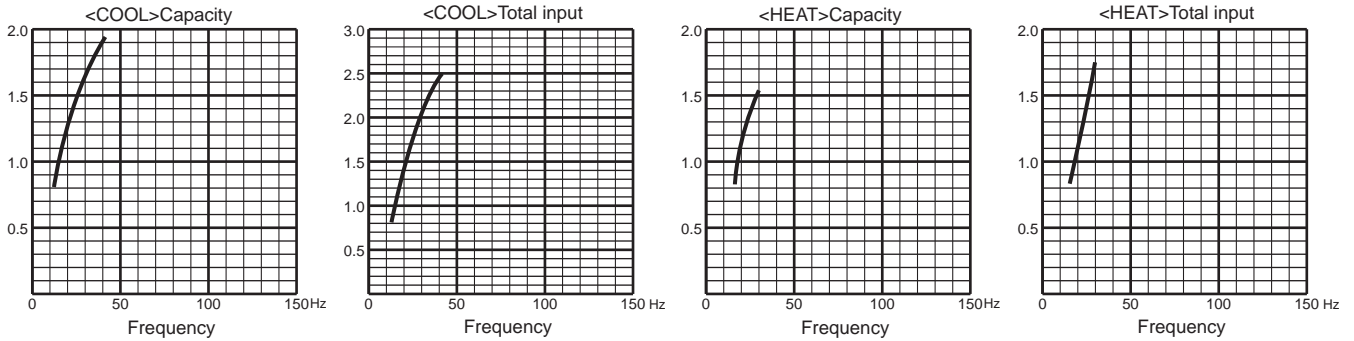

2. 18-class unit in single operation

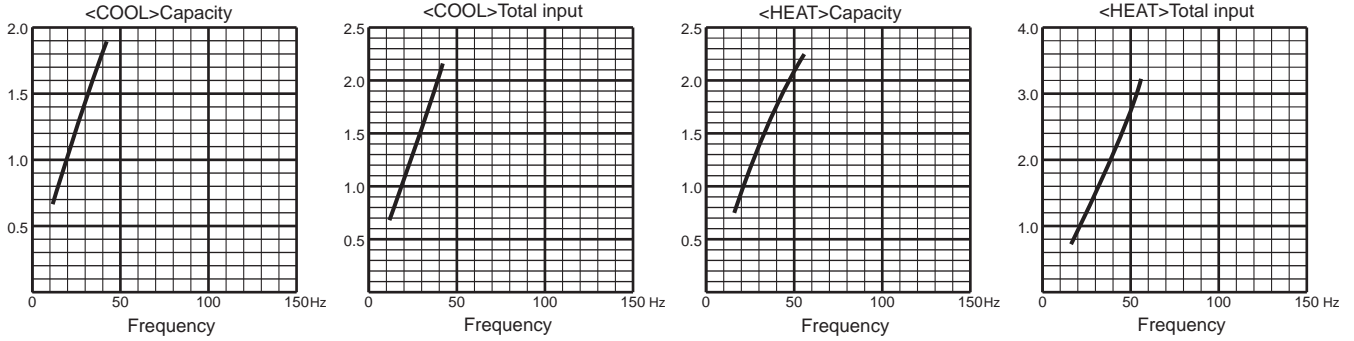

3. 20-class unit in single operation

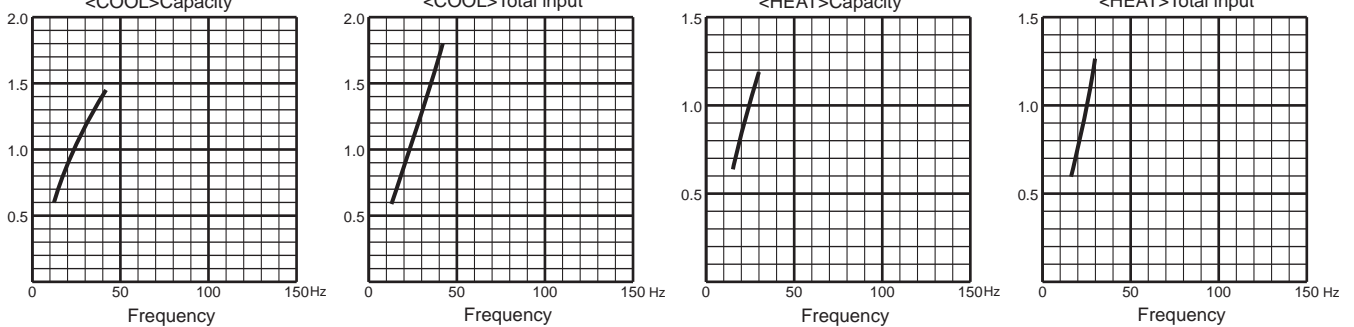

4. 22-class unit in single operation

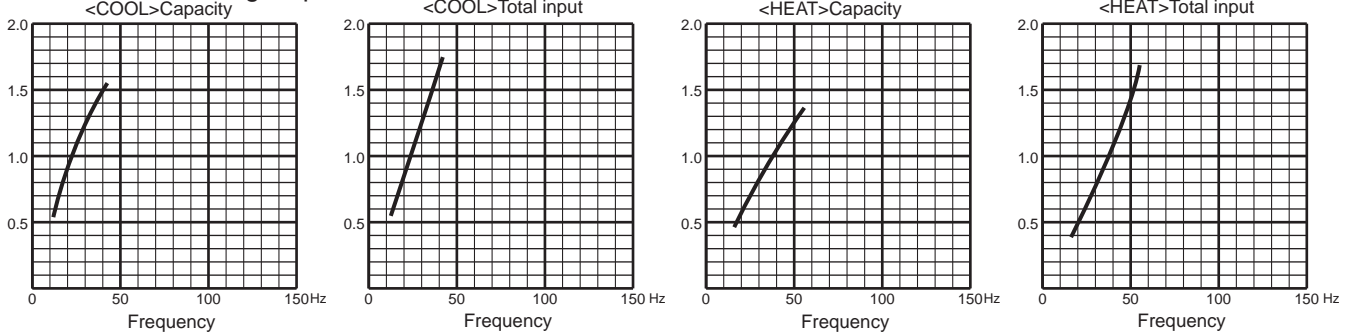

5. 25-class unit in single operation

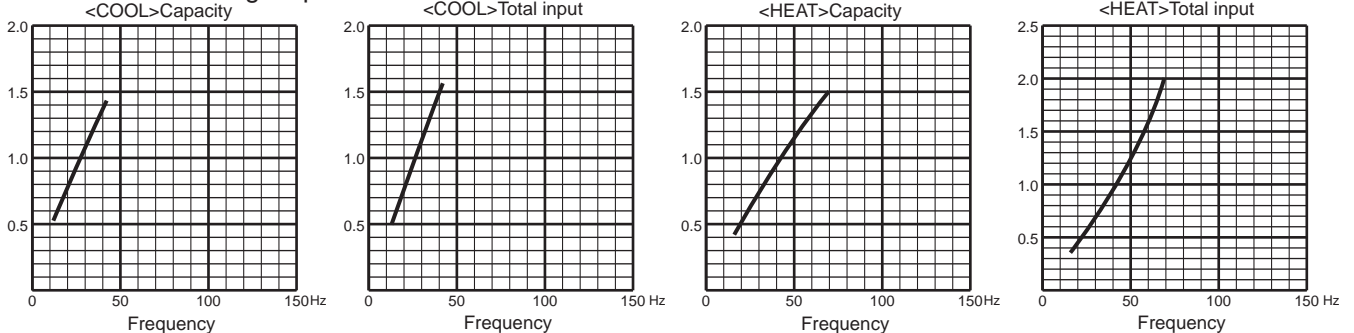

PERFORMANCE CURVES

MULTI SYSTEM

MXZ-2F42VF4

6. 35-class unit in single operation

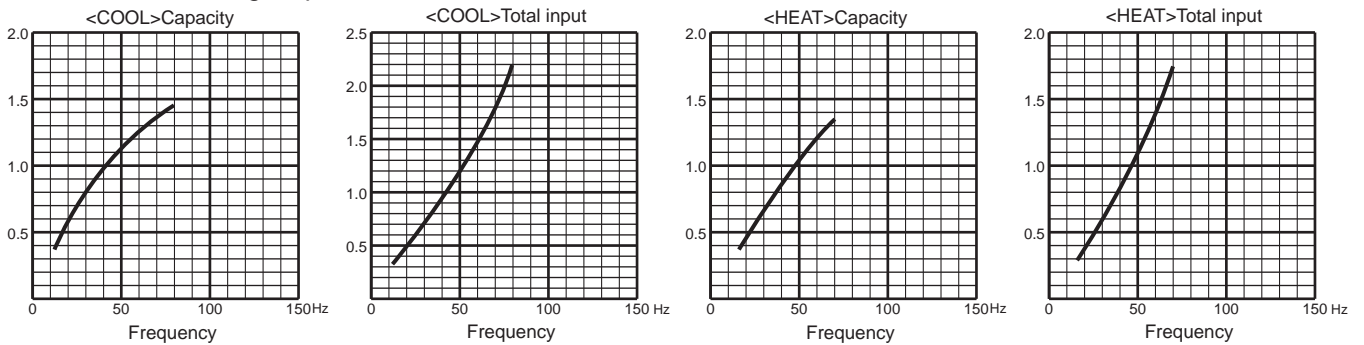

MXZ-2F53VF4 MXZ-2F53VFH4

1. 15-class unit in single operation

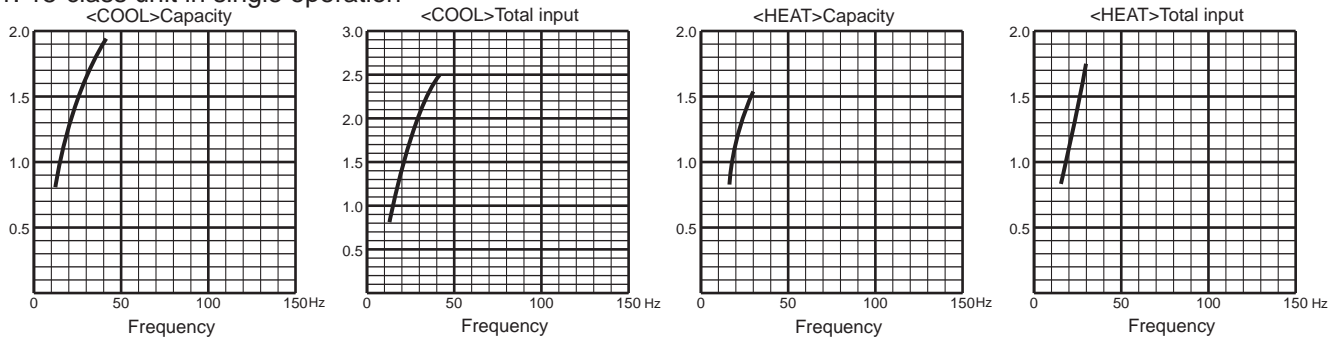

2. 18-class unit in single operation

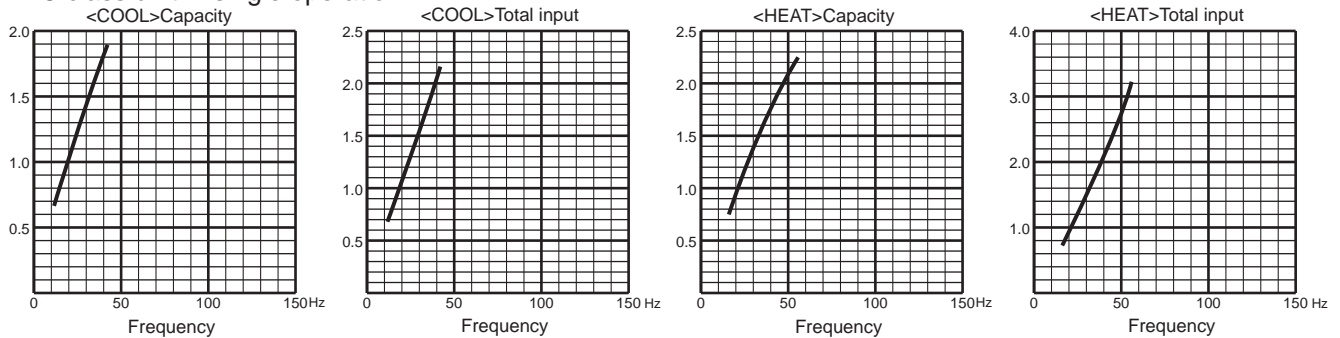

3. 20-class unit in single operation

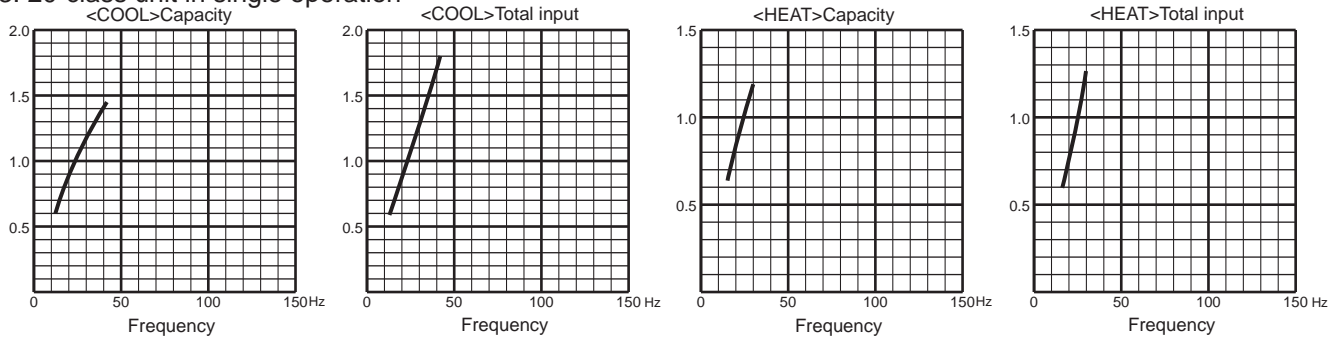

4. 22-class unit in single operation

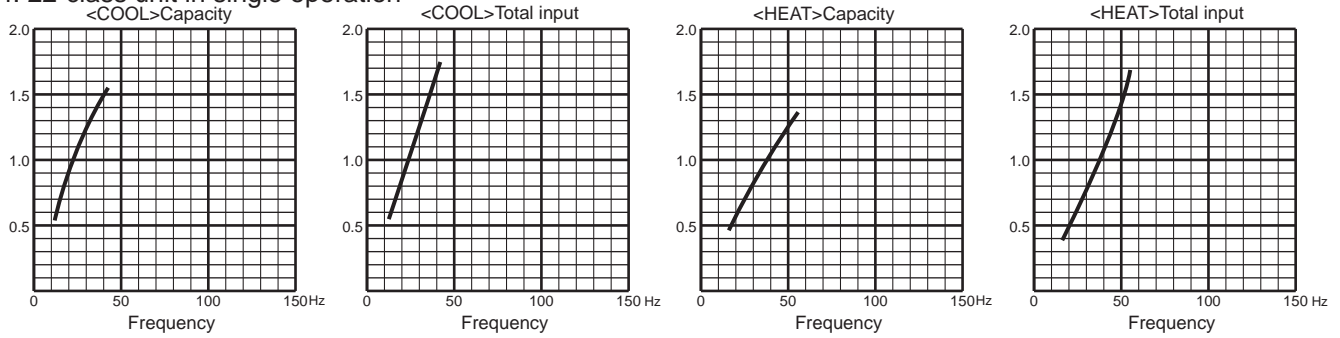

MULTI SYSTEM PERFORMANCE CURVES

MXZ-2F53VF4 MXZ-2F53VFH4

5. 25-class unit in single operation

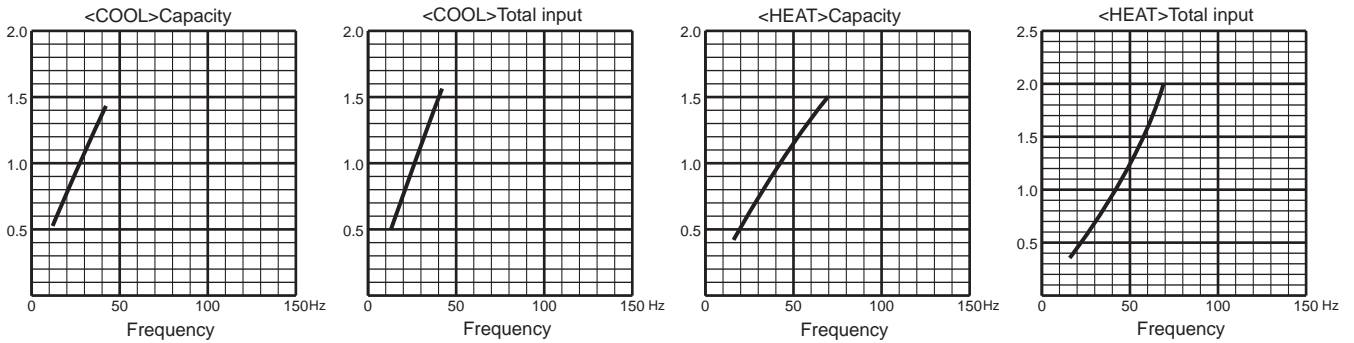

6. 35-class unit in single operation

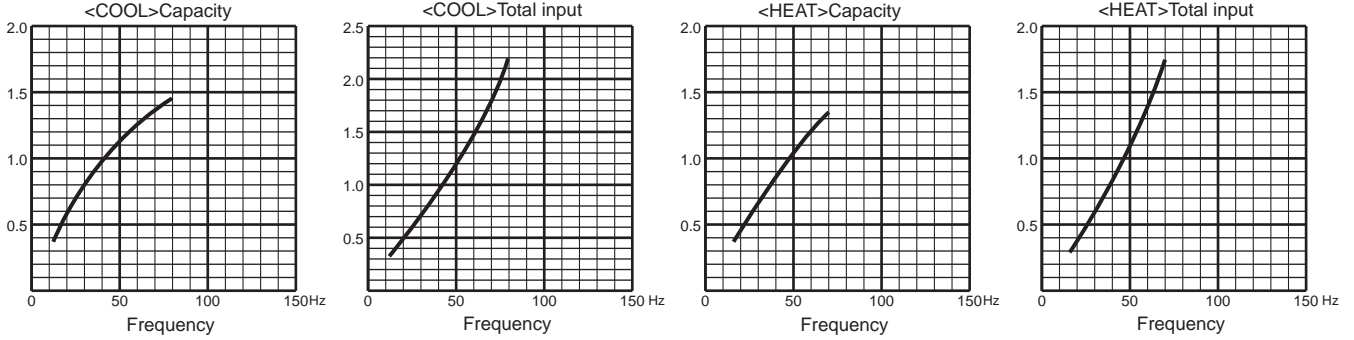

7. 42-class unit in single operation

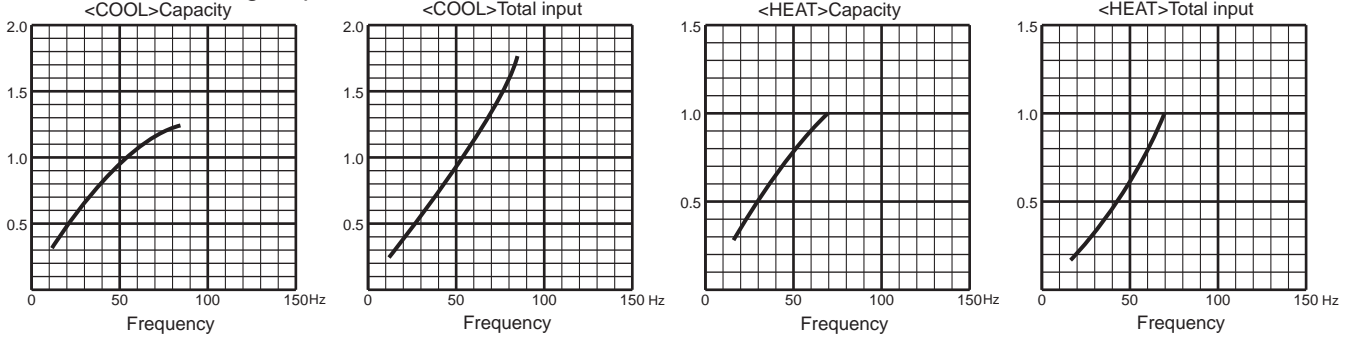

8. 50-class unit in single operation

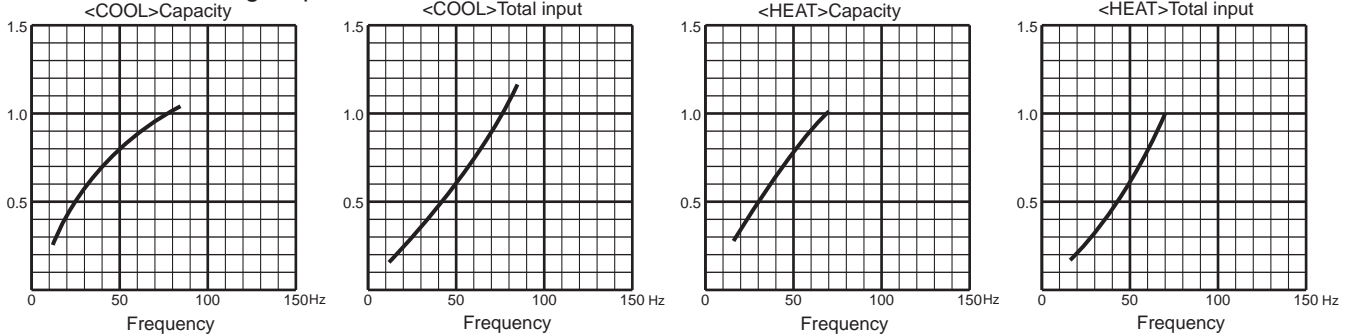

PERFORMANCE CURVES

MULTI SYSTEM

MXZ-3F54VF4

1. 15-class unit in single operation

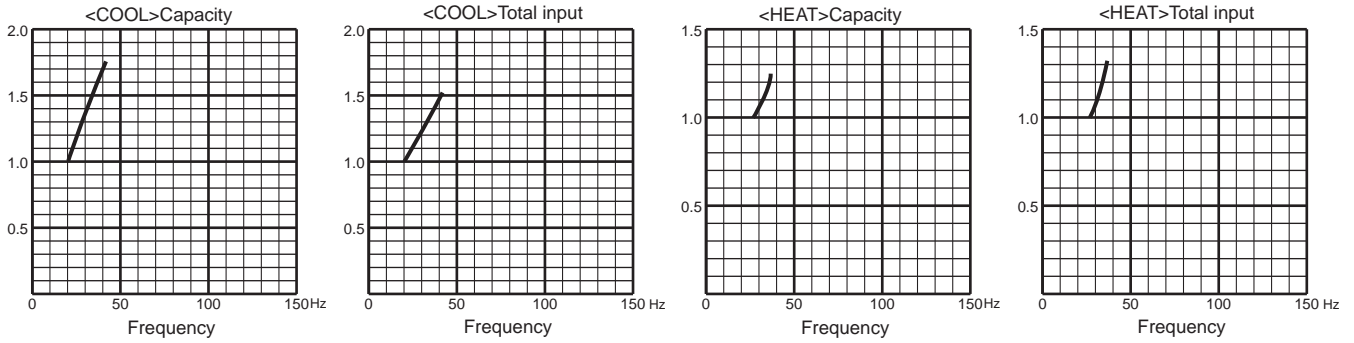

2. 18-class unit in single operation

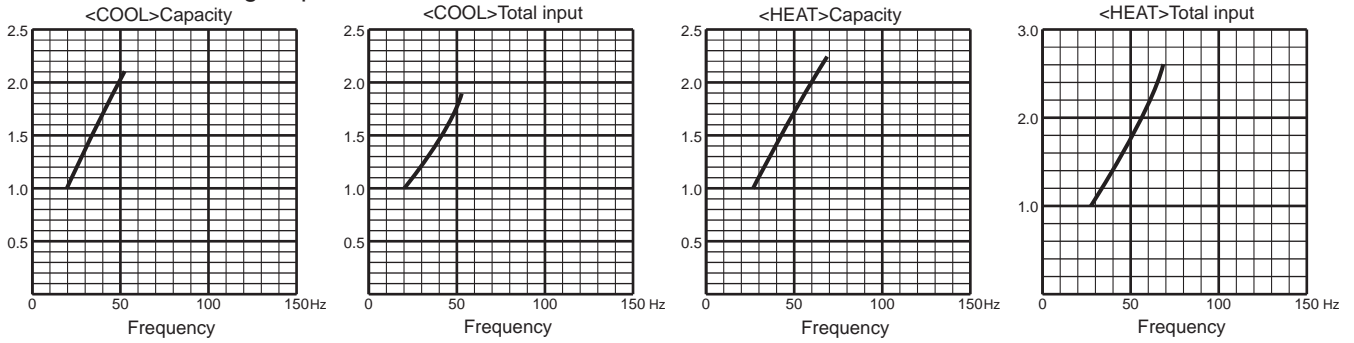

3. 20-class unit in single operation

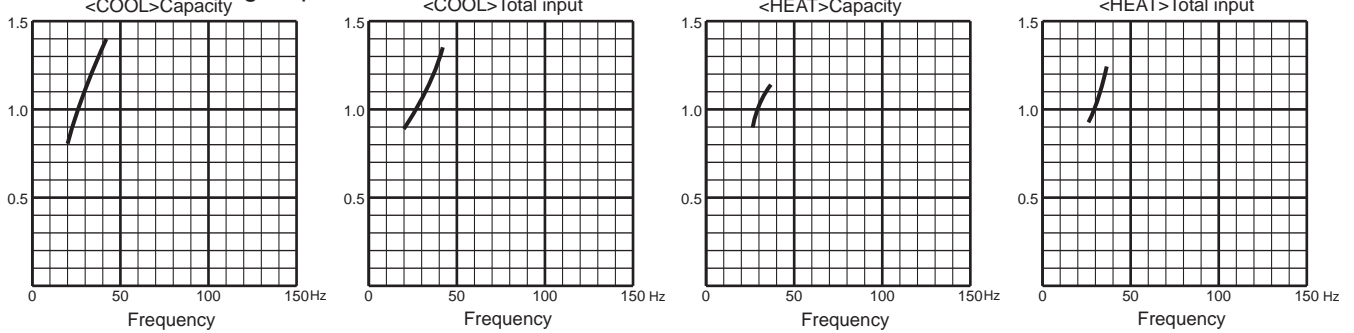

4. 22-class unit in single operation

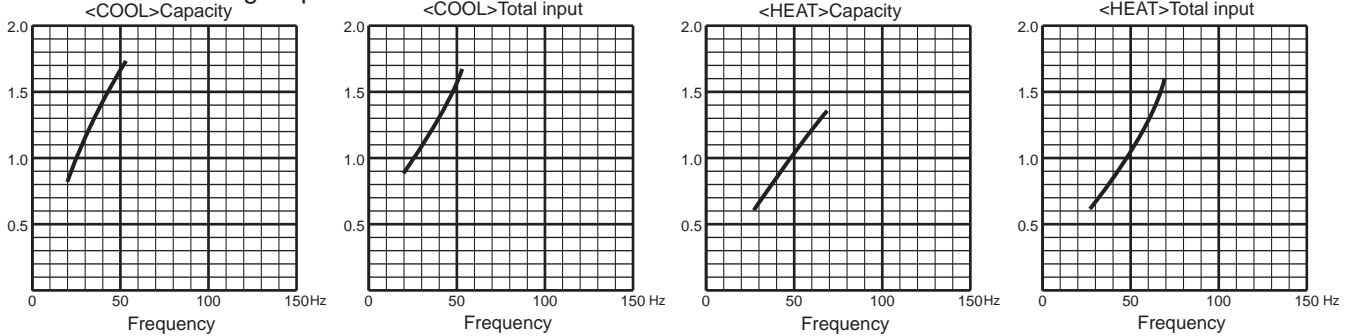

MXZ-3F54VF4

5. 25-class unit in single operation

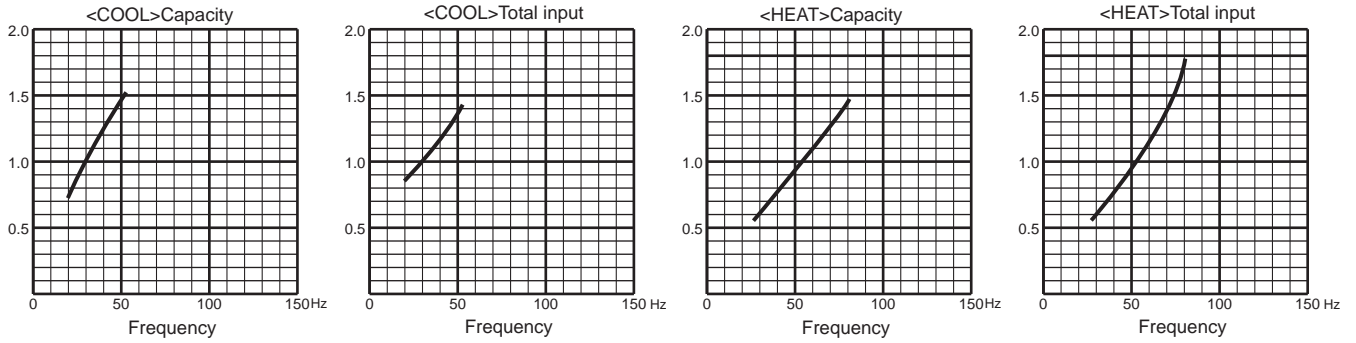

6. 35-class unit in single operation

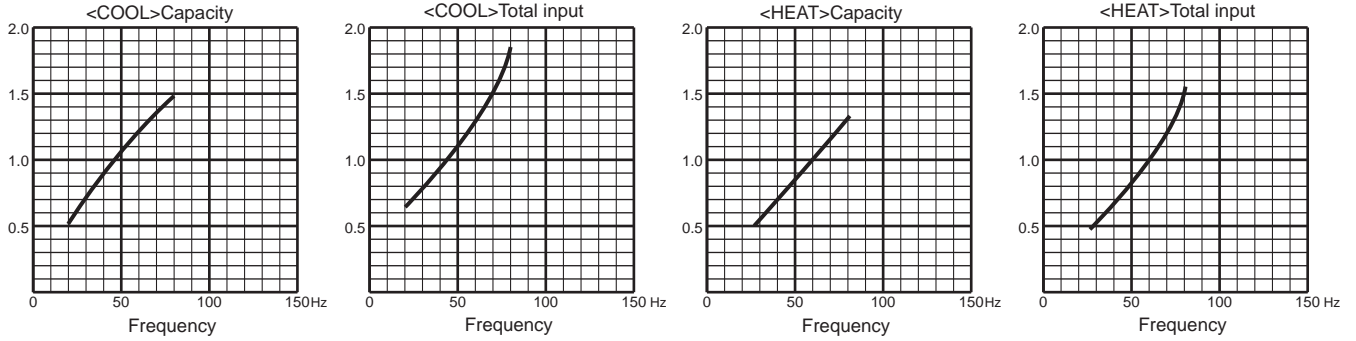

7. 42-class unit in single operation

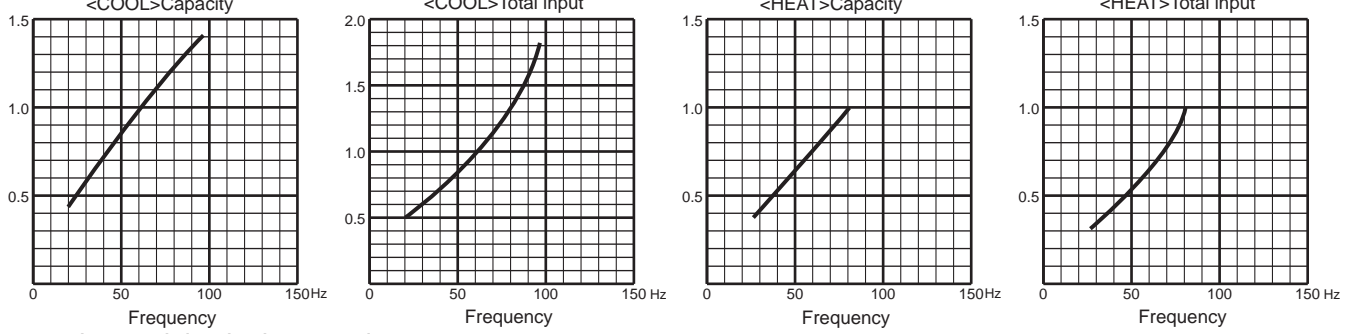

8. 50-class unit in single operation

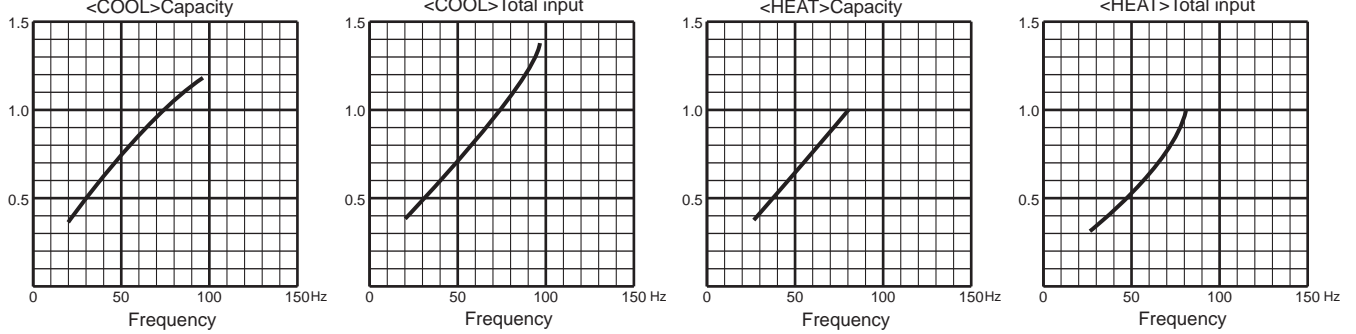

PERFORMANCE CURVES

MULTI SYSTEM

MXZ-3F68VF4

1. 15-class unit in single operation

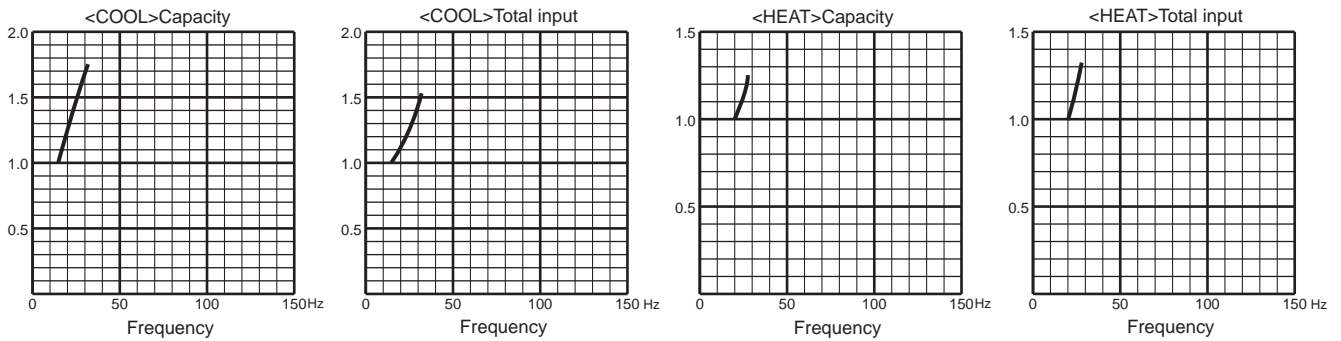

2. 18-class unit in single operation

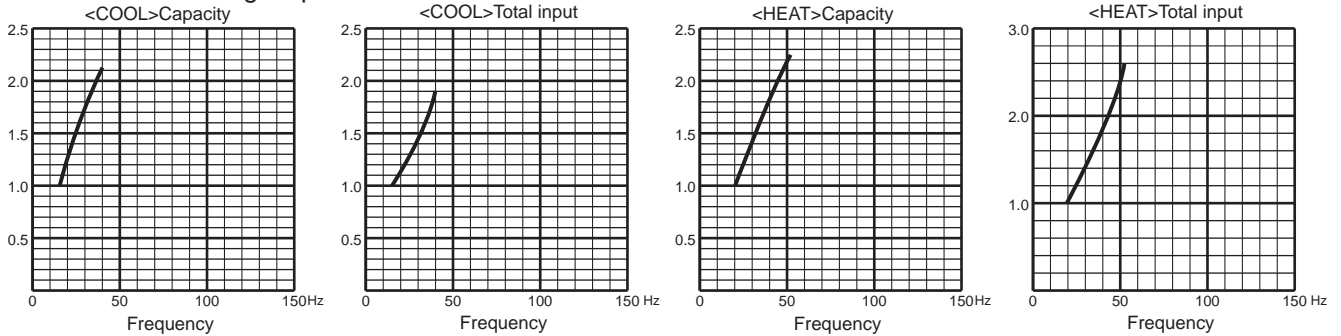

3. 20-class unit in single operation

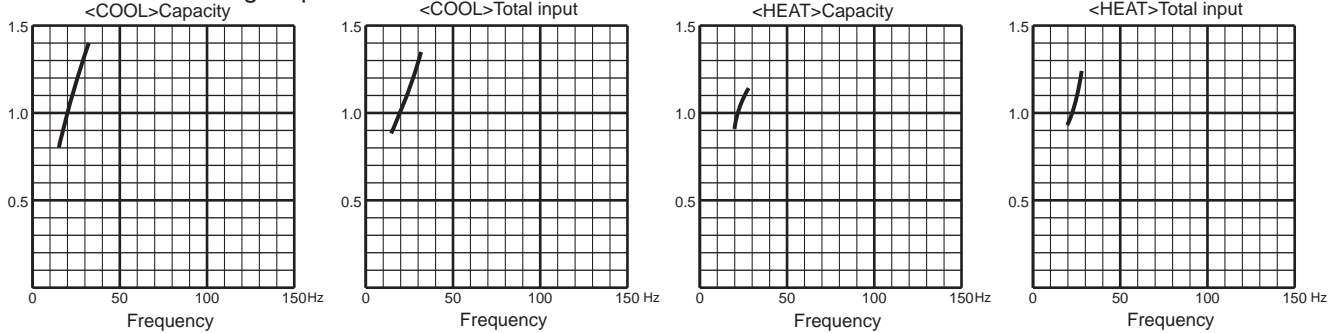

4. 22-class unit in single operation

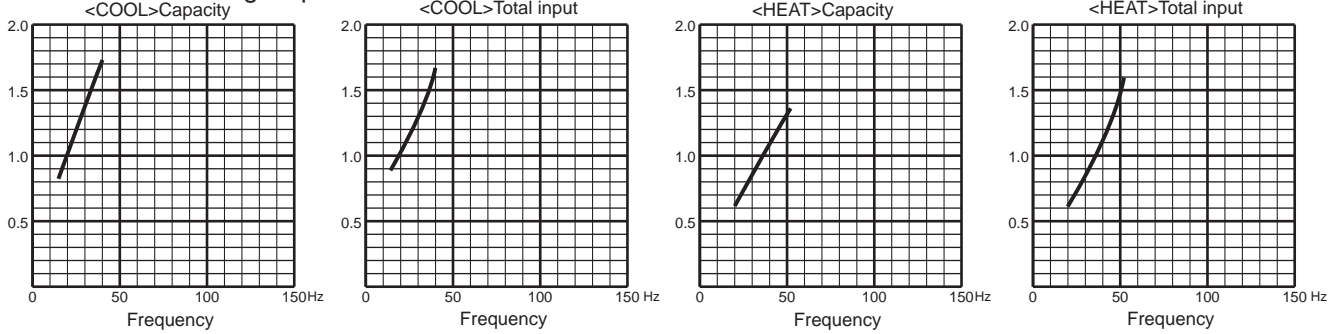

5. 25-class unit in single operation

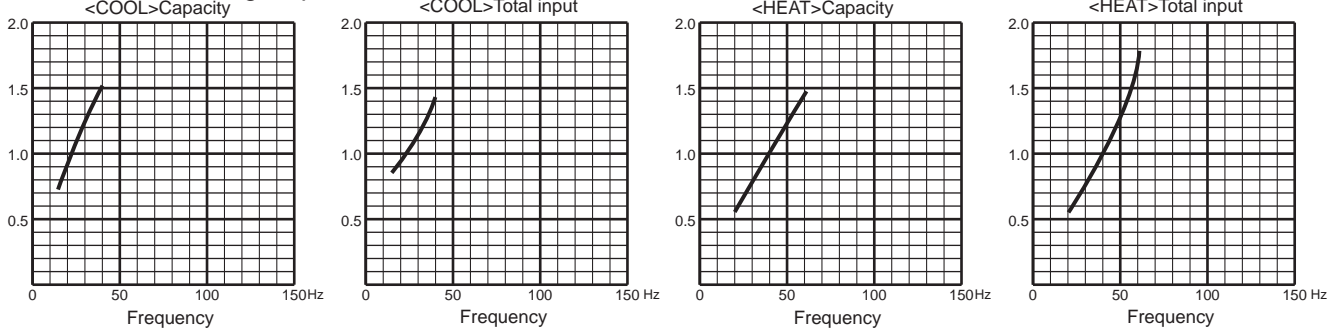

MXZ-3F68VF4

6. 35-class unit in single operation

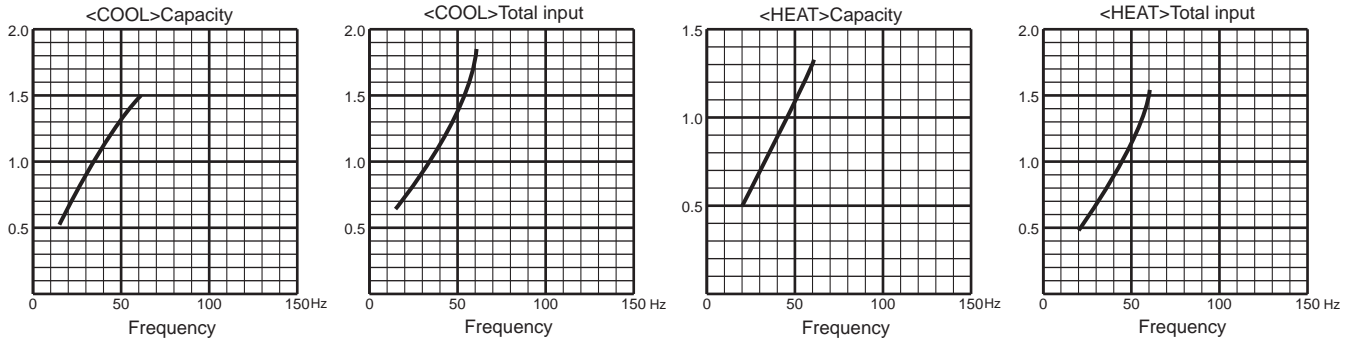

7. 42-class unit in single operation

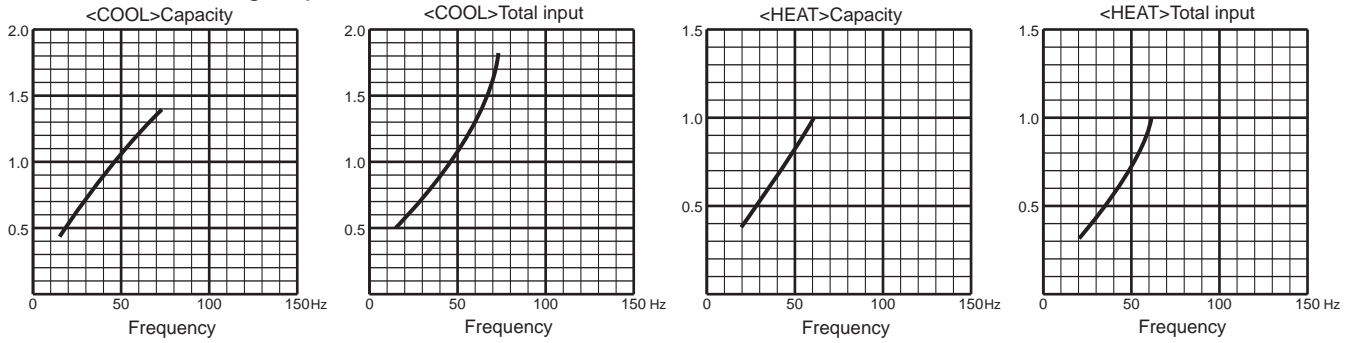

8. 50-class unit in single operation

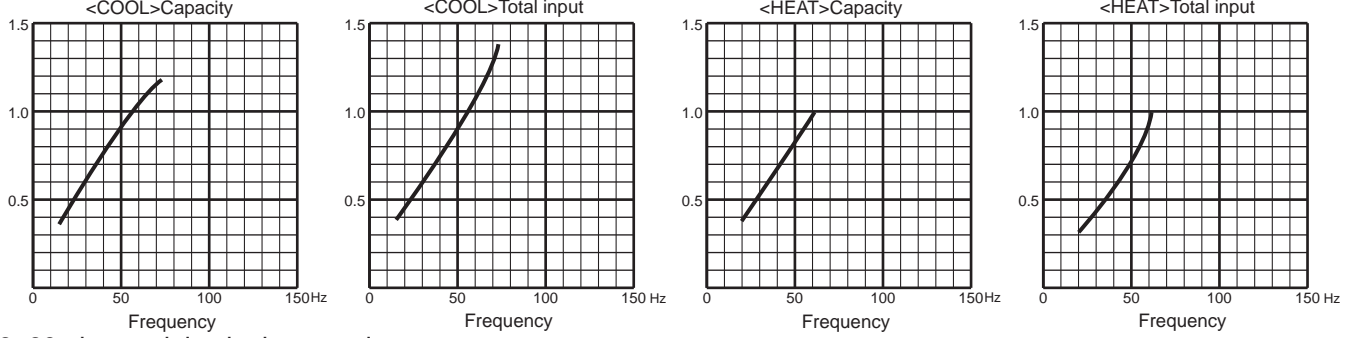

9. 60-class unit in single operation

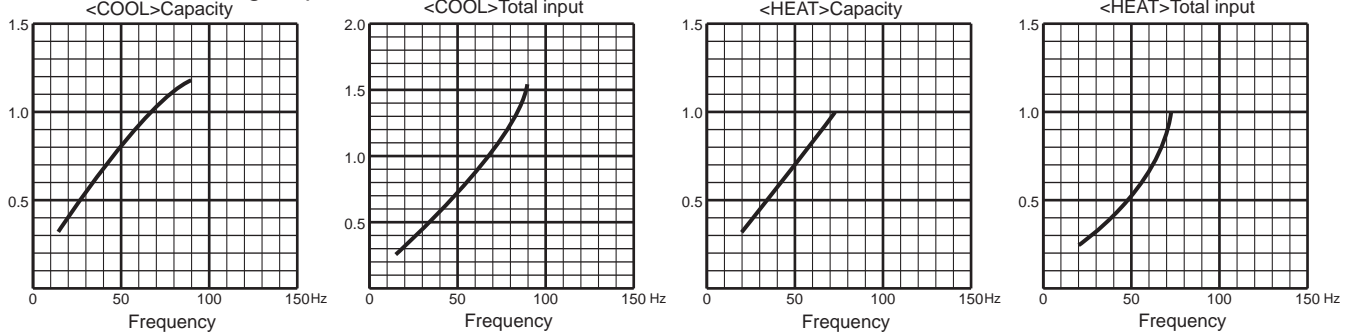

PERFORMANCE CURVES

MULTI SYSTEM

MXZ-4F72VF4

1. 15-class unit in single operation

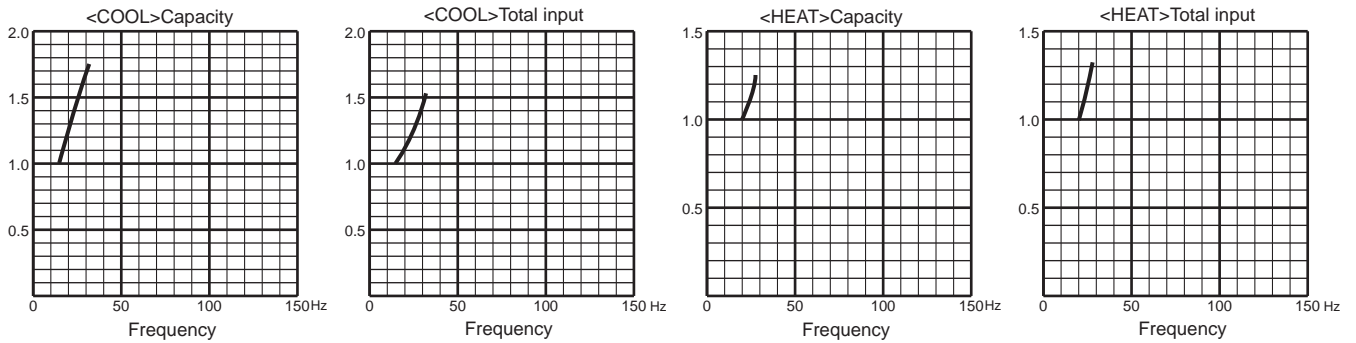

2. 18-class unit in single operation

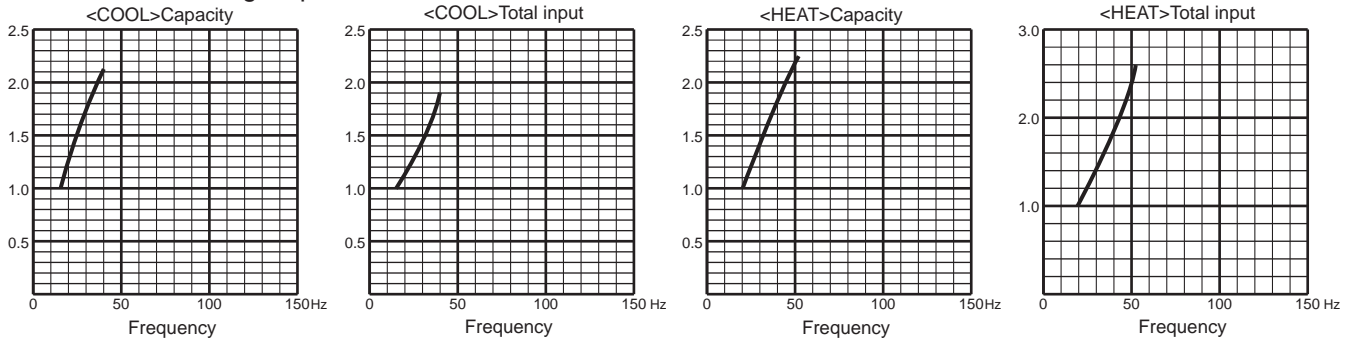

3. 20-class unit in single operation

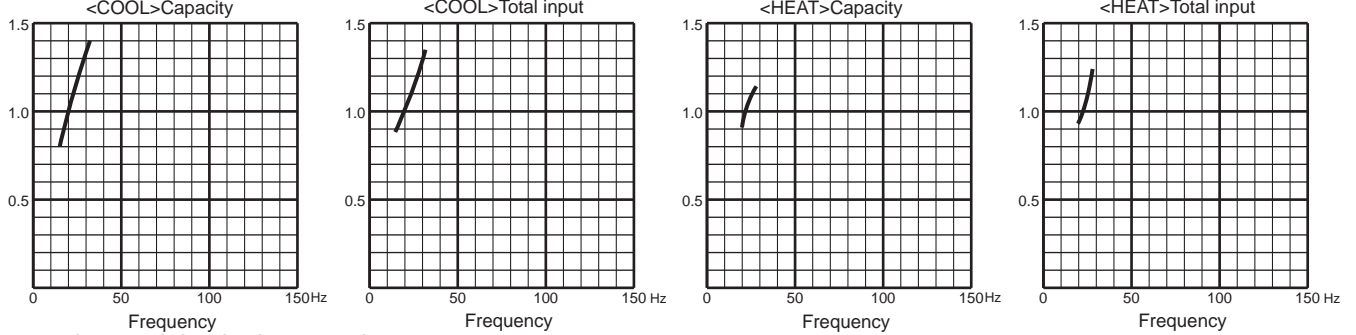

4. 22-class unit in single operation

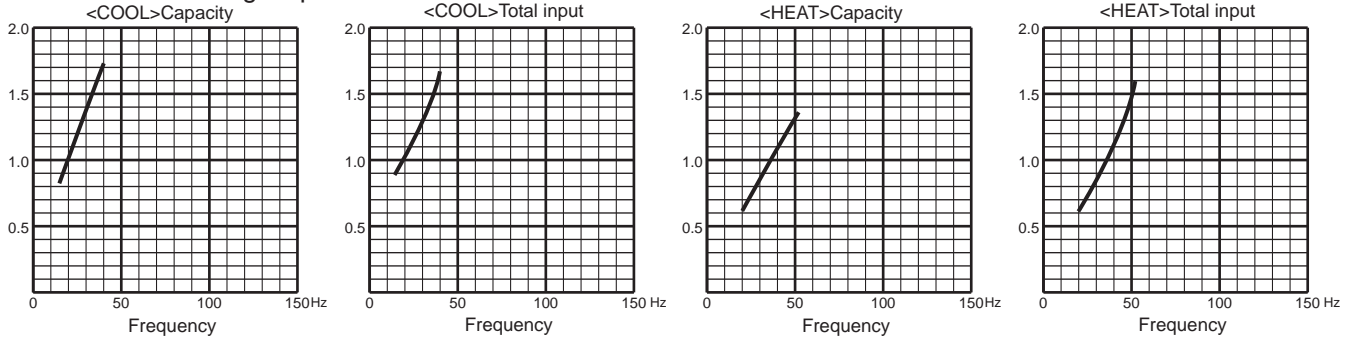

5. 25-class unit in single operation

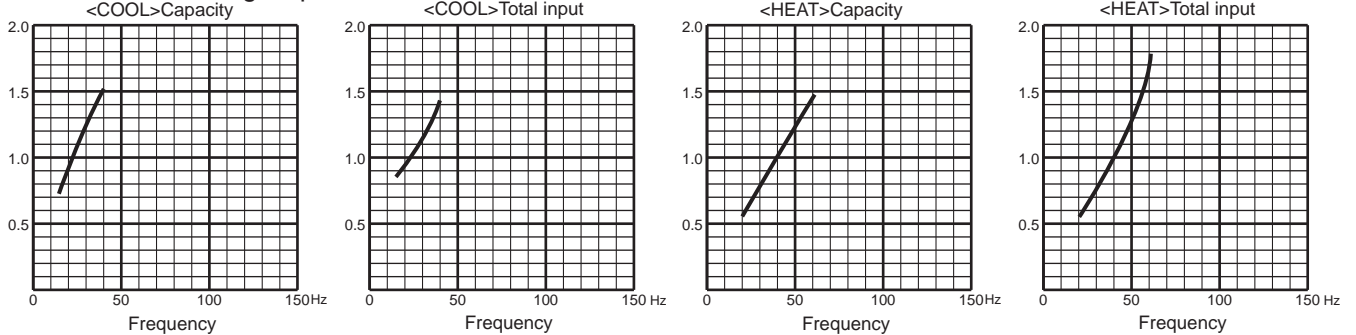

MXZ-4F72VF4

6. 35-class unit in single operation

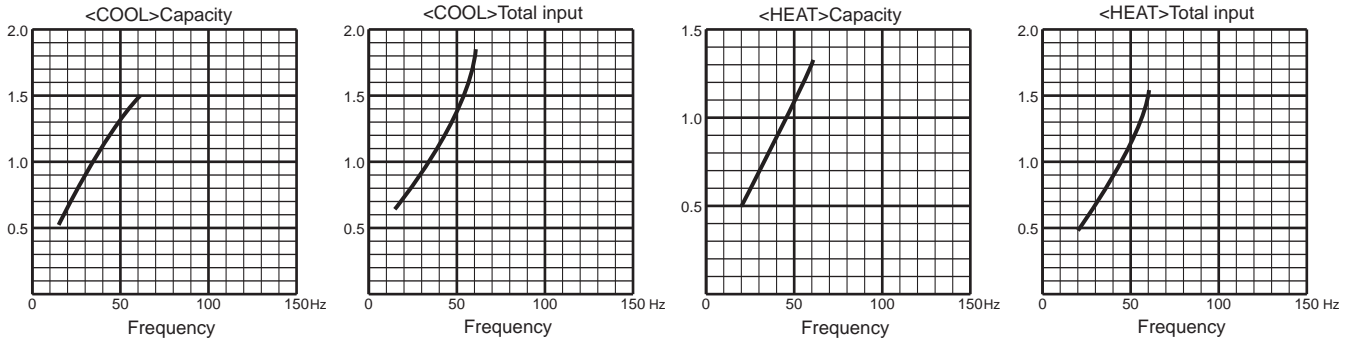

7. 42-class unit in single operation

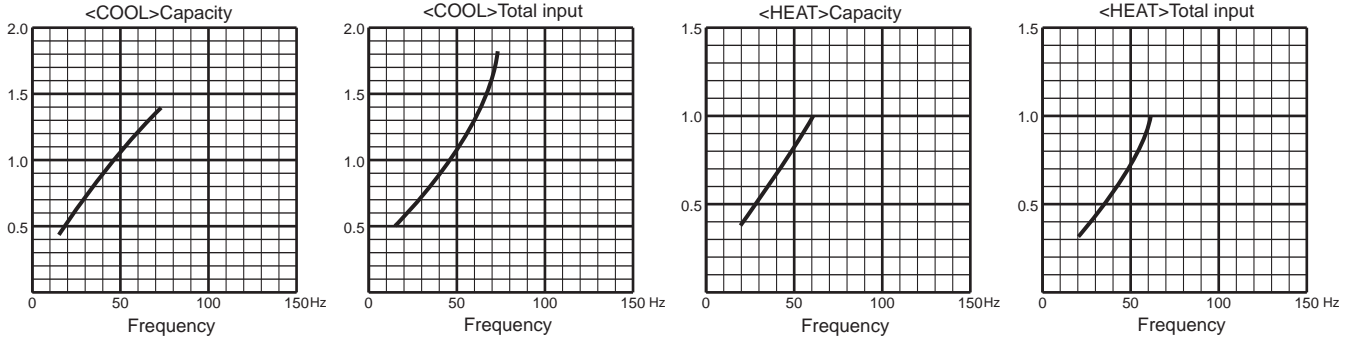

8. 50-class unit in single operation

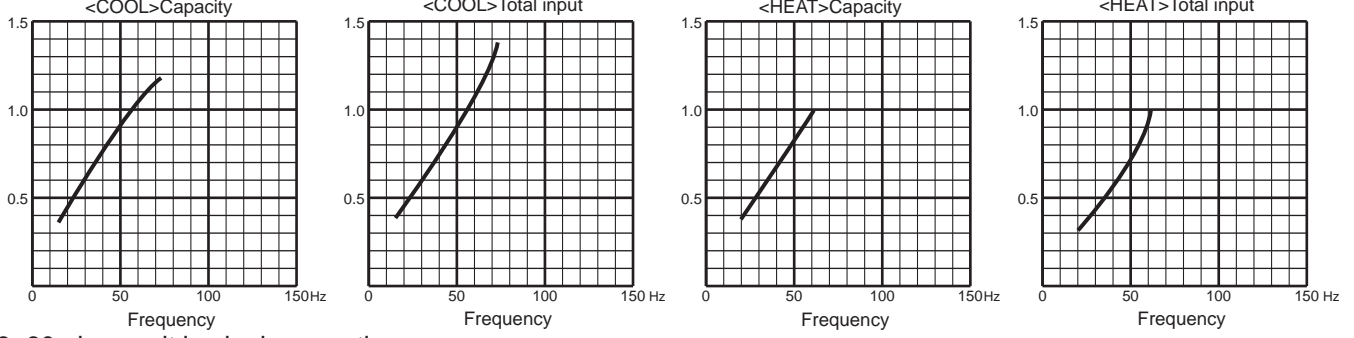

9. 60-class unit in single operation

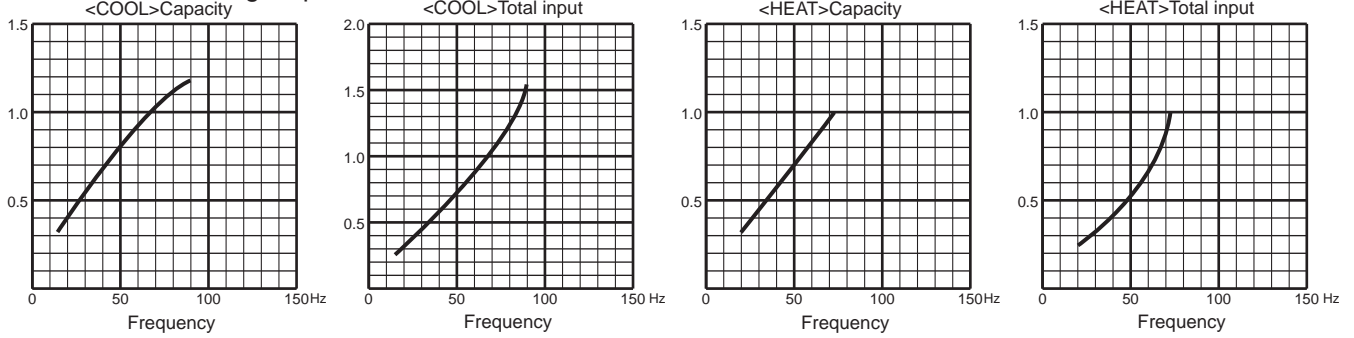

PERFORMANCE CURVES

MULTI SYSTEM

MXZ-4F80VF4

1. 15-class unit in single operation

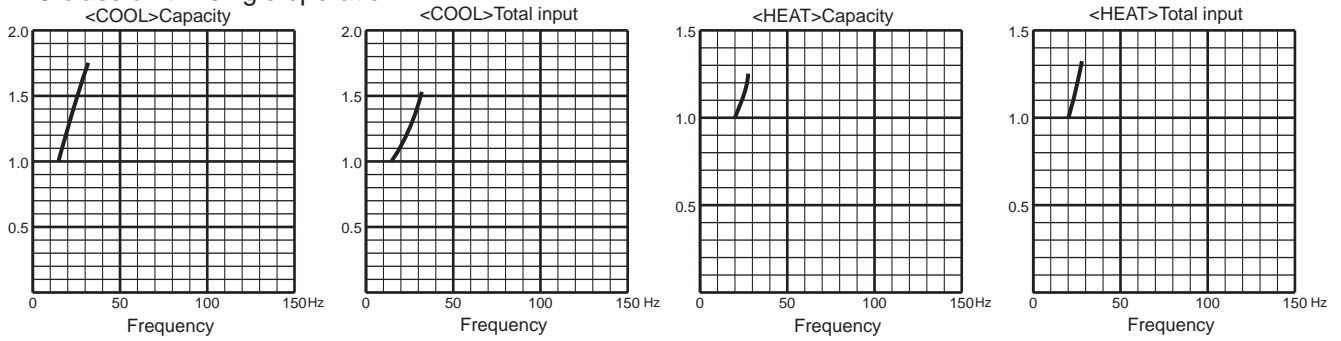

2. 18-class unit in single operation

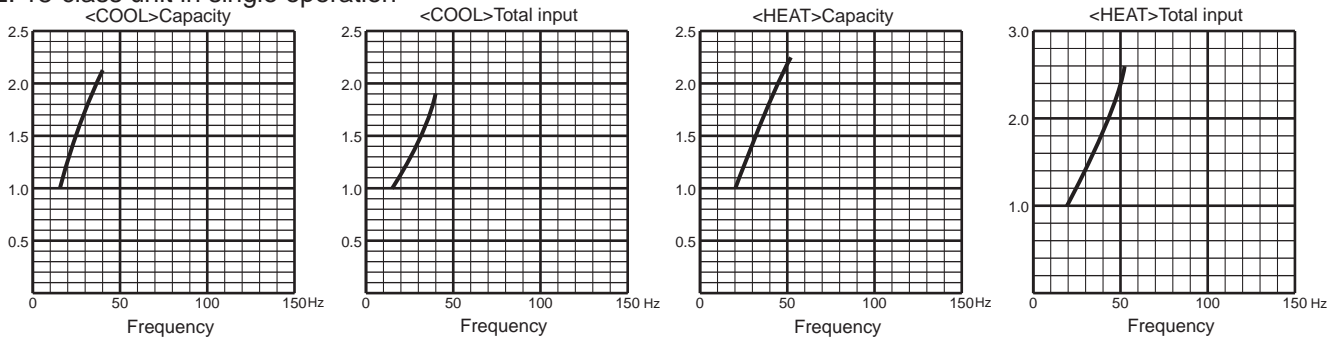

3. 20-class unit in single operation

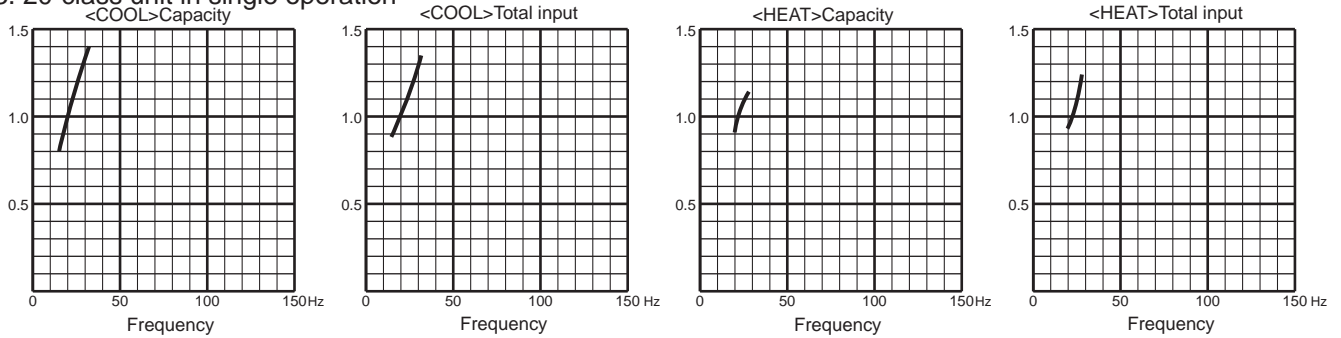

4. 22-class unit in single operation

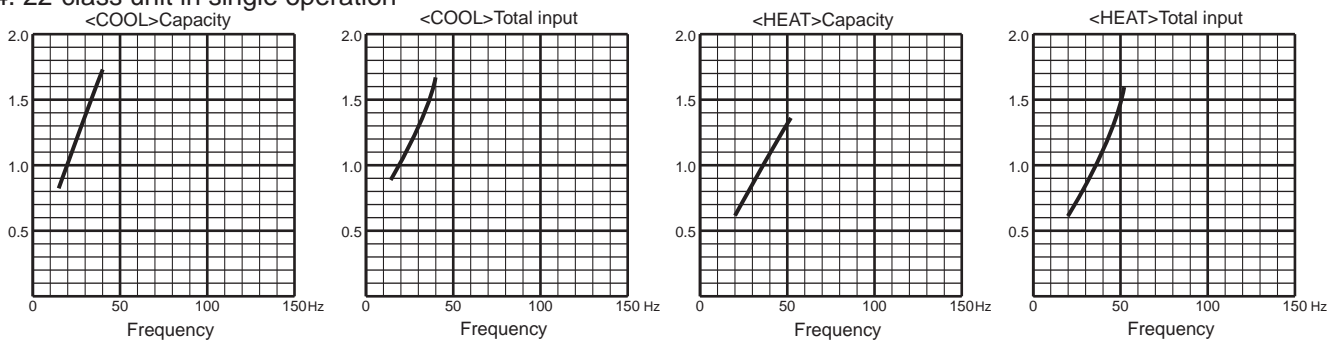

5. 25-class unit in single operation

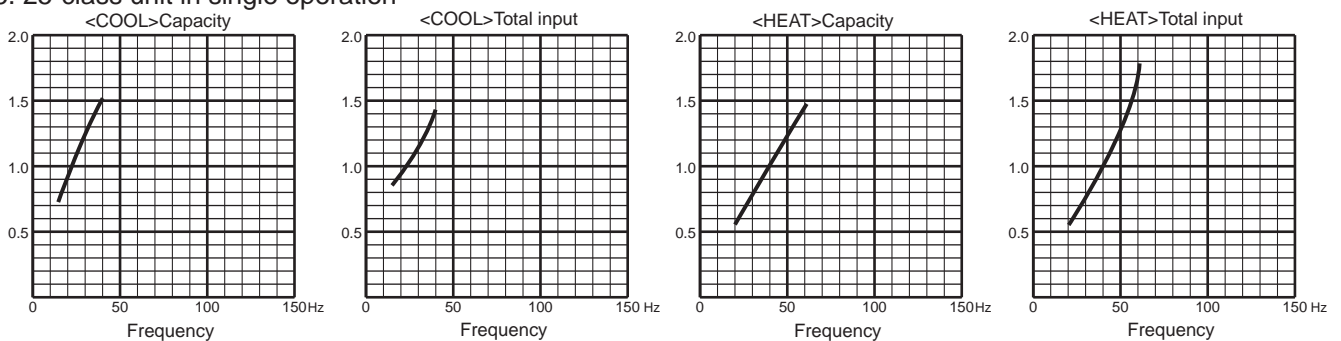

MXZ-4F80VF4

6. 35-class unit in single operation

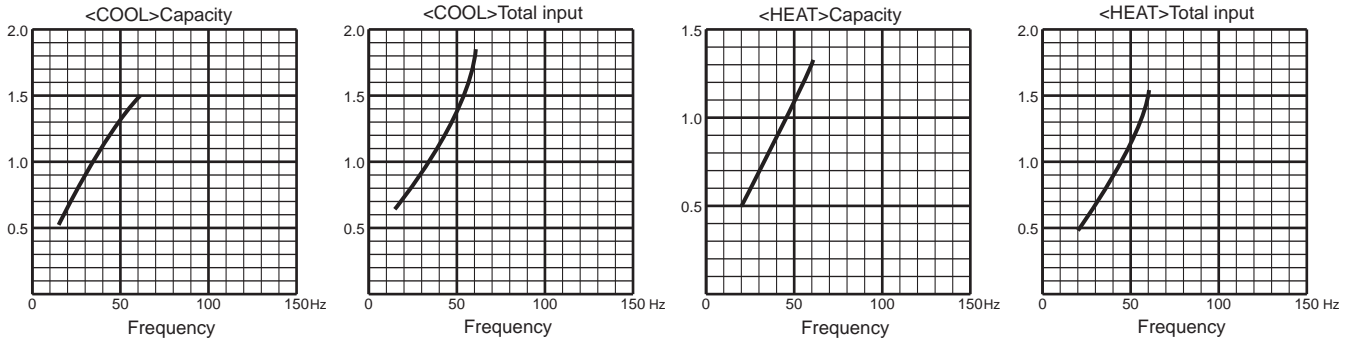

7. 42-class unit in single operation

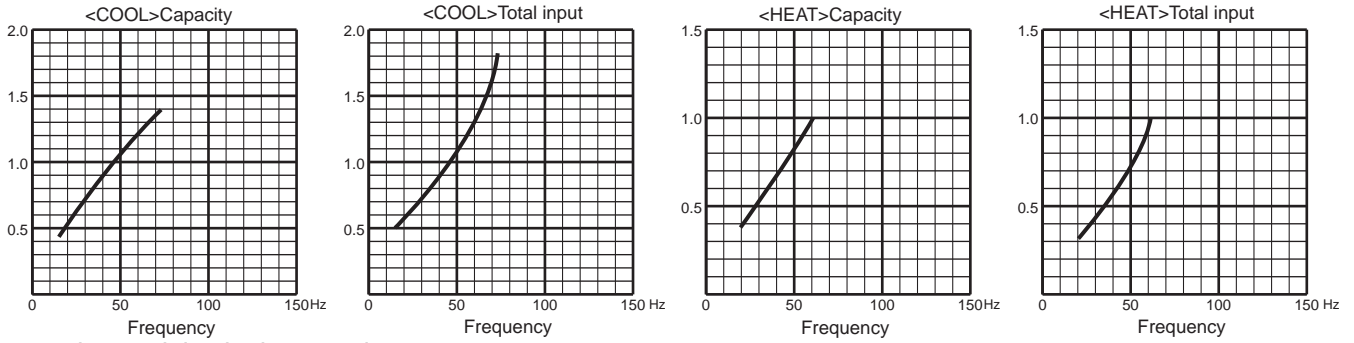

8. 50-class unit in single operation

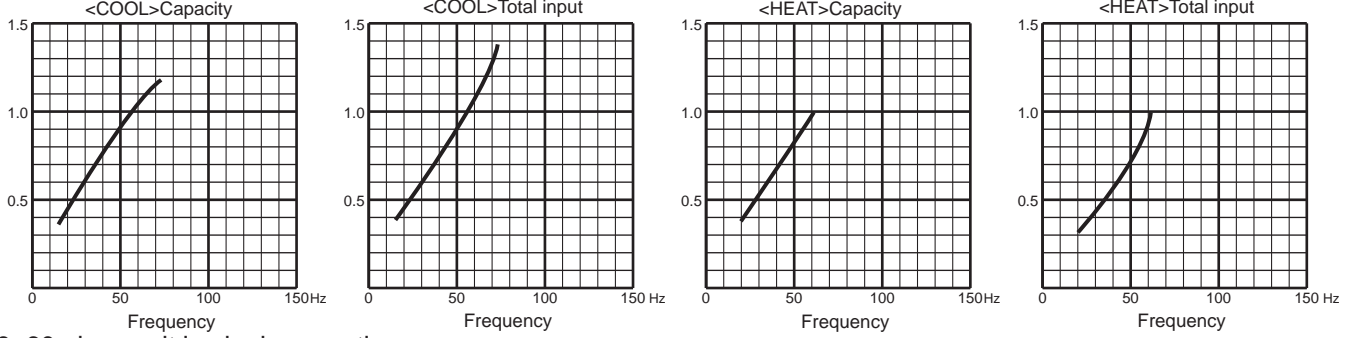

9. 60-class unit in single operation

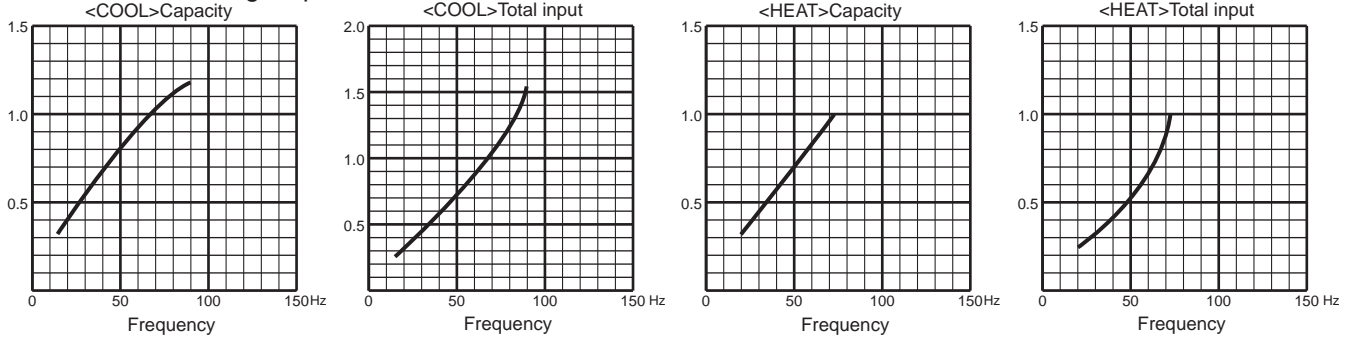

PERFORMANCE CURVES

MULTI SYSTEM

MXZ-4F83VF2

1. 15-class unit in single operation

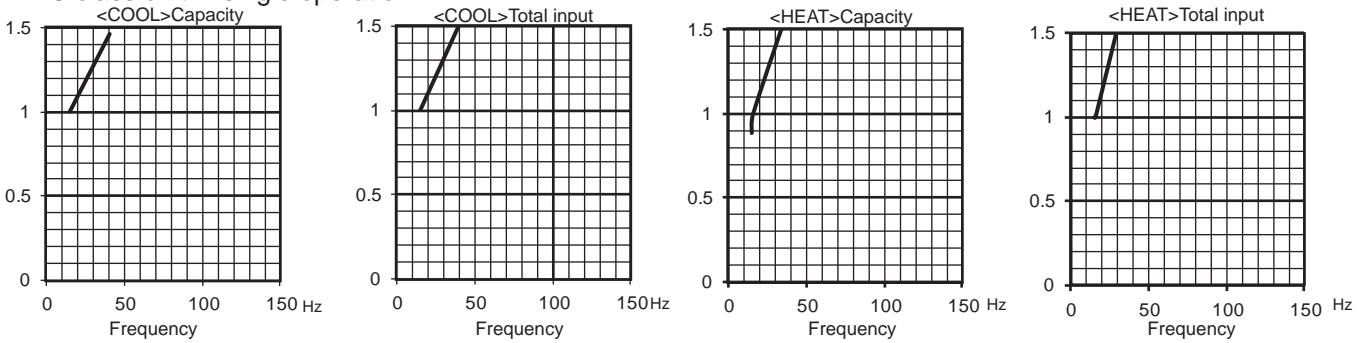

2. 18-class unit in single operation

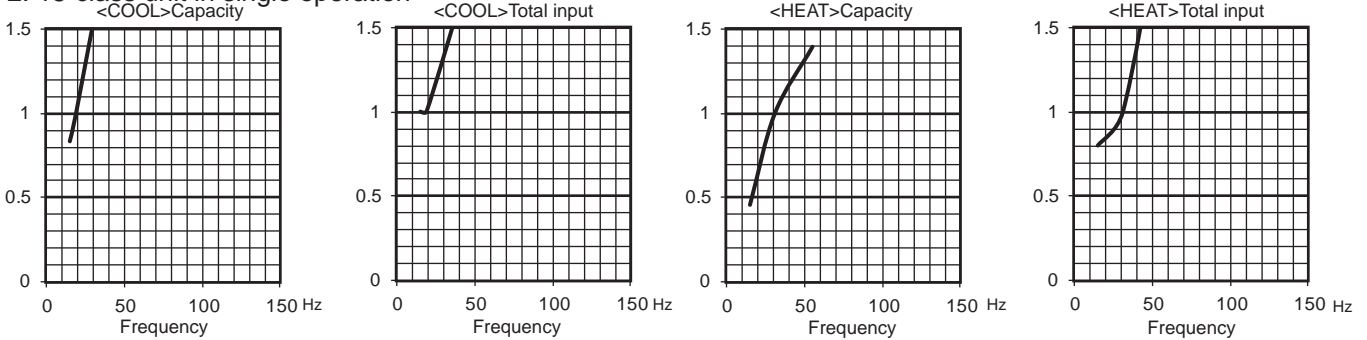

3. 20-class unit in single operation

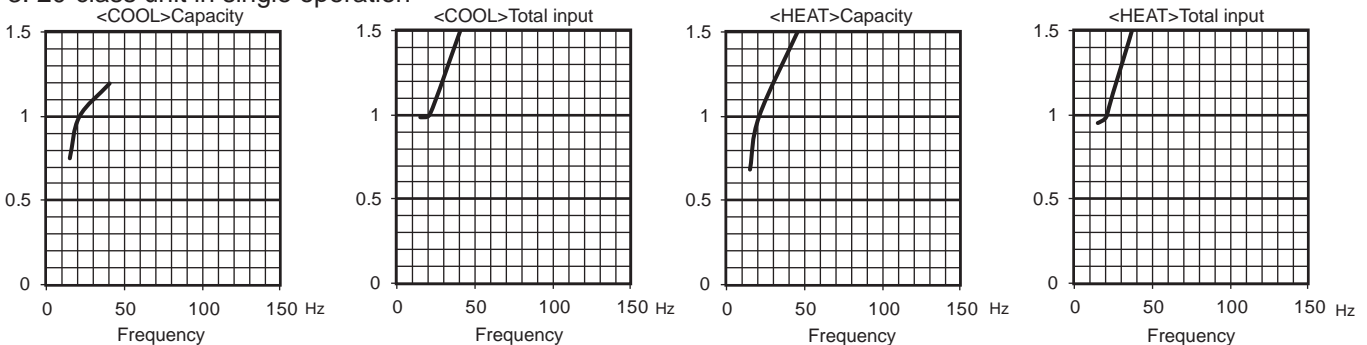

4. 22-class unit in single operation

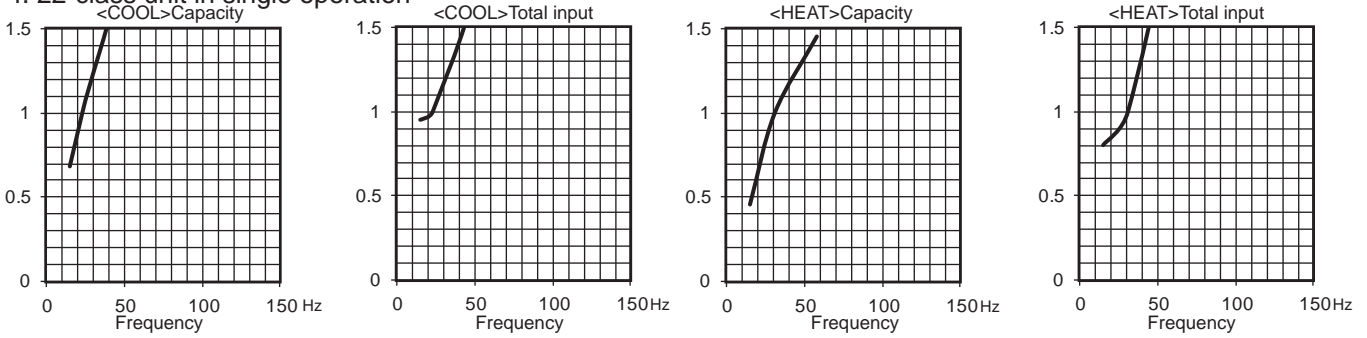

5. 25-class unit in single operation

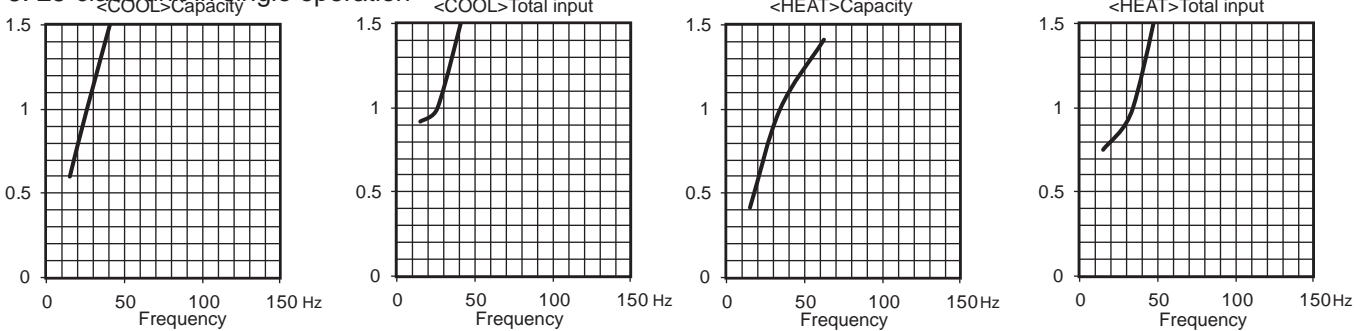

MXZ-4F83VF2

6. 35-class unit in single operation

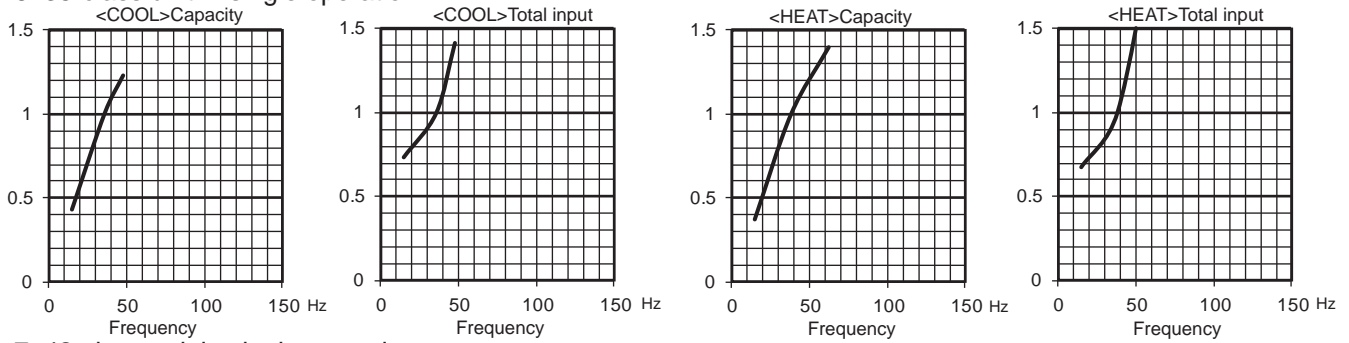

7. 42-class unit in single operation

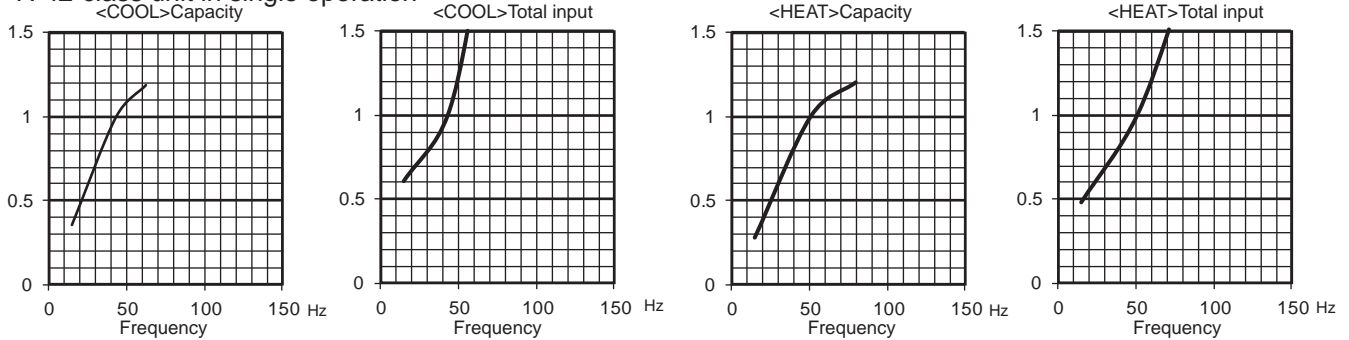

8. 50-class unit in single operation

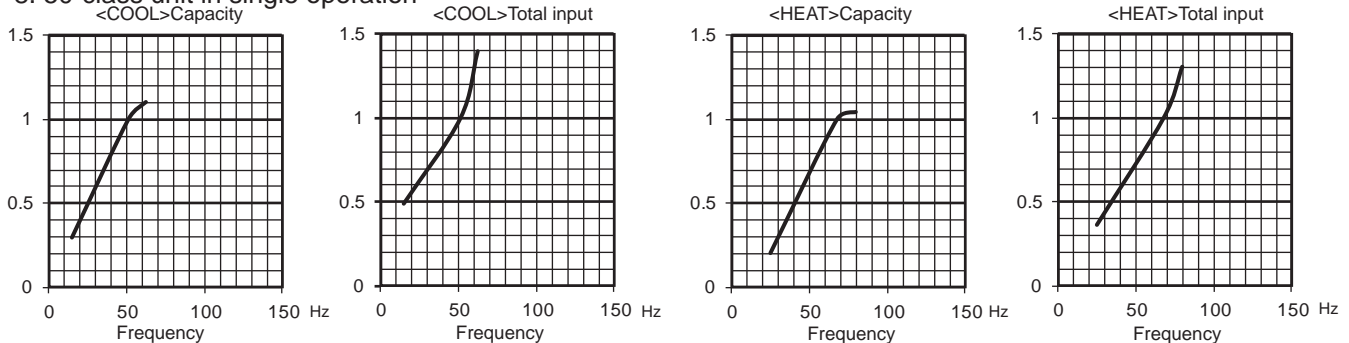

9. 60-class unit in single operation

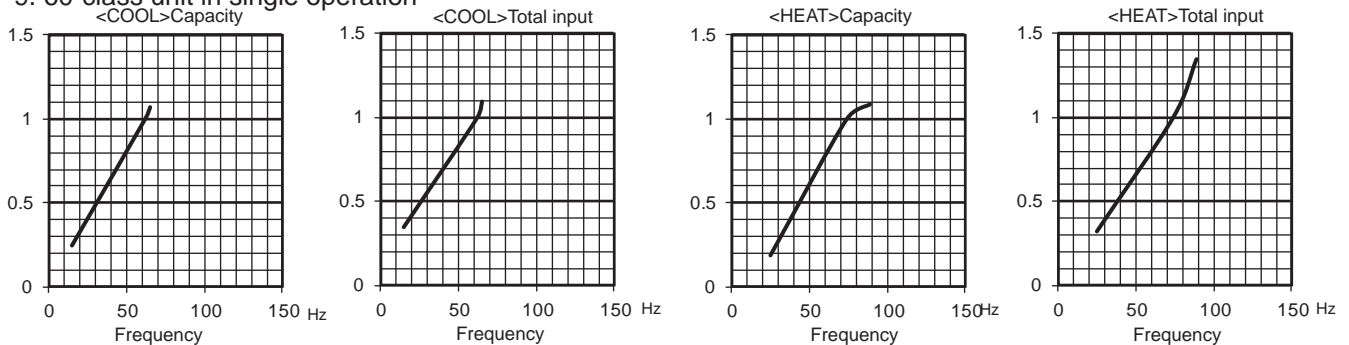

10. 71-class unit in single operation

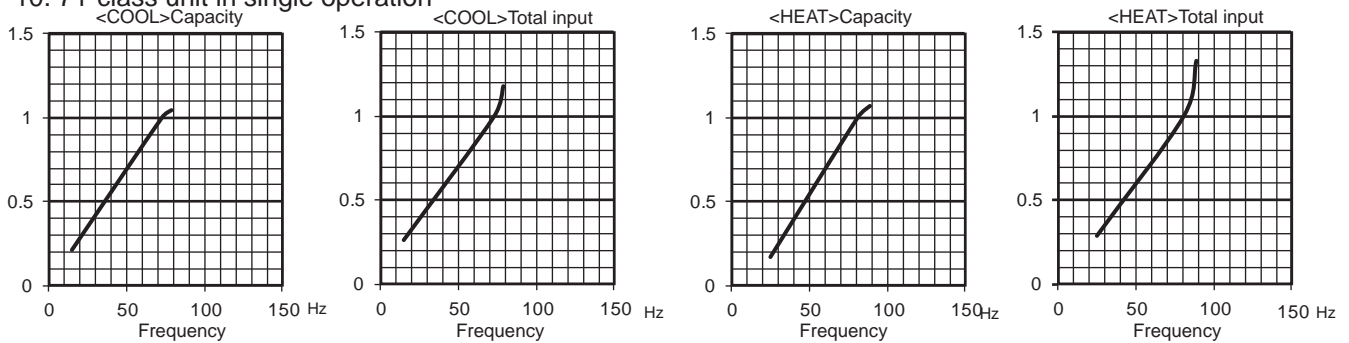

PERFORMANCE CURVES

MULTI SYSTEM

MXZ-5F102VF2

1. 15-class unit in single operation

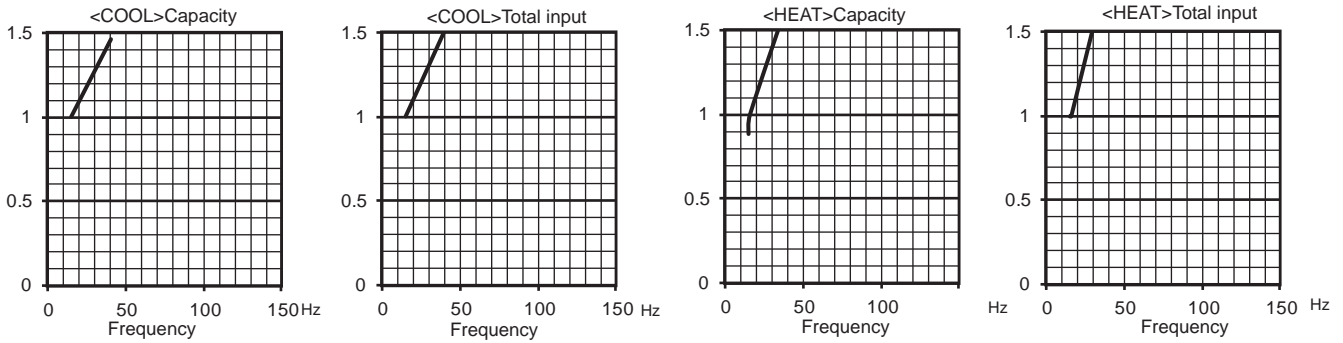

2. 18-class unit in single operation

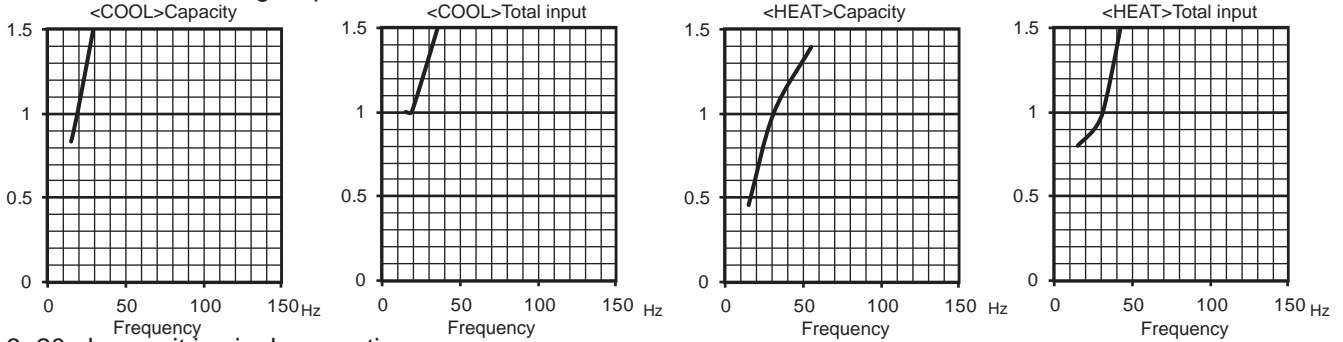

3. 20-class unit in single operation

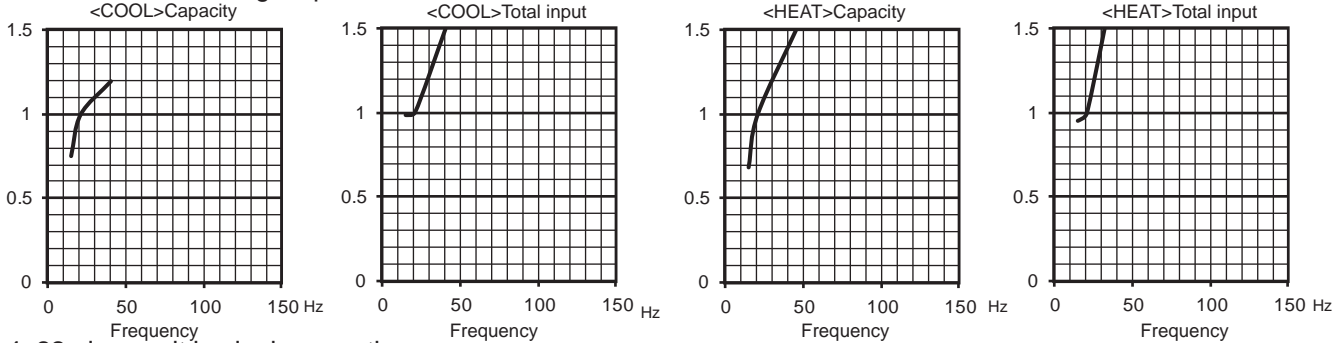

4. 22-class unit in single operation

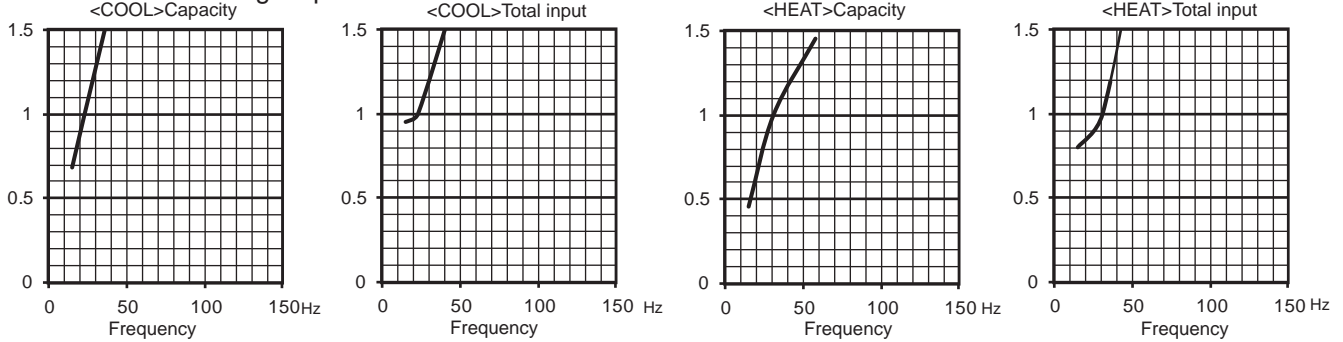

5. 25-class unit in single operation

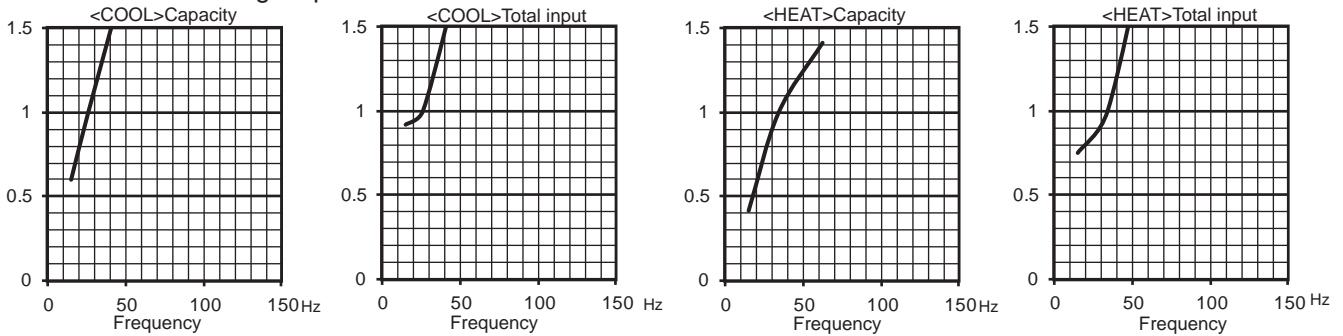

MXZ-5F102VF2

6. 35-class unit in single operation

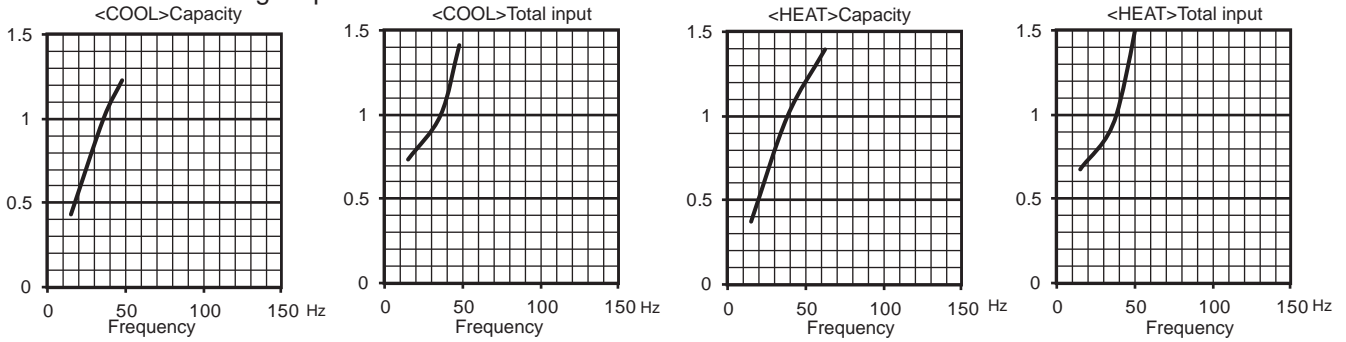

7. 42-class unit in single operation

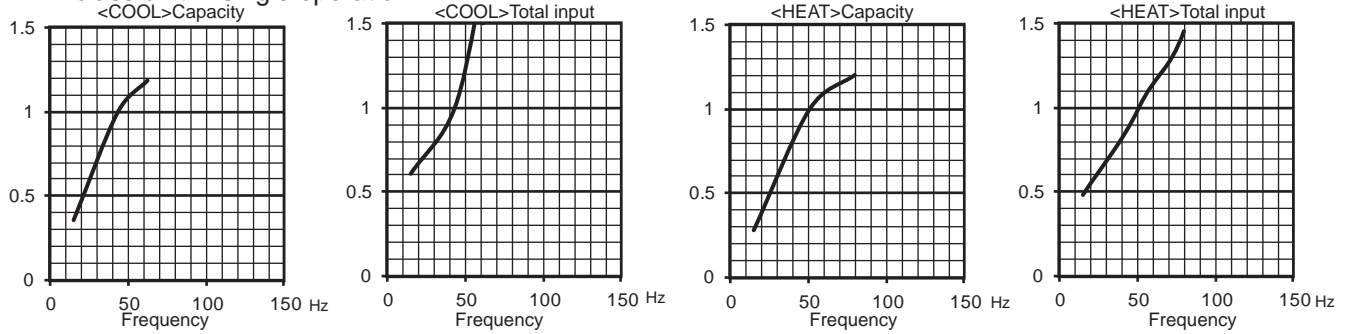

8. 50-class unit in single operation

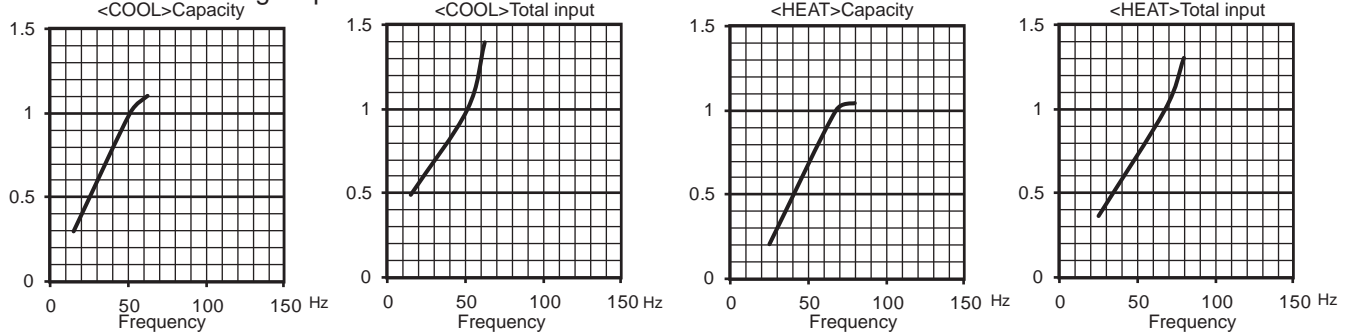

9. 60-class unit in single operation

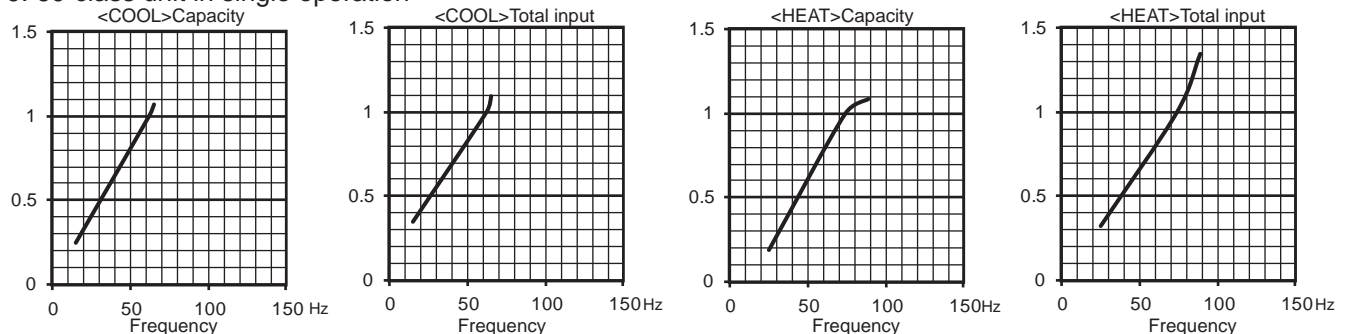

10. 71-class unit in single operation

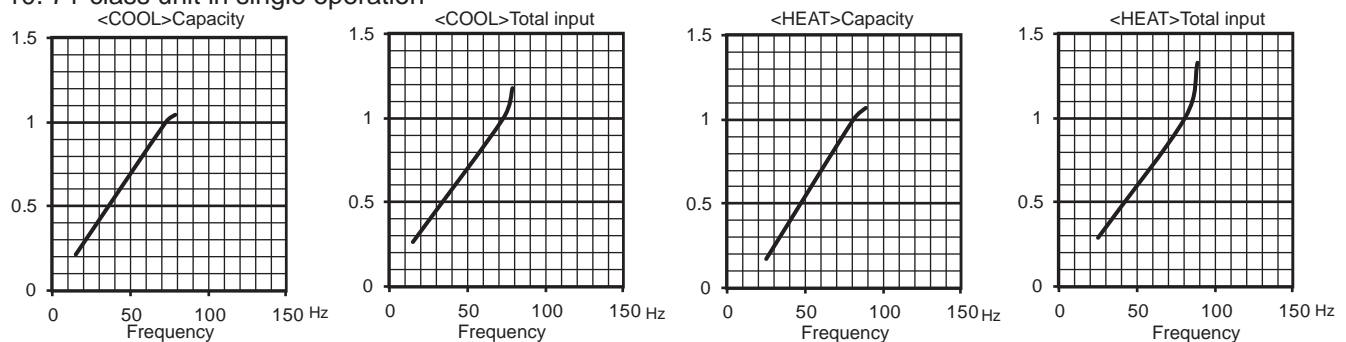

PERFORMANCE CURVES

MULTI SYSTEM

MXZ-6F120VF2

1. 15-class unit in single operation

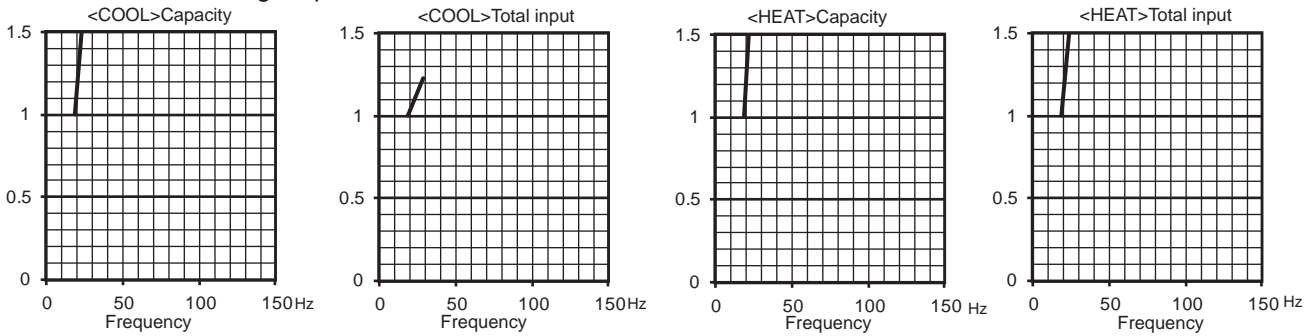

2. 18-class unit in single operation

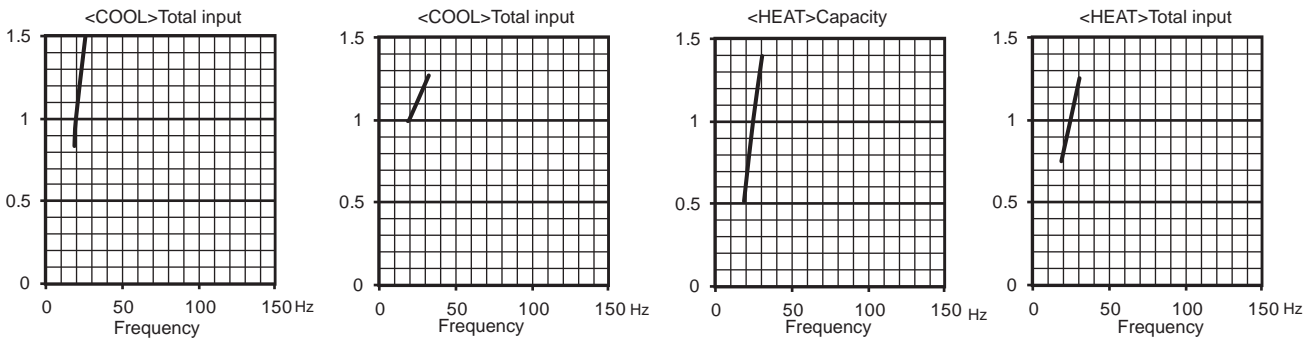

3. 20-class unit in single operation

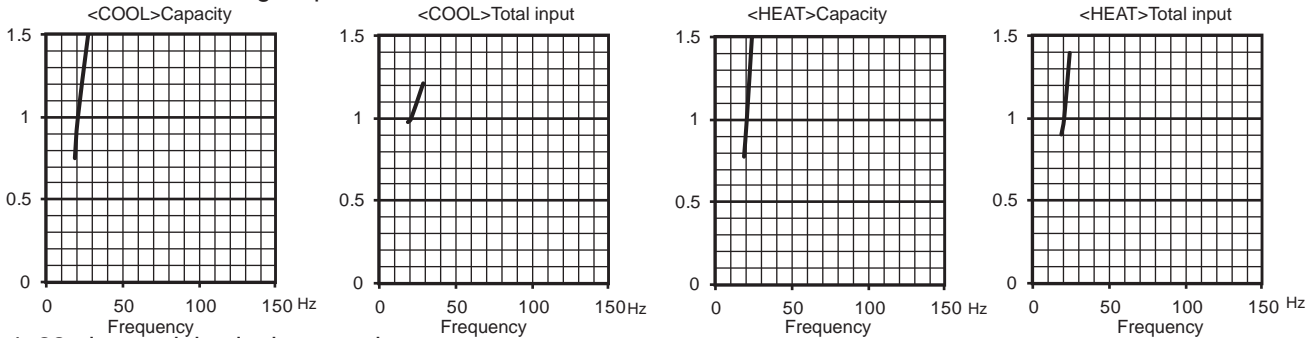

4. 22-class unit in single operation

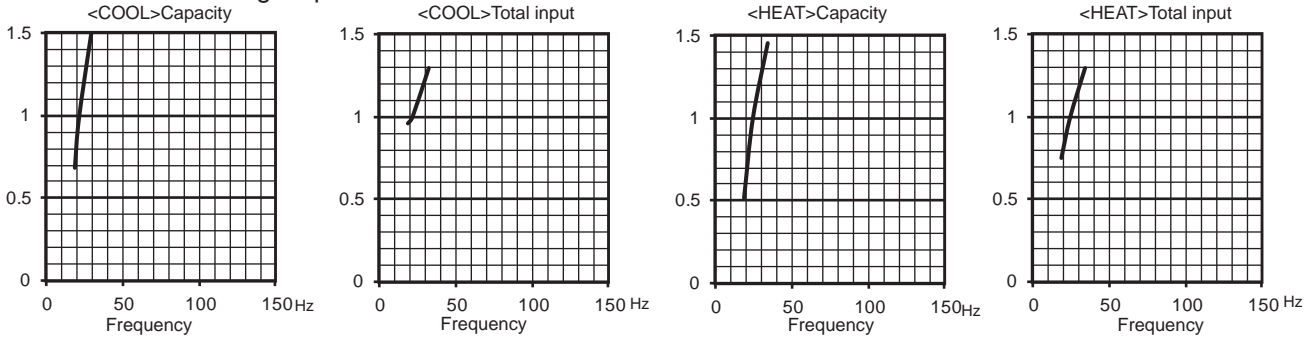

5. 25-class unit in single operation

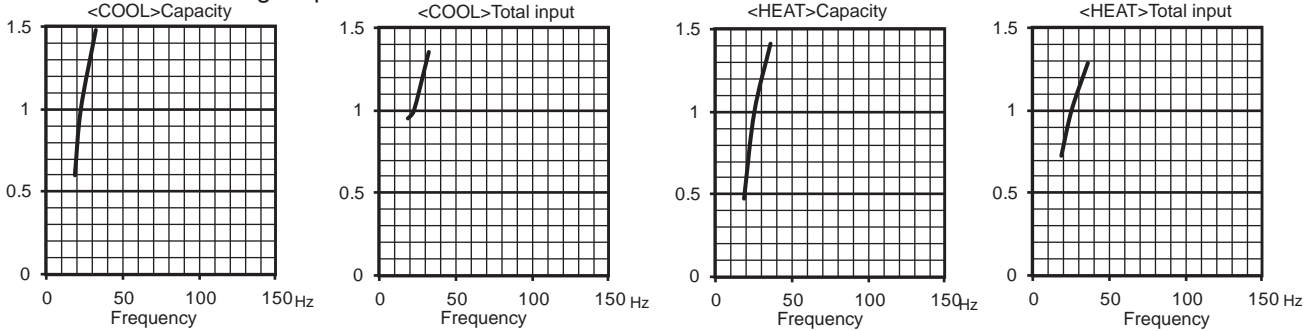

MXZ-6F120VF2

6. 35-class unit in single operation

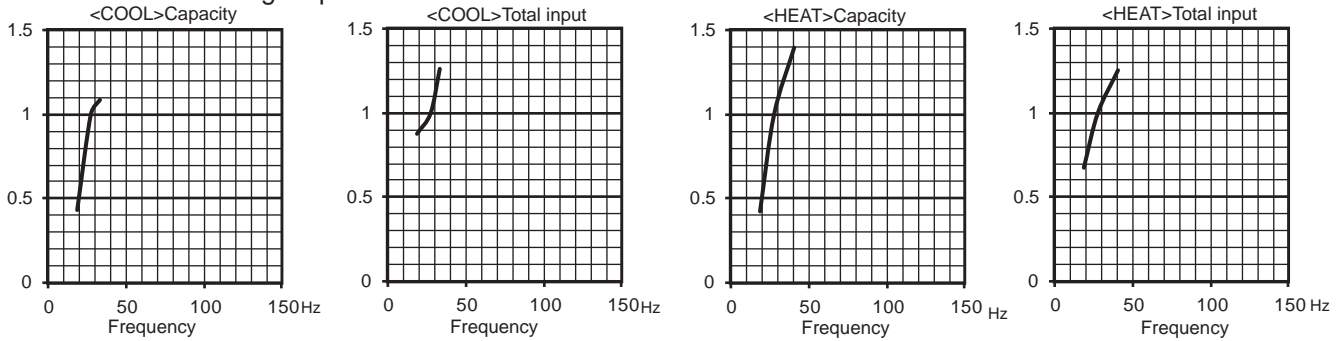

7. 42-class unit in single operation

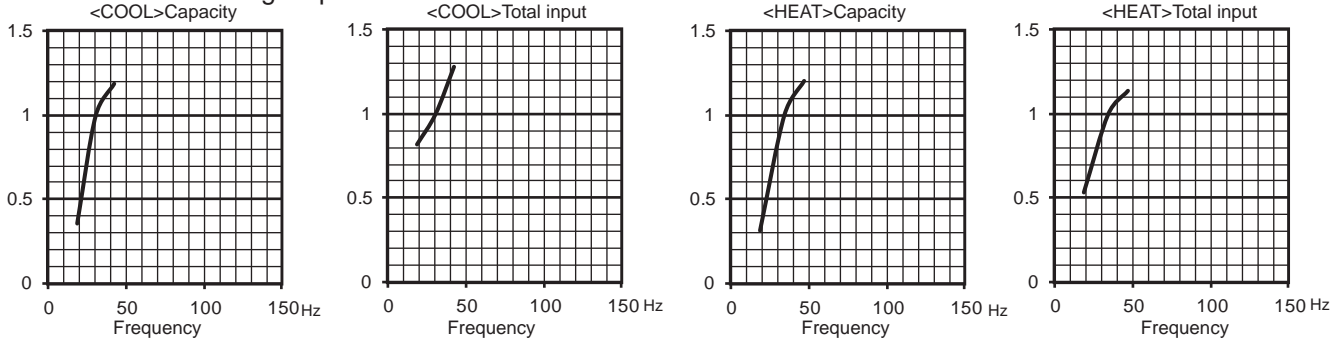

8. 50-class unit in single operation

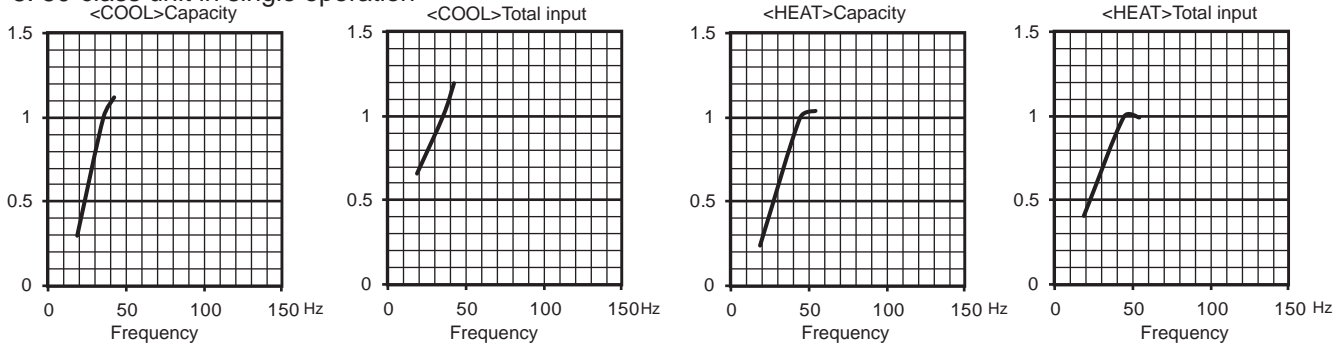

9. 60-class unit in single operation

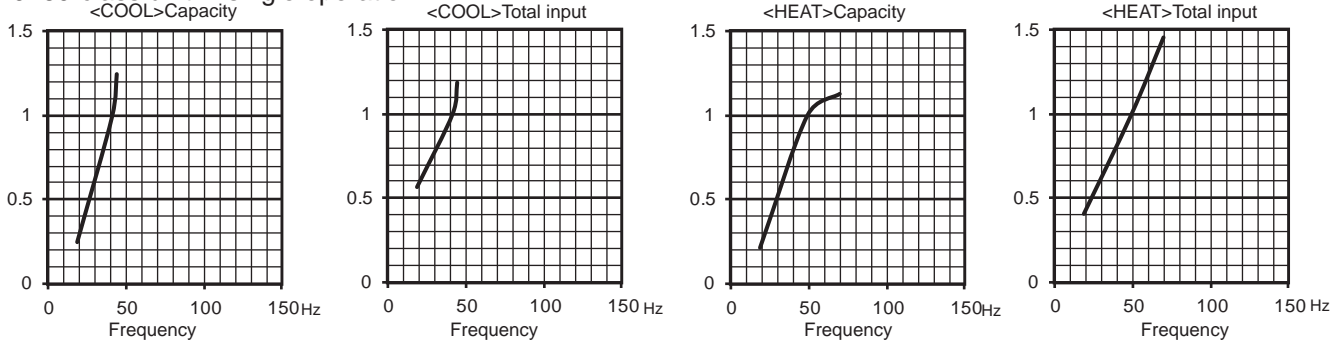

10. 71-class unit in single operation

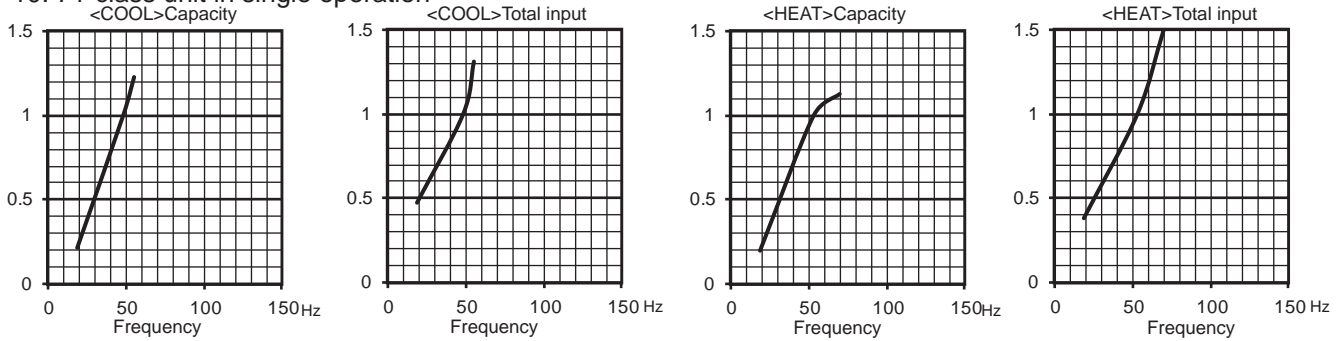

PERFORMANCE CURVES

MULTI SYSTEM

MXZ-2F53VFH22

1. 15-class unit in single operation

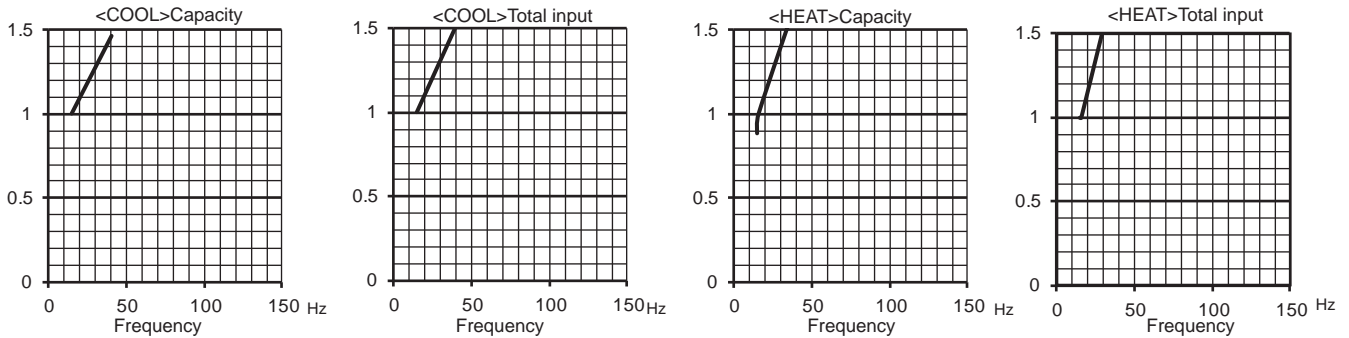

2. 18-class unit in single operation

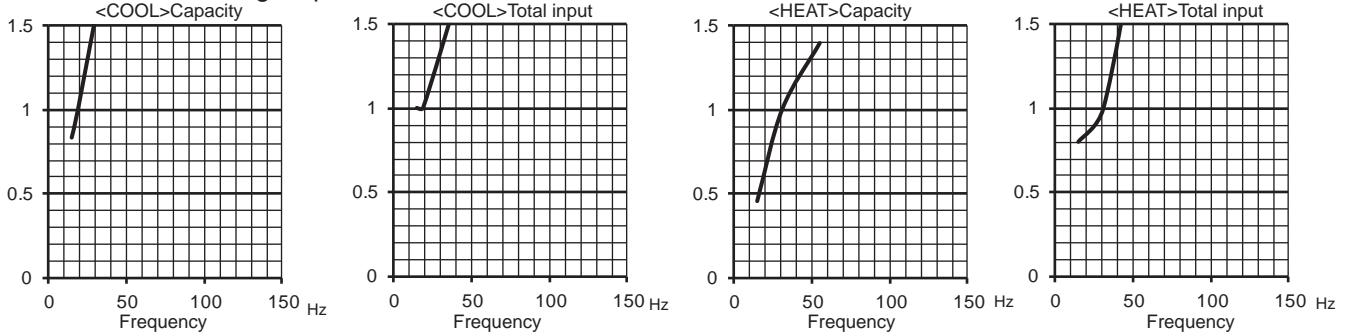

3. 20-class unit in single operation

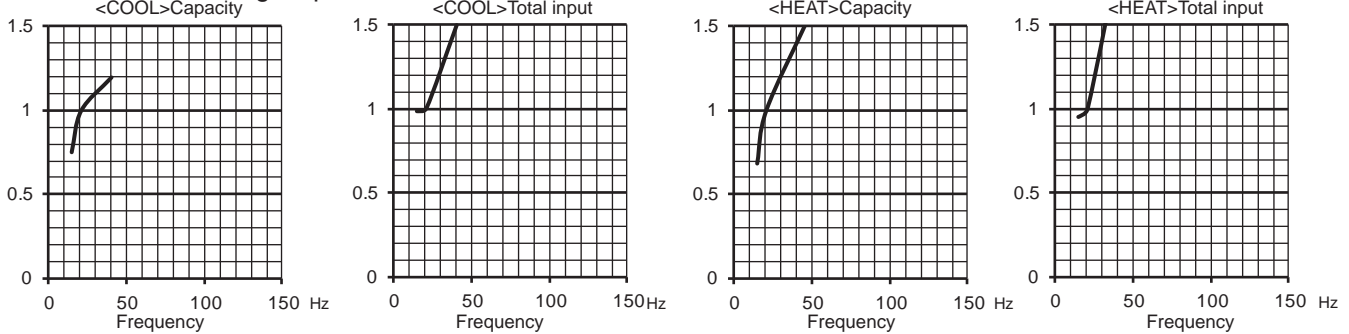

4. 22-class unit in single operation

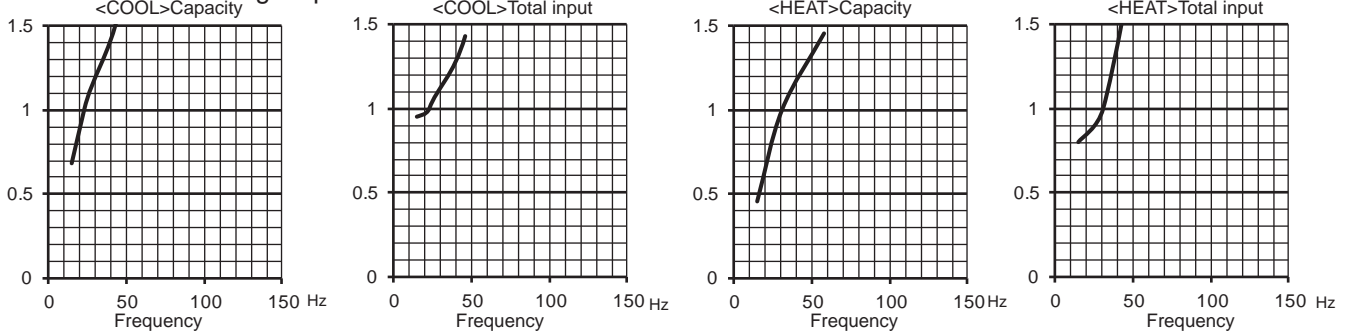

5. 25-class unit in single operation

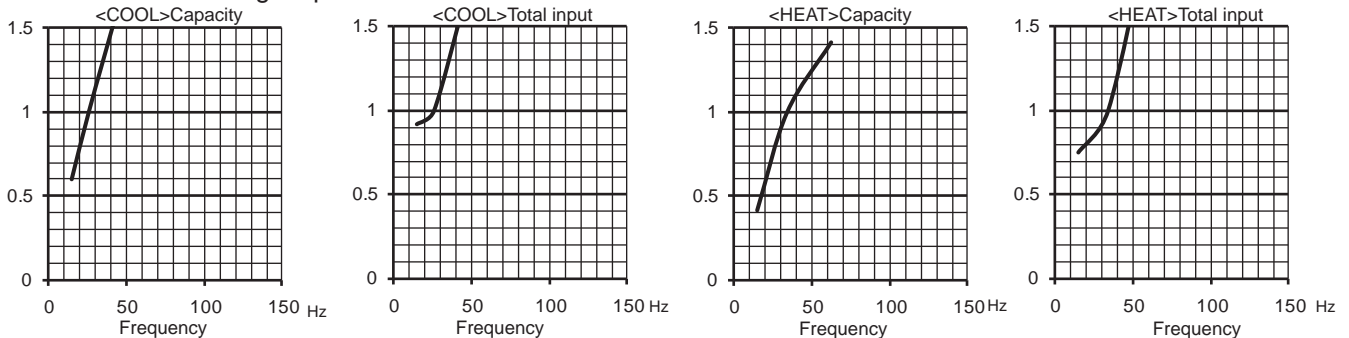

MXZ-2F53VFH2

6. 35-class unit in single operation

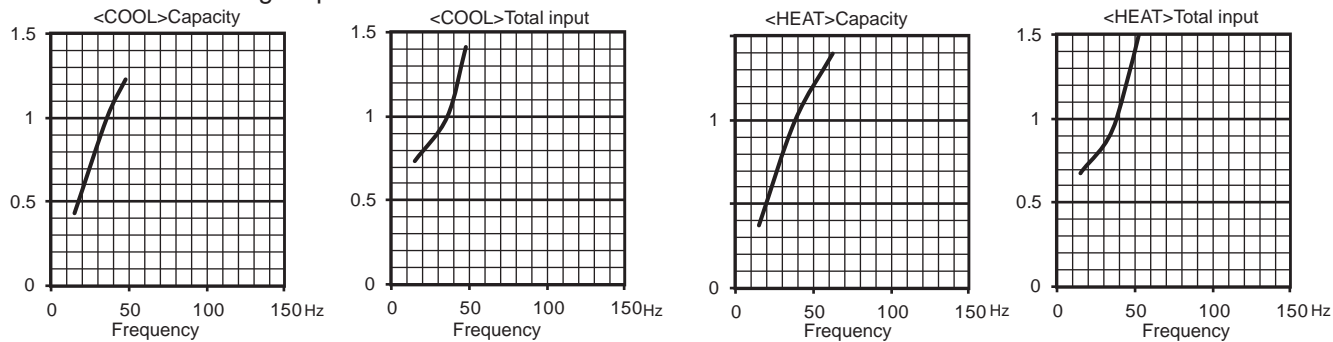

7. 42-class unit in single operation

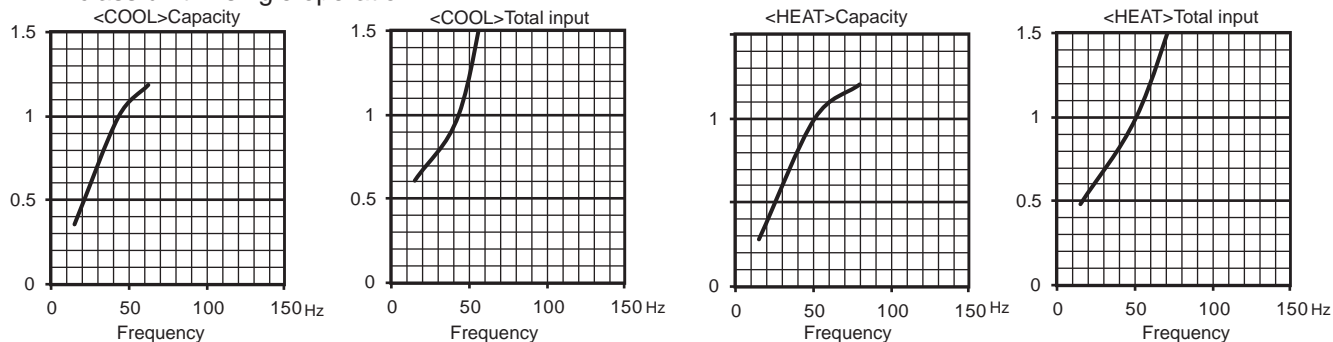

8. 50-class unit in single operation

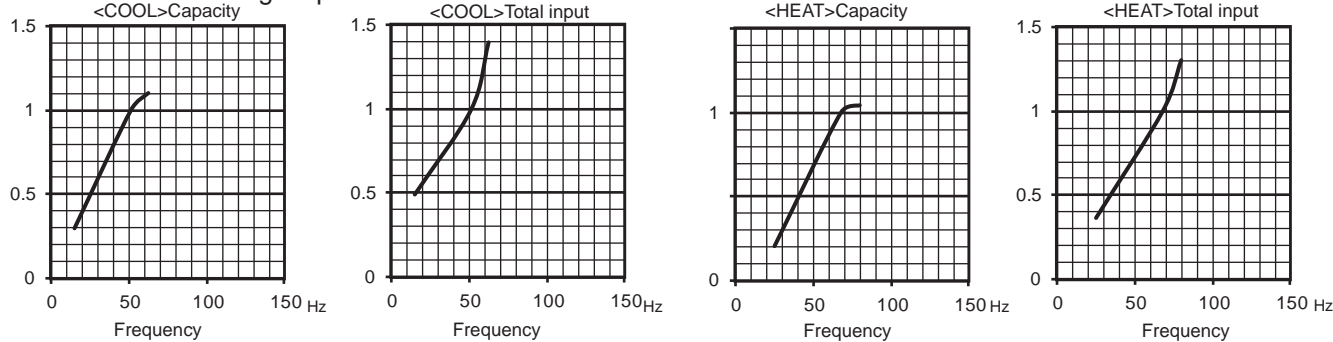

MXZ-4F83VFH2

1. 15-class unit in single operation

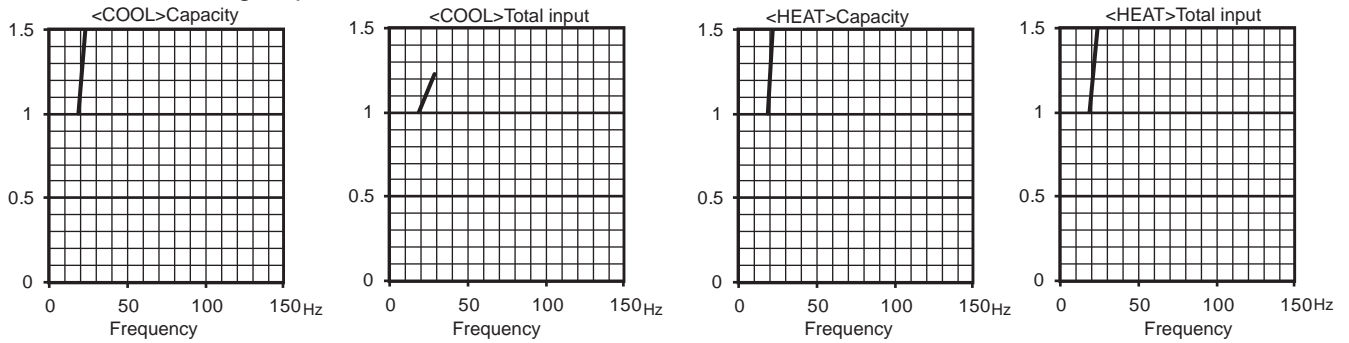

2. 18-class unit in single operation

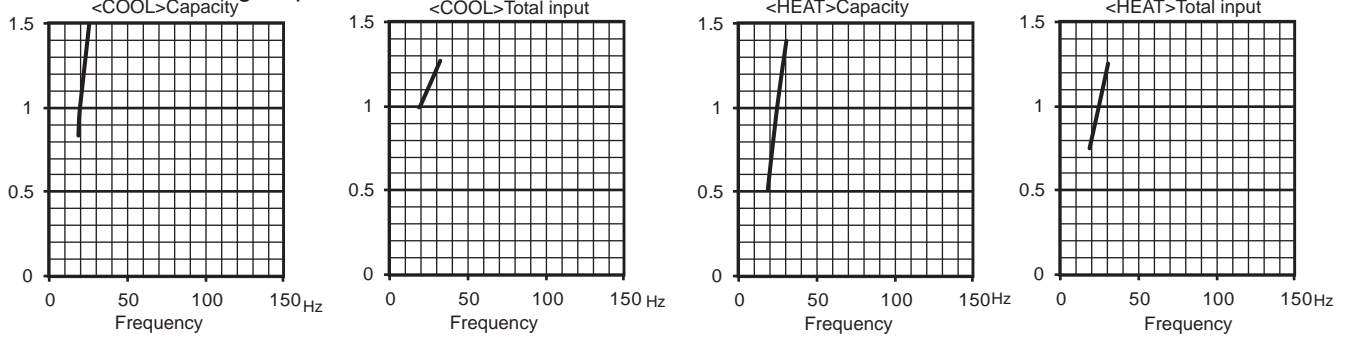

3. 20-class unit in single operation

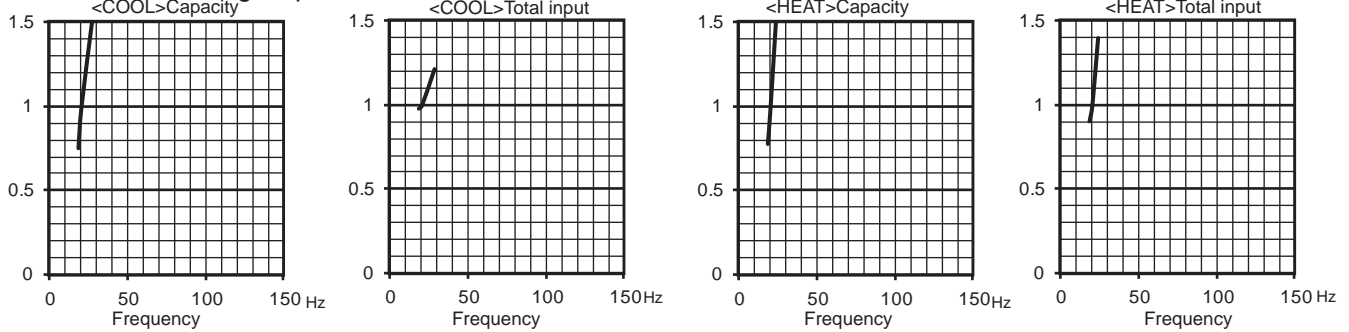

4. 22-class unit in single operation

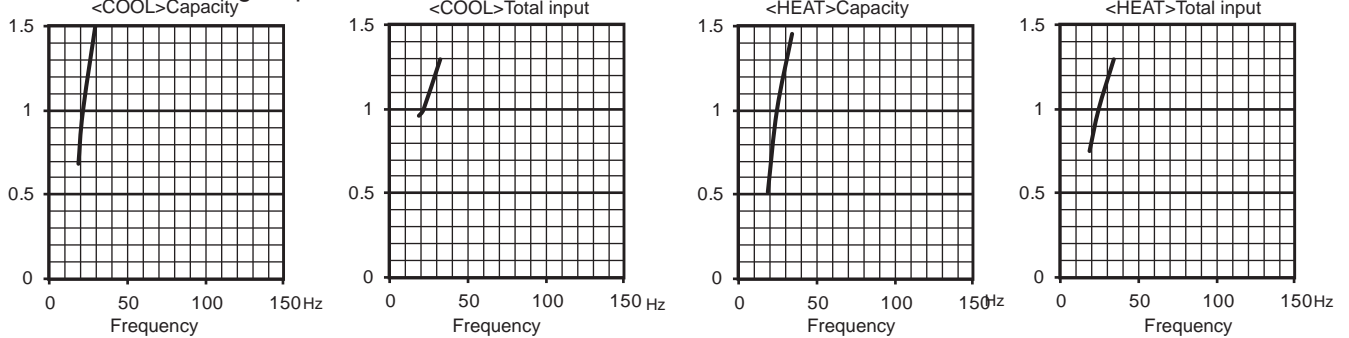

5. 25-class unit in single operation

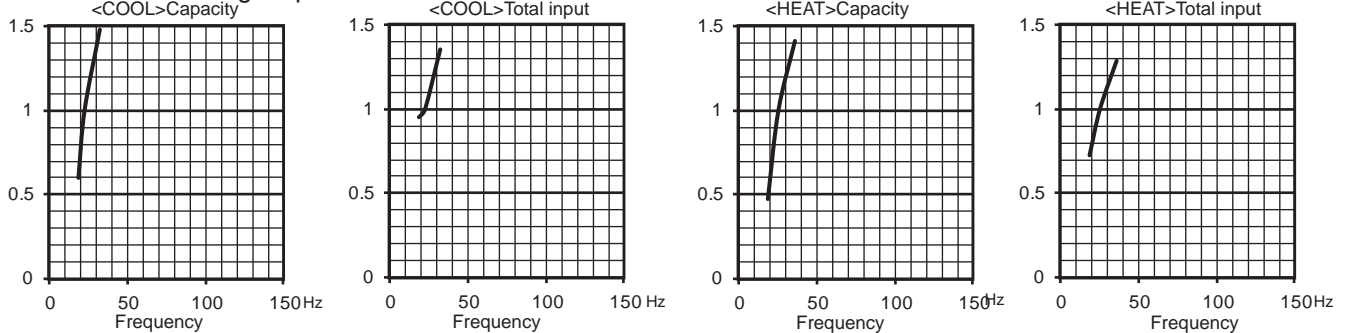

MXZ-4F83VFH22

6. 35-class unit in single operation

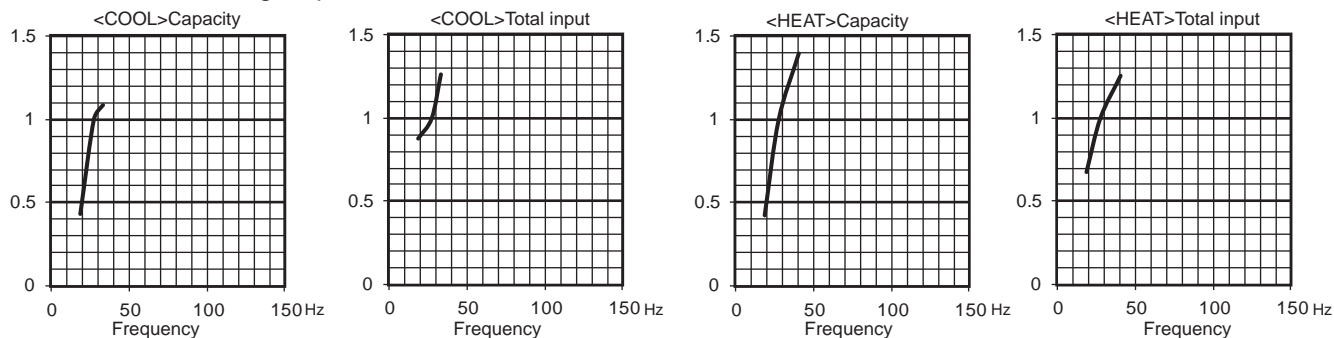

7. 42-class unit in single operation

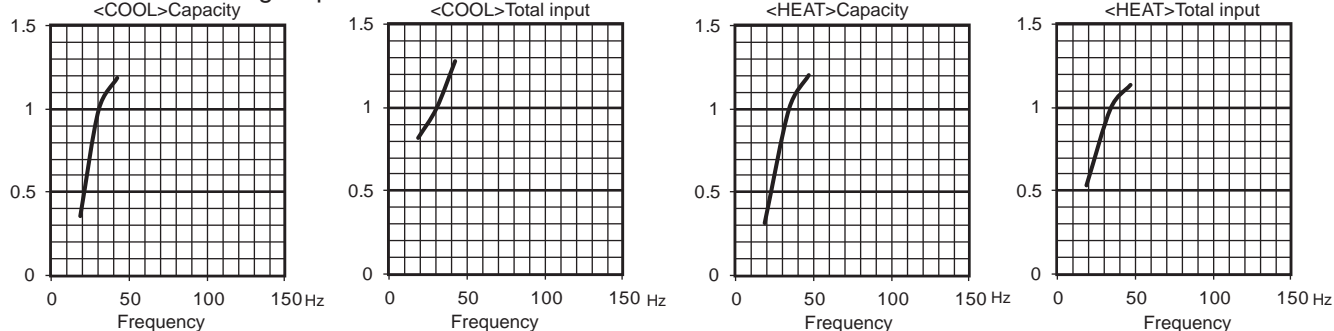

8. 50-class unit in single operation

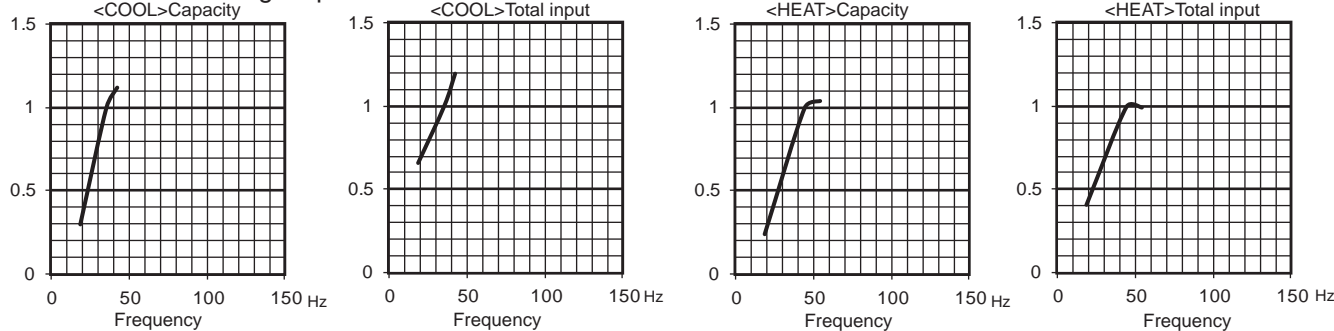

9. 60-class unit in single operation

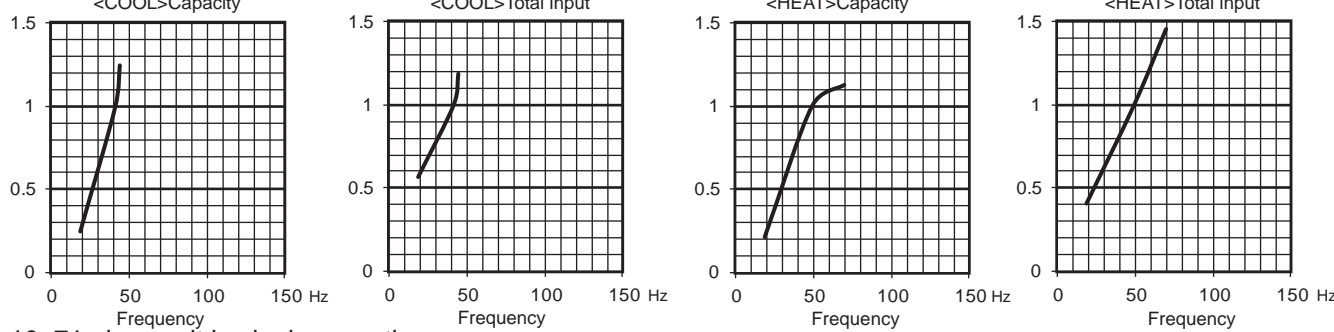

10. 71-class unit in single operation

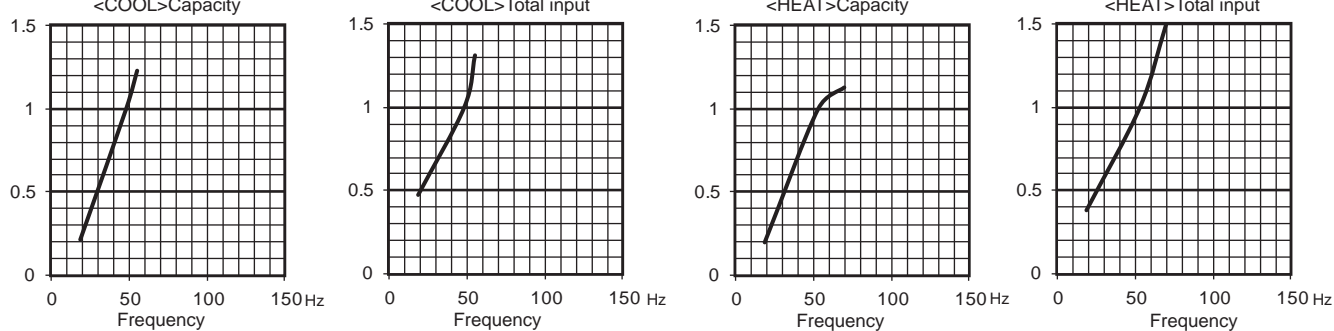

PERFORMANCE CURVES

MULTI SYSTEM

MXZ-2D33VA

1. 15-class unit in single operation

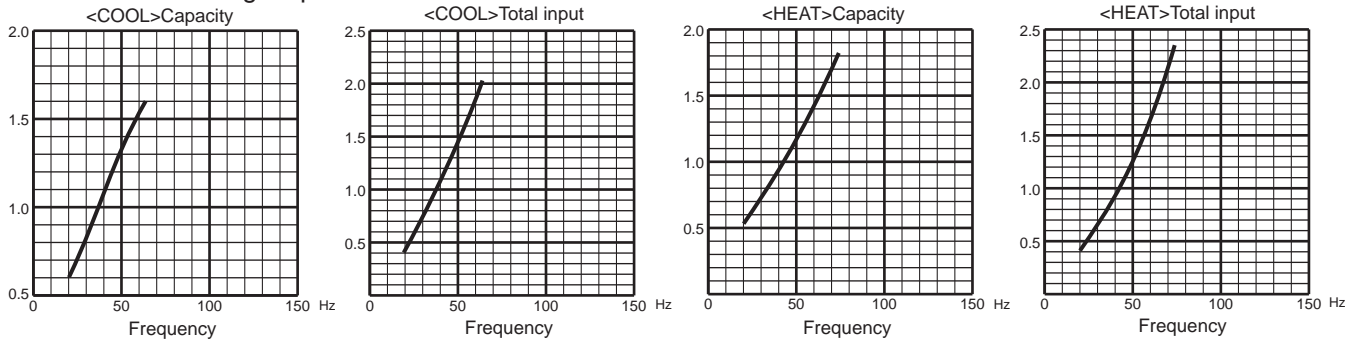

2. 18-class unit in single operation

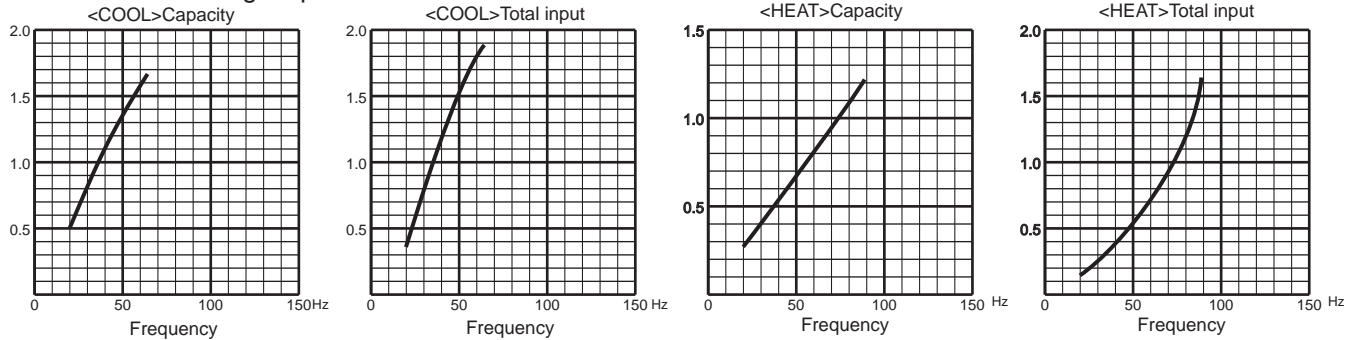

3. 20-class unit in single operation

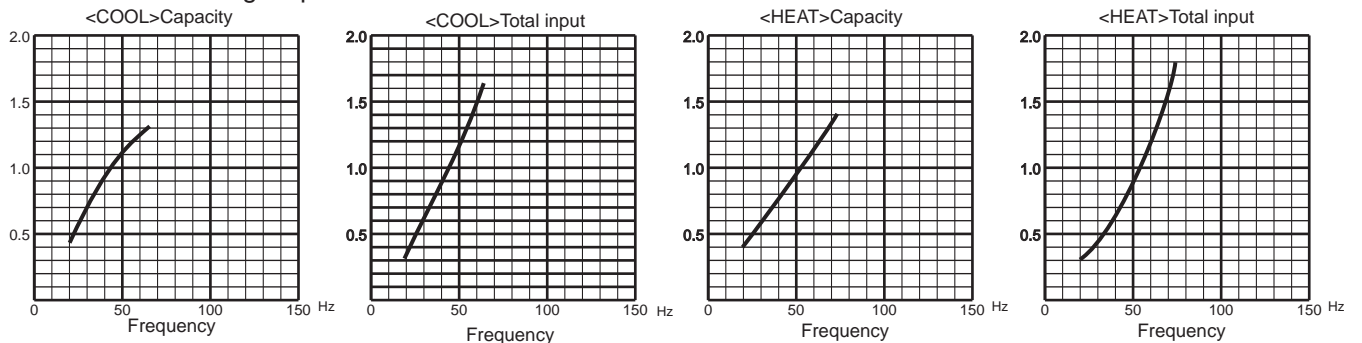

4. 22-class unit in single operation

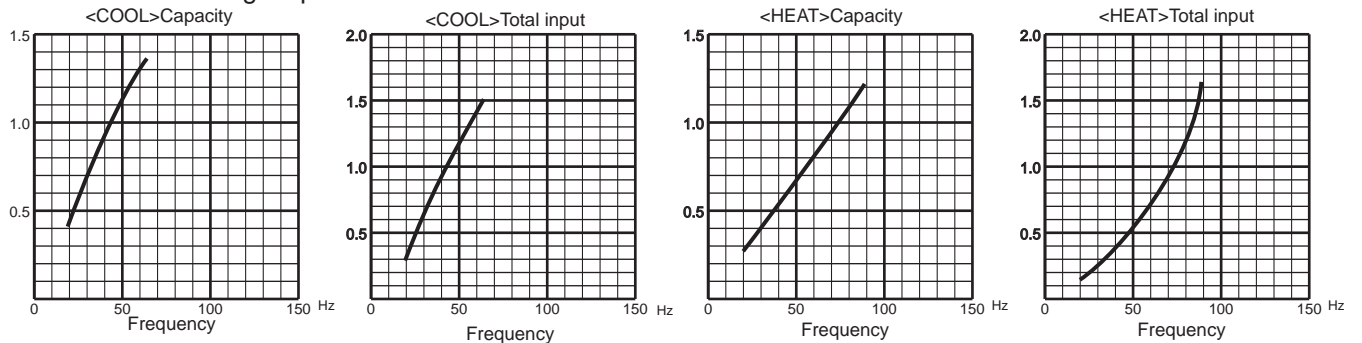

5. 25-class unit in single operation

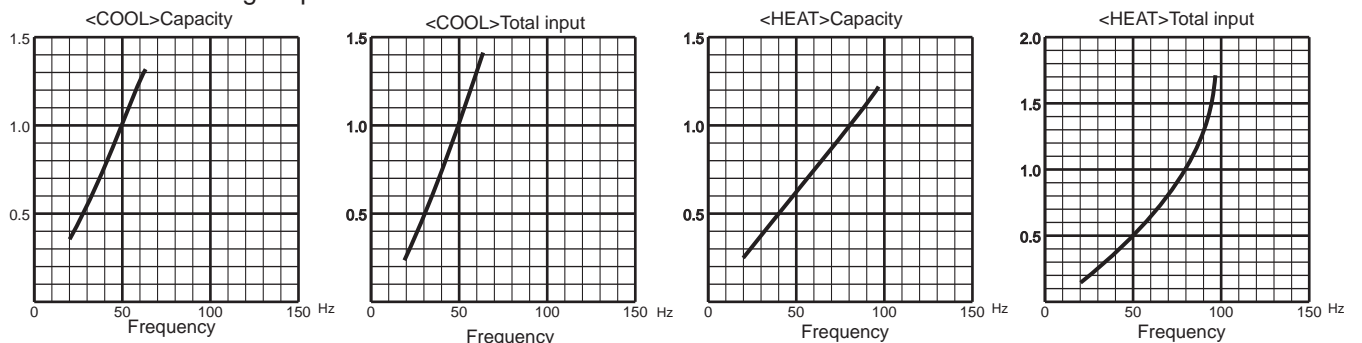

MXZ-2D42VA2 MXZ-2D53VA2 MXZ-2D53VAH2

1. 15-class unit in single operation

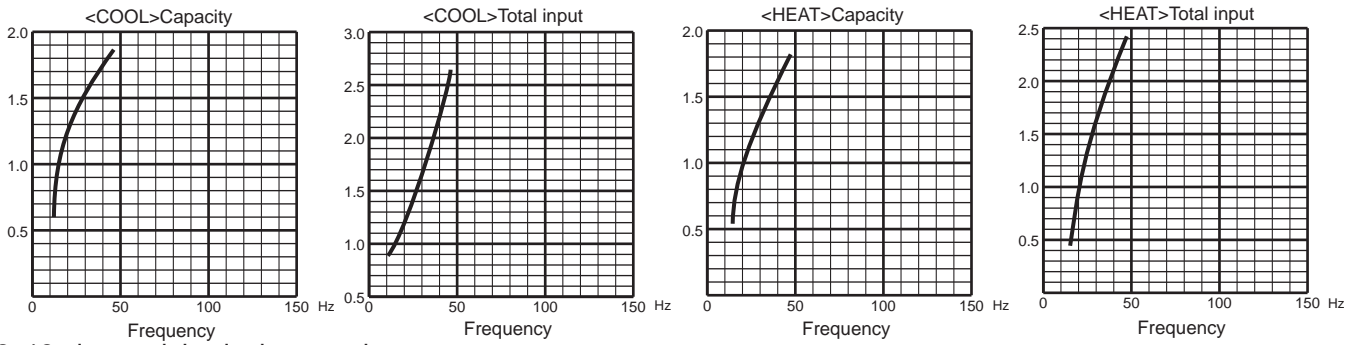

2. 18-class unit in single operation

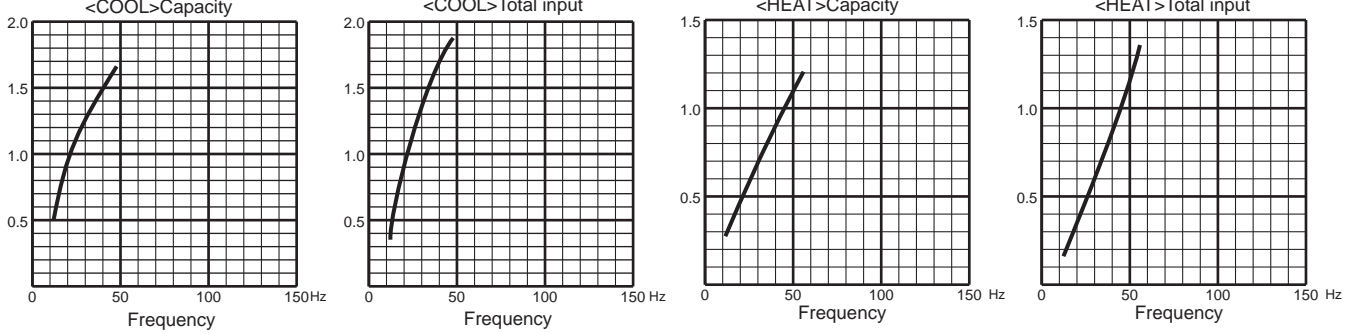

3. 20-class unit in single operation

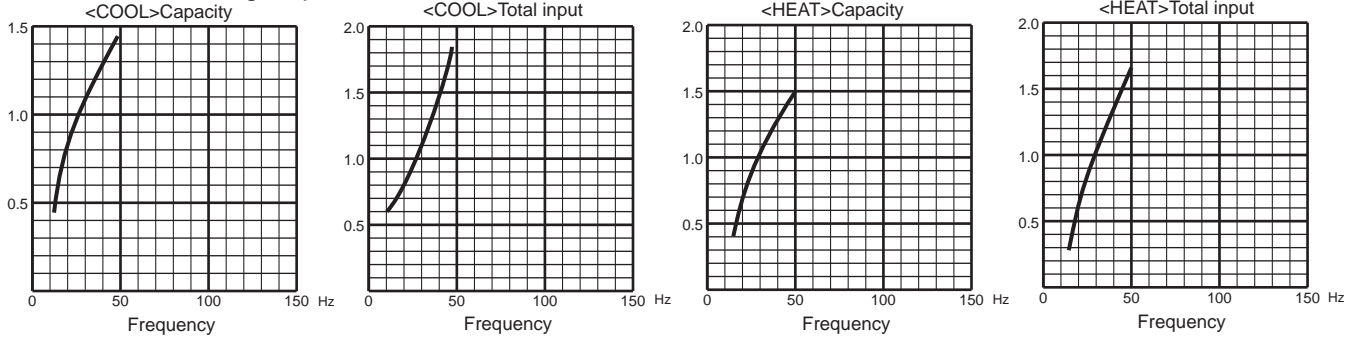

4. 22-class unit in single operation

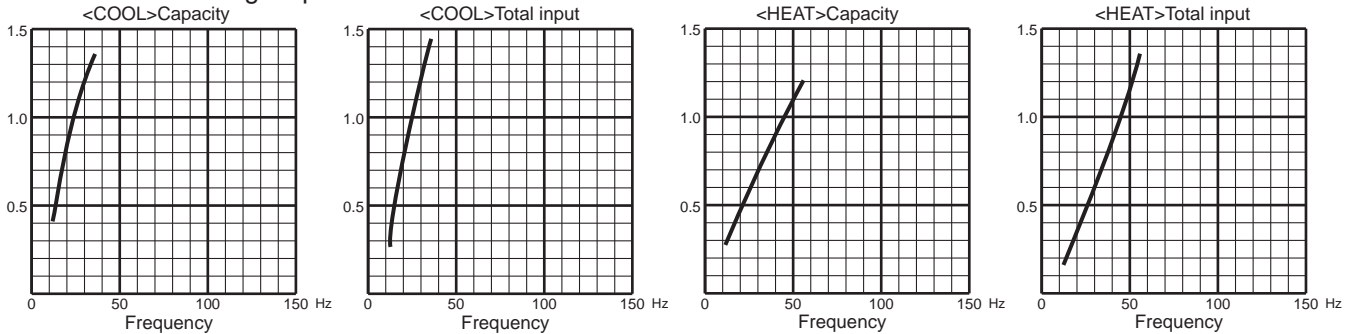

PERFORMANCE CURVES

MULTI SYSTEM

MXZ-2D42VA2 MXZ-2D53VA2 MXZ-2D53VAH2

5. 25-class unit in single operation

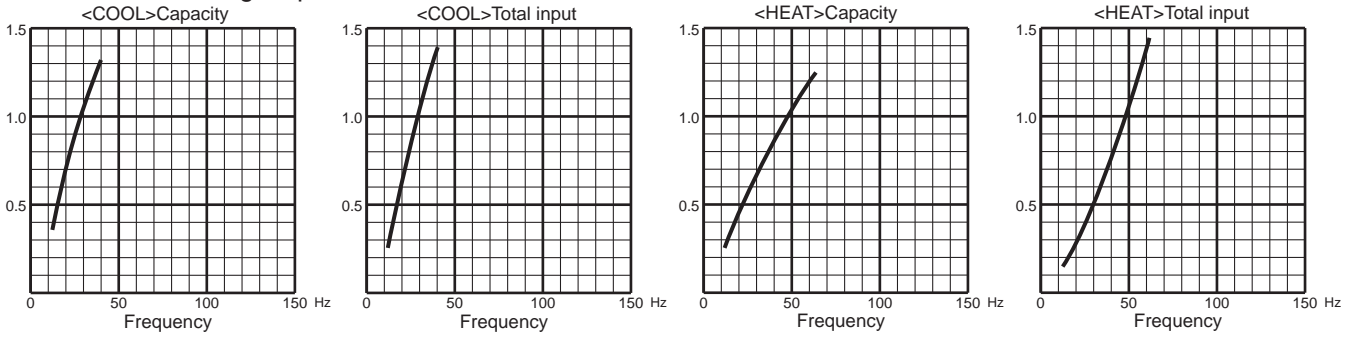

6. 35-class unit in single operation

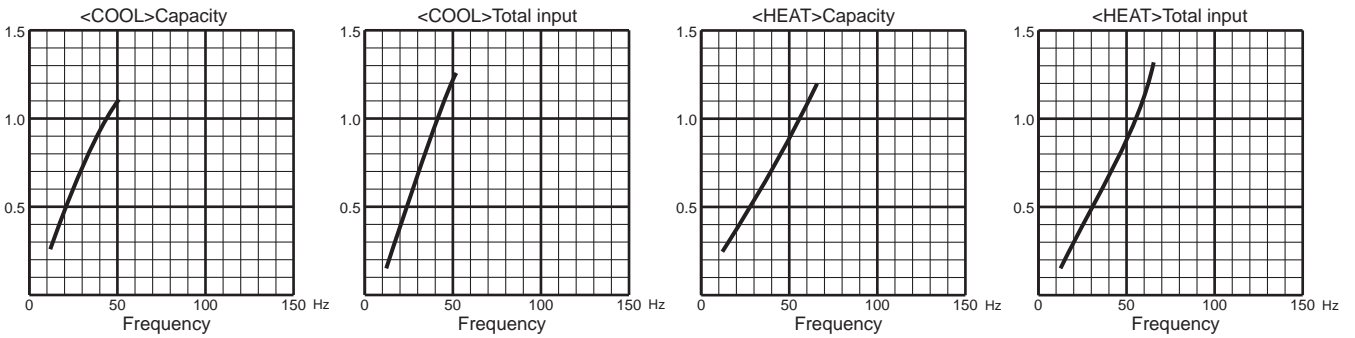

7. 42-class unit in single operation

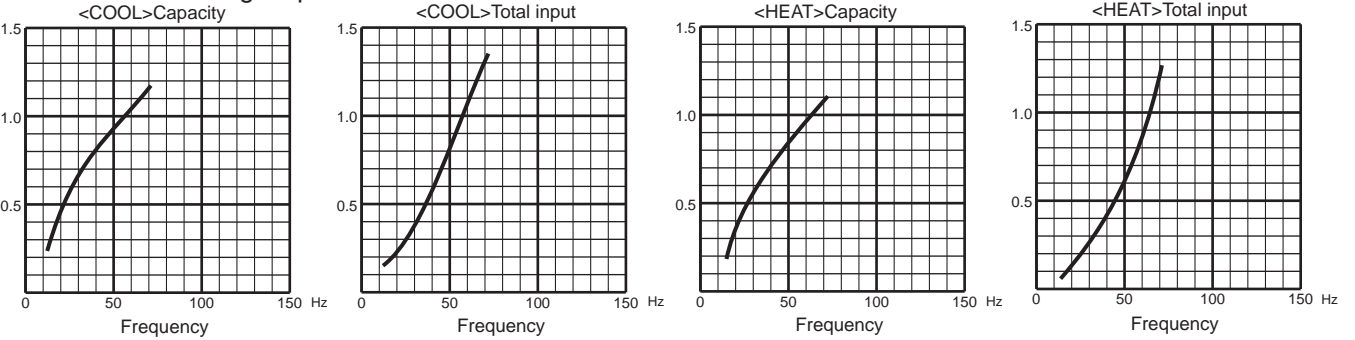

8. 50-class unit in single operation

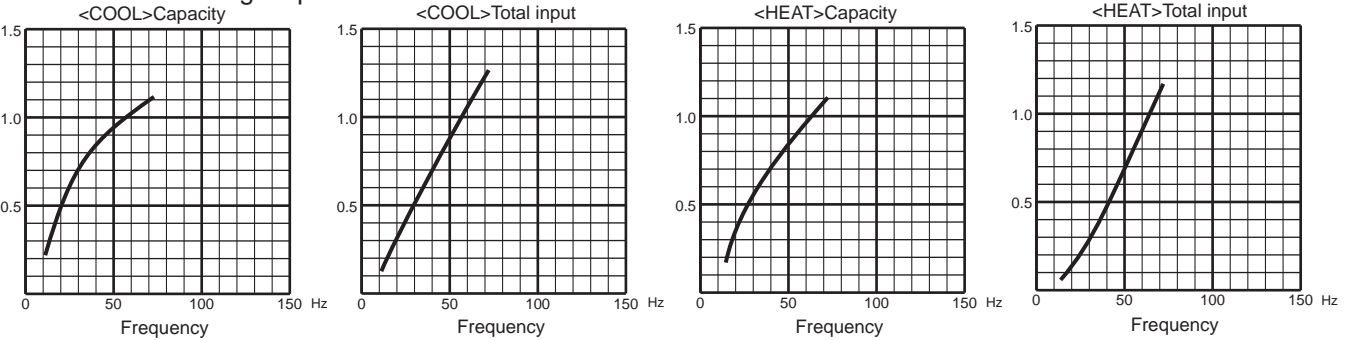

MXZ-2E53VAHZ

1. 15-class unit in single operation

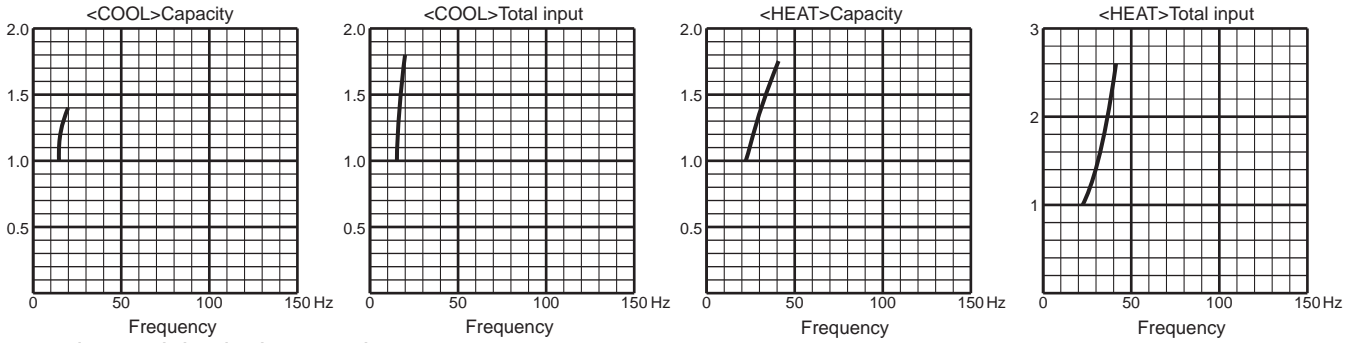

2. 18-class unit in single operation

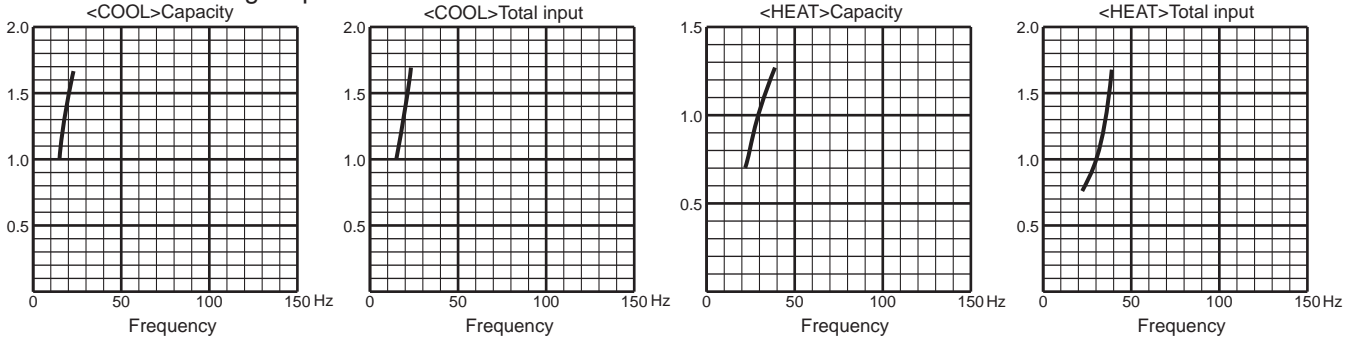

3. 20-class unit in single operation

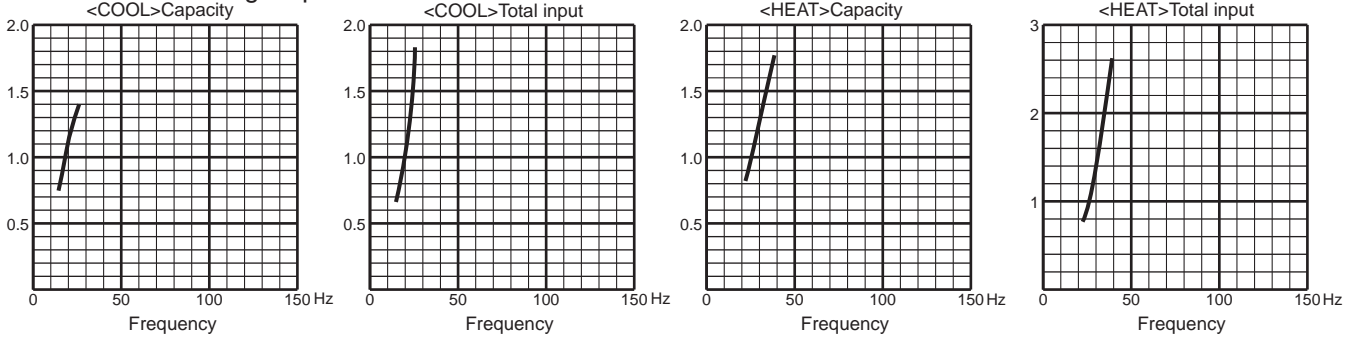

4. 22-class unit in single operation

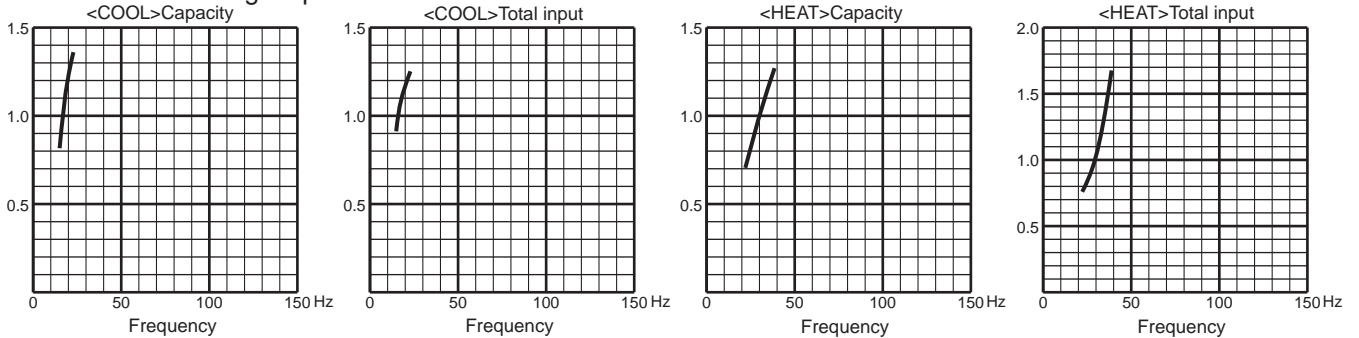

5. 25-class unit in single operation

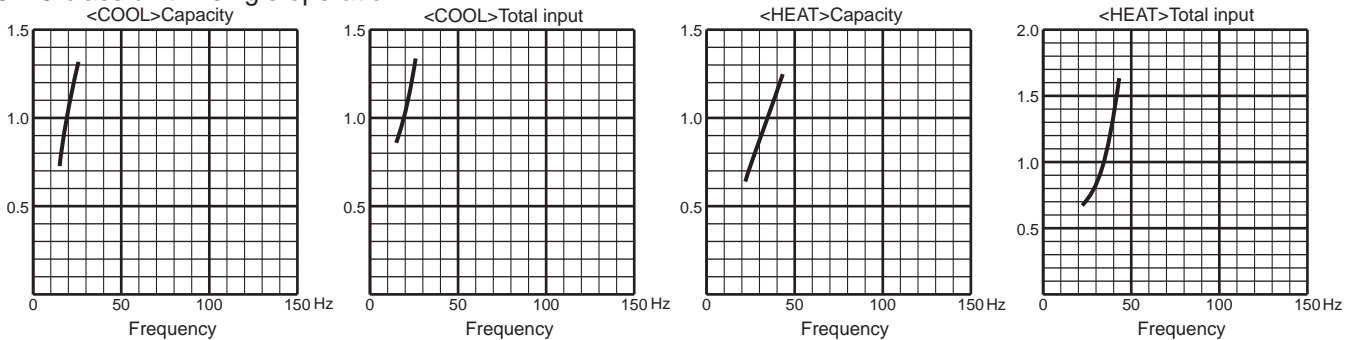

PERFORMANCE CURVES

MULTI SYSTEM

MXZ-2E53VAHZ

6. 35-class unit in single operation

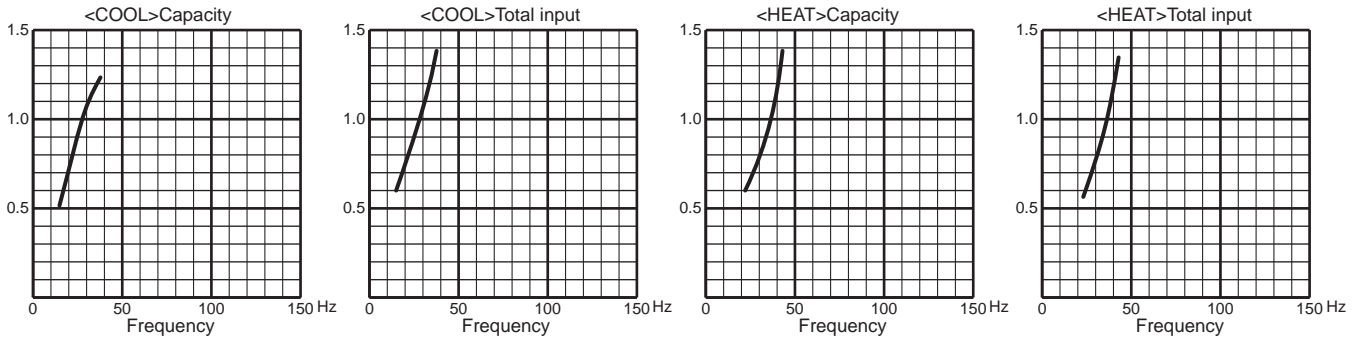

7. 42-class unit in single operation

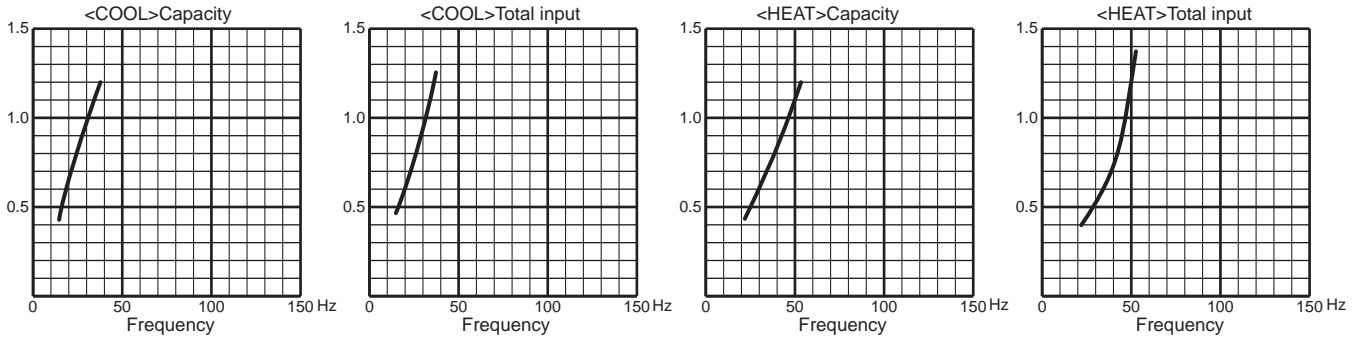

8. 50-class unit in single operation

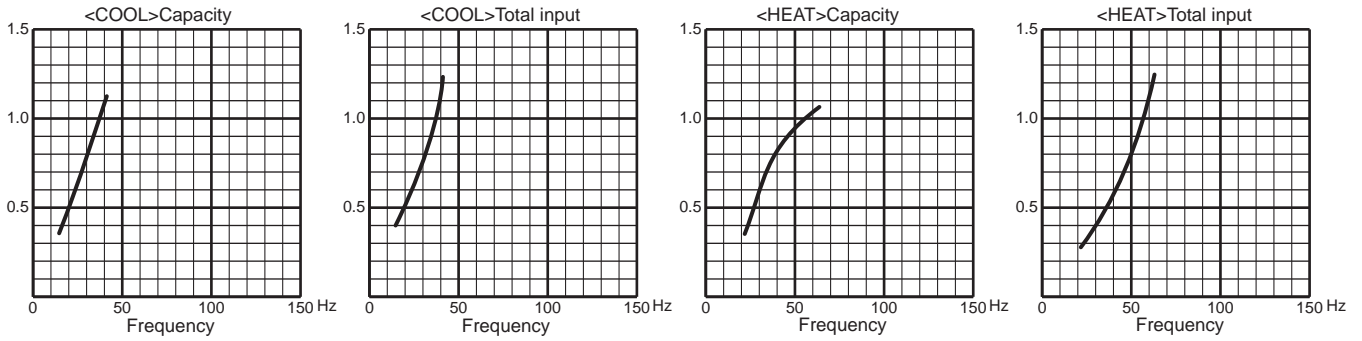

MXZ-3E54VA

1. 15-class unit in single operation

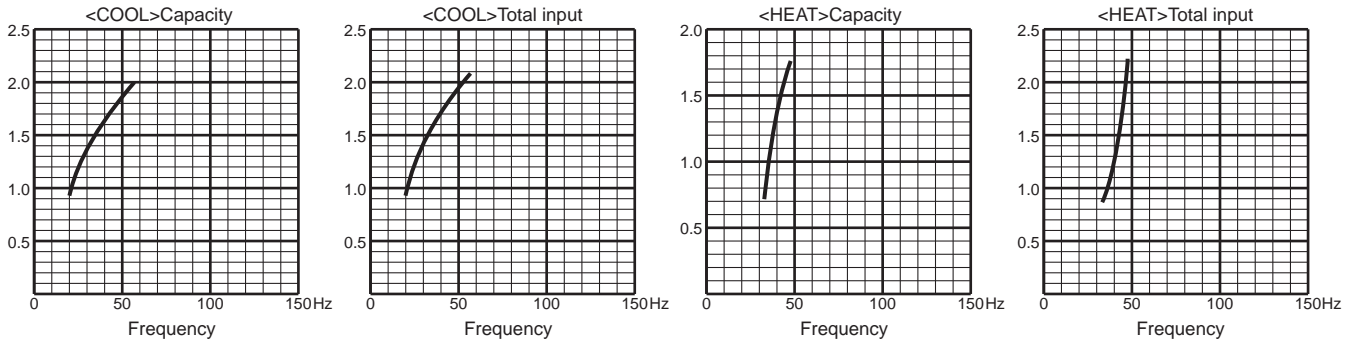

2. 18-class unit in single operation

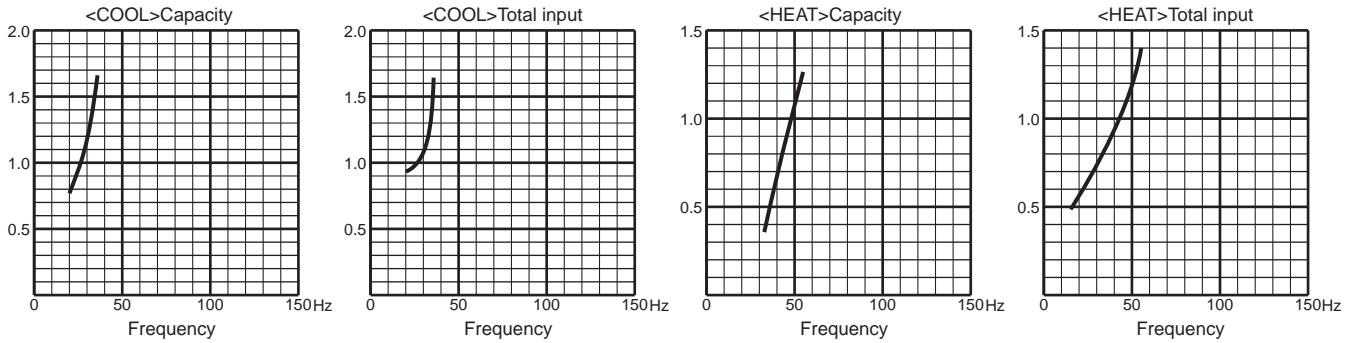

3. 20-class unit in single operation

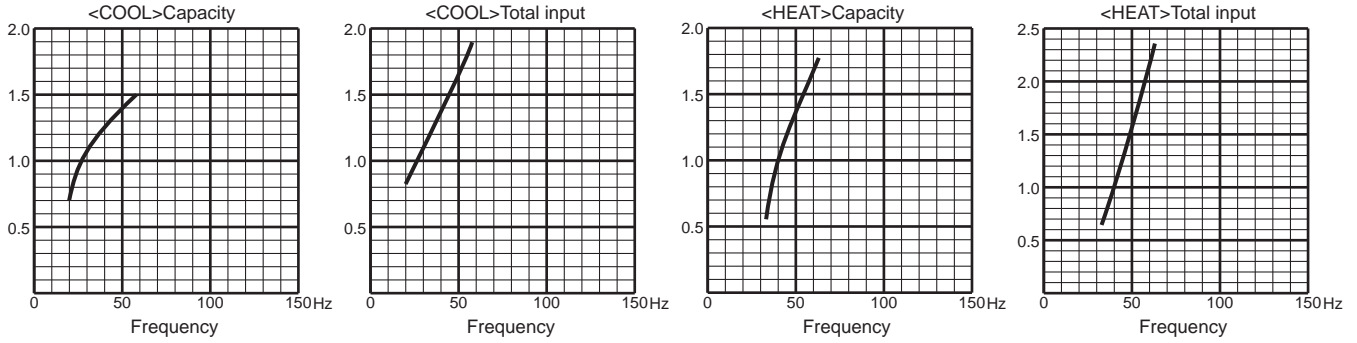

4. 22-class unit in single operation

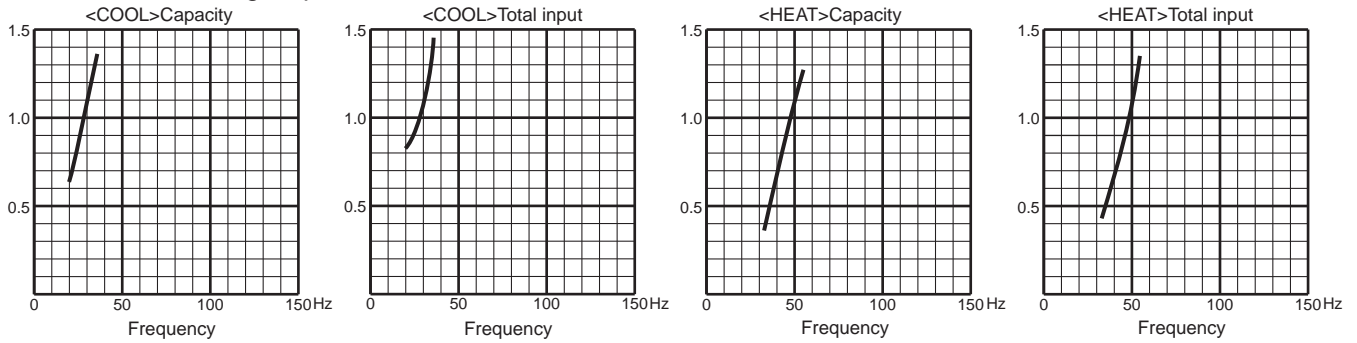

PERFORMANCE CURVES

MULTI SYSTEM

MXZ-3E54VA

5. 25-class unit in single operation

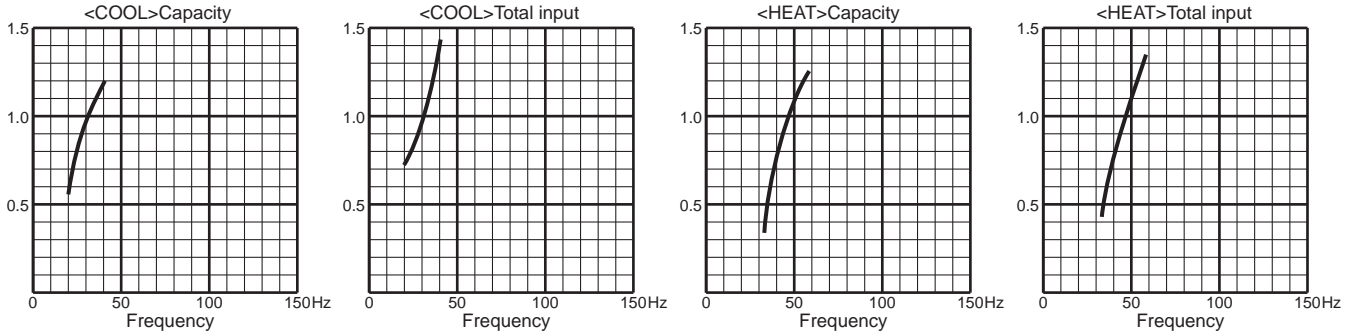

6. 35-class unit in single operation

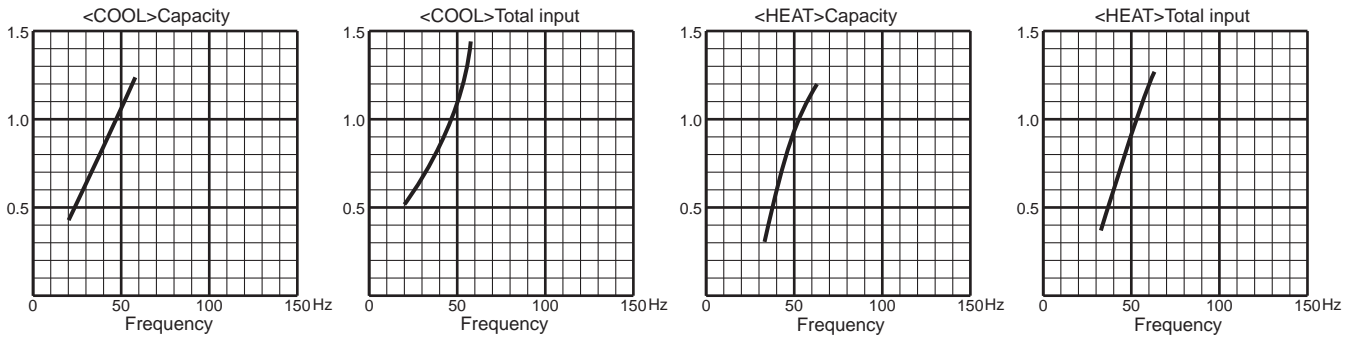

7. 42-class unit in single operation

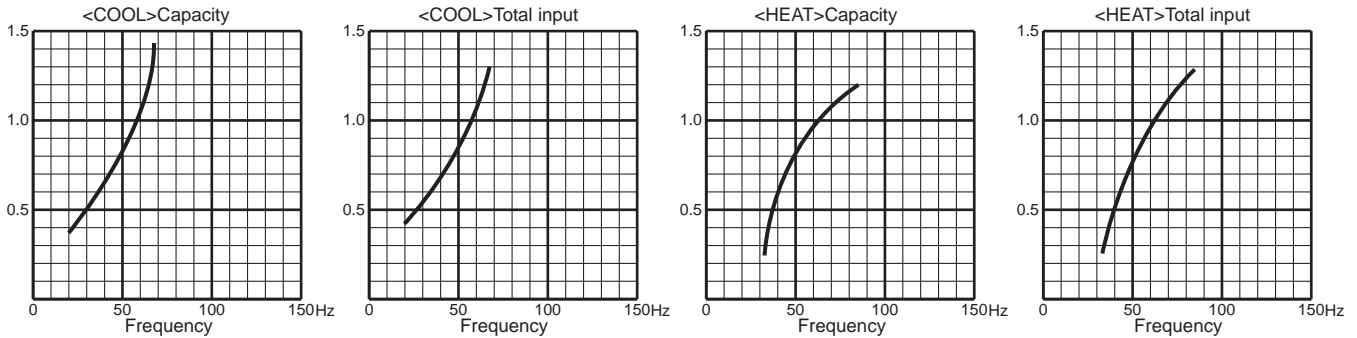

8. 50-class unit in single operation

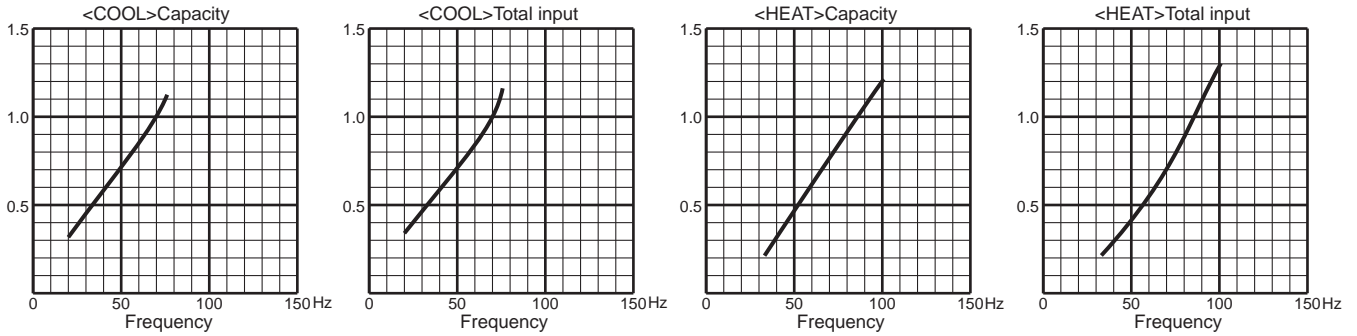

MULTI SYSTEM PERFORMANCE CURVES

MXZ-3E68VA

1. 15-class unit in single operation

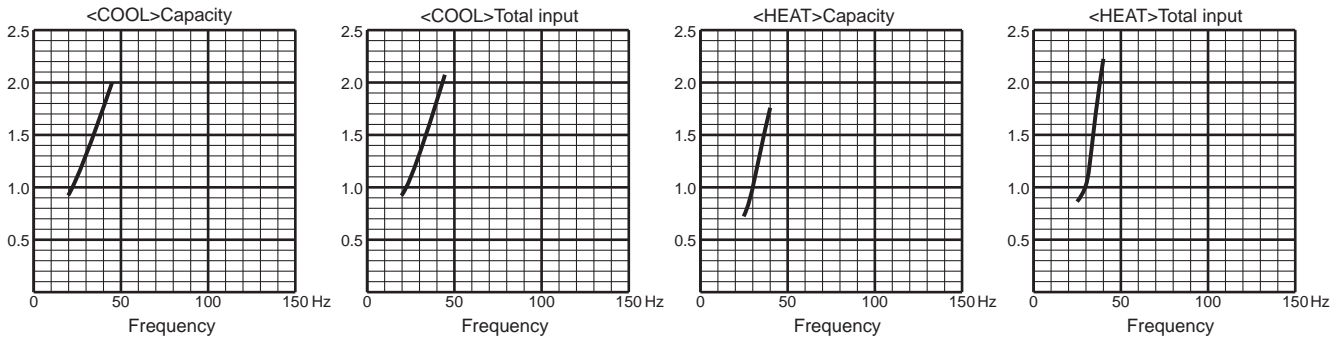

2. 18-class unit in single operation

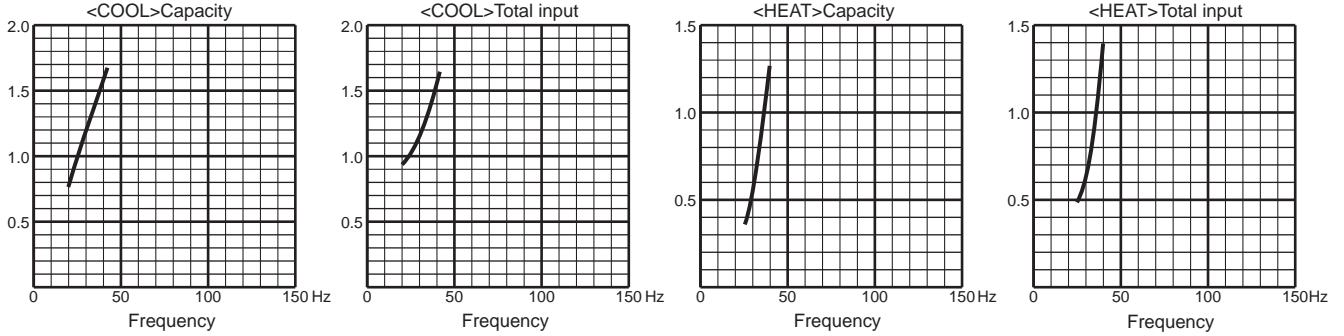

3. 20-class unit in single operation

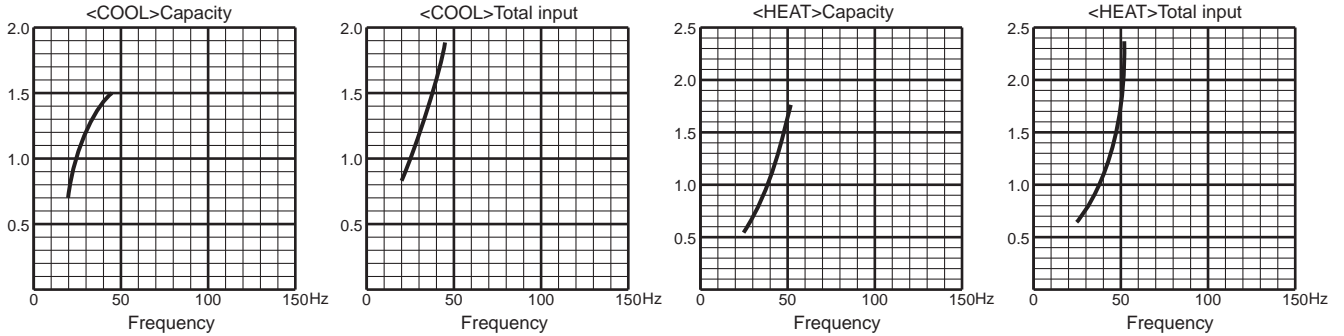

4. 22-class unit in single operation

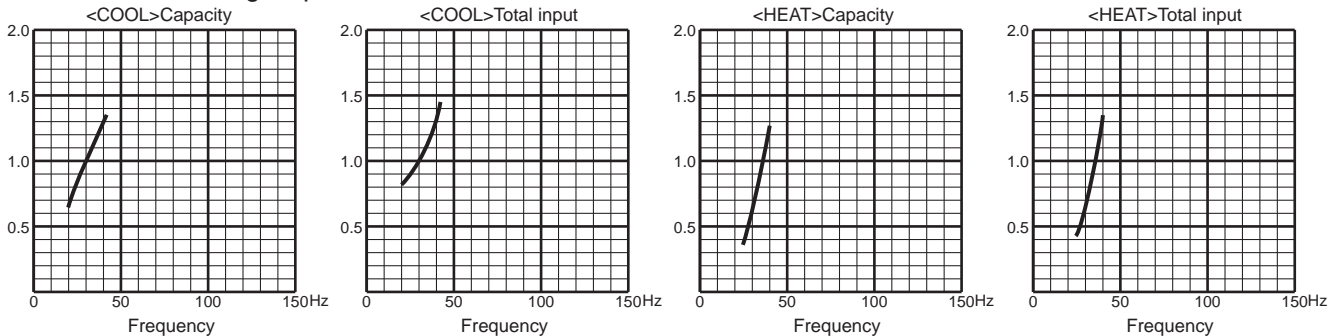

5. 25-class unit in single operation

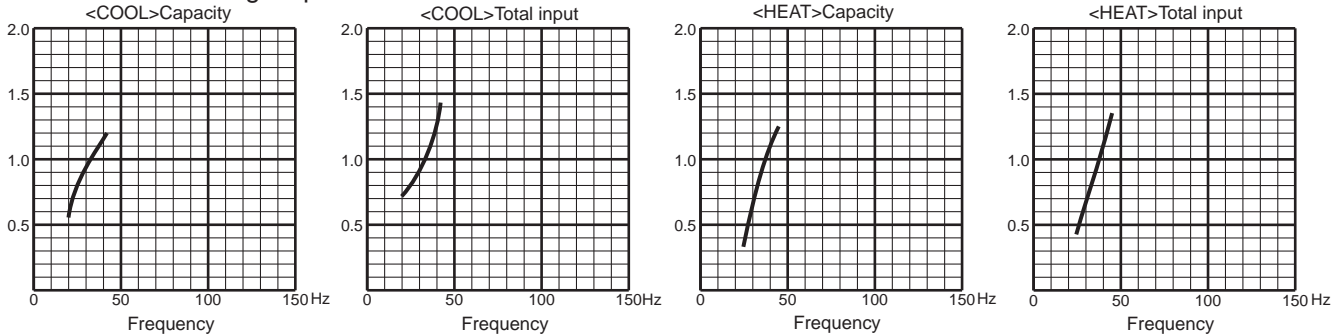

PERFORMANCE CURVES

MULTI SYSTEM

MXZ-3E68VA

6. 35-class unit in single operation

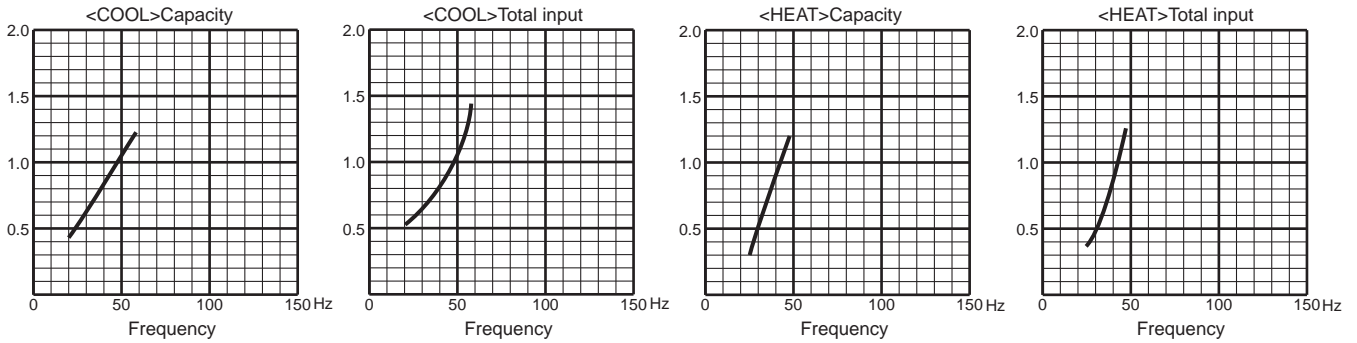

7. 42-class unit in single operation

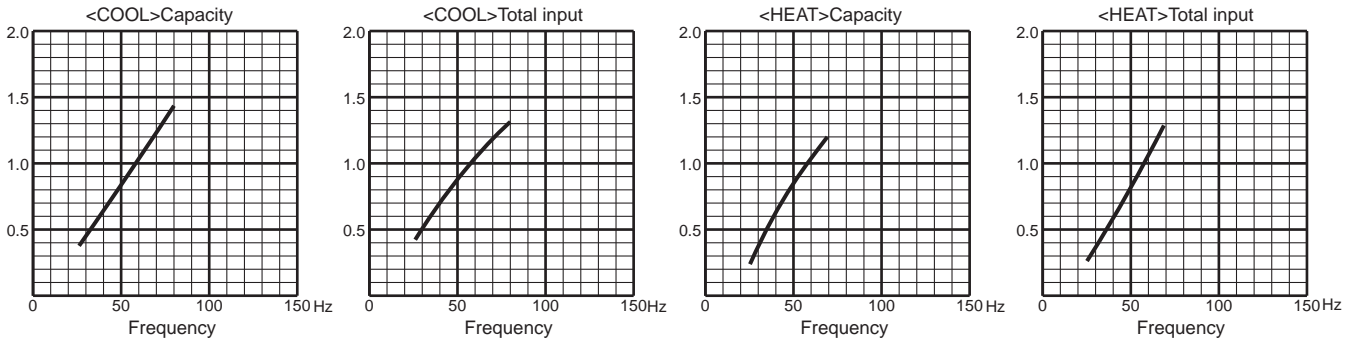

8. 50-class unit in single operation

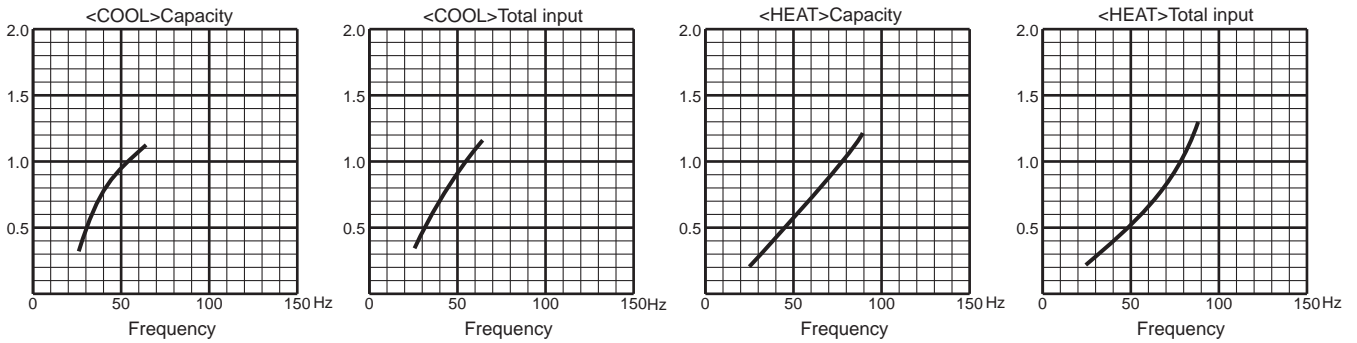

9. 60-class unit in single operation

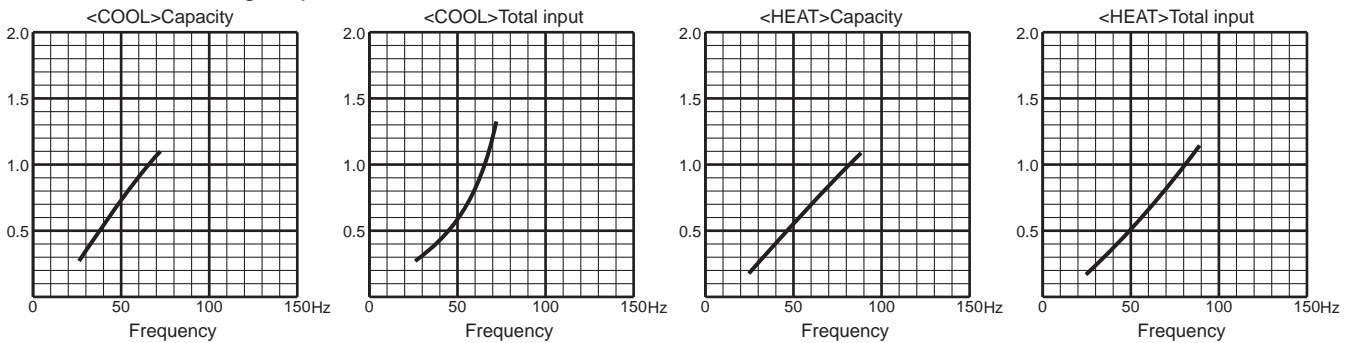

MXZ-4E72VA

1. 15-class unit in single operation

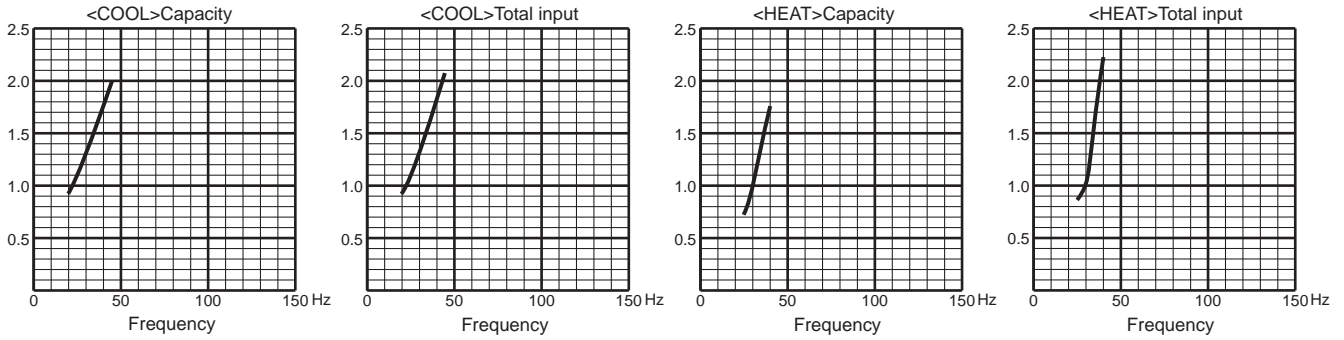

2. 18-class unit in single operation

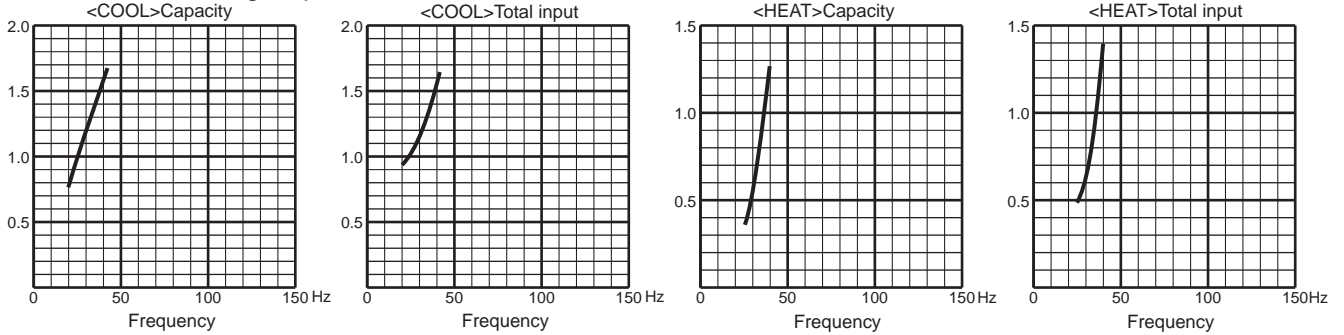

3. 20-class unit in single operation

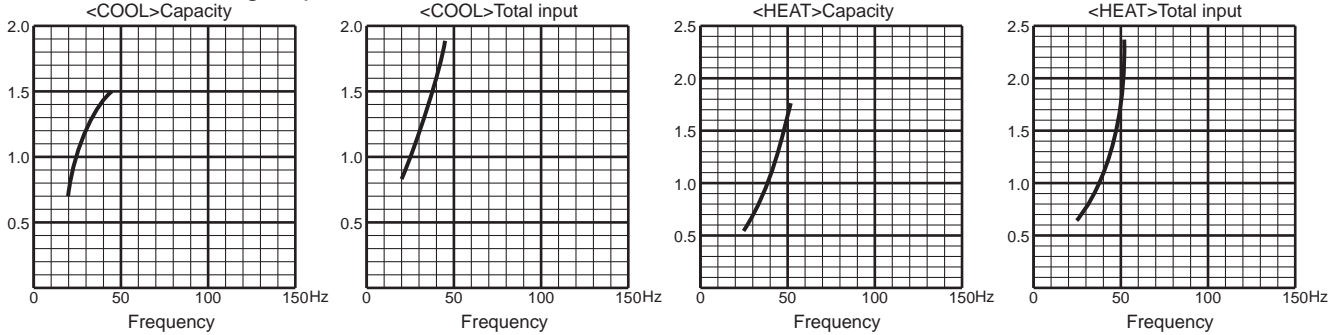

4. 22-class unit in single operation

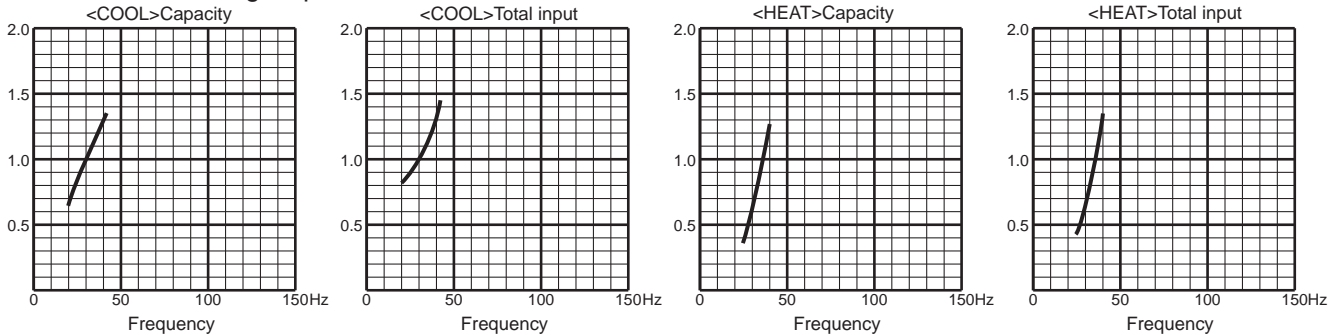

5. 25-class unit in single operation

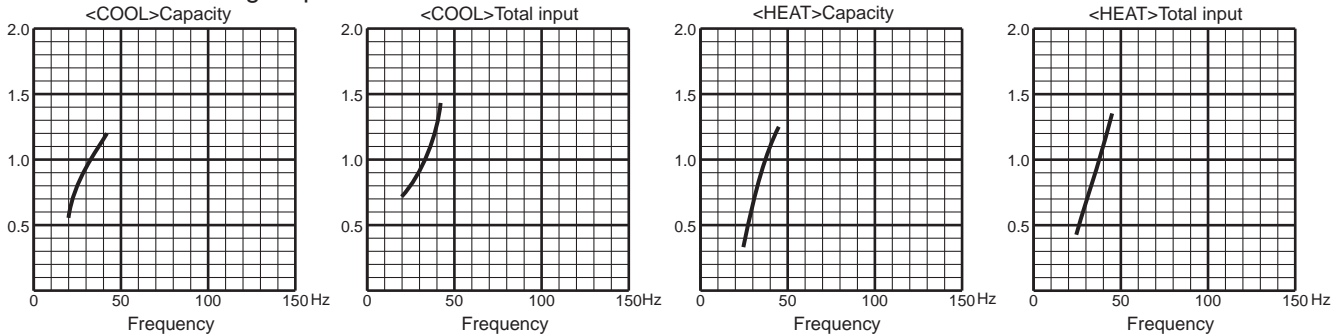

PERFORMANCE CURVES

MULTI SYSTEM

MXZ-4E72VA

6. 35-class unit in single operation

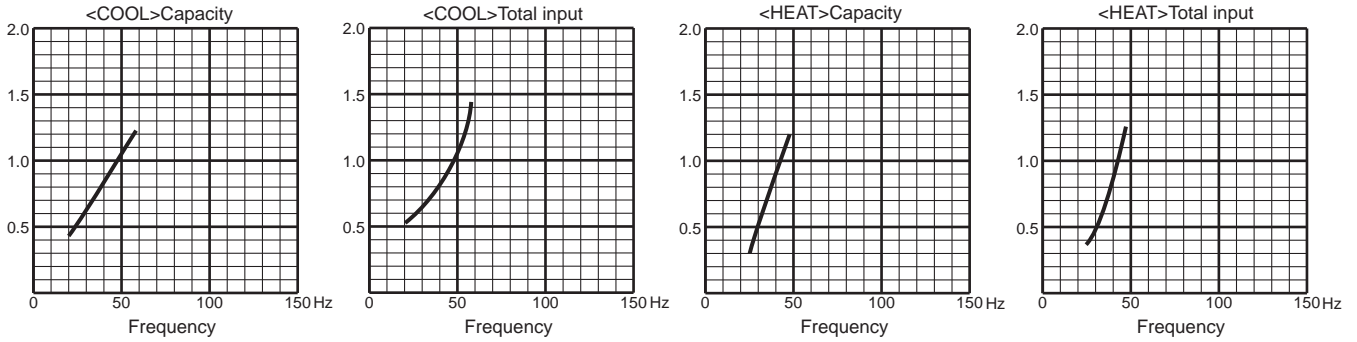

7. 42-class unit in single operation

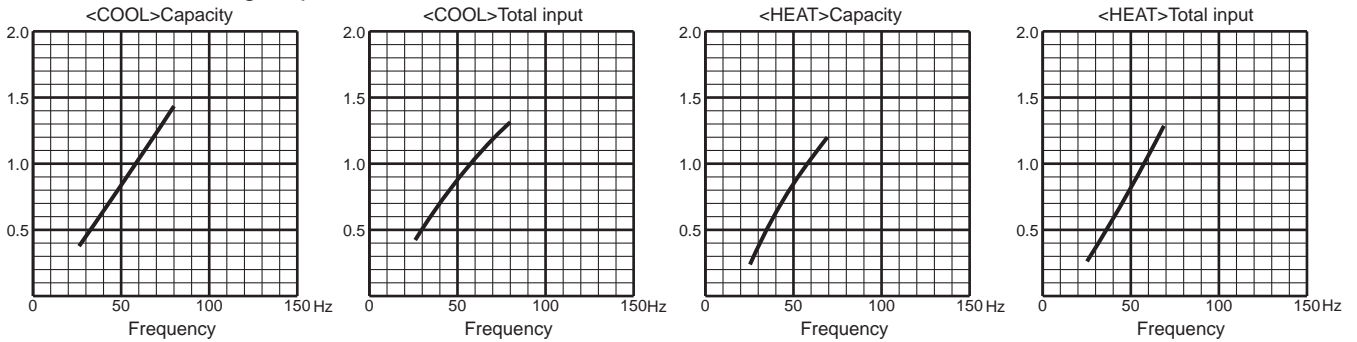

8. 50-class unit in single operation

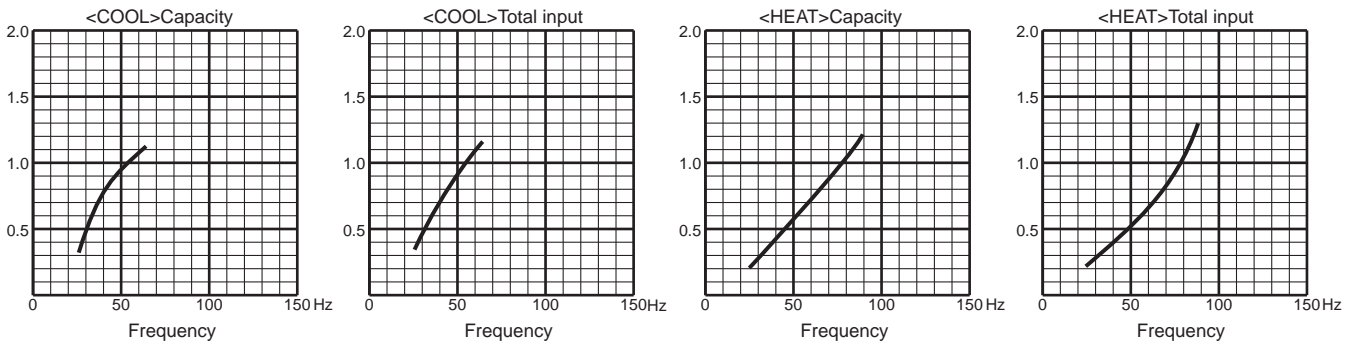

9. 60-class unit in single operation

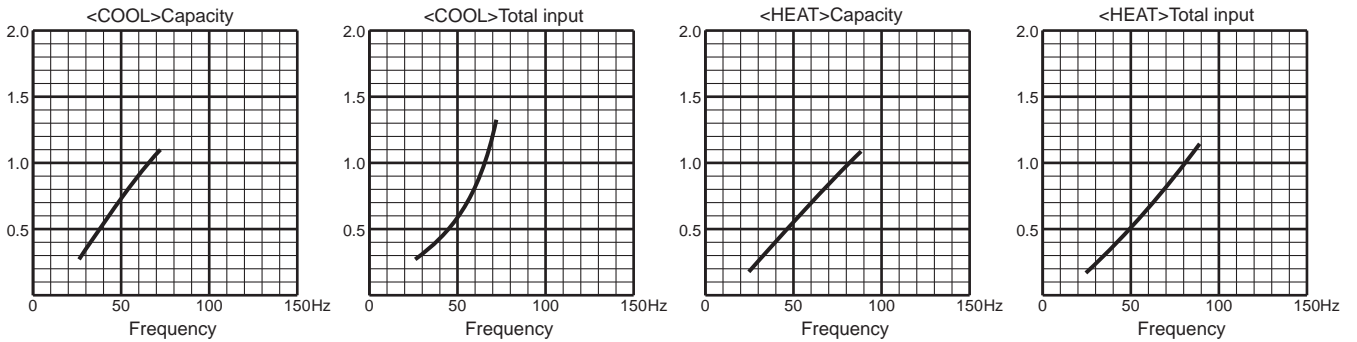

MXZ-4E83VA

1. 15-class unit in single operation

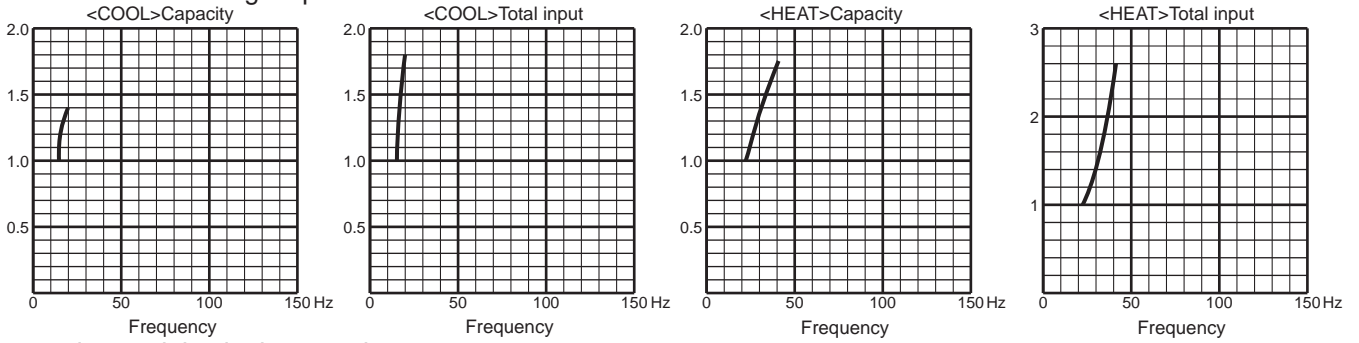

2. 18-class unit in single operation

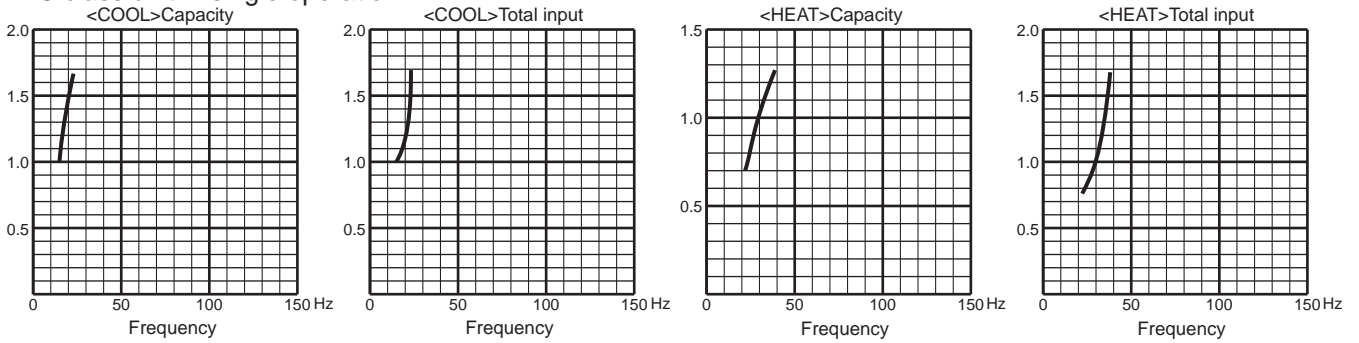

3. 20-class unit in single operation

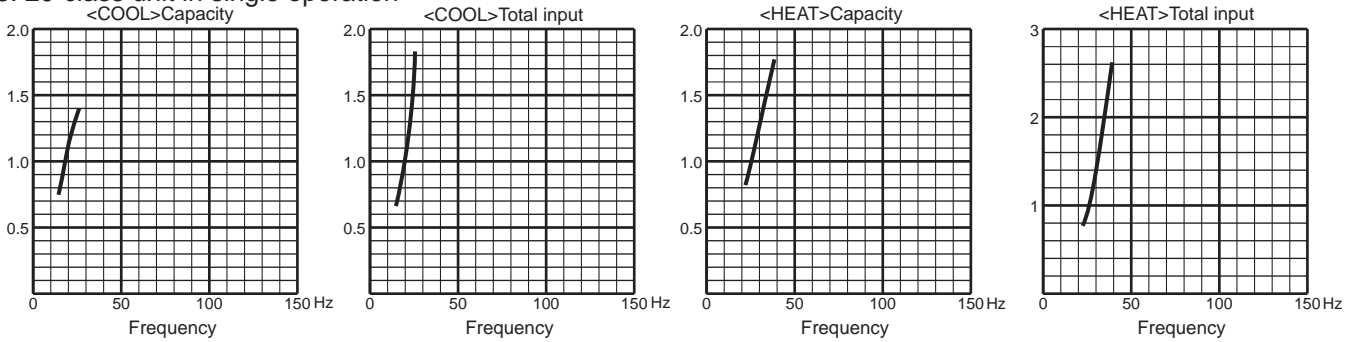

4. 22-class unit in single operation

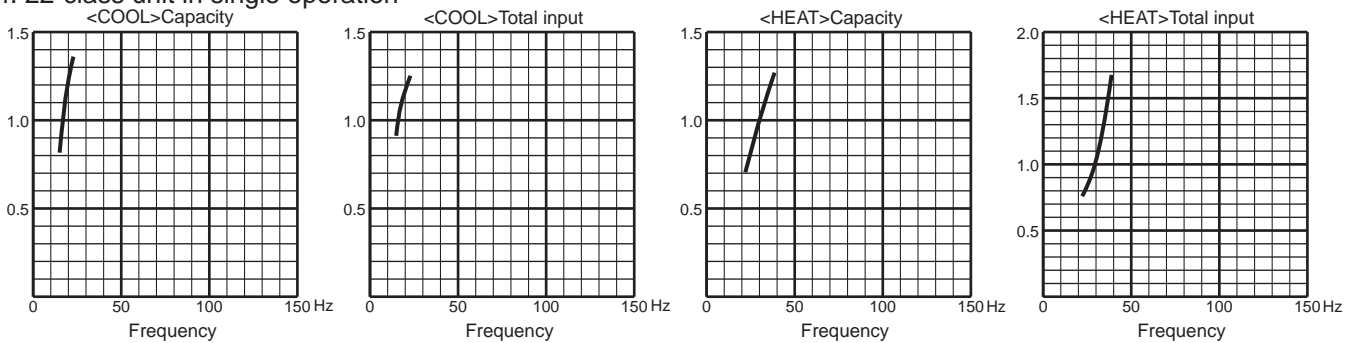

5. 25-class unit in single operation

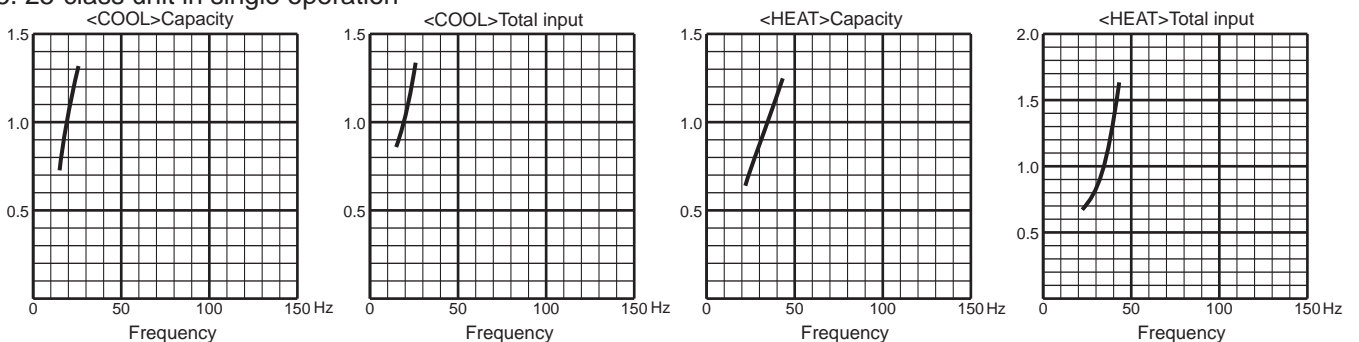

PERFORMANCE CURVES

MULTI SYSTEM

MXZ-4E83VA

6. 35-class unit in single operation

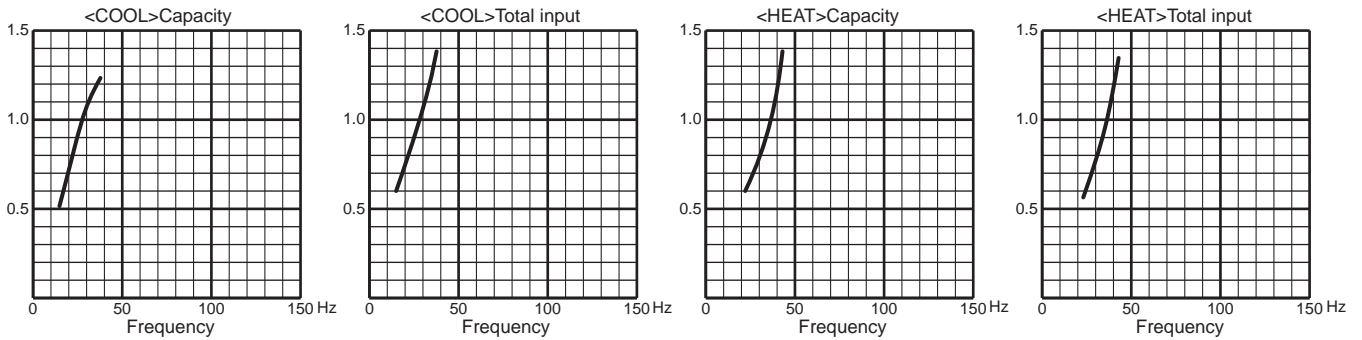

7. 42-class unit in single operation

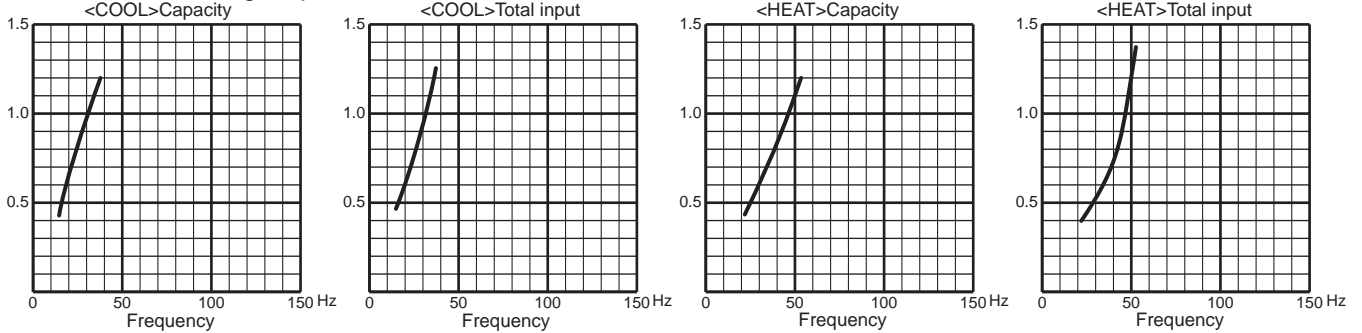

8. 50-class unit in single operation

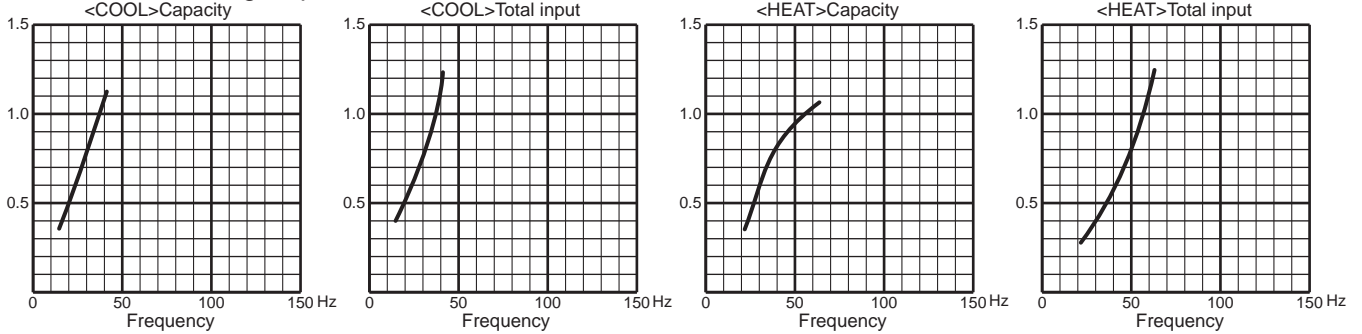

9. 60-class unit in single operation

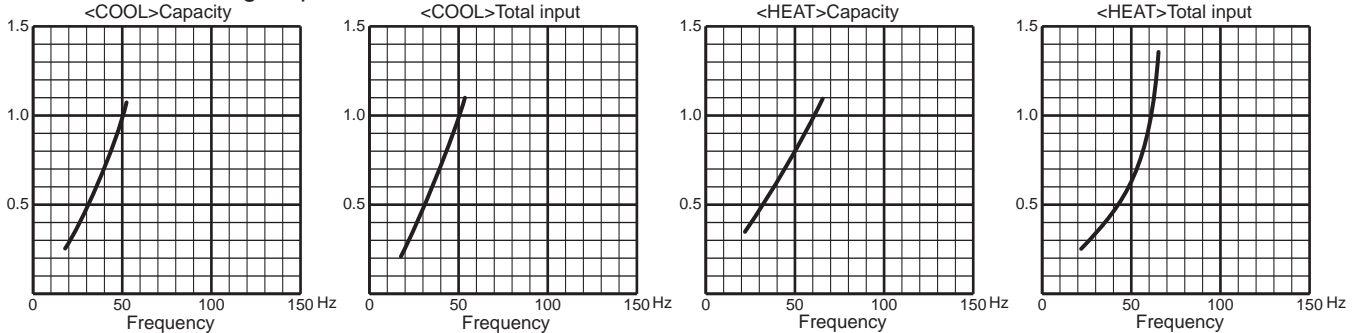

10. 71-class unit in single operation

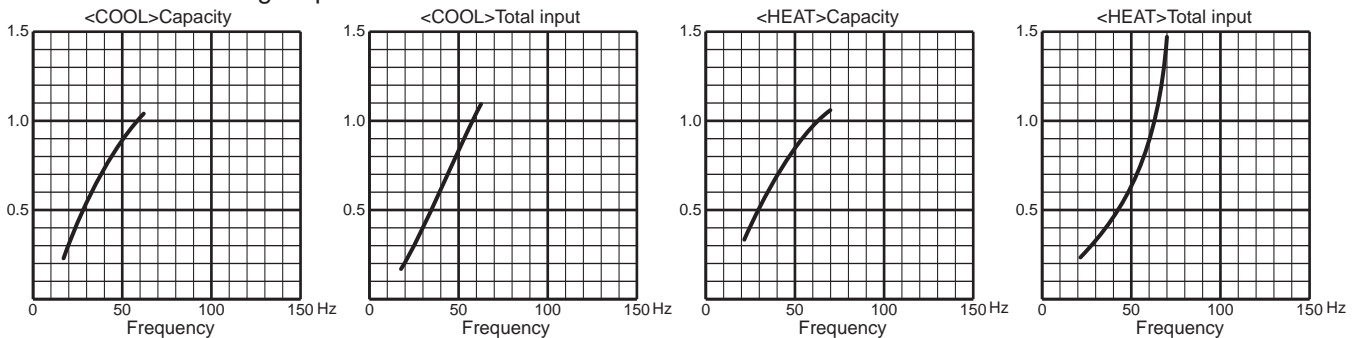

MXZ-4E83VAHZ

1. 15-class unit in single operation

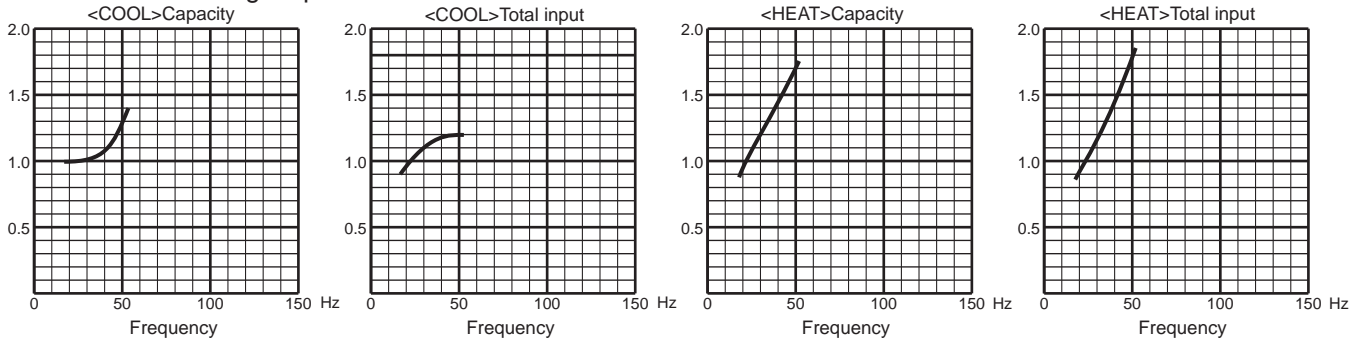

2. 18-class unit in single operation

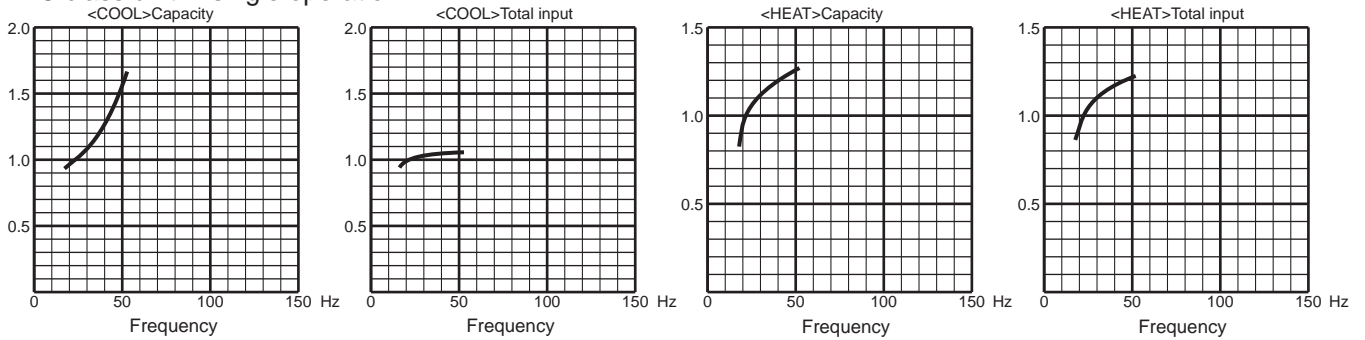

3. 20-class unit in single operation

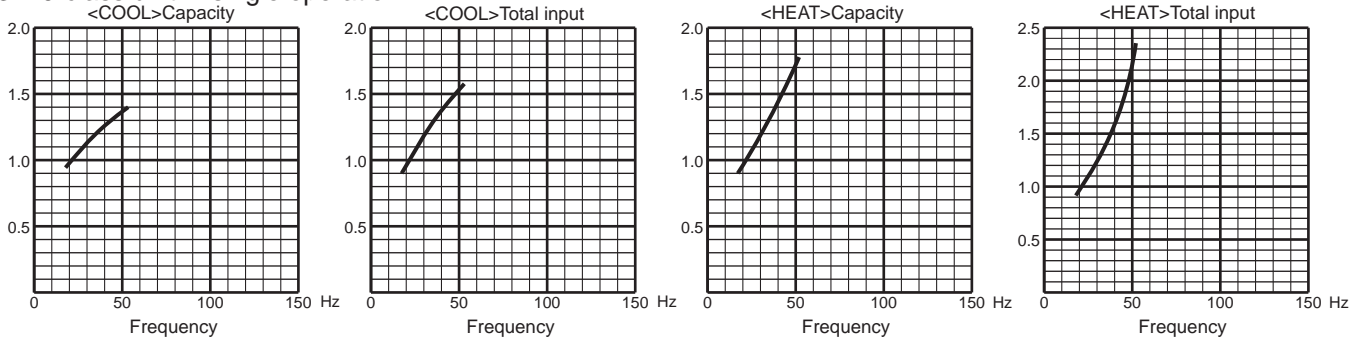

4. 22-class unit in single operation

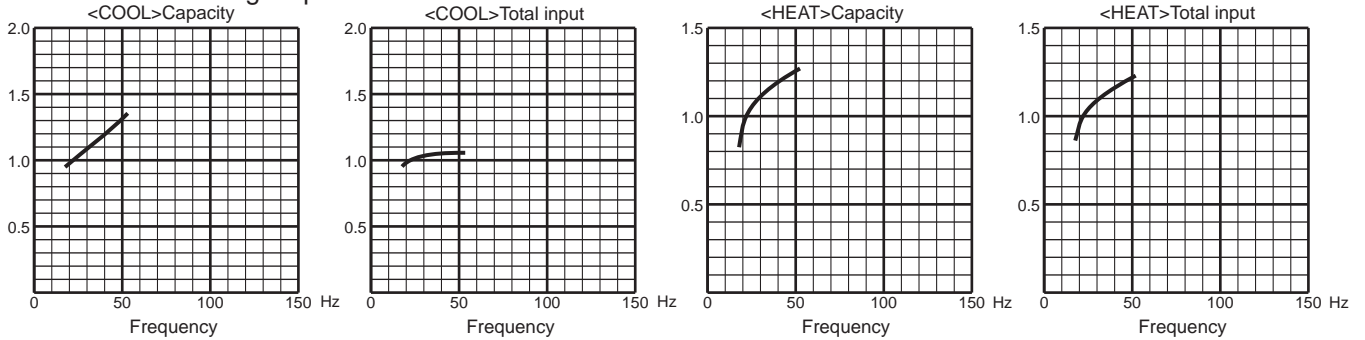

5. 25-class unit in single operation

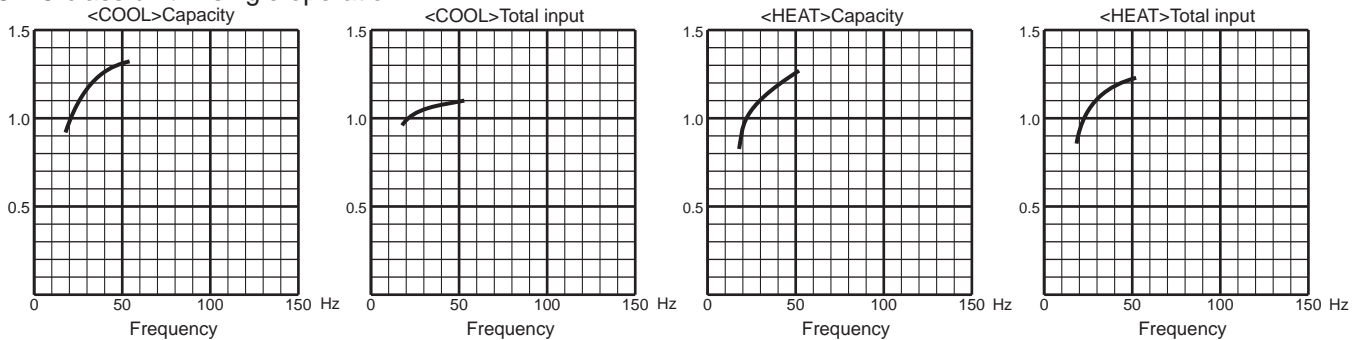

PERFORMANCE CURVES

MULTI SYSTEM

MXZ-4E83VAHZ

6. 35-class unit in single operation

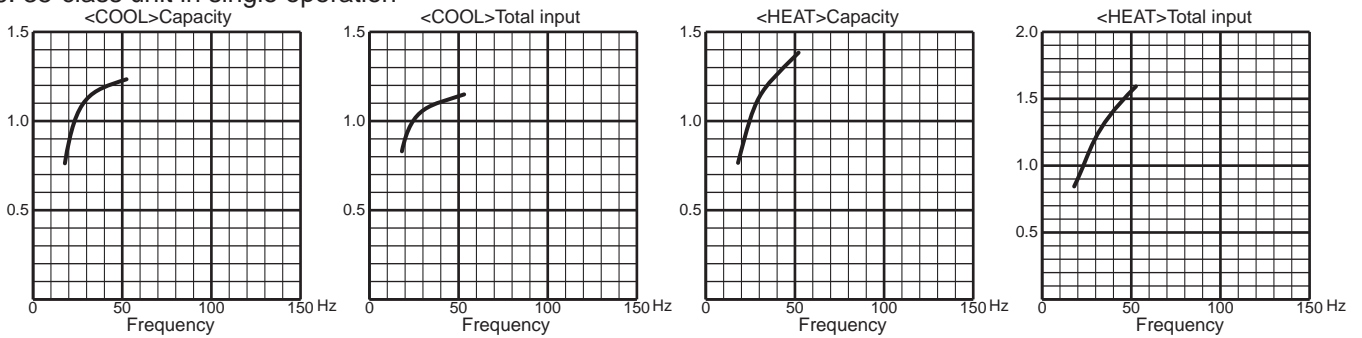

7. 42-class unit in single operation

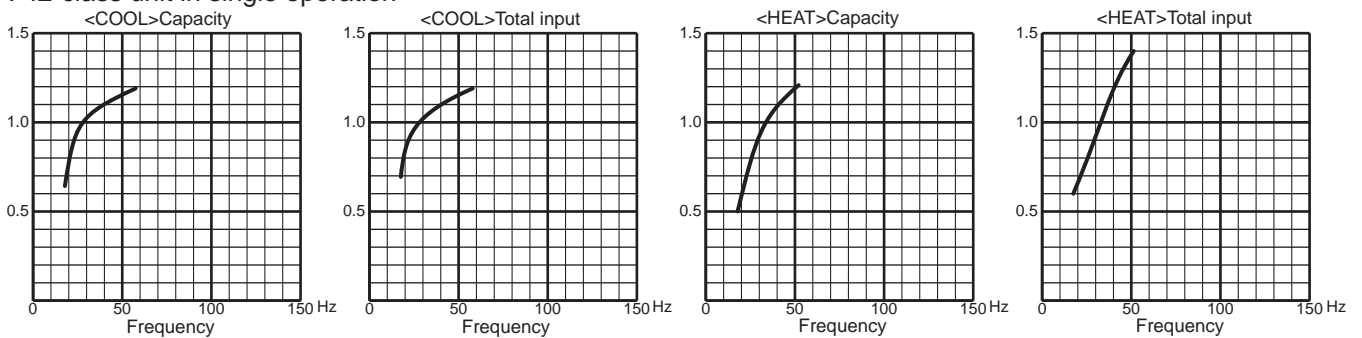

8. 50-class unit in single operation

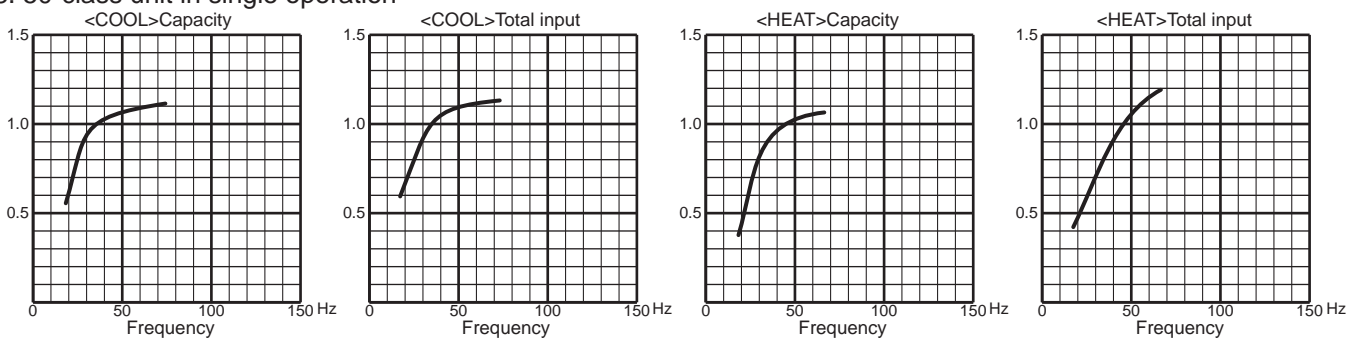

9. 60-class unit in single operation

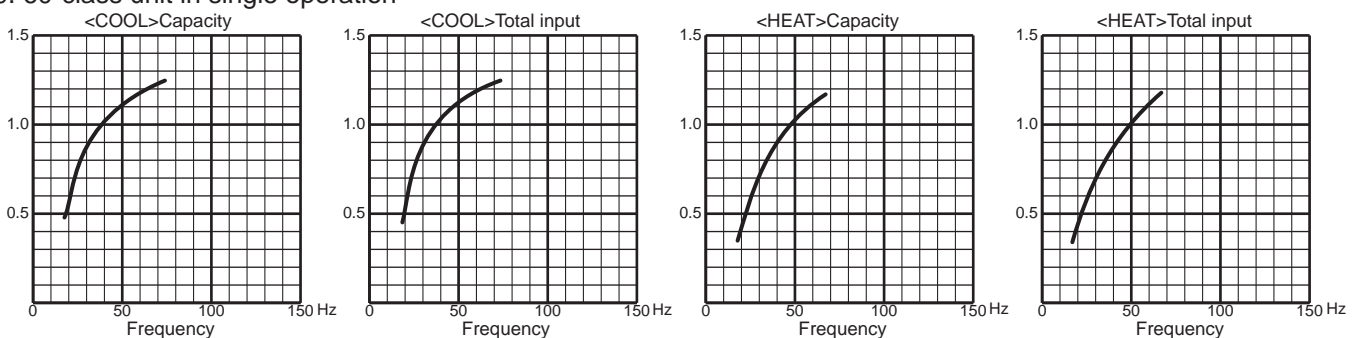

10. 71-class unit in single operation

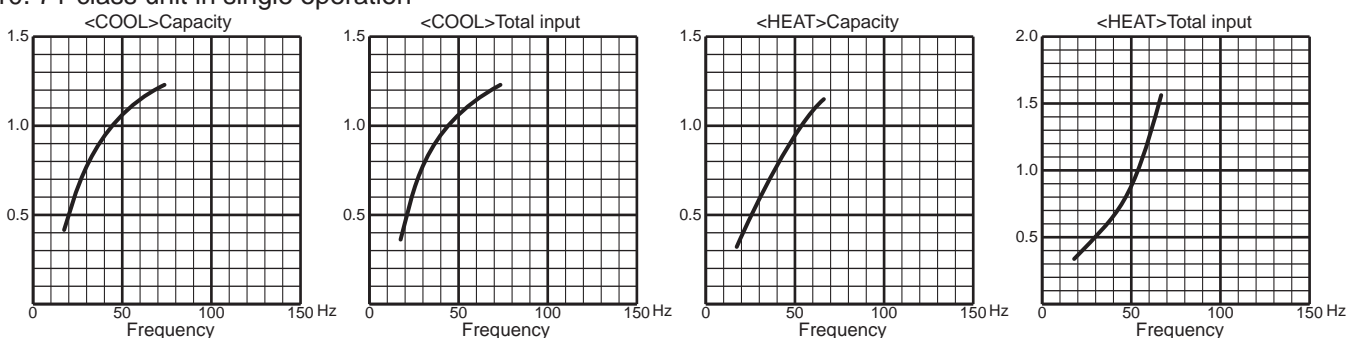

MXZ-5E102VA

1. 15-class unit in single operation

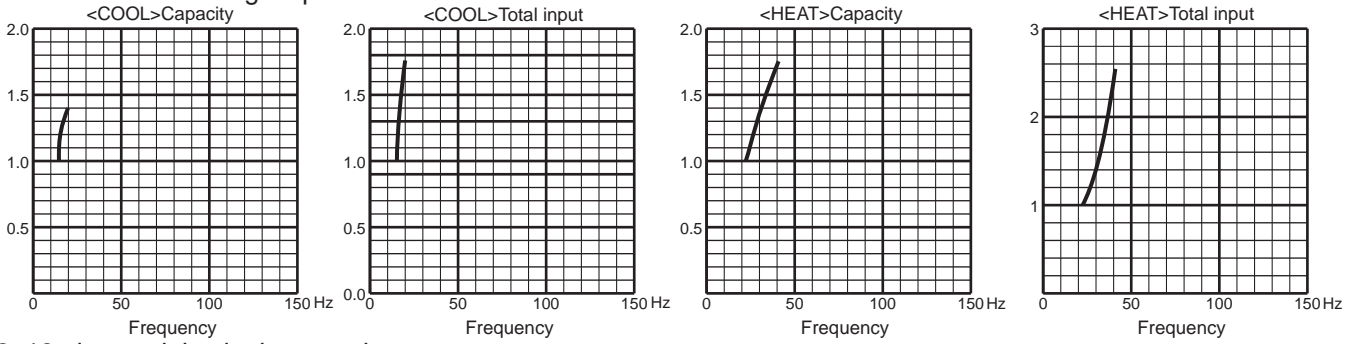

2. 18-class unit in single operation

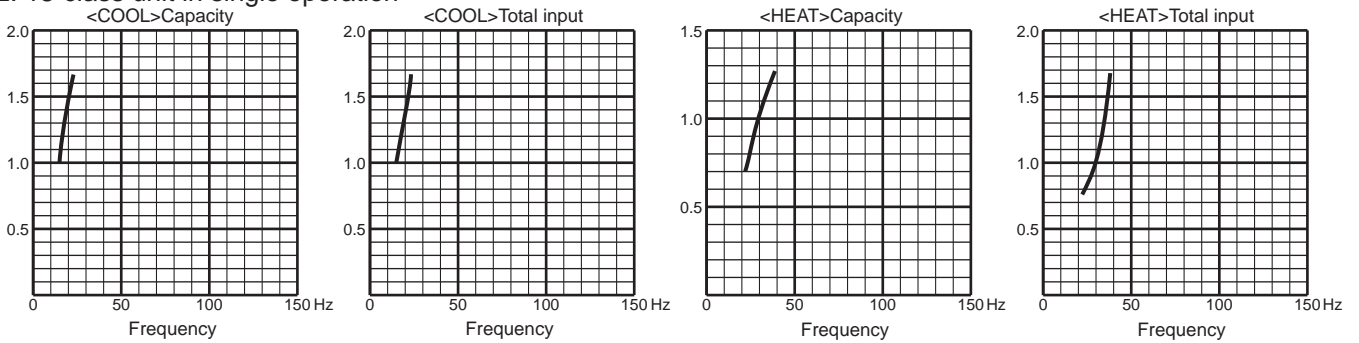

3. 20-class unit in single operation

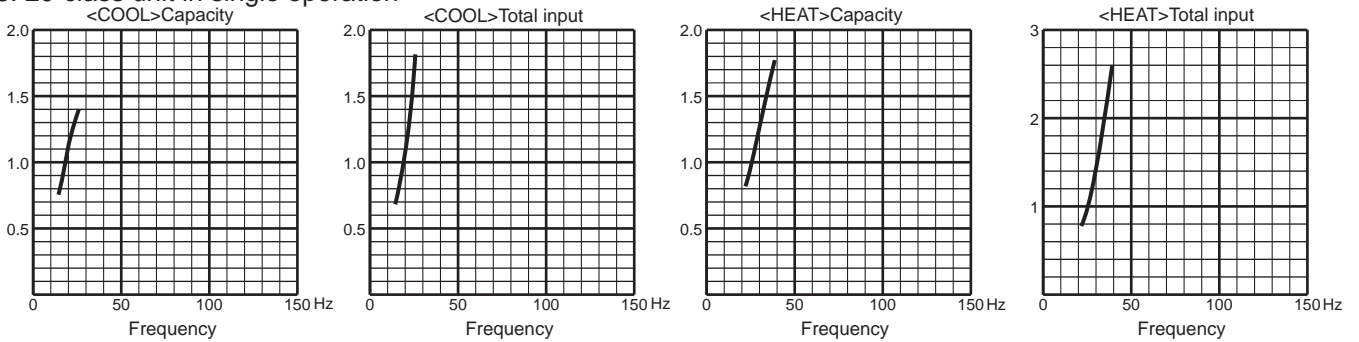

4. 22-class unit in single operation

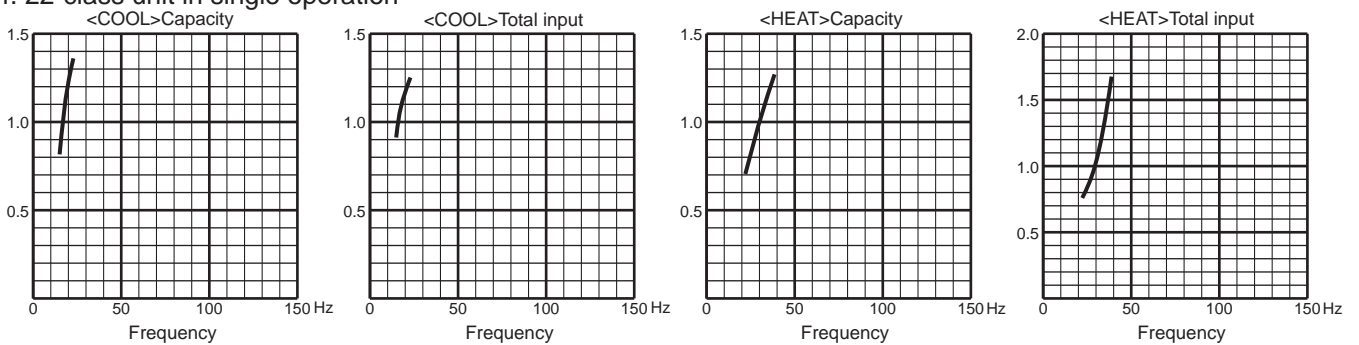

5. 25-class unit in single operation

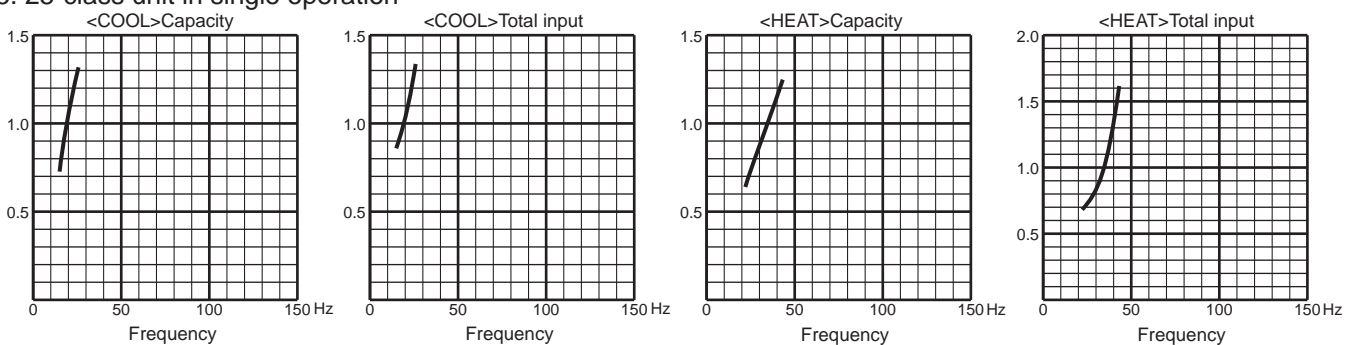

PERFORMANCE CURVES

MULTI SYSTEM

MXZ-5E102VA

6. 35-class unit in single operation

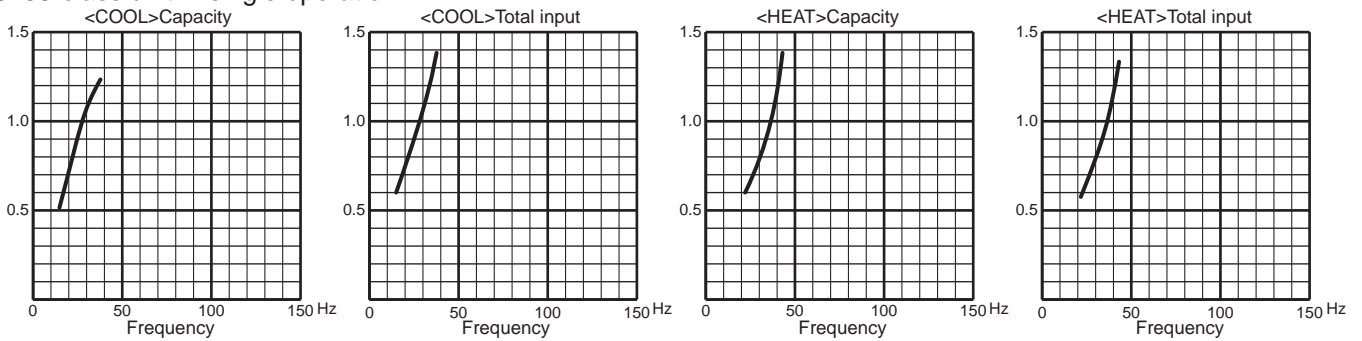

7. 42-class unit in single operation

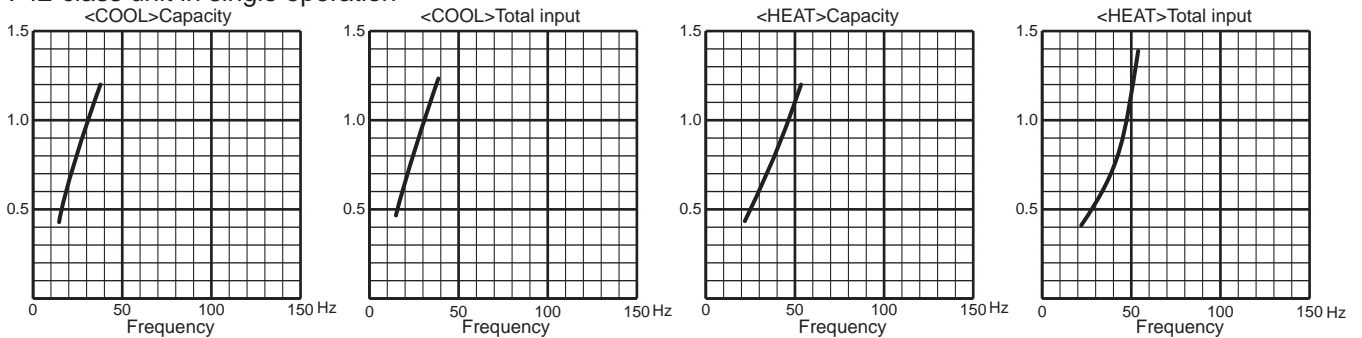

8. 50-class unit in single operation

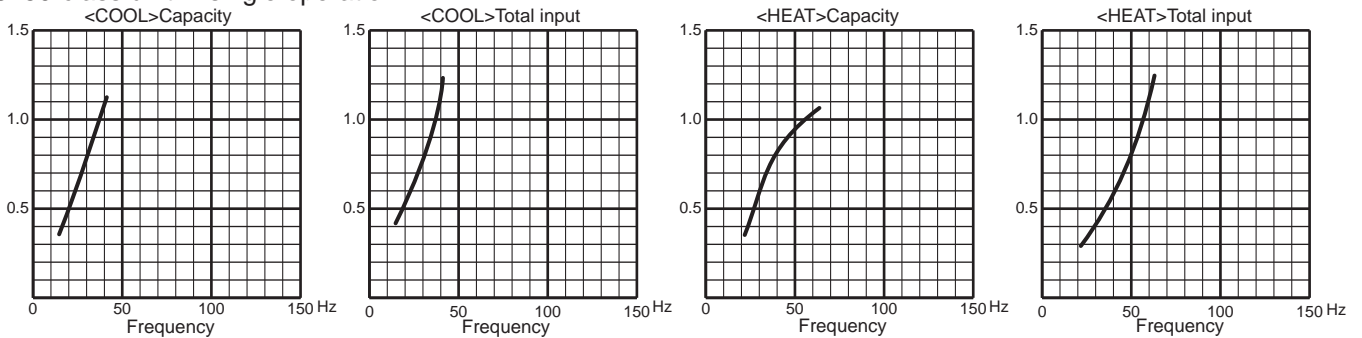

9. 60-class unit in single operation

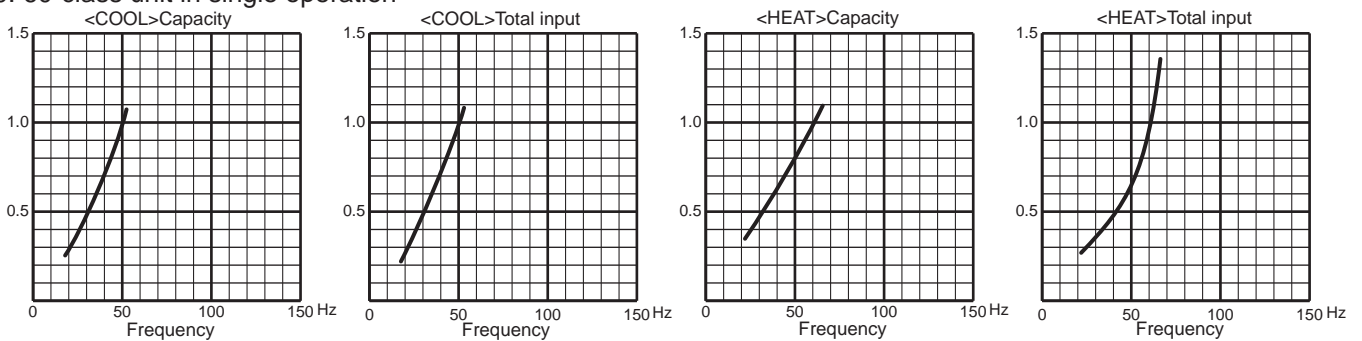

10. 71-class unit in single operation

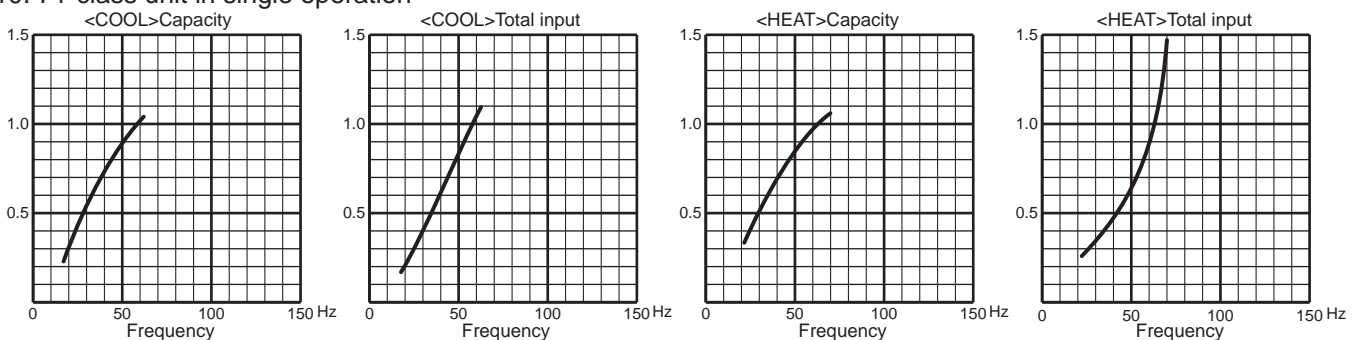

MXZ-6D122VA2

1. 15-class unit in single operation

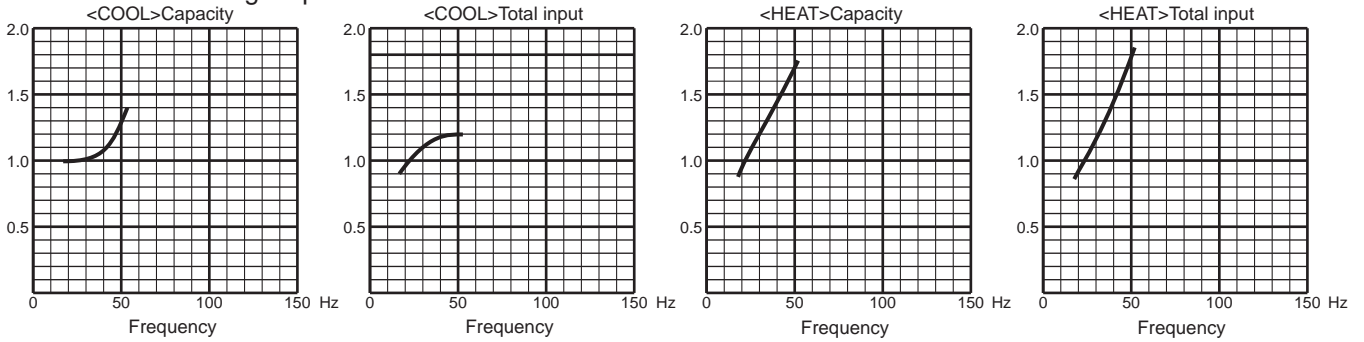

2. 18-class unit in single operation

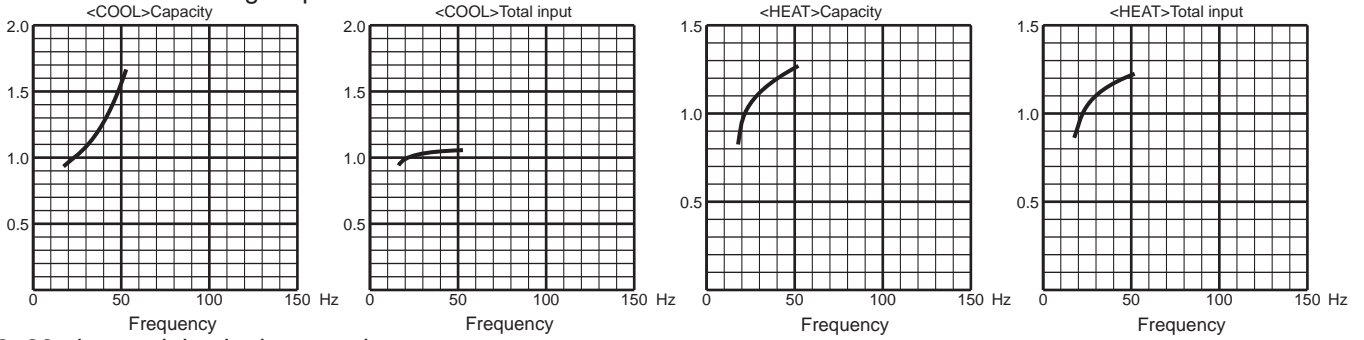

3. 20-class unit in single operation

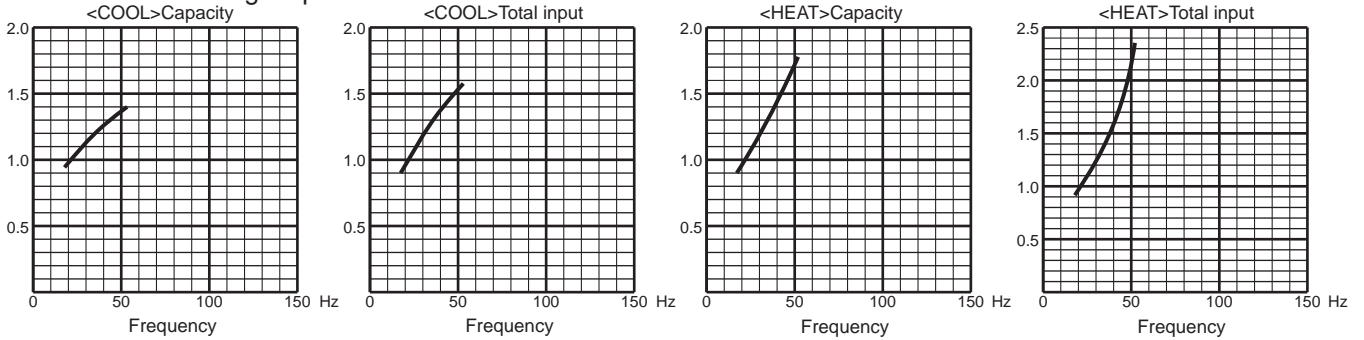

4. 22-class unit in single operation

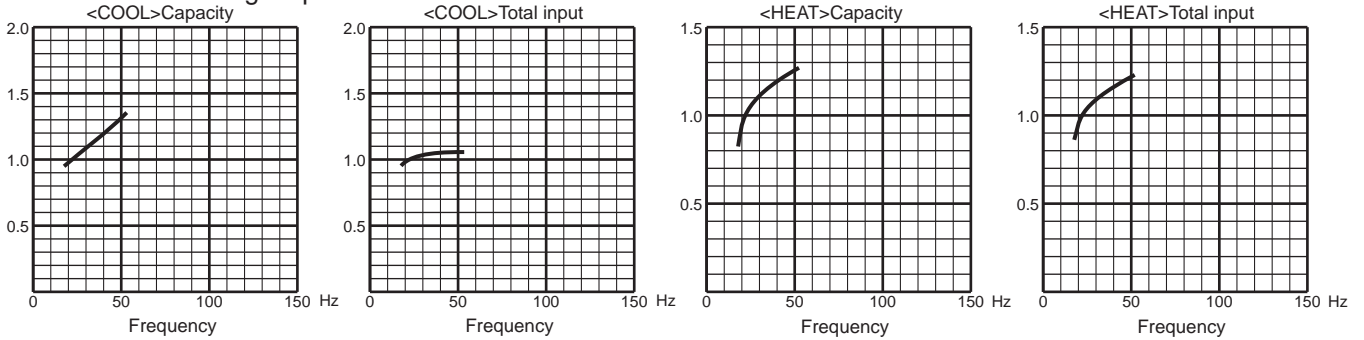

5. 25-class unit in single operation

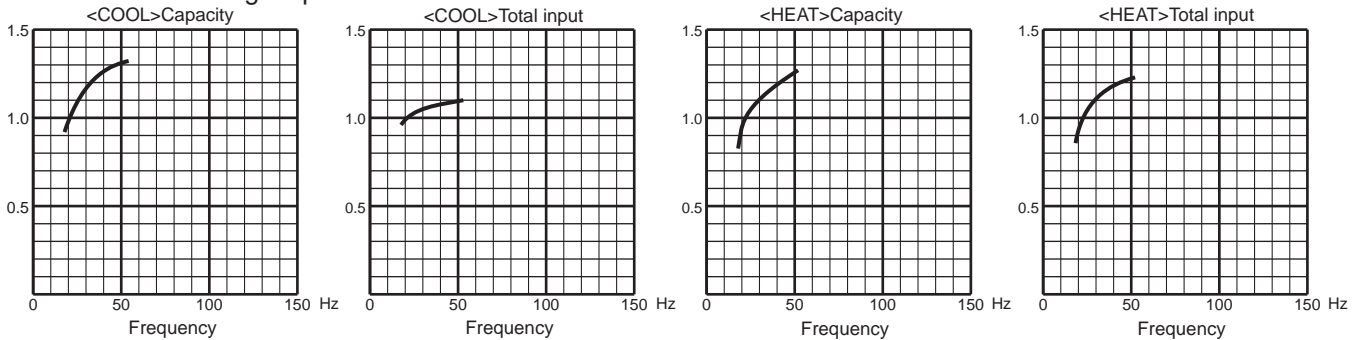

PERFORMANCE CURVES

MULTI SYSTEM

MXZ-6D122VA2

6. 35-class unit in single operation

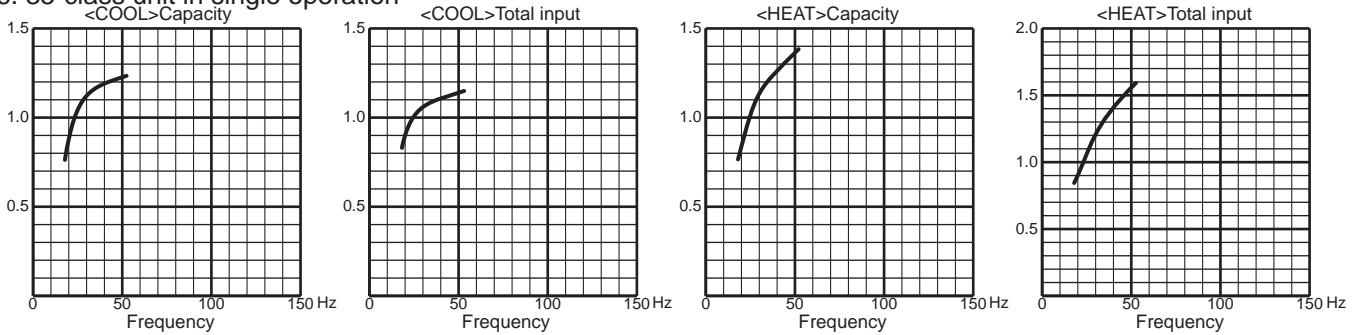

7. 42-class unit in single operation

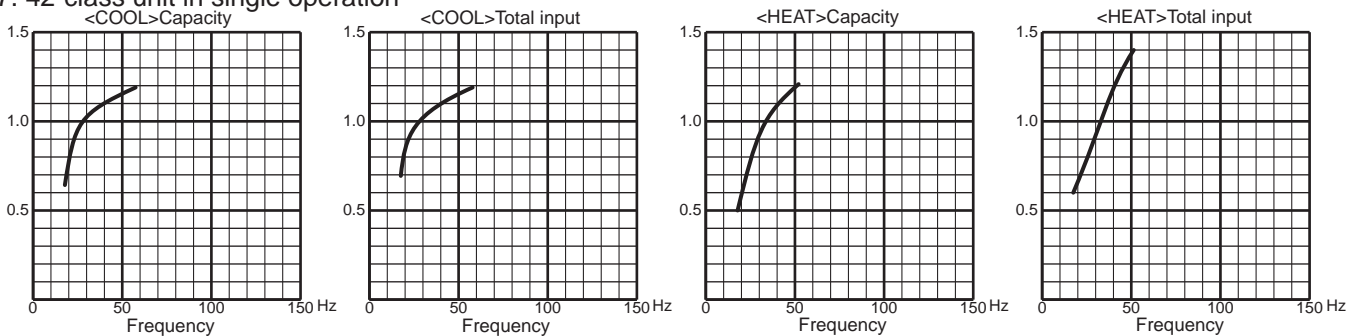

8. 50-class unit in single operation

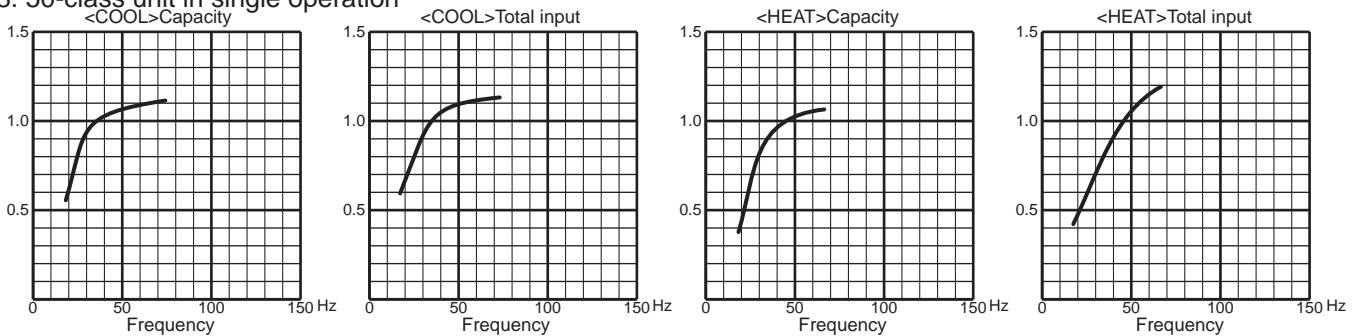

9. 60-class unit in single operation

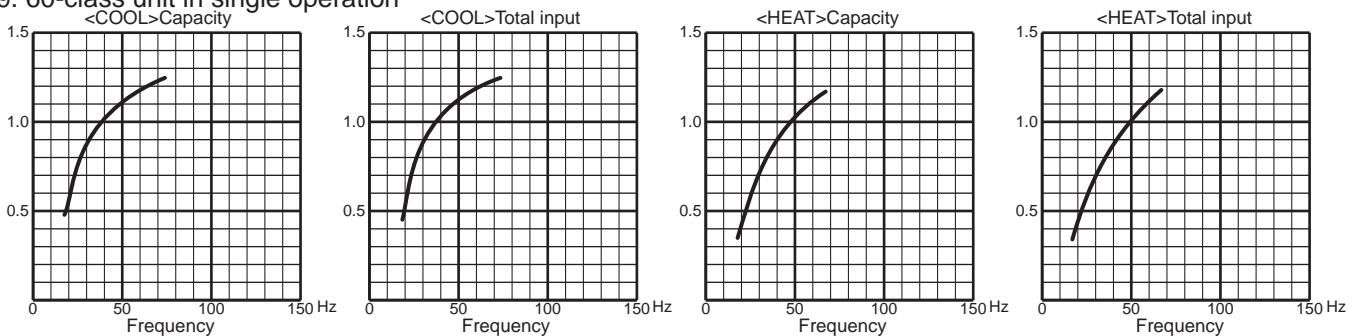

10. 71-class unit in single operation

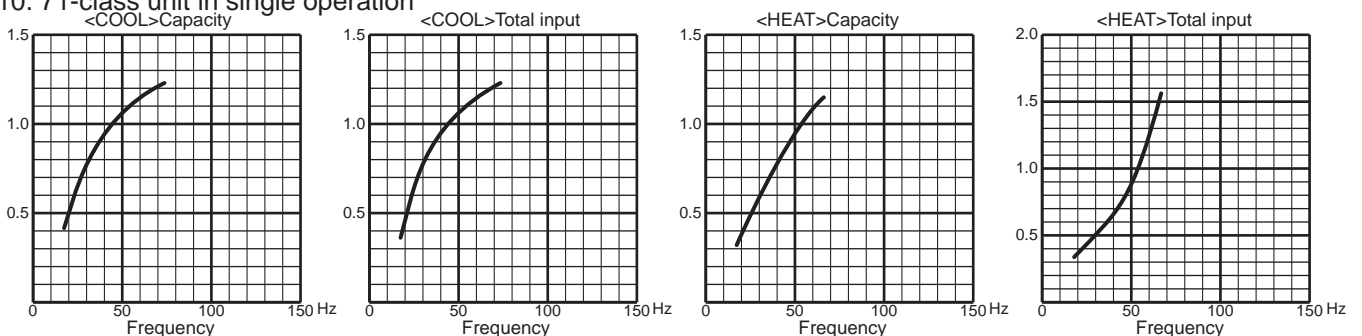

MULTI SYSTEM PERFORMANCE CURVES

MXZ-2DM40VA

1. 25-class unit in single operation

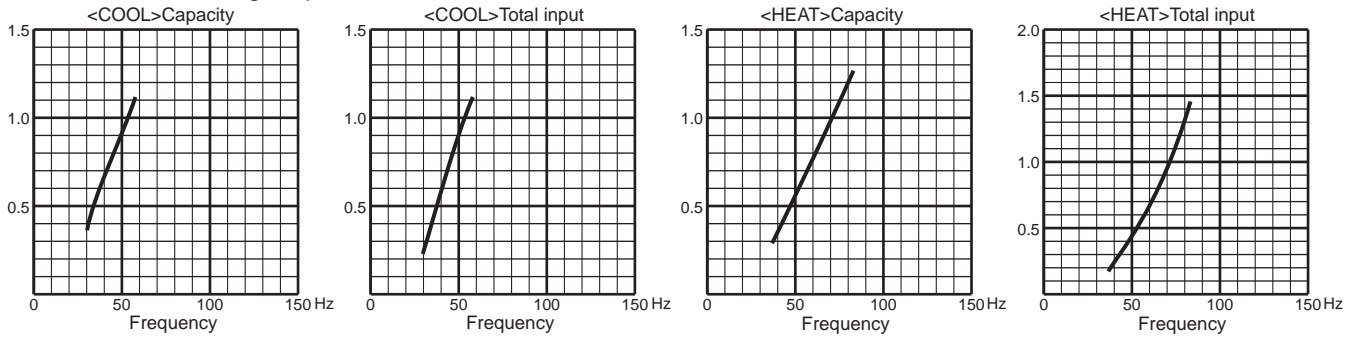

2. 35-class unit in single operation

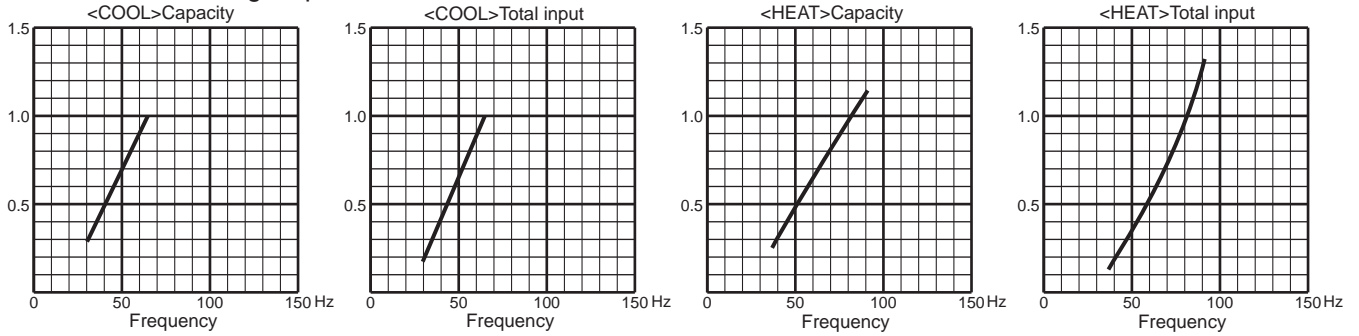

MXZ-3DM50VA

1. 25-class unit in single operation

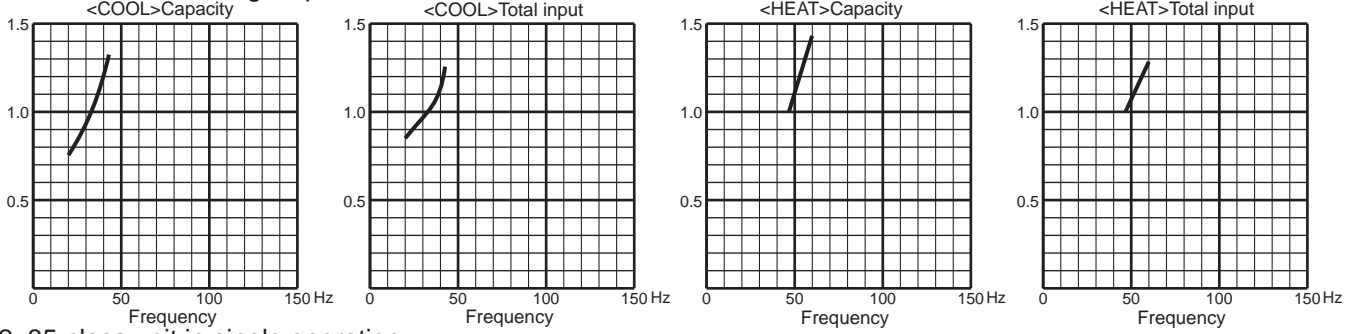

2. 35-class unit in single operation

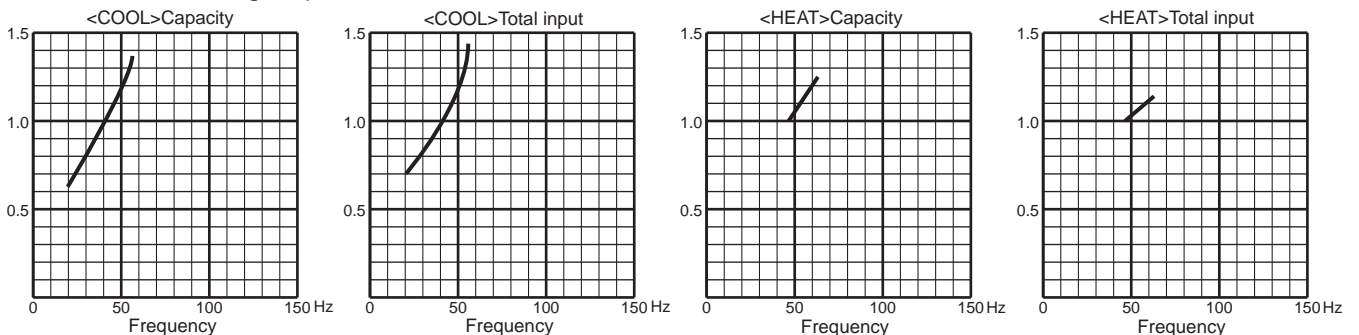

3. 50-class unit in single operation

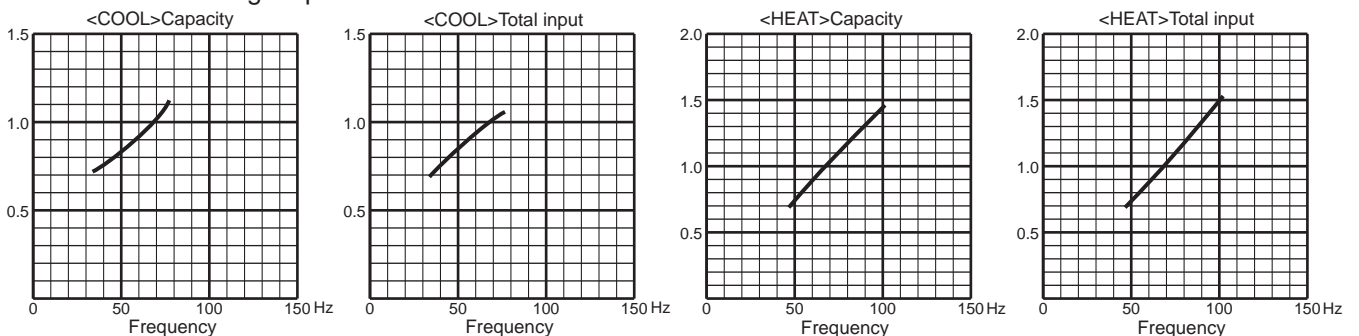

PERFORMANCE CURVES

MULTI SYSTEM

MXZ-2HA40VF2

1. 25-class unit in single operation

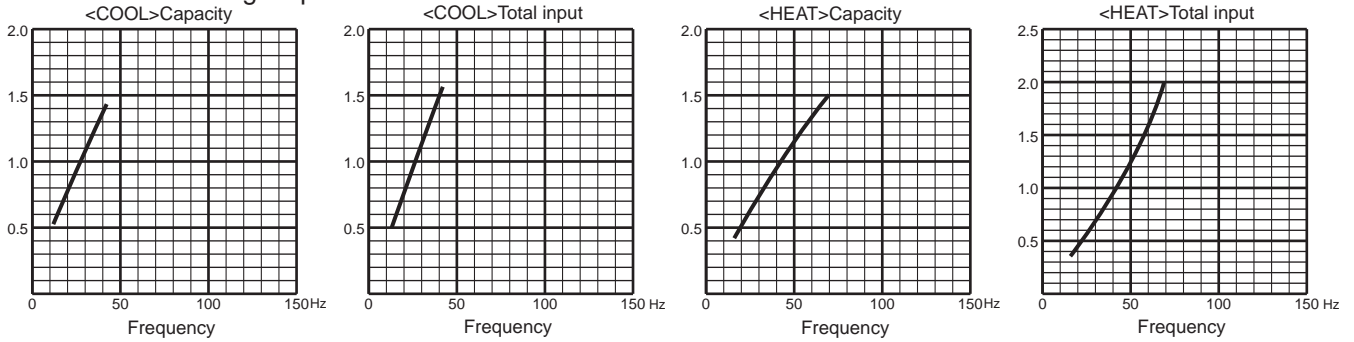

2. 35-class unit in single operation

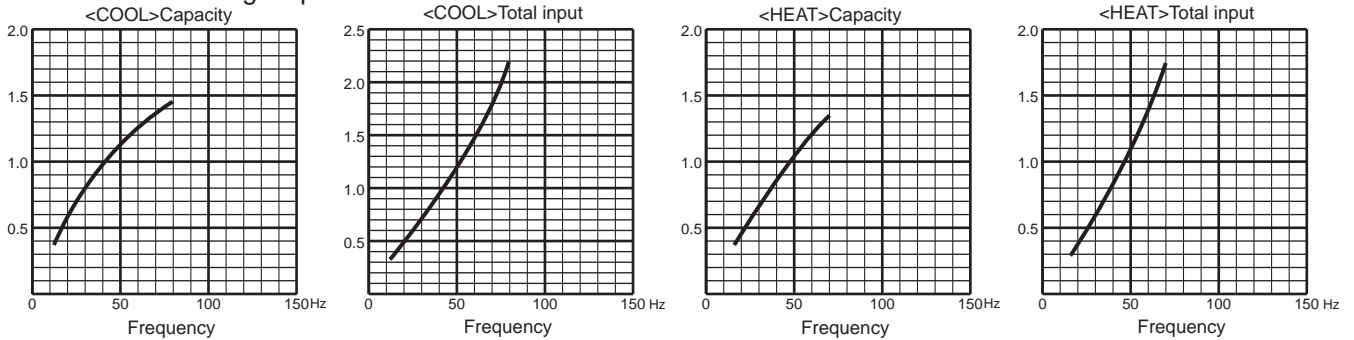

MXZ-2HA50VF2

1. 25-class unit in single operation

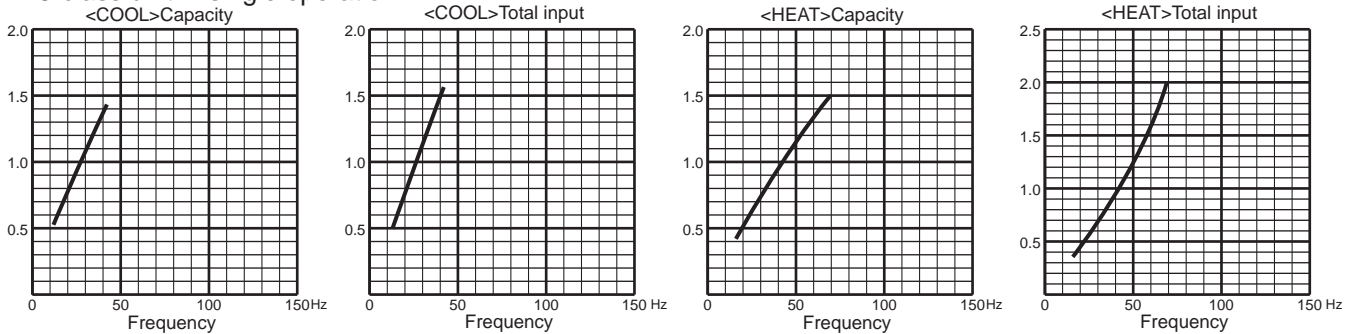

2. 35-class unit in single operation

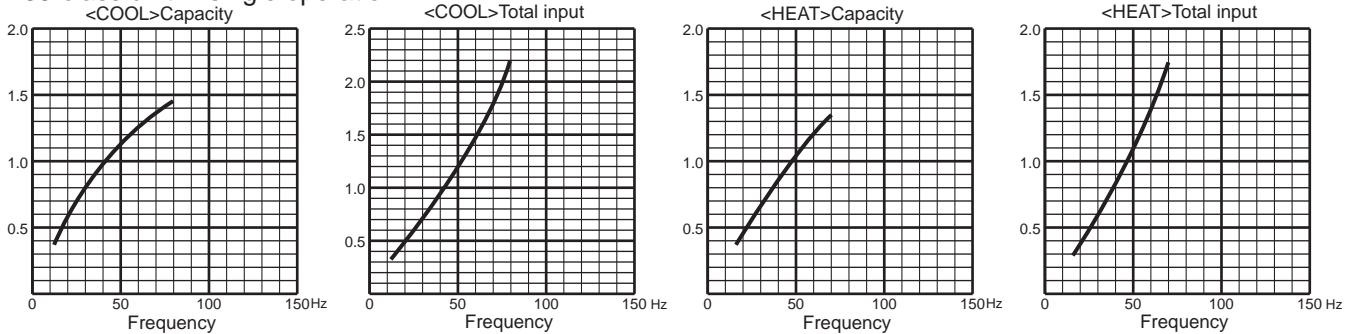

3. 42-class unit in single operation

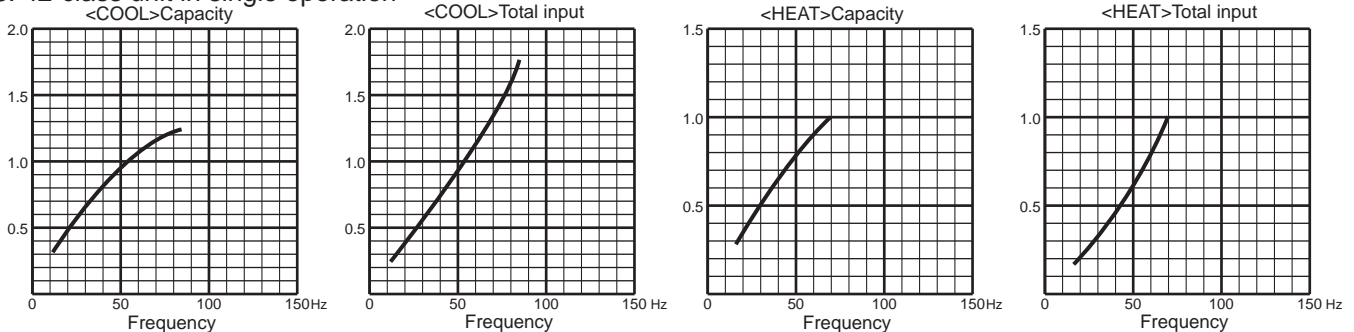

MXZ-3HA50VF2

1. 25-class unit in single operation

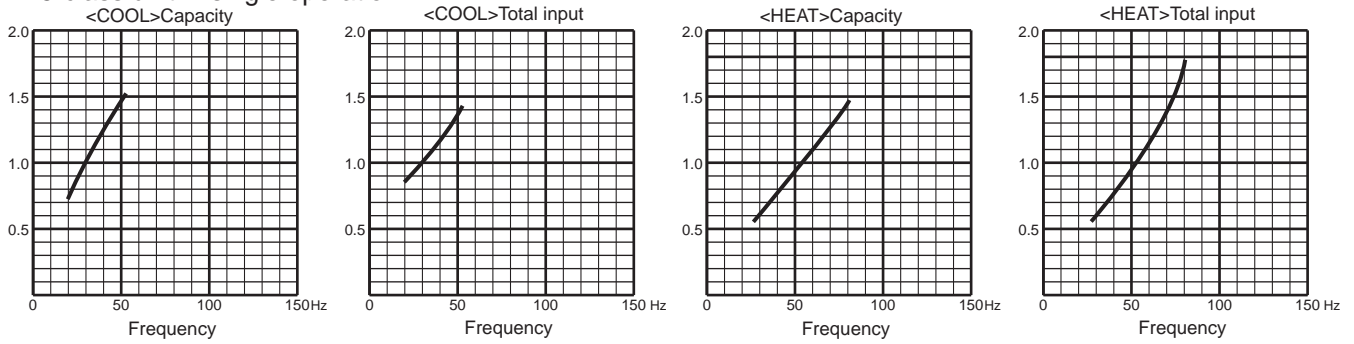

2. 35-class unit in single operation

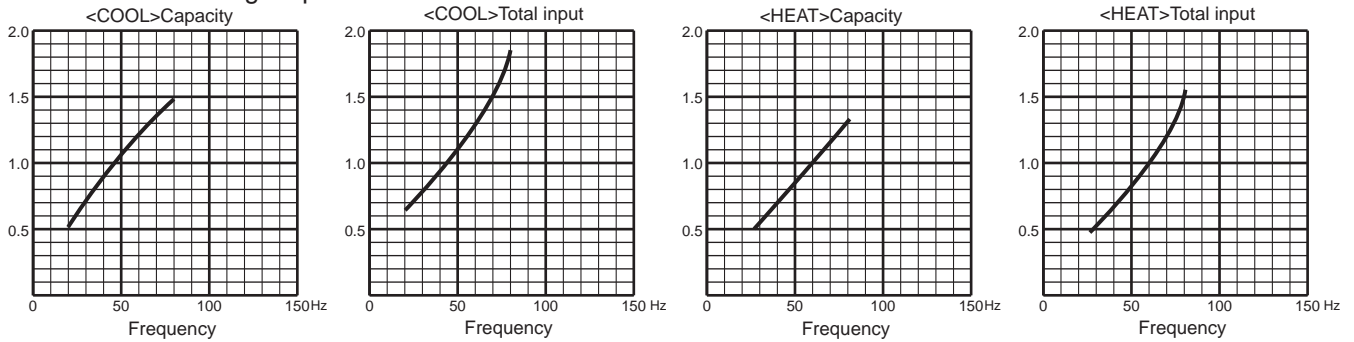

3. 42-class unit in single operation

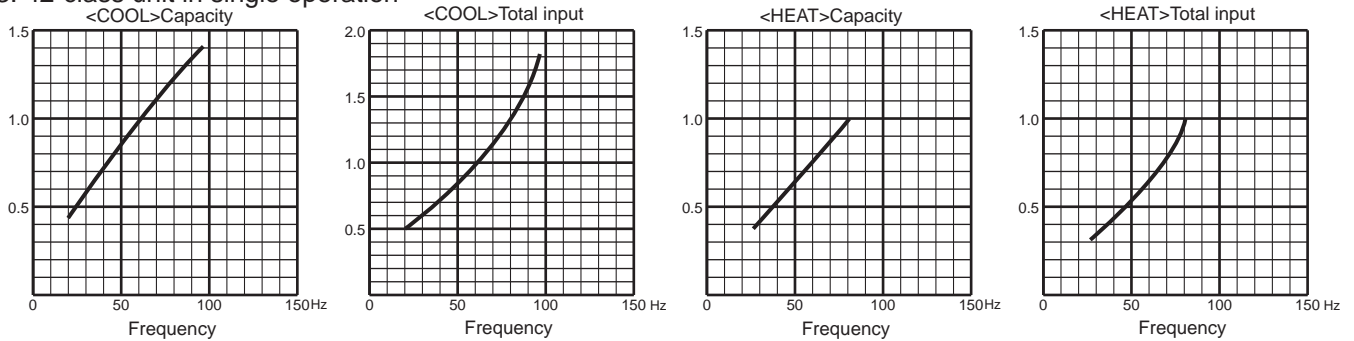

4. 50-class unit in single operation

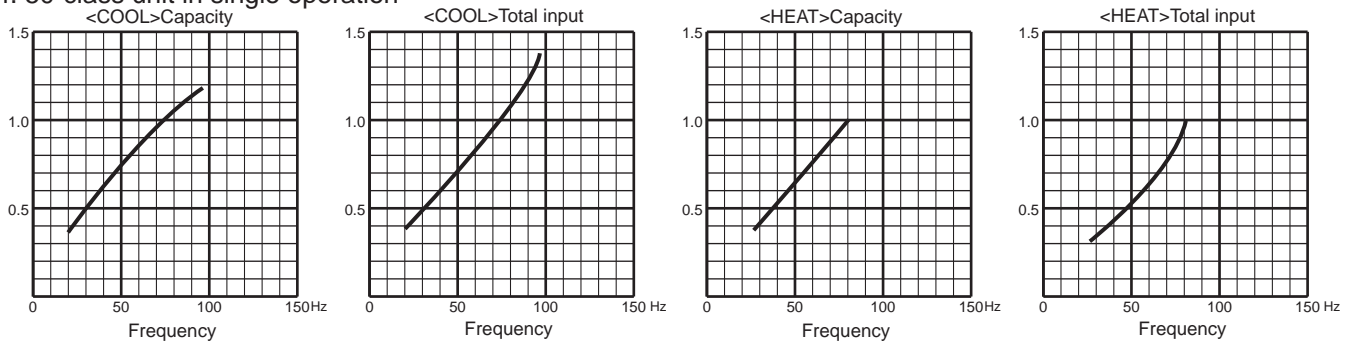

PERFORMANCE CURVES

MULTI SYSTEM

PXZ-4F75VG

1. 15-class unit in single operation

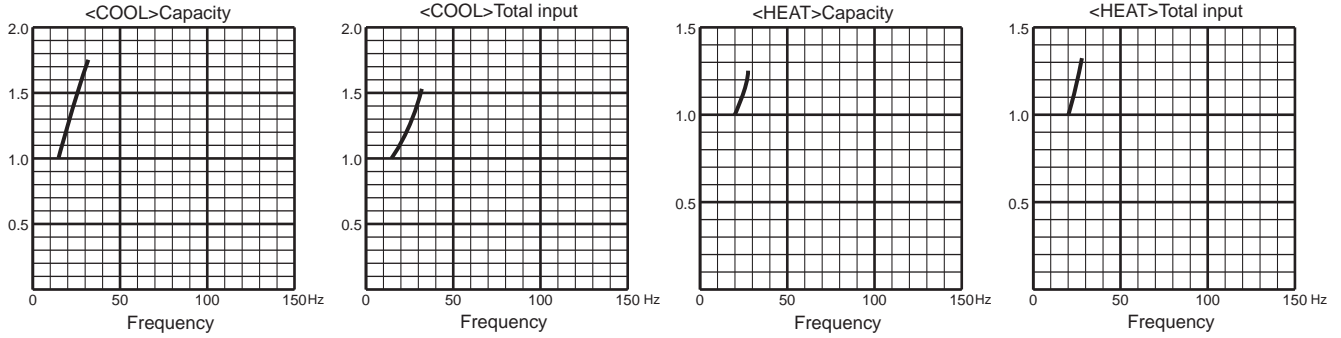

2. 18-class unit in single operation

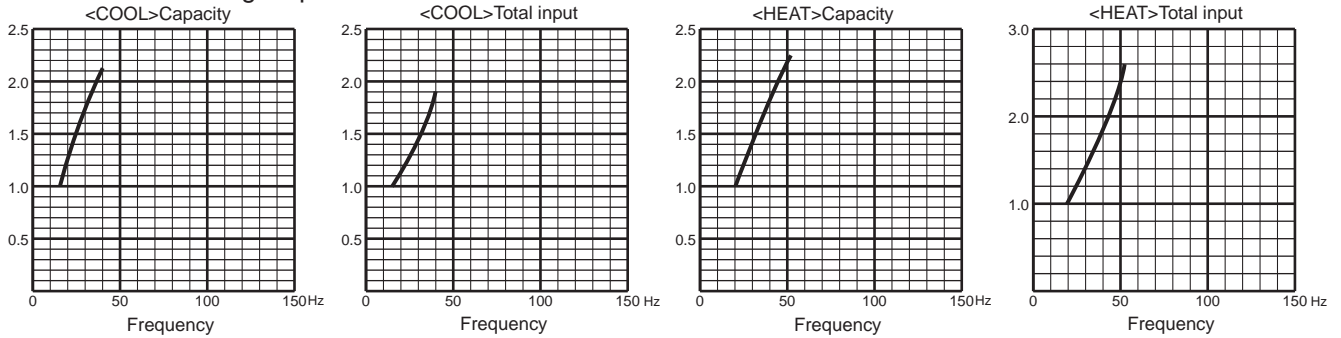

3. 20-class unit in single operation

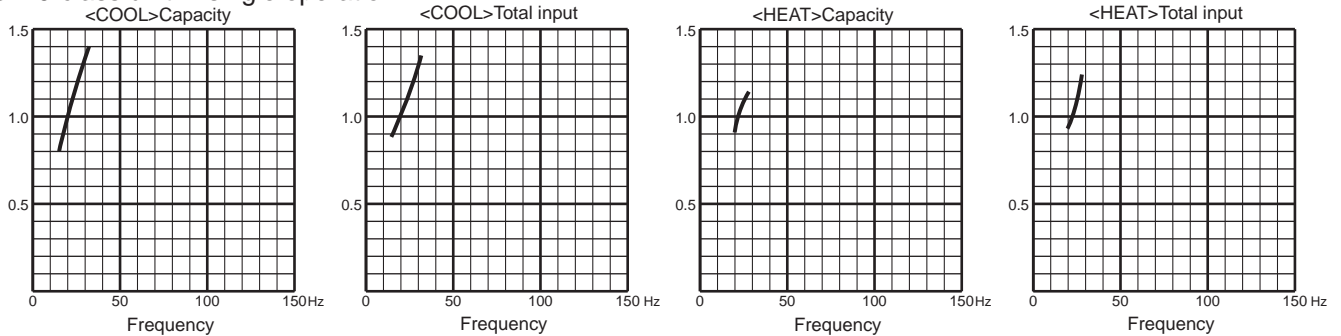

4. 22-class unit in single operation

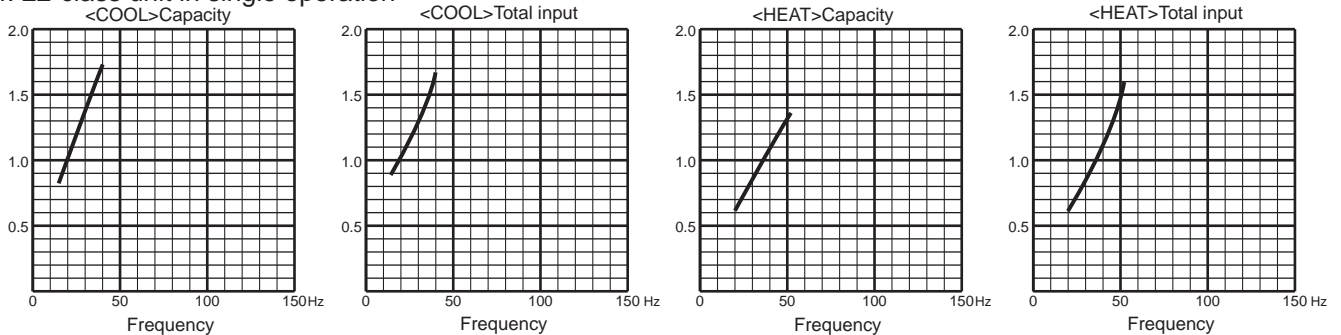

5. 25-class unit in single operation

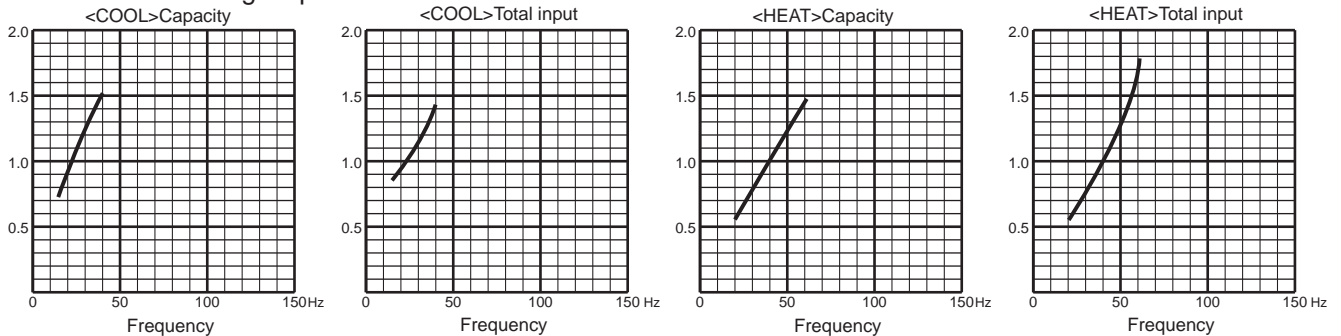

PXZ-4F75VG

6. 35-class unit in single operation

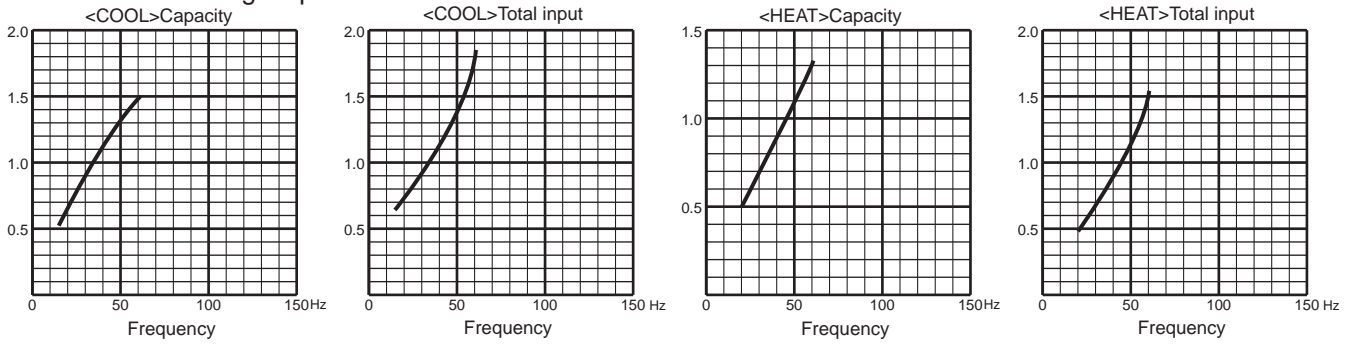

7. 42-class unit in single operation

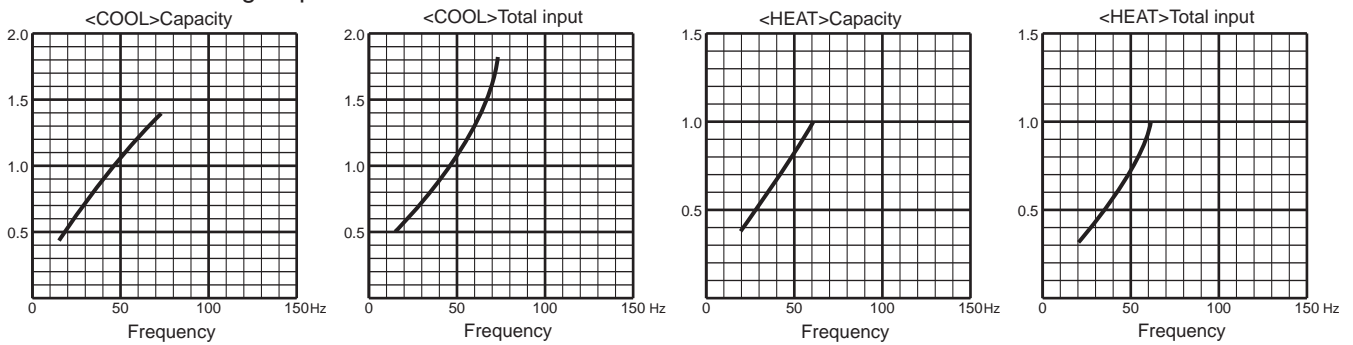

8. 50-class unit in single operation

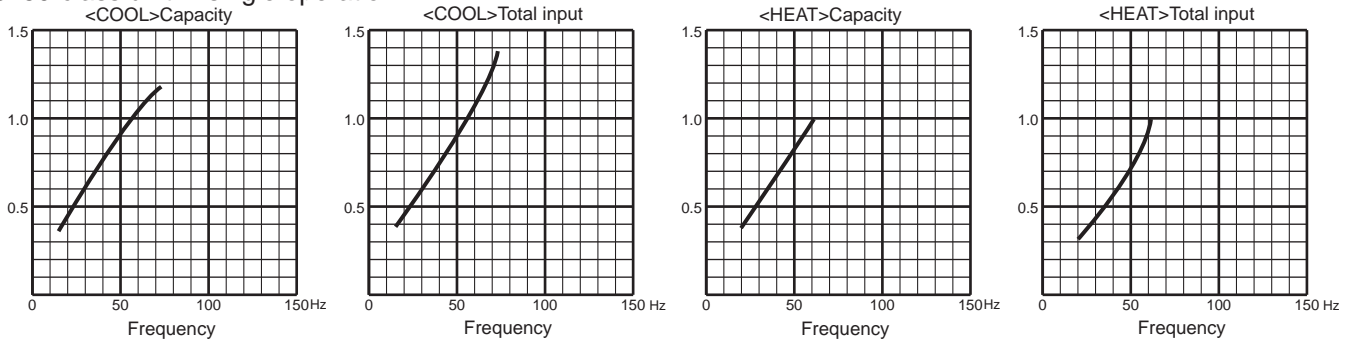

9. 60-class unit in single operation

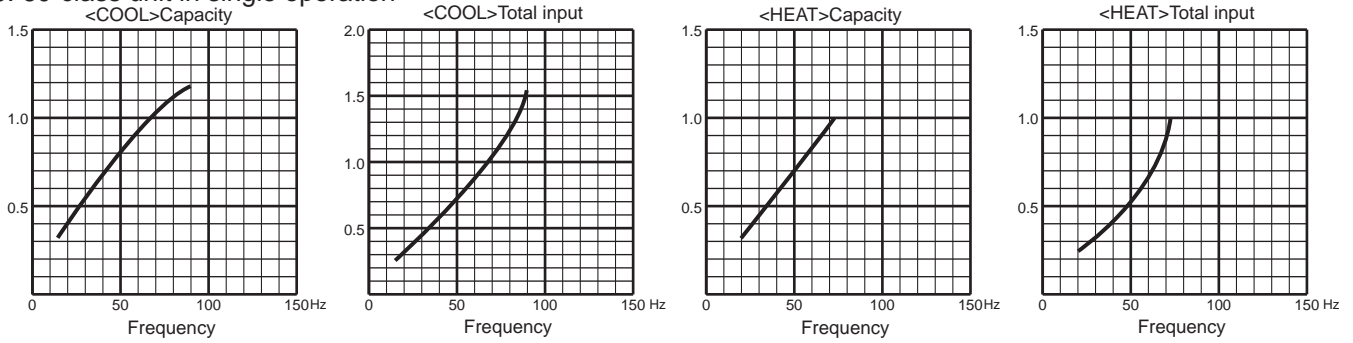

10. 71-class unit in single operation

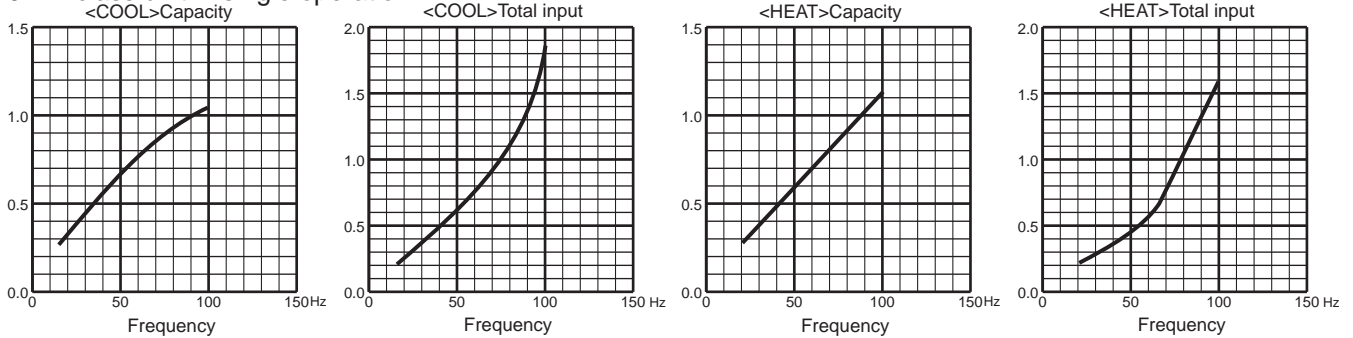

PERFORMANCE CURVES

MULTI SYSTEM

PXZ-5F85VG

1. 15-class unit in single operation

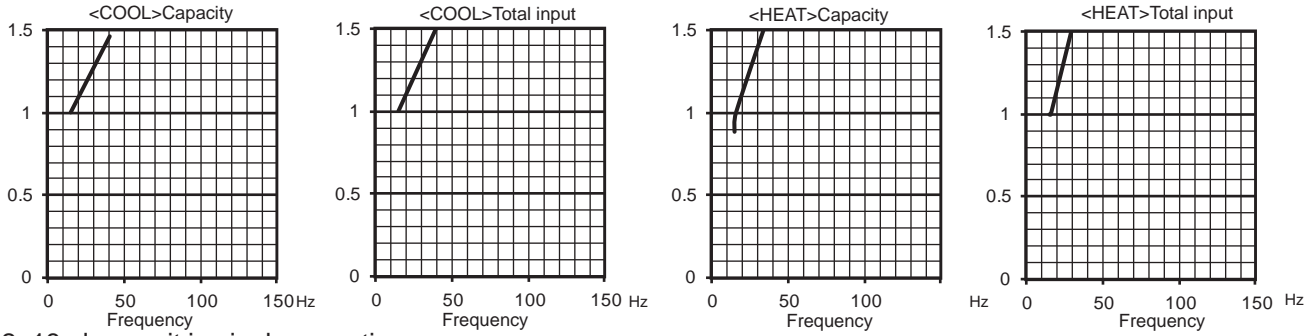

2. 18-class unit in single operation

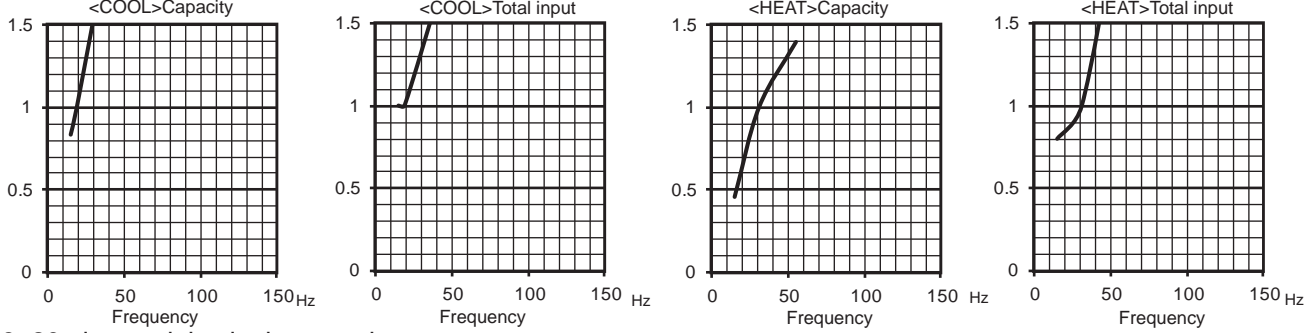

3. 20-class unit in single operation

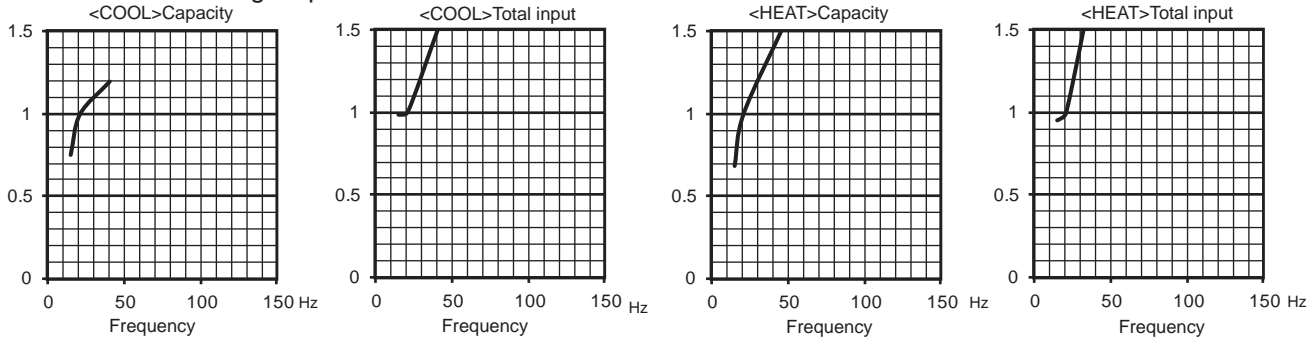

4. 22-class unit in single operation

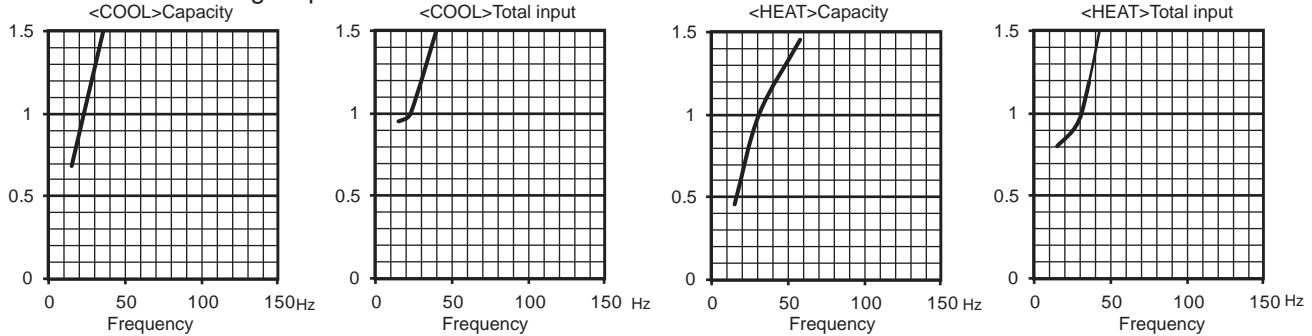

5. 25-class unit in single operation

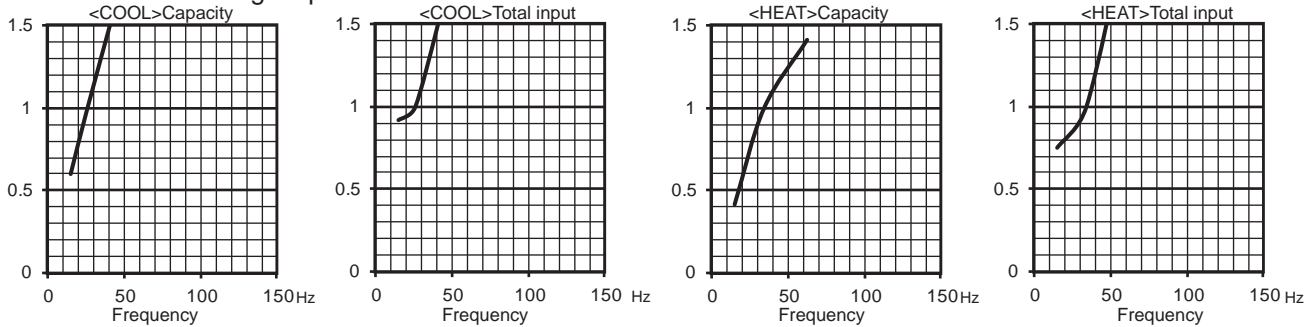

PXZ-5F85VG

6. 35-class unit in single operation

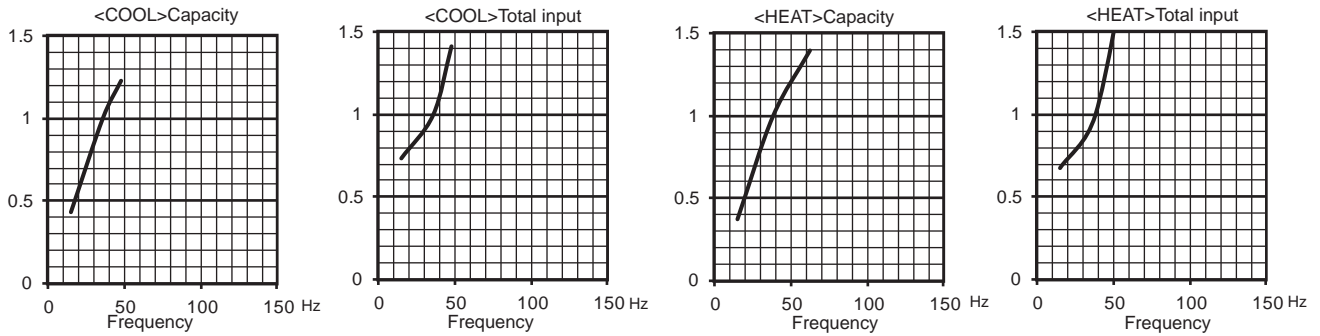

7. 42-class unit in single operation

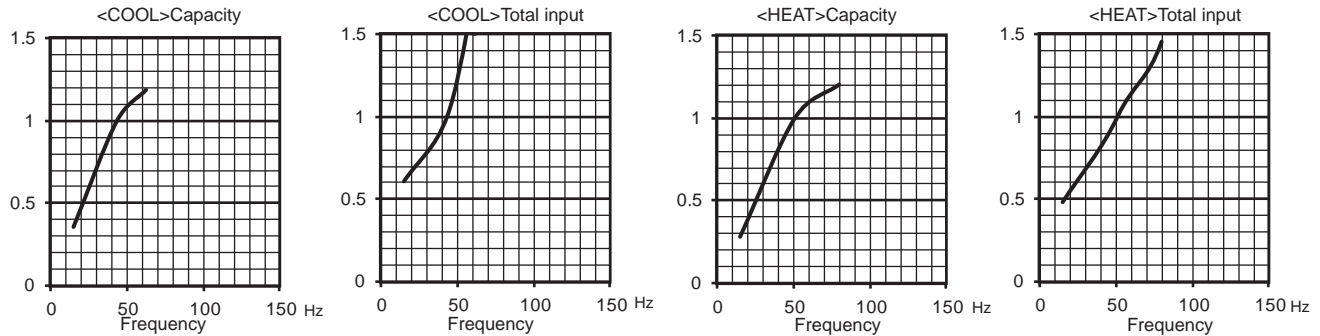

8. 50-class unit in single operation

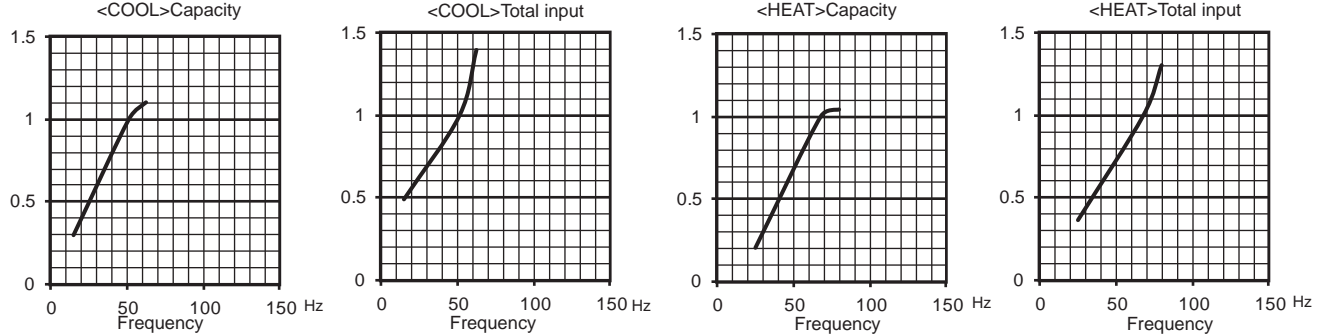

9. 60-class unit in single operation

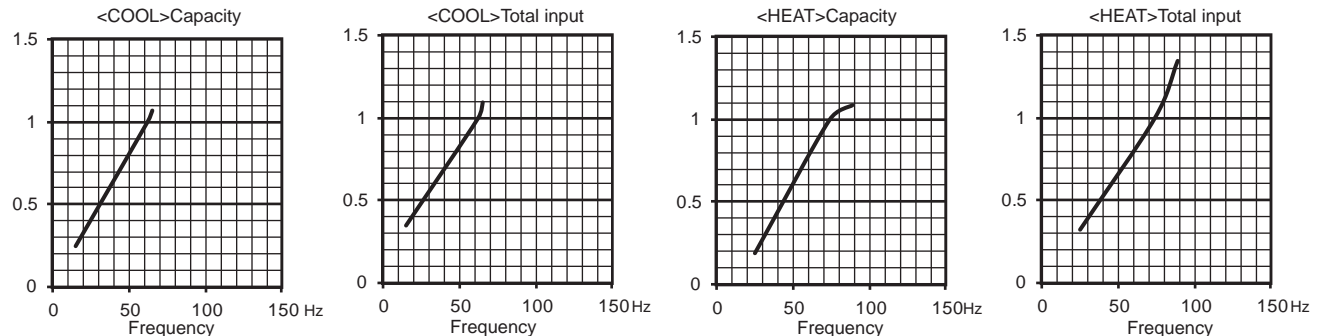

10. 71-class unit in single operation

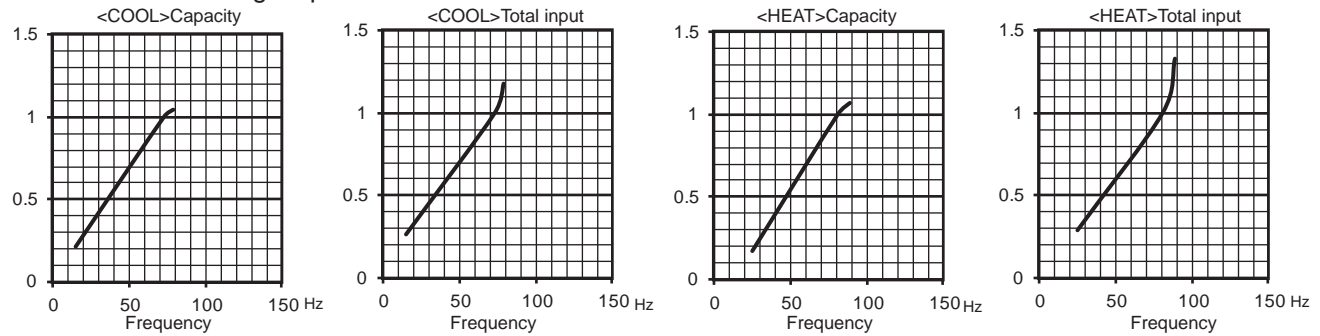

PERFORMANCE CURVES

MULTI SYSTEM

TEST RUN OPERATION (How to operate fixed-frequency operation)

1. Press EMERGENCY OPERATION switch to COOL or HEAT mode (COOL: Press once, HEAT: Press twice).
2. Test run operation starts and continues to operate for 30 minutes.
3. Compressor operates at rated frequency.
4. Indoor fan operates at High speed.
5. After 30 minutes, test run operation finishes and EMERGENCY OPERATION starts (Operation frequency of compressor varies).
6. To cancel test run operation (EMERGENCY OPERATION), press EMERGENCY OPERATION switch or any button on remote controller.

OUTDOOR LOW PRESSURE AND OUTDOOR UNIT CURRENT (single operation)

NOTE: The unit of pressure has been changed to MPa on the international system of units (SI unit system).
The conversion factor is: **1 (MPa [Gauge]) = 10.2 (kgf/cm² [Gauge])**

COOL operation

- ① Both indoor and outdoor unit are under the same temperature/humidity condition.
- ② Operation: TEST RUN OPERATION

Dry-bulb temperature (°C)	Relative humidity (%)
20	50
25	60
30	70

MXZ-2F33VF4

1. 15-class unit in single operation

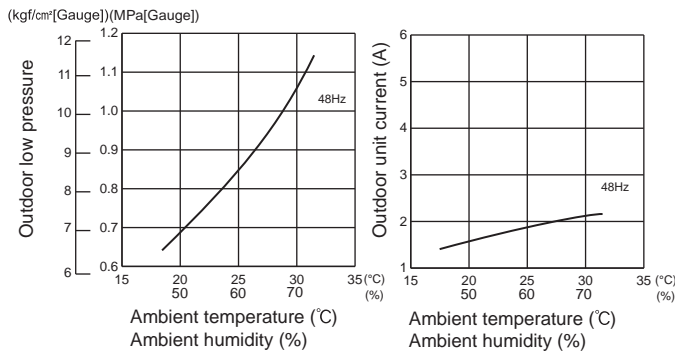

2. 18-class unit in single operation

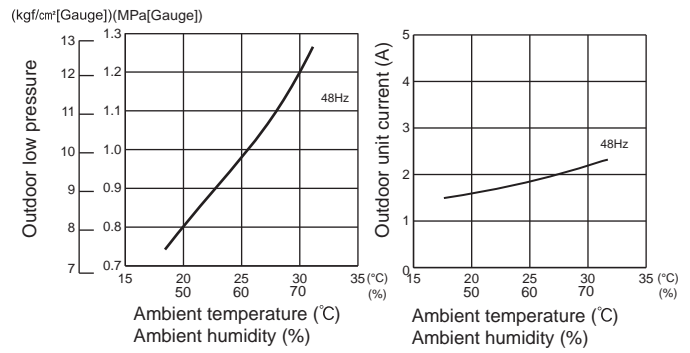

3. 20-class unit in single operation

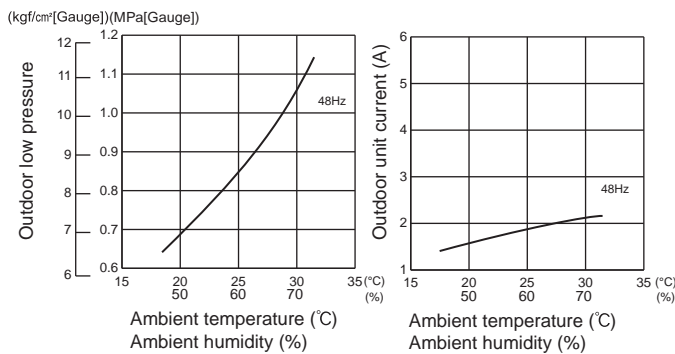

4. 22-class unit in single operation

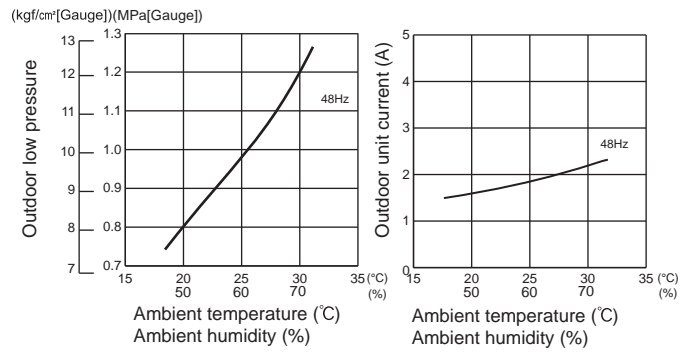

5. 25-class unit in single operation

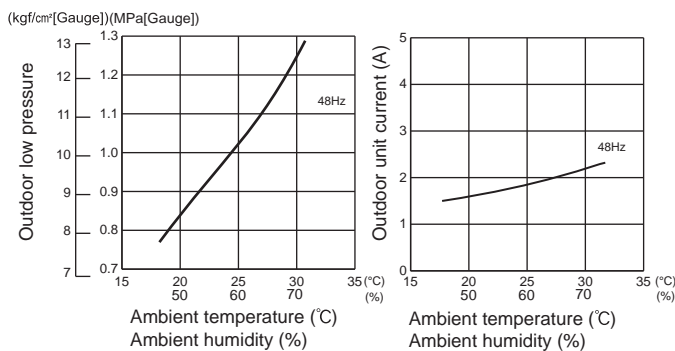

MULTI SYSTEM PERFORMANCE CURVES

MXZ-2F42VF4

1. 15-class unit in single operation

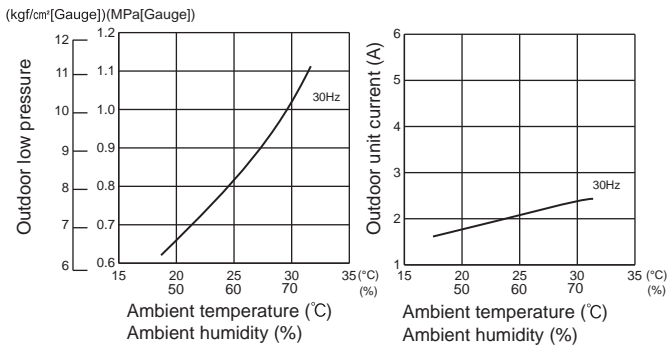

2. 18-class unit in single operation

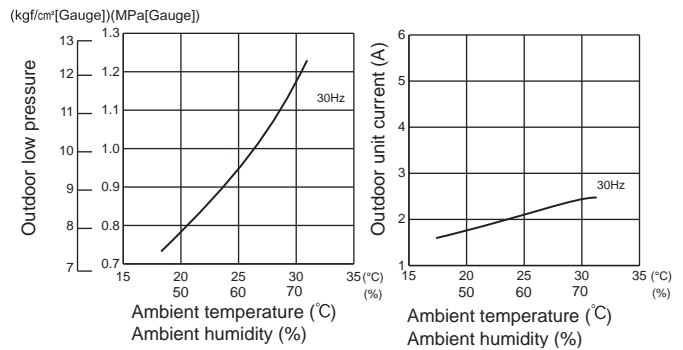

3. 20-class unit in single operation

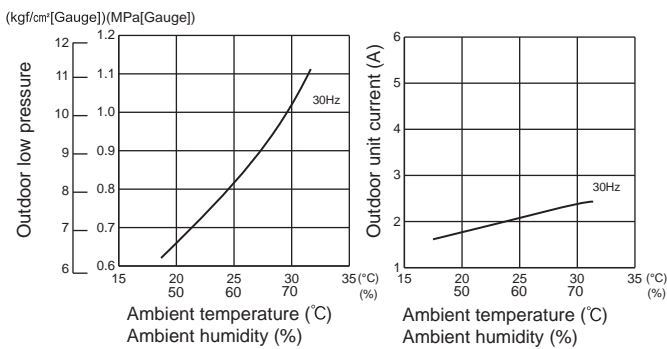

4. 22-class unit in single operation

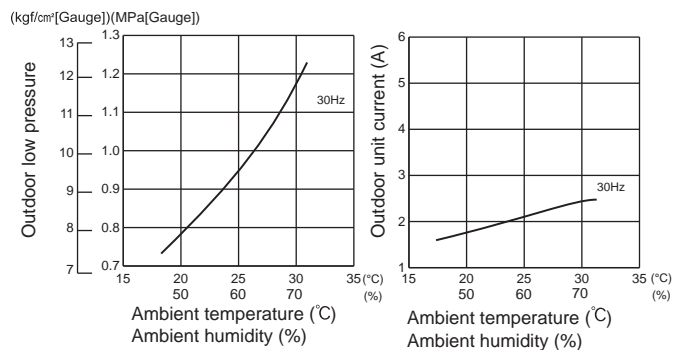

5. 25-class unit in single operation

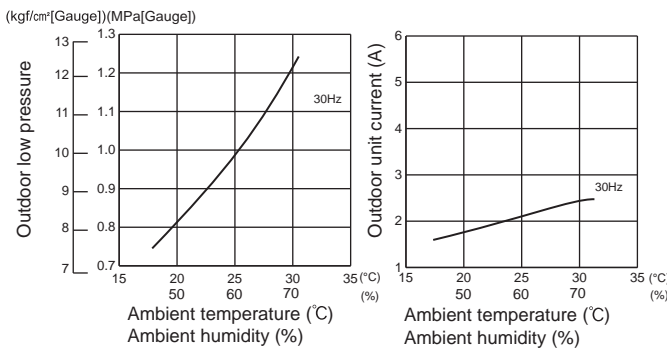

6. 35-class unit in single operation

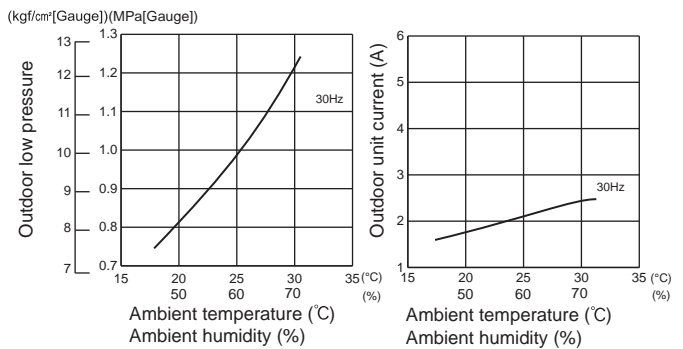

MXZ-2F53VF4 MXZ-2F53VFH4

1. 15-class unit in single operation

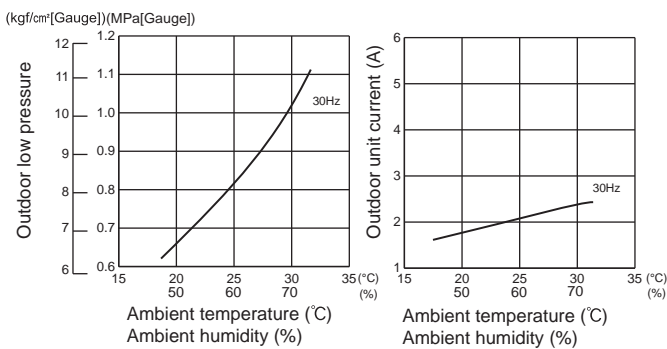

2. 18-class unit in single operation

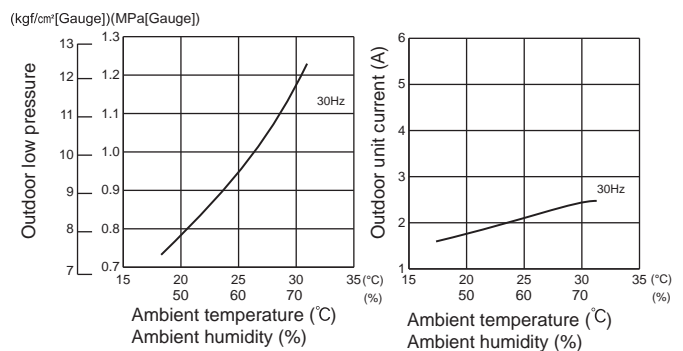

MXZ-2F53VF4 MXZ-2F53VFH4

3. 20-class unit in single operation

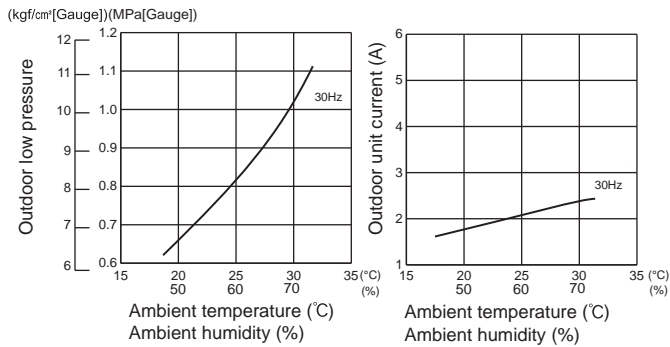

4. 22-class unit in single operation

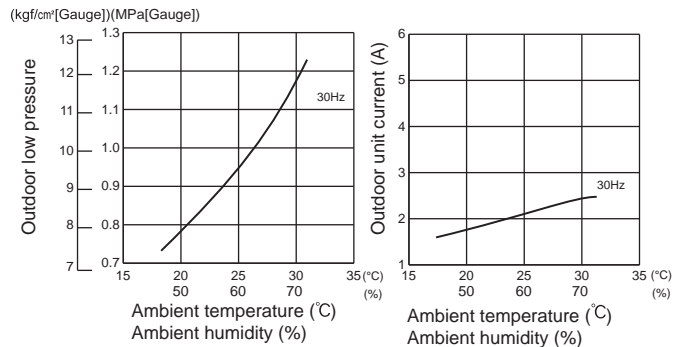

5. 25-class unit in single operation

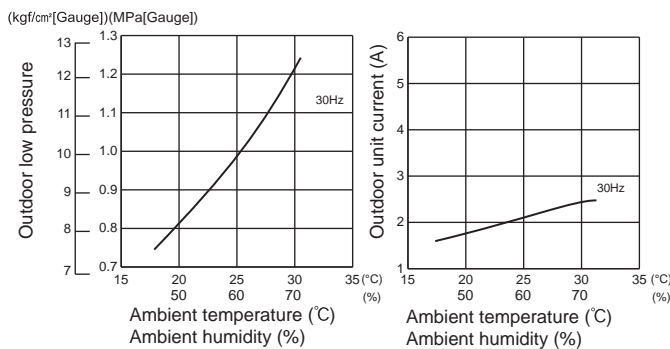

6. 35-class unit in single operation

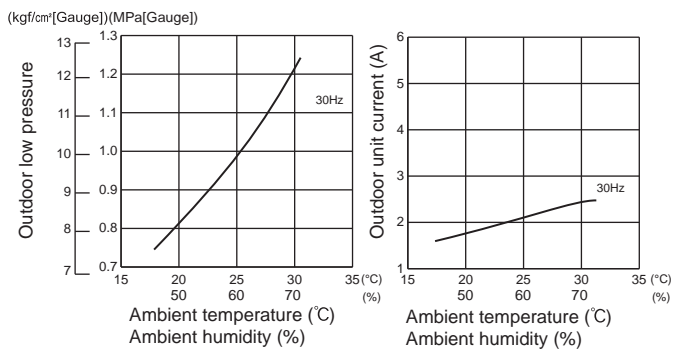

7. 42-class unit in single operation

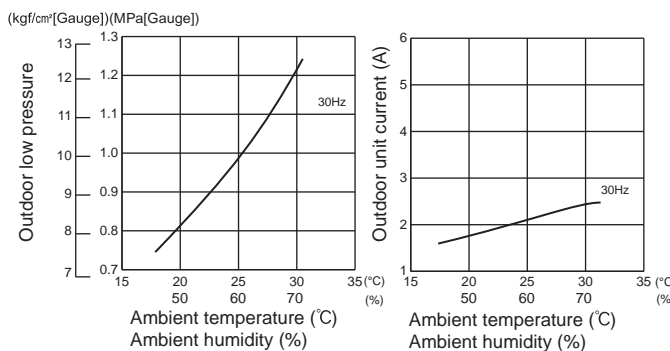

8. 50-class unit in single operation

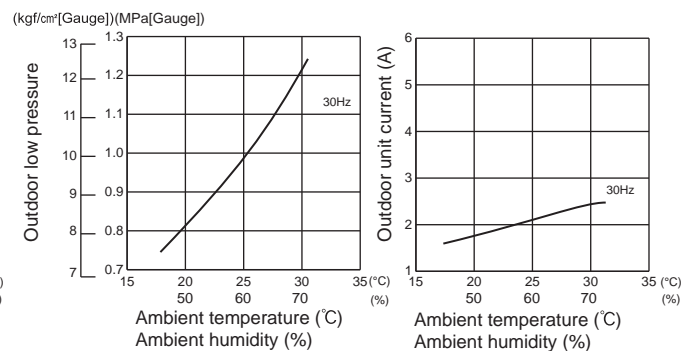

MXZ-3F54VF4

1. 15-class unit in single operation

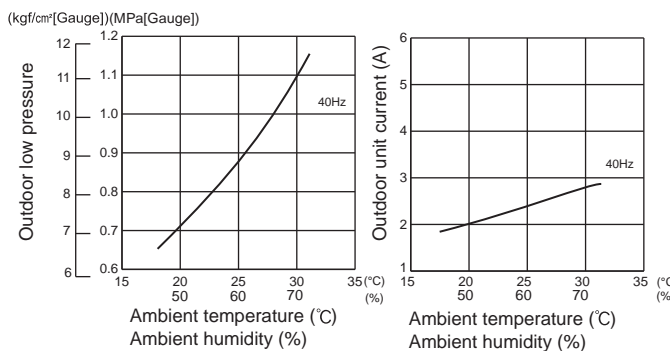

2. 18-class unit in single operation

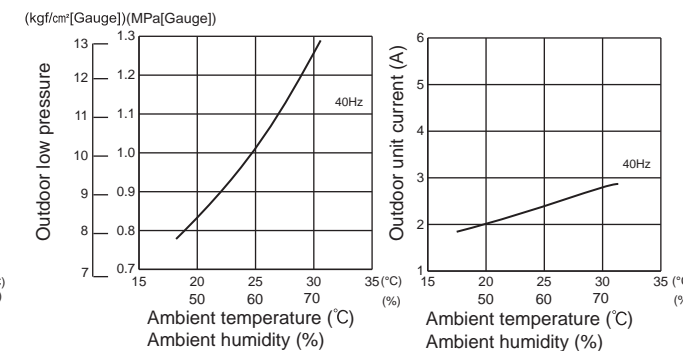

MULTI SYSTEM PERFORMANCE CURVES

MXZ-3F54VF4

3. 20-class unit in single operation

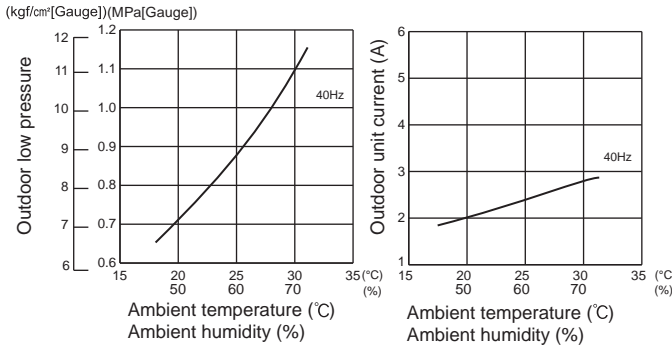

4. 22-class unit in single operation

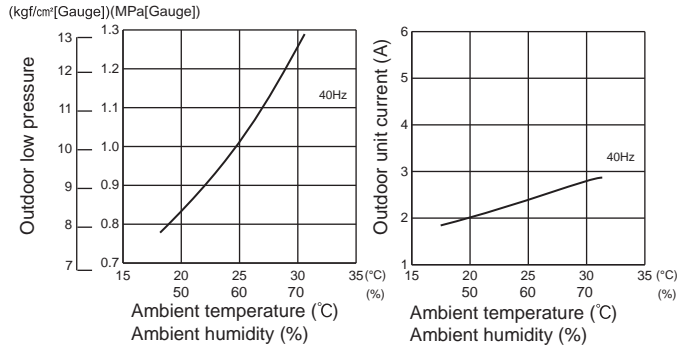

5. 25-class unit in single operation

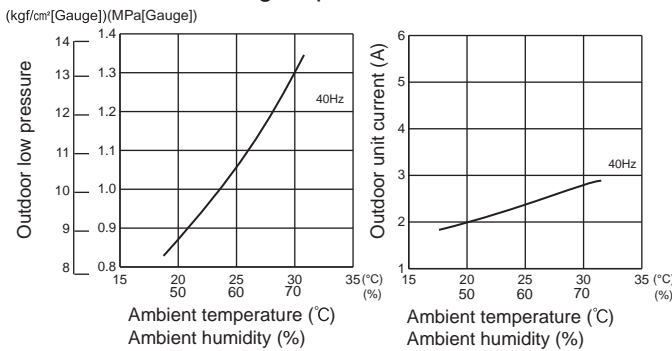

6. 35-class unit in single operation

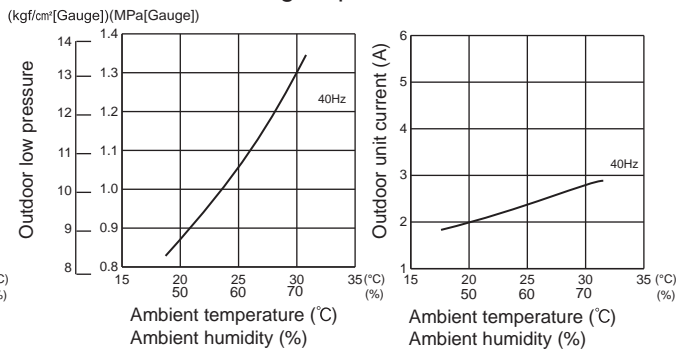

7. 42-class unit in single operation

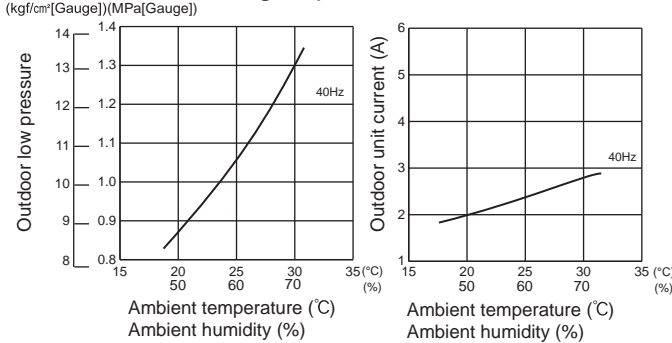

8. 50-class unit in single operation

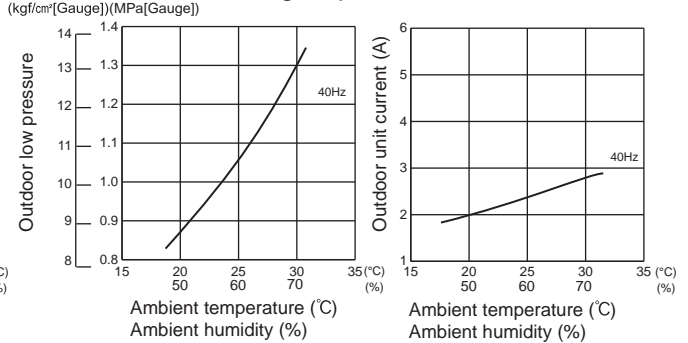

MXZ-3F68VF4 MXZ-4F72VF4

1. 15-class unit in single operation

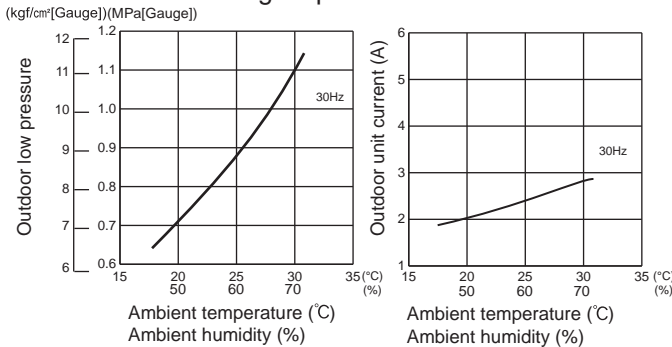

2. 18-class unit in single operation

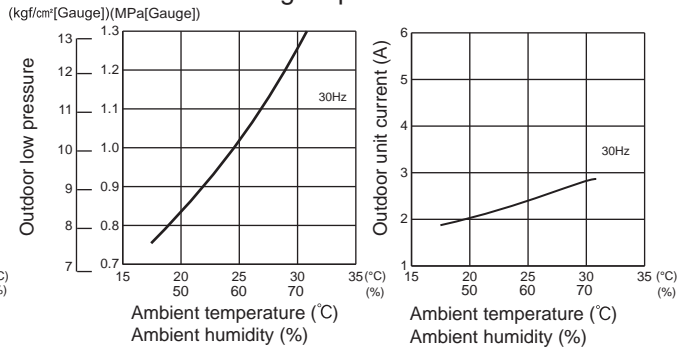

PERFORMANCE CURVES

MULTI SYSTEM

MXZ-3F68VF4 MXZ-4F72VF4

3. 20-class unit in single operation

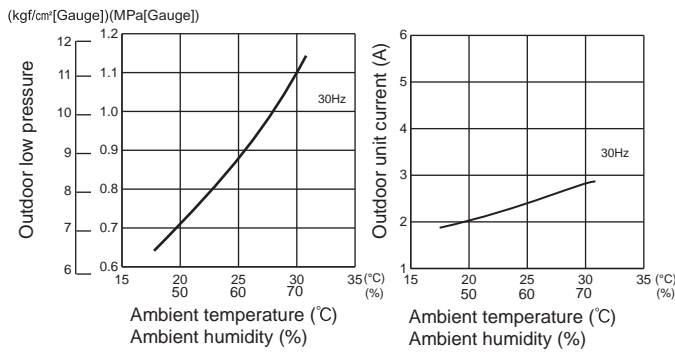

4. 22-class unit in single operation

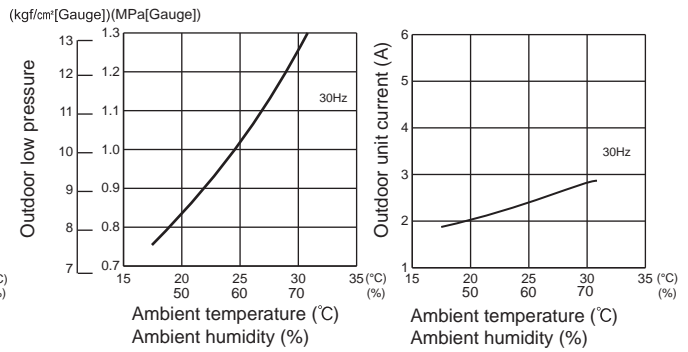

5. 25-class unit in single operation

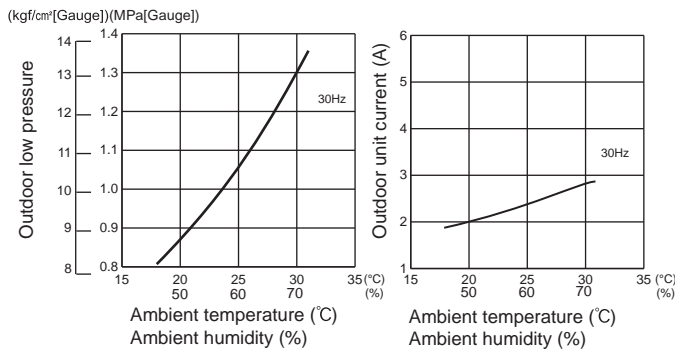

6. 35-class unit in single operation

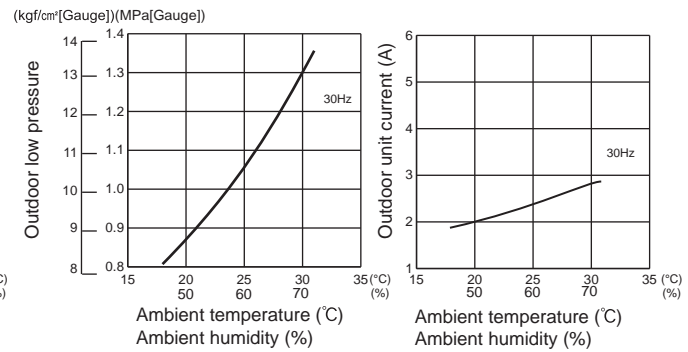

7. 42-class unit in single operation

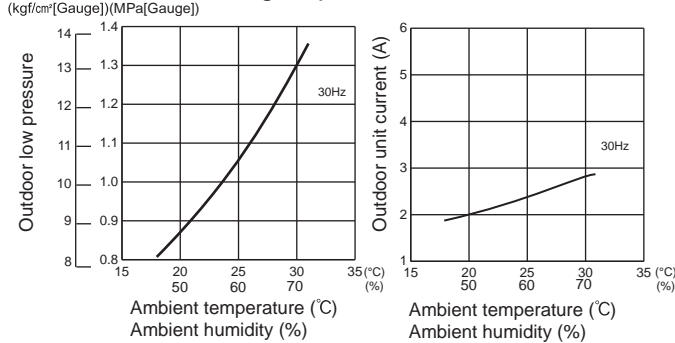

8. 50-class unit in single operation

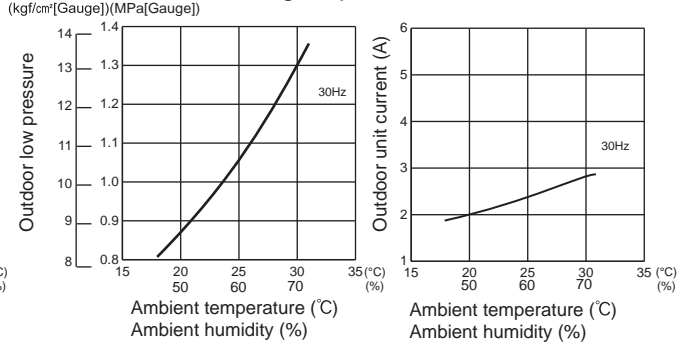

9. 60-class unit in single operation

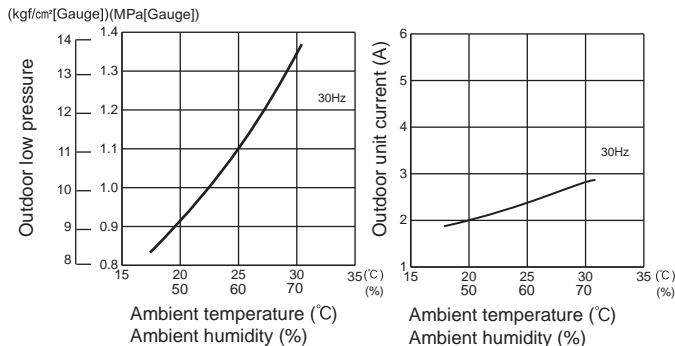

MXZ-4F80VF4

1. 15-class unit in single operation

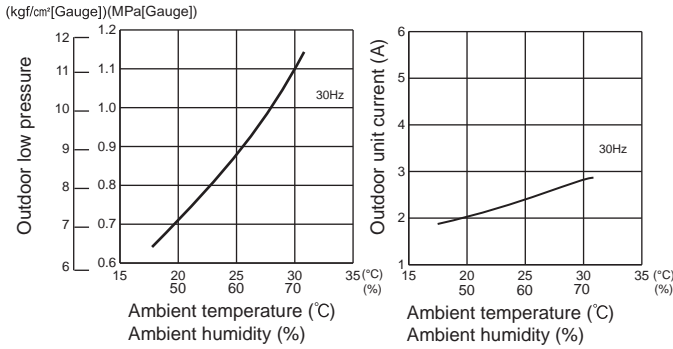

2. 18-class unit in single operation

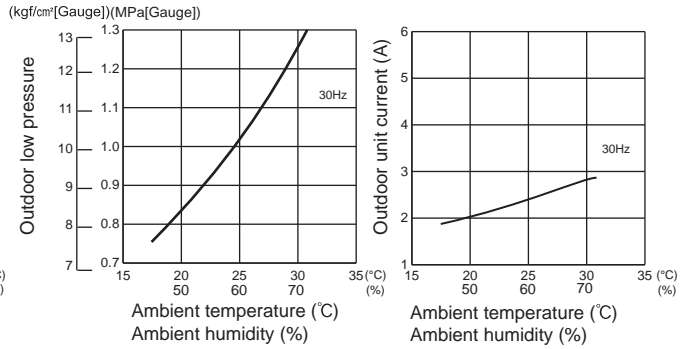

3. 20-class unit in single operation

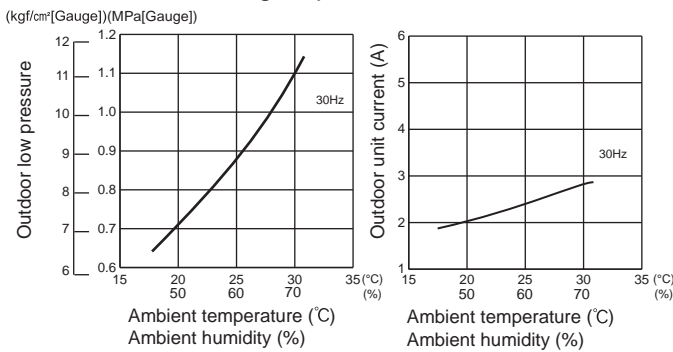

4. 22-class unit in single operation

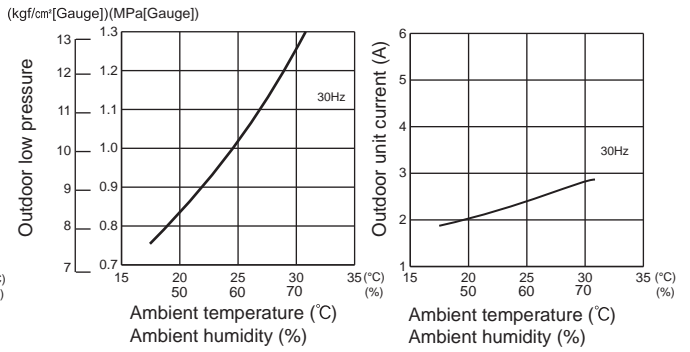

5. 25-class unit in single operation

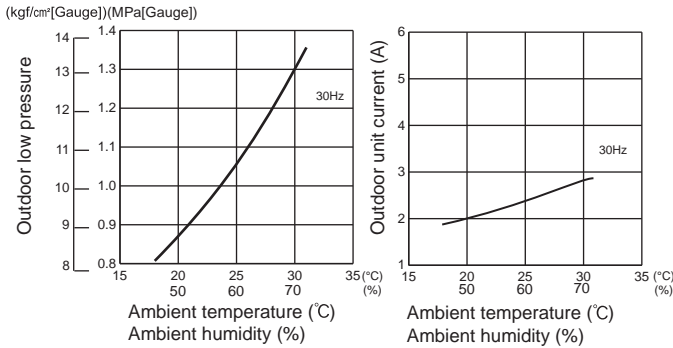

6. 35-class unit in single operation

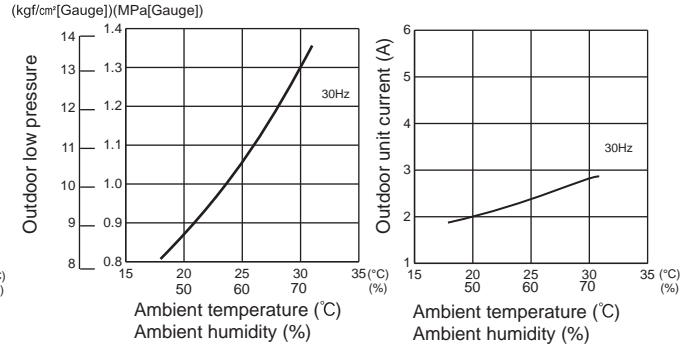

7. 42-class unit in single operation

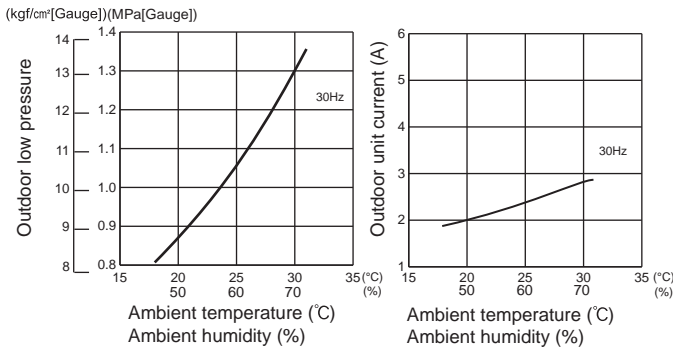

8. 50-class unit in single operation

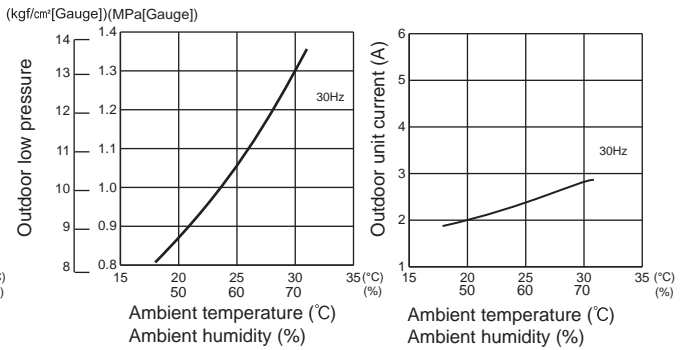

PERFORMANCE CURVES

MULTI SYSTEM

MXZ-4F80VF4

9. 60-class unit in single operation

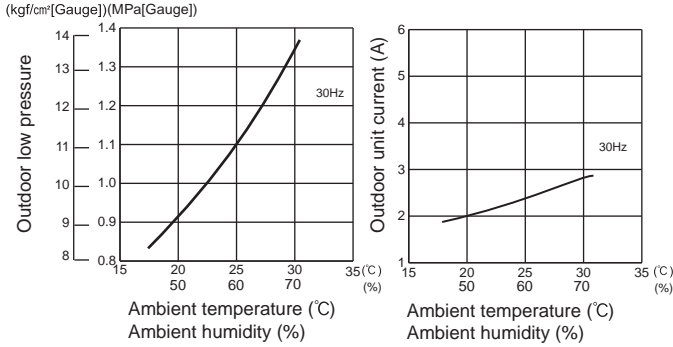

MXZ-4F83VF4

1. 15-class unit in single operation

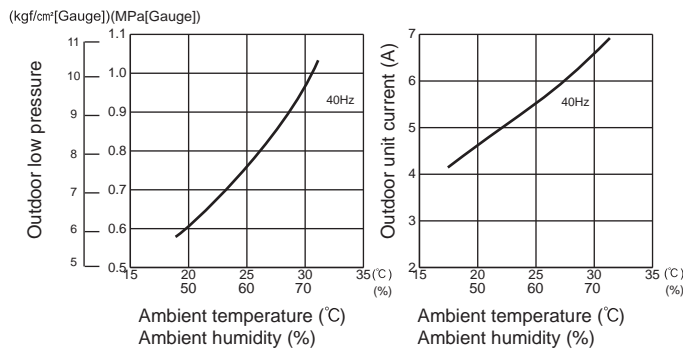

2. 18-class unit in single operation

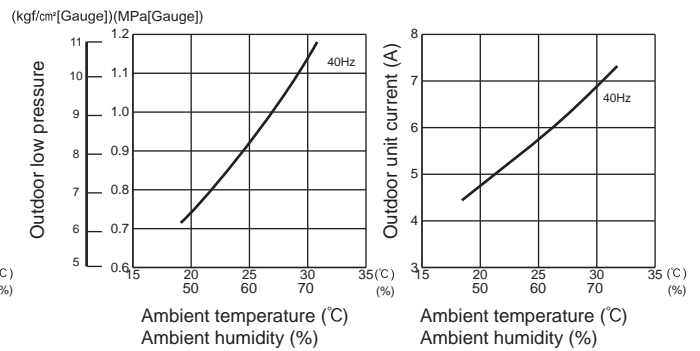

3. 20-class unit in single operation

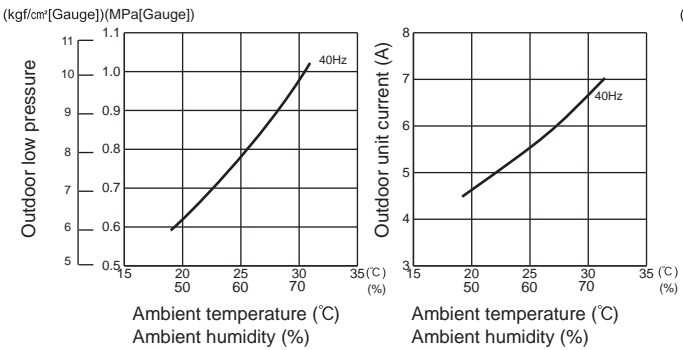

4. 22-class unit in single operation

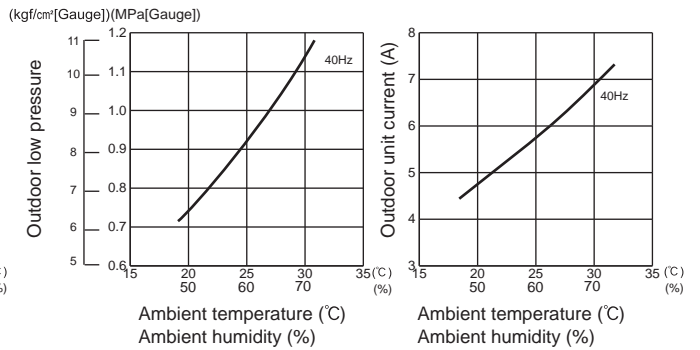

5. 25-class unit in single operation

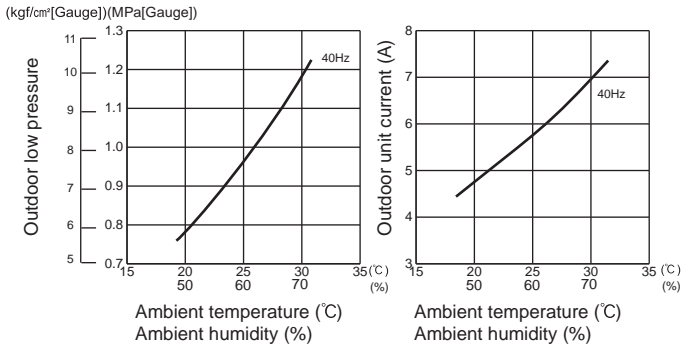

6. 35-class unit in single operation

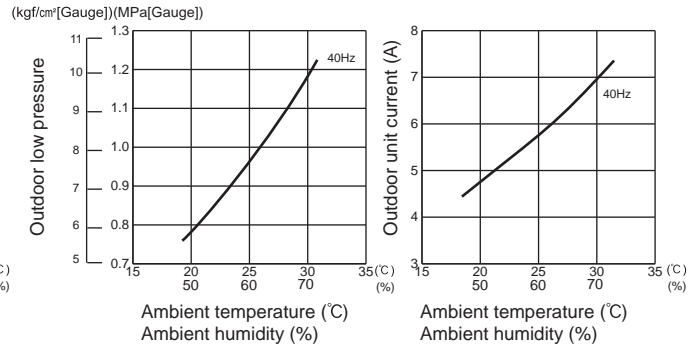

MXZ-4F83VF4

7. 42-class unit in single operation

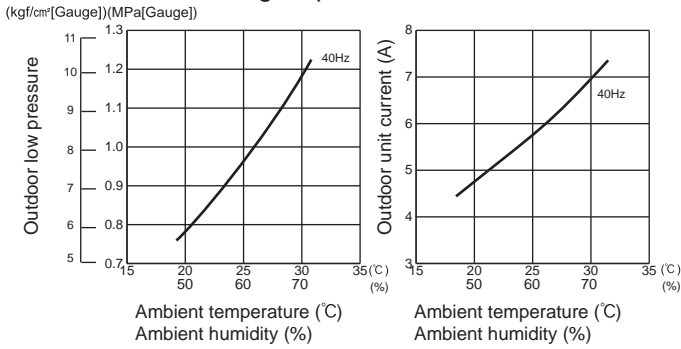

8. 50-class unit in single operation

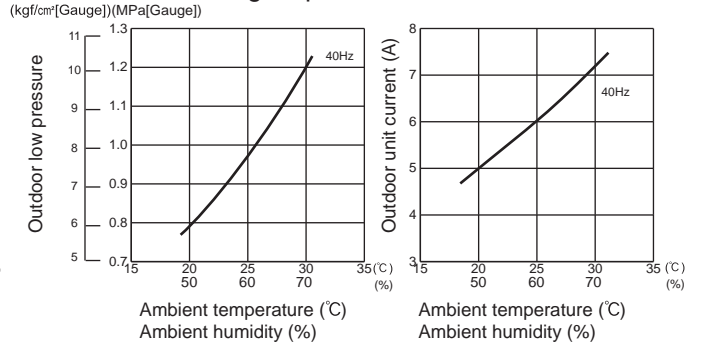

9. 60-class unit in single operation

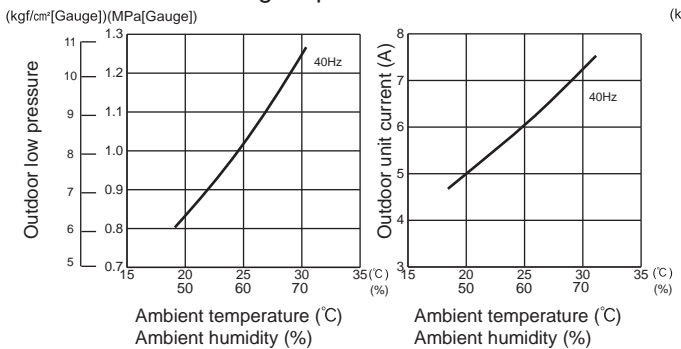

10. 71-class unit in single operation

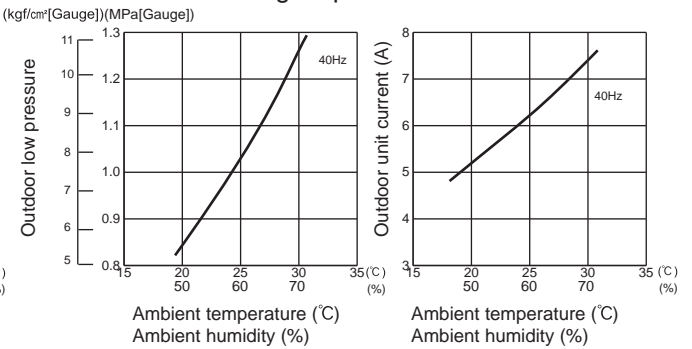

MXZ-5F102VF2

1. 15-class unit in single operation

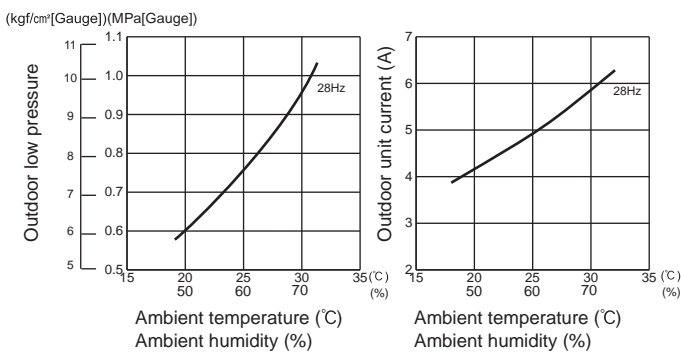

2. 18-class unit in single operation

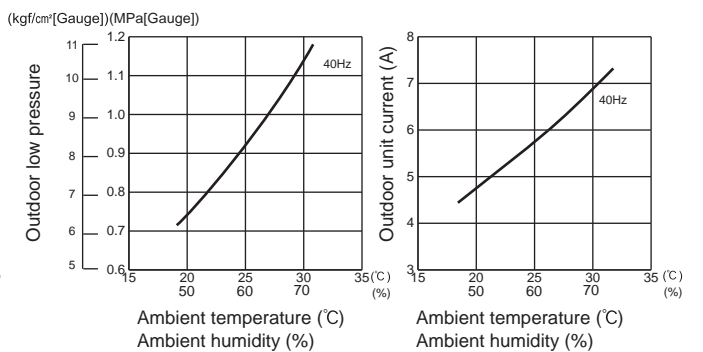

3. 20-class unit in single operation

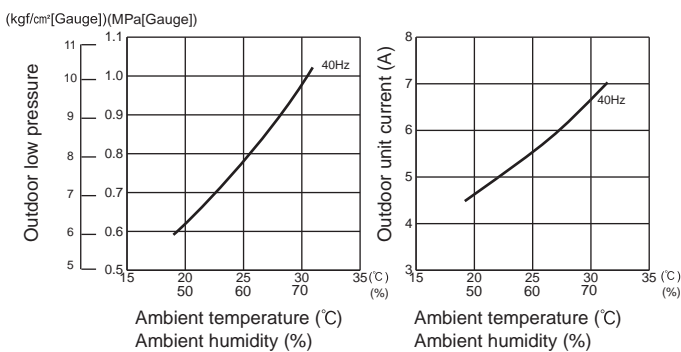

4. 22-class unit in single operation

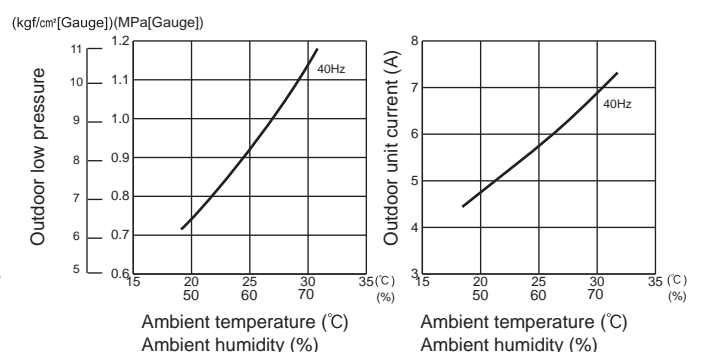

PERFORMANCE CURVES

MULTI SYSTEM

MXZ-5F102VF2

5. 25-class unit in single operation

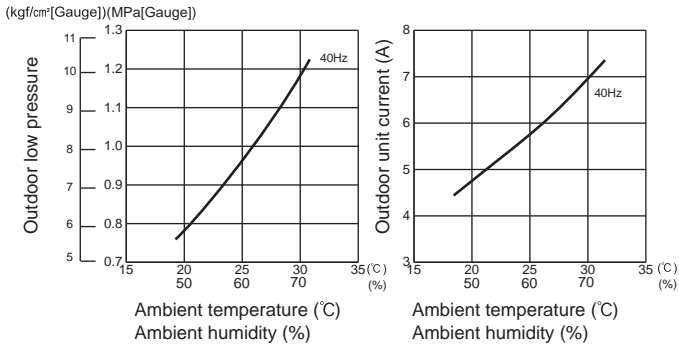

6. 35-class unit in single operation

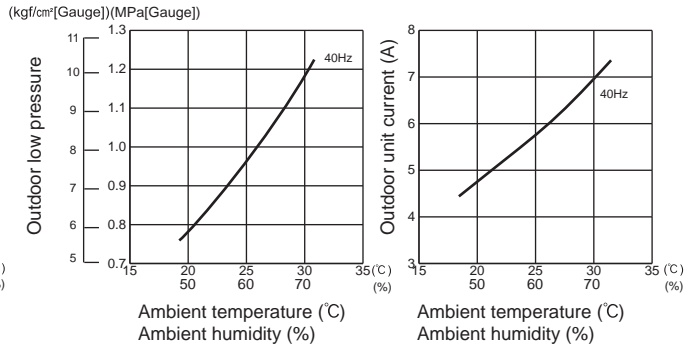

7. 42-class unit in single operation

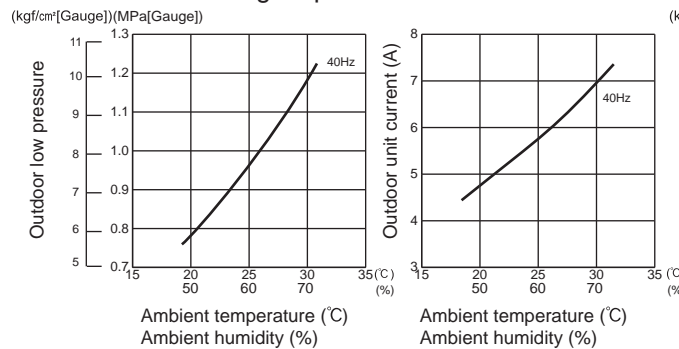

8. 50-class unit in single operation

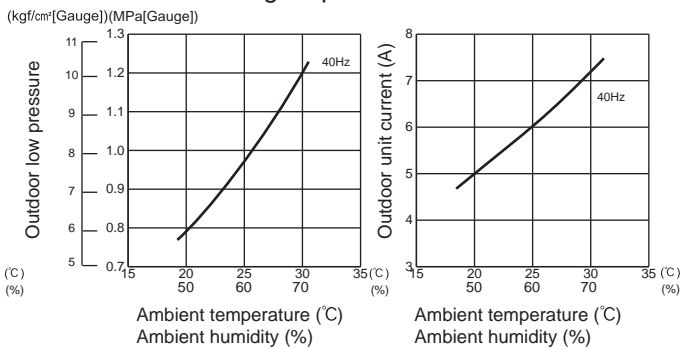

9. 60-class unit in single operation

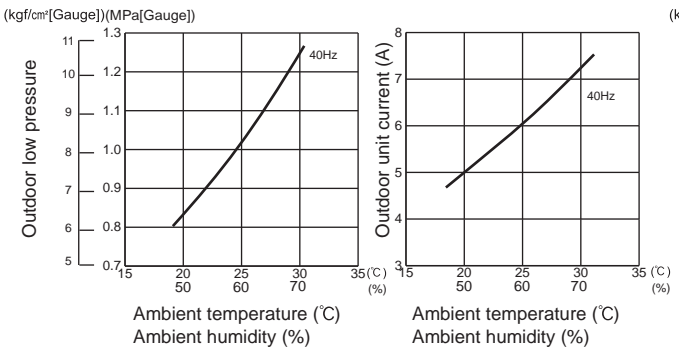

10. 71-class unit in single operation

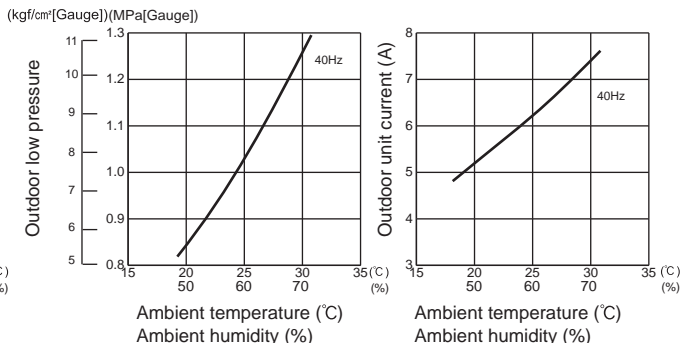

MXZ-6F120VF2

1. 15-class unit in single operation

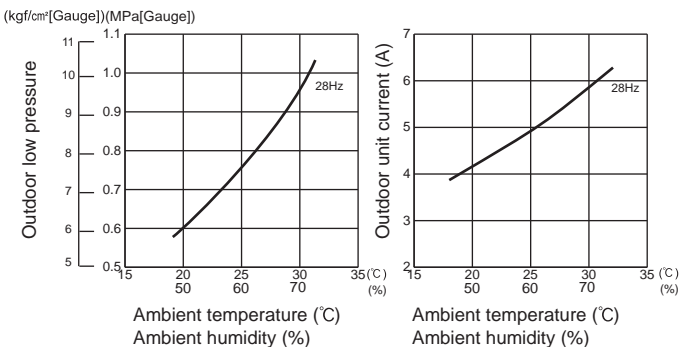

2. 18-class unit in single operation

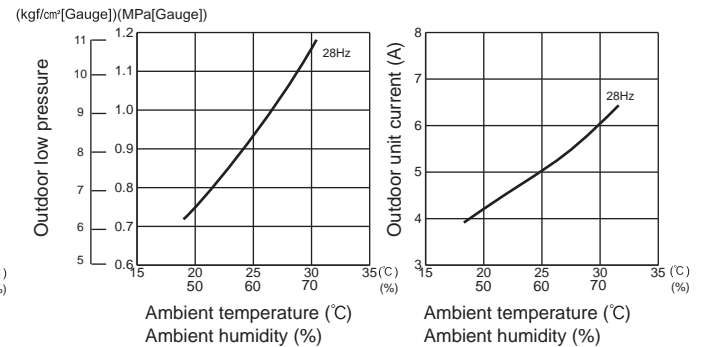

MXZ-6F120VF2

3. 20-class unit in single operation

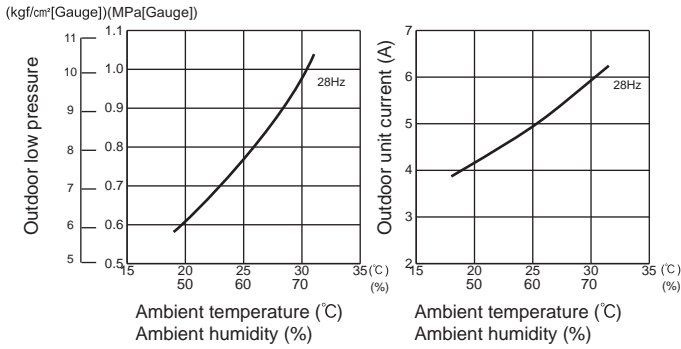

4. 22-class unit in single operation

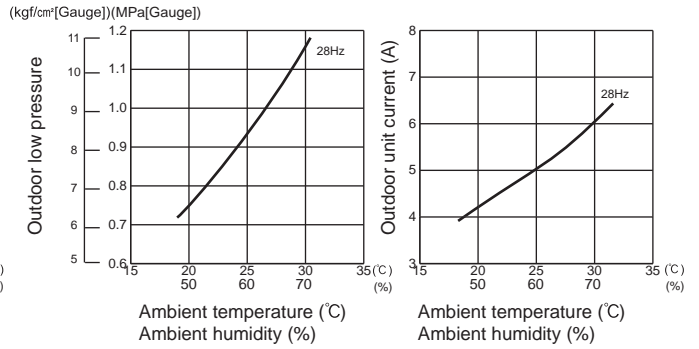

5. 25-class unit in single operation

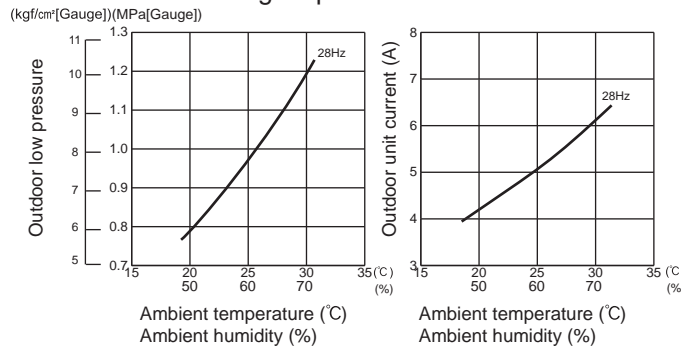

6. 35-class unit in single operation

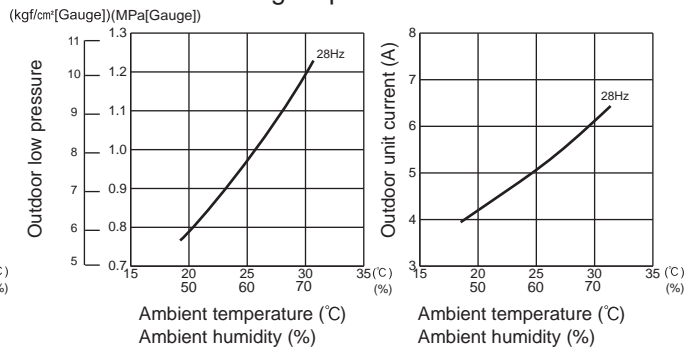

7. 42-class unit in single operation

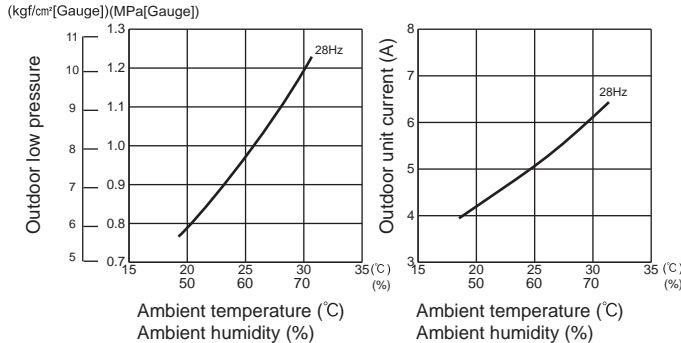

8. 50-class unit in single operation

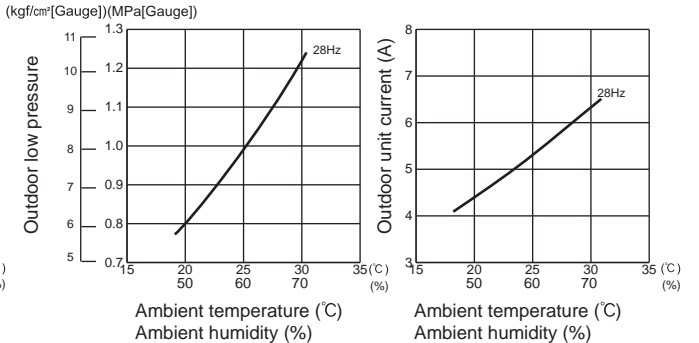

9. 60-class unit in single operation

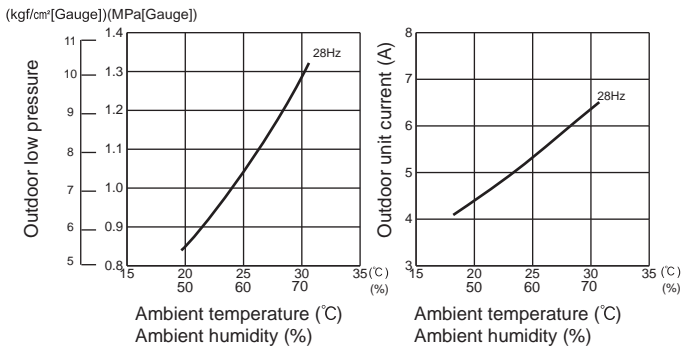

10. 71-class unit in single operation

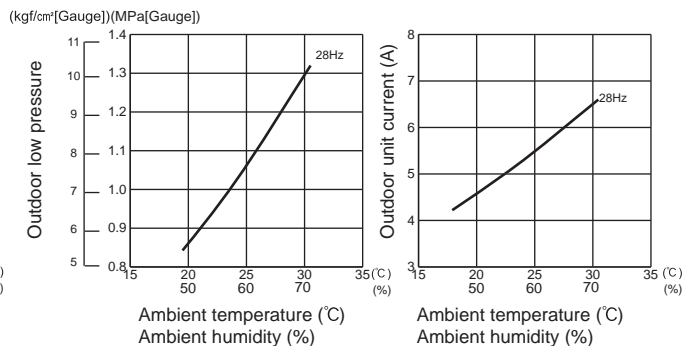

PERFORMANCE CURVES

MULTI SYSTEM

MXZ-2F53VFH22

1. 15-class unit in single operation

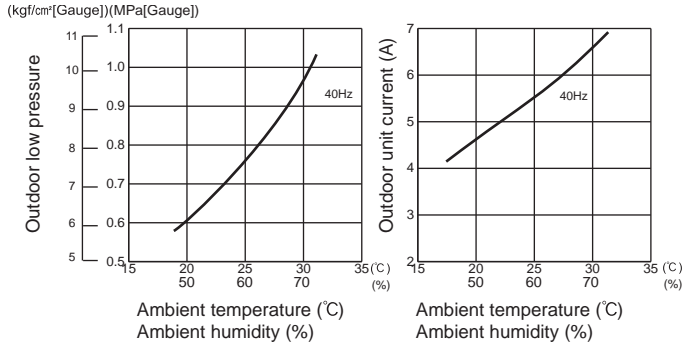

2. 18-class unit in single operation

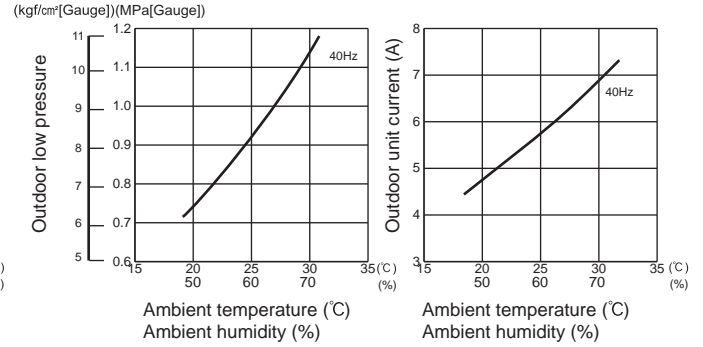

3. 20-class unit in single operation

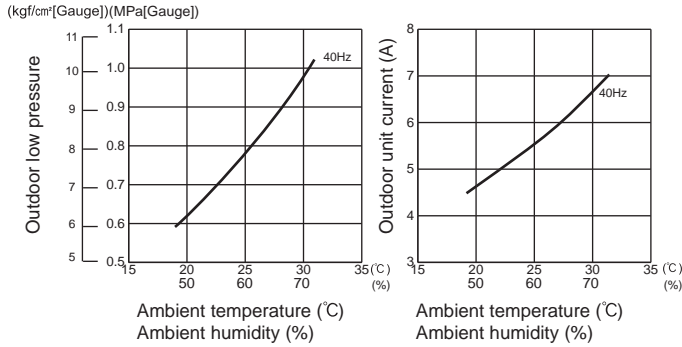

4. 22-class unit in single operation

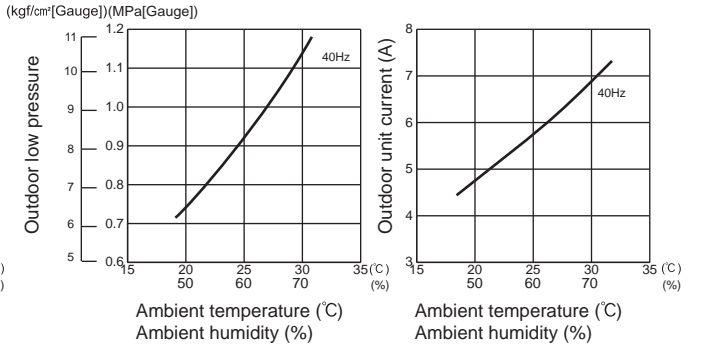

5. 25-class unit in single operation

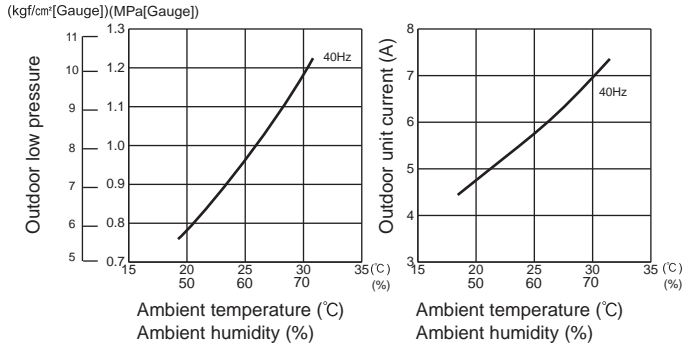

6. 35-class unit in single operation

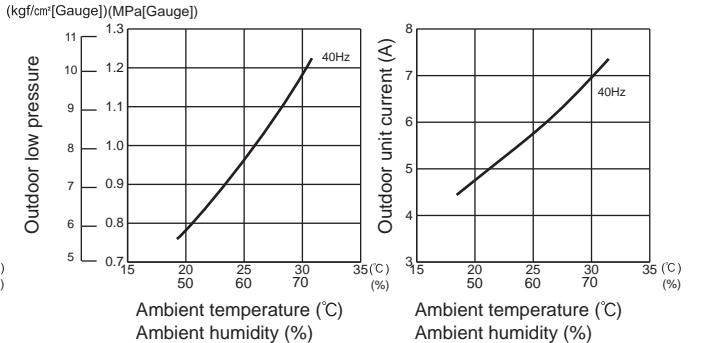

7. 42-class unit in single operation

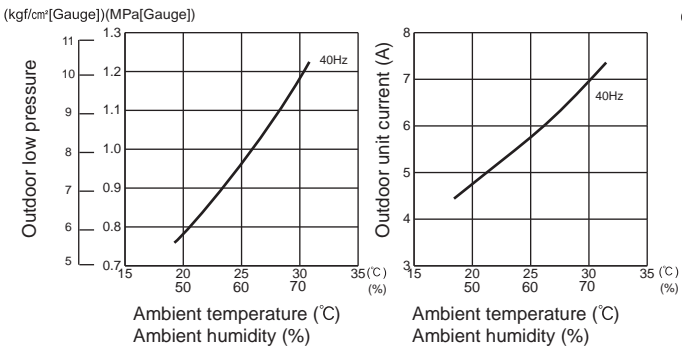

8. 50-class unit in single operation

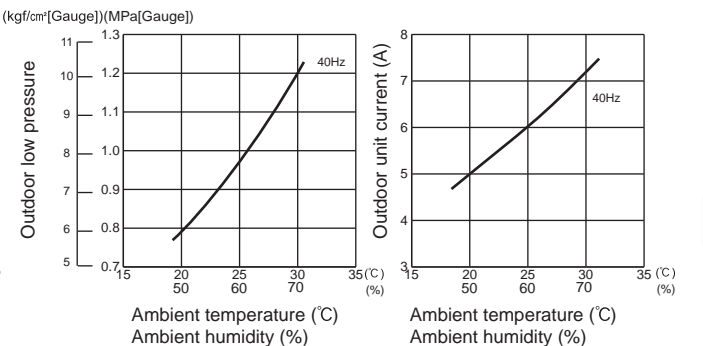

MXZ-4F83VFH22

1. 15-class unit in single operation

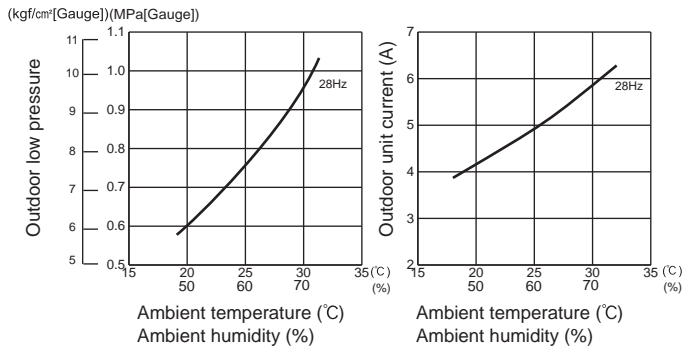

2. 18-class unit in single operation

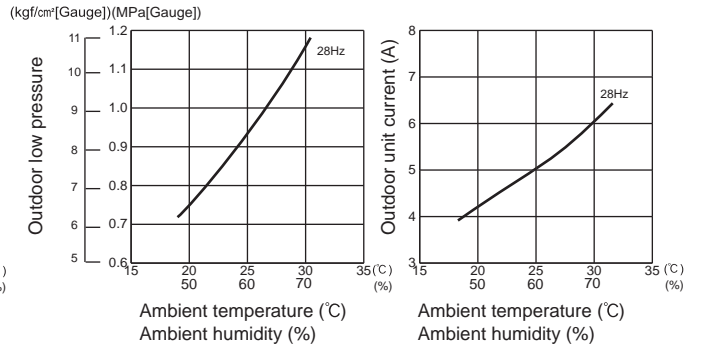

3. 20-class unit in single operation

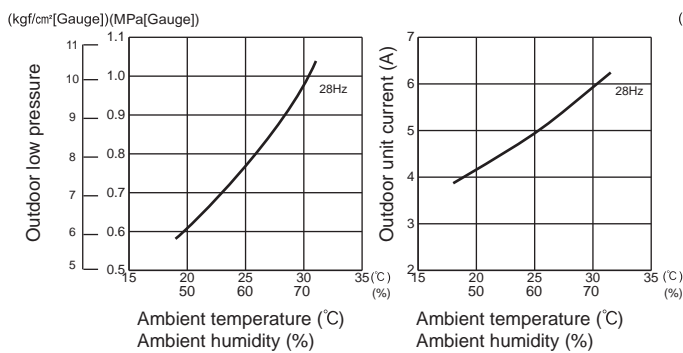

4. 22-class unit in single operation

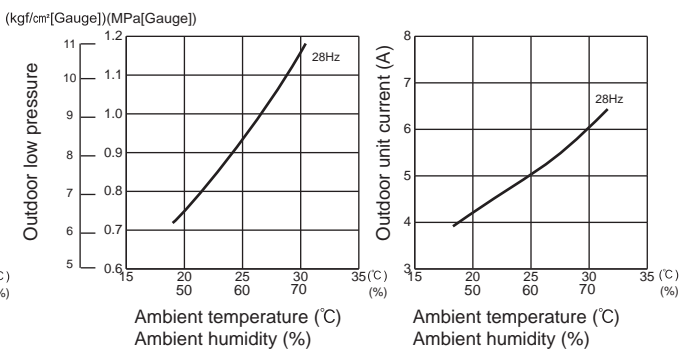

5. 25-class unit in single operation

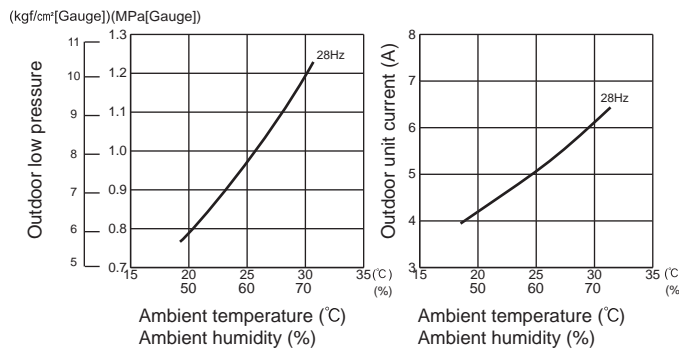

6. 35-class unit in single operation

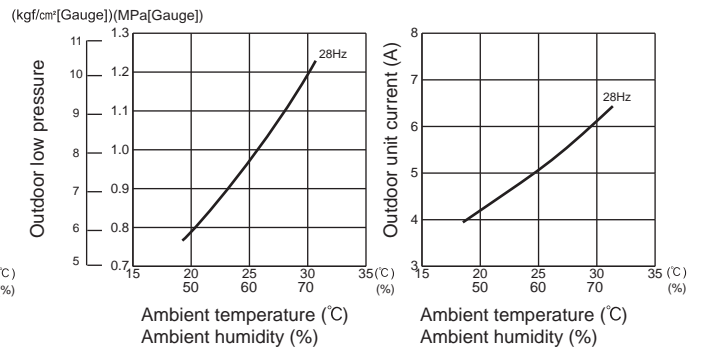

7. 42-class unit in single operation

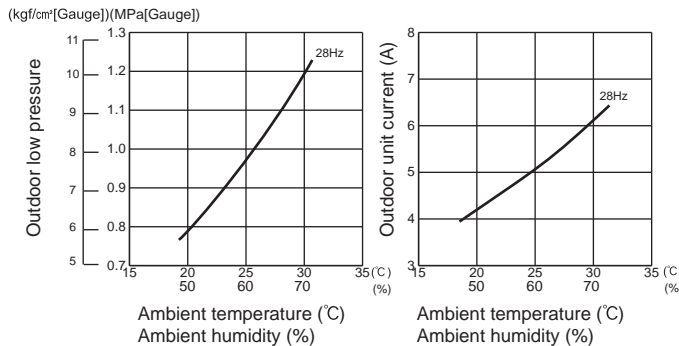

8. 50-class unit in single operation

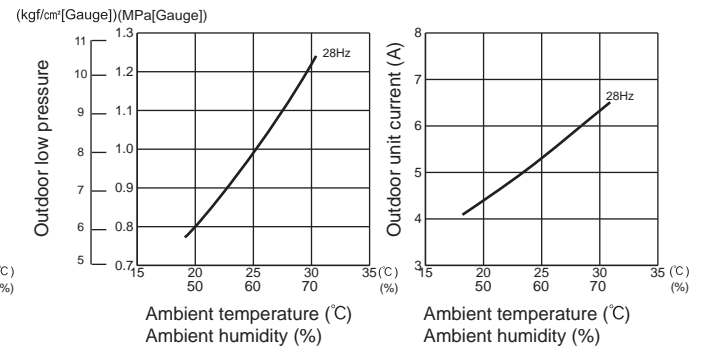

PERFORMANCE CURVES

MULTI SYSTEM

MXZ-4F83VFHZ2

9. 60-class unit in single operation

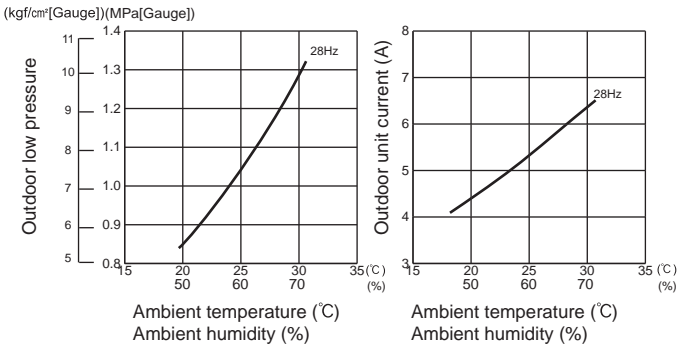

10. 71-class unit in single operation

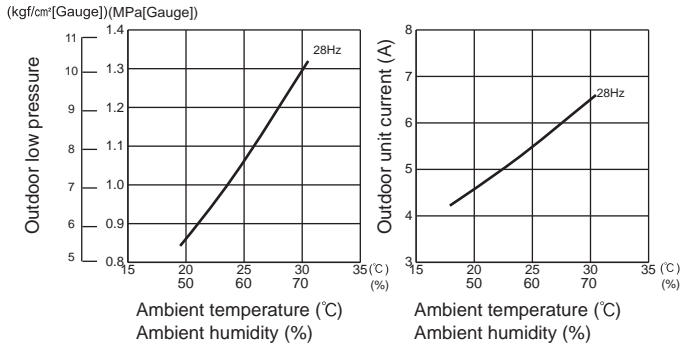

MXZ-2D33VA

1. 15-class unit in single operation

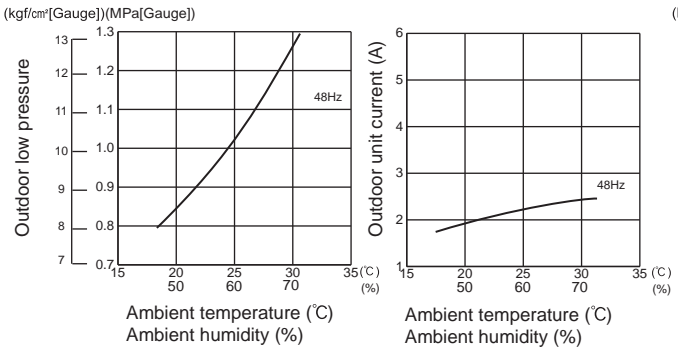

2. 18-class unit in single operation

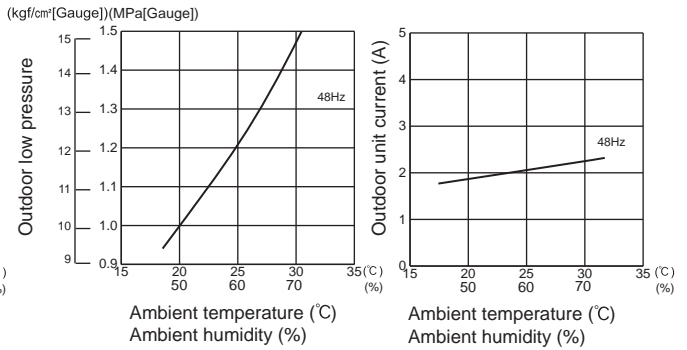

3. 20-class unit in single operation

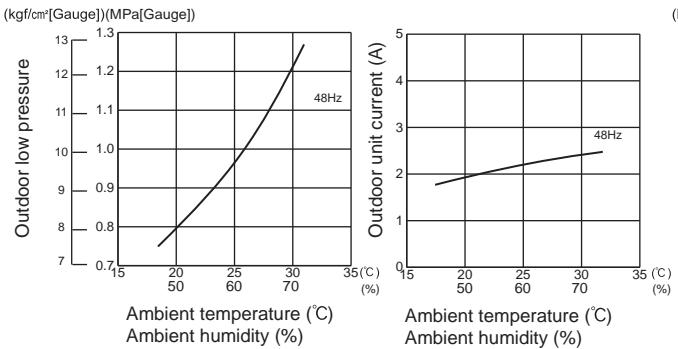

4. 22-class unit in single operation

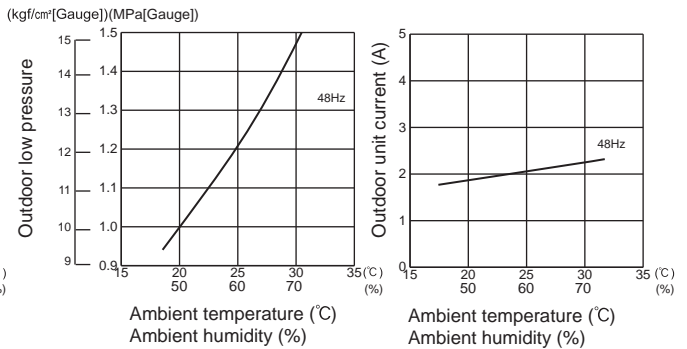

5. 25-class unit in single operation

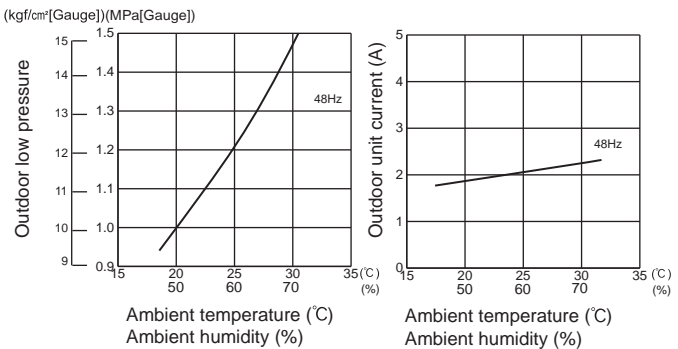

MXZ-2D42VA2 MXZ-2D53VA2 MXZ-2D53VAH2

1. 15-class unit in single operation

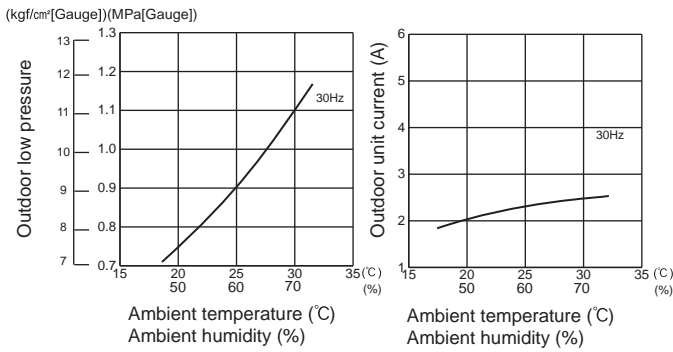

2. 18-class unit in single operation

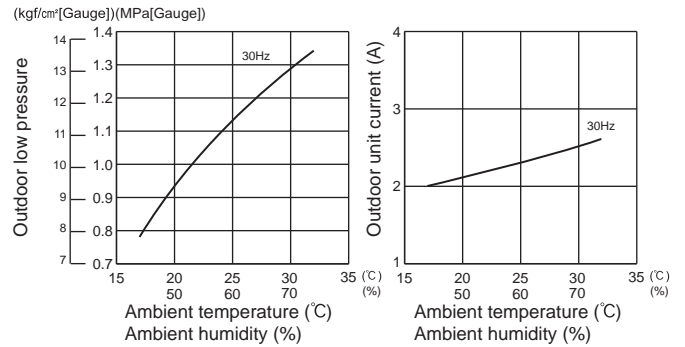

3. 20-class unit in single operation

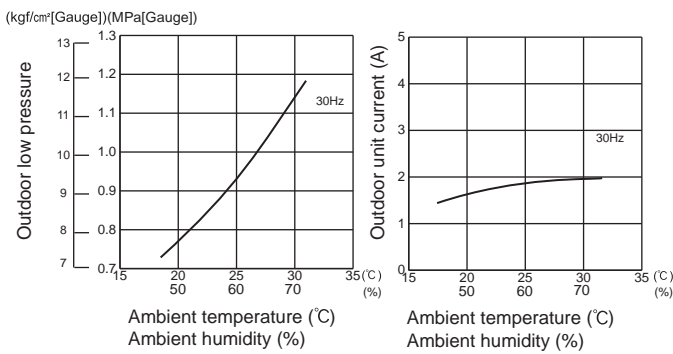

4. 22-class unit in single operation

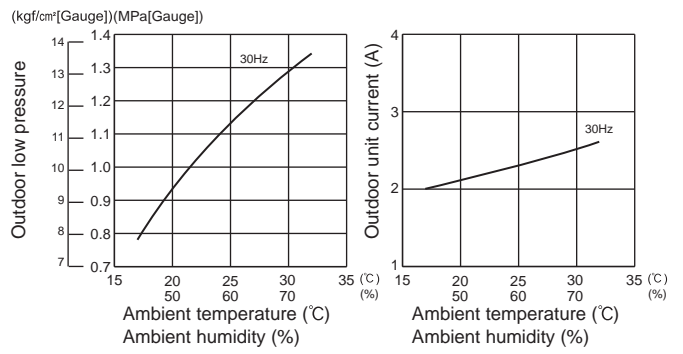

5. 25-class unit in single operation

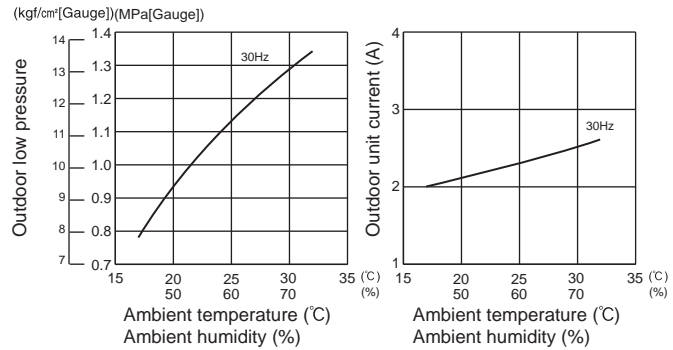

6. 35-class unit in single operation

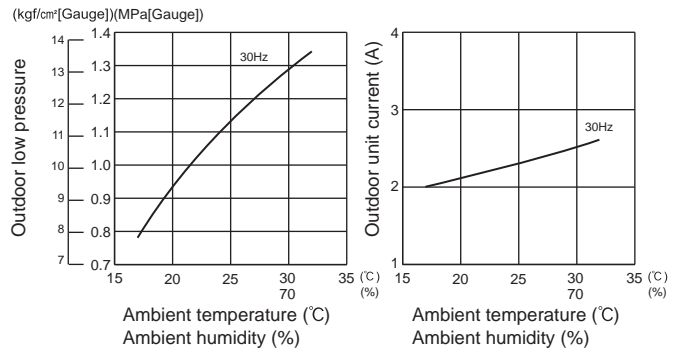

7. 42-class unit in single operation

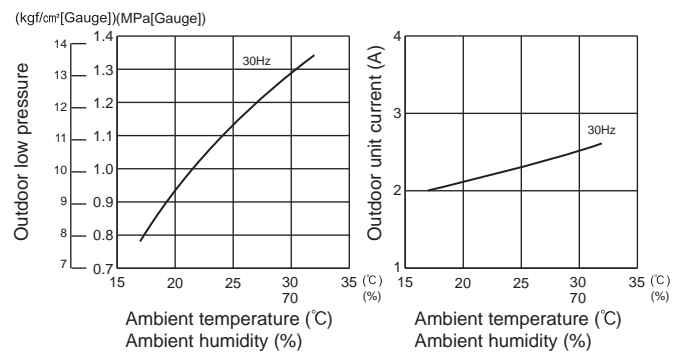

8. 50-class unit in single operation

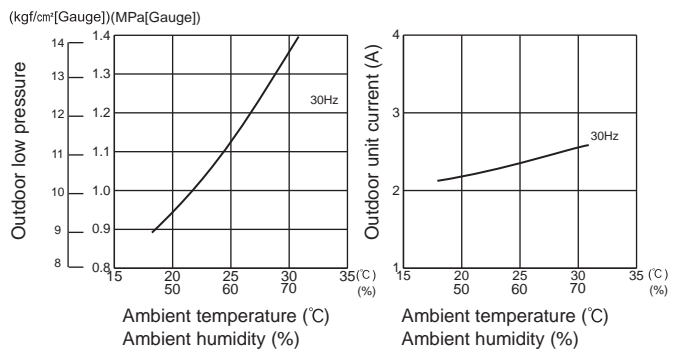

PERFORMANCE CURVES

MULTI SYSTEM

MXZ-2E53VAHZ

1. 15-class unit in single operation

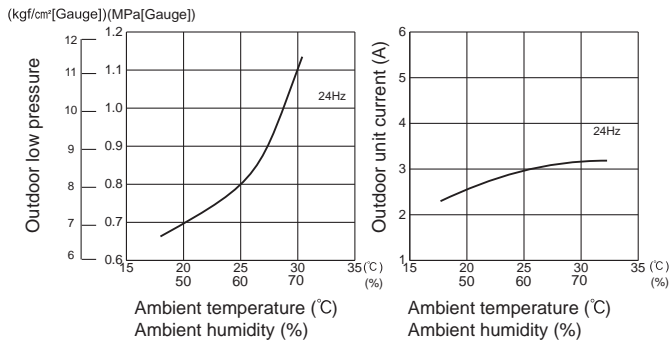

2. 18-class unit in single operation

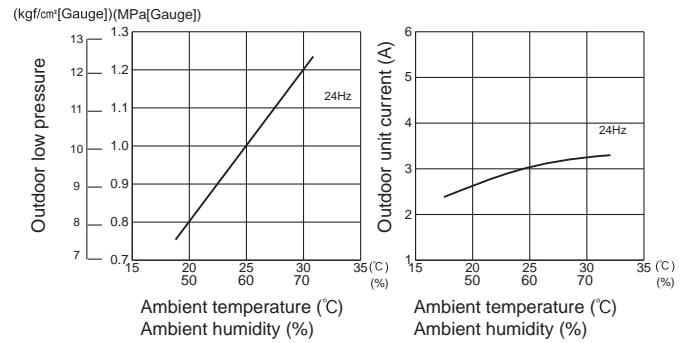

3. 20-class unit in single operation

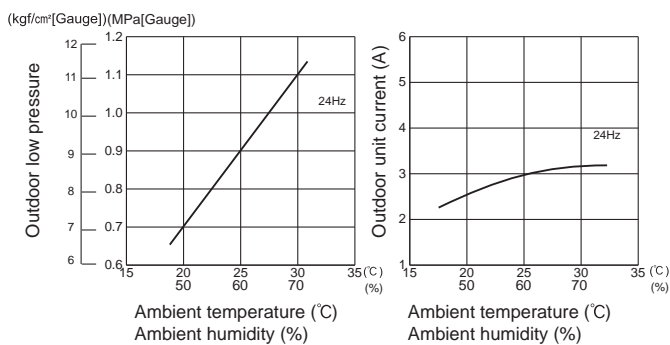

4. 22-class unit in single operation

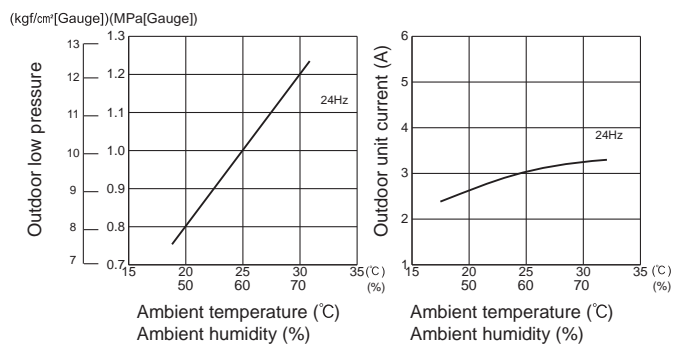

5. 25-class unit in single operation

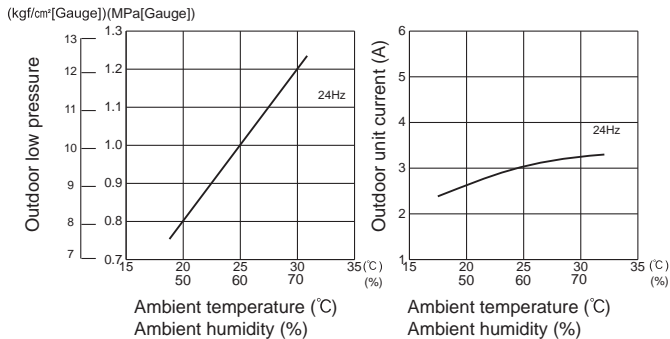

6. 35-class unit in single operation

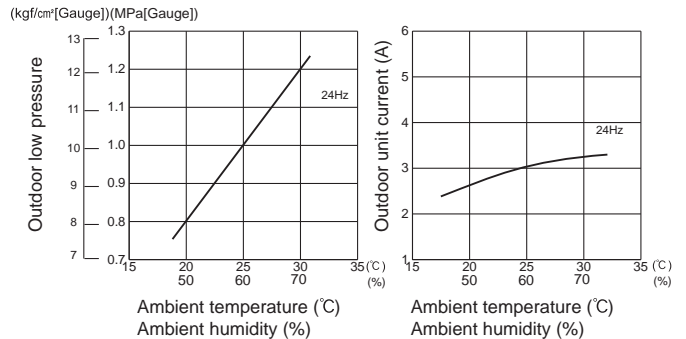

7. 42-class unit in single operation

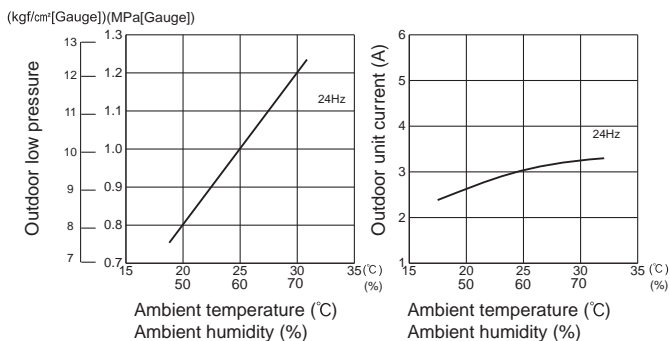

8. 50-class unit in single operation

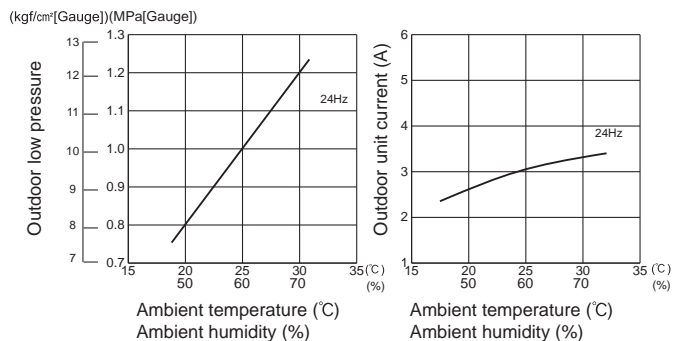

MXZ-3E54VA

1. 15-class unit in single operation

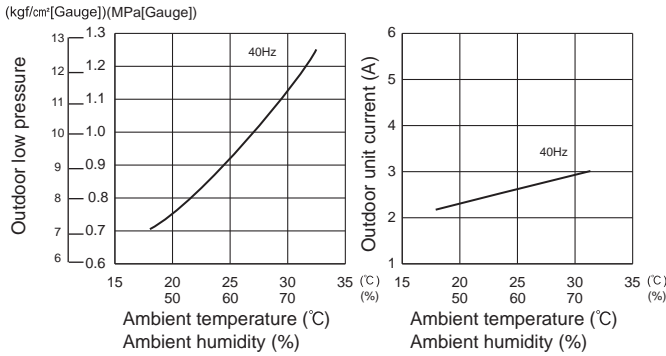

2. 18-class unit in single operation

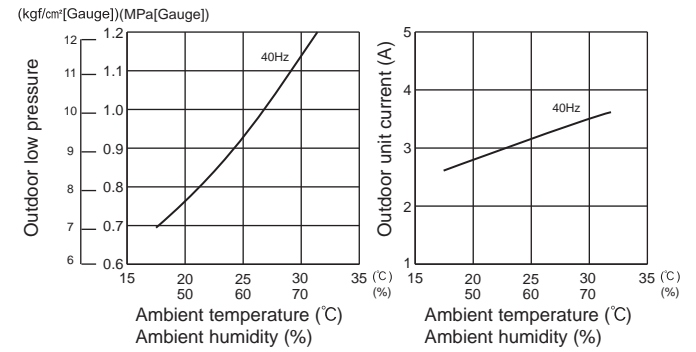

3. 20-class unit in single operation

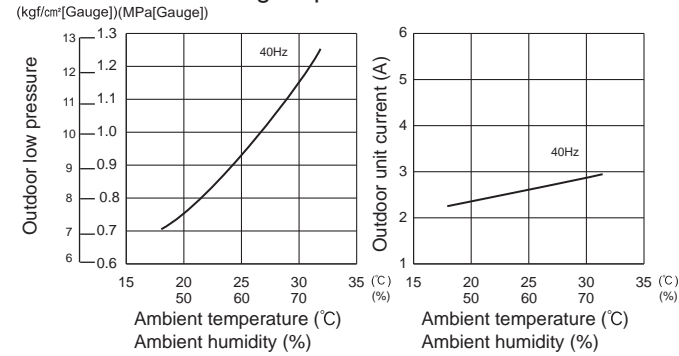

4. 22-class unit in single operation

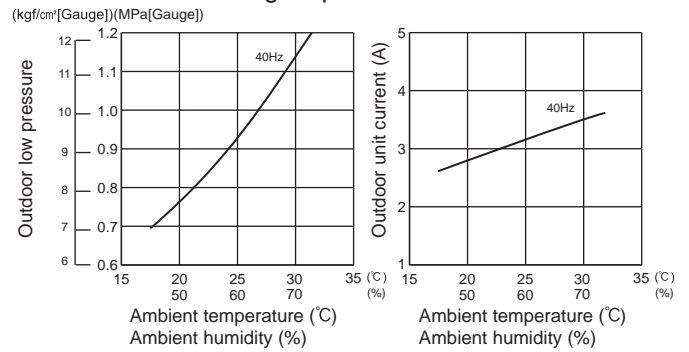

5. 25-class unit in single operation

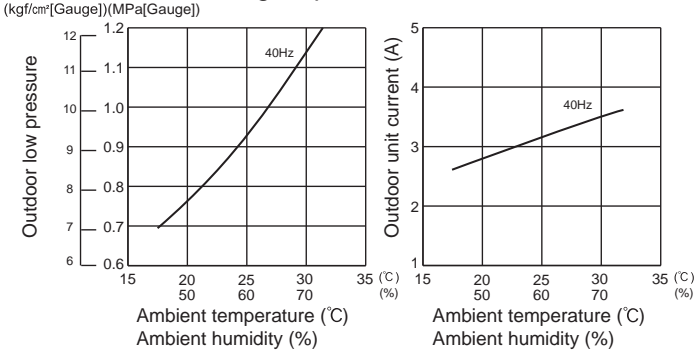

6. 35-class unit in single operation

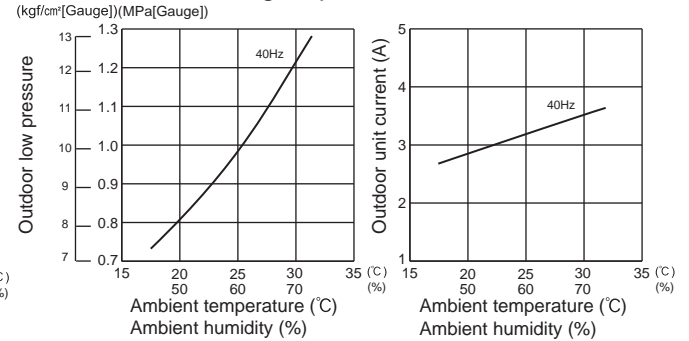

7. 42-class unit in single operation

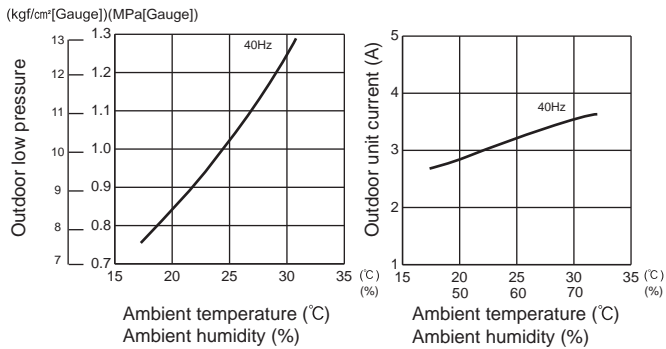

8. 50-class unit in single operation

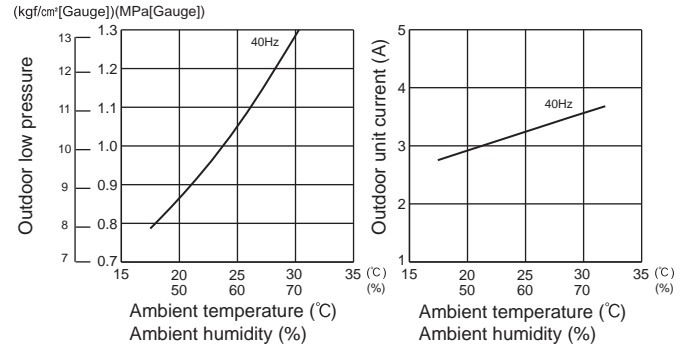

PERFORMANCE CURVES

MULTI SYSTEM

MXZ-3E68VA MXZ-4E72VA

1. 15-class unit in single operation

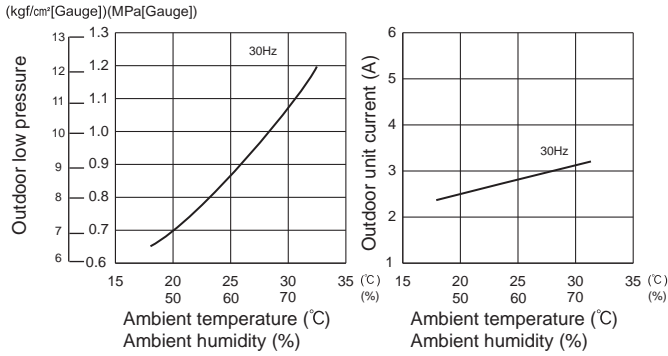

2. 18-class unit in single operation

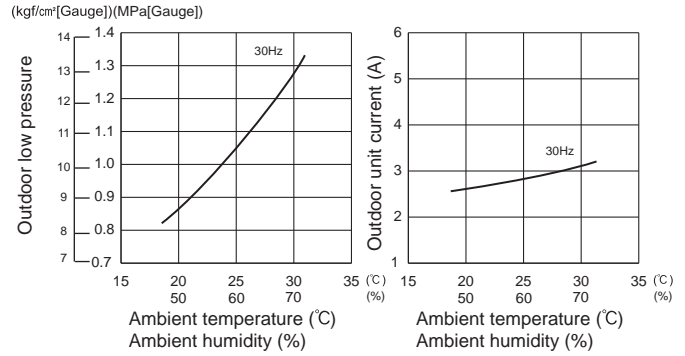

3. 20-class unit in single operation

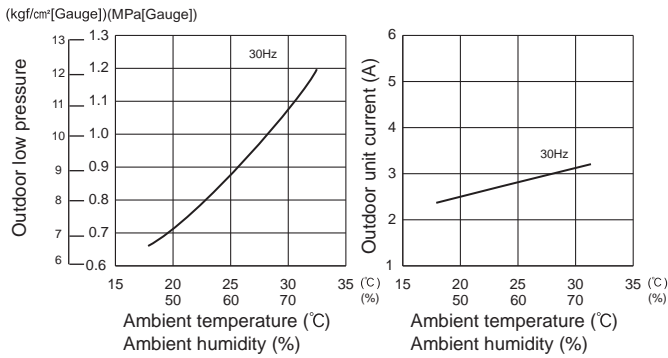

4. 22-class unit in single operation

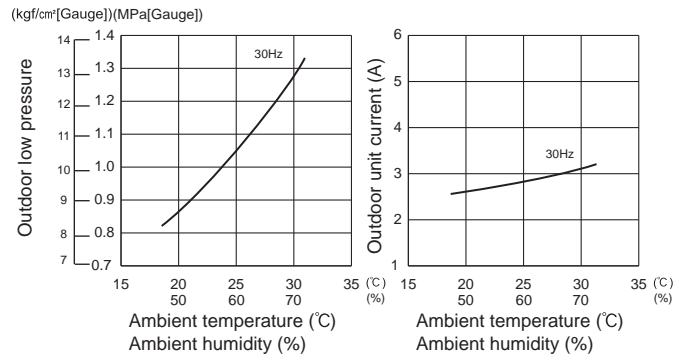

5. 25-class unit in single operation

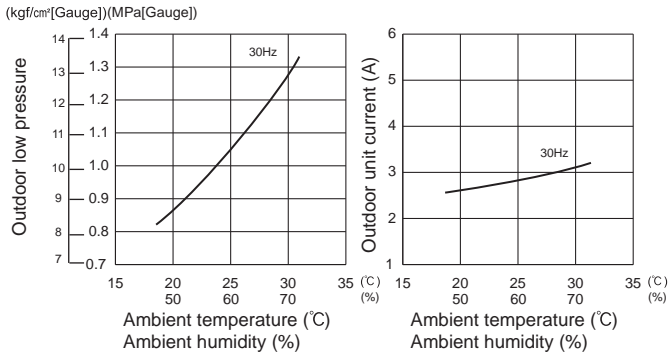

6. 35-class unit in single operation

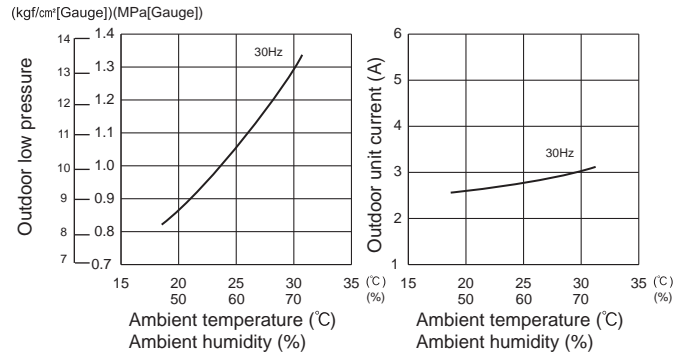

7. 42-class unit in single operation

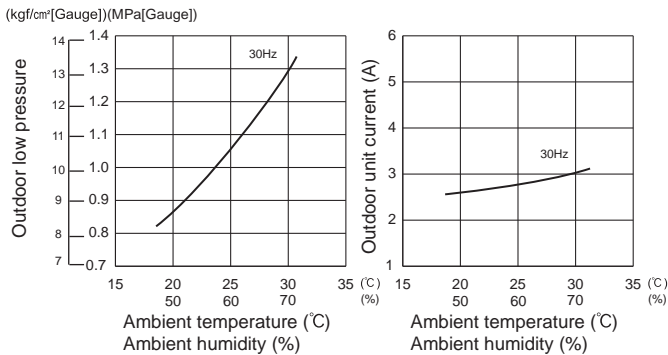

8. 50-class unit in single operation

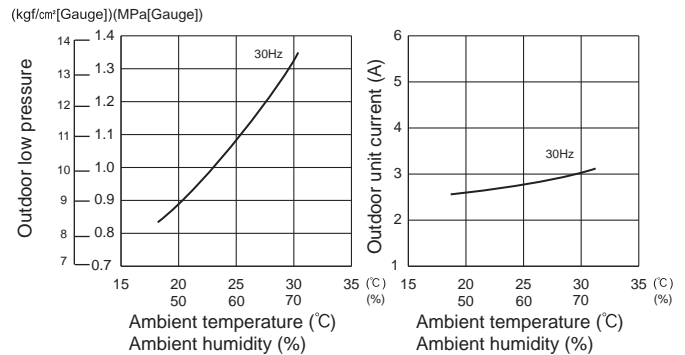

MXZ-3E68VA MXZ-4E72VA

9. 60-class unit in single operation

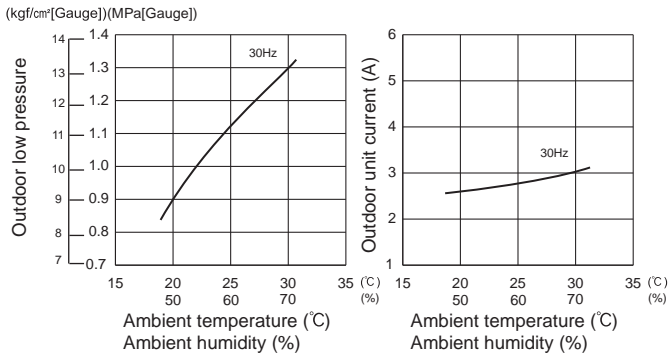

MXZ-4E83VA

1. 15-class unit in single operation

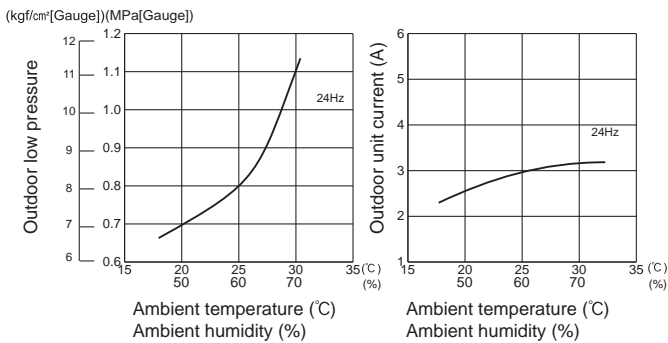

2. 18-class unit in single operation

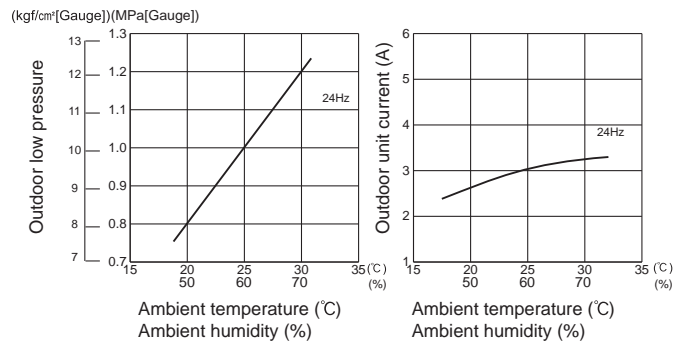

3. 20-class unit in single operation

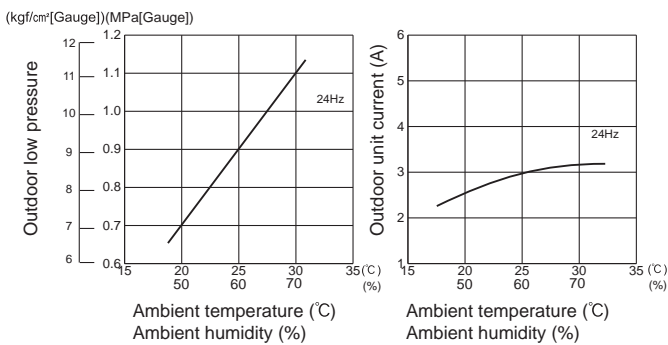

4. 22-class unit in single operation

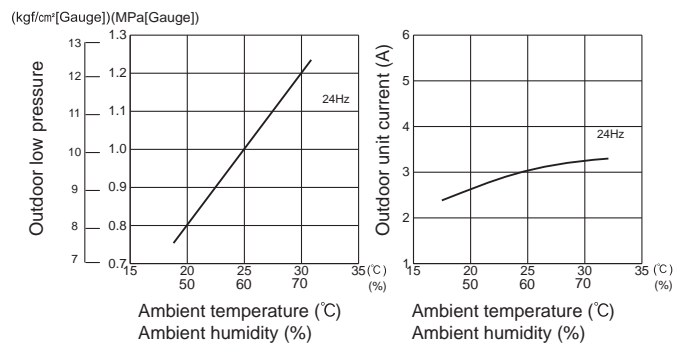

5. 25-class unit in single operation

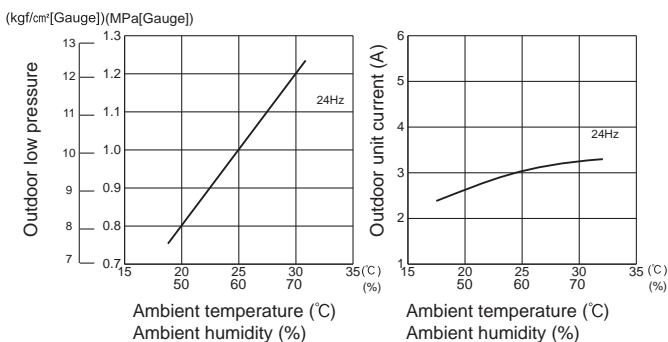

6. 35-class unit in single operation

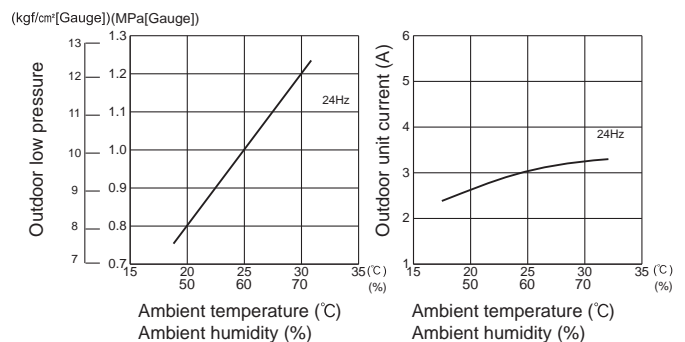

PERFORMANCE CURVES

MULTI SYSTEM

MXZ-4E83VA

7. 42-class unit in single operation

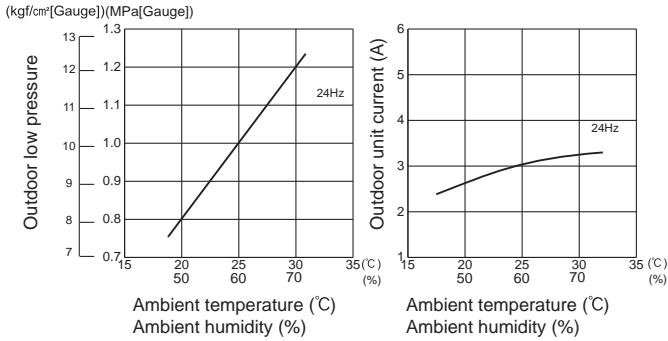

8. 50-class unit in single operation

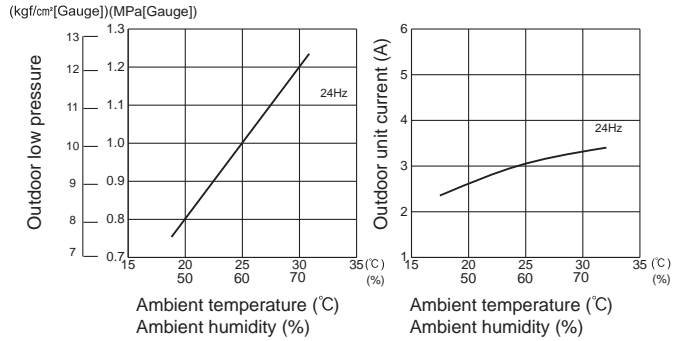

9. 60-class unit in single operation

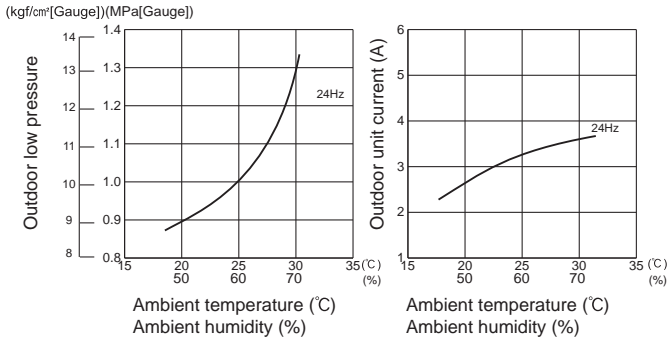

10. 71-class unit in single operation

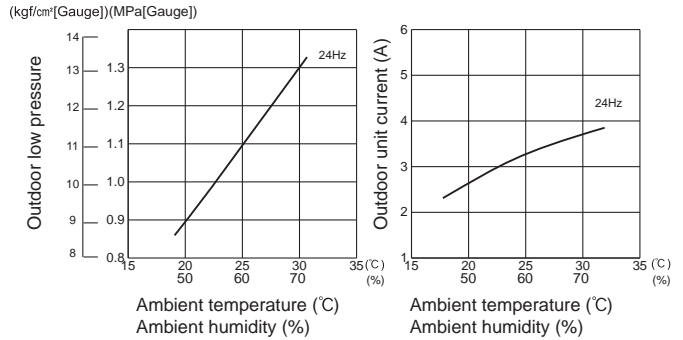

MXZ-4E83VAHZ

1. 15-class unit in single operation

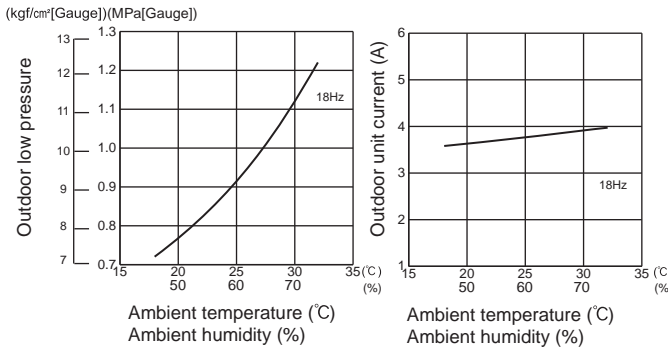

2. 18-class unit in single operation

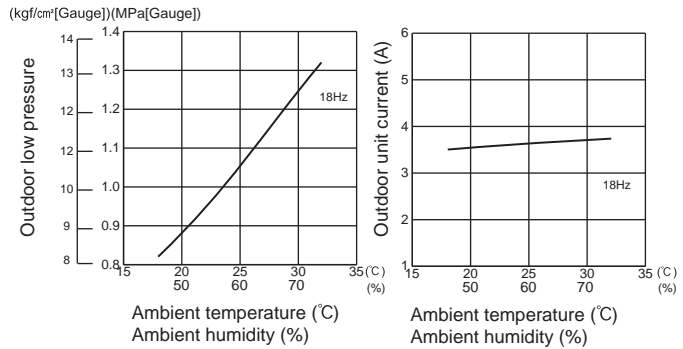

3. 20-class unit in single operation

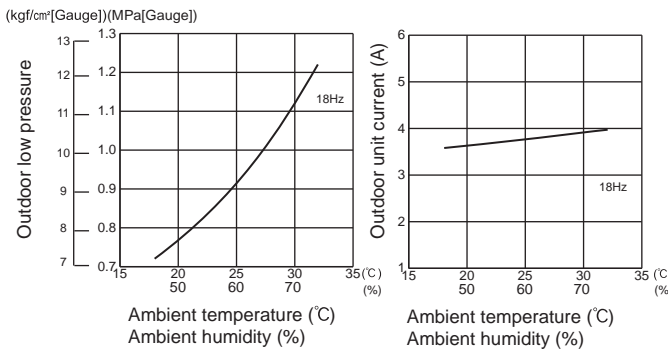

4. 22-class unit in single operation

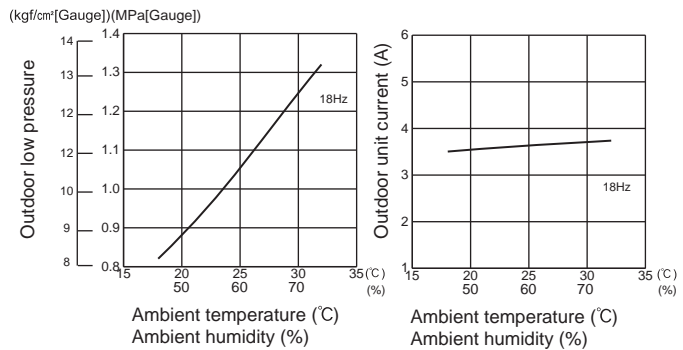

MXZ-4E83VAHZ

5. 25-class unit in single operation

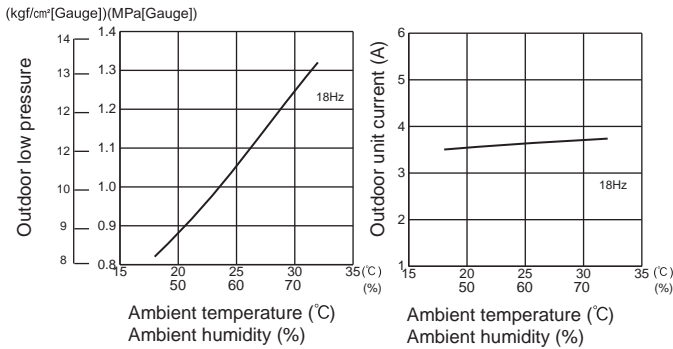

6. 35-class unit in single operation

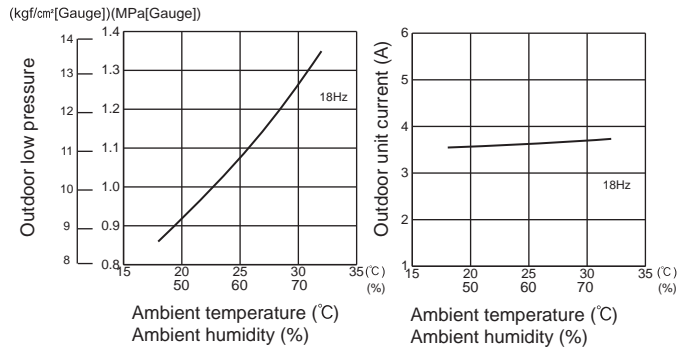

7. 42-class unit in single operation

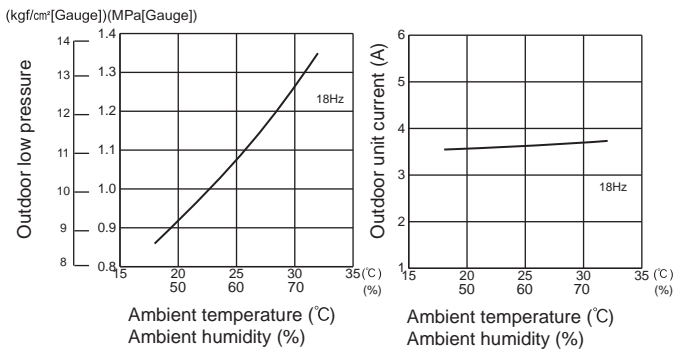

8. 50-class unit in single operation

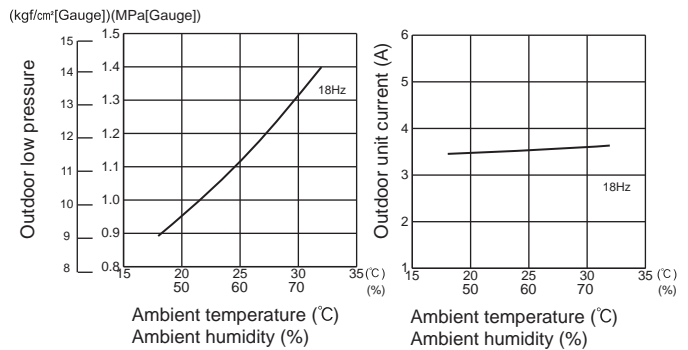

9. 60-class unit in single operation

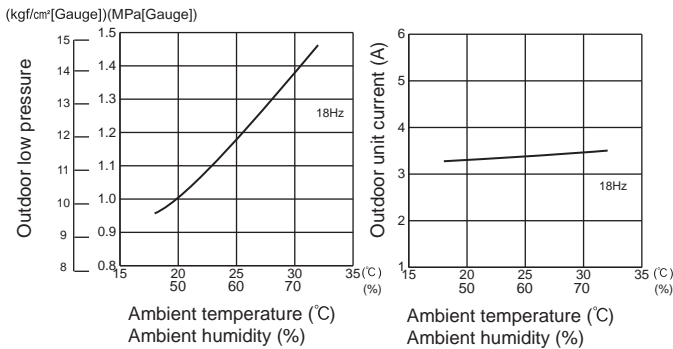

10. 71-class unit in single operation

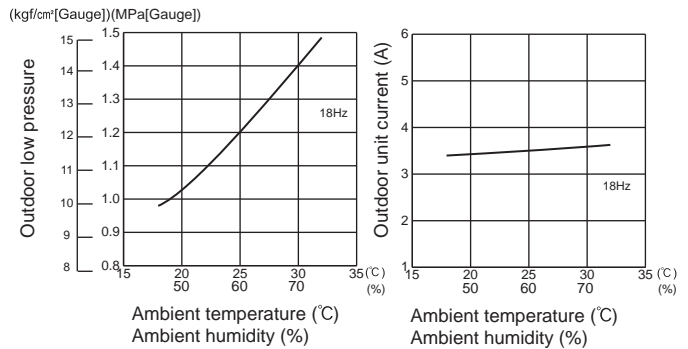

MXZ-5E102VA

1. 15-class unit in single operation

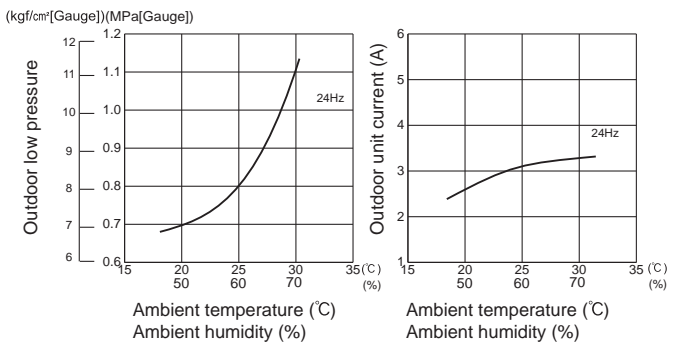

2. 18-class unit in single operation

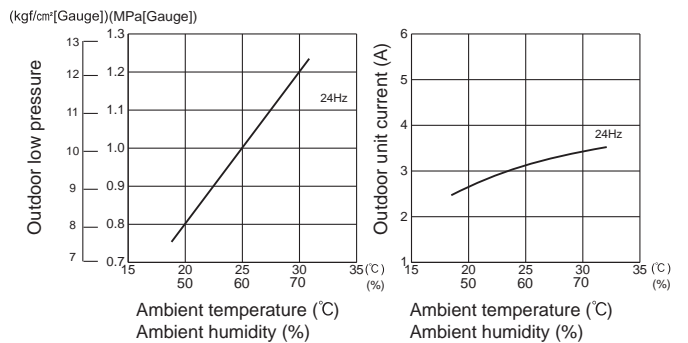

MXZ-5E102VA

3. 20-class unit in single operation

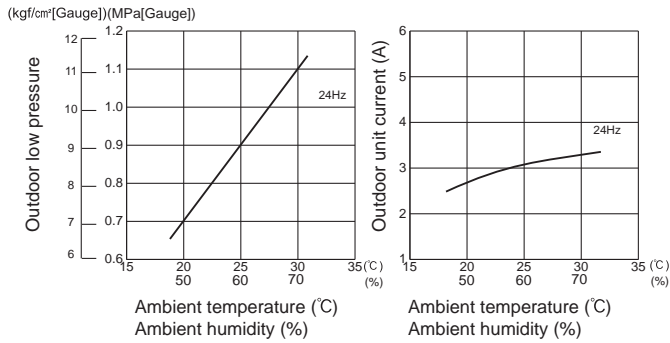

4. 22-class unit in single operation

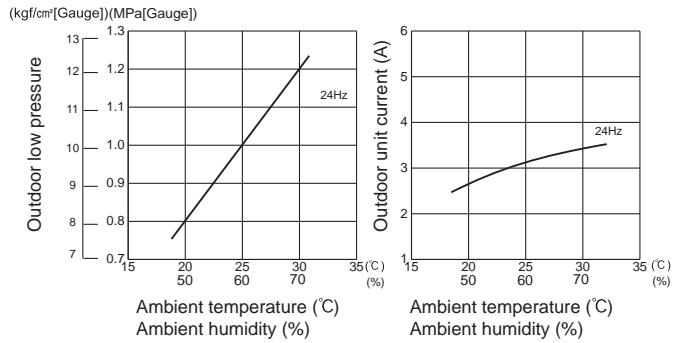

5. 25-class unit in single operation

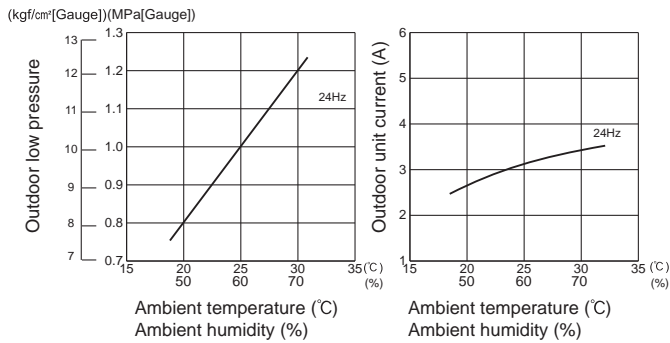

6. 35-class unit in single operation

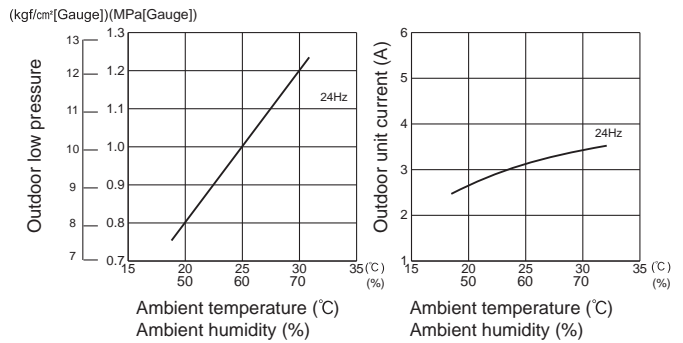

7. 42-class unit in single operation

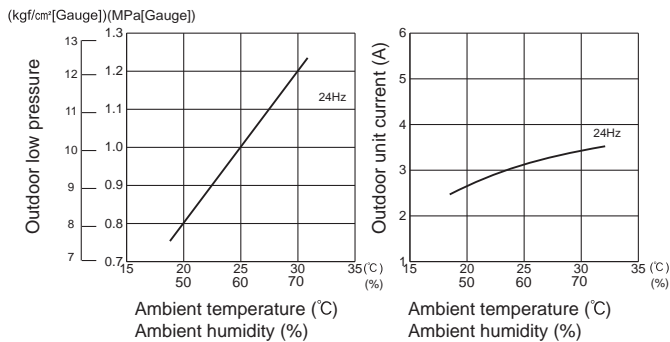

8. 50-class unit in single operation

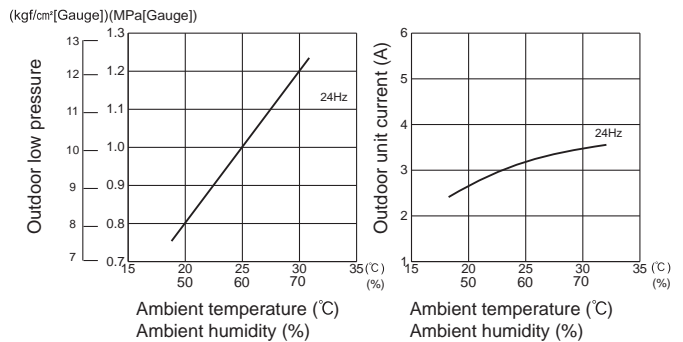

9. 60-class unit in single operation

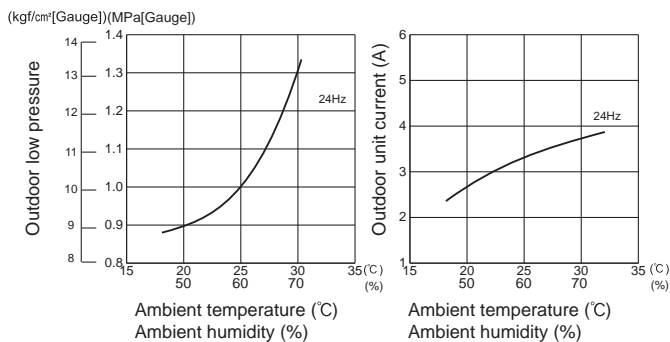

10. 71-class unit in single operation

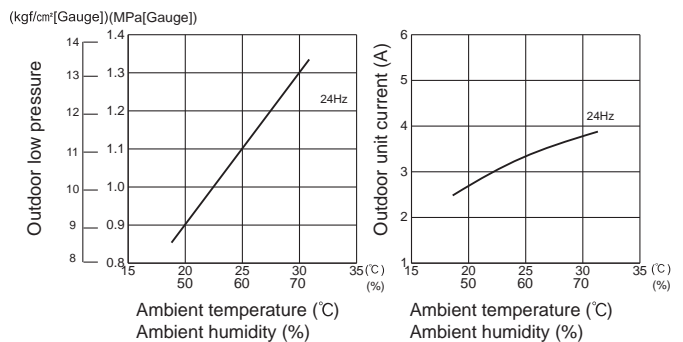

MXZ-6D122VA2

1. 15-class unit in single operation

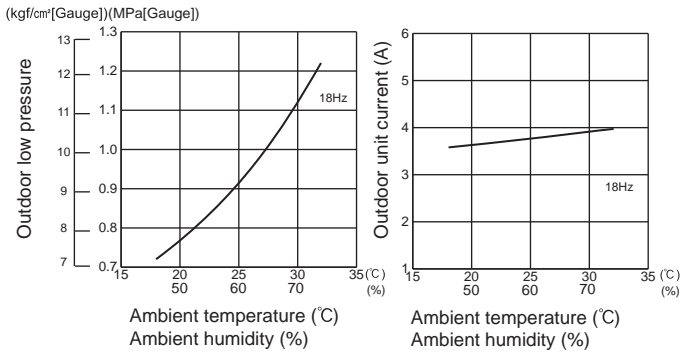

2. 18-class unit in single operation

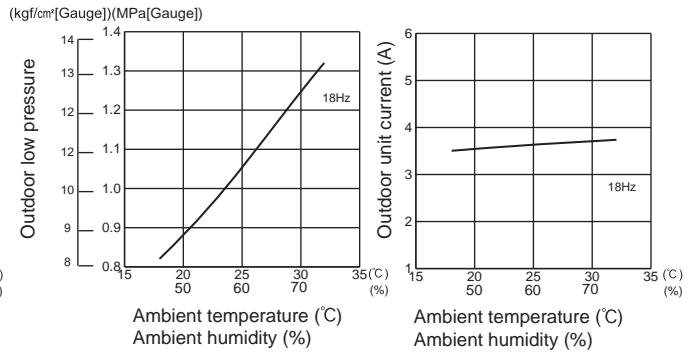

3. 20-class unit in single operation

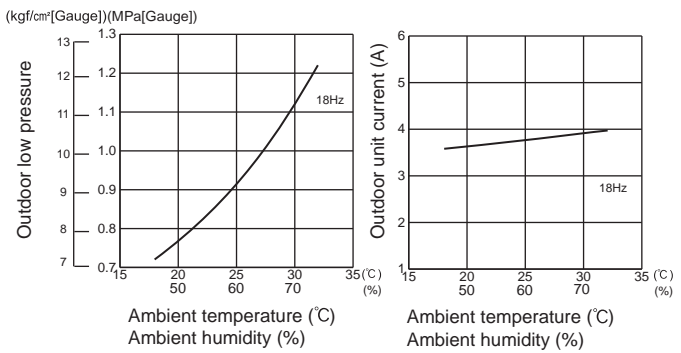

4. 22-class unit in single operation

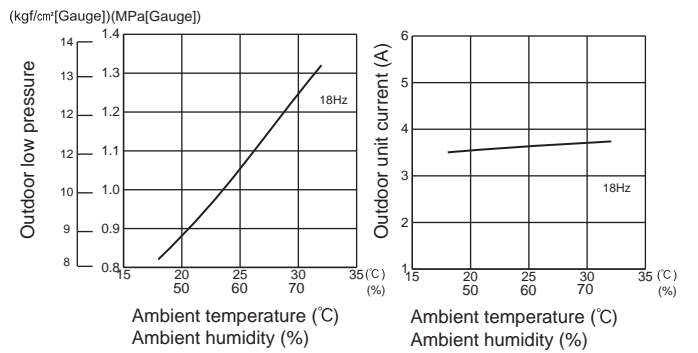

5. 25-class unit in single operation

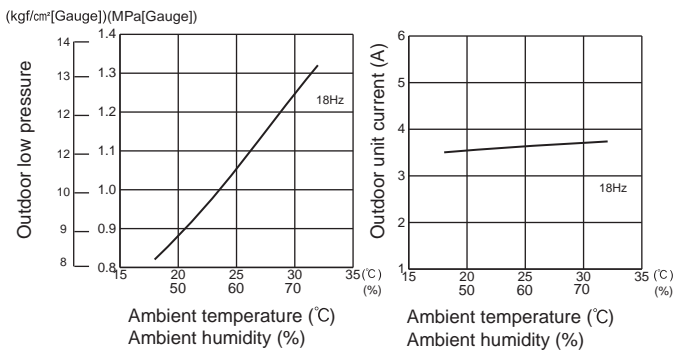

6. 35-class unit in single operation

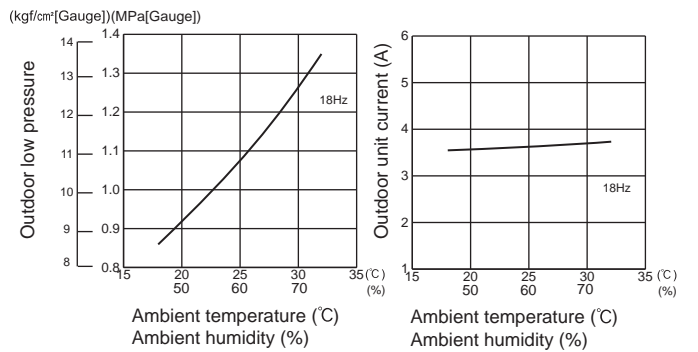

7. 42-class unit in single operation

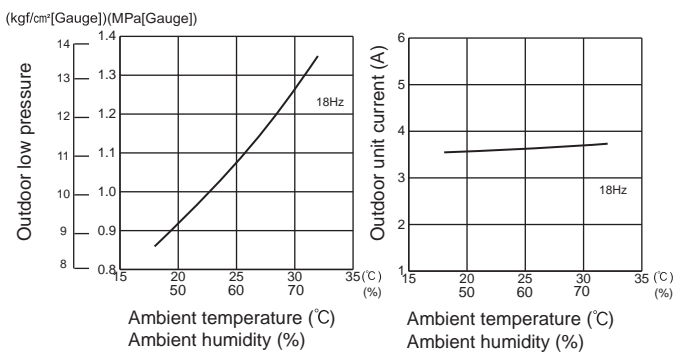

8. 50-class unit in single operation

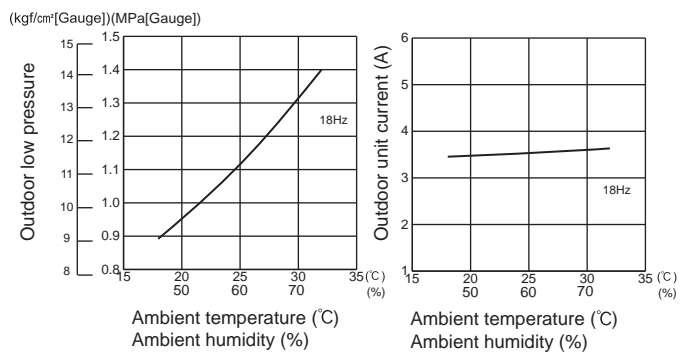

PERFORMANCE CURVES

MULTI SYSTEM

MXZ-6D122VA2

9. 60-class unit in single operation

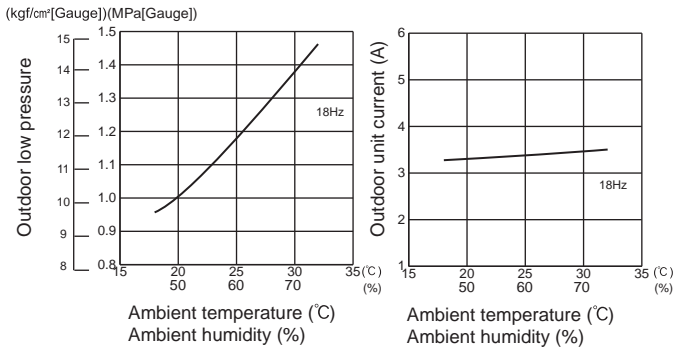

10. 71-class unit in single operation

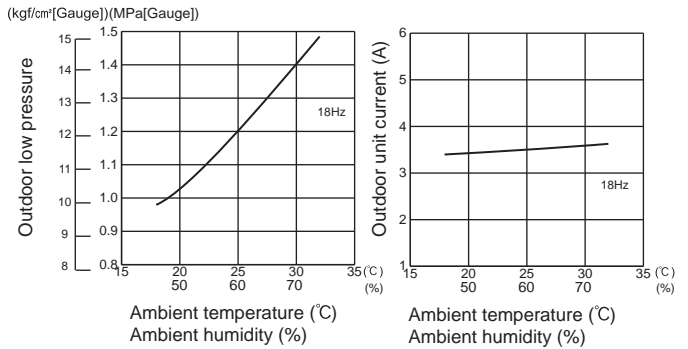

MXZ-2DM40VA

1. 25-class unit in single operation

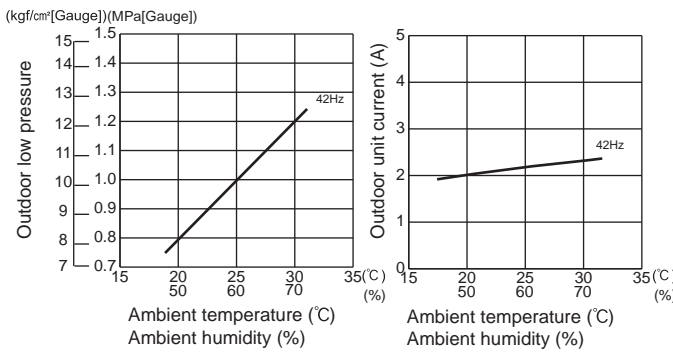

2. 35-class unit in single operation

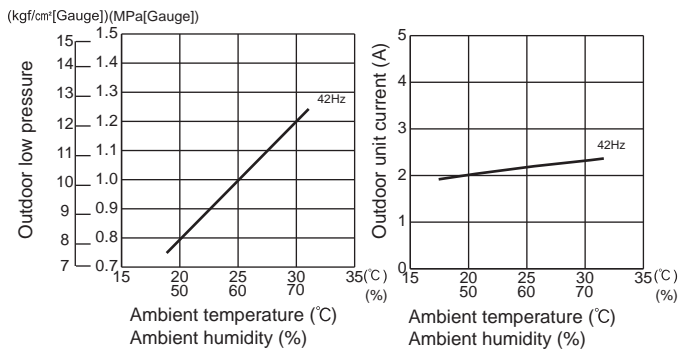

MXZ-3DM50VA

1. 25-class unit in single operation

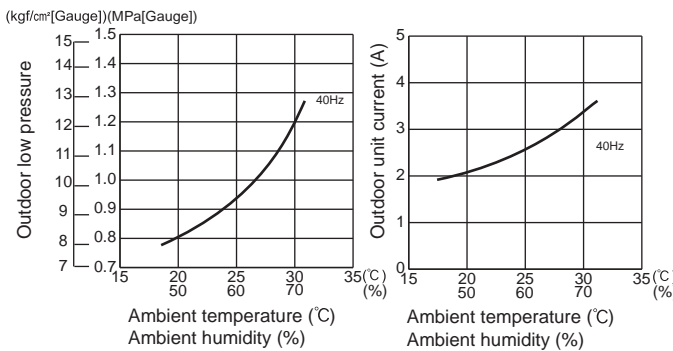

2. 35-class unit in single operation

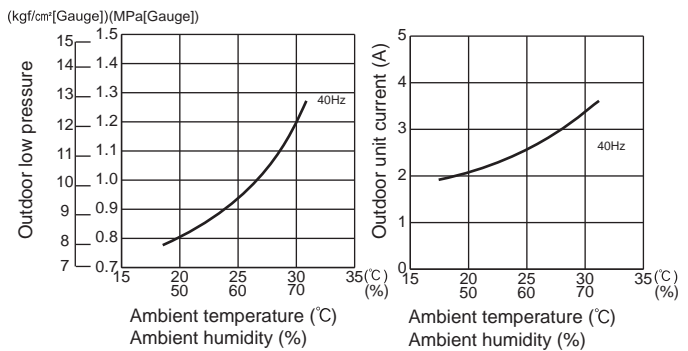

3. 50-class unit in single operation

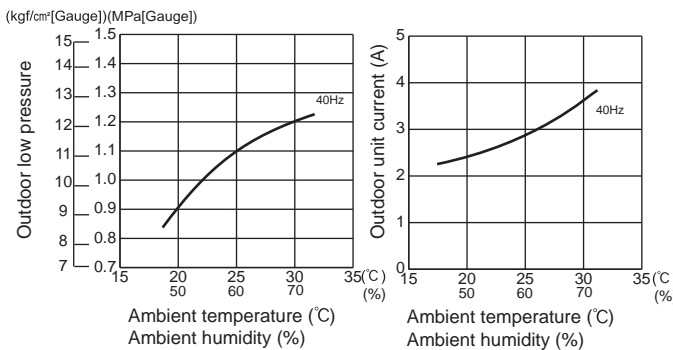

MULTI SYSTEM PERFORMANCE CURVES

MXZ-2HA40VF2

1. 25-class unit in single operation

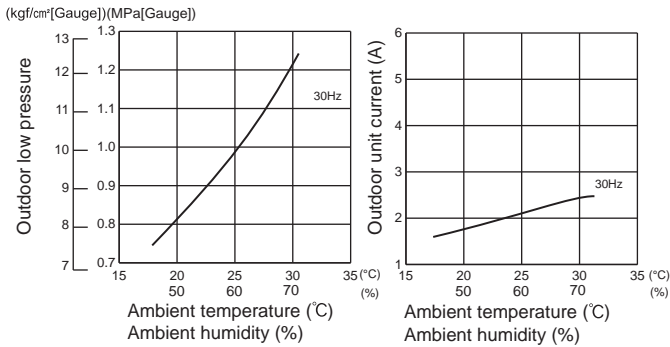

2. 35-class unit in single operation

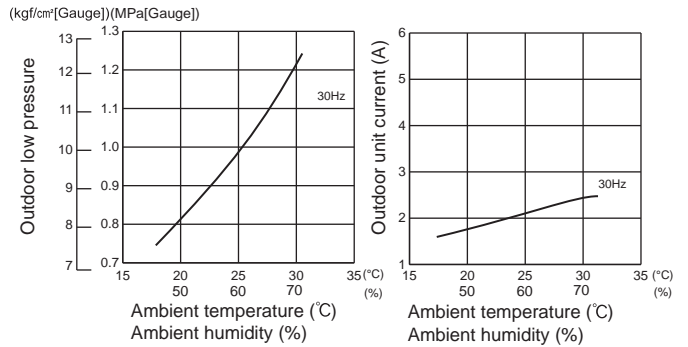

MXZ-2HA50VF2

1. 25-class unit in single operation

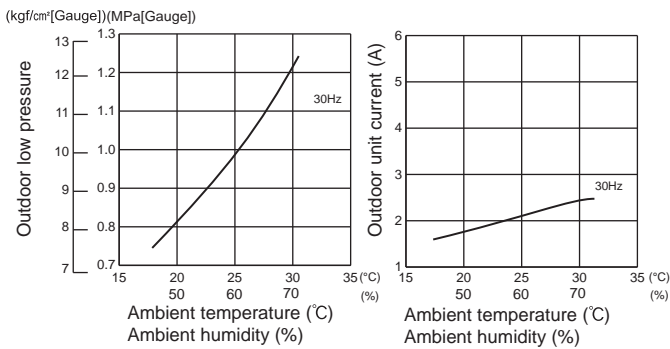

2. 35-class unit in single operation

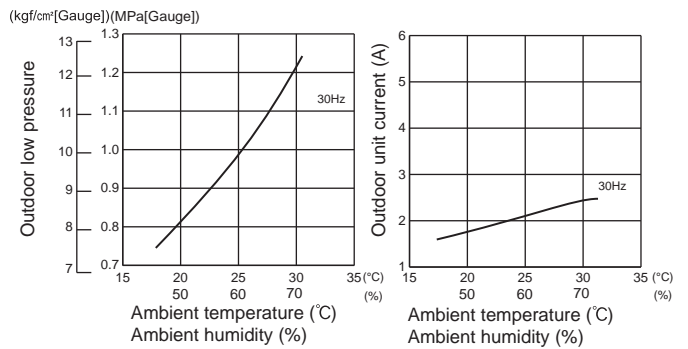

3. 42-class unit in single operation

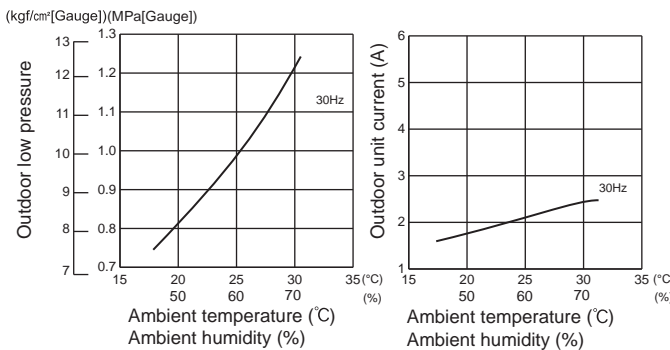

MXZ-3HA50VF2

1. 25-class unit in single operation

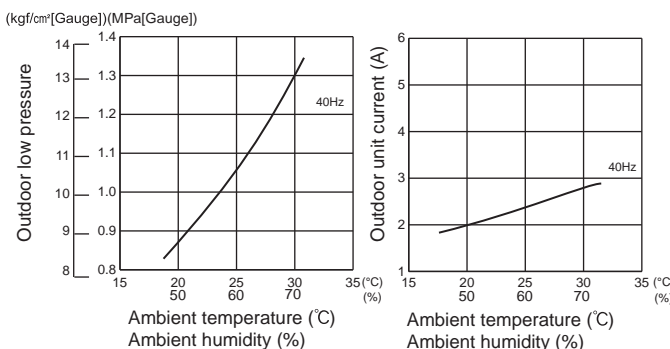

2. 35-class unit in single operation

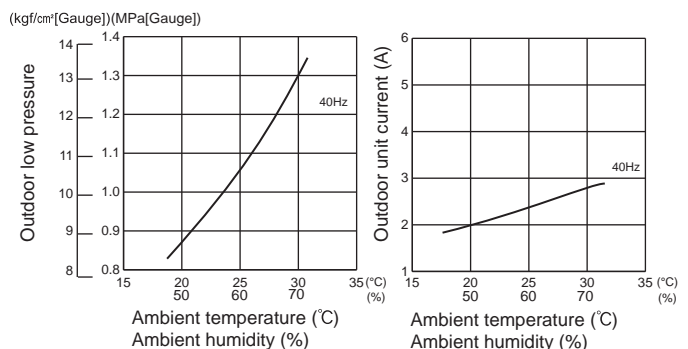

PERFORMANCE CURVES

MULTI SYSTEM

MXZ-3HA50VF2

3. 42-class unit in single operation

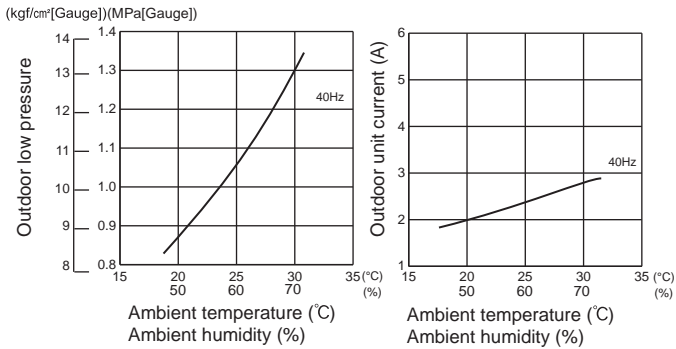

4. 50-class unit in single operation

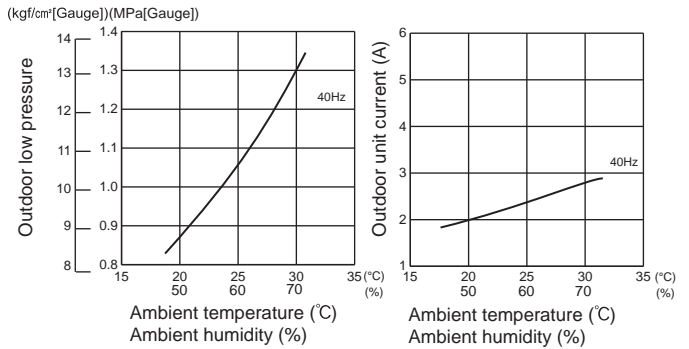

PXZ-4F75VG

1. 15-class unit in single operation

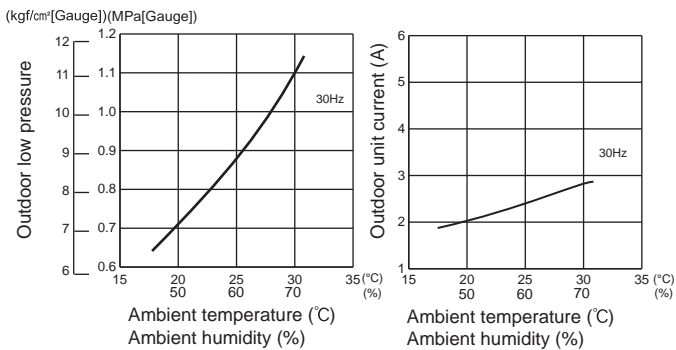

2. 18-class unit in single operation

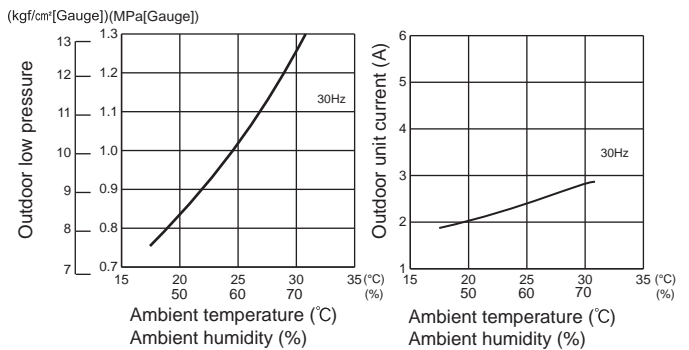

3. 20-class unit in single operation

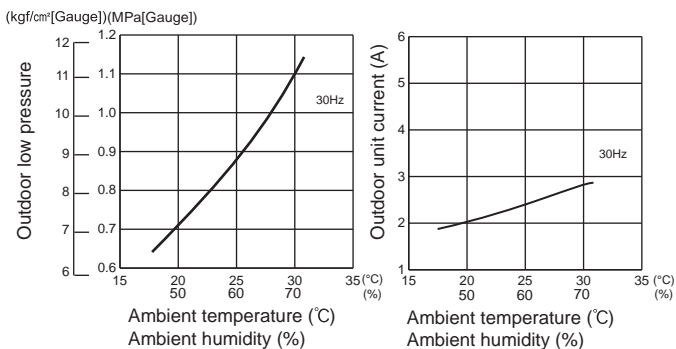

4. 22-class unit in single operation

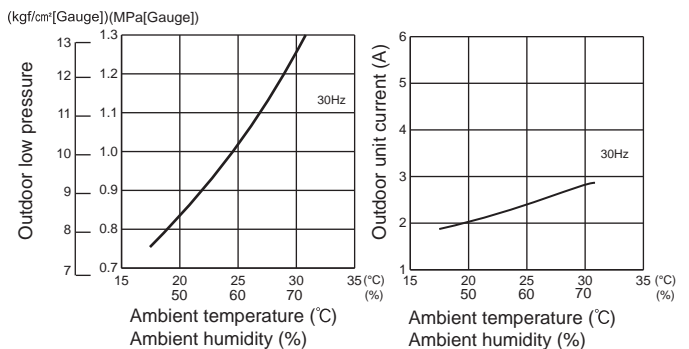

5. 25-class unit in single operation

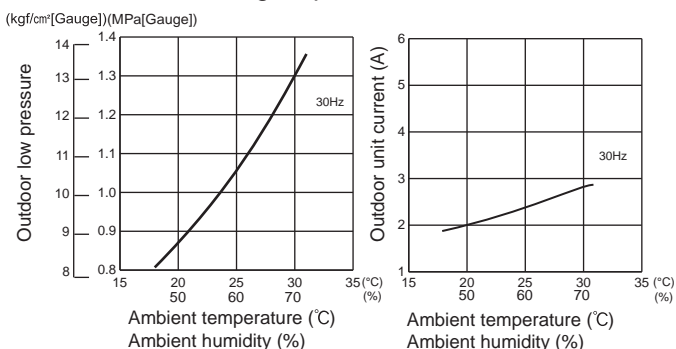

6. 35-class unit in single operation

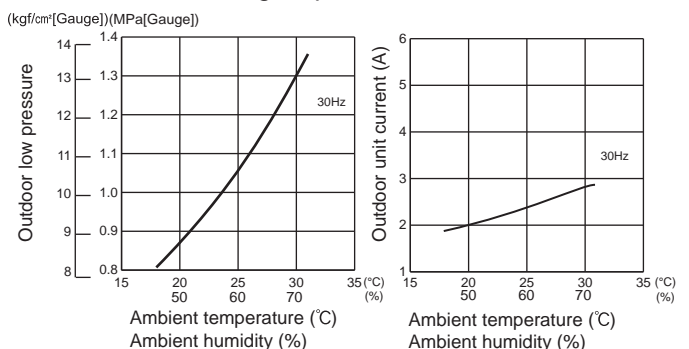

PXZ-4F75VG

7. 42-class unit in single operation

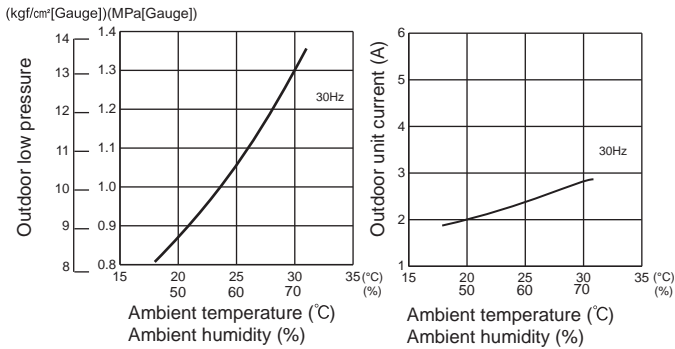

8. 50-class unit in single operation

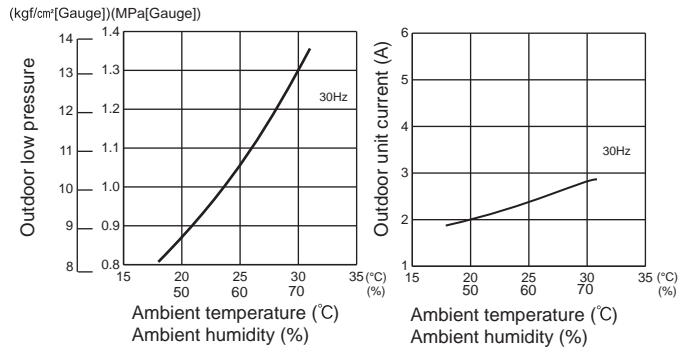

9. 60-class unit in single operation

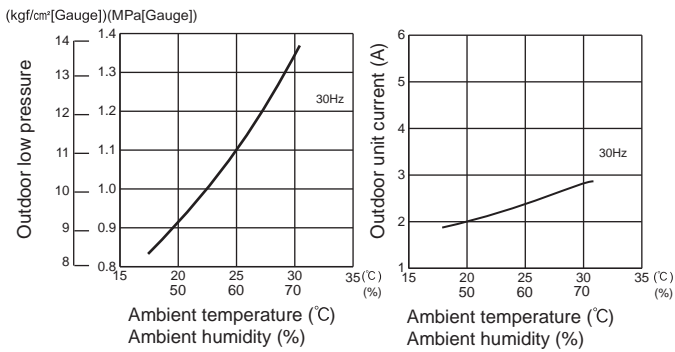

10. 71-class unit in single operation

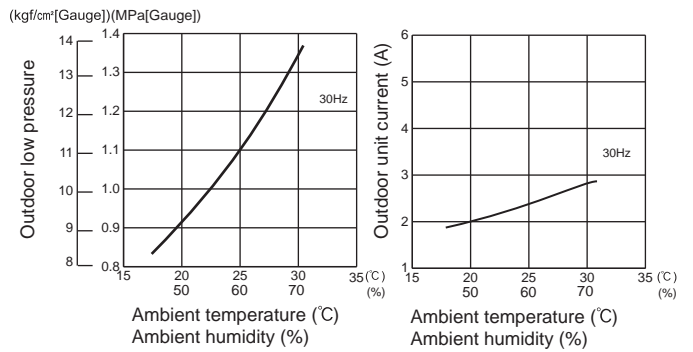

PXZ-5F85VG

1. 15-class unit in single operation

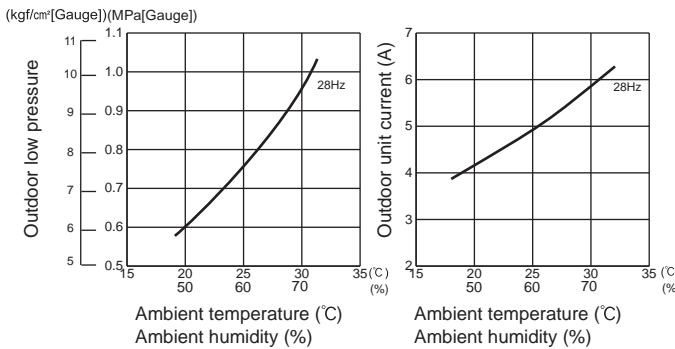

2. 18-class unit in single operation

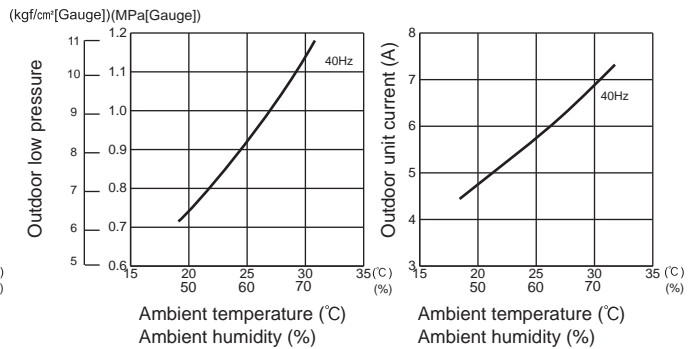

3. 20-class unit in single operation

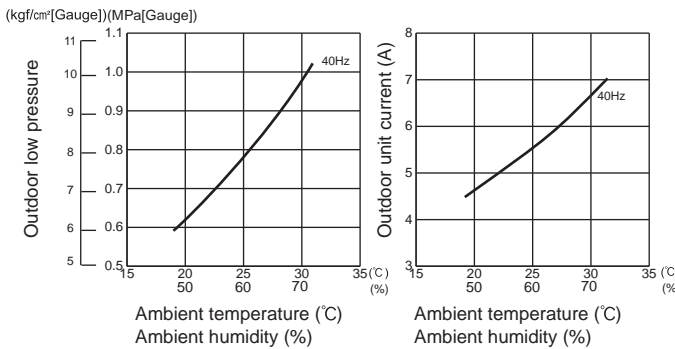

4. 22-class unit in single operation

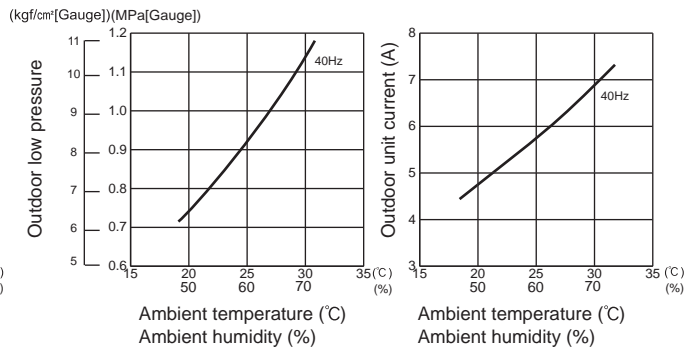

PERFORMANCE CURVES

MULTI SYSTEM

PXZ-5F85VG

5. 25-class unit in single operation

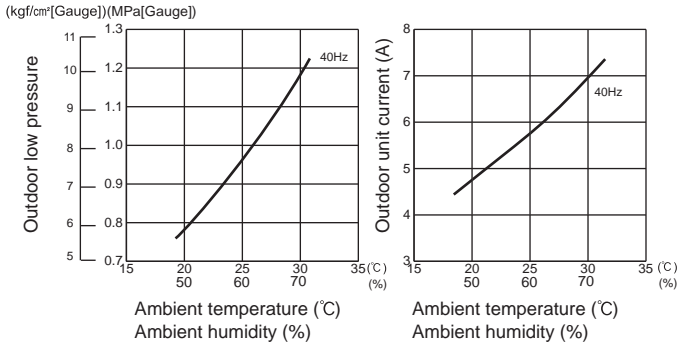

6. 35-class unit in single operation

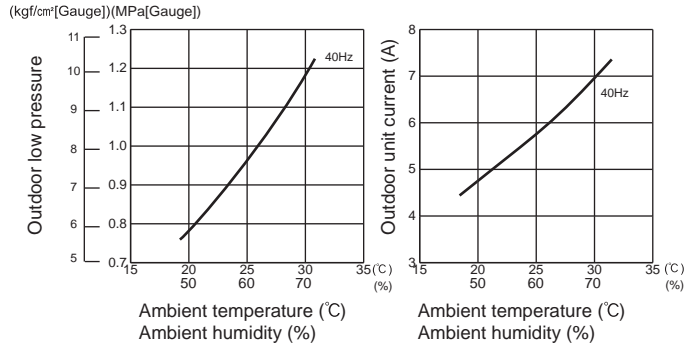

7. 42-class unit in single operation

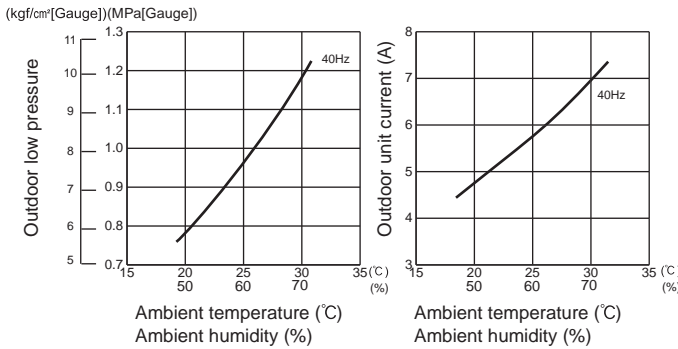

8. 50-class unit in single operation

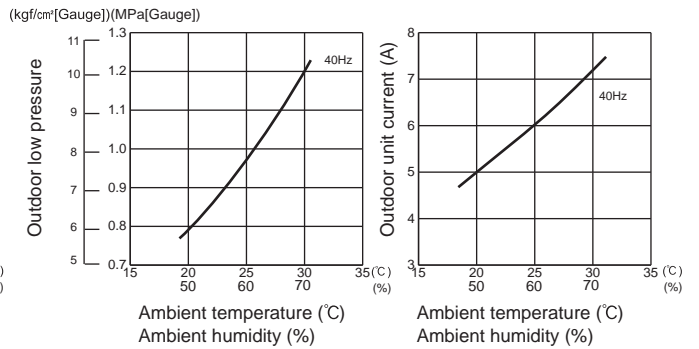

9. 60-class unit in single operation

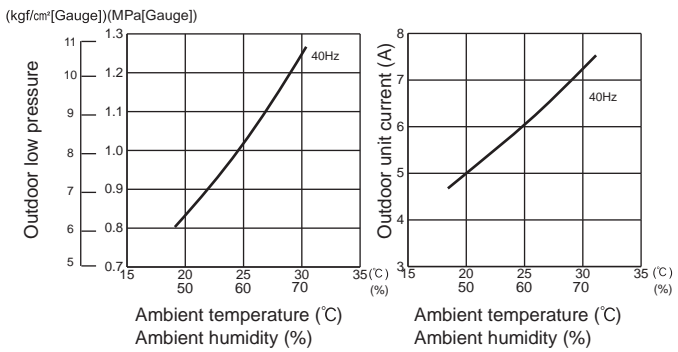

10. 71-class unit in single operation

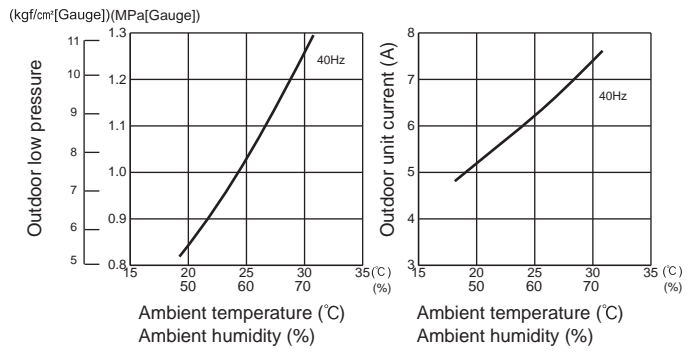

HEAT operation

① Condition:

	Indoor	Outdoor			
Dry bulb temperature (°C)	20.0	2	7	15	20.0
Wet bulb temperature (°C)	14.5	1	6	12	14.5

② Operation: TEST RUN OPERATION

MXZ-2F33VF4

1. 15-class unit in single operation

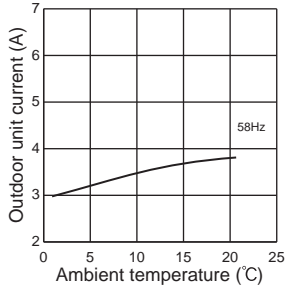

2. 18-class unit in single operation

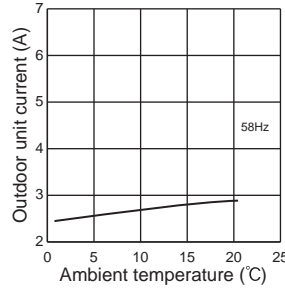

3. 20-class unit in single operation

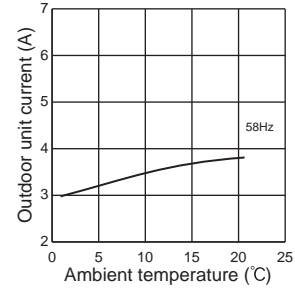

4. 22-class unit in single operation

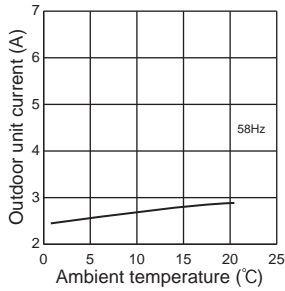

5. 25-class unit in single operation

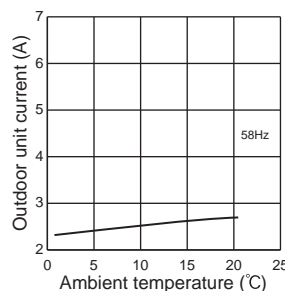

MXZ-2F42VF4

1. 15-class unit in single operation

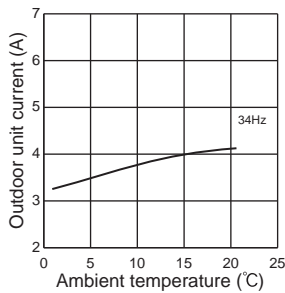

2. 18-class unit in single operation

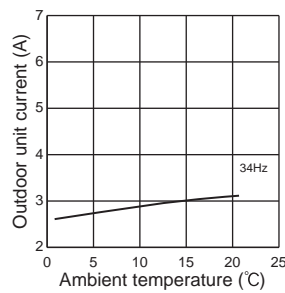

3. 20-class unit in single operation

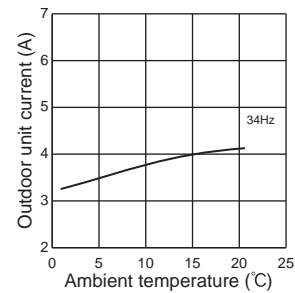

4. 22-class unit in single operation

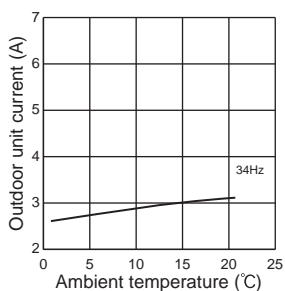

5. 25-class unit in single operation

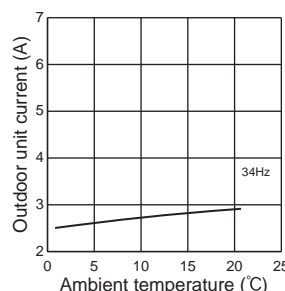

6. 35-class unit in single operation

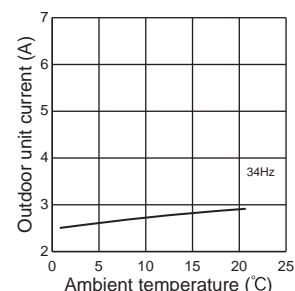

PERFORMANCE CURVES

MULTI SYSTEM

MXZ-2F53VF4 MXZ-2F53VFH4

1. 15-class unit in single operation

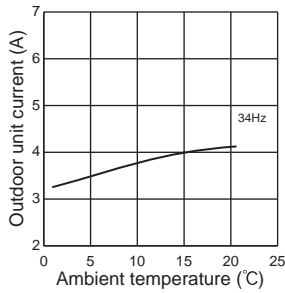

2. 18-class unit in single operation

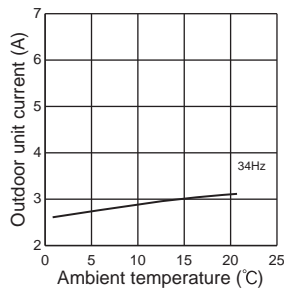

3. 20-class unit in single operation

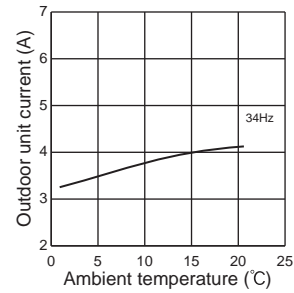

4. 22-class unit in single operation

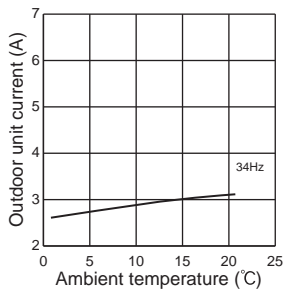

5. 25-class unit in single operation

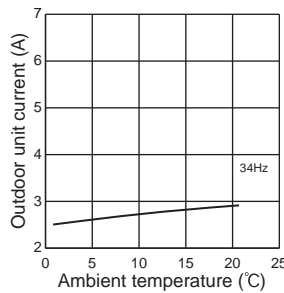

6. 35-class unit in single operation

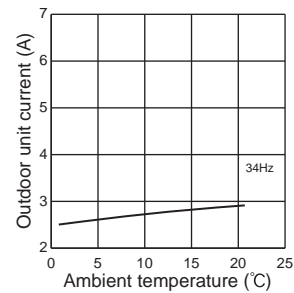

7. 42-class unit in single operation

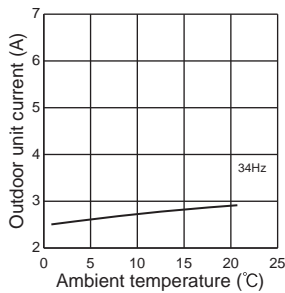

8. 50-class unit in single operation

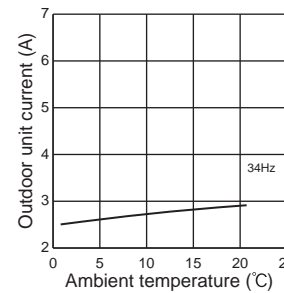

MXZ-3F54VF4

1. 15-class unit in single operation

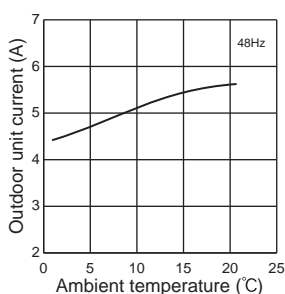

2. 18-class unit in single operation

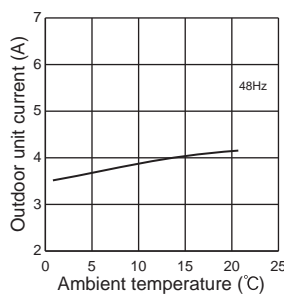

3. 20-class unit in single operation

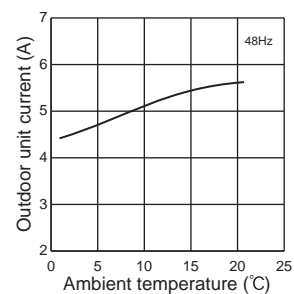

4. 22-class unit in single operation

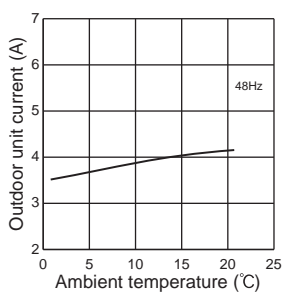

5. 25-class unit in single operation

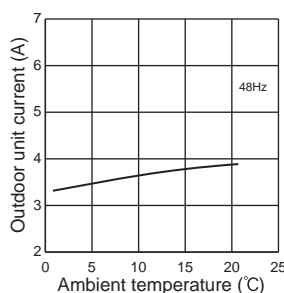

6. 35-class unit in single operation

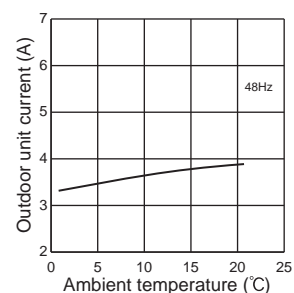

MXZ-3F54VF4

7. 42-class unit in single operation

8. 50-class unit in single operation

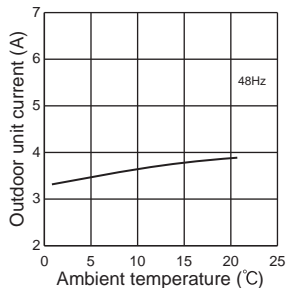
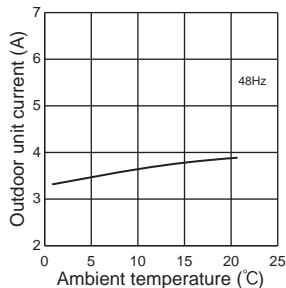

MXZ-3F68VF4 MXZ-4F72VF4

1. 15-class unit in single operation

2. 18-class unit in single operation

3. 20-class unit in single operation

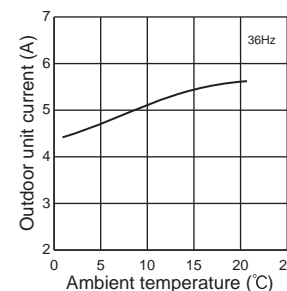
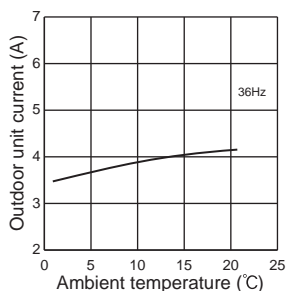
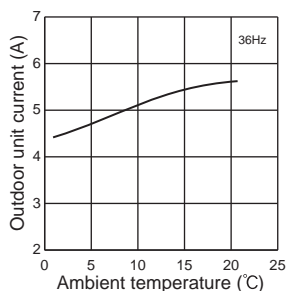

4. 22-class unit in single operation

5. 25-class unit in single operation

6. 35-class unit in single operation

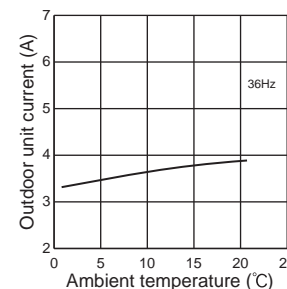
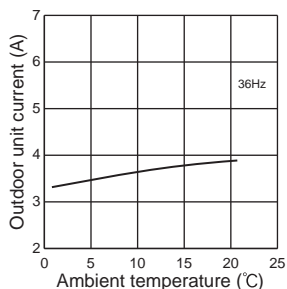
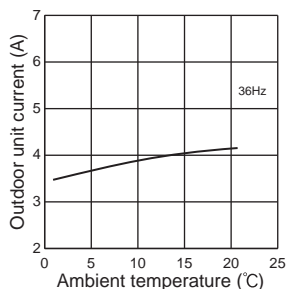

7. 42-class unit in single operation

8. 50-class unit in single operation

9. 60-class unit in single operation

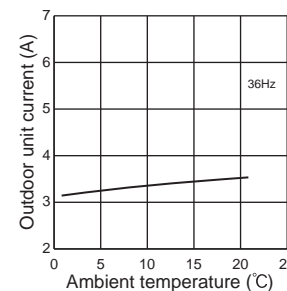
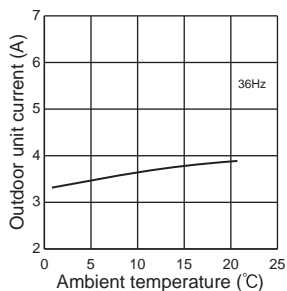
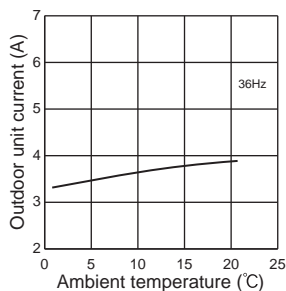

PERFORMANCE CURVES

MULTI SYSTEM

MXZ-4F80VF4

1. 15-class unit in single operation

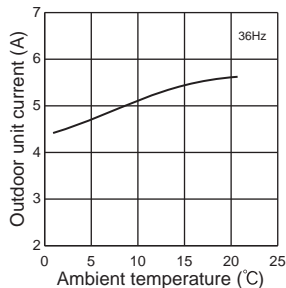

2. 18-class unit in single operation

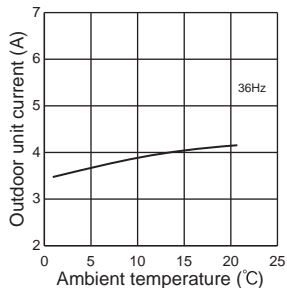

3. 20-class unit in single operation

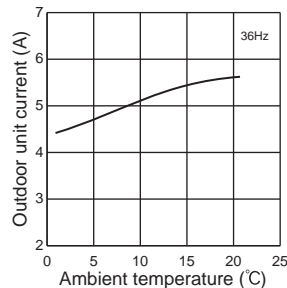

4. 22-class unit in single operation

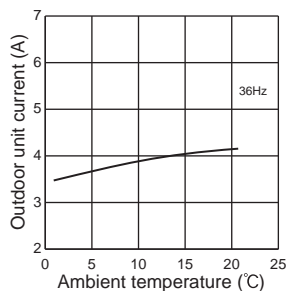

5. 25-class unit in single operation

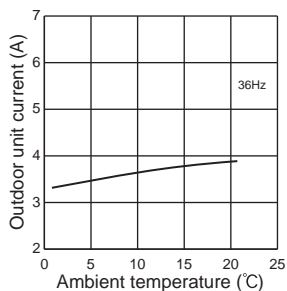

6. 35-class unit in single operation

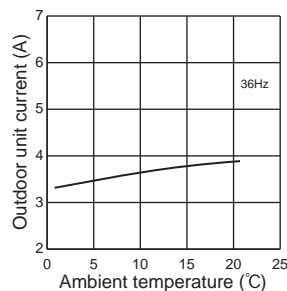

7. 42-class unit in single operation

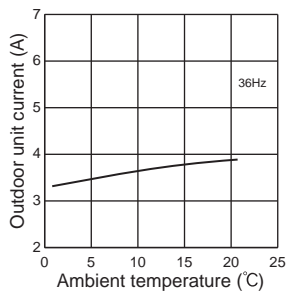

8. 50-class unit in single operation

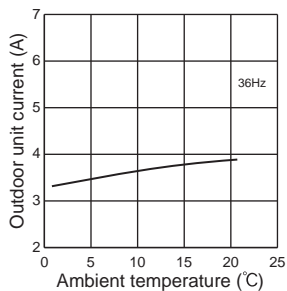

9. 60-class unit in single operation

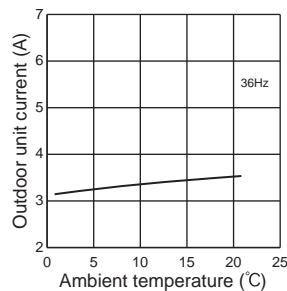

MXZ-4F83VF2

1. 15-class unit in single operation

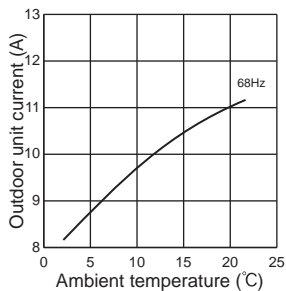

2. 18-class unit in single operation

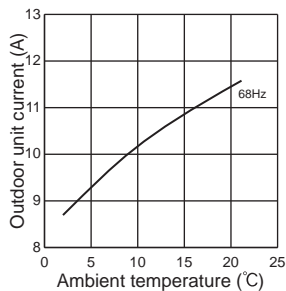

3. 20-class unit in single operation

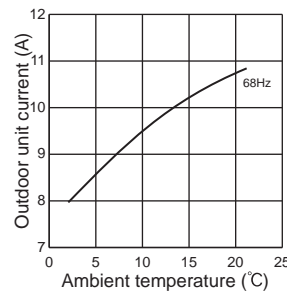

4. 22-class unit in single operation

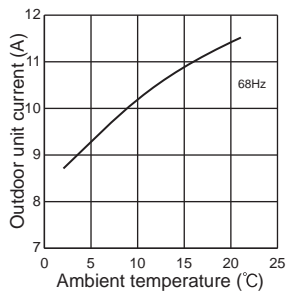

5. 25-class unit in single operation

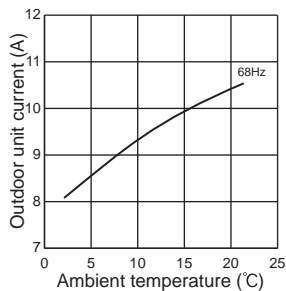

6. 35-class unit in single operation

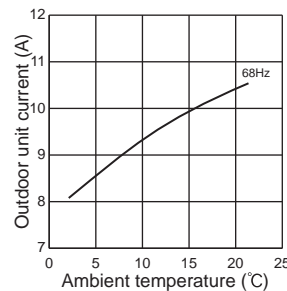

7. 42-class unit in single operation

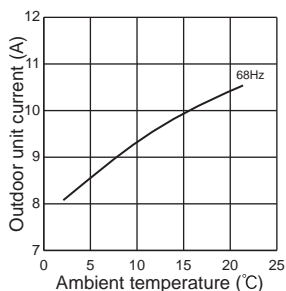

8. 50-class unit in single operation

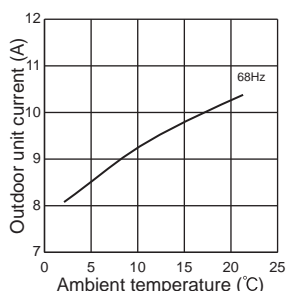

9. 60-class unit in single operation

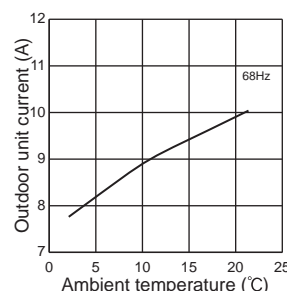

10. 71-class unit in single operation

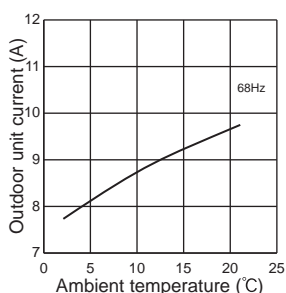

PERFORMANCE CURVES

MULTI SYSTEM

MXZ-5F102VF2

1. 15-class unit in single operation

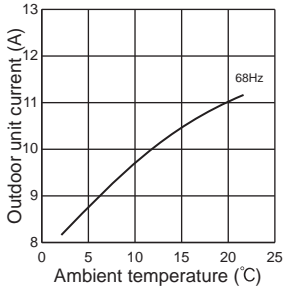

2. 18-class unit in single operation

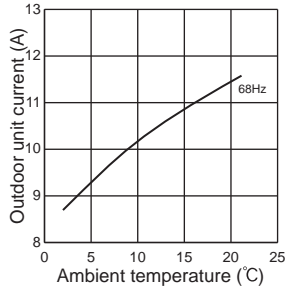

3. 20-class unit in single operation

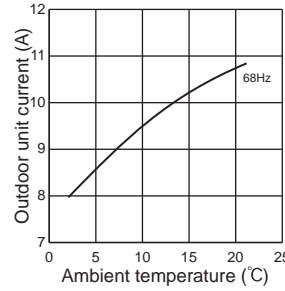

4. 22-class unit in single operation

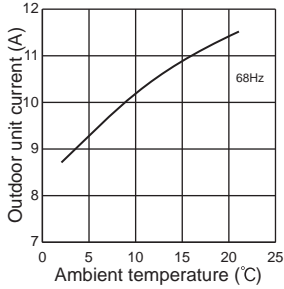

5. 25-class unit in single operation

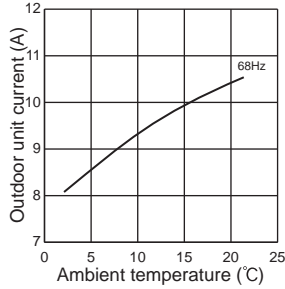

6. 35-class unit in single operation

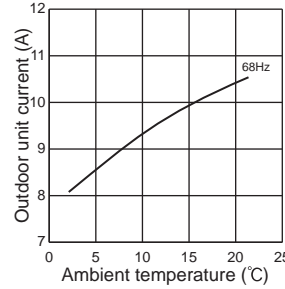

7. 42-class unit in single operation

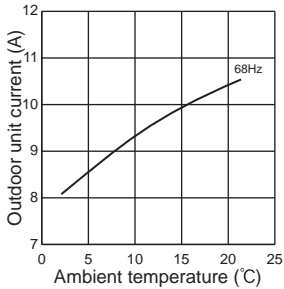

8. 50-class unit in single operation

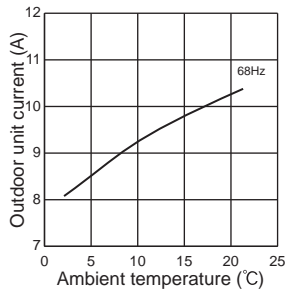

9. 60-class unit in single operation

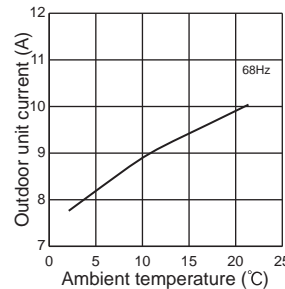

10. 71-class unit in single operation

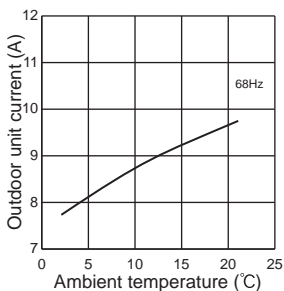

MXZ-6F120VF2

1. 15-class unit in single operation

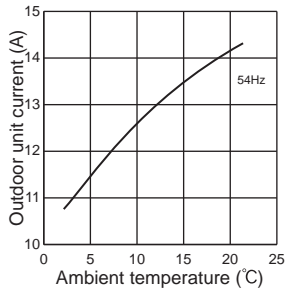

2. 18-class unit in single operation

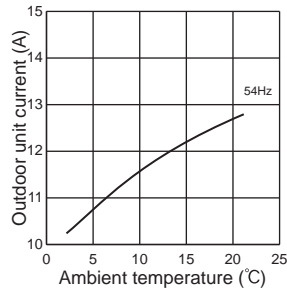

3. 20-class unit in single operation

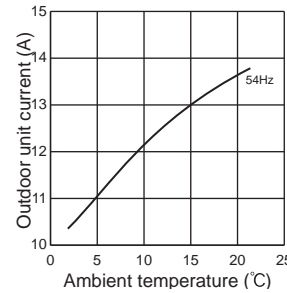

4. 22-class unit in single operation

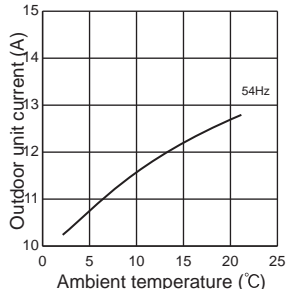

5. 25-class unit in single operation

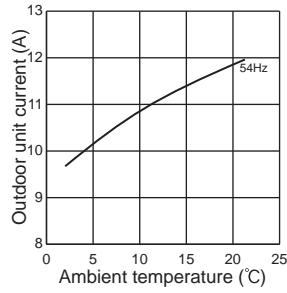

6. 35-class unit in single operation

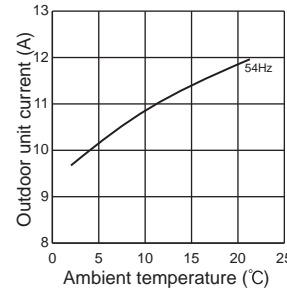

7. 42-class unit in single operation

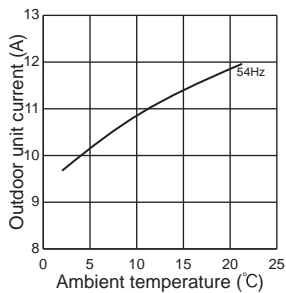

8. 50-class unit in single operation

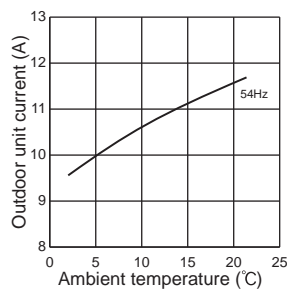

9. 60-class unit in single operation

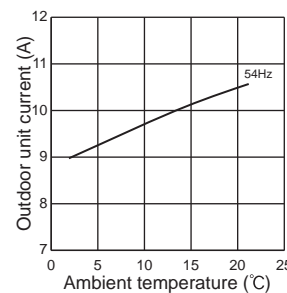

10. 71-class unit in single operation

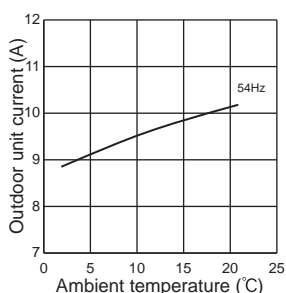

PERFORMANCE CURVES

MULTI SYSTEM

MXZ-2F53VFHZ2

1. 15-class unit in single operation

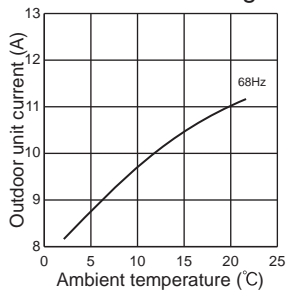

2. 18-class unit in single operation

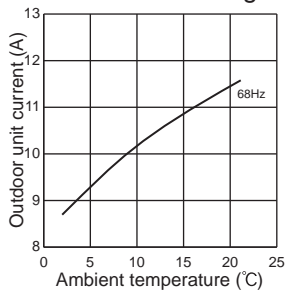

3. 20-class unit in single operation

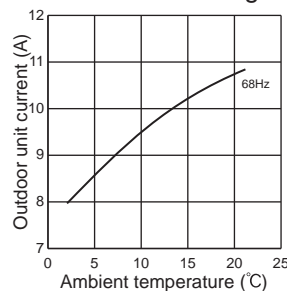

4. 22-class unit in single operation

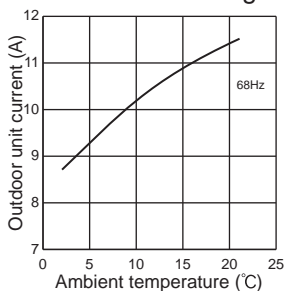

5. 25-class unit in single operation

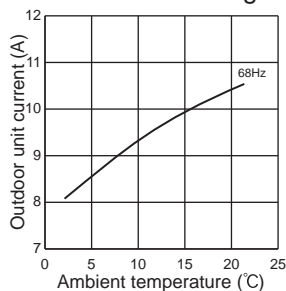

6. 35-class unit in single operation

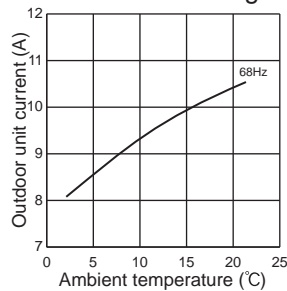

7. 42-class unit in single operation

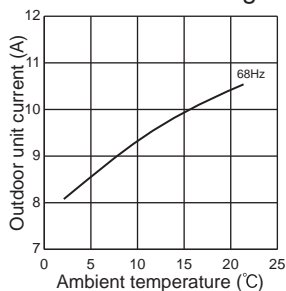

8. 50-class unit in single operation

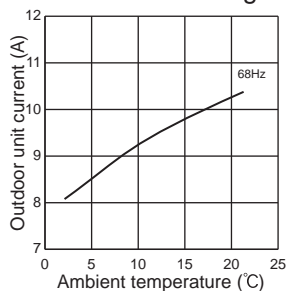

MXZ-4F83VFH22

1. 15-class unit in single operation

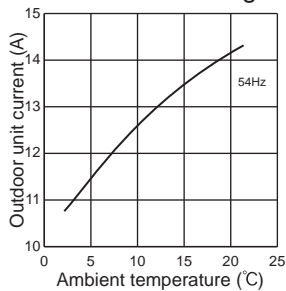

2. 18-class unit in single operation

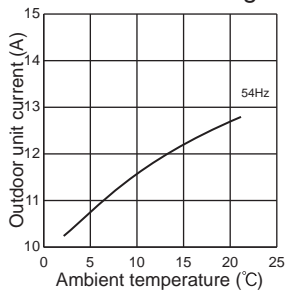

3. 20-class unit in single operation

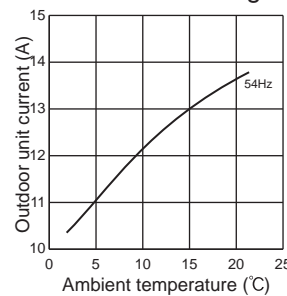

4. 22-class unit in single operation

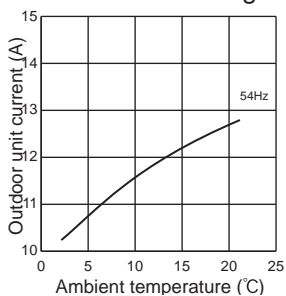

5. 25-class unit in single operation

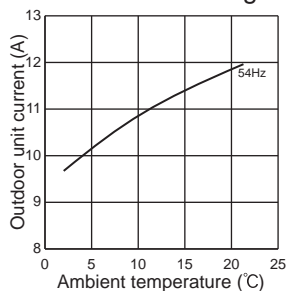

6. 35-class unit in single operation

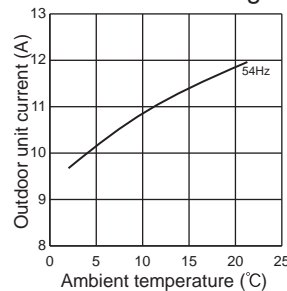

7. 42-class unit in single operation

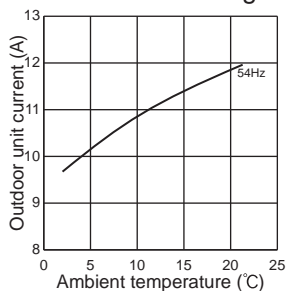

8. 50-class unit in single operation

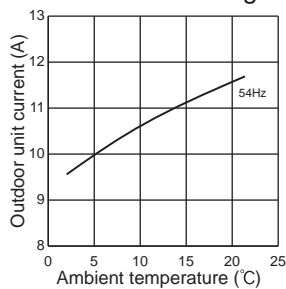

9. 60-class unit in single operation

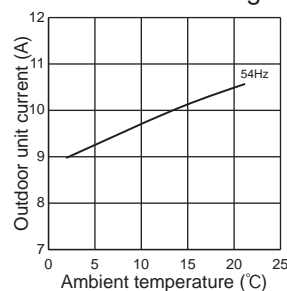

10. 71-class unit in single operation

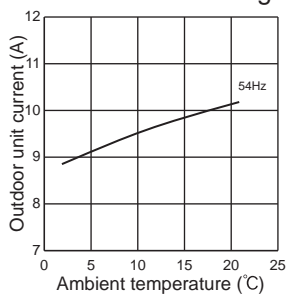

PERFORMANCE CURVES

MULTI SYSTEM

MXZ-2D33VA

1. 15-class unit in single operation

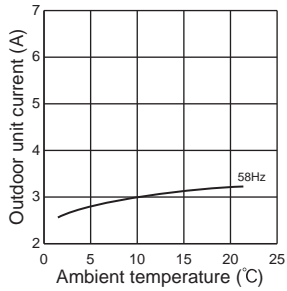

2. 18-class unit in single operation

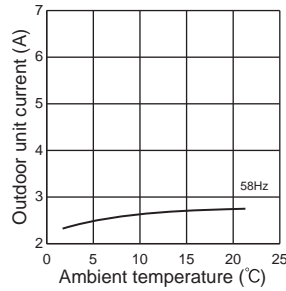

3. 20-class unit in single operation

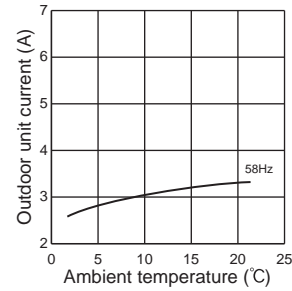

4. 22-class unit in single operation

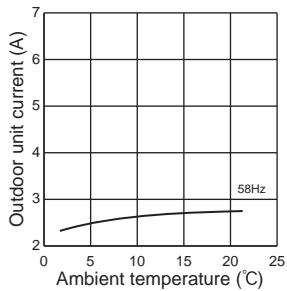

5. 25-class unit in single operation

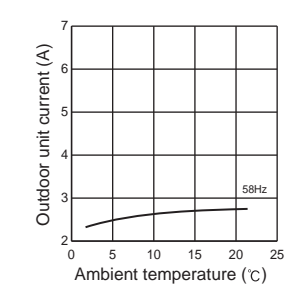

MXZ-2D42VA2 MXZ-2D53VA2 MXZ-2D53VAH2

1. 15-class unit in single operation

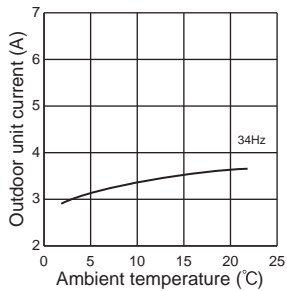

2. 18-class unit in single operation

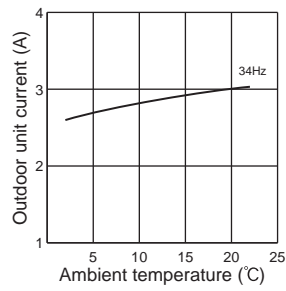

3. 20-class unit in single operation

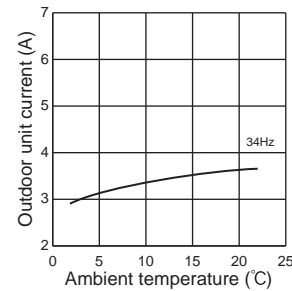

4. 22-class unit in single operation

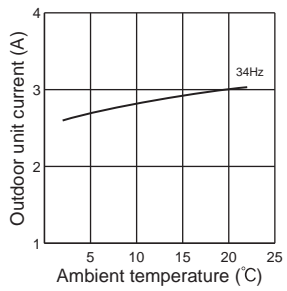

5. 25-class unit in single operation

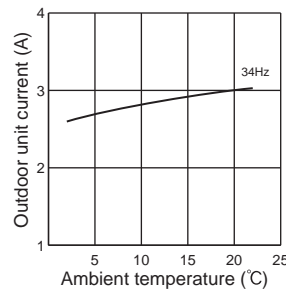

6. 35-class unit in single operation

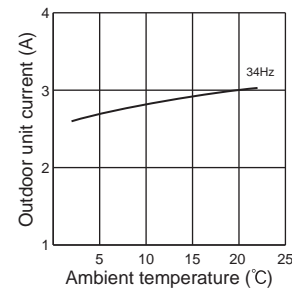

7. 42-class unit in single operation

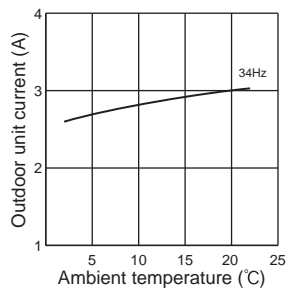

8. 50-class unit in single operation

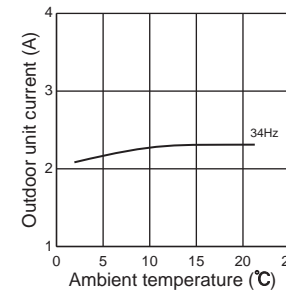

MXZ-2E53VAHZ

1. 15-class unit in single operation

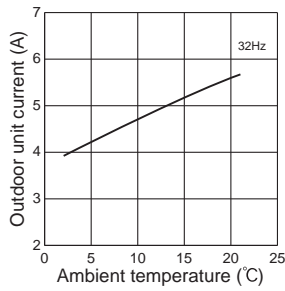

2. 18-class unit in single operation

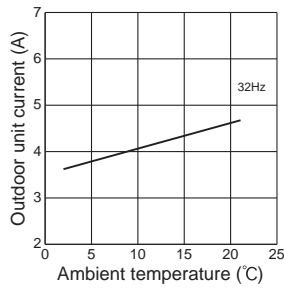

3. 20-class unit in single operation

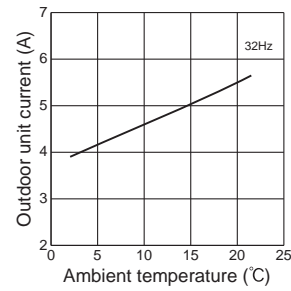

4. 22-class unit in single operation

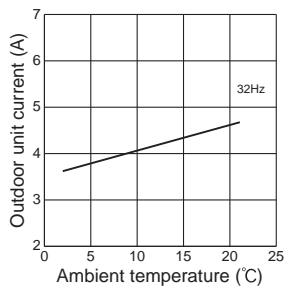

5. 25-class unit in single operation

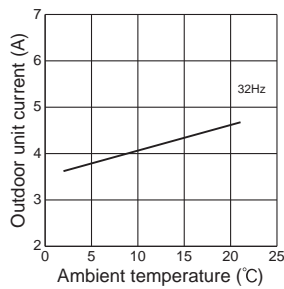

6. 35-class unit in single operation

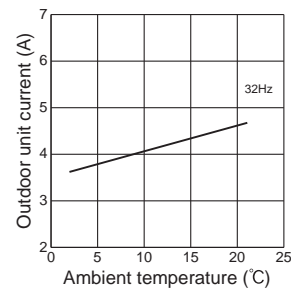

7. 42-class unit in single operation

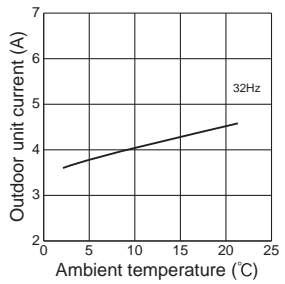

8. 50-class unit in single operation

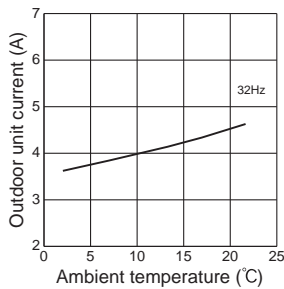

MXZ-3E54VA

1. 15-class unit in single operation

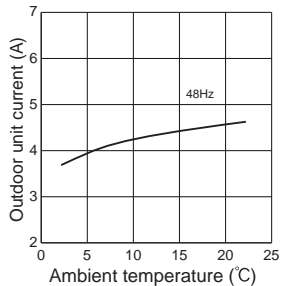

2. 18-class unit in single operation

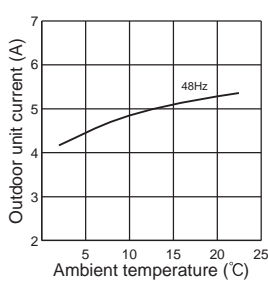

3. 20-class unit in single operation

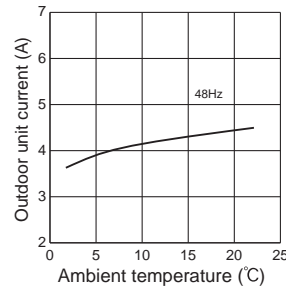

4. 22-class unit in single operation

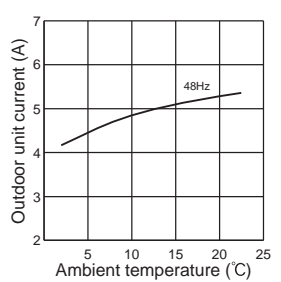

5. 25-class unit in single operation

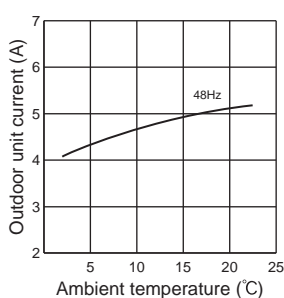

6. 35-class unit in single operation

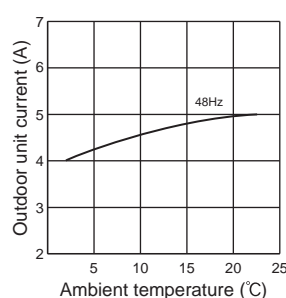

7. 42-class unit in single operation

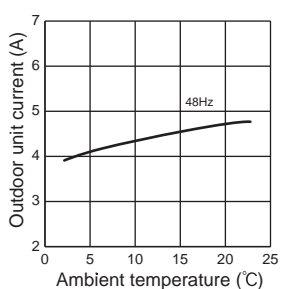

8. 50-class unit in single operation

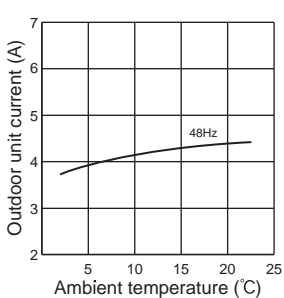

MXZ-3E68VA MXZ-4E72VA

1. 15-class unit in single operation

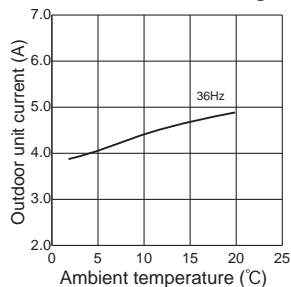

2. 18-class unit in single operation

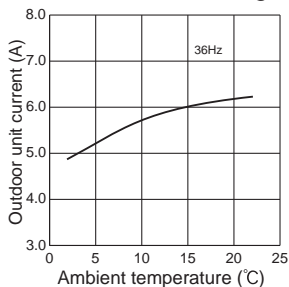

3. 20-class unit in single operation

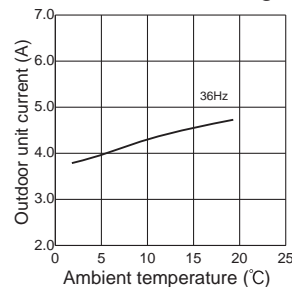

4. 22-class unit in single operation

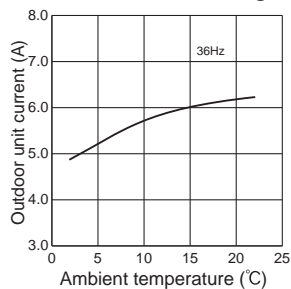

5. 25-class unit in single operation

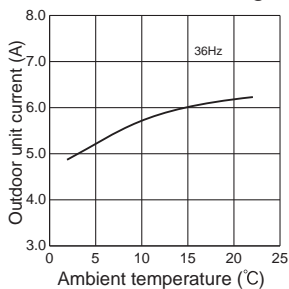

6. 35-class unit in single operation

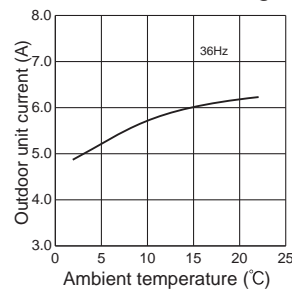

MXZ-3E68VA MXZ-4E72VA

7. 42-class unit in single operation

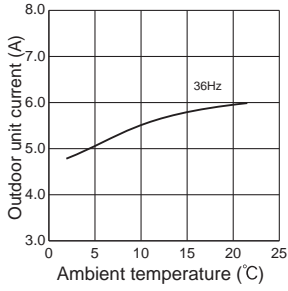

8. 50-class unit in single operation

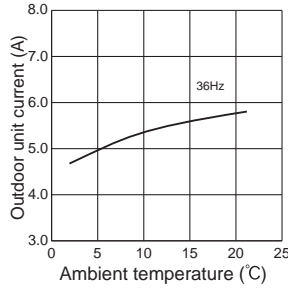

9. 60-class unit in single operation

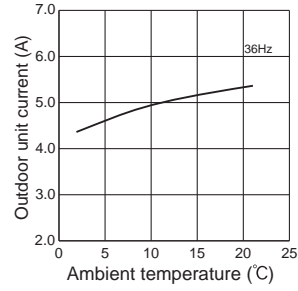

MXZ-4E83VA

1. 15-class unit in single operation

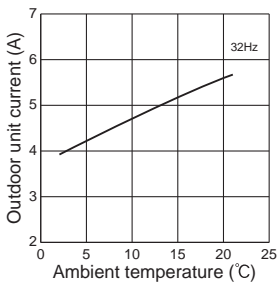

2. 18-class unit in single operation

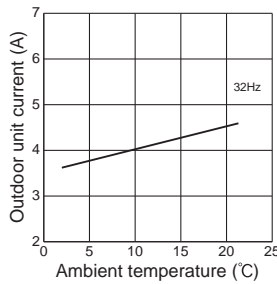

3. 20-class unit in single operation

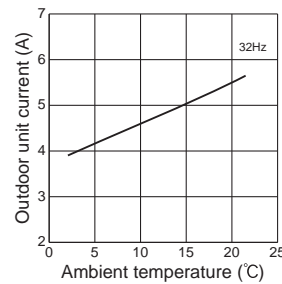

4. 22-class unit in single operation

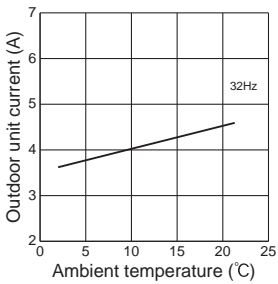

5. 25-class unit in single operation

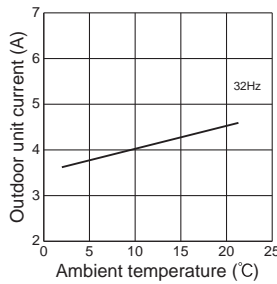

6. 35-class unit in single operation

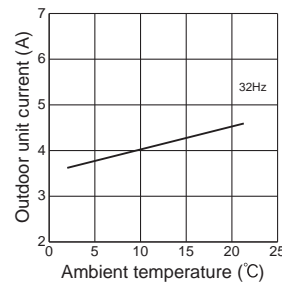

7. 42-class unit in single operation

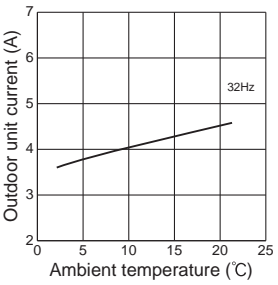

8. 50-class unit in single operation

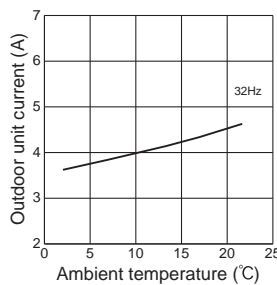

9. 60-class unit in single operation

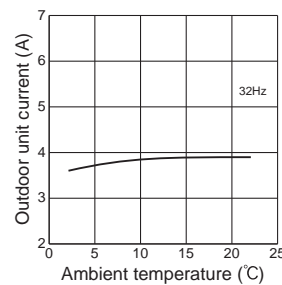

10. 71-class unit in single operation

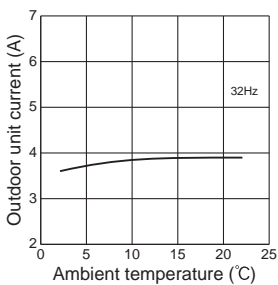

PERFORMANCE CURVES

MULTI SYSTEM

MXZ-4E83VAHZ

1. 15-class unit in single operation

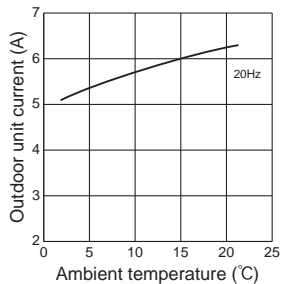

2. 18-class unit in single operation

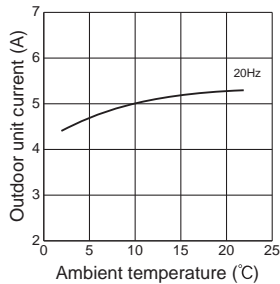

3. 20-class unit in single operation

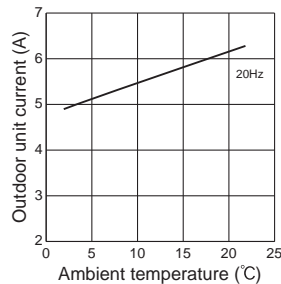

4. 22-class unit in single operation

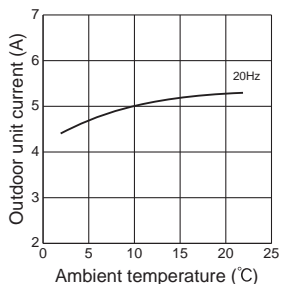

5. 25-class unit in single operation

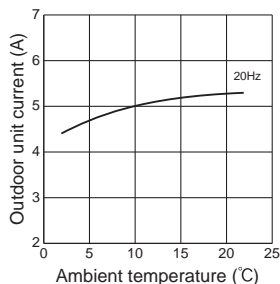

6. 35-class unit in single operation

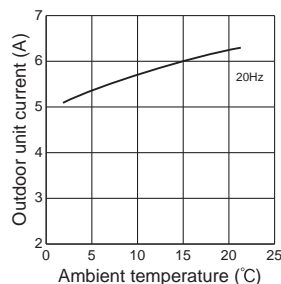

7. 42-class unit in single operation

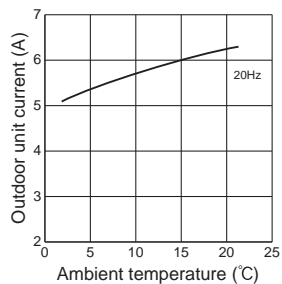

8. 50-class unit in single operation

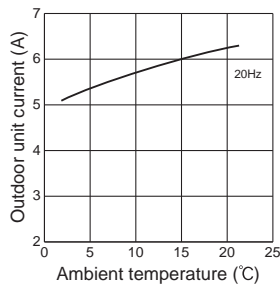

9. 60-class unit in single operation

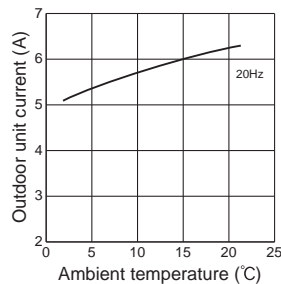

10. 71-class unit in single operation

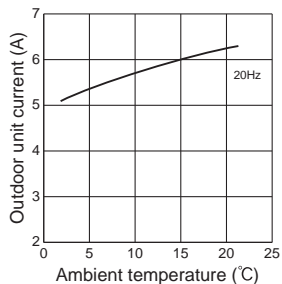

MXZ-5E102VA

1. 15-class unit in single operation

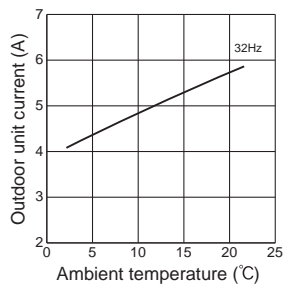

2. 18-class unit in single operation

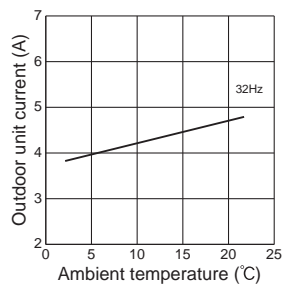

3. 20-class unit in single operation

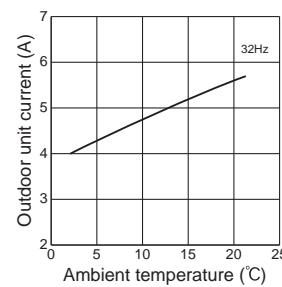

4. 22-class unit in single operation

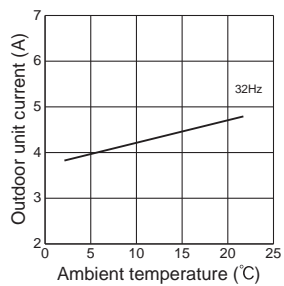

5. 25-class unit in single operation

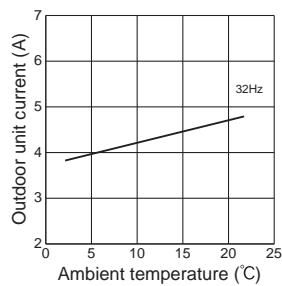

6. 35-class unit in single operation

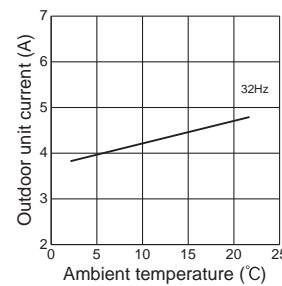

7. 42-class unit in single operation

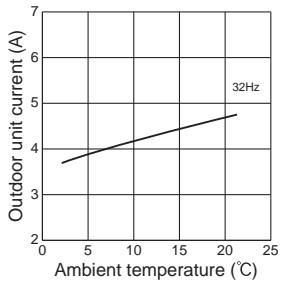

8. 50-class unit in single operation

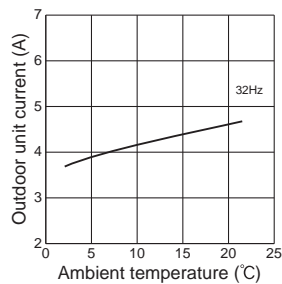

9. 60-class unit in single operation

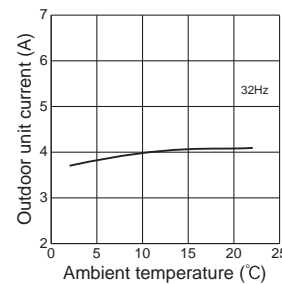

10. 71-class unit in single operation

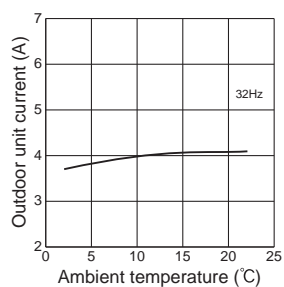

PERFORMANCE CURVES

MULTI SYSTEM

MXZ-6D122VA2

1. 15-class unit in single operation

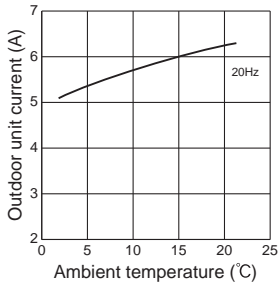

2. 20-class unit in single operation

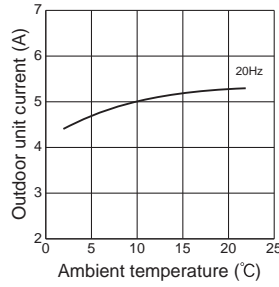

3. 18-class unit in single operation

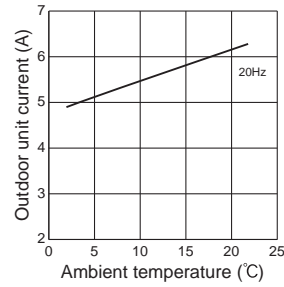

4. 22-class unit in single operation

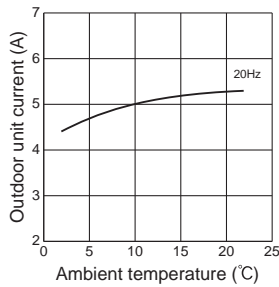

5. 25-class unit in single operation

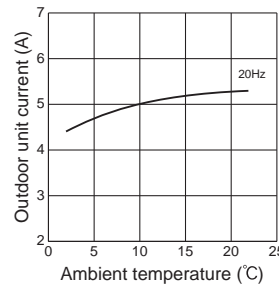

6. 35-class unit in single operation

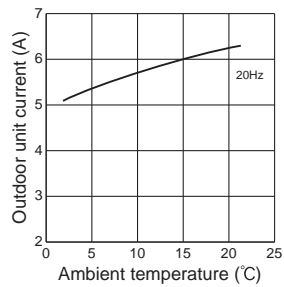

7. 42-class unit in single operation

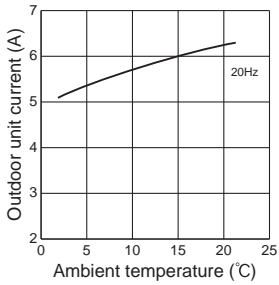

8. 50-class unit in single operation

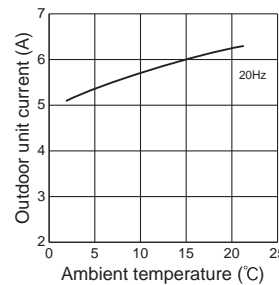

9. 60-class unit in single operation

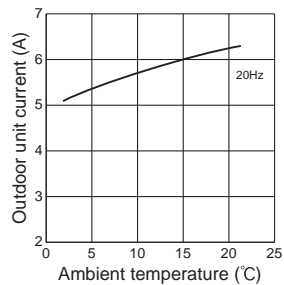

10. 71-class unit in single operation

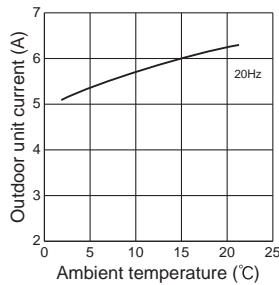

MXZ-2DM40VA

- 1. 25-class unit in single operation
- 2. 35-class unit in single operation

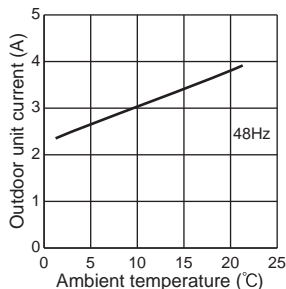
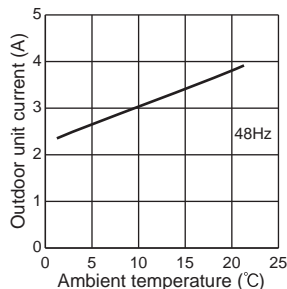

MXZ-3DM50VA

- 1. 25-class unit in single operation
- 2. 35-class unit in single operation
- 3. 50-class unit in single operation

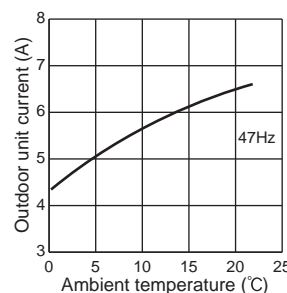
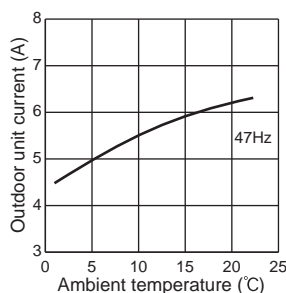
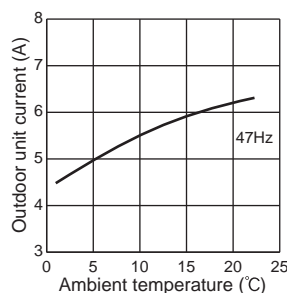

MXZ-2HA40VF2

- 1. 25-class unit in single operation
- 2. 35-class unit in single operation

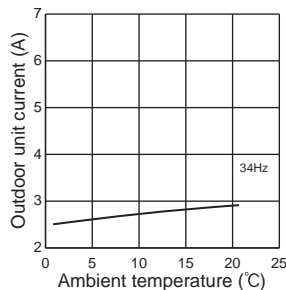
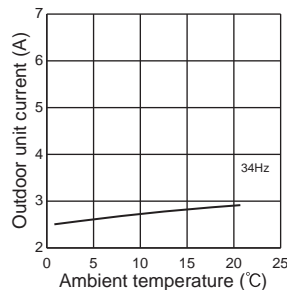

MXZ-2HA50VF2

- 1. 25-class unit in single operation
- 2. 35-class unit in single operation
- 3. 42-class unit in single operation

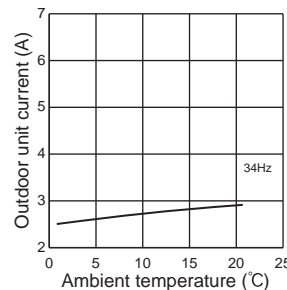
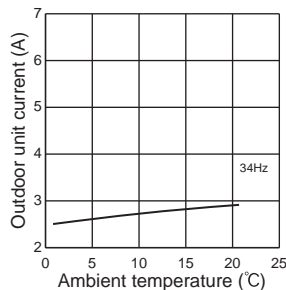
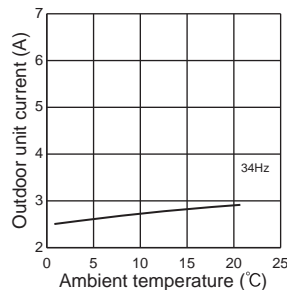

PERFORMANCE CURVES

MULTI SYSTEM

MXZ-3HA50VF2

1. 25-class unit in single operation

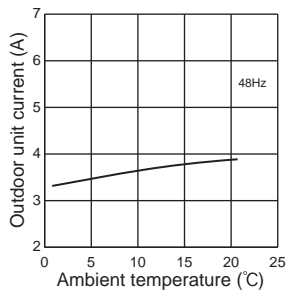

2. 35-class unit in single operation

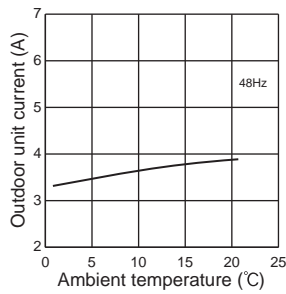

3. 42-class unit in single operation

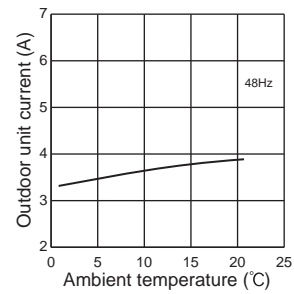

4. 50-class unit in single operation

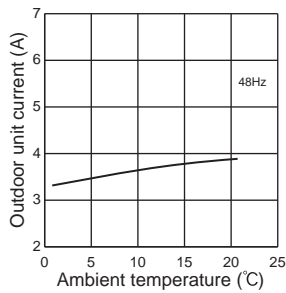

PXZ-4F75VG

1. 15-class unit in single operation

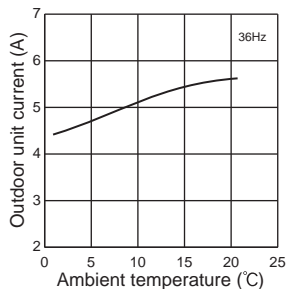

2. 18-class unit in single operation

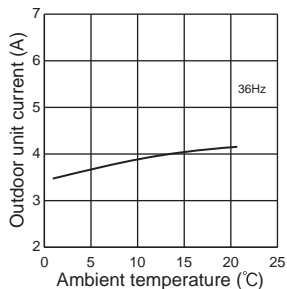

3. 20-class unit in single operation

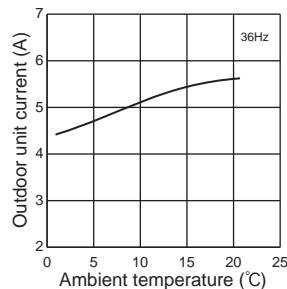

4. 22-class unit in single operation

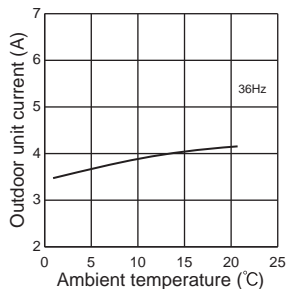

5. 25-class unit in single operation

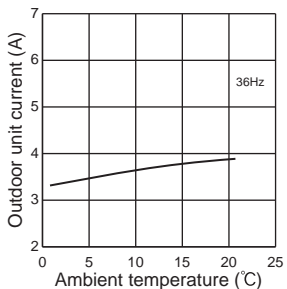

6. 35-class unit in single operation

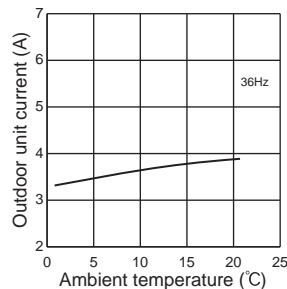

7. 42-class unit in single operation

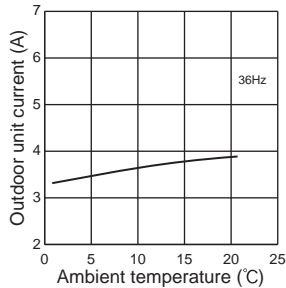

8. 50-class unit in single operation

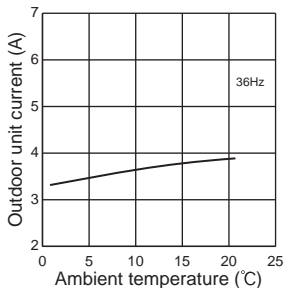

9. 60-class unit in single operation

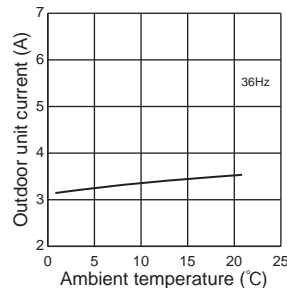

10. 71-class unit in single operation

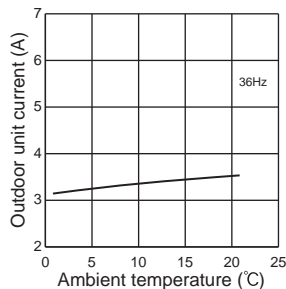

PERFORMANCE CURVES

MULTI SYSTEM

PXZ-5F85VG

1. 15-class unit in single operation

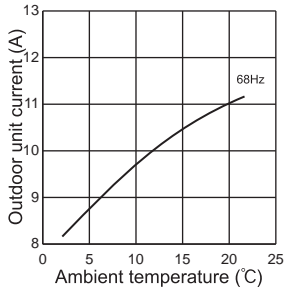

2. 18-class unit in single operation

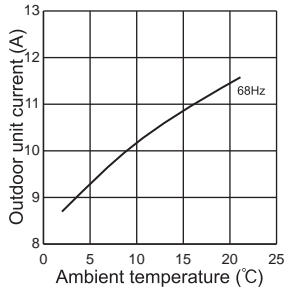

3. 20-class unit in single operation

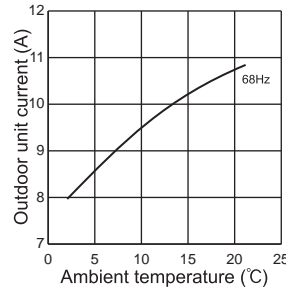

4. 22-class unit in single operation

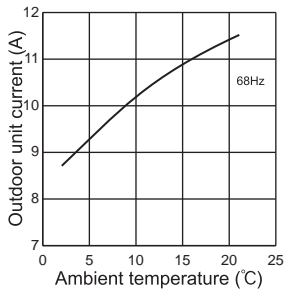

5. 25-class unit in single operation

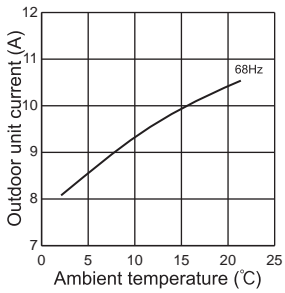

6. 35-class unit in single operation

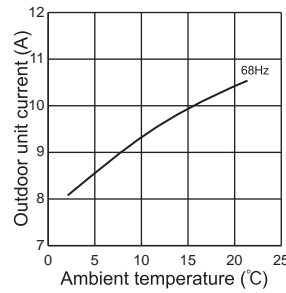

7. 42-class unit in single operation

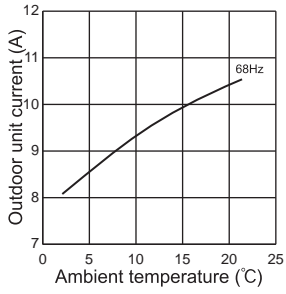

8. 50-class unit in single operation

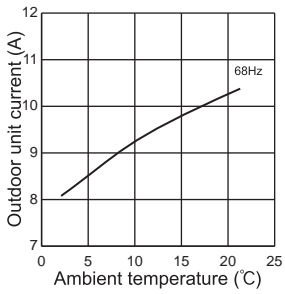

9. 60-class unit in single operation

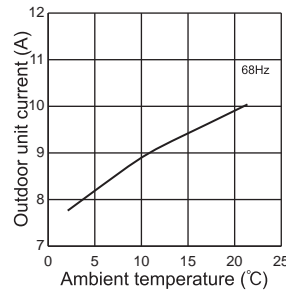

10. 71-class unit in single operation

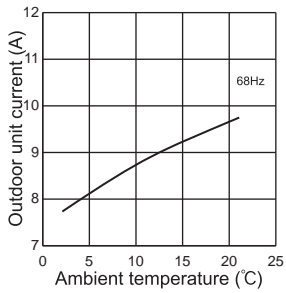

C.4.6 NOISE CRITERIA CURVES

C.4.6.1 Inverter Heat Pump

MXZ-2F33VF4

FAN SPEED	FUNCTION	SPL(dB(A))	LINE
High	Cooling	49	●—●
High	Heating	50	○—○

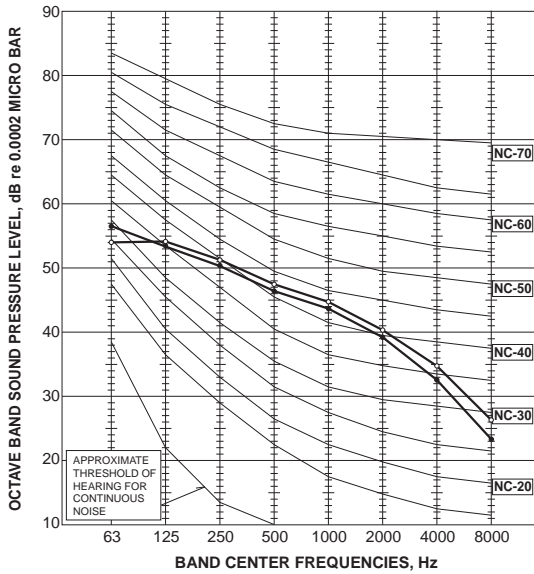

MXZ-2F42VF4

FAN SPEED	FUNCTION	SPL(dB(A))	LINE
High	Cooling	44	●—●
High	Heating	50	○—○

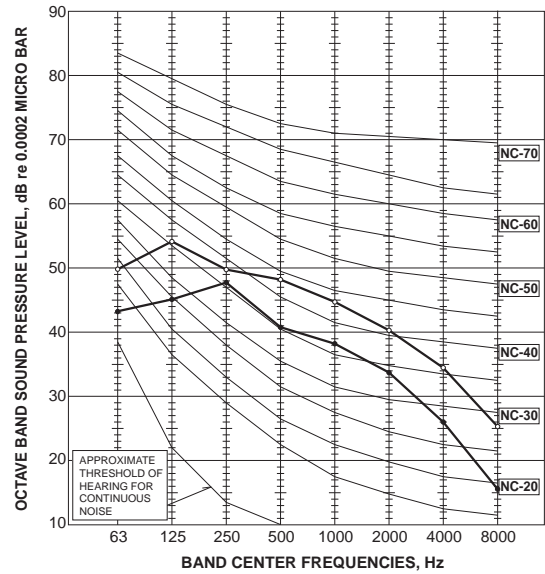

MXZ-2F53VF4

MXZ-2F53VFH4

FAN SPEED	FUNCTION	SPL(dB(A))	LINE
High	Cooling	46	●—●
High	Heating	51	○—○

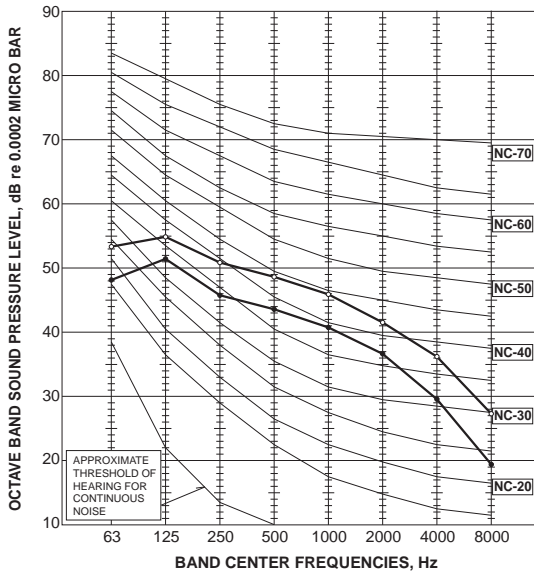

MXZ-3F54VF4

FAN SPEED	FUNCTION	SPL(dB(A))	LINE
High	Cooling	46	●—●
High	Heating	50	○—○

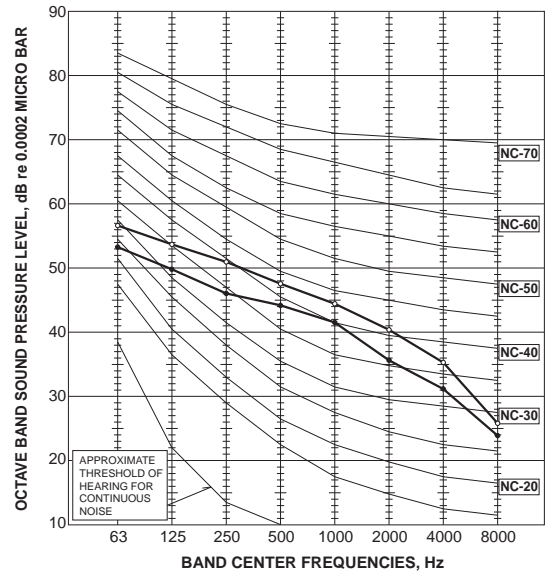

NOISE CRITERIA CURVES

MULTI SYSTEM

<Notes>

- 1) Sound data is taken when the system is running stably.
- 2) Relatively large noise could be heard transiently in the case 4-way valve, or LEV operates.

MXZ-3F68VF4

FAN SPEED	FUNCTION	SPL(dB(A))	LINE
High	Cooling	48	●—●
High	Heating	53	○—○

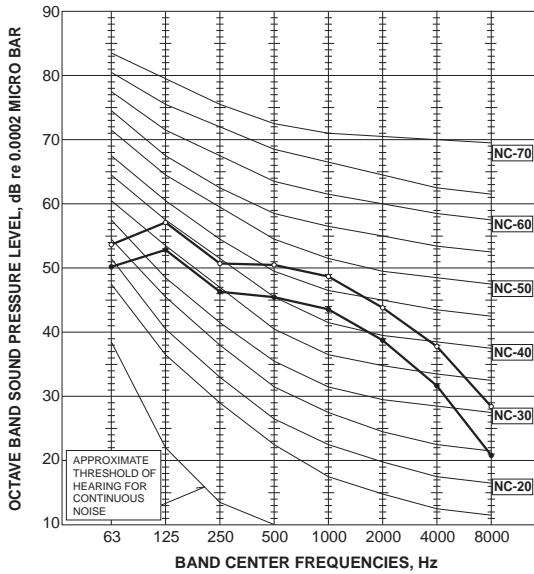

MXZ-4F72VF4

FAN SPEED	FUNCTION	SPL(dB(A))	LINE
High	Cooling	48	●—●
High	Heating	54	○—○

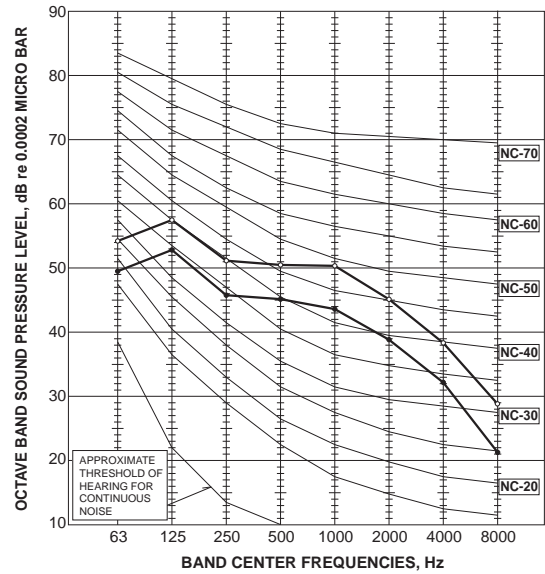

MXZ-4F80VF4

FAN SPEED	FUNCTION	SPL(dB(A))	LINE
High	Cooling	50	●—●
High	Heating	55	○—○

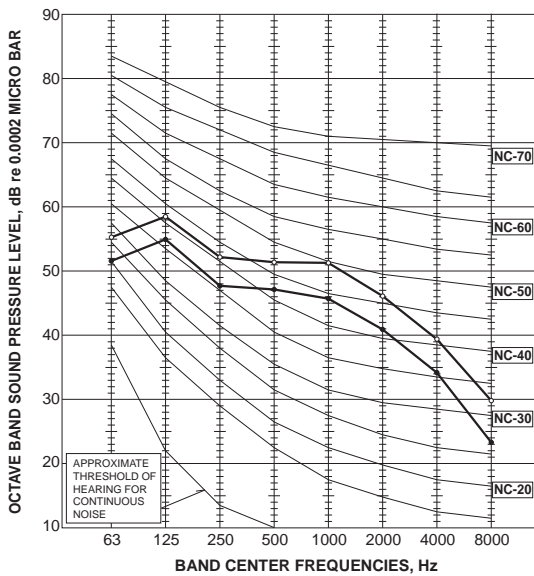

<Notes>

- 1) Sound data is taken when the system is running stably.
- 2) Relatively large noise could be heard transiently in the case 4-way valve, or LEV operates.

MXZ-4F83VF2

FAN SPEED	FUNCTION	SPL(dB(A))	LINE
High	Cooling	49	●—●
High	Heating	51	○—○

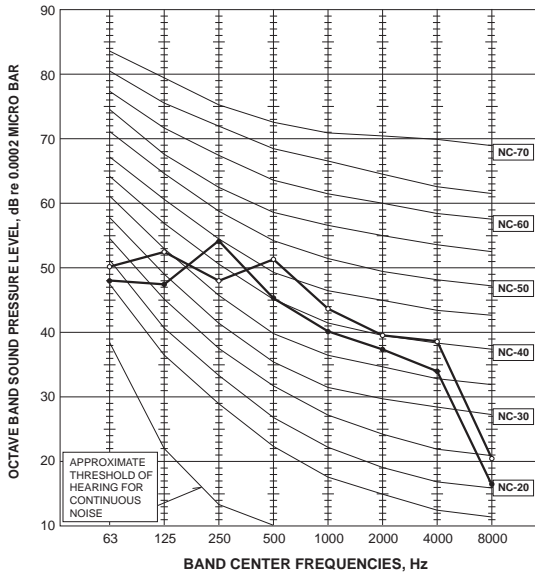

MXZ-5F102VF2

FAN SPEED	FUNCTION	SPL(dB(A))	LINE
High	Cooling	52	●—●
High	Heating	56	○—○

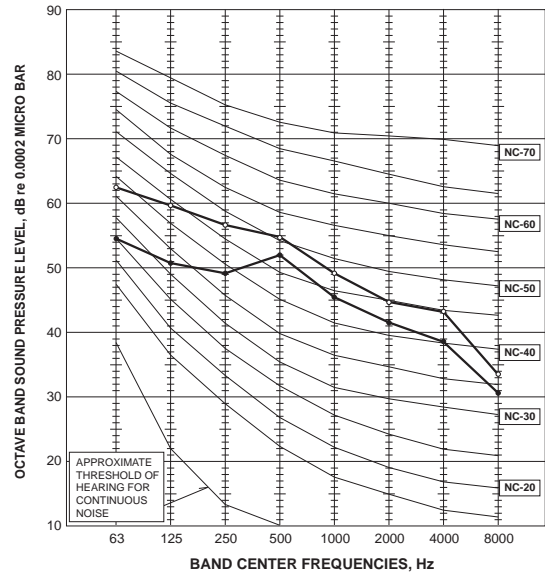

MXZ-6F120VF2

FAN SPEED	FUNCTION	SPL(dB(A))	LINE
High	Cooling	55	●—●
High	Heating	57	○—○

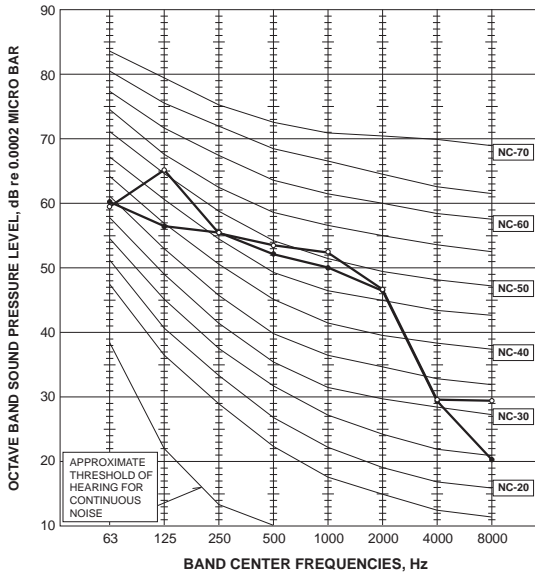

MXZ-2F53VFH22

FAN SPEED	FUNCTION	SPL(dB(A))	LINE
High	Cooling	45	●—●
High	Heating	47	○—○

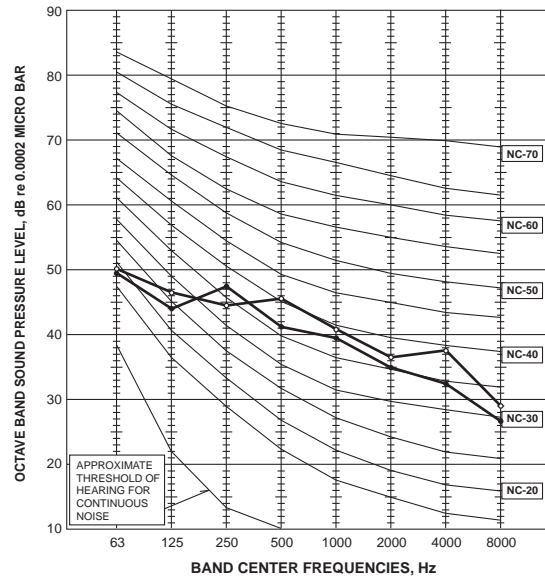

NOISE CRITERIA CURVES

MULTI SYSTEM

<Notes>

- 1) Sound data is taken when the system is running stably.
- 2) Relatively large noise could be heard transiently in the case 4-way valve, or LEV operates.

MXZ-4F83VFH22

FAN SPEED	FUNCTION	SPL(dB(A))	LINE
High	Cooling	55	●—●
High	Heating	57	○—○

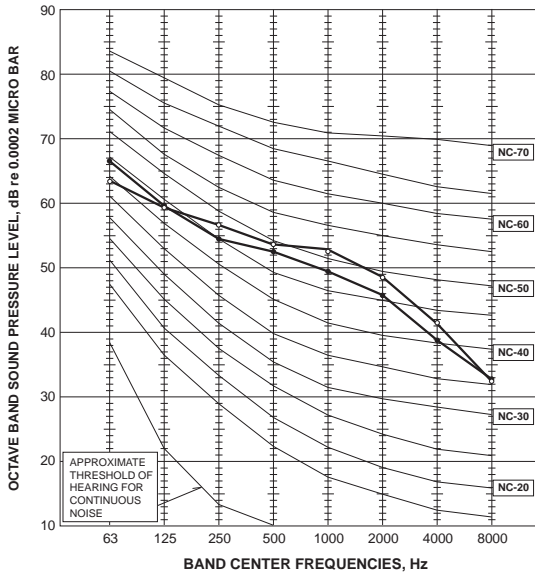

MXZ-2D33VA

FAN SPEED	FUNCTION	SPL(dB(A))	LINE
High	Cooling	49	●—●
High	Heating	50	○—○

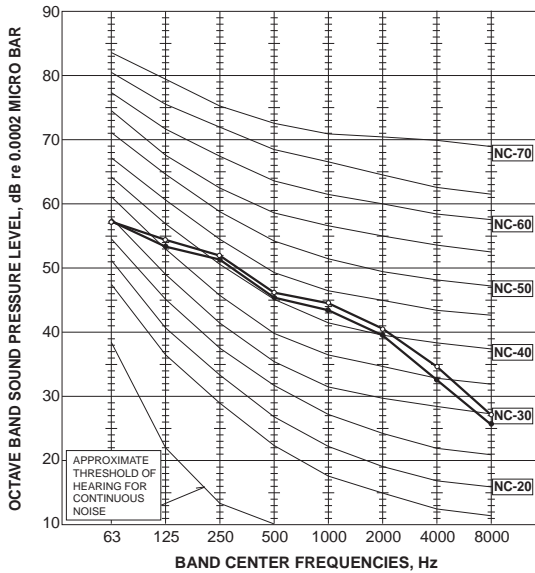

MXZ-2D42VA2

FAN SPEED	FUNCTION	SPL(dB(A))	LINE
High	Cooling	46	●—●
High	Heating	51	○—○

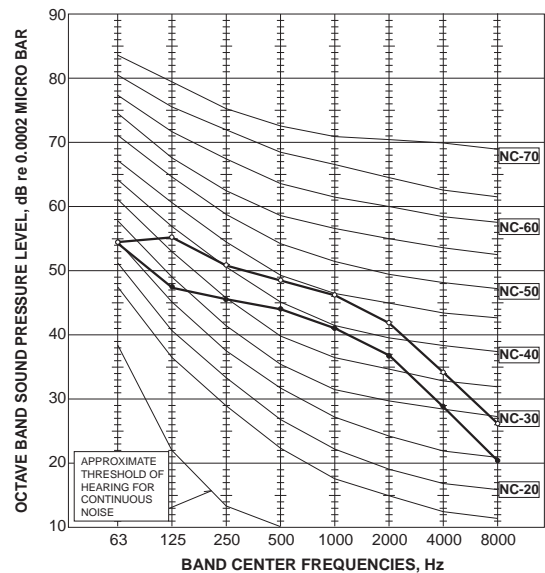

<Notes>

- 1) Sound data is taken when the system is running stably.
- 2) Relatively large noise could be heard transiently in the case 4-way valve, or LEV operates.

MXZ-2D53VA2
MXZ-2D53VAH2

FAN SPEED	FUNCTION	SPL(dB(A))	LINE
High	Cooling	50	●—●
High	Heating	53	○—○

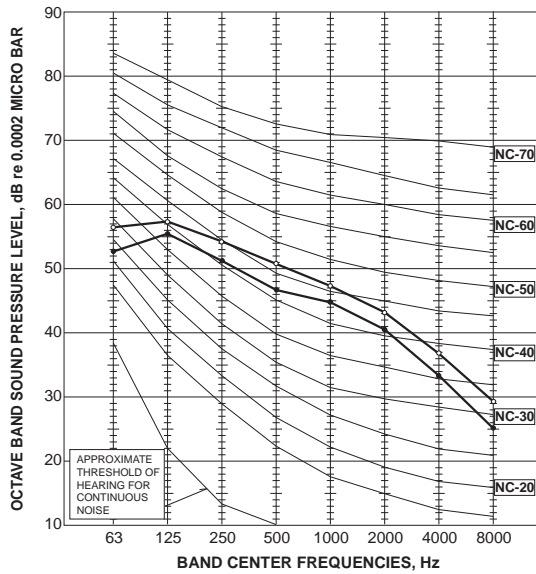

MXZ-2E53VAHZ

FAN SPEED	FUNCTION	SPL(dB(A))	LINE
High	Cooling	45	●—●
High	Heating	47	○—○

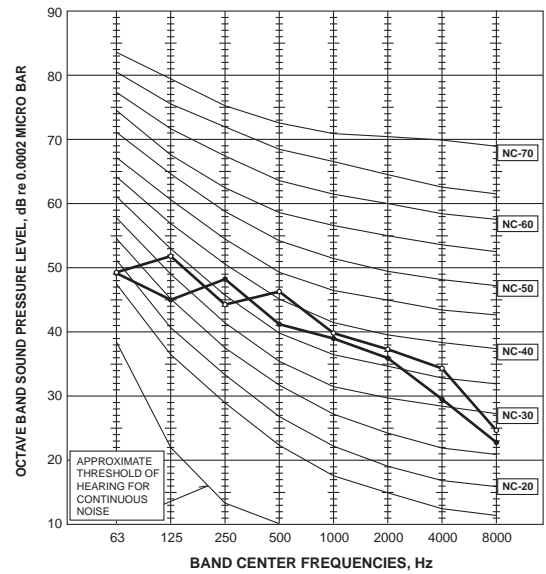

MXZ-3E54VA

FAN SPEED	FUNCTION	SPL(dB(A))	LINE
High	Cooling	50	●—●
High	Heating	53	○—○

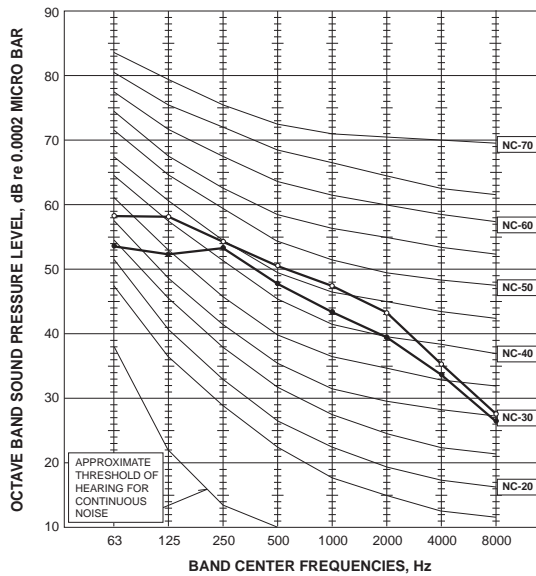

MXZ-3E68VA

FAN SPEED	FUNCTION	SPL(dB(A))	LINE
High	Cooling	50	●—●
High	Heating	53	○—○

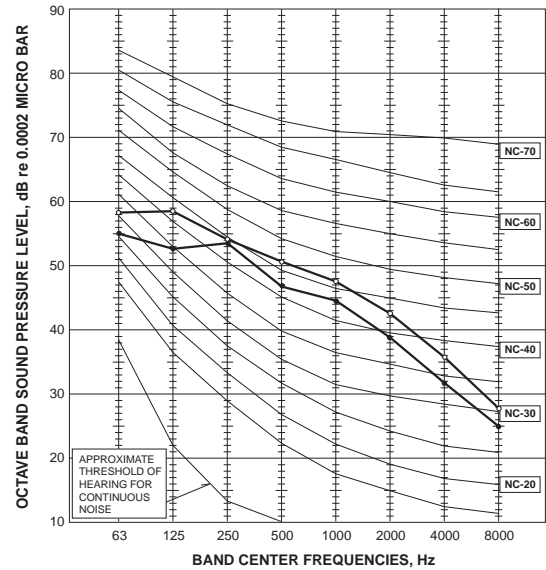

NOISE CRITERIA CURVES

MULTI SYSTEM

<Notes>

- 1) Sound data is taken when the system is running stably.
- 2) Relatively large noise could be heard transiently in the case 4-way valve, or LEV operates.

MXZ-4E72VA

FAN SPEED	FUNCTION	SPL(dB(A))	LINE
High	Cooling	50	●—●
High	Heating	53	○—○

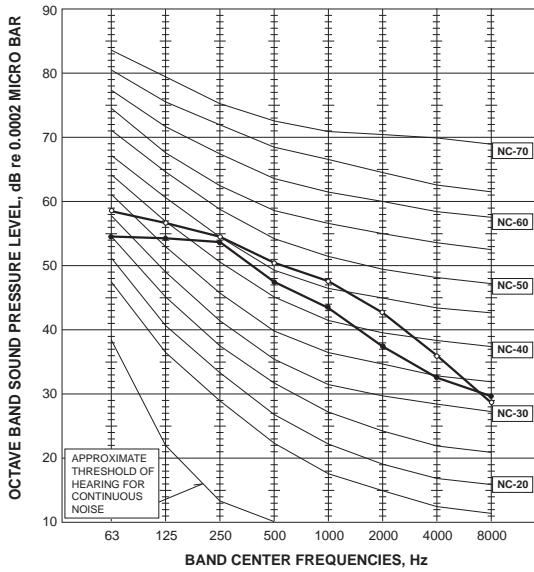

MXZ-4E83VA

FAN SPEED	FUNCTION	SPL(dB(A))	LINE
High	Cooling	49	●—●
High	Heating	51	○—○

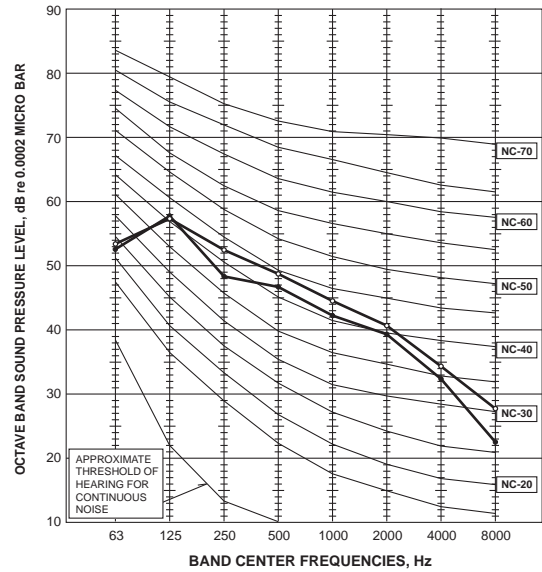

MXZ-4E83VAHZ

FAN SPEED	FUNCTION	SPL(dB(A))	LINE
High	Cooling	53	●—●
High	Heating	57	○—○

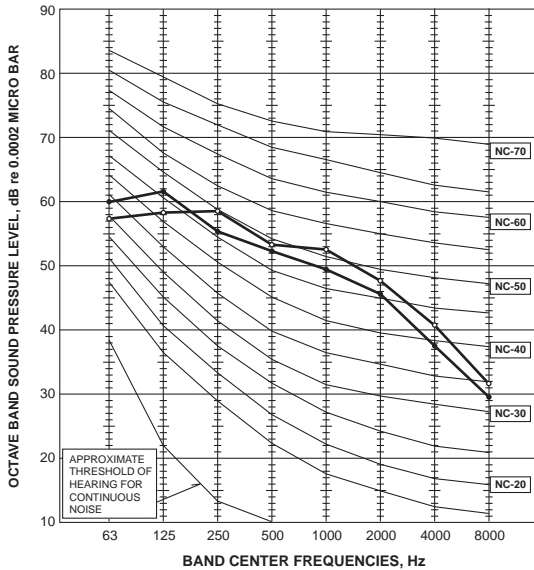

MXZ-5E102VA

FAN SPEED	FUNCTION	SPL(dB(A))	LINE
High	Cooling	52	●—●
High	Heating	56	○—○

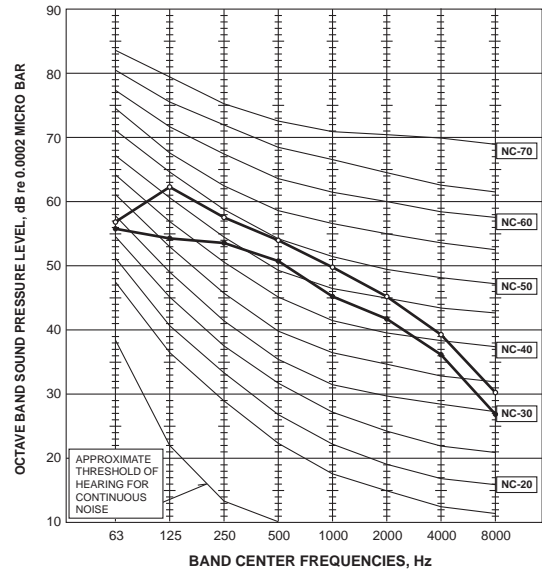

<Notes>

- 1) Sound data is taken when the system is running stably.
- 2) Relatively large noise could be heard transiently in the case 4-way valve, or LEV operates.

MXZ-6D122VA2

FAN SPEED	FUNCTION	SPL(dB(A))	LINE
High	Cooling	55	●—●
High	Heating	57	○—○

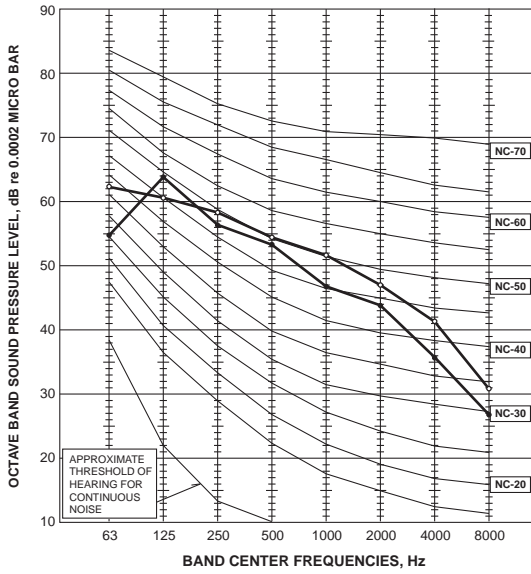

MXZ-2DM40VA

FAN SPEED	FUNCTION	SPL(dB(A))	LINE
High	Cooling	48	●—●
High	Heating	52	○—○

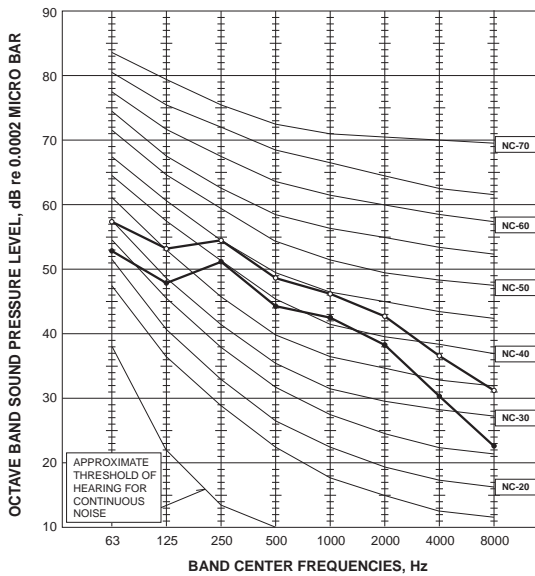

MXZ-3DM50VA

FAN SPEED	FUNCTION	SPL(dB(A))	LINE
High	Cooling	50	●—●
High	Heating	53	○—○

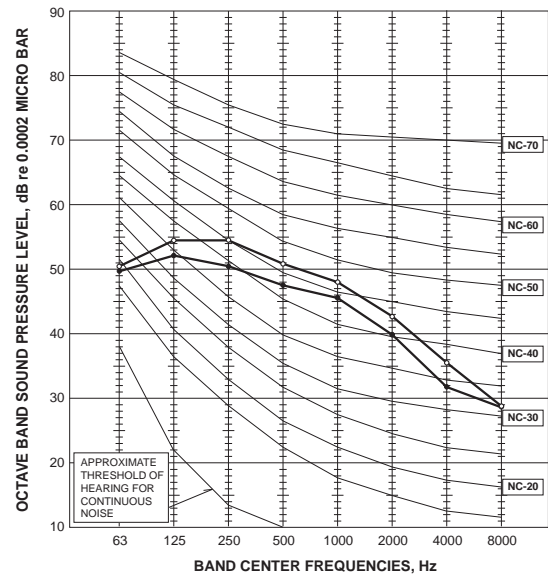

NOISE CRITERIA CURVES

MULTI SYSTEM

<Notes>

- 1) Sound data is taken when the system is running stably.
- 2) Relatively large noise could be heard transiently in the case 4-way valve, or LEV operates.

MXZ-2HA40VF2

FAN SPEED	FUNCTION	SPL(dB(A))	LINE
High	Cooling	44	●—●
High	Heating	50	○—○

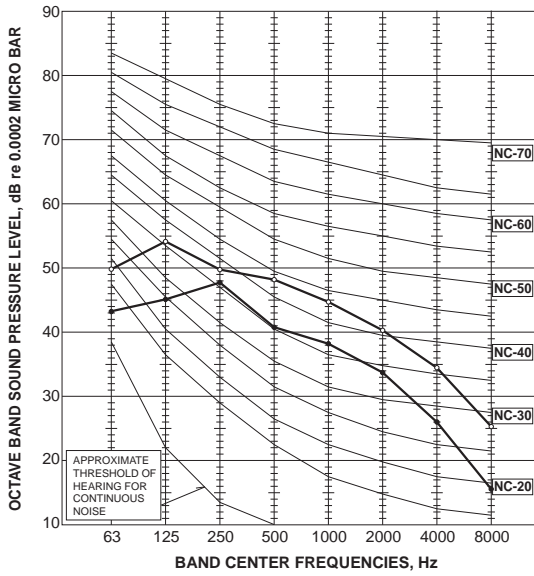

MXZ-2HA50VF2

FAN SPEED	FUNCTION	SPL(dB(A))	LINE
High	Cooling	47	●—●
High	Heating	51	○—○

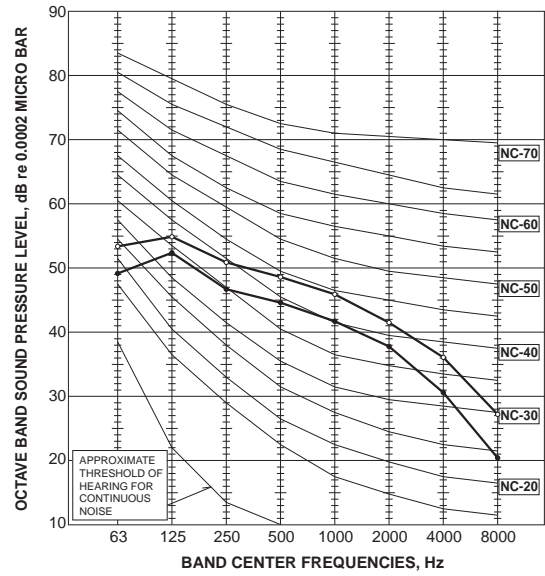

MXZ-3HA50VF2

FAN SPEED	FUNCTION	SPL(dB(A))	LINE
High	Cooling	46	●—●
High	Heating	50	○—○

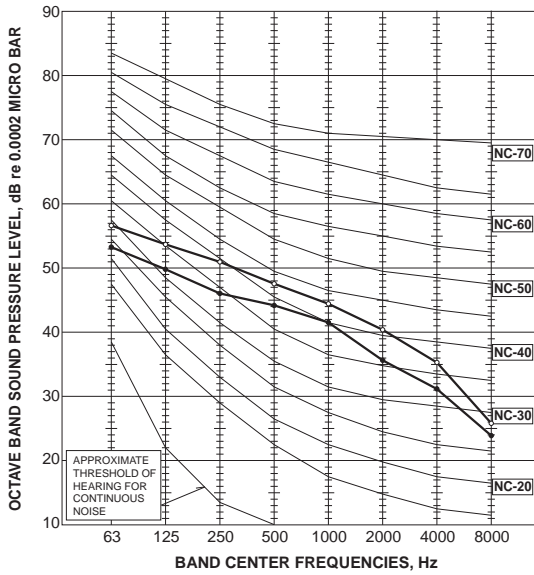

<Notes>

- 1) Sound data is taken when the system is running stably.
- 2) Relatively large noise could be heard transiently in the case 4-way valve, or LEV operates.

PXZ-4F75VG

FAN SPEED	FUNCTION	SPL(dB(A))	LINE
High	Cooling	48	●—●
High	Heating	54	○—○

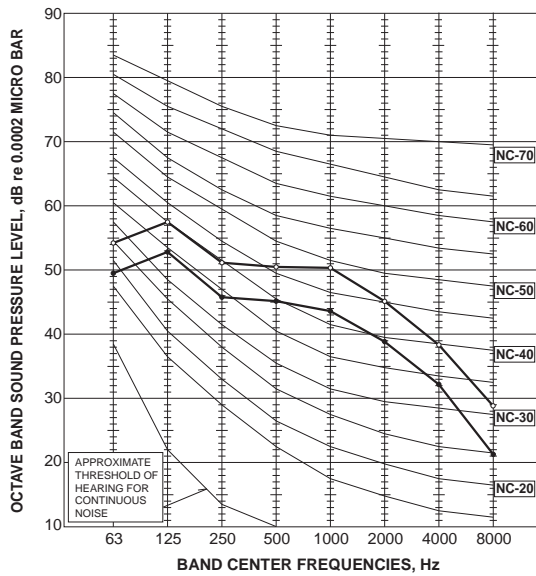

PXZ-5F85VG

FAN SPEED	FUNCTION	SPL(dB(A))	LINE
High	Cooling	52	●—●
High	Heating	56	○—○

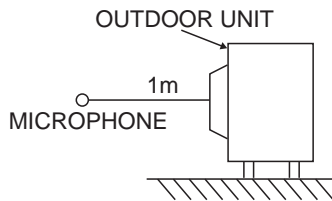
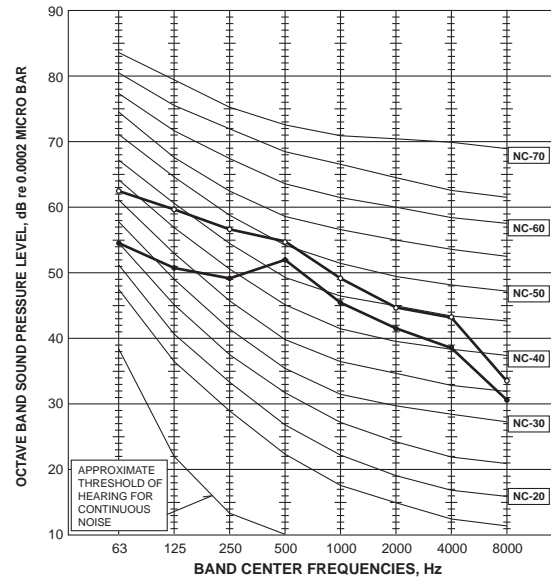

Test conditions

Cooling :Dry-bulb temperature 35.0°C Wet-bulb temperature 24.0°C
 Heating :Dry-bulb temperature 7.0°C Wet-bulb temperature 6.0°C

<Notes>

- 1) Sound data is taken when the system is running stably.
- 2) Relatively large noise could be heard transiently in the case 4-way valve, or LEV operates.

C.4.7 ACTUATOR CONTROL

C.4.7.1 MXZ Series

Relation between main sensor and actuator

Sensor	Purpose	Actuator					
		Compressor	LEV	Outdoor fan motor	4-way valve	2-way solenoid valve *1	Defrost heater *2
Discharge temperature thermistor	Protection	○	○			○	
Indoor coil temperature thermistor	Cooling: Coil frost prevention	○				○	
	Heating: High pressure protection	○	○				
Defrost thermistor	Heating: Defrosting	○	○	○	○		
Fin temperature thermistor	Protection	○		○			
Ambient temperature thermistor	Control/Protection	○	○	○		○	
	Heating: Defrosting (Heater)						○
Outdoor heat exchanger temperature thermistor	Cooling: Control/Protection	○	○	○		○	
Capacity code	Control	○	○				

*1 MXZ-6F120VF2, MXZ-4F83VFH2, MXZ-4E83VAHZ, MXZ-6D122VA2

*2 MXZ-2F53VFH4, MXZ-2D53VAH2

MXZ-2F53VFH2, MXZ-4F83VFH2, MXZ-2E53VAHZ, MXZ-4E83VAHZ

C.4.8 CAPACITY CORRECTION RATIO CURVE FOR PIPING LENGTH

C.4.8.1 for MXZ R410A model

Correction ratio of capacity according to the length of piping (cooling)

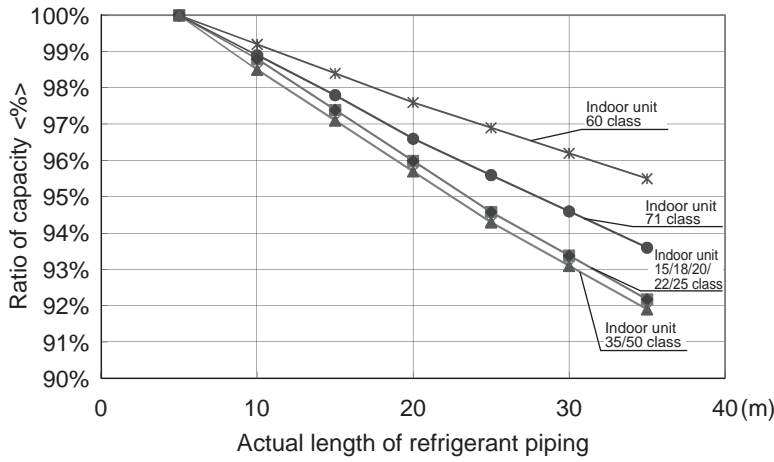

Correction ratio of capacity according to the length of piping (heating)

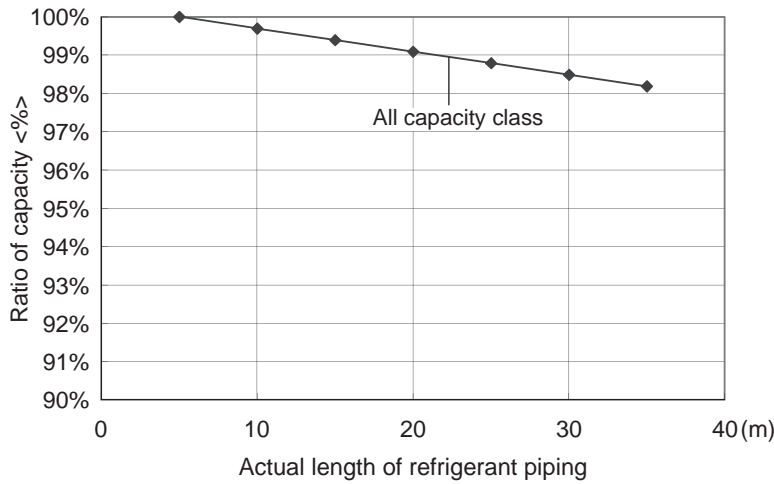

The length intended for the capacity calculation, which counts the length of refrigerant piping and the number of bends, is called actual length.

$$[\text{Length of refrigerant piping (m)} + (\text{Number of bends} \times 0.3 \text{ m}) = \text{Actual length of refrigerant piping (m)}]$$

CAPACITY CORRECTION RATIO CURVE FOR PIPING LENGTH

MULTI SYSTEM

C.4.8.2 for MXZ R32 model

Correction ratio of capacity according to the length of piping (cooling)

M series

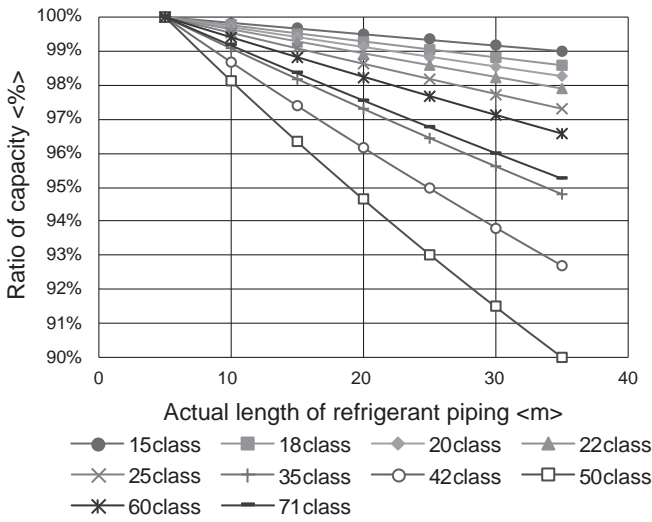

S series

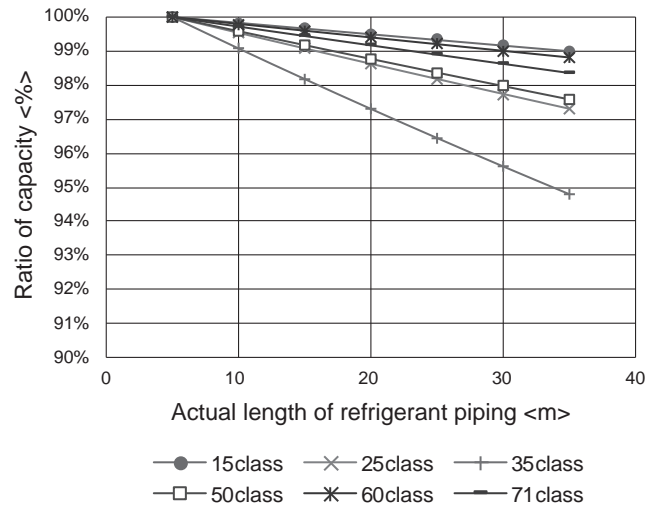

P series

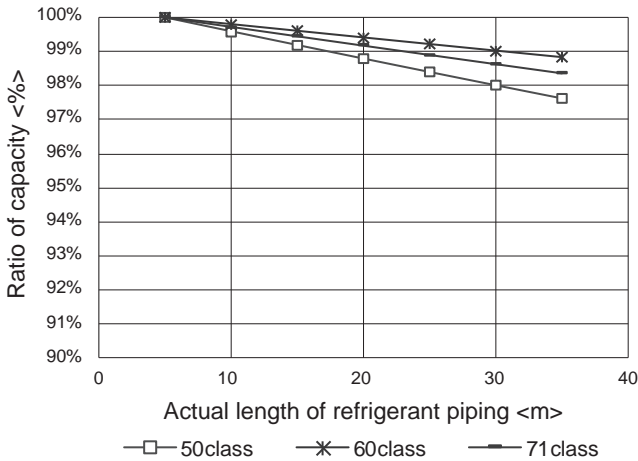

The length intended for the capacity calculation, which counts the length of refrigerant piping and the number of bends, is called actual length.

$$[\text{Length of refrigerant piping (m)} + (\text{Number of bends} \times 0.3 \text{ m}) = \text{Actual length of refrigerant piping (m)}]$$

Correction ratio of capacity according to the length of piping (heating)

