

# TECHNICAL & SERVICE MANUAL

[Model Name]	[Service Ref.]
SUZ-M25VA	SUZ-M25VA.TH SUZ-M25VAR1.TH SUZ-M25VAR2.TH
SUZ-M25VA-ET	SUZ-M25VA-ET.TH SUZ-M25VA-ETR2.TH
SUZ-M25VA-ER	SUZ-M25VA-ERR2.TH
SUZ-M35VA	SUZ-M35VA.TH SUZ-M35VAR1.TH SUZ-M35VAR2.TH
SUZ-M35VA-ET	SUZ-M35VA-ET.TH SUZ-M35VA-ETR2.TH
SUZ-M35VA-ER	SUZ-M35VA-ERR2.TH
SUZ-M50VA	SUZ-M50VA.TH SUZ-M50VAR1.TH SUZ-M50VAR2.TH
SUZ-M50VA-ET	SUZ-M50VA-ET.TH SUZ-M50VA-ETR2.TH
SUZ-M50VA-ER	SUZ-M50VA-ERR2.TH
SUZ-M60VA	SUZ-M60VA.TH SUZ-M60VAR1.TH SUZ-M60VAR2.TH
SUZ-M60VA-ET	SUZ-M60VA-ET.TH SUZ-M60VA-ETR2.TH
SUZ-M60VA-ER	SUZ-M60VA-ERR2.TH
SUZ-M71VA	SUZ-M71VA.TH SUZ-M71VAR1.TH
SUZ-M71VA-ET	SUZ-M71VA-ET.TH SUZ-M71VA-ETR1.TH
SUZ-M71VA-ER	SUZ-M71VA-ERR1.TH

**R32**

Revision:  
 • Connectable indoor units have been added in REVISED EDITION-G.

OCH684-F is void.

Note:  
 • This service manual describes service data of the outdoor units only.

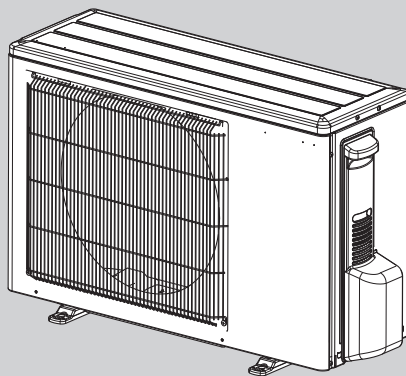

SUZ-M25VA.TH  
 SUZ-M35VA.TH

## CONTENTS

TECHNICAL CHANGES.....	2
1. COMBINATION OF INDOOR AND OUTDOOR UNITS .....	3
2. SAFETY PRECAUTION .....	4
3. PARTS NAMES AND FUNCTIONS .....	12
4. SPECIFICATION .....	13
5. NOISE CRITERIA CURVES .....	15
6. OUTLINES AND DIMENSIONS .....	16
7. WIRING DIAGRAM .....	18
8. REFRIGERANT SYSTEM DIAGRAM ..	22
9. ACTUATOR CONTROL .....	25
10. SERVICE FUNCTIONS .....	26
11. TROUBLESHOOTING .....	26
12. DISASSEMBLY PROCEDURE .....	38
13. REMOTE CONTROLLER .....	49

PARTS CATALOG (OCB684)



# TECHNICAL CHANGES

Service ref. have been changed as follows.

SUZ-M25VAR1.TH	➔	SUZ-M25VAR2.TH
SUZ-M35VAR1.TH	➔	SUZ-M35VAR2.TH
SUZ-M50VAR1.TH	➔	SUZ-M50VAR2.TH
SUZ-M60VAR1.TH	➔	SUZ-M60VAR2.TH
SUZ-M71VA.TH	➔	SUZ-M71VAR1.TH
SUZ-M25VA-ET.TH	➔	SUZ-M25VA-ETR2.TH
SUZ-M35VA-ET.TH	➔	SUZ-M35VA-ETR2.TH
SUZ-M50VA-ET.TH	➔	SUZ-M50VA-ETR2.TH
SUZ-M60VA-ET.TH	➔	SUZ-M60VA-ETR2.TH
SUZ-M71VA-ET.TH	➔	SUZ-M71VA-ETR1.TH





• Connection with SFZ will be added.

SUZ-M25VA.TH	➔	SUZ-M25VAR1.TH
SUZ-M35VA.TH	➔	SUZ-M35VAR1.TH
SUZ-M50VA.TH	➔	SUZ-M50VAR1.TH
SUZ-M60VA.TH	➔	SUZ-M60VAR1.TH

• Connection with MFZ-KT will be added.



## MEANINGS OF SYMBOLS DISPLAYED ON THE UNIT

	<b>WARNING</b> (Risk of fire)	This mark is for R32 refrigerant only. Refrigerant type is written on nameplate of outdoor unit. In case that refrigerant type is R32, this unit uses a flammable refrigerant. If refrigerant leaks and comes in contact with fire or heating part, it will create harmful gas and there is risk of fire.
	Read the OPERATION MANUAL carefully before operation.	
	Service personnel are required to carefully read the OPERATION MANUAL and INSTALLATION MANUAL before operation.	
	Further information is available in the OPERATION MANUAL, INSTALLATION MANUAL, and the like.	

## 2-1. ALWAYS OBSERVE FOR SAFETY

**Before obtaining access to terminal, all supply circuits must be disconnected.**

## 2-2. CAUTIONS RELATED TO NEW REFRIGERANT

## Cautions for units utilizing refrigerant R32

**Preparation before the repair service**

- Prepare the proper tools.
- Prepare the proper protectors.
- Provide adequate ventilation.
- After stopping the operation of the air conditioner, turn off the power-supply breaker.
- Discharge the condenser before the work involving the electric parts.

**Use new refrigerant pipes.**

In the case of using the existing pipes for R22, be careful with the following.

- Be sure to clean the pipes and make sure that the insides of the pipes are clean.
- Change flare nut to the one provided with this product. Use a newly flared pipe.
- Avoid using thin pipes.

**Make sure that the inside and outside of refrigerant piping is clean and it has no contaminants such as sulfur, oxides, dirt, shaving particles, etc., which are hazard to refrigerant cycle.**  
**In addition, use pipes with specified thickness.**

Contamination inside refrigerant piping can cause deterioration of refrigerant oil, etc.

**Store the piping indoors, and keep both ends of the piping sealed until just before brazing. (Leave elbow joints, etc. in their packaging.)**

If dirt, dust or moisture enters into refrigerant cycle, that can cause deterioration of refrigerant oil or malfunction of compressor.

**The refrigerant oil applied to flare and flange connections must be ester oil, ether oil or alkylbenzene oil in a small amount.**

If large amount of mineral oil enters, that can cause deterioration of refrigerant oil, etc.

**Do not use refrigerant other than R32.**

If other refrigerant (R22, etc.) is used, chlorine in refrigerant can cause deterioration of refrigerant oil, etc.

**Precautions during the repair service**

- Do not perform the work involving the electric parts with wet hands.
- Do not pour water into the electric parts.
- Do not touch the refrigerant.
- Do not touch the hot or cold areas in the refrigerating cycle.
- When the repair or the inspection of the circuit needs to be done without turning off the power, exercise great caution not to touch the live parts.
- When opening or closing the valve below freezing temperatures, refrigerant may spurt out from the gap between the valve stem and the valve body, resulting in injuries.

**Use a vacuum pump with a reverse flow check valve.**

Vacuum pump oil may flow back into refrigerant cycle and that can cause deterioration of refrigerant oil, etc.

**Use the following tools specifically designed for use with R32 refrigerant.**

The following tools are necessary to use R32 refrigerant.

Tools for R32	
Gauge manifold	Flare tool
Charge hose	Size adjustment gauge
Gas leak detector	Vacuum pump adaptor
Torque wrench	Electronic refrigerant charging scale

**Handle tools with care.**

If dirt, dust or moisture enters into refrigerant cycle, that can cause deterioration of refrigerant oil or malfunction of compressor.

**Use the specified refrigerant only.****Never use any refrigerant other than that specified.**

Doing so may cause a burst, an explosion, or fire when the unit is being used, serviced, or disposed of. Correct refrigerant is specified in the manuals and on the spec labels provided with our products.

We will not be held responsible for mechanical failure, system malfunction, unit breakdown or accidents caused by failure to follow the instructions.

**Ventilate the room if refrigerant leaks during operation. If refrigerant comes into contact with a flame, poisonous gases will be released.**

## **[1] Warning for service**

- (1) Do not alter the unit.
- (2) For installation and relocation work, follow the instructions in the Installation Manual and use tools and pipe components specifically made for use with refrigerant specified in the outdoor unit installation manual.
- (3) Ask a dealer or an authorized technician to install, relocate and repair the unit.  
For appliances not accessible to the general public.
- (4) Refrigerant pipes connection shall be accessible for maintenance purposes.
- (5) If the air conditioner is installed in a small room or closed room, measures must be taken to prevent the refrigerant concentration in the room from exceeding the safety limit in the event of refrigerant leakage. Should the refrigerant leak and cause the concentration limit to be exceeded, hazards due to lack of oxygen in the room may result.
- (6) Keep gas-burning appliances, electric heaters, and other fire sources (ignition sources) away from the location where installation, repair, and other air conditioner work will be performed.  
If refrigerant comes into contact with a flame, poisonous gases will be released.
- (7) When installing or relocating, or servicing the air conditioner, use only the specified refrigerant (R32) to charge the refrigerant lines.  
Do not mix it with any other refrigerant and do not allow air to remain in the lines.  
If air is mixed with the refrigerant, then it can be the cause of abnormal high pressure in the refrigerant line, and may result in an explosion and other hazards.
- (8) After installation has been completed, check for refrigerant leaks. If refrigerant leaks into the room and comes into contact with the flame of a heater or portable cooking range, poisonous gases will be released.
- (9) Do not use low temperature solder alloy in the case of brazing the refrigerant pipes.
- (10) When performing brazing work, be sure to ventilate the room sufficiently. Make sure that there are no hazardous or flammable materials nearby.  
When performing the work in a closed room, small room, or similar location, make sure that there are no refrigerant leaks before performing the work.  
If refrigerant leaks and accumulates, it may ignite or poisonous gases may be released.
- (11) Do not install the unit in places where refrigerant may build-up or places with poor ventilation such as a semi-basement or a sunken place in outdoor: Refrigerant is heavier than air, and inclined to fall away from the leak source.
- (12) Do not use means to accelerate the defrosting process or to clean, other than those recommended by the manufacturer.
- (13) The appliance shall be stored in a room without continuously operating ignition sources (for example: open flames, an operating gas appliance or an operating electric heater).
- (14) Do not pierce or burn.
- (15) Be aware that refrigerants may not contain an odor.
- (16) Pipe-work shall be protected from physical damage.
- (17) The installation of pipe-work shall be kept to a minimum.
- (18) Compliance with national gas regulations shall be observed.
- (19) Keep any required ventilation openings clear of obstruction.
- (20) Servicing shall be performed only as recommended by the manufacturer.
- (21) The appliance shall be stored in a well-ventilated area where the room size corresponds to the room area as specified for operation.
- (22) Maintenance, service and repair operations shall be performed by authorized technician with required qualification.
- (23) Be sure to have appropriate ventilation in order to prevent ignition. Furthermore, be sure to carry out fire prevention measures that there are no dangerous or flammable objects in the surrounding area.

## [2] Cautions for unit using R32 refrigerant

Basic work procedures are the same as those for conventional units using refrigerant R410A. However, pay careful attention to the following points.

### (1) Information on servicing

#### (1-1) Checks on the Area

Prior to beginning work on systems containing flammable refrigerants, safety checks are necessary to ensure that the risk of ignition is minimized.

For repair to the refrigerating systems, (1-3) to (1-7) shall be completed prior to conducting work on the systems.

#### (1-2) Work Procedure

Work shall be undertaken under a controlled procedure so as to minimize the risk of a flammable gas or vapor being present while the work is being performed.

#### (1-3) General Work Area

All maintenance staff and others working in the local area shall be instructed on the nature of work being carried out.

Work in confined spaces shall be avoided. The area around the workspace shall be sectioned off. Ensure that the conditions within the area have been made safe by control of flammable material.

#### (1-4) Checking for Presence of Refrigerant

The area shall be checked with an appropriate refrigerant detector prior to and during work, to ensure the technician is aware of potentially toxic or flammable atmospheres. Ensure that the leak detection equipment being used is suitable for use with all applicable refrigerants, i.e. non-sparking, adequately sealed or intrinsically safe.

#### (1-5) Presence of Fire Extinguisher

If any hot work is to be conducted on the refrigeration equipment or any associated parts, appropriate fire extinguishing equipment shall be available to hand.

Have a dry powder or CO2 fire extinguisher adjacent to the charging area.

#### (1-6) No Ignition Sources

No person carrying out work in relation to a refrigeration system which involves exposing any pipe work shall use any sources of ignition in such a manner that it may lead to the risk of fire or explosion. All possible ignition sources, including cigarette smoking, should be kept sufficiently far away from the site of installation, repairing, removing and disposal, during which refrigerant can possibly be released to the surrounding space. Prior to work taking place, the area around the equipment is to be surveyed to make sure that there are no flammable hazards or ignition risks. "No Smoking" signs shall be displayed.

#### (1-7) Ventilated Area

Ensure that the area is in the open or that it is adequately ventilated before breaking into the system or conducting any hot work. A degree of ventilation shall continue during the period that the work is carried out. The ventilation should safely disperse any released refrigerant and preferably expel it externally into the atmosphere.

#### (1-8) Checks on the Refrigeration Equipment

Where electrical components are being changed, they shall be fit for the purpose and to the correct specification. At all times the manufacturer's maintenance and service guidelines shall be followed. If in doubt, consult the manufacturer's technical department for assistance.

The following checks shall be applied to installations using flammable refrigerants:

- The charge size is in accordance with the room size within which the refrigerant containing parts are installed.
- The ventilation machinery and outlets are operating adequately and are not obstructed.
- Marking to the equipment continues to be visible and legible. Markings and signs that are illegible shall be corrected.
- Refrigeration pipe or components are installed in a position where they are unlikely to be exposed to any substance which may corrode refrigerant containing components, unless the components are constructed of materials which are inherently resistant to being corroded or are suitably protected against being corroded.

#### (1-9) Checks on Electrical Devices

Repair and maintenance to electrical components shall include initial safety checks and component inspection procedures. If a fault exists that could compromise safety, then no electrical supply shall be connected to the circuit until it is satisfactorily dealt with. If the fault cannot be corrected immediately but it is necessary to continue operation, an adequate temporary solution shall be used. This shall be reported to the owner of the equipment so all parties are advised. Initial safety checks shall include that:

- capacitors are discharged: this shall be done in a safe manner to avoid possibility of sparking;
- no live electrical components and wiring are exposed while charging, recovering or purging the system;
- there is continuity of earth bonding

### (2) Repairs to Sealed Components

#### (2-1) During repairs to sealed components, all electrical supplies shall be disconnected from the equipment being worked upon prior to any removal of sealed covers, etc. If it is absolutely necessary to have an electrical supply to equipment during servicing, then a permanently operating form of leak detection shall be located at the most critical point to warn of a potentially hazardous situation.

#### (2-2) Particular attention shall be paid to the following to ensure that by working on electrical components, the casing is not altered in such a way that the level of protection is affected. This shall include damage to cables, excessive number of connections, terminals not made to original specification, damage to seals, incorrect fitting of glands, etc.

Ensure that the apparatus is mounted securely.

Ensure that seals or sealing materials have not degraded to the point that they no longer serve the purpose of preventing the ingress of flammable atmospheres.

Replacement parts shall be in accordance with the manufacturer's specifications.

(3) Repair to Intrinsically Safe Components

Do not apply any permanent inductive or capacitance loads to the circuit without ensuring that this will not exceed the permissible voltage and current permitted for the equipment in use.

Intrinsically safe components are the only types that can be worked on while live in the presence of a flammable atmosphere. The test apparatus shall be at the correct rating.

Replace components only with parts specified by the manufacturer. Other parts may result in the ignition of refrigerant in the atmosphere from a leak.

(4) Cabling

Check that cabling will not be subject to wear, corrosion, excessive pressure, vibration, sharp edges or any other adverse environmental effects. The check shall also take into account the effects of aging or continual vibration from sources such as compressors or fans.

(5) Detection of Flammable Refrigerants

Under no circumstances shall potential sources of ignition be used in the searching for or detection of refrigerant leaks. A halide torch (or any other detector using a naked flame) shall not be used.

(6) Leak Detection Methods

Electronic leak detectors may be used to detect refrigerant leaks but, in the case of flammable refrigerants, the sensitivity may not be adequate, or may need re-calibration. (Detection equipment shall be calibrated in a refrigerant-free area.)

Ensure that the detector is not a potential source of ignition and is suitable for the refrigerant used. Leak detection equipment shall be set at a percentage of the LFL of the refrigerant and shall be calibrated to the refrigerant employed, and the appropriate percentage of gas (25% maximum) is confirmed.

Leak detection fluids are suitable for use with most refrigerants but the use of detergents containing chlorine shall be avoided as the chlorine may react with the refrigerant and corrode the copper pipe-work.

If a leak is suspected, all naked flames shall be removed/extinguished.

If a leakage of refrigerant is found which requires brazing, all of the refrigerant shall be recovered from the system, or isolated (by means of shut off valves) in a part of the system remote from the leak. For appliances containing flammable refrigerants, oxygen free nitrogen (OFN) shall then be purged through the system both before and during the brazing process.

(7) Removal and Evacuation

When breaking into the refrigerant circuit to make repairs – or for any other purpose conventional procedures shall be used. However, for flammable refrigerants it is important that best practice is followed since flammability is a consideration. The following procedure shall be adhered to:

- remove refrigerant
- purge the circuit with inert gas
- evacuate
- purge again with inert gas
- open the circuit by cutting or brazing.

The refrigerant charge shall be recovered into the correct recovery cylinders. For appliances containing flammable refrigerants, the system shall be “flushed” with OFN to render the unit safe. This process may need to be repeated several times.

Compressed air or oxygen shall not be used for purging refrigerant systems.

For appliances containing flammable refrigerants, flushing shall be achieved by breaking the vacuum in the system with OFN and continuing to fill until the working pressure is achieved, then venting to atmosphere, and finally pulling down to a vacuum. This process shall be repeated until no refrigerant is within the system. When the final OFN charge is used, the system shall be vented down to atmospheric pressure to enable work to take place. This operation is absolutely vital if brazing operations on the pipe-work are to take place.

Ensure that the outlet for the vacuum pump is not close to any ignition sources and that ventilation is available.

(8) Charging Procedures

In addition to conventional charging procedures, the following requirements shall be followed:

- Ensure that contamination of different refrigerants does not occur when using charging equipment. Hoses or lines shall be as short as possible to minimize the amount of refrigerant contained in them.
- Cylinders shall be kept upright.
- Ensure that the refrigeration system is earthed prior to charging the system with refrigerant.
- Label the system when charging is complete (if not already).
- Extreme care shall be taken not to overfill the refrigeration system.

Prior to recharging the system, it shall be pressure-tested with the appropriate purging gas. The system shall be leak-tested on completion of charging but prior to commissioning. A follow up leak test shall be carried out prior to leaving the site.

(9) Decommissioning

Before carrying out this procedure, it is essential that the technician is completely familiar with the equipment and all its detail. It is recommended good practice that all refrigerants are recovered safely. Prior to the task being carried out, an oil and refrigerant sample shall be taken in case analysis is required prior to re-use of reclaimed refrigerant. It is essential that electrical power is available before the task is commenced.

- a) Become familiar with the equipment and its operation.

- b) Isolate system electrically.
- c) Before attempting the procedure, ensure that:
  - mechanical handling equipment is available, if required, for handling refrigerant cylinders;
  - all personal protective equipment is available and being used correctly;
  - the recovery process is supervised at all times by a competent person;
  - recovery equipment and cylinders conform to the appropriate standards.
- d) Pump down refrigerant system, if possible.
- e) If a vacuum is not possible, make a manifold so that refrigerant can be removed from various parts of the system.
- f) Make sure that cylinder is situated on the scales before recovery takes place.
- g) Start the recovery machine and operate in accordance with manufacturer's instructions.
- h) Do not overfill cylinders. (No more than 80 % volume liquid charge).
- i) Do not exceed the maximum working pressure of the cylinder, even temporarily.
- j) When the cylinders have been filled correctly and the process completed, make sure that the cylinders and the equipment are removed from site promptly and all isolation valves on the equipment are closed off.
- k) Recovered refrigerant shall not be charged into another refrigeration system unless it has been cleaned and checked.

(10) Labelling

Equipment shall be labelled stating that it has been de-commissioned and emptied of refrigerant. The label shall be dated and signed. For appliances containing flammable refrigerants, ensure that there are labels on the equipment stating the equipment contains flammable refrigerant.

(11) Recovery

When removing refrigerant from a system, either for servicing or decommissioning, it is recommended good practice that all refrigerants are removed safely. When transferring refrigerant into cylinders, ensure that only appropriate refrigerant recovery cylinders are employed. Ensure that the correct number of cylinders for holding the total system charge are available. All cylinders to be used are designated for the recovered refrigerant and labelled for that refrigerant (i.e. special cylinders for the recovery of refrigerant). Cylinders shall be complete with pressure-relief valve and associated shut-off valves in good working order. Empty recovery cylinders are evacuated and, if possible, cooled before recovery occurs.

The recovery equipment shall be in good working order with a set of instructions concerning the equipment that is at hand and shall be suitable for the recovery of all appropriate refrigerants including, when applicable, flammable refrigerants. In addition, a set of calibrated weighing scales shall be available and in good working order. Hoses shall be complete with leak-free disconnect couplings and in good condition. Before using the recovery machine, check that it is in satisfactory working order, has been properly maintained and that any associated electrical components are sealed to prevent ignition in the event of a refrigerant release. Consult manufacturer if in doubt.

The recovered refrigerant shall be returned to the refrigerant supplier in the correct recovery cylinder, and the relevant waste transfer note arranged. Do not mix refrigerants in recovery units and especially not in cylinders. If compressors or compressor oils are to be removed, ensure that they have been evacuated to an acceptable level to make certain that flammable refrigerant does not remain within the lubricant. The evacuation process shall be carried out prior to returning the compressor to the suppliers. Only electric heating to the compressor body shall be employed to accelerate this process. When oil is drained from a system, it shall be carried out safely.

### 2-3. Choosing the outdoor unit installation location

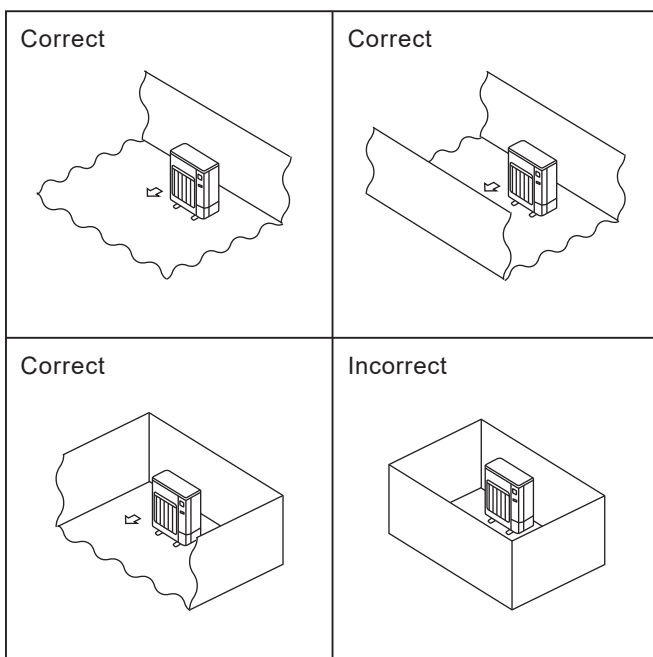

R32 is heavier than air—as well as other refrigerants—so tends to accumulate at the base (in the vicinity of the floor). If R32 accumulates around base, it may reach a flammable concentration in case room is small. To avoid ignition, maintaining a safe work environment is required by ensuring appropriate ventilation. If a refrigerant leak is confirmed in a room or an area where there is insufficient ventilation, refrain from using of flames until the work environment can be improved by ensuring appropriate ventilation.

Install outdoor units in a place where at least one of the four sides is open, and in a sufficiently large space without depressions.



## 2-4. Minimum installation area

If you unavoidably install a unit in a space where all four sides are blocked or there are depressions, confirm that one of these situations (A, B or C) is satisfied.

Note: These countermeasures are for keeping safety not for specification guarantee.

A) Secure sufficient installation space (minimum installation area  $A_{min}$ ).

Install in a space with an installation area of  $A_{min}$  or more, corresponding to refrigerant amount M (factory-charged refrigerant + locally added refrigerant).

M [kg]	$A_{min}$ [m <sup>2</sup> ]
1.0	12
1.5	17
2.0	23
2.5	28
3.0	34
3.5	39
4.0	45
4.5	50
5.0	56
5.5	62
6.0	67
6.5	73
7.0	78
7.5	84

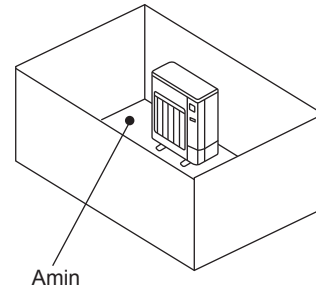

B) Install in a space with a depression height of  $\leq 0.125$  [m]

Height from the bottom of  
0.125 [m] or less

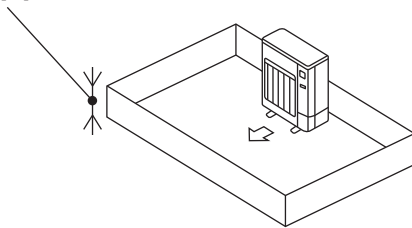

Height from the bottom of  
0.125 [m] or less

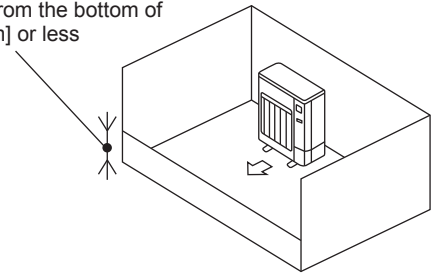

C) Create an appropriate ventilation open area.

Make sure that the width of the open area is 0.9 [m] or more and the height of the open area is 0.15 [m] or more.

However, the height from the bottom of the installation space to the bottom edge of the open area should be 0.125 [m] or less.

Open area should be 75% or more opening.

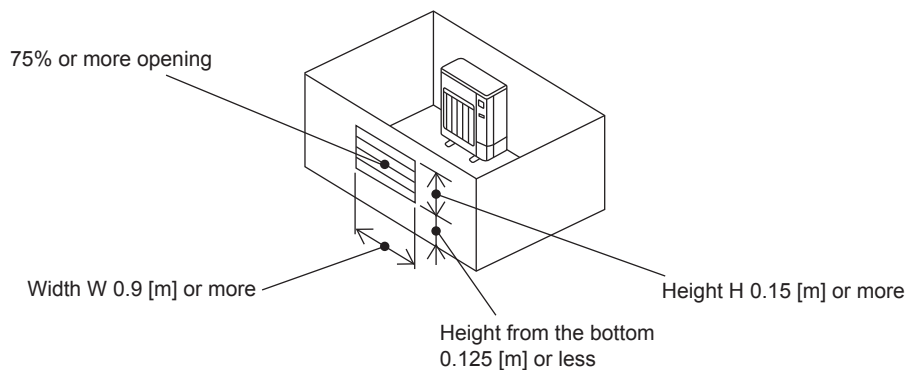

■ Indoor units

Install in a room with a floor area of  $A_{min}$  or more, corresponding to refrigerant amount  $M$  (factory-charged refrigerant + locally added refrigerant).

\* For the factory-charged refrigerant amount, refer to the spec nameplate or installation manual.

For the amount to be added locally, refer to the installation manual.

Install the indoor unit so that the height from the floor to the bottom of the indoor unit is  $h_0$ ;

for wall mounted: 1.8 m or more

for ceiling suspended, cassette and ceiling concealed: 2.2 m or more

for floor standing (PSA-M): 0 m

for floor standing (MFZ-KT): Refer to indoor unit installation manual.

for floor standing concealed: Refer to indoor unit installation manual.

\* There are restrictions in installation height for each model, so read the installation manual for the particular unit.

Case 1: for wall mounted, ceiling suspended, cassette and concealed

M [kg]	$A_{min}$ [m <sup>2</sup> ]
1.0	4
1.5	6
2.0	8
2.5	10
3.0	12
3.5	14
4.0	16
4.5	20
5.0	24
5.5	29
6.0	35
6.5	41
7.0	47
7.5	54

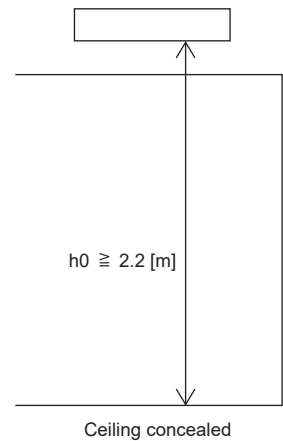
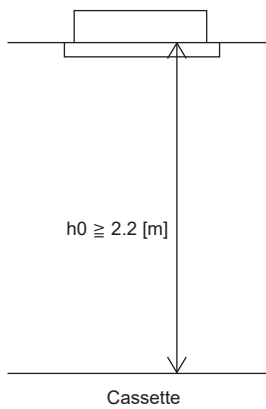
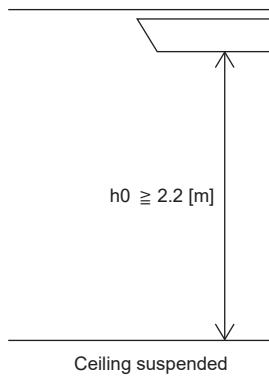
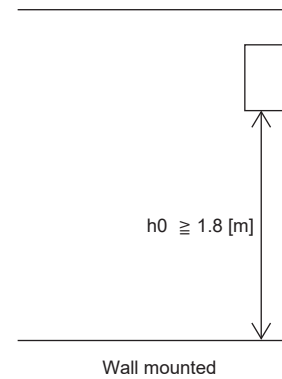

Case 2: for floor standing (PSA-M)

M [kg]	$A_{min}$ [m <sup>2</sup> ]
< 1.84	No requirements
1.84	6
2.0	6
2.5	7
3.0	9
3.5	10
4.0	11
4.5	13
5.0	14
5.5	15
6.0	17
6.5	18
7.0	20
7.5	21

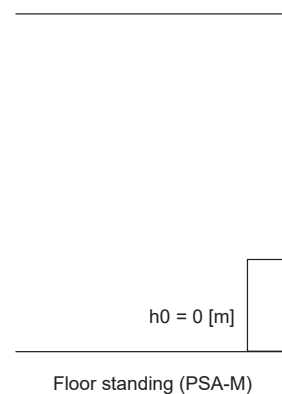

Case 3: for floor standing (MFZ-KT)

M [kg]	Amin [m²]
1.00	No requirements
1.10	
1.20	
1.30	
1.40	
1.50	
1.60	
1.70	
1.80	
1.84	
1.90	3.75
2.00	3.95
2.10	4.15
2.20	4.34
2.30	4.54
2.40	4.74

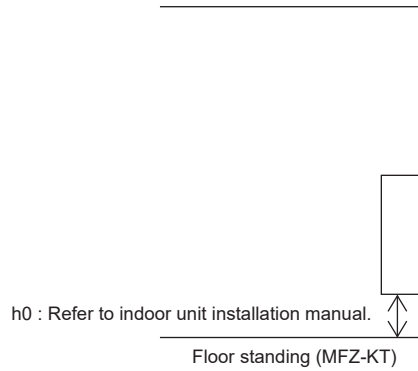

Case 4: for floor standing concealed

Case 4-1: When duct is installed

M [kg]	Amin [m²]		
	$h \geq 1.8$	$1.4 \leq h < 1.8$	$1.0 \leq h < 1.4$
1.00	No requirements		
1.10			
1.20			
1.30			
1.40			
1.50			
1.60			
1.70			
1.80			
1.84			
1.90	4.6	5.9	8.3
2.00	4.9	6.3	8.7
2.10	5.1	6.6	9.2
2.20	5.4	6.9	9.6
2.30	5.6	7.2	10.0
2.40	5.8	7.5	10.5

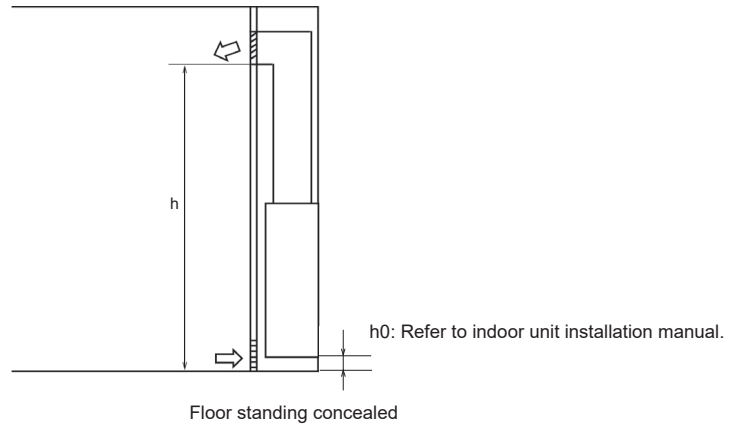

\* The height h of the air outlet port shall not be less than 1.0 m

Case 4-2: When air outlet grille is installed

M [kg]	Amin [m²]		
	$\varphi = 90^\circ$	$60^\circ \leq \varphi < 90^\circ$	$30^\circ \leq \varphi < 60^\circ$
1.00	No requirements		
1.10			
1.20			
1.30			
1.40			
1.50			
1.60			
1.70			
1.80			
1.84			
1.90	4.3	5.1	8.6
2.00	4.5	5.4	9.0
2.10	4.7	5.7	9.5
2.20	4.9	5.9	9.9
2.30	5.2	6.2	10.4
2.40	5.4	6.5	10.8

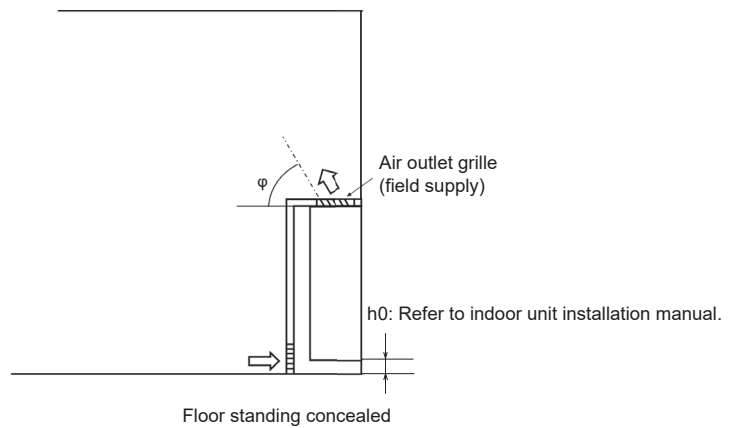

\* The grille angle shall not be less than 30°

SUZ-M25VA.TH  
 SUZ-M25VAR1.TH  
 SUZ-M25VAR2.TH  
 SUZ-M25VA-ET.TH  
 SUZ-M25VA-ETR2.TH  
 SUZ-M25VA-ERR2.TH  
 SUZ-M35VA.TH  
 SUZ-M35VAR1.TH  
 SUZ-M35VAR2.TH  
 SUZ-M35VA-ET.TH  
 SUZ-M35VA-ETR2.TH  
 SUZ-M35VA-ERR2.TH

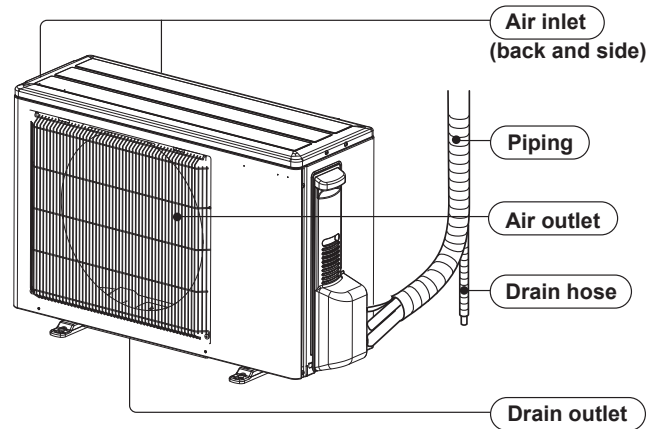

SUZ-M50VA.TH  
 SUZ-M50VAR1.TH  
 SUZ-M50VAR2.TH  
 SUZ-M50VA-ET.TH  
 SUZ-M50VA-ETR2.TH  
 SUZ-M50VA-ERR2.TH

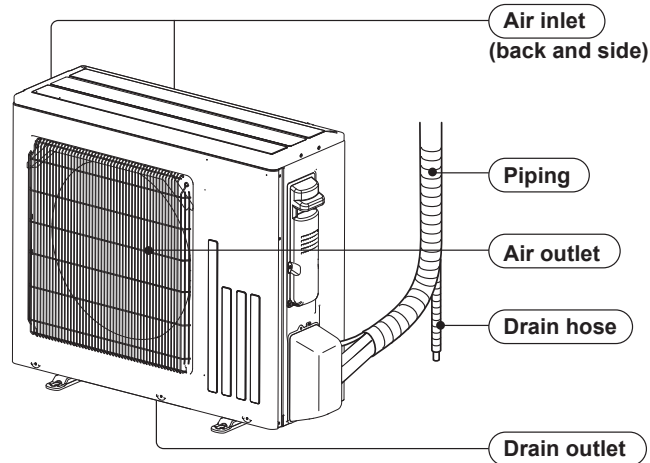

SUZ-M60VA.TH  
 SUZ-M60VAR1.TH  
 SUZ-M60VAR2.TH  
 SUZ-M60VA-ET.TH  
 SUZ-M60VA-ETR2.TH  
 SUZ-M60VA-ERR2.TH  
 SUZ-M71VA.TH  
 SUZ-M71VAR1.TH  
 SUZ-M71VA-ET.TH  
 SUZ-M71VA-ETR1.TH  
 SUZ-M71VA-ERR1.TH

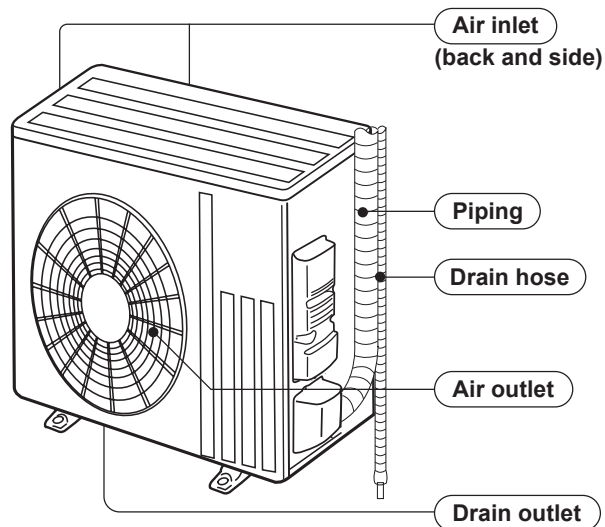

Model	SUZ-M·VA
Drain socket	1

## 4

## SPECIFICATION

Service ref.			SUZ-M25VA.TH SUZ-M25VAR1.TH SUZ-M25VAR2.TH SUZ-M25VA-ET.TH SUZ-M25VA-ETR2.TH SUZ-M25VA-ERR2.TH	SUZ-M35VA.TH SUZ-M35VAR1.TH SUZ-M35VAR2.TH SUZ-M35VA-ET.TH SUZ-M35VA-ETR2.TH SUZ-M35VA-ERR2.TH	SUZ-M50VA.TH SUZ-M50VAR1.TH SUZ-M50VAR2.TH SUZ-M50VA-ET.TH SUZ-M50VA-ETR2.TH SUZ-M50VA-ERR2.TH	SUZ-M60VA.TH SUZ-M60VAR1.TH SUZ-M60VAR2.TH SUZ-M60VA-ET.TH SUZ-M60VA-ETR2.TH SUZ-M60VA-ERR2.TH	SUZ-M71VA.TH SUZ-M71VAR1.TH SUZ-M71VA-ET.TH SUZ-M71VA-ETR1.TH SUZ-M71VA-ERR1.TH	
Power supply			Single phase 230 V, 50 Hz					
Compressor	Model		KVB073FYXMC	SVB092FBAMT	SVB130FBBMT		SVB172FCKMT	
	Output		W	470	660	900	1,200	
	Current*	Cooling	A	3.0	4.1	7.1	8.4	9.1
		Heating	A	3.7	5.0	8.0	9.3	9.5
Refrigeration oil (Model)		L	0.27 (FW68S)	0.35 (FW68S)		0.40 (FW68S)		
Fan motor	Model		RC0J50-NC		RC0J50-RA	RC0J60-BC		
	Current*	Cooling	A	0.22	0.20	0.29	0.84	
		Heating	A	0.20	0.23	0.29	0.84	
Dimensions W × H × D		mm	800 × 550 × 285		800 × 714 × 285	840 × 880 × 330		
Weight		kg	30	35	41	54	55	
Special remarks	Air flow*	Cooling	High	m <sup>3</sup> /h	2,178	2,058	2,748	3,006
			Low	1,038	906	1,320	1,716	
		Heating	High	2,076	1,962	2,622	3,006	
			Med.	1,788	1,686	2,238	2,892	
			Low	1,452	1,260	1,704	2,280	
	Sound pressure level*	Cooling	dB(A)	45	48		49	
		Heating	dB(A)	46	48	49	51	
	Sound power level			59		64	65	66
	Fan speed	Cooling	High	rpm	940		840	
			Low	470	460	490	450	
		Heating	High	900	840		860	
			Med.	780		810		
			Low	640	600	610	650	
Fan speed regulator			3					
Refrigerant filling capacity (R32)		kg	0.65	0.90	1.20	1.25	1.45	

Note: Test conditions are based on ISO 5151

Cooling: Indoor D.B. 27°C W.B. 19°C

Outdoor D.B. 35°C

Heating: Indoor D.B. 20°C

Outdoor D.B. 7°C W.B. 6°C

Refrigerant piping length (one way): 5 m

\*Measured under rated operating frequency.

## Specifications and rating conditions of main electric parts

Item	Service ref.	SUZ-M25VA.TH	SUZ-M35VA.TH	SUZ-M50VA.TH	SUZ-M60VA.TH	SUZ-M71VA.TH
		SUZ-M25VAR1.TH SUZ-M25VAR2.TH SUZ-M25VA-ET.TH SUZ-M25VA-ETR2.TH SUZ-M25VA-ERR2.TH	SUZ-M35VAR1.TH SUZ-M35VAR2.TH SUZ-M35VA-ET.TH SUZ-M35VA-ETR2.TH SUZ-M35VA-ERR2.TH	SUZ-M50VAR1.TH SUZ-M50VAR2.TH SUZ-M50VA-ET.TH SUZ-M50VA-ETR2.TH SUZ-M50VA-ERR2.TH	SUZ-M60VAR1.TH SUZ-M60VAR2.TH SUZ-M60VA-ET.TH SUZ-M60VA-ETR2.TH SUZ-M60VA-ERR2.TH	SUZ-M71VAR1.TH SUZ-M71VA-ET.TH SUZ-M71VA-ETR1.TH SUZ-M71VA-ERR1.TH
Smoothing capacitor	(C61)	—	620 μF 420 V	620 μF 420 V	—	—
	(C62, C63)	620 μF 420 V	620 μF 420 V	620 μF 420 V	—	—
	(CB1, 2, 3)	—	—	—	560 μF 450 V	
Diode module	(DB61)	15 A 600 V	15 A 600 V	25 A 600 V	—	—
	(DB65)	25 A 600 V			—	—
Fuse	(F61)	25 A 250 V			—	—
	(F62)	15 A 250 V			—	—
	(F701, F801, F901)	T3.15 A L250 V			—	—
	(F601, F880, F901)	—	—	—	T3.15 A L250 V	
Power module	(IC700)	15 A 600 V		20 A 600 V		
	(IC932)	5 A 600 V				
Switch power transistor	(Q821)	30 A 600 V			—	—
Expansion valve coil	(LEV)	12 V DC				
Reactor	(L61)	18 mH	23 mH		—	—
	(L)	—	—	—	282 μH	
Diode	(D3A, D3B)	—	—	—	20 A 600 V	
Diode module	(DB41A, DB41B)	—	—	—	20 A 600 V	
Current-Limiting PTC thermistor	(PTC64, PTC65)	33Ω				
Terminal block	(TB1)	5P			3P	
Relay	(X63)	3 A 250 V			—	—
	(X64)	20 A 250 V				
	(X601)	—	—	—	3 A 250 V	
	(X602)	—	—	—	3 A 250 V	
R.V. coil	(21S4)	220–240 V AC				

# 5

# NOISE CRITERIA CURVES

SUZ-M25VA.TH  
 SUZ-M25VAR1.TH  
 SUZ-M25VAR2.TH  
 SUZ-M25VA-ET.TH  
 SUZ-M25VA-ETR2.TH  
 SUZ-M25VA-ERR2.TH

FAN SPEED	FUNCTION	SPL(dB(A))	LINE
High Med.	COOLING	45	●—●
	HEATING	46	○—○

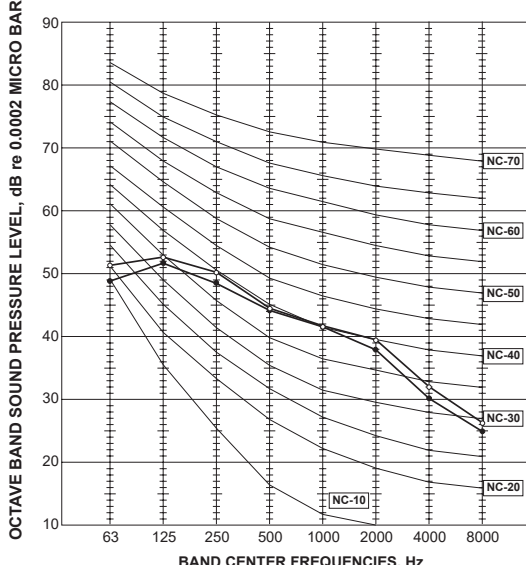

SUZ-M35VA.TH  
 SUZ-M35VAR1.TH  
 SUZ-M35VAR2.TH  
 SUZ-M35VA-ET.TH  
 SUZ-M35VA-ETR2.TH  
 SUZ-M35VA-ERR2.TH

FAN SPEED	FUNCTION	SPL(dB(A))	LINE
High Med.	COOLING	48	●—●
	HEATING	48	○—○

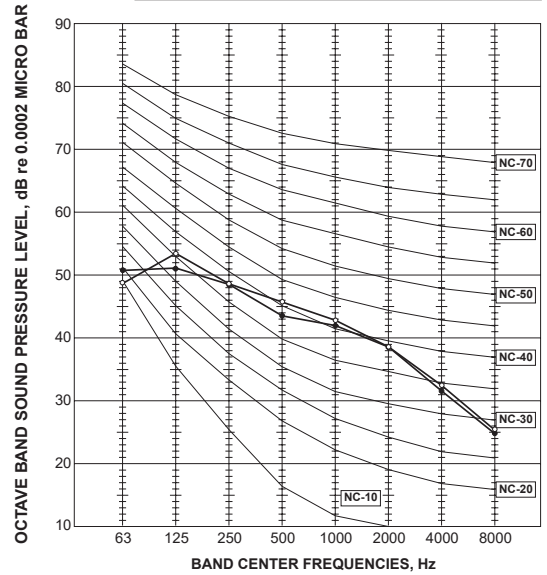

SUZ-M50VA.TH  
 SUZ-M50VAR1.TH  
 SUZ-M50VAR2.TH  
 SUZ-M50VA-ET.TH  
 SUZ-M50VA-ETR2.TH  
 SUZ-M50VA-ERR2.TH

FAN SPEED	FUNCTION	SPL(dB(A))	LINE
High	COOLING	48	●—●
	HEATING	49	○—○

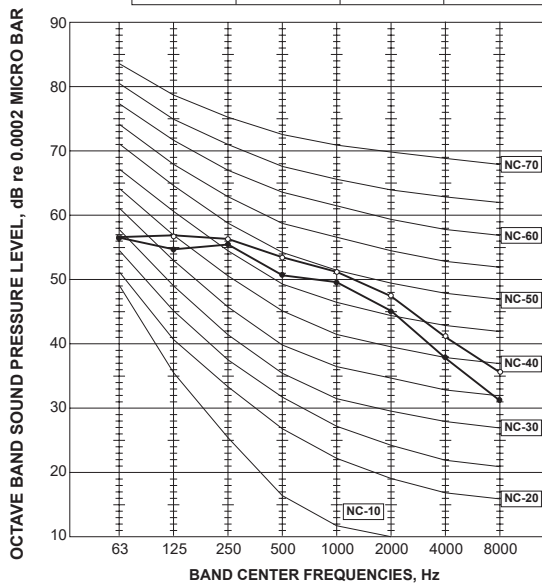

SUZ-M60VA.TH  
 SUZ-M60VAR1.TH  
 SUZ-M60VAR2.TH  
 SUZ-M60VA-ET.TH  
 SUZ-M60VA-ETR2.TH  
 SUZ-M60VA-ERR2.TH

SUZ-M71VA.TH  
 SUZ-M71VAR1.TH  
 SUZ-M71VA-ET.TH  
 SUZ-M71VA-ETR1.TH  
 SUZ-M71VA-ERR1.TH

FAN SPEED	FUNCTION	SPL(dB(A))	LINE
High	COOLING	49	●—●
	HEATING	51	○—○

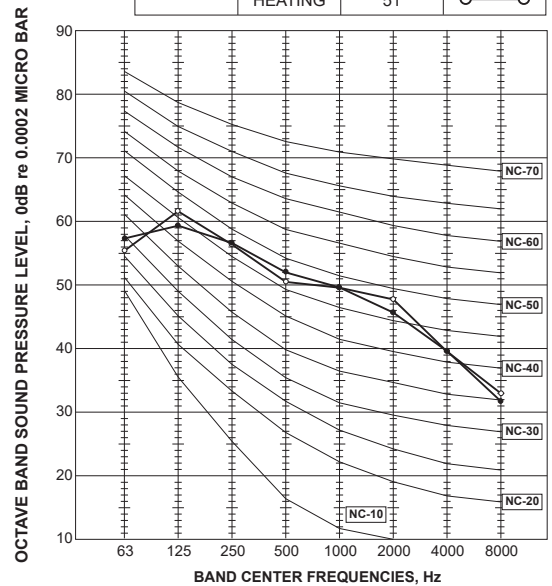

**Test conditions**

Cooling: Dry-bulb temperature 35°C  
 Heating: Dry-bulb temperature 7°C  
 Wet-bulb temperature 6°C

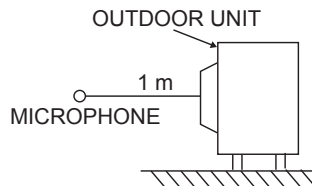

Unit: mm

SUZ-M25VA.TH  
 SUZ-M25VAR1.TH  
 SUZ-M25VAR2.TH  
 SUZ-M25VA-ET.TH  
 SUZ-M25VA-ETR2.TH  
 SUZ-M25VA-ERR2.TH

SUZ-M35VA.TH  
 SUZ-M35VAR1.TH  
 SUZ-M35VAR2.TH  
 SUZ-M35VA-ET.TH  
 SUZ-M35VA-ETR2.TH  
 SUZ-M35VA-ERR2.TH

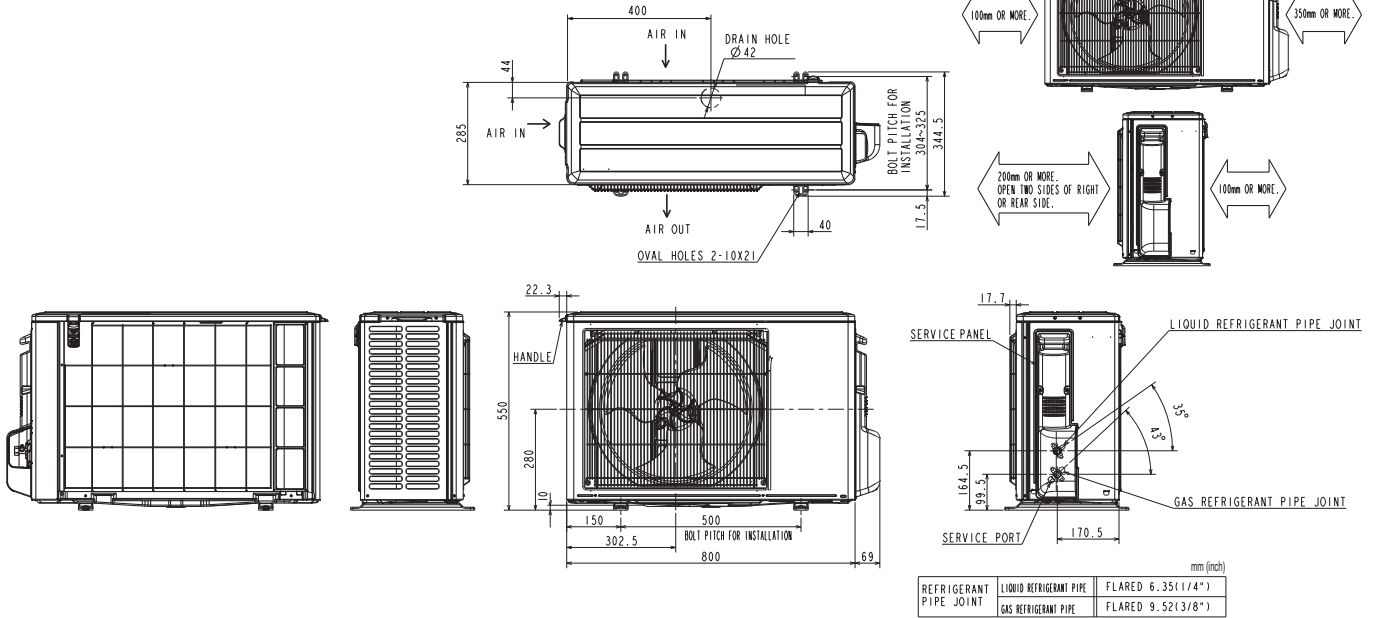

SUZ-M50VA.TH  
 SUZ-M50VAR1.TH  
 SUZ-M50VAR2.TH  
 SUZ-M50VA-ET.TH  
 SUZ-M50VA-ETR2.TH  
 SUZ-M50VA-ERR2.TH

Unit: mm

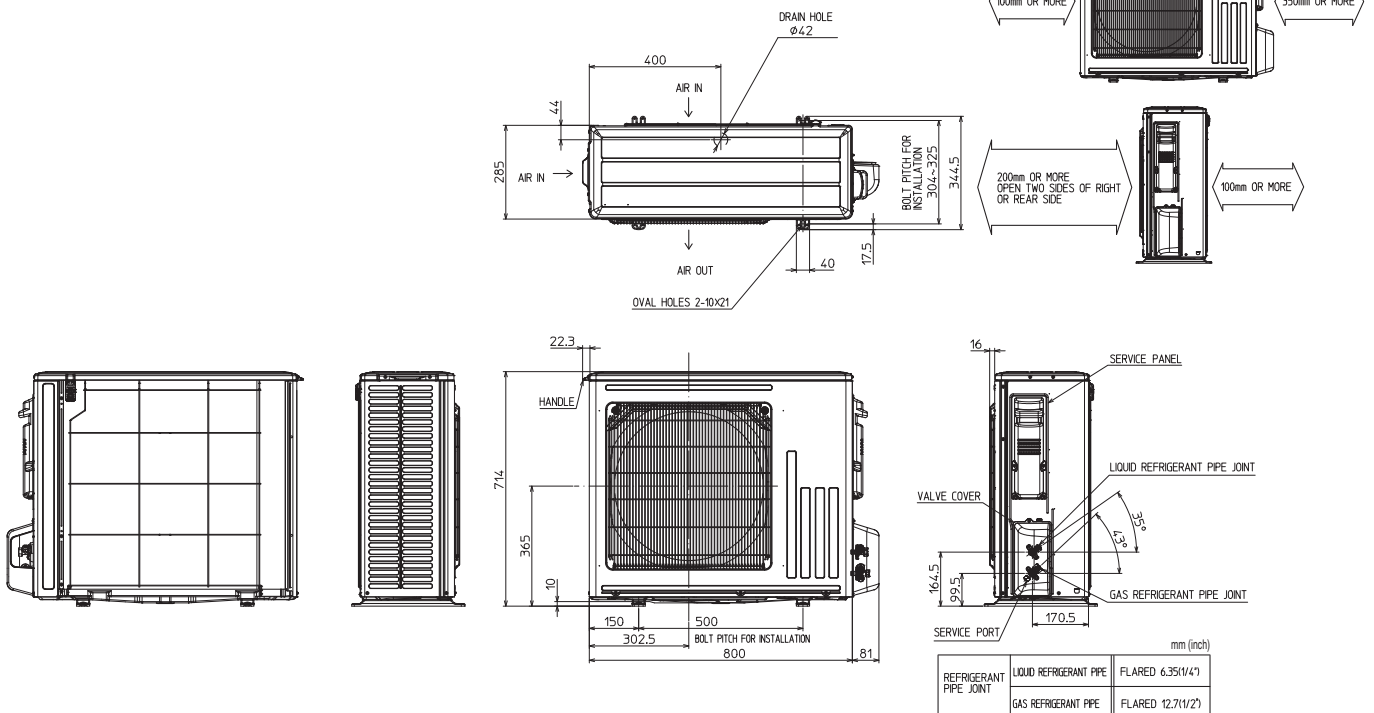



Unit: mm

SUZ-M60VA.TH  
 SUZ-M60VAR1.TH  
 SUZ-M60VAR2.TH  
 SUZ-M60VA-ET.TH  
 SUZ-M60VA-ETR2.TH  
 SUZ-M60VA-ERR2.TH

SUZ-M71VA.TH  
 SUZ-M71VAR1.TH  
 SUZ-M71VA-ET.TH  
 SUZ-M71VA-ETR1.TH  
 SUZ-M71VA-ERR1.TH

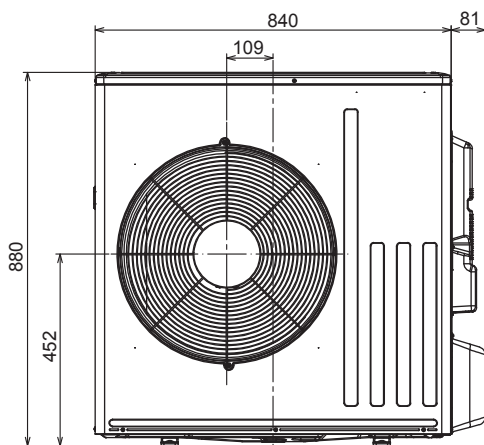
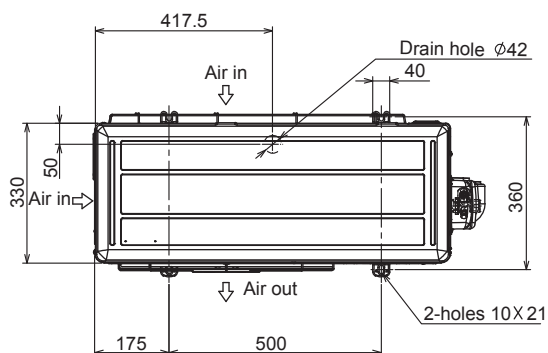

REQUIRED SPACE

\*1 500 mm or more when front and sides of the unit are clear

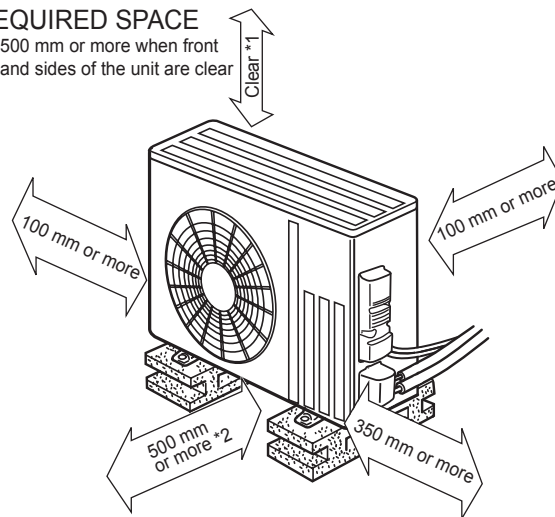

\*2 When any 2 sides of left, right and rear of the unit are clear

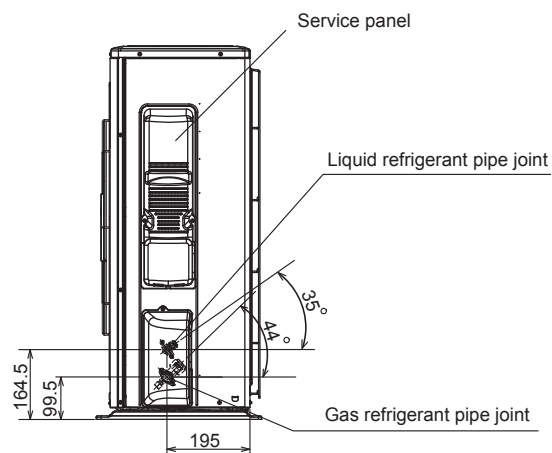

mm (inch)

MODEL NAME		SUZ-M60VA	SUZ-M71VA
REFRIGERANT PIPE JOINT	LIQUID REFRIGERANT PIPE	FLARED 6.35(1/4")	FLARED 9.52(3/8")
	GAS REFRIGERANT PIPE	FLARED 15.88(5/8")	

SUZ-M25VA.TH  
 SUZ-M25VAR1.TH  
 SUZ-M25VAR2.TH  
 SUZ-M25VA-ET.TH  
 SUZ-M25VA-ETR2.TH  
 SUZ-M25VA-ERR2.TH

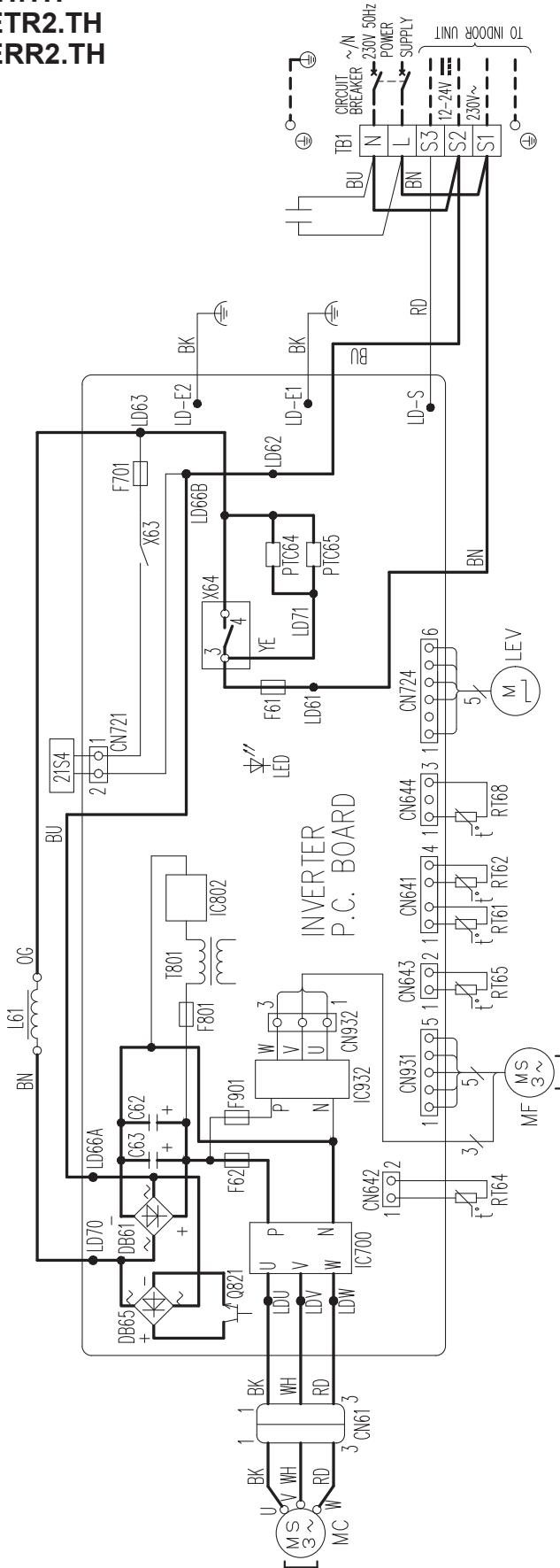



NOTES:  
 1. About the indoor side electric wiring, refer to, the indoor unit electric wiring diagram for servicing.  
 2. Use copper supply wires.  
 3. Symbols indicate,   : Terminal block   : Connector

SYMBOL	NAME	SYMBOL	NAME	SYMBOL	NAME
CN61	CONNECTOR	LEV	EXPANSION VALVE COIL	RT65	AMBIENT TEMP. THERMISTOR
C62, C63	SMOOTHING CAPACITOR	L61	REACTOR	RT68	OUTDOOR HEAT EXCHANGER TEMP. THERMISTOR
DB61, DB65	DIODE MODULE	MC	COMPRESSOR	TB1	TERMINAL BLOCK
F61	FUSE (25A 250V)	MF	FAN MOTOR	T801	TRANSFORMER
F62	FUSE (15A 250V)	PTC64, PTC65	CIRCUIT PROTECTION	X63, X64	RELAY
F701, F801, F901	FUSE (13,15A/250V)	Q821	SWITCHING POWER TRANSISTOR	Z1S4	REVERSING VALVE COIL
IC700, IC932	POWER MODULE	RT61	DEFROST THERMISTOR		
IC802	POWER DEVICE	RT62	DISCHARGE TEMP. THERMISTOR		
LED	LED	RT64	FIN TEMP. THERMISTOR		

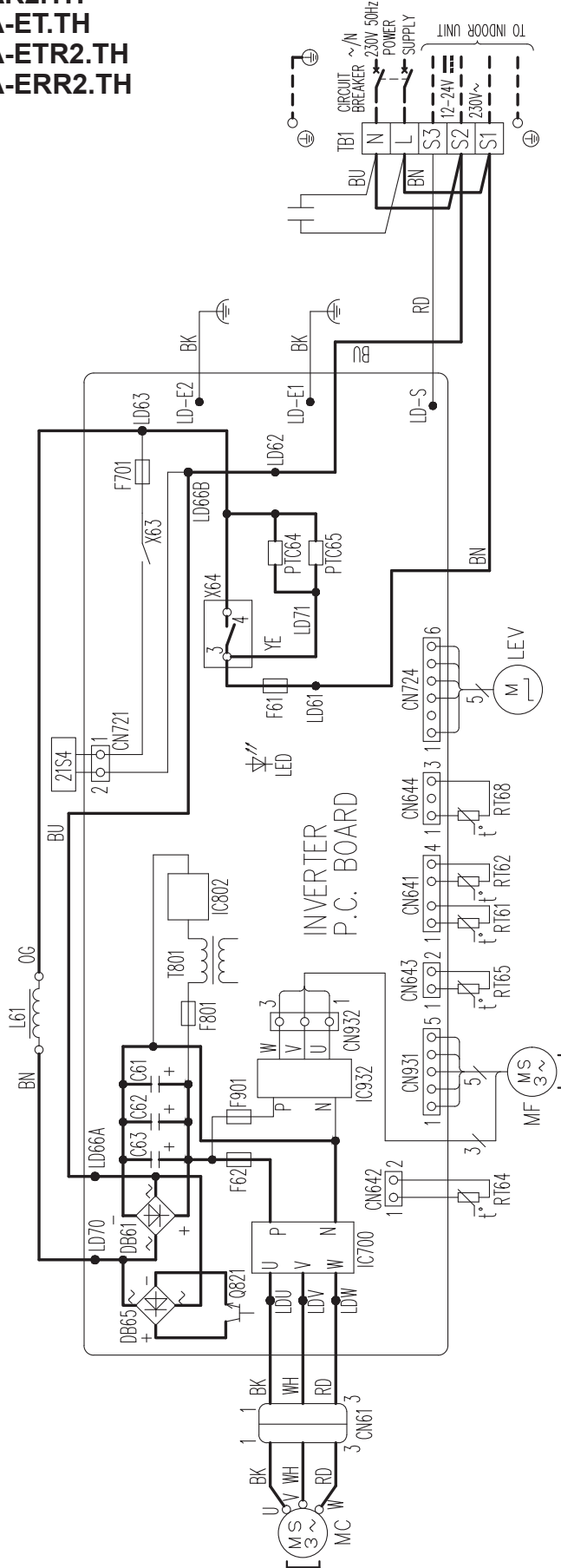
**SUZ-M35VA.TH**  
**SUZ-M35VAR1.TH**  
**SUZ-M35VAR2.TH**  
**SUZ-M35VA-ET.TH**  
**SUZ-M35VA-ETR2.TH**  
**SUZ-M35VA-ERR2.TH**



**NOTES:**

1. About the indoor side electric wiring, refer to the indoor unit electric wiring diagram for servicing.
2. Use copper supply wires.
3. Symbols indicate,  : Terminal block  
 : Connector

SYMBOL	NAME	SYMBOL	NAME	SYMBOL	NAME
CN61	CONNECTOR	LEV	EXPANSION VALVE COIL	RT65	AMBIENT TEMP. THERMISTOR
C61, C62, C63	SMOOTHING CAPACITOR	L61	REACTOR	RT68	OUTDOOR HEAT EXCHANGER TEMP. THERMISTOR
DB61, DB65	DIODE MODULE	MC	COMPRESSOR	TB1	TERMINAL BLOCK
F61	FUSE (25A 250V)	MF	FAN MOTOR	T801	TRANSFORMER
F62	FUSE (15A 250V)	O821	CIRCUIT PROTECTION	X63, X64	RELAY
F701, F801, F901	FUSE (13.15A/250V)	IC700	SWITCHING POWER TRANSISTOR	21S4	REVERSING VALVE COIL
IC700, IC932	POWER MODULE	R161	DEFROST THERMISTOR		
IC802	POWER DEVICE	RT62	DISCHARGE TEMP. THERMISTOR		
LED	LED	RT64	FIN TEMP. THERMISTOR		

SUZ-M50VA.TH  
 SUZ-M50VAR1.TH  
 SUZ-M50VAR2.TH  
 SUZ-M50VA-ET.TH  
 SUZ-M50VA-ETR2.TH  
 SUZ-M50VA-ERR2.TH

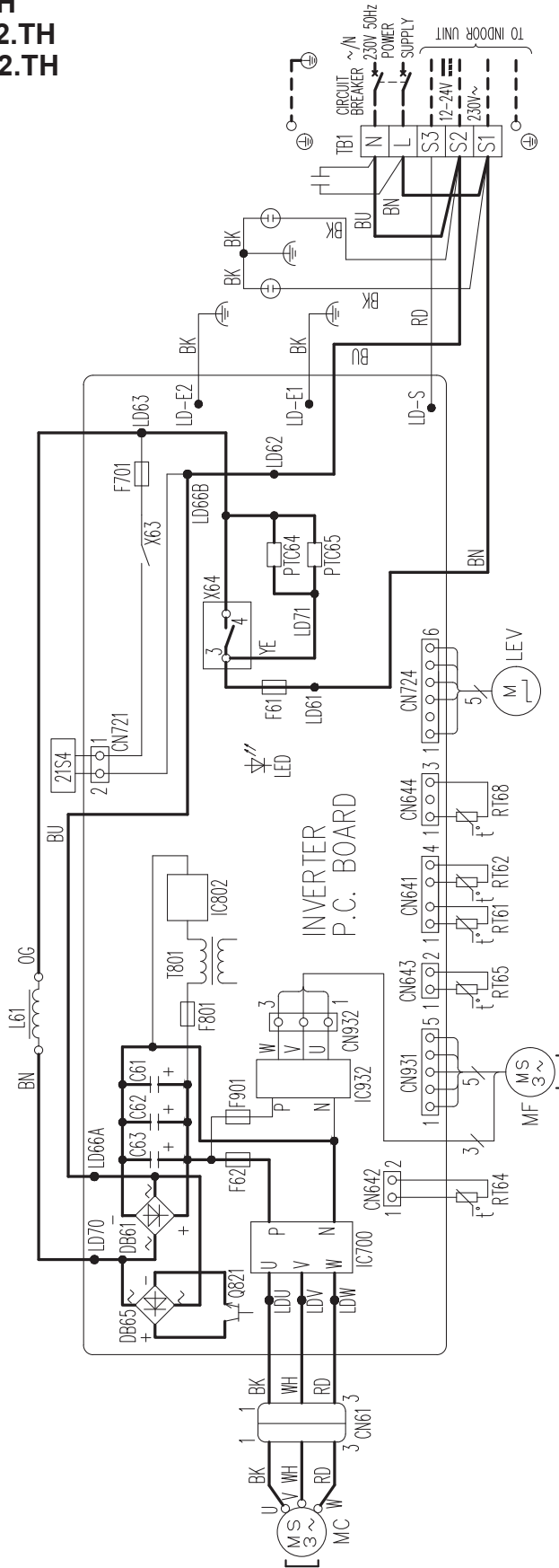

- NOTES:
- 1.About the indoor side electric wiring, refer to the indoor unit electric wiring diagram for servicing.
  - 2.Use copper supply wires.
  - 3.Symbols indicate, □ : Terminal block ○ : Connector

SYMBOL	NAME	SYMBOL	NAME	SYMBOL	NAME
CN61	CONNECTOR	LEV	EXPANSION VALVE COIL	RT65	AMBIENT TEMP. THERMISTOR
C61,C62,C63	SMOOTHING CAPACITOR	L61	REACTOR	RT68	OUTDOOR HEAT EXCHANGER TEMP. THERMISTOR
DB61,DB65	DIODE MODULE	MC	COMPRESSOR	TB1	TEMP. THERMISTOR
F61	FUSE (25A, 250V)	MF	FAN MOTOR	T801	TERMINAL BLOCK
F62	FUSE (15A, 250V)	PT064,PT065	CIRCUIT PROTECTION	X63,X64	TRANSFORMER
F701,F801,F901	FUSE (13.15AL/250V)	Q821	SWITCHING POWER TRANSISTOR	21S4	RELAY
IC700,IC932	POWER MODULE	R161	DEFROST THERMISTOR		REVERSING VALVE COIL
IC802	POWER DEVICE	RT62	DISCHARGE TEMP. THERMISTOR		
LED	LED	RT64	FIN TEMP. THERMISTOR		

SUZ-M60VA.TH  
 SUZ-M60VAR1.TH  
 SUZ-M60VAR2.TH  
 SUZ-M60VA-ET.TH  
 SUZ-M60VA-ETR2.TH  
 SUZ-M60VA-ERR2.TH

SUZ-M71VA.TH  
 SUZ-M71VAR1.TH  
 SUZ-M71VA-ET.TH  
 SUZ-M71VA-ETR1.TH  
 SUZ-M71VA-ERR1.TH

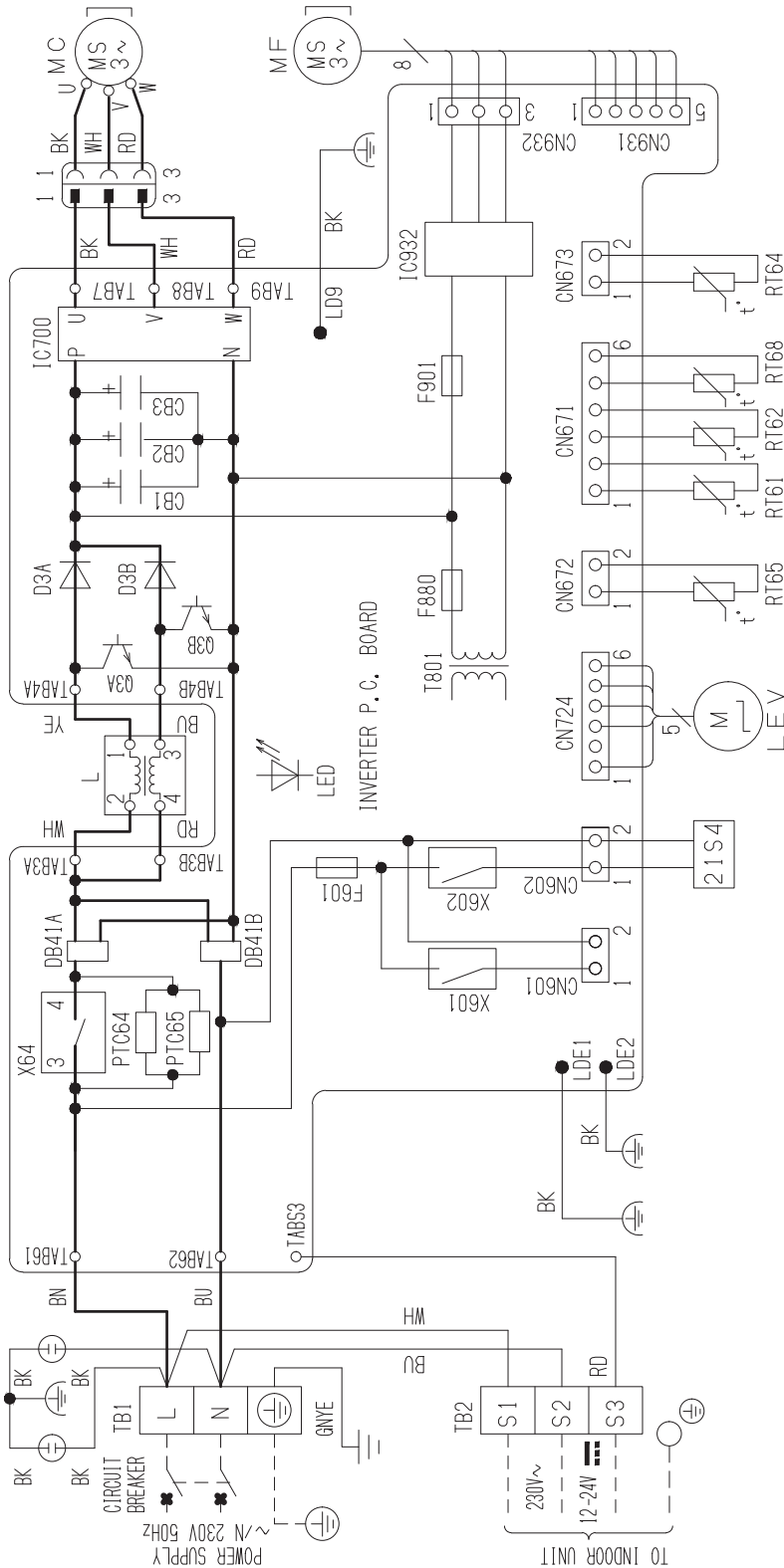

SYMBOL	NAME	SYMBOL	NAME	SYMBOL	NAME	SYMBOL	NAME
CB1, CB2, CB3	SMOOTHING CAPACITOR	L	REACTOR	RT61	DEFROST THERMISTOR	T801	TRANSFORMER
DB41A, DB41B	DIODE MODULE	LED	LED	RT62	DISCHARGE TEMP. THERMISTOR	X64	RELAY
D3A, D3B	DIODE	LEV	EXPANSION VALVE COIL	RT64	FIN TEMP. THERMISTOR	X601, X602	RELAY
F601	FUSE (T3, 15AL250V)	MC	COMPRESSOR	RT65	AMBIENT TEMP. THERMISTOR	21S4	REVERSING VALVE COIL
F880	FUSE (T3, 15AL250V)	MF	FAN MOTOR	RT68	OUTDOOR HEAT EXCHANGER TEMP. THERMISTOR		
F901	FUSE (T3, 15AL250V)	PTC64, PTC65	CIRCUIT PROTECTION	TB1, TB2	TERMINAL BLOCK		
IC700, IC932	POWER MODULE	Q3A, Q3B	SWITCHING POWER TRANSISTOR				

NOTES  
 1. About the indoor side electric wiring, refer to the indoor unit electric wiring diagram for servicing.  
 2. Use copper supply wires.  
 3. Symbols indicate, □:Terminal block, ○○○○:Connector

SUZ-M25VA.TH  
 SUZ-M25VAR1.TH  
 SUZ-M25VAR2.TH  
 SUZ-M25VA-ET.TH  
 SUZ-M25VA-ETR2.TH  
 SUZ-M25VA-ERR2.TH

SUZ-M35VA.TH  
 SUZ-M35VAR1.TH  
 SUZ-M35VAR2.TH  
 SUZ-M35VA-ET.TH  
 SUZ-M35VA-ETR2.TH  
 SUZ-M35VA-ERR2.TH

Unit: mm

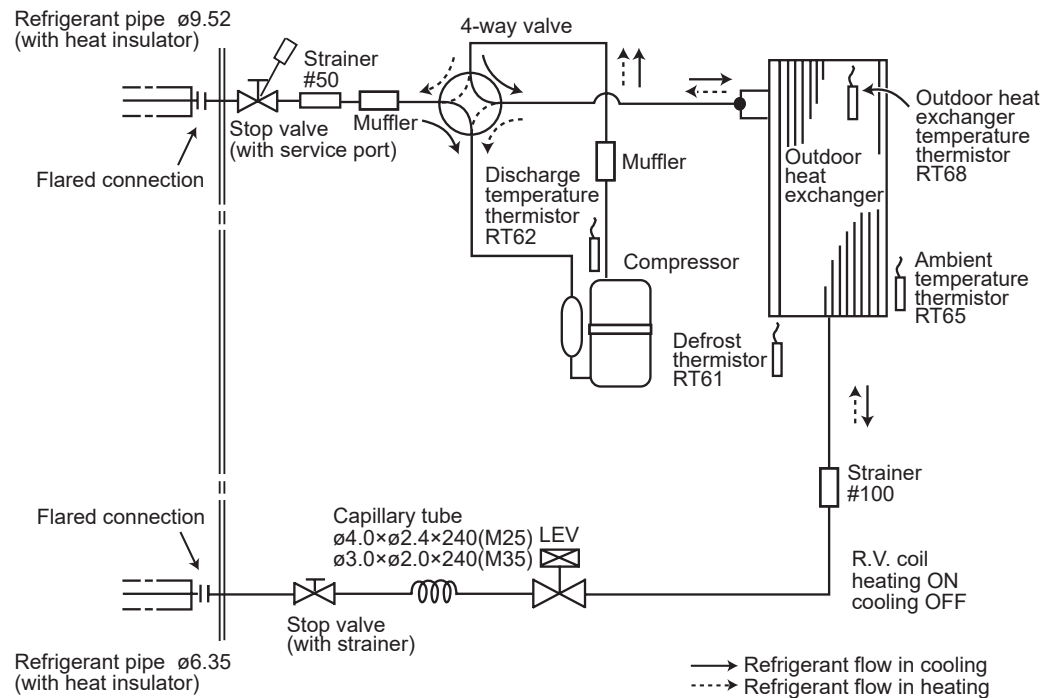

SUZ-M50VA.TH  
 SUZ-M50VAR1.TH  
 SUZ-M50VAR2.TH  
 SUZ-M50VA-ET.TH  
 SUZ-M50VA-ETR2.TH  
 SUZ-M50VA-ERR2.TH

Unit: mm

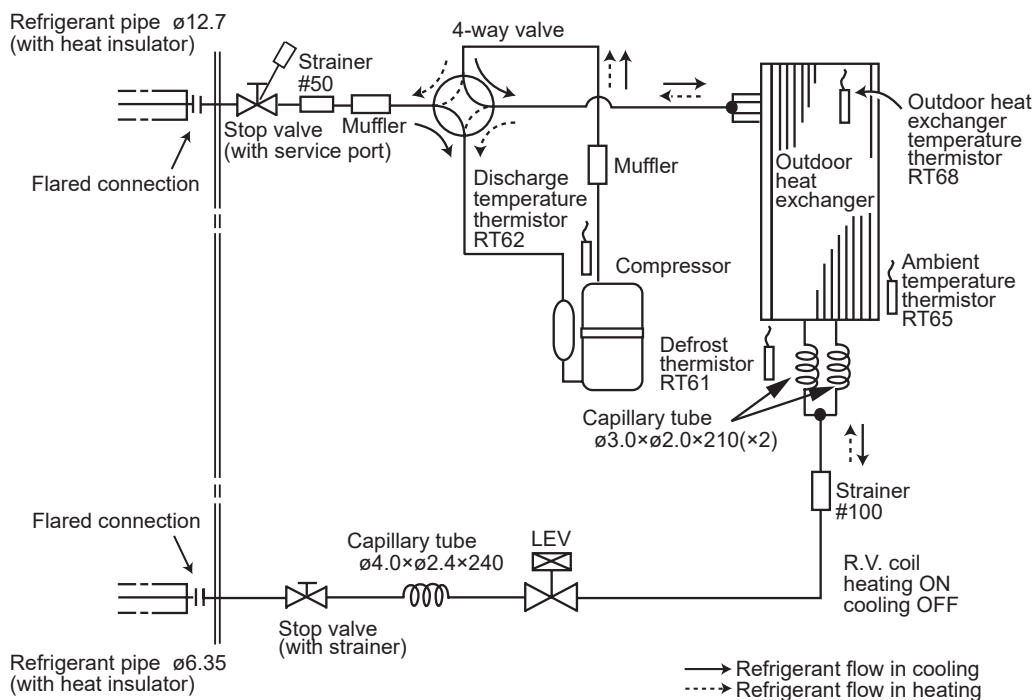

SUZ-M60VA.TH  
 SUZ-M60VAR1.TH  
 SUZ-M60VAR2.TH  
 SUZ-M60VA-ET.TH  
 SUZ-M60VA-ETR2.TH  
 SUZ-M60VA-ERR2.TH

SUZ-M71VA.TH  
 SUZ-M71VAR1.TH  
 SUZ-M71VA-ET.TH  
 SUZ-M71VA-ETR1.TH  
 SUZ-M71VA-ERR1.TH

Unit: mm

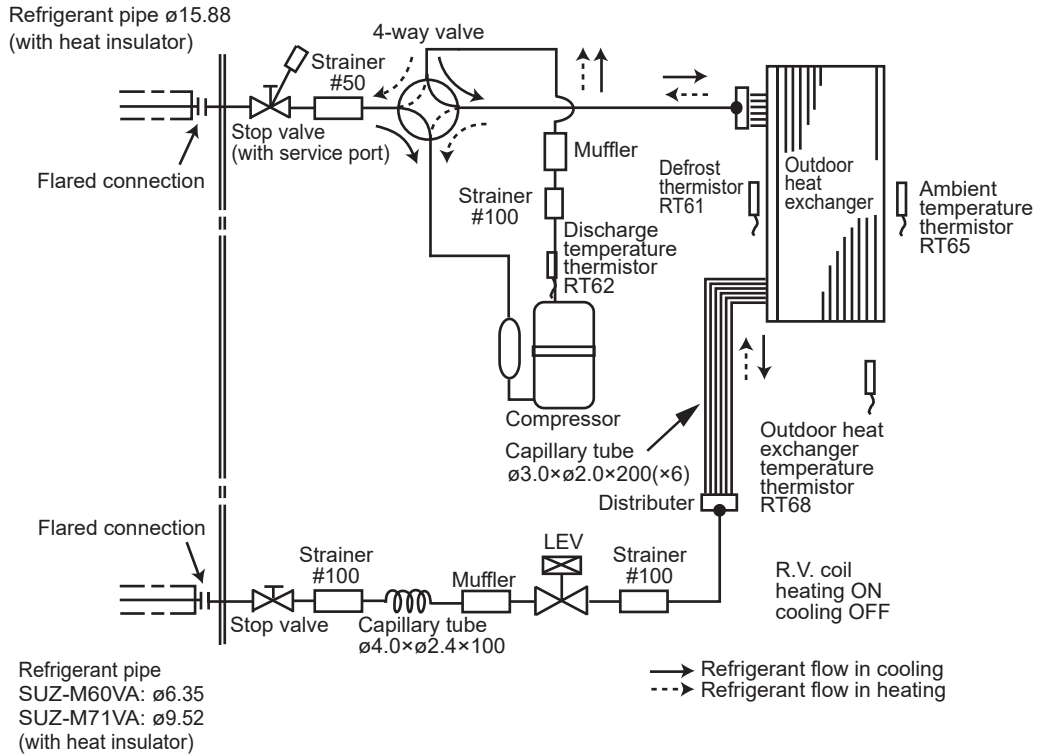

## MAX. REFRIGERANT PIPING LENGTH

Service ref.	Refrigerant piping: m		Piping size O.D.: mm	
	Max. Length A	Max. Height difference B	Gas	Liquid
SUZ-M25VA(R1/R2).TH SUZ-M25VA-ET(R2).TH SUZ-M25VA-ERR2.TH	20	12	9.52	6.35
SUZ-M35VA(R1/R2).TH SUZ-M35VA-ET(R2).TH SUZ-M35VA-ERR2.TH				
SUZ-M50VA(R1/R2).TH SUZ-M50VA-ET(R2).TH SUZ-M50VA-ERR2.TH	30	30	12.7	
SUZ-M60VA(R1/R2).TH SUZ-M60VA-ET(R2).TH SUZ-M60VA-ERR2.TH			15.88	
SUZ-M71VA(R1).TH SUZ-M71VA-ET(R1).TH SUZ-M71VA-ERR1.TH				9.52

## MAX. HEIGHT DIFFERENCE

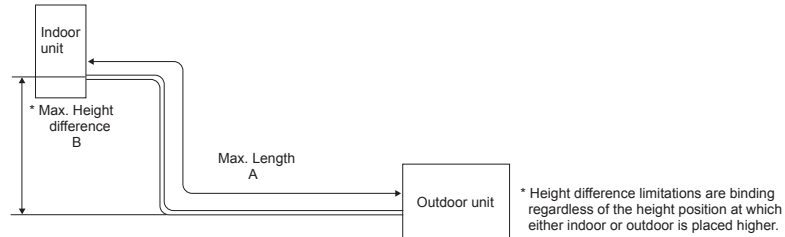

## ADDITIONAL REFRIGERANT CHARGE (R32: g)

Service ref.	Outdoor unit precharged	Refrigerant piping length (one way)			
		7 m	10 m	15 m	20 m
SUZ-M25VA(R1/R2).TH SUZ-M25VA-ET(R2).TH SUZ-M25VA-ERR2.TH	650	0	60	160	260
SUZ-M35VA(R1/R2).TH SUZ-M35VA-ET(R2).TH SUZ-M35VA-ERR2.TH	900	0	60	160	260

Calculation:  $X_g = 20g/m \times (\text{Refrigerant piping length}(m) - 7)$

Service ref.	Outdoor unit precharged	Refrigerant piping length (one way)					
		7 m	10 m	15 m	20 m	25 m	30 m
SUZ-M50VA(R1/R2).TH SUZ-M50VA-ET(R2).TH SUZ-M50VA-ERR2.TH	1,200	0	60	160	260	360	460
SUZ-M60VA(R1/R2).TH SUZ-M60VA-ET(R2).TH SUZ-M60VA-ERR2.TH	1,250	0	60	160	260	360	460

Calculation:  $X_g = 20g/m \times (\text{Refrigerant piping length}(m) - 7)$

Service ref.	Outdoor unit precharged	Refrigerant piping length (one way)					
		7 m	10 m	15 m	20 m	25 m	30 m
SUZ-M71VA(R1).TH SUZ-M71VA-ET(R1).TH SUZ-M71VA-ERR1.TH	1,450	0	120	320	520	720	920

Calculation:  $X_g = 40g/m \times (\text{Refrigerant piping length}(m) - 7)$

## Pumping Down

When relocating or disposing of the air conditioner, pump down the system by following the procedure below so that no refrigerant is released into the atmosphere.

- ① Turn off the power supply (circuit breaker).
- ② Connect the gauge manifold valve to the service port of the stop valve on the gas pipe side of the outdoor unit.
- ③ Fully close the stop valve on the liquid pipe side of the outdoor unit.
- ④ Supply power (circuit breaker).
- ⑤ Perform the refrigerant collecting operation (cooling test run).
  - For the PAR-4xMAA ("x" represents 0 or later), select "Service" → "Test Run" from the main menu to start the test run, and then select the cooling mode.
  - For details or for other information about starting the test run when using remote controllers, refer to the installation manual for the indoor unit or the remote controller.
- ⑥ Fully close the stop valve on the gas pipe side of the outdoor unit when the pressure gauge shows 0.05 to 0 MPa [Gauge] (approx. 0.5 to 0 kgf/cm<sup>2</sup>) and quickly stop the air conditioner.
  - Push the "ON/OFF" button on the remote controller to stop the air conditioner.

Note:

When the extension piping is very long with a large refrigerant amount, it may not be possible to perform a pump down operation. In this case, use refrigerant recovery equipment to collect all of the refrigerant in the system.

- ⑦ Turn off the power supply (circuit breaker), remove the gauge manifold valve, and then disconnect the refrigerant pipes.

**⚠Warning: When pumping down the refrigerant, stop the compressor before disconnecting the refrigerant pipes.**

- If the refrigerant pipes are disconnected while the compressor is operating and the stop valve (ball valve) is open, the pressure in the refrigeration cycle could become extremely high if air is drawn in, causing the pipes to burst, personal injury, etc.
- Do not perform pump down work when there is a gas leak. The intake of air or other gases causes abnormally high pressure in the refrigeration cycle, which may cause explosion or injury.



**9-1. OUTDOOR FAN MOTOR CONTROL**

The fan motor turns ON/OFF, interlocking with the compressor.

[ON] The fan motor turns ON 5 seconds before the compressor starts up.

[OFF] The fan motor turns OFF 15 seconds after the compressor has stopped running.

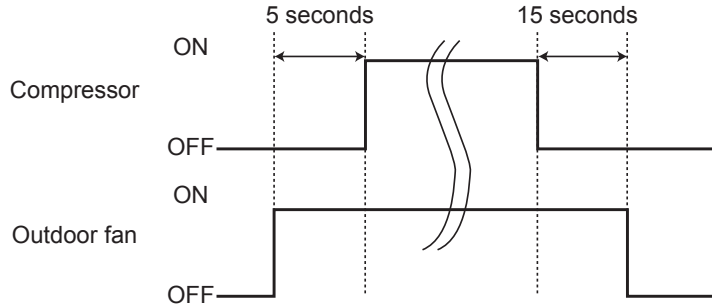

**9-2. R.V. COIL CONTROL**

- Heating ..... ON
- Cooling ..... OFF
- Dry ..... OFF

**NOTE:** The 4-way valve reverses for 5 seconds right before startup of the compressor.

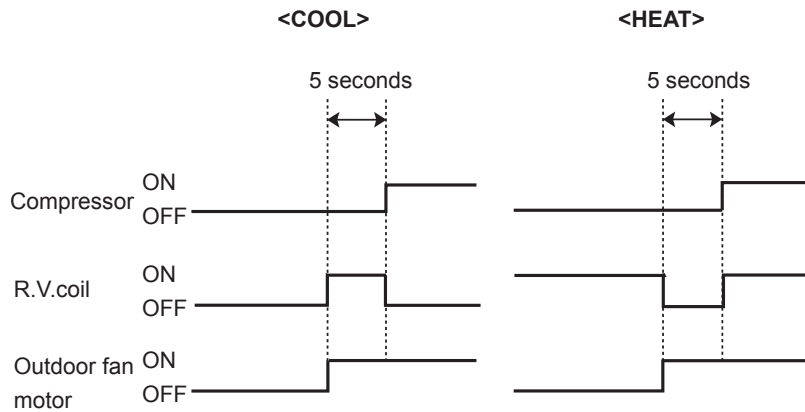

**9-3. RELATION BETWEEN MAIN SENSOR AND ACTUATOR**

Sensor	Purpose	Actuator				
		Compressor	LEV	Outdoor fan motor	R.V.coil	Indoor fan motor
Discharge temperature thermistor	Protection	○	○			
Indoor coil temperature thermistor	Cooling: Coil frost prevention	○				
	Heating: High pressure protection	○	○			
Defrost thermistor	Heating: Defrosting	○	○	○	○	○
Fin temperature thermistor	Protection	○		○		
Ambient temperature thermistor	Cooling: Low ambient temperature operation	○	○	○		
Outdoor heat exchanger temperature thermistor	Cooling: Low ambient temperature operation	○	○	○		
	Cooling: High pressure protection	○	○	○		

## CHANGE IN DEFROST SETTING

### Changing defrost finish temperature

<JS> To change the defrost finish temperature, cut/solder the JS wire of the outdoor inverter P.C. board. (Refer to "11-6-1. Inverter P.C. board".)

Jumper wire		Defrost finish temperature (°C)			
		SUZ-M25	SUZ-M35	SUZ-M50	SUZ-M60 SUZ-M71
JS	Soldered (Initial setting)	5	9	9	10
	None (cut)	8	13	18	18

## 11-1. CAUTIONS ON TROUBLESHOOTING

### 1. Before troubleshooting, check the following items:

- 1) Check the power supply voltage.
- 2) Check the indoor/outdoor connecting wire for miswiring.

### 2. Take care of the following during servicing.

- 1) Before servicing the air conditioner, be sure to turn OFF the main unit first with the remote controller, and turn off the breaker.
- 2) Be sure to turn OFF the power supply before removing the front panel, the cabinet, the top panel, and the electronic control P.C. board.
- 3) When removing the electrical parts, be careful of the residual voltage of smoothing capacitor.
- 4) When removing the electronic control P.C. board, hold the edge of the board with care NOT to apply stress on the components.
- 5) When connecting or disconnecting the connectors, hold the housing of the connector. DO NOT pull the lead wires.

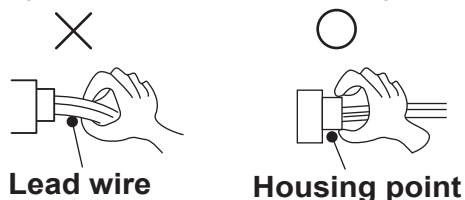

Lead wire

Housing point

### 3. Troubleshooting procedure

- 1) Check if the OPERATION INDICATOR lamp on the outdoor P.C. board is blinking on and off to indicate an abnormality. To make sure, check how many times the abnormality indication is blinking on and off before starting service work.
- 2) Before servicing check that the connector and terminal are connected properly.
- 3) If the electronic control P.C. board is supposed to be defective, check the copper foil pattern for disconnection and the components for bursting and discoloration.
- 4) When troubleshooting, refer to "11-2. Troubleshooting check table" and "11-3. HOW TO PROCEED "SELF-DIAGNOSIS"".

# 11-2. TROUBLESHOOTING CHECK TABLE

No.	Symptoms	LED indication	check code	Abnormal point/ Condition	Condition	Remedy		
1	Outdoor unit does not operate.	1-time blink every 2.5 seconds	UP	Outdoor power system	Overcurrent protection cut-out operates 3 consecutive times within 1 minute after the compressor gets started.	•Reconnect connector of compressor. •Refer to 11-5. Ⓐ "How to check inverter/compressor". •Check stop valve.		
2			U3	Outdoor thermistors	Discharge temperature thermistor shorts, or opens during compressor running.	•Refer to 11-5. Ⓔ "Check of outdoor thermistors".		
			U4	Fin temperature thermistor, defrost thermistor, P.C. board temperature thermistor, outdoor heat exchanger temperature thermistor or ambient temperature thermistor shorts, or opens during compressor running.				
3		6-time blink every 2.5 seconds OFF	FC	Outdoor control system	Nonvolatile memory data cannot be read properly.	•Replace inverter P.C. board.		
4			E8 / E9	Serial signal	The communication fails between the indoor and outdoor unit for 3 minutes.	•Check of indoor/outdoor connecting wire •Replace indoor or outdoor P.C. board if abnormality is displayed again.		
5			UE	Stop valve/ Closed valve	Closed valve is detected by compressor current.	• Check stop valve.		
6			PL	Outdoor refrigerant system abnormality	A closed valve and air trapped in the refrigerant circuit are detected based on the temperature sensed by the indoor and outdoor thermistors and the current of the compressor.	• Check for a gas leak in a connecting piping, etc. •Check stop valve. •Refer to 11-5. Ⓣ "Check of outdoor refrigerant circuit".		
7	20-time blink every 2.5 seconds OFF	EE	Combination error with indoor units	Abnormal if a connection of indoor unit and outdoor unit which uses different refrigerant is detected.	• Connect a proper unit.			
8	'Outdoor unit stops and restarts 3 minutes later' is repeated.	2-time blink every 2.5 seconds OFF		Overcurrent protection	Large current flows into intelligent power module.	•Reconnect connector of compressor. •Refer to 11-5. Ⓐ "How to check inverter/compressor". •Check stop valve.		
9				Discharge temperature overheat protection	Temperature of discharge temperature thermistor exceeds 116°C, compressor stops. Compressor can restart if discharge temperature thermistor reads 100°C or less 3 minutes later.	•Check refrigerant circuit and refrigerant amount. •Refer to 11-5. Ⓛ "Check of LEV".		
10				Fin temperature /P.C. board temperature thermistor overheat protection	Temperature of fin temperature thermistor on the heat sink exceeds 72 to 86°C or temperature of P.C. board temperature thermistor on the inverter P.C. board exceeds 72 to 85°C.	•Check around outdoor unit. •Check outdoor unit air passage. •Refer to 11-5. Ⓣ "Check of outdoor fan motor".		
11				High pressure protection	Indoor coil thermistor exceeds 70°C in HEAT mode. Defrost thermistor exceeds 70°C in COOL mode.	•Check refrigerant circuit and refrigerant amount. •Check stop valve.		
12				Compressor synchronous abnormality	The waveform of compressor current is distorted.	•Reconnect connector of compressor. •Refer to 11-5. Ⓐ "How to check inverter/compressor".		
13				Outdoor fan motor	Outdoor fan has stopped 3 times in a row within 30 seconds after outdoor fan startup.	•Refer to 11-5. Ⓢ "Check of outdoor fan motor." •Refer to 11-5. Ⓣ "Check of inverter P.C. board."		
14				Each phase current of compressor	Each phase current of compressor cannot be detected normally.	•Refer to 11-5. Ⓐ "How to check inverter/compressor".		
15				DC voltage	DC voltage of inverter cannot be detected normally.	•Refer to 11-5. Ⓐ "How to check inverter/compressor".		
16			Outdoor unit operates.	1-time blink every 2.5 seconds OFF		Frequency drop by current protection	When the input current exceeds approximately 7A(M25)/8A(M35)/12A(M50)/14A(M60)/16A(M71), compressor frequency lowers.	The unit is normal, but check the following. •Check if indoor filters are clogged. •Check if refrigerant is short. •Check if indoor/outdoor unit air circulation is short cycled.
17		Frequency drop by high pressure protection			Temperature of indoor coil thermistor exceeds 55°C in HEAT mode, compressor frequency lowers.			
		Frequency drop by defrosting in COOL mode			Indoor coil thermistor reads 8°C or less in COOL mode, compressor frequency lowers.			
18		4-time blink every 2.5 seconds OFF			Frequency drop by discharge temperature protection	Temperature of discharge temperature thermistor exceeds 111°C, compressor frequency lowers.	•Check refrigerant circuit and refrigerant amount. •Refer to 11-5. Ⓛ "Check of LEV". •Refer to 11-5. Ⓔ "Check of outdoor thermistors".	
19		7-time blink every 2.5 seconds OFF			Low discharge temperature protection	Temperature of discharge temperature thermistor has been 50°C or less for 20 minutes.	•Refer to 11-5. Ⓛ "Check of LEV". •Check refrigerant circuit and refrigerant amount.	
20	8-time blink every 2.5 seconds OFF	(M25/35/50)	PAM protection PAM: Pulse Amplitude Modulation	The overcurrent flows into PFC (Power factor correction: IC820) or the bus-bar voltage reaches 394 V or more, PAM stops and restarts.	This is not malfunction. PAM protection will be activated in the following cases: 1. Instantaneous power voltage drop. (Short time power failure) 2. When the power supply voltage is high.			
		(M60/71)	Zero cross detecting circuit	Zero cross signal for PAM control cannot be detected.				
21		9-time blink every 2.5 seconds OFF	Inverter check mode	The connector of compressor is disconnected, inverter check mode starts.	• Check if the connector of the compressor is correctly connected. •Refer to 11-5. Ⓐ "How to check inverter/compressor".			

Notes: 1. The location of LED is illustrated at the right figure. Refer to "11-6. Test point diagram and voltage".  
2. LED is lighted during normal operation.

The blinking frequency shows the number of times the LED blinks after every 2.5-second OFF.  
(Example) When the blinking frequency is "2".

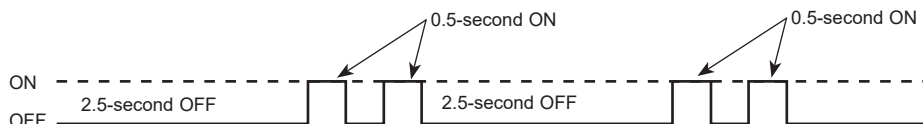

Inverter P.C. board

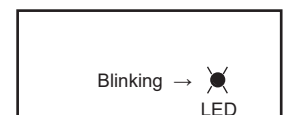

### 11-3. HOW TO PROCEED "SELF-DIAGNOSIS"

Refer to "13-8. SELF-DIAGNOSIS" to search for the error history.

• Refer to the following tables for details on the check codes.

[Output pattern A]

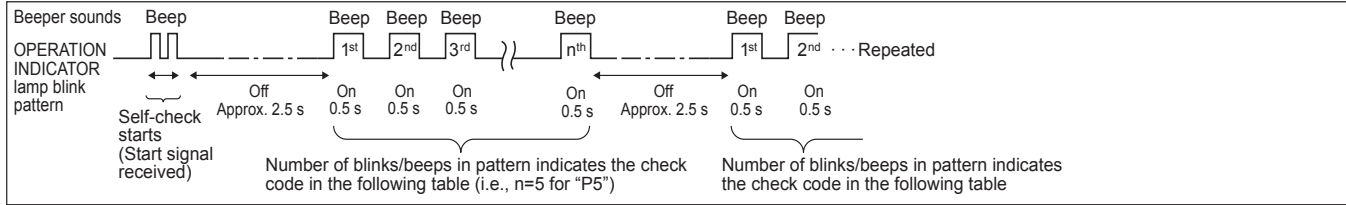

[Output pattern B]

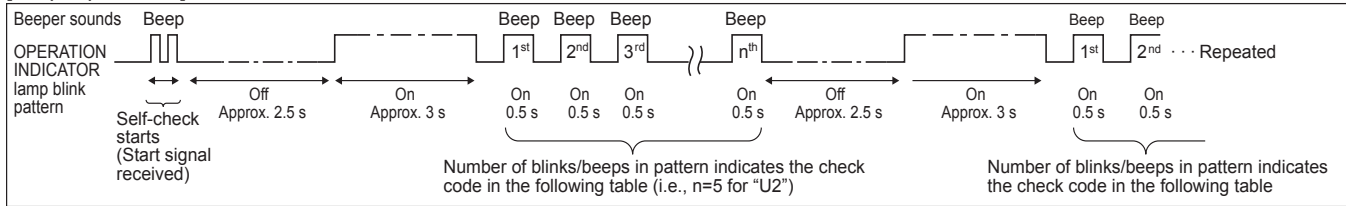

[Output pattern A] Errors detected by indoor unit

Wireless remote controller	Wired remote controller	Symptom	Remark
Beeper sounds/OPERATION INDICATOR lamp blinks (Number of times)	Check code		
1	P1	Intake sensor error	As for indoor unit, refer to indoor unit's service manual.
2	P2	Pipe (TH2) sensor error	
	P9	Pipe (TH5) sensor error	
3	E6,E7	Indoor/outdoor unit communication error	
4	P4	Drain sensor error/Float switch connector (CN4F) open	
5	P5	Drain pump error	
	PA	Forced compressor stop (due to water leakage abnormality)	
6	P6	Freezing/Overheating protection operation	
7	EE	Combination error between indoor and outdoor units	
9	E4,E5	Remote controller signal receiving error	
12	Fb (FB)*	Indoor unit control system error (memory error, etc.)	
14	PL	Abnormality of refrigerant circuit	
-	E0,E3	Remote controller transmission error	
-	E1,E2	Remote controller control board error	

[Output pattern B] Errors detected by unit other than indoor unit (outdoor unit, etc.)

Wireless remote controller	Wired remote controller	Symptom
Beeper sounds/OPERATION INDICATOR lamp blinks (Number of times)	Check code	
1	E9	Indoor/outdoor unit communication error (Transmitting error) (Outdoor unit)
2	UP	Compressor overcurrent interruption
3	U3,U4	Open/short of outdoor unit thermistors
14	PL or Others	Abnormality of refrigerant circuit or other errors (Refer to the technical manual for the outdoor unit.)

Notes: 1. If the beeper does not sound again after the initial 2 beeps to confirm the self-check start signal was received and the OPERATION INDICATOR lamp does not come on, there are no error records.

2. If the beeper sounds 3 times continuously "beep, beep, beep (0.4 + 0.4 + 0.4 second)" after the initial 2 beeps to confirm the self-check start signal was received, the specified refrigerant address is incorrect.

\*The check code in the parenthesis indicates PAR-4xMAA model. ("x" represents 0 or later).

## 11-4. TROUBLE CRITERION OF MAIN PARTS

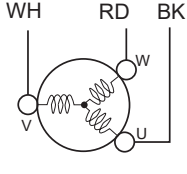
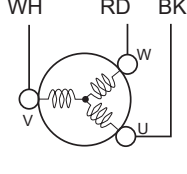
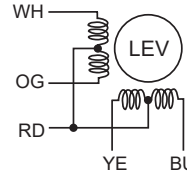
Parts name	Check method and criterion	Figure																									
Defrost thermistor (RT61) Fin temperature thermistor (RT64) Ambient temperature thermistor (RT65) Outdoor heat exchanger temperature thermistor (RT68)	Measure the resistance with a tester.  Refer to "11-6. Test point diagram and voltage", 11-6-1. (M25/35/50) or 11-6-2. (M60/71) "Inverter P.C. board", for the chart of thermistor.																										
Discharge temperature thermistor (RT62)	Measure the resistance with a tester. Before measurement, hold the thermistor with your hands to warm it up. Refer to "11-6. Test point diagram and voltage", 11-6-1. (M25/35/50) or 11-6-2. (M60/71) "Inverter P.C. board", for the chart of thermistor.																										
Compressor	Measure the resistance between terminals with a tester. (Temperature: -10 to 40°C)																										
	<table border="1"> <thead> <tr> <th></th> <th colspan="4">Normal</th> </tr> <tr> <th></th> <th>SUZ-M25</th> <th>SUZ-M35</th> <th>SUZ-M50/60</th> <th>SUZ-M71</th> </tr> </thead> <tbody> <tr> <td>U-V</td> <td>1.59 to 2.16 Ω</td> <td>1.60 to 2.17 Ω</td> <td>0.82 to 1.11 Ω</td> <td>0.87 to 1.18 Ω</td> </tr> <tr> <td>U-W</td> <td></td> <td></td> <td></td> <td></td> </tr> <tr> <td>V-W</td> <td></td> <td></td> <td></td> <td></td> </tr> </tbody> </table>		Normal					SUZ-M25	SUZ-M35	SUZ-M50/60	SUZ-M71	U-V	1.59 to 2.16 Ω	1.60 to 2.17 Ω	0.82 to 1.11 Ω	0.87 to 1.18 Ω	U-W					V-W					
	Normal																										
	SUZ-M25	SUZ-M35	SUZ-M50/60	SUZ-M71																							
U-V	1.59 to 2.16 Ω	1.60 to 2.17 Ω	0.82 to 1.11 Ω	0.87 to 1.18 Ω																							
U-W																											
V-W																											
Outdoor fan motor	Measure the resistance between terminals with a tester. (Temperature: -10 to 40°C)																										
	<table border="1"> <thead> <tr> <th>Color of the lead wire</th> <th colspan="3">Normal</th> </tr> <tr> <th></th> <th>SUZ-M25/35</th> <th>SUZ-M50</th> <th>SUZ-M60/71</th> </tr> </thead> <tbody> <tr> <td>WH - BK</td> <td rowspan="3">32 to 43 Ω</td> <td rowspan="3">15 to 20 Ω</td> <td rowspan="3">25 to 34 Ω</td> </tr> <tr> <td>BK - RD</td> </tr> <tr> <td>RD - WH</td> </tr> </tbody> </table>	Color of the lead wire	Normal				SUZ-M25/35	SUZ-M50	SUZ-M60/71	WH - BK	32 to 43 Ω	15 to 20 Ω	25 to 34 Ω	BK - RD	RD - WH												
Color of the lead wire	Normal																										
	SUZ-M25/35	SUZ-M50	SUZ-M60/71																								
WH - BK	32 to 43 Ω	15 to 20 Ω	25 to 34 Ω																								
BK - RD																											
RD - WH																											
R.V. coil (21S4)	Measure the resistance between terminals with a tester. (Temperature: -10 to 40°C)																										
	<table border="1"> <thead> <tr> <th colspan="2">Normal</th> </tr> <tr> <th>SUZ-M25/35/50</th> <th>SUZ-M60/71</th> </tr> </thead> <tbody> <tr> <td>1.41 to 2.00 kΩ</td> <td>1.17 to 1.66 kΩ</td> </tr> </tbody> </table>	Normal		SUZ-M25/35/50	SUZ-M60/71	1.41 to 2.00 kΩ	1.17 to 1.66 kΩ																				
Normal																											
SUZ-M25/35/50	SUZ-M60/71																										
1.41 to 2.00 kΩ	1.17 to 1.66 kΩ																										
Expansion valve coil (LEV)	Measure the resistance with a tester. (Temperature: -10 to 40°C)																										
	<table border="1"> <thead> <tr> <th>Color of the lead wire</th> <th>Normal</th> </tr> </thead> <tbody> <tr> <td>RD - OG</td> <td rowspan="4">37 to 54 Ω</td> </tr> <tr> <td>RD - WH</td> </tr> <tr> <td>RD - BU</td> </tr> <tr> <td>RD - YE</td> </tr> </tbody> </table>	Color of the lead wire	Normal	RD - OG	37 to 54 Ω	RD - WH	RD - BU	RD - YE																			
Color of the lead wire	Normal																										
RD - OG	37 to 54 Ω																										
RD - WH																											
RD - BU																											
RD - YE																											



## 11-5. TROUBLESHOOTING FLOW

### A How to check inverter/compressor

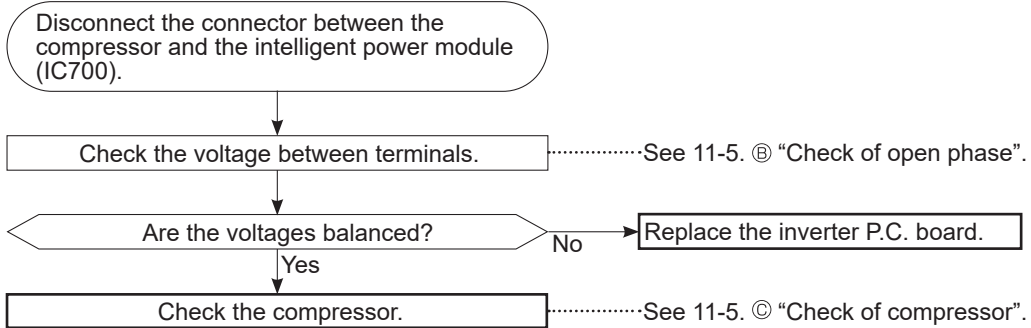

### B Check of open phase

- With the connector between the compressor and the intelligent power module disconnected, activate the inverter and check if the inverter is normal by measuring the voltage balance between the terminals.

Output voltage is 50–130 V. (The voltage may differ according to the tester.)

< Operation method (Test run operation)>

- For the PAR-4xMAA model. ("x" represents 0 or later), select "Service" → "Test Run" from the main menu to start the test run, and then select the cooling mode.
- For details or for other information about starting the test run when using remote controllers, refer to the installation manual for the indoor unit or the remote controller.

<Measurement point>

Measure AC voltage between the lead wires at 3 points.

- BK (U) - WH (V)
- BK (U) - RD (W)
- WH (V) - RD (W)

Notes: 1. Output voltage varies according to power supply voltage.

2. Measure the voltage by analog type tester.

3. During this check, LED of the inverter P.C. board blinks 9 times. (M25/35/50: Refer to 11-6-1, M60/71: 11-6-2)

### C Check of compressor

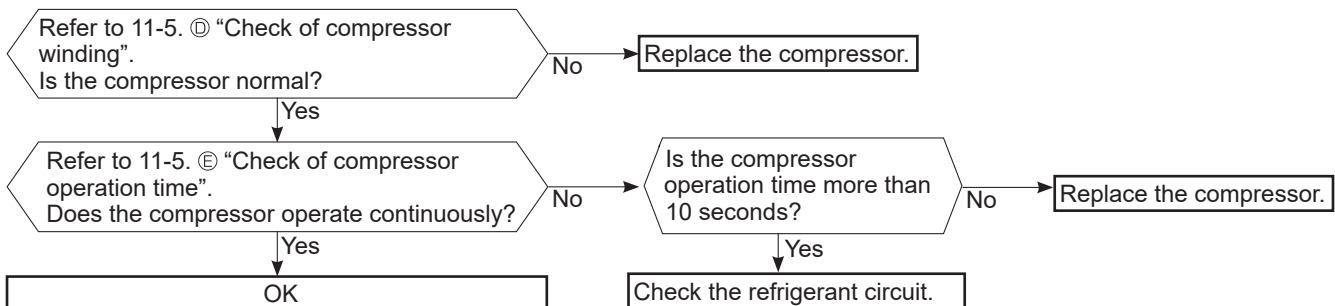

### D Check of compressor winding

- Disconnect the connector between the compressor and the intelligent power module, and measure the resistance between the compressor terminals.

<Measurement point>

Measure the resistance between the lead wires at 3 points.

BK-WH

BK-RD

WH-RD

<Judgement>

Refer to "11-4. TROUBLE CRITERION OF MAIN PARTS".

0 [Ω] .....Abnormal [short]

Infinite [Ω] .....Abnormal [open]

**NOTE:** Be sure to zero the ohmmeter before measurement.

### E Check of compressor operation time

- Connect the compressor and activate the inverter. Then measure the time until the inverter stops due to overcurrent.

<Operation method>

Start heating or cooling test run.

(TEST RUN OPERATION : Refer to 11-5 ⑥.)

<Measurement>

Measure the time from the start of compressor to the stop of compressor due to overcurrent.

<<Judgement>>

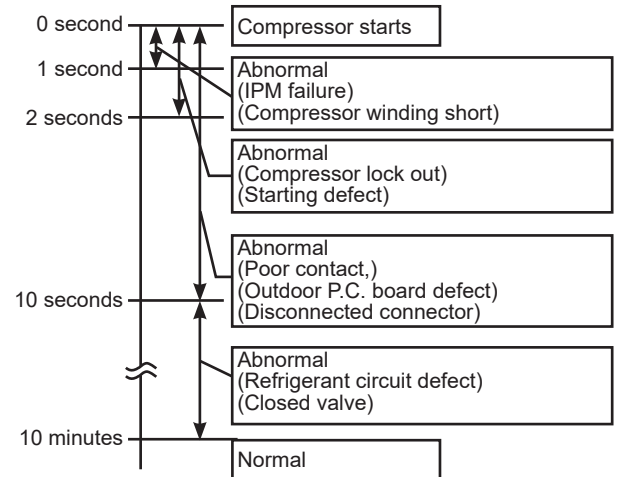

### F Check of outdoor thermistors

Disconnect the connector of thermistor in the outdoor P.C. board (see below table), and measure the resistance of thermistor.

Is the resistance of thermistor normal?

(M25/35/50: Refer to 11-6-1, M60/71: 11-6-2.)

No

Replace the thermistor except RT64.  
When RT64 is abnormal, replace the inverter P.C. board.

Yes

Reconnect the connector of thermistor.  
Turn ON the power supply and press EMERGENCY OPERATION switch.

Does the unit operate for 10 minutes or more without showing thermistor abnormality?

No

Replace the inverter P.C. board.

Yes

OK  
(Cause is poor contact.)

Thermistor	Symbol	Connector, Pin No.		Board
		SUZ-M25/35/50	SUZ-M60/71	
Defrost	RT61	Between CN641 pin1 and pin2	Between CN671 pin1 and pin2	Inverter P.C. board
Discharge temperature	RT62	Between CN641 pin3 and pin4	Between CN671 pin3 and pin4	
Fin temperature	RT64	Between CN642 pin1 and pin2	Between CN673 pin1 and pin2	
Ambient temperature	RT65	Between CN643 pin1 and pin2	Between CN672 pin1 and pin2	
Outdoor heat exchanger temperature	RT68	Between CN644 pin1 and pin3	Between CN671 pin5 and pin6	

## G Check of R.V. coil

- First of all, measure the resistance of R.V. coil to check if the coil is defective. Refer to "11-4. TROUBLE CRITERION OF MAIN PARTS".

In case CN721(M25/35/50)/CN602(M60/71) is not connected or R.V. coil is open, voltage is generated between the terminal pins of the connector although any signal is not being transmitted to R.V. coil.

Check if CN721(M25/35/50)/CN602(M60/71) is connected.

### Unit operates in COOL mode even if it is set to HEAT mode.

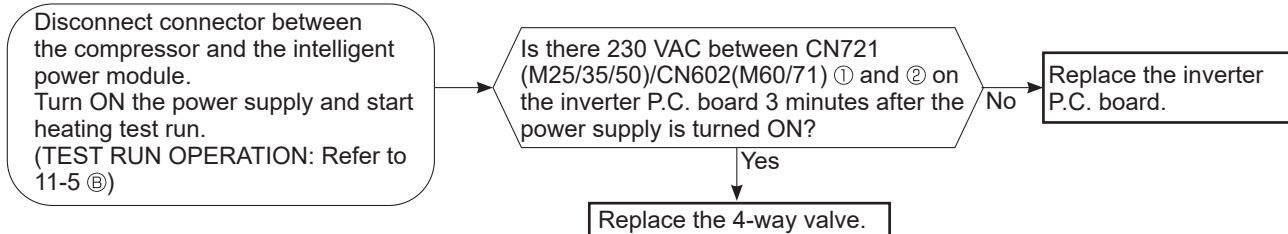

### Unit operates in HEAT mode even if it is set to COOL mode.

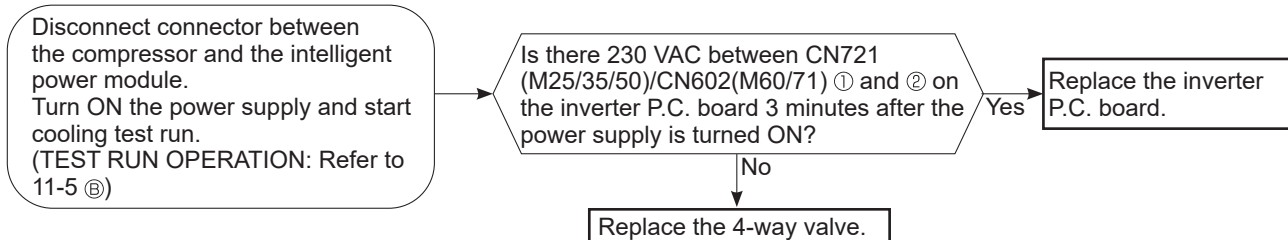

## H Check of outdoor fan motor

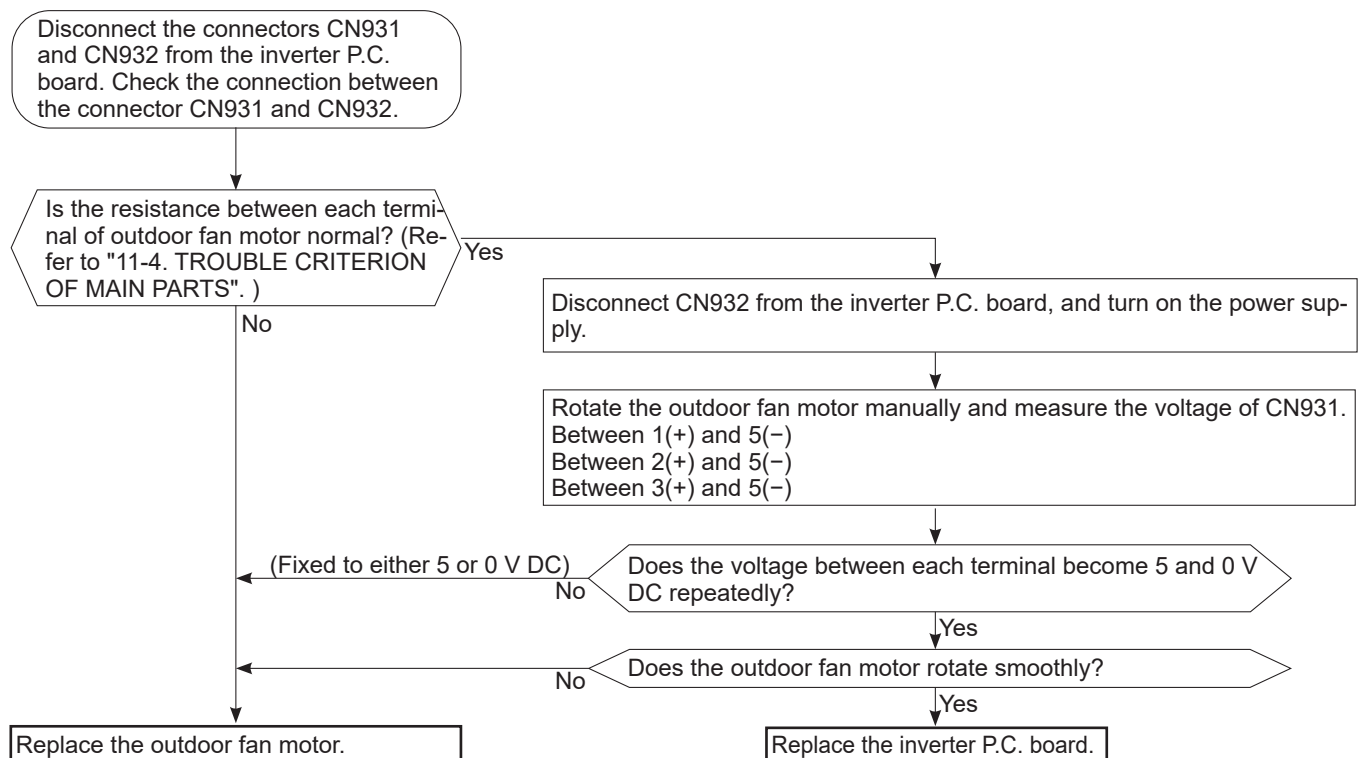



### ① Check of LEV

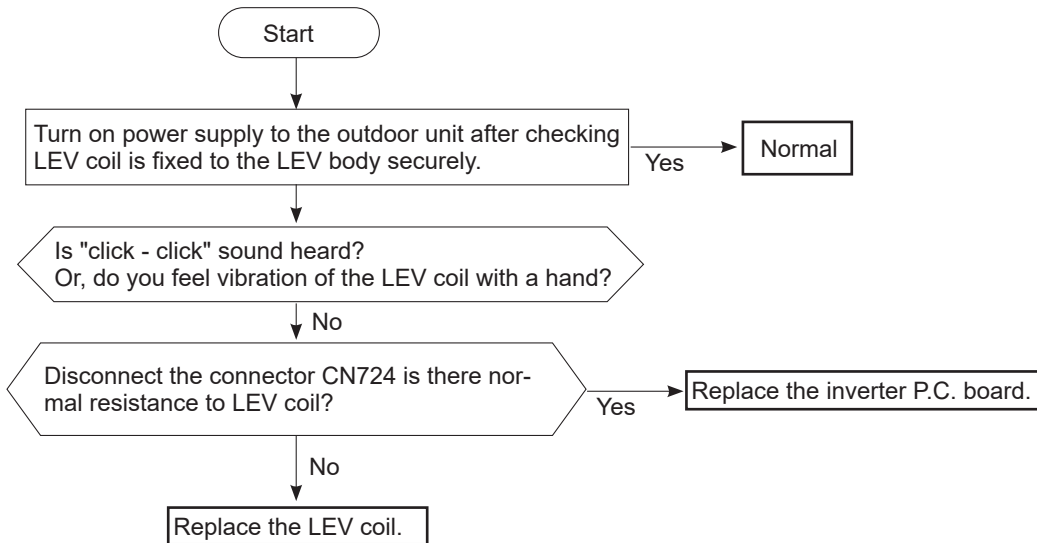

### ② Check of inverter P.C. board

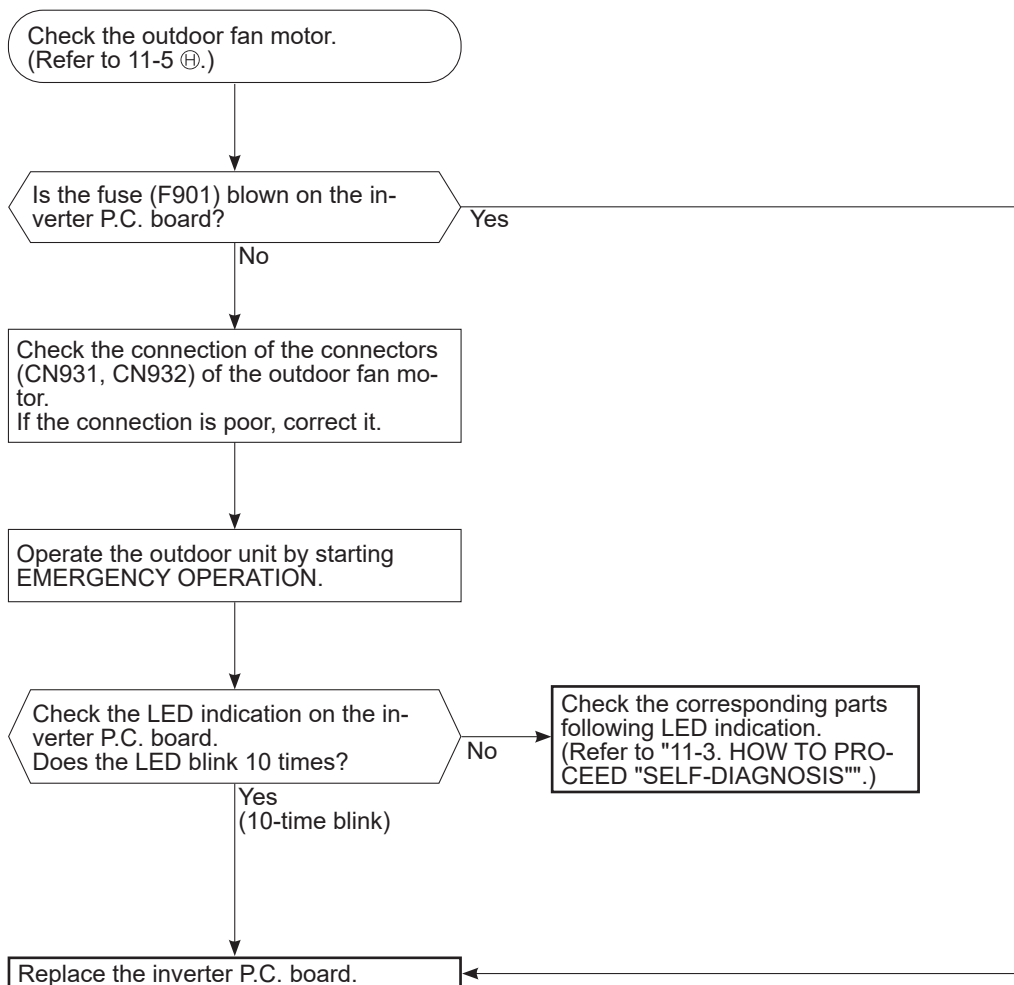

## K Electromagnetic noise enters into TV sets or radios

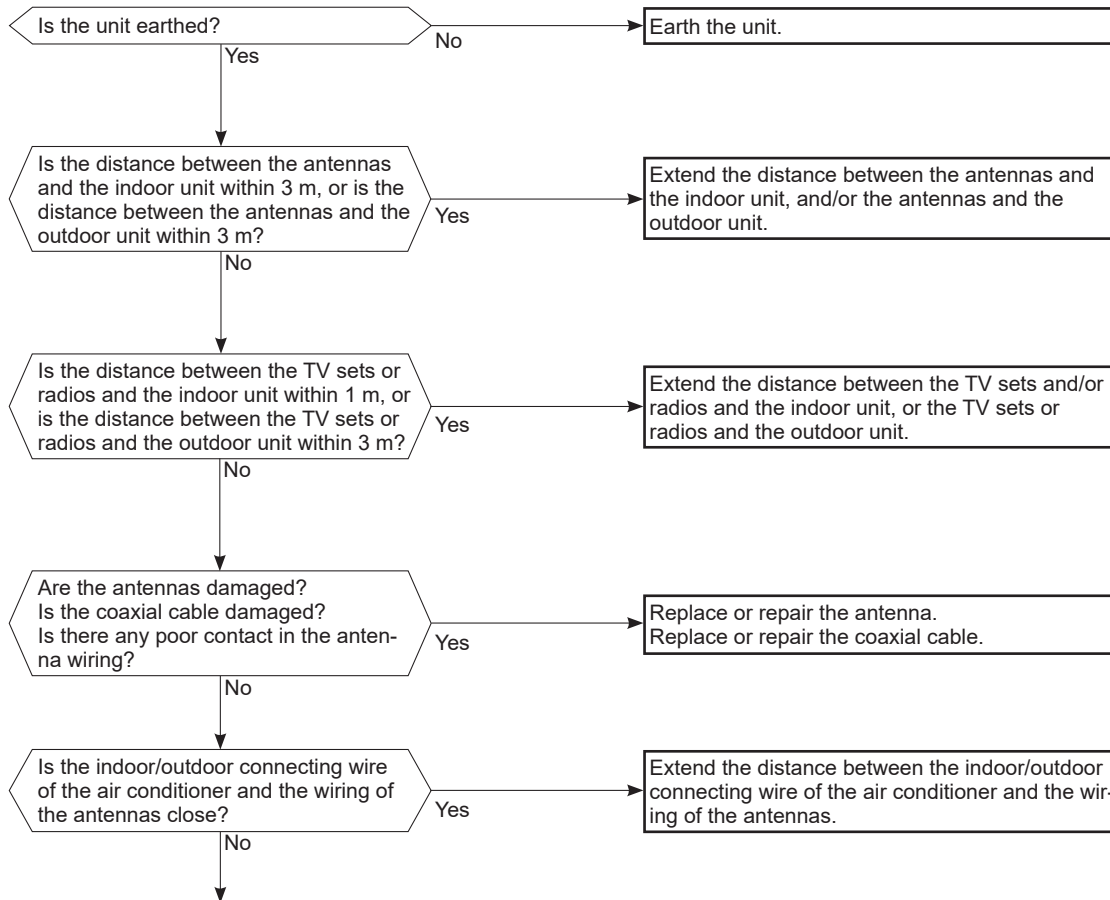

Even if all of the above conditions are fulfilled, the electromagnetic noise may enter, depending on the electric field strength or the installation condition (combination of specific conditions such as antennas or wiring).  
Check the following before asking for service.

1. Devices affected by the electromagnetic noise  
TV sets, radios (FM/AM broadcast, shortwave)
2. Channel, frequency, broadcast station affected by the electromagnetic noise
3. Channel, frequency, broadcast station unaffected by the electromagnetic noise
4. Layout of;  
indoor/outdoor unit of the air conditioner, indoor/outdoor wiring, earth wire, antennas, wiring from antennas, receiver
5. Electric field intensity of the broadcast station affected by the electromagnetic noise
6. Presence or absence of amplifier such as booster
7. Operation condition of air conditioner when the electromagnetic noise enters in
  - 1) Turn OFF the power supply once, and then turn ON the power supply. In this situation, check for the electromagnetic noise.
  - 2) Within 3 minutes after turning ON the power supply, press OPERATE/STOP (ON/OFF) button on the remote controller for power ON, and check for the electromagnetic noise.
  - 3) After a short time (3 minutes later after turning ON), the outdoor unit starts running. During operation, check for the electromagnetic noise.
  - 4) Press OPERATE/STOP (ON/OFF) button on the remote controller for power OFF, when the outdoor unit stops but the indoor/outdoor communication still runs on. In this situation, check for the electromagnetic noise.

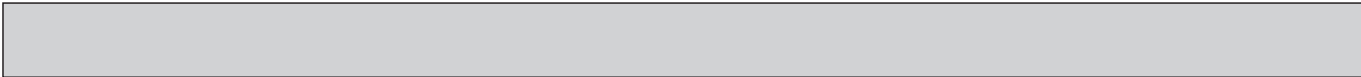

**L Check of outdoor refrigerant circuit**

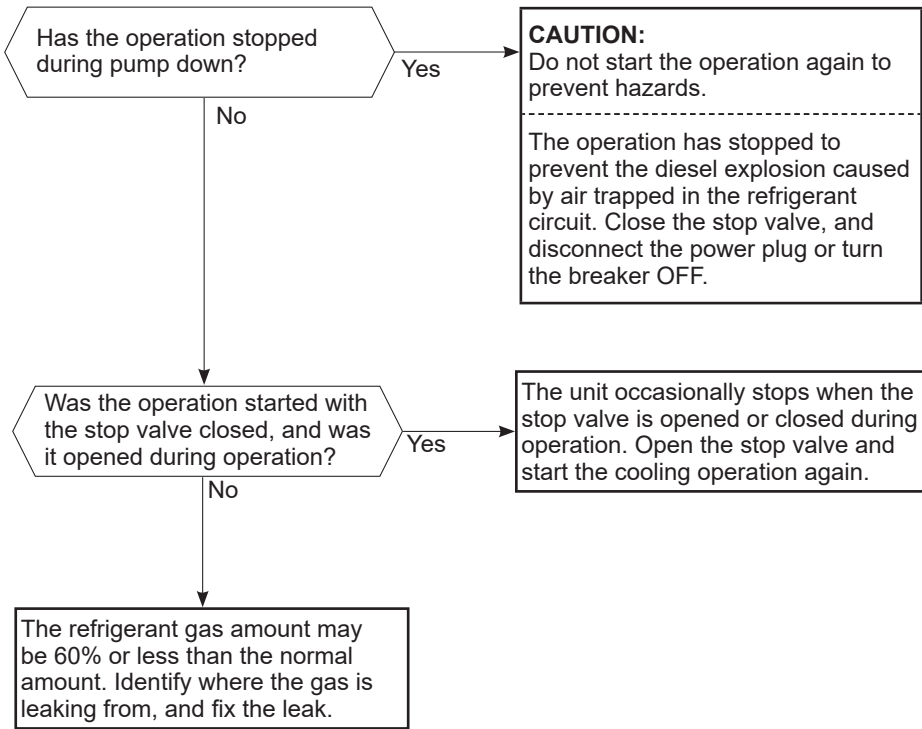

Note: If the abnormality cannot be reset with remote controllers, it is detected in the connected indoor unit. Please refer to the indoor unit's service manual.

# 11-6. TEST POINT DIAGRAM AND VOLTAGE

## 11-6-1. Inverter P.C. board

<b>SUZ-M25VA.TH</b>	<b>SUZ-M35VA.TH</b>	<b>SUZ-M50VA.TH</b>
<b>SUZ-M25VAR1.TH</b>	<b>SUZ-M35VAR1.TH</b>	<b>SUZ-M50VAR1.TH</b>
<b>SUZ-M25VAR2.TH</b>	<b>SUZ-M35VAR2.TH</b>	<b>SUZ-M50VAR2.TH</b>
<b>SUZ-M25VA-ET.TH</b>	<b>SUZ-M35VA-ET.TH</b>	<b>SUZ-M50VA-ET.TH</b>
<b>SUZ-M25VA-ETR2.TH</b>	<b>SUZ-M35VA-ETR2.TH</b>	<b>SUZ-M50VA-ETR2.TH</b>
<b>SUZ-M25VA-ERR2.TH</b>	<b>SUZ-M35VA-ERR2.TH</b>	<b>SUZ-M50VA-ERR2.TH</b>

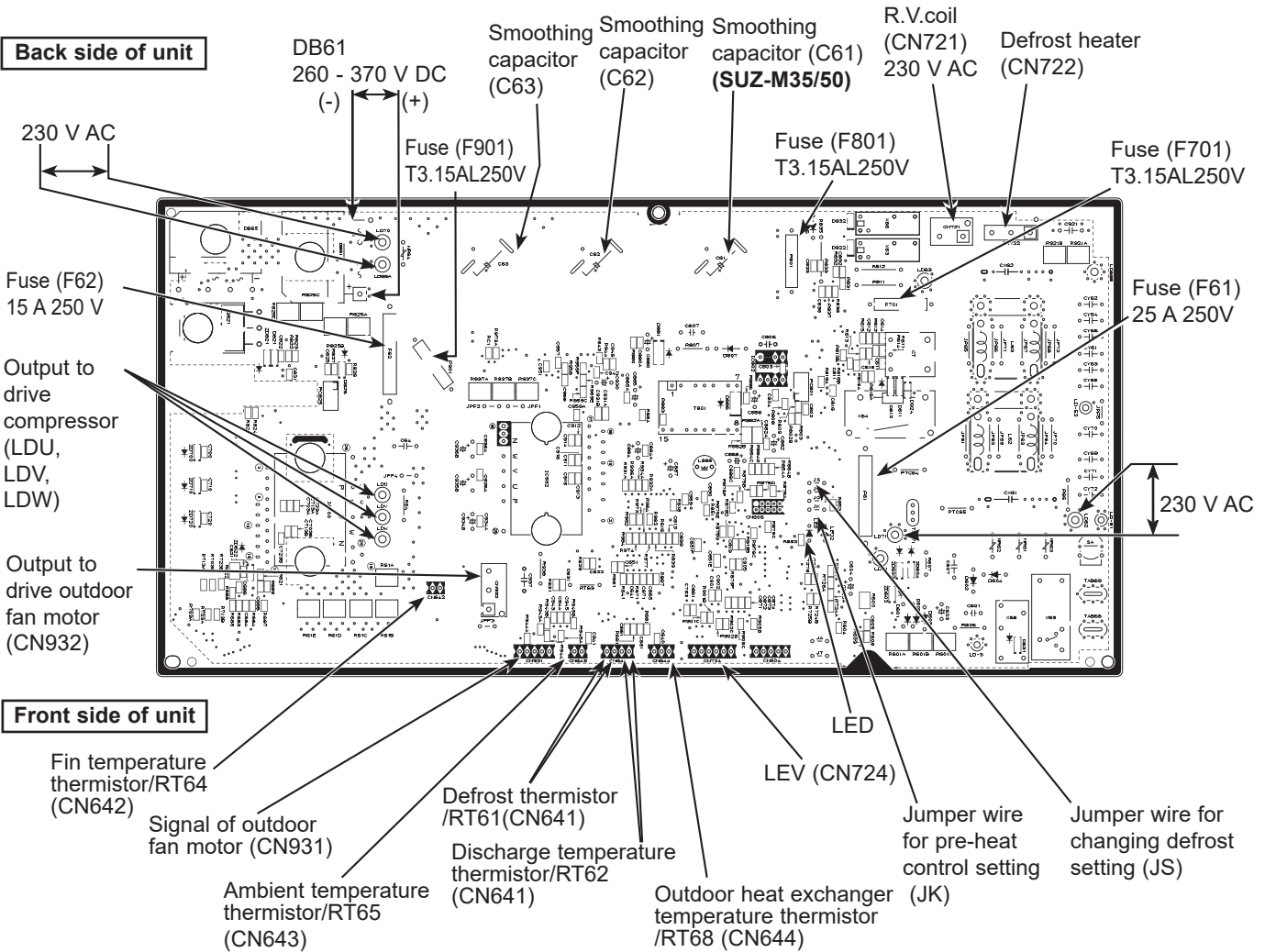

Defrost thermistor (RT61)  
Ambient temperature thermistor (RT65)  
Outdoor heat exchanger temperature thermistor (RT68)

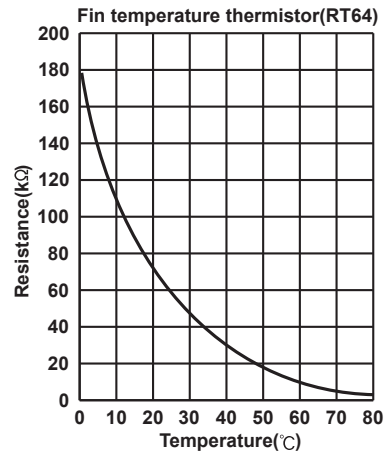
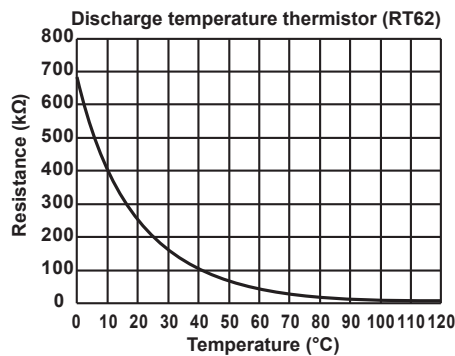
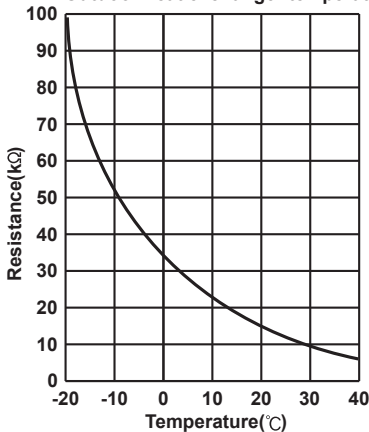

11-6-2. Inverter P.C. board  
 SUZ-M60VA.TH  
 SUZ-M60VAR1.TH  
 SUZ-M60VAR2.TH  
 SUZ-M60VA-ET.TH  
 SUZ-M60VA-ETR2.TH  
 SUZ-M60VA-ERR2.TH

SUZ-M71VA.TH  
 SUZ-M71VAR1.TH  
 SUZ-M71VA-ET.TH  
 SUZ-M71VA-ETR1.TH  
 SUZ-M71VA-ERR1.TH

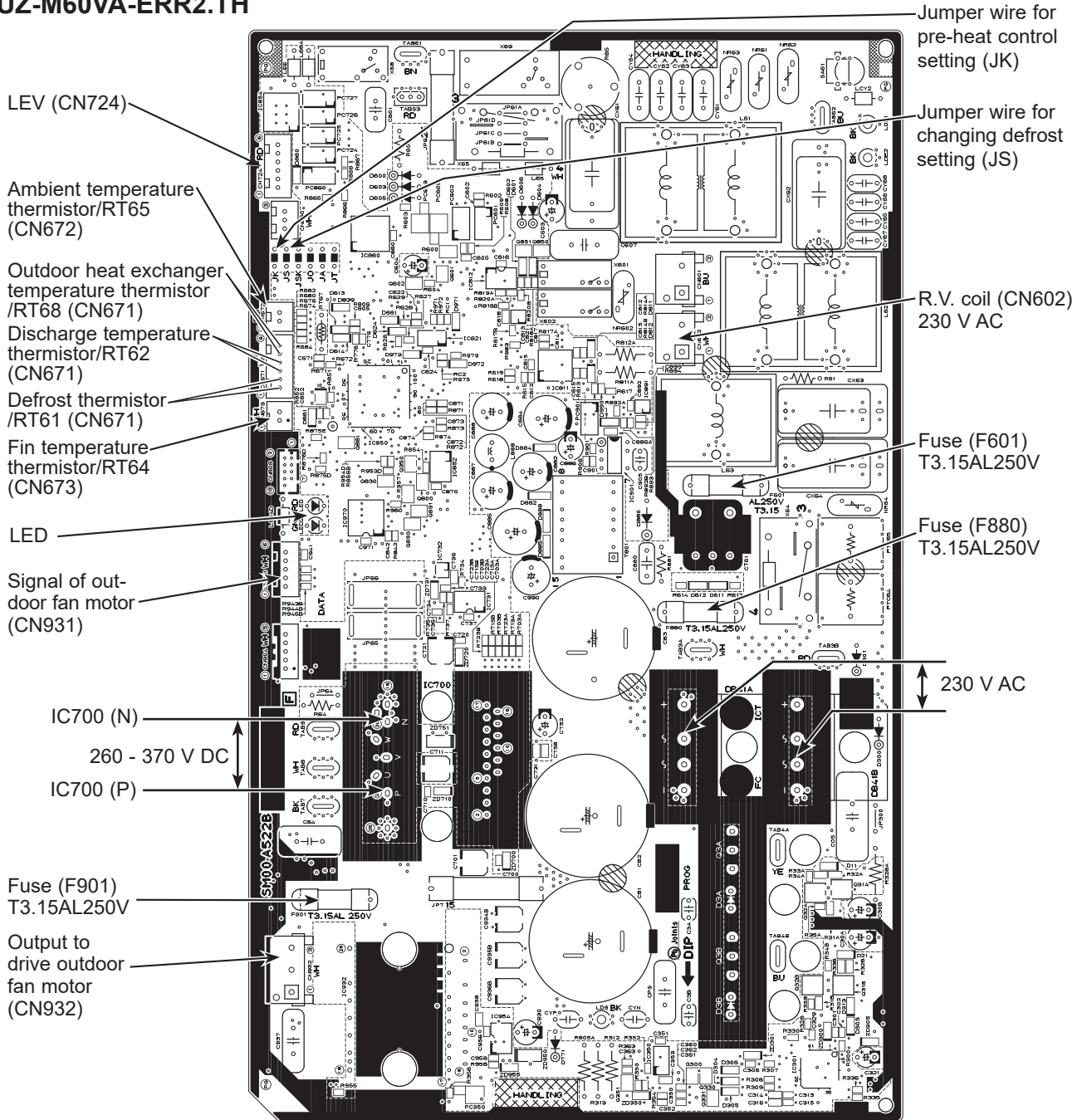

Defrost thermistor (RT61)  
 Ambient temperature thermistor (RT65)  
 Outdoor heat exchanger temperature thermistor (RT68)

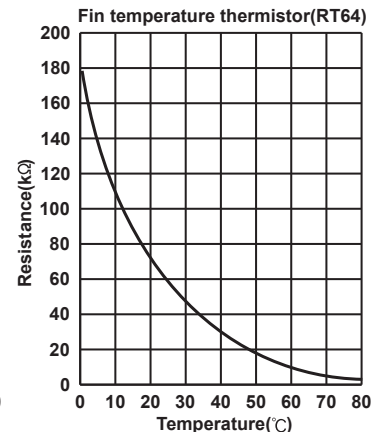
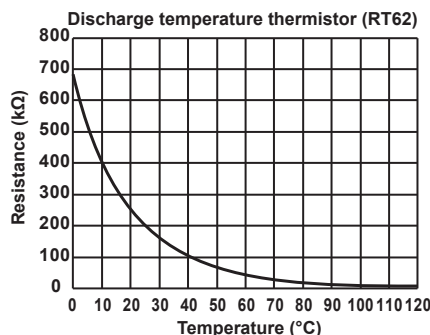
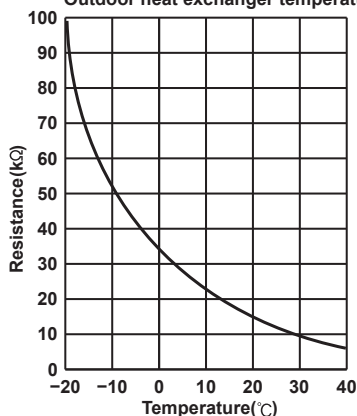

<"Terminal with locking mechanism" Detaching points>

The terminal which has the locking mechanism can be detached as shown below.  
 There are 2 types (Refer to (1) and (2)) of the terminal with locking mechanism.  
 The terminal without locking mechanism can be detached by pulling it out.  
 Check the shape of the terminal before detaching.

(1) Slide the sleeve and check if there is a locking lever or not.

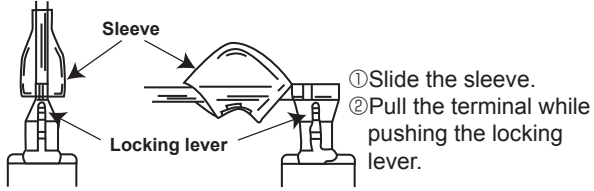

(2) The terminal with this connector has the locking mechanism.

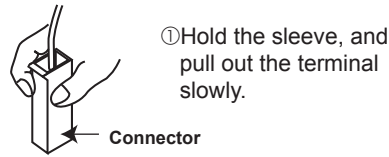

**SUZ-M25VA.TH**  
**SUZ-M25VAR1.TH**  
**SUZ-M25VAR2.TH**  
**SUZ-M25VA-ET.TH**  
**SUZ-M25VA-ETR2.TH**  
**SUZ-M25VA-ERR2.TH**

**SUZ-M35VA.TH**  
**SUZ-M35VAR1.TH**  
**SUZ-M35VAR2.TH**  
**SUZ-M35VA-ET.TH**  
**SUZ-M35VA-ETR2.TH**  
**SUZ-M35VA-ERR2.TH**

—————> : Indicates the visible parts in the photos/figures.  
 - - - - -> : Indicates the invisible parts in the photos/figures.

**NOTE:** Turn OFF the power supply before disassembly.

OPERATING PROCEDURE	PHOTOS/FIGURES
<p><b>1. Removing the cabinet</b></p> <p>(1) Remove the screw fixing the service panel.                      (2) Pull down the service panel and remove it.                      (3) Disconnect the power supply cord and indoor/outdoor connecting wire.                      (4) Remove the screws fixing the top panel.                      (5) Remove the top panel.                      (6) Remove the screws fixing the cabinet.                      (7) Remove the cabinet.                      (8) Remove the screws fixing the back panel.                      (9) Remove the back panel.</p> <p><b>Photo 3</b></p>	<p><b>Photo 1</b></p> <p><b>Photo 2</b></p>

## OPERATING PROCEDURE

### 2. Removing the inverter assembly, inverter P.C. board

- (1) Remove the cabinet and panels. (Refer to section 1.)
- (2) Disconnect the lead wire to the reactor and the following connectors:
  - <Inverter P.C. board>
  - CN721 (R.V. coil)
  - CN931, CN932 (Fan motor)
  - CN641 (Defrost thermistor and discharge temperature thermistor)
  - CN643 (Ambient temperature thermistor)
  - CN644 (Outdoor heat exchanger temperature thermistor)
  - CN724 (LEV)
- (3) Remove the compressor connector (CN61).
- (4) Remove the screws fixing the heat sink support and the separator.
- (5) Remove the fixing screws of the terminal block support and the back panel.
- (6) Remove the inverter assembly.
- (7) Remove the screw of the earth wire and screw of the terminal block support.
- (8) Remove the heat sink support from the P.C. board support.
- (9) Remove the screw of the inverter P.C. board and remove the inverter P.C. board from the P.C. board support.

### 3. Removing R.V. coil

- (1) Remove the cabinet and panels. (Refer to section 1.)
- (2) Disconnect the following connectors:
  - <Inverter P.C. board>
  - CN721 (R.V. coil)
- (3) Remove the R.V. coil.

### 4. Removing the discharge temperature thermistor, defrost thermistor, outdoor heat exchanger temperature thermistor and ambient temperature thermistor

- (1) Remove the cabinet and panels. (Refer to section 1.)
- (2) Disconnect the lead wire to the reactor and the following connectors:
  - <Inverter P.C. board>
  - CN641 (Defrost thermistor and discharge temperature thermistor)
  - CN643 (Ambient temperature thermistor)
  - CN644 (Outdoor heat exchanger temperature thermistor)
- (3) Pull out the discharge temperature thermistor from its holder.
- (4) Pull out the defrost thermistor from its holder. (Photo 7)
- (5) Pull out the outdoor heat exchanger temperature thermistor from its holder. (Photo 7)
- (6) Pull out the ambient temperature thermistor from its holder.

## PHOTOS/FIGURES

**Photo 4**

Screws of the heat sink support and the separator      Screws of the terminal block support and the back panel

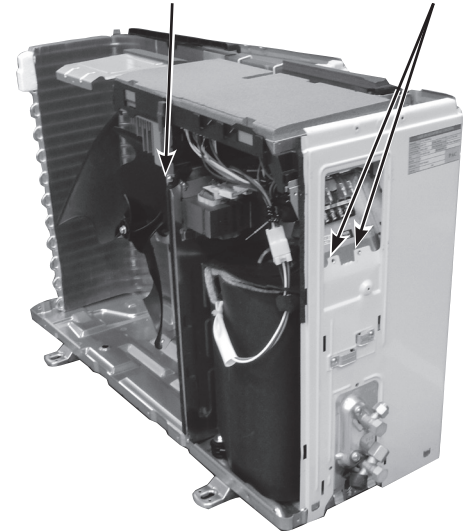

**Photo 5 (Inverter assembly)**

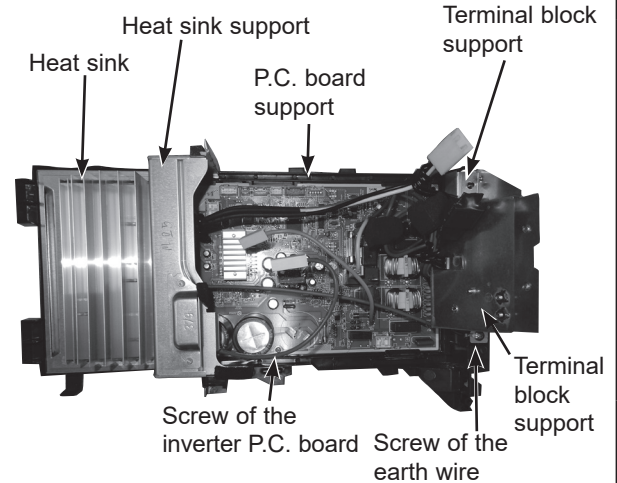

**Photo 6**

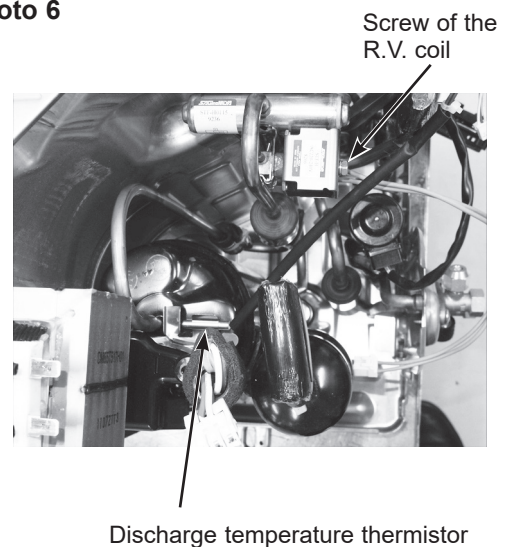

## OPERATING PROCEDURE

### 5. Removing outdoor fan motor

- (1) Remove the cabinet and panels. (Refer to section 1.)
- (2) Disconnect the following connectors:  
<Inverter P.C. board>  
CN931, CN932 (Fan motor)
- (3) Remove the propeller fan nut.
- (4) Remove the propeller fan.
- (5) Remove the screws fixing the fan motor.
- (6) Remove the fan motor.

### 6. Removing the compressor and 4-way valve

- (1) Remove the cabinet and panels. (Refer to section 1.)
- (2) Remove the inverter assembly. (Refer to section 2.)
- (3) Recover gas from the refrigerant circuit.  
**NOTE:** Recover gas from the pipes until the pressure gauge shows 0 kg/cm<sup>2</sup> (0 MPa).
- (4) Detach the brazed part of the suction and the discharge pipe connected with compressor.
- (5) Remove the nuts of compressor legs.
- (6) Remove the compressor.
- (7) Detach the brazed part of pipes connected with 4-way valve.

### 7. Removing the LEV assembly

- (1) Detaching the brazed part of pipes connected with LEV valve.

Photo 10

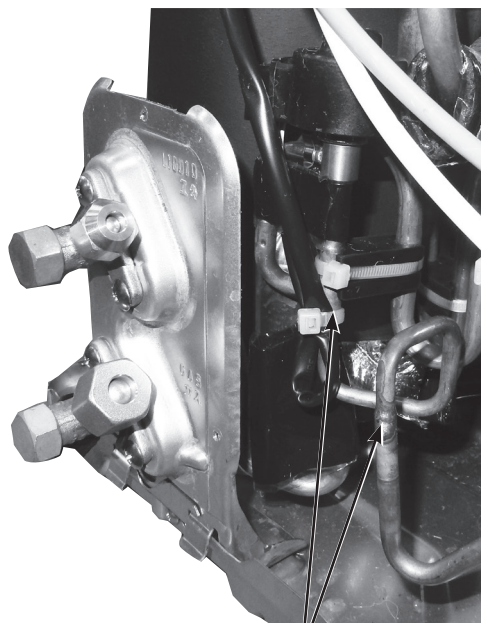

Brazed parts of LEV valve

## PHOTOS/FIGURES

Photo 7

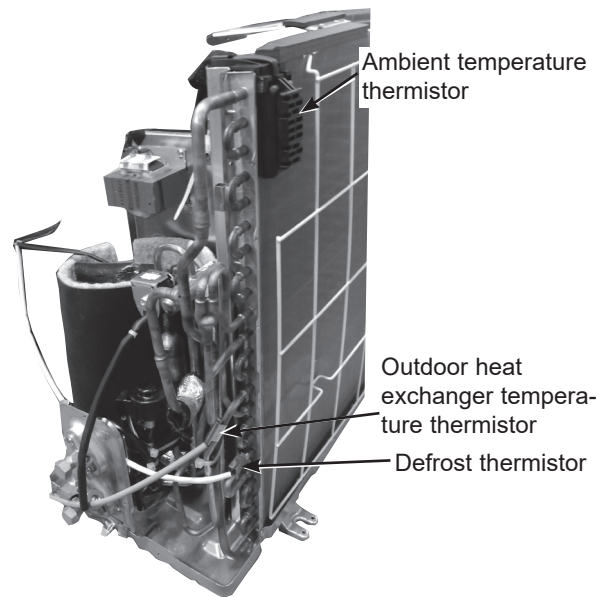

**NOTE:** SUZ-M25/35VA are different in the installation position of thermistors.

Screws of the outdoor fan motor

Photo 8

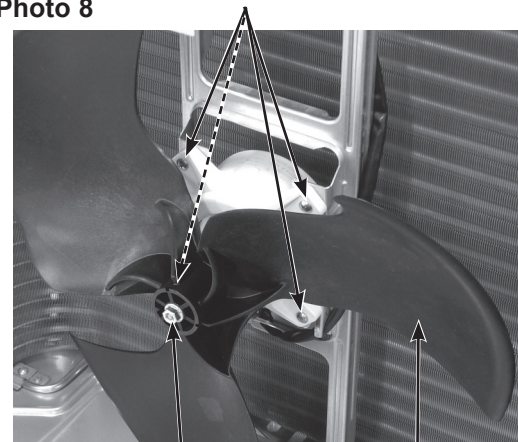

Propeller fan nut

Propeller fan

Photo 9

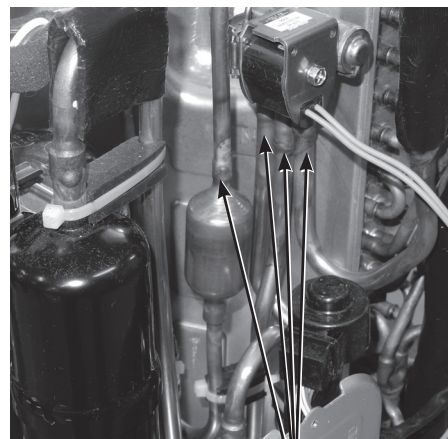

Brazed parts of 4-way valve



**SUZ-M50VA.TH**  
**SUZ-M50VAR1.TH**  
**SUZ-M50VAR2.TH**  
**SUZ-M50VA-ET.TH**  
**SUZ-M50VA-ETR2.TH**  
**SUZ-M50VA-ERR2.TH**

**NOTE:** Turn OFF the power supply before disassembly.

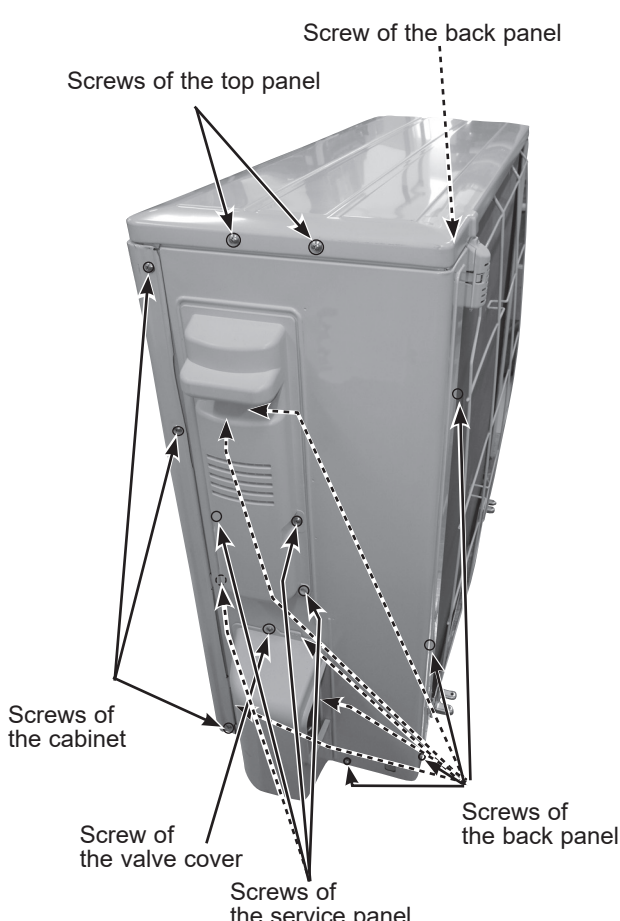
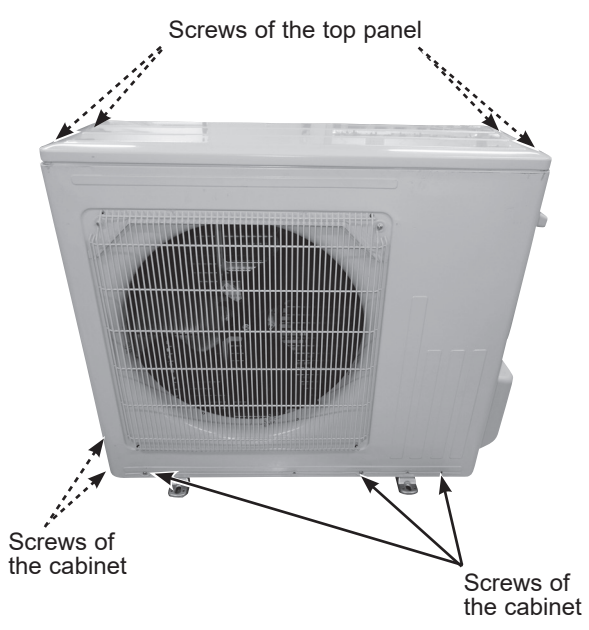
OPERATING PROCEDURE	PHOTOS/FIGURES
<p><b>1. Removing the cabinet</b></p> <ol style="list-style-type: none"> <li>(1) Remove the screws of the service panel.</li> <li>(2) Remove the screws of the top panel.</li> <li>(3) Remove the screw of the valve cover.</li> <li>(4) Remove the service panel.</li> <li>(5) Remove the top panel.</li> <li>(6) Remove the valve cover.</li> <li>(7) Disconnect the power supply and indoor/outdoor connecting wire.</li> <li>(8) Remove the screws of the cabinet.</li> <li>(9) Remove the cabinet.</li> <li>(10) Remove the screws of the back panel.</li> <li>(11) Remove the back panel.</li> </ol> <p><b>Photo 2</b></p> 	<p><b>Photo 1</b></p> 

## OPERATING PROCEDURE

### 2. Removing the inverter assembly and inverter P.C. board

- (1) Remove the cabinet and panels. (Refer to section 1.)
- (2) Disconnect the lead wire to the reactor and the following connectors:
  - <Inverter P.C. board>
  - CN721 (R.V. coil)
  - CN931, CN932 (Fan motor)
  - CN641 (Defrost thermistor and discharge temperature thermistor)
  - CN643 (Ambient temperature thermistor)
  - CN644 (Outdoor heat exchanger temperature thermistor)
  - CN724 (LEV)
- (3) Remove the compressor connector (CN61).
- (4) Remove the screws fixing the heat sink support and the separator.
- (5) Remove the fixing screw of the P.B. support and the separator.
- (6) Remove the fixing screws of the terminal block support and the back panel.
- (7) Remove the inverter assembly.
- (8) Remove the heat sink support from the P.C. board support.
- (9) Remove the screw of the inverter P.C. board and remove the inverter P.C. board from the P.C. board support.

#### \* Connection procedure when attaching the inverter P.C. board (Photo 4)

1. Connect the lead wires of the heat exchanger temperature thermistor, the defrost thermistor and discharge temperature thermistor to the connector on the inverter P.C. board. Pull the lead wires toward you and put them on the right hook on the P.C. board support.
2. Connect the lead wires of the LEV to the connector on the inverter P.C. board. Pull the lead wires toward you and put them on the right hook on the P.C. board support.
3. Connect the lead wires of the ambient temperature thermistor to the connector on the inverter P.C. board. Pull the lead wires toward you and put them on the left hook on the P.C. board support so that the fan motor lead wires are bundled up as shown in Photo 4.

## PHOTOS/FIGURES

Photo 3

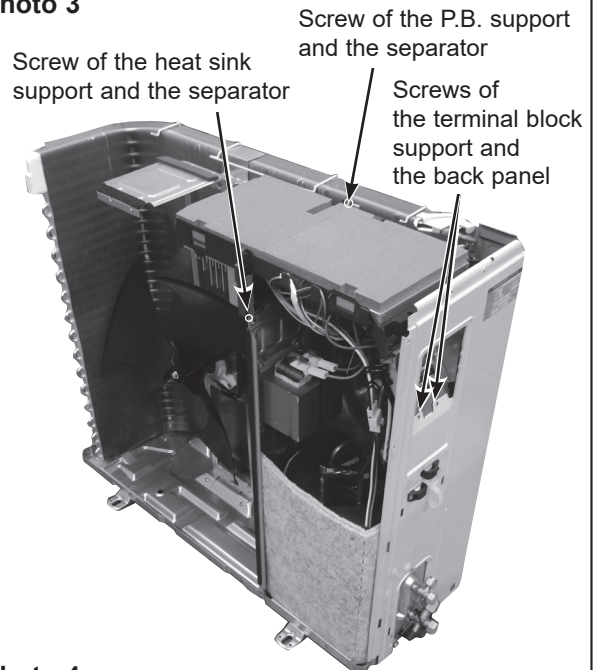
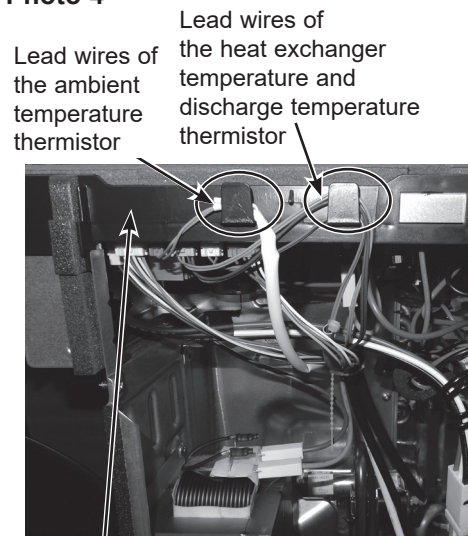
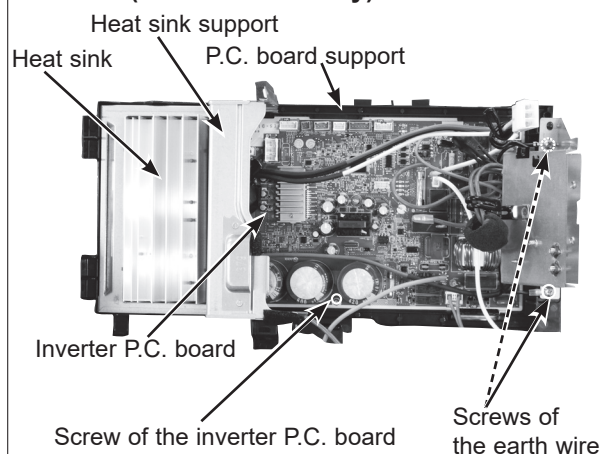

Photo 4



Inverter P.C. board support

Photo 5 (Inverter assembly)



## OPERATING PROCEDURE

### 3. Removing R. V. coil

- (1) Remove the cabinet and panels. (Refer to section 1.)
- (2) Disconnect the following connectors:  
<Inverter P.C. board>  
CN721 (R.V. coil)
- (3) Remove the R.V. coil.

### 4. Removing the discharge temperature thermistor, defrost thermistor, outdoor heat exchanger temperature thermistor and ambient temperature thermistor

- (1) Remove the cabinet and panels. (Refer to section 1.)
- (2) Disconnect the lead wire to the reactor and the following connectors:  
<Inverter P.C. board>  
CN641 (Defrost thermistor and discharge temperature thermistor)  
CN643 (Ambient temperature thermistor)  
CN644 (Outdoor heat exchanger temperature thermistor)
- (3) Pull out the discharge temperature thermistor from its holder.
- (4) Pull out the defrost thermistor from its holder.
- (5) Pull out the outdoor heat exchanger temperature thermistor from its holder.
- (6) Pull out the ambient temperature thermistor from its holder.

### 5. Removing outdoor fan motor

- (1) Remove the cabinet and panels. (Refer to section 1.)
- (2) Disconnect the following connectors:  
<Inverter P.C. board>  
CN931, CN932 (Fan motor)
- (3) Remove the propeller fan nut.
- (4) Remove the propeller fan.
- (5) Remove the screws fixing the fan motor.
- (6) Remove the fan motor.

## PHOTOS/FIGURES

**Photo 6** Screw of the R.V. coil



Discharge temperature thermistor

**Photo 7**

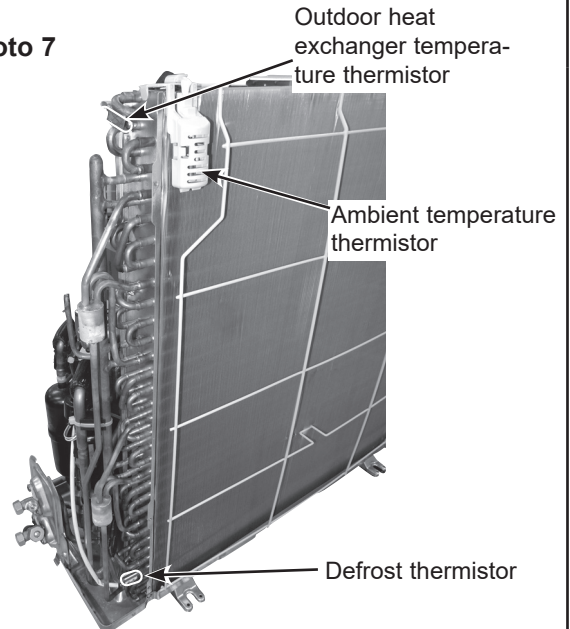

**Photo 8**

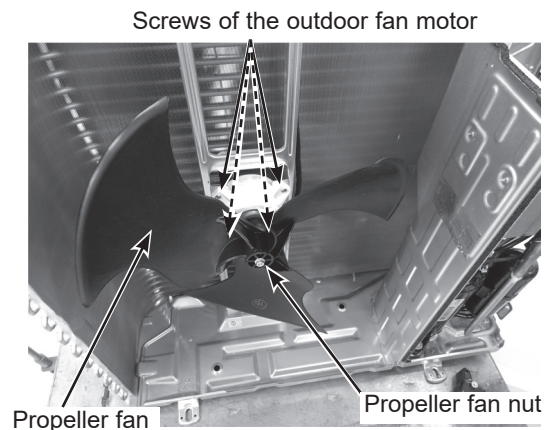

## OPERATING PROCEDURE

### 6. Removing the compressor and 4-way valve

- (1) Remove the cabinet and panels. (Refer to section 1.)
- (2) Remove the inverter assembly. (Refer to section 2.)
- (3) Recover gas from the refrigerant circuit.

**NOTE:** Recover gas from the pipes until the pressure gauge shows 0 kg/cm<sup>2</sup> (0 MPa).

- (4) Detach the brazed part of the suction and the discharge pipe connected with compressor.
- (5) Remove the compressor nuts.
- (6) Remove the compressor.
- (7) Detach the brazed part of pipes connected with 4-way valve.

## PHOTOS/FIGURES

Photo 9

Suction pipe  
brazed part

Discharge pipe  
brazed part

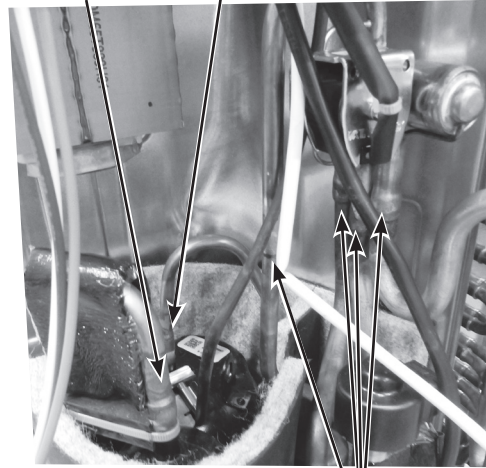

Brazed parts of 4-way valve

SUZ-M60VA.TH  
 SUZ-M60VAR1.TH  
 SUZ-M60VAR2.TH  
 SUZ-M60VA-ET.TH  
 SUZ-M60VA-ETR2.TH  
 SUZ-M60VA-ERR2.TH

SUZ-M71VA.TH  
 SUZ-M71VAR1.TH  
 SUZ-M71VA-ET.TH  
 SUZ-M71VA-ETR1.TH  
 SUZ-M71VA-ERR1.TH

NOTE: Turn OFF the power supply before disassembly.

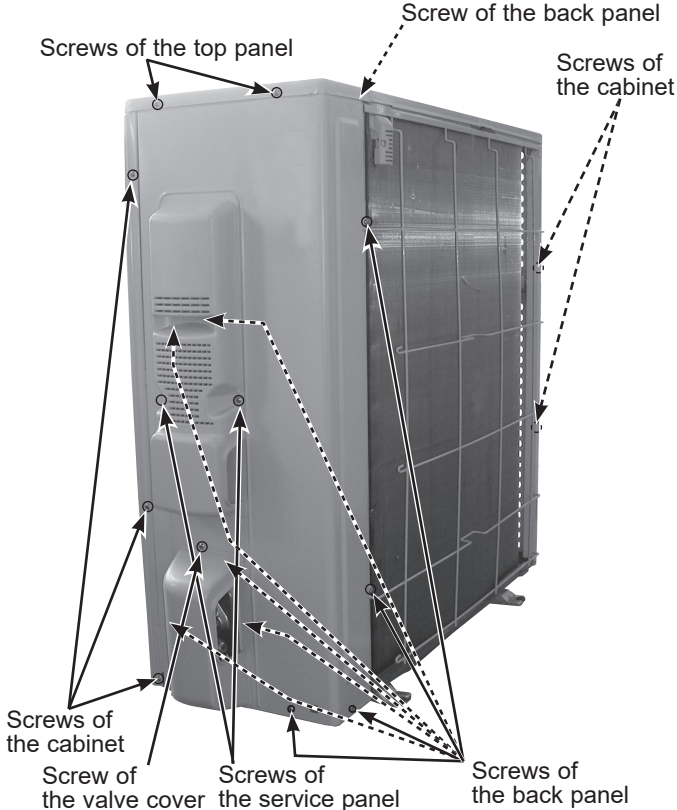
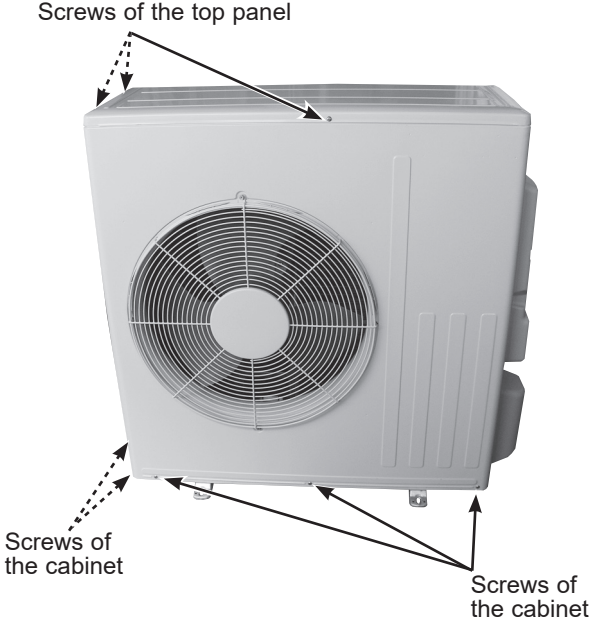
OPERATING PROCEDURE	PHOTOS/FIGURES
<p><b>1. Removing the cabinet</b></p> <ol style="list-style-type: none"> <li>(1) Remove the screws of the service panel.</li> <li>(2) Remove the screws of the top panel.</li> <li>(3) Remove the screw of the valve cover.</li> <li>(4) Remove the service panel.</li> <li>(5) Remove the top panel.</li> <li>(6) Remove the valve cover.</li> <li>(7) Disconnect the power supply and indoor/outdoor connecting wire.</li> <li>(8) Remove the screws of the cabinet.</li> <li>(9) Remove the cabinet.</li> <li>(10) Remove the screws of the back panel.</li> <li>(11) Remove the back panel.</li> </ol> <p><b>Photo 2</b></p> 	<p><b>Photo 1</b></p> 

## OPERATING PROCEDURE

### 2. Removing the inverter assembly and inverter P.C. board

- (1) Remove the cabinet and the service panel. (Refer to 1.)
- (2) Disconnect the lead wire to the reactor and the following connectors:
  - <Inverter P.C. board>
  - CN602 (R.V. coil)
  - CN931, CN932 (Fan motor)
  - CN671 (Defrost thermistor, discharge temperature thermistor and outdoor heat exchanger temperature thermistor)
  - CN672 (Ambient temperature thermistor)
  - CN724 (LEV)
- (3) Remove the compressor connector.
- (4) Remove the earth wires and the lead wires of the inverter P.C. board.
- (5) Remove the screws of the P.B. support.
- (6) Remove the P.B. support from the relay panel.
- (7) Remove the screws of the inverter P.C. board.
- (8) Remove the inverter P.C. board from P.B. support.

#### \* Notes about attaching the inverter P.C. board

1. When attaching the inverter P.C. board, clip the lead wires of the reactor to the wire saddles on the bottom of relay panel.
2. After attaching the inverter P.C. board, make sure that the lead wires are connected and placed as shown in Photo 3.

## PHOTOS/FIGURES

**Photo 3**

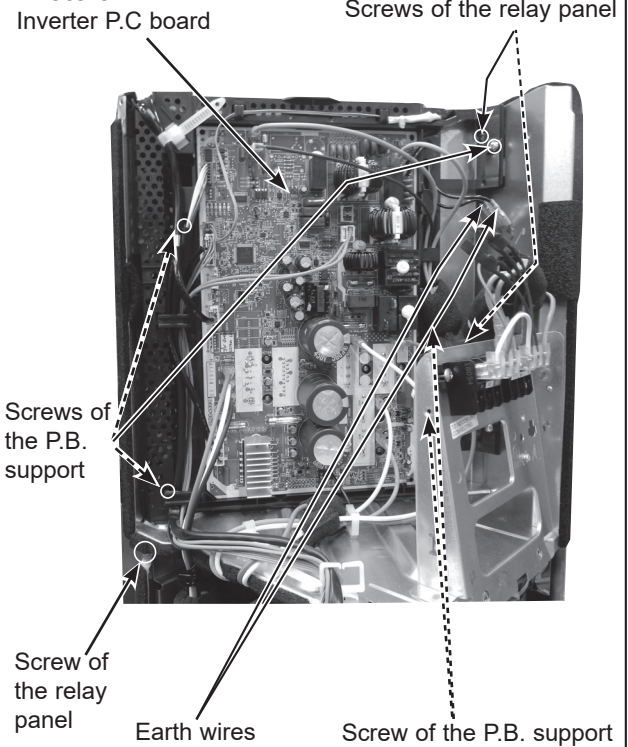

**Photo 4**

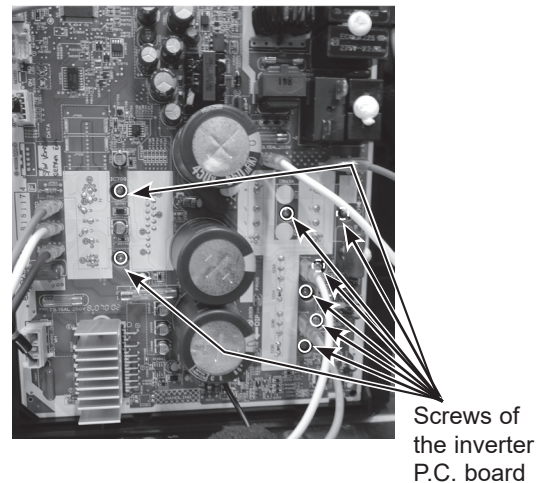

## OPERATING PROCEDURE

### 3. Removing R.V. coil

- (1) Remove the cabinet and panels. (Refer to 1.)
- (2) Disconnect the following connector:  
<Inverter P.C. board>  
CN602 (R.V. coil)
- (3) Remove the R.V. coil.

### 4. Removing the discharge temperature thermistor, defrost thermistor, outdoor heat exchanger temperature thermistor and ambient temperature thermistor

- (1) Remove the cabinet and panels. (Refer to 1.)
- (2) Disconnect the lead wire to the reactor and the following connectors:  
<Inverter P.C. board>  
CN671 (Defrost thermistor, discharge temperature thermistor and outdoor heat exchanger temperature thermistor)  
CN672 (Ambient temperature thermistor)
- (3) Pull out the discharge temperature thermistor from its holder. (Photo 8)
- (4) Pull out the defrost thermistor from its holder.
- (5) Pull out the outdoor heat exchanger temperature thermistor from its holder.
- (6) Pull out the ambient temperature thermistor from its holder.

## PHOTOS/FIGURES

Photo 5

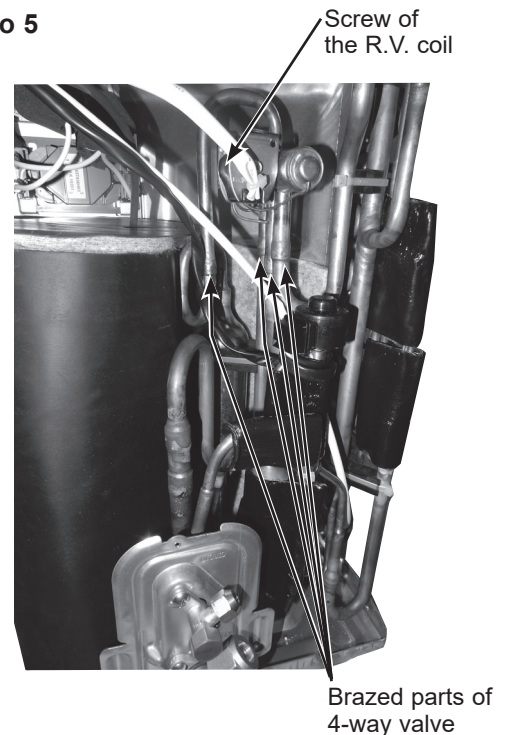
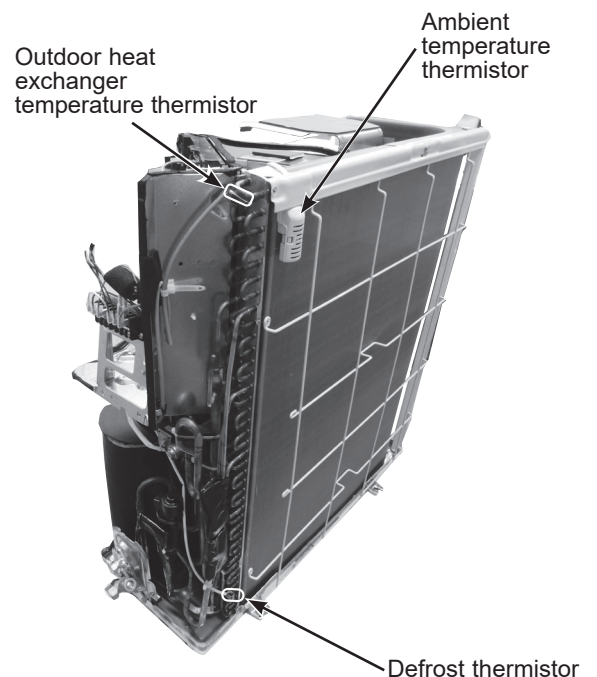

Photo 6



## OPERATING PROCEDURE

### 5. Removing outdoor fan motor

- (1) Remove the top panel, cabinet and service panel. (Refer to 1.)
- (2) Disconnect the following connectors:  
<Inverter P.C. board>  
CN931, CN932 (Fan motor)
- (3) Remove the propeller fan nut.
- (4) Remove the propeller fan.
- (5) Remove the screws fixing the fan motor.
- (6) Remove the fan motor.

### 6. Removing the compressor and 4-way valve

- (1) Remove the top panel, cabinet and service panel. (Refer to 1.)
- (2) Remove the back panel. (Refer to 1.)
- (3) Remove the screws fixing the relay panel.
- (4) Remove the relay panel.
- (5) Remove the inverter assembly. (Refer to 2.)
- (6) Recover gas from the refrigerant circuit.  
**NOTE:** Recover gas from the pipes until the pressure gauge shows 0 kg/cm<sup>2</sup> (0 MPa).
- (7) Detach the brazed part of the suction and the discharge pipe connected with compressor.
- (8) Remove the compressor nuts.
- (9) Remove the compressor.
- (10) Detach the brazed parts of 4-way valve and pipe. (Photo 5)

## PHOTOS/FIGURES

Photo 7

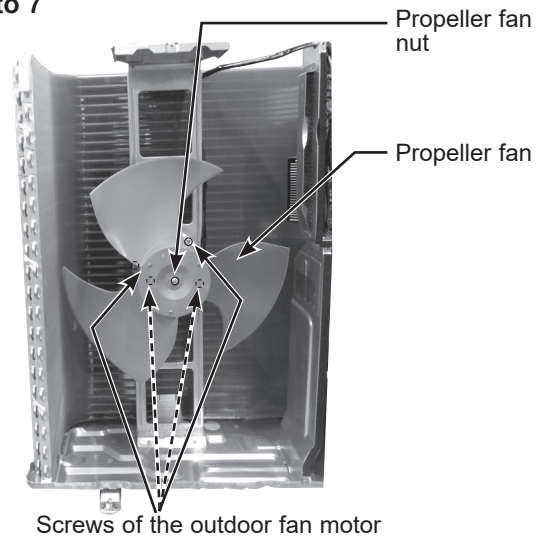
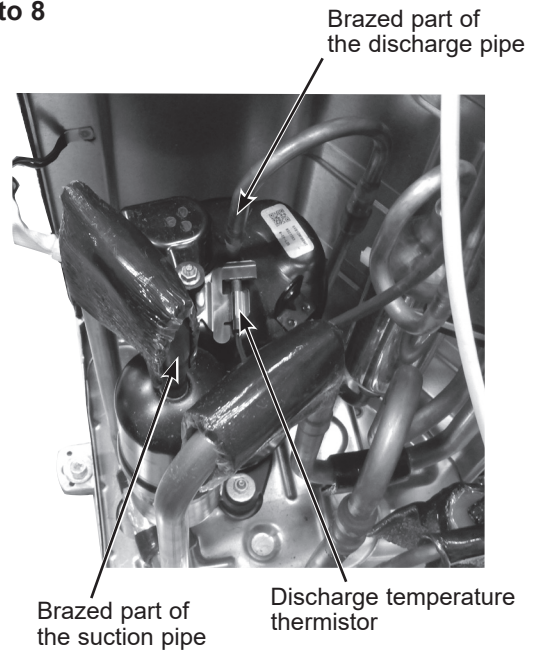

Photo 8





## 13-1. REMOTE CONTROLLER FUNCTIONS

&lt;PAR-41MAA&gt;

## Controller interface

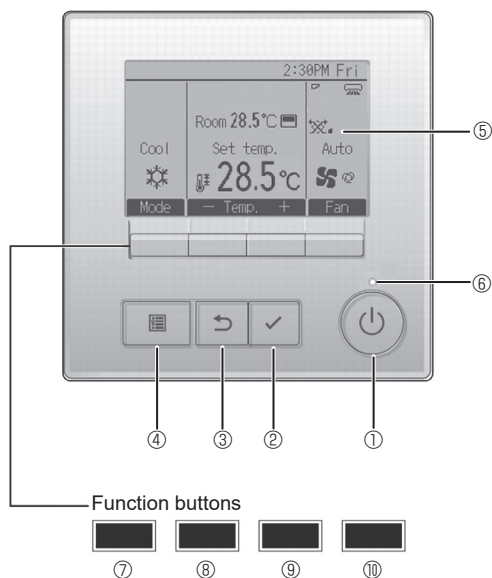

## ① [ON/OFF] button

Press to turn ON/OFF the indoor unit.

## ② [SELECT] button

Press to save the setting.

## ③ [RETURN] button

Press to return to the previous screen.

## ④ [MENU] button

Press to bring up the Main menu.

## ⑤ Backlit LCD

Operation settings will appear.

When the backlight is off, pressing any button turns the backlight on and it will stay lit for a certain period of time depending on the screen.

When the backlight is off, pressing any button turns the backlight on and does not perform its function. (except for the [ON/OFF] button)

The functions of the function buttons change depending on the screen.

Refer to the button function guide that appears at the bottom of the LCD for the functions they serve on a given screen.

When the system is centrally controlled, the button function guide that corresponds to the locked button will not appear.

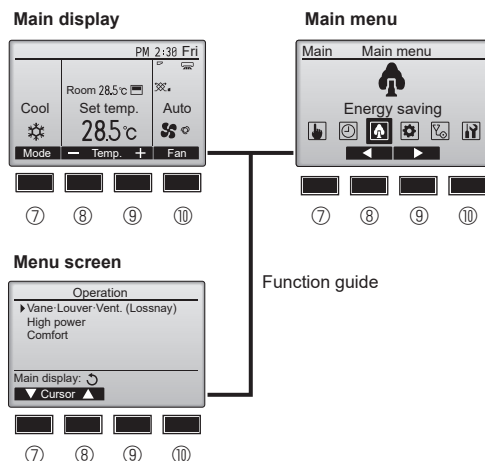

## ⑥ ON/OFF lamp

This lamp lights up in green while the unit is in operation. It blinks while the remote controller is starting up or when there is an error.

## ⑦ Function button [F1]

Main display: Press to change the operation mode.

Menu screen: The button function varies with the screen.

## ⑧ Function button [F2]

Main display: Press to decrease temperature.

Main menu: Press to move the cursor left.

Menu screen: The button function varies with the screen.

## ⑨ Function button [F3]

Main display: Press to increase temperature.

Main menu: Press to move the cursor right.

Menu screen: The button function varies with the screen.

## ⑩ Function button [F4]

Main display: Press to change the fan speed.

Menu screen: The button function varies with the screen.

## Display

The main display can be displayed in two different modes: "Full" and "Basic". The initial setting is "Full". To switch to the "Basic" mode, change the setting on the Main display setting. (Refer to operation manual included with remote controller.)

<Full mode>

\* All icons are displayed for explanation.

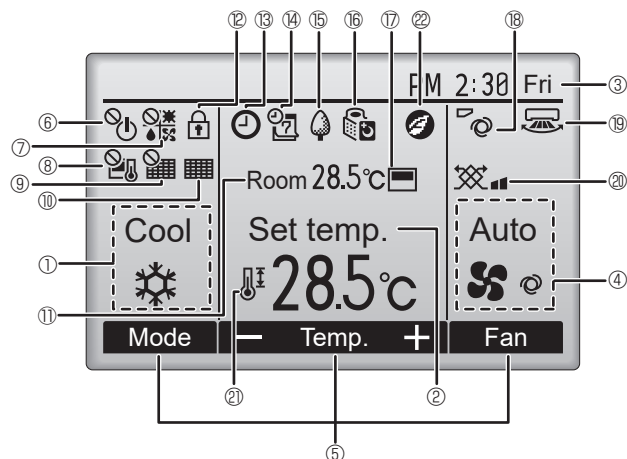

<Basic mode>

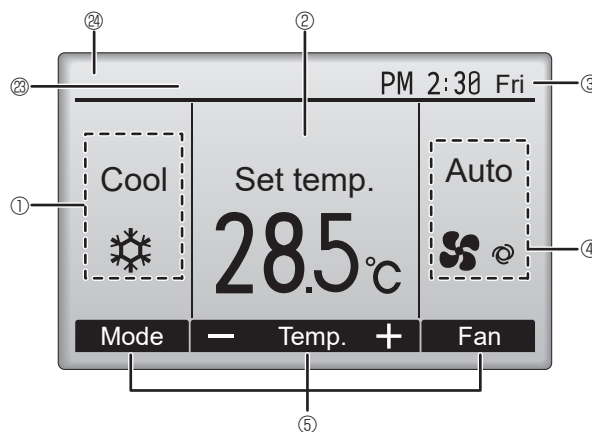

### ① Operation mode

### ② Preset temperature

### ③ Clock

### ④ Fan speed

### ⑤ Button function guide

Functions of the corresponding buttons appear here.



Appears when the ON/OFF operation is centrally controlled.



Appears when the operation mode is centrally controlled.



Appears when the preset temperature is centrally controlled.



Appears when the filter reset function is centrally controlled.



Indicates when filter needs maintenance.

### ⑪ Room temperature



Appears when the buttons are locked.



Appears when the On/Off timer, Night setback, or Auto-off timer function is enabled.



appears when the timer is disabled by the centralized control system.



Appears when the Weekly timer is enabled.



Appears while the units are operated in the energy saving mode. (Will not appear on some models of indoor units)



Appears while the outdoor units are operated in the silent mode.



Appears when the built-in thermistor on the remote controller is activated to monitor the room temperature (⑪).



appears when the thermistor on the indoor unit is activated to monitor the room temperature.



Indicates the vane setting.



Indicates the louver setting.



Indicates the ventilation setting.



Appears when the preset temperature range is restricted.



Appears when an energy saving operation is performed using a "3D i-See sensor" function.

### ⑳ Centrally controlled

Appears for a certain period of time when a centrally-controlled item is operated.

### ㉑ Preliminary error display

A check code appears during the preliminary error.

Most settings (except ON/OFF, mode, fan speed, temperature) can be made from the Main menu.

\*1 These functions are not applied to the floor standing models.

## Menu structure

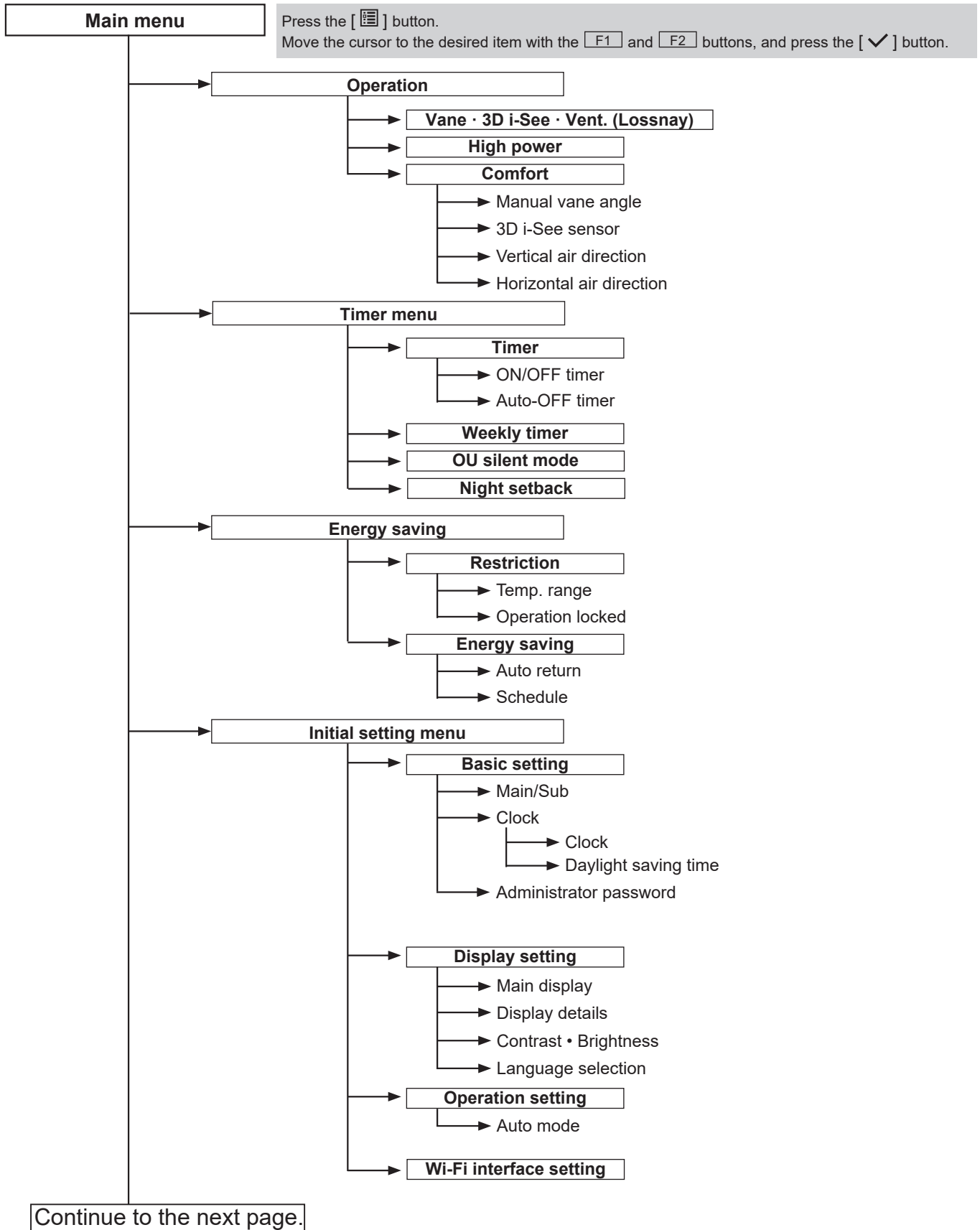

Not all functions are available on all models of indoor units.

Continue from the previous page.

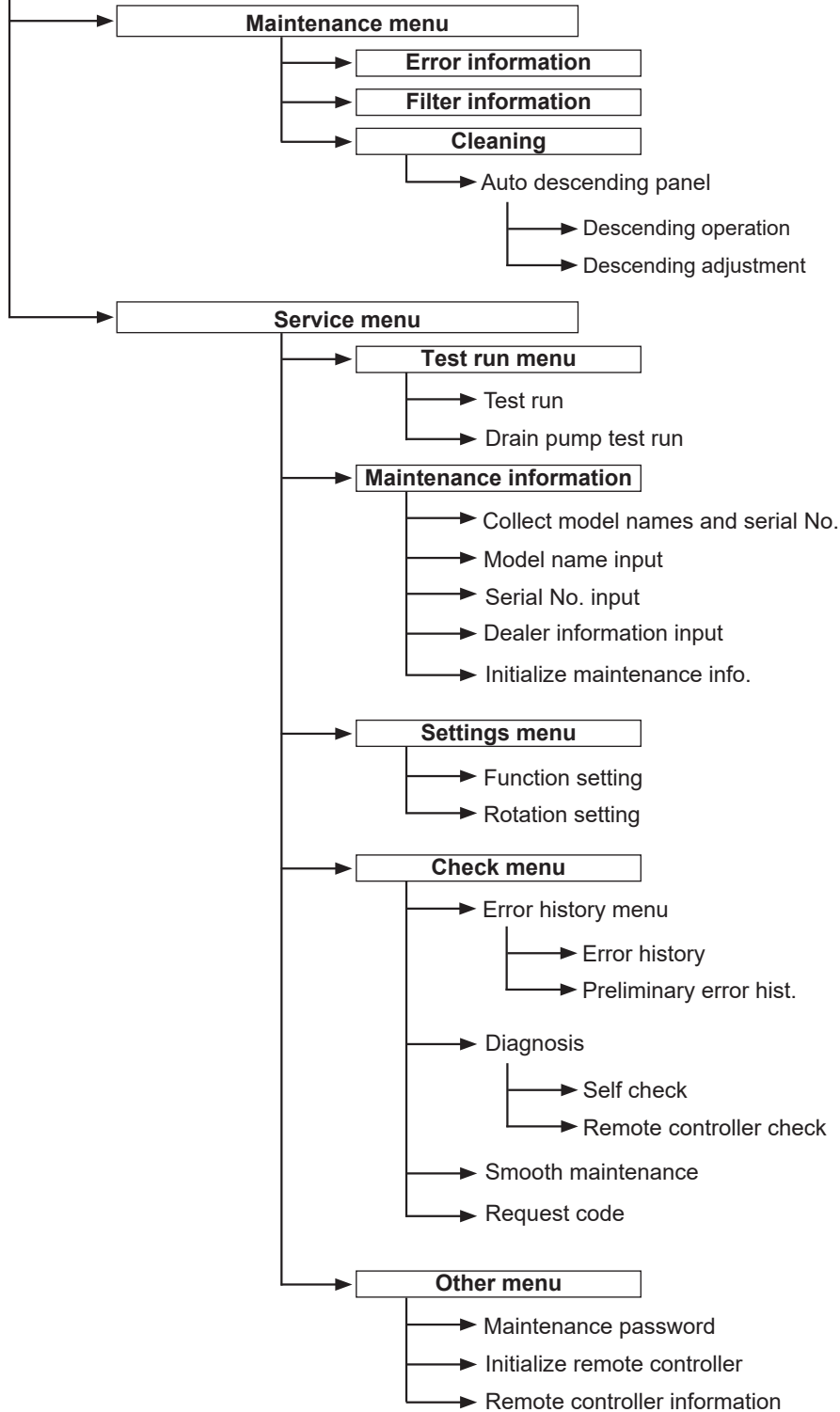

**Not all functions are available on all models of indoor units.**



**Main menu list**

Main menu	Setting and display items		Setting details
Operation	Vane · 3D i-See · Vent. (Vane.Vent. (Lossnay))		<b>Vane:</b> Use to set the vertical air direction. <b>Louver:</b> Use to set the horizontal air direction. <b>3D i-See sensor:</b> This setting is available only for the air conditioners that support easy setting function of motion sensing air direction. <b>Vent:</b> Use to set the amount of ventilation.
	High power <sup>*3</sup>		<b>Use to reach the comfortable room temperature quickly.</b> • Units can be operated in the High-power mode for up to 30 minutes.
	Comfort	Manual vane angle	<b>Vertical air direction</b> • Sets the vertical airflow direction (vane) of each unit. <b>Horizontal air direction</b> • Sets the horizontal airflow direction (vane) of each unit.
		3D i-See sensor	<b>Use to set the following functions for 3D i-See sensor.</b> • Air distribution • Energy saving option • Seasonal airflow
Timer	Timer	ON/OFF timer <sup>*1</sup>	<b>Use to set the operation ON/OFF times.</b> • Time can be set in 5-minute increments.
		Auto-OFF timer	<b>Use to set the Auto-OFF time.</b> • Time can be set to a value from 30 to 240 in 10-minute increments.
	Weekly timer <sup>*1, *2</sup>		<b>Use to set the weekly operation ON/OFF times.</b> • Up to 8 operation patterns can be set for each day. (Not valid when the ON/OFF timer is enabled.)
	OU silent mode <sup>*1, *3</sup>		<b>Use to set the time periods in which priority is given to quiet operation of outdoor units over temperature control. Set the Start/Stop times for each day of the week.</b> • Select the desired silent level from "Normal," "Middle," and "Quiet."
	Night setback <sup>*1</sup>		<b>Use to make Night setback settings.</b> • Select "Yes" to enable the setting, and "No" to disable the setting. The temperature range and the start/stop times can be set.
Energy saving	Restriction	Temp. range <sup>*2</sup>	<b>Use to restrict the preset temperature range.</b> • Different temperature ranges can be set for different operation modes.
		Operation lock	<b>Use to lock selected functions.</b> • The locked functions cannot be operated.
	Energy saving	Auto return <sup>*2</sup>	<b>Use to get the units to operate at the preset temperature after performing energy saving operation for a specified time period.</b> • Time can be set to a value from 30 and 120 in 10-minute increments. (This function will not be valid when the preset temperature ranges are restricted.)
		Schedule <sup>*1, *3</sup>	<b>Set the start/stop times to operate the units in the energy saving mode for each day of the week, and set the energy saving rate.</b> • Up to 4 energy saving operation patterns can be set for each day. • Time can be set in 5-minute increments. • Energy saving rate can be set to a value from 0% or 50 to 90% in 10% increments.
	Energy data (for unit time, month, and day)		<b>Displays the amount of power consumption during operation.</b> • Unit time data: Data for the last one-month period can be displayed in 30-minute units. • Monthly/daily data: Data for the last 14-month period are displayed in day-and-month-units. * Data can be deleted. * Data are obtained based on the power consumption estimated from the operating state.

<sup>\*1</sup> Clock setting is required.

<sup>\*2</sup> 1°C increments.

<sup>\*3</sup> This function is available only when certain outdoor units are connected.

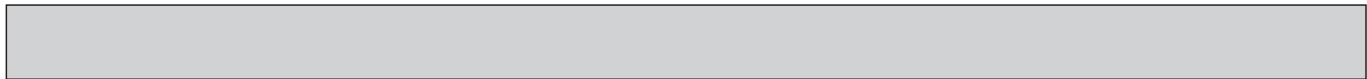

Main menu	Setting and display items		Setting details
Initial setting	Basic setting	Main/Sub	When connecting 2 remote controllers, one of them needs to be designated as a sub controller.
		Clock	Use to set the current time.
		Daylight saving time	Set the daylight saving time.
		Administrator password	The administrator password is required to make the settings for the following items. • Timer setting • Energy saving setting • Weekly timer setting • Restriction setting • Outdoor unit silent mode setting • Night set back
	Display setting	Main display	Use to switch between "Full" and "Basic" modes for the Main display, and use to change the background colors of the display to black.
		Display details	Make the settings for the remote controller related items as necessary. <b>Clock:</b> The initial settings are "Yes" and "24h" format. <b>Temperature:</b> Set either Celsius (°C) or Fahrenheit (°F). <b>Room temp.:</b> Set Show or Hide. <b>Auto mode:</b> Set Auto mode display or Only Auto display.
		Contrast • Brightness	Use to adjust screen contrast and brightness.
		Language selection	Use to select the desired language.
Operation setting	Auto mode	Whether or not to use Auto mode can be selected by using the button. This setting is valid only when indoor units with Auto mode function are connected.	
Maintenance	Error information		Use to check error information when an error occurs. • Check code, error source, refrigerant address, model name, manufacturing number, contact information (dealer's phone number) can be displayed. (The model name, manufacturing number, and contact information need to be registered in advance to be displayed.)
	Filter information		Use to check the filter status. • The filter sign can be reset.
	Cleaning	Auto descending panel	Use to lift and lower the auto descending panel (Optional parts).
Service	Test run		Select "Test run" from the Service menu to bring up the Test run menu. • Test run • Drain pump test run
	Input maintenance info.		Select "Input maintenance info." from the Service menu to bring up the Maintenance information screen. The following settings can be made from the Maintenance Information screen. • Model name input • Serial No. input • Dealer information input • Initialize maintenance info.
	Settings	Function setting	Make the settings for the indoor unit functions via the remote controller as necessary.
	Check	Error history	Display the error history and execute "delete error history".
		Diagnosis	<b>Self check:</b> Error history of each unit can be checked via the remote controller. <b>Remote controller check:</b> When the remote controller does not work properly, use the remote controller checking function to troubleshoot the problem.
		Smooth maintenance * <sup>3</sup>	Use to display the maintenance data of indoor/outdoor units.
		Request code * <sup>3</sup>	Use to check operation data such as thermistor temperature and error information.
	Others	Maintenance password	Use to change the maintenance password.
Initialize remote controller		Use to initialize the remote controller to the factory shipment status.	
Remote controller information		Use to display the remote controller model name, software version, and serial number.	

\*<sup>3</sup> This function is available only when certain outdoor units are connected.

<PAR-SL97A-E>

**Controller interface**

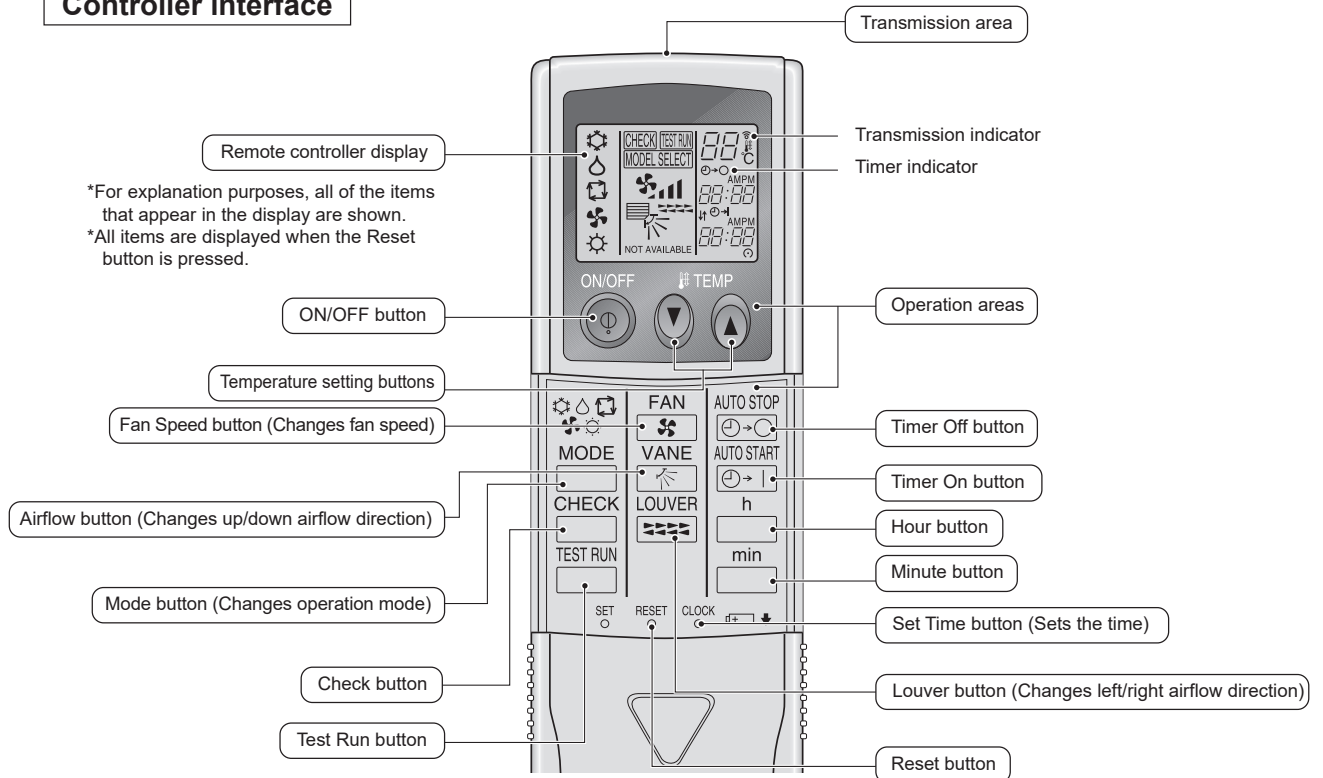

- When using the wireless remote controller, point it towards the receiver on the indoor unit.
- If the remote controller is operated within approximately two minutes after power is supplied to the indoor unit, the indoor unit may beep twice as the unit is performing the initial automatic check.
- The indoor unit beeps to confirm that the signal transmitted from the remote controller has been received. Signals can be received up to approximately 7 meters in a direct line from the indoor unit in an area 45° to the left and right of the unit. However, illumination such as fluorescent lights and strong light can affect the ability of the indoor unit to receive signals.
- If the operation lamp near the receiver on the indoor unit is blinking, the unit needs to be inspected. Consult your dealer for service.
- Handle the remote controller carefully! Do not drop the remote controller or subject it to strong shocks. In addition, do not get the remote controller wet or leave it in a location with high humidity.
- To avoid misplacing the remote controller, install the holder included with the remote controller on a wall and be sure to always place the remote controller in the holder after use.

<PAR-SL101A-E>

**Controller interface**

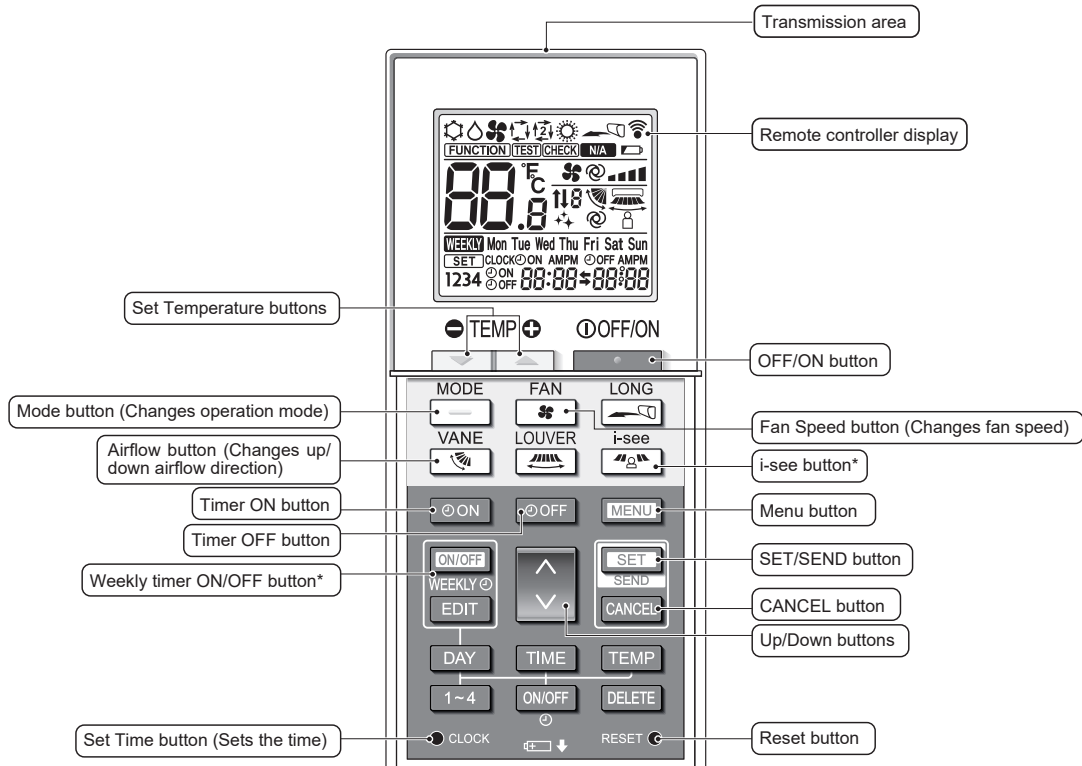

**Note:**

\* This button is enabled or disabled depending on the model of the indoor unit.

**Display**

**Operation mode**

- Cool (snowflake icon)
- Dry (water drop icon)
- Fan (fan icon)
- Auto (single set point) (fan with arrow icon)
- Heat (sun icon)
- Auto (dual set point) (fan with arrow and sun icon)

**Temperature setting**  
The units of temperature can be changed. For details, refer to the Installation Manual.

**Vane setting**

Step 1 Step 2 Step 3 Step 4 Step 5 Swing Auto

**Not available**  
Appears when a non-supported function is selected.

**Battery replacement indicator**  
Appears when the remaining battery power is low.

**Fan speed setting**

Auto

**3D i-See sensor (Air distribution)**

Default Direct Indirect

When Direct or Indirect is selected, the vane setting is set to "Auto".



## 13-2. ERROR INFORMATION

When an error occurs, the following screen will appear.  
Check the error status, stop the operation, and consult your dealer.

1. Check code, error unit, refrigerant address, date and time of occurrence, model name, and serial number will appear.  
The model name and serial number will appear only if the information have been registered.

Press the **F1** or **F2** button to go to the next page.

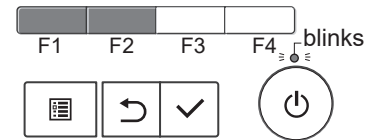
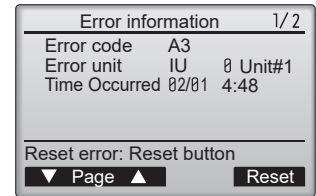

Contact information (dealer's phone number) will appear if the information has been registered.

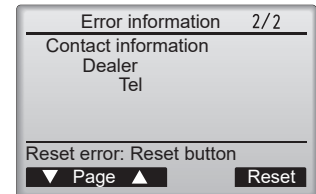

2. Press the **F4** button or the  button to reset the error that is occurring.

Errors cannot be reset while the ON/OFF operation is prohibited.

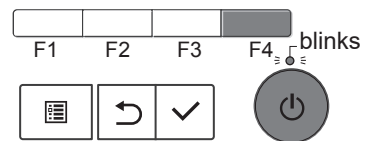
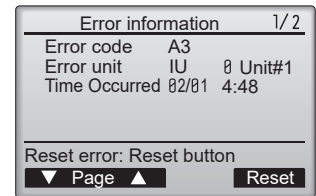

Select "OK" with the **F4** button.

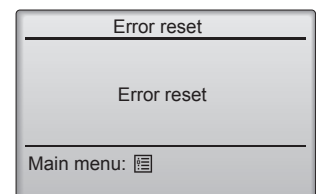
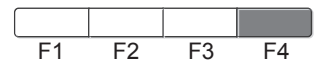
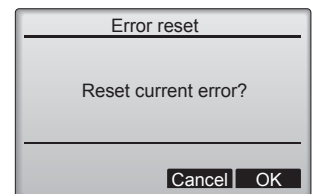

### Navigating through the screens

- To go back to the Service menu ..... [  ] button

## • Checking the error information

While no errors are occurring, page 2/2 of the error information can be viewed by selecting "Error information" from the Maintenance menu.

Errors cannot be reset from this screen.

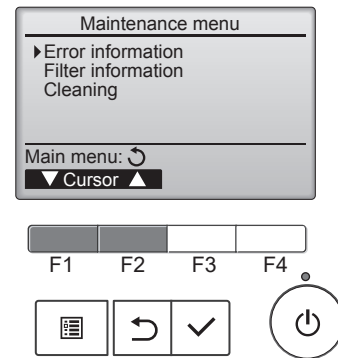

### 13-3. SERVICE MENU

#### Maintenance password is required

1. Select "Service" from the Main menu, and press the [ ✓ ] button.

\*At the main display, the menu button and select "Service" to make the maintenance setting.

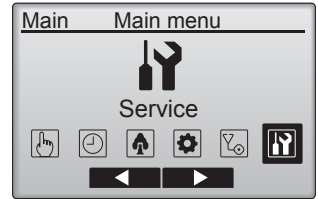

2. When the Service menu is selected, a window will appear asking for the password.

To enter the current maintenance password (4 numerical digits), move the cursor to the digit you want to change with the [ F1 ] or [ F2 ] button.



Set each number (0 through 9) with the [ F3 ] or [ F4 ] button.



Then, press the [ ✓ ] button.

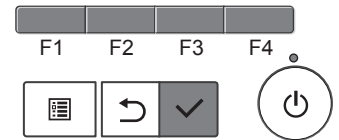
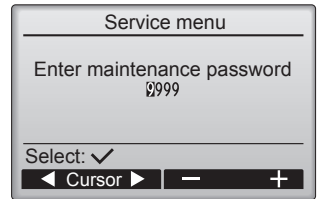

**Note:** The initial maintenance password is "9999". Change the default password as necessary to prevent unauthorized access. Have the password available for those who need it. If you forget your maintenance password, you can initialize the password to the default password "9999" by pressing and holding the [ F1 ] button for 10 seconds on the maintenance password setting screen.

3. If the password matches, the Service menu will appear.

**Note:** Air conditioning units may need to be stopped to make only at "Settings". There may be some settings that cannot be made when the system is centrally controlled.



A screen will appear that indicates the setting has been saved.

#### Navigating through the screens

- To go back to the Service menu .....[ List icon ] button
- To return to the previous screen.....[ Return ] button

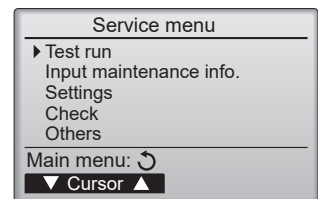

## 13-4. TEST RUN

### 13-4-1. PAR-41MAA

1. Select "Service" from the Main menu, and press the [ ✓ ] button.

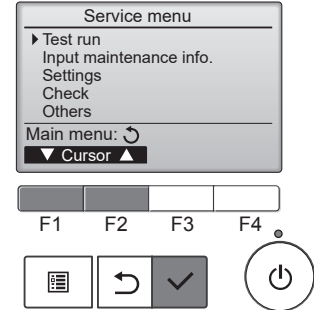

Select "Test run" with the [ F1 ] or [ F2 ] button, and press the [ ✓ ] button.

2. Select "Test run" with the [ F1 ] or [ F2 ] button, and press the [ ✓ ] button.

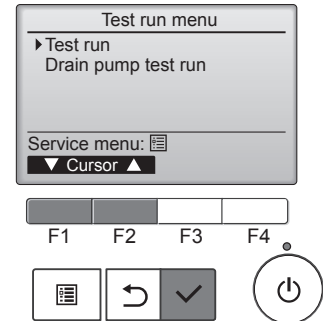

#### Test run operation

Press the [ F1 ] button to go through the operation modes in the order of "Cool and Heat".

Cool mode: Check the cold air blows out.  
Heat mode: Check the heat blows out.

Check the operation of the outdoor unit's fan.

Press the [ ✓ ] button and open the Vane setting screen.

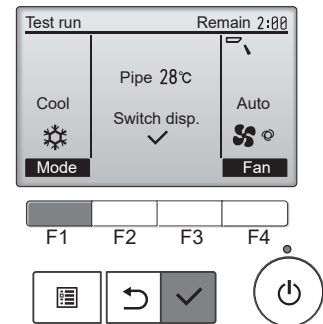

#### Auto vane check

Check the auto vane with the [ F1 ] [ F2 ] [ F3 ] buttons.

Press the [ ↻ ] button to return to "Test run operation".

Press the [ Power ] button.





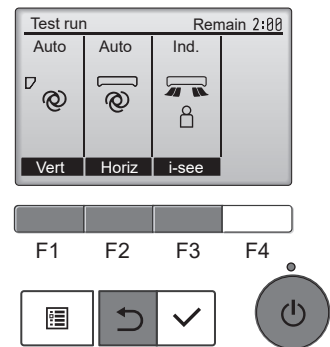





When the test run is completed, the "Test run menu" screen will appear.  
The test run will automatically stop after 2 hours.

\*The function is available only for the model with vanes.



### 13-4-2. PAR-SL97A-E

Measure an impedance between the power supply terminal block on the outdoor unit and ground with a 500 V Megger and check that it is equal to or greater than 1.0 MΩ.







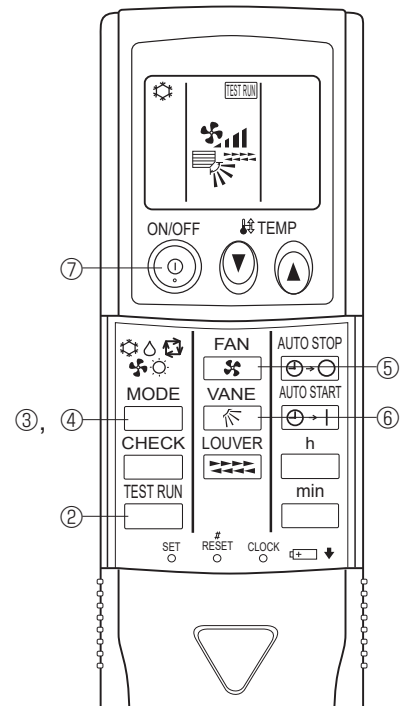







1. Turn on the main power to the unit.
2. Press the  button twice continuously.  
(Start this operation from the status of remote controller display turned off.)  
A  and current operation mode are displayed.
3. Press the  (  ) button to activate  mode, then check whether cool air blows out from the unit.
4. Press the  (  ) button to activate  mode, then check whether warm air blows out from the unit.
5. Press the  button and check whether strong air blows out from the unit.
6. Press the  button and check whether the auto vane operates properly.
7. Press the ON/OFF button to stop the test run.

**Note:**

- Point the remote controller towards the indoor unit receiver while following steps 2 to 7.
- It is not possible to run in FAN, DRY or AUTO mode.



### 13-4-3. PAR-SL101A-E

1. Press the  button 1 to stop the air conditioner.
  - If the weekly timer is enabled ( is on), press the  button 3 to disable it ( is off).
2. Press the  button 2 for 5 seconds.
  -  comes on and the unit enters the service mode.
3. Press the  button 2.
  -  comes on and the unit enters the test run mode.
4. Press the following buttons to start the test run.
  - : Switch the operation mode between cooling and heating and start the test run.
  - : Switch the fan speed and start the test run.
  - : Switch the airflow direction and start the test run.
  - : Switch the louver and start the test run.
  - : Start the test run.
5. Stop the test run.
  - Press the  button 1 to stop the test run.
  - After 2 hours, the stop signal is transmitted.

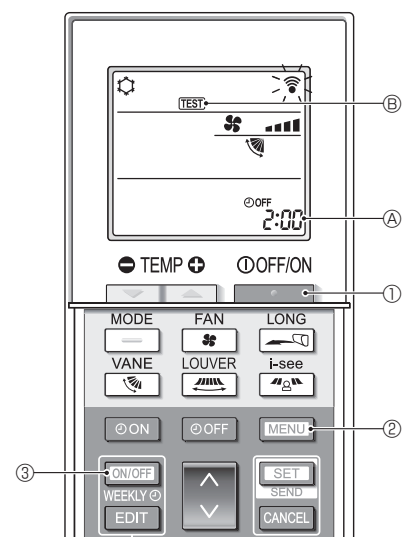

## 13-5. FUNCTION SETTING

### 13-5-1. PAR-41MAA

1. Select "Service" from the Main menu, and press the [ ✓ ] button.



Select "Setting" from the Service menu, and press the [ ✓ ] button.



Select "Function setting", and press the [ ✓ ] button.

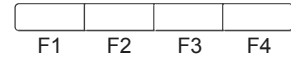
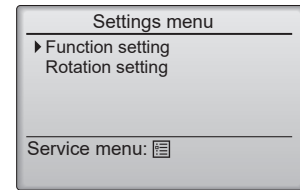

<The display format and the setting method vary with indoor units.>

#### Pattern 1

2. Set the indoor unit refrigerant addresses and unit numbers with the [ F1 ] through [ F4 ] buttons, and then press the [ ✓ ] button to confirm the current setting.
3. When data collection from the indoor units is completed, the current settings appears highlighted. Non-highlighted items indicate that no function settings are made. Screen appearance varies depending on the "Unit No." setting.

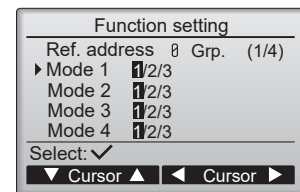

4. Use the [ F1 ] or [ F2 ] button to move the cursor to select the mode number, and change the setting number with the [ F3 ] or [ F4 ] button.
5. When the settings are completed, press the [ ✓ ] button to send the setting data from the remote controller to the indoor units.
6. When the transmission is successfully completed, the screen will return to the Function setting screen.

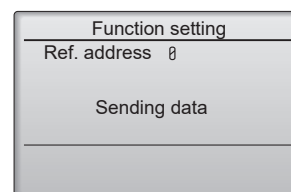
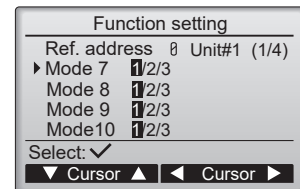

## Pattern 2

4. Toggle through the pages with the **F3** or **F4** button.
5. Select the mode number with the **F1** or **F2** button, and then press the [ ✓ ] button.
6. Select the setting number with the **F1** or **F2** button.  
Setting range for modes 1 through 28: 1 through 3  
Setting range for modes 31 through 66: 1 through 15
7. When the settings are completed, press the [ ✓ ] button to send the setting data from the remote controller to the indoor units.
8. When the transmission is successfully completed, the screen will return to the Function setting screen.

### Note:

- Refer to the indoor unit Installation Manual for the detailed information about initial settings, mode numbers, and setting numbers for the indoor units.
- Be sure to write down the settings for all functions if any of the initial settings has been changed after the completion of installation work.

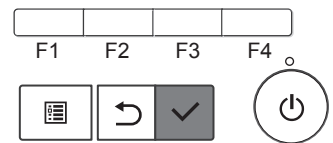
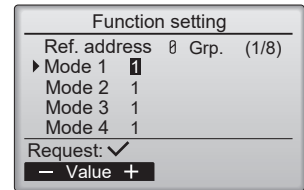
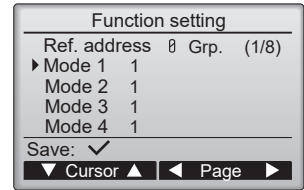

### 13-5-2. PAR-SL97A-E

Functions can be selected with the wireless remote controller. Function selection using wireless remote controller is available only for refrigerant system with wireless function. Refrigerant address cannot be specified by the wireless remote controller.

#### [Flow of function selection procedure]

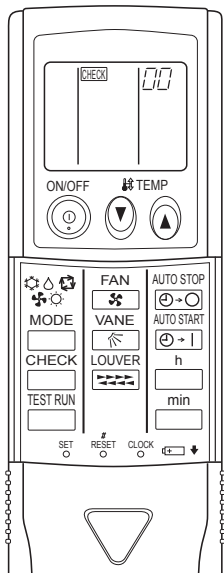

#### Flow of function selection procedure

The flow of the function selection procedure is shown below. This example shows how to turn off the function that raises the set temperature by 4 degrees during HEAT operation. (Mode 24: 2)  
The procedure is given after the flow chart.

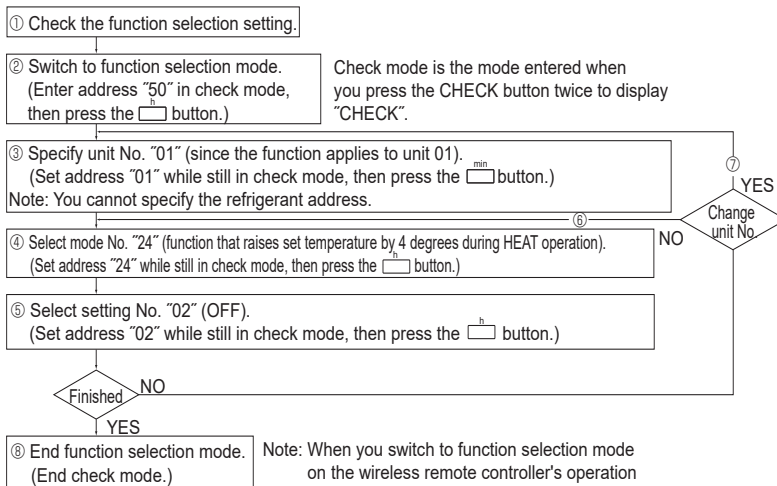

Note: When you switch to function selection mode on the wireless remote controller's operation area, the unit ends function selection mode automatically if nothing is input for 10 minutes or longer.

#### [Operating instructions]

1. Check the function settings.
2. Press the  button twice continuously. → **CHECK** is lit and "00" blinks.  
Press the  button once to set "50". Direct the wireless remote controller toward the receiver of the indoor unit and press the  button.
3. Set the unit number.  
Press the  button to set the unit number. (Press "01" to specify the indoor unit whose unit number is 01.)  
Direct the wireless remote controller toward the receiver of the indoor unit and press the  button.  
(By setting unit number with the  button, specified indoor unit starts performing fan operation. Detect which unit is assigned to which number using this function. If unit number is set to AL, all the indoor units in same refrigerant system start performing fan operation simultaneously.)

#### Notes:

1. If a unit number that cannot be recognized by the unit is entered, 3 beeps of 0.4 seconds will be heard. Reenter the unit number setting.
2. If the signal was not received by the sensor, you will not hear a beep or a "double beep" may be heard. Reenter the unit number setting.

#### 4. Select a mode.

Press the  button to set a mode. Press "24" to turn on the function that raises the set temperature by 4 degrees during heat operation. Direct the wireless remote controller toward the sensor of the indoor unit and press the  button.  
→ The sensor-operation indicator will blink and beeps will be heard to indicate the current setting number.

Current setting number: 1 = 1 beep (1 second)  
2 = 2 beeps (1 second each)  
3 = 3 beeps (1 second each)

#### Notes:

1. If a mode number that cannot be recognized by the unit is entered, 3 beeps of 0.4 seconds will be heard. Reenter the mode number.
2. If the signal was not received by the sensor, you will not hear a beep or a "double beep" may be heard. Reenter the mode number.

#### 5. Select the setting number.

Press the  button to select the setting number. (02: Not available)  
Direct the wireless remote controller toward the receiver of the indoor unit and press the  button.  
→ The sensor-operation indicator will blink and beeps will be heard to indicate the setting number.

Setting number: 1 = 2 beeps (0.4 seconds each)  
2 = 2 beeps (0.4 seconds each, repeated twice)  
3 = 2 beeps (0.4 seconds each, repeated 3 times)

#### Notes:

1. If a setting number that cannot be recognized by the unit is entered, the setting will turn back to the original setting.
  2. If the signal was not received by the sensor, you will not hear a beep or a "double beep" may be heard. Reenter the setting number.
6. Repeat steps ④ and ⑤ to make an additional setting without changing unit number.
  7. Repeat steps ③ to ⑤ to change unit number and make function settings on it.
  8. Complete the function settings

Press  button.

**Do not use the wireless remote controller for 30 seconds after completing the function setting.**



### 13-5-3. PAR-SL101A-E

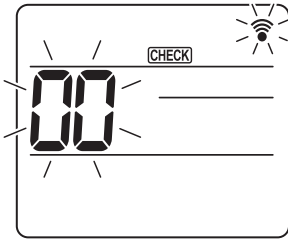

Fig. 1

1. Going to the function select mode  
 Press the **[MENU]** button between of 5 seconds.  
 (Start this operation from the status of remote controller display turned off.)  
 [CHECK] is lit and "00" blinks. (Fig. 1)  
 Press the **[↓]** button to set the "50".  
 Direct the wireless remote controller toward the receiver of the indoor unit and press the **[SET]** button.

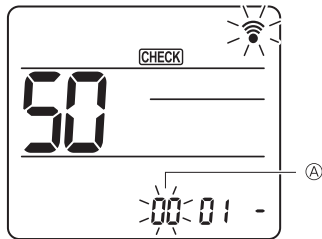

Fig. 2

2. Setting the unit number  
 Press the **[↓]** button to set unit number **Ⓐ**. (Fig. 2)  
 Direct the wireless remote controller toward the receiver of the indoor unit and press the **[SET]** button.

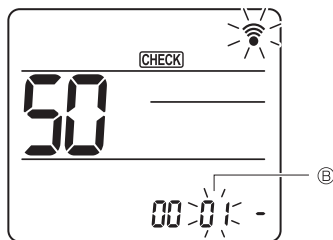

Fig. 3

3. Select a mode  
 Press the **[↓]** button to set Mode number **Ⓑ**. (Fig. 3)  
 Direct the wireless remote controller toward the receiver of the indoor unit and press the **[SET]** button.  
 Current setting number:
  - 1=1 beep (1 second)
  - 2=2 beep (1 second each)
  - 3=3 beep (1 second each)

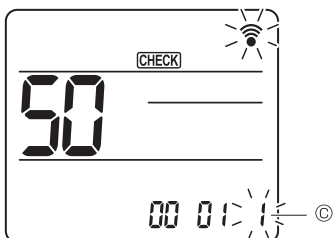

Fig. 4

4. Selecting the setting number  
 Use the **[↓]** button to change the Setting number **Ⓒ**. (Fig. 4)  
 Direct the wireless remote controller toward the receiver of the indoor unit and press the **[SET]** button.
5. To select multiple functions continuously  
 Repeat select **Ⓒ** and **Ⓓ** to change multiple function settings continuously.
6. Complete function selection  
 Direct the wireless remote controller toward the sensor of the indoor unit and press the **[OFF/ON]** button.

**Note:** Be sure to write down the settings for all functions if any of the initial settings has been changed after the completion of installation work.

## 13-6. ROTATION SETTING

### Setting method of each function by wired remote controller

#### ■ PAR-41MAA

1. Stop operation 

Select "Service" from the Main menu, and press the [✓] button.

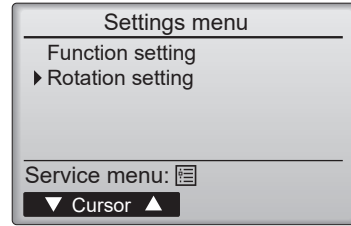

Select "Settings" with the [F1] or [F2] button, and press the [✓] button.

Select "Rotation setting" with the [F1] or [F2] button, and press the [✓] button.

2. Set the rotation function.

Select "Rotation" with the [F1] button.

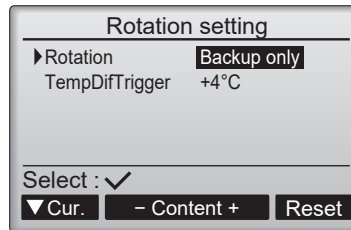

Select the rotation period or "Backup only" with the [F2] or [F3] button.

- "Rotation" setup  
None, 1 day, 3 days, 5 days, 7 days, 14 days, 28days, Backup only

#### Notes:

- When 1 to 28 days are selected, the backup function is also enabled.
- When "Backup only" is selected, the rotation function will be disabled. The systems with refrigerant addresses of 00 or 01 (00 system/ 01 system) will be operated as a main system while the 02 system is the standby mode as backup.

3. Set the support function.

Select "TempDifTrigger" with the [F1] button.

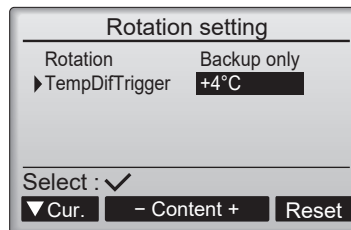

Select "the difference between the suction temperature and the set temperature" with the [F2] or [F3] button.

- "TempDifTrigger" setup  
None, +4°C, +6°C, +8°C

#### Notes:

- The support function is available only in the COOL mode. (Not available in the HEAT, DRY and AUTO mode.)
- The support function is enabled when any option other than "None" is selected from the "Rotation" setup.

4. Update the setting.

Press the [✓] button to update the setting.

#### Reset method

- Press the [F4] button in step ⑤ or ⑥ to reset the operation time of the rotation function. Once it is reset, operation will start from the 00 or 01 systems.

Note: When the 02 system is in the backup operation, the 00 or 01 systems will be operated again.

## 13-7. ERROR HISTORY

1. Select "Service" from the Main menu, and press the [ ✓ ] button.



Select "Check" with the [ F1 ] or [ F2 ] button, and press the [ ✓ ] button.



Select "Error history" with the [ F1 ] or [ F2 ] button, and press the [ ✓ ] button.

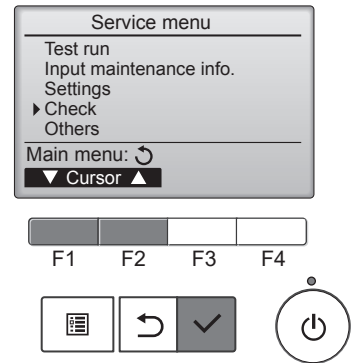

2. Select "Error history" from the Error history menu, and press the [ ✓ ] button.

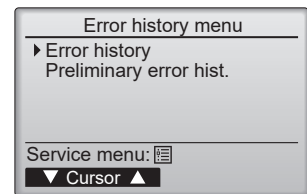

3. 16 error history records will appear.

4 records are shown per page, and the top record on the first page indicates the latest error record.

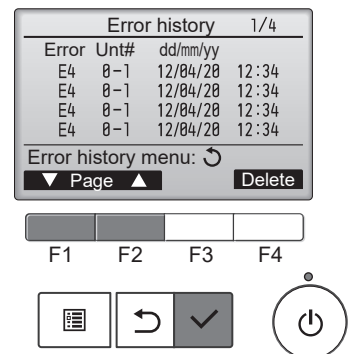

4. Deleting the error history

To delete the error history, press the [ F4 ] button (Delete) on the screen that shows error history.

A confirmation screen will appear asking if you want to delete the error history.



Press the [ F4 ] button (OK) to delete the history.



"Error history deleted" will appear on the screen.

Press the [ ↶ ] button to go back to the Error history menu screen.

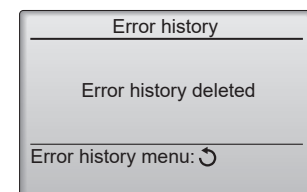
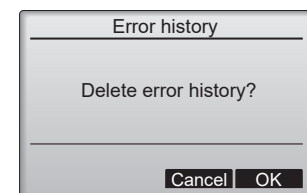

## 5. Preliminary error history

Select "Preliminary error hist." from the Error history menu, and press the [ ✓ ] button.

32 preliminary error history records will appear.

4 records are shown per page, and the top record on the first page indicates the latest error record.

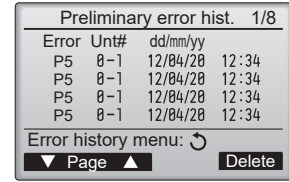

Preliminary error hist. 1/8			
Error	Unt#	dd/mm/yy	
P5	0-1	12/04/20	12:34
P5	0-1	12/04/20	12:34
P5	0-1	12/04/20	12:34
P5	0-1	12/04/20	12:34

Error history menu: ↻  
▼ Page ▲ Delete

## 6. Deleting the preliminary error history

To delete the preliminary error history, press the [ F4 ] button (Delete) on the screen that shows preliminary error history. A confirmation screen will appear asking if you want to delete the preliminary error history.



Press the [ F4 ] button (OK) to delete the preliminary error history.



"Preliminary error history deleted" will appear on the screen. Press the [ ↻ ] button to go back to the Error history menu.

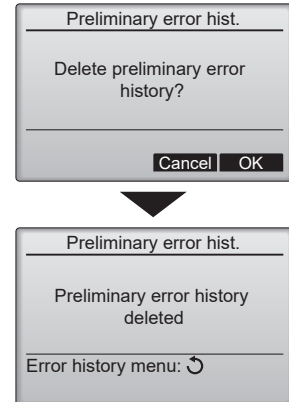

## 13-8. SELF-DIAGNOSIS

### 13-8-1. PAR-41MAA

1. Select "Service" from the Main menu, and press the [ ✓ ] button.

Select "Check" from the Service menu, and press the [ ✓ ] button.

Select "Diagnosis" from the Check menu, and press the [ ✓ ] button.

Select "Self check" with the [ F1 ] or [ F2 ] button, and press the [ ✓ ] button.

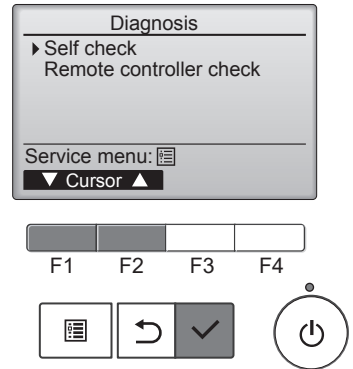

2. With the [ F1 ] or [ F2 ] button, enter the refrigerant address, and press the [ ✓ ] button.

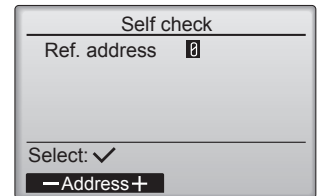

3. Check code, unit number, attribute will appear. "-" will appear if no error history is available.

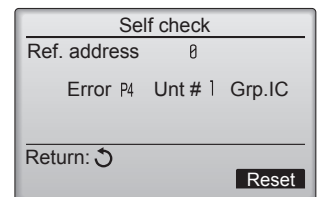

**When there is no error history**

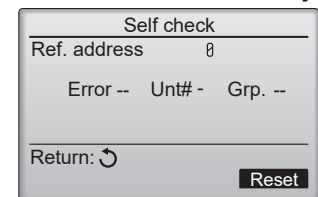

4. Resetting the error history

Press the [ F4 ] button (Reset) on the screen that shows the error history.



A confirmation screen will appear asking if you want to delete the error history.

Press the [ F4 ] button (OK) to delete the error history.

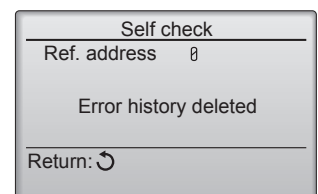
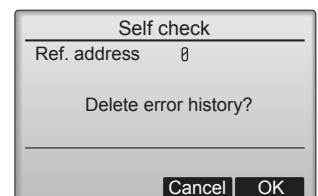
If deletion fails, "Request rejected" will appear. "Unit not exist" will appear if no indoor units that are correspond to the entered address are found.



#### Navigating through the screens

- To go back to the Service menu ..... [  ] button
- To return to the previous screen..... [  ] button

### 13-8-2. PAR-SL97A-E

When a malfunction occurs to air conditioner, both indoor unit and outdoor unit will stop and operation lamp blinks to inform unusual stop.

#### <Malfunction-diagnosis method at maintenance service>

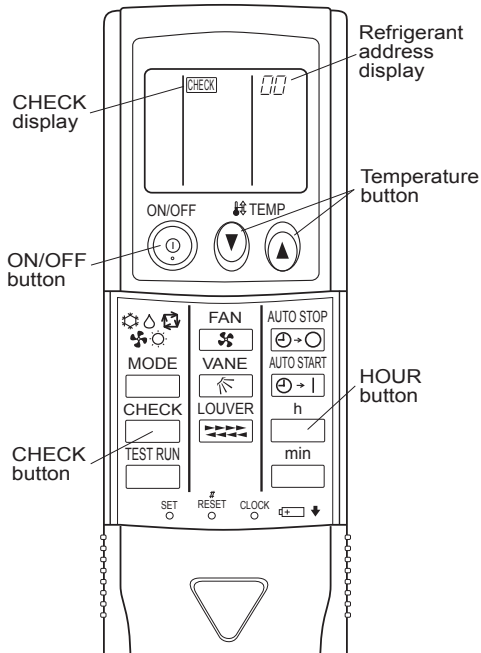

#### [Procedure]

1. Press the CHECK button twice.
  - "CHECK" lights, and refrigerant address "00" blinks.
  - Check that the remote controller's display has stopped before continuing.
2. Press the TEMP  $\uparrow$   $\downarrow$  buttons.
  - Select the refrigerant address of the indoor unit for the self-diagnosis.
  - Note: Set refrigerant address using the outdoor unit's DIP switch (SW1). (For more information, see the outdoor unit installation manual.)
3. Point the remote controller at the sensor on the indoor unit and press the HOUR button.
  - If an air conditioner error occurs, the indoor unit's sensor emits an intermittent buzzer sound, the operation light blinks, and the check code is output.
  - (It takes 3 seconds at most for check code to appear.)
4. Point the remote controller at the sensor on the indoor unit and press the ON/OFF button.
  - The check mode is cancelled.

### 13-8-3. PAR-SL101A-E

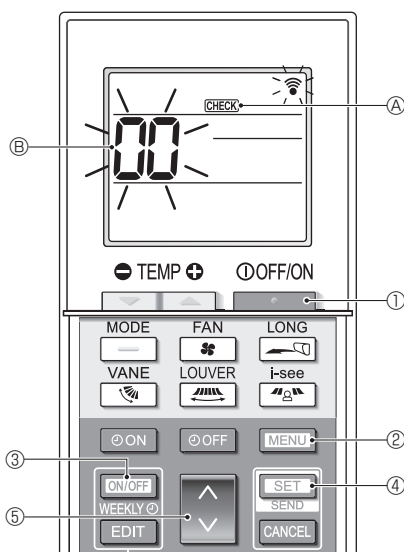

#### [Procedure]

1. Press the  $\ominus$  button ① to stop the air conditioner.
  - If the weekly timer is enabled (WEEKLY is on), press the  $\ominus$  button ③ to disable it (WEEKLY is off).
2. Press the MENU button ② for 5 seconds.
  - CHECK ⑥ comes on and the unit enters the self-check mode.
3. Press the  $\downarrow$  button ⑤ to select the refrigerant address (M-NET address) ⑥ of the indoor unit for which you want to perform the self-check.
4. Press the SET button ④.
  - If an error is detected, the check code is indicated by the number of beeps from the indoor unit and the number of blinks of the OPERATION INDICATOR lamp.
5. Press the  $\ominus$  button ①.
  - CHECK ⑥ and the refrigerant address (M-NET address) ⑥ go off and the self-check is completed.

## 13-9. REMOTE CONTROLLER CHECK

If operations cannot be completed with the remote controller, diagnose the remote controller with this function.

1. Select "Service" from the Main menu, and press the [ ✓ ] button.



Select "Check" from the Service menu, and press the [ ✓ ] button.



Select "Diagnosis" from the Check menu, and press the [ ✓ ] button.



Select "Remote controller check" with the [ F1 ] or [ F2 ] button, and press the [ ✓ ] button.

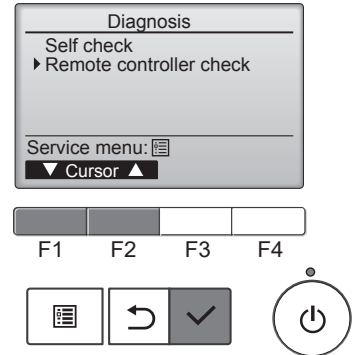

2. Select "Remote controller check" from the Diagnosis menu, and press the [ ✓ ] button to start the remote controller check and see the check results.

To cancel the remote controller check and exit the "Remote controller check" menu screen, press the [ ⏏ ] or the [ ↶ ] button.

The remote controller will not reboot itself.

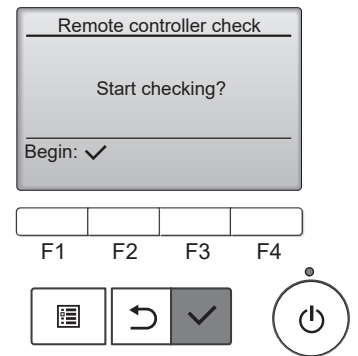

3.
  - OK: No problems are found with the remote controller. Check other parts for problems.
  - E3, 6832: There is noise on the transmission line, or the indoor unit or another remote controller is faulty. Check the transmission line and the other remote controllers.
  - NG (ALL0, ALL1): Send-receive circuit fault. The remote controller needs replacing.
  - ERC: The number of data errors is the discrepancy between the number of bits in the data transmitted from the remote controller and that of the data that was actually transmitted over the transmission line. If data errors are found, check the transmission line for external noise interference.

Remote controller check results screen

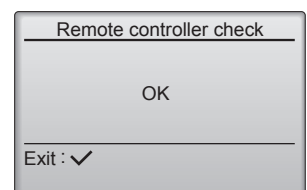

If the [ ✓ ] button is pressed after the remote controller check results are displayed, remote controller check will end, and the remote controller will automatically reboot itself.

**Check the remote controller display and see if anything is displayed (including lines). Nothing will appear on the remote controller display if the correct voltage (8.5–12 VDC) is not supplied to the remote controller. If this is the case, check the remote controller wiring and indoor units.**

## 13-10. SMOOTH MAINTENANCE

1. Select "Service" from the Main menu, and press the [ ✓ ] button.



Select "Check" with the [ F1 ] or [ F2 ] button, and press the [ ✓ ] button.



Select "Smooth maintenance" with the [ F1 ] or [ F2 ] button, and press the [ ✓ ] button.

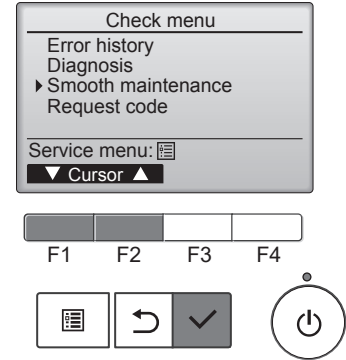

2. Set each item.

Select the item to be changed with the [ F1 ] or [ F2 ] button.



Select the required setting with the [ F3 ] or [ F4 ] button.

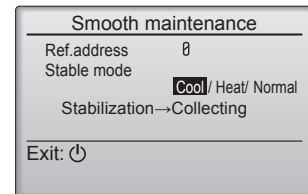
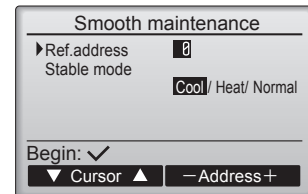

- <Ref.address> setting [ 0 ] – [ 15 ]
- <Stable mode> setting [ Cool ] / [ Heat ] / [ Normal ]



Press the [ ✓ ] button, Fixed operation will start.  
Note: Stable mode will take approx. 20 minutes.

3. The operation data will appear.

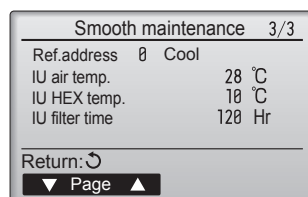
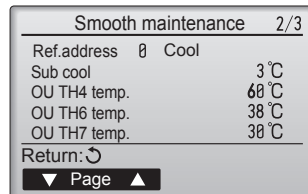
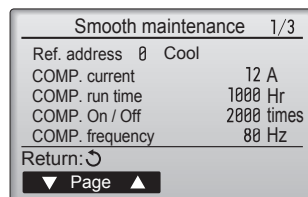
The Compressor-Accumulated operating (COMP. run) time is 10-hour unit, and the Compressor-Number of operation times (COMP. ON/OFF) is a 100-time unit (fractions discarded).



### Navigating through the screens

- To go back to the Service menu ..... [  ] button
- To return to the previous screen..... [  ] button



■ Refrigerant address

Single refrigerant system

In the case of single refrigerant system, the refrigerant address is "00" and no operation is required. Simultaneous twin, triple units belong to this category (single refrigerant system).

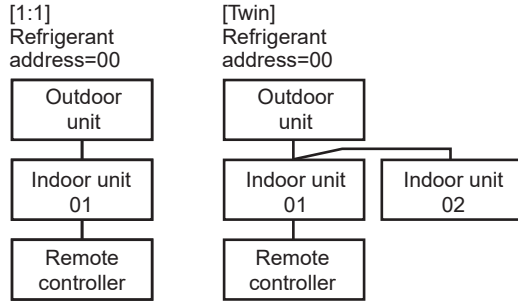

Multi refrigerant system (group control)

Up to 16 refrigerant systems (16 outdoor units) can be connected as a group by 1 remote controller. To check or set the refrigerant addresses.

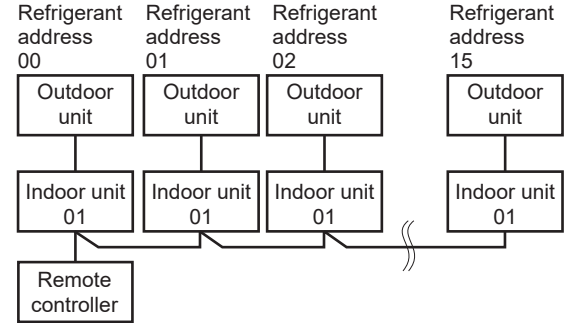

### 13-11. REQUEST CODE

Details on the operation data including each thermistor temperature and error history can be confirmed with the remote controller.

1. Select "Service" from the Main menu, and press the [ ✓ ] button.

Select "Check" with the [ F1 ] or [ F2 ] button, and press the [ ✓ ] button.

Select "Request code" with the [ F1 ] or [ F2 ] button, and press the [ ✓ ] button.

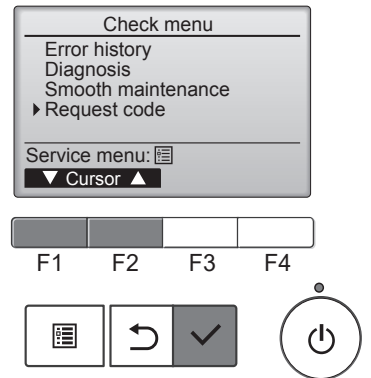

2. Set the Refrigerant address and Request code.

Select the item to be changed with the [ F1 ] or [ F2 ] button.

Select the required setting with the [ F3 ] or [ F4 ] button.

- <Ref.address>setting [ 0 ] - [ 15 ]
- <Request code>setting

Press the [ ✓ ] button, Data will be collected and displayed.

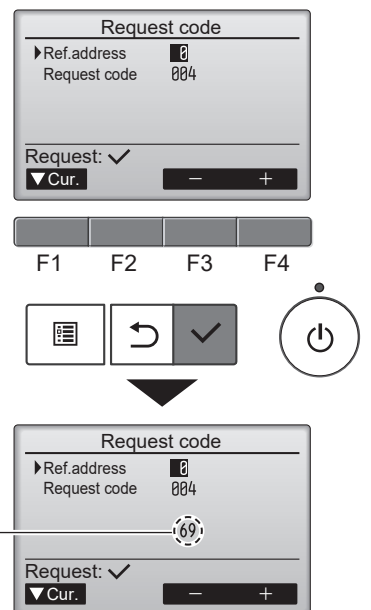

Request code: 004  
Discharge temperature: 69°C

# Mr. SLIM

## MITSUBISHI ELECTRIC CORPORATION

HEAD OFFICE: TOKYO BUILDING, 2-7-3, MARUNOUCHI, CHIYODA-KU, TOKYO100-8310, JAPAN

---

©Copyright 2018 MITSUBISHI ELECTRIC CORPORATION  
Issued: Dec. 2022 No. OCH684 REVISED EDITION-G  
Issued: Mar. 2022 No. OCH684 REVISED EDITION-F  
Issued: Oct. 2021 No. OCH684 REVISED EDITION-E  
Issued: Jul. 2020 No. OCH684 REVISED EDITION-D  
Issued: Jan. 2020 No. OCH684 REVISED EDITION-C  
Issued: Jun. 2019 No. OCH684 REVISED EDITION-B  
Issued: Jan. 2019 No. OCH684 REVISED EDITION-A  
Published: Dec. 2018 No. OCH684  
Made in Japan

Specifications are subject to change without notice.