

# PARTS CATALOG

## Series SLZ Ceiling Cassettes R32/R410A

Indoor unit  
[Model Name]

[Service Ref.]

SLZ-M15FA	<b>SLZ-M15FA.TH</b> <b>SLZ-M15FA.TH-ER</b>
SLZ-M25FA	<b>SLZ-M25FA.TH</b> <b>SLZ-M25FA.TH-ER</b>
SLZ-M35FA	<b>SLZ-M35FA.TH</b> <b>SLZ-M35FA.TH-ER</b>
SLZ-M50FA	<b>SLZ-M50FA.TH</b> <b>SLZ-M50FA.TH-ER</b>
SLZ-M60FA	<b>SLZ-M60FA.TH</b> <b>SLZ-M60FA.TH-ER</b>

Revision:

- Some descriptions have been modified in REVISED EDITION-A.

OCB522 is void.

### CONTENTS

1. SERVICE PARTS LIST..... 2

**SERVICE MANUAL (OCH522)**

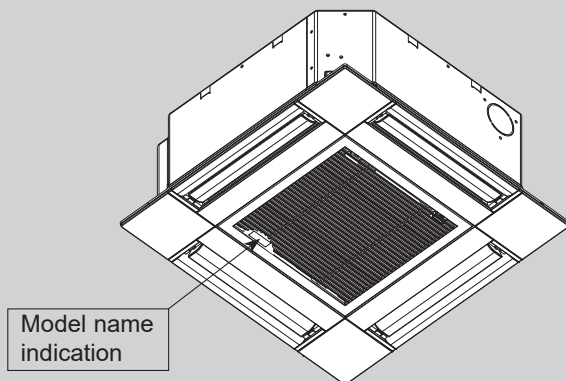

INDOOR UNIT

# 1

# SERVICE PARTS LIST

## GRILLE PARTS

SLP-2FA (Standard)

SLP-2FAL (with Signal Receiver)

SLP-2FALM (with Receiver and Remote Controller)

SLP-2FAE (with i-See sensor)

SLP-2FALE (with Receiver and i-See sensor)

SLP-2FALME (with Receiver, i-See sensor, and Remote Controller)

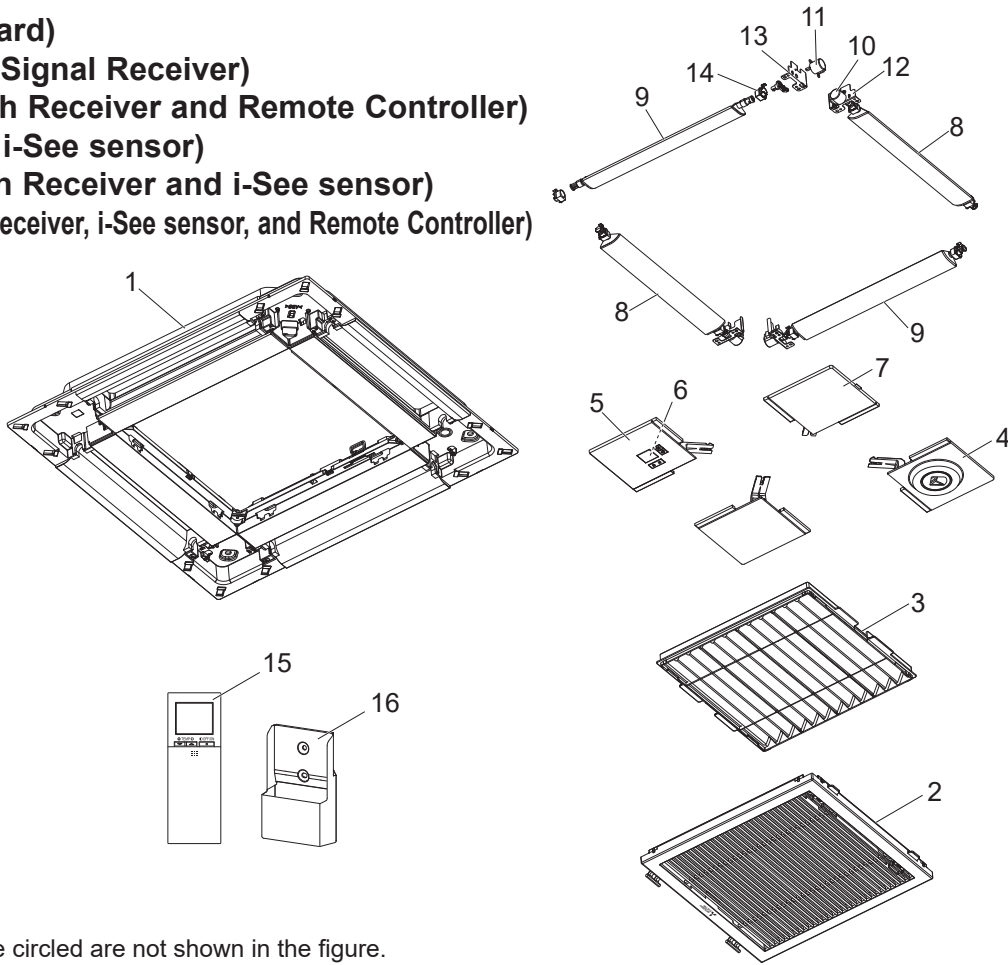

Parts numbers that are circled are not shown in the figure.

No.	Parts No.	Parts Name	Specification	Q'ty/unit						Wiring Diagram Symbol
				SLP-2FA	SLP-2FAL	SLP-2FALM	SLP-2FAE	SLP-2FALE	SLP-2FALME	
1	E27 C26 003	AIR OUTLET GRILLE		1	1	1	1	1	1	
2	E27 C26 010	INTAKE GRILLE		1	1	1	1	1	1	
3	E27 C26 100	AIR FILTER		1	1	1	1	1	1	
4	E27 C29 975	CORNER PANEL (i-See sensor)					1	1	1	
5	E27 C28 975	CORNER PANEL (Signal Receiver)			1	1		1	1	
6	E27 C27 317	WIRELESS REMOTE CONTROLLER BOARD			1	1		1	1	W.B
7	E27 C26 975	CORNER PANEL	Includes safety strap	4	3	3	3	2	2	
8	E27 C26 037	AUTO VANE -1	GREEN	2	2	2	2	2	2	
9	E27 C27 037	AUTO VANE -2	BLUE	2	2	2	2	2	2	
10	E27 C26 303	VANE MOTOR-1	GREEN	2	2	2	2	2	2	
11	E27 C27 303	VANE MOTOR-2	BLUE	2	2	2	2	2	2	
12	E27 C26 946	COUPLING-1	GREEN	2	2	2	2	2	2	
13	E27 C27 946	COUPLING-2	BLUE	2	2	2	2	2	2	
14	E27 C26 044	VANE BUSH		8	8	8	8	8	8	
15	E27 D44 426	WIRELESS REMOTE CONTROLLER				1			1	
16	E27 D44 083	HOLDER				1			1	
⑰	E27 C26 033	WIRE HOOK		2	2	2	2	2	2	
⑱	E27 C28 087	JUNCTION CABLE (Signal Receiver)			1	1		1	1	
⑲	E27 C27 087	JUNCTION CABLE (i-See sensor)					1	1	1	

## ELECTRICAL PARTS

SLZ-M15FA.TH    SLZ-M25FA.TH    SLZ-M35FA.TH    SLZ-M50FA.TH    SLZ-M60FA.TH  
 SLZ-M15FA.TH-ER    SLZ-M25FA.TH-ER    SLZ-M35FA.TH-ER    SLZ-M50FA.TH-ER    SLZ-M60FA.TH-ER

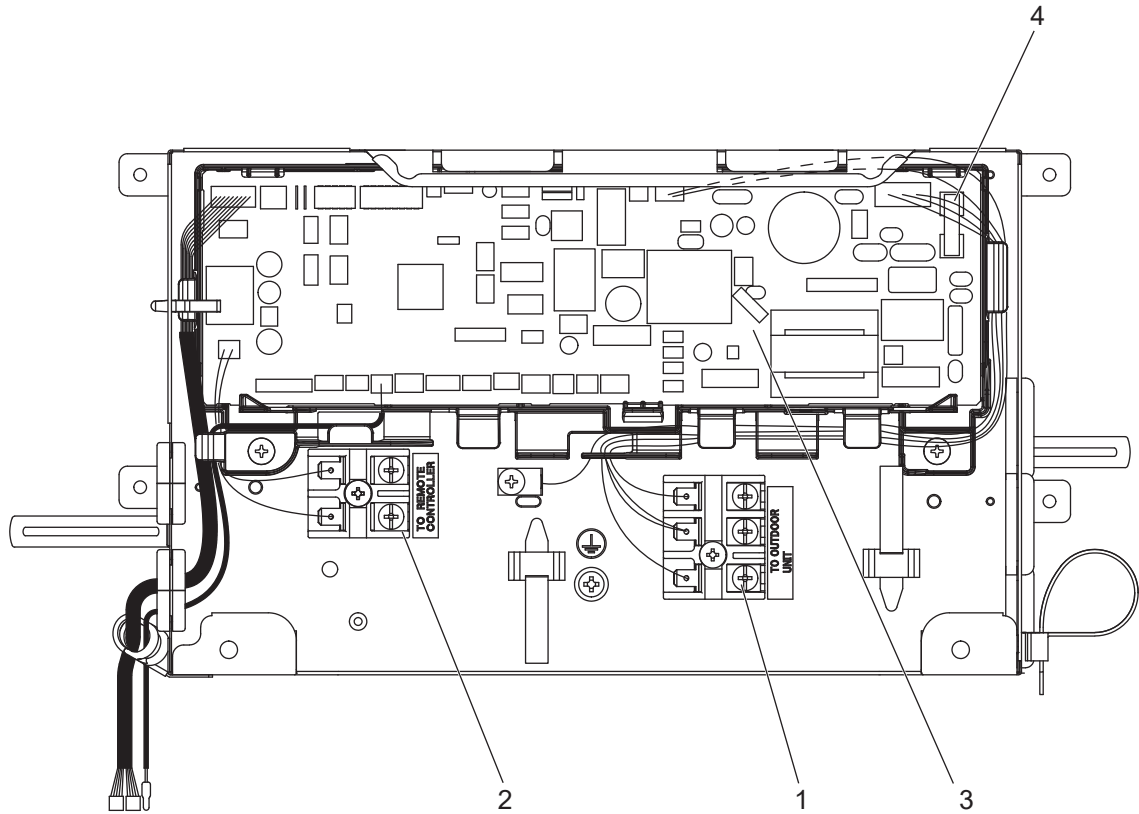

No.	Parts No.	Parts Name	Specification	Q'ty/unit					Remarks (Drawing No.)	Wiring Diagram Symbol
				SLZ-M15FA.TH(-ER)	SLZ-M25FA.TH(-ER)	SLZ-M35FA.TH(-ER)	SLZ-M50FA.TH(-ER)	SLZ-M60FA.TH(-ER)		
1	E27 162 375	TERMINAL BLOCK		1	1	1	1	1		TB4
2	E27 156 375	TERMINAL BLOCK		1	1	1	1	1		TB5
3	E27 K49 447	INDOOR CONTROLLER BOARD		1	1	1	1	1		I.B
4	E27 648 382	FUSE	FSL 250V/6.3A	1	1	1	1	1		F1

# FUNCTIONAL PARTS

- SLZ-M15FA.TH
- SLZ-M25FA.TH
- SLZ-M35FA.TH
- SLZ-M50FA.TH
- SLZ-M60FA.TH
- SLZ-M15FA.TH-ER
- SLZ-M25FA.TH-ER
- SLZ-M35FA.TH-ER
- SLZ-M50FA.TH-ER
- SLZ-M60FA.TH-ER

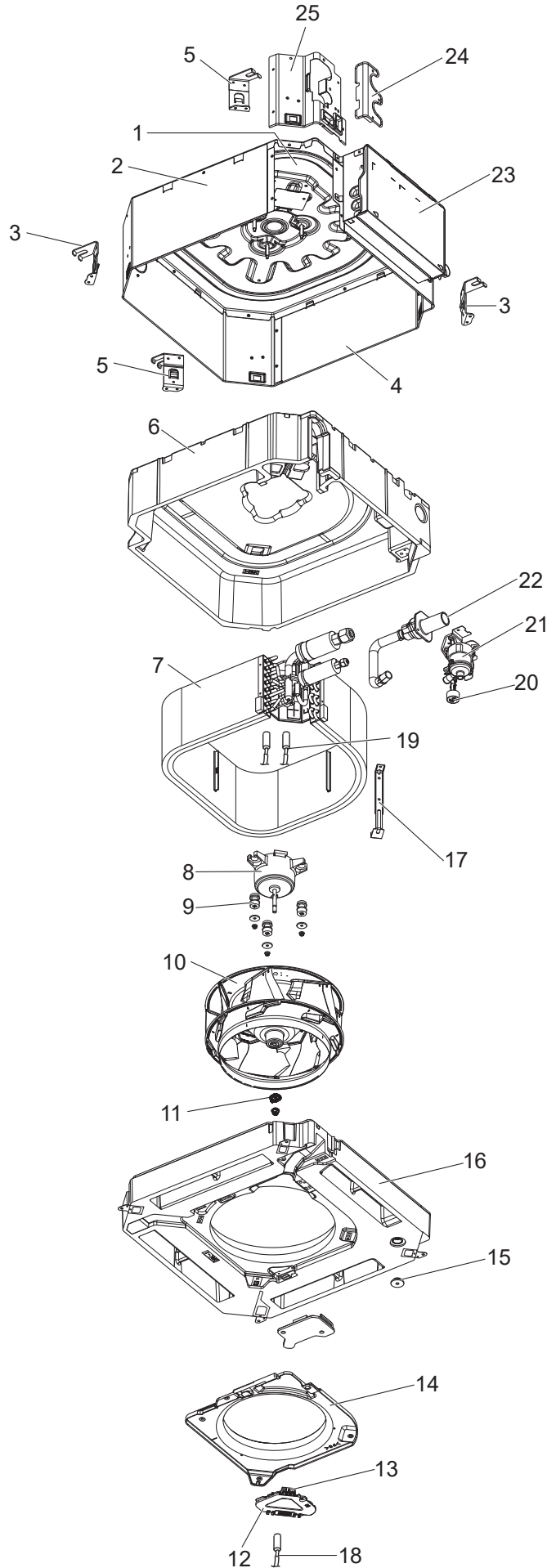

## FUNCTIONAL PARTS

No.	Parts No.	Parts Name	Specification	Q'ty/unit					Remarks (Drawing No.)	Wiring Diagram Symbol
				SLZ-M15FA.TH(-ER)	SLZ-M25FA.TH(-ER)	SLZ-M35FA.TH(-ER)	SLZ-M50FA.TH(-ER)	SLZ-M60FA.TH(-ER)		
1	E27 C12 290	BASE		1	1	1	1	1		
2	E27 C13 124	DRUM-B		1	1	1	1	1		
3	E27 C12 808	LEG-1		2	2	2	2	2		
4	E27 C12 124	DRUM-A		1	1	1	1	1		
5	E27 C12 809	LEG-2		2	2	2	2	2		
6	E27 C12 092	INNER COVER ASSY		1	1	1	1	1		
7	E27 K49 620	INDOOR HEAT EXCHANGER		1	1	1				
	E27 K52 620	INDOOR HEAT EXCHANGER					1			
	E27 K53 620	INDOOR HEAT EXCHANGER						1		
8	E27 C12 300	INDOOR FAN MOTOR		1	1	1	1	1		MF
9	E27 C12 105	MOTOR MOUNT		3	3	3	3	3		
10	E27 C12 502	TURBO FAN		1	1	1	1	1		
11	E27 K05 097	SPL WASHER		1	1	1	1	1		
12	E27 C12 091	CONNECTOR COVER		1	1	1	1	1		
13	E27 C12 090	CONNECTOR BOX		1	1	1	1	1		
14	E27 C12 509	BELL MOUTH		1	1	1	1	1		
15	E27 436 524	DRAIN PLUG		1	1	1	1	1		
16	E27 C12 700	DRAIN PAN		1	1	1	1	1		
17	E27 C12 648	COIL SUPPORT		1	1	1	1	1		
18	E27 C12 308	ROOM TEMP.DETECTION THERMISTOR		1	1	1	1	1		TH1
19	E27 C12 307	PIPE TEMP. THERMISTOR/LIQUID/GAS		1	1	1	1	1		TH2,TH5
20	E27 C12 145	FLOAT SWITCH ASSY		1	1	1	1	1		FS
21	E27 C12 355	DRAIN PUMP		1	1	1	1	1		DP
22	E27 C12 702	DRAIN HOSE		1	1	1	1	1		
23	E27 C12 088	CONTROL BOX COVER		1	1	1	1	1		
24	E27 C13 006	COVER (DRUM-U)		1	1	1	1	1		
25	E27 C12 006	COVER (DRUM)		1	1	1	1	1		

**Mr. SLIM**

**mitsubishi electric corporation**

HEAD OFFICE: TOKYO BUILDING 2-7-3, MARUNOUCHI, CHIYODA-KU, TOKYO 100-8310, JAPAN