

Revision C:

• MSZ-EF22/25/35/42/50VGW/B/S - **ET3**,
MSZ-EF18/22/25/35/42/50VGKW/B/S - **E2** and
MSZ-EF22/25/35/42/50VGKW/B/S - **ET2**, **ER2**
have been added.

OBB831 REVISED EDITION-B is void.

INDOOR UNIT PARTS CATALOG

**No. OBB831
REVISED EDITION-C**

Models

MSZ-EF18VGW/B/S - **E1**, **E2**

MSZ-EF22VGW/B/S - **E1**, **ET1**, **E2**, **ET2**, **ET3**

MSZ-EF25VGW/B/S - **E1**, **ET1**, **E2**, **ET2**, **ET3**

MSZ-EF35VGW/B/S - **E1**, **ET1**, **E2**, **ET2**, **ET3**

MSZ-EF42VGW/B/S - **E1**, **ET1**, **E2**, **ET2**, **ET3**

MSZ-EF50VGW/B/S - **E1**, **ET1**, **E2**, **ET2**, **ET3**

MSZ-EF18VGKW/B/S - **E1**, **E2**

MSZ-EF22VGKW/B/S - **E1**, **ET1**, **ER1**, **E2**, **ET2**, **ER2**

MSZ-EF25VGKW/B/S - **E1**, **ET1**, **ER1**, **E2**, **ET2**, **ER2**

MSZ-EF35VGKW/B/S - **E1**, **ET1**, **ER1**, **E2**, **ET2**, **ER2**

MSZ-EF42VGKW/B/S - **E1**, **ET1**, **ER1**, **E2**, **ET2**, **ER2**

MSZ-EF50VGKW/B/S - **E1**, **ET1**, **ER1**, **E2**, **ET2**, **ER2**



MSZ-EF-VGW/VGKW
MSZ-EF-VGB/VGKB
MSZ-EF-VGS/VGKS



CONTENTS

1. SERVICE PARTS LIST.....	2
2. OPTIONAL PARTS.....	69

SERVICE MANUAL (OBH831)

Revision A:

- MSZ-EF18/22/25/35/42/50VGW/B/S - [E2], MSZ-EF22/25/35/42/50VGW/B/S - [ET2], MSZ-EF18/22/25/35/42/50VGKW/B/S - [E1] and MSZ-EF22/25/35/42/50VGKW/B/S - [ET1] have been added.

Revision B:

- MSZ-EF22/25/35/42/50VGKW/B/S - [ER1] have been added.
- Parts number of BEARING MOUNT ASSEMBLY for MSZ-EF18/22/25/35/42/50VGW/B/S - [E2], MSZ-EF22/25/35/42/50VGW/B/S - [ET2], MSZ-EF18/22/25/35/42/50VGKW/B/S - [E1] and MSZ-EF22/25/35/42/50VGKW/B/S - [ET1] has been added.

Revision C:

- MSZ-EF22/25/35/42/50VGW/B/S - [ET3], MSZ-EF18/22/25/35/42/50VGKW/B/S - [E2] and MSZ-EF22/25/35/42/50VGKW/B/S - [ET2, ER2] have been added.

1 SERVICE PARTS LIST

MSZ-EF18VGW - [E1] MSZ-EF18VGB - [E1] MSZ-EF18VGS - [E1] MSZ-EF22VGW - [E1] MSZ-EF22VGB - [E1]
MSZ-EF22VGS - [E1] MSZ-EF25VGW - [E1] MSZ-EF25VGB - [E1] MSZ-EF25VGS - [E1] MSZ-EF35VGW - [E1]
MSZ-EF35VGB - [E1] MSZ-EF35VGS - [E1] MSZ-EF42VGW - [E1] MSZ-EF42VGB - [E1] MSZ-EF42VGS - [E1]
MSZ-EF50VGW - [E1] MSZ-EF50VGB - [E1] MSZ-EF50VGS - [E1]

1-1. INDOOR UNIT STRUCTURAL PARTS

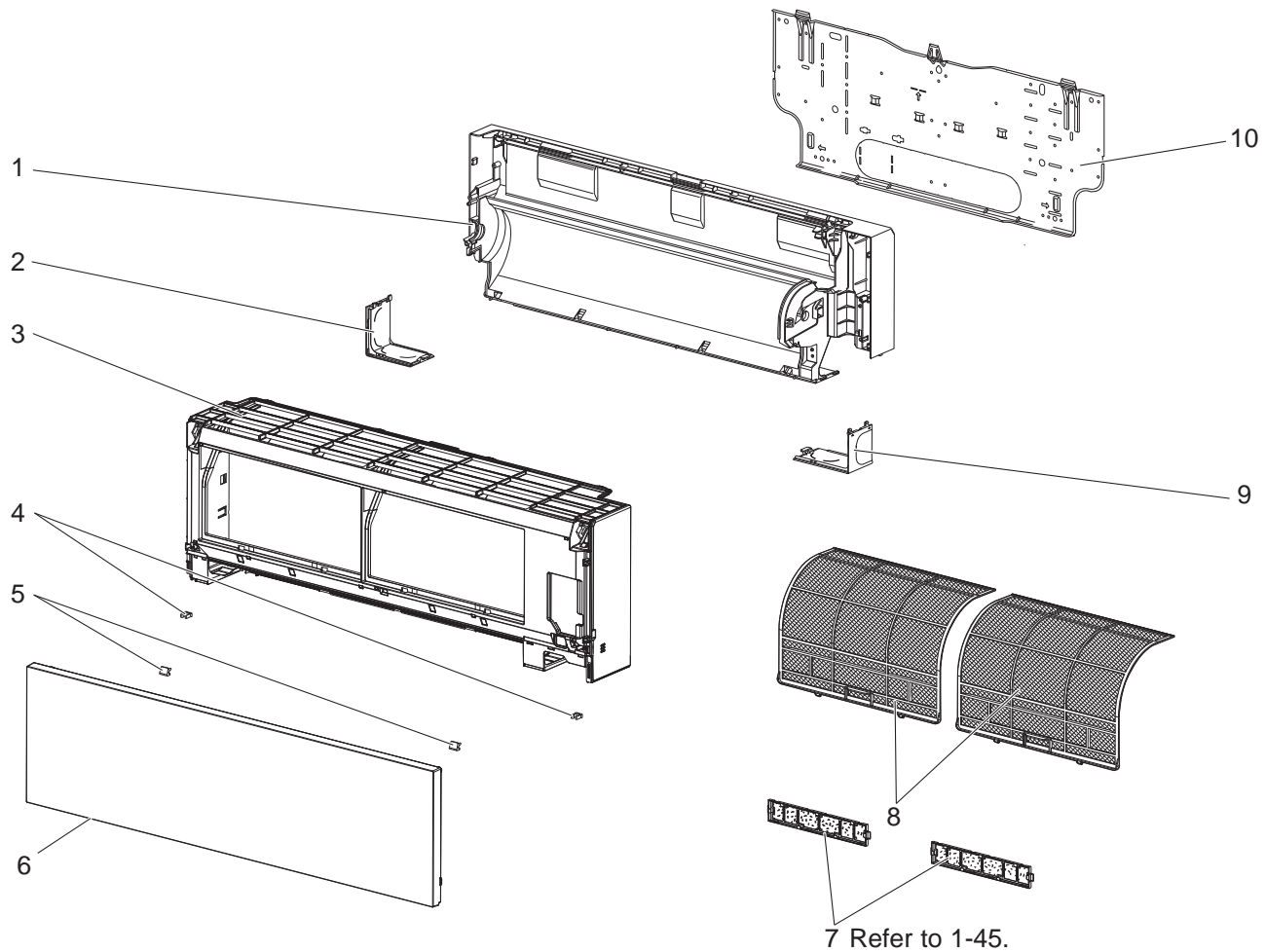

1-2. ACCESSORY AND REMOTE CONTROLLER

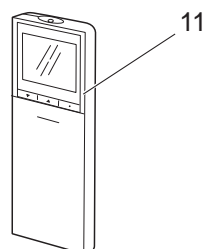

1-1. INDOOR UNIT STRUCTURAL PARTS

1. The part quantity below indicates the required number of pieces per unit.

No.	Part No.	Part name	MSZ-EF18VGW-E1	MSZ-EF18VGB-E1	MSZ-EF18VGS-E1	MSZ-EF22VGW-E1	MSZ-EF22VGB-E1	MSZ-EF22VGS-E1	MSZ-EF25VGW-E1	MSZ-EF25VGB-E1	MSZ-EF25VGS-E1	MSZ-EF35VGW-E1	MSZ-EF35VGB-E1	MSZ-EF35VGS-E1	MSZ-EF42VGW-E1	MSZ-EF42VGB-E1	MSZ-EF42VGS-E1	MSZ-EF50VGW-E1	MSZ-EF50VGB-E1	MSZ-EF50VGS-E1	Symbol in Wiring Diagram	Remarks	
1	E22 16H 234	BOX ASSEMBLY	1			1			1			1			1			1					
1	E22 G21 234	BOX ASSEMBLY		1			1			1			1			1			1				
1	E22 G26 234	BOX ASSEMBLY			1			1			1			1			1			1			
2	E22 16H 976	CORNER BOX LEFT	1			1			1			1			1			1					
2	E22 G21 976	CORNER BOX LEFT		1			1			1			1			1			1				
2	E22 G26 976	CORNER BOX LEFT			1			1			1			1			1			1			
3	E22 16H 000	PANEL ASSEMBLY	1			1			1			1			1			1				Includes No. 4, 6	
3	E22 14H 000	PANEL ASSEMBLY		1			1			1			1			1			1			Includes No. 4, 6	
3	E22 15H 000	PANEL ASSEMBLY			1			1			1			1			1			1		Includes No. 4, 6	
4	E22 F95 142	CATCH	2	2	2	2	2	2	2	2	2	2	2	2	2	2	2	2	2	2	2	2	2 PCS/SET
5	E22 16H 067	SCREW CAP	2			2			2			2			2			2			2	2 PCS/SET	
5	E22 G21 067	SCREW CAP		2			2			2			2			2			2			2 PCS/SET	
5	E22 G26 067	SCREW CAP			2			2			2			2			2			2		2 PCS/SET	
6	E22 16H 010	FRONT PANEL	1			1			1			1			1			1					
6	E22 T25 010	FRONT PANEL		1			1			1			1			1			1				
6	E22 T29 010	FRONT PANEL			1			1			1			1			1			1			
7	—	AIR CLEANING FILTER (SILVER-IONIZED AIR PURIFIER FILTER)	2	2	2	2	2	2	2	2	2	2	2	2	2	2	2	2	2	2	2	2	1 PC/SET
8	E22 16H 100	AIR FILTER (AIR PURIFYING FILTER)	2	2	2	2	2	2	2	2	2	2	2	2	2	2	2	2	2	2	2	2	1 PC/SET
9	E22 16H 975	CORNER BOX RIGHT	1			1			1			1			1			1					
9	E22 G21 975	CORNER BOX RIGHT		1			1			1			1			1			1				
9	E22 G26 975	CORNER BOX RIGHT			1			1			1			1			1			1			
10	E22 F95 970	INSTALLATION PLATE	1	1	1	1	1	1	1	1	1	1	1	1	1	1	1	1	1	1	1	1	

1-2. ACCESSORY AND REMOTE CONTROLLER

1. The part quantity below indicates the required number of pieces per unit.

No.	Part No.	Part name	MSZ-EF18VGW-E1	MSZ-EF18VGB-E1	MSZ-EF18VGS-E1	MSZ-EF22VGW-E1	MSZ-EF22VGB-E1	MSZ-EF22VGS-E1	MSZ-EF25VGW-E1	MSZ-EF25VGB-E1	MSZ-EF25VGS-E1	MSZ-EF35VGW-E1	MSZ-EF35VGB-E1	MSZ-EF35VGS-E1	MSZ-EF42VGW-E1	MSZ-EF42VGB-E1	MSZ-EF42VGS-E1	MSZ-EF50VGW-E1	MSZ-EF50VGB-E1	MSZ-EF50VGS-E1	Symbol in Wiring Diagram	Remarks
11	E22 16H 426	REMOTE CONTROLLER	1			1			1			1			1			1				SG19A
11	E22 14H 426	REMOTE CONTROLLER		1	1		1	1		1	1		1	1		1	1		1	1		SG19B

MSZ-EF18VGW - E1 MSZ-EF18VGB - E1 MSZ-EF18VGS - E1
MSZ-EF22VGW - E1 MSZ-EF22VGB - E1 MSZ-EF22VGS - E1
MSZ-EF25VGW - E1 MSZ-EF25VGB - E1 MSZ-EF25VGS - E1
MSZ-EF35VGW - E1 MSZ-EF35VGB - E1 MSZ-EF35VGS - E1
MSZ-EF42VGW - E1 MSZ-EF42VGB - E1 MSZ-EF42VGS - E1
MSZ-EF50VGW - E1 MSZ-EF50VGB - E1 MSZ-EF50VGS - E1

1-3. INDOOR UNIT ELECTRICAL PARTS AND FUNCTIONAL PARTS

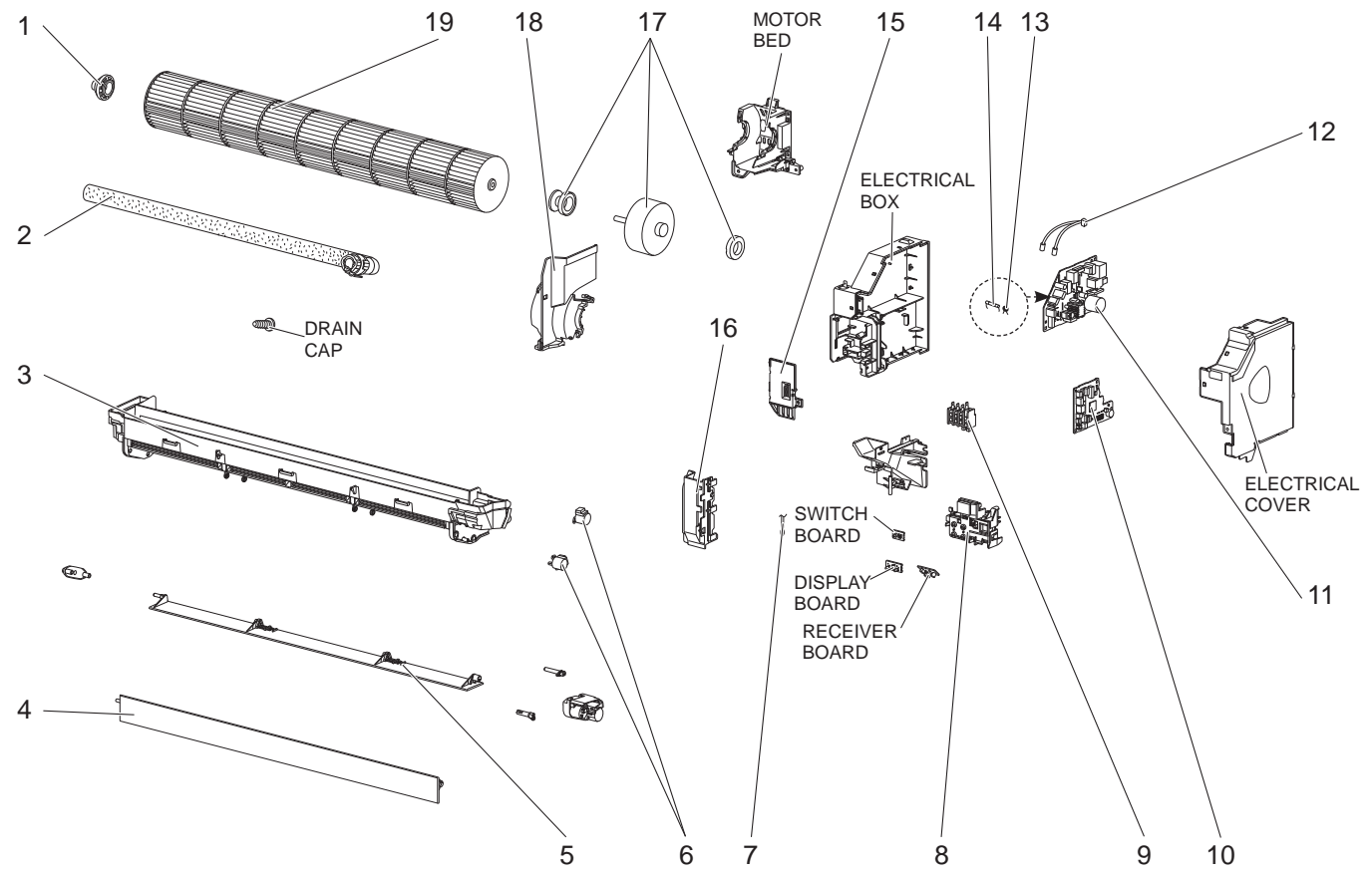

1-3. INDOOR UNIT ELECTRICAL PARTS AND FUNCTIONAL PARTS

1. The part quantity below indicates the required number of pieces per unit.

No.	Part No.	Part name	MSZ-EF18VGW-E1	MSZ-EF18VGB-E1	MSZ-EF18VGS-E1	MSZ-EF22VGW-E1	MSZ-EF22VGB-E1	MSZ-EF22VGS-E1	MSZ-EF25VGW-E1	MSZ-EF25VGB-E1	MSZ-EF25VGS-E1	MSZ-EF35VGW-E1	MSZ-EF35VGB-E1	MSZ-EF35VGS-E1	MSZ-EF42VGW-E1	MSZ-EF42VGB-E1	MSZ-EF42VGS-E1	MSZ-EF50VGW-E1	MSZ-EF50VGB-E1	MSZ-EF50VGS-E1	Symbol in Wiring Diagram	Remarks	
1	E22 A89 509	BEARING MOUNT ASSEMBLY	1	1	1	1	1	1	1	1	1	1	1	1	1	1	1	1	1	1		Includes Sleeve bearing	
2	E22 P72 702	DRAIN HOSE	1	1	1	1	1	1	1	1	1	1	1	1	1	1	1	1	1	1			
3	E22 16H 235	NOZZLE ASSEMBLY	1			1			1			1			1			1				Full assembly except DRAIN HOSE	
3	E22 G21 235	NOZZLE ASSEMBLY		1			1			1			1			1			1				
3	E22 G26 235	NOZZLE ASSEMBLY			1			1			1			1			1			1			
4	E22 16H 040	VANE UPPER	1			1			1			1			1			1					
4	E22 G21 040	VANE UPPER		1			1			1			1			1			1				
4	E22 G26 040	VANE UPPER			1			1			1			1			1			1			
5	E22 16H 041	VANE LOWER	1			1			1			1			1			1					
5	E22 G21 041	VANE LOWER		1			1			1			1			1			1				
5	E22 G26 041	VANE LOWER			1			1			1			1			1			1			
6	E22 A89 303	VANE MOTOR	2	2	2	2	2	2	2	2	2	2	2	2	2	2	2	2	2	2	2	MV	UP & DOWN, 1 PC/SET
7	E22 F95 308	ROOM TEMPERATURE THERMISTOR	1	1	1	1	1	1	1	1	1	1	1	1	1	1	1	1	1	1	1	RT11	
8	E22 F95 095	DISPLAY P.C. BOARD HOLDER	1	1	1	1	1	1	1	1	1	1	1	1	1	1	1	1	1	1	1		
9	E22 T21 375	TERMINAL BLOCK	1	1	1	1	1	1	1	1	1	1	1	1	1	1	1	1	1	1	1	TB	
10	E22 17H 452	ELECTRONIC CONTROL P.C. BOARD	1	1	1	1	1	1														Includes RECEIVER P.C. BOARD, DISPLAY P.C. BOARD and SWITCH P.C. BOARD.	
10	E22 22H 452	ELECTRONIC CONTROL P.C. BOARD							1	1	1												
10	E22 25H 452	ELECTRONIC CONTROL P.C. BOARD										1	1	1									
10	E22 28H 452	ELECTRONIC CONTROL P.C. BOARD													1	1	1						
10	E22 31H 452	ELECTRONIC CONTROL P.C. BOARD																1	1	1			
11	E22 17H 440	POWER P.C. BOARD	1	1	1	1	1	1	1	1	1	1	1	1	1	1	1	1	1	1	1		
12	E22 F95 307	INDOOR COIL THERMISTOR	1	1	1	1	1	1	1	1	1	1	1	1	1	1	1	1	1	1	1	RT12,RT13	
13	E22 B75 385	VARISTOR	1	1	1	1	1	1	1	1	1	1	1	1	1	1	1	1	1	1	1	NR11	
14	E22 A49 382	FUSE	1	1	1	1	1	1	1	1	1	1	1	1	1	1	1	1	1	1	1	F11	T3.15AL250V
15	E22 F95 784	V.A. CLAMP	1	1	1	1	1	1	1	1	1	1	1	1	1	1	1	1	1	1	1		
16	E22 F95 541	WATER CUT	1	1	1	1	1	1	1	1	1	1	1	1	1	1	1	1	1	1	1		
17	E22 16H 300	INDOOR FAN MOTOR	1	1	1	1	1	1	1	1	1	1	1	1	1	1	1	1	1	1	1	MF	RC0J40-□□ Includes FAN MOTOR RUBBER MOUNT (2 PCS/SET)
18	E22 F95 333	MOTOR BAND	1	1	1	1	1	1	1	1	1	1	1	1	1	1	1	1	1	1	1		
19	E22 F95 302	LINE FLOW FAN	1	1	1	1	1	1	1	1	1	1	1	1	1	1	1	1	1	1	1		

- MSZ-EF18VGW - E1 MSZ-EF18VGB - E1 MSZ-EF18VGS - E1
- MSZ-EF22VGW - E1 MSZ-EF22VGB - E1 MSZ-EF22VGS - E1
- MSZ-EF25VGW - E1 MSZ-EF25VGB - E1 MSZ-EF25VGS - E1
- MSZ-EF35VGW - E1 MSZ-EF35VGB - E1 MSZ-EF35VGS - E1
- MSZ-EF42VGW - E1 MSZ-EF42VGB - E1 MSZ-EF42VGS - E1
- MSZ-EF50VGW - E1 MSZ-EF50VGB - E1 MSZ-EF50VGS - E1

1-4. INDOOR UNIT HEAT EXCHANGER

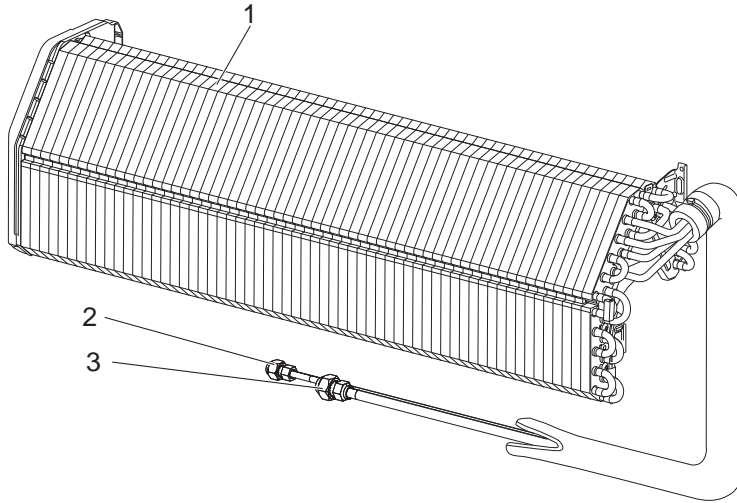



1-4. INDOOR UNIT HEAT EXCHANGER

1. The part quantity below indicates the required number of pieces per unit.

No.	Part No.	Part name	MSZ-EF18VGW-E1	MSZ-EF18VGB-E1	MSZ-EF18VGS-E1	MSZ-EF22VGW-E1	MSZ-EF22VGB-E1	MSZ-EF22VGS-E1	MSZ-EF25VGW-E1	MSZ-EF25VGB-E1	MSZ-EF25VGS-E1	MSZ-EF35VGW-E1	MSZ-EF35VGB-E1	MSZ-EF35VGS-E1	MSZ-EF42VGW-E1	MSZ-EF42VGB-E1	MSZ-EF42VGS-E1	MSZ-EF50VGW-E1	MSZ-EF50VGB-E1	MSZ-EF50VGS-E1	Symbol in Wiring Diagram	Remarks
			1	1	1	1	1	1	1	1	1	1	1	1	1	1	1	1	1	1		
1	E22 F95 620	INDOOR HEAT EXCHANGER	1	1	1	1	1	1	1	1	1	1	1	1	1	1	1	1	1	1		
2	E22 151 667	UNION (LIQUID)	1	1	1	1	1	1	1	1	1	1	1	1	1	1	1	1	1	1		ø6.35
3	E22 815 666	UNION (GAS)	1	1	1	1	1	1	1	1	1	1	1	1	1	1	1	1	1	1		ø9.52

- MSZ-EF18VGW - E2 MSZ-EF18VGB - E2 MSZ-EF18VGS - E2
- MSZ-EF22VGW - E2 MSZ-EF22VGB - E2 MSZ-EF22VGS - E2
- MSZ-EF25VGW - E2 MSZ-EF25VGB - E2 MSZ-EF25VGS - E2
- MSZ-EF35VGW - E2 MSZ-EF35VGB - E2 MSZ-EF35VGS - E2
- MSZ-EF42VGW - E2 MSZ-EF42VGB - E2 MSZ-EF42VGS - E2
- MSZ-EF50VGW - E2 MSZ-EF50VGB - E2 MSZ-EF50VGS - E2

1-5. INDOOR UNIT STRUCTURAL PARTS

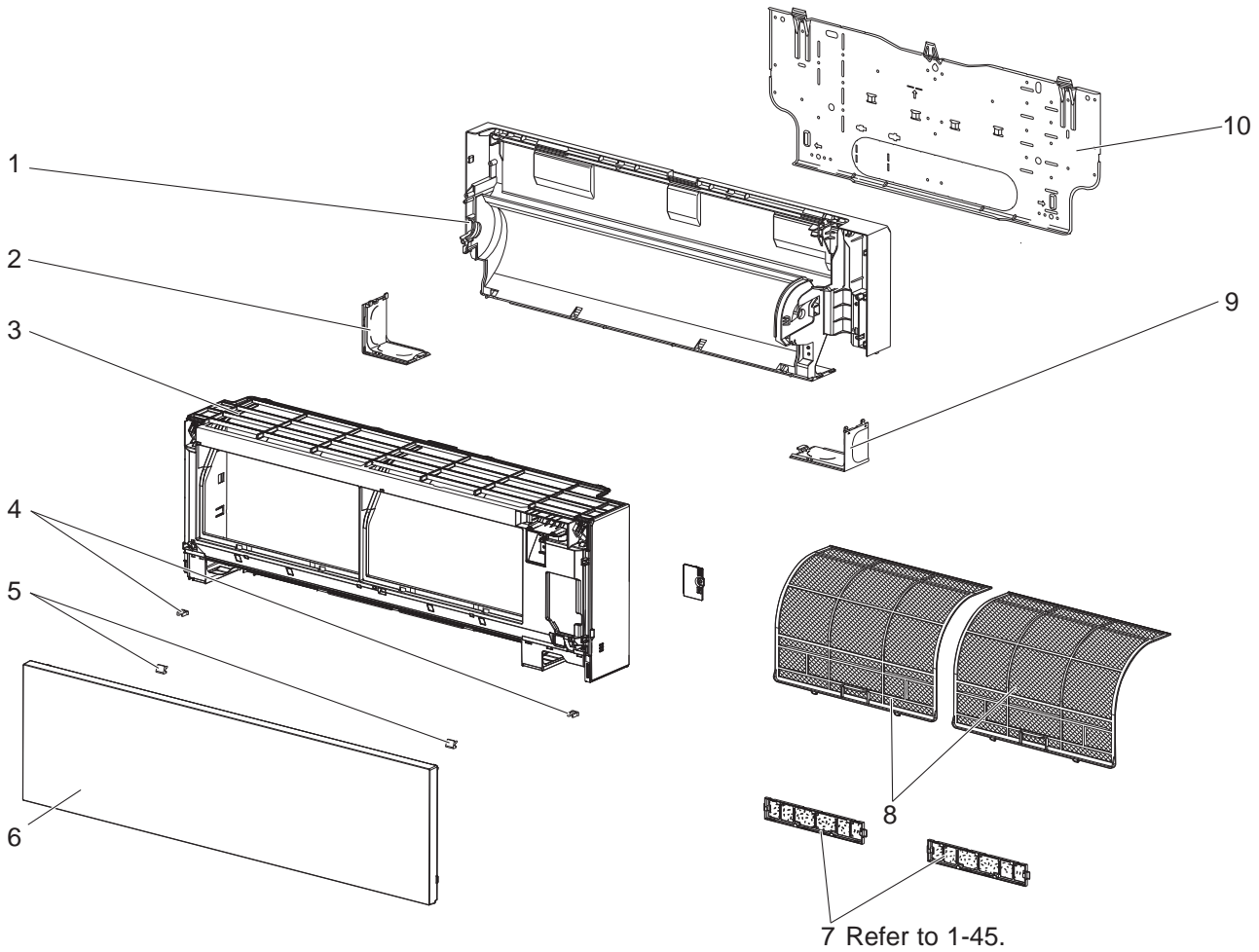

1-6. ACCESSORY AND REMOTE CONTROLLER

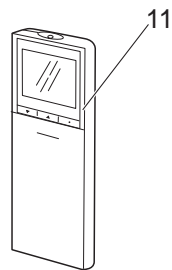

1-5. INDOOR UNIT STRUCTURAL PARTS

1. The part quantity below indicates the required number of pieces per unit.

No.	Part No.	Part name	MSZ-EF18VGV-E2	MSZ-EF18VGB-E2	MSZ-EF18VGS-E2	MSZ-EF22VGV-E2	MSZ-EF22VGB-E2	MSZ-EF22VGS-E2	MSZ-EF25VGV-E2	MSZ-EF25VGB-E2	MSZ-EF25VGS-E2	MSZ-EF35VGV-E2	MSZ-EF35VGB-E2	MSZ-EF35VGS-E2	MSZ-EF42VGV-E2	MSZ-EF42VGB-E2	MSZ-EF42VGS-E2	MSZ-EF50VGV-E2	MSZ-EF50VGB-E2	MSZ-EF50VGS-E2	Symbol in Wiring Diagram	Remarks	
1	E22 16H 234	BOX ASSEMBLY	1			1			1			1			1			1					
1	E22 G21 234	BOX ASSEMBLY		1			1			1			1			1			1				
1	E22 G26 234	BOX ASSEMBLY			1			1			1			1			1			1			
2	E22 16H 976	CORNER BOX LEFT	1			1			1			1			1			1					
2	E22 G21 976	CORNER BOX LEFT		1			1			1			1			1			1				
2	E22 G26 976	CORNER BOX LEFT			1			1			1			1			1			1			
3	E22 45L 000	PANEL ASSEMBLY	1			1			1			1			1			1				Includes No. 4, 6	
3	E22 46L 000	PANEL ASSEMBLY		1			1			1			1			1			1			Includes No. 4, 6	
3	E22 47L 000	PANEL ASSEMBLY			1			1			1			1			1			1		Includes No. 4, 6	
4	E22 F95 142	CATCH	2	2	2	2	2	2	2	2	2	2	2	2	2	2	2	2	2	2	2	2	2 PCS/SET
5	E22 16H 067	SCREW CAP	2			2			2			2			2			2				2 PCS/SET	
5	E22 G21 067	SCREW CAP		2			2			2			2			2			2			2 PCS/SET	
5	E22 G26 067	SCREW CAP			2			2			2			2			2			2		2 PCS/SET	
6	E22 16H 010	FRONT PANEL	1			1			1			1			1			1					
6	E22 T25 010	FRONT PANEL		1			1			1			1			1			1				
6	E22 T29 010	FRONT PANEL			1			1			1			1			1			1			
7	—	AIR CLEANING FILTER (SILVER-IONIZED AIR PURIFIER FILTER)	2	2	2	2	2	2	2	2	2	2	2	2	2	2	2	2	2	2	2	2	1 PC/SET
8	E22 16H 100	AIR FILTER (AIR PURIFYING FILTER)	2	2	2	2	2	2	2	2	2	2	2	2	2	2	2	2	2	2	2	2	1 PC/SET
9	E22 16H 975	CORNER BOX RIGHT	1			1			1			1			1			1					
9	E22 G21 975	CORNER BOX RIGHT		1			1			1			1			1			1				
9	E22 G26 975	CORNER BOX RIGHT			1			1			1			1			1			1			
10	E22 F95 970	INSTALLATION PLATE	1	1	1	1	1	1	1	1	1	1	1	1	1	1	1	1	1	1	1		

1-6. ACCESSORY AND REMOTE CONTROLLER

1. The part quantity below indicates the required number of pieces per unit.

No.	Part No.	Part name	MSZ-EF18VGV-E2	MSZ-EF18VGB-E2	MSZ-EF18VGS-E2	MSZ-EF22VGV-E2	MSZ-EF22VGB-E2	MSZ-EF22VGS-E2	MSZ-EF25VGV-E2	MSZ-EF25VGB-E2	MSZ-EF25VGS-E2	MSZ-EF35VGV-E2	MSZ-EF35VGB-E2	MSZ-EF35VGS-E2	MSZ-EF42VGV-E2	MSZ-EF42VGB-E2	MSZ-EF42VGS-E2	MSZ-EF50VGV-E2	MSZ-EF50VGB-E2	MSZ-EF50VGS-E2	Symbol in Wiring Diagram	Remarks
11	E22 16H 426	REMOTE CONTROLLER	1			1			1			1			1			1				SG19A
11	E22 14H 426	REMOTE CONTROLLER		1	1		1	1		1	1		1	1		1	1		1	1		SG19B

MSZ-EF18VGW - E2 MSZ-EF18VGB - E2 MSZ-EF18VGS - E2
MSZ-EF22VGW - E2 MSZ-EF22VGB - E2 MSZ-EF22VGS - E2
MSZ-EF25VGW - E2 MSZ-EF25VGB - E2 MSZ-EF25VGS - E2
MSZ-EF35VGW - E2 MSZ-EF35VGB - E2 MSZ-EF35VGS - E2
MSZ-EF42VGW - E2 MSZ-EF42VGB - E2 MSZ-EF42VGS - E2
MSZ-EF50VGW - E2 MSZ-EF50VGB - E2 MSZ-EF50VGS - E2

1-7. INDOOR UNIT ELECTRICAL PARTS AND FUNCTIONAL PARTS

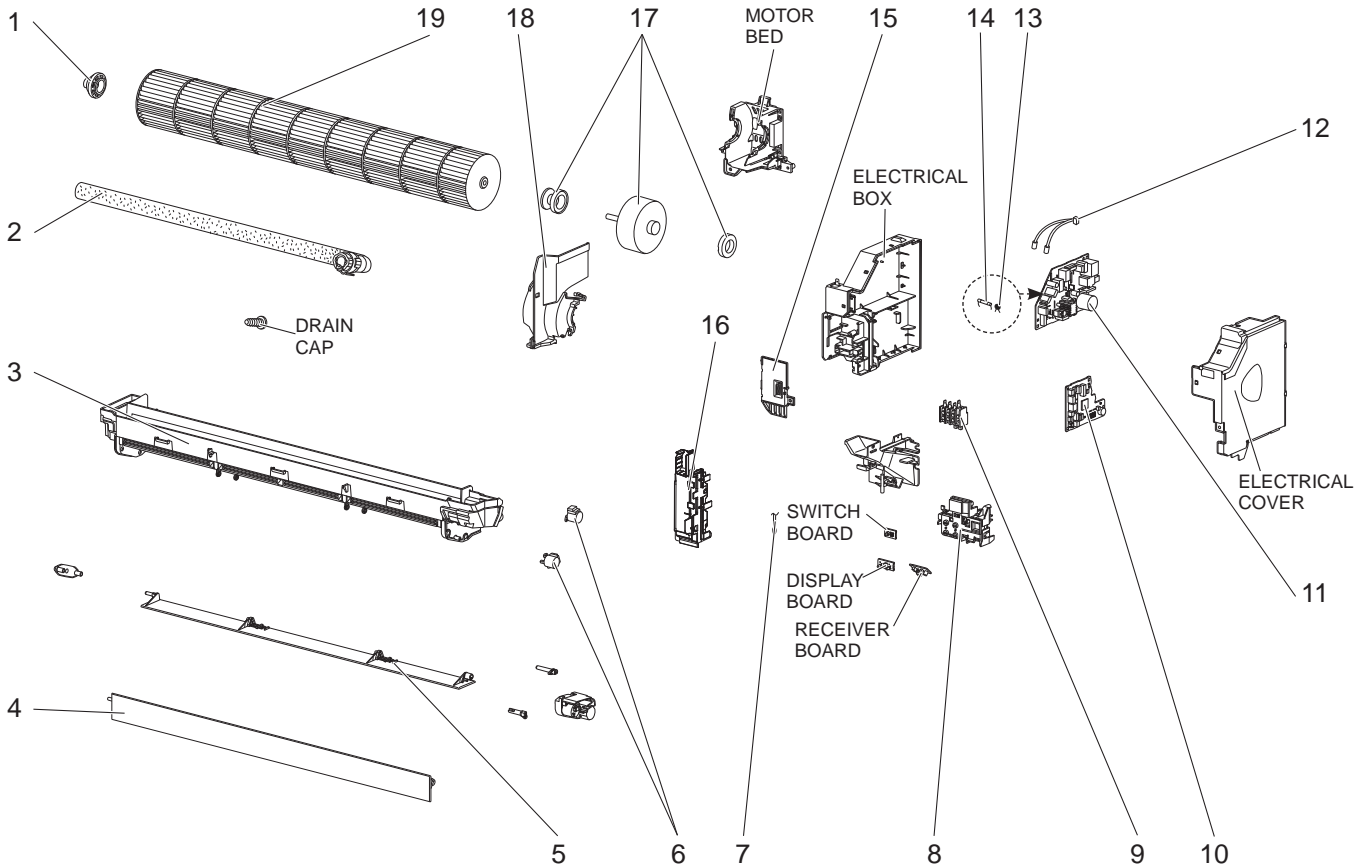

1-7. INDOOR UNIT ELECTRICAL PARTS AND FUNCTIONAL PARTS

1. The part quantity below indicates the required number of pieces per unit.

No.	Part No.	Part name	MSZ-EF18VGV-E2	MSZ-EF18VGB-E2	MSZ-EF18VGS-E2	MSZ-EF22VGV-E2	MSZ-EF22VGB-E2	MSZ-EF22VGS-E2	MSZ-EF25VGV-E2	MSZ-EF25VGB-E2	MSZ-EF25VGS-E2	MSZ-EF35VGV-E2	MSZ-EF35VGB-E2	MSZ-EF35VGS-E2	MSZ-EF42VGV-E2	MSZ-EF42VGB-E2	MSZ-EF42VGS-E2	MSZ-EF50VGV-E2	MSZ-EF50VGB-E2	MSZ-EF50VGS-E2	Symbol in Wiring Diagram	Remarks	
1	E22 A89 509	BEARING MOUNT ASSEMBLY	1	1	1	1	1	1	1	1	1	1	1	1	1	1	1	1	1	1		Includes Sleeve bearing	
2	E22 P72 702	DRAIN HOSE	1	1	1	1	1	1	1	1	1	1	1	1	1	1	1	1	1	1			
3	E22 16H 235	NOZZLE ASSEMBLY	1			1			1			1			1			1				Full assembly except DRAIN HOSE	
3	E22 G21 235	NOZZLE ASSEMBLY		1			1			1			1			1			1				
3	E22 G26 235	NOZZLE ASSEMBLY			1			1			1			1			1			1			
4	E22 16H 040	VANE UPPER	1			1			1			1			1			1					
4	E22 G21 040	VANE UPPER		1			1			1			1			1			1				
4	E22 G26 040	VANE UPPER			1			1			1			1			1			1			
5	E22 16H 041	VANE LOWER	1			1			1			1			1			1					
5	E22 G21 041	VANE LOWER		1			1			1			1			1			1				
5	E22 G26 041	VANE LOWER			1			1			1			1			1			1			
6	E22 A89 303	VANE MOTOR	2	2	2	2	2	2	2	2	2	2	2	2	2	2	2	2	2	2	2	MV1, MV2	UP & DOWN, 1 PC/SET
7	E22 F95 308	ROOM TEMPERATURE THERMISTOR	1	1	1	1	1	1	1	1	1	1	1	1	1	1	1	1	1	1	1	RT11	
8	E22 F95 095	DISPLAY P.C. BOARD HOLDER	1	1	1	1	1	1	1	1	1	1	1	1	1	1	1	1	1	1	1		
9	E22 T21 375	TERMINAL BLOCK	1	1	1	1	1	1	1	1	1	1	1	1	1	1	1	1	1	1	1	TB	
10	E22 45L 452	ELECTRONIC CONTROL P.C. BOARD	1	1	1	1	1	1														Includes RECEIVER P.C. BOARD, DISPLAY P.C. BOARD and SWITCH P.C. BOARD.	
10	E22 51L 452	ELECTRONIC CONTROL P.C. BOARD							1	1	1												
10	E22 54L 452	ELECTRONIC CONTROL P.C. BOARD										1	1	1									
10	E22 57L 452	ELECTRONIC CONTROL P.C. BOARD													1	1	1						
10	E22 60L 452	ELECTRONIC CONTROL P.C. BOARD																1	1	1			
11	E22 45L 440	POWER P.C. BOARD	1	1	1	1	1	1	1	1	1	1	1	1	1	1	1						
11	E22 60L 440	POWER P.C. BOARD																1	1	1			
12	E22 F95 307	INDOOR COIL THERMISTOR	1	1	1	1	1	1	1	1	1	1	1	1	1	1	1	1	1	1	1	RT12,RT13	
13	E22 B75 385	VARISTOR	1	1	1	1	1	1	1	1	1	1	1	1	1	1	1	1	1	1	1	NR11	
14	E22 42J 382	FUSE	1	1	1	1	1	1	1	1	1	1	1	1	1	1	1	1	1	1	1	F11	T3.15AL250V
15	E22 F95 784	V.A. CLAMP	1	1	1	1	1	1	1	1	1	1	1	1	1	1	1	1	1	1	1		
16	E22 45L 541	WATER CUT	1	1	1	1	1	1	1	1	1	1	1	1	1	1	1	1	1	1	1		
17	E22 29L 300	INDOOR FAN MOTOR	1	1	1	1	1	1	1	1	1	1	1	1	1	1	1	1	1	1	1	MF	RC0J40-□□ Includes FAN MOTOR RUBBER MOUNT (2 PCS/SET)
18	E22 F95 333	MOTOR BAND	1	1	1	1	1	1	1	1	1	1	1	1	1	1	1	1	1	1	1		
19	E22 F95 302	LINE FLOW FAN	1	1	1	1	1	1	1	1	1	1	1	1	1	1	1	1	1	1	1		

- MSZ-EF18VGW - E2 MSZ-EF18VGB - E2 MSZ-EF18VGS - E2
- MSZ-EF22VGW - E2 MSZ-EF22VGB - E2 MSZ-EF22VGS - E2
- MSZ-EF25VGW - E2 MSZ-EF25VGB - E2 MSZ-EF25VGS - E2
- MSZ-EF35VGW - E2 MSZ-EF35VGB - E2 MSZ-EF35VGS - E2
- MSZ-EF42VGW - E2 MSZ-EF42VGB - E2 MSZ-EF42VGS - E2
- MSZ-EF50VGW - E2 MSZ-EF50VGB - E2 MSZ-EF50VGS - E2

1-8. INDOOR UNIT HEAT EXCHANGER

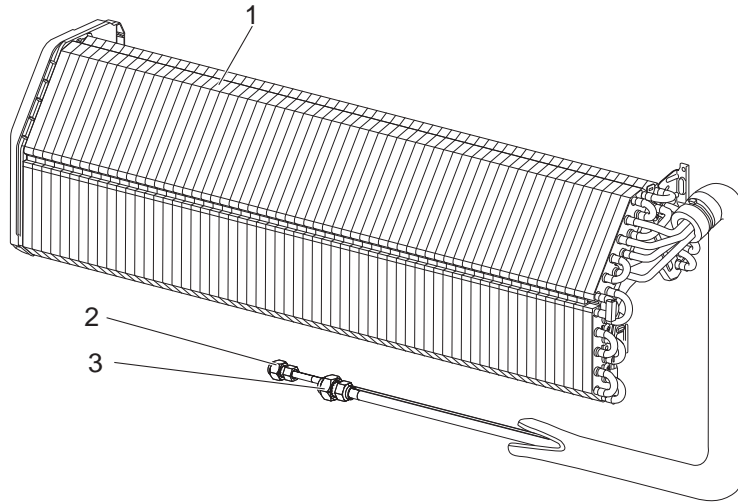



1-8. INDOOR UNIT HEAT EXCHANGER

1. The part quantity below indicates the required number of pieces per unit.

No.	Part No.	Part name	MSZ-EF18VGW-E2	MSZ-EF18VGB-E2	MSZ-EF18VGS-E2	MSZ-EF22VGW-E2	MSZ-EF22VGB-E2	MSZ-EF22VGS-E2	MSZ-EF25VGW-E2	MSZ-EF25VGB-E2	MSZ-EF25VGS-E2	MSZ-EF35VGW-E2	MSZ-EF35VGB-E2	MSZ-EF35VGS-E2	MSZ-EF42VGW-E2	MSZ-EF42VGB-E2	MSZ-EF42VGS-E2	MSZ-EF50VGW-E2	MSZ-EF50VGB-E2	MSZ-EF50VGS-E2	Symbol in Wiring Diagram	Remarks
			1	1	1	1	1	1	1	1	1	1	1	1	1	1	1	1	1	1		
1	E22 F95 620	INDOOR HEAT EXCHANGER	1	1	1	1	1	1	1	1	1	1	1	1	1	1	1	1	1	1		
2	E22 151 667	UNION (LIQUID)	1	1	1	1	1	1	1	1	1	1	1	1	1	1	1	1	1	1		ø6.35
3	E22 815 666	UNION (GAS)	1	1	1	1	1	1	1	1	1	1	1	1	1	1	1	1	1	1		ø9.52

MSZ-EF22VGW -ET1 MSZ-EF22VGB -ET1 MSZ-EF22VGS -ET1
MSZ-EF25VGW -ET1 MSZ-EF25VGB -ET1 MSZ-EF25VGS -ET1
MSZ-EF35VGW -ET1 MSZ-EF35VGB -ET1 MSZ-EF35VGS -ET1
MSZ-EF42VGW -ET1 MSZ-EF42VGB -ET1 MSZ-EF42VGS -ET1
MSZ-EF50VGW -ET1 MSZ-EF50VGB -ET1 MSZ-EF50VGS -ET1

1-9. INDOOR UNIT STRUCTURAL PARTS

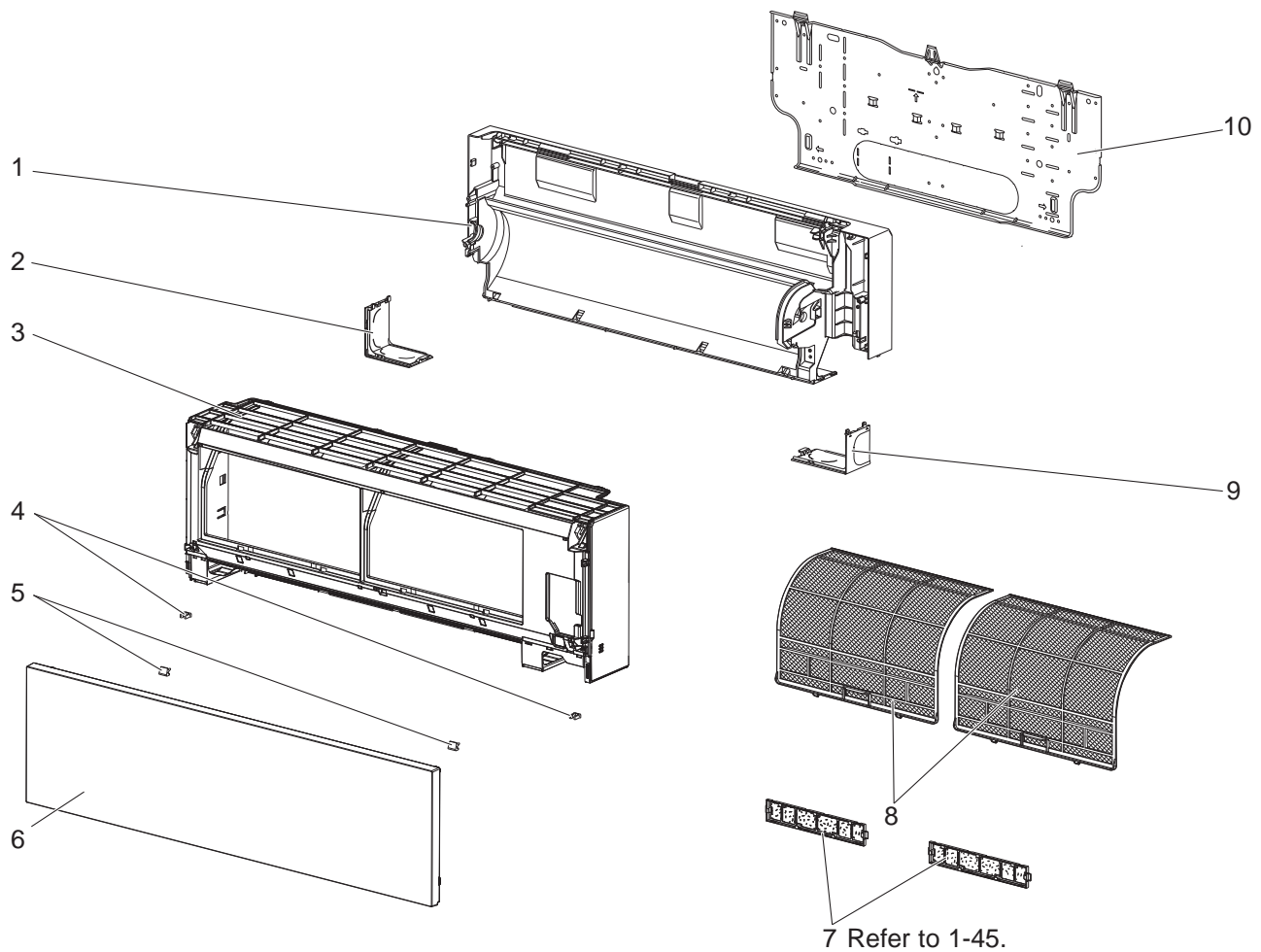

1-10. ACCESSORY AND REMOTE CONTROLLER

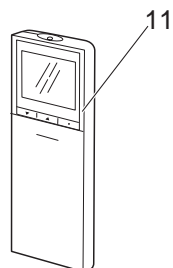

1-9. INDOOR UNIT STRUCTURAL PARTS

1. The part quantity below indicates the required number of pieces per unit.

No.	Part No.	Part name	MSZ-EF22VGW-ET1	MSZ-EF22VGB-ET1	MSZ-EF22VGS-ET1	MSZ-EF25VGW-ET1	MSZ-EF25VGB-ET1	MSZ-EF25VGS-ET1	MSZ-EF35VGW-ET1	MSZ-EF35VGB-ET1	MSZ-EF35VGS-ET1	MSZ-EF42VGW-ET1	MSZ-EF42VGB-ET1	MSZ-EF42VGS-ET1	MSZ-EF50VGW-ET1	MSZ-EF50VGB-ET1	MSZ-EF50VGS-ET1	Symbol in Wiring Diagram	Remarks
1	E22 16H 234	BOX ASSEMBLY	1			1			1			1			1				
1	E22 G21 234	BOX ASSEMBLY		1			1			1			1			1			
1	E22 G26 234	BOX ASSEMBLY			1			1			1			1			1		
2	E22 16H 976	CORNER BOX LEFT	1			1			1			1			1				
2	E22 G21 976	CORNER BOX LEFT		1			1			1			1			1			
2	E22 G26 976	CORNER BOX LEFT			1			1			1			1			1		
3	E22 34H 000	PANEL ASSEMBLY	1			1			1			1			1				Includes No. 4, 6
3	E22 32H 000	PANEL ASSEMBLY		1			1			1			1			1			Includes No. 4, 6
3	E22 33H 000	PANEL ASSEMBLY			1			1			1			1			1		Includes No. 4, 6
4	E22 F95 142	CATCH	2	2	2	2	2	2	2	2	2	2	2	2	2	2	2		2 PCS/SET
5	E22 16H 067	SCREW CAP	2			2			2			2			2				2 PCS/SET
5	E22 G21 067	SCREW CAP		2			2			2			2			2			2 PCS/SET
5	E22 G26 067	SCREW CAP			2			2			2			2			2		2 PCS/SET
6	E22 16H 010	FRONT PANEL	1			1			1			1			1				
6	E22 T25 010	FRONT PANEL		1			1			1			1			1			
6	E22 T29 010	FRONT PANEL			1			1			1			1			1		
7	—	AIR CLEANING FILTER (SILVER-IONIZED AIR PURIFIER FILTER)	2	2	2	2	2	2	2	2	2	2	2	2	2	2	2		1 PC/SET
8	E22 16H 100	AIR FILTER (AIR PURIFYING FILTER)	2	2	2	2	2	2	2	2	2	2	2	2	2	2	2		1 PC/SET
9	E22 16H 975	CORNER BOX RIGHT	1			1			1			1			1				
9	E22 G21 975	CORNER BOX RIGHT		1			1			1			1			1			
9	E22 G26 975	CORNER BOX RIGHT			1			1			1			1			1		
10	E22 F95 970	INSTALLATION PLATE	1	1	1	1	1	1	1	1	1	1	1	1	1	1	1		

1-10. ACCESSORY AND REMOTE CONTROLLER

1. The part quantity below indicates the required number of pieces per unit.

No.	Part No.	Part name	MSZ-EF22VGW-ET1	MSZ-EF22VGB-ET1	MSZ-EF22VGS-ET1	MSZ-EF25VGW-ET1	MSZ-EF25VGB-ET1	MSZ-EF25VGS-ET1	MSZ-EF35VGW-ET1	MSZ-EF35VGB-ET1	MSZ-EF35VGS-ET1	MSZ-EF42VGW-ET1	MSZ-EF42VGB-ET1	MSZ-EF42VGS-ET1	MSZ-EF50VGW-ET1	MSZ-EF50VGB-ET1	MSZ-EF50VGS-ET1	Symbol in Wiring Diagram	Remarks
11	E22 16H 426	REMOTE CONTROLLER	1			1			1			1			1				SG19A
11	E22 14H 426	REMOTE CONTROLLER		1	1		1	1		1	1		1	1		1	1		SG19B

MSZ-EF22VGW -[ET1] MSZ-EF22VGB -[ET1] MSZ-EF22VGS -[ET1]
MSZ-EF25VGW -[ET1] MSZ-EF25VGB -[ET1] MSZ-EF25VGS -[ET1]
MSZ-EF35VGW -[ET1] MSZ-EF35VGB -[ET1] MSZ-EF35VGS -[ET1]
MSZ-EF42VGW -[ET1] MSZ-EF42VGB -[ET1] MSZ-EF42VGS -[ET1]
MSZ-EF50VGW -[ET1] MSZ-EF50VGB -[ET1] MSZ-EF50VGS -[ET1]

1-11. INDOOR UNIT ELECTRICAL PARTS AND FUNCTIONAL PARTS

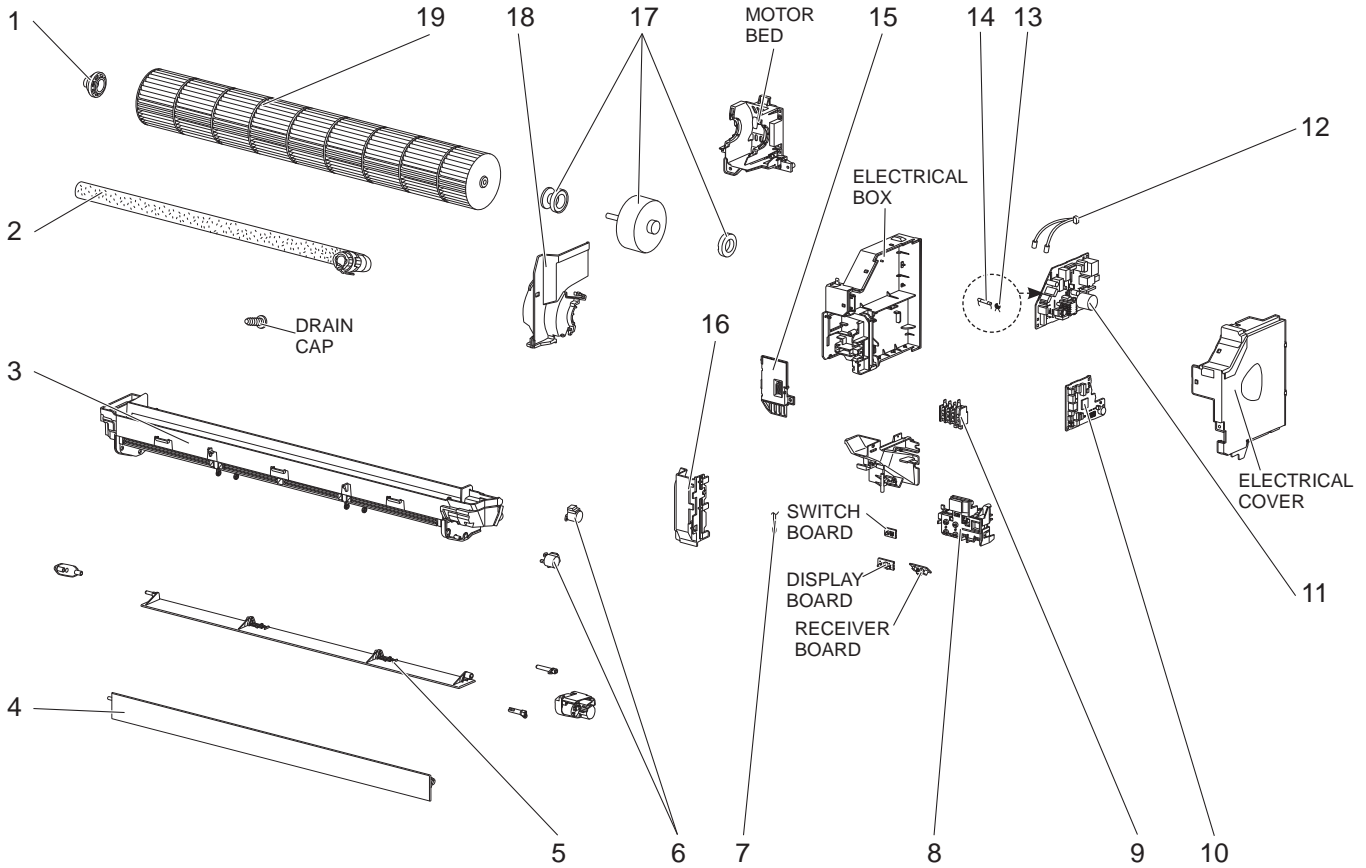

1-11. INDOOR UNIT ELECTRICAL PARTS AND FUNCTIONAL PARTS

1. The part quantity below indicates the required number of pieces per unit.

No.	Part No.	Part name	MSZ-EF22VGW-ET1	MSZ-EF22VGB-ET1	MSZ-EF22VGS-ET1	MSZ-EF25VGW-ET1	MSZ-EF25VGB-ET1	MSZ-EF25VGS-ET1	MSZ-EF35VGW-ET1	MSZ-EF35VGB-ET1	MSZ-EF35VGS-ET1	MSZ-EF42VGW-ET1	MSZ-EF42VGB-ET1	MSZ-EF42VGS-ET1	MSZ-EF50VGW-ET1	MSZ-EF50VGB-ET1	MSZ-EF50VGS-ET1	Symbol in Wiring Diagram	Remarks
1	E22 A89 509	BEARING MOUNT ASSEMBLY	1	1	1	1	1	1	1	1	1	1	1	1	1	1	1		Includes Sleeve bearing
2	E22 P72 702	DRAIN HOSE	1	1	1	1	1	1	1	1	1	1	1	1	1	1	1		
3	E22 16H 235	NOZZLE ASSEMBLY	1			1			1			1			1				Full assembly except DRAIN HOSE
3	E22 G21 235	NOZZLE ASSEMBLY		1			1			1			1			1			
3	E22 G26 235	NOZZLE ASSEMBLY			1			1			1			1			1		
4	E22 16H 040	VANE UPPER	1			1			1			1			1				
4	E22 G21 040	VANE UPPER		1			1			1			1			1			
4	E22 G26 040	VANE UPPER			1			1			1			1			1		
5	E22 16H 041	VANE LOWER	1			1			1			1			1				
5	E22 G21 041	VANE LOWER		1			1			1			1			1			
5	E22 G26 041	VANE LOWER			1			1			1			1			1		
6	E22 A89 303	VANE MOTOR	2	2	2	2	2	2	2	2	2	2	2	2	2	2	2	MV	UP & DOWN, 1 PC/SET
7	E22 F95 308	ROOM TEMPERATURE THERMISTOR	1	1	1	1	1	1	1	1	1	1	1	1	1	1	1	RT11	
8	E22 F95 095	DISPLAY P.C. BOARD HOLDER	1	1	1	1	1	1	1	1	1	1	1	1	1	1	1		
9	E22 T21 375	TERMINAL BLOCK	1	1	1	1	1	1	1	1	1	1	1	1	1	1	1	TB	
10	E22 17H 452	ELECTRONIC CONTROL P.C. BOARD	1	1	1														Includes RECEIVER P.C. BOARD, DISPLAY P.C. BOARD and SWITCH P.C. BOARD.
10	E22 22H 452	ELECTRONIC CONTROL P.C. BOARD				1	1	1											
10	E22 25H 452	ELECTRONIC CONTROL P.C. BOARD							1	1	1								
10	E22 28H 452	ELECTRONIC CONTROL P.C. BOARD										1	1	1					
10	E22 31H 452	ELECTRONIC CONTROL P.C. BOARD													1	1	1		
11	E22 17H 440	POWER P.C. BOARD	1	1	1	1	1	1	1	1	1	1	1	1	1	1	1		
12	E22 F95 307	INDOOR COIL THERMISTOR	1	1	1	1	1	1	1	1	1	1	1	1	1	1	1	RT12,RT13	
13	E22 B75 385	VARISTOR	1	1	1	1	1	1	1	1	1	1	1	1	1	1	1	NR11	
14	E22 A49 382	FUSE	1	1	1	1	1	1	1	1	1	1	1	1	1	1	1	F11	T3.15AL250V
15	E22 F95 784	V.A. CLAMP	1	1	1	1	1	1	1	1	1	1	1	1	1	1	1		
16	E22 F95 541	WATER CUT	1	1	1	1	1	1	1	1	1	1	1	1	1	1	1		
17	E22 16H 300	INDOOR FAN MOTOR	1	1	1	1	1	1	1	1	1	1	1	1	1	1	1	MF	RC0J40-□□ Includes FAN MOTOR RUBBER MOUNT (2 PCS/SET)
18	E22 F95 333	MOTOR BAND	1	1	1	1	1	1	1	1	1	1	1	1	1	1	1		
19	E22 F95 302	LINE FLOW FAN	1	1	1	1	1	1	1	1	1	1	1	1	1	1	1		

MSZ-EF22VGW -[ET1] MSZ-EF22VGB -[ET1] MSZ-EF22VGS -[ET1]
MSZ-EF25VGW -[ET1] MSZ-EF25VGB -[ET1] MSZ-EF25VGS -[ET1]
MSZ-EF35VGW -[ET1] MSZ-EF35VGB -[ET1] MSZ-EF35VGS -[ET1]
MSZ-EF42VGW -[ET1] MSZ-EF42VGB -[ET1] MSZ-EF42VGS -[ET1]
MSZ-EF50VGW -[ET1] MSZ-EF50VGB -[ET1] MSZ-EF50VGS -[ET1]

1-12. INDOOR UNIT HEAT EXCHANGER

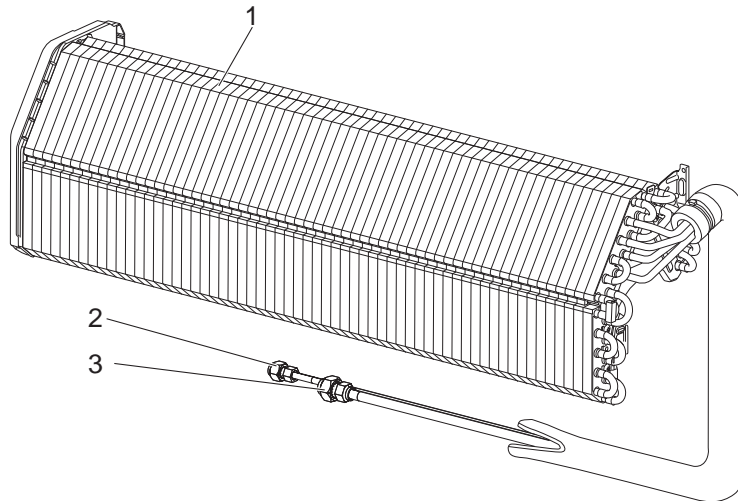



1-12. INDOOR UNIT HEAT EXCHANGER

1. The part quantity below indicates the required number of pieces per unit.

No.	Part No.	Part name	MSZ-EF22VGW-ET1	MSZ-EF22VGB-ET1	MSZ-EF22VGS-ET1	MSZ-EF25VGW-ET1	MSZ-EF25VGB-ET1	MSZ-EF25VGS-ET1	MSZ-EF35VGW-ET1	MSZ-EF35VGB-ET1	MSZ-EF35VGS-ET1	MSZ-EF42VGW-ET1	MSZ-EF42VGB-ET1	MSZ-EF42VGS-ET1	MSZ-EF50VGW-ET1	MSZ-EF50VGB-ET1	MSZ-EF50VGS-ET1	Symbol in Wiring Diagram	Remarks
1	E22 F95 620	INDOOR HEAT EXCHANGER	1	1	1	1	1	1	1	1	1	1	1	1	1	1	1		
2	E22 151 667	UNION (LIQUID)	1	1	1	1	1	1	1	1	1	1	1	1	1	1	1		ø6.35
3	E22 815 666	UNION (GAS)	1	1	1	1	1	1	1	1	1	1	1	1	1	1	1		ø9.52

MSZ-EF22VGW -ET2 MSZ-EF22VGB -ET2 MSZ-EF22VGS -ET2
MSZ-EF25VGW -ET2 MSZ-EF25VGB -ET2 MSZ-EF25VGS -ET2
MSZ-EF35VGW -ET2 MSZ-EF35VGB -ET2 MSZ-EF35VGS -ET2
MSZ-EF42VGW -ET2 MSZ-EF42VGB -ET2 MSZ-EF42VGS -ET2
MSZ-EF50VGW -ET2 MSZ-EF50VGB -ET2 MSZ-EF50VGS -ET2

1-13. INDOOR UNIT STRUCTURAL PARTS

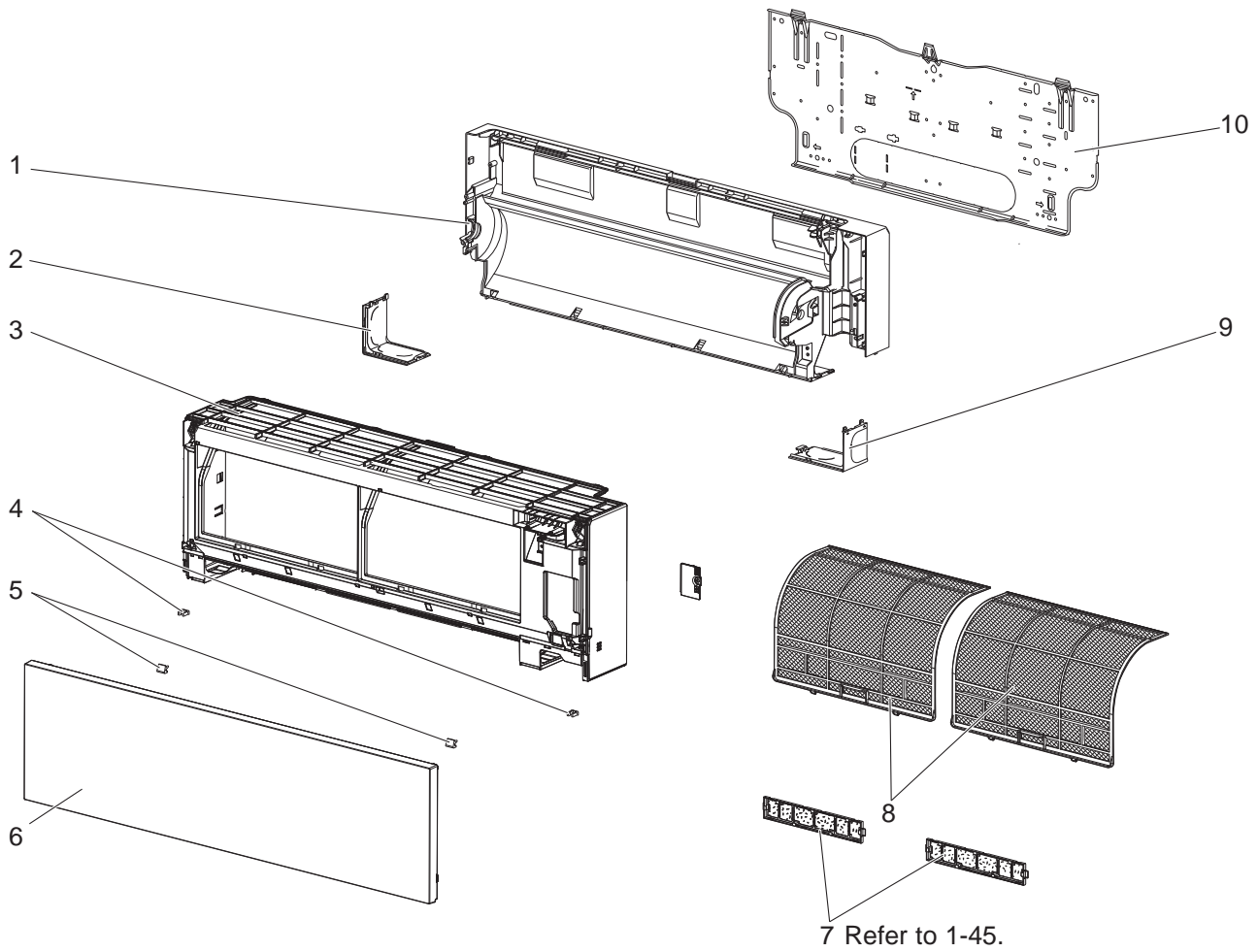

1-14. ACCESSORY AND REMOTE CONTROLLER

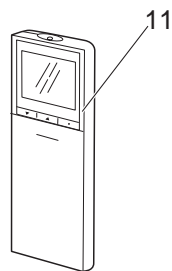

1-13. INDOOR UNIT STRUCTURAL PARTS

1. The part quantity below indicates the required number of pieces per unit.

No.	Part No.	Part name	MSZ-EF22VGW-ET2	MSZ-EF22VGB-ET2	MSZ-EF22VGS-ET2	MSZ-EF25VGW-ET2	MSZ-EF25VGB-ET2	MSZ-EF25VGS-ET2	MSZ-EF35VGW-ET2	MSZ-EF35VGB-ET2	MSZ-EF35VGS-ET2	MSZ-EF42VGW-ET2	MSZ-EF42VGB-ET2	MSZ-EF42VGS-ET2	MSZ-EF50VGW-ET2	MSZ-EF50VGB-ET2	MSZ-EF50VGS-ET2	Symbol in Wiring Diagram	Remarks
1	E22 16H 234	BOX ASSEMBLY	1			1			1			1			1				
1	E22 G21 234	BOX ASSEMBLY		1			1			1			1			1			
1	E22 G26 234	BOX ASSEMBLY			1			1			1			1			1		
2	E22 16H 976	CORNER BOX LEFT	1			1			1			1			1				
2	E22 G21 976	CORNER BOX LEFT		1			1			1			1			1			
2	E22 G26 976	CORNER BOX LEFT			1			1			1			1			1		
3	E22 48L 000	PANEL ASSEMBLY	1			1			1			1			1				Includes No. 4, 6
3	E22 49L 000	PANEL ASSEMBLY		1			1			1			1			1			Includes No. 4, 6
3	E22 50L 000	PANEL ASSEMBLY			1			1			1			1			1		Includes No. 4, 6
4	E22 F95 142	CATCH	2	2	2	2	2	2	2	2	2	2	2	2	2	2	2		2 PCS/SET
5	E22 16H 067	SCREW CAP	2			2			2			2			2				2 PCS/SET
5	E22 G21 067	SCREW CAP		2			2			2			2			2			2 PCS/SET
5	E22 G26 067	SCREW CAP			2			2			2			2			2		2 PCS/SET
6	E22 16H 010	FRONT PANEL	1			1			1			1			1				
6	E22 T25 010	FRONT PANEL		1			1			1			1			1			
6	E22 T29 010	FRONT PANEL			1			1			1			1			1		
7	—	AIR CLEANING FILTER (SILVER-IONIZED AIR PURIFIER FILTER)	2	2	2	2	2	2	2	2	2	2	2	2	2	2	2		1 PC/SET
8	E22 16H 100	AIR FILTER (AIR PURIFYING FILTER)	2	2	2	2	2	2	2	2	2	2	2	2	2	2	2		1 PC/SET
9	E22 16H 975	CORNER BOX RIGHT	1			1			1			1			1				
9	E22 G21 975	CORNER BOX RIGHT		1			1			1			1			1			
9	E22 G26 975	CORNER BOX RIGHT			1			1			1			1			1		
10	E22 F95 970	INSTALLATION PLATE	1	1	1	1	1	1	1	1	1	1	1	1	1	1	1		

1-14. ACCESSORY AND REMOTE CONTROLLER

1. The part quantity below indicates the required number of pieces per unit.

No.	Part No.	Part name	MSZ-EF22VGW-ET2	MSZ-EF22VGB-ET2	MSZ-EF22VGS-ET2	MSZ-EF25VGW-ET2	MSZ-EF25VGB-ET2	MSZ-EF25VGS-ET2	MSZ-EF35VGW-ET2	MSZ-EF35VGB-ET2	MSZ-EF35VGS-ET2	MSZ-EF42VGW-ET2	MSZ-EF42VGB-ET2	MSZ-EF42VGS-ET2	MSZ-EF50VGW-ET2	MSZ-EF50VGB-ET2	MSZ-EF50VGS-ET2	Symbol in Wiring Diagram	Remarks
11	E22 16H 426	REMOTE CONTROLLER	1			1			1			1			1				SG19A
11	E22 14H 426	REMOTE CONTROLLER		1	1	1	1	1	1	1	1	1	1	1	1	1	1		SG19B

MSZ-EF22VGW -[ET2] MSZ-EF22VGB -[ET2] MSZ-EF22VGS -[ET2]
MSZ-EF25VGW -[ET2] MSZ-EF25VGB -[ET2] MSZ-EF25VGS -[ET2]
MSZ-EF35VGW -[ET2] MSZ-EF35VGB -[ET2] MSZ-EF35VGS -[ET2]
MSZ-EF42VGW -[ET2] MSZ-EF42VGB -[ET2] MSZ-EF42VGS -[ET2]
MSZ-EF50VGW -[ET2] MSZ-EF50VGB -[ET2] MSZ-EF50VGS -[ET2]

1-15. INDOOR UNIT ELECTRICAL PARTS AND FUNCTIONAL PARTS

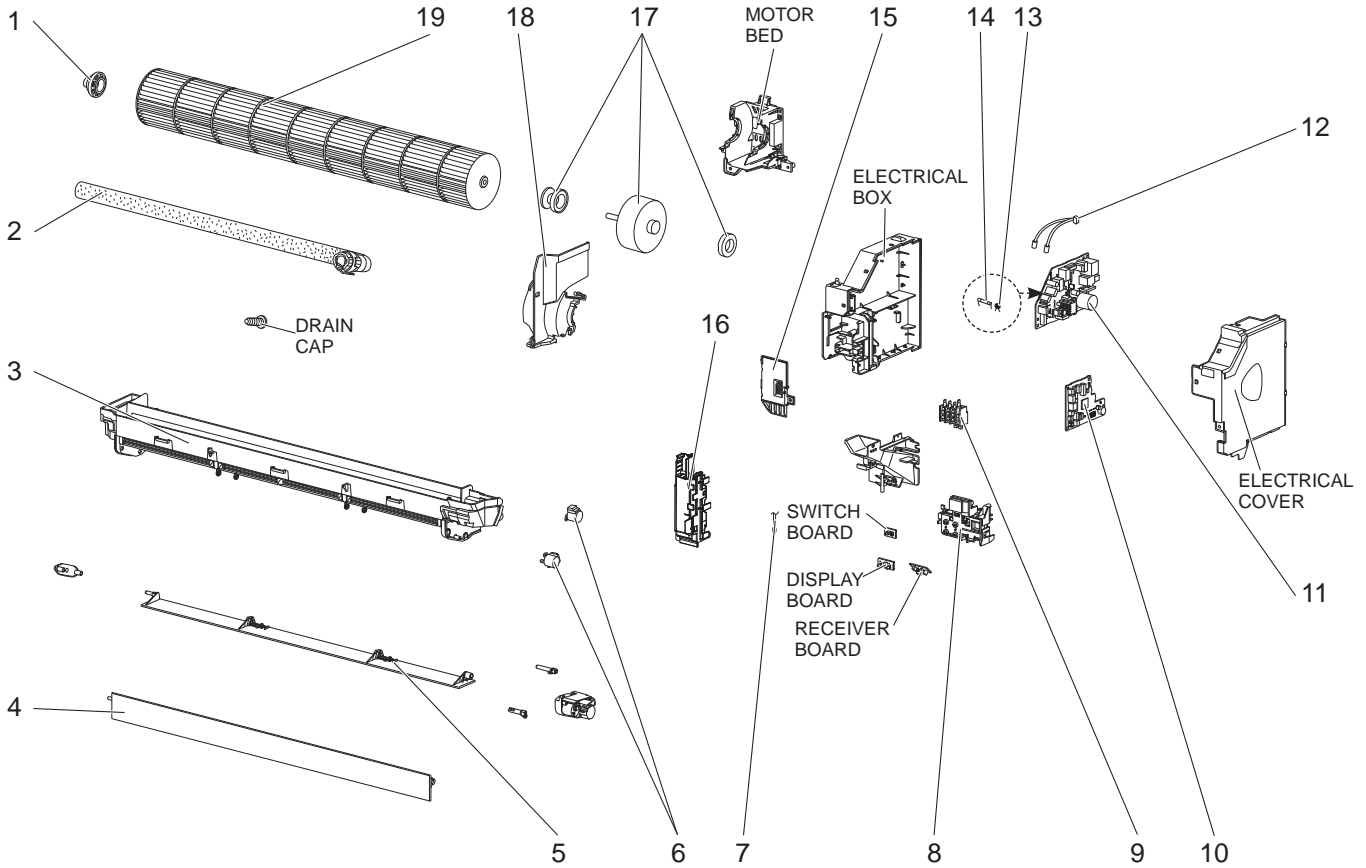

1-15. INDOOR UNIT ELECTRICAL PARTS AND FUNCTIONAL PARTS

1. The part quantity below indicates the required number of pieces per unit.

No.	Part No.	Part name	MSZ-EF22VGW-ET2	MSZ-EF22VGB-ET2	MSZ-EF22VGS-ET2	MSZ-EF25VGW-ET2	MSZ-EF25VGB-ET2	MSZ-EF25VGS-ET2	MSZ-EF35VGW-ET2	MSZ-EF35VGB-ET2	MSZ-EF35VGS-ET2	MSZ-EF42VGW-ET2	MSZ-EF42VGB-ET2	MSZ-EF42VGS-ET2	MSZ-EF50VGW-ET2	MSZ-EF50VGB-ET2	MSZ-EF50VGS-ET2	Symbol in Wiring Diagram	Remarks
1	E22 A89 509	BEARING MOUNT ASSEMBLY	1	1	1	1	1	1	1	1	1	1	1	1	1	1	1		Includes Sleeve bearing
2	E22 P72 702	DRAIN HOSE	1	1	1	1	1	1	1	1	1	1	1	1	1	1	1		
3	E22 16H 235	NOZZLE ASSEMBLY	1			1			1			1			1				Full assembly except DRAIN HOSE
3	E22 G21 235	NOZZLE ASSEMBLY		1			1			1			1			1			
3	E22 G26 235	NOZZLE ASSEMBLY			1			1			1			1			1		
4	E22 16H 040	VANE UPPER	1			1			1			1			1				
4	E22 G21 040	VANE UPPER		1			1			1			1			1			
4	E22 G26 040	VANE UPPER			1			1			1			1			1		
5	E22 16H 041	VANE LOWER	1			1			1			1			1				
5	E22 G21 041	VANE LOWER		1			1			1			1			1			
5	E22 G26 041	VANE LOWER			1			1			1			1			1		
6	E22 A89 303	VANE MOTOR	2	2	2	2	2	2	2	2	2	2	2	2	2	2	2	MV1, MV2	UP & DOWN, 1 PC/SET
7	E22 F95 308	ROOM TEMPERATURE THERMISTOR	1	1	1	1	1	1	1	1	1	1	1	1	1	1	1	RT11	
8	E22 F95 095	DISPLAY P.C. BOARD HOLDER	1	1	1	1	1	1	1	1	1	1	1	1	1	1	1		
9	E22 T21 375	TERMINAL BLOCK	1	1	1	1	1	1	1	1	1	1	1	1	1	1	1	TB	
10	E22 45L 452	ELECTRONIC CONTROL P.C. BOARD	1	1	1														Includes RECEIVER P.C. BOARD, DISPLAY P.C. BOARD and SWITCH P.C. BOARD.
10	E22 51L 452	ELECTRONIC CONTROL P.C. BOARD				1	1	1											
10	E22 54L 452	ELECTRONIC CONTROL P.C. BOARD							1	1	1								
10	E22 57L 452	ELECTRONIC CONTROL P.C. BOARD										1	1	1					
10	E22 60L 452	ELECTRONIC CONTROL P.C. BOARD													1	1	1		
11	E22 45L 440	POWER P.C. BOARD	1	1	1	1	1	1	1	1	1	1	1	1					
11	E22 60L 440	POWER P.C. BOARD													1	1	1		
12	E22 F95 307	INDOOR COIL THERMISTOR	1	1	1	1	1	1	1	1	1	1	1	1	1	1	1	RT12,RT13	
13	E22 B75 385	VARISTOR	1	1	1	1	1	1	1	1	1	1	1	1	1	1	1	NR11	
14	E22 42J 382	FUSE	1	1	1	1	1	1	1	1	1	1	1	1	1	1	1	F11	T3.15A/250V
15	E22 F95 784	V.A. CLAMP	1	1	1	1	1	1	1	1	1	1	1	1	1	1	1		
16	E22 45L 541	WATER CUT	1	1	1	1	1	1	1	1	1	1	1	1	1	1	1		
17	E22 29L 300	INDOOR FAN MOTOR	1	1	1	1	1	1	1	1	1	1	1	1	1	1	1	MF	RC0J40-□□ Includes FAN MOTOR RUBBER MOUNT (2 PCS/SET)
18	E22 F95 333	MOTOR BAND	1	1	1	1	1	1	1	1	1	1	1	1	1	1	1		
19	E22 F95 302	LINE FLOW FAN	1	1	1	1	1	1	1	1	1	1	1	1	1	1	1		

MSZ-EF22VGW -ET2 MSZ-EF22VGB -ET2 MSZ-EF22VGS -ET2
MSZ-EF25VGW -ET2 MSZ-EF25VGB -ET2 MSZ-EF25VGS -ET2
MSZ-EF35VGW -ET2 MSZ-EF35VGB -ET2 MSZ-EF35VGS -ET2
MSZ-EF42VGW -ET2 MSZ-EF42VGB -ET2 MSZ-EF42VGS -ET2
MSZ-EF50VGW -ET2 MSZ-EF50VGB -ET2 MSZ-EF50VGS -ET2

1-16. INDOOR UNIT HEAT EXCHANGER

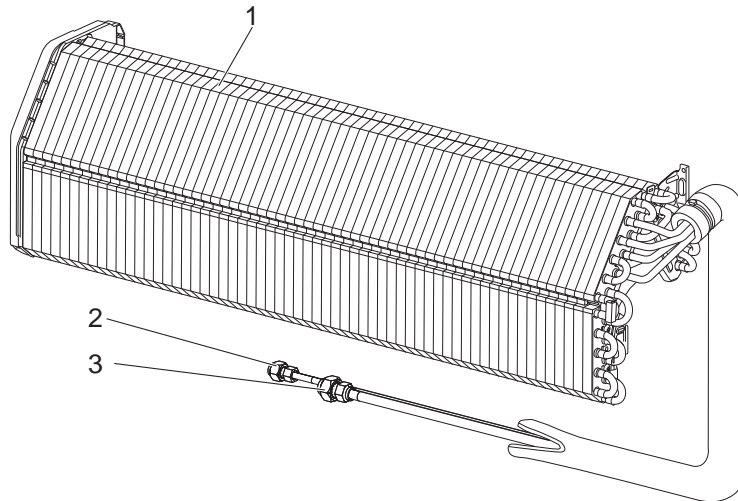



1-16. INDOOR UNIT HEAT EXCHANGER

1. The part quantity below indicates the required number of pieces per unit.

No.	Part No.	Part name	MSZ-EF22VGW-ET2	MSZ-EF22VGB-ET2	MSZ-EF22VGS-ET2	MSZ-EF25VGW-ET2	MSZ-EF25VGB-ET2	MSZ-EF25VGS-ET2	MSZ-EF35VGW-ET2	MSZ-EF35VGB-ET2	MSZ-EF35VGS-ET2	MSZ-EF42VGW-ET2	MSZ-EF42VGB-ET2	MSZ-EF42VGS-ET2	MSZ-EF50VGW-ET2	MSZ-EF50VGB-ET2	MSZ-EF50VGS-ET2	Symbol in Wiring Diagram	Remarks
			1	1	1	1	1	1	1	1	1	1	1	1	1	1	1		
1	E22 F95 620	INDOOR HEAT EXCHANGER	1	1	1	1	1	1	1	1	1	1	1	1	1	1	1		
2	E22 151 667	UNION (LIQUID)	1	1	1	1	1	1	1	1	1	1	1	1	1	1	1		ø6.35
3	E22 815 666	UNION (GAS)	1	1	1	1	1	1	1	1	1	1	1	1	1	1	1		ø9.52

MSZ-EF22VGW -ET3 **MSZ-EF22VGB -ET3** **MSZ-EF22VGS -ET3**
MSZ-EF25VGW -ET3 **MSZ-EF25VGB -ET3** **MSZ-EF25VGS -ET3**
MSZ-EF35VGW -ET3 **MSZ-EF35VGB -ET3** **MSZ-EF35VGS -ET3**
MSZ-EF42VGW -ET3 **MSZ-EF42VGB -ET3** **MSZ-EF42VGS -ET3**
MSZ-EF50VGW -ET3 **MSZ-EF50VGB -ET3** **MSZ-EF50VGS -ET3**

1-17. INDOOR UNIT STRUCTURAL PARTS

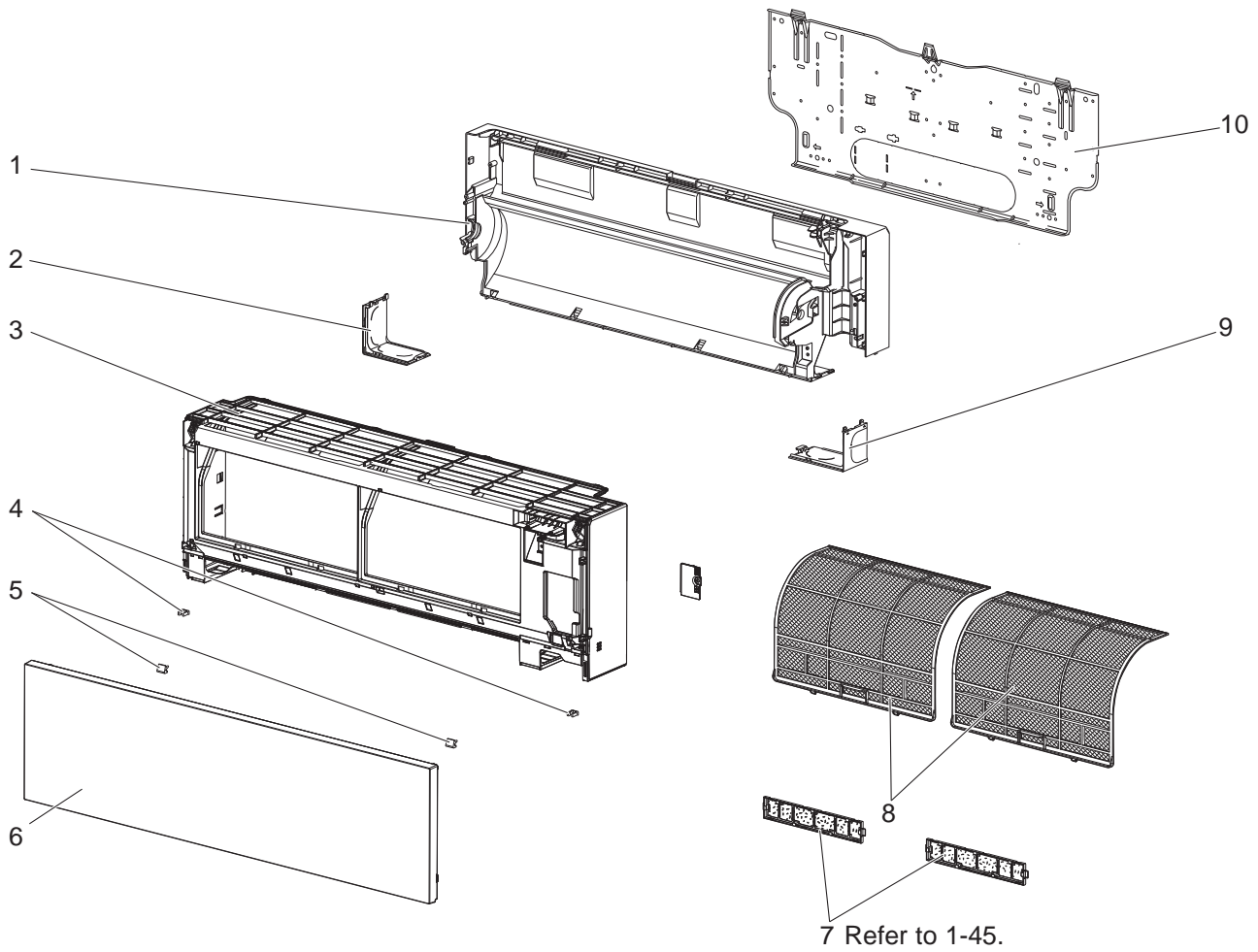

1-18. ACCESSORY AND REMOTE CONTROLLER

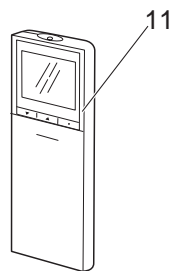

1-17. INDOOR UNIT STRUCTURAL PARTS

1. The part quantity below indicates the required number of pieces per unit.

No.	Part No.	Part name	MSZ-EF22VGW-ET3	MSZ-EF22VGB-ET3	MSZ-EF22VGS-ET3	MSZ-EF25VGW-ET3	MSZ-EF25VGB-ET3	MSZ-EF25VGS-ET3	MSZ-EF35VGW-ET3	MSZ-EF35VGB-ET3	MSZ-EF35VGS-ET3	MSZ-EF42VGW-ET3	MSZ-EF42VGB-ET3	MSZ-EF42VGS-ET3	MSZ-EF50VGW-ET3	MSZ-EF50VGB-ET3	MSZ-EF50VGS-ET3	Symbol in Wiring Diagram	Remarks
1	E22 16H 234	BOX ASSEMBLY	1			1			1			1			1				
1	E22 G21 234	BOX ASSEMBLY		1			1			1			1			1			
1	E22 G26 234	BOX ASSEMBLY			1			1			1			1			1		
2	E22 16H 976	CORNER BOX LEFT	1			1			1			1			1				
2	E22 G21 976	CORNER BOX LEFT		1			1			1			1			1			
2	E22 G26 976	CORNER BOX LEFT			1			1			1			1			1		
3	E22 20Y 000	PANEL ASSEMBLY	1			1			1			1			1				Includes No.4 ,5, 6
3	E22 25Y 000	PANEL ASSEMBLY		1			1			1			1			1			Includes No.4 ,5, 6
3	E22 30Y 000	PANEL ASSEMBLY			1			1			1			1			1		Includes No.4 ,5, 6
4	E22 F95 142	CATCH	2	2	2	2	2	2	2	2	2	2	2	2	2	2	2		2 PCS/SET
5	E22 16H 067	SCREW CAP	2			2			2			2			2				2 PCS/SET
5	E22 G21 067	SCREW CAP		2			2			2			2			2			2 PCS/SET
5	E22 G26 067	SCREW CAP			2			2			2			2			2		2 PCS/SET
6	E22 16H 010	FRONT PANEL	1			1			1			1			1				
6	E22 T25 010	FRONT PANEL		1			1			1			1			1			
6	E22 T29 010	FRONT PANEL			1			1			1			1			1		
7	—	AIR CLEANING FILTER (SILVER-IONIZED AIR PURIFIER FILTER)	2	2	2	2	2	2	2	2	2	2	2	2	2	2	2		1 PC/SET
8	E22 16H 100	AIR FILTER (AIR PURIFYING FILTER)	2	2	2	2	2	2	2	2	2	2	2	2	2	2	2		1 PC/SET
9	E22 16H 975	CORNER BOX RIGHT	1			1			1			1			1				
9	E22 G21 975	CORNER BOX RIGHT		1			1			1			1			1			
9	E22 G26 975	CORNER BOX RIGHT			1			1			1			1			1		
10	E22 F95 970	INSTALLATION PLATE	1	1	1	1	1	1	1	1	1	1	1	1	1	1	1		

1-18. ACCESSORY AND REMOTE CONTROLLER

1. The part quantity below indicates the required number of pieces per unit.

No.	Part No.	Part name	MSZ-EF22VGW-ET3	MSZ-EF22VGB-ET3	MSZ-EF22VGS-ET3	MSZ-EF25VGW-ET3	MSZ-EF25VGB-ET3	MSZ-EF25VGS-ET3	MSZ-EF35VGW-ET3	MSZ-EF35VGB-ET3	MSZ-EF35VGS-ET3	MSZ-EF42VGW-ET3	MSZ-EF42VGB-ET3	MSZ-EF42VGS-ET3	MSZ-EF50VGW-ET3	MSZ-EF50VGB-ET3	MSZ-EF50VGS-ET3	Symbol in Wiring Diagram	Remarks
11	E22 16H 426	REMOTE CONTROLLER	1			1			1			1			1				SG19A
11	E22 14H 426	REMOTE CONTROLLER		1	1		1	1		1	1		1	1		1	1		SG19B

MSZ-EF22VGW -[ET3] MSZ-EF22VGB -[ET3] MSZ-EF22VGS -[ET3]
MSZ-EF25VGW -[ET3] MSZ-EF25VGB -[ET3] MSZ-EF25VGS -[ET3]
MSZ-EF35VGW -[ET3] MSZ-EF35VGB -[ET3] MSZ-EF35VGS -[ET3]
MSZ-EF42VGW -[ET3] MSZ-EF42VGB -[ET3] MSZ-EF42VGS -[ET3]
MSZ-EF50VGW -[ET3] MSZ-EF50VGB -[ET3] MSZ-EF50VGS -[ET3]

1-19. INDOOR UNIT ELECTRICAL PARTS AND FUNCTIONAL PARTS

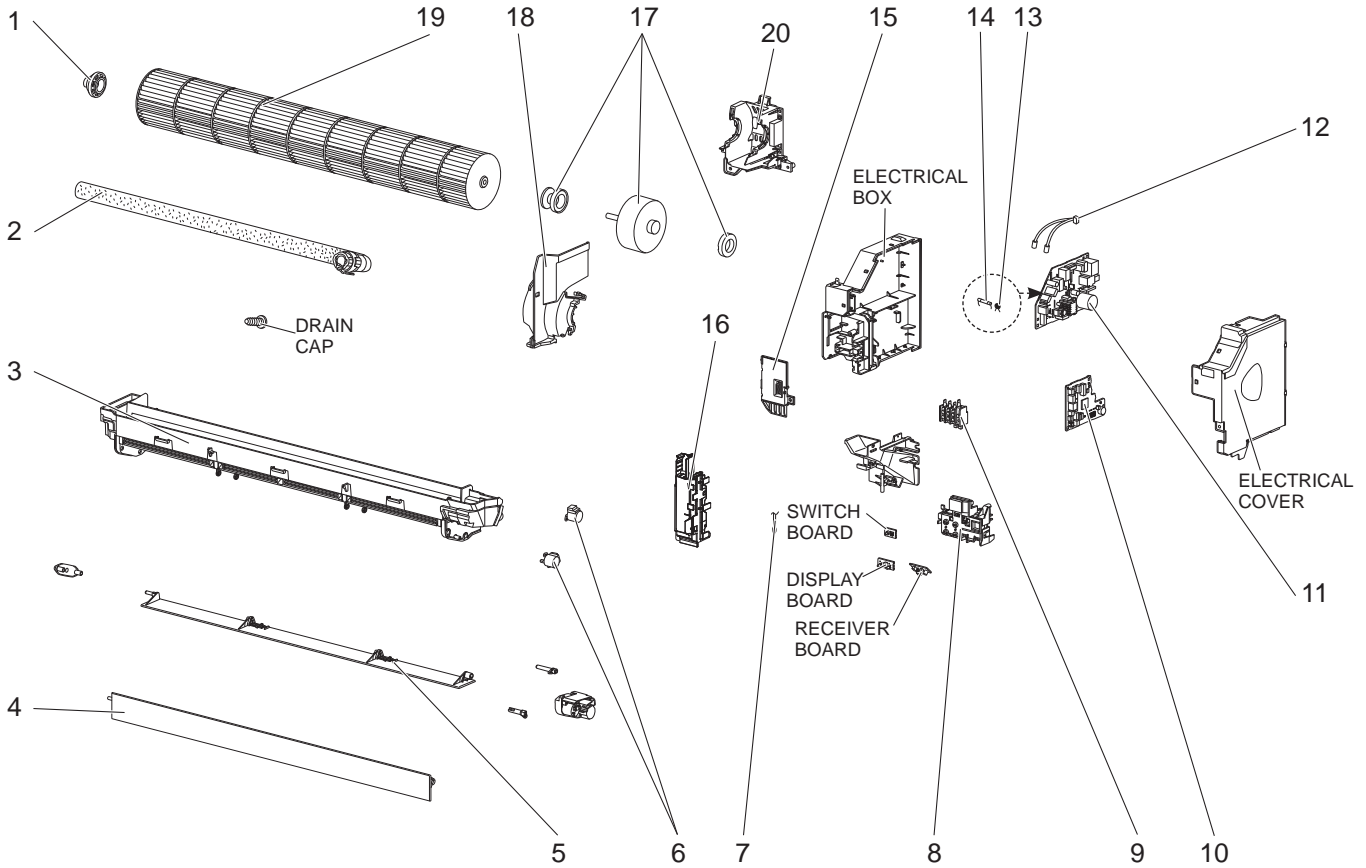

1-19. INDOOR UNIT ELECTRICAL PARTS AND FUNCTIONAL PARTS

1. The part quantity below indicates the required number of pieces per unit.

No.	Part No.	Part name	MSZ-EF22VGW-ET3	MSZ-EF22VGB-ET3	MSZ-EF22VGS-ET3	MSZ-EF25VGW-ET3	MSZ-EF25VGB-ET3	MSZ-EF25VGS-ET3	MSZ-EF35VGW-ET3	MSZ-EF35VGB-ET3	MSZ-EF35VGS-ET3	MSZ-EF42VGW-ET3	MSZ-EF42VGB-ET3	MSZ-EF42VGS-ET3	MSZ-EF50VGW-ET3	MSZ-EF50VGB-ET3	MSZ-EF50VGS-ET3	Symbol in Wiring Diagram	Remarks
1	E22 A89 509	BEARING MOUNT ASSEMBLY	1	1	1	1	1	1	1	1	1	1	1	1	1	1	1		Includes Sleeve bearing
2	E22 P72 702	DRAIN HOSE	1	1	1	1	1	1	1	1	1	1	1	1	1	1	1		
3	E22 16H 235	NOZZLE ASSEMBLY	1			1			1			1			1				Full assembly except DRAIN HOSE
3	E22 G21 235	NOZZLE ASSEMBLY		1			1			1			1			1			
3	E22 G26 235	NOZZLE ASSEMBLY			1			1			1			1			1		
4	E22 16H 040	VANE UPPER	1			1			1			1			1				
4	E22 G21 040	VANE UPPER		1			1			1			1			1			
4	E22 G26 040	VANE UPPER			1			1			1			1			1		
5	E22 16H 041	VANE LOWER	1			1			1			1			1				
5	E22 G21 041	VANE LOWER		1			1			1			1			1			
5	E22 G26 041	VANE LOWER			1			1			1			1			1		
6	E22 A89 303	VANE MOTOR	2	2	2	2	2	2	2	2	2	2	2	2	2	2	2	MV1, MV2	UP & DOWN, 1 PC/SET
7	E22 F95 308	ROOM TEMPERATURE THERMISTOR	1	1	1	1	1	1	1	1	1	1	1	1	1	1	1	RT11	
8	E22 F95 095	DISPLAY P.C. BOARD HOLDER	1	1	1	1	1	1	1	1	1	1	1	1	1	1	1		
9	E22 T21 375	TERMINAL BLOCK	1	1	1	1	1	1	1	1	1	1	1	1	1	1	1	TB	
10	E22 45X 452	ELECTRONIC CONTROL P.C. BOARD	1	1	1														Includes RECEIVER P.C. BOARD, DISPLAY P.C. BOARD and SWITCH P.C. BOARD.
10	E22 51X 452	ELECTRONIC CONTROL P.C. BOARD				1	1	1											
10	E22 54X 452	ELECTRONIC CONTROL P.C. BOARD							1	1	1								
10	E22 57X 452	ELECTRONIC CONTROL P.C. BOARD										1	1	1					
10	E22 60X 452	ELECTRONIC CONTROL P.C. BOARD													1	1	1		
11	E22 45X 440	POWER P.C. BOARD	1	1	1	1	1	1	1	1	1	1	1	1					
11	E22 60X 440	POWER P.C. BOARD													1	1	1		
12	E22 F95 307	INDOOR COIL THERMISTOR	1	1	1	1	1	1	1	1	1	1	1	1	1	1	1	RT12,RT13	
13	E22 B75 385	VARIATOR	1	1	1	1	1	1	1	1	1	1	1	1	1	1	1	NR11	
14	E22 42J 382	FUSE	1	1	1	1	1	1	1	1	1	1	1	1	1	1	1	F11	T3.15AL250V
15	E22 F95 784	V.A. CLAMP	1	1	1	1	1	1	1	1	1	1	1	1	1	1	1		
16	E22 45L 541	WATER CUT	1	1	1	1	1	1	1	1	1	1	1	1	1	1	1		
17	E22 29L 300	INDOOR FAN MOTOR	1	1	1	1	1	1	1	1	1	1	1	1	1	1	1	MF	RC0J40-□□ Includes FAN MOTOR RUBBER MOUNT (2 PCS/SET)
18	E22 F95 333	MOTOR BAND	1	1	1	1	1	1	1	1	1	1	1	1	1	1	1		
19	E22 F95 302	LINE FLOW FAN	1	1	1	1	1	1	1	1	1	1	1	1	1	1	1		
20	E22 45X 333	MOTOR BED	1	1	1	1	1	1	1	1	1	1	1	1	1	1	1		

MSZ-EF22VGW -ET3 MSZ-EF22VGB -ET3 MSZ-EF22VGS -ET3
MSZ-EF25VGW -ET3 MSZ-EF25VGB -ET3 MSZ-EF25VGS -ET3
MSZ-EF35VGW -ET3 MSZ-EF35VGB -ET3 MSZ-EF35VGS -ET3
MSZ-EF42VGW -ET3 MSZ-EF42VGB -ET3 MSZ-EF42VGS -ET3
MSZ-EF50VGW -ET3 MSZ-EF50VGB -ET3 MSZ-EF50VGS -ET3

1-20. INDOOR UNIT HEAT EXCHANGER

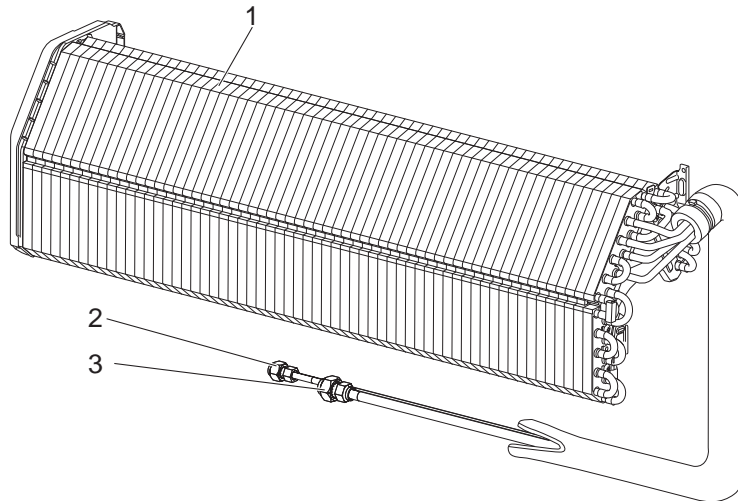

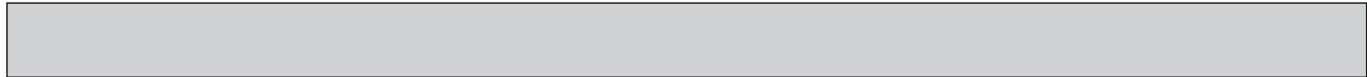

1-20. INDOOR UNIT HEAT EXCHANGER

1. The part quantity below indicates the required number of pieces per unit.

No.	Part No.	Part name	MSZ-EF22VGW-ET3	MSZ-EF22VGB-ET3	MSZ-EF22VGS-ET3	MSZ-EF25VGW-ET3	MSZ-EF25VGB-ET3	MSZ-EF25VGS-ET3	MSZ-EF35VGW-ET3	MSZ-EF35VGB-ET3	MSZ-EF35VGS-ET3	MSZ-EF42VGW-ET3	MSZ-EF42VGB-ET3	MSZ-EF42VGS-ET3	MSZ-EF50VGW-ET3	MSZ-EF50VGB-ET3	MSZ-EF50VGS-ET3	Symbol in Wiring Diagram	Remarks
			1	1	1	1	1	1	1	1	1	1	1	1	1	1	1		
1	E22 F95 620	INDOOR HEAT EXCHANGER	1	1	1	1	1	1	1	1	1	1	1	1	1	1	1		
2	E22 151 667	UNION (LIQUID)	1	1	1	1	1	1	1	1	1	1	1	1	1	1	1		ø6.35
3	E22 815 666	UNION (GAS)	1	1	1	1	1	1	1	1	1	1	1	1	1	1	1		ø9.52

MSZ-EF18VGKW - E1 MSZ-EF18VGKB - E1 MSZ-EF18VGKS - E1
MSZ-EF22VGKW - E1 MSZ-EF22VGKB - E1 MSZ-EF22VGKS - E1
MSZ-EF25VGKW - E1 MSZ-EF25VGKB - E1 MSZ-EF25VGKS - E1
MSZ-EF35VGKW - E1 MSZ-EF35VGKB - E1 MSZ-EF35VGKS - E1
MSZ-EF42VGKW - E1 MSZ-EF42VGKB - E1 MSZ-EF42VGKS - E1
MSZ-EF50VGKW - E1 MSZ-EF50VGKB - E1 MSZ-EF50VGKS - E1

1-21. INDOOR UNIT STRUCTURAL PARTS

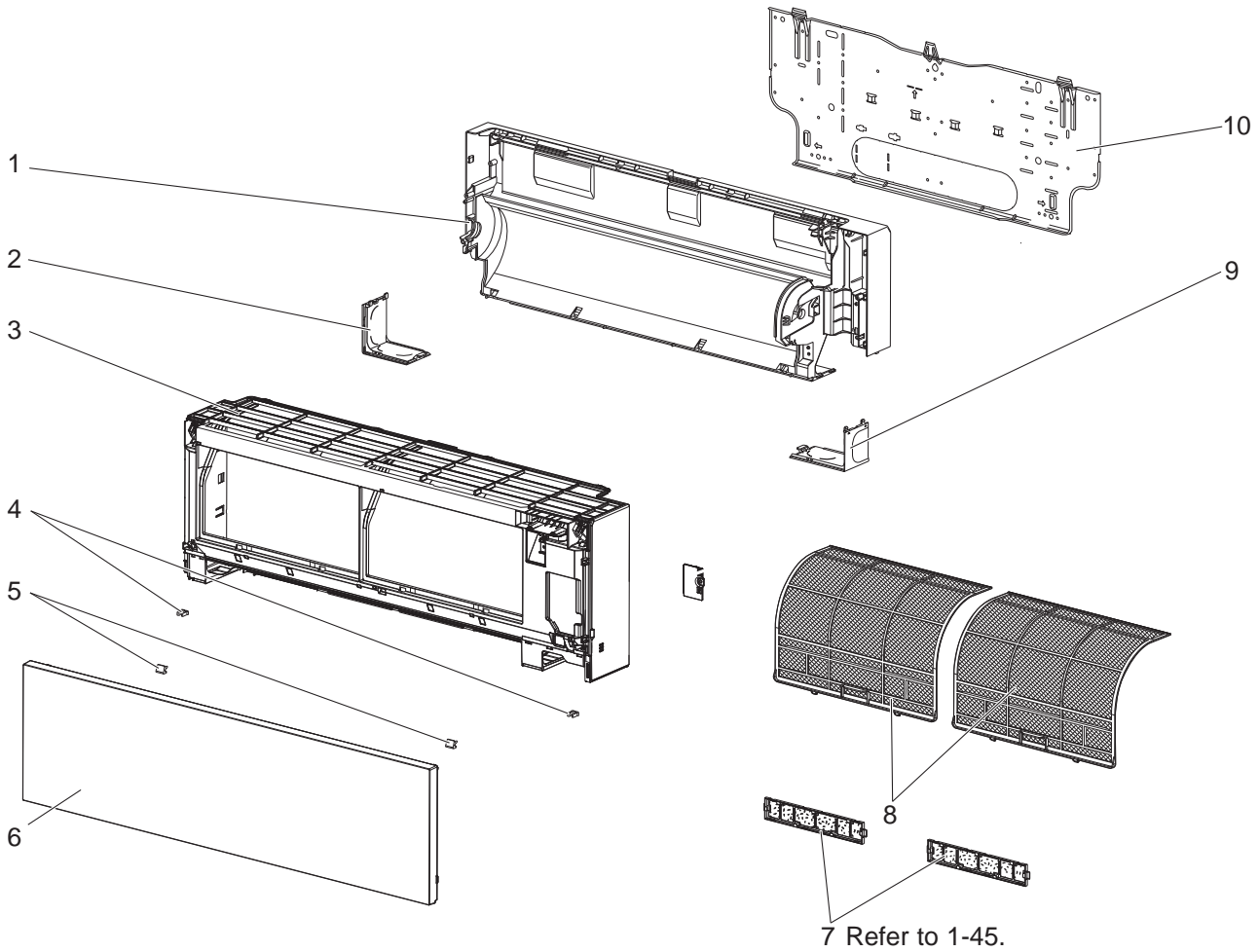

1-22. ACCESSORY AND REMOTE CONTROLLER

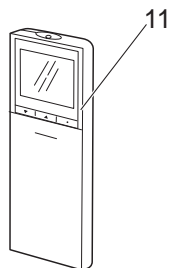

1-21. INDOOR UNIT STRUCTURAL PARTS

1. The part quantity below indicates the required number of pieces per unit.

No.	Part No.	Part name	MSZ-EF18VGKW-E1	MSZ-EF18VGKB-E1	MSZ-EF18VGKS-E1	MSZ-EF22VGKW-E1	MSZ-EF22VGKB-E1	MSZ-EF22VGKS-E1	MSZ-EF25VGKW-E1	MSZ-EF25VGKB-E1	MSZ-EF25VGKS-E1	MSZ-EF35VGKW-E1	MSZ-EF35VGKB-E1	MSZ-EF35VGKS-E1	MSZ-EF42VGKW-E1	MSZ-EF42VGKB-E1	MSZ-EF42VGKS-E1	MSZ-EF50VGKW-E1	MSZ-EF50VGKB-E1	MSZ-EF50VGKS-E1	Symbol in Wiring Diagram	Remarks	
1	E22 16H 234	BOX ASSEMBLY	1			1			1			1			1			1					
1	E22 G21 234	BOX ASSEMBLY		1			1			1			1			1			1				
1	E22 G26 234	BOX ASSEMBLY			1			1			1			1			1			1			
2	E22 16H 976	CORNER BOX LEFT	1			1			1			1			1			1					
2	E22 G21 976	CORNER BOX LEFT		1			1			1			1			1			1				
2	E22 G26 976	CORNER BOX LEFT			1			1			1			1			1			1			
3	E22 45L 000	PANEL ASSEMBLY	1			1			1			1			1			1				Includes No. 4, 6	
3	E22 46L 000	PANEL ASSEMBLY		1			1			1			1			1			1			Includes No. 4, 6	
3	E22 47L 000	PANEL ASSEMBLY			1			1			1			1			1			1		Includes No. 4, 6	
4	E22 F95 142	CATCH	2	2	2	2	2	2	2	2	2	2	2	2	2	2	2	2	2	2	2	2	2 PCS/SET
5	E22 16H 067	SCREW CAP	2			2			2			2			2			2				2 PCS/SET	
5	E22 G21 067	SCREW CAP		2			2			2			2			2			2			2 PCS/SET	
5	E22 G26 067	SCREW CAP			2			2			2			2			2			2		2 PCS/SET	
6	E22 16H 010	FRONT PANEL	1			1			1			1			1			1					
6	E22 T25 010	FRONT PANEL		1			1			1			1			1			1				
6	E22 T29 010	FRONT PANEL			1			1			1			1			1			1			
7	—	AIR CLEANING FILTER (SILVER-IONIZED AIR PURIFIER FILTER)	2	2	2	2	2	2	2	2	2	2	2	2	2	2	2	2	2	2	2	2	1 PC/SET
8	E22 16H 100	AIR FILTER (AIR PURIFYING FILTER)	2	2	2	2	2	2	2	2	2	2	2	2	2	2	2	2	2	2	2	2	1 PC/SET
9	E22 16H 975	CORNER BOX RIGHT	1			1			1			1			1			1					
9	E22 G21 975	CORNER BOX RIGHT		1			1			1			1			1			1				
9	E22 G26 975	CORNER BOX RIGHT			1			1			1			1			1			1			
10	E22 F95 970	INSTALLATION PLATE	1	1	1	1	1	1	1	1	1	1	1	1	1	1	1	1	1	1	1		

1-22. ACCESSORY AND REMOTE CONTROLLER

1. The part quantity below indicates the required number of pieces per unit.

No.	Part No.	Part name	MSZ-EF18VGKW-E1	MSZ-EF18VGKB-E1	MSZ-EF18VGKS-E1	MSZ-EF22VGKW-E1	MSZ-EF22VGKB-E1	MSZ-EF22VGKS-E1	MSZ-EF25VGKW-E1	MSZ-EF25VGKB-E1	MSZ-EF25VGKS-E1	MSZ-EF35VGKW-E1	MSZ-EF35VGKB-E1	MSZ-EF35VGKS-E1	MSZ-EF42VGKW-E1	MSZ-EF42VGKB-E1	MSZ-EF42VGKS-E1	MSZ-EF50VGKW-E1	MSZ-EF50VGKB-E1	MSZ-EF50VGKS-E1	Symbol in Wiring Diagram	Remarks
11	E22 16H 426	REMOTE CONTROLLER	1					1				1						1				SG19A
11	E22 14H 426	REMOTE CONTROLLER		1	1		1	1		1	1		1	1		1	1		1	1		SG19B

MSZ-EF18VGKW - E1 MSZ-EF18VGKB - E1 MSZ-EF18VGKS - E1
MSZ-EF22VGKW - E1 MSZ-EF22VGKB - E1 MSZ-EF22VGKS - E1
MSZ-EF25VGKW - E1 MSZ-EF25VGKB - E1 MSZ-EF25VGKS - E1
MSZ-EF35VGKW - E1 MSZ-EF35VGKB - E1 MSZ-EF35VGKS - E1
MSZ-EF42VGKW - E1 MSZ-EF42VGKB - E1 MSZ-EF42VGKS - E1
MSZ-EF50VGKW - E1 MSZ-EF50VGKB - E1 MSZ-EF50VGKS - E1

1-23. INDOOR UNIT ELECTRICAL PARTS AND FUNCTIONAL PARTS

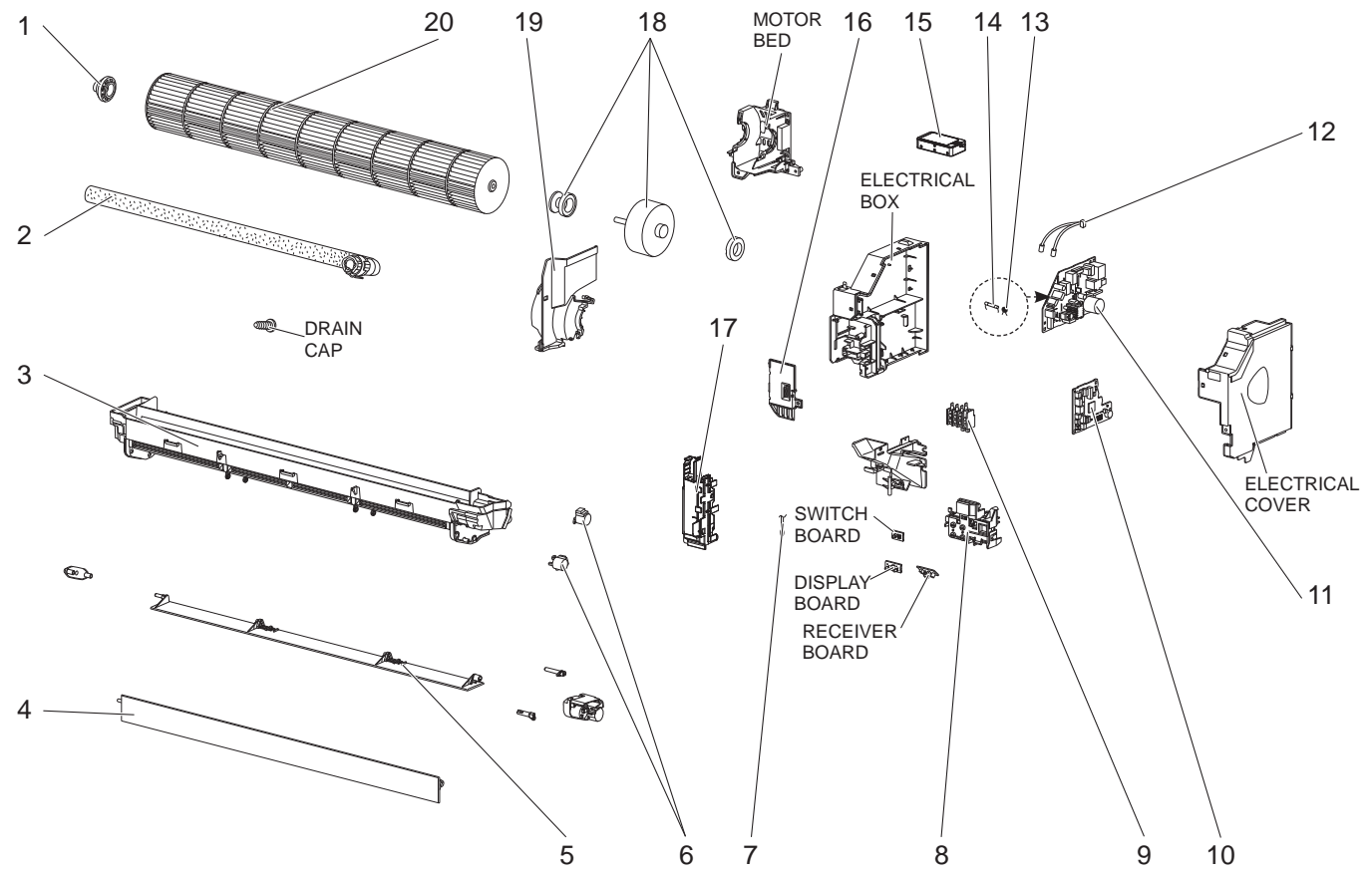

1-23. INDOOR UNIT ELECTRICAL PARTS AND FUNCTIONAL PARTS

1. The part quantity below indicates the required number of pieces per unit.

No.	Part No.	Part name	MSZ-EF18VGKW-E1	MSZ-EF18VGKB-E1	MSZ-EF18VGKS-E1	MSZ-EF22VGKW-E1	MSZ-EF22VGKB-E1	MSZ-EF22VGKS-E1	MSZ-EF25VGKW-E1	MSZ-EF25VGKB-E1	MSZ-EF25VGKS-E1	MSZ-EF35VGKW-E1	MSZ-EF35VGKB-E1	MSZ-EF35VGKS-E1	MSZ-EF42VGKW-E1	MSZ-EF42VGKB-E1	MSZ-EF42VGKS-E1	MSZ-EF50VGKW-E1	MSZ-EF50VGKB-E1	MSZ-EF50VGKS-E1	Symbol in Wiring Diagram	Remarks
1	E22 A89 509	BEARING MOUNT ASSEMBLY	1	1	1	1	1	1	1	1	1	1	1	1	1	1	1	1	1	1		Includes Sleeve bearing
2	E22 P72 702	DRAIN HOSE	1	1	1	1	1	1	1	1	1	1	1	1	1	1	1	1	1	1		
3	E22 16H 235	NOZZLE ASSEMBLY	1			1			1			1			1			1				Full assembly except DRAIN HOSE
3	E22 G21 235	NOZZLE ASSEMBLY		1					1			1			1			1				
3	E22 G26 235	NOZZLE ASSEMBLY			1				1			1			1			1				
4	E22 16H 040	VANE UPPER	1			1			1			1			1			1				
4	E22 G21 040	VANE UPPER		1			1			1			1			1			1			
4	E22 G26 040	VANE UPPER			1				1			1			1			1				
5	E22 16H 041	VANE LOWER	1			1			1			1			1			1				
5	E22 G21 041	VANE LOWER		1			1			1			1			1			1			
5	E22 G26 041	VANE LOWER			1				1			1			1			1				
6	E22 A89 303	VANE MOTOR	2	2	2	2	2	2	2	2	2	2	2	2	2	2	2	2	2	2	MV1, MV2	UP & DOWN, 1 PC/SET
7	E22 F95 308	ROOM TEMPERATURE THERMISTOR	1	1	1	1	1	1	1	1	1	1	1	1	1	1	1	1	1	1	RT11	
8	E22 F95 095	DISPLAY P.C. BOARD HOLDER	1	1	1	1	1	1	1	1	1	1	1	1	1	1	1	1	1	1		
9	E22 T21 375	TERMINAL BLOCK	1	1	1	1	1	1	1	1	1	1	1	1	1	1	1	1	1	1	TB	
10	E22 45L 452	ELECTRONIC CONTROL P.C. BOARD	1	1	1	1	1	1														Includes RECEIVER P.C. BOARD, DISPLAY P.C. BOARD and SWITCH P.C. BOARD.
10	E22 51L 452	ELECTRONIC CONTROL P.C. BOARD							1	1	1											
10	E22 54L 452	ELECTRONIC CONTROL P.C. BOARD										1	1	1								
10	E22 57L 452	ELECTRONIC CONTROL P.C. BOARD													1	1	1					
10	E22 60L 452	ELECTRONIC CONTROL P.C. BOARD																1	1	1		
11	E22 45L 440	POWER P.C. BOARD	1	1	1	1	1	1	1	1	1	1	1	1	1	1	1					
11	E22 60L 440	POWER P.C. BOARD																1	1	1		
12	E22 F95 307	INDOOR COIL THERMISTOR	1	1	1	1	1	1	1	1	1	1	1	1	1	1	1	1	1	1	RT12,RT13	
13	E22 B75 385	VARISTOR	1	1	1	1	1	1	1	1	1	1	1	1	1	1	1	1	1	1	NR11	
14	E22 42J 382	FUSE	1	1	1	1	1	1	1	1	1	1	1	1	1	1	1	1	1	1	F11	T3.15AL250V
15	E22 45L 457	Wi-Fi INTERFACE MAC-577IF2-E	1	1	1	1	1	1	1	1	1	1	1	1	1	1	1	1	1	1		MAC-577IF2-E
16	E22 F95 784	V.A. CLAMP	1	1	1	1	1	1	1	1	1	1	1	1	1	1	1	1	1	1		
17	E22 45L 541	WATER CUT	1	1	1	1	1	1	1	1	1	1	1	1	1	1	1	1	1	1		
18	E22 29L 300	INDOOR FAN MOTOR	1	1	1	1	1	1	1	1	1	1	1	1	1	1	1	1	1	1	MF	RC0J40-□□ Includes FAN MOTOR RUBBER MOUNT (2 PCS/SET)
19	E22 F95 333	MOTOR BAND	1	1	1	1	1	1	1	1	1	1	1	1	1	1	1	1	1	1		
20	E22 F95 302	LINE FLOW FAN	1	1	1	1	1	1	1	1	1	1	1	1	1	1	1	1	1	1		

- MSZ-EF18VGKW - E1 MSZ-EF18VGKB - E1 MSZ-EF18VGKS - E1
- MSZ-EF22VGKW - E1 MSZ-EF22VGKB - E1 MSZ-EF22VGKS - E1
- MSZ-EF25VGKW - E1 MSZ-EF25VGKB - E1 MSZ-EF25VGKS - E1
- MSZ-EF35VGKW - E1 MSZ-EF35VGKB - E1 MSZ-EF35VGKS - E1
- MSZ-EF42VGKW - E1 MSZ-EF42VGKB - E1 MSZ-EF42VGKS - E1
- MSZ-EF50VGKW - E1 MSZ-EF50VGKB - E1 MSZ-EF50VGKS - E1

1-24. INDOOR UNIT HEAT EXCHANGER

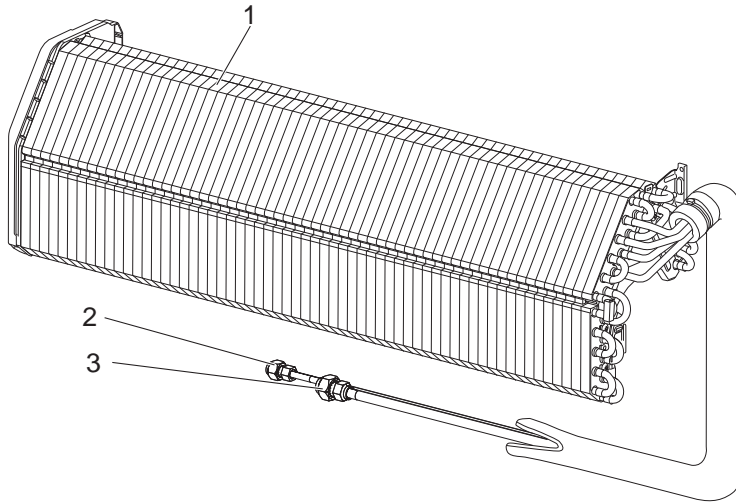



1-24. INDOOR UNIT HEAT EXCHANGER

1. The part quantity below indicates the required number of pieces per unit.

No.	Part No.	Part name	MSZ-EF18VGKW-E1	MSZ-EF18VGKB-E1	MSZ-EF18VGKS-E1	MSZ-EF22VGKW-E1	MSZ-EF22VGKB-E1	MSZ-EF22VGKS-E1	MSZ-EF25VGKW-E1	MSZ-EF25VGKB-E1	MSZ-EF25VGKS-E1	MSZ-EF35VGKW-E1	MSZ-EF35VGKB-E1	MSZ-EF35VGKS-E1	MSZ-EF42VGKW-E1	MSZ-EF42VGKB-E1	MSZ-EF42VGKS-E1	MSZ-EF50VGKW-E1	MSZ-EF50VGKB-E1	MSZ-EF50VGKS-E1	Symbol in Wiring Diagram	Remarks
1	E22 F95 620	INDOOR HEAT EXCHANGER	1	1	1	1	1	1	1	1	1	1	1	1	1	1	1	1	1	1		
2	E22 151 667	UNION (LIQUID)	1	1	1	1	1	1	1	1	1	1	1	1	1	1	1	1	1	1		ø6.35
3	E22 815 666	UNION (GAS)	1	1	1	1	1	1	1	1	1	1	1	1	1	1	1	1	1	1		ø9.52

MSZ-EF18VGKW - E2 MSZ-EF18VGKB - E2 MSZ-EF18VGKS - E2
MSZ-EF22VGKW - E2 MSZ-EF22VGKB - E2 MSZ-EF22VGKS - E2
MSZ-EF25VGKW - E2 MSZ-EF25VGKB - E2 MSZ-EF25VGKS - E2
MSZ-EF35VGKW - E2 MSZ-EF35VGKB - E2 MSZ-EF35VGKS - E2
MSZ-EF42VGKW - E2 MSZ-EF42VGKB - E2 MSZ-EF42VGKS - E2
MSZ-EF50VGKW - E2 MSZ-EF50VGKB - E2 MSZ-EF50VGKS - E2

1-25. INDOOR UNIT STRUCTURAL PARTS

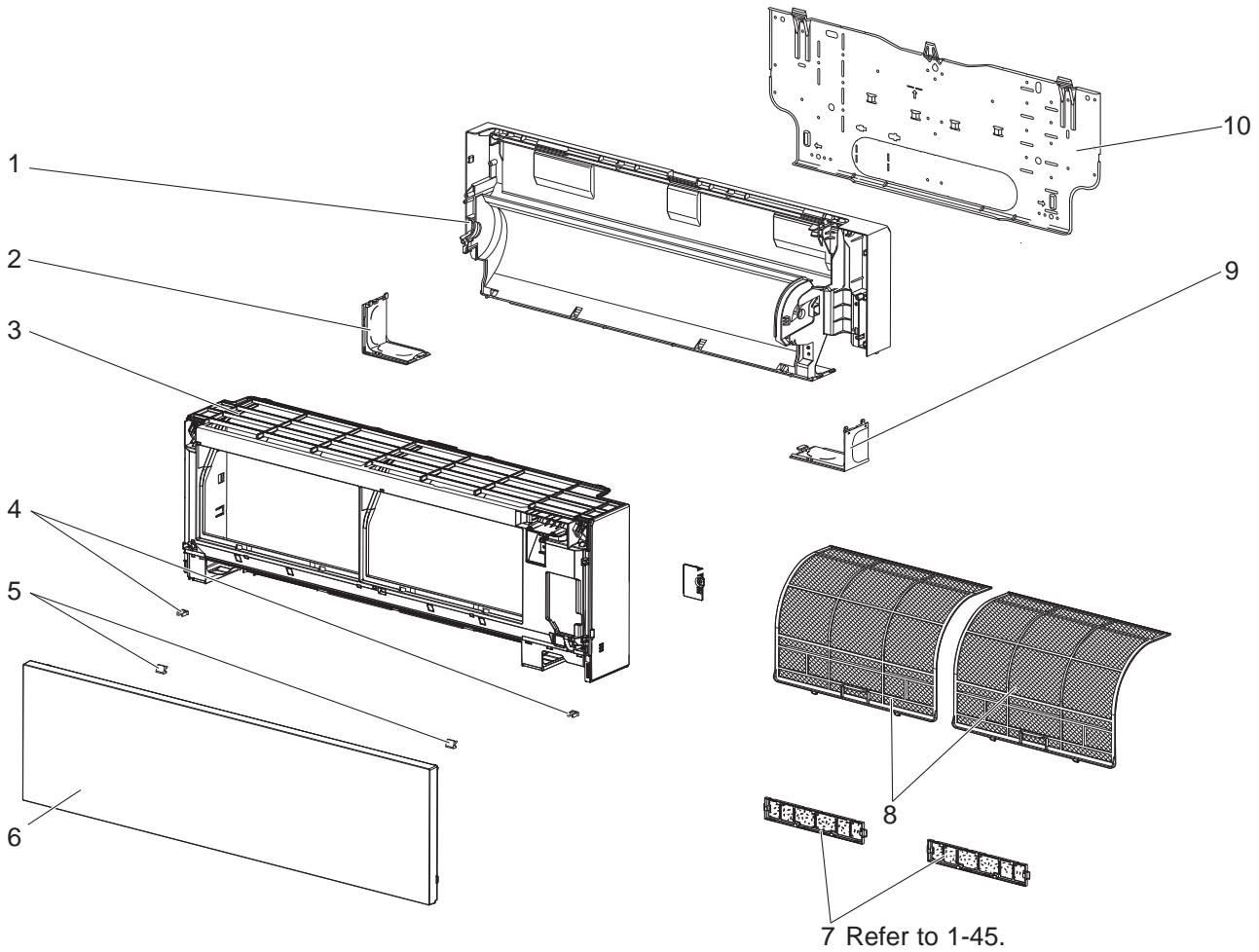

1-26. ACCESSORY AND REMOTE CONTROLLER

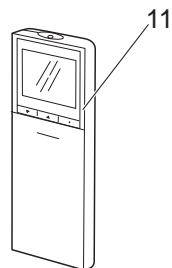

1-25. INDOOR UNIT STRUCTURAL PARTS

1. The part quantity below indicates the required number of pieces per unit.

No.	Part No.	Part name	MSZ-EF18VGKW-E2	MSZ-EF18VGKB-E2	MSZ-EF18VGKS-E2	MSZ-EF22VGKW-E2	MSZ-EF22VGKB-E2	MSZ-EF22VGKS-E2	MSZ-EF25VGKW-E2	MSZ-EF25VGKB-E2	MSZ-EF25VGKS-E2	MSZ-EF35VGKW-E2	MSZ-EF35VGKB-E2	MSZ-EF35VGKS-E2	MSZ-EF42VGKW-E2	MSZ-EF42VGKB-E2	MSZ-EF42VGKS-E2	MSZ-EF50VGKW-E2	MSZ-EF50VGKB-E2	MSZ-EF50VGKS-E2	Symbol in Wiring Diagram	Remarks	
1	E22 16H 234	BOX ASSEMBLY	1			1			1			1			1			1					
1	E22 G21 234	BOX ASSEMBLY		1			1			1			1			1			1				
1	E22 G26 234	BOX ASSEMBLY			1			1			1			1			1			1			
2	E22 16H 976	CORNER BOX LEFT	1			1			1			1			1			1					
2	E22 G21 976	CORNER BOX LEFT		1			1			1			1			1			1				
2	E22 G26 976	CORNER BOX LEFT			1			1			1			1			1			1			
3	E22 45X 000	PANEL ASSEMBLY	1			1			1			1			1			1				Includes No. 4, 5, 6	
3	E22 46X 000	PANEL ASSEMBLY		1			1			1			1			1			1			Includes No. 4, 5, 6	
3	E22 47X 000	PANEL ASSEMBLY			1			1			1			1			1			1		Includes No. 4, 5, 6	
4	E22 F95 142	CATCH	2	2	2	2	2	2	2	2	2	2	2	2	2	2	2	2	2	2	2	2	2 PCS/SET
5	E22 16H 067	SCREW CAP	2			2			2			2			2			2				2 PCS/SET	
5	E22 G21 067	SCREW CAP		2			2			2			2			2			2			2 PCS/SET	
5	E22 G26 067	SCREW CAP			2			2			2			2			2			2		2 PCS/SET	
6	E22 16H 010	FRONT PANEL	1			1			1			1			1			1					
6	E22 T25 010	FRONT PANEL		1			1			1			1			1			1				
6	E22 T29 010	FRONT PANEL			1			1			1			1			1			1			
7	—	AIR CLEANING FILTER (SILVER-IONIZED AIR PURIFIER FILTER)	2	2	2	2	2	2	2	2	2	2	2	2	2	2	2	2	2	2	2	2	1 PC/SET
8	E22 16H 100	AIR FILTER (AIR PURIFYING FILTER)	2	2	2	2	2	2	2	2	2	2	2	2	2	2	2	2	2	2	2	2	1 PC/SET
9	E22 16H 975	CORNER BOX RIGHT	1			1			1			1			1			1					
9	E22 G21 975	CORNER BOX RIGHT		1			1			1			1			1			1				
9	E22 G26 975	CORNER BOX RIGHT			1			1			1			1			1			1			
10	E22 F95 970	INSTALLATION PLATE	1	1	1	1	1	1	1	1	1	1	1	1	1	1	1	1	1	1	1		

1-26. ACCESSORY AND REMOTE CONTROLLER

1. The part quantity below indicates the required number of pieces per unit.

No.	Part No.	Part name	MSZ-EF18VGKW-E2	MSZ-EF18VGKB-E2	MSZ-EF18VGKS-E2	MSZ-EF22VGKW-E2	MSZ-EF22VGKB-E2	MSZ-EF22VGKS-E2	MSZ-EF25VGKW-E2	MSZ-EF25VGKB-E2	MSZ-EF25VGKS-E2	MSZ-EF35VGKW-E2	MSZ-EF35VGKB-E1	MSZ-EF35VGKS-E2	MSZ-EF42VGKW-E2	MSZ-EF42VGKB-E2	MSZ-EF42VGKS-E2	MSZ-EF50VGKW-E2	MSZ-EF50VGKB-E2	MSZ-EF50VGKS-E2	Symbol in Wiring Diagram	Remarks
11	E22 16H 426	REMOTE CONTROLLER	1			1			1			1			1			1				SG19A
11	E22 14H 426	REMOTE CONTROLLER		1	1		1	1		1	1		1	1		1	1		1	1		SG19B

MSZ-EF18VGKW - E2 MSZ-EF18VGKB - E2 MSZ-EF18VGKS - E2
MSZ-EF22VGKW - E2 MSZ-EF22VGKB - E2 MSZ-EF22VGKS - E2
MSZ-EF25VGKW - E2 MSZ-EF25VGKB - E2 MSZ-EF25VGKS - E2
MSZ-EF35VGKW - E2 MSZ-EF35VGKB - E2 MSZ-EF35VGKS - E2
MSZ-EF42VGKW - E2 MSZ-EF42VGKB - E2 MSZ-EF42VGKS - E2
MSZ-EF50VGKW - E2 MSZ-EF50VGKB - E2 MSZ-EF50VGKS - E2

1-27. INDOOR UNIT ELECTRICAL PARTS AND FUNCTIONAL PARTS

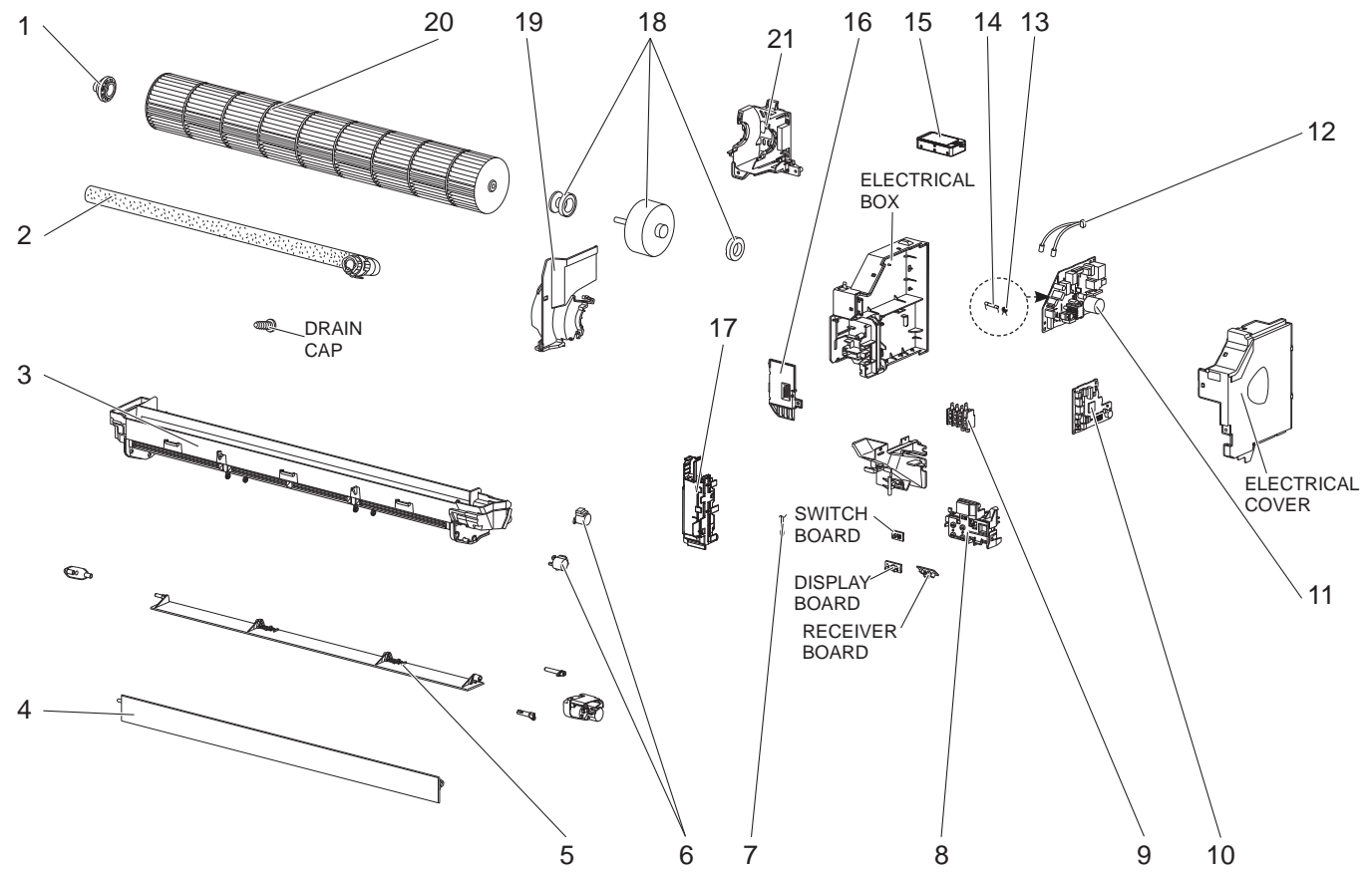

1-27. INDOOR UNIT ELECTRICAL PARTS AND FUNCTIONAL PARTS

1. The part quantity below indicates the required number of pieces per unit.

No.	Part No.	Part name	MSZ-EF18VGKW-E2	MSZ-EF18VGKB-E2	MSZ-EF18VGKS-E2	MSZ-EF22VGKW-E2	MSZ-EF22VGKB-E2	MSZ-EF22VGKS-E2	MSZ-EF25VGKW-E2	MSZ-EF25VGKB-E2	MSZ-EF25VGKS-E2	MSZ-EF35VGKW-E2	MSZ-EF35VGKB-E2	MSZ-EF35VGKS-E2	MSZ-EF42VGKW-E2	MSZ-EF42VGKB-E2	MSZ-EF42VGKS-E2	MSZ-EF50VGKW-E2	MSZ-EF50VGKB-E2	MSZ-EF50VGKS-E2	Symbol in Wiring Diagram	Remarks	
1	E22 A89 509	BEARING MOUNT ASSEMBLY	1	1	1	1	1	1	1	1	1	1	1	1	1	1	1	1	1	1		Includes Sleeve bearing	
2	E22 P72 702	DRAIN HOSE	1	1	1	1	1	1	1	1	1	1	1	1	1	1	1	1	1	1			
3	E22 16H 235	NOZZLE ASSEMBLY	1			1			1			1			1			1				Full assembly except DRAIN HOSE	
3	E22 G21 235	NOZZLE ASSEMBLY		1			1			1			1			1			1				
3	E22 G26 235	NOZZLE ASSEMBLY			1			1			1			1			1			1			
4	E22 16H 040	VANE UPPER	1			1			1			1			1			1					
4	E22 G21 040	VANE UPPER		1			1			1			1			1			1				
4	E22 G26 040	VANE UPPER			1			1			1			1			1			1			
5	E22 16H 041	VANE LOWER	1			1			1			1			1			1					
5	E22 G21 041	VANE LOWER		1			1			1			1			1			1				
5	E22 G26 041	VANE LOWER			1			1			1			1			1			1			
6	E22 A89 303	VANE MOTOR	2	2	2	2	2	2	2	2	2	2	2	2	2	2	2	2	2	2	2	MV1, MV2	UP & DOWN, 1 PC/SET
7	E22 F95 308	ROOM TEMPERATURE THERMISTOR	1	1	1	1	1	1	1	1	1	1	1	1	1	1	1	1	1	1	1	RT11	
8	E22 F95 095	DISPLAY P.C. BOARD HOLDER	1	1	1	1	1	1	1	1	1	1	1	1	1	1	1	1	1	1	1		
9	E22 T21 375	TERMINAL BLOCK	1	1	1	1	1	1	1	1	1	1	1	1	1	1	1	1	1	1	1	TB	
10	E22 45X 452	ELECTRONIC CONTROL P.C. BOARD	1	1	1	1	1	1														Includes RECEIVER P.C. BOARD, DISPLAY P.C. BOARD and SWITCH P.C. BOARD.	
10	E22 51X 452	ELECTRONIC CONTROL P.C. BOARD							1	1	1												
10	E22 54X 452	ELECTRONIC CONTROL P.C. BOARD										1	1	1									
10	E22 57X 452	ELECTRONIC CONTROL P.C. BOARD													1	1	1						
10	E22 60X 452	ELECTRONIC CONTROL P.C. BOARD																1	1	1			
11	E22 45X 440	POWER P.C. BOARD	1	1	1	1	1	1	1	1	1	1	1	1	1	1	1						
11	E22 60X 440	POWER P.C. BOARD																1	1	1			
12	E22 F95 307	INDOOR COIL THERMISTOR	1	1	1	1	1	1	1	1	1	1	1	1	1	1	1	1	1	1	1	RT12,RT13	
13	E22 B75 385	VARISTOR	1	1	1	1	1	1	1	1	1	1	1	1	1	1	1	1	1	1	1	NR11	
14	E22 42J 382	FUSE	1	1	1	1	1	1	1	1	1	1	1	1	1	1	1	1	1	1	1	F11	T3.15A/250V
15	E22 45X 457	Wi-Fi INTERFACE MAC-577IF2-E	1	1	1	1	1	1	1	1	1	1	1	1	1	1	1	1	1	1	1		MAC-577IF2-E
16	E22 F95 784	V.A. CLAMP	1	1	1	1	1	1	1	1	1	1	1	1	1	1	1	1	1	1	1		
17	E22 45L 541	WATER CUT	1	1	1	1	1	1	1	1	1	1	1	1	1	1	1	1	1	1	1		
18	E22 29L 300	INDOOR FAN MOTOR	1	1	1	1	1	1	1	1	1	1	1	1	1	1	1	1	1	1	1	MF	RC0J40-□□ Includes FAN MOTOR RUBBER MOUNT (2 PCS/SET)
19	E22 F95 333	MOTOR BAND	1	1	1	1	1	1	1	1	1	1	1	1	1	1	1	1	1	1	1		
20	E22 F95 302	LINE FLOW FAN	1	1	1	1	1	1	1	1	1	1	1	1	1	1	1	1	1	1	1		
21	E22 45X 333	MOTOR BED	1	1	1	1	1	1	1	1	1	1	1	1	1	1	1	1	1	1	1		

- MSZ-EF18VGKW - E2 MSZ-EF18VGKB - E2 MSZ-EF18VGKS - E2
- MSZ-EF22VGKW - E2 MSZ-EF22VGKB - E2 MSZ-EF22VGKS - E2
- MSZ-EF25VGKW - E2 MSZ-EF25VGKB - E2 MSZ-EF25VGKS - E2
- MSZ-EF35VGKW - E2 MSZ-EF35VGKB - E2 MSZ-EF35VGKS - E2
- MSZ-EF42VGKW - E2 MSZ-EF42VGKB - E2 MSZ-EF42VGKS - E2
- MSZ-EF50VGKW - E2 MSZ-EF50VGKB - E2 MSZ-EF50VGKS - E2

1-28. INDOOR UNIT HEAT EXCHANGER

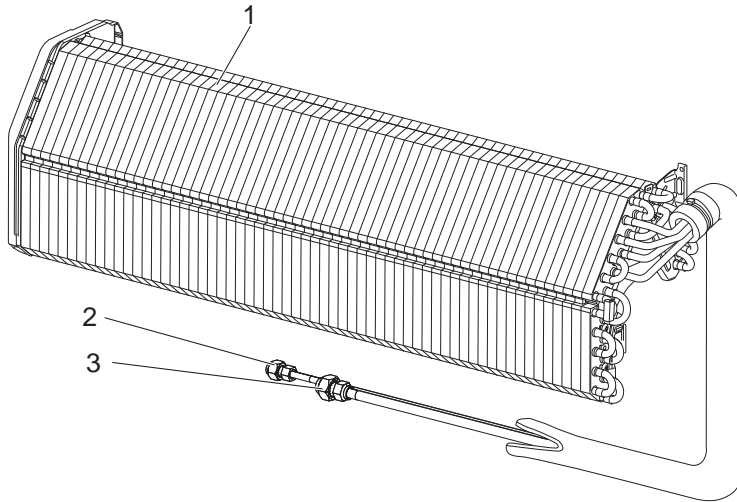



1-28. INDOOR UNIT HEAT EXCHANGER

1. The part quantity below indicates the required number of pieces per unit.

No.	Part No.	Part name	MSZ-EF18VGKW-E2	MSZ-EF18VGKB-E2	MSZ-EF18VGKS-E2	MSZ-EF22VGKW-E2	MSZ-EF22VGKB-E2	MSZ-EF22VGKS-E2	MSZ-EF25VGKW-E2	MSZ-EF25VGKB-E2	MSZ-EF25VGKS-E2	MSZ-EF35VGKW-E2	MSZ-EF35VGKB-E2	MSZ-EF35VGKS-E2	MSZ-EF42VGKW-E2	MSZ-EF42VGKB-E2	MSZ-EF42VGKS-E2	MSZ-EF50VGKW-E2	MSZ-EF50VGKB-E2	MSZ-EF50VGKS-E2	Symbol in Wiring Diagram	Remarks
			1	1	1	1	1	1	1	1	1	1	1	1	1	1	1	1	1	1		
1	E22 F95 620	INDOOR HEAT EXCHANGER	1	1	1	1	1	1	1	1	1	1	1	1	1	1	1	1	1	1		
2	E22 151 667	UNION (LIQUID)	1	1	1	1	1	1	1	1	1	1	1	1	1	1	1	1	1	1		ø6.35
3	E22 815 666	UNION (GAS)	1	1	1	1	1	1	1	1	1	1	1	1	1	1	1	1	1	1		ø9.52

MSZ-EF22VGKW -ET1 MSZ-EF22VGKB -ET1 MSZ-EF22VGKS -ET1
MSZ-EF25VGKW -ET1 MSZ-EF25VGKB -ET1 MSZ-EF25VGKS -ET1
MSZ-EF35VGKW -ET1 MSZ-EF35VGKB -ET1 MSZ-EF35VGKS -ET1
MSZ-EF42VGKW -ET1 MSZ-EF42VGKB -ET1 MSZ-EF42VGKS -ET1
MSZ-EF50VGKW -ET1 MSZ-EF50VGKB -ET1 MSZ-EF50VGKS -ET1

1-29. INDOOR UNIT STRUCTURAL PARTS

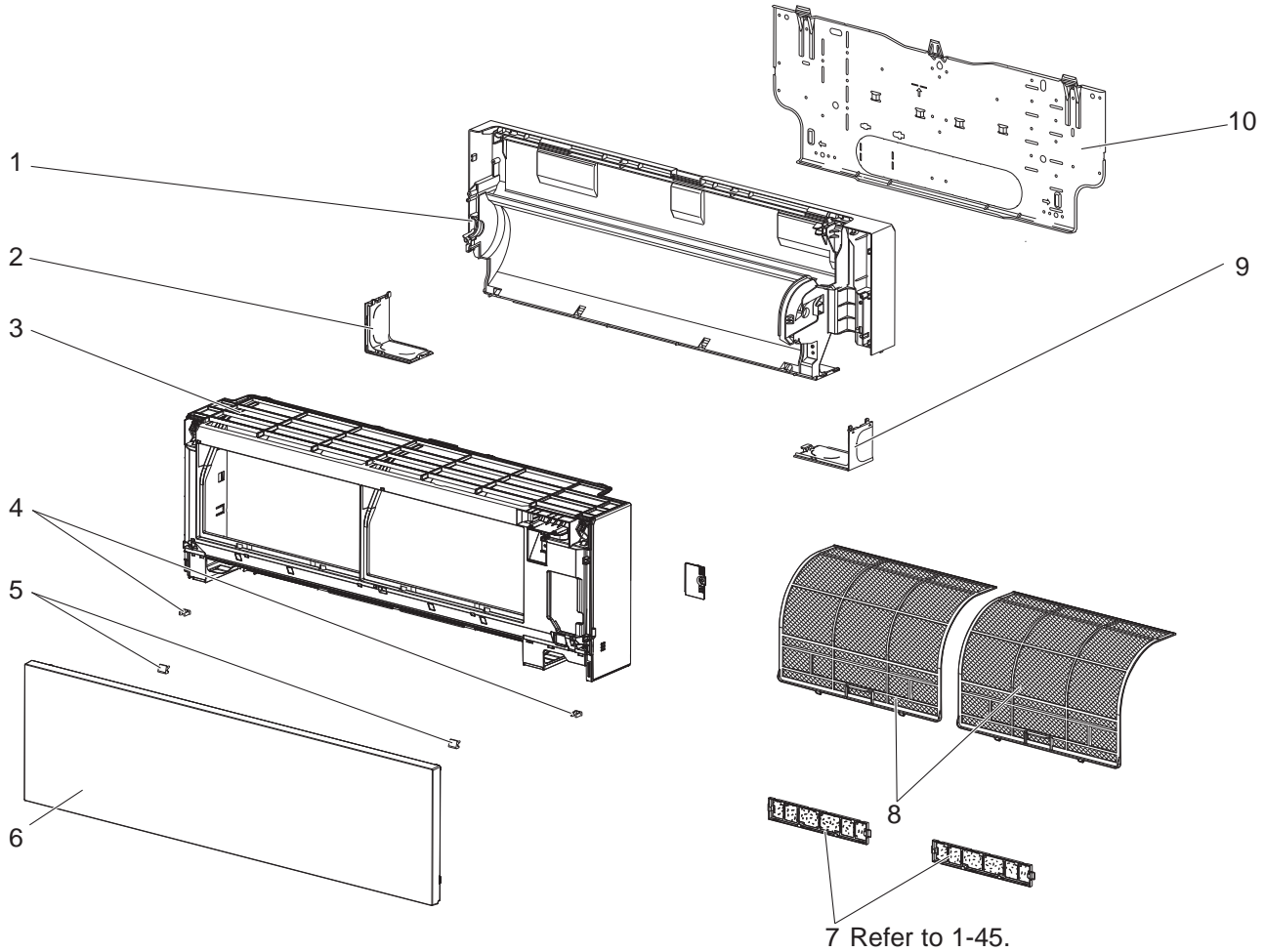

1-30. ACCESSORY AND REMOTE CONTROLLER

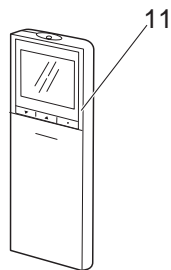

1-29. INDOOR UNIT STRUCTURAL PARTS

1. The part quantity below indicates the required number of pieces per unit.

No.	Part No.	Part name	MSZ-EF22VGKW-ET1	MSZ-EF22VGKB-ET1	MSZ-EF22VGKS-ET1	MSZ-EF25VGKW-ET1	MSZ-EF25VGKB-ET1	MSZ-EF25VGKS-ET1	MSZ-EF35VGKW-ET1	MSZ-EF35VGKB-ET1	MSZ-EF35VGKS-ET1	MSZ-EF42VGKW-ET1	MSZ-EF42VGKB-ET1	MSZ-EF42VGKS-ET1	MSZ-EF50VGKW-ET1	MSZ-EF50VGKB-ET1	MSZ-EF50VGKS-ET1	Symbol in Wiring Diagram	Remarks
1	E22 16H 234	BOX ASSEMBLY	1			1			1			1			1				
1	E22 G21 234	BOX ASSEMBLY		1		1			1			1			1				
1	E22 G26 234	BOX ASSEMBLY			1			1			1			1			1		
2	E22 16H 976	CORNER BOX LEFT	1			1			1			1			1				
2	E22 G21 976	CORNER BOX LEFT		1		1			1			1			1				
2	E22 G26 976	CORNER BOX LEFT			1			1			1			1			1		
3	E22 48L 000	PANEL ASSEMBLY	1			1			1			1			1				Includes No. 4, 6
3	E22 49L 000	PANEL ASSEMBLY		1		1			1			1			1				Includes No. 4, 6
3	E22 50L 000	PANEL ASSEMBLY			1			1			1			1			1		Includes No. 4, 6
4	E22 F95 142	CATCH	2	2	2	2	2	2	2	2	2	2	2	2	2	2	2		2 PCS/SET
5	E22 16H 067	SCREW CAP	2			2			2			2			2				2 PCS/SET
5	E22 G21 067	SCREW CAP		2		2			2			2			2				2 PCS/SET
5	E22 G26 067	SCREW CAP			2			2			2			2			2		2 PCS/SET
6	E22 16H 010	FRONT PANEL	1			1			1			1			1				
6	E22 T25 010	FRONT PANEL		1		1			1			1			1				
6	E22 T29 010	FRONT PANEL			1			1			1			1			1		
7	—	AIR CLEANING FILTER (SILVER-IONIZED AIR PURIFIER FILTER)	2	2	2	2	2	2	2	2	2	2	2	2	2	2	2		1 PC/SET
8	E22 16H 100	AIR FILTER (AIR PURIFYING FILTER)	2	2	2	2	2	2	2	2	2	2	2	2	2	2	2		1 PC/SET
9	E22 16H 975	CORNER BOX RIGHT	1			1			1			1			1				
9	E22 G21 975	CORNER BOX RIGHT		1		1			1			1			1				
9	E22 G26 975	CORNER BOX RIGHT			1			1			1			1			1		
10	E22 F95 970	INSTALLATION PLATE	1	1	1	1	1	1	1	1	1	1	1	1	1	1	1		

1-30. ACCESSORY AND REMOTE CONTROLLER

1. The part quantity below indicates the required number of pieces per unit.

No.	Part No.	Part name	MSZ-EF22VGKW-ET1	MSZ-EF22VGKB-ET1	MSZ-EF22VGKS-ET1	MSZ-EF25VGKW-ET1	MSZ-EF25VGKB-ET1	MSZ-EF25VGKS-ET1	MSZ-EF35VGKW-ET1	MSZ-EF35VGKB-ET1	MSZ-EF35VGKS-ET1	MSZ-EF42VGKW-ET1	MSZ-EF42VGKB-ET1	MSZ-EF42VGKS-ET1	MSZ-EF50VGKW-ET1	MSZ-EF50VGKB-ET1	MSZ-EF50VGKS-ET1	Symbol in Wiring Diagram	Remarks
11	E22 16H 426	REMOTE CONTROLLER	1			1			1			1			1				SG19A
11	E22 14H 426	REMOTE CONTROLLER		1	1	1	1		1	1		1	1		1	1			SG19B

MSZ-EF22VGKW -[ET1] MSZ-EF22VGKB -[ET1] MSZ-EF22VGKS -[ET1]
MSZ-EF25VGKW -[ET1] MSZ-EF25VGKB -[ET1] MSZ-EF25VGKS -[ET1]
MSZ-EF35VGKW -[ET1] MSZ-EF35VGKB -[ET1] MSZ-EF35VGKS -[ET1]
MSZ-EF42VGKW -[ET1] MSZ-EF42VGKB -[ET1] MSZ-EF42VGKS -[ET1]
MSZ-EF50VGKW -[ET1] MSZ-EF50VGKB -[ET1] MSZ-EF50VGKS -[ET1]

1-31. INDOOR UNIT ELECTRICAL PARTS AND FUNCTIONAL PARTS

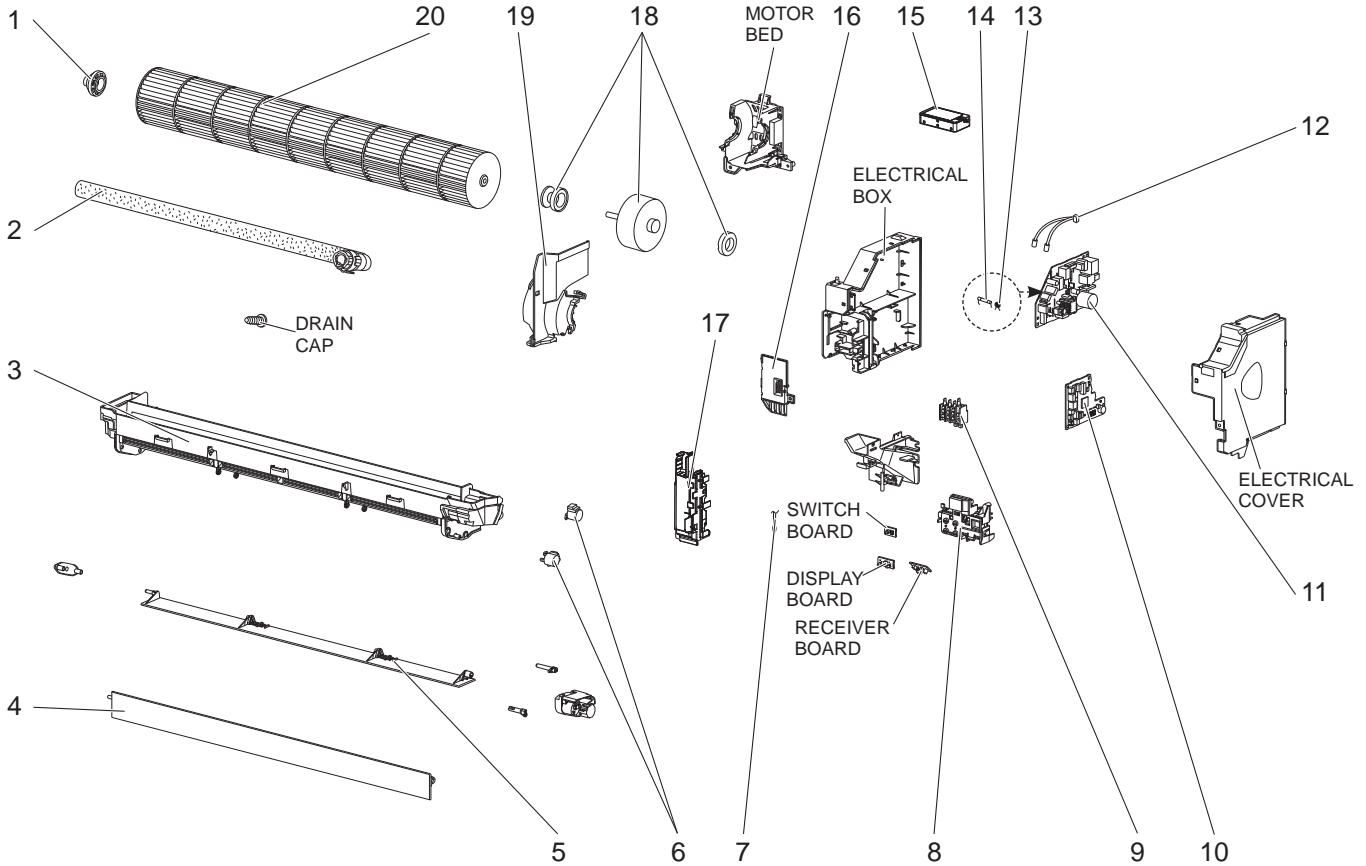

1-31. INDOOR UNIT ELECTRICAL PARTS AND FUNCTIONAL PARTS

1. The part quantity below indicates the required number of pieces per unit.

No.	Part No.	Part name	MSZ-EF22VGKW-ET1	MSZ-EF22VGKB-ET1	MSZ-EF22VGKS-ET1	MSZ-EF25VGKW-ET1	MSZ-EF25VGKB-ET1	MSZ-EF25VGKS-ET1	MSZ-EF35VGKW-ET1	MSZ-EF35VGKB-ET1	MSZ-EF35VGKS-ET1	MSZ-EF42VGKW-ET1	MSZ-EF42VGKB-ET1	MSZ-EF42VGKS-ET1	MSZ-EF50VGKW-ET1	MSZ-EF50VGKB-ET1	MSZ-EF50VGKS-ET1	Symbol in Wiring Diagram	Remarks
1	E22 A89 509	BEARING MOUNT ASSEMBLY	1	1	1	1	1	1	1	1	1	1	1	1	1	1	1		Includes Sleeve bearing
2	E22 P72 702	DRAIN HOSE	1	1	1	1	1	1	1	1	1	1	1	1	1	1	1		
3	E22 16H 235	NOZZLE ASSEMBLY	1			1			1			1			1				Full assembly except DRAIN HOSE
3	E22 G21 235	NOZZLE ASSEMBLY		1			1			1			1				1		
3	E22 G26 235	NOZZLE ASSEMBLY			1			1			1			1			1		
4	E22 16H 040	VANE UPPER	1			1			1			1			1				
4	E22 G21 040	VANE UPPER		1			1			1			1			1			
4	E22 G26 040	VANE UPPER			1			1			1			1			1		
5	E22 16H 041	VANE LOWER	1			1			1			1			1				
5	E22 G21 041	VANE LOWER		1			1			1			1			1			
5	E22 G26 041	VANE LOWER			1			1			1			1			1		
6	E22 A89 303	VANE MOTOR	2	2	2	2	2	2	2	2	2	2	2	2	2	2	2	MV1, MV2	UP & DOWN, 1 PC/SET
7	E22 F95 308	ROOM TEMPERATURE THERMISTOR	1	1	1	1	1	1	1	1	1	1	1	1	1	1	1	RT11	
8	E22 F95 095	DISPLAY P.C. BOARD HOLDER	1	1	1	1	1	1	1	1	1	1	1	1	1	1	1		
9	E22 T21 375	TERMINAL BLOCK	1	1	1	1	1	1	1	1	1	1	1	1	1	1	1	TB	
10	E22 45L 452	ELECTRONIC CONTROL P.C. BOARD	1	1	1														Includes RECEIVER P.C. BOARD, DISPLAY P.C. BOARD and SWITCH P.C. BOARD.
10	E22 51L 452	ELECTRONIC CONTROL P.C. BOARD				1	1	1											
10	E22 54L 452	ELECTRONIC CONTROL P.C. BOARD							1	1	1								
10	E22 57L 452	ELECTRONIC CONTROL P.C. BOARD										1	1	1					
10	E22 60L 452	ELECTRONIC CONTROL P.C. BOARD													1	1	1		
11	E22 45L 440	POWER P.C. BOARD	1	1	1	1	1	1	1	1	1	1	1	1					
11	E22 60L 440	POWER P.C. BOARD													1	1	1		
12	E22 F95 307	INDOOR COIL THERMISTOR	1	1	1	1	1	1	1	1	1	1	1	1	1	1	1	RT12,RT13	
13	E22 B75 385	VARISTOR	1	1	1	1	1	1	1	1	1	1	1	1	1	1	1	NR11	
14	E22 42J 382	FUSE	1	1	1	1	1	1	1	1	1	1	1	1	1	1	1	F11	T3.15AL250V
15	E22 45L 457	Wi-Fi INTERFACE MAC-577IF2-E	1	1	1	1	1	1	1	1	1	1	1	1	1	1	1		MAC-577IF2-E
16	E22 F95 784	V.A. CLAMP	1	1	1	1	1	1	1	1	1	1	1	1	1	1	1		
17	E22 45L 541	WATER CUT	1	1	1	1	1	1	1	1	1	1	1	1	1	1	1		
18	E22 29L 300	INDOOR FAN MOTOR	1	1	1	1	1	1	1	1	1	1	1	1	1	1	1	MF	RC0J40-□□ Includes FAN MOTOR RUBBER MOUNT (2 PCS/SET)
19	E22 F95 333	MOTOR BAND	1	1	1	1	1	1	1	1	1	1	1	1	1	1	1		
20	E22 F95 302	LINE FLOW FAN	1	1	1	1	1	1	1	1	1	1	1	1	1	1	1		

MSZ-EF22VGKW -ET1 MSZ-EF22VGKB -ET1 MSZ-EF22VGKS -ET1
MSZ-EF25VGKW -ET1 MSZ-EF25VGKB -ET1 MSZ-EF25VGKS -ET1
MSZ-EF35VGKW -ET1 MSZ-EF35VGKB -ET1 MSZ-EF35VGKS -ET1
MSZ-EF42VGKW -ET1 MSZ-EF42VGKB -ET1 MSZ-EF42VGKS -ET1
MSZ-EF50VGKW -ET1 MSZ-EF50VGKB -ET1 MSZ-EF50VGKS -ET1

1-32. INDOOR UNIT HEAT EXCHANGER

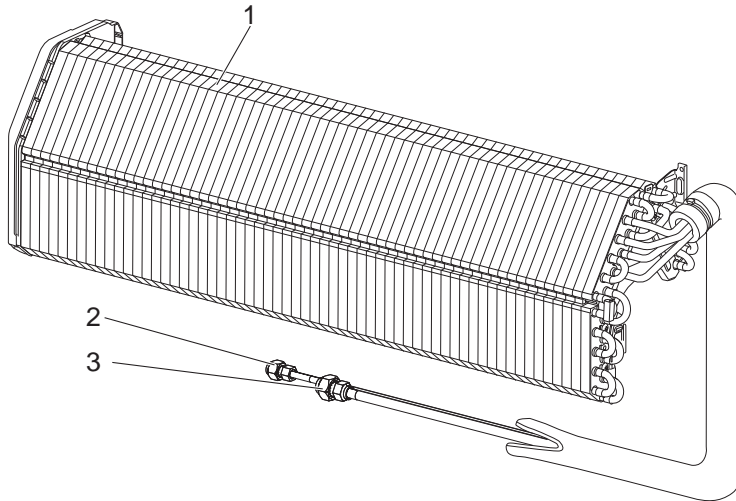



1-32. INDOOR UNIT HEAT EXCHANGER

1. The part quantity below indicates the required number of pieces per unit.

No.	Part No.	Part name	MSZ-EF22VGKW-ET1	MSZ-EF22VGKB-ET1	MSZ-EF22VGKS-ET1	MSZ-EF25VGKW-ET1	MSZ-EF25VGKB-ET1	MSZ-EF25VGKS-ET1	MSZ-EF35VGKW-ET1	MSZ-EF35VGKB-ET1	MSZ-EF35VGKS-ET1	MSZ-EF42VGKW-ET1	MSZ-EF42VGKB-ET1	MSZ-EF42VGKS-ET1	MSZ-EF50VGKW-ET1	MSZ-EF50VGKB-ET1	MSZ-EF50VGKS-ET1	Symbol in Wiring Diagram	Remarks
			1	1	1	1	1	1	1	1	1	1	1	1	1	1	1		
1	E22 F95 620	INDOOR HEAT EXCHANGER	1	1	1	1	1	1	1	1	1	1	1	1	1	1	1		
2	E22 151 667	UNION (LIQUID)	1	1	1	1	1	1	1	1	1	1	1	1	1	1	1		ø6.35
3	E22 815 666	UNION (GAS)	1	1	1	1	1	1	1	1	1	1	1	1	1	1	1		ø9.52

MSZ-EF22VGKW -ET2 MSZ-EF22VGKB -ET2 MSZ-EF22VGKS -ET2
MSZ-EF25VGKW -ET2 MSZ-EF25VGKB -ET2 MSZ-EF25VGKS -ET2
MSZ-EF35VGKW -ET2 MSZ-EF35VGKB -ET2 MSZ-EF35VGKS -ET2
MSZ-EF42VGKW -ET2 MSZ-EF42VGKB -ET2 MSZ-EF42VGKS -ET2
MSZ-EF50VGKW -ET2 MSZ-EF50VGKB -ET2 MSZ-EF50VGKS -ET2

1-33. INDOOR UNIT STRUCTURAL PARTS

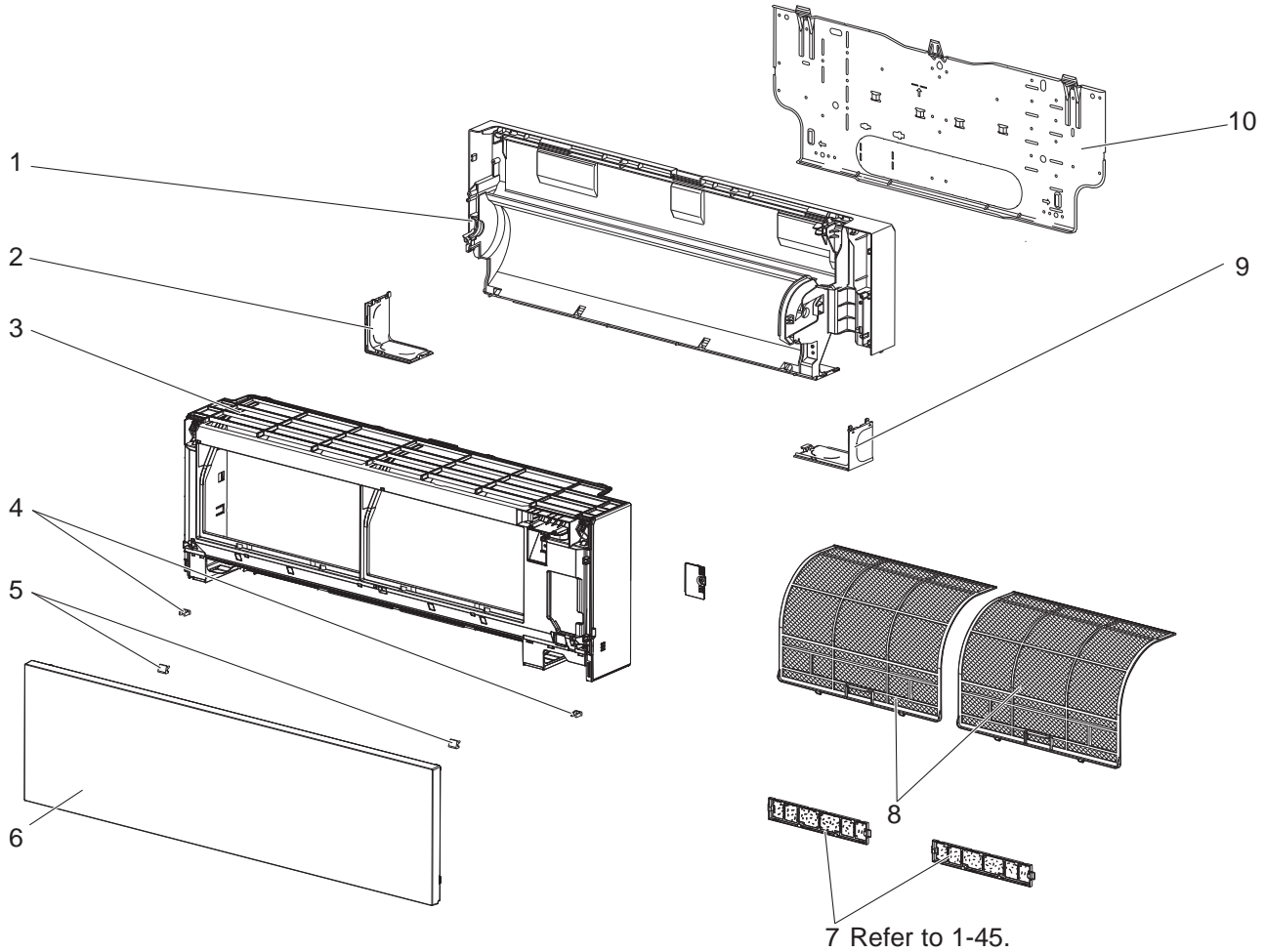

1-34. ACCESSORY AND REMOTE CONTROLLER

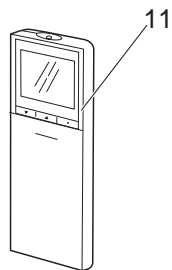

1-33. INDOOR UNIT STRUCTURAL PARTS

1. The part quantity below indicates the required number of pieces per unit.

No.	Part No.	Part name	MSZ-EF22VGKW-ET2	MSZ-EF22VGKB-ET2	MSZ-EF22VGKS-ET2	MSZ-EF25VGKW-ET2	MSZ-EF25VGKB-ET2	MSZ-EF25VGKS-ET2	MSZ-EF35VGKW-ET2	MSZ-EF35VGKB-ET2	MSZ-EF35VGKS-ET2	MSZ-EF42VGKW-ET2	MSZ-EF42VGKB-ET2	MSZ-EF42VGKS-ET2	MSZ-EF50VGKW-ET2	MSZ-EF50VGKB-ET2	MSZ-EF50VGKS-ET2	Symbol in Wiring Diagram	Remarks
1	E22 16H 234	BOX ASSEMBLY	1			1			1			1			1				
1	E22 G21 234	BOX ASSEMBLY		1		1			1			1			1				
1	E22 G26 234	BOX ASSEMBLY			1			1			1			1			1		
2	E22 16H 976	CORNER BOX LEFT	1			1			1			1			1				
2	E22 G21 976	CORNER BOX LEFT		1		1			1			1			1				
2	E22 G26 976	CORNER BOX LEFT			1			1			1			1			1		
3	E22 20Y 000	PANEL ASSEMBLY	1			1			1			1			1				Includes No.4 ,5, 6
3	E22 25Y 000	PANEL ASSEMBLY		1		1			1			1			1				Includes No.4 ,5, 6
3	E22 30Y 000	PANEL ASSEMBLY			1			1			1			1			1		Includes No.4 ,5, 6
4	E22 F95 142	CATCH	2	2	2	2	2	2	2	2	2	2	2	2	2	2	2		2 PCS/SET
5	E22 16H 067	SCREW CAP	2			2			2			2			2				2 PCS/SET
5	E22 G21 067	SCREW CAP		2		2			2			2			2				2 PCS/SET
5	E22 G26 067	SCREW CAP			2			2			2			2			2		2 PCS/SET
6	E22 16H 010	FRONT PANEL	1			1			1			1			1				
6	E22 T25 010	FRONT PANEL		1		1			1			1			1				
6	E22 T29 010	FRONT PANEL			1			1			1			1			1		
7	—	AIR CLEANING FILTER (SILVER-IONIZED AIR PURIFIER FILTER)	2	2	2	2	2	2	2	2	2	2	2	2	2	2	2		1 PC/SET
8	E22 16H 100	AIR FILTER (AIR PURIFYING FILTER)	2	2	2	2	2	2	2	2	2	2	2	2	2	2	2		1 PC/SET
9	E22 16H 975	CORNER BOX RIGHT	1			1			1			1			1				
9	E22 G21 975	CORNER BOX RIGHT		1		1			1			1			1				
9	E22 G26 975	CORNER BOX RIGHT			1			1			1			1			1		
10	E22 F95 970	INSTALLATION PLATE	1	1	1	1	1	1	1	1	1	1	1	1	1	1	1		

1-34. ACCESSORY AND REMOTE CONTROLLER

1. The part quantity below indicates the required number of pieces per unit.

No.	Part No.	Part name	MSZ-EF22VGKW-ET2	MSZ-EF22VGKB-ET2	MSZ-EF22VGKS-ET2	MSZ-EF25VGKW-ET2	MSZ-EF25VGKB-ET2	MSZ-EF25VGKS-ET2	MSZ-EF35VGKW-ET2	MSZ-EF35VGKB-ET2	MSZ-EF35VGKS-ET2	MSZ-EF42VGKW-ET2	MSZ-EF42VGKB-ET2	MSZ-EF42VGKS-ET2	MSZ-EF50VGKW-ET2	MSZ-EF50VGKB-ET2	MSZ-EF50VGKS-ET2	Symbol in Wiring Diagram	Remarks
11	E22 16H 426	REMOTE CONTROLLER	1			1			1			1			1				SG19A
11	E22 14H 426	REMOTE CONTROLLER		1	1	1	1		1	1		1	1		1	1			SG19B

MSZ-EF22VGKW -[ET2] MSZ-EF22VGKB -[ET2] MSZ-EF22VGKS -[ET2]
MSZ-EF25VGKW -[ET2] MSZ-EF25VGKB -[ET2] MSZ-EF25VGKS -[ET2]
MSZ-EF35VGKW -[ET2] MSZ-EF35VGKB -[ET2] MSZ-EF35VGKS -[ET2]
MSZ-EF42VGKW -[ET2] MSZ-EF42VGKB -[ET2] MSZ-EF42VGKS -[ET2]
MSZ-EF50VGKW -[ET2] MSZ-EF50VGKB -[ET2] MSZ-EF50VGKS -[ET2]

1-35. INDOOR UNIT ELECTRICAL PARTS AND FUNCTIONAL PARTS

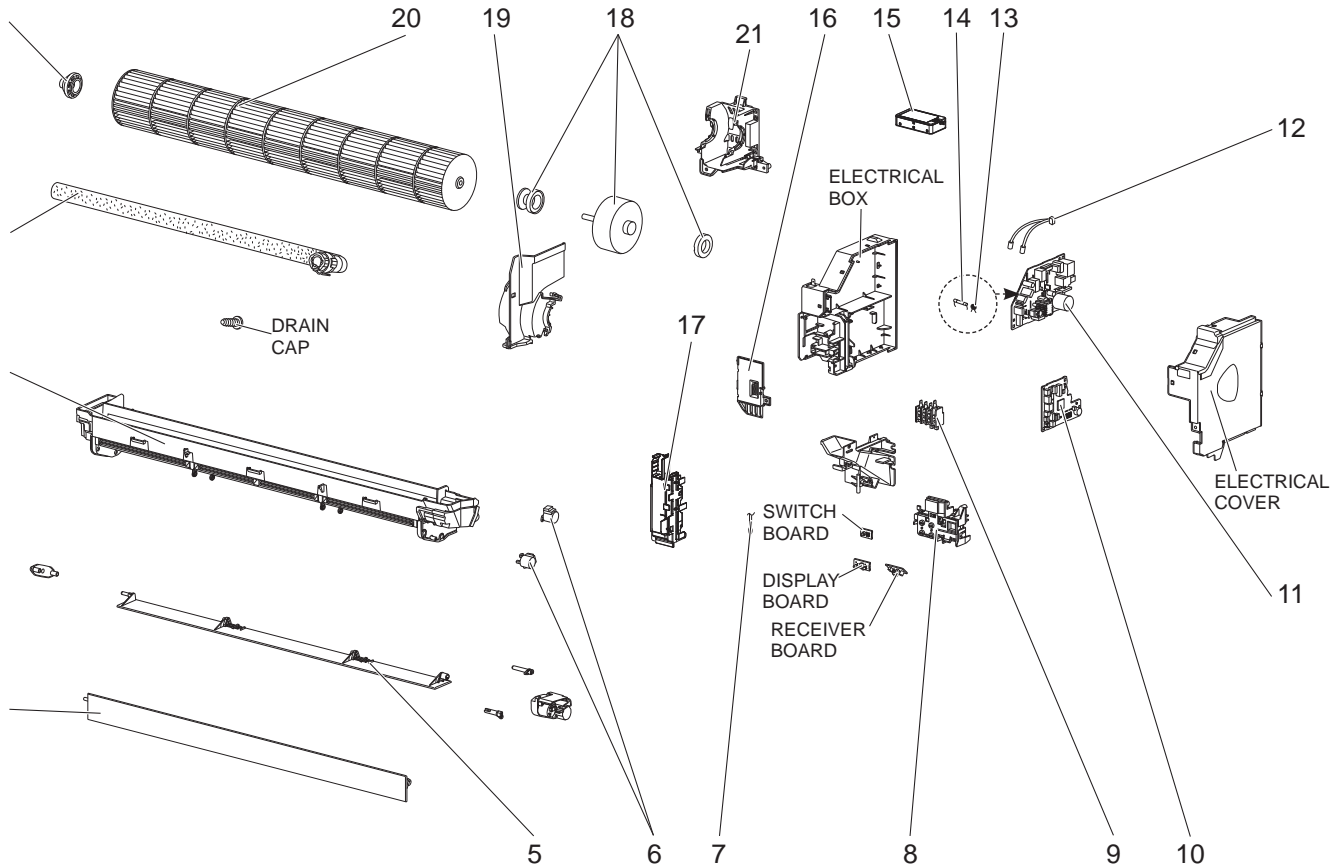

1-35. INDOOR UNIT ELECTRICAL PARTS AND FUNCTIONAL PARTS

1. The part quantity below indicates the required number of pieces per unit.

No.	Part No.	Part name	MSZ-EF22VGKW-ET2	MSZ-EF22VGKB-ET2	MSZ-EF22VGKS-ET2	MSZ-EF25VGKW-ET2	MSZ-EF25VGKB-ET2	MSZ-EF25VGKS-ET2	MSZ-EF35VGKW-ET2	MSZ-EF35VGKB-ET2	MSZ-EF35VGKS-ET2	MSZ-EF42VGKW-ET2	MSZ-EF42VGKB-ET2	MSZ-EF42VGKS-ET2	MSZ-EF50VGKW-ET2	MSZ-EF50VGKB-ET2	MSZ-EF50VGKS-ET2	Symbol in Wiring Diagram	Remarks
1	E22 A89 509	BEARING MOUNT ASSEMBLY	1	1	1	1	1	1	1	1	1	1	1	1	1	1	1		Includes Sleeve bearing
2	E22 P72 702	DRAIN HOSE	1	1	1	1	1	1	1	1	1	1	1	1	1	1	1		
3	E22 16H 235	NOZZLE ASSEMBLY	1			1			1			1			1			Full assembly except DRAIN HOSE	
3	E22 G21 235	NOZZLE ASSEMBLY		1			1			1			1			1			
3	E22 G26 235	NOZZLE ASSEMBLY			1			1			1			1			1		
4	E22 16H 040	VANE UPPER	1			1			1			1			1				
4	E22 G21 040	VANE UPPER		1			1			1			1			1			
4	E22 G26 040	VANE UPPER			1			1			1			1			1		
5	E22 16H 041	VANE LOWER	1			1			1			1			1				
5	E22 G21 041	VANE LOWER		1			1			1			1			1			
5	E22 G26 041	VANE LOWER			1			1			1			1			1		
6	E22 A89 303	VANE MOTOR	2	2	2	2	2	2	2	2	2	2	2	2	2	2	2	MV1, MV2	UP & DOWN, 1 PC/SET
7	E22 F95 308	ROOM TEMPERATURE THERMISTOR	1	1	1	1	1	1	1	1	1	1	1	1	1	1	1	RT11	
8	E22 F95 095	DISPLAY P.C. BOARD HOLDER	1	1	1	1	1	1	1	1	1	1	1	1	1	1	1		
9	E22 T21 375	TERMINAL BLOCK	1	1	1	1	1	1	1	1	1	1	1	1	1	1	1	TB	
10	E22 45X 452	ELECTRONIC CONTROL P.C. BOARD	1	1	1													Includes RECEIVER P.C. BOARD, DISPLAY P.C. BOARD and SWITCH P.C. BOARD.	
10	E22 51X 452	ELECTRONIC CONTROL P.C. BOARD				1	1	1											
10	E22 54X 452	ELECTRONIC CONTROL P.C. BOARD							1	1	1								
10	E22 57X 452	ELECTRONIC CONTROL P.C. BOARD										1	1	1					
10	E22 60X 452	ELECTRONIC CONTROL P.C. BOARD													1	1	1		
11	E22 45X 440	POWER P.C. BOARD	1	1	1	1	1	1	1	1	1	1	1	1					
11	E22 60X 440	POWER P.C. BOARD													1	1	1		
12	E22 F95 307	INDOOR COIL THERMISTOR	1	1	1	1	1	1	1	1	1	1	1	1	1	1	1	RT12,RT13	
13	E22 B75 385	VARISTOR	1	1	1	1	1	1	1	1	1	1	1	1	1	1	1	NR11	
14	E22 42J 382	FUSE	1	1	1	1	1	1	1	1	1	1	1	1	1	1	1	F11	T3.15AL250V
15	E22 45X 457	Wi-Fi INTERFACE MAC-577IF2-E	1	1	1	1	1	1	1	1	1	1	1	1	1	1	1		MAC-577IF2-E
16	E22 F95 784	V.A. CLAMP	1	1	1	1	1	1	1	1	1	1	1	1	1	1	1		
17	E22 45L 541	WATER CUT	1	1	1	1	1	1	1	1	1	1	1	1	1	1	1		
18	E22 29L 300	INDOOR FAN MOTOR	1	1	1	1	1	1	1	1	1	1	1	1	1	1	1	MF	RC0J40-□□ Includes FAN MOTOR RUBBER MOUNT (2 PCS/SET)
19	E22 F95 333	MOTOR BAND	1	1	1	1	1	1	1	1	1	1	1	1	1	1	1		
20	E22 F95 302	LINE FLOW FAN	1	1	1	1	1	1	1	1	1	1	1	1	1	1	1		
21	E22 45X 333	MOTOR BED	1	1	1	1	1	1	1	1	1	1	1	1	1	1	1		

MSZ-EF22VGKW -ET2 MSZ-EF22VGKB -ET2 MSZ-EF22VGKS -ET2
MSZ-EF25VGKW -ET2 MSZ-EF25VGKB -ET2 MSZ-EF25VGKS -ET2
MSZ-EF35VGKW -ET2 MSZ-EF35VGKB -ET2 MSZ-EF35VGKS -ET2
MSZ-EF42VGKW -ET2 MSZ-EF42VGKB -ET2 MSZ-EF42VGKS -ET2
MSZ-EF50VGKW -ET2 MSZ-EF50VGKB -ET2 MSZ-EF50VGKS -ET2

1-36. INDOOR UNIT HEAT EXCHANGER

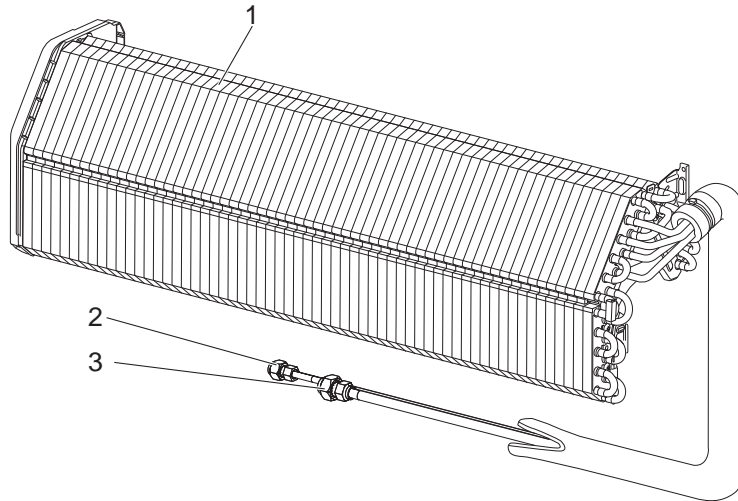



1-36. INDOOR UNIT HEAT EXCHANGER

1. The part quantity below indicates the required number of pieces per unit.

No.	Part No.	Part name	MSZ-EF22VGKW-ET2	MSZ-EF22VGKB-ET2	MSZ-EF22VGKS-ET2	MSZ-EF25VGKW-ET2	MSZ-EF25VGKB-ET2	MSZ-EF25VGKS-ET2	MSZ-EF35VGKW-ET2	MSZ-EF35VGKB-ET2	MSZ-EF35VGKS-ET2	MSZ-EF42VGKW-ET2	MSZ-EF42VGKB-ET2	MSZ-EF42VGKS-ET2	MSZ-EF50VGKW-ET2	MSZ-EF50VGKB-ET2	MSZ-EF50VGKS-ET2	Symbol in Wiring Diagram	Remarks
			1	1	1	1	1	1	1	1	1	1	1	1	1	1	1		
1	E22 F95 620	INDOOR HEAT EXCHANGER	1	1	1	1	1	1	1	1	1	1	1	1	1	1	1		
2	E22 151 667	UNION (LIQUID)	1	1	1	1	1	1	1	1	1	1	1	1	1	1	1		ø6.35
3	E22 815 666	UNION (GAS)	1	1	1	1	1	1	1	1	1	1	1	1	1	1	1		ø9.52

MSZ-EF22VGKW -ER1 MSZ-EF22VGKB -ER1 MSZ-EF22VGKS -ER1
MSZ-EF25VGKW -ER1 MSZ-EF25VGKB -ER1 MSZ-EF25VGKS -ER1
MSZ-EF35VGKW -ER1 MSZ-EF35VGKB -ER1 MSZ-EF35VGKS -ER1
MSZ-EF42VGKW -ER1 MSZ-EF42VGKB -ER1 MSZ-EF42VGKS -ER1
MSZ-EF50VGKW -ER1 MSZ-EF50VGKB -ER1 MSZ-EF50VGKS -ER1

1-37. INDOOR UNIT STRUCTURAL PARTS

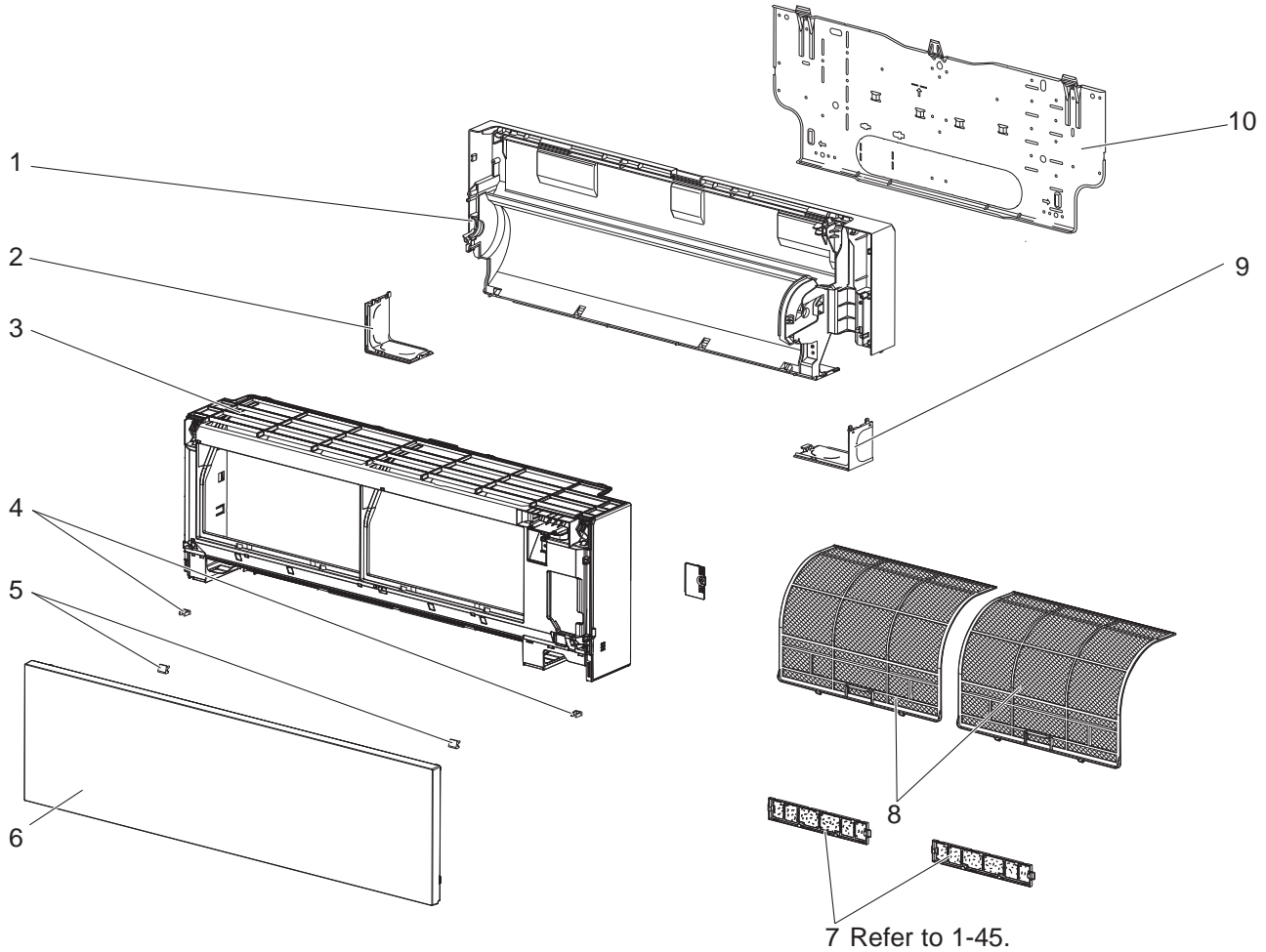

1-38. ACCESSORY AND REMOTE CONTROLLER

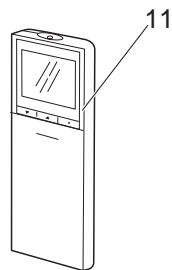

1-37. INDOOR UNIT STRUCTURAL PARTS

1. The part quantity below indicates the required number of pieces per unit.

No.	Part No.	Part name	MSZ-EF22VGKW-ER1	MSZ-EF22VGKB-ER1	MSZ-EF22VGKS-ER1	MSZ-EF25VGKW-ER1	MSZ-EF25VGKB-ER1	MSZ-EF25VGKS-ER1	MSZ-EF35VGKW-ER1	MSZ-EF35VGKB-ER1	MSZ-EF35VGKS-ER1	MSZ-EF42VGKW-ER1	MSZ-EF42VGKB-ER1	MSZ-EF42VGKS-ER1	MSZ-EF50VGKW-ER1	MSZ-EF50VGKB-ER1	MSZ-EF50VGKS-ER1	Symbol in Wiring Diagram	Remarks
1	E22 16H 234	BOX ASSEMBLY	1			1			1			1			1				
1	E22 G21 234	BOX ASSEMBLY		1			1			1			1			1			
1	E22 G26 234	BOX ASSEMBLY			1			1			1			1			1		
2	E22 16H 976	CORNER BOX LEFT	1			1			1			1			1				
2	E22 G21 976	CORNER BOX LEFT		1			1			1			1			1			
2	E22 G26 976	CORNER BOX LEFT			1			1			1			1			1		
3	E22 98M 000	PANEL ASSEMBLY	1			1			1			1			1				Includes No. 4, 6
3	E22 99M 000	PANEL ASSEMBLY		1			1			1			1			1			Includes No. 4, 6
3	E22 01N 000	PANEL ASSEMBLY			1			1			1			1			1		Includes No. 4, 6
4	E22 F95 142	CATCH	2	2	2	2	2	2	2	2	2	2	2	2	2	2	2		2 PCS/SET
5	E22 16H 067	SCREW CAP	2			2			2			2			2				2 PCS/SET
5	E22 G21 067	SCREW CAP		2			2			2			2			2			2 PCS/SET
5	E22 G26 067	SCREW CAP			2			2			2			2			2		2 PCS/SET
6	E22 16H 010	FRONT PANEL	1			1			1			1			1				
6	E22 T25 010	FRONT PANEL		1			1			1			1			1			
6	E22 T29 010	FRONT PANEL			1			1			1			1			1		
7	—	AIR CLEANING FILTER (SILVER-IONIZED AIR PURIFIER FILTER)	2	2	2	2	2	2	2	2	2	2	2	2	2	2	2		1 PC/SET
8	E22 16H 100	AIR FILTER (AIR PURIFYING FILTER)	2	2	2	2	2	2	2	2	2	2	2	2	2	2	2		1 PC/SET
9	E22 16H 975	CORNER BOX RIGHT	1			1			1			1			1				
9	E22 G21 975	CORNER BOX RIGHT		1			1			1			1			1			
9	E22 G26 975	CORNER BOX RIGHT			1			1			1			1			1		
10	E22 F95 970	INSTALLATION PLATE	1	1	1	1	1	1	1	1	1	1	1	1	1	1	1		

1-38. ACCESSORY AND REMOTE CONTROLLER

1. The part quantity below indicates the required number of pieces per unit.

No.	Part No.	Part name	MSZ-EF22VGKW-ER1	MSZ-EF22VGKB-ER1	MSZ-EF22VGKS-ER1	MSZ-EF25VGKW-ER1	MSZ-EF25VGKB-ER1	MSZ-EF25VGKS-ER1	MSZ-EF35VGKW-ER1	MSZ-EF35VGKB-ER1	MSZ-EF35VGKS-ER1	MSZ-EF42VGKW-ER1	MSZ-EF42VGKB-ER1	MSZ-EF42VGKS-ER1	MSZ-EF50VGKW-ER1	MSZ-EF50VGKB-ER1	MSZ-EF50VGKS-ER1	Symbol in Wiring Diagram	Remarks
11	E22 98M 426	REMOTE CONTROLLER	1			1			1			1			1				SG19A
11	E22 99M 426	REMOTE CONTROLLER		1	1		1	1		1	1		1	1		1	1		SG19B

MSZ-EF22VGKW -ER1 MSZ-EF22VGKB -ER1 MSZ-EF22VGKS -ER1
MSZ-EF25VGKW -ER1 MSZ-EF25VGKB -ER1 MSZ-EF25VGKS -ER1
MSZ-EF35VGKW -ER1 MSZ-EF35VGKB -ER1 MSZ-EF35VGKS -ER1
MSZ-EF42VGKW -ER1 MSZ-EF42VGKB -ER1 MSZ-EF42VGKS -ER1
MSZ-EF50VGKW -ER1 MSZ-EF50VGKB -ER1 MSZ-EF50VGKS -ER1

1-39. INDOOR UNIT ELECTRICAL PARTS AND FUNCTIONAL PARTS

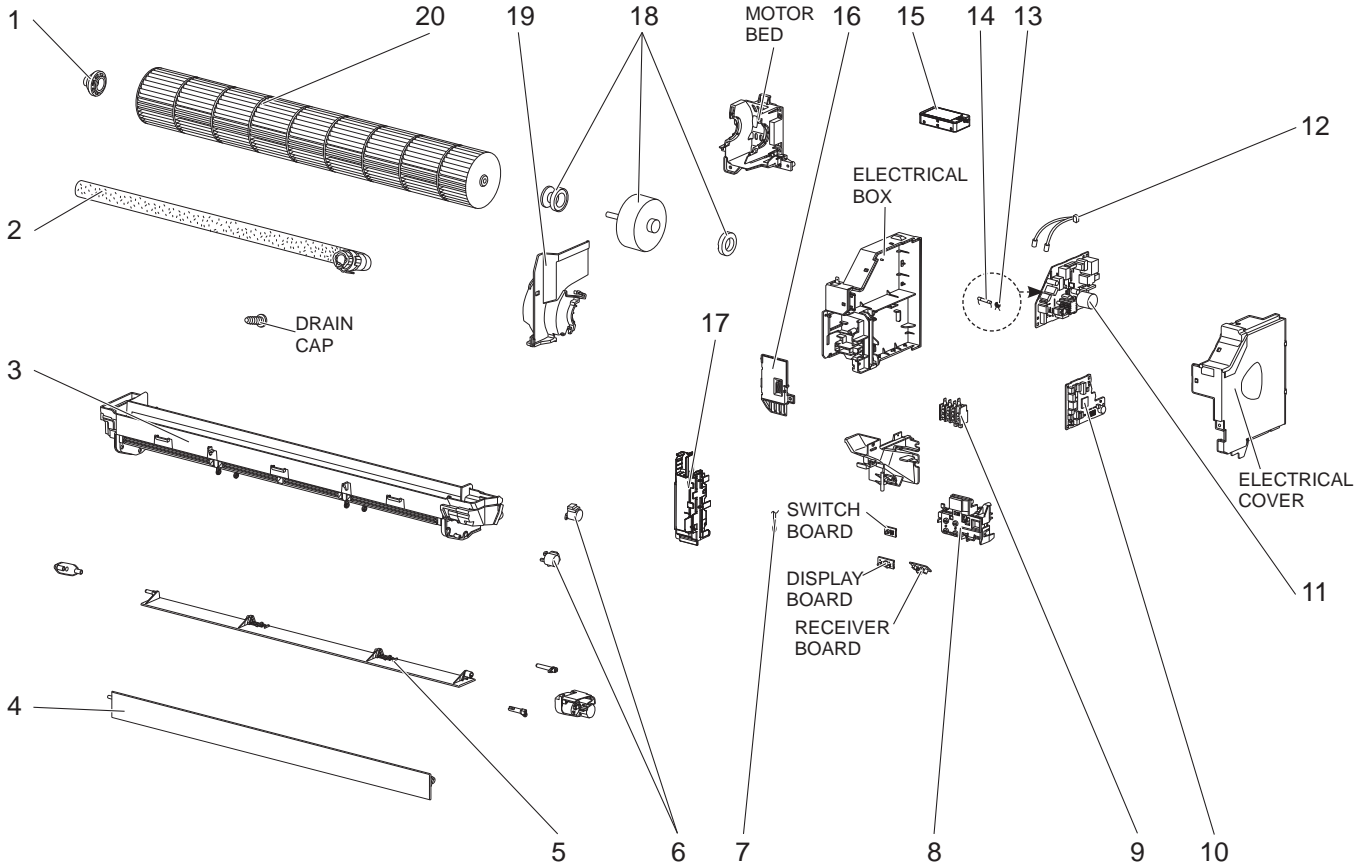

1-39. INDOOR UNIT ELECTRICAL PARTS AND FUNCTIONAL PARTS

1. The part quantity below indicates the required number of pieces per unit.

No.	Part No.	Part name	MSZ-EF22VGKW-ERT	MSZ-EF22VGKB-ERT	MSZ-EF22VGKS-ERT	MSZ-EF25VGKW-ERT	MSZ-EF25VGKB-ERT	MSZ-EF25VGKS-ERT	MSZ-EF35VGKW-ERT	MSZ-EF35VGKB-ERT	MSZ-EF35VGKS-ERT	MSZ-EF42VGKW-ERT	MSZ-EF42VGKB-ERT	MSZ-EF42VGKS-ERT	MSZ-EF50VGKW-ERT	MSZ-EF50VGKB-ERT	MSZ-EF50VGKS-ERT	Symbol in Wiring Diagram	Remarks
1	E22 A89 509	BEARING MOUNT ASSEMBLY	1	1	1	1	1	1	1	1	1	1	1	1	1	1	1		Includes Sleeve bearing
2	E22 P72 702	DRAIN HOSE	1	1	1	1	1	1	1	1	1	1	1	1	1	1	1		
3	E22 16H 235	NOZZLE ASSEMBLY	1			1			1			1			1			Full assembly except DRAIN HOSE	
3	E22 G21 235	NOZZLE ASSEMBLY		1			1			1			1			1			
3	E22 G26 235	NOZZLE ASSEMBLY			1			1			1			1			1		
4	E22 16H 040	VANE UPPER	1			1			1			1			1				
4	E22 G21 040	VANE UPPER		1			1			1			1			1			
4	E22 G26 040	VANE UPPER			1			1			1			1			1		
5	E22 16H 041	VANE LOWER	1			1			1			1			1				
5	E22 G21 041	VANE LOWER		1			1			1			1			1			
5	E22 G26 041	VANE LOWER			1			1			1			1			1		
6	E22 A89 303	VANE MOTOR	2	2	2	2	2	2	2	2	2	2	2	2	2	2	2	MV1, MV2	UP & DOWN, 1 PC/SET
7	E22 F95 308	ROOM TEMPERATURE THERMISTOR	1	1	1	1	1	1	1	1	1	1	1	1	1	1	1	RT11	
8	E22 F95 095	DISPLAY P.C. BOARD HOLDER	1	1	1	1	1	1	1	1	1	1	1	1	1	1	1		
9	E22 T21 375	TERMINAL BLOCK	1	1	1	1	1	1	1	1	1	1	1	1	1	1	1	TB	
10	E22 45L 452	ELECTRONIC CONTROL P.C. BOARD	1	1	1													Includes RECEIVER P.C. BOARD, DISPLAY P.C. BOARD and SWITCH P.C. BOARD.	
10	E22 51L 452	ELECTRONIC CONTROL P.C. BOARD				1	1	1											
10	E22 54L 452	ELECTRONIC CONTROL P.C. BOARD							1	1	1								
10	E22 57L 452	ELECTRONIC CONTROL P.C. BOARD										1	1	1					
10	E22 60L 452	ELECTRONIC CONTROL P.C. BOARD													1	1	1		
11	E22 45L 440	POWER P.C. BOARD	1	1	1	1	1	1	1	1	1	1	1	1					
11	E22 60L 440	POWER P.C. BOARD													1	1	1		
12	E22 F95 307	INDOOR COIL THERMISTOR	1	1	1	1	1	1	1	1	1	1	1	1	1	1	1	RT12,RT13	
13	E22 B75 385	VARISTOR	1	1	1	1	1	1	1	1	1	1	1	1	1	1	1	NR11	
14	E22 42J 382	FUSE	1	1	1	1	1	1	1	1	1	1	1	1	1	1	1	F11	T3.15AL250V
15	E22 45L 457	Wi-Fi INTERFACE MAC-577IF2-E	1	1	1	1	1	1	1	1	1	1	1	1	1	1	1		MAC-577IF2-E
16	E22 F95 784	V.A. CLAMP	1	1	1	1	1	1	1	1	1	1	1	1	1	1	1		
17	E22 45L 541	WATER CUT	1	1	1	1	1	1	1	1	1	1	1	1	1	1	1		
18	E22 29L 300	INDOOR FAN MOTOR	1	1	1	1	1	1	1	1	1	1	1	1	1	1	1	MF	RC0J40-□□ Includes FAN MOTOR RUBBER MOUNT (2 PCS/SET)
19	E22 F95 333	MOTOR BAND	1	1	1	1	1	1	1	1	1	1	1	1	1	1	1		
20	E22 F95 302	LINE FLOW FAN	1	1	1	1	1	1	1	1	1	1	1	1	1	1	1		

MSZ-EF22VGKW -ER1 MSZ-EF22VGKB -ER1 MSZ-EF22VGKS -ER1
MSZ-EF25VGKW -ER1 MSZ-EF25VGKB -ER1 MSZ-EF25VGKS -ER1
MSZ-EF35VGKW -ER1 MSZ-EF35VGKB -ER1 MSZ-EF35VGKS -ER1
MSZ-EF42VGKW -ER1 MSZ-EF42VGKB -ER1 MSZ-EF42VGKS -ER1
MSZ-EF50VGKW -ER1 MSZ-EF50VGKB -ER1 MSZ-EF50VGKS -ER1

1-40. INDOOR UNIT HEAT EXCHANGER

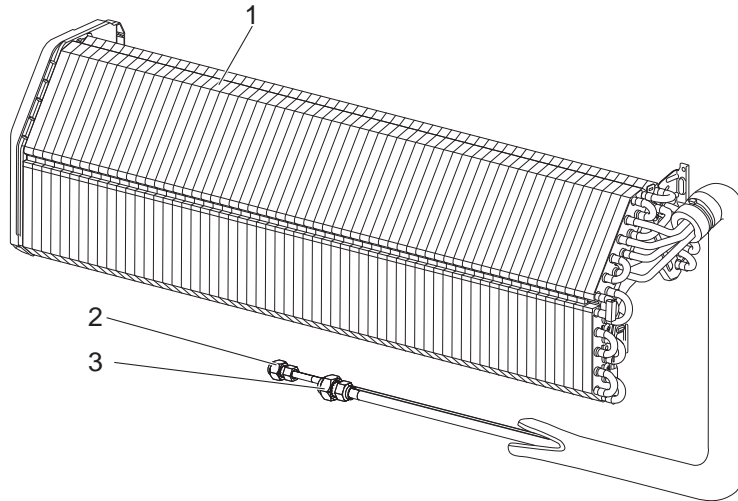



1-40. INDOOR UNIT HEAT EXCHANGER

1. The part quantity below indicates the required number of pieces per unit.

No.	Part No.	Part name	MSZ-EF22VGKW-ER1	MSZ-EF22VGKB-ER1	MSZ-EF22VGKS-ER1	MSZ-EF25VGKW-ER1	MSZ-EF25VGKB-ER1	MSZ-EF25VGKS-ER1	MSZ-EF35VGKW-ER1	MSZ-EF35VGKB-ER1	MSZ-EF35VGKS-ER1	MSZ-EF42VGKW-ER1	MSZ-EF42VGKB-ER1	MSZ-EF42VGKS-ER1	MSZ-EF50VGKW-ER1	MSZ-EF50VGKB-ER1	MSZ-EF50VGKS-ER1	Symbol in Wiring Diagram	Remarks
			1	1	1	1	1	1	1	1	1	1	1	1	1	1	1		
1	E22 F95 620	INDOOR HEAT EXCHANGER	1	1	1	1	1	1	1	1	1	1	1	1	1	1	1		
2	E22 151 667	UNION (LIQUID)	1	1	1	1	1	1	1	1	1	1	1	1	1	1	1		ø6.35
3	E22 815 666	UNION (GAS)	1	1	1	1	1	1	1	1	1	1	1	1	1	1	1		ø9.52

MSZ-EF22VGKW -ER2 MSZ-EF22VGKB -ER2 MSZ-EF22VGKS -ER2
MSZ-EF25VGKW -ER2 MSZ-EF25VGKB -ER2 MSZ-EF25VGKS -ER2
MSZ-EF35VGKW -ER2 MSZ-EF35VGKB -ER2 MSZ-EF35VGKS -ER2
MSZ-EF42VGKW -ER2 MSZ-EF42VGKB -ER2 MSZ-EF42VGKS -ER2
MSZ-EF50VGKW -ER2 MSZ-EF50VGKB -ER2 MSZ-EF50VGKS -ER2

1-41. INDOOR UNIT STRUCTURAL PARTS

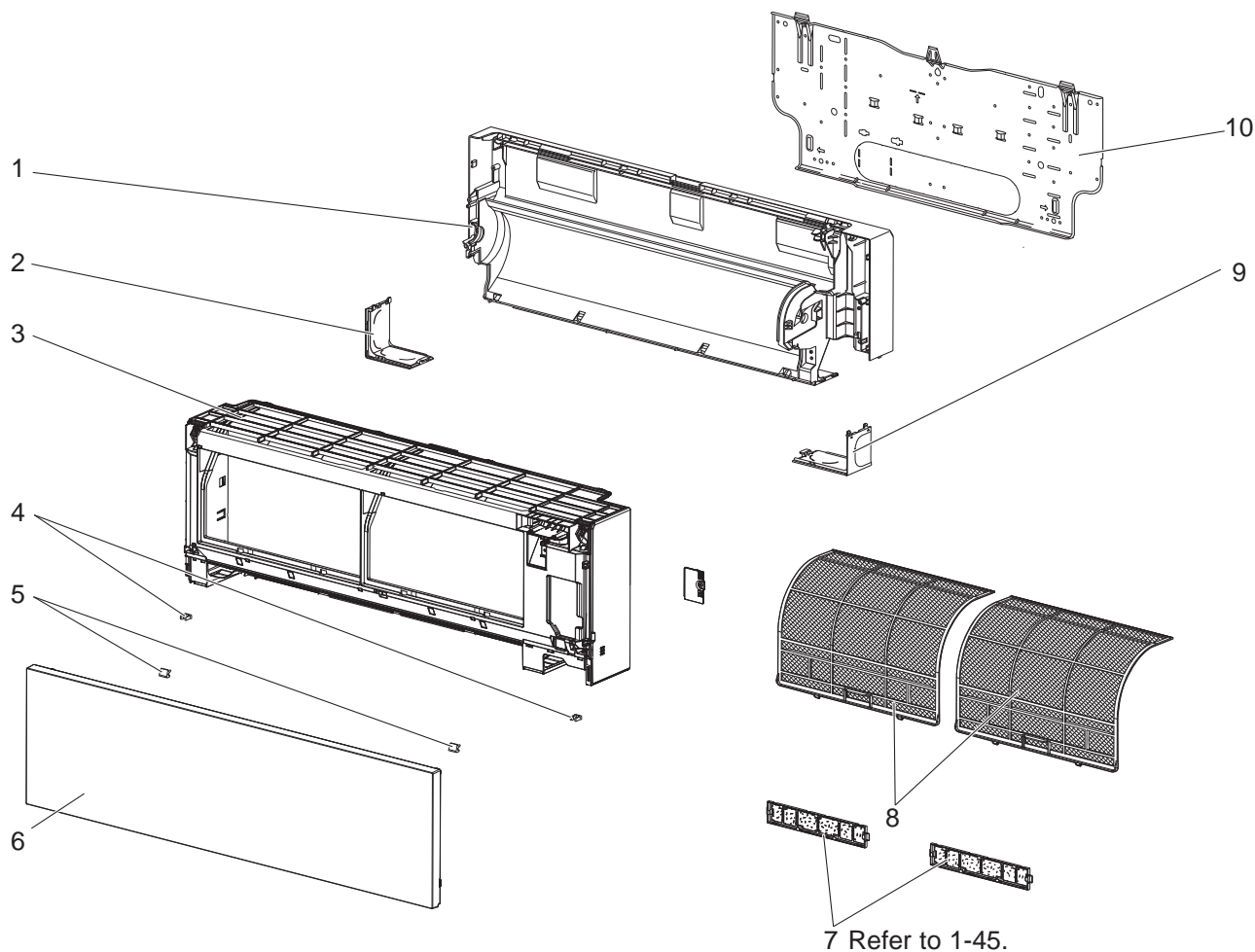

1-42. ACCESSORY AND REMOTE CONTROLLER

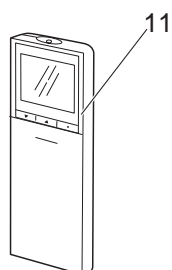

1-41. INDOOR UNIT STRUCTURAL PARTS

1. The part quantity below indicates the required number of pieces per unit.

No.	Part No.	Part name	MSZ-EF22VGKW-ER2	MSZ-EF22VGKB-ER2	MSZ-EF22VGKS-ER2	MSZ-EF25VGKW-ER2	MSZ-EF25VGKB-ER2	MSZ-EF25VGKS-ER2	MSZ-EF35VGKW-ER2	MSZ-EF35VGKB-ER2	MSZ-EF35VGKS-ER2	MSZ-EF42VGKW-ER2	MSZ-EF42VGKB-ER2	MSZ-EF42VGKS-ER2	MSZ-EF50VGKW-ER2	MSZ-EF50VGKB-ER2	MSZ-EF50VGKS-ER2	Symbol in Wiring Diagram	Remarks
1	E22 16H 234	BOX ASSEMBLY	1			1			1			1			1				
1	E22 G21 234	BOX ASSEMBLY		1			1			1			1			1			
1	E22 G26 234	BOX ASSEMBLY			1			1			1			1			1		
2	E22 16H 976	CORNER BOX LEFT	1			1			1			1			1				
2	E22 G21 976	CORNER BOX LEFT		1			1			1			1			1			
2	E22 G26 976	CORNER BOX LEFT			1			1			1			1			1		
3	E22 2C2 000	PANEL ASSEMBLY	1			1			1			1			1				Includes No.4 ,5, 6
3	E22 2C7 000	PANEL ASSEMBLY		1			1			1			1			1			Includes No.4 ,5, 6
3	E22 3C2 000	PANEL ASSEMBLY			1			1			1			1			1		Includes No.4 ,5, 6
4	E22 F95 142	CATCH	2	2	2	2	2	2	2	2	2	2	2	2	2	2	2		2 PCS/SET
5	E22 16H 067	SCREW CAP	2			2			2			2			2				2 PCS/SET
5	E22 G21 067	SCREW CAP		2			2			2			2			2			2 PCS/SET
5	E22 G26 067	SCREW CAP			2			2			2			2			2		2 PCS/SET
6	E22 16H 010	FRONT PANEL	1			1			1			1			1				
6	E22 T25 010	FRONT PANEL		1			1			1			1			1			
6	E22 T29 010	FRONT PANEL			1			1			1			1			1		
7	—	AIR CLEANING FILTER (SILVER-IONIZED AIR PURIFIER FILTER)	2	2	2	2	2	2	2	2	2	2	2	2	2	2	2		1 PC/SET
8	E22 16H 100	AIR FILTER (AIR PURIFYING FILTER)	2	2	2	2	2	2	2	2	2	2	2	2	2	2	2		1 PC/SET
9	E22 16H 975	CORNER BOX RIGHT	1			1			1			1			1				
9	E22 G21 975	CORNER BOX RIGHT		1			1			1			1			1			
9	E22 G26 975	CORNER BOX RIGHT			1			1			1			1			1		
10	E22 F95 970	INSTALLATION PLATE	1	1	1	1	1	1	1	1	1	1	1	1	1	1	1		

1-42. ACCESSORY AND REMOTE CONTROLLER

1. The part quantity below indicates the required number of pieces per unit.

No.	Part No.	Part name	MSZ-EF22VGKW-ER2	MSZ-EF22VGKB-ER2	MSZ-EF22VGKS-ER2	MSZ-EF25VGKW-ER2	MSZ-EF25VGKB-ER2	MSZ-EF25VGKS-ER2	MSZ-EF35VGKW-ER2	MSZ-EF35VGKB-ER2	MSZ-EF35VGKS-ER2	MSZ-EF42VGKW-ER2	MSZ-EF42VGKB-ER2	MSZ-EF42VGKS-ER2	MSZ-EF50VGKW-ER2	MSZ-EF50VGKB-ER2	MSZ-EF50VGKS-ER2	Symbol in Wiring Diagram	Remarks
11	E22 98M 426	REMOTE CONTROLLER	1			1			1			1			1				SG19A
11	E22 99M 426	REMOTE CONTROLLER		1	1		1	1		1	1		1	1		1	1		SG19B

MSZ-EF22VGKW -ER2 MSZ-EF22VGKB -ER2 MSZ-EF22VGKS -ER2
MSZ-EF25VGKW -ER2 MSZ-EF25VGKB -ER2 MSZ-EF25VGKS -ER2
MSZ-EF35VGKW -ER2 MSZ-EF35VGKB -ER2 MSZ-EF35VGKS -ER2
MSZ-EF42VGKW -ER2 MSZ-EF42VGKB -ER2 MSZ-EF42VGKS -ER2
MSZ-EF50VGKW -ER2 MSZ-EF50VGKB -ER2 MSZ-EF50VGKS -ER2

1-43. INDOOR UNIT ELECTRICAL PARTS AND FUNCTIONAL PARTS

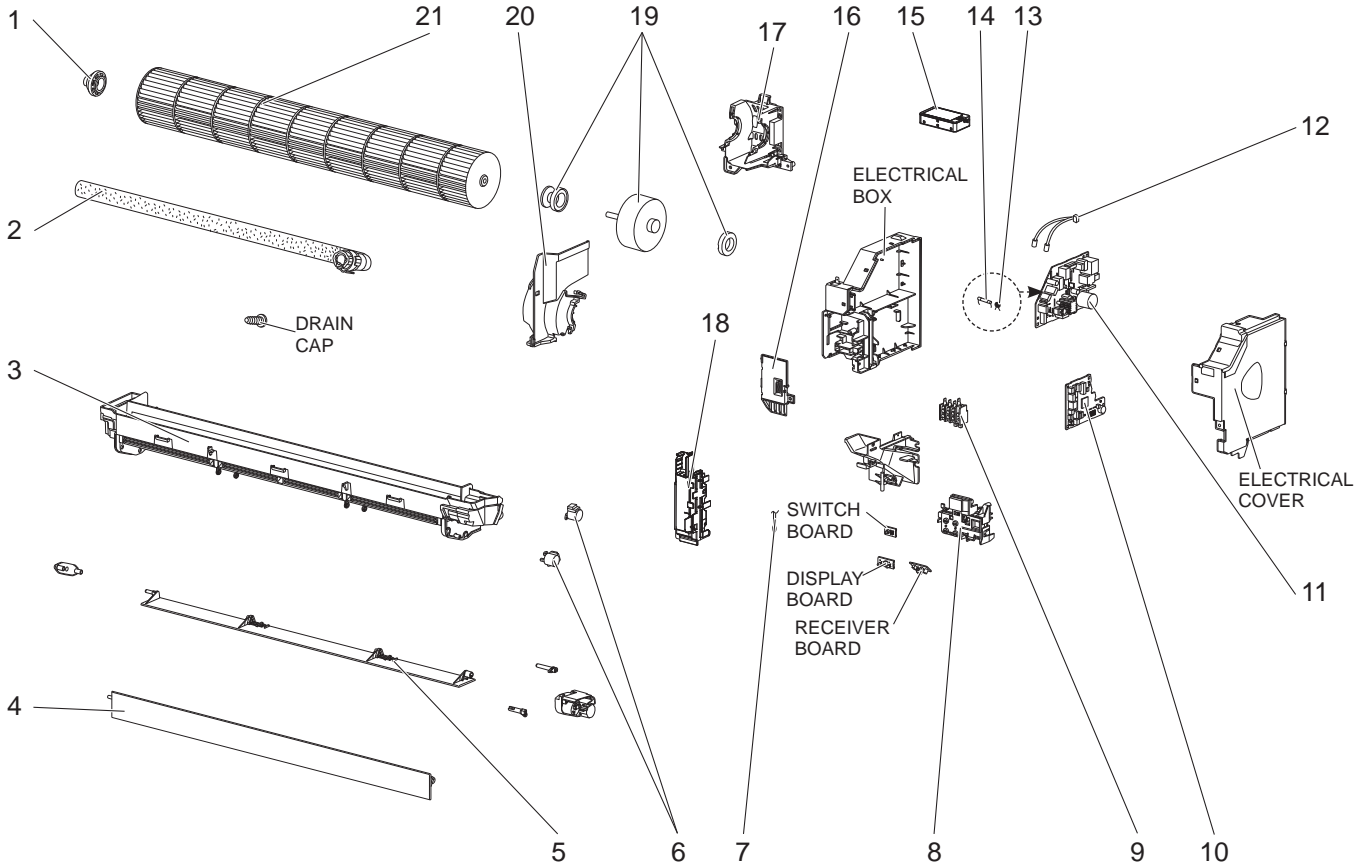

1-43. INDOOR UNIT ELECTRICAL PARTS AND FUNCTIONAL PARTS

1. The part quantity below indicates the required number of pieces per unit.

No.	Part No.	Part name	MSZ-EF22VGKW-ER2	MSZ-EF22VGKB-ER2	MSZ-EF22VGKS-ER2	MSZ-EF25VGKW-ER2	MSZ-EF25VGKB-ER2	MSZ-EF25VGKS-ER2	MSZ-EF35VGKW-ER2	MSZ-EF35VGKB-ER2	MSZ-EF35VGKS-ER2	MSZ-EF42VGKW-ER2	MSZ-EF42VGKB-ER2	MSZ-EF42VGKS-ER2	MSZ-EF50VGKW-ER2	MSZ-EF50VGKB-ER2	MSZ-EF50VGKS-ER2	Symbol in Wiring Diagram	Remarks
1	E22 A89 509	BEARING MOUNT ASSEMBLY	1	1	1	1	1	1	1	1	1	1	1	1	1	1	1		Includes Sleeve bearing
2	E22 P72 702	DRAIN HOSE	1	1	1	1	1	1	1	1	1	1	1	1	1	1	1		
3	E22 16H 235	NOZZLE ASSEMBLY	1			1			1			1			1			Full assembly except DRAIN HOSE	
3	E22 G21 235	NOZZLE ASSEMBLY		1			1			1			1			1			
3	E22 G26 235	NOZZLE ASSEMBLY			1			1			1			1			1		
4	E22 16H 040	VANE UPPER	1			1			1			1			1				
4	E22 G21 040	VANE UPPER		1			1			1			1			1			
4	E22 G26 040	VANE UPPER			1			1			1			1			1		
5	E22 16H 041	VANE LOWER	1			1			1			1			1				
5	E22 G21 041	VANE LOWER		1			1			1			1			1			
5	E22 G26 041	VANE LOWER			1			1			1			1			1		
6	E22 A89 303	VANE MOTOR	2	2	2	2	2	2	2	2	2	2	2	2	2	2	2	MV1, MV2	UP & DOWN, 1 PC/SET
7	E22 F95 308	ROOM TEMPERATURE THERMISTOR	1	1	1	1	1	1	1	1	1	1	1	1	1	1	1	RT11	
8	E22 F95 095	DISPLAY P.C. BOARD HOLDER	1	1	1	1	1	1	1	1	1	1	1	1	1	1	1		
9	E22 T21 375	TERMINAL BLOCK	1	1	1	1	1	1	1	1	1	1	1	1	1	1	1	TB	
10	E22 45X 452	ELECTRONIC CONTROL P.C. BOARD	1	1	1													Includes RECEIVER P.C. BOARD, DISPLAY P.C. BOARD and SWITCH P.C. BOARD.	
10	E22 51X 452	ELECTRONIC CONTROL P.C. BOARD				1	1	1											
10	E22 54X 452	ELECTRONIC CONTROL P.C. BOARD							1	1	1								
10	E22 57X 452	ELECTRONIC CONTROL P.C. BOARD										1	1	1					
10	E22 60X 452	ELECTRONIC CONTROL P.C. BOARD													1	1	1		
11	E22 45X 440	POWER P.C. BOARD	1	1	1	1	1	1	1	1	1	1	1	1					
11	E22 60X 440	POWER P.C. BOARD													1	1	1		
12	E22 F95 307	INDOOR COIL THERMISTOR	1	1	1	1	1	1	1	1	1	1	1	1	1	1	1	RT12,RT13	
13	E22 B75 385	VARISTOR	1	1	1	1	1	1	1	1	1	1	1	1	1	1	1	NR11	
14	E22 42J 382	FUSE	1	1	1	1	1	1	1	1	1	1	1	1	1	1	1	F11	T3.15AL250V
15	E22 45X 457	Wi-Fi INTERFACE MAC-577IF2-E	1	1	1	1	1	1	1	1	1	1	1	1	1	1	1		MAC-577IF2-E
16	E22 F95 784	V.A. CLAMP	1	1	1	1	1	1	1	1	1	1	1	1	1	1	1		
17	E22 45X 333	MOTOR BED	1	1	1	1	1	1	1	1	1	1	1	1	1	1	1		
18	E22 45L 541	WATER CUT	1	1	1	1	1	1	1	1	1	1	1	1	1	1	1		
19	E22 29L 300	INDOOR FAN MOTOR	1	1	1	1	1	1	1	1	1	1	1	1	1	1	1	MF	RC0J40-□□ Includes FAN MOTOR RUBBER MOUNT (2 PCS/SET)
20	E22 F95 333	MOTOR BAND	1	1	1	1	1	1	1	1	1	1	1	1	1	1	1		
21	E22 F95 302	LINE FLOW FAN	1	1	1	1	1	1	1	1	1	1	1	1	1	1	1		

MSZ-EF22VGKW -ER2 MSZ-EF22VGKB -ER2 MSZ-EF22VGKS -ER2
MSZ-EF25VGKW -ER2 MSZ-EF25VGKB -ER2 MSZ-EF25VGKS -ER2
MSZ-EF35VGKW -ER2 MSZ-EF35VGKB -ER2 MSZ-EF35VGKS -ER2
MSZ-EF42VGKW -ER2 MSZ-EF42VGKB -ER2 MSZ-EF42VGKS -ER2
MSZ-EF50VGKW -ER2 MSZ-EF50VGKB -ER2 MSZ-EF50VGKS -ER2

1-44. INDOOR UNIT HEAT EXCHANGER

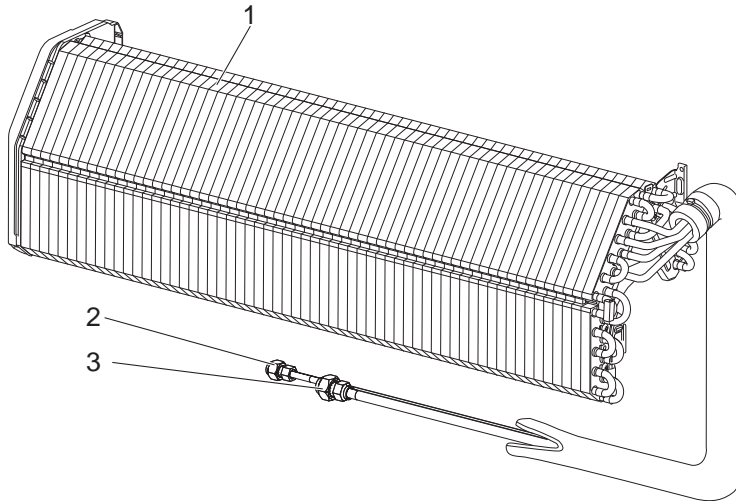

1-44. INDOOR UNIT HEAT EXCHANGER

1. The part quantity below indicates the required number of pieces per unit.

No.	Part No.	Part name	MSZ-EF22VGKW-ER2	MSZ-EF22VGKB-ER2	MSZ-EF22VGKS-ER2	MSZ-EF25VGKW-ER2	MSZ-EF25VGKB-ER2	MSZ-EF25VGKS-ER2	MSZ-EF35VGKW-ER2	MSZ-EF35VGKB-ER2	MSZ-EF35VGKS-ER2	MSZ-EF42VGKW-ER2	MSZ-EF42VGKB-ER2	MSZ-EF42VGKS-ER2	MSZ-EF50VGKW-ER2	MSZ-EF50VGKB-ER2	MSZ-EF50VGKS-ER2	Symbol in Wiring Diagram	Remarks
			1	1	1	1	1	1	1	1	1	1	1	1	1	1	1		
1	E22 F95 620	INDOOR HEAT EXCHANGER	1	1	1	1	1	1	1	1	1	1	1	1	1	1	1		
2	E22 151 667	UNION (LIQUID)	1	1	1	1	1	1	1	1	1	1	1	1	1	1	1		ø6.35
3	E22 815 666	UNION (GAS)	1	1	1	1	1	1	1	1	1	1	1	1	1	1	1		ø9.52

1-45. AIR CLEANING FILTER (Silver-ionized air purifier filter)

Every 3 months:

- Remove dirt by a vacuum cleaner.

When dirt cannot be removed by vacuum cleaning:

- Soak the filter and its frame in lukewarm water before rinsing it.
- After washing, dry it well in shade. Install all tabs of the air filter.

Every year:

- Replace it with a new air cleaning filter for best performance.

NOTE 1: Clean the filters regularly for best performance and to reduce power consumption.

NOTE 2: Dirty filters cause condensation in the air conditioner which will contribute to the growth of fungi such as mold. It is therefore recommended to clean air filters every 2 weeks.

SILVER-IONIZED AIR PURIFIER FILTER

Model		Part No.
MSZ-EF18VGW	MSZ-EF35VGW	MAC-2340FT-E
MSZ-EF18VGB	MSZ-EF35VGB	
MSZ-EF18VGS	MSZ-EF35VGS	
MSZ-EF22VGW	MSZ-EF42VGW	
MSZ-EF22VGB	MSZ-EF42VGB	
MSZ-EF22VGS	MSZ-EF42VGS	
MSZ-EF25VGW	MSZ-EF50VGW	
MSZ-EF25VGB	MSZ-EF50VGB	
MSZ-EF25VGS	MSZ-EF50VGS	
MSZ-EF18VGKW	MSZ-EF35VGKW	
MSZ-EF18VGKB	MSZ-EF35VGKB	
MSZ-EF18VGKS	MSZ-EF35VGKS	
MSZ-EF22VGKW	MSZ-EF42VGKW	
MSZ-EF22VGKB	MSZ-EF42VGKB	
MSZ-EF22VGKS	MSZ-EF42VGKS	
MSZ-EF25VGKW	MSZ-EF50VGKW	
MSZ-EF25VGKB	MSZ-EF50VGKB	
MSZ-EF25VGKS	MSZ-EF50VGKS	

Pull to remove from the air filter

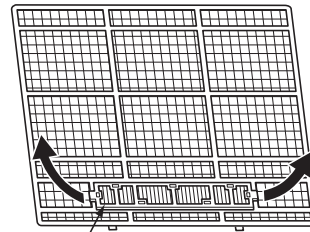

Air cleaning filter
(Silver-ionized air purifier filter)

V BLOCKING FILTER

Model		Part No.
MSZ-EF18VGW	MSZ-EF35VGW	MAC-2470FT-E
MSZ-EF18VGB	MSZ-EF35VGB	
MSZ-EF18VGS	MSZ-EF35VGS	
MSZ-EF22VGW	MSZ-EF42VGW	
MSZ-EF22VGB	MSZ-EF42VGB	
MSZ-EF22VGS	MSZ-EF42VGS	
MSZ-EF25VGW	MSZ-EF50VGW	
MSZ-EF25VGB	MSZ-EF50VGB	
MSZ-EF25VGS	MSZ-EF50VGS	
MSZ-EF18VGKW	MSZ-EF35VGKW	
MSZ-EF18VGKB	MSZ-EF35VGKB	
MSZ-EF18VGKS	MSZ-EF35VGKS	
MSZ-EF22VGKW	MSZ-EF42VGKW	
MSZ-EF22VGKB	MSZ-EF42VGKB	
MSZ-EF22VGKS	MSZ-EF42VGKS	
MSZ-EF25VGKW	MSZ-EF50VGKW	
MSZ-EF25VGKB	MSZ-EF50VGKB	
MSZ-EF25VGKS	MSZ-EF50VGKS	

2

OPTIONAL PARTS

2-1. SOFT DRY CLOTH

- Clean the panel with the soft dry cloth when it is dirty.

Model		Part No.
MSZ-EF18VGW	MSZ-EF35VGW	MAC-1001CL-E
MSZ-EF18VGS	MSZ-EF35VGS	
MSZ-EF22VGW	MSZ-EF42VGW	
MSZ-EF22VGS	MSZ-EF42VGS	
MSZ-EF25VGW	MSZ-EF50VGW	
MSZ-EF25VGS	MSZ-EF50VGS	
MSZ-EF18VGKW	MSZ-EF35VGKW	
MSZ-EF18VGKS	MSZ-EF35VGKS	
MSZ-EF22VGKW	MSZ-EF42VGKW	
MSZ-EF22VGKS	MSZ-EF42VGKS	
MSZ-EF25VGKW	MSZ-EF50VGKW	
MSZ-EF25VGKS	MSZ-EF50VGKS	

2-2. REMOTE CONTROLLER HOLDER

Model		Part No.
MSZ-EF18VGW	MSZ-EF35VGW	MAC-1300RC-E
MSZ-EF18VGB	MSZ-EF35VGB	
MSZ-EF18VGS	MSZ-EF35VGS	
MSZ-EF22VGW	MSZ-EF42VGW	
MSZ-EF22VGB	MSZ-EF42VGB	
MSZ-EF22VGS	MSZ-EF42VGS	
MSZ-EF25VGW	MSZ-EF50VGW	
MSZ-EF25VGB	MSZ-EF50VGB	
MSZ-EF25VGS	MSZ-EF50VGS	
MSZ-EF18VGKW	MSZ-EF35VGKW	
MSZ-EF18VGKB	MSZ-EF35VGKB	
MSZ-EF18VGKS	MSZ-EF35VGKS	
MSZ-EF22VGKW	MSZ-EF42VGKW	
MSZ-EF22VGKB	MSZ-EF42VGKB	
MSZ-EF22VGKS	MSZ-EF42VGKS	
MSZ-EF25VGKW	MSZ-EF50VGKW	
MSZ-EF25VGKB	MSZ-EF50VGKB	
MSZ-EF25VGKS	MSZ-EF50VGKS	

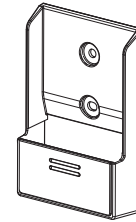

MITSUBISHI ELECTRIC CORPORATION

HEAD OFFICE: TOKYO BUILDING, 2-7-3, MARUNOUCHI, CHIYODA-KU, TOKYO 100-8310, JAPAN

© Copyright 2019 MITSUBISHI ELECTRIC CORPORATION

Issued: Nov. 2022. No. OBB831 REVISED EDITION-C

Issued: Jun. 2020. No. OBB831 REVISED EDITION-B

Issued: Jan. 2020. No. OBB831 REVISED EDITION-A

Published: Mar. 2019. No. OBB831

Made in Japan

Specifications are subject to change without notice.