

Air-cooled Chilling Unit

e-series

DATA BOOK

MODEL

EAHV-P900YAF(-N)(-BS)

EAHV-P900YAF-H(-N)(-BS)

EACV-P900YAF(-N)(-BS)

EAHV-P900YAL(-N)(-BS)

EAHV-P900YAL-H(-N)(-BS)

EACV-P900YAL(-N)(-BS)

CONTENTS

EAHV-P-YAF(-H)(-N), EAHV-P-YAL(-H)(-N)/EACV-P-YAF(-N), EACV-P-YAL(-N)

1. Product Specifications	2
1-1. Specifications.....	2
1-2. External Dimensions.....	5
1-3. Center of Gravity.....	12
1-4. Electrical Wiring Diagrams.....	14
1-5. Optional parts	19
2. Product Data	22
2-1. Capacity tables	22
2-2. Sound pressure levels	138
2-3. Vibration levels	151
2-4. Salt Protection Specifications	152
3. Installation.....	153
3-1. Selecting the Installation Site.....	153
3-2. Unit Installation	158
4. System Design.....	160
4-1. Water Pipe Installation	160
5. Wiring Design.....	168
5-1. System Configurations.....	168
5-2. Electrical Wiring Installation.....	186
6. Controller	189
6-1. PAR-W21MAA specifications	189
6-2. PAR-W31MAA specifications	190

1. Product Specifications

1-1. Specifications

Model		EAHV-P900YAL(-N)(-BS), EAHV-P900YAF(-N)(-BS)			
Power source		3-phase 4-wire 380-400-415V 50/60Hz			
Capacity change mode		Capacity priority	COP priority		
Cooling capacity *1*2	kW	90.00	63.00		
		kcal/h	77,400	54,180	
		BTU/h	307,080	214,956	
	Power input *5	kW	27.27	16.27	
		Current input 380-400-415V	A	46.0-43.7-42.2	27.5-26.1-25.2
	EER (Pump input is not included)		3.30	3.87	
	EER (Includes pump input based on EN14511) *6		3.08	3.76	
	SEER (Includes pump input based on EN14511) *6		4.88	-	
	ηsc		%	192.0	-
	IPLV *7		kW/kW	6.34	-
Water flow rate		m ³ /h	15.5	10.8	
Heating capacity *3*4	kW	90.00	63.00		
		kcal/h	77,400	54,180	
		BTU/h	307,080	214,956	
	Power input *5	kW	25.71	16.96	
		Current input 380-400-415V	A	43.4-41.2-39.7	28.6-27.2-26.2
	COP (Pump input is not included)		3.50	3.71	
	COP (Includes pump input based on EN14511) *6		3.25	3.61	
	SCOP (Reversible) Low/Medium (Includes pump input based on EN14511) *6		3.66/2.89	-	
	ηsh Low/Medium		%	143.0/113.0	-
	Water flow rate		m ³ /h	15.5	10.8
Maximum current input		A	61		
Water pressure drop *1		kPa	135	65	
Temp range	Cooling	°C	Outlet water 5-25 *9		
		°F	Outlet water 41-77 *9		
	Heating	°C	Outlet water 30-55 *9		
		°F	Outlet water 86-131 *9		
	Outdoor	°C	-15-43 *9		
		°F	5-109.4 *9		
Circulating water volume range		m ³ /h	7.7-25.8		
Sound pressure level (measured in anechoic room) at 1m *1		dB (A)	65	63	
Sound power level (measured in anechoic room) *1		dB (A)	77	75	
Diameter of water pipe (Standard piping)	Inlet	mm (in)	50A (2B) housing type joint		
	Outlet	mm (in)	50A (2B) housing type joint		
Diameter of water pipe (Inside header piping)	Inlet	mm (in)	100A (4B) housing type joint		
	Outlet	mm (in)	100A (4B) housing type joint		
External finish		Polyester powder coating steel plate			
External dimension H × W × D		mm	2450 × 2250 × 900		
Net weight	Standard piping	kg (lbs)	987 (2176)		
	Inside header piping	kg (lbs)	1022 (2253)		
Design pressure	R410A	MPa	4.15		
	Water	MPa	1.0		
Heat exchanger	Water side	Stainless steel plate and copper brazing			
	Air side	Plate fin and copper tube			
Compressor	Type	Inverter scroll hermetic compressor			
	Maker	MITSUBISHI ELECTRIC CORPORATION			
	Starting method	Inverter			
	Quantity	2			
	Motor output	kW	11.7 × 2		
	Case heater	kW	0.045 × 2		
Fan	Air flow rate	m ³ /min	77 × 6		
		L/s	1283 × 6		
		cfm	2719 × 6		
	Type, Quantity	Propeller fan × 6			
	Starting method	Inverter			
	Motor output	kW	0.19 × 6		
Protection	High pressure protection	High pressure sensor & High pressure switch at 4.15MPa (601psi)			
	Inverter circuit	Over-heat protection, Over current protection			
	Compressor	Over-heat protection			
Refrigerant	Type × charge	R410A × 19(kg) × 2 *8			
	Control	LEV			

Notes:	Unit converter
*1 Under normal cooling conditions at outdoor temp 35°C D.B./24°C W.B.(95°F D.B./75.2°F W.B.) outlet water temp 7°C(44.6°F) inlet water temp 12°C(53.6°F).	kcal/h = kW × 860
*2 Under normal cooling conditions at outdoor temp 35°C D.B./24°C W.B.(95°F D.B./75.2°F W.B.) outlet water temp 7°C(44.6°F) inlet water temp 12°C(53.6°F). Pump input is included in cooling capacity and power input based on EN14511.	BTU/h = kW × 3,412
*3 Under normal heating conditions at outdoor temp 7°C D.B./6°C W.B.(44.6°F D.B./42.8°F W.B.) outlet water temp 45°C(113°F) inlet water temp 40°C(104°F).	lbs = kg/0.4536
*4 Under normal heating conditions at outdoor temp 7°C D.B./6°C W.B.(44.6°F D.B./42.8°F W.B.) outlet water temp 45°C(113°F) inlet water temp 40°C(104°F). Pump input is included in heating capacity and power input based on EN14511.	cfm = m ³ /min × 35.31
*5 Pump input is not included.	
*6 Pump is not included in e-series.	
*7 Calculations according to standard performances (in accordance with AHRI 551-591).	
*8 The factory charged amount of refrigerant for EAHV-P900YAL(-N)(-BS) model is 5.95(kg)×2.	
*Please don't use the steel material for the water piping.	
*Please always make water circulate, or pull the circulation water out completely when not in use.	
*Please do not use groundwater or well water in direct.	
*The water circuit must be closed circuit.	
*Due to continuous improvement, the above specifications may be subject to change without notice.	
*9 Please refer to 2-1-7. Operation temperature range.	

EAHV-P-YAF(-H)(-N), YAL(-H)(-N)/EACV-P-YAF(-N), YAL(-N)

1. Product Specifications

Model		EAHV-P900YAL-H(-N)(-BS), EAHV-P900YAF-H(-N)(-BS)		
Power source		3-phase 4-wire 380-400-415V 50/60Hz		
Capacity change mode		Capacity priority	COP priority	
Heating capacity *1*2	kW	90.00	63.00	
	kcal/h	77,400	54,180	
	BTU/h	307,080	214,956	
	Power input *3	kW	25.71	16.96
	Current input 380-400-415V	A	43.4-41.2-39.7	28.6-27.2-26.2
	COP (Pump input is not included)		3.50	3.71
	COP (Includes pump input based on EN14511) *4		3.25	3.61
	SCOP (Reversible) Low/Medium (Includes pump input based on EN14511) *4		3.56/2.83	-
	ηsh Low/Medium	%	139.0/110.0	-
	Water flow rate	m ³ /h	15.5	10.8
Maximum current input	A	61		
Water pressure drop *1	kPa	135	65	
Temp range	Heating	°C	Outlet water 30-55 *6	
		°F	Outlet water 86-131 *6	
	Outdoor	°C	-15-43 *6	
		°F	5-109.4 *6	
Circulating water volume range		m ³ /h	7.7-25.8	
Sound pressure level (measured in anechoic room) at 1m *1		dB (A)	65	63
Sound power level (measured in anechoic room) *1		dB (A)	77	75
Diameter of water pipe (Standard piping)	Inlet	mm (in)	50A (2B) housing type joint	
	Outlet	mm (in)	50A (2B) housing type joint	
Diameter of water pipe (Inside header piping)	Inlet	mm (in)	100A (4B) housing type joint	
	Outlet	mm (in)	100A (4B) housing type joint	
External finish		Polyester powder coating steel plate		
External dimension H × W × D		mm	2450 × 2250 × 900	
Net weight	Standard piping	kg (lbs)	987 (2176)	
	Inside header piping	kg (lbs)	1022 (2253)	
Design pressure	R410A	MPa	4.15	
	Water	MPa	1.0	
Heat exchanger	Water side	Stainless steel plate and copper brazing		
	Air side	Plate fin and copper tube		
Compressor	Type	Inverter scroll hermetic compressor		
	Maker	MITSUBISHI ELECTRIC CORPORATION		
	Starting method	Inverter		
	Quantity	2		
	Motor output	kW	11.7 × 2	
	Case heater	kW	0.045 × 2	
	Lubricant	MEL32		
Fan	Air flow rate	m ³ /min	77 × 6	
		L/s	1283 × 6	
		cfm	2719 × 6	
	Type, Quantity	Propeller fan × 6		
	Starting method	Inverter		
Motor output	kW	0.19 × 6		
Protection	High pressure protection	High pressure sensor & High pressure switch at 4.15MPa (601psi)		
	Inverter circuit	Over-heat protection, Over current protection		
	Compressor	Over-heat protection		
Refrigerant	Type × charge	R410A × 19(kg) × 2 *5		
	Control	LEV		

Notes:	Unit converter
*1 Under normal heating conditions at outdoor temp 7°C D.B./6°C W.B.(44.6°F D.B./42.8°F W.B.) outlet water temp 45°C(113°F) inlet water temp 40°C(104°F).	kcal/h = kW × 860
*2 Under normal heating conditions at outdoor temp 7°C D.B./6°C W.B.(44.6°F D.B./42.8°F W.B.) outlet water temp 45°C(113°F) inlet water temp 40°C(104°F). Pump input is included in heating capacity and power input based on EN14511.	BTU/h = kW × 3,412
*3 Pump input is not included.	lbs = kg/0.4536
*4 Pump is not included in e-series.	cfm = m ³ /min × 35.31
*5 The factory charged amount of refrigerant for EAHV-P900YAL-H(-N)(-BS) model is 5.95(kg)×2.	
*Please don't use the steel material for the water piping material.	
*Please always make water circulate, or pull the circulation water out completely when not in use.	
*Please do not use groundwater or well water in direct.	
*The water circuit must be closed circuit.	
*Due to continuous improvement, the above specifications may be subject to change without notice.	
*6 Please refer to 2-1-7. Operation temperature range.	

1. Product Specifications

EAHV-P-YAF(-H)(-N), YAL(-H)(-N)/EACV-P-YAF(-N), YAL(-N)

Model		EACV-P900YAL(-N)(-BS), EACV-P900YAF(-N)(-BS)		
Power source		3-phase 4-wire 380-400-415V 50/60Hz		
Capacity change mode		Capacity priority	COP priority	
Cooling capacity *1*2 Water	kW	90.00	63.00	
	kcal/h	77,400	54,180	
	BTU/h	307,080	214,956	
	Power input *3	kW	27.27	16.27
	Current input 380-400-415V	A	46.0-43.7-42.2	27.5-26.1-25.2
	EER (Pump input is not included)		3.30	3.87
	EER (Includes pump input based on EN14511) *4		3.08	3.76
	SEER (Includes pump input based on EN14511) *4		4.88	-
	ηsc		%	192.0
	IPLV *5		kW/kW	6.34
	Water flow rate		m ³ /h	15.5
	Cooling capacity *6*7 Brine (ethylene glycol 35wt%)		kW	56.73
		kcal/h	48,788	
		BTU/h	193,563	
Power input *3		kW	25.98	
Current input 380-400-415V		A	43.9-41.7-40.2	
EER (Pump input is not included)		2.18	2.49	
EER (Includes pump input based on EN14511) *4		2.10	2.42	
Brine flow rate		m ³ /h	11.5	
Maximum current input		A	61	
Water pressure drop	Water *1	kPa	135	
	Brine (ethylene glycol 35wt%) *6*7	kPa	106	
Temp range	Cooling	°C	Outlet water 5-25 *9	
	Water	°F	Outlet water 41-77 *9	
	Cooling	°C	Outlet brine -10-25 *7*10	
	Brine (ethylene glycol 35wt%)	°F	Outlet brine 14-77 *7*10	
	Outdoor	°C	-15-43 *9*10	
		°F	5-109.4 *9*10	
Circulating water volume range		m ³ /h	7.7-25.8	
Sound pressure level (measured in anechoic room) at 1m *1		dB (A)	65	
Sound power level (measured in anechoic room) *1		dB (A)	77	
Diameter of water pipe (Standard piping)	Inlet	mm (in)	50A (2B) housing type joint	
	Outlet	mm (in)	50A (2B) housing type joint	
Diameter of water pipe (Inside header piping)	Inlet	mm (in)	100A (4B) housing type joint	
	Outlet	mm (in)	100A (4B) housing type joint	
External finish		Polyester powder coating steel plate		
External dimension H × W × D		mm	2450 × 2250 × 900	
Net weight	Standard piping	kg (lbs)	957 (2110)	
	Inside header piping	kg (lbs)	992 (2187)	
Design pressure	R410A	MPa	4.15	
	Water	MPa	1.0	
Heat exchanger	Water side	Stainless steel plate and copper brazing		
	Air side	Plate fin and copper tube		
Compressor	Type	Inverter scroll hermetic compressor		
	Maker	MITSUBISHI ELECTRIC CORPORATION		
	Starting method	Inverter		
	Quantity	2		
	Motor output	kW	11.7 × 2	
	Case heater	kW	0.045 × 2	
	Lubricant	MEL32		
Fan	Air flow rate	m ³ /min	77 × 6	
		L/s	1283 × 6	
		cfm	2719 × 6	
	Type, Quantity	Propeller fan × 6		
	Starting method	Inverter		
Motor output	kW	0.19 × 6		
Protection	High pressure protection	High pressure sensor & High pressure switch at 4.15MPa (601psi)		
	Inverter circuit	Over-heat protection, Over current protection		
	Compressor	Over-heat protection		
Refrigerant	Type × charge	R410A × 19(kg) × 2 *8		
	Control	LEV		

Notes:	Unit converter
*1 Under normal cooling conditions at outdoor temp 35°CDB./24°CWB.(95°FDB./75.2°FWB.) outlet water temp 7°C(44.6°F) inlet water temp 12°C(53.6°F).	kcal/h = kW × 860
*2 Under normal cooling conditions at outdoor temp 35°CDB./24°CWB.(95°FDB./75.2°FWB.) outlet water temp 7°C(44.6°F) inlet water temp 12°C(53.6°F). Pump input is included in cooling capacity and power input based on EN14511.	BTU/h = kW × 3,412
*3 Pump input is not included.	lbs = kg/0.4536
*4 Pump is not included in e-series.	cfm = m ³ /min × 35.31
*5 Calculations according to standard performances (in accordance with AHRI 551-591).	
*6 Under normal cooling conditions at outdoor temp 35°CDB/24°CWB(95°FDB/75.2°FWB) outlet brine temp -5°C(23.0°F) inlet brine temp 0°C(32.0°F).	
*7 Set the DipSW3-6 on both main and sub modules to ON.	
*8 The factory charged amount of refrigerant for EACV-P900YAL(-N)(-BS) model is 5.95(kg)×2.	
*Please don't use the steel material for the water piping.	
*Please always make water circulate, or pull the circulation water out completely when not in use.	
*Please do not use groundwater or well water in direct.	
*The water circuit must be closed circuit.	
*Due to continuous improvement, the above specifications may be subject to change without notice.	
*9 Please refer to 2-1-7. Operation temperature range.	
*10 Please refer to 2-1-7. Operation temperature range.	

1. Product Specifications

EAHV-P-YAF(-H)(-N), YAL(-H)(-N)/EACV-P-YAF(-N), YAL(-N)

EAHV-P900YAF(-H)-N(-BS), EAHV-P900YAL(-H)-N(-BS) EACV-P900YAF-N(-BS), EACV-P900YAL-N(-BS)

Unit: mm

<Field-supplied>
Please install a field supplied 100A strainer (20 mesh or more) near the water inlet.

①	NAME	CONNECTION TYPE
①	Water inlet	100A housing type joint (field-supplied Victaulic joint)*
②	Water outlet	100A housing type joint (field-supplied Victaulic joint)*
③	Drain piping	R1 male×3
④	Holes for wires	Power supply(φ52×1), Signal(φ28×2)

*Victaulic Standard groove specifications
Machine grooves to secure housing joints to field-supplied pipes based on the following dimensions.

Pipe size	100A
D	φ114.3 ^{+1.14} ₀
G	φ110.08 ^{+0.51} ₀
L	15.88±0.76
W	9.53±0.76

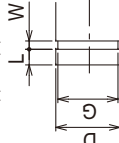

This space is for the end of multiple continuous installation units or 1 unit. It is not required between units continuous installation.

<INSIDE HEADER PIPING TYPE>

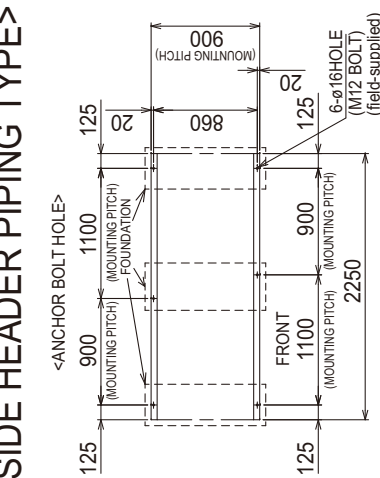

<PLAN> SERVICE SPACE (Case of leftside piping)

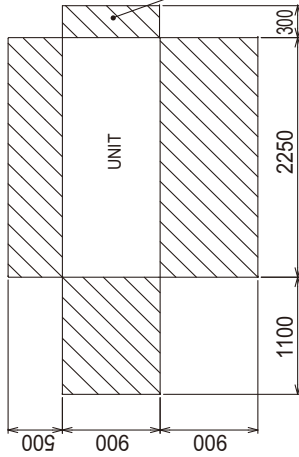

PIPE (field-supplied)
(Case of left side piping)

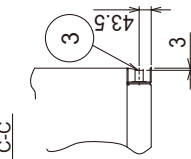
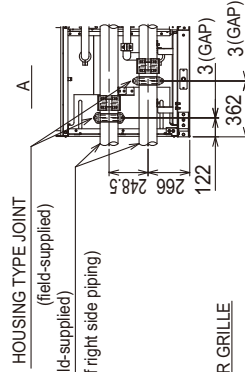
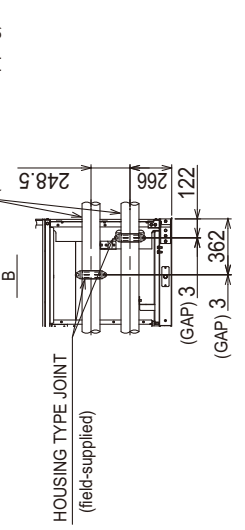

C-C

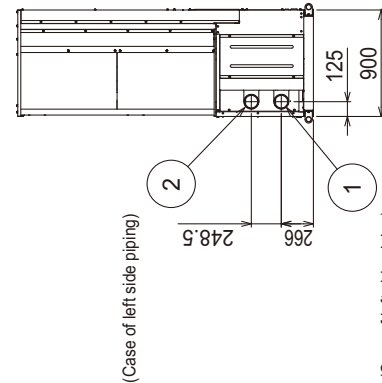
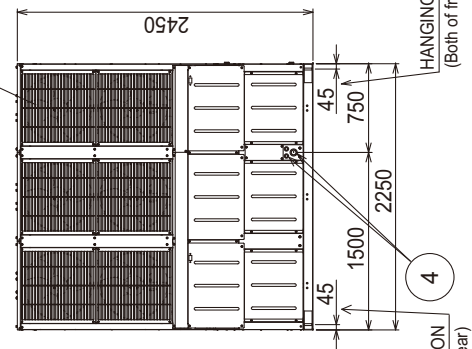
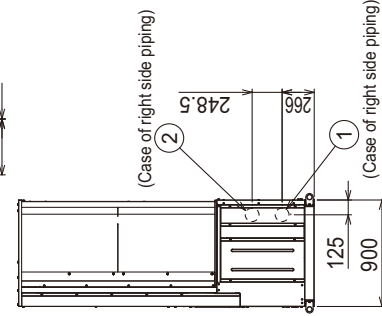
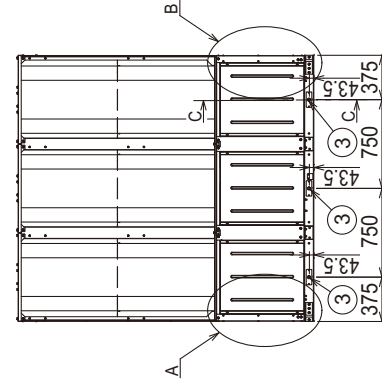
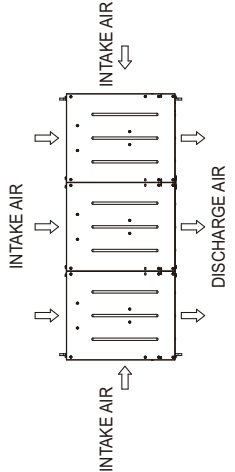

Please refer to the installation manual provided with the unit when installing the unit.
The specification of the product might be changed without a previous notice for the improvement.

1. Product Specifications

EAHV-P900YAF(-H)-N(-BS) × 2, EAHV-P900YAL(-H)-N(-BS) × 2
 EACV-P900YAF-N(-BS) × 2, EACV-P900YAL-N(-BS) × 2

Unit: mm

<INSIDE HEADER PIPING TYPE>

<PLAN>
 SERVICE SPACE
 (Case of left side piping)

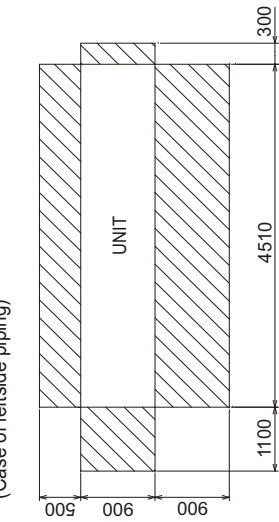

<Field-supplied>
 Please install a field supplied 100A strainer (20 mesh or more) near the water inlet.

NAME	CONNECTION TYPE
① Water inlet	100A housing type joint (field-supplied /craucalc joint)*
② Water outlet	100A housing type joint (field-supplied /craucalc joint)*
③ Drain piping	R1 male×3×2
④ Holes for wires	Power supply(φ52×1)×2, Signal(φ28×2)×2

*Vitrucalc Standard groove specifications
 Machine grooves to secure housing joints to field-supplied pipes based on the following dimensions.

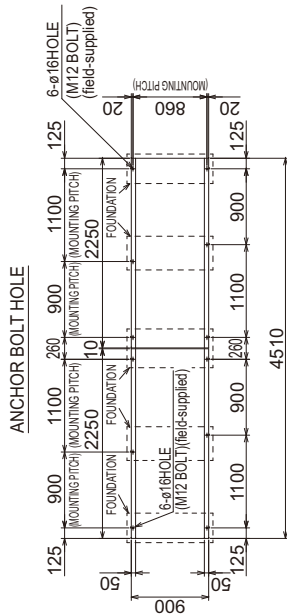
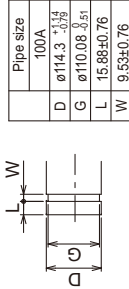

FRONT

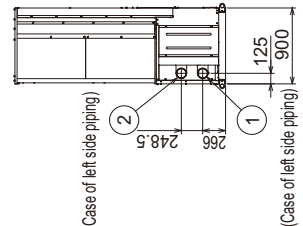
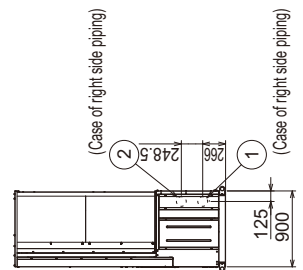
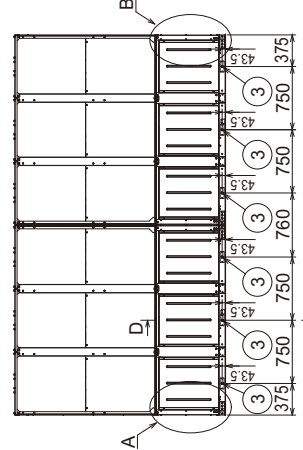
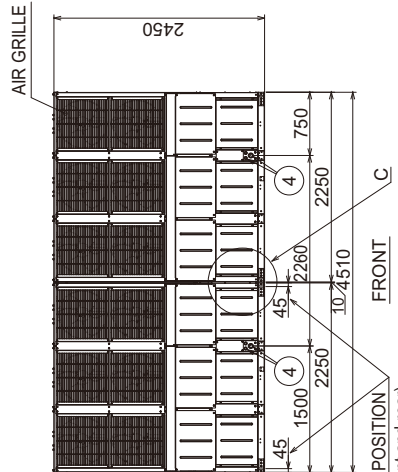
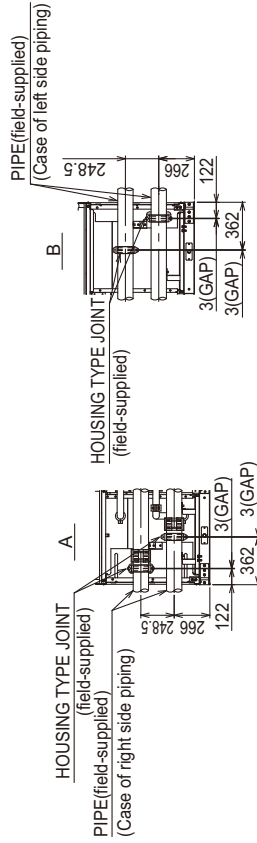
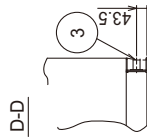
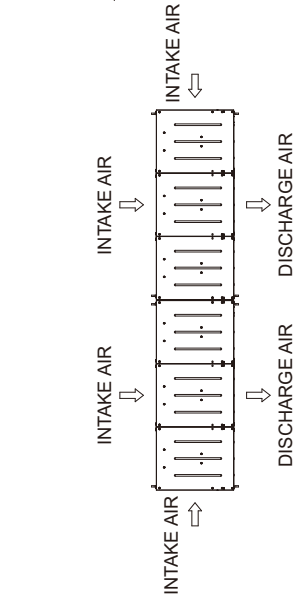
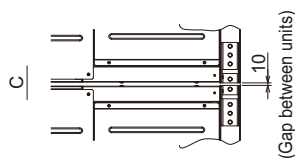

Please refer to the installation manual provided with the unit when installing the unit.
 The specification of the product might be changed without a previous notice for the improvement.

EAHV-P-YAF(-H)-N, YAL(-H)-N/EACV-P-YAF(-N), YAL(-N)

1. Product Specifications

1-3. Center of Gravity

Standard piping type

Unit: mm

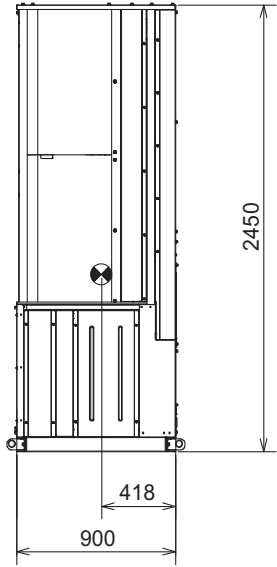

Left side

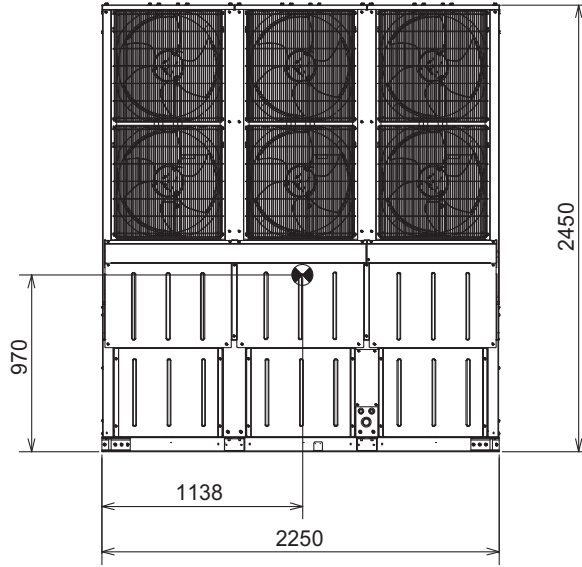

Service side

Inside header piping type

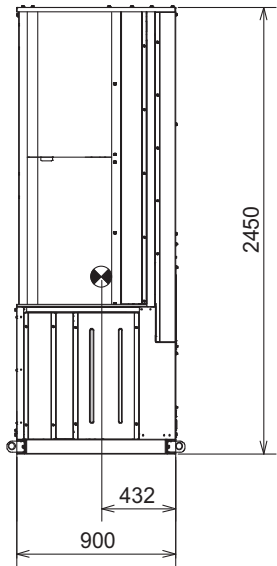

Left side

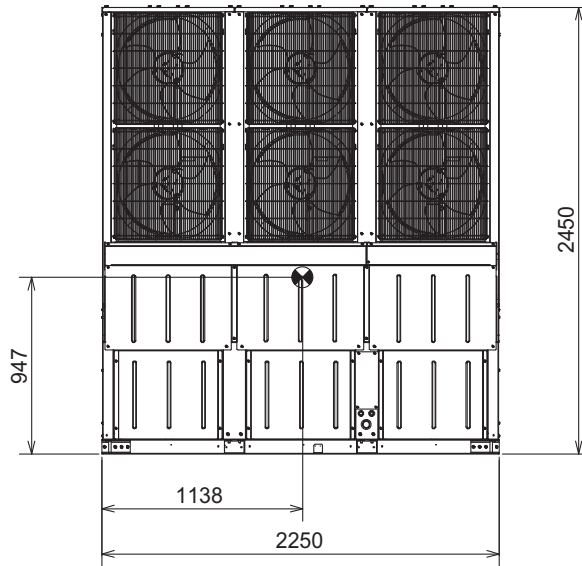

Service side

EAHV-P-YAF(-H)(-N), YAL(-H)(-N)/EACV-P-YAF(-N), YAL(-N)

1. Product Specifications

1-4. Electrical Wiring Diagrams

EAHV-P900YAF(-H)(-N)(-BS), EAHV-P900YAL(-H)(-N)(-BS)
 EACV-P900YAF(-N)(-BS), EACV-P900YAL(-N)(-BS)

EAHV-P-YAF(-H)(-N), YAL(-H)(-N)/EACV-P-YAF(-N), YAL(-N)

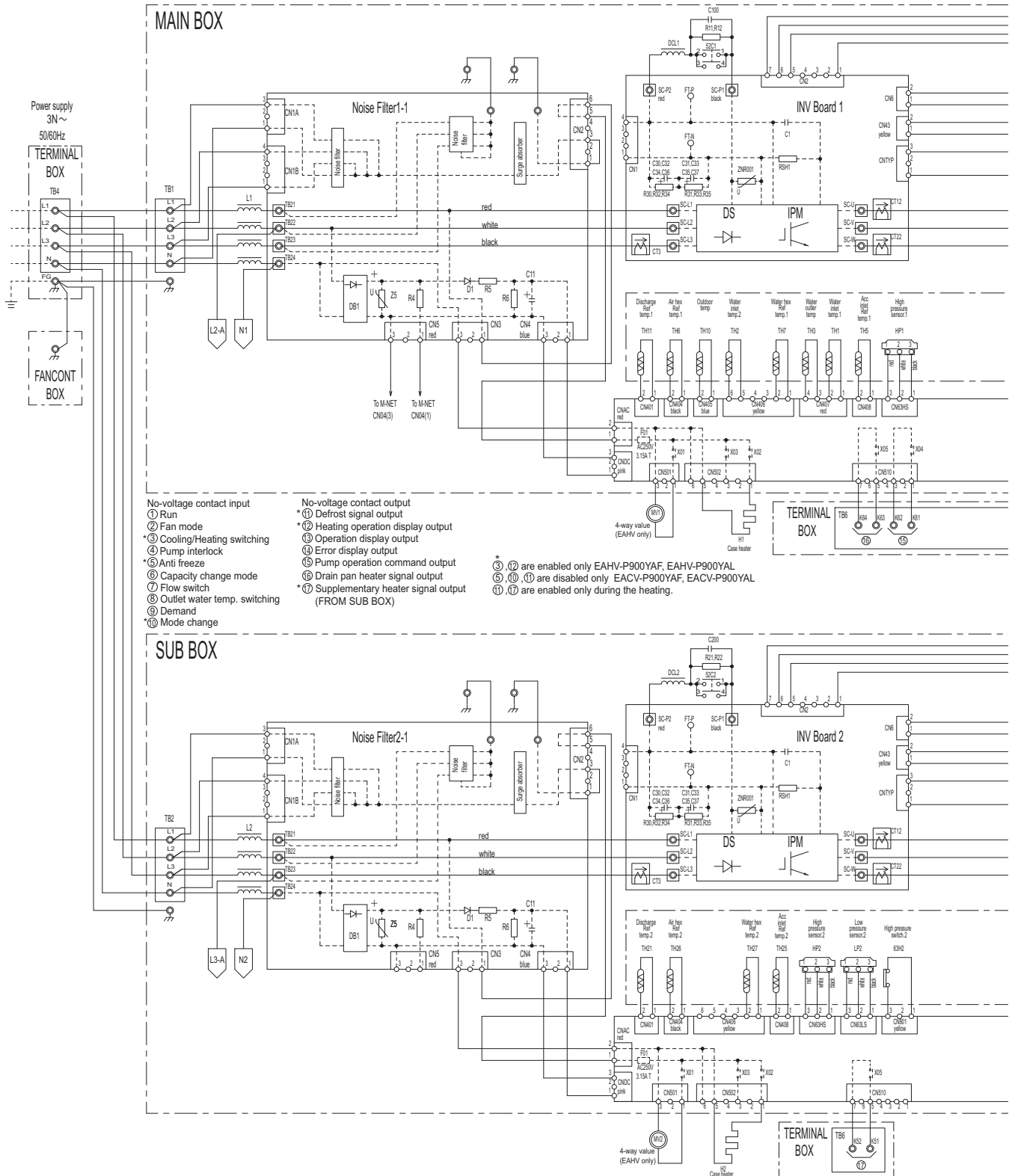

- | | |
|---|---|
| <p>No-voltage contact input</p> <ul style="list-style-type: none"> ① Run ② Fan mode *③ Cooling/Heating switching ④ Pump interlock *⑤ Anti freeze ⑥ Capacity change mode ⑦ Flow switch ⑧ Outlet water temp. switching *⑨ Demand *⑩ Mode change | <p>No-voltage contact output</p> <ul style="list-style-type: none"> *⑪ Defrost signal output *⑫ Heating operation display output ⑬ Operation display output ⑭ Error display output ⑮ Pump operation command output ⑯ Drain pan heater signal output *⑰ Supplementary heater signal output (FROM SUB BOX) |
|---|---|

* ③, ⑫ are enabled only EAHV-P900YAF, EAHV-P900YAL
 ⑤, ⑩, ⑪ are disabled only EACV-P900YAF, EACV-P900YAL
 ⑱, ⑲ are enabled only during the heating.

- Note1. Faston terminals have a locking function. Press the tab in the middle of the terminals to remove them. Check that the terminals are securely locked in place after insertion.
- Note2. Remove the short circuit wire between the terminals K10 and K11 to connect a flow switch.
- Note3. Be sure to connect the wires from terminals K4 and K6 to the interlock contact on the pump. A short-circuit may cause abnormal stop or malfunctions.
- Note4. Operation signals can be received from through the No-voltage contact.
- Note5. Use a 4-20mA signal output device with insulation. Feeding 30mA or more current may damaged the circuit board.
- Note6. Make sure that on site terminal connection is correct. With wrong connection, operation error may occur.
- The specification of the product might be changed without a previous notice for the improvement.

- Note7. Leave a space of at least 5 cm between the low voltage external wiring (No-voltage contact input and remote controller wiring) and wiring of 100V or greater. Do not place them in the same conduit tube or cable tray cable as this will damage the circuit board.
- Note8. When cable tray cable is used for the control cable wiring, use a separate cable tray for the following wiring.
 (a) Optional remote controller wiring
 (b) No-voltage contact input wiring
 (c) No-voltage contact output wiring
 (d) Analog input wiring
- Note9. Use a contact that takes 12VDC 1mA for No-voltage contact input. When the power voltage is 380V-400V-415V, No-voltage contact output will be 220VAC-230VAC-240VAC. The current range must be between 10mA and 1A.

1. Product Specifications

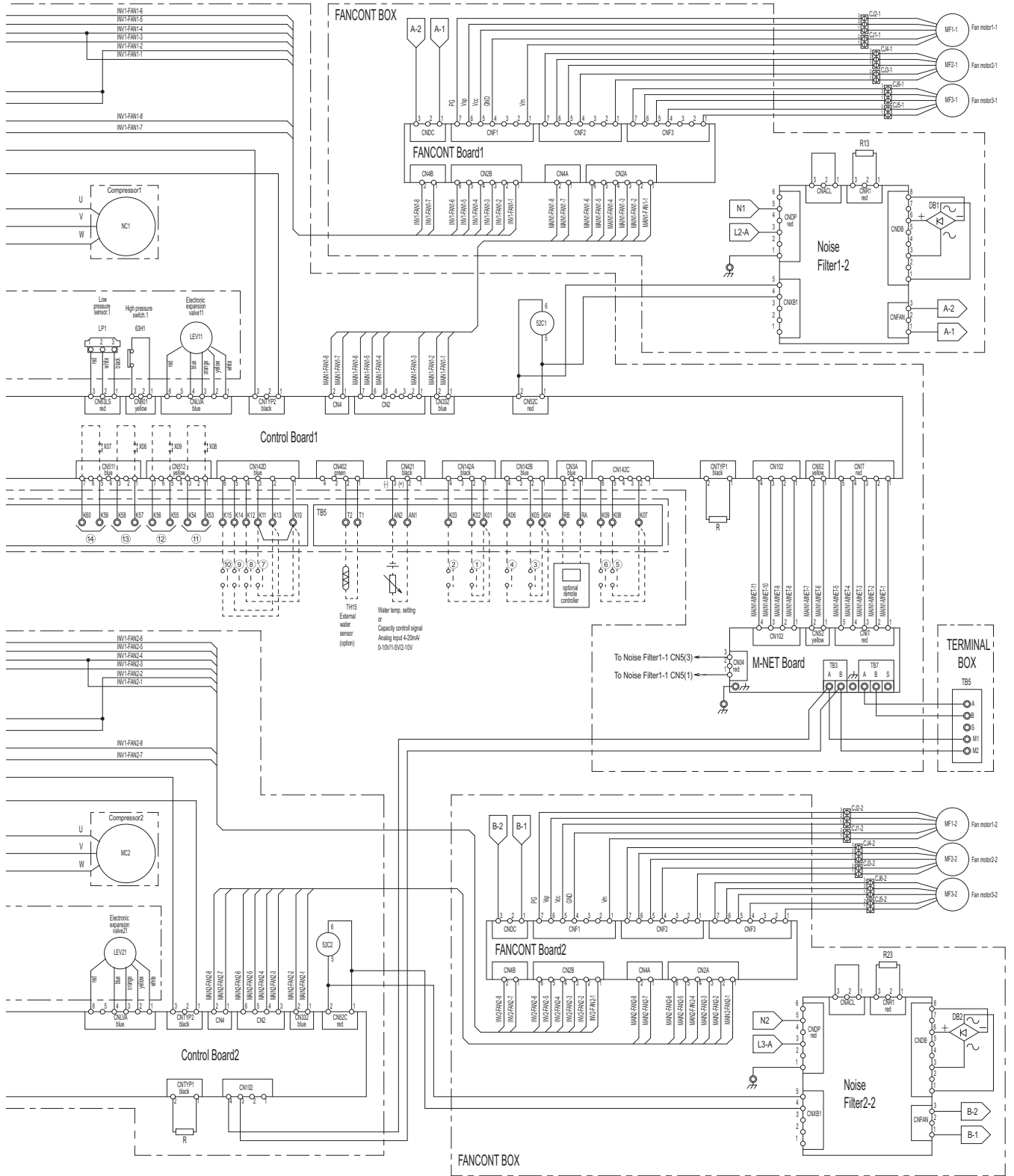

EAHV-P-YAF(-H)(-N), YAL(-H)(-N)/EACV-P-YAF(-N), YAL(-N)

1. Product Specifications

EAHV-P-YAF(-H)(-N), YAL(-H)(-N)/EACV-P-YAF(-N), YAL(-N)

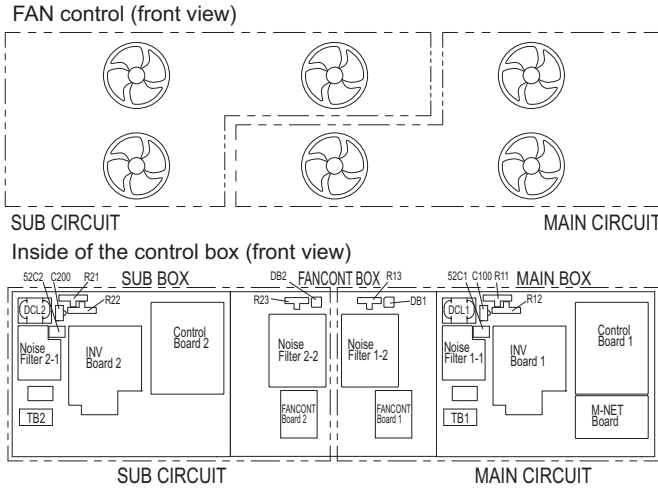

Error Codes

No.	Error code	Error type	Error reset *1	Preliminary error code *3
1	1102	Discharge temperature fault	○	1202
2	1138	Hot water abnormal rise	○	none
3	1176	Discharge SH fault	○	1276
4	1189	ACC inlet SH fault	○	1289
5	1301	Low pressure fault	○	1401
6	1302,1303	High pressure fault	○	1402
7	1503	Cold water abnormal drop	○	none
8	1510	Gas leak fault	○	none
9	1512	Low evaporation temperature fault	○	1612
10	2500	Water supply cutoff(Flow switch)	○	none
11	2501,2550	Water supply cutoff(Sensor)	○	none
12	4102	Open phase	×	4152
13	4106	Power supply fault *2	○	none
14	4115	Power supply frequency fault	×	none
15	4116	Fan motor fault	○	4166
16	4122	Fan interlock fault	○	4172
17	4126	Analog input error	—	none
18	422*	Inverter bus voltage fault	○	432*
19	423*	Inverter overheat protection fault	○	433*
20	424*	Inverter overheat protection	○	434*
21	425*	IPM error(inclusive)/overcurrent relay	○	435*
22	426*	Control box Fan fault	○	436*
23	5101	Water inlet temp 1 thermistor error(TH1)	○	none
24	5102	Water inlet temp 2 thermistor error(TH2)	○	none
25	5103	Water inlet temp 3 thermistor error(TH3)	○	none
26	5105	ACC inlet refrigerant temperature thermistor error(TH5/TH25)	○	none
27	5106	Air heat exchanger refrigerant thermistor error(TH6/TH26)	○	none
28	5107	Water heat exchanger refrigerant thermistor error(TH7/TH27)	○	none
29	5110	Outdoor temperature thermistor error(TH10)	○	none
30	5111	Discharge refrigerant temperature thermistor error(TH11/TH21)	○	1211
31	5114	THHS sensor/Circuit fault	○	1214
32	5115	External water sensor fault	○	none
33	5201	High pressure sensor fault	○	none
34	5202	Low pressure sensor fault	○	none
35	530*	ACCT sensor fault/Circuit fault	○	4301
36	0403	Serial communication error	○	431*
37	6500	Communication error between the MAIN and SUB units	—	none
38	6600		×	none
39	6602		—	none
40	6603	Communication error between the MAIN and SUB units	—	none
41	6606	(Simple multiple units control)	—	none
42	6607		—	none
43	6608		—	none
44	6831	Remote controller signal reception error 1	—	none
45	6832	Remote controller signal transmission error	—	none
46	6834	Remote controller signal reception error 2	—	none
47	6833	Remote controller over current	×	none
48	7113,7117	Model setting error	×	none

*1. Definition of symbols in the "Error reset" column.

- ... Errors that can be reset.
- ×

*2. Power supply fault can be detected only when the switch setting "Automatic recovery after power supply fault " on the unit is set to "Disable." (The default setting is "Enable.")

*3. If a unit comes to a stop due to a preliminary error, the unit will resume normal operation if the error conditions are cleared within a certain amount of time. If the error conditions persist beyond the predetermined time, the unit will come to an abnormal stop.

*4. " * " shows types of components. (0/1: COMP for MAIN circuit, 2: COMP for SUB circuit, 5: FAN 1, 6: FAN 2, 7: FAN 3)

Display setting(Control board display *)

SW3-3: OFF	SW3-3: ON
High pressure	High pressure
Low pressure	Low pressure
	Inlet water temperature
	Outlet water temperature
	Ambient temperature

* Display settings can be either of the MAIN BOX and the SUB box.
Display is switched in the 3 second intervals.

1. Product Specifications

When using a local controller, refer to the table below for the types of input/output signals that are available and the operations that correspond to the signals.

External Input/Output

Input type	Dry contact	ON (Close)	OFF (Open)	Terminal block
(a)UNIT OPERATION	Run/Stop	The unit will go into operation when the water temperature drops below the preset temperature.	The unit will stop except when the unit is in the Anti-Freeze mode.	TB5 K01-K02
(b)MODE CHANGE *EAHV-P900YA EAHV-P900YA-H	Heating ECO/Heating	Heating ECO mode (EAHV-P900YA: When "COOLING/HEATING SWITCHING" contact (item (j) below) is ON, this mode is enabled.)	Heating mode (EAHV-P900YA: When "COOLING/ HEATING SWITCHING" contact (item (j) below) is ON, this mode is enabled.)	TB6 K13-K15
(c)CAPACITY CHANGE MODE	COP priority/ Capacity priority	The unit will operate in the energy-efficient mode (COP priority mode).	The unit will operate at the maximum capacity setting (Capacity priority mode).	TB5 K07-K09
(d)FAN MODE	Forced/ Normal	When the outdoor temperature is 5°C or less, the fan will remain in operation after the compressor has stopped.	The fan will stop when the compressor stops.	TB5 K01-K03
(e)ANTI FREEZE *EAHV-P900YA EAHV-P900YA-H	On/Off	The unit will operate in the Anti-Freeze mode (with the target temperature 30°C) when the contact status of (a) "UNIT OPERATION" is "Stop" or the ON/OFF button on the remote controller is turned off. (EAHV-P900YA: When "COOLING/HEATING SWITCHING" contact (item (j) below) is ON, this mode is enabled.)	The unit will operate according to the status of the "UNIT OPERATION" contact (item (a) above) or the ON/OFF command from the remote controller.	TB5 K07-K08
(f)FLOW SWITCH	Normal/Error	The unit is allowed to operate.	The unit will not operate.	TB6 K10-K11
(g)PUMP INTERLOCK	Normal/Error	The unit is allowed to operate.	The unit will not operate.	TB5 K04-K06
(h)PEAK-DEMAND CONTROL	On/Off	The unit will operate at or below the maximum capacity level that was set for the Peak-demand control setting.	The unit will operate at or below the maximum capacity setting for either "Capacity Priority Mode" or "COP Priority Mode" that was selected for item (c) "CAPACITY CHANGE MODE" above.	TB6 K13-K14
(i)OUTLET WATER TEMP SWITCHING	2nd/1st	Setting temp 2 (Refer to page 177 Settings table)	Setting temp 1 (Refer to page 177 Settings table)	TB6 K10-K12
(j)COOLING/HEATING SWITCHING *EAHV-P900YA	Heating/ Cooling	Heating mode	Cooling mode	TB5 K04-K05
Analog				Terminal block
Input type		Action		
(k)WATER TEMP SETTING/ CAPACITY CONTROL SIGNAL	Water temperature or capacity control signal can be set by using the external analog input to the CN421 on the MAIN circuit board. One analog input type can be selected from the following types: 4-20 mA, 1-5 V, 0-10 V, or 2-10 V. *Use a 4-20 mA signal output device with insulation.			TB5 AN1(+)-AN2(-)
(l)EXTERNAL WATER SENSOR (optional)			-	TB5 T1-T2
Output type	Contact type	Conditions in which the contact closes (turns on)	Conditions in which the contact opens (turns off)	Terminal block
(m)ERROR INDICATOR	Close/Open	The unit has made an abnormal stop.	During normal operation	TB6 K59-K60
(n)OPERATION INDICATOR	Close/Open	The "UNIT OPERATION" contact (item (a) above) or the ON/OFF button on the remote controller is ON.	The "UNIT OPERATION" contact (item (a) above) or the ON/OFF button on the remote controller is OFF.	TB6 K57-K58
(o)PUMP OPERATION COMMAND	Close/Open	The pump will operate according to the status of the "UNIT OPERATION" contact or the ON/OFF button on the remote controller button.	Under all conditions other than the ones listed on the left	TB6 K61-K62
(p)SUPPLEMENTARY HEATER SIGNAL	Close/Open	Water and outdoor temperature has dropped below a setting water temperature and a set outdoor temperature.	Water temperature is at or above a set water temperature +2°C or the outdoor temperature is at or above a set outdoor temperature +2°C.	TB6 K51-K52
(q)DEFROST SIGNAL	Close/Open	The unit is in defrost mode.	The unit is not in defrost mode.	TB6 K53-K54
(r)DRAIN PAN HEATER SIGNAL	Close/Open	Outdoor temperature has dropped below a set outdoor temperature.	Outdoor temperature is at or above a set outdoor temperature +2°C.	TB6 K63-K64
(s)HEATING OPERATION DISPLAY	Close/Open	The unit is in heating mode.	The unit is in cooling mode.	TB6 K55-K56
RC/M-NET	REMOTE CONTROLLER	PAR-W21MAA or PAR-W31MAA		TB5 RA-RB
	Centralized controller	AE-200	* Sub-zero brine temperature cannot be displayed.	TB5 A-B
	M-NET			TB5 M1-M2

EAHV-P-YAF(-H)(-N), YAL(-H)(-N)/EACV-P-YAF(-N), YAL(-N)

1. Product Specifications

External signal interface

EAHV-P-YAF(-H)(-N), YAL(-H)(-N)/EACV-P-YAF(-N), YAL(-N)

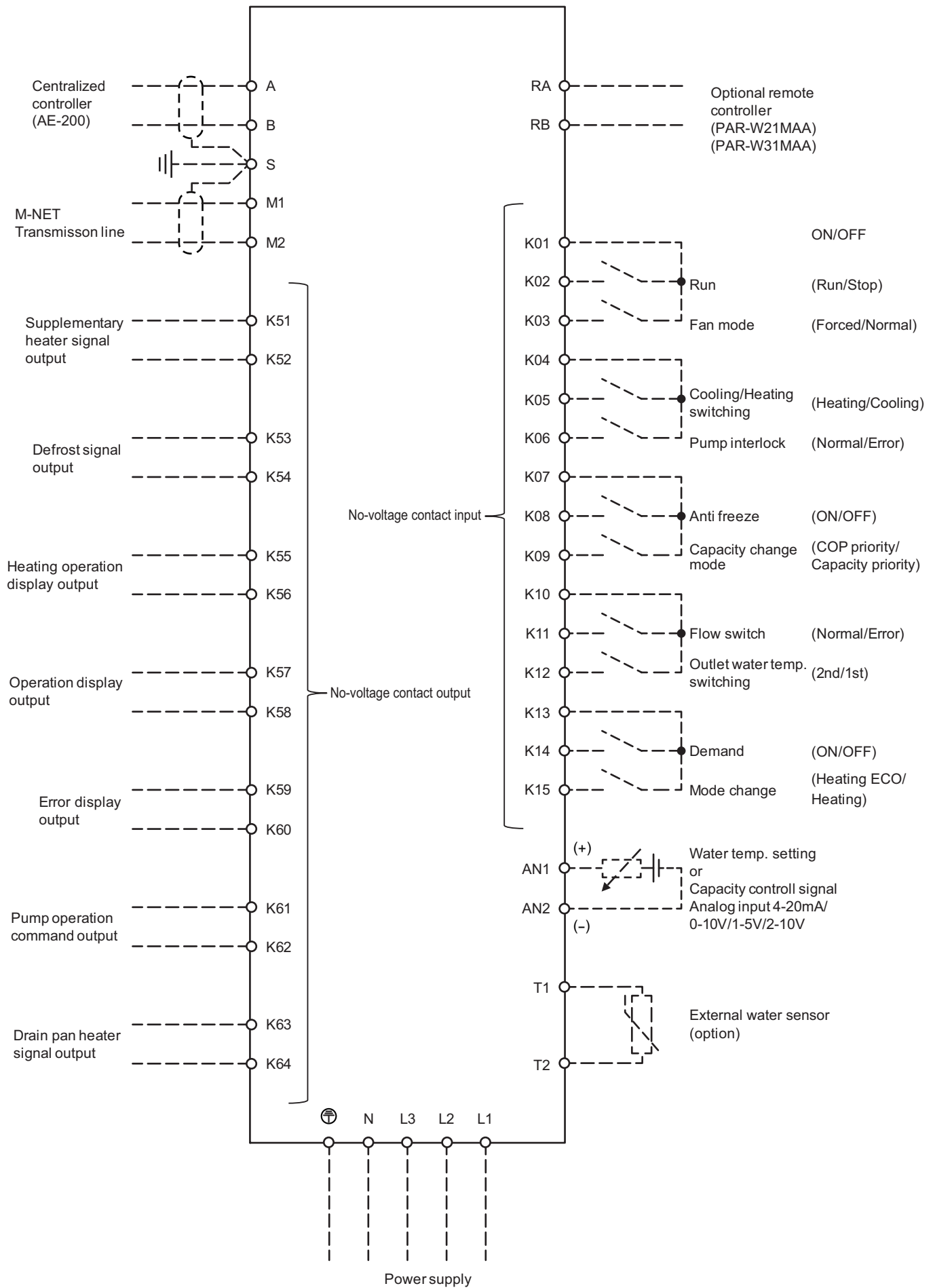

1. Product Specifications

1-5. Optional parts

1-5-1. Piping Kit EA-01HK (Only for Inside header (-N))

Refer to Installation/Instructions Manual.

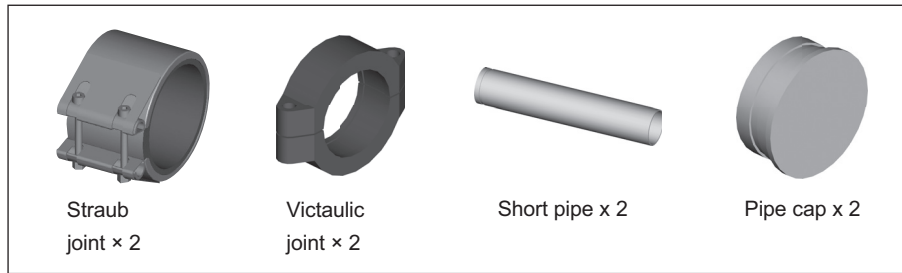

1-5-2. Connection Piping Kit EA-02HK (Only for Inside header (-N))

Refer to Installation/Instructions Manual.



1-5-3. Fin Guard EA-130FG

Parts list

FIN GUARD	SCREWS
(1) 1 pc.	(2) 10 pcs.

Installing the fin guard

Attach the fin guards to the opposite service side and left and right sides.

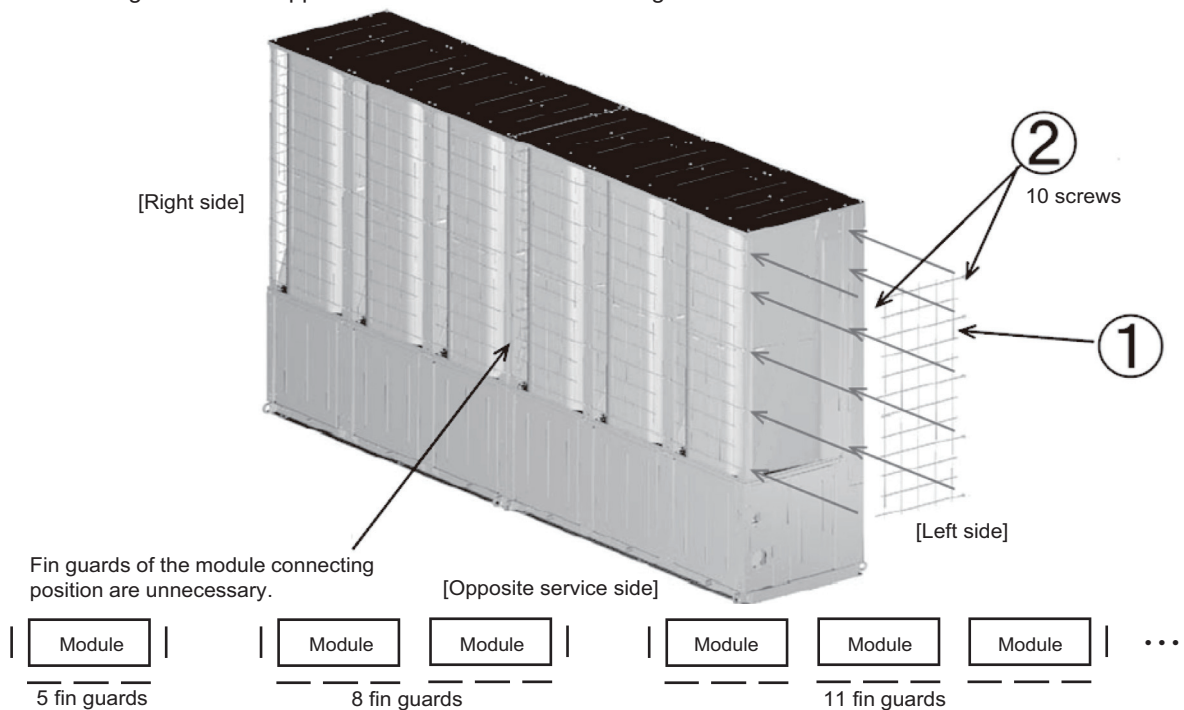

1. Product Specifications

1-5-4. Remote controller PAR-W21MAA

Refer to 6-1. PAR-W21MAA specifications.

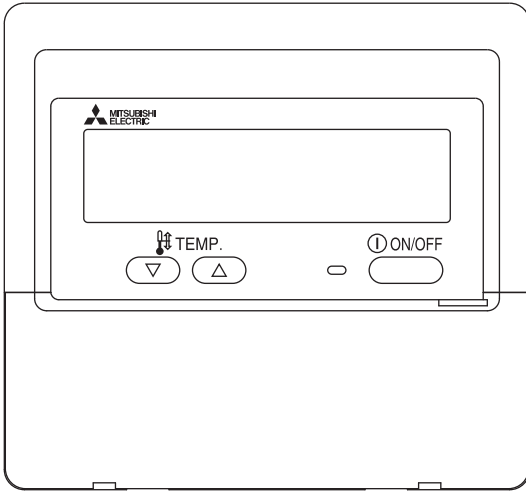

Panel closed

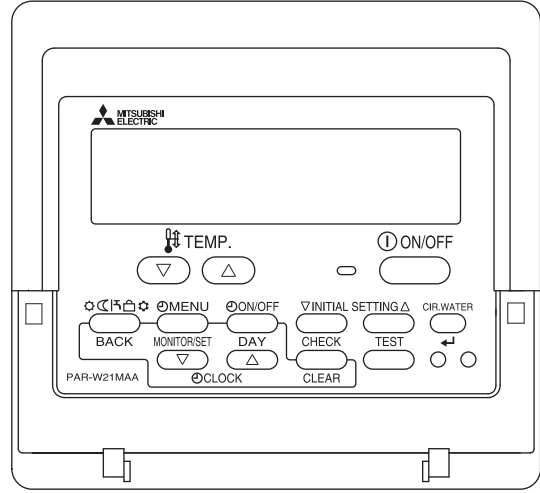

Panel open

1-5-5. Remote controller PAR-W31MAA

Refer to 6-2. PAR-W31MAA specifications.

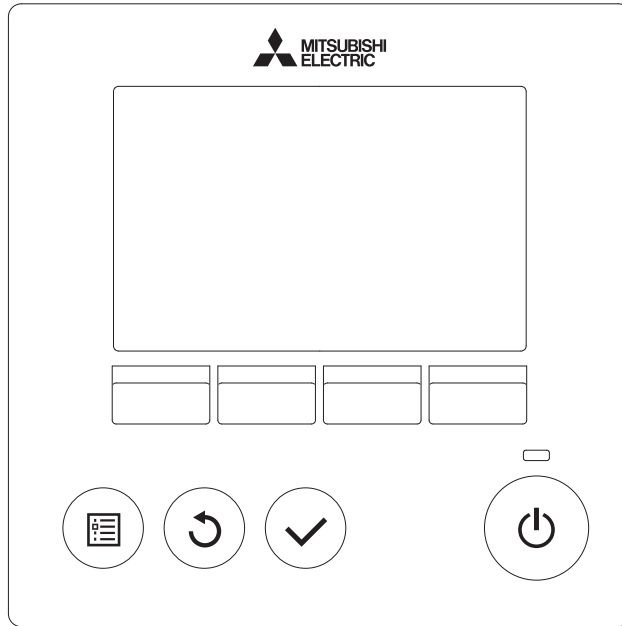

1-5-6. Y-shaped strainer YS-50A (Only for STANDARD PIPING TYPE)

Refer to Installation/Instructions Manual.

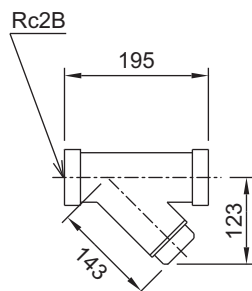

<Unit: mm>

Recommended torque: 200±20 (N·m)

1. Product Specifications

1-5-7. Representative-water temperature sensor TW-TH16

1. Required parts for installing a representative-water temperature sensor

- A) Representative-water temperature sensor
 - B) Cable for connecting between the sensor and the unit*
 - C) Cable terminal for connecting to the sensor and the unit terminal block*
(Terminals for M4 screws × 4)*
- * A) and B) are field-supplied.

Cable specifications

Size	2-core, 1.25 mm ² or larger
Type	CVVS or CPEVS
Length	20 m

2. Installing a representative-water temperature sensor

As shown in the figures below, install the sensor at the merged part of water pipes or the load-side tank. The sensor can be installed in either the vertical or the horizontal position. When installing the sensor in the horizontal position, make sure to place the cable-access-hole side down.

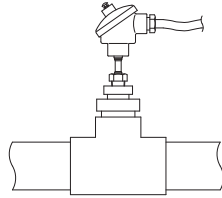

Vertical installation

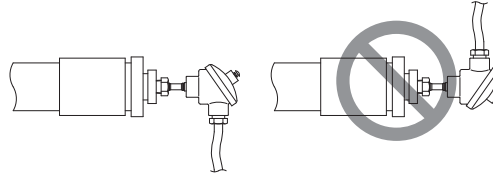

Horizontal installation

3. Wiring for a representative-water temperature sensor

As shown in the figures below, connect the cable to the representative-water temperature sensor and the terminal block in the unit control box.

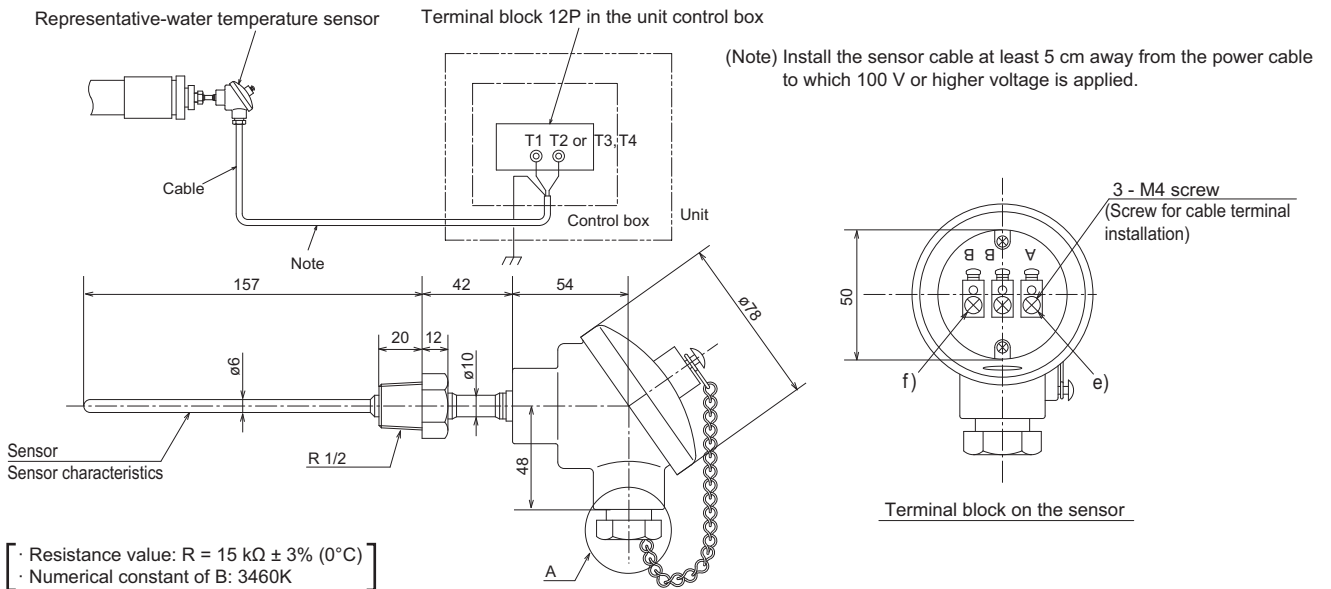

On the unit side, connect the sensor cable to the terminals T1 and T2 in the terminal block 12P in the unit control box.

Connect the shielded cable to the ground terminal.

On the sensor side, as shown in the figure at right, run the cable through d), c), and b), attach the field-supplied terminals for M4 screws to the cable, and then connect the terminals to the screws e) and f) (terminal A and B).

Cut the shielded cable and leave it unconnected.

(On the unit side, the shielded cable should be connected to the ground terminal already.)

Tighten the tightening screw d), and caulk the gap between the tightening screw d) and cable a) to prevent water leakage.

*1 In a multiple module connection system, install the temperature sensor where the cold/hot water from each module is sufficiently mixed to provide a representative temperature.

*2 The temperature sensor must be installed on a pipe between the outlet of the unit and the entrance to the load-side system.

*3 Install the sensor at least 5D (D: pipe diameter) away from pipe bends and other areas that can obstruct the normal water flow and so that the sensing probe (protective tube) will not vibrate from the whirl or shock flow.

*4 The sensor is for use at a flow rate of 3 m/sec or below.

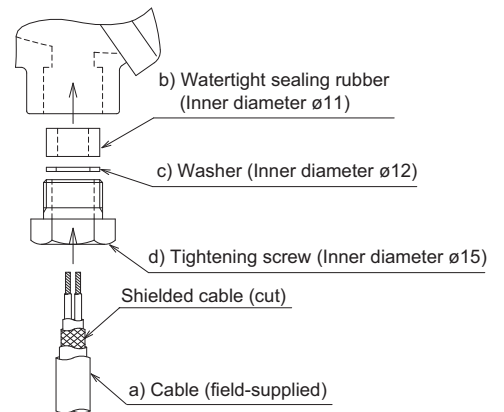

Enlarged view of area A: Cable installation

2. Product Data

2-1. Capacity tables

2-1-1. Correction by relative humidity

[EAHV]

■ Heating capacity correction diagram (relative humidity correction diagram)

The heating capacity changes depending on the relative humidity.

When the relative humidity is other than RH=85%, correct the capacity based on the following graph.

[Example] When the outdoor air temperature = 0°C and relative humidity RH=50%

Heating capacity in performance diagram × 0.926 <Correction value> = Heating capacity after correction

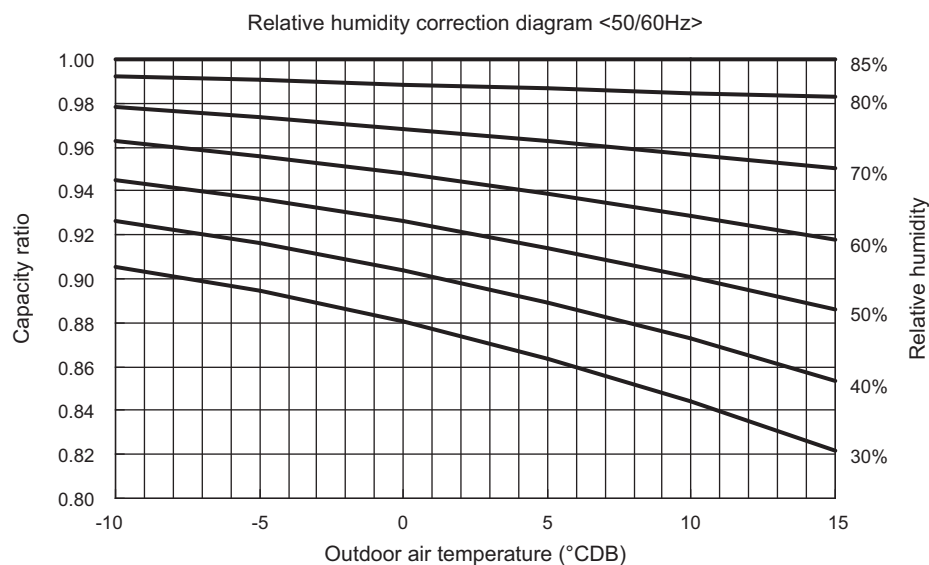

■ Heating capacity reduction factor by frosting (reference)

Outdoor air temperature (DB)	-7°C	-5°C	-3°C	0°C	3°C	5°C	7°C
Heating capacity reduction factor	0.87	0.87	0.86	0.84	0.87	0.98	1.00

* In the actual setup status, there are factors (weather, outside wind, relative humidity, etc.) other than outdoor air temperature, so consider the above factors as references.

2. Product Data

2-1-2. Correction by temperature

[Cold/hot water outlet/inlet temperature difference 5°C]

EAHV-P900YA

EACV-P900YA

■ Cooling Capacity [Water]

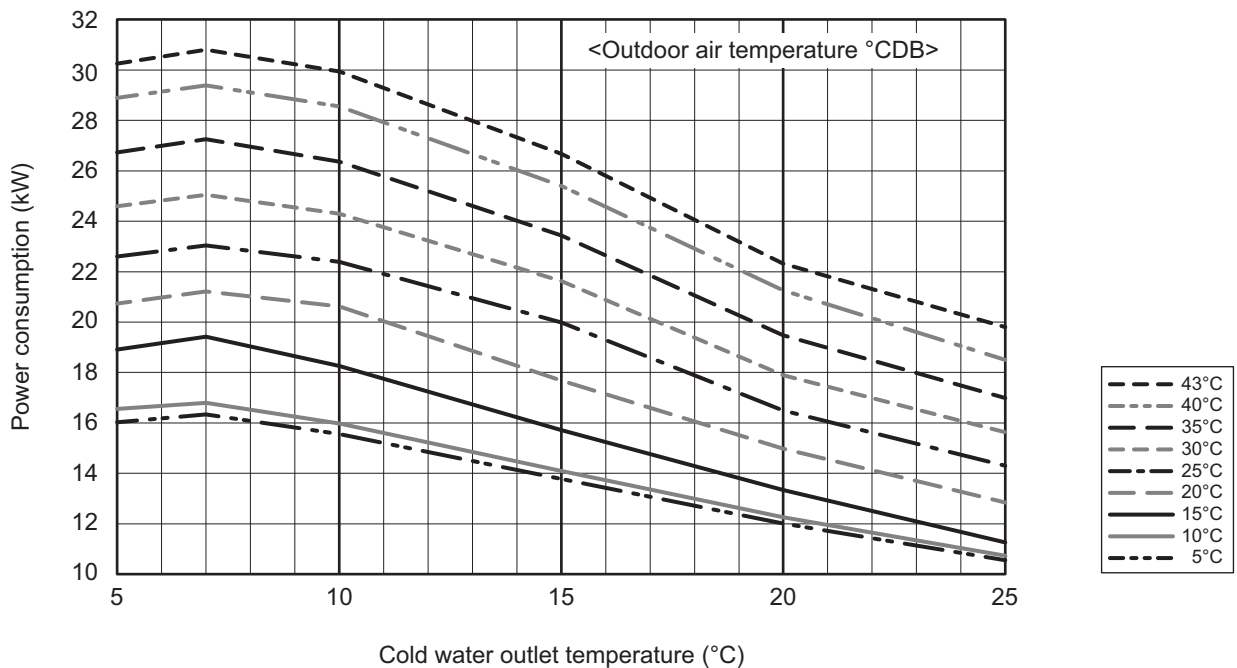
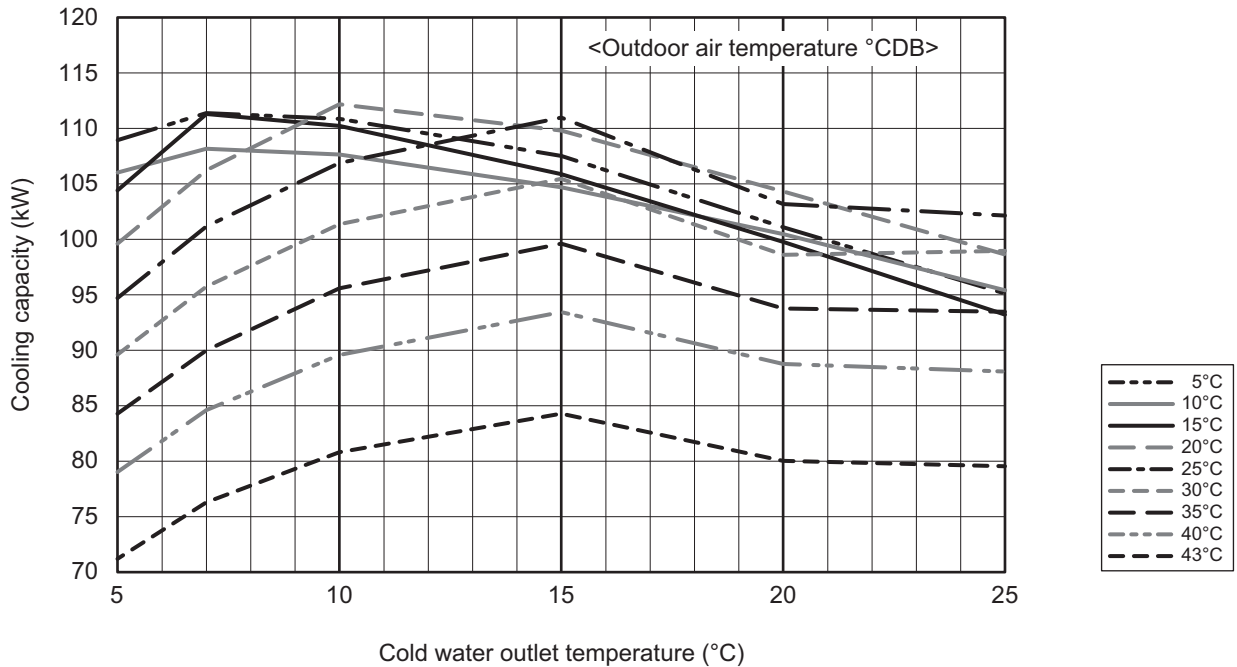

* When the cold water outlet temperature is 8°C or higher, the capacity control operation is performed to reduce the power consumption.

2. Product Data

[Cold/hot water outlet/inlet temperature difference 5°C]

EAHV-P900YA

■ Heating Capacity

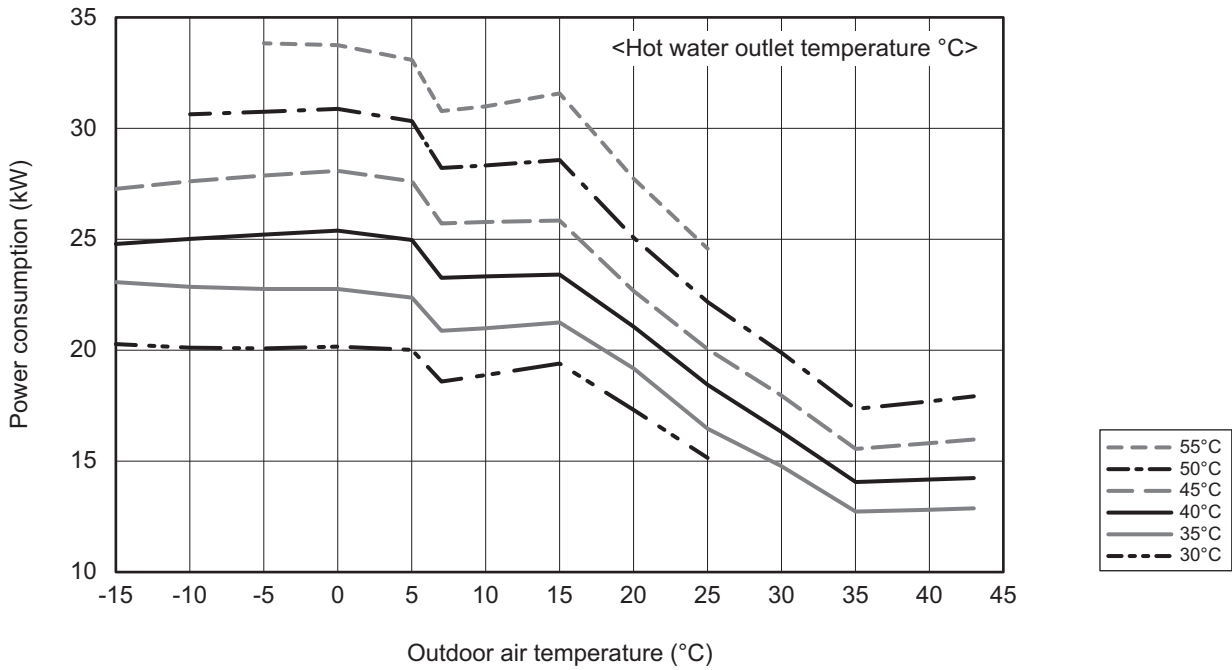
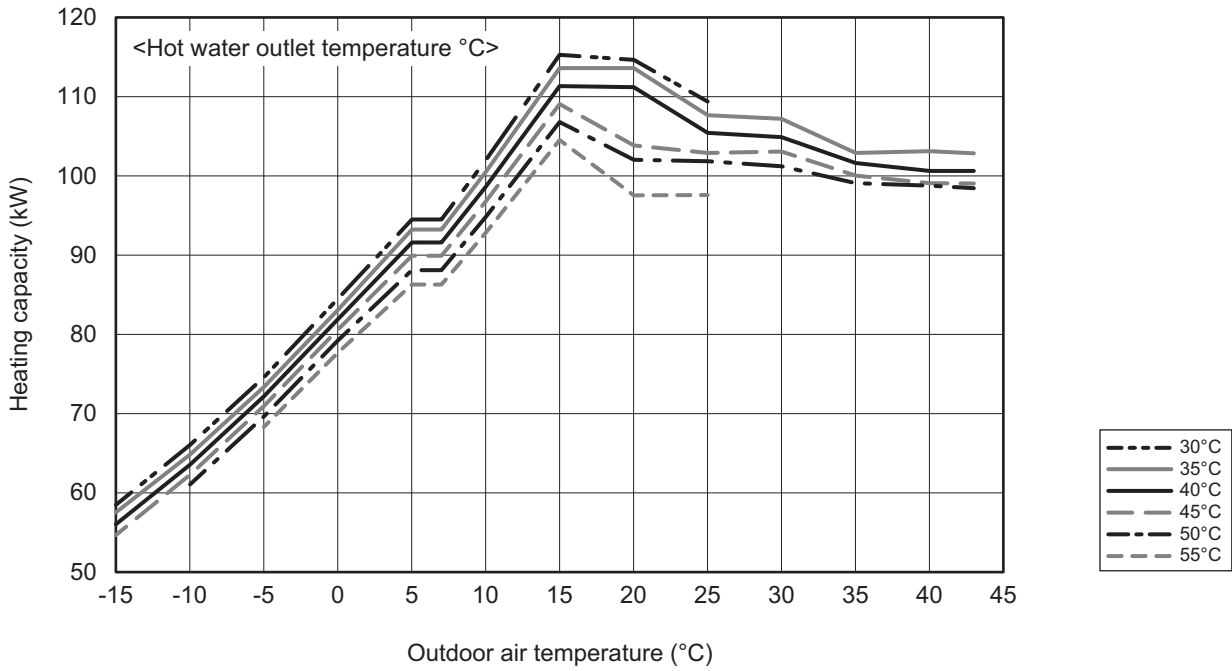

2. Product Data

[Cold/hot water outlet/inlet temperature difference 5°C]

EAHV-P900YA × 2

EACV-P900YA × 2

■ Cooling Capacity [Water]

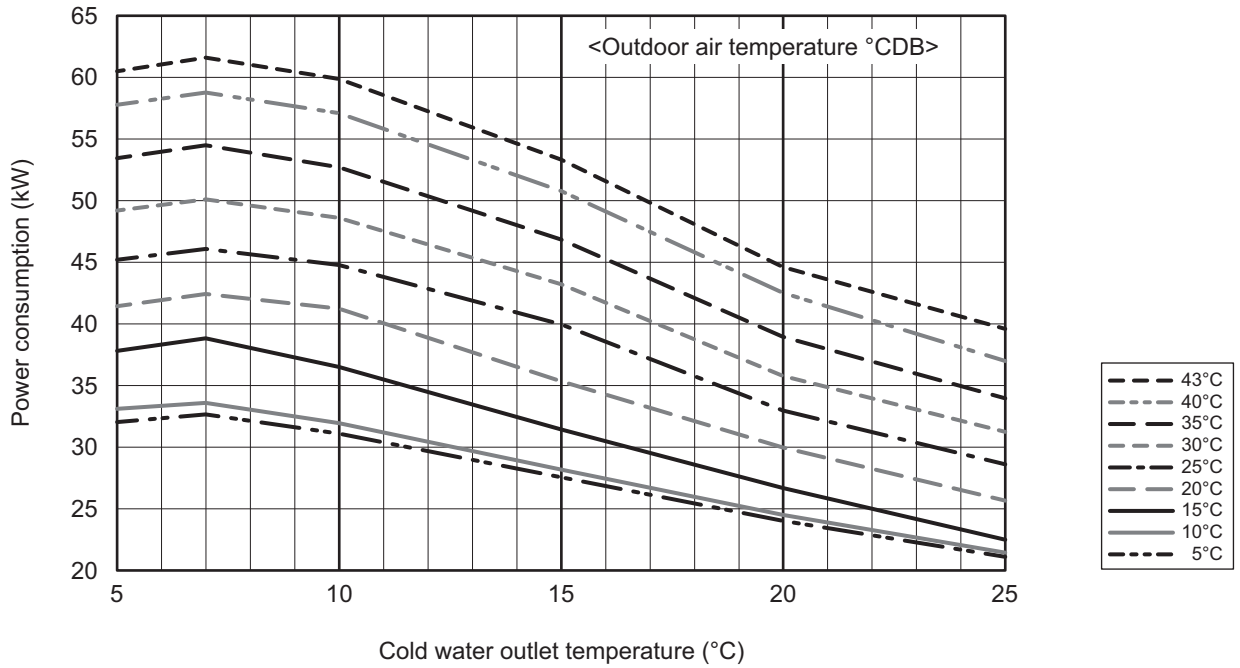
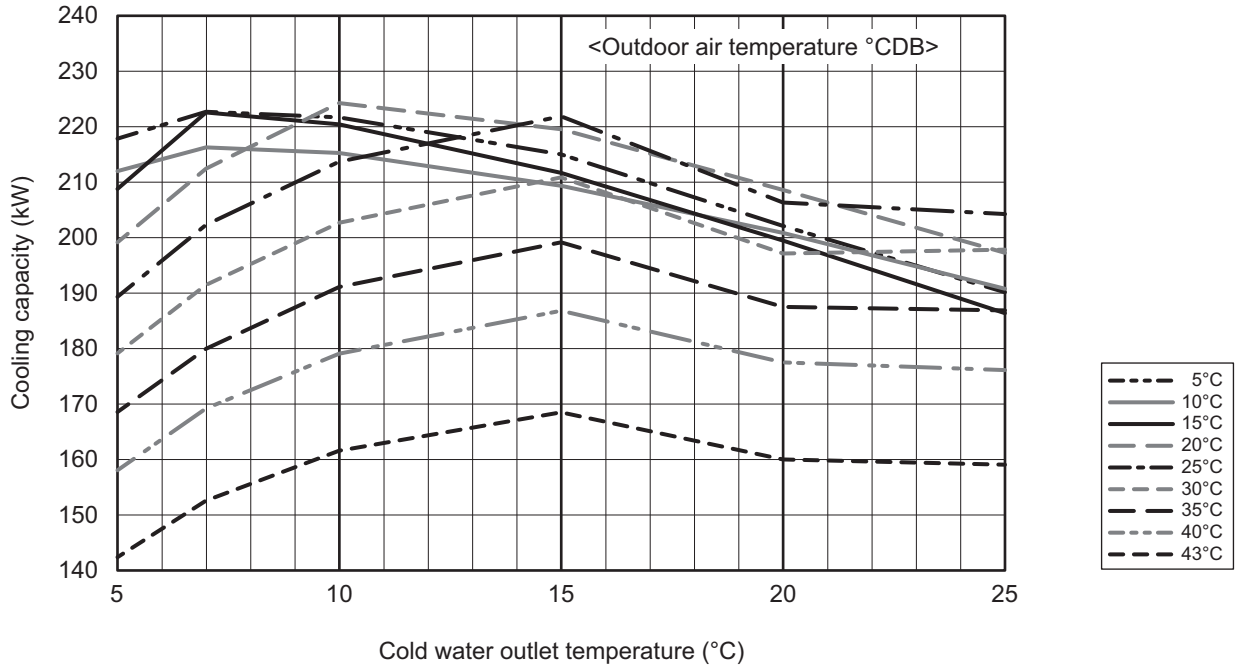

* When the cold water outlet temperature is 8°C or higher, the capacity control operation is performed to reduce the power consumption.

2. Product Data

[Cold/hot water outlet/inlet temperature difference 5°C]

EAHV-P900YA × 2

■ Heating Capacity

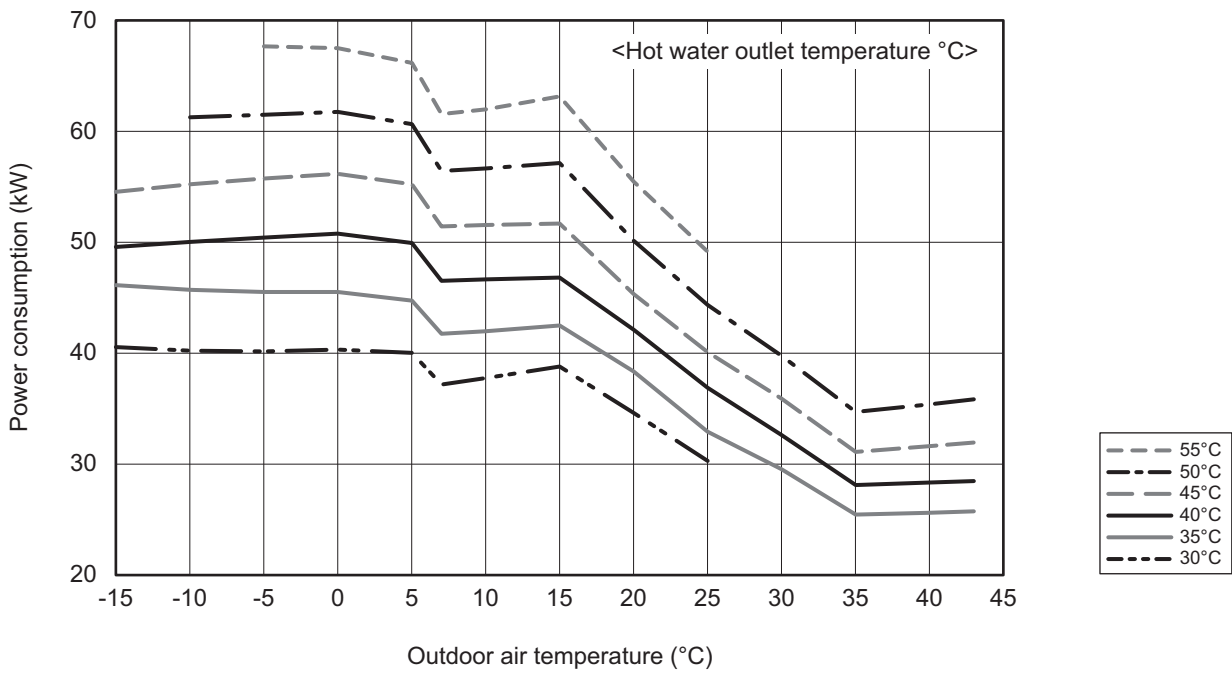
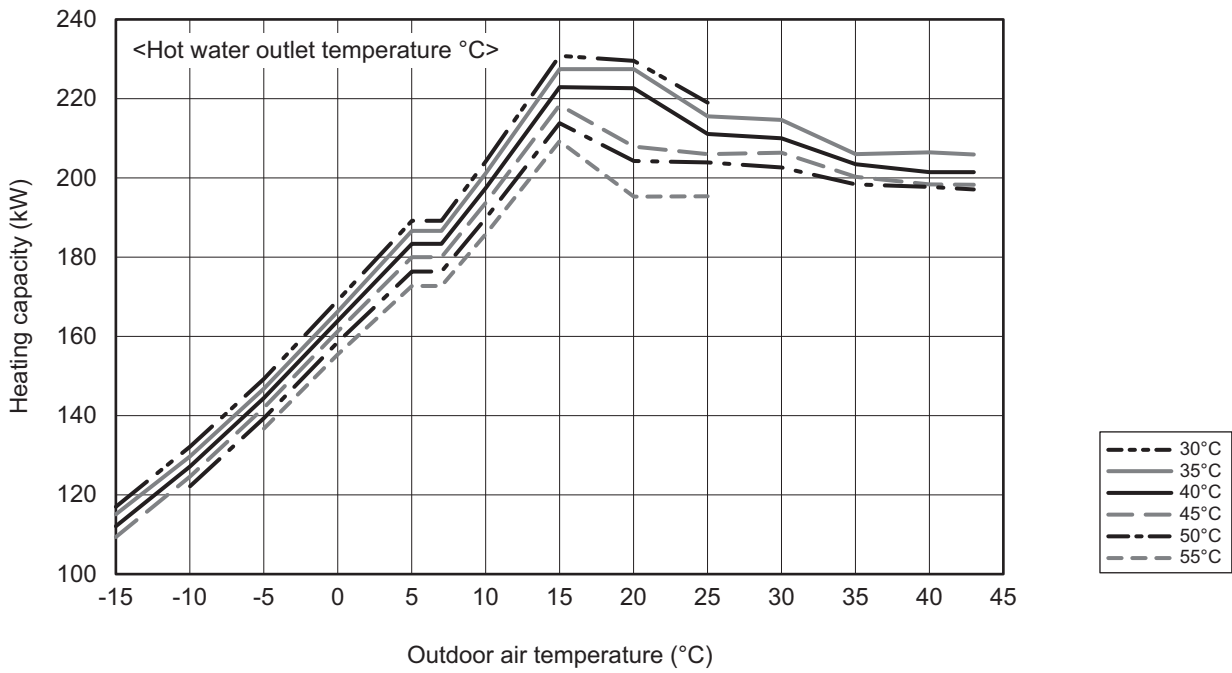

2. Product Data

[Cold/hot water outlet/inlet temperature difference 5°C]

EAHV-P900YA × 3

EACV-P900YA × 3

■ Cooling Capacity [Water]

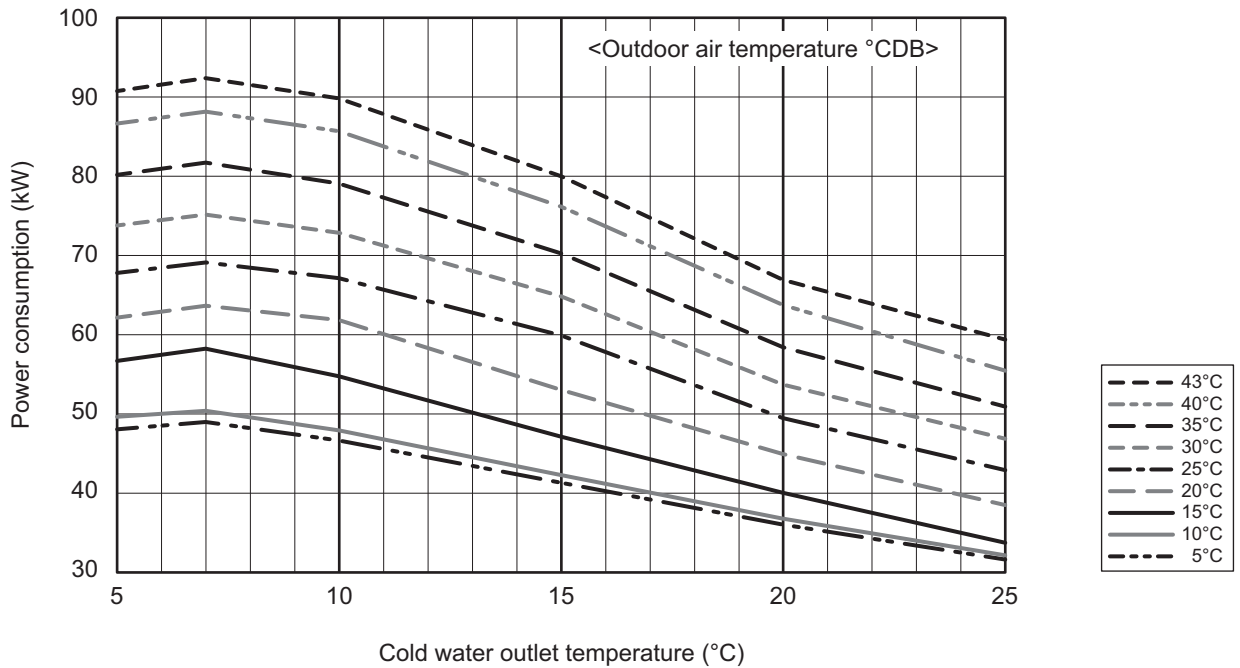
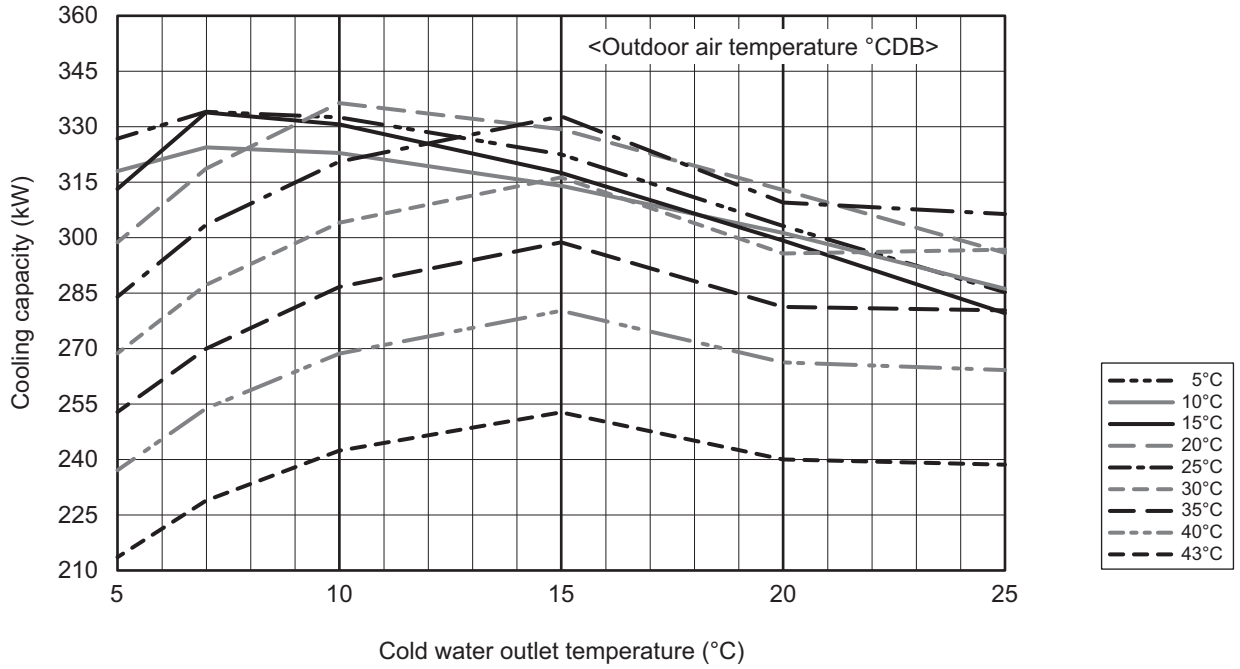

* When the cold water outlet temperature is 8°C or higher, the capacity control operation is performed to reduce the power consumption.

2. Product Data

[Cold/hot water outlet/inlet temperature difference 5°C]

EAHV-P900YA × 3

■ Heating Capacity

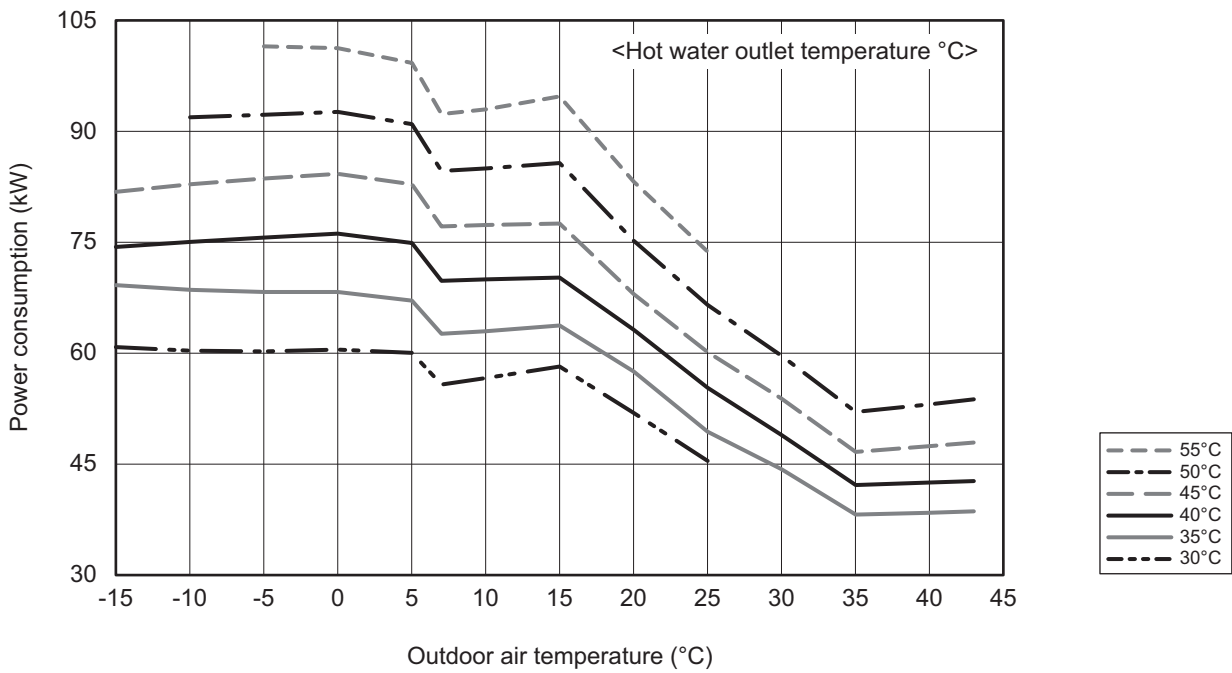
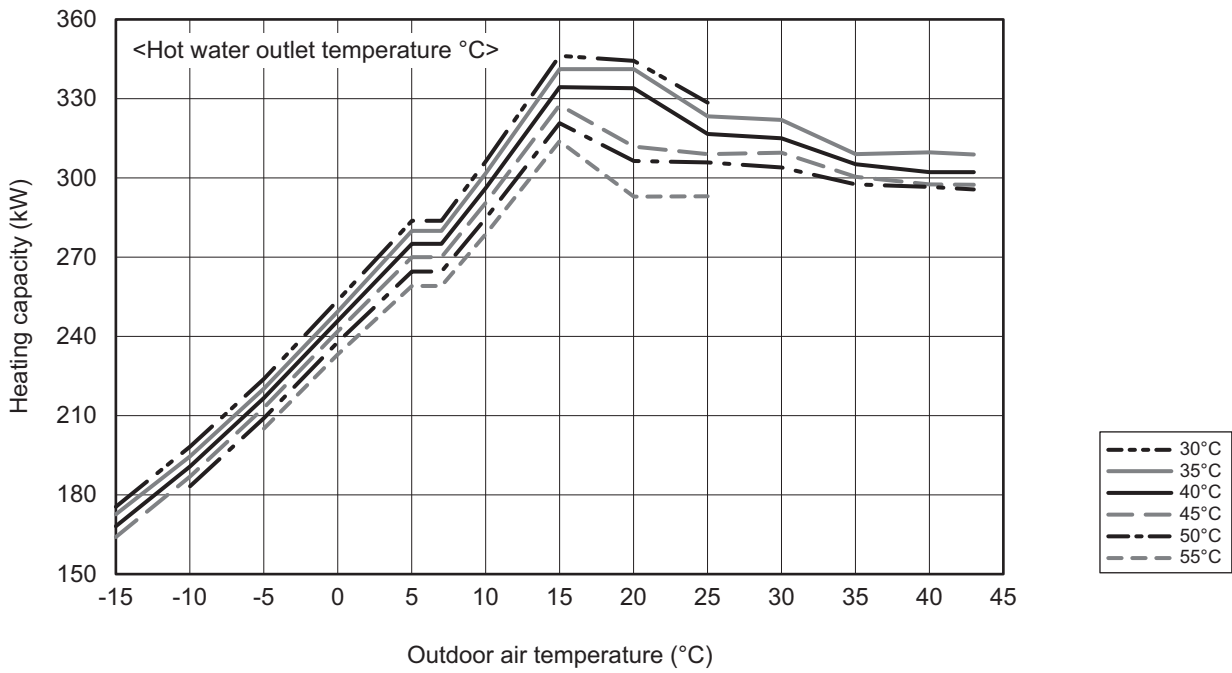

2. Product Data

[Cold/hot water outlet/inlet temperature difference 5°C]

EAHV-P900YA × 4

EACV-P900YA × 4

■ Cooling Capacity [Water]

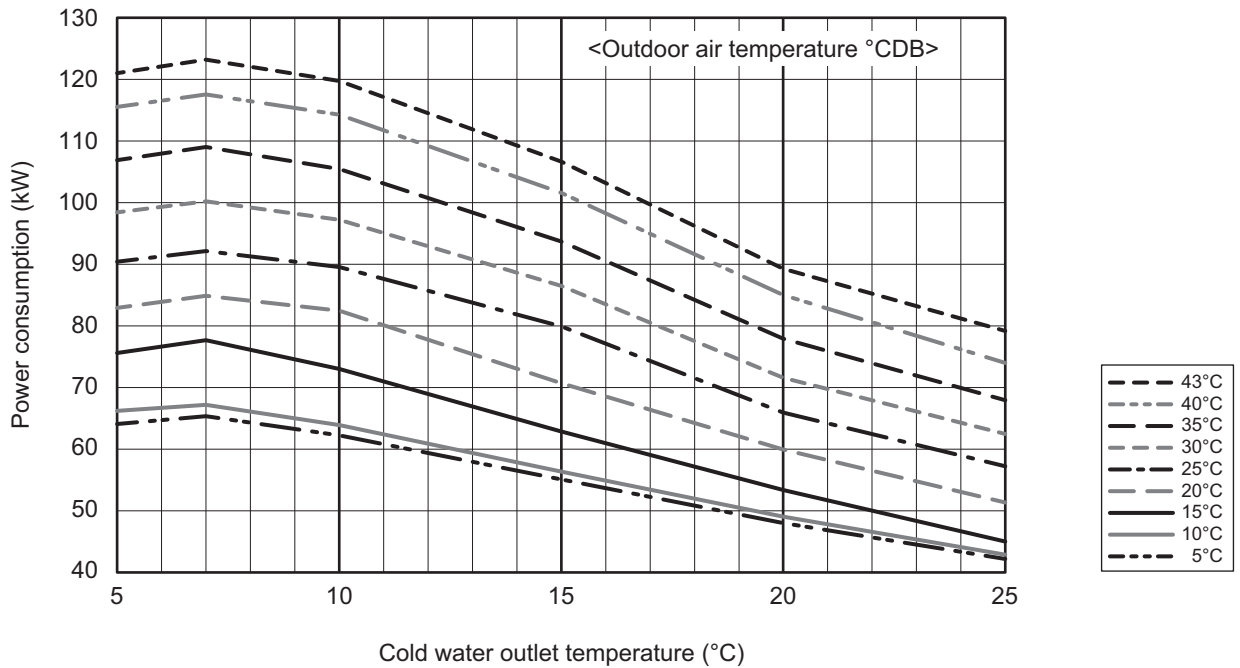
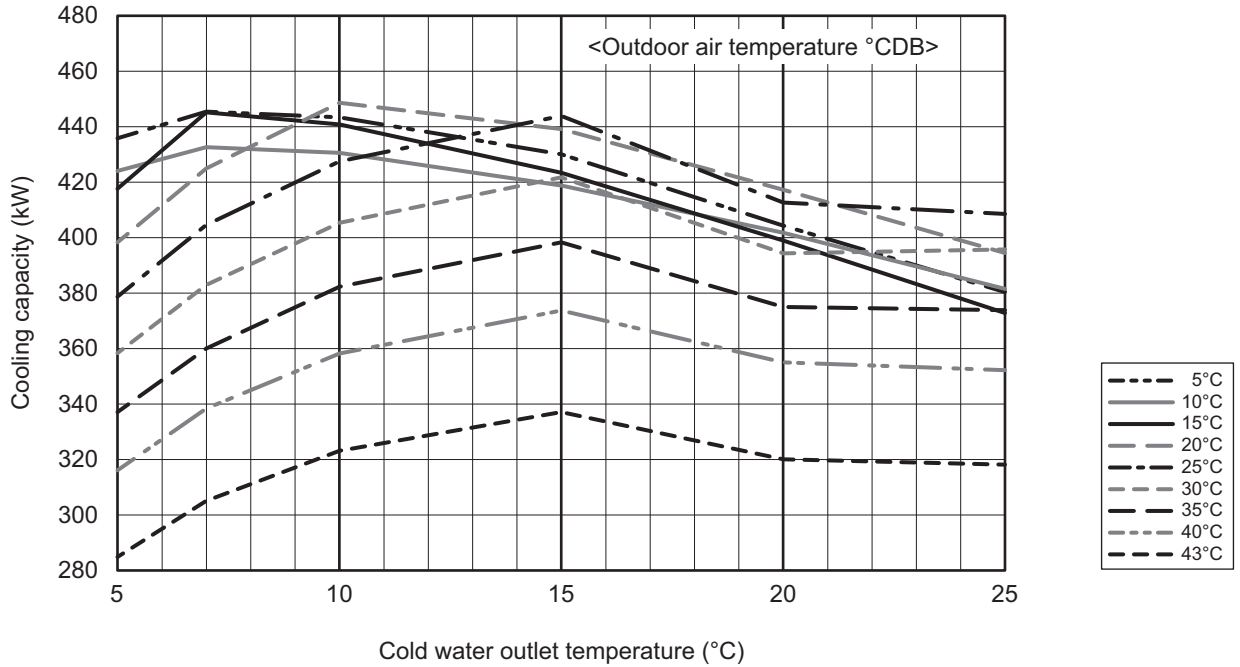

* When the cold water outlet temperature is 8°C or higher, the capacity control operation is performed to reduce the power consumption.

2. Product Data

[Cold/hot water outlet/inlet temperature difference 5°C]

EAHV-P900YA × 4

■ Heating Capacity

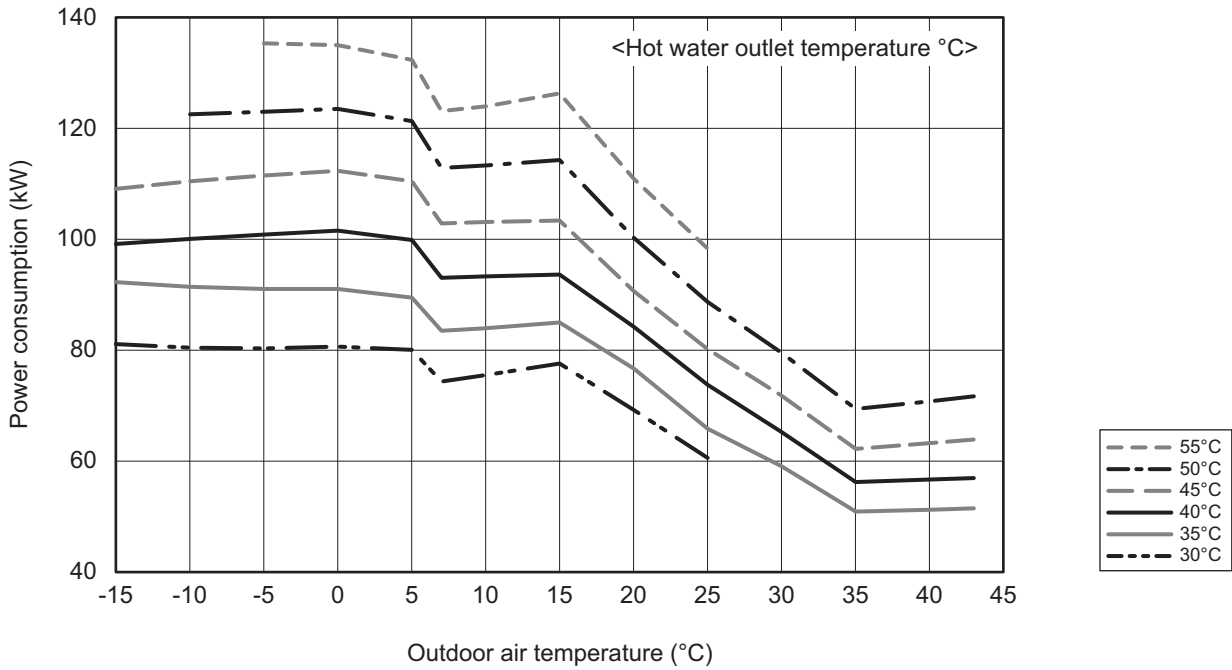
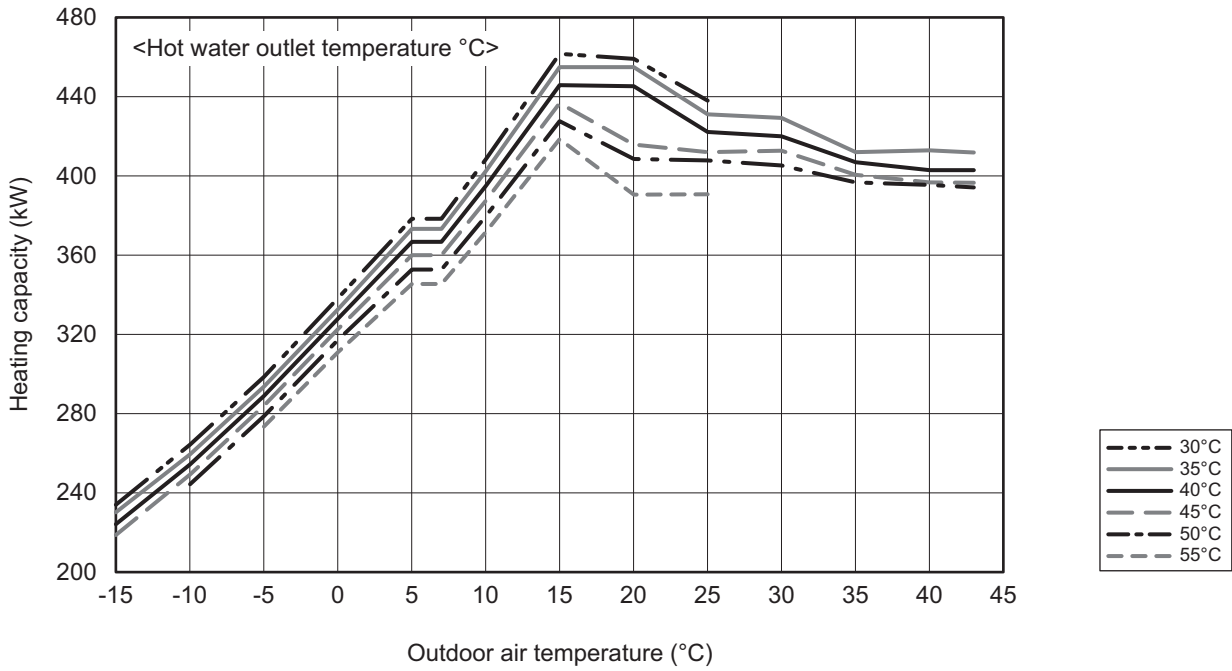

EAHV-P-YAF(-H)(-N), YAL(-H)(-N)/EACV-P-YAF(-N), YAL(-N)

2. Product Data

[Cold/hot water outlet/inlet temperature difference 5°C]

EAHV-P900YA × 5

EACV-P900YA × 5

■ Cooling Capacity [Water]

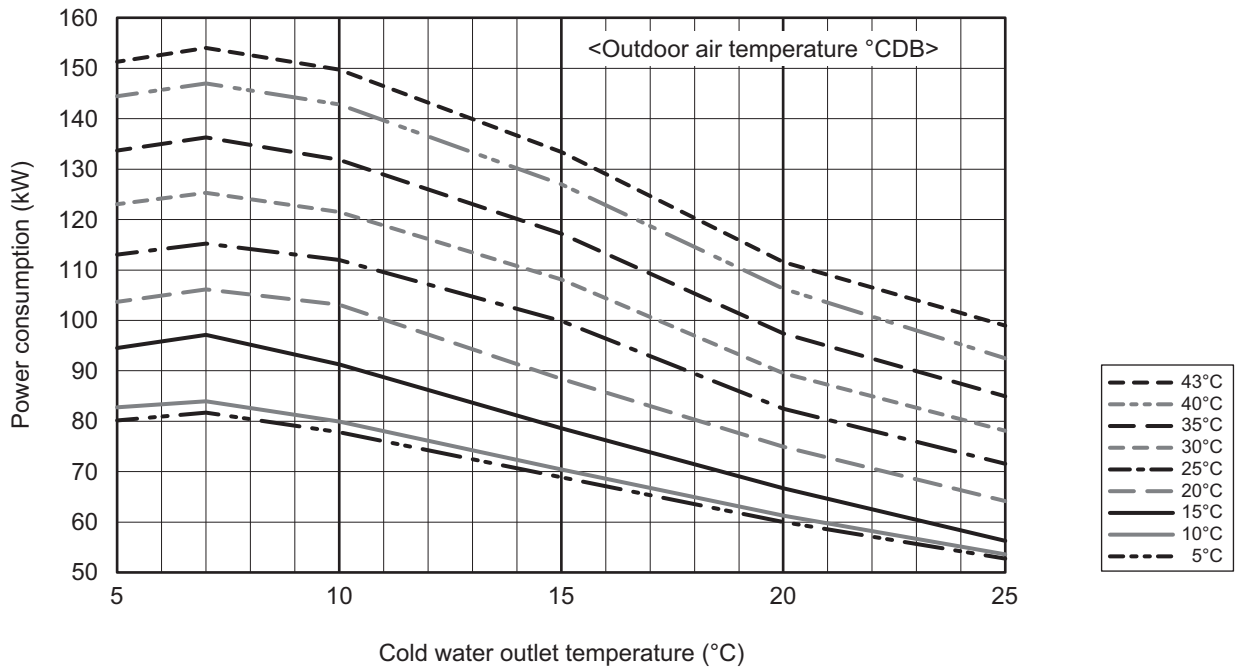
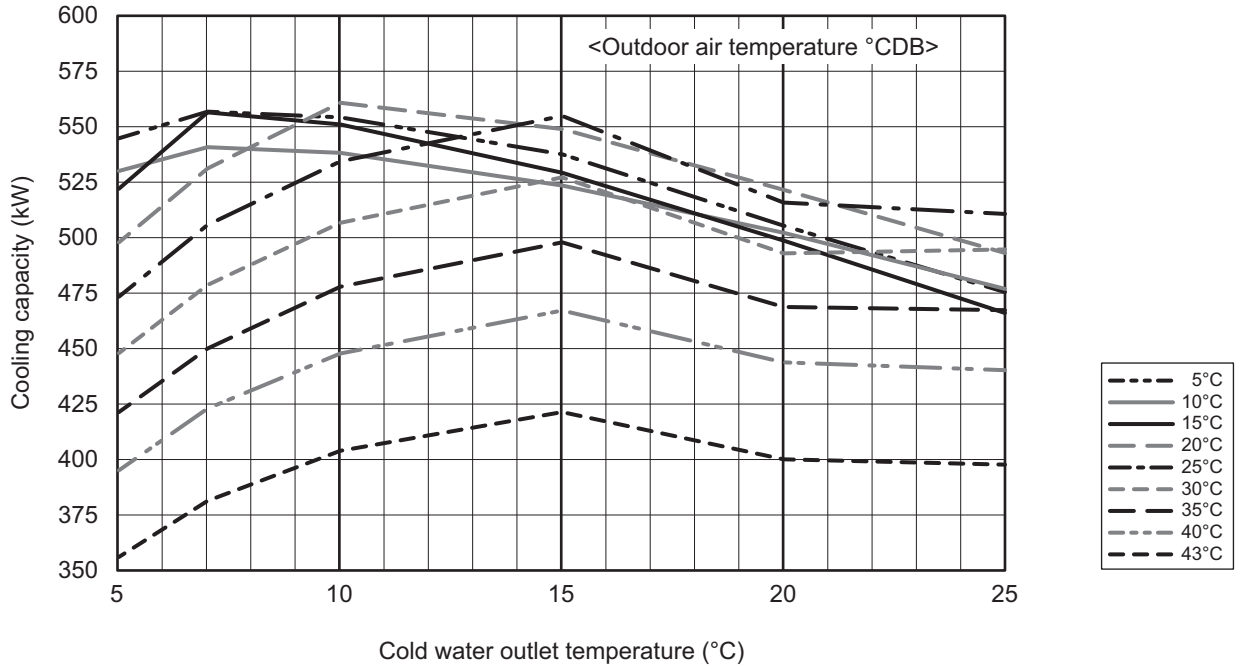

* When the cold water outlet temperature is 8°C or higher, the capacity control operation is performed to reduce the power consumption.

2. Product Data

[Cold/hot water outlet/inlet temperature difference 5°C]

EAHV-P900YA × 5

■ Heating Capacity

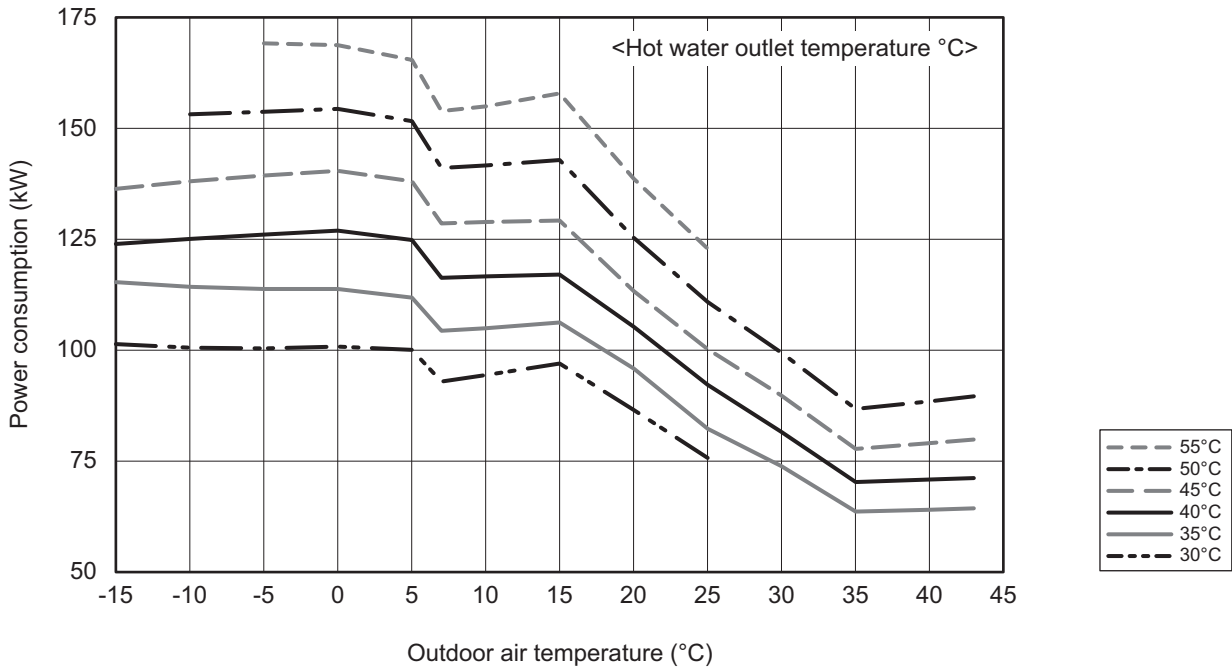
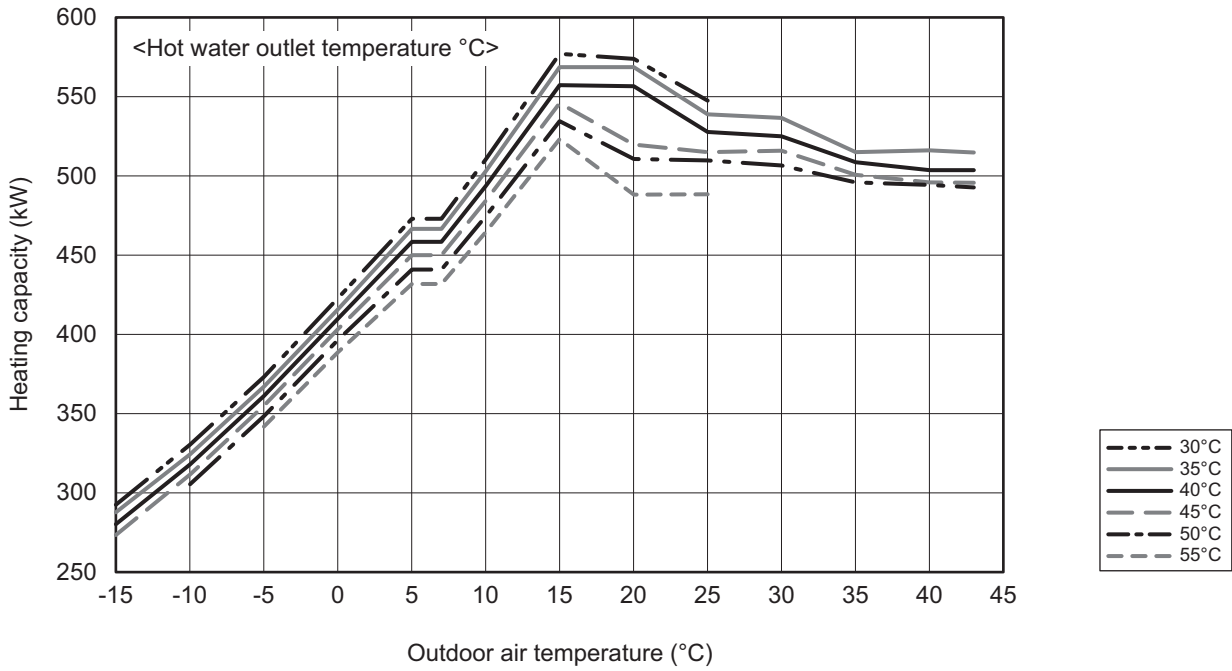

2. Product Data

[Cold/hot water outlet/inlet temperature difference 5°C]

EAHV-P900YA × 6

EACV-P900YA × 6

■ Cooling Capacity [Water]

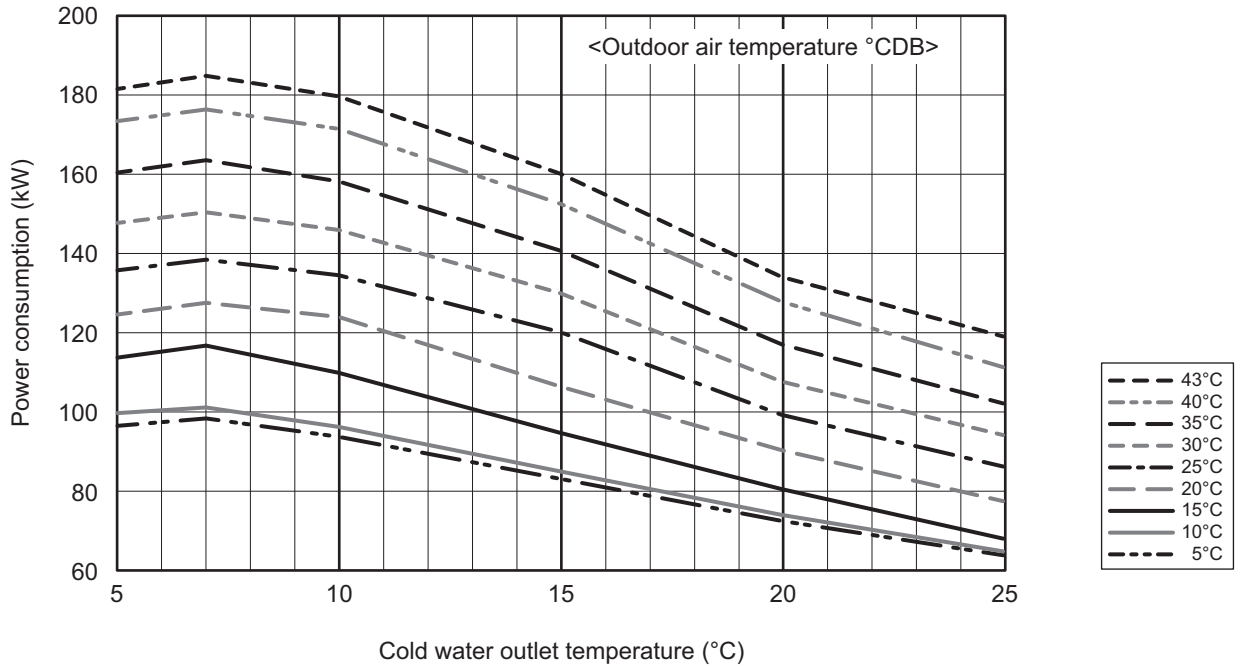
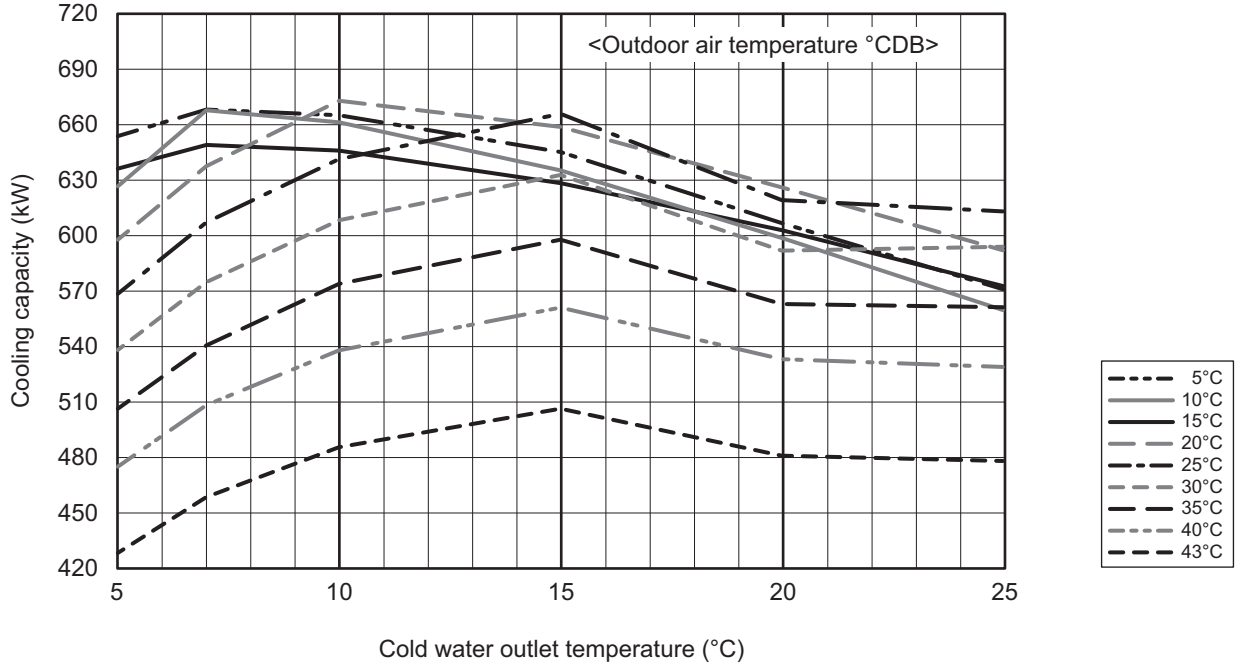

* When the cold water outlet temperature is 8°C or higher, the capacity control operation is performed to reduce the power consumption.

2. Product Data

[Cold/hot water outlet/inlet temperature difference 5°C]

EAHV-P900YA × 6

■ Heating Capacity

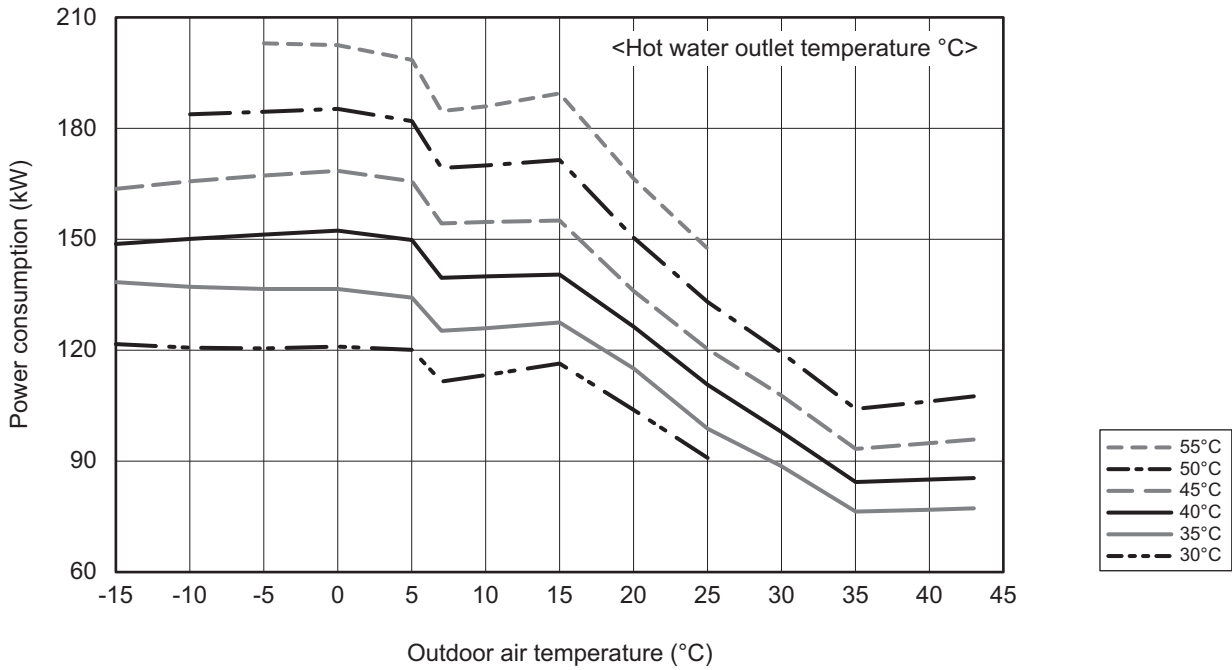
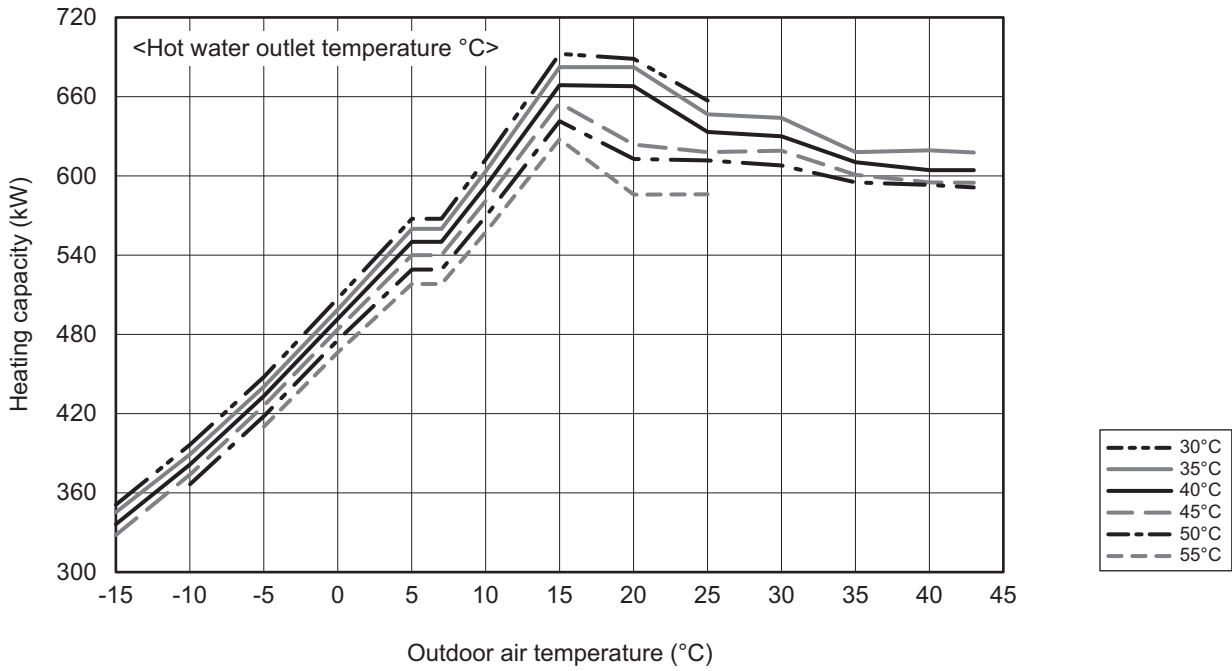

2. Product Data

[Cold brine outlet/inlet temperature difference 5°C]

EACV-P900YA

■ Cooling Capacity [Brine: ethylene glycol 35wt%]

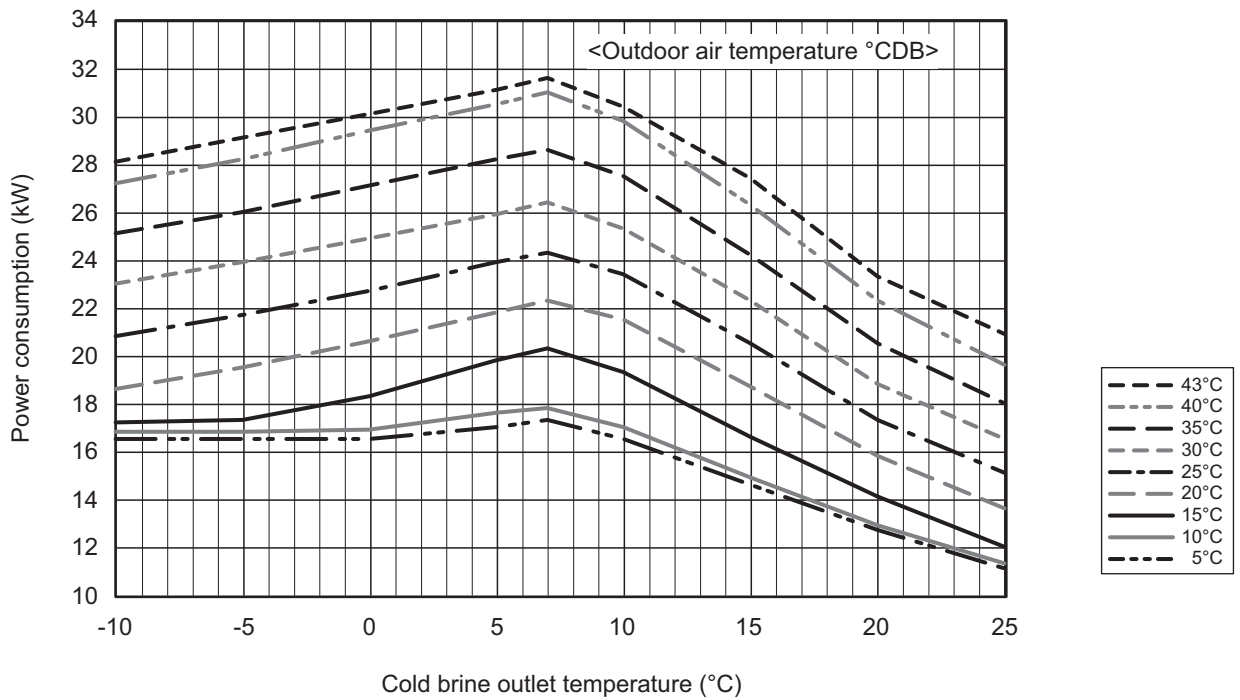
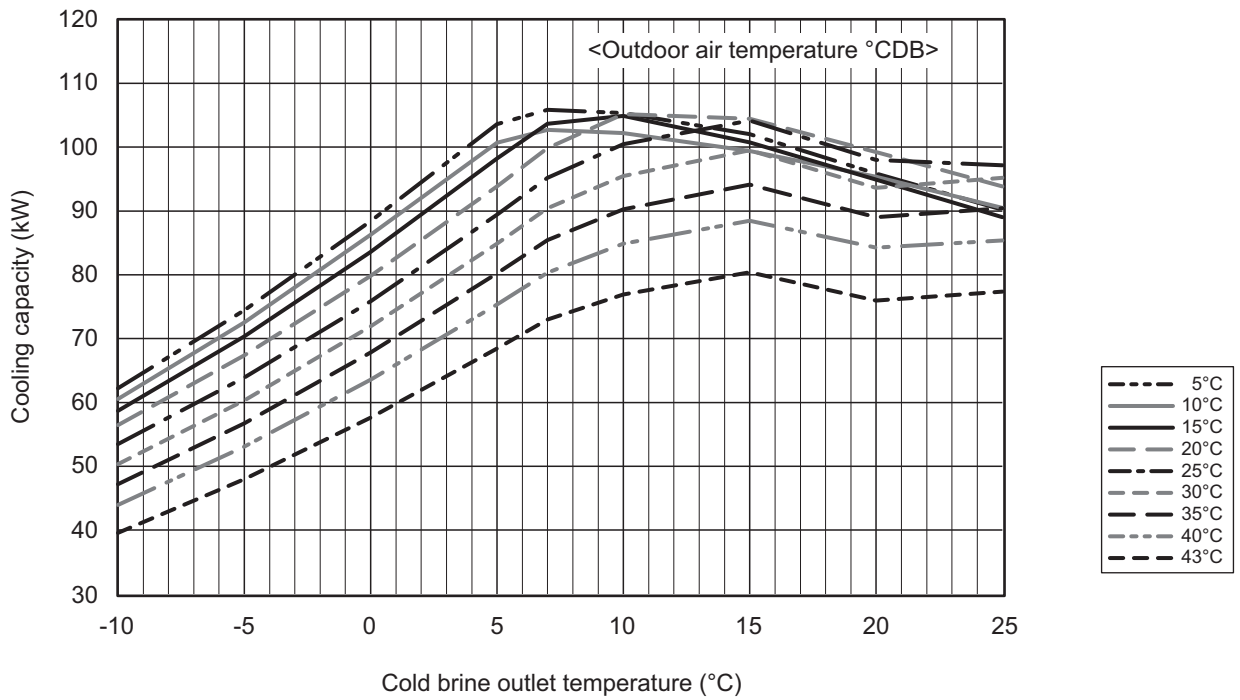

* When the cold brine outlet temperature is 8°C or higher, the capacity control operation is performed to reduce the power consumption.

2. Product Data

[Cold brine outlet/inlet temperature difference 5°C]

EACV-P900YA × 2

■ Cooling Capacity [Brine: ethylene glycol 35wt%]

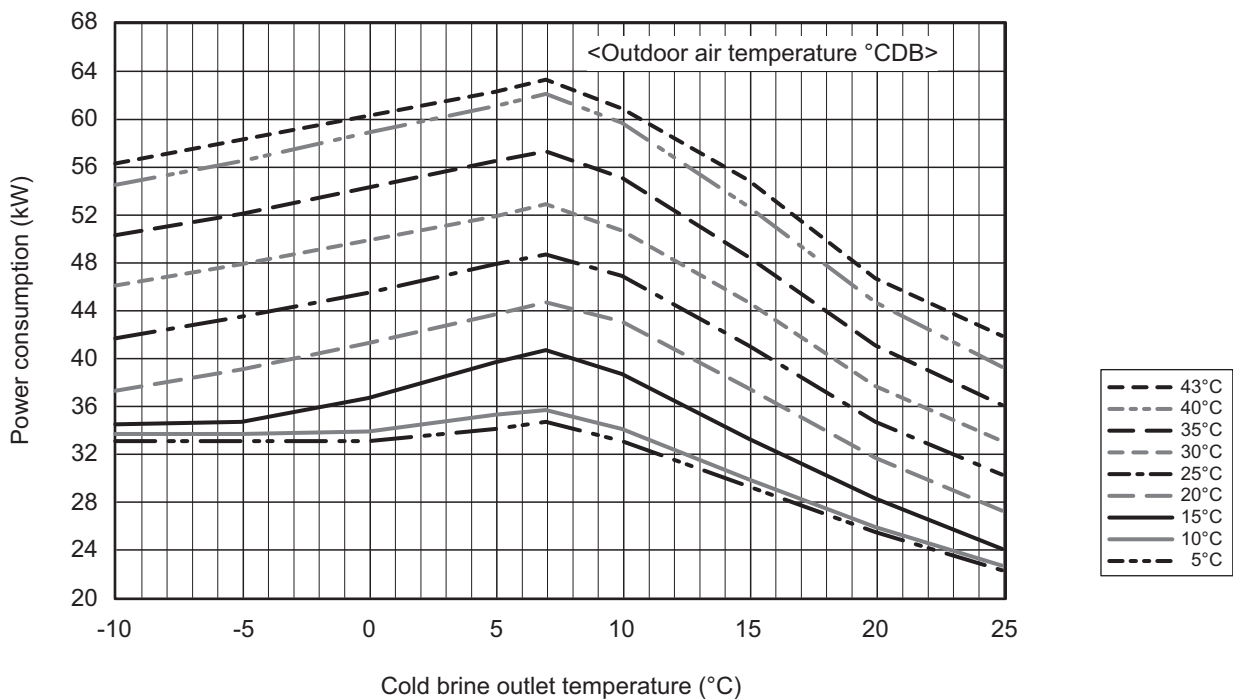
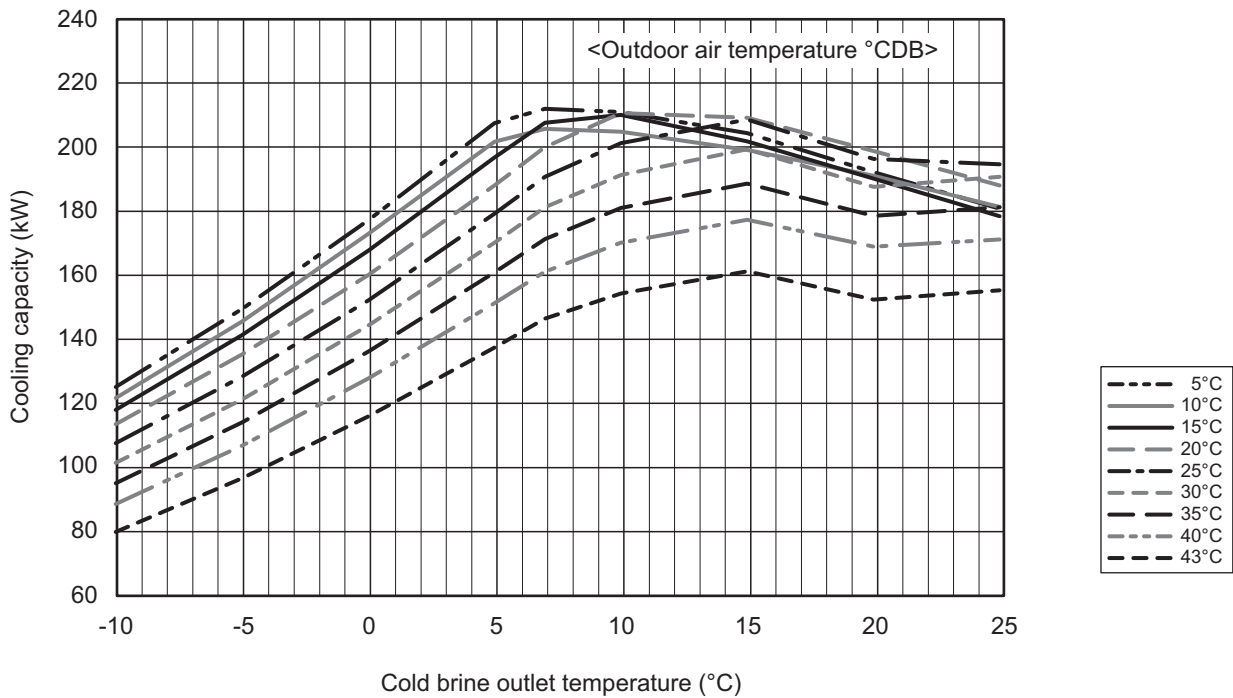

* When the cold brine outlet temperature is 8°C or higher, the capacity control operation is performed to reduce the power consumption.

2. Product Data

[Cold brine outlet/inlet temperature difference 5°C]

EACV-P900YA × 3

■ Cooling Capacity [Brine: ethylene glycol 35wt%]

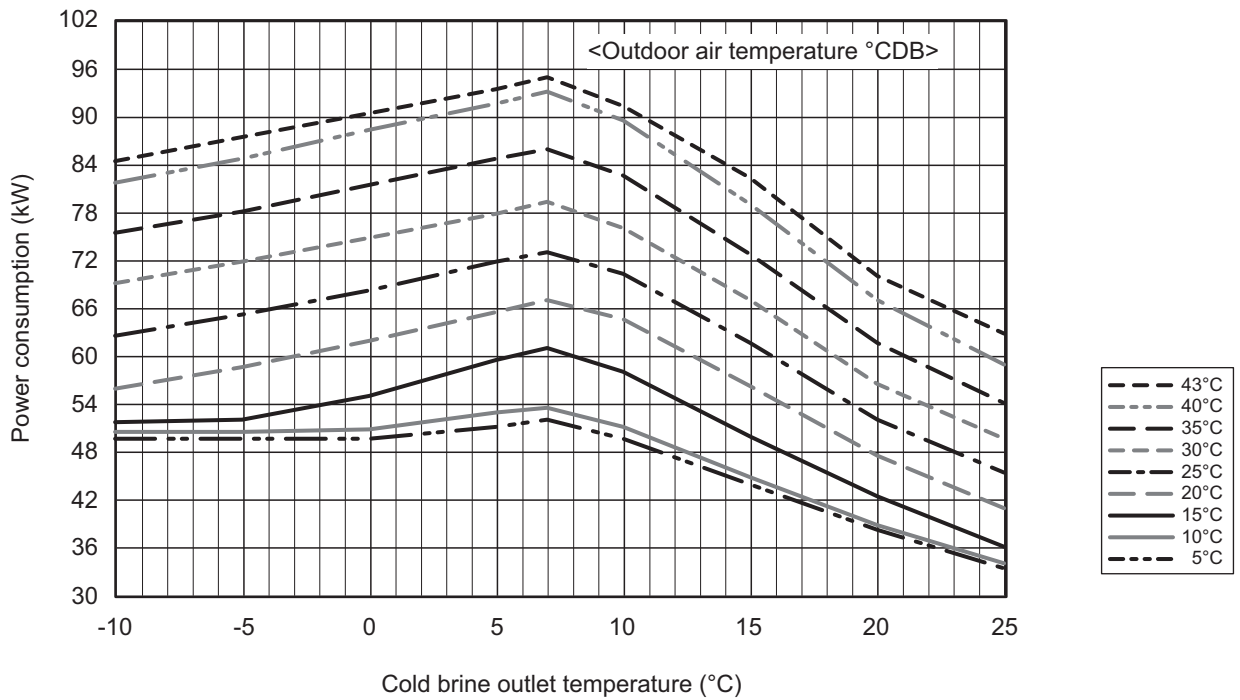
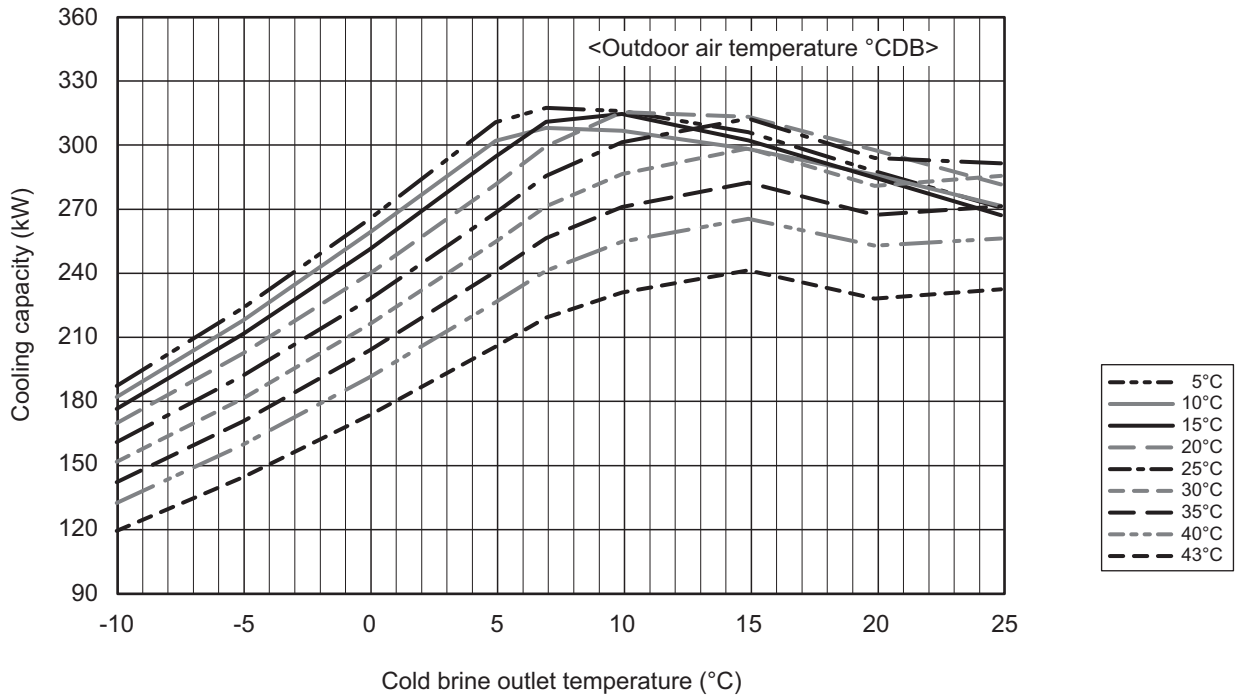

* When the cold brine outlet temperature is 8°C or higher, the capacity control operation is performed to reduce the power consumption.

2. Product Data

[Cold brine outlet/inlet temperature difference 5°C]

EACV-P900YA × 4

■ Cooling Capacity [Brine: ethylene glycol 35wt%]

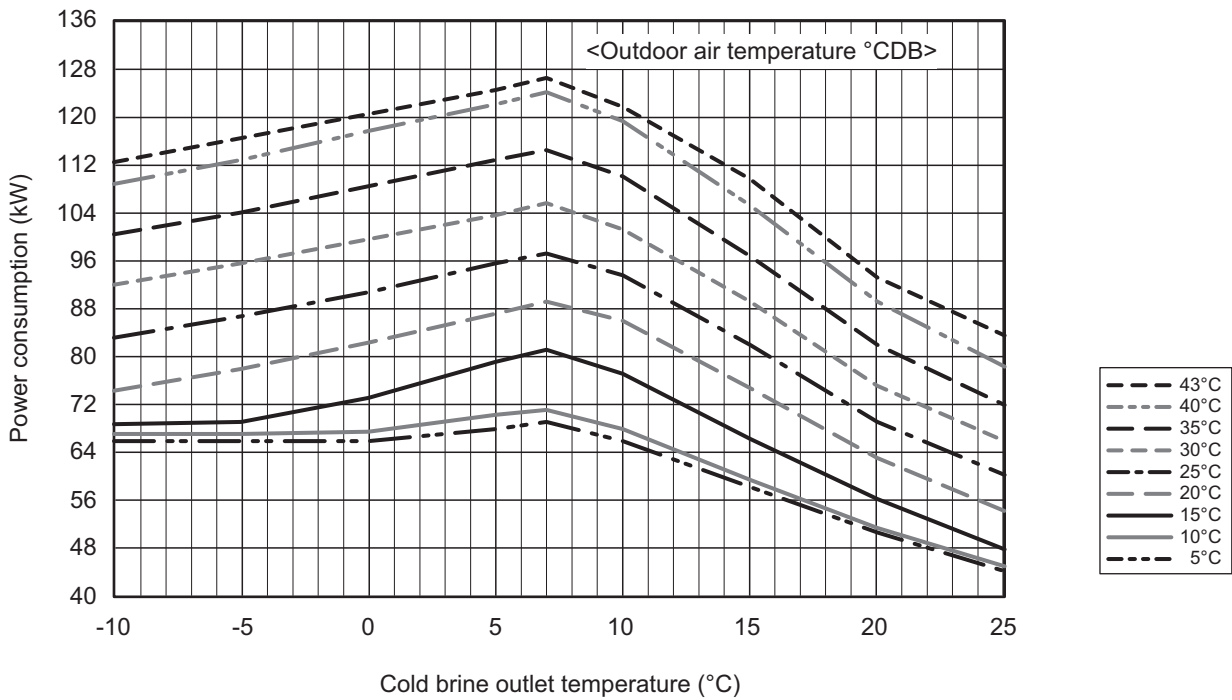
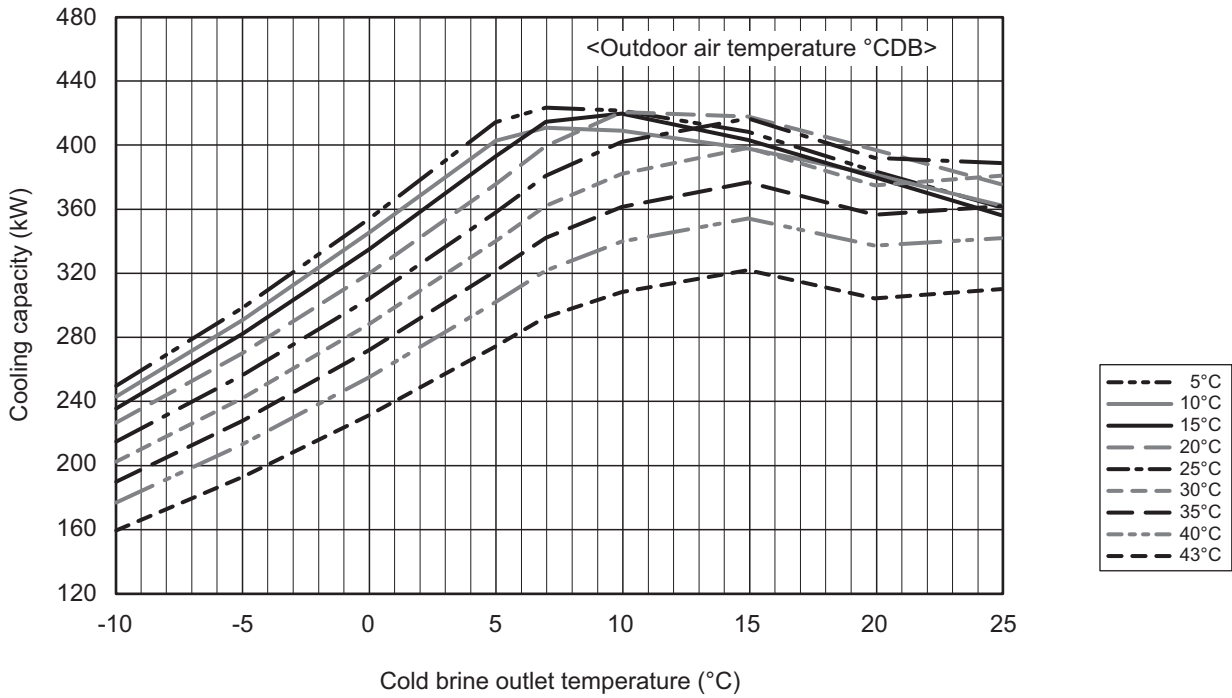

* When the cold brine outlet temperature is 8°C or higher, the capacity control operation is performed to reduce the power consumption.

EAHV-P-YAF(-H)(-N), YAL(-H)(-N)/EACV-P-YAF(-N), YAL(-N)

2. Product Data

[Cold brine outlet/inlet temperature difference 5°C]

EACV-P900YA × 5

■ Cooling Capacity [Brine: ethylene glycol 35wt%]

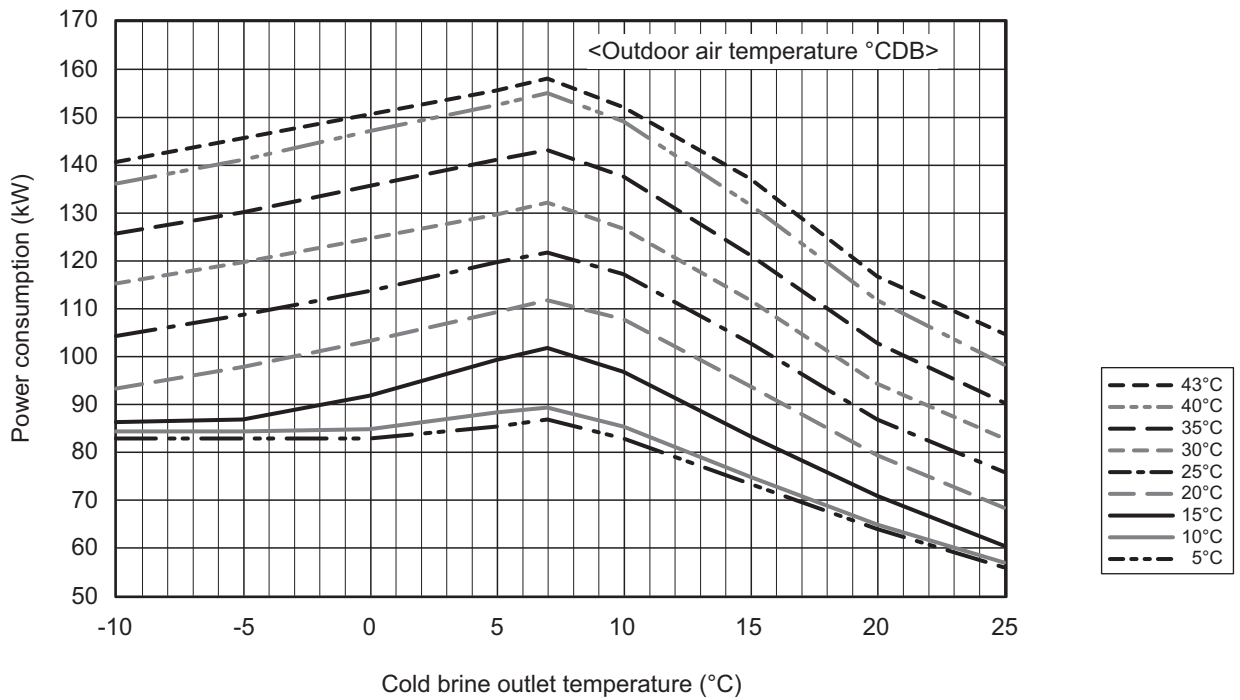
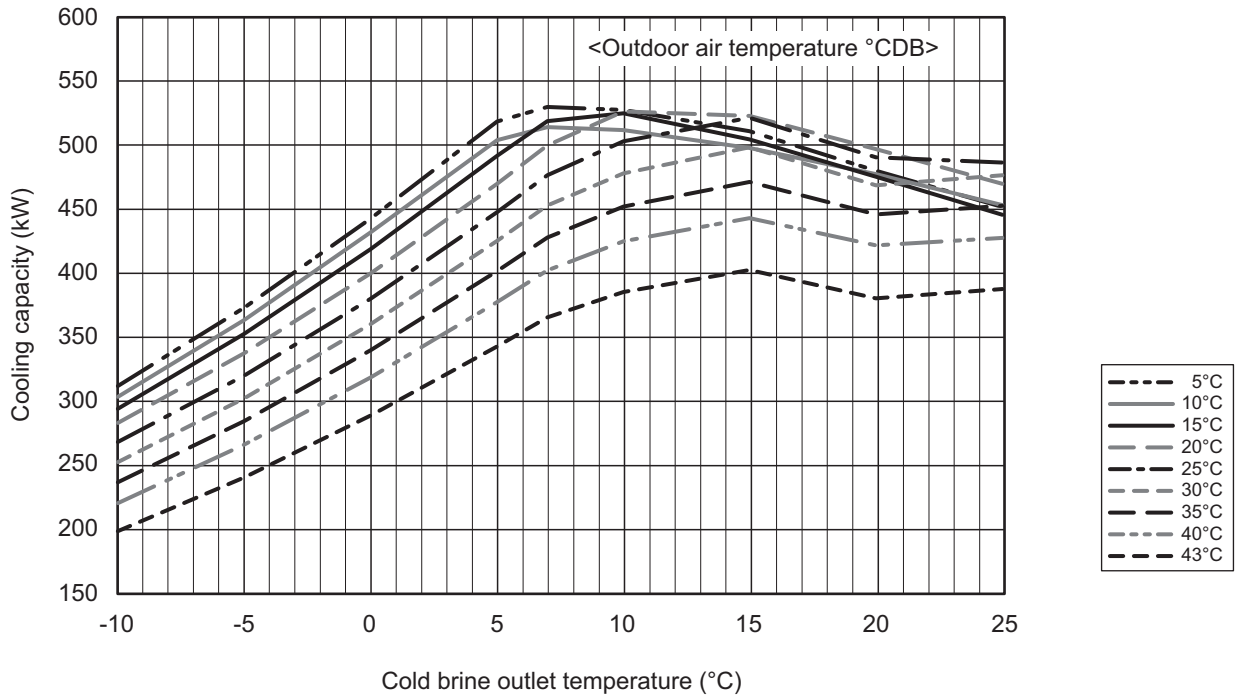

* When the cold brine outlet temperature is 8°C or higher, the capacity control operation is performed to reduce the power consumption.

2. Product Data

[Cold brine outlet/inlet temperature difference 5°C]

EACV-P900YA × 6

■ Cooling Capacity [Brine: ethylene glycol 35wt%]

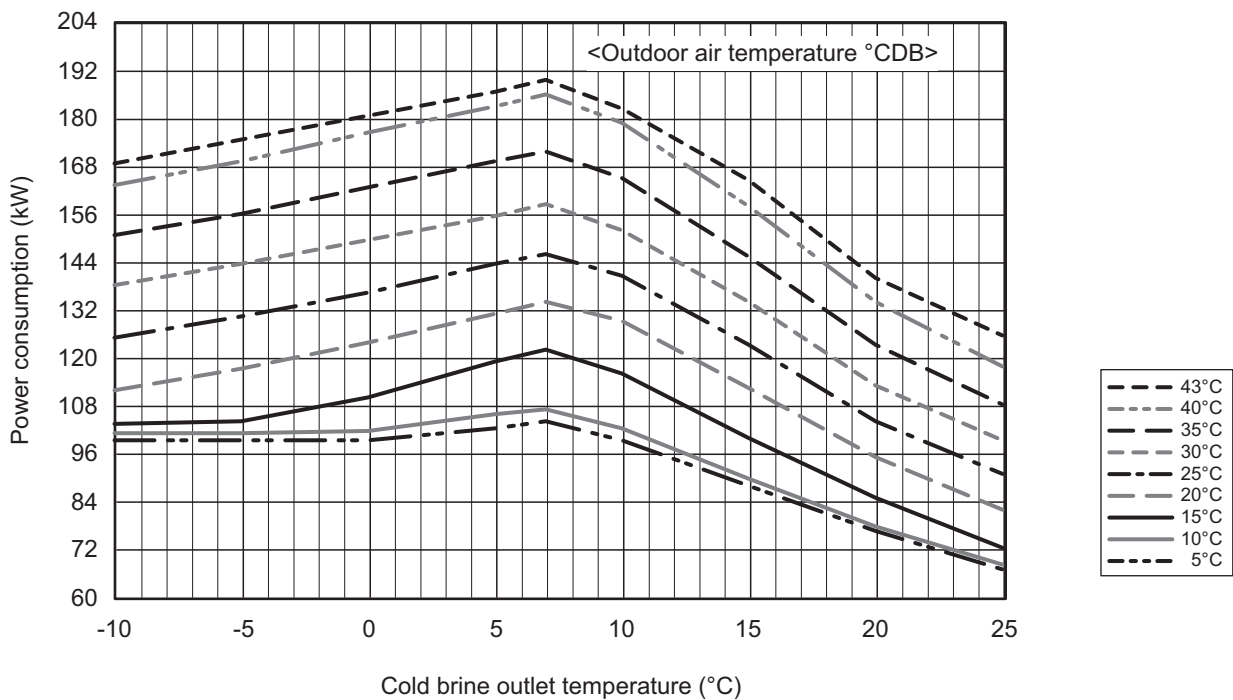
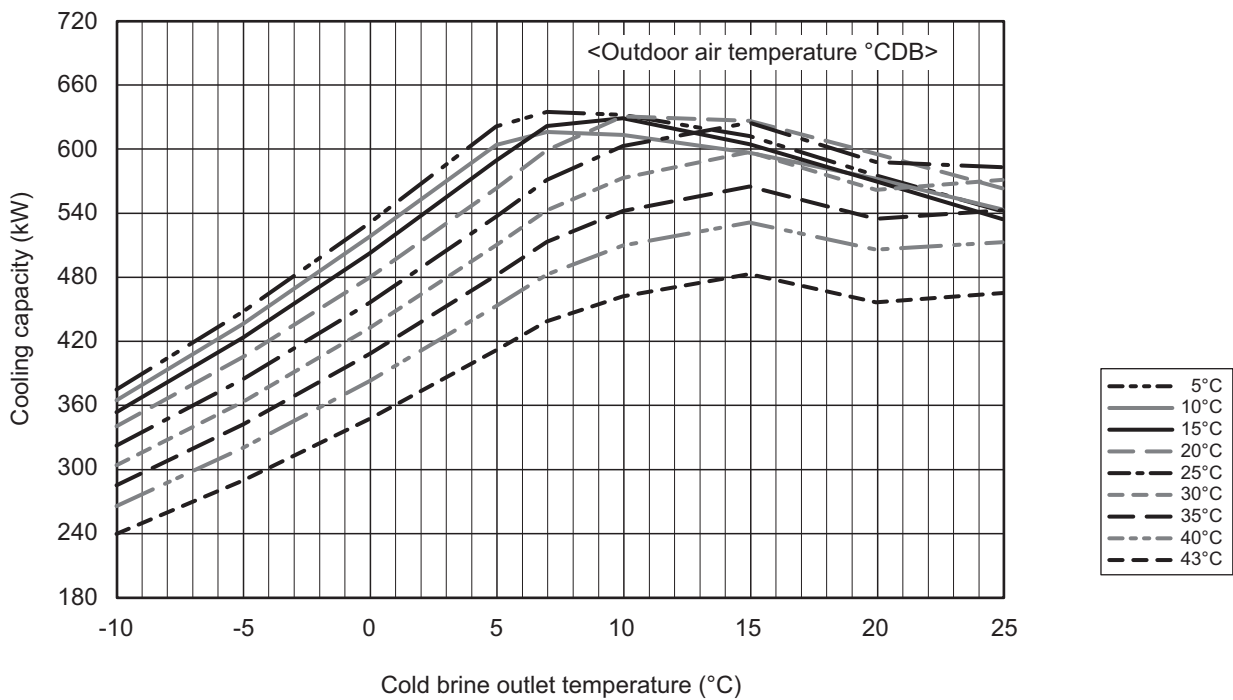

* When the cold brine outlet temperature is 8°C or higher, the capacity control operation is performed to reduce the power consumption.

EAHV-P-YAF(-H)(-N), YAL(-H)(-N)/EACV-P-YAF(-N), YAL(-N)

2. Product Data

[Cold/hot water outlet/inlet temperature difference 5°C]

COP priority mode

EAHV-P900YA

EACV-P900YA

■ Cooling Capacity [Water]

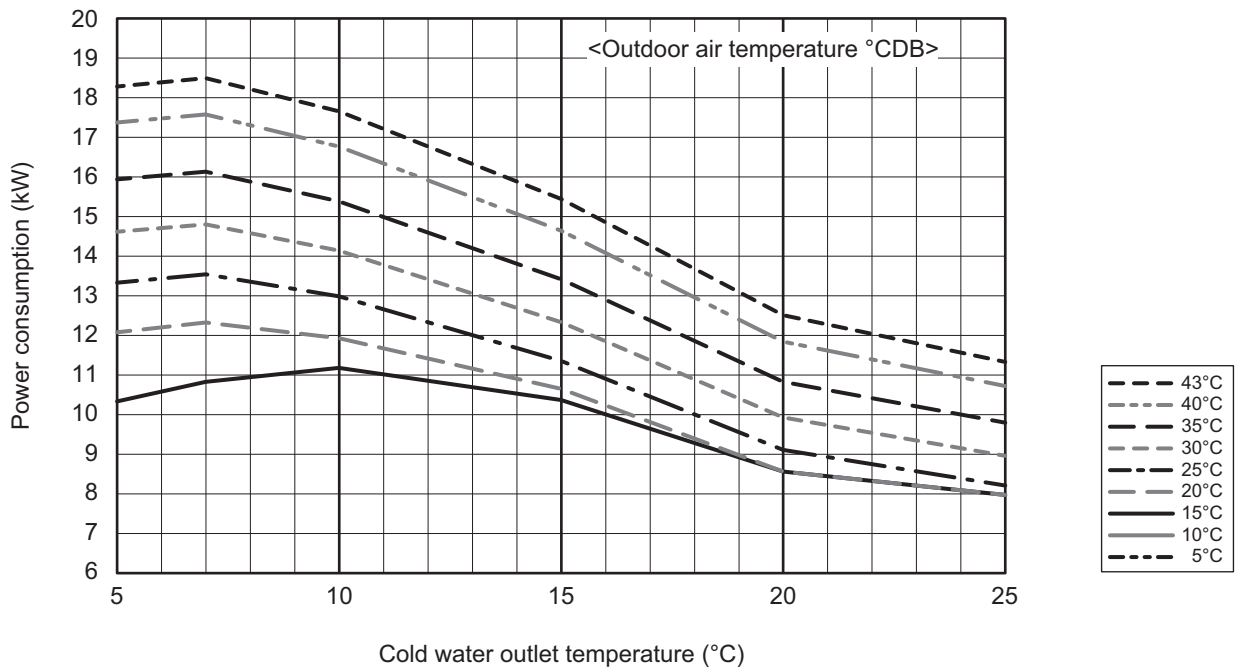
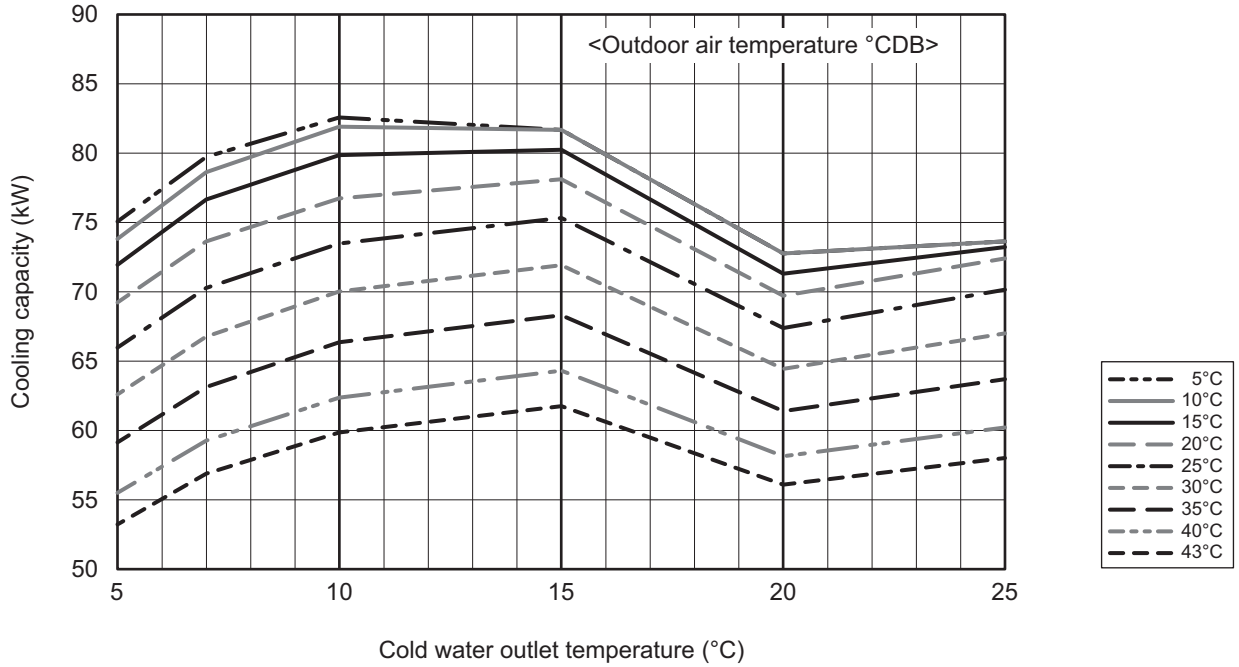

* When the cold water outlet temperature is 8°C or higher, the capacity control operation is performed to reduce the power consumption.

2. Product Data

[Cold/hot water outlet/inlet temperature difference 5°C]

COP priority mode

EAHV-P900YA

■ Heating Capacity

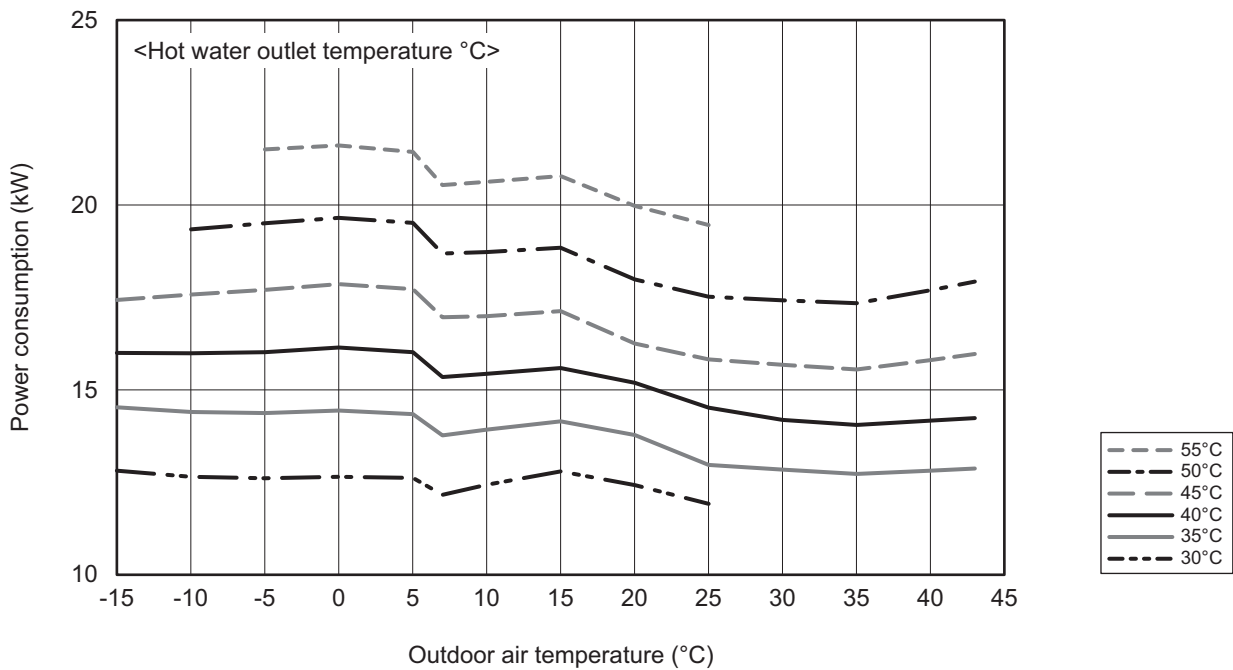
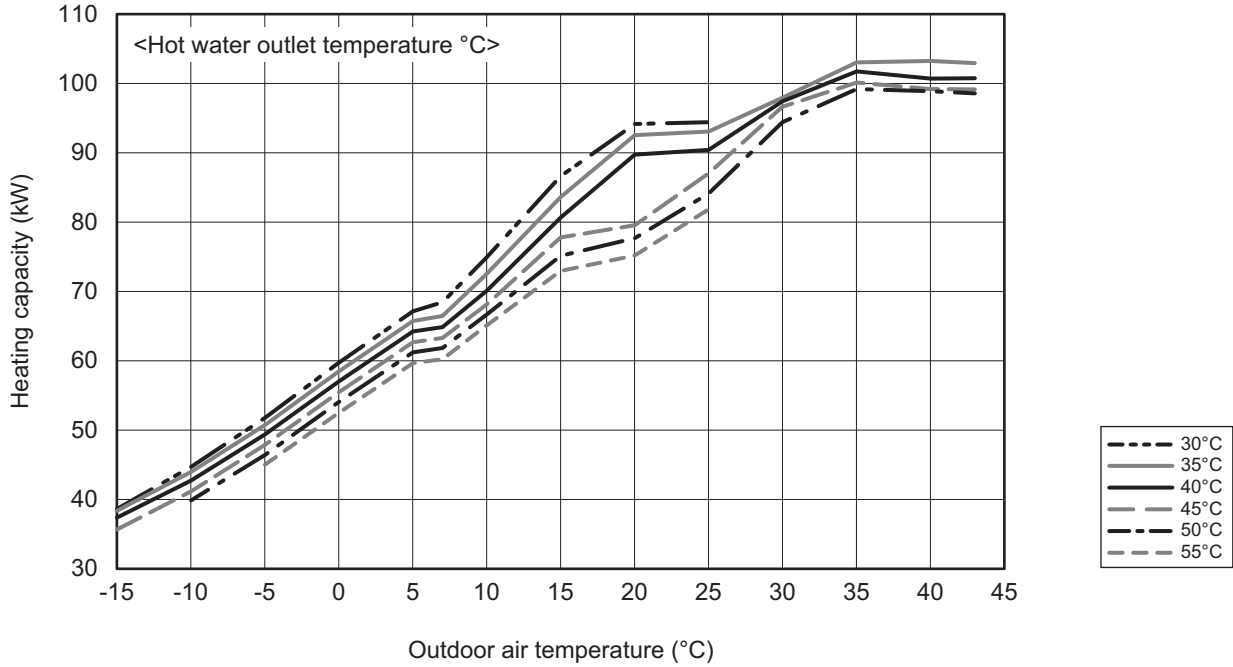

2. Product Data

[Cold/hot water outlet/inlet temperature difference 5°C]

COP priority mode

EAHV-P900YA × 2

EACV-P900YA × 2

■ Cooling Capacity [Water]

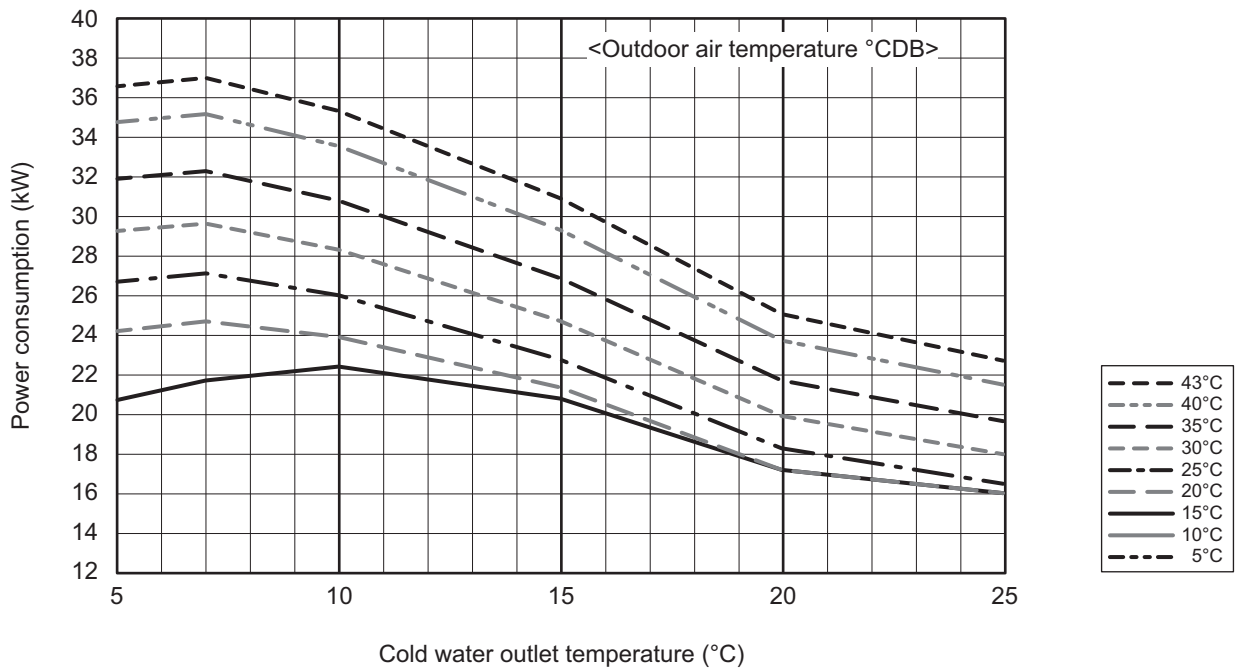
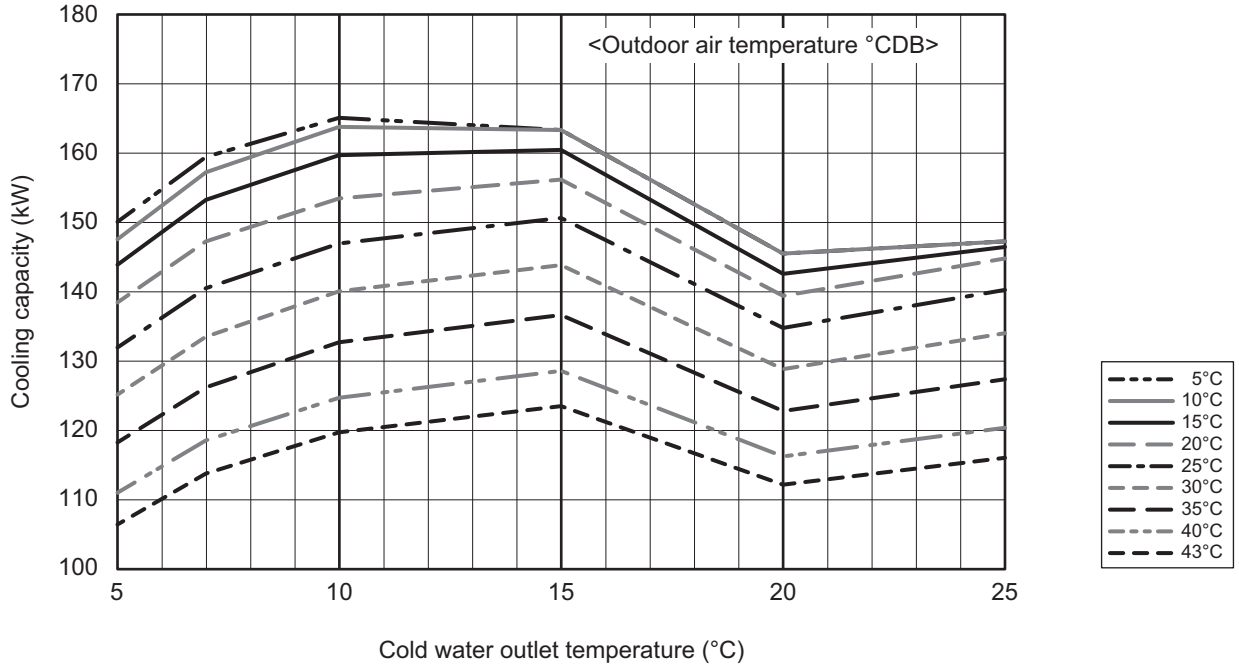

* When the cold water outlet temperature is 8°C or higher, the capacity control operation is performed to reduce the power consumption.

2. Product Data

[Cold/hot water outlet/inlet temperature difference 5°C]

COP priority mode

EAHV-P900YA × 2

■ Heating Capacity

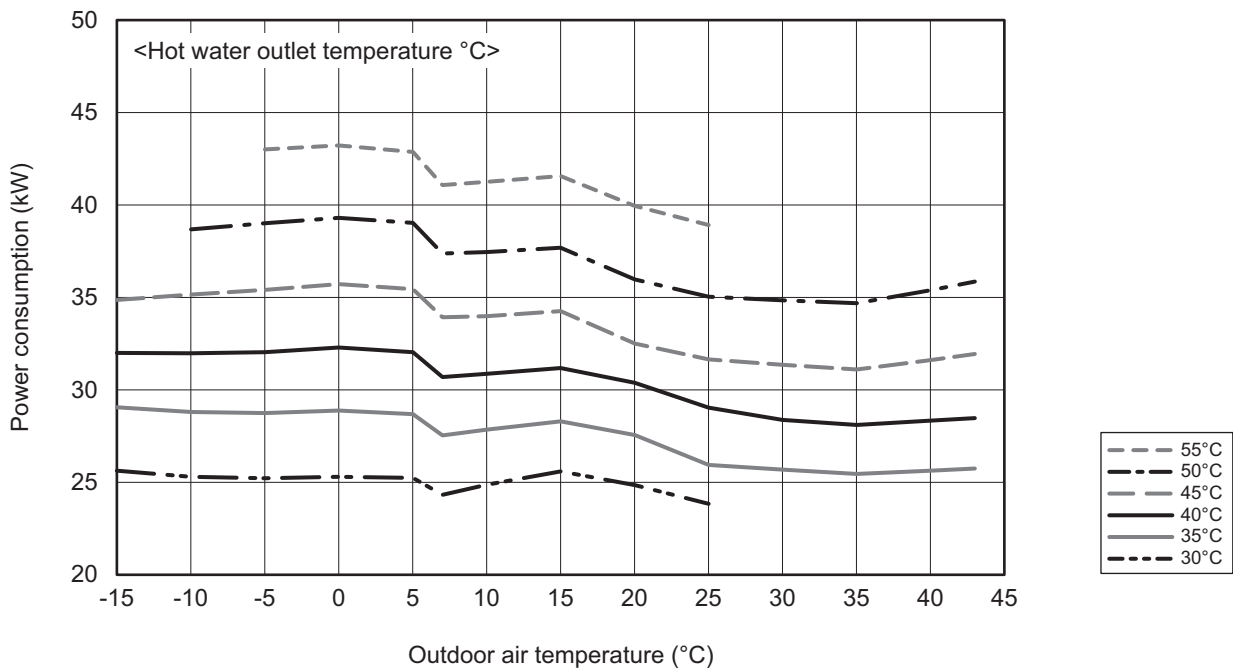
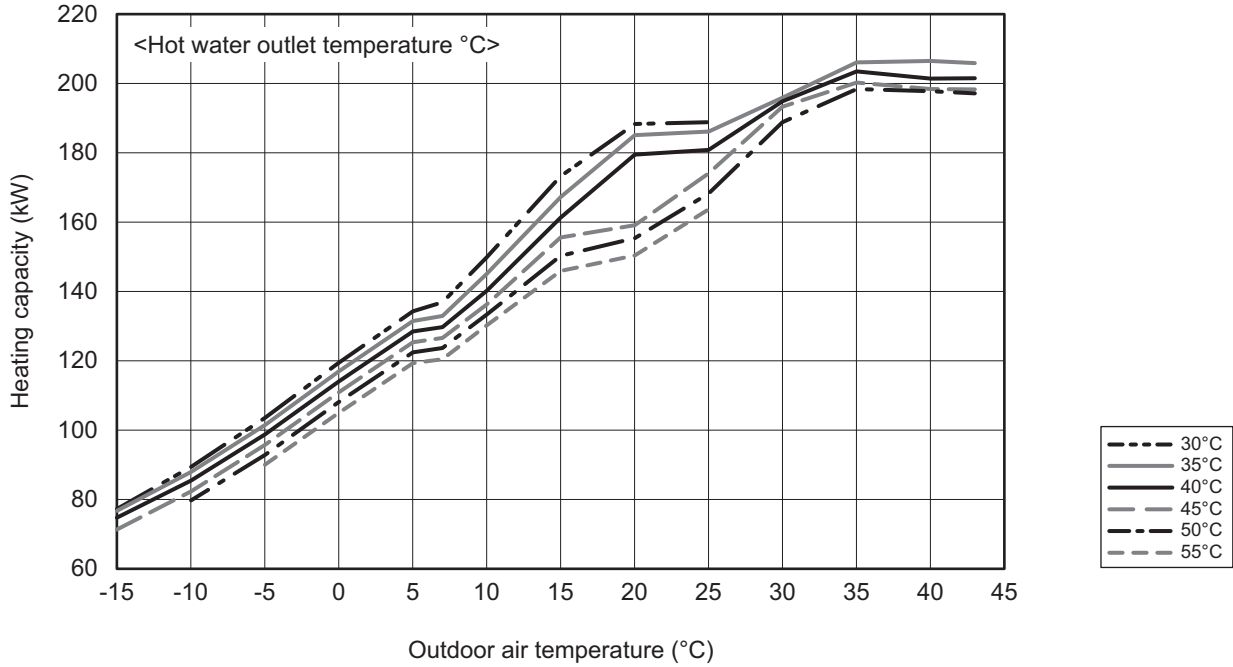

2. Product Data

[Cold/hot water outlet/inlet temperature difference 5°C]

COP priority mode

EAHV-P900YA × 3

EACV-P900YA × 3

■ Cooling Capacity [Water]

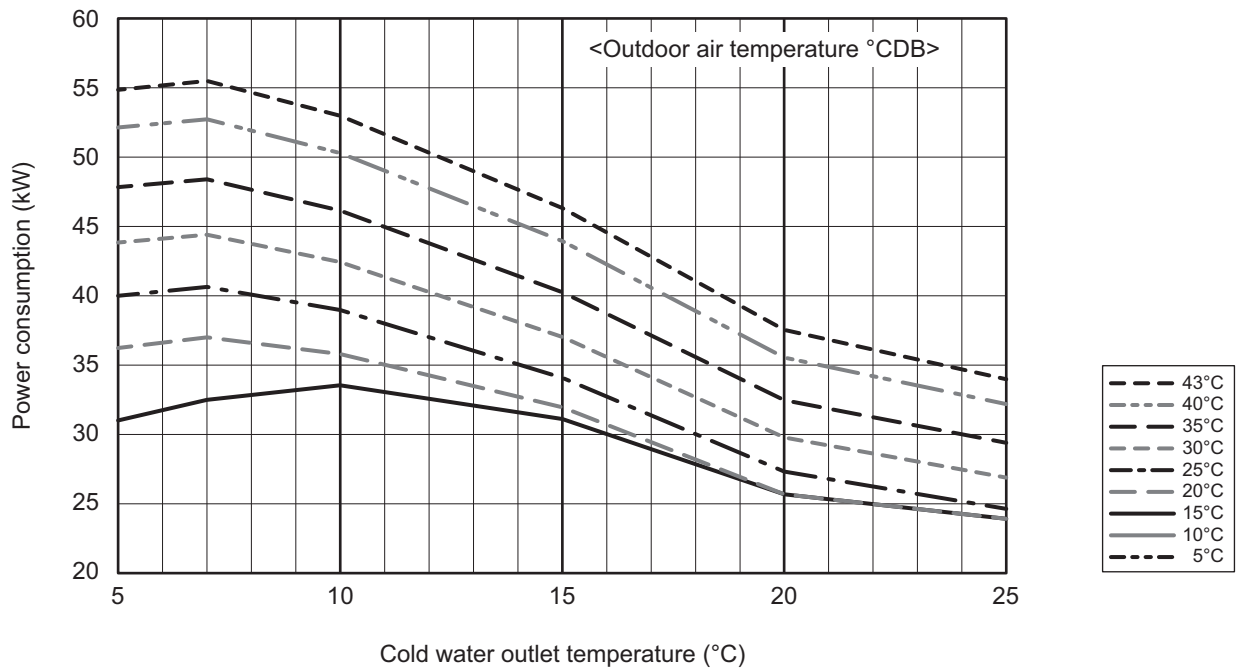
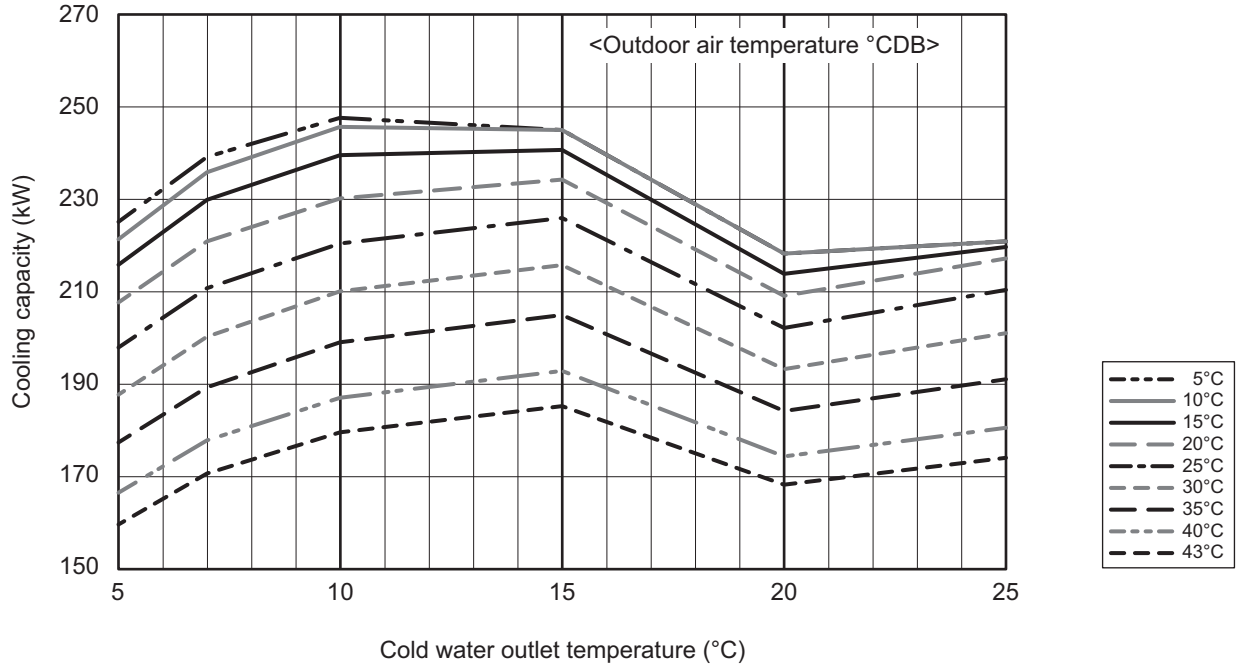

* When the cold water outlet temperature is 8°C or higher, the capacity control operation is performed to reduce the power consumption.

2. Product Data

[Cold/hot water outlet/inlet temperature difference 5°C]

COP priority mode

EAHV-P900YA × 3

■ Heating Capacity

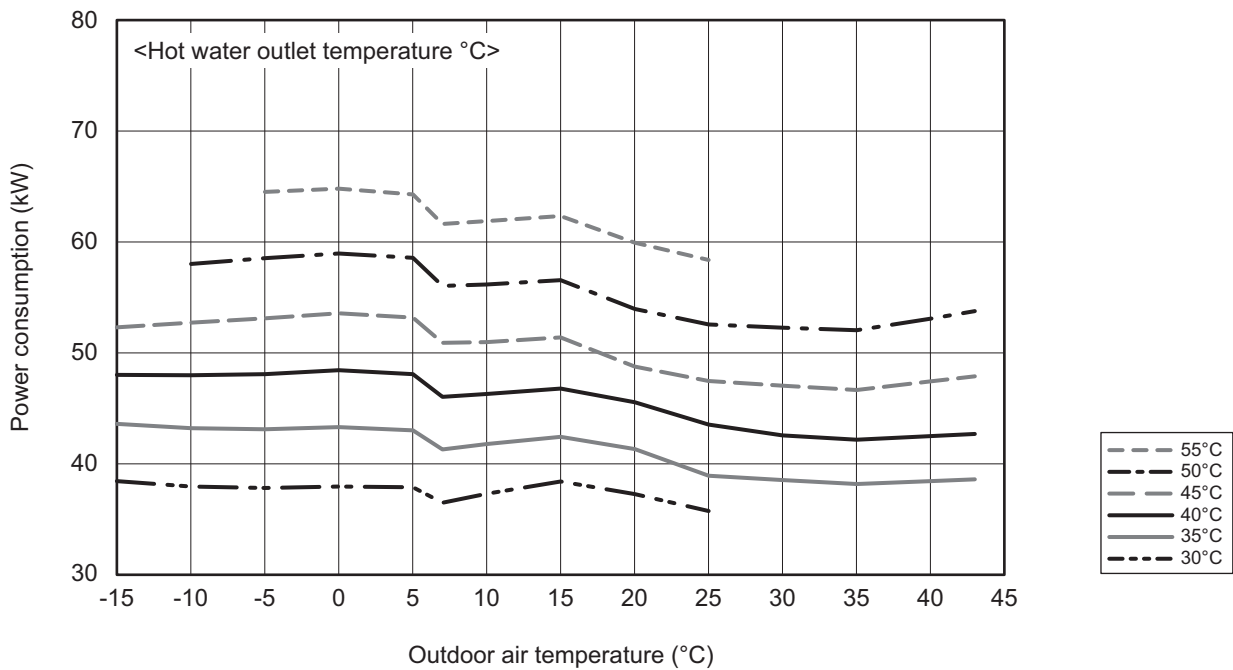
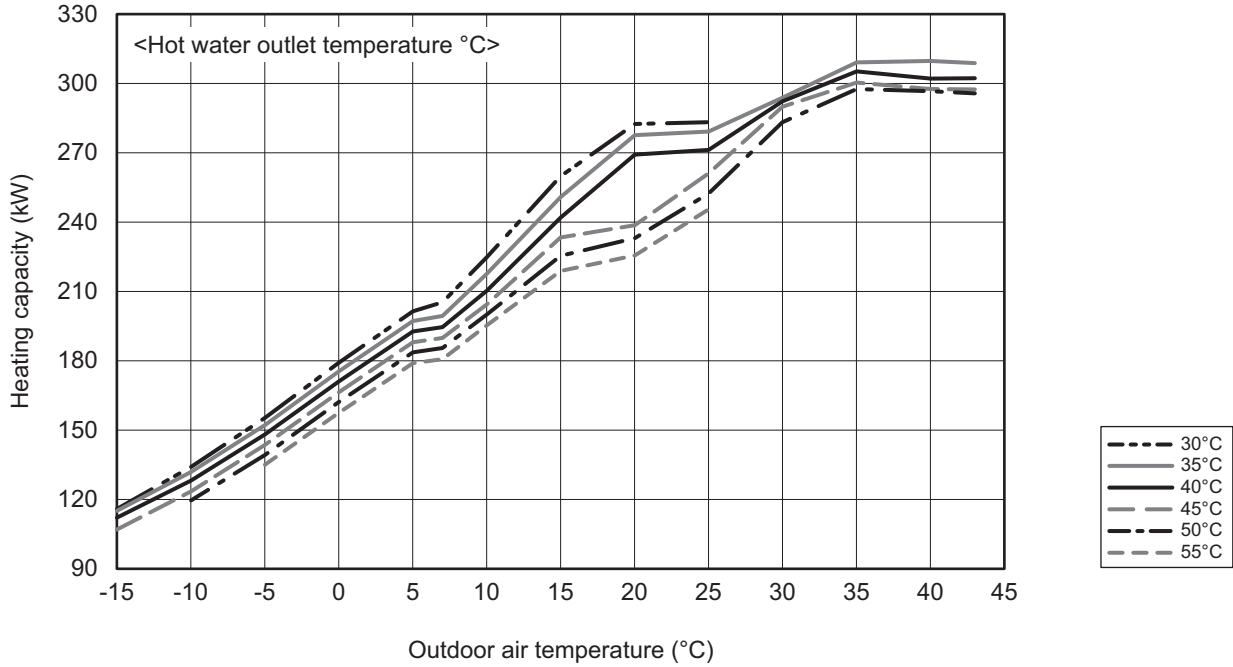

2. Product Data

[Cold/hot water outlet/inlet temperature difference 5°C]

COP priority mode

EAHV-P900YA × 4

EACV-P900YA × 4

■ Cooling Capacity [Water]

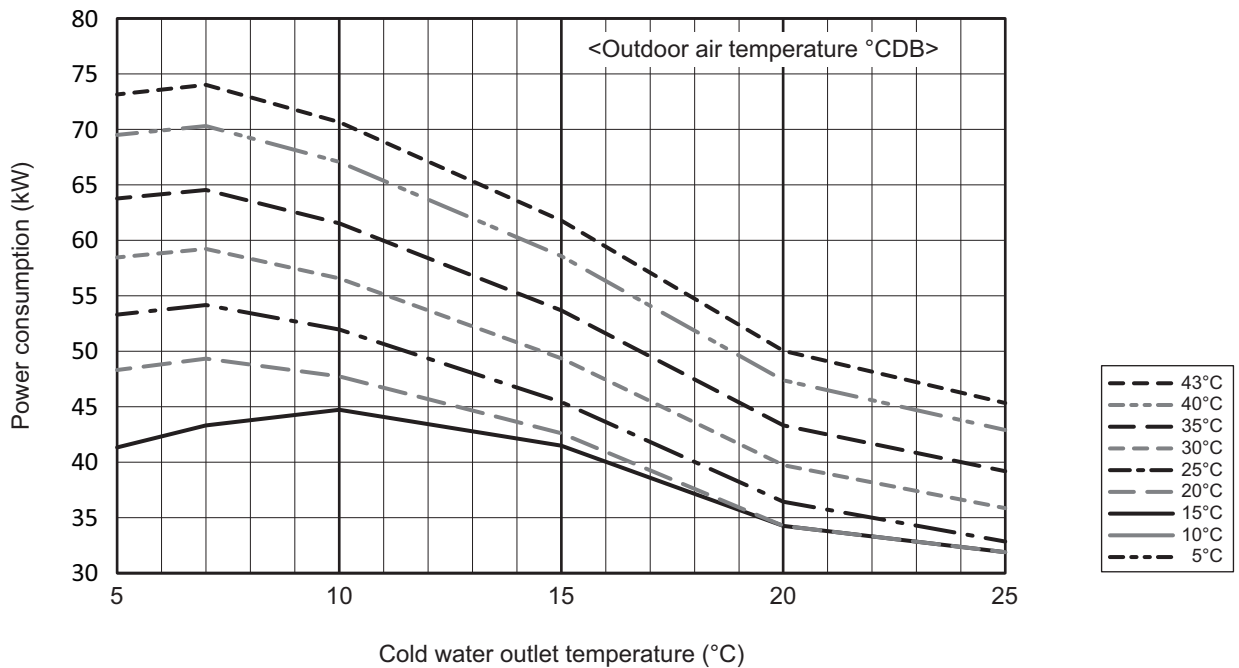
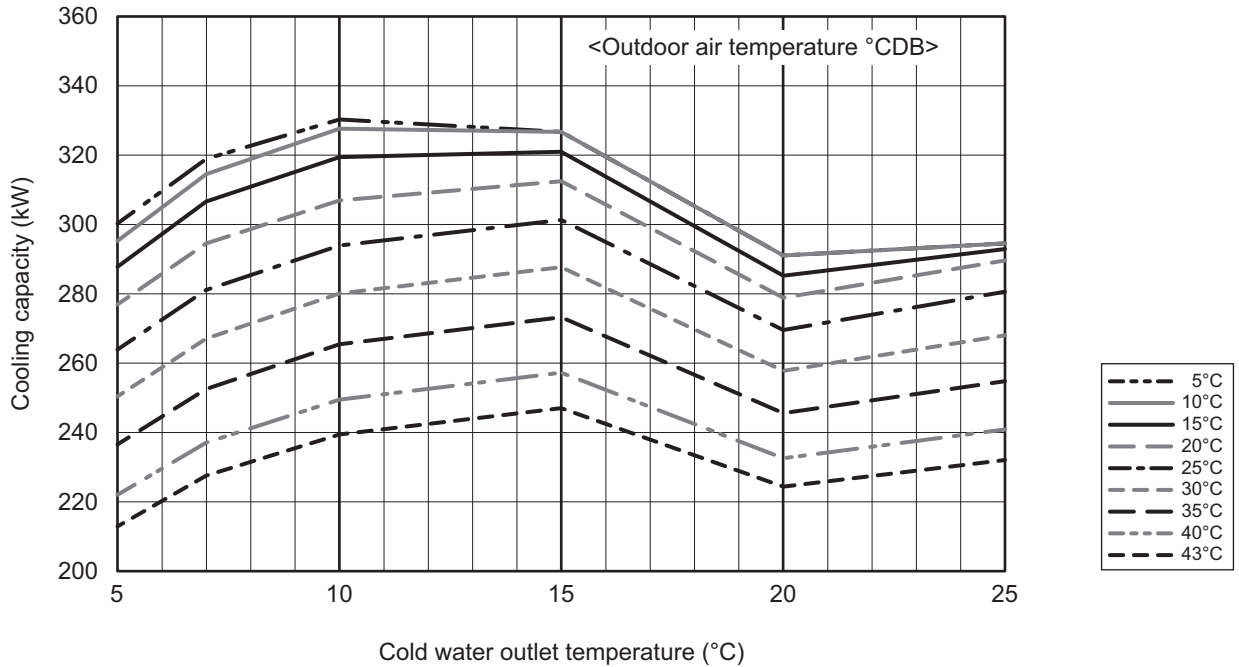

* When the cold water outlet temperature is 8°C or higher, the capacity control operation is performed to reduce the power consumption.

2. Product Data

[Cold/hot water outlet/inlet temperature difference 5°C]

COP priority mode

EAHV-P900YA × 4

■ Heating Capacity

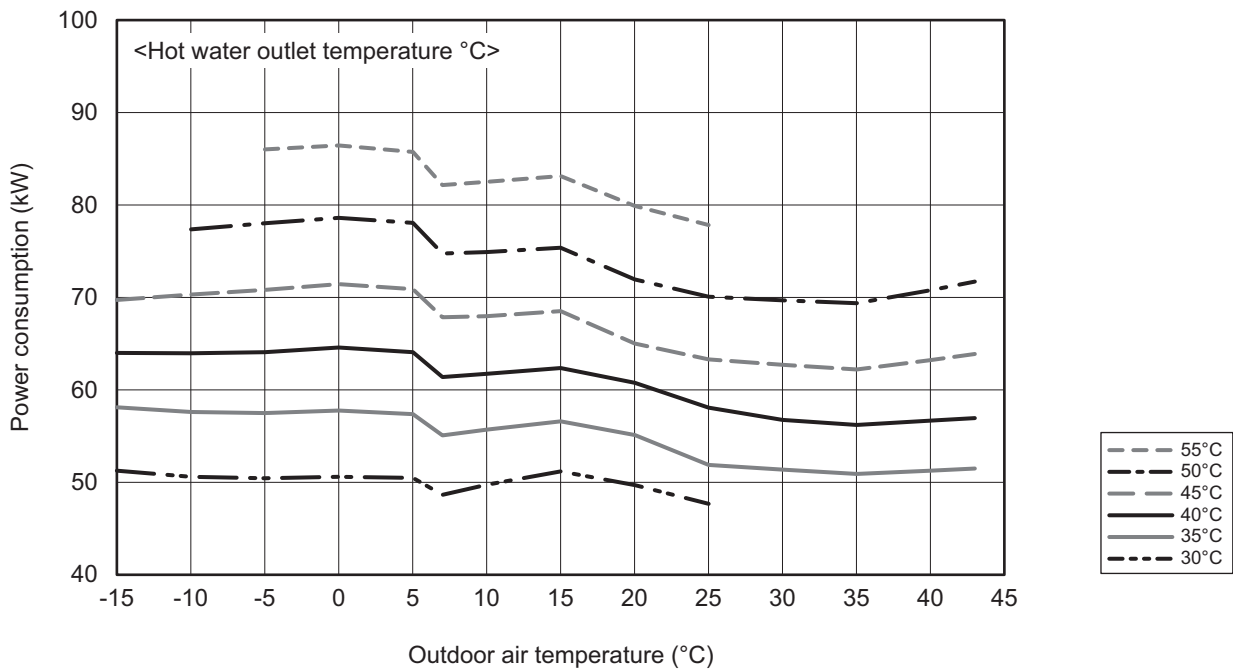
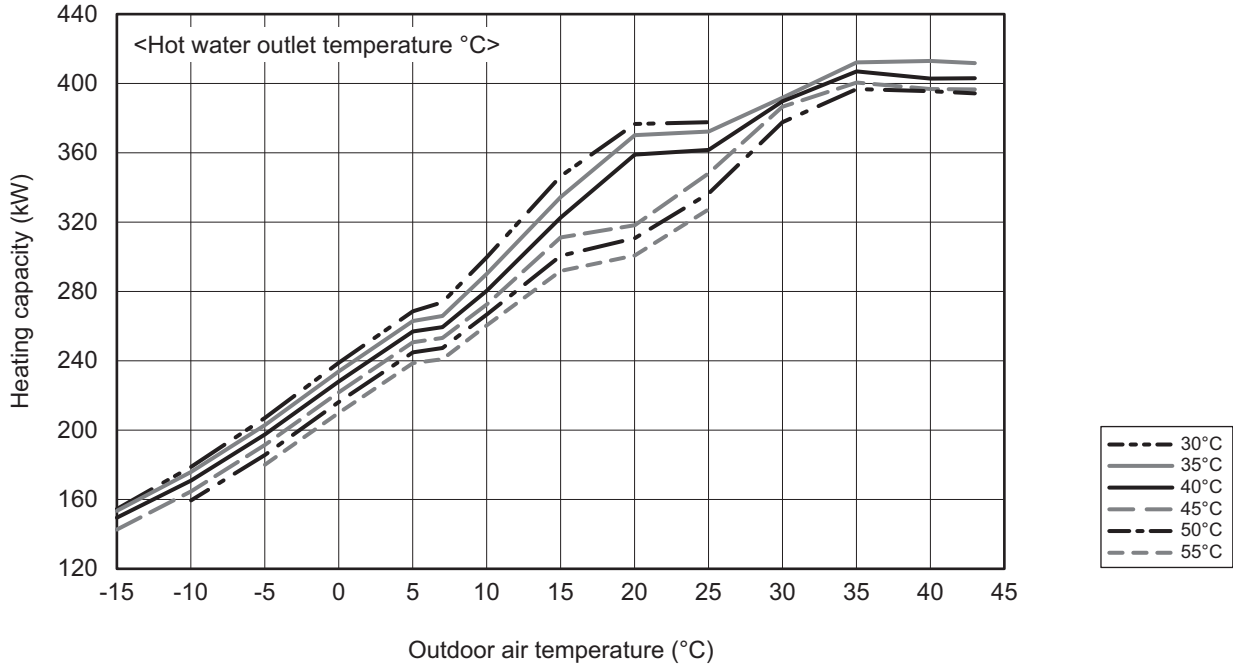

2. Product Data

[Cold/hot water outlet/inlet temperature difference 5°C]

COP priority mode

EAHV-P900YA × 5

EACV-P900YA × 5

■ Cooling Capacity [Water]

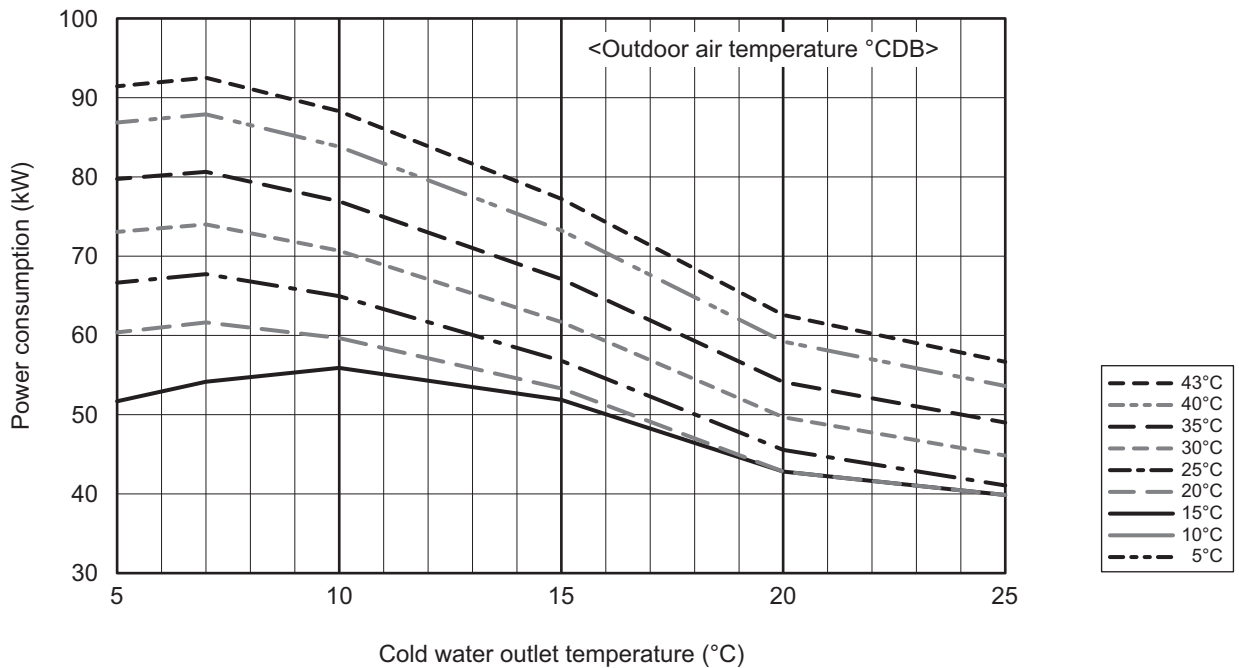
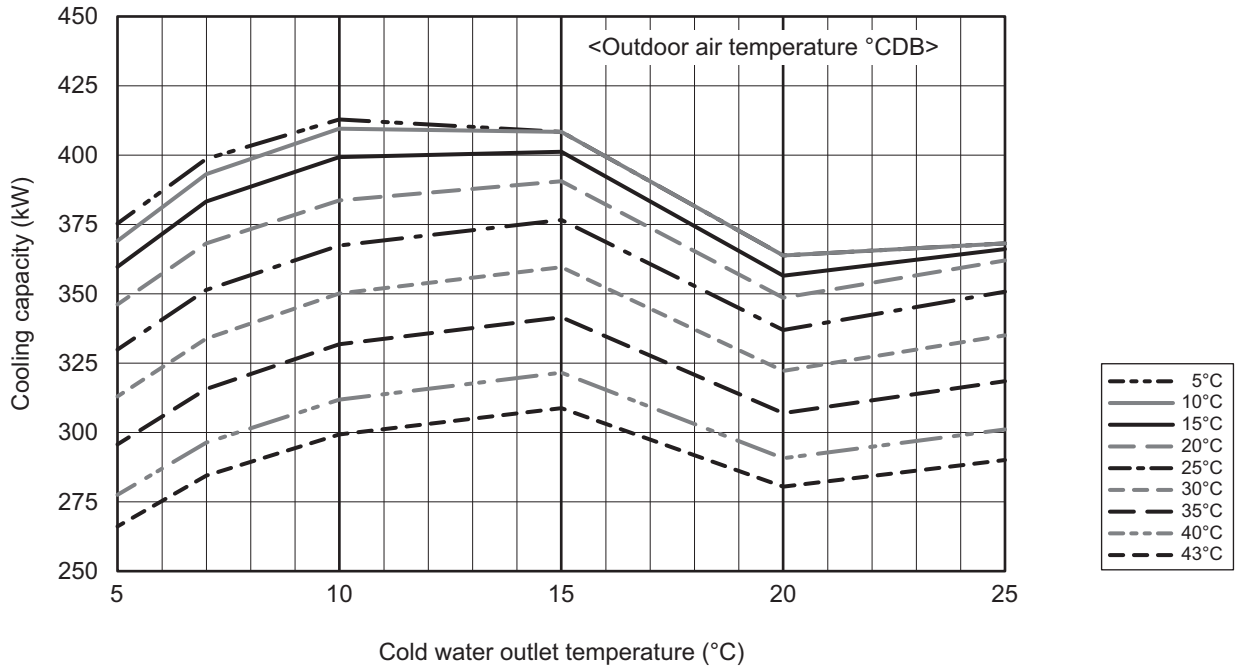

* When the cold water outlet temperature is 8°C or higher, the capacity control operation is performed to reduce the power consumption.

2. Product Data

[Cold/hot water outlet/inlet temperature difference 5°C]

COP priority mode

EAHV-P900YA × 5

■ Heating Capacity

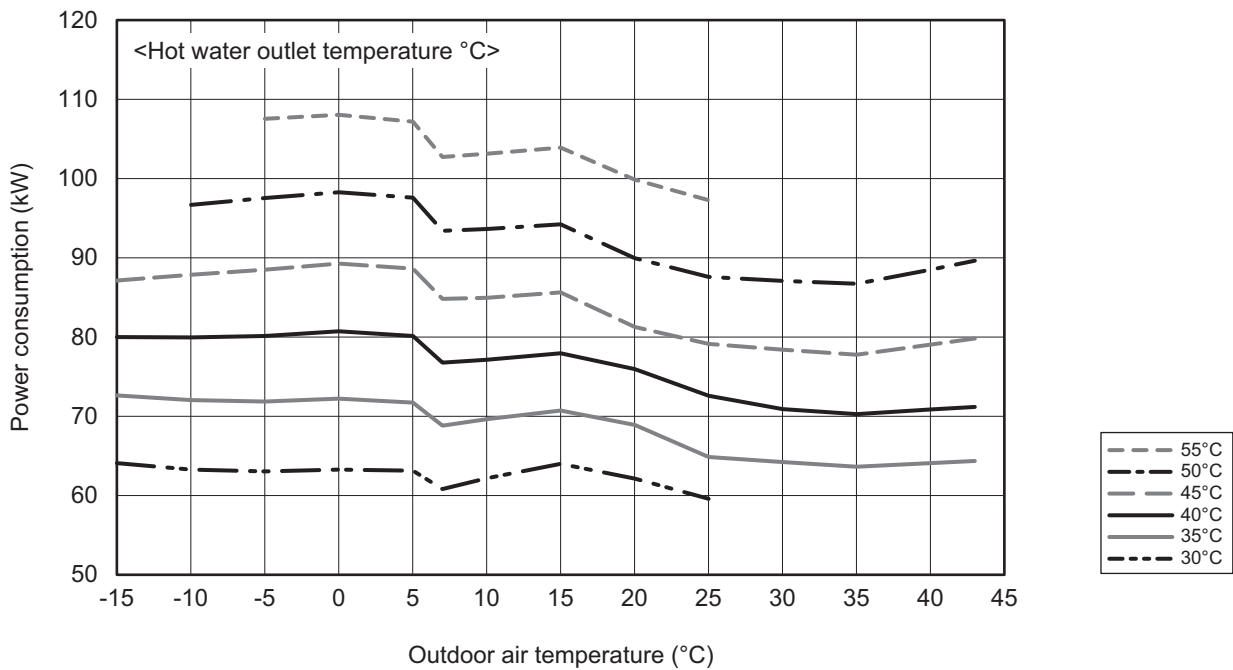
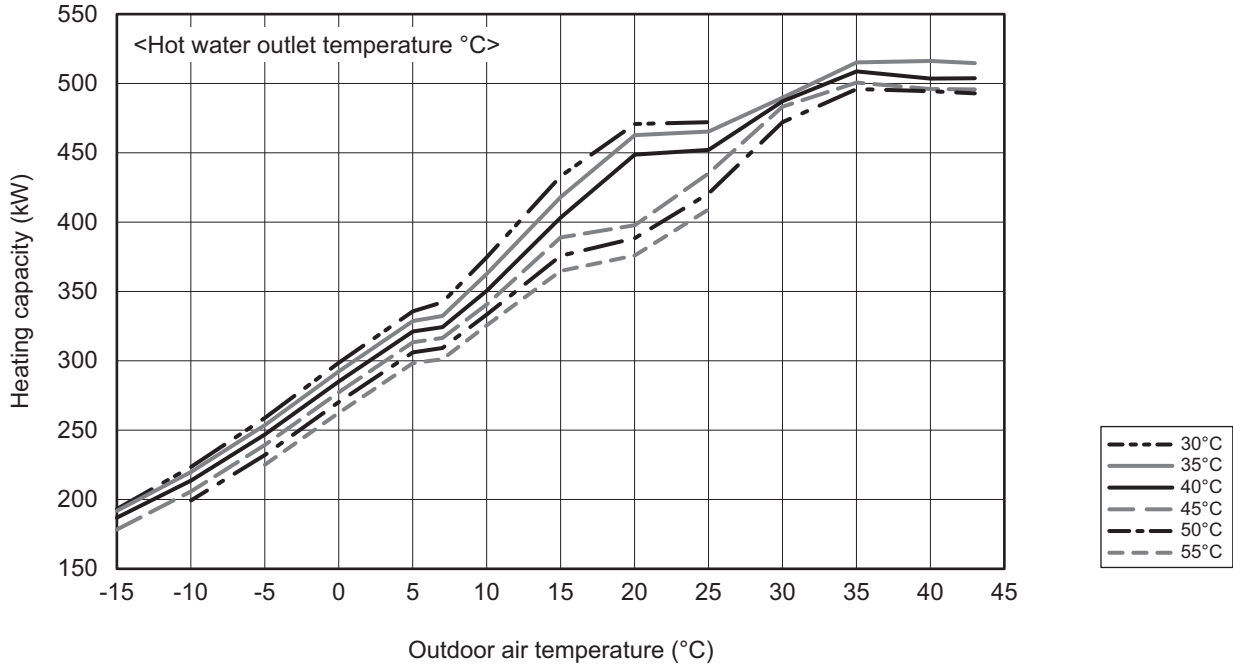

EAHV-P-YAF(-H)(-N), YAL(-H)(-N)/EACV-P-YAF(-N), YAL(-N)

2. Product Data

[Cold/hot water outlet/inlet temperature difference 5°C]

COP priority mode

EAHV-P900YA × 6

EACV-P900YA × 6

■ Cooling Capacity [Water]

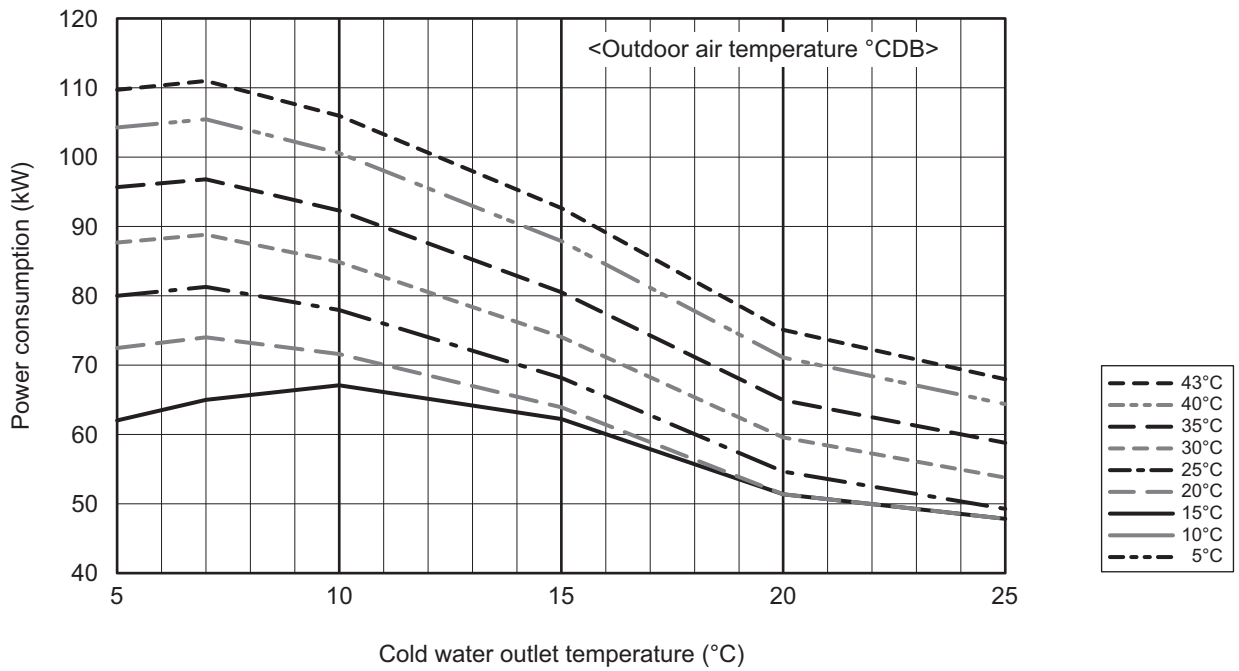
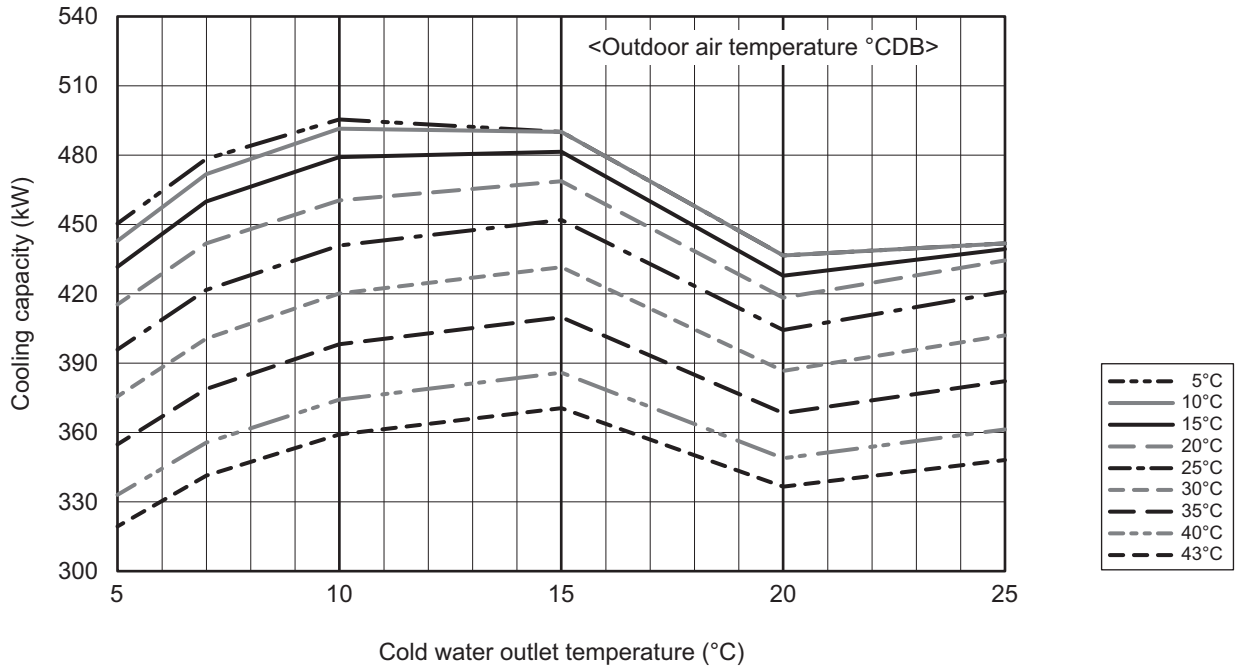

* When the cold water outlet temperature is 8°C or higher, the capacity control operation is performed to reduce the power consumption.

2. Product Data

[Cold/hot water outlet/inlet temperature difference 5°C]

COP priority mode

EAHV-P900YA × 6

■ Heating Capacity

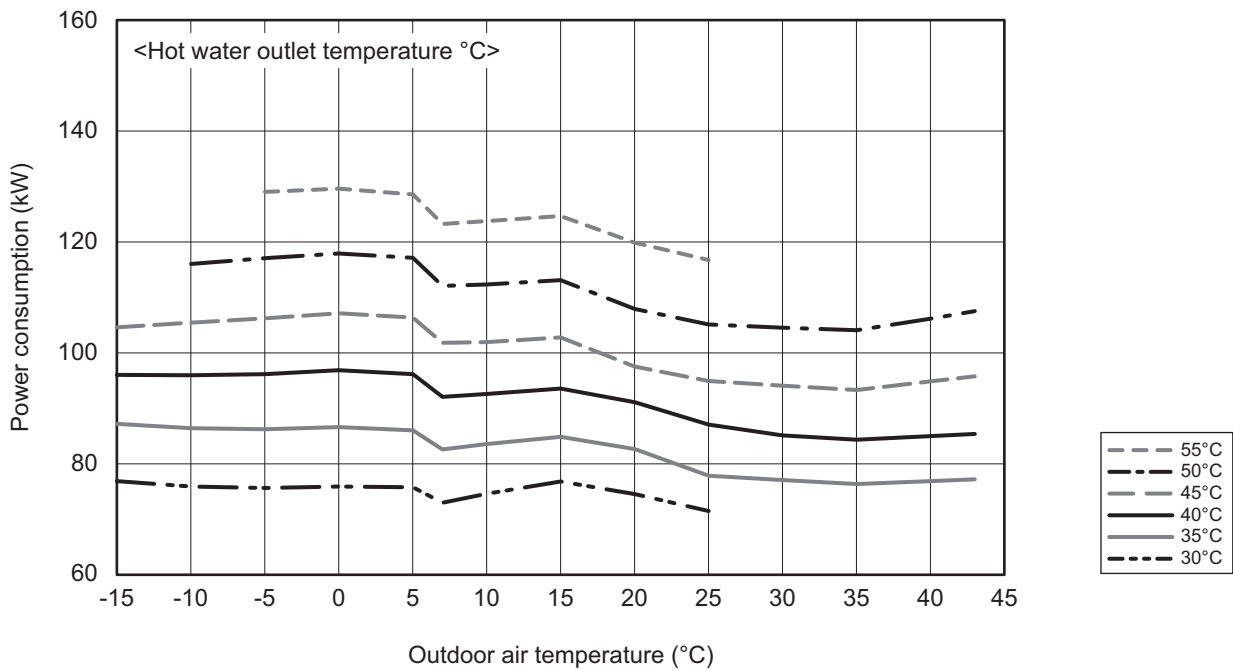
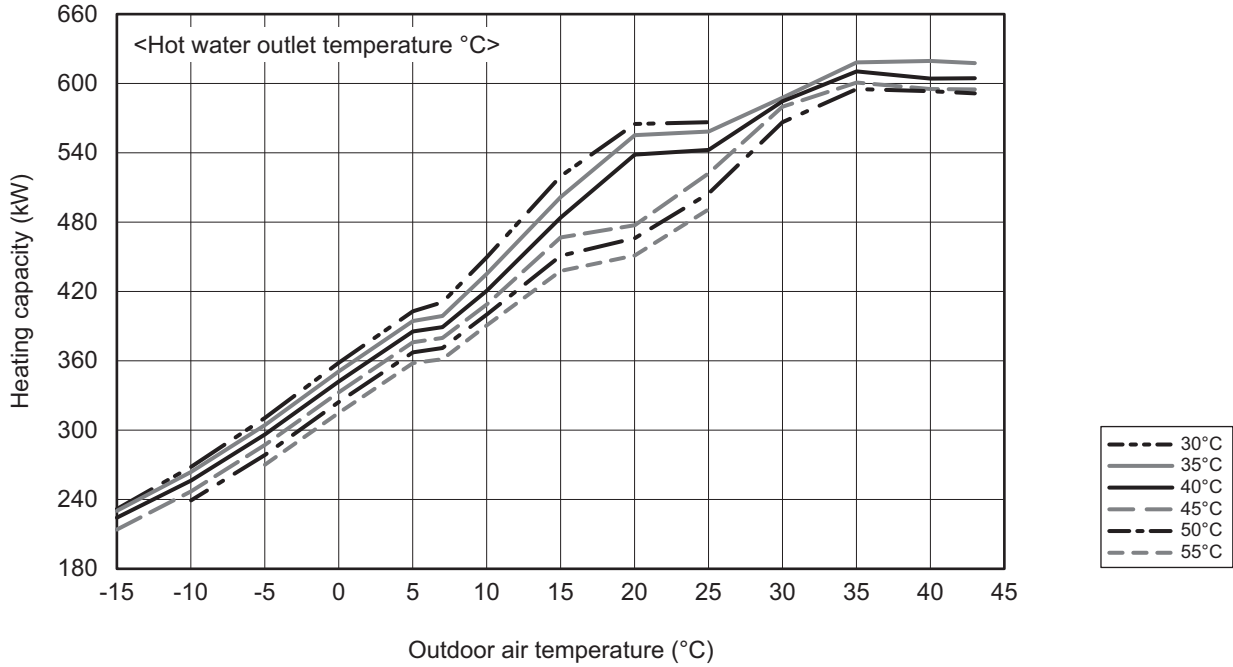

2. Product Data

[Cold brine outlet/inlet temperature difference 5°C]

COP priority mode

EACV-P900YA

■ Cooling Capacity [Brine: ethylene glycol 35wt%]

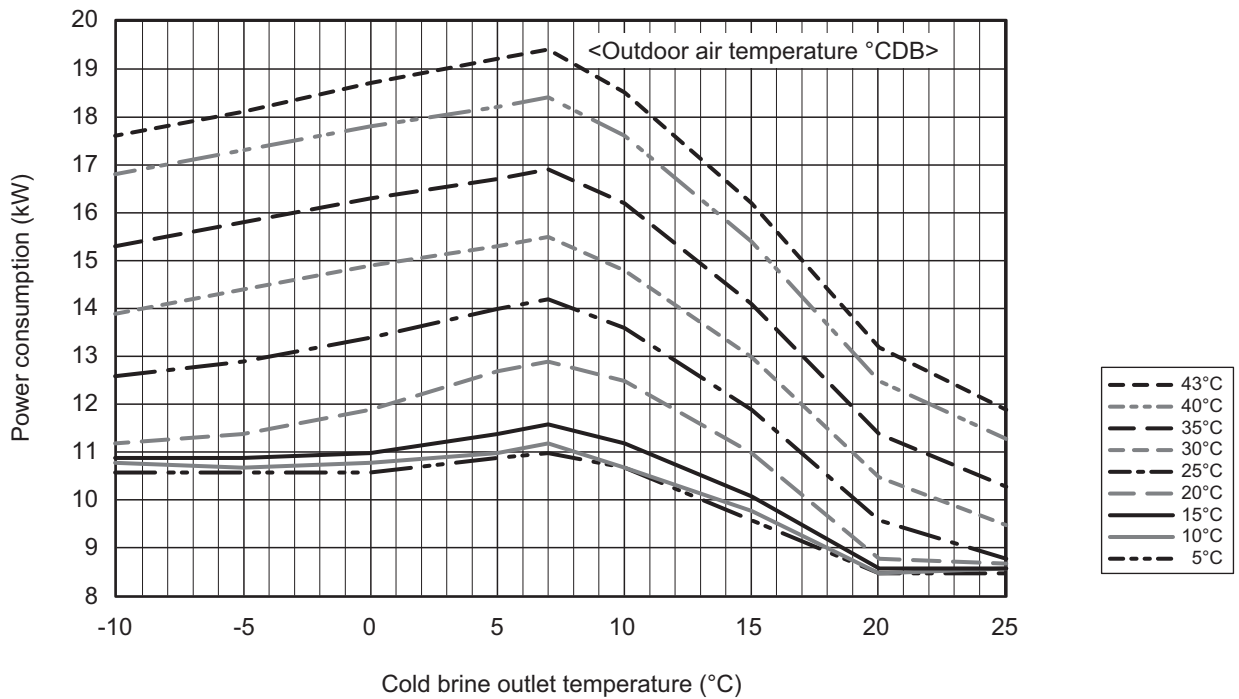
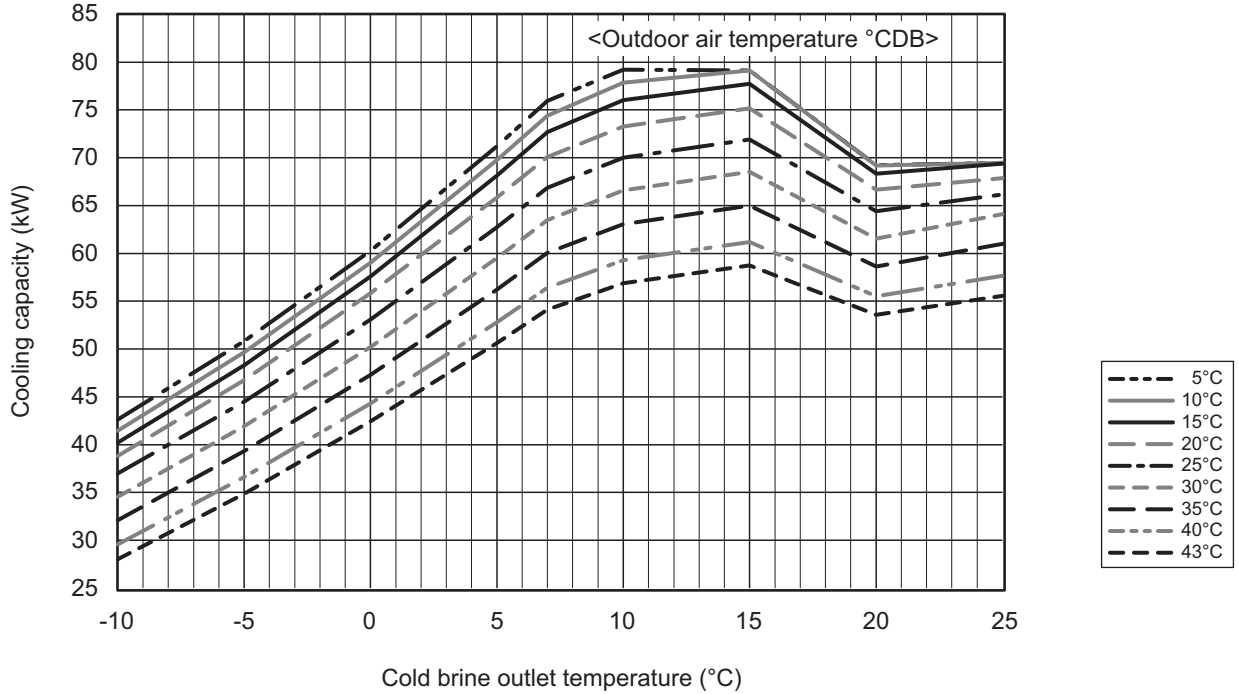

* When the cold brine outlet temperature is 8°C or higher, the capacity control operation is performed to reduce the power consumption.

2. Product Data

[Cold brine outlet/inlet temperature difference 5°C]

COP priority mode

EACV-P900YA × 2

■ Cooling Capacity [Brine: ethylene glycol 35wt%]

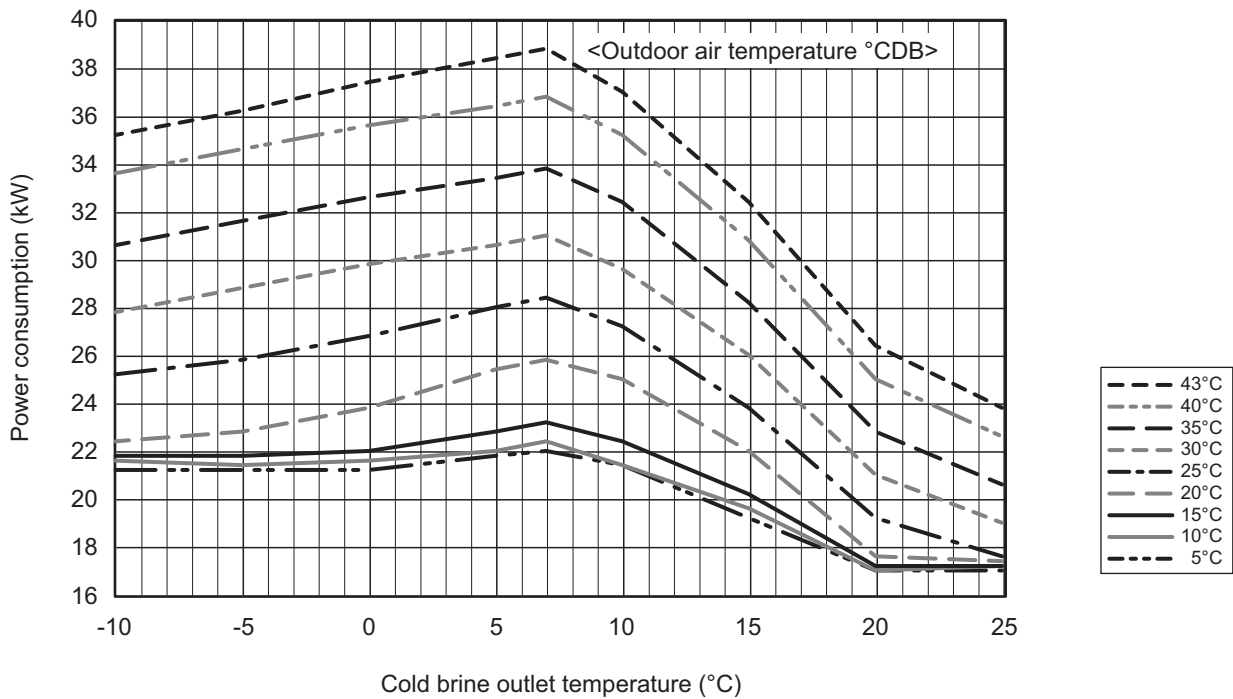
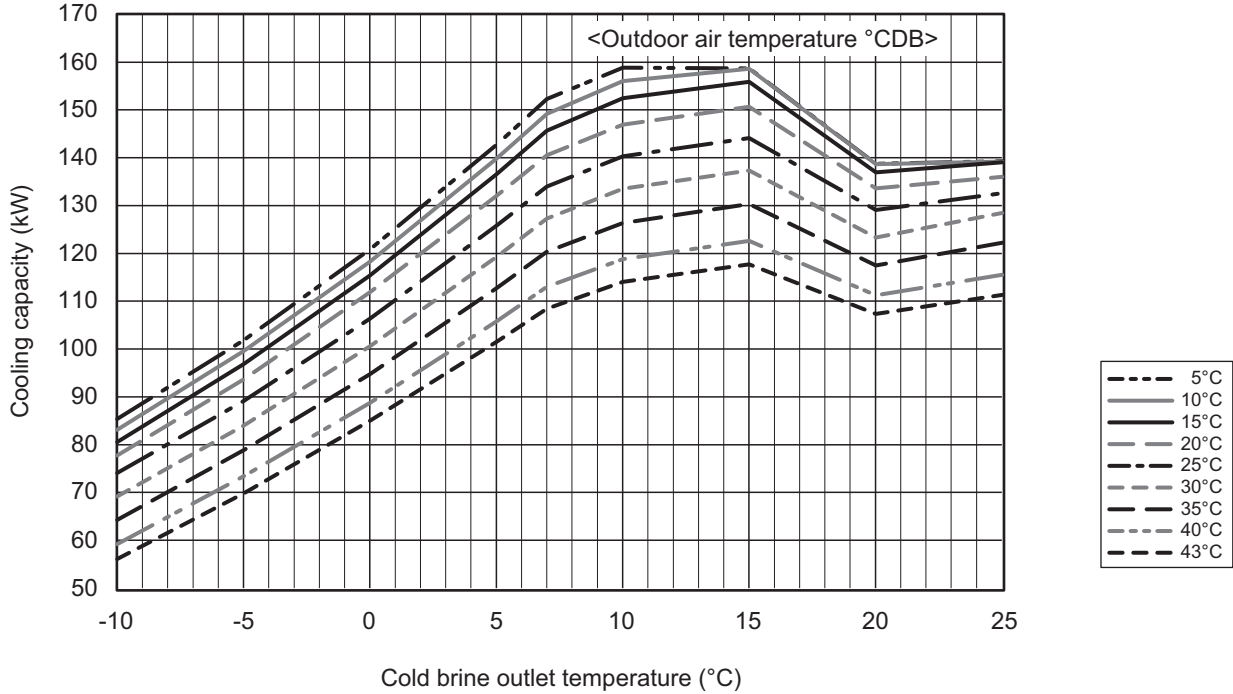

* When the cold brine outlet temperature is 8°C or higher, the capacity control operation is performed to reduce the power consumption.

2. Product Data

[Cold brine outlet/inlet temperature difference 5°C]

COP priority mode

EACV-P900YA × 3

■ Cooling Capacity [Brine: ethylene glycol 35wt%]

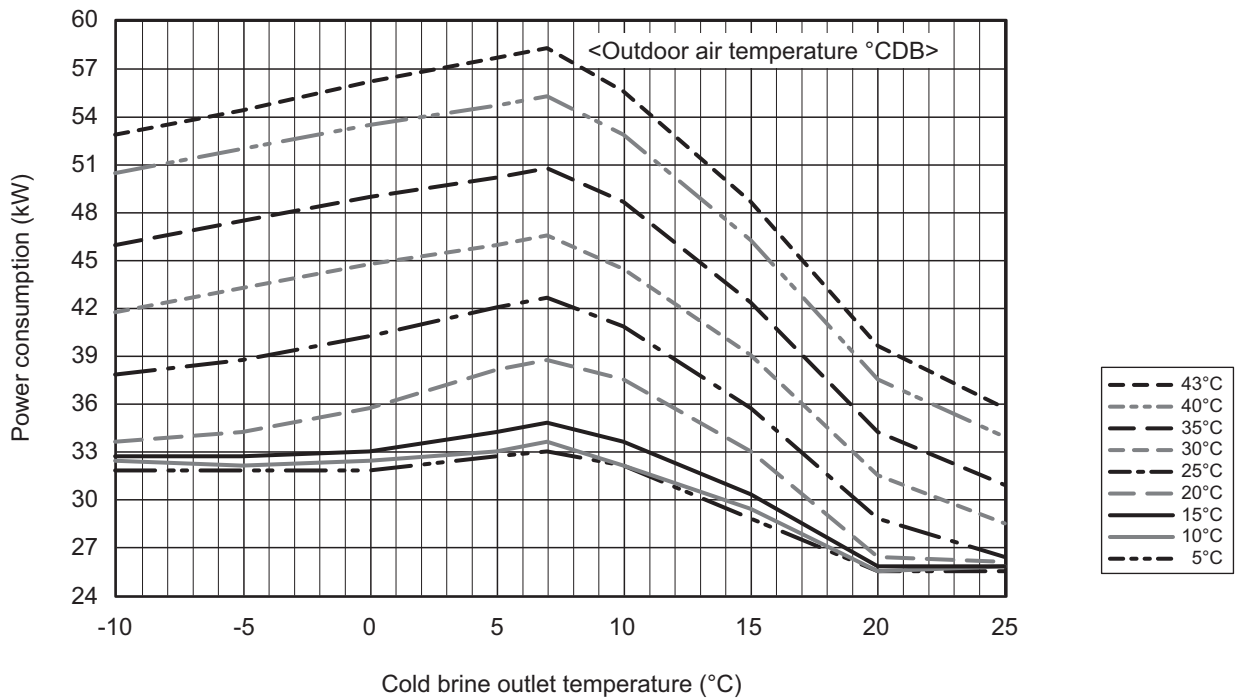
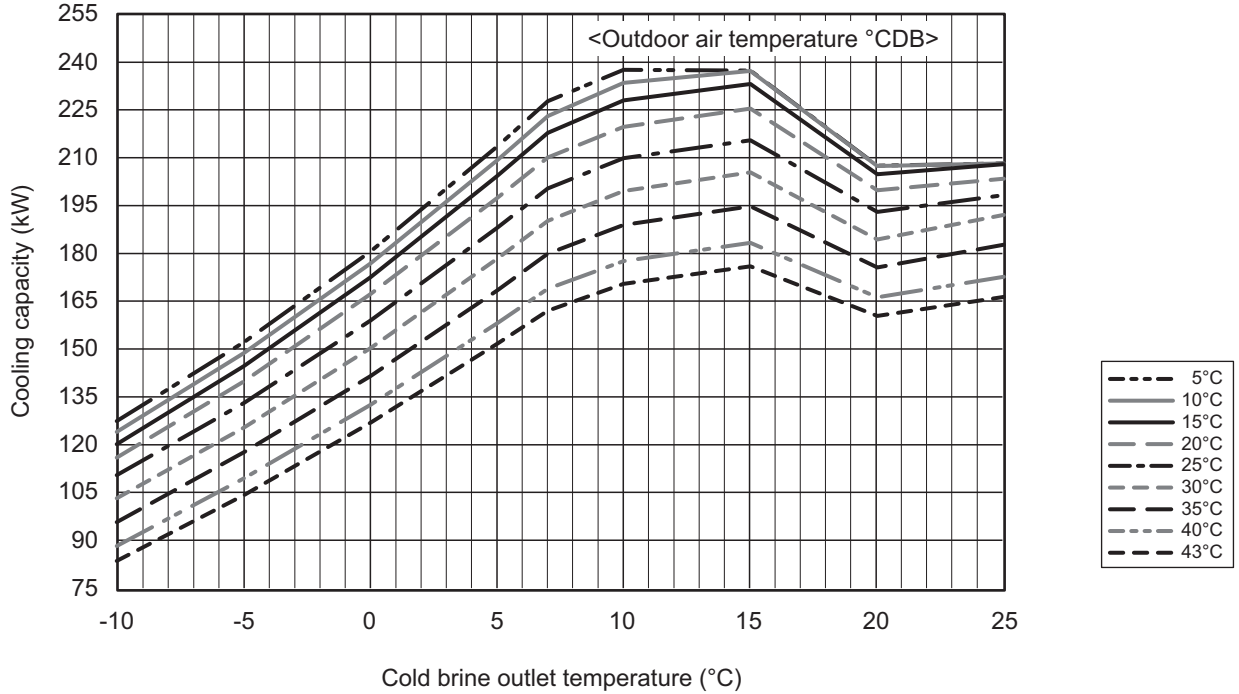

* When the cold brine outlet temperature is 8°C or higher, the capacity control operation is performed to reduce the power consumption.

2. Product Data

[Cold brine outlet/inlet temperature difference 5°C]

COP priority mode

EACV-P900YA × 4

■ Cooling Capacity [Brine: ethylene glycol 35wt%]

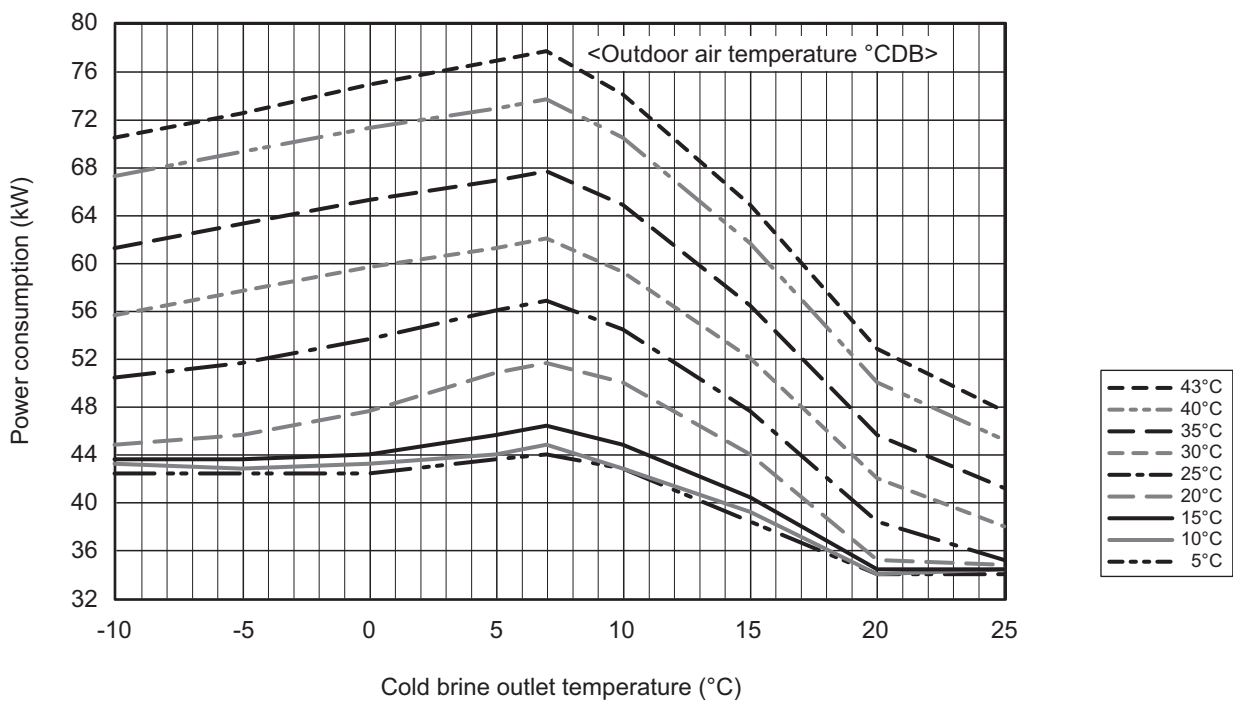
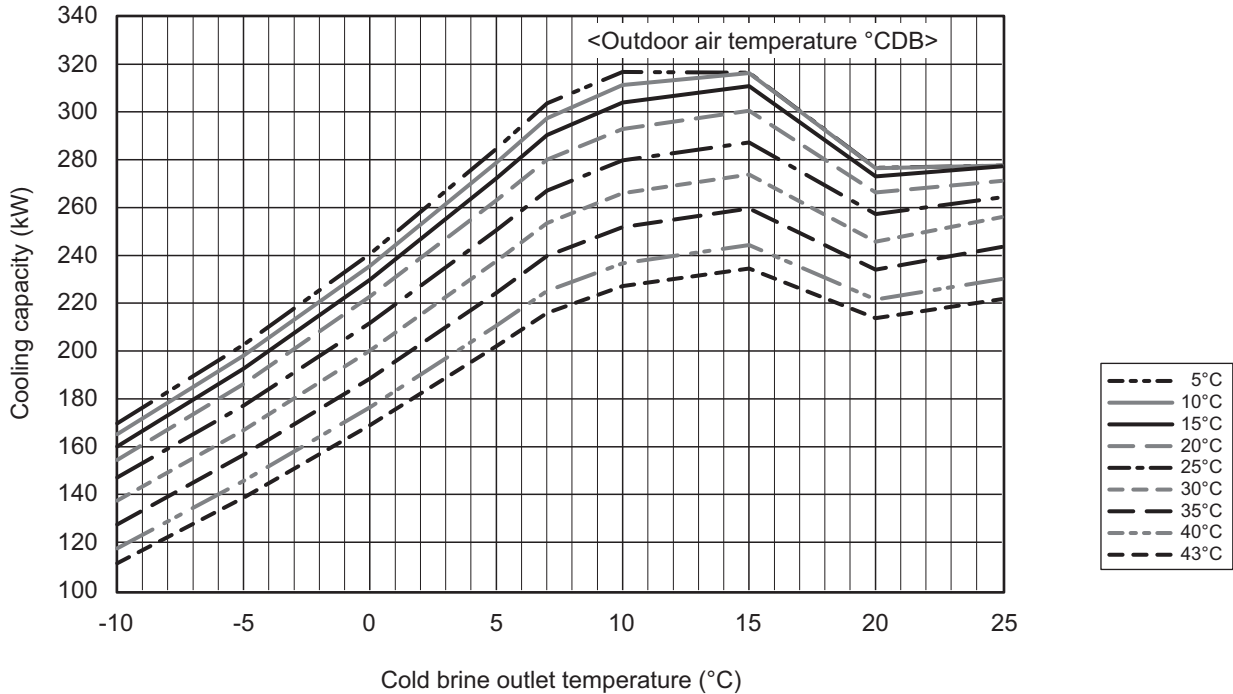

* When the cold brine outlet temperature is 8°C or higher, the capacity control operation is performed to reduce the power consumption.

2. Product Data

[Cold brine outlet/inlet temperature difference 5°C]

COP priority mode

EACV-P900YA × 5

■ Cooling Capacity [Brine: ethylene glycol 35wt%]

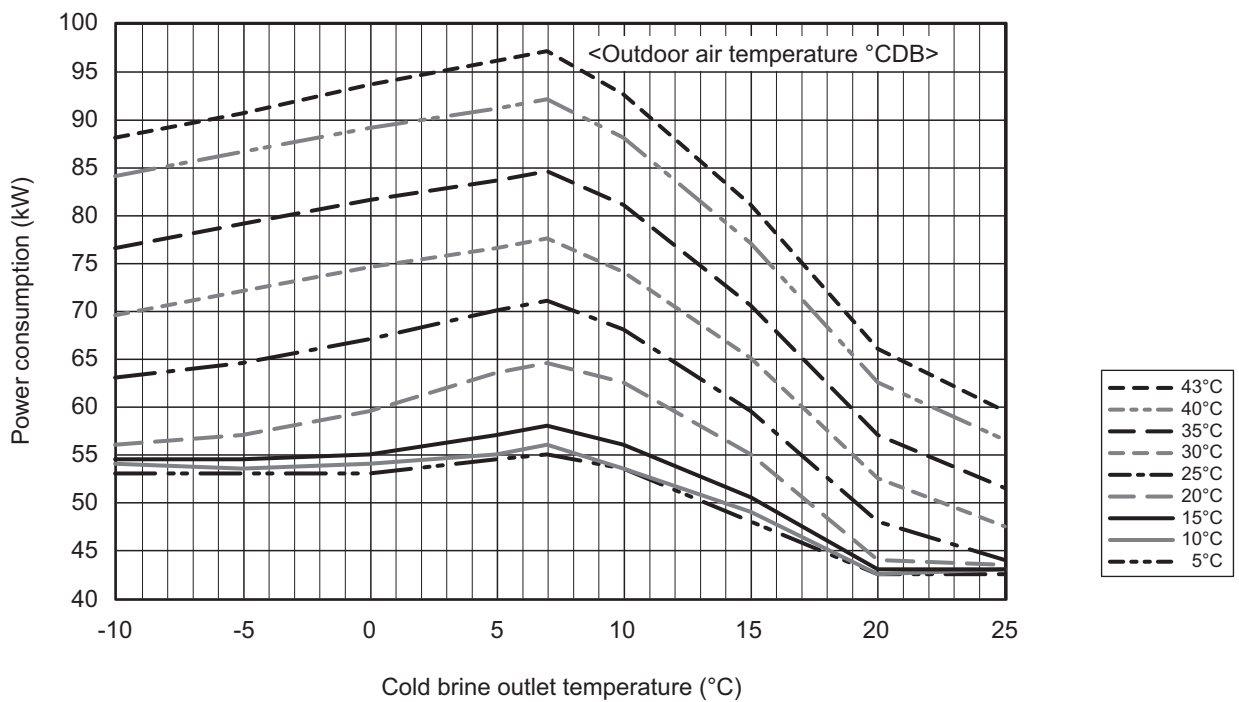
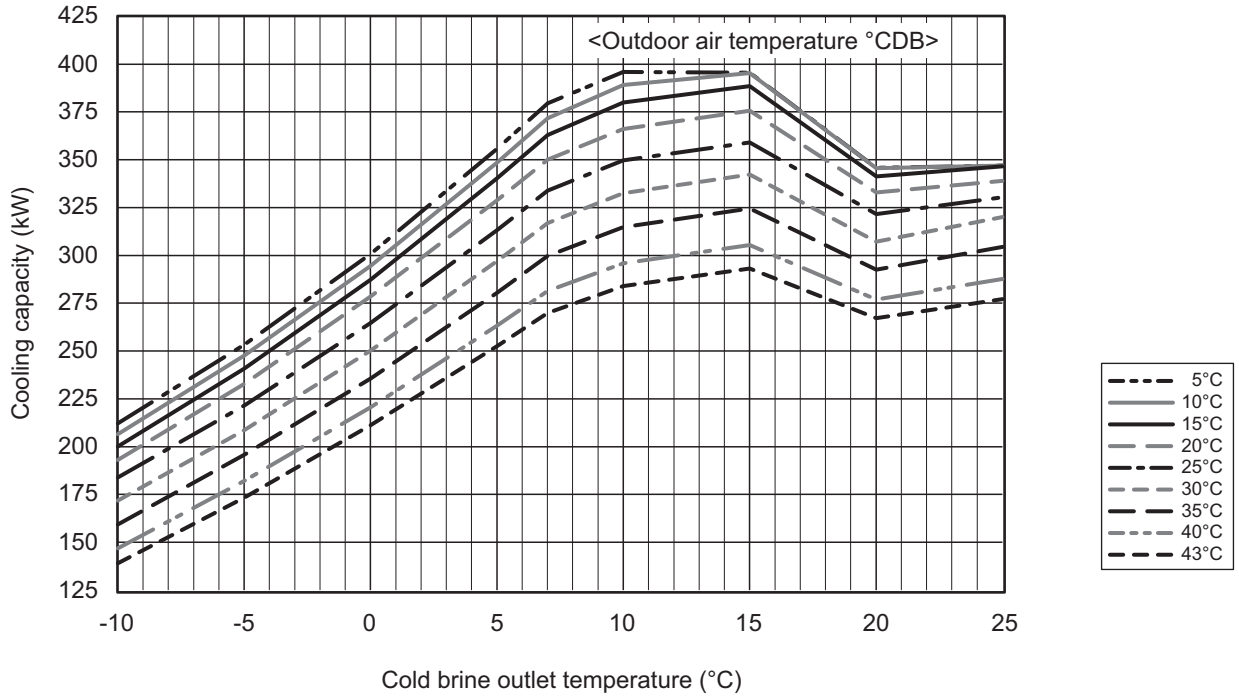

* When the cold brine outlet temperature is 8°C or higher, the capacity control operation is performed to reduce the power consumption.

2. Product Data

[Cold brine outlet/inlet temperature difference 5°C]

COP priority mode

EACV-P900YA × 6

■ Cooling Capacity [Brine: ethylene glycol 35wt%]

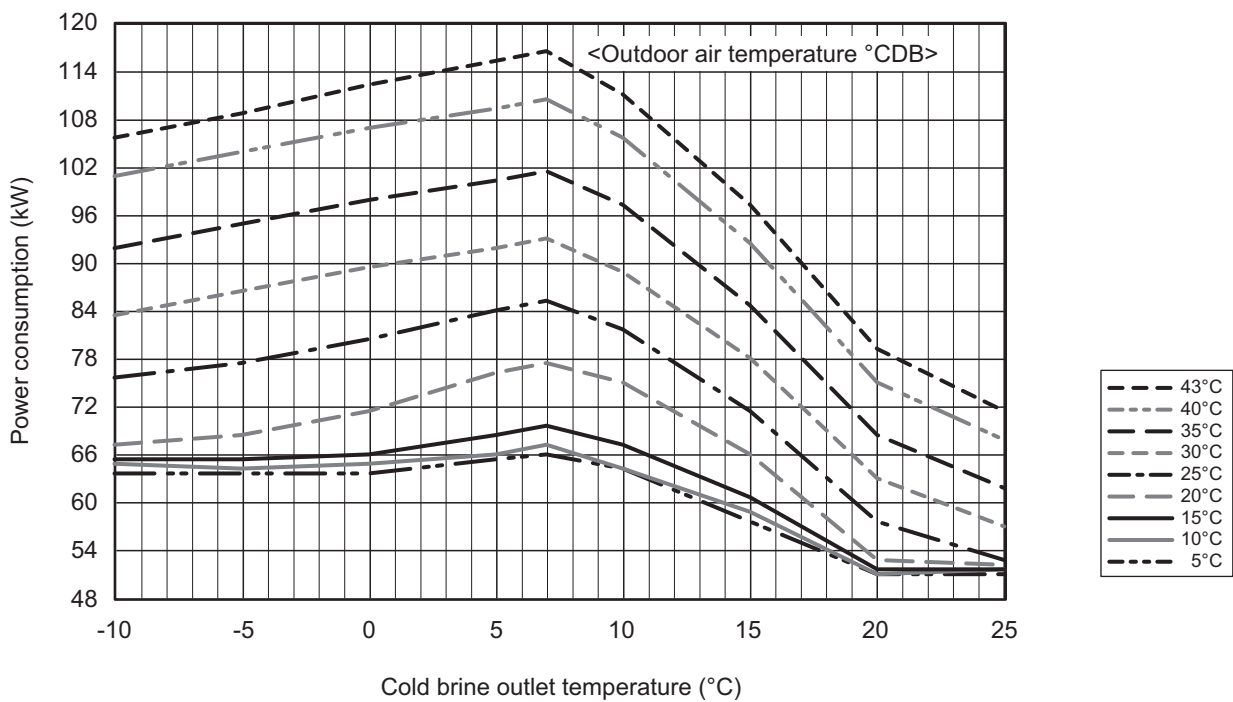
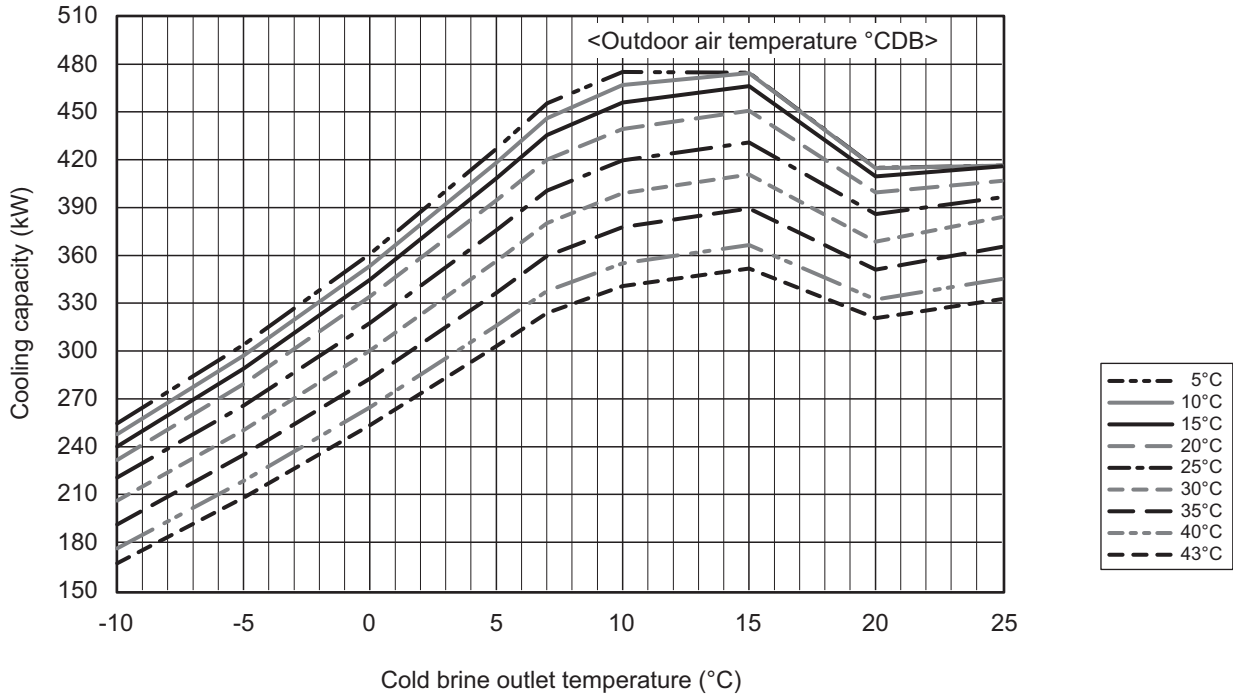

* When the cold brine outlet temperature is 8°C or higher, the capacity control operation is performed to reduce the power consumption.

2. Product Data

[Cold/hot water outlet/inlet temperature difference 7°C]

EAHV-P900YA
EACV-P900YA

■ Cooling Capacity [Water]

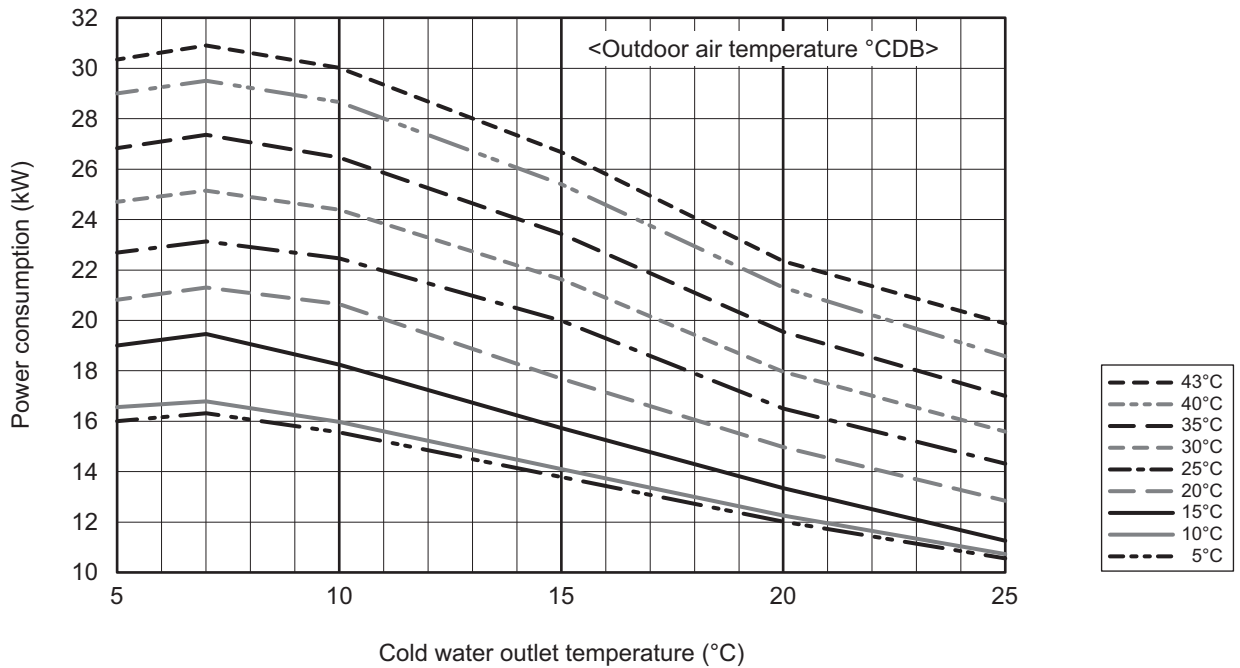
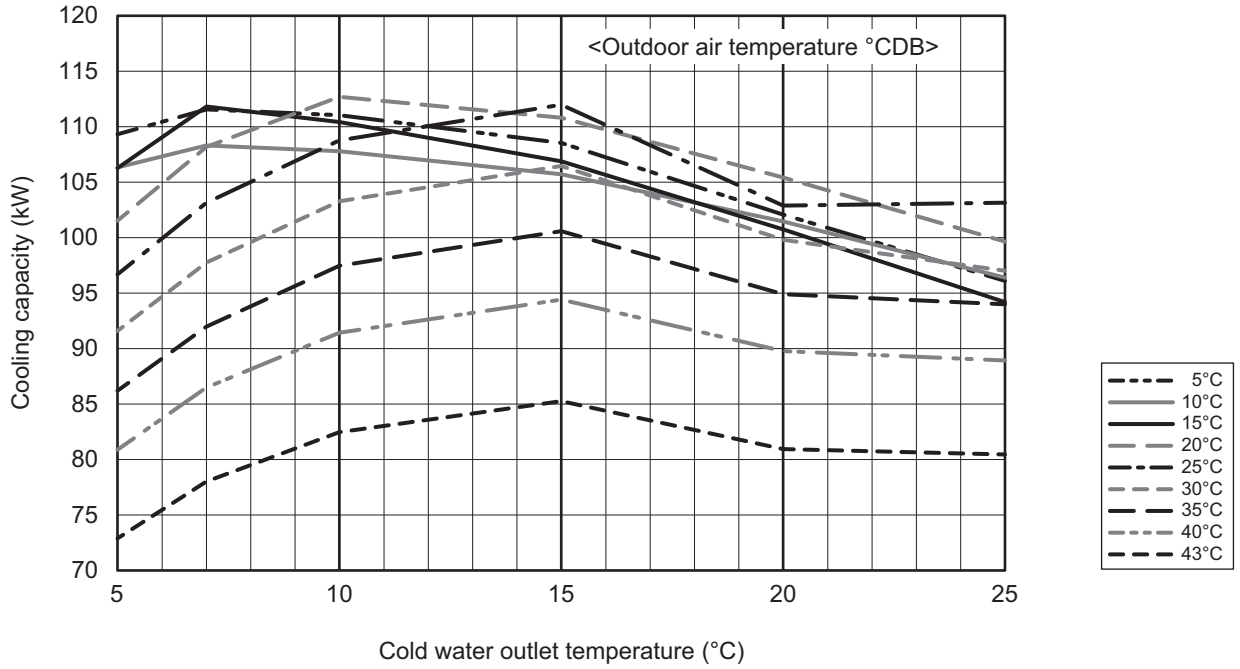

* When the cold water outlet temperature is 8°C or higher, the capacity control operation is performed to reduce the power consumption.

2. Product Data

[Cold/hot water outlet/inlet temperature difference 7°C]

EAHV-P900YA

■ Heating Capacity

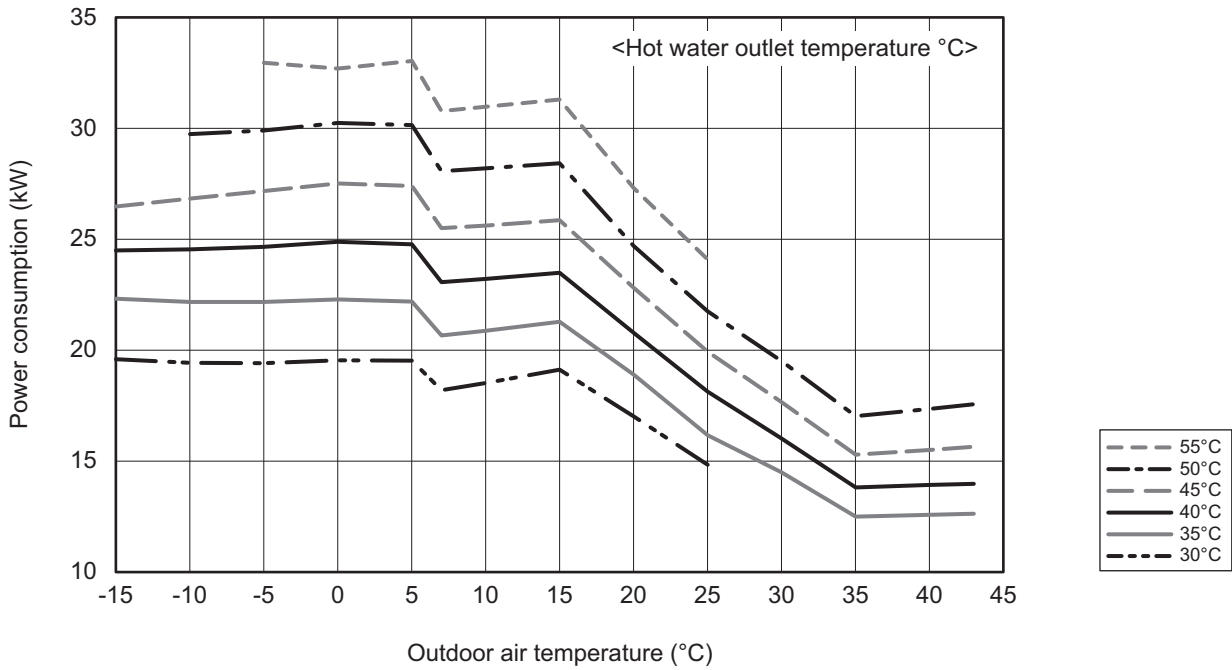
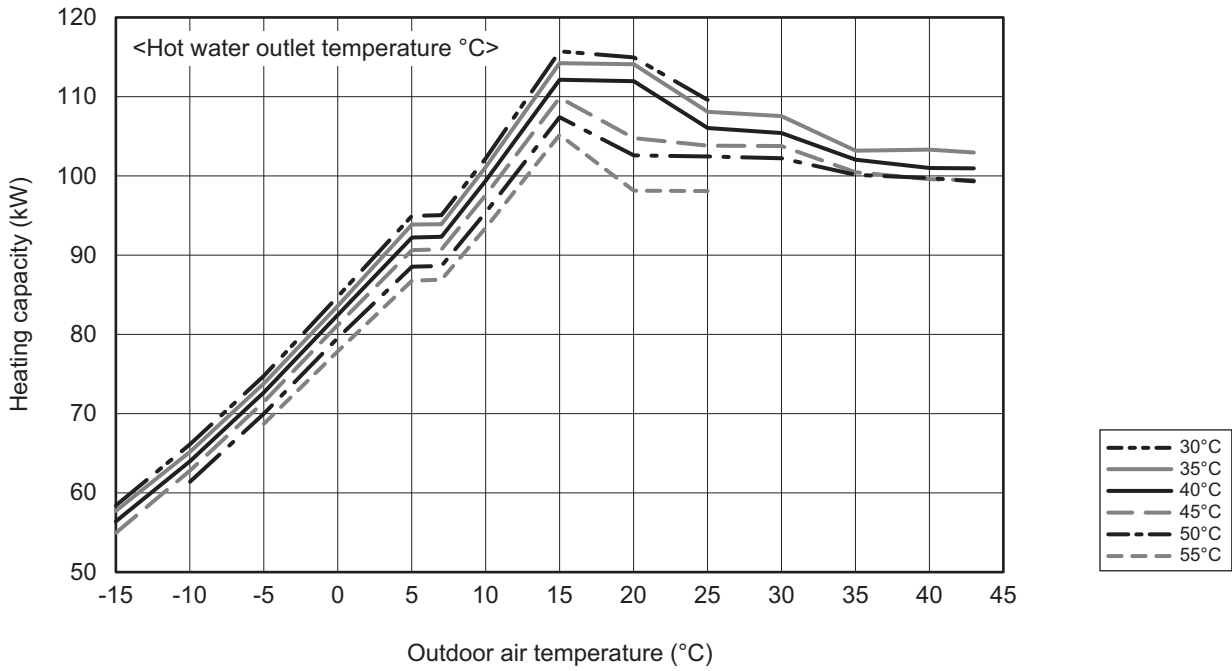

2. Product Data

[Cold/hot water outlet/inlet temperature difference 7°C]

EAHV-P900YA × 2

EACV-P900YA × 2

■ Cooling Capacity [Water]

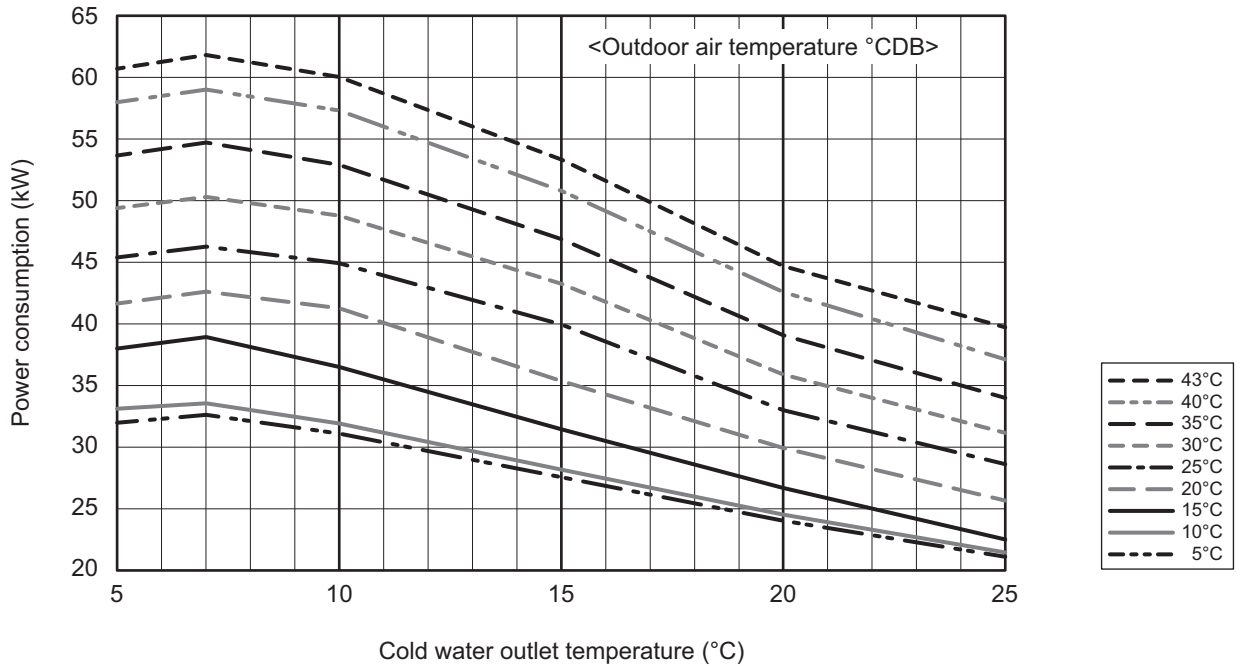
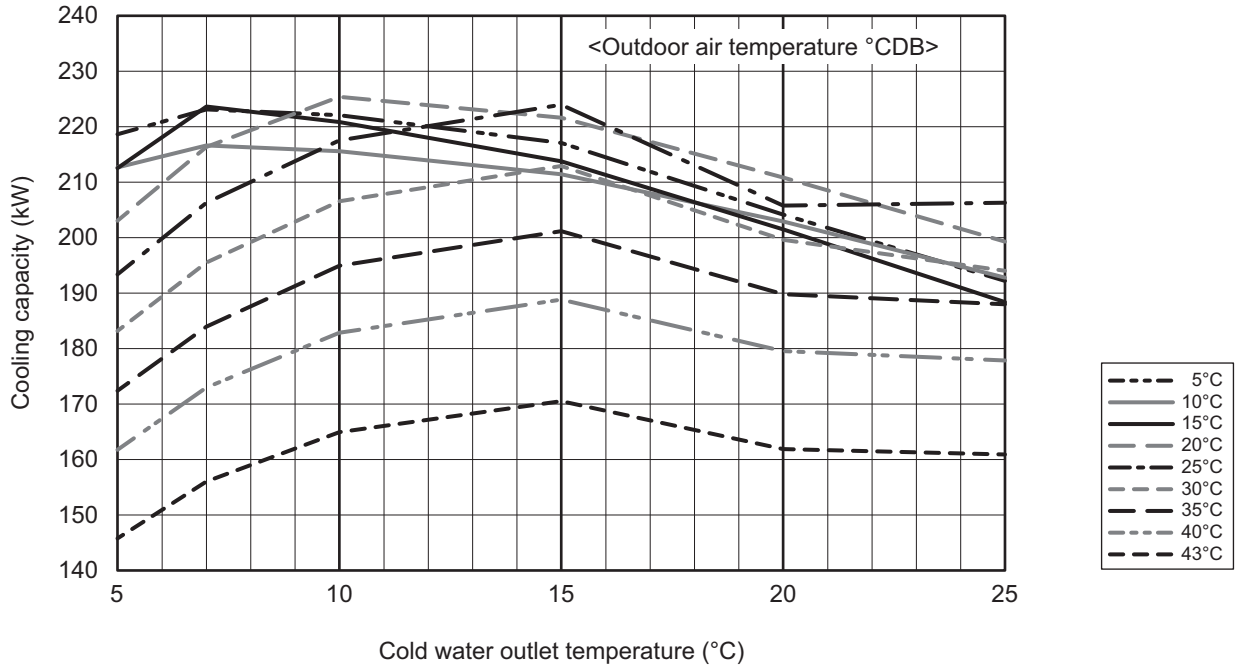

* When the cold water outlet temperature is 8°C or higher, the capacity control operation is performed to reduce the power consumption.

2. Product Data

[Cold/hot water outlet/inlet temperature difference 7°C]

EAHV-P900YA × 2

■ Heating Capacity

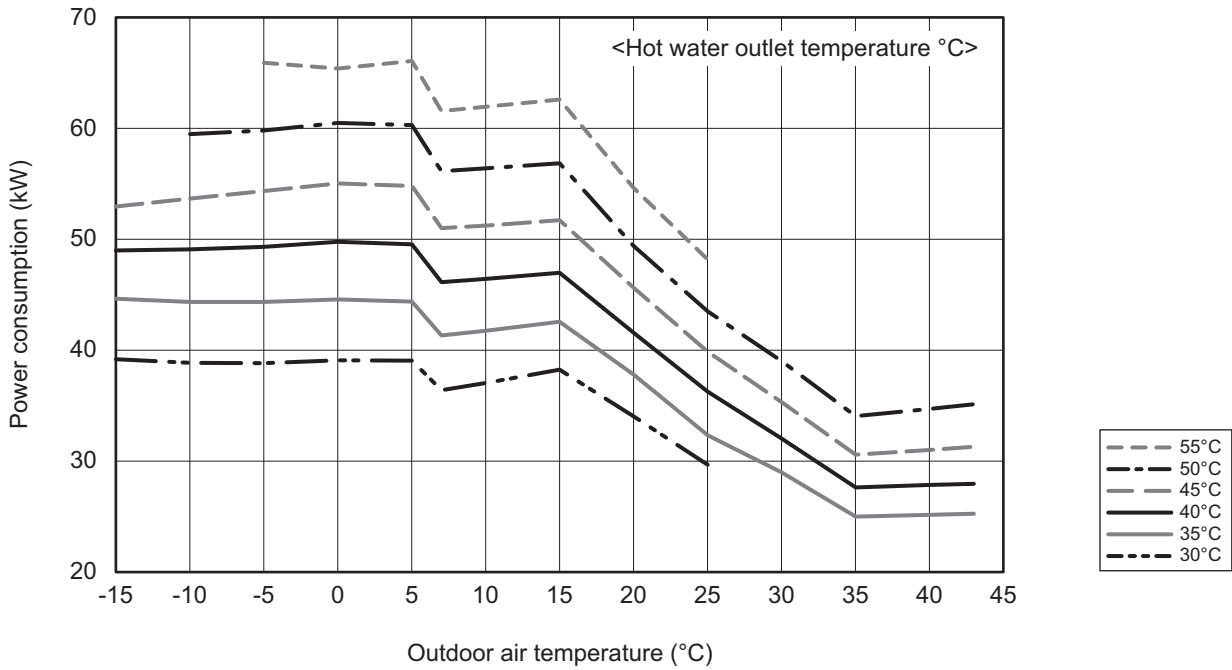
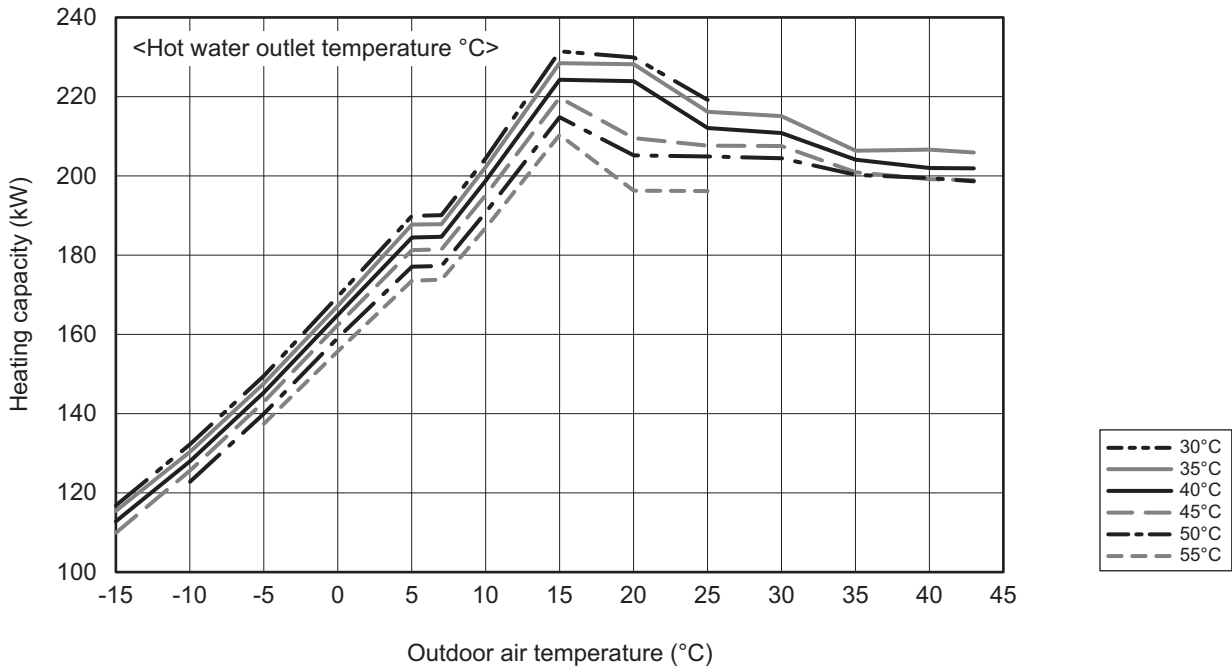

2. Product Data

[Cold/hot water outlet/inlet temperature difference 7°C]

EAHV-P900YA × 3

EACV-P900YA × 3

■ Cooling Capacity [Water]

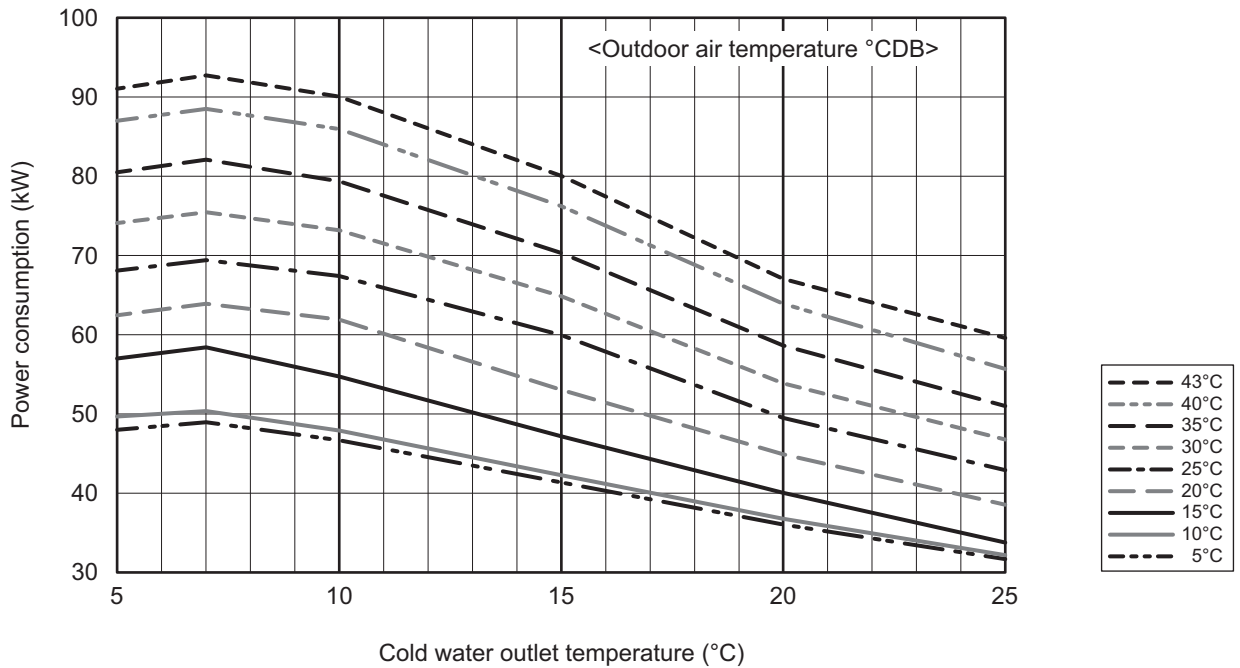
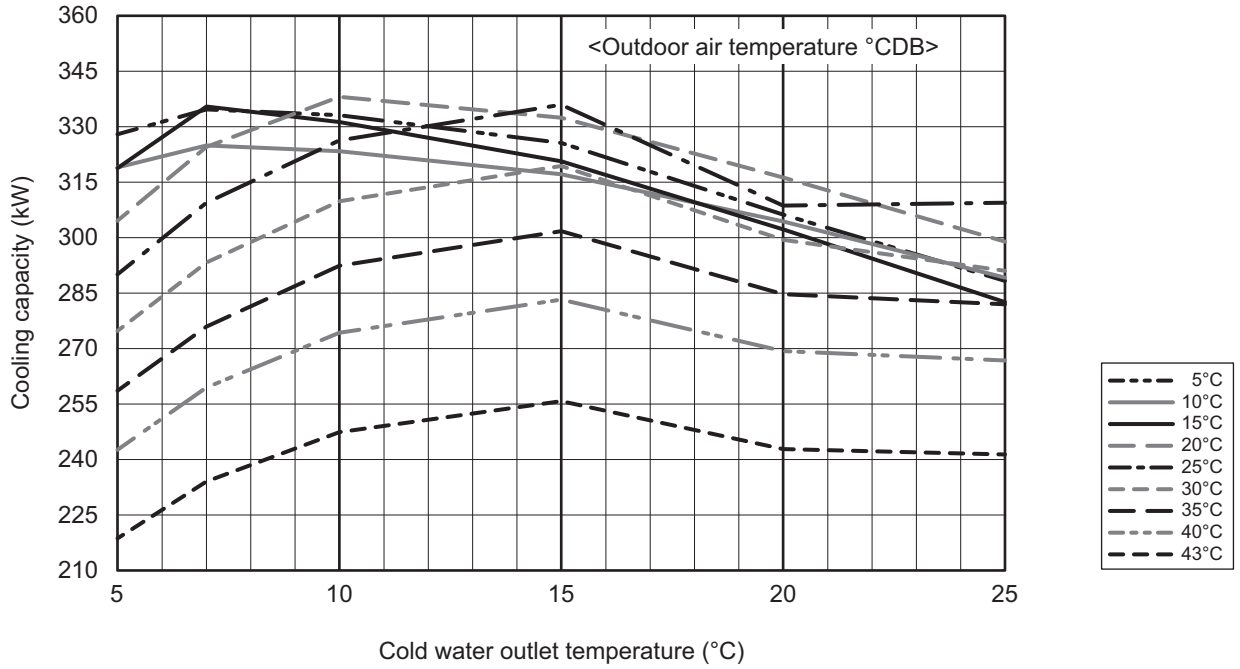

* When the cold water outlet temperature is 8°C or higher, the capacity control operation is performed to reduce the power consumption.

2. Product Data

[Cold/hot water outlet/inlet temperature difference 7°C]

EAHV-P900YA × 3

■ Heating Capacity

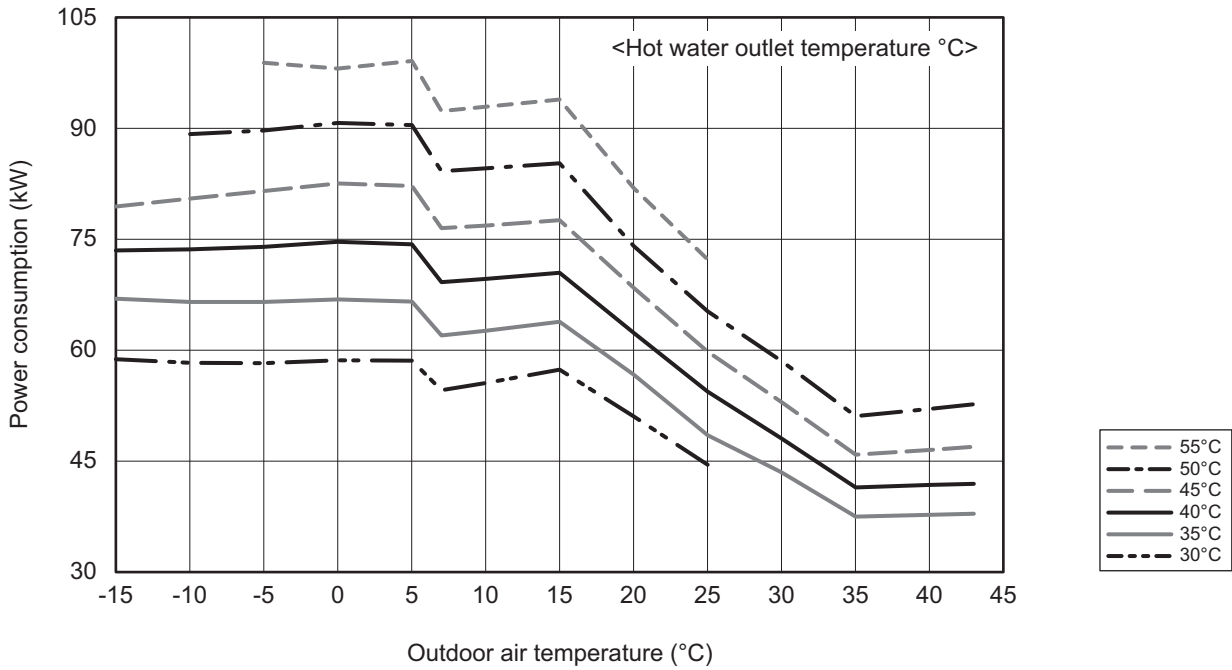
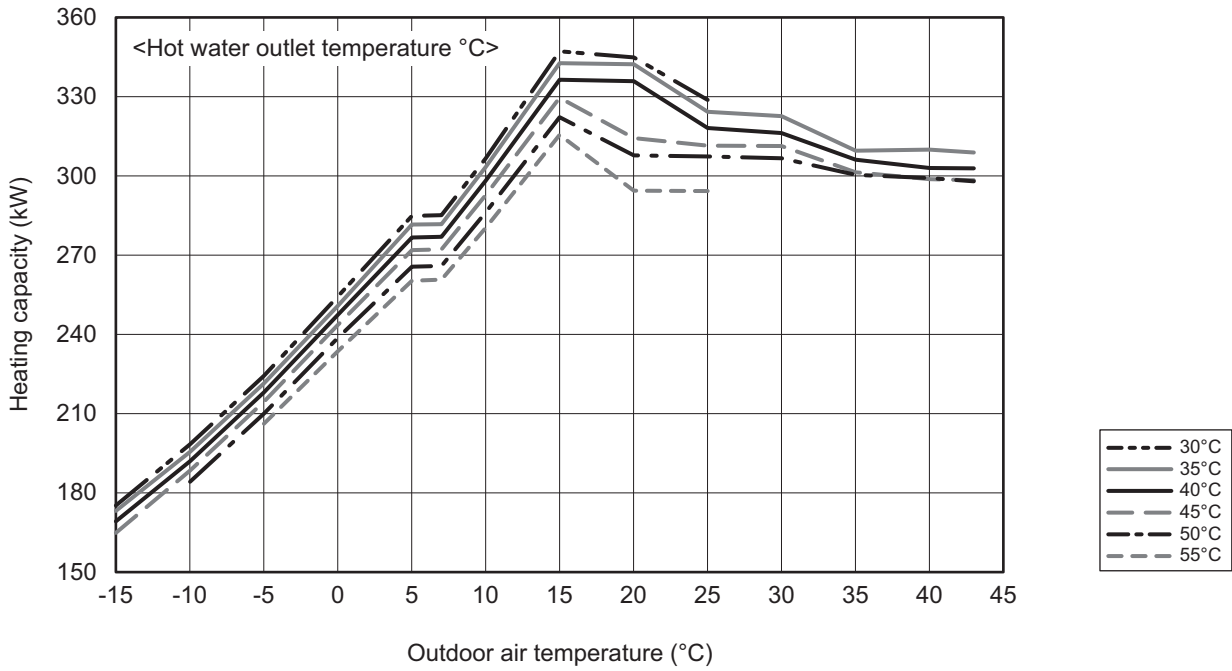

2. Product Data

[Cold/hot water outlet/inlet temperature difference 7°C]

EAHV-P900YA × 4

EACV-P900YA × 4

■ Cooling Capacity [Water]

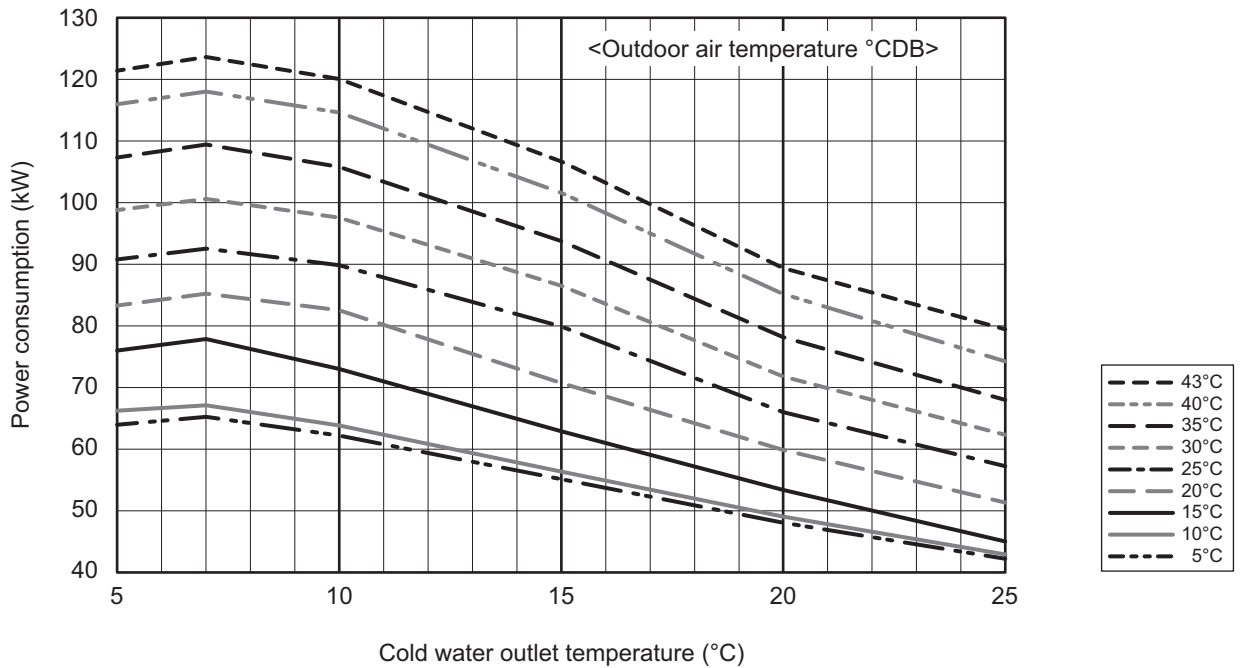
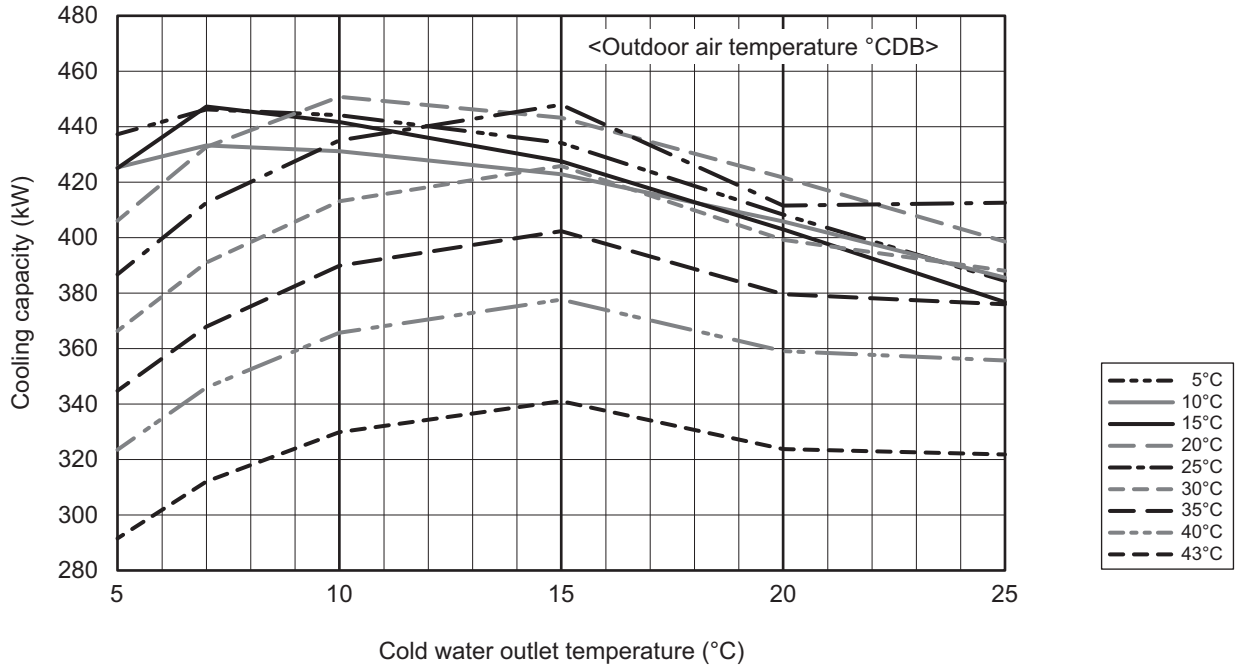

* When the cold water outlet temperature is 8°C or higher, the capacity control operation is performed to reduce the power consumption.

2. Product Data

[Cold/hot water outlet/inlet temperature difference 7°C]

EAHV-P900YA × 4

■ Heating Capacity

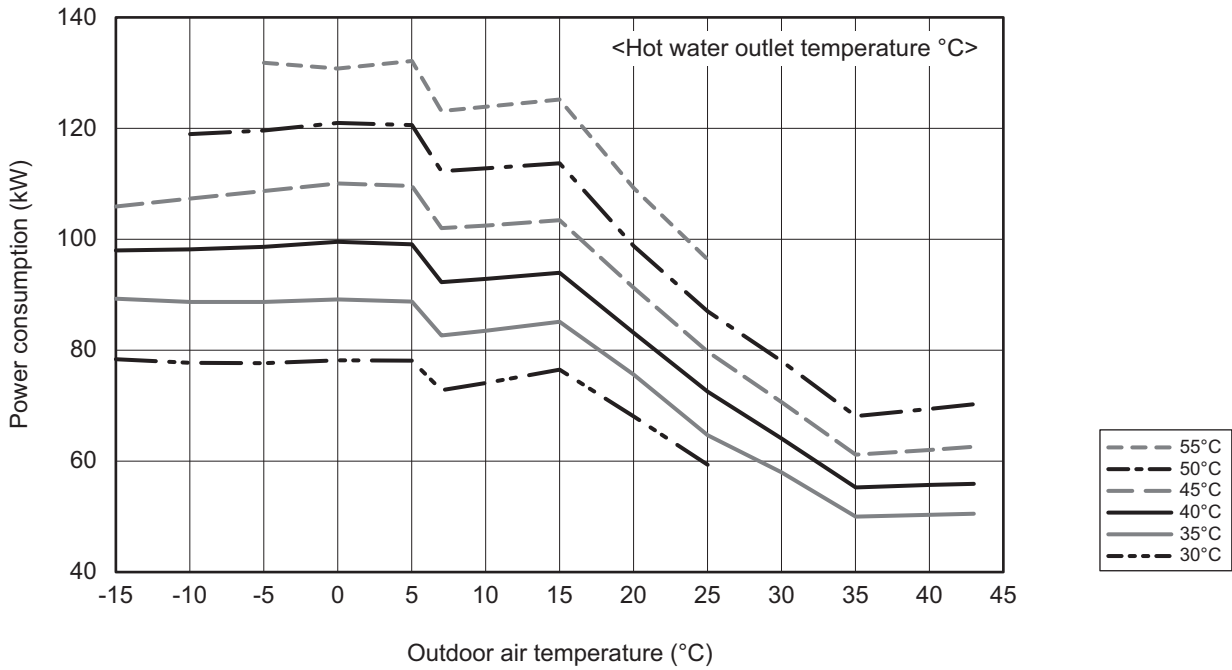
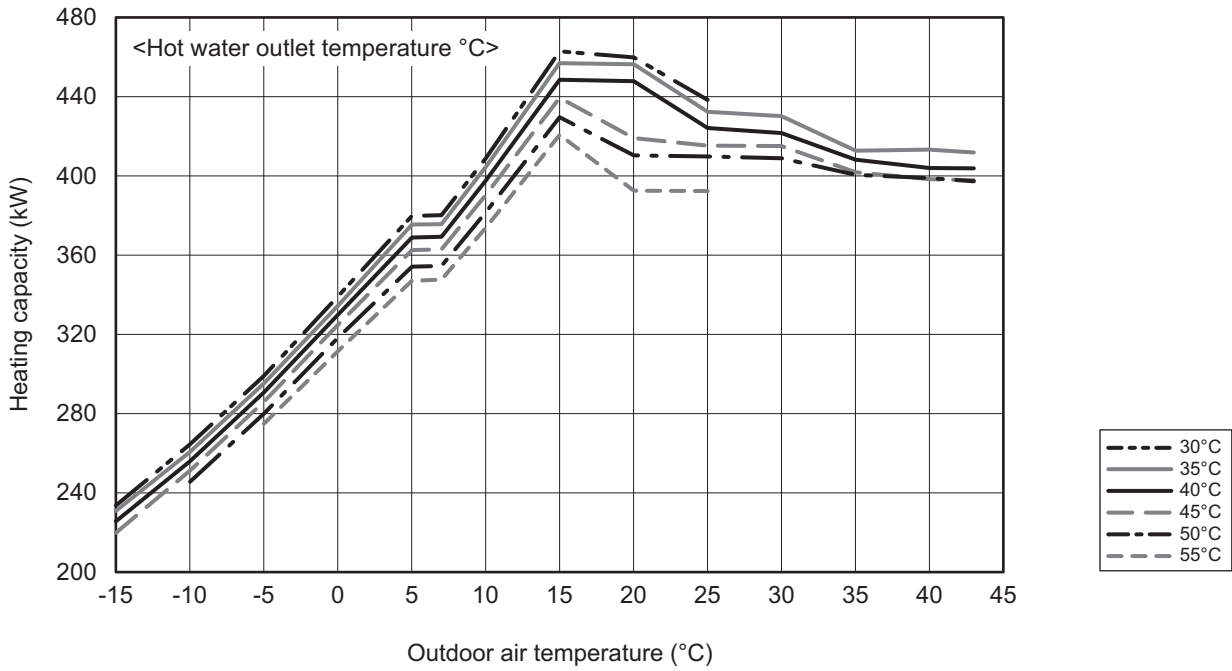

2. Product Data

[Cold/hot water outlet/inlet temperature difference 7°C]

EAHV-P900YA × 5

EACV-P900YA × 5

■ Cooling Capacity [Water]

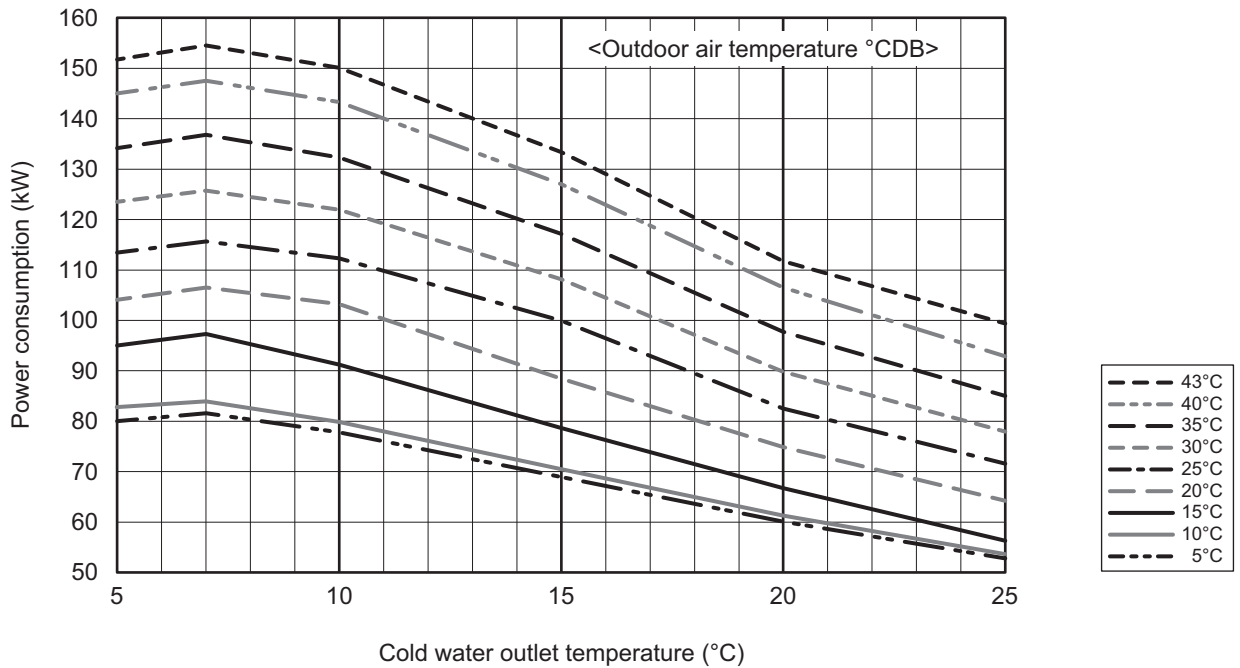
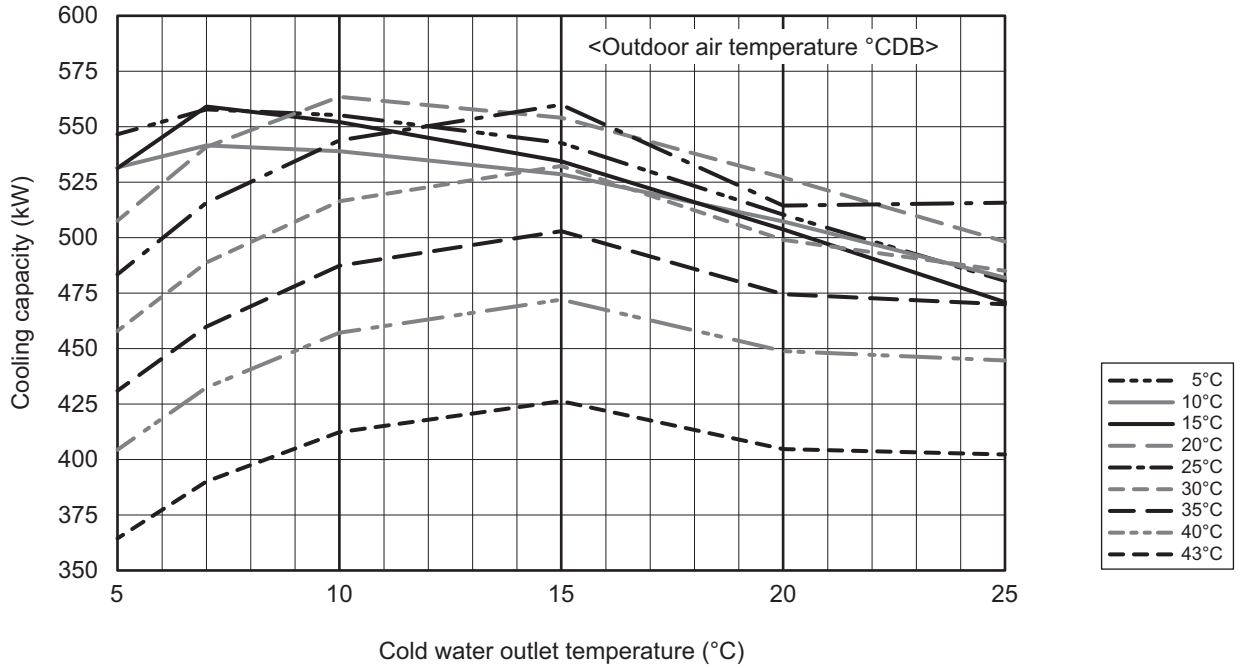

* When the cold water outlet temperature is 8°C or higher, the capacity control operation is performed to reduce the power consumption.

2. Product Data

[Cold/hot water outlet/inlet temperature difference 7°C]

EAHV-P900YA × 5

■ Heating Capacity

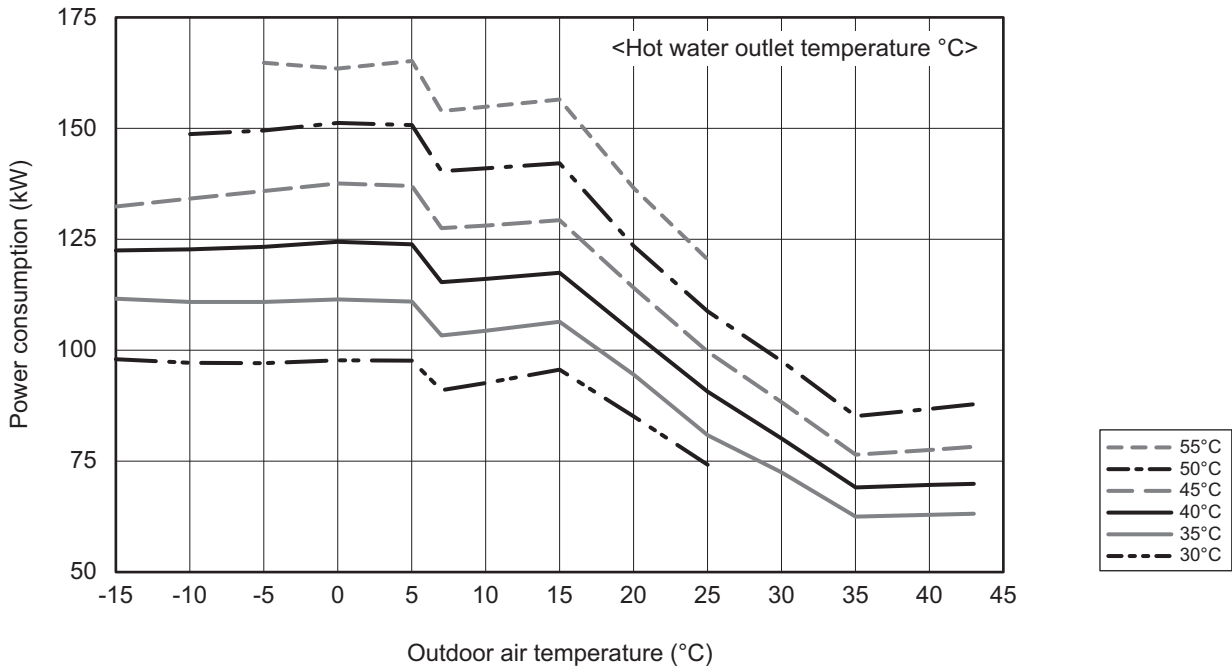
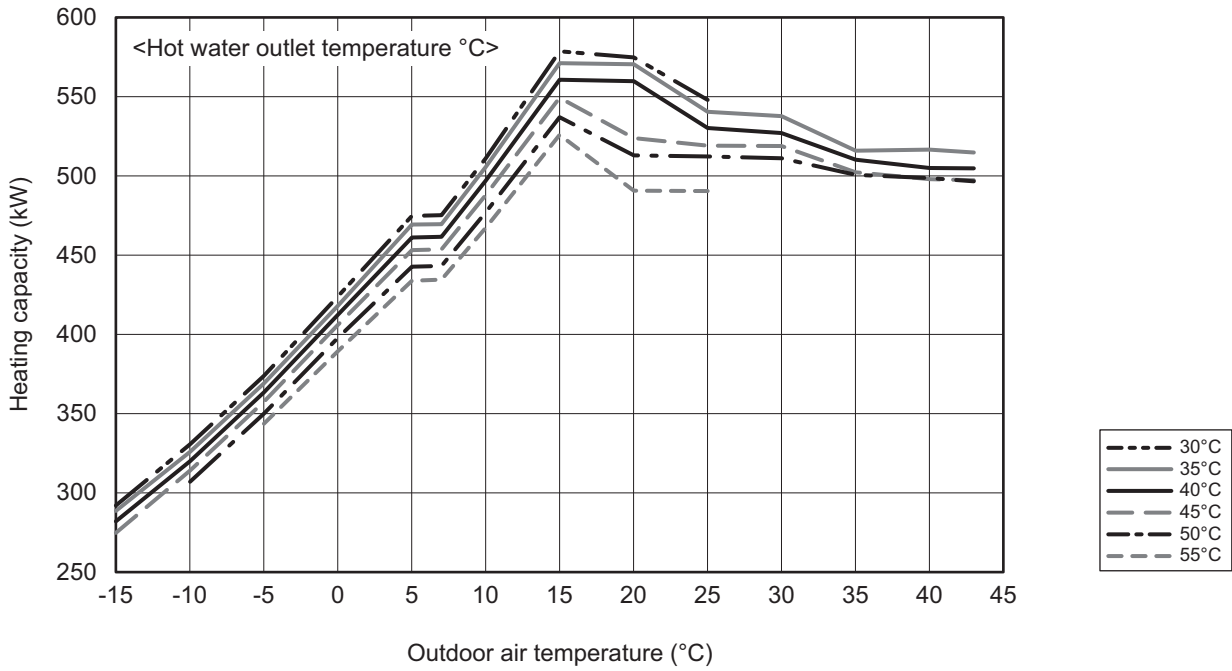

2. Product Data

[Cold/hot water outlet/inlet temperature difference 7°C]

EAHV-P900YA × 6

EACV-P900YA × 6

■ Cooling Capacity [Water]

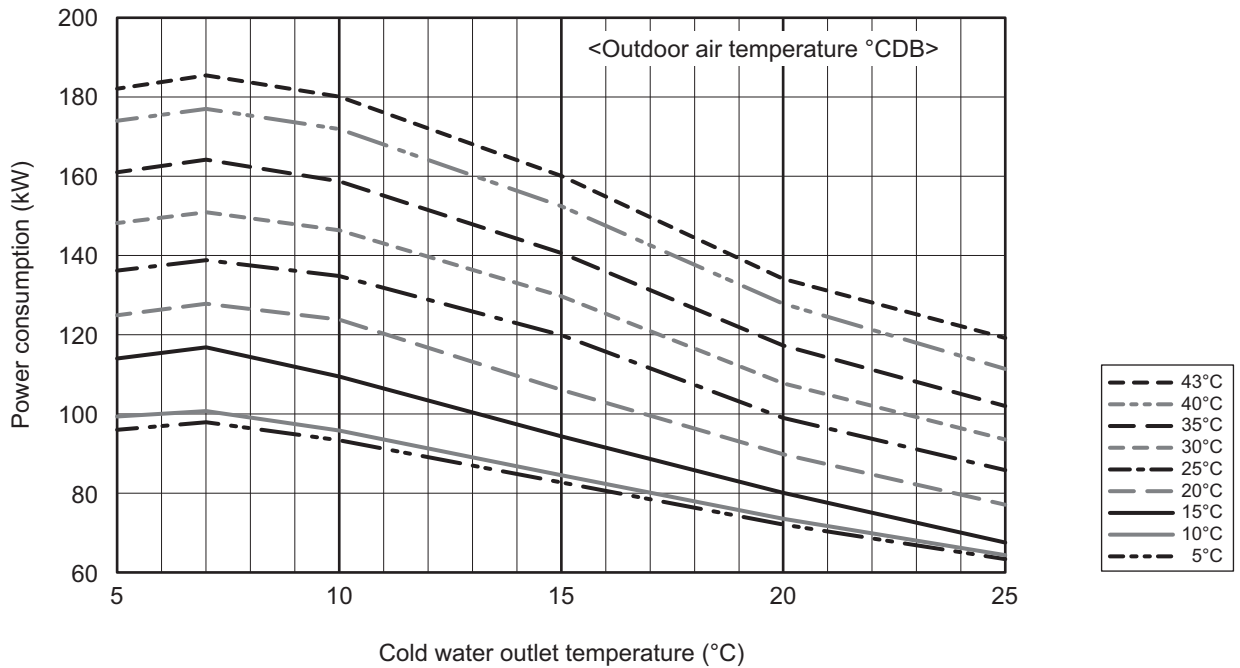
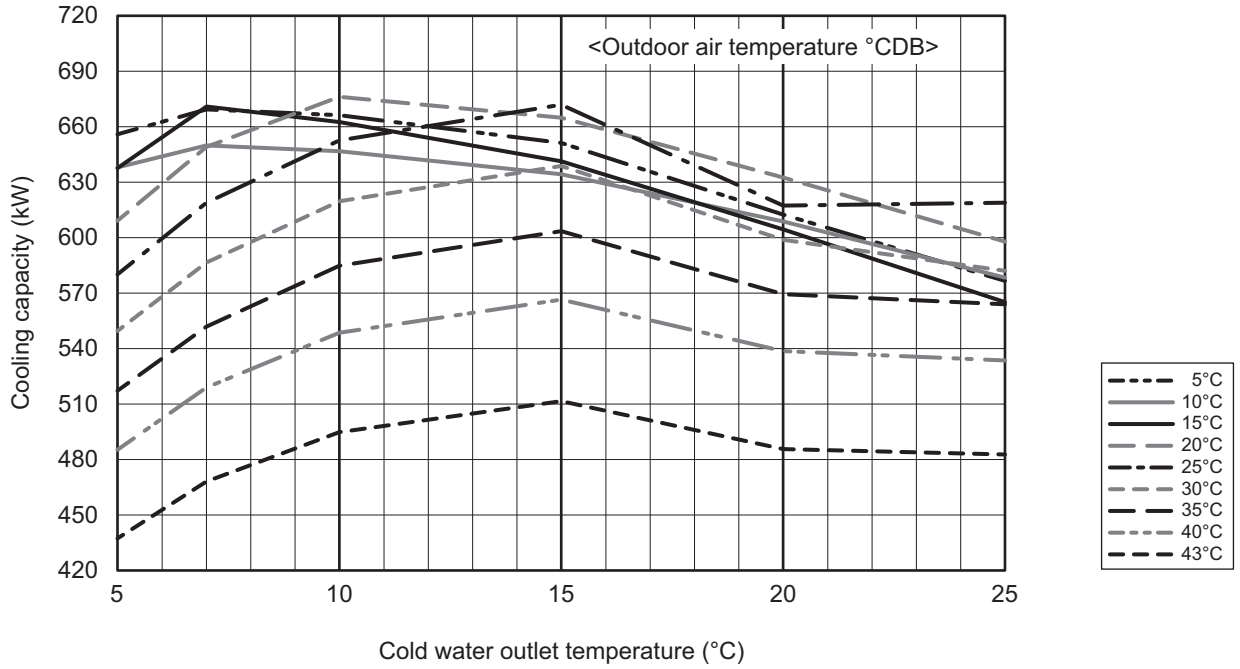

* When the cold water outlet temperature is 8°C or higher, the capacity control operation is performed to reduce the power consumption.

2. Product Data

[Cold/hot water outlet/inlet temperature difference 7°C]

EAHV-P900YA × 6

■ Heating Capacity

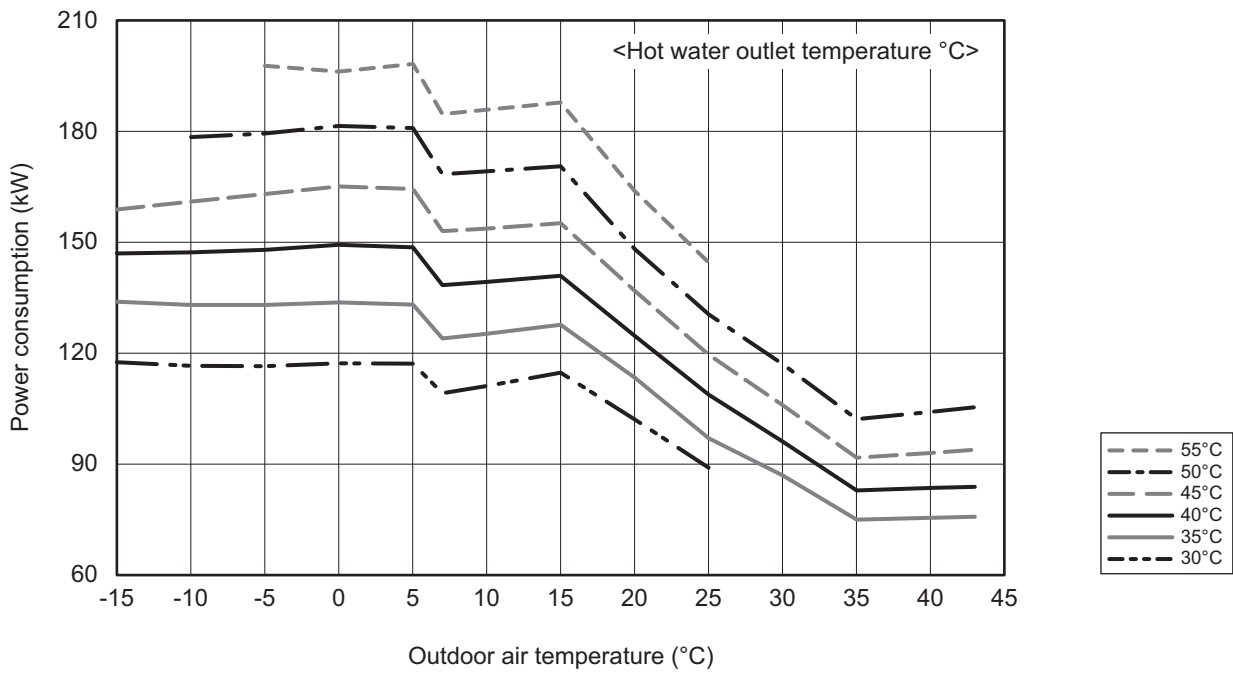
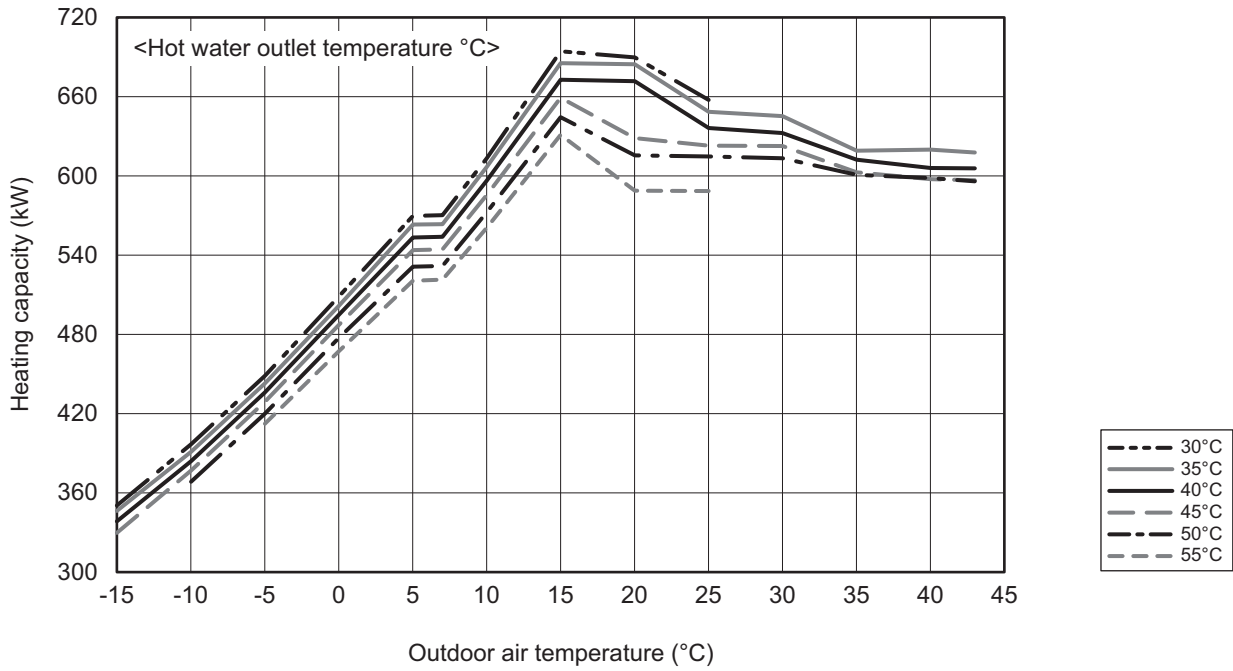

2. Product Data

[Cold brine outlet/inlet temperature difference 7°C]

EACV-P900YA

■ Cooling Capacity [Brine: ethylene glycol 35wt%]

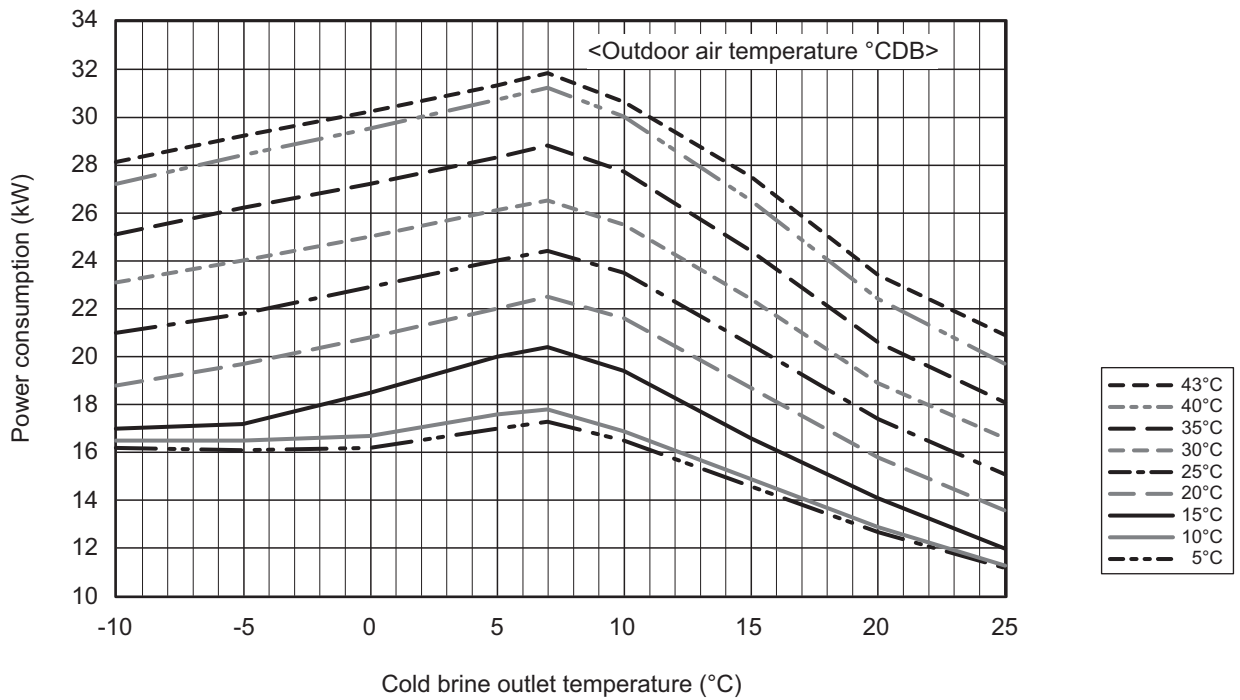
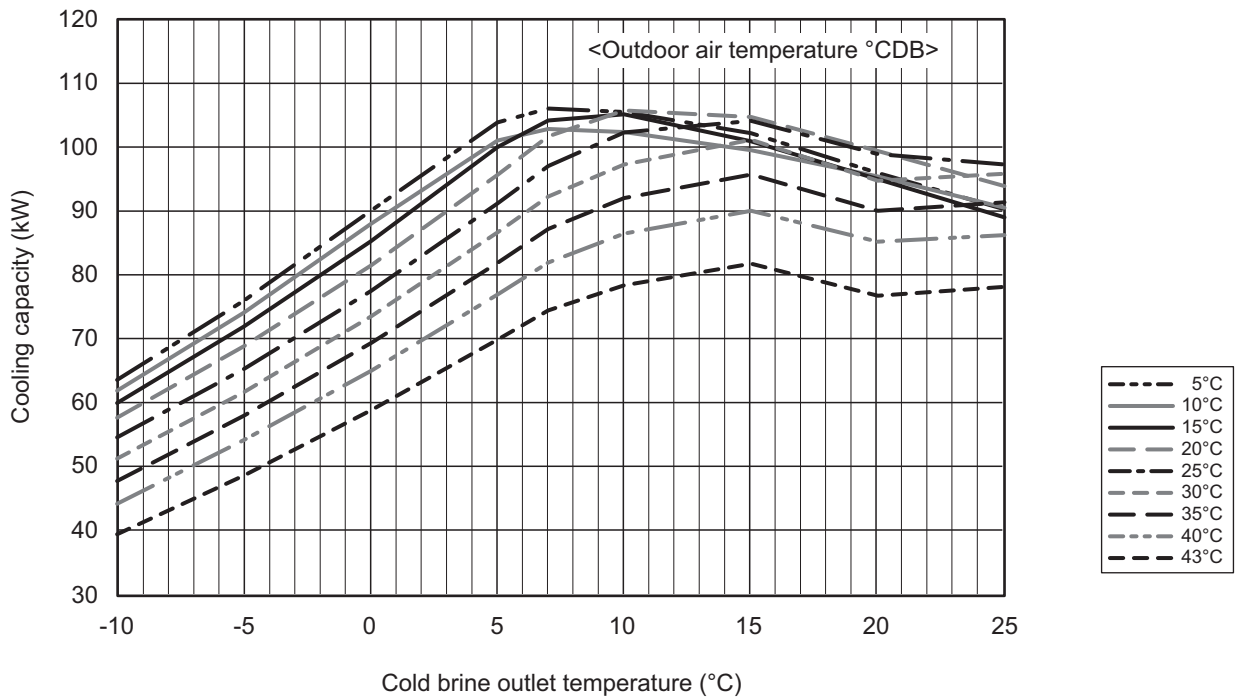

* When the cold brine outlet temperature is 8°C or higher, the capacity control operation is performed to reduce the power consumption.

2. Product Data

[Cold brine outlet/inlet temperature difference 7°C]

EACV-P900YA × 2

■ Cooling Capacity [Brine: ethylene glycol 35wt%]

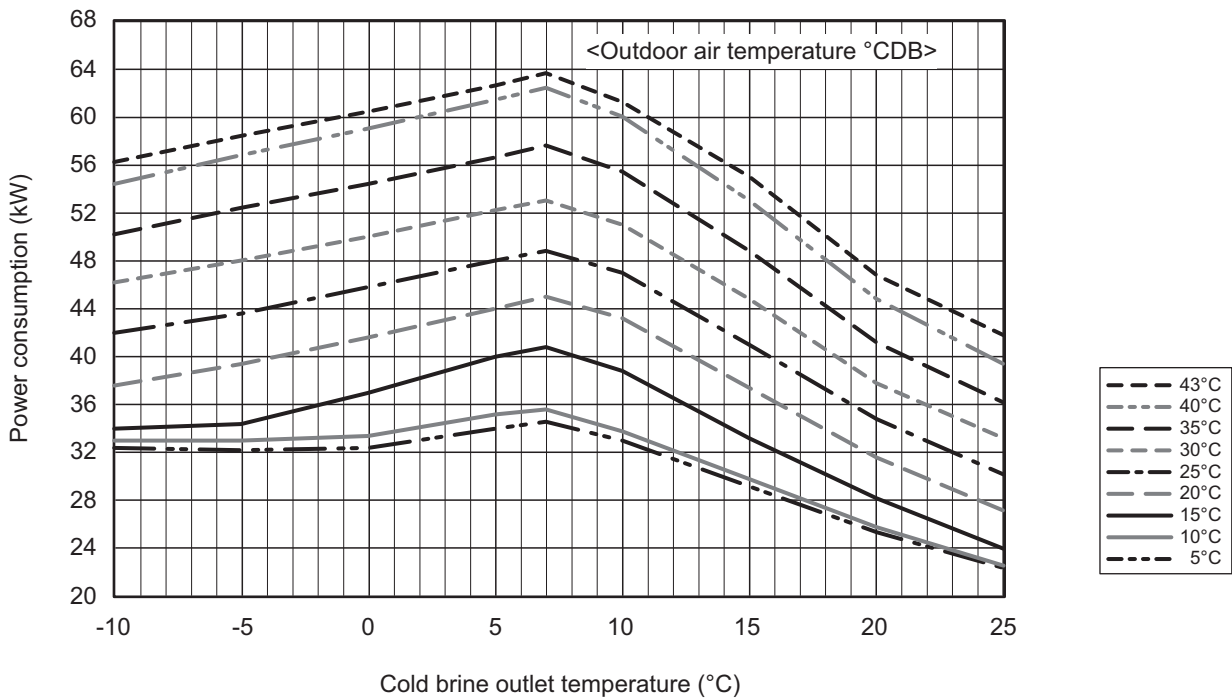
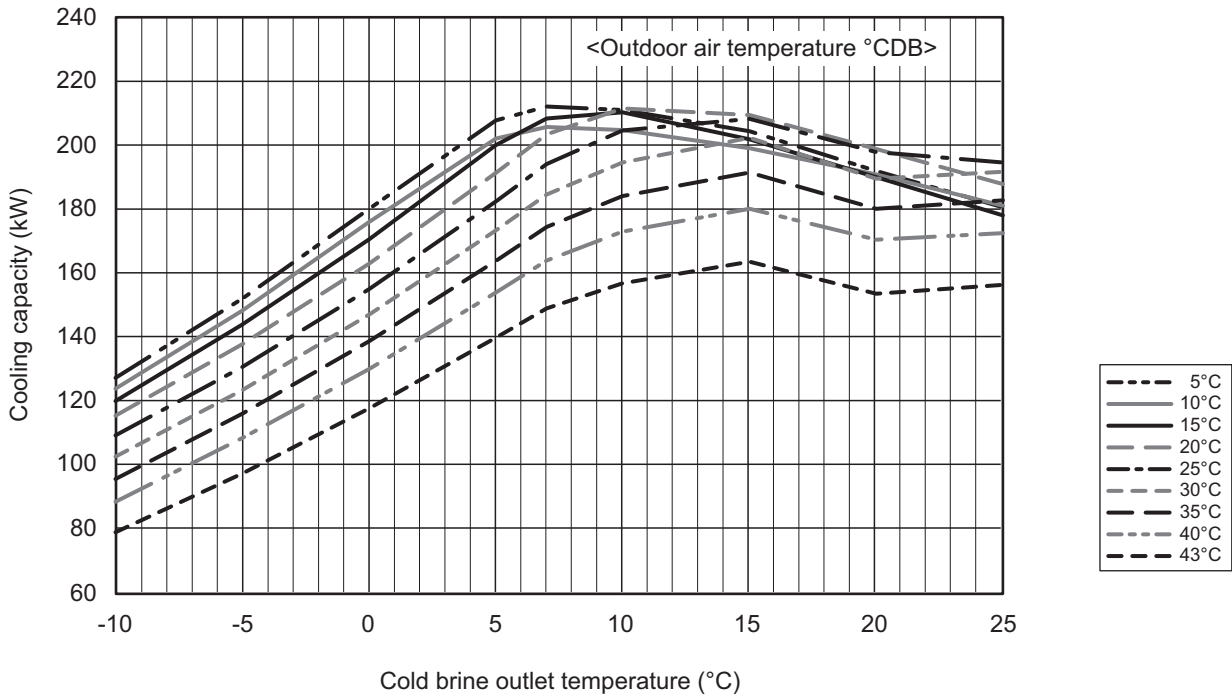

* When the cold brine outlet temperature is 8°C or higher, the capacity control operation is performed to reduce the power consumption.

2. Product Data

[Cold brine outlet/inlet temperature difference 7°C]

EACV-P900YA × 3

■ Cooling Capacity [Brine: ethylene glycol 35wt%]

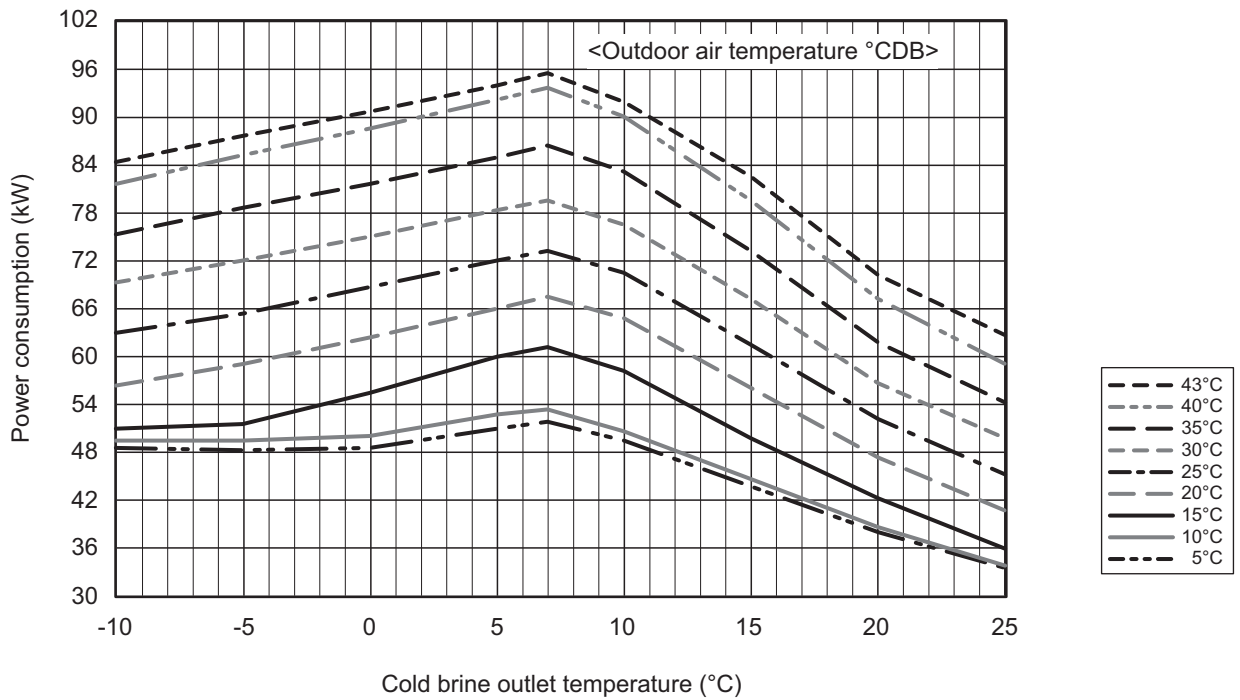
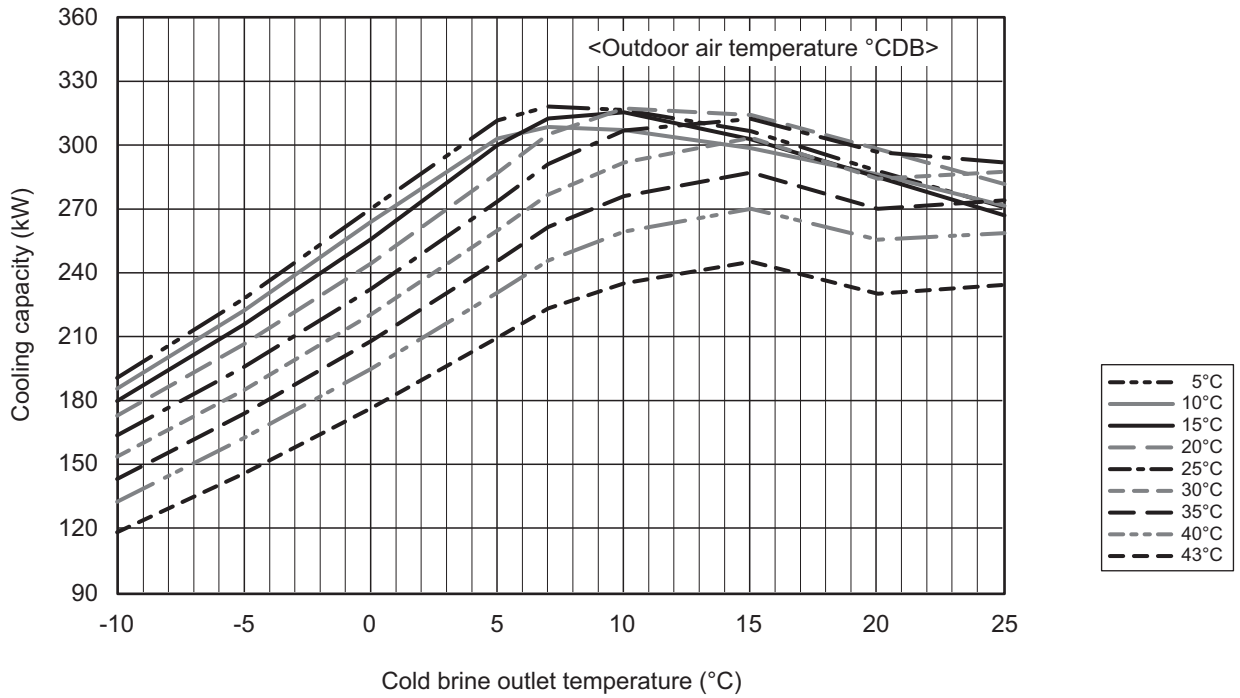

* When the cold brine outlet temperature is 8°C or higher, the capacity control operation is performed to reduce the power consumption.

2. Product Data

[Cold brine outlet/inlet temperature difference 7°C]

EACV-P900YA × 4

■ Cooling Capacity [Brine: ethylene glycol 35wt%]

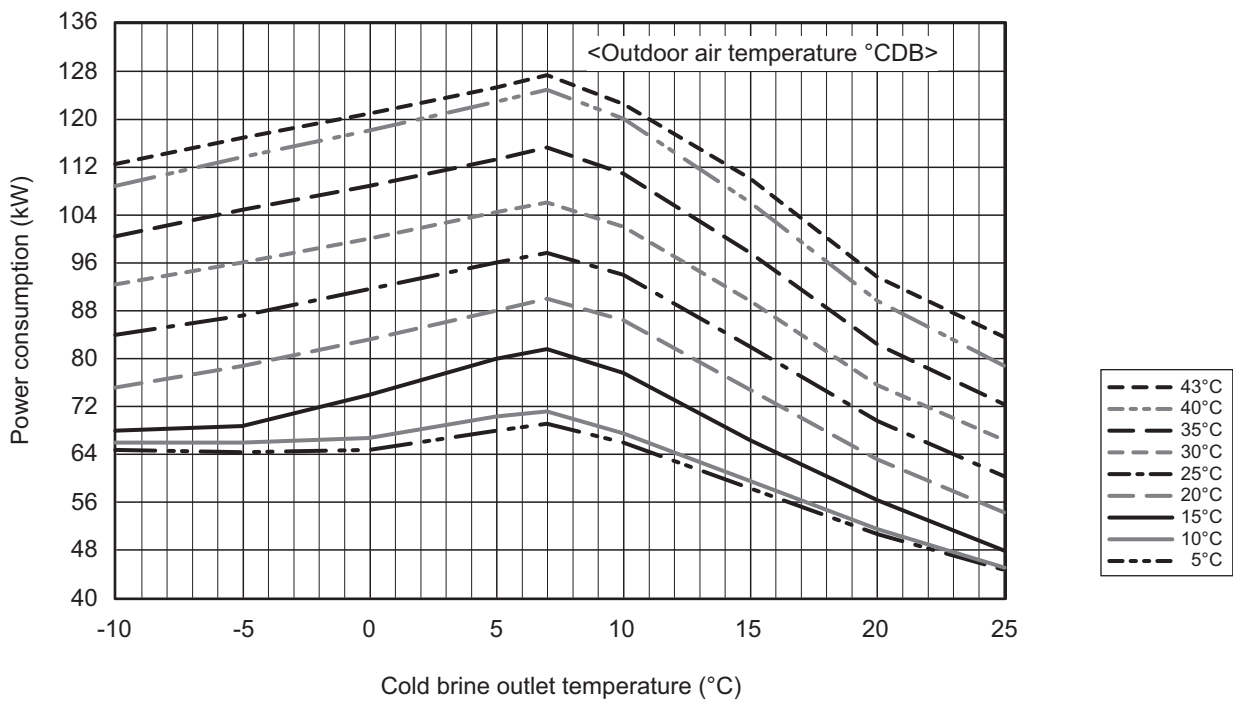
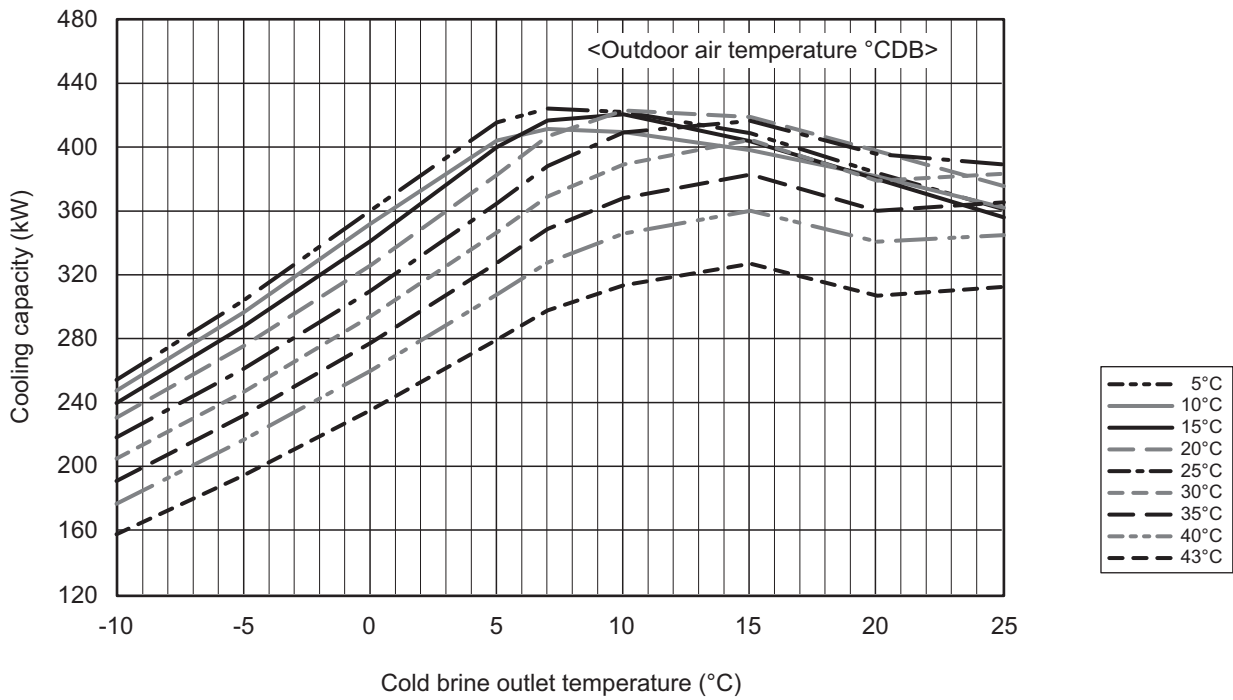

* When the cold brine outlet temperature is 8°C or higher, the capacity control operation is performed to reduce the power consumption.

2. Product Data

[Cold brine outlet/inlet temperature difference 7°C]

EACV-P900YA × 5

■ Cooling Capacity [Brine: ethylene glycol 35wt%]

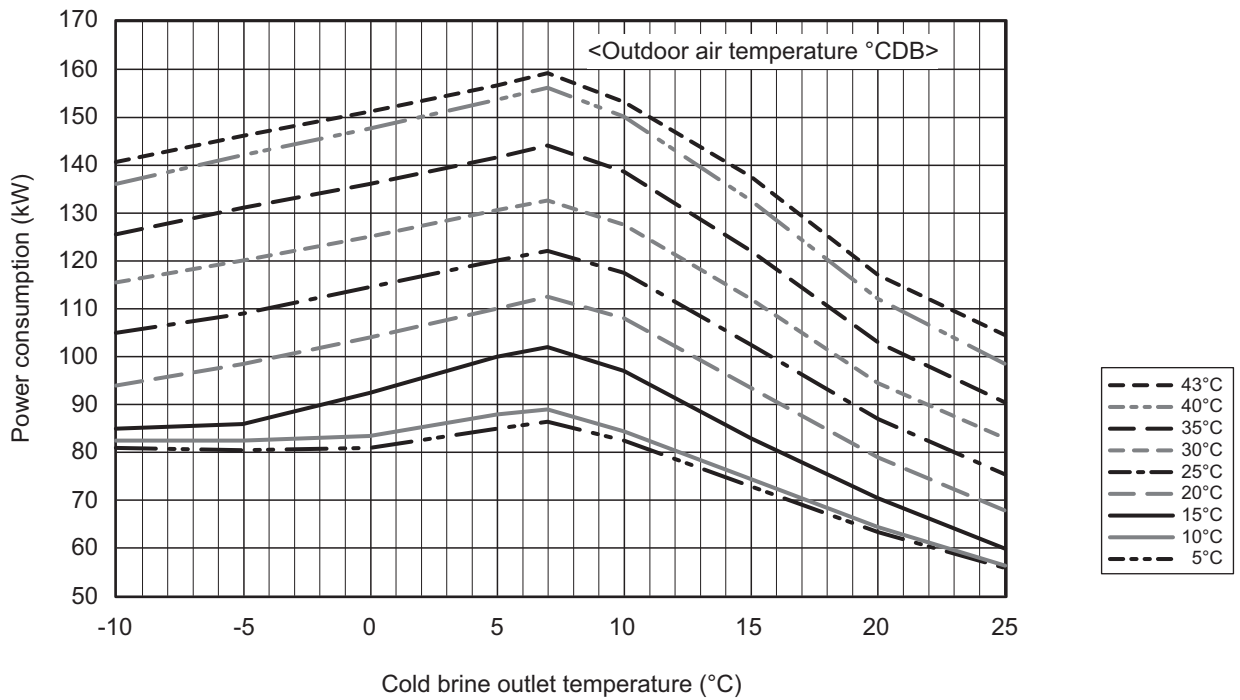
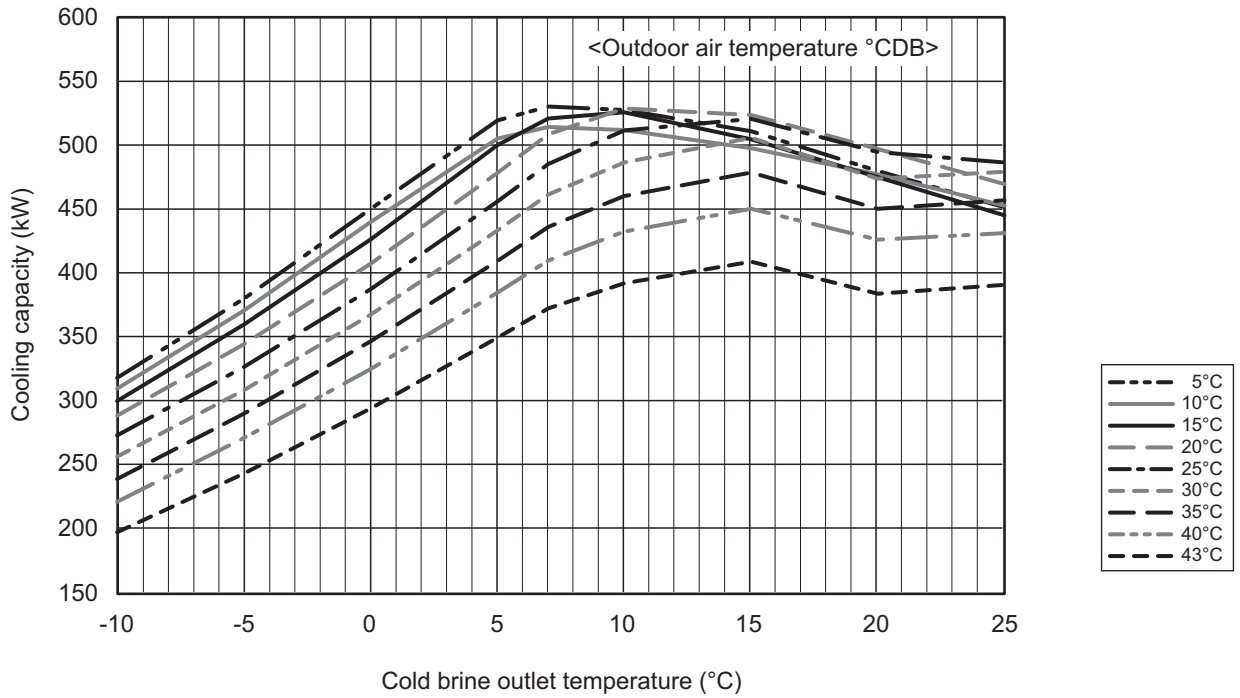

* When the cold brine outlet temperature is 8°C or higher, the capacity control operation is performed to reduce the power consumption.

2. Product Data

[Cold brine outlet/inlet temperature difference 7°C]

EACV-P900YA × 6

■ Cooling Capacity [Brine: ethylene glycol 35wt%]

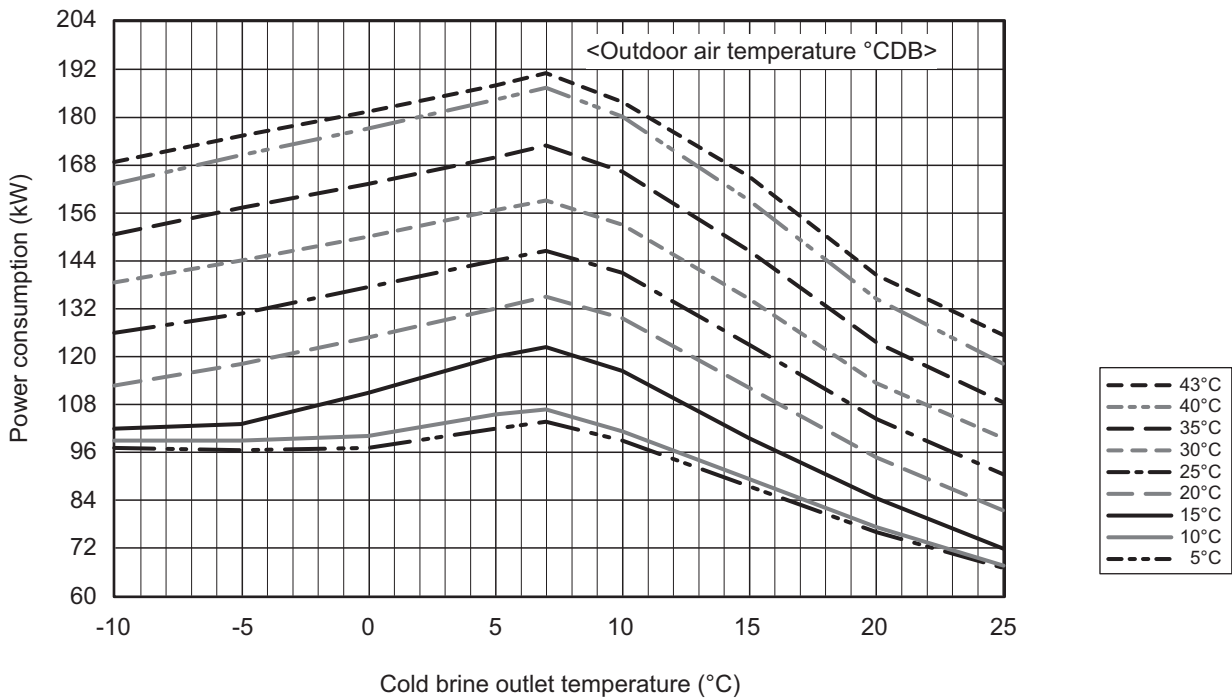
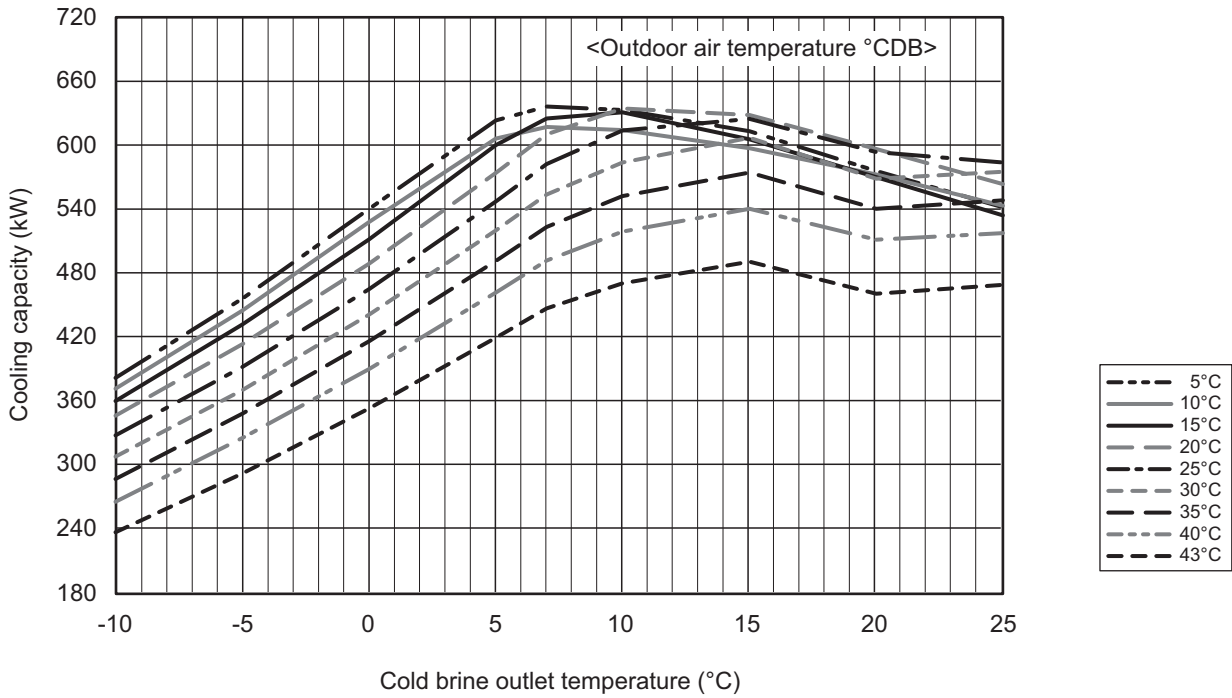

* When the cold brine outlet temperature is 8°C or higher, the capacity control operation is performed to reduce the power consumption.

2. Product Data

[Cold/hot water outlet/inlet temperature difference 7°C]

COP priority mode

EAHV-P900YA

EACV-P900YA

■ Cooling Capacity [Water]

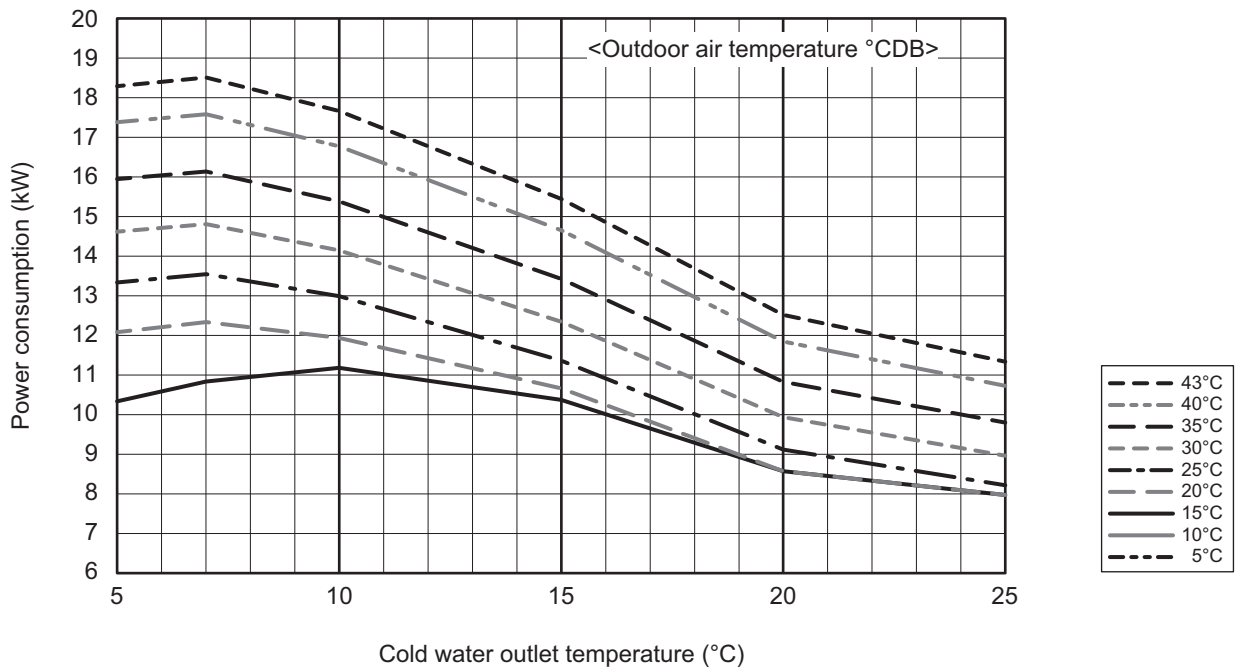
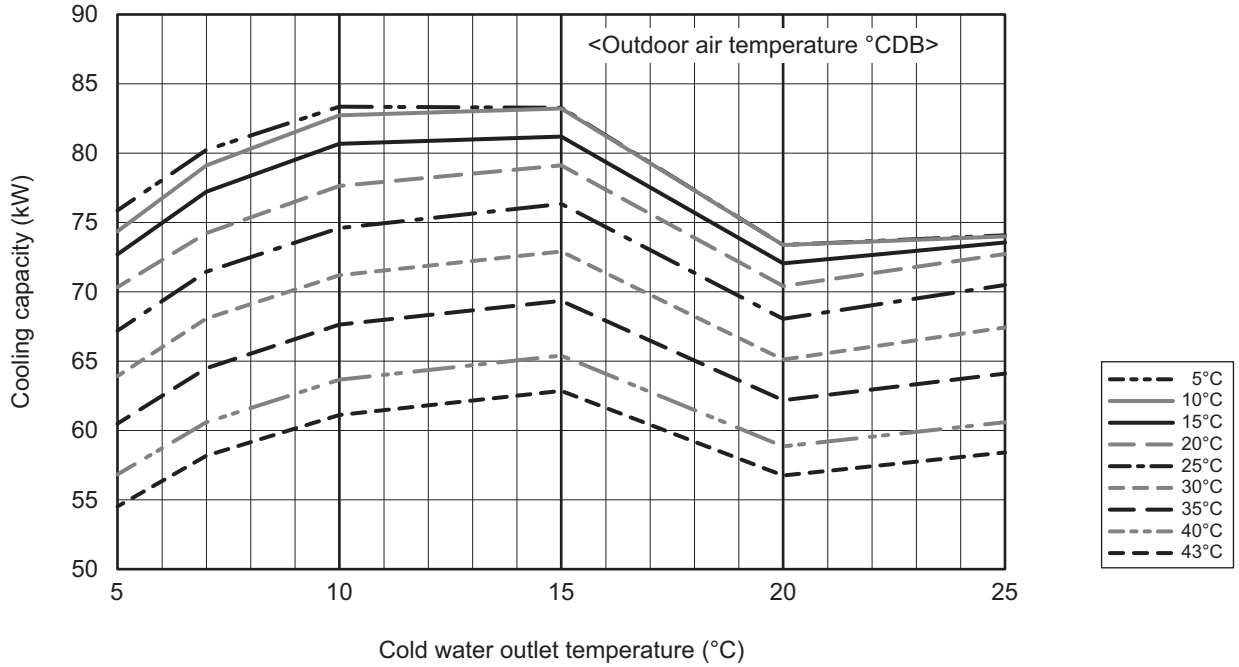

* When the cold water outlet temperature is 8°C or higher, the capacity control operation is performed to reduce the power consumption.

2. Product Data

[Cold/hot water outlet/inlet temperature difference 7°C]

COP priority mode

EAHV-P900YA

■ Heating Capacity

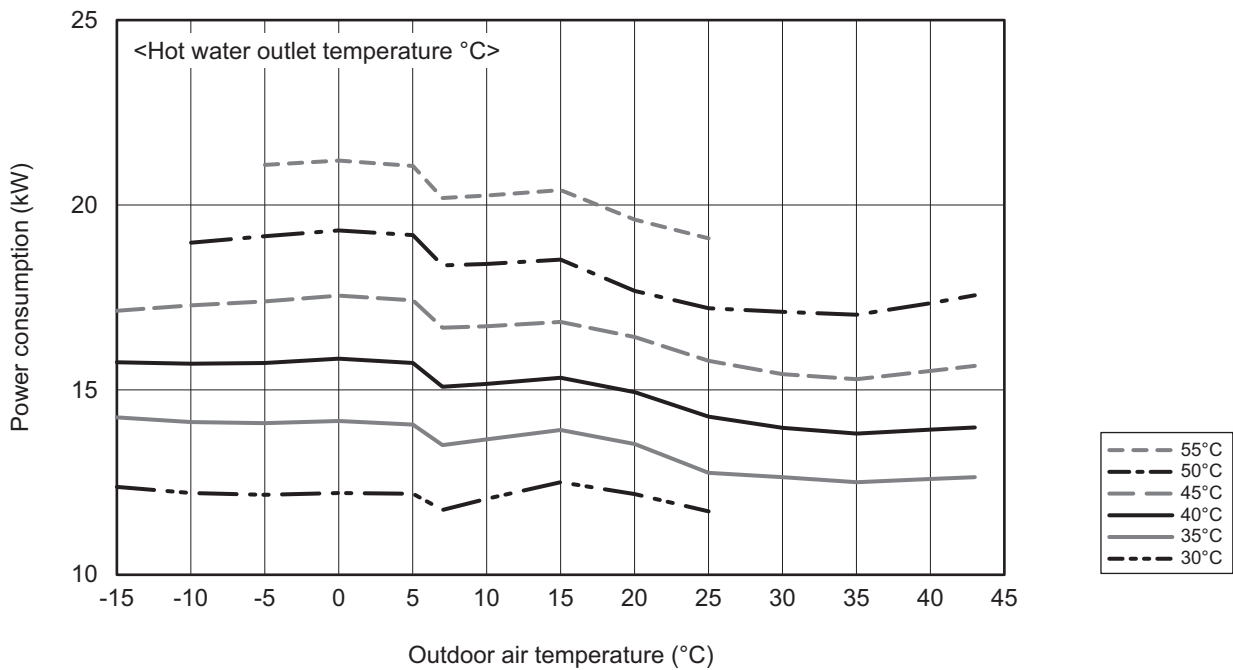
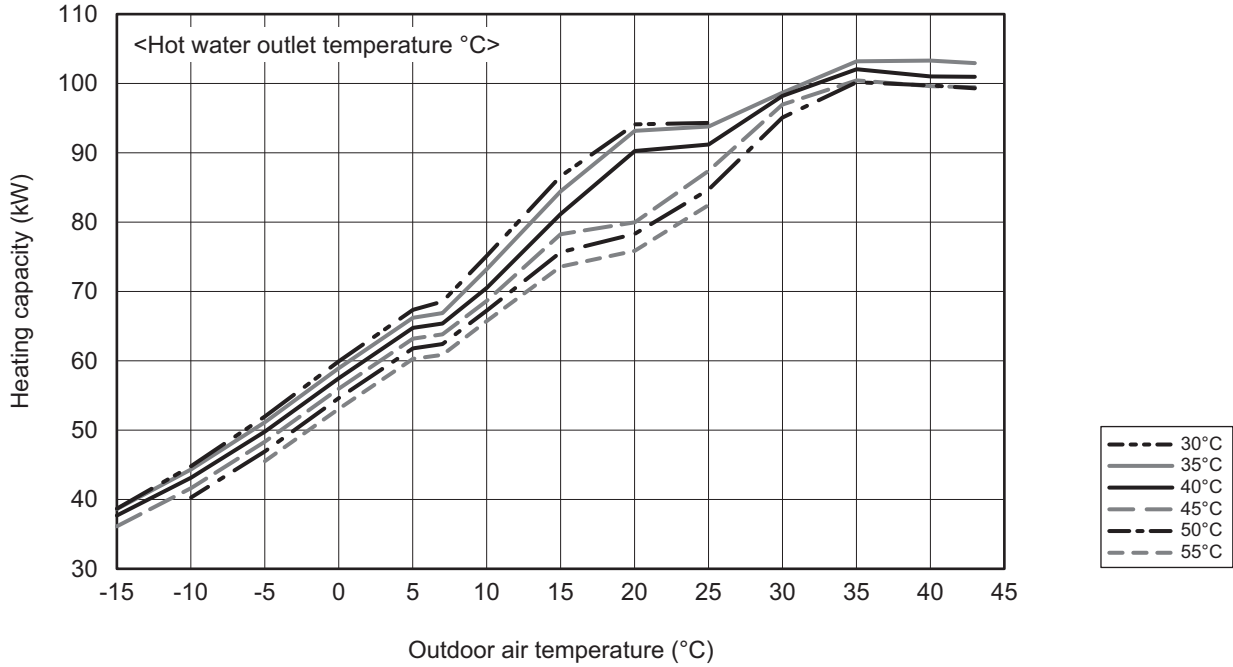

EAHV-P-YAF(-H)(-N), YAL(-H)(-N)/EACV-P-YAF(-N), YAL(-N)

2. Product Data

[Cold/hot water outlet/inlet temperature difference 7°C]

COP priority mode

EAHV-P900YA × 2

EACV-P900YA × 2

■ Cooling Capacity [Water]

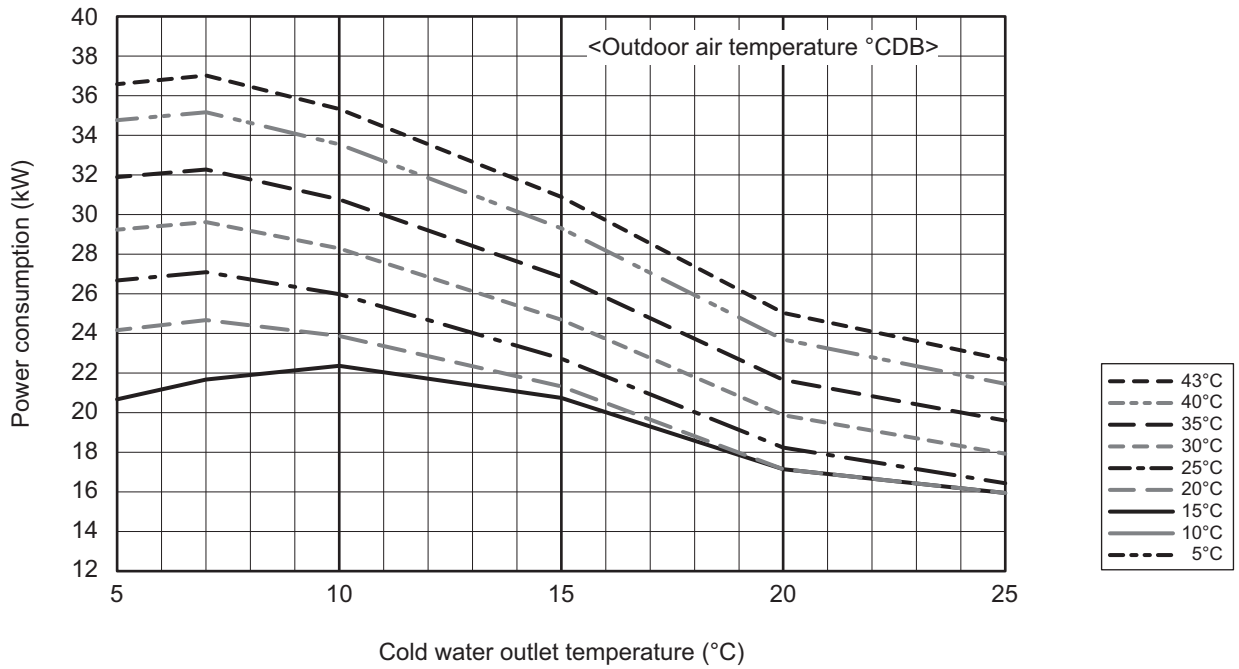
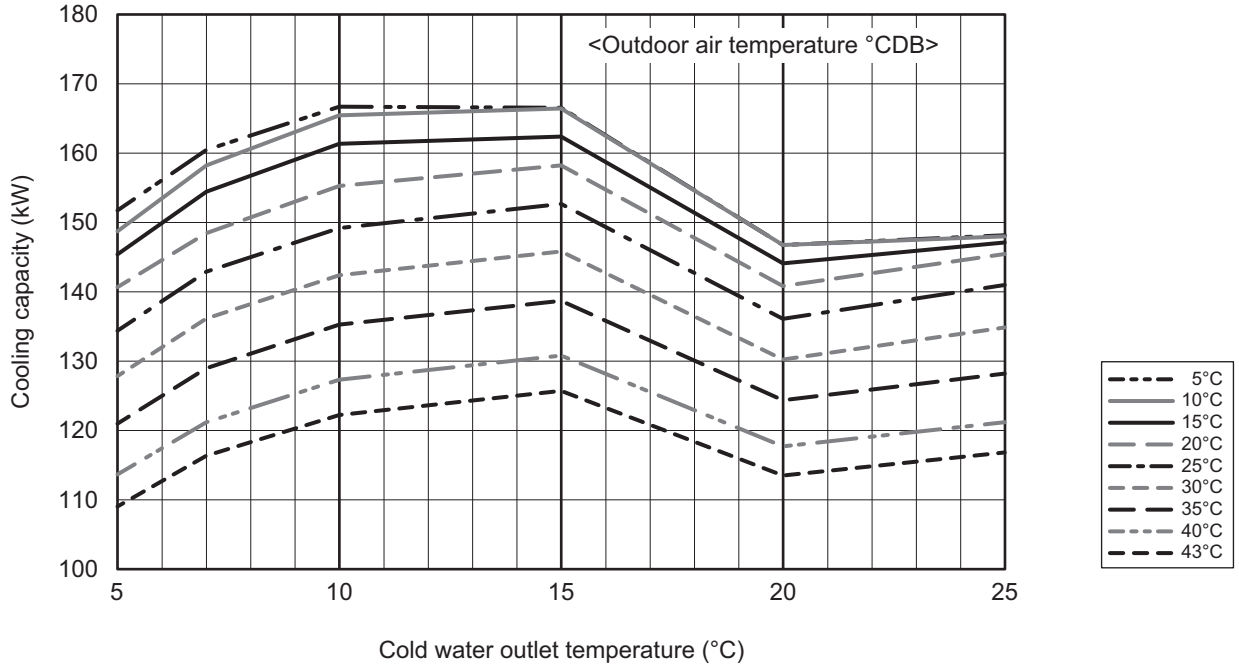

* When the cold water outlet temperature is 8°C or higher, the capacity control operation is performed to reduce the power consumption.

2. Product Data

[Cold/hot water outlet/inlet temperature difference 7°C]

COP priority mode

EAHV-P900YA × 2

■ Heating Capacity

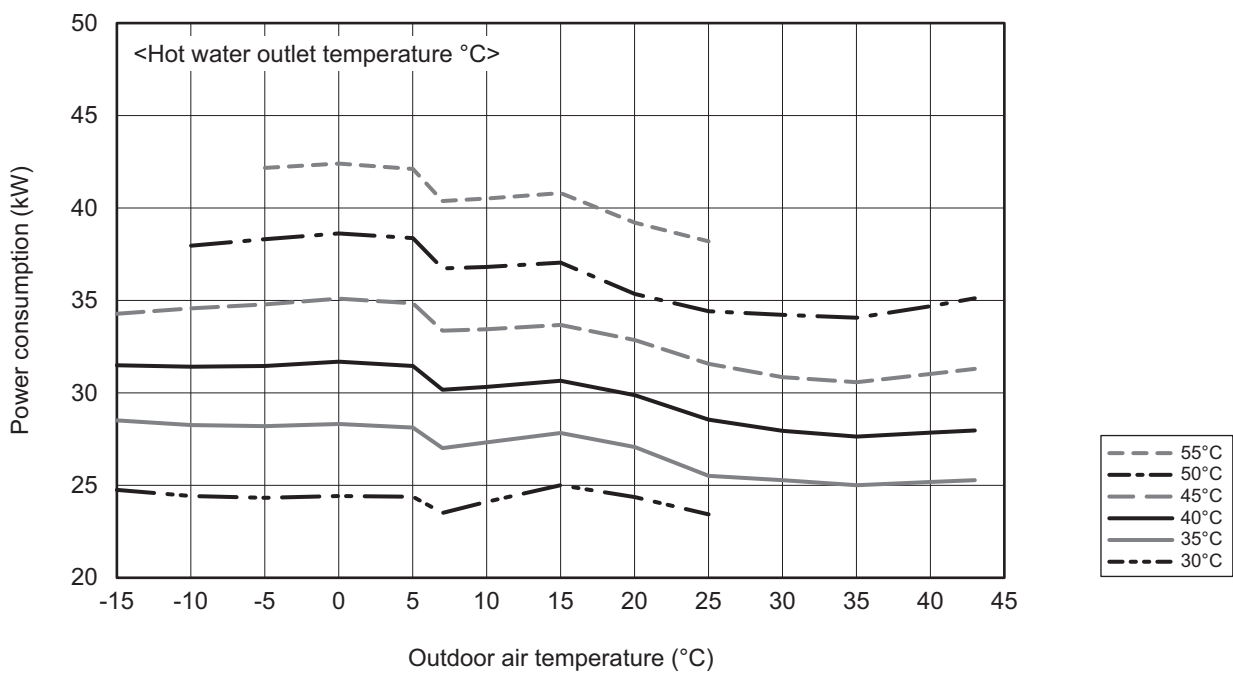
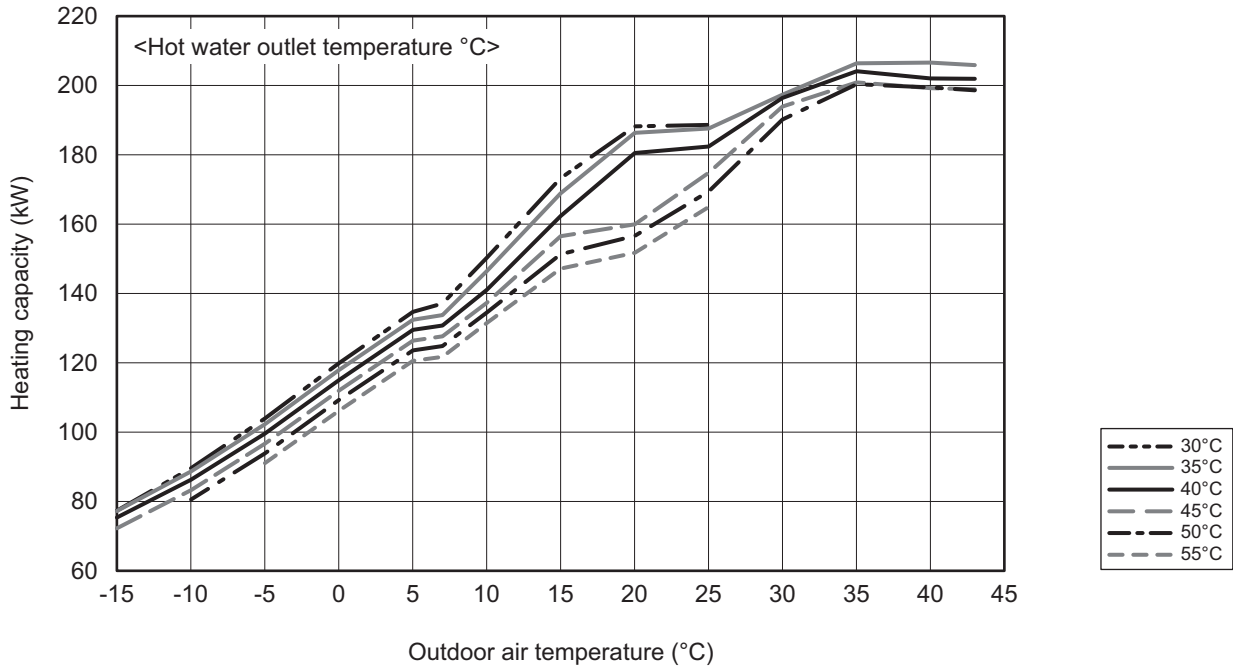

EAHV-P-YAF(-H)(-N), YAL(-H)(-N)/EACV-P-YAF(-N), YAL(-N)

2. Product Data

[Cold/hot water outlet/inlet temperature difference 7°C]

COP priority mode

EAHV-P900YA × 3

EACV-P900YA × 3

■ Cooling Capacity [Water]

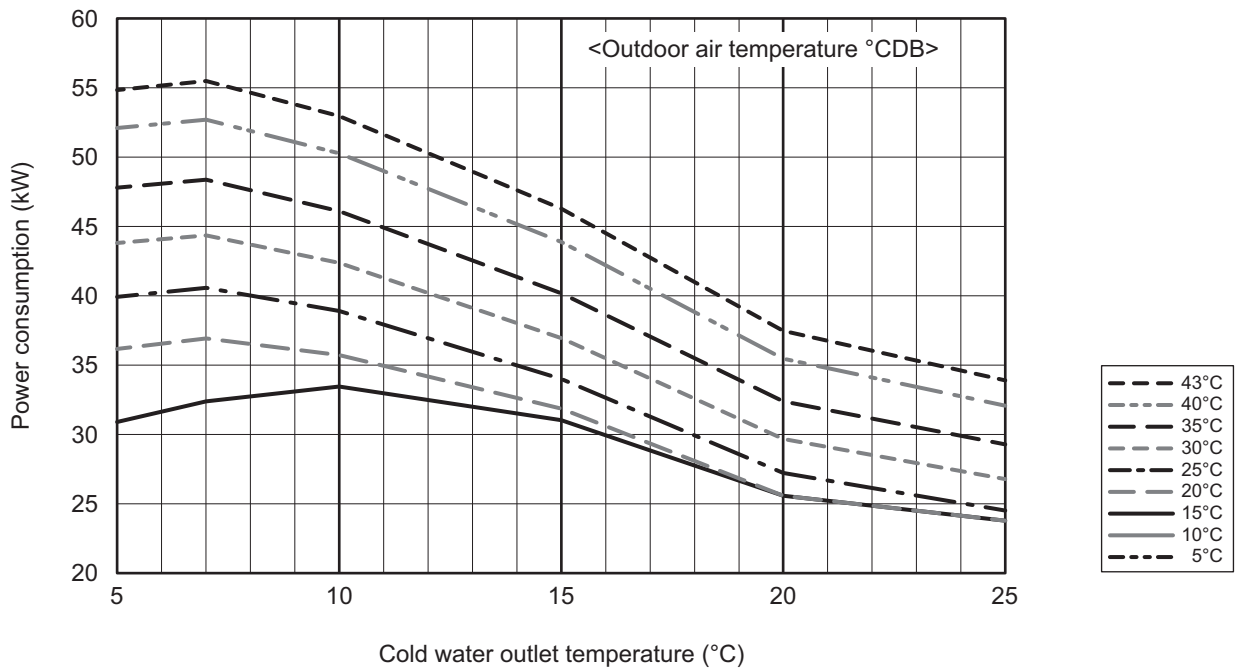
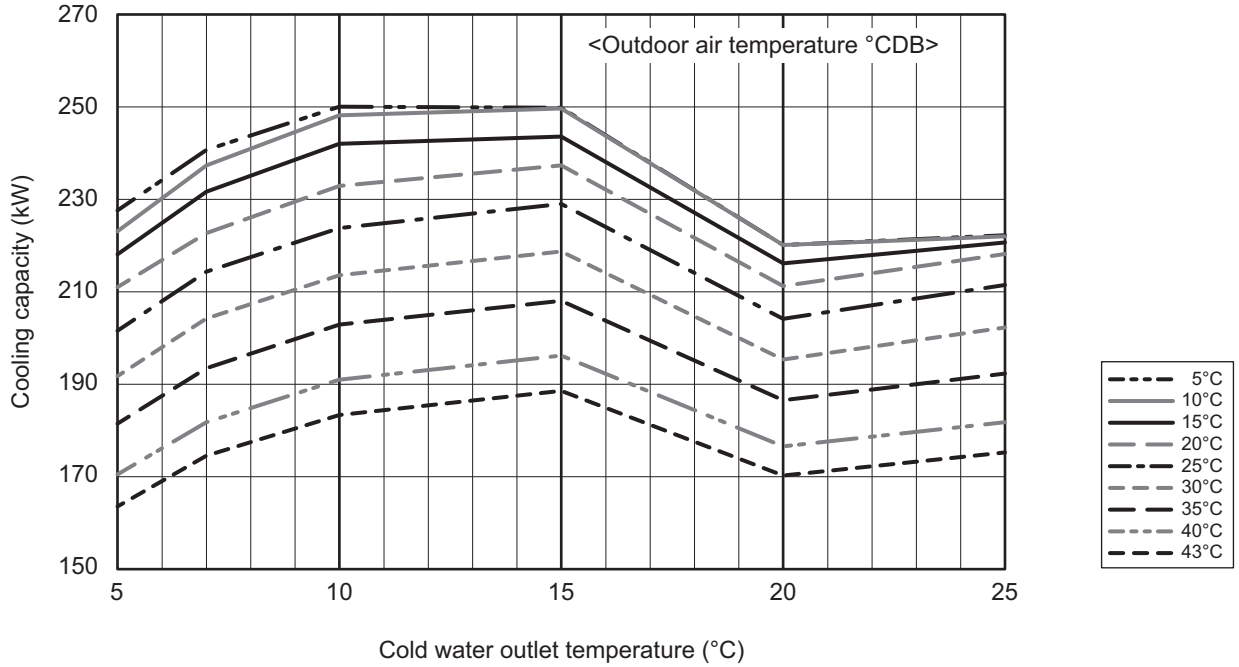

* When the cold water outlet temperature is 8°C or higher, the capacity control operation is performed to reduce the power consumption.

2. Product Data

[Cold/hot water outlet/inlet temperature difference 7°C]

COP priority mode

EAHV-P900YA × 3

■ Heating Capacity

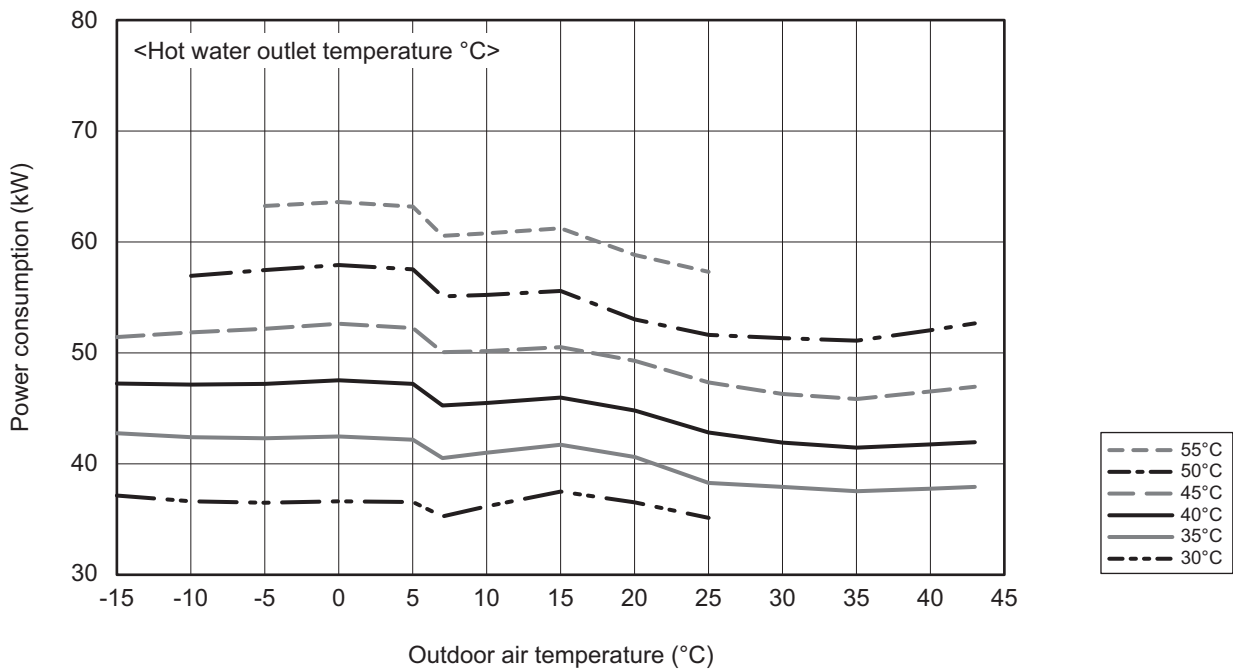
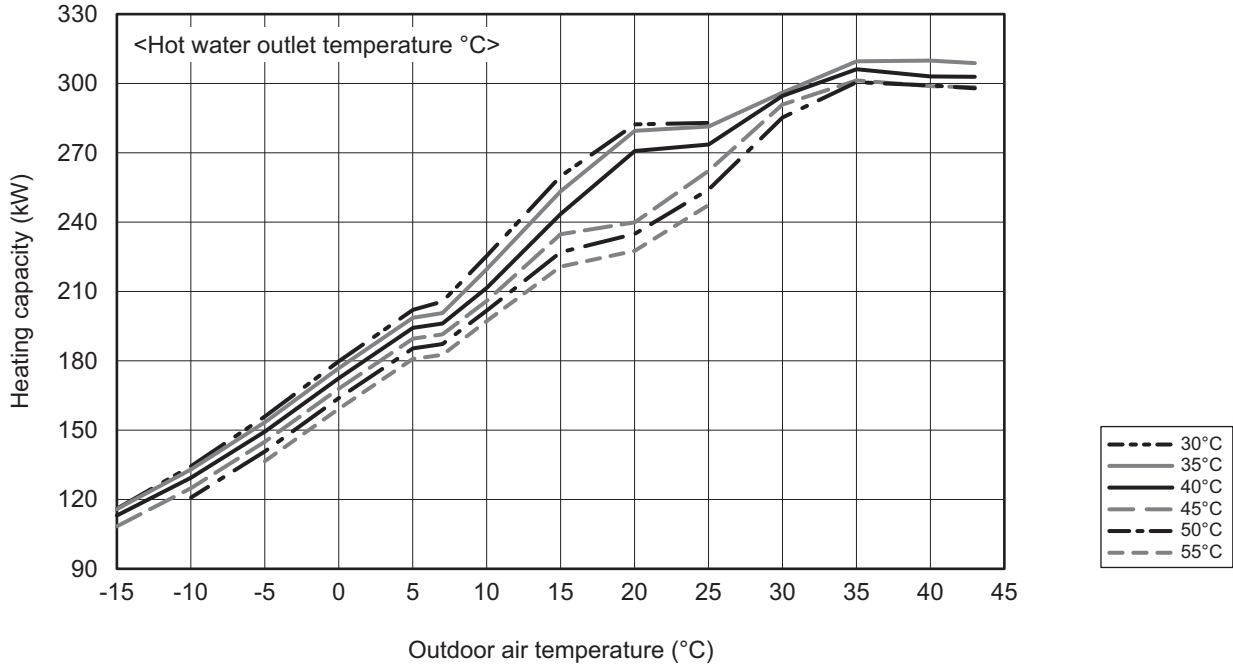

2. Product Data

[Cold/hot water outlet/inlet temperature difference 7°C]

COP priority mode

EAHV-P900YA × 4

EACV-P900YA × 4

■ Cooling Capacity [Water]

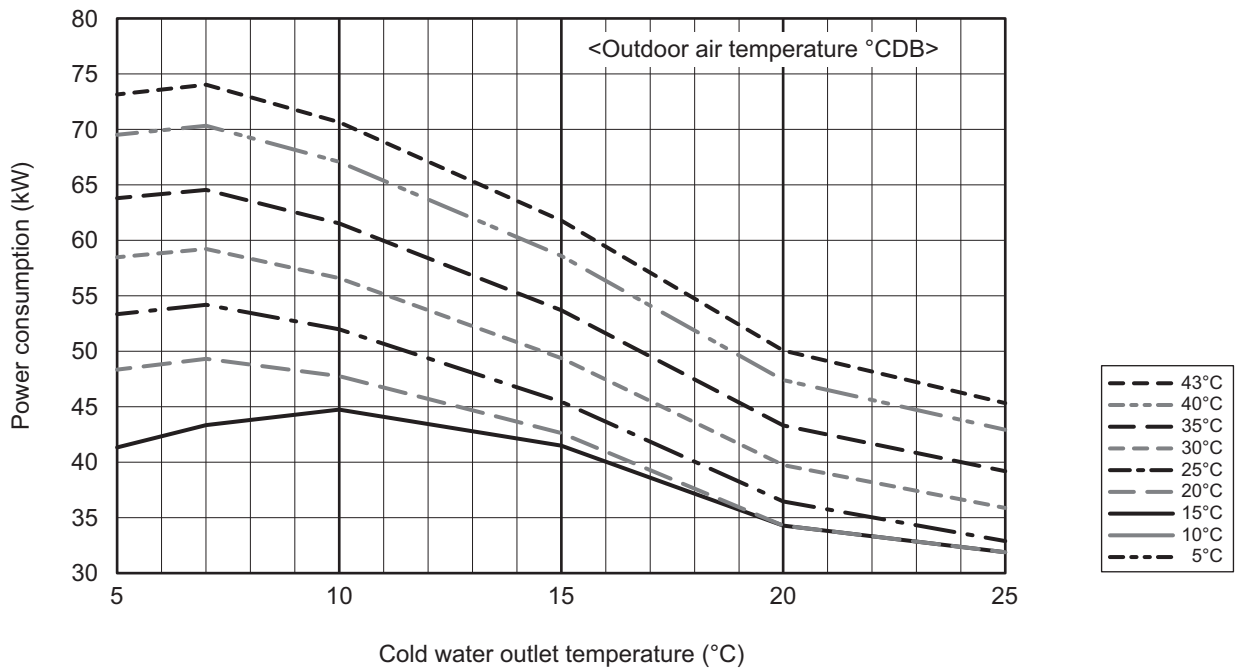
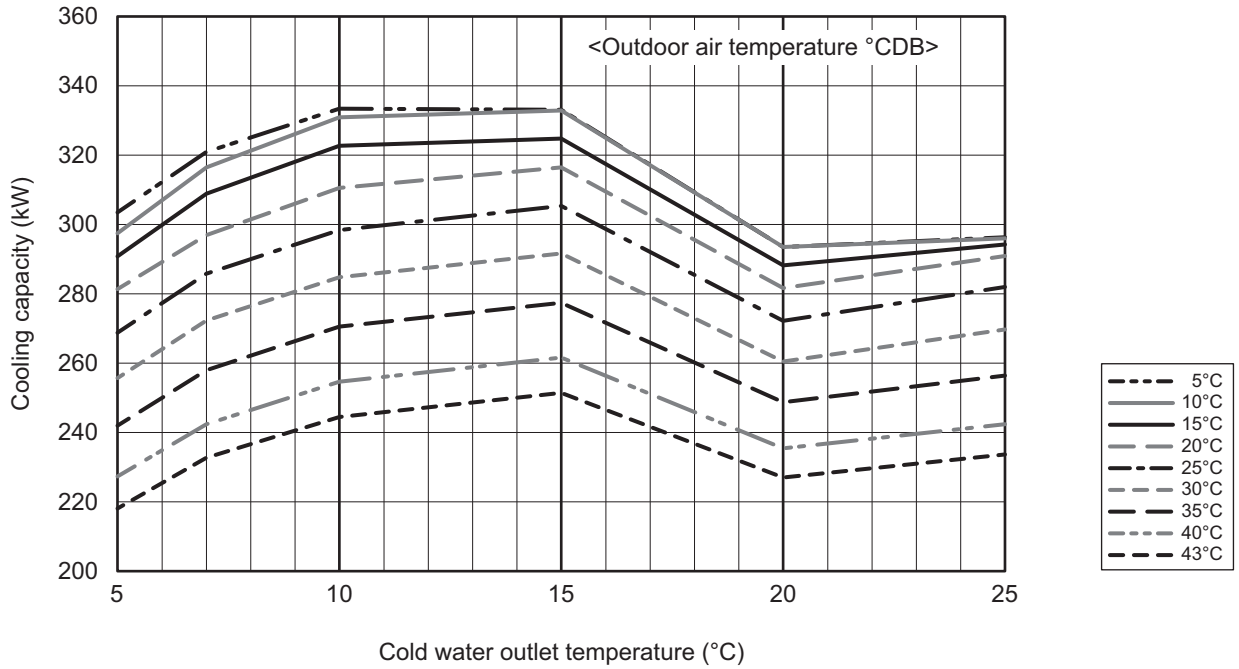

* When the cold water outlet temperature is 8°C or higher, the capacity control operation is performed to reduce the power consumption.

2. Product Data

[Cold/hot water outlet/inlet temperature difference 7°C]

COP priority mode

EAHV-P900YA × 4

■ Heating Capacity

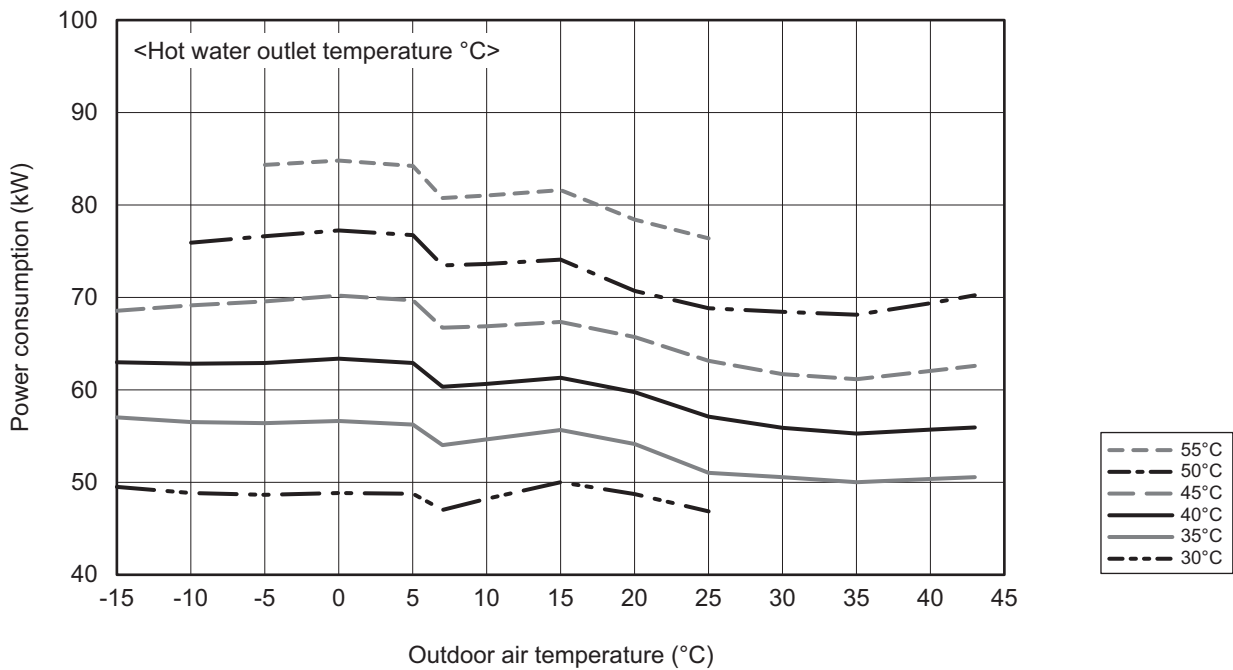
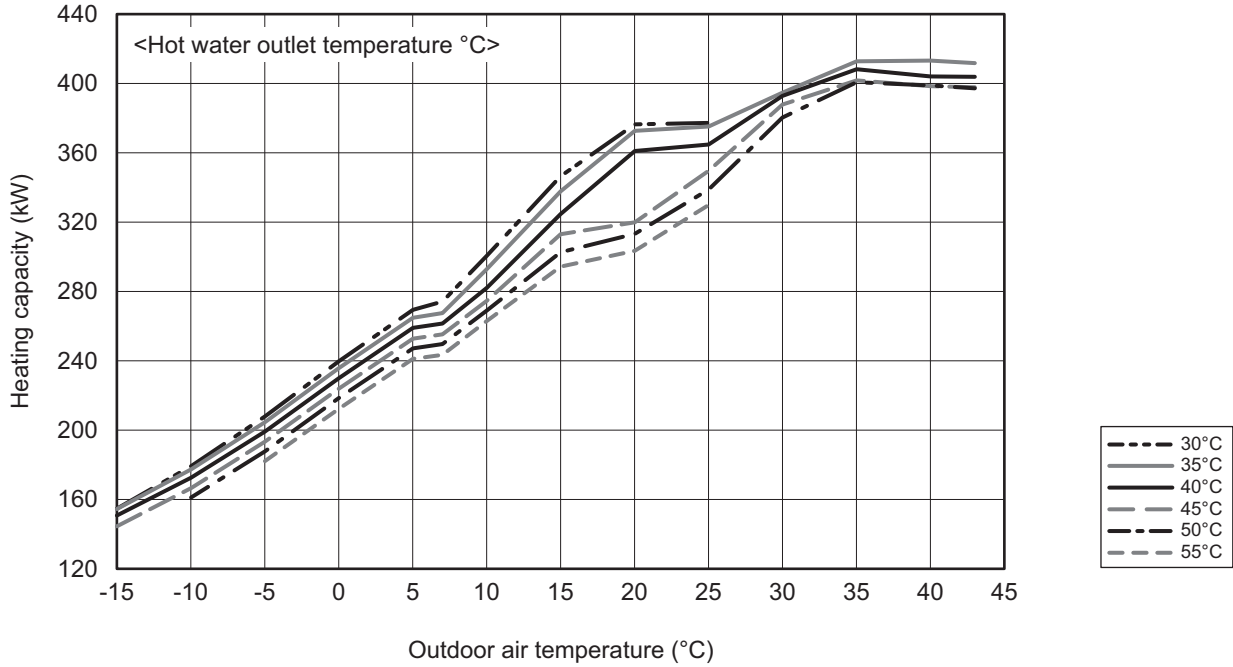

2. Product Data

[Cold/hot water outlet/inlet temperature difference 7°C]

COP priority mode

EAHV-P900YA × 5

EACV-P900YA × 5

■ Cooling Capacity [Water]

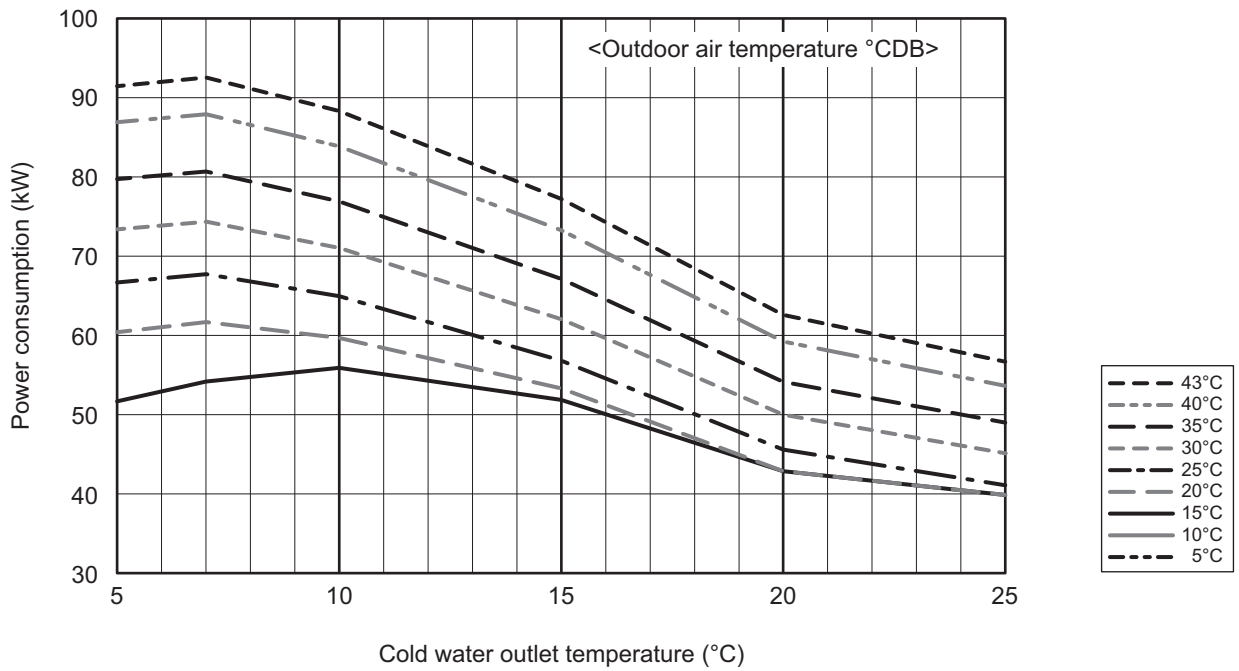
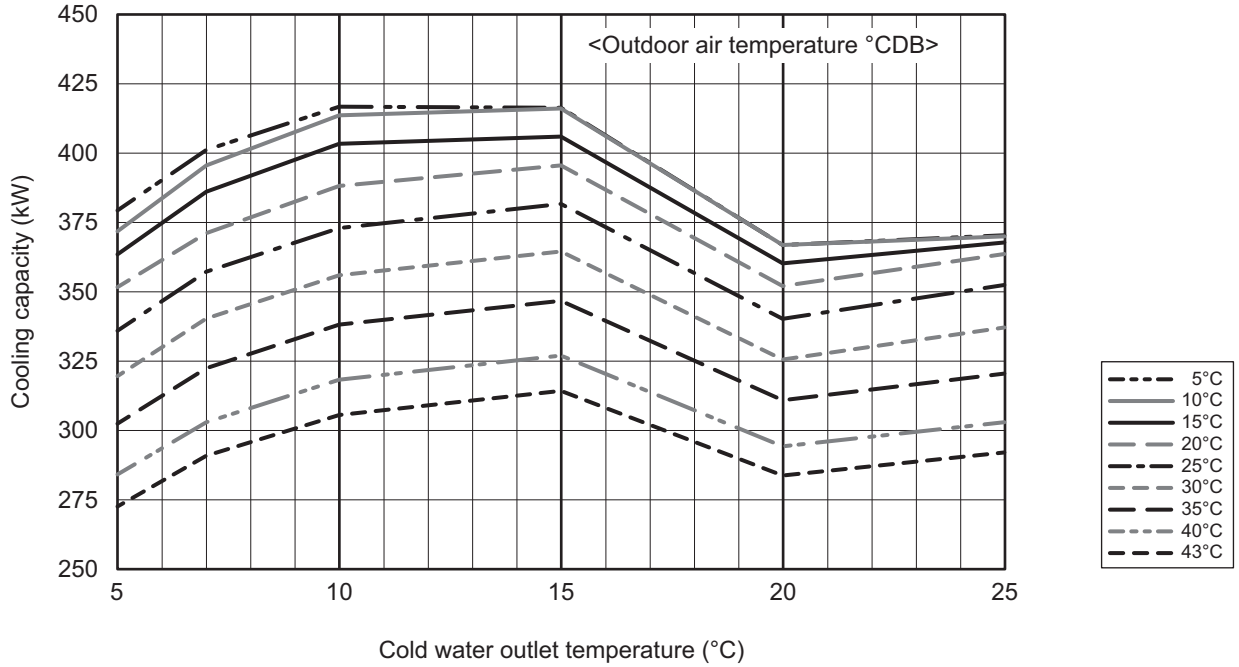

* When the cold water outlet temperature is 8°C or higher, the capacity control operation is performed to reduce the power consumption.

2. Product Data

[Cold/hot water outlet/inlet temperature difference 7°C]

COP priority mode

EAHV-P900YA × 5

■ Heating Capacity

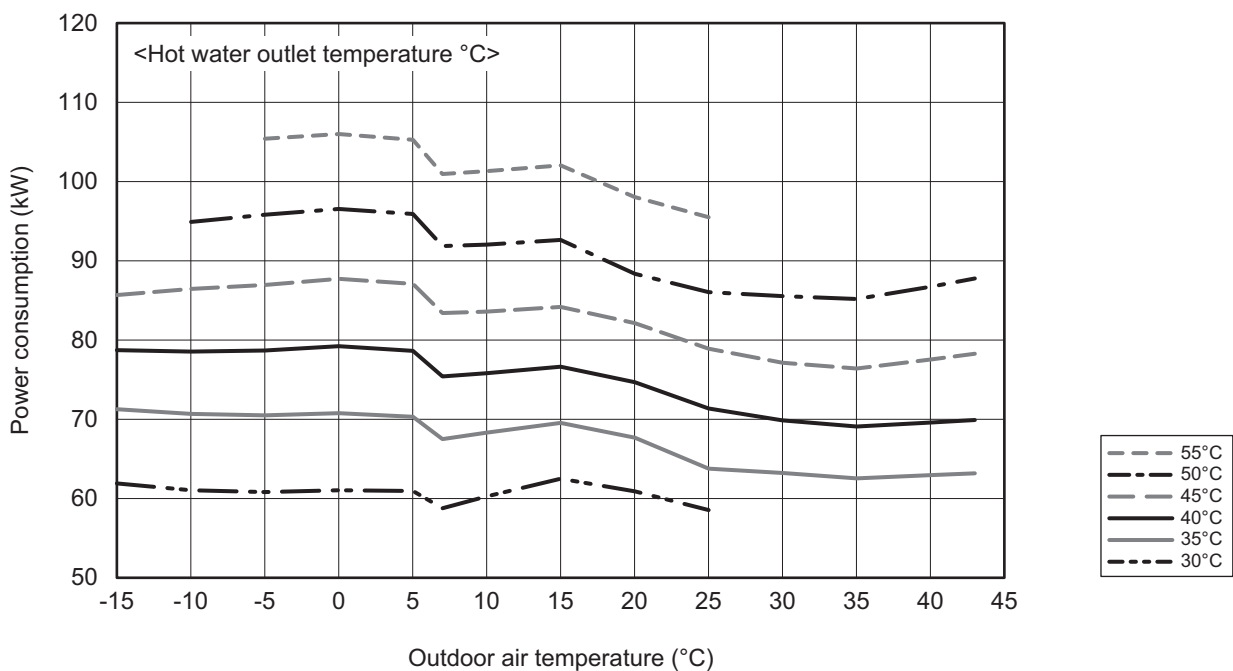
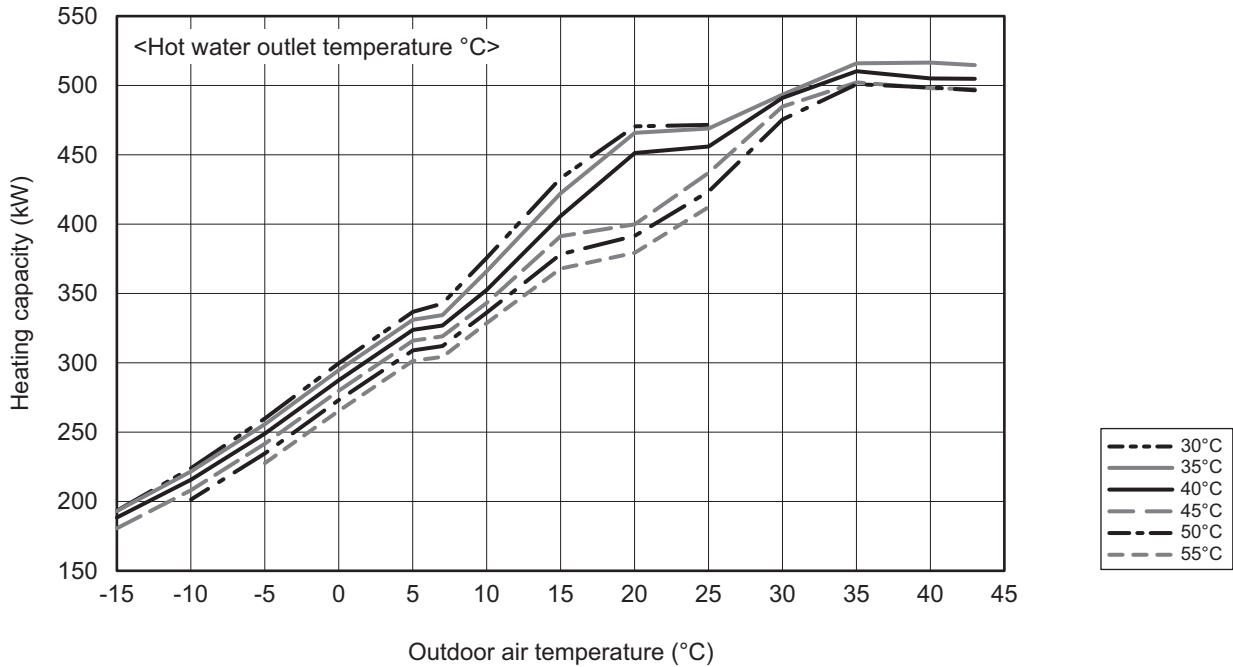

EAHV-P-YAF(-H)(-N), YAL(-H)(-N)/EACV-P-YAF(-N), YAL(-N)

2. Product Data

[Cold/hot water outlet/inlet temperature difference 7°C]

COP priority mode

EAHV-P900YA × 6

EACV-P900YA × 6

■ Cooling Capacity [Water]

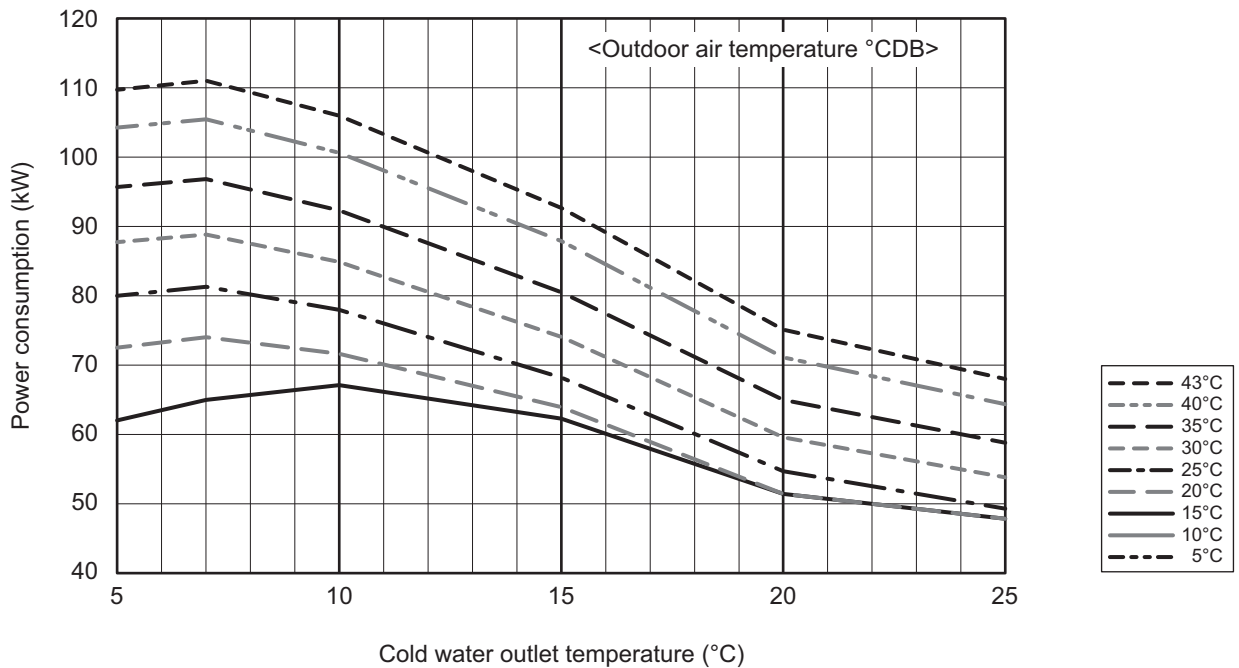
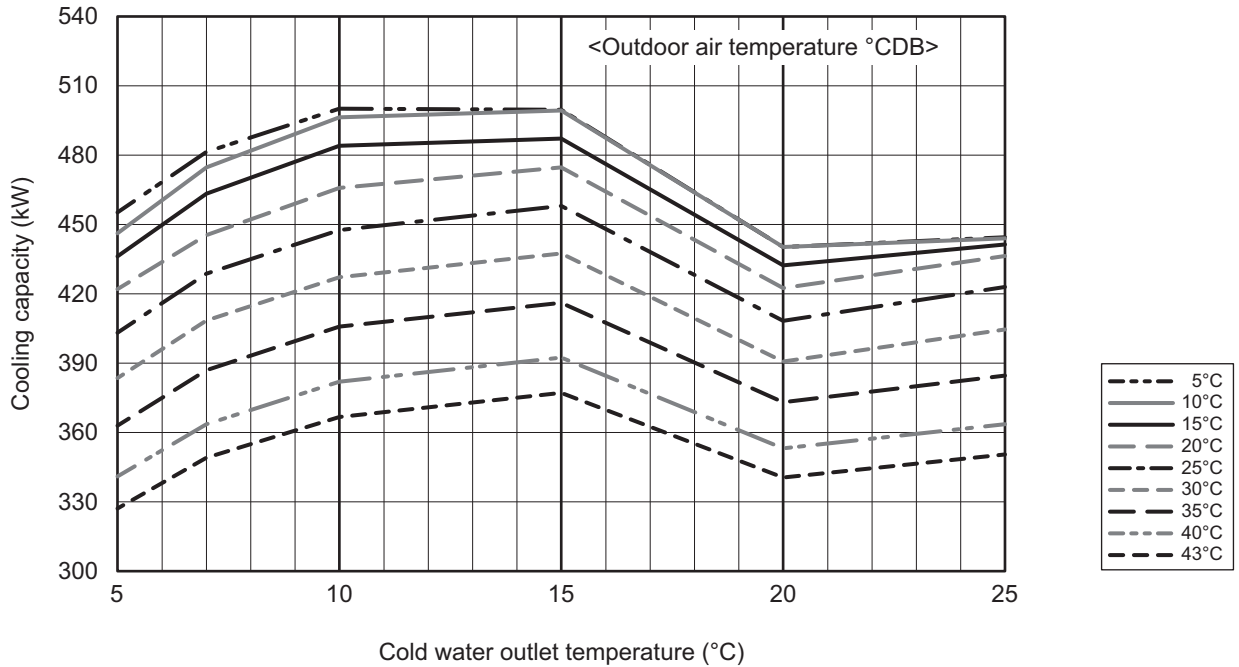

* When the cold water outlet temperature is 8°C or higher, the capacity control operation is performed to reduce the power consumption.

2. Product Data

[Cold/hot water outlet/inlet temperature difference 7°C]

COP priority mode

EAHV-P900YA × 6

■ Heating Capacity

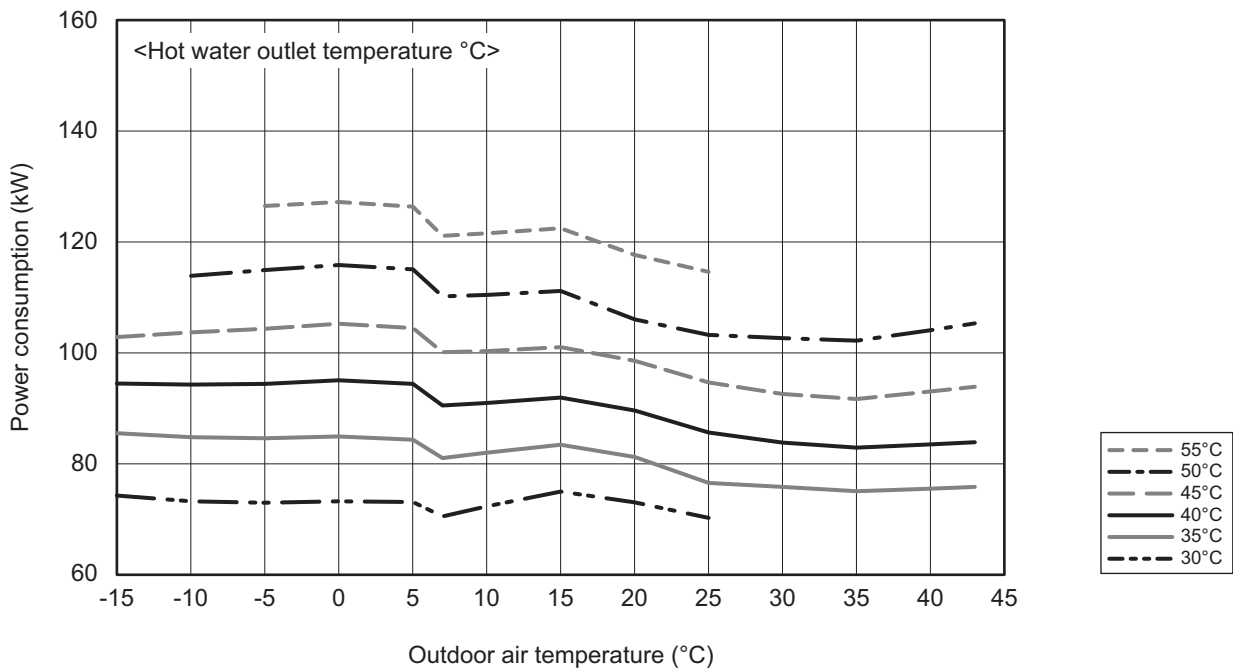
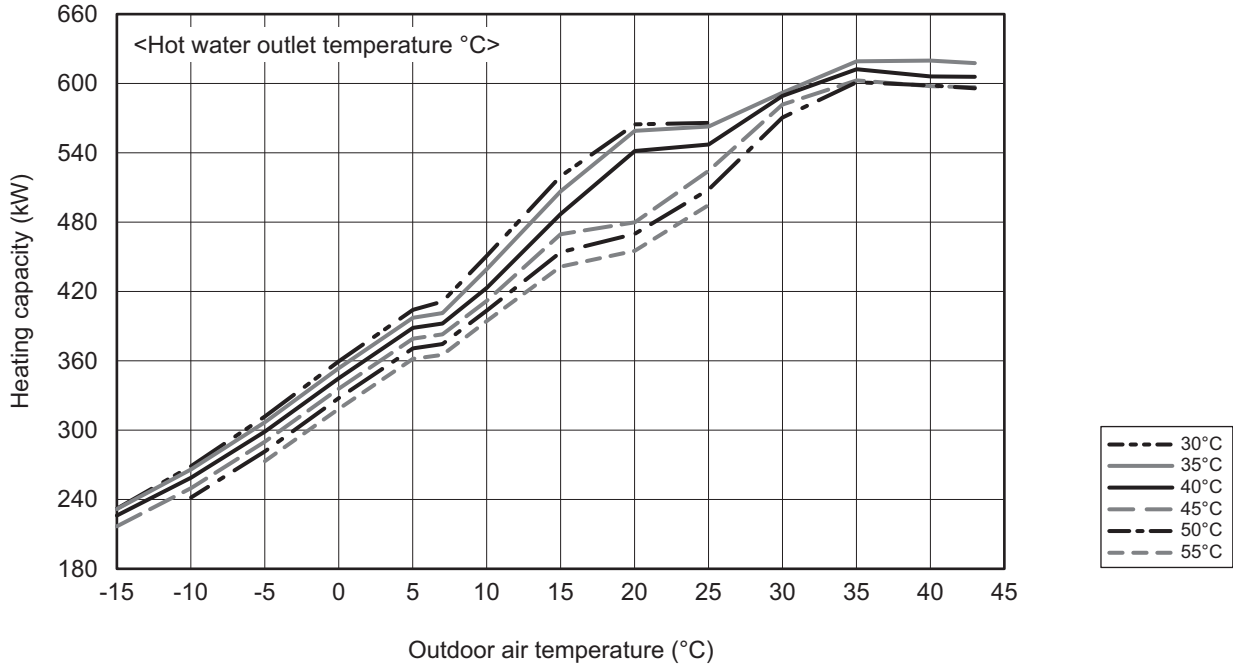

EALV-P-YAF(-H)(-N), YAL(-H)(-N)/EACV-P-YAF(-N), YAL(-N)

2. Product Data

[Cold brine outlet/inlet temperature difference 7°C]

COP priority mode

EACV-P900YA

■ Cooling Capacity [Brine: ethylene glycol 35wt%]

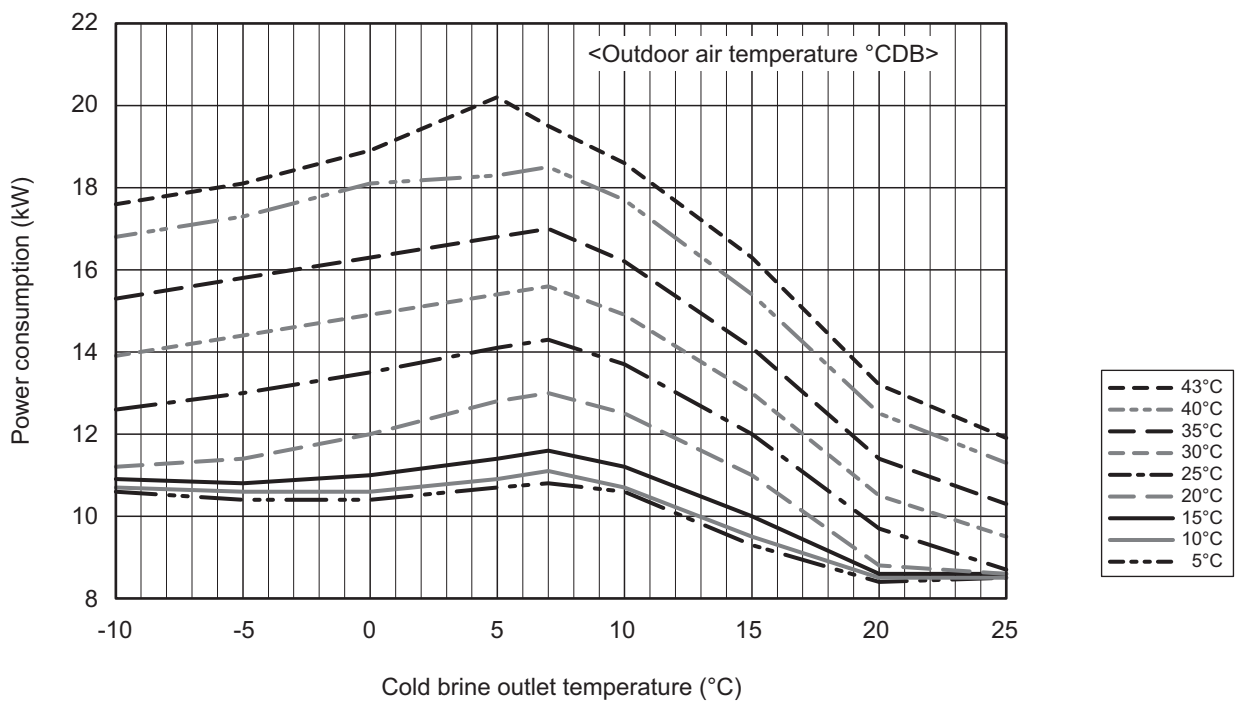
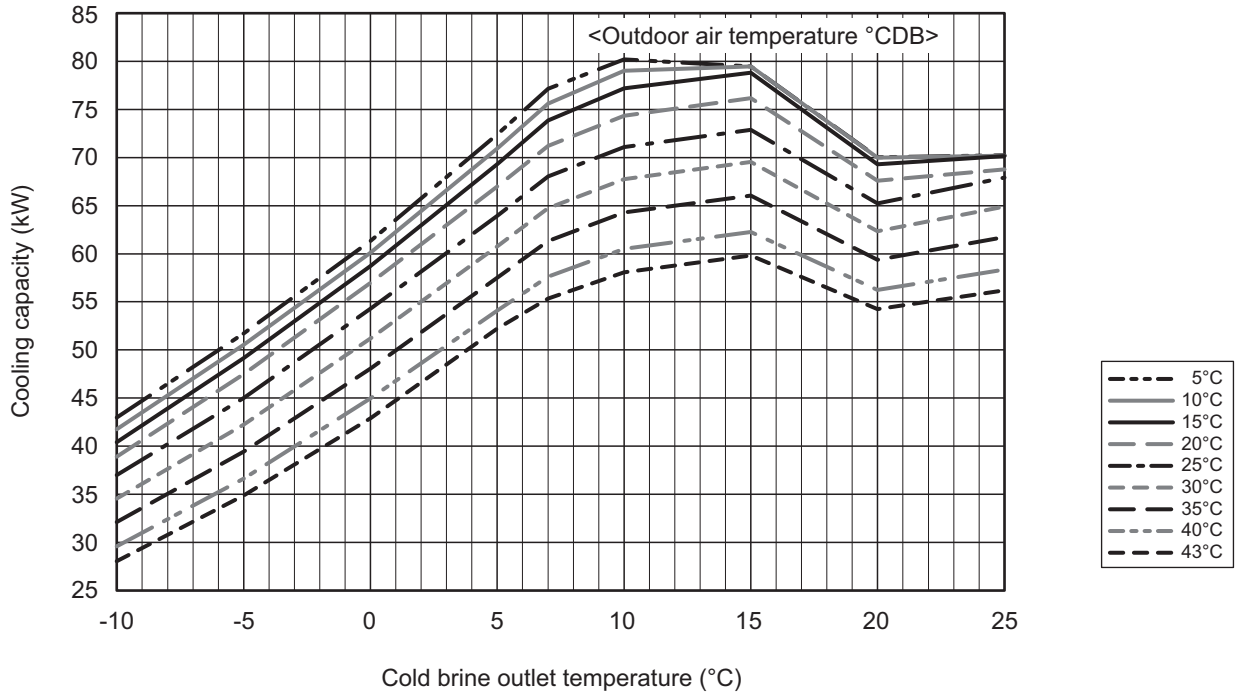

* When the cold brine outlet temperature is 8°C or higher, the capacity control operation is performed to reduce the power consumption.

2. Product Data

[Cold brine outlet/inlet temperature difference 7°C]

COP priority mode

EACV-P900YA × 2

■ Cooling Capacity [Brine: ethylene glycol 35wt%]

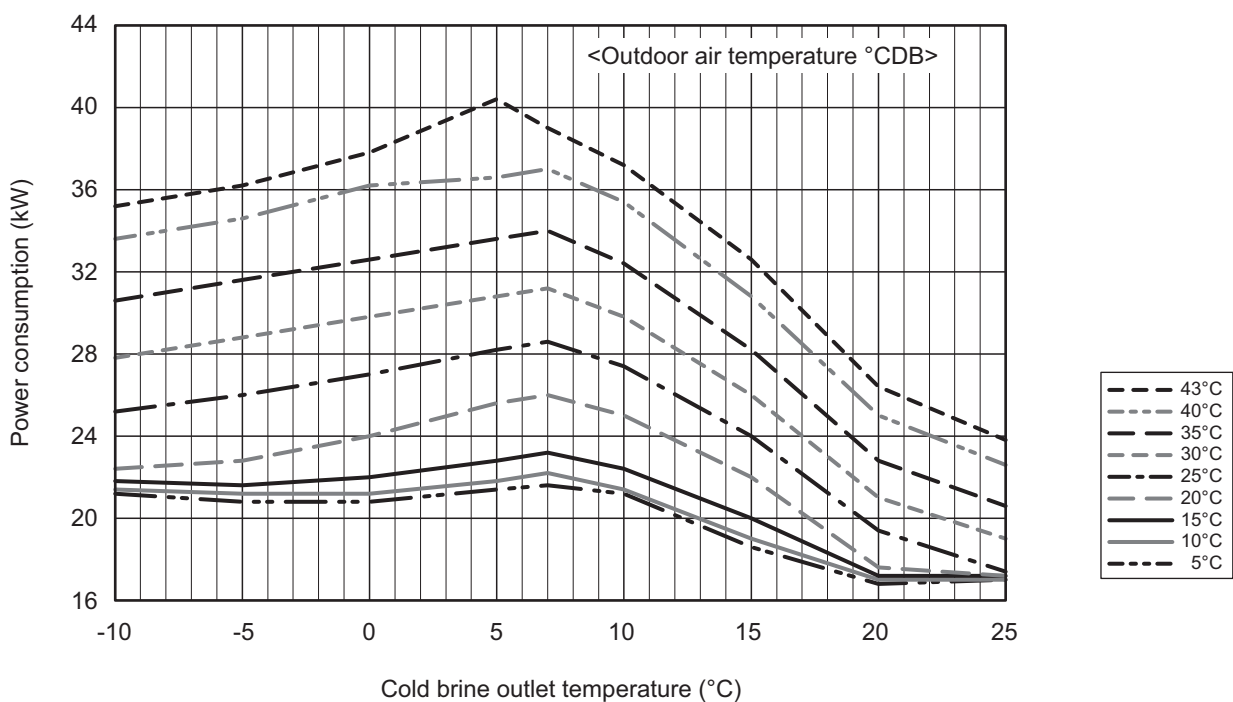
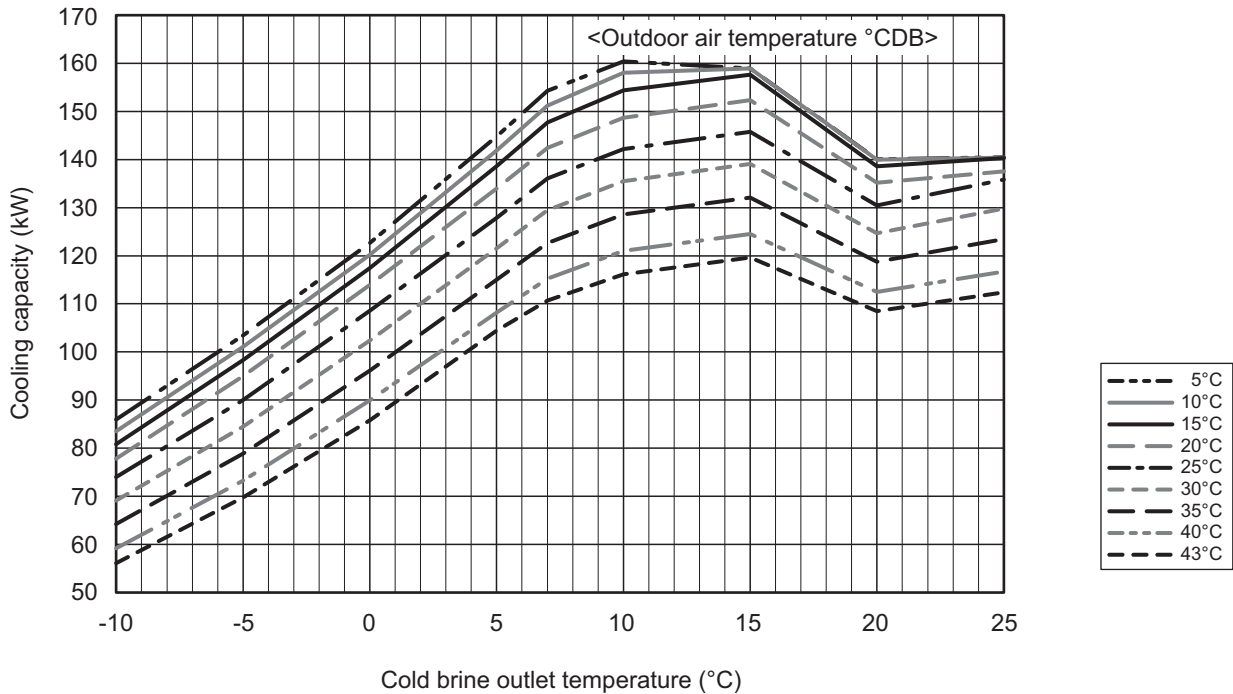

* When the cold brine outlet temperature is 8°C or higher, the capacity control operation is performed to reduce the power consumption.

2. Product Data

[Cold brine outlet/inlet temperature difference 7°C]

COP priority mode

EACV-P900YA × 3

■ Cooling Capacity [Brine: ethylene glycol 35wt%]

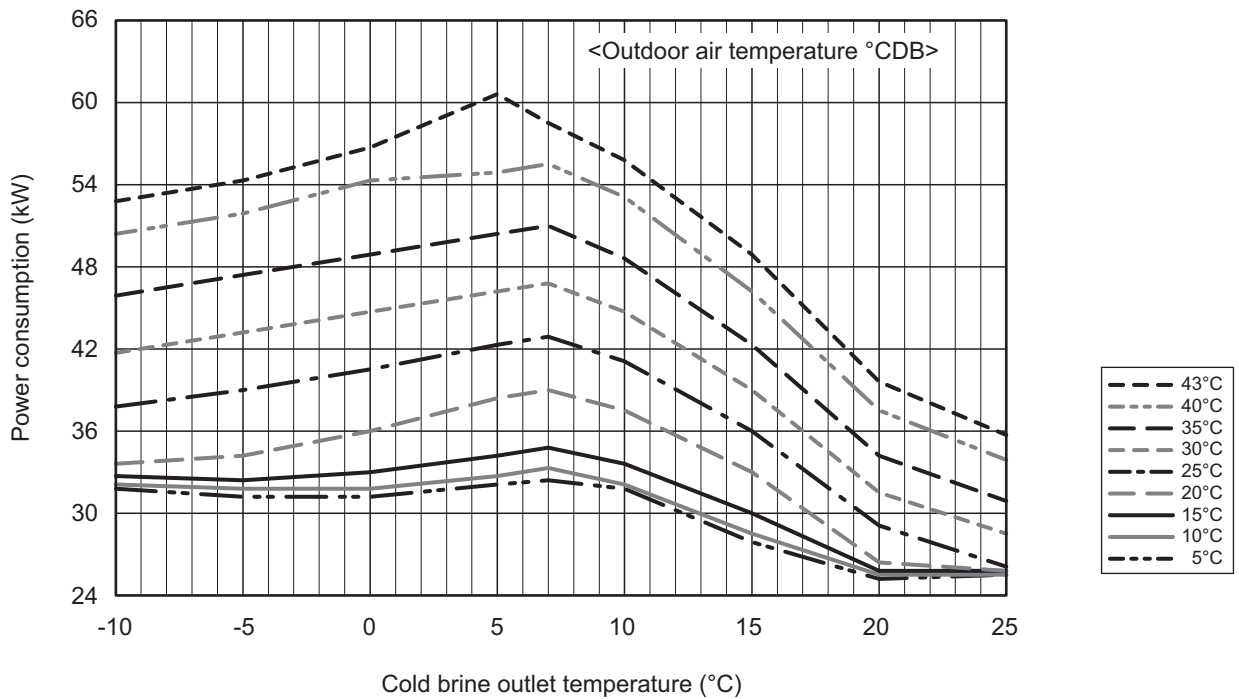
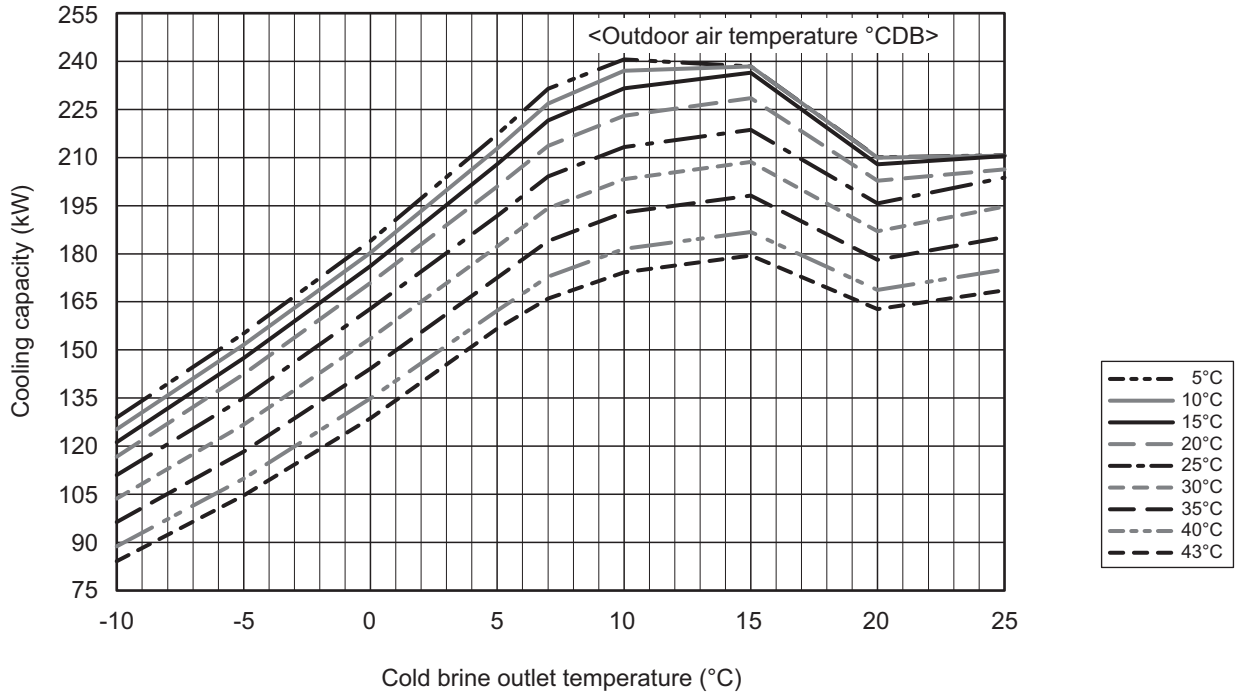

* When the cold brine outlet temperature is 8°C or higher, the capacity control operation is performed to reduce the power consumption.

2. Product Data

[Cold brine outlet/inlet temperature difference 7°C]

COP priority mode

EACV-P900YA × 4

■ Cooling Capacity [Brine: ethylene glycol 35wt%]

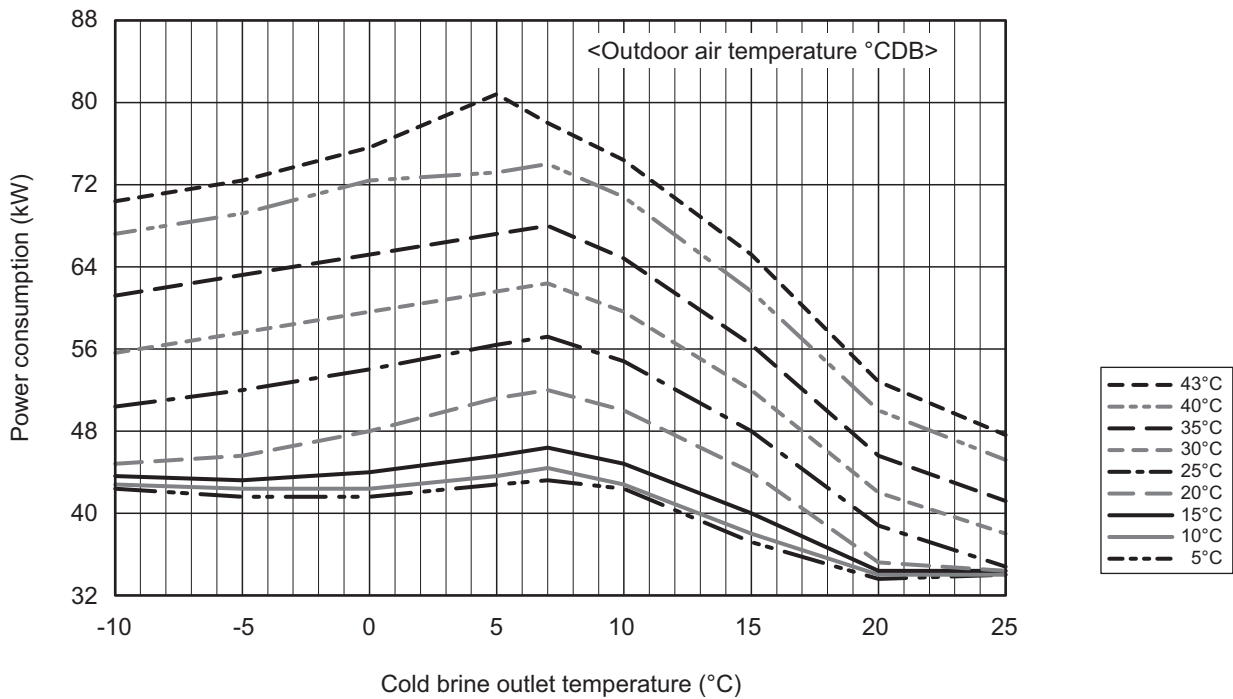
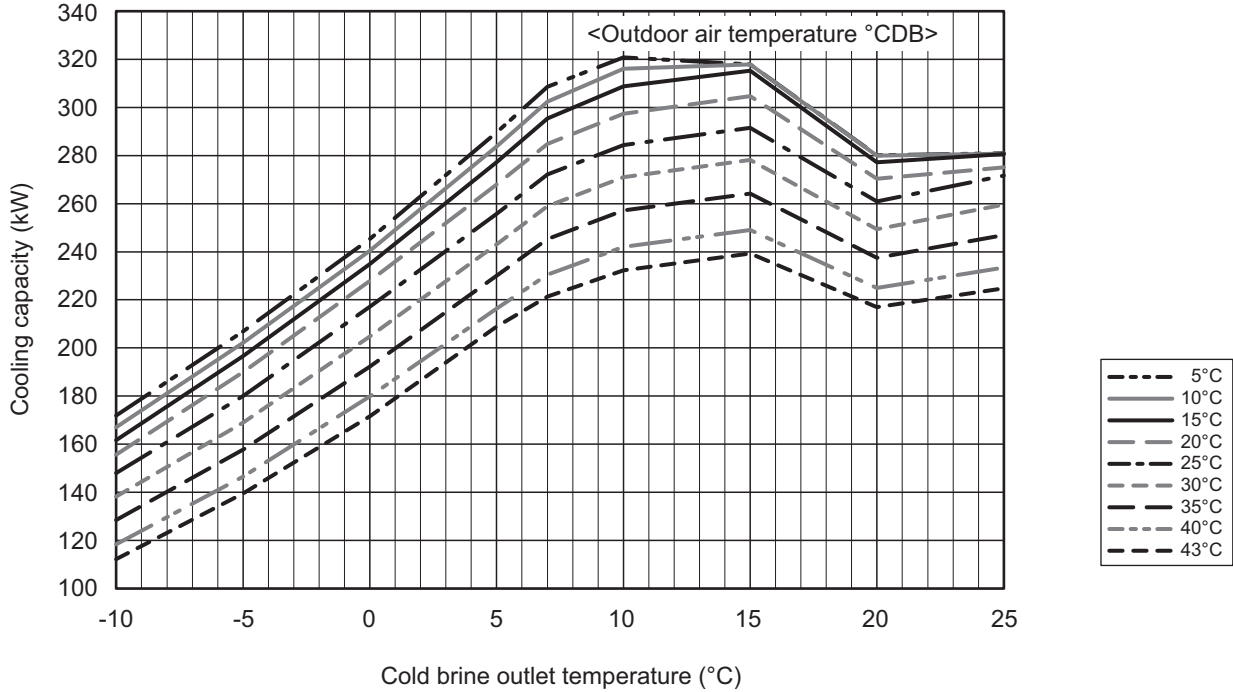

* When the cold brine outlet temperature is 8°C or higher, the capacity control operation is performed to reduce the power consumption.

2. Product Data

[Cold brine outlet/inlet temperature difference 7°C]

COP priority mode

EACV-P900YA × 5

■ Cooling Capacity [Brine: ethylene glycol 35wt%]

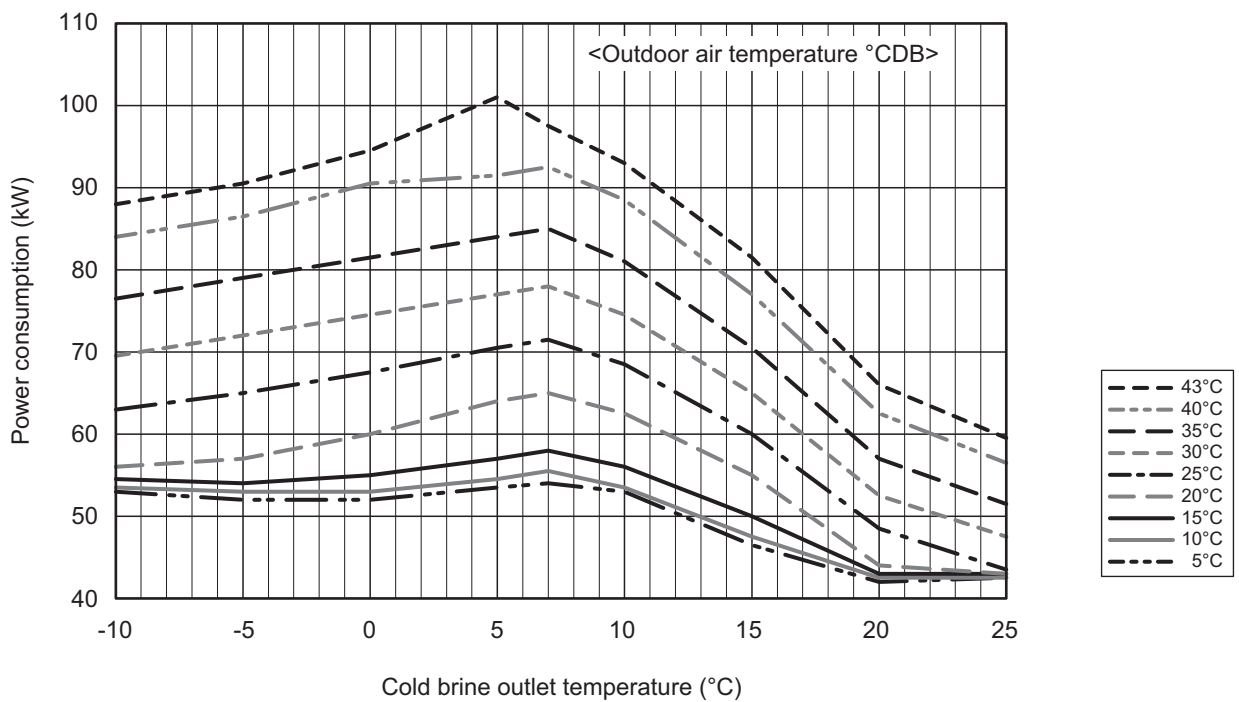
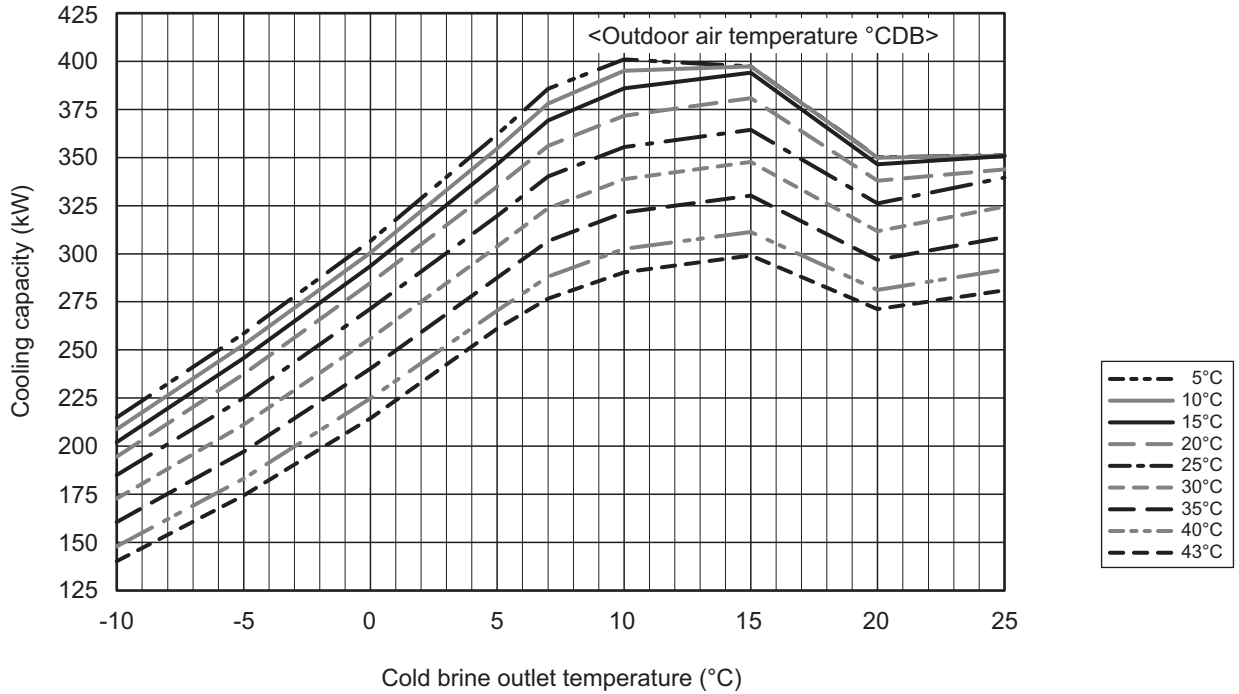

* When the cold brine outlet temperature is 8°C or higher, the capacity control operation is performed to reduce the power consumption.

2. Product Data

[Cold brine outlet/inlet temperature difference 7°C]

COP priority mode

EACV-P900YA × 6

■ Cooling Capacity [Brine: ethylene glycol 35wt%]

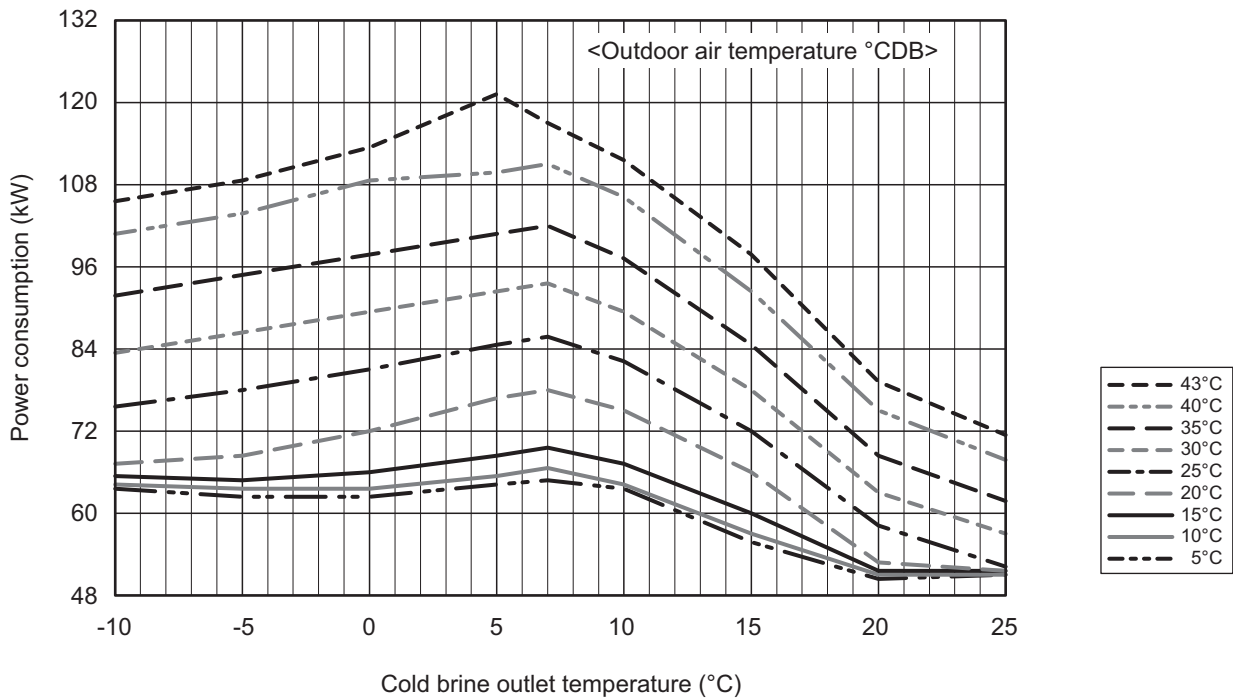
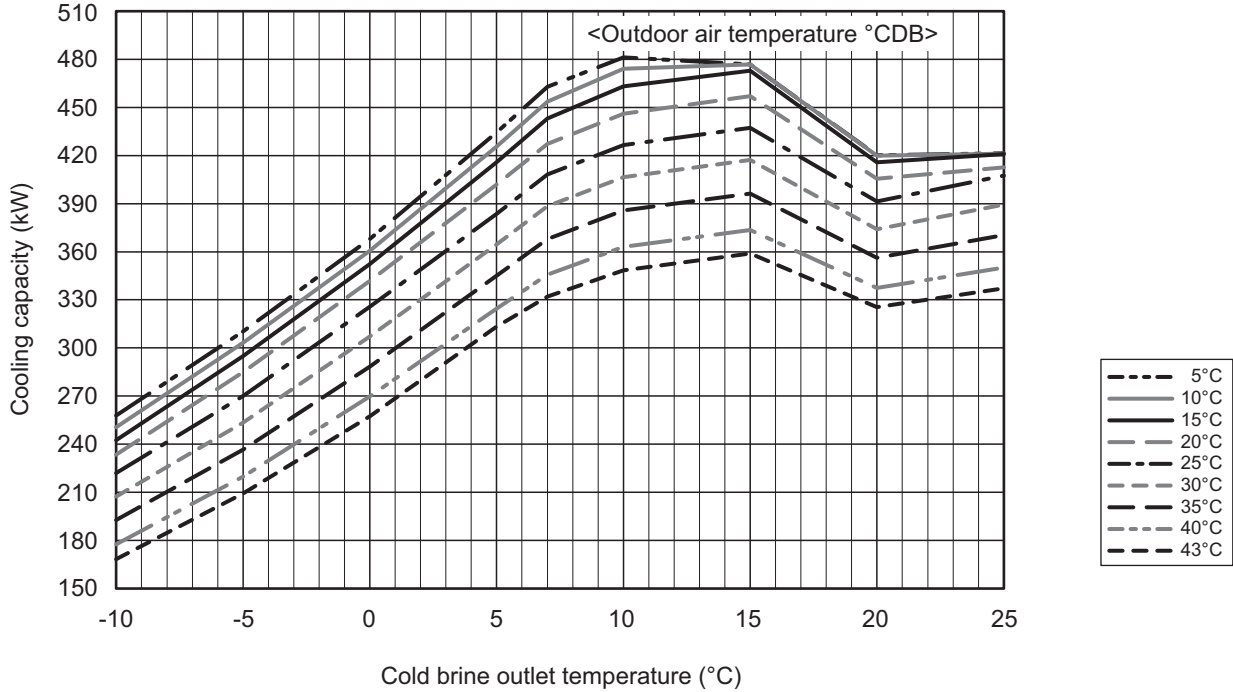

* When the cold brine outlet temperature is 8°C or higher, the capacity control operation is performed to reduce the power consumption.

2. Product Data

Cooling capacity: Cold water outlet/inlet temperature difference 5°C

Capacity change mode: Capacity priority

MODEL		EAHV-P900YA, EACV-P900YA													
Cold water outlet temperature	Outdoor air temperature °CDB	-15	-10	-5	0	5	10	15	20	25	30	35	40	43	
		5	Cooling capacity	kW	-	-	111.4	111.5	108.9	106.0	104.4	99.6	94.7	89.6	84.3
Power consumption	kW		-	-	15.5	15.7	16.0	16.6	18.9	20.7	22.6	24.6	26.7	28.9	30.3
Cold water flow rate	m ³ /h		-	-	19.2	19.2	18.7	18.2	18.0	17.1	16.3	15.4	14.5	13.6	12.2
Water pressure loss	kPa		-	-	208	208	198	188	182	166	150	134	118	104	84
7	Cooling capacity	kW	-	112.3	112.9	113.5	111.4	108.1	111.3	106.2	101.2	95.8	90.0	84.6	76.3
	Power consumption	kW	-	15.5	15.8	16.1	16.3	16.8	19.4	21.2	23.0	25.1	27.3	29.4	30.8
	Cold water flow rate	m ³ /h	-	19.3	19.4	19.5	19.2	18.6	19.1	18.3	17.4	16.5	15.5	14.6	13.1
	Water pressure loss	kPa	-	211	213	215	207	196	207	189	171	153	135	119	97
10	Cooling capacity	kW	-	111.0	111.5	112.0	110.9	107.6	110.2	112.2	106.9	101.3	95.6	89.6	80.8
	Power consumption	kW	-	14.8	15.1	15.3	15.6	16.0	18.3	20.6	22.4	24.3	26.4	28.6	29.9
	Cold water flow rate	m ³ /h	-	19.1	19.2	19.3	19.1	18.5	19.0	19.3	18.4	17.4	16.4	15.4	13.9
	Water pressure loss	kPa	-	206	208	210	205	194	203	210	191	172	153	134	109
15	Cooling capacity	kW	110.9	111.3	111.7	111.9	107.5	104.7	105.9	109.8	111.0	105.4	99.6	93.4	84.3
	Power consumption	kW	15.2	15.3	15.4	15.5	13.8	14.1	15.7	17.7	20.0	21.6	23.4	25.4	26.7
	Cold water flow rate	m ³ /h	19.1	19.2	19.2	19.2	18.5	18.0	18.2	18.9	19.1	18.1	17.1	16.1	14.5
	Water pressure loss	kPa	206	207	208	209	193	183	187	202	206	186	166	146	118
20	Cooling capacity	kW	111.3	111.2	111.2	111.2	101.1	100.5	99.7	104.3	103.2	98.6	93.8	88.8	80.0
	Power consumption	kW	15.7	15.8	15.8	15.9	12.0	12.3	13.3	15.0	16.5	17.9	19.5	21.3	22.3
	Cold water flow rate	m ³ /h	19.1	19.1	19.1	19.1	17.4	17.3	17.2	17.9	17.7	17.0	16.1	15.3	13.8
	Water pressure loss	kPa	207	207	207	207	171	169	166	182	178	163	147	131	106
25	Cooling capacity	kW	109.2	109.2	109.2	109.0	95.1	95.4	93.2	98.6	102.1	98.9	93.5	88.1	79.5
	Power consumption	kW	15.9	16.0	16.0	16.1	10.6	10.7	11.3	12.8	14.3	15.6	17.0	18.5	19.8
	Cold water flow rate	m ³ /h	18.8	18.8	18.8	18.8	16.4	16.4	16.0	17.0	17.6	17.0	16.1	15.1	13.7
	Water pressure loss	kPa	199	199	199	199	151	151	152	145	163	174	164	146	129

* The power consumption value is rounded off to the first decimal place.

Capacity change mode: Capacity priority

MODEL		EAHV-P900YA × 2, EACV-P900YA × 2													
Cold water outlet temperature	Outdoor air temperature °CDB	-15	-10	-5	0	5	10	15	20	25	30	35	40	43	
		5	Cooling capacity	kW	-	-	222.9	222.9	217.9	212.0	208.8	199.2	189.4	179.2	168.6
Power consumption	kW		-	-	30.9	31.4	32.1	33.1	37.8	41.5	45.2	49.2	53.5	57.8	60.5
Cold water flow rate	m ³ /h		-	-	38.3	38.3	37.5	36.5	35.9	34.3	32.6	30.8	29.0	27.2	24.5
Water pressure loss	kPa		-	-	208	208	198	188	180	164	149	134	120	105	86
7	Cooling capacity	kW	-	224.6	225.9	227.1	222.7	216.3	222.6	212.5	202.3	191.5	180.0	169.2	152.6
	Power consumption	kW	-	30.9	31.6	32.1	32.7	33.6	38.8	42.4	46.1	50.1	54.5	58.8	61.6
	Cold water flow rate	m ³ /h	-	38.6	38.9	39.1	38.3	37.2	38.3	36.5	34.8	32.9	31.0	29.1	26.2
	Water pressure loss	kPa	-	211	213	215	207	196	199	186	169	152	135	120	98
10	Cooling capacity	kW	-	221.9	223.0	224.1	221.7	215.3	220.4	224.3	213.7	202.7	191.1	179.1	161.6
	Power consumption	kW	-	29.6	30.1	30.6	31.1	32.0	36.5	41.2	44.8	48.6	52.7	57.1	59.9
	Cold water flow rate	m ³ /h	-	38.2	38.4	38.5	38.1	37.0	37.9	38.6	36.8	34.9	32.9	30.8	27.8
	Water pressure loss	kPa	-	206	208	210	205	194	203	205	188	170	152	134	110
15	Cooling capacity	kW	221.8	222.7	223.3	223.8	215.0	209.4	211.7	219.6	221.9	210.9	199.2	186.8	168.5
	Power consumption	kW	30.4	30.6	30.8	30.9	27.6	28.2	31.4	35.4	40.0	43.2	46.9	50.8	53.3
	Cold water flow rate	m ³ /h	38.2	38.3	38.4	38.5	37.0	36.0	36.4	37.8	38.2	36.3	34.3	32.1	29.0
	Water pressure loss	kPa	206	207	208	209	193	183	187	202	201	184	165	146	120
20	Cooling capacity	kW	222.6	222.5	222.4	222.4	202.1	200.9	199.5	208.6	206.3	197.2	187.5	177.5	160.0
	Power consumption	kW	31.5	31.5	31.6	31.7	24.0	24.5	26.7	30.0	33.0	35.8	39.0	42.5	44.6
	Cold water flow rate	m ³ /h	38.3	38.3	38.3	38.2	34.8	34.6	34.3	35.9	35.5	33.9	32.3	30.5	27.5
	Water pressure loss	kPa	207	207	207	207	171	169	166	182	178	163	147	131	106
25	Cooling capacity	kW	218.4	218.4	218.3	218.0	190.2	190.8	186.4	197.3	204.3	197.9	186.9	176.1	159.1
	Power consumption	kW	31.9	31.9	32.0	32.1	21.1	21.5	22.5	25.7	28.6	31.3	34.0	37.0	39.6
	Cold water flow rate	m ³ /h	37.6	37.6	37.6	37.5	32.7	32.8	32.1	33.9	35.1	34.0	32.2	30.3	27.4
	Water pressure loss	kPa	199	199	199	199	151	152	145	163	174	164	146	129	105

* The power consumption value is rounded off to the first decimal place.

2. Product Data

Cooling capacity: Cold water outlet/inlet temperature difference 5°C

Capacity change mode: Capacity priority

MODEL			EAHV-P900YA × 3, EACV-P900YA × 3												
Cold water outlet temperature	Outdoor air temperature °CDB		-15	-10	-5	0	5	10	15	20	25	30	35	40	43
			5	Cooling capacity	kW	-	-	334.3	334.4	326.8	318.0	313.3	298.8	284.1	268.8
Power consumption	kW	-		-	46.4	47.1	48.1	49.7	56.7	62.2	67.8	73.8	80.2	86.7	90.8
Cold water flow rate	m ³ /h	-		-	57.5	57.5	56.2	54.7	53.9	51.4	48.9	46.2	43.5	40.8	36.7
Water pressure loss	kPa	-		-	208	208	198	188	180	164	149	134	120	105	86
7	Cooling capacity	kW	-	336.9	338.8	340.6	334.1	324.4	333.9	318.7	303.5	287.3	270.0	253.8	228.9
	Power consumption	kW	-	46.4	47.4	48.2	49.0	50.4	58.3	63.7	69.1	75.2	81.8	88.2	92.4
	Cold water flow rate	m ³ /h	-	58.0	58.3	58.6	57.5	55.8	57.4	54.8	52.2	49.4	46.4	43.7	39.4
	Water pressure loss	kPa	-	211	213	215	207	196	199	186	169	152	135	120	98
10	Cooling capacity	kW	-	332.9	334.6	336.1	332.6	322.9	330.6	336.5	320.6	304.0	286.7	268.7	242.4
	Power consumption	kW	-	44.4	45.2	45.9	46.7	47.9	54.8	61.9	67.2	72.9	79.1	85.7	89.8
	Cold water flow rate	m ³ /h	-	57.3	57.5	57.8	57.2	55.5	56.9	57.9	55.1	52.3	49.3	46.2	41.7
	Water pressure loss	kPa	-	206	208	210	205	194	203	205	188	170	152	134	110
15	Cooling capacity	kW	332.7	334.0	335.0	335.7	322.6	314.1	317.6	329.4	332.9	316.3	298.8	280.3	252.8
	Power consumption	kW	45.6	45.9	46.2	46.4	41.3	42.3	47.2	53.0	59.9	64.9	70.3	76.2	80.0
	Cold water flow rate	m ³ /h	57.2	57.5	57.6	57.7	55.5	54.0	54.6	56.6	57.3	54.4	51.4	48.2	43.5
	Water pressure loss	kPa	206	207	208	209	193	183	187	202	201	184	165	146	120
20	Cooling capacity	kW	333.8	333.7	333.6	333.5	303.2	301.4	299.2	313.0	309.5	295.8	281.3	266.3	240.1
	Power consumption	kW	47.2	47.3	47.4	47.6	36.0	36.8	40.0	45.0	49.5	53.7	58.4	63.8	66.9
	Cold water flow rate	m ³ /h	57.4	57.4	57.4	57.4	52.2	51.8	51.5	53.8	53.2	50.9	48.4	45.8	41.3
	Water pressure loss	kPa	207	207	207	207	171	169	166	182	178	163	147	131	106
25	Cooling capacity	kW	327.6	327.6	327.5	327.1	285.3	286.2	279.6	295.9	306.4	296.8	280.4	264.2	238.6
	Power consumption	kW	47.8	47.9	48.0	48.2	31.7	32.2	33.8	38.5	42.9	46.9	50.9	55.5	59.4
	Cold water flow rate	m ³ /h	56.4	56.3	56.3	56.3	49.1	49.2	48.1	50.9	52.7	51.1	48.2	45.4	41.0
	Water pressure loss	kPa	199	199	199	199	151	152	145	163	174	164	146	129	105

* The power consumption value is rounded off to the first decimal place.

Capacity change mode: Capacity priority

MODEL			EAHV-P900YA × 4, EACV-P900YA × 4												
Cold water outlet temperature	Outdoor air temperature °CDB		-15	-10	-5	0	5	10	15	20	25	30	35	40	43
			5	Cooling capacity	kW	-	-	445.8	445.9	435.8	424.0	417.7	398.4	378.8	358.4
Power consumption	kW	-		-	61.9	62.8	64.1	66.2	75.6	82.9	90.4	98.4	106.9	115.6	121.0
Cold water flow rate	m ³ /h	-		-	76.7	76.7	75.0	72.9	71.8	68.5	65.1	61.6	58.0	54.4	49.0
Water pressure loss	kPa	-		-	208	208	198	188	180	164	149	134	120	105	86
7	Cooling capacity	kW	-	449.3	451.7	454.1	445.5	432.6	445.2	424.9	404.6	383.0	360.0	338.4	305.2
	Power consumption	kW	-	61.8	63.2	64.3	65.4	67.2	77.7	84.9	92.2	100.2	109.0	117.6	123.2
	Cold water flow rate	m ³ /h	-	77.3	77.7	78.1	76.6	74.4	76.6	73.1	69.6	65.9	61.9	58.2	52.5
	Water pressure loss	kPa	-	211	213	215	207	196	199	186	169	152	135	120	98
10	Cooling capacity	kW	-	443.9	446.1	448.1	443.4	430.6	440.9	448.6	427.5	405.4	382.3	358.3	323.2
	Power consumption	kW	-	59.1	60.3	61.2	62.2	63.9	73.0	82.5	89.6	97.2	105.4	114.2	119.8
	Cold water flow rate	m ³ /h	-	76.3	76.7	77.1	76.3	74.1	75.8	77.2	73.5	69.7	65.8	61.6	55.6
	Water pressure loss	kPa	-	206	208	210	205	194	203	205	188	170	152	134	110
15	Cooling capacity	kW	443.7	445.4	446.6	447.6	430.1	418.8	423.4	439.1	443.8	421.7	398.4	373.7	337.1
	Power consumption	kW	60.8	61.3	61.6	61.9	55.1	56.4	62.9	70.7	79.9	86.5	93.7	101.6	106.7
	Cold water flow rate	m ³ /h	76.3	76.6	76.8	77.0	74.0	72.0	72.8	75.5	76.3	72.5	68.5	64.3	58.0
	Water pressure loss	kPa	206	207	208	209	193	183	187	202	201	184	165	146	120
20	Cooling capacity	kW	445.1	445.0	444.9	444.7	404.3	401.8	399.0	417.3	412.7	394.4	375.1	355.0	320.1
	Power consumption	kW	62.9	63.1	63.3	63.4	48.0	49.0	53.4	59.9	66.0	71.6	77.9	85.0	89.3
	Cold water flow rate	m ³ /h	76.6	76.5	76.5	76.5	69.5	69.1	68.6	71.8	71.0	67.8	64.5	61.1	55.1
	Water pressure loss	kPa	207	207	207	207	171	169	166	182	178	163	147	131	106
25	Cooling capacity	kW	436.9	436.8	436.7	436.1	380.4	381.6	372.8	394.5	408.5	395.8	373.9	352.2	318.1
	Power consumption	kW	63.7	63.9	64.0	64.2	42.2	42.9	45.0	51.4	57.2	62.5	67.9	74.0	79.2
	Cold water flow rate	m ³ /h	75.1	75.1	75.1	75.0	65.4	65.6	64.1	67.9	70.3	68.1	64.3	60.6	54.7
	Water pressure loss	kPa	199	199	199	199	151	152	145	163	174	164	146	129	105

* The power consumption value is rounded off to the first decimal place.

2. Product Data

Cooling capacity: Cold water outlet/inlet temperature difference 5°C

Capacity change mode: Capacity priority

MODEL		EAHV-P900YA × 5, EACV-P900YA × 5													
Cold water outlet temperature	Outdoor air temperature °CDB	-15	-10	-5	0	5	10	15	20	25	30	35	40	43	
		5	Cooling capacity	kW	-	-	557.2	557.3	544.7	530.0	522.1	498.0	473.5	448.0	421.5
Power consumption	kW		-	-	77.3	78.5	80.1	82.8	94.6	103.7	113.0	123.0	133.7	144.5	151.3
Cold water flow rate	m ³ /h		-	-	95.8	95.9	93.7	91.2	89.8	85.7	81.4	77.1	72.5	68.0	61.2
Water pressure loss	kPa		-	-	208	208	198	188	180	164	149	134	120	105	86
7	Cooling capacity	kW	-	561.6	564.7	567.6	556.8	540.7	556.5	531.2	505.8	478.8	450.0	423.0	381.4
	Power consumption	kW	-	77.3	79.0	80.3	81.7	84.0	97.1	106.1	115.2	125.3	136.3	147.0	154.0
	Cold water flow rate	m ³ /h	-	96.6	97.1	97.6	95.8	93.0	95.7	91.4	87.0	82.3	77.4	72.8	65.6
	Water pressure loss	kPa	-	211	213	215	207	196	199	186	169	152	135	120	98
10	Cooling capacity	kW	-	554.8	557.6	560.2	554.3	538.2	551.1	560.8	534.3	506.7	477.9	447.8	404.0
	Power consumption	kW	-	73.9	75.3	76.5	77.8	79.9	91.3	103.1	112.0	121.5	131.8	142.8	149.7
	Cold water flow rate	m ³ /h	-	95.4	95.9	96.3	95.3	92.6	94.8	96.5	91.9	87.2	82.2	77.0	69.5
	Water pressure loss	kPa	-	206	208	210	205	194	203	205	188	170	152	134	110
15	Cooling capacity	kW	554.6	556.7	558.3	559.5	537.6	523.5	529.3	548.9	554.8	527.2	497.9	467.1	421.3
	Power consumption	kW	76.0	76.6	77.0	77.3	68.9	70.5	78.6	88.4	99.9	108.1	117.2	127.0	133.4
	Cold water flow rate	m ³ /h	95.4	95.8	96.0	96.2	92.5	90.0	91.0	94.4	95.4	90.7	85.6	80.3	72.5
	Water pressure loss	kPa	206	207	208	209	193	183	187	202	201	184	165	146	120
20	Cooling capacity	kW	556.4	556.2	556.1	555.9	505.4	502.3	498.7	521.6	515.8	492.9	468.8	443.8	400.1
	Power consumption	kW	78.7	78.9	79.1	79.3	60.0	61.3	66.7	74.9	82.4	89.5	97.4	106.3	111.6
	Cold water flow rate	m ³ /h	95.7	95.7	95.6	95.6	86.9	86.4	85.8	89.7	88.7	84.8	80.6	76.3	68.8
	Water pressure loss	kPa	207	207	207	207	171	169	166	182	178	163	147	131	106
25	Cooling capacity	kW	546.1	545.9	545.8	545.1	475.5	477.0	466.0	493.2	510.6	494.7	467.3	440.3	397.7
	Power consumption	kW	79.6	79.8	80.0	80.3	52.8	53.6	56.3	64.2	71.5	78.1	84.9	92.5	99.0
	Cold water flow rate	m ³ /h	93.9	93.9	93.9	93.8	81.8	82.0	80.1	84.8	87.8	85.1	80.4	75.7	68.4
	Water pressure loss	kPa	199	199	199	199	151	152	145	163	174	164	146	129	105

* The power consumption value is rounded off to the first decimal place.

Capacity change mode: Capacity priority

MODEL		EAHV-P900YA × 6, EACV-P900YA × 6													
Cold water outlet temperature	Outdoor air temperature °CDB	-15	-10	-5	0	5	10	15	20	25	30	35	40	43	
		5	Cooling capacity	kW	-	-	668.6	668.8	653.7	636.0	626.5	597.6	568.2	537.6	505.8
Power consumption	kW		-	-	92.8	94.2	96.2	99.3	113.5	124.4	135.6	147.6	160.4	173.3	181.5
Cold water flow rate	m ³ /h		-	-	115.0	115.0	112.4	109.4	107.8	102.8	97.7	92.5	87.0	81.6	73.5
Water pressure loss	kPa		-	-	208	208	198	188	180	164	149	134	120	105	86
7	Cooling capacity	kW	-	673.9	677.6	681.2	668.2	648.9	667.8	637.4	606.9	574.5	540.0	507.6	457.7
	Power consumption	kW	-	92.7	94.7	96.4	98.0	100.8	116.5	127.3	138.2	150.3	163.5	176.3	184.8
	Cold water flow rate	m ³ /h	-	115.9	116.6	117.2	114.9	111.6	114.9	109.6	104.4	98.8	92.9	87.3	78.7
	Water pressure loss	kPa	-	211	213	215	207	196	199	186	169	152	135	120	98
10	Cooling capacity	kW	-	665.8	669.1	672.2	665.1	645.9	661.3	672.9	641.2	608.0	573.4	537.4	484.9
	Power consumption	kW	-	88.7	90.4	91.8	93.4	95.9	109.6	123.7	134.3	145.8	158.2	171.4	179.6
	Cold water flow rate	m ³ /h	-	114.5	115.1	115.6	114.4	111.1	113.7	115.7	110.3	104.6	98.6	92.4	83.4
	Water pressure loss	kPa	-	206	208	210	205	194	203	205	188	170	152	134	110
15	Cooling capacity	kW	665.5	668.0	669.9	671.4	645.1	628.2	635.2	658.7	665.7	632.6	597.5	560.5	505.6
	Power consumption	kW	91.2	91.9	92.4	92.8	82.7	84.6	94.3	106.1	119.9	129.7	140.6	152.4	160.0
	Cold water flow rate	m ³ /h	114.5	114.9	115.2	115.5	111.0	108.0	109.2	113.3	114.5	108.8	102.8	96.4	87.0
	Water pressure loss	kPa	206	207	208	209	193	183	187	202	201	184	165	146	120
20	Cooling capacity	kW	667.7	667.5	667.3	667.1	606.4	602.7	598.5	625.9	619.0	591.5	562.6	532.5	480.1
	Power consumption	kW	94.4	94.6	94.9	95.1	72.0	73.6	80.1	89.9	98.9	107.4	116.9	127.5	133.9
	Cold water flow rate	m ³ /h	114.8	114.8	114.8	114.7	104.3	103.7	102.9	107.7	106.5	101.7	96.8	91.6	82.6
	Water pressure loss	kPa	207	207	207	207	171	169	166	182	178	163	147	131	106
25	Cooling capacity	kW	655.3	655.1	655.0	654.1	570.6	572.4	559.2	591.8	612.8	593.6	560.8	528.4	477.2
	Power consumption	kW	95.6	95.8	96.0	96.4	63.3	64.4	67.5	77.0	85.8	93.8	101.9	111.0	118.8
	Cold water flow rate	m ³ /h	112.7	112.7	112.7	112.5	98.1	98.5	96.2	101.8	105.4	102.1	96.5	90.9	82.1
	Water pressure loss	kPa	199	199	199	199	151	152	145	163	174	164	146	129	105

* The power consumption value is rounded off to the first decimal place.

2. Product Data

Cooling capacity: Cold water outlet/inlet temperature difference 5°C

Capacity change mode: COP priority

MODEL			EAHV-P900YA, EACV-P900YA												
Cold water outlet temperature	Outdoor air temperature °CDB		-15	-10	-5	0	5	10	15	20	25	30	35	40	43
			5	Cooling capacity	kW	-	-	76.5	76.5	75.1	73.8	72.0	69.2	66.0	62.6
Power consumption	kW	-		-	8.4	9.3	10.2	9.1	10.3	12.1	13.3	14.6	15.9	17.4	18.3
Cold water flow rate	m ³ /h	-		-	13.2	13.2	12.9	12.7	12.4	11.9	11.3	10.8	10.2	9.5	9.2
Water pressure loss	kPa	-		-	97	97	93	90	86	79	71	64	56	49	45
7	Cooling capacity	kW	-	80.5	80.5	80.6	79.7	78.6	76.7	73.6	70.3	66.8	63.0	59.3	56.9
	Power consumption	kW	-	10.8	10.7	10.7	10.9	9.8	10.8	12.3	13.5	14.8	16.3	17.6	18.5
	Cold water flow rate	m ³ /h	-	13.8	13.8	13.9	13.7	13.5	13.2	12.7	12.1	11.5	10.8	10.2	9.8
	Water pressure loss	kPa	-	108	108	108	106	103	97	90	81	73	65	57	52
10	Cooling capacity	kW	-	82.6	82.7	82.7	82.6	81.9	79.9	76.7	73.5	70.0	66.4	62.4	59.9
	Power consumption	kW	-	11.2	11.2	11.2	11.2	10.3	10.9	11.9	13.0	14.1	15.4	16.8	17.7
	Cold water flow rate	m ³ /h	-	14.2	14.2	14.2	14.2	14.1	13.7	13.2	12.6	12.0	11.4	10.7	10.3
	Water pressure loss	kPa	-	114	114	114	113	112	106	98	89	81	72	63	58
15	Cooling capacity	kW	81.6	81.7	81.7	81.7	82.2	82.2	80.2	78.1	75.3	71.9	68.3	64.3	61.8
	Power consumption	kW	11.1	11.0	11.0	11.0	10.4	10.2	10.4	10.7	11.4	12.3	13.4	14.6	15.4
	Cold water flow rate	m ³ /h	14.0	14.0	14.0	14.0	14.1	14.1	13.8	13.4	13.0	12.4	11.8	11.1	10.6
	Water pressure loss	kPa	111	111	111	111	113	112	107	101	94	85	77	68	62
20	Cooling capacity	kW	71.4	71.4	71.5	71.5	72.8	72.8	71.3	69.7	67.4	64.4	61.4	58.1	56.1
	Power consumption	kW	9.6	9.6	9.5	9.5	8.1	8.1	8.5	8.6	9.1	9.9	10.8	11.8	12.5
	Cold water flow rate	m ³ /h	12.3	12.3	12.3	12.3	12.5	12.5	12.3	12.0	11.6	11.1	10.6	10.0	9.6
	Water pressure loss	kPa	84	84	84	84	88	88	84	80	75	68	61	54	50
25	Cooling capacity	kW	71.9	71.9	71.9	72.0	73.8	73.6	73.2	72.4	70.2	67.0	63.7	60.2	58.0
	Power consumption	kW	9.7	9.7	9.7	9.6	7.4	7.5	8.0	7.8	8.2	9.0	9.8	10.7	11.3
	Cold water flow rate	m ³ /h	12.4	12.4	12.4	12.4	12.7	12.7	12.6	12.5	12.1	11.5	11.0	10.4	10.0
	Water pressure loss	kPa	85	85	85	86	90	90	89	87	81	74	66	59	54

* The power consumption value is rounded off to the first decimal place.

Capacity change mode: COP priority

MODEL			EAHV-P900YA × 2, EACV-P900YA × 2												
Cold water outlet temperature	Outdoor air temperature °CDB		-15	-10	-5	0	5	10	15	20	25	30	35	40	43
			5	Cooling capacity	kW	-	-	153.1	153.0	150.1	147.6	143.9	138.5	132.0	125.2
Power consumption	kW	-		-	16.8	18.7	20.5	18.2	20.7	24.2	26.7	29.2	31.9	34.8	36.6
Cold water flow rate	m ³ /h	-		-	26.3	26.3	25.8	25.4	24.8	23.8	22.7	21.5	20.3	19.1	18.3
Water pressure loss	kPa	-		-	97	97	93	90	86	79	71	64	56	49	45
7	Cooling capacity	kW	-	161.0	161.0	161.1	159.5	157.3	153.3	147.3	140.5	133.6	126.0	118.6	113.8
	Power consumption	kW	-	21.6	21.5	21.4	21.8	19.5	21.7	24.7	27.1	29.6	32.5	35.2	37.0
	Cold water flow rate	m ³ /h	-	27.7	27.7	27.7	27.4	27.0	26.4	25.3	24.2	23.0	21.6	20.4	19.6
	Water pressure loss	kPa	-	108	108	108	106	103	97	90	81	73	65	57	52
10	Cooling capacity	kW	-	165.3	165.3	165.4	165.1	163.8	159.7	153.5	147.0	140.1	132.7	124.7	119.7
	Power consumption	kW	-	22.4	22.4	22.3	22.4	20.7	21.8	23.9	26.0	28.3	30.8	33.5	35.3
	Cold water flow rate	m ³ /h	-	28.4	28.4	28.4	28.4	28.2	27.5	26.4	25.3	24.1	22.8	21.5	20.6
	Water pressure loss	kPa	-	114	114	114	113	112	106	98	89	81	72	63	58
15	Cooling capacity	kW	163.3	163.3	163.3	163.4	164.5	164.4	160.5	156.2	150.6	143.8	136.7	128.6	123.5
	Power consumption	kW	22.1	22.1	22.0	22.0	20.9	20.4	20.8	21.3	22.7	24.7	26.8	29.3	30.9
	Cold water flow rate	m ³ /h	28.1	28.1	28.1	28.1	28.3	28.3	27.6	26.9	25.9	24.7	23.5	22.1	21.2
	Water pressure loss	kPa	111	111	111	111	113	112	107	101	94	85	77	68	62
20	Cooling capacity	kW	142.9	142.9	142.9	142.9	145.5	145.5	142.6	139.4	134.8	128.9	122.8	116.3	112.2
	Power consumption	kW	19.2	19.1	19.1	19.0	16.3	16.3	17.0	17.1	18.2	19.9	21.7	23.7	25.0
	Cold water flow rate	m ³ /h	24.6	24.6	24.6	24.6	25.0	25.0	24.5	24.0	23.2	22.2	21.1	20.0	19.3
	Water pressure loss	kPa	84	84	84	84	88	88	84	80	75	68	61	54	50
25	Cooling capacity	kW	143.8	143.9	143.9	143.9	147.5	147.3	146.5	144.8	140.3	134.0	127.4	120.4	116.0
	Power consumption	kW	19.4	19.3	19.3	19.3	14.8	15.0	15.9	15.6	16.4	17.9	19.6	21.5	22.7
	Cold water flow rate	m ³ /h	24.7	24.7	24.7	24.8	25.4	25.3	25.2	24.9	24.1	23.1	21.9	20.7	20.0
	Water pressure loss	kPa	85	85	85	86	90	90	89	87	81	74	66	59	54

* The power consumption value is rounded off to the first decimal place.

2. Product Data

Cooling capacity: Cold water outlet/inlet temperature difference 5°C

Capacity change mode: COP priority

MODEL		EAHV-P900YA × 3, EACV-P900YA × 3													
Cold water outlet temperature	Outdoor air temperature °CDB	-15	-10	-5	0	5	10	15	20	25	30	35	40	43	
		5	Cooling capacity	kW	-	-	229.6	229.5	225.2	221.4	215.9	207.7	198.0	187.8	177.4
Power consumption	kW		-	-	25.3	28.0	30.7	27.3	31.0	36.2	40.0	43.8	47.8	52.1	54.8
Cold water flow rate	m ³ /h		-	-	39.5	39.5	38.7	38.1	37.1	35.7	34.0	32.3	30.5	28.6	27.5
Water pressure loss	kPa		-	-	97	97	93	90	86	79	71	64	56	49	45
7	Cooling capacity	kW	-	241.5	241.6	241.7	239.2	235.9	230.0	220.9	210.8	200.3	189.0	177.9	170.7
	Power consumption	kW	-	32.3	32.2	32.1	32.7	29.3	32.5	37.0	40.6	44.4	48.8	52.7	55.5
	Cold water flow rate	m ³ /h	-	41.5	41.5	41.6	41.1	40.6	39.6	38.0	36.3	34.5	32.4	30.6	29.4
	Water pressure loss	kPa	-	108	108	108	106	103	97	90	81	73	65	57	52
10	Cooling capacity	kW	-	247.9	248.0	248.0	247.7	245.7	239.6	230.2	220.5	210.1	199.1	187.1	179.6
	Power consumption	kW	-	33.6	33.6	33.5	33.6	31.0	32.6	35.8	39.0	42.4	46.1	50.3	53.0
	Cold water flow rate	m ³ /h	-	42.6	42.6	42.7	42.6	42.3	41.2	39.6	37.9	36.1	34.2	32.2	30.9
	Water pressure loss	kPa	-	114	114	114	113	112	106	98	89	81	72	63	58
15	Cooling capacity	kW	244.9	245.0	245.0	245.0	246.7	246.5	240.7	234.3	226.0	215.8	205.0	192.9	185.3
	Power consumption	kW	33.2	33.1	33.1	33.0	31.3	30.6	31.1	32.0	34.1	37.0	40.3	43.9	46.3
	Cold water flow rate	m ³ /h	42.1	42.1	42.1	42.1	42.4	42.4	41.4	40.3	38.9	37.1	35.3	33.2	31.9
	Water pressure loss	kPa	111	111	111	111	113	112	107	101	94	85	77	68	62
20	Cooling capacity	kW	214.3	214.3	214.4	214.4	218.3	218.3	213.9	209.1	202.2	193.3	184.2	174.4	168.3
	Power consumption	kW	28.8	28.7	28.6	28.6	24.4	24.4	25.4	25.7	27.3	29.8	32.5	35.5	37.5
	Cold water flow rate	m ³ /h	36.9	36.9	36.9	36.9	37.5	37.5	36.8	36.0	34.8	33.2	31.7	30.0	28.9
	Water pressure loss	kPa	84	84	84	84	88	88	84	80	75	68	61	54	50
25	Cooling capacity	kW	215.8	215.8	215.8	215.9	221.3	220.9	219.7	217.2	210.5	201.0	191.1	180.6	174.1
	Power consumption	kW	29.1	29.0	29.0	28.9	22.1	22.5	23.9	23.4	24.7	26.9	29.4	32.2	34.0
	Cold water flow rate	m ³ /h	37.1	37.1	37.1	37.1	38.1	38.0	37.8	37.4	36.2	34.6	32.9	31.1	29.9
	Water pressure loss	kPa	85	85	85	86	90	90	89	87	81	74	66	59	54

* The power consumption value is rounded off to the first decimal place.

Capacity change mode: COP priority

MODEL		EAHV-P900YA × 4, EACV-P900YA × 4													
Cold water outlet temperature	Outdoor air temperature °CDB	-15	-10	-5	0	5	10	15	20	25	30	35	40	43	
		5	Cooling capacity	kW	-	-	306.1	306.0	300.3	295.2	287.8	276.9	263.9	250.4	236.6
Power consumption	kW		-	-	33.7	37.3	41.0	36.4	41.3	48.3	53.3	58.5	63.8	69.5	73.1
Cold water flow rate	m ³ /h		-	-	52.7	52.6	51.6	50.8	49.5	47.6	45.4	43.1	40.7	38.2	36.6
Water pressure loss	kPa		-	-	97	97	93	90	86	79	71	64	56	49	45
7	Cooling capacity	kW	-	322.0	322.1	322.2	319.0	314.5	306.6	294.6	281.1	267.1	252.0	237.1	227.6
	Power consumption	kW	-	43.1	43.0	42.8	43.6	39.1	43.3	49.3	54.2	59.2	65.1	70.3	74.0
	Cold water flow rate	m ³ /h	-	55.4	55.4	55.4	54.9	54.1	52.7	50.7	48.3	45.9	43.2	40.8	39.1
	Water pressure loss	kPa	-	108	108	108	106	103	97	90	81	73	65	57	52
10	Cooling capacity	kW	-	330.5	330.6	330.7	330.2	327.6	319.4	307.0	294.0	280.1	265.5	249.5	239.5
	Power consumption	kW	-	44.9	44.8	44.6	44.7	41.4	43.5	47.7	52.0	56.6	61.5	67.1	70.6
	Cold water flow rate	m ³ /h	-	56.9	56.9	56.9	56.8	56.3	54.9	52.8	50.6	48.2	45.7	42.9	41.2
	Water pressure loss	kPa	-	114	114	114	113	112	106	98	89	81	72	63	58
15	Cooling capacity	kW	326.6	326.6	326.7	326.7	328.9	328.7	320.9	312.4	301.3	287.7	273.3	257.3	247.1
	Power consumption	kW	44.3	44.2	44.1	44.0	41.8	40.8	41.5	42.6	45.4	49.4	53.7	58.6	61.8
	Cold water flow rate	m ³ /h	56.2	56.2	56.2	56.2	56.6	56.5	55.2	53.7	51.8	49.5	47.0	44.2	42.5
	Water pressure loss	kPa	111	111	111	111	113	112	107	101	94	85	77	68	62
20	Cooling capacity	kW	285.7	285.8	285.8	285.9	291.1	291.1	285.3	278.9	269.6	257.8	245.6	232.6	224.4
	Power consumption	kW	38.3	38.2	38.2	38.1	32.5	32.5	33.9	34.3	36.4	39.7	43.3	47.4	50.1
	Cold water flow rate	m ³ /h	49.1	49.2	49.2	49.2	50.1	50.1	49.1	48.0	46.4	44.3	42.2	40.0	38.6
	Water pressure loss	kPa	84	84	84	84	88	88	84	80	75	68	61	54	50
25	Cooling capacity	kW	287.7	287.7	287.8	287.8	295.0	294.6	292.9	289.6	280.6	268.1	254.8	240.9	232.1
	Power consumption	kW	38.8	38.7	38.6	38.5	29.5	30.0	31.9	31.1	32.9	35.9	39.2	42.9	45.3
	Cold water flow rate	m ³ /h	49.5	49.5	49.5	49.5	50.7	50.7	50.4	49.8	48.3	46.1	43.8	41.4	39.9
	Water pressure loss	kPa	85	85	85	86	90	90	89	87	81	74	66	59	54

* The power consumption value is rounded off to the first decimal place.

2. Product Data

Cooling capacity: Cold water outlet/inlet temperature difference 5°C

Capacity change mode: COP priority

MODEL			EAHV-P900YA × 5, EACV-P900YA × 5												
Cold water outlet temperature	Outdoor air temperature °CDB		-15	-10	-5	0	5	10	15	20	25	30	35	40	43
			5	Cooling capacity	kW	-	-	382.7	382.5	375.3	369.0	359.8	346.1	329.9	313.0
Power consumption	kW	-		-	42.1	46.6	51.2	45.5	51.7	60.4	66.6	73.1	79.7	86.9	91.4
Cold water flow rate	m ³ /h	-		-	65.8	65.8	64.6	63.5	61.9	59.5	56.7	53.8	50.9	47.7	45.8
Water pressure loss	kPa	-		-	97	97	93	90	86	79	71	64	56	49	45
7	Cooling capacity	kW	-	402.5	402.6	402.8	398.7	393.1	383.3	368.2	351.4	333.9	315.0	296.4	284.5
	Power consumption	kW	-	53.9	53.7	53.6	54.4	48.8	54.2	61.7	67.7	74.0	81.4	87.9	92.5
	Cold water flow rate	m ³ /h	-	69.2	69.2	69.3	68.6	67.6	65.9	63.3	60.4	57.4	54.0	51.0	48.9
	Water pressure loss	kPa	-	108	108	108	106	103	97	90	81	73	65	57	52
10	Cooling capacity	kW	-	413.2	413.3	413.4	412.8	409.5	399.3	383.7	367.5	350.2	331.8	311.9	299.3
	Power consumption	kW	-	56.1	55.9	55.8	55.9	51.7	54.4	59.7	64.9	70.7	76.9	83.8	88.3
	Cold water flow rate	m ³ /h	-	71.1	71.1	71.1	71.0	70.4	68.7	66.0	63.2	60.2	57.1	53.6	51.5
	Water pressure loss	kPa	-	114	114	114	113	112	106	98	89	81	72	63	58
15	Cooling capacity	kW	408.2	408.3	408.3	408.4	411.2	410.9	401.2	390.5	376.6	359.6	341.6	321.6	308.8
	Power consumption	kW	55.4	55.2	55.1	55.0	52.2	51.0	51.9	53.3	56.8	61.7	67.1	73.2	77.2
	Cold water flow rate	m ³ /h	70.2	70.2	70.2	70.2	70.7	70.7	69.0	67.2	64.8	61.9	58.8	55.3	53.1
	Water pressure loss	kPa	111	111	111	111	113	112	107	101	94	85	77	68	62
20	Cooling capacity	kW	357.2	357.2	357.3	357.3	363.8	363.8	356.6	348.6	337.0	322.2	307.0	290.7	280.5
	Power consumption	kW	47.9	47.8	47.7	47.6	40.6	40.7	42.4	42.8	45.6	49.7	54.1	59.2	62.6
	Cold water flow rate	m ³ /h	61.4	61.4	61.5	61.5	62.6	62.6	61.3	60.0	58.0	55.4	52.8	50.0	48.2
	Water pressure loss	kPa	84	84	84	84	88	88	84	80	75	68	61	54	50
25	Cooling capacity	kW	359.6	359.7	359.7	359.8	368.8	368.2	366.2	362.1	350.8	335.1	318.5	301.1	290.1
	Power consumption	kW	48.5	48.4	48.3	48.2	36.9	37.5	39.9	38.9	41.1	44.8	49.0	53.6	56.7
	Cold water flow rate	m ³ /h	61.9	61.9	61.9	61.9	63.4	63.3	63.0	62.3	60.3	57.6	54.8	51.8	49.9
	Water pressure loss	kPa	85	85	85	86	90	90	89	87	81	74	66	59	54

* The power consumption value is rounded off to the first decimal place.

Capacity change mode: COP priority

MODEL			EAHV-P900YA × 6, EACV-P900YA × 6												
Cold water outlet temperature	Outdoor air temperature °CDB		-15	-10	-5	0	5	10	15	20	25	30	35	40	43
			5	Cooling capacity	kW	-	-	459.2	459.0	450.4	442.8	431.8	415.4	395.9	375.6
Power consumption	kW	-		-	50.5	56.0	61.5	54.6	62.0	72.5	80.0	87.7	95.7	104.3	109.7
Cold water flow rate	m ³ /h	-		-	79.0	78.9	77.5	76.2	74.3	71.4	68.1	64.6	61.0	57.3	54.9
Water pressure loss	kPa	-		-	97	97	93	90	86	79	71	64	56	49	45
7	Cooling capacity	kW	-	483.0	483.1	483.3	478.4	471.8	459.9	441.9	421.6	400.7	378.0	355.7	341.4
	Power consumption	kW	-	64.7	64.5	64.3	65.3	58.6	65.0	74.0	81.3	88.8	97.6	105.5	111.0
	Cold water flow rate	m ³ /h	-	83.1	83.1	83.1	82.3	81.1	79.1	76.0	72.5	68.9	64.8	61.2	58.7
	Water pressure loss	kPa	-	108	108	108	106	103	97	90	81	73	65	57	52
10	Cooling capacity	kW	-	495.8	495.9	496.1	495.4	491.4	479.1	460.5	441.0	420.2	398.2	374.2	359.2
	Power consumption	kW	-	67.3	67.1	67.0	67.1	62.1	65.3	71.6	77.9	84.9	92.3	100.6	106.0
	Cold water flow rate	m ³ /h	-	85.3	85.3	85.3	85.2	84.5	82.4	79.2	75.8	72.3	68.5	64.4	61.8
	Water pressure loss	kPa	-	114	114	114	113	112	106	98	89	81	72	63	58
15	Cooling capacity	kW	489.8	489.9	490.0	490.1	493.4	493.1	481.4	468.6	451.9	431.5	410.0	385.9	370.6
	Power consumption	kW	66.4	66.3	66.1	66.0	62.7	61.2	62.3	63.9	68.2	74.0	80.5	87.9	92.7
	Cold water flow rate	m ³ /h	84.3	84.3	84.3	84.3	84.9	84.8	82.8	80.6	77.7	74.2	70.5	66.4	63.7
	Water pressure loss	kPa	111	111	111	111	113	112	107	101	94	85	77	68	62
20	Cooling capacity	kW	428.6	428.7	428.7	428.8	436.6	436.6	427.9	418.3	404.4	386.6	368.4	348.8	336.6
	Power consumption	kW	57.5	57.4	57.2	57.1	48.8	48.8	50.9	51.4	54.7	59.6	65.0	71.1	75.1
	Cold water flow rate	m ³ /h	73.7	73.7	73.7	73.8	75.1	75.1	73.6	71.9	69.6	66.5	63.4	60.0	57.9
	Water pressure loss	kPa	84	84	84	84	88	88	84	80	75	68	61	54	50
25	Cooling capacity	kW	431.5	431.6	431.7	431.7	442.5	441.9	439.4	434.5	420.9	402.1	382.3	361.3	348.1
	Power consumption	kW	58.2	58.0	57.9	57.8	44.3	45.0	47.8	46.7	49.3	53.8	58.8	64.4	68.0
	Cold water flow rate	m ³ /h	74.2	74.2	74.2	74.3	76.1	76.0	75.6	74.7	72.4	69.2	65.7	62.1	59.9
	Water pressure loss	kPa	85	85	85	86	90	90	89	87	81	74	66	59	54

* The power consumption value is rounded off to the first decimal place.

EAHV-P-YAF(-H)(-N), YAL(-H)(-N)/EACV-P-YAF(-N), YAL(-N)

2. Product Data

Cooling capacity: Cold brine outlet/inlet temperature difference 5°C
[Brine ethylene glycol 35wt%]

Capacity change mode: Capacity priority

MODEL			EACV-P900YA												
Cold brine outlet temperature	Outdoor air temperature °CDB		-15	-10	-5	0	5	10	15	20	25	30	35	40	43
			-10	Cooling capacity	kW	65.2	65.2	65.2	63.8	62.2	60.5	58.7	56.5	53.5	50.4
Power consumption	kW	15.6		15.8	15.9	16.3	16.5	16.8	17.2	18.6	20.8	23.0	25.1	27.2	28.1
Cold brine flow rate	m ³ /h	13.3		13.3	13.3	13.0	12.7	12.4	12.0	11.5	10.9	10.3	9.6	9.0	8.1
brine pressure loss	kPa	143		143	143	137	130	123	115	106	95	84	73	63	51
-5	Cooling capacity	kW	78.3	78.3	78.3	76.2	74.5	72.5	70.4	67.4	63.9	60.3	56.73	53.1	48.0
	Power consumption	kW	15.4	15.6	15.8	16.2	16.5	16.8	17.3	19.5	21.7	23.9	26.0	28.2	29.1
	Cold brine flow rate	m ³ /h	15.9	15.9	15.9	15.5	15.1	14.7	14.3	13.7	13.0	12.2	11.5	10.8	9.7
	brine pressure loss	kPa	207	207	207	195	186	177	166	152	136	121	106	92	75
0	Cooling capacity	kW	93.5	93.6	93.6	90.3	88.4	86.3	83.6	79.8	75.9	71.9	67.8	63.6	57.6
	Power consumption	kW	15.4	15.6	15.8	16.2	16.5	16.9	18.3	20.6	22.7	24.9	27.1	29.4	30.1
	Cold brine flow rate	m ³ /h	18.9	18.9	18.9	18.3	17.9	17.4	16.9	16.1	15.3	14.5	13.7	12.9	11.7
	brine pressure loss	kPa	296	296	297	275	264	250	235	213	192	172	152	133	109
5	Cooling capacity	kW	105.5	105.8	105.8	105.9	103.6	100.7	98.2	93.9	89.4	84.9	80.2	75.4	68.4
	Power consumption	kW	15.9	16.3	16.4	16.8	17.0	17.6	19.8	21.8	23.9	25.9	28.2	30.5	31.1
	Cold brine flow rate	m ³ /h	21.2	21.3	21.3	21.3	20.9	20.3	19.8	18.9	18.0	17.1	16.2	15.2	13.8
	brine pressure loss	kPa	377	379	380	380	363	342	325	296	268	241	214	188	154
7	Cooling capacity	kW	105.9	106.7	107.2	107.8	105.9	102.7	103.6	99.8	95.2	90.4	85.4	80.3	73.0
	Power consumption	kW	15.9	16.4	16.8	17.0	17.3	17.8	20.3	22.3	24.3	26.4	28.6	31.0	31.6
	Cold brine flow rate	m ³ /h	21.3	21.5	21.6	21.7	21.3	20.7	20.9	20.1	19.1	18.2	17.2	16.2	14.7
	brine pressure loss	kPa	379	385	389	393	379	356	363	336	304	273	243	214	175
10	Cooling capacity	kW	107.8	108.5	108.9	109.3	105.4	102.2	104.9	105.2	100.5	95.5	90.3	84.9	76.9
	Power consumption	kW	16.8	17.1	17.3	17.5	16.5	17.0	19.3	21.5	23.4	25.3	27.5	29.8	30.4
	Cold brine flow rate	m ³ /h	21.7	21.8	21.9	21.9	21.2	20.5	21.1	21.1	20.2	19.2	18.1	17.0	15.4
	brine pressure loss	kPa	392	397	400	403	374	351	370	372	339	305	272	239	195
15	Cooling capacity	kW	113.7	114.2	114.5	114.8	102.1	99.4	100.8	104.5	104.2	99.5	94.1	88.5	80.4
	Power consumption	kW	18.1	18.2	18.3	18.4	14.6	14.9	16.6	18.7	20.5	22.3	24.2	26.3	27.4
	Cold brine flow rate	m ³ /h	22.8	22.9	22.9	23.0	20.4	19.9	20.2	20.9	20.9	19.9	18.9	17.7	16.1
	brine pressure loss	kPa	435	439	442	444	348	330	339	365	363	331	295	259	212
20	Cooling capacity	kW	105.8	105.8	105.8	105.7	95.9	95.4	94.9	99.3	98.0	93.6	89.1	84.2	75.9
	Power consumption	kW	16.5	16.6	16.6	16.7	12.7	12.9	14.1	15.8	17.3	18.8	20.5	22.3	23.3
	Cold brine flow rate	m ³ /h	21.2	21.2	21.2	21.1	19.2	19.1	19.0	19.9	19.6	18.7	17.8	16.8	15.2
	brine pressure loss	kPa	374	374	373	373	305	302	299	328	319	290	262	233	188
25	Cooling capacity	kW	103.8	103.8	103.8	103.7	90.2	90.5	89.0	93.9	97.1	95.2	90.4	85.4	77.4
	Power consumption	kW	16.8	16.8	16.8	16.9	11.1	11.3	12.0	13.6	15.1	16.5	18.0	19.6	20.9
	Cold brine flow rate	m ³ /h	20.7	20.7	20.7	20.7	18.0	18.1	17.8	18.8	19.4	19.0	18.1	17.1	15.5
	brine pressure loss	kPa	359	359	358	358	268	270	261	291	313	300	269	239	195

* The power consumption value is rounded off to the first decimal place.

Capacity change mode: Capacity priority

MODEL			EACV-P900YA × 2												
Cold brine outlet temperature	Outdoor air temperature °CDB		-15	-10	-5	0	5	10	15	20	25	30	35	40	43
			-10	Cooling capacity	kW	130.4	130.4	130.4	127.5	124.5	121.1	117.3	112.9	106.9	100.7
Power consumption	kW	31.1		31.5	31.8	32.6	33.0	33.6	34.3	37.2	41.6	45.9	50.1	54.3	56.2
Cold brine flow rate	m ³ /h	26.6		26.6	26.6	26.0	25.4	24.7	23.9	23.0	21.8	20.6	19.3	17.9	16.1
brine pressure loss	kPa	143		143	143	137	130	123	115	106	95	84	73	63	51
-5	Cooling capacity	kW	156.6	156.6	156.7	152.3	148.9	145.1	140.7	134.8	127.8	120.7	113.5	106.1	95.9
	Power consumption	kW	30.8	31.2	31.5	32.4	32.9	33.5	34.6	39.0	43.3	47.7	52.0	56.4	58.1
	Cold brine flow rate	m ³ /h	31.8	31.8	31.8	30.9	30.2	29.5	28.6	27.4	25.9	24.5	23.0	21.5	19.5
	brine pressure loss	kPa	207	207	207	195	186	177	166	152	136	121	106	92	75
0	Cooling capacity	kW	187.0	187.1	187.2	180.6	176.8	172.5	167.2	159.6	151.7	143.8	135.6	127.2	115.3
	Power consumption	kW	30.7	31.1	31.5	32.4	33.0	33.8	36.5	41.1	45.4	49.7	54.1	58.7	60.2
	Cold brine flow rate	m ³ /h	37.8	37.8	37.8	36.5	35.7	34.9	33.8	32.3	30.7	29.1	27.4	25.7	23.3
	brine pressure loss	kPa	296	296	297	275	264	250	235	213	192	172	152	133	109
5	Cooling capacity	kW	210.9	211.6	211.7	211.8	207.2	201.4	196.5	187.7	178.8	169.8	160.4	150.7	136.9
	Power consumption	kW	31.8	32.5	32.8	33.5	33.9	35.1	39.6	43.6	47.7	51.8	56.3	61.0	62.2
	Cold brine flow rate	m ³ /h	42.5	42.6	42.6	42.7	41.7	40.6	39.6	37.8	36.0	34.2	32.3	30.4	27.6
	brine pressure loss	kPa	377	379	380	380	363	342	325	296	268	241	214	188	154
7	Cooling capacity	kW	211.7	213.4	214.5	215.6	211.7	205.4	207.3	199.7	190.3	180.9	170.9	160.6	146.0
	Power consumption	kW	31.7	32.8	33.5	34.0	34.6	35.6	40.6	44.6	48.5	52.7	57.2	62.0	63.1
	Cold brine flow rate	m ³ /h	42.6	42.9	43.1	43.4	42.6	41.3	41.7	40.2	38.3	36.4	34.4	32.3	29.4
	brine pressure loss	kPa	379	385	389	393	379	356	363	336	304	273	243	214	175
10	Cooling capacity	kW	215.7	216.9	217.8	218.6	210.7	204.5	209.8	210.3	200.9	191.0	180.6	169.7	153.8
	Power consumption	kW	33.5	34.2	34.6	35.0	32.9	33.9	38.6	43.0	46.7	50.6	54.9	59.6	60.8
	Cold brine flow rate	m ³ /h	43.3	43.6	43.7	43.9	42.3	41.1	42.1	42.2	40.4	38.4	36.3	34.1	30.9
	brine pressure loss	kPa	392	397	400	403	374	351	370	372	339	305	272	239	195
15	Cooling capacity	kW	227.4	228.4	229.0	229.5	204.1	198.8	201.5	208.9	208.3	199.1	188.2	177.0	160.8
	Power consumption	kW	36.1	36.4	36.6	36.7	29.1	29.7	33.2	37.3	41.0	44.6	48.4	52.6	54.7
	Cold brine flow rate	m ³ /h	45.6	45.8	45.9	46.0	40.9	39.8	40.4	41.9	41.7	39.9	37.7	35.5	32.2
	brine pressure loss	kPa	435	439	442	444	348	330	339	365	363	331	295	259	212
20	Cooling capacity	kW	211.6	211.6	211.5	211.4	191.8	190.7	189.9	198.5	196.0	187.3	178.1	168.5	151.9
	Power consumption	kW	33.0	33.1	33.2	33.3	25.3	25.8	28.1	31.6	34.6	37.6	40.9	44.6	46.6
	Cold brine flow rate	m ³ /h	42.3	42.3	42.3	42.3	38.4	38.1	38.0	39.7	39.2	37.5	35.6	33.7	30.4
	brine pressure loss	kPa	374	374	373	373	305	302	299	328	319	290	262	233	188
25	Cooling capacity	kW	207.6	207.6	207.5	207.5	180.4	181.0	178.0	187.7	194.3	190.3	180.8	170.8	154.8
	Power consumption	kW	33.5	33.5	33.6	33.7	22.2	22.6	24.0	27.1	30.1	33.0	36.0	39.2	41.7
	Cold brine flow rate	m ³ /h	41.5	41.5	41.5	41.5	36.0	36.2	35.6	37.5	38.8	38.0	36.1	34.1	30.9
	brine pressure loss	kPa	359	359	358	358	268	270	261	291	313	300	269	239	195

* The power consumption value is rounded off to the first decimal place.

2. Product Data

Cooling capacity: Cold brine outlet/inlet temperature difference 5°C
[Brine ethylene glycol 35wt%]

Capacity change mode: Capacity priority

MODEL		EACV-P900YA × 3													
Cold brine outlet temperature	Outdoor air temperature °CDB	-15	-10	-5	0	5	10	15	20	25	30	35	40	43	
		-10	Cooling capacity	kW	195.6	195.6	195.7	191.3	186.7	181.6	176.0	169.4	160.4	151.1	141.6
	Power consumption	kW	46.6	47.2	47.7	48.8	49.5	50.3	51.5	55.8	62.4	68.8	75.1	81.4	84.2
	Cold brine flow rate	m ³ /h	39.9	39.9	39.9	39.0	38.1	37.1	35.9	34.6	32.7	30.8	28.9	26.9	24.2
	brine pressure loss	kPa	143	143	143	137	130	123	115	106	95	84	73	63	51
-5	Cooling capacity	kW	234.9	234.9	235.0	228.5	223.4	217.6	211.1	202.2	191.7	181.0	170.2	159.2	143.9
	Power consumption	kW	46.2	46.8	47.2	48.6	49.3	50.2	51.8	58.5	65.0	71.5	78.0	84.6	87.1
	Cold brine flow rate	m ³ /h	47.7	47.7	47.7	46.4	45.4	44.2	42.9	41.0	38.9	36.7	34.6	32.3	29.2
	brine pressure loss	kPa	207	207	207	195	186	177	166	152	136	121	106	92	75
0	Cooling capacity	kW	280.6	280.7	280.8	270.9	265.2	258.8	250.8	239.5	227.6	215.7	203.5	190.8	172.9
	Power consumption	kW	46.1	46.7	47.2	48.6	49.4	50.6	54.7	61.6	68.1	74.6	81.2	88.0	90.2
	Cold brine flow rate	m ³ /h	56.7	56.7	56.8	54.8	53.6	52.3	50.7	48.4	46.0	43.6	41.1	38.6	35.0
	brine pressure loss	kPa	296	296	297	275	264	250	235	213	192	172	152	133	109
5	Cooling capacity	kW	316.4	317.4	317.5	317.7	310.8	302.0	294.7	281.6	268.2	254.7	240.7	226.1	205.3
	Power consumption	kW	47.7	48.7	49.2	50.2	50.9	52.7	59.4	65.4	71.5	77.7	84.4	91.5	93.3
	Cold brine flow rate	m ³ /h	63.7	63.9	64.0	64.0	62.6	60.8	59.4	56.7	54.0	51.3	48.5	45.5	41.4
	brine pressure loss	kPa	377	379	380	380	363	342	325	296	268	241	214	188	154
7	Cooling capacity	kW	317.6	320.1	321.7	323.4	317.6	308.1	310.9	299.5	285.5	271.3	256.3	241.0	219.0
	Power consumption	kW	47.6	49.2	50.2	51.0	51.9	53.4	60.9	66.8	72.8	79.0	85.7	92.9	94.7
	Cold brine flow rate	m ³ /h	63.9	64.4	64.7	65.0	63.9	62.0	62.6	60.3	57.4	54.6	51.6	48.5	44.0
	brine pressure loss	kPa	379	385	389	393	379	356	363	336	304	273	243	214	175
10	Cooling capacity	kW	323.5	325.4	326.7	327.8	316.1	306.7	314.7	315.5	301.4	286.4	270.8	254.6	230.7
	Power consumption	kW	50.3	51.3	51.9	52.5	49.4	50.8	57.9	64.5	70.0	75.9	82.4	89.4	91.2
	Cold brine flow rate	m ³ /h	65.0	65.3	65.6	65.8	63.5	61.6	63.2	63.4	60.5	57.5	54.4	51.1	46.3
	brine pressure loss	kPa	392	397	400	403	374	351	370	372	339	305	272	239	195
15	Cooling capacity	kW	341.1	342.5	343.5	344.3	306.2	298.2	302.3	313.4	312.5	298.6	282.4	265.4	241.1
	Power consumption	kW	54.2	54.6	54.9	55.1	43.6	44.6	49.7	55.9	61.5	66.8	72.5	78.8	82.1
	Cold brine flow rate	m ³ /h	68.3	68.6	68.8	69.0	61.3	59.7	60.6	62.8	62.6	59.8	56.6	53.2	48.3
	brine pressure loss	kPa	435	439	442	444	348	330	339	365	363	331	295	259	212
20	Cooling capacity	kW	317.4	317.4	317.3	317.2	287.7	286.1	284.8	297.8	293.9	280.9	267.2	252.7	227.8
	Power consumption	kW	49.5	49.7	49.8	50.0	37.9	38.7	42.2	47.4	51.9	56.4	61.4	66.9	69.9
	Cold brine flow rate	m ³ /h	63.5	63.5	63.5	63.4	57.5	57.2	57.0	59.6	58.8	56.2	53.4	50.5	45.6
	brine pressure loss	kPa	374	374	373	373	305	302	299	328	319	290	262	233	188
25	Cooling capacity	kW	311.5	311.4	311.3	311.2	270.6	271.5	267.0	281.6	291.4	285.5	271.2	256.2	232.2
	Power consumption	kW	50.2	50.3	50.4	50.6	33.3	33.9	36.0	40.6	45.2	49.5	53.9	58.8	62.6
	Cold brine flow rate	m ³ /h	62.2	62.2	62.2	62.2	54.1	54.2	53.4	56.3	58.2	57.0	54.2	51.2	46.4
	brine pressure loss	kPa	359	359	358	358	268	270	261	291	313	300	269	239	195

* The power consumption value is rounded off to the first decimal place.

Capacity change mode: Capacity priority

MODEL		EACV-P900YA × 4													
Cold brine outlet temperature	Outdoor air temperature °CDB	-15	-10	-5	0	5	10	15	20	25	30	35	40	43	
		-10	Cooling capacity	kW	260.8	260.8	260.9	255.1	249.0	242.2	234.7	225.8	213.9	201.4	188.8
	Power consumption	kW	62.1	63.0	63.5	65.1	66.0	67.1	68.6	74.4	83.2	91.7	100.1	108.6	112.3
	Cold brine flow rate	m ³ /h	53.2	53.2	53.2	52.0	50.8	49.4	47.9	46.1	43.6	41.1	38.5	35.9	32.3
	brine pressure loss	kPa	143	143	143	137	130	123	115	106	95	84	73	63	51
-5	Cooling capacity	kW	313.2	313.2	313.4	304.7	297.9	290.1	281.5	269.5	255.6	241.3	226.9	212.3	191.9
	Power consumption	kW	61.6	62.4	63.0	64.7	65.7	66.9	69.1	77.9	86.6	95.3	104.0	112.8	116.2
	Cold brine flow rate	m ³ /h	63.6	63.6	63.6	61.9	60.5	58.9	57.2	54.7	51.9	49.0	46.1	43.1	39.0
	brine pressure loss	kPa	207	207	207	195	186	177	166	152	136	121	106	92	75
0	Cooling capacity	kW	374.1	374.2	374.4	361.2	353.6	345.0	334.5	319.3	303.5	287.6	271.3	254.4	230.6
	Power consumption	kW	61.4	62.2	62.9	64.8	65.9	67.5	72.9	82.2	90.8	99.4	108.2	117.4	120.3
	Cold brine flow rate	m ³ /h	75.6	75.6	75.7	73.0	71.5	69.7	67.6	64.5	61.3	58.1	54.8	51.4	46.6
	brine pressure loss	kPa	296	296	297	275	264	250	235	213	192	172	152	133	109
5	Cooling capacity	kW	421.9	423.2	423.4	423.7	414.3	402.7	392.9	375.4	357.6	339.6	320.9	301.5	273.8
	Power consumption	kW	63.6	64.9	65.6	66.9	67.8	70.2	79.2	87.1	95.3	103.6	112.5	121.9	124.4
	Cold brine flow rate	m ³ /h	85.0	85.2	85.3	85.3	83.5	81.1	79.1	75.6	72.0	68.4	64.6	60.7	55.1
	brine pressure loss	kPa	377	379	380	380	363	342	325	296	268	241	214	188	154
7	Cooling capacity	kW	423.5	426.8	429.0	431.2	423.5	410.8	414.6	399.3	380.7	361.7	341.8	321.3	292.0
	Power consumption	kW	63.4	65.6	66.9	68.0	69.2	71.1	81.1	89.1	97.0	105.3	114.3	123.9	126.2
	Cold brine flow rate	m ³ /h	85.2	85.8	86.3	86.7	85.2	82.6	83.4	80.3	76.6	72.8	68.8	64.6	58.7
	brine pressure loss	kPa	379	385	389	393	379	356	363	336	304	273	243	214	175
10	Cooling capacity	kW	431.3	433.9	435.6	437.1	421.5	408.9	419.5	420.6	401.9	381.9	361.1	339.4	307.6
	Power consumption	kW	67.0	68.4	69.2	69.9	65.8	67.7	77.2	86.0	93.3	101.2	109.8	119.1	121.5
	Cold brine flow rate	m ³ /h	86.6	87.1	87.5	87.8	84.6	82.1	84.2	84.5	80.7	76.7	72.5	68.2	61.8
	brine pressure loss	kPa	392	397	400	403	374	351	370	372	339	305	272	239	195
15	Cooling capacity	kW	454.8	456.7	458.0	459.0	408.2	397.6	403.1	417.8	416.6	398.1	376.5	353.9	321.5
	Power consumption	kW	72.2	72.7	73.1	73.4	58.1	59.4	66.3	74.5	82.0	89.1	96.7	105.1	109.4
	Cold brine flow rate	m ³ /h	91.1	91.5	91.8	92.0	81.8	79.7	80.7	83.7	83.5	79.8	75.4	70.9	64.4
	brine pressure loss	kPa	435	439	442	444	348	330	339	365	363	331	295	259	212
20	Cooling capacity	kW	423.3	423.1	423.0	422.9	383.6	381.5	379.7	397.0	391.9	374.5	356.2	337.0	303.8
	Power consumption	kW	66.0	66.2	66.4	66.6	50.5	51.6	56.2	63.1	69.2	75.2	81.8	89.2	93.2
	Cold brine flow rate	m ³ /h	84.7	84.6	84.6	84.6	76.7	76.3	75.9	79.4	78.4	74.9	71.2	67.4	60.8
	brine pressure loss	kPa	374	374	373	373	305	302	299	328	319	290	262	233	188
25	Cooling capacity	kW	415.3	415.2	415.1	415.0	360.8	362.0	356.1	375.4	388.6	380.7	361.6	341.5	309.6
	Power consumption	kW	66.9	67.0	67.2	67.4	44.4	45.2	47.9	54.1	60.2	66.0	71.9	78.4	83.4
	Cold brine flow rate	m ³ /h	83.0	83.0	82.9	82.9	72.1	72.3	71.1	75.0	77.6	76.1	72.3	68.2	61.9
	brine pressure loss	kPa	359	359	358	358	268	270	261	291	313	300	269	239	195

* The power consumption value is rounded off to the first decimal place.

2. Product Data

Cooling capacity: Cold brine outlet/inlet temperature difference 5°C
[Brine ethylene glycol 35wt%]

Capacity change mode: Capacity priority

MODEL		EACV-P900YA × 5												
Cold brine outlet temperature	Outdoor air temperature °CDB	-15	-10	-5	0	5	10	15	20	25	30	35	40	43
		-10	Cooling capacity kW	326.0	326.0	326.1	318.9	311.2	302.7	293.3	282.3	267.3	251.8	236.0
Power consumption kW	77.7		78.7	79.4	81.3	82.5	83.8	85.8	93.0	104.0	114.6	125.1	135.7	140.3
Cold brine flow rate m ³ /h	66.5		66.5	66.5	65.1	63.5	61.8	59.8	57.6	54.5	51.4	48.2	44.8	40.4
brine pressure loss kPa	143		143	143	137	130	123	115	106	95	84	73	63	51
-5	Cooling capacity kW	391.5	391.6	391.7	380.8	372.3	362.7	351.9	336.9	319.5	301.7	283.7	265.3	239.8
	Power consumption kW	77.0	78.0	78.7	80.9	82.1	83.6	86.3	97.4	108.3	119.1	130.0	141.0	145.2
	Cold brine flow rate m ³ /h	79.5	79.5	79.5	77.3	75.6	73.6	71.4	68.4	64.9	61.2	57.6	53.9	48.7
	brine pressure loss kPa	207	207	207	195	186	177	166	152	136	121	106	92	75
0	Cooling capacity kW	467.6	467.8	468.0	451.4	442.0	431.3	418.1	399.1	379.3	359.5	339.1	318.0	288.2
	Power consumption kW	76.7	77.8	78.6	81.0	82.4	84.3	91.1	102.7	113.5	124.3	135.3	146.7	150.3
	Cold brine flow rate m ³ /h	94.5	94.6	94.6	91.3	89.4	87.2	84.5	80.7	76.7	72.7	68.6	64.3	58.3
	brine pressure loss kPa	296	296	297	275	264	250	235	213	192	172	152	133	109
5	Cooling capacity kW	527.3	529.0	529.2	529.6	517.9	503.4	491.2	469.3	447.0	424.5	401.1	376.9	342.2
	Power consumption kW	79.4	81.1	82.0	83.6	84.7	87.8	99.0	108.9	119.1	129.5	140.6	152.4	155.5
	Cold brine flow rate m ³ /h	106.2	106.6	106.6	106.7	104.3	101.4	98.9	94.5	90.0	85.5	80.8	75.9	68.9
	brine pressure loss kPa	377	379	380	380	363	342	325	296	268	241	214	188	154
7	Cooling capacity kW	529.3	533.5	536.2	538.9	529.4	513.5	518.2	499.2	475.9	452.1	427.2	401.6	365.0
	Power consumption kW	79.3	82.0	83.6	85.0	86.4	88.9	101.4	111.4	121.3	131.6	142.8	154.9	157.8
	Cold brine flow rate m ³ /h	106.5	107.3	107.9	108.4	106.5	103.3	104.3	100.4	95.7	91.0	85.9	80.8	73.4
	brine pressure loss kPa	379	385	389	393	379	356	363	336	304	273	243	214	175
10	Cooling capacity kW	539.1	542.3	544.5	546.4	526.8	511.2	524.4	525.8	502.4	477.4	451.4	424.3	384.5
	Power consumption kW	83.7	85.5	86.5	87.4	82.2	84.6	96.5	107.4	116.6	126.4	137.2	148.9	151.9
	Cold brine flow rate m ³ /h	108.3	108.9	109.3	109.7	105.8	102.6	105.3	105.6	100.9	95.9	90.7	85.2	77.2
	brine pressure loss kPa	392	397	400	403	374	351	370	372	339	305	272	239	195
15	Cooling capacity kW	568.5	570.9	572.5	573.8	510.3	497.0	503.8	522.3	520.8	497.6	470.6	442.4	401.9
	Power consumption kW	90.2	90.9	91.4	91.8	72.6	74.3	82.9	93.1	102.5	111.3	120.9	131.4	136.8
	Cold brine flow rate m ³ /h	113.9	114.4	114.7	115.0	102.2	99.6	100.9	104.6	104.3	99.7	94.3	88.6	80.5
	brine pressure loss kPa	435	439	442	444	348	330	339	365	363	331	295	259	212
20	Cooling capacity kW	529.1	528.9	528.8	528.6	479.5	476.8	474.7	496.3	489.9	468.1	445.3	421.2	379.7
	Power consumption kW	82.5	82.7	83.0	83.2	63.1	64.5	70.3	78.9	86.5	93.9	102.2	111.4	116.5
	Cold brine flow rate m ³ /h	105.8	105.8	105.8	105.7	95.9	95.4	94.9	99.3	98.0	93.6	89.1	84.2	75.9
	brine pressure loss kPa	374	374	373	373	305	302	299	328	319	290	262	233	188
25	Cooling capacity kW	519.1	519.0	518.8	518.7	451.0	452.5	445.1	469.3	485.7	475.9	452.0	426.9	386.9
	Power consumption kW	83.6	83.8	84.0	84.2	55.5	56.5	59.9	67.6	75.3	82.5	89.9	97.9	104.3
	Cold brine flow rate m ³ /h	103.7	103.7	103.7	103.6	90.1	90.4	88.9	93.8	97.1	95.1	90.3	85.3	77.3
	brine pressure loss kPa	359	359	358	358	268	270	261	291	313	300	269	239	195

* The power consumption value is rounded off to the first decimal place.

Capacity change mode: Capacity priority

MODEL		EACV-P900YA × 6												
Cold brine outlet temperature	Outdoor air temperature °CDB	-15	-10	-5	0	5	10	15	20	25	30	35	40	43
		-10	Cooling capacity kW	391.2	391.3	391.3	382.6	373.5	363.3	352.0	338.7	320.8	302.2	283.2
Power consumption kW	93.2		94.4	95.3	97.6	99.0	100.6	102.9	111.6	124.8	137.5	150.1	162.8	168.4
Cold brine flow rate m ³ /h	79.8		79.8	79.8	78.1	76.2	74.1	71.8	69.1	65.4	61.7	57.8	53.8	48.4
brine pressure loss kPa	143		143	143	137	130	123	115	106	95	84	73	63	51
-5	Cooling capacity kW	469.7	469.9	470.0	457.0	446.8	435.2	422.2	404.3	383.4	362.0	340.4	318.4	287.8
	Power consumption kW	92.4	93.6	94.4	97.1	98.5	100.3	103.6	116.9	129.9	142.9	155.9	169.2	174.2
	Cold brine flow rate m ³ /h	95.4	95.4	95.4	92.8	90.7	88.4	85.7	82.1	77.8	73.5	69.1	64.6	58.4
	brine pressure loss kPa	207	207	207	195	186	177	166	152	136	121	106	92	75
0	Cooling capacity kW	561.1	561.3	561.6	541.7	530.4	517.5	501.7	478.9	455.2	431.4	406.9	381.6	345.9
	Power consumption kW	92.1	93.3	94.3	97.2	98.8	101.2	109.3	123.2	136.2	149.1	162.3	176.0	180.4
	Cold brine flow rate m ³ /h	113.4	113.5	113.5	109.5	107.2	104.6	101.4	96.8	92.0	87.2	82.3	77.1	69.9
	brine pressure loss kPa	296	296	297	275	264	250	235	213	192	172	152	133	109
5	Cooling capacity kW	632.8	634.8	635.0	635.5	621.5	604.1	589.4	563.1	536.4	509.4	481.3	452.2	410.6
	Power consumption kW	95.3	97.3	98.4	100.3	101.7	105.3	118.8	130.7	142.9	155.4	168.7	182.9	186.6
	Cold brine flow rate m ³ /h	127.5	127.9	127.9	128.0	125.2	121.7	118.7	113.4	108.0	102.6	97.0	91.1	82.7
	brine pressure loss kPa	377	379	380	380	363	342	325	296	268	241	214	188	154
7	Cooling capacity kW	635.2	640.2	643.5	646.7	635.2	616.2	621.9	599.0	571.0	542.6	512.7	481.9	437.9
	Power consumption kW	95.1	98.3	100.3	102.0	103.7	106.7	121.7	133.6	145.5	158.0	171.4	185.8	189.3
	Cold brine flow rate m ³ /h	127.8	128.8	129.4	130.1	127.8	124.0	125.1	120.5	114.9	109.1	103.1	96.9	88.1
	brine pressure loss kPa	379	385	389	393	379	356	363	336	304	273	243	214	175
10	Cooling capacity kW	647.0	650.8	653.4	655.7	632.2	613.4	629.3	630.9	602.8	572.9	541.7	509.1	461.4
	Power consumption kW	100.5	102.5	103.8	104.9	98.7	101.5	115.8	128.9	139.9	151.7	164.7	178.7	182.3
	Cold brine flow rate m ³ /h	129.9	130.7	131.2	131.7	127.0	123.2	126.4	126.7	121.1	115.1	108.8	102.2	92.7
	brine pressure loss kPa	392	397	400	403	374	351	370	372	339	305	272	239	195
15	Cooling capacity kW	682.2	685.1	687.0	688.5	612.3	596.5	604.6	626.7	624.9	597.2	564.7	530.9	482.3
	Power consumption kW	108.3	109.1	109.7	110.1	87.1	89.1	99.4	111.7	123.0	133.6	145.0	157.6	164.1
	Cold brine flow rate m ³ /h	136.7	137.3	137.6	137.9	122.7	119.5	121.1	125.6	125.2	119.6	113.1	106.4	96.6
	brine pressure loss kPa	435	439	442	444	348	330	339	365	363	331	295	259	212
20	Cooling capacity kW	634.9	634.7	634.5	634.3	575.4	572.2	569.6	595.5	587.9	561.8	534.3	505.5	455.7
	Power consumption kW	99.0	99.3	99.6	99.9	75.8	77.4	84.3	94.7	103.8	112.7	122.7	133.7	139.8
	Cold brine flow rate m ³ /h	127.0	126.9	126.9	126.9	115.1	114.4	113.9	119.1	117.6	112.4	106.9	101.1	91.1
	brine pressure loss kPa	374	374	373	373	305	302	299	328	319	290	262	233	188
25	Cooling capacity kW	622.9	622.8	622.6	622.5	541.3	543.0	534.1	563.1	582.9	571.0	542.4	512.3	464.3
	Power consumption kW	100.3	100.5	100.8	101.1	66.6	67.7	71.9	81.1	90.3	99.0	107.8	117.5	125.1
	Cold brine flow rate m ³ /h	124.5	124.4	124.4	124.4	108.1	108.5	106.7	112.5	116.5	114.1	108.4	102.4	92.8
	brine pressure loss kPa	359	359	358	358	268	270	261	291	313	300	269	239	195

* The power consumption value is rounded off to the first decimal place.

2. Product Data

Cooling capacity: Cold brine outlet/inlet temperature difference 5°C
[Brine ethylene glycol 35wt%]

Capacity change mode: COP priority

MODEL		EACV-P900YA													
Cold brine outlet temperature	Outdoor air temperature °CDB	-15	-10	-5	0	5	10	15	20	25	30	35	40	43	
		-10	Cooling capacity	kW	44.8	44.9	44.9	43.6	42.6	41.5	40.2	38.8	37.0	34.6	32.1
	Power consumption	kW	9.9	10.0	10.3	10.5	10.6	10.8	10.9	11.2	12.6	13.9	15.3	16.8	17.6
	Cold brine flow rate	m ³ /h	9.1	9.2	9.2	8.9	8.7	8.5	8.2	7.9	7.7	7.7	7.7	7.7	7.7
	brine pressure loss	kPa	66	66	66	62	59	56	53	49	46	46	46	46	46
-5	Cooling capacity	kW	54.0	54.0	54.0	51.8	50.8	49.7	48.3	46.7	44.5	41.9	39.3	36.6	34.9
	Power consumption	kW	10.0	10.1	10.2	10.5	10.6	10.7	10.9	11.4	12.9	14.4	15.8	17.3	18.1
	Cold brine flow rate	m ³ /h	11.0	11.0	11.0	10.5	10.3	10.1	9.8	9.5	9.0	8.5	8.0	7.7	7.7
	brine pressure loss	kPa	96	96	96	88	85	81	76	71	64	57	50	46	46
0	Cooling capacity	kW	64.7	64.8	64.8	61.4	60.3	59.0	57.6	55.8	53.1	50.2	47.3	44.3	42.4
	Power consumption	kW	10.0	10.2	10.2	10.5	10.6	10.8	11.0	11.9	13.4	14.9	16.3	17.8	18.7
	Cold brine flow rate	m ³ /h	13.1	13.1	13.1	12.4	12.2	11.9	11.6	11.3	10.7	10.1	9.6	9.0	8.6
	brine pressure loss	kPa	138	138	139	124	119	114	109	102	92	82	72	63	58
5	Cooling capacity	kW	72.6	72.6	72.6	72.5	71.2	69.8	68.1	65.9	62.8	59.5	56.2	52.8	50.6
	Power consumption	kW	10.4	10.5	10.6	10.7	10.9	11.0	11.4	12.7	14.0	15.3	16.7	18.2	19.2
	Cold brine flow rate	m ³ /h	14.6	14.6	14.6	14.6	14.3	14.1	13.7	13.3	12.6	12.0	11.3	10.6	10.2
	brine pressure loss	kPa	174	174	174	173	167	160	153	142	129	115	103	90	83
7	Cooling capacity	kW	76.7	76.7	76.7	76.6	76.0	74.4	72.7	70.1	66.9	63.5	60.0	56.4	54.1
	Power consumption	kW	11.0	11.1	11.2	11.3	11.0	11.2	11.6	12.9	14.2	15.5	16.9	18.4	19.4
	Cold brine flow rate	m ³ /h	15.4	15.4	15.4	15.4	15.3	15.0	14.6	14.1	13.5	12.8	12.1	11.3	10.9
	brine pressure loss	kPa	194	194	194	194	191	183	174	161	146	132	117	103	95
10	Cooling capacity	kW	78.7	78.7	78.7	78.6	79.2	77.9	76.0	73.3	70.0	66.6	63.1	59.3	56.9
	Power consumption	kW	11.7	11.7	11.7	11.8	10.7	10.7	11.2	12.5	13.6	14.8	16.2	17.6	18.5
	Cold brine flow rate	m ³ /h	15.8	15.8	15.8	15.8	15.9	15.6	15.3	14.7	14.1	13.4	12.7	11.9	11.4
	brine pressure loss	kPa	205	204	204	204	207	200	190	176	160	145	129	114	104
15	Cooling capacity	kW	80.5	77.7	77.7	77.7	79.1	79.1	77.8	75.2	71.9	68.5	65.0	61.2	58.7
	Power consumption	kW	12.3	11.5	11.6	11.6	9.6	9.8	10.1	11.0	11.9	13.0	14.1	15.4	16.2
	Cold brine flow rate	m ³ /h	16.1	15.6	15.6	15.6	15.9	15.9	15.6	15.1	14.4	13.7	13.0	12.3	11.8
	brine pressure loss	kPa	213	198	198	198	206	206	198	185	169	153	137	121	111
20	Cooling capacity	kW	68.7	68.0	68.0	67.9	69.2	69.2	68.3	66.7	64.4	61.5	58.6	55.5	53.6
	Power consumption	kW	10.0	10.1	10.1	10.1	8.5	8.5	8.6	8.8	9.6	10.5	11.4	12.5	13.2
	Cold brine flow rate	m ³ /h	13.7	13.6	13.6	13.6	13.8	13.8	13.7	13.3	12.9	12.3	11.7	11.1	10.7
	brine pressure loss	kPa	153	150	150	150	155	155	151	144	134	122	110	98	91
25	Cooling capacity	kW	69.7	69.0	68.3	68.2	69.5	69.5	69.4	67.9	66.2	64.1	61.0	57.7	55.6
	Power consumption	kW	10.1	10.0	10.3	10.5	8.5	8.6	8.6	8.7	8.8	9.5	10.3	11.3	11.9
	Cold brine flow rate	m ³ /h	15.2	13.8	13.6	13.6	13.9	13.9	13.9	13.6	13.2	12.8	12.2	11.5	11.1
	brine pressure loss	kPa	188	154	151	150	156	156	156	149	141	132	119	106	98

* The power consumption value is rounded off to the first decimal place.

Capacity change mode: COP priority

MODEL		EACV-P900YA × 2													
Cold brine outlet temperature	Outdoor air temperature °CDB	-15	-10	-5	0	5	10	15	20	25	30	35	40	43	
		-10	Cooling capacity	kW	89.5	89.7	89.7	87.1	85.2	83.0	80.4	77.6	74.0	69.1	64.2
	Power consumption	kW	19.7	19.9	20.5	21.0	21.2	21.5	21.8	22.4	25.1	27.8	30.6	33.5	35.2
	Cold brine flow rate	m ³ /h	18.3	18.3	18.3	17.8	17.4	16.9	16.4	15.8	15.4	15.4	15.4	15.4	15.4
	brine pressure loss	kPa	66	66	66	62	59	56	53	49	46	46	46	46	46
-5	Cooling capacity	kW	108.0	108.1	108.1	103.6	101.7	99.4	96.6	93.5	89.0	83.8	78.7	73.2	69.7
	Power consumption	kW	19.9	20.2	20.4	20.9	21.1	21.4	21.8	22.7	25.8	28.7	31.6	34.5	36.2
	Cold brine flow rate	m ³ /h	21.9	21.9	21.9	21.0	20.6	20.2	19.6	19.0	18.1	17.0	16.0	15.4	15.4
	brine pressure loss	kPa	96	96	96	88	85	81	76	71	64	57	50	46	46
0	Cooling capacity	kW	129.5	129.5	129.6	122.7	120.5	118.0	115.2	111.6	106.1	100.4	94.6	88.6	84.9
	Power consumption	kW	20.0	20.3	20.4	20.9	21.2	21.5	22.0	23.7	26.8	29.7	32.5	35.5	37.3
	Cold brine flow rate	m ³ /h	26.2	26.2	26.2	24.8	24.4	23.9	23.3	22.6	21.5	20.3	19.1	17.9	17.2
	brine pressure loss	kPa	138	138	139	124	119	114	109	102	92	82	72	63	58
5	Cooling capacity	kW	145.3	145.2	145.2	145.0	142.4	139.5	136.3	131.7	125.5	119.0	112.5	105.6	101.3
	Power consumption	kW	20.7	20.9	21.2	21.4	21.7	22.0	22.8	25.3	27.9	30.6	33.4	36.4	38.3
	Cold brine flow rate	m ³ /h	29.3	29.3	29.3	29.2	28.7	28.1	27.5	26.5	25.3	24.0	22.7	21.3	20.4
	brine pressure loss	kPa	174	174	174	173	167	160	153	142	129	115	103	90	83
7	Cooling capacity	kW	153.4	153.3	153.3	153.3	151.9	148.8	145.3	140.2	133.7	127.0	120.1	112.8	108.3
	Power consumption	kW	21.9	22.1	22.3	22.6	21.9	22.3	23.2	25.8	28.4	31.0	33.8	36.8	38.7
	Cold brine flow rate	m ³ /h	30.9	30.8	30.8	30.8	30.6	29.9	29.2	28.2	26.9	25.5	24.2	22.7	21.8
	brine pressure loss	kPa	194	194	194	194	191	183	174	161	146	132	117	103	95
10	Cooling capacity	kW	157.5	157.4	157.3	157.3	158.4	155.7	152.1	146.6	140.0	133.2	126.1	118.5	113.8
	Power consumption	kW	23.3	23.4	23.4	23.5	21.3	21.4	22.4	24.9	27.2	29.6	32.3	35.1	37.0
	Cold brine flow rate	m ³ /h	31.6	31.6	31.6	31.6	31.8	31.3	30.5	29.4	28.1	26.7	25.3	23.8	22.9
	brine pressure loss	kPa	205	204	204	204	207	200	190	176	160	145	129	114	104
15	Cooling capacity	kW	161.1	155.5	155.4	155.4	158.3	158.2	155.5	150.3	143.8	137.1	130.0	122.4	117.5
	Power consumption	kW	24.5	23.0	23.1	23.2	19.2	19.6	20.1	21.9	23.8	25.9	28.2	30.7	32.4
	Cold brine flow rate	m ³ /h	32.3	31.1	31.1	31.1	31.7	31.7	31.2	30.1	28.8	27.5	26.1	24.5	23.5
	brine pressure loss	kPa	213	198	198	198	206	206	198	185	169	153	137	121	111
20	Cooling capacity	kW	137.4	136.0	135.9	135.9	138.5	138.4	136.6	133.3	128.8	123.1	117.2	111.0	107.1
	Power consumption	kW	20.0	20.1	20.1	20.2	16.9	17.0	17.1	17.6	19.2	20.9	22.8	24.9	26.3
	Cold brine flow rate	m ³ /h	27.5	27.2	27.2	27.2	27.7	27.7	27.3	26.7	25.8	24.6	23.5	22.2	21.4
	brine pressure loss	kPa	153	150	150	150	155	155	151	144	134	122	110	98	91
25	Cooling capacity	kW	139.4	138.1	136.6	136.5	139.0	138.9	138.8	135.7	132.3	128.2	122.0	115.3	111.1
	Power consumption	kW	20.2	20.0	20.6	20.9	17.0	17.1	17.2	17.3	17.6	18.9	20.6	22.5	23.8
	Cold brine flow rate	m ³ /h	30.4	27.6	27.3	27.3	27.8	27.8	27.7	27.1	26.4	25.6	24.4	23.0	22.2
	brine pressure loss	kPa	188	154	151	150	156	156	156	149	141	132	119	106	98

* The power consumption value is rounded off to the first decimal place.

2. Product Data

Cooling capacity: Cold brine outlet/inlet temperature difference 5°C
[Brine ethylene glycol 35wt%]

Capacity change mode: COP priority

MODEL		EACV-P900YA × 3												
Cold brine outlet temperature	Outdoor air temperature °CDB	-15	-10	-5	0	5	10	15	20	25	30	35	40	43
		-10	Cooling capacity kW	134.3	134.6	134.6	130.7	127.8	124.4	120.6	116.5	111.0	103.7	96.3
Power consumption kW	29.5		29.8	30.7	31.4	31.8	32.2	32.7	33.6	37.7	41.7	45.9	50.2	52.8
Cold brine flow rate m ³ /h	27.4		27.5	27.5	26.7	26.1	25.4	24.6	23.8	23.1	23.1	23.1	23.1	23.1
brine pressure loss kPa	66		66	66	62	59	56	53	49	46	46	46	46	46
-5	Cooling capacity kW	162.0	162.1	162.1	155.4	152.5	149.0	144.9	140.2	133.5	125.8	118.0	109.9	104.6
	Power consumption kW	29.9	30.2	30.5	31.3	31.6	32.1	32.6	34.0	38.7	43.1	47.4	51.7	54.3
	Cold brine flow rate m ³ /h	32.9	32.9	32.9	31.6	31.0	30.3	29.4	28.5	27.1	25.5	24.0	23.1	23.1
	brine pressure loss kPa	96	96	96	88	85	81	76	71	64	57	50	46	46
0	Cooling capacity kW	194.2	194.3	194.4	184.1	180.8	177.1	172.7	167.5	159.2	150.6	141.9	132.8	127.3
	Power consumption kW	30.0	30.4	30.6	31.3	31.7	32.2	33.0	35.6	40.1	44.5	48.8	53.2	56.0
	Cold brine flow rate m ³ /h	39.3	39.3	39.3	37.2	36.6	35.8	34.9	33.9	32.2	30.4	28.7	26.9	25.7
	brine pressure loss kPa	138	138	139	124	119	114	109	102	92	82	72	63	58
5	Cooling capacity kW	217.9	217.9	217.8	217.5	213.6	209.3	204.4	197.6	188.3	178.6	168.7	158.4	151.9
	Power consumption kW	31.0	31.4	31.8	32.1	32.5	33.0	34.1	37.9	41.9	45.9	50.1	54.6	57.4
	Cold brine flow rate m ³ /h	43.9	43.9	43.9	43.8	43.0	42.2	41.2	39.8	37.9	36.0	34.0	31.9	30.6
	brine pressure loss kPa	174	174	174	173	167	160	153	142	129	115	103	90	83
7	Cooling capacity kW	230.0	230.0	230.0	229.9	227.9	223.2	218.0	210.3	200.6	190.5	180.1	169.2	162.4
	Power consumption kW	32.9	33.2	33.5	33.9	32.8	33.4	34.7	38.7	42.5	46.5	50.6	55.2	58.0
	Cold brine flow rate m ³ /h	46.3	46.3	46.3	46.3	45.8	44.9	43.9	42.3	40.4	38.3	36.2	34.0	32.7
	brine pressure loss kPa	194	194	194	194	191	183	174	161	146	132	117	103	95
10	Cooling capacity kW	236.2	236.1	236.0	235.9	237.7	233.6	228.1	219.8	210.0	199.8	189.2	177.8	170.7
	Power consumption kW	34.9	35.0	35.1	35.3	31.9	32.1	33.5	37.3	40.8	44.4	48.4	52.7	55.5
	Cold brine flow rate m ³ /h	47.4	47.4	47.4	47.4	47.4	47.7	46.9	45.8	44.1	42.2	40.1	38.0	35.7
	brine pressure loss kPa	205	204	204	204	207	200	190	176	160	145	129	114	104
15	Cooling capacity kW	241.6	233.2	233.1	233.0	237.4	237.4	233.3	225.5	215.7	205.6	195.0	183.6	176.2
	Power consumption kW	36.7	34.5	34.6	34.7	28.8	29.3	30.1	32.8	35.7	38.8	42.2	46.0	48.5
	Cold brine flow rate m ³ /h	48.4	46.7	46.7	46.7	46.7	47.6	47.6	46.7	45.2	43.2	41.2	39.1	36.8
	brine pressure loss kPa	213	198	198	198	206	206	198	185	169	153	137	121	111
20	Cooling capacity kW	206.1	204.0	203.9	203.8	207.7	207.6	205.0	200.0	193.2	184.6	175.9	166.5	160.7
	Power consumption kW	30.0	30.1	30.1	30.2	25.3	25.5	25.7	26.4	28.8	31.4	34.1	37.3	39.4
	Cold brine flow rate m ³ /h	41.2	40.8	40.8	40.8	41.5	41.5	41.0	40.0	38.6	36.9	35.2	33.3	32.1
	brine pressure loss kPa	153	150	150	150	155	155	151	144	134	122	110	98	91
25	Cooling capacity kW	209.1	207.1	204.9	204.7	208.4	208.4	208.2	203.6	198.5	192.3	183.0	173.0	166.7
	Power consumption kW	30.3	30.0	30.9	31.3	25.5	25.6	25.7	25.9	26.4	28.3	30.9	33.7	35.6
	Cold brine flow rate m ³ /h	45.6	41.4	40.9	40.9	41.6	41.6	41.6	40.7	39.7	38.4	36.6	34.6	33.3
	brine pressure loss kPa	188	154	151	150	156	156	156	149	141	132	119	106	98

* The power consumption value is rounded off to the first decimal place.

Capacity change mode: COP priority

MODEL		EACV-P900YA × 4												
Cold brine outlet temperature	Outdoor air temperature °CDB	-15	-10	-5	0	5	10	15	20	25	30	35	40	43
		-10	Cooling capacity kW	179.0	179.5	179.4	174.2	170.4	165.9	160.9	155.3	147.9	138.2	128.4
Power consumption kW	39.3		39.7	40.9	41.9	42.4	42.9	43.5	44.7	50.2	55.6	61.1	66.9	70.4
Cold brine flow rate m ³ /h	36.5		36.6	36.6	35.5	34.8	33.8	32.8	31.7	30.8	30.8	30.8	30.8	30.8
brine pressure loss kPa	66		66	66	62	59	56	53	49	46	46	46	46	46
-5	Cooling capacity kW	216.1	216.1	216.1	207.3	203.3	198.7	193.2	187.0	177.9	167.7	157.4	146.5	139.4
	Power consumption kW	39.8	40.3	40.7	41.7	42.2	42.7	43.5	45.4	51.6	57.4	63.2	68.9	72.4
	Cold brine flow rate m ³ /h	43.9	43.9	43.9	42.1	41.3	40.3	39.2	38.0	36.1	34.0	31.9	30.8	30.8
	brine pressure loss kPa	96	96	96	88	85	81	76	71	64	57	50	46	46
0	Cooling capacity kW	259.0	259.5	259.1	245.5	241.1	236.1	230.3	223.3	212.3	200.7	189.2	177.1	169.7
	Power consumption kW	40.0	40.5	40.8	41.8	42.3	43.0	43.9	47.4	53.5	59.3	65.0	70.9	74.6
	Cold brine flow rate m ³ /h	52.4	52.4	52.4	49.6	48.7	47.7	46.6	45.1	42.9	40.6	38.2	35.8	34.3
	brine pressure loss kPa	138	138	139	124	119	114	109	102	92	82	72	63	58
5	Cooling capacity kW	290.5	290.5	290.5	290.0	284.8	279.1	272.6	263.5	251.0	238.1	224.9	211.2	202.6
	Power consumption kW	41.3	41.8	42.3	42.7	43.3	44.0	45.5	50.6	55.8	61.2	66.8	72.7	76.5
	Cold brine flow rate m ³ /h	58.5	58.5	58.5	58.4	57.4	56.2	54.9	53.1	50.6	48.0	45.3	42.5	40.8
	brine pressure loss kPa	174	174	174	173	167	160	153	142	129	115	103	90	83
7	Cooling capacity kW	306.7	306.7	306.6	306.6	303.8	297.6	290.7	280.4	267.5	254.0	240.2	225.6	216.5
	Power consumption kW	43.8	44.2	44.6	45.1	43.8	44.6	46.3	51.6	56.7	62.0	67.5	73.5	77.4
	Cold brine flow rate m ³ /h	61.7	61.7	61.7	61.7	61.1	59.9	58.5	56.4	53.8	51.1	48.3	45.4	43.6
	brine pressure loss kPa	194	194	194	194	191	183	174	161	146	132	117	103	95
10	Cooling capacity kW	315.0	314.8	314.7	314.5	316.9	311.4	304.2	293.1	280.0	266.4	252.2	237.1	227.6
	Power consumption kW	46.5	46.7	46.8	47.0	42.5	42.8	44.7	49.7	54.3	59.2	64.5	70.2	74.0
	Cold brine flow rate m ³ /h	63.2	63.2	63.2	63.2	63.6	62.5	61.1	58.9	56.2	53.5	50.7	47.6	45.7
	brine pressure loss kPa	205	204	204	204	207	200	190	176	160	145	129	114	104
15	Cooling capacity kW	322.1	310.9	310.8	310.7	316.6	316.5	311.0	300.7	287.6	274.1	260.1	244.7	234.9
	Power consumption kW	48.9	46.0	46.1	46.3	38.4	39.1	40.1	43.7	47.5	51.7	56.3	61.4	64.7
	Cold brine flow rate m ³ /h	64.5	62.3	62.3	62.2	63.4	63.4	62.3	60.2	57.6	54.9	52.1	49.0	47.1
	brine pressure loss kPa	213	198	198	198	206	206	198	185	169	153	137	121	111
20	Cooling capacity kW	274.7	272.0	271.9	271.8	276.9	276.8	273.3	266.7	257.6	246.2	234.5	222.1	214.3
	Power consumption kW	40.0	40.1	40.2	40.3	33.8	34.0	34.2	35.2	38.4	41.8	45.5	49.7	52.5
	Cold brine flow rate m ³ /h	54.9	54.4	54.4	54.4	55.4	55.4	54.7	53.3	51.5	49.2	46.9	44.4	42.9
	brine pressure loss kPa	153	150	150	150	155	155	151	144	134	122	110	98	91
25	Cooling capacity kW	278.8	276.2	273.2	272.9	277.9	277.8	277.5	271.5	264.6	256.4	244.0	230.6	222.3
	Power consumption kW	40.3	40.0	41.2	41.7	34.0	34.1	34.3	34.5	35.1	37.8	41.2	45.0	47.5
	Cold brine flow rate m ³ /h	60.8	55.2	54.6	54.5	55.5	55.5	55.5	54.2	52.9	51.2	48.7	46.1	44.4
	brine pressure loss kPa	188	154	151	150	156	156	156	149	141	132	119	106	98

* The power consumption value is rounded off to the first decimal place.

2. Product Data

Cooling capacity: Cold brine outlet/inlet temperature difference 5°C
[Brine ethylene glycol 35wt%]

Capacity change mode: COP priority

MODEL		EACV-P900YA × 5													
Cold brine outlet temperature	Outdoor air temperature °CDB	-15	-10	-5	0	5	10	15	20	25	30	35	40	43	
-10	Cooling capacity	kW	223.8	224.4	224.3	217.8	213.0	207.4	201.1	194.1	184.9	172.8	160.4	147.9	140.1
	Power consumption	kW	49.2	49.7	51.2	52.3	52.9	53.6	54.4	55.9	62.7	69.5	76.4	83.6	88.0
	Cold brine flow rate	m ³ /h	45.7	45.8	45.8	44.4	43.5	42.3	41.0	39.6	38.5	38.5	38.5	38.5	38.5
	brine pressure loss	kPa	66	66	66	62	59	56	53	49	46	46	46	46	46
-5	Cooling capacity	kW	270.1	270.2	270.2	259.1	254.1	248.4	241.5	233.7	222.4	209.6	196.7	183.1	174.3
	Power consumption	kW	49.8	50.4	50.8	52.1	52.7	53.4	54.3	56.7	64.5	71.7	79.0	86.1	90.5
	Cold brine flow rate	m ³ /h	54.8	54.9	54.9	52.6	51.6	50.4	49.0	47.4	45.2	42.6	39.9	38.5	38.5
	brine pressure loss	kPa	96	96	96	88	85	81	76	71	64	57	50	46	46
0	Cooling capacity	kW	323.7	323.9	323.9	306.8	301.4	295.1	287.9	279.1	265.4	250.9	236.5	221.4	212.2
	Power consumption	kW	50.0	50.6	51.0	52.2	52.9	53.7	54.9	59.2	66.9	74.1	81.3	88.7	93.3
	Cold brine flow rate	m ³ /h	65.4	65.5	65.5	62.0	60.9	59.7	58.2	56.4	53.6	50.7	47.8	44.8	42.9
	brine pressure loss	kPa	138	138	139	124	119	114	109	102	92	82	72	63	58
5	Cooling capacity	kW	363.1	363.1	363.1	362.5	356.1	348.9	340.7	329.3	313.8	297.6	281.2	263.9	253.2
	Power consumption	kW	51.7	52.3	52.9	53.4	54.1	55.0	56.8	63.2	69.7	76.5	83.4	90.9	95.7
	Cold brine flow rate	m ³ /h	73.1	73.1	73.1	73.0	71.7	70.3	68.6	66.3	63.2	59.9	56.6	53.2	51.0
	brine pressure loss	kPa	174	174	174	173	167	160	153	142	129	115	103	90	83
7	Cooling capacity	kW	383.4	383.4	383.3	383.2	379.8	372.1	363.4	350.5	334.3	317.5	300.2	282.0	270.6
	Power consumption	kW	54.7	55.2	55.7	56.4	54.7	55.7	57.8	64.5	70.8	77.4	84.3	91.9	96.7
	Cold brine flow rate	m ³ /h	77.1	77.1	77.1	77.1	76.4	74.8	73.1	70.5	67.3	63.9	60.4	56.7	54.4
	brine pressure loss	kPa	194	194	194	194	191	183	174	161	146	132	117	103	95
10	Cooling capacity	kW	393.7	393.5	393.4	393.2	396.1	389.3	380.2	366.4	350.0	333.0	315.3	296.4	284.5
	Power consumption	kW	58.1	58.3	58.5	58.7	53.1	53.5	55.8	62.1	67.9	74.0	80.6	87.8	92.5
	Cold brine flow rate	m ³ /h	79.1	79.0	79.0	79.0	79.5	78.2	76.4	73.6	70.3	66.9	63.3	59.5	57.1
	brine pressure loss	kPa	205	204	204	204	207	200	190	176	160	145	129	114	104
15	Cooling capacity	kW	402.7	388.7	388.5	388.4	395.7	395.6	388.8	375.8	359.5	342.6	325.1	305.9	293.7
	Power consumption	kW	61.1	57.5	57.7	57.8	47.9	48.8	50.1	54.6	59.4	64.6	70.3	76.7	80.8
	Cold brine flow rate	m ³ /h	80.7	77.9	77.8	77.8	79.3	79.3	77.9	75.3	72.0	68.7	65.1	61.3	58.8
	brine pressure loss	kPa	213	198	198	198	206	206	198	185	169	153	137	121	111
20	Cooling capacity	kW	343.4	339.9	339.8	339.7	346.2	346.0	341.6	333.3	322.0	307.7	293.1	277.6	267.8
	Power consumption	kW	50.0	50.1	50.2	50.3	42.2	42.5	42.8	44.0	48.0	52.2	56.9	62.1	65.6
	Cold brine flow rate	m ³ /h	68.7	68.0	68.0	67.9	69.2	69.2	68.3	66.7	64.4	61.5	58.6	55.5	53.6
	brine pressure loss	kPa	153	150	150	150	155	155	151	144	134	122	110	98	91
25	Cooling capacity	kW	348.5	345.2	341.5	341.1	347.4	347.3	346.9	339.4	330.8	320.6	304.9	288.3	277.8
	Power consumption	kW	50.4	50.0	51.5	52.1	42.5	42.7	42.9	43.1	43.9	47.2	51.4	56.2	59.3
	Cold brine flow rate	m ³ /h	76.0	69.0	68.2	68.2	69.4	69.4	69.3	67.8	66.1	64.0	60.9	57.6	55.5
	brine pressure loss	kPa	188	154	151	150	156	156	156	149	141	132	119	106	98

* The power consumption value is rounded off to the first decimal place.

Capacity change mode: COP priority

MODEL		EACV-P900YA × 6													
Cold brine outlet temperature	Outdoor air temperature °CDB	-15	-10	-5	0	5	10	15	20	25	30	35	40	43	
-10	Cooling capacity	kW	268.5	269.2	269.1	261.3	255.7	248.9	241.3	232.9	221.9	207.3	192.5	177.4	168.2
	Power consumption	kW	59.0	59.6	61.4	62.8	63.5	64.3	65.3	67.1	75.3	83.4	91.7	100.3	105.6
	Cold brine flow rate	m ³ /h	54.8	54.9	54.9	53.3	52.2	50.8	49.2	47.5	46.2	46.2	46.2	46.2	46.2
	brine pressure loss	kPa	66	66	66	62	59	56	53	49	46	46	46	46	46
-5	Cooling capacity	kW	324.1	324.2	324.2	310.9	305.0	298.1	289.9	280.4	266.9	251.5	236.0	219.7	209.2
	Power consumption	kW	59.7	60.4	61.0	62.5	63.2	64.1	65.2	68.0	77.3	86.1	94.7	103.3	108.5
	Cold brine flow rate	m ³ /h	65.8	65.8	65.8	63.1	61.9	60.5	58.8	56.9	54.2	51.1	47.9	46.2	46.2
	brine pressure loss	kPa	96	96	96	88	85	81	76	71	64	57	50	46	46
0	Cooling capacity	kW	388.5	388.6	388.7	368.2	361.6	354.1	345.5	334.9	318.4	301.1	283.8	265.7	254.6
	Power consumption	kW	60.0	60.7	61.2	62.6	63.4	64.4	65.9	71.1	80.2	88.9	97.5	106.4	111.9
	Cold brine flow rate	m ³ /h	78.5	78.6	78.6	74.4	73.1	71.6	69.8	67.7	64.4	60.9	57.4	53.7	51.5
	brine pressure loss	kPa	138	138	139	124	119	114	109	102	92	82	72	63	58
5	Cooling capacity	kW	435.8	435.7	435.7	435.0	427.3	418.6	408.9	395.2	376.6	357.1	337.4	316.7	303.9
	Power consumption	kW	62.0	62.7	63.5	64.1	64.9	66.0	68.2	75.8	83.7	91.8	100.1	109.1	114.8
	Cold brine flow rate	m ³ /h	87.8	87.8	87.8	87.6	86.1	84.3	82.4	79.6	75.8	71.9	68.0	63.8	61.2
	brine pressure loss	kPa	174	174	174	173	167	160	153	142	129	115	103	90	83
7	Cooling capacity	kW	460.1	460.0	460.0	459.9	455.8	446.5	436.0	420.6	401.2	381.0	360.3	338.4	324.8
	Power consumption	kW	65.7	66.3	66.9	67.7	65.6	66.8	69.4	77.4	85.0	92.9	101.2	110.3	116.0
	Cold brine flow rate	m ³ /h	92.6	92.5	92.5	92.5	91.7	89.8	87.7	84.6	80.7	76.6	72.5	68.1	65.3
	brine pressure loss	kPa	194	194	194	194	191	183	174	161	146	132	117	103	95
10	Cooling capacity	kW	472.4	472.2	472.0	471.8	475.3	467.1	456.2	439.7	420.0	399.6	378.3	355.6	341.4
	Power consumption	kW	69.7	70.0	70.2	70.5	63.7	64.2	67.0	74.5	81.5	88.8	96.7	105.3	110.9
	Cold brine flow rate	m ³ /h	94.9	94.8	94.8	94.7	95.5	93.8	91.6	88.3	84.3	80.2	76.0	71.4	68.6
	brine pressure loss	kPa	205	204	204	204	207	200	190	176	160	145	129	114	104
15	Cooling capacity	kW	483.2	466.4	466.2	466.1	474.9	474.7	466.5	451.0	431.4	411.2	390.1	367.1	352.4
	Power consumption	kW	73.3	69.0	69.2	69.4	57.5	58.6	60.1	65.6	71.3	77.5	84.4	92.0	97.0
	Cold brine flow rate	m ³ /h	96.8	93.4	93.4	93.4	95.1	95.1	93.5	90.4	86.4	82.4	78.2	73.6	70.6
	brine pressure loss	kPa	213	198	198	198	206	206	198	185	169	153	137	121	111
20	Cooling capacity	kW	412.1	407.9	407.8	407.7	415.4	415.1	409.9	400.0	386.4	369.3	351.7	333.1	321.4
	Power consumption	kW	60.0	60.1	60.2	60.4	50.6	50.9	51.3	52.8	57.6	62.7	68.2	74.5	78.7
	Cold brine flow rate	m ³ /h	82.4	81.6	81.6	81.5	83.1	83.0	82.0	80.0	77.3	73.9	70.4	66.6	64.3
	brine pressure loss	kPa	153	150	150	150	155	155	151	144	134	122	110	98	91
25	Cooling capacity	kW	418.2	414.3	409.8	409.4	416.9	416.7	416.3	407.2	397.0	384.7	365.9	345.9	333.4
	Power consumption	kW	60.5	60.0	61.8	62.6	51.0	51.2	51.4	51.8	52.7	56.6	61.7	67.4	71.2
	Cold brine flow rate	m ³ /h	91.2	82.8	81.9	81.8	83.3	83.3	83.2	81.4	79.3	76.9	73.1	69.1	66.6
	brine pressure loss	kPa	188	154	151	150	156	156	156	149	141	132	119	106	98

* The power consumption value is rounded off to the first decimal place.

EAHV-P-YAF(-H)(-N), YAL(-H)(-N)/EACV-P-YAF(-N), YAL(-N)

2. Product Data

Cooling capacity: Cold water outlet/inlet temperature difference 7°C

Capacity change mode: Capacity priority

MODEL		EAHV-P900YA, EACV-P900YA													
Cold water outlet temperature	Outdoor air temperature °CDB	-15	-10	-5	0	5	10	15	20	25	30	35	40	43	
		5	Cooling capacity	kW	-	-	111.6	111.6	109.3	106.3	106.3	101.5	96.7	91.6	86.2
Power consumption	kW		-	-	15.5	15.7	16.0	16.6	19.0	20.8	22.7	24.7	26.8	29.0	30.3
Cold water flow rate	m ³ /h		-	-	13.7	13.7	13.4	13.1	13.1	12.5	11.9	11.3	10.6	9.9	9.0
Water pressure loss	kPa		-	-	106	106	101	96	96	87	78	70	62	54	43
7	Cooling capacity	kW	-	112.5	113.1	113.7	111.5	108.3	111.8	108.2	103.1	97.8	92.0	86.5	78.0
	Power consumption	kW	-	15.5	15.8	16.1	16.3	16.8	19.5	21.3	23.1	25.1	27.4	29.5	30.9
	Cold water flow rate	m ³ /h	-	13.8	13.9	14.0	13.7	13.3	13.7	13.3	12.7	12.0	11.3	10.6	9.6
	Water pressure loss	kPa	-	107	109	110	106	99	106	99	90	80	71	62	50
10	Cooling capacity	kW	-	111.2	111.7	112.2	111.0	107.8	110.4	112.7	108.8	103.3	97.5	91.4	82.5
	Power consumption	kW	-	14.8	15.1	15.3	15.6	16.0	18.2	20.6	22.5	24.4	26.5	28.6	30.0
	Cold water flow rate	m ³ /h	-	13.7	13.7	13.8	13.6	13.2	13.6	13.8	13.4	12.7	12.0	11.2	10.1
	Water pressure loss	kPa	-	105	106	107	104	98	103	108	100	90	80	70	56
15	Cooling capacity	kW	111.9	112.3	112.7	112.9	108.5	105.7	106.9	110.8	112.0	106.4	100.6	94.4	85.3
	Power consumption	kW	15.2	15.3	15.4	15.5	13.8	14.1	15.7	17.7	20.0	21.6	23.4	25.4	26.7
	Cold water flow rate	m ³ /h	13.7	13.8	13.8	13.9	13.3	13.0	13.1	13.6	13.8	13.1	12.4	11.6	10.5
	Water pressure loss	kPa	106	107	108	108	100	94	97	104	106	96	85	75	60
20	Cooling capacity	kW	112.2	112.2	112.2	112.1	102.1	101.5	100.7	105.4	102.9	99.8	94.9	89.8	80.9
	Power consumption	kW	15.7	15.8	15.8	15.9	12.0	12.3	13.3	15.0	16.5	17.9	19.5	21.3	22.3
	Cold water flow rate	m ³ /h	13.8	13.8	13.8	13.8	12.5	12.5	12.4	13.0	12.6	12.3	11.7	11.0	9.9
	Water pressure loss	kPa	107	107	107	107	88	87	86	94	89	84	75	67	54
25	Cooling capacity	kW	110.1	110.0	109.9	109.9	96.1	96.4	94.2	99.6	103.1	97.0	94.0	88.9	80.5
	Power consumption	kW	15.8	15.9	15.9	16.0	10.6	10.7	11.3	12.8	14.3	15.6	17.0	18.6	19.9
	Cold water flow rate	m ³ /h	13.5	13.5	13.5	13.5	11.8	11.8	11.6	12.2	12.7	11.9	11.5	10.9	9.9
	Water pressure loss	kPa	103	102	102	102	77	78	74	84	90	79	74	66	53

* The power consumption value is rounded off to the first decimal place.

Capacity change mode: Capacity priority

MODEL		EAHV-P900YA × 2, EACV-P900YA × 2													
Cold water outlet temperature	Outdoor air temperature °CDB	-15	-10	-5	0	5	10	15	20	25	30	35	40	43	
		5	Cooling capacity	kW	-	-	223.2	223.3	218.6	212.6	212.5	203.0	193.4	183.2	172.4
Power consumption	kW		-	-	31.0	31.5	32.0	33.1	38.0	41.6	45.4	49.4	53.7	58.0	60.7
Cold water flow rate	m ³ /h		-	-	27.4	27.4	26.9	26.1	26.1	24.9	23.8	22.5	21.2	19.9	17.9
Water pressure loss	kPa		-	-	106	106	101	96	96	87	78	70	62	54	43
7	Cooling capacity	kW	-	225.0	226.2	227.4	223.1	216.6	223.6	216.3	206.3	195.5	183.9	173.0	156.0
	Power consumption	kW	-	31.0	31.6	32.2	32.6	33.6	38.9	42.6	46.2	50.3	54.7	59.0	61.8
	Cold water flow rate	m ³ /h	-	27.6	27.8	27.9	27.4	26.6	27.5	26.6	25.3	24.0	22.6	21.2	19.2
	Water pressure loss	kPa	-	107	109	110	106	99	106	99	90	80	71	62	50
10	Cooling capacity	kW	-	222.3	223.4	224.4	222.0	215.6	220.8	225.4	217.5	206.5	194.9	182.8	164.9
	Power consumption	kW	-	29.7	30.2	30.6	31.1	31.9	36.5	41.3	44.9	48.8	52.9	57.3	60.0
	Cold water flow rate	m ³ /h	-	27.3	27.4	27.6	27.3	26.5	27.1	27.7	26.7	25.4	23.9	22.5	20.3
	Water pressure loss	kPa	-	105	106	107	104	98	103	108	100	90	80	70	56
15	Cooling capacity	kW	223.8	224.7	225.3	225.8	217.0	211.4	213.7	221.6	223.9	212.9	201.2	188.8	170.5
	Power consumption	kW	30.4	30.6	30.8	30.9	27.6	28.2	31.4	35.4	40.0	43.2	46.9	50.8	53.3
	Cold water flow rate	m ³ /h	27.5	27.6	27.7	27.7	26.7	26.0	26.3	27.2	27.5	26.2	24.7	23.2	21.0
	Water pressure loss	kPa	106	107	108	108	100	94	97	104	106	96	85	75	60
20	Cooling capacity	kW	224.5	224.4	224.3	224.2	204.1	202.9	201.5	210.8	205.8	199.6	189.8	179.6	161.8
	Power consumption	kW	31.5	31.5	31.6	31.7	24.0	24.5	26.7	29.9	33.0	35.9	39.1	42.6	44.7
	Cold water flow rate	m ³ /h	27.6	27.6	27.6	27.5	25.1	24.9	24.8	25.9	25.3	24.5	23.3	22.1	19.9
	Water pressure loss	kPa	107	107	107	107	88	87	86	94	89	84	75	67	54
25	Cooling capacity	kW	220.3	219.9	219.9	219.8	192.2	192.8	188.4	199.3	206.3	194.0	188.0	177.9	160.9
	Power consumption	kW	31.6	31.8	31.8	31.9	21.1	21.5	22.5	25.7	28.6	31.2	34.0	37.1	39.7
	Cold water flow rate	m ³ /h	27.1	27.0	27.0	27.0	23.6	23.7	23.1	24.5	25.3	23.8	23.1	21.9	19.8
	Water pressure loss	kPa	103	102	102	102	77	78	74	84	90	79	74	66	53

* The power consumption value is rounded off to the first decimal place.

2. Product Data

Cooling capacity: Cold water outlet/inlet temperature difference 7°C

Capacity change mode: Capacity priority

MODEL			EAHV-P900YA × 3, EACV-P900YA × 3												
Cold water outlet temperature	Outdoor air temperature °CDB		-15	-10	-5	0	5	10	15	20	25	30	35	40	43
			5	Cooling capacity	kW	-	-	334.8	334.9	327.9	319.0	318.8	304.5	290.1	274.7
Power consumption	kW	-		-	46.5	47.2	48.0	49.7	57.0	62.4	68.1	74.1	80.5	87.0	91.0
Cold water flow rate	m ³ /h	-		-	41.1	41.1	40.3	39.2	39.2	37.4	35.6	33.8	31.8	29.8	26.9
Water pressure loss	kPa	-		-	106	106	101	96	96	87	78	70	62	54	43
7	Cooling capacity	kW	-	337.5	339.3	341.0	334.6	324.9	335.4	324.5	309.4	293.3	275.9	259.4	234.1
	Power consumption	kW	-	46.5	47.5	48.3	48.9	50.3	58.4	63.9	69.4	75.4	82.1	88.5	92.7
	Cold water flow rate	m ³ /h	-	41.5	41.7	41.9	41.1	39.9	41.2	39.9	38.0	36.0	33.9	31.9	28.8
	Water pressure loss	kPa	-	107	109	110	106	99	106	99	90	80	71	62	50
10	Cooling capacity	kW	-	333.5	335.1	336.6	333.0	323.3	331.2	338.1	326.3	309.8	292.4	274.2	247.4
	Power consumption	kW	-	44.5	45.3	45.9	46.7	47.9	54.7	61.9	67.4	73.1	79.4	85.9	90.0
	Cold water flow rate	m ³ /h	-	41.0	41.2	41.3	40.9	39.7	40.7	41.5	40.1	38.1	35.9	33.7	30.4
	Water pressure loss	kPa	-	105	106	107	104	98	103	108	100	90	80	70	56
15	Cooling capacity	kW	335.7	337.0	338.0	338.7	325.6	317.1	320.6	332.4	335.9	319.3	301.8	283.3	255.8
	Power consumption	kW	45.6	45.9	46.2	46.4	41.3	42.3	47.2	53.0	59.9	64.9	70.3	76.2	80.0
	Cold water flow rate	m ³ /h	41.2	41.4	41.5	41.6	40.0	39.0	39.4	40.8	41.3	39.2	37.1	34.8	31.4
	Water pressure loss	kPa	106	107	108	108	100	94	97	104	106	96	85	75	60
20	Cooling capacity	kW	336.7	336.6	336.5	336.4	306.2	304.4	302.2	316.2	308.7	299.4	284.7	269.3	242.8
	Power consumption	kW	47.2	47.3	47.4	47.6	36.0	36.8	40.0	44.9	49.5	53.8	58.6	63.9	67.0
	Cold water flow rate	m ³ /h	41.4	41.4	41.3	41.3	37.6	37.4	37.1	38.9	37.9	36.8	35.0	33.1	29.8
	Water pressure loss	kPa	107	107	107	107	88	87	86	94	89	84	75	67	54
25	Cooling capacity	kW	330.4	329.9	329.8	329.7	288.3	289.2	282.6	298.9	309.4	291.0	282.0	266.8	241.4
	Power consumption	kW	47.4	47.6	47.8	47.9	31.7	32.2	33.8	38.5	42.9	46.7	51.0	55.7	59.6
	Cold water flow rate	m ³ /h	40.6	40.5	40.5	40.5	35.4	35.5	34.7	36.7	38.0	35.8	34.6	32.8	29.7
	Water pressure loss	kPa	103	102	102	102	77	78	74	84	90	79	74	66	53

* The power consumption value is rounded off to the first decimal place.

Capacity change mode: Capacity priority

MODEL			EAHV-P900YA × 4, EACV-P900YA × 4												
Cold water outlet temperature	Outdoor air temperature °CDB		-15	-10	-5	0	5	10	15	20	25	30	35	40	43
			5	Cooling capacity	kW	-	-	446.3	446.5	437.2	425.3	425.0	406.1	386.7	366.3
Power consumption	kW	-		-	62.0	63.0	64.0	66.2	76.0	83.3	90.7	98.8	107.3	116.0	121.4
Cold water flow rate	m ³ /h	-		-	54.8	54.9	53.7	52.2	52.2	49.9	47.5	45.0	42.4	39.7	35.8
Water pressure loss	kPa	-		-	106	106	101	96	96	87	78	70	62	54	43
7	Cooling capacity	kW	-	450.1	452.4	454.7	446.2	433.2	447.2	432.7	412.6	391.0	367.8	345.9	312.1
	Power consumption	kW	-	62.0	63.3	64.3	65.3	67.1	77.8	85.2	92.5	100.6	109.4	118.0	123.6
	Cold water flow rate	m ³ /h	-	55.3	55.6	55.9	54.8	53.2	54.9	53.2	50.7	48.0	45.2	42.5	38.3
	Water pressure loss	kPa	-	107	109	110	106	99	106	99	90	80	71	62	50
10	Cooling capacity	kW	-	444.7	446.8	448.7	444.0	431.1	441.7	450.8	435.0	413.1	389.8	365.7	329.9
	Power consumption	kW	-	59.3	60.4	61.3	62.2	63.9	73.0	82.5	89.8	97.5	105.8	114.6	120.1
	Cold water flow rate	m ³ /h	-	54.6	54.9	55.1	54.6	53.0	54.3	55.4	53.4	50.7	47.9	44.9	40.5
	Water pressure loss	kPa	-	105	106	107	104	98	103	108	100	90	80	70	56
15	Cooling capacity	kW	447.7	449.4	450.6	451.6	434.1	422.8	427.4	443.1	447.8	425.7	402.4	377.7	341.1
	Power consumption	kW	60.8	61.3	61.6	61.9	55.1	56.4	62.9	70.7	79.9	86.5	93.7	101.6	106.7
	Cold water flow rate	m ³ /h	55.0	55.2	55.4	55.5	53.3	51.9	52.5	54.4	55.0	52.3	49.4	46.4	41.9
	Water pressure loss	kPa	106	107	108	108	100	94	97	104	106	96	85	75	60
20	Cooling capacity	kW	448.9	448.8	448.6	448.5	408.3	405.8	403.0	421.6	411.6	399.2	379.6	359.1	323.7
	Power consumption	kW	62.9	63.1	63.3	63.4	48.0	49.0	53.4	59.9	66.0	71.8	78.2	85.2	89.4
	Cold water flow rate	m ³ /h	55.2	55.1	55.1	55.1	50.2	49.9	49.5	51.8	50.6	49.0	46.6	44.1	39.8
	Water pressure loss	kPa	107	107	107	107	88	87	86	94	89	84	75	67	54
25	Cooling capacity	kW	440.5	439.8	439.7	439.6	384.4	385.6	376.8	398.5	412.5	388.0	376.0	355.7	321.8
	Power consumption	kW	63.2	63.5	63.7	63.9	42.2	42.9	45.0	51.4	57.2	62.3	68.0	74.3	79.5
	Cold water flow rate	m ³ /h	54.1	54.0	54.0	54.0	47.2	47.4	46.3	49.0	50.7	47.7	46.2	43.7	39.5
	Water pressure loss	kPa	103	102	102	102	77	78	74	84	90	79	74	66	53

* The power consumption value is rounded off to the first decimal place.

2. Product Data

Cooling capacity: Cold water outlet/inlet temperature difference 7°C

Capacity change mode: Capacity priority

MODEL		EAHV-P900YA × 5, EACV-P900YA × 5													
Cold water outlet temperature	Outdoor air temperature °CDB	-15	-10	-5	0	5	10	15	20	25	30	35	40	43	
		5	Cooling capacity	kW	-	-	557.9	558.2	546.4	531.6	531.3	507.6	483.4	457.9	431.0
Power consumption	kW		-	-	77.4	78.7	80.0	82.8	95.0	104.1	113.4	123.5	134.1	144.9	151.7
Cold water flow rate	m ³ /h		-	-	68.5	68.6	67.1	65.3	65.3	62.4	59.4	56.3	53.0	49.7	44.8
Water pressure loss	kPa		-	-	106	106	101	96	96	87	78	70	62	54	43
7	Cooling capacity	kW	-	562.6	565.5	568.4	557.7	541.6	559.0	540.8	515.7	488.8	459.8	432.4	390.1
	Power consumption	kW	-	77.5	79.1	80.4	81.6	83.9	97.3	106.5	115.6	125.7	136.8	147.5	154.5
	Cold water flow rate	m ³ /h	-	69.1	69.5	69.8	68.5	66.5	68.7	66.4	63.4	60.0	56.5	53.1	47.9
	Water pressure loss	kPa	-	107	109	110	106	99	106	99	90	80	71	62	50
10	Cooling capacity	kW	-	555.9	558.5	560.9	555.1	538.9	552.1	563.5	543.8	516.3	487.3	457.1	412.4
	Power consumption	kW	-	74.2	75.5	76.6	77.8	79.8	91.2	103.2	112.3	121.9	132.3	143.2	150.1
	Cold water flow rate	m ³ /h	-	68.3	68.6	68.9	68.2	66.2	67.8	69.2	66.8	63.4	59.9	56.2	50.7
	Water pressure loss	kPa	-	105	106	107	104	98	103	108	100	90	80	70	56
15	Cooling capacity	kW	559.6	561.7	563.3	564.5	542.6	528.5	534.3	553.9	559.8	532.2	502.9	472.1	426.3
	Power consumption	kW	76.0	76.6	77.0	77.3	68.9	70.5	78.6	88.4	99.9	108.1	117.2	127.0	133.4
	Cold water flow rate	m ³ /h	68.7	69.0	69.2	69.4	66.7	64.9	65.6	68.1	68.8	65.4	61.8	58.0	52.4
	Water pressure loss	kPa	106	107	108	108	100	94	97	104	106	96	85	75	60
20	Cooling capacity	kW	561.2	561.0	560.8	560.6	510.4	507.3	503.7	527.0	514.4	499.0	474.5	448.9	404.6
	Power consumption	kW	78.7	78.9	79.1	79.3	60.0	61.3	66.7	74.8	82.5	89.7	97.7	106.5	111.7
	Cold water flow rate	m ³ /h	68.9	68.9	68.9	68.9	62.7	62.3	61.9	64.8	63.2	61.3	58.3	55.1	49.7
	Water pressure loss	kPa	107	107	107	107	88	87	86	94	89	84	75	67	54
25	Cooling capacity	kW	550.6	549.8	549.6	549.5	480.5	482.0	471.0	498.2	515.6	485.0	470.0	444.6	402.3
	Power consumption	kW	79.0	79.4	79.6	79.8	52.8	53.6	56.3	64.2	71.5	77.9	85.0	92.8	99.3
	Cold water flow rate	m ³ /h	67.6	67.5	67.5	67.5	59.0	59.2	57.9	61.2	63.4	59.6	57.7	54.6	49.4
	Water pressure loss	kPa	103	102	102	102	77	78	74	84	90	79	74	66	53

* The power consumption value is rounded off to the first decimal place.

Capacity change mode: Capacity priority

MODEL		EAHV-P900YA × 6, EACV-P900YA × 6													
Cold water outlet temperature	Outdoor air temperature °CDB	-15	-10	-5	0	5	10	15	20	25	30	35	40	43	
		5	Cooling capacity	kW	-	-	669.5	669.8	655.7	637.9	637.6	609.1	580.1	549.5	517.2
Power consumption	kW		-	-	92.9	94.5	96.0	99.4	114.0	124.9	136.1	148.2	161.0	173.9	182.0
Cold water flow rate	m ³ /h		-	-	82.3	82.3	80.6	78.4	78.3	74.8	71.3	67.5	63.5	59.6	53.7
Water pressure loss	kPa		-	-	106	106	101	96	96	87	78	70	62	54	43
7	Cooling capacity	kW	-	675.1	678.6	682.1	669.2	649.9	670.8	649.0	618.9	586.5	551.7	518.9	468.1
	Power consumption	kW	-	93.0	94.9	96.5	97.9	100.7	116.8	127.8	138.7	150.9	164.1	176.9	185.4
	Cold water flow rate	m ³ /h	-	82.9	83.4	83.8	82.2	79.8	82.4	79.7	76.0	72.1	67.8	63.7	57.5
	Water pressure loss	kPa	-	107	109	110	106	99	106	99	90	80	71	62	50
10	Cooling capacity	kW	-	667.0	670.2	673.1	666.1	646.7	662.5	676.1	652.5	619.6	584.8	548.5	494.8
	Power consumption	kW	-	89.0	90.6	91.9	93.3	95.8	109.5	123.8	134.7	146.3	158.7	171.9	180.1
	Cold water flow rate	m ³ /h	-	82.0	82.3	82.7	81.8	79.5	81.4	83.1	80.2	76.1	71.8	67.4	60.8
	Water pressure loss	kPa	-	105	106	107	104	98	103	108	100	90	80	70	56
15	Cooling capacity	kW	671.5	674.0	675.9	677.4	651.1	634.2	641.2	664.7	671.7	638.6	603.5	566.5	511.6
	Power consumption	kW	91.2	91.9	92.4	92.8	82.7	84.6	94.3	106.1	119.9	129.7	140.6	152.4	160.0
	Cold water flow rate	m ³ /h	82.5	82.8	83.0	83.2	80.0	77.9	78.8	81.7	82.5	78.5	74.1	69.6	62.9
	Water pressure loss	kPa	106	107	108	108	100	94	97	104	106	96	85	75	60
20	Cooling capacity	kW	673.4	673.2	672.9	672.7	612.4	608.7	604.5	632.5	617.3	598.8	569.4	538.7	485.5
	Power consumption	kW	94.4	94.6	94.9	95.1	72.0	73.6	80.1	89.8	99.0	107.7	117.2	127.8	134.0
	Cold water flow rate	m ³ /h	82.7	82.7	82.7	82.6	75.2	74.8	74.3	77.7	75.8	73.6	70.0	66.2	59.7
	Water pressure loss	kPa	107	107	107	107	88	87	86	94	89	84	75	67	54
25	Cooling capacity	kW	660.8	659.7	659.6	659.4	576.6	578.4	565.2	597.8	618.8	582.0	564.0	533.6	482.7
	Power consumption	kW	94.9	95.3	95.5	95.8	63.3	64.4	67.5	77.0	85.8	93.5	102.0	111.4	119.2
	Cold water flow rate	m ³ /h	81.2	81.1	81.0	81.0	70.8	71.1	69.4	73.4	76.0	71.5	69.3	65.6	59.3
	Water pressure loss	kPa	103	102	102	102	77	78	74	84	90	79	74	66	53

* The power consumption value is rounded off to the first decimal place.

2. Product Data

Cooling capacity: Cold water outlet/inlet temperature difference 7°C

Capacity change mode: COP priority

MODEL			EAHV-P900YA, EACV-P900YA												
Cold water outlet temperature	Outdoor air temperature °CDB		-15	-10	-5	0	5	10	15	20	25	30	35	40	43
			5	Cooling capacity	kW	-	-	77.3	77.1	75.9	74.4	72.7	70.3	67.2	63.9
Power consumption	kW	-		-	8.4	9.3	10.2	9.1	10.3	12.1	13.3	14.6	15.9	17.4	18.3
Cold water flow rate	m ³ /h	-		-	9.5	9.5	9.3	9.1	8.9	8.6	8.3	7.9	7.7	7.7	7.7
Water pressure loss	kPa	-		-	49	48	47	45	42	39	35	31	30	30	30
7	Cooling capacity	kW	-	81.0	80.9	81.0	80.2	79.1	77.2	74.2	71.4	68.1	64.5	60.6	58.2
	Power consumption	kW	-	10.8	10.7	10.7	10.9	9.8	10.8	12.3	13.5	14.8	16.1	17.6	18.5
	Cold water flow rate	m ³ /h	-	10.0	9.9	10.0	9.9	9.7	9.5	9.1	8.8	8.4	7.9	7.7	7.7
	Water pressure loss	kPa	-	54	54	54	53	51	48	44	41	36	32	30	30
10	Cooling capacity	kW	-	83.6	83.6	83.5	83.3	82.7	80.7	77.6	74.6	71.2	67.6	63.7	61.1
	Power consumption	kW	-	11.2	11.2	11.2	11.2	10.3	10.9	11.9	13.0	14.1	15.4	16.8	17.7
	Cold water flow rate	m ³ /h	-	10.3	10.3	10.3	10.2	10.2	9.9	9.5	9.2	8.7	8.3	7.8	7.7
	Water pressure loss	kPa	-	58	58	57	57	56	53	49	45	40	36	31	30
15	Cooling capacity	kW	82.7	82.7	82.7	82.6	83.3	83.2	81.2	79.1	76.3	72.9	69.3	65.4	62.9
	Power consumption	kW	11.1	11.0	11.0	11.0	10.4	10.2	10.4	10.7	11.4	12.3	13.4	14.6	15.4
	Cold water flow rate	m ³ /h	10.2	10.2	10.2	10.2	10.2	10.2	10.0	9.7	9.4	9.0	8.5	8.0	7.7
	Water pressure loss	kPa	56	56	56	56	57	57	54	51	47	43	38	33	30
20	Cooling capacity	kW	72.0	72.0	72.0	72.0	73.4	73.4	72.0	70.4	68.0	65.1	62.2	58.9	56.8
	Power consumption	kW	9.6	9.6	9.5	9.5	8.1	8.1	8.5	8.6	9.1	9.9	10.8	11.8	12.5
	Cold water flow rate	m ³ /h	8.9	8.8	8.8	8.8	9.0	9.0	8.8	8.7	8.4	8.0	7.7	7.7	7.7
	Water pressure loss	kPa	41	41	41	41	43	43	41	39	36	33	30	30	30
25	Cooling capacity	kW	72.2	72.2	72.2	72.3	74.1	74.0	73.6	72.7	70.5	67.4	64.1	60.6	58.4
	Power consumption	kW	9.7	9.7	9.7	9.6	7.4	7.5	8.0	7.8	8.2	9.0	9.8	10.7	11.3
	Cold water flow rate	m ³ /h	8.9	8.9	8.9	8.9	9.1	9.1	9.0	8.9	8.7	8.3	7.9	7.7	7.7
	Water pressure loss	kPa	42	42	42	42	44	44	43	42	39	36	32	30	30

* The power consumption value is rounded off to the first decimal place.

* When conditions are met that only allow the unit to operate at a capacity below 63 kW and when the water flow rate cannot be reduced to a rate below the minimum required flow rate, the temperature difference between the cold water inlet and outlet will be less than 7°C.

Capacity change mode: COP priority

MODEL			EAHV-P900YA × 2, EACV-P900YA × 2												
Cold water outlet temperature	Outdoor air temperature °CDB		-15	-10	-5	0	5	10	15	20	25	30	35	40	43
			5	Cooling capacity	kW	-	-	154.5	154.2	151.7	148.7	145.4	140.6	134.4	127.9
Power consumption	kW	-		-	16.8	18.7	20.5	18.2	20.7	24.2	26.7	29.2	31.9	34.8	36.6
Cold water flow rate	m ³ /h	-		-	19.0	18.9	18.6	18.3	17.9	17.3	16.5	15.7	15.4	15.4	15.4
Water pressure loss	kPa	-		-	49	48	47	45	42	39	35	31	30	30	30
7	Cooling capacity	kW	-	162.0	161.9	162.1	160.5	158.2	154.4	148.5	142.9	136.1	129.0	121.2	116.4
	Power consumption	kW	-	21.6	21.5	21.4	21.8	19.5	21.7	24.7	27.1	29.6	32.3	35.2	37.0
	Cold water flow rate	m ³ /h	-	19.9	19.9	19.9	19.7	19.4	19.0	18.2	17.6	16.7	15.8	15.4	15.4
	Water pressure loss	kPa	-	54	54	54	53	51	48	44	41	36	32	30	30
10	Cooling capacity	kW	-	167.2	167.1	167.0	166.7	165.4	161.3	155.2	149.2	142.4	135.2	127.3	122.2
	Power consumption	kW	-	22.4	22.4	22.3	22.4	20.7	21.8	23.9	26.0	28.3	30.8	33.5	35.3
	Cold water flow rate	m ³ /h	-	20.5	20.5	20.5	20.5	20.3	19.8	19.1	18.3	17.5	16.6	15.6	15.4
	Water pressure loss	kPa	-	58	58	57	57	56	53	49	45	40	36	31	30
15	Cooling capacity	kW	165.5	165.4	165.4	165.3	166.5	166.4	162.4	158.2	152.7	145.8	138.7	130.8	125.7
	Power consumption	kW	22.1	22.1	22.0	22.0	20.9	20.4	20.8	21.3	22.7	24.7	26.8	29.3	30.9
	Cold water flow rate	m ³ /h	20.3	20.3	20.3	20.3	20.5	20.4	19.9	19.4	18.8	17.9	17.0	16.1	15.4
	Water pressure loss	kPa	56	56	56	56	57	57	54	51	47	43	38	33	30
20	Cooling capacity	kW	144.1	144.0	144.0	143.9	146.7	146.7	144.1	140.8	136.1	130.2	124.3	117.7	113.5
	Power consumption	kW	19.2	19.1	19.1	19.0	16.3	16.3	17.0	17.1	18.2	19.9	21.7	23.7	25.0
	Cold water flow rate	m ³ /h	17.7	17.7	17.7	17.7	18.0	18.0	17.7	17.3	16.7	16.0	15.4	15.4	15.4
	Water pressure loss	kPa	41	41	41	41	43	43	41	39	36	33	30	30	30
25	Cooling capacity	kW	144.4	144.4	144.4	144.6	148.2	148.0	147.1	145.4	141.0	134.9	128.2	121.2	116.8
	Power consumption	kW	19.4	19.3	19.3	19.3	14.8	15.0	15.9	15.6	16.4	17.9	19.6	21.5	22.7
	Cold water flow rate	m ³ /h	17.7	17.7	17.7	17.8	18.2	18.2	18.1	17.9	17.3	16.6	15.8	15.4	15.4
	Water pressure loss	kPa	42	42	42	42	44	44	43	42	39	36	32	30	30

* The power consumption value is rounded off to the first decimal place.

* When conditions are met that only allow the unit to operate at a capacity below 126 kW and when the water flow rate cannot be reduced to a rate below the minimum required flow rate, the temperature difference between the cold water inlet and outlet will be less than 7°C.

2. Product Data

Cooling capacity: Cold water outlet/inlet temperature difference 7°C

Capacity change mode: COP priority

MODEL		EAHV-P900YA × 3, EACV-P900YA × 3													
Cold water outlet temperature	Outdoor air temperature °CDB	-15	-10	-5	0	5	10	15	20	25	30	35	40	43	
		5	Cooling capacity	kW	-	-	231.8	231.3	227.6	223.1	218.1	211.0	201.6	191.8	181.5
Power consumption	kW		-	-	25.3	28.0	30.7	27.3	31.0	36.2	40.0	43.8	47.8	52.1	54.8
Cold water flow rate	m ³ /h		-	-	28.5	28.4	28.0	27.4	26.8	25.9	24.8	23.6	23.1	23.1	23.1
Water pressure loss	kPa		-	-	49	48	47	45	42	39	35	31	30	30	30
7	Cooling capacity	kW	-	243.0	242.8	243.1	240.7	237.3	231.6	222.7	214.3	204.2	193.5	181.8	174.5
	Power consumption	kW	-	32.3	32.2	32.1	32.7	29.3	32.5	37.0	40.6	44.4	48.4	52.7	55.5
	Cold water flow rate	m ³ /h	-	29.9	29.8	29.9	29.6	29.2	28.5	27.4	26.3	25.1	23.8	23.1	23.1
	Water pressure loss	kPa	-	54	54	54	53	51	48	44	41	36	32	30	30
10	Cooling capacity	kW	-	250.8	250.7	250.5	250.0	248.2	242.0	232.9	223.7	213.6	202.9	191.0	183.4
	Power consumption	kW	-	33.6	33.6	33.5	33.6	31.0	32.6	35.8	39.0	42.4	46.1	50.3	53.0
	Cold water flow rate	m ³ /h	-	30.8	30.8	30.8	30.7	30.5	29.7	28.6	27.5	26.2	24.9	23.5	23.1
	Water pressure loss	kPa	-	58	58	57	57	56	53	49	45	40	36	31	30
15	Cooling capacity	kW	248.2	248.1	248.0	247.9	249.8	249.7	243.6	237.3	229.0	218.7	208.0	196.2	188.6
	Power consumption	kW	33.2	33.1	33.1	33.0	31.3	30.6	31.1	32.0	34.1	37.0	40.3	43.9	46.3
	Cold water flow rate	m ³ /h	30.5	30.5	30.5	30.5	30.7	30.7	29.9	29.2	28.1	26.9	25.6	24.1	23.2
	Water pressure loss	kPa	56	56	56	56	57	57	54	51	47	43	38	33	30
20	Cooling capacity	kW	216.1	216.0	216.0	215.9	220.1	220.1	216.1	211.2	204.1	195.3	186.5	176.6	170.3
	Power consumption	kW	28.8	28.7	28.6	28.6	24.4	24.4	25.4	25.7	27.3	29.8	32.5	35.5	37.5
	Cold water flow rate	m ³ /h	26.6	26.5	26.5	26.5	27.0	27.0	26.5	26.0	25.1	24.0	23.1	23.1	23.1
	Water pressure loss	kPa	41	41	41	41	43	43	41	39	36	33	30	30	30
25	Cooling capacity	kW	216.6	216.6	216.5	216.9	222.2	222.0	220.7	218.1	211.4	202.3	192.3	181.8	175.2
	Power consumption	kW	29.1	29.0	29.0	28.9	22.1	22.5	23.9	23.4	24.7	26.9	29.4	32.2	34.0
	Cold water flow rate	m ³ /h	26.6	26.6	26.6	26.6	27.3	27.3	27.1	26.8	26.0	24.9	23.6	23.1	23.1
	Water pressure loss	kPa	42	42	42	42	44	44	43	42	39	36	32	30	30

* The power consumption value is rounded off to the first decimal place.

* When conditions are met that only allow the unit to operate at a capacity below 189 kW and when the water flow rate cannot be reduced to a rate below the minimum required flow rate, the temperature difference between the cold water inlet and outlet will be less than 7°C.

Capacity change mode: COP priority

MODEL		EAHV-P900YA × 4, EACV-P900YA × 4													
Cold water outlet temperature	Outdoor air temperature °CDB	-15	-10	-5	0	5	10	15	20	25	30	35	40	43	
		5	Cooling capacity	kW	-	-	309.0	308.4	303.4	297.4	290.8	281.3	268.8	255.7	242.0
Power consumption	kW		-	-	33.7	37.3	41.0	36.4	41.3	48.3	53.3	58.5	63.8	69.5	73.1
Cold water flow rate	m ³ /h		-	-	38.0	37.9	37.3	36.5	35.7	34.6	33.0	31.4	30.8	30.8	30.8
Water pressure loss	kPa		-	-	49	48	47	45	42	39	35	31	30	30	30
7	Cooling capacity	kW	-	324.0	323.8	324.2	320.9	316.4	308.8	296.9	285.8	272.3	257.9	242.4	232.7
	Power consumption	kW	-	43.1	43.0	42.8	43.6	39.1	43.3	49.3	54.2	59.2	64.5	70.3	74.0
	Cold water flow rate	m ³ /h	-	39.8	39.8	39.8	39.4	38.9	37.9	36.5	35.1	33.5	31.7	30.8	30.8
	Water pressure loss	kPa	-	54	54	54	53	51	48	44	41	36	32	30	30
10	Cooling capacity	kW	-	334.4	334.2	334.0	333.4	330.9	322.7	310.5	298.3	284.8	270.5	254.6	244.5
	Power consumption	kW	-	44.9	44.8	44.6	44.7	41.4	43.5	47.7	52.0	56.6	61.5	67.1	70.6
	Cold water flow rate	m ³ /h	-	41.1	41.1	41.0	41.0	40.7	39.6	38.1	36.7	35.0	33.2	31.3	30.8
	Water pressure loss	kPa	-	58	58	57	57	56	53	49	45	40	36	31	30
15	Cooling capacity	kW	331.0	330.8	330.7	330.5	333.1	332.9	324.8	316.4	305.3	291.6	277.3	261.6	251.4
	Power consumption	kW	44.3	44.2	44.1	44.0	41.8	40.8	41.5	42.6	45.4	49.4	53.7	58.6	61.8
	Cold water flow rate	m ³ /h	40.7	40.6	40.6	40.6	40.9	40.9	39.9	38.9	37.5	35.8	34.1	32.1	30.9
	Water pressure loss	kPa	56	56	56	56	57	57	54	51	47	43	38	33	30
20	Cooling capacity	kW	288.2	288.1	288.0	287.9	293.5	293.5	288.1	281.7	272.2	260.4	248.7	235.4	227.0
	Power consumption	kW	38.3	38.2	38.2	38.1	32.5	32.5	33.9	34.3	36.4	39.7	43.3	47.4	50.1
	Cold water flow rate	m ³ /h	35.4	35.4	35.4	35.4	36.1	36.1	35.4	34.6	33.4	32.0	30.8	30.8	30.8
	Water pressure loss	kPa	41	41	41	41	43	43	41	39	36	33	30	30	30
25	Cooling capacity	kW	288.9	288.8	288.7	289.1	296.3	295.9	294.2	290.8	281.9	269.7	256.4	242.4	233.7
	Power consumption	kW	38.8	38.7	38.6	38.5	29.5	30.0	31.9	31.1	32.9	35.9	39.2	42.9	45.3
	Cold water flow rate	m ³ /h	35.5	35.5	35.5	35.5	36.4	36.4	36.1	35.7	34.6	33.1	31.5	30.8	30.8
	Water pressure loss	kPa	42	42	42	42	44	44	43	42	39	36	32	30	30

* The power consumption value is rounded off to the first decimal place.

* When conditions are met that only allow the unit to operate at a capacity below 252 kW and when the water flow rate cannot be reduced to a rate below the minimum required flow rate, the temperature difference between the cold water inlet and outlet will be less than 7°C.

2. Product Data

Cooling capacity: Cold water outlet/inlet temperature difference 7°C

Capacity change mode: COP priority

MODEL			EAHV-P900YA × 5, EACV-P900YA × 5												
Cold water outlet temperature	Outdoor air temperature °CDB		-15	-10	-5	0	5	10	15	20	25	30	35	40	43
			5	Cooling capacity	kW	-	-	386.3	385.4	379.3	371.8	363.5	351.6	335.9	319.6
Power consumption	kW	-		-	42.1	46.6	51.2	45.5	51.7	60.4	66.6	73.1	79.7	86.9	91.4
Cold water flow rate	m ³ /h	-		-	47.5	47.4	46.6	45.7	44.7	43.2	41.3	39.3	38.5	38.5	38.5
Water pressure loss	kPa	-		-	49	48	47	45	42	39	35	31	30	30	30
7	Cooling capacity	kW	-	405.0	404.7	405.2	401.2	395.5	386.0	371.2	357.2	340.3	322.4	303.0	290.9
	Power consumption	kW	-	53.9	53.7	53.6	54.4	48.8	54.2	61.7	67.7	74.0	80.7	87.9	92.5
	Cold water flow rate	m ³ /h	-	49.8	49.7	49.8	49.3	48.6	47.4	45.6	43.9	41.8	39.6	38.5	38.5
	Water pressure loss	kPa	-	54	54	54	53	51	48	44	41	36	32	30	30
10	Cooling capacity	kW	-	418.0	417.8	417.5	416.7	413.6	403.4	388.1	372.9	355.9	338.1	318.3	305.6
	Power consumption	kW	-	56.1	55.9	55.8	55.9	51.7	54.4	59.7	64.9	70.7	76.9	83.8	88.3
	Cold water flow rate	m ³ /h	-	51.4	51.3	51.3	51.2	50.8	49.6	47.7	45.8	43.7	41.5	39.1	38.5
	Water pressure loss	kPa	-	58	58	57	57	56	53	49	45	40	36	31	30
15	Cooling capacity	kW	413.7	413.6	413.4	413.2	416.3	416.1	405.9	395.5	381.7	364.5	346.7	326.9	314.3
	Power consumption	kW	55.4	55.2	55.1	55.0	52.2	51.0	51.9	53.3	56.8	61.7	67.1	73.2	77.2
	Cold water flow rate	m ³ /h	50.8	50.8	50.8	50.8	51.2	51.1	49.9	48.6	46.9	44.8	42.6	40.2	38.6
	Water pressure loss	kPa	56	56	56	56	57	57	54	51	47	43	38	33	30
20	Cooling capacity	kW	360.2	360.1	360.0	359.8	366.8	366.8	360.2	352.1	340.2	325.6	310.8	294.3	283.8
	Power consumption	kW	47.9	47.8	47.7	47.6	40.6	40.7	42.4	42.8	45.6	49.7	54.1	59.2	62.6
	Cold water flow rate	m ³ /h	44.3	44.2	44.2	44.2	45.1	45.1	44.2	43.3	41.8	40.0	38.5	38.5	38.5
	Water pressure loss	kPa	41	41	41	41	43	43	41	39	36	33	30	30	30
25	Cooling capacity	kW	361.1	361.0	360.9	361.4	370.4	369.9	367.8	363.5	352.4	337.1	320.6	303.0	292.1
	Power consumption	kW	48.5	48.4	48.3	48.2	36.9	37.5	39.9	38.9	41.1	44.8	49.0	53.6	56.7
	Cold water flow rate	m ³ /h	44.4	44.3	44.3	44.4	45.5	45.4	45.2	44.7	43.3	41.4	39.4	38.5	38.5
	Water pressure loss	kPa	42	42	42	42	44	44	43	42	39	36	32	30	30

* The power consumption value is rounded off to the first decimal place.

* When conditions are met that only allow the unit to operate at a capacity below 315 kW and when the water flow rate cannot be reduced to a rate below the minimum required flow rate, the temperature difference between the cold water inlet and outlet will be less than 7°C.

Capacity change mode: COP priority

MODEL			EAHV-P900YA × 6, EACV-P900YA × 6												
Cold water outlet temperature	Outdoor air temperature °CDB		-15	-10	-5	0	5	10	15	20	25	30	35	40	43
			5	Cooling capacity	kW	-	-	463.5	462.5	455.1	446.1	436.2	421.9	403.1	383.6
Power consumption	kW	-		-	50.5	56.0	61.5	54.6	62.0	72.5	80.0	87.7	95.7	104.3	109.7
Cold water flow rate	m ³ /h	-		-	56.9	56.8	55.9	54.8	53.6	51.8	49.5	47.1	46.2	46.2	46.2
Water pressure loss	kPa	-		-	49	48	47	45	42	39	35	31	30	30	30
7	Cooling capacity	kW	-	486.0	485.6	486.3	481.4	474.6	463.2	445.4	428.7	408.4	386.9	363.6	349.1
	Power consumption	kW	-	64.7	64.5	64.3	65.3	58.6	65.0	74.0	81.3	88.8	96.8	105.5	111.0
	Cold water flow rate	m ³ /h	-	59.7	59.7	59.7	59.1	58.3	56.9	54.7	52.7	50.2	47.5	46.2	46.2
	Water pressure loss	kPa	-	54	54	54	53	51	48	44	41	36	32	30	30
10	Cooling capacity	kW	-	501.6	501.3	501.0	500.0	496.3	484.0	465.7	447.5	427.1	405.7	381.9	366.7
	Power consumption	kW	-	67.3	67.1	67.0	67.1	62.1	65.3	71.6	77.9	84.9	92.3	100.6	106.0
	Cold water flow rate	m ³ /h	-	61.6	61.6	61.6	61.4	61.0	59.5	57.2	55.0	52.5	49.8	46.9	46.2
	Water pressure loss	kPa	-	58	58	57	57	56	53	49	45	40	36	31	30
15	Cooling capacity	kW	496.5	496.3	496.1	495.8	499.6	499.3	487.1	474.6	458.0	437.4	416.0	392.3	377.1
	Power consumption	kW	66.4	66.3	66.1	66.0	62.7	61.2	62.3	63.9	68.2	74.0	80.5	87.9	92.7
	Cold water flow rate	m ³ /h	61.0	61.0	60.9	60.9	61.4	61.3	59.8	58.3	56.3	53.7	51.1	48.2	46.3
	Water pressure loss	kPa	56	56	56	56	57	57	54	51	47	43	38	33	30
20	Cooling capacity	kW	432.2	432.1	432.0	431.8	440.2	440.2	432.2	422.5	408.3	390.7	373.0	353.1	340.5
	Power consumption	kW	57.5	57.4	57.2	57.1	48.8	48.8	50.9	51.4	54.7	59.6	65.0	71.1	75.1
	Cold water flow rate	m ³ /h	53.1	53.1	53.1	53.0	54.1	54.1	53.1	51.9	50.2	48.0	46.2	46.2	46.2
	Water pressure loss	kPa	41	41	41	41	43	43	41	39	36	33	30	30	30
25	Cooling capacity	kW	433.3	433.2	433.1	433.7	444.5	443.9	441.4	436.3	422.9	404.6	384.7	363.5	350.5
	Power consumption	kW	58.2	58.0	57.9	57.8	44.3	45.0	47.8	46.7	49.3	53.8	58.8	64.4	68.0
	Cold water flow rate	m ³ /h	53.2	53.2	53.2	53.3	54.6	54.5	54.2	53.6	52.0	49.7	47.3	46.2	46.2
	Water pressure loss	kPa	42	42	42	42	44	44	43	42	39	36	32	30	30

* The power consumption value is rounded off to the first decimal place.

* When conditions are met that only allow the unit to operate at a capacity below 378 kW and when the water flow rate cannot be reduced to a rate below the minimum required flow rate, the temperature difference between the cold water inlet and outlet will be less than 7°C.

2. Product Data

Cooling capacity: Cold brine outlet/inlet temperature difference 7°C
 [Brine ethylene glycol 35wt%]

Capacity change mode: Capacity priority

MODEL			EACV-P900YA												
Cold brine outlet temperature	Outdoor air temperature °CDB		-15	-10	-5	0	5	10	15	20	25	30	35	40	43
-10	Cooling capacity	kW	66.9	66.9	66.9	65.3	63.8	62.1	60.2	57.9	54.8	51.5	48.0	44.5	39.7
	Power consumption	kW	14.7	15.0	15.3	15.9	16.2	16.5	17.0	18.8	21.0	23.1	25.1	27.2	28.1
	Cold brine flow rate	m ³ /h	9.7	9.7	9.7	9.5	9.3	9.0	8.8	8.4	8.0	7.7	7.7	7.7	7.7
	brine pressure loss	kPa	75	75	75	71	68	64	60	56	50	46	46	46	46
-5	Cooling capacity	kW	80.3	80.3	80.3	78.0	76.1	74.2	72.1	69.0	65.4	61.8	58.2	54.4	48.9
	Power consumption	kW	14.6	14.9	15.2	15.9	16.1	16.5	17.2	19.7	21.8	24.0	26.2	28.4	29.2
	Cold brine flow rate	m ³ /h	11.6	11.6	11.6	11.3	11.0	10.8	10.4	10.0	9.5	9.0	8.4	7.9	7.7
	brine pressure loss	kPa	108	108	109	102	97	92	87	79	71	63	56	48	46
0	Cooling capacity	kW	95.8	95.9	95.9	92.3	90.1	88.1	85.4	81.6	77.6	73.6	69.5	65.1	59.0
	Power consumption	kW	14.6	14.9	15.2	16.0	16.2	16.7	18.5	20.8	22.9	25.0	27.2	29.5	30.2
	Cold brine flow rate	m ³ /h	13.8	13.8	13.8	13.3	13.0	12.7	12.3	11.8	11.2	10.6	10.0	9.4	8.5
	brine pressure loss	kPa	155	155	155	143	137	130	122	111	100	90	80	70	57
5	Cooling capacity	kW	105.8	106.5	106.0	106.1	103.9	101.0	100.0	95.7	91.3	86.7	82.0	77.1	70.0
	Power consumption	kW	16.1	16.6	16.5	16.8	17.0	17.6	20.0	22.0	24.0	26.1	28.3	30.7	31.3
	Cold brine flow rate	m ³ /h	15.2	15.3	15.2	15.3	14.9	14.5	14.4	13.8	13.1	12.5	11.8	11.1	10.1
	brine pressure loss	kPa	189	191	190	190	182	172	168	153	139	125	111	98	80
7	Cooling capacity	kW	106.2	106.9	107.4	108.0	106.0	102.9	104.2	101.7	97.1	92.3	87.3	82.1	74.6
	Power consumption	kW	16.0	16.5	16.8	17.1	17.3	17.8	20.4	22.5	24.4	26.5	28.8	31.2	31.8
	Cold brine flow rate	m ³ /h	15.2	15.4	15.4	15.5	15.2	14.8	15.0	14.6	13.9	13.3	12.5	11.8	10.7
	brine pressure loss	kPa	190	192	194	196	189	178	182	174	158	142	126	111	91
10	Cooling capacity	kW	108.1	108.7	109.1	109.4	105.5	102.4	105.1	105.8	102.3	97.3	92.1	86.6	78.5
	Power consumption	kW	16.9	17.2	17.4	17.5	16.5	16.9	19.4	21.6	23.5	25.5	27.7	30.0	30.6
	Cold brine flow rate	m ³ /h	15.5	15.6	15.6	15.7	15.1	14.7	15.1	15.2	14.7	14.0	13.2	12.4	11.3
	brine pressure loss	kPa	196	198	200	201	187	175	185	188	175	158	141	124	101
15	Cooling capacity	kW	114.0	114.4	114.7	114.8	102.2	99.5	100.9	104.8	104.2	101.2	95.8	90.1	81.9
	Power consumption	kW	18.1	18.3	18.3	18.4	14.6	14.9	16.6	18.7	20.5	22.4	24.4	26.5	27.5
	Cold brine flow rate	m ³ /h	16.3	16.4	16.4	16.4	14.6	14.2	14.4	15.0	14.9	14.5	13.7	12.9	11.7
	brine pressure loss	kPa	218	220	221	221	174	165	169	183	181	170	152	134	110
20	Cooling capacity	kW	107.1	107.0	107.0	107.0	96.0	95.5	95.1	99.4	99.0	94.8	90.1	85.3	76.9
	Power consumption	kW	16.4	16.4	16.5	16.6	12.7	12.9	14.1	15.8	17.4	18.9	20.6	22.4	23.4
	Cold brine flow rate	m ³ /h	15.3	15.3	15.3	15.3	13.7	13.6	13.6	14.2	14.1	13.5	12.9	12.2	11.0
	brine pressure loss	kPa	191	191	191	190	152	151	149	164	162	148	134	119	96
25	Cooling capacity	kW	105.0	104.9	104.9	104.9	90.3	90.6	89.1	94.0	97.3	95.9	91.4	86.3	78.3
	Power consumption	kW	16.6	16.6	16.7	16.8	11.2	11.3	12.0	13.6	15.1	16.6	18.1	19.7	20.9
	Cold brine flow rate	m ³ /h	15.0	15.0	15.0	15.0	12.9	12.9	12.7	13.4	13.9	13.7	13.0	12.3	11.2
	brine pressure loss	kPa	183	183	183	182	134	135	130	145	156	152	137	122	100

* The power consumption value is rounded off to the first decimal place.

Capacity change mode: Capacity priority

MODEL			EACV-P900YA × 2												
Cold brine outlet temperature	Outdoor air temperature °CDB		-15	-10	-5	0	5	10	15	20	25	30	35	40	43
-10	Cooling capacity	kW	133.7	133.8	133.8	130.6	127.6	124.2	120.4	115.7	109.6	103.0	96.1	88.9	79.4
	Power consumption	kW	29.4	30.0	30.6	31.7	32.3	33.0	34.0	37.5	41.9	46.1	50.2	54.4	52.2
	Cold brine flow rate	m ³ /h	19.5	19.5	19.5	19.0	18.6	18.1	17.5	16.9	16.0	15.4	15.4	15.4	15.4
	brine pressure loss	kPa	75	75	75	71	68	64	60	56	50	46	46	46	46
-5	Cooling capacity	kW	160.5	160.6	160.7	156.0	152.2	148.5	144.2	138.0	130.9	123.7	116.3	108.8	97.7
	Power consumption	kW	29.1	29.8	30.3	31.8	32.2	33.0	34.4	39.3	43.6	48.0	52.3	56.8	54.3
	Cold brine flow rate	m ³ /h	23.3	23.3	23.3	22.6	22.1	21.5	20.9	20.0	19.0	17.9	16.9	15.8	15.4
	brine pressure loss	kPa	108	108	109	102	97	92	87	79	71	63	56	48	46
0	Cooling capacity	kW	191.6	191.7	191.9	184.6	180.3	176.1	170.7	163.2	155.2	147.2	138.9	130.3	118.1
	Power consumption	kW	29.1	29.8	30.3	31.9	32.4	33.4	36.9	41.5	45.7	50.0	54.4	59.0	56.4
	Cold brine flow rate	m ³ /h	27.7	27.7	27.7	26.6	26.0	25.4	24.6	23.5	22.4	21.2	20.0	18.8	17.0
	brine pressure loss	kPa	155	155	155	143	137	130	122	111	100	90	80	70	57
5	Cooling capacity	kW	211.5	213.0	212.0	212.2	207.8	202.1	200.1	191.4	182.6	173.5	164.0	154.1	140.0
	Power consumption	kW	32.1	33.1	32.9	33.5	33.9	35.1	40.0	43.9	48.0	52.1	56.6	61.4	58.6
	Cold brine flow rate	m ³ /h	30.4	30.6	30.5	30.5	29.9	29.1	28.8	27.5	26.3	24.9	23.6	22.2	20.1
	brine pressure loss	kPa	189	191	190	190	182	172	168	153	139	125	111	98	80
7	Cooling capacity	kW	212.3	213.8	214.9	215.9	212.1	205.7	208.4	203.4	194.2	184.6	174.6	164.1	149.2
	Power consumption	kW	32.0	33.0	33.6	34.1	34.6	35.6	40.7	44.9	48.8	53.0	57.5	62.4	59.5
	Cold brine flow rate	m ³ /h	30.5	30.7	30.9	31.0	30.5	29.5	29.9	29.2	27.9	26.5	25.1	23.6	21.4
	brine pressure loss	kPa	190	192	194	196	189	178	182	174	158	142	126	111	91
10	Cooling capacity	kW	216.2	217.4	218.2	218.9	211.0	204.8	210.3	211.5	204.6	194.7	184.2	173.2	157.0
	Power consumption	kW	33.7	34.3	34.7	35.0	32.9	33.8	38.7	43.1	47.0	50.9	55.3	60.0	57.1
	Cold brine flow rate	m ³ /h	31.0	31.2	31.3	31.4	30.2	29.4	30.1	30.3	29.3	27.9	26.4	24.8	22.5
	brine pressure loss	kPa	196	198	200	201	187	175	185	188	175	158	141	124	101
15	Cooling capacity	kW	228.1	228.9	229.5	229.7	204.4	199.1	201.8	209.5	208.3	202.3	191.5	180.2	163.8
	Power consumption	kW	36.2	36.5	36.6	36.7	29.1	29.7	33.2	37.3	41.0	44.8	48.7	52.9	51.0
	Cold brine flow rate	m ³ /h	32.6	32.7	32.8	32.9	29.2	28.5	28.9	30.0	29.8	28.9	27.4	25.8	23.4
	brine pressure loss	kPa	218	220	221	221	174	165	169	183	181	170	152	134	110
20	Cooling capacity	kW	214.2	214.1	214.0	213.9	192.0	191.0	190.1	198.9	197.9	189.6	180.3	170.6	153.7
	Power consumption	kW	32.7	32.8	33.0	33.1	25.3	25.8	28.1	31.6	34.7	37.7	41.1	44.8	42.8
	Cold brine flow rate	m ³ /h	30.6	30.6	30.6	30.6	27.4	27.3	27.2	28.4	28.3	27.1	25.8	24.4	22.0
	brine pressure loss	kPa	191	191	191	190	152	151	149	164	162	148	134	119	96
25	Cooling capacity	kW	209.9	209.8	209.8	209.7	180.7	181.2	178.2	187.9	194.7	191.8	182.9	172.7	156.5
	Power consumption	kW	33.1	33.2	33.3	33.5	22.3	22.6	24.0	27.1	30.1	33.1	36.1	39.3	37.8
	Cold brine flow rate	m ³ /h	30.0	29.9	29.9	29.9	25.8	25.9	25.4	26.8	27.8	27.4	26.1	24.6	22.3
	brine pressure loss	kPa	183	183	183	182	134	135	130	145	156	152	137	122	100

* The power consumption value is rounded off to the first decimal place.

2. Product Data

Cooling capacity: Cold brine outlet/inlet temperature difference 7°C
 [Brine ethylene glycol 35wt%]

Capacity change mode: Capacity priority

Cold brine outlet temperature	MODEL		EACV-P900YA × 3												
	Outdoor air temperature °CDB		-15	-10	-5	0	5	10	15	20	25	30	35	40	43
-10	Cooling capacity	kW	200.6	200.7	200.8	195.9	191.4	186.3	180.6	173.6	164.4	154.5	144.1	133.4	119.1
	Power consumption	kW	44.0	90.0	91.6	95.0	96.9	99.0	101.9	112.4	125.5	138.2	150.6	163.2	156.5
	Cold brine flow rate	m ³ /h	29.2	29.2	29.2	28.5	27.9	27.1	26.3	25.3	23.9	23.1	23.1	23.1	23.1
	brine pressure loss	kPa	75	75	75	71	68	64	60	56	50	46	46	46	46
-5	Cooling capacity	kW	240.8	240.9	241.0	234.1	228.4	222.7	216.3	207.0	196.3	185.5	174.5	163.2	146.6
	Power consumption	kW	43.7	89.2	90.8	95.2	96.6	98.9	103.0	117.8	130.8	143.8	156.9	170.2	162.9
	Cold brine flow rate	m ³ /h	34.9	34.9	34.9	33.9	33.1	32.3	31.3	30.0	28.4	26.9	25.3	23.7	23.1
	brine pressure loss	kPa	108	108	109	102	97	92	87	79	71	63	56	48	46
0	Cooling capacity	kW	287.5	287.6	287.8	277.0	270.4	264.2	256.1	244.8	232.9	220.8	208.4	195.4	177.1
	Power consumption	kW	43.6	89.2	90.8	95.5	97.1	100.1	110.5	124.3	137.1	150.0	163.2	177.0	169.2
	Cold brine flow rate	m ³ /h	41.5	41.5	41.5	40.0	39.0	38.1	36.9	35.3	33.6	31.9	30.1	28.2	25.6
	brine pressure loss	kPa	155	155	155	143	137	130	122	111	100	90	80	70	57
5	Cooling capacity	kW	317.3	319.6	318.0	318.2	311.8	303.1	300.1	287.1	273.8	260.2	246.0	231.2	210.0
	Power consumption	kW	48.1	99.1	98.6	100.5	101.7	105.3	119.8	131.7	143.8	156.3	169.8	184.0	175.7
	Cold brine flow rate	m ³ /h	45.6	45.9	45.7	45.8	44.8	43.6	43.1	41.3	39.4	37.4	35.4	33.2	30.2
	brine pressure loss	kPa	189	191	190	190	182	172	168	153	139	125	111	98	80
7	Cooling capacity	kW	318.5	320.7	322.3	323.9	318.1	308.6	312.6	305.1	291.2	276.9	261.9	246.2	223.8
	Power consumption	kW	47.9	98.8	100.6	102.2	103.6	106.6	122.0	134.6	146.4	159.0	172.5	187.0	178.4
	Cold brine flow rate	m ³ /h	45.7	46.1	46.3	46.5	45.7	44.3	44.9	43.8	41.8	39.8	37.6	35.4	32.1
	brine pressure loss	kPa	190	192	194	196	189	178	182	174	158	142	126	111	91
10	Cooling capacity	kW	324.4	326.1	327.3	328.3	316.5	307.1	315.4	317.3	306.9	292.0	276.3	259.8	235.5
	Power consumption	kW	50.6	102.9	104.0	105.0	98.5	101.4	115.9	129.1	140.8	152.7	165.7	179.8	171.3
	Cold brine flow rate	m ³ /h	46.5	46.7	46.9	47.1	45.4	44.0	45.2	45.5	44.0	41.9	39.6	37.2	33.8
	brine pressure loss	kPa	196	198	200	201	187	175	185	188	175	158	141	124	101
15	Cooling capacity	kW	342.1	343.3	344.2	344.5	306.6	298.6	302.8	314.3	312.5	303.5	287.3	270.3	245.7
	Power consumption	kW	54.3	109.3	109.8	110.1	87.2	89.1	99.4	111.8	123.0	134.3	145.9	158.6	153.0
	Cold brine flow rate	m ³ /h	48.9	49.1	49.2	49.3	43.9	42.7	43.3	45.0	44.7	43.4	41.1	38.7	35.1
	brine pressure loss	kPa	218	220	221	221	174	165	169	183	181	170	152	134	110
20	Cooling capacity	kW	321.3	321.1	321.0	320.9	288.1	286.5	285.2	298.3	296.9	284.4	270.4	255.8	230.6
	Power consumption	kW	49.0	98.4	98.8	99.1	75.8	77.4	84.3	94.6	104.1	113.1	123.1	134.2	128.2
	Cold brine flow rate	m ³ /h	45.9	45.9	45.8	45.8	41.1	40.9	40.7	42.6	42.4	40.6	38.6	36.5	32.9
	brine pressure loss	kPa	191	191	191	190	152	151	149	164	162	148	134	119	96
25	Cooling capacity	kW	314.9	314.8	314.7	314.6	271.0	271.8	267.3	281.9	292.0	287.7	274.3	259.0	234.8
	Power consumption	kW	49.6	99.6	99.9	100.3	66.7	67.8	71.8	81.1	90.3	99.2	108.2	117.9	113.4
	Cold brine flow rate	m ³ /h	44.9	44.9	44.9	44.9	38.7	38.8	38.1	40.2	41.7	41.1	39.1	37.0	33.5
	brine pressure loss	kPa	183	183	183	182	134	135	130	145	156	152	137	122	100

* The power consumption value is rounded off to the first decimal place.

Capacity change mode: Capacity priority

Cold brine outlet temperature	MODEL		EACV-P900YA × 4												
	Outdoor air temperature °CDB		-15	-10	-5	0	5	10	15	20	25	30	35	40	43
-10	Cooling capacity	kW	267.5	267.6	267.7	261.1	255.1	248.4	240.7	231.5	219.2	206.1	192.1	177.8	158.8
	Power consumption	kW	58.7	60.0	61.1	63.3	64.6	66.0	68.0	74.9	83.7	92.2	100.4	108.8	104.3
	Cold brine flow rate	m ³ /h	38.9	39.0	39.0	38.0	37.1	36.2	35.0	33.7	31.9	30.8	30.8	30.8	30.8
	brine pressure loss	kPa	75	75	75	71	68	64	60	56	50	46	46	46	46
-5	Cooling capacity	kW	321.0	321.2	321.3	312.1	304.5	296.9	288.3	275.9	261.8	247.4	232.6	217.7	195.5
	Power consumption	kW	58.2	59.5	60.6	63.5	64.4	66.0	68.7	78.5	87.2	95.9	104.6	113.5	108.6
	Cold brine flow rate	m ³ /h	46.5	46.5	46.6	45.2	44.1	43.0	41.8	40.0	37.9	35.8	33.7	31.5	30.8
	brine pressure loss	kPa	108	108	109	102	97	92	87	79	71	63	56	48	46
0	Cooling capacity	kW	383.3	383.5	383.7	369.3	360.5	352.2	341.4	326.3	310.5	294.4	277.9	260.6	236.2
	Power consumption	kW	58.2	59.5	60.6	63.7	64.8	66.7	73.7	82.9	91.4	100.0	108.8	118.0	112.8
	Cold brine flow rate	m ³ /h	55.3	55.3	55.4	53.3	52.0	50.8	49.3	47.1	44.8	42.5	40.1	37.6	34.1
	brine pressure loss	kPa	155	155	155	143	137	130	122	111	100	90	80	70	57
5	Cooling capacity	kW	423.0	426.1	424.0	424.3	415.7	404.2	400.1	382.9	365.1	347.0	328.1	308.3	280.0
	Power consumption	kW	64.1	66.1	65.8	67.0	67.8	70.2	79.9	87.8	95.9	104.2	113.2	122.7	117.1
	Cold brine flow rate	m ³ /h	60.8	61.3	61.0	61.0	59.8	58.1	57.5	55.0	52.5	49.9	47.2	44.3	40.3
	brine pressure loss	kPa	189	191	190	190	182	172	168	153	139	125	111	98	80
7	Cooling capacity	kW	424.6	427.6	429.7	431.8	424.2	411.5	416.7	406.8	388.3	369.3	349.1	328.3	298.4
	Power consumption	kW	63.9	65.9	67.1	68.1	69.1	71.1	81.3	89.7	97.6	106.0	115.0	124.7	119.0
	Cold brine flow rate	m ³ /h	61.0	61.4	61.7	62.0	60.9	59.1	59.8	58.4	55.8	53.0	50.1	47.1	42.9
	brine pressure loss	kPa	190	192	194	196	189	178	182	174	158	142	126	111	91
10	Cooling capacity	kW	432.5	434.8	436.4	437.8	422.0	409.5	420.6	423.1	409.2	389.3	368.4	346.4	314.1
	Power consumption	kW	67.4	68.6	69.4	70.0	65.7	67.6	77.3	86.1	93.9	101.8	110.5	119.9	114.2
	Cold brine flow rate	m ³ /h	62.0	62.3	62.6	62.8	60.5	58.7	60.3	60.7	58.7	55.8	52.8	49.7	45.0
	brine pressure loss	kPa	196	198	200	201	187	175	185	188	175	158	141	124	101
15	Cooling capacity	kW	456.1	457.8	458.9	459.4	408.8	398.2	403.7	419.0	416.6	404.6	383.1	360.4	327.5
	Power consumption	kW	72.4	72.9	73.2	73.4	58.1	59.4	66.3	74.5	82.0	89.6	97.3	105.7	102.0
	Cold brine flow rate	m ³ /h	65.3	65.5	65.6	65.7	58.5	57.0	57.7	59.9	59.7	57.9	54.8	51.6	46.9
	brine pressure loss	kPa	218	220	221	221	174	165	169	183	181	170	152	134	110
20	Cooling capacity	kW	428.3	428.2	428.0	427.8	384.1	381.9	380.2	397.7	395.9	379.2	360.6	341.1	307.5
	Power consumption	kW	65.4	65.6	65.9	66.1	50.6	51.6	56.2	63.1	69.4	75.4	82.1	89.5	85.5
	Cold brine flow rate	m ³ /h	61.2	61.2	61.1	61.1	54.9	54.5	54.3	56.8	56.5	54.2	51.5	48.7	43.9
	brine pressure loss	kPa	191	191	191	190	152	151	149	164	162	148	134	119	96
25	Cooling capacity	kW	419.8	419.7	419.6	419.4	361.3	362.4	356.4	375.8	389.4	383.7	365.7	345.4	313.0
	Power consumption	kW	66.2	66.4	66.6	66.9	44.5	45.2	47.9	54.1	60.2	66.2	72.1	78.6	75.6
	Cold brine flow rate	m ³ /h	59.9	59.9	59.9	59.9	51.6	51.7	50.9	53.6	55.6	54.7	52.2	49.3	44.7
	brine pressure loss	kPa	183	183	183	182	134	135	130	145	156	152	137	122	100

* The power consumption value is rounded off to the first decimal place.

EAHV-P-YAF(-H)(-N), YAL(-H)(-N)/EACV-P-YAF(-N), YAL(-N)

2. Product Data

Cooling capacity: Cold brine outlet/inlet temperature difference 7°C
[Brine ethylene glycol 35wt%]

Capacity change mode: Capacity priority

MODEL		EACV-P900YA × 5													
Cold brine outlet temperature	Outdoor air temperature °CDB	-15	-10	-5	0	5	10	15	20	25	30	35	40	43	
		-10	Cooling capacity kW	334.4	334.5	334.6	326.4	318.9	310.5	300.9	289.3	274.1	257.6	240.1	222.3
	Power consumption kW	73.3	75.0	76.3	79.2	80.8	82.5	84.9	93.6	104.6	115.2	125.5	136.0	130.4	
	Cold brine flow rate m ³ /h	48.7	48.7	48.7	47.5	46.4	45.2	43.8	42.1	39.9	38.5	38.5	38.5	38.5	
	brine pressure loss kPa	75	75	75	71	68	64	60	56	50	46	46	46	46	
-5	Cooling capacity kW	401.3	401.5	401.7	390.1	380.6	371.1	360.4	344.9	327.2	309.2	290.8	272.1	244.3	
	Power consumption kW	72.7	74.4	75.7	79.3	80.5	82.5	85.9	98.2	109.0	119.8	130.7	141.8	135.7	
	Cold brine flow rate m ³ /h	58.1	58.2	58.2	56.5	55.1	53.8	52.2	50.0	47.4	44.8	42.1	39.4	38.5	
	brine pressure loss kPa	108	108	109	102	97	92	87	79	71	63	56	48	46	
0	Cooling capacity kW	479.1	479.3	479.6	461.6	450.7	440.3	426.8	407.9	388.1	368.1	347.3	325.7	295.2	
	Power consumption kW	72.7	74.4	75.7	79.6	80.9	83.4	92.1	103.6	114.3	125.0	136.0	147.5	141.0	
	Cold brine flow rate m ³ /h	69.1	69.2	69.2	66.6	65.0	63.5	61.6	58.9	56.0	53.1	50.1	47.0	42.6	
	brine pressure loss kPa	155	155	155	143	137	130	122	111	100	90	80	70	57	
5	Cooling capacity kW	528.8	532.6	530.0	530.4	519.6	505.2	500.2	478.6	456.4	433.7	410.1	385.3	350.0	
	Power consumption kW	80.1	82.6	82.2	83.7	84.7	87.8	99.9	109.7	119.9	130.3	141.5	153.3	146.4	
	Cold brine flow rate m ³ /h	76.0	76.6	76.2	76.3	74.7	72.6	71.9	68.8	65.6	62.4	59.0	55.4	50.3	
	brine pressure loss kPa	189	191	190	190	182	172	168	153	139	125	111	98	80	
7	Cooling capacity kW	530.8	534.6	537.1	539.8	530.2	514.4	520.9	508.5	485.4	461.6	436.4	410.3	373.0	
	Power consumption kW	79.9	82.3	83.8	85.1	86.3	88.9	101.7	112.2	122.0	132.5	143.7	155.9	148.7	
	Cold brine flow rate m ³ /h	76.2	76.8	77.1	77.5	76.1	73.9	74.8	73.0	69.7	66.3	62.7	58.9	53.6	
	brine pressure loss kPa	190	192	194	196	189	178	182	174	158	142	126	111	91	
10	Cooling capacity kW	540.6	543.5	545.4	547.2	527.5	511.9	525.7	528.9	511.5	486.6	460.5	433.0	392.6	
	Power consumption kW	84.2	85.8	86.7	87.5	82.1	84.5	96.6	107.6	117.3	127.2	138.1	149.8	142.8	
	Cold brine flow rate m ³ /h	77.5	77.9	78.2	78.5	75.6	73.4	75.4	75.8	73.3	69.8	66.0	62.1	56.3	
	brine pressure loss kPa	196	198	200	201	187	175	185	188	175	158	141	124	101	
15	Cooling capacity kW	570.2	572.2	573.6	574.2	510.9	497.7	504.6	523.8	520.8	505.8	478.8	450.5	409.4	
	Power consumption kW	90.5	91.1	91.5	91.8	72.7	74.3	82.8	93.2	102.5	111.9	121.6	132.2	127.5	
	Cold brine flow rate m ³ /h	81.6	81.9	82.1	82.1	73.1	71.2	72.2	74.9	74.6	72.4	68.5	64.4	58.6	
	brine pressure loss kPa	218	220	221	221	174	165	169	183	181	170	152	134	110	
20	Cooling capacity kW	535.4	535.2	535.0	534.8	480.1	477.4	475.3	497.2	494.9	474.0	450.7	426.4	384.3	
	Power consumption kW	81.7	82.0	82.3	82.6	63.2	64.5	70.2	78.9	86.8	94.3	102.6	111.8	106.9	
	Cold brine flow rate m ³ /h	76.5	76.4	76.4	76.4	68.6	68.2	67.9	71.0	70.7	67.7	64.4	60.9	54.9	
	brine pressure loss kPa	191	191	191	190	152	151	149	164	162	148	134	119	96	
25	Cooling capacity kW	524.8	524.6	524.4	524.3	451.6	453.0	445.4	469.8	486.7	479.6	457.2	431.7	391.3	
	Power consumption kW	82.7	83.0	83.3	83.6	55.6	56.5	59.9	67.6	75.3	82.7	90.2	98.2	94.5	
	Cold brine flow rate m ³ /h	74.9	74.9	74.8	74.8	64.5	64.6	63.6	67.0	69.5	68.4	65.2	61.6	55.8	
	brine pressure loss kPa	183	183	183	182	134	135	130	145	156	152	137	122	100	

* The power consumption value is rounded off to the first decimal place.

Capacity change mode: Capacity priority

MODEL		EACV-P900YA × 6													
Cold brine outlet temperature	Outdoor air temperature °CDB	-15	-10	-5	0	5	10	15	20	25	30	35	40	43	
		-10	Cooling capacity kW	401.2	401.4	401.5	391.7	382.7	372.6	361.1	347.2	328.9	309.1	288.2	266.8
	Power consumption kW	88.0	90.0	91.6	95.0	96.9	99.0	101.9	112.4	125.5	138.2	150.6	163.2	156.5	
	Cold brine flow rate m ³ /h	58.4	58.4	58.5	57.0	55.7	54.2	52.6	50.6	47.9	46.2	46.2	46.2	46.2	
	brine pressure loss kPa	75	75	75	71	68	64	60	56	50	46	46	46	46	
-5	Cooling capacity kW	481.6	481.8	482.0	468.1	456.7	445.4	432.5	413.9	392.7	371.1	349.0	326.5	293.2	
	Power consumption kW	87.3	89.2	90.8	95.2	96.6	98.9	103.0	117.8	130.8	143.8	156.9	170.2	162.9	
	Cold brine flow rate m ³ /h	69.8	69.8	69.8	67.8	66.2	64.5	62.7	60.0	56.9	53.8	50.6	47.3	46.2	
	brine pressure loss kPa	108	108	109	102	97	92	87	79	71	63	56	48	46	
0	Cooling capacity kW	574.9	575.2	575.6	553.9	540.8	528.4	512.2	489.5	465.7	441.7	416.8	390.9	354.3	
	Power consumption kW	87.2	89.2	90.8	95.5	97.1	100.1	110.5	124.3	137.1	150.0	163.2	177.0	169.2	
	Cold brine flow rate m ³ /h	83.0	83.0	83.0	79.9	78.0	76.2	73.9	70.6	67.2	63.7	60.1	56.4	51.1	
	brine pressure loss kPa	155	155	155	143	137	130	122	111	100	90	80	70	57	
5	Cooling capacity kW	634.5	639.1	636.0	636.5	623.5	606.2	600.2	574.3	547.7	520.4	492.1	462.4	420.0	
	Power consumption kW	96.1	99.1	98.6	100.5	101.7	105.3	119.8	131.7	143.8	156.3	169.8	184.0	175.7	
	Cold brine flow rate m ³ /h	91.2	91.9	91.4	91.5	89.6	87.2	86.3	82.6	78.8	74.8	70.8	66.5	60.4	
	brine pressure loss kPa	189	191	190	190	182	172	168	153	139	125	111	98	80	
7	Cooling capacity kW	636.9	641.5	644.6	647.7	636.3	617.2	625.1	610.2	582.5	553.9	523.7	492.4	447.6	
	Power consumption kW	95.8	98.8	100.6	102.2	103.6	106.6	122.0	134.6	146.4	159.0	172.5	187.0	178.4	
	Cold brine flow rate m ³ /h	91.5	92.1	92.6	93.0	91.4	88.6	89.8	87.6	83.6	79.5	75.2	70.7	64.3	
	brine pressure loss kPa	190	192	194	196	189	178	182	174	158	142	126	111	91	
10	Cooling capacity kW	648.7	652.2	654.5	656.7	633.0	614.3	630.8	634.6	613.8	584.0	552.6	519.6	471.1	
	Power consumption kW	101.1	102.9	104.0	105.0	98.5	101.4	115.9	129.1	140.8	152.7	165.7	179.8	171.3	
	Cold brine flow rate m ³ /h	93.0	93.5	93.8	94.1	90.7	88.1	90.4	91.0	88.0	83.7	79.2	74.5	67.5	
	brine pressure loss kPa	196	198	200	201	187	175	185	188	175	158	141	124	101	
15	Cooling capacity kW	684.2	686.7	688.4	689.1	613.1	597.3	605.5	628.6	624.9	607.0	574.6	540.6	491.3	
	Power consumption kW	108.6	109.3	109.8	110.1	87.2	89.1	99.4	111.8	123.0	134.3	145.9	158.6	153.0	
	Cold brine flow rate m ³ /h	97.9	98.2	98.5	98.6	87.7	85.4	86.6	89.9	89.5	86.8	82.2	77.3	70.3	
	brine pressure loss kPa	218	220	221	221	174	165	169	183	181	170	152	134	110	
20	Cooling capacity kW	642.5	642.3	642.0	641.8	576.1	572.9	570.3	596.6	593.8	568.8	540.9	511.7	461.2	
	Power consumption kW	98.0	98.4	98.8	99.1	75.8	77.4	84.3	94.6	104.1	113.1	123.1	134.2	128.2	
	Cold brine flow rate m ³ /h	91.8	91.7	91.7	91.7	82.3	81.8	81.5	85.2	84.8	81.2	77.3	73.1	65.9	
	brine pressure loss kPa	191	191	191	190	152	151	149	164	162	148	134	119	96	
25	Cooling capacity kW	629.7	629.5	629.3	629.1	542.0	543.6	534.5	563.7	584.1	575.5	548.6	518.1	469.6	
	Power consumption kW	99.2	99.6	99.9	100.3	66.7	67.8	71.8	81.1	90.3	99.2	108.2	117.9	113.4	
	Cold brine flow rate m ³ /h	89.9	89.8	89.8	89.8	77.3	77.6	76.3	80.4	83.3	82.1	78.3	73.9	67.0	
	brine pressure loss kPa	183	183	183	182	134	135	130	145	156	152	137	122	100	

* The power consumption value is rounded off to the first decimal place.

2. Product Data

Cooling capacity: Cold brine outlet/inlet temperature difference 7°C
 [Brine ethylene glycol 35wt%]

Capacity change mode: COP priority

MODEL		EACV-P900YA													
Cold brine outlet temperature	Outdoor air temperature °CDB	-15	-10	-5	0	5	10	15	20	25	30	35	40	43	
-10	Cooling capacity	kW	45.4	45.5	45.5	43.9	43.0	41.8	40.4	38.9	37.0	34.6	32.1	29.6	28.0
	Power consumption	kW	9.6	9.9	10.1	10.4	10.6	10.7	10.9	11.2	12.6	13.9	15.3	16.8	17.6
	Cold brine flow rate	m ³ /h	7.7	7.7	7.7	7.7	7.7	7.7	7.7	7.7	7.7	7.7	7.7	7.7	7.7
	brine pressure loss	kPa	46	46	46	46	46	46	46	46	46	46	46	46	46
-5	Cooling capacity	kW	55.4	55.4	55.4	52.7	51.7	50.5	49.1	47.5	45.0	42.2	39.4	36.6	34.9
	Power consumption	kW	9.5	9.7	9.8	10.2	10.4	10.6	10.8	11.4	13.0	14.4	15.8	17.3	18.1
	Cold brine flow rate	m ³ /h	8.0	8.0	8.0	7.7	7.7	7.7	7.7	7.7	7.7	7.7	7.7	7.7	7.7
	brine pressure loss	kPa	50	50	50	46	46	46	46	46	46	46	46	46	46
0	Cooling capacity	kW	66.2	66.2	66.2	62.4	61.3	60.1	58.7	57.0	54.3	51.2	48.1	45.0	42.9
	Power consumption	kW	9.7	9.9	10.0	10.2	10.4	10.6	11.0	12.0	13.5	14.9	16.3	18.1	18.9
	Cold brine flow rate	m ³ /h	9.6	9.6	9.6	9.0	8.8	8.7	8.5	8.2	7.8	7.7	7.7	7.7	7.7
	brine pressure loss	kPa	72	72	72	64	62	59	56	53	48	46	46	46	46
5	Cooling capacity	kW	73.6	73.6	73.6	73.5	72.4	70.9	69.3	67.0	63.9	60.8	57.5	54.1	52.2
	Power consumption	kW	10.1	10.2	10.4	10.6	10.7	10.9	11.4	12.8	14.1	15.4	16.8	18.3	20.2
	Cold brine flow rate	m ³ /h	10.6	10.6	11	10.6	10.4	10.2	10.0	9.6	9.2	8.7	8.3	7.8	7.7
	brine pressure loss	kPa	89	89	89	89	86	83	79	73	67	60	53	47	46
7	Cooling capacity	kW	77.7	77.7	77.7	77.7	77.2	75.6	73.8	71.2	68.0	64.7	61.3	57.6	55.3
	Power consumption	kW	10.7	10.8	11.0	11.2	10.8	11.1	11.6	13.0	14.3	15.6	17.0	18.5	19.5
	Cold brine flow rate	m ³ /h	11.2	11.2	11.2	11.2	11.1	10.9	10.6	10.2	9.8	9.3	8.8	8.3	7.9
	brine pressure loss	kPa	99	99	99	99	98	94	89	83	76	68	61	54	49
10	Cooling capacity	kW	79.8	79.8	79.7	79.7	80.2	79.0	77.2	74.4	71.1	67.8	64.3	60.5	58.1
	Power consumption	kW	11.5	11.6	11.7	11.7	10.6	10.7	11.2	12.5	13.7	14.9	16.2	17.7	18.6
	Cold brine flow rate	m ³ /h	11.4	11.4	11.4	11.4	11.5	11.3	11.1	10.7	10.2	9.7	9.2	8.7	8.3
	brine pressure loss	kPa	105	105	105	104	106	103	98	90	82	75	67	59	54
15	Cooling capacity	kW	81.7	78.7	78.7	78.6	79.5	79.5	78.8	76.2	72.9	69.5	66.0	62.3	59.8
	Power consumption	kW	11.9	11.4	11.5	11.5	9.3	9.5	10.0	11.0	12.0	13.0	14.1	15.4	16.3
	Cold brine flow rate	m ³ /h	11.7	11.3	11.3	11.2	11.4	11.4	11.3	10.9	10.4	9.9	9.4	8.9	8.6
	brine pressure loss	kPa	109	101	101	101	103	103	102	95	86	78	70	62	57
20	Cooling capacity	kW	69.4	68.8	68.8	68.8	70.0	70.0	69.3	67.6	65.2	62.3	59.4	56.2	54.2
	Power consumption	kW	10.1	10.0	10.0	10.0	8.4	8.5	8.6	8.8	9.7	10.5	11.4	12.5	13.2
	Cold brine flow rate	m ³ /h	11.0	9.9	9.8	9.8	10.0	10.0	10.0	9.8	9.7	9.3	8.8	8.3	8.0
	brine pressure loss	kPa	96	78	77	77	80	80	79	76	74	68	61	54	50
25	Cooling capacity	kW	70.4	69.7	69.0	69.0	70.2	70.2	70.1	68.8	67.9	64.9	61.7	58.3	56.2
	Power consumption	kW	10.2	10.1	10.4	10.4	8.5	8.5	8.6	8.6	8.7	9.5	10.3	11.3	11.9
	Cold brine flow rate	m ³ /h	11.0	9.9	9.8	9.8	10.0	10.0	10.0	9.8	9.7	9.3	8.8	8.3	8.0
	brine pressure loss	kPa	96	78	77	77	80	80	79	76	74	68	61	54	50

* The power consumption value is rounded off to the first decimal place.

* When conditions are met that only allow the unit to operate at a capacity below 54 kW and when the brine flow rate cannot be reduced to a rate below the minimum required flow rate, the temperature difference between the cold brine inlet and outlet will be less than 7°C.

Capacity change mode: COP priority

MODEL		EACV-P900YA × 2													
Cold brine outlet temperature	Outdoor air temperature °CDB	-15	-10	-5	0	5	10	15	20	25	30	35	40	43	
-10	Cooling capacity	kW	90.7	90.9	90.9	87.8	85.9	83.5	80.8	77.8	74.0	69.1	64.2	59.1	56.1
	Power consumption	kW	19.2	19.8	20.1	20.7	21.1	21.4	21.8	22.4	25.1	27.8	30.6	33.5	35.2
	Cold brine flow rate	m ³ /h	15.4	15.4	15.4	15.4	15.4	15.4	15.4	15.4	15.4	15.4	15.4	15.4	15.4
	brine pressure loss	kPa	46	46	46	46	46	46	46	46	46	46	46	46	46
-5	Cooling capacity	kW	110.8	110.8	110.8	105.4	103.4	101.1	98.3	94.9	90.0	84.5	78.9	73.2	69.7
	Power consumption	kW	18.9	19.3	19.6	20.4	20.7	21.1	21.6	22.7	25.9	28.8	31.6	34.5	36.2
	Cold brine flow rate	m ³ /h	16.0	16.1	16.1	15.4	15.4	15.4	15.4	15.4	15.4	15.4	15.4	15.4	15.4
	brine pressure loss	kPa	50	50	50	46	46	46	46	46	46	46	46	46	46
0	Cooling capacity	kW	132.5	132.5	132.5	124.9	122.6	120.2	117.4	113.9	108.5	102.4	96.1	90.0	85.8
	Power consumption	kW	19.4	19.7	20.0	20.4	20.8	21.2	21.9	23.9	26.9	29.8	32.6	36.2	37.7
	Cold brine flow rate	m ³ /h	19.1	19.1	19.1	18.0	17.7	17.3	16.9	16.4	15.7	15.4	15.4	15.4	15.4
	brine pressure loss	kPa	72	72	72	64	62	59	56	53	48	46	46	46	46
5	Cooling capacity	kW	147.2	147.2	147.2	147.0	144.8	141.8	138.6	134.0	127.9	121.5	115.0	108.2	104.4
	Power consumption	kW	20.1	20.4	20.8	21.2	21.3	21.8	22.7	25.5	28.1	30.8	33.5	36.5	40.4
	Cold brine flow rate	m ³ /h	21.2	21.2	21.2	21.1	20.8	20.4	19.9	19.3	18.4	17.5	16.5	15.5	15.4
	brine pressure loss	kPa	89	89	89	89	86	83	79	73	67	60	53	47	46
7	Cooling capacity	kW	155.4	155.4	155.3	155.3	154.3	151.2	147.7	142.4	136.1	129.5	122.6	115.3	110.7
	Power consumption	kW	21.3	21.6	21.9	22.3	21.6	22.1	23.1	26.0	28.5	31.1	33.9	36.9	38.9
	Cold brine flow rate	m ³ /h	22.3	22.3	22.3	22.3	22.2	21.7	21.2	20.5	19.5	18.6	17.6	16.6	15.9
	brine pressure loss	kPa	99	99	99	99	98	94	89	83	76	68	61	54	49
10	Cooling capacity	kW	159.6	159.5	159.5	159.3	160.4	158.1	154.4	148.7	142.2	135.5	128.6	121.0	116.2
	Power consumption	kW	22.9	23.1	23.3	23.4	21.1	21.3	22.3	25.0	27.3	29.8	32.4	35.3	37.2
	Cold brine flow rate	m ³ /h	22.9	22.9	22.9	22.8	23.0	22.7	22.1	21.3	20.4	19.4	18.4	17.3	16.7
	brine pressure loss	kPa	105	105	105	104	106	103	98	90	82	75	67	59	54
15	Cooling capacity	kW	163.4	157.4	157.3	157.3	158.9	159.0	157.7	152.4	145.8	139.0	132.1	124.5	119.6
	Power consumption	kW	23.7	22.8	22.9	23.0	18.6	19.0	20.0	22.0	23.9	26.0	28.2	30.8	32.5
	Cold brine flow rate	m ³ /h	23.4	22.5	22.5	22.5	22.7	22.7	22.6	21.8	20.9	19.9	18.9	17.8	17.1
	brine pressure loss	kPa	109	101	101	101	103	103	102	95	86	78	70	62	57
20	Cooling capacity	kW	138.8	137.6	137.6	137.5	140.1	140.0	138.6	135.2	130.5	124.7	118.7	112.4	108.5
	Power consumption	kW	20.2	19.9	19.9	20.0	16.8	17.0	17.1	17.6	19.3	21.0	22.8	24.9	26.3
	Cold brine flow rate	m ³ /h	21.9	19.9	19.7	19.7	20.0	20.0	20.0	19.6	19.4	18.5	17.6	16.7	16.0
	brine pressure loss	kPa	96	78	77	77	80	80	79	76	74	68	61	54	50
25	Cooling capacity	kW	140.8	139.4	138.0	138.0	140.4	140.4	140.3	137.6	135.8	129.8	123.4	116.7	112.4
	Power consumption	kW	20.4	20.2	20.7	20.7	16.9	17.0	17.1	17.2	17.4	19.0	20.6	22.6	23.8
	Cold brine flow rate	m ³ /h	21.9	19.9	19.7	19.7	20.0	20.0	20.0	19.6	19.4	18.5	17.6	16.7	16.0
	brine pressure loss	kPa	96	78	77	77	80	80	79	76	74	68	61	54	50

* The power consumption value is rounded off to the first decimal place.

* When conditions are met that only allow the unit to operate at a capacity below 108 kW and when the brine flow rate cannot be reduced to a rate below the minimum required flow rate, the temperature difference between the cold brine inlet and outlet will be less than 7°C.

2. Product Data

Cooling capacity: Cold brine outlet/inlet temperature difference 7°C
 [Brine ethylene glycol 35wt%]

Capacity change mode: COP priority

MODEL		EACV-P900YA × 3												
Cold brine outlet temperature	Outdoor air temperature °CDB	-15	-10	-5	0	5	10	15	20	25	30	35	40	43
		-10	Cooling capacity kW	136.1	136.4	136.4	131.8	128.9	125.3	121.2	116.7	110.9	103.7	96.3
	Power consumption kW	28.8	29.7	30.1	31.1	31.6	32.0	32.6	33.5	37.6	41.7	45.9	50.2	52.8
	Cold brine flow rate m ³ /h	23.1	23.1	23.1	23.1	23.1	23.1	23.1	23.1	23.1	23.1	23.1	23.1	23.1
	brine pressure loss kPa	46	46	46	46	46	46	46	46	46	46	46	46	46
	-5	Cooling capacity kW	166.1	166.2	166.2	158.2	155.1	151.6	147.4	142.4	135.0	126.7	118.3	109.9
	Power consumption kW	28.3	28.9	29.4	30.5	31.1	31.7	32.4	34.0	38.8	43.1	47.4	51.7	54.3
	Cold brine flow rate m ³ /h	24.1	24.1	24.1	23.1	23.1	23.1	23.1	23.1	23.1	23.1	23.1	23.1	23.1
	brine pressure loss kPa	50	50	50	46	46	46	46	46	46	46	46	46	46
	0	Cooling capacity kW	198.7	198.7	198.7	187.3	184.0	180.3	176.1	170.9	162.8	153.6	144.2	135.0
	Power consumption kW	29.0	29.5	29.9	30.6	31.2	31.8	32.8	35.9	40.4	44.6	48.9	54.3	56.5
	Cold brine flow rate m ³ /h	28.7	28.7	28.7	27.0	26.5	26.0	25.4	24.7	23.5	23.1	23.1	23.1	23.1
	brine pressure loss kPa	72	72	72	64	62	59	56	53	48	46	46	46	46
	5	Cooling capacity kW	220.8	220.8	220.8	220.5	217.2	212.8	207.8	200.9	191.8	182.3	172.4	162.3
	Power consumption kW	30.1	30.6	31.2	31.8	32.0	32.7	34.0	38.2	42.1	46.1	50.3	54.8	60.6
	Cold brine flow rate m ³ /h	31.7	31.7	31.7	31.7	31.2	30.6	29.9	28.9	27.6	26.2	24.8	23.3	23.1
	brine pressure loss kPa	89	89	89	89	86	83	79	73	67	60	53	47	46
	7	Cooling capacity kW	233.1	233.0	233.0	233.0	231.5	226.8	221.5	213.6	204.1	194.2	184.0	172.9
	Power consumption kW	32.0	32.4	32.9	33.4	32.4	33.1	34.6	38.9	42.7	46.7	50.8	55.4	58.3
	Cold brine flow rate m ³ /h	33.5	33.5	33.5	33.5	33.2	32.6	31.8	30.7	29.3	27.9	26.4	24.8	23.8
	brine pressure loss kPa	99	99	99	99	98	94	89	83	76	68	61	54	49
	10	Cooling capacity kW	239.3	239.3	239.2	239.0	240.6	237.1	231.6	223.1	213.3	203.3	192.8	181.5
	Power consumption kW	34.4	34.6	34.9	35.0	31.6	31.9	33.5	37.5	40.9	44.6	48.5	52.9	55.7
	Cold brine flow rate m ³ /h	34.3	34.3	34.3	34.3	34.5	34.0	33.2	32.0	30.6	29.1	27.6	26.0	25.0
	brine pressure loss kPa	105	105	105	104	106	103	98	90	82	75	67	59	54
	15	Cooling capacity kW	245.1	236.1	236.0	235.9	238.4	238.5	236.5	228.5	218.7	208.6	198.1	186.8
	Power consumption kW	35.6	34.2	34.3	34.5	27.8	28.5	30.0	32.9	35.8	38.9	42.3	46.2	48.7
	Cold brine flow rate m ³ /h	35.1	33.8	33.8	33.7	34.1	34.1	33.8	32.7	31.3	29.8	28.3	26.7	25.7
	brine pressure loss kPa	109	101	101	101	103	103	102	95	86	78	70	62	57
	20	Cooling capacity kW	208.1	206.5	206.4	206.3	210.1	209.9	207.9	202.8	195.7	187.0	178.1	168.7
	Power consumption kW	30.3	29.8	29.9	30.0	25.2	25.4	25.6	26.4	28.9	31.4	34.2	37.4	39.4
	Cold brine flow rate m ³ /h	32.9	29.8	29.5	29.5	30.1	30.0	30.0	29.4	29.1	27.8	26.4	25.0	24.1
	brine pressure loss kPa	96	78	77	77	80	80	79	76	74	68	61	54	50
	25	Cooling capacity kW	211.2	209.1	207.0	206.9	210.7	210.6	210.4	206.4	203.7	194.7	185.2	175.0
	Power consumption kW	30.6	30.3	31.0	31.1	25.4	25.5	25.7	25.8	26.1	28.4	30.9	33.8	35.7
	Cold brine flow rate m ³ /h	32.9	29.8	29.5	29.5	30.1	30.0	30.0	29.4	29.1	27.8	26.4	25.0	24.1
	brine pressure loss kPa	96	78	77	77	80	80	79	76	74	68	61	54	50

* The power consumption value is rounded off to the first decimal place.

* When conditions are met that only allow the unit to operate at a capacity below 162 kW and when the brine flow rate cannot be reduced to a rate below the minimum required flow rate, the temperature difference between the cold brine inlet and outlet will be less than 7°C.

Capacity change mode: COP priority

MODEL		EACV-P900YA × 4												
Cold brine outlet temperature	Outdoor air temperature °CDB	-15	-10	-5	0	5	10	15	20	25	30	35	40	43
		-10	Cooling capacity kW	181.4	181.8	181.8	175.7	171.8	167.0	161.6	155.6	147.9	138.2	128.4
	Power consumption kW	38.4	39.6	40.2	41.4	42.1	42.7	43.5	44.7	50.1	55.6	61.1	66.9	70.4
	Cold brine flow rate m ³ /h	30.8	30.8	30.8	30.8	30.8	30.8	30.8	30.8	30.8	30.8	30.8	30.8	30.8
	brine pressure loss kPa	46	46	46	46	46	46	46	46	46	46	46	46	46
	-5	Cooling capacity kW	221.5	221.6	221.7	210.9	206.8	202.2	196.6	189.9	180.0	168.9	157.8	146.5
	Power consumption kW	37.8	38.5	39.2	40.7	41.4	42.2	43.2	45.4	51.7	57.5	63.2	68.9	72.4
	Cold brine flow rate m ³ /h	32.1	32.1	32.1	30.8	30.8	30.8	30.8	30.8	30.8	30.8	30.8	30.8	30.8
	brine pressure loss kPa	50	50	50	46	46	46	46	46	46	46	46	46	46
	0	Cooling capacity kW	265.0	265.0	265.0	249.7	245.3	240.4	234.8	227.9	217.1	204.8	192.2	179.9
	Power consumption kW	38.7	39.3	39.9	40.8	41.6	42.4	43.7	47.8	53.8	59.5	65.2	72.3	75.3
	Cold brine flow rate m ³ /h	38.2	38.2	38.2	36.0	35.4	34.7	33.9	32.9	31.3	30.8	30.8	30.8	30.8
	brine pressure loss kPa	72	72	72	64	62	59	56	53	48	46	46	46	46
	5	Cooling capacity kW	294.4	294.4	294.4	294.0	289.5	283.7	277.1	267.9	255.8	243.1	229.9	216.4
	Power consumption kW	40.1	40.8	41.5	42.3	42.6	43.6	45.3	50.9	56.1	61.5	67.0	73.0	80.8
	Cold brine flow rate m ³ /h	42.3	42.3	42.3	42.3	41.6	40.8	39.8	38.5	36.8	34.9	33.1	31.1	30.8
	brine pressure loss kPa	89	89	89	89	86	83	79	73	67	60	53	47	46
	7	Cooling capacity kW	310.7	310.7	310.7	310.6	308.7	302.4	295.4	284.9	272.1	259.0	245.3	230.5
	Power consumption kW	42.6	43.2	43.8	44.6	43.1	44.1	46.2	51.9	56.9	62.2	67.8	73.8	77.7
	Cold brine flow rate m ³ /h	44.6	44.6	44.6	44.6	44.3	43.4	42.4	40.9	39.1	37.2	35.2	33.1	31.8
	brine pressure loss kPa	99	99	99	99	98	94	89	83	76	68	61	54	49
	10	Cooling capacity kW	319.1	319.1	318.9	318.7	320.8	316.1	308.8	297.4	284.4	271.0	257.1	242.0
	Power consumption kW	45.8	46.2	46.5	46.7	42.1	42.5	44.6	49.9	54.5	59.5	64.7	70.5	74.3
	Cold brine flow rate m ³ /h	45.8	45.7	45.7	45.7	46.0	45.3	44.3	42.6	40.8	38.9	36.9	34.7	33.3
	brine pressure loss kPa	105	105	105	104	106	103	98	90	82	75	67	59	54
	15	Cooling capacity kW	326.8	314.8	314.7	314.5	317.9	317.9	315.3	304.7	291.6	278.1	264.1	249.0
	Power consumption kW	47.4	45.6	45.8	45.9	37.1	37.9	40.0	43.9	47.7	51.9	56.4	61.6	64.9
	Cold brine flow rate m ³ /h	46.8	45.0	45.0	45.0	45.5	45.5	45.1	43.6	41.7	39.8	37.8	35.6	34.2
	brine pressure loss kPa	109	101	101	101	103	103	102	95	86	78	70	62	57
	20	Cooling capacity kW	277.5	275.3	275.2	275.0	280.1	279.9	277.2	270.4	260.9	249.4	237.5	224.9
	Power consumption kW	40.4	39.7	39.8	40.0	33.6	33.9	34.1	35.2	38.5	41.9	45.6	49.8	52.6
	Cold brine flow rate m ³ /h	43.8	39.8	39.4	39.4	40.1	40.1	40.0	39.3	38.8	37.0	35.2	33.3	32.1
	brine pressure loss kPa	96	78	77	77	80	80	79	76	74	68	61	54	50
	25	Cooling capacity kW	281.6	278.7	276.0	275.9	280.9	280.8	280.5	275.1	271.6	259.6	246.9	233.4
	Power consumption kW	40.8	40.4	41.3	41.4	33.8	34.0	34.2	34.4	34.8	37.9	41.2	45.1	47.5
	Cold brine flow rate m ³ /h	43.8	39.8	39.4	39.4	40.1	40.1	40.0	39.3	38.8	37.0	35.2	33.3	32.1
	brine pressure loss kPa	96	78	77	77	80	80	79	76	74	68	61	54	50

* The power consumption value is rounded off to the first decimal place.

* When conditions are met that only allow the unit to operate at a capacity below 216 kW and when the brine flow rate cannot be reduced to a rate below the minimum required flow rate, the temperature difference between the cold brine inlet and outlet will be less than 7°C.

2. Product Data

Cooling capacity: Cold brine outlet/inlet temperature difference 7°C

[Brine ethylene glycol 35wt%]

Capacity change mode: COP priority

Cold brine outlet temperature	MODEL	Outdoor air temperature °CDB	EACV-P900YA × 5												
			-15	-10	-5	0	5	10	15	20	25	30	35	40	43
-10	Cooling capacity	kW	226.8	227.3	227.3	219.6	214.8	208.8	202.0	194.5	184.9	172.8	160.4	147.9	140.1
	Power consumption	kW	48.0	49.5	50.2	51.8	52.6	53.4	54.3	55.9	62.7	69.5	76.4	83.6	88.0
	Cold brine flow rate	m ³ /h	38.5	38.5	38.5	38.5	38.5	38.5	38.5	38.5	38.5	38.5	38.5	38.5	38.5
	brine pressure loss	kPa	46	46	46	46	46	46	46	46	46	46	46	46	46
-5	Cooling capacity	kW	276.9	277.0	277.1	263.6	258.5	252.7	245.7	237.3	225.0	211.1	197.2	183.1	174.3
	Power consumption	kW	47.2	48.1	49.0	50.9	51.8	52.8	54.0	56.7	64.6	71.8	79.0	86.1	90.5
	Cold brine flow rate	m ³ /h	40.1	40.1	40.1	38.5	38.5	38.5	38.5	38.5	38.5	38.5	38.5	38.5	38.5
	brine pressure loss	kPa	50	50	50	46	46	46	46	46	46	46	46	46	46
0	Cooling capacity	kW	331.2	331.2	331.2	312.1	306.6	300.5	293.5	284.9	271.4	256.0	240.3	224.9	214.5
	Power consumption	kW	48.4	49.2	49.8	51.0	52.0	53.0	54.6	59.7	67.3	74.4	81.5	90.4	94.1
	Cold brine flow rate	m ³ /h	47.8	47.8	47.8	45.0	44.2	43.4	42.4	41.1	39.2	38.5	38.5	38.5	38.5
	brine pressure loss	kPa	72	72	72	64	62	59	56	53	48	46	46	46	46
5	Cooling capacity	kW	368.0	368.0	368.0	367.5	361.9	354.6	346.4	334.9	319.7	303.8	287.4	270.4	261.1
	Power consumption	kW	50.1	51.0	51.9	52.9	53.3	54.5	56.7	63.6	70.1	76.8	83.8	91.3	101.0
	Cold brine flow rate	m ³ /h	52.9	52.9	52.9	52.8	52.0	51.0	49.8	48.2	46.0	43.7	41.3	38.8	38.5
	brine pressure loss	kPa	89	89	89	89	86	83	79	73	67	60	53	47	46
7	Cooling capacity	kW	388.4	388.4	388.4	388.3	385.9	378.0	369.2	356.1	340.2	323.7	306.6	288.2	276.6
	Power consumption	kW	53.3	54.0	54.8	55.7	53.9	55.2	57.7	64.8	71.1	77.8	84.7	92.3	97.1
	Cold brine flow rate	m ³ /h	55.8	55.8	55.8	55.8	55.4	54.3	53.0	51.1	48.9	46.5	44.0	41.4	39.7
	brine pressure loss	kPa	99	99	99	99	98	94	89	83	76	68	61	54	49
10	Cooling capacity	kW	398.9	398.8	398.6	398.4	401.0	395.2	386.0	371.8	355.5	338.8	321.4	302.5	290.4
	Power consumption	kW	57.2	57.7	58.1	58.4	52.7	53.1	55.8	62.4	68.2	74.3	80.9	88.2	92.9
	Cold brine flow rate	m ³ /h	57.2	57.2	57.2	57.1	57.5	56.7	55.3	53.3	51.0	48.6	46.1	43.4	41.6
	brine pressure loss	kPa	105	105	105	104	106	103	98	90	82	75	67	59	54
15	Cooling capacity	kW	408.6	393.5	393.4	393.2	397.3	397.4	394.2	380.9	364.4	347.6	330.1	311.3	299.1
	Power consumption	kW	59.3	57.0	57.2	57.4	46.4	47.4	50.0	54.8	59.6	64.8	70.5	77.0	81.1
	Cold brine flow rate	m ³ /h	58.4	56.3	56.3	56.2	56.8	56.9	56.4	54.5	52.1	49.7	47.2	44.5	42.8
	brine pressure loss	kPa	109	101	101	101	103	103	102	95	86	78	70	62	57
20	Cooling capacity	kW	346.9	344.1	344.0	343.8	350.1	349.9	346.5	338.0	326.2	311.7	296.9	281.1	271.2
	Power consumption	kW	50.5	49.6	49.8	50.0	42.0	42.3	42.7	44.0	48.1	52.4	57.0	62.2	65.7
	Cold brine flow rate	m ³ /h	54.8	49.7	49.2	49.2	50.1	50.1	50.0	49.1	48.4	46.3	44.0	41.6	40.1
	brine pressure loss	kPa	96	78	77	77	80	80	79	76	74	68	61	54	50
25	Cooling capacity	kW	352.0	348.4	345.0	344.9	351.1	351.0	350.7	343.9	339.5	324.5	308.6	291.7	281.0
	Power consumption	kW	51.0	50.5	51.6	51.7	42.3	42.4	42.7	43.0	43.5	47.3	51.5	56.3	59.4
	Cold brine flow rate	m ³ /h	54.8	49.7	49.2	49.2	50.1	50.1	50.0	49.1	48.4	46.3	44.0	41.6	40.1
	brine pressure loss	kPa	96	78	77	77	80	80	79	76	74	68	61	54	50

* The power consumption value is rounded off to the first decimal place.

* When conditions are met that only allow the unit to operate at a capacity below 270 kW and when the brine flow rate cannot be reduced to a rate below the minimum required flow rate, the temperature difference between the cold brine inlet and outlet will be less than 7°C.

Capacity change mode: COP priority

Cold brine outlet temperature	MODEL	Outdoor air temperature °CDB	EACV-P900YA × 6												
			-15	-10	-5	0	5	10	15	20	25	30	35	40	43
-10	Cooling capacity	kW	272.2	272.8	272.7	263.5	257.7	250.5	242.4	233.4	221.9	207.3	192.5	177.4	168.2
	Power consumption	kW	57.6	59.4	60.2	62.1	63.1	64.0	65.2	67.0	75.2	83.4	91.7	100.3	105.6
	Cold brine flow rate	m ³ /h	46.2	46.2	46.2	46.2	46.2	46.2	46.2	46.2	46.2	46.2	46.2	46.2	46.2
	brine pressure loss	kPa	46	46	46	46	46	46	46	46	46	46	46	46	46
-5	Cooling capacity	kW	332.3	332.4	332.5	316.3	310.2	303.3	294.9	284.8	270.0	253.4	236.6	219.7	209.2
	Power consumption	kW	56.6	57.8	58.7	61.0	62.1	63.3	64.7	68.0	77.5	86.2	94.8	103.3	108.5
	Cold brine flow rate	m ³ /h	48.1	48.2	48.2	46.2	46.2	46.2	46.2	46.2	46.2	46.2	46.2	46.2	46.2
	brine pressure loss	kPa	50	50	50	46	46	46	46	46	46	46	46	46	46
0	Cooling capacity	kW	397.5	397.5	397.4	374.6	367.9	360.6	352.2	341.8	325.6	307.3	288.3	269.9	257.4
	Power consumption	kW	58.0	59.0	59.8	61.2	62.4	63.6	65.5	71.7	80.7	89.2	97.7	108.5	112.9
	Cold brine flow rate	m ³ /h	57.3	57.3	57.3	54.0	53.1	52.0	50.8	49.3	47.0	46.2	46.2	46.2	46.2
	brine pressure loss	kPa	72	72	72	64	62	59	56	53	48	46	46	46	46
5	Cooling capacity	kW	441.6	441.6	441.6	441.0	434.3	425.5	415.7	401.9	383.7	364.6	344.9	324.5	313.3
	Power consumption	kW	60.1	61.2	62.3	63.5	63.9	65.4	68.0	76.3	84.1	92.2	100.5	109.5	121.1
	Cold brine flow rate	m ³ /h	63.5	63.5	63.5	63.4	62.4	61.2	59.8	57.8	55.2	52.4	49.6	46.6	46.2
	brine pressure loss	kPa	89	89	89	89	86	83	79	73	67	60	53	47	46
7	Cooling capacity	kW	466.1	466.1	466.0	465.9	463.0	453.6	443.0	427.3	408.2	388.5	367.9	345.8	332.0
	Power consumption	kW	63.9	64.8	65.7	66.8	64.7	66.2	69.2	77.8	85.4	93.3	101.6	110.7	116.5
	Cold brine flow rate	m ³ /h	66.9	66.9	66.9	66.9	66.5	65.1	63.6	61.4	58.6	55.8	52.8	49.7	47.7
	brine pressure loss	kPa	99	99	99	99	98	94	89	83	76	68	61	54	49
10	Cooling capacity	kW	478.7	478.6	478.4	478.0	481.2	474.2	463.2	446.1	426.6	406.6	385.7	363.0	348.5
	Power consumption	kW	68.7	69.2	69.7	70.0	63.2	63.7	66.9	74.9	81.8	89.2	97.0	105.8	111.4
	Cold brine flow rate	m ³ /h	68.6	68.6	68.6	68.5	69.0	68.0	66.4	64.0	61.2	58.3	55.3	52.0	50.0
	brine pressure loss	kPa	105	105	105	104	106	103	98	90	82	75	67	59	54
15	Cooling capacity	kW	490.3	472.3	472.0	471.8	476.8	476.9	473.0	457.1	437.3	417.1	396.2	373.5	358.9
	Power consumption	kW	71.1	68.4	68.6	68.9	55.6	56.9	60.0	65.8	71.5	77.8	84.6	92.4	97.3
	Cold brine flow rate	m ³ /h	70.1	67.6	67.5	67.5	68.2	68.2	67.7	65.4	62.6	59.7	56.7	53.4	51.3
	brine pressure loss	kPa	109	101	101	101	103	103	102	95	86	78	70	62	57
20	Cooling capacity	kW	416.3	412.9	412.7	412.6	420.2	419.9	415.7	405.6	391.4	374.0	356.2	337.3	325.4
	Power consumption	kW	60.6	59.5	59.7	60.0	50.4	50.8	51.2	52.8	57.7	62.8	68.4	74.7	78.8
	Cold brine flow rate	m ³ /h	65.7	59.7	59.1	59.1	60.1	60.1	60.1	58.9	58.1	55.6	52.8	50.0	48.1
	brine pressure loss	kPa	96	78	77	77	80	80	79	76	74	68	61	54	50
25	Cooling capacity	kW	422.4	418.1	414.0	413.9	421.3	421.1	420.8	412.7	407.4	389.4	370.3	350.0	337.2
	Power consumption	kW	61.2	60.6	61.9	62.1	50.7	50.9	51.3	51.6	52.1	56.8	61.8	67.6	71.3
	Cold brine flow rate	m ³ /h	65.7	59.7	59.1	59.1	60.1	60.1	60.1	58.9	58.1	55.6	52.8	50.0	48.1
	brine pressure loss	kPa	96	78	77	77	80	80	79	76	74	68	61	54	50

* The power consumption value is rounded off to the first decimal place.

* When conditions are met that only allow the unit to operate at a capacity below 324 kW and when the brine flow rate cannot be reduced to a rate below the minimum required flow rate, the temperature difference between the cold brine inlet and outlet will be less than 7°C.

2. Product Data

Heating capacity: Hot water outlet/inlet temperature difference 5°C

Capacity change mode: Capacity priority

MODEL			EAHV-P900YA													
Hot water outlet temperature	Outdoor air temperature °CDB		-15	-10	-5	0	5	7	10	15	20	25	30	35	40	43
	30	Heating capacity	kW	58.5	66.1	74.6	84.5	94.6	94.6	102.1	115.4	114.8	109.5	-	-	-
Power consumption		kW	20.3	20.1	20.1	20.2	20.0	18.6	18.9	19.4	17.3	15.1	-	-	-	-
Hot water flow rate		m ³ /h	10.1	11.4	12.8	14.5	16.3	16.3	17.6	19.9	19.7	18.8	-	-	-	-
Water pressure loss		kPa	55	72	92	119	149	150	174	223	220	200	-	-	-	-
35	Heating capacity	kW	57.5	64.9	73.4	83.1	93.3	93.3	100.6	113.7	113.7	107.8	107.3	103.0	103.2	102.9
	Power consumption	kW	23.1	22.9	22.8	22.8	22.4	20.9	21.0	21.3	19.2	16.5	14.8	12.7	12.8	12.9
	Hot water flow rate	m ³ /h	9.9	11.2	12.6	14.3	16.0	16.0	17.3	19.6	19.6	18.5	18.5	17.7	17.8	17.7
	Water pressure loss	kPa	53	69	89	115	145	145	169	216	216	194	193	177	178	177
40	Heating capacity	kW	56.0	63.6	72.2	81.9	91.6	91.6	98.7	111.4	111.3	105.5	105.0	101.7	100.7	100.7
	Power consumption	kW	24.8	25.0	25.2	25.4	25.0	23.3	23.3	23.4	21.1	18.4	16.3	14.1	14.2	14.2
	Hot water flow rate	m ³ /h	9.6	10.9	12.4	14.1	15.8	15.8	17.0	19.2	19.1	18.2	18.1	17.5	17.3	17.3
	Water pressure loss	kPa	50	66	86	112	140	140	163	208	207	186	184	173	170	170
45	Heating capacity	kW	54.7	62.3	71.0	80.6	90.0	90.0	96.8	109.2	103.9	103.0	103.2	100.1	99.2	99.1
	Power consumption	kW	27.3	27.6	27.9	28.1	27.6	25.7	25.8	25.8	22.7	20.1	17.9	15.6	15.8	16.0
	Hot water flow rate	m ³ /h	9.4	10.7	12.2	13.9	15.5	15.5	16.7	18.8	17.9	17.7	17.7	17.2	17.1	17.0
	Water pressure loss	kPa	47	63	83	108	135	135	157	199	181	177	178	168	164	164
50	Heating capacity	kW	-	61.1	69.7	79.2	88.2	88.2	94.9	106.9	102.1	101.9	101.3	99.2	98.9	98.5
	Power consumption	kW	-	30.6	30.7	30.9	30.3	28.2	28.3	28.6	25.1	22.2	19.9	17.3	17.7	17.9
	Hot water flow rate	m ³ /h	-	10.5	12.0	13.6	15.2	15.2	16.3	18.4	17.6	17.5	17.4	17.1	17.0	16.9
	Water pressure loss	kPa	-	61	80	104	130	130	150	191	174	174	172	164	163	162
55	Heating capacity	kW	-	-	68.4	77.7	86.3	86.3	92.9	104.6	97.6	97.7	-	-	-	-
	Power consumption	kW	-	-	33.8	33.7	33.1	30.8	31.0	31.6	27.7	24.6	-	-	-	-
	Hot water flow rate	m ³ /h	-	-	11.8	13.4	14.8	14.8	16.0	18.0	16.8	16.8	-	-	-	-
	Water pressure loss	kPa	-	-	77	100	124	124	144	183	159	159	-	-	-	-

- * The power consumption value is rounded off to the first decimal place.
- * Outdoor air temperature from -6°C to +25°C: Hot water 55°C can be supplied.
- * Outdoor air temperature -10°C: Maximam water temperature 50°C.
- * Outdoor air temperature -15°C: Maximam water temperature 45°C.
- * This table shows the capacity when the relative humidity is 85%.
- * The performance is the value not including the defrost correction.

Capacity change mode: Capacity priority

MODEL			EAHV-P900YA × 2													
Hot water outlet temperature	Outdoor air temperature °CDB		-15	-10	-5	0	5	7	10	15	20	25	30	35	40	43
	30	Heating capacity	kW	117.0	132.2	149.3	169.1	189.2	189.2	204.1	230.8	229.5	218.9	-	-	-
Power consumption		kW	40.5	40.2	40.2	40.3	40.0	37.2	37.8	38.8	34.6	30.3	-	-	-	-
Hot water flow rate		m ³ /h	20.1	22.7	25.7	29.1	32.5	32.5	35.1	39.7	39.5	37.7	-	-	-	-
Water pressure loss		kPa	55	72	92	119	149	150	174	223	220	200	-	-	-	-
35	Heating capacity	kW	115.1	129.7	146.8	166.2	186.6	186.6	201.2	227.4	227.4	215.5	214.6	206.0	206.4	205.8
	Power consumption	kW	46.1	45.7	45.5	45.5	44.7	41.7	42.0	42.5	38.3	32.9	29.5	25.4	25.6	25.7
	Hot water flow rate	m ³ /h	19.8	22.3	25.2	28.6	32.1	32.1	34.6	39.1	39.1	37.1	36.9	35.4	35.5	35.4
	Water pressure loss	kPa	53	69	89	115	145	145	169	216	216	194	193	177	178	177
40	Heating capacity	kW	112.0	127.1	144.4	163.9	183.3	183.3	197.4	222.8	222.6	211.1	210.0	203.4	201.4	201.4
	Power consumption	kW	49.6	50.0	50.4	50.8	49.9	46.5	46.6	46.8	42.1	36.9	32.6	28.1	28.3	28.5
	Hot water flow rate	m ³ /h	19.3	21.9	24.8	28.2	31.5	31.5	34.0	38.3	38.3	36.3	36.1	35.0	34.6	34.6
	Water pressure loss	kPa	50	66	86	112	140	140	163	208	207	186	184	173	170	170
45	Heating capacity	kW	109.3	124.6	141.9	161.3	180.0	180.0	193.7	218.3	207.9	206.0	206.3	200.2	198.3	198.2
	Power consumption	kW	54.5	55.2	55.7	56.2	55.2	51.4	51.5	51.7	45.3	40.1	35.9	31.1	31.6	31.9
	Hot water flow rate	m ³ /h	18.8	21.4	24.4	27.7	31.0	31.0	33.3	37.5	35.8	35.4	35.5	34.4	34.1	34.1
	Water pressure loss	kPa	47	63	83	108	135	135	157	199	181	177	178	168	164	164
50	Heating capacity	kW	-	122.2	139.4	158.5	176.3	176.3	189.8	213.8	204.2	203.8	202.6	198.3	197.7	197.1
	Power consumption	kW	-	61.2	61.5	61.7	60.6	56.4	56.6	57.1	50.1	44.4	39.8	34.7	35.4	35.8
	Hot water flow rate	m ³ /h	-	21.0	24.0	27.3	30.3	30.3	32.6	36.8	35.1	35.1	34.8	34.1	34.0	33.9
	Water pressure loss	kPa	-	61	80	104	130	130	150	191	174	174	172	164	163	162
55	Heating capacity	kW	-	-	136.7	155.5	172.7	172.7	185.8	209.2	195.3	195.3	-	-	-	-
	Power consumption	kW	-	-	67.6	67.5	66.1	61.6	62.0	63.1	55.4	49.1	-	-	-	-
	Hot water flow rate	m ³ /h	-	-	23.5	26.7	29.7	29.7	32.0	36.0	33.6	33.6	-	-	-	-
	Water pressure loss	kPa	-	-	77	100	124	124	144	183	159	159	-	-	-	-

- * The power consumption value is rounded off to the first decimal place.
- * Outdoor air temperature from -6°C to +25°C: Hot water 55°C can be supplied.
- * Outdoor air temperature -10°C: Maximam water temperature 50°C.
- * Outdoor air temperature -15°C: Maximam water temperature 45°C.
- * This table shows the capacity when the relative humidity is 85%.
- * The performance is the value not including the defrost correction.

2. Product Data

Heating capacity: Hot water outlet/inlet temperature difference 5°C

Capacity change mode: Capacity priority

MODEL		EAHV-P900YA × 3														
Hot water outlet temperature	Outdoor air temperature °CDB	-15	-10	-5	0	5	7	10	15	20	25	30	35	40	43	
30	Heating capacity	kW	175.5	198.2	223.9	253.6	283.7	283.8	306.2	346.2	344.3	328.4	-	-	-	-
	Power consumption	kW	60.8	60.3	60.2	60.5	60.1	55.8	56.6	58.2	51.9	45.4	-	-	-	-
	Hot water flow rate	m ³ /h	30.2	34.1	38.5	43.6	48.8	48.8	52.7	59.6	59.2	56.5	-	-	-	-
	Water pressure loss	kPa	55	72	92	119	149	150	174	223	220	200	-	-	-	-
35	Heating capacity	kW	172.6	194.6	220.1	249.3	279.9	279.9	301.7	341.1	341.1	323.3	321.9	309.0	309.6	308.8
	Power consumption	kW	69.2	68.6	68.3	68.3	67.1	62.6	63.0	63.8	57.5	49.4	44.3	38.2	38.4	38.6
	Hot water flow rate	m ³ /h	29.7	33.5	37.9	42.9	48.1	48.1	51.9	58.7	58.7	55.6	55.4	53.1	53.3	53.1
	Water pressure loss	kPa	53	69	89	115	145	145	169	216	216	194	193	177	178	177
40	Heating capacity	kW	168.1	190.7	216.6	245.8	274.9	274.9	296.2	334.3	333.9	316.6	314.9	305.1	302.1	302.1
	Power consumption	kW	74.3	75.0	75.6	76.1	74.9	69.8	70.0	70.2	63.2	55.3	48.9	42.2	42.5	42.7
	Hot water flow rate	m ³ /h	28.9	32.8	37.3	42.3	47.3	47.3	50.9	57.5	57.4	54.5	54.2	52.5	52.0	52.0
	Water pressure loss	kPa	50	66	86	112	140	140	163	208	207	186	184	173	170	170
45	Heating capacity	kW	164.0	186.9	212.9	241.9	270.0	270.0	290.5	327.5	311.8	309.0	309.5	300.4	297.5	297.4
	Power consumption	kW	81.8	82.8	83.6	84.2	82.8	77.1	77.3	77.5	68.0	60.2	53.8	46.7	47.4	47.9
	Hot water flow rate	m ³ /h	28.2	32.2	36.6	41.6	46.4	46.4	50.0	56.3	53.6	53.1	53.2	51.7	51.2	51.1
	Water pressure loss	kPa	47	63	83	108	135	135	157	199	181	177	178	168	164	164
50	Heating capacity	kW	-	183.3	209.1	237.7	264.5	264.5	284.7	320.7	306.3	305.8	303.9	297.5	296.6	295.6
	Power consumption	kW	-	91.9	92.2	92.6	90.9	84.6	85.0	85.7	75.2	66.5	59.7	52.0	53.1	53.8
	Hot water flow rate	m ³ /h	-	31.5	36.0	40.9	45.5	45.5	49.0	55.2	52.7	52.6	52.3	51.2	51.0	50.8
	Water pressure loss	kPa	-	61	80	104	130	130	150	191	174	174	172	164	163	162
55	Heating capacity	kW	-	-	205.1	233.2	259.0	259.0	278.7	313.8	292.9	293.0	-	-	-	-
	Power consumption	kW	-	-	101.5	101.2	99.2	92.3	93.0	94.7	83.2	73.7	-	-	-	-
	Hot water flow rate	m ³ /h	-	-	35.3	40.1	44.5	44.5	47.9	54.0	50.4	50.4	-	-	-	-
	Water pressure loss	kPa	-	-	77	100	124	124	144	183	159	159	-	-	-	-

* The power consumption value is rounded off to the first decimal place.

* Outdoor air temperature from -6°C to +25°C: Hot water 55°C can be supplied.

* Outdoor air temperature -10°C: Maximum water temperature 50°C.

* Outdoor air temperature -15°C: Maximum water temperature 45°C.

* This table shows the capacity when the relative humidity is 85%.

* The performance is the value not including the defrost correction.

Capacity change mode: Capacity priority

MODEL		EAHV-P900YA × 4														
Hot water outlet temperature	Outdoor air temperature °CDB	-15	-10	-5	0	5	7	10	15	20	25	30	35	40	43	
30	Heating capacity	kW	234.0	264.3	298.6	338.1	378.3	378.4	408.3	461.6	459.1	437.9	-	-	-	-
	Power consumption	kW	81.1	80.4	80.3	80.6	80.1	74.4	75.5	77.5	69.2	60.5	-	-	-	-
	Hot water flow rate	m ³ /h	40.2	45.5	51.4	58.2	65.1	65.1	70.2	79.4	79.0	75.3	-	-	-	-
	Water pressure loss	kPa	55	72	92	119	149	150	174	223	220	200	-	-	-	-
35	Heating capacity	kW	230.2	259.4	293.5	332.5	373.2	373.2	402.3	454.8	454.7	431.1	429.2	412.0	412.9	411.7
	Power consumption	kW	92.3	91.4	91.0	91.0	89.5	83.5	84.0	85.0	76.7	65.9	59.1	50.9	51.3	51.5
	Hot water flow rate	m ³ /h	39.6	44.6	50.5	57.2	64.2	64.2	69.2	78.2	78.2	74.1	73.8	70.9	71.0	70.8
	Water pressure loss	kPa	53	69	89	115	145	145	169	216	216	194	193	177	178	177
40	Heating capacity	kW	224.1	254.3	288.8	327.7	366.6	366.6	394.9	445.7	445.2	422.1	419.9	406.8	402.8	402.8
	Power consumption	kW	99.1	100.0	100.8	101.5	99.8	93.0	93.3	93.6	84.2	73.7	65.2	56.2	56.7	56.9
	Hot water flow rate	m ³ /h	38.5	43.7	49.7	56.4	63.1	63.1	67.9	76.7	76.6	72.6	72.2	70.0	69.3	69.3
	Water pressure loss	kPa	50	66	86	112	140	140	163	208	207	186	184	173	170	170
45	Heating capacity	kW	218.6	249.3	283.9	322.6	360.0	360.0	387.3	436.6	415.8	412.0	412.7	400.5	396.6	396.5
	Power consumption	kW	109.1	110.4	111.5	112.3	110.4	102.8	103.1	103.4	90.6	80.2	71.8	62.2	63.2	63.9
	Hot water flow rate	m ³ /h	37.6	42.9	48.8	55.5	61.9	61.9	66.6	75.1	71.5	70.9	71.0	68.9	68.2	68.2
	Water pressure loss	kPa	47	63	83	108	135	135	157	199	181	177	178	168	164	164
50	Heating capacity	kW	-	244.4	278.8	317.0	352.6	352.6	379.6	427.5	408.4	407.7	405.2	396.6	395.4	394.1
	Power consumption	kW	-	122.5	123.0	123.5	121.2	112.8	113.3	114.2	100.2	88.7	79.5	69.4	70.8	71.7
	Hot water flow rate	m ³ /h	-	42.0	47.9	54.5	60.7	60.7	65.3	73.5	70.3	70.1	69.7	68.2	68.0	67.8
	Water pressure loss	kPa	-	61	80	104	130	130	150	191	174	174	172	164	163	162
55	Heating capacity	kW	-	-	273.4	310.9	345.3	345.3	371.6	418.5	390.6	390.7	-	-	-	-
	Power consumption	kW	-	-	135.3	135.0	132.3	123.1	124.0	126.2	110.9	98.3	-	-	-	-
	Hot water flow rate	m ³ /h	-	-	47.0	53.5	59.4	59.4	63.9	72.0	67.2	67.2	-	-	-	-
	Water pressure loss	kPa	-	-	77	100	124	124	144	183	159	159	-	-	-	-

* The power consumption value is rounded off to the first decimal place.

* Outdoor air temperature from -6°C to +25°C: Hot water 55°C can be supplied.

* Outdoor air temperature -10°C: Maximum water temperature 50°C.

* Outdoor air temperature -15°C: Maximum water temperature 45°C.

* This table shows the capacity when the relative humidity is 85%.

* The performance is the value not including the defrost correction.

2. Product Data

Heating capacity: Hot water outlet/inlet temperature difference 5°C

Capacity change mode: Capacity priority

MODEL			EAHV-P900YA × 5													
Hot water outlet temperature	Outdoor air temperature °CDB		-15	-10	-5	0	5	7	10	15	20	25	30	35	40	43
			30	Heating capacity	kW	292.4	330.4	373.2	422.6	472.9	473.0	510.3	577.0	573.9	547.3	-
Power consumption	kW	101.4		100.5	100.4	100.8	100.1	92.9	94.4	96.9	86.5	75.7	-	-	-	-
Hot water flow rate	m ³ /h	50.3		56.8	64.2	72.7	81.3	81.4	87.8	99.3	98.7	94.1	-	-	-	-
Water pressure loss	kPa	55		72	92	119	149	150	174	223	220	200	-	-	-	-
35	Heating capacity	kW	287.7	324.3	366.9	415.6	466.5	466.5	502.9	568.5	568.4	538.8	536.4	515.0	516.1	514.6
	Power consumption	kW	115.4	114.3	113.8	113.8	111.9	104.4	105.0	106.3	95.8	82.3	73.8	63.6	64.1	64.3
	Hot water flow rate	m ³ /h	49.5	55.8	63.1	71.5	80.2	80.2	86.5	97.8	97.8	92.7	92.3	88.6	88.8	88.5
	Water pressure loss	kPa	53	69	89	115	145	145	169	216	216	194	193	177	178	177
40	Heating capacity	kW	280.1	317.8	361.0	409.7	458.2	458.2	493.6	557.1	556.5	527.7	524.9	508.5	503.5	503.6
	Power consumption	kW	123.9	125.1	126.1	126.9	124.8	116.3	116.6	117.0	105.3	92.2	81.5	70.3	70.8	71.2
	Hot water flow rate	m ³ /h	48.2	54.7	62.1	70.5	78.8	78.8	84.9	95.8	95.7	90.8	90.3	87.5	86.6	86.6
	Water pressure loss	kPa	50	66	86	112	140	140	163	208	207	186	184	173	170	170
45	Heating capacity	kW	273.3	311.6	354.9	403.2	450.0	450.0	484.1	545.8	519.7	515.0	515.9	500.6	495.8	495.6
	Power consumption	kW	136.4	138.0	139.4	140.4	138.1	128.6	128.9	129.2	113.3	100.3	89.7	77.8	79.0	79.8
	Hot water flow rate	m ³ /h	47.0	53.6	61.0	69.3	77.4	77.4	83.3	93.9	89.4	88.6	88.7	86.1	85.3	85.2
	Water pressure loss	kPa	47	63	83	108	135	135	157	199	181	177	178	168	164	164
50	Heating capacity	kW	-	305.5	348.4	396.2	440.8	440.8	474.5	534.4	510.6	509.6	506.5	495.8	494.3	492.6
	Power consumption	kW	-	153.1	153.7	154.4	151.6	141.1	141.6	142.8	125.3	110.9	99.4	86.7	88.5	89.6
	Hot water flow rate	m ³ /h	-	52.5	59.9	68.1	75.8	75.8	81.6	91.9	87.8	87.6	87.1	85.3	85.0	84.7
	Water pressure loss	kPa	-	61	80	104	130	130	150	191	174	174	172	164	163	162
55	Heating capacity	kW	-	-	341.8	388.7	431.7	431.7	464.6	523.1	488.2	488.3	-	-	-	-
	Power consumption	kW	-	-	169.1	168.7	165.4	153.9	155.0	157.8	138.6	122.8	-	-	-	-
	Hot water flow rate	m ³ /h	-	-	58.8	66.9	74.2	74.2	79.9	90.0	84.0	84.0	-	-	-	-
	Water pressure loss	kPa	-	-	77	100	124	124	144	183	159	159	-	-	-	-

- * The power consumption value is rounded off to the first decimal place.
- * Outdoor air temperature from -6°C to +25°C: Hot water 55°C can be supplied.
- * Outdoor air temperature -10°C: Maximum water temperature 50°C.
- * Outdoor air temperature -15°C: Maximum water temperature 45°C.
- * This table shows the capacity when the relative humidity is 85%.
- * The performance is the value not including the defrost correction.

Capacity change mode: Capacity priority

MODEL			EAHV-P900YA × 6													
Hot water outlet temperature	Outdoor air temperature °CDB		-15	-10	-5	0	5	7	10	15	20	25	30	35	40	43
			30	Heating capacity	kW	350.9	396.5	447.8	507.2	567.5	567.6	612.4	692.4	688.6	656.8	-
Power consumption	kW	121.6		120.6	120.5	120.9	120.1	111.5	113.3	116.3	103.8	90.8	-	-	-	-
Hot water flow rate	m ³ /h	60.4		68.2	77.0	87.2	97.6	97.6	105.3	119.1	118.4	113.0	-	-	-	-
Water pressure loss	kPa	55		72	92	119	149	150	174	223	220	200	-	-	-	-
35	Heating capacity	kW	345.3	389.1	440.3	498.7	559.8	559.8	603.5	682.2	682.1	646.6	643.7	618.0	619.3	617.5
	Power consumption	kW	138.4	137.2	136.6	136.6	134.2	125.2	125.9	127.5	115.0	98.8	88.6	76.3	76.9	77.2
	Hot water flow rate	m ³ /h	59.4	66.9	75.7	85.8	96.3	96.3	103.8	117.3	117.3	111.2	110.7	106.3	106.5	106.2
	Water pressure loss	kPa	53	69	89	115	145	145	169	216	216	194	193	177	178	177
40	Heating capacity	kW	336.1	381.4	433.2	491.6	549.9	549.9	592.3	668.5	667.8	633.2	629.9	610.2	604.2	604.3
	Power consumption	kW	148.7	150.1	151.3	152.3	149.8	139.6	139.9	140.4	126.3	110.6	97.8	84.3	85.0	85.4
	Hot water flow rate	m ³ /h	57.8	65.6	74.5	84.6	94.6	94.6	101.9	115.0	114.9	108.9	108.3	105.0	103.9	103.9
	Water pressure loss	kPa	50	66	86	112	140	140	163	208	207	186	184	173	170	170
45	Heating capacity	kW	328.0	373.9	425.8	483.8	540.0	540.0	581.0	654.9	623.6	618.0	619.0	600.7	594.9	594.7
	Power consumption	kW	163.6	165.6	167.2	168.5	165.7	154.3	154.6	155.0	135.9	120.3	107.7	93.3	94.8	95.8
	Hot water flow rate	m ³ /h	56.4	64.3	73.2	83.2	92.9	92.9	99.9	112.6	107.3	106.3	106.5	103.3	102.3	102.3
	Water pressure loss	kPa	47	63	83	108	135	135	157	199	181	177	178	168	164	164
50	Heating capacity	kW	-	366.6	418.1	475.4	529.0	529.0	569.3	641.3	612.7	611.5	607.8	594.9	593.1	591.2
	Power consumption	kW	-	183.7	184.4	185.2	181.9	169.3	169.9	171.4	150.4	133.1	119.3	104.1	106.2	107.5
	Hot water flow rate	m ³ /h	-	63.1	71.9	81.8	91.0	91.0	97.9	110.3	105.4	105.2	104.5	102.3	102.0	101.7
	Water pressure loss	kPa	-	61	80	104	130	130	150	191	174	174	172	164	163	162
55	Heating capacity	kW	-	-	410.1	466.4	518.0	518.0	557.5	627.7	585.8	586.0	-	-	-	-
	Power consumption	kW	-	-	202.9	202.4	198.4	184.7	185.9	189.4	166.3	147.4	-	-	-	-
	Hot water flow rate	m ³ /h	-	-	70.5	80.2	89.1	89.1	95.9	108.0	100.8	100.8	-	-	-	-
	Water pressure loss	kPa	-	-	77	100	124	124	144	183	159	159	-	-	-	-

- * The power consumption value is rounded off to the first decimal place.
- * Outdoor air temperature from -6°C to +25°C: Hot water 55°C can be supplied.
- * Outdoor air temperature -10°C: Maximum water temperature 50°C.
- * Outdoor air temperature -15°C: Maximum water temperature 45°C.
- * This table shows the capacity when the relative humidity is 85%.
- * The performance is the value not including the defrost correction.

2. Product Data

Heating capacity: Hot water outlet/inlet temperature difference 5°C

Capacity change mode: COP priority

MODEL		EAHV-P900YA														
Hot water outlet temperature	Outdoor air temperature °CDB	-15	-10	-5	0	5	7	10	15	20	25	30	35	40	43	
		30	Heating capacity	kW	38.6	44.7	51.8	59.7	67.1	68.4	74.9	86.6	94.1	94.4	-	-
Power consumption	kW		12.8	12.6	12.6	12.7	12.6	12.2	12.4	12.8	12.4	11.9	-	-	-	-
Hot water flow rate	m ³ /h		7.7	7.7	8.9	10.3	11.5	11.8	12.9	14.9	16.2	16.2	-	-	-	-
Water pressure loss	kPa		30	30	42	58	74	77	93	125	148	149	-	-	-	-
35	Heating capacity	kW	38.4	44.0	50.7	58.5	65.7	66.4	72.5	83.6	92.5	93.0	97.9	103.0	103.2	102.9
	Power consumption	kW	14.5	14.4	14.4	14.4	14.3	13.8	13.9	14.1	13.8	13.0	12.8	12.7	12.8	12.9
	Hot water flow rate	m ³ /h	7.7	7.7	8.7	10.1	11.3	11.4	12.5	14.4	15.9	16.0	16.8	17.7	17.8	17.7
	Water pressure loss	kPa	30	30	40	55	71	72	87	116	143	145	160	177	178	177
40	Heating capacity	kW	37.4	42.7	49.3	57.0	64.2	64.8	70.1	80.6	89.7	90.4	97.4	101.7	100.7	100.7
	Power consumption	kW	16.0	16.0	16.0	16.1	16.0	15.3	15.4	15.6	15.2	14.5	14.2	14.1	14.2	14.2
	Hot water flow rate	m ³ /h	7.7	7.7	8.5	9.8	11.0	11.2	12.1	13.9	15.4	15.5	16.8	17.5	17.3	17.3
	Water pressure loss	kPa	30	30	38	52	67	69	81	108	134	136	159	173	170	170
45	Heating capacity	kW	35.7	41.2	47.8	55.5	62.7	63.0	68.1	77.8	79.6	87.0	96.6	100.1	99.2	99.1
	Power consumption	kW	17.4	17.6	17.7	17.9	17.7	17.0	17.0	17.1	16.3	15.8	15.7	15.6	15.8	16.0
	Hot water flow rate	m ³ /h	7.7	7.7	8.2	9.5	10.8	10.8	11.7	13.4	13.7	15.0	16.6	17.2	17.1	17.0
	Water pressure loss	kPa	30	30	35	49	64	65	76	100	105	126	156	168	164	164
50	Heating capacity	kW	-	39.9	46.4	54.0	61.2	61.8	66.7	75.1	77.7	84.1	94.4	99.2	98.9	98.5
	Power consumption	kW	-	19.3	19.5	19.6	19.5	18.7	18.7	18.8	18.0	17.5	17.4	17.3	17.7	17.9
	Hot water flow rate	m ³ /h	-	7.7	8.0	9.3	10.5	10.6	11.5	12.9	13.4	14.5	16.2	17.1	17.0	16.9
	Water pressure loss	kPa	-	30	33	46	61	62	73	94	100	118	149	164	163	162
55	Heating capacity	kW	-	-	45.0	52.5	59.6	60.2	65.1	73.0	75.2	81.8	-	-	-	-
	Power consumption	kW	-	-	21.5	21.6	21.4	20.5	20.6	20.8	20.0	19.5	-	-	-	-
	Hot water flow rate	m ³ /h	-	-	7.7	9.0	10.3	10.4	11.2	12.6	12.9	14.1	-	-	-	-
	Water pressure loss	kPa	-	-	30	43	57	59	69	88	94	111	-	-	-	-

* The power consumption value is rounded off to the first decimal place.

* Outdoor air temperature from -6°C to +25°C: Hot water 55°C can be supplied.

* Outdoor air temperature -10°C: Maximum water temperature 50°C.

* Outdoor air temperature -15°C: Maximum water temperature 45°C.

* This table shows the capacity when the relative humidity is 85%.

* The performance is the value not including the defrost correction.

* When conditions are met that only allow the unit to operate at a capacity below 45 kW and when the water flow rate cannot be reduced to a rate below the minimum required flow rate, the temperature difference between the hot water inlet and outlet will be less than 5°C.

Capacity change mode: COP priority

MODEL		EAHV-P900YA × 2														
Hot water outlet temperature	Outdoor air temperature °CDB	-15	-10	-5	0	5	7	10	15	20	25	30	35	40	43	
		30	Heating capacity	kW	77.2	89.4	103.6	119.4	134.3	136.8	149.9	173.3	188.2	188.8	-	-
Power consumption	kW		25.6	25.3	25.2	25.3	25.2	24.3	24.9	25.6	24.9	23.8	-	-	-	-
Hot water flow rate	m ³ /h		15.4	15.4	17.8	20.5	23.1	23.5	25.8	29.8	32.4	32.5	-	-	-	-
Water pressure loss	kPa		30	30	42	58	74	77	93	125	148	149	-	-	-	-
35	Heating capacity	kW	76.7	87.9	101.4	116.9	131.5	132.9	145.0	167.2	185.0	186.0	195.8	206.0	206.4	205.8
	Power consumption	kW	29.1	28.8	28.7	28.9	28.7	27.5	27.8	28.3	27.6	25.9	25.7	25.4	25.6	25.7
	Hot water flow rate	m ³ /h	15.4	15.4	17.4	20.1	22.6	22.9	24.9	28.8	31.8	32.0	33.7	35.4	35.5	35.4
	Water pressure loss	kPa	30	30	40	55	71	72	87	116	143	145	160	177	178	177
40	Heating capacity	kW	74.7	85.5	98.7	114.0	128.5	129.7	140.2	161.3	179.4	180.8	194.8	203.4	201.4	201.4
	Power consumption	kW	32.0	32.0	32.0	32.3	32.0	30.7	30.9	31.2	30.4	29.0	28.4	28.1	28.3	28.5
	Hot water flow rate	m ³ /h	15.4	15.4	17.0	19.6	22.1	22.3	24.1	27.7	30.9	31.1	33.5	35.0	34.6	34.6
	Water pressure loss	kPa	30	30	38	52	67	69	81	108	134	136	159	173	170	170
45	Heating capacity	kW	71.3	82.3	95.7	110.9	125.3	126.0	136.2	155.5	159.1	174.0	193.3	200.2	198.3	198.2
	Power consumption	kW	34.9	35.1	35.4	35.7	35.4	34.0	34.0	34.2	32.5	31.6	31.4	31.1	31.6	31.9
	Hot water flow rate	m ³ /h	15.4	15.4	16.5	19.1	21.6	21.6	23.4	26.8	27.4	29.9	33.2	34.4	34.1	34.1
	Water pressure loss	kPa	30	30	35	49	64	65	76	100	105	126	156	168	164	164
50	Heating capacity	kW	-	79.7	92.8	108.1	122.4	123.7	133.4	150.3	155.4	168.2	188.8	198.3	197.7	197.1
	Power consumption	kW	-	38.7	39.0	39.3	39.0	37.4	37.4	37.7	36.0	35.0	34.8	34.7	35.4	35.8
	Hot water flow rate	m ³ /h	-	15.4	16.0	18.6	21.1	21.3	22.9	25.8	26.7	28.9	32.5	34.1	34.0	33.9
	Water pressure loss	kPa	-	30	33	46	61	62	73	94	100	118	149	164	163	162
55	Heating capacity	kW	-	-	90.0	105.0	119.3	120.4	130.2	145.9	150.3	163.6	-	-	-	-
	Power consumption	kW	-	-	43.0	43.2	42.9	41.1	41.2	41.6	39.9	38.9	-	-	-	-
	Hot water flow rate	m ³ /h	-	-	15.5	18.1	20.5	20.7	22.4	25.1	25.9	28.1	-	-	-	-
	Water pressure loss	kPa	-	-	30	43	57	59	69	88	94	111	-	-	-	-

* The power consumption value is rounded off to the first decimal place.

* Outdoor air temperature from -6°C to +25°C: Hot water 55°C can be supplied.

* Outdoor air temperature -10°C: Maximum water temperature 50°C.

* Outdoor air temperature -15°C: Maximum water temperature 45°C.

* This table shows the capacity when the relative humidity is 85%.

* The performance is the value not including the defrost correction.

* When conditions are met that only allow the unit to operate at a capacity below 90 kW and when the water flow rate cannot be reduced to a rate below the minimum required flow rate, the temperature difference between the hot water inlet and outlet will be less than 5°C.

2. Product Data

Heating capacity: Hot water outlet/inlet temperature difference 5°C

Capacity change mode: COP priority

MODEL			EAHV-P900YA × 3													
Hot water outlet temperature	Outdoor air temperature °CDB		-15	-10	-5	0	5	7	10	15	20	25	30	35	40	43
			30	Heating capacity	kW	115.8	134.0	155.3	179.1	201.4	205.3	224.8	259.9	282.3	283.2	-
Power consumption	kW	38.4		37.9	37.8	38.0	37.9	36.5	37.3	38.4	37.3	35.8	-	-	-	-
Hot water flow rate	m ³ /h	23.1		23.1	26.7	30.8	34.6	35.3	38.7	44.7	48.6	48.7	-	-	-	-
Water pressure loss	kPa	30		30	42	58	74	77	93	125	148	149	-	-	-	-
35	Heating capacity	kW	115.1	131.9	152.1	175.4	197.2	199.3	217.5	250.8	277.6	279.1	293.8	309.0	309.6	308.8
	Power consumption	kW	43.6	43.2	43.1	43.3	43.0	41.3	41.8	42.4	41.3	38.9	38.5	38.2	38.4	38.6
	Hot water flow rate	m ³ /h	23.1	23.1	26.2	30.2	33.9	34.3	37.4	43.1	47.7	48.0	50.5	53.1	53.3	53.1
	Water pressure loss	kPa	30	30	40	55	71	72	87	116	143	145	160	177	178	177
40	Heating capacity	kW	112.1	128.2	148.0	171.0	192.7	194.5	210.3	241.9	269.1	271.1	292.2	305.1	302.1	302.1
	Power consumption	kW	48.0	48.0	48.1	48.4	48.1	46.0	46.3	46.8	45.6	43.5	42.5	42.2	42.5	42.7
	Hot water flow rate	m ³ /h	23.1	23.1	25.5	29.4	33.1	33.5	36.2	41.6	46.3	46.6	50.3	52.5	52.0	52.0
	Water pressure loss	kPa	30	30	38	52	67	69	81	108	134	136	159	173	170	170
45	Heating capacity	kW	107.0	123.5	143.5	166.4	188.0	189.0	204.3	233.3	238.7	261.1	289.9	300.4	297.5	297.4
	Power consumption	kW	52.3	52.7	53.1	53.6	53.2	51.0	51.0	51.4	48.8	47.5	47.0	46.7	47.4	47.9
	Hot water flow rate	m ³ /h	23.1	23.1	24.7	28.6	32.3	32.4	35.1	40.1	41.1	44.9	49.9	51.7	51.2	51.1
	Water pressure loss	kPa	30	30	35	49	64	65	76	100	105	126	156	168	164	164
50	Heating capacity	kW	-	119.6	139.2	162.1	183.7	185.5	200.1	225.4	233.1	252.4	283.2	297.5	296.6	295.6
	Power consumption	kW	-	58.0	58.5	58.9	58.5	56.0	56.2	56.5	54.0	52.6	52.3	52.0	53.1	53.8
	Hot water flow rate	m ³ /h	-	23.1	23.9	27.9	31.6	31.9	34.4	38.8	40.1	43.4	48.7	51.2	51.0	50.8
	Water pressure loss	kPa	-	30	33	46	61	62	73	94	100	118	149	164	163	162
55	Heating capacity	kW	-	-	135.0	157.4	178.9	180.7	195.3	218.9	225.5	245.4	-	-	-	-
	Power consumption	kW	-	-	64.5	64.8	64.3	61.6	61.9	62.3	59.9	58.4	-	-	-	-
	Hot water flow rate	m ³ /h	-	-	23.2	27.1	30.8	31.1	33.6	37.7	38.8	42.2	-	-	-	-
	Water pressure loss	kPa	-	-	30	43	57	59	69	88	94	111	-	-	-	-

* The power consumption value is rounded off to the first decimal place.

* Outdoor air temperature from -6°C to +25°C: Hot water 55°C can be supplied.

* Outdoor air temperature -10°C: Maximum water temperature 50°C.

* Outdoor air temperature -15°C: Maximum water temperature 45°C.

* This table shows the capacity when the relative humidity is 85%.

* The performance is the value not including the defrost correction.

* When conditions are met that only allow the unit to operate at a capacity below 135 kW and when the water flow rate cannot be reduced to a rate below the minimum required flow rate, the temperature difference between the hot water inlet and outlet will be less than 5°C.

Capacity change mode: COP priority

MODEL			EAHV-P900YA × 4													
Hot water outlet temperature	Outdoor air temperature °CDB		-15	-10	-5	0	5	7	10	15	20	25	30	35	40	43
			30	Heating capacity	kW	154.4	178.7	207.1	238.8	268.6	273.7	299.7	346.5	376.5	377.6	-
Power consumption	kW	51.3		50.6	50.4	50.6	50.5	48.6	49.7	51.2	49.7	47.7	-	-	-	-
Hot water flow rate	m ³ /h	30.8		30.8	35.6	41.1	46.2	47.1	51.6	59.6	64.8	65.0	-	-	-	-
Water pressure loss	kPa	30		30	42	58	74	77	93	125	148	149	-	-	-	-
35	Heating capacity	kW	153.5	175.9	202.8	233.8	263.0	265.7	290.0	334.4	370.1	372.1	391.7	412.0	412.9	411.7
	Power consumption	kW	58.1	57.6	57.5	57.8	57.4	55.1	55.7	56.6	55.1	51.9	51.4	50.9	51.3	51.5
	Hot water flow rate	m ³ /h	30.8	30.8	34.9	40.2	45.2	45.7	49.9	57.5	63.7	64.0	67.4	70.9	71.0	70.8
	Water pressure loss	kPa	30	30	40	55	71	72	87	116	143	145	160	177	178	177
40	Heating capacity	kW	149.4	171.0	197.4	228.0	257.0	259.4	280.4	322.6	358.8	361.5	389.6	406.8	402.8	402.8
	Power consumption	kW	64.0	64.0	64.1	64.6	64.1	61.4	61.7	62.4	60.7	58.1	56.7	56.2	56.7	56.9
	Hot water flow rate	m ³ /h	30.8	30.8	33.9	39.2	44.2	44.6	48.2	55.5	61.7	62.2	67.0	70.0	69.3	69.3
	Water pressure loss	kPa	30	30	38	52	67	69	81	108	134	136	159	173	170	170
45	Heating capacity	kW	142.7	164.7	191.4	221.8	250.7	252.0	272.4	311.1	318.3	348.1	386.6	400.5	396.6	396.5
	Power consumption	kW	69.7	70.3	70.8	71.4	70.9	68.0	68.0	68.5	65.0	63.3	62.7	62.2	63.2	63.9
	Hot water flow rate	m ³ /h	30.8	30.8	32.9	38.2	43.1	43.2	46.9	53.5	54.7	59.9	66.5	68.9	68.2	68.2
	Water pressure loss	kPa	30	30	35	49	64	65	76	100	105	126	156	168	164	164
50	Heating capacity	kW	-	159.4	185.6	216.2	244.9	247.3	266.7	300.6	310.8	336.5	377.5	396.6	395.4	394.1
	Power consumption	kW	-	77.3	78.0	78.6	78.1	74.7	74.9	75.4	72.0	70.1	69.7	69.4	70.8	71.7
	Hot water flow rate	m ³ /h	-	30.8	31.9	37.2	42.1	42.5	45.9	51.7	53.4	57.9	64.9	68.2	68.0	67.8
	Water pressure loss	kPa	-	30	33	46	61	62	73	94	100	118	149	164	163	162
55	Heating capacity	kW	-	-	180.0	209.9	238.5	240.9	260.4	291.9	300.6	327.2	-	-	-	-
	Power consumption	kW	-	-	86.0	86.4	85.7	82.2	82.5	83.1	79.9	77.8	-	-	-	-
	Hot water flow rate	m ³ /h	-	-	31.0	36.1	41.0	41.4	44.8	50.2	51.7	56.3	-	-	-	-
	Water pressure loss	kPa	-	-	30	43	57	59	69	88	94	111	-	-	-	-

* The power consumption value is rounded off to the first decimal place.

* Outdoor air temperature from -6°C to +25°C: Hot water 55°C can be supplied.

* Outdoor air temperature -10°C: Maximum water temperature 50°C.

* Outdoor air temperature -15°C: Maximum water temperature 45°C.

* This table shows the capacity when the relative humidity is 85%.

* The performance is the value not including the defrost correction.

* When conditions are met that only allow the unit to operate at a capacity below 180 kW and when the water flow rate cannot be reduced to a rate below the minimum required flow rate, the temperature difference between the hot water inlet and outlet will be less than 5°C.

2. Product Data

Heating capacity: Hot water outlet/inlet temperature difference 5°C

Capacity change mode: COP priority

MODEL		EAHV-P900YA × 5														
Hot water outlet temperature	Outdoor air temperature °CDB	-15	-10	-5	0	5	7	10	15	20	25	30	35	40	43	
30	Heating capacity	kW	193.0	223.4	258.9	298.5	335.7	342.1	374.7	433.1	470.6	472.1	-	-	-	-
	Power consumption	kW	64.1	63.2	63.0	63.3	63.1	60.8	62.2	64.0	62.1	59.6	-	-	-	-
	Hot water flow rate	m ³ /h	38.5	38.5	44.5	51.3	57.7	58.8	64.4	74.5	80.9	81.2	-	-	-	-
	Water pressure loss	kPa	30	30	42	58	74	77	93	125	148	149	-	-	-	-
35	Heating capacity	kW	191.8	219.8	253.5	292.3	328.7	332.2	362.6	418.0	462.6	465.1	489.6	515.0	516.1	514.6
	Power consumption	kW	72.6	72.0	71.9	72.2	71.7	68.8	69.6	70.7	68.9	64.9	64.2	63.6	64.1	64.3
	Hot water flow rate	m ³ /h	38.5	38.5	43.6	50.3	56.5	57.1	62.4	71.9	79.6	80.0	84.2	88.6	88.8	88.5
	Water pressure loss	kPa	30	30	40	55	71	72	87	116	143	145	160	177	178	177
40	Heating capacity	kW	186.8	213.7	246.7	285.0	321.2	324.2	350.6	403.2	448.5	451.9	487.0	508.5	503.5	503.6
	Power consumption	kW	80.0	79.9	80.1	80.7	80.1	76.7	77.1	77.9	75.9	72.6	70.9	70.3	70.8	71.2
	Hot water flow rate	m ³ /h	38.5	38.5	42.4	49.0	55.2	55.8	60.3	69.4	77.1	77.7	83.8	87.5	86.6	86.6
	Water pressure loss	kPa	30	30	38	52	67	69	81	108	134	136	159	173	170	170
45	Heating capacity	kW	178.3	205.8	239.2	277.3	313.4	315.0	340.5	388.9	397.8	435.1	483.2	500.6	495.8	495.6
	Power consumption	kW	87.1	87.9	88.5	89.3	88.6	85.0	85.0	85.6	81.3	79.1	78.4	77.8	79.0	79.8
	Hot water flow rate	m ³ /h	38.5	38.5	41.1	47.7	53.9	54.0	58.6	66.9	68.4	74.8	83.1	86.1	85.3	85.2
	Water pressure loss	kPa	30	30	35	49	64	65	76	100	105	126	156	168	164	164
50	Heating capacity	kW	-	199.3	232.0	270.2	306.1	309.1	333.4	375.7	388.4	420.6	471.9	495.8	494.3	492.6
	Power consumption	kW	-	96.7	97.5	98.2	97.6	93.4	93.6	94.2	89.9	87.6	87.1	86.7	88.5	89.6
	Hot water flow rate	m ³ /h	-	38.5	39.9	46.5	52.7	53.2	57.3	64.6	66.8	72.3	81.2	85.3	85.0	84.7
	Water pressure loss	kPa	-	30	33	46	61	62	73	94	100	118	149	164	163	162
55	Heating capacity	kW	-	-	225.0	262.4	298.2	301.1	325.5	364.9	375.8	409.0	-	-	-	-
	Power consumption	kW	-	-	107.5	108.0	107.1	102.7	103.1	103.9	99.9	97.3	-	-	-	-
	Hot water flow rate	m ³ /h	-	-	38.7	45.1	51.3	51.8	56.0	62.8	64.6	70.4	-	-	-	-
	Water pressure loss	kPa	-	-	30	43	57	59	69	88	94	111	-	-	-	-

* The power consumption value is rounded off to the first decimal place.

* Outdoor air temperature from -6°C to +25°C: Hot water 55°C can be supplied.

* Outdoor air temperature -10°C: Maximum water temperature 50°C.

* Outdoor air temperature -15°C: Maximum water temperature 45°C.

* This table shows the capacity when the relative humidity is 85%.

* The performance is the value not including the defrost correction.

* When conditions are met that only allow the unit to operate at a capacity below 225 kW and when the water flow rate cannot be reduced to a rate below the minimum required flow rate, the temperature difference between the hot water inlet and outlet will be less than 5°C.

Capacity change mode: COP priority

MODEL		EAHV-P900YA × 6														
Hot water outlet temperature	Outdoor air temperature °CDB	-15	-10	-5	0	5	7	10	15	20	25	30	35	40	43	
30	Heating capacity	kW	231.6	268.1	310.7	358.2	402.9	410.5	449.6	519.8	564.7	566.5	-	-	-	-
	Power consumption	kW	76.9	75.9	75.6	75.9	75.7	73.0	74.6	76.8	74.6	71.5	-	-	-	-
	Hot water flow rate	m ³ /h	46.2	46.2	53.4	61.6	69.3	70.6	77.3	89.4	97.1	97.4	-	-	-	-
	Water pressure loss	kPa	30	30	42	58	74	77	93	125	148	149	-	-	-	-
35	Heating capacity	kW	230.2	263.8	304.2	350.7	394.5	398.6	435.1	501.6	555.1	558.1	587.5	618.0	619.3	617.5
	Power consumption	kW	87.2	86.4	86.2	86.6	86.1	82.6	83.5	84.9	82.7	77.8	77.1	76.3	76.9	77.2
	Hot water flow rate	m ³ /h	46.2	46.2	52.3	60.3	67.9	68.6	74.8	86.3	95.5	96.0	101.1	106.3	106.5	106.2
	Water pressure loss	kPa	30	30	40	55	71	72	87	116	143	145	160	177	178	177
40	Heating capacity	kW	224.1	256.5	296.1	342.0	385.5	389.1	420.7	483.9	538.2	542.3	584.4	610.2	604.2	604.3
	Power consumption	kW	96.0	95.9	96.1	96.8	96.1	92.1	92.6	93.5	91.1	87.1	85.1	84.3	85.0	85.4
	Hot water flow rate	m ³ /h	46.2	46.2	50.9	58.8	66.3	66.9	72.4	83.2	92.6	93.3	100.5	105.0	103.9	103.9
	Water pressure loss	kPa	30	30	38	52	67	69	81	108	134	136	159	173	170	170
45	Heating capacity	kW	214.0	247.0	287.1	332.8	376.0	378.0	408.6	466.6	477.4	522.1	579.8	600.7	594.9	594.7
	Power consumption	kW	104.6	105.4	106.2	107.1	106.3	102.0	102.0	102.7	97.5	94.9	94.1	93.3	94.8	95.8
	Hot water flow rate	m ³ /h	46.2	46.2	49.4	57.2	64.7	64.8	70.3	80.3	82.1	89.8	99.7	103.3	102.3	102.3
	Water pressure loss	kPa	30	30	35	49	64	65	76	100	105	126	156	168	164	164
50	Heating capacity	kW	-	239.1	278.4	324.3	367.3	371.0	400.1	450.9	466.1	504.7	566.3	594.9	593.1	591.2
	Power consumption	kW	-	116.0	117.0	117.9	117.1	112.1	112.3	113.1	107.9	105.1	104.5	104.1	106.2	107.5
	Hot water flow rate	m ³ /h	-	46.2	47.9	55.8	63.2	63.8	68.8	77.5	80.2	86.8	97.4	102.3	102.0	101.7
	Water pressure loss	kPa	-	30	33	46	61	62	73	94	100	118	149	164	163	162
55	Heating capacity	kW	-	-	270.0	314.9	357.8	361.3	390.6	437.8	451.0	490.8	-	-	-	-
	Power consumption	kW	-	-	129.0	129.6	128.6	123.2	123.7	124.7	119.8	116.7	-	-	-	-
	Hot water flow rate	m ³ /h	-	-	46.4	54.2	61.5	62.1	67.2	75.3	77.6	84.4	-	-	-	-
	Water pressure loss	kPa	-	-	30	43	57	59	69	88	94	111	-	-	-	-

* The power consumption value is rounded off to the first decimal place.

* Outdoor air temperature from -6°C to +25°C: Hot water 55°C can be supplied.

* Outdoor air temperature -10°C: Maximum water temperature 50°C.

* Outdoor air temperature -15°C: Maximum water temperature 45°C.

* This table shows the capacity when the relative humidity is 85%.

* The performance is the value not including the defrost correction.

* When conditions are met that only allow the unit to operate at a capacity below 270 kW and when the water flow rate cannot be reduced to a rate below the minimum required flow rate, the temperature difference between the hot water inlet and outlet will be less than 5°C.

2. Product Data

Heating capacity: Hot water outlet/inlet temperature difference 7°C

Capacity change mode: Capacity priority

MODEL			EAHV-P900YA													
Hot water outlet temperature	Outdoor air temperature °CDB		-15	-10	-5	0	5	7	10	15	20	25	30	35	40	43
			30	Heating capacity	kW	58.4	66.1	74.8	84.8	94.9	95.0	102.2	115.7	114.9	109.6	-
Power consumption	kW	19.6		19.4	19.4	19.5	19.5	18.2	18.5	19.1	17.0	14.8	-	-	-	-
Hot water flow rate	m ³ /h	7.7		8.1	9.2	10.4	11.7	11.7	12.6	14.2	14.1	13.5	-	-	-	-
Water pressure loss	kPa	30		34	45	59	76	76	88	114	112	102	-	-	-	-
35	Heating capacity	kW	57.7	65.2	73.8	83.6	93.8	93.9	101.1	114.2	114.1	108.1	107.5	103.2	103.3	102.9
	Power consumption	kW	22.3	22.2	22.2	22.3	22.2	20.7	20.9	21.3	18.9	16.2	14.5	12.5	12.6	12.6
	Hot water flow rate	m ³ /h	7.7	8.0	9.1	10.3	11.5	11.5	12.4	14.0	14.0	13.3	13.2	12.7	12.7	12.6
	Water pressure loss	kPa	30	33	44	58	74	74	86	111	110	99	98	90	90	89
40	Heating capacity	kW	56.4	64.0	72.7	82.4	92.2	92.3	99.4	112.1	112.0	106.0	105.4	102.0	101.0	101.0
	Power consumption	kW	24.5	24.5	24.7	24.9	24.8	23.1	23.2	23.5	20.8	18.1	16.0	13.8	13.9	14.0
	Hot water flow rate	m ³ /h	7.7	7.9	8.9	10.1	11.3	11.3	12.2	13.8	13.8	13.0	12.9	12.5	12.4	12.4
	Water pressure loss	kPa	30	32	42	56	71	71	83	107	106	95	94	88	86	86
45	Heating capacity	kW	54.9	62.8	71.5	81.2	90.6	90.7	97.6	109.9	104.7	103.8	103.8	100.4	99.6	99.5
	Power consumption	kW	26.5	26.8	27.2	27.5	27.4	25.5	25.6	25.9	22.8	19.9	17.7	15.3	15.5	15.6
	Hot water flow rate	m ³ /h	7.7	7.7	8.8	10.0	11.1	11.1	12.0	13.5	12.9	12.8	12.7	12.3	12.2	12.2
	Water pressure loss	kPa	30	30	41	54	68	69	80	102	93	91	91	85	83	83
50	Heating capacity	kW	-	61.4	70.0	79.5	88.5	88.6	95.4	107.4	102.6	102.4	102.2	100.1	99.7	99.3
	Power consumption	kW	-	29.7	29.9	30.2	30.1	28.1	28.2	28.4	24.7	21.8	19.5	17.0	17.3	17.6
	Hot water flow rate	m ³ /h	-	7.7	8.6	9.8	10.9	10.9	11.7	13.2	12.6	12.6	12.6	12.3	12.2	12.2
	Water pressure loss	kPa	-	30	39	52	65	65	76	98	89	89	88	84	84	83
55	Heating capacity	kW	-	-	68.7	77.8	86.8	86.9	93.5	105.2	98.1	98.1	-	-	-	-
	Power consumption	kW	-	-	33.0	32.7	33.0	30.8	31.0	31.3	27.3	24.1	-	-	-	-
	Hot water flow rate	m ³ /h	-	-	8.4	9.6	10.7	10.7	11.5	12.9	12.1	12.0	-	-	-	-
	Water pressure loss	kPa	-	-	37	49	62	63	73	93	81	81	-	-	-	-

* The power consumption value is rounded off to the first decimal place.

* Outdoor air temperature from -6°C to +25°C: Hot water 55°C can be supplied.

* Outdoor air temperature -10°C: Maximam water temperature 50°C.

* Outdoor air temperature -15°C: Maximam water temperature 45°C.

* This table shows the capacity when the relative humidity is 85%.

* The performance is the value not including the defrost correction.

* When conditions are met that only allow the unit to operate at a capacity below 63 kW and when the water flow rate cannot be reduced to a rate below the minimum required flow rate, the temperature difference between the hot water inlet and outlet will be less than 7°C.

Capacity change mode: Capacity priority

MODEL			EAHV-P900YA × 2													
Hot water outlet temperature	Outdoor air temperature °CDB		-15	-10	-5	0	5	7	10	15	20	25	30	35	40	43
			30	Heating capacity	kW	116.8	132.2	149.5	169.5	189.9	190.0	204.5	231.4	229.8	219.2	-
Power consumption	kW	39.2		38.9	38.8	39.1	39.0	36.4	37.0	38.2	34.0	29.7	-	-	-	-
Hot water flow rate	m ³ /h	15.4		16.2	18.4	20.8	23.3	23.3	25.1	28.4	28.2	26.9	-	-	-	-
Water pressure loss	kPa	30		34	45	59	76	76	88	114	112	102	-	-	-	-
35	Heating capacity	kW	115.5	130.4	147.6	167.2	187.7	187.8	202.2	228.4	228.1	216.2	215.0	206.3	206.6	205.9
	Power consumption	kW	44.6	44.4	44.3	44.6	44.4	41.3	41.8	42.6	37.8	32.3	29.0	25.0	25.2	25.3
	Hot water flow rate	m ³ /h	15.4	16.0	18.1	20.5	23.1	23.1	24.8	28.1	28.0	26.6	26.4	25.3	25.4	25.3
	Water pressure loss	kPa	30	33	44	58	74	74	86	111	110	99	98	90	90	89
40	Heating capacity	kW	112.8	128.0	145.3	164.9	184.4	184.6	198.8	224.3	223.9	212.1	210.8	204.0	202.0	201.9
	Power consumption	kW	49.0	49.1	49.3	49.7	49.5	46.1	46.4	47.0	41.6	36.3	32.0	27.6	27.8	28.0
	Hot water flow rate	m ³ /h	15.4	15.7	17.9	20.3	22.7	22.7	24.4	27.6	27.5	26.1	25.9	25.1	24.8	24.8
	Water pressure loss	kPa	30	32	42	56	71	71	83	107	106	95	94	88	86	86
45	Heating capacity	kW	109.9	125.6	143.0	162.4	181.2	181.4	195.1	219.7	209.5	207.6	207.5	200.9	199.1	198.9
	Power consumption	kW	53.0	53.7	54.3	55.0	54.8	51.0	51.2	51.7	45.6	39.9	35.3	30.6	31.0	31.3
	Hot water flow rate	m ³ /h	15.4	15.4	17.6	19.9	22.3	22.3	24.0	27.0	25.7	25.5	25.5	24.7	24.5	24.4
	Water pressure loss	kPa	30	30	41	54	68	69	80	102	93	91	91	85	83	83
50	Heating capacity	kW	-	122.8	140.0	159.1	177.1	177.3	190.8	214.8	205.1	204.9	204.4	200.3	199.4	198.6
	Power consumption	kW	-	59.5	59.8	60.5	60.3	56.1	56.4	56.8	49.4	43.5	39.0	34.1	34.7	35.1
	Hot water flow rate	m ³ /h	-	15.4	17.2	19.5	21.8	21.8	23.4	26.4	25.2	25.2	25.1	24.6	24.5	24.4
	Water pressure loss	kPa	-	30	39	52	65	65	76	98	89	89	88	84	84	83
55	Heating capacity	kW	-	-	137.4	155.7	173.5	173.8	186.9	210.3	196.2	196.1	-	-	-	-
	Power consumption	kW	-	-	65.9	65.4	66.1	61.6	61.9	62.6	54.6	48.2	-	-	-	-
	Hot water flow rate	m ³ /h	-	-	16.9	19.1	21.3	21.3	23.0	25.8	24.1	24.1	-	-	-	-
	Water pressure loss	kPa	-	-	37	49	62	63	73	93	81	81	-	-	-	-

* The power consumption value is rounded off to the first decimal place.

* Outdoor air temperature from -6°C to +25°C: Hot water 55°C can be supplied.

* Outdoor air temperature -10°C: Maximam water temperature 50°C.

* Outdoor air temperature -15°C: Maximam water temperature 45°C.

* This table shows the capacity when the relative humidity is 85%.

* The performance is the value not including the defrost correction.

* When conditions are met that only allow the unit to operate at a capacity below 126 kW and when the water flow rate cannot be reduced to a rate below the minimum required flow rate, the temperature difference between the hot water inlet and outlet will be less than 7°C.

2. Product Data

Heating capacity: Hot water outlet/inlet temperature difference 7°C

Capacity change mode: Capacity priority

MODEL		EAHV-P900YA × 3														
Hot water outlet temperature	Outdoor air temperature °CDB	-15	-10	-5	0	5	7	10	15	20	25	30	35	40	43	
30	Heating capacity	kW	175.2	198.3	224.3	254.3	284.8	285.1	306.7	347.1	344.8	328.8	-	-	-	-
	Power consumption	kW	58.8	58.3	58.2	58.6	58.6	54.6	55.5	57.3	51.0	44.5	-	-	-	-
	Hot water flow rate	m ³ /h	23.1	24.4	27.6	31.2	35.0	35.0	37.7	42.6	42.4	40.4	-	-	-	-
	Water pressure loss	kPa	30	34	45	59	76	76	88	114	112	102	-	-	-	-
35	Heating capacity	kW	173.2	195.5	221.4	250.8	281.5	281.7	303.3	342.7	342.2	322.6	309.5	309.9	308.8	
	Power consumption	kW	66.9	66.5	66.5	66.9	66.6	62.0	62.6	63.8	56.7	48.5	43.5	37.5	37.8	37.9
	Hot water flow rate	m ³ /h	23.1	24.0	27.2	30.8	34.6	34.6	37.3	42.1	42.0	39.8	39.6	38.0	38.1	37.9
	Water pressure loss	kPa	30	33	44	58	74	74	86	111	110	99	98	90	90	89
40	Heating capacity	kW	169.2	192.0	218.0	247.3	276.7	276.9	298.2	336.4	335.9	318.1	316.1	306.0	303.0	302.9
	Power consumption	kW	73.5	73.6	74.0	74.6	74.3	69.2	69.6	70.5	62.3	54.4	48.1	41.4	41.8	41.9
	Hot water flow rate	m ³ /h	23.1	23.6	26.8	30.4	34.0	34.0	36.6	41.3	41.3	39.1	38.8	37.6	37.2	37.2
	Water pressure loss	kPa	30	32	42	56	71	71	83	107	106	95	94	88	86	86
45	Heating capacity	kW	164.8	188.4	214.4	243.5	271.8	272.1	292.7	329.6	314.2	311.4	311.3	301.3	298.7	298.4
	Power consumption	kW	79.4	80.5	81.5	82.5	82.2	76.5	76.8	77.6	68.4	59.8	53.0	45.9	46.5	46.9
	Hot water flow rate	m ³ /h	23.1	23.1	26.3	29.9	33.4	33.4	36.0	40.5	38.6	38.3	38.2	37.0	36.7	36.7
	Water pressure loss	kPa	30	30	41	54	68	69	80	102	93	91	91	85	83	83
50	Heating capacity	kW	-	184.3	210.0	238.6	265.6	265.9	286.1	322.2	307.7	307.3	306.6	300.4	299.1	297.9
	Power consumption	kW	-	89.2	89.7	90.7	90.4	84.2	84.6	85.3	74.1	65.3	58.5	51.1	52.0	52.7
	Hot water flow rate	m ³ /h	-	23.1	25.8	29.3	32.6	32.7	35.2	39.6	37.8	37.8	37.7	36.9	36.7	36.6
	Water pressure loss	kPa	-	30	39	52	65	65	76	98	89	89	88	84	84	83
55	Heating capacity	kW	-	-	206.1	233.5	260.3	260.6	280.4	315.5	294.3	294.2	-	-	-	-
	Power consumption	kW	-	-	98.9	98.1	99.1	92.3	92.9	93.9	81.9	72.3	-	-	-	-
	Hot water flow rate	m ³ /h	-	-	25.3	28.7	32.0	32.0	34.4	38.8	36.2	36.1	-	-	-	-
	Water pressure loss	kPa	-	-	37	49	62	63	73	93	81	81	-	-	-	-

* The power consumption value is rounded off to the first decimal place.

* Outdoor air temperature from -6°C to +25°C: Hot water 55°C can be supplied.

* Outdoor air temperature -10°C: Maximam water temperature 50°C.

* Outdoor air temperature -15°C: Maximam water temperature 45°C.

* This table shows the capacity when the relative humidity is 85%.

* The performance is the value not including the defrost correction.

* When conditions are met that only allow the unit to operate at a capacity below 189 kW and when the water flow rate cannot be reduced to a rate below the minimum required flow rate, the temperature difference between the hot water inlet and outlet will be less than 7°C.

Capacity change mode: Capacity priority

MODEL		EAHV-P900YA × 4														
Hot water outlet temperature	Outdoor air temperature °CDB	-15	-10	-5	0	5	7	10	15	20	25	30	35	40	43	
30	Heating capacity	kW	233.6	264.4	299.0	339.0	379.7	380.1	408.9	462.8	459.7	438.3	-	-	-	-
	Power consumption	kW	78.4	77.7	77.6	78.1	78.1	72.8	74.1	76.4	68.0	59.4	-	-	-	-
	Hot water flow rate	m ³ /h	30.8	32.5	36.7	41.7	46.7	46.7	50.2	56.9	56.5	53.9	-	-	-	-
	Water pressure loss	kPa	30	34	45	59	76	76	88	114	112	102	-	-	-	-
35	Heating capacity	kW	231.0	260.7	295.2	334.4	375.4	375.6	404.4	456.9	456.2	432.4	430.1	412.7	413.2	411.7
	Power consumption	kW	89.3	88.7	88.7	89.2	88.7	82.6	83.5	85.1	75.6	64.7	58.0	50.0	50.3	50.5
	Hot water flow rate	m ³ /h	30.8	32.0	36.3	41.1	46.1	46.2	49.7	56.1	56.1	53.1	52.8	50.7	50.8	50.6
	Water pressure loss	kPa	30	33	44	58	74	74	86	111	110	99	98	90	90	89
40	Heating capacity	kW	225.7	256.0	290.7	329.8	368.9	369.2	397.6	448.5	447.8	424.1	421.5	408.1	404.0	403.8
	Power consumption	kW	98.0	98.2	98.6	99.5	99.1	92.2	92.8	94.0	83.1	72.5	64.1	55.3	55.7	55.9
	Hot water flow rate	m ³ /h	30.8	31.4	35.7	40.5	45.3	45.4	48.8	55.1	55.0	52.1	51.8	50.1	49.6	49.6
	Water pressure loss	kPa	30	32	42	56	71	71	83	107	106	95	94	88	86	86
45	Heating capacity	kW	219.7	251.2	285.9	324.7	362.4	362.8	390.2	439.4	419.0	415.1	415.1	401.7	398.3	397.8
	Power consumption	kW	105.9	107.3	108.7	110.0	109.6	102.0	102.5	103.4	91.2	79.7	70.6	61.1	62.0	62.6
	Hot water flow rate	m ³ /h	30.8	30.9	35.1	39.9	44.5	44.6	47.9	54.0	51.5	51.0	51.0	49.4	48.9	48.9
	Water pressure loss	kPa	30	30	41	54	68	69	80	102	93	91	91	85	83	83
50	Heating capacity	kW	-	245.7	280.0	318.2	354.2	354.6	381.5	429.6	410.2	409.8	408.8	400.5	398.8	397.1
	Power consumption	kW	-	119.0	119.6	120.9	120.6	112.2	112.7	113.7	98.7	87.0	78.0	68.1	69.4	70.2
	Hot water flow rate	m ³ /h	-	30.8	34.4	39.1	43.5	43.6	46.9	52.8	50.4	50.3	50.2	49.2	49.0	48.8
	Water pressure loss	kPa	-	30	39	52	65	65	76	98	89	89	88	84	84	83
55	Heating capacity	kW	-	-	274.8	311.4	347.0	347.5	373.8	420.6	392.5	392.3	-	-	-	-
	Power consumption	kW	-	-	131.8	130.8	132.1	123.1	123.9	125.2	109.2	96.4	-	-	-	-
	Hot water flow rate	m ³ /h	-	-	33.8	38.3	42.6	42.7	45.9	51.7	48.2	48.2	-	-	-	-
	Water pressure loss	kPa	-	-	37	49	62	63	73	93	81	81	-	-	-	-

* The power consumption value is rounded off to the first decimal place.

* Outdoor air temperature from -6°C to +25°C: Hot water 55°C can be supplied.

* Outdoor air temperature -10°C: Maximam water temperature 50°C.

* Outdoor air temperature -15°C: Maximam water temperature 45°C.

* This table shows the capacity when the relative humidity is 85%.

* The performance is the value not including the defrost correction.

* When conditions are met that only allow the unit to operate at a capacity below 252 kW and when the water flow rate cannot be reduced to a rate below the minimum required flow rate, the temperature difference between the hot water inlet and outlet will be less than 7°C.

2. Product Data

Heating capacity: Hot water outlet/inlet temperature difference 7°C

Capacity change mode: Capacity priority

MODEL			EAHV-P900YA × 5													
Hot water outlet temperature	Outdoor air temperature °CDB		-15	-10	-5	0	5	7	10	15	20	25	30	35	40	43
			30	Heating capacity	kW	292.0	330.5	373.8	423.8	474.7	475.1	511.1	578.5	574.6	547.9	-
Power consumption	kW	98.0		97.1	97.0	97.7	97.6	91.0	92.6	95.6	85.1	74.2	-	-	-	-
Hot water flow rate	m ³ /h	38.5		40.6	45.9	52.1	58.3	58.4	62.8	71.1	70.6	67.3	-	-	-	-
Water pressure loss	kPa	30		34	45	59	76	76	88	114	112	102	-	-	-	-
35	Heating capacity	kW	288.7	325.9	369.0	418.0	469.2	469.6	505.6	571.1	570.3	540.5	537.6	515.8	516.5	514.7
	Power consumption	kW	111.6	110.9	110.8	111.4	110.9	103.3	104.4	106.4	94.5	80.8	72.5	62.5	62.9	63.2
	Hot water flow rate	m ³ /h	38.5	40.0	45.3	51.4	57.6	57.7	62.1	70.2	70.1	66.4	66.0	63.4	63.5	63.2
	Water pressure loss	kPa	30	33	44	58	74	74	86	111	110	99	98	90	90	89
40	Heating capacity	kW	282.1	320.0	363.4	412.2	461.1	461.5	497.0	560.7	559.8	530.1	526.9	510.1	505.0	504.8
	Power consumption	kW	122.5	122.7	123.3	124.4	123.9	115.3	116.0	117.4	103.9	90.6	80.1	69.1	69.6	69.9
	Hot water flow rate	m ³ /h	38.5	39.3	44.6	50.6	56.6	56.7	61.1	68.9	68.8	65.1	64.7	62.7	62.0	62.0
	Water pressure loss	kPa	30	32	42	56	71	71	83	107	106	95	94	88	86	86
45	Heating capacity	kW	274.6	314.0	357.4	405.9	453.0	453.5	487.8	549.3	523.7	518.9	518.8	502.1	497.8	497.3
	Power consumption	kW	132.4	134.1	135.8	137.5	137.0	127.5	128.1	129.3	114.0	99.7	88.3	76.4	77.5	78.2
	Hot water flow rate	m ³ /h	38.5	38.6	43.9	49.9	55.7	55.7	59.9	67.5	64.3	63.8	63.7	61.7	61.2	61.1
	Water pressure loss	kPa	30	30	41	54	68	69	80	102	93	91	91	85	83	83
50	Heating capacity	kW	-	307.1	350.0	397.7	442.7	443.2	476.9	537.0	512.8	512.2	510.9	500.7	498.5	496.4
	Power consumption	kW	-	148.7	149.5	151.2	150.7	140.3	140.9	142.1	123.4	108.8	97.5	85.2	86.7	87.8
	Hot water flow rate	m ³ /h	-	38.5	43.0	48.9	54.4	54.4	58.6	66.0	63.0	62.9	62.8	61.5	61.2	61.0
	Water pressure loss	kPa	-	30	39	52	65	65	76	98	89	89	88	84	84	83
55	Heating capacity	kW	-	-	343.5	389.2	433.8	434.4	467.3	525.8	490.6	490.4	-	-	-	-
	Power consumption	kW	-	-	164.8	163.5	165.2	153.9	154.8	156.5	136.5	120.5	-	-	-	-
	Hot water flow rate	m ³ /h	-	-	42.2	47.8	53.3	53.4	57.4	64.6	60.3	60.2	-	-	-	-
	Water pressure loss	kPa	-	-	37	49	62	63	73	93	81	81	-	-	-	-

* The power consumption value is rounded off to the first decimal place.

* Outdoor air temperature from -6°C to +25°C: Hot water 55°C can be supplied.

* Outdoor air temperature -10°C: Maximam water temperature 50°C.

* Outdoor air temperature -15°C: Maximam water temperature 45°C.

* This table shows the capacity when the relative humidity is 85%.

* The performance is the value not including the defrost correction.

* When conditions are met that only allow the unit to operate at a capacity below 315 kW and when the water flow rate cannot be reduced to a rate below the minimum required flow rate, the temperature difference between the hot water inlet and outlet will be less than 7°C.

Capacity change mode: Capacity priority

MODEL			EAHV-P900YA × 6													
Hot water outlet temperature	Outdoor air temperature °CDB		-15	-10	-5	0	5	7	10	15	20	25	30	35	40	43
			30	Heating capacity	kW	350.4	396.6	448.6	508.6	569.6	570.1	613.4	694.2	689.5	657.5	-
Power consumption	kW	117.6		116.6	116.4	117.2	117.1	109.2	111.1	114.7	102.1	89.1	-	-	-	-
Hot water flow rate	m ³ /h	46.2		48.7	55.1	62.5	70.0	70.0	75.4	85.3	84.7	80.8	-	-	-	-
Water pressure loss	kPa	30		34	45	59	76	76	88	114	112	102	-	-	-	-
35	Heating capacity	kW	346.5	391.1	442.8	501.6	563.0	563.5	606.7	685.3	684.4	648.6	645.1	619.0	619.8	617.6
	Power consumption	kW	133.9	133.1	133.0	133.7	133.1	123.9	125.3	127.7	113.3	97.0	87.0	75.0	75.5	75.8
	Hot water flow rate	m ³ /h	46.2	48.0	54.4	61.6	69.2	69.2	74.5	84.2	84.1	79.7	79.3	76.0	76.1	75.9
	Water pressure loss	kPa	30	33	44	58	74	74	86	111	110	99	98	90	90	89
40	Heating capacity	kW	338.5	384.0	436.0	494.7	553.3	553.8	596.4	672.8	671.7	636.2	632.3	612.1	606.0	605.7
	Power consumption	kW	146.9	147.2	148.0	149.2	148.6	138.3	139.2	140.9	124.7	108.8	96.1	82.9	83.5	83.9
	Hot water flow rate	m ³ /h	46.2	47.2	53.6	60.8	68.0	68.0	73.3	82.7	82.5	78.2	77.7	75.2	74.4	74.4
	Water pressure loss	kPa	30	32	42	56	71	71	83	107	106	95	94	88	86	86
45	Heating capacity	kW	329.6	376.8	428.9	487.1	543.6	544.2	585.3	659.1	628.5	622.7	622.6	602.6	597.4	596.7
	Power consumption	kW	158.9	161.0	163.0	165.0	164.4	153.0	153.7	155.2	136.8	119.6	106.0	91.7	93.0	93.9
	Hot water flow rate	m ³ /h	46.2	46.3	52.7	59.8	66.8	66.9	71.9	81.0	77.2	76.5	76.5	74.0	73.4	73.3
	Water pressure loss	kPa	30	30	41	54	68	69	80	102	93	91	91	85	83	83
50	Heating capacity	kW	-	368.5	420.0	477.2	531.3	531.8	572.3	644.4	615.3	614.6	613.1	600.8	598.2	595.7
	Power consumption	kW	-	178.4	179.4	181.4	180.8	168.3	169.1	170.5	148.1	130.5	117.0	102.2	104.1	105.3
	Hot water flow rate	m ³ /h	-	46.2	51.6	58.6	65.3	65.3	70.3	79.2	75.6	75.5	75.3	73.8	73.5	73.2
	Water pressure loss	kPa	-	30	39	52	65	65	76	98	89	89	88	84	84	83
55	Heating capacity	kW	-	-	412.2	467.0	520.5	521.3	560.7	630.9	588.7	588.4	-	-	-	-
	Power consumption	kW	-	-	197.7	196.1	198.2	184.7	185.8	187.8	163.8	144.6	-	-	-	-
	Hot water flow rate	m ³ /h	-	-	50.6	57.4	64.0	64.0	68.9	77.5	72.3	72.3	-	-	-	-
	Water pressure loss	kPa	-	-	37	49	62	63	73	93	81	81	-	-	-	-

* The power consumption value is rounded off to the first decimal place.

* Outdoor air temperature from -6°C to +25°C: Hot water 55°C can be supplied.

* Outdoor air temperature -10°C: Maximam water temperature 50°C.

* Outdoor air temperature -15°C: Maximam water temperature 45°C.

* This table shows the capacity when the relative humidity is 85%.

* The performance is the value not including the defrost correction.

* When conditions are met that only allow the unit to operate at a capacity below 378 kW and when the water flow rate cannot be reduced to a rate below the minimum required flow rate, the temperature difference between the hot water inlet and outlet will be less than 7°C.

2. Product Data

Heating capacity: Hot water outlet/inlet temperature difference 7°C

Capacity change mode: COP priority

MODEL		EAHV-P900YA														
Hot water outlet temperature	Outdoor air temperature °CDB	-15	-10	-5	0	5	7	10	15	20	25	30	35	40	43	
30	Heating capacity	kW	38.7	44.8	52.0	59.9	67.3	68.6	75.1	86.6	94.1	94.3	-	-	-	-
	Power consumption	kW	12.4	12.2	12.2	12.2	12.2	11.8	12.1	12.5	12.2	11.7	-	-	-	-
	Hot water flow rate	m ³ /h	7.7	7.7	7.7	7.7	8.3	8.4	9.2	10.6	11.6	11.6	-	-	-	-
	Water pressure loss	kPa	30	30	30	30	36	37	46	62	74	74	-	-	-	-
35	Heating capacity	kW	38.6	44.3	51.1	58.9	66.2	66.9	73.2	84.4	93.2	93.8	98.7	103.2	103.3	102.9
	Power consumption	kW	14.3	14.1	14.1	14.2	14.1	13.5	13.7	13.9	13.5	12.8	12.6	12.5	12.6	12.6
	Hot water flow rate	m ³ /h	7.7	7.7	7.7	7.7	8.1	8.2	9.0	10.4	11.4	11.5	12.1	12.7	12.7	12.6
	Water pressure loss	kPa	30	30	30	30	34	35	43	59	73	74	82	90	90	89
40	Heating capacity	kW	37.7	43.2	49.8	57.5	64.7	65.3	70.5	81.1	90.3	91.2	98.2	102.0	101.0	101.0
	Power consumption	kW	15.7	15.7	15.7	15.8	15.7	15.1	15.2	15.3	14.9	14.3	14.0	13.8	13.9	14.0
	Hot water flow rate	m ³ /h	7.7	7.7	7.7	7.7	8.0	8.0	8.7	10.0	11.1	11.2	12.1	12.5	12.4	12.4
	Water pressure loss	kPa	30	30	30	30	32	33	40	54	68	69	81	88	86	86
45	Heating capacity	kW	36.1	41.6	48.3	56.0	63.2	63.8	68.6	78.3	80.0	87.4	96.9	100.4	99.6	99.5
	Power consumption	kW	17.1	17.3	17.4	17.5	17.4	16.7	16.7	16.8	16.4	15.8	15.4	15.3	15.5	15.6
	Hot water flow rate	m ³ /h	7.7	7.7	7.7	7.7	7.8	7.8	8.4	9.6	9.8	10.7	11.9	12.3	12.2	12.2
	Water pressure loss	kPa	30	30	30	30	31	31	37	50	52	63	79	85	83	83
50	Heating capacity	kW	-	40.3	46.9	54.6	61.8	62.4	67.2	75.6	78.3	84.7	95.1	100.1	99.7	99.3
	Power consumption	kW	-	19.0	19.2	19.3	19.2	18.4	18.4	18.5	17.7	17.2	17.1	17.0	17.3	17.6
	Hot water flow rate	m ³ /h	-	7.7	7.7	7.7	7.7	7.7	8.3	9.3	9.6	10.4	11.7	12.3	12.2	12.2
	Water pressure loss	kPa	-	30	30	30	30	30	35	46	50	59	76	84	84	83
55	Heating capacity	kW	-	-	45.5	53.1	60.2	60.8	65.7	73.6	75.8	82.5	-	-	-	-
	Power consumption	kW	-	-	21.1	21.2	21.1	20.2	20.3	20.4	19.6	19.1	-	-	-	-
	Hot water flow rate	m ³ /h	-	-	7.7	7.7	7.7	7.7	8.1	9.0	9.3	10.1	-	-	-	-
	Water pressure loss	kPa	-	-	30	30	30	30	34	44	47	56	-	-	-	-

* The power consumption value is rounded off to the first decimal place.

* Outdoor air temperature from -6°C to +25°C: Hot water 55°C can be supplied.

* Outdoor air temperature -10°C: Maximum water temperature 50°C.

* Outdoor air temperature -15°C: Maximum water temperature 45°C.

* This table shows the capacity when the relative humidity is 85%.

* The performance is the value not including the defrost correction.

* When conditions are met that only allow the unit to operate at a capacity below 63 kW and when the water flow rate cannot be reduced to a rate below the minimum required flow rate, the temperature difference between the hot water inlet and outlet will be less than 7°C.

Capacity change mode: COP priority

MODEL		EAHV-P900YA × 2														
Hot water outlet temperature	Outdoor air temperature °CDB	-15	-10	-5	0	5	7	10	15	20	25	30	35	40	43	
30	Heating capacity	kW	77.3	89.6	103.9	119.8	134.7	137.1	150.3	173.2	188.1	188.6	-	-	-	-
	Power consumption	kW	24.8	24.4	24.3	24.4	24.4	23.5	24.1	25.0	24.4	23.4	-	-	-	-
	Hot water flow rate	m ³ /h	15.4	15.4	15.4	15.4	16.5	16.8	18.5	21.3	23.1	23.2	-	-	-	-
	Water pressure loss	kPa	30	30	30	30	36	37	46	62	74	74	-	-	-	-
35	Heating capacity	kW	77.2	88.6	102.2	117.8	132.4	133.8	146.4	168.9	186.3	187.5	197.3	206.3	206.6	205.9
	Power consumption	kW	28.5	28.3	28.2	28.3	28.1	27.0	27.3	27.8	27.1	25.5	25.3	25.0	25.2	25.3
	Hot water flow rate	m ³ /h	15.4	15.4	15.4	15.4	16.3	16.4	18.0	20.7	22.9	23.0	24.2	25.3	25.4	25.3
	Water pressure loss	kPa	30	30	30	30	34	35	43	59	73	74	82	90	90	89
40	Heating capacity	kW	75.4	86.3	99.6	115.0	129.4	130.7	141.0	162.3	180.5	182.4	196.4	204.0	202.0	201.9
	Power consumption	kW	31.5	31.4	31.5	31.7	31.5	30.2	30.3	30.7	29.9	28.5	27.9	27.6	27.8	28.0
	Hot water flow rate	m ³ /h	15.4	15.4	15.4	15.4	15.9	16.1	17.3	19.9	22.2	22.4	24.1	25.1	24.8	24.8
	Water pressure loss	kPa	30	30	30	30	32	33	40	54	68	69	81	88	86	86
45	Heating capacity	kW	72.3	83.2	96.6	111.9	126.4	127.6	137.2	156.5	159.9	174.7	193.9	200.9	199.1	198.9
	Power consumption	kW	34.3	34.6	34.8	35.1	34.8	33.4	33.4	33.7	32.9	31.6	30.9	30.6	31.0	31.3
	Hot water flow rate	m ³ /h	15.4	15.4	15.4	15.4	15.5	15.7	16.9	19.2	19.6	21.5	23.8	24.7	24.5	24.4
	Water pressure loss	kPa	30	30	30	30	31	31	37	50	52	63	79	85	83	83
50	Heating capacity	kW	-	80.6	93.8	109.2	123.6	124.8	134.5	151.3	156.6	169.4	190.1	200.3	199.4	198.6
	Power consumption	kW	-	38.0	38.3	38.6	38.4	36.7	36.8	37.0	35.3	34.4	34.2	34.1	34.7	35.1
	Hot water flow rate	m ³ /h	-	15.4	15.4	15.4	15.4	15.3	16.5	18.6	19.2	20.8	23.4	24.6	24.5	24.4
	Water pressure loss	kPa	-	30	30	30	30	30	35	46	50	59	76	84	84	83
55	Heating capacity	kW	-	-	91.0	106.1	120.5	121.7	131.4	147.2	151.7	164.9	-	-	-	-
	Power consumption	kW	-	-	42.2	42.4	42.1	40.4	40.5	40.8	39.2	38.2	-	-	-	-
	Hot water flow rate	m ³ /h	-	-	15.4	15.4	15.4	15.4	16.1	18.1	18.6	20.3	-	-	-	-
	Water pressure loss	kPa	-	-	30	30	30	30	34	44	47	56	-	-	-	-

* The power consumption value is rounded off to the first decimal place.

* Outdoor air temperature from -6°C to +25°C: Hot water 55°C can be supplied.

* Outdoor air temperature -10°C: Maximum water temperature 50°C.

* Outdoor air temperature -15°C: Maximum water temperature 45°C.

* This table shows the capacity when the relative humidity is 85%.

* The performance is the value not including the defrost correction.

* When conditions are met that only allow the unit to operate at a capacity below 126 kW and when the water flow rate cannot be reduced to a rate below the minimum required flow rate, the temperature difference between the hot water inlet and outlet will be less than 7°C.

2. Product Data

Heating capacity: Hot water outlet/inlet temperature difference 7°C

Capacity change mode: COP priority

MODEL			EAHV-P900YA × 3													
Hot water outlet temperature	Outdoor air temperature °CDB		-15	-10	-5	0	5	7	10	15	20	25	30	35	40	43
			30	Heating capacity	kW	116.0	134.4	155.9	179.7	202.0	205.7	225.4	259.8	282.2	282.9	-
Power consumption	kW	37.1		36.6	36.5	36.6	36.6	35.3	36.2	37.5	36.5	35.1	-	-	-	-
Hot water flow rate	m ³ /h	23.1		23.1	23.1	23.1	24.8	25.3	27.7	31.9	34.7	34.8	-	-	-	-
Water pressure loss	kPa	30		30	30	30	36	37	46	62	74	74	-	-	-	-
35	Heating capacity	kW	115.8	132.9	153.3	176.7	198.6	200.6	219.6	253.3	279.5	281.3	296.0	309.5	309.9	308.8
	Power consumption	kW	42.8	42.4	42.3	42.5	42.2	40.5	41.0	41.7	40.6	38.3	37.9	37.5	37.8	37.9
	Hot water flow rate	m ³ /h	23.1	23.1	23.1	23.1	24.4	24.7	27.0	31.1	34.3	34.6	36.4	38.0	38.1	37.9
	Water pressure loss	kPa	30	30	30	30	34	35	43	59	73	74	82	90	90	89
40	Heating capacity	kW	113.1	129.5	149.4	172.4	194.2	196.0	211.5	243.4	270.8	273.6	294.6	306.0	303.0	302.9
	Power consumption	kW	47.2	47.1	47.2	47.5	47.2	45.2	45.5	46.0	44.8	42.8	41.9	41.4	41.8	41.9
	Hot water flow rate	m ³ /h	23.1	23.1	23.1	23.1	23.9	24.1	26.0	29.9	33.3	33.6	36.2	37.6	37.2	37.2
	Water pressure loss	kPa	30	30	30	30	32	33	40	54	68	69	81	88	86	86
45	Heating capacity	kW	108.4	124.8	145.0	167.9	189.6	191.4	205.9	234.8	239.9	262.1	290.8	301.3	298.7	298.4
	Power consumption	kW	51.4	51.9	52.2	52.6	52.2	50.0	50.1	50.5	49.3	47.3	46.3	45.9	46.5	46.9
	Hot water flow rate	m ³ /h	23.1	23.1	23.1	23.1	23.3	23.5	25.3	28.8	29.5	32.2	35.7	37.0	36.7	36.7
	Water pressure loss	kPa	30	30	30	30	31	31	37	50	52	63	79	85	83	83
50	Heating capacity	kW	-	120.9	140.7	163.8	185.4	187.2	201.7	226.9	234.9	254.0	285.2	300.4	299.1	297.9
	Power consumption	kW	-	56.9	57.5	57.9	57.5	55.1	55.2	55.6	53.0	51.6	51.3	51.1	52.0	52.7
	Hot water flow rate	m ³ /h	-	23.1	23.1	23.1	23.1	23.0	24.8	27.9	28.9	31.2	35.0	36.9	36.7	36.6
	Water pressure loss	kPa	-	30	30	30	30	30	35	46	50	59	76	84	84	83
55	Heating capacity	kW	-	-	136.5	159.2	180.7	182.5	197.2	220.8	227.5	247.4	-	-	-	-
	Power consumption	kW	-	-	63.2	63.6	63.2	60.6	60.8	61.2	58.8	57.3	-	-	-	-
	Hot water flow rate	m ³ /h	-	-	23.1	23.1	23.1	23.1	24.2	27.1	28.0	30.4	-	-	-	-
	Water pressure loss	kPa	-	-	30	30	30	30	30	34	44	47	56	-	-	-

* The power consumption value is rounded off to the first decimal place.

* Outdoor air temperature from -6°C to +25°C: Hot water 55°C can be supplied.

* Outdoor air temperature -10°C: Maximam water temperature 50°C.

* Outdoor air temperature -15°C: Maximam water temperature 45°C.

* This table shows the capacity when the relative humidity is 85%.

* The performance is the value not including the defrost correction.

* When conditions are met that only allow the unit to operate at a capacity below 189 kW and when the water flow rate cannot be reduced to a rate below the minimum required flow rate, the temperature difference between the hot water inlet and outlet will be less than 7°C.

Capacity change mode: COP priority

MODEL			EAHV-P900YA × 4													
Hot water outlet temperature	Outdoor air temperature °CDB		-15	-10	-5	0	5	7	10	15	20	25	30	35	40	43
			30	Heating capacity	kW	154.6	179.3	207.9	239.7	269.3	274.2	300.5	346.4	376.2	377.2	-
Power consumption	kW	49.5		48.8	48.6	48.8	48.7	47.0	48.2	50.0	48.7	46.8	-	-	-	-
Hot water flow rate	m ³ /h	30.8		30.8	30.8	30.8	33.1	33.7	36.9	42.6	46.2	46.3	-	-	-	-
Water pressure loss	kPa	30		30	30	30	36	37	46	62	74	74	-	-	-	-
35	Heating capacity	kW	154.4	177.2	204.5	235.6	264.8	267.5	292.8	337.7	372.6	375.0	394.7	412.7	413.2	411.7
	Power consumption	kW	57.0	56.5	56.4	56.6	56.2	54.0	54.7	55.6	54.1	51.0	50.6	50.0	50.3	50.5
	Hot water flow rate	m ³ /h	30.8	30.8	30.8	30.8	32.5	32.9	36.0	41.5	45.8	46.1	48.5	50.7	50.8	50.6
	Water pressure loss	kPa	30	30	30	30	34	35	43	59	73	74	82	90	90	89
40	Heating capacity	kW	150.8	172.6	199.1	229.9	258.9	261.4	282.0	324.5	361.0	364.8	392.8	408.1	404.0	403.8
	Power consumption	kW	63.0	62.8	62.9	63.4	62.9	60.3	60.6	61.3	59.8	57.1	55.9	55.3	55.7	55.9
	Hot water flow rate	m ³ /h	30.8	30.8	30.8	30.8	31.8	32.1	34.6	39.9	44.4	44.8	48.3	50.1	49.6	49.6
	Water pressure loss	kPa	30	30	30	30	32	33	40	54	68	69	81	88	86	86
45	Heating capacity	kW	144.6	166.4	193.3	223.9	252.8	255.2	274.5	313.0	319.8	349.5	387.8	401.7	398.3	397.8
	Power consumption	kW	68.5	69.1	69.6	70.2	69.7	66.7	66.9	67.4	65.7	63.1	61.7	61.1	62.0	62.6
	Hot water flow rate	m ³ /h	30.8	30.8	30.8	30.8	31.1	31.4	33.7	38.5	39.3	42.9	47.6	49.4	48.9	48.9
	Water pressure loss	kPa	30	30	30	30	31	31	37	50	52	63	79	85	83	83
50	Heating capacity	kW	-	161.2	187.6	218.4	247.2	249.6	269.0	302.6	313.3	338.7	380.2	400.5	398.8	397.1
	Power consumption	kW	-	75.9	76.6	77.2	76.7	73.5	73.6	74.1	70.7	68.8	68.4	68.1	69.4	70.2
	Hot water flow rate	m ³ /h	-	30.8	30.8	30.8	30.8	30.7	33.0	37.2	38.5	41.6	46.7	49.2	49.0	48.8
	Water pressure loss	kPa	-	30	30	30	30	30	35	46	50	59	76	84	84	83
55	Heating capacity	kW	-	-	182.0	212.3	241.0	243.4	262.9	294.4	303.4	329.9	-	-	-	-
	Power consumption	kW	-	-	84.3	84.8	84.2	80.7	81.0	81.6	78.4	76.4	-	-	-	-
	Hot water flow rate	m ³ /h	-	-	30.8	30.8	30.8	30.8	32.3	36.2	37.3	40.5	-	-	-	-
	Water pressure loss	kPa	-	-	30	30	30	30	34	44	47	56	-	-	-	-

* The power consumption value is rounded off to the first decimal place.

* Outdoor air temperature from -6°C to +25°C: Hot water 55°C can be supplied.

* Outdoor air temperature -10°C: Maximam water temperature 50°C.

* Outdoor air temperature -15°C: Maximam water temperature 45°C.

* This table shows the capacity when the relative humidity is 85%.

* The performance is the value not including the defrost correction.

* When conditions are met that only allow the unit to operate at a capacity below 252 kW and when the water flow rate cannot be reduced to a rate below the minimum required flow rate, the temperature difference between the hot water inlet and outlet will be less than 7°C.

2. Product Data

Heating capacity: Hot water outlet/inlet temperature difference 7°C

Capacity change mode: COP priority

MODEL		EAHV-P900YA × 5														
Hot water outlet temperature	Outdoor air temperature °CDB	-15	-10	-5	0	5	7	10	15	20	25	30	35	40	43	
30	Heating capacity	kW	193.3	224.1	259.9	299.6	336.6	342.8	375.6	433.0	470.3	471.5	-	-	-	-
	Power consumption	kW	61.9	61.0	60.8	61.0	60.9	58.8	60.3	62.5	60.9	58.6	-	-	-	-
	Hot water flow rate	m ³ /h	38.5	38.5	38.5	38.5	41.4	42.1	46.1	53.2	57.8	57.9	-	-	-	-
	Water pressure loss	kPa	30	30	30	30	36	37	46	62	74	74	-	-	-	-
35	Heating capacity	kW	193.0	221.5	255.6	294.5	331.0	334.4	366.1	422.1	465.8	468.8	493.3	515.8	516.5	514.7
	Power consumption	kW	71.3	70.7	70.5	70.8	70.3	67.5	68.3	69.5	67.7	63.8	63.2	62.5	62.9	63.2
	Hot water flow rate	m ³ /h	38.5	38.5	38.5	38.5	40.7	41.1	45.0	51.9	57.2	57.6	60.6	63.4	63.5	63.2
	Water pressure loss	kPa	30	30	30	30	34	35	43	59	73	74	82	90	90	89
40	Heating capacity	kW	188.5	215.8	248.9	287.4	323.6	326.7	352.5	405.6	451.3	456.0	491.0	510.1	505.0	504.8
	Power consumption	kW	78.7	78.5	78.6	79.2	78.6	75.4	75.8	76.6	74.7	71.3	69.8	69.1	69.6	69.9
	Hot water flow rate	m ³ /h	38.5	38.5	38.5	38.5	39.8	40.1	43.3	49.8	55.4	56.0	60.3	62.7	62.0	62.0
	Water pressure loss	kPa	30	30	30	30	32	33	40	54	68	69	81	88	86	86
45	Heating capacity	kW	180.7	208.0	241.6	279.8	316.0	319.1	343.1	391.3	399.8	436.8	484.7	502.1	497.8	497.3
	Power consumption	kW	85.7	86.4	86.9	87.7	87.1	83.4	83.6	84.2	82.1	78.9	77.1	76.4	77.5	78.2
	Hot water flow rate	m ³ /h	38.5	38.5	38.5	38.5	38.8	39.2	42.2	48.1	49.1	53.7	59.6	61.7	61.2	61.1
	Water pressure loss	kPa	30	30	30	30	31	31	37	50	52	63	79	85	83	83
50	Heating capacity	kW	-	201.5	234.5	272.9	308.9	312.0	336.2	378.2	391.6	423.4	475.3	500.7	498.5	496.4
	Power consumption	kW	-	94.9	95.8	96.5	95.9	91.8	92.0	92.6	88.4	86.0	85.5	85.2	86.7	87.8
	Hot water flow rate	m ³ /h	-	38.5	38.5	38.5	38.5	38.3	41.3	46.5	48.1	52.0	58.4	61.5	61.2	61.0
	Water pressure loss	kPa	-	30	30	30	30	30	35	46	50	59	76	84	84	83
55	Heating capacity	kW	-	-	227.5	265.3	301.2	304.2	328.6	368.0	379.2	412.3	-	-	-	-
	Power consumption	kW	-	-	105.4	106.0	105.3	100.9	101.3	102.0	98.0	95.5	-	-	-	-
	Hot water flow rate	m ³ /h	-	-	38.5	38.5	38.5	38.5	40.4	45.2	46.6	50.7	-	-	-	-
	Water pressure loss	kPa	-	-	30	30	30	30	34	44	47	56	-	-	-	-

* The power consumption value is rounded off to the first decimal place.

* Outdoor air temperature from -6°C to +25°C: Hot water 55°C can be supplied.

* Outdoor air temperature -10°C: Maximum water temperature 50°C.

* Outdoor air temperature -15°C: Maximum water temperature 45°C.

* This table shows the capacity when the relative humidity is 85%.

* The performance is the value not including the defrost correction.

* When conditions are met that only allow the unit to operate at a capacity below 315 kW and when the water flow rate cannot be reduced to a rate below the minimum required flow rate, the temperature difference between the hot water inlet and outlet will be less than 7°C.

Capacity change mode: COP priority

MODEL		EAHV-P900YA × 6														
Hot water outlet temperature	Outdoor air temperature °CDB	-15	-10	-5	0	5	7	10	15	20	25	30	35	40	43	
30	Heating capacity	kW	232.0	268.9	311.8	359.5	404.0	411.3	450.8	519.6	564.4	565.7	-	-	-	-
	Power consumption	kW	74.3	73.2	73.0	73.2	73.1	70.5	72.3	75.0	73.1	70.3	-	-	-	-
	Hot water flow rate	m ³ /h	46.2	46.2	46.2	46.2	49.6	50.5	55.4	63.8	69.3	69.5	-	-	-	-
	Water pressure loss	kPa	30	30	30	30	36	37	46	62	74	74	-	-	-	-
35	Heating capacity	kW	231.6	265.8	306.7	353.4	397.2	401.3	439.3	506.6	558.9	562.5	592.0	619.0	619.8	617.6
	Power consumption	kW	85.5	84.8	84.6	84.9	84.4	81.0	82.0	83.5	81.2	76.5	75.8	75.0	75.5	75.8
	Hot water flow rate	m ³ /h	46.2	46.2	46.2	46.2	48.8	49.3	54.0	62.2	68.7	69.1	72.7	76.0	76.1	75.9
	Water pressure loss	kPa	30	30	30	30	34	35	43	59	73	74	82	90	90	89
40	Heating capacity	kW	226.2	258.9	298.7	344.9	388.3	392.1	423.0	486.8	541.5	547.2	589.2	612.1	606.0	605.7
	Power consumption	kW	94.4	94.2	94.4	95.0	94.4	90.5	91.0	92.0	89.6	85.6	83.8	82.9	83.5	83.9
	Hot water flow rate	m ³ /h	46.2	46.2	46.2	46.2	47.7	48.2	52.0	59.8	66.5	67.2	72.4	75.2	74.4	74.4
	Water pressure loss	kPa	30	30	38	53	68	70	82	110	136	139	161	174	171	170
45	Heating capacity	kW	216.8	249.7	289.9	335.8	379.2	382.9	411.7	469.5	479.7	524.2	581.7	602.6	597.4	596.7
	Power consumption	kW	102.8	103.7	104.3	105.2	104.5	100.1	100.3	101.0	98.6	94.7	92.6	91.7	93.0	93.9
	Hot water flow rate	m ³ /h	46.2	46.2	46.2	46.2	46.6	47.0	50.6	57.7	58.9	64.4	71.5	74.0	73.4	73.3
	Water pressure loss	kPa	30	30	30	30	31	31	37	50	52	63	79	85	83	83
50	Heating capacity	kW	-	241.8	281.4	327.5	370.7	374.4	403.5	453.8	469.9	508.1	570.4	600.8	598.2	595.7
	Power consumption	kW	-	113.9	114.9	115.8	115.1	110.2	110.4	111.1	106.0	103.2	102.6	102.2	104.1	105.3
	Hot water flow rate	m ³ /h	-	46.2	46.2	46.2	46.2	46.0	49.6	55.8	57.7	62.4	70.1	73.8	73.5	73.2
	Water pressure loss	kPa	-	30	30	30	30	30	35	46	50	59	76	84	84	83
55	Heating capacity	kW	-	-	273.0	318.4	361.5	365.1	394.3	441.6	455.0	494.8	-	-	-	-
	Power consumption	kW	-	-	126.5	127.2	126.3	121.1	121.5	122.4	117.6	114.6	-	-	-	-
	Hot water flow rate	m ³ /h	-	-	46.2	46.2	46.2	46.2	48.4	54.2	55.9	60.8	-	-	-	-
	Water pressure loss	kPa	-	-	30	30	30	30	34	44	47	56	-	-	-	-

* The power consumption value is rounded off to the first decimal place.

* Outdoor air temperature from -6°C to +25°C: Hot water 55°C can be supplied.

* Outdoor air temperature -10°C: Maximum water temperature 50°C.

* Outdoor air temperature -15°C: Maximum water temperature 45°C.

* This table shows the capacity when the relative humidity is 85%.

* The performance is the value not including the defrost correction.

* When conditions are met that only allow the unit to operate at a capacity below 378 kW and when the water flow rate cannot be reduced to a rate below the minimum required flow rate, the temperature difference between the hot water inlet and outlet will be less than 7°C.

2. Product Data

2-1-3. Capacity table

EER for cooling [Water]

Water flow rate 15.5 m³/h

Capacity	Air temp (°CD.B)	Outlet water temp (°C)					
		5	7	10	15	20	25
105kW (117%)	-15	-	-	-	7.32	6.88	6.77
	-10	-	7.92	7.14	7.29	6.85	6.93
	-5	7.49	7.82	7.14	7.27	6.83	6.91
	0	7.32	7.70	7.10	7.24	6.81	6.90
	5	7.08	7.44	7.80	7.97	-	-
	10	6.47	6.80	7.08	7.39	-	-
	15	5.51	5.96	6.48	6.82	-	-
	20	-	5.05	5.71	6.59	6.92	-
	25	-	-	4.86	5.84	6.26	-
	30	-	-	-	5.00	-	-
	35	-	-	-	-	-	-
90kW (100%)	-15	-	-	-	7.37	6.93	7.04
	-10	-	7.97	7.21	7.35	6.91	7.03
	-5	7.52	7.87	7.18	7.33	6.90	7.01
	0	7.42	7.76	7.15	7.31	6.88	6.99
	5	7.17	7.60	7.05	7.27	6.78	6.85
	10	6.84	7.26	6.86	7.10	6.64	6.72
	15	6.15	6.58	6.61	6.90	6.48	6.57
	20	5.14	5.54	6.14	6.65	6.30	6.34
	25	4.32	4.70	5.26	6.23	6.07	6.09
	30	3.62	3.98	4.50	5.35	5.74	5.81
	35	-	3.30	3.79	4.54	4.90	5.72
75kW (83%)	-15	-	-	-	7.51	7.05	7.17
	-10	-	7.95	7.29	7.49	7.04	7.16
	-5	7.50	7.88	7.27	7.48	7.03	7.14
	0	7.40	7.80	7.25	7.46	7.01	7.10
	5	7.18	7.63	7.14	7.39	6.90	6.97
	10	6.91	7.34	6.96	7.23	6.76	6.84
	15	6.52	6.93	6.73	7.04	6.60	6.70
	20	5.56	5.95	6.40	6.81	6.43	6.47
	25	4.71	5.06	5.63	6.48	6.22	6.22
	30	3.99	4.31	4.82	5.74	5.92	6.02
	35	3.37	3.66	4.10	4.89	5.26	5.75
60kW (67%)	-15	-	-	-	8.78	9.33	-
	-10	-	8.07	7.47	8.78	9.33	-
	-5	7.61	8.02	7.46	7.63	8.05	9.27
	0	7.47	7.97	7.45	7.62	7.12	8.06
	5	7.27	7.76	7.30	7.53	7.01	7.00
	10	7.04	7.52	7.14	7.39	6.89	6.90
	15	6.73	7.19	6.94	7.22	6.75	6.78
	20	6.06	6.48	6.67	7.02	6.59	6.57
	25	5.08	5.47	6.08	6.75	6.40	6.35
	30	4.29	4.63	5.19	6.20	6.15	6.17
	35	3.63	3.93	4.41	5.29	5.69	5.94
45kW (50%)	-15	-	-	-	-	-	-
	-10	-	-	-	-	-	-
	-5	7.76	8.31	9.11	-	-	-
	0	6.28	6.76	7.47	8.57	9.02	-
	5	7.43	7.89	7.37	7.39	7.83	8.80
	10	7.24	7.69	7.24	7.31	6.76	7.65
	15	7.00	7.44	7.08	7.18	6.67	6.54
	20	6.60	7.03	6.88	7.04	6.55	6.38
	25	5.53	5.91	6.53	6.85	6.41	6.22
	30	4.66	5.03	5.58	6.52	6.23	6.10
	35	3.94	4.26	4.77	5.61	5.95	5.94
30kW (33%)	-15	-	-	-	-	-	-
	-10	-	-	-	-	-	-
	-5	-	-	-	-	-	-
	0	11.83	12.38	-	-	-	-
	5	7.52	7.86	8.34	-	-	-
	10	6.99	7.28	6.89	7.61	7.91	-
	15	6.84	7.14	6.62	6.61	6.90	7.54
	20	6.63	6.93	6.51	6.37	6.02	6.56
	25	5.74	6.01	6.33	6.27	5.79	5.68
	30	4.84	5.10	5.59	6.11	5.69	5.39
	35	4.14	4.39	4.76	5.47	5.55	5.30
40	3.53	3.78	4.13	4.66	5.03	5.16	
43	3.20	3.43	3.76	4.27	4.52	5.00	

EAHV-P-YAF(-H)(-N), YAL(-H)(-N)/EACV-P-YAF(-N), YAL(-N)

2. Product Data

EER for cooling [Brine ethylene glycol 35wt%]

Brine flow rate 11.5 m³/h

Capacity	Air temp (°C.D.B)	Outlet brine temp (°C)								
		-10	-5	0	5	7	10	15	20	25
105kW (117%)	-15	-	-	-	-	-	-	-	-	-
	-10	-	-	-	-	-	-	-	-	-
	-5	-	-	-	-	-	-	-	-	-
	0	-	-	-	-	-	-	-	-	-
	5	-	-	-	-	-	-	-	-	-
	10	-	-	-	-	-	-	-	-	-
	15	-	-	-	-	-	-	-	-	-
	20	-	-	-	-	-	-	-	-	-
	25	-	-	-	-	-	-	-	-	-
	30	-	-	-	-	-	-	-	-	-
90kW (100%)	-15	-	-	9.02	7.45	7.72	6.77	6.88	6.48	6.56
	-10	-	-	8.94	7.29	7.60	6.74	6.86	6.44	6.54
	-5	-	-	8.85	7.13	7.46	6.70	6.82	6.41	6.51
	0	-	-	8.54	6.91	7.29	6.65	6.79	6.38	6.48
	5	-	-	7.95	8.87	8.99	9.08	9.22	-	-
	10	-	-	-	7.09	7.41	7.70	7.95	-	-
	15	-	-	-	5.51	5.90	6.43	7.00	7.22	-
	20	-	-	-	4.64	5.01	5.56	6.46	6.83	7.32
	25	-	-	-	3.92	4.27	4.78	5.65	6.02	6.89
	30	-	-	-	-	3.61	4.09	4.86	5.20	6.07
75kW (83%)	-15	-	7.34	9.11	7.28	7.59	6.80	6.98	-	-
	-10	-	7.29	9.04	7.18	7.50	6.78	6.95	6.54	-
	-5	-	7.25	8.97	7.05	7.39	6.75	6.92	6.51	6.61
	0	-	7.03	8.53	6.91	7.26	6.71	6.89	6.48	6.59
	5	-	6.69	8.13	9.37	9.66	10.19	10.45	9.16	9.20
	10	-	-	7.44	8.46	8.87	9.58	10.07	9.01	9.13
	15	-	-	5.21	6.16	6.55	7.19	8.30	8.68	9.02
	20	-	-	4.18	5.04	5.38	5.94	7.00	7.43	7.56
	25	-	-	3.48	4.28	4.60	5.10	6.04	6.45	7.56
	30	-	-	-	3.64	3.93	4.38	5.20	5.56	6.53
60kW (67%)	-15	5.91	7.32	9.06	-	-	-	-	-	-
	-10	5.89	7.28	9.00	7.17	7.54	6.92	-	-	-
	-5	5.87	7.26	8.96	7.08	7.46	6.89	7.06	-	-
	0	5.76	7.02	8.42	7.01	7.36	6.87	7.03	6.59	-
	5	5.54	6.77	8.16	9.40	9.89	10.41	8.97	9.36	9.28
	10	5.10	6.41	7.65	8.78	9.26	10.06	8.82	9.24	9.24
	15	-	5.11	6.20	7.23	7.66	8.37	8.53	9.01	9.16
	20	-	3.76	4.59	5.46	5.83	6.43	7.52	7.94	8.92
	25	-	3.10	3.82	4.61	4.95	5.50	6.50	6.89	7.97
	30	-	2.57	3.21	3.91	4.21	4.71	5.60	5.97	6.94
45kW (50%)	-15	-	-	-	-	-	-	-	-	-
	-10	-	-	-	-	-	-	-	-	-
	-5	5.86	7.25	9.01	7.20	7.56	-	-	-	-
	0	5.69	7.02	8.49	7.10	7.50	6.96	-	-	-
	5	5.55	6.80	8.24	9.52	9.99	10.55	8.86	9.18	8.92
	10	5.24	6.50	7.87	9.08	9.55	10.27	8.78	9.10	8.89
	15	4.79	5.93	7.19	8.31	8.75	9.43	8.55	8.94	8.85
	20	3.46	4.29	5.24	6.19	6.56	7.13	8.07	8.39	8.68
	25	2.76	3.40	4.16	5.02	5.37	5.89	6.76	7.08	8.22
	30	2.30	2.83	3.47	4.24	4.57	5.08	5.91	6.22	7.00
30kW (33%)	-15	-	-	-	-	-	-	-	-	-
	-10	-	-	-	-	-	-	-	-	-
	-5	-	-	-	-	-	-	-	-	-
	0	-	-	-	-	-	-	-	-	-
	5	5.65	6.86	8.17	9.08	9.35	9.70	-	-	-
	10	5.40	6.67	7.96	8.81	9.10	9.52	7.83	8.02	-
	15	5.08	6.36	7.59	8.43	8.72	9.15	7.69	7.93	7.63
	20	4.07	5.04	5.99	6.66	6.90	7.24	7.46	7.72	7.53
	25	3.04	3.80	4.63	5.41	5.70	6.11	6.74	6.98	7.35
	30	2.50	3.12	3.84	4.58	4.87	5.28	5.91	6.14	6.72
35	2.08	2.58	3.20	3.88	4.15	4.54	5.15	5.38	5.90	
40	1.73	2.15	2.67	3.28	3.52	3.88	4.44	4.68	5.14	
43	1.56	1.93	2.40	2.94	3.17	3.50	4.03	4.28	4.70	

2. Product Data

COP for heating

Water flow rate 15.5 m³/h

Capacity	Air temp (°C/D.B)	Outlet water temp (°C)					
		30	35	40	45	50	55
105kW (117%)	-15	-	-	-	-	-	-
	-10	-	-	-	-	-	-
	-5	-	-	-	-	-	-
	0	-	-	-	-	-	-
	5	-	-	-	-	-	-
	7	-	-	-	-	-	-
	10	-	-	-	-	-	-
	15	6.38	5.65	4.95	4.31	3.76	3.32
	20	7.17	6.48	5.79	5.10	4.41	3.81
	25	7.76	7.21	6.47	5.74	5.04	4.31
	30	-	7.61	6.94	6.14	5.40	-
35	-	8.18	7.66	6.86	5.85	-	
40	-	8.68	7.96	6.79	5.78	-	
43	-	8.91	7.90	6.68	5.65	-	
90kW (100%)	-15	-	-	-	-	-	-
	-10	-	-	-	-	-	-
	-5	-	-	-	-	-	-
	0	-	-	-	-	-	-
	5	4.88	4.22	3.69	3.26	-	-
	7	5.25	4.52	3.96	3.50	-	-
	10	5.86	5.03	4.37	3.86	3.41	3.02
	15	6.86	5.95	5.18	4.52	3.94	3.46
	20	7.81	6.98	6.06	5.27	4.56	3.94
	25	8.64	7.88	7.00	6.04	5.19	4.45
	30	-	8.47	7.71	6.72	5.74	-
35	-	9.29	8.07	6.90	5.89	-	
40	-	9.34	8.13	6.93	5.76	-	
43	-	9.38	7.95	6.70	5.72	-	
75kW (83%)	-15	-	-	-	-	-	-
	-10	-	-	-	-	-	-
	-5	-	-	-	-	-	-
	0	4.41	3.81	3.33	2.93	2.59	2.31
	5	5.21	4.50	3.93	3.46	3.06	2.70
	7	5.54	4.76	4.16	3.67	3.24	2.86
	10	6.07	5.23	4.55	4.00	3.54	3.12
	15	7.06	6.11	5.31	4.63	4.03	3.52
	20	8.34	7.22	6.25	5.41	4.66	4.01
	25	9.58	8.37	7.22	6.21	5.32	4.54
	30	-	9.24	7.95	6.82	5.82	-
35	-	9.38	8.03	6.90	5.81	-	
40	-	9.28	8.05	6.87	5.74	-	
43	-	9.24	7.97	6.75	5.62	-	
60kW (67%)	-15	-	-	-	-	-	-
	-10	3.22	2.84	2.51	2.23	2.02	-
	-5	3.92	3.40	2.97	2.62	2.31	2.08
	0	4.64	4.00	3.48	3.06	2.70	2.39
	5	5.37	4.62	4.02	3.54	3.11	2.74
	7	5.70	4.89	4.26	3.74	3.29	2.89
	10	6.23	5.36	4.65	4.08	3.58	3.13
	15	7.17	6.22	5.40	4.71	4.10	3.56
	20	8.40	7.30	6.32	5.47	4.72	4.09
	25	9.74	8.47	7.32	6.31	5.40	4.61
	30	-	9.13	7.94	6.88	5.88	-
35	-	9.36	8.08	6.88	5.84	-	
40	-	9.23	7.93	6.86	5.82	-	
43	-	9.22	7.90	6.82	5.78	-	
45kW (50%)	-15	2.88	2.57	2.28	2.01	-	-
	-10	3.40	2.97	2.61	2.29	2.01	-
	-5	4.00	3.44	2.99	2.62	2.30	2.10
	0	4.67	3.99	3.46	3.02	2.65	2.32
	5	5.44	4.65	4.01	3.49	3.05	2.66
	7	5.74	4.92	4.26	3.71	3.23	2.81
	10	6.22	5.38	4.67	4.07	3.54	3.07
	15	6.99	6.12	5.36	4.69	4.08	3.52
	20	8.11	7.11	6.21	5.43	4.72	4.07
	25	9.27	8.13	7.10	6.16	5.33	4.60
	30	-	8.64	7.52	6.51	5.59	-
35	-	8.60	7.47	6.44	5.51	-	
40	-	8.55	7.41	6.38	5.44	-	
43	-	8.53	7.39	6.35	5.38	-	
30kW (33%)	-15	2.79	2.46	2.17	1.90	-	-
	-10	-	-	2.48	2.16	1.87	-
	-5	-	-	-	-	2.17	1.99
	0	-	-	-	-	2.52	2.18
	5	5.12	4.41	3.82	3.34	2.91	2.52
	7	5.32	4.61	4.01	3.51	3.06	2.66
	10	5.62	4.92	4.31	3.79	3.31	2.87
	15	6.08	5.39	4.77	4.22	3.69	3.21
	20	6.91	6.14	5.43	4.79	4.19	3.64
	25	7.84	6.93	6.10	5.37	4.68	4.06
	30	-	7.22	6.32	5.51	4.77	-
35	-	7.19	6.29	5.47	4.72	-	
40	-	7.18	6.27	5.45	4.68	-	
43	-	7.17	6.26	5.43	4.65	-	

EAHV-P-YAF(-H)(-N), YAL(-H)(-N)/EACV-P-YAF(-N), YAL(-N)

2. Product Data

2-1-4. Correction by water flow rate

EAHV-P900YA

EACV-P900YA

■ Heating

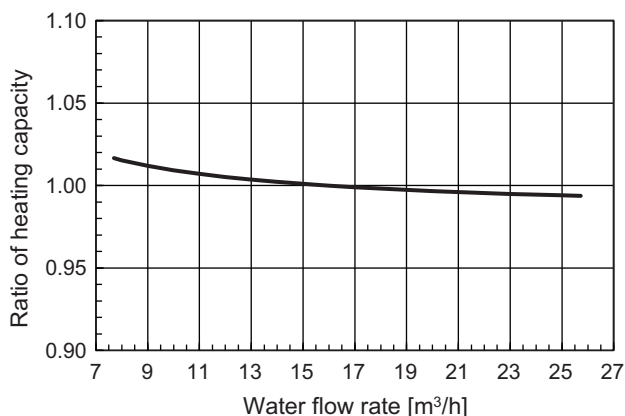

*Conditions
Outdoor temperature 7°C
Outlet water temperature 45°C

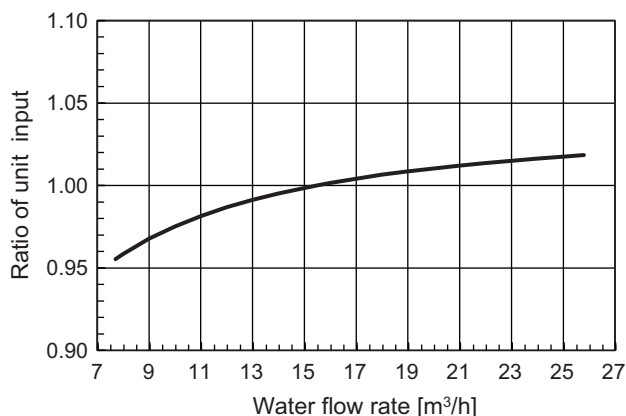

*Conditions
Outdoor temperature 7°C
Outlet water temperature 45°C

■ Cooling [Water]

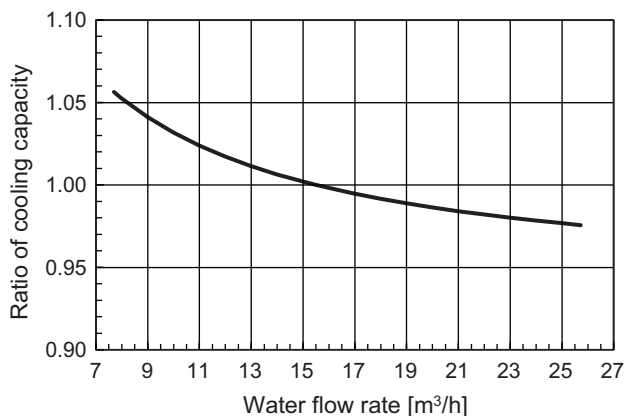

*Conditions
Outdoor temperature 35°C
Outlet water temperature 7°C

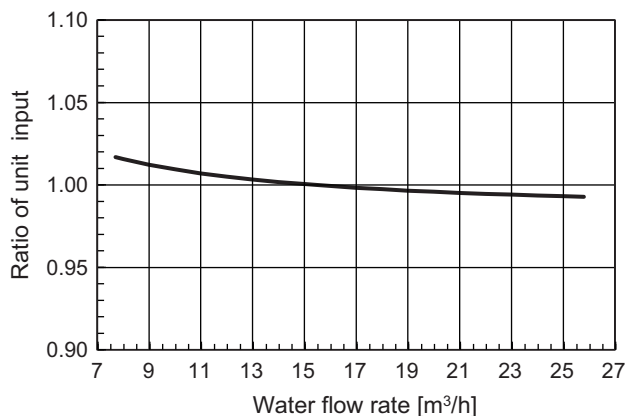

*Conditions
Outdoor temperature 35°C
Outlet water temperature 7°C

EACV-P900YA

■ Cooling [Brine: ethylene glycol 35wt%]

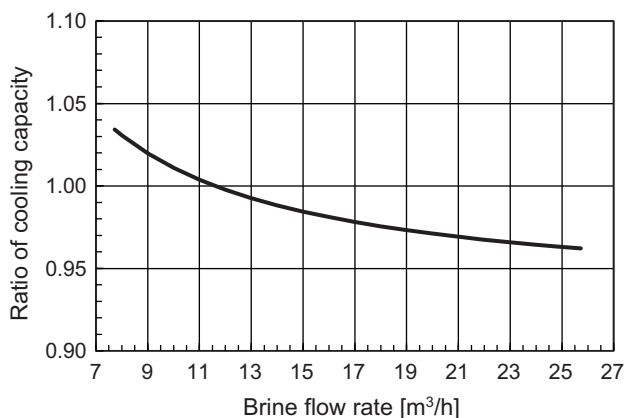

*Conditions
Outdoor temperature 35°C
Outlet brine temperature -5°C

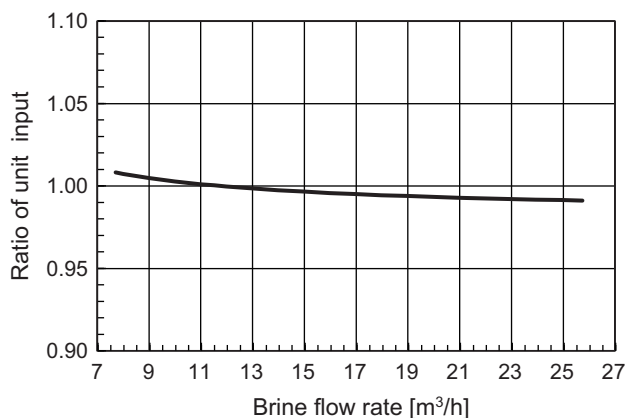

*Conditions
Outdoor temperature 35°C
Outlet brine temperature -5°C

2. Product Data

2-1-5. Water pressure drop

EAHV-P900YA
EACV-P900YA
[Water]

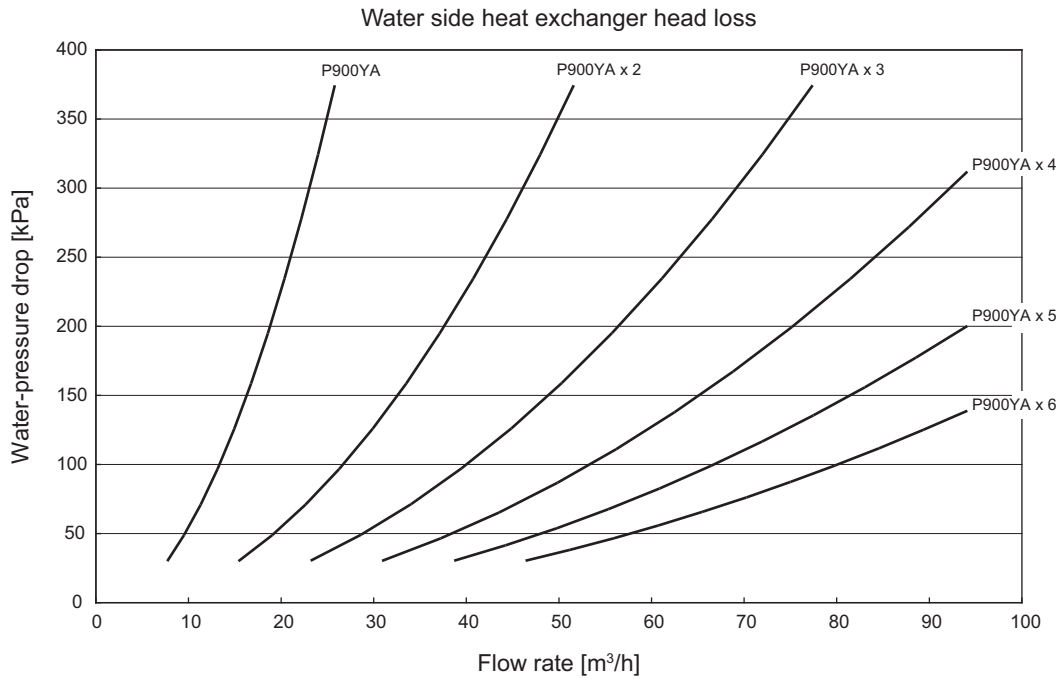

EACV-P900YA
[Brine: ethylene glycol 35wt%]

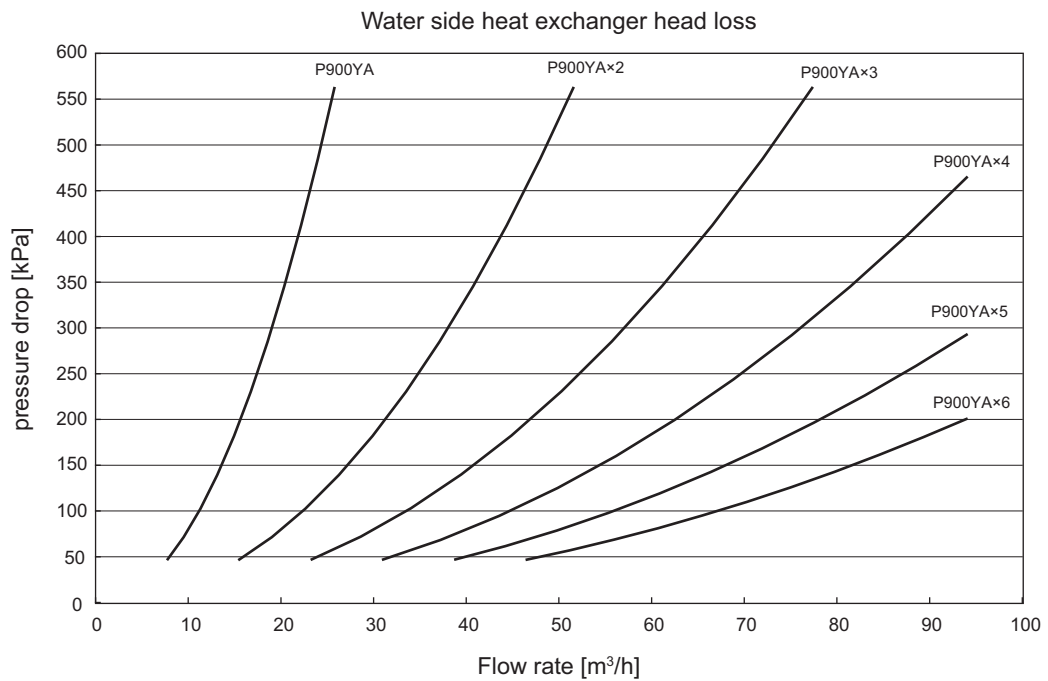

2. Product Data

2-1-6. Characteristics of the brine

Brine concentration is decided by the freezing temperature. First, it is necessary to decide the freezing temperature and find out brine concentration which will correspond to the freezing temperature.

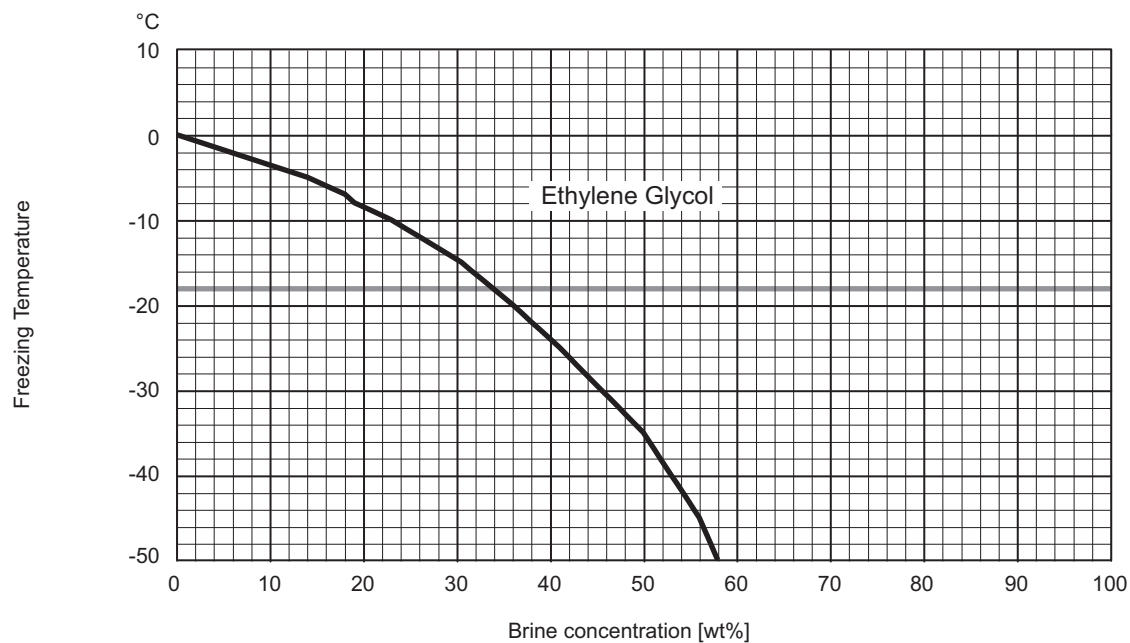

Note

The graph was referred from chemical company data.

But Freezing Temperature condition will be slightly different based on each company.

Please confirm detail data to the chemical company directly.

It is recommended to set the brine concentration to a percentage that will keep the freezing temperature at -18°C or less.

2. Product Data

2-1-7. Operation temperature range

EAHV-P900YA

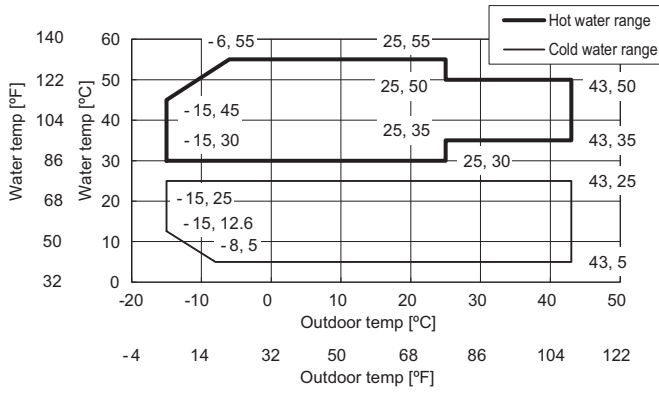

EAHV-P900YA-H

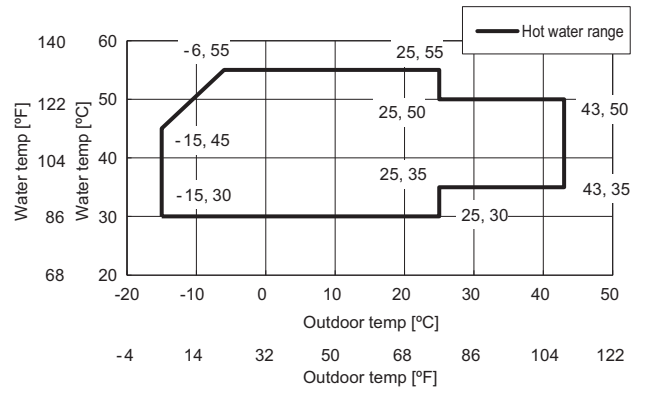

EACV-P900YA

[Water]

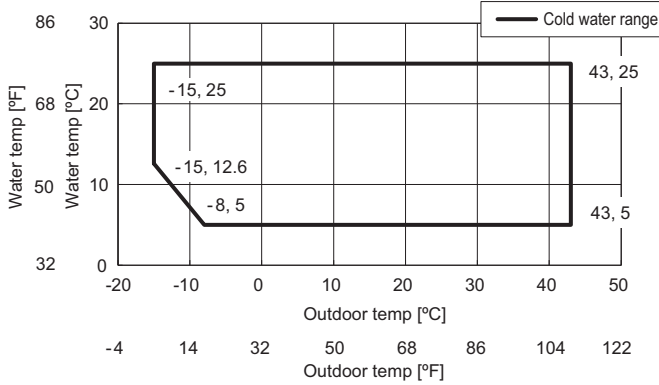

EACV-P900YA

[Brine: ethylene glycol 35wt%]

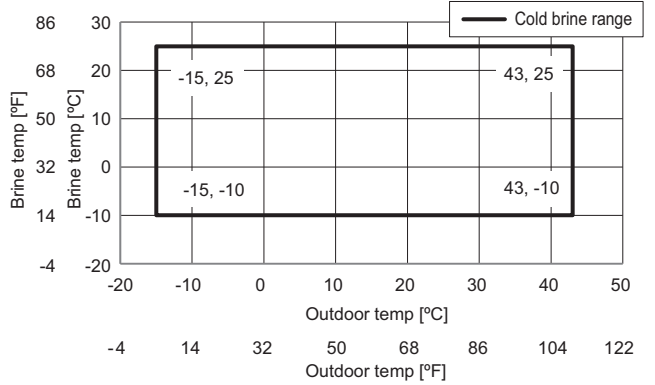

EAHV-P-YAF(-H)(-N), YAL(-H)(-N)/EACV-P-YAF(-N), YAL(-N)

2. Product Data

2-2. Sound pressure levels

Measurement condition

EAHV-P900YA

EACV-P900YA

EAHV-P-YAF(-H)(-N), YAL(-H)(-N)/EACV-P-YAF(-N), YAL(-N)

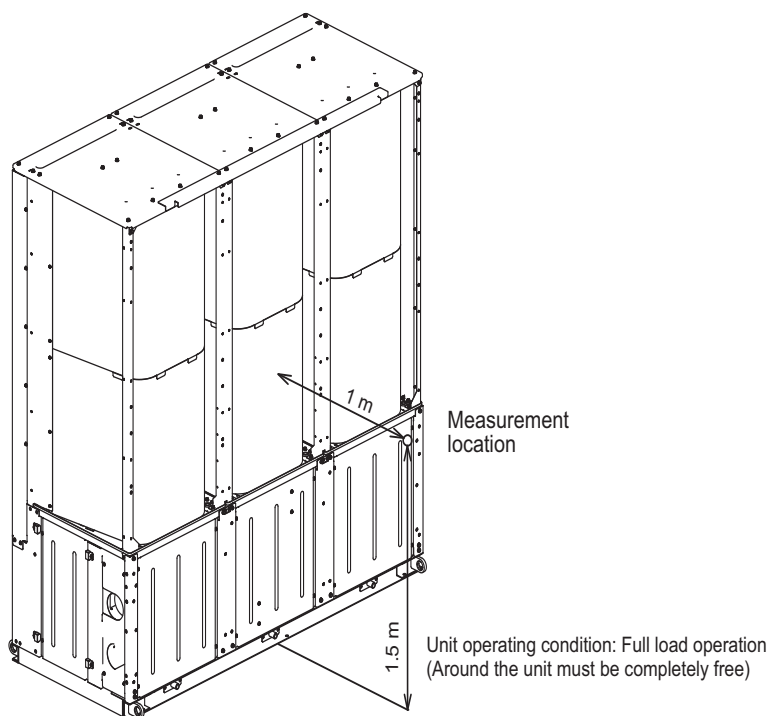

Noise value

The following values are the planned value.

Noise value dB <A> (anechoic room level)

EAHV-P900YA EACV-P900YA	EAHV-P900YA × 2 EACV-P900YA × 2	EAHV-P900YA × 3 EACV-P900YA × 3	EAHV-P900YA × 4 EACV-P900YA × 4	EAHV-P900YA × 5 EACV-P900YA × 5	EAHV-P900YA × 6 EACV-P900YA × 6
65	66	67	67	68	68

* The above values are obtained by converting the values measured in location with less echo sound to the anechoic room level.
The values could be larger than those values if the operating conditions are different or the measuring location is affected by echo sound.
(It could be roughly 4 dB to 6 dB higher though it depends on the installation conditions.)
Regarding the installation, consider the effect of echo sound, implement soundproof treatment as necessary.

2. Product Data

EAHV-P900YA
EACV-P900YA

EAHV-P-YAF(-H)(-N), YAL(-H)(-N)/EACV-P-YAF(-N), YAL(-N)

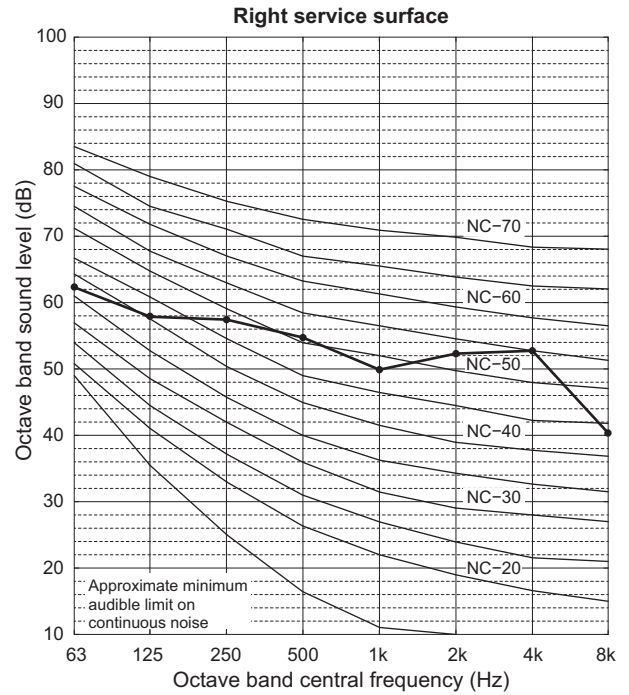
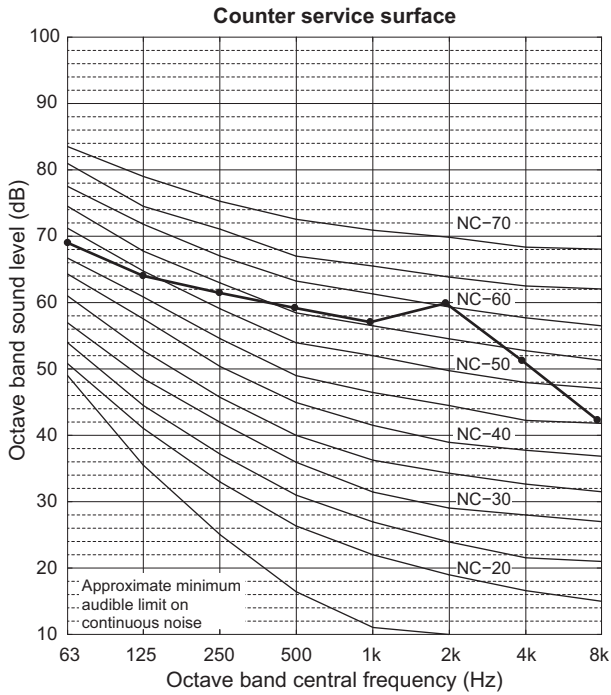
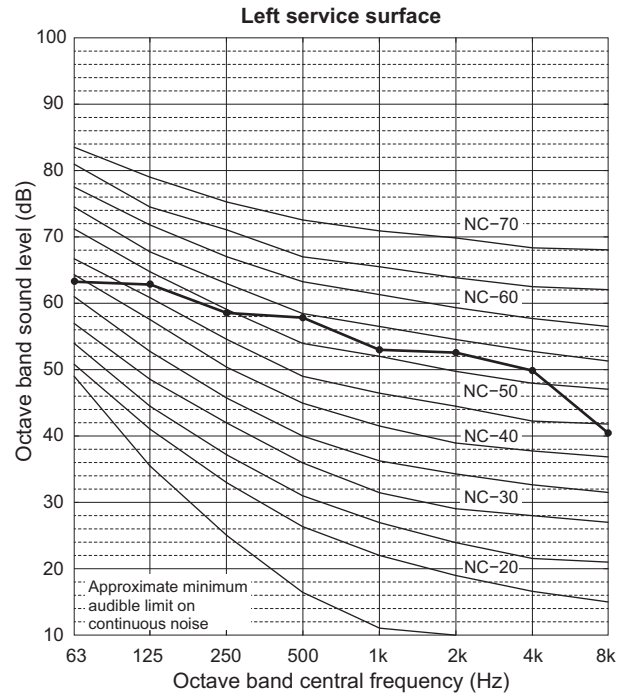
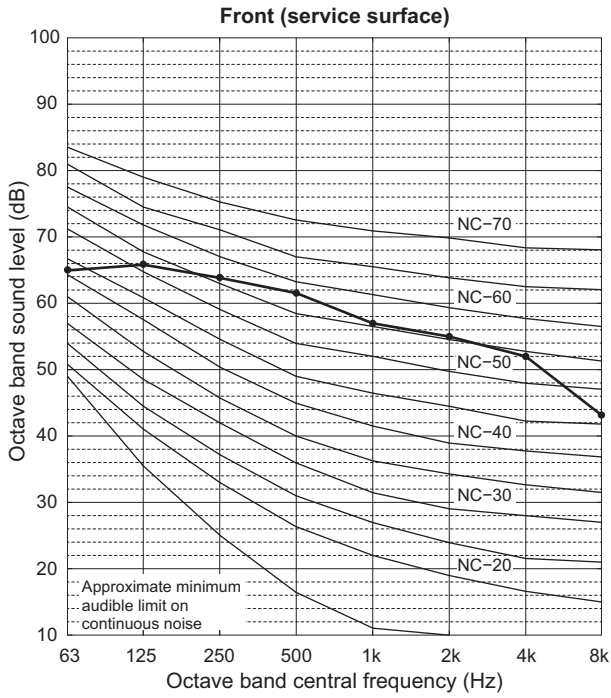

2. Product Data

EAHV-P900YA (COP priority mode)
EACV-P900YA (COP priority mode)

EAHV-P-YAF(-H)(-N), YAL(-H)(-N)/EACV-P-YAF(-N), YAL(-N)

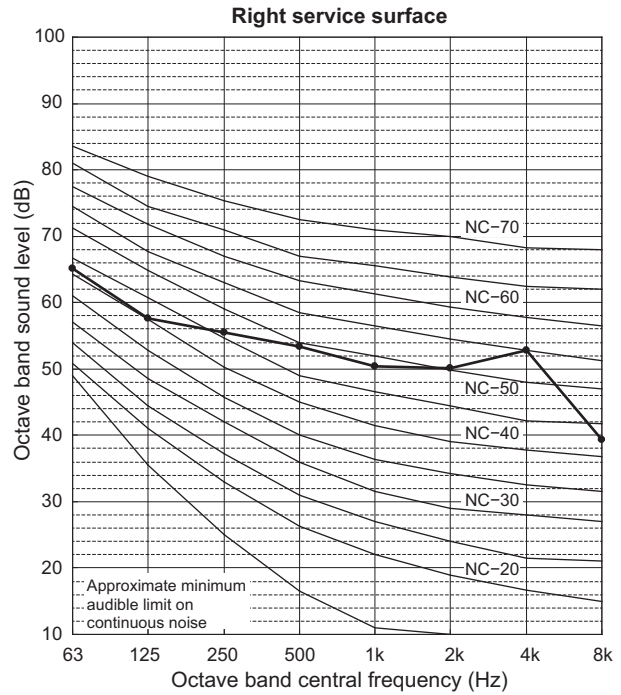
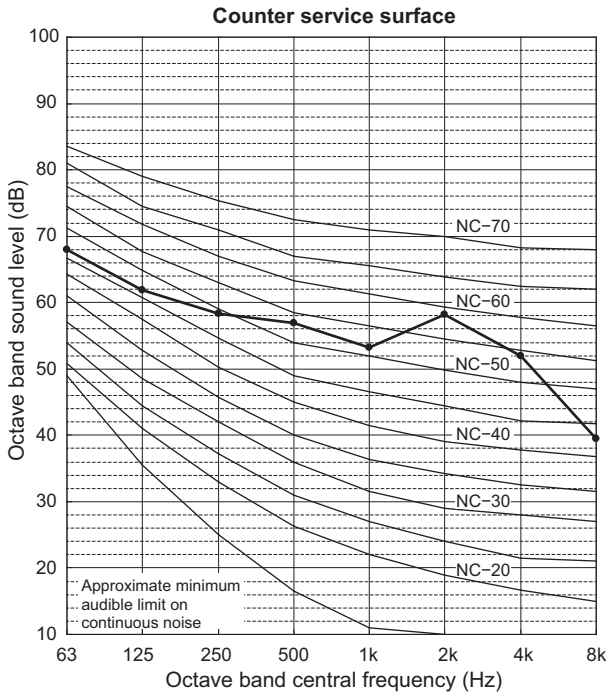
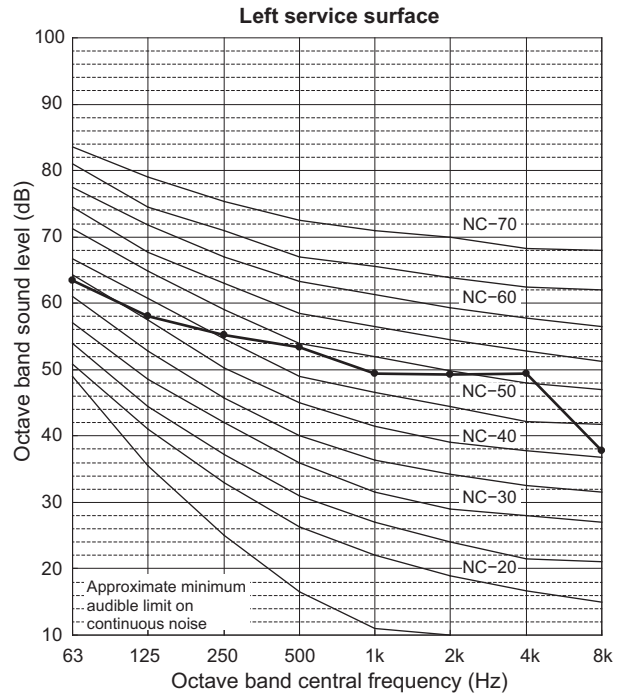
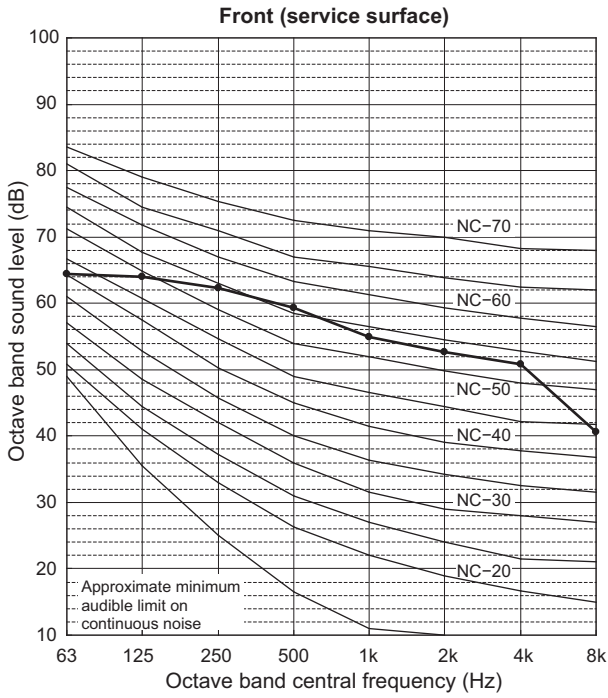

2. Product Data

EAHV-P900YA × 2
EACV-P900YA × 2

EAHV-P-YAF(-H)(-N), YAL(-H)(-N)/EACV-P-YAF(-N), YAL(-N)

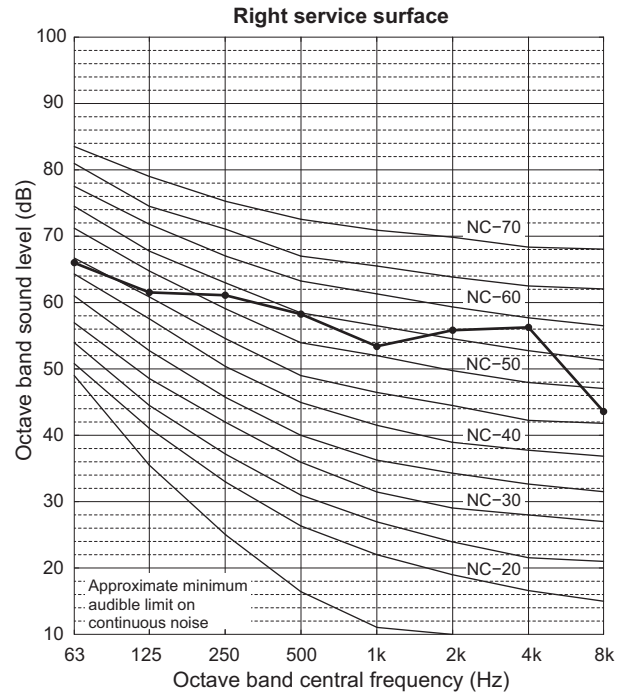
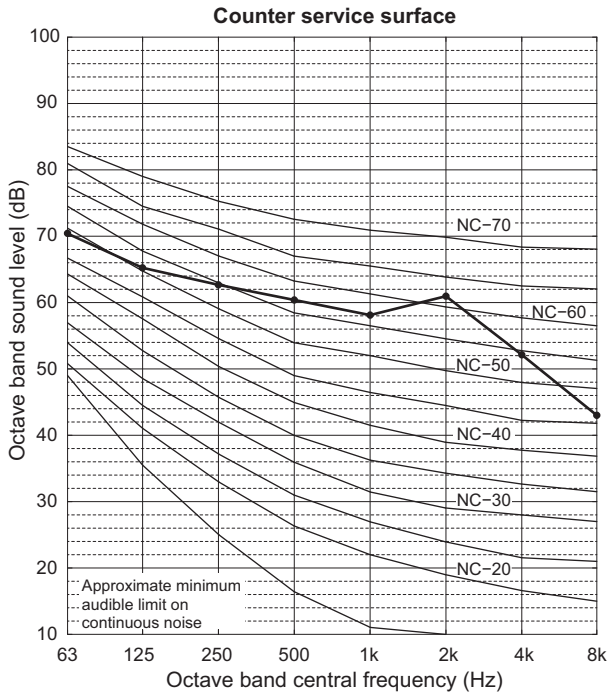
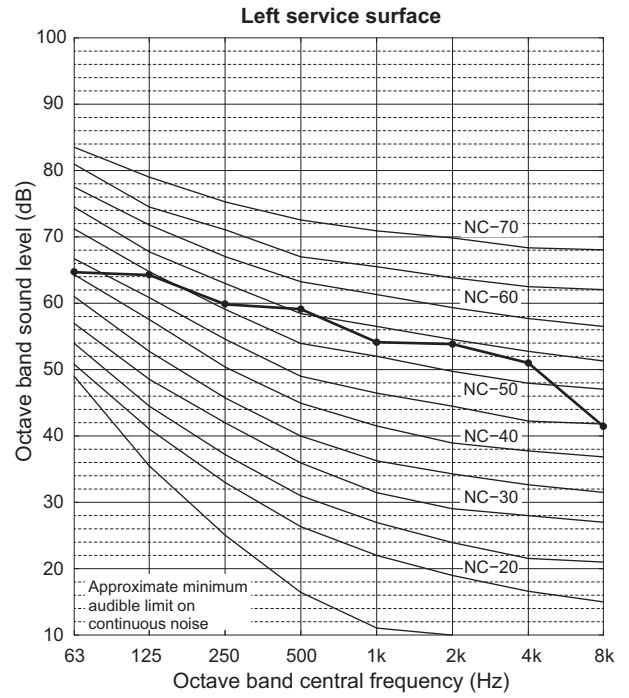
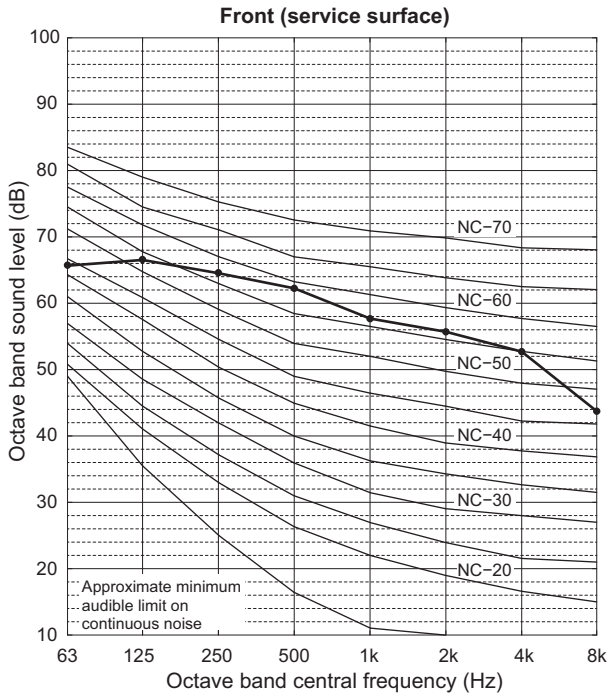

2. Product Data

EAHV-P900YA × 2 (COP priority mode)
EACV-P900YA × 2 (COP priority mode)

EAHV-P-YAF(-H)(-N), YAL(-H)(-N)/EACV-P-YAF(-N), YAL(-N)

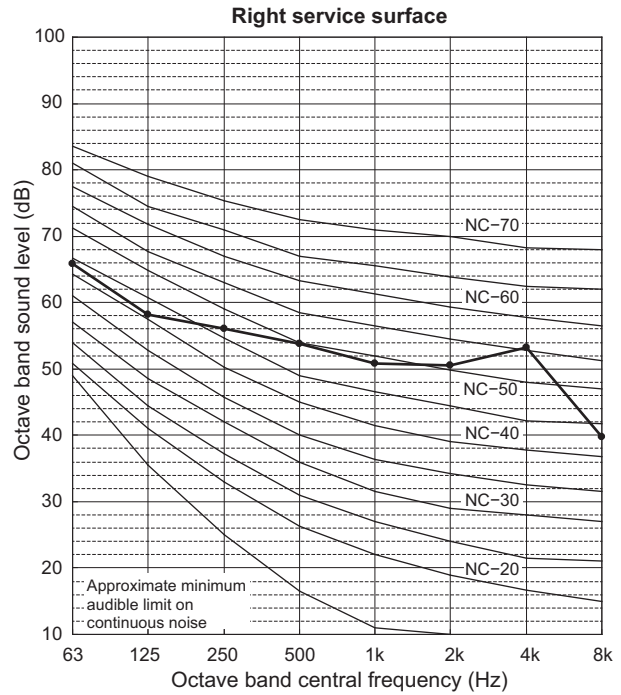
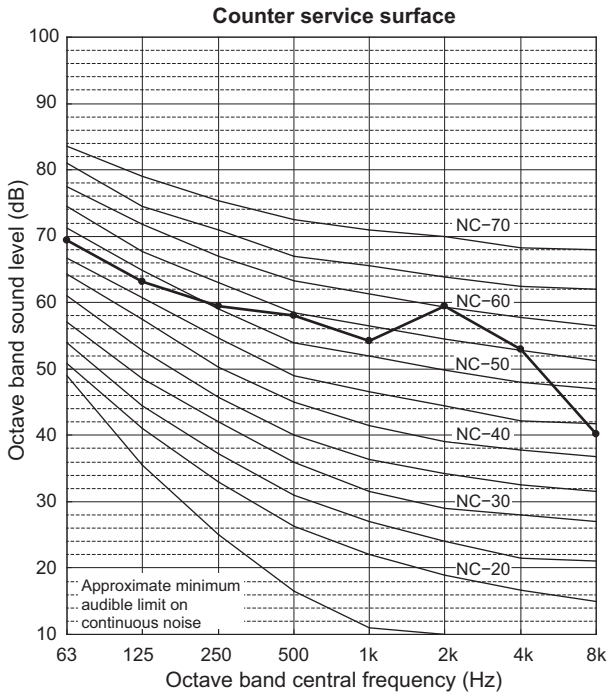
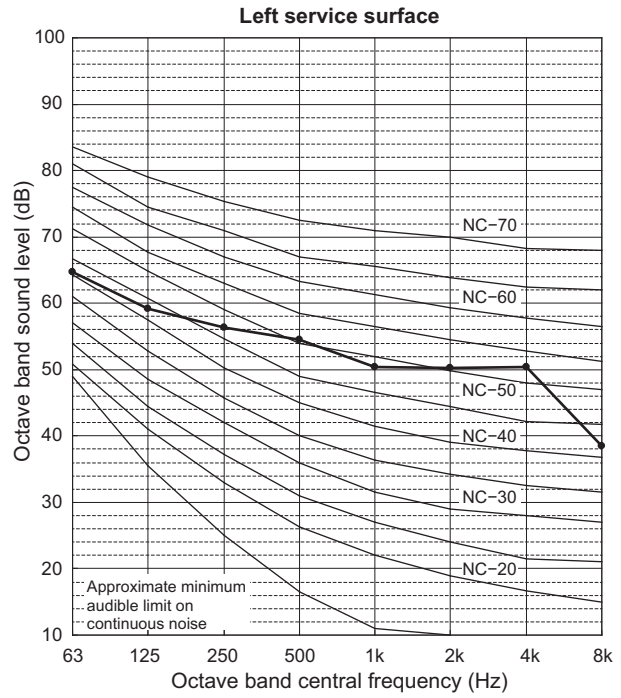
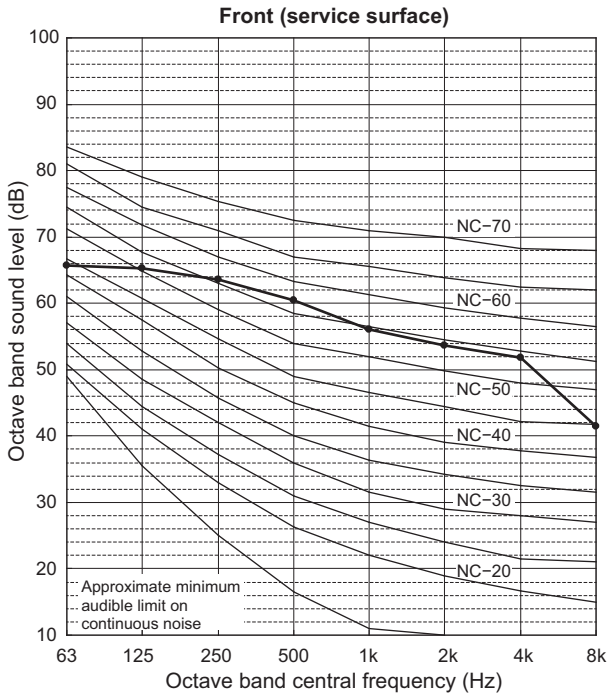

2. Product Data

EAHV-P900YA × 3
EACV-P900YA × 3

EAHV-P-YAF(-H)(-N), YAL(-H)(-N)/EACV-P-YAF(-N), YAL(-N)

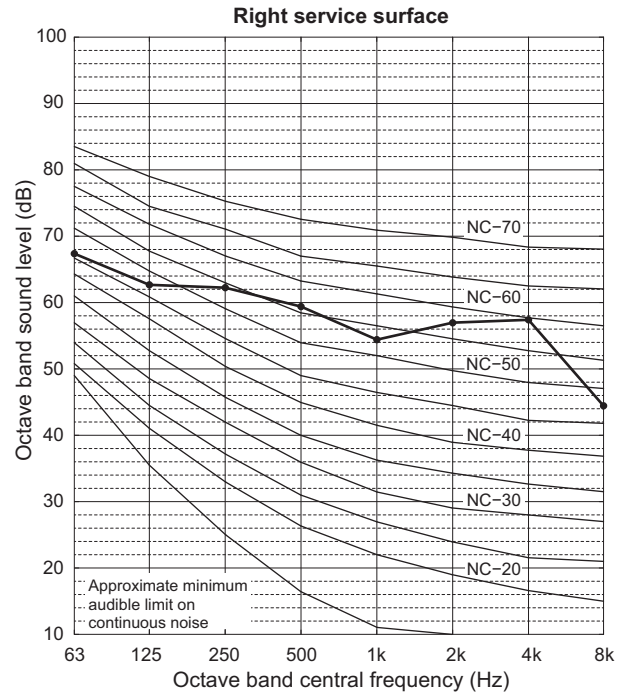
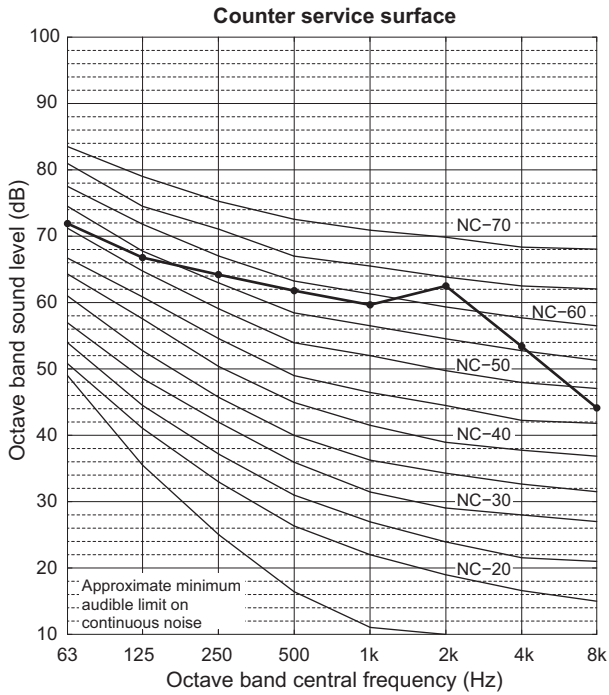
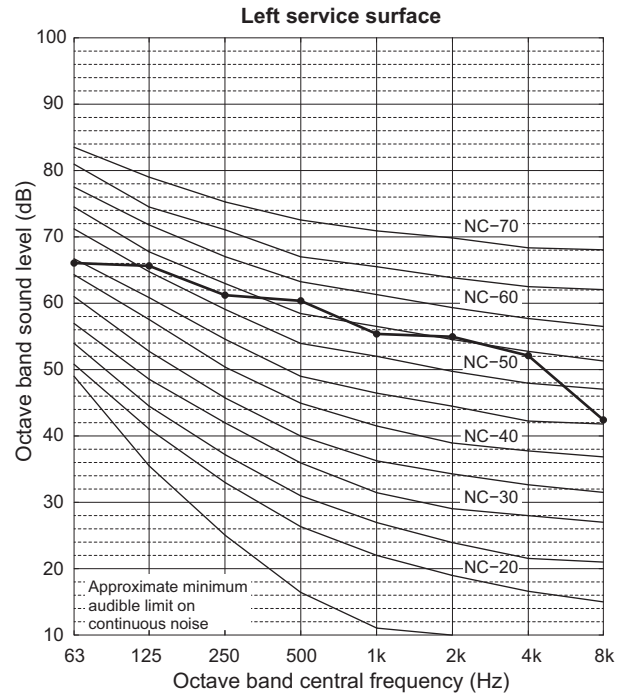
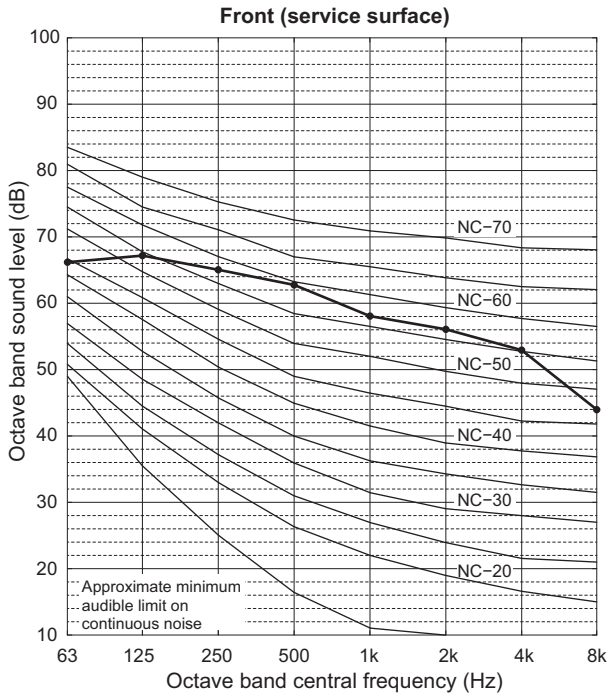

2. Product Data

EAHV-P900YA × 3 (COP priority mode)
 EACV-P900YA × 3 (COP priority mode)

EAHV-P-YAF(-H)(-N), YAL(-H)(-N)/EACV-P-YAF(-N), YAL(-N)

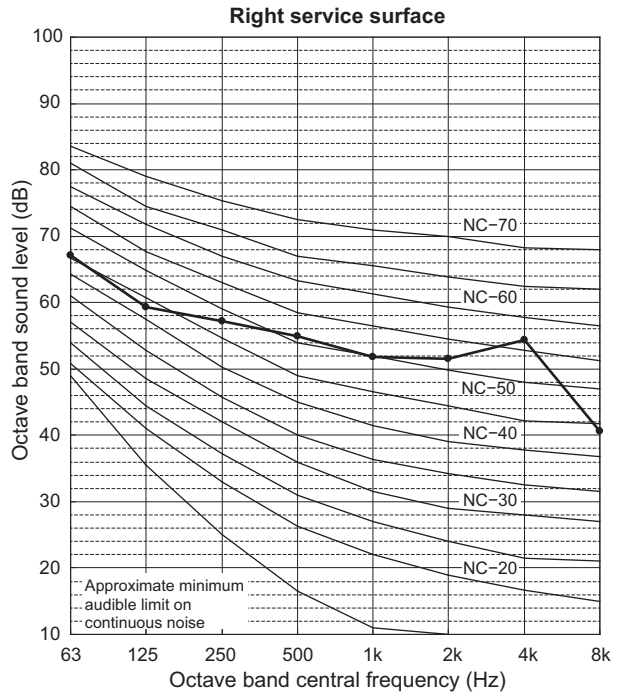
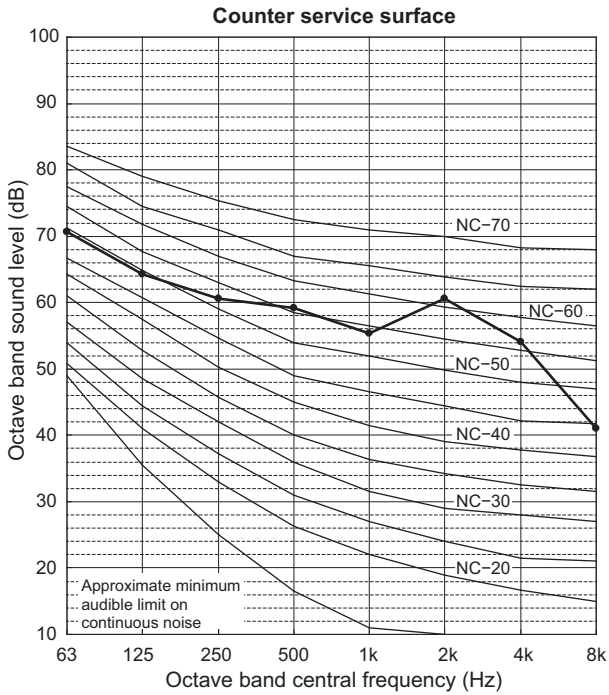
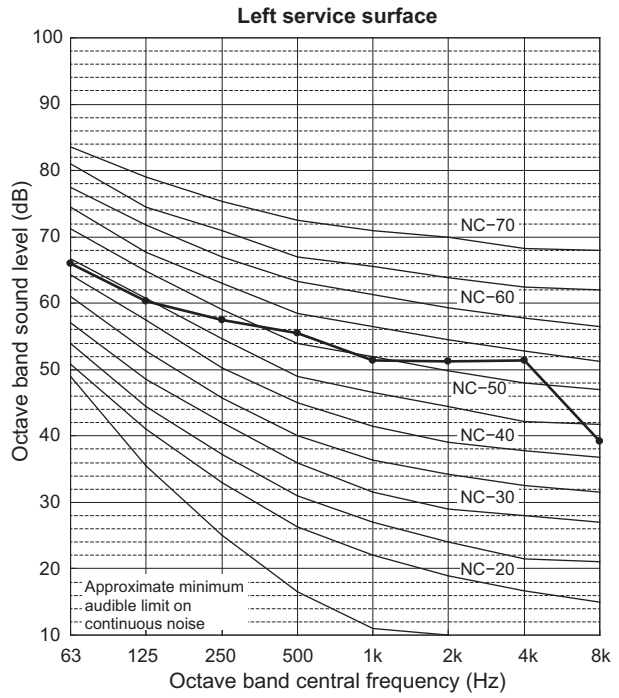
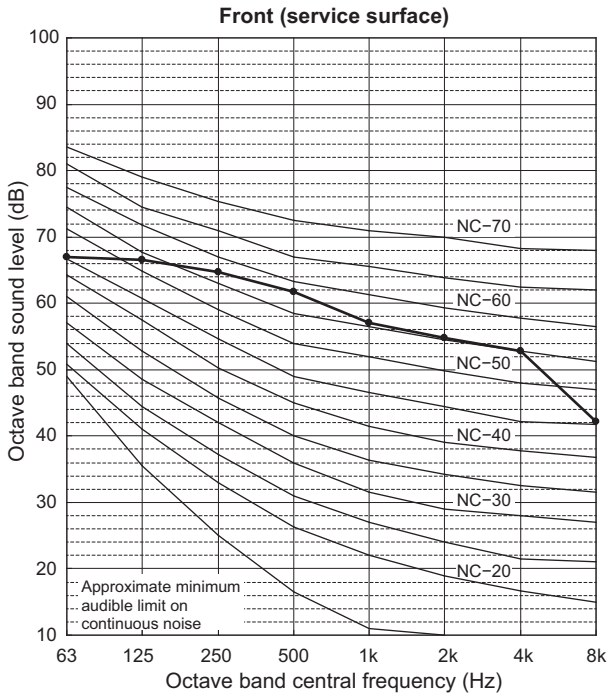

2. Product Data

EAHV-P900YA × 4
EACV-P900YA × 4

EAHV-P-YAF(-H)(-N), YAL(-H)(-N)/EACV-P-YAF(-N), YAL(-N)

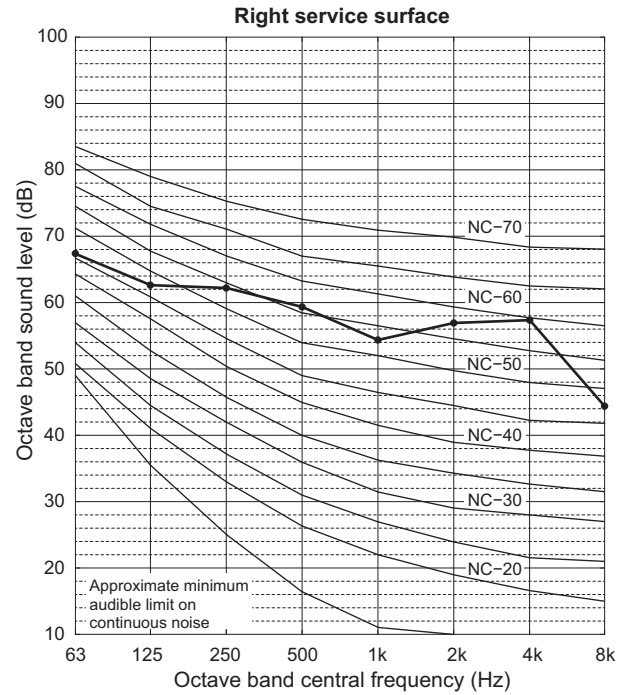
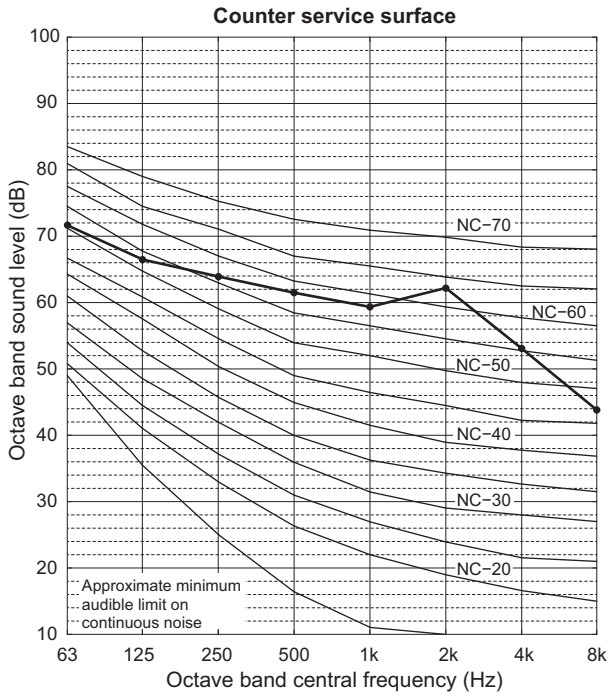
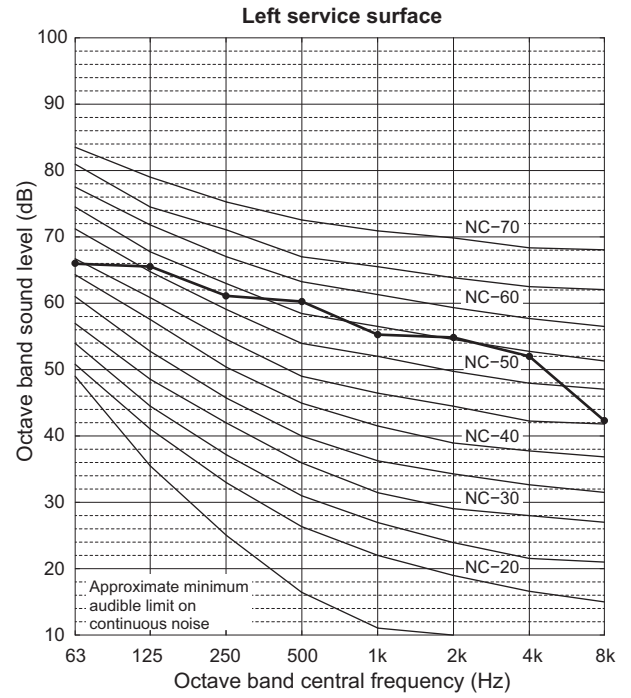
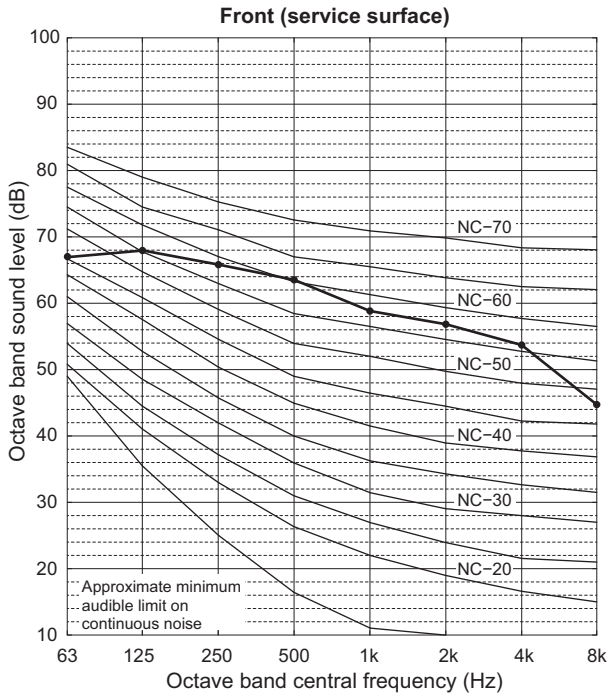

2. Product Data

EAHV-P900YA × 4 (COP priority mode)

EACV-P900YA × 4 (COP priority mode)

EAHV-P-YAF(-H)(-N), YAL(-H)(-N)/EACV-P-YAF(-N), YAL(-N)

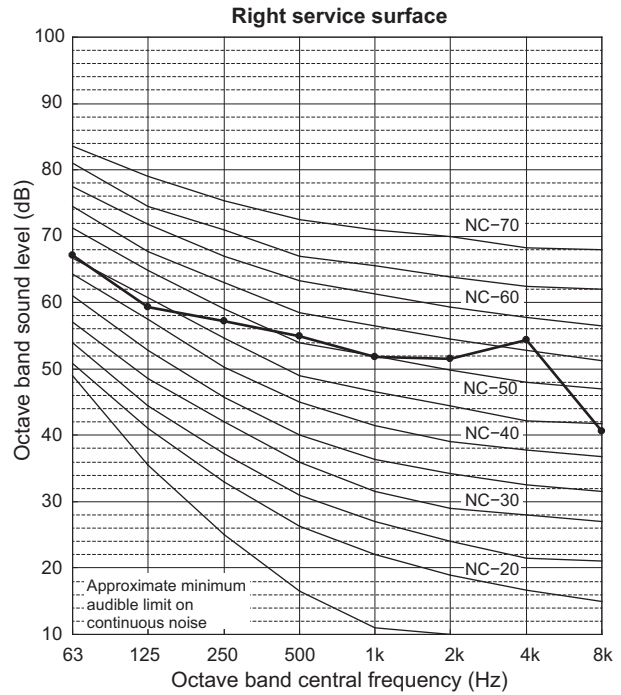
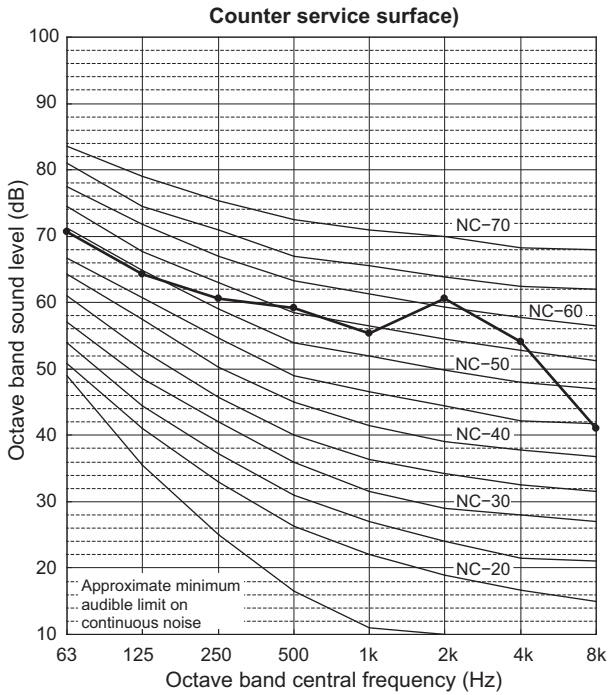
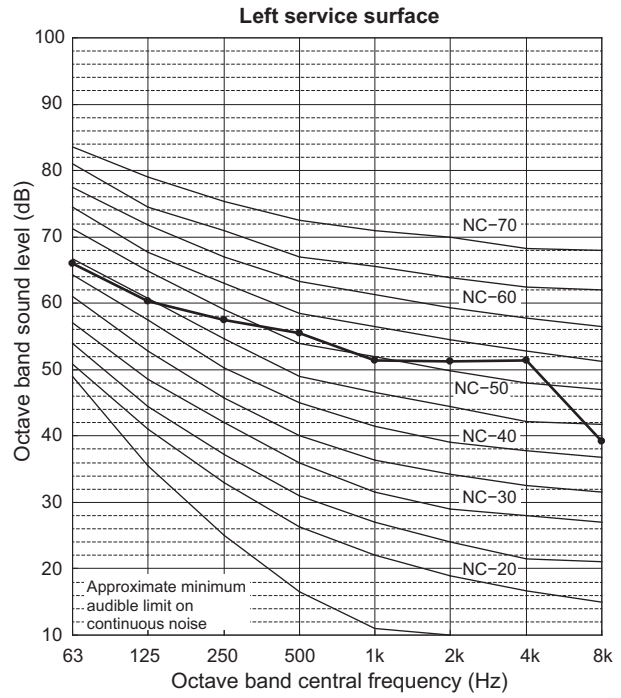
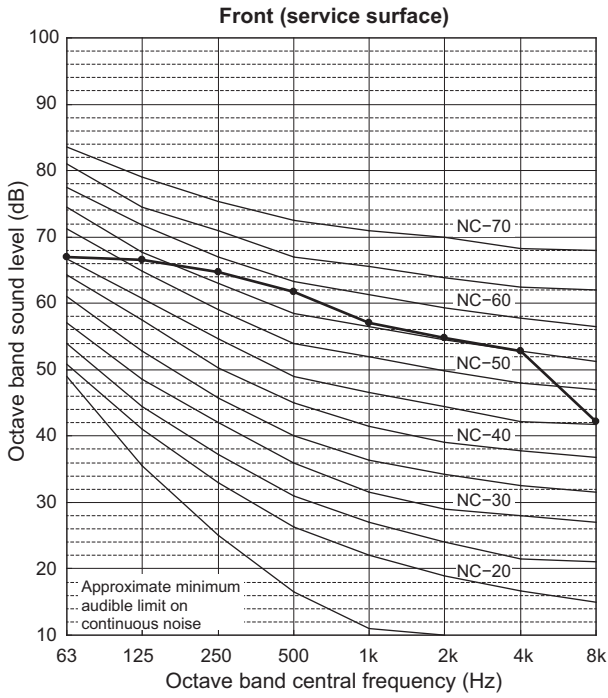

2. Product Data

EAHV-P900YA × 5
EACV-P900YA × 5

EAHV-P-YAF(-H)(-N), YAL(-H)(-N)/EACV-P-YAF(-N), YAL(-N)

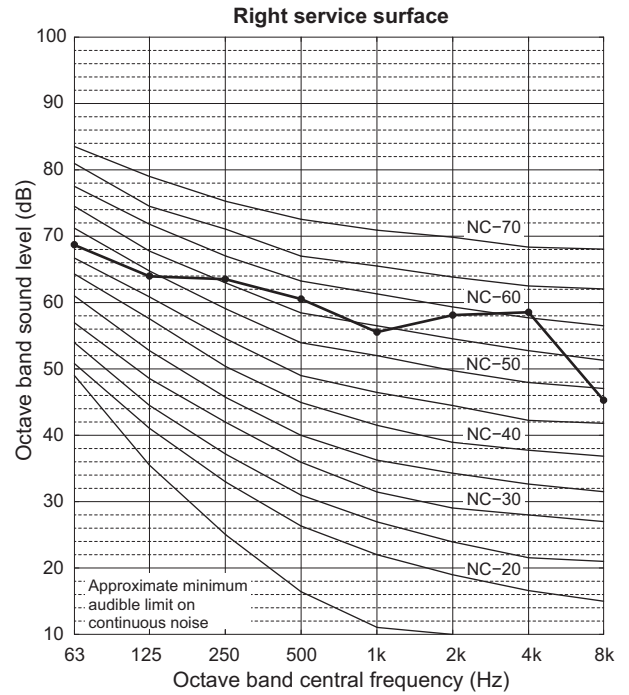
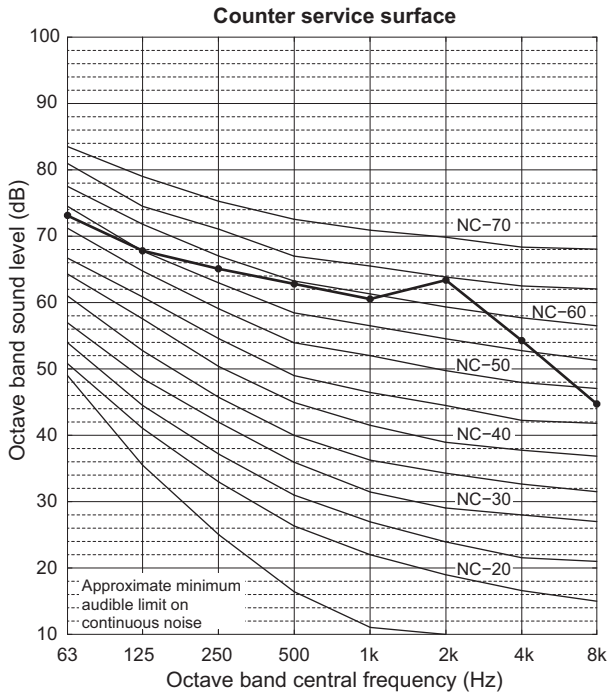
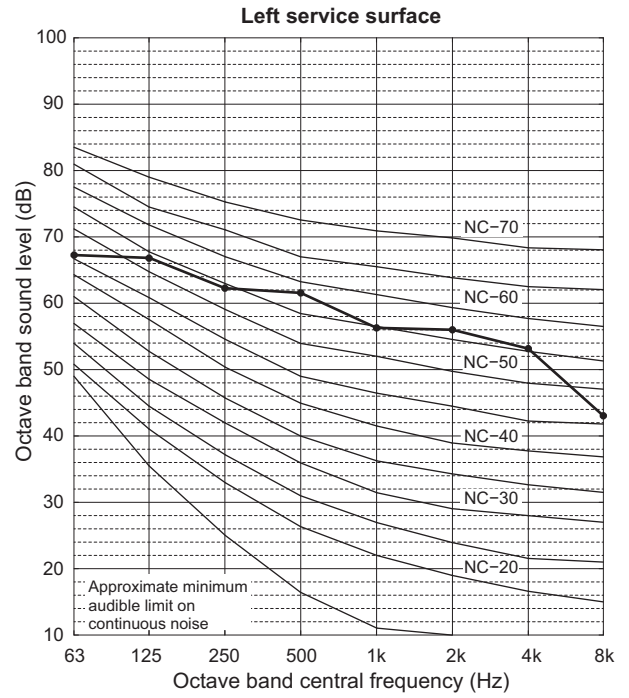
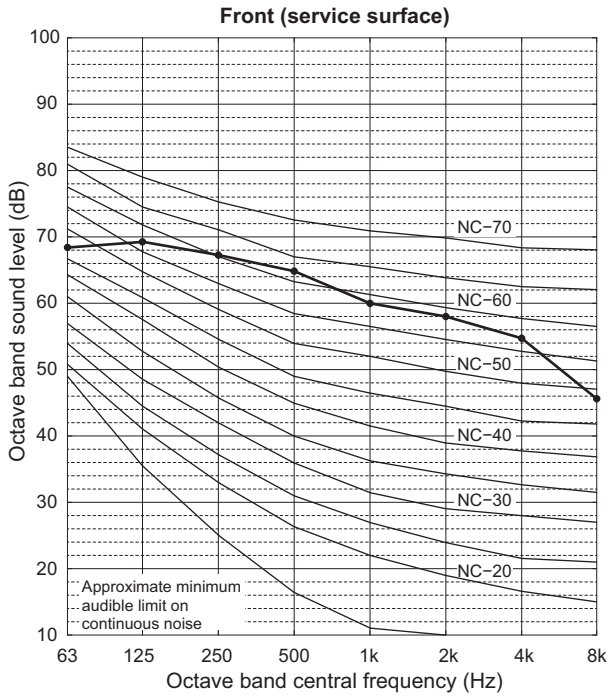

2. Product Data

EAHV-P900YA × 5 (COP priority mode)
 EACV-P900YA × 5 (COP priority mode)

EAHV-P-YAF(-H)(-N), YAL(-H)(-N)/EACV-P-YAF(-N), YAL(-N)

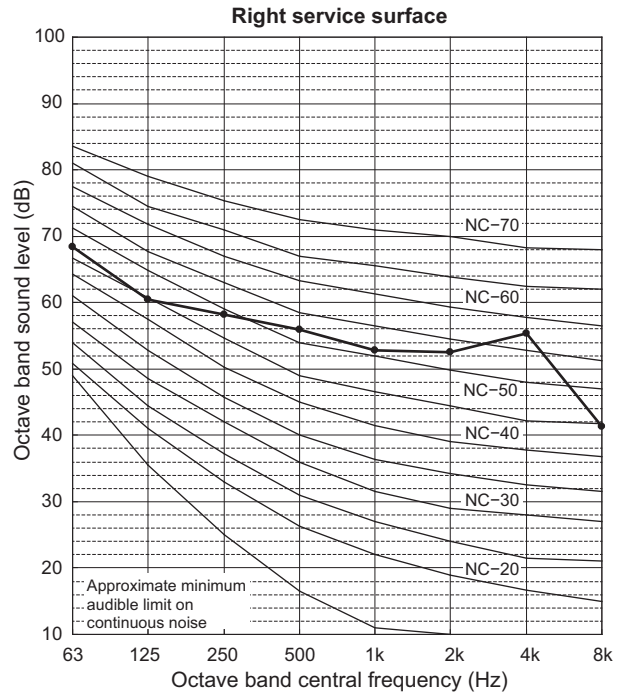
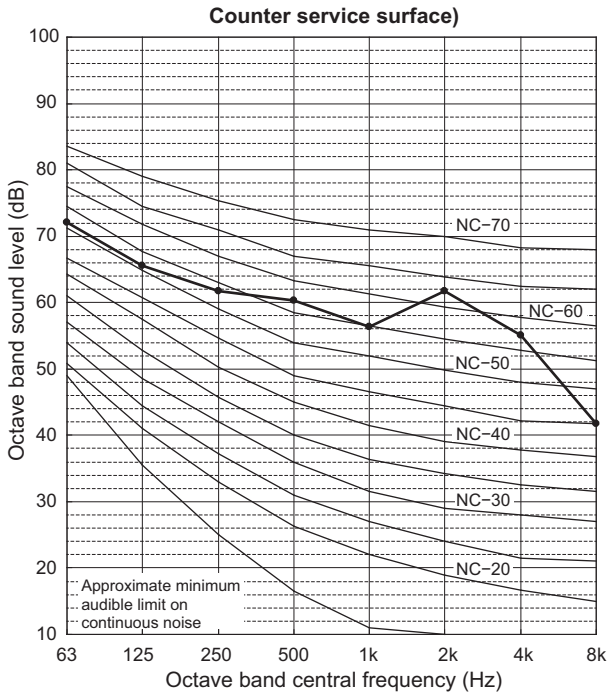
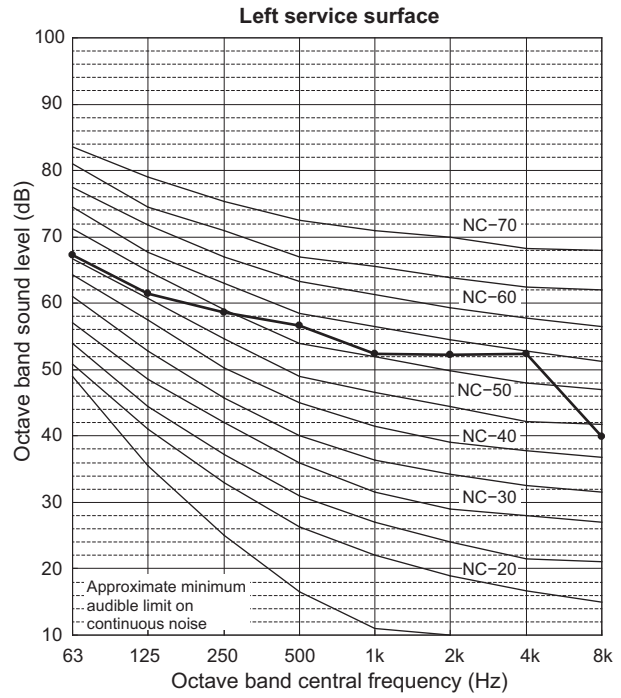
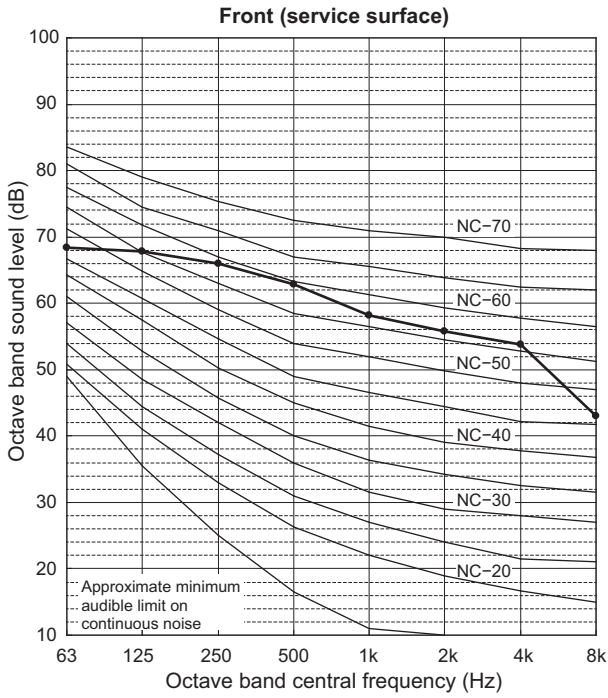

2. Product Data

EAHV-P900YA × 6
EACV-P900YA × 6

EAHV-P-YAF(-H)(-N), YAL(-H)(-N)/EACV-P-YAF(-N), YAL(-N)

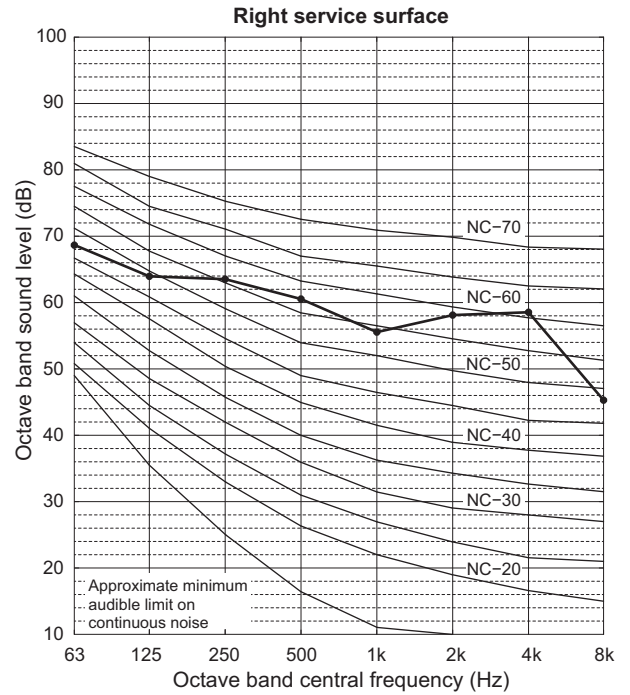
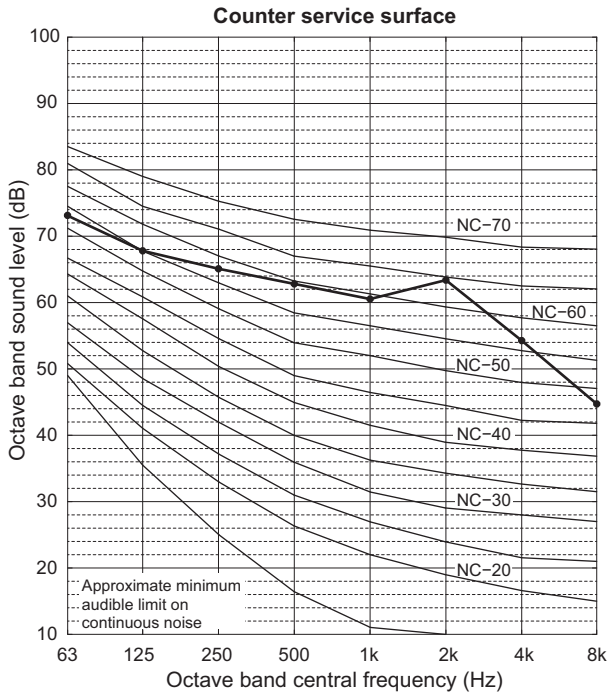
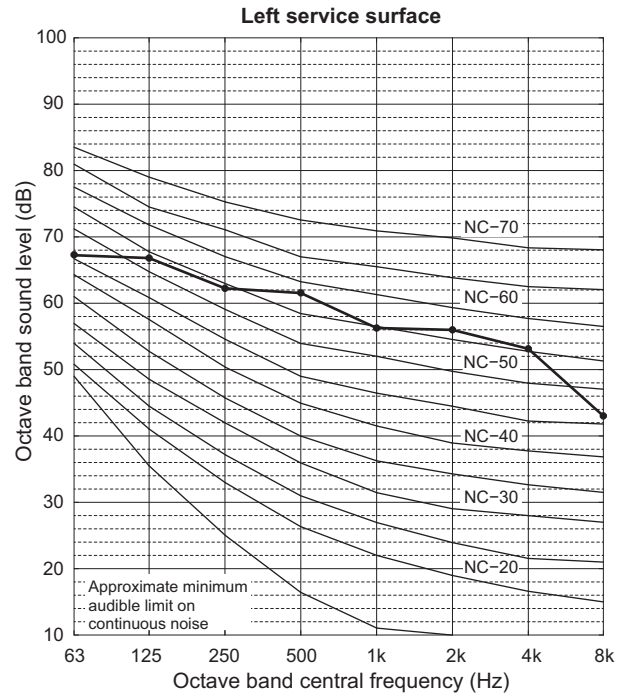
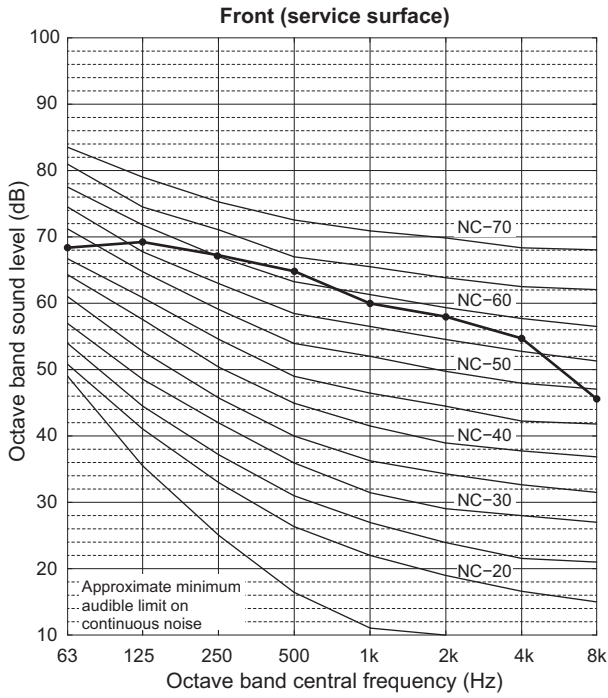

2. Product Data

EAHV-P900YA × 6 (COP priority mode)
 EACV-P900YA × 6 (COP priority mode)

EAHV-P-YAF(-H)(-N), YAL(-H)(-N)/EACV-P-YAF(-N), YAL(-N)

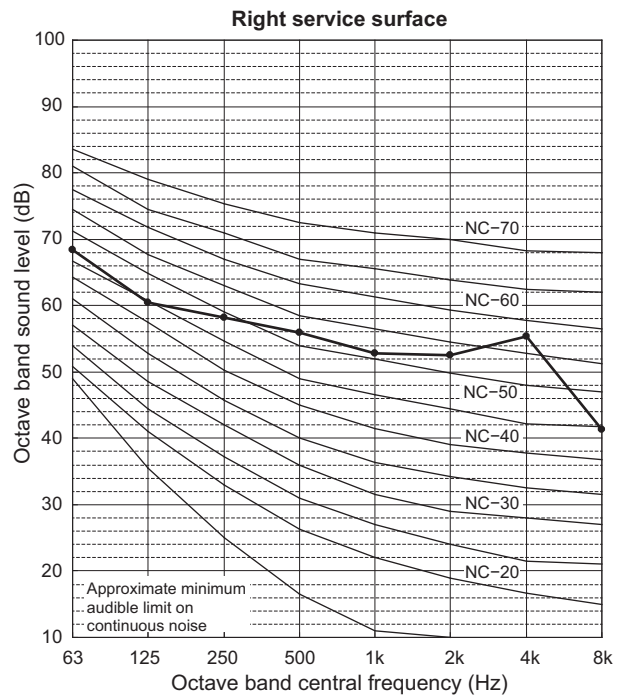
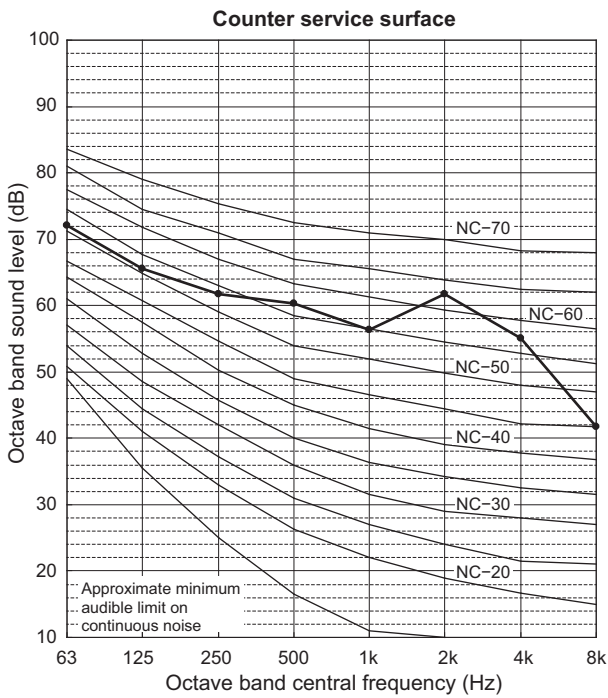
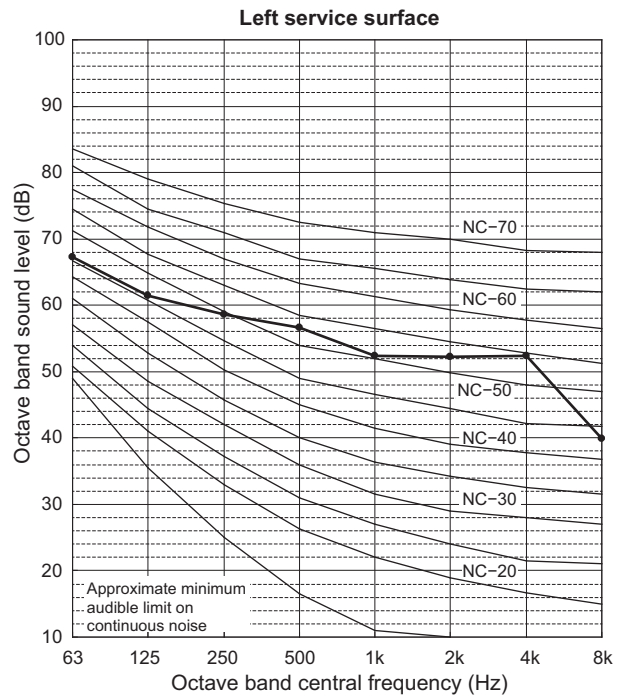
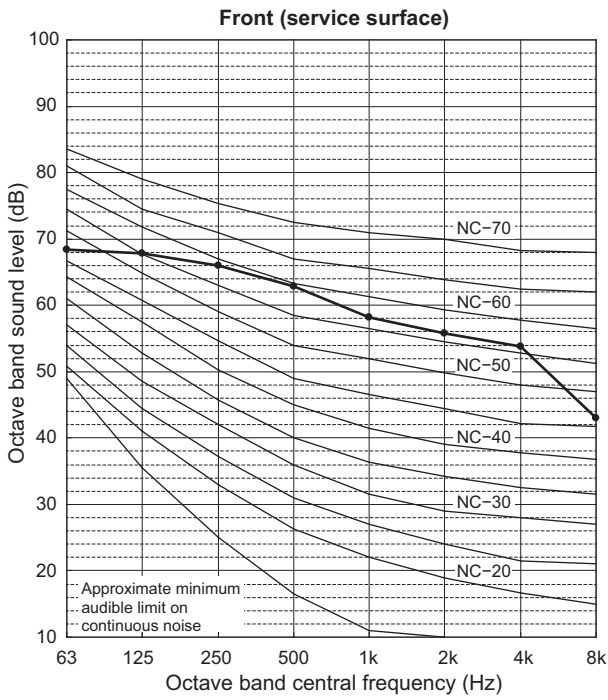

2. Product Data

2-3. Vibration levels

EAHV-P900YA
EACV-P900YA



EAHV-P-YAF(-H)(-N), YAL(-H)(-N)/EACV-P-YAF(-N), YAL(-N)

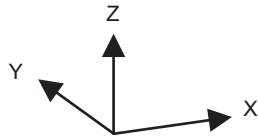

unit: μm (one side amplitude effective value)

	X	Y	Z
A	1	2	5
B	1	1	3
C	2	1	3
D	1	1	3

* The above values are the planned value.

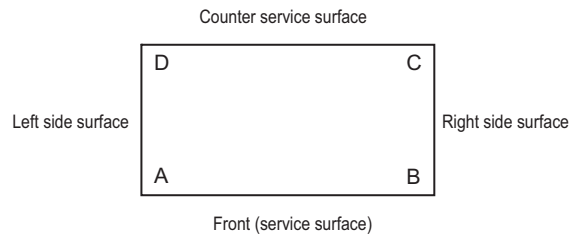

Note

1. Unit operation condition
 - Full load operation
2. Unit installation conditions
 - Directly placed on the surface plate in the test room in the Works

2. Product Data

2-4. Salt Protection Specifications

No.	Name	Base material	EAHV/EACV		Surface treatment	Treatment thickness	
			P900YA	P900YA-BS		External	Internal
			standard	salt damage protection			
1	Air guide	Polypropylene resin	●	●	-	-	-
2	Front & Top panel	Alloyed galvanized sheet	●		Polyester resin coating	30 μm or more	30 μm or more
				●	Polyester resin coating	60 μm or more	60 μm or more
3	Fan	Polypropylene resin	●	●	-	-	-
4	Motor	Frame; Unsaturated polyester resin	●	●	-	-	-
		Heat sink; Aluminum diecast	●	●	No treatment	-	-
5	Motor support	Aluminum-zinc alloy magnesium plating sheet	●		No treatment	-	-
		Alloyed galvanized sheet		●	Polyester resin coating	60 μm or more	60 μm or more
6	Heat exchanger (Only fin)	Aluminum plate	●	●	Cellulose series and urethane series resin coating	1 μm or more	-
7	Bottom frame (Including drain pan)	Alloyed galvanized sheet	●	●	Polyester resin coating	60 μm or more	60 μm or more
8	Compressor	Carbon steel	●	●	Epoxy resin coating	13 μm or more	13 μm or more
9	Pillar	Alloyed galvanized sheet	●		Polyester resin coating	30 μm or more	30 μm or more
				●	Polyester resin coating	60 μm or more	60 μm or more
10	Water-side heat exchanger (Including water piping)	Stainless steel	●	●	No treatment	-	-
11	Electrical parts box	Galvanized sheet	●	●	No treatment	-	-
12	Printed circuit board	Composite material <CEM-3>	●	●	Polyurethane coating	10 μm or more	10 μm or more
13	Terminal box	Alloyed galvanized sheet	●	●	Polyester resin coating	30 μm or more	30 μm or more
14	Receiver	Carbon steel	●		Phenolic Modified alkyd resin dip	30 μm or more	-
				●	Epoxy resin and polyurethane resin coating	70 μm or more	-
15	Accumulator	Carbon steel	●		Phenolic Modified alkyd resin dip	30 μm or more	-
				●	Epoxy resin and polyurethane resin coating	70 μm or more	-
16	Fin guard (Option)	Iron wires	●	●	Polyethylene resin coating	300 μm or more	300 μm or more
17	Screw	Carbon steel	●	●	Zinc-nickel alloy plating + Geomet filming	-	-

Application Guide

	Distance from sea		
	300 m	500 m	1 km
Direct sea breeze			
Facing inland sea	BS	STD	STD
Facing ocean		BS	BS
Island location		BS	BS
Indirect sea breeze			
Facing inland sea	BS	STD	STD
Facing ocean		BS	BS
Island location		BS	BS

Caution;

- 1 Set the outdoor unit to the place with rare direct sea breeze.
- 2 Don't attach a sunshade. A rain will clean the attached salt.
- 3 Set the outdoor unit horizontally. The water should not keep in the unit.
- 4 Please wash the outdoor unit periodically.
- 5 Repair the scratch on the panel as soon as possible.
- 6 Inspect periodically. Paint or change parts if necessary.

3. Installation

3-1. Selecting the Installation Site

3-1-1. Installation Conditions

Select the installation site in consultation with the client.

Select a site to install the unit that meets the following conditions:

- ♦The unit will not be subject to heat from other heat sources.
- ♦The noise from the unit will not be a problem.
- ♦The unit will not be exposed to strong winds.
- ♦Water from the unit can be drained properly.
- ♦Enough space for installation and service as shown in 3-1. Selecting the Installation Site.
- ♦There is a possibility of injuring with the fin of the heat exchanger, so abide by following contents.

- 1) Appliances are not accessible to the general public.
 - 2) Limit the installation to a place where the general public cannot touch the product.
 - 3) When installing in a location where the general public can touch the product, install the optional fin guard.
- Option Parts: EA-130FG

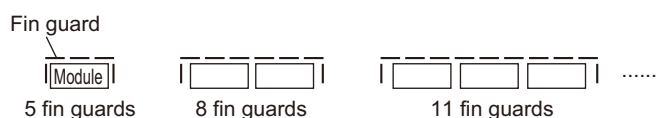

1. Protection against winds

- ♦Pay attention to the wind direction and installation location to ensure that the air heat exchanger is not directly exposed to strong winds.
- ♦If unable to avoid strong winds, install wind breaking hoods or walls, etc.

2. Cold Climate Installation

Observe the following when installing the units in areas where snow or strong winds prevail.

- ♦Avoid direct exposure to rain, winds, and snow.
- ♦If the unit is installed in the direct line of rain, winds, or snow, install snow hoods. Use a snow net or snow fence as necessary to protect the unit.
- ♦Install the unit on a base approximately twice as high as the expected snowfall.
- ♦If the unit of heating mode is continuously operated for a long time with the outdoor temperature below the freezing point, install a heater at the drain pan of the unit to prevent freezing of drain.

3-1-2. Installation Space Requirement

1. If there are no walls, etc. in surrounding area

(1) Single unit installation space

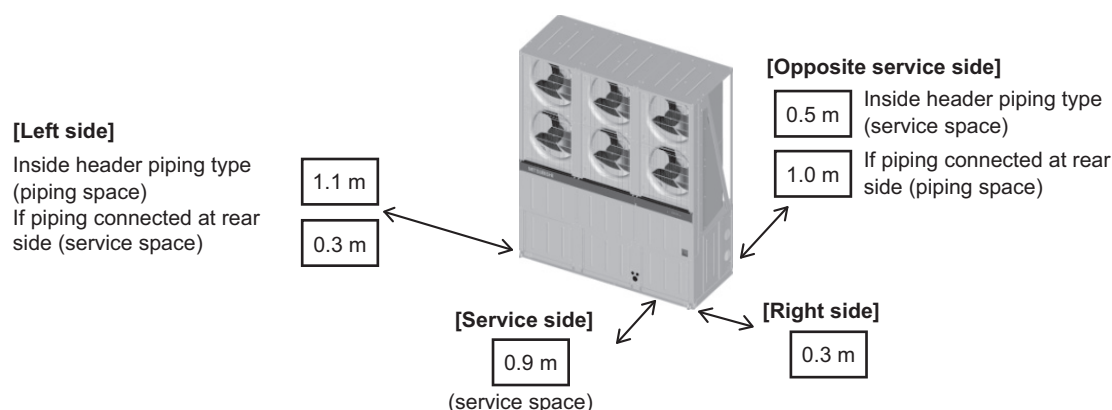

*The inside header piping type shows case of piping from the left side of the unit.

3. Installation

(2) Connected modules installation space

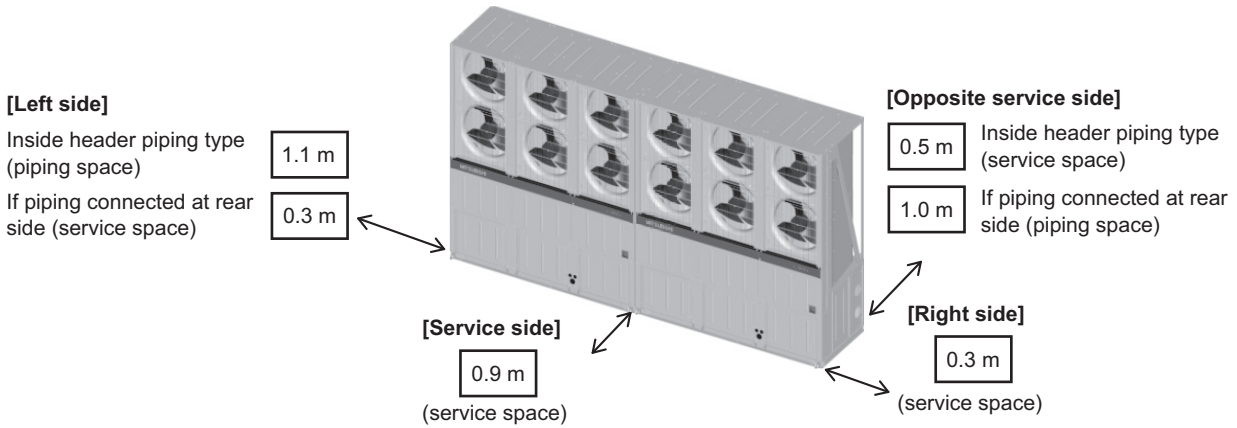

*The inside header piping type shows case of piping from the left side of the unit.

(3) Discharge side installation space (if 2 rows)

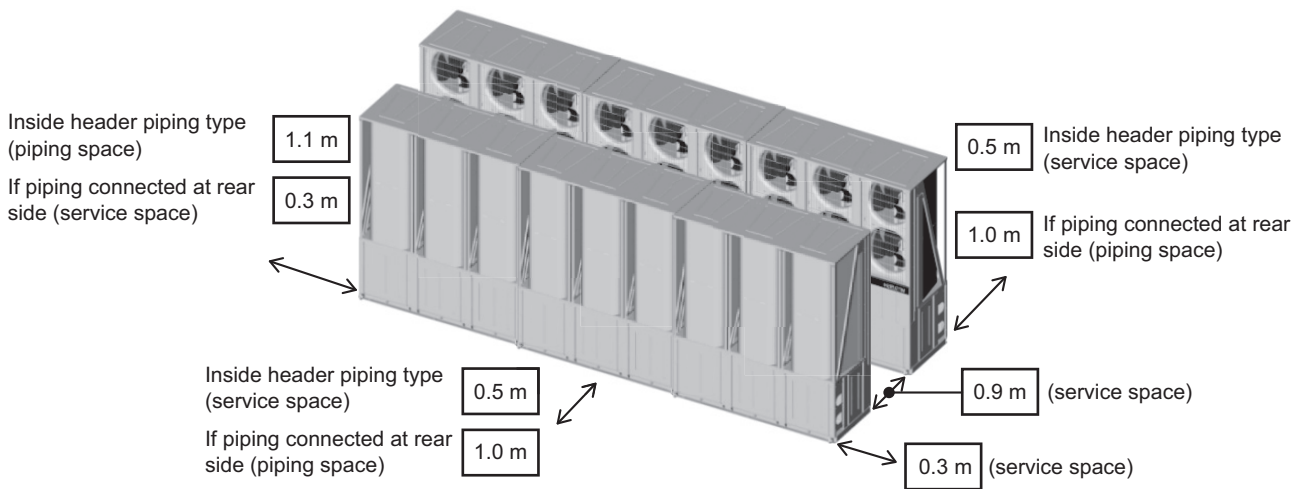

*The inside header piping type shows case of piping from the left side of the diagram.

*Even if installed as shown in this diagram, a short cycle may occur due to the influence of wind.

(4) Discharge side installation space (if 4 rows × 2)

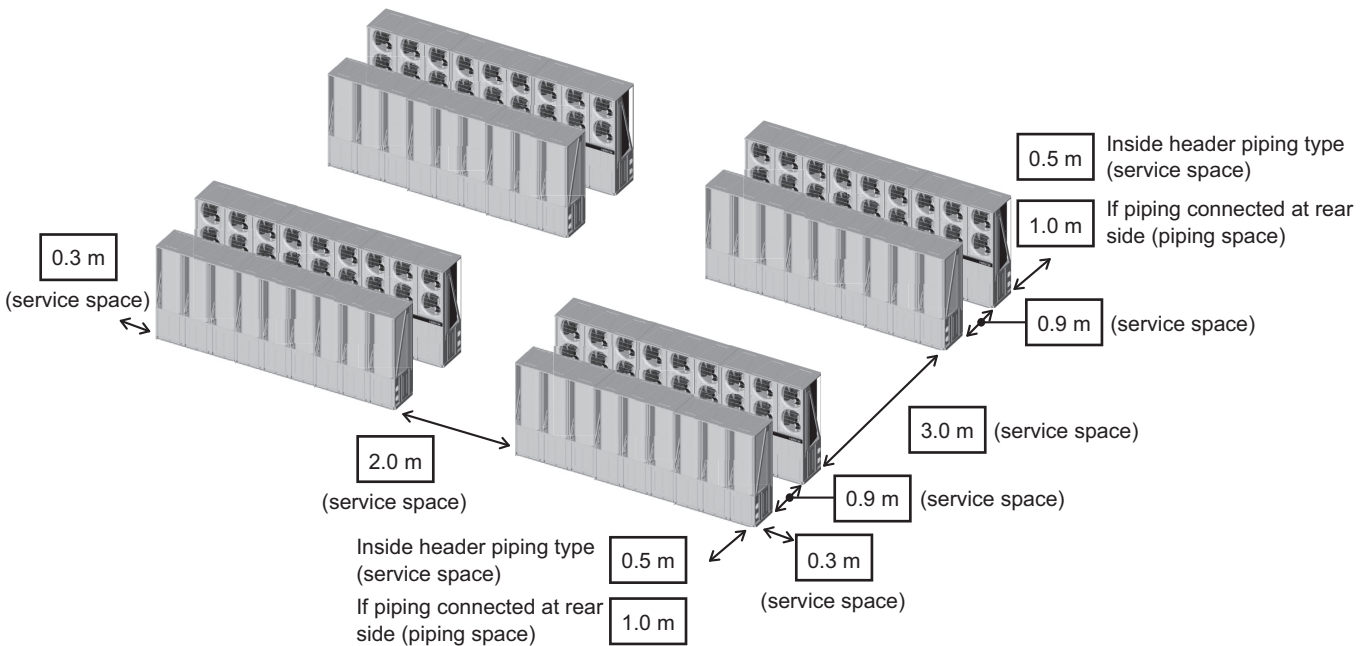

*The inside header piping type shows case of piping from the left side of the diagram.

*Even if installed as shown in this diagram, a short cycle may occur due to the influence of wind.

EAHV-P-YAF(-H)(-N), YAL(-H)(-N)/EACV-P-YAF(-N), YAL(-N)

3. Installation

2. If there are walls, etc. in surrounding area

(1) If installing a single unit in front of a wall

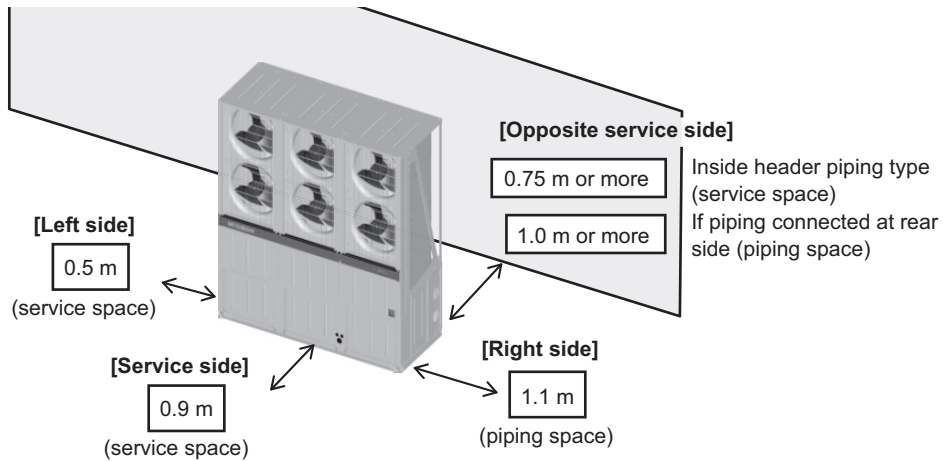

*The inside header piping type shows case of piping from the right side of the unit.

*Even if installed as shown in this diagram, a short cycle may occur due to the influence of wind.

(2) If installing 3 connected modules in front of a wall

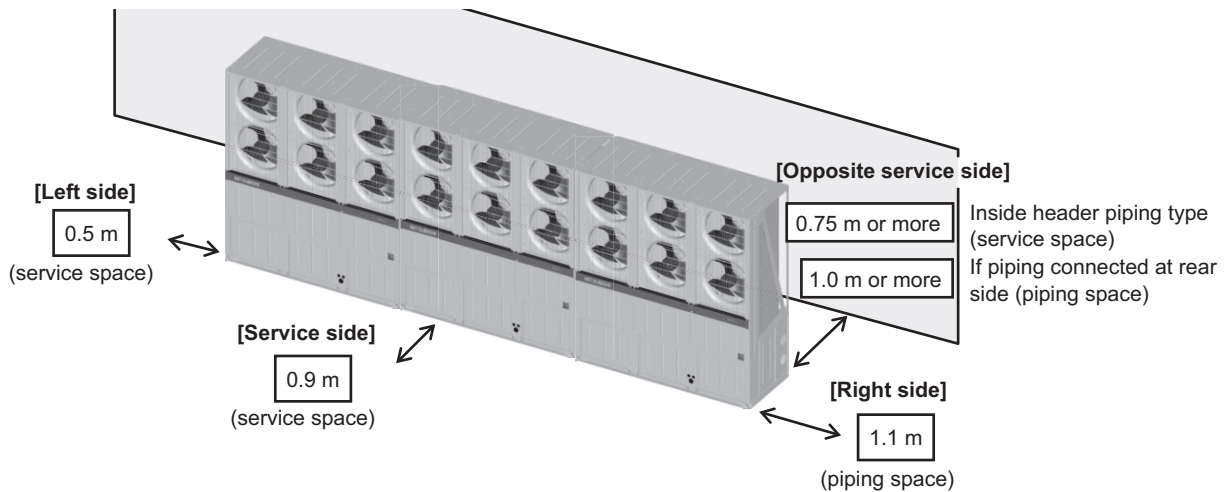

*The inside header piping type shows case of piping from the right side of the unit.

*Even if installed as shown in this diagram, a short cycle may occur due to the influence of wind.

(3) If installing 4 to 6 connected modules in front of a wall

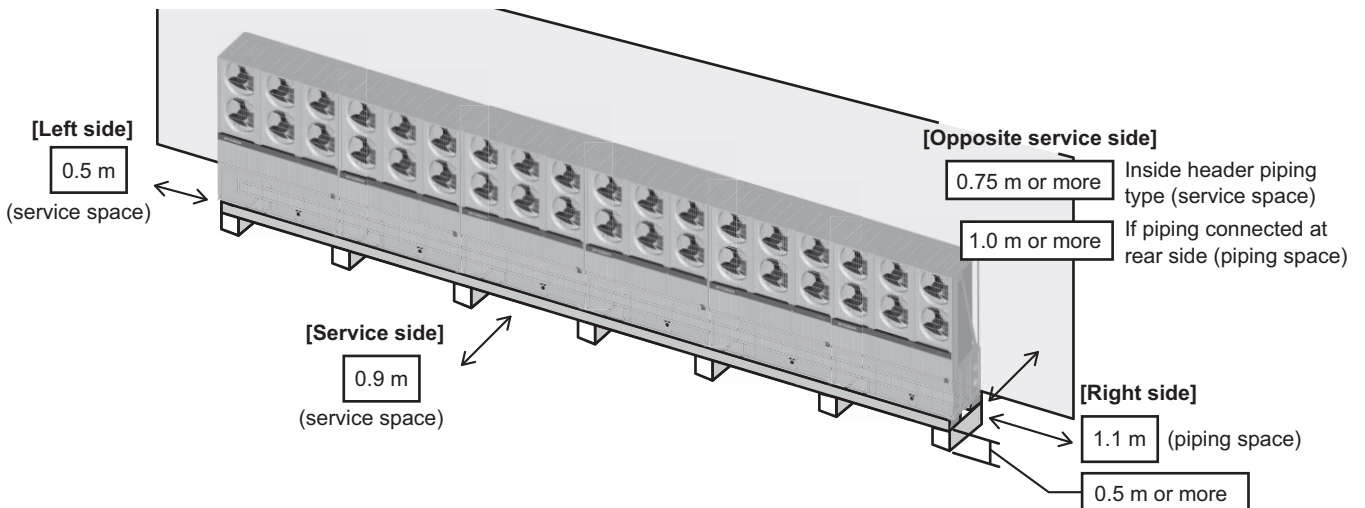

*The inside header piping type shows case of piping from the right side of the unit.

*Even if installed as shown in this diagram, a short cycle may occur due to the influence of wind.

3. Installation

(4) If installing multiple sets of 3 connected modules in front of a wall

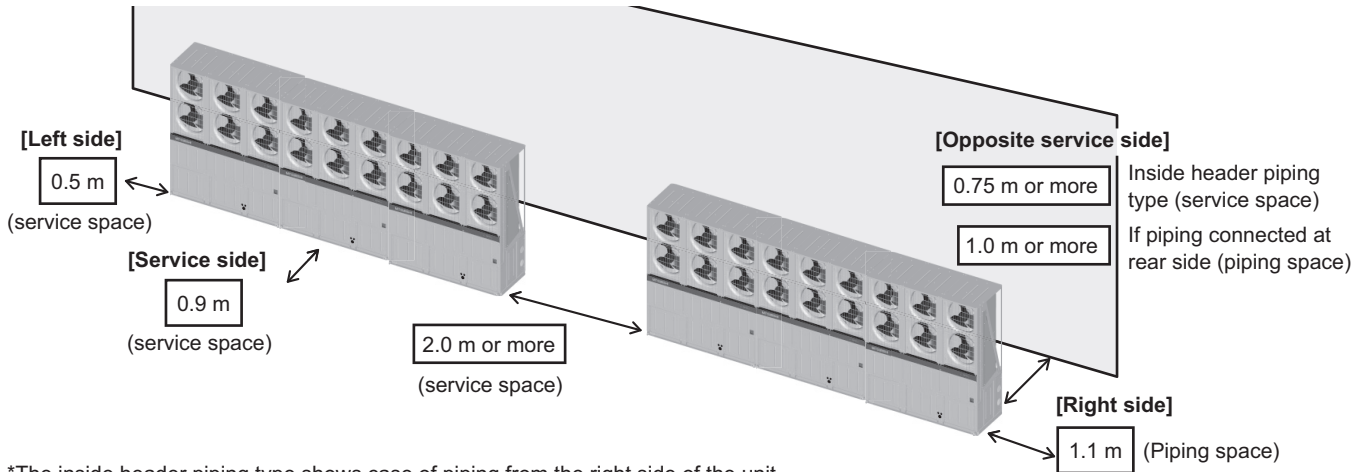

*The inside header piping type shows case of piping from the right side of the unit.

*Even if installed as shown in this diagram, a short cycle may occur due to the influence of wind.

(5) If installing 4 to 6 connected modules in front of a wall (when intake side facing out)

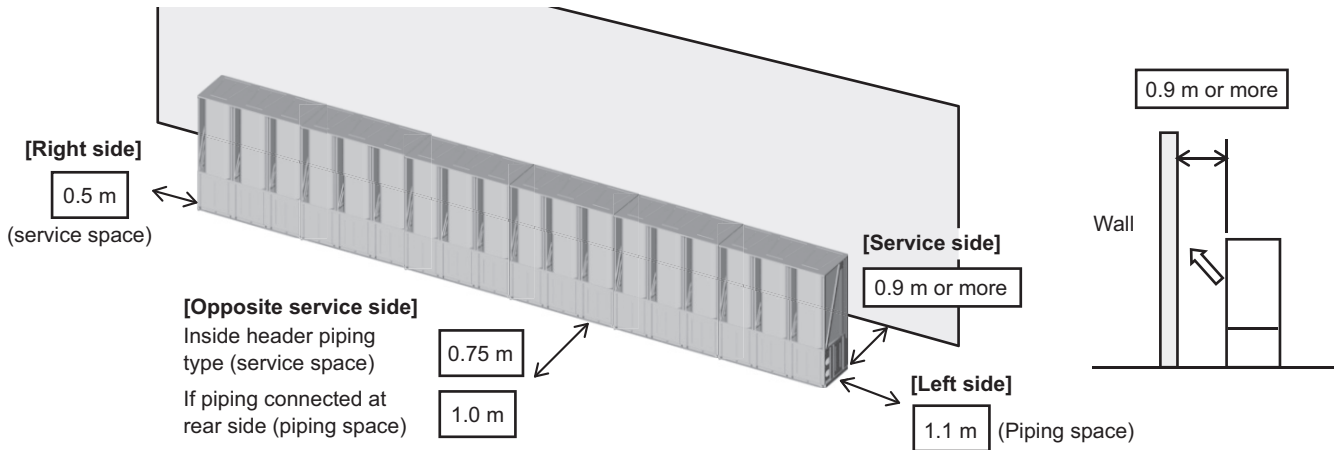

*The inside header piping type shows case of piping from the right side of the unit.

*Even if installed as shown in this diagram, a short cycle may occur due to the influence of wind.

EAHV-P-YAF(-H)(-N), YAL(-H)(-N)/EACV-P-YAF(-N), YAL(-N)

3. Installation

3. If surrounding area enclosed by walls

(1) If installing a single unit on an L-shaped wall

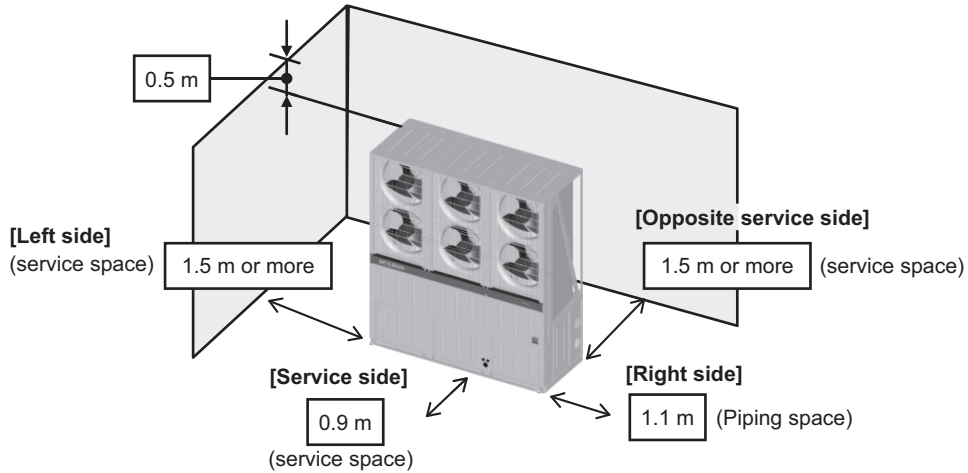

*The inside header piping type shows case of piping from the left side of the unit.

*Wall height 2.9 m (unit height: 2.4 + 0.5 m)

*Even if installed as shown in this diagram, a short cycle may occur due to the influence of wind.

(2) If entire surrounding area enclosed by walls (but vent holes installed at bottom of wall)

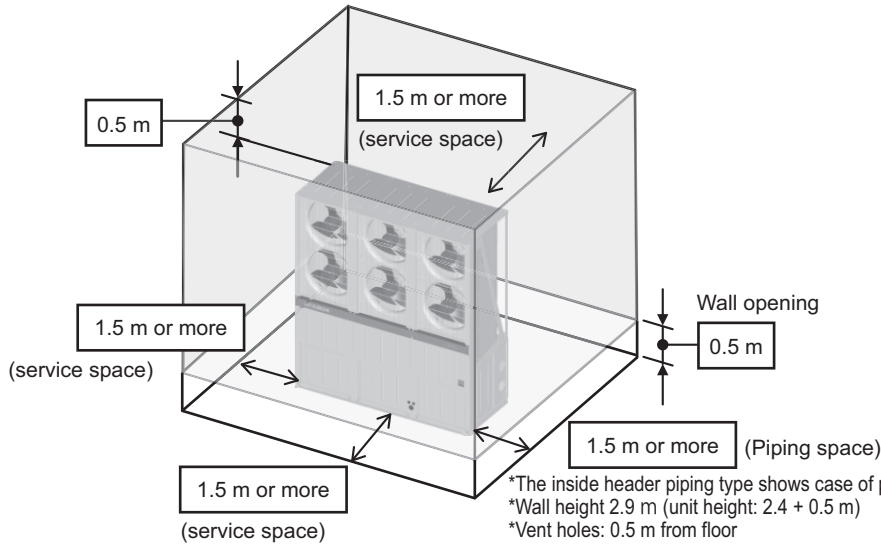

*The inside header piping type shows case of piping from the left side of the diagram.

*Wall height 2.9 m (unit height: 2.4 + 0.5 m)

*Vent holes: 0.5 m from floor

*Even if installed as shown in this diagram, a short cycle may occur due to the influence of wind.

(3) If entire surrounding area enclosed by walls, and units face one another (but vent holes installed at bottom of wall)

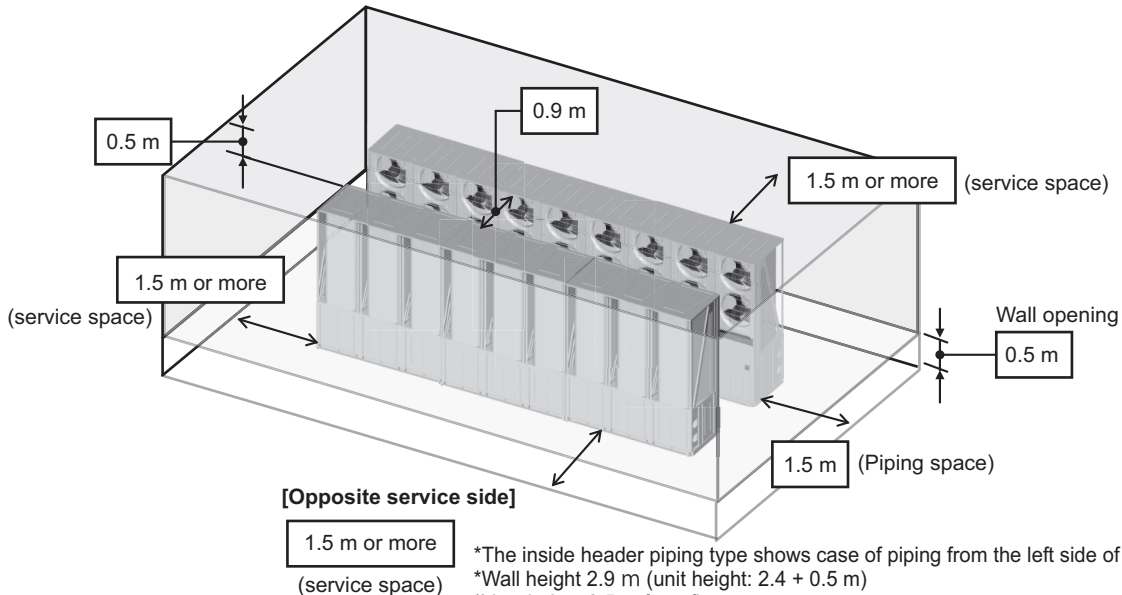

*The inside header piping type shows case of piping from the left side of the diagram.

*Wall height 2.9 m (unit height: 2.4 + 0.5 m)

*Vent holes: 0.5 m from floor

*Even if installed as shown in this diagram, a short cycle may occur due to the influence of wind.

3. Installation

3-2. Unit Installation

Units should be installed only by personnel certified by Mitsubishi Electric.

3-2-1. Product suspension method

- If transporting the product suspended, use the two suspension sections at the front and rear.
- Always feed rope through the four suspension sections so that the unit is not subjected to shocks.
- Use two ropes that are 8 m or longer. (Use four ropes that are 4 m or longer.)
- Use suspension equipment that is capable of supporting the weight of the product.
- Always suspend the product in four sections. (do not suspend the product two sections as this is dangerous)
- Use the appropriate protective pads to ensure that the rope does not rub against the outer panel.
- Refer to the center of gravity position, and suspend the unit while taking care to prevent a deviated center of gravity.

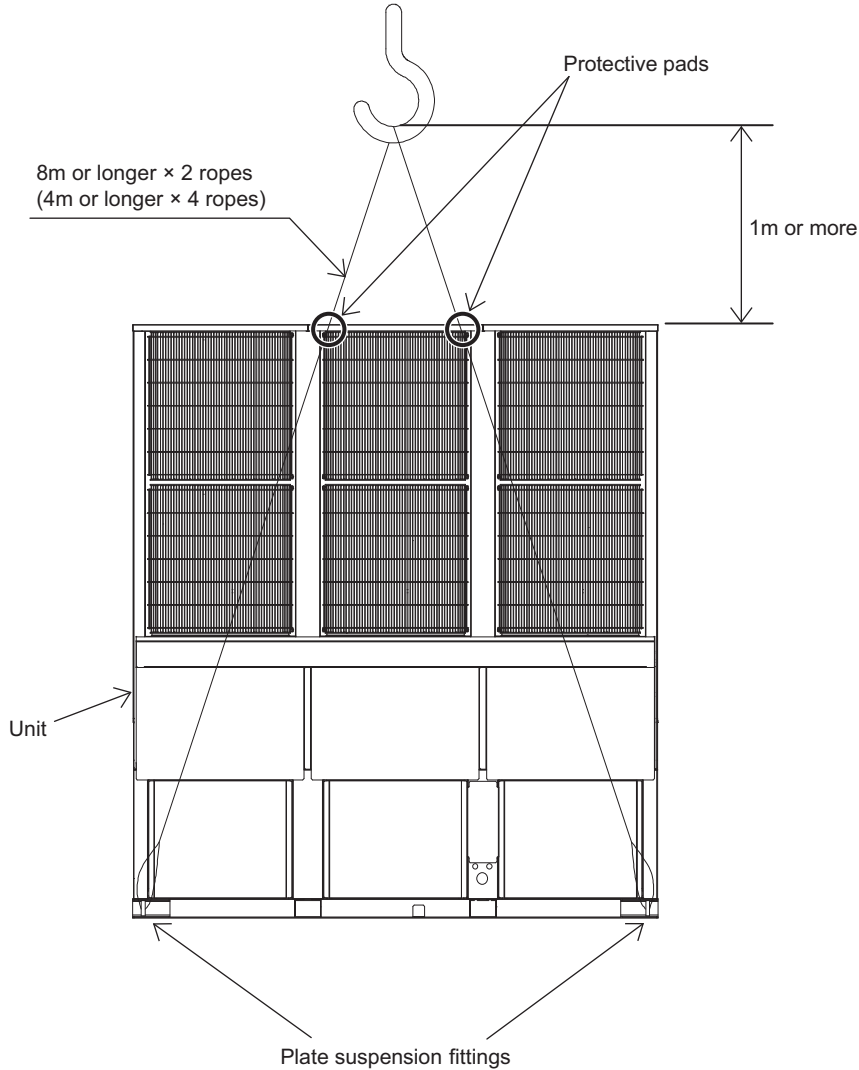

⚠ Warning:

- Lift the unit by placing the slings at designated locations. Support the unit securely at four points to keep it from slipping and sliding. If the unit is not properly supported, it may fall and cause personal injury.

EAHV-P-YAF(-H)(-N), YAL(-H)(-N)/EACV-P-YAF(-N), YAL(-N)

3. Installation

3-2-2. Installation on foundation

- Securely fix the unit with bolts to keep the unit from falling down during earthquakes.
- Install the unit on a foundation made of concrete or iron.
- Noise and vibrations from the unit may be transmitted through the floor and walls. Provide adequate protection against noise and vibration.

Warning:

- Be sure to install the unit on a surface strong enough to withstand its weight to keep the unit from falling down and causing injury.
- Provide adequate protection against earthquakes. Improper installation may cause the unit to fall down, resulting in personal injury.

When building the foundation, take the floor strength, and piping and wiring routes into consideration.

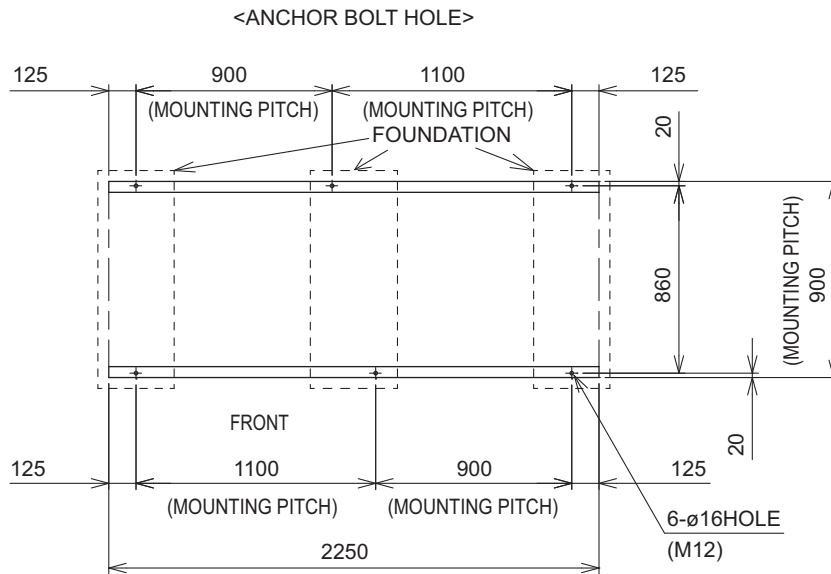
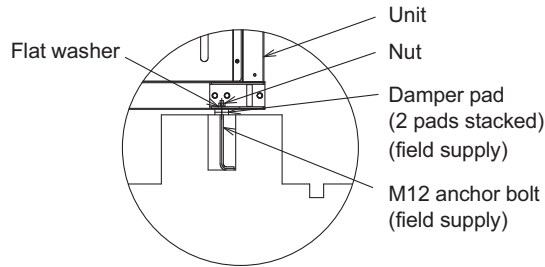

4. System Design

4-1. Water Pipe Installation

4-1-1. Schematic Piping Diagram and Piping System Components

1. Water circuit

Please build the water circuit so that it is a closed system.

Do not use water directly for showers or other applications.

Do not allow other heat source water to mix with the water circuit.

Build a water circuit as inlet water temperature fluctuation is within 5°C/10 minutes.

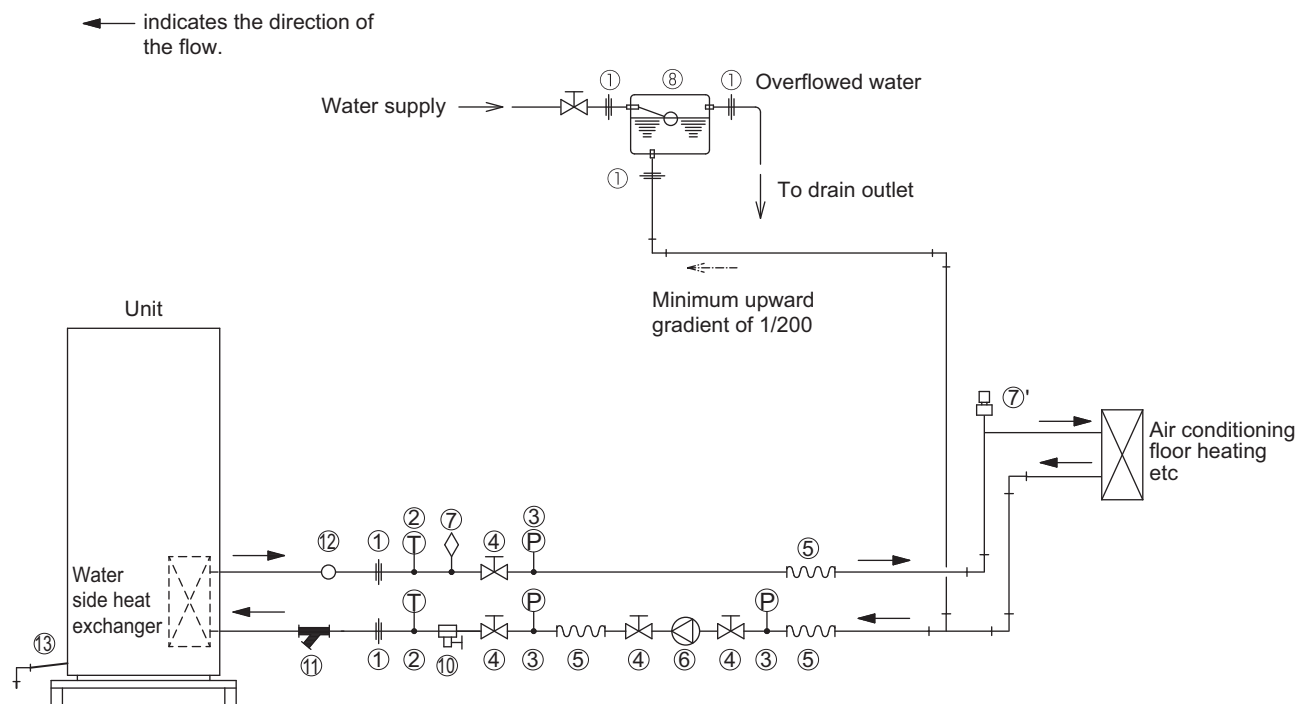

① Union joints/flange joints	Required to allow for a replacement of equipment.
② Thermometer	Required to check the performance and monitor the operation of the units.
③ Water pressure gauge	Recommended for checking the operation status.
④ Valve	Required to allow for a replacement or cleaning of the flow adjuster.
⑤ Flexible joint	Recommended to prevent the noise and vibration from the pump from being transmitted.
⑥ Pump	Use a pump that is large enough to compensate for the total water pressure loss and supply sufficient water to the unit.
⑦ Air vent valve	Install air venting valves to the places where air can accumulate. Automatic air vent valves (such as ⑦') are effective.
⑧ Expansion tank	Install an expansion tank to accommodate expanded water and to supply water.
⑨ Water pipe	Use pipes that allow for easy air purging, and provide adequate insulation.
⑩ Drain valve	Install drain valves so that water can be drained for servicing.
⑪ Strainer	Install a strainer near the unit to keep foreign materials from entering the water-side head exchanger.
⑫ Flow switch	Required to protect the unit.
⑬ Drain pipe	Install the drain pipe with a downward inclination of between 1/100 and 1/200. To prevent drain water from freezing in winter, install the drain pipe as steep an angle as practically possible and minimize the straight line. For cold climate installation, take an appropriate measure (e.g., drain heater) to prevent the drain water from freezing.

4. System Design

2. Brine circuit

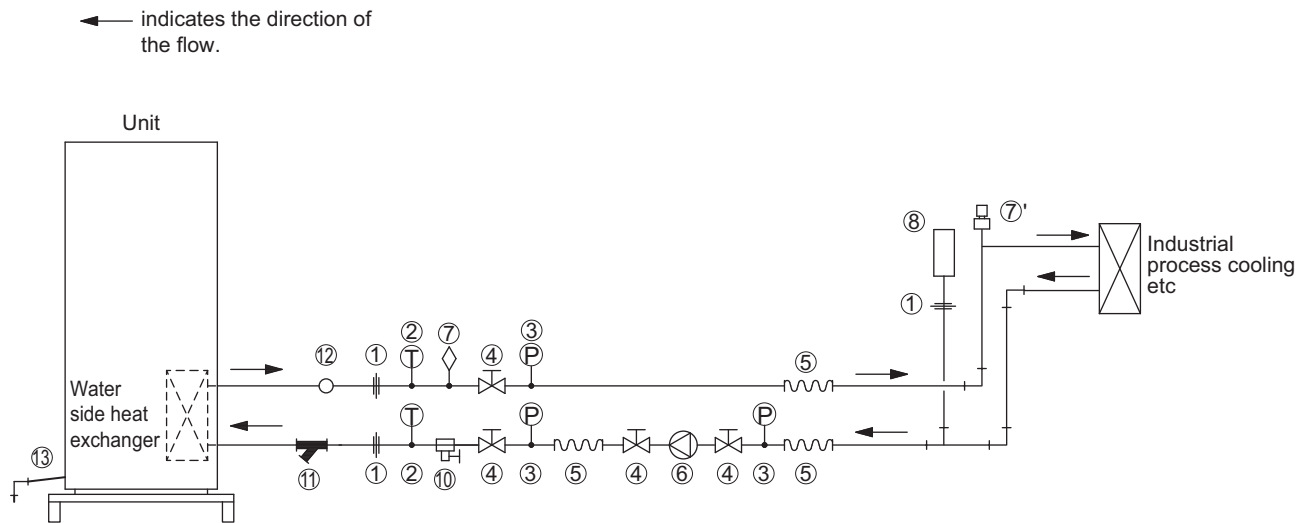

① Union joints/flange joints	Required to allow for a replacement of equipment.
② Thermometer	Required to check the performance and monitor the operation of the units.
③ Water pressure gauge	Recommended for checking the operation status.
④ Valve	Required to allow for a replacement or cleaning of the flow adjuster.
⑤ Flexible joint	Recommended to prevent the noise and vibration from the pump from being transmitted.
⑥ Pump	Use a pump that is large enough to compensate for the total water pressure loss and supply sufficient water to the unit.
⑦ Air vent valve	Install air venting valves to the places where air can accumulate. Automatic air vent valves (such as ⑦') are effective.
⑧ Closed expansion tank	Use a closed expansion tank to help manage the concentrate of brine.
⑨ Water pipe	Use pipes that allow for easy air purging, and provide adequate insulation.
⑩ Drain valve	Install drain valves so that water can be drained for servicing.
⑪ Strainer	Install a strainer near the unit to keep foreign materials from entering the water-side head exchanger.
⑫ Flow switch	Required to protect the unit.
⑬ Drain pipe	Install the drain pipe with a downward inclination of between 1/100 and 1/200. To prevent drain water from freezing in winter, install the drain pipe as steep an angle as practically possible and minimize the straight line. For cold climate installation, take an appropriate measure (e.g., drain heater) to prevent the drain water from freezing.

4. System Design

4-1-2. Water piping attachment method

Standard piping type

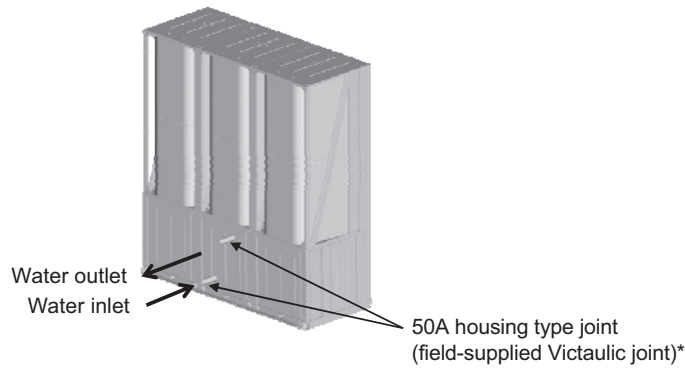

* Victaulic standard groove specifications

Machine grooves to secure housing joints to field-supplied pipes based on the following dimensions.

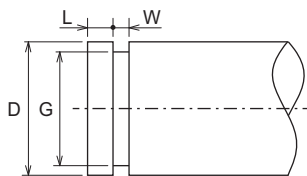

	Pipe size
	50A
D	$\varnothing 60.3 \pm 0.61$
G	$\varnothing 57.15 \begin{smallmatrix} 0 \\ -0.38 \end{smallmatrix}$
L	15.88 ± 0.76
W	7.95 ± 0.76

Inside header piping type

It requires optional Inside header piping kit.

Option Parts: EA-01HK

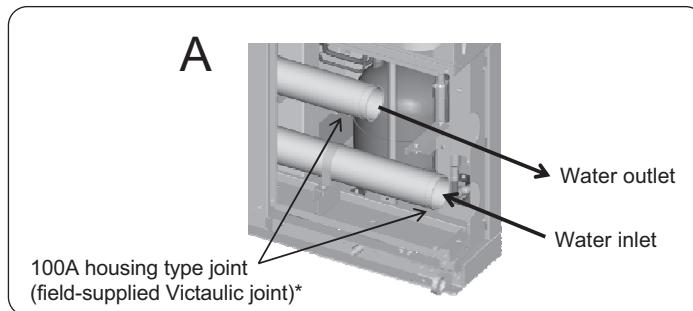
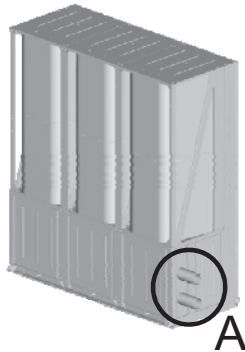

* Victaulic standard groove specifications

Machine grooves to secure housing joints to field-supplied pipes based on the following dimensions.

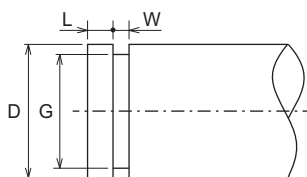

	Pipe size
	100A
D	$\varnothing 114.3 \begin{smallmatrix} +1.14 \\ -0.79 \end{smallmatrix}$
G	$\varnothing 110.08 \begin{smallmatrix} 0 \\ -0.51 \end{smallmatrix}$
L	15.88 ± 0.76
W	9.53 ± 0.76

EAHV-P-YAF(-H)(-N), YAL(-H)(-N)/EACV-P-YAF(-N), YAL(-N)

4. System Design

On-site module connection and terminal work

The module connection requires the option of both Inside header piping kit (EA-01HK) and Inside header connecting kit (EA-02HK). Inside header connecting kit requires the same number as the number of connections.

Option Parts: EA-01HK

EA-02HK

* Refer to the installation instructions that came with the optional parts for the details of installation of the optional parts.

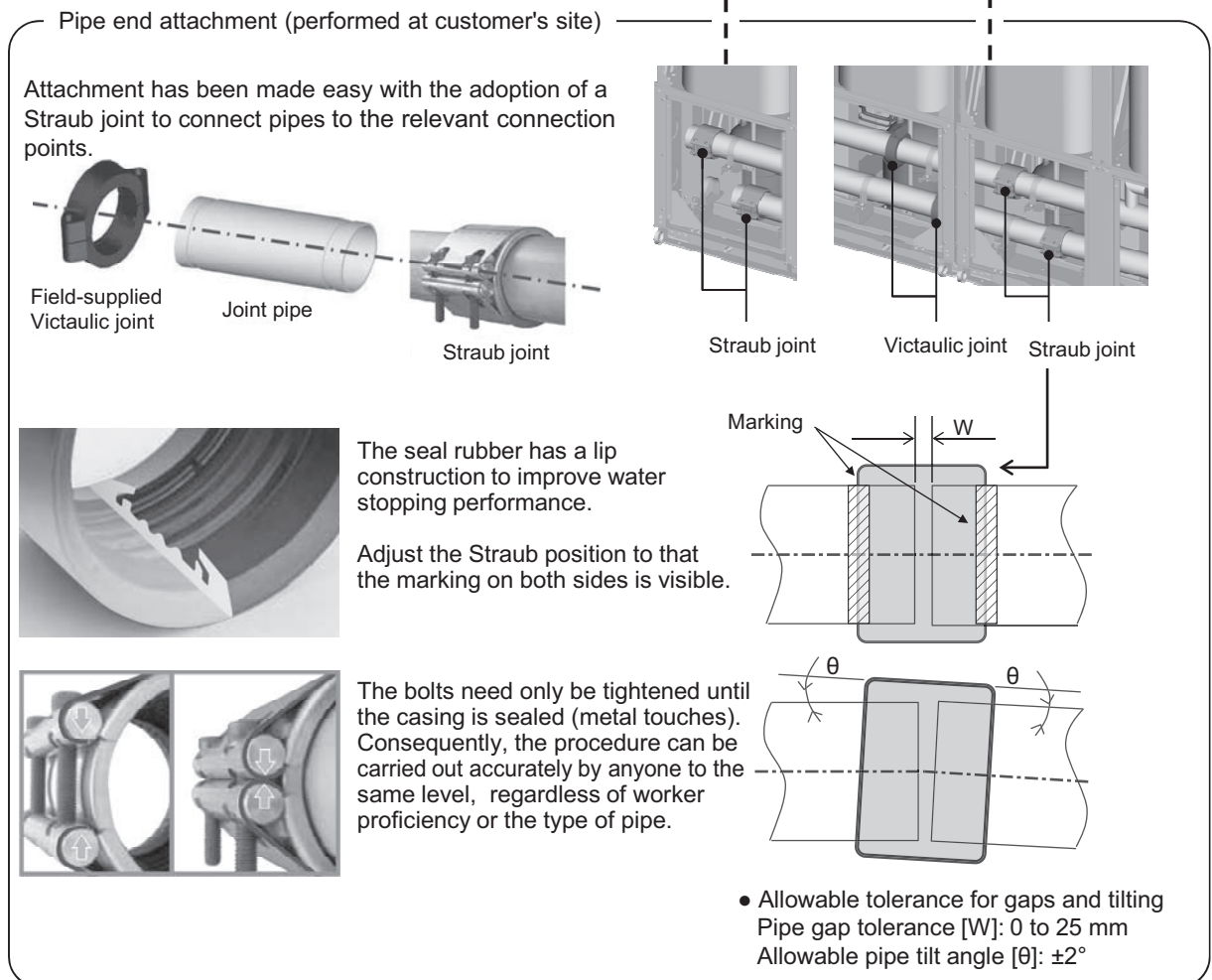
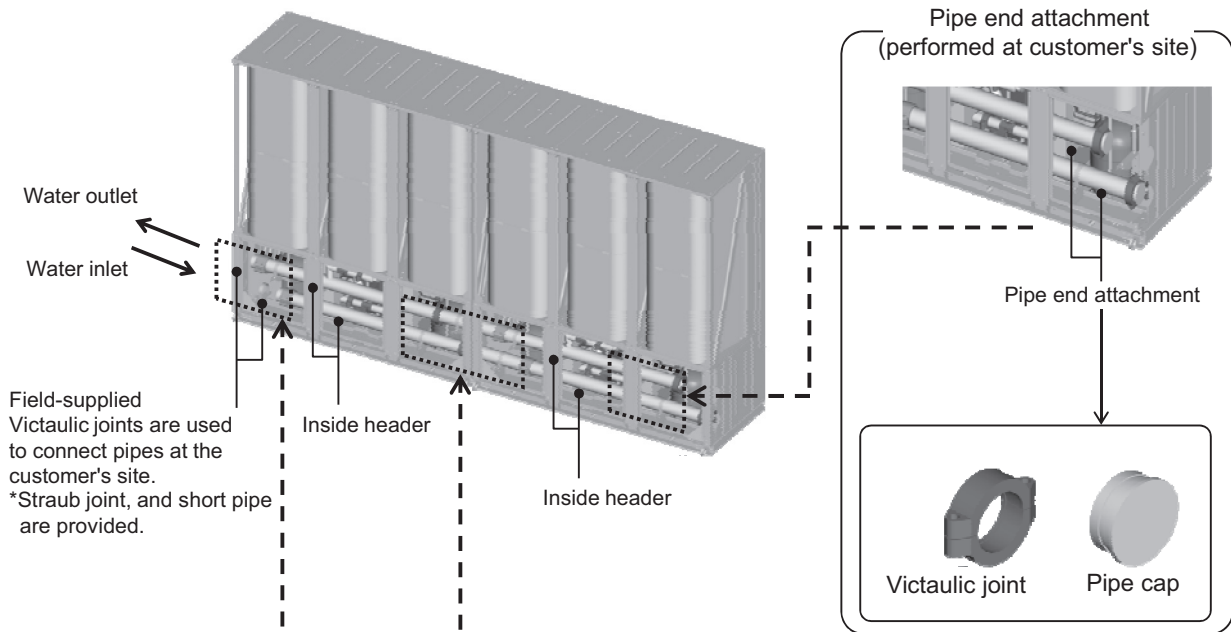

The Victaulic joints and Straub joints used in the explanation are actual product names.

4. System Design

4-1-3. Notes on pipe corrosion

Water processing and water quality control

Poor-quality circulating water can cause scale build-up and corrosion in the water-side heat exchanger, reducing heat-exchange performance. Properly control the quality of the circulating water.

- Removing foreign objects and impurities in the pipes

During installation, keep foreign objects, such as welding and sealant fragments and rust, out of the pipes.

- Water Quality Control

- (1) Poor-quality water can corrode or scale up the heat exchanger. Regular water treatment is recommended.

Water circulation systems using open heat storage tanks are particularly prone to corrosion.

When using an open heat storage tank, install a water-to-water heat exchanger, and use a closed-loop circuit.

If a water supply tank is installed, keep contact with air to a minimum, and keep the level of dissolved oxygen in the water no higher than 1 mg/ℓ.

- (2) Water quality standard

Items		Lower mid-range temperature water system Water Temp. ≤ 60°C		Higher mid-range temperature water system Water Temp. > 60°C		Tendency	
		Recirculating water	Make-up water	Recirculating water	Make-up water	Corrosive	Scale-forming
Standard items	pH (25 °C)	7.0 ~ 8.0	7.0 ~ 8.0	7.0 ~ 8.0	7.0 ~ 8.0	○	○
	Electric conductivity (mS/m) (25 °C) (μs/cm) (25 °C)	30 or less [300 or less]	30 or less [300 or less]	30 or less [300 or less]	30 or less [300 or less]	○	○
	Chloride ion (mg Cl/ℓ)	50 or less	50 or less	30 or less	30 or less	○	
	Sulfate ion (mg SO ₄ ²⁻ /ℓ)	50 or less	50 or less	30 or less	30 or less	○	
	Acid consumption (pH4.8) (mg CaCO ₃ /ℓ)	50 or less	50 or less	50 or less	50 or less		○
	Total hardness (mg CaCO ₃ /ℓ)	70 or less	70 or less	70 or less	70 or less		○
	Calcium hardness (mg CaCO ₃ /ℓ)	50 or less	50 or less	50 or less	50 or less		○
	Ionic silica (mg SiO ₂ /ℓ)	30 or less	30 or less	30 or less	30 or less		○
Reference items	Iron (mg Fe/ℓ)	1.0 or less	0.3 or less	1.0 or less	0.3 or less	○	○
	Copper (mg Cu/ℓ)	1.0 or less	1.0 or less	1.0 or less	0.1 or less	○	
	Sulfide ion (mg S ²⁻ /ℓ)	Not to be detected	Not to be detected	Not to be detected	Not to be detected	○	
	Ammonium ion (mg NH ₄ ⁺ /ℓ)	0.3 or less	0.1 or less	0.1 or less	0.1 or less	○	
	Residual chlorine (mg Cl/ℓ)	0.25 or less	0.3 or less	0.1 or less	0.3 or less	○	
	Free carbon dioxide (mg CO ₂ /ℓ)	0.4 or less	4.0 or less	0.4 or less	4.0 or less	○	
	Ryzner stability index	-	-	-	-	○	○

Reference: Guideline of Water Quality for Refrigeration and Air Conditioning Equipment. (JRA GL02E-1994)

- (3) Please consult with a water quality control specialist about water quality control methods and water quality calculations before using anti-corrosive solutions for water quality management.

- (4) When replacing an air conditioner (including when only the heat exchanger is replaced), first analyze the water quality and check for possible corrosion.

Corrosion can occur in water systems in which there has been no signs of corrosion. If the water quality level has dropped, adjust the water quality before replacing the unit.

- (5) Suspended solids in the water

Sand, pebbles, suspended solids, and corrosion products in water can damage the heating surface of the heat exchanger and cause corrosion. Install a good quality strainer (20 mesh or more) at the inlet of the unit to filter out suspended solids.

Removing foreign substances from the water system

Consider installing a settlement tank or a bypass strainer to remove foreign substances from the water system.

Select a strainer capable of handling two to three percent of the circulating water. The figure below shows a sample system with a bypass strainer.

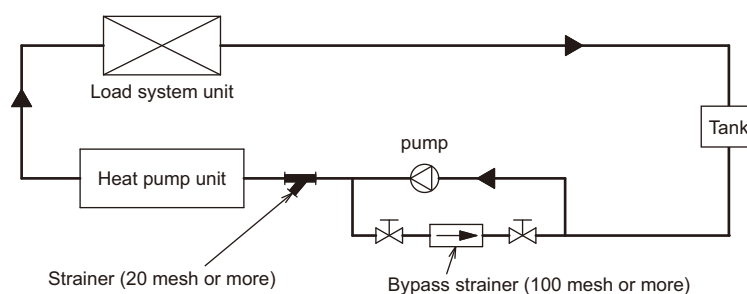

4. System Design

(6) Connecting pipes made from different materials

If different types of metals are placed in direct contact with each other, the contact surface will corrode.

Install an insulating material between pipes that are made of different materials to keep them out of direct contact with each other.

(7) Piping material

Use hot water output piping material that can withstand heat of 60°C or more. Use hot water input piping material that can withstand the maximum input water temperature. All piping must be made of SUS or similar material to withstand corrosion.

4-1-4. Installing the Strainer and Flow Switch

1. Installing the strainer

Install a strainer on the inlet pipe near the unit to filter out suspended solids and prevent clogging or corrosion of the heat exchanger.

Install a strainer in a way that allows for easy access for cleaning, and instruct the user to clean it regularly.

Operating the units with a clogged strainer may cause the units to make an abnormal stop. Select a location to install a strainer, taking into consideration the installation angle, insulation thickness, and maintenance space.

* The dimensions given below indicate the amount of space necessary when screwing in a Y-shaped strainer.

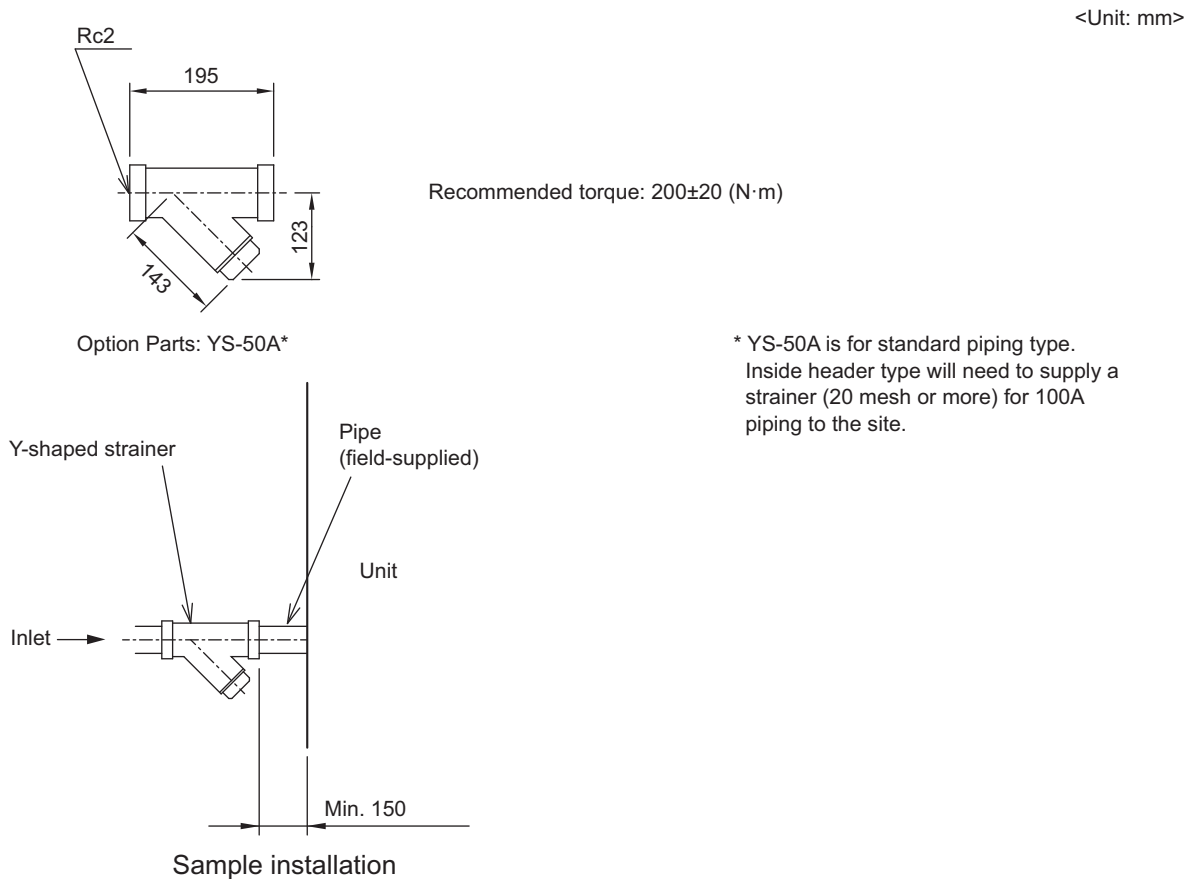

2. Installing a flow switch

Install a flow switch that meets the following specifications on the water pipe.

Connect the flow switch to the flow switch contact on the unit.

Minimum flow rate = 7.7 m³/h (128 L/min)

Unit usage range (water flow rate): 7.7 - 25.8 m³/h

4. System Design

4-1-5. Ensuring enough water in the water circuit

1. Required amount of water

If the amount of water in the water circuit (circulating water circuit) is insufficient, the unit operation hours may become shorter or the amount of water temperature change to be controlled may become extremely large.

Also, the defrost operation during the heating mode may not function properly. Refer to the table below for the minimum amount of water required in the circuit.

If the water pipe is too short to keep enough amount of water, install a cushion tank in the water pipe to ensure enough amount of water.

Model	Minimum amount of water (ℓ)
EAHV-P900YA	780
EACV-P900YA	420

2. Calculating the required amount of water in the water circuit

The required amount of water in the water circuit can be obtained from the following formula.

(Required amount of water in the water circuit) = (Amount of water that can be held in the water pipe) + (Amount of water that can be held in the heat source unit) + (Amount of water that can be held in the load-side unit)

The amount of water that can be held per meter of the water pipe (ℓ/m)

Pipe size					
1 1/2B (40A)	2B (50A)	2 1/2B (65A)	3B (80A)	4B (100A)	5B (125A)
1.36	2.20	3.62	5.12	8.71	13.44

The amount of water that can be held in the heat source unit (ℓ)

Standard piping type	Inside header piping type
20	55

3. Inlet/Outlet pipe connection size and material

The table below shows the inlet/outlet pipe connection size.

Inlet/Outlet pipe connection size

Model	Inlet pipe connection	Outlet pipe connection
Standard piping type	50A housing type joint (Field-supplied Victaulic joint)	50A housing type joint (Field-supplied Victaulic joint)
Inside header piping type	100A housing type joint (Field-supplied Victaulic joint)	100A housing type joint (Field-supplied Victaulic joint)

4. System Design

4-1-6. Water Piping Size and Location

1. Standard piping type

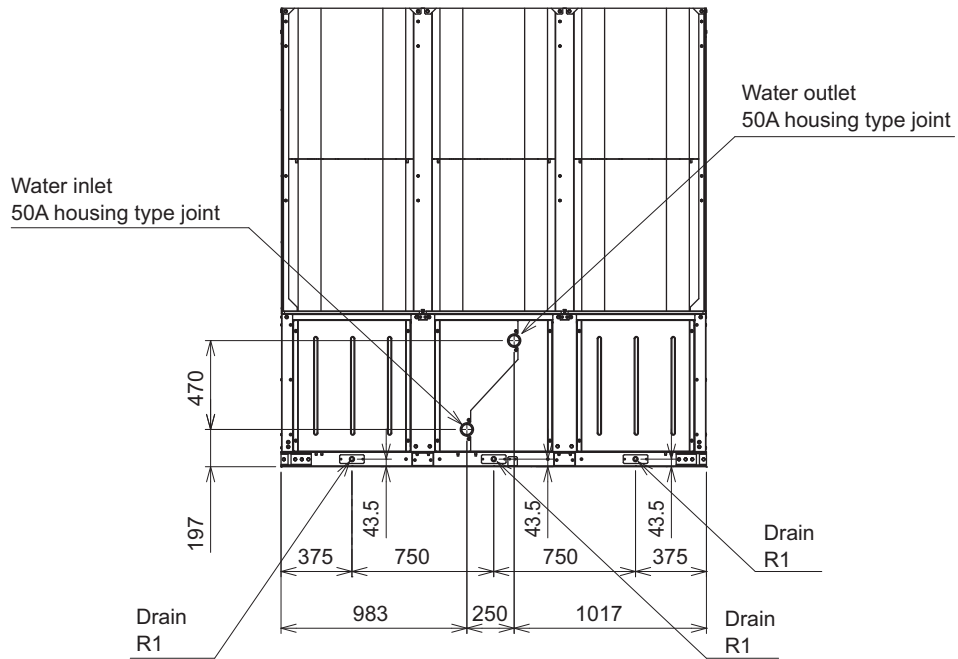

2. Inside header piping type

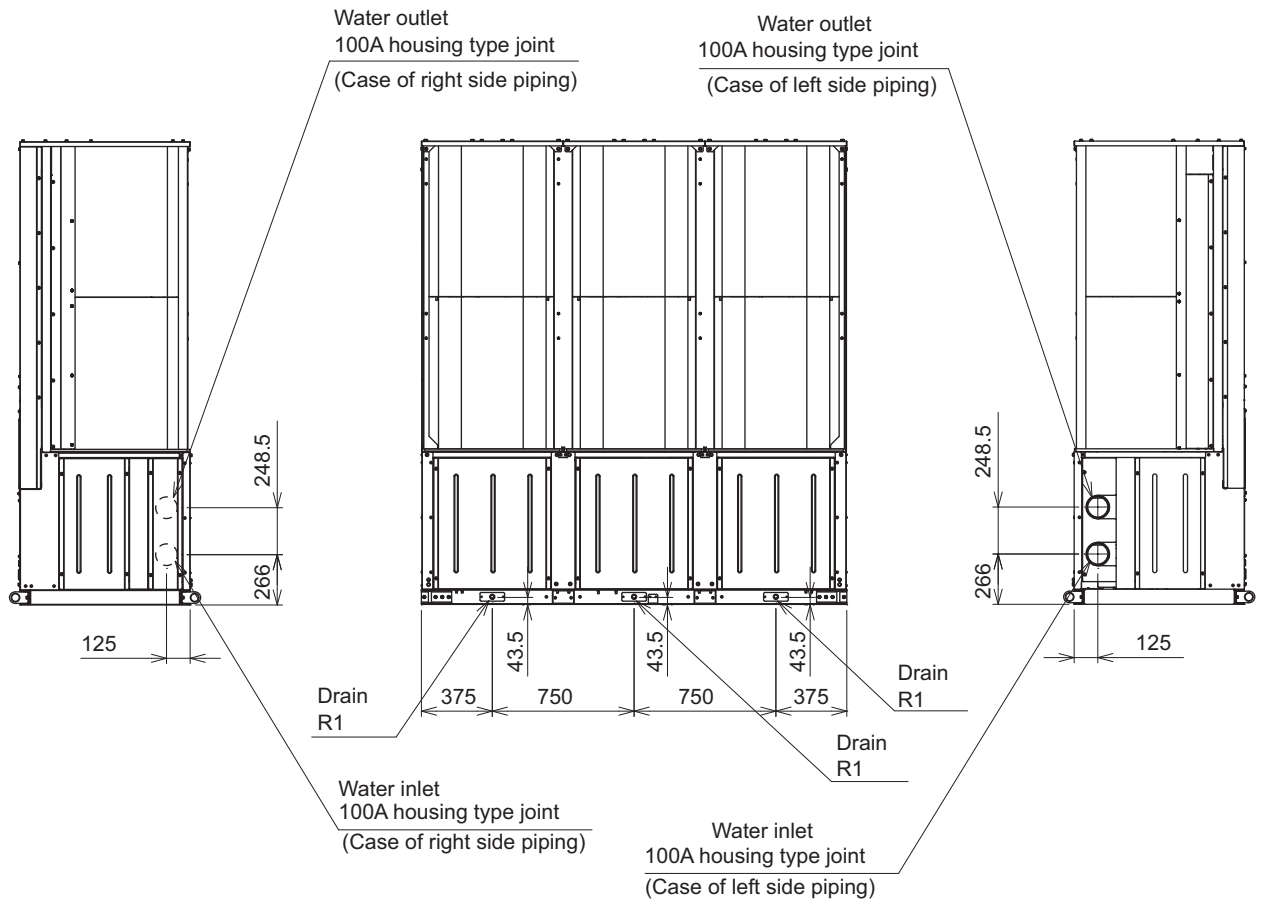

5. Wiring Design

5-1. System Configurations

The system must be configured only by personnel certified by Mitsubishi Electric.

5-1-1. Schematic Diagrams of Individual and Multiple Module Connection Systems

(1) Individual system

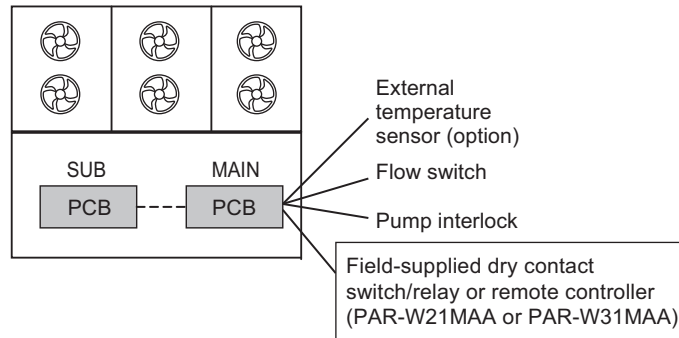

(2) Multiple module connection system (2-6 modules)

* A group of module that consists of one main module and up to 5 sub modules is operated collectively by connecting an external water temperature sensor and a dry contact switch/relay to the main module.

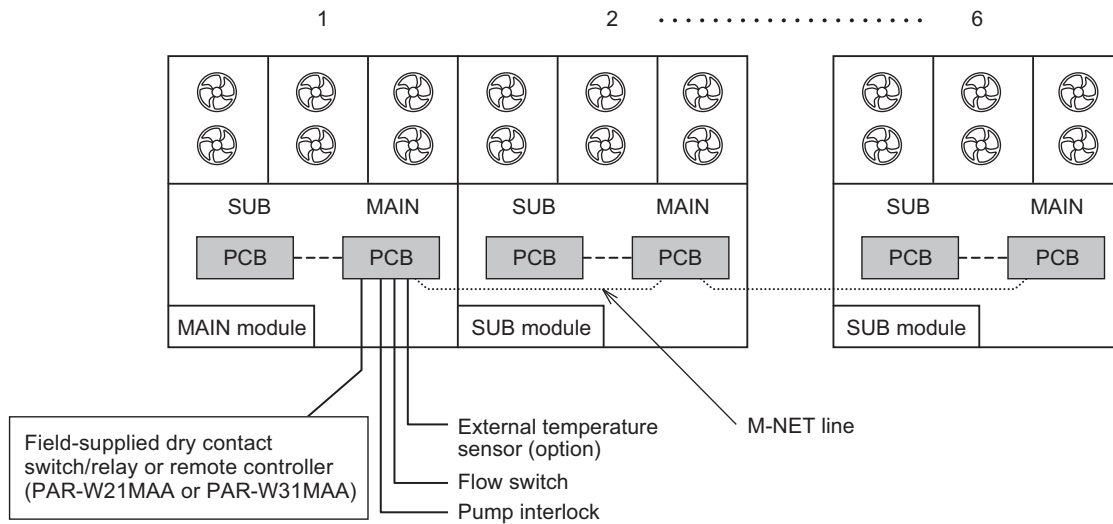

5-1-2. Switch Types and the Factory Settings

(1) Switch names and functions

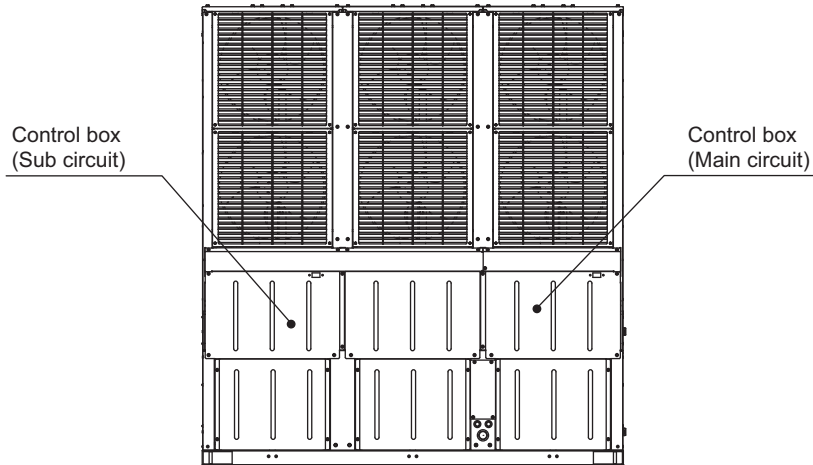

There are four main ways to set the settings as follows:

- 1) Dip switches (SW1 - SW3, SW421)
- 2) Dip switches used in combination with the push switches
- 3) Rotary switches
- 4) Slide switches

See below for how these switches are used to set certain items.

Different types of switches on the PCB

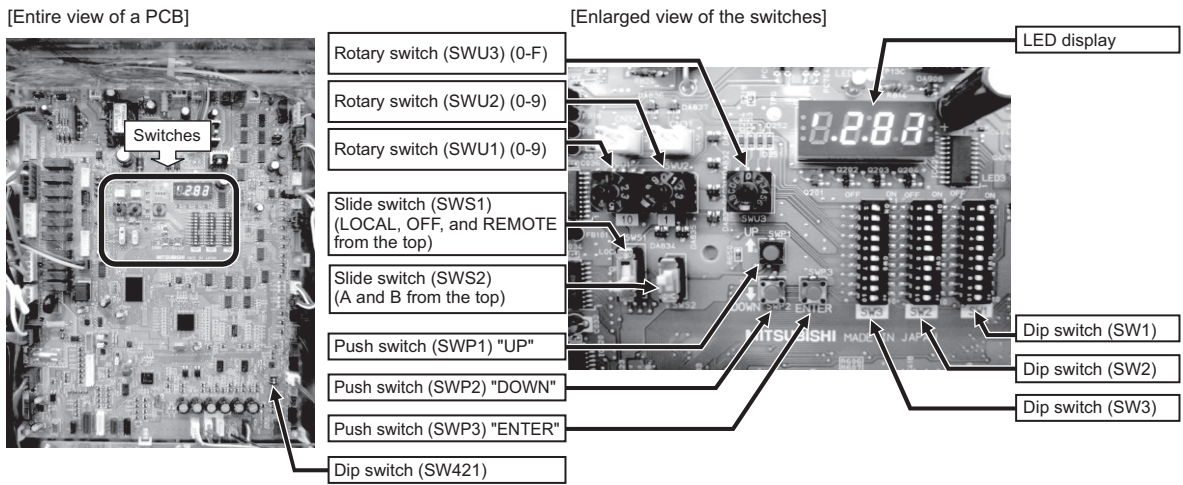

		Initial Setting				
		MAIN circuit	SUB circuit			
Rotary switch (SWU1)	Sets the 10's digit of the unit address (Multiple system).	"0"	"5"			
Rotary switch (SWU2)	Sets the 1's digit of the unit address (Multiple system).	"1"	"1"			
Rotary switch (SWU3)	Unused	"0"	"0"			
Slide switch (SWS1)	<table border="1" style="display: inline-table; vertical-align: middle;"> <tr><td>LOCAL</td></tr> <tr><td>OFF</td></tr> <tr><td>REMOTE</td></tr> </table> The action that the switch takes when set to a certain position depends on the type of system configuration (e.g., individual or multiple system)	LOCAL	OFF	REMOTE	REMOTE	OFF (Unused)
LOCAL						
OFF						
REMOTE						
Slide switch (SWS2)	Cooling/Heating switching (Only EAHV-P900YA) (Effective only when SWS1 is set to LOCAL.)	A	A (Unused)			
Push switch (SWP1)	Switches the display between the current value for a specific item. Increases value.	-	-			
Push switch (SWP2)	Switches the display between the current value for a specific item. Decreases value.	-	-			
Push switch (SWP3)	Enables the change of value. Saves the changed value.	-	-			
Dip switches (SW1-3)	Setting change or view the settings	-	-			
Dip switch (SW421)	Analog input type setting (Refer to Page 180)	-	(Unused)			

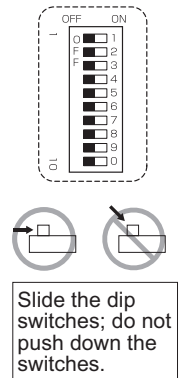

5. Wiring Design

(2) Factory Switch Settings (Dip switch settings table)

SW	Function	Usage	Factory setting		OFF setting	ON setting	SUB module	Setting timing	
			MAIN circuit	SUB circuit					
SW1	1	Settings change or view the settings	These switches are used for setting change with push switch SWP 1, 2 and 3.	OFF	OFF	The 7-segment LED display is changed.	Depends on the setting	Depends on the setting	
	2								
	3								
	4								
	5								
	6								
	7								
	8								
	9								
	10								
SW2	1	Model setting		Depends on the unit	-	Leave the setting as it is.	Depends on the unit	At a reset	
	2								
	3								
	4								
	5	Water-temperature control option	Selects either the external water temperature sensor or the built-in sensor to be used to control water temperature.	OFF	-	Built-in sensor on the unit	External water temperature sensor (option)	Required	At a reset
	6	Model setting		OFF	-	Leave the setting as it is.		Fixed OFF	At a reset
	7	Analog input setting	Allows or disallows the analog signals from a remote location.	OFF	-	Disallows the external analog signals.	Allows the external analog signals.	Fixed OFF	At a reset
	8	Analog input signal switching	Selects either the water temperature or the capacity control ratio. (Effective only when SW2-7 is set to ON.)	OFF	-	Water temperature	Capacity control ratio	Fixed OFF	At a reset
	9	Auto restart after power failure	Enables or disables the automatic restoration of operation after power failure (in the same mode as the unit was in before a power failure).	ON	-	An alarm will be issued when power is restored after a power outage. The alarm will be reset when the power is turned off and then turned back on.	Automatically restores operation after power failure.	Required	Any time
	10	Model setting		OFF	OFF	Leave the setting as it is.		Fixed OFF	Any time
SW3	1	Analog input type setting	Selects analog input 4-20mA/ 0-10V/1-5V/2-10V. (Effective only when SW2-7 is set to ON and SW3-4 is set to OFF.)	OFF	-	1	2	Fixed OFF	Any time
	2					4-20mA: OFF	OFF		
	3	Display setting *1	Switches the LED display of the control board. (Display is switched in the 3 second intervals.)	ON	ON	High pressure Low pressure	High pressure Low pressure Inlet water temperature Outlet water temperature Ambient temperature	Required	Any time
	4	BMS setting *2		OFF	-	No input from BMS	Input from BMS	Fixed OFF	At a reset
	5	Model setting		OFF	-	Leave the setting as it is.		Fixed OFF	At a reset
	6	Water/Brine setting *3		OFF	OFF	Water, Brine (outlet 5 - 25°C)	Brine (outlet -10 - 25°C)	Required	At a reset
	7	Model setting		OFF	-	Leave the setting as it is.		Fixed OFF	At a reset
	8								
	9	Model setting		OFF	OFF	Leave the setting as it is.		Fixed OFF	Any time
	10	Model setting		OFF	-	Leave the setting as it is.		Fixed OFF	Any time

"-" in the table indicates that the function in the corresponding row will be disabled regardless of the actual switch setting. The factory setting for these items is OFF.

*1. LED display

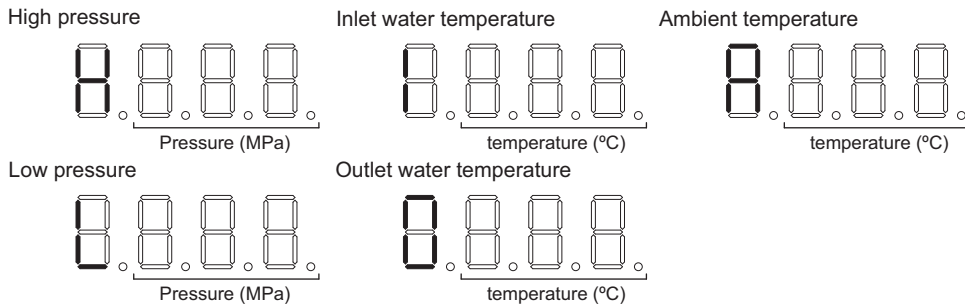

*2. Connection to a BMS requires an installation of Procon A1M (Modbus interface), which is available from MITSUBISHI ELECTRIC UK.

SW2-7	SW2-8	SW3-4	Input from BMS
ON	OFF	ON	Target temperature
ON	ON	ON	Capacity
OFF	OFF	ON	Outdoor temperature

*3. Effective only on the EACV model

5-1-3. Configuring the Settings

The settings must be set only by a qualified personnel.

1. Making the settings

Use the LED display and the three push switches (SWP1 (↑), SWP2 (↓), and SWP3 (Enter)) to change the current settings on the circuit board and to monitor various monitored values.

(1) Setting procedures

Take the following steps to set the push switches SWP1 through SWP3. These switches must be set after the dip switch SW1 has been set.

1)

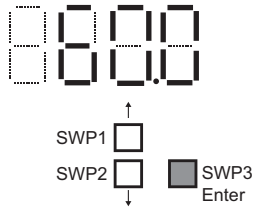

Normally a value of setting item appears on the display.



Press SWP3 (Enter) to enable the configuration changes.

2)

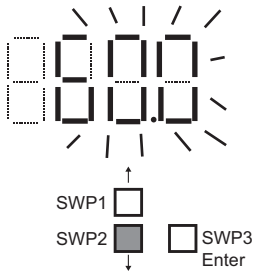

The current setting value will blink.



The left figure shows that the current setting value is "60.0."

To decrease this value to 58.0, for example, press SWP2 (↓).

Press SWP1 (↑) to increase the value.

3)

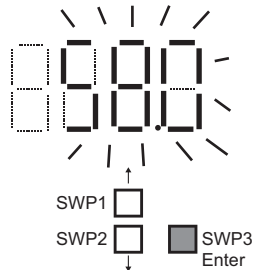

When the desired value is displayed (58.0 in the example at left), press SWP3 (Enter).



The displayed value will stop blinking and stay lit.

A lit LED indicates that the new setting has been saved.

* Pressing SWP1 (↑) or SWP2 (↓) will change the blinking setting value, but the change will not be saved until SWP3 (Enter) is pressed.
Press and hold SWP1 (↑) or SWP2 (↓) for one second or longer to fast forward through the numbers.

5. Wiring Design

(2) Table of settings items

Set the dip switch SW1 as shown in the table below to set the value for the items in the "Setting item" column.

No.	Dip switch setting (SW1) *1 ■ : ON □ : OFF										Setting Item	Default	Need or non-need to set the setting *6				Notes
													MAIN		SUB		
													M	S	M	S	
1				4	5	6		8	9	10	Maximum peak-demand capacity	100%	○	-	-	-	Range 60-100%
2	1			4				7	8	10	Peak-demand control start time	13:00	○	-	○	-	Effective only when K13 and K14 on TB6 are set to OFF
3		2		4				7	8	10	Peak-demand control end time	13:00	○	-	○	-	Effective only when K13 and K14 on TB6 are set to OFF
4	1			4					9	10	Setting temp 1 (Cooling mode) *2	7°C	○	-	-	-	Range 5-25°C (-10 - 25°C)*5
5	1					6			9	10	Setting temp 2 (Cooling mode) *2	7°C	○	-	-	-	Range 5-25°C (-10 - 25°C)*5
6		2		4					9	10	Setting temp 1 (Heating mode) *3	45°C	○	-	-	-	Range 30-55°C
7		2				6			9	10	Setting temp 2 (Heating mode) *3	45°C	○	-	-	-	Range 30-55°C
8	1	2		4				7	8	10	Setting water temp A at Heating ECO mode *3	55°C	○	-	-	-	Range 30-55°C
9			3	4				7	8	10	Setting outdoor temp A at Heating ECO mode *3	0°C	○	-	-	-	Range -30-50°C
10	1		3	4				7	8	10	Setting water temp B at Heating ECO mode *3	35°C	○	-	-	-	Range 30-55°C
11		2	3	4				7	8	10	Setting outdoor temp B at Heating ECO mode *3	25°C	○	-	-	-	Range -30-50°C
12					5			7	8	10	Setting water temp C at Heating ECO mode *3	45°C	○	-	-	-	Range 30-55°C
13	1				5			7	8	10	Setting outdoor temp C at Heating ECO mode *3	15°C	○	-	-	-	Range -30-50°C
14			3		5				8	10	Enable/disable schedule setting *4	0	○	-	-	-	Set to "1" to enable scheduled operation.
15			3	4					8	10	ON time 1 (at schedule mode without remote) *2	0:00	○	-	-	-	Cooling mode ON
16	1		3	4					8	10	OFF time 1 (at schedule mode without remote) *2	0:00	○	-	-	-	Cooling mode OFF
17		2	3	4					8	10	ON time 2 (at schedule mode without remote) *3	0:00	○	-	-	-	Heating mode ON
18	1	2	3	4					8	10	OFF time 2 (at schedule mode without remote) *3	0:00	○	-	-	-	Heating mode OFF
19	1	2			5			7	8	10	ON time 3 (at schedule mode without remote) *3	0:00	○	-	-	-	Heating ECO mode ON
20			3		5			7	8	10	OFF time 3 (at schedule mode without remote) *3	0:00	○	-	-	-	Heating ECO mode OFF
21	1	2		4					9	10	Thermo differential 1 (Cooling mode) *2	2°C	○	-	○	-	Range 0.2-5°C
22			3	4					9	10	Thermo differential 2 (Cooling mode) *2	2°C	○	-	○	-	Range 0.2-5°C
23	1		3	4					9	10	Thermo differential 1 (Heating mode) *3	2°C	○	-	○	-	Range 0.2-5°C
24		2	3	4					9	10	Thermo differential 2 (Heating mode) *3	2°C	○	-	○	-	Range 0.2-5°C
25					5	6			8	10	Drain pan heater operation outdoor temp	0°C	○	-	○	-	Range -40-20°C
26	1		3					7	8	10	Supplementary heater operation water temp *3	40°C	○	-	○	-	Range 0-55°C
27	1	2	3					7	8	10	Supplementary heater operation outdoor temp *3	-10°C	○	-	○	-	Range -30-50°C
28		2			5			7	8	10	Select a heating curve *3	1	○	-	-	-	0: 2-point system, 1: curve
29		2	3	4	5	6	7	8	9	10	Current time	-	○	○	○	○	
30	1		3	4	5	6	7	8	9	10	Month/Date setting	-	○	○	○	○	
31			3	4	5	6	7	8	9	10	Year setting	-	○	○	○	○	

*1: Do not apply undue force when changing the Dip switch settings as this may cause malfunctions.

*2: They are enabled during the cooling. (EAHV-P900YA, EACV-P900YA)

*3: They are enabled during the heating. (EAHV-P900YA)

*4: Disable the schedule setting when using the remote controller.

*5: Applicable only when Dip SW3-6 is set to ON (Brine setting)

*6: MAIN: MAIN module

SUB: SUB module

M: MAIN circuit

S: SUB circuit

5. Wiring Design

2. System configuration

(1) System configuration procedures: Individual system

1) Set the dip switches on the MAIN circuit board.

Switch settings on the MAIN circuit

Set the dip switches (labeled A in the figure below) that correspond to the items below, according to the local system.

- Water temperature control based on the external water temperature reading
- Analog signals from a remote location

Refer to "Dip switch settings table" (page 169) for further details.

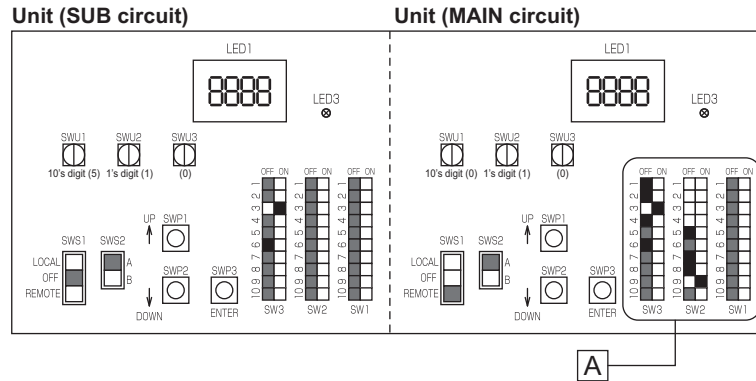

2) Switch on the power to the unit.

Check for loose or incorrect wiring, and then switch on the power to the unit.

When the power is switched on, the following codes will appear on the LED:

- [EEEE] will appear on LED1 in the MAIN circuit board (labeled A in the figure below).
- [9999] will appear on LED1 in the SUB circuit board (labeled B in the figure below).

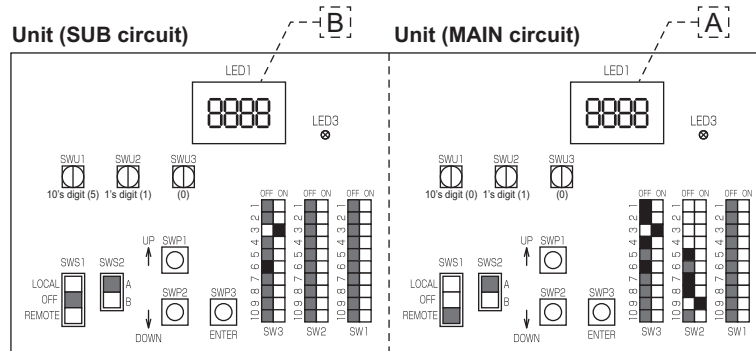

Within 50 seconds after the power is switched on, the following codes will appear on the LED:

- [****] will appear on LED1 in the MAIN circuit board (labeled A in the figure above).
- [0000]→[****] will appear on LED1 in the SUB circuit board (labeled B in the figure above).

****	Model
0000	EACV-P900YA
0001	EAHV-P900YA
0002	EAHV-P900YA-H

Then, the setting item "SW3-3" will appear on the LED.

5. Wiring Design

(2) System configuration procedures: Multiple modules connection system

1) Set the rotary switches.

System configuration diagram

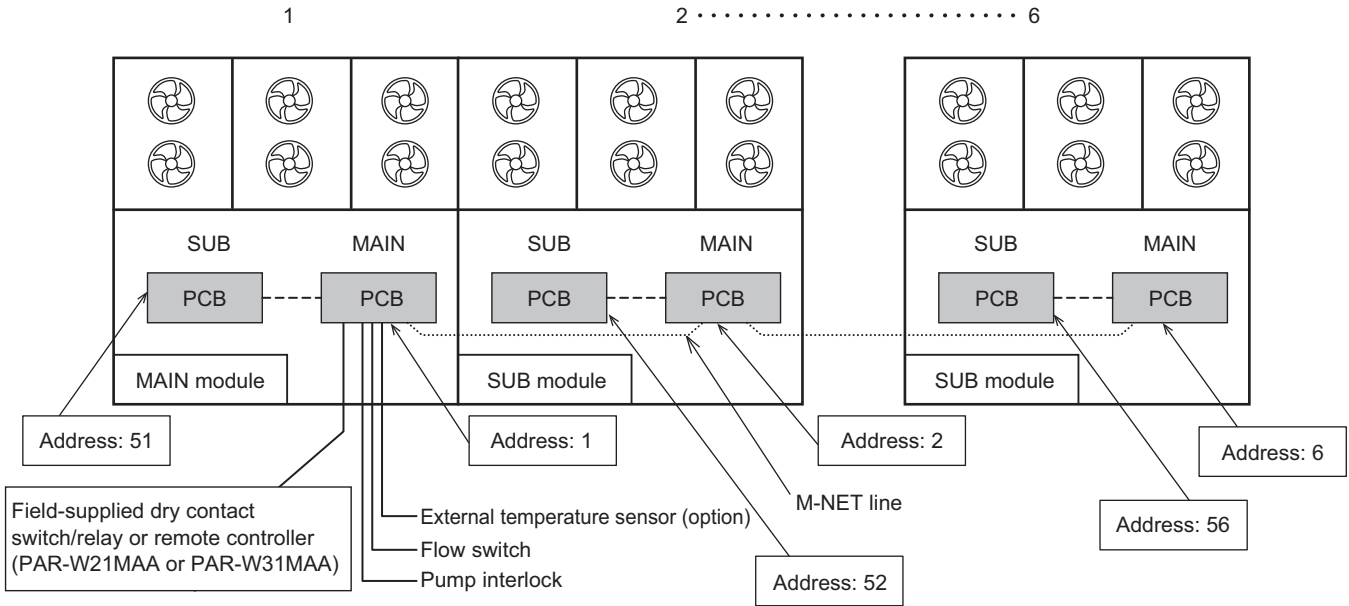

Setting the switches on the main module

Make sure the address of the MAIN circuit on the main module is set to "1" (labeled A in the figure below) and that the address of the SUB circuit on the main module is set to "51" (labeled B in the figure below). The address of each SUB circuit should equal the sum of the MAIN circuit address on the same module and 50.

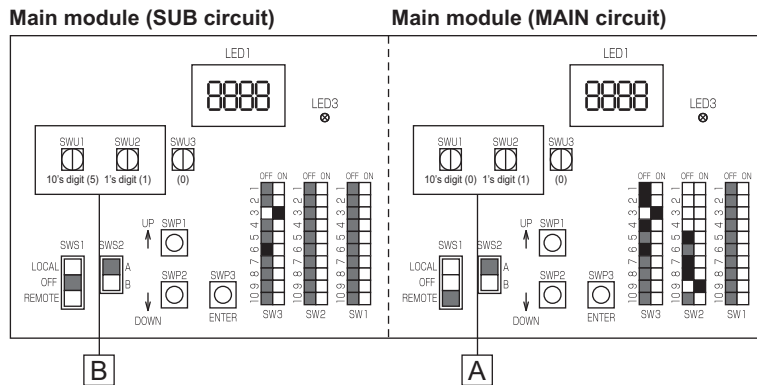

Setting the switches on all sub modules

MAIN circuit

[1] Set the MAIN circuit addresses with the rotary switches. (labeled A in the figure below). Set the 10's digit with SWU1, and set the 1's digit with SWU2. Assign sequential addresses to the MAIN circuit on all sub modules starting with 2.

SUB circuit

[2] Set the SUB circuit addresses with the rotary switches (labeled B in the figure below). Set the 10's digit with SWU1, and set the 1's digit with SWU2. Assign sequential addresses to the SUB circuit on all sub modules starting with 52.

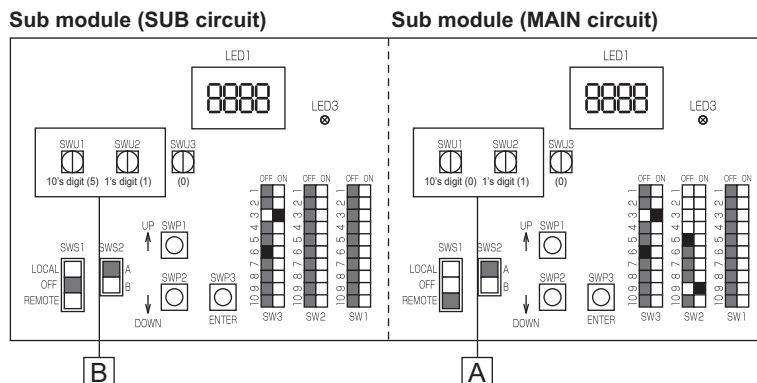

5. Wiring Design

2) Switch on the power to the unit.

Check for loose or incorrect wiring, and then switch on the power to all modules.
When the power is switched on, the following codes will appear on the LED:

- [EEEE] will appear on LED1 in the MAIN circuit board.
- [9999] will appear on LED1 in the SUB circuit board.

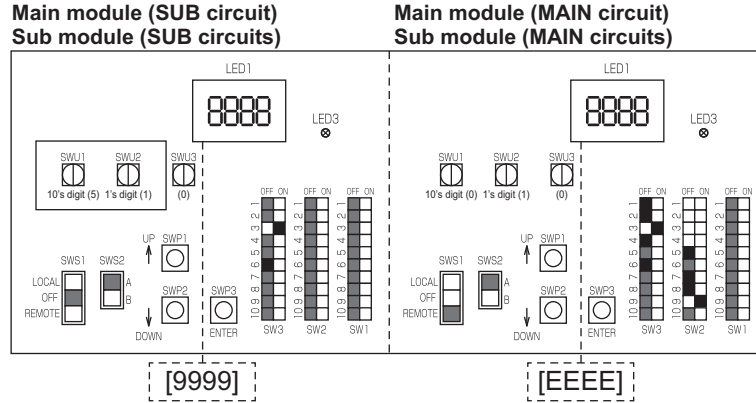

Within 50 seconds after the power is switched on, the following codes will appear on the LED:

- [****] will appear on LED1 in the MAIN circuit board.
- [0000]→[****] will appear on LED1 in the SUB circuit board.

****	Model
0000	EACV-P900YA
0001	EAHV-P900YA
0002	EAHV-P900YA-H

Then, the setting item "SW3-3" will appear on the LED.

3) Perform an initial setup on the main and sub modules

Perform the initial setup of all modules in accordance with the table below.

No.	Dip switch setting (SW1) ■: ON □:OFF								Setting Item	Main module	Sub module	Default	
1								8	10	Setting the multiple modules	1	1	0
2	1							8	10	Setting the main module	1	0	0
3		2						8	10	Setting the total number of modules	2-6	-	1
4			3					8	10	Setting the pump system *	0 or 1	0 or 1	1

* Change the setting to "0" in the multiple modules of the Standard piping type in one pump system and the Inside header piping type.

"Setting the pump system" is "0"...One-pump system

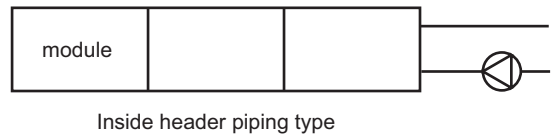
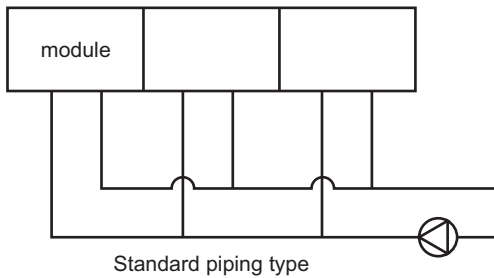

"Setting the pump system" is "1"...Multiple-pump system

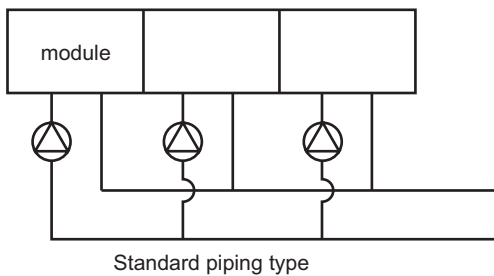

5. Wiring Design

Slide switch (SWS1) settings
Individual system (SWS1 in the SUB circuit is ineffective.)

SWS1 Setting		Unit Operation	
MAIN circuit	SUB circuit	MAIN circuit	SUB circuit
LOCAL	-	Follows the input signal of the MAIN circuit	Follows the input signal of the MAIN circuit
OFF	-	Ignores the signal input	Ignores the signal input
REMOTE	-	Follows the input signal fed through a No-voltage contact interface	Follows the input signal of the MAIN circuit

Multiple system (SWS1 in the SUB circuit is ineffective.)

SWS1 Setting		Unit Operation			
Main module MAIN circuit	Sub module MAIN circuit	Main module MAIN circuit	Main module SUB circuit	Sub module MAIN circuit	Sub module SUB circuit
LOCAL	LOCAL	Follows the input signal of the MAIN circuit on the Main module	Follows the input signal of the MAIN circuit on the Main module	Follows the input signal of the MAIN circuit on the Sub module	Follows the input signal of the MAIN circuit on the Sub module
	OFF			Ignores the signal input	Ignores the signal input
	REMOTE			Follows the input signal of the MAIN circuit on the Main module	Follows the input signal of the MAIN circuit on the Main module
OFF	LOCAL	Ignores the signal input	Ignores the signal input	Follows the input signal of the MAIN circuit on the Sub module	Follows the input signal of the MAIN circuit on the Sub module
	OFF			Ignores the signal input	Ignores the signal input
	REMOTE			Ignores the signal input	Ignores the signal input
REMOTE	LOCAL	Follows the input signal fed through a dry contact interface	Follows the input signal of the MAIN circuit on the Main module	Follows the input signal of the MAIN circuit on the Sub module	Follows the input signal of the MAIN circuit on the Sub module
	OFF			Ignores the signal input	Ignores the signal input
	REMOTE			Follows the input signal of the MAIN circuit on the Main module	Follows the input signal of the MAIN circuit on the Main module

Slide switch (SWS2) settings
Effective only when SWS1 is set to LOCAL. (Only EAHV-P900YA)

SWS2 setting		Unit operation	
MAIN circuit	SUB circuit	MAIN circuit	SUB circuit
A	-	Cooling	Cooling
B	-	Heating	Heating

5. Wiring Design

Priority order of the water-temperature-setting-input-sources

Water temperature can be controlled by using the signals from the four types of input sources (Heating, Heating ECO, Cooling, Analog heating). The setting for the item with higher priority will override the settings for the items with lower priorities. The water temperature will be controlled according to the temperature setting in the "Target water temperature" column that corresponds to a specific combination of the settings for the four items.

No-voltage contact input K04-K05 ON: Heating (EAHV-P900YA, EAHV-P900YA-H)

Priority 1	Priority 2	Priority 3	Priority 4	Priority 5			Target water temperature	Sensor that becomes active (when SW2-5 is set to ON) (*1)	
No-voltage contact input K07-K08	Analog input or BMS (SW 3-4:ON)	Main board on the unit	No-voltage contact input K13-K15	Remote controller PAR-W21MAA or PAR-W31MAA Input from centralized controller AE-200 or BMS (*4)					
Anti freeze		Schedule setting	Mode change	No remote controller	Manual setting	Schedule setting			
ON	Ineffective	Ineffective	Ineffective	-	Ineffective	Ineffective	30°C	TH3	
OFF	SW2-7: ON	Ineffective	Ineffective	-	Ineffective	Ineffective	Temperature setting for the analog signal input	TH15	
	SW2-7: OFF	When schedule has been set	Ineffective	-	Ineffective	Ineffective	Heating or Heating ECO	TH15	
			ON (Heating ECO)	-	Ineffective	Ineffective	Heating ECO	TH15	
		When no schedule has been set	OFF (Heating)	When no RC is used	-	-	-	Heating	TH15
				-	Anti freeze	-	-	30°C	TH3
				-	Heating ECO	-	-	Heating ECO	TH15
				-	Heating	-	-	Heating	TH15
				-	Cooling (*2)	-	-	Cooling	TH15
-	-	When schedule has been set (*3)	-	-	When schedule has been set (*3)	Target water temp is controlled according to the setting on the remote controller.	TH15		

*1: If SW2-5 is set to OFF, water temperature will be controlled by the built-in thermistor TH3 on the unit.

*2: This mode is disabled in EAHV-P900YA-H.

*3: EAHV-P900YA can also set Cooling.

*4: AE-200 and BMS cannot both be simultaneously connected. Only connect one or the other.

No-voltage contact input K04-K05 OFF: Cooling (EAHV-P900YA, EACV-P900YA)

* When the operation mode is Cooling, K07-K08 (Anti freeze) and K13-K15 (Mode change) are disabled.

Priority 1	Priority 2	Priority 3			Target water temperature	Sensor that becomes active (when SW2-5 is set to ON) (*1)	
Analog input	Main board on the unit	Remote controller PAR-W21MAA or PAR-W31MAA Input from centralized controller AE-200 or BMS (*4)					
	Schedule setting	No remote controller	Manual setting	Schedule setting			
SW2-7: ON	Ineffective	-	Ineffective	Ineffective	Temperature setting for the analog signal input	TH15	
SW2-7: OFF	When schedule has been set	-	Ineffective (Cooling)	Ineffective (Cooling)	Cooling	TH15	
		When no RC is used	-	-	-	Cooling	TH15
	When no schedule has been set	-	-	Anti freeze (*2)	-	30°C	TH3
			-	Heating ECO (*2)	-	Heating ECO	TH15
			-	Heating (*2)	-	Heating	TH15
			-	Cooling	-	Cooling	TH15
			-	-	When schedule has been set (*3)	-	When schedule has been set (*3)

*1: If SW2-5 is set to OFF, water temperature will be controlled by the built-in thermistor TH3 on the unit.

*2: This mode is disabled in EACV-P900YA.

*3: EAHV-P900YA can also set Heating or Heating ECO.

*4: AE-200 and BMS cannot both be simultaneously connected. Only connect one or the other.

5. Wiring Design

3. Setting procedures

(1) Water-temperature setting

Different water temperature settings can be set for different modes.

Set the dip switches on the circuit board as follows to make the settings for the items described in this section.

Press the push switch SWP3 to enable the configuration changes.

Press the push switches SWP1 (↑) or SWP2 (↓) to increase or decrease the value.

When the desired value is displayed, press SWP3 to save the setting value.

Settings table

N o.	Dip switch setting (SW1) ■: ON □:OFF										Setting Item	Initial value	Unit	Setting			Setting change from an optional remote controller (PAR-W21MAA or PAR-W31MAA) *1
	1	2	3	4	5	6	7	8	9	10				Increments	Lower limit	Upper limit	
1	1			4				9	10	Setting temp 1 (Cooling mode)	7	°C	0.1°C	5 (-10)*4	25	Possible *2	
2	1				6			9	10	Setting temp 2 (Cooling mode)	7	°C	0.1°C	5 (-10)*4	25	Possible *3	
3		2		4				9	10	Setting temp 1 (Heating mode)	45	°C	0.1°C	30	55	Possible *2	
4		2			6			9	10	Setting temp 2 (Heating mode)	45	°C	0.1°C	30	55	Possible *3	
5	1	2		4		7	8		10	Setting water temp A at Heating ECO mode	55	°C	0.1°C	30	55	Not possible	
6			3	4		7	8		10	Setting outdoor temp A at Heating ECO mode	0	°C	0.1°C	-30	50	Not possible	
7	1		3	4		7	8		10	Setting water temp B at Heating ECO mode	35	°C	0.1°C	30	55	Not possible	
8		2	3	4		7	8		10	Setting outdoor temp B at Heating ECO mode	25	°C	0.1°C	-30	50	Not possible	
9					5	7	8		10	Setting water temp C at Heating ECO mode	45	°C	0.1°C	30	55	Not possible	
10	1				5	7	8		10	Setting outdoor temp C at Heating ECO mode	15	°C	0.1°C	-30	50	Not possible	
11		2			5	7	8		10	Select a heating curve	1	-	0: 2-point system, 1: curve			Not possible	

*1 Temperature setting increments: 1°C (PAR-W21MAA), 0.5°C (PAR-W31MAA)

*2 No-voltage contact K10-K12: OFF

*3 No-voltage contact K10-K12: ON

*4 Applicable only when Dip SW3-6 is set to ON (Brine setting). To remotely set the temperature to a sub-zero temperature, a PAR-W31MAA remote controller is required.

Heating ECO (2-point system)

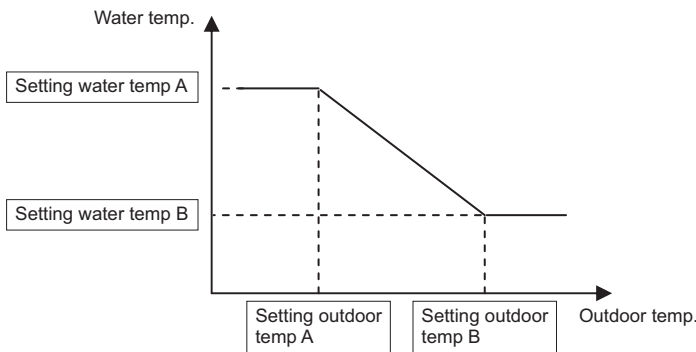

When the outdoor temp A and B are set to the same value.

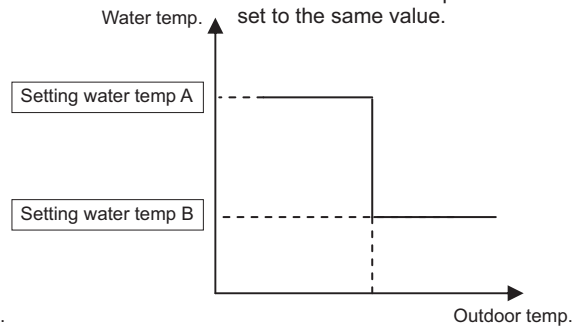

*Setting temp C cannot be used.

Heating ECO (Curve)

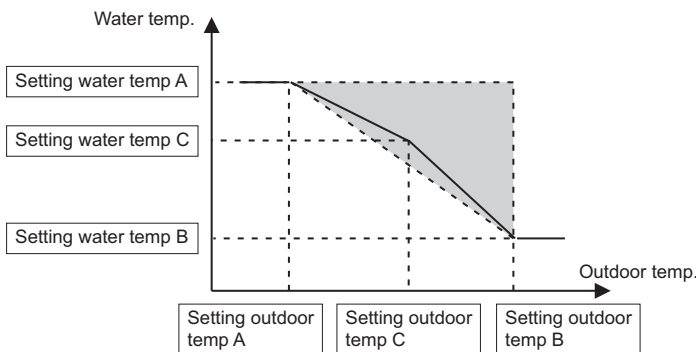

*Always use a value for setting C that is between setting value A and setting value B.

5. Wiring Design

(2) Scheduled operation

Up to three sets of start/end times can be assigned for each day.

Note Disable the schedule setting when using the remote controller.

The operation schedule function will operate only when SWS1 is set to "REMOTE."

Set the dip switches on the circuit board as follows to make the settings for the items described in this section.

Press the push switch SWP3 to enable the configuration changes.

Press the push switches SWP1 (↑) or SWP2 (↓) to increase or decrease the value.

When the desired value is displayed, press SWP3 to save the setting value.

Settings table

No.	Dip switch setting (SW1) ■: ON □:OFF										Setting Item	Initial value	Unit	Setting		
														Incre-ments	Lower limit	Upper limit
1			3		5			8		10	Enable/disable schedule setting	0	-	0: Disable, 1: Enable		
2			3	4			8			10	ON time 1 (Cooling mode without remote)	0000	Hour: minute	1 minute	0000	2359
3	1		3	4			8			10	OFF time 1 (Cooling mode without remote)	0000	Hour: minute	1 minute	0000	2359
4		2	3	4			8			10	ON time 2 (Heating mode without remote)	0000	Hour: minute	1 minute	0000	2359
5	1	2	3	4			8			10	OFF time 2 (Heating mode without remote)	0000	Hour: minute	1 minute	0000	2359
6	1	2			5		7	8		10	ON time 3 (Heating ECO mode without remote)	0000	Hour: minute	1 minute	0000	2359
7			3		5		7	8		10	OFF time 3 (Heating ECO mode without remote)	0000	Hour: minute	1 minute	0000	2359
8		2	3	4	5	6	7	8	9	10	Current time	-	Hour: minute	1 minute	0000	2359
9	1		3	4	5	6	7	8	9	10	Month/Date setting	-	Month: day	1 day	0101	1231
10			3	4	5	6	7	8	9	10	Year setting	-	Year	1 year	2000	2099

Note A mode (preset temperatures) can be selected for each operation time period.

See the next page for how to make the settings.

5. Wiring Design

[When the operation ON/OFF times do not overlap]

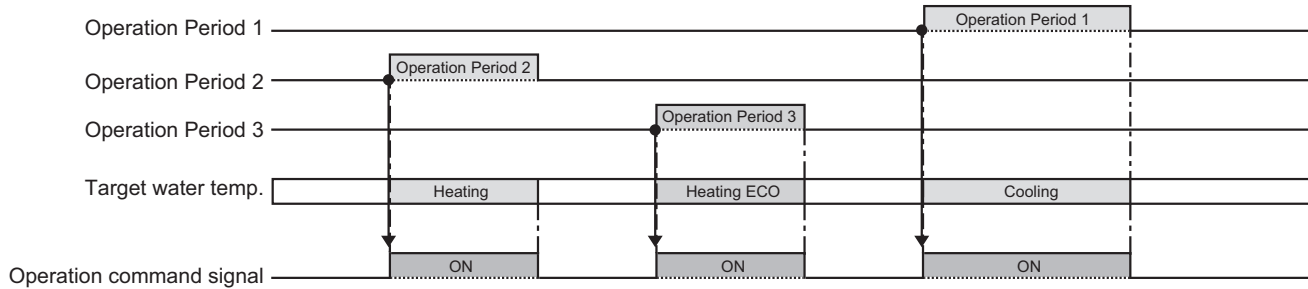

If two operation periods overlap, the settings for the period with a larger number will be ineffective.
 If ON time 1 and ON time 3 are set to the same value, the setting for ON time 3 will be ineffective.

[When operation period 1 and 2 overlap]

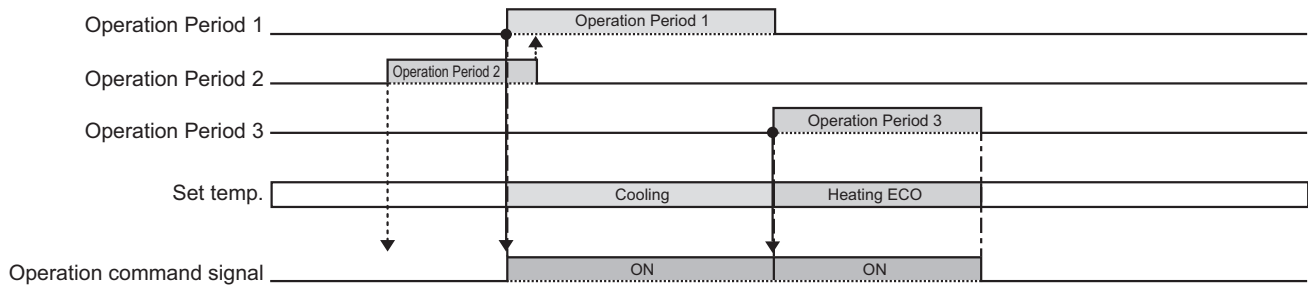

[When operation periods 1 and 3 overlap]

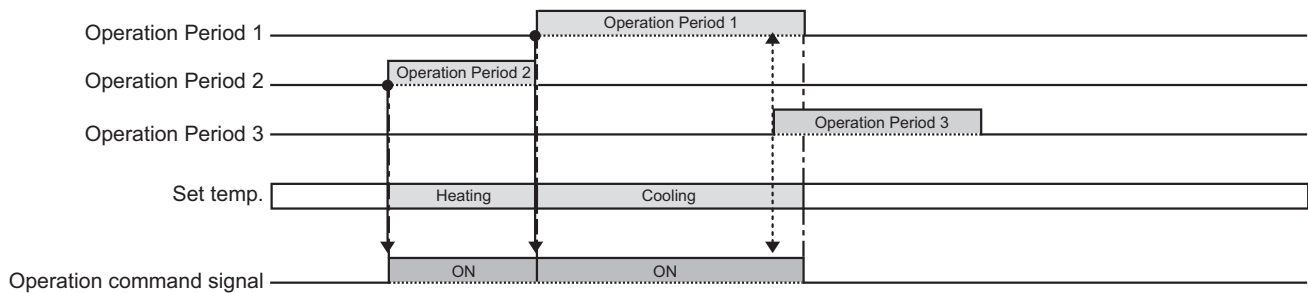

[When operation periods 2 and 3 overlap]

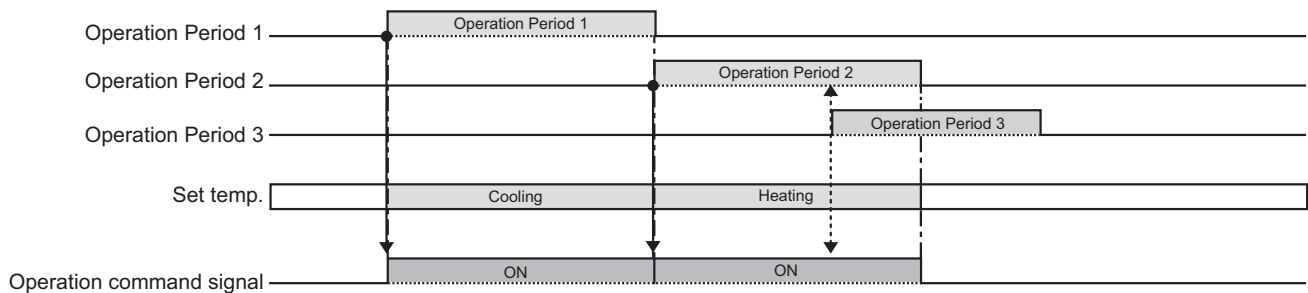

If "ON time 1 - OFF time 1", "ON time 2 - OFF time 2", "ON time 3 - OFF time 3" overlap, the settings for the period with a larger number will be ineffective.

[When operation periods 1 and 2 overlap and operation periods 2 and 3 overlap]

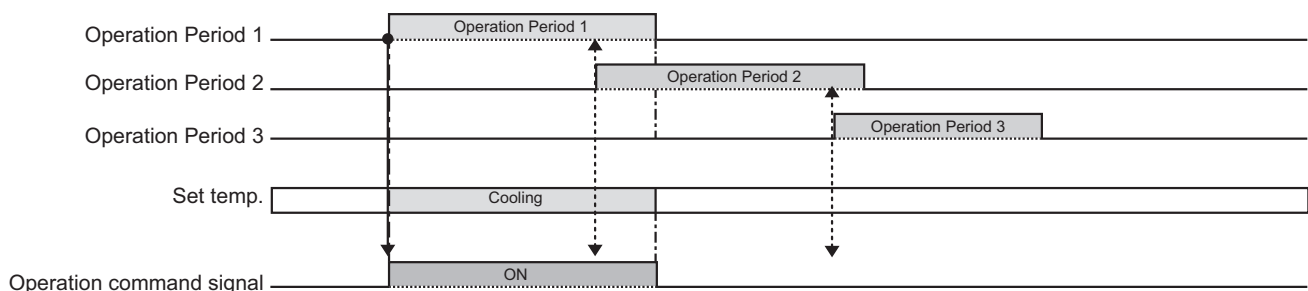

EAHV-P-YAF(-H)(-N), YAL(-H)(-N)/EACV-P-YAF(-N), YAL(-N)

5. Wiring Design

(3) Peak-demand control operation

Peak-demand control is a function used to control the power consumptions of the units during peak-demand hours.

The compressor's maximum operating frequency will be controlled according to the peak-demand control signal.

Set the dip switches on the circuit board as follows to make the settings for the items described in this section.

Press the push switch SWP3 to enable the configuration changes.

Press the push switches SWP1 (↑) or SWP2 (↓) to increase or decrease the value.

When the desired value is displayed, press SWP3 to save the setting value.

Settings table

No.	Dip switch setting (SW1) <input type="checkbox"/> : ON <input type="checkbox"/> :OFF										Setting Item	Initial value	Unit	Setting			Setting change from an optional remote controller (PAR-W21MAA or PAR-W31MAA)
				4	5	6		8	9	10				Increments	Lower limit	Upper limit	
1				4	5	6		8	9	10	Maximum peak-demand capacity	100	%	1%	60	100	Not possible
2	1			4				7	8	10	Peak-demand control start time	1300	Hour: minute	1 minute	0000	2359	Not possible
3		2		4				7	8	10	Peak-demand control end time	1300	Hour: minute	1 minute	0000	2359	Not possible

(4) Remote water temperature or capacity control ratio setting input signal type

When SW2-7 is ON, SW2-8 is OFF and SW3-4 is OFF external analog signals can be used to set the water temperatures.

When SW2-7 and SW2-8 are ON, external analog signals can be used to set the capacity control ratio.

Analog input type can be selected from the following four types:

4-20 mA

0-10 V

1-5 V

2-10 V

Select SW3-1 and SW3-2 to set the type of analog input signal from a remote location.

Set the dip switches on the circuit board as follows to change the settings.

	SW421-1	SW421-2	SW3-1	SW3-2
4-20 mA	ON	ON	OFF	OFF
1-5 V	OFF	ON	ON	OFF
0-10 V	OFF	OFF	OFF	ON
2-10 V	OFF	OFF	ON	ON

* Incorrectly setting SW421 may cause damage to the circuit board.

5. Wiring Design

(5) Setting the water temperature using analog signal input

When dip switch SW2-7 is set to ON (Enable external input), SW2-8 is set to OFF and SW3-4 is set to OFF, the target water temperature varies with the preset temperatures A and B and the type of analog input signal.

Set the dip switches on the circuit board as follows to make the settings for the items described in this section.

Press the push switch SWP3 to enable the configuration changes.

Press the push switches SWP1 (↑) or SWP2 (↓) to increase or decrease the value.

When the desired value is displayed, press SWP3 to save the setting value.

Settings table

No.	Dip switch setting (SW1) ■: ON □:OFF										Setting Item	Initial value	Unit	Setting			Setting change from an optional remote controller (PAR-W21MAA or PAR-W31MAA)
	1	2	3	4	5	6	7	8	9	10				Increments	Lower limit	Upper limit	
1		2		4	5	6		8		10	Preset temp. A (Cooling)	5	°C	1°C	5 (-10)*1	25	Not possible
2	1	2		4	5	6		8		10	Preset temp. B (Cooling)	25	°C	1°C	5 (-10)*1	25	Not possible
3	1						7	8		10	Preset temp. A (Heating)	30	°C	1°C	30	55	Not possible
4		2					7	8		10	Preset temp. B (Heating)	55	°C	1°C	30	55	Not possible

*1 Applicable when using brine (Dip SW3-6 set to ON)

* Due to the resistance of the wire that is connected to the analog input, the preset temperature may not properly be sent. If this is the case, check the current value of the analog input, and adjust the output value of the connected signal output device. Refer to the tables below for how to display the value of the analog input.

No.	Dip switch setting (SW1) ■: ON □:OFF										Monitorable items	Unit
1		2					7				Current value (4-20 mA)	mA
2	1	2					7				SV voltage value (1-5 V)	V
3			3				7				10V voltage value (0-10 V or 2-10 V)	V

• When the water temperature setting input signal type is 4-20 mA

- External analog input signal of 6 mA: Preset temp. A
- External analog input signal of 18 mA: Preset temp. B
- External analog input signal of between 6 and 18 mA: the preset temperature will be linearly interpolated.

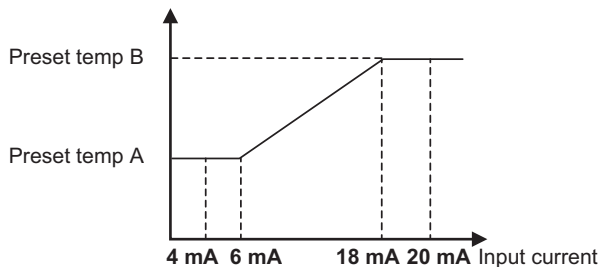

• When the water temperature setting input signal type is 0-10 V

- External analog input signal of 1 V: Preset temp. A
- External analog input signal of 9 V: Preset temp. B
- External analog input signal of between 1 and 9 V: the preset temperature will be linearly interpolated.

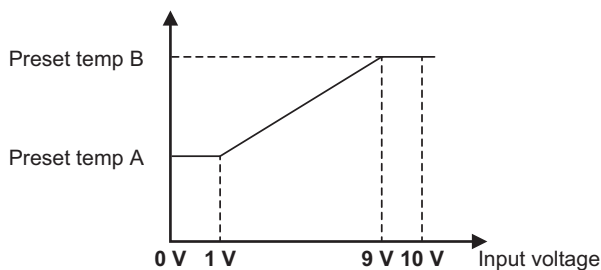

5. Wiring Design

- When the water temperature setting input signal type is 1-5 V

- External analog input signal of 1.5 V: Preset temp. A
- External analog input signal of 4.5 V: Preset temp. B
- External analog input signal of between 1.5 and 4.5 V: the preset temperature will be linearly interpolated.

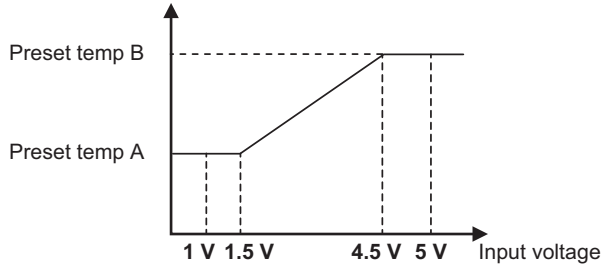

- When the water temperature setting input signal type is 2-10 V

- External analog input signal of 3 V: Preset temp. A
- External analog input signal of 9 V: Preset temp. B
- External analog input signal of between 3 and 9 V: the preset temperature will be linearly interpolated.

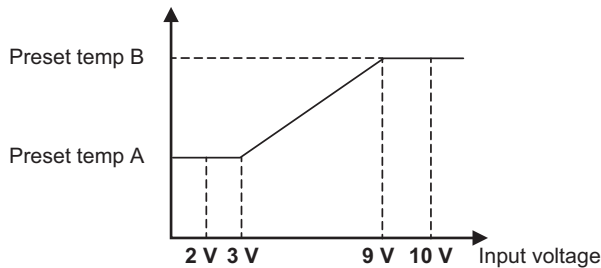

(6) Setting the capacity control ratio using analog signal input

When dip switch SW2-7 is set to ON (Enable external input), SW2-8 is set to ON and SW3-4 is set to OFF, the capacity control ratio varies with the type of analog input signal.

- When the capacity control setting input signal type is 4-20 mA

- External analog input signal of 6 mA: 0%
- External analog input signal of 18 mA: 100%
- External analog input signal of between 6 and 18 mA: the percent will be linearly interpolated.

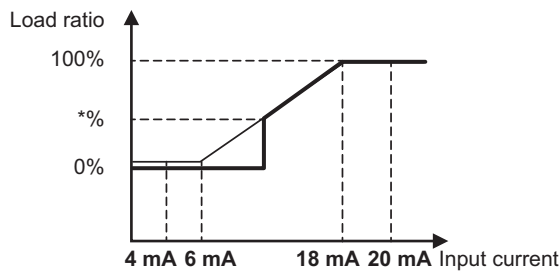

- When the capacity control setting input signal type is 0-10 V

- External analog input signal of 1 V: 0%
- External analog input signal of 9 V: 100%
- External analog input signal of between 1 and 9 V: the percent will be linearly interpolated.

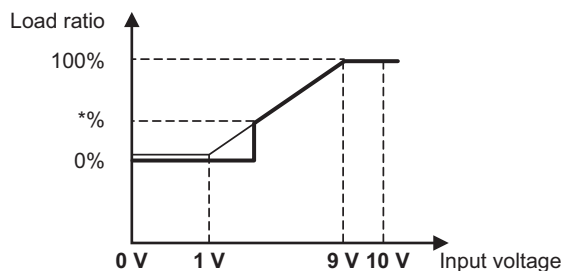

5. Wiring Design

- When the capacity control setting input signal type is 1-5 V
 - External analog input signal of 1.5 V: 0%
 - External analog input signal of 4.5 V: 100%
 - External analog input signal of between 1.5 and 4.5 V: the percent will be linearly interpolated.

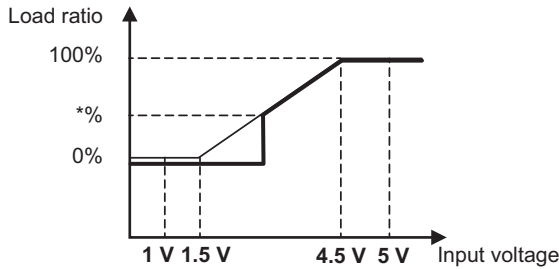

- When the capacity control setting input signal type is 2-10 V
 - External analog input signal of 3 V: 0%
 - External analog input signal of 9 V: 100%
 - External analog input signal of between 3 and 9 V: the percent will be linearly interpolated.

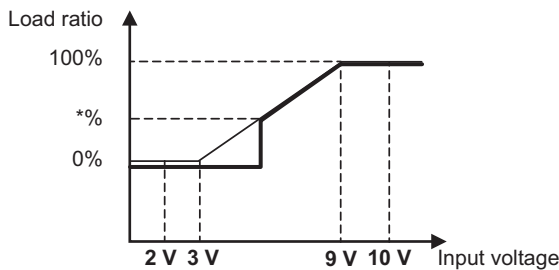

*: When the compressor frequency drops below 16 Hz, the compressor stops.
The frequency value that causes the compressor to stop varies depending on the outside temperature and water temperature.

(7) Setting the supplementary heater signal output conditions

A temperature at which the signal output to operate supplementary heaters can be selected.

Supplementary heater signal output conditions

The operation command signal is ON and at least one of the following two conditions is met.

[1] Water-temperature control option (SW2-5) is set to OFF, the inlet water temperature drops below a set water temperature, and the outdoor temperature drops below a set outdoor temperature.

[2] Water-temperature control option (SW2-5) is set to ON, the external water temperature sensor reading (TH15) drops below a set water temperature, and the outdoor temperature drops below a set outdoor temperature.

The supplementary heater signal is output from K51-K52.

Supplementary heater signal output stop conditions

The operation command signal is OFF or at least one of the following two conditions is met.

[1] The inlet water temperature is at or above a set water temperature +2°C or the outdoor temperature is at or above a set outdoor temperature +2°C.

[2] External water temperature sensor reading (TH15) is at or above a set water temperature +2°C.

Set the dip switches on the circuit board as follows to make the settings for the items described in this section.

Press the push switch SWP3 to enable the configuration changes.

Press the push switches SWP1 (↑) or SWP2 (↓) to increase or decrease the value.

When the desired value is displayed, press SWP3 to save the setting value.

Settings table

No.	Dip switch setting (SW1) ■: ON □:OFF										Setting Item	Initial value	Unit	Setting			Setting change from an optional remote controller (PAR-W21MAA or PAR-W31MAA)	
	1	2	3	4	5	6	7	8	9	10				Increments	Lower limit	Upper limit		
1	■	□	■	□	□	□	■	■	■	■	10	Supplementary heater operation water temp	40	°C	0.1°C	0	55	Not possible
2	■	■	■	□	□	□	■	■	■	■	10	Supplementary heater operation outdoor temp	-10		0.1°C	-30	50	Not possible

EAHV-P-YAF(-H)(-N), YAL(-H)(-N)/EACV-P-YAF(-N), YAL(-N)

5. Wiring Design

(8) Setting the drain pan heater signal output condition

A temperature at which the signal output to operate drain pan heaters can be selected.

Drain pan heater signal output condition

The following condition is met.

- The outdoor temperature drops below a set outdoor temperature.

The drain pan signal is output from K63-K64.

Drain pan heater signal output stop condition

The following condition is met.

- The outdoor temperature is at or above a set outdoor temperature +2°C.

Set the dip switches on the circuit board as follows to make the settings for the items described in this section.

Press the push switch SWP3 to enable the configuration changes.

Press the push switches SWP1 (↑) or SWP2 (↓) to increase or decrease the value.

When the desired value is displayed, press SWP3 to save the setting value.

Settings table

No.	Dip switch setting (SW1) ■: ON □:OFF								Setting Item	Initial value	Unit	Setting			Setting change from an optional remote controller (PAR-W21MAA or PAR-W31MAA)
					5	6	8	10				Increments	Lower limit	Upper limit	
1					■	■		■	Drain pan heater operation outdoor temp	0	°C	1°C	-40	20	Not possible

5. Wiring Design

5-2. Electrical Wiring Installation

5-2-1. Main Power Supply Wiring and Switch Capacity

Schematic Drawing of Wiring (Example)

- <A> Switch (with current breaking capability)
- Current leakage breaker
- <C> unit

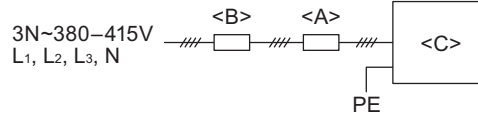

Main power supply wire size, switch capacities, and system impedance

Model	Minimum wire thickness (mm ²)			Current leakage breaker	Local switch (A)		No-fuse breaker (A)	Max. Permissible System Impedance
	Main cable	Branch	Ground		Capacity	Fuse		
EAHV/EACV-P900YA	25	-	25	75 A 100 mA 0.1 sec. or less	75	75	75	0.12 Ω

- 1) Use a dedicated power supply for each unit. Ensure that each unit is wired individually.
- 2) When installing wiring, consider ambient conditions (e.g., temperature).
- 3) The wire size is the minimum value for metal conduit wiring. If voltage drop is a problem, use a wire that is one size thicker. Make sure the power-supply voltage does not drop more than 5%.
- 4) Specific wiring requirements should adhere to the wiring regulations of the region.
- 5) Power supply cords of appliances shall not be lighter than polychloroprene sheathed flexible cord (design 60245 IEC57).
- 6) A switch with at least 3 mm contact separation in each pole shall be provided by the Air Conditioner installer.
- 7) Do not install a phase advancing capacitor on the motor. Doing so may damage the capacitor and result in fire.

⚠ WARNING

- Be sure to use specified wires and ensure no external force is imparted to terminal connections. Loose connections may cause overheating and fire.
- Be sure to use the appropriate type of overcurrent protection switch. Note that overcurrent may include direct current.

⚠ CAUTION

- Some installation sites may require an installation of an earth leakage breaker for the inverter. If no earth leakage breaker is installed, there is a danger of electric shock.
- Only use properly rated breakers and fuses. Using a fuse or wire of the wrong capacity may cause malfunction or fire.

Note

- This device is intended for the connection to a power supply system with a maximum permissible system impedance shown in the above table at the interface point (power service box) of the user's supply.
- Ensure that this device is connected only to a power supply system that fulfills the requirements above. If necessary, consult the public power supply company for the system impedance at the interface point.
- This equipment complies with IEC 61000-3-12 provided that the short-circuit power S_{sc} is greater than or equal to $S_{sc}(*2)$ at the interface point between the user's supply and the public system. It is the responsibility of the installer or user of the equipment to ensure, in consultation with the distribution network operator if necessary, that the equipment is connected only to a supply with a short-circuit power S_{sc} greater than or equal to $S_{sc}(*2)$.

$S_{sc}(*2)$

S_{sc} (MVA)
4.74

Control cable specifications

Remote controller cable	Size	0.3 mm ² (Max. 200 m total)*2
	Recommended cable types	CVV
M-NET cable between units *1	Size	Min. 1.25 mm ² (Max. 120 m total)
	Recommended cable types	Shielded cable CVVS, CPEVS or MVVS
External input wire size		Min. 0.3 mm ²
External output wire size		1.25 mm ²

*1 Use a CVVS or CPEVS cable (Max. total length of 200 m) if there is a source of electrical interference near by (e.g., factory) or the total length of control wiring exceeds 120 m.

*2 When the wiring length exceeds 10 m, use field-supplied wire of 1.25 mm².

5. Wiring Design

5-2-2. Cable Connections

1. Schematic Diagram of a Unit and Terminal Block Arrangement

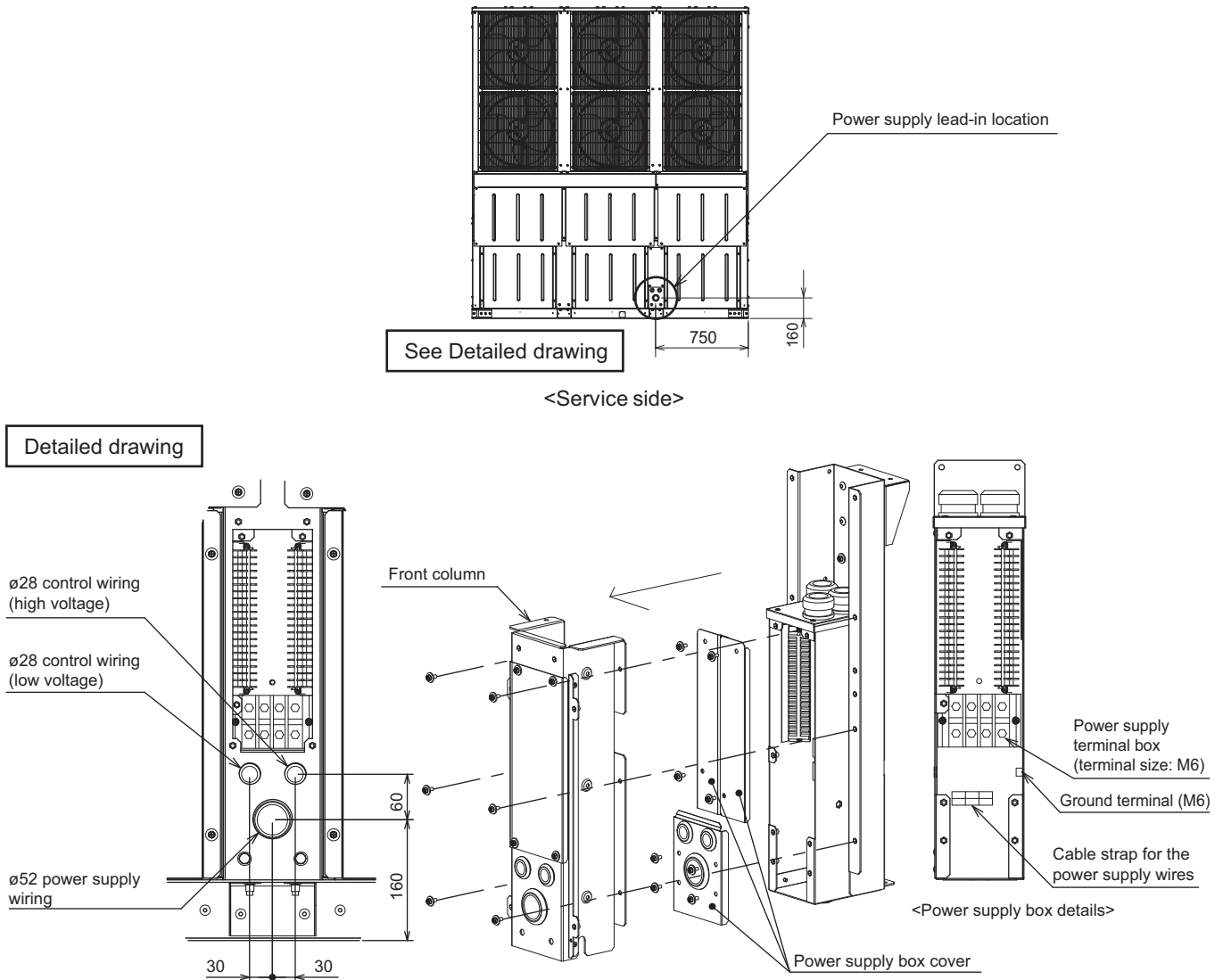

- [1] Remove the front column and power supply box cover.
- [2] Wire the power supply and control wires. The power supply box is covered with a bush with membrane.
Cut the bush with membrane before connecting wires to the terminal box.
- [3] Fasten the power supply wires by the cable strap.
- [4] Secure the cable conduit, and then waterproof the area around the pipe with silicon, etc.
- [5] Reattach the power supply box cover and front column.

2. Precautions when fastening screws

- * Faulty contacts due to loose screws may cause overheating and fire.
- * Using the circuit board while it is damaged may cause overheating and fire.

<1> Screw fastening torque

Power supply terminal block (TB4)...M6 screw: **2.5 to 3.0 N·m**

Use the following methods to check that the screws have been fastened.

5. Wiring Design

1) Check that the spring washer is in a parallel position.

* If the screw is biting into the washer, simply fastening the screw to the specified torque cannot determine whether it has been installed properly.

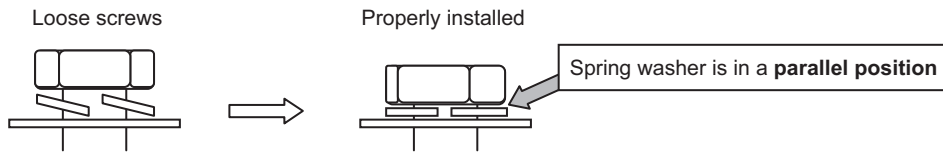

2) Check that the wiring does not move at the screw terminal.

<2> Take extra care not to ruin the screw thread due to fastening the screw at an angle.

* To prevent fastening the screw at an angle, install the round terminals so they are back to back.

<3> After fastening the screw, use a permanent marker to tick off the screw head, washer and terminal.

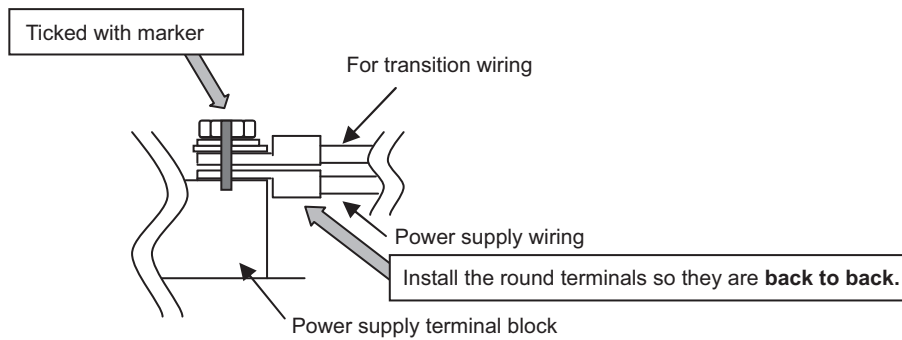

Important: Power supply cables larger than 25 mm² in diameter are not connectable to the power supply terminal block (TB4). Use a pull box to connect them.

3. Installing the conduit tube

- Always use a conduit to run the power supply wiring.
- Select the conduit size based on the hole.
- The cable conduits must be prepared locally.
- Do not store the 24VDC or less low-voltage circuit and 100VAC or higher main circuit and control circuit cables in the same multi-core cable, or bundle them together.
- Attach cable conduits securely to the foundation, etc. to ensure that excessive loads are not applied to the power supply terminal box.
- Seal the area around the cable conduit connection to ensure that no water penetrates the cable conduit connection port.

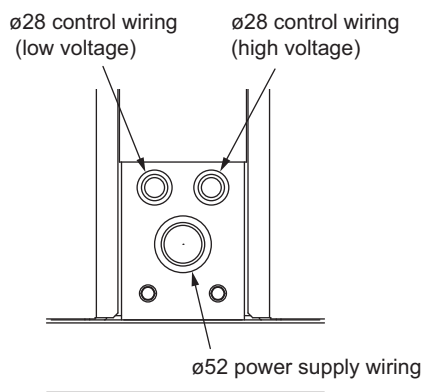

6. Controller

6-1. PAR-W21MAA specifications

Item	Description	Operations	Display
ON/OFF	Runs and stops the operation of a group of units	○	○
Operation mode switching	Switches between Heating/Heating ECO/Anti-freeze/Cooling * Available operation modes vary depending on the unit to be connected. * Switching limit setting can be made via a remote controller.	○	○
Water temperature setting	Temperature can be set within the ranges below. (in increments of 1°C or 1°F) Heating 30°C ~ 55°C Heating ECO 30°C ~ 55°C Anti-freeze 30°C Cooling 5°C ~ 25°C * The settable range varies depending on the unit to be connected.	○	○
Water temperature display	-20°C ~ 90°C (in increments of 1°C or 1°F) * The settable range varies depending on the unit to be connected.	×	○
Permit/Prohibit local operation	Individually prohibits operations of each local remote control function: ON/OFF, Operation modes, water temperature setting, Circulating water replacement warning reset. * Upper level controller may not be connected depending on the unit to be connected.	×	○
Weekly scheduler	ON/OFF/Water temperature setting can be done up to 6 times one day in the week. (in increments of a minute)	○	○
Error	When an error is currently occurring on a unit, the afflicted unit and the error code are displayed.	×	○
Self check (Error history)	Searches the latest error history by pressing the CHECK button twice.	○	○
Test run	Enables the Test run mode by pressing the TEST button twice. * Test run mode is not available depending on the unit to be connected.	○	○
LANGUAGE setting	The language on the dot matrix LCD can be changed. (Seven languages) English/German/Spanish/Russian/Italian/French/Swedish	○	○
Operation locking function	Remote controller operation can be locked or unlocked. • All-switch locking • Locking except ON/OFF switch	○	○

* Not available when brine is used (Dip SW3-6 set to ON)

6. Controller

6-2. PAR-W31MAA specifications

Item	Description	Operations	Display
ON/OFF	Runs and stops the operation of a group of units	○	○
Operation mode switching	Switches between Heating/Heating ECO/Anti-freeze/Cooling * Available operation modes vary depending on the unit to be connected. * Switching limit setting can be made via a remote controller.	○	○
Water temperature setting	Temperature can be set within the ranges below. (in increments of 0.5°C or 0.5°F) Heating 30°C ~ 55°C Heating ECO 30°C ~ 55°C Anti-freeze 30°C Cooling 5°C ~ 25°C, (-10°C ~ 25°C) *1 * The settable range varies depending on the unit to be connected.	○	○
Water temperature display	-20°C ~ 90°C (in increments of 0.5°C or 0.5°F) * The settable range varies depending on the unit to be connected.	×	○
Permit/Prohibit local operation	Individually prohibits operations of each local remote control function: ON/OFF, Operation modes, water temperature setting, Circulating water replacement warning reset. * Upper level controller may not be connected depending on the unit to be connected.	×	○
Weekly scheduler	ON/OFF/Water temperature setting can be done up to 6 times one day in the week. (in increments of a minute)	○	○
Error	When an error is currently occurring on a unit, the afflicted unit and the error code are displayed.	×	○
Self check (Error history)	Searches the latest error history by pressing the CHECK button twice.	○	○
LANGUAGE setting	The language on the dot matrix LCD can be changed. (11 languages) English/French/German/Swedish/Spanish/Italian/Danish/Dutch/Finnish/Norwegian/Portuguese	○	○
Operation locking function	Remote controller operation can be locked or unlocked. • All-switch locking • Locking except ON/OFF switch	○	○

*1 Applicable when using brine (Dip SW3-6 set to ON)

⚠ Warning

- Do not use refrigerant other than the type indicated in the manuals provided with the unit and on the nameplate.
 - Doing so may cause the unit or pipes to burst, or result in explosion or fire during use, repair, or at the time of disposal of the unit.
 - It may also be in violation of applicable laws.
 - MITSUBISHI ELECTRIC CORPORATION cannot be held responsible for malfunctions or accidents resulting from the use of the wrong type of refrigerant.
- Our chilling units contain a fluorinated greenhouse gas, R410A.

MITSUBISHI ELECTRIC CORPORATION

www.MitsubishiElectric.com