

OUTDOOR UNIT

SERVICE MANUAL



No. OBH629

Models

MUZ-SF25VE - E1

MUZ-SF25VEH - E1

MUZ-SF35VE - E1

MUZ-SF35VEH - E1

MUZ-SF42VE - E1

MUZ-SF42VEH - E1

MUZ-SF50VE - E1

MUZ-SF50VEH - E1

Indoor unit service manual
MSZ-SF•VE Series (OBH600)

MUZ-SF25VE MUZ-SF25VEH
MUZ-SF35VE MUZ-SF35VEH
MUZ-SF42VE MUZ-SF42VEH

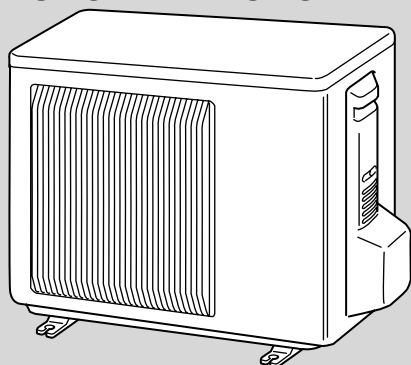

CONTENTS

1. TECHNICAL CHANGES	3
2. PART NAMES AND FUNCTIONS	4
3. SPECIFICATION	5
4. NOISE CRITERIA CURVES	6
5. OUTLINES AND DIMENSIONS	8
6. WIRING DIAGRAM	9
7. REFRIGERANT SYSTEM DIAGRAM	11
8. PERFORMANCE CURVES	13
9. ACTUATOR CONTROL	27
10. SERVICE FUNCTIONS	28
11. TROUBLESHOOTING	28
12. DISASSEMBLY INSTRUCTIONS	45

PARTS CATALOG (OBB629)

NOTE:
RoHS compliant products have <G> mark on the spec name plate.



Use the specified refrigerant only

Never use any refrigerant other than that specified.

Doing so may cause a burst, an explosion, or fire when the unit is being used, serviced, or disposed of.

Correct refrigerant is specified in the manuals and on the spec labels provided with our products.

We will not be held responsible for mechanical failure, system malfunction, unit breakdown or accidents caused by failure to follow the instructions.

<Preparation before the repair service>

- Prepare the proper tools.
- Prepare the proper protectors.
- Provide adequate ventilation.
- After stopping the operation of the air conditioner, turn off the power-supply breaker and remove the power plug.
- Discharge the capacitor before the work involving the electric parts.

<Precautions during the repair service>

- Do not perform the work involving the electric parts with wet hands.
- Do not pour water into the electric parts.
- Do not touch the refrigerant.
- Do not touch the hot or cold areas in the refrigeration cycle.
- When the repair or the inspection of the circuit needs to be done without turning off the power, exercise great caution not to touch the live parts.

1

TECHNICAL CHANGES

MUZ-SF25VE -^{E1}

MUZ-SF25VEH -^{E1}

MUZ-SF35VE -^{E1}

MUZ-SF35VEH -^{E1}

MUZ-SF42VE -^{E1}

MUZ-SF42VEH -^{E1}

MUZ-SF50VE -^{E1}

MUZ-SF50VEH -^{E1}

1. New model

2

PART NAMES AND FUNCTIONS

MUZ-SF25VE MUZ-SF25VEH
 MUZ-SF35VE MUZ-SF35VEH
 MUZ-SF42VE MUZ-SF42VEH

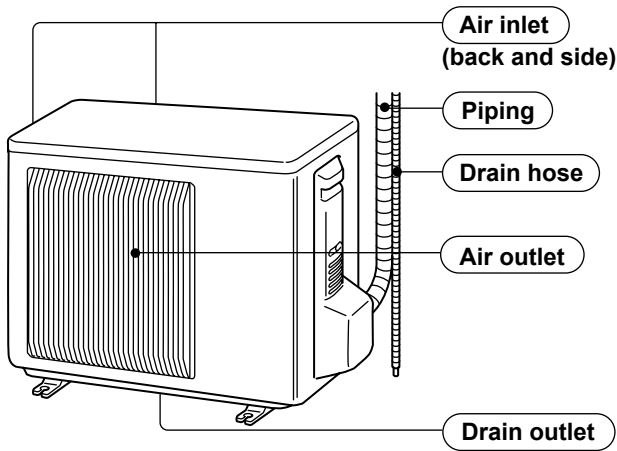

MUZ-SF50VE MUZ-SF50VEH

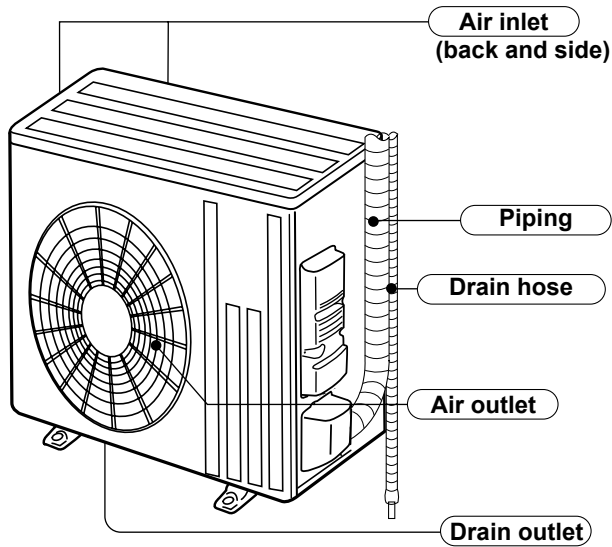

ACCESSORIES

MODELS	MUZ-SF25VE MUZ-SF35VE MUZ-SF42VE MUZ-SF50VE
Drain socket	1

3

SPECIFICATION

Outdoor model			MUZ-SF25VE MUZ-SF25VEH	MUZ-SF35VE MUZ-SF35VEH	MUZ-SF42VE MUZ-SF42VEH	MUZ-SF50VE MUZ-SF50VEH		
Power supply			Single phase, 230 V, 50 Hz					
Capacity Rated frequency (Min.-Max.)	Cooling	kW	2.5 (0.9 - 3.4)	3.5 (1.1 - 3.8)	4.2 (0.8 - 4.5)	5.0 (1.4 - 5.4)		
	Heating		3.2 (1.0 - 4.1)	4.0 (1.3 - 4.6)	5.4 (1.3 - 6.0)	5.8 (1.6 - 7.3)		
Breaker Capacity		A	10			16		
Electrical data	Power input *1 (Total)	Cooling	600	1,080	1,340	1,660		
		Heating	780	1,030	1,580	1,700		
	Running current *1 (Total)	Cooling	3.2	4.9	6.0	7.4		
		Heating	3.9	4.7	7.0	7.6		
	Power factor *1 (Total)	Cooling	81	95	97	97		
		Heating	86	95	98	97		
Starting current *1 (Total)		A	3.9	4.9	7.0	7.6		
Coefficient of performance (COP) *1 (Total)		Cooling	4.17	3.24	3.13	3.01		
		Heating	4.10	3.88	3.42	3.41		
Compressor	Model		KNB073FKVMC	KNB092FNDMC	SNB130FGAMT	SNB130FGBMT		
	Output		W	550	650	900	900	
	Current *1	Cooling	A	3.04	4.74	5.84	7.22	
		Heating	A	3.70	4.48	6.78	7.33	
	Refrigeration oil (Model)		L	0.32 (FV50S)	0.27 (FV50S)	0.35 (FV50S)		
Fan motor	Model		RC0J50-FA			RC0J60-BD		
	Current *1	Cooling	A	0.20	0.24	0.30	0.84	
		Heating	A	0.29	0.30	0.28	0.93	
Dimensions W × H × D		mm	800 × 550 × 285			840 × 880 × 330		
Weight		kg	31	31	35	55		
Special remarks	Dehumidification		Cooling	ℓ/h	0.3	1.0	1.7	2.2
	Air flow *1	Cooling	High	m ³ /h	1,698	1,956	1,806	2,868
			Low		1,698	1,806	1,038	1,602
		Heating	High		2,064	2,178	2,016	2,778
			Med.		1,698	1,932	1,770	2,778
			Low		1,350	1,476	1,326	2,124
					47	49	50	52
	Sound level *1		Heating	dB(A)	48	50	51	52
	Fan speed	Cooling	High	rpm	740	800	810	840
			Low		740	740	490	480
		Heating	High		890	890	900	810
			Med.		740	790	770	810
			Low		600	610	610	620
					Fan speed regulator		3	
Refrigerant filling capacity (R410A)		kg	0.7	0.8	1.15	1.55		

NOTE: Test conditions are based on ISO 5151.

Cooling: Indoor Dry-bulb temperature 27°C

Wet-bulb temperature 19°C

Outdoor Dry-bulb temperature 35°C

Heating: Indoor Dry-bulb temperature 20°C

Wet-bulb temperature 6°C

Outdoor Dry-bulb temperature 7°C

Refrigerant piping length (one way): 5 m

*1 Measured under rated operating frequency.

Specifications and rated conditions of main electric parts

Item	Model	MUZ-SF25VE	MUZ-SF25VEH	MUZ-SF35VE	MUZ-SF35VEH	MUZ-SF42VE	MUZ-SF42VEH	MUZ-SF50VE	MUZ-SF50VEH	
Smoothing capacitor	(C61, C62)	620 μF 420 V								
	(C63)	—				620 μF 420 V				
Diode module	(DB61)	15 A 600 V						25 A 600 V		
Fuse	(F61)	T20AL250V								
	(F701, F801, F901)	T3.15AL250V								
Defrost heater	(H)	—	230 V 130 W	—	230 V 130 W	—	230V 130W	—	230V 130W	
Intelligent power module	(IC700)	15 A 600 V				20 A 600 V				
	(IC932)	8A600V								
Expansion valve coil	(LEV)	12 V DC								
Reactor	(L61)	18 mH			23 mH					
Power factor controller	(IC820)	20A 600V								
Current-limiting PTC thermistor	(PTC64, PTC65)	33 Ω								
Terminal block	(TB)	5 P								
Relay	(X63)	3 A 250 V								
	(X64)	20 A 250 V								
	(X66)	—	3 A 250 V	—	3 A 250 V	—	3 A 250 V	—	3 A 250 V	
	(X69)	10A 230V								
R.V.coil	(21S4)	220 - 240 V AC								
Heater protector	(26H)	—	Open 45°C	—	Open 45°C	—	Open 45°C	—	Open 45°C	

4 NOISE CRITERIA CURVES

MUZ-SF25VE MUZ-SF25VEH

FUNCTION	SPL(dB(A))	LINE
COOLING	47	●—●
HEATING	48	○—○

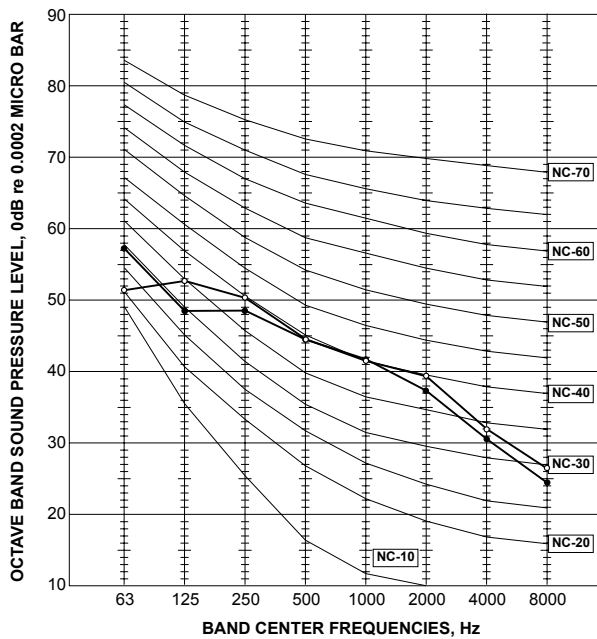

MUZ-SF35VE MUZ-SF35VEH

FUNCTION	SPL(dB(A))	LINE
COOLING	49	●—●
HEATING	50	○—○

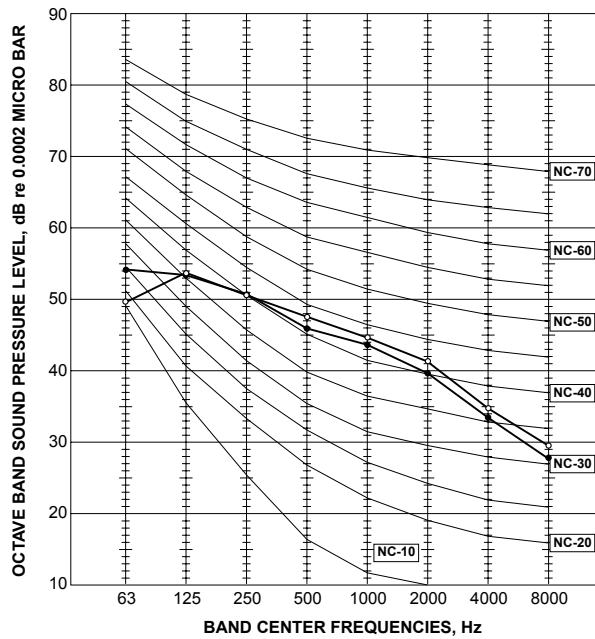

MUZ-SF42VE MUZ-SF42VEH

FUNCTION	SPL(dB(A))	LINE
COOLING	50	●—●
HEATING	51	○—○

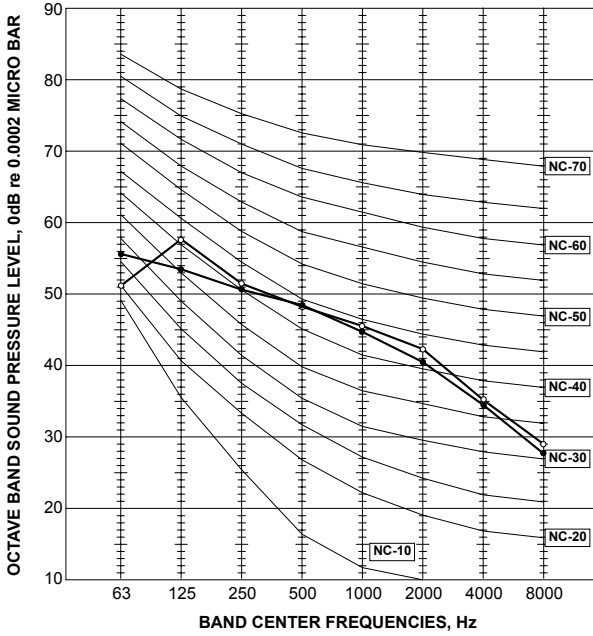

MUZ-SF50VE MUZ-SF50VEH

FUNCTION	SPL(dB(A))	LINE
COOLING	52	●—●
HEATING	52	○—○

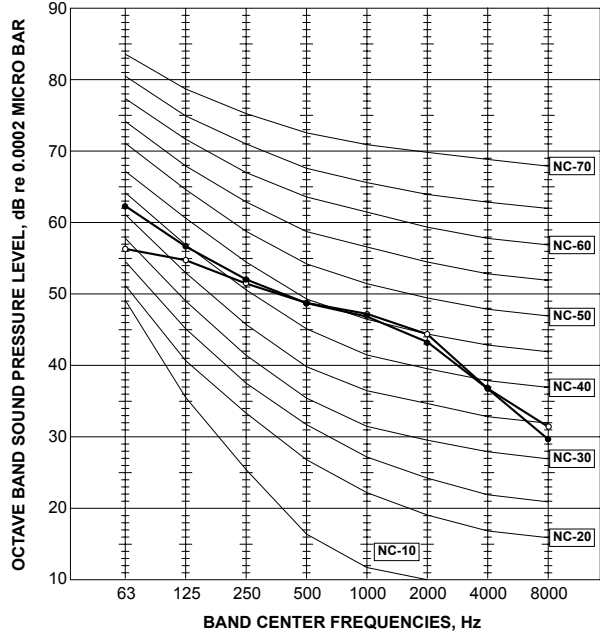

Test conditions

Cooling: Dry-bulb temperature 35°C

Heating: Dry-bulb temperature 7°C Wet-bulb temperature 6°C

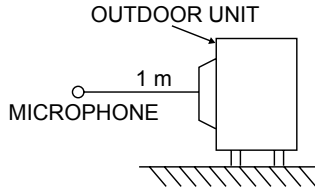

5

OUTLINES AND DIMENSIONS

MUZ-SF25VE MUZ-SF25VEH MUZ-SF35VE MUZ-SF35VEH
 MUZ-SF42VE MUZ-SF42VEH

Unit: mm

REQUIRED SPACE

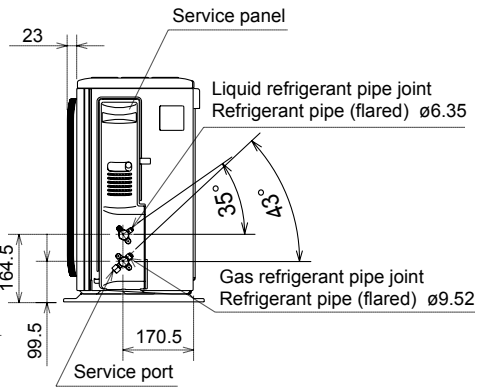
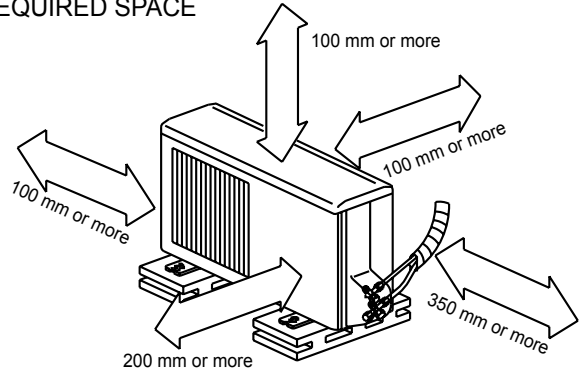
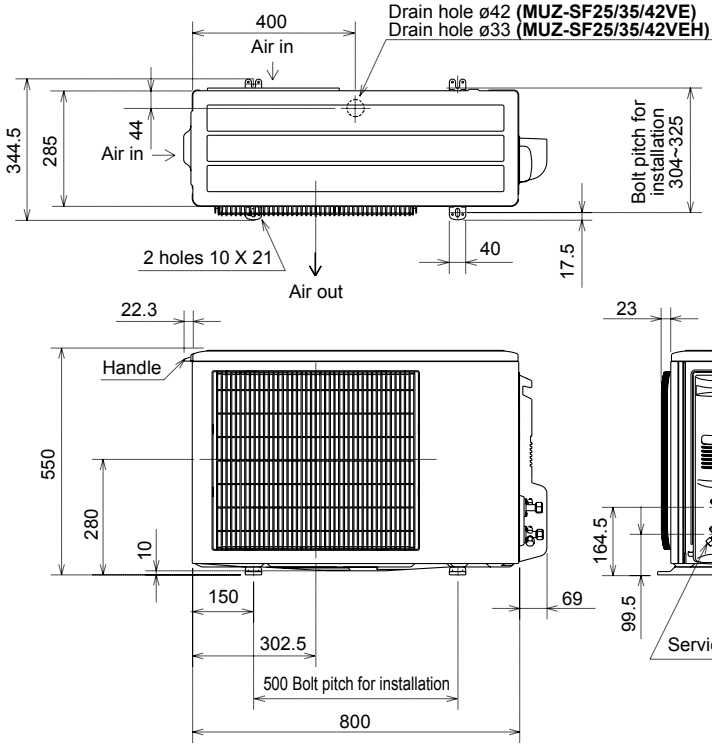

MUZ-SF50VE MUZ-SF50VEH

REQUIRED SPACE

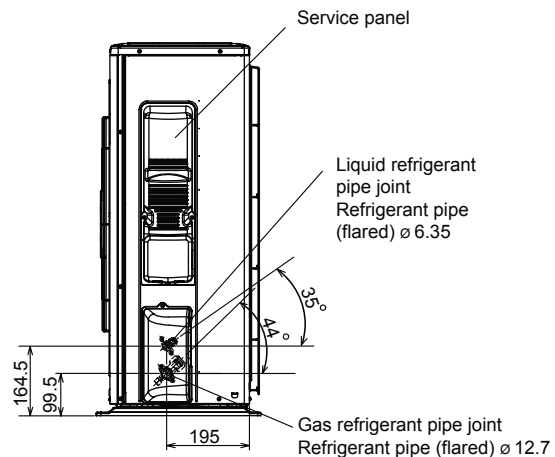
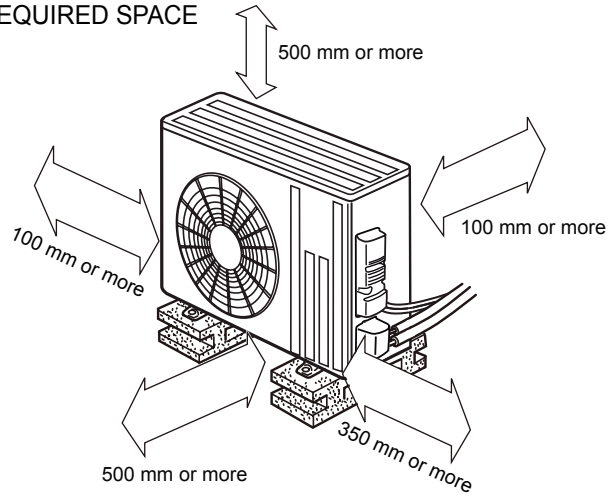
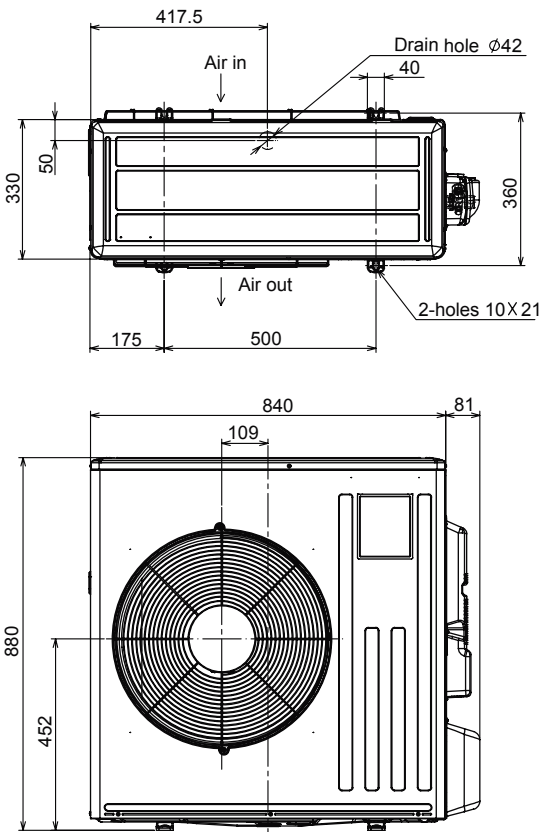

6

WIRING DIAGRAM

MUZ-SF25VE MUZ-SF35VE

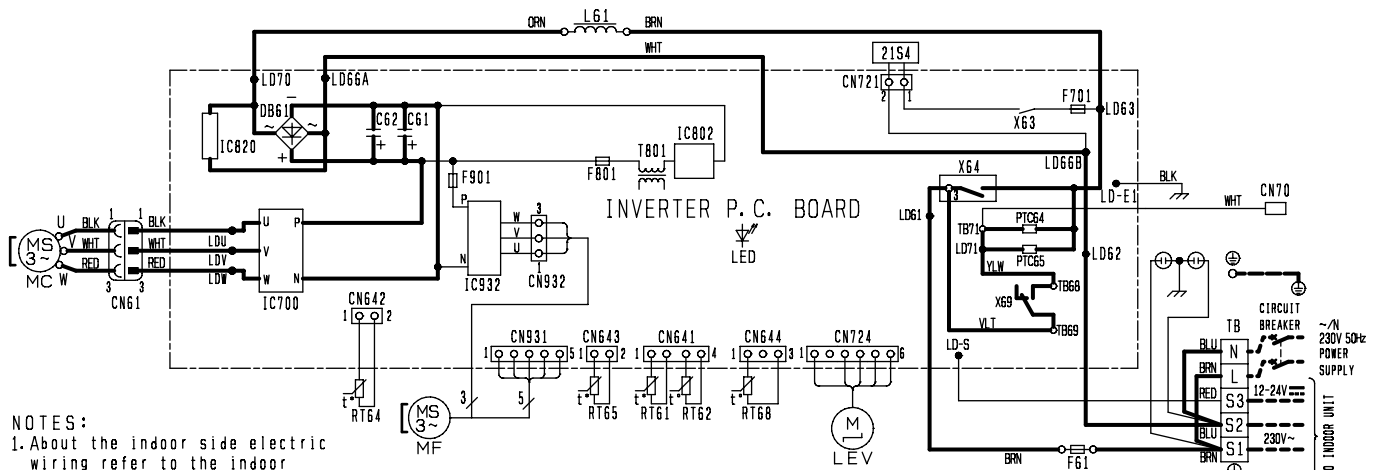

- NOTES:
- About the indoor side electric wiring refer to the indoor unit electric wiring diagram for servicing.
 - Use copper conductors only. (For field wiring).

SYMBOL	NAME	SYMBOL	NAME	SYMBOL	NAME
CN70	CONNECTOR	LEV	EXPANSION VALVE COIL	RT65	AMBIENT TEMP. THERMISTOR
C61,C62	SMOOTHING CAPACITOR	LG1	REACTOR	RT68	OUTDOOR HEAT EXCHANGER TEMP. THERMISTOR.
DB61	DIODE MODULE	MC	COMPRESSOR	TB	TERMINAL BLOCK
F61	FUSE (T20AL250V)	MF	FAN MOTOR	T801	TRANSFORMER
F701,F801,F901	FUSE (T3.15AL250V)	PTC64,PTC65	CIRCUIT PROTECTION	X63, X64, X69	RELAY
IC700, IC820, IC932	POWER MODULE	RT61	DEFROST THERMISTOR	21S4	REVERSING VALVE COIL
IC802	POWER DEVICE	RT62	DISCHARGE TEMP. THERMISTOR		
LED	LED	RT64	FIN TEMP. THERMISTOR		

MUZ-SF25VEH MUZ-SF35VEH

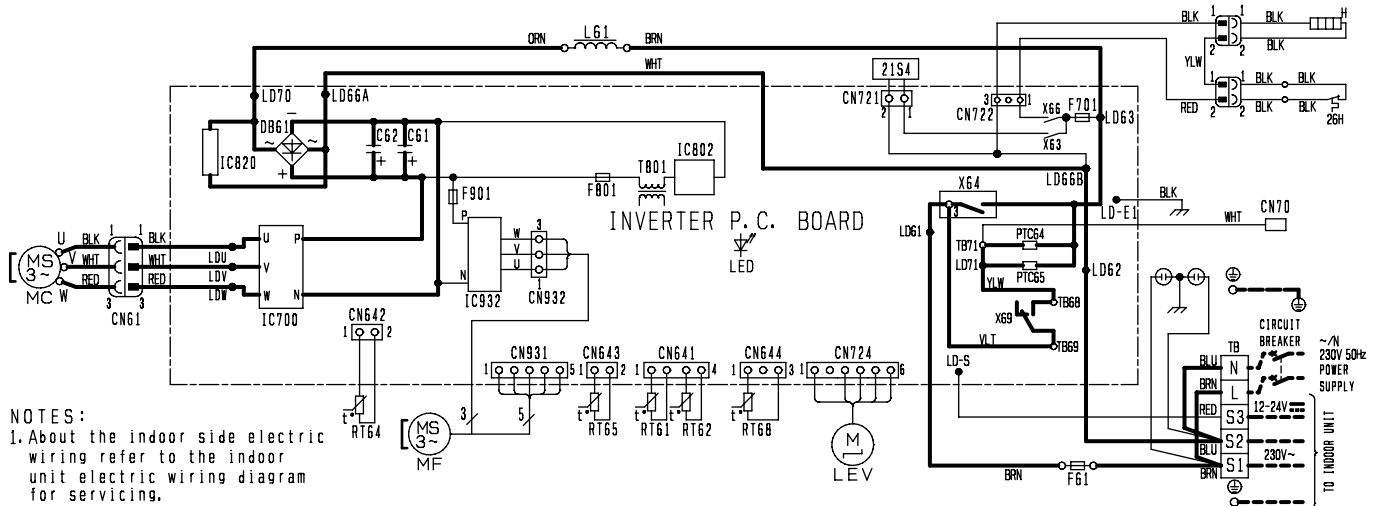

- NOTES:
- About the indoor side electric wiring refer to the indoor unit electric wiring diagram for servicing.
 - Use copper conductors only. (For field wiring).

SYMBOL	NAME	SYMBOL	NAME	SYMBOL	NAME
CN70	CONNECTOR	LEV	EXPANSION VALVE COIL	RT68	OUTDOOR HEAT EXCHANGER TEMP. THERMISTOR.
C61,C62	SMOOTHING CAPACITOR	LG1	REACTOR	TB	TERMINAL BLOCK
DB61	DIODE MODULE	MC	COMPRESSOR	T801	TRANSFORMER
F61	FUSE (T20AL250V)	MF	FAN MOTOR	X63, X64, X66, X69	RELAY
F701,F801,F901	FUSE (T3.15AL250V)	PTC64,PTC65	CIRCUIT PROTECTION	21S4	REVERSING VALVE COIL
H	DEFROST HEATER	RT61	DEFROST THERMISTOR	26H	HEATER PROTECTOR
IC700, IC820, IC932	POWER MODULE	RT62	DISCHARGE TEMP. THERMISTOR		
IC802	POWER DEVICE	RT64	FIN TEMP. THERMISTOR		
LED	LED	RT65	AMBIENT TEMP. THERMISTOR		

MUZ-SF42VE MUZ-SF50VE

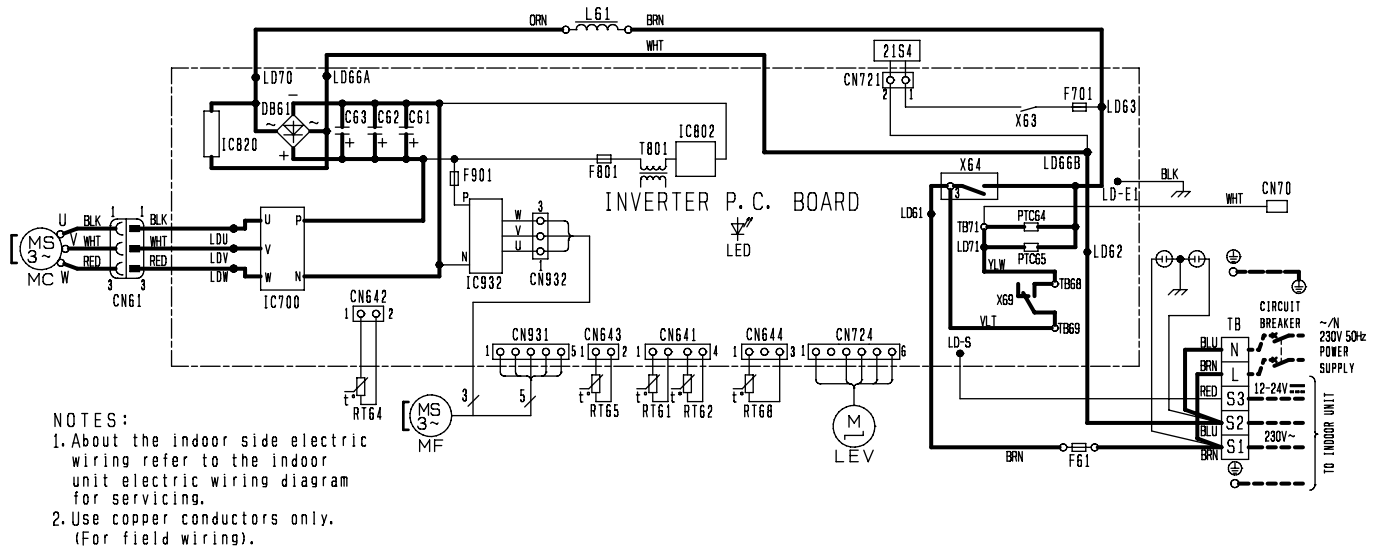

SYMBOL	NAME	SYMBOL	NAME	SYMBOL	NAME
CN70	CONNECTOR	LEV	EXPANSION VALVE COIL	RT65	AMBIENT TEMP. THERMISTOR
C61, C62, C63	SMOOTHING CAPACITOR	L61	REACTOR	RT68	OUTDOOR HEAT EXCHANGER TEMP. THERMISTOR.
DB61	DIODE MODULE	MC	COMPRESSOR	TB	TERMINAL BLOCK
F61	FUSE (T20AL250V)	MF	FAN MOTOR	T801	TRANSFORMER
F701, F801, F901	FUSE (T3. 15AL250V)	PTC64, PTC65	CIRCUIT PROTECTION	X63, X64, X69	RELAY
IC700, IC820, IC932	POWER MODULE	RT61	DEFROST THERMISTOR	21S4	REVERSING VALVE COIL
IC802	POWER DEVICE	RT62	DISCHARGE TEMP. THERMISTOR		
LED	LED	RT64	F IN TEMP. THERMISTOR		

MUZ-SF42VEH MUZ-SF50VEH

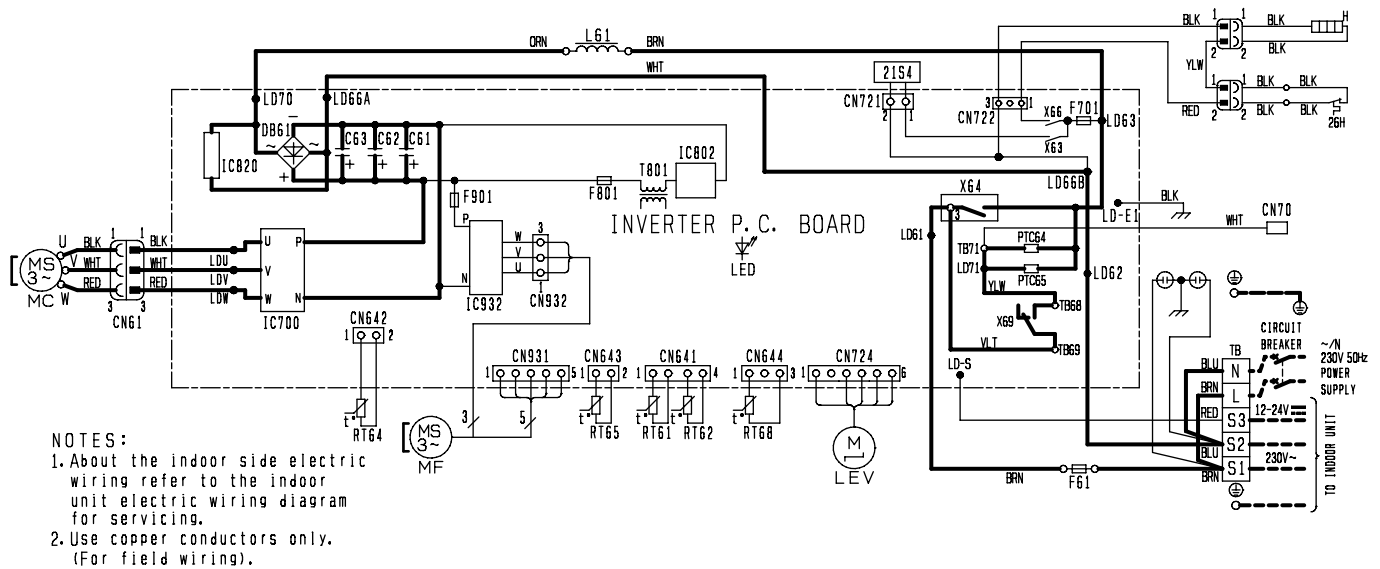

SYMBOL	NAME	SYMBOL	NAME	SYMBOL	NAME
CN70	CONNECTOR	LEV	EXPANSION VALVE COIL	RT68	OUTDOOR HEAT EXCHANGER TEMP. THERMISTOR.
C61, C62, C63	SMOOTHING CAPACITOR	L61	REACTOR	TB	TERMINAL BLOCK
DB61	DIODE MODULE	MC	COMPRESSOR	T801	TRANSFORMER
F61	FUSE (T20AL250V)	MF	FAN MOTOR	X63, X64, X66, X69	RELAY
F701, F801, F901	FUSE (T3. 15AL250V)	PTC64, PTC65	CIRCUIT PROTECTION	21S4	REVERSING VALVE COIL
H	DEFROST HEATER	RT61	DEFROST THERMISTOR	26H	HEATER PROTECTOR
IC700, IC820, IC932	POWER MODULE	RT62	DISCHARGE TEMP. THERMISTOR		
IC802	POWER DEVICE	RT64	F IN TEMP. THERMISTOR		
LED	LED	RT65	AMBIENT TEMP. THERMISTOR		

7

REFRIGERANT SYSTEM DIAGRAM

MUZ-SF25VE MUZ-SF25VEH MUZ-SF35VE MUZ-SF35VEH

Unit: mm

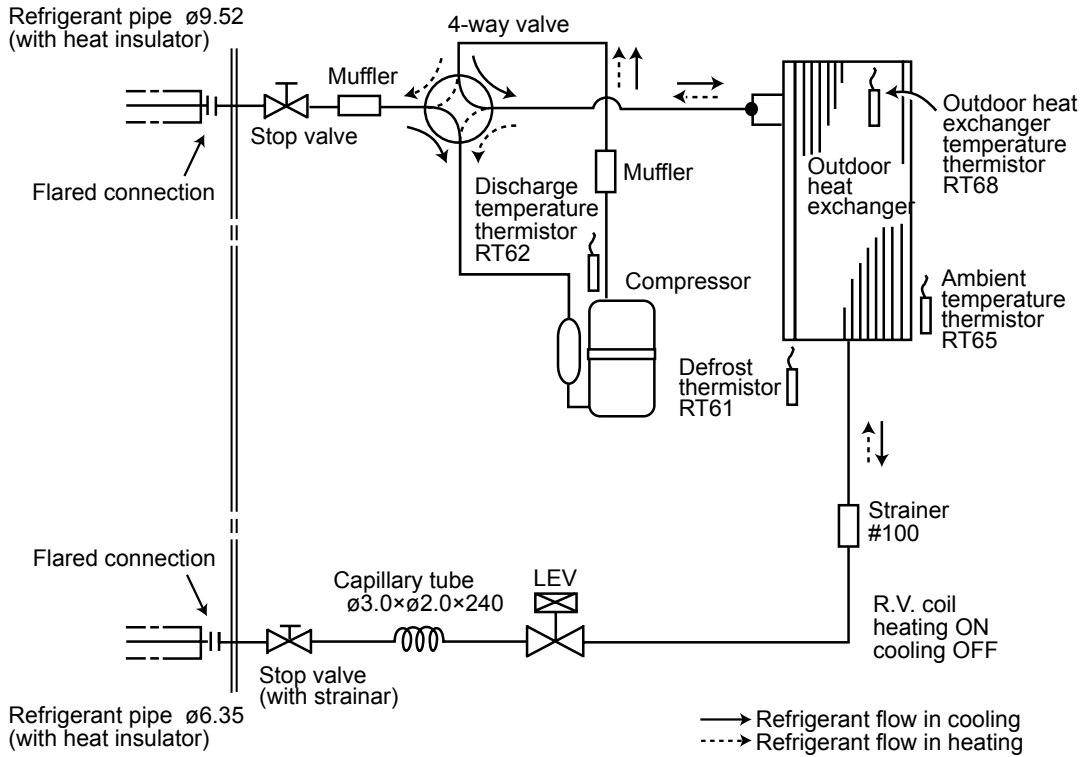

MUZ-SF42VE MUZ-SF42VEH

Unit: mm

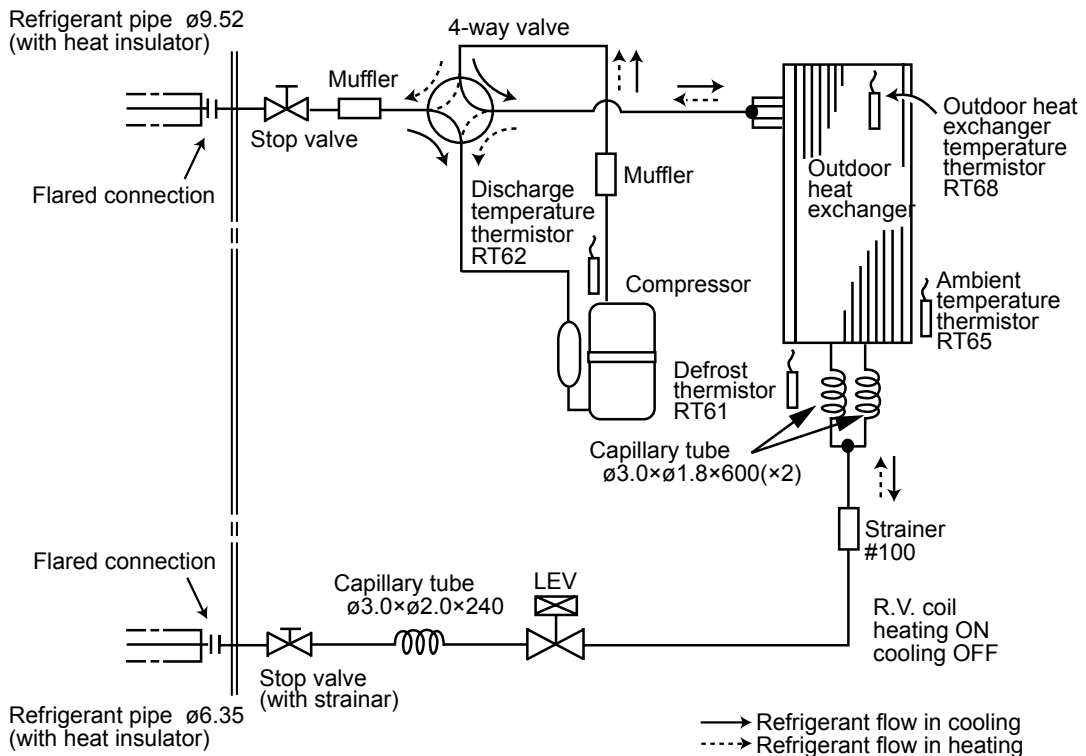

MUZ-SF50VE MUZ-SF50VEH

Unit: mm

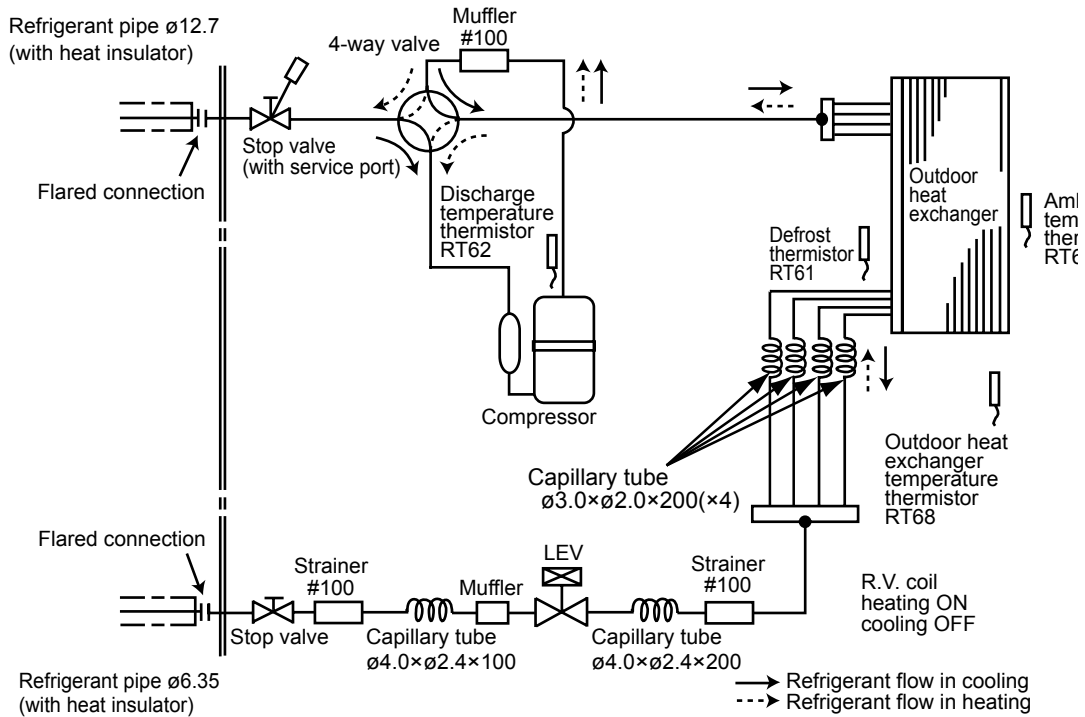

MAX. REFRIGERANT PIPING LENGTH and MAX. HEIGHT DIFEFRENCE

	Refrigerant piping: m		Piping size O.D: mm	
	Max. Length A	Max. Height difference B	Gas	Liquid
MUZ-SF25/35/42	20	12	9.52	6.35
MUZ-SF50	30	15	12.7	

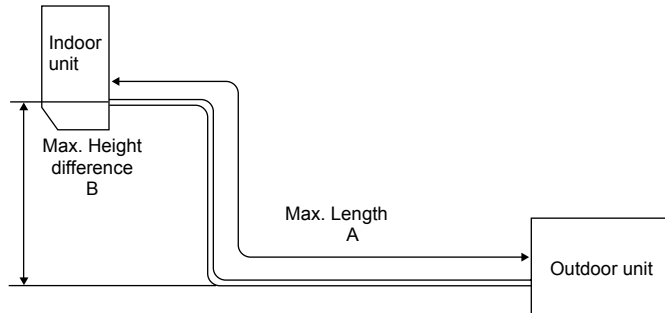

ADDITIONAL REFRIGERANT CHARGE (R410A: g)

Model	Outdoor unit precharged	Refrigerant piping length (one way)									
		7 m	8 m	9 m	10 m	11 m	12 m	13 m	14 m	15 m	20 m
MUZ-SF25	700	0	30	60	90	120	150	180	210	240	390
MUZ-SF35	800										
MUZ-SF42	1,150										

Calculation: X g = 30 g/m × (Refrigerant piping length (m) - 7)

Model	Outdoor unit precharged	Refrigerant piping length (one way)					
		7 m	10 m	15 m	20 m	25 m	30 m
MUZ-SF50	1,550	0	60	160	260	360	460

Calculation: X g = 20 g/m × (Refrigerant piping length (m) - 7)

NOTE: Refrigerant piping exceeding 7 m requires additional refrigerant charge according to the calculation.

**MUZ-SF25VE MUZ-SF25VEH MUZ-SF35VE MUZ-SF35VEH
MUZ-SF42VE MUZ-SF42VEH MUZ-SF50VE MUZ-SF50VEH**

The standard specifications apply only to the operation of the air conditioner under normal conditions. Since operating conditions vary according to the areas where these units are installed, the following information has been provided to clarify the operating characteristics of the air conditioner under the conditions indicated by the performance curve.

(1) GUARANTEED VOLTAGE

198 ~ 264 V, 50 Hz

(2) AIR FLOW

Air flow should be set at MAX.

(3) MAIN READINGS

- | | | |
|--|---------|-----------|
| (1) Indoor intake air wet-bulb temperature: | °C [WB] | } Cooling |
| (2) Indoor outlet air wet-bulb temperature: | °C [WB] | |
| (3) Outdoor intake air dry-bulb temperature: | °C [DB] | |
| (4) Total input: | W | } Heating |
| (5) Indoor intake air dry-bulb temperature: | °C [DB] | |
| (6) Outdoor intake air wet-bulb temperature: | °C [WB] | |
| (7) Total input: | W | |

Indoor air wet and dry bulb temperature difference on the left side of the following chart shows the difference between the indoor intake air wet and dry bulb temperature and the indoor outlet air wet and dry bulb temperature for your reference at service.

How to measure the indoor air wet and dry bulb temperature difference

- Attach at least 2 sets of wet and dry bulb thermometers to the indoor air intake as shown in the figure, and at least 2 sets of wet and dry bulb thermometers to the indoor air outlet. The thermometers must be attached to the position where air speed is high.
- Attach at least 2 sets of wet and dry bulb thermometers to the outdoor air intake. Cover the thermometers to prevent direct rays of the sun.
- Check that the air filter is cleaned.
- Open windows and doors of room.
- Press the EMERGENCY OPERATION switch once (twice) to start the EMERGENCY COOL (HEAT) MODE.
- When system stabilizes after more than 15 minutes, measure temperature and take an average temperature.
- 10 minutes later, measure temperature again and check that the temperature does not change.

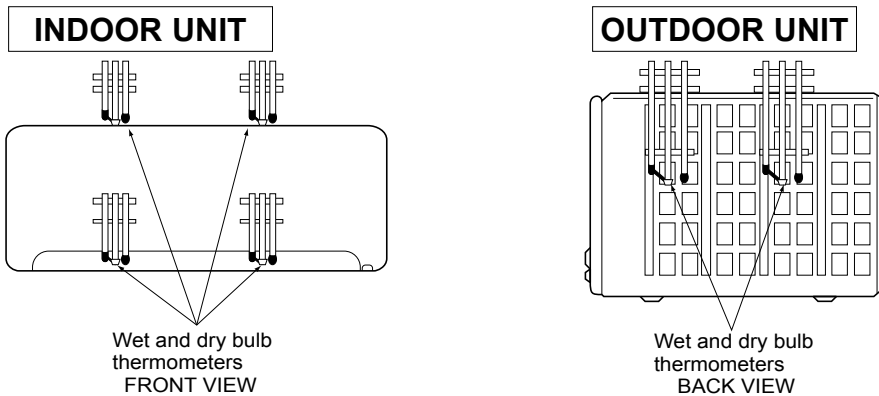

8-1. CAPACITY AND INPUT CURVES

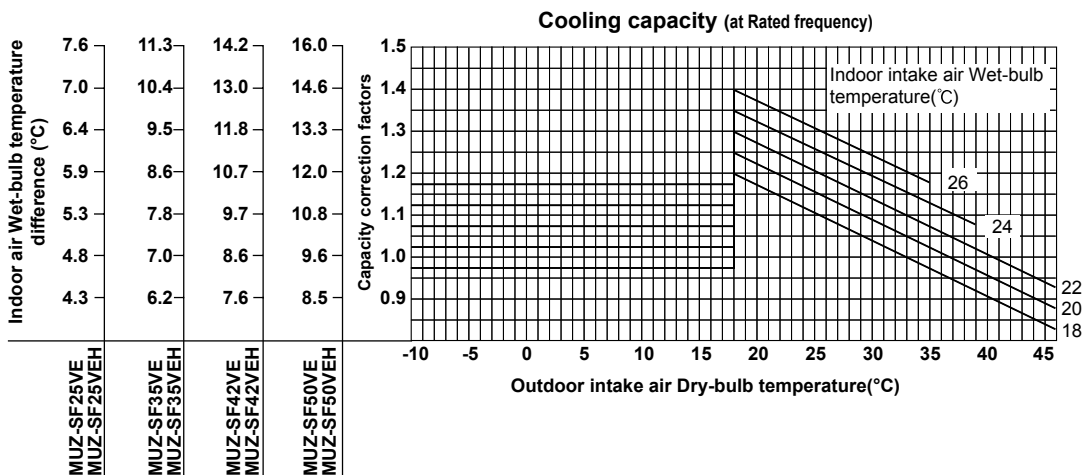

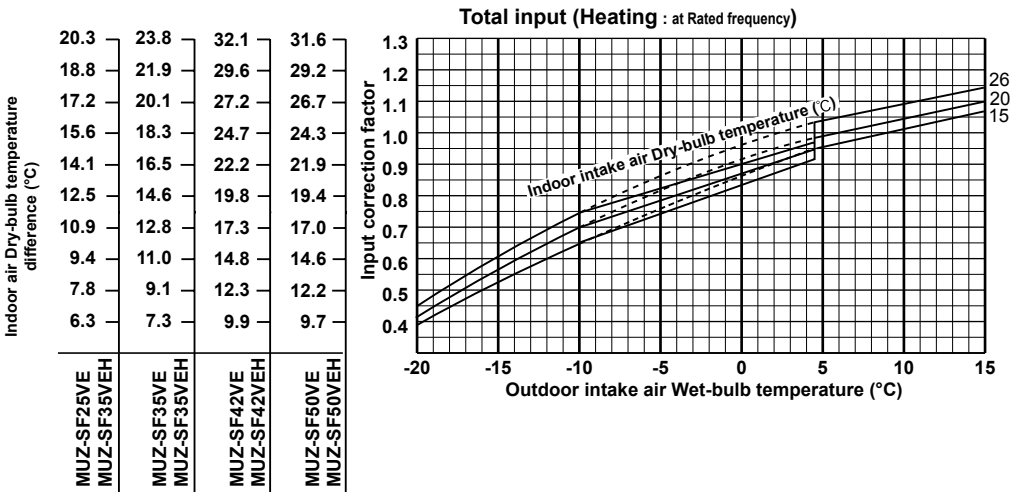
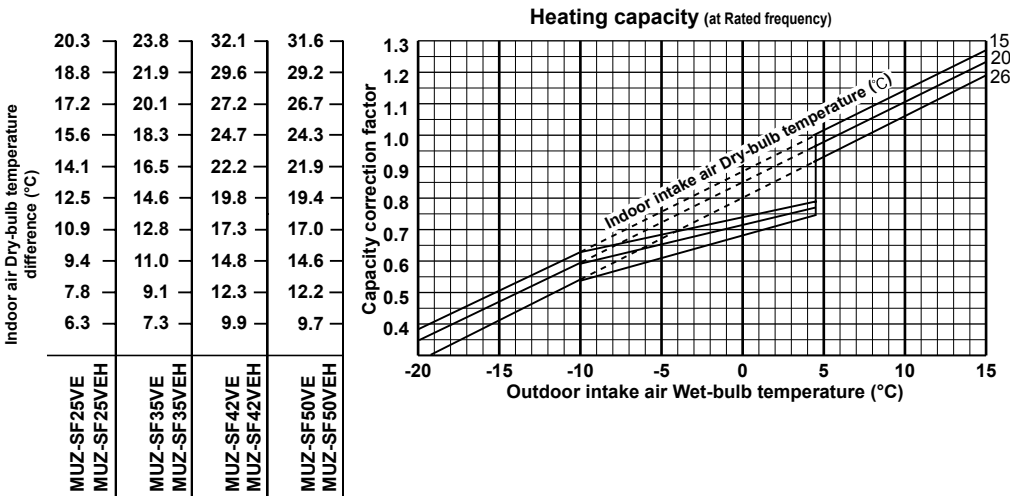
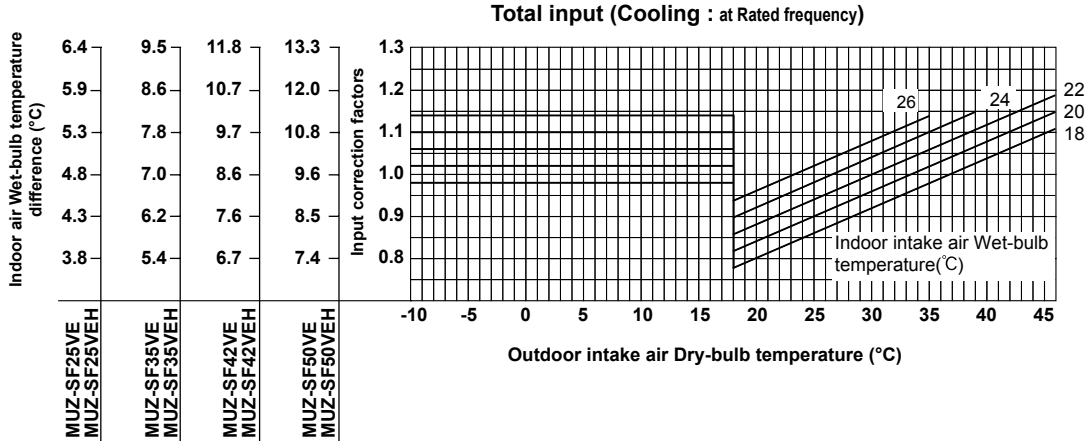
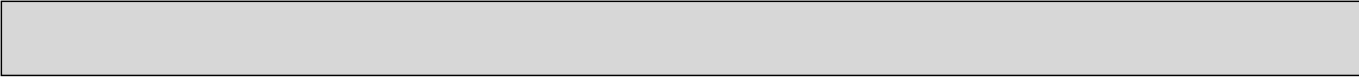

**Lower limit of guaranteed
 operating range in heating**
MUZ-SF25/35/42/50VE: -15°C
MUZ-SF25/35/42/50VEH: -20°C

NOTE: The above broken lines are for the heating operation without any frost and defrost operation.

8-2. CAPACITY AND INPUT CORRECTION BY OPERATIONAL FREQUENCY OF COMPRESSOR

MUZ-SF25VE MUZ-SF25VEH

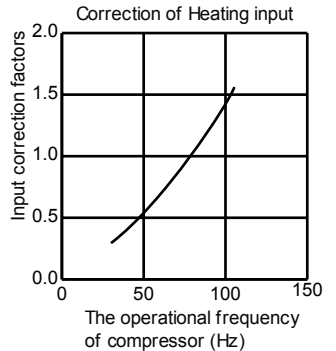
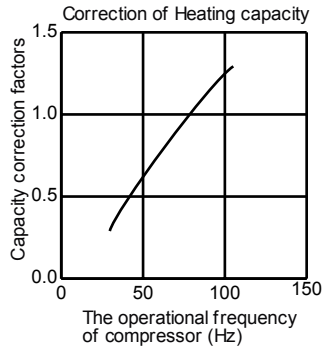
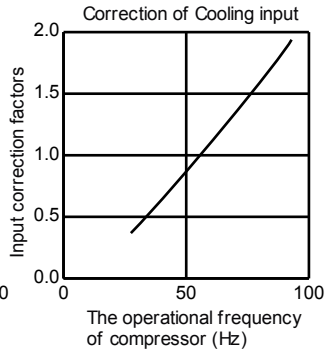
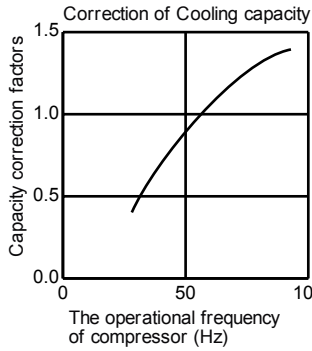

MUZ-SF35VE MUZ-SF35VEH

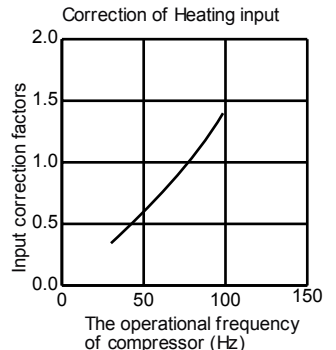
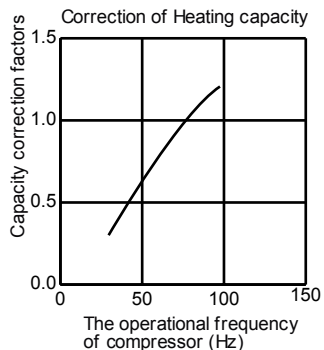
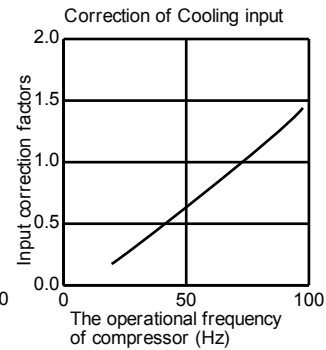
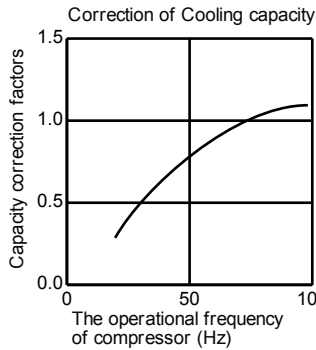

MUZ-SF42VE MUZ-SF42VEH

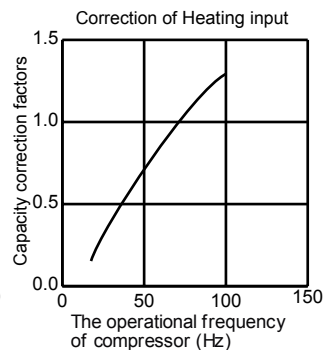
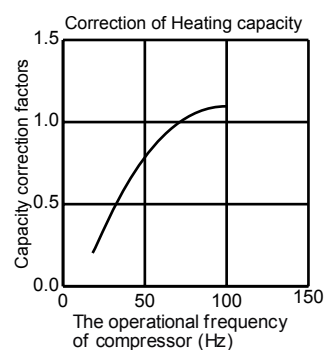
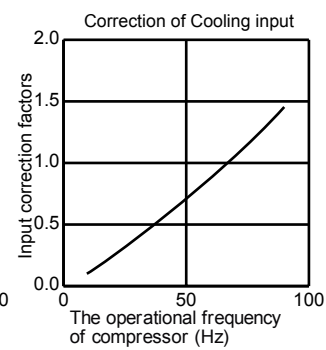
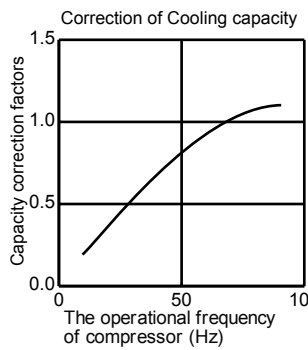

MUZ-SF50VE MUZ-SF50VEH

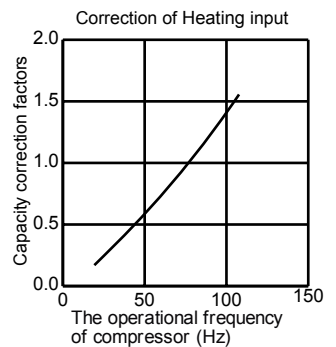
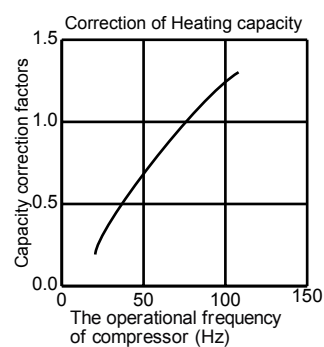
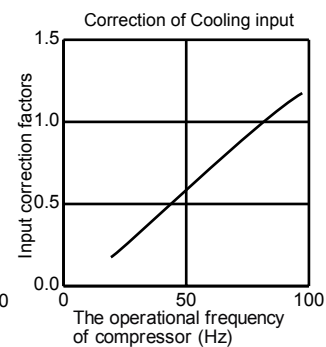
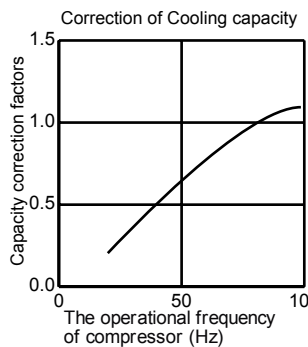

8-3. HOW TO OPERATE FIXED-FREQUENCY OPERATION

<Test run operation>

1. Press EMERGENCY OPERATION switch to start COOL or HEAT mode (COOL: Press once, HEAT: Press twice).
2. Test run operation starts and continues to operate for 30 minutes.
3. Compressor operates at rated frequency in COOL mode or 58 Hz in HEAT mode.
4. Indoor fan operates at High speed.
5. After 30 minutes, test run operation finishes and EMERGENCY OPERATION starts (operation frequency of compressor varies).
6. To cancel test run operation (EMERGENCY OPERATION), press EMERGENCY OPERATION switch or any button on remote controller.

8-4. OUTDOOR LOW PRESSURE AND OUTDOOR UNIT CURRENT

COOL operation

- ① Both indoor and outdoor unit are under the same temperature/humidity condition.
- ② Operation: TEST RUN OPERATION (Refer to 8-3.)

Dry-bulb temperature (°C)	Relative humidity (%)
20	50
25	60
30	70

Outdoor low pressure

MUZ-SF25VE MUZ-SF25VEH

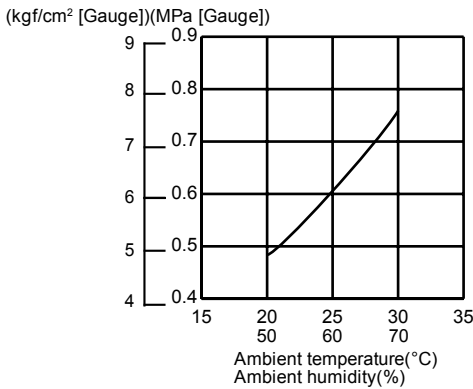

MUZ-SF35VE MUZ-SF35VEH

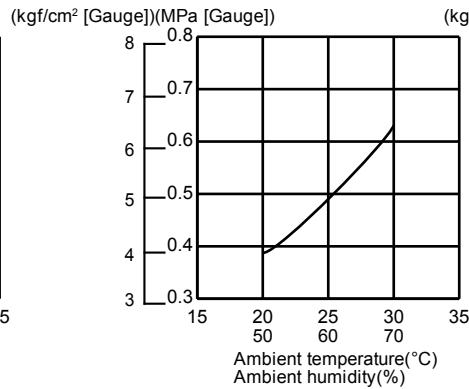

MUZ-SF42VE MUZ-SF42VEH

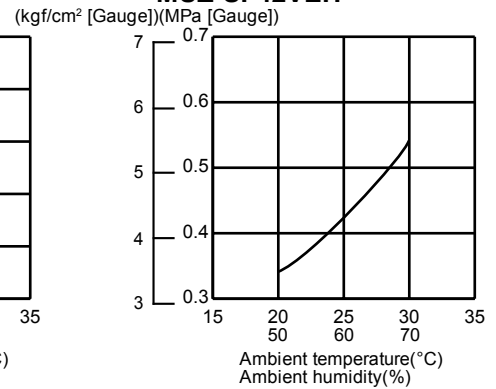

MUZ-SF50VE MUZ-SF50VEH

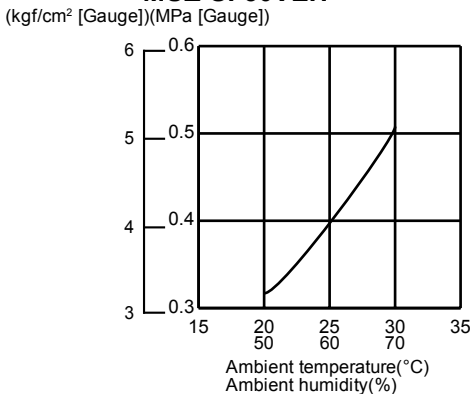

NOTE:

The unit of pressure has been changed to MPa on the international system of units (SI unit system)
The conversion factor is: **1 (MPa [Gauge]) = 10.2 (kgf/cm² [Gauge])**

Outdoor unit current

MUZ-SF25VE MUZ-SF25VEH

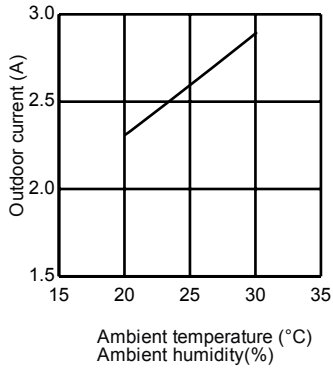

MUZ-SF35VE MUZ-SF35VEH

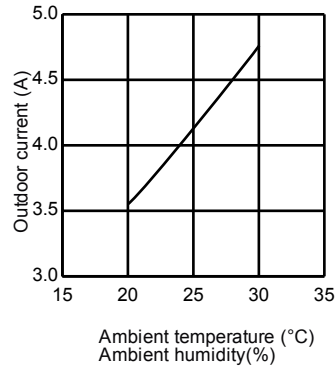

MUZ-SF42VE MUZ-SF42VEH

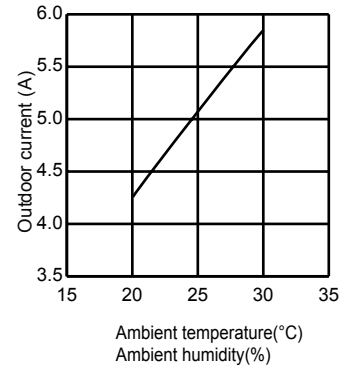

MUZ-SF50VE MUZ-SF50VEH

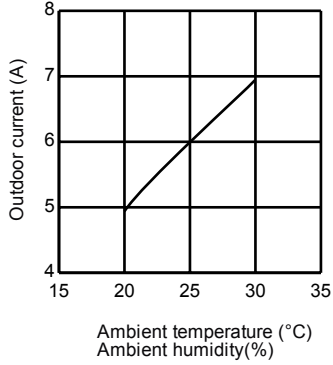

HEAT operation

① Condition:

	Indoor	Outdoor			
Dry bulb temperature (°C)	20.0	2	7	15	20.0
Wet bulb temperature (°C)	14.5	1	6	12	14.5

② Operation: Test run operation (Refer to 8-3.)

Outdoor unit current

MUZ-SF25VE MUZ-SF25VEH

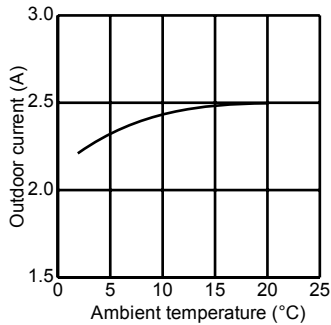

MUZ-SF35VE MUZ-SF35VEH

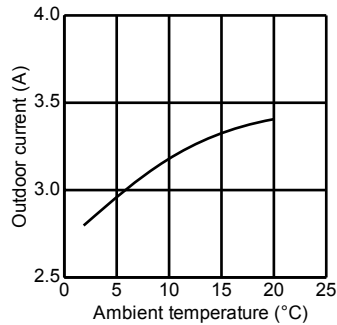

MUZ-SF42VE MUZ-SF42VEH

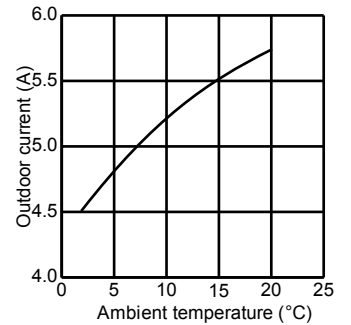

MUZ-SF50VE MUZ-SF50VEH

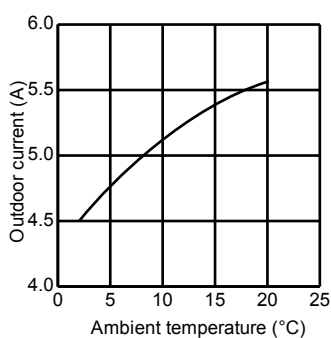

PERFORMANCE DATA COOL operation at Rated frequency

MUZ-SF25VE MUZ-SF25VEH

CAPACITY: 2.5 kW

SHF: 0.92

INPUT: 600 W

INDOOR DB (°C)	INDOOR WB (°C)	OUTDOOR DB (°C)															
		21				25				27				30			
		Q	SHC	SHF	INPUT	Q	SHC	SHF	INPUT	Q	SHC	SHF	INPUT	Q	SHC	SHF	INPUT
21	18	2.94	2.17	0.74	480	2.81	2.08	0.74	504	2.70	2.00	0.74	528	2.60	1.92	0.74	552
21	20	3.06	1.90	0.62	504	2.94	1.82	0.62	534	2.85	1.77	0.62	546	2.75	1.71	0.62	570
22	18	2.94	2.29	0.78	480	2.81	2.19	0.78	504	2.70	2.11	0.78	528	2.60	2.03	0.78	552
22	20	3.06	2.02	0.66	504	2.94	1.94	0.66	534	2.85	1.88	0.66	546	2.75	1.82	0.66	570
22	22	3.19	1.72	0.54	522	3.08	1.66	0.54	555	3.00	1.62	0.54	570	2.88	1.55	0.54	594
23	18	2.94	2.41	0.82	480	2.81	2.31	0.82	504	2.70	2.21	0.82	528	2.60	2.13	0.82	552
23	20	3.06	2.14	0.70	504	2.94	2.06	0.70	534	2.85	2.00	0.70	546	2.75	1.93	0.70	570
23	22	3.19	1.85	0.58	522	3.08	1.78	0.58	555	3.00	1.74	0.58	570	2.88	1.67	0.58	594
24	18	2.94	2.53	0.86	480	2.81	2.42	0.86	504	2.70	2.32	0.86	528	2.60	2.24	0.86	552
24	20	3.06	2.27	0.74	504	2.94	2.17	0.74	534	2.85	2.11	0.74	546	2.75	2.04	0.74	570
24	22	3.19	1.98	0.62	522	3.08	1.91	0.62	555	3.00	1.86	0.62	570	2.88	1.78	0.62	594
24	24	3.35	1.68	0.50	546	3.23	1.61	0.50	576	3.15	1.58	0.50	594	3.05	1.53	0.50	624
25	18	2.94	2.64	0.90	480	2.81	2.53	0.90	504	2.70	2.43	0.90	528	2.60	2.34	0.90	552
25	20	3.06	2.39	0.78	504	2.94	2.29	0.78	534	2.85	2.22	0.78	546	2.75	2.15	0.78	570
25	22	3.19	2.10	0.66	522	3.08	2.03	0.66	555	3.00	1.98	0.66	570	2.88	1.90	0.66	594
25	24	3.35	1.81	0.54	546	3.23	1.74	0.54	576	3.15	1.70	0.54	594	3.05	1.65	0.54	624
26	18	2.94	2.76	0.94	480	2.81	2.64	0.94	504	2.70	2.54	0.94	528	2.60	2.44	0.94	552
26	20	3.06	2.51	0.82	504	2.94	2.41	0.82	534	2.85	2.34	0.82	546	2.75	2.26	0.82	570
26	22	3.19	2.23	0.70	522	3.08	2.15	0.70	555	3.00	2.10	0.70	570	2.88	2.01	0.70	594
26	24	3.35	1.94	0.58	546	3.23	1.87	0.58	576	3.15	1.83	0.58	594	3.05	1.77	0.58	624
26	26	3.45	1.59	0.46	576	3.35	1.54	0.46	606	3.30	1.52	0.46	624	3.20	1.47	0.46	642
27	18	2.94	2.88	0.98	480	2.81	2.76	0.98	504	2.70	2.65	0.98	528	2.60	2.55	0.98	552
27	20	3.06	2.63	0.86	504	2.94	2.53	0.86	534	2.85	2.45	0.86	546	2.75	2.37	0.86	570
27	22	3.19	2.36	0.74	522	3.08	2.28	0.74	555	3.00	2.22	0.74	570	2.88	2.13	0.74	594
27	24	3.35	2.08	0.62	546	3.23	2.00	0.62	576	3.15	1.95	0.62	594	3.05	1.89	0.62	624
27	26	3.45	1.73	0.50	576	3.35	1.68	0.50	606	3.30	1.65	0.50	624	3.20	1.60	0.50	642
28	18	2.94	2.94	1.00	480	2.81	2.81	1.00	504	2.70	2.70	1.00	528	2.60	2.60	1.00	552
28	20	3.06	2.76	0.90	504	2.94	2.64	0.90	534	2.85	2.57	0.90	546	2.75	2.48	0.90	570
28	22	3.19	2.49	0.78	522	3.08	2.40	0.78	555	3.00	2.34	0.78	570	2.88	2.24	0.78	594
28	24	3.35	2.21	0.66	546	3.23	2.13	0.66	576	3.15	2.08	0.66	594	3.05	2.01	0.66	624
28	26	3.45	1.86	0.54	576	3.35	1.81	0.54	606	3.30	1.78	0.54	624	3.20	1.73	0.54	642
29	18	2.94	2.94	1.00	480	2.81	2.81	1.00	504	2.70	2.70	1.00	528	2.60	2.60	1.00	552
29	20	3.06	2.88	0.94	504	2.94	2.76	0.94	534	2.85	2.68	0.94	546	2.75	2.59	0.94	570
29	22	3.19	2.61	0.82	522	3.08	2.52	0.82	555	3.00	2.46	0.82	570	2.88	2.36	0.82	594
29	24	3.35	2.35	0.70	546	3.23	2.26	0.70	576	3.15	2.21	0.70	594	3.05	2.14	0.70	624
29	26	3.45	2.00	0.58	576	3.35	1.94	0.58	606	3.30	1.91	0.58	624	3.20	1.86	0.58	642
30	18	2.94	2.94	1.00	480	2.81	2.81	1.00	504	2.70	2.70	1.00	528	2.60	2.60	1.00	552
30	20	3.06	3.00	0.98	504	2.94	2.88	0.98	534	2.85	2.79	0.98	546	2.75	2.70	0.98	570
30	22	3.19	2.74	0.86	522	3.08	2.64	0.86	555	3.00	2.58	0.86	570	2.88	2.47	0.86	594
30	24	3.35	2.48	0.74	546	3.23	2.39	0.74	576	3.15	2.33	0.74	594	3.05	2.26	0.74	624
30	26	3.45	2.14	0.62	576	3.35	2.08	0.62	606	3.30	2.05	0.62	624	3.20	1.98	0.62	642
31	18	2.94	2.94	1.00	480	2.81	2.81	1.00	504	2.70	2.70	1.00	528	2.60	2.60	1.00	552
31	20	3.06	3.06	1.00	504	2.94	2.94	1.00	534	2.85	2.85	1.00	546	2.75	2.75	1.00	570
31	22	3.19	2.87	0.90	522	3.08	2.77	0.90	555	3.00	2.70	0.90	570	2.88	2.59	0.90	594
31	24	3.35	2.61	0.78	546	3.23	2.52	0.78	576	3.15	2.46	0.78	594	3.05	2.38	0.78	624
31	26	3.45	2.28	0.66	576	3.35	2.21	0.66	606	3.30	2.18	0.66	624	3.20	2.11	0.66	642
32	18	2.94	2.94	1.00	480	2.81	2.81	1.00	504	2.70	2.70	1.00	528	2.60	2.60	1.00	552
32	20	3.06	3.06	1.00	504	2.94	2.94	1.00	534	2.85	2.85	1.00	546	2.75	2.75	1.00	570
32	22	3.19	3.00	0.94	522	3.08	2.89	0.94	555	3.00	2.82	0.94	570	2.88	2.70	0.94	594
32	24	3.35	2.75	0.82	546	3.23	2.64	0.82	576	3.15	2.58	0.82	594	3.05	2.50	0.82	624
32	26	3.45	2.42	0.70	576	3.35	2.35	0.70	606	3.30	2.31	0.70	624	3.20	2.24	0.70	642

NOTE Q : Total capacity (kW) SHF : Sensible heat factor DB : Dry-bulb temperature
 SHC : Sensible heat capacity (kW) INPUT : Total power input (W) WB : Wet-bulb temperature

PERFORMANCE DATA COOL operation at Rated frequency
MUZ-SF25VE MUZ-SF25VEH

CAPACITY: 2.5 kW SHF: 0.92 INPUT: 600 W

INDOOR DB (°C)	INDOOR WB (°C)	OUTDOOR DB (°C)											
		35				40				46			
		Q	SHC	SHF	INPUT	Q	SHC	SHF	INPUT	Q	SHC	SHF	INPUT
21	18	2.45	1.81	0.74	588	2.25	1.67	0.74	624	2.08	1.54	0.74	648
21	20	2.58	1.60	0.62	612	2.40	1.49	0.62	642	2.23	1.38	0.62	678
22	18	2.45	1.91	0.78	588	2.25	1.76	0.78	624	2.08	1.62	0.78	648
22	20	2.58	1.70	0.66	612	2.40	1.58	0.66	642	2.23	1.47	0.66	678
22	22	2.73	1.47	0.54	636	2.55	1.38	0.54	672	2.38	1.28	0.54	696
23	18	2.45	2.01	0.82	588	2.25	1.85	0.82	624	2.08	1.70	0.82	648
23	20	2.58	1.80	0.70	612	2.40	1.68	0.70	642	2.23	1.56	0.70	678
23	22	2.73	1.58	0.58	636	2.55	1.48	0.58	672	2.38	1.38	0.58	696
24	18	2.45	2.11	0.86	588	2.25	1.94	0.86	624	2.08	1.78	0.86	648
24	20	2.58	1.91	0.74	612	2.40	1.78	0.74	642	2.23	1.65	0.74	678
24	22	2.73	1.69	0.62	636	2.55	1.58	0.62	672	2.38	1.47	0.62	696
24	24	2.88	1.44	0.50	660	2.70	1.35	0.50	690	2.55	1.28	0.50	720
25	18	2.45	2.21	0.90	588	2.25	2.03	0.90	624	2.08	1.87	0.9	648
25	20	2.58	2.01	0.78	612	2.40	1.87	0.78	642	2.23	1.74	0.78	678
25	22	2.73	1.80	0.66	636	2.55	1.68	0.66	672	2.38	1.57	0.66	696
25	24	2.88	1.55	0.54	660	2.70	1.46	0.54	690	2.55	1.38	0.54	720
26	18	2.45	2.30	0.94	588	2.25	2.12	0.94	624	2.08	1.95	0.94	648
26	20	2.58	2.11	0.82	612	2.40	1.97	0.82	642	2.23	1.82	0.82	678
26	22	2.73	1.91	0.70	636	2.55	1.79	0.70	672	2.38	1.66	0.70	696
26	24	2.88	1.67	0.58	660	2.70	1.57	0.58	690	2.55	1.48	0.58	720
26	26	3.03	1.39	0.46	684	2.85	1.31	0.46	714	2.68	1.23	0.46	744
27	18	2.45	2.40	0.98	588	2.25	2.21	0.98	624	2.08	2.03	0.98	648
27	20	2.58	2.21	0.86	612	2.40	2.06	0.86	642	2.23	1.91	0.86	678
27	22	2.73	2.02	0.74	636	2.55	1.89	0.74	672	2.38	1.76	0.74	696
27	24	2.88	1.78	0.62	660	2.70	1.67	0.62	690	2.55	1.58	0.62	720
27	26	3.03	1.51	0.50	684	2.85	1.43	0.50	714	2.68	1.34	0.50	744
28	18	2.45	2.45	1.00	588	2.25	2.25	1.00	624	2.08	2.08	1.00	648
28	20	2.58	2.32	0.90	612	2.40	2.16	0.90	642	2.23	2.00	0.90	678
28	22	2.73	2.13	0.78	636	2.55	1.99	0.78	672	2.38	1.85	0.78	696
28	24	2.88	1.90	0.66	660	2.70	1.78	0.66	690	2.55	1.68	0.66	720
28	26	3.03	1.63	0.54	684	2.85	1.54	0.54	714	2.68	1.44	0.54	744
29	18	2.45	2.45	1.00	588	2.25	2.25	1.00	624	2.08	2.08	1.00	648
29	20	2.58	2.42	0.94	612	2.40	2.26	0.94	642	2.23	2.09	0.94	678
29	22	2.73	2.23	0.82	636	2.55	2.09	0.82	672	2.38	1.95	0.82	696
29	24	2.88	2.01	0.70	660	2.70	1.89	0.70	690	2.55	1.79	0.70	720
29	26	3.03	1.75	0.58	684	2.85	1.65	0.58	714	2.68	1.55	0.58	744
30	18	2.45	2.45	1.00	588	2.25	2.25	1.00	624	2.08	2.08	1.00	648
30	20	2.58	2.52	0.98	612	2.40	2.35	0.98	642	2.23	2.18	0.98	678
30	22	2.73	2.34	0.86	636	2.55	2.19	0.86	672	2.38	2.04	0.86	696
30	24	2.88	2.13	0.74	660	2.70	2.00	0.74	690	2.55	1.89	0.74	720
30	26	3.03	1.88	0.62	684	2.85	1.77	0.62	714	2.68	1.66	0.62	744
31	18	2.45	2.45	1.00	588	2.25	2.25	1.00	624	2.08	2.08	1.00	648
31	20	2.58	2.58	1.00	612	2.40	2.40	1.00	642	2.23	2.23	1.00	678
31	22	2.73	2.45	0.90	636	2.55	2.30	0.90	672	2.38	2.14	0.90	696
31	24	2.88	2.24	0.78	660	2.70	2.11	0.78	690	2.55	1.99	0.78	720
31	26	3.03	2.00	0.66	684	2.85	1.88	0.66	714	2.68	1.77	0.66	744
32	18	2.45	2.45	1.00	588	2.25	2.25	1.00	624	2.08	2.08	1.00	648
32	20	2.58	2.58	1.00	612	2.40	2.40	1.00	642	2.23	2.23	1.00	678
32	22	2.73	2.56	0.94	636	2.55	2.40	0.94	672	2.38	2.23	0.94	696
32	24	2.88	2.36	0.82	660	2.70	2.21	0.82	690	2.55	2.09	0.82	720
32	26	3.03	2.12	0.70	684	2.85	2.00	0.70	714	2.68	1.87	0.70	744

NOTE Q : Total capacity (kW) SHF : Sensible heat factor DB : Dry-bulb temperature
 SHC : Sensible heat capacity (kW) INPUT : Total power input (W) WB : Wet-bulb temperature

PERFORMANCE DATA COOL operation at Rated frequency

MUZ-SF35VE MUZ-SF35VEH

CAPACITY: 3.5 kW

SHF: 0.80

INPUT: 1080 W

INDOOR DB (°C)	INDOOR WB (°C)	OUTDOOR DB (°C)															
		21				25				27				30			
		Q	SHC	SHF	INPUT	Q	SHC	SHF	INPUT	Q	SHC	SHF	INPUT	Q	SHC	SHF	INPUT
21	18	4.11	2.55	0.62	864	3.94	2.44	0.62	907	3.78	2.34	0.62	950	3.64	2.26	0.62	994
21	20	4.29	2.14	0.50	907	4.11	2.06	0.50	961	3.99	2.00	0.50	983	3.85	1.93	0.50	1026
22	18	4.11	2.71	0.66	864	3.94	2.60	0.66	907	3.78	2.49	0.66	950	3.64	2.40	0.66	994
22	20	4.29	2.32	0.54	907	4.11	2.22	0.54	961	3.99	2.15	0.54	983	3.85	2.08	0.54	1026
22	22	4.46	1.87	0.42	940	4.31	1.81	0.42	999	4.20	1.76	0.42	1026	4.03	1.69	0.42	1069
23	18	4.11	2.88	0.70	864	3.94	2.76	0.70	907	3.78	2.65	0.70	950	3.64	2.55	0.70	994
23	20	4.29	2.49	0.58	907	4.11	2.39	0.58	961	3.99	2.31	0.58	983	3.85	2.23	0.58	1026
23	22	4.46	2.05	0.46	940	4.31	1.98	0.46	999	4.20	1.93	0.46	1026	4.03	1.85	0.46	1069
24	18	4.11	3.04	0.74	864	3.94	2.91	0.74	907	3.78	2.80	0.74	950	3.64	2.69	0.74	994
24	20	4.29	2.66	0.62	907	4.11	2.55	0.62	961	3.99	2.47	0.62	983	3.85	2.39	0.62	1026
24	22	4.46	2.23	0.50	940	4.31	2.15	0.50	999	4.20	2.10	0.50	1026	4.03	2.01	0.50	1069
24	24	4.69	1.78	0.38	983	4.52	1.72	0.38	1037	4.41	1.68	0.38	1069	4.27	1.62	0.38	1123
25	18	4.11	3.21	0.78	864	3.94	3.07	0.78	907	3.78	2.95	0.78	950	3.64	2.84	0.78	994
25	20	4.29	2.83	0.66	907	4.11	2.71	0.66	961	3.99	2.63	0.66	983	3.85	2.54	0.66	1026
25	22	4.46	2.41	0.54	940	4.31	2.32	0.54	999	4.20	2.27	0.54	1026	4.03	2.17	0.54	1069
25	24	4.69	1.97	0.42	983	4.52	1.90	0.42	1037	4.41	1.85	0.42	1069	4.27	1.79	0.42	1123
26	18	4.11	3.37	0.82	864	3.94	3.23	0.82	907	3.78	3.10	0.82	950	3.64	2.98	0.82	994
26	20	4.29	3.00	0.70	907	4.11	2.88	0.70	961	3.99	2.79	0.70	983	3.85	2.70	0.70	1026
26	22	4.46	2.59	0.58	940	4.31	2.50	0.58	999	4.20	2.44	0.58	1026	4.03	2.33	0.58	1069
26	24	4.69	2.16	0.46	983	4.52	2.08	0.46	1037	4.41	2.03	0.46	1069	4.27	1.96	0.46	1123
26	26	4.83	1.64	0.34	1037	4.69	1.59	0.34	1091	4.62	1.57	0.34	1123	4.48	1.52	0.34	1156
27	18	4.11	3.54	0.86	864	3.94	3.39	0.86	907	3.78	3.25	0.86	950	3.64	3.13	0.86	994
27	20	4.29	3.17	0.74	907	4.11	3.04	0.74	961	3.99	2.95	0.74	983	3.85	2.85	0.74	1026
27	22	4.46	2.77	0.62	940	4.31	2.67	0.62	999	4.20	2.60	0.62	1026	4.03	2.50	0.62	1069
27	24	4.69	2.35	0.50	983	4.52	2.26	0.50	1037	4.41	2.21	0.50	1069	4.27	2.14	0.50	1123
27	26	4.83	1.84	0.38	1037	4.69	1.78	0.38	1091	4.62	1.76	0.38	1123	4.48	1.70	0.38	1156
28	18	4.11	3.70	0.90	864	3.94	3.54	0.90	907	3.78	3.40	0.90	950	3.64	3.28	0.90	994
28	20	4.29	3.34	0.78	907	4.11	3.21	0.78	961	3.99	3.11	0.78	983	3.85	3.00	0.78	1026
28	22	4.46	2.95	0.66	940	4.31	2.84	0.66	999	4.20	2.77	0.66	1026	4.03	2.66	0.66	1069
28	24	4.69	2.53	0.54	983	4.52	2.44	0.54	1037	4.41	2.38	0.54	1069	4.27	2.31	0.54	1123
28	26	4.83	2.03	0.42	1037	4.69	1.97	0.42	1091	4.62	1.94	0.42	1123	4.48	1.88	0.42	1156
29	18	4.11	3.87	0.94	864	3.94	3.70	0.94	907	3.78	3.55	0.94	950	3.64	3.42	0.94	994
29	20	4.29	3.52	0.82	907	4.11	3.37	0.82	961	3.99	3.27	0.82	983	3.85	3.16	0.82	1026
29	22	4.46	3.12	0.70	940	4.31	3.01	0.70	999	4.20	2.94	0.70	1026	4.03	2.82	0.70	1069
29	24	4.69	2.72	0.58	983	4.52	2.62	0.58	1037	4.41	2.56	0.58	1069	4.27	2.48	0.58	1123
29	26	4.83	2.22	0.46	1037	4.69	2.16	0.46	1091	4.62	2.13	0.46	1123	4.48	2.06	0.46	1156
30	18	4.11	4.03	0.98	864	3.94	3.86	0.98	907	3.78	3.70	0.98	950	3.64	3.57	0.98	994
30	20	4.29	3.69	0.86	907	4.11	3.54	0.86	961	3.99	3.43	0.86	983	3.85	3.31	0.86	1026
30	22	4.46	3.30	0.74	940	4.31	3.19	0.74	999	4.20	3.11	0.74	1026	4.03	2.98	0.74	1069
30	24	4.69	2.91	0.62	983	4.52	2.80	0.62	1037	4.41	2.73	0.62	1069	4.27	2.65	0.62	1123
30	26	4.83	2.42	0.50	1037	4.69	2.35	0.50	1091	4.62	2.31	0.50	1123	4.48	2.24	0.50	1156
31	18	4.11	4.11	1.00	864	3.94	3.94	1.00	907	3.78	3.78	1.00	950	3.64	3.64	1.00	994
31	20	4.29	3.86	0.90	907	4.11	3.70	0.90	961	3.99	3.59	0.90	983	3.85	3.47	0.90	1026
31	22	4.46	3.48	0.78	940	4.31	3.36	0.78	999	4.20	3.28	0.78	1026	4.03	3.14	0.78	1069
31	24	4.69	3.10	0.66	983	4.52	2.98	0.66	1037	4.41	2.91	0.66	1069	4.27	2.82	0.66	1123
31	26	4.83	2.61	0.54	1037	4.69	2.53	0.54	1091	4.62	2.49	0.54	1123	4.48	2.42	0.54	1156
32	18	4.11	4.11	1.00	864	3.94	3.94	1.00	907	3.78	3.78	1.00	950	3.64	3.64	1.00	994
32	20	4.29	4.03	0.94	907	4.11	3.87	0.94	961	3.99	3.75	0.94	983	3.85	3.62	0.94	1026
32	22	4.46	3.66	0.82	940	4.31	3.53	0.82	999	4.20	3.44	0.82	1026	4.03	3.30	0.82	1069
32	24	4.69	3.28	0.70	983	4.52	3.16	0.70	1037	4.41	3.09	0.70	1069	4.27	2.99	0.70	1123
32	26	4.83	2.80	0.58	1037	4.69	2.72	0.58	1091	4.62	2.68	0.58	1123	4.48	2.60	0.58	1156

NOTE Q : Total capacity (kW) SHF : Sensible heat factor DB : Dry-bulb temperature
 SHC : Sensible heat capacity (kW) INPUT : Total power input (W) WB : Wet-bulb temperature

PERFORMANCE DATA COOL operation at Rated frequency
MUZ-SF35VE MUZ-SF35VEH

CAPACITY: 3.5 kW SHF: 0.80 INPUT: 1080 W

INDOOR DB (°C)	INDOOR WB (°C)	OUTDOOR DB (°C)											
		35				40				46			
		Q	SHC	SHF	INPUT	Q	SHC	SHF	INPUT	Q	SHC	SHF	INPUT
21	18	3.43	2.13	0.62	1058	3.15	1.95	0.62	1123	2.91	1.80	0.62	1166
21	20	3.61	1.80	0.50	1102	3.36	1.68	0.50	1156	3.12	1.56	0.50	1220
22	18	3.43	2.26	0.66	1058	3.15	2.08	0.66	1123	2.91	1.92	0.66	1166
22	20	3.61	1.95	0.54	1102	3.36	1.81	0.54	1156	3.12	1.68	0.54	1220
22	22	3.82	1.60	0.42	1145	3.57	1.50	0.42	1210	3.33	1.40	0.42	1253
23	18	3.43	2.40	0.70	1058	3.15	2.21	0.70	1123	2.91	2.03	0.70	1166
23	20	3.61	2.09	0.58	1102	3.36	1.95	0.58	1156	3.12	1.81	0.58	1220
23	22	3.82	1.75	0.46	1145	3.57	1.64	0.46	1210	3.33	1.53	0.46	1253
24	18	3.43	2.54	0.74	1058	3.15	2.33	0.74	1123	2.91	2.15	0.74	1166
24	20	3.61	2.24	0.62	1102	3.36	2.08	0.62	1156	3.12	1.93	0.62	1220
24	22	3.82	1.91	0.50	1145	3.57	1.79	0.50	1210	3.33	1.66	0.50	1253
24	24	4.03	1.53	0.38	1188	3.78	1.44	0.38	1242	3.57	1.36	0.38	1296
25	18	3.43	2.68	0.78	1058	3.15	2.46	0.78	1123	2.91	2.27	0.78	1166
25	20	3.61	2.38	0.66	1102	3.36	2.22	0.66	1156	3.12	2.06	0.66	1220
25	22	3.82	2.06	0.54	1145	3.57	1.93	0.54	1210	3.33	1.80	0.54	1253
25	24	4.03	1.69	0.42	1188	3.78	1.59	0.42	1242	3.57	1.50	0.42	1296
26	18	3.43	2.81	0.82	1058	3.15	2.58	0.82	1123	2.91	2.38	0.82	1166
26	20	3.61	2.52	0.70	1102	3.36	2.35	0.70	1156	3.12	2.18	0.70	1220
26	22	3.82	2.21	0.58	1145	3.57	2.07	0.58	1210	3.33	1.93	0.58	1253
26	24	4.03	1.85	0.46	1188	3.78	1.74	0.46	1242	3.57	1.64	0.46	1296
26	26	4.24	1.44	0.34	1231	3.99	1.36	0.34	1285	3.75	1.27	0.34	1339
27	18	3.43	2.95	0.86	1058	3.15	2.71	0.86	1123	2.91	2.50	0.86	1166
27	20	3.61	2.67	0.74	1102	3.36	2.49	0.74	1156	3.12	2.31	0.74	1220
27	22	3.82	2.37	0.62	1145	3.57	2.21	0.62	1210	3.33	2.06	0.62	1253
27	24	4.03	2.01	0.50	1188	3.78	1.89	0.50	1242	3.57	1.79	0.50	1296
27	26	4.24	1.61	0.38	1231	3.99	1.52	0.38	1285	3.75	1.42	0.38	1339
28	18	3.43	3.09	0.90	1058	3.15	2.84	0.90	1123	2.91	2.61	0.90	1166
28	20	3.61	2.81	0.78	1102	3.36	2.62	0.78	1156	3.12	2.43	0.78	1220
28	22	3.82	2.52	0.66	1145	3.57	2.36	0.66	1210	3.33	2.19	0.66	1253
28	24	4.03	2.17	0.54	1188	3.78	2.04	0.54	1242	3.57	1.93	0.54	1296
28	26	4.24	1.78	0.42	1231	3.99	1.68	0.42	1285	3.75	1.57	0.42	1339
29	18	3.43	3.22	0.94	1058	3.15	2.96	0.94	1123	2.91	2.73	0.94	1166
29	20	3.61	2.96	0.82	1102	3.36	2.76	0.82	1156	3.12	2.55	0.82	1220
29	22	3.82	2.67	0.70	1145	3.57	2.50	0.70	1210	3.33	2.33	0.70	1253
29	24	4.03	2.33	0.58	1188	3.78	2.19	0.58	1242	3.57	2.07	0.58	1296
29	26	4.24	1.95	0.46	1231	3.99	1.84	0.46	1285	3.75	1.72	0.46	1339
30	18	3.43	3.36	0.98	1058	3.15	3.09	0.98	1123	2.91	2.85	0.98	1166
30	20	3.61	3.10	0.86	1102	3.36	2.89	0.86	1156	3.12	2.68	0.86	1220
30	22	3.82	2.82	0.74	1145	3.57	2.64	0.74	1210	3.33	2.46	0.74	1253
30	24	4.03	2.50	0.62	1188	3.78	2.34	0.62	1242	3.57	2.21	0.62	1296
30	26	4.24	2.12	0.50	1231	3.99	2.00	0.50	1285	3.75	1.87	0.50	1339
31	18	3.43	3.43	1.00	1058	3.15	3.15	1.00	1123	2.91	2.91	1.00	1166
31	20	3.61	3.24	0.90	1102	3.36	3.02	0.90	1156	3.12	2.80	0.90	1220
31	22	3.82	2.98	0.78	1145	3.57	2.78	0.78	1210	3.33	2.59	0.78	1253
31	24	4.03	2.66	0.66	1188	3.78	2.49	0.66	1242	3.57	2.36	0.66	1296
31	26	4.24	2.29	0.54	1231	3.99	2.15	0.54	1285	3.75	2.02	0.54	1339
32	18	3.43	3.43	1.00	1058	3.15	3.15	1.00	1123	2.91	2.91	1.00	1166
32	20	3.61	3.39	0.94	1102	3.36	3.16	0.94	1156	3.12	2.93	0.94	1220
32	22	3.82	3.13	0.82	1145	3.57	2.93	0.82	1210	3.33	2.73	0.82	1253
32	24	4.03	2.82	0.70	1188	3.78	2.65	0.70	1242	3.57	2.50	0.70	1296
32	26	4.24	2.46	0.58	1231	3.99	2.31	0.58	1285	3.75	2.17	0.58	1339

NOTE Q : Total capacity (kW) SHF : Sensible heat factor DB : Dry-bulb temperature
 SHC : Sensible heat capacity (kW) INPUT : Total power input (W) WB : Wet-bulb temperature

PERFORMANCE DATA COOL operation at Rated frequency

MUZ-SF42VE MUZ-SF42VEH

CAPACITY: 4.2 kW

SHF: 0.72

INPUT: 1340 W

INDOOR DB (°C)	INDOOR WB (°C)	OUTDOOR DB (°C)															
		21				25				27				30			
		Q	SHC	SHF	INPUT	Q	SHC	SHF	INPUT	Q	SHC	SHF	INPUT	Q	SHC	SHF	INPUT
21	18	4.94	2.66	0.54	1072	4.73	2.55	0.54	1126	4.54	2.45	0.54	1179	4.37	2.36	0.54	1233
21	20	5.15	2.16	0.42	1126	4.94	2.07	0.42	1193	4.79	2.01	0.42	1219	4.62	1.94	0.42	1273
22	18	4.94	2.86	0.58	1072	4.73	2.74	0.58	1126	4.54	2.63	0.58	1179	4.37	2.53	0.58	1233
22	20	5.15	2.37	0.46	1126	4.94	2.27	0.46	1193	4.79	2.20	0.46	1219	4.62	2.13	0.46	1273
22	22	5.36	1.82	0.34	1166	5.17	1.76	0.34	1240	5.04	1.71	0.34	1273	4.83	1.64	0.34	1327
23	18	4.94	3.06	0.62	1072	4.73	2.93	0.62	1126	4.54	2.81	0.62	1179	4.37	2.71	0.62	1233
23	20	5.15	2.57	0.50	1126	4.94	2.47	0.50	1193	4.79	2.39	0.50	1219	4.62	2.31	0.50	1273
23	22	5.36	2.03	0.38	1166	5.17	1.96	0.38	1240	5.04	1.92	0.38	1273	4.83	1.84	0.38	1327
24	18	4.94	3.26	0.66	1072	4.73	3.12	0.66	1126	4.54	2.99	0.66	1179	4.37	2.88	0.66	1233
24	20	5.15	2.78	0.54	1126	4.94	2.66	0.54	1193	4.79	2.59	0.54	1219	4.62	2.49	0.54	1273
24	22	5.36	2.25	0.42	1166	5.17	2.17	0.42	1240	5.04	2.12	0.42	1273	4.83	2.03	0.42	1327
24	24	5.63	1.69	0.30	1219	5.42	1.63	0.30	1286	5.29	1.59	0.30	1327	5.12	1.54	0.30	1394
25	18	4.94	3.45	0.70	1072	4.73	3.31	0.70	1126	4.54	3.18	0.70	1179	4.37	3.06	0.70	1233
25	20	5.15	2.98	0.58	1126	4.94	2.86	0.58	1193	4.79	2.78	0.58	1219	4.62	2.68	0.58	1273
25	22	5.36	2.46	0.46	1166	5.17	2.38	0.46	1240	5.04	2.32	0.46	1273	4.83	2.22	0.46	1327
25	24	5.63	1.91	0.34	1219	5.42	1.84	0.34	1286	5.29	1.80	0.34	1327	5.12	1.74	0.34	1394
26	18	4.94	3.65	0.74	1072	4.73	3.50	0.74	1126	4.54	3.36	0.74	1179	4.37	3.23	0.74	1233
26	20	5.15	3.19	0.62	1126	4.94	3.06	0.62	1193	4.79	2.97	0.62	1219	4.62	2.86	0.62	1273
26	22	5.36	2.68	0.50	1166	5.17	2.58	0.50	1240	5.04	2.52	0.50	1273	4.83	2.42	0.50	1327
26	24	5.63	2.14	0.38	1219	5.42	2.06	0.38	1286	5.29	2.01	0.38	1327	5.12	1.95	0.38	1394
26	26	5.80	1.51	0.26	1286	5.63	1.46	0.26	1353	5.54	1.44	0.26	1394	5.38	1.40	0.26	1434
27	18	4.94	3.85	0.78	1072	4.73	3.69	0.78	1126	4.54	3.54	0.78	1179	4.37	3.41	0.78	1233
27	20	5.15	3.40	0.66	1126	4.94	3.26	0.66	1193	4.79	3.16	0.66	1219	4.62	3.05	0.66	1273
27	22	5.36	2.89	0.54	1166	5.17	2.79	0.54	1240	5.04	2.72	0.54	1273	4.83	2.61	0.54	1327
27	24	5.63	2.36	0.42	1219	5.42	2.28	0.42	1286	5.29	2.22	0.42	1327	5.12	2.15	0.42	1394
27	26	5.80	1.74	0.30	1286	5.63	1.69	0.30	1353	5.54	1.66	0.30	1394	5.38	1.61	0.30	1434
28	18	4.94	4.05	0.82	1072	4.73	3.87	0.82	1126	4.54	3.72	0.82	1179	4.37	3.58	0.82	1233
28	20	5.15	3.60	0.70	1126	4.94	3.45	0.70	1193	4.79	3.35	0.70	1219	4.62	3.23	0.70	1273
28	22	5.36	3.11	0.58	1166	5.17	3.00	0.58	1240	5.04	2.92	0.58	1273	4.83	2.80	0.58	1327
28	24	5.63	2.59	0.46	1219	5.42	2.49	0.46	1286	5.29	2.43	0.46	1327	5.12	2.36	0.46	1394
28	26	5.80	1.97	0.34	1286	5.63	1.91	0.34	1353	5.54	1.88	0.34	1394	5.38	1.83	0.34	1434
29	18	4.94	4.24	0.86	1072	4.73	4.06	0.86	1126	4.54	3.90	0.86	1179	4.37	3.76	0.86	1233
29	20	5.15	3.81	0.74	1126	4.94	3.65	0.74	1193	4.79	3.54	0.74	1219	4.62	3.42	0.74	1273
29	22	5.36	3.32	0.62	1166	5.17	3.20	0.62	1240	5.04	3.12	0.62	1273	4.83	2.99	0.62	1327
29	24	5.63	2.81	0.50	1219	5.42	2.71	0.50	1286	5.29	2.65	0.50	1327	5.12	2.56	0.50	1394
29	26	5.80	2.20	0.38	1286	5.63	2.14	0.38	1353	5.54	2.11	0.38	1394	5.38	2.04	0.38	1434
30	18	4.94	4.44	0.90	1072	4.73	4.25	0.90	1126	4.54	4.08	0.90	1179	4.37	3.93	0.90	1233
30	20	5.15	4.01	0.78	1126	4.94	3.85	0.78	1193	4.79	3.73	0.78	1219	4.62	3.60	0.78	1273
30	22	5.36	3.53	0.66	1166	5.17	3.41	0.66	1240	5.04	3.33	0.66	1273	4.83	3.19	0.66	1327
30	24	5.63	3.04	0.54	1219	5.42	2.93	0.54	1286	5.29	2.86	0.54	1327	5.12	2.77	0.54	1394
30	26	5.80	2.43	0.42	1286	5.63	2.36	0.42	1353	5.54	2.33	0.42	1394	5.38	2.26	0.42	1434
31	18	4.94	4.64	0.94	1072	4.73	4.44	0.94	1126	4.54	4.26	0.94	1179	4.37	4.11	0.94	1233
31	20	5.15	4.22	0.82	1126	4.94	4.05	0.82	1193	4.79	3.93	0.82	1219	4.62	3.79	0.82	1273
31	22	5.36	3.75	0.70	1166	5.17	3.62	0.70	1240	5.04	3.53	0.70	1273	4.83	3.38	0.70	1327
31	24	5.63	3.26	0.58	1219	5.42	3.14	0.58	1286	5.29	3.07	0.58	1327	5.12	2.97	0.58	1394
31	26	5.80	2.67	0.46	1286	5.63	2.59	0.46	1353	5.54	2.55	0.46	1394	5.38	2.47	0.46	1434
32	18	4.94	4.84	0.98	1072	4.73	4.63	0.98	1126	4.54	4.45	0.98	1179	4.37	4.28	0.98	1233
32	20	5.15	4.42	0.86	1126	4.94	4.24	0.86	1193	4.79	4.12	0.86	1219	4.62	3.97	0.86	1273
32	22	5.36	3.96	0.74	1166	5.17	3.82	0.74	1240	5.04	3.73	0.74	1273	4.83	3.57	0.74	1327
32	24	5.63	3.49	0.62	1219	5.42	3.36	0.62	1286	5.29	3.28	0.62	1327	5.12	3.18	0.62	1394
32	26	5.80	2.90	0.50	1286	5.63	2.81	0.50	1353	5.54	2.77	0.50	1394	5.38	2.69	0.50	1434

NOTE Q : Total capacity (kW) SHF : Sensible heat factor DB : Dry-bulb temperature
 SHC : Sensible heat capacity (kW) INPUT : Total power input (W) WB : Wet-bulb temperature

PERFORMANCE DATA COOL operation at Rated frequency
MUZ-SF42VE MUZ-SF42VEH

CAPACITY: 4.2 kW SHF: 0.72 INPUT: 1340 W

INDOOR DB (°C)	INDOOR WB (°C)	OUTDOOR DB (°C)											
		35				40				46			
		Q	SHC	SHF	INPUT	Q	SHC	SHF	INPUT	Q	SHC	SHF	INPUT
21	18	4.12	2.22	0.54	1313	3.78	2.04	0.54	1394	3.49	1.88	0.54	1447
21	20	4.33	1.82	0.42	1367	4.03	1.69	0.42	1434	3.74	1.57	0.42	1514
22	18	4.12	2.39	0.58	1313	3.78	2.19	0.58	1394	3.49	2.02	0.58	1447
22	20	4.33	1.99	0.46	1367	4.03	1.85	0.46	1434	3.74	1.72	0.46	1514
22	22	4.58	1.56	0.34	1420	4.28	1.46	0.34	1501	3.99	1.36	0.34	1554
23	18	4.12	2.55	0.62	1313	3.78	2.34	0.62	1394	3.49	2.16	0.62	1447
23	20	4.33	2.16	0.50	1367	4.03	2.02	0.50	1434	3.74	1.87	0.50	1514
23	22	4.58	1.74	0.38	1420	4.28	1.63	0.38	1501	3.99	1.52	0.38	1554
24	18	4.12	2.72	0.66	1313	3.78	2.49	0.66	1394	3.49	2.30	0.66	1447
24	20	4.33	2.34	0.54	1367	4.03	2.18	0.54	1434	3.74	2.02	0.54	1514
24	22	4.58	1.92	0.42	1420	4.28	1.80	0.42	1501	3.99	1.68	0.42	1554
24	24	4.83	1.45	0.30	1474	4.54	1.36	0.30	1541	4.28	1.29	0.30	1608
25	18	4.12	2.88	0.70	1313	3.78	2.65	0.70	1394	3.49	2.44	0.7	1447
25	20	4.33	2.51	0.58	1367	4.03	2.34	0.58	1434	3.74	2.17	0.58	1514
25	22	4.58	2.11	0.46	1420	4.28	1.97	0.46	1501	3.99	1.84	0.46	1554
25	24	4.83	1.64	0.34	1474	4.54	1.54	0.34	1541	4.28	1.46	0.34	1608
26	18	4.12	3.05	0.74	1313	3.78	2.80	0.74	1394	3.49	2.58	0.74	1447
26	20	4.33	2.68	0.62	1367	4.03	2.50	0.62	1434	3.74	2.32	0.62	1514
26	22	4.58	2.29	0.50	1420	4.28	2.14	0.50	1501	3.99	2.00	0.50	1554
26	24	4.83	1.84	0.38	1474	4.54	1.72	0.38	1541	4.28	1.63	0.38	1608
26	26	5.08	1.32	0.26	1528	4.79	1.24	0.26	1595	4.49	1.17	0.26	1662
27	18	4.12	3.21	0.78	1313	3.78	2.95	0.78	1394	3.49	2.72	0.78	1447
27	20	4.33	2.86	0.66	1367	4.03	2.66	0.66	1434	3.74	2.47	0.66	1514
27	22	4.58	2.47	0.54	1420	4.28	2.31	0.54	1501	3.99	2.15	0.54	1554
27	24	4.83	2.03	0.42	1474	4.54	1.91	0.42	1541	4.28	1.80	0.42	1608
27	26	5.08	1.52	0.30	1528	4.79	1.44	0.30	1595	4.49	1.35	0.30	1662
28	18	4.12	3.38	0.82	1313	3.78	3.10	0.82	1394	3.49	2.86	0.82	1447
28	20	4.33	3.03	0.70	1367	4.03	2.82	0.70	1434	3.74	2.62	0.70	1514
28	22	4.58	2.66	0.58	1420	4.28	2.48	0.58	1501	3.99	2.31	0.58	1554
28	24	4.83	2.22	0.46	1474	4.54	2.09	0.46	1541	4.28	1.97	0.46	1608
28	26	5.08	1.73	0.34	1528	4.79	1.63	0.34	1595	4.49	1.53	0.34	1662
29	18	4.12	3.54	0.86	1313	3.78	3.25	0.86	1394	3.49	3.00	0.86	1447
29	20	4.33	3.20	0.74	1367	4.03	2.98	0.74	1434	3.74	2.77	0.74	1514
29	22	4.58	2.84	0.62	1420	4.28	2.66	0.62	1501	3.99	2.47	0.62	1554
29	24	4.83	2.42	0.50	1474	4.54	2.27	0.50	1541	4.28	2.14	0.50	1608
29	26	5.08	1.93	0.38	1528	4.79	1.82	0.38	1595	4.49	1.71	0.38	1662
30	18	4.12	3.70	0.90	1313	3.78	3.40	0.90	1394	3.49	3.14	0.90	1447
30	20	4.33	3.37	0.78	1367	4.03	3.14	0.78	1434	3.74	2.92	0.78	1514
30	22	4.58	3.02	0.66	1420	4.28	2.83	0.66	1501	3.99	2.63	0.66	1554
30	24	4.83	2.61	0.54	1474	4.54	2.45	0.54	1541	4.28	2.31	0.54	1608
30	26	5.08	2.13	0.42	1528	4.79	2.01	0.42	1595	4.49	1.89	0.42	1662
31	18	4.12	3.87	0.94	1313	3.78	3.55	0.94	1394	3.49	3.28	0.94	1447
31	20	4.33	3.55	0.82	1367	4.03	3.31	0.82	1434	3.74	3.07	0.82	1514
31	22	4.58	3.20	0.70	1420	4.28	3.00	0.70	1501	3.99	2.79	0.70	1554
31	24	4.83	2.80	0.58	1474	4.54	2.63	0.58	1541	4.28	2.48	0.58	1608
31	26	5.08	2.34	0.46	1528	4.79	2.20	0.46	1595	4.49	2.07	0.46	1662
32	18	4.12	4.03	0.98	1313	3.78	3.70	0.98	1394	3.49	3.42	0.98	1447
32	20	4.33	3.72	0.86	1367	4.03	3.47	0.86	1434	3.74	3.21	0.86	1514
32	22	4.58	3.39	0.74	1420	4.28	3.17	0.74	1501	3.99	2.95	0.74	1554
32	24	4.83	2.99	0.62	1474	4.54	2.81	0.62	1541	4.28	2.66	0.62	1608
32	26	5.08	2.54	0.50	1528	4.79	2.39	0.50	1595	4.49	2.25	0.50	1662

NOTE Q : Total capacity (kW) SHF : Sensible heat factor DB : Dry-bulb temperature
 SHC : Sensible heat capacity (kW) INPUT : Total power input (W) WB : Wet-bulb temperature

PERFORMANCE DATA COOL operation at Rated frequency
MUZ-SF50VE MUZ-SF50VEH

CAPACITY: 5.0 kW SHF: 0.70 INPUT: 1660 W

INDOOR DB (°C)	INDOOR WB (°C)	OUTDOOR DB (°C)											
		35				40				46			
		Q	SHC	SHF	INPUT	Q	SHC	SHF	INPUT	Q	SHC	SHF	INPUT
21	18	4.90	2.55	0.52	1627	4.50	2.34	0.52	1726	4.15	2.16	0.52	1793
21	20	5.15	2.06	0.40	1693	4.80	1.92	0.40	1776	4.45	1.78	0.40	1876
22	18	4.90	2.74	0.56	1627	4.50	2.52	0.56	1726	4.15	2.32	0.56	1793
22	20	5.15	2.27	0.44	1693	4.80	2.11	0.44	1776	4.45	1.96	0.44	1876
22	22	5.45	1.74	0.32	1760	5.10	1.63	0.32	1859	4.75	1.52	0.32	1926
23	18	4.90	2.94	0.60	1627	4.50	2.70	0.60	1726	4.15	2.49	0.60	1793
23	20	5.15	2.47	0.48	1693	4.80	2.30	0.48	1776	4.45	2.14	0.48	1876
23	22	5.45	1.96	0.36	1760	5.10	1.84	0.36	1859	4.75	1.71	0.36	1926
24	18	4.90	3.14	0.64	1627	4.50	2.88	0.64	1726	4.15	2.66	0.64	1793
24	20	5.15	2.68	0.52	1693	4.80	2.50	0.52	1776	4.45	2.31	0.52	1876
24	22	5.45	2.18	0.40	1760	5.10	2.04	0.40	1859	4.75	1.90	0.40	1926
24	24	5.75	1.61	0.28	1826	5.40	1.51	0.28	1909	5.10	1.43	0.28	1992
25	18	4.90	3.33	0.68	1627	4.50	3.06	0.68	1726	4.15	2.82	0.68	1793
25	20	5.15	2.88	0.56	1693	4.80	2.69	0.56	1776	4.45	2.49	0.56	1876
25	22	5.45	2.40	0.44	1760	5.10	2.24	0.44	1859	4.75	2.09	0.44	1926
25	24	5.75	1.84	0.32	1826	5.40	1.73	0.32	1909	5.10	1.63	0.32	1992
26	18	4.90	3.53	0.72	1627	4.50	3.24	0.72	1726	4.15	2.99	0.72	1793
26	20	5.15	3.09	0.60	1693	4.80	2.88	0.60	1776	4.45	2.67	0.60	1876
26	22	5.45	2.62	0.48	1760	5.10	2.45	0.48	1859	4.75	2.28	0.48	1926
26	24	5.75	2.07	0.36	1826	5.40	1.94	0.36	1909	5.10	1.84	0.36	1992
26	26	6.05	1.45	0.24	1892	5.70	1.37	0.24	1975	5.35	1.28	0.24	2058
27	18	4.90	3.72	0.76	1627	4.50	3.42	0.76	1726	4.15	3.15	0.76	1793
27	20	5.15	3.30	0.64	1693	4.80	3.07	0.64	1776	4.45	2.85	0.64	1876
27	22	5.45	2.83	0.52	1760	5.10	2.65	0.52	1859	4.75	2.47	0.52	1926
27	24	5.75	2.30	0.40	1826	5.40	2.16	0.40	1909	5.10	2.04	0.40	1992
27	26	6.05	1.69	0.28	1892	5.70	1.60	0.28	1975	5.35	1.50	0.28	2058
28	18	4.90	3.92	0.80	1627	4.50	3.60	0.80	1726	4.15	3.32	0.80	1793
28	20	5.15	3.50	0.68	1693	4.80	3.26	0.68	1776	4.45	3.03	0.68	1876
28	22	5.45	3.05	0.56	1760	5.10	2.86	0.56	1859	4.75	2.66	0.56	1926
28	24	5.75	2.53	0.44	1826	5.40	2.38	0.44	1909	5.10	2.24	0.44	1992
28	26	6.05	1.94	0.32	1892	5.70	1.82	0.32	1975	5.35	1.71	0.32	2058
29	18	4.90	4.12	0.84	1627	4.50	3.78	0.84	1726	4.15	3.49	0.84	1793
29	20	5.15	3.71	0.72	1693	4.80	3.46	0.72	1776	4.45	3.20	0.72	1876
29	22	5.45	3.27	0.60	1760	5.10	3.06	0.60	1859	4.75	2.85	0.60	1926
29	24	5.75	2.76	0.48	1826	5.40	2.59	0.48	1909	5.10	2.45	0.48	1992
29	26	6.05	2.18	0.36	1892	5.70	2.05	0.36	1975	5.35	1.93	0.36	2058
30	18	4.90	4.31	0.88	1627	4.50	3.96	0.88	1726	4.15	3.65	0.88	1793
30	20	5.15	3.91	0.76	1693	4.80	3.65	0.76	1776	4.45	3.38	0.76	1876
30	22	5.45	3.49	0.64	1760	5.10	3.26	0.64	1859	4.75	3.04	0.64	1926
30	24	5.75	2.99	0.52	1826	5.40	2.81	0.52	1909	5.10	2.65	0.52	1992
30	26	6.05	2.42	0.40	1892	5.70	2.28	0.40	1975	5.35	2.14	0.40	2058
31	18	4.90	4.51	0.92	1627	4.50	4.14	0.92	1726	4.15	3.82	0.92	1793
31	20	5.15	4.12	0.80	1693	4.80	3.84	0.80	1776	4.45	3.56	0.80	1876
31	22	5.45	3.71	0.68	1760	5.10	3.47	0.68	1859	4.75	3.23	0.68	1926
31	24	5.75	3.22	0.56	1826	5.40	3.02	0.56	1909	5.10	2.86	0.56	1992
31	26	6.05	2.66	0.44	1892	5.70	2.51	0.44	1975	5.35	2.35	0.44	2058
32	18	4.90	4.70	0.96	1627	4.50	4.32	0.96	1726	4.15	3.98	0.96	1793
32	20	5.15	4.33	0.84	1693	4.80	4.03	0.84	1776	4.45	3.74	0.84	1876
32	22	5.45	3.92	0.72	1760	5.10	3.67	0.72	1859	4.75	3.42	0.72	1926
32	24	5.75	3.45	0.60	1826	5.40	3.24	0.60	1909	5.10	3.06	0.60	1992
32	26	6.05	2.90	0.48	1892	5.70	2.74	0.48	1975	5.35	2.57	0.48	2058

NOTE Q : Total capacity (kW) SHF : Sensible heat factor DB : Dry-bulb temperature
 SHC : Sensible heat capacity (kW) INPUT : Total power input (W) WB : Wet-bulb temperature

PERFORMANCE DATA HEAT operation at Rated frequency
MUZ-SF25VE MUZ-SF25VEH

CAPACITY: 3.2 kW INPUT: 780 W

INDOOR DB (°C)	OUTDOOR WB (°C)													
	-10		-5		0		5		10		15		20	
	Q	INPUT	Q	INPUT	Q	INPUT	Q	INPUT	Q	INPUT	Q	INPUT	Q	INPUT
15	2.02	507	2.43	608	2.85	686	3.26	741	3.68	788	4.06	811	4.48	827
21	1.92	546	2.30	647	2.72	718	3.10	772	3.52	811	3.90	835	4.30	866
26	1.73	585	2.14	686	2.53	757	2.94	811	3.36	850	3.74	874	4.16	897

MUZ-SF35VE MUZ-SF35VEH

CAPACITY: 4.0 kW INPUT: 1030 W

INDOOR DB (°C)	OUTDOOR WB (°C)													
	-10		-5		0		5		10		15		20	
	Q	INPUT	Q	INPUT	Q	INPUT	Q	INPUT	Q	INPUT	Q	INPUT	Q	INPUT
15	2.52	670	3.04	803	3.56	906	4.08	979	4.60	1040	5.08	1071	5.60	1092
21	2.40	721	2.88	855	3.40	948	3.88	1020	4.40	1071	4.88	1102	5.38	1143
26	2.16	773	2.68	906	3.16	999	3.68	1071	4.20	1123	4.68	1154	5.20	1185

MUZ-SF42VE MUZ-SF42VEH

CAPACITY: 5.4 kW INPUT: 1580 W

INDOOR DB (°C)	OUTDOOR WB (°C)													
	-10		-5		0		5		10		15		20	
	Q	INPUT	Q	INPUT	Q	INPUT	Q	INPUT	Q	INPUT	Q	INPUT	Q	INPUT
15	3.40	1027	4.10	1232	4.81	1390	5.51	1501	6.21	1596	6.86	1643	7.56	1675
21	3.24	1106	3.89	1311	4.59	1454	5.24	1564	5.94	1643	6.59	1691	7.26	1754
26	2.92	1185	3.62	1390	4.27	1533	4.97	1643	5.67	1722	6.32	1770	7.02	1817

MUZ-SF50VE MUZ-SF50VEH

CAPACITY: 5.8 kW INPUT: 1700 W

INDOOR DB (°C)	OUTDOOR WB (°C)													
	-10		-5		0		5		10		15		20	
	Q	INPUT	Q	INPUT	Q	INPUT	Q	INPUT	Q	INPUT	Q	INPUT	Q	INPUT
15	3.65	1105	4.41	1326	5.16	1496	5.92	1615	6.67	1717	7.37	1768	8.12	1802
21	3.48	1190	4.18	1411	4.93	1564	5.63	1683	6.38	1768	7.08	1819	7.80	1887
26	3.13	1275	3.89	1496	4.58	1649	5.34	1768	6.09	1853	6.79	1904	7.54	1955

NOTE: Q: Total capacity (kW) INPUT : Total power input (W) DB: Dry-bulb temperature WB: Wet-bulb temperature

**MUZ-SF25VE MUZ-SF25VEH MUZ-SF35VE MUZ-SF35VEH
MUZ-SF42VE MUZ-SF42VEH MUZ-SF50VE MUZ-SF50VEH**

9-1. OUTDOOR FAN MOTOR CONTROL

The fan motor turns ON/OFF, interlocking with the compressor.

[ON] The fan motor turns ON 5 seconds before the compressor starts up.

[OFF] The fan motor turns OFF 15 seconds after the compressor has stopped running.

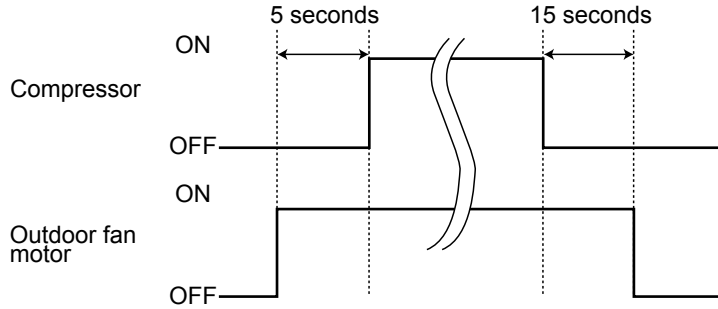

9-2. R.V. COIL CONTROL

- Heating ON
- Cooling OFF
- Dry OFF

NOTE: The 4-way valve reverses for 5 seconds right before start-up of the compressor.

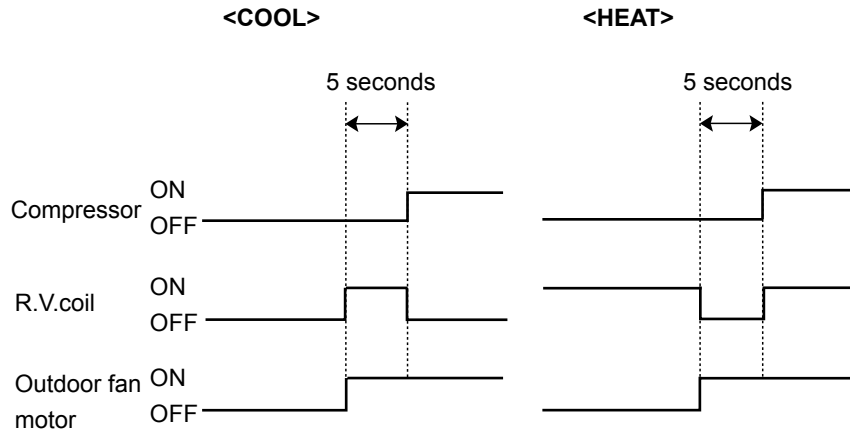

9-3. RELATION BETWEEN MAIN SENSOR AND ACTUATOR

Sensor	Purpose	Actuator					
		Compressor	LEV	Outdoor fan motor	R.V.coil	Indoor fan motor	Defrost heater
Discharge temperature thermistor	Protection	○	○				
Indoor coil temperature thermistor	Cooling: Coil frost prevention	○					
	Heating: High pressure protection	○	○				
Defrost thermistor	Heating: Defrosting	○	○	○	○	○	
Fin temperature thermistor	Protection	○		○			
Ambient temperature thermistor	Cooling: Low ambient temperature operation	○	○	○			
	Heating: Defrosting (Heater)						○
Outdoor heat exchanger temperature thermistor	Cooling: Low ambient temperature operation	○	○	○			
	Cooling: High pressure protection	○	○	○			

10

SERVICE FUNCTIONS

**MUZ-SF25VE MUZ-SF25VEH MUZ-SF35VE MUZ-SF35VEH
 MUZ-SF42VE MUZ-SF42VEH MUZ-SF50VE MUZ-SF50VEH**

10-1. CHANGE IN DEFROST SETTING

Changing defrost finish temperature

<JS> To change the defrost finish temperature, cut/solder the JS wire of the outdoor inverter P.C. board. (Refer to 11-6-1.)

Jumper wire		Defrost finish temperature (°C)	
		MUZ-SF25/35/42	MUZ-SF50
JS	Soldered (Initial setting)	5	9
	None (Cut)	10	18

10-2. PRE-HEAT CONTROL SETTING

PRE-HEAT CONTROL

When moisture gets into the refrigerant cycle, it may interfere the start-up of the compressor at low outside temperature. The pre-heat control prevents this interference. The pre-heat control turns ON when the defrost thermistor reads 20°C or below. When pre-heat control is turned ON, compressor is energized. (About 50 W)

<JK> To activate the pre-heat control, cut the JK wire of the inverter P.C. board. (Refer to 11-6.1)

NOTE: When the inverter P.C. board is replaced, check the Jumper wires, and cut/solder them if necessary.

11

TROUBLESHOOTING

**MUZ-SF25VE MUZ-SF25VEH MUZ-SF35VE MUZ-SF35VEH
 MUZ-SF42VE MUZ-SF42VEH MUZ-SF50VE MUZ-SF50VEH**

11-1. CAUTIONS ON TROUBLESHOOTING

1. Before troubleshooting, check the following

- 1) Check the power supply voltage.
- 2) Check the indoor/outdoor connecting wire for miswiring.

2. Take care of the following during servicing

- 1) Before servicing the air conditioner, be sure to turn OFF the main unit first with the remote controller, and then after confirming the horizontal vane is closed, turn OFF the breaker and/or disconnect the power plug.
- 2) Be sure to turn OFF the power supply before removing the front panel, the cabinet, the top panel, and the electronic control P.C. board.
- 3) When removing the electrical parts, be careful of the residual voltage of smoothing capacitor.
- 4) When removing the electronic control P.C. board, hold the edge of the board with care NOT to apply stress on the components.
- 5) When connecting or disconnecting the connectors, hold the housing of the connector. DO NOT pull the lead wires.

<Incorrect>

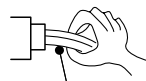

Lead wiring

<Correct>

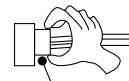

Housing point

3. Troubleshooting procedure

- 1) Check if the OPERATION INDICATOR lamp on the indoor unit is flashing on and off to indicate an abnormality. To make sure, check how many times the OPERATION INDICATOR lamp is flashing on and off before starting service work.
- 2) Before servicing, check that the connector and terminal are connected properly.
- 3) When the electronic control P.C. board seems to be defective, check the copper foil pattern for disconnection and the components for bursting and discoloration.
- 4) Refer to 11-2 and 11-3.

11-2. FAILURE MODE RECALL FUNCTION

Outline of the function

This air conditioner can memorize the abnormal condition which has occurred once.

Even though LED indication listed on the troubleshooting check table (11-3.) disappears, the memorized failure details can be recalled.

1. Flow chart of failure mode recall function for the indoor/outdoor unit

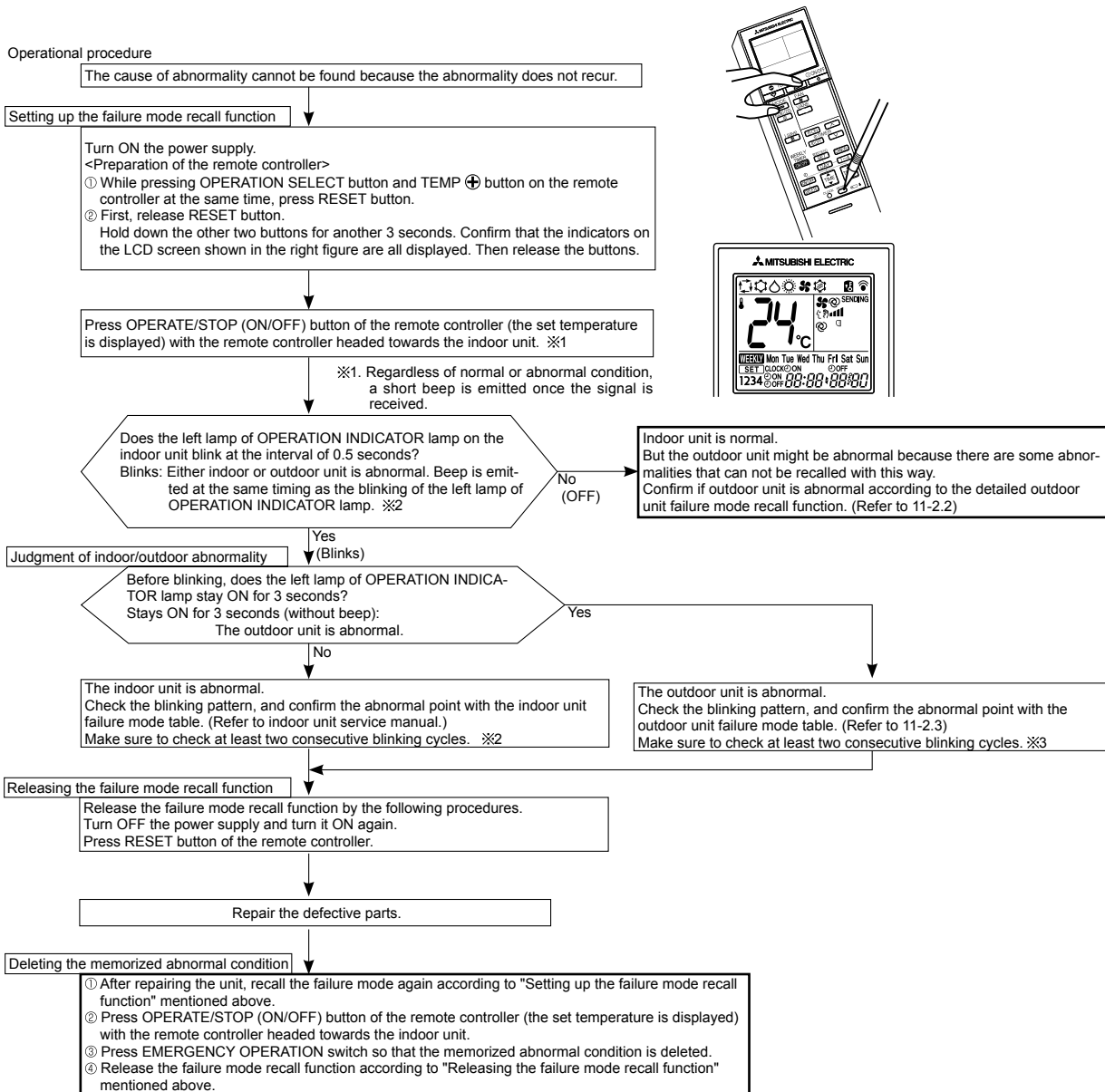

NOTE: 1. Make sure to release the failure mode recall function once it is set up, otherwise the unit cannot operate properly.
2. If the abnormal condition is not deleted from the memory, the last abnormal condition is kept memorized.

※2. Blinking pattern when the indoor unit is abnormal:

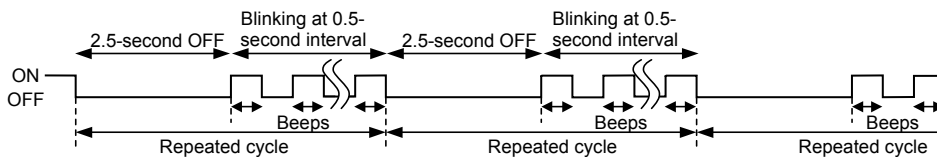

※3. Blinking pattern when the outdoor unit is abnormal:

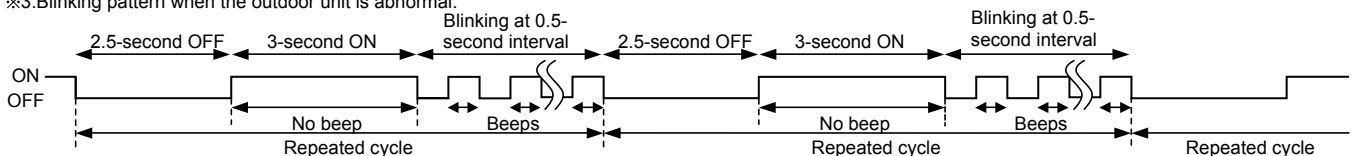

2. Flow chart of the detailed outdoor unit failure mode recall function

Operational procedure

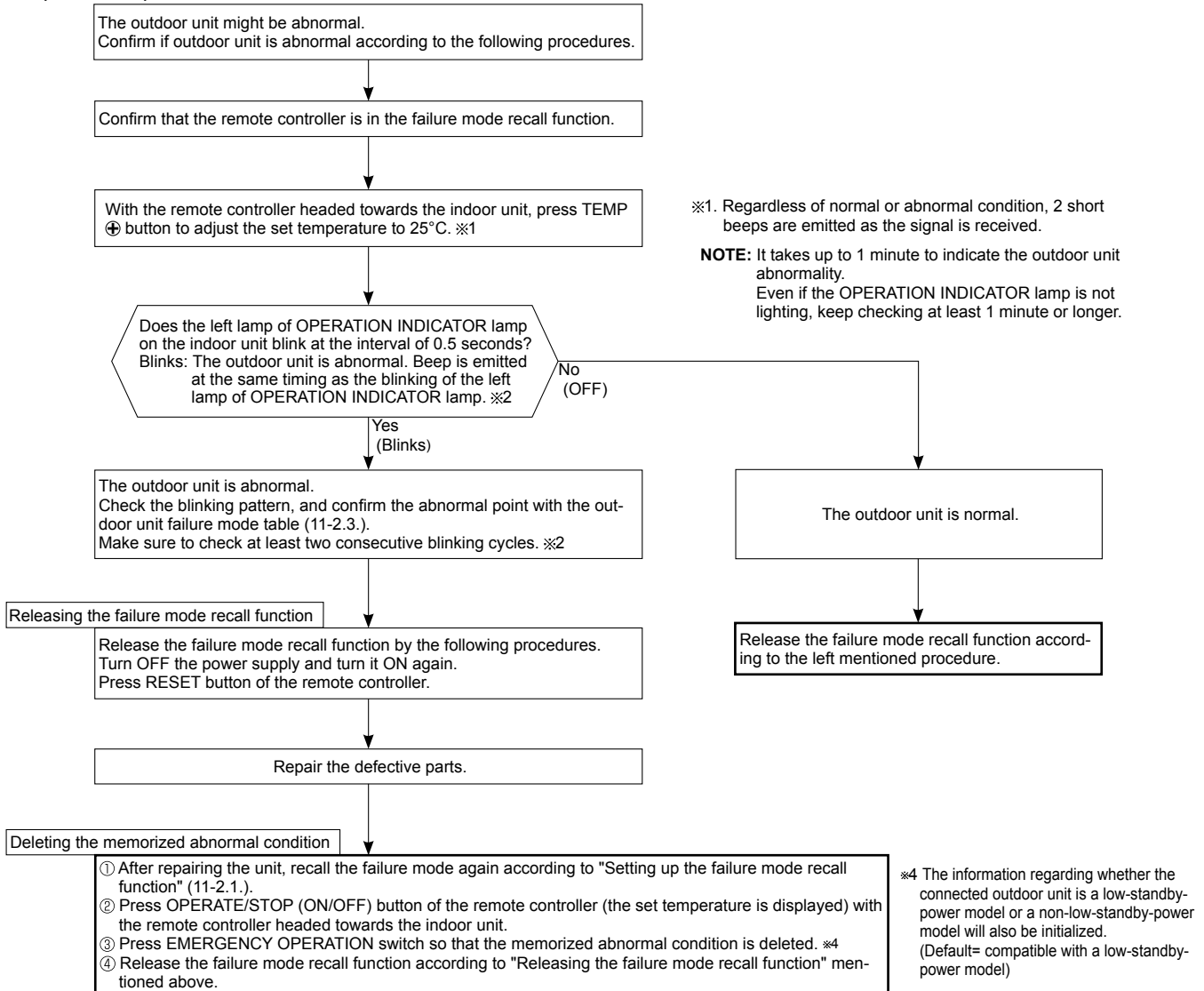

NOTE: 1. Make sure to release the failure mode recall function once it is set up, otherwise the unit cannot operate properly.
2. If the abnormal condition is not deleted from the memory, the last abnormal condition is kept memorized.

※2. Blinking pattern when outdoor unit is abnormal:

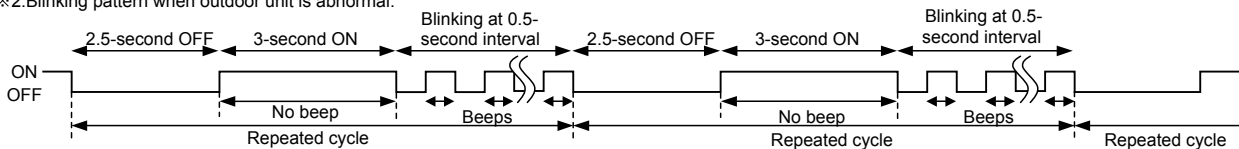

3. Outdoor unit failure mode table

The left lamp of OPERATION INDICATOR lamp (Indoor unit)	Abnormal point (Failure mode/protection)	LED indication (Outdoor P.C. board)	Condition	Remedy	Indoor/outdoor unit failure mode recall function	Outdoor unit failure mode recall function
OFF	None (Normal)	—	—	—	—	—
1-time flash 2.5 seconds OFF	Indoor/outdoor communication, receiving error	—	Any signals from the inverter P.C. board cannot be received normally for 3 minutes.	•Refer to 11-5. ㉔ How to check miswiring and serial signal error.	○	○
	Indoor/outdoor communication, receiving error	—	Although the inverter P.C. board sends signal "0", signal "1" has been received 30 consecutive times.	•Refer to 11-5. ㉔ How to check miswiring and serial signal error.		
2-time flash 2.5 seconds OFF	Outdoor power system	—	Overcurrent protection cut-out operates 3 consecutive times within 1 minute after the compressor gets started.	•Reconnect connectors. •Refer to 11-5. ㉔ How to check inverter/compressor". •Check stop valve.	○	○
3-time flash 2.5 seconds OFF	Discharge temperature thermistor	1-time flash every 2.5 seconds	Thermistor shorts or opens during compressor running.	•Refer to 11-5. ㉔ "Check of outdoor thermistors". Defective outdoor thermistors can be identified by checking the blinking pattern of LED.	○	○
	Defrost thermistor					
	Fin temperature thermistor	3-time flash 2.5 seconds OFF				
	P.C. board temperature thermistor	4-time flash 2.5 seconds OFF				
	Ambient temperature thermistor	2-time flash 2.5 seconds OFF				
	Outdoor heat exchanger temperature thermistor	—				
4-time flash 2.5 seconds OFF	Overcurrent	11-time flash 2.5 seconds OFF	Large current flows into intelligent power module.	•Reconnect compressor connector. •Refer to 11-5. ㉔ How to check inverter/compressor". •Check stop valve.	—	○
	Compressor synchronous abnormality (Compressor start-up failure protection)	12-time flash 2.5 seconds OFF	Waveform of compressor current is distorted.	•Reconnect compressor connector. •Refer to 11-5. ㉔ How to check inverter/compressor".	—	○
5-time flash 2.5 seconds OFF	Discharge temperature	—	Temperature of discharge temperature thermistor exceeds 116°C, compressor stops. Compressor can restart if discharge temperature thermistor reads 100°C or less 3 minutes later.	•Check refrigerant circuit and refrigerant amount. •Refer to 11-5. ㉔ Check of LEV".	—	○
6-time flash 2.5 seconds OFF	High pressure	—	Temperature indoor coil thermistor exceeds 70°C in HEAT mode. Temperature defrost thermistor exceeds 70°C in COOL mode.	•Check refrigerant circuit and refrigerant amount. •Check stop valve.	—	○
7-time flash 2.5 seconds OFF	Fin temperature/ P.C. board temperature	7-time flash 2.5 seconds OFF	Temperature of fin temperature thermistor on the inverter P.C. board exceeds 75 ~ 86°C, or temperature of P.C. board temperature thermistor on the inverter P.C. board exceeds 72 ~ 85°C.	•Check around outdoor unit. •Check outdoor unit air passage. •Refer to 11-5. ㉔ Check of outdoor fan motor".	—	○
8-time flash 2.5 seconds OFF	Outdoor fan motor	—	Outdoor fan has stopped 3 times in a row within 30 seconds after outdoor fan start-up.	•Refer to 11-5. ㉔ Check of outdoor fan motor". Refer to 11-5. ㉔ Check of inverter P.C. board".	—	○
9-time flash 2.5 seconds OFF	Nonvolatile memory data	5-time flash 2.5 seconds OFF	Nonvolatile memory data cannot be read properly.	•Replace the inverter P.C. board.		
	Power module	6-time flash 2.5 seconds OFF	The interface short circuit occurs in the output of the intelligent power module (IC700). The compressor winding shorts circuit.	•Refer to 11-5. ㉔ How to check inverter/compressor".	○	○
10-time flash 2.5 seconds OFF	Discharge temperature	—	Temperature of discharge temperature thermistor has been 50°C or less for 20 minutes.	•Refer to 11-5. ㉔ Check of LEV". •Check refrigerant circuit and refrigerant amount.	—	○
11-time flash 2.5 seconds OFF	DC voltage	8-time flash 2.5 seconds OFF	DC voltage of inverter cannot be detected normally.	•Refer to 11-5. ㉔ How to check inverter/compressor".	—	○
	Each phase current of compressor	9-time flash 2.5 seconds OFF	Each phase current of compressor cannot be detected normally.			
14-time flash 2.5 seconds OFF	Stop valve (Closed valve)	14-time flash 2.5 seconds OFF	Closed valve is detected by compressor current.	•Check stop valve.		
	4-way valve/ Pipe temperature	16-time flash 2.5 seconds OFF	The 4-way valve does not work properly. The indoor coil thermistor detects an abnormal temperature.	•Check 4-way valve. •Replace inverter P.C. board.	○	○

NOTE: Blinking patterns of this mode differ from the ones of Troubleshooting check table (11-3.).

11-3. TROUBLESHOOTING CHECK TABLE

No.	Symptom	LED indication	Abnormal point/ Condition	Condition	Remedy
1	Outdoor unit does not operate.	1-time flash every 2.5 seconds	Outdoor power system	Overcurrent protection cut-out operates 3 consecutive times within 1 minute after the compressor gets started.	<ul style="list-style-type: none"> •Reconnect connector of compressor. •Refer to 11-5.Ⓐ "How to check inverter/compressor". •Check stop valve.
2			Outdoor thermistors	Discharge temperature thermistor, fin temperature thermistor, defrost thermistor, P.C. board temperature thermistor, outdoor heat exchanger temperature thermistor or ambient temperature thermistor shorts or opens during compressor running.	•Refer to 11-5.Ⓒ "Check of outdoor thermistors".
3			Outdoor control system	Nonvolatile memory data cannot be read properly. (The left lamp of OPERATION INDICATOR lamp of the indoor unit lights up or flashes 7-time.)	•Replace inverter P.C. board.
4		6-time flash 2.5 seconds OFF	Serial signal	The communication fails between the indoor and outdoor unit for 3 minutes.	•Refer to 11-5.Ⓜ "How to check miswiring and serial signal error.
5		11-time flash 2.5 seconds OFF	Stop valve/ Closed valve	Closed valve is detected by compressor current.	•Check stop valve.
6		14-time flash 2.5 seconds OFF	Outdoor unit (Other abnormality)	Outdoor unit is defective.	•Refer to 11-2.2. "Flow chart of the detailed outdoor unit failure mode recall function".
7		16-time flash 2.5 seconds OFF	4-way valve/ Pipe temperature	The 4-way valve does not work properly. The indoor coil thermistor detects an abnormal temperature.	<ul style="list-style-type: none"> •Refer to 11-5.Ⓓ "Check of R.V. coil". •Replace inverter P.C. board.
8	'Outdoor unit stops and restarts 3 minutes later' is repeated.	2-time flash 2.5 seconds OFF	Overcurrent protection	Large current flows into intelligent power module.	<ul style="list-style-type: none"> •Reconnect connector of compressor. •Refer to 11-5.Ⓐ "How to check inverter/compressor". •Check stop valve.
9		3-time flash 2.5 seconds OFF	Discharge temperature overheat protection	Temperature of discharge temperature thermistor exceeds 116°C, compressor stops. Compressor can restart if discharge temperature thermistor reads 100°C or less 3 minutes later.	<ul style="list-style-type: none"> •Check refrigerant circuit and refrigerant amount. •Refer to 11-5.Ⓚ "Check of LEV".
10		4-time flash 2.5 seconds OFF	Fin temperature /P.C. board temperature thermistor overheat protection	Temperature of fin temperature thermistor on the heat sink exceeds 75 ~ 86°C or temperature of P.C. board temperature thermistor on the inverter P.C. board exceeds 72 ~ 85°C.	<ul style="list-style-type: none"> •Check around outdoor unit. •Check outdoor unit air passage. •Refer to 11-5.Ⓛ "Check of outdoor fan motor".
11		5-time flash 2.5 seconds OFF	High pressure protection	Indoor coil thermistor exceeds 70°C in HEAT mode. Defrost thermistor exceeds 70°C in COOL mode.	<ul style="list-style-type: none"> •Check refrigerant circuit and refrigerant amount. •Check stop valve.
12		8-time flash 2.5 seconds OFF	Compressor synchronous abnormality	The waveform of compressor current is distorted.	<ul style="list-style-type: none"> •Reconnect connector of compressor. •Refer to 11-5.Ⓐ "How to check inverter/compressor".
13		10-time flash 2.5 seconds OFF	Outdoor fan motor	Outdoor fan has stopped 3 times in a row within 30 seconds after outdoor fan start-up.	<ul style="list-style-type: none"> •Refer to 11-5.Ⓛ "Check of outdoor fan motor. •Refer to 11-5.Ⓛ "Check of inverter P.C. board.
14		12-time flash 2.5 seconds OFF	Each phase current of compressor	Each phase current of compressor cannot be detected normally.	•Refer to 11-5.Ⓐ "How to check inverter/compressor".
15		13-time flash 2.5 seconds OFF	DC voltage	DC voltage of inverter cannot be detected normally.	•Refer to 11-5.Ⓐ "How to check inverter/compressor".
16		Outdoor unit operates.	1-time flash 2.5 seconds OFF	Frequency drop by current protection	When the input current exceeds approximately 7A(EF25)/8A(EF35)/9A(EF42)/12A(EF50), compressor frequency lowers.
17	3-time flash 2.5 seconds OFF	Frequency drop by high pressure protection	Temperature of indoor coil thermistor exceeds 55°C in HEAT mode, compressor frequency lowers.	<ul style="list-style-type: none"> •Check if indoor filters are clogged. •Check if refrigerant is short. •Check if indoor/outdoor unit air circulation is short cycled. 	
		Frequency drop by defrosting in COOL mode	Indoor coil thermistor reads 8°C or less in COOL mode, compressor frequency lowers.		
18	4-time flash 2.5 seconds OFF	Frequency drop by discharge temperature protection	Temperature of discharge temperature thermistor exceeds 111°C, compressor frequency lowers.	<ul style="list-style-type: none"> •Check refrigerant circuit and refrigerant amount. •Refer to 11-5.Ⓚ "Check of LEV". •Refer to 11-5.Ⓒ "Check of outdoor thermistors". 	
19	5-time flash 2.5 seconds OFF	Outside temperature thermistor protection	When the outside temperature thermistor shorts or opens, protective operation without that thermistor is performed.	•Refer to 11-5.Ⓒ Check of outdoor thermistors.	
20	Outdoor unit operates.	7-time flash 2.5 seconds OFF	Low discharge temperature protection	Temperature of discharge temperature thermistor has been 50°C or less for 20 minutes.	<ul style="list-style-type: none"> •Refer to 11-5.Ⓚ "Check of LEV". •Check refrigerant circuit and refrigerant amount.
21	Outdoor unit operates.	8-time flash 2.5 seconds OFF	PAM protection PAM: Pulse Amplitude Modulation	The overcurrent flows into PFC (Power factor correction : IC820) or the bus-bar voltage reaches 394 V or more, PAM stops and restarts.	This is not malfunction. PAM protection will be activated in the following cases: 1 Instantaneous power voltage drop. (Short time power failure) 2 When the power supply voltage is high.
22		9-time flash 2.5 seconds OFF	Inverter check mode	The connector of compressor is disconnected, inverter check mode starts.	•Check if the connector of the compressor is correctly connected. Refer to 11-5.Ⓐ "How to check inverter/compressor".

NOTE: 1. The location of LED is illustrated at the right figure. Refer to 11-6.1.
2. LED is lighted during normal operation.

Inverter P.C. board

The flashing frequency shows the number of times the LED blinks after every 2.5-second OFF.
(Example) When the flashing frequency is "2".

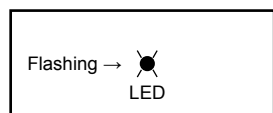
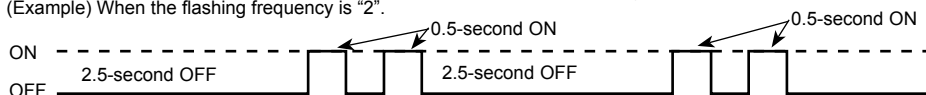

11-4. TROUBLE CRITERION OF MAIN PARTS

MUZ-SF25VE MUZ-SF25VEH MUZ-SF35VE MUZ-SF35VEH MUZ-SF42VE MUZ-SF42VEH MUZ-SF50VE MUZ-SF50VEH

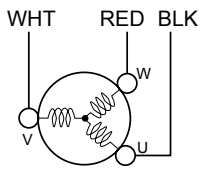
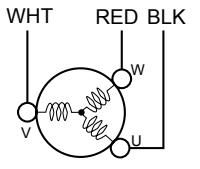
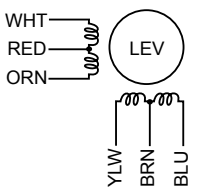
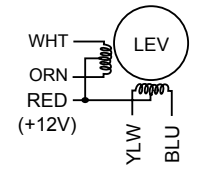
Part name	Check method and criterion	Figure																								
Defrost thermistor (RT61) Fin temperature thermistor (RT64) Ambient temperature thermistor (RT65) Outdoor heat exchanger temperature thermistor (RT68)	Measure the resistance with a tester. Refer to 11-6. "Test point diagram and voltage", 1. "Inverter P.C. board", for the chart of thermistor.																									
Discharge temperature thermistor (RT62)	Measure the resistance with a tester. Before measurement, hold the thermistor with your hands to warm it up. Refer to 11-6. "Test point diagram and voltage", 1. "Inverter P.C. board", for the chart of thermistor.																									
Compressor	Measure the resistance between terminals using a tester. (Temperature: -10 ~ 40°C) <table border="1" style="margin-left: 20px;"> <thead> <tr> <th rowspan="2"></th> <th colspan="4">Normal (Ω)</th> </tr> <tr> <th>MUZ-SF25</th> <th>MUZ-SF35</th> <th>MUZ-SF42</th> <th>MUZ-SF50</th> </tr> </thead> <tbody> <tr> <td>U-V</td> <td></td> <td></td> <td></td> <td></td> </tr> <tr> <td>U-W</td> <td>1.20 ~ 1.72</td> <td>1.36 ~ 1.93</td> <td>1.52 ~ 2.17</td> <td>0.78 ~ 1.11</td> </tr> <tr> <td>V-W</td> <td></td> <td></td> <td></td> <td></td> </tr> </tbody> </table>		Normal (Ω)				MUZ-SF25	MUZ-SF35	MUZ-SF42	MUZ-SF50	U-V					U-W	1.20 ~ 1.72	1.36 ~ 1.93	1.52 ~ 2.17	0.78 ~ 1.11	V-W					
	Normal (Ω)																									
	MUZ-SF25	MUZ-SF35	MUZ-SF42	MUZ-SF50																						
U-V																										
U-W	1.20 ~ 1.72	1.36 ~ 1.93	1.52 ~ 2.17	0.78 ~ 1.11																						
V-W																										
Outdoor fan motor	Measure the resistance between lead wires using a tester. (Temperature: -10 ~ 40°C) <table border="1" style="margin-left: 20px;"> <thead> <tr> <th rowspan="2">Color of lead wire</th> <th colspan="2">Normal (Ω)</th> </tr> <tr> <th>MUZ-SF25/35/42</th> <th>MUZ-SF50</th> </tr> </thead> <tbody> <tr> <td>RED - BLK</td> <td rowspan="3">29 ~ 42</td> <td rowspan="3">12 ~ 17</td> </tr> <tr> <td>BLK - WHT</td> </tr> <tr> <td>WHT - RED</td> </tr> </tbody> </table>	Color of lead wire	Normal (Ω)		MUZ-SF25/35/42	MUZ-SF50	RED - BLK	29 ~ 42	12 ~ 17	BLK - WHT	WHT - RED															
Color of lead wire	Normal (Ω)																									
	MUZ-SF25/35/42	MUZ-SF50																								
RED - BLK	29 ~ 42	12 ~ 17																								
BLK - WHT																										
WHT - RED																										
R. V. coil (21S4)	Measure the resistance using a tester. (Temperature: -10 ~ 40°C) <table border="1" style="margin-left: 20px;"> <thead> <tr> <th>Normal (kΩ)</th> </tr> </thead> <tbody> <tr> <td>1.19 ~ 1.78</td> </tr> </tbody> </table>	Normal (kΩ)	1.19 ~ 1.78																							
Normal (kΩ)																										
1.19 ~ 1.78																										
Expansion valve coil (LEV)	Measure the resistance using a tester. (Temperature: -10 ~ 40°C) MUZ-SF25/35/42 <table border="1" style="margin-left: 20px;"> <thead> <tr> <th>Color of lead wire</th> <th>Normal (Ω)</th> </tr> </thead> <tbody> <tr> <td>WHT - RED</td> <td rowspan="4">37 ~ 54</td> </tr> <tr> <td>RED - ORN</td> </tr> <tr> <td>YLW - BRN</td> </tr> <tr> <td>BRN - BLU</td> </tr> </tbody> </table>	Color of lead wire	Normal (Ω)	WHT - RED	37 ~ 54	RED - ORN	YLW - BRN	BRN - BLU																		
	Color of lead wire	Normal (Ω)																								
WHT - RED	37 ~ 54																									
RED - ORN																										
YLW - BRN																										
BRN - BLU																										
Measure the resistance using a tester. (Temperature: -10 ~ 40°C) MUZ-SF50 <table border="1" style="margin-left: 20px;"> <thead> <tr> <th>Color of lead wire</th> <th>Normal (Ω)</th> </tr> </thead> <tbody> <tr> <td>RED - ORN</td> <td rowspan="4">37 ~ 54</td> </tr> <tr> <td>RED - WHT</td> </tr> <tr> <td>RED - BLU</td> </tr> <tr> <td>RED - YLW</td> </tr> </tbody> </table>	Color of lead wire	Normal (Ω)	RED - ORN	37 ~ 54	RED - WHT	RED - BLU	RED - YLW																			
Color of lead wire	Normal (Ω)																									
RED - ORN	37 ~ 54																									
RED - WHT																										
RED - BLU																										
RED - YLW																										
Defrost heater MUZ-SF-VEH	Measure the resistance using a tester. (Temperature: -10 ~ 40°C) <table border="1" style="margin-left: 20px;"> <thead> <tr> <th>Normal (Ω)</th> </tr> </thead> <tbody> <tr> <td>349 ~ 428</td> </tr> </tbody> </table>	Normal (Ω)	349 ~ 428																							
Normal (Ω)																										
349 ~ 428																										

11-5. TROUBLESHOOTING FLOW

A How to check inverter/compressor

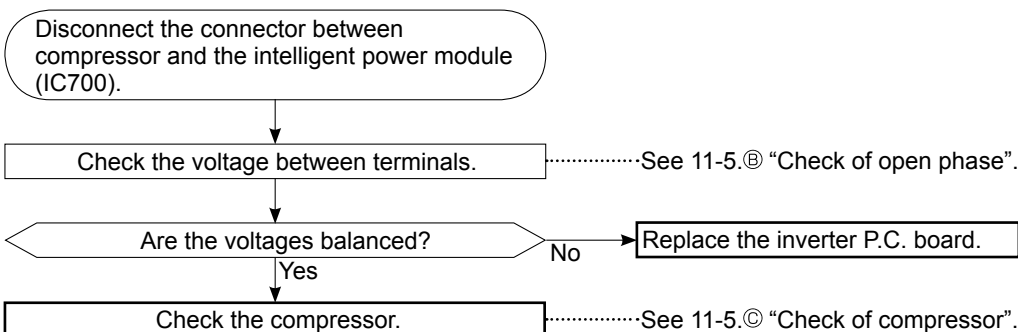

B Check of open phase

- With the connector between the compressor and the intelligent power module disconnected, activate the inverter and check if the inverter is normal by measuring the **voltage balance** between the terminals.

Output voltage is 50 - 130 V. (The voltage may differ according to the tester.)

<< Operation method >>

Start cooling or heating operation by pressing EMERGENCY OPERATION switch on the indoor unit. (TEST RUN OPERATION: Refer to 8-3.)

<< Measurement point >>

At 3 points

BLK (U)-WHT (V)

※ Measure AC voltage between the lead wires at 3 points.

BLK (U)-RED (W)

WHT(V)-RED (W)

- NOTE:**
1. Output voltage varies according to power supply voltage.
 2. Measure the voltage by analog type tester.
 3. During this check, LED of the inverter P.C. board flashes 9 times. (Refer to 11-6.1.)

C Check of compressor

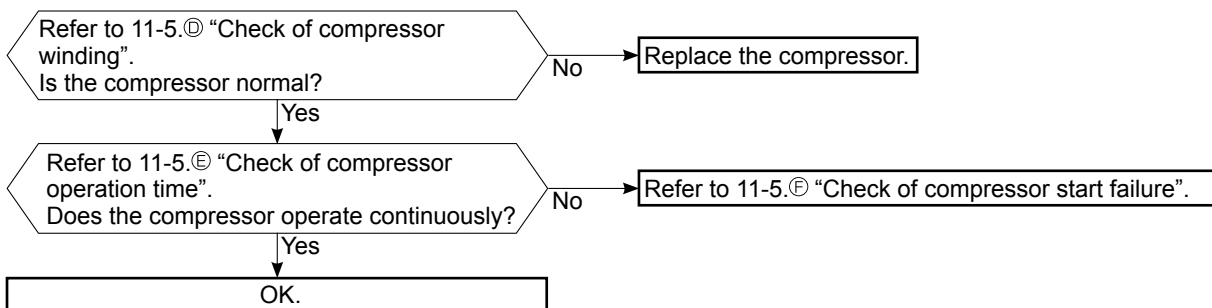

D Check of compressor winding

- Disconnect the connector between the compressor and intelligent power module, and measure the resistance between the compressor terminals.

<<Measurement point>>

at 3 points

BLK-WHT

BLK-RED

WHT-RED

※ Measure the resistance between the lead wires at 3 points.

<<Judgement>>

Refer to 11-4.

0 [Ω]Abnormal [short]

Infinite [Ω]Abnormal [open]

NOTE: Be sure to zero the ohmmeter before measurement.

E Check of compressor operation time

- Connect the compressor and activate the inverter. Then measure the time until the inverter stops due to over current.

<<Operation method>>

Start heating or cooling operation by pressing EMERGENCY OPERATION switch on the indoor unit. (TEST RUN OPERATION: Refer to 8-3.)

<<Measurement>>

Measure the time from the start of compressor to the stop of compressor due to overcurrent.

<<Judgement>>

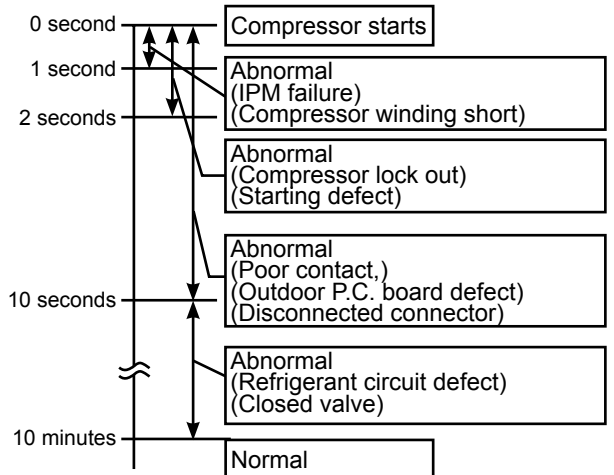

F Check of compressor start failure

Confirm that ①~④ is normal.

• Electrical circuit check

①. Contact of the compressor connector

②. Output voltage of inverter P.C. board and balance of them (See 11-5.Ⓔ)

③. Direct current voltage between DB61(+) and (-) on the inverter P.C. board

④. Voltage between outdoor terminal block S1-S2

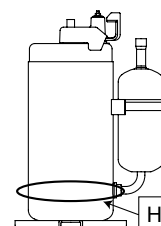
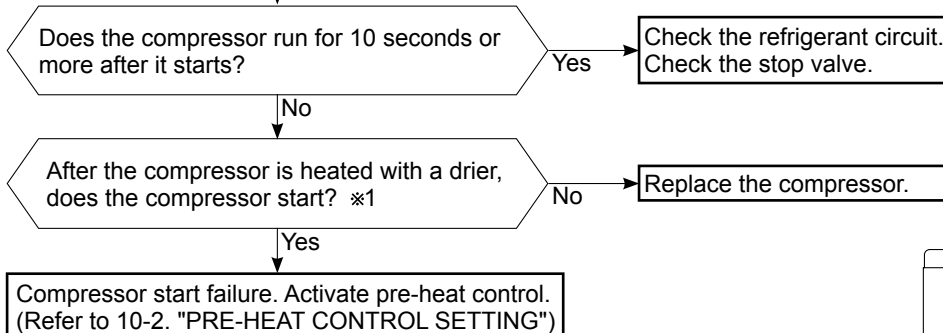

※1
Heat the compressor with a drier for about 20 minutes. Do not recover refrigerant gas while heating.

G Check of outdoor thermistors

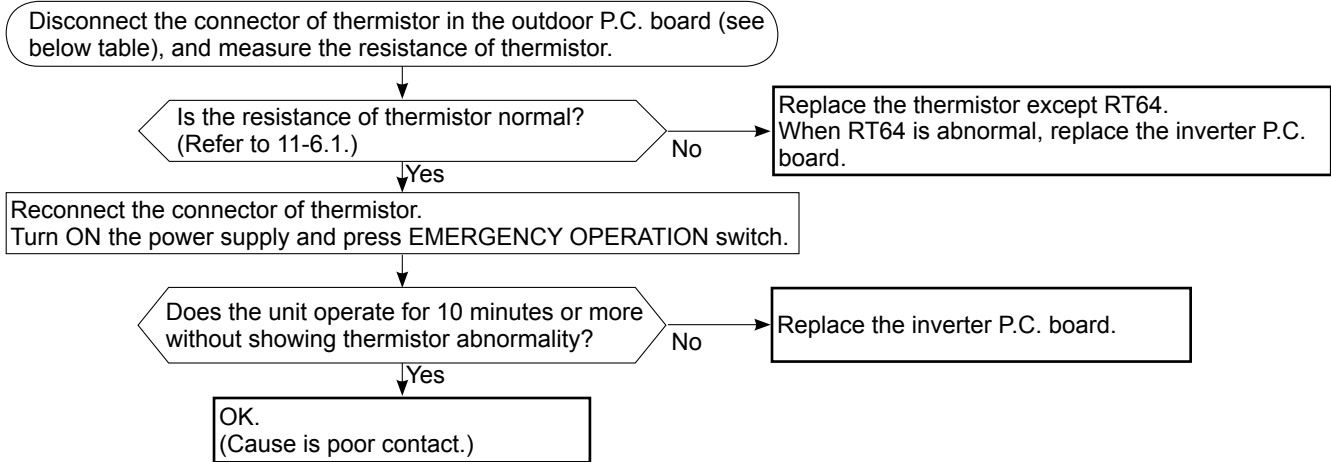

Thermistor	Symbol	Connector, Pin No.	Board
Defrost	RT61	Between CN641 pin1 and pin2	Inverter P.C. board
Discharge temperature	RT62	Between CN641 pin3 and pin4	
Fin temperature	RT64	Between CN642 pin1 and pin2	
Ambient temperature	RT65	Between CN643 pin1 and pin2	
Outdoor heat exchanger temperature	RT68	Between CN644 pin1 and pin3	

H Check of R.V. coil

- ※ First of all, measure the resistance of R.V. coil to check if the coil is defective. Refer to 11-4.
- ※ In case CN721 is disconnected or R.V. coil is open, voltage is generated between the terminal pins of the connector although no signal is being transmitted to R.V. coil. Check if CN721 is connected.

Unit operates COOL mode even if it is set to HEAT mode.

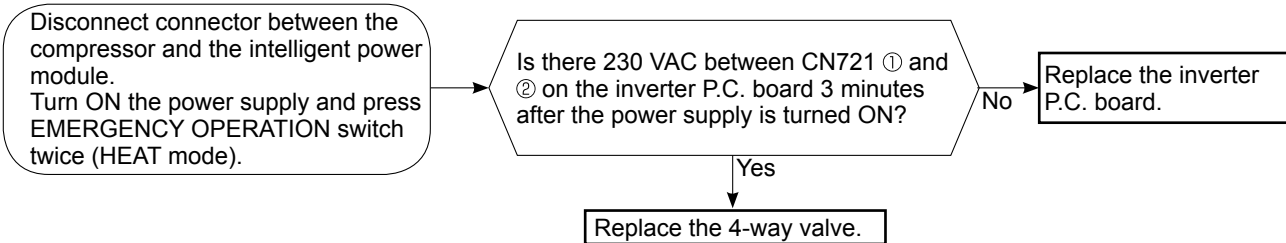

Unit operates HEAT mode even if it is set to COOL mode.

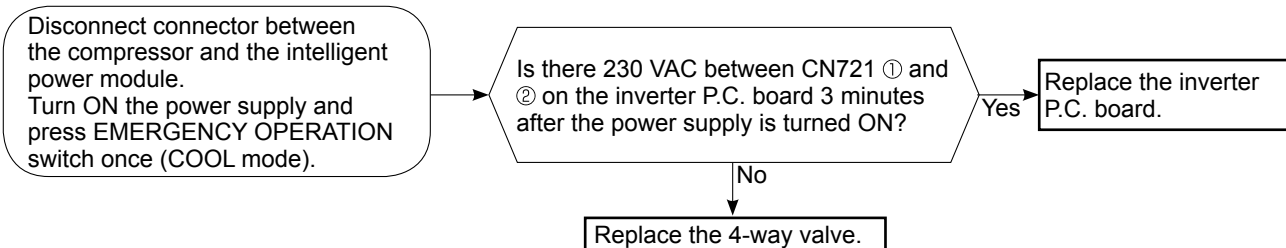

① Check of outdoor fan motor

Disconnect the connectors CN931 and CN932 from the inverter P.C. board.
Check the connection between the connector CN931 and CN932.

Is the resistance between each terminal of outdoor fan motor normal?
(Refer to 11-4.)

Yes

Disconnect CN932 from the inverter P.C. board, and turn on the power supply.

Rotate the outdoor fan motor manually and measure the voltage of CN931.
Between 1(+) and 5(-)
Between 2(+) and 5(-)
Between 3(+) and 5(-)

Does the voltage between each terminal become 5 and 0 VDC repeatedly?

No

(Fixed to either 5 or 0 VDC)

Yes

Does the outdoor fan motor rotate smoothly?

No

Yes

Replace the outdoor fan motor.

Replace the inverter P.C. board.

J Check of power supply

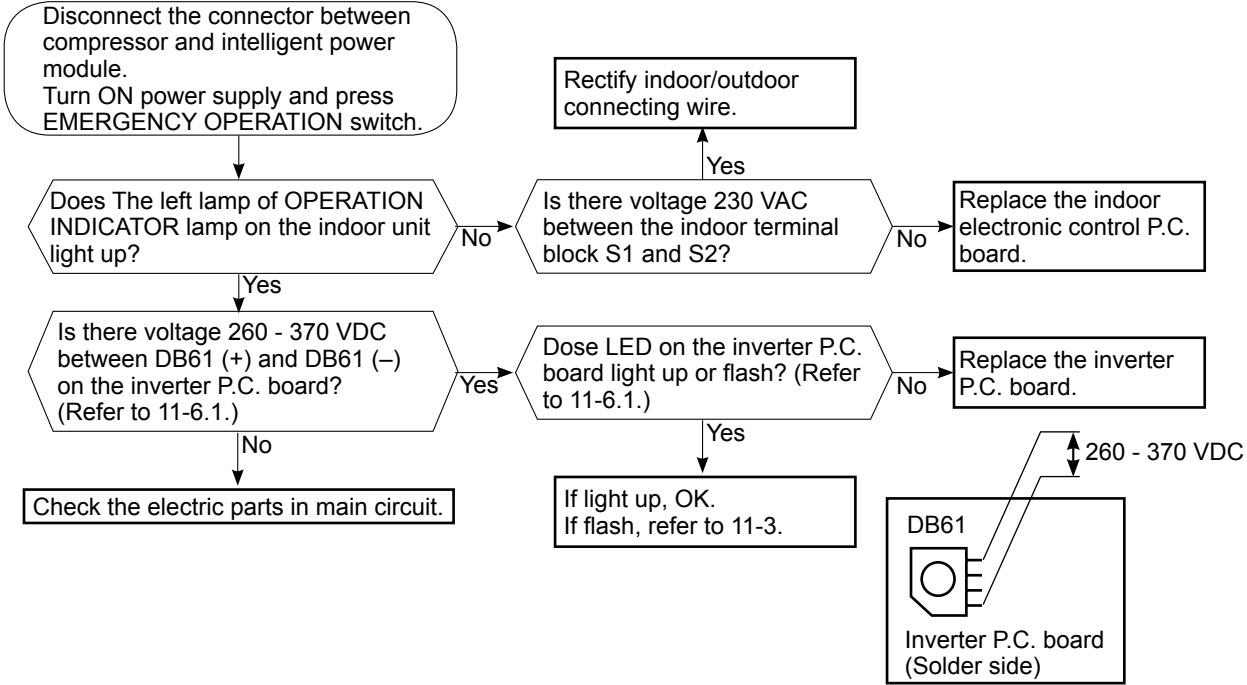

K Check of LEV (Expansion valve)

Turn ON the power supply.

<Preparation of the remote controller>

- ① While pressing both OPERATION SELECT button and TEMP \oplus button on the remote controller at the same time, press RESET button.
- ② First, release RESET button.
Hold down the other two buttons for another 3 seconds. Confirm that the indicators on the LCD screen shown in the right figure are all displayed. Then release the buttons.

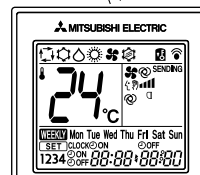
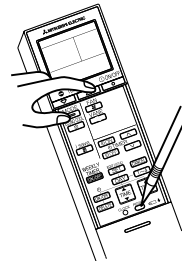

Press OPERATE/STOP (ON/OFF) button of the remote controller (the set temperature is displayed) with the remote controller headed towards the indoor unit. ※1

Expansion valve operates in full-opening direction.

Do you hear the expansion valve "click, click....." ?
Do you feel the expansion valve vibrate on touching it ?

Yes

OK

No

Is LEV coil properly fixed to the expansion valve?

No

Properly fix the LEV coil to the expansion valve.

Yes

Does the resistance of LEV coil have the characteristics? (Refer to 11-4.)

Yes

Measure each voltage between connector pins of CN724 on the inverter P.C. board.
1. Pin③(-) — Pin①(+)
2. Pin④(-) — Pin①(+)
3. Pin⑤(-) — Pin①(+)
4. Pin⑥(-) — Pin①(+)
Is there about 3 - 5 VAC between each?
NOTE: Measure the voltage by an analog tester.

No

Replace the inverter P.C. board.

No

Replace the LEV coil.

Yes

Replace the expansion valve.

※1. Regardless of normal or abnormal condition, a short beep is emitted once the signal is received.

NOTE: After check of LEV, do the undermentioned operations.

1. Turn OFF the power supply and turn it ON again.
2. Press RESET button on the remote controller.

Ⓛ Check of inverter P.C. board

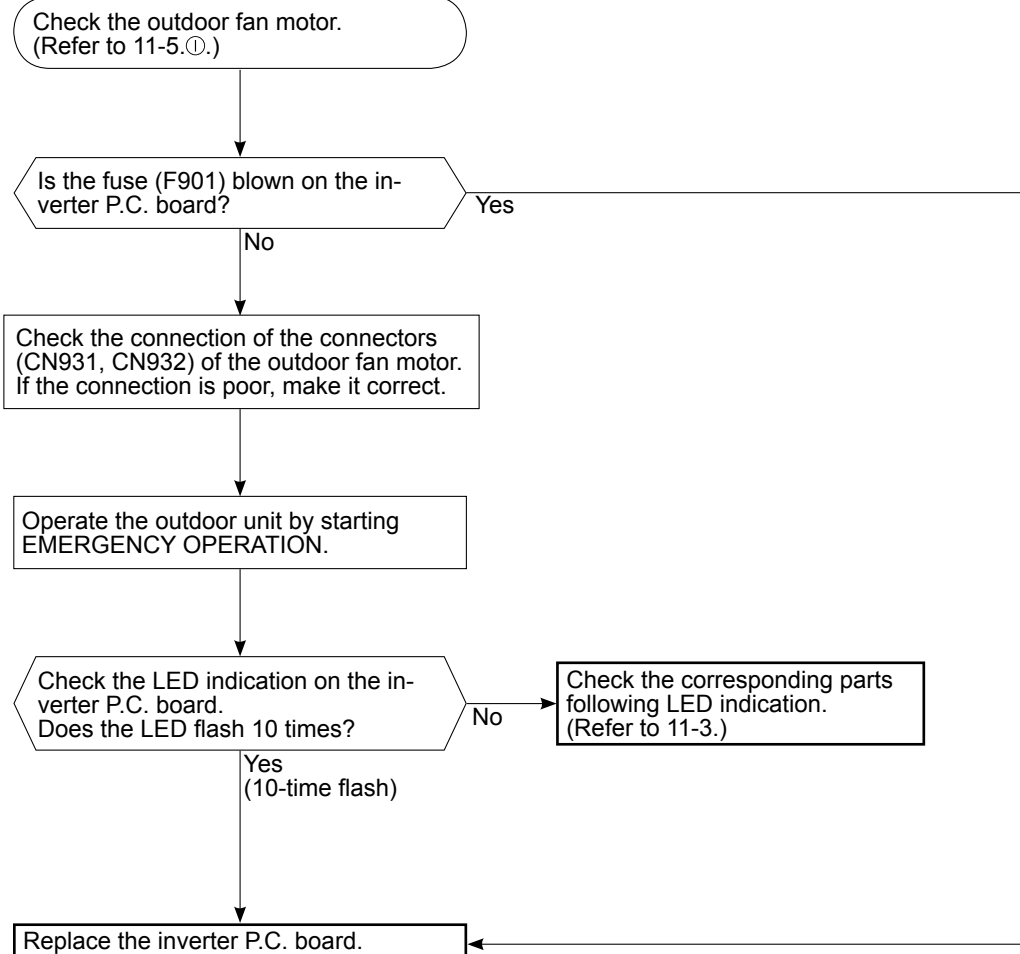

M How to check miswiring and serial signal error

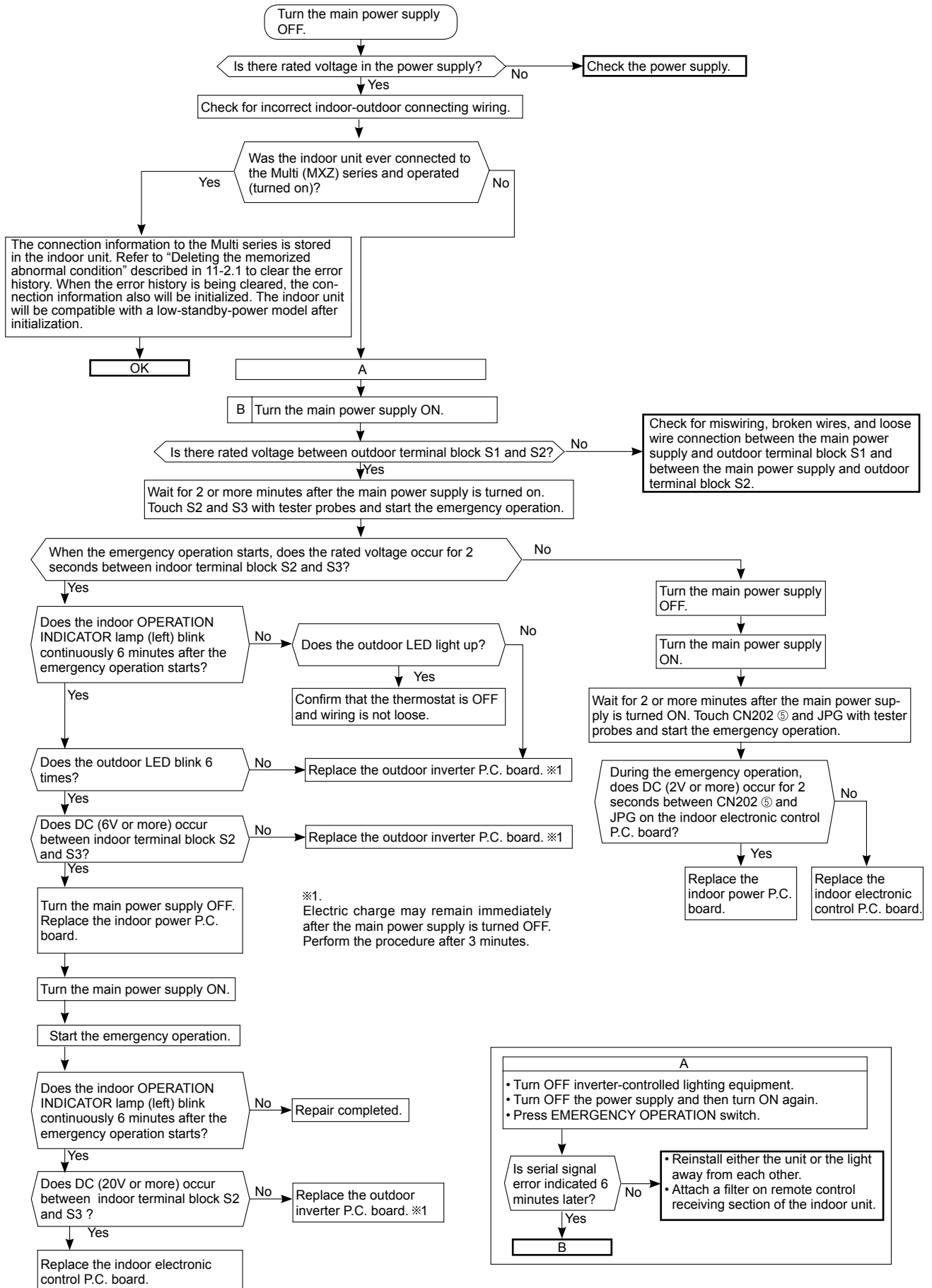

Ⓝ Electromagnetic noise enters into TV sets or radios

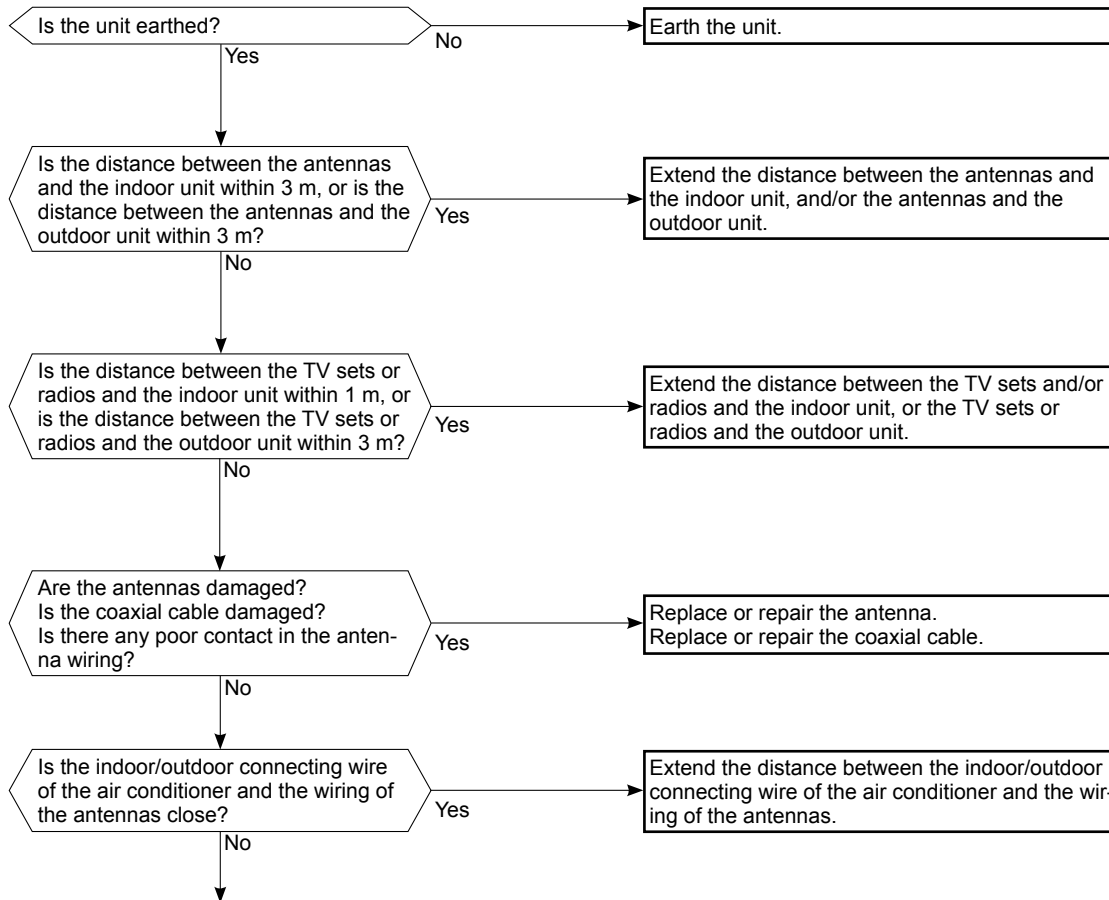

Even if all of the above conditions are fulfilled, the electromagnetic noise may enter, depending on the electric field strength or the installation condition (combination of specific conditions such as antennas or wiring). Check the following before asking for service.

1. Devices affected by the electromagnetic noise
TV sets, radios (FM/AM broadcast, shortwave)
2. Channel, frequency, broadcast station affected by the electromagnetic noise
3. Channel, frequency, broadcast station unaffected by the electromagnetic noise
4. Layout of:
indoor/outdoor unit of the air conditioner, indoor/outdoor wiring, earth wire, antennas, wiring from antennas, receiver
5. Electric field intensity of the broadcast station affected by the electromagnetic noise
6. Presence or absence of amplifier such as booster
7. Operation condition of air conditioner when the electromagnetic noise enters in
 - 1) Turn OFF the power supply once, and then turn ON the power supply. In this situation, check for the electromagnetic noise.
 - 2) Within 3 minutes after turning ON the power supply, press OPERATE/STOP (ON/OFF) button on the remote controller for power ON, and check for the electromagnetic noise.
 - 3) After a short time (3 minutes later after turning ON), the outdoor unit starts running. During operation, check for the electromagnetic noise.
 - 4) Press OPERATE/STOP (ON/OFF) button on the remote controller for power OFF, when the outdoor unit stops but the indoor/outdoor communication still runs on. In this situation, check for the electromagnetic noise.



⊙ Check of defrost heater

MUZ-SF•VEH

Check the following points before checking electric continuity.

- 1. Does the resistance of ambient temperature thermistor have the characteristics? Refer to 11-6.1.
- 2. Is the resistance of defrost heater normal? Refer to 11-4.
- 3. Does the heater protector remain conducted (not open)?
- 4. Are both ambient temperature thermistor and circuit of defrost heater securely connected to connectors?

In HEAT mode, for more than 5 minutes, let the ambient temperature thermistor continue to read 5°C or below, and let the defrost thermistor continue to read -1°C or below.

NOTE: In case both thermistors are more than the above temperature, cool them with cold water etc...

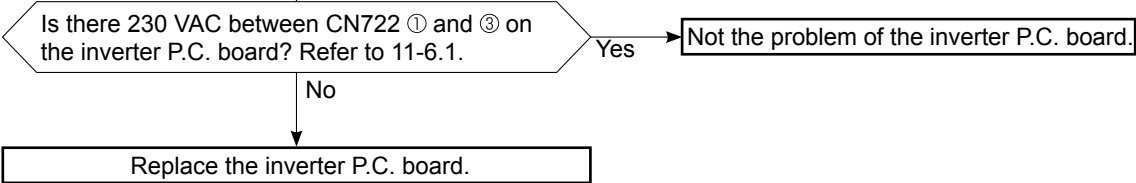

11-6. TEST POINT DIAGRAM AND VOLTAGE

1. Inverter P.C. board

MUZ-SF25VE MUZ-SF25VEH MUZ-SF35VE MUZ-SF35VEH
MUZ-SF42VE MUZ-SF42VEH MUZ-SF50VE MUZ-SF50VEH

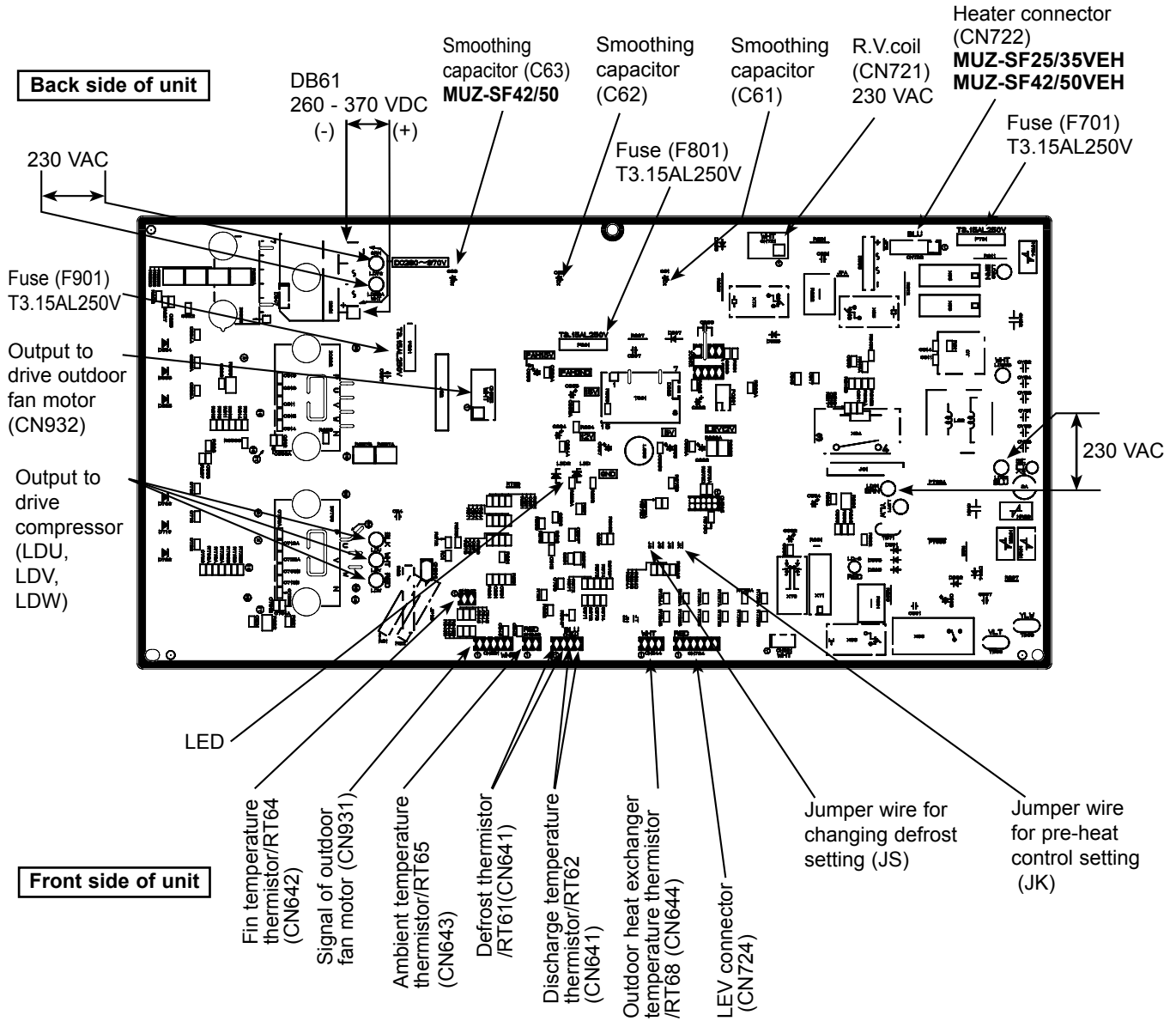

Defrost thermistor(RT61)
 Ambient temperature thermistor(RT65)
 Outdoor heat exchanger temperature thermistor(RT68)

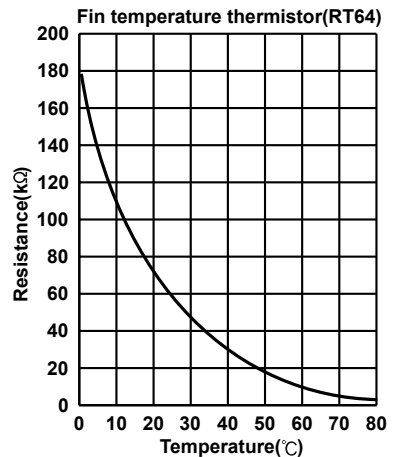
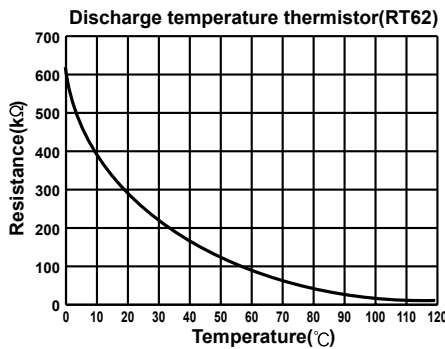
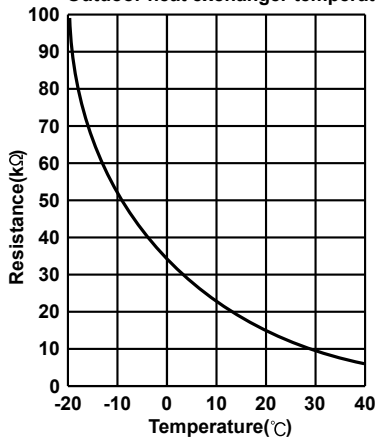

<"Terminal with locking mechanism" Detaching points>

The terminal which has the locking mechanism can be detached as shown below.
There are two types (refer to (1) and (2)) of the terminal with locking mechanism.
The terminal without locking mechanism can be detached by pulling it out.
Check the shape of the terminal before detaching.

(1) Slide the sleeve and check if there is a locking lever or not.

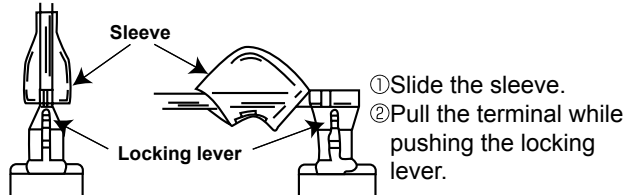

(2) The terminal with this connector has the locking mechanism.

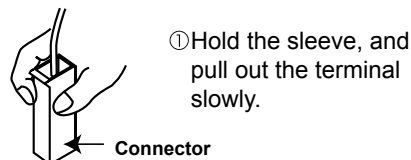

12-1. MUZ-SF25VE MUZ-SF25VEH MUZ-SF35VE MUZ-SF35VEH MUZ-SF42VE MUZ-SF42VEH

NOTE: Turn OFF power supply before disassembly.

OPERATING PROCEDURE	PHOTOS
<p>1. Removing the cabinet</p> <ol style="list-style-type: none"> (1) Remove the screw fixing the service panel. (2) Pull down the service panel and remove it. (3) Disconnect the power supply and indoor/outdoor connecting wire. (4) Remove the screws fixing the top panel. (5) Remove the top panel. (6) Remove the screws fixing the cabinet. (7) Remove the cabinet. (8) Remove the screws fixing the back panel. (9) Remove the back panel. 	<p>Photo 1</p> <p>Photo 2</p>

OPERATING PROCEDURE

2. Removing the inverter assembly, inverter P.C. board

- (1) Remove the cabinet and panels. (Refer to 1.)
- (2) Disconnect the lead wire to the reactor and the following connectors:
<Inverter P.C. board>
CN721 (R.V. coil)
CN722 (Defrost heater) **MUZ-SF25/35/42VEH**
CN931, CN932 (Fan motor)
CN641 (Defrost thermistor and discharge temperature thermistor)
CN643 (Ambient temperature thermistor)
CN644 (Outdoor heat exchanger temperature thermistor)
CN724 (LEV)
- (3) Remove the compressor connector (CN61).
- (4) Remove the screws fixing the heat sink support and the separator.
- (5) Remove the fixing screws of the terminal block support and the back panel.
- (6) Remove the inverter assembly.
- (7) Remove the screw of the earth wire and screw of the terminal block support.
- (8) Remove the heat sink support from the P.C. board support.
- (9) Remove the screw of the inverter P.C. board and remove the inverter P.C. board from the P.C. board support.

3. Removing R.V. coil

- (1) Remove the cabinet and panels. (Refer to 1.)
- (2) Disconnect the following connectors:
<Inverter P.C. board>
CN721 (R.V. coil)
- (3) Remove the R.V. coil.

4. Removing the discharge temperature thermistor, defrost thermistor, outdoor heat exchanger temperature thermistor and ambient temperature thermistor

- (1) Remove the cabinet and panels. (Refer to 1.)
- (2) Disconnect the lead wire to the reactor and the following connectors:
<Inverter P.C. board>
CN641 (Defrost thermistor and discharge temperature thermistor)
CN643 (Ambient temperature thermistor)
CN644 (Outdoor heat exchanger temperature thermistor)
- (3) Pull out the discharge temperature thermistor from its holder.
- (4) Pull out the defrost thermistor from its holder. (Photo 6)
- (5) Pull out the outdoor heat exchanger temperature thermistor from its holder. (Photo 6)
- (6) Pull out the ambient temperature thermistor from its holder.

PHOTOS

Photo 3

Screws of the heat sink support and the separator Screws of the terminal block support and the back panel

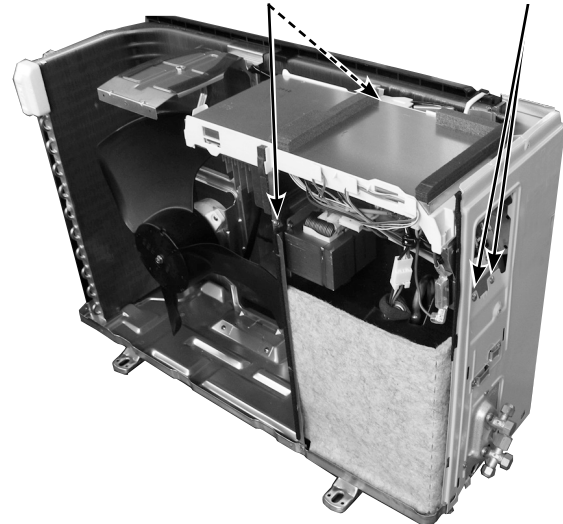

Note: As for **MUZ-SF25VE(H)**, the shape of the outdoor heat exchanger is a flat type.

Photo 4 (Inverter assembly)

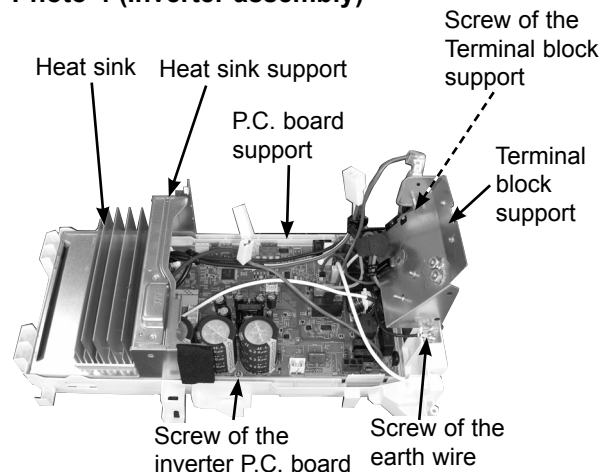

Photo 5

Screw of the R.V. coil



Discharge temperature thermistor

OPERATING PROCEDURE

5. Removing outdoor fan motor

- (1) Remove the cabinet and panels. (Refer to 1.)
- (2) Disconnect the following connectors:
<Inverter P.C. board>
CN931, CN932 (Fan motor)
- (3) Remove the propeller nut.
- (4) Remove the propeller.
- (5) Remove the screws fixing the fan motor.
- (6) Remove the fan motor.

6. Removing the compressor and 4-way valve

- (1) Remove the cabinet and panels. (Refer to 1.)
- (2) Remove the inverter assembly. (Refer to 2.)
- (3) Recover gas from the refrigerant circuit.
NOTE: Recover gas from the pipes until the pressure gauge shows 0 kg/cm² (0 MPa).
- (4) Detach the brazed part of the suction and the discharge pipe connected with compressor.
- (5) Remove the nuts of compressor legs.
- (6) Remove the compressor.
- (7) Detach the brazed part of pipes connected with 4-way valve.

PHOTOS

Photo 6

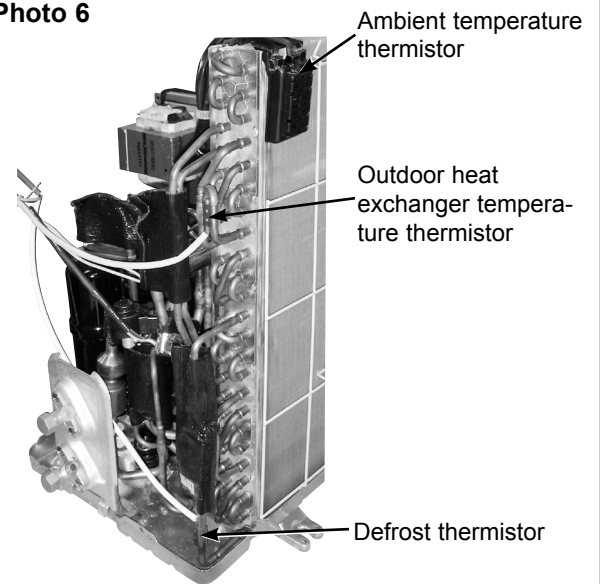

Photo 7

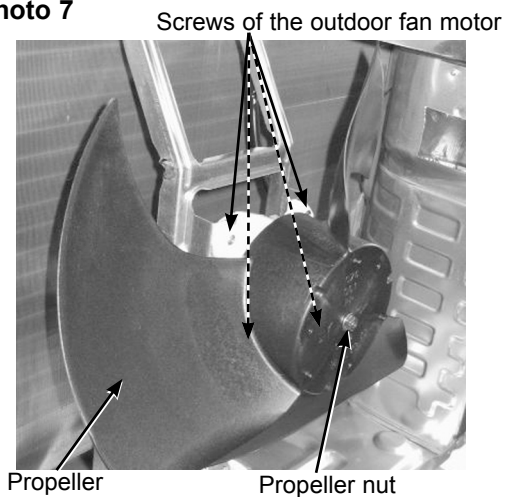
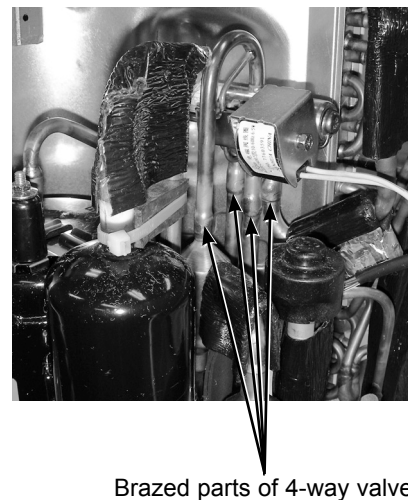
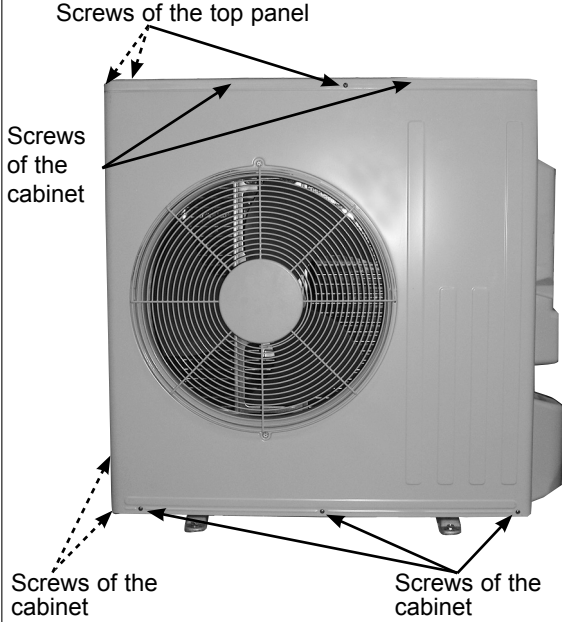
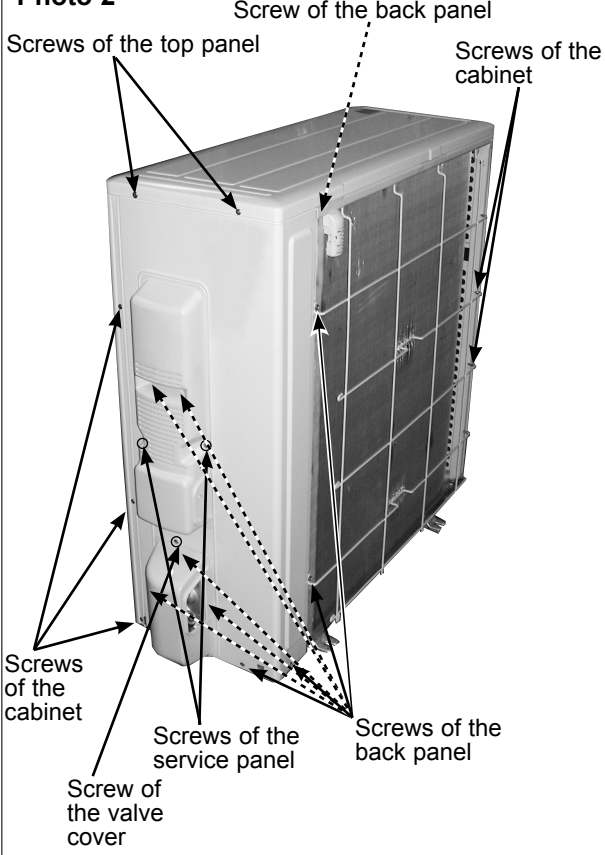

Photo 8



12-2. MUZ-SF50VE MUZ-SF50VEH

NOTE: Turn OFF power supply before disassembly.

OPERATING PROCEDURE	PHOTOS
<p>1. Removing the cabinet</p> <ol style="list-style-type: none">(1) Remove the screws of the service panel.(2) Remove the screws of the top panel.(3) Remove the screw of the valve cover.(4) Remove the service panel.(5) Remove the top panel.(6) Remove the valve cover.(7) Disconnect the power supply and indoor/outdoor connecting wire.(8) Remove the screws of the cabinet.(9) Remove the cabinet.(10) Remove the screws of the back panel.(11) Remove the back panel.	<p>Photo 1</p>  <p>Screws of the top panel</p> <p>Screws of the cabinet</p> <p>Screws of the cabinet</p> <p>Screws of the cabinet</p> <p>Photo 2</p>  <p>Screw of the back panel</p> <p>Screws of the top panel</p> <p>Screws of the cabinet</p> <p>Screws of the cabinet</p> <p>Screws of the service panel</p> <p>Screw of the valve cover</p> <p>Screws of the back panel</p>

OPERATING PROCEDURE

2. Removing the inverter assembly, inverter P.C. board

- (1) Remove the cabinet and panels. (Refer to 1.)
- (2) Disconnect the lead wire to the reactor and the following connectors:
 - <Inverter P.C. board>
 - CN721 (R.V. coil)
 - CN722 (Defrost heater) **MUZ-SF50VEH**
 - CN931, CN932 (Fan motor)
 - CN641 (Defrost thermistor and discharge temperature thermistor)
 - CN643 (Ambient temperature thermistor)
 - CN644 (Outdoor heat exchanger temperature thermistor)
 - CN724 (LEV)
- (3) Remove the compressor connector.
- (4) Remove the screws fixing the heat sink support and the separator.
- (5) Remove the fixing screws of the terminal block support and the back panel.
- (6) Remove the inverter assembly.
- (7) Remove the screw of the earth wire, screw of the P.C. board cover and screws of the terminal block support.
- (8) Remove the heat sink support from the P.C. board support.
- (9) Remove the screw of the inverter P.C. board and the inverter P.C. board from the P.C. board support.

3. Removing R.V. coil

- (1) Remove the cabinet and panels. (Refer to 1.)
- (2) Disconnect the following connector:
 - <Inverter P.C. board>
 - CN721 (R.V. coil)
- (3) Remove the R.V. coil.

PHOTOS

Photo 3

Screw of the heat sink support and the separator

Screw of the terminal block support and the back panel

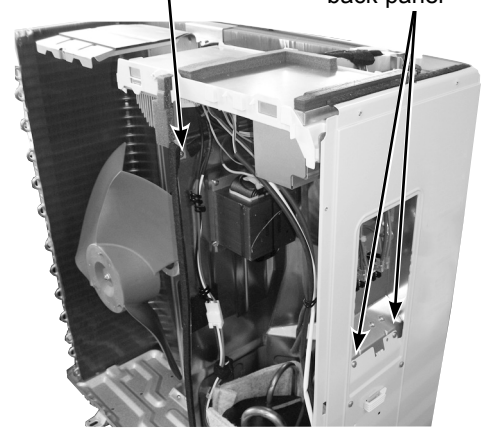

Photo 4

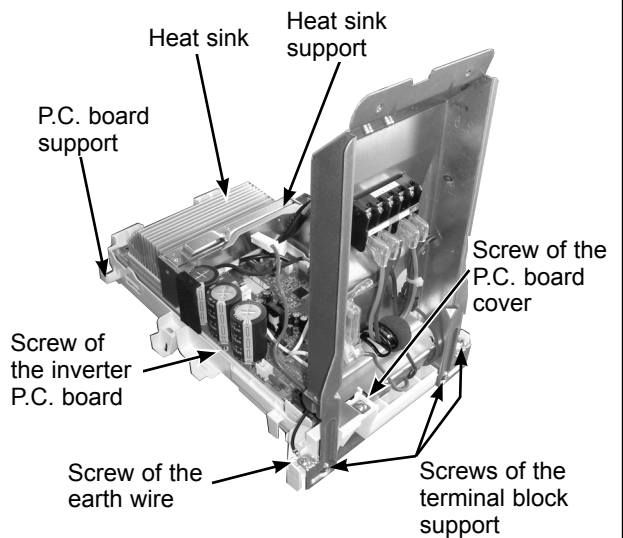
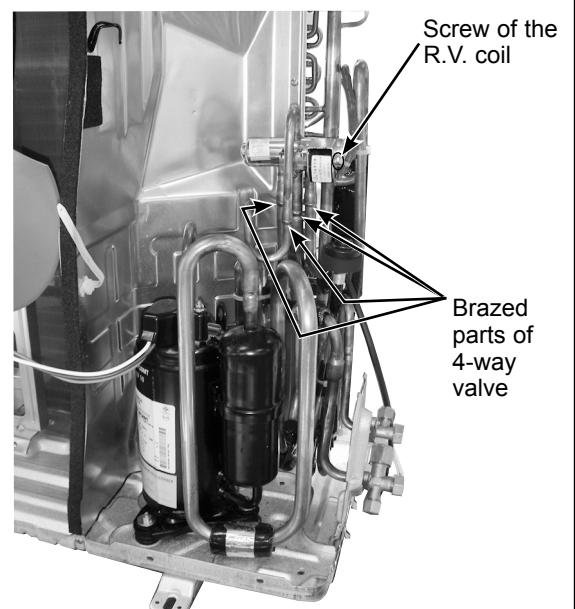

Photo 5



OPERATING PROCEDURE

4. Removing the discharge temperature thermistor, defrost thermistor, outdoor heat exchanger temperature thermistor and ambient temperature thermistor

- (1) Remove the cabinet and panels. (Refer to 1.)
- (2) Disconnect the lead wire to the reactor and the following connectors:
<Inverter P.C. board>
CN641 (Defrost thermistor and discharge temperature thermistor)
CN643 (Ambient temperature thermistor)
CN644 (Outdoor heat exchanger temperature thermistor)
- (3) Pull out the discharge temperature thermistor from its holder.
- (4) Pull out the defrost thermistor from its holder.
- (5) Pull out the outdoor heat exchanger temperature thermistor from its holder.
- (6) Pull out the ambient temperature thermistor from its holder.

5. Removing outdoor fan motor

- (1) Remove the top panel, cabinet and service panel. (Refer to 1.)
- (2) Disconnect the following connectors:
<Inverter P.C. board>
CN931 and CN932 (Fan motor)
- (3) Remove the propeller nut.
- (4) Remove the propeller.
- (5) Remove the screws fixing the fan motor.
- (6) Remove the fan motor.

6. Removing the compressor and 4-way valve

- (1) Remove the top panel, cabinet and service panel. (Refer to 1.)
- (2) Remove the back panel. (Refer to 1.)
- (3) Remove the inverter assembly. (Refer to 2.)
- (4) Recover gas from the refrigerant circuit.
NOTE: Recover gas from the pipes until the pressure gauge shows 0 kg/cm² (0 MPa).
- (5) Detach the brazed part of the suction and the discharge pipe connected with compressor.
- (6) Remove the compressor nuts.
- (7) Remove the compressor.
- (8) Detach the brazed part of 4-way valve and pipe. (Photo 5)

PHOTOS

Photo 6

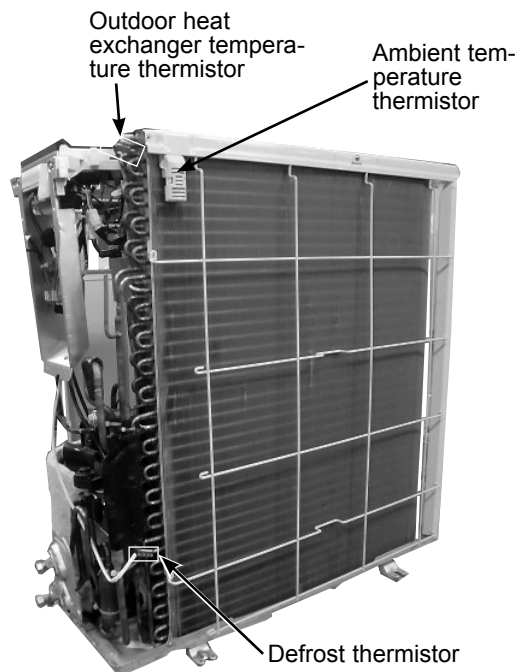

Photo 7

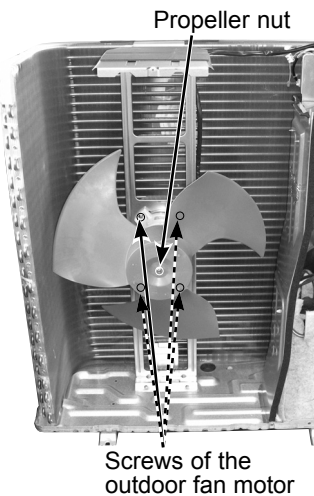
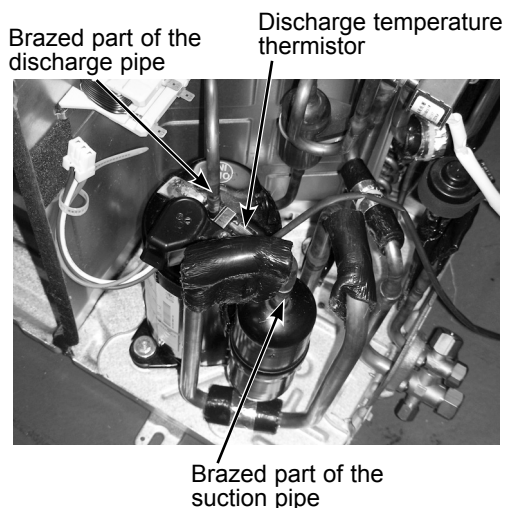

Photo 8



mitsubishi electric corporation

HEAD OFFICE: TOKYO BLDG., 2-7-3, MARUNOUCHI, CHIYODA-KU, TOKYO 100-8310, JAPAN

© Copyright 2012 MITSUBISHI ELECTRIC CORPORATION
Distributed in Nov. 2012. No. OBH629
Made in Japan

New publication, effective Nov. 2012
Specifications are subject to change without notice.