



Condensing Unit
(Inverter scroll compressor installed)

ECOV-X15VA(-BS)

INSTALLATION MANUAL

For safe and correct use, please read this installation manual thoroughly before installing the condensing unit.

en



<http://www.mitsubishielectric.com/ldg/ibim/>

Go to the above website to download manuals, select model name, then choose language.

Contents

	Pages
Safety Precautions	5
Installation process and safety precautions for use with R744	13
1. Precautions for the handling of R744	14
1-1. Characteristics of R744	14
1-2. Notes for the handling of R744	14
1-3. Precautions for working with R744	14
2. Usage conditions/environment.....	15
2-1. Usage conditions	15
2-2. Usage conditions/environment	15
3. Unit components and parts list	16
3-1. Unit components	16
3-1-1. ECOV-X15VA.....	16
3-2. Package contents	16
3-3. Transporting and unpacking the unit	17
4. Precautions for installation.....	18
4-1. Precautions for installing the unit.....	18
4-2. Specifications of general commercial parts	19
4-2-1. Refrigerant pipes.....	19
5. Selecting the installation site.....	20
5-1. Statutory compliance	20
5-2. Consideration for pollution prevention and environment protection.....	20
5-3. Selecting the installation site	20
5-3-1. Installation environment and restrictions.....	20
5-4. Height difference between devices.....	20
5-4-1. Height difference between the condensing unit and the evaporator	20
5-5. Required space.....	21
5-5-1. Installation examples: Maximum ambient operating temperature of 43°C (109°F)	21
5-5-2. Minimum servicing space.....	21
5-6. Measures against strong winds	22
5-7. Measures against snow	22
5-7-1. Installing the unit in a winter snow area	22
6. Installation work.....	23
6-1. Progress of construction of building and construction conditions	23
6-1-1. Installation on the foundation	23
6-1-2. Installation bolt	23
6-1-3. Anti-vibration measures	23
6-1-4. Sound insulation work.....	24
6-1-5. Fixing the top of the unit to the wall.....	24

Contents

	Pages
7. Refrigerant piping work.....	25
7-1. General information	25
7-1-1. Removing the bypass pipe.....	25
7-1-2. Notes on water and contaminants.....	25
7-1-3. Pipe size	26
7-1-4. Height difference between devices	26
7-1-5. Supporting the pipes	26
7-1-6. Notes on contaminants while flaring the pipes.....	26
7-2. Installation of suction pipe	26
7-2-1. Installing the horizontal pipe.....	26
7-3. Installation of liquid pipe	27
7-3-1. Installing the solenoid valve <liquid>.....	27
7-3-2. Installing the strainer <liquid>	27
7-3-3. Installing the dryer.....	27
7-3-4. Installing the sight glass.....	27
7-3-5. Installing a pressure relief device.....	27
7-3-6. When the ambient temperature around the pipe rises high	27
7-3-7. When the evaporator is installed below the main suction pipe	27
7-3-8. When there are multiple evaporators in the system.....	27
7-3-9. About the evaporator to be connected	28
7-4. Installation of heat recovery port.....	28
7-5. Connecting pipes	29
7-5-1. Brazing.....	29
7-6. Pipe routing: Single and collective installations	30
8. Electrical wiring.....	31
8-1. Notes on wiring	31
8-2. Wire capacity	32
8-3. Electrical characteristics	33
8-4. Connecting wires	34
8-5. Output signal to external devices.....	35
8-6. How to use MODBUS®	37
8-6-1. Precautions for using MODBUS®	37
8-6-2. RS485 communication specifications	37
8-6-3. MODBUS® wiring procedure.....	37
8-7. Electric circuit diagram.....	38

Contents

	Pages
9. Air tightness test/Vacuum drying	39
9-1. Air tightness test	39
9-1-1. Purpose of air tightness test.....	39
9-1-2. Air tightness test pressure.....	39
9-1-3. Air tightness test procedure	39
9-1-4. Refrigerant leakage detection	40
9-2. Vacuum drying.....	40
9-2-1. Purpose of vacuum drying	40
9-2-2. Vacuum drying procedure.....	40
9-2-3. Connection of the vacuum pump	42
9-2-4. Procedures for stopping the vacuum pump	43
9-2-5. Required precision of vacuum gauge.....	43
9-2-6. Operating the valve check joint.....	43
9-2-7. Parts names.....	44
10. Refrigerant charging	45
10-1. Refrigerant charging procedure	45
10-2. Allowable amount of refrigerant to be charged	46
10-3. Insulating	47
11. Test run	48
11-1. To ensure proper test run	48
11-2. Setting the pressure switch <high pressure>.....	48
11-3. Setting the target evaporation temperature	49
11-4. Test run procedure	50
11-4-1. Initial processing	50
11-4-2. Operation	50
11-4-3. Stop the unit. (Pump down stop).....	50
11-4-4. Display of the MAIN board (inside the control box).....	51
11-5. Checking the unit condition.....	51
11-5-1. Regular operation check.....	51
11-5-2. Preventing short-cycling operation.....	52
11-5-3. Troubleshooting	52
12. Post-installation inspection	53
12-1. Installation check list.....	53
12-2. Check items for refrigerant circuit components.....	54
13. Providing guidance on the usage to the end users	55
13-1. Maintenance	55
13-2. Preventing continuous liquid refrigerant flood-back.....	55
13-3. Regular operation check.....	55
13-4. Cleaning the heat exchanger fins	55
13-5. Cleaning the panels	55
13-6. Handling of the all-aluminum heat exchanger	55
13-7. Cleaning the discharge heat duct mesh	56
14. Specifications	57

Safety Precautions

- ♦ Please read the following safety precautions carefully before installing the unit to ensure safety.
- ♦ To ensure your safety, be sure to observe the precautions described in this section.



WARNING

Indicates a risk of death or serious injury.



CAUTION

Indicates a risk of serious injury or structural damage.

- ♦ Make sure that this manual is passed on to the end user to retain for future reference.
- ♦ Retain this manual for future reference. When the unit is reinstalled or repaired, have this manual available to those who provide these services. Make sure that this manual is passed on to any future users.



WARNING

All electric work must be performed by qualified personnel.
Air tightness test must be performed by qualified personnel.
Brazing work must be performed by qualified personnel.

General Precautions



WARNING

Do not use the type of refrigerant other than the one indicated on the nameplate and in the manuals for the unit. Doing so may cause the pipes or the units to burst or explode, or cause a fire during use, during repair, or at the time of disposal of the unit. It may also be in violation of applicable laws. MITSUBISHI ELECTRIC CORPORATION cannot be held responsible for malfunctions or accidents resulting from the use of the wrong type of refrigerant.

This appliance is not intended for use by persons (including children) with reduced physical, sensory or mental capabilities, or lack of experience and knowledge, unless they have been given supervision or instruction concerning use of the appliance by a person responsible for their safety. Children shall not play with the appliance.

Do not install the unit in a place where large amounts of oil, steam, organic solvents, or corrosive gases, such as sulfuric gas, are present or where acidic/alkaline solutions or sprays containing sulfur are used frequently. These substances can compromise the performance of the unit or cause certain components of the unit to corrode, which can result in refrigerant leakage, water leakage, injury, electric shock, malfunctions, smoke, or fire.

Do not try to defeat the protective features of the unit or make unauthorized setting changes. Forcing the unit to operate by defeating the safety features of the devices such as the pressure switch or the temperature switch, making unauthorized changes to the switch settings, or using accessories other than the ones recommended by Mitsubishi Electric may result in smoke, fire, burst pipes or units, or an explosion.

To reduce the risk of injury from falling tools, keep children away while installing, inspecting, or repairing the unit.

The refrigeration system is under high pressure. Do not tamper with it. Contact qualified service personnel before disposal. Tampering with the system may result in refrigerant or water leakage, injury, electric shock, or fire.

Always replace a fuse with one with the correct current rating. The use of improperly rated fuses or a substitution of fuses with steel or copper wire may result in fire.

To reduce the risk of burns or electric shock, do not touch any electrical parts with bare hands during or immediately after stopping operation.

To reduce the risk of short circuit, current leakage, electric shock, malfunctions, smoke, or fire, do not splash water on electric parts.

To reduce the risk of electric shock, malfunctions, smoke, or fire, do not operate the switches/buttons or touch other electrical parts with wet hands.

Do not change the settings for the safety or protective features of the unit. Incorrect settings may cause the unit to burst or explode.

To reduce the risk of pipe burst or explosion, do not allow gas refrigerant and refrigerant oil to be trapped in the refrigerant circuit.

To reduce the risk of injury or electric shock, stop the unit and turn off the main power before cleaning, maintaining, or inspecting the unit. Coming in contact with the fan and other rotating parts may cause injury.

To reduce the risk of burns or frost bites, do not touch the refrigerant pipes or refrigerant circuit components with bare hands during and immediately after operation.

Do not touch the pipes with bare hands. Pipes become hot, posing a risk of burn injury.

Keep the space well ventilated. Refrigerant leaking into an air-tight space can cause oxygen deprivation. Refrigerant (CO₂) concentration above 0.1% can adversely affect health. If leaked refrigerant comes in contact with fire, toxic gas may be generated.

CAUTION

Do not place flammable objects or use flammable spray near the unit. Doing so may result in fire ignition, fire, or explosion.

Do not operate the unit without panels and safety guards properly installed. Coming in contact with the rotating parts, high-voltage parts, or high-temperature parts poses injury, electric shock, or burn injury hazards.

To reduce the risk of injury, do not sit, stand, or place objects on the unit.

Do not install the unit over things that are vulnerable to water damage from condensation dripping.

To reduce the risk of injury, do not touch the fan blades, heat exchanger fins, or sharp edges of components with bare hands.

When tightening or loosening the check joint, use two spanners. The use of a single spanner may cause the pipe to twist and become damaged, resulting in refrigerant leakage, oil spatter, or oxygen deprivation.

Design the refrigerant circuit so that the circuit will meet all specifications. Refrigerant circuits that do not meet the specifications may cause electric leakage, fire, or burst pipes or units.

Stop the unit, turn off the unit, and contact your dealer or a customer service center if any abnormality (e.g., a burning smell) is noticed. Continued use of the unit may result in an electric shock, damage to the refrigerant circuit components, or fire.

To reduce the risk of electric shock, smoke, or fire due to infiltration of dust and water, properly install all required covers on the unit.

To reduce the risk of electric shock, smoke, or fire due to infiltration of dust and water, properly install all required covers and panels on the terminal box and control box.

To reduce the risk of injury from the unit falling or falling over, periodically check the installation base for damage.

This appliance is intended to be used by expert or trained users in shops, in light industry and on farms, or for commercial use by lay persons.

Consult an authorized agency for the proper disposal of the unit. Refrigerant oil and refrigerant that may be left in the unit pose a risk of fire, explosion, or environmental pollution.

Wear protective gear to keep oil spatter from getting on your skin.

Wear protective gear before touching any electrical components. Touching high-temperature or high-voltage components with bare hands poses burn or electric shock hazards. Some components (e.g., terminals) on the circuit boards or terminal blocks carry voltage for several minutes after the ON/OFF switch or the main power is turned off, posing electric shock hazards.

To reduce the risk of injury, do not insert fingers or foreign objects into air inlet/outlet grills of the fan.

To reduce the risk of injury, always wear protective gear when working on the unit.

Do not release refrigerant into the atmosphere. Have it properly disposed of by an authorized agency according to the applicable laws and regulations.

Transportation and Installation

WARNING

Lift the unit by placing the slings at designated locations. Support the unit securely at four points to keep it from slipping and sliding. If the unit is not properly supported, it may fall and cause personal injury.

CAUTION

To reduce the risk of injury, do not carry the unit by the PP bands that are used on some packages.

To reduce the risk of injury, products weighing 20 kg or above must be carried by two or more people.

Installation

WARNING

Do not install the unit where there is a risk of leaking flammable gas. If flammable gas accumulates around the unit, it may ignite and cause a fire or explosion.

To reduce the risk of injury from coming in contact with the unit, install the unit where it is not accessible to people other than maintenance personnel.

Do not install the unit indoor, in a depressed space, or in a halfway basement. Leaked refrigerant can accumulate in these types of spaces.

To reduce the risk of injury, properly dispose of the packing materials. Plastic bags pose suffocation hazard to children.

Install a pressure relief device in accordance with applicable local regulations. Failure to do so may result in a burst.

All installation work must be performed by the dealer or qualified personnel according to the instructions detailed in the Installation Manual. Improper installation work may cause refrigerant leakage, water leakage, injury, electric shock, or fire.

Remove packing materials from the unit before operating the unit. Note that some accessories may be taped to the unit. Properly install all accessories that are required. Failing to remove the packing materials or failing to install required accessories may result in refrigerant leakage, oxygen deprivation, smoke, or fire.

Take appropriate measures to safeguard against refrigerant leakage and resultant oxygen starvation. Install a refrigerant leak detector as required by the applicable regulations for a given space.

Any additional parts must be installed by the dealer or qualified personnel. Only use the parts specified by Mitsubishi Electric. Installation by unauthorized personnel or use of unauthorized parts or accessories may result in water leakage, injury, electric shock, or fire.

Properly install the unit in accordance with all applicable instructions and regulations. Failure to do so may cause the unit to topple over or fall down and cause personal injury.

Install the unit horizontally, using a level. A unit installed on an inclined surface can result in water leakage or topple over and cause injury.

To reduce the risk of injury from units falling or falling over, install the unit on a surface that is strong enough to support its weight.

CAUTION

To reduce the risk of rain water or drain water from entering the room and damaging the interior, drainage work must be performed by your dealer or qualified personnel according to the instructions detailed in the Installation Manual.

Piping Work

WARNING

Use caution when operating the refrigerant service valve. Refrigerant may spew out and cause oxygen starvation, frost bites, or injuries.

To reduce the risk of refrigerant catching fire and causing burns, remove the refrigerant gas and the residual refrigerant oil in the pipes before heating them.

To reduce the risk of pipe damage, refrigerant leakage, or oxygen deprivation, use pipes that meet the pipe thickness specifications, which vary by the type of refrigerant used, pipe diameter, and pipe material.

Evacuate the refrigerant circuit using a vacuum pump. Allowing the type of gasses other than the one specified to infiltrate into the refrigerant circuit may result in a burst or an explosion.

To reduce the risk of explosion or deterioration of refrigerant oil caused by chloride, do not use oxygen, flammable gas, or refrigerant that contains chloride as a pressurizing gas.

CAUTION

To reduce the risk of a burst or an explosion due to an abnormal pressure rise, do not allow any substances other than R744 (such as air) to enter the refrigerant circuit.

To prevent a burst or an explosion, do not heat the unit with refrigerant gas in the refrigerant circuit.

To reduce the risk of oxygen deprivation or gas poisoning, check for gas leakage with an appropriate leak detector, and keep fire sources away.

Conduct an air-tightness test at the pressure specified on the unit and in the installation manual. Conducting an air tightness test above the specified pressure may result in damage to the unit and resultant refrigerant leakage, which can cause oxygen deprivation.

Insulate pipe connections after completing the air tightness test. Performing an air tightness test with the pipe being insulated may lead to failure to detect refrigerant leakage and cause oxygen deprivation.

To reduce the risk of pipe damage and resultant refrigerant leakage or oxygen deprivation, keep the field-installed pipes out of contact with the edges of components.

To keep the ceiling and floor from getting wet due to condensation, properly insulate the pipes.

Wiring Work

WARNING

Replace damaged circuit boards immediately. Continued use of damaged circuit boards may result in abnormal heat generation or fire.

To reduce the risk of wire breakage, overheating, smoke, or fire, keep undue force from being applied to the wires.

To reduce the risk of wire breakage, overheating, smoke, or fire, properly secure the wires in place and provide adequate slack in the wires so as not to stress the terminals.

Tighten terminal screws to the specified torque. Loose screws or wire contact may cause smoke or fire.

To reduce the risk of injury or electric shock, turn off the main power before performing electrical work.

All electric work must be performed by a qualified electrician according to the local regulations, standards, and the instructions detailed in the Installation Manual. Use specified electrical wires and a dedicated circuit. Capacity shortage in the power supply circuit or improper installation may result in electric shock, malfunction, smoke, or fire.

To reduce the risk of electric shock, smoke, or fire, install an inverter circuit breaker on the power supply to each unit.

Use properly rated breakers and fuses (earth leakage breaker, local switch <switch + fuse>, no fuse breaker). The use of breaker with a breaking capacity greater than the specified capacity may cause electric shock, malfunctions, smoke, or fire.

CAUTION

To reduce the risk of current leakage, wire breakage, smoke, or fire, keep the wiring out of contact with the refrigerant pipes and other parts, especially sharp edges.

To reduce the risk of current leakage, overheating, smoke, or fire, use properly rated wires with adequate current carrying capacity.

Do not let bare wires protrude from the terminal block. Bare wires coming in contact with each other may cause electric shock, smoke, or fire.

Proper grounding must be provided by a licensed electrician. Do not connect the grounding wire to a gas pipe, water pipe, lightning rod, or telephone wire. Improper grounding may result in electric shock, smoke, fire, or malfunction due to electrical noise interference.

If the supply cord is damaged, it must be repaired by the manufacturer, its service agent or similarly persons in order to avoid a hazard.

To reduce the risk of short circuit, electric shock, or malfunctions, keep wire shavings out of the terminal blocks.

Relocation and Repairs

WARNING

Do not alter or modify the unit. The unit must only be moved, disassembled, or repaired by your dealer or qualified personnel. Unauthorized alteration, modification, or installation of the unit by unqualified personnel may result in refrigerant leakage, water leakage, injury, electric shock, or fire.

If the supply cord is damaged, it must be replaced by the manufacturer, its service agent, or similarly qualified persons in order to avoid a hazard.

CAUTION

To reduce the risk of short circuit, electric shock, malfunctions, or fire, keep circuit boards dust free, and do not touch them with bare hands or tools.

To reduce the risk of refrigerant or water leakage, check the pipe supports and insulation for damage during inspection or repair, and replace or repair the ones that are found to be deteriorated.

To reduce the risk of short circuit, current leakage, electric shock, smoke, or fire, do not perform maintenance work in the rain.

To reduce the risk of injury, electric shock, or fire, properly reinstall all removed components after completing repair work.

R744 is cold. Avoid skin contact with R744.

To reduce the risk of frost burn, wear leather gloves before touching the refrigerant hose or the valve.

Extract the refrigerant from the check joint connected to the refrigerant service valve (three-way valve) <suction>.

The pressure of the refrigerant system using R744 is high. When removing R744 for maintenance or other purposes from the system, fix the refrigerant hose, and remove R744 gradually.

When removing R744 from the system, wrap the tip of the hose with a cloth, and remove R744 gradually. Refrigerant in the dry ice state may spew out along with a large amount of oil.

When removing R744 from the system, keep R744 away from plants and the building structures.

Observe all applicable local laws and regulations for the removal of R744.

Additional Precautions

To avoid damage to the unit, use appropriate tools to install, inspect, or repair the unit.

Recover all refrigerant in the unit, and dispose of it properly according to any applicable laws and regulations.

Do not repeatedly turn on and off the main power supply switch in less than 10 minutes. Doing so may stress the compressor and cause the compressor and the electrical parts to malfunction.

Operate the unit within the specified usage range. The use of the unit outside the specified operation range may cause the unit to malfunction.

Do not block the inlets or outlets of the unit. Obstruction of air flow may reduce the performance of the unit or cause the unit to malfunction.

Do not touch the switches on the unit or the components of the refrigerant circuit for no good reason. Doing so may change the operating mode and result in damage to the unit.

Only use R744. The use of refrigerant other than R744 may result in damage to the refrigerant system components.

Provide a maintenance access to allow for the inspection of pipes above the ceiling or the buried pipes.

Take appropriate measures against electrical noise interference when installing the air conditioning units in hospitals or facilities with radio communication capabilities. Inverter, high-frequency medical, or wireless communication equipment as well as power generators may cause the air conditioning system to malfunction. Air conditioning system may also adversely affect the operation of these types of equipment by creating electrical noise.

Direct the blazing torch flame away from the adjacent wires and sheet metal to keep them from being overheated and damaged.

Prepare tools for exclusive use with R744. Do not use the following tools if they have been used with other types of refrigerant: gauge manifold, charging hose, refrigerant leak detector, check valve, refrigerant charge spout, vacuum gauge, and refrigerant recovery equipment. If other types of refrigerant, refrigerant oil, or water remaining on these tools enter the refrigerant circuit, the refrigerant oil in the new system may deteriorate and the equipment may malfunction.

Use a vacuum pump with a check valve so that the vacuum pump oil will not backflow into the refrigerant circuit and cause the refrigerant oil to deteriorate.

Have a set of tools for exclusive use with R744. Consult your nearest Mitsubishi Electric Dealer.

Keep dust, dirt, and water off the charging hose. Infiltration of dust, dirt, or water into the refrigerant circuit may cause the refrigerant oil to deteriorate or damage the compressor.

Use refrigerant piping and couplings that are suitable for use with R744. Keep the inner and outer surfaces of pipes and couplings clean and free of such contaminants as sulfur, oxides, dust, dirt, shaving particles, oil, and moisture. Failure to do so may result in the deterioration of refrigerant oil and compressor failure.

Store the piping materials indoors, and keep both ends of the pipes sealed until immediately before brazing. Keep elbows and other joints in plastic bags. Infiltration of dust, dirt, or water into the refrigerant circuit may cause the refrigerant oil to deteriorate or damage the compressor.

To reduce the risk of oxidized film from entering the refrigerant pipe and causing the refrigerant oil to deteriorate or damaging the compressor, braze pipes under nitrogen purge.

Do not use the existing pipes. The high and low pressures in R744 systems are higher than those in the systems using other types of refrigerants, and the use of pipes not suitable for R744 may result in damage to the unit.

Charge the refrigerant from the high-pressure side. Charging the refrigerant from the low-pressure side may result in compressor damage.

Do not use a charging cylinder.

To reduce the risk of power capacity shortage, always use a dedicated power supply circuit.

To reduce the risk of both the breaker on the unit side and the upstream breaker from tripping and causing problems, split the power supply system or provide protection coordination between the earth leakage breaker and no-fuse breaker.

Have a backup system, if failure of the unit has a potential for causing significant problems or damages.

The installer must carry an R744 leak detector when installing or uninstalling the unit.

Connect an evaporator that is compatible with R744. The use of a refrigerant other than R744 may damage the equipment.

**The design pressure must not be exceeded.
(Equipment pressure: High pressure 12 MPa;
Low pressure 8.5 MPa)**

This unit <ECOV-X15VA> is a condensing unit, complying with condensing unit requirements of IEC60335-2-40, must only be connected to other units that have been confirmed as complying to corresponding evaporator requirements of this international standard.

Installation process and safety precautions for use with R744

<Steps for installation>	<Safety precautions for use with R744>	<Page>
Determination of installation area	<ul style="list-style-type: none"> • Check that the unit is intended for use with R744. • Check the equipment pressure. (High pressure 12.0 MPa, Low pressure 8.5 MPa) • Use new pipes only. 	
Check of condensing unit specifications		
Drawing of working diagrams		
Installation of showcase/unit cooler	<ul style="list-style-type: none"> • Check that the unit is intended for use with R744. 	
Refrigerant piping work (Dry, clean, tight)	<p>*1</p> <ul style="list-style-type: none"> • Check that the inside of the pipes is in proper condition. • Braze the pipes under nitrogen purge. • Use a torque wrench to tighten nuts. • Carry an R744 leak detector. 	<u>P25</u>
Drain piping work		
Electrical wiring		
Foundation work of condensing unit		
Installation of condensing unit		<u>P20</u>
Refrigerant piping work	<p>Refer to *1.</p> <ul style="list-style-type: none"> • Do not allow the refrigerant oil to be exposed to air for more than 10 minutes, even during servicing. • Install a pressure relief device in accordance with applicable local regulations. 	<u>P25</u>
Electric wiring of condensing unit		<u>P31</u>
Air tightness test	<ul style="list-style-type: none"> • Perform an air tightness test. (Liquid line pressure: 12.0 MPa; Suction line pressure: 8.0 MPa) x 24 hours An air-tightness test is conducted on the condensing unit before shipment. 	<u>P39</u>
Heat-insulating work		
Vacuum drying	<ul style="list-style-type: none"> • Perform vacuum drying for one hour after the vacuum level reaches 266 Pa on the vacuum gauge. • Use a specified vacuum pump with a check valve. 	<u>P39</u>
Refrigerant charging	<ul style="list-style-type: none"> • Use the proper amount of refrigerant and the proper amount of additionally charged refrigerant. • Charge the system with liquid refrigerant only. • Use a specified gauge manifold and a specified charging hose. • Write down the amount of charged refrigerant on the nameplate on the front of the unit. 	<u>P45</u>
Target evaporation temperature setting		
Test run	<ul style="list-style-type: none"> • Check that the unit is not under short-cycling operation. • Check that the target evaporating temperature is appropriate. 	<u>P48</u>
Leakage check		
Providing guidance on the usage to the end users		<u>P55</u>

1. Precautions for the handling of R744

1-1. Characteristics of R744

R744 is a natural refrigerant with the ozone depletion coefficient of zero and the global warming coefficient of 1.

The pressure of R744 at the normal temperature (25°C(77°F)) is as high as 6.4 MPa, which is approximately five times that of R404A (1.24 MPa), requiring more stringent safety precautions.

1-2. Notes for the handling of R744

Seek appropriate treatment if exposed to R744.

(1) If R744 was inhaled

Move to an area with fresh air. Keep warm, and seek medical attention immediately.

(2) Skin contact with R744

Do not rub the affected area. Warm the affected area with lukewarm water, wrap a piece of gauze around, and seek medical attention immediately.

(3) If R744 gets in the eyes

Rinse the affected area with clean water, and seek medical attention immediately.

1-3. Precautions for working with R744

The pressure of the refrigerant system using R744 is high. When removing R744 for maintenance or other purposes from the system, fix the refrigerant hose, wrap the tip of the hose with a cloth, and remove R744 gradually.

R744 is cold. Avoid skin contact with R744.

Wear leather gloves before touching the refrigerant hose or the valve.

2. Usage conditions/environment

2-1. Usage conditions

Usage	-	Low/Medium temperature
Refrigerant type	-	R744
Evaporation temperature	°C (°F)	-45 to -5 (-49 to 23)
Suction pressure	MPa	0.73 to 2.94
Heat level of suction gas	K	10 to 40
Suction gas temperature	°C (°F)	18 (64) or below
Discharge pressure	MPa	1.60 to 11.0
Discharge gas temperature	°C (°F)	115 (239) or below
Outside air temperature	°C (°F)	-25 to 43 (-13 to 109)
Power supply voltage	-	Single phase 220/230/240 V ± 10%, 50 Hz
Connected pipe length (suction/liquid)	m (ft)	25 (82) or below ^{*1*2*3}
Installation location	-	Outdoor ^{*4}

*1 Length that meets the piping work conditions stated in the Installation Manual, guarantees the proper oil return to the unit, and prevents refrigerant overcharge.

*2 Indicates an equivalent length.

*3 Refer to the relevant pages for details about the connected pipe length and allowable amount of refrigerant to be charged. (Page 46)

*4 Refer to the relevant pages. (Page 20)

2-2. Usage conditions/environment

Follow the condition/environment specified below for installation.

Do not install the unit on moving vehicles such as cars or ships.

Do not install the unit in a place where acidic solutions or sprays containing sulfur are used frequently.

Avoid unsuitable places (hot springs, places where chemicals are frequently used) for installation.

Install the unit in an area where the noise from the unit will not disturb the neighbors.

Do not install the unit in a place where it is subjected to radiant heat from other heat sources.

Properly install the unit on a stable, load-bearing surface.

Do not install the unit in any environment where it can be exposed to airborne iron or copper powder, acidic or alkaline atmosphere, or an accumulation of a large amount of sand containing sea salt particles. Such environments can cause corrosion of the aluminum pipes.

Do not install the unit in a place where large amount of oil, steam, ammonia, or corrosive gas such as sulfuric gas is present. (Such place includes near a chimney opening.)

Do not install the unit in a space that is not large enough as specified in the Installation Manual. (Page 21)

Do not install the unit in an area with heavy snowfall exceeding the tolerance of snow prevention work advised in this manual. (Page 22)

Do not install the unit in an area where the air is stagnant, such as indoors, in a halfway basement, or in a depressed space.

3. Unit components and parts list

3-1. Unit components

3-1-1. ECOV-X15VA

(Unit: in. [mm])

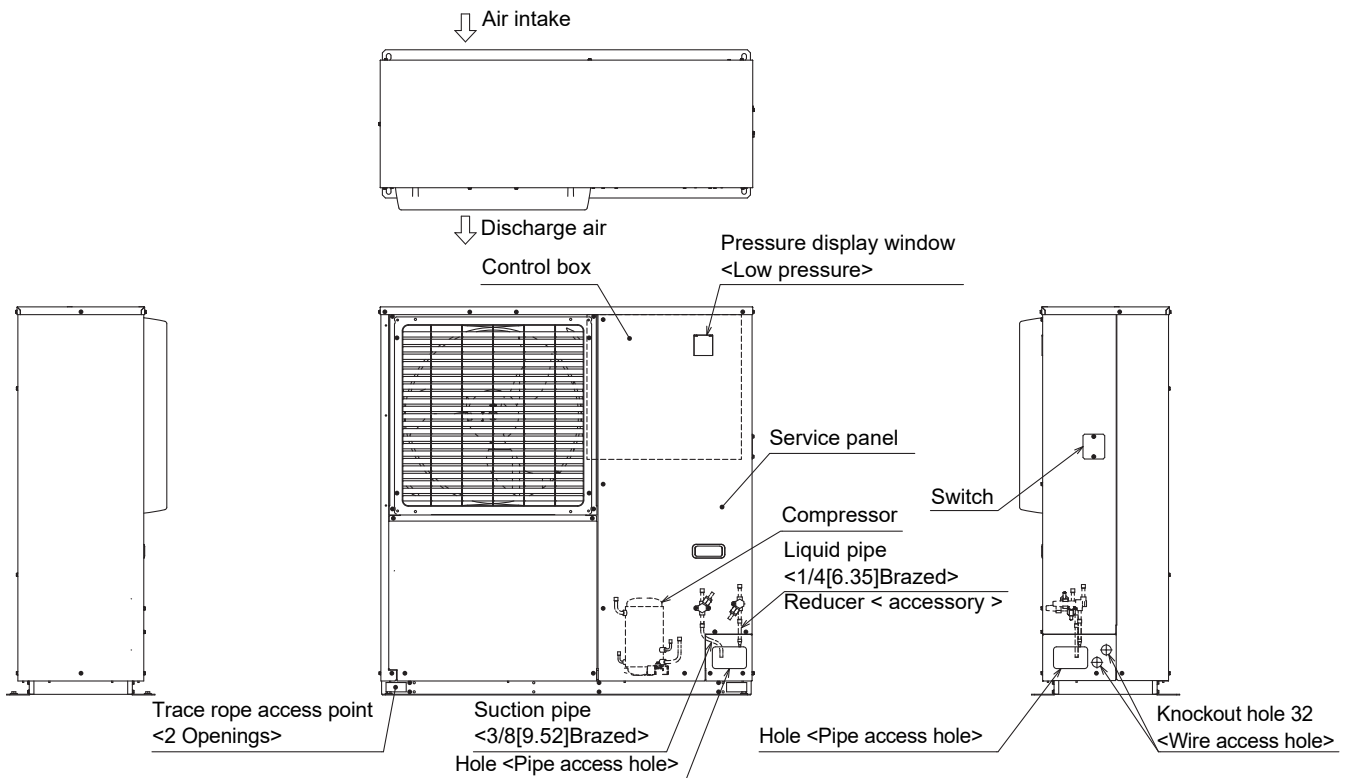

3-2. Package contents

Type	ECOV-X15VA
Fuse ^{*1}	6A
Connector for emergency operation ^{*1}	1
Termination resistance for MODBUS ^{®*1,*2}	1
Reducer	1

^{*1} Packaged in the control box.

^{*2} For usage, refer to the MODBUS[®] Interface Manual.

Please contact the supplier for the MODBUS[®] Interface Manual.

MODBUS[®] is a registered trademark of SCHNEIDER ELECTRIC USA, INC. in the United States.

3-3. Transporting and unpacking the unit

1) Transporting the unit

- Do not lift the unit. The unit must not be lifted and carried by hand.
The handles on the unit are intended to be used for positioning during installation.
- If PP bands are used on the package of the unit, do not lift the unit in a way that applies a load on any of the PP bands.
- The unit must be upright during transportation and installation.

2) Unpacking the unit

- Plastic bags can pose suffocation and choking hazards. Keep out of the reach of children and tear them before disposal.

3) Lifting the unit

- If the unit needs to be lifted for installation, pass ropes through the two hanging parts at right and left under the unit.
- The ropes must support the unit at four points. Take measures to prevent any shock to the unit while it is lifted.
- The roping angle must be within 40 to 60 degrees as shown in the figure below.
- Use two ropes with sufficient length. <7 m or longer>
The thickness of the ropes must match the size of the rope suspension parts.
If the ropes are too thin, they may break and cause the unit to fall.
- The surfaces of the unit that come into contact with the ropes may be scratched if unprotected. Use rags or cloths to protect the surfaces.

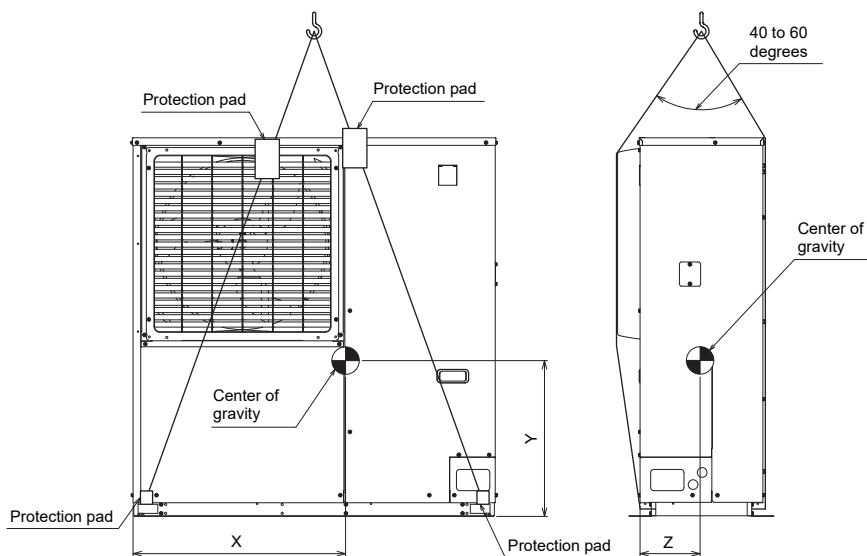

Model	ECOV-X15VA
Weight (kg) (lbs)	115 (253)
X (mm) (in.)	710 (28)
Y (mm) (in.)	528 (21)
Z (mm) (in.)	201 (8)

4. Precautions for installation

4-1. Precautions for installing the unit

Note

- Protect and maintain the pipes to prevent infiltration of contaminants such as water and dirt.
- Nitrogen purge is required to prevent formation of oxide scale while brazing the pipes.

The unit contains a rotary compressor. The usage of this unit is different from that of a unit containing a reciprocating compressor. Improper use may cause damage to the compressor. Read carefully and follow the directions below.

[1] Use R744 refrigerant.

The design pressure on the liquid-line side is 12 MPa, and that on the suction-line side is 8 MPa. (Refer to "4-2-1.Refrigerant pipes".)

Only use the refrigerant that is specified by Mitsubishi Electric.

[2] Entire compressor is hot.

The entire compressor is hot during operation and immediately after stoppage. Wait for the pressure and temperature inside the compressor to drop, especially before conducting a test run, maintenance, or servicing.

[3] Use PAG oil as refrigerant oil.

The refrigerant oil used in this unit easily absorbs moisture and tends to cause deterioration of the refrigerant oil or formation of sludge (hydrate). Therefore, complete vacuum drying is required.

Ensure to follow the basic requirements and precautions for piping work to prevent infiltration of water or dirt.

[4] Do not change the wiring connection on the secondary side.

Do not change the phase of the wiring between the Inverter board and the compressor.

Do not change the phase at the compressor terminal block.

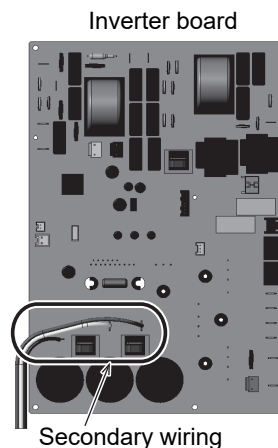

[5] Vacuum drying without specified tools is prohibited.

Vacuum drying must be performed by a specialist. Do not force the unit to operate with the refrigerant service valve (ball valve) <suction> closed. Refer to the relevant pages for the vacuum drying procedures. (Page 40)

[6] Forced stop of the evaporator fan is prohibited.

Do not operate the unit with the evaporator fan stopped (except for the short period of time immediately after defrosting). Close the solenoid valve <liquid> and pump down-stop the unit before stopping the evaporator fan.

[7] Closing the refrigerant service valve <suction> during operation is prohibited.

Do not perform a refrigerant service that suddenly lowers the low pressure, such as closing the refrigerant service valve (three-way valve) <suction> during operation.

Spend at least 30 seconds decreasing the pressure, for example, from 1.2 MPa to 1.0 MPa.

[8] Do not remove the compressor fixing sheet metal.

Do not remove the sheet metal holding the compressor. Operating the unit without the sheet metal may result in an accident.

4-2. Specifications of general commercial parts

4-2-1. Refrigerant pipes

Do not reuse the existing pipes!

[1] Piping materials/Wall thickness

The design pressures of the liquid line and suction line are as shown in the table below.

Liquid line (Unit outlet)	Suction line (Unit inlet)	Hot gas routing line
12.0 MPa	8.0 MPa	12.0 MPa

The thickness of pipes to be used depends on the type of refrigerant used, pipe diameter, and pipe material. Use pipes with appropriate thickness for a given application.

The pipe sizes for the liquid line (unit outlet) and suction line (unit inlet) are as shown in the table below.

mm (in.)	
Liquid line (Unit outlet)	Suction line (Unit inlet)
ø6.35 (1/4)	ø9.52 (3/8)

Use the included reducer to connect the liquid piping.

[2] Copper pipe bending

Make sure that no wrinkles form when bending copper pipes. Such wrinkles may reduce the pipe thickness and/or increase the resistance to refrigerant flow.

[3] Brazing material

In a corrosive atmosphere, such as where there is a high sulfurous acid gas concentration, use silver filler. Do not use low-temperature fillers as they do not have sufficient strength.

[4] Flux

Select the flux according to the type and shape of substrate, filler type, and brazing method.

[5] Insulation

Refer to the relevant pages for details about heat insulation. (Page 47)

[6] Electrical wiring

For more information on transmission lines (MODBUS[®]), refer to the MODBUS[®] Interface Manual.

Refer to the relevant pages for more information on the power line, grounding wire, and control wire (220-240 V). (Page 33)

[7] Dryer

Refer to the relevant page for details about the dryer. (Page 27)

[8] Sight glass

Refer to the relevant page for details about the sight glass. (Page 27)

5. Selecting the installation site

5-1. Statutory compliance

Select an installation location that is in compliance with the applicable laws and regulations related to noise, vibration, and installation environment.

5-2. Consideration for pollution prevention and environment protection

Select an installation location in consideration of pollution prevention and environment protection.

5-3. Selecting the installation site

Select an installation location that meets the following requirements so that the unit functions properly.

5-3-1. Installation environment and restrictions

- Select a place where the gas cooler inlet air temperature is -25 to 43°C (-13 to 109°F) and there is good airflow.
- Do not install the unit in a location where the gas cooler is exposed to direct sunlight. Take appropriate measures to protect the unit from the sunlight as necessary.
- Install the unit in a location where the noise or vibrations from the unit will not be a problem. (The unit must be installed according to the applicable laws and regulations.)
- Do not place any inflammable materials (such as foamed styrol and cardboards) near the unit.
- Select a place where there is plenty of space for operation or servicing.
- Take appropriate measures to prevent unauthorized access to the installation site and machine room.
- Do not install the unit indoor, in a depressed space, or in a halfway basement.
- Install a pressure relief device in accordance with applicable local regulations.
- Install a gas leak detector according to the applicable laws and regulations.
- **The all-aluminum heat exchanger may corrode if it comes into contact with substances contained in water spray. Do not spray water on the unit.**
- Do not install the unit in any environment where it can be exposed to airborne iron or copper powder, acidic or alkaline atmosphere, or accumulation of a large amount of sand containing sea salt particles. Such environments can cause corrosion in the aluminum pipes.
- Provide a certain amount of space around the unit for operation, maintenance, servicing, and heat dissipation. Insufficient space may decrease the refrigerant capacity and cause an operation failure.

5-4. Height difference between devices

5-4-1. Height difference between the condensing unit and the evaporator

1) When installing the evaporator above the unit

Keep the height difference (between the end part of the liquid pipe on the unit and the one on the evaporator) within 8 m.

A large height difference may cause a pressure drop due to the head difference of liquid refrigerant, generating flash gas.

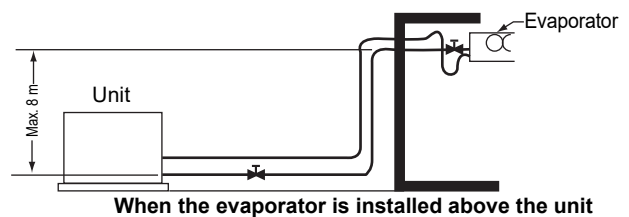

2) When installing the evaporator below the unit

Keep the height difference (between the highest suction pipe and the lowest suction pipe) within 20 m.

A large height difference may cause a poor oil return to the compressor, resulting in a compressor failure. Install an oil return trap at every 5 m.

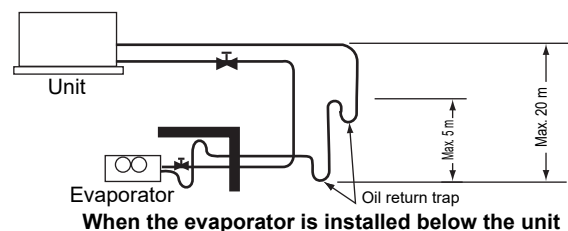

5-5. Required space

- Minimum installation spaces are shown below that are required for the use of the unit at the maximum ambient operating temperature. Up to three units can be installed side by side in each block.
- Letters "D" and "h" in the figure represent arbitrary values. (e.g. 100, 200) (The air flow direction is upward in the examples.)

5-5-1. Installation examples: Maximum ambient operating temperature of 43°C (109°F)

(Unit: mm)

- [1] Installation of a single unit with objects blocking the rear and top of the unit (unblocked on the sides and at the top)

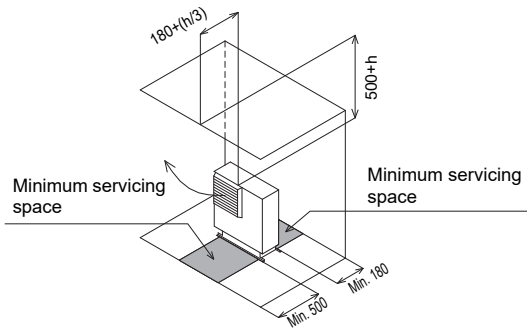

- [2] Installation of a single unit with objects blocking both sides and the rear of the unit (unblocked in the front and at the top)

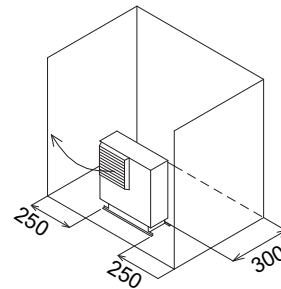

- [3] Side-by-side installation of multiple units with objects blocking the rear of the units (unblocked in the front, on the sides, and at the top)

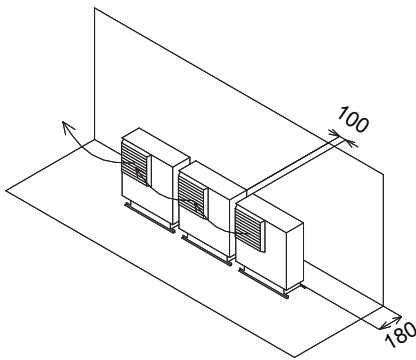

- [4] Side-by-side installation of multiple units with objects blocking the rear and front of the units (unblocked on the sides and at the top)

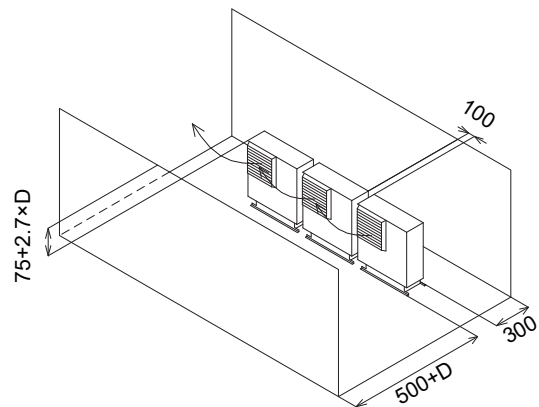

5-5-2. Minimum servicing space

Provide a space around the unit for installation work and maintenance as shown in the figure.

*1 To route the pipe from the right side of the unit, a space of approximately 300 mm is required on the right side.

(Unit: mm)

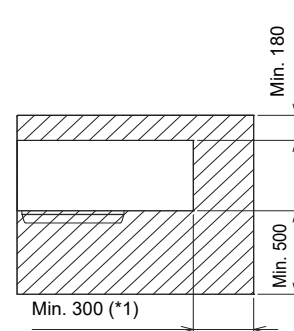

Minimum servicing space

5-6. Measures against strong winds

Precautions for installing the unit in a place exposed to strong winds

This unit is standard-equipped with air deflector grills to protect itself against headwinds. However, if the unit is installed on a roof or in an isolated place with no surrounding buildings, take appropriate measures so that the air discharge outlet on the unit is not exposed to winds. If strong winds blow directly into the air discharge outlet, the unit cannot hold sufficient air and will fail to operate properly.

Air guides are available as optional parts. Install air guides as necessary to direct wind away from the unit.

If powder snow is expected to blow on the front side of the unit in winter, install a wall in front of the unit to keep the snow from entering the unit. When powder snow blows directly into the air discharge outlet while the unit is stopped, the snow entering the unit may cause operation problems.

[1] Installing the unit near a wall

Install the unit so that the air discharge outlet will face the wall. Leave 500 mm (20 in.) between the unit and the wall.

If the wall height exceeds the unit height, refer to the installation examples in the previous section to determine the amount of the space between the unit and the wall.

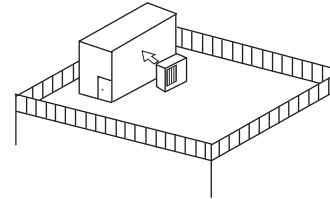

[2] Installing the unit in a place exposed to winds

Install the unit so that the air discharge outlet is perpendicular to the direction of the winds.

If powder snow is expected to blow directly into the air discharge outlet, install a wall in front of the unit to keep the snow from entering the unit. Leave 500 mm (20 in.) between the unit and the wall.

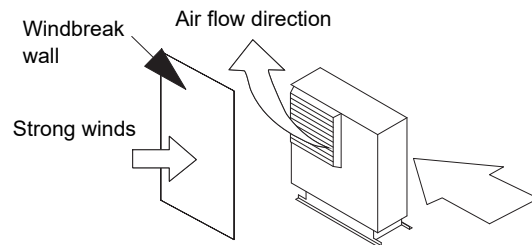

Do not direct the air discharge outlet downward.

- Air deflector grills can direct the air upward (factory setting), to the left, or to the right. Select the air flow direction to suit the local installation conditions. (Refer to the figures on the right.)

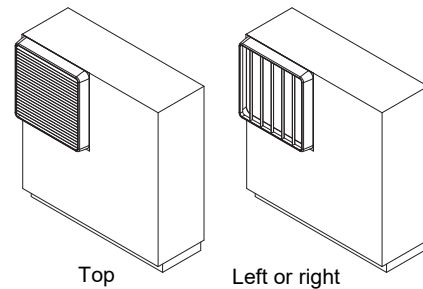

Air deflector grill installation examples

5-7. Measures against snow

5-7-1. Installing the unit in a winter snow area

Install the unit on a raised base (locally procured).

Insulate the area between the base and the outdoor unit by putting a rubber cushion or applying an electrically insulated coating to prevent the base from rusting.

If the unit is not installed on a raised base and not operated for a long time, moisture will accumulate inside the unit, forming rust.

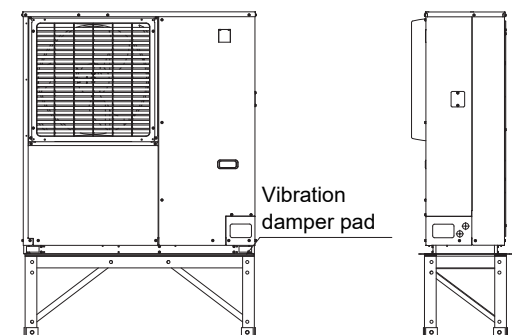

Example of installing the unit on a raised base

6. Installation work

- Do not install the unit indoor, in a depressed space, or in a halfway basement.

6-1. Progress of construction of building and construction conditions

Perform installation work when the building is ready for the installation of the unit.

6-1-1. Installation on the foundation

- Form the base on a level surface (inclination no more than 1.5°) and with strong and solid materials such as concrete and angle steel to prevent the unit from toppling over under strong winds or earthquakes.
 - Weakness or inclination of the base may cause abnormal vibrations or noise.
 - Weakness of the base may cause the unit to vibrate, resulting in looseness or crack in the pipes.
 - Generally, the base for the unit is formed with concrete. A mass of the base needs to be more than three times the weight of the unit to support the unit and to absorb vibration. It is recommended that the mass of the base is more than three times the weight of the unit.
- Alternatively, the unit may be directly connected to a construction with strong foundation.

6-1-2. Installation bolt

- Secure the unit with anchor bolts as shown in the figure below so that the unit will not topple over. (M12 installation bolts are to be locally procured.)
- Be sure to bolt down 4 points.
- Select the installation dimensions from the available installation holes shown in the external dimensions diagram (brochures) according to the base.

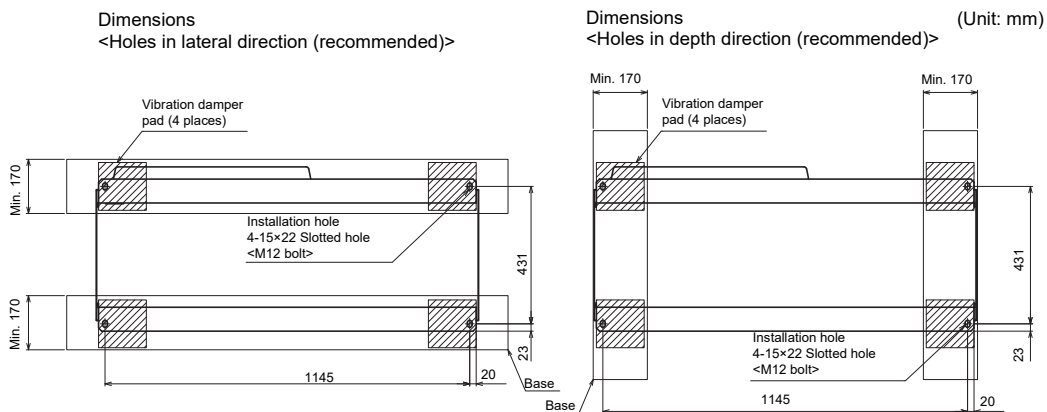

6-1-3. Anti-vibration measures

- Vibrations and noise may be transmitted from the unit through walls and floors, depending on the installation conditions. Take appropriate anti-vibration measures (e.g., vibration damper pad, vibration isolation base) as needed. (See the figure on the right.)
- The size of damper pad depends on the size and shape of the unit installation hole.

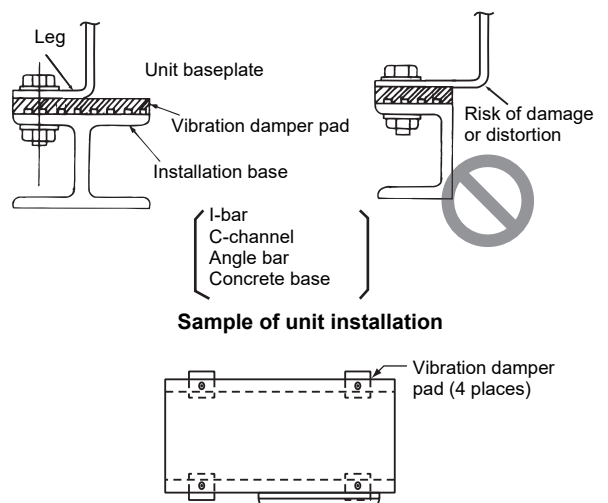

• Sandwich the damper pad between the unit and the base.

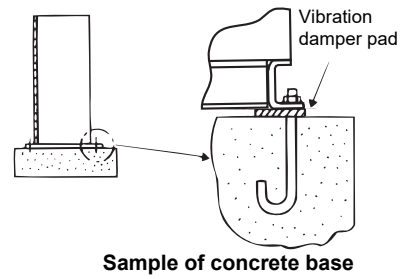
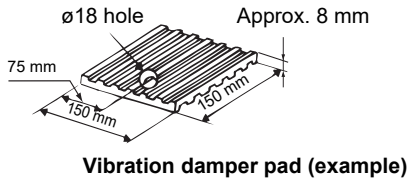

6-1-4. Sound insulation work

Attach sound insulation boards around the unit when installing the unit on a base that is more than 300 mm (12 in.) tall. (See the figure on the right.)

However, keep a space of approximately 100 mm (4 in.) over the boards because complete insulation may interrupt the ventilation in the unit (or the machine room or the control box may not be cooled).

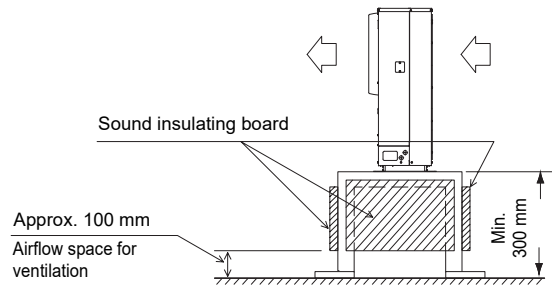

6-1-5. Fixing the top of the unit to the wall

In addition to anchoring the unit's installation legs to the base, fix the top of the unit to prevent it from falling over due to winds, as necessary. Remove one screw from the right and the left side of the top panel, and use the screw hole to fix the top of the unit.

As a fixing screw, locally procure a self-tapping screw (M5 screw length ± 12 mm).

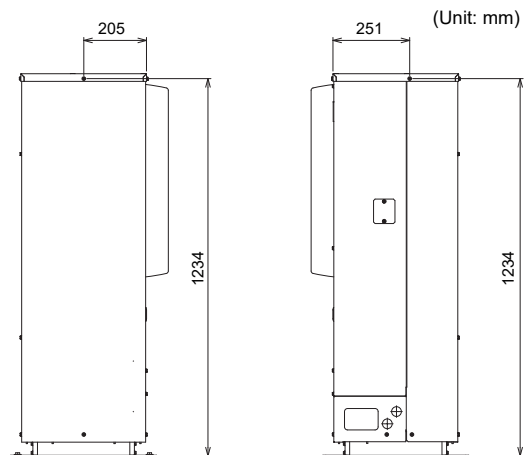

Fixing hole on the top panel

Note

- Do not block the water-vent holes.

7. Refrigerant piping work

7-1. General information

Do not reuse the existing pipes!

- Improper design and installation of refrigerant piping may affect the function and life of cooling equipment, or occurrence of problems. Design and install a water piping system according to the applicable regulations and the following instructions.

7-1-1. Removing the bypass pipe

The unit is charged with nitrogen gas prior to the shipment from the factory.

To prevent infiltration of water or contaminants, do not leave the pipe open until immediately before connecting the pipe. To connect the bypass pipe, remove the gas in the pipe. Then weld the pipe after checking that the residual pressure is not left.

To remove the pipe that bypasses the suction pipe and liquid pipe, first cut the bypass pipe at the section labeled (A) to remove the nitrogen gas from the pipe, and then debraze the pipe from sections labeled (a) and (b) in the figure on the right.

Do not directly heat the brazed sections using a burner or other heating device to remove the bypass pipe. Note that refrigerant oil may remain in the bypass piping. Be careful when removing it.

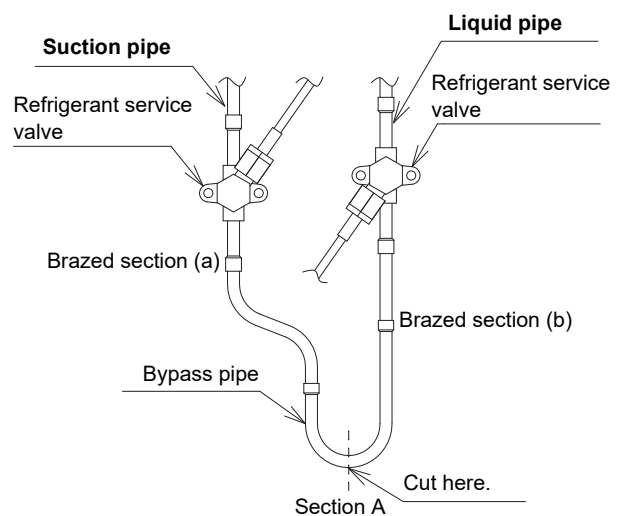

Note

- When brazing the suction pipe or liquid pipe, use a slate board to protect the control devices and wires from the torch flame.

7-1-2. Notes on water and contaminants

The refrigerant oil used in this unit easily absorbs moisture and tends to cause deterioration of the refrigerant oil or formation of sludge (hydrate).

Use caution to prevent infiltration of contaminants such as water and dirt during piping work.

Note

- Protect and maintain the pipes to prevent infiltration of contaminants such as water and dirt.
 - Nitrogen purge is required to prevent formation of oxide scale while brazing the pipe.
- 1) Storage location
Store the pipes indoors. (Warehouse at site or owner's warehouse)
If the pipes are left outdoors, dust, dirt, or moisture may infiltrate and contaminate the pipes.
 - 2) Sealing the pipe ends
Seal both ends of the pipes until just before brazing.
Keep elbow pipes and T-joints in plastic bags.

7-1-3. Pipe size

Select the size of the suction pipe and liquid pipe according to the diameter of the connection port of the condensing unit, not of the evaporator.

Select the size of the suction pipe in consideration of oil return and pressure loss.

Because the refrigerant oil of this unit is non-miscible, select the liquid piping size considering the refrigerant oil return.

Model	Suction pipe [mm (in.)]	Liquid pipe [mm (in.)]
ECOV-X15VA	ø9.52 (3/8)	ø6.35 (1/4)

The pipe sizes shown above are standard pipe sizes.

The design pressure of the liquid pipe is 12.0 MPa, and the design pressure of the suction pipe is 8.0 MPa. Use pipes that can withstand the above design pressure.

Use the included reducer to connect the liquid piping.

7-1-4. Height difference between devices

When the unit is installed in a high place, ensure there is enough space for transporting a heavy load such as a refrigerant cylinder during servicing or test runs, and install the service valve at the most appropriate place for servicing.

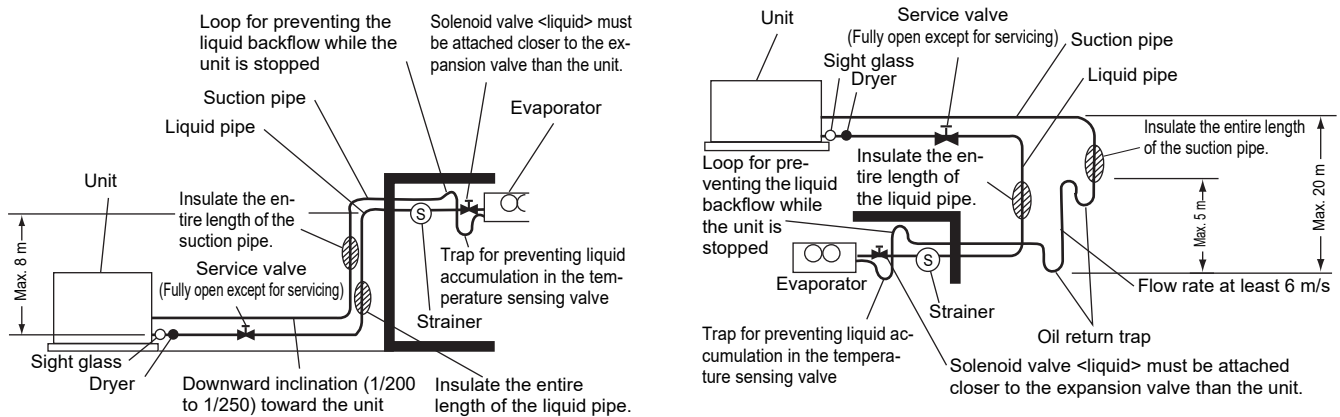

Note

- Do not increase the liquid pipe diameter at the rising part of the liquid pipe because the refrigerant oil of this unit is non-miscible.
- Install a pressure relief device in an appropriate location in accordance with applicable local regulations.

7-1-5. Supporting the pipes

Support the pipes in proper distance. Install a bent pipe or a slide valve (horizontal loop) to absorb expansion and contraction of the pipes that is caused by temperature fluctuation.

7-1-6. Notes on contaminants while flaring the pipes

To reduce the risk of failures of the compressor or valves, follow the instructions below to prevent abrasive components contained in sandpaper or cutting tools from entering the refrigerant circuit.

- To deburr pipes, use a reamer or other deburring tools, not sandpaper or sanding tools that use abrasive materials.
- To cut pipes, use a pipe cutter, not a grinder or other tools that use abrasive materials.
- When cutting or deburring pipes, do not allow cutting chips or other foreign matters to enter the pipes.
- If cutting chips or other foreign matters entered pipes, wipe inside the pipes to remove them.

Purge the pipes of dust with nitrogen gas or dry air before connecting the pipes. (Do not use the tools that generate a large amount of shaving particles, such as saw and grind stone.)

7-2. Installation of suction pipe

7-2-1. Installing the horizontal pipe

Install the horizontal pipe in such a way that it has a downward inclination (at least 1/200) towards the unit.

7-3. Installation of liquid pipe

7-3-1. Installing the solenoid valve <liquid>

Install the solenoid valve <liquid> right in front of the expansion valve (upstream side). Installing the solenoid valve near the outdoor unit may cause capacity shortage to the pump down and the high pressure switch may cut the unit.

7-3-2. Installing the strainer <liquid>

Install the strainer at the solenoid valve <liquid> inlet. Check the strainer during test run and remove contaminants.

7-3-3. Installing the dryer

Be sure to attach a dryer to the unit outlet (liquid pipe).

When installing the dryer, do not leave the dryer open for more than 30 seconds. Install the dryer in the correct orientation. Failure to install the dryer may cause damage to the compressor.

Procure a dryer locally.

Select the most suitable dryer that meets the following criteria.

- R744-compatible
- With a 100% molecular sieve solid core
- Design pressure of 12.0 MPa or higher

7-3-4. Installing the sight glass

Provide a sight glass to the unit outlet (liquid pipe).

Procure a sight glass locally.

Select a sight glass that meets the following criteria.

- R744-compatible
- Design pressure of 12.0 MPa or higher
- With a water-level indicator

7-3-5. Installing a pressure relief device

Install a pressure relief device in accordance with applicable local regulations.

7-3-6. When the ambient temperature around the pipe rises high

If the liquid pipe is heated by the effect of other heat source, flash gas is generated and a poor cooling problem occurs.

Route the liquid pipe where the temperature is low. Insulate the liquid pipe if it is installed in place where the temperature is high.

7-3-7. When the evaporator is installed below the main suction pipe

When an evaporator is installed below the main suction pipe, provide a small trap on the evaporator outlet to prevent the effect from the liquid refrigerant to the temperature sensing valve of the expansion valve. Provide an interlocking opposite trap above the main suction pipe to prevent the liquid refrigerant/oil from flowing from the main suction pipe to the riser pipe during stop operation. A solenoid valve must be installed to each evaporator that is installed above the main suction pipe as shown in the figure on the right.

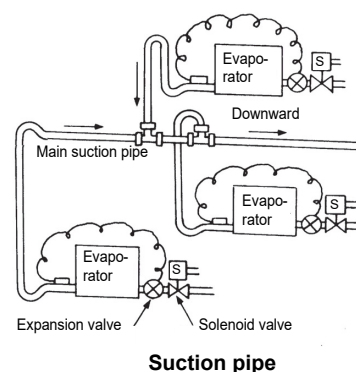

7-3-8. When there are multiple evaporators in the system

Equalize the pressure loss of each pipe circuit to equalize the flowing amount of the refrigerant to each evaporator. Branching point must be below the pipe. If the twinning pipe is installed above the pipe, a sufficient amount of the liquid refrigerant is not fed to the branched circuit, causing a poor cooling problem.

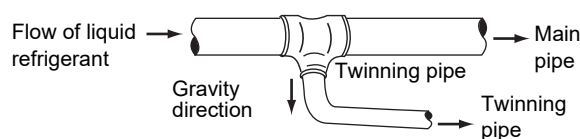

7-3-9. About the evaporator to be connected

If the evaporator is too large or the refrigerant flow rate in the evaporator is not sufficient, refrigerant oil may accumulate in the evaporator and cause the compressor to fail. Consider the refrigerant oil return. (For 1 pass: pipe diameter of 1/2 inch or less; for 2 passes: pipe diameter of 3/8 inch or less as a guideline. If these conditions cannot be satisfied, reduce the evaporator volume to 150 cc or less.)

Use an electronic expansion valve for the expansion valve.

7-4. Installation of heat recovery port

- To perform heat recovery, route the hot gas pipe from the hot gas outlet on the back of the unit or in the middle of the discharge pipe. Remove the pipe as shown on the right.
- Use the pipe sizes in the following table after external unit routing.

Model	Pipe size [mm (in.)]	
	Unit port	Pipe locally procured
ECOV-X15VA	ø9.52 (3/8)	ø9.52 (3/8)

When removing the hot gas pipe, remove the brazed part as shown in the figure on the right, cut the straight part with a pipe cutter, and then take the hot gas out using the field-supplied elbow as shown in the figure on the right.

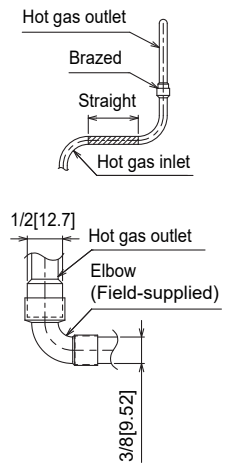

(Unit: mm)

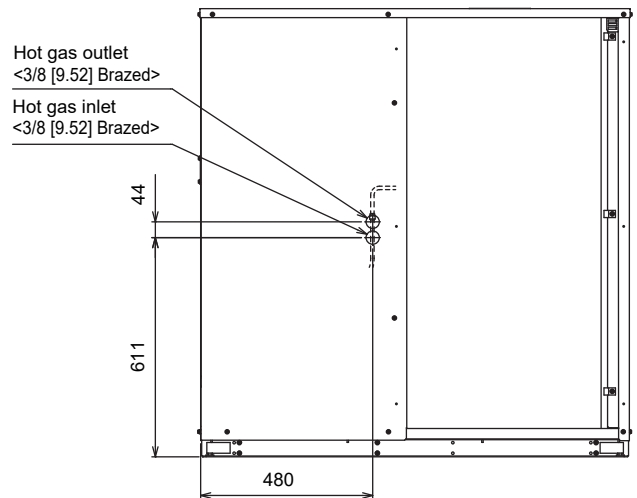

- Large piping vibration may be caused by pressure pulsation depending on the operating conditions of the unit, the shape and length of the pipes, and the method to support the pipes.
If large vibration occurs during a test run, change the support intervals and the method for fixing the pipes to prevent vibration. When attaching support fittings on the building or ceiling, take appropriate anti-vibration measures to prevent the piping vibration from being transmitted to the building.
- Provide insulation or protective cover to the parts of the pipes that can come into contact with a human body.
- When brazing the pipes, cool down the pipes with a wet cloth if packings are used in the pipe fixing parts.
The unit is filled with nitrogen gas. Remove the nitrogen gas before brazing the pipes.
- To avoid the thermal impact from the hot gas pipe, allow at least 100 mm (4 in.) between the hot gas pipe and the liquid pipe.
- When brazing the suction pipe or liquid pipe, use a slate board to protect the control devices and wires from the torch flame. Minimize the welding flame so as to prevent the flame from touching the check joint.

- There is no set-up for hot gas defrosting.
Due to the use of independent local hot gas (e.g. floor heating), only hot gas pipe routing is available.
- When using hot gas piping, ensure that refrigerant oil does not accumulate in the piping or heat exchanger.
- When using a plate heat exchanger, connect the refrigerant piping as shown in the figure below.

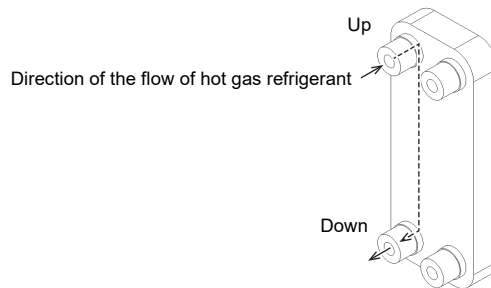

7-5. Connecting pipes

7-5-1. Brazing

- Use a clean copper pipe so as not to allow dirt and water to infiltrate inside the piping system.
- In a corrosive atmosphere, such as where there is high sulfurous acid gas concentration, use silver filler.
- Do not use low-temperature fillers because they do not have sufficient strength.
- When re-brazing, use the same filler material.
- Use an appropriate flux according to the type and shape of the substrate, filler type, and brazing method.
- Do not conduct refrigerant piping work outdoors when raining.
- If the installed pipes are left unconnected to any equipment, braze and seal both ends of the pipes.
- Flux generally contains chloride. Flux staying in the refrigerant circuit will cause sludge to form.

Procedures

1. When brazing, as shown in the figure below, heat the minimum necessary area to a temperature suitable for the filler material.

When brazing, supply a flow of an inert gas, such as dry nitrogen gas, through the pipes to prevent formation of oxide scale.

After finishing piping, keep the nitrogen gas flowing until the pipes have become cool enough to be touched by hand. (Be careful not to burn hands and fingers.)

After brazing, cool the pipes without using water.

Do not move the brazed pipes until the braze has solidified. (No vibration must be applied.)

2. Completely remove all the flux after brazing.

Stuff something in the gap between the hose from the cylinder and the pipe to keep air from entering the pipe.

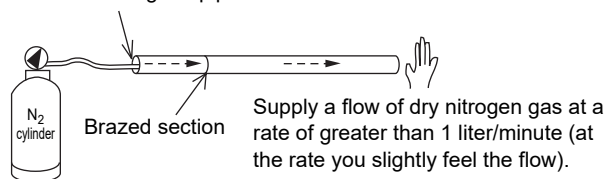

Brazing the pipe under nitrogen purge

Note

- Ensure that the flame does not touch any surrounding wiring and plates during brazing. Prevent fire by using a metal plate as a shield and a wet towel.
Contact with flame may cause fire damage and/or failure.
- When using anti-oxidant for brazing, check its components.
(The anti-oxidant must not contain any components that may lead to corrosion of the pipes if it is mixed with refrigerant or refrigerant oil.)
- The dryer and filters (strainer, etc.) in the unit may be clogged with oxide scale, which shortens the unit life. Clean or replace the dryer and filters when they are clogged.
- Brazing must be performed by qualified personnel.

7-6. Pipe routing: Single and collective installations

- 1) The pipe can be routed from the front, right, or bottom of the unit. When multiple units are installed collectively or consecutively, any unit that has another unit on its right cannot have a pipe routed on its right side.
- 2) Install the pipes so that they are out of contact with the wires, panels, and compressor.

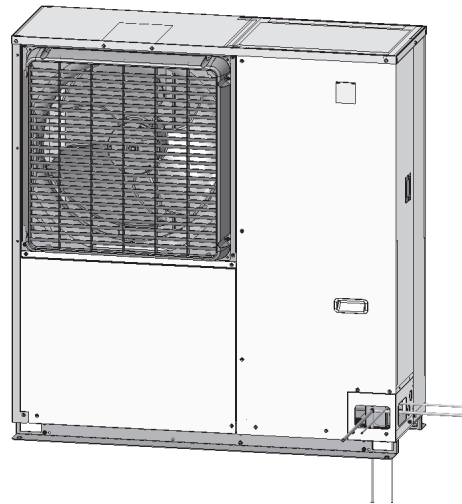

8. Electrical wiring

8-1. Notes on wiring

- Install an earth leakage breaker.
Installation must be according to the applicable laws and regulations.
(Earth leakage breaker is required for all refrigerating appliances including show cases.)
- Do not wire at any place where dew may drop from suction parts.
- Ensure that no electric wires come into contact with high-temperature parts (compressor, heat exchanger, discharge pipe) or the edges of the unit.
- Wear protective gloves to prevent injury on wiring the unit.
- Do not route wires through insulation, such as pipes, to prevent overheat.
- Install the transmission cable at least 5 cm (2 in.) away from the power cable to avoid electrical noise interference. (Do not place them in the same conduit.)
- Before inspecting inside the control box, turn off the main power of the unit, wait at least 10 minutes, and check that the power-supply voltage of the unit is 0 VAC and that the voltage of the electrolytic capacitor (main inverter circuit) is no greater than 20 VDC. Check the voltage across pins L and N of TB1 of the unit power supply voltage (AC), and across FT-P and FT-N pins. Remove the fan motor connector (CNM1). (See the figures below for the voltage check position and location of the connectors.)

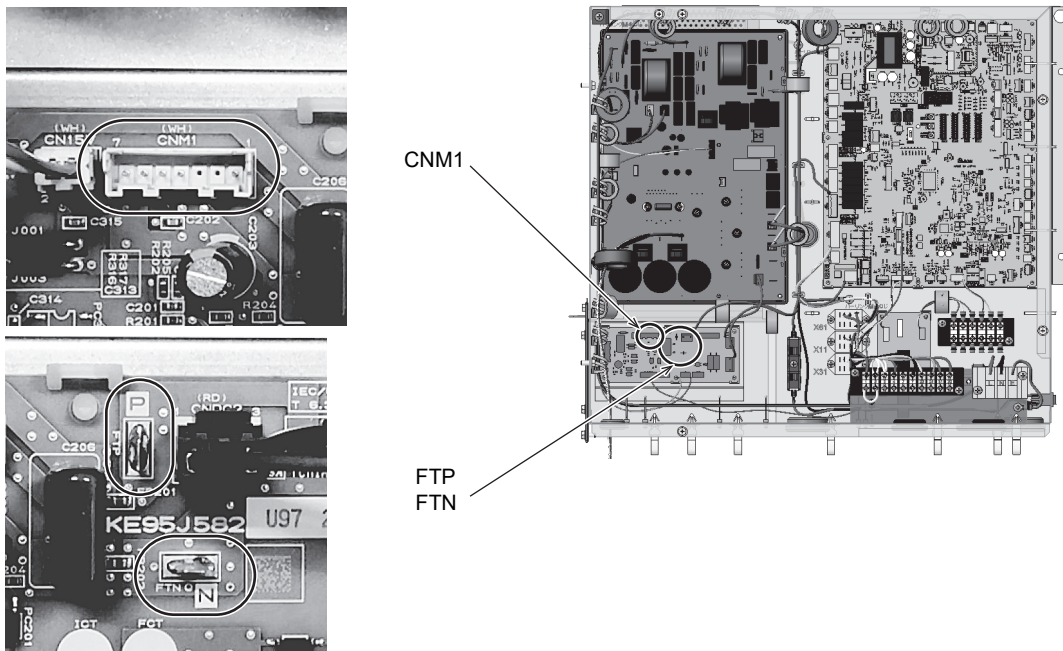

- Before starting servicing, disconnect the outdoor fan connector (CNM1).
When connecting and disconnecting connectors, make sure that the outdoor fan is not running and that the voltage of the main circuit capacitor is no greater than 20 VDC.
If the outdoor fan rotates due to strong wind, the main circuit capacitor will be charged and pose a risk of electric shock.
Refer to the wiring nameplate for details.
When finishing servicing, connect the outdoor fan connector (CNM1) as it was.
- When the ON/OFF switch (SW1) is ON, the components may still be carrying current even when the compressor is stopped. Do not touch the charging part of the power supply wiring. When performing a test run, if there is the possibility that refrigerant may be left inside the compressor after a long stoppage period or flood-back error stop, disconnect the power supply wiring from the terminal block of the compressor after power shutoff, and measure the insulation resistance of the compressor to check that the compressor is not ground-faulted.
- If the insulation resistance is 1 MΩ or below, energize the belt heater for 3 hours or more. Energize the unit and keep the ON/OFF switch (SW1) OFF for at least 12 hours.
(When the compressor is energized to evaporate the liquid refrigerant inside, the insulation resistance rises.)

Note

- If the power supply cord is damaged, it must be replaced by the manufacturer, its service agent, or qualified personnel in order to avoid hazards.
- Do not keep switching on and off the main power in a short period. Changing the ON/OFF status within 10 minutes will apply undue force to the electronic parts, resulting in malfunctions. Once the power is turned on (or off), wait for at least 10 minutes before turning it off (or on).

8-2. Wire capacity

Maximum allowable voltage for this unit is shown in the figure.

Wire capacity must be according to the applicable laws and regulations. The range of allowable voltage is listed in the next section "Electrical characteristics".

The wire size is the minimum value for the metal conduit wiring. If the voltage drops, use a wire that is one size thicker in diameter.

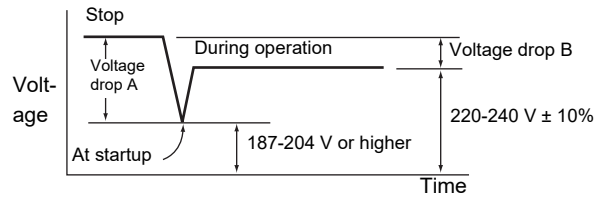

Note

Starting voltage cannot be measured with a tester, but starting voltage drop (Voltage drop A) is about 5 times the voltage difference (Voltage drop B) between stoppage voltage and operation voltage. The amount of starting voltage can be estimated by subtracting operation voltage from voltage with the unit stopped.

$$\text{(Voltage drop A)} \approx 5 \times \text{(Voltage drop B)}$$

Starting voltage drop A can be disregarded because this unit starts with inverter.

8-3. Electrical characteristics

Model			ECOV-X15VA		
Power source			Single phase, 220/230/240 V, 50 Hz		
Safety class			Class I		
Electrical characteristics	Electric power consumption <Note 1>	kW	1.90		
	Running current (220V/230V/240V) <Note 1>	A	9.0/8.6/8.2		
	Starting current	A	5.5/5.3/5.1		
	Maximum current	A	10.5		
Compressor	Rotation per minute (RPM)	min ⁻¹	4200		
	Electric heater <oil>	W	20		
Condenser	Fan	Motor output	W	74	
Electrical wiring	Electric wire size <Note 2>	mm ²	3.2 or larger		
	Overcurrent protector	Local switch	A	16	
		Branch switch	A	16	
	Switch capacity	Local switch	A	16	
		Branch switch	A	16	
	Control circuit wire size	mm ²	2.0 or larger		
	Grounding wire diameter	mm ²	2.0 or larger		
	Phase advance capacitor (Compressor)	Capacity	μF	N/A	
			kVA	N/A	
<Note 5>		Wire size	mm ²	N/A	

Note 1 Measurement conditions are as follows.

Outside air temperature: 32°C (89°F), evaporation temperature: -10°C (14°F), suction superheat: 10 K

Inverter compressor operating frequency: 70 Hz

Note 2 Specific wiring requirements should adhere to the wiring regulations of the region.

Note 3 Power supply cords of appliances shall not be lighter than polychloroprene sheathed flexible cord (design 60245 IEC57).

Note 4 An earth leakage breaker with at least 3 mm (2/16 in.) contact separation in each pole shall be provided by the installer.

Leaked current varies depending on wire length, wire routing, and/or presence of devices that emit high frequency.

Select high-harmonic-type earth leakage breakers.

Note 5 Do not use a phase-advancing capacitor with inverter compressor.

If MODBUS[®] is used, follow the instructions below.

- Do not connect a power supply to the terminal block for transmission lines. If connected, the electronic parts will burn out.
- Use shielded cables for transmission wiring.
Wiring using a multi-core cable with different types of transmission wires compromises correct transmission of signals and results in a malfunction.
- When splicing transmission wires, make sure to splice the shielded cables as well.

For details, refer to section 8-6.

8-4. Connecting wires

[1] Connecting the wires inside the control box

Procedures

1. Connect the power supply line to the power supply terminal block (TB1).
2. If necessary, connect the control line (220 to 240 V). (See 8-5.)
3. If necessary, connect the transmission line (MODBUS[®]). (See 8-6.)

Model	Wire type	Connected to	Notes
ECO-V-X15VA	Power supply line	Power supply terminal block inside the unit control box (TB1)	-
	Control line (220 to 240 V)	Auxiliary terminal block (1 to 32)	-
	Transmission line (MODBUS [®])	Terminals for transmission lines (+, -, SG)	-

Connection locations

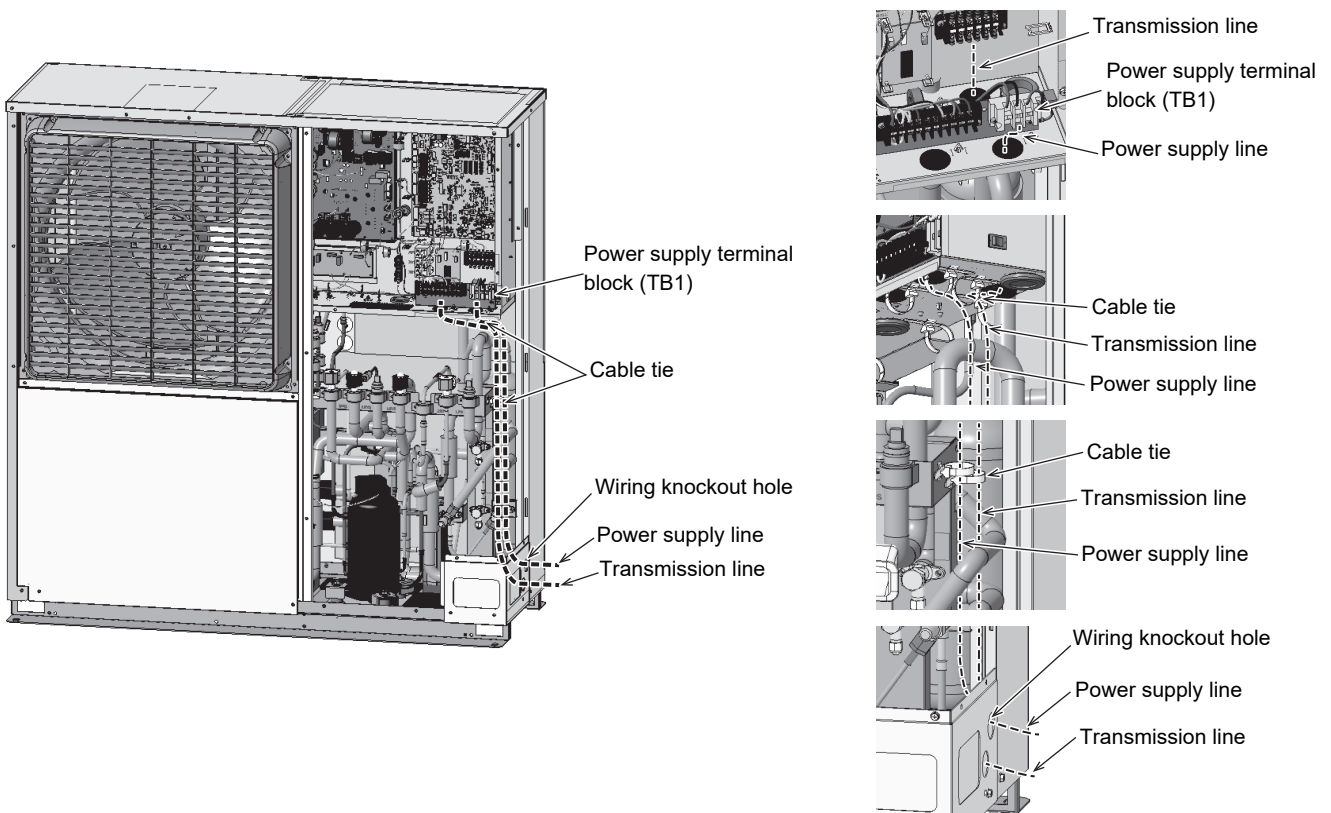

Note

- Do not bundle the power supply line and the transmission line together. Keep them away from each other.
- When connecting wiring, keep the wiring out of contact with the refrigerant service valves and pipes.
- Hold the power cable to the liquid pipe, using a tie band as shown below so that the power cable does not come into contact with the refrigerant service valve, pipes, or edges of metal plates. Friction against the valves and pipes can damage the wiring.



- When connecting MODBUS[®] wiring, be sure to connect to **the terminals (+, -, SG) for transmission lines**.
- For details on the MODBUS[®] set-up, refer to the MODBUS[®] Interface Manual.
Please contact the supplier for the MODBUS[®] Interface Manual.

8-5. Output signal to external devices

Operation signals can be output from the terminal block on the control box.

[1] Alarm signal

Alarm signals can be output from terminal blocks 7 and 23.

The output signal voltage of terminal blocks 7 and 23 are 220 to 240 VAC. <Use a current of 0.01 to 0.3 A.>

Alarm signal will be output if the refrigerator has come to an abnormal stop.

[2] Pre-alarm signal

Pre-alarm signals can be output from terminal blocks 7 and 24. Output-signal between terminal blocks 7 and 24 is 220-240 VAC. <Use a current of 0.01 to 0.3 A.>

A pre-alarm signal will be output when the condensing unit detects a pre-alarm signal.

Refer to the DATA BOOK for more information on pre-alarms.

[3] Compressor operation signal

Compressor operation signals can be output from terminal blocks 7 and 32.

The output signal voltage of terminal blocks 7 and 32 are 220 to 240 VAC. <Use a current of 0.01 to 0.3 A.>

Signals will be output when the compressor is in operation. Signals will not be output when the compressor is not in operation.

[4] Condensing unit operation signal

Condensing unit operation signals can be output from terminal blocks 4 and 7.

The output signal voltage of terminal blocks 4 and 7 are 220 to 240 VAC. <Use a current of 0.01 to 0.3 A.>

Signals will be output when the condensing unit is operating normally (including the times when the compressor is stopped to prevent an excessive drop in low pressure).

Signals will not be output if the condensing unit has come to an abnormal stop.

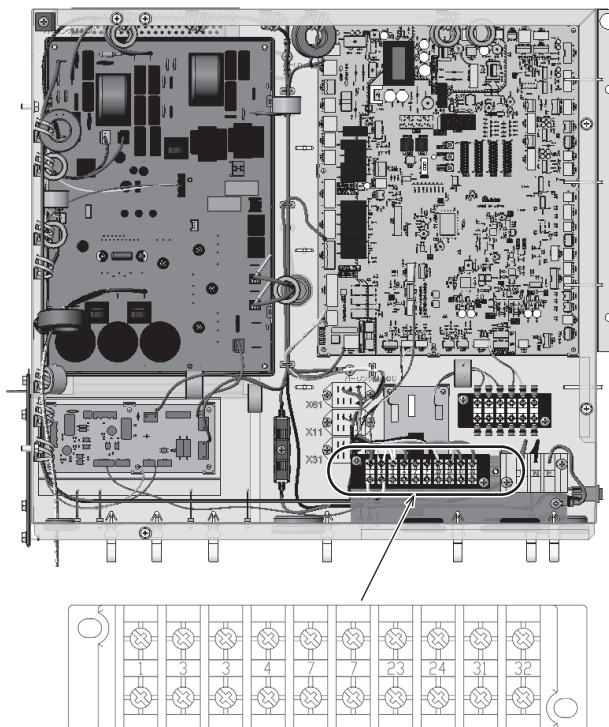

[5] Precautions for screwing

When replacing electrical parts inside the control box, use the following recommended tightening torques for screwing.

Recommended tightening torque

	Screw	Recommended tightening torque (N·m)
Power supply terminal block (TB1)	M4	1.0 to 1.3
Auxiliary terminal block (including terminal block for transmission lines)	M3.5	0.82 to 1.0

Follow the procedure below to check that the screws are properly tightened.

Procedures

1. If wires are connected, make sure that they are not loose on the screw terminals.
2. Tighten the screws straight so as to **prevent the screw's threads from being damaged**.
To prevent screws from being tightened diagonally, **mate the flat sides of the round terminals** when attaching.
3. **After tightening the screws, mark the screw head, washer, and terminal with a check using a marker.**

(Example)

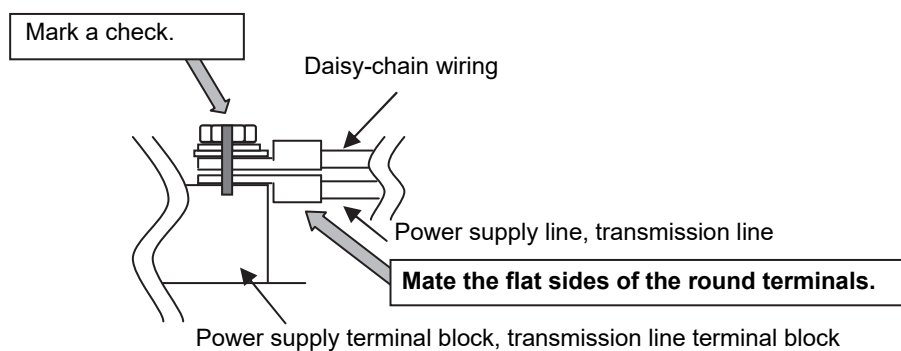

8-6. How to use MODBUS®

8-6-1. Precautions for using MODBUS®

- Do not connect a power supply to the terminal block for transmission lines (+, -, SG). If connected, the electronic parts will burn out.
- When connecting MODBUS® wiring, be sure to connect to **the terminals (+, -, SG) for transmission lines**.
- Use shielded cables for transmission wiring. For information on recommended cables, refer to section 8-6-2. Wiring using a multi-core cable with different types of transmission wires compromises correct transmission of signals and results in a malfunction.
- When splicing transmission wires, make sure to splice the shielded cables as well.
- For details on the MODBUS® set-up, refer to the MODBUS® Interface Manual.
- Please contact the supplier for the MODBUS® Interface Manual.

8-6-2. RS485 communication specifications

The table below shows the RS485 communication specifications of the refrigerator.

Item		Specifications
Transmission signal		RS-485 two-wire half-duplex transmission
Electrical specifications		RS-485 compliant
Communication protocol		MODBUS®-RTU
Transmission system		Asynchronous
Connection type		Daisy chain
Maximum communication cable length		1200 m
Terminating resistor		120 Ω, 1/2 W
Recommended cable	Type	Shielded cable
	Number of pairs	2 or 3
	Conductor resistance (20°C) (68°F)	88 Ω/km or less
	Insulation resistance (20°C) (68°F)	10000 MΩ-km or above
	Capacitance (1 Hz)	60 nF/km or less
	Characteristic impedance (100 kHz)	110±10 Ω

8-6-3. MODBUS® wiring procedure

[1] Preparing the cables

Prepare cables for wiring. (Refer to section 8-6-2.)

[2] Turning off the power

Check that the power of each unit is turned off before the wiring work.

[3] Connecting the communication devices

Connect the MODBUS[®] communication devices with cables.

Daisy-chain the MODBUS[®] communication devices as shown in Figure 3-1.

Communication may not be established properly if the devices are connected in the star wiring configuration or branched from the module as shown in Figure 3-2.

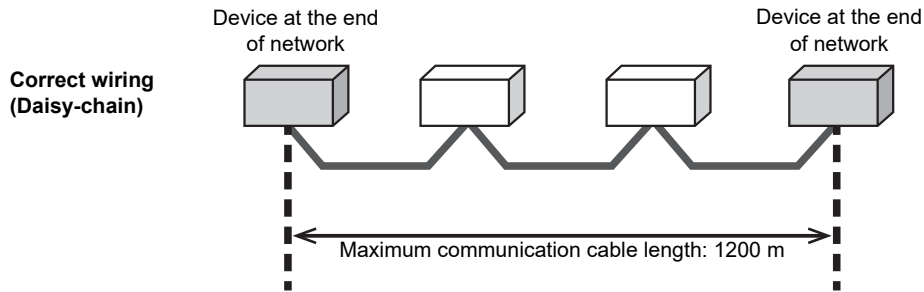

Figure 3-1 Example of correct wiring between communication devices

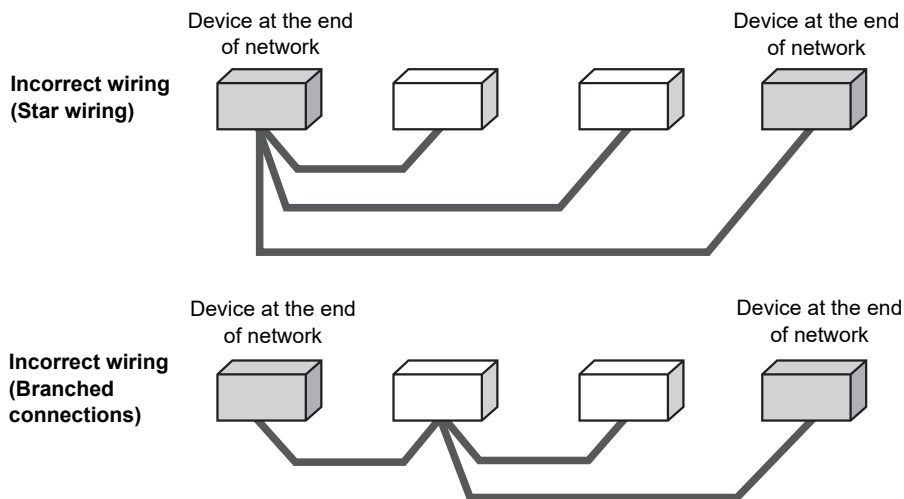

Figure 3-2 Examples of incorrect wiring between communication devices

[4] Connecting the terminating resistor

When this unit is at the end of the network, connect the supplied terminating resistor (120 Ω) to the unit. The terminating resistor is packaged in the control box.

8-7. Electric circuit diagram

For examples of internal wiring and on-site wiring connection of this unit, refer to the wiring diagram on the nameplate on the unit.

For the connection to the load devices, such as show case and unit cooler, refer to the manuals for the load devices.

9. Air tightness test/Vacuum drying

9-1. Air tightness test

9-1-1. Purpose of air tightness test

Check for any refrigerant leakage in the refrigerant pipes and the indoor unit.
The condensing unit has been subjected to an air tightness test prior to shipping.

9-1-2. Air tightness test pressure

When the refrigerant piping is completed, perform the air tightness test before insulating the pipes. The condensing unit has been tested prior to shipping.

The air tightness test pressure must be at or higher than the design pressure. Refer to 9-1-3. Air tightness test procedure for details.

The pressure used for the air tightness test must not exceed 12.0 MPa to protect the unit.

The design pressure for the refrigerant pipes and the indoor unit is shown in the table below.

Design pressure for refrigerant pipes and indoor unit	
High pressure side: 12.0 MPa	Low pressure side: 8.0 MPa

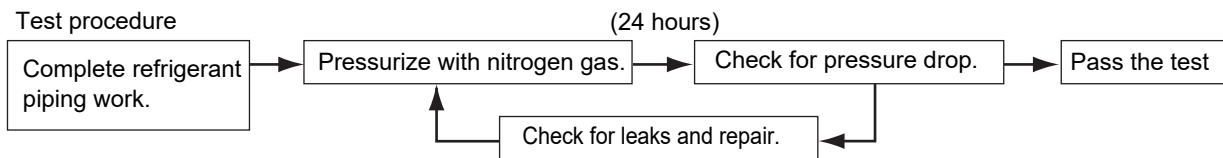

9-1-3. Air tightness test procedure

Procedures

1. The air tightness test is performed by pressurizing the refrigerant pipes up to the unit's design pressure with nitrogen gas. Connect the devices to the check joint connected to the refrigerant service valve (three-way valve) <suction> and the high-pressure check joint. See the figure on the right for connections. The check joints are all designed to be connected with Swagelok fittings. Air tightness test inside the condensing unit is not necessary.
2. Open the refrigerant service valve (three-way valve) <liquid> and the refrigerant service valve (three-way valve) <suction> halfway. For usage of the refrigerant service valves, refer to sections 9-2-6. (Page 43).
3. Do not pressurize the system up to the design pressure at once. Increase the pressure in small increments. Pressurize the system to 0.5 MPa, stop increasing the pressure for at least 5 minutes, and check that the pressure does not drop.
4. Pressurize the system to 1.5 MPa, stop increasing the pressure for at least 5 minutes, and check that the pressure does not drop.
5. Write down the outside air temperature and pressure after pressurizing the system to the design pressure.

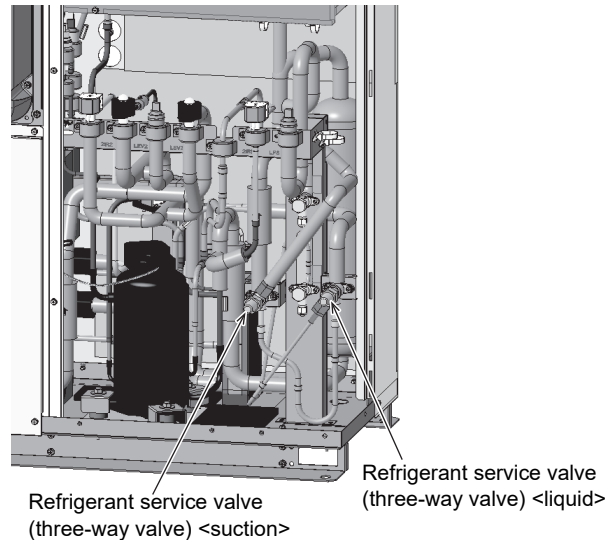

6. Apply a foaming agent. If no bubbles occur, there are no leaks.

Leave the system in the defined value for 24 hours. If the pressure is maintained, there are no leaks.

When the outside air temperature changes by 1°C, the pressure changes by approximately 0.01 MPa. Adjust the test conditions as necessary.

If the pipe is pressurized before cooled down after welding, the pressure drops after the pipe cools down.

The pressure changes (up/down) depending on the outside air temperature. (Gas in the container (scale-invariant) is in proportion to absolute temperature.)

$$\text{Absolute pressure during measurement} = \text{absolute pressure during pressurization} \times \frac{(273^\circ\text{C} + \text{temperature during measurement})}{(273^\circ\text{C} + \text{temperature during pressurization})}$$

Absolute pressure = gauge pressure + 0.10133 (MPa)

(Gauge pressure indicates the gauge manifold-specified value.)

A pressure drop indicates a refrigerant leakage in the system. Find the refrigerant leaking area, and fix it.

If a leakage is found, inspect the welded part using soap water.

Nitrogen purge must be done before welding.

9-1-4. Refrigerant leakage detection

Special care for refrigerant leakage is important. Use a refrigerant leak detector for R744.

9-2. Vacuum drying

9-2-1. Purpose of vacuum drying

Completely evaporate any moisture that has entered the evaporator from the refrigerant pipes using vacuum in order to release it outside the system.

9-2-2. Vacuum drying procedure

[1] Level standard of a vacuum pump

Use a vacuum pump capable of attaining a vacuum pressure of 66 Pa at a point of 5 minutes from the startup of operation.

[2] Vacuum drying time

1) Perform vacuum drying for one hour after the vacuum level reaches 266 Pa on the vacuum gauge. (Thorough vacuum drying eliminates moisture in the pipes.)

2) Check that the vacuum pressure does not drop one hour after the vacuum drying is completed.

[3] Vacuum drying procedure

Be sure to use a vacuum pump for vacuum drying of the system. Vacuum drying must be performed by a specialist.

The low pressure is digitally displayed on the Main board. **Unless the unit is energized during the vacuum drying, the low-pressure is not displayed on the Main board. Check the low-pressure by using a gauge manifold and a vacuum gauge.**

Procedures

1. Open the solenoid valve and the LEV of the refrigerator by following the steps 2 through 4 below. (vacuum-drying mode)
2. Turn off the power to the unit.
3. Set the dipswitch SW4-10 to ON.
4. Turn on the unit.

The solenoid valve and the LEV will open.

* The compressor/fan will not operate when SW1 is set to ON.

5. Connect to the vacuum pump.

For information on the vacuum pump connection, refer to the relevant page. (Page 42)

6. Evacuate the air from the check joint connected to the refrigerant service valve (three-way valve) <liquid> in the high-pressure circuit.

Because a check valve is used in the low-pressure circuit, perform vacuum drying with the high-pressure circuit first (the capacity will be larger).

7. Evacuate the air from the check joint connected to the refrigerant service valve (three-way valve) <suction> in the low-pressure circuit.

When performing vacuum drying, open the refrigerant service valve (three-way valve) <liquid> and the refrigerant service valve (three-way valve) <suction> halfway.

For how to open the refrigerant service valve (three-way valve) <liquid> and the refrigerant service valve (three-way valve) <suction> halfway, refer to section 9-2-6. (Page 43).

(The condensing unit is filled with nitrogen. Attempting vacuum drying without opening the three-way valve as described above will not eliminate air out of the condensing unit.)

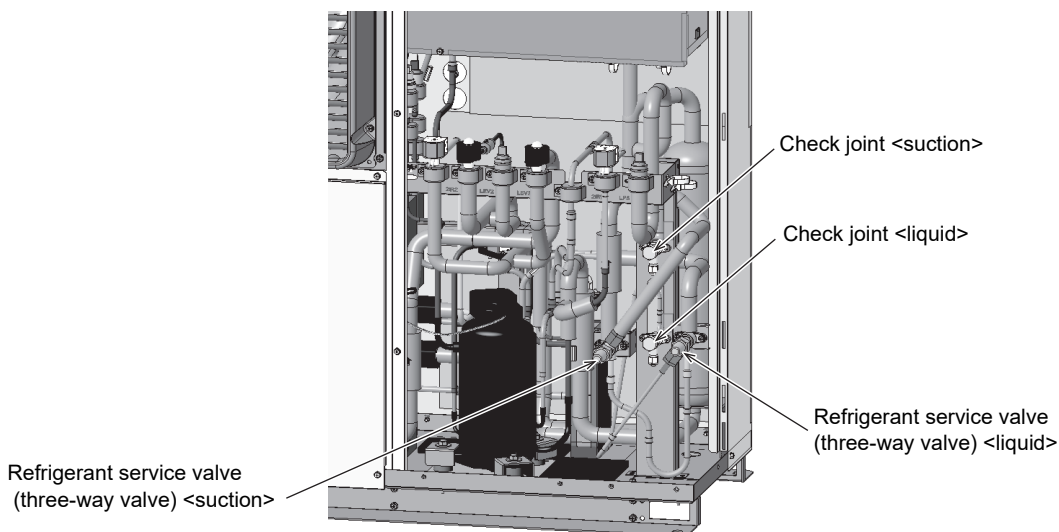

8. When the vacuum drying is completed, close the check joint and remove the vacuum pump.
9. Follow the procedure below to cancel the vacuum-drying mode.
10. Turn off the power to the unit.
11. Set the dipswitch SW4-10 to OFF.
12. Turning the unit power back on will cancel the vacuum-drying mode.

* The compressor/fan may operate if SW1 is set to ON.

9-2-3. Connection of the vacuum pump

[1] ECOV-X15VA

Symbol	Component	Trigger threshold
CJ1	Check joint	
CJ2	Check joint	
LEV2	Electronic expansion valve	
LEV3	Electronic expansion valve	
PSH	Pressure sensor<high pressure>	
PSM	Pressure sensor<low pressure>	
PSL	Pressure sensor<low pressure>	
SV1	Stop valve	
SV2	Stop valve	
TH1	Thermistor<discharge pipe temperature>	
TH4	Thermistor<gascooler outlet pipe temperature>	
TH6	Thermistor<outside air temperature>	
TH7	Thermistor<suction pipe temperature>	
TH8	Thermistor<liquid pipe temperature>	
21R1	Solenoid valve	Open while energized
21R2	Solenoid valve	Open while energized
63H	Pressure switch<high pressure>	12MPa OFF:8.5MPa ON

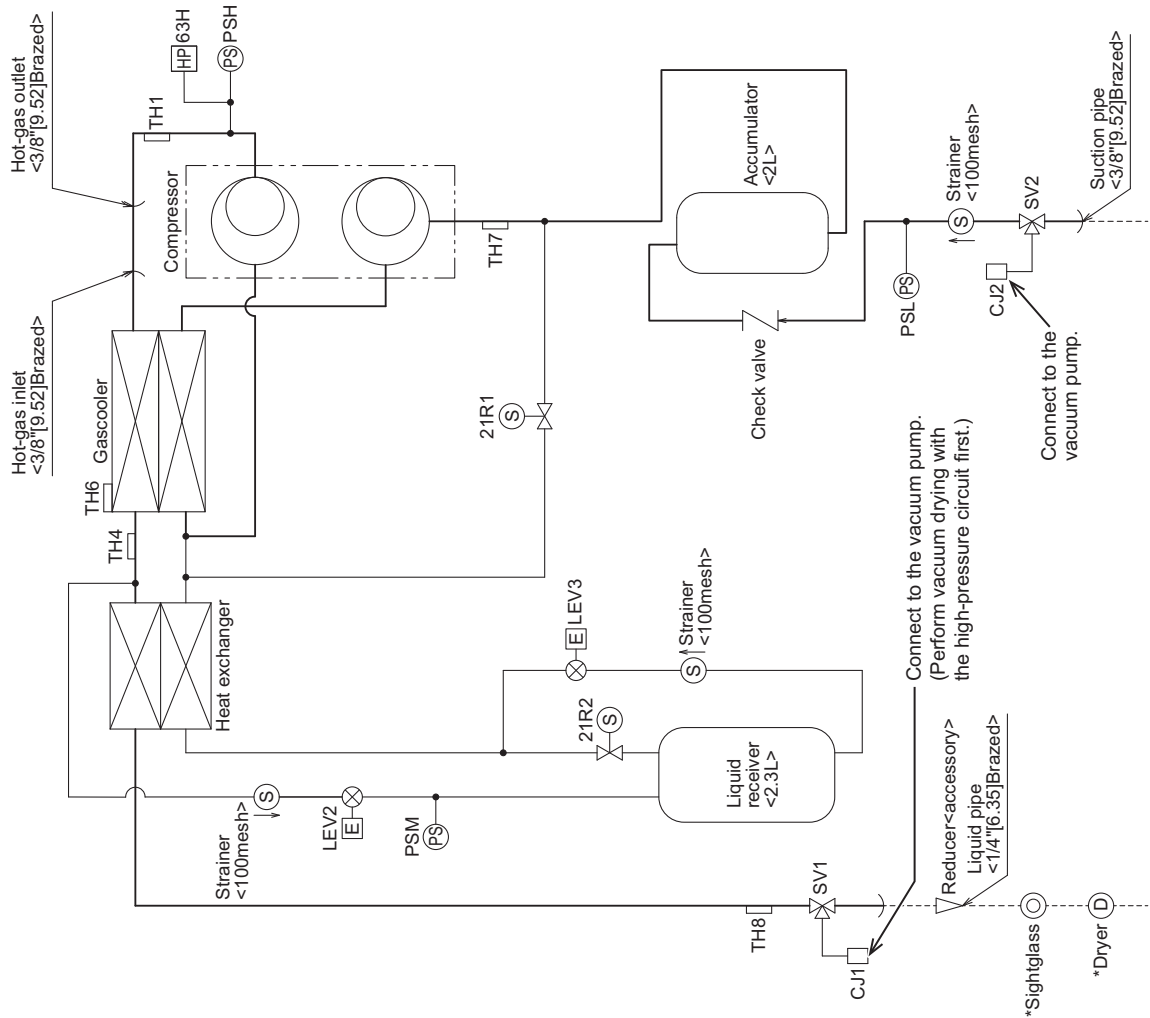

Note 1. Those items marked with an asterisk are field-supplied.

9-2-4. Procedures for stopping the vacuum pump

To prevent the backflow of vacuum pump oil to the unit, open the relief valve on the vacuum pump, or draw in air by loosening the charging hose. Then stop operating the vacuum pump.

Use the same procedures when stopping a vacuum pump with a check valve.

9-2-5. Required precision of vacuum gauge

1) Use a vacuum gauge that can measure the vacuum pressure of 266 Pa and measure at 1 Torr (130 Pa) increments.

2) A general gauge manifold cannot measure the vacuum pressure of 266 Pa.

9-2-6. Operating the valve check joint

1) Procedure to operate the refrigerant service valve (three-way valve) <liquid> and the refrigerant service valve (three-way valve) <suction>

- Remove the cap, and turn the valve rod with pliers. Turn the valve rod counterclockwise to open the valve, and clockwise to close it.
- Tighten the cap to a torque of 25 to 35 N·m at the completion of valve operation. Failure to replace the cap will lead to refrigerant leakage. Do not damage the refrigerant sealing inside the cap.

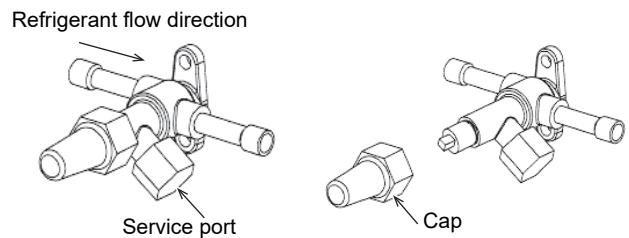

- Fully open
Both the upstream and downstream pass refrigerant. Service port does not.

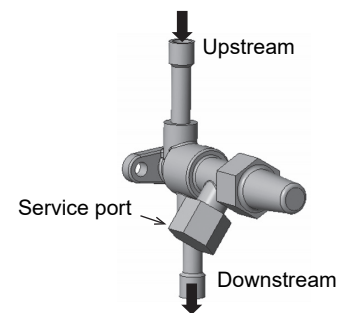

- Half open
The upstream, downstream, and service port all pass refrigerant.

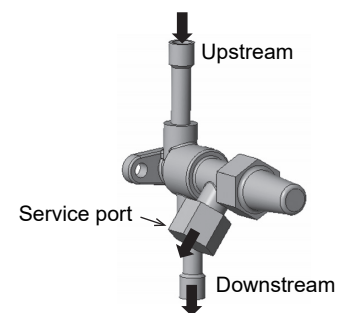

- Fully closed
The downstream and service port pass refrigerant. Upstream does not.

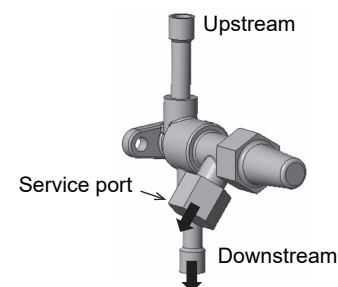

2) Procedure to operate the check joint

- Remove the cap, and turn the valve rod with a 4-mm Allen wrench. Turn the valve rod counterclockwise to open the valve, and clockwise to close it.
- Tighten the cap to a torque of 15 N·m at the completion of valve rod operation.
Failure to replace the cap will lead to refrigerant leakage.
Do not damage the refrigerant sealing inside the cap.
- Securely tighten the cap on the charge port to a torque of 6 N·m.
Failure to tighten the cap will lead to refrigerant leakage.
- The type of screw used for the check joint in the condensing unit is 7/16-20 UNF.

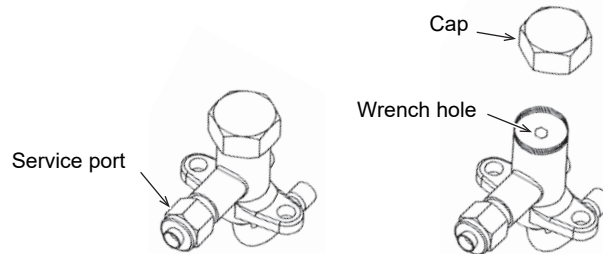

9-2-7. Parts names

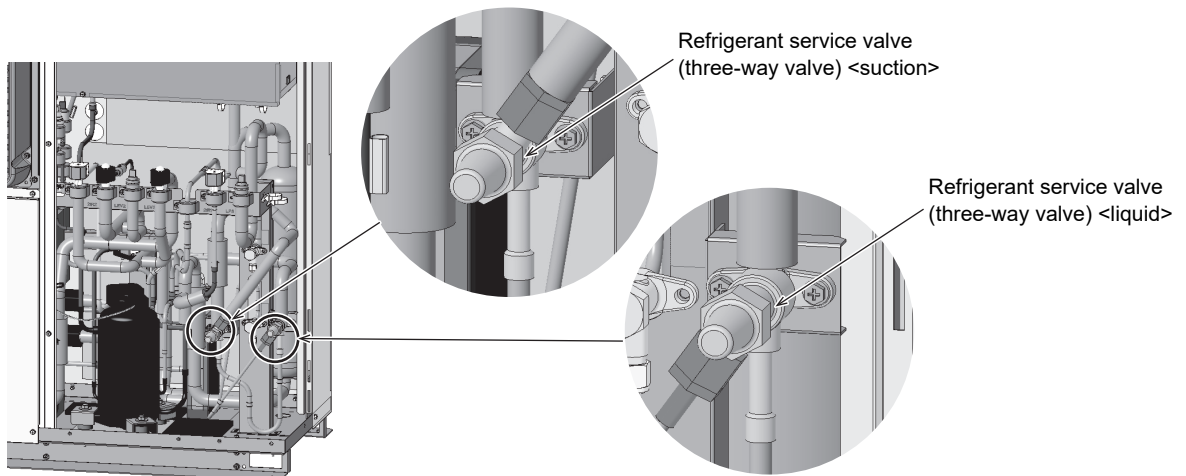

10. Refrigerant charging

10-1. Refrigerant charging procedure

**Charge the system with refrigerant from the high-pressure side first.
Charging the system from the low-pressure side first may damage the compressor.**

Follow the instructions below to charge refrigerant.

Procedures

1. Complete vacuum drying.
2. Weigh the refrigerant cylinder. <Before charging>
3. Charge the system with refrigerant through the check joint connected to the refrigerant service valve (three-way valve) <liquid>.

Note

- Charge the high-pressure side with liquid refrigerant.
Gradually add R744 in gas form to the refrigerant system until the internal pressure reaches 0.52 MPa.
If R744 is charged in liquid form when the internal pressure is below 0.52 MPa, dry ice may form inside the system.
- Open the refrigerant service valve (three-way valve) <liquid> half-way to charge refrigerant.
- Do not charge liquid refrigerant from low-pressure side first.
Charging liquid refrigerant from low-pressure side first may cause damage to the compressor.
The compressor may suffer damage if the pressure on the compressor suction side is higher than the compressor discharge side (counter pressure).

4. Weigh the refrigerant cylinder.
5. Check that proper amount of refrigerant has been charged.

The amount of refrigerant to be charged = Cylinder weight before charging - Cylinder weight after charging

6. After the refrigerant has been charged, fully open the refrigerant service valve (three-way valve) <liquid> and the refrigerant service valve (three-way valve) <suction>.
Then open the check joint to remove the refrigerant accumulated inside the pipe between the check joint and the three-way valve. Close the check joint cap. Do this with both the refrigerant service valve (three-way valve) <liquid> and the refrigerant service valve (three-way valve) <suction>.
7. After test run, check the operating conditions of the system, and then add an allowable amount of refrigerant if necessary. Overcharged refrigerant can raise the pressure inside the pipes. When adding refrigerant, charge additional refrigerant from the check joint connected to the refrigerant service valve (three-way valve) <suction> while operating the unit.

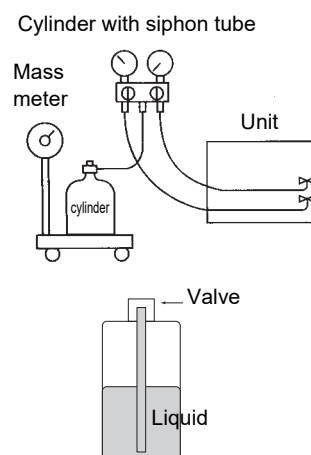
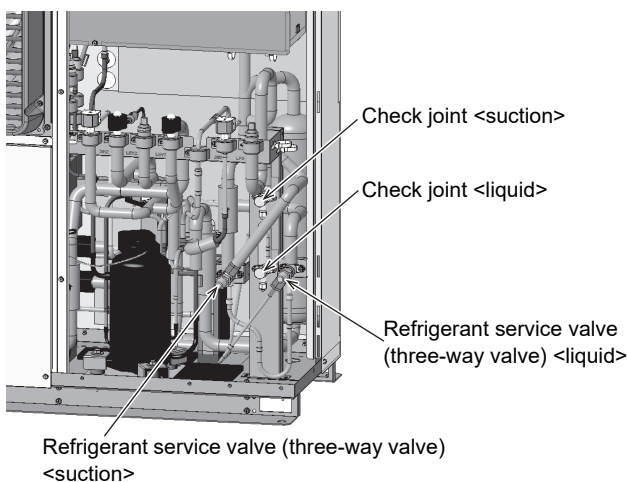

Note

- After the refrigerant is charged, fully open the refrigerant service valve (three-way valve) <liquid> and the refrigerant service valve (three-way valve) <suction>, open the check joint, remove the refrigerant accumulated inside the pipe between the check joint and the three-way valves, and close the check joint cap. Do this with both the refrigerant service valve (three-way valve) <liquid> and the refrigerant service valve (three-way valve) <suction>.
- Remove the refrigerant according to the applicable laws and regulations.

10-2. Allowable amount of refrigerant to be charged

Charge the refrigerant according to the table below.

(Install an additional accumulator if the amount of refrigerant exceeds the allowable amount shown in the table.)

(kg)

Standard refrigerant charge	Pipe length (m)	Medium temperature (ET -5~-20°C)				Low temperature (ET -20~-45°C)			
		Evaporator internal volume (L)				Evaporator internal volume (L)			
		1	2	3	4	1	2	3	4
	10	1.40	1.60	1.75	1.95	1.40	1.55	1.75	1.90
	20	1.50	1.70	1.90	2.05	1.50	1.65	1.85	2.00
	25	1.60	1.75	1.95	2.10	1.55	1.70	1.90	2.05

Maximum refrigerant charge	Pipe length (m)	Medium temperature (ET -5~-20°C)				Low temperature (ET -20~-45°C)			
		Evaporator internal volume (L)				Evaporator internal volume (L)			
		1	2	3	4	1	2	3	4
	10	1.80	2.05	2.30	2.50	1.80	2.05	2.25	2.50
	20	1.95	2.20	2.45	2.65	1.90	2.15	2.40	2.65
	25	2.05	2.30	2.50	2.75	2.00	2.20	2.45	2.70

- The internal volume of the condensing unit is 7.07 L.
- When increasing the liquid pipe diameter to $\varnothing 9.52$, add 0.3 kg of refrigerant per 10 m of pipes to the amount of charge specified in the table above.
- If the value is not found in the table, calculate the amount of refrigerant to be charged by interpolation.
- Do not overcharge refrigerant more than the maximum amount.
- For information on evaporator internal volume, contact the manufacture of the indoor unit.
- After charging the refrigerant, check that no flash gas (bubbles) is seen through the sight glass while the unit is in operation. If the flash gas (bubbles) does not disappear, check the following:
 - 1) Check for refrigerant leakage.
 - 2) Check for liquid flood-back.
- Procure a sight glass locally.

10-3. Insulating

- Insulating must be done after air tightness test.
- The liquid pipe and suction pipe must be insulated. Refer to the table below. Use foamed polyurethane and styrol with no hygroscopicity for insulation.

(Unit: mm)

Pipe	Insulation	Cold storage		Freezer storage	
		Thickness of insulation (recommended)		Thickness of insulation (recommended)	
Suction pipe	a	Pit piping	25 or more	Pit piping	50 or more
		Ceiling piping	50 or more	Pit piping	75 or more
Liquid pipe	b	20 or more			

* Calculate the thickness of the insulation with 0°C (32°F) as the cold storage refrigerant temperature for suction pipe and -30°C (-22°F) for freezer storage refrigerant temperature, and 0°C (32°F) for liquid pipe.

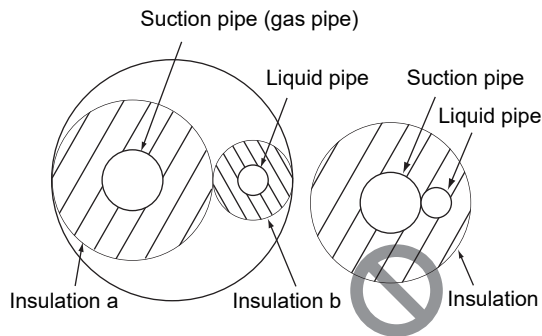

Prohibition of heat exchange between the suction pipe and the liquid pipe

- Do not exchange heat between the suction pipe and the liquid pipe.
- Hot gas pipe is always high temperature. Insulate pipes if they are installed in a place accessible to people. Use insulation that is rated for temperatures of at least 150°C (302°F), such as insulation tubes or glass wool insulation.

11. Test run

11-1. To ensure proper test run

Check if the wiring work has been done properly.

After wiring work, be sure to measure the insulation resistance between the cable run and ground, and that between each wire with a high voltage insulation megger tester to check that the resistance is 1 MΩ or more. (Do not measure the insulation resistance of the control board to prevent damage to the electronic circuit boards.)

After checking that the installation work has been done properly, power ON the main switch (earth leakage breakers etc.).

Check the phase order of the power supply and the inter-phase voltage. If the voltage is out of the ±10% range, discuss the countermeasure with the customer.

The crankcase heater that is used for preventing the foaming of lubricating oil is powered only when the compressor is stopped.

Before starting up the unit after leaving it alone more than half a day with its main switch OFF, energize the unit at least 3 hours to heat the lubricating oil.

Fully open the refrigerant service valve.

Make sure that the compressor or fan is generating no abnormal noise or vibration. When there is any abnormality, immediately stop and inspect the unit.

After the operation becomes stable, check that the operation pressure and the temperature of each device are in the proper range. Refer to "Checking the unit condition". (Page 51)

There are round holes on the bottom of the product for draining water in rainy weather and for discharging heat in the product. Do not block these holes.

11-2. Setting the pressure switch <high pressure>

- 1) The unit is equipped with a pressure switch <high pressure> in the refrigerant circuit as a safety device. The default values of the switch are fixed and unchangeable.
- 2) Do not change the settings or do not replace the switch.
- 3) The default values of the pressure switch <compressor discharge pressure> are as follows.

Safety device	Default setting value (MPa)	
	OFF	ON
Pressure switch <compressor discharge pressure>: 63H	12.0	8.5

11-3. Setting the target evaporation temperature

Set the dip switch (SW2) according to the following table to set the target evaporation temperature.

Note

- Always turn off the power of the unit before setting the dip switch (SW2).

1: ON 0: OFF

Dip switch (SW2)						Target evaporation temperature
1	2	3	4	5	6	
0	1	0	0	1	0	-5
1	1	0	0	1	0	-6
0	0	1	0	1	0	-7
1	0	1	0	1	0	-8
0	1	1	0	1	0	-9
1	1	1	0	1	0	-10
0	0	0	1	1	0	-11
1	0	0	1	1	0	-12
0	1	0	1	1	0	-13
1	1	0	1	1	0	-14
0	0	1	1	1	0	-15
1	0	1	1	1	0	-16
0	1	1	1	1	0	-17
1	1	1	1	1	0	-18
0	0	0	0	0	1	-19
1	0	0	0	0	1	-20
0	1	0	0	0	1	-21
1	1	0	0	0	1	-22
0	0	1	0	0	1	-23
1	0	1	0	0	1	-24
0	1	1	0	0	1	-25

Dip switch (SW2)						Target evaporation temperature
1	2	3	4	5	6	
1	1	1	0	0	1	-26
0	0	0	1	0	1	-27
1	0	0	1	0	1	-28
0	1	0	1	0	1	-29
1	1	0	1	0	1	-30
0	0	1	1	0	1	-31
1	0	1	1	0	1	-32
0	1	1	1	0	1	-33
1	1	1	1	0	1	-34
0	0	0	0	1	1	-35
1	0	0	0	1	1	-36
0	1	0	0	1	1	-37
1	1	0	0	1	1	-38
0	0	1	0	1	1	-39
1	0	1	0	1	1	-40
0	1	1	0	1	1	-41
1	1	1	0	1	1	-42
0	0	0	1	1	1	-43
1	0	0	1	1	1	-44
0	1	0	1	1	1	-45

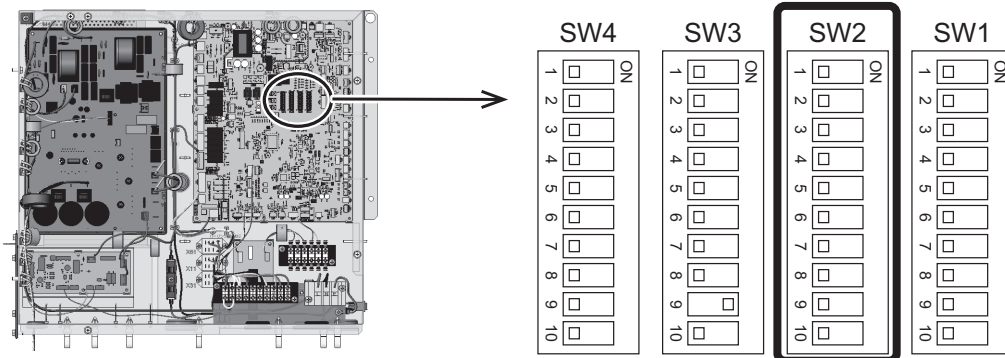

- Before operating the unit, set the target evaporation temperature using the dip switch (SW2).
If the target evaporation temperature is not set, operation starts with the target evaporation temperature tentatively set to -10°C.
- Even when using MODBUS® to set the target evaporation temperature, always use the dip switch (SW2) to set the target evaporation temperature before operating the unit.
When the power to the unit is shut off due to a power outage, the unit starts up with the target evaporation temperature that has been set with the dip switch (SW2) upon recovery of the power.
Until the target evaporation temperature is set again using MODBUS®, the target evaporation temperature that has been set with the dip switch (SW2) is effective.
- For instructions on how to set the target evaporation temperature using MODBUS®, refer to the MODBUS® Interface Manual.
- Please contact the supplier for the MODBUS® Interface Manual.



Switches 1 to 5 are ON, and switches 6 to 10 are OFF in the figure on the left.

11-4. Test run procedure

11-4-1. Initial processing

It will take approximately two minutes (max. five minutes) for the low pressure to be displayed on the digital display on the MAIN board after the unit is turned on.

If the low pressure does not appear on the digital display after a while, check for wiring errors.

1) What to expect during the initial processing

During the initial setting of the LEV, the LEV will make clicking noises, but this is not a malfunction.

During the initial setting of the circuit board, a value will appear on the digital display for a few seconds.

11-4-2. Operation

[1] Operate the unit operation. (Capacity control)

1) Check that dip switch SW3-5 is OFF.

Capacity control operation is performed using the inverter.

2) Set the ON/OFF switch (SW1) to ON.

The unit starts operating.

Low pressure will be displayed on the digital display on the MAIN board.

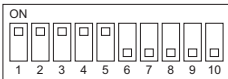

Switches 1 to 5 are ON, and switches 6 to 10 are OFF in the figure on the left.

11-4-3. Stop the unit. (Pump down stop)

[1] Stop the unit.

Set the ON/OFF switch (SW1) to OFF.

The unit stops operating.

Note

- To prevent refrigerant flood-back upon resuming operation, turn off the switch (SW1) after low-pressure cutoff from pump down operation.

[2] Stop the unit after pump down. (Pump-down mode)

Use the pump-down mode when closing the solenoid valve on the liquid line, recovering the refrigerant to the liquid receiver, and providing maintenance for the load-side equipment.

1) Set the ON/OFF switch (SW1) to OFF to stop the operation.

2) Set the unit power to OFF.

3) Set dip switch SW3-5 to ON to start the fixed frequency mode. Set dip switch SW3-1 on the unit to ON to start the pump-down mode.

4) Close the solenoid valve <liquid> or the refrigerant service valve (three-way valve) <liquid>.

5) Turn on the unit power supply, and the ON/OFF switch (SW1) to ON to start the operation.

The unit operates at the low-pressure cutoff OFF-threshold of 0.58 MPa and the ON-threshold of 0.73 MPa.

After completing the pump down process, set the ON/OFF switch (SW1) to OFF to stop the operation, and set dip switches SW3-5 and 3-1 to OFF with the unit power set to OFF.

* Do not operate the unit in the above settings except to perform maintenance.

* Even after pump down stop, approximately 1 MPa of refrigerant will remain on the low-pressure side. Refrigerant may spew out during servicing.

- If the system is overcharged with refrigerant, performing a pump-down operation through the liquid service valve in high ambient temperature (30°C (86°F) or above) may result in high-pressure cut off.
- If a pumpdown is performed on a system with refrigerant overcharge and is then stopped for a long time, the pressure may rise. Do not perform a pumpdown, and instead stop the unit by turning off the operation switch.
- Drain the refrigerant when the unit will be stopped for an extended period or when servicing the unit. Drain the refrigerant from the refrigerant service valve (three-way valve) <suction>.

11-4-4. Display of the MAIN board (inside the control box)

Operation status display on LED4

Symbol	Operation status
oFF	Compressor stoppage (by using operation switch)
run	Compressor in operation
LPoF	Low-pressure cutoff function is stopped.
0H	Compressor stoppage (by using capacity control)
00H	Compressor preliminary stoppage (during the 3-minute restart delay mode)
000H	Compressor error stoppage
oL1	Oil return operation in progress
udry	Evacuation mode
P01-P07	Pre-alarm

Note 1: This model stops the compressor when the solenoid valve <liquid> or other valves are closed and the low pressure falls below a certain level. (Low-pressure cutoff)

The low-pressure cutoff ON- and OFF-thresholds vary depending on the target evaporation temperature.

Note 2: If the low pressure has not reached the low-pressure cutoff ON-threshold even after the lapse of the low pressure cutoff restart delay time, the LED repeatedly shows "LPoF," "0H," and "low pressure" in order.

11-5. Checking the unit condition

11-5-1. Regular operation check

Check that the discharge pressure is not abnormally high.

Outside air temperature (°C) (°F)	0 (32)	5 (41)	10 (50)	15 (59)	20 (68)	25 (77)	30 (86)	35 (95)	40 (104)
Discharge pressure (MPa)	5.5	5.5	5.7	6.0	6.5	7.0	8.0	9.0	9.5

Check that the unit's suction gas temperature does not exceed 20°C (68°F).

Check if the compressor is not flooding. If the compressor is flooding, adjust the opening of the expansion valve on the load side.

The solenoid valve may open or close while the compressor is stopping. This is not a malfunction.

- The table below shows the temperature of each part when the unit is properly adjusted.

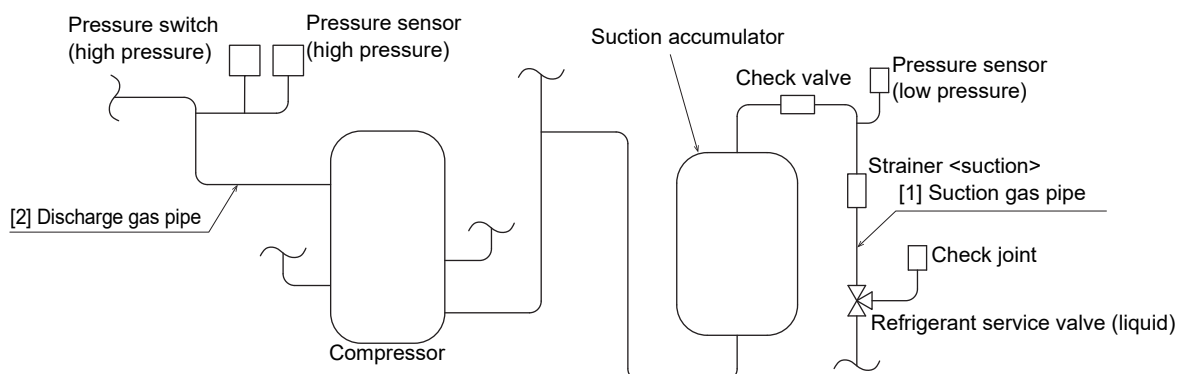

Evaporation temperature (°C) (°F)	-10 (-14)	-35 (-31)
[1] Unit suction gas temperature (°C) (°F)	0 to 10 (32 to 50)	-15 to -5 (5 to 23)
[2] Discharge gas temperature (°C) (°F)	50 to 70 (122 to 158)	70 to 90 (158 to 194)

- Power supply: Single phase 220 to 240 V, 50 Hz
- Gas cooler return air temperature: 32°C (89°F)
- Operation at 40 Hz

Note

- Do not operate the unit with the compressor being flooded. Because the refrigerant oil used in this unit is non-miscible, if the unit is operated with a flooded compressor, refrigerant oil will not properly return to the compressor, resulting in compressor damage.

11-5-2. Preventing short-cycling operation

1) Checking if the operation is in short-cycling or not

Check the cycle of operation/stop time. If it is within 15 minutes, the operation is in short-cycling.

Eliminate the cause of the short-cycling.

The unit is equipped with a delay timer (at a maximum 200 seconds) to prevent frequent short-cycling operations.

2) Preventing short-cycling operation (frequent repeat of operation/stop)

As an essential measure to prevent short-cycling operation, the operation pattern needs to be set as shown in the figure.

- Short-cycling operation may cause a lack of lubricating oil because of a large oil trip at the startup.
- A large amount of current flows to the built-in motor when the unit starts, which may cause the motor to be overheated, resulting in burn-damage to the coil.

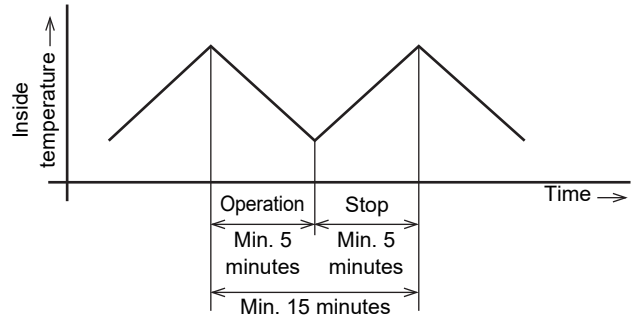

3) Major cause of short-cycling

Followings are possible major causes of short-cycling.

- Setting failure of low pressure control
For example, the low pressure differential is set to 0.2 MPa or below.
- Clogged strainer <suction>
- Leakage in the injection circuit or in solenoid valve <liquid> on the evaporator side caused by device fault or foreign substances.
- Refrigerant undercharge
- Condensing unit selection error (Unit capacity is too large.)
- Frosted evaporator

11-5-3. Troubleshooting

[1] How to interpret the currently occurring abnormality

If the following code and value are shown on the digital display of the MAIN board, perform troubleshooting according to "Error codes and messages for troubleshooting" in the DATA BOOK.

- 4-digit code → Detailed code → 000H → Low pressure (Alternating blinking display)

Note

- After the test run, check for leakage.

12. Post-installation inspection

12-1. Installation check list

When the installation work is complete, inspect the installation according to the following list.

If there are any problems, be sure to correct them. (Otherwise, not only may the functionality be restricted, safety may also be compromised.)

Check items	Details	Results
Space requirements	Is there enough space left around the condensing unit as required?	
	Is the unit installed indoor, in a depressed space, or in a halfway basement?	
Refrigerant pipes	Are measures taken for pressure rise in the piping? (Is a pressure relief device installed in accordance with applicable local regulations?)	
	Has a gas leak check been performed?	
	Is the refrigerant service valve fully open?	
Electric circuit	Are all wiring properly connected to the terminals?	
	Is an earth leakage breaker installed?	
Are any measures taken to protect against refrigerant leakage? (Is a gas detector installed according to applicable laws and regulations?)		
Are all pipes properly secured and kept out of contact with the electrical wiring or building structures?		
Are all wiring kept out of contact with high-temperature components?		
Is the unit properly grounded?		
Are all terminal screws and nuts securely tightened?		

Check items	Details	Results	
Test run	Noise/vibration	Is the unit free of abnormal noise or vibration?	
	Refrigerant leakage	Is the unit free of refrigerant leaking sound?	
	Operating pressure	Are the high and low pressures within the normal range?	
	Electric system	Does the unit operate without chattering (when turning the unit ON/OFF)?	
	ON/OFF cycle	Does the unit operate without short-cycling?	

12-2. Check items for refrigerant circuit components

Check item	Causes or remedies
<p>Check for any dirt or clogging in the strainer.</p> <p>Check the strainer.</p> <p>A heavily clogged strainer can cause the unit to generate abnormal sound.</p>	<p>Check that the heat exchanger fins are not clogged.</p> <p>A clogged condenser fin can cause the high pressure and discharge gas temperature to rise dangerously high.</p>
<p>Check that the refrigerant service valve (three-way valve) <suction and liquid> are open.</p> <p>If the valve is left closed, the unit will perform short-cycling operation, which may result in a poor cooling problem or compressor damage.</p>	<p>When the refrigerant service valve (three-way valve) <liquid> needs to be closed, check that liquid refrigerant is not trapped in the pipe section between the two closed valves.</p>
<p>Check that the caps on the check joint and refrigerant service valve are securely attached.</p> <p>If the cap or the check joint on the suction side or the liquid side of the refrigerant service valve (three-way valve) is off or loose, air can infiltrate and cause dangerously high pressure.</p>	<p>The section of the pipe between the solenoid valve <liquid> (evaporator side), locally installed valve on the pipe, and refrigerant service valve <liquid> can trap liquid refrigerant and cause the pipe to burst.</p> <p>Perform a pump down with the refrigerant service valve (three-way valve) <liquid> closed to remove the liquid refrigerant and prevent pipe damage.</p>
<p>Check that the surface of the compressor, liquid trap, or accumulator is not rusted.</p> <p>Check for corrosion at the time of installation and every 5 years thereafter, and record the check results.</p>	<p>Check for any clogging in the strainer.</p> <p>A clogged strainer or dryer will reduce injection speed and cause the discharge gas temperature to rise.</p>

Note

- Write down the amount of the charged refrigerant on the rating nameplate with an indelible pen.

13. Providing guidance on the usage to the end users

- According to this Installation Manual and a separately provided instruction manual, explain the correct use to the end users.
- If the end users are not present, provide explanation to the owner and/or building manager.
- The "Safety Precautions" section provides important safety precautions. Ensure that the users abide by the rules. (Page 5)
- Provide this Installation Manual along with the supplied instruction manual to the users after installation.
- If the users change, hand a copy of this Installation Manual to the new users.

13-1. Maintenance

Regular maintenance is important.

To use the unit safely and maximize its life, it is recommended that the unit undergo periodic inspections.

13-2. Preventing continuous liquid refrigerant flood-back

Continuous frosting of the compressor bottom except during the defrost cycle when the evaporator fan is stopped to prevent warm air from being supplied suggests that liquid refrigerant is continuously flooding the compressor.

Check the following items to prevent continuous liquid refrigerant flooding: opening of the evaporator's expansion valve, installation position/state of the temperature sensing tube, and evaporator fan (proper operation including

rotation speed).

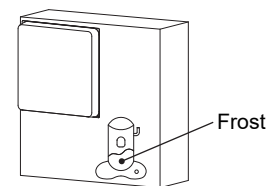

13-3. Regular operation check

Regularly check the operation condition of the unit. If the unit does not cool properly, clean the gas cooler.

For the appropriate temperature of certain components when the unit is operating properly, refer to "Checking the unit condition". (Page 51)

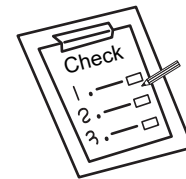

13-4. Cleaning the heat exchanger fins

Keep the heat exchanger fins clean by regularly hosing them down with water. Dirty fins may cause the high pressure to rise or a poor cooling problem.

Use caution not to let the fan motor or control box get wet.

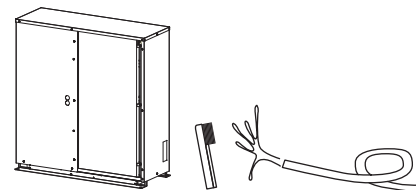

13-5. Cleaning the panels

Wipe with a soft cloth soaked in water with mild detergent, and then wipe off the detergent with a wet cloth. Do not use benzene, thinner, or polishing powder to clean the unit. Benzene and thinner can damage the coating and cause the unit to rust.



13-6. Handling of the all-aluminum heat exchanger

Because the heat transfer pipe and fins of the heat exchanger are made of aluminum, they may corrode when in contact with copper or iron materials. Do not touch the aluminum part with gloves that have touched sheet metal or copper pipes.

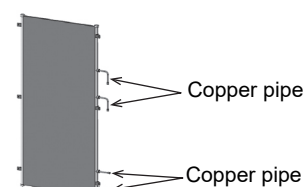

13-7. Cleaning the discharge heat duct mesh

Keep the discharge heat duct mesh on the divider in the center of the unit clean and clog-free.

14. Specifications

Model(s): ECOV-X15VA (-BS)

Refrigerant fluid(s): R-744 (CO₂)

Item	Symbol	Value		Unit
Evaporating temperature	t	-10°C	-35°C	°C

Parameters at full load and ambient temperature 32°C

Rated cooling capacity	P _A	4.000	1.980	kW
Rated power input	D _A	1.900	1.720	kW
Rated COP	COP _A	2.10	1.15	

Parameters at full load and ambient temperature 25°C

Cooling capacity	P ₂	4.280	2.070	kW
Power input	D ₂	1.620	1.490	kW
COP	COP ₂	2.64	1.39	

Parameters at full load and ambient temperature 43°C (where applicable)

Cooling capacity	P ₃	2.690	1.310	kW
Power input	D ₃	1.920	1.740	kW
COP	COP ₃	1.40	0.75	

Other items

GWP	R-744 (CO ₂)	1
GWP Note	Natural refrigerant	
Capacity control	variable	
Sound pressure level*1	-10°C	56 dB (A)
	-35°C	54 dB (A)
Temperature range	-25°C to 43°C	
Contact details	MITSUBISHI ELECTRIC CORPORATION AIR-CONDITIONING & REFRIGERATION SYSTEMS WORKS 5-66, Tebira, 6-Chome, Wakayama City 640-8686, Japan	

*1 Measured at a distance of 1 meter from the product.

Please be sure to put the contact address/telephone number
on this manual before handing it to the customer.

mitsubishi electric corporation
HEAD OFFICE: TOKYO BLDG., 2-7-3, MARUNOUCHI, CHIYODA-KU, TOKYO 100-8310, JAPAN