



# Lossnay Energy Recovery Ventilator

MODELS:

**LGH-160RVXT3-E**

**LGH-200RVXT3-E**

**LGH-250RVXT3-E**

## Installation Instructions

**For use by dealer/contractor**

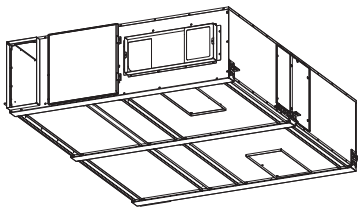

### Contents

1. Safety precautions.....	2
2. Outline drawings.....	5
3. Before installation.....	5
4. Standard installation examples.....	6
5. Installation method.....	7
5.1 Installing the Lossnay unit.....	7
5.2 Electrical installation.....	9
6. Function settings.....	20
7. Check points after installation work.....	36
8. Trial operation.....	37
8.1 Trial operation using the remote controller (PZ-62DR series)....	37
8.2 Lossnay trial operation.....	37
8.3 Lossnay trial operation in a whole system.....	37
8.4 If trouble occurs during trial operation.....	38

This product needs to be installed properly in order to ensure maximum functionality as well as safety.





Please make sure to read this installation manual before starting the installation.

- Installation must be performed by a dealer or installation contractor. Please note that improper installation may cause malfunction or accident.

“Operating Instructions” and this manual must be handed over to the customer after completing the installation.

# 1. Safety precautions

The following signs indicate that death or serious injury may be caused by failure to heed the precautions described below.

 <b>WARNING</b>		Incorrect handling could cause serious injury or death.
 Do not disassemble	<p><b>Do not modify or disassemble.</b> It could cause fire, electric shock or injury.</p>	
 Prohibition of use in bath or shower room	<p><b>The Lossnay unit and remote controller should not be installed where it is highly humid, like a bathroom, or other wet place.</b> It could cause electric shock or power leakage.</p>	
 Connect the grounding wire.	<p><b>Connect the product properly to ground.</b> Malfunctioning or power leaks can cause electrical shock.</p>	
 The instructions given must be followed.	<p><b>Follow the laws and regulations of each country for electrical wiring.</b> It could cause fire, electric shock or injury.</p>	
	<p><b>Use the specified power supply and voltage.</b> Use of incorrect power supply or voltage could cause fire or electric shock.</p>	
	<p><b>Select a place with sufficient strength and install the main unit securely.</b> It could cause injury or death.</p>	
	<p><b>Wiring work must be performed by qualified professionals, and be implemented safely and securely in accordance with appropriate standards and regulations.</b> Poor connection or improper wiring work could cause electric shock or fire.</p>	
	<p><b>Make sure to install an all-pole electric leakage isolator securely. All supply circuits must be disconnected before obtaining access to the terminal devices. Use the specified cable size and connect the cables securely to prevent disconnection when they are pulled.</b> If there is a defect in the connection, there is a possibility of fire.</p>	
	<p><b>Select an adequate place for the opening to introduce outdoor air, where it will not intake the exhaust fumes like combustion gas, or others, and there is no risk of blockage.</b> Shortage of fresh air could put the room in a state of oxygen deficiency.</p>	
	<p><b>A duct made of steel must be installed with care not to be connected electrically with metal, wire, stainless steel plate, or others.</b> It could cause fire when power leakage occurs.</p>	
	<p><b>It is prohibited to use the unit where salt, sulphur, chlorine or hot spring steam damage is expected.</b> It could cause fire, electric shock or injury.</p>	
	<p><b>Do not touch the product for at least 5 minutes after the power is shut off.</b> It could cause electric shock.</p>	
<p><b>Upside-down installation and vertical installation are prohibited.</b> It could cause injury or malfunction.</p>		



## CAUTION

Incorrect handling could cause injury or damage to property or household effects.



Prohibited

**Do not place a burning appliance in a place where it is exposed directly to the air from the Lossnay unit.**  
It could cause an accident as a result of incomplete combustion.

**Do not use at a place where it is exposed to high temperatures (40°C or higher), naked flames, or in environment with combustible fumes.**  
It could cause fire.

**When using the product where it is exposed to high temperatures and humidity (40°C or higher, RH 80% or higher), or where fog occurs frequently, moisture is likely to condense in the core, and may result in condensation build up in the unit. The product should not be used under such conditions.**  
It could cause malfunction.

**Do not use in an environment such as a chemical factory, where hazardous gases such as acidic gases, alkaline gases, organic solvent fumes, paint fumes, or gases containing corrosive components are generated.**  
It could cause malfunction.

**Do not install this product in a place where it is exposed to ultraviolet light.**  
UV may damage covering insulation.

**Avoid to install air inlets and outlets where insects are likely to gather like a place near interior or exterior lights. In that case, choose hoods have repellent net.**  
It could cause intrusion of small insects.

**Do not put strong shock on the product.**  
It could cause malfunction.

**Put on gloves during installation.**  
It could cause injury.

**Make sure the power supply isolator is turned off when Lossnay is not used for a long period of time after the installation.**  
It could cause electric shock, power leakage, or fire as a result of deteriorated insulation.

**Always use the specified suspension bolts, nuts and washers or correctly rated wire / chain hangers.**  
Use of hardware with insufficient strength could result in the product dropping.

**Install weather louver or "Weather cover" for OA inlet & EA outlet to prevent rainwater from entering the Lossnay unit. Ducts to outdoor (OA and EA) shall decline by 1/30 or more downward to outdoor. They shall be longer than 3 m and properly insulated.**  
The entry of rain water may cause power leakage, fire, or damage to household property.

**The control box cover must be closed after the installation.**  
Dust or humidity may cause power leakage or fire.

**When connecting external devices (electric heater, damper, lamp, monitoring unit, etc.) using output signals of the Lossnay unit, make sure to install safety equipment for the external devices.**  
It could cause fire, damage, etc. without safety equipment.

**Select a duct heater in compliance with local and national laws, ordinances, and standards.**  
**Select a duct heater that meets adequate standard in each country.**

**Install the duct heater separated from the product by a distance of 2 m or more.**  
Failure to do so may result in fire or equipment damage due to the transmission of residual heat from the heater.

**In cold area or strong wind area, outdoor air may enter the unit because of the pressure difference or external wind even when the unit stops. It is recommended to install an electrically operated damper to block outdoor air in such cases.**

**In cold weather areas, even if they are within the range of operating conditions, dewing or freezing could occur on the main unit, where the duct is connected, or other sections, depending on the conditions of outdoor air and indoor temperature and moisture. Make sure to check the operating conditions and other precautions, and do not use the product if dewing or freezing is anticipated.**

**Do not connect the field supply fan to the product so that the air volume exceeds the maximum air volume of Lossnay's P-Q curve. It may not work properly.**

**Other than EU countries:**

**This appliance is not intended for use by persons (including children) with reduced physical sensory or mental capabilities, or lack of experience and knowledge, unless they have been given supervision or instruction concerning use of the appliance by a person responsible for their safety. Children should be supervised to ensure that they do not play with the appliance.**

**EU countries:**

**This appliance can be used by children aged from 8 years and above and persons with reduced physical, sensory or mental capabilities or lack of experience and knowledge if they have been given supervision or instruction concerning use of the appliance in a safe way and understand the hazards involved. Children shall not play with the appliance. Cleaning and user maintenance shall not be made by children without supervision.**



The instructions given must be followed.

## Bypass operation

RVXT3 series does not have bypass damper.

Bypass operation of RVXT3 is realized by only one fan motor operation from 2 fan motors in supply and exhaust path.

Air path to 2 fan motors in each supply and exhaust are separated physically after the heat exchange core.

This structure contribute that one fan motor operation in each supply and exhaust path makes less-energy recovery operation possible.

In bypass mode, the maximum air flow is 70 % of energy recovery mode. **So as in Night purge function also.**

### Note:

- When RVXT3 operates air flow 75 % or more, RVXT3 moves into energy recovery mode and stops bypass monitor output even bypass condition is satisfied at bypass mode.
- The display on the remote controller keeps bypass mode.
- In bypass mode, the fan with outlet shutter operate trickly from 60 % to 70 % air flow. If it is necessary to stop that operation, it is possible to change the maximum air flow for bypass mode in Function setting **No. 35** of PZ-62DR series.

Energy recovery operation (Lossnay mode)

Bypass operation (bypass mode)

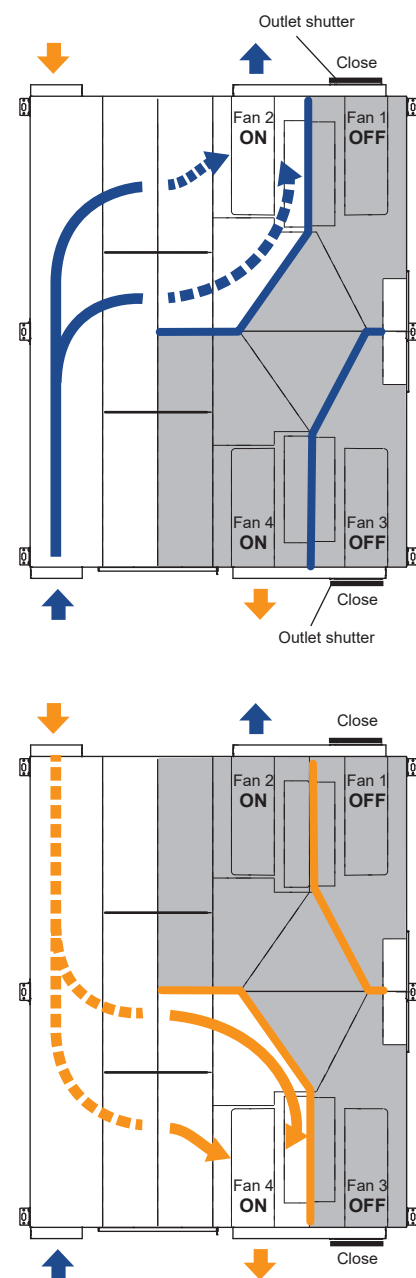
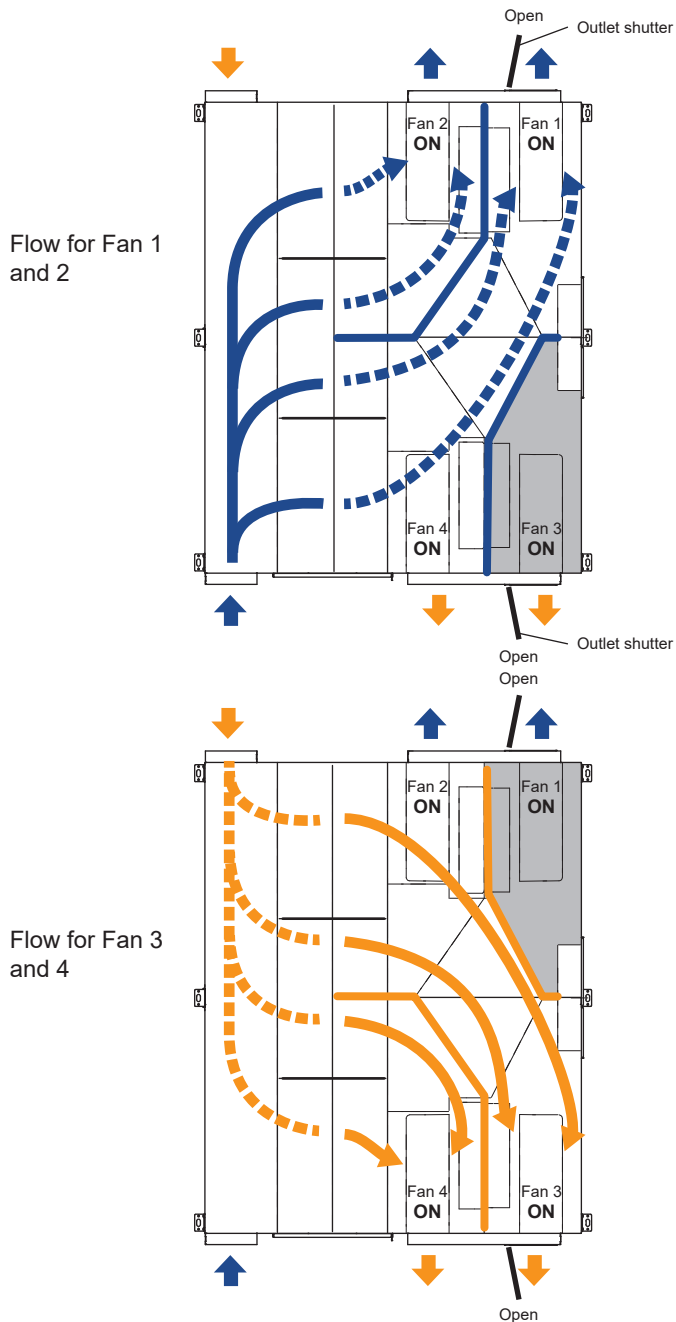

### ⚠ CAUTION

- Outlet shutter is necessary to shut out the backward flow during bypass operation.
- Leave the carton cover for the outlet flange until just before connecting duct in order not to damage on the shutter.
- Even if using screws to fix the flange and duct, take care the screws not to interfere the shutter.

## 2. Outline drawings

### LGH-160RVXT3-E, LGH-200RVXT3-E, LGH-250RVXT3-E

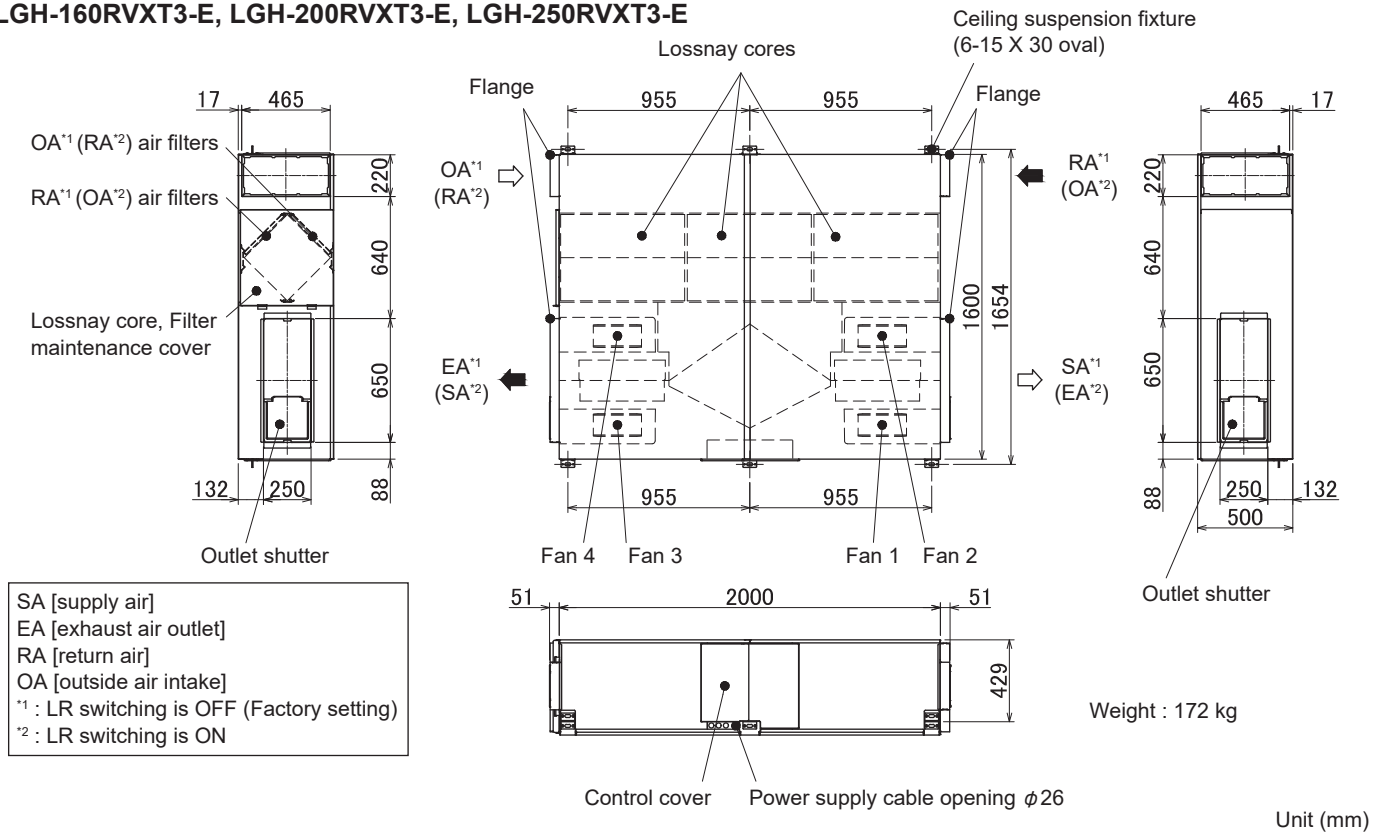

### Reference for maintenance space

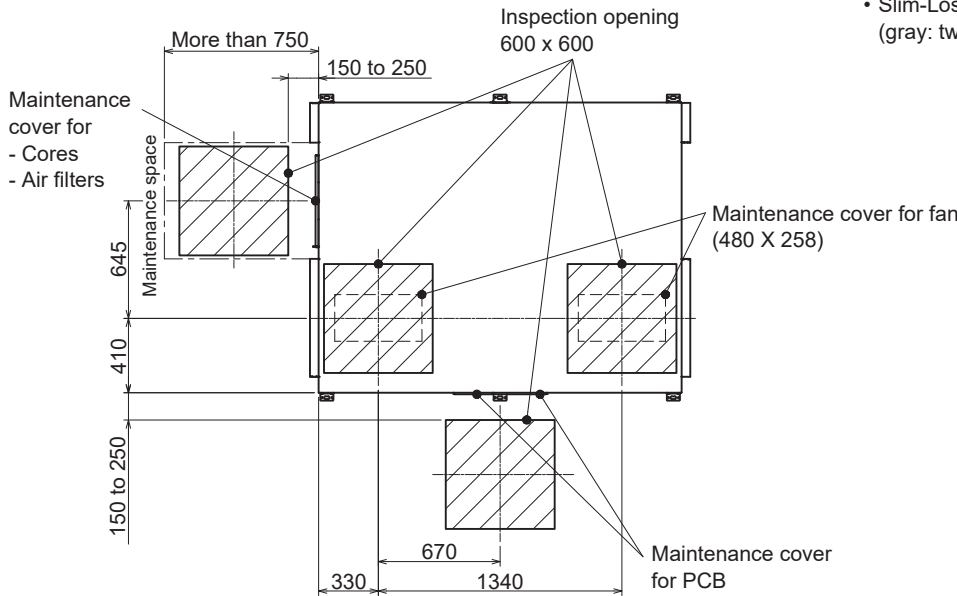

### Accessory parts

- Slim-Lossnay connection cable (gray: two wires)..... x1

## 3. Before installation

- Shutter cover cartons should be removed just before connecting duct. If the shutter move freely, it could be damaged during the installation.
- If carrying the product into the building is difficult due to the product's size, it is possible to stand the product up like the picture below.

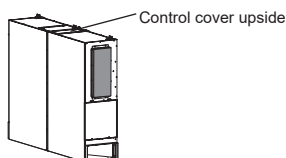

### CAUTION

- Before standing the product up, remove the Lossnay cores and filters (See page 5 of the operating instructions.)
- Deep caution is necessary during the carry.
- Vertical installation is prohibited.
- Do not hold flanges during the carrying.
- Do not remove shutter cover cardboards while carrying.

# 4. Standard installation examples

## LR switching is OFF (Factory setting)

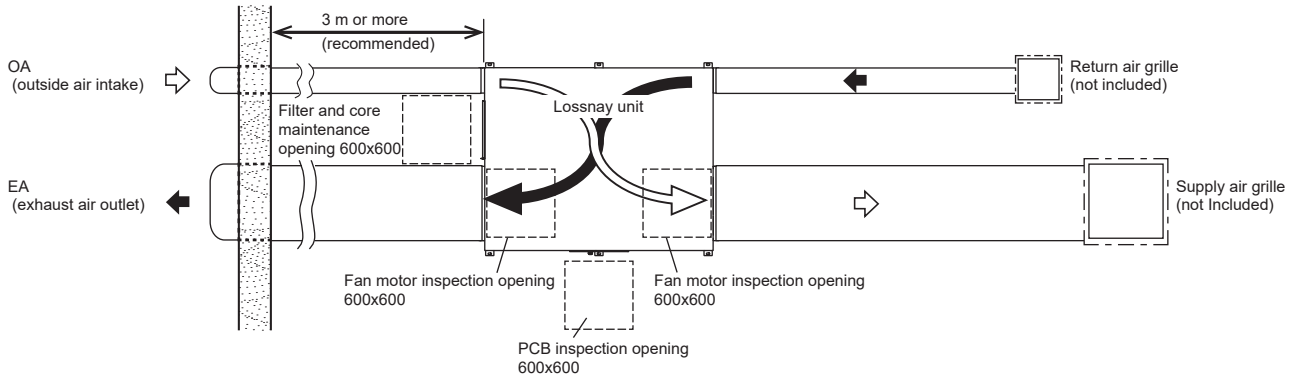

## LR switching is ON (Changed from factory setting)

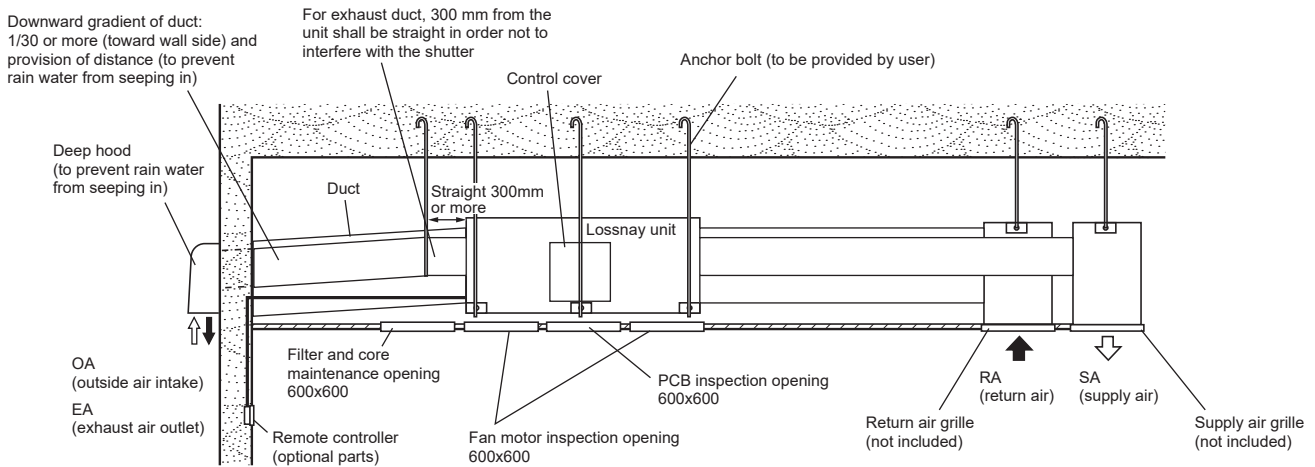
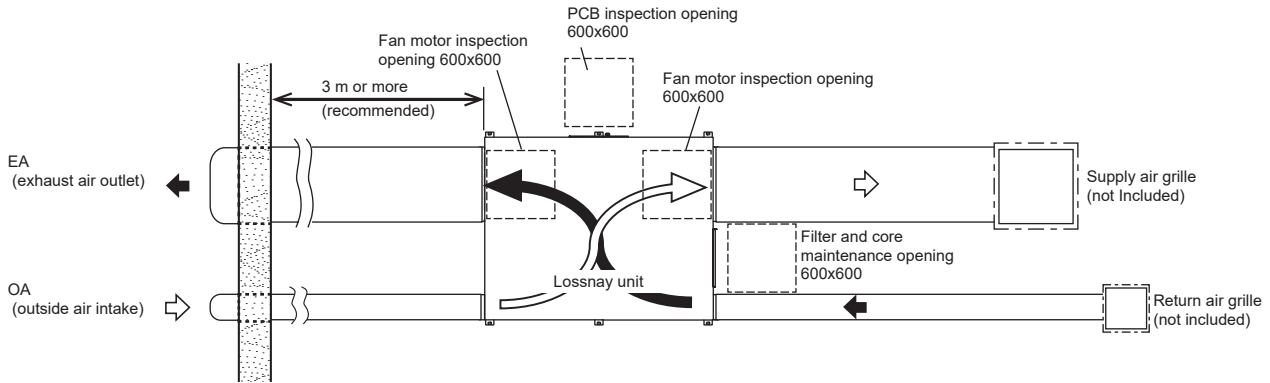

### ⚠ CAUTION

- Do not install Lossnay unit vertically or on an incline. It shall be leveled with in  $\pm 0.5^\circ$ .
- Do not install Lossnay unit up-side-down.
- When RA comes from a space which have strong odor like aromatic or detergent in wash room or shower room, the SA location is recommended not to arrange directly over the human living space.
- Ducts should be fixed individually in accordance with the necessity so that their weight will not be applied to the Lossnay unit.
- In the case any of them is not observed, water leakage happens from the unit.
  - The surrounding air condition of the unit shall be between 0 and 40°C, and the dew point of the ambient air shall be lower than 11°C in winter (e.g. 20°C 56%RH or less).
- When fake ceiling is close to the unit, the maintenance opening for filter and core has to be well considered in order not to interfere the frame of the grid ceiling with core or filter.

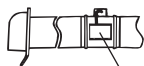

Electrically operated damper  
(Protection against the intrusion of cold air while Lossnay is stopped in winter)  
(To be provided by the customer)

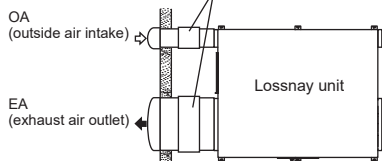

- In a region where there is risk of freezing in winter, it is recommended to install an Electrically operated damper, or the like, in order to prevent the intrusion of (cold) outdoor air while Lossnay is stopped.

# 5. Installation method

## 5.1 Installing the Lossnay unit

### 5.1.1 Determination of air path

RVXT3 series have LR switching function which can change air path according to the structure of other equipment around the unit. Firstly decide to use or not to use this function and write down the check box on the maintenance cover name plate.

#### ⚠ CAUTION

- If this setting is incorrect, the air path becomes reverse. It may cause condensation or malfunction.
- In order to LR switching enabled, set dip SW2-10 as ON (Refer to  on the page 23 for detail).
- After installation finished, check the setting is correct along with the intention by trial operation.

LR switching is OFF (Factory setting)

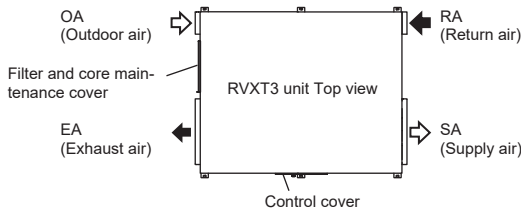

LR switching is ON

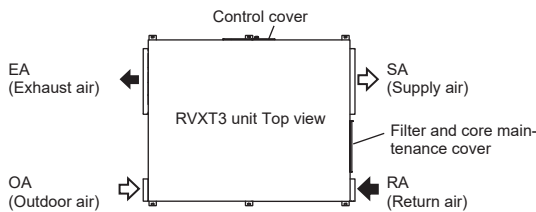

Filter and core maintenance cover

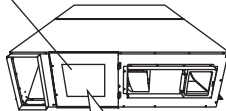

Check the selected one. This information is necessary when using optional filters or product inspection.

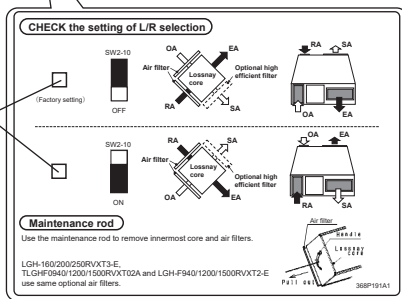

\* The drawing may be different from this picture.

### 5.1.2 Preparing the anchor bolts (M12)

Mount the washers (outer diameter of >24 mm) and nuts onto the pre-processed anchor bolts (M12), as shown in the figure below.

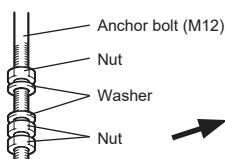

**⚠ CAUTION**  
**USE TWO NUTS**

### 5.1.3 Mounting Lossnay unit

- (1) Hang the ceiling suspension fixtures on the anchor bolts and adjust in such a way that Lossnay unit is leveled with in  $\pm 0.5^\circ$ .
- (2) Tighten up securely using double nuts.

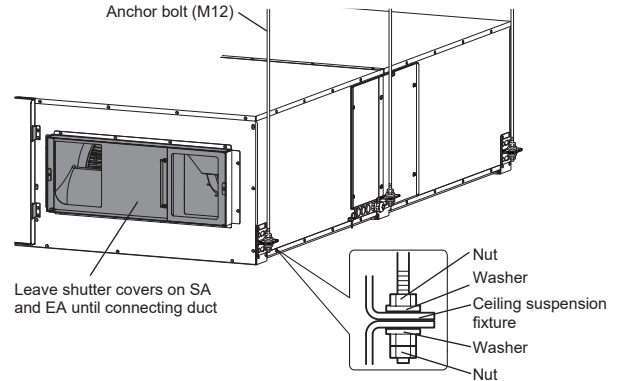

#### ⚠ CAUTION

- Install the anchor bolts to ensure the product's weight or earthquake load. (Correctly rated wire/chain may also be used)
- The unit shall be leveled with in  $\pm 0.5^\circ$ .

### 5.1.4 Connecting the ducts

- (1) Remove shutter covers of outlets.
- (2) Fasten the duct securely to the duct connecting flange, and wrap aluminum tape (field supply) around the joints so that there is no air leakage.
- (3) Suspend the ducts from the ceiling so that their weight will not be applied to the Lossnay unit.
- (4) The two outdoor ducts must be covered with heat-insulating material in order to prevent condensation from forming.

#### ⚠ CAUTION

- When using screws to fix the duct and flange, make sure to place the screw within 30 mm from the unit. The gap between the tip of duct and the bottom of flange shall be 20 mm or less. Otherwise, the screw may interfere the shutter operation.
- Do not bend, shrink or convert duct shape during 300 mm from the tip of flange. Otherwise it could interfere shutter operation.

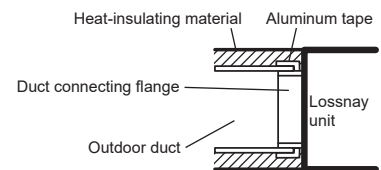
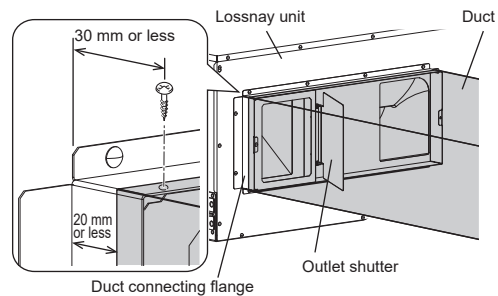

\* This picture shows the air path of factory setting. In case LR switching is enabled, the path becomes opposite.

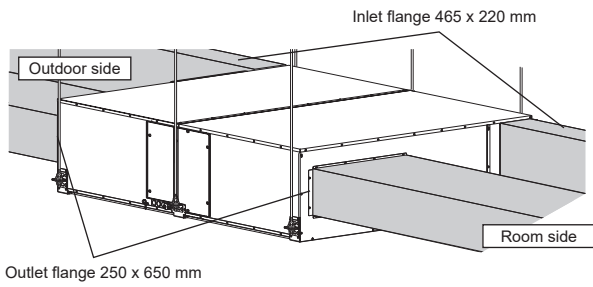

## ⚠ CAUTION

- When on-site commissioning is planned, a straight duct length more than  $10xD$  ( $D$ =duct diameter or equivalent) from the source of turbulence like bends, contractions and dampers etc, to the measurement point is recommended for correct measurement.

In the United Kingdom, on-site measurement should therefore be measured in accordance with BSRIA guideline (Commissioning Air System. Application procedures for buildings AG3/89.3(2001))

- Before attaching the ducts, check that no (debris or any other) foreign matter (scraps of paper, vinyl, etc.) has found its way inside the ducts.
- Do not touch the shutter on the flange when connecting the ducts.
- If it is expected that the ambient temperature around the place where the Lossnay unit is installed will be high during the summer air conditioning season, it is recommended that the indoor duct work be covered with insulation material.
- Do not carry out the following types of duct construction. (Doing so could cause a drop in the air volume and generate abnormal noises.)

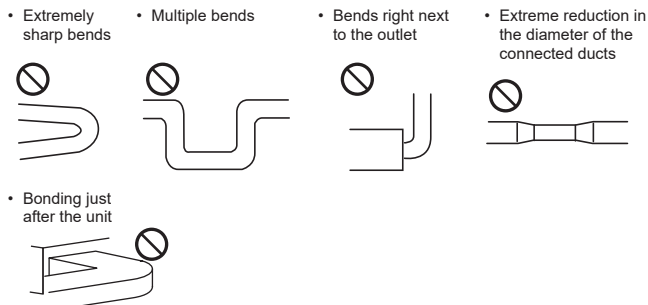



## 5.2 Electrical installation

With this product, the wiring installation method will vary according to the design of the system.

Perform electrical installation to meet local electrical regulations.

\* Always use double insulated cable for the transmission cables.

\* Wiring work must be performed by qualified professionals.

\* All supply circuits is disconnected and all LED on the circuit board shall be lit off, before accessing to the terminal devices.

\* This appliance incorporates an earth connection for functional purposes.

### 5.2.1 Names of components in control box

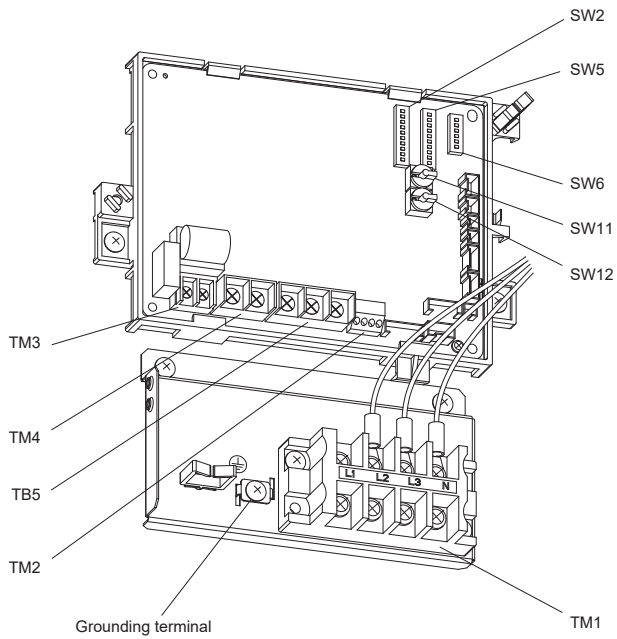

#### ⚠ CAUTION

- Do not pull out preconnected connectors unnecessarily during installation.

### 5.2.2 Wire connection diagram

- \* TM1, TM2, TM3, TM4, TB5 shown in dotted lines are field work.
- \* Be sure to connect the ground wire.
- \* A power supply isolator must be installed.
- \* Always use an isolator for the main switch power connection.
- \* Select proper circuit breaker according to the electrical current information in the chart below.
- \* Do not disconnect connectors while power supplied.

Maximum current (A) (380-415V 3N~ 50Hz / 380 3N~ 60Hz)	L1	L2	L3	N
LGH-160RVXT3-E	0	2.2-2.0 / 2.2	2.2-2.0 / 2.2	2.9-2.8 / 2.8
LGH-200RVXT3-E	0	3.0-2.8 / 3.0	3.0-2.8 / 3.0	3.9-3.7 / 3.7
LGH-250RVXT3-E	0	4.2-3.8 / 4.2	4.2-3.8 / 4.2	5.0-4.8 / 4.8

Maximum input (W) (380-415V 3N~ 50Hz / 380 3N~ 60Hz)	L1-N	L2-N	L3-N
LGH-160RVXT3-E	0	370-360 / 370	370-360 / 370
LGH-200RVXT3-E	0	530-520 / 530	530-520 / 530
LGH-250RVXT3-E	0	740-730 / 750	740-730 / 750

Even the power supply for these models is three phase 4 wire, actual usage is two of single phase.  
 Note the following;  
 - Electric current exist even for neutral.  
 - There is no load between L1 and neutral.  
 - The load of each phase is unbalanced. If it affects any problem to the load of whole building, consider to rotate the power supply phase to the unit.

#### CAUTION

- Make sure to connect Neutral.
- Do not connect power cables L1, L2 or L3 to N on the TM1.
- Mis-wiring causes the damage to the circuit board.
- Use same mm<sup>2</sup> / AWG with L1, L2 and L3 for Neutral.  
 Otherwise it may cause fire.

- \* Make sure that the current leakage breaker is one compatible with higher harmonics.
- \* Always use a current leakage breaker that is compatible with higher harmonics as this unit is equipped with an inverter.
- \* The use of an inadequate breaker can cause the incorrect operation of inverter.
- \* After installation, be sure to confirm the unit supplies the air flow correctly by trial operation to avoid mis wiring. Please see **8. Trial operation** for more detail.

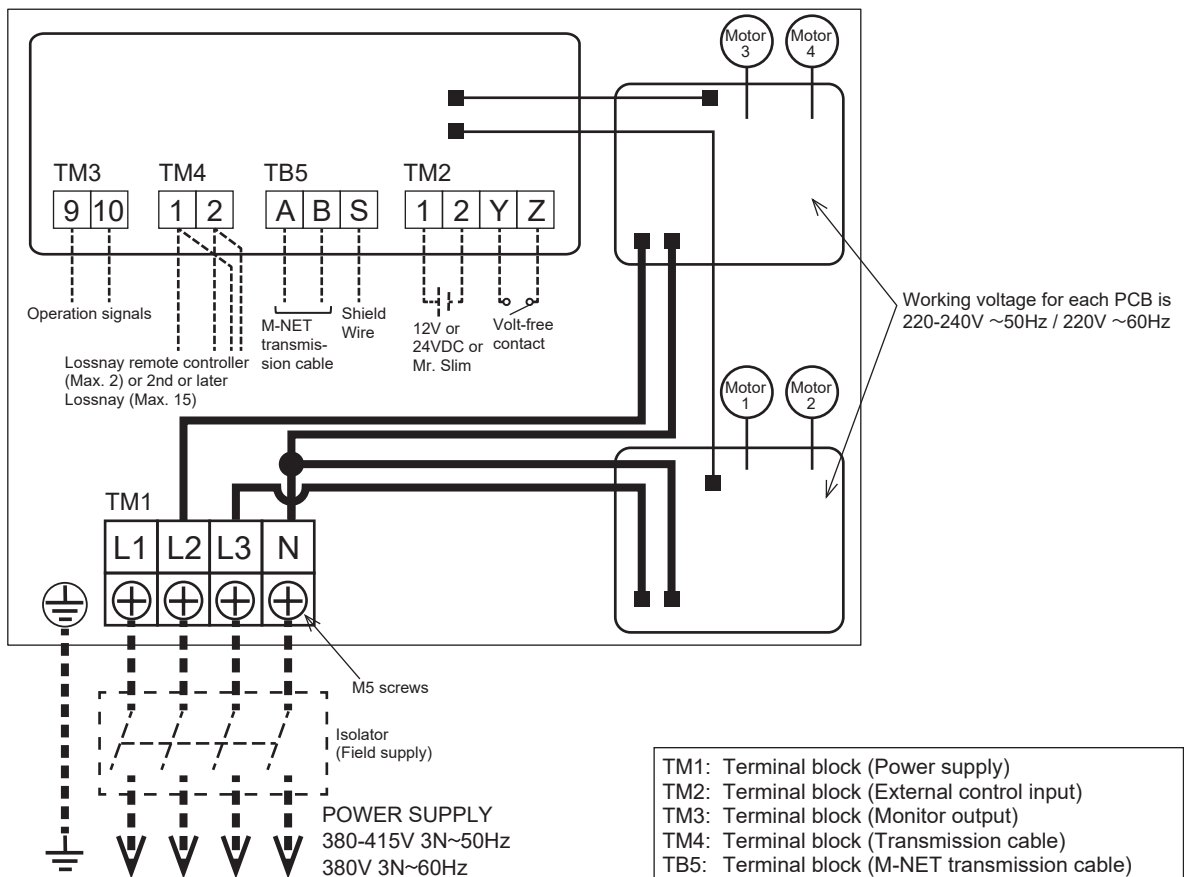

### 5.2.3 Connecting the power supply cable

- (1) Loosen the black screws.  
Control cover can remove without removing screws.

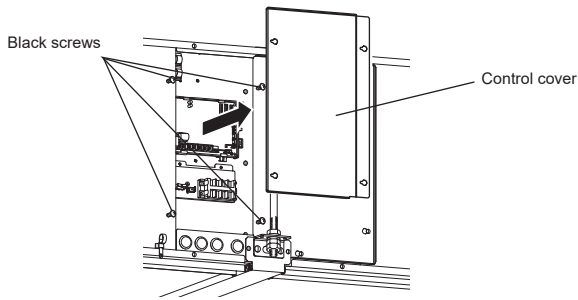

- (2) Connecting the power supply cable and transmission cable.  
Pass the Power supply cable through the bush\* and connect to the TM1 terminal block using the round terminals. Screw size of TM1 is M5. Connect the ground wire to the ground terminal and secure tightening the bush. (\* Use an item that can firmly secure the cable such as a cable gland.)

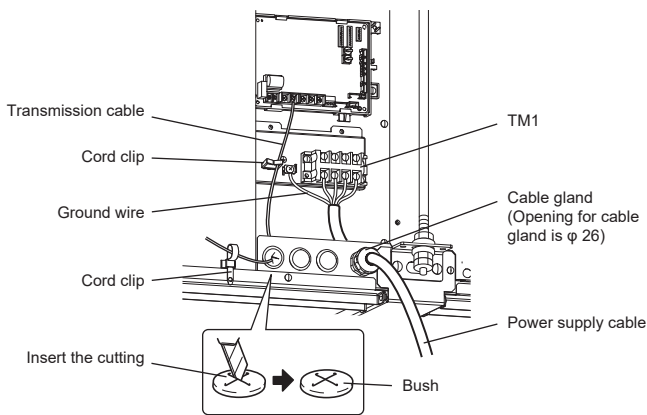

Be sure to tighten the ground wire to the grounding screw using the round terminals with anti spread washer.

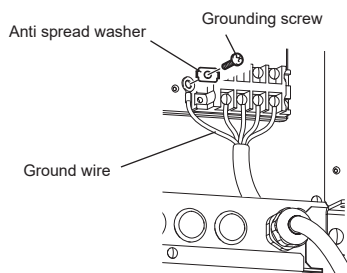

#### ⚠ CAUTION

- Always separate the power supply cable and transmission cable by 5 cm (2") or more to prevent malfunctioning of the unit.
- If the length of the stripped Power supply cable is too long, the conductors may touch and short out.
- Power supply cable size : 1.0 mm<sup>2</sup> or more.
- Power supply cable into the control box must be U trapped appropriately.

- (1) Tighten the ground wire and transmission cables to the terminal block.

- (2) Secure the transmission cables using the cord clips.

Upon completion of the wiring connections, replace the control box cover.

- When using optional signal output terminal (PZ-4GS-E), please follow the install manual of it for the electrical installation as well.

## The following system configuration can be created. Connect the necessary parts.

- 1 When connecting with remote controller (PZ-62DR series)
- 2 When interlocked with indoor unit of air conditioner or other external device including other manufactures
- 3 When operating multiple Lossnay units
- 4 Signal output from Lossnay unit
- 5 When switching fan speed externally (when a sensor or other equipment is connected)
- 6 When switching Bypass externally
- 7 To change fan speed by 0 - 10 VDC input
- 8 When using the remote/local switching and the ON/OFF input (level signal)
- 9 When connecting to the City Multi, Mitsubishi Electric Air-Conditioner Network System (MELANS)
- 10 To start/stop Lossnay stand-alone operation without using the remote control
- 11 Control via Wi-Fi interface or MELCOBEMS MINI
- 12 When connecting CO<sub>2</sub> sensor PZ-70CSD-E or PZ-70CSW-E
- 13 Leader-follower function

### CAUTION

- When connecting external devices (electric heater, damper, lamp, monitoring unit, etc.) using output signals of the Lossnay unit, be sure to install safety equipment for the external devices. (It could cause fire, damage, etc. without safety equipment.)
- Seal the opening between the bushing and the cables in order not to intrude insects.
- Except SW2-1, before DIP-SW setting is changed, always the power supply to Lossnay unit has to be cutoff. Otherwise, it may cause electrical shock, injury or non-reflection of the change.

### 1 When connecting with remote controller (PZ-62DR series)

- \* When controlling Lossnay units with MELANS, connect wires according to 9 .
- Securely connect the transmission cable from the remote controller to ① and ② of the input terminal block (TM4). (No polarity)
- Wire type: two-core sheathed cable
- Wire diameter: 0.3 mm<sup>2</sup>
- If there are two remote controllers, connect them in the same way.
- Keep the overall length of the transmission cable between Lossnay and the remote controller within 200 m.

### Note

- Do not tighten screws of terminal block TM4 and TB5 with a torque larger than 1.2 N·m. It could damage the circuit board.
- Take care not to connect the power supply cable or M-NET transmission cable.
- When connecting multiple cables to the terminal, use round terminal.
- Solid wire (single-stranded wire) cannot be connected.
- PZ-61DR-E is not available.

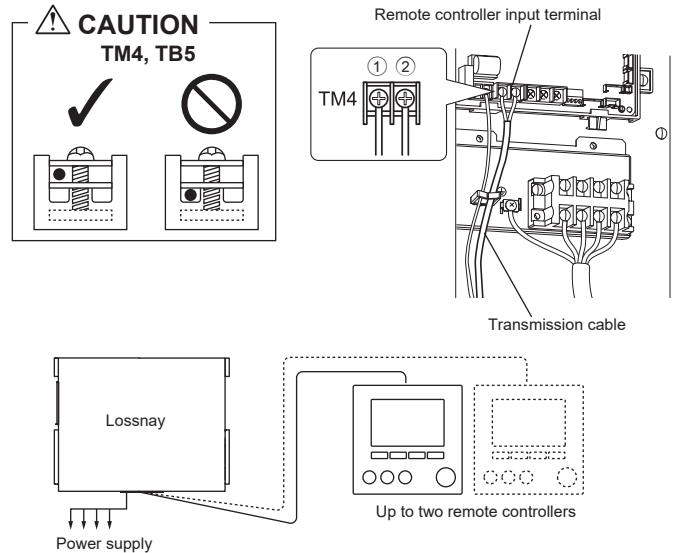

**2 When interlocked with indoor unit of air conditioner or other external device including other manufactures**

**CAUTION**

- The connection may vary according to the output signal type of the external unit.
- Do not press the terminal with a force of more than 19.6 N when connecting the cable to TM2.

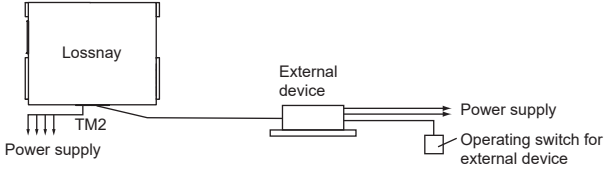

**When using Mitsubishi Mr. Slim air conditioner with MA Remote controller**

Confirm that the pulse input switch (SW2-2) is set to "OFF". (Factory setting is "OFF".) (Refer to function settings **No. 28**)

Connect the Slim-Lossnay connection cable connector side to CN2L on the circuit board for the Mr. Slim indoor unit, then connect the lead wire side to the ① and ② of the input terminal block (TM2) for the Lossnay external controller input. (No polarity)

- Always separate the power supply cable and the Slim-Lossnay connection cable by 5 cm or more to prevent the unit from malfunctioning.
- The Slim-Lossnay connection cable is 100 mm long. When wiring, extend it as far as necessary.

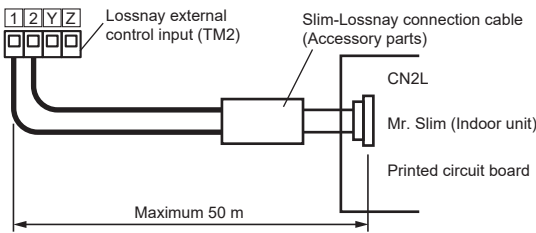

**Note**

- Use MA remote controller of Mr. Slim for switching Lossnay ON/OFF or the fan speed.
- The ventilation mode is fixed to "automatic ventilation" from MA remote controller.
- Ensure that all connections are secure and that the appropriate insulation is provided. Use extension cable sheathed cable or cable from 0.5 mm<sup>2</sup> to 1.5 mm<sup>2</sup>.
- Only one Lossnay and one Mr. Slim unit can be interlocked. Multiple units interlock is not possible.
- Lossnay can not be connected M-NET in this case.

[SW2-2] setting vary depending on the types of output signal of external device.

**When the external device has a charged operating signal of 12 VDC or 24 VDC**

- If the input is pulse signal, move the pulse input switch [SW2-2] to the ON position. (Refer to function settings **No. 28**)
- When level signal is selected, the signal width has to be more than 10 seconds for ON and OFF .
- When pulse signal is selected, a pulse width has to be at least 200 m sec. to turn Lossnay ON, and 10 sec. interval is necessary to next output.
- The wiring should be as shown by the following picture.

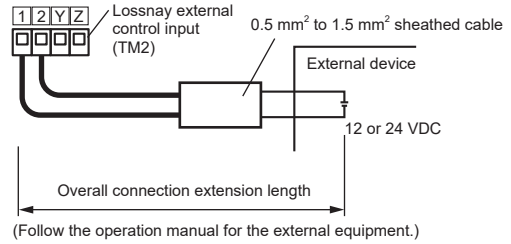

**When the external device has an Volt-free contact signal**

- If the input is pulse signal, move the pulse input switch [SW2-2] to the ON position. (Refer to function settings **No. 28**)
- When level signal is selected, the signal width has to be more than 10 seconds for ON and OFF .
- When pulse signal is selected, a pulse width has to be at least 200 m sec. to turn Lossnay ON, and 10 sec. interval is necessary to next output.
- The wiring should be as shown by the following picture.

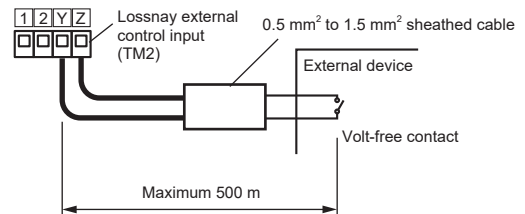

**CAUTION**

- If an optocoupler or any other type of polar coupler is used at the Volt-free contact, connect the positive side to Y and the negative side to Z.

### 3 When operating multiple Lossnay units

In the case that Lossnay units are RVS, RVX3, RVXT3 series with PZ-62DR series, up to 15 multiple units can be operated at the same time.

(1) Connect the Lossnay unit from Unit 1 to Unit 2, and from Unit 2 to Unit 3 and so on up to a maximum of 15 units using a transmission cable.

Wire type: two-core sheathed cable  
Wire diameter: 0.3 mm<sup>2</sup>

(2) When it is interlocked with an external device, set the Lossnay unit which has external signal input to "Main".

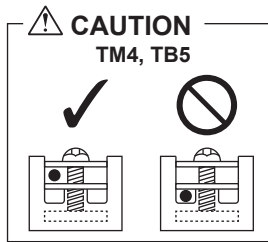
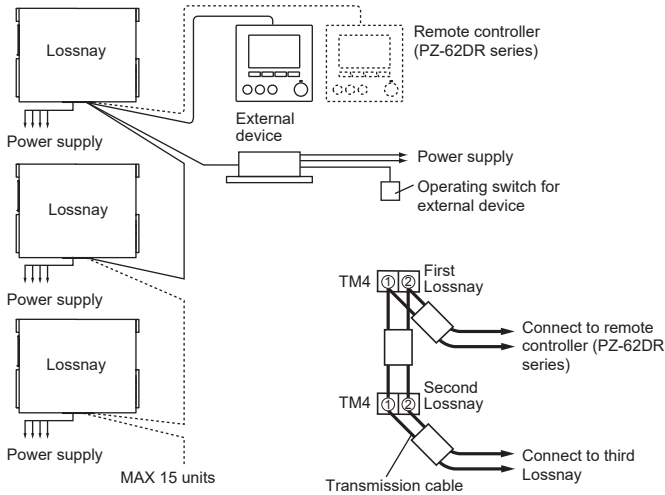

#### Note

- Do not tighten screws of terminal block TM4 and TB5 with a torque larger than 1.2 N·m. It could damage the circuit board.
- When connecting multiple cables to the terminal, use round terminal.
- Solid wire (single-stranded wire) cannot be connected.
- Only one unit can be set as main Lossnay. The operating signal and pulse signal of the external device can be connected to Main Lossnay only.
- Connect the power supply cable to each Lossnay unit.
- When setting the Lossnay address for use with a Mitsubishi Electric Air-Conditioner Network System (MELANS) etc., the Lossnay with the smallest address in the group will be the Main Lossnay. When not setting the address, set the address to "1" for only one unit in the group. The Lossnay with an address of "1" is the Main Lossnay. (Refer to "Setting the address" on the section 6 for more detail.)
- When multiple type of Lossnay units are in the group, RVS series can NOT be the main unit.
- Without PZ-62DR series, RVS, RVX3 and RVXT3 series can not be mixed in a group.

### 4 Signal output from Lossnay unit

Set DIP-SW or Function setting on PZ-62DR series as following table depending on the necessary output signal from Lossnay unit. For more information of signal output, see function settings **No. 12** to **No. 16**.

DIP-SW setting		Function setting on PZ-62DR series	Signal output
SW5-1	SW5-2		
-	-	0	Dip-SW priority (PZ-62DR series factory setting)
OFF	OFF	1	Operation monitor (Dip-SW factory setting)
ON	OFF	2	Malfunction monitor
OFF	ON	3	Bypass monitor
ON	ON	4	Supply fan operation monitor
N/A	N/A	5	Exhaust fan operation monitor
N/A	N/A	6	Pre-heater signal output
N/A	N/A	7	After-heater signal output

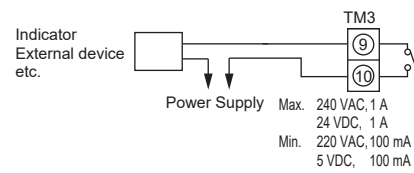

#### CAUTION

- Do not tighten screws of terminal block TM3 with a torque larger than 0.5 N·m. It could damage the circuit board.
  - When connecting multiple cables to the terminal, use round terminal.
  - If multiple output signals are necessary, use optional signal output terminal (PZ-4GS-E).
- When using Pre-heater output signal, the wiring should be as shown by the following picture.

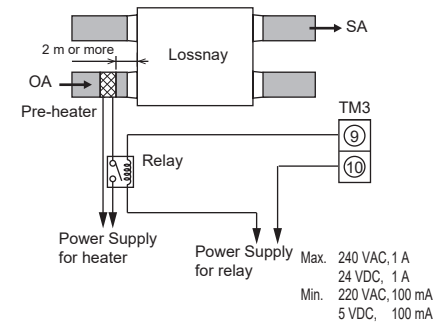

#### CAUTION

- Failure to follow below instructions, it could cause a fire.
- Choose a OA pre-heater which can control the heater outlet air temperature even both the air flow is maximum and minimum. Otherwise it could fall the supply fan into intermittent operation.
- Select a duct heater in compliance with local and national laws, ordinance and standards.
- Always select a heater that is equipped with a non-self-resetting safety device.
- Do not directly supply power from the Lossnay unit to the duct heater. Doing so could cause fire.
- Install a circuit breaker for the duct heater in compliance with all applicable laws, ordinances, and standards.
- Install the duct heater separated from the product by a distance of 2 m or more. Failure to do so may result in equipment damage due to the transmission of residual heat from the heater.
- Ensure that the duct heater and Lossnay are wired and that the Lossnay function settings have been configured, and then always check operation by trial operation.
- For the duct heater output, see function setting **No. 60** and **No. 61**.

When using After-heater output signal, the wiring should be as shown by the following picture.

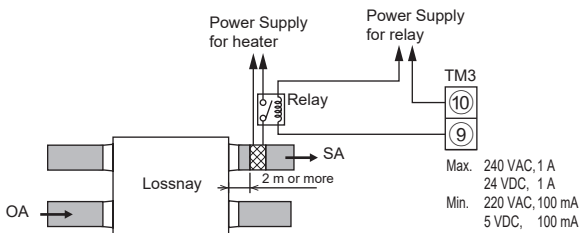

For the heater, observe the cautions listed in Pre-heater.

### 5 When switching fan speed externally (when a sensor or other equipment is connected)

Using a field supply sensor, etc., make connection by inserting the optional remote controller adapter (PAC-SA88HA-E) in the connector CN17 as shown by the figure.

Lossnay will operate at the fan speed following the table below, regardless of the remote controller setting.

CN17	Fan speed
1-2 (Brown-Red)	4
1-3 (Brown-Orange)	3
1-4 (Brown-Yellow)	2
1-5 (Brown-Green)	1

#### Example "Fan speed 4"

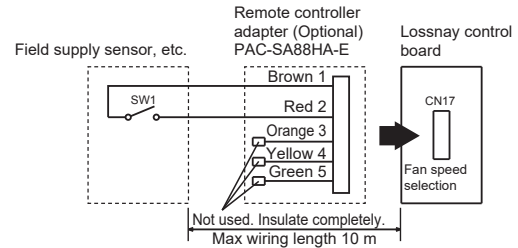

Use this in such a way that it ventilates at low fan speed normally, and when the external sensor detects contamination of indoor air, or SW1 is on, it changes to high fan speed operation.

When multiple Lossnay units are controlled by one input, PZ-62DR series is necessary.

The signal has to be inputted into main unit referring to **3**.

Cannot be used in conjunction with the following functions:

- To change fan speed by 0 - 10 VDC input.
- Connecting CO<sub>2</sub> sensor PZ-70CSD-E or PZ-70CSW-E.

### 6 When switching Bypass externally.

Establish the wire connection by inserting the optional remote controller adapter (PAC-SA88HA-E) in the connector CN26.

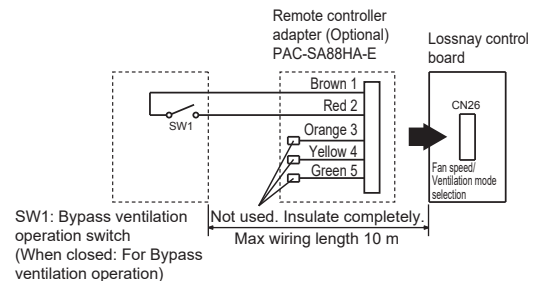

With SW1 is "ON", the ventilation mode of Lossnay is changed to the Bypass ventilation regardless of the setting on the remote controller.

When multiple Lossnay units are controlled by one input, PZ-62DR series is necessary.

The signal has to be inputted into main unit referring to **3**.

\* When the outdoor air temperature drops lower than 8°C or air flow is 75 % or higher, it changes to the energy recovery ventilation. (In this case, ventilation mode icon on the display of the remote controller does not change from the previous mode, it might be different from the actual unit operation.)

## 7 To change fan speed by 0 - 10 VDC input

Establish the wire connection by inserting the optional remote controller adapter (PAC-SA88HA-E) in the connector CN26.

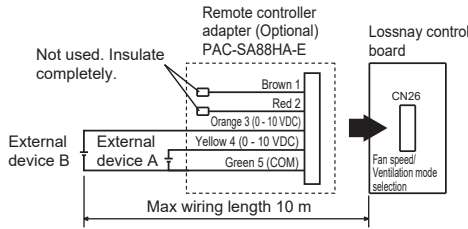

External device A : 3rd party CO<sub>2</sub> sensor / BMS / 3rd party pressure sensor (for return air constant pressure control)

External device B : 3rd party pressure sensor (for supply air constant pressure control) / 3rd party PM2.5 sensor (CN105 communication only)

To change fan speed by 0 - 10 VDC input, the wiring should be as shown by the above picture. Refer to function settings **No. 66** for more details.

When multiple Lossnay units are controlled by one input, PZ-62DR series is necessary.

The signal has to be inputted into main unit referring to **3**.

Cannot be used in conjunction with the following functions:  
- Switching fan speed externally (CN17).

### ⚠ WARNING

- 0-10 VDC input from the external device to use CN26 shall be insulated from main power supply like 220-240 V. Otherwise it could cause electrical shock or death.

### ⚠ CAUTION

- Make sure of correct polarity.
- Do not apply voltages higher than 10 VDC.

## 8 When using the remote/local switching and the ON/OFF input (level signal)

Insert the optional remote ON/OFF adapter (PAC-SE55RA-E) in CN32 on the Lossnay control circuit board.

When multiple Lossnay units are controlled by one input, the signal has to be inputted into main unit referring to **3**.

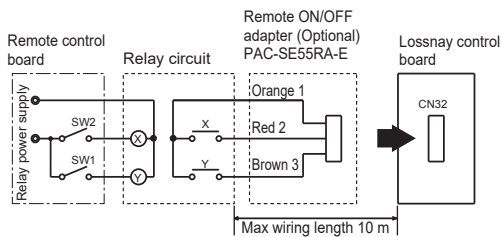

SW1: When this is ON, Lossnay cannot be turned ON/OFF by the Remote Controller (PZ-62DR series).

SW2: When SW1 is ON, Lossnay can be turned ON by setting SW2 at ON or turned OFF by setting SW2 at OFF.

SW1: Remote/local selector switch

SW2: ON/OFF switch

X, Y: Relay (Contact rated load: 0.1 A at 15 VDC or more, Minimum applicable load: 1 mA or less)

## 9 When connecting to the City Multi, Mitsubishi Electric Air-Conditioner Network System (MELANS)

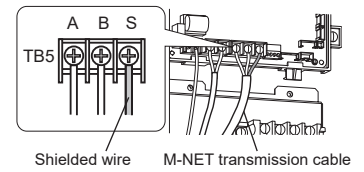
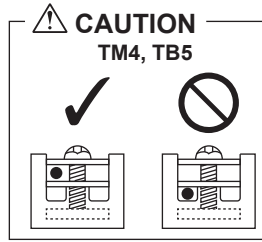

- Connect a shielded wire to terminal TB5 (S) on the circuit board. Address setting is required. (Refer to function setting section.)  
M-NET transmission cable: Connect any of the City Multi indoor unit, or Mitsubishi Electric Air-Conditioner Network System (MELANS) - to the Lossnay.
- Remote Controller  
**PZ-62DR series:**  
Connect to TM4 (1, 2) on the circuit board. (See Section **1** "When connecting with remote controller (PZ-62DR series)".)  
• Securely connect the M-NET transmission cables to TB5 (A, B). (No-Polar)  
Type: Shielded wire (CVVS/CPEVS)  
Wire diameter: 1.25 mm<sup>2</sup>

### ⚠ CAUTION

- Do not tighten screws on the terminal block with a torque larger than 1.2 N·m. It may damage the circuit board.
- Always use shielded wires only for the M-NET transmission cables, and finish the shield properly.
- Be sure to cut M-NET power supply during Lossnay wiring, otherwise it causes malfunction.

### When interlocking with Mitsubishi M-NET air conditioner

- In case of PZ-62DR series

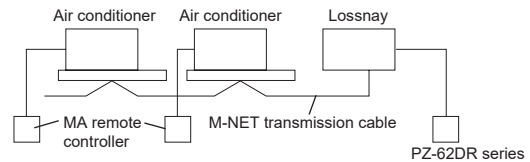

### When connecting to PZ-62DR series and MELANS

- Connect the power feeding unit.

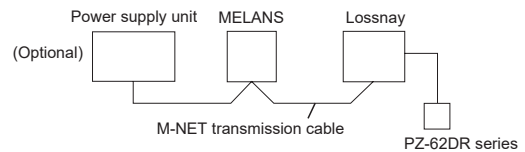

- \* Limit the total length of transmission cables no longer than 500 m. Limit the wiring length between Lossnay and the power supply unit (Optional) or the outdoor unit no longer than 200 m.

### Note

- LGH-RVX3-E series, RVS-E series, RVXT3-E series can be set as the same group in case with PZ-62DR series. Other model are not possible.

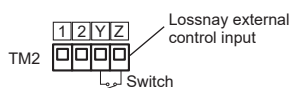

**10 To start/stop Lossnay stand-alone operation without using the remote control**

Start/stop the unit by a switch connected to TM2 **Y** **Z**.  
When turned the unit ON, it operates at fan speed 4 and automatic ventilation mode without any other external input.

**⚠ CAUTION**

- Do not start/stop the unit by turning the power supply to the unit ON/OFF.

## 11 Control via Wi-Fi interface or MELCOBEMS MINI

Connect the lead wire of a Wi-Fi interface or MELCOBEMS MINI to CN105 on circuit board of Lossnay unit.

**Regarding the model name of the connectable Wi-Fi interface or MELCOBEMS MINI, please contact the sales company in your market.**

### CAUTION

- For the installation of the Wi-Fi interface, there are some precautions. Refer to the Installation manual of the Wi-Fi interface for more details.
- After the installation, be sure to do a test run prior to the start of actual operations.
- Follow the system configuration examples listed below.

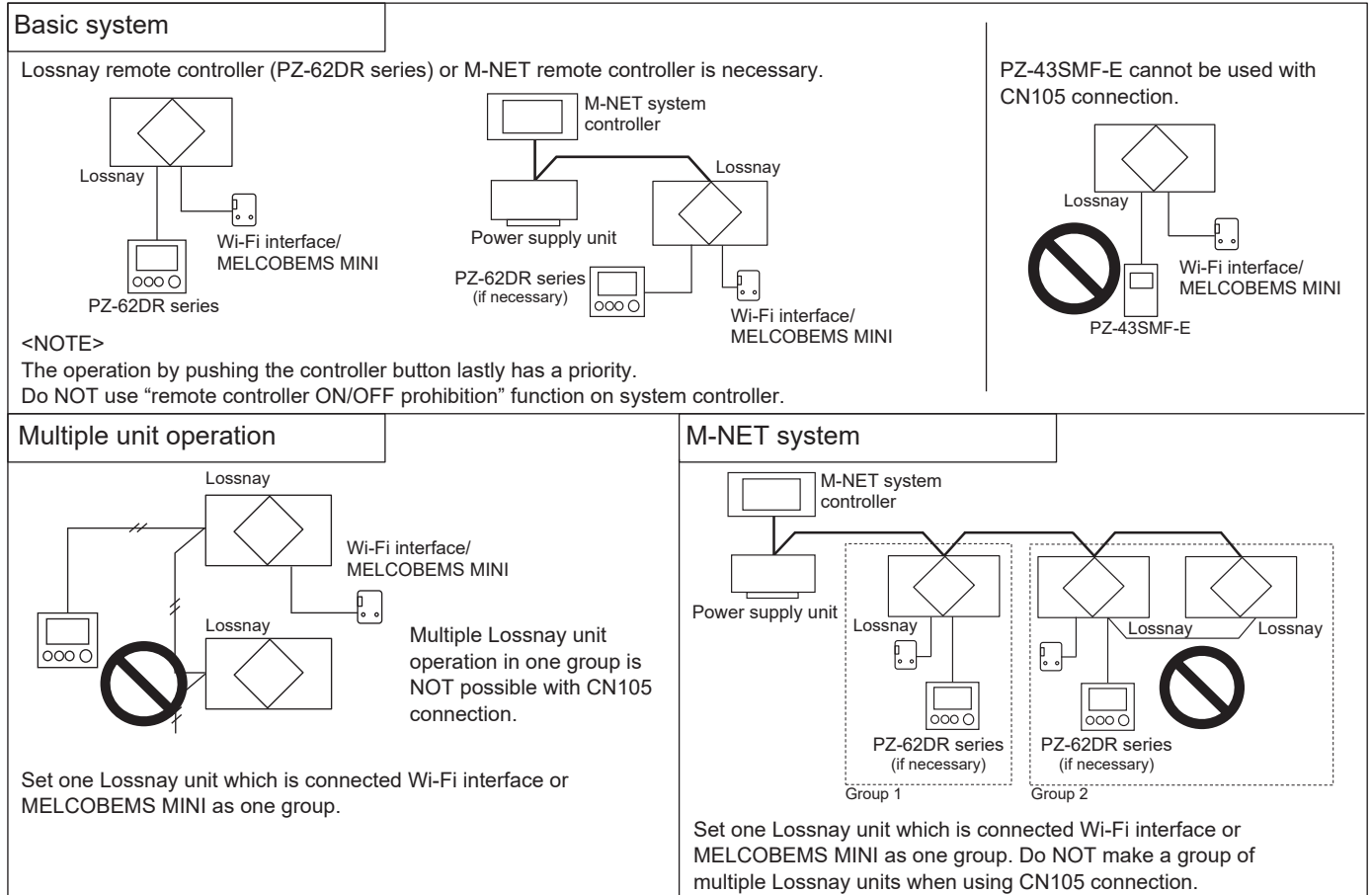

System controller	Prohibit remote controller	Do NOT use "remote controller ON/OFF prohibition" function on system controller.
External control	ON/OFF switching by CN32	NOT available with CN105 connection control.
	External fan speed control (CN17, CN26)	The unit follows external input signal. Therefore, the fan speed selection through CN105 connection control become invalid.
	External Bypass control (CN26)	The unit follows external input signal. Therefore, the ventilation mode selection through CN105 connection control become invalid.
Interlocking	Interlock with Mr. Slim	Interlocking with Mr. Slim unit by Slim-Lossnay connection cable (CN2L-TM2①② connection) is NOT possible.
	Interlock mode setting	Only "ON/OFF interlock mode" is available. Please set function <b>No. 19</b> as 0 on PZ-62DR series (factory setting).

## 12 When connecting CO<sub>2</sub> sensor PZ-70CSD-E or PZ-70CSW-E

When CO<sub>2</sub> sensor is connected, "Auto" fan speed can be selected.  
In "Auto" mode, the fan speed changes automatically according to CO<sub>2</sub> concentration.  
Connect and install correctly by following the installation manual of PZ-70CSD-E or PZ-70CSW-E.

### Note

- PZ-70CSB-E can not be installed in LGH-RVXT3-E series.
- LGH-RVXT3-E series can cover large space due to its large air flow. Therefore when CO<sub>2</sub> concentration is partial, the actual fan speed may not match the average concentration.
- When connecting PZ-70CSW-E or PZ-70CSD-E, shift the ferrite core on the cable 220 mm off from the original position to sensor unit side in order not to interface.

### 13 Leader-follower function

Follower units synchronize the fan operation, ventilation mode and protective operation to the leader unit. This function is available when multiple Lossnay units are necessary to realize large air flow at common duct.

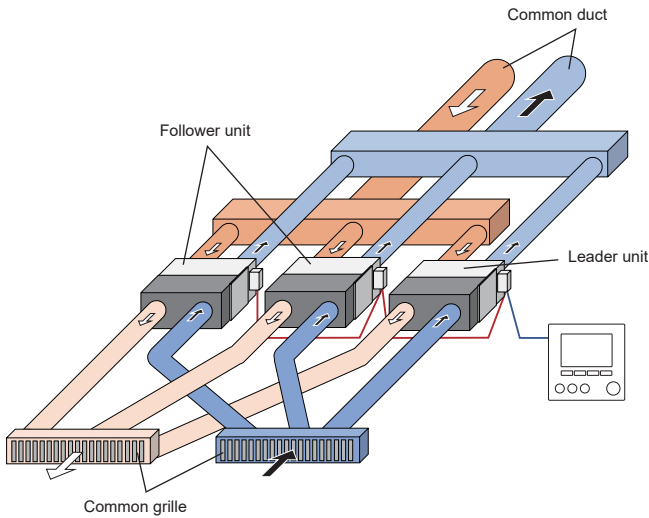

\* This picture shows an example other than RVXT series. Mind the ducting in case of RVXT series.

- (1) Connect leader, follower units and PZ-62DR series via TM4 with transmission cable.  
Maximum 3 followers are allowed for one Leader.  
Wire type: two-core sheathed cable  
Wire diameter: 0.3 mm<sup>2</sup>  
Keep the cable length between lossnay units within 10 m.
- (2) Turn leader unit DIP-SW5-4 "ON" and follower units DIP-SW5-5 "ON"
- (3) When connecting to MELANS, only set the address for the leader and connect it to MELANS. Keep the address setting for the follower as "00". The follower cannot be connected to MELANS.
- (4) When connecting external devices which can control Lossnay or Lossnay output signal, always input to / output from the leader unit. (Only malfunction monitor output signal is available from follower units.)
- (5) For trial operation, DIP-SW2-1 of the leader shall be turned "ON". If SW for follower unit is turned "ON", the follower does not operate. When using this function, approximately 15 sec delay may occur to the start of trial operation.

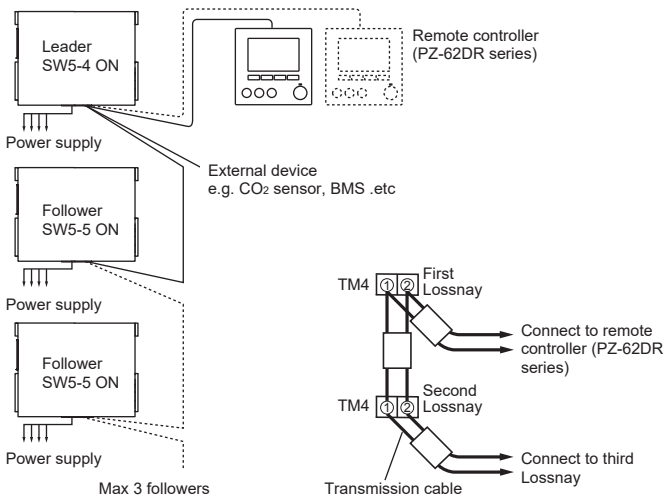

#### Note

- Do not tighten screws of terminal block TM4 with a torque larger than 1.2 N·m.  
It could damage the circuit board.
- Use round terminal for multiple wires connection.
- Solid wire (single-stranded wire ) cannot be connected.
- Connect the power supply cable to each Lossnay unit.

#### CAUTION

- Only same model can use this function. For example, not available between LGH-160RVXT3-E and LGH-200RVXT3-E, or LGH-200RVXT3-E and LGH-200RVX3-E.
- PZ-62DR series is mandatory to use this function. (PZ-43SMF-E cannot be used.)
- When using Leader-follower, the maximum number of Lossnay units that can be connected in one group is four (one Leader unit and three Follower units). It is not possible to mix Lossnay units that do not use Leader-follower within the same group.
- Duct pressure loss of each unit shall be closer.
- Outdoor intake of all units has to be close. If there is a big temperature gap, it may cause core freezing or condensation.
- When one unit in a leader-follower group has an error, all units stop even other units are normal.
- Do not install pre-heater and after-heater for individual duct for each unit. Otherwise it could cause fire or malfunction.
- Connect all units in Leader-follower group to same circuit breaker.
- This function should be set while the power is NOT supplied to the unit.  
If setting is done during the unit is supplied the power, be sure to reboot the unit.
- Theoretically, when several fans which operate at same load are combined in parallel, air flow rate will be added up as many and static pressure will be unchanged from one fan operation.  
But, in the actual installation, due to by pressure loss at the junction point and asymmetry ducting of each unit etc. drift, vortex or turbulence flow will happens. Then, air flow specification of the total unit would be different from theory.
- If communication is lost between the leader unit and follower units due to transmission line disconnection or other issues, the leader unit will not be able to detect abnormalities in the follower units. Please use the malfunction monitor output of the follower units to monitor their status as needed.

# 6. Function settings

Address setting is required when connecting to City Multi and MELANS.

## Setting the address

Use the following procedure when setting the address for dedicated Lossnay.  
 (The method in determining the addresses will depend on the existing system. Refer to the appropriate technical documents for details.)

- (1) Remove the control cover.
- (2) Turn the address setting switch on the circuit board.
  - SW12 indicates the tens digit and SW11 indicates the ones digit.
  - The factory setting is "00".

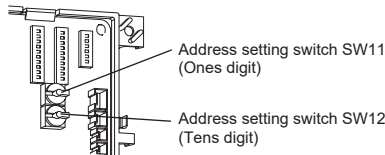

\* When the address number has been changed, the data in the memory is automatically reset. (All function setting data is initialized)

## Change the function settings from the remote controller PZ-62DR series.

Please refer to the Instruction book of PZ-62DR series for how to set the function settings.

## Changing the function selection switches (SW-2, 5 and 6)

Set the selection switches (SW-2 and 5) to perform the appropriate function.

\* All function except "Trial operation (SW2-1)", "Auto fan speed setting (SW5-9) without Lossnay or M-NET remote controller", "Leader-follower function (SW5-4, SW5-5)" and "LR switching (SW2-10)" can be set also from the remote controller (PZ-62DR series). If the function is switched later using the remote controller, it operates according to the setting on the remote controller.

### ⚠ CAUTION

- **Except SW2-1, before DIP-SW setting is changed, always the power supply to Lossnay unit has to be cutoff. Otherwise, it may cause electrical shock, injury or non-reflection of the change.**

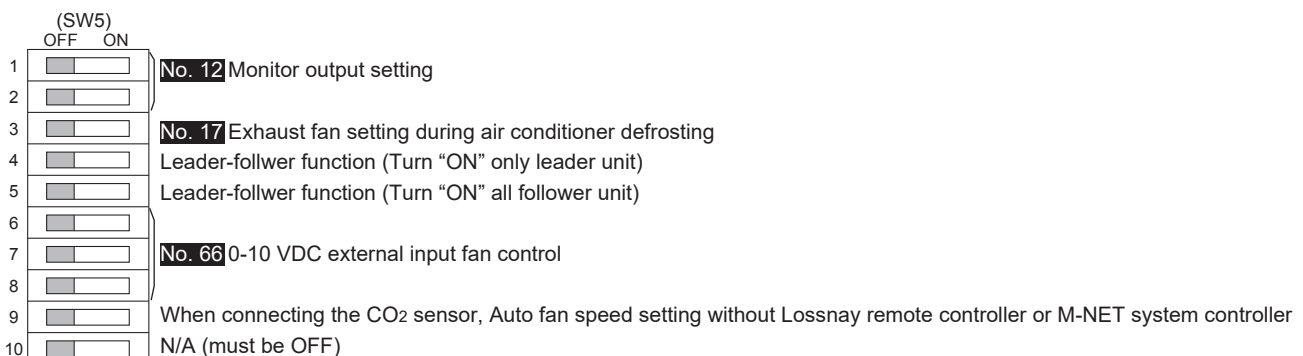
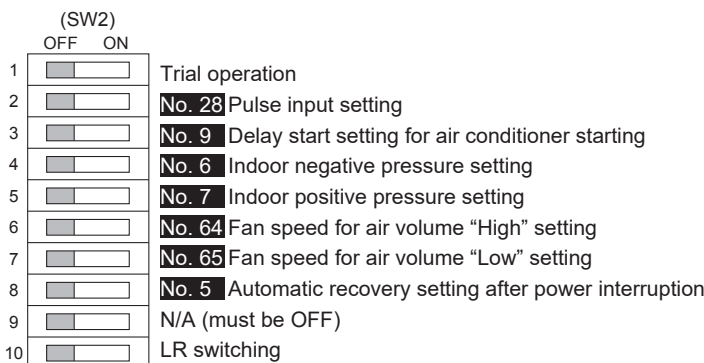

DIP-SW6 is to identify the model for circuit board. When replacing to new circuit board, set the same setting as old one.

(SW6)

	SW6-1	SW6-2	SW6-3	SW6-4	SW6-5	SW6-6
LGH-160RVXT3-E	OFF	ON	OFF	ON	OFF	OFF
LGH-200RVXT3-E	ON	ON	OFF	ON	OFF	OFF
LGH-250RVXT3-E	OFF	OFF	ON	ON	OFF	OFF

\* Do not change from factory setting. If changed, please set as factory setting.

No	Function	Setting Data															Factory setting	DIP-SW No.		
		0	1	2	3	4	5	6	7	8	9	10	11	12	13	14			15	
1	Filter maintenance and fan power up setting against filter choking	Indicator N/A Fan power up N/A	Indicator available Fan power up N/A	Indicator available Fan power up available	Indicator N/A Fan power up available	—	—	—	—	—	—	—	—	—	—	—	—	0	—	
2	Lossnay core maintenance indicator setting	N/A	Available	—	—	—	—	—	—	—	—	—	—	—	—	—	—	0	—	
5	Automatic recovery setting after power interruption	Dip-SW priority	Stop when the power is On	Start when the power is On	Return to the state before interruption	—	—	—	—	—	—	—	—	—	—	—	—	0	2-8	
6	Indoor negative pressure setting	Dip-SW priority	N/A	Supply 1 down	Supply 2 down	—	—	—	—	—	—	—	—	—	—	—	—	0	2-4	
7	Indoor positive pressure setting	Dip-SW priority	N/A	Exhaust 1 down	Exhaust 2 down	—	—	—	—	—	—	—	—	—	—	—	—	0	2-5	
8	Max. fan speed setting during the first 30 minutes	N/A	Available	—	—	—	—	—	—	—	—	—	—	—	—	—	—	0	—	
9	Delay start setting for air conditioner starting	Dip-SW priority	N/A	15 min	30 min	—	—	—	—	—	—	—	—	—	—	—	—	0	2-3	
12	Monitor output setting TM3 ⑨⑩	Dip-SW priority	Operation monitor	Malfunction monitor	Bypass monitor	Supply fan monitor	Exhaust fan monitor	Pre-heater output	SA fan monitor output with delay operation (for After heater)	—	—	—	—	—	—	—	—	0	5-1 5-2	
13	Monitor output setting PZ-4GS-E COM-OUT1	Operation monitor	Malfunction monitor	Bypass monitor	Supply fan monitor	Exhaust fan monitor	Pre-heater output	SA fan monitor output with delay operation (for After heater)	—	—	—	—	—	—	—	—	—	1	—	
14	Monitor output setting PZ-4GS-E COM-OUT2	Operation monitor	Malfunction monitor	Bypass monitor	Supply fan monitor	Exhaust fan monitor	Pre-heater output	SA fan monitor output with delay operation (for After heater)	—	—	—	—	—	—	—	—	—	2	—	
15	Monitor output setting PZ-4GS-E COM-OUT3	Operation monitor	Malfunction monitor	Bypass monitor	Supply fan monitor	Exhaust fan monitor	Pre-heater output	SA fan monitor output with delay operation (for After heater)	—	—	—	—	—	—	—	—	—	3	—	
16	Monitor output setting PZ-4GS-E COM-OUT4	Operation monitor	Malfunction monitor	Bypass monitor	Supply fan monitor	Exhaust fan monitor	Pre-heater output	SA fan monitor output with delay operation (for After heater)	—	—	—	—	—	—	—	—	—	4	—	
17	Exhaust fan setting during air conditioner defrosting	No change	Stop	Dip-SW priority	—	—	—	—	—	—	—	—	—	—	—	—	—	2	5-3	
18	Exhaust fan setting at OA temperature lower than -15 °C	No change	Forced to fan speed 2 or less	—	—	—	—	—	—	—	—	—	—	—	—	—	—	0	—	
19	Interlock mode setting	ON/OFF interlock	ON interlock	OFF interlock	External input given priority	—	—	—	—	—	—	—	—	—	—	—	—	0	—	
28	Pulse input setting	Dip-SW priority	Non-pulse input	Pulse input	—	—	—	—	—	—	—	—	—	—	—	—	—	0	2-2	
30	Night purge setting 1) Air volume	N/A	Fan speed 1	Fan speed 2	Fan speed 3	Fan speed 4	—	—	—	—	—	—	—	—	—	—	—	0	—	
31	Night purge setting 2) Outdoor and indoor temperature gap	0 K (0°C)	1 K (1°C)	2 K (2°C)	3 K (3°C)	4 K (4°C)	5 K (5°C)	6 K (6°C)	7 K (7°C)	—	—	—	—	—	—	—	—	5	—	
32	Night purge setting 3) The lowest outdoor temperature	Setting Data 0 to 15 --> The lowest outdoor temperature for Night purge 15°C to 30°C															2	—		
33	Night purge setting 4) Outdoor temperature detection period	24 hrs	48 hrs	72 hrs	—	—	—	—	—	—	—	—	—	—	—	—	—	2	—	
34	Input priority setting	Bunch control priority	Individual control priority	—	—	—	—	—	—	—	—	—	—	—	—	—	—	0	—	
35	Maximum air flow setting in bypass operation	Not limited	50 % or less	—	—	—	—	—	—	—	—	—	—	—	—	—	—	0	—	
36	Outdoor temperature display setting	N/A	Available	—	—	—	—	—	—	—	—	—	—	—	—	—	—	1	—	
37	Indoor temperature display setting	N/A	Available	—	—	—	—	—	—	—	—	—	—	—	—	—	—	1	—	
38	CO2 concentration display setting	N/A	Available	—	—	—	—	—	—	—	—	—	—	—	—	—	—	1	—	
39	Calculated supply air temperature display setting	N/A	Available	—	—	—	—	—	—	—	—	—	—	—	—	—	—	0	—	
40	Temperature exchange efficiency setting (10 digit)	Setting Data 0 to 9 --> 10 digit of temperature exchange efficiency 0 to 9										—	—	—	—	—	—	7	—	
41	Temperature exchange efficiency setting (1 digit)	Setting Data 0 to 9 --> 1 digit of temperature exchange efficiency 0 to 9										—	—	—	—	—	—	—	0	—
42	Outdoor temperature correction	Setting Data 0 to 14 --> Outdoor temperature correction -7 K (-7°C) to 7 K (7°C)															—	7	—	
43	Indoor temperature correction	Setting Data 0 to 14 --> Room temperature correction -7 K (-7°C) to 7 K (7°C)															—	7	—	
44	CO2 concentration correction	Setting Data 0 to 10 --> CO2 concentration correction -500ppm~500ppm (100ppm in increments)										—	—	—	—	—	—	—	5	—
45	Supply fan monitor threshold	Fan speed 1 or higher	Fan speed 2 or higher	Fan speed 3 or higher	Fan speed 4	—	—	—	—	—	—	—	—	—	—	—	—	0	—	
46	Exhaust fan monitor threshold	Fan speed 1 or higher	Fan speed 2 or higher	Fan speed 3 or higher	Fan speed 4	—	—	—	—	—	—	—	—	—	—	—	—	0	—	
47	Constant pressure control setting 1) Air flow changing interval	1 min	3 min	5 min	7 min	10 min	15 min	30min	—	—	—	—	—	—	—	—	—	2	—	
48	Constant pressure control setting 2) Target voltage for SA - Ones digit	0.0 V	1.0 V	2.0 V	3.0 V	4.0 V	5.0 V	6.0 V	7.0 V	8.0 V	9.0 V	N/A	—	—	—	—	—	10	—	

No	Function	Setting Data														Factory setting	DIP-SW No.		
		0	1	2	3	4	5	6	7	8	9	10	11	12	13			14	15
49	Constant pressure control setting 3) Target voltage for SA - Ones decimal place	0.0 V	0.1 V	0.2 V	0.3 V	0.4 V	0.5 V	0.6 V	0.7 V	0.8 V	0.9 V	—	—	—	—	—	—	0	—
50	Constant pressure control setting 4) Target voltage for RA - Ones digit	0.0 V	1.0 V	2.0 V	3.0 V	4.0 V	5.0 V	6.0 V	7.0 V	8.0 V	9.0 V	N/A	—	—	—	—	—	10	—
51	Constant pressure control setting 5) Target voltage for RA - Ones decimal place	0.0 V	0.1 V	0.2 V	0.3 V	0.4 V	0.5 V	0.6 V	0.7 V	0.8 V	0.9 V	—	—	—	—	—	—	0	—
52	Automatic ventilation mode setting 1) Outdoor and indoor temperature gap	Setting Data 0 to 7 --> Temperature gap 0 K (0°C) to 7 K (7°C)										—	—	—	—	—	—	0	—
53	Automatic ventilation mode setting 2) The lowest outdoor temperature setting	Setting Data 0 to 15 --> Lowest outdoor temperature 10°C to 25°C														6	—		
54	Automatic ventilation mode setting 3) The lowest indoor temperature setting	Setting Data 0 to 15 --> Lowest indoor temperature 15°C to 30°C														1	—		
60	Pre-heater output setting 1) ON temperature	0 °C	-1 °C	-2 °C	-3 °C	-4 °C	-5 °C	-6 °C	-7 °C	-8 °C	-9 °C	-10 °C	-11 °C	-12 °C	-13 °C	-14 °C	-15 °C	0	—
61	Pre-heater output setting 2) OFF interval	1 hr	2 hrs	3 hrs	4 hrs	5 hrs	—	—	—	—	—	—	—	—	—	—	—	0	—
62	LED usage setting for PZ-70CSW-E during non operation	Unlit	Lit	—	—	—	—	—	—	—	—	—	—	—	—	—	—	0	—
64	Fan speed for air volume "High" input	Dip-SW priority	Fan speed 4	Fan speed 3	—	—	—	—	—	—	—	—	—	—	—	—	—	0	2-6
65	Fan speed for air volume "Low" input	Dip-SW priority	Fan speed 2	Fan speed 1	—	—	—	—	—	—	—	—	—	—	—	—	—	0	2-7
66	0-10 VDC external input fan control	Dip-SW priority	N/A	3rd party's CO <sub>2</sub> sensor	—	BMS Pattern Z	CO <sub>2</sub> sensor PZ-70CSW-E	—	CO <sub>2</sub> sensor PZ-70CSD-E	—	SA constant pressure	SA & RA constant pressure	SA constant pressure & CO <sub>2</sub> display	PM2.5 communication	3rd party's CO <sub>2</sub> sensor & PM2.5 communication	CO <sub>2</sub> sensor PZ-70CSW-E & PM2.5 communication	CO <sub>2</sub> sensor PZ-70CSD-E & PM2.5 communication	0	5-6 5-7 5-8
67	Threshold minutes for PZ-70CSW-E LED	10 min	15 min	20 min	25 min	30 min	—	—	—	—	—	—	—	—	—	—	—	2	—
68	Threshold concentration for PZ-70CSW-E LED	1000 ppm	1100 ppm	1200 ppm	1300 ppm	1400 ppm	1500 ppm	1600 ppm	1700 ppm	1800 ppm	1900 ppm	2000 ppm	—	—	—	—	—	5	—
69	Emergency stop setting	Emergency stop	Normal stop	—	—	—	—	—	—	—	—	—	—	—	—	—	—	0	—
73	Air flow setting for supply fan speed 3	100 %	95 %	90 %	85 %	80 %	75 %	70 %	65 %	60 %	55 %	50 %	45 %	40 %	35 %	30 %	25 %	5	—
74	Air flow setting for supply fan speed 2	100 %	95 %	90 %	85 %	80 %	75 %	70 %	65 %	60 %	55 %	50 %	45 %	40 %	35 %	30 %	25 %	10	—
75	Air flow setting for supply fan speed 1	100 %	95 %	90 %	85 %	80 %	75 %	70 %	65 %	60 %	55 %	50 %	45 %	40 %	35 %	30 %	25 %	15	—
76	Air flow setting for exhaust fan speed 3	100 %	95 %	90 %	85 %	80 %	75 %	70 %	65 %	60 %	55 %	50 %	45 %	40 %	35 %	30 %	25 %	5	—
77	Air flow setting for exhaust fan speed 2	100 %	95 %	90 %	85 %	80 %	75 %	70 %	65 %	60 %	55 %	50 %	45 %	40 %	35 %	30 %	25 %	10	—
78	Air flow setting for exhaust fan speed 1	100 %	95 %	90 %	85 %	80 %	75 %	70 %	65 %	60 %	55 %	50 %	45 %	40 %	35 %	30 %	25 %	15	—
83	Filter maintenance interval setting - Thousands digit	0	1	2	3	4	5	6	7	8	9	—	—	—	—	—	—	3	—
84	Filter maintenance interval setting - Hundreds digit	0	1	2	3	4	5	6	7	8	9	—	—	—	—	—	—	0	—
85	Lossnay core maintenance interval setting - Thousands digit	0	1	2	3	4	5	6	7	8	9	—	—	—	—	—	—	6	—
86	Lossnay core maintenance interval setting - Hundreds digit	0	1	2	3	4	5	6	7	8	9	—	—	—	—	—	—	0	—
87	Air flow setting for supply fan speed 4	100 %	95 %	90 %	85 %	80 %	75 %	70 %	65 %	60 %	55 %	50 %	45 %	40 %	35 %	30 %	25 %	0	—
88	Air flow setting for exhaust fan speed 4	100 %	95 %	90 %	85 %	80 %	75 %	70 %	65 %	60 %	55 %	50 %	45 %	40 %	35 %	30 %	25 %	0	—
89	CO <sub>2</sub> sensor setting - maximum side - Hundreds digits	600 ppm	700 ppm	800 ppm	900 ppm	1000 ppm	1100 ppm	1200 ppm	1300 ppm	1400 ppm	1500 ppm	1600 ppm	1700 ppm	1800 ppm	1900 ppm	2000 ppm	—	4	—
90	CO <sub>2</sub> sensor setting - maximum side - tens digits	0 ppm	50 ppm	—	—	—	—	—	—	—	—	—	—	—	—	—	—	0	—
91	CO <sub>2</sub> sensor setting - minimum side - Hundreds digits	300 ppm	400 ppm	500 ppm	600 ppm	700 ppm	800 ppm	900 ppm	1000 ppm	1100 ppm	1200 ppm	1300 ppm	1400 ppm	1500 ppm	1600 ppm	1700 ppm	—	1	—
92	CO <sub>2</sub> sensor setting - minimum side - tens digits	0 ppm	50 ppm	—	—	—	—	—	—	—	—	—	—	—	—	—	—	1	—
93	CO <sub>2</sub> sensor correction	-250 ppm	-200 ppm	-150 ppm	-100 ppm	-50 ppm	0 ppm	50 ppm	100 ppm	150 ppm	200 ppm	250 ppm	—	—	—	—	—	5	—
94	Indoor negative / positive pressure setting at auto fan speed setting	N/A	Supply fan	Exhaust fan	—	—	—	—	—	—	—	—	—	—	—	—	—	0	—
95	Indoor negative / positive pressure setting at auto fan speed setting	N/A	5 %	10 %	15 %	20 %	25 %	30 %	35 %	40 %	45 %	50 %	55 %	60 %	65 %	70 %	75 %	0	—
100	Initialization (No.1~99)	N/A	Initialize	—	—	—	—	—	—	—	—	—	—	—	—	—	—	0	—

This table shows the summary of function settings. Please refer to the following pages for more details.

The functions indicated with "N/A" in the "DIP-SW No." column are available only when using with remote controller PZ-62DR series.

**PZ-62DR series can set Night purge setting (No. 30), Bypass setting (No. 52, No. 53, No. 54), CO<sub>2</sub> sensor setting (No. 89, No. 90, No. 91, No. 92), Filter maintenance interval setting (No. 83, No. 84), Lossnay core maintenance interval setting (No. 85, No. 86) and Air flow setting (No. 73 - No. 78, No. 87, No. 88) by different way more easily.**

**Refer to the remote controller PZ-62DR series operation manual for more detail.**

**A, B, C DIP-SW only function**

**A Auto fan speed setting without Lossnay remote controller or M-NET system controller**

When CO<sub>2</sub> sensor is connected but any remote controller is not connected, SW 5-9 has to be ON in order to operate according to CO<sub>2</sub> concentration.

When SW 5-9 is ON, any Lossnay remote controller or M-NET system controller can not be connected and not possible to interlock with City Multi or Mr. Slim unit.

Constant pressure control is not available without PZ-62DR series.

DIP-SW		Setting check	Auto fan speed setting without Lossnay or M-NET system controller
SW No.	Setting		
SW5-9	OFF (Factory setting)		N/A
	ON		Fan speed changes according to CO <sub>2</sub> concentration

**B LR switching**

RVXT3 series can switch air flow direction according to DIP-SW setting.

Refer to "Installing the Lossnay unit" on the page 7 for detail.

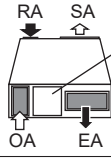
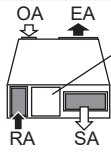
DIP-SW		Setting check	LR switching
SW No.	Setting		
SW2-10	OFF (Factory setting)		 Filter and Lossnay core maintenance cover
	ON		 Filter and Lossnay core maintenance cover

After installation finished, check the setting is correct along with the intention by trial operation.

**C Leader-follower**

Follower units synchronize the fan operation, ventilation mode and protective operation to the leader unit.

Refer to 13 for detail.

Up to 3 units can follow the leader. All units have to be same model.

DIP-SW		Setting check	Leader
SW No.	Setting		
SW5-4	OFF (Factory setting)		Leader-follower function is N/A.
	ON		The selected unit becomes a leader. Only one unit can be a leader in a group.

Even there are followers in a group, leader-follower function is not available as long as there is no leader.

DIP-SW		Setting check	Follower
SW No.	Setting		
SW5-5	OFF (Factory setting)		Leader-follower function is N/A.
	ON		The selected unit becomes a follower. Up to 3 followers can be set as one leader.

Even there is a leader in a group, leader-follower function is not available as long as there is no followers.

**No. 1 Filter maintenance and fan power up setting against filter choking**

Set the schedule for filter cleaning based on the estimated concentration of dust in the air.

This function is not available when 100 % air flow is already selected.

When fan power up is available, exhaust and supply fans power up at 1,000 hrs, 2,000 hrs and 3,000 hrs gradually.

Estimated hour differs by actual operated fan speed.

This function is N/A from Lossnay unit DIP-SW.

The target interval can be selected at No. 83, No. 84.

DIP-SW		Setting check	PZ-62DR series		Setting check	Filter maintenance indicator	Fan power UP
SW No.	Setting		Function No.	Setting Data			
N/A	-	-	1	0 (Factory setting)		N/A	N/A
	-	-		1		Appears at the interval of estimated 3,000 hrs	N/A
	-	-		2		Appears at the interval of estimated 3,000 hrs	Available
	-	-		3		N/A	Available

**CAUTION**

- When the cumulative operation time of the Lossnay exceeded the estimated hours, the maintenance icon will appear on the air conditioner remote controller or the Lossnay remote controller. After cleaning the filter, the maintenance icon can be reset. Refer to the Instruction book for the remote controller.

**No. 2 Lossnay core maintenance indicator setting**

When using PZ-62DR series, set to enable Lossnay core maintenance display. Estimated hour differs by actual operated fan speed.

This function is N/A from Lossnay unit DIP-SW.

The target interval can be selected at No. 85, No. 86.

DIP-SW		Setting check	PZ-62DR series		Setting check	Lossnay core maintenance indicator
SW No.	Setting		Function No.	Setting Data		
N/A	-	-	2	0 (Factory setting)		N/A
	-	-		1		Indicate at estimated 6,000 hrs

**CAUTION**

- When the cumulative operation time of the Lossnay exceeded the estimated hours, the maintenance icon will appear on the Lossnay remote controller. After cleaning the Lossnay core, the maintenance icon can be reset. Refer to the Instruction book for the remote controller.

**No. 5 Automatic recovery setting after power interruption**

Sets for automatic recovery following power interruption.

DIP-SW		Setting check	PZ-62DR series		Setting check	Lossnay operation when the power is recovered
SW No.	Setting		Function No.	Setting Data		
SW2-8	-	-	5	0 (Factory setting)		DIP-SW priority
	OFF (Factory setting)			1		Lossnay remains stopped.
	-	-		2		Lossnay starts operation.
	ON			3		Lossnay returns to the state before interruption*

\* If a power failure happens when Lossnay is operating by external signal via TM2 ①② or Y|Z, Lossnay returns the condition before power failure regardless of the external input condition after power recovery.

## No. 6 Indoor negative pressure setting

Exhaust fan speed becomes bigger than supply fan speed.

Remote controller indicates fan speed of exhaust fan.

Fan speed Display	Exhaust fan	Supply fan	
		1 down	2 down
4	4	3	2
3	3	2	1
2	2	1	1
1	1	1	1

DIP-SW		Setting check	PZ-62DR series		Setting check	Down level of supply fan speed
SW No.	Setting		Function No.	Setting Data		
SW2-4	—	—	6	0 (Factory setting)		DIP-SW priority
	OFF (Factory setting)			1		N/A
	ON			2		Supply fan speed is 1 down to exhaust fan speed
	—	—		3		Supply fan speed is 2 down to exhaust fan speed

## No. 7 Indoor positive pressure setting

Supply fan speed becomes bigger than exhaust fan speed.

Remote controller indicates fan speed of supply fan.

Fan speed Display	Supply fan	Exhaust fan	
		1 down	2 down
4	4	3	2
3	3	2	1
2	2	1	1
1	1	1	1

DIP-SW		Setting check	PZ-62DR series		Setting check	Down level of exhaust fan speed
SW No.	Setting		Function No.	Setting Data		
SW2-5	—	—	7	0 (Factory setting)		DIP-SW priority
	OFF (Factory setting)			1		N/A
	ON			2		Exhaust fan speed is 1 down to supply fan speed
	—	—		3		Exhaust fan speed is 2 down to supply fan speed

## No. 8 Max. fan speed setting during the first 30 minutes

This sets the fan to run forcibly for 30 minutes when operation starts to ventilate the indoor area. After 30 minutes, fan speed can be changed. Use this setting if the indoor air is contaminated at night when the system is shut down and you desire to ventilate the indoor area quickly when operation is started in the morning.

This function is N/A from Lossnay unit DIP-SW.

While this function is working,  and selected fan speed are displayed on the screen of PZ-62DR series.

DIP-SW		Setting check	PZ-62DR series		Setting check	Max. fan speed setting during the first 30 minutes
SW No.	Setting		Function No.	Setting Data		
N/A	—	—	8	0 (Factory setting)		N/A
	—	—		1		Available

## No. 9 Delay start setting for air conditioner starting

Delays Lossnay operation for 30 minutes when City Multi or Mr. Slim starts operating or when a external device starts operating.

This function is available only when Lossnay is interlocked with air conditioners.

DIP-SW		Setting check	PZ-62DR series		Setting check	Lossnay delay start
SW No.	Setting		Function No.	Setting Data		
SW2-3	—	—	9	0 (Factory setting)		DIP-SW priority
	OFF (Factory setting)			1		N/A
	—	—		2		15 min
	ON			3		30 min

## No. 12-16 Monitor output setting

Set operation monitor output from TM3 ⑨⑩ synchronized with fan operation, ventilation mode or occurrence of malfunction.

Monitor output setting for PZ-4GS-E COM-OUT1 to 4 can be set from the remote controller as well.

See page 21 for which function No. is applied for the each terminal.

DIP-SW		Setting check	PZ-62DR series		Setting check	Monitor output setting
SW No.	Setting for TM3		Function No.12	Function No.13-16		
SW5-1 SW5-2	—	—	0 (Factory setting)	—		DIP-SW priority
	5-1 OFF 5-2 OFF (Factory setting)		1	0		Operation monitor output The output turns ON while Lossnay is operating.
	5-1 ON 5-2 OFF		2	1		Malfunction monitor output The output turns ON when a malfunction occurs on the Lossnay unit.
	5-1 OFF 5-2 ON		3	2		Bypass ventilation operation monitor output Corresponds to operation mode output of the Bypass. * When air flow is 75 % or more, RVXT3 stops the bypass monitor output even bypass condition is satisfied.
	5-1 ON 5-2 ON		4	3		SA fan monitor output * When supply fan stops due to cold outdoor temp. or defrosting, output stops.
			5	4		EA fan monitor output
			6	5		Pre-heater output Output starts 10 seconds after supply fan starts operation. Fan continues to operate for 3 min. after stopping the output. Lossnay starts output when outdoor temp. is 0°C or less, and stops output when detecting temp. becomes 15°C Lossnay stops the output every 1 hour. Error code is shown on the remote controller and the output stops in the case of following. 1) Outdoor temperature higher than 15°C within 15 minutes after the output starts. 2) Outdoor temperature -20°C or lower, 5 minutes after the output starts.
			7	6		SA fan monitor output with delay operation (for After heater) Output starts 10 seconds after supply fan starts operation. Fan continues to operate for 3 min. after stopping the output.

- To use as the after-heater output, observe the cautions listed in **4** in the page 14.
- For heater selection, observe the cautions listed in **4** in the page 14.



## No. 17 Exhaust fan setting during air conditioner defrosting

This function can be used under the condition Lossnay supply duct is connected to Mr. Slim or City Multi indoor unit.

Sets the operation of the exhaust fan during defrosting of the air conditioner (when supply fan stop).

To enable this function, it is necessary to set the indoor unit also.

Please refer to its manual.

DIP-SW		Setting check	PZ-62DR series		Setting check	Exhaust fan operation during air conditioner defrosting
SW No.	Setting		Function No.	Setting Data		
SW5-3	OFF (Factory setting)		17	0		No change
	ON			1		Stop
	-			2 (Factory setting)		DIP-SW priority

## No. 18 Exhaust fan setting at OA temperature lower than -15 °C

Sets the operation of the exhaust fan when the outdoor air is lower than -15 °C (when supply fan stop).

This function is N/A from Lossnay unit DIP-SW.

DIP-SW		Setting check	PZ-62DR series		Setting check	Exhaust fan operation at outdoor temp. -15 °C or less
SW No.	Setting		Function No.	Setting Data		
N/A	-		18	0 (Factory setting)		No change
	-			1		Forced to fan speed 2 or less

- If EA and SA is set unbalanced, the Lossnay core defrosting may not work correctly. For continuous unbalanced operation, a pre-heater is recommended to install.

## No. 19 Interlock mode setting

These settings indicate how Lossnay should operate when City Multi or external devices are started or stopped.

This function is N/A from Lossnay unit DIP-SW.

DIP-SW		Setting check	PZ-62DR series		Setting check	Interlock setting
SW No.	Setting		Function No.	Setting Data		
N/A	-		19	0 (Factory setting)		The Lossnay will start and stop according to the operation of the external devices. Subsequent operation will be possible using the remote controller for the Lossnay or MELANS.
	-			1		The Lossnay will start whenever external devices are operated. Stopping Lossnay operation will be possible using its remote controller or MELANS.
	-			2		The Lossnay will stop whenever external devices are stopped. Starting Lossnay operation will be possible using its remote controller or MELANS.
	-			3		The Lossnay will start and stop according to the operation of the external devices. Control via the Lossnay remote controller or MELANS will only be possible when external devices are stopped.

## No. 28 Pulse input setting

Set external input signal type from external device for TM2.

DIP-SW		Setting check	PZ-62DR series		Setting check	Pulse input setting
SW No.	Setting		Function No.	Setting Data		
SW2-2	-		28	0 (Factory setting)		DIP-SW priority
	OFF (Factory setting)			1		NOT pulse input
	ON			2		Pulse input

When pulse signal is selected, **No. 9** and **No. 19** are not available.

Keep factory settings for **No. 9** and **No. 19**.

Either interlocking with City Multi or Mr. Slim is not possible.

## No. 30 Night purge setting 1) Air volume

Set fan speed during Night purge. To use Night purge function, it is necessary to set **No. 30**, **No. 31**, **No. 32** correctly.

This function is N/A from Lossnay unit DIP-SW.

It can also be set on the PZ-62DR series's Ventilation settings screen. When using PZ-62DR series and AE-200A together, set all conditions from AE-200A.

DIP-SW		Setting check	PZ-62DR series		Setting check	Air volume
SW No.	Setting		Function No.	Setting Data		
N/A	-		30	0 (Factory setting)		N/A (Night purge function is not available)
	-			1		Fan speed 1
	-			2		Fan speed 2
	-			3		Fan speed 3
	-			4		Fan speed 4

### Note:

Even 75 % or more air flow is set as fan speed 4 in this setting for this product, the maximum air flow in Night purge is approx. 70 %.

## No. 31 Night purge setting 2) Outdoor and indoor temperature gap

Set one of conditions for Night purge start, temperature gap between indoor and outdoor.

When the actual gap between indoor and outdoor becomes bigger than the setting, Night purge starts.

This function is N/A from Lossnay unit DIP-SW.

When using PZ-62DR series and AE-200A together, set all conditions from AE-200A.

DIP-SW		Setting check	PZ-62DR series		Setting check	Outdoor and indoor temperature gap
SW No.	Setting		Function No.	Setting Data		
N/A	-		31	0		0 K (0 °C) or more
	-			1		1 K (1 °C) or more
	-			2		2 K (2 °C) or more
	-			3		3 K (3 °C) or more
	-			4		4 K (4 °C) or more
	-			5 (Factory setting)		5 K (5 °C) or more
	-			6		6 K (6 °C) or more
-	7	7 K (7 °C) or more				

### No. 32 Night purge setting 3) The lowest outdoor temperature

Set one of conditions for Night purge start, maximum outdoor temperature within 72 hours.

When this setting temperature is low, it is likely to start Night purge.

This function is N/A from Lossnay unit DIP-SW.

When using PZ-62DR series and AE-200A together, set all conditions from AE-200A.

DIP-SW		Setting check	PZ-62DR series		Setting check	The lowest outdoor temperature
SW No.	Setting		Function No.	Setting Data		
N/A	-	-	32	0		15 °C or more
	-	-		1		16 °C or more
	-	-		2		17 °C or more
	-	-		(Factory setting)		
	-	-		3		18 °C or more
	-	-		4		19 °C or more
	-	-		5		20 °C or more
	-	-		6		21 °C or more
	-	-		7		22 °C or more
	-	-		8		23 °C or more
	-	-		9		24 °C or more
	-	-		10		25 °C or more
	-	-		11		26 °C or more
	-	-		12		27 °C or more
	-	-		13		28 °C or more
-	-	14		29 °C or more		
-	-	15		30 °C or more		

### No. 33 Night purge setting 4) Outdoor temperature detection period

Night purge is decided to start or not by the OA temperature within X hour.

X hour can be selected from 24, 48 or 72 hrs.

It is possible to operate Night purge on Sunday midnight or Monday early morning by selecting longer setting.

This function is N/A from Lossnay unit DIP-SW.

DIP-SW		Setting check	PZ-62DR series		Setting check	OA temperature detection period
SW No.	Setting		Function No.	Setting Data		
N/A	-	-	33	0		24 hrs
	-	-		1		48 hrs
	-	-		2		72 hrs
				(Factory setting)		

### No. 34 Input priority setting

Set to follow input to the main unit from air conditioner, fan speed controller, etc.

When multiple Lossnay units fan speed is externally controlled via CN17 or CN26, select individual control or bunch control.

When bunch control is selected, connect PZ-62DR series and input external signal to the main unit.

This function is N/A from Lossnay unit DIP-SW.

DIP-SW		Setting check	PZ-62DR series		Setting check	Input priority setting
SW No.	Setting		Function No.	Setting Data		
N/A	-	-	34	0		Bunch control priority
	-	-		(Factory setting)		
				1		

### No. 35 Maximum air flow setting in bypass operation

When setting the bypass ventilation mode or auto ventilation mode via remote control operation, it is possible to limit the maximum air flow during bypass operation. This setting also applies to the maximum air flow during night purging.

This function is N/A from Lossnay unit DIP-SW.

DIP-SW		Setting check	PZ-62DR series		Setting check	Maximum air flow setting in bypass operation
SW No.	Setting		Function No.	Setting Data		
N/A	-	-	35	0		Not limited. When air flow is 75 % or more in bypass operation, the unit operates in energy recovery mode to realize higher air flow.
	-	-		(Factory setting)		
				1		

#### Note:

When the unit operates at Auto fan speed according to 0-10 VDC input, to keep air flow has higher priority.

Therefore even this function setting is set 50% or less, the unit shifts to energy recovery mode to realize higher air flow.

### No. 36 Outdoor temperature display setting

Set to display outdoor temperature detected by Lossnay unit thermistor.

This function is N/A from Lossnay unit DIP-SW.

This function is available only when "Sensor value" is set to "Yes" (Display) by the remote controller PZ-62DR series.

DIP-SW		Setting check	PZ-62DR series		Setting check	Outdoor temperature display
SW No.	Setting		Function No.	Setting Data		
N/A	-	-	36	0		N/A
	-	-		(Factory setting)	1	

### No. 37 Indoor temperature display setting

Set to display indoor temperature detected by Lossnay unit thermistor.

This function is N/A from Lossnay unit DIP-SW.

This function is available only when "Sensor value" is set to "Yes" (Display) by the remote controller PZ-62DR series.

DIP-SW		Setting check	PZ-62DR series		Setting check	Indoor temperature display
SW No.	Setting		Function No.	Setting Data		
N/A	-	-	37	0		N/A
	-	-		(Factory setting)	1	

### No. 38 CO<sub>2</sub> concentration display setting

Set to display CO<sub>2</sub> concentration when the CO<sub>2</sub> sensor is used. This function is N/A from Lossnay unit DIP-SW.

DIP-SW		Setting check	PZ-62DR series		Setting check	CO <sub>2</sub> concentration display
SW No.	Setting		Function No.	Setting Data		
N/A	-	-	38	0		N/A
	-	-		1 (Factory setting)		Available on the screen of PZ-62DR series

- This function is available only when "Sensor value" is set to "Yes" (Display) by the remote controller PZ-62DR series.
- When displaying CO<sub>2</sub> concentration, supply air temperature cannot be displayed simultaneously.
- CO<sub>2</sub> concentration display shows the value detected by a CO<sub>2</sub> sensor connected to Lossnay unit. The value may differ from the actual indoor CO<sub>2</sub> concentration. This function cannot be used as a measuring instrument.
- If the CO<sub>2</sub> sensor is installed in the ductwork, there may be a significant difference between the CO<sub>2</sub> concentration displayed on the remote controller and the actual indoor CO<sub>2</sub> concentration for the first 15 minutes after starting operation.
- The displayed range is from 400 ppm to 2000 ppm.

### No. 39 Calculated supply air temperature display setting

Set to display calculated supply air temperature or not. This function is N/A from Lossnay unit DIP-SW. In addition, this function is available only when "Sensor value" is set to "Yes"(Display) by the remote controller PZ-62DR series. CO<sub>2</sub> concentration and supply air temperature can not be displayed at the same time.

DIP-SW		Setting check	PZ-62DR series		Setting check	Calculated supply air temperature display
SW No.	Setting		Function No.	Setting Data		
N/A	-	-	39	0 (Factory setting)		N/A
	-	-		1		Available on the screen of PZ-62DR series

- CO<sub>2</sub> concentration and supply air temperature can not be displayed at the same time.

### No. 40, 41 Temperature exchange efficiency setting

Set the 10 digit of temperature exchange efficiency which is used to calculate supply air temperature. This function is N/A from Lossnay unit DIP-SW.

DIP-SW		Setting check	PZ-62DR series		Setting check	10 digit of temperature exchange efficiency
SW No.	Setting		Function No.	Setting Data		
N/A	-	-	40	0		0
	-	-		1		1
	-	-		2		2
	-	-		3		3
	-	-		4		4
	-	-		5		5
	-	-		6		6
	-	-		7 (Factory setting)		7
	-	-		8		8
	-	-		9		9

DIP-SW		Setting check	PZ-62DR series		Setting check	1 digit of temperature exchange efficiency
SW No.	Setting		Function No.	Setting Data		
N/A	-	-	41	0 (Factory setting)		0
	-	-		1		1
	-	-		2		2
	-	-		3		3
	-	-		4		4
	-	-		5		5
	-	-		6		6
	-	-		7		7
	-	-		8		8
	-	-		9		9

### No. 42 Outdoor temperature correction

Set the correction for the outdoor temperature displayed on the PZ-62DR series screen by function No. 36. This function is N/A from Lossnay unit DIP-SW.

DIP-SW		Setting check	PZ-62DR series		Setting check	The correction to thermistor detection
SW No.	Setting		Function No.	Setting Data		
N/A	-	-	42	0		-7 K (-7 °C)
	-	-		1		-6 K (-6 °C)
	-	-		2		-5 K (-5 °C)
	-	-		3		-4 K (-4 °C)
	-	-		4		-3 K (-3 °C)
	-	-		5		-2 K (-2 °C)
	-	-		6		-1 K (-1 °C)
	-	-		7 (Factory setting)		0 K (0 °C)
	-	-		8		+1 K (+1 °C)
	-	-		9		+2 K (+2 °C)
	-	-		10		+3 K (+3 °C)
	-	-		11		+4 K (+4 °C)
	-	-		12		+5 K (+5 °C)
	-	-		13		+6 K (+6 °C)
-	-	14		+7 K (+7 °C)		

### No. 43 Indoor temperature correction

Set the correction for the indoor temperature displayed on the PZ-62DR series screen by function No. 37. This function is N/A from Lossnay unit DIP-SW.

DIP-SW		Setting check	PZ-62DR series		Setting check	The correction to thermistor detection
SW No.	Setting		Function No.	Setting Data		
N/A	-	-	43	0		-7 K (-7 °C)
	-	-		1		-6 K (-6 °C)
	-	-		2		-5 K (-5 °C)
	-	-		3		-4 K (-4 °C)
	-	-		4		-3 K (-3 °C)
	-	-		5		-2 K (-2 °C)
	-	-		6		-1 K (-1 °C)
	-	-		7 (Factory setting)		0 K (0 °C)
	-	-		8		+1 K (+1 °C)
	-	-		9		+2 K (+2 °C)
	-	-		10		+3 K (+3 °C)
	-	-		11		+4 K (+4 °C)
	-	-		12		+5 K (+5 °C)
	-	-		13		+6 K (+6 °C)
-	-	14		+7 K (+7 °C)		

### No. 44 CO<sub>2</sub> concentration correction

CO<sub>2</sub> concentration displayed on the PZ-62DR series can be corrected. This function is available when there is CO<sub>2</sub> concentration gap due to the location of CO<sub>2</sub> sensor. This function is N/A from Lossnay unit DIP-SW.

DIP-SW		Setting check	PZ-62DR series		Setting check	CO <sub>2</sub> concentration correction
SW No.	Setting		Function No.	Setting Data		
N/A	-	-	44	0		-500 ppm
	-	-		1		-400 ppm
	-	-		2		-300 ppm
	-	-		3		-200 ppm
	-	-		4		-100 ppm
	-	-		5 (Factory setting)		±0 ppm
	-	-		6		100 ppm
	-	-		7		200 ppm
	-	-		8		300 ppm
	-	-		9		400 ppm
-	-	10		500 ppm		

### No. 45 Supply fan monitor threshold

The threshold fan speed of supply fan monitor output can be selected. This function is N/A from Lossnay unit DIP-SW.

DIP-SW		Setting check	PZ-62DR series		Setting check	Supply fan monitor threshold
SW No.	Setting		Function No.	Setting Data		
N/A	-	-	45	0 (Factory setting)		Fan speed 1 or higher
	-	-		1		Fan speed 2 or higher
	-	-		2		Fan speed 3 or higher
	-	-		3		Fan speed 4
	-	-				

### No. 46 Exhaust fan monitor threshold

The threshold fan speed of exhaust fan monitor output can be selected. This function is N/A from Lossnay unit DIP-SW.

DIP-SW		Setting check	PZ-62DR series		Setting check	Exhaust fan monitor threshold
SW No.	Setting		Function No.	Setting Data		
N/A	-	-	46	0 (Factory setting)		Fan speed 1 or higher
	-	-		1		Fan speed 2 or higher
	-	-		2		Fan speed 3 or higher
	-	-		3		Fan speed 4
	-	-				

### No. 47 Constant pressure control setting 1) Air flow changing interval

This function is available when constant pressure control is used. It is possible to change the frequency of the adjustment. This function is N/A from Lossnay unit DIP-SW.

DIP-SW		Setting check	PZ-62DR series		Setting check	Air flow changing interval
SW No.	Setting		Function No.	Setting Data		
N/A	-	-	47	0		1 minute
	-	-		1		3 minutes
	-	-		2 (Factory setting)		5 minutes
	-	-		3		7 minutes
	-	-		4		10 minutes
	-	-		5		15 minutes
	-	-		6		30 minutes

When Leader-follower function is used simultaneously, this setting shall not to be set shorter than factory setting.

### No. 48-51 Constant pressure control setting 2) – 5) Target voltage

This function is available when constant pressure control is used. Refer to No. 66 for constant pressure control. It is possible to change the target voltage according to required pressure. Pressure sensor which can output 0-10 VDC which is equal to 0-500 Pa has to be used.

No. 48 and No. 49 is for supply air setting.

No. 50 and No. 51 is for return air setting.

These functions are N/A from Lossnay unit DIP-SW.

DIP-SW		Setting check	PZ-62DR series		Setting check	Target voltage integer for SA - Ones digit
SW No.	Setting		Function No.	Setting Data		
N/A	-	-	48	0		0.0 V
	-	-		1		1.0 V
	-	-		2		2.0 V
	-	-		3		3.0 V
	-	-		4		4.0 V
	-	-		5		5.0 V
	-	-		6		6.0 V
	-	-		7		7.0 V
	-	-		8		8.0 V
	-	-		9		9.0 V
	-	-		10 (Factory setting)		N/A

DIP-SW		Setting check	PZ-62DR series		Setting check	Target voltage decimal for SA - Ones decimal place
SW No.	Setting		Function No.	Setting Data		
N/A	-	-	49	0 (Factory setting)		0.0 V
	-	-		1		0.1 V
	-	-		2		0.2 V
	-	-		3		0.3 V
	-	-		4		0.4 V
	-	-		5		0.5 V
	-	-		6		0.6 V
	-	-		7		0.7 V
	-	-		8		0.8 V
	-	-		9		0.9 V

For example, No. 48 is set 7 and No. 49 is set 5, the target voltage becomes 7.5 VDC.

It is equal to 375 Pa for 0-500 Pa = 0-10 VDC sensor.

(500 Pa ÷ 10.0 VDC × 7.5 VDC = 375 Pa)

When only SA constant pressure control is enabled, EA fan operates same fan speed with SA fan.

DIP-SW		Setting check	PZ-62DR series		Setting check	Target voltage integer for RA - Ones digit
SW No.	Setting		Function No.	Setting Data		
N/A	-	-	50	0		0.0 V
	-	-		1		1.0 V
	-	-		2		2.0 V
	-	-		3		3.0 V
	-	-		4		4.0 V
	-	-		5		5.0 V
	-	-		6		6.0 V
	-	-		7		7.0 V
	-	-		8		8.0 V
	-	-		9		9.0 V
	-	-		10 (Factory setting)		N/A

DIP-SW		Setting check	PZ-62DR series		Setting check	Target voltage decimal for RA - Ones decimal place
SW No.	Setting		Function No.	Setting Data		
N/A	-	-	51	0 (Factory setting)		0.0 V
	-	-		1		0.1 V
	-	-		2		0.2 V
	-	-		3		0.3 V
	-	-		4		0.4 V
	-	-		5		0.5 V
	-	-		6		0.6 V
	-	-		7		0.7 V
	-	-		8		0.8 V
	-	-		9		0.9 V

RA constant pressure control only is not possible. RA constant pressure control is always accompanied with SA control.

### No. 52 Automatic ventilation mode setting 1) Outdoor and indoor temperature gap

Set one of conditions for Bypass mode in auto ventilation operation, temperature gap between indoor and outdoor.

This function is N/A from Lossnay unit DIP-SW.

This function can also be set on the **Auto Bypass** settings screen of the PZ-62DR series.

DIP-SW		Setting check	PZ-62DR series		Setting check	Gap between Indoor temp. and Outdoor temp.
SW No.	Setting		Function No.	Setting Data		
N/A	-	-	52	0 (Factory setting)		0 K (0 °C) or more
	-	-		1		1 K (1 °C) or more
	-	-		2		2 K (2 °C) or more
	-	-		3		3 K (3 °C) or more
	-	-		4		4 K (4 °C) or more
	-	-		5		5 K (5 °C) or more
	-	-		6		6 K (6 °C) or more
	-	-		7		7 K (7 °C) or more

### No. 53 Automatic ventilation mode setting 2) The lowest outdoor temperature

Set one of conditions for Bypass mode in auto ventilation operation, minimum outdoor temperature which comes in indoor directly. This function is N/A from Lossnay unit DIP-SW. This function can also be set on the **Auto Bypass** settings screen of the PZ-62DR series.

DIP-SW			PZ-62DR series		Outdoor temperature
SW No.	Setting	Setting check	Function No.	Setting Data	
N/A	-	-	53	0	10 °C or more
	-	-		1	11 °C or more
	-	-		2	12 °C or more
	-	-		3	13 °C or more
	-	-		4	14 °C or more
	-	-		5	15 °C or more
	-	-		6	16 °C or more
	-	-		(Factory setting)	
	-	-		7	17 °C or more
	-	-		8	18 °C or more
	-	-		9	19 °C or more
	-	-		10	20 °C or more
	-	-		11	21 °C or more
	-	-		12	22 °C or more
	-	-		13	23 °C or more
-	-	14	24 °C or more		
-	-	15	25 °C or more		

### No. 54 Automatic ventilation mode setting 3) The lowest indoor temperature setting

Set one of conditions for Bypass mode in auto ventilation operation, minimum indoor temperature. This function is N/A from Lossnay unit DIP-SW. When Lossnay is interlocked to Mr. Slim or City Multi indoor unit, the target temperature of the indoor unit is the lowest indoor temperature for Bypass mode. This function can also be set on the **Auto Bypass** settings screen of the PZ-62DR series.

DIP-SW			PZ-62DR series		Indoor temperature
SW No.	Setting	Setting check	Function No.	Setting Data	
N/A	-	-	54	0	15 °C or more
	-	-		1	16 °C or more
	-	-		(Factory setting)	
	-	-		2	17 °C or more
	-	-		3	18 °C or more
	-	-		4	19 °C or more
	-	-		5	20 °C or more
	-	-		6	21 °C or more
	-	-		7	22 °C or more
	-	-		8	23 °C or more
	-	-		9	24 °C or more
	-	-		10	25 °C or more
	-	-		11	26 °C or more
	-	-		12	27 °C or more
	-	-		13	28 °C or more
-	-	14	29 °C or more		
-	-	15	30 °C or more		

User can set conditions to go into Bypass mode in automatic ventilation mode by function **No. 52**, **No. 53**, and **No. 54**. Setting examples are shown below. Function **No. 52**, **No. 53**, and **No. 54** can also be set on the Auto bypass setting screen of PZ-62DR series.

#### Example 1

Bypass/Energy recovery ventilation map in automatic ventilation mode

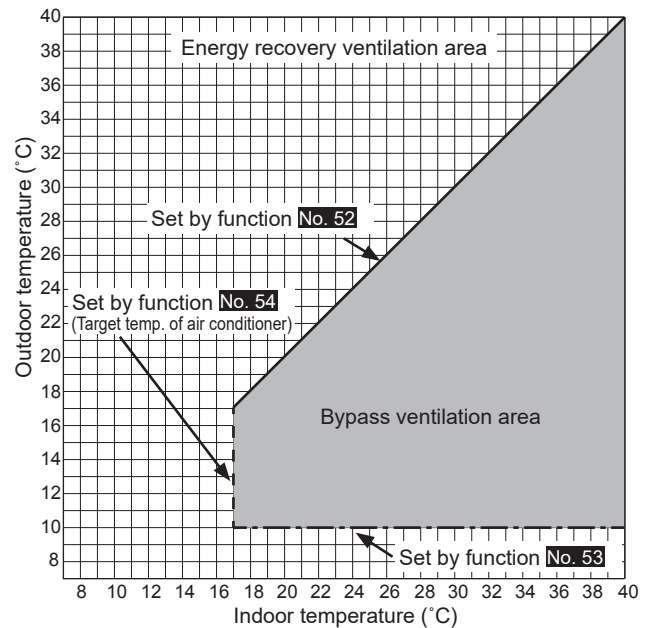

Function No.	Setting Data
52	0 (0°C)
53	0 (10°C)
54	2 (17°C)

#### Example 2

Bypass/Energy recovery ventilation map in automatic ventilation mode

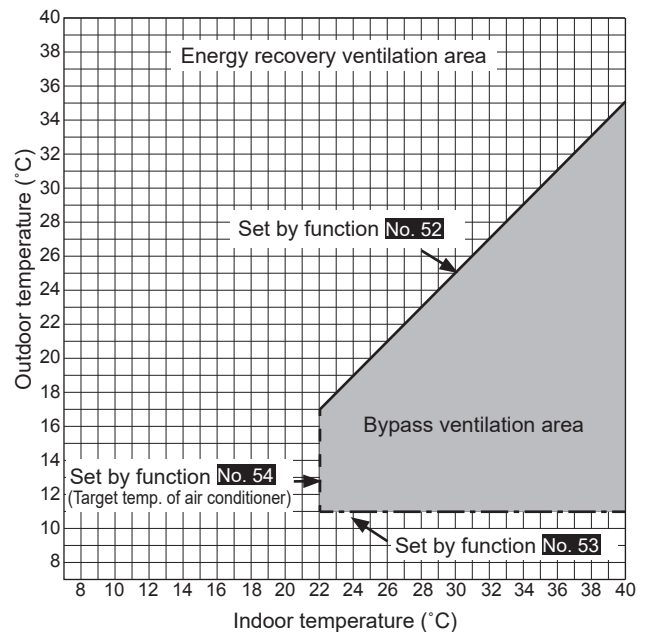

Function No.	Setting Data
52	5 (5°C)
53	1 (11°C)
54	7 (22°C)

When the setting of function **No. 53** is low, with using the pre-heater function, the outdoor temperature may be detected as higher and the mode may change to Bypass mode even in winter. Set the setting to 16°C or more, or use Energy recovery ventilation mode.

**No. 60 Pre-heater output setting 1)  
ON temperature**

Set the outdoor temperature for Pre-heater output ON.  
When detecting temp. becomes the setting or less, Pre-heater output starts.  
This function is N/A from Lossnay unit DIP-SW.

DIP-SW		Setting check	PZ-62DR series		Setting check	Outdoor temp. for Pre-heater output ON
SW No.	Setting		Function No.	Setting Data		
N/A	-	-	60	0 (Factory setting)		0 °C or less
	-	-		1		-1 °C or less
	-	-		2		-2 °C or less
	-	-		3		-3 °C or less
	-	-		4		-4 °C or less
	-	-		5		-5 °C or less
	-	-		6		-6 °C or less
	-	-		7		-7 °C or less
	-	-		8		-8 °C or less
	-	-		9		-9 °C or less
	-	-		10		-10 °C or less
	-	-		11		-11 °C or less
	-	-		12		-12 °C or less
	-	-		13		-13 °C or less
	-	-		14		-14 °C or less
-	-	15		-15 °C or less		

**No. 61 Pre-heater output setting 2)  
OFF interval**

Set the Pre-heater output interval. Output stops according to the set hours.  
This function is N/A from Lossnay unit DIP-SW.

DIP-SW		Setting check	PZ-62DR series		Setting check	Pre-heater output OFF interval
SW No.	Setting		Function No.	Setting Data		
N/A	-	-	61	0 (Factory setting)		1 hr
	-	-		1		2 hrs
	-	-		2		3 hrs
	-	-		3		4 hrs
	-	-		4		5 hrs

**No. 62 LED usage setting for PZ-70CSW-E during non operation**

Wall mount type CO<sub>2</sub> sensor PZ-70CSW-E has LED which indicate the concentration level.  
It is possible to select lit or unlit during Lossnay unit is not operating.  
Refer to the Installation manual of PZ-70CSW-E for more detail.  
This function is N/A from Lossnay unit DIP-SW.

DIP-SW		Setting check	PZ-62DR series		Setting check	LED usage setting for PZ-70CSW-E
SW No.	Setting		Function No.	Setting Data		
N/A	-	-	62	0 (Factory setting)		Unlit
	-	-		1		Lit

**No. 64 Fan speed for air volume "High" input**

Set the fan speed setting when receiving "High" signal from remote controllers (e.g. remote controller of City Multi and Mr. Slim, Lossnay simple remote controller) which have High/Low air volume.

DIP-SW		Setting check	PZ-62DR series		Setting check	Operating fan speed
SW No.	Setting		Function No.	Setting Data		
SW2-6	-	-	64	0 (Factory setting)		DIP-SW priority
	OFF (Factory setting)			1		Fan speed 4
	ON			2		Fan speed 3

**No. 65 Fan speed for air volume "Low" input**

Set the fan speed setting when receiving "Low" signal from remote controllers (e.g. remote controller of City Multi and Mr. Slim, Lossnay simple remote controller) which have High/Low setting for ventilation fan speed.

DIP-SW		Setting check	PZ-62DR series		Setting check	Operating fan speed
SW No.	Setting		Function No.	Setting Data		
SW2-7	-	-	65	0 (Factory setting)		DIP-SW priority
	OFF (Factory setting)			1		Fan speed 2
	ON			2		Fan speed 1

**No. 66 0-10 VDC external input fan control**

According to the type of external input, set this item.  
Lossnay changes fan speed according to input voltage to CN26 when 3rd party's CO<sub>2</sub> sensor, pressure sensor or BMS is setting.  
When connecting with PZ-70CSW-E or PZ-70CSD-E, refer to their manuals for detail.  
Do not set other than following settings.  
Refer to 7 (page 16) for detail connection.  
\* The function of [CO<sub>2</sub> control: No/Yes ] on PZ-62DR series is not applicable for this product. Do not change that setting.

**⚠ WARNING**

- 0-10 VDC input from the external device to use CN26 shall be insulated from main power supply like 220-240 V.  
Otherwise it could cause electrical shock to death.

**⚠ CAUTION**

- Do not input 10 VDC or higher.  
It may cause malfunction.

DIP-SW		Setting check	PZ-62DR series		Setting check	0-10 VDC external input fan control
SW No.	Setting		Function No.	Setting Data		
SW5-6 SW5-7 SW5-8	-	-	66	0 (Factory setting)		DIP-SW priority
	5-6 OFF 5-7 OFF 5-8 OFF (Factory setting)			1		No external fan speed control input
	5-6 OFF 5-7 OFF 5-8 ON			2		[Yellow 4 and Green 5 of PAC-SA88HA-E (CN26)] Fan speed control by 3rd party's CO <sub>2</sub> sensor (0-10 VDC equals to 0-2000 ppm)
	5-6 OFF 5-7 ON 5-8 ON			4		[Yellow 4 and Green 5 of PAC-SA88HA-E (CN26)] BMS control Refer to pattern Z on the following page.
	5-6 ON 5-7 OFF 5-8 OFF			5		[Yellow 4 and Green 5 of PAC-SA88HA-E (CN26)] PZ-70CSW-E control
	5-6 ON 5-7 ON 5-8 OFF			7		[Yellow 4 and Green 5 of PAC-SA88HA-E (CN26)] PZ-70CSD-E control

DIP-SW		Setting check	PZ-62DR series		Setting check	0-10 VDC external input fan control
SW No.	Setting		Function No.	Setting Data		
N/A	-	-	66	9	[Orange 3 and Green 5 of PAC-SA88HA-E (CN26)] Constant pressure control for the supply air by 3rd party's pressure sensor. Refer to <b>Constant pressure control</b> . <b>Note:</b> Exhaust fan operates as same fan speed as supply fan in this setting.	
	-	-		10	[Orange 3 and Green 5 of PAC-SA88HA-E (CN26)] Constant pressure control for the supply air by 3rd party's pressure sensor. [Yellow 4 and Green 5 of PAC-SA88HA-E (CN26)] Constant pressure control for the return air by 3rd party's pressure sensor. Refer to <b>Constant pressure control</b> .	
	-	-		11	[Orange 3 and Green 5 of PAC-SA88HA-E (CN26)] Constant pressure control for the supply air by 3rd party's pressure sensor. [Yellow 4 and Green 5 of PAC-SA88HA-E (CN26)] Displaying CO <sub>2</sub> concentration on PZ-70CSD-E. (No Fan speed control) <b>Note:</b> Constant pressure control has a priority. Refer to <b>Constant pressure control</b> . Exhaust air operates as same fan speed as supply fan in this setting.	
	-	-		12	[Orange 3 and Green 5 of PAC-SA88HA-E (CN26)] Measure the PM2.5 concentration by 3rd party's PM2.5 sensor. (0-10 VDC equals to 0-1000 µg/m <sup>3</sup> ) <b>Note:</b> PM2.5 level is communicated via CN105. PM2.5 level is not displayed on PZ-62DR series. (No Fan speed control)	
	-	-		13	[Orange 3 and Green 5 of PAC-SA88HA-E (CN26)] Measure the PM2.5 concentration by 3rd party's PM2.5 sensor. (0-10 VDC equals to 0-1000 µg/m <sup>3</sup> ) [Yellow 4 and Green 5 of PAC-SA88HA-E (CN26)] Fan speed control by 3rd party's CO <sub>2</sub> sensor. (0-10 VDC equals to 0-2000 ppm) <b>Note:</b> PM2.5 level is communicated via CN105. PM2.5 level is not displayed on PZ-62DR series.	
	-	-		14	[Orange 3 and Green 5 of PAC-SA88HA-E (CN26)] Measure the PM2.5 concentration by 3rd party's PM2.5 sensor. (0-10 VDC equals to 0-1000 µg/m <sup>3</sup> ) [Yellow 4 and Green 5 of PAC-SA88HA-E (CN26)] Fan speed control by PZ-70CSW-E. <b>Note:</b> PM2.5 level is communicated via CN105. PM2.5 level is not displayed on PZ-62DR series.	
-	-	15	[Orange 3 and Green 5 of PAC-SA88HA-E (CN26)] Measure the PM2.5 concentration by 3rd party's PM2.5 sensor. (0-10 VDC equals to 0-1000 µg/m <sup>3</sup> ) [Yellow 4 and Green 5 of PAC-SA88HA-E (CN26)] Fan speed control by PZ-70CSD-E. <b>Note:</b> PM2.5 level is communicated via CN105. PM2.5 level is not displayed on PZ-62DR series.			

**[Pattern Z]**

Lossnay changes fan speed as the table below. (Connection example: BMS (Building Management System))

Input voltage[VDC]	Fan speed	Fan speed changing from Remote controller
0 - 1.0	-	Available
1.5 - 2.5	1	N/A
3.5 - 4.5	2	N/A
5.5 - 7	3	N/A
8.5 - 10	4	N/A

When the input voltage is in-between, it will cause unstable operation.

**«Constant pressure control»**

This function is available when connecting pressure sensor in supply duct or both supply and return duct.

PZ-62DR series is mandatory for this function.

- Select a sensor which can output 0-10 VDC and it equals to 0-500 Pa. Set the requiring pressure (voltage) according to function **No. 48**, **No. 49**, **No. 50** and **No. 51**.
- Constant pressure control becomes ON, when "Auto" fan speed is selected.
- The unit changes fan speed according to the gap between current pressure level and requiring level.  
The unit can operate 5 % air flow pitches, then sometimes, it may fluctuate up and down according to the condition, and it may not achieve the target pressure exactly.  
When the fluctuation is annoying, change the control interval according to function **No. 47**.
- It is not possible to connecting pressure sensor only to the return duct.
- In constant pressure control, it is not possible to control Lossnay in a group collectively. Please connect a pressure sensor to each Lossnay in the group and perform the function setting. Set function **No. 34** to "Individual control priority".

**⚠ CAUTION**

- It takes a few minutes to get close to the target pressure.
- When air flow is too big or too small in this mode, check the pressure sensor.

**No. 67 Threshold minutes for PZ-70CSW-E LED**

LED turns from orange (MID) to red (HIGH) when the CO<sub>2</sub> level is kept over the limit concentration for decided minutes.

The threshold minutes can be changed.

Refer to the Installation manual of PZ-70CSW-E for more detail.

This function is N/A from Lossnay unit DIP-SW.

DIP-SW		Setting check	PZ-62DR series		Setting check	Threshold minutes for PZ-70CSW-E LED
SW No.	Setting		Function No.	Setting Data		
N/A	-	-	67	0	-	10 min
	-	-		1	-	15 min
	-	-		2	(Factory setting)	20 min
	-	-		3	-	25 min
	-	-		4	-	30 min

## No. 68 Threshold concentration for PZ-70CSW-E LED

The threshold concentration for wall mounted CO<sub>2</sub> sensor LED from green (LOW) to orange (MID) can be changed.  
Refer to the Installation manual of PZ-70CSW-E for more detail.  
This function is N/A from Lossnay unit DIP-SW.

DIP-SW		Setting check	PZ-62DR series		Setting check	Threshold concentration for PZ-70CSW-E LED
SW No.	Setting		Function No.	Setting Data		
N/A	–	–	68	0		1000 ppm
	–	–		1		1100 ppm
	–	–		2		1200 ppm
	–	–		3		1300 ppm
	–	–		4		1400 ppm
	–	–		5 (Factory setting)		1500 ppm
	–	–		6		1600 ppm
	–	–		7		1700 ppm
	–	–		8		1800 ppm
	–	–		9		1900 ppm
	–	–		10		2000 ppm

## No. 69 Emergency stop setting

This function can select the priority of Remote OFF signal to CN32.  
When the emergency stop is selected and Lossnay receives remote off signal, Lossnay does not operate Night purge, after cooling or some other operations until remote off signal stops.  
This function is N/A from Lossnay unit DIP-SW.

DIP-SW		Setting check	PZ-62DR series		Setting check	Mode	Lossnay operation
SW No.	Setting		Function No.	Setting Data			
N/A	–	–	69	0 (Factory setting)		Emergency stop	When stopped by Remote OFF input, Night purge, after cooling and some other operation does <b>NOT</b> work.
	–	–		1		Normal stop	When stopped by Remote OFF input, Night purge, after cooling and some other operation does work.

- When installing the centralized management devices (including the system controller) in Mitsubishi Electric Air-Conditioner Network System (MELANS), perform emergency stop by the centralized management devices. In this case, do not use the function **No. 69**.



**No. 73-78, 87, 88 Air flow**

Adjust the output of the fan speed. This function can also be set on the Air flow settings screen of the PZ-62DR series.  
 This function is N/A from Lossnay unit DIP-SW.

PZ-62DR series					PZ-62DR series					PZ-62DR series							
Function No.	Setting Data	Setting check	Fan output	Fan speed	Fan	Function No.	Setting Data	Setting check	Fan output	Fan speed	Fan	Function No.	Setting Data	Setting check	Fan output	Fan speed	Fan
87	0 (Factory setting)		100%	4	SA	75	0		100%	1	SA	77	0		100%	2	EA
	1		95%														
	2		90%														
	3		85%														
	4		80%														
	5		75%														
	6		70%														
	7		65%														
	8		60%														
	9		55%														
	10		50%														
	11		45%														
	12		40%														
	13		35%														
	14		30%														
	15		25%														
73	0		100%	3	SA	88	0 (Factory setting)		100%	4	EA	78	0		100%	1	EA
	1		95%														
	2		90%														
	3		85%														
	4		80%														
	5 (Factory setting)		75%														
	6		70%														
	7		65%														
	8		60%														
	9		55%														
	10		50%														
	11		45%														
	12		40%														
	13		35%														
	14		30%														
	15		25%														
74	0		100%	2	SA	76	0		100%	3	EA	76	0		100%	3	EA
	1		95%														
	2		90%														
	3		85%														
	4		80%														
	5		75%														
	6		70%														
	7		65%														
	8		60%														
	9		55%														
	10 (Factory setting)		50%														
	11		45%														
	12		40%														
	13		35%														
	14		30%														
	15		25%														

- Fan output percentage of Fan speed 4 cannot be set to lower values than that of Fan speed 3.  
 Example: When function **No. 73** is set to "5" (75%), the setting data for function **No. 87** can be selected from "0" (100%) to "5" (75%).
- Fan output percentage of Fan speed 3 cannot be set to higher values than that of Fan speed 4, or lower values than that of Fan speed 2. Likewise, fan output percentage of Fan speed 2 cannot be set to higher values than that of Fan speed 3, or lower values than that of Fan speed 1.  
 Example: When function **No. 87** is set to "2" (90%) and function **No. 74** is set to "7" (65%), the setting data for function **No. 73** can be selected from "2" (90%) to "7" (65%).
- Fan output percentage of Fan speed 1 cannot be set to higher values than that of Fan speed 2.  
 Example: When function **No. 74** is set to "5" (75%), the setting data for function **No. 75** can be selected from "5" (75%) to "15" (25%).

**No. 83, 84 Filter maintenance interval setting**

Filter cleaning sign is displayed on the remote controller according to the set interval in this function.  
 The interval can be set from 100 hrs to 9900 hrs depending on the site situation.  
 This function can also be set on the Maintenance interval settings screen of the PZ-62DR series.  
 This function is N/A from Lossnay unit DIP-SW.

DIP-SW		Setting check	PZ-62DR series		Setting check	Filter maintenance interval setting - Thousands digit
SW No.	Setting		Function No.	Setting Data		
N/A	-	-	83	0		0
	-	-		1		1
	-	-		2		2
	-	-		3		3
	-	-		4		4
	-	-		5		5
	-	-		6		6
	-	-		7		7
	-	-		8		8
-	-	9		9		

DIP-SW		Setting check	PZ-62DR series		Setting check	Filter maintenance interval setting - Hundreds digit
SW No.	Setting		Function No.	Setting Data		
N/A	-	-	84	0		0
	-	-		(Factory setting)		1
	-	-		1		2
	-	-		2		3
	-	-		3		4
	-	-		4		5
	-	-		5		6
	-	-		6		7
	-	-		7		8
-	-	8		9		

**No. 85, 86 Lossnay core maintenance interval setting**

Lossnay core maintenance sign is displayed on the remote controller according to the set interval in this function.  
 The interval can be set from 100 hrs to 9900 hrs depending on the site situation.  
 This function can also be set on the Maintenance interval settings screen of the PZ-62DR series.  
 This function is N/A from Lossnay unit DIP-SW.

DIP-SW		Setting check	PZ-62DR series		Setting check	Lossnay core maintenance interval setting - Thousands digit
SW No.	Setting		Function No.	Setting Data		
N/A	-	-	85	0		0
	-	-		1		1
	-	-		2		2
	-	-		3		3
	-	-		4		4
	-	-		5		5
	-	-		6		6
	-	-		(Factory setting)		7
	-	-		7		8
-	-	8		9		

DIP-SW		Setting check	PZ-62DR series		Setting check	Lossnay core maintenance interval setting - Hundreds digit
SW No.	Setting		Function No.	Setting Data		
N/A	-	-	86	0		0
	-	-		(Factory setting)		1
	-	-		1		2
	-	-		2		3
	-	-		3		4
	-	-		4		5
	-	-		5		6
	-	-		6		7
	-	-		7		8
-	-	8		9		

**No. 89, 90 CO2 sensor setting - maximum side**

It is possible to set the CO2 concentration which fan speed turn into 4. When it is necessary to set 50 ppm, set Function **No. 90** as 1.  
 This function can also be set on the CO2 control setting screen of the PZ-62DR series.  
 (For example, the target is 950 ppm, Function **No. 89** is 3 and **No. 90** is 1.)  
 This function is N/A from Lossnay unit DIP-SW.

DIP-SW		Setting check	PZ-62DR series		Setting check	CO2 sensor setting - maximum side - Hundreds digit
SW No.	Setting		Function No.	Setting Data		
N/A	-	-	89	0		600 ppm
	-	-		1		700 ppm
	-	-		2		800 ppm
	-	-		3		900 ppm
	-	-		4		1000 ppm
	-	-		(Factory setting)		1100 ppm
	-	-		5		1200 ppm
	-	-		6		1300 ppm
	-	-		7		1400 ppm
	-	-		8		1500 ppm
	-	-		9		1600 ppm
	-	-		10		1700 ppm
	-	-		11		1800 ppm
	-	-		12		1900 ppm
-	-	13		2000 ppm		
-	-	14		2000 ppm		

DIP-SW		Setting check	PZ-62DR series		Setting check	CO2 sensor setting - maximum side - Tens digits
SW No.	Setting		Function No.	Setting Data		
N/A	-	-	90	0		0 ppm
	-	-		(Factory setting)	1	50 ppm

**No. 91, 92 CO2 sensor setting - minimum side**

It is possible to set the CO2 concentration which fan speed turn into 1. When it is necessary to set 50 ppm, set Function **No. 92** as 1.  
 This function can also be set on the CO2 control setting screen of the PZ-62DR series.  
 (For example, the target is 950 ppm, Function **No. 91** is 6 and **No. 92** is 1.)  
 This function is N/A from Lossnay unit DIP-SW.

DIP-SW		Setting check	PZ-62DR series		Setting check	CO2 sensor setting - minimum side - Hundreds digits
SW No.	Setting		Function No.	Setting Data		
N/A	-	-	91	0		300 ppm
	-	-		1		400 ppm
	-	-		(Factory setting)		500 ppm
	-	-		2		600 ppm
	-	-		3		700 ppm
	-	-		4		800 ppm
	-	-		5		900 ppm
	-	-		6		1000 ppm
	-	-		7		1100 ppm
	-	-		8		1200 ppm
	-	-		9		1300 ppm
	-	-		10		1400 ppm
	-	-		11		1500 ppm
	-	-		12		1600 ppm
-	-	13		1700 ppm		
-	-	14		1700 ppm		

DIP-SW		Setting check	PZ-62DR series		Setting check	CO2 sensor setting - minimum side - Tens digits
SW No.	Setting		Function No.	Setting Data		
N/A	-	-	92	0		0 ppm
	-	-		(Factory setting)	1	50 ppm

## No. 93 CO<sub>2</sub> sensor correction

CO<sub>2</sub> concentration can be corrected when CO<sub>2</sub> sensor is connected. In this function, the control value of CO<sub>2</sub> level is corrected.

On the other hand, **No. 44** changes the displayed CO<sub>2</sub> level only. This function is N/A from Lossnay unit DIP-SW.

DIP-SW		Setting check	PZ-62DR series		Setting check	CO <sub>2</sub> sensor analogue correction
SW No.	Setting		Function No.	Setting Data		
N/A	—	—	93	0	—	-250 ppm
	—	—		1	—	-200 ppm
	—	—		2	—	-150 ppm
	—	—		3	—	-100 ppm
	—	—		4	—	-50 ppm
	—	—		5 (Factory setting)	—	±0 ppm
	—	—		6	—	50 ppm
	—	—		7	—	100 ppm
	—	—		8	—	150 ppm
	—	—		9	—	200 ppm
—	—	10	—	250 ppm		

## No. 94, 95 Indoor negative / positive pressure setting at auto fan speed setting

At auto fan speed setting operation, by reducing the air flow of the supply fan or exhaust fan, the indoor negative or positive pressure can be adjusted.

This function is N/A from Lossnay unit DIP-SW.

- Select the fan to be targeted at **No. 94**.
- Select the percentage of air flow reduction at **No. 95**. However, the air flow cannot be reduced below 25 %.

For example, if the air volume reduction rate of the exhaust fan is set to 50 %, the air flow of the supply fan will be 75 % and the air flow of the exhaust fan will be 25 %. Even if the air flow of the supply fan becomes 70 %, the air flow of the exhaust fan will not go below 25 %. In this case, if the air flow of the supply fan goes below 70 %, it will not be possible to maintain the balance with the exhaust fan.

- Even when function setting **No. 66** is set as constant pressure control on the supply air side, the exhaust side air flow can be reduced by selecting “Exhaust fan” at **No. 94** on the other hand “Supply fan” can not be selected.

When constant pressure control is selected for both the supply and the return side, this function is not available.

DIP-SW		Setting check	PZ-62DR series		Setting check	Fan that reduce air flow
SW No.	Setting		Function No.	Setting Data		
N/A	—	—	94	0 (Factory setting)	—	N/A
	—	—		1	—	Supply fan
	—	—		2	—	Exhaust fan

DIP-SW		Setting check	PZ-62DR series		Setting check	Percentage of air flow reduction comparing to opposite fan
SW No.	Setting		Function No.	Setting Data		
N/A	—	—	95	0 (Factory setting)	—	N/A
	—	—		1	—	5%
	—	—		2	—	10%
	—	—		3	—	15%
	—	—		4	—	20%
	—	—		5	—	25%
	—	—		6	—	30%
	—	—		7	—	35%
	—	—		8	—	40%
	—	—		9	—	45%
	—	—		10	—	50%
	—	—		11	—	55%
	—	—		12	—	60%
	—	—		13	—	65%
	—	—		14	—	70%
—	—	15	—	75%		

## No. 100 Initialization (No.1~99)

Set to initialize the remote PZ-62DR series setting.

All settings which are changed by users are cancelled.

DIP-SW		Setting check	PZ-62DR series		Setting check	Initialization
SW No.	Setting		Function No.	Setting Data		
N/A	—	—	100	0 (Factory setting)	—	N/A
	—	—		1	—	Available

## 7. Check points after installation work

After installation work has been completed, check the following points once again.

If any failure is detected, be sure to fix it.

Check the following points before trial operation, and place a check mark  in the corresponding check box.

	Reference page	Check box
<b>(1) Check points - Main unit installation work</b>		
The length of 3 m or more is provided for the outdoor side ducts (OA, EA) from a building wall surface.	4. <i>Standard installation examples</i> 5.1.4 <i>Connecting the ducts</i>	
A downward gradient of 1/30 or more toward a building wall is provided for the outdoor side ducts (OA, EA).	4. <i>Standard installation examples</i> 5.1.4 <i>Connecting the ducts</i>	
The two outdoor side ducts (OA, EA) are covered with a heat-insulating material.	5.1.4 <i>Connecting the ducts</i>	
Check LR switching condition on the maintenance cover name plate.	5.1.1 <i>Fix the air path</i>	
<b>(2) Check points - Wiring work</b>		
A combination of power supply voltage, model name, and remote controller is correct.	5.2 <i>Electrical installation</i>	
The wires are correctly connected according to the wire connection diagram.	5.2 <i>Electrical installation</i>	
The wires are securely connected to the terminal blocks.	5.2 <i>Electrical installation</i>	
The wires are securely fixed.	5.2 <i>Electrical installation</i>	
The connectors on the circuit board are securely connected.	5.2 <i>Electrical installation</i>	
The grounding cable is installed securely.	5.2 <i>Electrical installation</i>	
The cables are correctly fixed by using the cord clips and cable glands.	5.2 <i>Electrical installation</i>	
In terms of size and specification, the proper power supply cable and transmission cables are used.	5.2 <i>Electrical installation</i>	
The cable is U trapped before entering the control box.	5.2 <i>Electrical installation</i>	
<b>(3) Check points - Function setting</b>		
The "Main" Lossnay is correctly set.	6. <i>Function settings</i>	
The address setting switches (SW11, SW12) are correctly set.	6. <i>Function settings</i>	
The function selection switches (SW2, SW5) are correctly set.	6. <i>Function settings</i>	
The function settings by the remote controller are correct. (For details, refer to the Installation Manual of the remote controller PZ-62DR series.)	6. <i>Function settings</i>	

To prevent early failures, be sure to check the check points after installation work.

# 8. Trial operation

After the system has been installed and before the ceiling panel is installed, make sure that wires are properly connected, then test the system's operation, referring to the operation manual for the remote controller.

## 8.1 Trial operation using the remote controller (PZ-62DR series)

Follow the procedure shown in the operation manual for the remote controller the functions below.

- (1) Start operation
- (2) Fan speed selection
- (3) Ventilation mode selection
- (4) Stop operation

## 8.2 Lossnay trial operation

This function can be used in the following situations.

- When there is no remote controller installed for operating the Lossnay
- When heater output, malfunction monitor output, operation monitor output, and other output are connected
- When the outdoor temperature is 8 °C or lower (To check Bypass monitor output)
- LR switching condition has to be checked. Only supply fan runs at first 1 minute to confirm LR switching has been set correctly.
- Leader-follower function is enabled.
- The wiring of PZ-70CSW-E when it is connected.

- (1) Supply power to the Lossnay unit.
- (2) Turn the trial operation switch (DIP-SW SW2-1) "On."

### CAUTION

- Wear insulated gloves or such kind of protective tool.

Operation of Fan Speed and Ventilation mode

					Minutes					0					1					2					3					4									
					Second					0					10					20					30					40					50				
TM3		PZ-4GS-E			Fan output	Supply	100 % *1					70 %					100 %																						
DIP-SW SW No. Setting		PZ-62DR series		PZ-62DR series		Exhaust	STOP *1					70 %					100 %																						
		Function No.	Setting data	Function No.	Setting data	Ventilation mode					-					Bypass					Lossnay																		
5-1 OFF 5-2 OFF		12	1	13-16	0	Lossnay operation monitor					ON																												
5-1 ON 5-2 OFF			2		1	Malfunction monitor output					ON																												
5-1 OFF 5-2 ON			3		2	Bypass monitor output					OFF					ON					OFF																		
5-1 ON 5-2 ON			4		3	SA fan monitor output					ON																												
-			5		4	EA fan monitor output					OFF					ON																							
-			6		5	Pre-heater output					OFF										ON																		
-			7		6	SA fan monitor output with delay operation (for after heater)					OFF										ON																		
					LED lit on PZ-70CSW-E *2 (Optional parts)					G					O					R					G					O					R				

\*1 Check for LR switching is correctly set or not by operating only supply fan. Sufficient care is necessary due to LR (air path) switching function on RVXT3 series.

\*2 G: Green, O: Orange, R: Red

Error code "0900" appears on the remote controller. The timing in the chart is a general guideline.

- (3) Check each function is operating normally.
- (4) Turn the trial operation switch (DIP-SW SW2-1) "Off."

## 8.3 Lossnay trial operation in a whole system

### 8.3.1 For Interlock system with air conditioners or external devices

- Use the remote controller for the air conditioner or the operating switches for the external device to check that the air conditioner and Lossnay are interlocked.
- When delay start time is set (when City Multi or Mr. Slim that is connected using a Slim-Lossnay interlocking cable starts operating), check Lossnay operation after the delay start time has passed.

### 8.3.2 For MELANS system

- Check Lossnay operation by using the Mitsubishi Electric Air-Conditioner Network System (MELANS).

## 8.4 If trouble occurs during trial operation

Symptom	Remedy																									
Lossnay does not operate even when the operation switch of the remote controller (PZ-62DR series) is pressed.	<ul style="list-style-type: none"> <li>Check the power supply voltage and connection rightness. (The specified power supply is Three-phase and neutral 380-415 V 50Hz / 380 V 60Hz)</li> <li>Check for a short circuit or disconnection in the transmission cable. (Check that the voltage between terminals in the transmission cables is 10 to 13 VDC for the PZ-62DR series.)</li> <li>Check that a clearance of 5 cm is provided between the transmission cable and the power supply cable and other transmission cables.</li> <li>Operate Lossnay independently using the trial operation switch (SW2-1) to see if it operates properly or not. <table border="1" style="margin-left: 20px;"> <tr> <td>Lossnay operates</td> <td>⇒</td> <td>Check the signal lines</td> </tr> <tr> <td>Lossnay doesn't operate</td> <td>⇒</td> <td>Check the power supply</td> </tr> </table> </li> </ul>	Lossnay operates	⇒	Check the signal lines	Lossnay doesn't operate	⇒	Check the power supply																			
Lossnay operates	⇒	Check the signal lines																								
Lossnay doesn't operate	⇒	Check the power supply																								
When M-NET is used, the Lossnay does not operate by M-NET system controller.	<ul style="list-style-type: none"> <li>Check if there are three or more remote controller connected. (The maximum is two.)</li> <li>Check the power supply. (Specified power supply: Three-phase and neutral 380-415 V 50Hz / 380 V 60Hz, cable diameter, switch capacity)</li> <li>Check if the power supply unit is connected or not, and if the power is supplied or not (For a system with Lossnay only, it is necessary to install the power supply unit.)</li> <li>Check the transmission cable for short-circuit or broken wire (Check if 20 - 30 VDC is detected between the terminals of transmission cable).</li> <li>Check that a clearance of 5 cm is provided between the transmission cable and the power supply cable and other transmission cables.</li> <li>Operate Lossnay independently to see if it operates properly or not. <table border="1" style="margin-left: 20px;"> <tr> <td>Lossnay operates</td> <td>⇒</td> <td>Inspect the transmission cable</td> </tr> <tr> <td>Lossnay doesn't operate</td> <td>⇒</td> <td>Check the power supply</td> </tr> </table> </li> </ul>	Lossnay operates	⇒	Inspect the transmission cable	Lossnay doesn't operate	⇒	Check the power supply																			
Lossnay operates	⇒	Inspect the transmission cable																								
Lossnay doesn't operate	⇒	Check the power supply																								
Air conditioner indoor unit or external device does not interlock.	<ul style="list-style-type: none"> <li>Check Lossnay registration condition in the system remote controller.</li> <li>Check if the pulse input switch (SW2-2) is off. (Can be set from PZ-62DR series)</li> <li>Check the overall cable length between the indoor unit or external device and Lossnay. (Refer to technical manuals or other such documents.)</li> <li>Check the connections at the external control input terminal block (TM2). In the case of voltage charged 12 or 24 VDC output device: Connect to external control input terminals ① and ②. In the case of Volt-free contact output device: Connect to external control input terminals Y and Z. In the case of Mr. Slim (A control or K control): Connect to external control input terminals ① and ②.</li> <li>Perform the registration using the remote controller for the air conditioner or MELANS. (Refer to the installation instructions for the remote controller for the air conditioner or MELANS.)</li> <li>Check if the delay start time has been set.</li> <li>Check the following items after removing the transmission cable from external device. <table border="1" style="margin-left: 20px;"> <thead> <tr> <th></th> <th>Operation signal</th> <th>Stop signal</th> </tr> </thead> <tbody> <tr> <td>Charged 12 or 24 VDC output device</td> <td>12 or 24 VDC</td> <td>0 VDC</td> </tr> <tr> <td>Volt-free contact output device</td> <td>Resistance: 0 Ω</td> <td>Unlimited resistance Ω</td> </tr> <tr> <td>Mr. Slim</td> <td>2 to 6 VDC (pulse signal)</td> <td>2 to 6 VDC (pulse signal)</td> </tr> </tbody> </table> </li> </ul>		Operation signal	Stop signal	Charged 12 or 24 VDC output device	12 or 24 VDC	0 VDC	Volt-free contact output device	Resistance: 0 Ω	Unlimited resistance Ω	Mr. Slim	2 to 6 VDC (pulse signal)	2 to 6 VDC (pulse signal)													
	Operation signal	Stop signal																								
Charged 12 or 24 VDC output device	12 or 24 VDC	0 VDC																								
Volt-free contact output device	Resistance: 0 Ω	Unlimited resistance Ω																								
Mr. Slim	2 to 6 VDC (pulse signal)	2 to 6 VDC (pulse signal)																								
Lossnay does not stop.	<ul style="list-style-type: none"> <li>When multiple Lossnay units are connected, check the external signal is inputted into the main unit.</li> </ul>																									
Lossnay does not stop.	<ul style="list-style-type: none"> <li>Check that the trial operation switch (SW2-1) is set to off.</li> </ul>																									
The inspection indicator lamp (LED 1 Green) in the control box flashes.	<table border="1" style="width: 100%;"> <tbody> <tr> <td>1 flash</td> <td>Fault on fan 1 motor</td> <td rowspan="13" style="vertical-align: middle; text-align: center;">Turn the power off and consult your dealer.</td> </tr> <tr> <td>2 flashes</td> <td>Fault on fan 2 motor</td> </tr> <tr> <td>4 flashes</td> <td>Fault on OA thermistor</td> </tr> <tr> <td>5 flashes</td> <td>Fault on RA thermistor</td> </tr> <tr> <td>6 flashes</td> <td>Fault on fan 3 motor</td> </tr> <tr> <td>7 flashes</td> <td>Fault on fan 4 motor</td> </tr> <tr> <td>8 flashes</td> <td>Fault on Pre-heater capacity or relay</td> </tr> <tr> <td>9 flashes</td> <td>Fault on remote controller communication</td> </tr> <tr> <td>10 flashes</td> <td>Fault on function setting</td> </tr> <tr> <td>11 flashes</td> <td>Fault on power supply to remote controller</td> </tr> <tr> <td>12 flashes</td> <td>Fault on CO<sub>2</sub> sensor, PZ-70CSD-E or PZ-70CSW-E</td> </tr> <tr> <td>13 flashes</td> <td>DIP-SW 2-9 is ON. Change it OFF position.</td> </tr> </tbody> </table> <ul style="list-style-type: none"> <li>15 or 30 minutes in the delay start setting, LED lits ON.</li> <li>LED blinks just after power supply ON.</li> </ul>	1 flash	Fault on fan 1 motor	Turn the power off and consult your dealer.	2 flashes	Fault on fan 2 motor	4 flashes	Fault on OA thermistor	5 flashes	Fault on RA thermistor	6 flashes	Fault on fan 3 motor	7 flashes	Fault on fan 4 motor	8 flashes	Fault on Pre-heater capacity or relay	9 flashes	Fault on remote controller communication	10 flashes	Fault on function setting	11 flashes	Fault on power supply to remote controller	12 flashes	Fault on CO <sub>2</sub> sensor, PZ-70CSD-E or PZ-70CSW-E	13 flashes	DIP-SW 2-9 is ON. Change it OFF position.
1 flash	Fault on fan 1 motor	Turn the power off and consult your dealer.																								
2 flashes	Fault on fan 2 motor																									
4 flashes	Fault on OA thermistor																									
5 flashes	Fault on RA thermistor																									
6 flashes	Fault on fan 3 motor																									
7 flashes	Fault on fan 4 motor																									
8 flashes	Fault on Pre-heater capacity or relay																									
9 flashes	Fault on remote controller communication																									
10 flashes	Fault on function setting																									
11 flashes	Fault on power supply to remote controller																									
12 flashes	Fault on CO <sub>2</sub> sensor, PZ-70CSD-E or PZ-70CSW-E																									
13 flashes	DIP-SW 2-9 is ON. Change it OFF position.																									
The inspection indicator lamp (LED 2 Red) in the control box flashes.	<table border="1" style="width: 100%;"> <tbody> <tr> <td>1 to 8 flashes</td> <td>Error in M-NET communication</td> <td>Turn off the power and immediately contact your dealer.</td> </tr> </tbody> </table>		1 to 8 flashes	Error in M-NET communication	Turn off the power and immediately contact your dealer.																					
1 to 8 flashes	Error in M-NET communication	Turn off the power and immediately contact your dealer.																								

- When an error code blinks on the remote controller, follow the procedures shown in the installation and operating manuals provided with the remote controller.
- If the remote controller is not used, operate after approximately 2 minutes of turning on the power for the Lossnay.

## MITSUBISHI ELECTRIC CORPORATION

HEAD OFFICE:

TOKYO BLDG., 2-7-3, MARUNOUCHI, CHIYODA-KU, TOKYO 100-8310, JAPAN