

LOSSNAY ENERGY RECOVERY VENTILATOR HANDBOOK

MODELS

LGH-160RVXT3-E

LGH-200RVXT3-E

LGH-250RVXT3-E

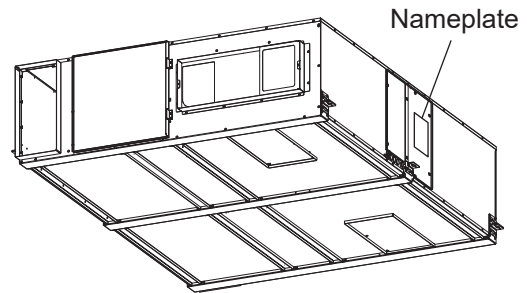

Remote controller (Optional)

PZ-62DR-EA

PZ-62DR-EB

PZ-43SMF-E

Filter (Optional)

PZ-250TRF-E

PZ-250TMFR-E

PZ-250THFR-E

PZ-250TPF-E

Warning:









Repair work must be performed by the manufacturer, its service agent or a similarly qualified person in order to avoid hazards.



Contents

1. Safety precautions	3
2. Changed points	4
3. Specifications	4-5
4. Outside dimensions	6-8
5. Electrical wiring diagram	9
6. Circuit board diagrams	10-11
7. Troubleshooting	12-41
7-1 Service flowchart	12-13
7-2 Check details	13-41
8. Overhauling procedures	42-55
9. Parts catalog	56-80
LGH-160RVXT3-E	57-64
LGH-200RVXT3-E	65-72
LGH-250RVXT3-E	73-80

1. Safety precautions

- Read the following precautions thoroughly before the maintenance, and then inspect and repair the product in a safe manner.
- The types and levels of danger that may arise if the product is handled improperly are described with the warning symbols shown below.

 Warning		Improper handling of the product may result in serious injury or death.	
<p>◇ Electric shock If you must inspect the circuitry while the power is on, do not touch the live parts.</p> <p>(Failure to observe this warning may result in electric shock.)</p>	 <small>Caution against electric shock</small>	<p>◇ Turn off the power supply Be sure to shut off the power supply isolator before disassembling the unit for repair.</p> <p>(Failure to observe this warning may result in electric shock.)</p>	 <small>Be sure to follow this instruction.</small>
<p>◇ Modification is prohibited Do not modify the unit.</p> <p>(Failure to observe this warning may result in electric shock, fire and/or injury.)</p>	 <small>Prohibited</small>	<p>◇ Use proper parts and tools For repair, be sure to use the parts listed in the parts catalog of the applicable model and use the proper tools.</p> <p>(Failure to observe this warning may result in electric shock, fire and/or injury.)</p>	 <small>Be sure to follow this instruction.</small>
<p>◇ Proper electric work Qualified electricians shall conduct electric work in accordance with your local electric work regulations and the installation manuals.</p> <p>(Improper connection or wiring installation may result in electric shock and/or fire.)</p>	 <small>Be sure to follow this instruction.</small>	<p>◇ Replace damaged and/or degraded parts Be sure to replace the power cord and lead wires if they are damaged and/or degraded.</p> <p>(Failure to observe this warning may result in electric shock and/or fire.)</p>	 <small>Be sure to follow this instruction.</small>
		<p>◇ Check insulation Upon completing repair work, always measure the insulation resistance. Verify that it is at least 10 MΩ (with a 500-V DC insulation resistance tester), and then turn on the power.</p> <p>(Inadequate insulation may result in electric shock.)</p>	 <small>Be sure to follow this instruction.</small>

 Caution		Improper handling of the product may result in injury or damage to properties including buildings and equipment.	
<p>◇ Caution for injury Do not work at a location where you do not have a sure footing.</p> <p>(Failure to observe this caution may result in a fall.)</p>	 <small>Prohibited</small>	<p>◇ Wear gloves Wear gloves when servicing.</p> <p>(Failure to observe this caution may result in injury to your hands from sharp metal or other edges.)</p>	 <small>Be sure to follow this instruction.</small>

Notes for servicing

- Inspect the earth condition, and repair it if it is incomplete. Make sure that a power supply isolator and an over-load protection device are installed. If they are not installed, recommend the customer to install them.
- Make sure that the product operates properly upon completion of repair. Clean the product and the surrounding area, and then notify the customer of the completion of repair.

2. Changed points

New model	Former model	Changes from the former model
LGH-160RVXT3-E	LGH-150RVXT-E ①	<ul style="list-style-type: none"> • Higher and balanced static pressure • Leader-Follower function is added. • Constant Pressure control is added. • Power supply is changed from single-phase to three-phase. • Reversible installation is possible. • Outlet shutters are added. • Filter curtains are added. • The control circuit board is changed. • The DC motors are changed. • The motor fix plates are changed. • The centrifugal fans are changed. • Dual barrier coating is applied to the centrifugal fans. <p><For LGH-160RVXT3-E> The 150 type is changed to the 160 type. (Air volume specification is changed from 1500 m³/h to 1600 m³/h.)</p>
LGH-200RVXT3-E	LGH-200RVXT-E ①	
LGH-250RVXT3-E	LGH-250RVXT-E ①	

3. Specifications

Model name	LGH-160RVXT3-E, LGH-200RVXT3-E, LGH-250RVXT3-E
Heat exchange system	Energy recovery ventilating system
Heat exchanger material	Special treated paper plate heat exchanger
Cladding	Galvanized steel sheet
Heat insulation material	Self-extinguishing urethane foam
Motor	EC motor
Filter	ISO Coarse 60% (ISO 16890:2016)
Surrounding air condition	Shall be between -10°C and 40°C, 80%RH or less
Suction air condition	Shall be lower than 40°C, 80%RH
Supply fan operation under low outdoor temperature	-10°C to -15°C : Intermittent operation 60 min ON, 10 min OFF -15°C or less: Sensing operation 55 min OFF, 5 min ON
Function	Energy recovery ventilation/Bypass ventilation
Electrical power supply	380-415 V 3 N~ 50 Hz/ 380 V 3 N~ 60 Hz
Insulation resistance	10 MΩ or more
Dielectric strength	1000 V AC 1 minute

Model name	Input power (W)				Air volume		External static pressure (Pa)	Temperature exchange efficiency (%)	Noise (dB)	Weight (kg)
	L1-N	L2-N	L3-N	Σ	(m ³ /h)	(L/s)				
LGH-160RVXT3-E	0	354	354	708	1600	444	190	82	38	172
LGH-200RVXT3-E	0	522	522	1044	2000	556	190	80	40	172
LGH-250RVXT3-E	0	724	724	1448	2500	694	190	77	44	172

- * The above values apply during energy recovery ventilation when the fan speed is set to Fan speed 4 at the rating pressure loss and 400 V / 50 Hz.
- * For the specifications at the other frequency or voltages, see the spec. sheets.
- * The values given in the table for the noise level reflect the levels measured at a position 4.9 feet (1.5 m) immediately below the unit in an anechoic chamber.
- * Noise change or increase may occur because of the Bypass-Automatic function or Automatic fan speed change by timer setting and/or other functions.
- * Temperature Exchange efficiency (%) is based on a winter condition.
- * On-site commissioning measurements by pitot tube method could be as much 20% different from ISO test room conditions. If the measuring point is close to sources of turbulence like bends, contractions and dampers, etc., it is difficult to measure air volume correctly. A straight duct length more than 10 D (D=duct diameter) from the source of turbulence is recommended for correct measurement. On-site measurement should therefore be measured in accordance with BSRIA guideline (Commissioning Air System. Application procedures for buildings AG3/89.3 (2001)).

■ Remote controller

Model name	PZ-62DR-EA, PZ-62DR-EB	PZ-43SMF-E
Power supply requirement	12 V DC (Supplied from Lossnay unit)	
Power consumption	0.3 W	
Transmission cable	Non polarized 2-core cable (0.3 mm ² (AWG22) sheathed cable)	
Total wiring length	200 m maximum	
The number of controllable Lossnay units	15 Lossnay units maximum (Max. 2 remote controllers installable)	
Environmental condition	Temperature: 0°C to 40°C, Humidity: 30% to 90% relative humidity (no condensation)	
Size	120 x 120 x 19 mm	120 x 70 x 15 mm
Weight	0.25 kg	0.10 kg
Color	Grayish white	White

4. Outside dimensions

LGH-160RVXT3-E, LGH-200RVXT3-E, LGH-250RVXT3-E

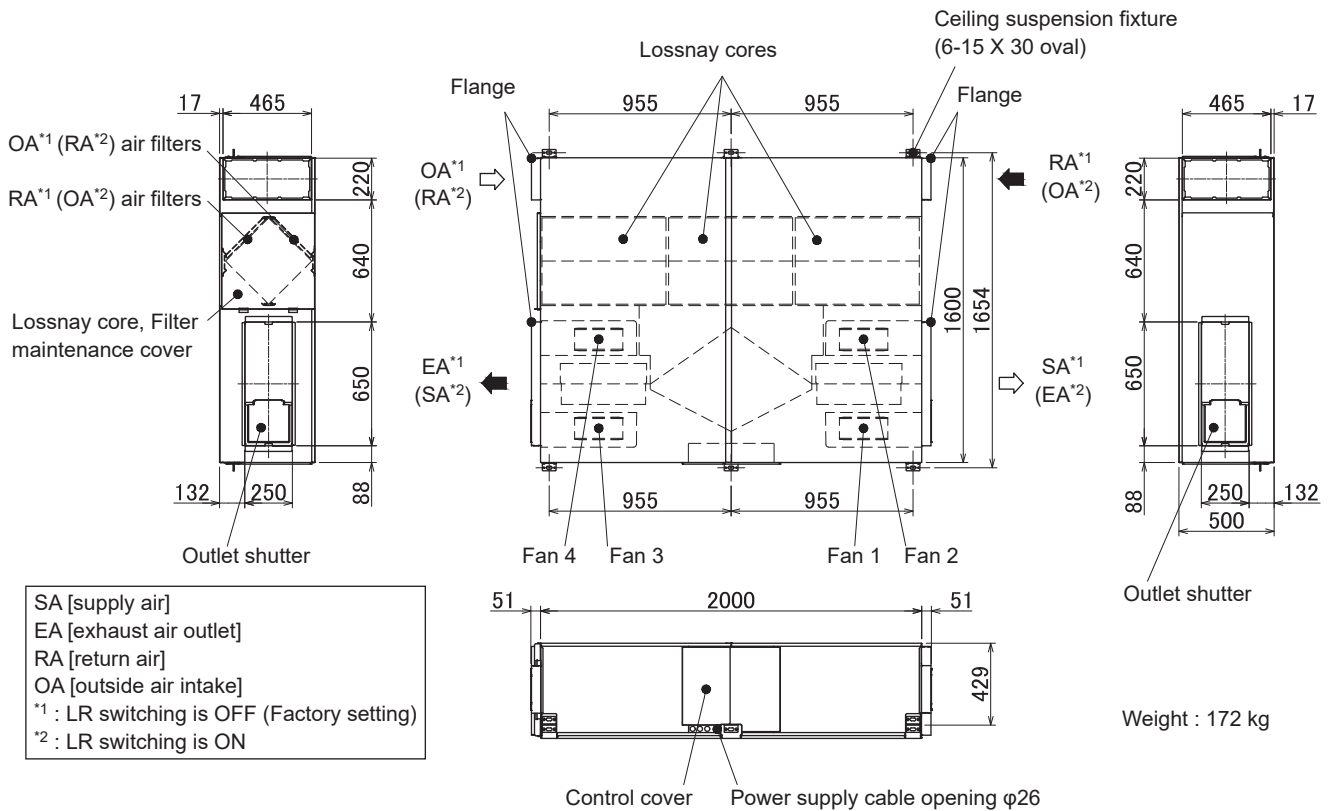

Reference for maintenance space

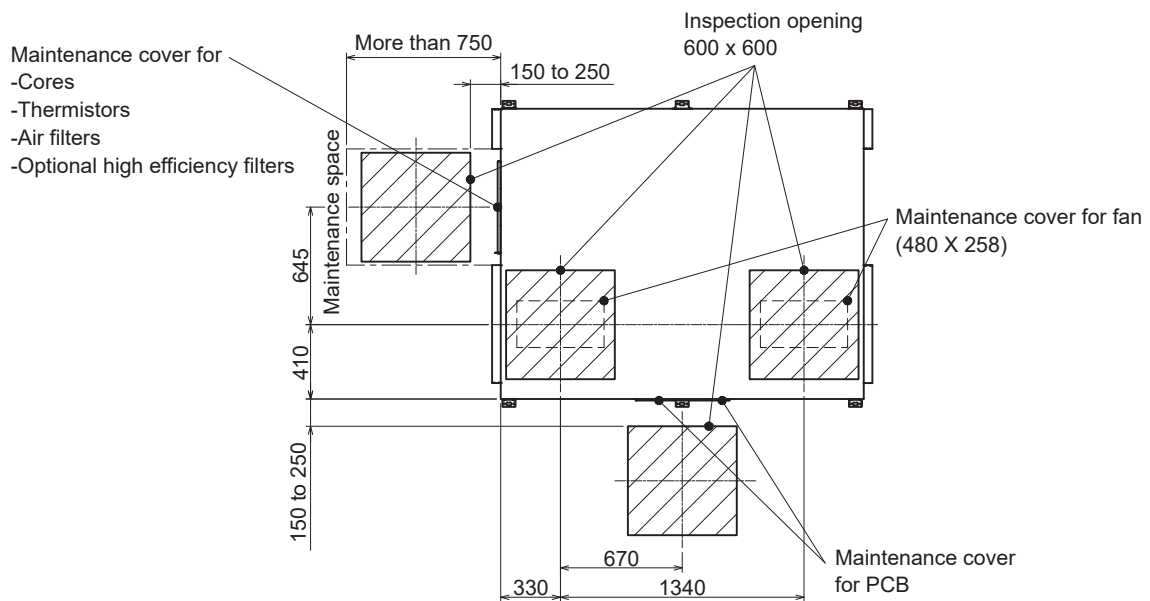

Unit: (mm)

PZ-62DR-EA, PZ-62DR-EB

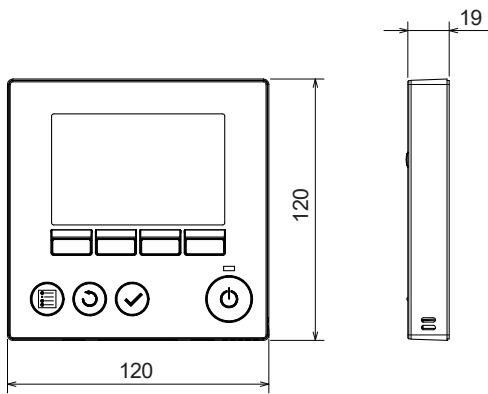

Unit: (mm)

PZ-43SMF-E

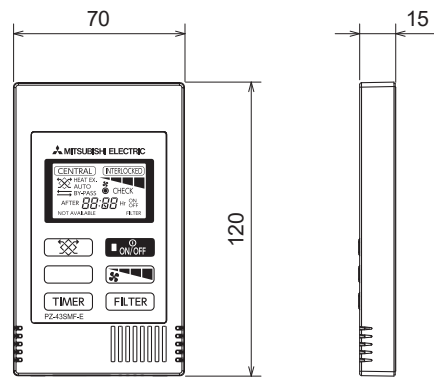

Unit: (mm)

PZ-250TRF-E

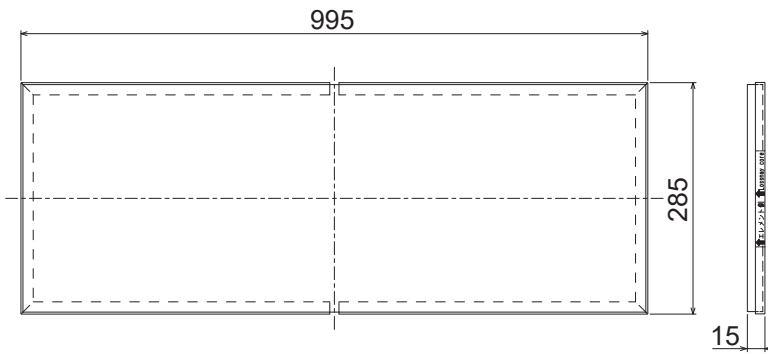

* The filters are comprised of one set of the same filters as those built in the product.

The number of filters per set	Applicable Lossnay model
4	LGH-160RVXT3-E LGH-200RVXT3-E LGH-250RVXT3-E

Unit: (mm)

PZ-250TMFR-E

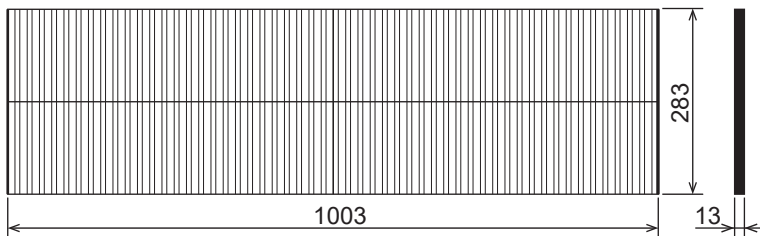

The number of filters per set	Applicable Lossnay model
2	LGH-160RVXT3-E LGH-200RVXT3-E LGH-250RVXT3-E

Unit: (mm)

PZ-250THFR-E, PZ-250TPF-E

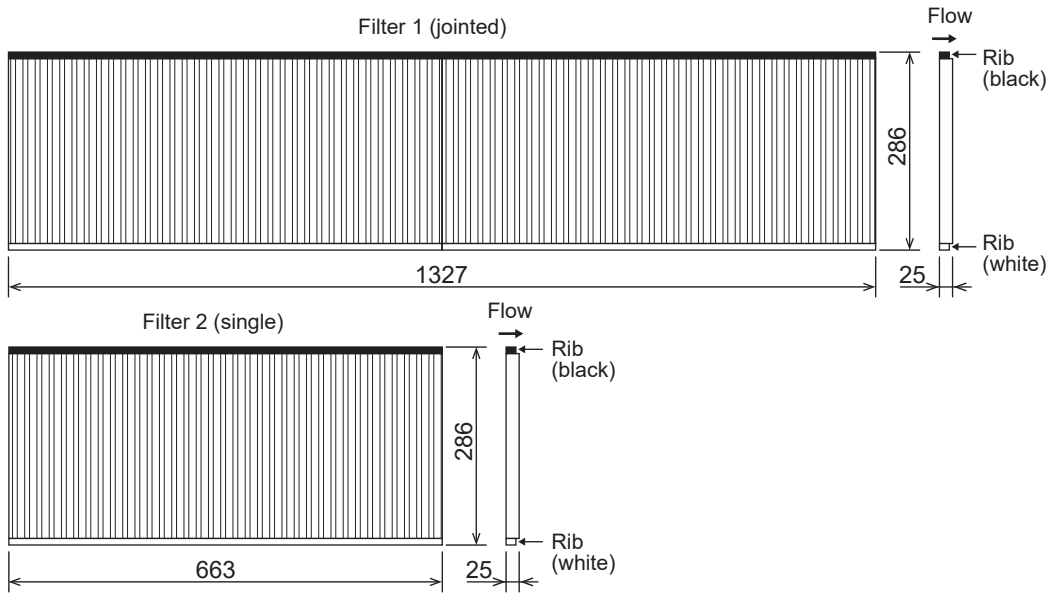

The number of filters per set		Applicable Lossnay model
Filter 1 (jointed)	Filter 2 (single)	LGH-160RVXT3-E
		LGH-200RVXT3-E
1	1	LGH-250RVXT3-E

Unit: (mm)

5. Electrical wiring diagram

LGH-160RVXT3-E, LGH-200RVXT3-E, LGH-250RVXT3-E

- * Wiring for TM1, TM2, TM3, TM4, and TB5 shown in dotted lines are field work.
- * Be sure to connect the earth wire.
- * An all pole electric leakage isolator must be installed.
- * Always use an isolator for the main power connection.

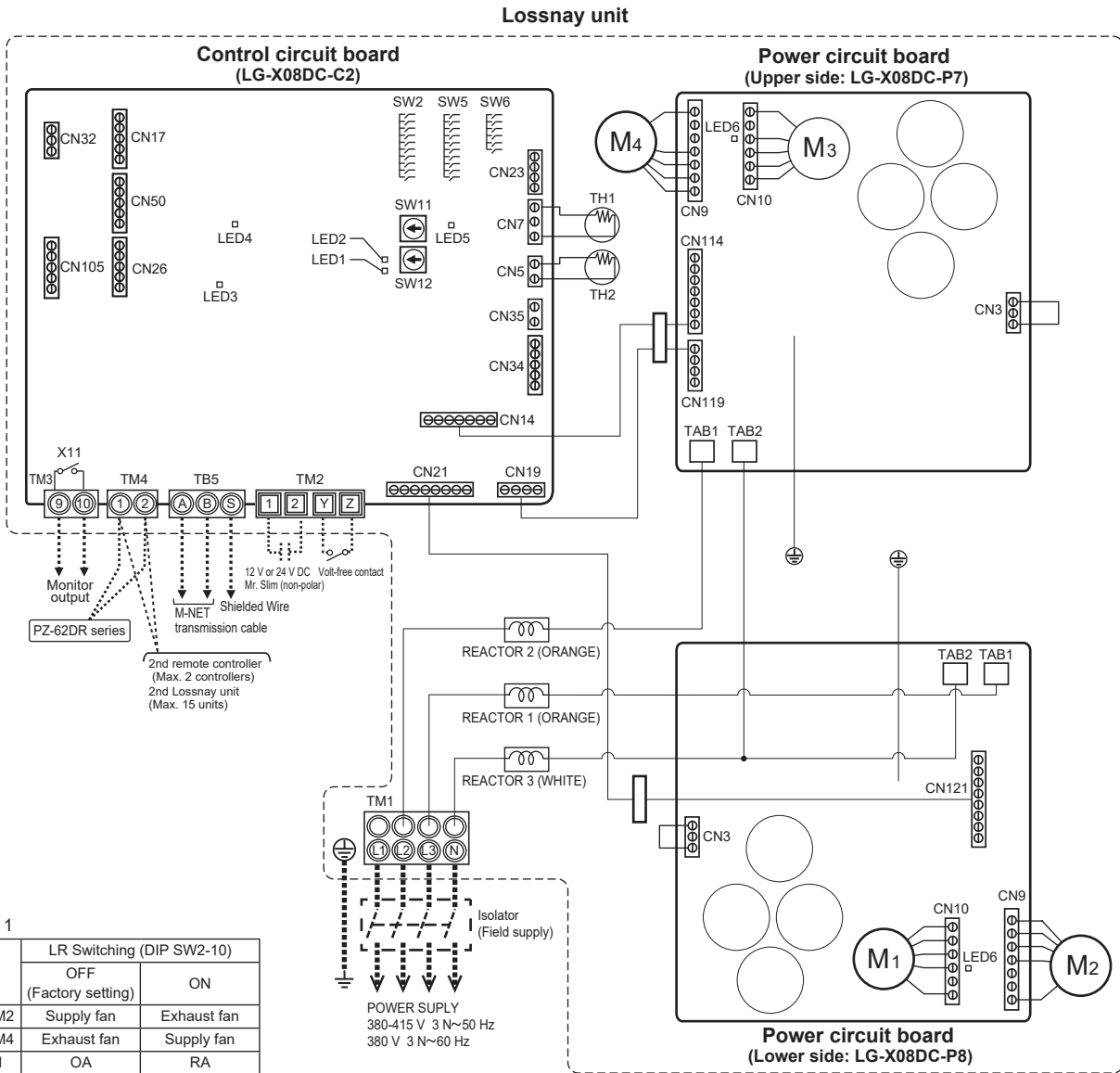

Table 1

	LR Switching (DIP SW2-10)	
	OFF (Factory setting)	ON
M1, M2	Supply fan	Exhaust fan
M3, M4	Exhaust fan	Supply fan
TH1	OA	RA
TH2	RA	OA

Definition of symbols

M1: Motor for supply fan (outside) (See Table 1.)	CN3: Connector	CN34: Connector (CO ₂ sensor output)
M2: Motor for supply fan (inside) (See Table 1.)	CN5: Connector (Thermistor)	CN35: Connector (CO ₂ sensor input)
M3: Motor for exhaust fan (inside) (See Table 1.)	CN7: Connector (Thermistor)	CN50: Connector (Optional components: External monitor output)
M4: Motor for exhaust fan (outside) (See Table 1.)	CN9: Connector (Fan motor)	CN105: Connector (For IT communication)
TH1: Thermistor for outdoor air (See Table 1.)	CN10: Connector (Fan motor)	SW11: Address setting rotary switch (ones digit)
TH2: Thermistor for return air (See Table 1.)	CN17: Connector (Fan speed 1/2/3/4)	SW12: Address setting rotary switch (tens digit)
SW2, 5: Switch (Function selection)	CN14: Connector	LED1: Inspection indicator lamp
SW6: Switch (Model selection)	CN114: Connector	LED2: M-NET indicator lamp
TM1: Terminal block (Power supply)	CN19: Connector	LED3: Remote controller power supply indicator lamp
TM2: Terminal block (External control input)	CN119: Connector	LED4, LED6: Power supply indicator lamp
TM3: Terminal block (Monitor output)	CN21: Connector	LED5: CO ₂ sensor power supply indicator lamp (When the CO ₂ sensor is connected)
TM4: Terminal block (Remote controller transmission cable)	CN121: Connector	SYMBOL : Terminal block, : Connector on PCB
TB5: Terminal block (M-NET transmission cable)	CN23: Connector (CO ₂ sensor power supply)	
X11: Relay contact	CN26: Connector (Bypass switching/CO ₂ sensor input)	
	CN32: Connector (Remote control selection)	

Select proper isolator according to the electrical current information in the chart below.

Model	LGH-160RVXT3-E	LGH-200RVXT3-E	LGH-250RVXT3-E
Maximum current when operating [A]	2.9	3.9	5.0

- * Make sure that the current leakage breaker is one compatible with higher harmonics.
- * Always use a current leakage breaker that is compatible with higher harmonics as this unit is equipped with an inverter.
- * The use of an inadequate breaker can cause the incorrect operation of the inverter.

6. Circuit board diagrams

● Circuit board diagrams and check points

(1) Control circuit board

Caution:

Before servicing (including replacing the circuit boards), be sure to turn off the power supply isolator and check that all the LEDs on the control circuit board and power circuit board are not lit. A large-capacity electrolytic capacitor on the circuit board may carry voltage for several minutes after the isolator is turned off.

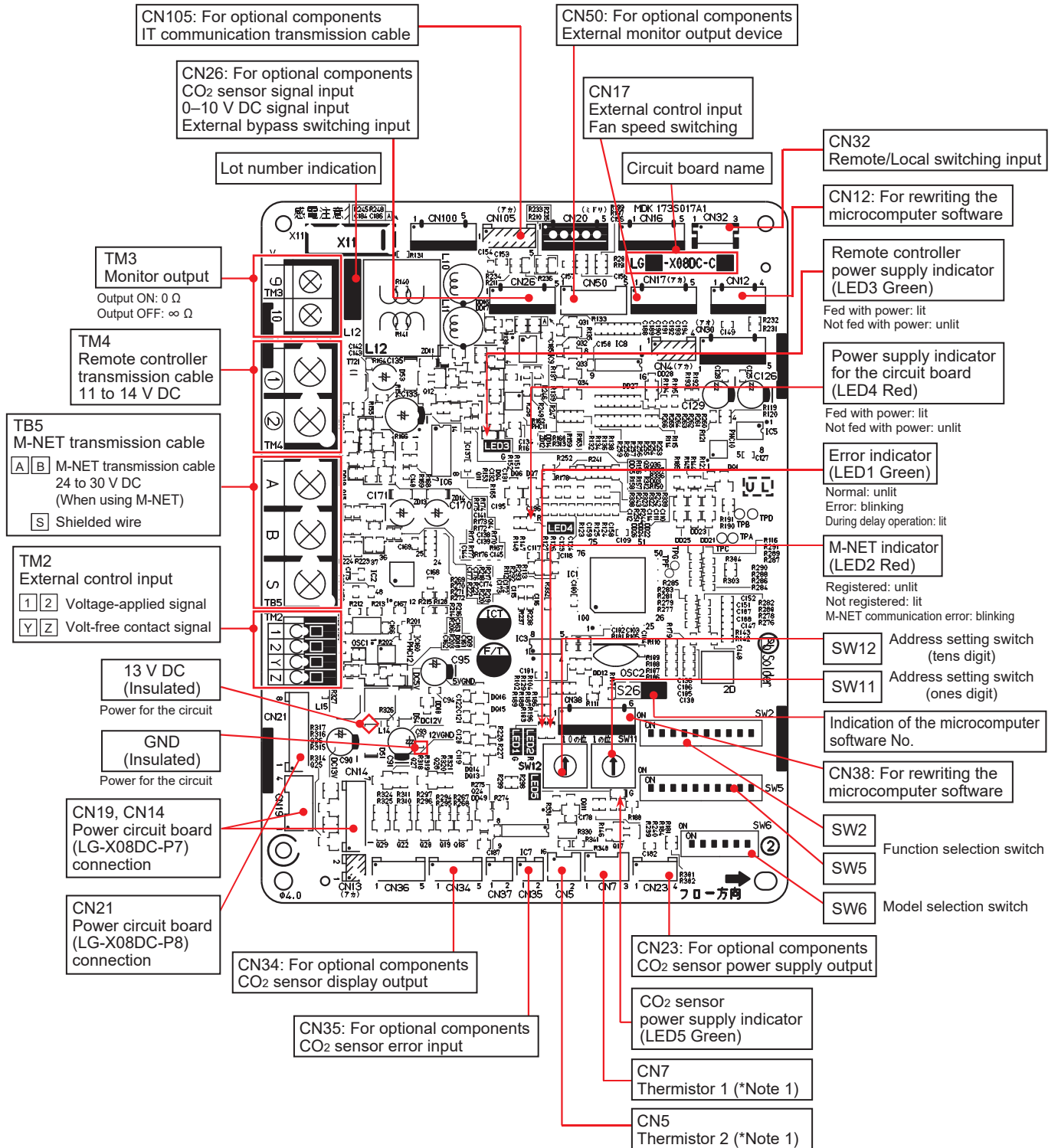

*Note 1:
See Table 1 (page 9).

(2) Power circuit board

The Lossnay units (LGH-160RVXT3-E, LGH-200RVXT3-E, and LGH-250RVXT3-E) are equipped with two types of the power circuit board (LG-X08DC-P7 and LG-X08DC-P8).

Caution:

The power circuit consists of live parts. The power circuit board is not insulated from the power line, except for the connection part with the control circuit board. Before servicing (including replacing the circuit boards), be sure to turn off the power supply isolator and check that all the LEDs on the control circuit board and power circuit board are not lit. A large-capacity electrolytic capacitor on the circuit board may carry voltage for several minutes after the isolator is turned off.

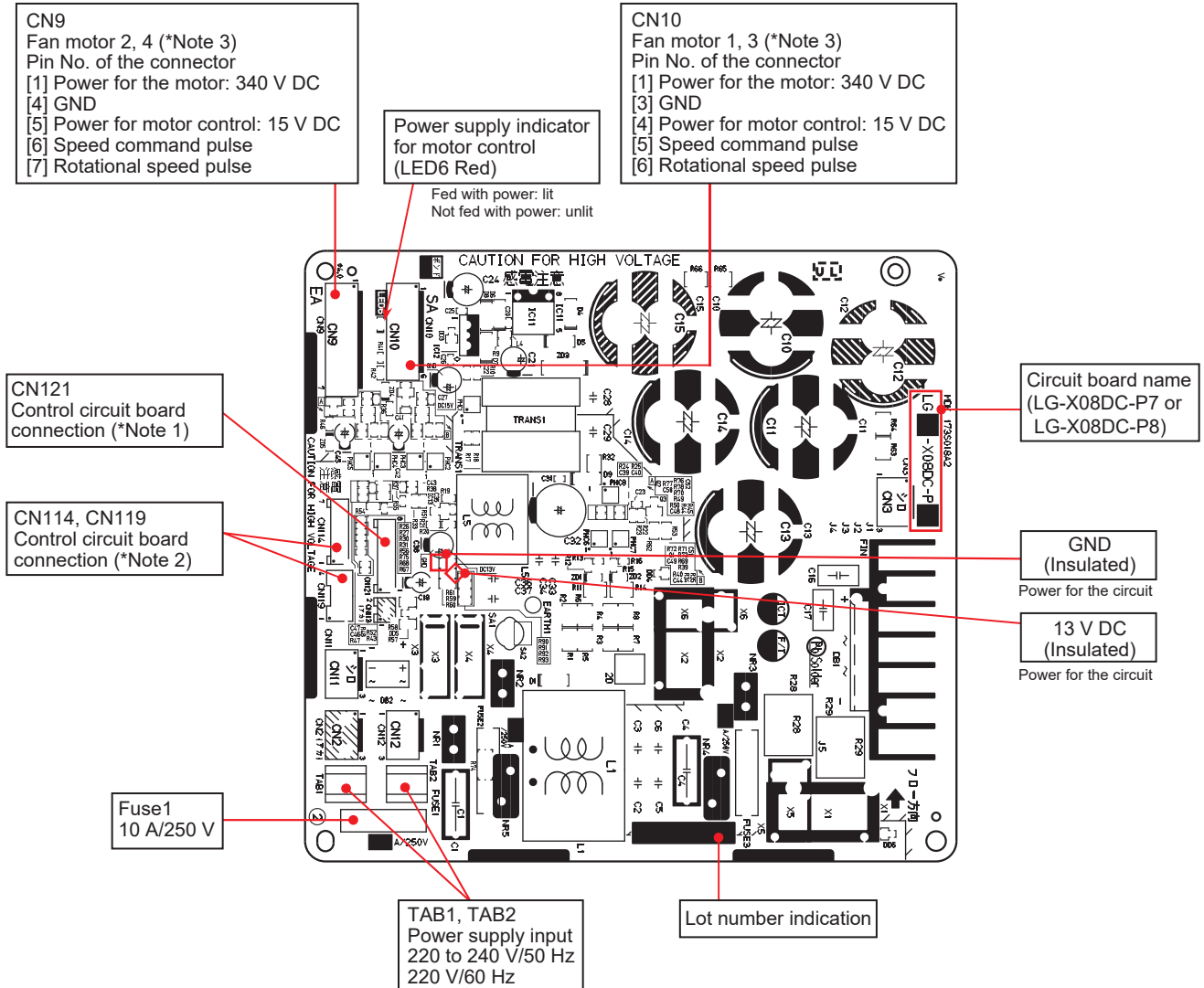

*Note 1:

The connection is only used on LG-X08DC-P8.

*Note 2:

The connections are only used on LG-X08DC-P7.

*Note 3:

See Table 1 (page 9).

7. Troubleshooting

■ Work precautions

- Before starting the service, the power supply isolator must be turned off. Pay sufficient attention to avoid electric shock or injury.
- When removing or touching the cables, circuit boards or other parts, be sure to turn off the power supply isolator.
- Even after the power supply isolator is turned off, the capacitor on the circuit board retains high voltage for a while. Therefore, before servicing, wait for at least five minutes, and then use a tester to check that the voltage has dropped.
- Once the power supply is turned off, be sure to wait for at least five minutes before turning the power back on again.
- When servicing, power supply to M-NET must be turned off. Live-line working may cause a circuit board failure.
- When servicing, recreate the malfunction two or three times before starting repairs.
- When servicing, always keep proper footing.
- When disconnecting the motor connectors, make sure that the power supply is turned off. Even when the fan motor is stopped, disconnecting the live-line connectors will cause a motor malfunction.
- When removing the circuit board, always hold it at both ends and remove carefully in order not to apply force to the surface mounted parts.
- When removing the circuit board, be careful of the metal edges on the board.
- When removing or inserting the connectors for the circuit board, hold the entire housing section. Never pull on the lead wires.
- When circuit board failure is considered to be a cause, check closely for any broken section on the copper foil patterns, burning or discoloration of parts.
- If the circuit board is replaced, make sure that the switch settings on the new board are the same as the old board.
- Be sure to connect the power supply wires correctly.
- When carrying out wiring, power supply to M-NET must be turned off, otherwise it will cause a malfunction.

7-1 Service flowchart

After checking the check items below, follow the troubleshooting for servicing.

Applicable Device	Applicable Model
Lossnay Energy Recovery Ventilator	LGH-160RVXT3-E, LGH-200RVXT3-E, LGH-250RVXT3-E
Lossnay Remote Controller	PZ-62DR-EA, PZ-62DR-EB, PZ-43SMF-E

No.	Preliminary check item	Details
1	Product information	<ul style="list-style-type: none"> • Model name of the product • Serial number of the product, manufacturing lot number of the circuit board • Microcomputer software version marked on the circuit board
2	Fault status	<ul style="list-style-type: none"> • Fault status (For example, the fan does not operate.) • Error code display on the remote controller • Operation setting of the remote controller (ventilation mode setting, fan speed setting, etc.)
3	Frequency of fault occurrence	<ul style="list-style-type: none"> • Frequency of fault occurrence (frequency of date and time of occurrence, regularity of occurrence, etc.) • Operating time up to fault occurrence • Date of start of use, date of fault occurrence
4	Timing of fault occurrence	<ul style="list-style-type: none"> • Remote controller operation performed before fault occurrence • Operating status, etc.
5	System settings	<ul style="list-style-type: none"> • Function selection switch settings and address setting of the product • Model name and address setting of the Lossnay remote controller or system controller, etc. • Function settings on the PZ-62DR series when the PZ-62DR series is used
6	System drawings	<ul style="list-style-type: none"> • System Configuration • Wiring • Record of the Lossnay function setting statuses

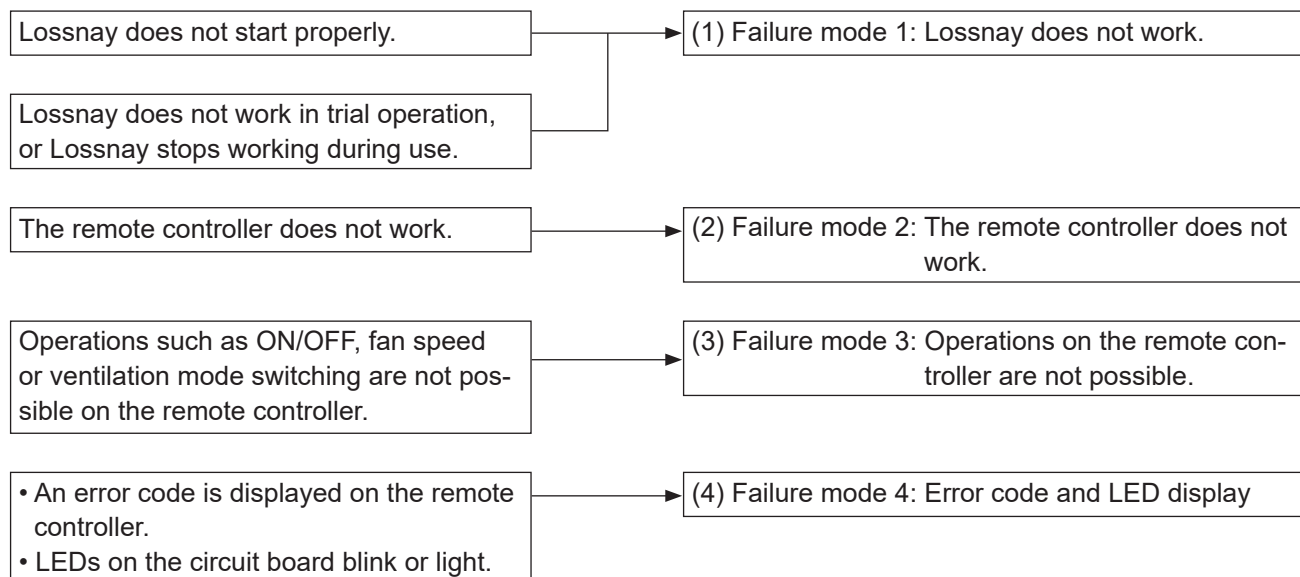

7-2 Check details

(1) Failure mode 1: Lossnay does not work.

● Initial Check Items

Check the following details if Lossnay does not work.

[1] Power supply

No.	Check Item	Corrective action
1	Is the main power supply on?	Turn the main power supply on.
2	Is the current capacity of the power supply isolator appropriate?	Use an appropriate power supply isolator.
3	Is the designated cable used for the power supply cable?	Use the designated cable.
4	Is the specified power supply supplied to the power supply terminal (TM1)? 380-415 V/50 Hz, 380 V/60 Hz	Supply the specified power supply.
5	Is the power supply cable incorrectly wired, is there a faulty connection or are screws loose?	Connect the cable securely and correctly, and tighten the screws firmly.
6	Is there a faulty connection on the power supply terminals (TM1, TAB1, and TAB2)?	Connect the lead wires securely.
7	Is there a faulty connection to the reactor?	Connect the lead wires securely.
8	Are the power supply indicator lamps (LED4 on the control circuit board and LED6 on the power circuit boards, red) lit?	The LED lights while power is supplied. If not lit, check the above items.

[2] Transmission cables (remote controller transmission cable, M-NET transmission cable, external input/output signal cable, and connection cable for IT communication appliances)

No.	Check Item	Corrective action
1	Are the designated cables used for the remote controller transmission cable and M-NET transmission cable? (See Table 2-1 and Table 2-2.)	Use the designated transmission cables.
2	Are the designated cables used for the external input/output signal cable? (See Table 2-3.)	Use the designated cables.
3	Are the transmission cables wired using multicore cables?	Use the designated transmission cables.
4	Are multiple transmission cables wired in the same piping duct?	Wire the transmission cable away from one another.
5	Is the power supply cable wired at least 5 cm away from transmission cables?	Wire the power supply cable at least 5 cm away from the transmission cables.
6	Are the transmission cables connected to the designated terminal block? (See Table 2-1 and Table 2-2.)	Connect the transmission cables to the designated terminal blocks.
7	Are the transmission cables incorrectly wired, is there a faulty connection or are screws loose?	Connect the cable securely and correctly, and tighten the screws firmly.
8	Is the wiring length of the transmission cable within the regulations? (See Table 2-1 and Table 2-2.)	Wire the cables within the regulations.
9	Are communication cables wired at least 5 cm away from the other communication cables?	Wire the cables at least 5 cm away from the other cables.
10	Does the external input signal match the specifications? (See Table 2-3.)	Input the signal that matches the specifications.
11	Is the external input signal input to the Lossnay set as the main Lossnay?	Input the signal to the Lossnay set as the main Lossnay (with address number 1 or the smallest number other than 0).

Table 2-1
M-NET transmission cable specifications

Cable	M-NET transmission cable
Type	Shielded cable CVVS, CPEVS
Number of cores	2-core cable
Cable diameter	1.25 mm ² (AWG 16)
Max. extension (Note 1)	200 m
Total extension (Note 2)	500 m
Terminal block	TB5 [A] [B]

(Note 1) Distance from the power supply unit to the furthest unit or system controller

(Note 2) Overall length of the cable between the units and the system controllers

Table 2-2
Remote controller transmission cable specifications

Cable	PZ-62DR series or PZ-43SMF-E transmission cable
Type	Sheathed cable
Number of cores	2-core cable
Cable diameter	0.3 mm ² (AWG 22)
Total extension	200 m
Terminal block	TM4 [1] [2]

Table 2-3 External input/output specifications

Function Name	Terminal or connector on the circuit board	Signal specifications	Materials Used	Total extension
External control input (volt-free contact) (Note 4)	TM2 [Y] [Z]	Level/pulse (Note 1)	Twisted lead 0.5 mm ² (AWG 20) to 1.5 mm ² (AWG 15)	500 m
External control input (12 V DC, 24 V DC) (Note 4)	TM2 [1] [2]	Level/pulse (Note 1)	Twisted lead 0.5 mm ² (AWG 20) to 1.5 mm ² (AWG 15)	(Note 2)
Mr. Slim indoor unit control signal	TM2 [1] [2]	Serial signal	Slim-Lossnay connection cable (Accessory parts) 0.5 mm ² (AWG 20) to 1.5 mm ² (AWG 15) sheathed PVC cable	50 m
Remote/local switching (Note 4)	CN32 [1] [3]	Level (Volt-free contact)	Remote ON/OFF adaptor (PAC-SE55RA-E or PAC-715AD)	10 m
Remote ON/OFF input (Note 4)	CN32 [1] [2]			
Fan speed 4 input (volt-free contact) (Note 3)	CN17 [1] [2]	Level (Volt-free contact)	Remote display adaptor (PAC-SA88HA-E or PAC-725AD)	
Fan speed 3 input (volt-free contact) (Note 3)	CN17 [1] [3]			
Fan speed 2 input (volt-free contact) (Note 3)	CN17 [1] [4]			
Fan speed 1 input (volt-free contact) (Note 3)	CN17 [1] [5]			
Bypass mode input (volt-free contact) (Note 3)	CN26 [1] [2]			
Fan speed switching input (0 to 10 V DC) (Note 3)	CN26 [4] [5]	Analog		

<Caution>

- In the group with the multiple Lossnay units, input the signals to the main Lossnay (with address number 1 or the smallest number other than 0).

(Note 1) The input signal must conform to the following specifications:

Level signal Volt-free contact, 12 V DC, 24 V DC

Pulse signal Volt-free contact, 12 V DC, 24 V DC, the duration of ON and OFF should be 200 msec. or more

In the case of relay contact input, use a relay having a contact rating of 15 V DC/0.1 A or higher and a minimum applicable load of 1 mA or less.

(Note 2) Check the specifications of the external device.

(Note 3) In the group with the multiple Lossnay units, make sure that:

- Connect the signal cables only to the main Lossnay unit when controlling the all Lossnay units together using the PZ-62DR series.
- Connect the signal cables to each Lossnay unit when controlling the Lossnay units individually without using the PZ-62DR series.
- The optional CO₂ sensor (PZ-70CSW-E, PZ-70CSD-E) cannot be used together.

(Note 4) In the group with the multiple Lossnay units, input the signal only to the main Lossnay unit (with address number 1 or the smallest number other than 0).

[3] Monitor output signal cable

No.	Check Item	Corrective action
1	Is the signal cable wired by multicore cable?	Wire the cable using a 2-core cable.
2	Are the signal cables and transmission cables wired in the same piping duct?	Wire the signal cables away from the transmission cables.
3	Is the power supply cable wired at least 5 cm away from signal cables?	Wire the power supply cable at least 5 cm away from the signal cables.
4	Is the signal cable connected to the designated terminal block? (See Table 3-1.)	Connect the signal cable to the designated terminal block.
5	Is the signal cable incorrectly wired, is there a faulty connection or are screws loose?	Connect the cable securely and correctly, and tighten the screws firmly.
6	Is the output capacity of the signal cable within rating? (See Table 3-1.)	Use the signal cable within rating.
7	Is the function selection for the external output signal set correctly?	Set the function selection switches (SW5-1 and 5-2) on the circuit board correctly, or set the function settings (No. 12 to 16) of the PZ-62DR series correctly.

Table 3-1 Monitor output specifications

Terminal block	TM3 [9] [10]
Function Name	Operation monitor (Factory default setting) (Note 1)
Signal specifications	Volt-free contact
Output rating	240 V AC, 1 A
	24 V DC, 1 A
Min. applicable load	220 V AC, 100 mA
	5 V DC, 100 mA

(Note 1) Output can be changed with function settings.

[4] Function setting



No.	Check Item	Corrective action
1	Is the main Lossnay (and its address setting) set correctly?	Check the address setting switches (SW11, SW12) on the circuit board. When controlling with external input signals without connecting to MELANS, set one of the units in the group as the main Lossnay (with address number 1 or the smallest number other than 0). Connect the signal cables to the main Lossnay unit.
2	Are the function selection switches on the circuit board set correctly to suit the required application?	Set the function selection switches (SW2, SW5) on the circuit board correctly.
3	Is the applicable model used as the Lossnay remote controller?	Use the PZ-62DR series. (The air conditioner remote controller including PAR-40MAA cannot be used.)
4	When the PZ-62DR series is used, are the function selections set correctly to suit the required application?	Set the function selections correctly. After setting the functions with the PZ-62DR series, operating the model selection switch (SW6) or address setting switches (SW11, SW12) on the control circuit board resets the settings to the initial settings.
5	For a function that can be set with both the PZ-62DR series and the function selection switches on the control circuit board, was the function set with the function selection switches after the function is set with the PZ-62DR series?	Set the function again with the PZ-62DR series. For the function that can be set with both the PZ-62DR series and the function selection switches, after the function was set with the PZ-62DR series, setting with the function selection switches is disabled.

[5] LED Indications on the circuit boards

No.	LED	Contents	Check Item	Corrective action
1	LED1 (green)	Lossnay unit error indicator	Blinking: Starting up, error occurred	In the case of an error, see Failure Mode 4.
			Lit: During delay operation	Lossnay operates after the delay time has passed.
			Unlit: Other than above	It is normal.
2	LED2 (red)	M-NET System error indicator	Blinking: Error occurred	See Failure Mode 4.
			Lit: No M-NET connection information	When not using M-NET, it is normal. When using M-NET, perform group registration with the system controller.
			Unlit: Other than above	It is normal.
3	LED3 (green)	Remote controller power supply indicator	Lit: Power is supplied to the remote controller (Main Lossnay).	The LED goes out when power is supplied to the remote controller from other Lossnay units in a group with multiple Lossnay units.
			Unlit: Power is not supplied to the remote controller (Sub Lossnay).	
4	LED4 (red)	Power supply indicator (control circuit board)	Check that this LED is lit.	The LED lights while power is supplied to the control circuit board. (Do not touch the circuit board when the LED is lit to avoid electric shock.)
5	LED5 (green)	CO ₂ sensor power supply indicator	Lit: Power is supplied to the CO ₂ sensor when PZ-70CSW-E or PZ-70CSD-E is connected.	If the LED is not lit when PZ-70CSW-E or PZ-70CSD-E is connected, set the function setting (No. 66: CO ₂ sensor or BMS setting) of the PZ-62DR series to "5: PZ-70CSW-E" or "7: PZ-70CSD-E".
			Unlit: Power is not supplied to the CO ₂ sensor. (PZ-70CSW-E or PZ-70CSD-E is not connected.)	
6	LED6 (red)	Power supply indicator (power circuit board)	Check that this LED is lit.	The LED lights while power is supplied to the power circuit board. (Do not touch the circuit board when the LED is lit to avoid electric shock.)

● Individual function check items

[6] If Lossnay does not work in the trial operation, or if Lossnay stops working during use, check the following items.

No.	Problem	Factor	Corrective action
1	The fan does not operate even though the trial operation switch (SW2-1) on the circuit board is turned ON.	The connectors between the fan motor and circuit board are disconnected.	Check the connector (CN9) for the fan motor 2 or 4 and the connector (CN10) for the fan motor 1 or 3 . *Before connecting or disconnecting the motor connectors (CN9, CN10), turn off the power supply isolator, and check that the all LEDs on the circuit board are not lit.
		The connectors between the control circuit board and power circuit board are disconnected.	Check the connector connections. Control circuit board: CN14, CN19, CN21 Power circuit board: CN114, CN119, CN121
		Fan motor failure	If the fan can be turned manually, replace the DC motor of the fan. Check the resistance between the motor leads. (See (6) Motor resistance table (page 41).) If the measured value is significantly different from the values specified in the table, replace the DC motor of the fan.
		When the leader-follower function is set, the switch settings for the leader and follower units are incorrect.	For the leader unit, set the function selection switch (SW5-4) to ON. For the follower units, set the function selection switch (SW5-5) to ON.
		Circuit board failure	If LEDs6 located between CN9 and CN10 on the power circuit boards are not lit, check power supply to TAB1 and TAB2. If no error is found with power supply, replace the power circuit board. If the problem persists, replace the DC motor of the fan.
		Power with the rated voltage is not supplied to the product.	Check the power supply voltage.
		The connector (CN3) is disconnected.	Check the connector connections. Power circuit board: CN3
2	Though the remote controller display indicates the fan is running, the fan stops by itself.	The Lossnay unit is operating in the protective mode (intermittent operation).	When the PZ-62DR series is used, it displays the icon “  ” that indicates the protective operation is in-progress. For details, see the Lossnay Operating/Installation Instructions or PZ-62DR series Instruction Book.
		The Lossnay unit is set to the delay operation.	When the PZ-62DR series is used, it displays the icon “  ” that indicates the delay operation is in-progress. LED1 (green) on the control circuit board lights. Lossnay operates in 30 minutes (or 15 minutes) after the interlocked air conditioner is operated to run. Check the function selection switch (SW2-3) on the circuit board or the function setting (No. 9) of the PZ-62DR series.
		The interlocked air conditioner (Mr. Slim indoor unit or City Multi indoor unit) is stopped due to defrosting.	The supply fan has been stopped to prevent cold air from blowing out. When the air conditioner starts operating, the fan operation is started automatically.

No.	Problem	Factor	Corrective action
2	Though the remote controller display indicates the fan is running, the fan stops by itself.	Wiring for the three-phase power supply is incorrect, or the power wires are disconnected. (Open phase)	Check the power wires for the three-phase power supply.
		Wiring for the reactors is disconnected.	Check the wiring for the reactors.
3	[When wall-mounted type CO ₂ sensor PZ-70CSW-E is used] The LED display lamps of the CO ₂ sensor do not light even though the trial operation switch (SW2-1) on the Lossnay circuit board is turned ON.	CO ₂ sensor setting is set incorrectly.	Check the setting. <ul style="list-style-type: none"> When the function setting (No. 66) of the PZ-62DR series is set to "0", the function selection switches (SW5-6 to SW5-8) on the Lossnay circuit board should be: SW5-6 ON, SW5-7 OFF, SW5-8 OFF When the function setting (No. 66) of the PZ-62DR series is set to other than "0", set it to "5".
		The connectors between the LED circuit board (of the CO ₂ sensor) and control circuit board (of the Lossnay unit) are disconnected.	Check the connector connections. LED circuit board: CN100 Control circuit board: CN34 For details about the CO ₂ sensor PZ-70CSW-E, see its Installation and Instruction Manual.
		The lead wires connecting the LED circuit board (of the CO ₂ sensor) and control circuit board (of the Lossnay unit) are broken.	Measure the voltage between the pins of connector (CN100) with the trial operation switch (SW2-1) ON. When the values shown below are detected, the lead wires are not broken. <ul style="list-style-type: none"> Between the pins 1 and 2 of CN100, voltage is applied in a cycle of 20-second 0 V and 10-second 12 V DC. Between the pins 1 and 3 of CN100, voltage is applied in a cycle of 20-second 0 V and 10-second 12 V DC. Between the pins 1 and 4 of CN100, voltage is applied in a cycle of 20-second 0 V and 10-second 12 V DC. When extending the CO ₂ sensor wiring cables, check that they are properly connected. For details about the CO ₂ sensor PZ-70CSW-E, see its Installation and Instruction Manual.
		LED circuit board failure	If the problem persists, replace the wall-mounted type CO ₂ sensor. For details about the CO ₂ sensor PZ-70CSW-E, see its Installation and Instruction Manual.
	When the leader-follower function is set, a CO ₂ sensor is connected to the follower unit.	Connect the CO ₂ sensor to the leader unit.	

No.	Problem	Factor	Corrective action
4	[When wall-mounted type CO ₂ sensor PZ-70CSW-E is used] CO ₂ concentration display of the PZ-62DR series does not change even though the number of persons in a room is changed.	Ventilation air volume by the Lossnay unit is large enough or too small against the change in the number of persons in a room.	In this case, CO ₂ concentration displayed value may be always low or high.
		The lead wires connecting the CO ₂ sensor circuit board and Lossnay control circuit board are broken.	If the lead wire to pin 3 of the connector on the CO ₂ sensor circuit board is broken, detected CO ₂ concentration value may be fixed. When extending the CO ₂ sensor wiring cables, check that they are properly connected. For details about the CO ₂ sensor PZ-70CSW-E, see its Installation and Instruction Manual.
		The lead wires connecting the LED circuit board (of the CO ₂ sensor) and control circuit board (of the Lossnay unit) are broken.	Check the connector connections. LED circuit board: CN100 Control circuit board: CN34 When extending the CO ₂ sensor wiring cables, check that they are properly connected. For details about the CO ₂ sensor PZ-70CSW-E, see its Installation and Instruction Manual.
5	The fan does not stop even though the remote controller is operated to stop operation.	The pre-heater or operation monitor with delay operation is set to be used.	If the pre-heater or operation monitor with delay operation is set to be used, the fan continues operating for three minutes after the stop operation. Check the function settings (No. 12 to 16) of the PZ-62DR series. (See the Lossnay Operating/Installation Instructions or PZ-62DR series Instruction Book.)
6	Even though the remote controller is operated to change the fan speed, the fan speed does not change.	The indoor negative pressure setting or the indoor positive pressure setting is set.	Check the function selection switches (SW2-4 and SW2-5) on the circuit board or the function settings (No. 6 and 7) of the PZ-62DR series. (See the Lossnay Operating/Installation Instructions or PZ-62DR series Instruction Book.)
		The external fan speed input is set. (CN17)	When the PZ-62DR series is used, it displays the icon "🌀". Check the fan speed switching input (CN17).
		The external fan speed input is set. (CN26)	When the PZ-62DR series is used, it displays the icon "🌀". Check the function selection switches (SW5-6, SW5-7, and SW5-8) on the circuit board or the function setting (No. 66) of the PZ-62DR series. (See the Lossnay Operating/Installation Instructions or PZ-62DR series Instruction Book.)
		The system is operating in the protective mode (intermittent operation).	When the PZ-62DR series is used, it displays the icon "🛑" that indicates the protective operation is in-progress. For details, see the Lossnay Operating/Installation Instructions or PZ-62DR series Instruction Book.
		Airflow setting is performed with the PZ-62DR series.	Check the "Airflow" screen or the function settings (No. 73 to 78, 87, and 88) of the PZ-62DR series. (See the Lossnay Operating/Installation Instructions or PZ-62DR series Instruction Book.)
7	The fan operation is unstable.	The motor rotation speed is under control.	This product controls the motor by detecting the motor rotation speed. The fan operation may be unstable during rotation speed control (for maximum about 10 minutes).

No.	Problem	Factor	Corrective action
8	Air volume is abnormally large or small.	The model selection switch (SW6) is not set correctly after the circuit board is replaced.	Make the SW6 setting appropriate for the model. (See Chapter 8. (14) Setting status record (page 54).)
9	Even though the remote controller is operated to change the ventilation mode, the ventilation mode is not changed.	The outdoor temperature is 8°C or lower.	When the outdoor temperature is 8°C or lower, the ventilation mode is fixed to the Energy recovery operation (Lossnay mode).
		The signal is input to the Bypass mode switching input (CN26 [1] [2]).	Check the Bypass mode switching input (CN26 [1] [2]). (See the Lossnay Operating/Installation Instructions or PZ-62DR series Instruction Book.)
		The Lossnay unit is performing the Night-purge operation.	When the PZ-62DR series is used, the ventilation mode cannot be changed during the Night-purge operation. (See the Lossnay Operating/Installation Instructions or PZ-62DR series Instruction Book.)
		The pre-heater is ON, or within one hour after the pre-heater is turned OFF.	When the pre-heater is ON, or for one hour after the pre-heater is turned OFF, the ventilation mode is fixed to the Energy recovery operation (Lossnay mode).
10	The ventilation mode cannot be switched when Lossnay is operating in the automatic mode.	Temperature condition for Lossnay mode or Bypass mode is not satisfied.	Check the temperature map. For details, see the Lossnay Operating/Installation Instructions or PZ-62DR series Instruction Book.
		It has not passed 30 minutes since the ventilation mode is switched.	Switching of the ventilation mode is controlled in 30 minutes cycle.
		The outdoor temperature is 8°C or lower.	When the outdoor temperature is 8°C or lower, the ventilation mode is fixed to the Energy recovery operation (Lossnay mode).
		The signal is input to the Bypass mode switching input (CN26 [1] [2]).	Check the Bypass mode switching input (CN26 [1] [2]). (See the Lossnay Operating/Installation Instructions or PZ-62DR series Instruction Book.)
		The operation mode of the interlocked air conditioner (Mr. Slim indoor unit or City Multi indoor unit) is set to fan operation or heating.	If the operation mode of the interlocked air conditioner is fan operation or heating, the ventilation mode of Lossnay is fixed to the Energy recovery operation (Lossnay mode).
		The pre-heater is ON, or within one hour after the pre-heater is turned OFF.	When the pre-heater is ON, or for one hour after the pre-heater is turned OFF, the ventilation mode is fixed to the Energy recovery operation (Lossnay mode).
		Lossnay is operating at the air flow of 75% or more.	When the air flow is 75% or more, the ventilation mode is fixed to the Energy recovery operation (Lossnay mode).

No.	Problem	Factor	Corrective action
11	Air volume is too small.	Is the air filter clogged?	Clean the air filter.
		Pressure loss in the duct is too high.	Set the supply/exhaust fan power up setting. (See the Lossnay Operating/Installation Instructions or PZ-62DR series Instruction Book.)
		The model selection switch (SW6) is not set correctly after the circuit board is replaced.	Make the SW6 setting appropriate for the model. (See Chapter 8. (14) Setting status record (page 54).)
		The indoor negative pressure setting or the indoor positive pressure setting is set.	Check the function selection switches (SW2-4 and SW2-5) on the circuit board or the function settings (No. 6 and 7) of the PZ-62DR series. (See the Lossnay Operating/Installation Instructions or PZ-62DR series Instruction Book.)
		Power supply voltage is low.	Check the power supply voltage.
		In interlock with the air conditioner, the outdoor air intake port of the Lossnay unit is connected with the air conditioner by using a duct.	In this case, even if the Lossnay remote controller is operated to start Lossnay while the air conditioner is stopped, Lossnay will not supply air.
		Airflow setting is performed with the PZ-62DR series.	Check the "Airflow" screen or the function settings (No. 73 to 78, 87, and 88) of the PZ-62DR series. (See the Lossnay Operating/Installation Instructions or PZ-62DR series Instruction Book.)
		When the constant pressure control is used, Lossnay is not operating properly.	Check the pressure sensors and their wiring.
12	Air volume is too large.	Function setting (No. 35) of the PZ-62DR series "Maximum air flow setting in bypass operation" is set to 1: 50% or less.	In bypass operation, the maximum air flow is limited to 50%.
		When the constant pressure control is used, Lossnay is not operating properly.	Check the pressure sensors and their wiring.
13	Actual fan speed of the Lossnay unit differs from the fan speed set with the remote controller.	The signal is input to the fan speed input (CN17).	Check the fan speed input (CN17). (See the Lossnay Operating/Installation Instructions or PZ-62DR series Instruction Book.)
		The signal (0 to 10 V DC) is input to the fan speed switching input (CN26 [4] [5]).	Check the fan speed switching input (CN26 [4] [5]). (See the Lossnay Operating/Installation Instructions or PZ-62DR series Instruction Book.)
		Function setting (No. 8) of the PZ-62DR series "Max. fan speed setting during the first 30 minutes" is enabled.	Lossnay operates at maximum fan speed for 30 minutes when operation starts. While this function is working, the icon "🌀" and selected fan speed are displayed on the screen of the PZ-62DR series. (See the Lossnay Operating/Installation Instructions or PZ-62DR series Instruction Book.)
		The indoor negative pressure setting or the indoor positive pressure setting is set.	Check the function selection switches (SW2-4 and SW2-5) on the circuit board or the function settings (No. 6 and 7) of the PZ-62DR series. (See the Lossnay Operating/Installation Instructions or PZ-62DR series Instruction Book.)
14	The Night-purge operation cannot be stopped with the PZ-62DR series.	Usual ON/OFF button operation cannot stop the Night-purge operation.	Press the ON/OFF button once to display the operation screen, and then press the ON/OFF button again.

No.	Problem	Factor	Corrective action
15	Even though the Night-purge is set, Lossnay does not perform the Night-purge operation.	Conditions of the Night-purge are not satisfied.	When the Night-purge conditions such as the indoor/outdoor temperature are not satisfied, Lossnay does not perform the Night-purge operation. For details, see the Lossnay Operating/Installation Instructions or PZ-62DR series Instruction Book.
		The Night-purge schedule is not set.	Check the setting of the PZ-62DR series or the system controller that supports Night-purge operation. For details, see the Lossnay Operating/Installation Instructions or PZ-62DR series Instruction Book.
16	The Night-purge operation stops in halfway through.	The operating condition became outside the Night-purge conditions.	When the operating condition becomes outside the Night-purge conditions, the Night-purge operation ends. For details, see the Lossnay Operating/Installation Instructions or PZ-62DR series Instruction Book.
		The Lossnay remote controller or the system controller was operated to start or stop the operation of the Lossnay unit.	When the start or stop operation is performed during the Night-purge operation, the Night-purge operation ends.
		A controller other than the PZ-62DR series or a controller that is not supporting Night-purge is operated to change the ventilation mode.	When a controller other than those supporting Night-purge is operated to change the ventilation mode, the system performs the normal ventilating operation. (See the Lossnay Operating/Installation Instructions or PZ-62DR series Instruction Book.)
17	Air volume is small during Night-purge operation.	The maximum air flow during Night-purge operation is approx. 70%.	This is not a malfunction.
18	The Lossnay unit does not operate with the MELCloud application. (When the Wi-Fi interface is used)	The connection cable for the Wi-Fi interface is too close to the power supply cable or the other communication cables.	Wire the connection cable for the Wi-Fi interface at least 5 cm away from the power supply cable or the other communication cables.
		The system configuration is not appropriate.	Refer to the notes for the system configuration, for example, on leaflets supplied with the Lossnay unit.
		If the above does not solve the problem	Refer to the Wi-Fi interface manuals.
19	When the supply fan is stopped, the exhaust fan operates at the higher fan speed than the fan speed set with the remote controller.	The Lossnay unit is operating in the protective mode (intermittent operation). (Outdoor temperature is -5°C or lower.)	During the intermittent operation, the exhaust fan operates at fan speed 4.

(2) Failure mode 2: The remote controller does not work.

If the remote controller does not work, check the following items.

[1] PZ-62DR series

No.	Problem	Factor	Corrective action
1	Nothing is displayed on the remote controller. The ON/OFF lamp does not blink.	The power of the Lossnay unit is not ON.	Check the items described in (1) [1].
		Faulty connection of the remote controller transmission cable	Check the items described in (1) [2].
		In one group, three or more PZ-62DR series controllers are connected.	Only up to two PZ-62DR series controllers can be connected in one group.
		In one group, 16 or more Lossnay units are connected.	Only up to 15 Lossnay units can be connected in one group.
		The wiring length of the remote controller exceeds 200 m.	The wiring length of the remote controller shall be within 200 m.
		In one group, two or more Lossnay units are set as the main Lossnay (with address number 1 or the smallest number other than 0).	Only one Lossnay unit can be set as the main Lossnay in one group.
		When the leader-follower function is set, all the Lossnay units are set as follower units.	For the leader unit, set the function selection switch (SW5-4) to ON. For the follower units, set the function selection switch (SW5-5) to ON.
2	The remote controller continues to display "Please Wait". Error code "6831" is displayed.	The remote controller is starting up.	The remote controller displays "Please Wait" during start-up for maximum three minutes.
		Faulty connection of the remote controller transmission cable	Check the items described in (1) [2].
		The remote controller transmission cable is connected to the terminal block (TB5 [A] [B]) for the M-NET transmission cable.	Connect the remote controller transmission cable to the terminal block (TM4 [1] [2]).
		PZ-43SMF-E is used together.	The PZ-62DR series and PZ-43SMF-E cannot be used together.
		The old model remote controller (PZ-61DR-E) is connected.	Use the PZ-62DR series remote controller.
3	It takes time for the remote controller to be fed with power after turning the Lossnay unit ON.	The Lossnay unit is starting up.	The remote controller is not fed with power during start-up of the Lossnay unit for maximum one minute.

[2] PZ-43SMF-E

No.	Problem	Factor	Corrective action
1	The power indicator “●” is not displayed.	The power of the Lossnay unit is not ON.	Check the items described in (1) [1].
		Faulty connection of the remote controller transmission cable	Check the items described in (1) [2].
		In one group, three or more PZ-43SMF-E controllers are connected.	Only up to two PZ-43SMF-E controllers can be connected in one group.
		In one group, 16 or more Lossnay units are connected.	Only up to 15 Lossnay units can be connected in one group.
		The wiring length of the remote controller exceeds 200 m.	The wiring length of the remote controller shall be within 200 m.
		In one group, two or more Lossnay units are set as the main Lossnay (with address number 1 or the smallest number other than 0).	Only one Lossnay unit can be set as the main Lossnay in one group. (See the Lossnay Operating/Installation Instructions or PZ-62DR series Instruction Book.)
2	“H0” is displayed on the remote controller.	The remote controller is starting up.	The remote controller displays “H0” during start-up for a maximum of one minute.
3	It takes time for the remote controller to be fed with power after turning the Lossnay unit ON.	The Lossnay unit is starting up.	The remote controller is not fed with power during start-up of the Lossnay unit for a maximum of one minute.
4	The inspection number “6801” is displayed on the remote controller.	Faulty connection of the remote controller transmission cable	Check the items described in (1) [2].
		The remote controller transmission cable is connected to the terminal block (TB5 [A] [B]) for the M-NET transmission cable.	Connect the remote controller transmission cable to the terminal block (TM4 [1] [2]).
		The PZ-62DR series is used together.	PZ-43SMF-E and the PZ-62DR series cannot be used together.
5	Operations with the remote controller are not possible.	The function selection switch (SW5-9) on the circuit board is set to ON.	When PZ-43SMF-E is used, set the function selection switch (SW5-9) to OFF.
6	When the leader-follower function is set, Lossnay units are not operating properly.	When the leader-follower function is set, PZ-43SMF-E cannot be used.	Replace the remote controller with the PZ-62DR series.

(3) Failure mode 3: Operations on the remote controller are not possible.

● Initial Check Items

If the system cannot be operated with the remote controller, check the following items.

No.	Check item	Notes
1	Are the function selection switches (SW2, SW5) and model selection switch (SW6) on the Lossnay circuit board set correctly to suit the required application?	Depending on the settings of the function selection switches, Lossnay may automatically operate or stop, or specific operation may be unable to be performed with the remote controller.
2	When the PZ-62DR series is used, are the function selections set correctly to suit the required application?	Depending on the settings of the function selections, Lossnay may automatically operate or stop, or specific operation may be unable to be performed with the remote controller.
3	When the PZ-62DR series is used, are icons and characters displayed on the PZ-62DR series screen?	Based on the icon and characters, you can check statuses such as the timer operation, Night-purge, and protective operation. (See the Lossnay Operating/Installation Instructions or PZ-62DR series Instruction Book.)
4	Is the system controller of M-NET used?	The system controller can be used to start/stop Lossnay, change fan speed or ventilation mode, and prohibit the start/stop operation by the PZ-62DR series.
5	Is the external input used?	<p>If the interlock mode is set to "External input given priority" (function setting (No. 19) is set to "3") and if the external device is operating, the stop operation by the PZ-62DR series is prohibited. (See the Lossnay Operating/Installation Instructions or PZ-62DR series Instruction Book.)</p> <p>If the Remote/Local switching (CN32) is set to remote, the start/stop operation by the Lossnay remote controller is prohibited. (See the Lossnay Operating/Installation Instructions or PZ-62DR series Instruction Book.)</p> <p>Priority is given to the operation by the fan speed switching input and Bypass mode switching input. (CN17, CN26) (See the Lossnay Operating/Installation Instructions or PZ-62DR series Instruction Book.)</p>
6	Is the Wi-Fi interface connected?	When the Lossnay unit is operated with the MELCloud application, the Lossnay unit operates according to the latter signal.

● **Individual check items**

If the system cannot be started/stopped using the remote controller, check the following items.

[1] PZ-62DR series

No.	Problem	Factor	Corrective action
1	Some Lossnay units in the group do not operate.	The power of the Lossnay unit is not ON.	Check the items described in (1) [1].
		Faulty connection of the remote controller transmission cable	Check the items described in (1) [2].
		The remote controller transmission cables are not correctly connected between the terminals (TM4 [1] [2]) of the Lossnay units in the group.	Connect the remote controller transmission cables correctly between the terminals (TM4 [1] [2]) of the Lossnay units in the group.
		The system is operating in the protective mode (intermittent operation).	For details, see the Lossnay Operating/Installation Instructions or PZ-62DR series Instruction Book.
2	The screen display of the remote controller changes by itself. Even if you press the buttons, the screen returns to the original screen right away.	Faulty connection of the remote controller transmission cable	Check the items described in (1) [2].
		The group wiring and the group setting of the system controller do not match.	Check the group wiring or the group setting of the system controller.
		When the system controller is used, the Lossnay unit, which is set as the main Lossnay, is not set to the address with the smallest number in the group, or the address is duplicated.	Lossnay unit with the smallest address number in the group will be set as the main Lossnay automatically. Do not assign the same address number to the other Lossnay units.
3	The ventilation mode cannot be changed with the remote controller.	The Lossnay unit is performing the Night-purge operation.	The ventilation mode cannot be changed during the Night-purge operation. (See the Lossnay Operating/Installation Instructions or PZ-62DR series Instruction Book.)
		The signal is input to the Bypass mode switching input (CN26 [1] [2]).	Check the Bypass mode switching input (CN26 [1] [2]). (See the Lossnay Operating/Installation Instructions or PZ-62DR series Instruction Book.)
4	Even though the function settings (No. 37 and/or 39) of the PZ-62DR series are set to "1", the indoor temperature and/or supply air temperature are not displayed.	The Lossnay unit is performing the Bypass mode ventilation.	The indoor temperature and/or supply air temperature are not displayed during the Bypass mode. In addition, this function is available only when "Sensor value" is set to "Yes" (Display) by the remote controller PZ-62DR series.
5	Even though the function settings (No. 36, 37 and/or 39) of the PZ-62DR series are set to "1", the outdoor temperature, indoor temperature and/or supply air temperature are not displayed.	The setting of the PZ-62DR series is not correct.	Select "Yes" at "Sensor value" menu of the PZ-62DR series. For details, see the Installation Manual of the PZ-62DR series.

No.	Problem	Factor	Corrective action
6	Even though the function settings (No. 36, 37 and/or 39) of the PZ-62DR series are set to "1", "LO" or "HI" is displayed on the remote controller.	The indoor, outdoor, and/or supply air temperature are outside the display range.	<ul style="list-style-type: none"> • Outdoor temperature display range: 2°C to 36°C • Indoor temperature display range: 9°C to 37°C • Calculated supply air temperature display range: 9°C to 37°C If the temperature exceeds the display range, "HI" will be displayed, and if less than the display range, "LO" will be displayed.
7	CO ₂ concentration is not displayed on the PZ-62DR series.	With the function setting No. 38, CO ₂ concentration indication setting is set to "0: N/A".	Set the function setting No. 38 to "1: Available on the screen of the PZ-62DR series". (See the PZ-62DR series Installation manual and the Lossnay Installation Instructions.)
		The detected CO ₂ concentration is outside the display range.	Detectable CO ₂ concentration range: 300 to 2000 ppm If the concentration exceeds 2000 ppm, "2000" will be displayed, and if less than 400 ppm, "LO" will be displayed.
		The CO ₂ sensor is in warm-up operation. (For 15 minutes after power is supplied to the CO ₂ sensor)	The PZ-62DR series does not display CO ₂ concentration while the CO ₂ sensor is in warm-up operation. (It displays "--- ppm" during warm-up operation.)

[2] Interlocking with air conditioners (Mr. Slim indoor unit or City Multi indoor unit) or external devices

No.	Problem	Factor	Corrective action
1	Lossnay interlock settings cannot be performed with the remote controller.	The power of the Lossnay unit is not ON.	Check the items described in (1) [1].
		Faulty connection of the remote controller transmission cable	Check the items described in (1) [2].
		Lossnay address setting is incorrect.	Check the Lossnay address.
2	Lossnay does not perform interlock operation.	The power of the Lossnay unit is not ON.	Check the items described in (1) [1].
		Faulty connection of the remote controller transmission cable or external input/output signal cables	Check the items described in (1) [2].
		The Lossnay unit is not set for interlock operation.	Set the interlock setting.
		The terminal block connected and the type of external signal do not match (charged or volt-free).	Check the type of external signal and the connections of the external control input terminal (TM2).
		The type of external signal and input setting do not match (level signal or pulse signal).	Check the type of external signal and the setting of the input (level or pulse). (See the Lossnay Operating/Installation Instructions or PZ-62DR series Instruction Book.)
		The Lossnay unit is set to the delay operation.	When the PZ-62DR series is used, it displays the icon “  ” that indicates the delay operation is in-progress. LED1 (green) on the control circuit board lights. The Lossnay unit starts operation in 30 minutes (or 15 minutes) after starting operation by the air conditioner or external signal. Check the function selection switch (SW2-3) on the circuit board or the function setting (No. 9) of the PZ-62DR series. (See the Lossnay Operating/Installation Instructions or PZ-62DR series Instruction Book.)
		The interlock mode of the Lossnay unit is set to “ON Interlock” or “OFF Interlock”.	Check the interlock mode setting. (See the Lossnay Operating/Installation Instructions or PZ-62DR series Instruction Book.)
		In a group with multiple Lossnay units, no Lossnay unit is set to the main Lossnay.	When externally controlling multiple Lossnay units without using M-NET (and address setting), set one Lossnay unit as the main Lossnay to input external control signal. (Set its address to the smallest number in the group, or set it to 1 and then set the other units address to 0.)
		In a group with multiple Lossnay units, external control signal is input to a Lossnay unit other than the main Lossnay.	
The Lossnay unit is operating in the protective mode (intermittent operation).	For details, see the Lossnay Operating/Installation Instructions or PZ-62DR series Instruction Book.		

[3] System controller

No.	Problem	Factor	Corrective action
1	The group of Lossnay cannot be set with the system controller.	The power of the Lossnay unit is not ON.	Check the items described in (1) [1].
		M-NET transmission cable is connected to the remote controller terminal block (TM4 [1] [2]).	Connect the M-NET transmission cable to the M-NET transmission cable terminal block (TB5 [A] [B]).
		Lossnay address setting is incorrect.	Check the address setting switches (SW11 and SW12) on the Lossnay circuit board.
		Power is not supplied to the M-NET transmission cable.	If the system is configured with only Lossnay units, connect the power supply unit. (See the Lossnay Operating/Installation Instructions or PZ-62DR series Instruction Book.)
		The wiring length of the M-NET transmission cable is longer than specified. (Longer than 200 m from the power supply unit, or longer than 500 m in total length)	Check the wiring length of the transmission cable. (See the Lossnay Operating/Installation Instructions or PZ-62DR series Instruction Book.)
2	Some Lossnay units in the group do not operate.	The power of the Lossnay unit is not ON.	Check the items described in (1) [1].
		Faulty connection of the M-NET transmission cable	Check the items described in (1) [2].
		The remote controller transmission cables are not correctly connected between the terminals (TM4 [1] [2]) of the Lossnay units in the group.	Connect the remote controller transmission cables correctly between the terminals (TM4 [1] [2]) of the Lossnay units in the group.
		The Lossnay unit is operating in the protective mode (intermittent operation).	For details, see the Lossnay Operating/Installation Instructions or PZ-62DR series Instruction Book.
3	The screen display of the system controller changes by itself. Even if you press the buttons, the screen returns to the original screen right away.	Faulty connection of the remote controller transmission cable	Check the items described in (1) [2].
		When the PZ-62DR series is used, the group wiring and the group setting of the system controller do not match.	Check the group wiring or the group setting of the system controller.
		The address of the Lossnay unit, which is set as the main Lossnay, is not set to the smallest number in the group.	Lossnay unit with the smallest address number in the group will be set as the main Lossnay automatically. Do not assign the same address number to the other Lossnay units.
4	The addresses of the follower units cannot be registered with the system controller when using the leader-follower function.	The follower units cannot be connected to M-NET.	Do not select the addresses of the follower units on the system controller screen.

[4] When the Wi-Fi interface is connected to the Lossnay unit

No.	Problem	Factor	Corrective action
1	The Lossnay unit does not operate with the MELCloud application. (When the Wi-Fi interface is used)	The connection cable for the Wi-Fi interface is too close to the power supply cable or the other communication cables.	Wire the connection cable for the Wi-Fi interface at least 5 cm away from the power supply cable or the other communication cables.
		The system configuration is not appropriate.	Refer to the notes for the system configuration, for example, on leaflets supplied with the Lossnay unit.
		If the above does not solve the problem	Refer to the Wi-Fi interface manuals.

(4) Failure mode 4: Error code and LED display

An error code displayed on the remote controller (PZ-62DR series, PZ-43SMF-E) or the M-NET controller, and blinking or illumination of LED1 (green) or LED2 (red) on the circuit board show the type of an error.

The LED blink interval is 0.25 seconds for both on and off. The display duration is approximately 7 seconds.

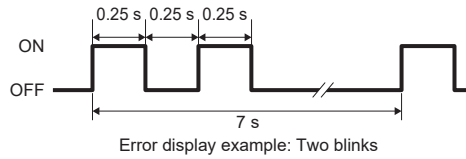

Notes:

When the leader-follower function is set, multiple Lossnay units are recognized as a single system. Therefore, the system controller displays the error code using the leader unit's address. (If an error occurs in a follower unit, the PZ-62DR series displays the M-NET address of the faulty unit as '---' (no address).)

The procedure to identify the malfunctioning unit is as follows:

1. Check the address of the malfunctioning system on the system controller.
2. Check the address of the malfunctioning unit on the PZ-62DR series to identify the leader unit or follower unit.
3. If the malfunctioning unit is a follower unit, check LED1 on each follower unit's control circuit board.

Error display list

Error Code	LED1 (green)	LED2 (red)	Symptom	Cause	Corrective action
0900	—	—	Trial operation	The trial operation switch (SW2-1) on the circuit board is set to "ON".	Check the trial operation switch. (See the Lossnay Operating/ Installation Instructions or PZ-62DR series Instruction Book.)
3126	8 blinks	—	External device error	When the terminals (TM3 [9] [10]) or Lossnay signal output terminal PZ-4GS-E are set for pre-heater output (the function setting No. 12 of the PZ-62DR series is set to "6", and No. 13 to 16 are set to "5"), the following conditions were satisfied. <ul style="list-style-type: none"> • Outdoor air temperature detected by OA thermistor stays at 70°C or higher for one minute. • Outdoor air temperature detected by OA thermistor exceeds 15°C within 15 minutes after the pre-heater output starts. • Outdoor air temperature is still -20°C or lower 5 minutes after the pre-heater output starts. Causes of the above phenomena are described below.	See below.
				The pre-heater is connected to the wrong terminal.	Connect the pre-heater to the terminals (TM3 [9] [10]). (See the Lossnay Operating/ Installation Instructions or PZ-62DR series Instruction Book.)
				Faulty connection of the pre-heater	Check the pre-heater connections.
				The output capacity of the pre-heater is too large with respect to the air volume of the Lossnay unit.	Adjust the output capacity of the pre-heater. When the pre-heater is used, run the Lossnay at a higher fan speed.

Error Code	LED1 (green)	LED2 (red)	Symptom	Cause	Corrective action
3126	8 blinks	—	External device error	The output capacity of the pre-heater is too small with respect to the air volume of the Lossnay unit.	Adjust the output capacity of the pre-heater. When the pre-heater is used, run the Lossnay at a lower fan speed.
				Pre-heater failure	Replace the pre-heater.
				Pre-heater relay failure	Replace the relay for the pre-heater.
				Circuit board failure	First, replace the control circuit board. If the problem persists, then replace both power circuit boards.
4101	11 blinks	—	Overcurrent error of the remote controller terminal	Shorting between the remote controller terminals	Check the remote controller wiring.
				The group contains two or more Lossnay units with the same address.	Set unique addresses to these units.
				M-NET transmission cable is connected to the remote controller terminal block (TM4 [1] [2]).	Connect the M-NET transmission cable to the M-NET transmission cable terminal block (TB5 [A] [B]).
				Three or more remote controllers are connected.	Up to two remote controllers can be connected.
				Circuit board failure	Replace the control circuit board.
				Remote controller failure	Replace the remote controller.
4116	1 blink	—	Abnormal rotation of the fan motor 1 (Centrifugal fan does not work, insufficient motor speed, excessive motor speed, or rotation detected when operation is stopped)	Faulty connection of the supply fan motor connector (CN10) on the power circuit board	Check the connector (CN10) connection on the power circuit board. (Lower side: LG-X08DC-P8)
				Faulty connection of the connectors (CN19–CN119) between the control circuit board and power circuit board (Upper side) (CN21–CN121) between the control circuit board and power circuit board (Lower side)	Check the connector connections (CN19–CN119) and (CN21–CN121).
				The model selection switch (SW6) is not set correctly.	Make the SW6 setting appropriate for the model. (See Chapter 8. (14) Setting status record (page 54).)
				The temperature around the product is high.	Use the product at a temperature of 40°C or lower.
				The motor and centrifugal fan are not fixed securely.	Check the installation state of the motor and centrifugal fan, and fix them securely.
				Deformed centrifugal fan	Replace the centrifugal fan.
				Foreign objects around the centrifugal fan	Check the air course and around the centrifugal fan, and remove any foreign matter.
				Fan motor failure	Replace the DC motor. (See page 18.)
				Circuit board failure	Replace the power circuit board. (Lower side: LG-X08DC-P8)
				When operation is stopped, the fan rotates due to outside wind.	Prevent the outside wind from intruding.

Error Code	LED1 (green)	LED2 (red)	Symptom	Cause	Corrective action
4116	2 blinks	—	Abnormal rotation of the fan motor 2 (Centrifugal fan does not work, insufficient motor speed, excessive motor speed, or rotation detected when operation is stopped)	Faulty connection of the exhaust fan motor connector (CN9) on the power circuit board	Check the connector (CN9) connection on the power circuit board. (Lower side: LG-X08DC-P8)
				Faulty connection of the connectors (CN19–CN119) between the control circuit board and power circuit board (Upper side) (CN21–CN121) between the control circuit board and power circuit board (Lower side)	Check the connector connections (CN19–CN119) and (CN21–CN121).
				The model selection switch (SW6) is not set correctly.	Make the SW6 setting appropriate for the model. (See Chapter 8. (14) Setting status record (page 54).)
				The temperature around the product is high.	Use the product at a temperature of 40°C or lower.
				The motor and centrifugal fan are not fixed securely.	Check the installation state of the motor and centrifugal fan, and fix them securely.
				Deformed centrifugal fan	Replace the centrifugal fan.
				Foreign objects around the centrifugal fan	Check the air course and around the centrifugal fan, and remove any foreign matter.
				Fan motor failure	Replace the DC motor. (See page 18.)
				Circuit board failure	Replace the power circuit board. (Lower side: LG-X08DC-P8)
			When operation is stopped, the fan rotates due to outside wind.	Prevent the outside wind from intruding.	

Error Code	LED1 (green)	LED2 (red)	Symptom	Cause	Corrective action
4116	6 blinks	—	Abnormal rotation of the fan motor 3 (Centrifugal fan does not work, insufficient motor speed, excessive motor speed, or rotation detected when operation is stopped)	Faulty connection of the supply fan motor connector (CN10) on the power circuit board	Check the connector (CN10) connection on the power circuit board. (Upper side: LG-X08DC-P7)
				Faulty connection of the connectors (CN19–CN119) between the control circuit board and power circuit board (Upper side) (CN21–CN121) between the control circuit board and power circuit board (Lower side)	Check the connector connections (CN19–CN119) and (CN21–CN121).
				The model selection switch (SW6) is not set correctly.	Make the SW6 setting appropriate for the model. (See Chapter 8. (14) Setting status record (page 54).)
				The temperature around the product is high.	Use the product at a temperature of 40°C or lower.
				The motor and centrifugal fan are not fixed securely.	Check the installation state of the motor and centrifugal fan, and fix them securely.
				Deformed centrifugal fan	Replace the centrifugal fan.
				Foreign objects around the centrifugal fan	Check the air course and around the centrifugal fan, and remove any foreign matter.
				Fan motor failure	Replace the DC motor. (See page 18.)
				Circuit board failure	Replace the power circuit board. (Upper side: LG-X08DC-P7)
			When operation is stopped, the fan rotates due to outside wind.	Prevent the outside wind from intruding.	

Error Code	LED1 (green)	LED2 (red)	Symptom	Cause	Corrective action
4116	7 blinks	—	Abnormal rotation of the fan motor 4 (Centrifugal fan does not work, insufficient motor speed, excessive motor speed, or rotation detected when operation is stopped)	Faulty connection of the exhaust fan motor connector (CN9) on the power circuit board	Check the connector (CN9) connection on the power circuit board. (Upper side: LG-X08DC-P7)
				Faulty connection of the connectors (CN19–CN119) between the control circuit board and power circuit board (Upper side) (CN21–CN121) between the control circuit board and power circuit board (Lower side)	Check the connector connections (CN19–CN119) and (CN21–CN121).
				The model selection switch (SW6) is not set correctly.	Make the SW6 setting appropriate for the model. (See Chapter 8. (14) Setting status record (page 54).)
				The temperature around the product is high.	Use the product at a temperature of 40°C or lower.
				The motor and centrifugal fan are not fixed securely.	Check the installation state of the motor and centrifugal fan, and fix them securely.
				Deformed centrifugal fan	Replace the centrifugal fan.
				Foreign objects around the centrifugal fan	Check the air course and around the centrifugal fan, and remove any foreign matter.
				Fan motor failure	Replace the DC motor. (See page 18.)
				Circuit board failure	Replace the power circuit board. (Upper side: LG-X08DC-P7)
5101	4 blinks	—	Outdoor air (OA) thermistor related error	Faulty connection of the thermistor connector on the control circuit board	Check the connector connection. • If the function selection switch (SW2-10) is ON, check the connector (CN5). • If the function selection switch (SW2-10) is OFF, check the connector (CN7).
				Thermistor failure	Disconnect the above connector, and check the resistance of the thermistor. If the equivalent thermistor resistance differs greatly from the ambient temperatures, replace the thermistor. (See (5) Temperatures and thermistor resistance table (page 41).)

Error Code	LED1 (green)	LED2 (red)	Symptom	Cause	Corrective action
5102	5 blinks	—	Return air (RA) thermistor related error	Faulty connection of the thermistor connector on the control circuit board	Check the connector connection. <ul style="list-style-type: none"> • If the function selection switch (SW2-10) is ON, check the connector (CN5). • If the function selection switch (SW2-10) is OFF, check the connector (CN7).
				Thermistor failure	Disconnect the above connector, and check the resistance of the thermistor. If the equivalent thermistor resistance differs greatly from the ambient temperatures, replace the thermistor. (See (5) Temperatures and thermistor resistance table (page 41).)
5501	12 blinks	—	CO ₂ sensor error (Optional components: PZ-70CSW-E, PZ-70CSD-E)	The connectors for the CO ₂ sensor are disconnected.	Check the connector connections (CN34 (only for PZ-70CSW-E), CN23, CN26, and CN35) on the control circuit board.
				CO ₂ sensor failure	Check the CO ₂ sensor wiring according to the PZ-70CSW-E/ PZ-70CSD-E Installation and Instruction Manual. If the problem persists even after correcting the wiring, replace the CO ₂ sensor.
				Even though the CO ₂ sensor is not connected, CO ₂ sensor setting (the function selection switches (SW5-6 to SW5-8) on the circuit board or the function setting (No. 66) of the PZ-62DR series) is set as shown below. <ul style="list-style-type: none"> • “The PZ-70CSW-E connected” (SW5-6: ON, SW5-7 and SW5-8: OFF, or No.66: 5) • “PZ-70CSD-E connected” (SW5-6 and SW5-7: ON, SW5-8: OFF, or No.66: 7) 	When the CO ₂ sensor is not connected, set the function selection switches (SW5-6 to SW5-8) on the circuit board to OFF, or the function setting (No. 66) of the PZ-62DR series to “1: No external fan speed control input”.
6201	—	—	PZ-62DR series circuit board failure	Remote controller failure	Replace the PZ-62DR series remote controller.
6202	—	—	PZ-62DR series circuit board failure	Clock function of the remote controller is not working properly.	Replace the PZ-62DR series remote controller.
6600	—	6 blinks	Multiple address error	The system contains two or more units (*1) with the same address in the same M-NET transmission cable line.	Find the units (*1) with the same address, and set unique addresses to these units.

(*1) This refers to devices assigned an address number in MELANS such as the Lossnay unit, City Multi indoor unit, City Multi outdoor unit, or system controller.

Error Code	LED1 (green)	LED2 (red)	Symptom	Cause	Corrective action
6602	—	2 blinks	Transmission error (transmission processor hardware error)	Faulty connection of the M-NET transmission cable	Check the items described in (1) [2].
				<ul style="list-style-type: none"> • Wiring was performed with power still supplied to the M-NET transmission cable. • Accidental communication error 	Restart the system after completing wiring. If the error re-occurs, check for noise on the transmission cable. If the above does not correct the problem, replace the Lossnay control circuit board.
				Power is supplied to the same transmission cable from two or more power supply units. The power supply unit is connected to the TB3 terminal of the transmission booster.	Check the wiring of the power supply unit and the transmission booster.
				The PZ-62DR series is connected to the terminals (TB5 [A] [B]).	Connect the PZ-62DR series to the terminals (TM4 [1] [2]). (See the Lossnay Operating/ Installation Instructions or PZ-62DR series Instruction Book.)
				Malfunction of the unit (*1) where an error occurs	Check the unit (*1) where the error occurs.
6603	—	5 blinks	Transmission error (transmission bus busy)	Faulty connection of the M-NET transmission cable	Check the items described in (1) [2].
				<ul style="list-style-type: none"> • Wiring was performed with power still supplied to the M-NET transmission cable. • Accidental communication error 	Restart the system after completing wiring. If the error re-occurs, check for noise on the transmission cable. If the above does not correct the problem, replace the Lossnay control circuit board.
				Power is supplied to the same transmission cable from two or more power supply units. The power supply unit is connected to the TB3 terminal of the transmission booster.	Check the wiring of the power supply unit and the transmission booster.
				The PZ-62DR series is connected to the terminals (TB5 [A] [B]).	Connect the PZ-62DR series to the terminals (TM4 [1] [2]). (See the Lossnay Operating/ Installation Instructions or PZ-62DR series Instruction Book.)
				Malfunction of the unit (*1) where an error occurs	Check the unit (*1) where the error occurs.

(*1) This refers to devices assigned an address number in MELANS such as the Lossnay unit, City Multi indoor unit, City Multi outdoor unit, or system controller.

Error Code	LED1 (green)	LED2 (red)	Symptom	Cause	Corrective action
6606	—	3 blinks	Transmission/reception error (communication error with transmission processor)	Faulty connection of the M-NET transmission cable	Check the items described in (1) [2].
				<ul style="list-style-type: none"> • Wiring was performed with power still supplied to the M-NET transmission cable. • Accidental communication error 	Restart the system after completing wiring. If the error re-occurs, check for noise on the transmission cable. If the above does not correct the problem, replace the Lossnay control circuit board.
				Malfunction of the unit (*1) where an error occurs	Check the unit (*1) where the error occurs.
6607	—	8 blinks	Transmission/reception error (no ACK error)	The power of the Lossnay unit is not ON.	Check the power of the Lossnay unit.
				The Lossnay address was changed.	Check the Lossnay address.
				The PZ-62DR series is connected to the terminals (TB5 [A] [B]).	Connect the PZ-62DR series to the terminals (TM4 [1] [2]) (See the Lossnay Operating/Installation Instructions or PZ-62DR series Instruction Book.)
6608	—	8 blinks	Transmission/reception error (no response error)	Multiple M-NET transmission cables are wired using multicore cables.	Using the applicable cable, wire the transmission cable away from one another.
				The M-NET transmission cable is not securely connected.	Check the transmission cable connections.
				The wiring length of the M-NET transmission cable is longer than specified. • Max. extension: 200 m • Total extension: 500 m	Check the wiring length of the transmission cable.
				The PZ-62DR series is connected to the terminals (TB5 [A] [B]).	Connect the PZ-62DR series to the terminals (TM4 [1] [2]). (See the Lossnay Operating/Installation Instructions or PZ-62DR series Instruction Book.)
6801	9 blinks	—	PZ-43SMF-E communication error	Multiple PZ-43SMF-E transmission cables are wired using multicore cables.	Using the applicable cable, wire the transmission cable away from one another.
				The power supply cable is too close to the PZ-43SMF-E transmission cable.	Wire the power supply cable at least 5 cm away from the transmission cable.
				Faulty connection of the PZ-43SMF-E transmission cable	Check the transmission cable connections.
				The wiring length of the PZ-43SMF-E transmission cable is longer than specified (200 m or more).	Check the wiring length of the transmission cable.
				PZ-43SMF-E is connected to the terminals (TB5 [A] [B]).	Connect PZ-43SMF-E to the terminals (TM4 [1] [2]). (See the Lossnay Operating/Installation Instructions or PZ-62DR series Instruction Book.)

(*1) This refers to devices assigned an address number in MELANS such as the Lossnay unit, City Multi indoor unit, City Multi outdoor unit, or system controller.

Error Code	LED1 (green)	LED2 (red)	Symptom	Cause	Corrective action
6831	9 blinks	—	PZ-62DR series communication error (no reception)	Faulty connection of the PZ-62DR series transmission cable	Check the items described in (1) [2]. If the error re-occurs, check for noise on the transmission cable. If the above does not correct the problem, replace the Lossnay control circuit board or PZ-62DR series remote controller.
				The PZ-62DR series is connected to the terminals (TB5 [A] [B]).	Connect the PZ-62DR series to the terminals (TM4 [1] [2]). (See the Lossnay Operating/Installation Instructions or PZ-62DR series Instruction Book.)
6832	9 blinks	—	PZ-62DR series communication error (synchronization recovery error)	Faulty connection of the PZ-62DR series transmission cable	Check the items described in (1) [2]. If the error re-occurs, check for noise on the transmission cable. If the above does not correct the problem, replace the Lossnay control circuit board or PZ-62DR series remote controller.
6833	9 blinks	—	PZ-62DR series communication error (hardware error)	Faulty connection of the PZ-62DR series transmission cable	Check the items described in (1) [2]. If the error re-occurs, check for noise on the transmission cable. If the above does not correct the problem, replace the Lossnay control circuit board or PZ-62DR series remote controller.
6834	9 blinks	—	PZ-62DR series communication error (start bit detection error)	Faulty connection of the PZ-62DR series transmission cable	Check the items described in (1) [2]. If the error re-occurs, check for noise on the transmission cable. If the above does not correct the problem, replace the Lossnay control circuit board or PZ-62DR series remote controller.
				Communication error between the leader and follower units when the leader-follower function is set	Check for faulty connection of the transmission cables between the leader and follower units.
7113	10 blinks	—	Function setting error	The group contains two or more Lossnay units with the same address.	Set unique addresses to these units.
				The model selection switch (SW6) is not set correctly.	Make the SW6 setting appropriate for the model. (See Chapter 8. (14) Setting status record (page 54).)
				Improper power circuit board is used. The applicable circuit boards must be used as shown below. LG-X08DC-P7 (Upper side) LG-X08DC-P8 (Lower side)	Check that the applicable power circuit board is connected.
				The setting of the leader-follower function is incorrect.	For the leader unit, set the function selection switch (SW5-4) to ON. For the follower units, set the function selection switch (SW5-5) to ON.

(5) Temperatures and thermistor resistance table

Temperature (°C)	Resistance value (kΩ)	Temperature (°C)	Resistance value (kΩ)	Temperature (°C)	Resistance value (kΩ)	Temperature (°C)	Resistance value (kΩ)	Temperature (°C)	Resistance value (kΩ)
-30	64.2 to ∞	-7	19.4	8	9.9	23	5.4	38	3.1
⋮	⋮	-6	18.5	9	9.5	24	5.2	39	3.0
-20	37.2	-5	17.7	10	9.1	25	5.0	40	2.9
-19	35.3	-4	16.9	11	8.7	26	4.8	41	2.8
-18	33.5	-3	16.1	12	8.4	27	4.6	42	2.7
-17	31.8	-2	15.4	13	8.0	28	4.5	43	2.6
-16	30.2	-1	14.7	14	7.7	29	4.3	44	2.5
-15	28.7	0	14.0	15	7.4	30	4.2	45	2.5
-14	27.3	1	13.4	16	7.1	31	4.0	46	2.4
-13	26.0	2	12.8	17	6.8	32	3.9	47	2.3
-12	24.7	3	12.3	18	6.6	33	3.7	48	2.2
-11	23.6	4	11.8	19	6.3	34	3.6	49	2.2
-10	22.4	5	11.3	20	6.1	35	3.5	50	2.1
-9	21.4	6	10.8	21	5.8	36	3.3	⋮	⋮
-8	20.4	7	10.3	22	5.6	37	3.2	90	0 to 0.7

* Measure the thermistor (TH2) resistance across pin No. 1 and 2 of CN5, and the thermistor (TH1) resistance across pin No. 1 and 3 of CN7.

(6) Motor resistance table

⚠ Cautions:

- Before disconnecting the motor connectors, make sure that the power is turned OFF and the circuit board is discharged adequately.
- Even after the power supply is cut off, the capacitor is charged. Therefore, high voltage is applied to the motor for a while. Make sure that the LEDs on the circuit boards are turned OFF before starting work.
- Never touch the circuit board while the power is ON. It causes electric shock and failure of the unit.

Replace the DC motor in the following cases.

[1] If it is hard to rotate the motor shaft by hand

[2] If the resistance between the motor leads is significantly different from the values specified in the table below

*Before measuring the resistance, the motor connectors must be disconnected from the circuit board.

*Be sure to measure the resistance by touching COM line of the tester to Pin No. 3 (of Fan motor 1 or 3 connector) or No. 4 (of Fan motor 2 or 4 connector).

Pin No.	Fan motor 1 or 3 connector	3-1	3-4	3-5	3-6
	Fan motor 2 or 4 connector	4-1	4-5	4-6	4-7
Normal resistance		About 800 kΩ	About 40 kΩ	About 17 kΩ	∞ kΩ

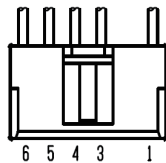

Fan motor 1 or 3 connector

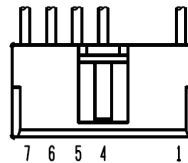

Fan motor 2 or 4 connector

8. Overhauling procedures

■ Work precautions

- When touching the electric components such as circuit boards and fan motors, do not touch the components for more than 5 minutes after power-off, and then start working. If LED4 or LED6 on the circuit board is lit, do not touch the electric components.
 - Before replacing parts or components, follow the instructions described in the troubleshooting.
 - When servicing, always keep proper footing.
 - When servicing, be sure to turn off the power supply isolator. Pay sufficient attention to avoid electric shock or injury.
 - Be sure to connect the power supply wires correctly.
 - Avoid application of abnormal voltage.
 - Pay attention not to drop the parts or components.
 - When the tightening torque for assembling is specified, be sure to tighten to the specified tightening torque.
 - After connecting the lead wires, make sure that they are securely connected.
 - After completing repairs, check that the product operates properly.
- * **Always wear a pair of gloves when servicing.**

<External and internal view of the product>

Names within angle brackets < > are part names listed in the parts catalog.

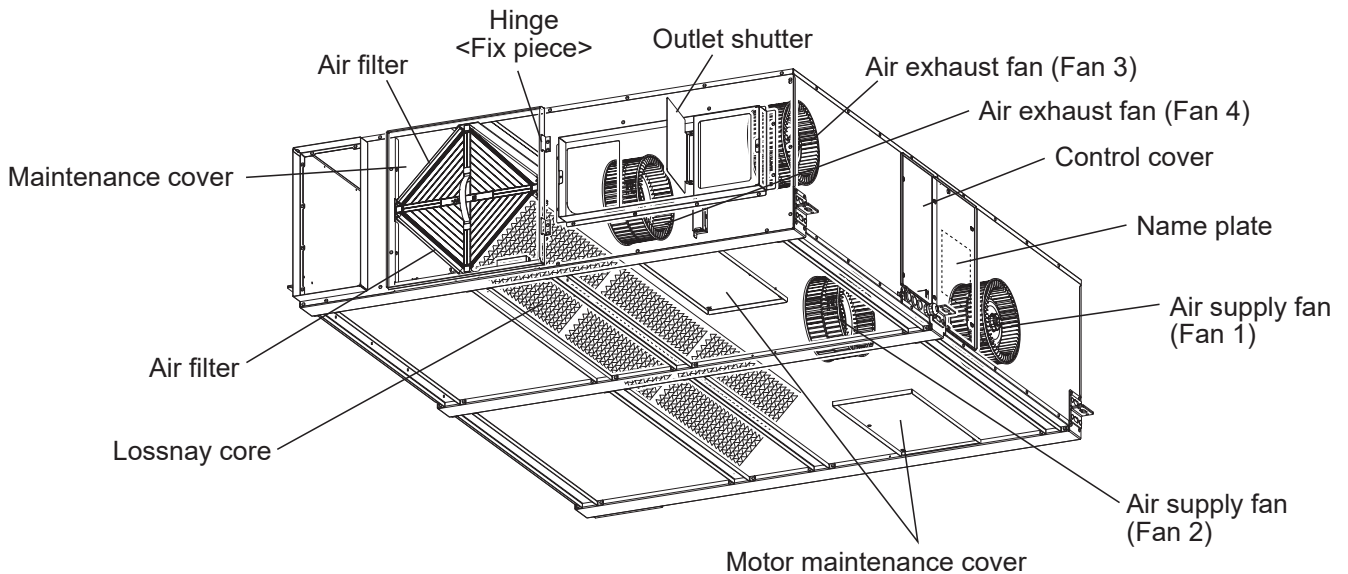

Above drawing shows the fan names when LR Switching is at the factory setting. Fan direction would be changed as shown in the table below by LR Switching setting.

	LR Switching (DIP SW2-10)	
	OFF (Factory setting)	ON
Fan 1 Fan 2	Supply fan	Exhaust fan
Fan 3 Fan 4	Exhaust fan	Supply fan

(1) Turning power off

- [1] Shut down the unit.
- [2] Turn off the power supply isolator.

Precaution
When servicing, power supply to M-NET must be turned off. Live-line working may cause a circuit board failure.

(2) Fan parts

- [1] Remove the screws (two PTT screws 4×8, indicated by ○) .
- [2] Loosen the screws (four PTT screws 4×8, indicated by □) and remove the motor maintenance cover by sliding it .

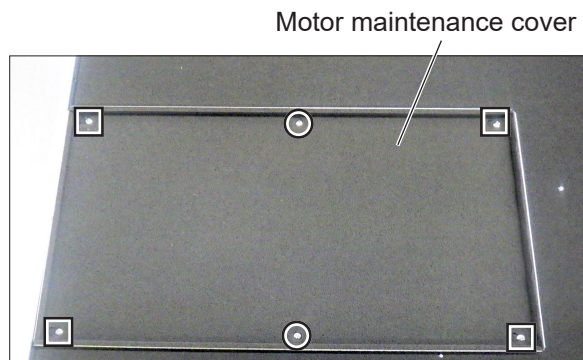

- [3] Remove the screws (two PTT screws 4×8, indicated by ○).
- [4] Remove the separator by sliding it in the direction of the arrow.

Precaution
Be careful not to injure yourself with the edges of the openings.

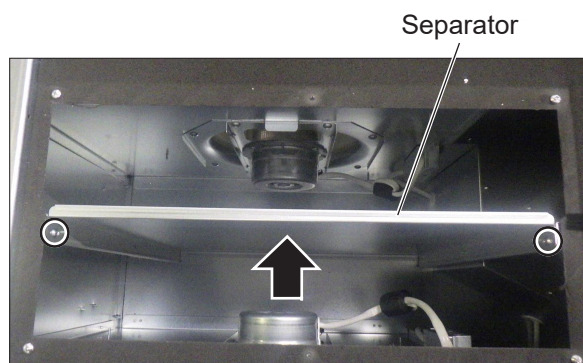

- [5] Push the tab, and remove the connector cover.
- [6] Open the cord clamber.

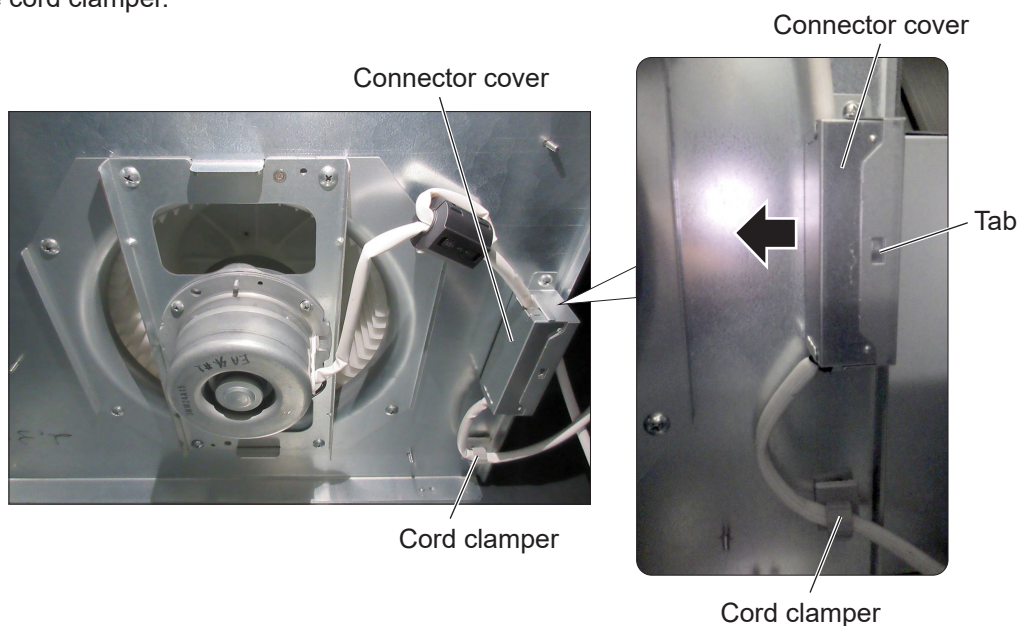

[7] Disconnect the connectors.

Precaution
When disconnecting the motor connectors, make sure that the power supply is turned off. Even when the fan motor is stopped, disconnecting the live-line connectors will cause a motor malfunction.

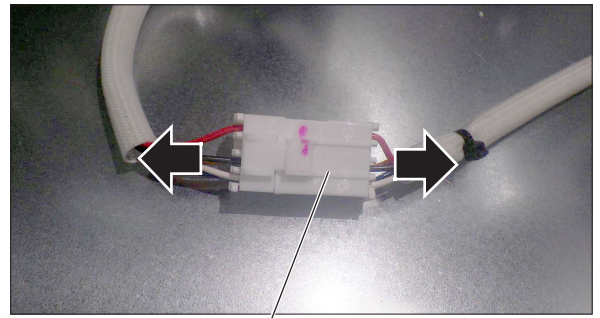

Connector

[8] Remove the screws (eight PTT screws 5×10, indicated by ○), and remove the fan assembly.

Note: Remove the other fan assemblies in the same way.

Precaution
When taking out the fan assembly, hold the DC motor or motor leg. Do not hold the centrifugal fan.

Assembly precaution
When attaching the centrifugal fan, tighten the special nut to the tightening torque of 7.50 ± 0.3 N·m.

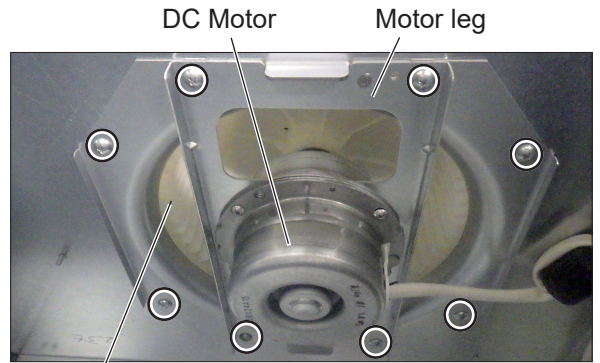

Centrifugal fan

(3) Terminal block parts

[1] Loosen the black screws (nine special screws PT 4×8, indicated by ○), and remove both control covers.

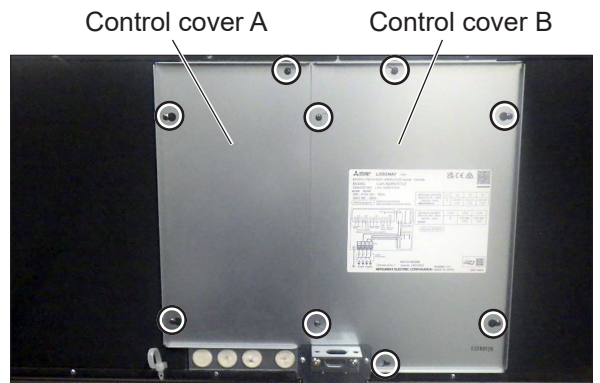

[2] Check that LED4 on the control circuit board is OFF, and then disconnect the connectors (indicated by ○) from the power circuit boards and reactors.

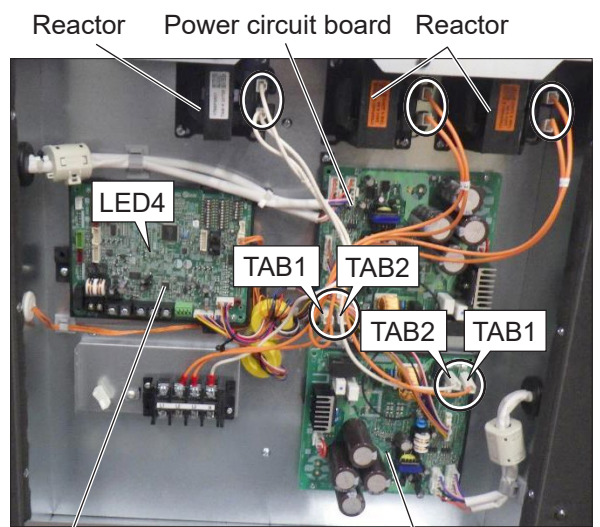

Control circuit board

Power circuit board

[3] Remove the screws (two PTT screws 4×12, indicated by ○), and remove the terminal block with the lead wires.

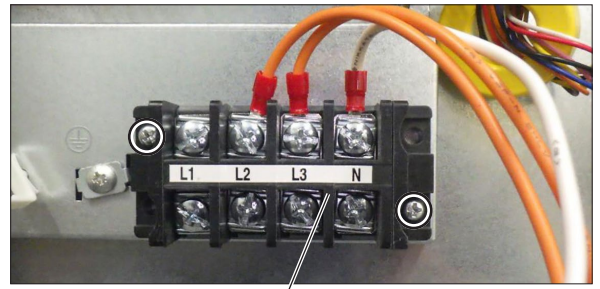

Terminal block

Assembly precaution

Number indications are attached on the lead wires. When replacing the terminal block parts, reconnect the lead wires according to the numbers shown in the right picture.

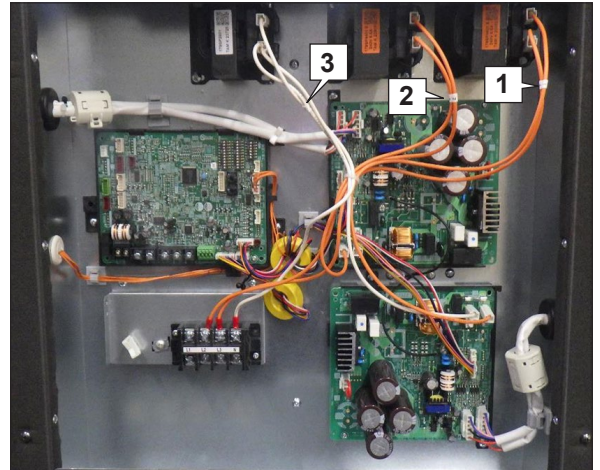

(4) Reactors

[1] Remove the control covers. → See (3) [1].

[2] Check that LED4 on the control circuit board is OFF, and then disconnect the connectors (indicated by ○) from each reactor.

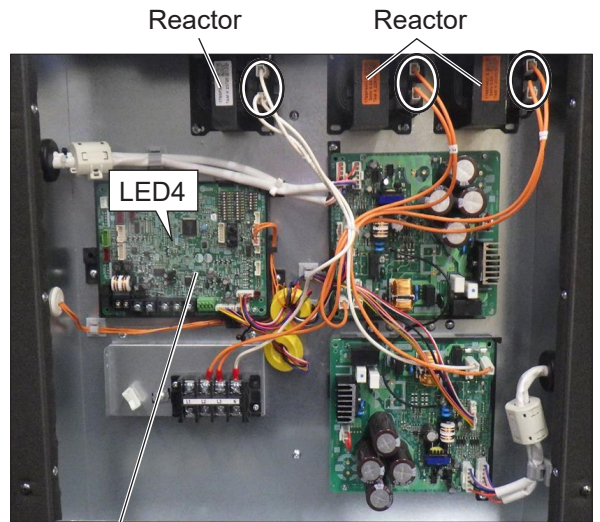

Control circuit board

[3] Remove the screws (two PT screws 4×8 for each, indicated by ○), and remove the reactor.

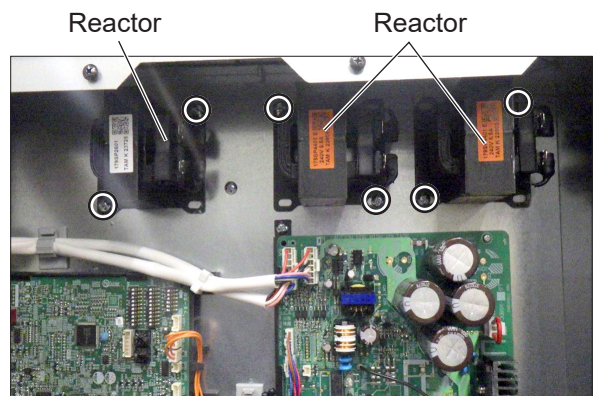

Assembly precaution
 Number indications are attached on the lead wires.
 When replacing the reactors, install them to the correct positions, and reconnect the lead wires according to the numbers shown in the right picture.

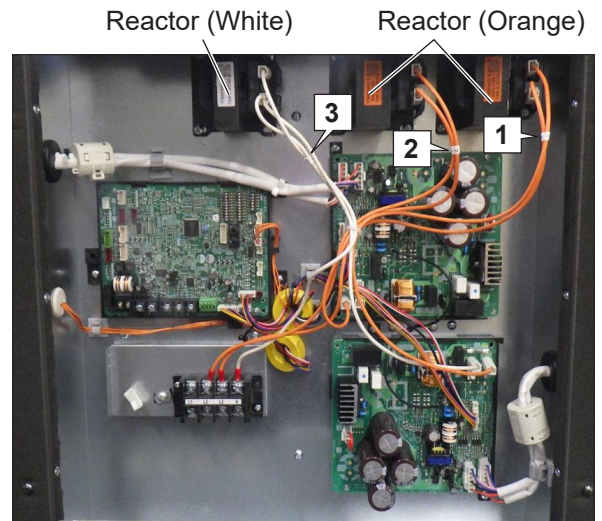

(5) Control circuit board

Precaution
 Before replacing the circuit boards, see (12) Procedures for replacing the circuit boards (page 51).

- [1] Remove the control covers. → See (3) [1].
- [2] Check that LED4 on the control circuit board is OFF, and then disconnect the connectors (indicated by ○) from the control circuit board.
- [3] Remove the screws (two PT screws 4×8, indicated by △), and remove the control circuit board.

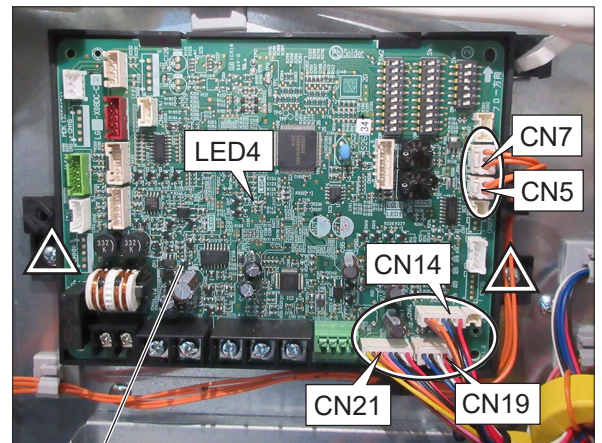

Control circuit board

(6) Power circuit boards

Precaution
 Before replacing the circuit boards, see (12) Procedures for replacing the circuit boards (page 51).

- [1] Remove the control covers. → See (3) [1].
- [2] Check that LED4 on the control circuit board is OFF, and then disconnect the connectors (indicated by ○) from the power circuit boards.

Precaution
 When disconnecting the motor connectors, make sure that the power supply is turned off and all LEDs are unlit. Even when the fan motors are stopped, disconnecting the live-line connectors will cause a motor malfunction.

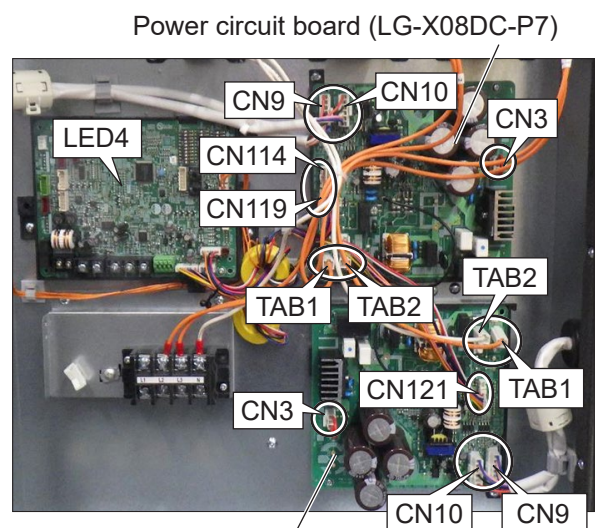

Power circuit board (LG-X08DC-P8)

- [3] Remove the screws (one PT screw 4×8 BS for each, indicated by ○).
- [4] Remove the screws (two PT screws 4×8 for each, indicated by △), and remove each power circuit board.

Assembly precaution
Be aware of the difference between the power circuit boards.

Power circuit board (LG-X08DC-P7: Upper side)

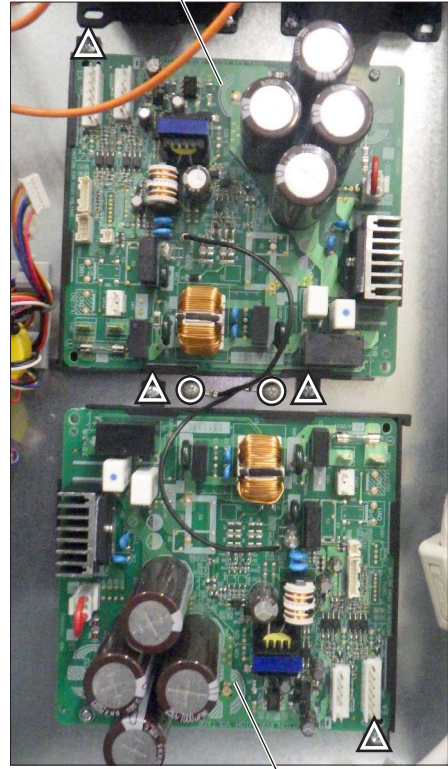

Power circuit board (LG-X08DC-P8: Lower side)

(7) Lossnay cores

- [1] Remove the black screws (two special screws PT 4x12*, indicated by ○), and open the maintenance cover.

*Special screws PT 4x8 are used for some Lossnay units.

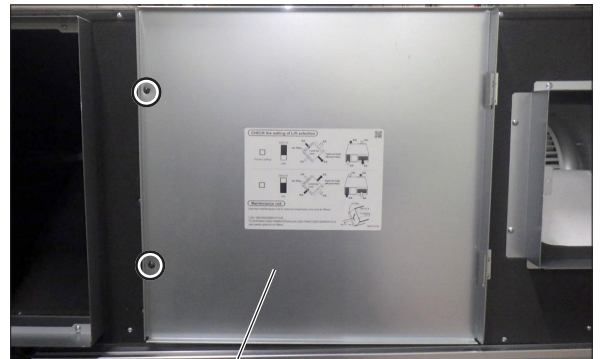

Maintenance cover

- [2] Remove the front filters from the main unit.
- [3] Remove the back filters from the main unit by using the maintenance rod.

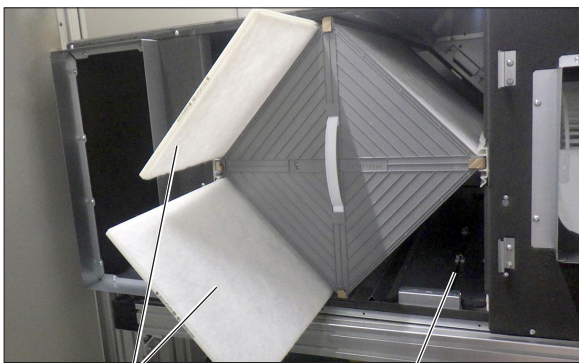

Front filter

Maintenance rod



Back filter

Maintenance rod

[4] Hold the handle, and draw the Lossnay cores out from the main unit.

[5] Use the maintenance rod to remove the second and third Lossnay cores.

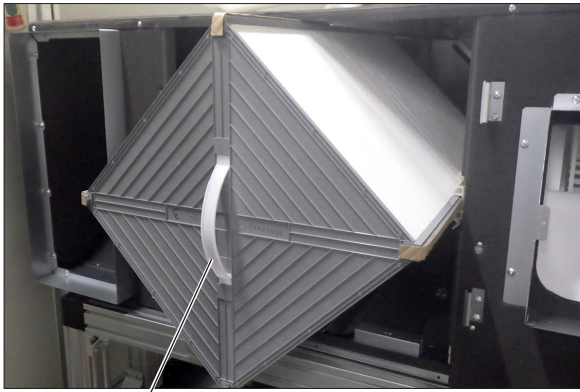

Handle

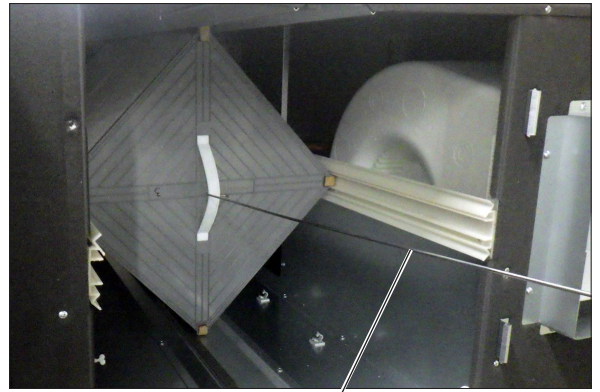

Maintenance rod

(8) Filter curtains

[1] Remove the maintenance cover. → See (7) [1].

[2] Remove the filters and Lossnay cores from the main unit. → See (7) [2] to [5].

[3] Remove the screws (two PTT screws 4×8 for each, indicated by ○), and remove the filter curtains.



Filter curtain

Assembly precaution

When using the advanced high efficiency filters, install them with the filter curtains opened.
For details, see the Operating Instructions for the filters.

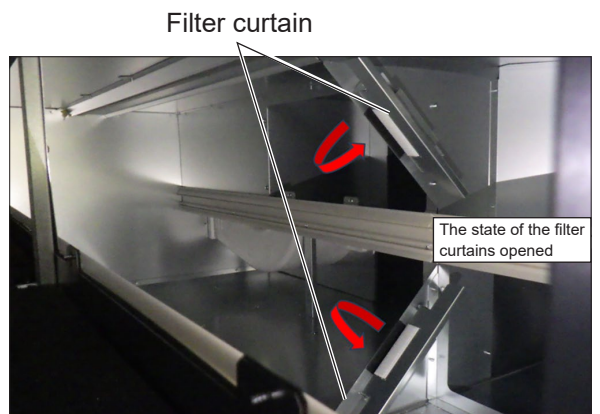

Filter curtain

The state of the filter curtains opened

(9) Lossnay core holders

[1] Remove the maintenance cover. → See (7) [1].

[2] Remove the filters and Lossnay cores from the main unit. → See (7) [2] to [5].

[3] Remove the screws (special screws 4×8*, indicated by ○) to remove the Lossnay core holders.

*Three screws for each front (shorter) holder

*Five screws for each back (longer) holder

Assembly precaution

When attaching the Lossnay core holders, tighten the special screws to the specified tightening torque (0.78 N·m).

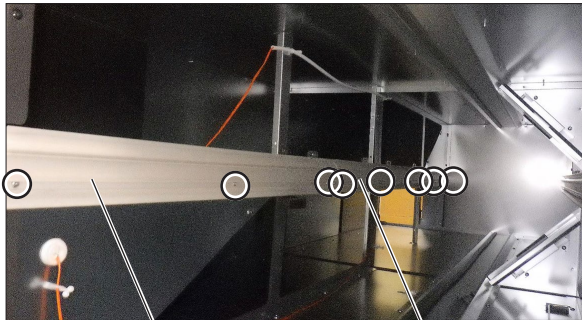

Lossnay core holder
(Front)



Lossnay core holder
(Back)

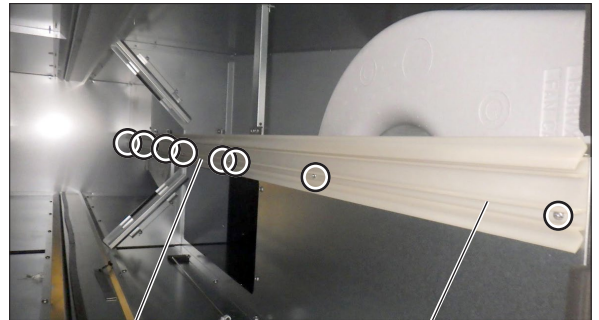

Lossnay core holder
(Back)

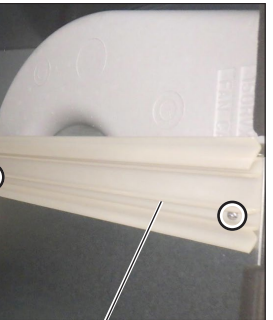

Lossnay core holder
(Front)

(10) Thermistors

[1] Open the maintenance cover. → See (7) [1].

[2] Remove the filters and Lossnay cores from the main unit. → See (7) [2] to [5].

[3] Push the tab, and remove the connector cover.



Connector cover

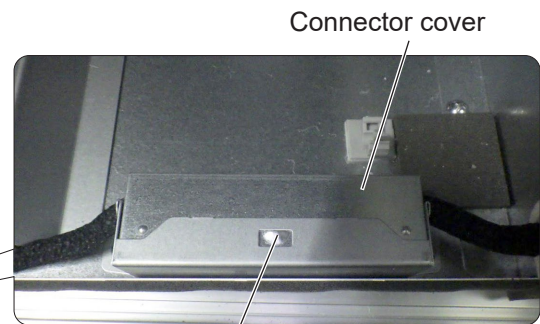

Connector cover

Tab

[4] Disconnect the thermistor connectors.

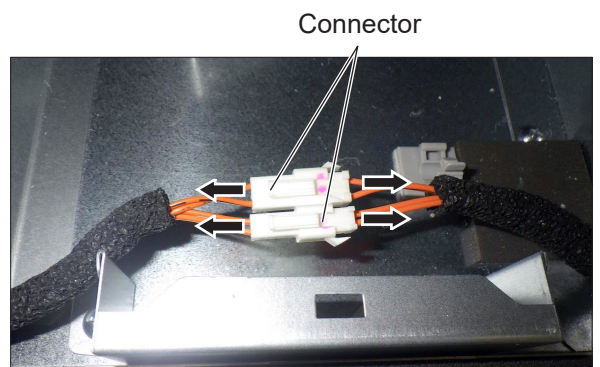

Connector

[5] Open the cord clips (indicated by ○), and remove the thermistor leads.

Assembly precaution
When wiring the thermistor leads, run the thermistor 1 lead through the bush.

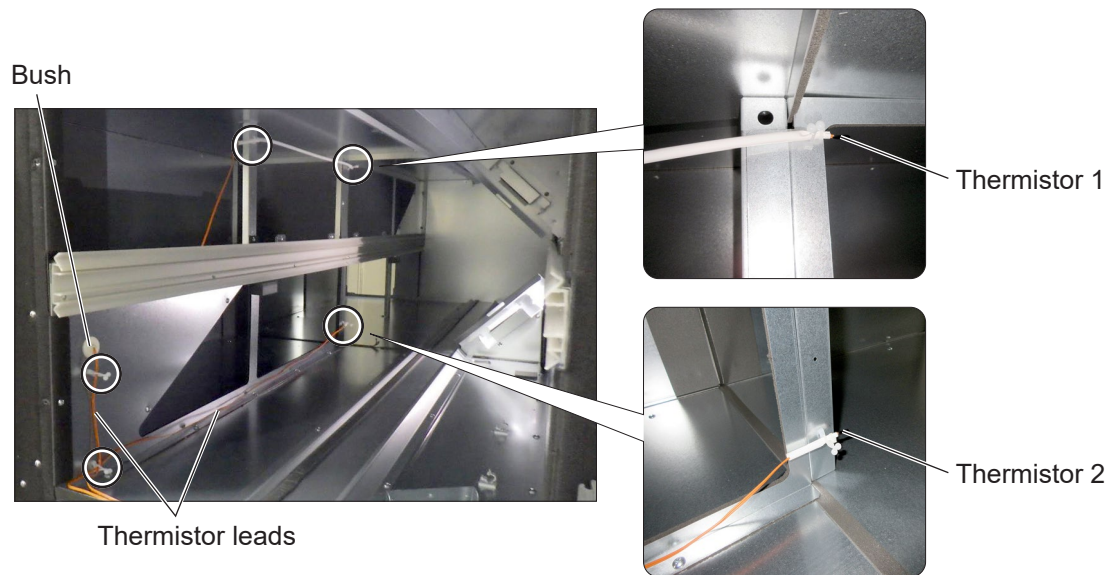

(11) Shutters

- [1] Disconnect the SA (EA) duct from the Lossnay unit.
- [2] Remove the screws (three PTT screws 4×8 for each, indicated by ○), and remove the shutter.

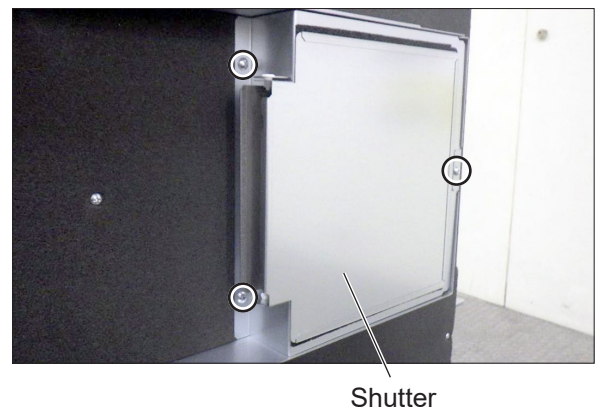

* When reassembling

- Reassemble the unit in the reverse order of disassembly.
- After reassembly, always make a test run to make sure that the unit operates properly.

(12) Procedures for replacing the circuit boards

Notes

- Before removing the circuit boards for replacement, check the following Steps 1 and 2.
- When the Lossnay remote controller PZ-62DR series is connected, be sure to replace the circuit boards as described in the Steps.

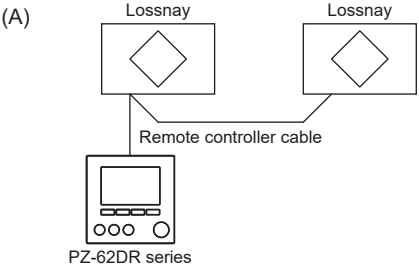
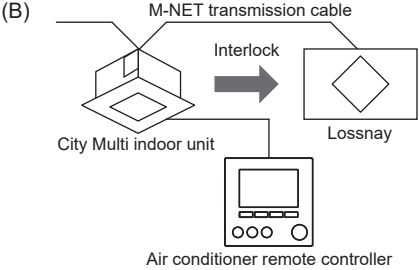
Step	Details	Check item	
1	<p>Check the system configuration.</p> <p>Check if the PZ-62DR series is connected to the circuit board to be replaced.</p> <p>The following describes settings required when replacing the circuit boards per the system configuration. Check which system configuration is applicable, and then replace the circuit boards.</p> <p>(A)  <ul style="list-style-type: none"> ① Setting of the function selection switches on the circuit board ② Setting of the PZ-62DR series functions ③ Address setting (when M-NET is used) <p style="text-align: right;">➔ Go to Step 2.</p> <p>(B)  <ul style="list-style-type: none"> ① Setting of the function selection switches on the circuit board ② Address setting <p style="text-align: right;">➔ Go to Step 3.</p> </p></p>	PZ-62DR series connection	
		System Configuration	
2	<p>Check the settings on the PZ-62DR series.</p> <p>Regarding the settings on the PZ-62DR series, prepare the data recorded at the time of installation (setting status record, etc.).</p> <p>In the case there is no data recorded at the time of installation, and if the Lossnay unit can be operated with the PZ-62DR series, use the form in “(14) Setting status record (page 54)” to record the settings on the PZ-62DR series. To check the settings on the PZ-62DR series, see the Lossnay Operating/Installation Instructions or the PZ-62DR series Instruction Book.</p> <ul style="list-style-type: none"> • On the function setting screen of the PZ-62DR series, display the M-NET address of the Lossnay unit for which you wish to check the settings. • The address can be checked by the address setting switches (SW12 and SW11) on the Lossnay circuit board. 	Setting status record	
3	<p>Setting status record of the address setting switches and function selection switches on the circuit board</p> <p>Using the form in “(14) Setting status record (page 54)”, record setting statuses necessary for replacing the circuit board.</p> <p>Remove the control covers, and check the setting status of each switch on the circuit board.</p> <p>If the function setting statuses were recorded at the time of installation, this step can be skipped.</p> <p>[1] Address setting (SW12 and SW11)</p> <p>[2] Function selection switches (SW2, SW5) and model selection switch (SW6) setting</p> <p>[3] External input (as necessary, record the connection status)</p>	Setting status record	

Step	Details	Check item																																																														
4	<p>Removing the circuit boards</p> <ul style="list-style-type: none"> For the working precautions, see page 42. For removing the circuit boards, see (5) Control circuit board (page 46) and (6) Power circuit boards (page 46). 																																																															
5	<p>Attaching the circuit boards</p> <p>[1] According to the function status record data prepared in Step 3, set the address setting switches, function selection switches, and model selection switch of the new circuit board.</p> <ol style="list-style-type: none"> Address setting (SW12 and SW11) Function selection switches (SW2, SW5) and model selection switch (SW6) setting <p>[2] Attach the power circuit board in the reverse order of the steps for removing. There are two types of the power circuit board. When replacing the circuit board, use the applicable circuit board according to the table below.</p> <table border="1"> <thead> <tr> <th>Power circuit board</th> <th>Position of the circuit board</th> </tr> </thead> <tbody> <tr> <td>LG-X08DC-P7</td> <td>Upper side</td> </tr> <tr> <td>LG-X08DC-P8</td> <td>Lower side</td> </tr> </tbody> </table> <p>Be sure to connect the connectors listed in the following table.</p> <table border="1"> <thead> <tr> <th>Connector</th> <th>Symbol on the circuit board</th> <th>Check</th> </tr> </thead> <tbody> <tr> <td>For power supply connection</td> <td>TAB1, TAB2</td> <td></td> </tr> <tr> <td>For fan motor connection</td> <td>CN9, CN10</td> <td></td> </tr> <tr> <td>For control circuit board connection*</td> <td>CN114, CN119, CN121</td> <td></td> </tr> </tbody> </table> <p>*LG-X08DC-P7 : CN114, CN119 LG-X08DC-P8 : CN121</p> <p>[3] Attach the control circuit board in the reverse order of the steps for removing, and then connect the connectors, remote controller transmission cable, M-NET transmission cable, and external signal cable, etc. Be sure to connect the connectors or terminals listed in the following table. (Connect PZ-62DR series or PZ-43SMF-E transmission cable terminal, M-NET transmission cable terminal, and connector/terminal for external signal cable only when they are used.)</p> <table border="1"> <thead> <tr> <th>Connector and terminal</th> <th>Symbol on the circuit board</th> <th>Check</th> </tr> </thead> <tbody> <tr> <td>For thermistor connection</td> <td>CN5, CN7</td> <td></td> </tr> <tr> <td>For power circuit board connection</td> <td>CN14, CN19, CN21</td> <td></td> </tr> <tr> <td>PZ-62DR series or PZ-43SMF-E transmission cable terminal</td> <td>TM4 [1] [2]</td> <td></td> </tr> <tr> <td>M-NET transmission cable terminal</td> <td>TB5 [A] [B]</td> <td></td> </tr> <tr> <td>For external signal cable connection</td> <td>TM2, TM3, CN17, CN23, CN26, CN32, CN34, CN35, CN50, CN105</td> <td></td> </tr> </tbody> </table> <p>[4] Reattach the control covers.</p>	Power circuit board	Position of the circuit board	LG-X08DC-P7	Upper side	LG-X08DC-P8	Lower side	Connector	Symbol on the circuit board	Check	For power supply connection	TAB1, TAB2		For fan motor connection	CN9, CN10		For control circuit board connection*	CN114, CN119, CN121		Connector and terminal	Symbol on the circuit board	Check	For thermistor connection	CN5, CN7		For power circuit board connection	CN14, CN19, CN21		PZ-62DR series or PZ-43SMF-E transmission cable terminal	TM4 [1] [2]		M-NET transmission cable terminal	TB5 [A] [B]		For external signal cable connection	TM2, TM3, CN17, CN23, CN26, CN32, CN34, CN35, CN50, CN105		<table border="1"> <tbody> <tr> <td>Address setting</td> <td></td> </tr> <tr> <td>Function setting</td> <td></td> </tr> <tr> <td>Model selection</td> <td></td> </tr> <tr> <td>Circuit board fixing screw (1 pc.)</td> <td></td> </tr> <tr> <td>PCB fix plate fixing screw (2 pcs.)</td> <td></td> </tr> <tr> <td>Earth fixing screw (1 pc.)</td> <td></td> </tr> <tr> <td>Circuit board fixing screw (1 pc.)</td> <td></td> </tr> <tr> <td>PCB fix plate fixing screw (2 pcs.)</td> <td></td> </tr> <tr> <td>Connector connection</td> <td></td> </tr> <tr> <td>PZ-62DR series transmission cable connection</td> <td></td> </tr> <tr> <td>M-NET transmission cable connection</td> <td></td> </tr> <tr> <td>External signal cable connection</td> <td></td> </tr> <tr> <td>Cover screw (black) (9 pcs.)</td> <td></td> </tr> </tbody> </table>	Address setting		Function setting		Model selection		Circuit board fixing screw (1 pc.)		PCB fix plate fixing screw (2 pcs.)		Earth fixing screw (1 pc.)		Circuit board fixing screw (1 pc.)		PCB fix plate fixing screw (2 pcs.)		Connector connection		PZ-62DR series transmission cable connection		M-NET transmission cable connection		External signal cable connection		Cover screw (black) (9 pcs.)	
Power circuit board	Position of the circuit board																																																															
LG-X08DC-P7	Upper side																																																															
LG-X08DC-P8	Lower side																																																															
Connector	Symbol on the circuit board	Check																																																														
For power supply connection	TAB1, TAB2																																																															
For fan motor connection	CN9, CN10																																																															
For control circuit board connection*	CN114, CN119, CN121																																																															
Connector and terminal	Symbol on the circuit board	Check																																																														
For thermistor connection	CN5, CN7																																																															
For power circuit board connection	CN14, CN19, CN21																																																															
PZ-62DR series or PZ-43SMF-E transmission cable terminal	TM4 [1] [2]																																																															
M-NET transmission cable terminal	TB5 [A] [B]																																																															
For external signal cable connection	TM2, TM3, CN17, CN23, CN26, CN32, CN34, CN35, CN50, CN105																																																															
Address setting																																																																
Function setting																																																																
Model selection																																																																
Circuit board fixing screw (1 pc.)																																																																
PCB fix plate fixing screw (2 pcs.)																																																																
Earth fixing screw (1 pc.)																																																																
Circuit board fixing screw (1 pc.)																																																																
PCB fix plate fixing screw (2 pcs.)																																																																
Connector connection																																																																
PZ-62DR series transmission cable connection																																																																
M-NET transmission cable connection																																																																
External signal cable connection																																																																
Cover screw (black) (9 pcs.)																																																																

Step	Details	Check item	
6	<p>Function setting with the PZ-62DR series</p> <p>When the PZ-62DR series is connected, according to the function status record data prepared in Step 2, set the function settings with the PZ-62DR series. If the PZ-62DR series is not connected, skip this step and proceed to Step 7. To perform function settings with the PZ-62DR series, see the Lossnay Operating/Installation Instructions or PZ-62DR series Instruction Book.</p> <p>The selection method for “M-NET address” on the function setting screen differs between when the address setting switch on the Lossnay circuit board is set (the address is other than “00”) and when it is not set (the address is “00”). Check the address setting of the replaced circuit board.</p> <p><When the address switch setting is other than “00”> For all function settings, always select the address of the Lossnay unit which the circuit boards were replaced. Even when there are multiple Lossnay units in the group, do not select “All”.</p> <p><When the address switch is “00”> Always select “All”.</p> <p>Note:</p> <ul style="list-style-type: none"> • When changing the settings of the function selection switches and address setting switches on the circuit board after the functions were set with the PZ-62DR series, reset the function settings according to “(13) Initialization (page 53)”. After resetting the function settings, perform the function settings again in the order of Step 5 [1] and Step 6. • If you change the M-NET address after the functions were set with the PZ-62DR series, the settings with the PZ-62DR series will be reset. In this case, set the functions again with the PZ-62DR series. 	Address setting	
		Function setting	
7	<p>Restarting the system</p> <p>Turn the power back on to the Lossnay unit which the circuit boards have been replaced, or when using M-NET, turn the power back on to the power supply unit connected to the Lossnay unit. In trial operation, make sure that the Lossnay unit with replaced circuit boards operates properly, and finish replacement work.</p>	Trial operation	

(13) Initialization

Set to initialize the remote controller PZ-62DR series function setting.

All function settings which are changed by users are cancelled.

DIP-SW		Setting check	PZ-62DR series		Setting check	Initialization
SW No.	Setting		Function No.	Setting data		
N/A	-	-	100	0		N/A
	-	-		1		Available

(14) Setting status record

[1] Basic information

Date: _____

Installation location: _____

Model name: LGH- (160 · 200 · 250) RVXT3-E _____

Serial number on the nameplate (eight-digit): _____

Address setting: _____

Lot number marked on the circuit board: _____

Microcomputer software version marked on the circuit board: _____

Lossnay remote controller: (Used · Not used) Model name: (PZ-62DR-EA · PZ-62DR-EB · PZ-43SMF-E)

Interlocking with City Multi: (Set · Not set) Model name: _____ M-NET address: _____

Interlocking with Mr. Slim: (Set · Not set) Model name: _____

System controller: (Used · Not used) Model name: _____

Wi-Fi interface: (Used · Not used) Model name: _____

CO₂ sensor: (Used · Not used) Model name: (PZ-70CSW-E · PZ-70CSD-E · Other manufacturer's sensor)

Other sensor: (Used · Not used) Model name: (Other manufacturer's sensor)

Monitor output device: (Used · Not used) Model name: (PZ-4GS-E)

The number of Lossnay units in a group: _____

Address number (The smallest number in the group): _____

LR switching (DIP SW2-10): (ON · OFF)

Leader-follower function: (Set · Not set)

[2] Function selection switches

Enter the setting status of the function selection switches on the circuit board.

SW2	ON	OFF	SW5	ON	OFF
1	<input type="checkbox"/>	<input type="checkbox"/>	1	<input type="checkbox"/>	<input type="checkbox"/>
2	<input type="checkbox"/>	<input type="checkbox"/>	2	<input type="checkbox"/>	<input type="checkbox"/>
3	<input type="checkbox"/>	<input type="checkbox"/>	3	<input type="checkbox"/>	<input type="checkbox"/>
4	<input type="checkbox"/>	<input type="checkbox"/>	4	<input type="checkbox"/>	<input type="checkbox"/>
5	<input type="checkbox"/>	<input type="checkbox"/>	5	<input type="checkbox"/>	<input type="checkbox"/>
6	<input type="checkbox"/>	<input type="checkbox"/>	6	<input type="checkbox"/>	<input type="checkbox"/>
7	<input type="checkbox"/>	<input type="checkbox"/>	7	<input type="checkbox"/>	<input type="checkbox"/>
8	<input type="checkbox"/>	<input type="checkbox"/>	8	<input type="checkbox"/>	<input type="checkbox"/>
9	<input type="checkbox"/>	<input type="checkbox"/>	9	<input type="checkbox"/>	<input type="checkbox"/>
10	<input type="checkbox"/>	<input type="checkbox"/>	10	<input type="checkbox"/>	<input type="checkbox"/>

: Factory setting

Model selection switch

SW6	ON	OFF
1	<input type="checkbox"/>	<input type="checkbox"/>
2	<input type="checkbox"/>	<input type="checkbox"/>
3	<input type="checkbox"/>	<input type="checkbox"/>
4	<input type="checkbox"/>	<input type="checkbox"/>
5	<input type="checkbox"/>	<input type="checkbox"/>
6	<input type="checkbox"/>	<input type="checkbox"/>

Note: SW6 setting differs according to the model.

Model	SW6-1	SW6-2	SW6-3	SW6-4	SW6-5	SW6-6
LGH-160RVXT3-E	OFF	ON	OFF	ON	OFF	OFF
LGH-200RVXT3-E	ON	ON	OFF	ON	OFF	OFF
LGH-250RVXT3-E	OFF	OFF	ON	ON	OFF	OFF

: Factory setting

[3] Function settings

Enter the setting data of the functions set with the PZ-62DR series.

Function No.	Setting Data	Function No.	Setting Data	Function No.	Setting Data	Function No.	Setting Data
1	(0)	32	(2)	50	(10)	77	(10)
2	(0)	33	(2)	51	(0)	78	(15)
5	(0)	34	(0)	52	(0)	83	(3)
6	(0)	35	(0)	53	(6)	84	(0)
7	(0)	36	(1)	54	(1)	85	(6)
8	(0)	37	(1)	60	(0)	86	(0)
9	(0)	38	(1)	61	(0)	87	(0)
12	(0)	39	(0)	62	(0)	88	(0)
13	(1)	40	(7)	64	(0)	89	(4)
14	(2)	41	(0)	65	(0)	90	(0)
15	(3)	42	(7)	66	(0)	91	(1)
16	(4)	43	(7)	67	(2)	92	(1)
17	(2)	44	(5)	68	(5)	93	(5)
18	(0)	45	(0)	69	(0)	94	(0)
19	(0)	46	(0)	73	(5)	95	(0)
28	(0)	47	(2)	74	(10)	100	(0)
30	(0)	48	(10)	75	(15)		
31	(5)	49	(0)	76	(5)		

() : Factory setting



[4] External input/output

Enter the usage of the external input/output on the control circuit board.

Terminal or connector on the circuit board	Function Name	Used	Not used	Connected device
TM2 [1] [2]	External control input	<input type="checkbox"/>	<input type="checkbox"/>	
TM2 [Y] [Z]	External control input	<input type="checkbox"/>	<input type="checkbox"/>	
TM3 [9] [10]	Monitor output	<input type="checkbox"/>	<input type="checkbox"/>	
CN17 [1] [2]	Fan speed 4 input	<input type="checkbox"/>	<input type="checkbox"/>	
CN17 [1] [3]	Fan speed 3 input	<input type="checkbox"/>	<input type="checkbox"/>	
CN17 [1] [4]	Fan speed 2 input	<input type="checkbox"/>	<input type="checkbox"/>	
CN17 [1] [5]	Fan speed 1 input	<input type="checkbox"/>	<input type="checkbox"/>	
CN23	Power for the CO ₂ sensor	<input type="checkbox"/>	<input type="checkbox"/>	
CN26 [1] [2]	Bypass mode input	<input type="checkbox"/>	<input type="checkbox"/>	
CN26 [4] [5]	CO ₂ sensor input/0-10 V DC signal input	<input type="checkbox"/>	<input type="checkbox"/>	
CN26 [3] [5]	0-10 V DC signal input	<input type="checkbox"/>	<input type="checkbox"/>	
CN32	Remote/local switching	<input type="checkbox"/>	<input type="checkbox"/>	
CN34	LED on the CO ₂ sensor control	<input type="checkbox"/>	<input type="checkbox"/>	
CN35	Malfunction of the CO ₂ sensor input	<input type="checkbox"/>	<input type="checkbox"/>	
CN50	Monitor output PZ-4GS-E	<input type="checkbox"/>	<input type="checkbox"/>	
CN105	IT communication	<input type="checkbox"/>	<input type="checkbox"/>	

9. Parts catalog

Please note the following when using the parts catalog.

1. When ordering parts, the part number, part name, and the number of parts are required.
2. It may take time for you to receive the parts. Make an inquiry about a rush order.
3. Specifications may be subject to change without notice.
4. Parts marked with  and  are critical for safety.
5. To maintain safety and performance, use the parts specified in the parts catalog.
6. When replacing the parts to which the nameplate is attached, remove the nameplate and attach it to the new parts.

Description of screw abbreviations

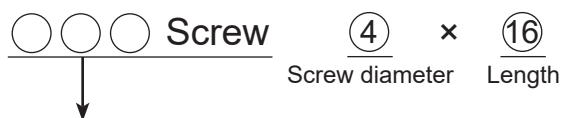

Abbreviation	Description
PC screw	Cross recess flat head machine screw
PRC screw	Cross recess oval head machine screw
PP screw	Cross recess pan head machine screw
SW · PP screw	Cross recess pan head screw with spring washer
PPT screw	Cross recess tapping screw
PCT screw	Cross recess flat head tapping screw
PTT screw	Cross recess truss head tapping screw
PT screw	Cross recess truss head machine screw
SET screw	Slotted head stop screw
SQ · SET screw	Square head stop screw
P · SET screw	Pan head stop screw
PMT screw	Primer truss head screw
HS · SET screw	Hexagon head stop screw
P · R · W screw	Cross recess round wood screw
P · C · W screw	Cross recess flat head wood screw
P · R · C · W screw	Cross recess round and flat wood screw
R · W screw	Slotted round wood screw
PW · PP screw	Cross recess pan head screw with small washer
SW-PW · PP screw	Cross recess pan head machine screw with spring washer and flat washer

Structural parts

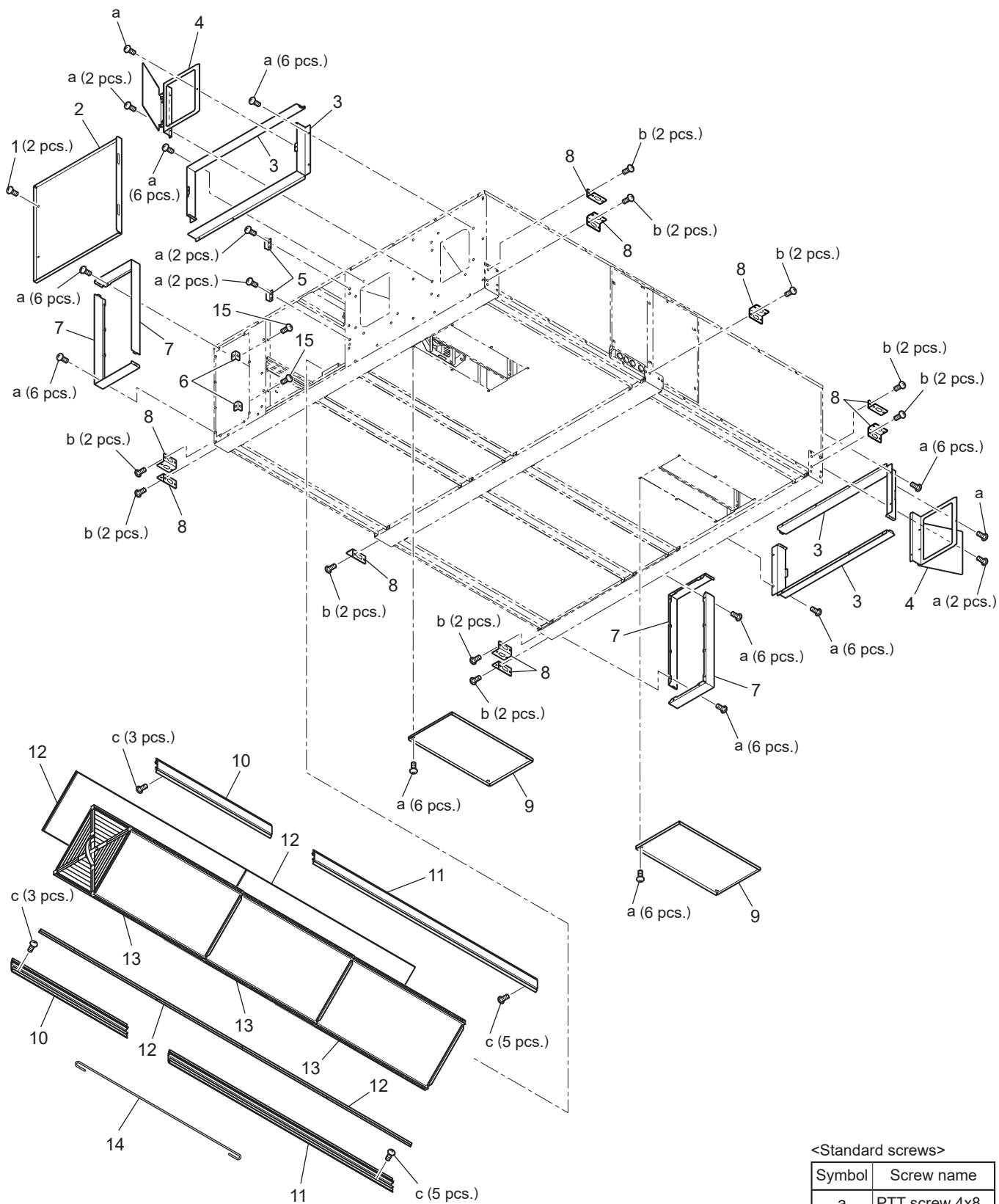

<Standard screws>

Symbol	Screw name
a	PTT screw 4x8
b	PT screw 6x12
c	PPT screw 4x8

Structural parts

LGH-160RVXT3-E

No.	Name of part	Parts No.	Q'ty pcs/unit	Critical for safety	Remarks
1	Special screw 4x12	W00 000 249	2		
2	Maintenance cover	W50 025 833	1		
3	Flange SA/EA	W50 025 709	4		
4	Shutter	W50 025 834	2		
5	Fix piece	W50 013 722	2		
6	Lock piece	W50 025 713	2		
7	Flange OA/RA	W50 025 708	4		
8	Hanger	W50 004 382	10		
9	Maintenance cover	W50 025 710	2		For the fans
10	Lossnay core holder	W50 025 381	2		675mm
11	Lossnay core holder	W50 025 382	2		1315mm
12	Filter	W50 025 717	4	⚠	
13	Lossnay core	W50 025 832	3	⚠	
14	Maintenance rod	W50 025 707	1		
15	Special screw 4x8	W00 000 089	11		

Fan parts

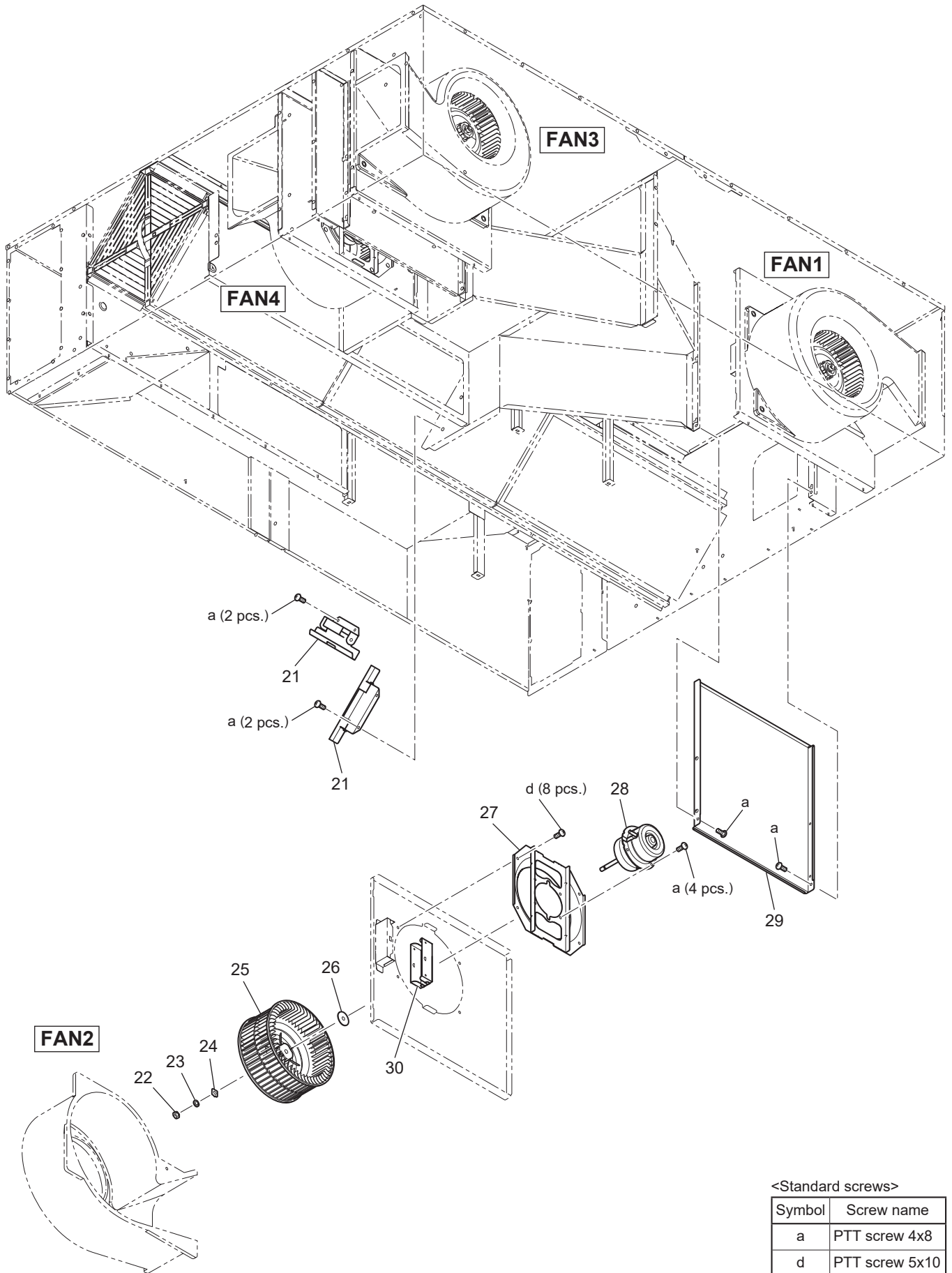

Fan parts

LGH-160RVXT3-E

No.	Name of part	Parts No.	Q'ty pcs/unit	Critical for safety	Remarks
21	Filter curtain	W50 025 715	2		
22	Special nut (M10)	W00 000 195	4		Left-handed
23	Spring washer (10)	W00 000 301	4		
24	Tab washer	W50 013 712	4		
25	Centrifugal fan	W50 025 480	4		Dia. 245mm
26	Special washer (10)	W50 003 478	4		Outer dia. 40mm
27	Motor fix plate	W50 025 712	4		
28	DC motor	W50 025 453	4	⚠	With the ferrite core
29	Separator	W50 025 711	2		
30	Connector cover (B)	W50 024 708	4		

Control parts

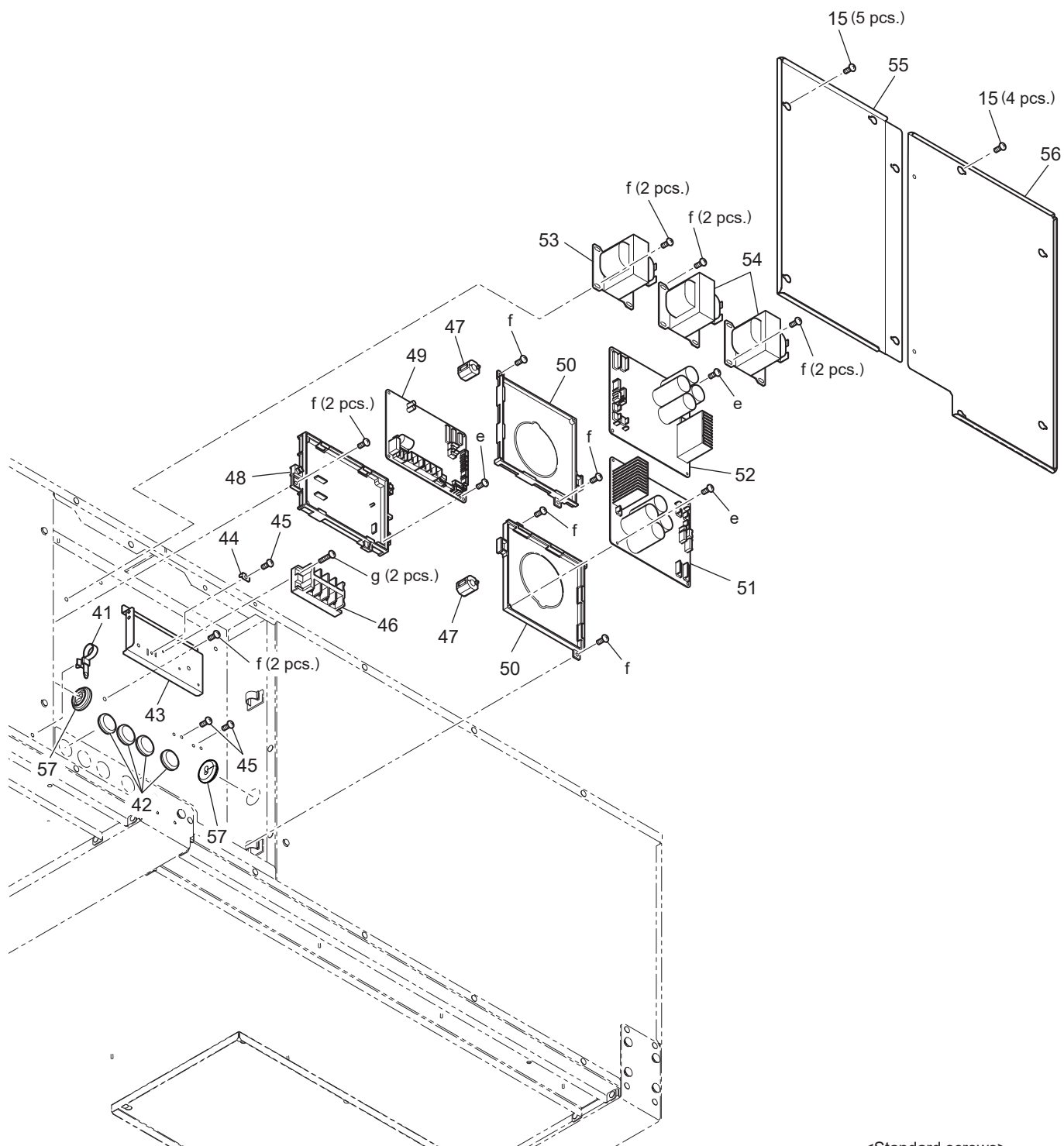

<Standard screws>

Symbol	Screw name
g	PTT screw 4x12
e	PPT screw 3x8
f	PT screw 4x8

Control parts

LGH-160RVXT3-E

No.	Name of part	Parts No.	Q'ty pcs/unit	Critical for safety	Remarks
41	Cord band	W00 000 258	1		
42	Bush	W00 000 289	4		
43	Fix plate	W50 025 704	1		
44	Earth fix plate	W82 001 706	1		
45	PT screw 4x8 BS	W00 000 011	3		
46	Terminal block	W50 025 215	1	⚠	With the lead
47	Ferrite core	W50 024 180	2	⚠	MRFC-13
48	PCB fix plate	W50 021 706	1		
49	Circuit board	W50 025 171	1	⚠	LG-X08DC-C2
50	PCB fix plate	W50 025 380	2		
51	Circuit board	W50 024 174	1	⚠	LG-X08DC-P8
52	Circuit board	W50 024 171	1	⚠	LG-X08DC-P7
53	Reactor	W50 004 179	1	⚠	AC10A
54	Reactor	W50 004 180	2	⚠	AC6.5A
55	Control cover A	W50 025 705	1		
56	Control cover B	W50 025 706	1		
57	Cord bush	W50 024 225	2		

Wiring parts

Lossnay unit

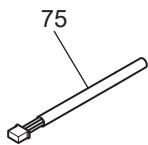
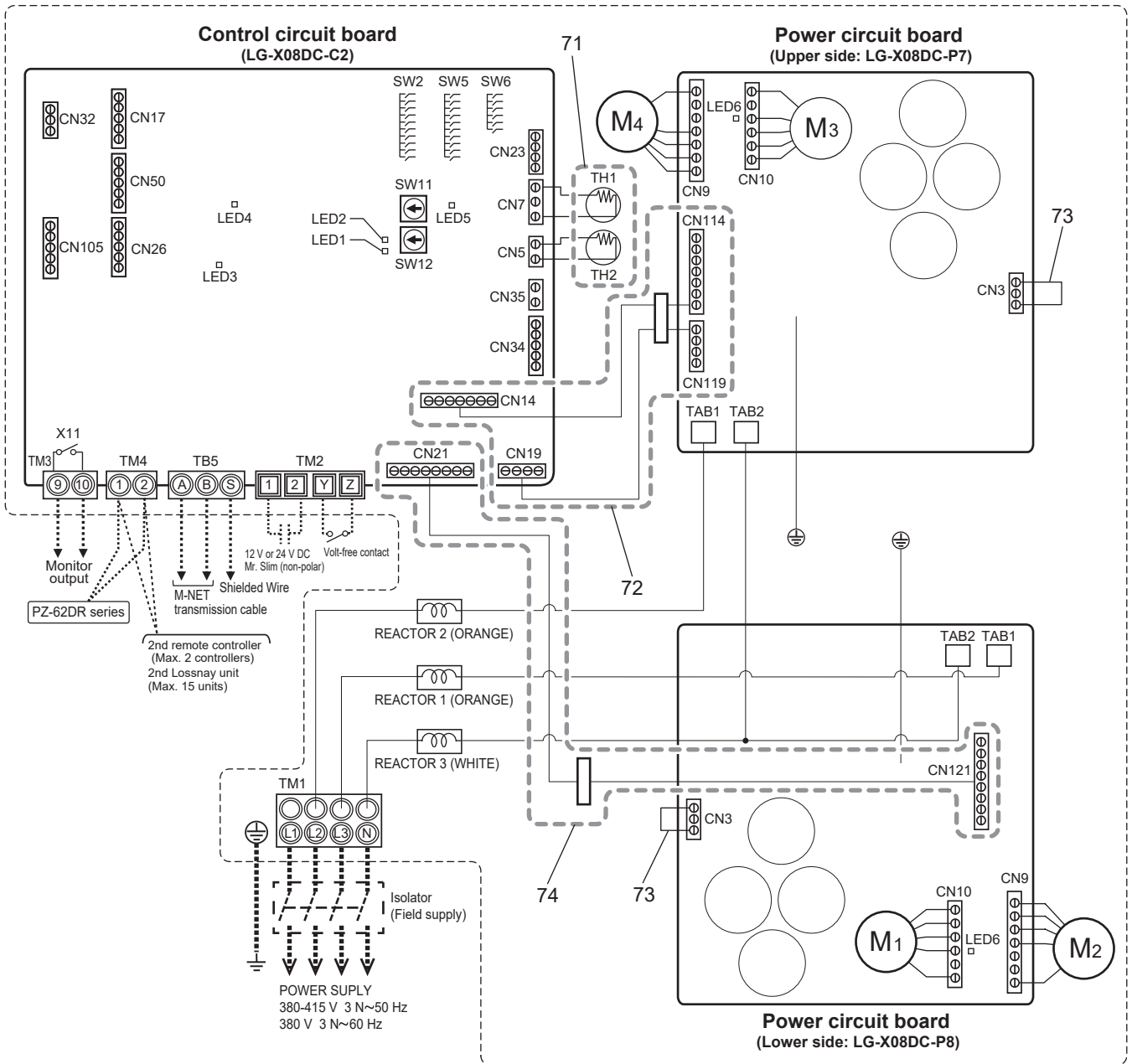

Wiring parts

LGH-160RVXT3-E

No.	Name of part	Parts No.	Q'ty pcs/unit	Critical for safety	Remarks
71	Thermistor	W50 025 217	1	⚠	
72	Lead wire	W50 025 213	1	⚠	CN14-114, CN19-119
73	Lead wire	W50 025 216	2	⚠	Short
74	Lead wire	W50 025 214	1	⚠	CN21-121
75	Lead wire	W50 004 231	1	⚠	100mm

Structural parts

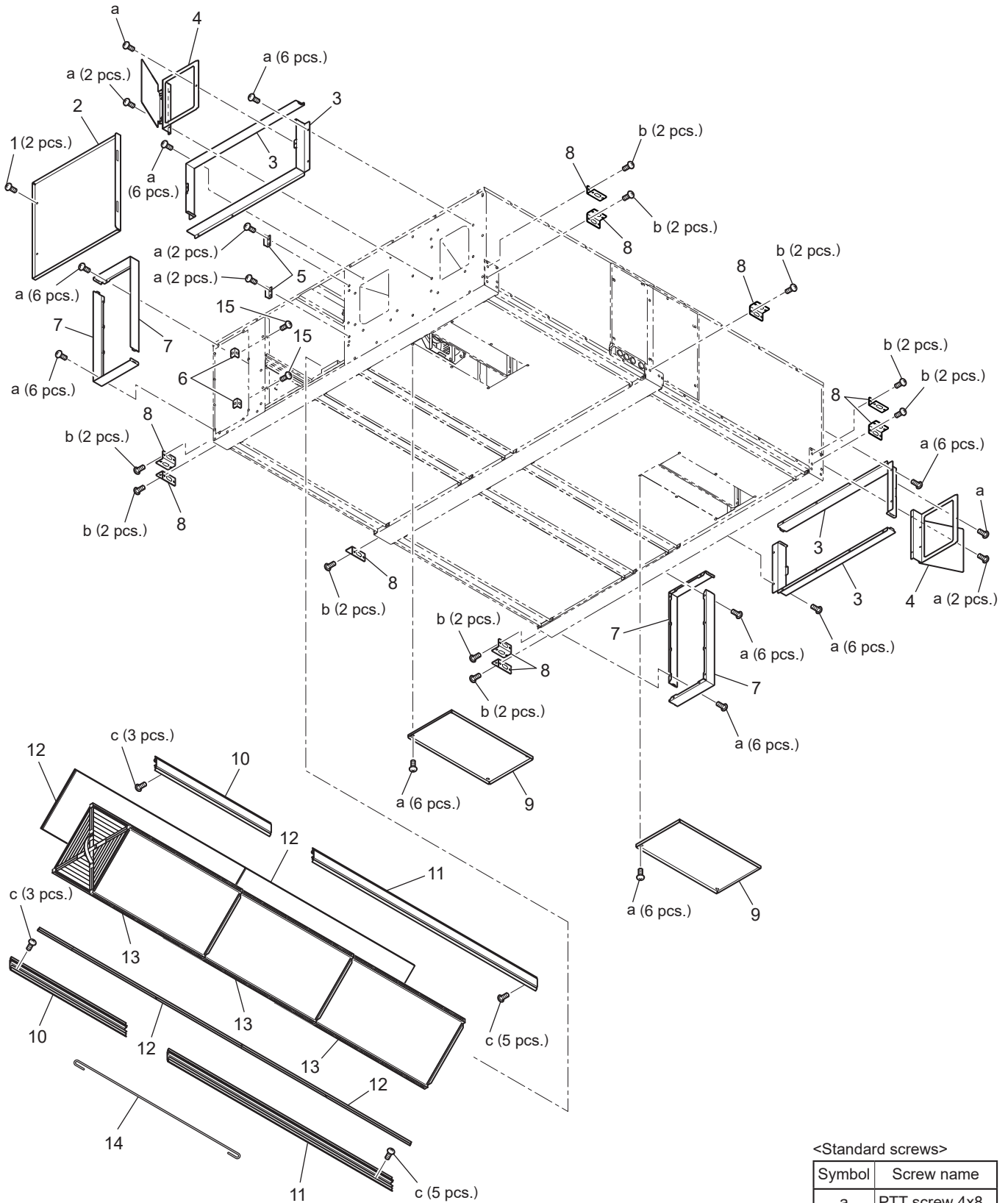

<Standard screws>

Symbol	Screw name
a	PTT screw 4x8
b	PT screw 6x12
c	PPT screw 4x8

Structural parts

LGH-200RVXT3-E

No.	Name of part	Parts No.	Q'ty pcs/unit	Critical for safety	Remarks
1	Special screw 4x12	W00 000 249	2		
2	Maintenance cover	W50 025 833	1		
3	Flange SA/EA	W50 025 709	4		
4	Shutter	W50 025 834	2		
5	Fix piece	W50 013 722	2		
6	Lock piece	W50 025 713	2		
7	Flange OA/RA	W50 025 708	4		
8	Hanger	W50 004 382	10		
9	Maintenance cover	W50 025 710	2		For the fans
10	Lossnay core holder	W50 025 381	2		675mm
11	Lossnay core holder	W50 025 382	2		1315mm
12	Filter	W50 025 717	4	⚠	
13	Lossnay core	W50 025 832	3	⚠	
14	Maintenance rod	W50 025 707	1		
15	Special screw 4x8	W00 000 089	11		

Fan parts

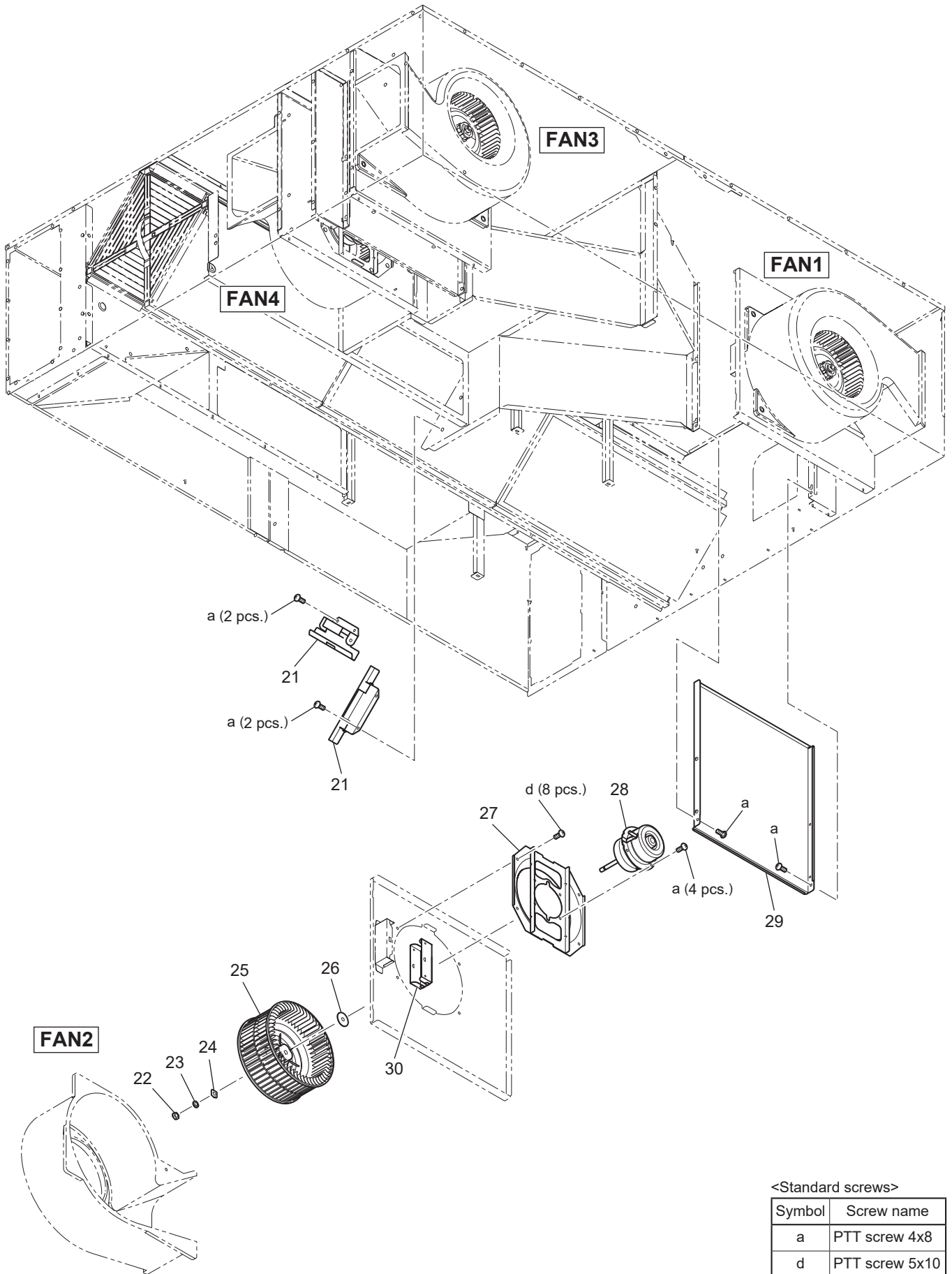

Fan parts

LGH-200RVXT3-E

No.	Name of part	Parts No.	Q'ty pcs/unit	Critical for safety	Remarks
21	Filter curtain	W50 025 715	2		
22	Special nut (M10)	W00 000 195	4		Left-handed
23	Spring washer (10)	W00 000 301	4		
24	Tab washer	W50 013 712	4		
25	Centrifugal fan	W50 025 480	4		Dia. 245mm
26	Special washer (10)	W50 003 478	4		Outer dia. 40mm
27	Motor fix plate	W50 025 712	4		
28	DC motor	W50 025 454	4	⚠	With the ferrite core
29	Separator	W50 025 711	2		
30	Connector cover (B)	W50 024 708	4		

Control parts

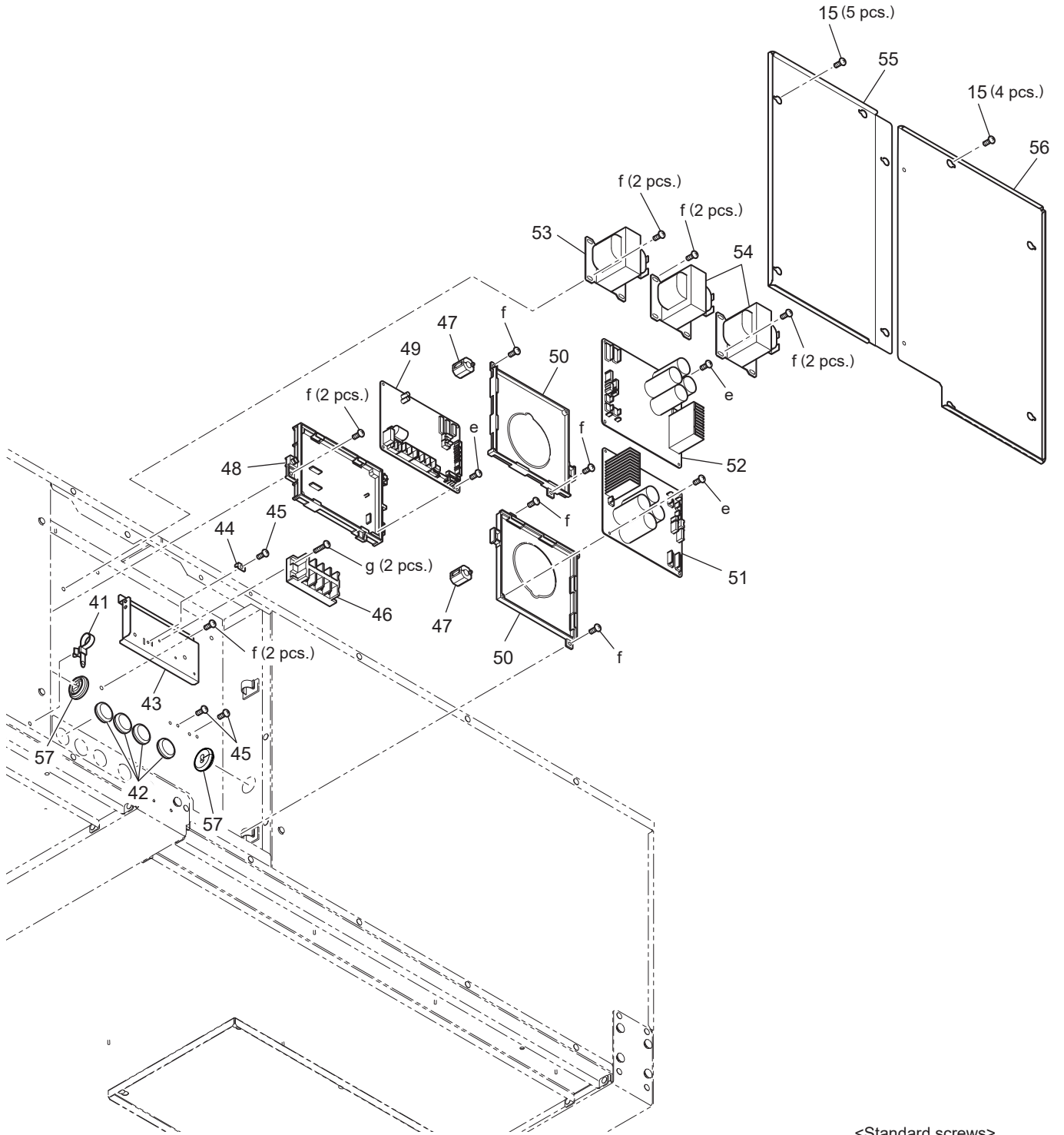

<Standard screws>

Symbol	Screw name
g	PTT screw 4x12
e	PPT screw 3x8
f	PT screw 4x8

Control parts

LGH-200RVXT3-E

No.	Name of part	Parts No.	Q'ty pcs/unit	Critical for safety	Remarks
41	Cord band	W00 000 258	1		
42	Bush	W00 000 289	4		
43	Fix plate	W50 025 704	1		
44	Earth fix plate	W82 001 706	1		
45	PT screw 4x8 BS	W00 000 011	3		
46	Terminal block	W50 025 215	1	⚠	With the lead
47	Ferrite core	W50 024 180	2	⚠	MRFC-13
48	PCB fix plate	W50 021 706	1		
49	Circuit board	W50 025 171	1	⚠	LG-X08DC-C2
50	PCB fix plate	W50 025 380	2		
51	Circuit board	W50 024 174	1	⚠	LG-X08DC-P8
52	Circuit board	W50 024 171	1	⚠	LG-X08DC-P7
53	Reactor	W50 004 179	1	⚠	AC10A
54	Reactor	W50 004 180	2	⚠	AC6.5A
55	Control cover A	W50 025 705	1		
56	Control cover B	W50 025 706	1		
57	Cord bush	W50 024 225	2		

Wiring parts

Lossnay unit

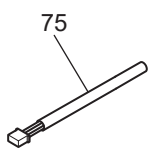
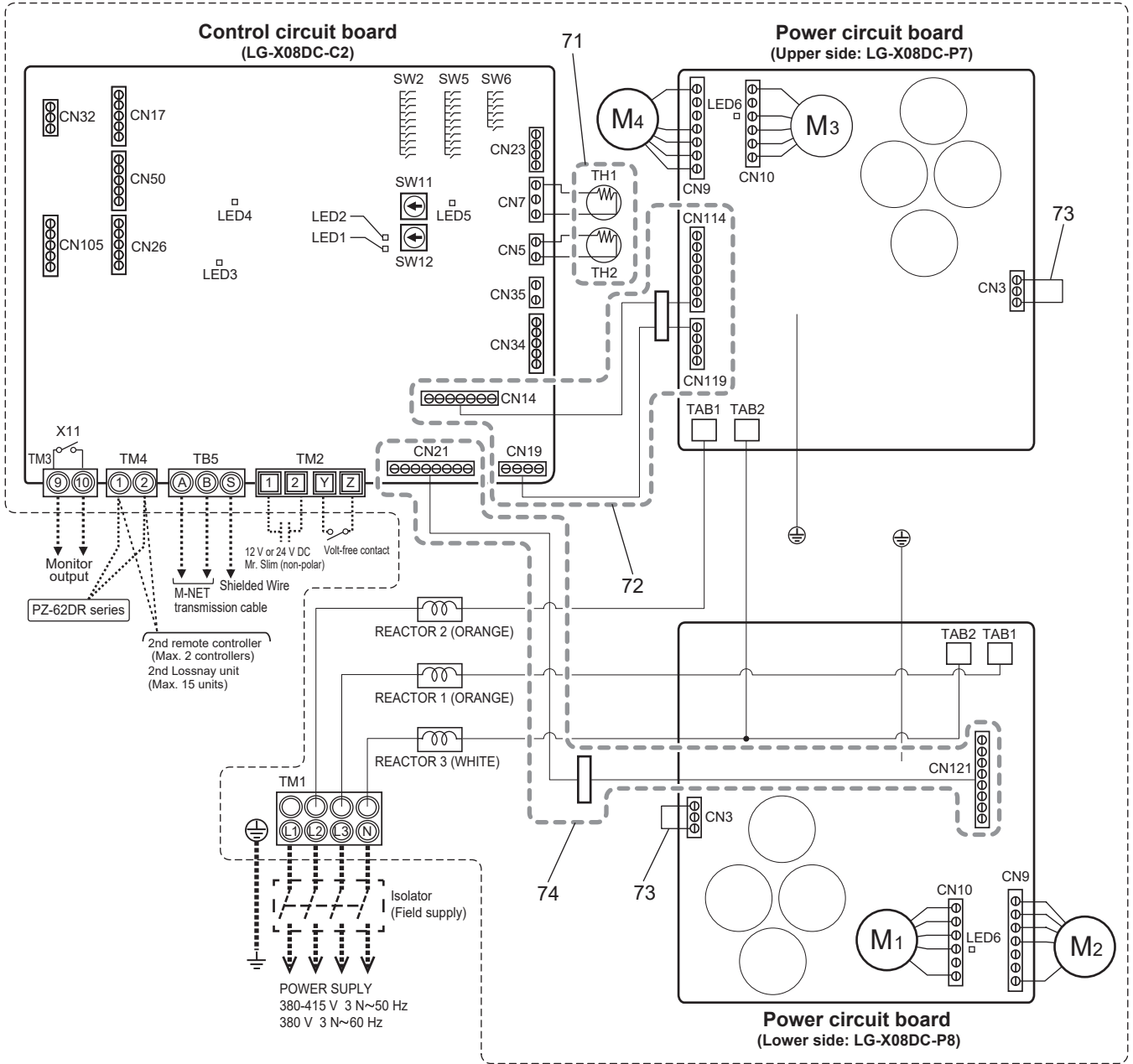

Wiring parts

LGH-200RVXT3-E

No.	Name of part	Parts No.	Q'ty pcs/unit	Critical for safety	Remarks
71	Thermistor	W50 025 217	1	⚠	
72	Lead wire	W50 025 213	1	⚠	CN14-114, CN19-119
73	Lead wire	W50 025 216	2	⚠	Short
74	Lead wire	W50 025 214	1	⚠	CN21-121
75	Lead wire	W50 004 231	1	⚠	100mm

Structural parts

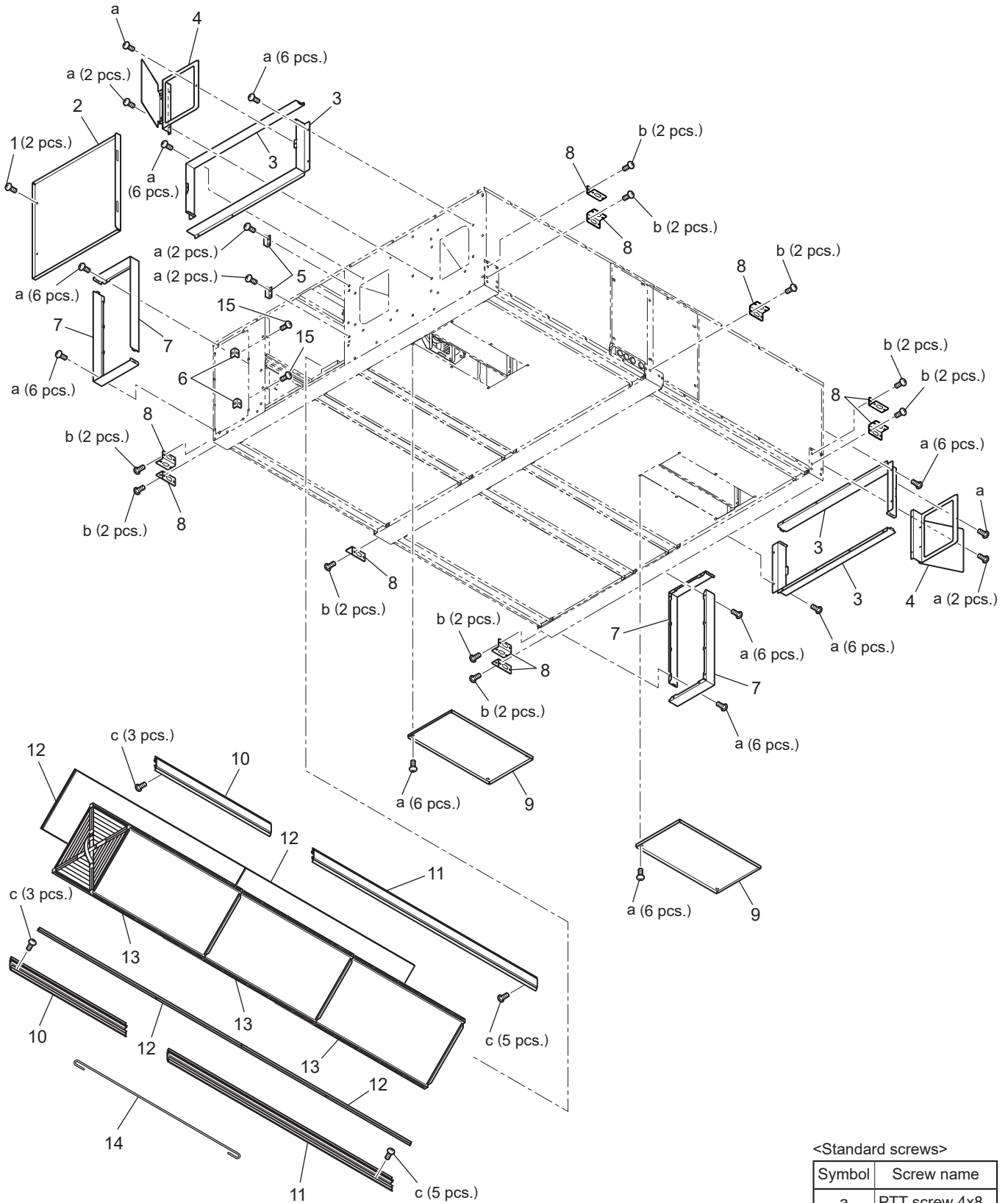

<Standard screws>

Symbol	Screw name
a	PTT screw 4x8
b	PT screw 6x12
c	PPT screw 4x8

Structural parts

LGH-250RVXT3-E

No.	Name of part	Parts No.	Q'ty pcs/unit	Critical for safety	Remarks
1	Special screw 4x12	W00 000 249	2		
2	Maintenance cover	W50 025 833	1		
3	Flange SA/EA	W50 025 709	4		
4	Shutter	W50 025 834	2		
5	Fix piece	W50 013 722	2		
6	Lock piece	W50 025 713	2		
7	Flange OA/RA	W50 025 708	4		
8	Hanger	W50 004 382	10		
9	Maintenance cover	W50 025 710	2		For the fans
10	Lossnay core holder	W50 025 381	2		675mm
11	Lossnay core holder	W50 025 382	2		1315mm
12	Filter	W50 025 717	4	⚠	
13	Lossnay core	W50 025 832	3	⚠	
14	Maintenance rod	W50 025 707	1		
15	Special screw 4x8	W00 000 089	11		

Fan parts

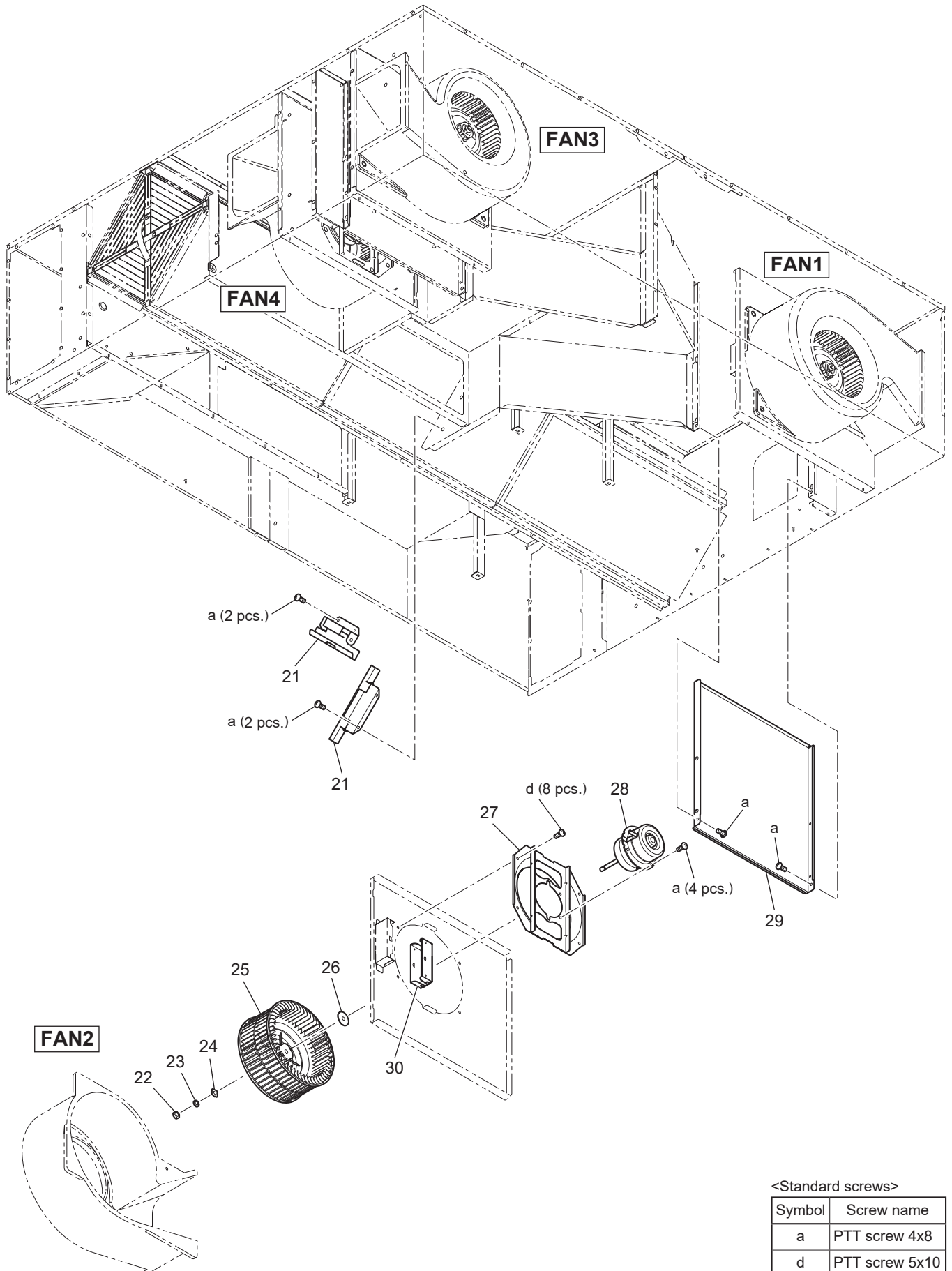

Fan parts

LGH-250RVXT3-E

No.	Name of part	Parts No.	Q'ty pcs/unit	Critical for safety	Remarks
21	Filter curtain	W50 025 715	2		
22	Special nut (M10)	W00 000 195	4		Left-handed
23	Spring washer (10)	W00 000 301	4		
24	Tab washer	W50 013 712	4		
25	Centrifugal fan	W50 025 480	4		Dia. 245mm
26	Special washer (10)	W50 003 478	4		Outer dia. 40mm
27	Motor fix plate	W50 025 712	4		
28	DC motor	W50 025 455	4	⚠	With the ferrite core
29	Separator	W50 025 711	2		
30	Connector cover (B)	W50 024 708	4		

Control parts

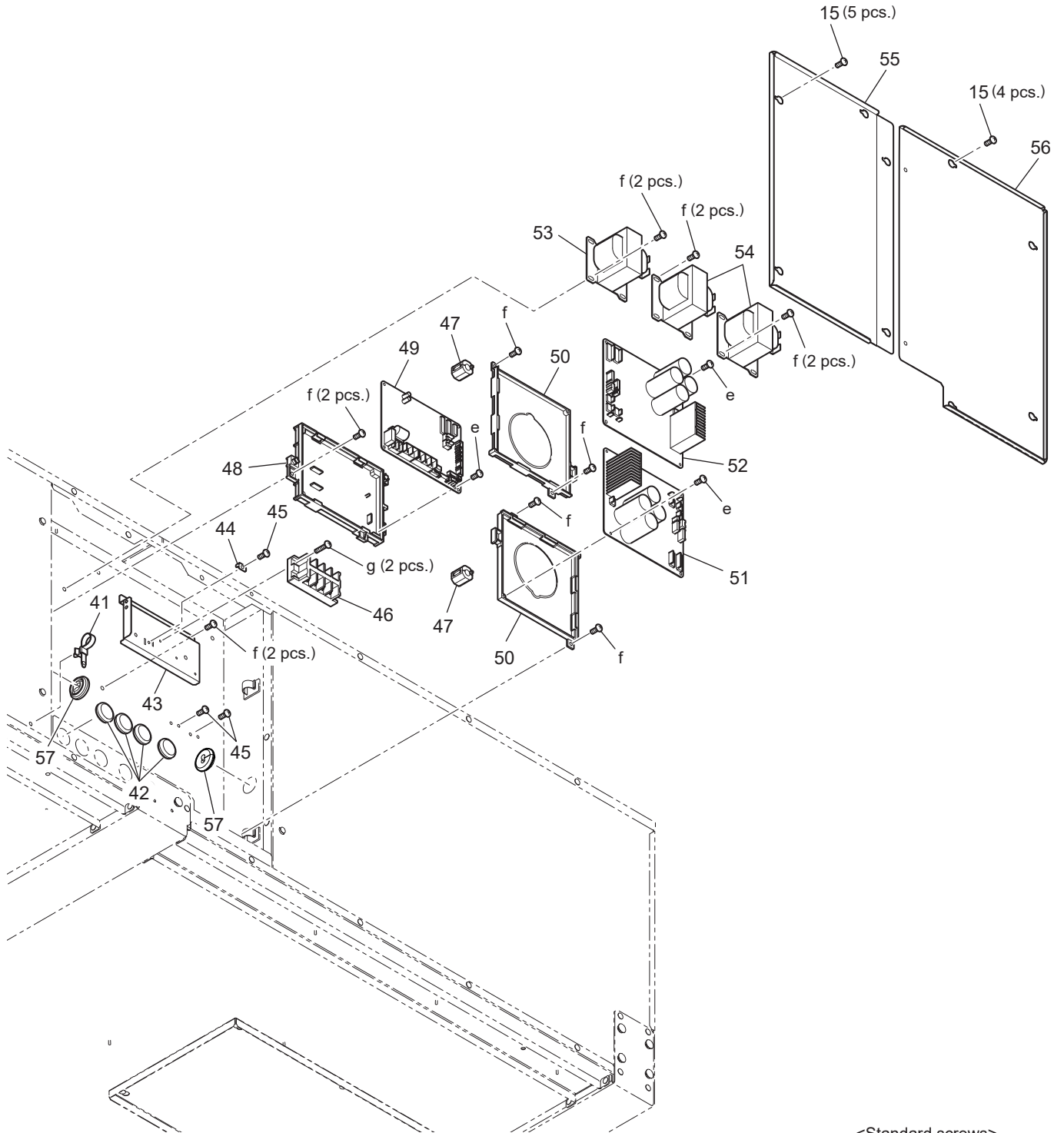

<Standard screws>

Symbol	Screw name
g	PTT screw 4x12
e	PPT screw 3x8
f	PT screw 4x8

Control parts

LGH-250RVXT3-E

No.	Name of part	Parts No.	Q'ty pcs/unit	Critical for safety	Remarks
41	Cord band	W00 000 258	1		
42	Bush	W00 000 289	4		
43	Fix plate	W50 025 704	1		
44	Earth fix plate	W82 001 706	1		
45	PT screw 4x8 BS	W00 000 011	3		
46	Terminal block	W50 025 215	1	⚠	With the lead
47	Ferrite core	W50 024 180	2	⚠	MRFC-13
48	PCB fix plate	W50 021 706	1		
49	Circuit board	W50 025 171	1	⚠	LG-X08DC-C2
50	PCB fix plate	W50 025 380	2		
51	Circuit board	W50 024 174	1	⚠	LG-X08DC-P8
52	Circuit board	W50 024 171	1	⚠	LG-X08DC-P7
53	Reactor	W50 004 179	1	⚠	AC10A
54	Reactor	W50 004 180	2	⚠	AC6.5A
55	Control cover A	W50 025 705	1		
56	Control cover B	W50 025 706	1		
57	Cord bush	W50 024 225	2		

Wiring parts

Lossnay unit

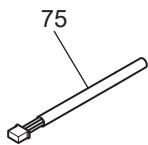
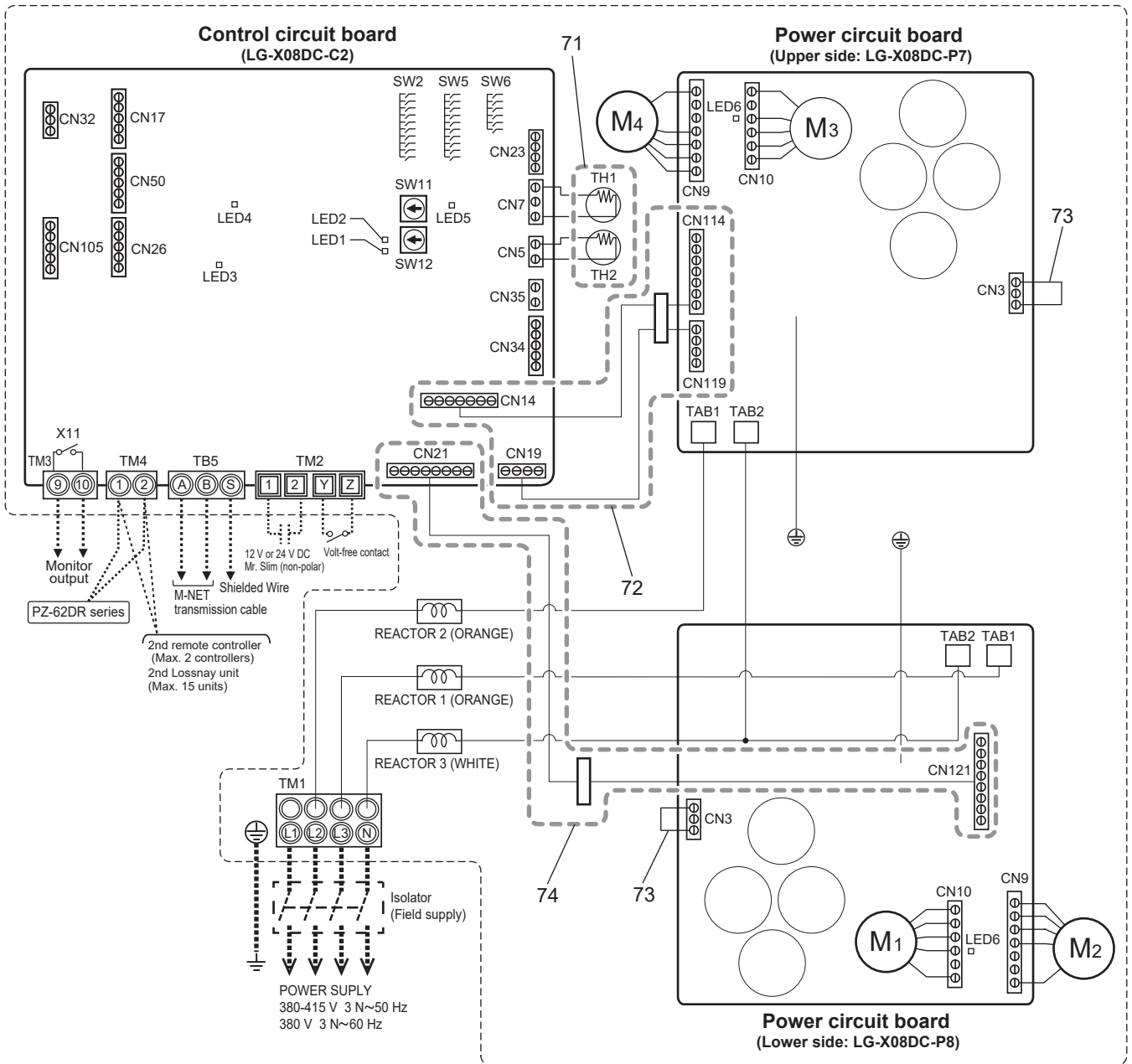

Wiring parts

LGH-250RVXT3-E

No.	Name of part	Parts No.	Q'ty pcs/unit	Critical for safety	Remarks
71	Thermistor	W50 025 217	1	⚠	
72	Lead wire	W50 025 213	1	⚠	CN14-114, CN19-119
73	Lead wire	W50 025 216	2	⚠	Short
74	Lead wire	W50 025 214	1	⚠	CN21-121
75	Lead wire	W50 004 231	1	⚠	100mm