

MODEL	LGH-250RVXT3-E	SIGN	
-------	----------------	------	--

Heat exchange system	Energy recovery ventilating system						
Heat exchanger (Lossnay core)	Special treated paper plate heat exchanger						
Cladding	Galvanized steel sheet						
Motor	EC motor						
Filter	Non-woven fabrics filter (ISO 16890 Coarse 60%)						
Surrounding air condition	-10°C to 40 °C, 80%RH or less						
Suction air condition	Lower than 40°C, 80%RH.						
Supply fan operation under low outdoor temperature	-10°C to -15°C : Intermittent operation 60 min ON, 10 min OFF -15°C or less : Sensing operation 55 min OFF, 5 min ON						
Weight	172kg						
Electrical power supply	380 - 415V 3N~ 50Hz / 380V 3N~ 60Hz						
Fan speed	4	3	2	1	Test condition		
Default Airflow setting	100%	75%	50%	25%			
Input power [W]	L1-N	0	0	0	EN13053: 2019		
	L2-N	724	348	142		43	
	L3-N	724	348	142		43	
	Total	1448	696	284		86	
Airflow	[m ³ /h]	2500	1875	1250		625	
	[L/s]	694	521	347		174	
Specific fan power [W/(L/s)]		2.09	1.34	0.82		0.50	
External static pressure [Pa]		190	107	48		12	
Temp. exchange efficiency [%]	Heating	77.0	78.0	80.0		84.0	EN308: 2022
	Cooling	65.0	70.5	76.5		81.0	
Enthalpy exchange efficiency [%]	Heating	75.0	76.0	78.0	81.5		
	Cooling	54.0	59.0	66.0	73.0		
Noise [dB]		44.0	38.0	31.5	23.0	A-weighted sound pressure level (1.5m)	
Exhaust Air Transfer Ratio [%]		5.0			EN308: 2022 / 75% Fan Speed		
External leakage [%]		5.0			EN1886: 2007/ 75% Fan Speed		
Maximum current [A] (380-415V 3N~ 50Hz / 380 3N~ 60Hz)	L1	0		Maximum input power [W] (380-415V 3N~ 50Hz / 380 3N~ 60Hz)	L1-N	0	
	L2	4.2 - 3.8 / 4.2			L2-N	740 - 730 / 750	
	L3	4.2 - 3.8 / 4.2			L3-N	740 - 730 / 750	
	N	5.0 - 4.8 / 4.8			Total	1480 - 1460 / 1500	
Insulation resistance	10MΩ or more						
Dielectric strength	AC 1000V 1 minute						
Inrush current	5.4 A @10ms						

■ Characteristic curve

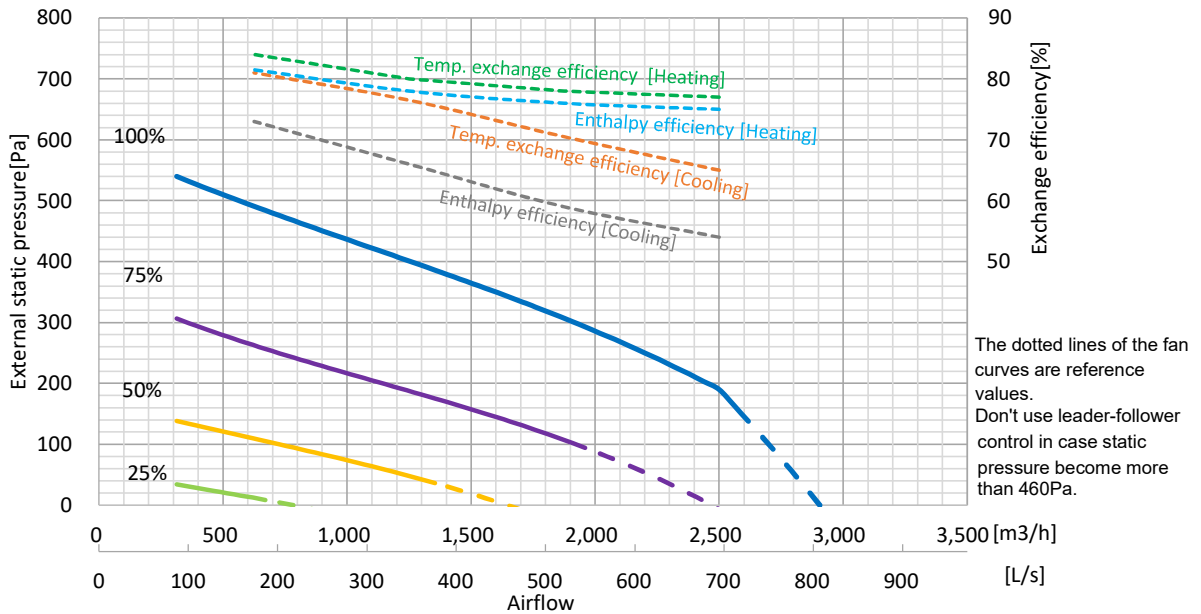

■ Attention

- The input power, the efficiency and the noise are based on the rating air volume, 400V/50Hz. Noise (A-weighted sound pressure level) is measured 1.5m off from the center of the unit in an anechoic chamber.
- Heat recovery ventilation mode starts automatically while detecting OA temperature lower than 8°C, even Bypass mode is selected. Remote controller continues to display "Bypass ventilation" in this case.
- Do not use the booster fan to exceed airflow rate/pressure shown in Q-H diagram of the unit.
- In bypass mode, the maximum air flow is 70% of heat recovery mode. See "Bypass operation" section for more detail.
- Power supply must be connected to 3 phase 4 wire power line but the unit uses it as 2 lines of single phase power. See "Wiring diagram" section for more detail.
- It is prohibited to use the unit where salt, sulphur or hot spring steam damage is expected.
- Do not use with acid, alkalis, organic solvent, oil mist, paint, or harmful gas as pesticide, corrosive gas, etc.
- In cold area or strong wind area, outdoor air may enter the unit because of the pressure difference or external wind even when the unit stops. It is recommended to install an electrically damper to block outdoor air in such cases.
- Avoid to install air inlets and outlets where insects are likely to gather like a place near interior or exterior lights. In that case, select hoods or louvers which have repellent net.

※Specifications may be subject to change without notice.

SPECIFICATIONS	DATE	TYPE	CEILING RECESSED LOSSNAY
	15-May-24	MODEL	LGH-250RVXT3-E
MITSUBISHI ELECTRIC CORPORATION	NUMBER	N23HHGU0026	1/5

Outline drawings

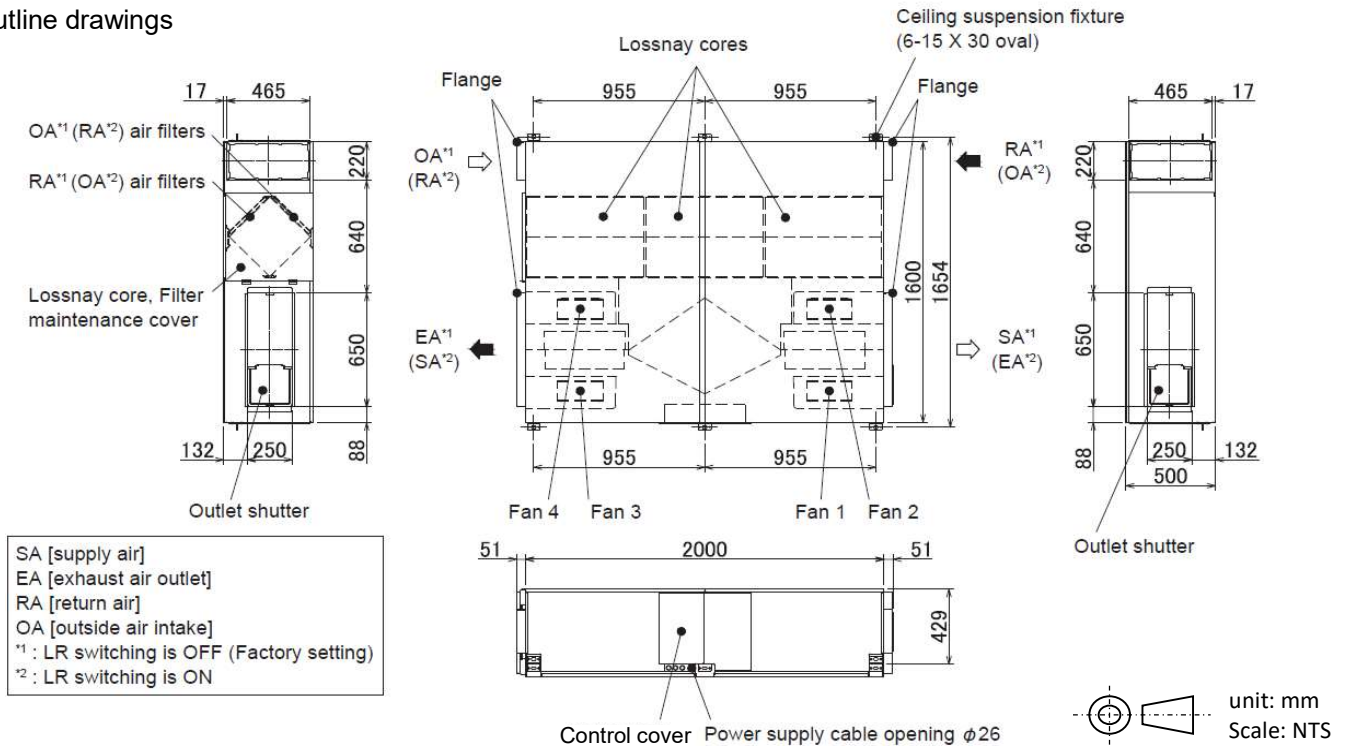

Reference for maintenance space

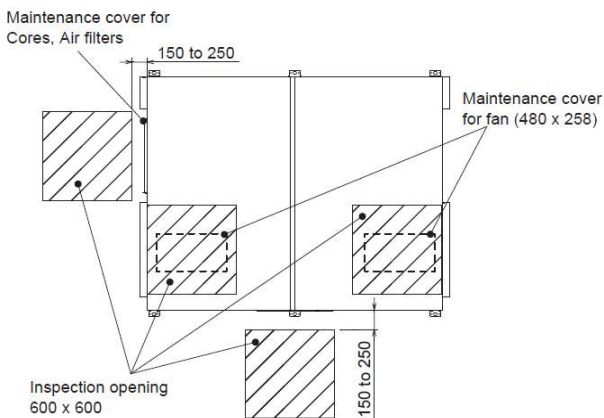

LR switching

RVXT3 can not be installed up-side-down. Instead, it has the function to be able to change air path for supply side and exhaust side to be opposite.

LR switching is OFF (Factory setting)

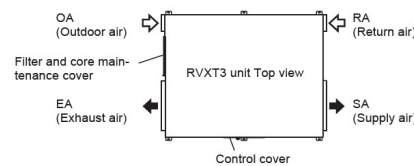

LR switching is ON

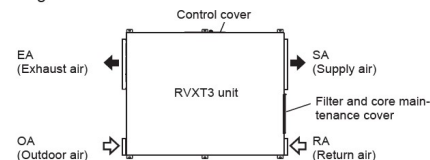

Caution for installation

- Do not modify the unit as it may cause malfunction.
- Install the anchor bolts to ensure the product's weight or earthquake load. Correctly rated wire/chain may also be used.
- Leave sufficient space and make inspection opening for the filter and Lossnay core removal side for maintenance purpose.
- The unit shall be installed horizontally. In each case, the tolerance is $\pm 0.5^\circ$.
- Take care in locating air inlet to prevent intake of dirty air or disgusting smell from exhaust gas of factory, air from rubbish disposal, etc.
- Take care as below to prevent from condensation.
 - The outdoor side (OA, EA) and SA ducts must be heat-insulated in order to prevent from condensation.
 - If the ambient temperature around the Lossnay unit is close to outdoor condition, it is recommended to insulate RA and SA ducts and additional insulation foam on the unit surface.
 - Condensation and freezing may occur on the Lossnay unit surface, because of the outdoor air condition or humidity condition above the ceiling. A supplemental insulation foam for the unit surface is necessary in that case.
 - When the supply air is set twice as much as the exhaust air or more by airflow function, the Lossnay body indoor side and SA duct must be put additional insulation. Without additional insulation, it could cause condensation and water drop from the unit.
- Do not install this product in a place where it is exposed to ultraviolet light. UV may be damage covering insulation.
- Outdoor air may enter the Lossnay owing to the pressure difference between indoor and outdoor or external winds even when the product is not operated. It is recommended to install an electrically operated damper to block the outdoor air.
- Install louvers or covers for OA inlet & EA outlet to prevent rainwater from entering the Lossnay unit. The outdoor side duct (OA and EA) shall decline by 1/30 or more downward to outdoor.
- When RA duct is not installed and RA is suctioned directly from the unit surrounding space, a repellent net is necessary for the RA inlet to prevent large size dust or something from intruding into the unit.
- Take precautions when using the product in a quiet location.
- Do not use under high temperature and humidity condition. Condensation will occur and water will gather inside the Lossnay cores under high temperature and humidity condition, such as warm swimming pool, bathroom, greenhouse or foggy place.

※Specifications may be subject to change without notice.

OUTLINE DRAWINGS	DATE	TYPE MODEL	CEILING RECESSED LOSSNAY LGH-250RVXT3-E	
	15-May-24			
MITSUBISHI ELECTRIC CORPORATION	NUMBER	N23HHGU0026		2/5

■ Wiring diagrams

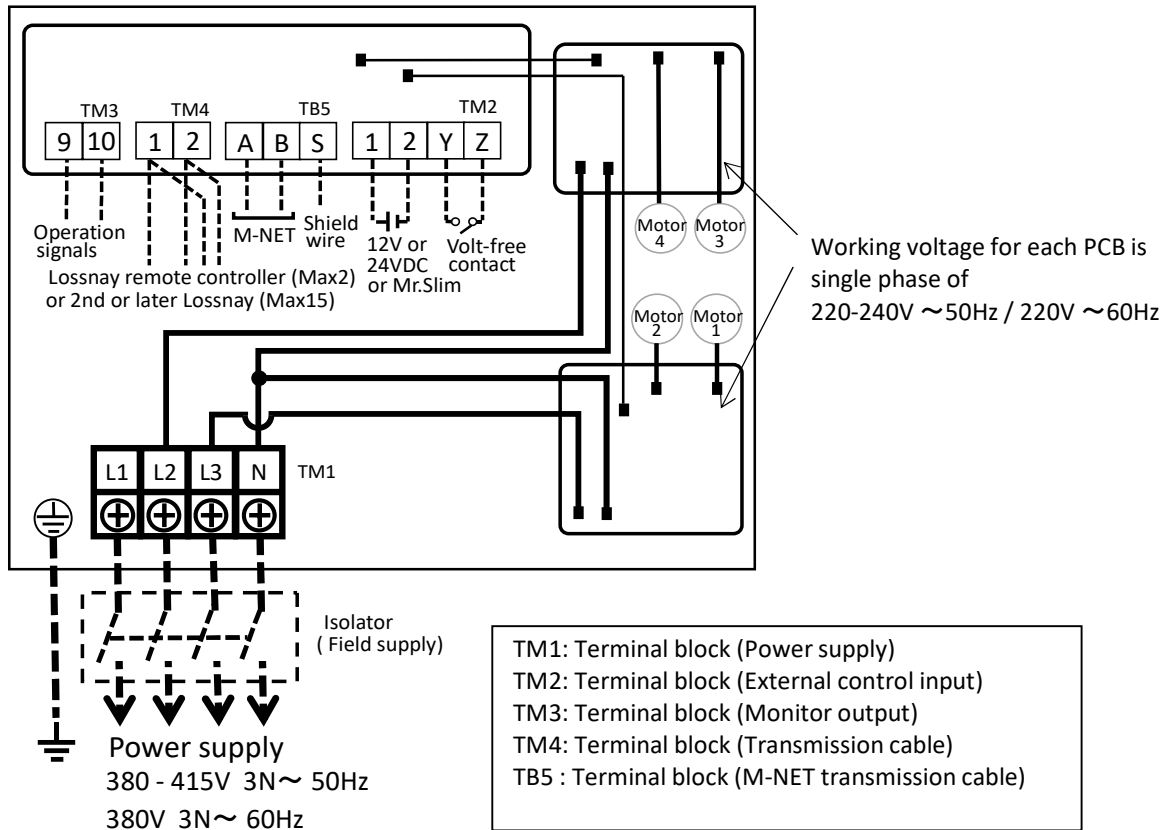

• Power supply must be connected to 3 phase 4 wire power line even the unit uses it as two of single phase power. It means L1 line does not connect to any load on the unit.

• Make sure to connect Neutral line.

Use the wire which has same mm² / AWG diameter as L1, L2 and L3 for Neutral connection because the current flows on Neutral line as well.

■ Caution for electrical work

1. Make sure to ground and install an all-pole electrical leakage isolator securely.
2. Select proper circuit breaker according to the electrical current on the 1st page. Always use a current leakage breaker that is compatible with higher harmonics as this unit is equipped with an inverter. The use of an inadequate breaker can cause the incorrect operation of inverter.
3. Perform electrical installation to meet appropriate regulations and standards.
4. Always use double insulated cable for the transmission cables.
5. Wiring work must be performed by qualified professionals.
6. All supply circuits must be disconnected before obtaining access to the terminal devices.
7. When only Lossnay units are used in M-NET, power supply unit is required to connect to centralized controller. Number of power supply units or the transmission boosters should correspond with the connected Lossnay units.
8. In the case of installing a duct heater interlocked with Lossnay, be sure to observe the following:
 - ① Choose a OA pre-heater which can control the heater outlet air temperature even both the air flow is maximum and minimum. Otherwise it could fall the supply fan into intermittent operation.
 - ② Select a duct heater in compliance with local and national laws, ordinances, and standards. Select a duct heater that is tested by a certification body.
 - ③ Always select a heater that is equipped with a non-self-resetting safety device.
 - ④ Do not directly supply power from the Lossnay unit to the duct heater. Doing so could cause fire.
 - ⑤ Install a circuit breaker for the duct heater in compliance with all applicable laws, ordinances, and standards.
 - ⑥ Install the duct heater separated from the product by a distance of 2 m or more.
 - ⑦ Ensure that the duct heater and Lossnay are wired and that the Lossnay function settings have been configured, and then always check operation by trial operation.
9. With this product, the wiring installation method will vary according to the design of the system. Refer to the installation manual for more detail.

※Specifications may be subject to change without notice.

WIRING DIAGRAMS	DATE	TYPE MODEL	CEILING RECESSED LOSSNAY	
	15-May-24		LGH-250RVXT3-E	
MITSUBISHI ELECTRIC CORPORATION		NUMBER	N23HHGU0026	3/5

■ Bypass operation

RVXT3 series does not have bypass damper.

Bypass operation of RVXT3 is realized by only one fan motor operation from 2 fan motors in supply and exhaust path.

Air path to 2 fan motors in each supply and exhaust are separated physically after the heat exchange core.

This structure contribute that one fan motor operation in each supply and exhaust path makes less-heat-recovery operation possible.

In bypass mode, the maximum air flow is 70 % of heat recovery mode. So as in Night-purge function also.

Note:

- When RVXT3 operates air flow 75 % or more at "Auto" fan speed according to 0-10 VDC input control, RVXT3 moves into heat recovery mode and stops bypass monitor output even bypass condition is satisfied at bypass mode.
- The display on the remote controller keeps bypass mode.
- In bypass mode, the fan with outlet shutter operate trickly from 60 % to 70 % airflow. If it is necessary to stop that operation, it is possible to change the maximum airflow for bypass mode in Function setting. See installation manual for more detail.

Energy recovery operation (Lossnay mode)

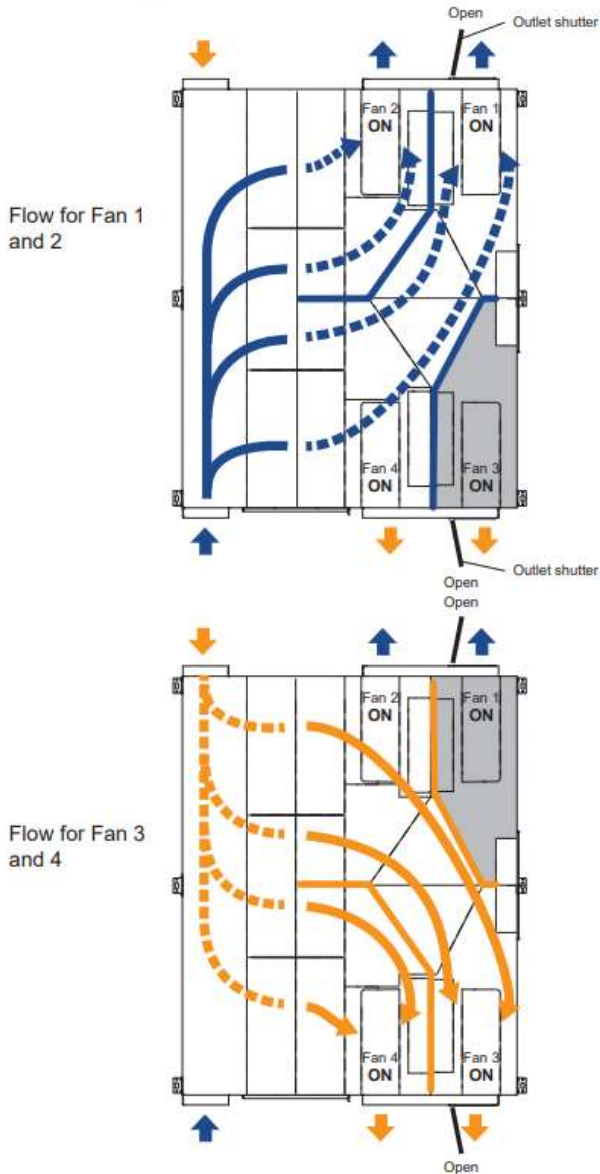

Bypass operation (bypass mode)

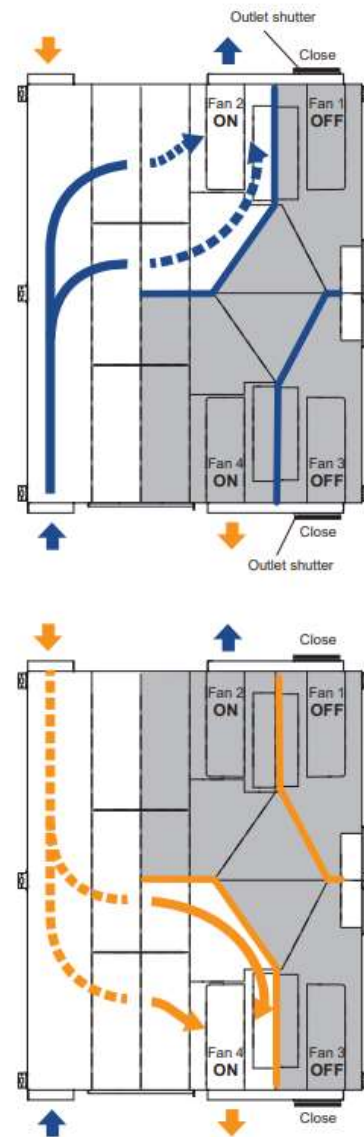

■ Maintenance and lifetime

Remove all dust and dirt on air filters and Lossnay cores at regular intervals to prevent from a deterioration in the Lossnay function.

Refer to each model's operation instructions for the suggested maintenance period and methods.

General indication of lifetime of the main parts is as below. Time below is unrelated to guaranteed period for service.

And parts exchange period varies with usage condition.

Lossnay cores	: Around 10 years with maintenance at stated periods.
Air Filters	: Around 5 years with maintenance at stated periods
Motor	: 30,000 hours
Circuit board	: 25,000 hours
Thermistor	: Around 5 years

※Specifications may be subject to change without notice.

SAFTY NOTES	DATE	TYPE	CEILING RECESSED LOSSNAY
	15-May-24	MODEL	LGH-250RVXT3-E
MITSUBISHI ELECTRIC CORPORATION	NUMBER	N23HHGU0026	4/5

■ Lifting transportation

⚠️ WARNIN When lifting the unit, hook the slings for four ceiling suspension fixture holes of the unit. Slings of each sides must be at least 3 m (10 ft) long or more. Each sling must be able to support the gross weight including the package. Make the unit levelled during the lifting. Improper lifting will cause the unit to topple or fall, resulting in serious injury.

⚠️ CAUTION Note the package is damaged during the lifting. Do not lift the unit when the carton is wet.

Detail of ceiling suspension

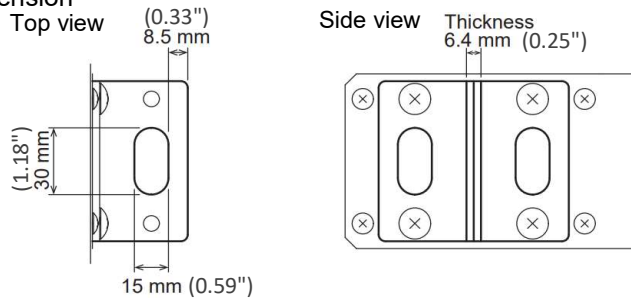

Cut each corner of the carton box 200mm (8") x 200mm (8"), and make the access to the fixture possible. Hook slings to four fixtures with fix pieces. When using two slings, hook them to the ceiling fixture diagonally.

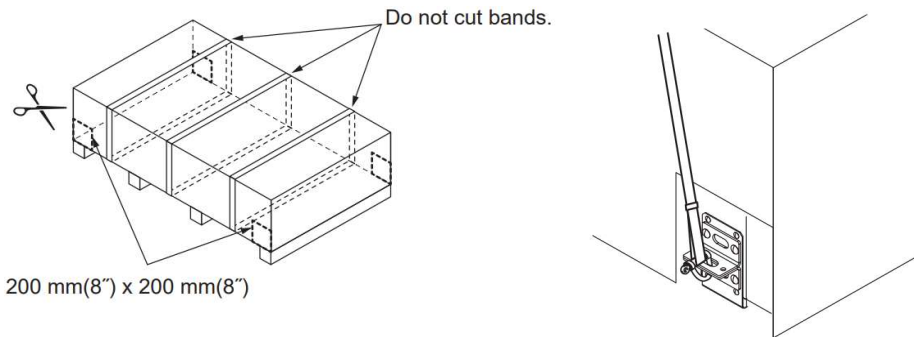

Make the angle between each sling 60° or less. Do not put anything on the unit during the lifting. Keep level during the lifting.

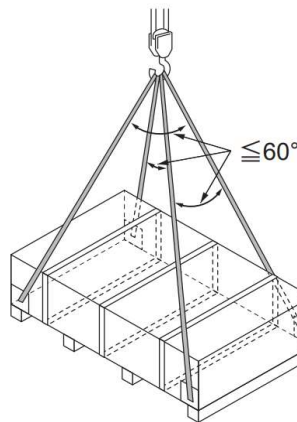

■ Forklift transportation

⚠️ WARNIN Use a forklift with the fork length 1m (3.3 ft) or more and enough power to lift this product. Always fork the side indicated on the package, because of the center of gravity position. Improper lifting will cause the unit to topple or fall, resulting in serious injury.

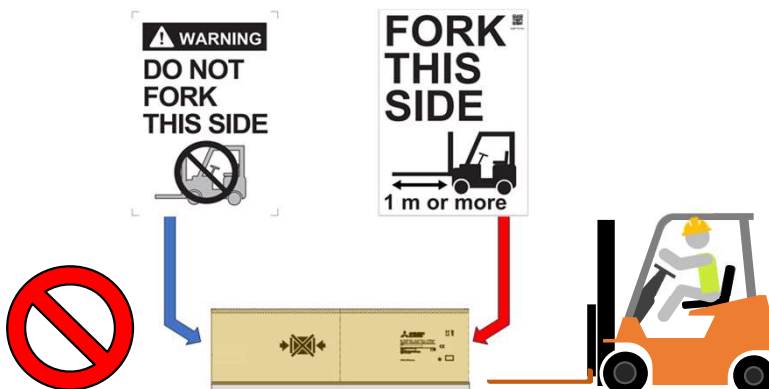

※Specifications may be subject to change without notice.

SAFTY NOTES	DATE	TYPE	CEILING RECESSED LOSSNAY	
	15-May-24	MODEL	LGH-250RVXT3-E	
MITSUBISHI ELECTRIC CORPORATION		NUMBER	N23HHGU0026	5/5