



Lossnay Energy Recovery Ventilator

MODELS:

LGH-160RVXT3-E

LGH-200RVXT3-E

LGH-250RVXT3-E

Operating Instructions











For the user

Please read this manual carefully before use for proper and safe use.

Do not attempt to install the product by yourself.

Safety precautions

The following signs indicate that death or serious injury may be caused by failure to heed the precautions described below.

|  WARNING | | Incorrect handling could cause serious injury or death. |
|---|---|---|
|  Prohibited | <p>Do not turn the unit on or off when flammable gas has leaked. It could catch fire or cause explosion with sparks released from electrical components. Open windows to ventilate.</p> | |
|  Do not disassemble | <p>Do not modify or disassemble. It could cause fire, electric shock or injury.</p> | |
|  Do not wet | <p>Do not apply water to the unit and remote controller. Electrical shock can result.</p> | |
|  Do not touch | <p>Do not poke your fingers or sticks into the air intake and outlet while the product is operating. Failure to heed this warning may result in injury.</p> | |
|  Wet hands prohibited | <p>Do not operate with wet hands. Electrical shock can result.</p> | |
|  The instructions given must be followed. | <p>Use the specified power supply and voltage. Use of incorrect power supply could cause fire or electric shock.</p> | |
| | <p>Make sure the power supply isolator is turned off before starting maintenance. It could cause electric shock or injury if it is turned on.</p> | |
| | <p>When any abnormal conditions (burning smell, water leakage or others) are observed, stop operation, turn off the power supply isolator and consult your dealer. Continuing operation under such conditions could cause, electric shock, fire, or damage.</p> | |
| | <p>Do not touch the product for at least 5 minutes after the power is shut off. Electrical shock can result.</p> | |
|  CAUTION | | Incorrect handling could cause injury or damage to property or household effects. |
|  Prohibited | <p>Do not place a burning appliance in a place where it is exposed directly to the wind from Lossnay. It could cause an accident as a result of incomplete combustion.</p> | |
| | <p>Do not operate with the "Bypass" when heating the room in winter. Condensed water may drip from the unit and wet the surface of ceiling.</p> | |
| | <p>Do not use at a place where exposed to high temperatures (40°C or higher), naked flames, or in environment with heavy fumes. It could cause fire.</p> | |
| | <p>Do not use in an environment such as a chemical factory, where hazardous gases such as acidic gases, alkaline gases, organic solvent fumes, paint fumes, or gases containing corrosive components are generated. It could malfunction.</p> | |
|  The instructions given must be followed. | <p>Securely install parts after maintenance. It could cause injury if parts fall.</p> | |
| | <p>Put on gloves during maintenance. It could cause injury.</p> | |
| | <p>Make sure the power supply isolator is turned off when Lossnay is not used for a long period of time. It could cause electric shock, power leakage, or fire as a result of deteriorated insulation.</p> | |
| | <p>When outdoor temperature becomes lower than -10°C, the supply fan starts intermittent operation for defrosting operation. -10°C to -15°C : Intermittent operation 10min OFF, 60min ON. -15°C or less : Intermittent operation 55 min OFF, 5 min ON.</p> | |
| | <p>Other than EU countries: This appliance is not intended for use by persons (including children) with reduced physical sensory or mental capabilities, or lack of experience and knowledge, unless they have been given supervision or instruction concerning use of the appliance by a person responsible for their safety. Children should be supervised to ensure that they do not play with the appliance.</p> | |
| | <p>EU countries: This appliance can be used by children aged from 8 years and above and persons with reduced physical, sensory or mental capabilities or lack of experience and knowledge if they have been given supervision or instruction concerning use of the appliance in a safe way and understand the hazards involved. Children shall not play with the appliance. Cleaning and user maintenance shall not be made by children without supervision.</p> | |

Names of the parts

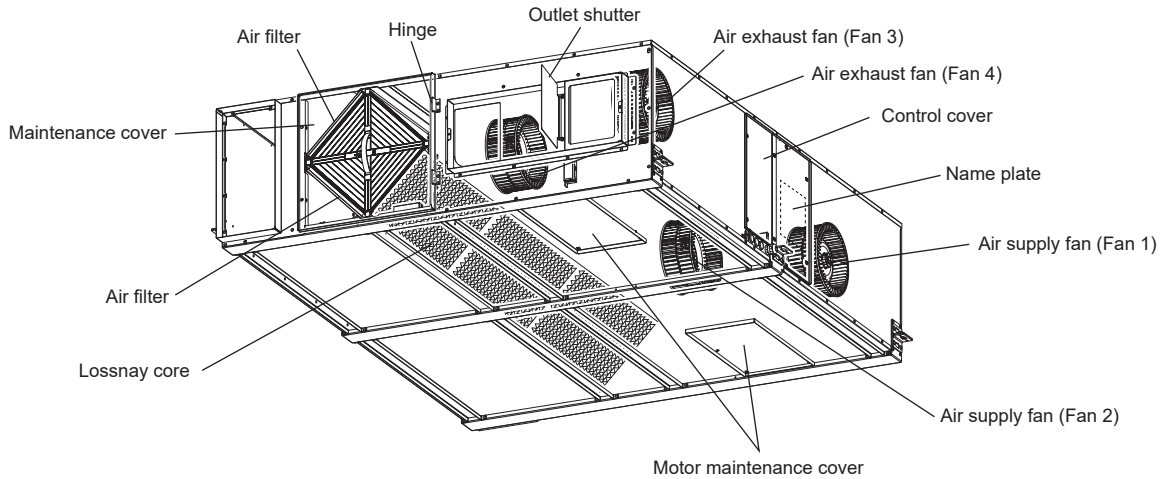

Model name can be found on the Name plate.

Above drawing shows when LR Switching is Factory setting.
Fan direction would be changed as shown in table below by LR Switching setting.

| | LR Switching (DIP SW 2-10) | |
|-------|----------------------------|-------------|
| | OFF (Factory setting) | ON |
| Fan 1 | Supply fan | Exhaust fan |
| Fan 2 | Supply fan | Exhaust fan |
| Fan 3 | Exhaust fan | Supply fan |
| Fan 4 | Exhaust fan | Supply fan |

Operation

Lossnay can be connected with Lossnay remote controller (PZ-62DR series), and other Systems (City Multi, Mr. Slim, Central controller (MELANS))

Following shows the use of PZ-62DR series. Please refer to the manuals for the other systems.

For connection of a Lossnay remote controller (PZ-62DR series)

If the Lossnay's operation is linked with the operation of an external device such as an air conditioner, the method of use will differ, so carry out the appropriate operation in accordance with the following table. Also, please see the installation and user manual for the Lossnay remote controller (PZ-62DR series).

<Not connected to an external device>

| Example of System | Operation | Function |
|-------------------|----------------------------------|--|
| | Run using the remote controller. | If 2 remote controllers are used, the last touch has priority. |

<Connected to an external device>

| | | |
|--|--|---|
| | Lossnay unit can be turned ON or OFF when the signal from external device is connected to Lossnay ON/OFF terminal. | If you would like to turn ON the Lossnay alone while the external device is OFF, operate it by the Lossnay remote controller. |
| | | The fan speed is fixed on fan speed 4. (factory setting) The ventilation mode is "Auto Ventilation Mode". |

■ Display and Function button (PZ-62DR series)

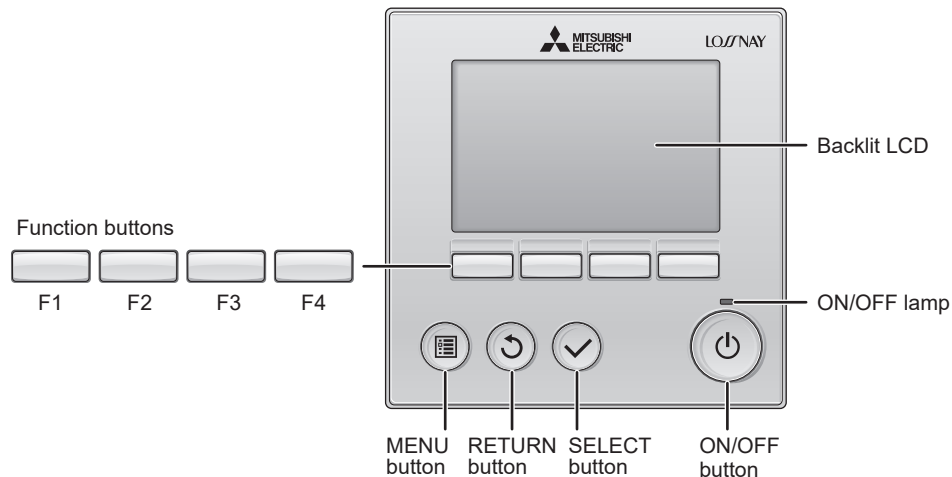

■ AUTOMATIC VENTILATION setting

The automatic ventilation mode automatically provides the correct ventilation for the conditions in the room. The following shows the effect "Bypass" ventilation will have under various conditions.

1. Reduces cooling load

If the air outside is cooler than the air inside the building during the cooling season (such as early morning or at night), "Bypass" ventilation will draw in the cooler outside air and reduce the cooling load on the system.

2. Night purge

"Bypass" ventilation can be used to release hot air from inside the building that has accumulated in buildings a business district during the hot summer season.

3. Office equipment room cooling

During cold season, fresh air can be drawn in and used as is to cool rooms where the temperature has risen due to the use of office equipment.

Note

- In bypass mode, the maximum air flow is 70 % of energy recovery mode. So as in night purge function also.
- At the factory setting, when RVXT3 operates air flow 75 % or more at "Auto" fan speed under 0-10 VDC input control, RVXT3 moves into energy recovery mode and stops bypass monitor output even bypass condition is satisfied at bypass mode.
- In bypass mode, the fan with outlet shutter operate trickly from 60 % to 70 % airflow. If it is necessary to stop that operation, it is possible to change the maximum airflow for bypass mode in Function setting [No. 35](#). Refer to the installation manual for detail.

⚠ CAUTION

- In the case of "Bypass" ventilation, the supply air temperature slightly rises more than the outside air temperature because of the heat effect around the ducts or the unit motors and so on.

■ "Auto" fan speed control

When CO₂ sensor or pressure sensor is connected, "Auto" fan speed can be selected.

In "Auto" mode, the fan speed changes automatically according to the CO₂ sensor concentration or pressure condition.

Maintenance

Remove all dust and dirt on air filters and Lossnay cores at regular intervals in order to prevent a deterioration in the Lossnay functions.

Guideline: Clean the air filters once a year.
(or when  are indicated on the remote controller)

Clean the Lossnay cores once two year.
(Clean the Lossnay cores once a year if possible.)
(Frequency should be increased depending on the extent of dirt.)

⚠ WARNING

- **Make sure the power supply isolator is turned off before starting maintenance.**

It could cause electric shock or injury if it is turned on.

- **Do not touch the product for at least 5 minutes after the power is shut off.**

Electrical shock can result.

⚠ CAUTION

- **Put on gloves during maintenance.**
It could cause injury.
- **Securely install parts after maintenance.**
It could cause injury if parts fall.

Removing the parts

1) Maintenance cover

1. Remove the two black screws.
2. Open the maintenance cover.

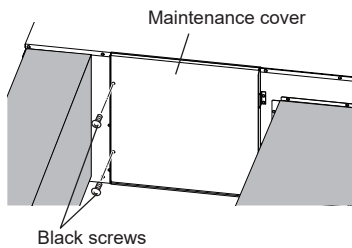

2) Air filters and Lossnay cores

(Air filters: 4pieces, Lossnay core: 3pieces)

1. Remove the front filters from the main unit.

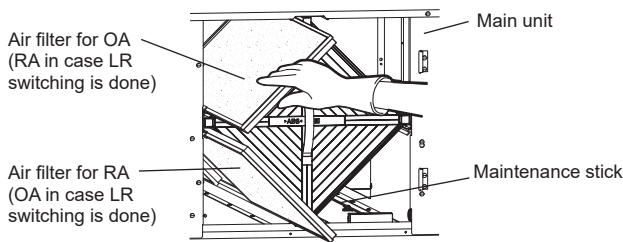

2. Remove the back filters from the main unit with the maintenance stick.

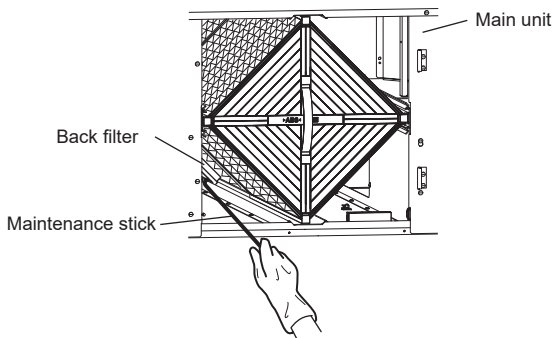

3. Hold the handle and draw the Lossnay cores out from the main unit.

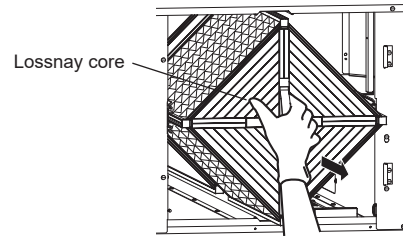

4. Use the maintenance stick to remove the second or third Lossnay cores.

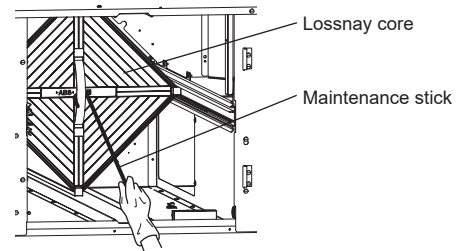

Cleaning the parts

1) Air filters

Use a vacuum cleaner to remove light dust. To remove stubborn dirt wash in a mild solution of detergent and lukewarm water. (under 40°C)

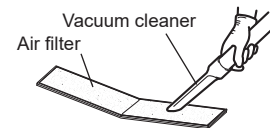

⚠ CAUTION

- **Never wash the filters in very hot water and never wash them by rubbing them.**
- **Do not dry the filters by exposing them to a flame.**

2) Lossnay cores

Use a vacuum cleaner to suck up the dust and dirt on the exposed surfaces of the Lossnay cores.
Use a soft brush only to clean exposed surface areas.

Do NOT wash in water.

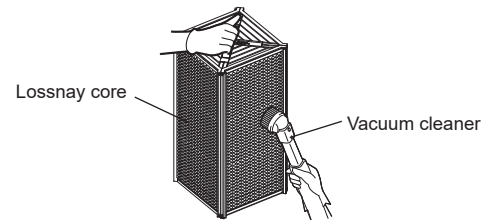

⚠ CAUTION

- **Do not use the hard nozzle of the vacuum cleaner. It may damage the exposed surfaces of the Lossnay cores.**
- **Under no circumstances should the Lossnay cores be washed in water.**

Assembly after maintenance

Bearing in mind the following points, assemble the parts following the sequence for their removal in reverse.

- Arrange the Lossnay core with the air filter. RA and OA filters are placed on the left side of the core.
- Filter has front and back side. Set the correct side of the filter according to the arrow on the filter frame.
- Put Maintenance stick back where it was. Be sure to hold it with cable clips securely.

Note:

- If  are indicated on the remote controller, turn off the indication, after maintenance.

Specifications

| Model name | Input power (W) | | | Air volume (m ³ /h) | Static pressure | | Exchange efficiency (%) | | | Noise (dB(A)) |
|----------------|-----------------|------|------|--------------------------------|-----------------|--------------|-------------------------|----------|---------|---------------|
| | L1-N | L2-N | L3-N | | Supply (Pa) | Exhaust (Pa) | Temperature | Enthalpy | | |
| | | | | | | | | Heating | Cooling | |
| LGH-160RVXT3-E | 0 | 354 | 354 | 1600 | 190 | 190 | 82 | 80 | 61.5 | 38 |
| LGH-200RVXT3-E | 0 | 522 | 522 | 2000 | 190 | 190 | 80 | 78.5 | 56.5 | 40 |
| LGH-250RVXT3-E | 0 | 724 | 724 | 2500 | 190 | 190 | 77 | 75 | 54 | 44 |

- * The above values apply during Lossnay ventilation when the fan speed is set to Fan speed 4 at the rating pressure loss and 400 V / 50 Hz at factory setting of L/R swiching condition.
- * For the specifications at the other frequency or voltages, contact your dealer.
- * The values given in the table for the noise level reflect the levels measured at a position 1.5 meters immediately below the unit in an anechoic chamber.
- * Noise change or increase may occur because of the Bypass-Automatic function or Automatic fan speed change by timer setting and/or other functions.
- * Temperature Exchange efficiency (%) are based on winter condition.
- * For detail specification, contact your dealer or check specification sheet.
- * On-site commissioning measurements by pitot tube method could be as much 20% difference from JIS test room conditions. If the measuring point is close to sources of turbulence like bends, contractions and dampers etc, it is difficult to measure air volume correctly. A straight duct length more than 10D (D=duct diameter or equivalent) from the source of turbulence is recommended for correct measurement. On-site measurement should therefore be measured in accordance with BSRIA guideline (Commissioning Air System. Application procedures for buildings AG3/89.3(2001))

After-sales servicing

Consult with your dealer about the after-sales services provided for this Lossnay product.

If you hear strange sounds, if no air is blown out or if some other trouble occurs, switch off the power and contact your dealer. Consult with your dealer concerning the cost of inspection or repair work.

■ Recommended inspection and maintenance

After several years of use, the following might occur. We recommend inspection and maintenance by a professional.

- Entry of dust due to deterioration of filters
- Abnormal noise or vibration due to the motor reaching the end of its service life
- Air leakage due to the Lossnay core reaching the end of its service life

The following are consumables:

- Motor
- Supply air filter
- Exhaust air filter
- Lossnay core
- Circuit board
- Thermistor

■ Repair costs include technical fee, cost of parts, (and business trip charges), etc.

■ When an error code blinks on the remote controller, contact your dealer.

| | | |
|---|--|--|
| Attentive inspection | Inspect your unit of good service! | |
|  | <p>Have you noticed?</p> <ul style="list-style-type: none"> ● Fan do not run when the unit is turned on. ● Abnormal noises or vibrations while the unit is running ● Retarded or irregular rotations (Motors are component which requires maintenance.) ● Burnt odor ● Corroded or damaged mounting parts or location | <div style="background-color: black; color: white; padding: 10px; display: inline-block;"> Stop running. </div> <p style="font-size: small; margin-top: 5px;">Turn off the unit. Then, contact your dealer for prevention of failure or hazard. The dealer should appraise the possible cost.</p> |

MITSUBISHI ELECTRIC CORPORATION

HEAD OFFICE:

TOKYO BLDG., 2-7-3, MARUNOUCHI, CHIYODA-KU, TOKYO 100-8310, JAPAN