



SPLIT-TYPE AIR CONDITIONERS

Revision B:

12. DISASSEMBLY INSTRUCTIONS has been modified.

OBH938 REVISED EDITION-A is void.

OUTDOOR UNIT

SERVICE MANUAL

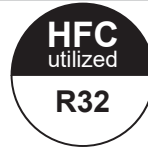

No. OBH938
REVISED EDITION-B

Models

MUZ-AY15VG - E1, ET1

MUZ-AY20VG - E1, ET1

Indoor unit service manual
MSZ-AY·VG Series (OBH937)

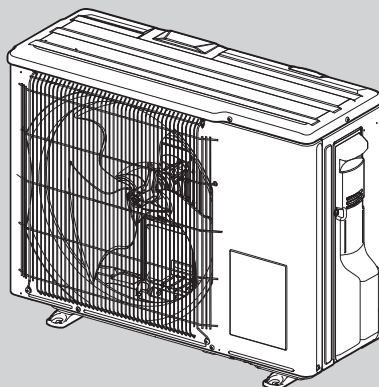

MUZ-AY15VG

CONTENTS

1. TECHNICAL CHANGES	2
2. SERVICING PRECAUTIONS FOR UNITS USING REFRIGERANT R32	3
3. PART NAMES AND FUNCTIONS	5
4. SPECIFICATION	6
5. NOISE CRITERIA CURVES	8
6. OUTLINES AND DIMENSIONS	9
7. WIRING DIAGRAM	10
8. REFRIGERANT SYSTEM DIAGRAM	12
9. PERFORMANCE CURVES	14
10. ACTUATOR CONTROL	23
11. SERVICE FUNCTIONS	24
12. TROUBLESHOOTING	25
13. DISASSEMBLY INSTRUCTIONS	45

PARTS CATALOG (OBB938)

Use the specified refrigerant only

Never use any refrigerant other than that specified.

Doing so may cause a burst, an explosion, or fire when the unit is being used, serviced, or disposed of.

Correct refrigerant is specified in the manuals and on the spec labels provided with our products.

We will not be held responsible for mechanical failure, system malfunction, unit breakdown or accidents caused by failure to follow the instructions.

<Preparation before the repair service>

- Prepare the proper tools.
- Prepare the proper protectors.
- Provide adequate ventilation.
- After stopping the operation of the air conditioner, turn off the power-supply breaker and pull the power plug.
- Discharge the capacitor before the work involving the electric parts.

<Precautions during the repair service>

- Do not perform the work involving the electric parts with wet hands.
- Do not pour water into the electric parts.
- Do not touch the refrigerant.
- Do not touch the hot or cold areas in the refrigeration cycle.
- When the repair or the inspection of the circuit needs to be done without turning off the power, exercise great caution not to touch the live parts.

WARNING

- When the refrigeration circuit has a leak, do not execute pump down with the compressor.
- When pumping down the refrigerant, stop the compressor before disconnecting the refrigerant pipes. The compressor may burst if air etc. get into it.
- When opening or closing the valve below freezing temperatures, refrigerant may spurt out from the gap between the valve stem and the valve body, resulting in injuries.

Revision A:

- TROUBLESHOOTING CRITERION OF MAIN PARTS has been corrected. [Expansion valve coil (LEV) in 12-4.]

Revision B:

- 12. DISASSEMBLY INSTRUCTIONS has been modified.

1

TECHNICAL CHANGES

MUZ-AY15VG - [E1], [ET1]

MUZ-AY20VG - [E1], [ET1]

1. New model

Servicing precautions for units using refrigerant R32



WARNING

This unit uses a flammable refrigerant.

If refrigerant leaks and comes in contact with fire or heating part, it will create harmful gas and there is risk of fire.

- Do not use means to accelerate the defrosting process or to clean, other than those recommended by the manufacturer.
- The appliance shall be stored in a room without continuously operating ignition sources (for example: open flames, an operating gas appliance or an operating electric heater.)
- Do not pierce or burn.
- Be aware that refrigerants may not contain an odor.
- Pipe-work shall be protected from physical damage.
- The installation of pipe-work shall be kept to a minimum.
- Compliance with national gas regulations shall be observed.
- Keep any required ventilation openings clear of obstruction.
- Servicing shall be performed only as recommended by the manufacturer.
- The appliance shall be stored so as to prevent mechanical damage from occurring.

Basic work procedures are the same as those for conventional units using refrigerant R410A. However, pay careful attention to the following points.

1. Information on servicing
 - (1) Checks on the Area

Prior to beginning work on systems containing flammable refrigerants, safety checks are necessary to ensure that the risk of ignition is minimized.
 - (2) Work Procedure

Work shall be undertaken under a controlled procedure so as to minimize the risk of a flammable gas or vapor being present while the work is being performed.
 - (3) General Work Area

All maintenance staff and others working in the local area shall be instructed on the nature of work being carried out. Work in confined spaces shall be avoided. The area around the workspace shall be sectioned off. Ensure that the conditions within the area have been made safe by control of flammable material.
 - (4) Checking for Presence of Refrigerant

The area shall be checked with an appropriate refrigerant detector prior to and during work, to ensure the technician is aware of potentially toxic or flammable atmospheres. Ensure that the leak detection equipment being used is suitable for use with all applicable refrigerants, i.e. non-sparking, adequately sealed or intrinsically safe.
 - (5) Presence of Fire Extinguisher

If any hot work is to be conducted on the refrigeration equipment or any associated parts, appropriate fire extinguishing equipment shall be available to hand. Have a dry powder or CO₂ fire extinguisher adjacent to the charging area.
 - (6) No Ignition Sources

No person carrying out work in relation to a refrigeration system which involves exposing any pipe work shall use any sources of ignition in such a manner that it may lead to the risk of fire or explosion. All possible ignition sources, including cigarette smoking, should be kept sufficiently far away from the site of installation, repairing, removing and disposal, during which refrigerant can possibly be released to the surrounding space. Prior to work taking place, the area around the equipment is to be surveyed to make sure that there are no flammable hazards or ignition risks. "No Smoking" signs shall be displayed.
 - (7) Ventilated Area

Ensure that the area is in the open or that it is adequately ventilated before breaking into the system or conducting any hot work. A degree of ventilation shall continue during the period that the work is carried out. The ventilation should safely disperse any released refrigerant and preferably expel it externally into the atmosphere.
 - (8) Checks on the Refrigeration Equipment

Where electrical components are being changed, they shall be fit for the purpose and to the correct specification. At all times the manufacturer's maintenance and service guidelines shall be followed. If in doubt, consult the manufacturer's technical department for assistance.

The following checks shall be applied to installations using flammable refrigerants:

 - The charge size is in accordance with the room size within which the refrigerant containing parts are installed.
 - The ventilation machinery and outlets are operating adequately and are not obstructed.
 - If an indirect refrigerating circuit is being used, the secondary circuit shall be checked for the presence of refrigerant.
 - Marking to the equipment continues to be visible and legible. Markings and signs that are illegible shall be corrected.
 - Refrigeration pipe or components are installed in a position where they are unlikely to be exposed to any substance which may corrode refrigerant containing components, unless the components are constructed of materials which are inherently resistant to being corroded or are suitably protected against being corroded.
 - (9) Checks on Electrical Devices

Repair and maintenance to electrical components shall include initial safety checks and component inspection procedures. If a fault exists that could compromise safety, then no electrical supply shall be connected to the circuit until it is satisfactorily dealt with. If the fault cannot be corrected immediately but it is necessary to continue operation, an adequate temporary solution shall be used. This shall be reported to the owner of the equipment so all parties are advised.

Initial safety checks shall include that:

 - capacitors are discharged: this shall be done in a safe manner to avoid possibility of sparking;
 - no live electrical components and wiring are exposed while charging, recovering or purging the system;
 - there is continuity of earth bonding
2. Repairs to Sealed Components
 - (1) During repairs to sealed components, all electrical supplies shall be disconnected from the equipment being worked upon prior to any removal of sealed covers, etc. If it is absolutely necessary to have an electrical supply to equipment during servicing, then a permanently operating form of leak detection shall be located at the most critical point to warn of a potentially hazardous situation.
 - (2) Particular attention shall be paid to the following to ensure that by working on electrical components, the casing is not altered in such a way that the level of protection is affected. This shall include damage to cables, excessive number of connections, terminals not made to original specification, damage to seals, incorrect fitting of glands, etc.

Ensure that the apparatus is mounted securely.

Ensure that seals or sealing materials have not degraded to the point that they no longer serve the purpose of preventing the ingress of flammable atmospheres. Replacement parts shall be in accordance with the manufacturer's specifications.
3. Repair to intrinsically Safe Components

Do not apply any permanent inductive or capacitance loads to the circuit without ensuring that this will not exceed the permissible voltage and current permitted for the equipment in use.

Intrinsically safe components are the only types that can be worked on while live in the presence of a flammable atmosphere. The test apparatus shall be at the correct rating.

Replace components only with parts specified by the manufacturer. Other parts may result in the ignition of refrigerant in the atmosphere from a leak.
4. Cabling

Check that cabling will not be subject to wear, corrosion, excessive pressure, vibration, sharp edges or any other adverse environmental effects. The check shall also take into account the effects of aging or continual vibration from sources such as compressors or fans.

5. Detection of Flammable Refrigerants

Under no circumstances shall potential sources of ignition be used in the searching for or detection of refrigerant leaks. A halide torch (or any other detector using a naked flame) shall not be used.

6. Leak Detection Methods

Electronic leak detectors may be used to detect refrigerant leaks but, in the case of flammable refrigerants, the sensitivity may not be adequate, or may need recalibration. (Detection equipment shall be calibrated in a refrigerant-free area.) Ensure that the detector is not a potential source of ignition and is suitable for the refrigerant used. Leak detection equipment shall be set at a percentage of the LFL of the refrigerant and shall be calibrated to the refrigerant employed, and the appropriate percentage of gas (25 % maximum) is confirmed.

Leak detection fluids are suitable for use with most refrigerants but the use of detergents containing chlorine shall be avoided as the chlorine may react with the refrigerant and corrode the copper pipe-work.

If a leak is suspected, all naked flames shall be removed/extinguished.

If a leakage of refrigerant is found which requires brazing, all of the refrigerant shall be recovered from the system, or isolated (by means of shut off valves) in a part of the system remote from the leak. For appliances containing flammable refrigerants, oxygen free nitrogen (OFN) shall then be purged through the system both before and during the brazing process.

7. Removal and Evacuation

When breaking into the refrigerant circuit to make repairs - or for any other purpose conventional procedures shall be used. However, for flammable refrigerants it is important that best practice is followed since flammability is a consideration. The following procedure shall be adhered to:

- remove refrigerant
- purge the circuit with inert gas
- evacuate
- purge again with inert gas
- open the circuit by cutting or brazing.

The refrigerant charge shall be recovered into the correct recovery cylinders. For appliances containing flammable refrigerants, the system shall be "flushed" with OFN to render the unit safe. This process may need to be repeated several times. Compressed air or oxygen shall not be used for purging refrigerant systems.

For appliances containing flammable refrigerants, flushing shall be achieved by breaking the vacuum in the system with OFN and continuing to fill until the working pressure is achieved, then venting to atmosphere, and finally pulling down to a vacuum. This process shall be repeated until no refrigerant is within the system. When the final OFN charge is used, the system shall be vented down to atmospheric pressure to enable work to take place. This operation is absolutely vital if brazing operations on the pipe-work are to take place.

Ensure that the outlet for the vacuum pump is not close to any ignition sources and that ventilation is available.

8. Charging Procedures

In addition to conventional charging procedures, the following requirements shall be followed:

- Ensure that contamination of different refrigerants does not occur when using charging equipment. Hoses or lines shall be as short as possible to minimize the amount of refrigerant contained in them.
- Cylinders shall be kept upright.
- Ensure that the refrigeration system is earthed prior to charging the system with refrigerant.
- Label the system when charging is complete (if not already).
- Extreme care shall be taken not to overfill the refrigeration system.

Prior to recharging the system, it shall be pressure-tested with the appropriate purging gas. The system shall be leak-tested on completion of charging but prior to commissioning. A follow up leak test shall be carried out prior to leaving the site.

9. Decommissioning

Before carrying out this procedure, it is essential that the technician is completely familiar with the equipment and all its detail. It is recommended good practice that all refrigerants are recovered safely. Prior to the task being carried out, an oil and refrigerant sample shall be taken in case analysis is required prior to reuse of reclaimed refrigerant. It is essential that electrical power is available before the task is commenced.

(1) Become familiar with the equipment and its operation.

(2) Isolate system electrically.

(3) Before attempting the procedure, ensure that:

- mechanical handling equipment is available, if required, for handling refrigerant cylinders;
- all personal protective equipment is available and being used correctly;
- the recovery process is supervised at all times by a competent person;
- recovery equipment and cylinders conform to the appropriate standards.

(4) Pump down refrigerant system, if possible.

(5) If a vacuum is not possible, make a manifold so that refrigerant can be removed from various parts of the system.

(6) Make sure that cylinder is situated on the scales before recovery takes place.

(7) Start the recovery machine and operate in accordance with manufacturer's instructions.

(8) Do not overfill cylinders. (no more than 80 % volume liquid charge).

(9) Do not exceed the maximum working pressure of the cylinder, even temporarily.

(10) When the cylinders have been filled correctly and the process completed, make sure that the cylinders and the equipment are removed from site promptly and all isolation valves on the equipment are closed off.

(11) Recovered refrigerant shall not be charged into another refrigeration system unless it has been cleaned and checked.

10. Labeling

Equipment shall be labeled stating that it has been de-commissioned and emptied of refrigerant. The label shall be dated and signed. For appliances containing flammable refrigerants, ensure that there are labels on the equipment stating the equipment contains flammable refrigerant.

11. Recovery

When removing refrigerant from a system, either for servicing or decommissioning, it is recommended good practice that all refrigerants are removed safely. When transferring refrigerant into cylinders, ensure that only appropriate refrigerant recovery cylinders are employed. Ensure that the correct number of cylinders for holding the total system charge are available. All cylinders to be used are designated for the recovered refrigerant and labeled for that refrigerant (i.e. special cylinders for the recovery of refrigerant). Cylinders shall be complete with pressure-relief valve and associated shut-off valves in good working order. Empty recovery cylinders are evacuated and, if possible, cooled before recovery occurs.

The recovery equipment shall be in good working order with a set of instructions concerning the equipment that is at hand and shall be suitable for the recovery of all appropriate refrigerants including, when applicable, flammable refrigerants. In addition, a set of calibrated weighing scales shall be available and in good working order. Hoses shall be complete with leak-free disconnect couplings and in good condition. Before using the recovery machine, check that it is in satisfactory working order, has been properly maintained and that any associated electrical components are sealed to prevent ignition in the event of a refrigerant release. Consult manufacturer if in doubt.

The recovered refrigerant shall be returned to the refrigerant supplier in the correct recovery cylinder, and the relevant waste transfer note arranged. Do not mix refrigerants in recovery units and especially not in cylinders.

If compressors or compressor oils are to be removed, ensure that they have been evacuated to an acceptable level to make certain that flammable refrigerant does not remain within the lubricant. The evacuation process shall be carried out prior to returning the compressor to the suppliers. Only electric heating to the compressor body shall be employed to accelerate this process. When oil is drained from a system, it shall be carried out safely.

3

PART NAMES AND FUNCTIONS

MUZ-AY15VG

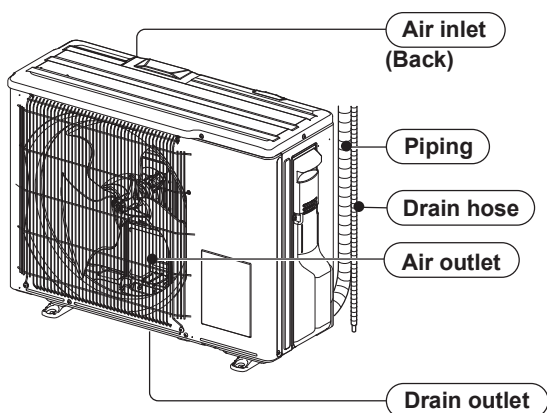

MUZ-AY20VG

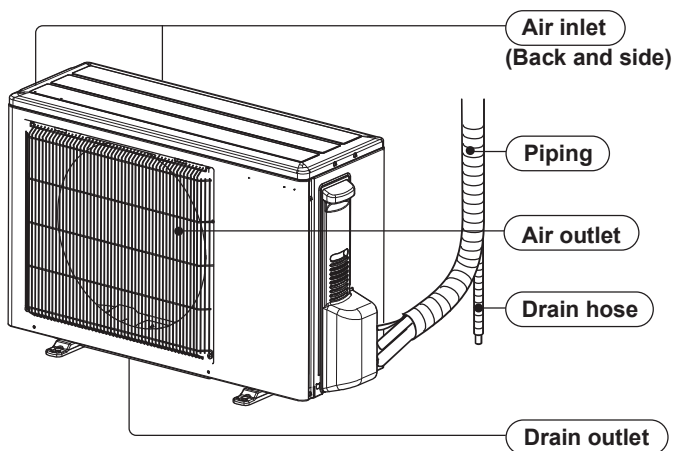

ACCESSORIES

MODELS	MUZ-AY15VG MUZ-AY20VG
Drain socket	1

4

SPECIFICATION

Outdoor model				MUZ-AY15VG	MUZ-AY20VG	
Power supply				Single phase, 230 V, 50 Hz		
Capacity Rated (Min.-Max.)	Cooling	kW	1.5 (0.5 - 2.2)		2.0 (0.6 - 2.7)	
	Heating		2.0 (0.5 - 3.1)		2.5 (0.5 - 3.5)	
Breaker Capacity			A	10		
Electrical data	Power input *1 (Set)	Cooling	W	370	460	
		Heating	W	500	600	
	Running current *1 (Set)	Cooling	A	2.1	2.6	
		Heating	A	2.8	3.2	
	Power factor *1 (Set)	Cooling	%	76	76	
		Heating	%	77	81	
Starting current *1 (Set)		A	2.8	3.2		
Coefficient of performance (COP) *1 (Set)		Cooling		4.17	4.35	
		Heating		4.00	4.17	
Compressor	Model			KVB059FTMMC	KVB073FYTMC	
	Output		W	490	470	
	Current *1	Cooling	A	1.69	2.19	
		Heating	A	2.39	2.81	
	Refrigeration oil (Model)		L	0.27 (FW68S)		
Fan motor	Model			RC0J20-AB	RC0J50-NC	
	Current *1	Cooling	A	0.24	0.22	
		Heating	A	0.24	0.20	
Dimensions W × H × D			mm	699 × 538 × 249	800 × 550 × 285	
Weight			kg	23	27.5	
Special remarks	Dehumidification		Cooling	L/h	0.3	0.6
	Airflow *1	Cooling	High	m³/h	1,818	2,178
			Med		1,560	2,178
			Low		990	1,038
		Heating	High		1,818	2,076
			Med.		1,260	1,788
			Low		990	1,284
	Sound level *1		Cooling	dB(A)	45	47
			Heating	dB(A)	45	48
	Fan speed	Cooling	High	rpm	840	940
			Med		730	940
			Low		480	470
		Heating	High		840	900
			Med.		600	780
			Low		480	570
Fan speed regulator				3		
Refrigerant filling capacity (R32)			kg	0.49	0.55	

NOTE: Test conditions are based on ISO 5151.

Cooling: Indoor Dry-bulb temperature 27°C
 Outdoor Dry-bulb temperature 35°C
 Heating: Indoor Dry-bulb temperature 20°C
 Outdoor Dry-bulb temperature 7°C

Wet-bulb temperature 19°C

Wet-bulb temperature 6°C

Refrigerant piping length (one way): 5 m

*1 Measured under rated operating frequency.

Specifications and rated conditions of main electric parts

Item	Model	MUZ-AY15VG	MUZ-AY20VG
		Smoothing capacitor	(C61)
	(C62)	—	600 μF/ 620 μF 420 V
Diode module	(DB61)	25 A 600 V	
	(DB65)	25 A 600 V	
Fuse	(F61)	15A 250V	25A 250V
	(F62)	15A 250V	
	(F701, F801, F901)	T3.15AL250V	
Power module	(IC700)	10 A 600 V	15 A 600 V
	(IC932)	5 A 600 V	
Expansion valve coil	(LEV)	12 V DC	
Reactor	(L61)	18 mH	
Switch power transistor	(Q821)	30 A/37 A 600 V	
Current-limiting PTC thermistor	(PTC64)	33 Ω	
	(PTC65)	33 Ω	
Terminal block	(TB1)	5 P	
Relay	(X63)	3 A 250 V	
	(X64)	20 A 250 V	
	(X69)	10 A 250 V	
R.V.coil	(21S4)	220 - 240 V AC	

5

NOISE CRITERIA CURVES

MUZ-AY15VG

FAN SPEED	FUNCTION	SPL(dB(A))	LINE
Super High	COOLING	50	●—●
	HEATING	50	○—○

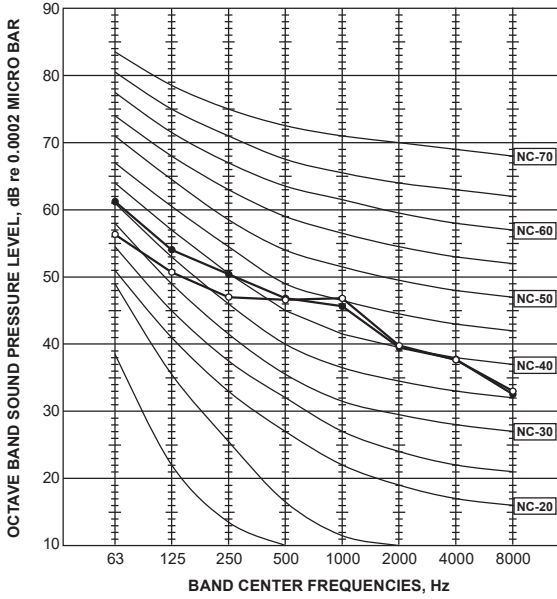

MUZ-AY20VG

FAN SPEED	FUNCTION	SPL(dB(A))	LINE
Super High	COOLING	47	●—●
	HEATING	48	○—○

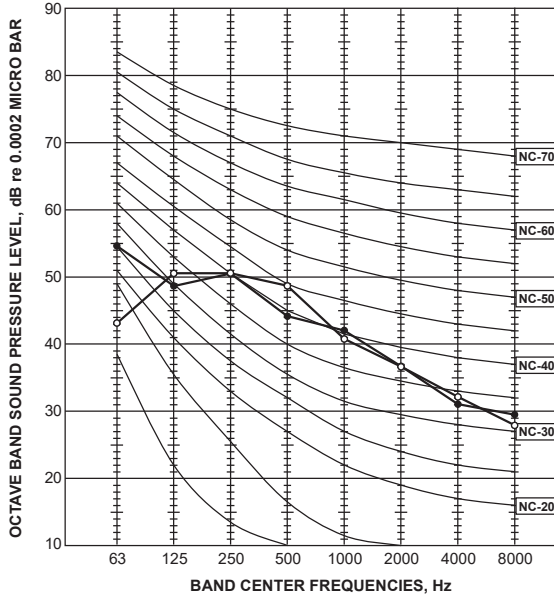

Test conditions

Cooling: Dry-bulb temperature 35°C

Heating: Dry-bulb temperature 7°C Wet-bulb temperature 6°C

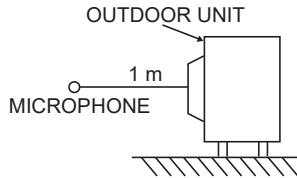

6

OUTLINES AND DIMENSIONS

MUZ-AY15VG

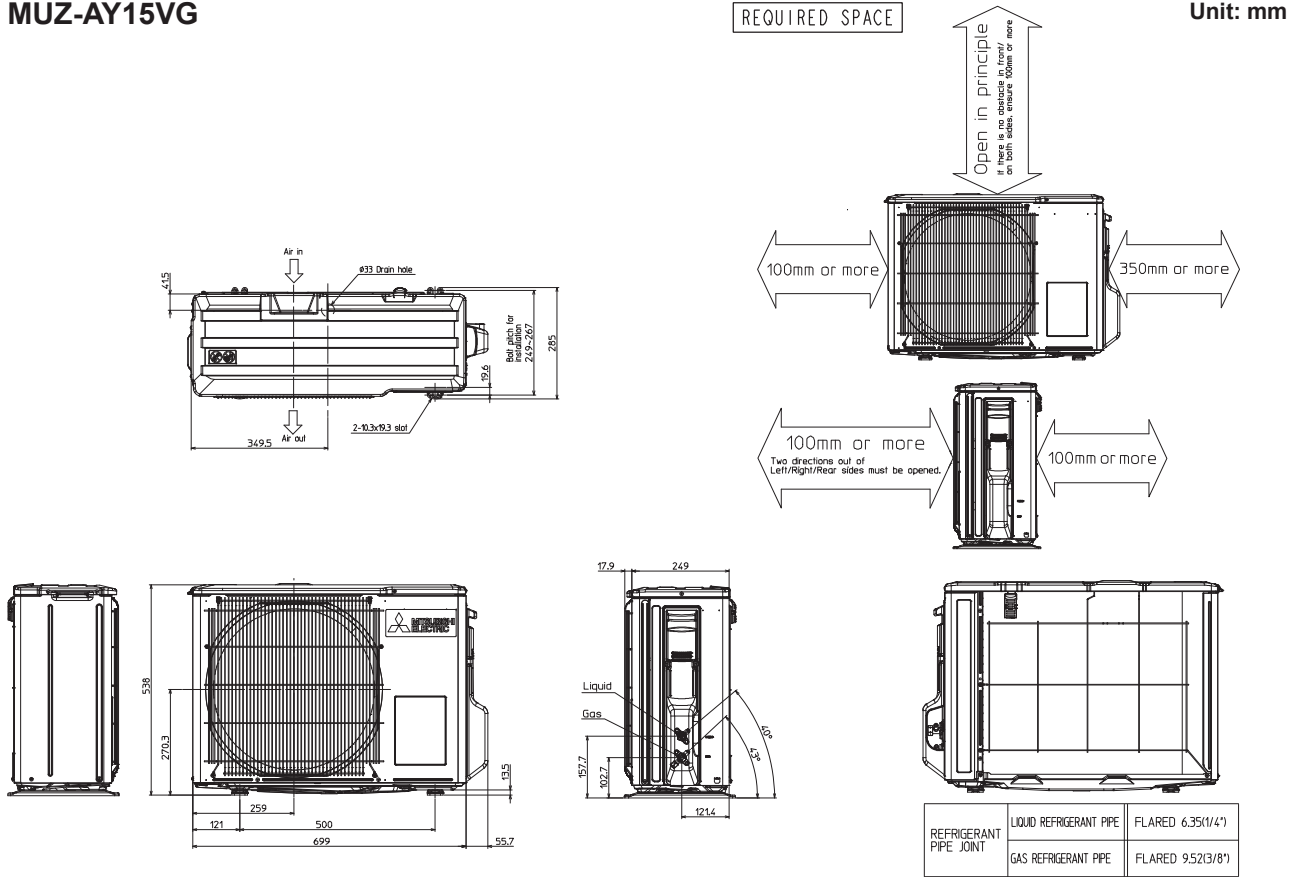

MUZ-AY20VG

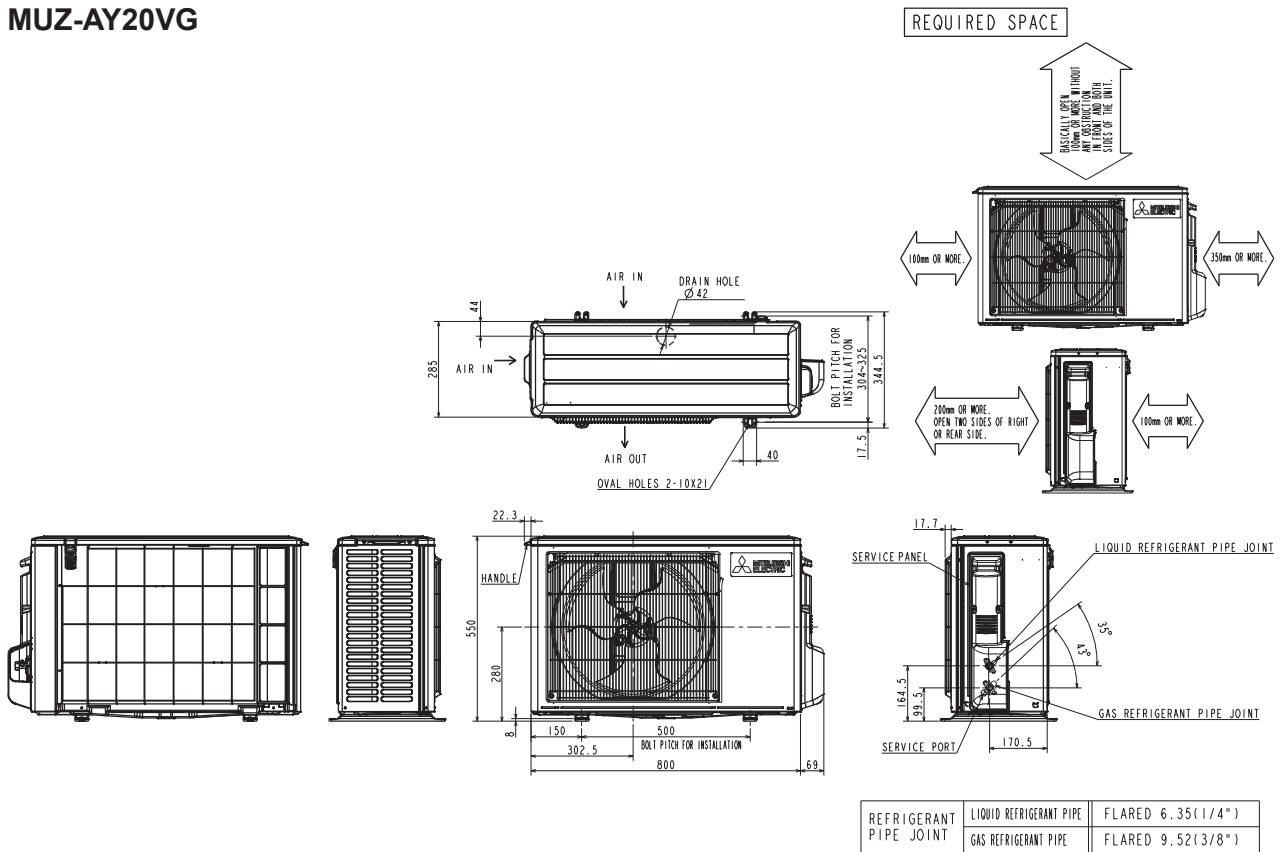

7

WIRING DIAGRAM

MUZ-AY15VG - [E1]

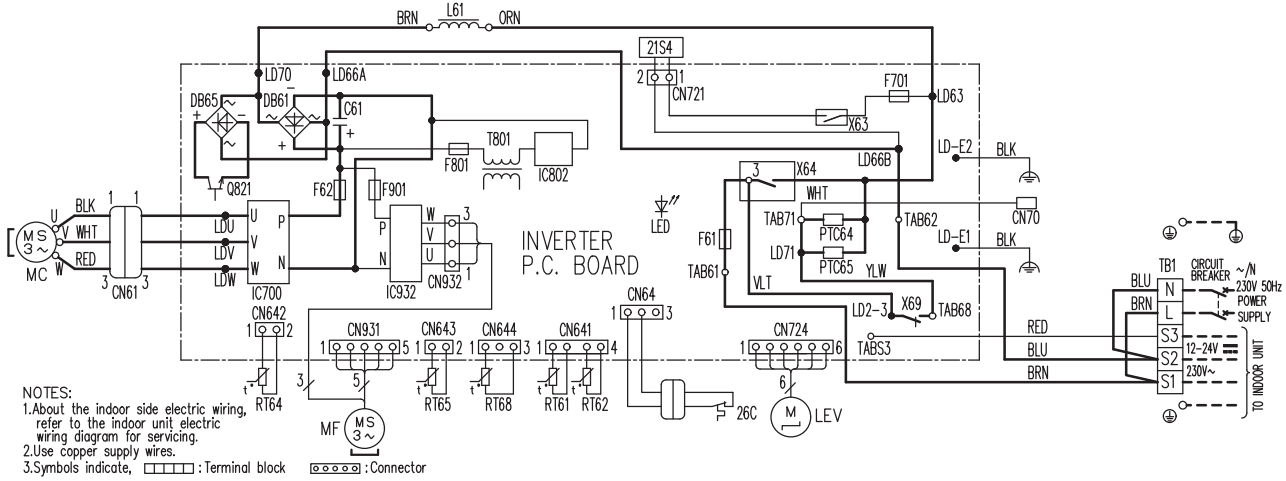

SYMBOL	NAME	SYMBOL	NAME	SYMBOL	NAME
CN61	CONNECTOR	L61	REACTOR	RT65	AMBIENT TEMP. THERMISTOR
C61	SMOOTHING CAPACITOR	MC	COMPRESSOR	RT68	OUTDOOR HEAT EXCHANGER TEMP. THERMISTOR
DB61, DB65	DIODE MODULE	MF	FAN MOTOR	TB1	TERMINAL BLOCK
F61, F62	FUSE (15A 250V)	PTC64, PTC65	CIRCUIT PROTECTION	T801	TRANSFORMER
F701, F801, F901	FUSE (T3.15AL250V)	Q821	SWITCHING POWER TRANSISTOR	X63, X64, X69	RELAY
IC700, IC932	POWER MODULE	RT61	DEFROST THERMISTOR	21S4	REVERSING VALVE COIL
IC802	POWER DEVICE	RT62	DISCHARGE TEMP. THERMISTOR	26C	COMPRESSOR PROTECTOR
LED	LED	RT64	FIN TEMP. THERMISTOR		
LEV	EXPANSION VALVE COIL				

MUZ-AY15VG - [ET1]

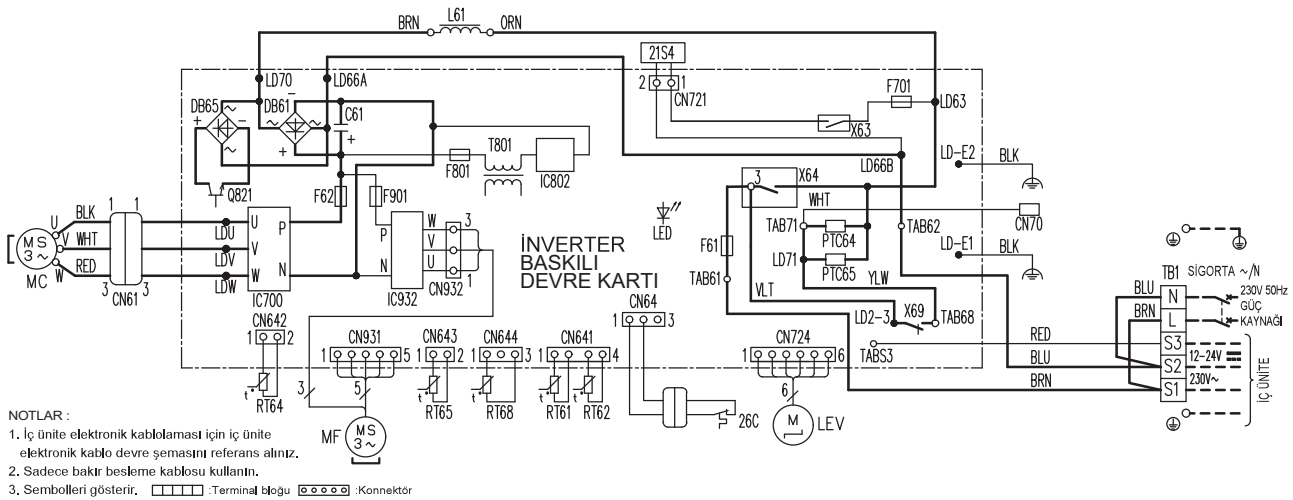

SEMBOL	PARÇA ADI	SEMBOL	PARÇA ADI	SEMBOL	PARÇA ADI
CN61	KONNEKTÖR	L61	REAKTÖR	RT65	ORTAM SICAKLIK TERMİSTÖRÜ
C61	KAPASİTÖR	MC	KOMPRESÖR	RT68	DIŞ ÜNİTE EŞANJÖR SICAKLIK TERMİSTÖRÜ
DB61, DB65	DİYOT MODÜLÜ	MF	FAN MOTORU	TB1	TERMİNAL BLOĞU
F61, F62	SİGORTA (15A 250V)	PTC64, PTC65	DEVRE KORUMASI	T801	TRANSFORMATÖR
F701, F801, F901	SİGORTA (T3. 15AL250V)	Q821	SIVIÇLI GÜÇ TRANSİSTÖRÜ	X63, X64, X69	RÖLE
IC700, IC932	GÜÇ MODÜLÜ	RT61	DEFROST TERMİSTÖRÜ	21S4	4 YOLLU VANA SARGISI
IC802	GÜÇ CİHAZI	RT62	BASMA SICAKLIK TERMİSTÖRÜ	26C	KOMPRESÖR KORUYUCU
LED	LED	RT64	FIN SICAKLIK TERMİSTÖRÜ		
LEV	GENLEŞME VANASI SARGISI				

MUZ-AY20VG - [E1]

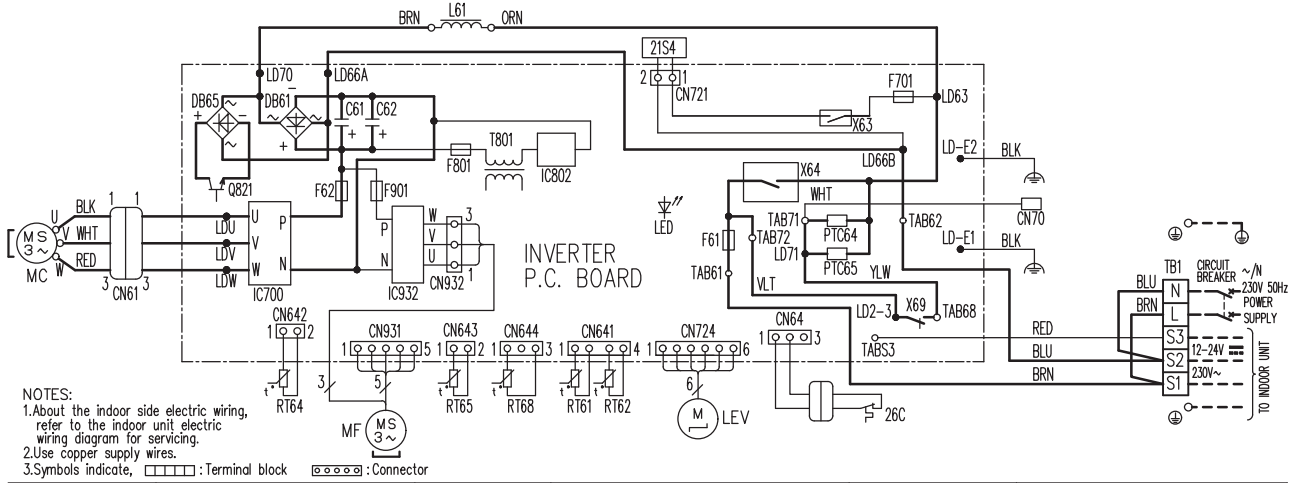

SYMBOL	NAME	SYMBOL	NAME	SYMBOL	NAME
CN61	CONNECTOR	LEV	EXPANSION VALVE COIL	RT65	AMBIENT TEMP. THERMISTOR
C61,C62	SMOOTHING CAPACITOR	L61	REACTOR	RT68	OUTDOOR HEAT EXCHANGER TEMP. THERMISTOR
DB61,DB65	DIODE MODULE	MC	COMPRESSOR	TB1	TERMINAL BLOCK
F61	FUSE (25A 250V)	MF	FAN MOTOR	T801	TRANSFORMER
F62	FUSE (15A 250V)	PTC64,PTC65	CIRCUIT PROTECTION	X63,X64,X69	RELAY
F701,F801,F901	FUSE (T3.15AL250V)	Q821	SWITCHING POWER TRANSISTOR	21S4	REVERSING VALVE COIL
IC700,IC932	POWER MODULE	RT61	DEFROST THERMISTOR	26C	COMPRESSOR PROTECTOR
IC802	POWER DEVICE	RT62	DISCHARGE TEMP. THERMISTOR		
LED	LED	RT64	FIN TEMP. THERMISTOR		

MUZ-AY20VG - [E1]

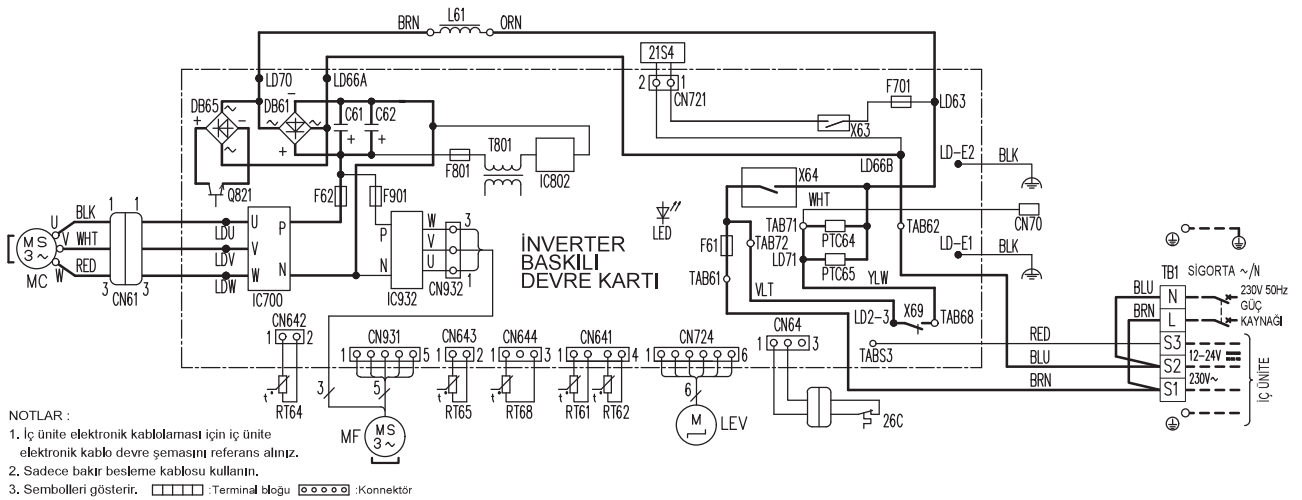

SEMBOL	PARÇA ADI	SEMBOL	PARÇA ADI	SEMBOL	PARÇA ADI
CN61	KONNEKTÖR	LEV	GENLEŞME VANASI SARGISI	RT65	ORTAM SICAKLIK TERMİSTÖRÜ
C61,C62	KAPASİTÖR	L61	REAKTÖR	RT68	DIŞ ÜNİTE EŞANJÖR SICAKLIK TERMİSTÖRÜ
DB61,DB65	DIYOT MODÜLÜ	MC	KOMPRESÖR	TB1	TERMİNAL BLOĞU
F61	SİGORTA (25A 250V)	MF	FAN MOTORU	T801	TRANSFORMATÖR
F62	SİGORTA (15A 250V)	PTC64,PTC65	DEVRE KORUMASI	X63,X64,X69	RÖLE
F701,F801,F901	SİGORTA (T3. 15AL250V)	Q821	SIVIÇLI GÜÇ TRANSİTÖRÜ	21S4	4 YOLLU VANA SARGISI
IC700,IC932	GÜÇ MODÜLÜ	RT61	DEFROST TERMİSTÖRÜ	26C	KOMPRESÖR KORUYUCU
IC802	GÜÇ CİHAZI	RT62	BASMA SICAKLIK TERMİSTÖRÜ		
LED	LED	RT64	FIN SICAKLIK TERMİSTÖRÜ		

MUZ-AY15VG

Unit: mm

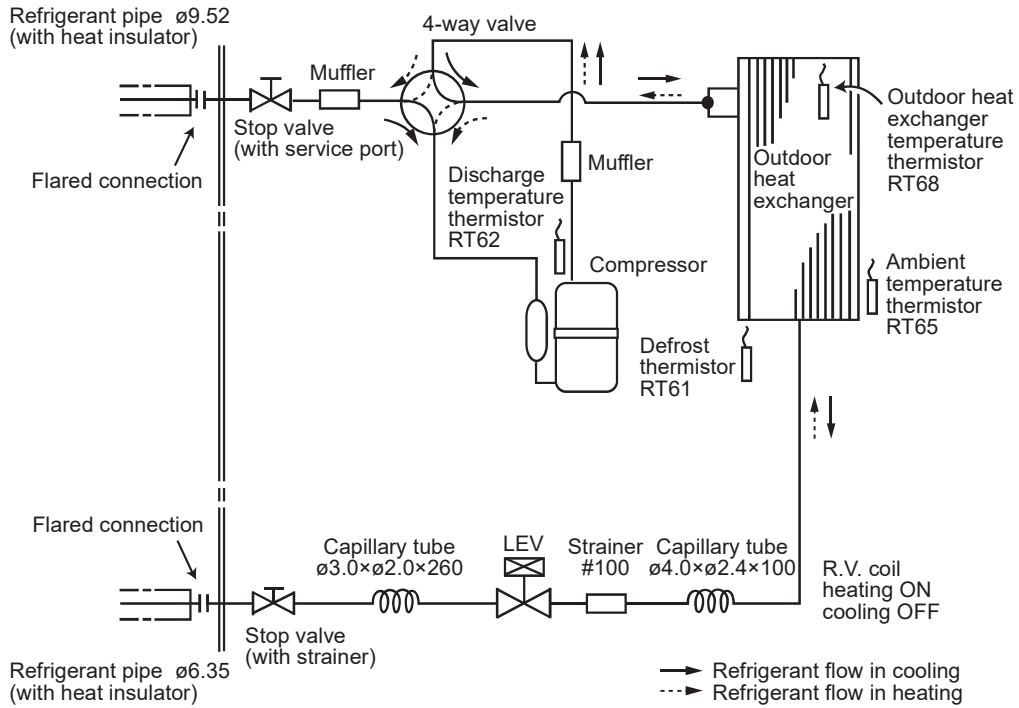

MUZ-AY20VG

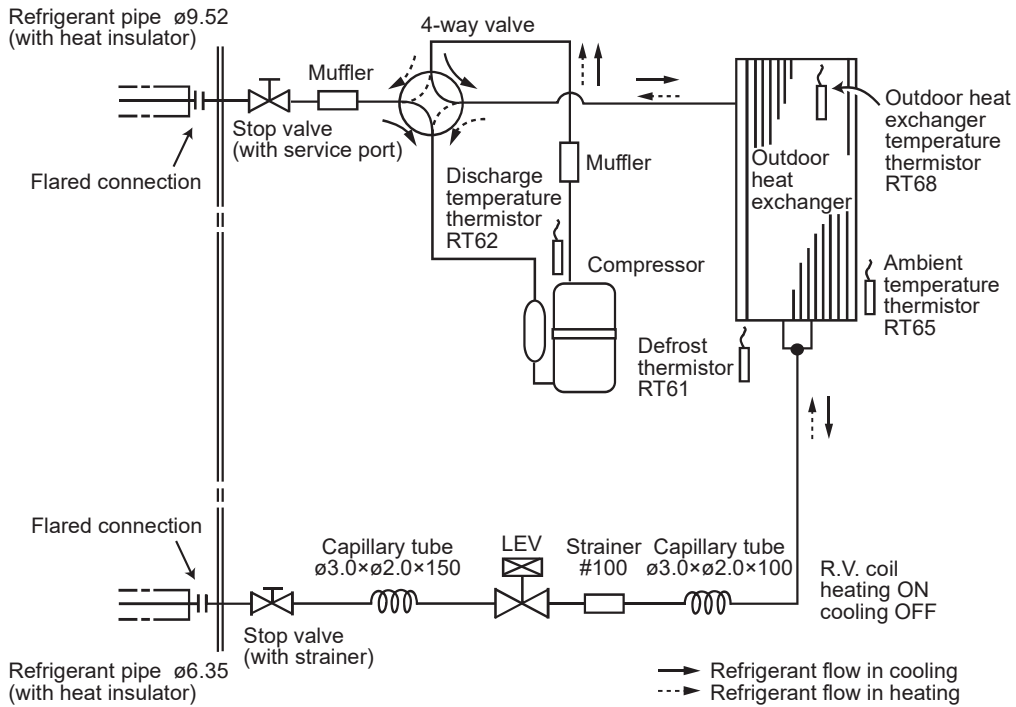

MAX. REFRIGERANT PIPING LENGTH and MAX. HEIGHT DIFFERENCE

Model	Refrigerant piping: m		Piping size O.D: mm	
	Max. Length A	Max. Height difference B	Gas	Liquid
MUZ-AY15VG MUZ-AY20VG	20	12	9.52	6.35

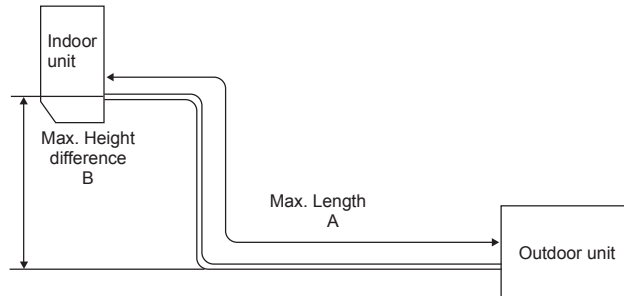

ADDITIONAL REFRIGERANT CHARGE (R32: g)

Model	Outdoor unit precharged	Refrigerant piping length (one way)									
		7 m	8 m	9 m	10 m	11 m	12 m	13 m	14 m	15 m	20 m
MUZ-AY15VG	490	-	10	30	50	70	90	110	130	150	250
MUZ-AY20VG	550	-	10	30	50	70	90	110	130	150	250

Calculation: $X \text{ g} = 20 \text{ g/m} \times (\text{Refrigerant piping length (m)} - 7.5)$

NOTE: Refrigerant piping exceeding 7.5 m requires additional refrigerant charge according to the calculation.

MUZ-AY15VG MUZ-AY20VG

The standard specifications apply only to the operation of the air conditioner under normal conditions. Since operating conditions vary according to the areas where these units are installed, the following information has been provided to clarify the operating characteristics of the air conditioner under the conditions indicated by the performance curve.

(1) GUARANTEED VOLTAGE

198 ~ 264 V, 50 Hz

(2) AIRFLOW

Airflow should be set at MAX.

(3) MAIN READINGS

- | | | |
|--|---------|-----------|
| (1) Indoor intake air wet-bulb temperature: | °C [WB] | } Cooling |
| (2) Indoor outlet air wet-bulb temperature: | °C [WB] | |
| (3) Outdoor intake air dry-bulb temperature: | °C [DB] | |
| (4) Total input: | W | |
| (5) Indoor intake air dry-bulb temperature: | °C [DB] | } Heating |
| (6) Outdoor intake air wet-bulb temperature: | °C [WB] | |
| (7) Total input: | W | |

Indoor air wet and dry bulb temperature difference on the left side of the following chart shows the difference between the indoor intake air wet and dry bulb temperature and the indoor outlet air wet and dry bulb temperature for your reference at service.

How to measure the indoor air wet and dry bulb temperature difference

- Attach at least 2 sets of wet and dry bulb thermometers to the indoor air intake as shown in the figure, and at least 2 sets of wet and dry bulb thermometers to the indoor air outlet. The thermometers must be attached to the position where air speed is high.
- Attach at least 2 sets of wet and dry bulb thermometers to the outdoor air intake.
Cover the thermometers to prevent direct rays of the sun.
- Check that the air filter is cleaned.
- Open windows and doors of room.
- Press the emergency operation switch once (twice) to start the EMERGENCY COOL (HEAT) MODE.
- When system stabilizes after more than 15 minutes, measure temperature and take an average temperature.
- 10 minutes later, measure temperature again and check that the temperature does not change.

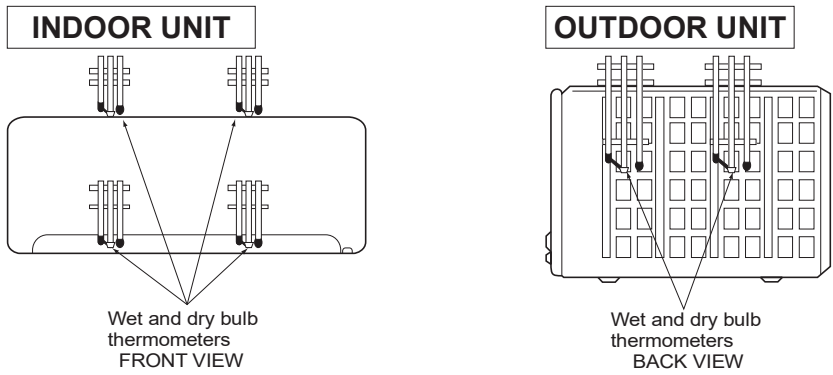

9-1. CAPACITY AND INPUT CURVES

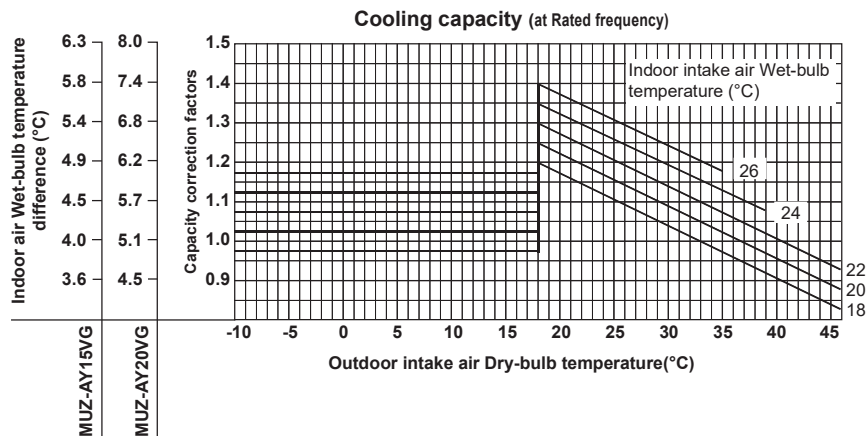

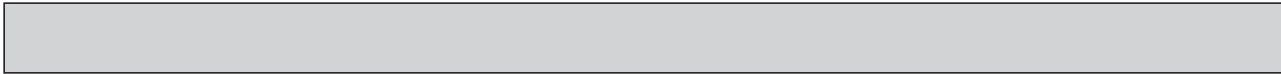

Total input (Cooling : at Rated frequency)

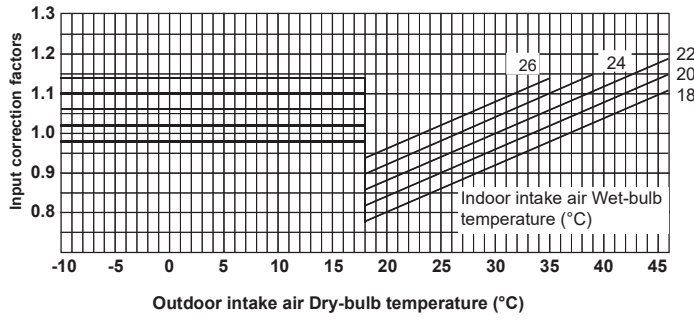

Heating capacity (at Rated frequency)

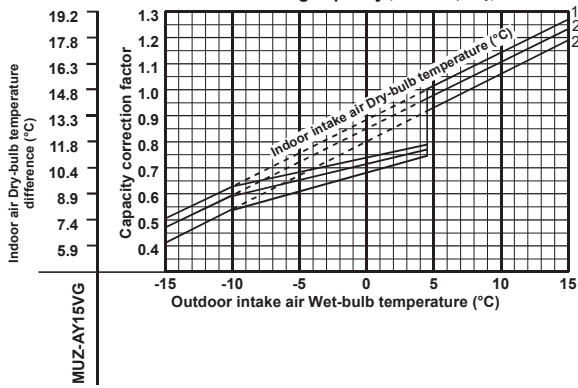

Heating capacity (at Rated frequency)

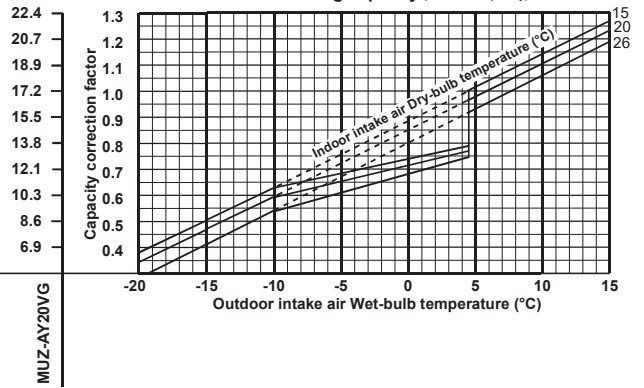

Total input (Heating : at Rated frequency)

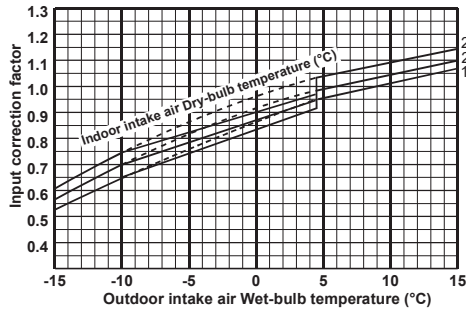

Total input (Heating : at Rated frequency)

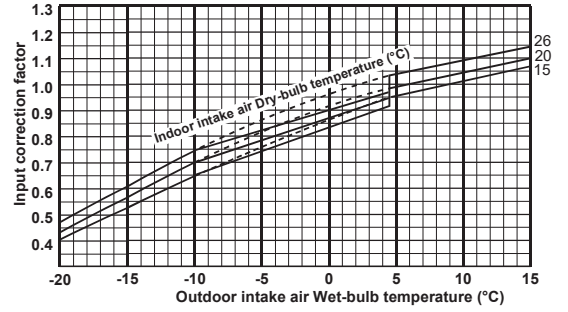

Lower limit of guaranteed operating range in heating
 MUZ-AY15VG: -15°C, MUZ-AY20VG: -20°C

NOTE: The above broken lines are for the heating operation without any frost and defrost operation.

9-2. CAPACITY AND INPUT CORRECTION BY OPERATIONAL FREQUENCY OF COMPRESSOR

MUZ-AY15VG

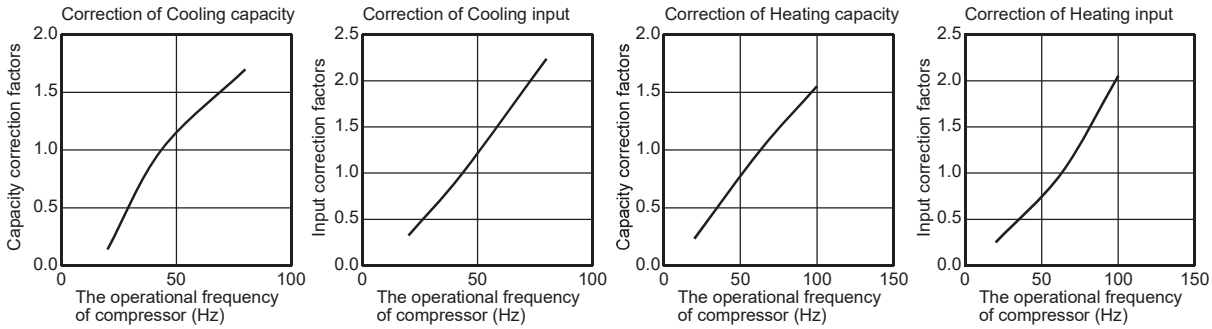

MUZ-AY20VG

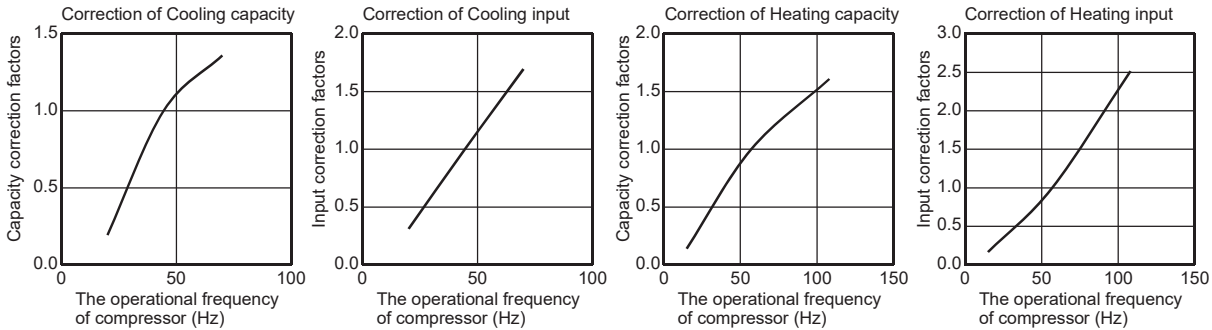

9-3. HOW TO OPERATE FIXED-FREQUENCY OPERATION

<Test run operation>

1. Press the emergency operation switch to start COOL or HEAT mode (COOL: Press once, HEAT: Press twice).
2. Test run operation starts and continues to operate for 30 minutes.
3. Compressor operates at rated frequency in COOL mode or 58 Hz in HEAT mode.
4. Indoor fan operates at High speed.
5. After 30 minutes, test run operation finishes and EMERGENCY OPERATION starts (operation frequency of compressor varies).
6. To cancel test run operation (EMERGENCY OPERATION), press the emergency operation switch or any button on remote controller.

9-4. OUTDOOR LOW PRESSURE AND OUTDOOR UNIT CURRENT

COOL operation

- ① Both indoor and outdoor unit are under the same temperature/humidity condition.
- ② Operation: TEST RUN OPERATION (Refer to 9-3.)

Dry-bulb temperature (°C)	Relative humidity (%)
20	50
25	60
30	70

Outdoor low pressure

MUZ-AY15VG

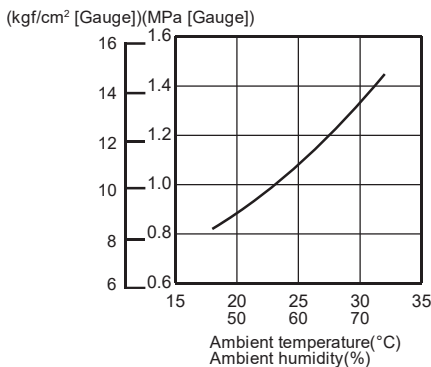

MUZ-AY20VG

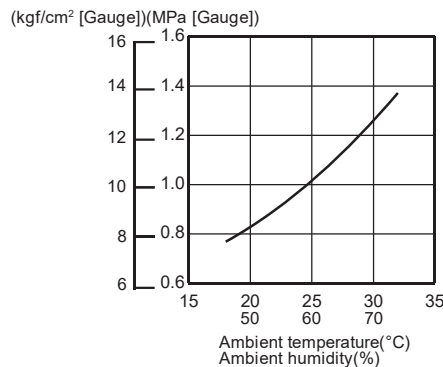

NOTE:

The unit of pressure has been changed to MPa on the international system of units (SI unit system)
The conversion factor is: **1 (MPa [Gauge]) = 10.2 (kgf/cm² [Gauge])**



Outdoor unit current

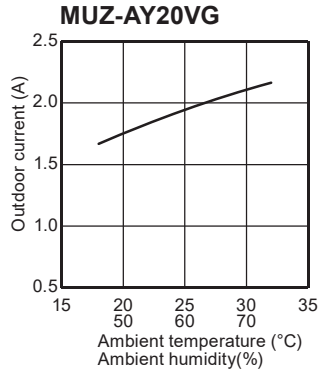
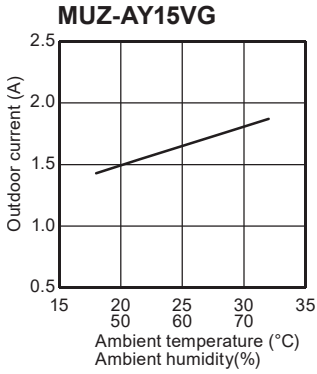

HEAT operation

① Condition:

	Indoor	Outdoor			
Dry bulb temperature (°C)	20.0	2	7	15	20.0
Wet bulb temperature (°C)	14.5	1	6	12	14.5

② Operation: Test run operation (Refer to 9-3.)

Outdoor unit current

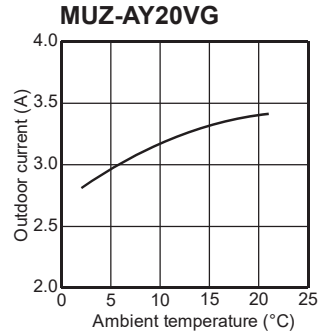
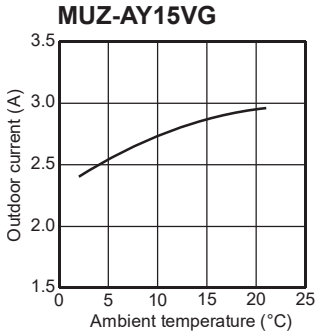

PERFORMANCE DATA COOL operation at Rated frequency

MUZ-AY15VG

CAPACITY: 1.5 kW

SHF: 0.86

INPUT: 370 W

INDOOR DB (°C)	INDOOR WB (°C)	OUTDOOR DB (°C)															
		21				25				27				30			
		Q	SHC	SHF	INPUT	Q	SHC	SHF	INPUT	Q	SHC	SHF	INPUT	Q	SHC	SHF	INPUT
21	18	1.76	1.20	0.68	296	1.69	1.15	0.68	311	1.62	1.10	0.68	326	1.56	1.06	0.68	340
21	20	1.84	1.03	0.56	311	1.76	0.99	0.56	329	1.71	0.96	0.56	337	1.65	0.92	0.56	352
22	18	1.76	1.27	0.72	296	1.69	1.22	0.72	311	1.62	1.17	0.72	326	1.56	1.12	0.72	340
22	20	1.84	1.10	0.60	311	1.76	1.06	0.60	329	1.71	1.03	0.60	337	1.65	0.99	0.60	352
22	22	1.91	0.92	0.48	322	1.85	0.89	0.48	342	1.80	0.86	0.48	352	1.73	0.83	0.48	366
23	18	1.76	1.34	0.76	296	1.69	1.28	0.76	311	1.62	1.23	0.76	326	1.56	1.19	0.76	340
23	20	1.84	1.18	0.64	311	1.76	1.13	0.64	329	1.71	1.09	0.64	337	1.65	1.06	0.64	352
23	22	1.91	0.99	0.52	322	1.85	0.96	0.52	342	1.80	0.94	0.52	352	1.73	0.90	0.52	366
24	18	1.76	1.41	0.80	296	1.69	1.35	0.80	311	1.62	1.30	0.80	326	1.56	1.25	0.80	340
24	20	1.84	1.25	0.68	311	1.76	1.20	0.68	329	1.71	1.16	0.68	337	1.65	1.12	0.68	352
24	22	1.91	1.07	0.56	322	1.85	1.03	0.56	342	1.80	1.01	0.56	352	1.73	0.97	0.56	366
24	24	2.01	0.88	0.44	337	1.94	0.85	0.44	355	1.89	0.83	0.44	366	1.83	0.81	0.44	385
25	18	1.76	1.48	0.84	296	1.69	1.42	0.84	311	1.62	1.36	0.84	326	1.56	1.31	0.84	340
25	20	1.84	1.32	0.72	311	1.76	1.27	0.72	329	1.71	1.23	0.72	337	1.65	1.19	0.72	352
25	22	1.91	1.15	0.60	322	1.85	1.11	0.60	342	1.80	1.08	0.60	352	1.73	1.04	0.60	366
25	24	2.01	0.96	0.48	337	1.94	0.93	0.48	355	1.89	0.91	0.48	366	1.83	0.88	0.48	385
26	18	1.76	1.55	0.88	296	1.69	1.49	0.88	311	1.62	1.43	0.88	326	1.56	1.37	0.88	340
26	20	1.84	1.40	0.76	311	1.76	1.34	0.76	329	1.71	1.30	0.76	337	1.65	1.25	0.76	352
26	22	1.91	1.22	0.64	322	1.85	1.18	0.64	342	1.80	1.15	0.64	352	1.73	1.10	0.64	366
26	24	2.01	1.05	0.52	337	1.94	1.01	0.52	355	1.89	0.98	0.52	366	1.83	0.95	0.52	385
26	26	2.07	0.83	0.40	355	2.01	0.80	0.40	374	1.98	0.79	0.40	385	1.92	0.77	0.40	396
27	18	1.76	1.62	0.92	296	1.69	1.55	0.92	311	1.62	1.49	0.92	326	1.56	1.44	0.92	340
27	20	1.84	1.47	0.80	311	1.76	1.41	0.80	329	1.71	1.37	0.80	337	1.65	1.32	0.80	352
27	22	1.91	1.30	0.68	322	1.85	1.25	0.68	342	1.80	1.22	0.68	352	1.73	1.17	0.68	366
27	24	2.01	1.13	0.56	337	1.94	1.08	0.56	355	1.89	1.06	0.56	366	1.83	1.02	0.56	385
27	26	2.07	0.91	0.44	355	2.01	0.88	0.44	374	1.98	0.87	0.44	385	1.92	0.84	0.44	396
28	18	1.76	1.69	0.96	296	1.69	1.62	0.96	311	1.62	1.56	0.96	326	1.56	1.50	0.96	340
28	20	1.84	1.54	0.84	311	1.76	1.48	0.84	329	1.71	1.44	0.84	337	1.65	1.39	0.84	352
28	22	1.91	1.38	0.72	322	1.85	1.33	0.72	342	1.80	1.30	0.72	352	1.73	1.24	0.72	366
28	24	2.01	1.21	0.60	337	1.94	1.16	0.60	355	1.89	1.13	0.60	366	1.83	1.10	0.60	385
28	26	2.07	0.99	0.48	355	2.01	0.96	0.48	374	1.98	0.95	0.48	385	1.92	0.92	0.48	396
29	18	1.76	1.76	1.00	296	1.69	1.69	1.00	311	1.62	1.62	1.00	326	1.56	1.56	1.00	340
29	20	1.84	1.62	0.88	311	1.76	1.55	0.88	329	1.71	1.50	0.88	337	1.65	1.45	0.88	352
29	22	1.91	1.45	0.76	322	1.85	1.40	0.76	342	1.80	1.37	0.76	352	1.73	1.31	0.76	366
29	24	2.01	1.29	0.64	337	1.94	1.24	0.64	355	1.89	1.21	0.64	366	1.83	1.17	0.64	385
29	26	2.07	1.08	0.52	355	2.01	1.05	0.52	374	1.98	1.03	0.52	385	1.92	1.00	0.52	396
30	18	1.76	1.76	1.00	296	1.69	1.69	1.00	311	1.62	1.62	1.00	326	1.56	1.56	1.00	340
30	20	1.84	1.69	0.92	311	1.76	1.62	0.92	329	1.71	1.57	0.92	337	1.65	1.52	0.92	352
30	22	1.91	1.53	0.80	322	1.85	1.48	0.80	342	1.80	1.44	0.80	352	1.73	1.38	0.80	366
30	24	2.01	1.37	0.68	337	1.94	1.32	0.68	355	1.89	1.29	0.68	366	1.83	1.24	0.68	385
30	26	2.07	1.16	0.56	355	2.01	1.13	0.56	374	1.98	1.11	0.56	385	1.92	1.08	0.56	396
31	18	1.76	1.76	1.00	296	1.69	1.69	1.00	311	1.62	1.62	1.00	326	1.56	1.56	1.00	340
31	20	1.84	1.76	0.96	311	1.76	1.69	0.96	329	1.71	1.64	0.96	337	1.65	1.58	0.96	352
31	22	1.91	1.61	0.84	322	1.85	1.55	0.84	342	1.80	1.51	0.84	352	1.73	1.45	0.84	366
31	24	2.01	1.45	0.72	337	1.94	1.39	0.72	355	1.89	1.36	0.72	366	1.83	1.32	0.72	385
31	26	2.07	1.24	0.60	355	2.01	1.21	0.60	374	1.98	1.19	0.60	385	1.92	1.15	0.60	396
32	18	1.76	1.76	1.00	296	1.69	1.69	1.00	311	1.62	1.62	1.00	326	1.56	1.56	1.00	340
32	20	1.84	1.84	1.00	311	1.76	1.76	1.00	329	1.71	1.71	1.00	337	1.65	1.65	1.00	352
32	22	1.91	1.68	0.88	322	1.85	1.62	0.88	342	1.80	1.58	0.88	352	1.73	1.52	0.88	366
32	24	2.01	1.53	0.76	337	1.94	1.47	0.76	355	1.89	1.44	0.76	366	1.83	1.39	0.76	385
32	26	2.07	1.32	0.64	355	2.01	1.29	0.64	374	1.98	1.27	0.64	385	1.92	1.23	0.64	396

NOTE Q : Total capacity (kW) SHF : Sensible heat factor DB : Dry-bulb temperature
 SHC : Sensible heat capacity (kW) INPUT : Total power input (W) WB : Wet-bulb temperature

PERFORMANCE DATA COOL operation at Rated frequency

MUZ-AY15VG

CAPACITY: 1.5 kW

SHF: 0.86

INPUT: 370 W

INDOOR DB (°C)	INDOOR WB (°C)	OUTDOOR DB (°C)											
		35				40				46			
		Q	SHC	SHF	INPUT	Q	SHC	SHF	INPUT	Q	SHC	SHF	INPUT
21	18	1.47	1.00	0.68	363	1.35	0.92	0.68	385	1.25	0.85	0.68	400
21	20	1.55	0.87	0.56	377	1.44	0.81	0.56	396	1.34	0.75	0.56	418
22	18	1.47	1.06	0.72	363	1.35	0.97	0.72	385	1.25	0.90	0.72	400
22	20	1.55	0.93	0.60	377	1.44	0.86	0.60	396	1.34	0.80	0.60	418
22	22	1.64	0.78	0.48	392	1.53	0.73	0.48	414	1.43	0.68	0.48	429
23	18	1.47	1.12	0.76	363	1.35	1.03	0.76	385	1.25	0.95	0.76	400
23	20	1.55	0.99	0.64	377	1.44	0.92	0.64	396	1.34	0.85	0.64	418
23	22	1.64	0.85	0.52	392	1.53	0.80	0.52	414	1.43	0.74	0.52	429
24	18	1.47	1.18	0.80	363	1.35	1.08	0.80	385	1.25	1.00	0.80	400
24	20	1.55	1.05	0.68	377	1.44	0.98	0.68	396	1.34	0.91	0.68	418
24	22	1.64	0.92	0.56	392	1.53	0.86	0.56	414	1.43	0.80	0.56	429
24	24	1.73	0.76	0.44	407	1.62	0.71	0.44	426	1.53	0.67	0.44	444
25	18	1.47	1.23	0.84	363	1.35	1.13	0.84	385	1.25	1.05	0.84	400
25	20	1.55	1.11	0.72	377	1.44	1.04	0.72	396	1.34	0.96	0.72	418
25	22	1.64	0.98	0.60	392	1.53	0.92	0.60	414	1.43	0.86	0.60	429
25	24	1.73	0.83	0.48	407	1.62	0.78	0.48	426	1.53	0.73	0.48	444
26	18	1.47	1.29	0.88	363	1.35	1.19	0.88	385	1.25	1.10	0.88	400
26	20	1.55	1.17	0.76	377	1.44	1.09	0.76	396	1.34	1.01	0.76	418
26	22	1.64	1.05	0.64	392	1.53	0.98	0.64	414	1.43	0.91	0.64	429
26	24	1.73	0.90	0.52	407	1.62	0.84	0.52	426	1.53	0.80	0.52	444
26	26	1.82	0.73	0.40	422	1.71	0.68	0.40	440	1.61	0.64	0.40	459
27	18	1.47	1.35	0.92	363	1.35	1.24	0.92	385	1.25	1.15	0.92	400
27	20	1.55	1.24	0.80	377	1.44	1.15	0.80	396	1.34	1.07	0.80	418
27	22	1.64	1.11	0.68	392	1.53	1.04	0.68	414	1.43	0.97	0.68	429
27	24	1.73	0.97	0.56	407	1.62	0.91	0.56	426	1.53	0.86	0.56	444
27	26	1.82	0.80	0.44	422	1.71	0.75	0.44	440	1.61	0.71	0.44	459
28	18	1.47	1.41	0.96	363	1.35	1.30	0.96	385	1.25	1.20	0.96	400
28	20	1.55	1.30	0.84	377	1.44	1.21	0.84	396	1.34	1.12	0.84	418
28	22	1.64	1.18	0.72	392	1.53	1.10	0.72	414	1.43	1.03	0.72	429
28	24	1.73	1.04	0.60	407	1.62	0.97	0.60	426	1.53	0.92	0.60	444
28	26	1.82	0.87	0.48	422	1.71	0.82	0.48	440	1.61	0.77	0.48	459
29	18	1.47	1.47	1.00	363	1.35	1.35	1.00	385	1.25	1.25	1.00	400
29	20	1.55	1.36	0.88	377	1.44	1.27	0.88	396	1.34	1.17	0.88	418
29	22	1.64	1.24	0.76	392	1.53	1.16	0.76	414	1.43	1.08	0.76	429
29	24	1.73	1.10	0.64	407	1.62	1.04	0.64	426	1.53	0.98	0.64	444
29	26	1.82	0.94	0.52	422	1.71	0.89	0.52	440	1.61	0.83	0.52	459
30	18	1.47	1.47	1.00	363	1.35	1.35	1.00	385	1.25	1.25	1.00	400
30	20	1.55	1.42	0.92	377	1.44	1.32	0.92	396	1.34	1.23	0.92	418
30	22	1.64	1.31	0.80	392	1.53	1.22	0.80	414	1.43	1.14	0.80	429
30	24	1.73	1.17	0.68	407	1.62	1.10	0.68	426	1.53	1.04	0.68	444
30	26	1.82	1.02	0.56	422	1.71	0.96	0.56	440	1.61	0.90	0.56	459
31	18	1.47	1.47	1.00	363	1.35	1.35	1.00	385	1.25	1.25	1.00	400
31	20	1.55	1.48	0.96	377	1.44	1.38	0.96	396	1.34	1.28	0.96	418
31	22	1.64	1.37	0.84	392	1.53	1.29	0.84	414	1.43	1.20	0.84	429
31	24	1.73	1.24	0.72	407	1.62	1.17	0.72	426	1.53	1.10	0.72	444
31	26	1.82	1.09	0.60	422	1.71	1.03	0.60	440	1.61	0.96	0.60	459
32	18	1.47	1.47	1.00	363	1.35	1.35	1.00	385	1.25	1.25	1.00	400
32	20	1.55	1.55	1.00	377	1.44	1.44	1.00	396	1.34	1.34	1.00	418
32	22	1.64	1.44	0.88	392	1.53	1.35	0.88	414	1.43	1.25	0.88	429
32	24	1.73	1.31	0.76	407	1.62	1.23	0.76	426	1.53	1.16	0.76	444
32	26	1.82	1.16	0.64	422	1.71	1.09	0.64	440	1.61	1.03	0.64	459

NOTE Q : Total capacity (kW) SHF : Sensible heat factor DB : Dry-bulb temperature
 SHC : Sensible heat capacity (kW) INPUT : Total power input (W) WB : Wet-bulb temperature

PERFORMANCE DATA COOL operation at Rated frequency

MUZ-AY20VG

CAPACITY: 2.0 kW

SHF: 0.8

INPUT: 460 W

INDOOR DB (°C)	INDOOR WB (°C)	OUTDOOR DB (°C)															
		21				25				27				30			
		Q	SHC	SHF	INPUT	Q	SHC	SHF	INPUT	Q	SHC	SHF	INPUT	Q	SHC	SHF	INPUT
21	18	2.35	1.46	0.62	368	2.25	1.40	0.62	386	2.16	1.34	0.62	405	2.08	1.29	0.62	423
21	20	2.45	1.23	0.50	386	2.35	1.18	0.50	409	2.28	1.14	0.50	419	2.20	1.10	0.50	437
22	18	2.35	1.55	0.66	368	2.25	1.49	0.66	386	2.16	1.43	0.66	405	2.08	1.37	0.66	423
22	20	2.45	1.32	0.54	386	2.35	1.27	0.54	409	2.28	1.23	0.54	419	2.20	1.19	0.54	437
22	22	2.55	1.07	0.42	400	2.46	1.03	0.42	426	2.40	1.01	0.42	437	2.30	0.97	0.42	455
23	18	2.35	1.65	0.70	368	2.25	1.58	0.70	386	2.16	1.51	0.70	405	2.08	1.46	0.70	423
23	20	2.45	1.42	0.58	386	2.35	1.36	0.58	409	2.28	1.32	0.58	419	2.20	1.28	0.58	437
23	22	2.55	1.17	0.46	400	2.46	1.13	0.46	426	2.40	1.10	0.46	437	2.30	1.06	0.46	455
24	18	2.35	1.74	0.74	368	2.25	1.67	0.74	386	2.16	1.60	0.74	405	2.08	1.54	0.74	423
24	20	2.45	1.52	0.62	386	2.35	1.46	0.62	409	2.28	1.41	0.62	419	2.20	1.36	0.62	437
24	22	2.55	1.28	0.50	400	2.46	1.23	0.50	426	2.40	1.20	0.50	437	2.30	1.15	0.50	455
24	24	2.68	1.02	0.38	419	2.58	0.98	0.38	442	2.52	0.96	0.38	455	2.44	0.93	0.38	478
25	18	2.35	1.83	0.78	368	2.25	1.76	0.78	386	2.16	1.68	0.78	405	2.08	1.62	0.78	423
25	20	2.45	1.62	0.66	386	2.35	1.55	0.66	409	2.28	1.50	0.66	419	2.20	1.45	0.66	437
25	22	2.55	1.38	0.54	400	2.46	1.33	0.54	426	2.40	1.30	0.54	437	2.30	1.24	0.54	455
25	24	2.68	1.13	0.42	419	2.58	1.08	0.42	442	2.52	1.06	0.42	455	2.44	1.02	0.42	478
26	18	2.35	1.93	0.82	368	2.25	1.85	0.82	386	2.16	1.77	0.82	405	2.08	1.71	0.82	423
26	20	2.45	1.72	0.70	386	2.35	1.65	0.70	409	2.28	1.60	0.70	419	2.20	1.54	0.70	437
26	22	2.55	1.48	0.58	400	2.46	1.43	0.58	426	2.40	1.39	0.58	437	2.30	1.33	0.58	455
26	24	2.68	1.23	0.46	419	2.58	1.19	0.46	442	2.52	1.16	0.46	455	2.44	1.12	0.46	478
26	26	2.76	0.94	0.34	442	2.68	0.91	0.34	465	2.64	0.90	0.34	478	2.56	0.87	0.34	492
27	18	2.35	2.02	0.86	368	2.25	1.94	0.86	386	2.16	1.86	0.86	405	2.08	1.79	0.86	423
27	20	2.45	1.81	0.74	386	2.35	1.74	0.74	409	2.28	1.69	0.74	419	2.20	1.63	0.74	437
27	22	2.55	1.58	0.62	400	2.46	1.53	0.62	426	2.40	1.49	0.62	437	2.30	1.43	0.62	455
27	24	2.68	1.34	0.50	419	2.58	1.29	0.50	442	2.52	1.26	0.50	455	2.44	1.22	0.50	478
27	26	2.76	1.05	0.38	442	2.68	1.02	0.38	465	2.64	1.00	0.38	478	2.56	0.97	0.38	492
28	18	2.35	2.12	0.90	368	2.25	2.03	0.90	386	2.16	1.94	0.90	405	2.08	1.87	0.90	423
28	20	2.45	1.91	0.78	386	2.35	1.83	0.78	409	2.28	1.78	0.78	419	2.20	1.72	0.78	437
28	22	2.55	1.68	0.66	400	2.46	1.62	0.66	426	2.40	1.58	0.66	437	2.30	1.52	0.66	455
28	24	2.68	1.45	0.54	419	2.58	1.39	0.54	442	2.52	1.36	0.54	455	2.44	1.32	0.54	478
28	26	2.76	1.16	0.42	442	2.68	1.13	0.42	465	2.64	1.11	0.42	478	2.56	1.08	0.42	492
29	18	2.35	2.21	0.94	368	2.25	2.12	0.94	386	2.16	2.03	0.94	405	2.08	1.96	0.94	423
29	20	2.45	2.01	0.82	386	2.35	1.93	0.82	409	2.28	1.87	0.82	419	2.20	1.80	0.82	437
29	22	2.55	1.79	0.70	400	2.46	1.72	0.70	426	2.40	1.68	0.70	437	2.30	1.61	0.70	455
29	24	2.68	1.55	0.58	419	2.58	1.50	0.58	442	2.52	1.46	0.58	455	2.44	1.42	0.58	478
29	26	2.76	1.27	0.46	442	2.68	1.23	0.46	465	2.64	1.21	0.46	478	2.56	1.18	0.46	492
30	18	2.35	2.30	0.98	368	2.25	2.21	0.98	386	2.16	2.12	0.98	405	2.08	2.04	0.98	423
30	20	2.45	2.11	0.86	386	2.35	2.02	0.86	409	2.28	1.96	0.86	419	2.20	1.89	0.86	437
30	22	2.55	1.89	0.74	400	2.46	1.82	0.74	426	2.40	1.78	0.74	437	2.30	1.70	0.74	455
30	24	2.68	1.66	0.62	419	2.58	1.60	0.62	442	2.52	1.56	0.62	455	2.44	1.51	0.62	478
30	26	2.76	1.38	0.50	442	2.68	1.34	0.50	465	2.64	1.32	0.50	478	2.56	1.28	0.50	492
31	18	2.35	2.35	1.00	368	2.25	2.25	1.00	386	2.16	2.16	1.00	405	2.08	2.08	1.00	423
31	20	2.45	2.21	0.90	386	2.35	2.12	0.90	409	2.28	2.05	0.90	419	2.20	1.98	0.90	437
31	22	2.55	1.99	0.78	400	2.46	1.92	0.78	426	2.40	1.87	0.78	437	2.30	1.79	0.78	455
31	24	2.68	1.77	0.66	419	2.58	1.70	0.66	442	2.52	1.66	0.66	455	2.44	1.61	0.66	478
31	26	2.76	1.49	0.54	442	2.68	1.45	0.54	465	2.64	1.43	0.54	478	2.56	1.38	0.54	492
32	18	2.35	2.35	1.00	368	2.25	2.25	1.00	386	2.16	2.16	1.00	405	2.08	2.08	1.00	423
32	20	2.45	2.30	0.94	386	2.35	2.21	0.94	409	2.28	2.14	0.94	419	2.20	2.07	0.94	437
32	22	2.55	2.09	0.82	400	2.46	2.02	0.82	426	2.40	1.97	0.82	437	2.30	1.89	0.82	455
32	24	2.68	1.88	0.70	419	2.58	1.81	0.70	442	2.52	1.76	0.70	455	2.44	1.71	0.70	478
32	26	2.76	1.60	0.58	442	2.68	1.55	0.58	465	2.64	1.53	0.58	478	2.56	1.48	0.58	492

NOTE Q : Total capacity (kW) SHF : Sensible heat factor DB : Dry-bulb temperature
 SHC : Sensible heat capacity (kW) INPUT : Total power input (W) WB : Wet-bulb temperature

PERFORMANCE DATA COOL operation at Rated frequency

MUZ-AY20VG

CAPACITY: 2.0 kW

SHF: 0.8

INPUT: 460 W

INDOOR DB (°C)	INDOOR WB (°C)	OUTDOOR DB (°C)											
		35				40				46			
		Q	SHC	SHF	INPUT	Q	SHC	SHF	INPUT	Q	SHC	SHF	INPUT
21	18	1.96	1.22	0.62	451	1.80	1.12	0.62	478	1.66	1.03	0.62	497
21	20	2.06	1.03	0.50	469	1.92	0.96	0.50	492	1.78	0.89	0.50	520
22	18	1.96	1.29	0.66	451	1.80	1.19	0.66	478	1.66	1.10	0.66	497
22	20	2.06	1.11	0.54	469	1.92	1.04	0.54	492	1.78	0.96	0.54	520
22	22	2.18	0.92	0.42	488	2.04	0.86	0.42	515	1.90	0.80	0.42	534
23	18	1.96	1.37	0.70	451	1.80	1.26	0.70	478	1.66	1.16	0.70	497
23	20	2.06	1.19	0.58	469	1.92	1.11	0.58	492	1.78	1.03	0.58	520
23	22	2.18	1.00	0.46	488	2.04	0.94	0.46	515	1.90	0.87	0.46	534
24	18	1.96	1.45	0.74	451	1.80	1.33	0.74	478	1.66	1.23	0.74	497
24	20	2.06	1.28	0.62	469	1.92	1.19	0.62	492	1.78	1.10	0.62	520
24	22	2.18	1.09	0.50	488	2.04	1.02	0.50	515	1.90	0.95	0.50	534
24	24	2.30	0.87	0.38	506	2.16	0.82	0.38	529	2.04	0.78	0.38	552
25	18	1.96	1.53	0.78	451	1.80	1.40	0.78	478	1.66	1.29	0.78	497
25	20	2.06	1.36	0.66	469	1.92	1.27	0.66	492	1.78	1.17	0.66	520
25	22	2.18	1.18	0.54	488	2.04	1.10	0.54	515	1.90	1.03	0.54	534
25	24	2.30	0.97	0.42	506	2.16	0.91	0.42	529	2.04	0.86	0.42	552
26	18	1.96	1.61	0.82	451	1.80	1.48	0.82	478	1.66	1.36	0.82	497
26	20	2.06	1.44	0.70	469	1.92	1.34	0.70	492	1.78	1.25	0.70	520
26	22	2.18	1.26	0.58	488	2.04	1.18	0.58	515	1.90	1.10	0.58	534
26	24	2.30	1.06	0.46	506	2.16	0.99	0.46	529	2.04	0.94	0.46	552
26	26	2.42	0.82	0.34	524	2.28	0.78	0.34	547	2.14	0.73	0.34	570
27	18	1.96	1.69	0.86	451	1.80	1.55	0.86	478	1.66	1.43	0.86	497
27	20	2.06	1.52	0.74	469	1.92	1.42	0.74	492	1.78	1.32	0.74	520
27	22	2.18	1.35	0.62	488	2.04	1.26	0.62	515	1.90	1.18	0.62	534
27	24	2.30	1.15	0.50	506	2.16	1.08	0.50	529	2.04	1.02	0.50	552
27	26	2.42	0.92	0.38	524	2.28	0.87	0.38	547	2.14	0.81	0.38	570
28	18	1.96	1.76	0.90	451	1.80	1.62	0.90	478	1.66	1.49	0.90	497
28	20	2.06	1.61	0.78	469	1.92	1.50	0.78	492	1.78	1.39	0.78	520
28	22	2.18	1.44	0.66	488	2.04	1.35	0.66	515	1.90	1.25	0.66	534
28	24	2.30	1.24	0.54	506	2.16	1.17	0.54	529	2.04	1.10	0.54	552
28	26	2.42	1.02	0.42	524	2.28	0.96	0.42	547	2.14	0.90	0.42	570
29	18	1.96	1.84	0.94	451	1.80	1.69	0.94	478	1.66	1.56	0.94	497
29	20	2.06	1.69	0.82	469	1.92	1.57	0.82	492	1.78	1.46	0.82	520
29	22	2.18	1.53	0.70	488	2.04	1.43	0.70	515	1.90	1.33	0.70	534
29	24	2.30	1.33	0.58	506	2.16	1.25	0.58	529	2.04	1.18	0.58	552
29	26	2.42	1.11	0.46	524	2.28	1.05	0.46	547	2.14	0.98	0.46	570
30	18	1.96	1.92	0.98	451	1.80	1.76	0.98	478	1.66	1.63	0.98	497
30	20	2.06	1.77	0.86	469	1.92	1.65	0.86	492	1.78	1.53	0.86	520
30	22	2.18	1.61	0.74	488	2.04	1.51	0.74	515	1.90	1.41	0.74	534
30	24	2.30	1.43	0.62	506	2.16	1.34	0.62	529	2.04	1.26	0.62	552
30	26	2.42	1.21	0.50	524	2.28	1.14	0.50	547	2.14	1.07	0.50	570
31	18	1.96	1.96	1.00	451	1.80	1.80	1.00	478	1.66	1.66	1.00	497
31	20	2.06	1.85	0.90	469	1.92	1.73	0.90	492	1.78	1.60	0.90	520
31	22	2.18	1.70	0.78	488	2.04	1.59	0.78	515	1.90	1.48	0.78	534
31	24	2.30	1.52	0.66	506	2.16	1.43	0.66	529	2.04	1.35	0.66	552
31	26	2.42	1.31	0.54	524	2.28	1.23	0.54	547	2.14	1.16	0.54	570
32	18	1.96	1.96	1.00	451	1.80	1.80	1.00	478	1.66	1.66	1.00	497
32	20	2.06	1.94	0.94	469	1.92	1.80	0.94	492	1.78	1.67	0.94	520
32	22	2.18	1.79	0.82	488	2.04	1.67	0.82	515	1.90	1.56	0.82	534
32	24	2.30	1.61	0.70	506	2.16	1.51	0.70	529	2.04	1.43	0.70	552
32	26	2.42	1.40	0.58	524	2.28	1.32	0.58	547	2.14	1.24	0.58	570

NOTE Q : Total capacity (kW) SHF : Sensible heat factor DB : Dry-bulb temperature
 SHC : Sensible heat capacity (kW) INPUT : Total power input (W) WB : Wet-bulb temperature



PERFORMANCE DATA HEAT operation at Rated frequency

MUZ-AY15VG

CAPACITY: 2.0kW INPUT: 500 W

INDOOR DB (°C)	OUTDOOR WB (°C)															
	-15		-10		-5		0		5		10		15		20	
	Q	INPUT	Q	INPUT	Q	INPUT	Q	INPUT	Q	INPUT	Q	INPUT	Q	INPUT	Q	INPUT
15	1.00	260	1.26	325	1.52	390	1.78	440	2.04	475	2.30	505	2.54	520	2.80	530
21	0.94	275	1.20	350	1.44	415	1.70	460	1.94	495	2.20	520	2.44	535	2.69	555
26	0.82	300	1.08	375	1.34	440	1.58	485	1.84	520	2.10	545	2.34	560	2.60	575

MUZ-AY20VG

CAPACITY: 2.5 kW INPUT: 600 W

INDOOR DB (°C)	OUTDOOR WB (°C)																	
	-20		-15		-10		-5		0		5		10		15		20	
	Q	INPUT	Q	INPUT	Q	INPUT	Q	INPUT	Q	INPUT	Q	INPUT	Q	INPUT	Q	INPUT	Q	INPUT
15	0.95	240	1.25	312	1.58	390	1.90	468	2.23	528	2.55	570	2.88	606	3.18	624	3.50	636
21	0.88	252	1.18	330	1.50	420	1.80	498	2.13	552	2.43	594	2.75	624	3.05	642	3.36	666
26	0.70	270	1.03	360	1.35	450	1.68	528	1.98	582	2.30	624	2.63	654	2.93	672	3.25	690

NOTE: Q: Total capacity (kW) INPUT : Total power input (W) DB: Dry-bulb temperature WB: Wet-bulb temperature

MUZ-AY15VG MUZ-AY20VG

10-1. OUTDOOR FAN MOTOR CONTROL

The fan motor turns ON/OFF, interlocking with the compressor.

[ON] The fan motor turns ON 5 seconds before the compressor starts up.

[OFF] The fan motor turns OFF 15 seconds after the compressor has stopped running.

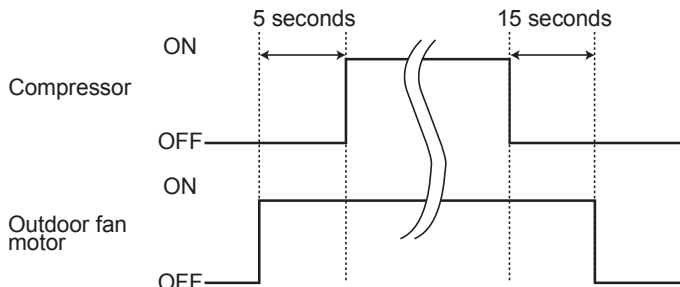

10-2. R.V. COIL CONTROL

- Heating ON
- Cooling OFF
- Dry OFF

NOTE: The 4-way valve reverses for 5 seconds right before startup of the compressor.

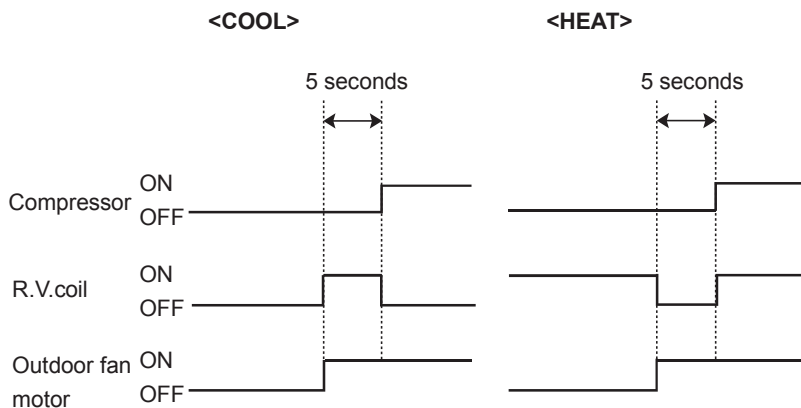

10-3. RELATION BETWEEN MAIN SENSOR AND ACTUATOR

Sensor	Purpose	Actuator				
		Compressor	LEV	Outdoor fan motor	R.V. coil	Indoor fan motor
Discharge temperature thermistor	Protection	○	○			
Indoor coil temperature thermistor	Cooling: Coil frost prevention	○				
	Heating: High pressure protection	○	○			
Defrost thermistor	Heating: Defrosting	○	○	○	○	○
Fin temperature thermistor	Protection	○		○		
Ambient temperature thermistor	Cooling: Low ambient temperature operation	○	○	○		
Outdoor heat exchanger temperature thermistor	Cooling: Low ambient temperature operation	○	○	○		
	Cooling: High pressure protection	○	○	○		

MUZ-AY15VG MUZ-AY20VG**11-1. CHANGE IN DEFROST SETTING****Changing defrost finish temperature**

<JS> To change the defrost finish temperature, cut/solder the JS wire of the outdoor inverter P.C. board.
(Refer to 12-6-1.)

Jumper wire		Defrost finish temperature (°C)
JS	Soldered (Initial setting)	8
	None (Cut)	13

11-2. PRE-HEAT CONTROL SETTING**PRE-HEAT CONTROL**

When moisture gets into the refrigerant cycle, it may interfere the start-up of the compressor at low outside temperature. The pre-heat control prevents this interference. The pre-heat control turns ON when the discharge temperature thermistor is 20°C or below. When the pre-heat control turns ON, the compressor is energized. (About 50 W)

Pre-heat control setting

<JK>

ON: To activate the pre-heat control, cut the JK wire of the inverter P.C. board.

OFF: To deactivate the pre-heat control, solder the JK wire of the inverter P.C. board.

(Refer to 12-6.1)

NOTE: When the inverter P.C. board is replaced, check the jumper wires, and cut/solder them if necessary.

MUZ-AY15VG MUZ-AY20VG**12-1. CAUTIONS ON TROUBLESHOOTING****1. Before troubleshooting, check the following**

- 1) Check the power supply voltage.
- 2) Check the indoor/outdoor connecting wire for miswiring.

2. Take care of the following during servicing

- 1) Before servicing the air conditioner, be sure to turn OFF the main unit first with the remote controller, and then after confirming the horizontal vane is closed, turn OFF the breaker and/or disconnect the power plug.
- 2) Be sure to turn OFF the power supply before removing the front panel, the cabinet, the top panel, and the electronic control P.C. board.
- 3) When removing the electrical parts, be careful of the residual voltage of smoothing capacitor.
- 4) When removing the electronic control P.C. board, hold the edge of the board with care NOT to apply stress on the components.
- 5) When connecting or disconnecting the connectors, hold the connector housing. DO NOT pull the lead wires.

<Incorrect>



Lead wiring

<Correct>



Connector housing

3. Troubleshooting procedure

- 1) Check if the Operation indicator lamp on the indoor unit is blinking on and off to indicate an abnormality.
To make sure, check how many times the Operation indicator lamp is blinking on and off before starting service work.
- 2) Before servicing, verify that all connectors and terminals are connected properly.
- 3) When the electronic control P.C. board seems to be defective, check for disconnection of the copper foil pattern and burnt or discolored components.
- 4) Refer to 12-2 and 12-3.

12-2. FAILURE MODE RECALL FUNCTION

Outline of the function

This air conditioner can memorize the abnormal condition which has occurred once.

Even though LED indication listed on the troubleshooting check table (12-3.) disappears, the memorized failure details can be recalled.

1. Flow chart of failure mode recall function for the indoor/outdoor unit

Operational procedure

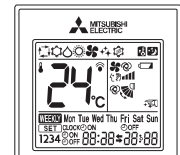
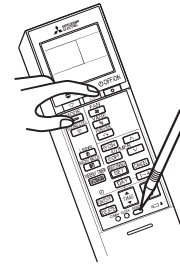
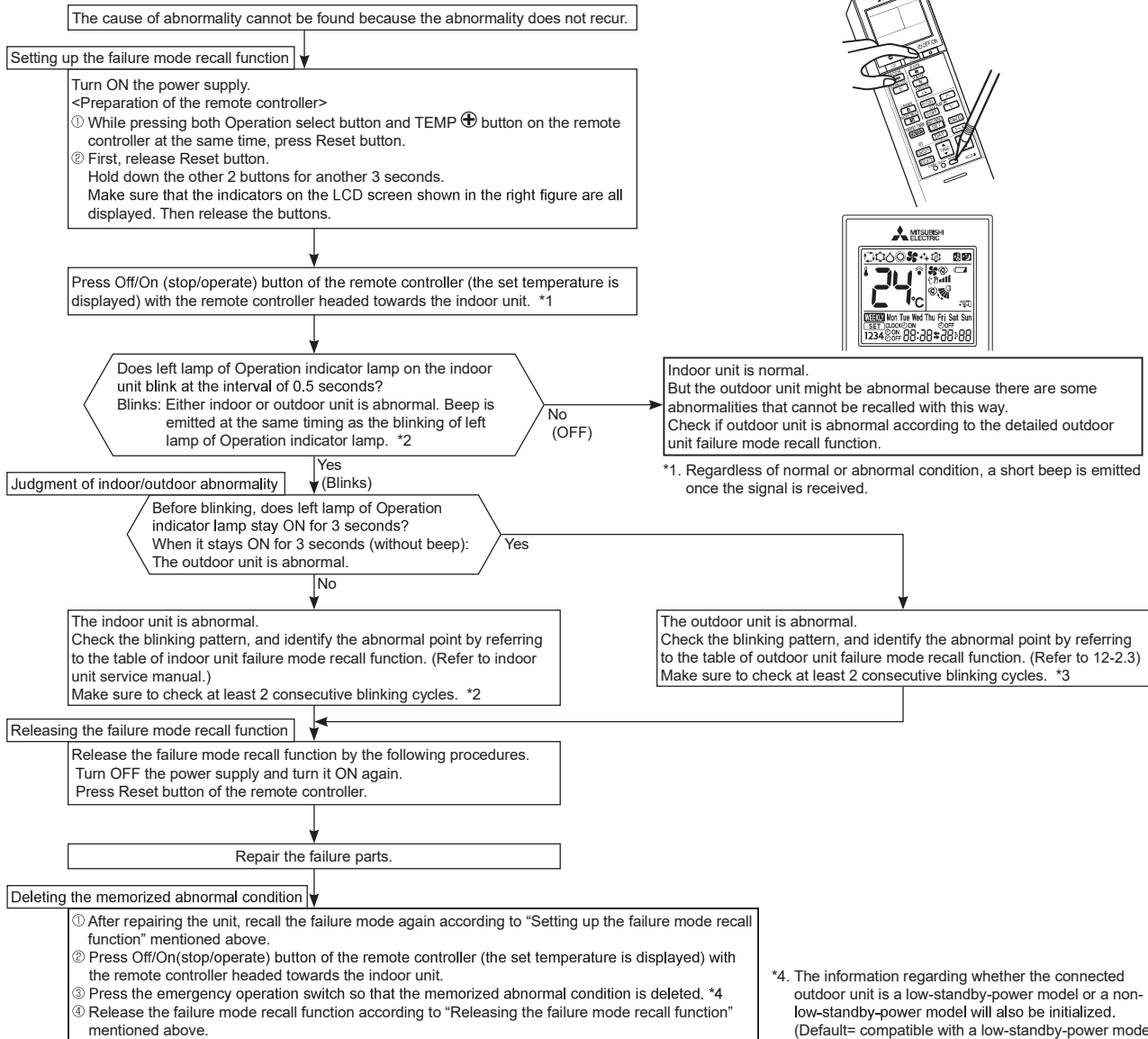

NOTE: 1. Make sure to release the failure mode recall function after it is set up, otherwise the unit cannot operate properly.
 2. If the abnormal condition is not deleted from the memory, the last abnormal condition is kept memorized.

*2. Blinking pattern when the indoor unit is abnormal:

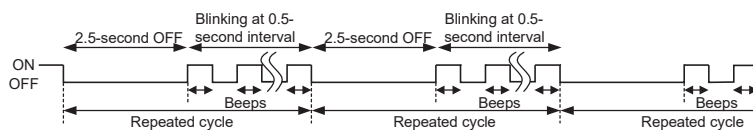

*3. Blinking pattern when the outdoor unit is abnormal:

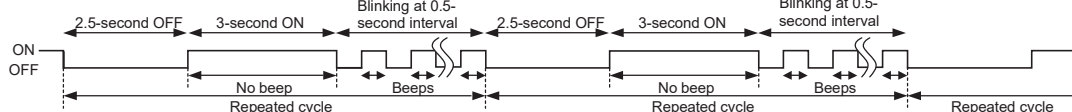

2. Flow chart of the detailed outdoor unit failure mode recall function

Operational procedure

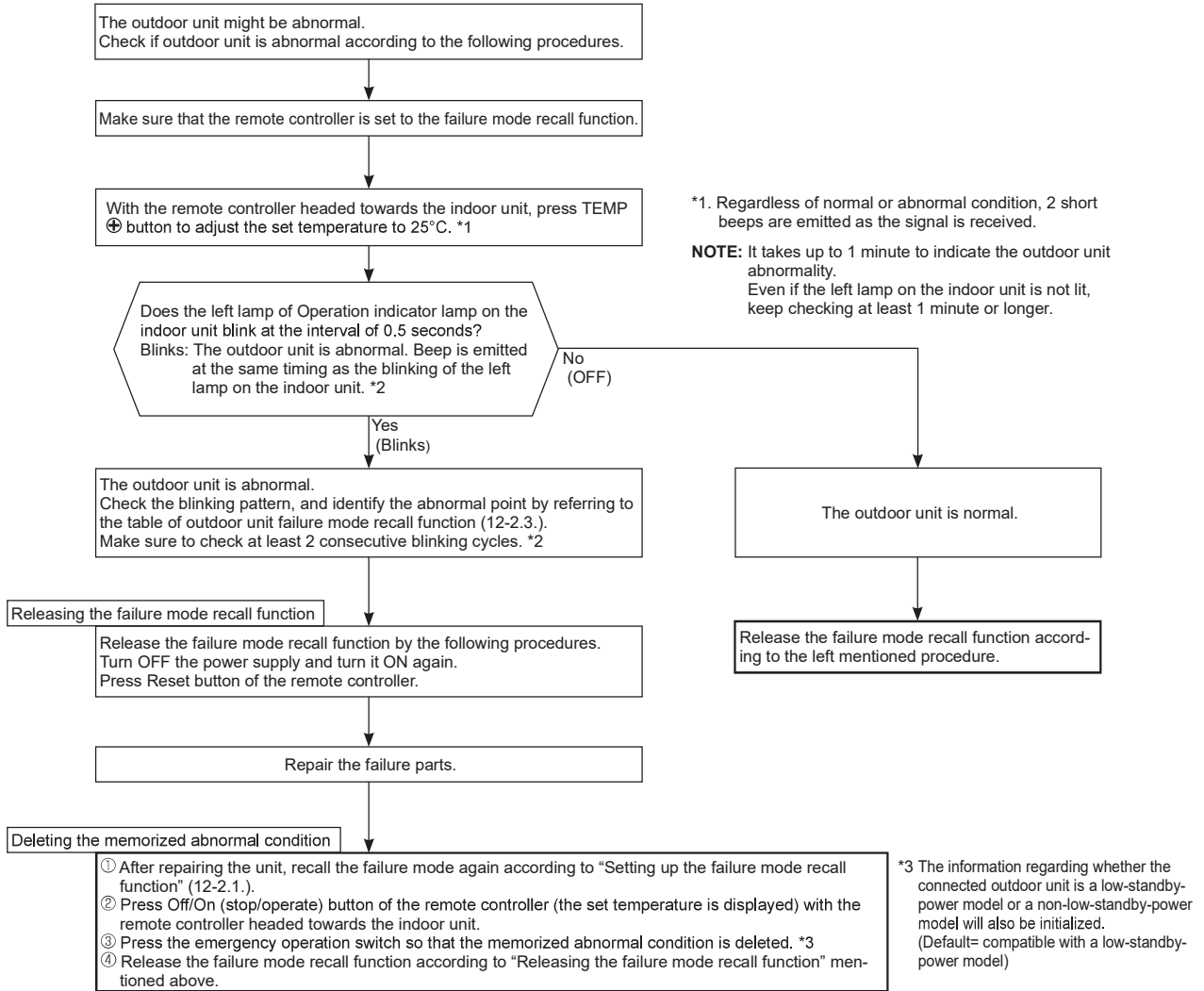

NOTE: 1. Make sure to release the failure mode recall function after it is set up, otherwise the unit cannot operate properly.
2. If the abnormal condition is not deleted from the memory, the last abnormal condition is kept memorized.

*2. Blinking pattern when outdoor unit is abnormal:

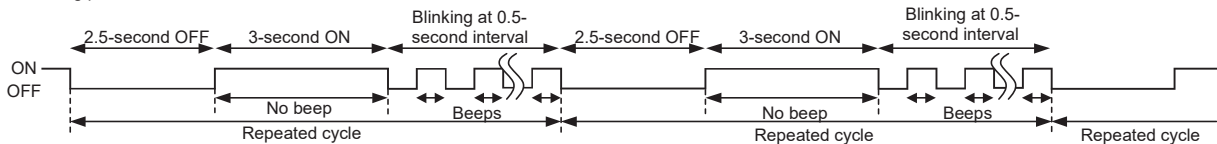



3. Table of outdoor unit failure mode recall function

NOTE: Blinking patterns of this mode differ from the ones of TROUBLESHOOTING CHECK TABLE (12-3.).

Left lamp (Indoor unit)	Abnormal point (Failure mode/protection)	LED indication (Outdoor P.C. board)	Condition	Remedy	Indoor/outdoor unit failure mode recall function	Outdoor unit failure mode recall function
OFF	None (Normal)	—	—	—	—	—
1-time blink 2.5 seconds OFF	Indoor/outdoor communication, receiving error	—	Any signals from the inverter P.C. board cannot be received normally for 3 minutes.	•Refer to 12-5.㉞ "How to check miswiring and serial signal error".	○	○
	Indoor/outdoor communication, receiving error	—	Although the inverter P.C. board sends signal "0", signal "1" has been received 30 consecutive times.	•Refer to 12-5.㉞ "How to check miswiring and serial signal error".		
2-time blink 2.5 seconds OFF	Outdoor power system	—	Overcurrent protection cut-out operates 3 consecutive times within 1 minute after the compressor gets started.	•Reconnect connectors. •Refer to 12-5.㉞ "How to check inverter/compressor". •Check stop valve.	○	○
3-time blink 2.5 seconds OFF	Discharge temperature thermistor	1-time blink every 2.5 seconds	Thermistor shorts or opens during compressor running.	•Refer to 12-5.㉞ "Check of outdoor thermistors". Defective outdoor thermistors can be identified by checking the blinking pattern of LED. •Replace the inverter P.C. board.	○	○
	Defrost thermistor	3-time blink 2.5 seconds OFF				
	Fin temperature thermistor	2-time blink 2.5 seconds OFF				
	Ambient temperature thermistor	—				
	Outdoor heat exchanger temperature thermistor	4-time blink 2.5 seconds OFF				
4-time blink 2.5 seconds OFF	Overcurrent	11-time blink 2.5 seconds OFF	Large current flows into power module (IC700).	•Reconnect compressor connector. •Refer to 12-5.㉞ "How to check inverter/compressor". •Check stop valve.	—	○
	Compressor synchronous abnormality (Compressor start-up failure protection)	12-time blink 2.5 seconds OFF	Waveform of compressor current is distorted.	•Reconnect compressor connector. •Refer to 12-5.㉞ "How to check inverter/compressor".	—	○
5-time blink 2.5 seconds OFF	Discharge temperature	—	Temperature of discharge temperature thermistor exceeds 116°C, compressor stops. Compressor can restart if discharge temperature thermistor reads 100°C or less 3 minutes later.	•Check refrigerant circuit and refrigerant amount. •Refer to 12-5.㉞ "Check of LEV".	—	○
6-time blink 2.5 seconds OFF	High pressure	—	Temperature of indoor coil thermistor exceeds 70°C in HEAT mode. Temperature of defrost thermistor exceeds 70°C in COOL mode.	•Check refrigerant circuit and refrigerant amount. •Check stop valve.	—	○
7-time blink 2.5 seconds OFF	Fin temperature/P.C. board temperature	7-time blink 2.5 seconds OFF	Temperature of fin temperature thermistor on the inverter P.C. board exceeds 75 ~ 86°C, or temperature of P.C. board temperature thermistor on the inverter P.C. board exceeds 72 ~ 85°C.	•Check around outdoor unit. •Check outdoor unit air passage. •Refer to 12-5.㉞ "Check of outdoor fan motor".	—	○
8-time blink 2.5 seconds OFF	Outdoor fan motor	—	Outdoor fan has stopped 3 times in a row within 30 seconds after outdoor fan startup.	•Refer to 12-5.㉞ "Check of outdoor fan motor". Refer to 12-5.㉞ "Check of inverter P.C. board".	—	○
9-time blink 2.5 seconds OFF	Nonvolatile memory data	5-time blink 2.5 seconds OFF	Nonvolatile memory data cannot be read properly.	•Replace the inverter P.C. board.	○	○
	Power module (IC700)	6-time blink 2.5 seconds OFF	The interface short circuit occurs in the output of the power module (IC700). The compressor winding shorts circuit.	•Refer to 12-5.㉞ "How to check inverter/compressor".	—	

NOTE: Blinking patterns of this mode differ from the ones of TROUBLESHOOTING CHECK TABLE (12-3.).

Left lamp (Indoor unit)	Abnormal point (Failure mode/protection)	LED indication (Outdoor P.C. board)	Condition	Remedy	Indoor/outdoor unit failure mode recall function	Outdoor unit failure mode recall function
10-time blink 2.5 seconds OFF	Discharge temperature	—	Temperature of discharge temperature thermistor has been 50°C or less for 20 minutes.	<ul style="list-style-type: none"> Refer to 12-5.④ "Check of LEV". Check refrigerant circuit and refrigerant amount. 	—	○
11-time blink 2.5 seconds OFF	Bus-bar voltage (DC)	8-time blink 2.5 seconds OFF	Bus-bar voltage of inverter cannot be detected normally.	<ul style="list-style-type: none"> Refer to 12-5.④ "How to check inverter/compressor". 	—	○
	Each phase current of compressor	9-time blink 2.5 seconds OFF	Each phase current of compressor cannot be detected normally.			
14-time blink 2.5 seconds OFF *1	Stop valve (Closed valve)	14-time blink 2.5 seconds OFF	<ul style="list-style-type: none"> Closed valve is detected by compressor current. An abnormality of the indoor thermistors, the defrost thermistor or ambient temperature thermistor is detected. 	<ul style="list-style-type: none"> Check stop valve. Refer to "TEST POINT DIAGRAM AND VOLTAGE" on the service manual of indoor and outdoor unit for the characteristics of the thermistors. (Do not start the operation again without repair to prevent hazards.) 	○	○
	4-way valve/ Pipe temperature	16-time blink 2.5 seconds OFF	<ul style="list-style-type: none"> The 4-way valve does not work properly. The indoor coil thermistor detects an abnormal temperature. An abnormality of the indoor thermistor is detected. 	<ul style="list-style-type: none"> Check the 4-way valve. Replace the inverter P.C. board. Refer to "TEST POINT DIAGRAM AND VOLTAGE" on the service manual of indoor and outdoor unit for the characteristics of the thermistors. (Do not start the operation again without repair to prevent hazards.) 		
16-time blink 2.5 seconds OFF	Outdoor refrigerant system abnormality	1-time blink 2.5 seconds OFF	<ul style="list-style-type: none"> A closed valve and air trapped in the refrigerant circuit are detected based on the temperature sensed by the indoor and outdoor thermistors and the current of the compressor. An abnormality of the indoor thermistors, the defrost thermistor or ambient temperature thermistor is detected. 	<ul style="list-style-type: none"> Check for a gas leak in a connecting piping etc. Check the stop valve. Refer to 12-5.④ "Check of outdoor refrigerant circuit". Refer to "TEST POINT DIAGRAM AND VOLTAGE" on the service manual of indoor and outdoor unit for the characteristics of the thermistors. (Do not start the operation again without repair to prevent hazards.) 	○	○

*1 There is possibility that diesel explosion may occur due to the air mixed in the refrigerant circuit.
 First, ensure that there are no leakage points on the valves, flare connections, etc. that allow the air to flow into the refrigerant circuit, or no blockage points (e.g. clogged or closed valves) in the refrigerant circuit that cause an increase in pressure.
 If there is no abnormal point like above and the system operates cooling and heating modes normally, the indoor thermistor might have a problem, resulting in false detection.
 Check both the indoor coil thermistor and the room temperature thermistor, and replace faulty thermistor(s), if any.
 (Do not start the operation again without repair to prevent hazards.)

12-3. TROUBLESHOOTING CHECK TABLE

No.	Symptom	LED indication	Abnormal point/ Condition	Condition	Remedy
1	Outdoor unit does not operate.	1-time blink every 2.5 seconds	Outdoor power system	Overcurrent protection cut-out operates 3 consecutive times within 1 minute after the compressor gets started.	<ul style="list-style-type: none"> •Reconnect connector of compressor. •Refer to 12-5.Ⓐ "How to check inverter/compressor". •Check stop valve.
2			Outdoor thermistors	Discharge temperature thermistor, fin temperature thermistor, defrost thermistor, outdoor heat exchanger temperature thermistor or ambient temperature thermistor shorts or opens during compressor running.	<ul style="list-style-type: none"> •Refer to 12-5.Ⓒ "Check of outdoor thermistors".
3			Outdoor control system	P.C. board temperature thermistor shorts or opens during compressor running.	<ul style="list-style-type: none"> •Replace inverter P.C. board.
4	'Outdoor unit stops and restarts 3 minutes later' is repeated.	6-time blink 2.5 seconds OFF	Serial signal	The communication fails between the indoor and outdoor unit for 3 minutes.	<ul style="list-style-type: none"> •Refer to 12-5.Ⓜ "How to check miswiring and serial signal error".
5		11-time blink 2.5 seconds OFF	Stop valve/ Closed valve	Closed valve is detected by compressor current.	<ul style="list-style-type: none"> •Check stop valve.
6		14-time blink 2.5 seconds OFF	Outdoor unit (Other abnormality)	Outdoor unit is defective.	<ul style="list-style-type: none"> •Refer to 12-2.2. "Flow chart of the detailed outdoor unit failure mode recall function".
7		16-time blink 2.5 seconds OFF	4-way valve/ Pipe temperature	The 4-way valve does not work properly. The indoor coil thermistor detects an abnormal temperature.	<ul style="list-style-type: none"> •Refer to 12-5.Ⓟ "Check of R.V. coil". •Replace the inverter P.C. board.
8		17-time blink 2.5 seconds OFF	Outdoor refrigerant system abnormality	A closed valve and air trapped in the refrigerant circuit are detected based on the temperature sensed by the indoor and outdoor thermistors and the current of the compressor.	<ul style="list-style-type: none"> •Check for a gas leak in a connecting piping etc. •Check the stop valve. •Refer to 12-5.Ⓢ "Check of outdoor refrigerant circuit".
9		2-time blink 2.5 seconds OFF	Overcurrent protection	Large current flows into power module (IC700).	<ul style="list-style-type: none"> •Reconnect connector of compressor. •Refer to 12-5.Ⓐ "How to check inverter/compressor". •Check stop valve.
10		3-time blink 2.5 seconds OFF	Discharge temperature overheat protection	Temperature of discharge temperature thermistor exceeds 116°C, compressor stops. Compressor can restart if discharge temperature thermistor reads 100°C or less 3 minutes later.	<ul style="list-style-type: none"> •Check refrigerant circuit and refrigerant amount. •Refer to 12-5.Ⓠ "Check of LEV".
11		4-time blink 2.5 seconds OFF	Fin temperature /P.C. board temperature thermistor overheat protection	Temperature of fin temperature thermistor on the heat sink exceeds 75 ~ 86°C or temperature of P.C. board temperature thermistor on the inverter P.C. board exceeds 72 ~ 85°C.	<ul style="list-style-type: none"> •Check around outdoor unit. •Check outdoor unit air passage. •Refer to 12-5.Ⓣ "Check of outdoor fan motor".
12	5-time blink 2.5 seconds OFF	High pressure protection	Indoor coil thermistor exceeds 70°C in HEAT mode. Defrost thermistor exceeds 70°C in COOL mode.	<ul style="list-style-type: none"> •Check refrigerant circuit and refrigerant amount. •Check stop valve. 	
13	8-time blink 2.5 seconds OFF	Compressor synchronous abnormality	The waveform of compressor current is distorted.	<ul style="list-style-type: none"> •Reconnect connector of compressor. •Refer to 12-5.Ⓐ "How to check inverter/compressor". 	
14	10-time blink 2.5 seconds OFF	Outdoor fan motor	Outdoor fan has stopped 3 times in a row within 30 seconds after outdoor fan start-up.	<ul style="list-style-type: none"> •Refer to 12-5.Ⓡ "Check of outdoor fan motor". •Refer to 12-5.Ⓡ "Check of inverter P.C. board." 	
15	12-time blink 2.5 seconds OFF	Each phase current of compressor	Each phase current of compressor cannot be detected normally.	<ul style="list-style-type: none"> •Refer to 12-5.Ⓐ "How to check inverter/compressor". 	
16	13-time blink 2.5 seconds OFF	Bus-bar voltage (DC)	Bus-bar voltage of inverter cannot be detected normally.	<ul style="list-style-type: none"> •It occurs with following case. Instantaneous power voltage drop. (Short time power failure) •Refer to 12-5.Ⓢ "Check of power supply". •Refer to 12-5.Ⓐ "How to check inverter/compressor". 	
17	Outdoor unit operates.	1-time blink 2.5 seconds OFF	Deceleration of the operational frequency of the compressor by the current protection control	When the input current exceeds approximately 10A, compressor frequency lowers.	<ul style="list-style-type: none"> The unit is normal, but check the following. •Check if indoor filters are clogged. •Check if refrigerant is short. •Check if indoor/outdoor unit air circulation is short cycled.
18		3-time blink 2.5 seconds OFF	Deceleration of the operational frequency of the compressor by the high pressure protection	Temperature of indoor coil thermistor exceeds 55°C in HEAT mode, compressor frequency lowers.	
			Deceleration of the operational frequency of the compressor by the overcooling prevention of the indoor heat exchanger	Indoor coil thermistor reads 8°C or less in COOL mode, compressor frequency lowers.	



No.	Symptom	LED indication	Abnormal point/Condition	Condition	Remedy
19	Outdoor unit operates.	4-time blink 2.5 seconds OFF	Deceleration of the operational frequency of the compressor by the discharge temperature protection	Temperature of discharge temperature thermistor exceeds 111°C, compressor frequency lowers.	<ul style="list-style-type: none"> •Check refrigerant circuit and refrigerant amount. •Refer to 12-5.Ⓔ "Check of LEV". •Refer to 12-5.Ⓕ "Check of outdoor thermistors".
20		5-time blink 2.5 seconds OFF	Ambient temperature thermistor protection	When the ambient temperature thermistor shorts or opens, protective operation without that thermistor is performed.	<ul style="list-style-type: none"> •Refer to 12-5.Ⓖ "Check of outdoor thermistors".
21		7-time blink 2.5 seconds OFF	Low discharge temperature protection	Temperature of discharge temperature thermistor has been 50°C or less for 20 minutes.	<ul style="list-style-type: none"> •Refer to 12-5.Ⓔ "Check of LEV". •Check refrigerant circuit and refrigerant amount.
22		8-time blink 2.5 seconds OFF	PAM protection PAM: Pulse Amplitude Modulation	The overcurrent flows into PFC (Power factor correction: IC820) or the bus-bar voltage reaches 394 V or more, PAM stops and restarts.	<p>This is not malfunction. PAM protection will be activated in the following cases:</p> <ol style="list-style-type: none"> 1 Instantaneous power voltage drop. (Short time power failure) 2 When the power supply voltage is high.
23		9-time blink 2.5 seconds OFF	Inverter check mode	The connector of compressor is disconnected, inverter check mode starts.	<ul style="list-style-type: none"> •Check if the connector of the compressor is correctly connected. Refer to 12-5.Ⓐ "How to check inverter/compressor".

NOTE: 1. The location of LED is illustrated at the right figure. Refer to 12-6.1.
 2. LED is lit during normal operation.

The blinking frequency shows the number of times the LED blinks after every 2.5-second OFF.
 (Example) When the blinking frequency is "2".

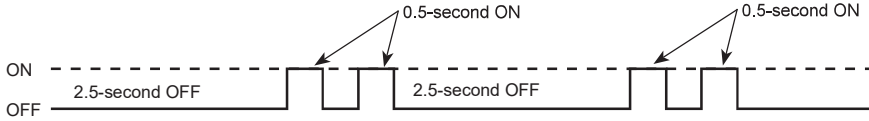

Inverter P.C. board

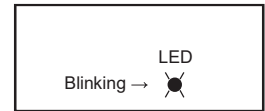

12-4. TROUBLESHOOTING CRITERION OF MAIN PARTS

Part name	Check method and criterion	Figure							
Defrost thermistor (RT61) Fin temperature thermistor (RT64) Ambient temperature thermistor (RT65) Outdoor heat exchanger temperature thermistor (RT68)	Measure the resistance with a multimeter. Refer to 12-6. "Test point diagram and voltage", 1. "Inverter P.C. board", for the chart of thermistor.								
Discharge temperature thermistor (RT62)	Measure the resistance with a multimeter. Before measurement, hold the thermistor with your hands to warm it up. Refer to 12-6. "Test point diagram and voltage", 1. "Inverter P.C. board", for the chart of thermistor.								
Compressor	Measure the resistance between terminals using a multimeter. (Temperature: -10 to 40°C) <table border="1" data-bbox="415 779 976 898"> <thead> <tr> <th></th> <th>Normal (Ω)</th> </tr> </thead> <tbody> <tr> <td>U-V</td> <td rowspan="3">1.59 - 2.16</td> </tr> <tr> <td>U-W</td> </tr> <tr> <td>V-W</td> </tr> </tbody> </table>		Normal (Ω)	U-V	1.59 - 2.16	U-W	V-W		
	Normal (Ω)								
U-V	1.59 - 2.16								
U-W									
V-W									
Outdoor fan motor	Measure the resistance between lead wires using a multimeter. (Temperature: -10 to 40°C) <table border="1" data-bbox="415 968 862 1087"> <thead> <tr> <th>Color of lead wire</th> <th>Normal (Ω)</th> </tr> </thead> <tbody> <tr> <td>RED - BLK</td> <td rowspan="3">32 - 43</td> </tr> <tr> <td>BLK - WHT</td> </tr> <tr> <td>WHT - RED</td> </tr> </tbody> </table>	Color of lead wire	Normal (Ω)	RED - BLK	32 - 43	BLK - WHT	WHT - RED		
Color of lead wire	Normal (Ω)								
RED - BLK	32 - 43								
BLK - WHT									
WHT - RED									
R. V. coil (21S4)	Measure the resistance using a multimeter. (Temperature: -10 to 40°C) <table border="1" data-bbox="415 1129 699 1192"> <thead> <tr> <th>Normal (kΩ)</th> </tr> </thead> <tbody> <tr> <td>1.41 - 2.00</td> </tr> </tbody> </table>	Normal (k Ω)	1.41 - 2.00						
Normal (k Ω)									
1.41 - 2.00									
Expansion valve coil (LEV)	Measure the resistance using a multimeter. (Temperature: -10 to 40°C) <table border="1" data-bbox="415 1234 837 1392"> <thead> <tr> <th>Color of lead wire</th> <th>Normal (Ω)</th> </tr> </thead> <tbody> <tr> <td>BRN - ORN</td> <td rowspan="4">37 - 54</td> </tr> <tr> <td>BRN - WHT</td> </tr> <tr> <td>RED - BLU</td> </tr> <tr> <td>RED - YLW</td> </tr> </tbody> </table>	Color of lead wire	Normal (Ω)	BRN - ORN	37 - 54	BRN - WHT	RED - BLU	RED - YLW	
Color of lead wire	Normal (Ω)								
BRN - ORN	37 - 54								
BRN - WHT									
RED - BLU									
RED - YLW									

12-5. TROUBLESHOOTING FLOW

A How to check inverter/compressor

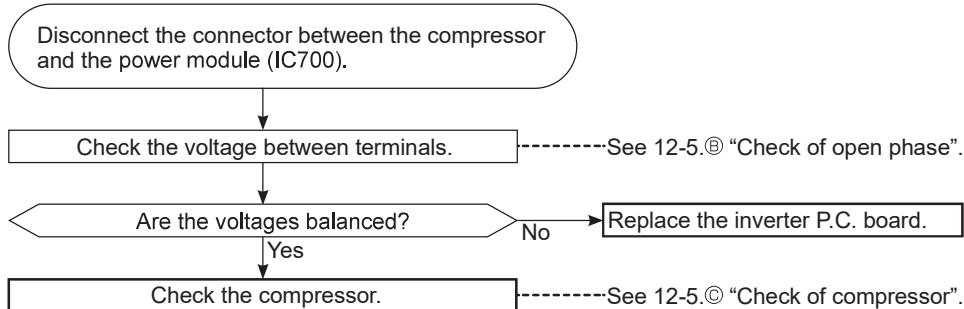

B Check of open phase

- With the connector between the compressor and the power module (IC700) disconnected, activate the inverter and check if the inverter is normal by measuring the **voltage balance** between the terminals.

Output voltage is 50 - 130 V. (The voltage may differ according to the multimeter.)

<< Operation method >>

Start cooling or heating operation by pressing the emergency operation switch on the indoor unit. (TEST RUN OPERATION: Refer to 9-3.)

<< Measurement point >>

At 3 points *Measure AC voltage between the lead wires at 3 points.

BLK (U)-WHT (V)

BLK (U)-RED (W)

WHT(V)-RED (W)

NOTE: 1. Output voltage varies according to power supply voltage.

2. Measure the voltage by analog type multimeter.

3. During this check, LED of the inverter P.C. board blinks 9 times. (Refer to 12-6.1.)

C Check of compressor

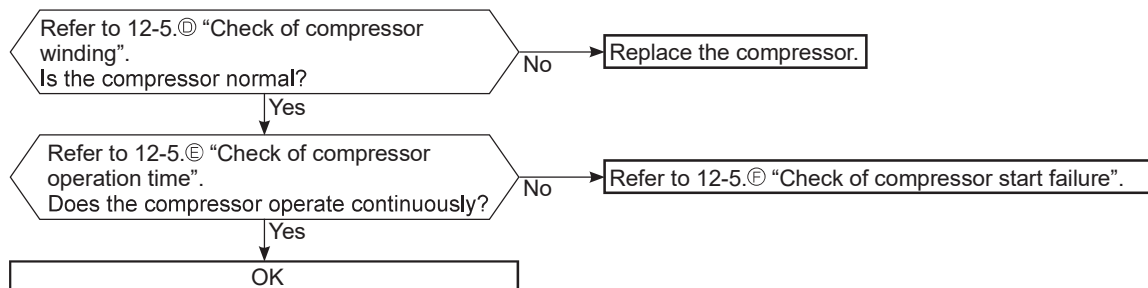

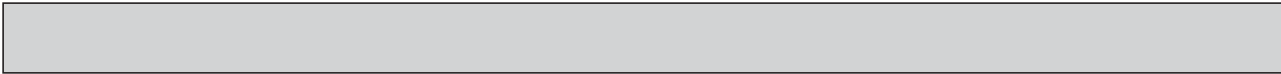

D Check of compressor winding

• Disconnect the connector between the compressor and the power module (IC700), and measure the resistance between the compressor terminals.

<<Measurement point>>

At 3 points *Measure the resistance between the lead wires at 3 points.

- BLK-WHT
- BLK-RED
- WHT-RED

<<Judgement>>

Refer to 12-4.

0 [Ω]Abnormal [short]

Infinite [Ω]Abnormal [open]

NOTE: Be sure to zero the ohmmeter before measurement.

E Check of compressor operation time

• Connect the compressor and activate the inverter. Then measure the time until the inverter stops due to overcurrent.

<<Operation method>>

Start heating or cooling operation by pressing the emergency operation switch on the indoor unit. (TEST RUN OPERATION: Refer to 9-3.)

<<Measurement>>

Measure the time from the start of compressor to the stop of compressor due to overcurrent.

<<Judgement>>

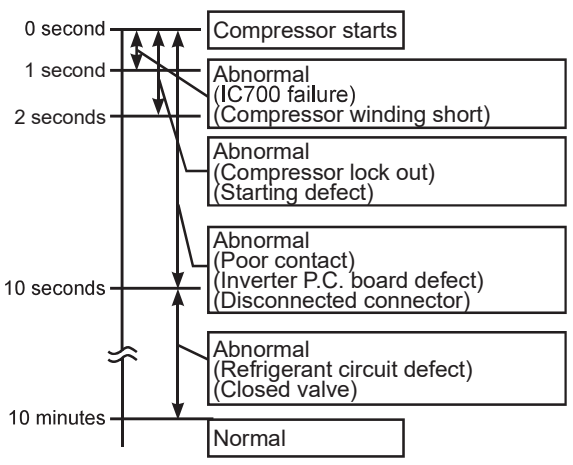

F Check of compressor start failure

Confirm that ①~④ is normal.

- Electrical circuit check
- ①. Contact of the compressor connector
- ②. Output voltage of inverter P.C. board and balance of them (See 12-5.Ⓔ)
- ③. Direct current voltage between DB61(+) and (-) on the inverter P.C. board
- ④. Voltage between outdoor terminal block S1-S2

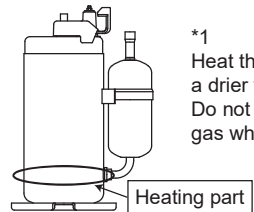
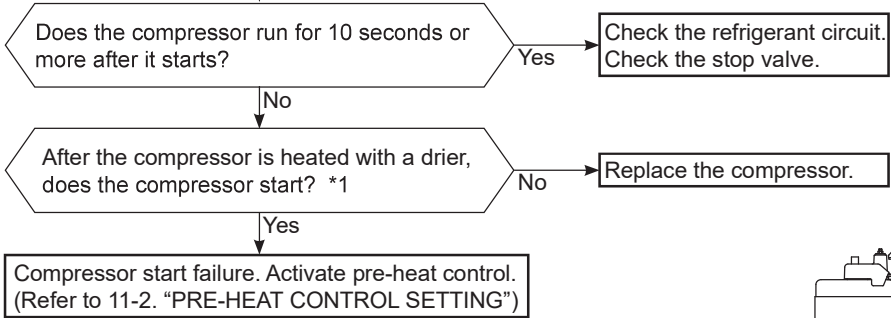

*1 Heat the compressor with a drier for about 20 minutes. Do not recover refrigerant gas while heating.

G Check of outdoor thermistors

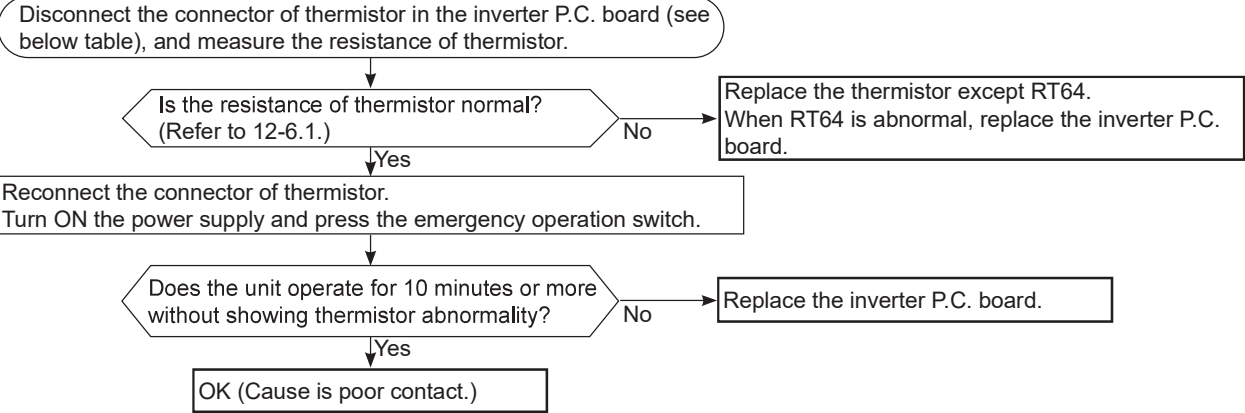

Thermistor	Symbol	Connector, Pin No.	Board
Defrost	RT61	Between CN641 pin1 and pin2	Inverter P.C. board
Discharge temperature	RT62	Between CN641 pin3 and pin4	
Fin temperature	RT64	Between CN642 pin1 and pin2	
Ambient temperature	RT65	Between CN643 pin1 and pin2	
Outdoor heat exchanger temperature	RT68	Between CN644 pin1 and pin3	

H Check of R.V. coil

- First of all, measure the resistance of R.V. coil to check if the coil is defective. Refer to 12-4.
- In case CN721 is disconnected or R.V. coil is open, voltage is generated between the terminal pins of the connector although no signal is being transmitted to R.V. coil. Check if CN721 is connected.

Unit operates in COOL mode even if it is set to HEAT mode.

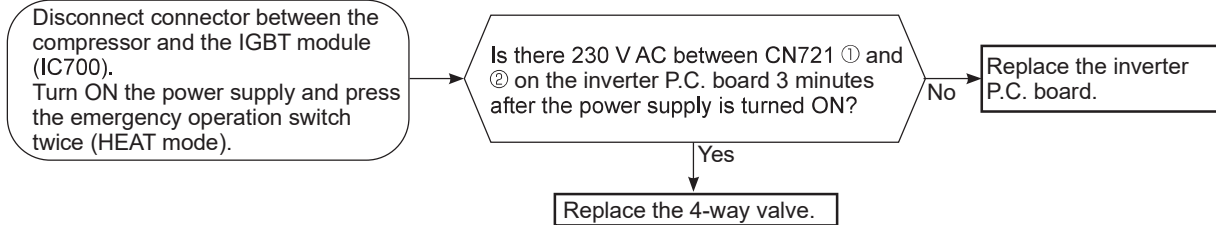

Unit operates in HEAT mode even if it is set to COOL mode.

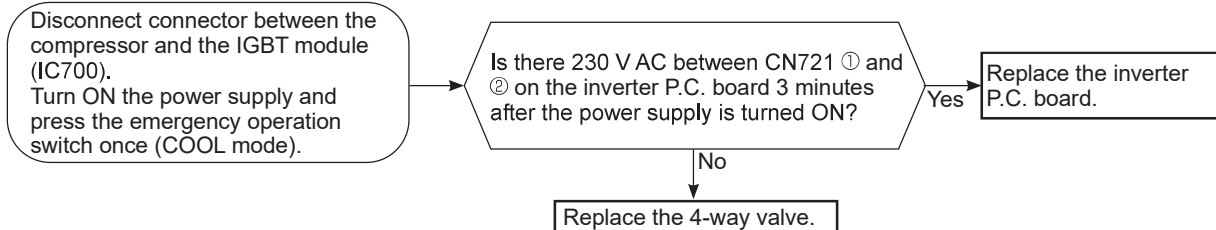

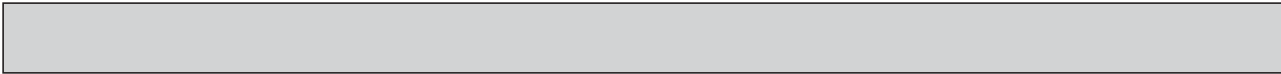

① Check of outdoor fan motor

Disconnect the connectors CN931 and CN932 from the inverter P.C. board.
Check the connection between the connector CN931 and CN932.

Is the resistance between each terminal of outdoor fan motor normal?
(Refer to 12-4.)

Yes

No

Disconnect CN932 from the inverter P.C. board, and turn on the power supply.

Rotate the outdoor fan motor manually and measure the voltage of CN931.
Between 1(+) and 5(-)
Between 2(+) and 5(-)
Between 3(+) and 5(-)

(Fixed to either 5 or 0 V DC)

No

Does the voltage between each terminal become 5 and 0 V DC repeatedly?

Yes

No

Does the outdoor fan motor rotate smoothly?

Yes

Replace the outdoor fan motor.

Replace the inverter P.C. board.

Ⓜ Check of power supply

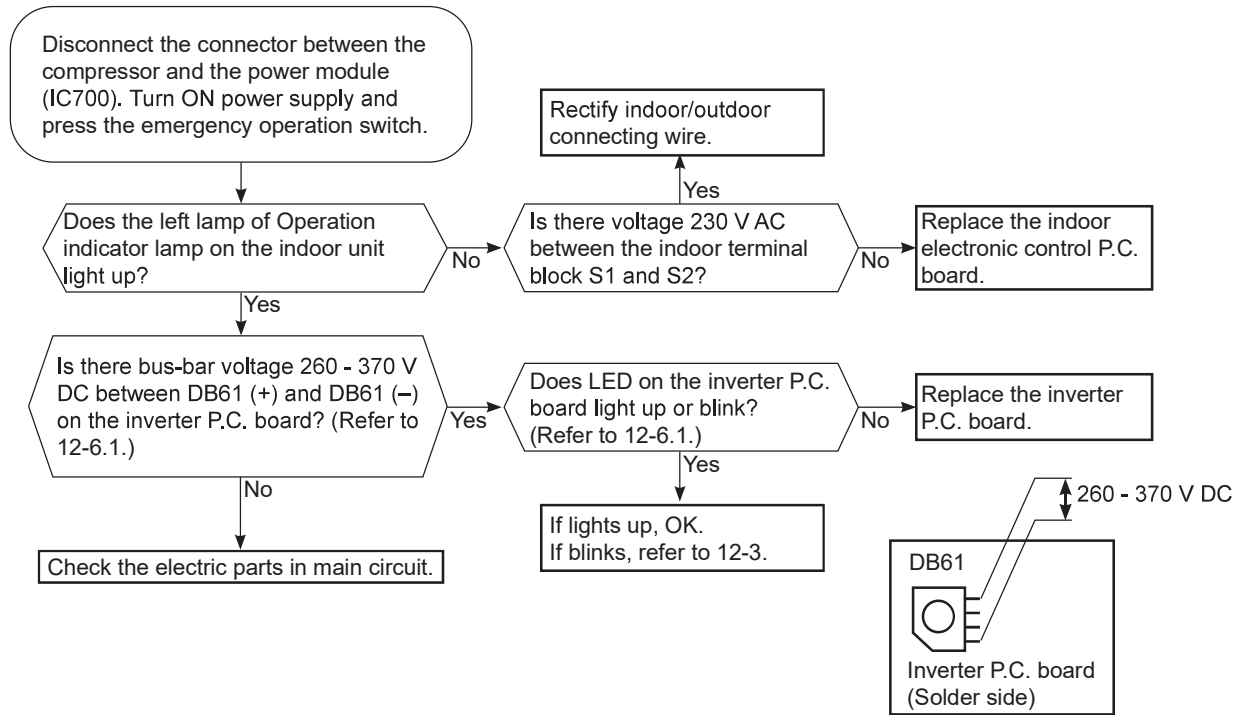

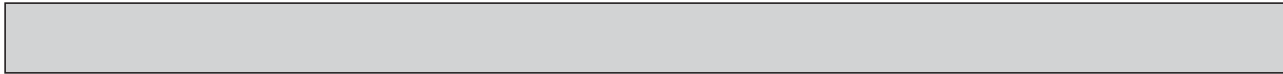

Ⓚ Check of LEV (Expansion valve)

Turn ON the power supply.
 <Preparation of the remote controller>
 ① While pressing both Operation select button and TEMP Ⓚ button on the remote controller at the same time, press Reset button.
 ② First, release Reset button.
 Hold down the other 2 buttons for another 3 seconds. Make sure that the indicators on the LCD screen shown in the right figure are all displayed. Then release the buttons.

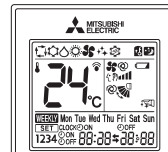
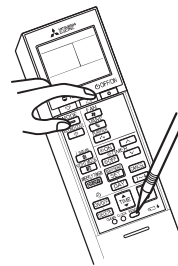

Press Off/On (stop/operate) button of the remote controller (the set temperature is displayed) with the remote controller headed towards the indoor unit. *1

Expansion valve operates in full-opening direction.

Do you hear the expansion valve "click, click....."?
 Do you feel the expansion valve vibrate when touching it?

Yes → OK

*1. Regardless of normal or abnormal condition, a short beep is emitted once the signal is received.

Is LEV coil properly fixed to the expansion valve?

No → Properly fix the LEV coil to the expansion valve.

Yes

Does the resistance of LEV coil have the characteristics? (Refer to 12-4.)

No → Replace the LEV coil.

Yes

Measure each voltage between connector pins of CN724 on the inverter P.C. board.

1. Pin③(-) — Pin①(+)
2. Pin④(-) — Pin①(+)
3. Pin⑤(-) — Pin①(+)
4. Pin⑥(-) — Pin①(+)

Is there about 3 - 5 V AC between each?
 NOTE: Measure the voltage by an analog multimeter.

No → Replace the inverter P.C. board.

Yes

Replace the expansion valve.

NOTE: After check of LEV, take the following steps.
 1. Turn OFF the power supply and turn it ON again.
 2. Press Reset button on the remote controller.



Ⓐ Check of inverter P.C. board

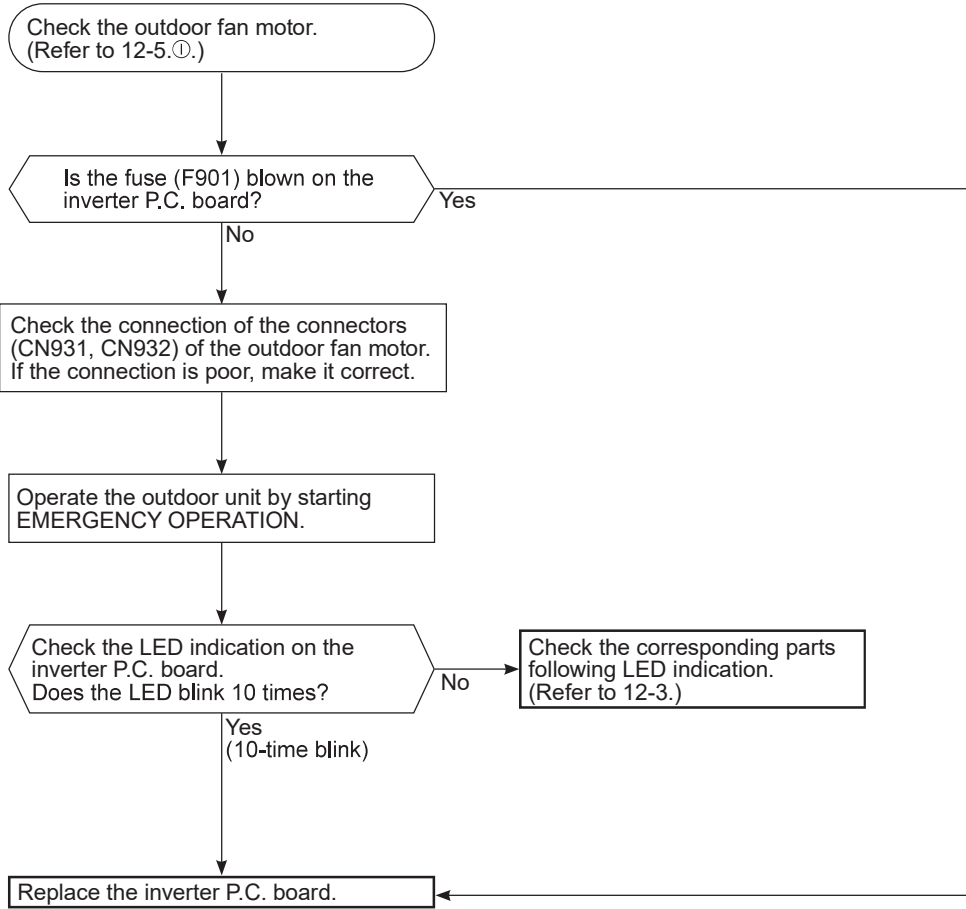

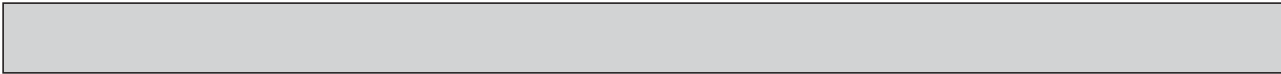

M How to check miswiring and serial signal error

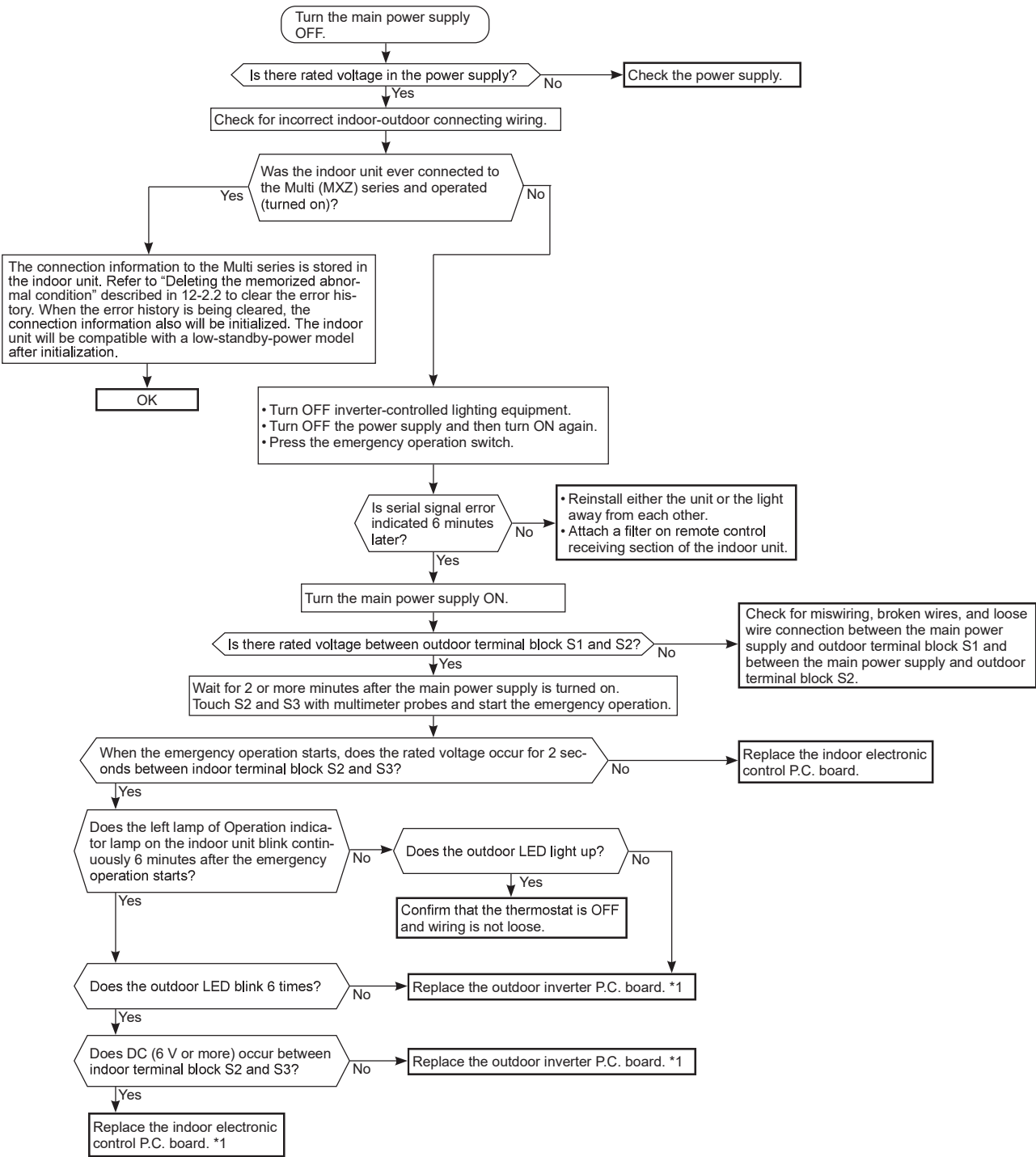

*1. Electric charge may remain immediately after the main power supply is turned OFF. Perform the procedure after 3 minutes.

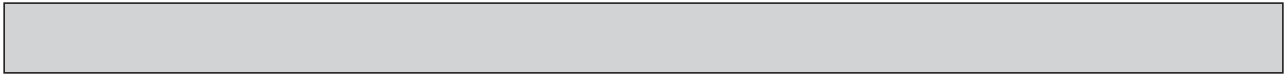

Ⓝ Check of the outdoor refrigerant circuit

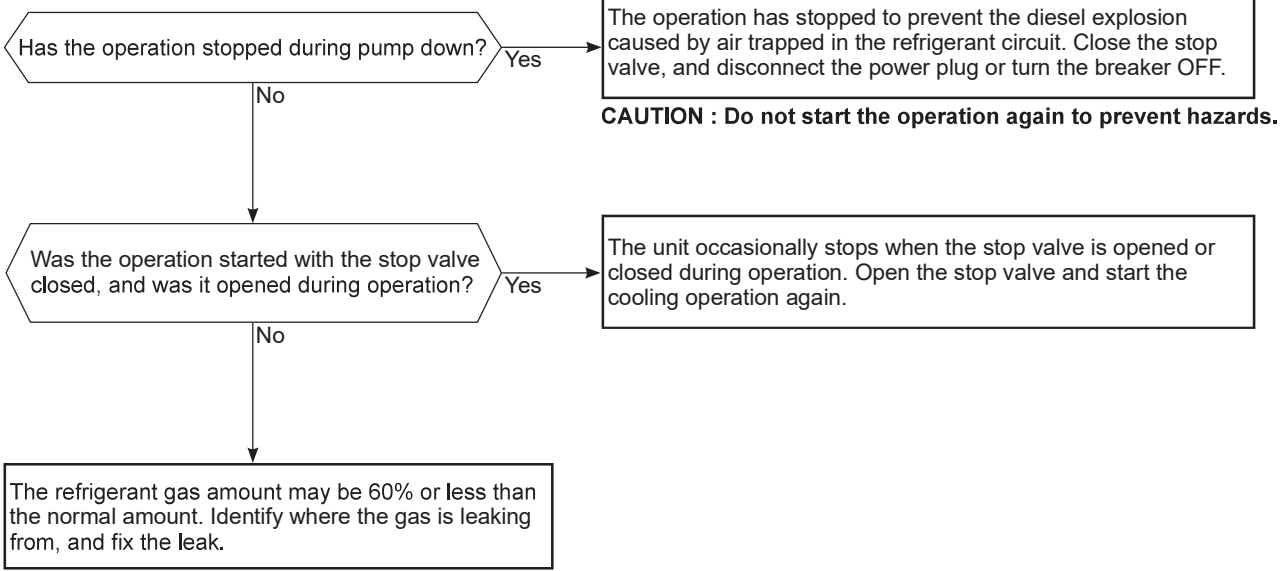

Ⓞ Check of compressor protector

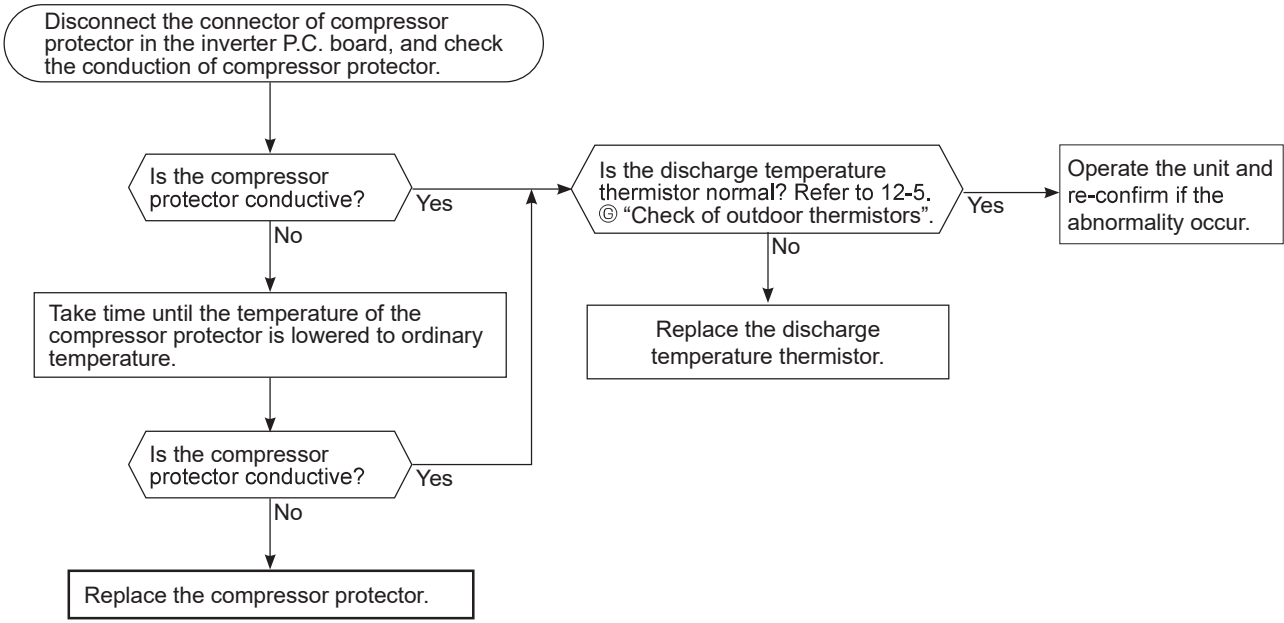

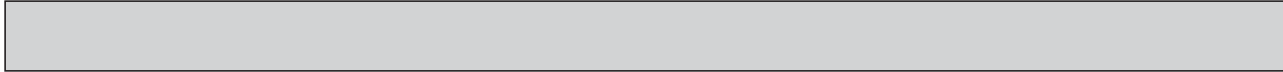

P Electromagnetic noise enters into TV sets or radios

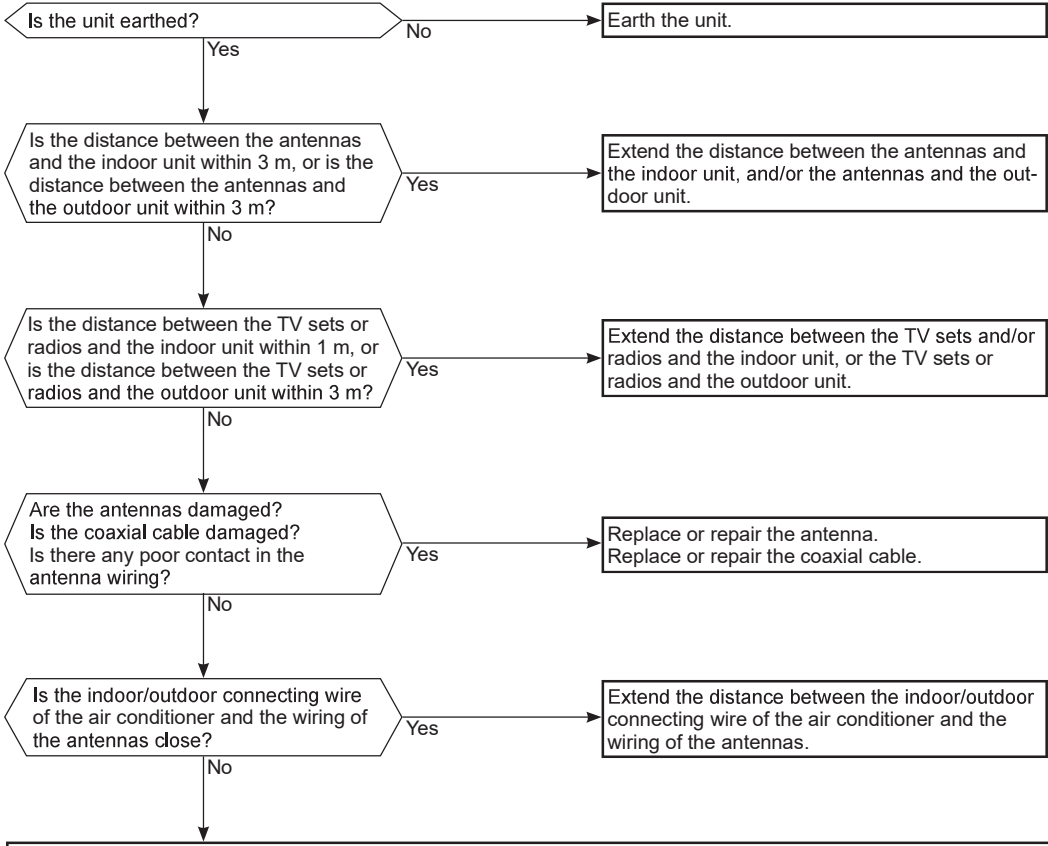

Even if all of the above conditions are fulfilled, the electromagnetic noise may enter, depending on the electric field strength or the installation condition (combination of specific conditions such as antennas or wiring). Check the following before asking for service.

1. Devices affected by the electromagnetic noise
TV sets, radios (FM/AM broadcast, shortwave)
2. Channel, frequency, broadcast station affected by the electromagnetic noise
3. Channel, frequency, broadcast station unaffected by the electromagnetic noise
4. Layout of:
indoor/outdoor unit of the air conditioner, indoor/outdoor wiring, earth wire, antennas, wiring from antennas, receiver
5. Electric field intensity of the broadcast station affected by the electromagnetic noise
6. Presence or absence of amplifier such as booster
7. Operation condition of air conditioner when the electromagnetic noise enters in
 - 1) Turn OFF the power supply once, and then turn ON the power supply. In this situation, check for the electromagnetic noise.
 - 2) Within 3 minutes after turning ON the power supply, press Off/On (stop/operate) button on the remote controller for power ON, and check for the electromagnetic noise.
 - 3) After a short time (3 minutes later after turning ON), the outdoor unit starts running. During operation, check for the electromagnetic noise.
 - 4) Press Off/On (stop/operate) button on the remote controller for power OFF, when the outdoor unit stops but the indoor/outdoor communication still runs on. In this situation, check for the electromagnetic noise.

12-6. TEST POINT DIAGRAM AND VOLTAGE

1. Inverter P.C. board

MUZ-AY15VG

Back side of unit

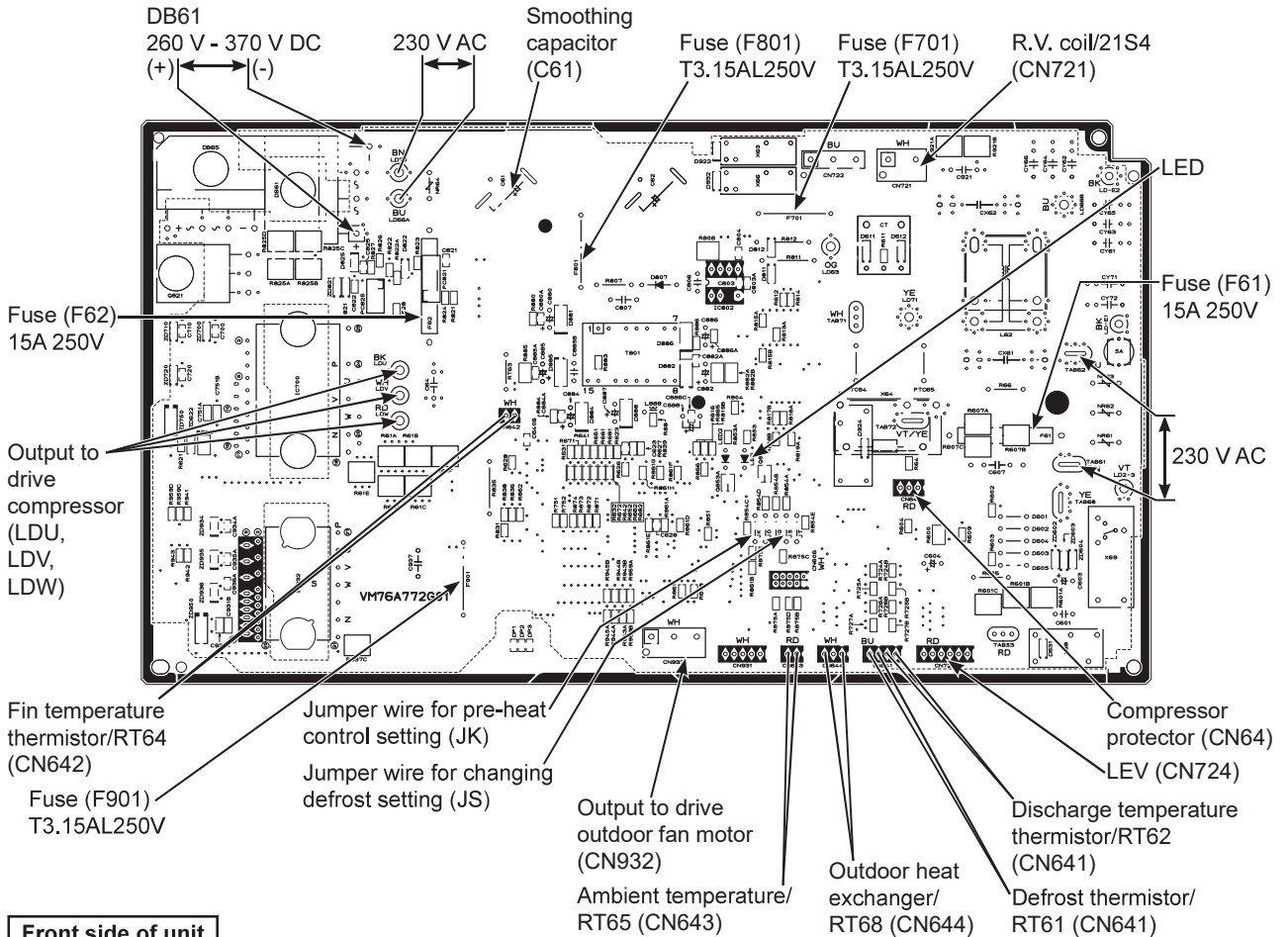

Front side of unit

Defrost thermistor (RT61)
Ambient temperature thermistor (RT65)
Outdoor heat exchanger
temperature thermistor (RT68)

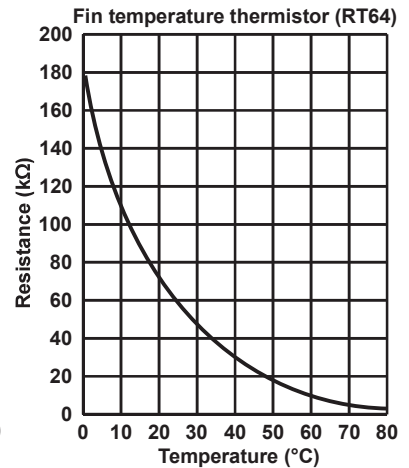
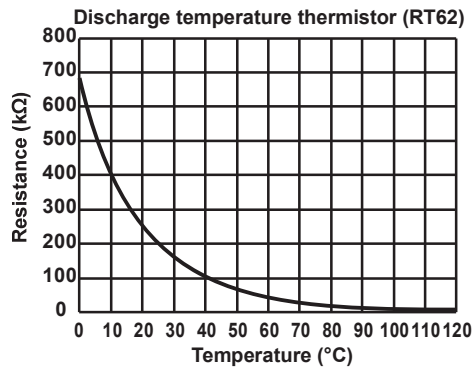
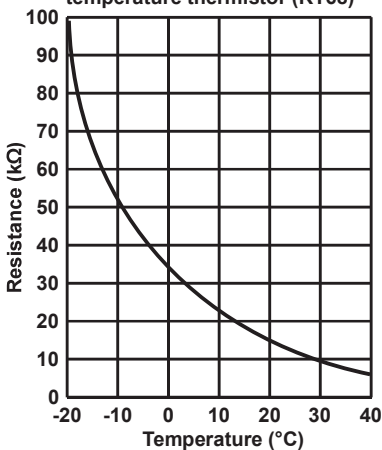

MUZ-AY20VG

Back side of unit

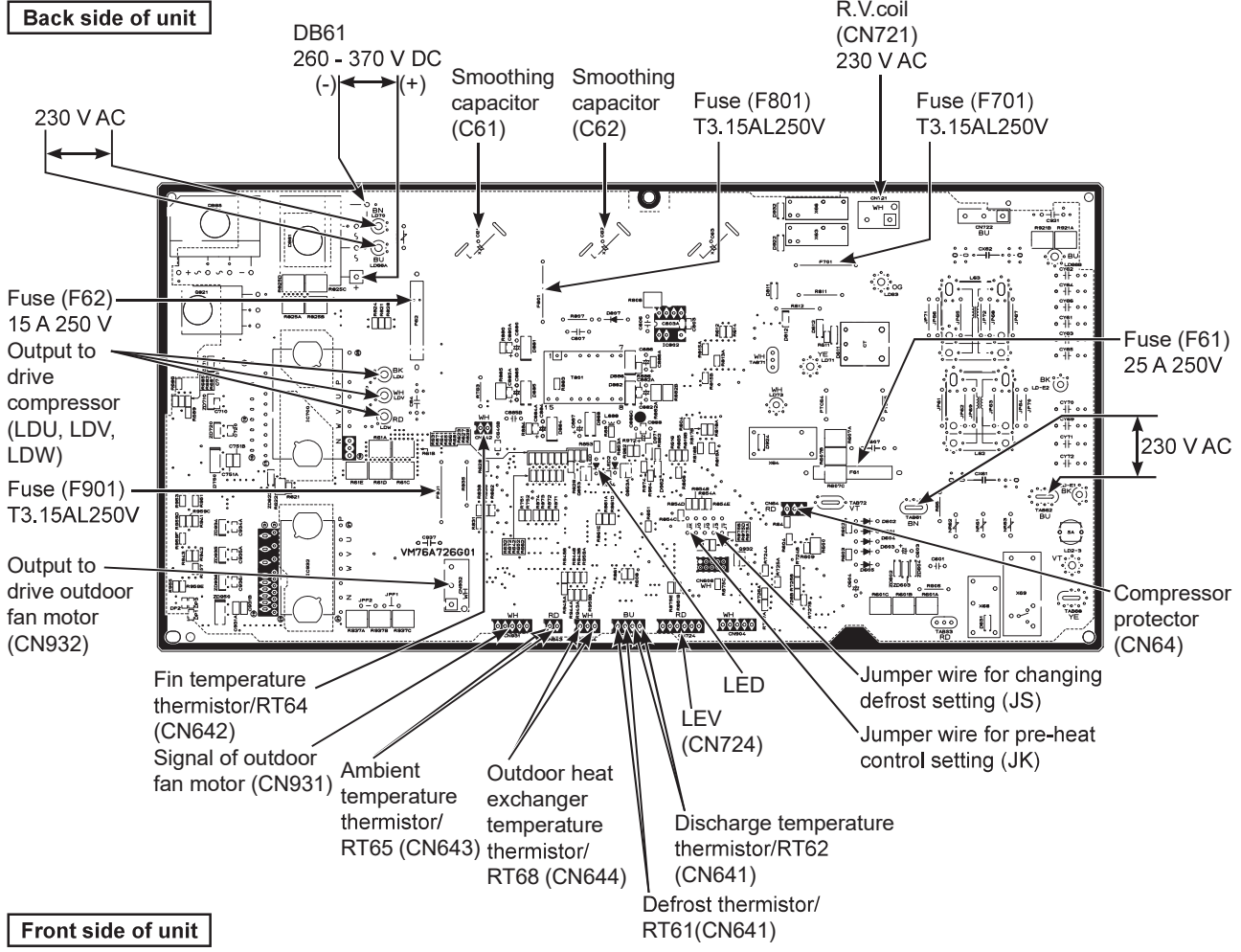

Front side of unit

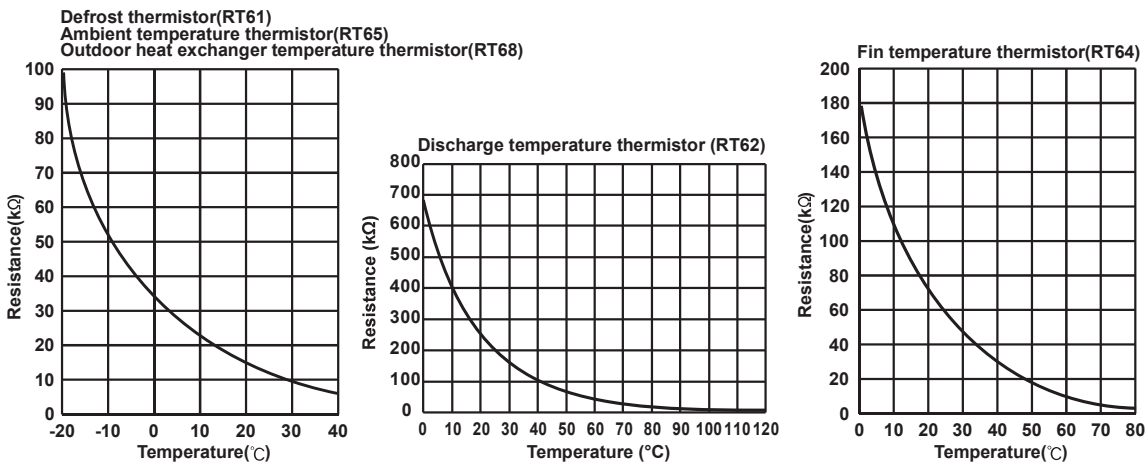

<Detaching method of the terminal with locking mechanism>

The terminal which has the locking mechanism can be detached as shown below.

There are 2 types of the terminal with locking mechanism.

The terminal without locking mechanism can be detached by pulling it out.

Check the shape of the terminal before detaching.

(1) Slide the sleeve and check if there is a locking lever or not.

(2) The terminal with this connector shown below has the locking mechanism.

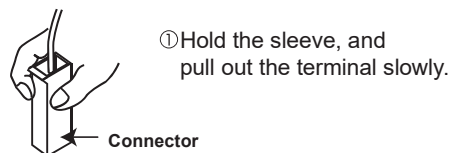
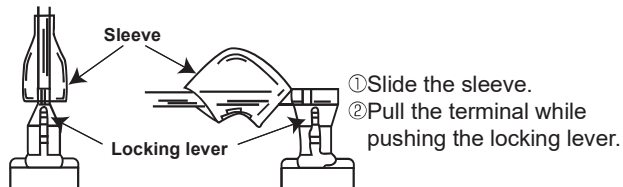

13-1. MUZ-AY15VG

NOTE: Turn OFF the power supply before disassembly.

→: Indicates the visible parts in the photos.
 ---→: Indicates the invisible parts in the photos.

OPERATING PROCEDURE	PHOTOS/FIGURES
<p>1. Removing the cabinet</p> <ol style="list-style-type: none"> (1) Remove the screws fixing the service panel. (2) Pull down the service panel and remove it. (3) Disconnect the power supply cord and indoor/outdoor connecting wire. (4) Remove the screws fixing the top panel. (5) Remove the top panel. (6) Remove the screws fixing the cabinet. (7) Remove the cabinet. (8) Remove the screws fixing the back panel. (9) Remove the screws of the terminal block support and the back panel. (10) Remove the back panel. <p>Photo 2</p>	<p>Photo 1</p> <p>Photo 3</p>

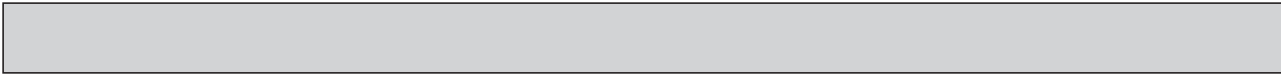

OPERATING PROCEDURE

2. Removing the inverter assembly, inverter P.C. board

(1) Remove the cabinet and the panels. (Refer to section 1.)

(2) Disconnect the lead wire to the reactor and the following connectors:
 <Inverter P.C. board>
 CN721 (R.V. coil)
 CN931, CN932 (Fan motor)
 CN641 (Defrost thermistor and discharge temperature thermistor)
 CN643 (Ambient temperature thermistor)
 CN644 (Outdoor heat exchanger temperature thermistor)
 CN724 (Expansion valve coil)
 CN64 (Compressor protector)

(3) Remove the compressor connector (CN61).

(4) Remove the screw fixing the heat sink support and the separator.

(5) Remove the screw fixing the P.C. board support and the motor support.

***1. There are two types: P.C. board support with this screw hole and P.C. board support without this hole.**

(6) Remove the inverter assembly.

(7) Remove the screws of the earth wire and the terminal block support.

(8) Remove the screw of the terminal block and remove the terminal block.

(9) Remove the heat sink support from the P.C. board support.

(10) Unhook the catch of the inverter P.C. board and remove the inverter P.C. board from the P.C. board support.

NOTE: Connection procedure when attaching the inverter P.C. board (Photo 5)

Connect the lead wires of the compressor protector to the connector on the inverter P.C. board. Pull the lead wires of the compressor protector toward you and put them on the left hook on the P.C. board support.

3. Removing the R.V. coil

(1) Remove the cabinet and the panels. (Refer to section 1.)

(2) Disconnect the following connectors:
 <Inverter P.C. board>
 CN721 (R.V. coil)

(3) Remove the R.V. coil.

Photo 7

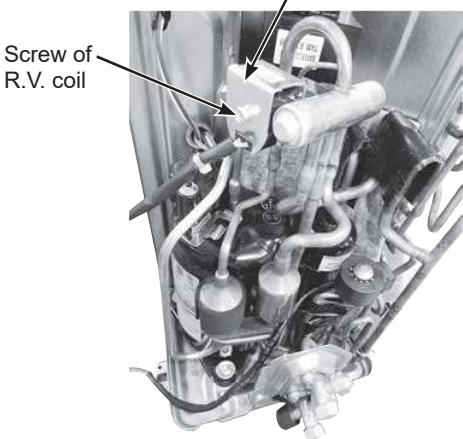

PHOTOS/FIGURES

Photo 4

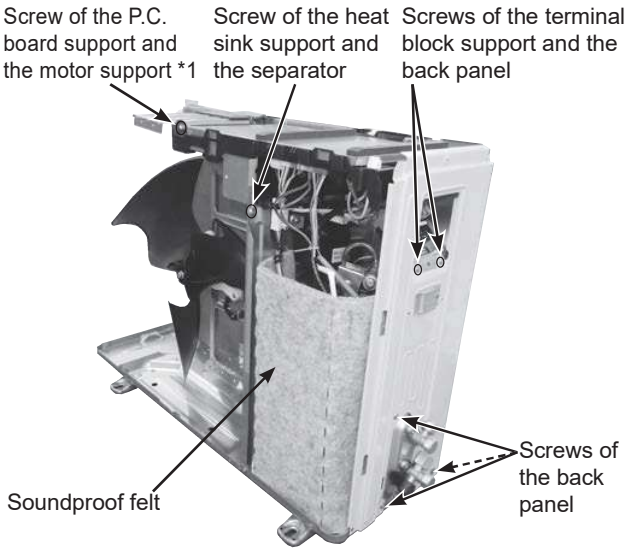

Photo 5

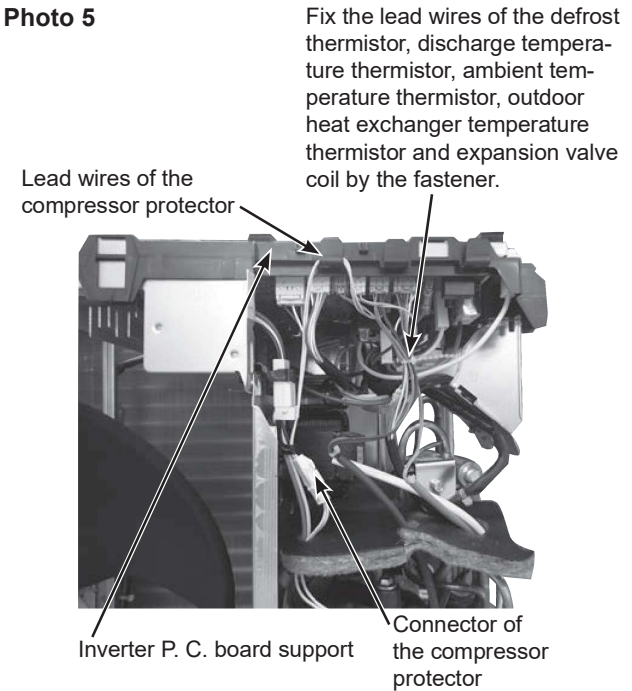
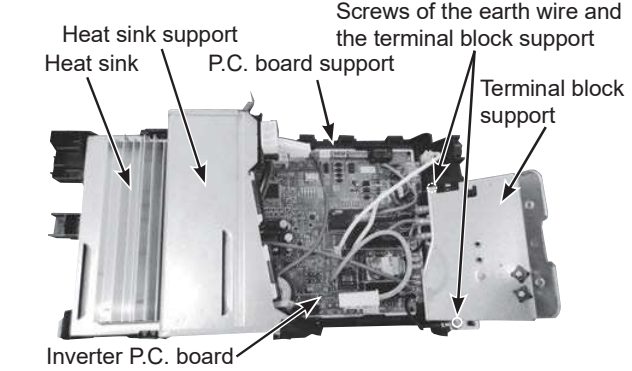
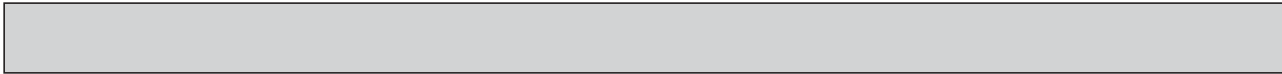

Photo 6 (Inverter assembly)





OPERATING PROCEDURE

4. Removing the discharge temperature thermistor, the defrost thermistor, the ambient temperature thermistor and the outdoor heat exchanger temperature thermistor

- (1) Remove the cabinet and the panels. (Refer to section 1.)
- (2) Disconnect the lead wire to the reactor and the following connectors:
<Inverter P.C. board>
CN641 (Defrost thermistor and discharge temperature thermistor)
CN643 (Ambient temperature thermistor)
CN644 (Outdoor heat exchanger temperature thermistor)
- (3) Pull out the discharge temperature thermistor from its holder.
- (4) Pull out the defrost thermistor from its holder. (Photo 9)
- (5) Pull out the outdoor heat exchanger temperature thermistor from its holder.
- (6) Pull out the ambient temperature thermistor from its holder.

5. Removing the outdoor fan motor

- (1) Remove the cabinet and the panels. (Refer to section 1.)
- (2) Disconnect the following connectors:
<Inverter P.C. board>
CN931, CN932 (Fan motor)
- (3) Remove the fan motor lead wire from where it is fastened on the separator.
- (4) Remove the propeller fan nut.
- (5) Remove the propeller fan.
- (6) Remove the screws fixing the fan motor.
- (7) Remove the fan motor.

Figure 1

Attach the compressor protector to the protector holder with the surface on which the model name is printed facing the area hatched in the figure.

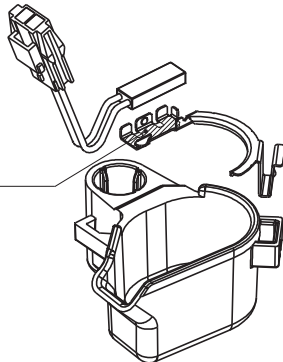

PHOTOS/FIGURES

Photo 8

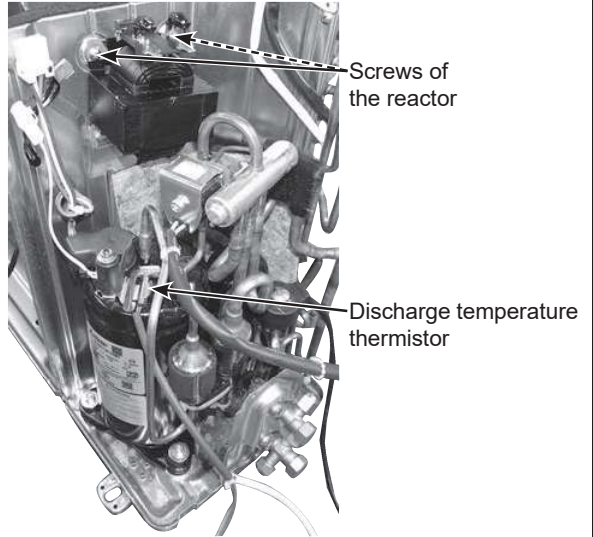

Photo 9

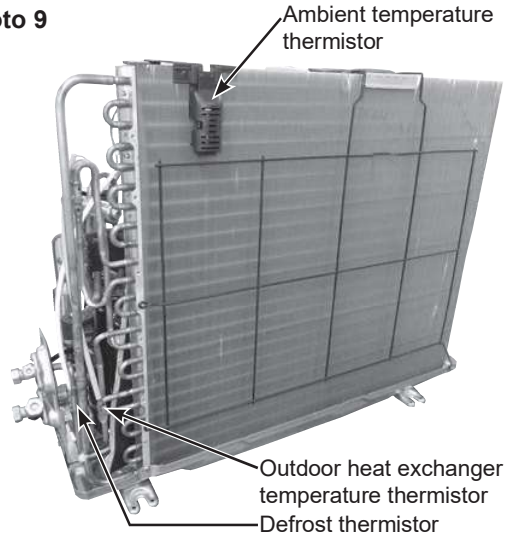
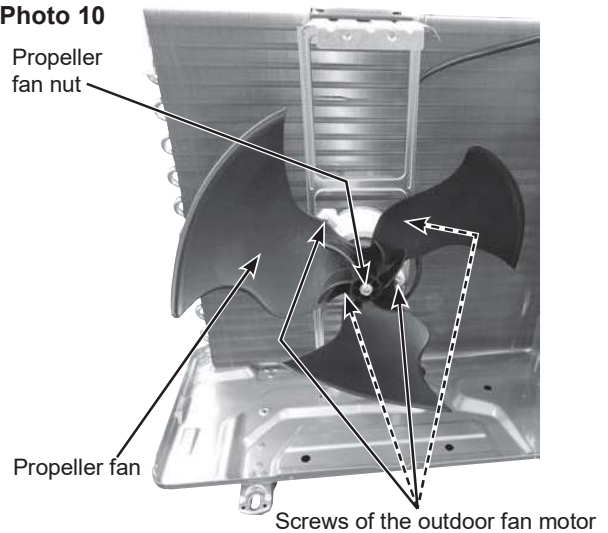
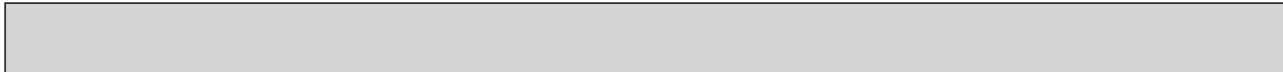

Photo 10





OPERATING PROCEDURE

6. Removing the compressor and the 4-way valve

- (1) Remove the cabinet and the panels. (Refer to section 1.)
- (2) Remove the inverter assembly. (Refer to section 2.)
- (3) Remove the screws of the reactor and remove the reactor.
- (4) Remove the screws of the separator and remove the separator.
- (5) Remove the soundproof felt.
- (6) Remove the terminal cover and the compressor lead wire.
- (7) Recover gas from the refrigerant circuit.
NOTE: Recover gas from the pipes until the pressure gauge shows 0 kg/cm² (0 MPa).
- (8) Detach the brazed part of the suction and the discharge pipe connected with the compressor.
- (9) Detach the brazed part of pipes connected with the 4-way valve.
- (10) Remove the nuts of compressor legs.
- (11) Remove the compressor.

7. Removing the LEV assembly

- (1) Detaching the brazed part of pipes connected with LEV valve.

PHOTOS/FIGURES

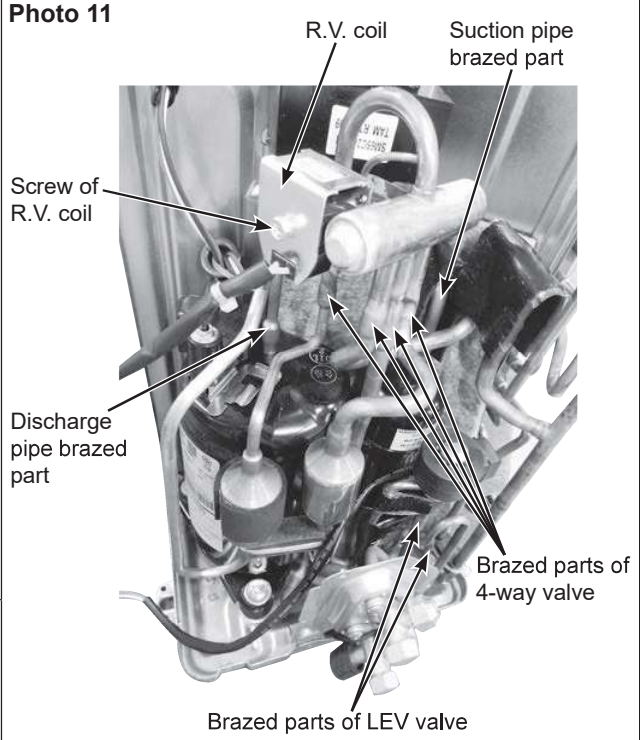

13-2. MUZ-AY20VG

NOTE: Turn OFF the power supply before disassembly.

OPERATING PROCEDURE

1. Removing the cabinet

- (1) Remove the screw fixing the service panel.
- (2) Pull down the service panel and remove it.
- (3) Disconnect the power supply cord and indoor/outdoor connecting wire.
- (4) Remove the screws fixing the top panel.
- (5) Remove the top panel.
- (6) Remove the screws fixing the cabinet.
- (7) Remove the cabinet.
- (8) Remove the screws fixing the back panel.
- (9) Remove the screws of the terminal block support and the back panel.
- (10) Remove the back panel.

Photo 2

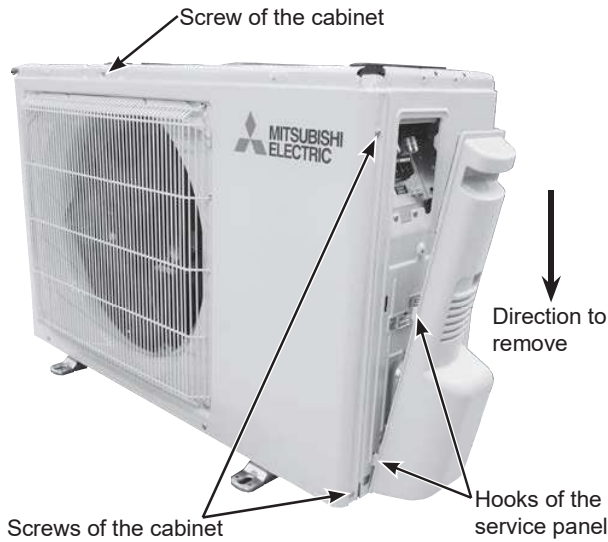

PHOTOS/FIGURES

Photo 1

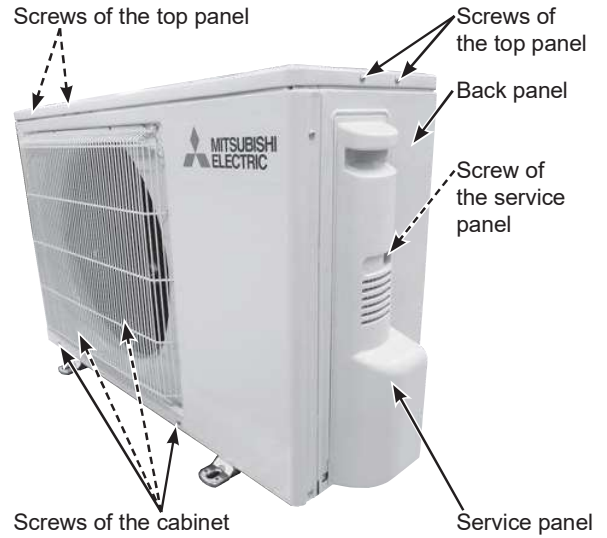

Photo 3

Screws of the terminal block support and the back panel



OPERATING PROCEDURE

2. Removing the inverter assembly and inverter P.C. board

- (1) Remove the cabinet and panels. (Refer to section 1.)
- (2) Disconnect the lead wire to the reactor and the following connectors:
 - <Inverter P.C. board>
 - CN721 (R.V. coil)
 - CN931, CN932 (Fan motor)
 - CN641 (Defrost thermistor and discharge temperature thermistor)
 - CN643 (Ambient temperature thermistor)
 - CN644 (Outdoor heat exchanger temperature thermistor)
 - CN724 (Expansion valve coil)
 - CN64 (Compressor protector)
- (3) Remove the compressor connector (CN61).
- (4) Remove the screws fixing the heat sink support and the separator.
- (5) Remove the fixing screw of the P.B. support and the separator.
- (6) Remove the fixing screws of the terminal block support and the back panel.
- (7) Remove the inverter assembly.
- (8) Remove the heat sink support from the P.C. board support.
- (9) Remove the screw of the inverter P.C. board and remove the inverter P.C. board from the P.C. board support.

NOTE: Connection procedure when attaching the inverter P.C. board (Photo 5)

Connect the lead wires of the expansion valve coil to the connector on the inverter P.C. board. Pull the lead wires of the expansion valve coil toward you and put them on the left and the middle hooks on the P.C. board support so that the other lead wires are bundled up as shown in Photo 5.

PHOTOS/FIGURES

Photo 4

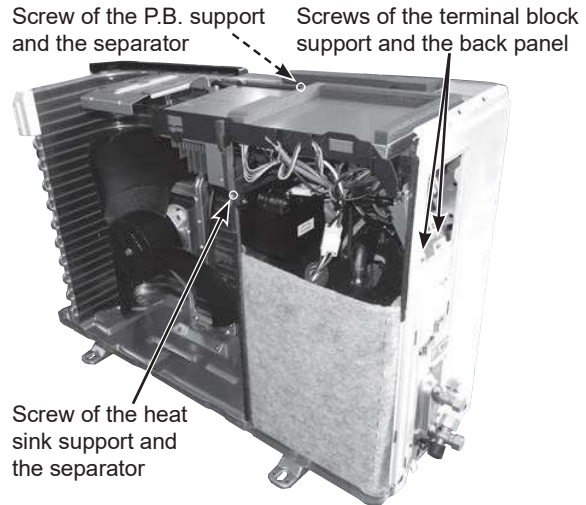
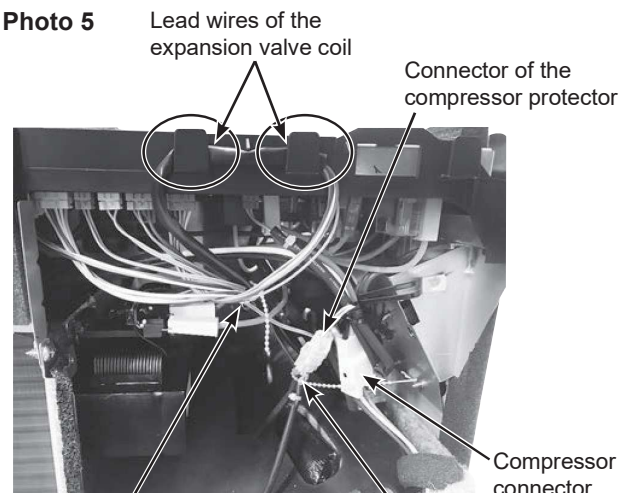

Photo 5



Fix the lead wires of the fan motor, the ambient temperature thermistor, the defrost thermistor, the discharge temperature thermistor, the outdoor heat exchanger temperature thermistor, and the expansion valve coil by the fastener.

Fix the lead wires of compressor protector and the discharge temperature thermistor by the fastener.

Photo 6 (Inverter assembly)

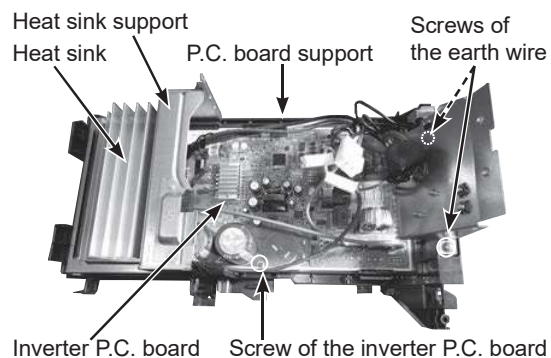



OPERATING PROCEDURE

- 3. Removing R.V. coil**
- (1) Remove the cabinet and panels. (Refer to section 1.)
 - (2) Disconnect the following connectors:
<Inverter P.C. board>
CN721 (R.V. coil)
 - (3) Remove the R.V. coil.

- 4. Removing the discharge temperature thermistor, defrost thermistor, outdoor heat exchanger temperature thermistor and ambient temperature thermistor**
- (1) Remove the cabinet and panels. (Refer to section 1.)
 - (2) Disconnect the lead wire to the reactor and the following connectors:
<Inverter P.C. board>
CN641 (Defrost thermistor and discharge temperature thermistor)
CN643 (Ambient temperature thermistor)
CN644 (Outdoor heat exchanger temperature thermistor)
 - (3) Pull out the discharge temperature thermistor from its holder.
 - (4) Pull out the defrost thermistor from its holder.
 - (5) Pull out the outdoor heat exchanger temperature thermistor from its holder.
 - (6) Pull out the ambient temperature thermistor from its holder.

- 5. Removing outdoor fan motor**
- (1) Remove the cabinet and panels. (Refer to section 1.)
 - (2) Disconnect the following connectors:
<Inverter P.C. board>
CN931, CN932 (Fan motor)
 - (3) Remove the propeller fan nut.
 - (4) Remove the propeller fan.
 - (5) Remove the screws fixing the fan motor.
 - (6) Remove the fan motor.

PHOTOS/FIGURES

Photo 7

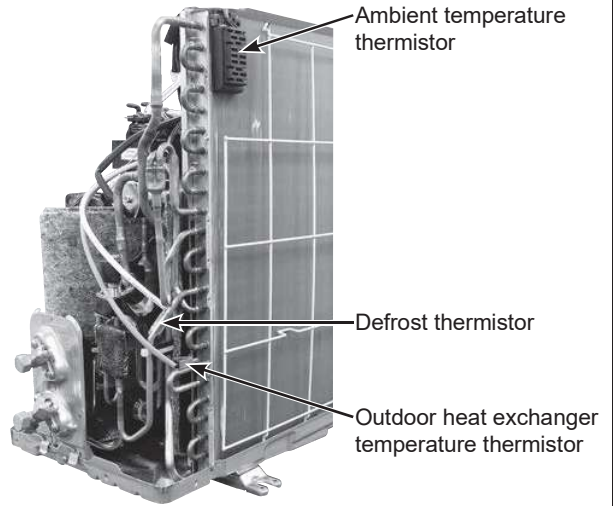
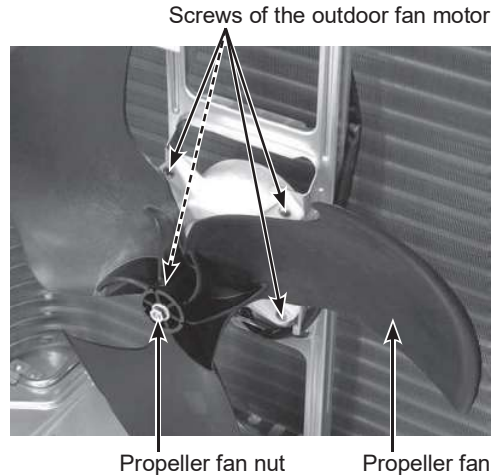
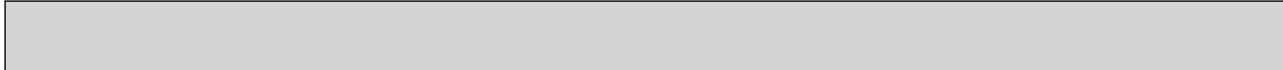

Photo 8





OPERATING PROCEDURE

- 6. Removing the compressor and 4-way valve**
- (1) Remove the cabinet and panels. (Refer to section 1.)
 - (2) Remove the inverter assembly. (Refer to section 2.)
 - (3) Recover gas from the refrigerant circuit.
 - NOTE:** Recover gas from the pipes until the pressure gauge shows 0 kg/cm² (0 MPa).
 - (4) Detach the brazed part of the suction and the discharge pipe connected with compressor.
 - (5) Remove the compressor nuts.
 - (6) Remove the compressor.
 - (7) Detach the brazed part of pipes connected with 4-way valve.

Figure 1

Attach the compressor protector to the protector holder with the surface on which the model name is printed facing the area hatched in the figure.

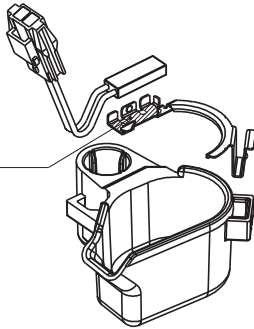

7. Removing the LEV assembly

- (1) Detaching the brazed part of pipes connected with LEV valve.

PHOTOS/FIGURES

Photo 9

Compressor protector Discharge pipe brazed part Suction pipe brazed part



Discharge temperature thermistor Brazed parts of 4-way valve

Photo 10



Brazed parts of LEV valve

MITSUBISHI ELECTRIC CORPORATION

HEAD OFFICE: TOKYO BUILDING, 2-7-3, MARUNOUCHI, CHIYODA-KU, TOKYO 100-8310, JAPAN

© Copyright 2023 MITSUBISHI ELECTRIC CORPORATION
 Issued: Mar. 2025. No. OBH938 REVISED EDITION-B
 Issued: Nov. 2023. No. OBH938 REVISED EDITION-A
 Published: Aug. 2023. No. OBH938
 Made in Japan

Specifications are subject to change without notice.