

Configuration Settings (from default)

DIP SWITCH	SETTING	FUNCTION
SW2-1 (FTC6)	ON	ZONE1 OPERATION STOP AT THERMOSTAT OPEN
SW2-8 (FTC6)	ON	WITH FLOW SENSOR
SW3-1 (FTC6)	ON	ZONE2 OPERATION STOP AT THERMOSTAT OPEN
SW3-6 (FTC6)	ON	2-ZONE VALVE ON/OFF CONTROL
SW8-3 (OUTDOOR)	ON	INDEPENDENT POWER SUPPLIES

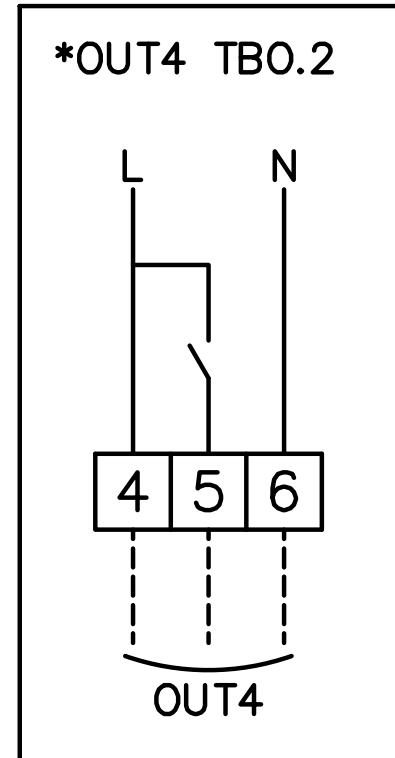

TABLE 1

EQUIPMENT	RECOMMENDED PRIMARY PIPE WORK (mm)	FLOW RATE RANGE (L/MIN)	MIN. SPACE HEATING CIRCUIT VOL. (L)	STARTING CURRENT (A)	MAX CURRENT (A)	MCB (A)	MIN. CABLE (mm ²)
PUZ-WM50VHA	22	6.5-14.3	7	2	13	16	1.5
PUZ-WM60VAA	22	8.6-17.2	9	2	13	16	2.5
PUZ-WM85VAA	28	10.8-24.4	12	2	22	25	2.5
PUZ-WM85YAA	28	10.8-24.4	12	2	11.5	16	1.5
PUZ-WM112VAA	35	14.4-32.1	16	2	28	32	4
PUZ-WM112YAA	35	14.4-32.1	16	2	13	16	1.5
PUZ-HWM140VHA	35	17.9-40.1	20	2	35	40	6
PUZ-HWM140YHA	35	17.9-40.1	20	2	13	16	1.5
FTC6 BOARD					10	16	1.5
IMMERSION H.					13	16	2.5

Copyright in this drawing is the property of Mitsubishi Electric. It must not be reproduced nor amended nor used for the execution of any works whether in connection with the proposed works for which it is prepared or otherwise without the express consent in writing of Mitsubishi Electric.

All dimensions are in mm unless otherwise stated

For information only, DO NOT SCALE drawing

All works shall be carried out in accordance with the Specification

Contractor must verify all dimensions on site before commencing any work or shop drawings

LEGEND

- AAV AUTOMATIC AIR VENT (After removing the air, automatic air vent(s) must be closed)
- IV ISOLATING VALVE
- DOC DRAIN OFF COCK
- NRV NON RETURN VALVE
- DRV DOUBLE REGULATING VALVE
- PRV/SV PRESSURE RELIEF VALVE/SAFETY VALVE
- STR STRAINER
- BV BYPASS VALVE
- FC FLEXIBLE CONNECTION
- PRV PRESSURE REDUCING VALVE
- P PUMP
- TEMPERATURE SENSOR
- TF1 FILTER/STRAINER
- FS FLOW SENSOR
- BFPD BACK FLOW PREVENTION DEVICE (if fitted)
- TPRV/SV TEMPERATURE PRESSURE RELIEF VALVE/SAFETY VALVE

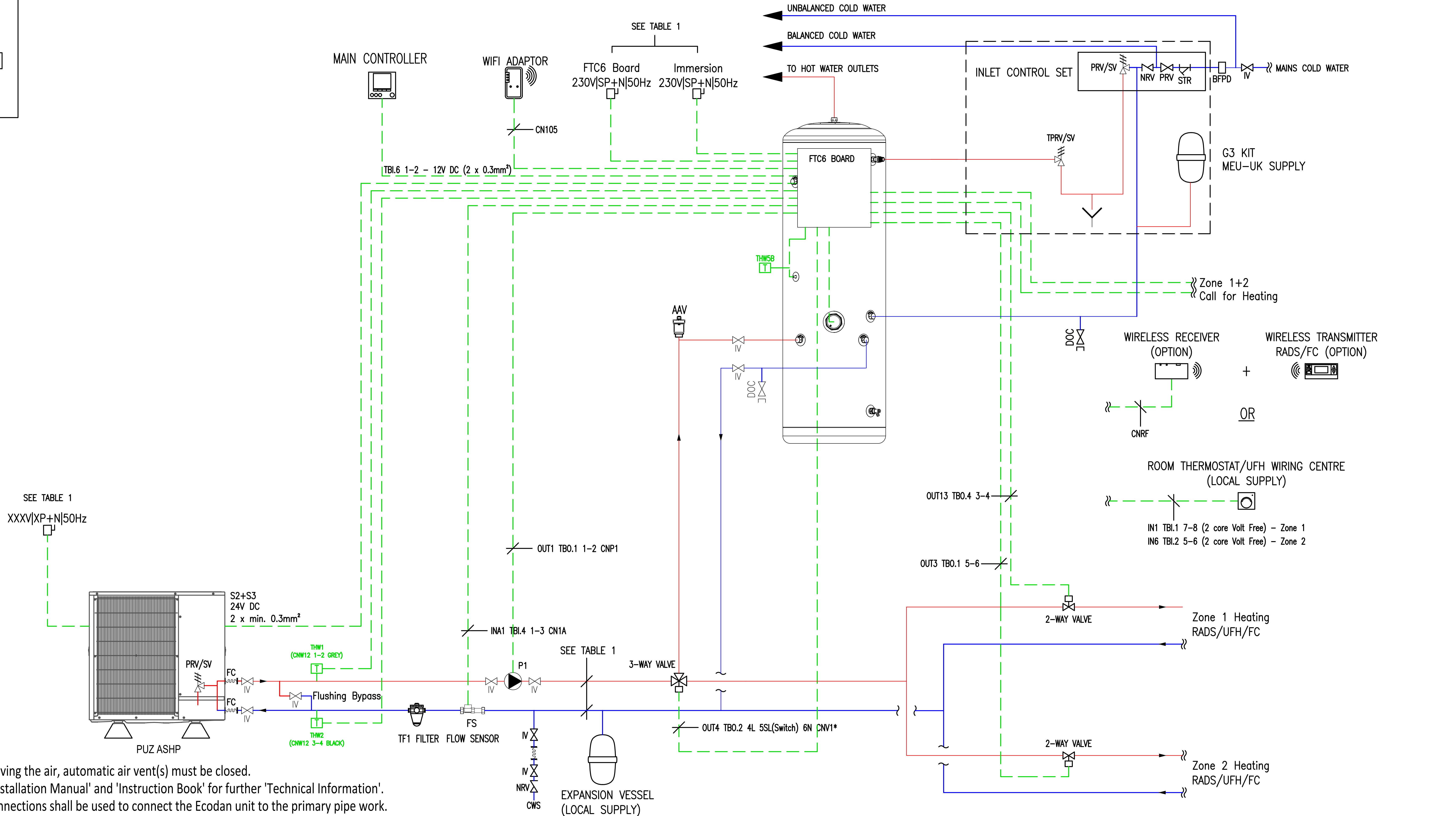

NOTES

- After removing the air, automatic air vent(s) must be closed.
- Refer to 'Installation Manual' and 'Instruction Book' for further 'Technical Information'.
- Flexible connections shall be used to connect the Ecodan unit to the primary pipe work.
- All electrical work must be carried out in accordance with the current version of BS7671.
- A back flow prevention device may include check valves, a water meter or an additional PRV.
- The Ecodan outdoor unit must be installed on anti-vibration mounts. Rubber mounting blocks are recommended.
- Isolation valves and flushing bypass circuit are recommended for the outdoor unit. This is best practice and not required for warranty purposes.
- Adequate provision should be made to prevent condensate from collecting around the outdoor units. A soak away, drip tray or drain socket set can be used.
- The contractor should make the necessary arrangements to ensure the design of the system meets the requirement of the application and comply with all current building regulations.
- If a device that prevents backflow is installed on the cold water supply to the PRV then a means of accommodating expansion due to local warming of the pipe is recommended to be fitted between the device and PRV.
- It is the responsibility of the installing contractor to provide adequate protection against freezing of pipe work. MEUK recommend 25% glycol dosage of the primary circuit. If the water circuit freezes and damages the equipment the warranty will become void.
- All water systems should be designed, installed and commissioned in accordance with industry good practice guidelines; such as, but not limited to: BSRIA Guide BG2/2010 - Water System Commissioning, BSRIA Guide BG29/2011 - Pre-Commissioning of Pipework Systems, BSRIA Guide BG50/2013 - Water Treatment for Closed Heating & Cooling Systems, CIBSE Commissioning Code W - Water distribution systems.

REV	DESCRIPTION	DESN	CHKD	DATE
CLIENT				
PROJECT				
FTC6 w/ Versatile Cylinder 2 x Heating				
TITLE				
MECHANICAL SERVICES MITSUBISHI ECODAN FTC6 WITH VERSATILE CYLINDER 2 HEATING ZONES				
SCALE	NTS	ORIGINAL SIZE	AO	DATE
DATE	JANUARY 2023			
DRAWN	M. G.	DESIGNED	M. G.	INIT
CHECKED	A. S.	INIT		
DRAWING NUMBER	MEU-UK/FTC6/WMXXX/VC/2Z			REVISION
				0