

Configuration Settings (from default)

DIP SWITCH	SETTING	FUNCTION
SW1-3 (FTC6)	OFF	WITHOUT DHW TANK
SW1-4 (FTC6)	OFF	WITHOUT IMMERSION HEATER
SW2-1 (FTC6)	ON	ZONE1 OPERATION STOP AT THERMOSTAT OPEN
SW2-6 (FTC6)	ON	WITH MIXING TANK
SW2-7 (FTC6)	ON	2-ZONE TEMPERATURE CONTROL
SW2-8 (FTC6)	ON	WITH FLOW SENSOR
SW3-1 (FTC6)	ON	ZONE2 OPERATION STOP AT THERMOSTAT OPEN
SW8-3 (OUTDOOR)	ON	INDEPENDENT POWER SUPPLIES

TABLE 1

EQUIPMENT	RECOMMENDED PRIMARY PIPE WORK (mm)	FLOW RATE RANGE (L/MIN)	MIN. SPACE HEATING CIRCUIT VOL. (L)	STARTING CURRENT (A)	MAX CURRENT (A)	MCB (A)	MIN. CABLE (mm <sup>2</sup> )
PUZ-WM50VHA	22	6.5-14.3	7	2	13	16	1.5
PUZ-WM60VAA	22	8.6-17.2	9	2	13	16	2.5
PUZ-WM85VAA	28	10.8-24.4	12	2	22	25	2.5
PUZ-WM85YAA	28	10.8-24.4	12	2	11.5	16	1.5
PUZ-WM112VAA	35	14.4-32.1	16	2	28	32	4
PUZ-WM112YAA	35	14.4-32.1	16	2	13	16	1.5
PUZ-HWM140VHA	35	17.9-40.1	20	2	35	40	6
PUZ-HWM140YHA	35	17.9-40.1	20	2	13	16	1.5
FTC6 BOARD					10	16	1.5
IMMERSION H.							

Copyright in this drawing is the property of Mitsubishi Electric. It must not be reproduced nor amended nor used for the execution of any works whether in connection with the proposed works for which it is prepared or otherwise without the express consent in writing of Mitsubishi Electric.

All dimensions are in mm unless otherwise stated

For information only, DO NOT SCALE drawing

All works shall be carried out in accordance with the Specification

Contractor must verify all dimensions on site before commencing any work or shop drawings

LEGEND

- AAV AUTOMATIC AIR VENT (After removing the air, automatic air vent(s) must be closed)
- IV ISOLATING VALVE
- DOC DRAIN OFF COCK
- NRV NON RETURN VALVE
- DRV DOUBLE REGULATING VALVE
- PRV/SV PRESSURE RELIEF VALVE/SAFETY VALVE
- STR STRAINER
- BV BYPASS VALVE
- FC FLEXIBLE CONNECTION
- PRV PRESSURE REDUCING VALVE
- PG PRESSURE GAUGE
- P PUMP
- TEMPERATURE SENSOR
- TF1 FILTER/STRAINER
- FS FLOW SENSOR
- SCALE TRAP
- BFPD BACK FLOW PREVENTION DEVICE (if fitted)

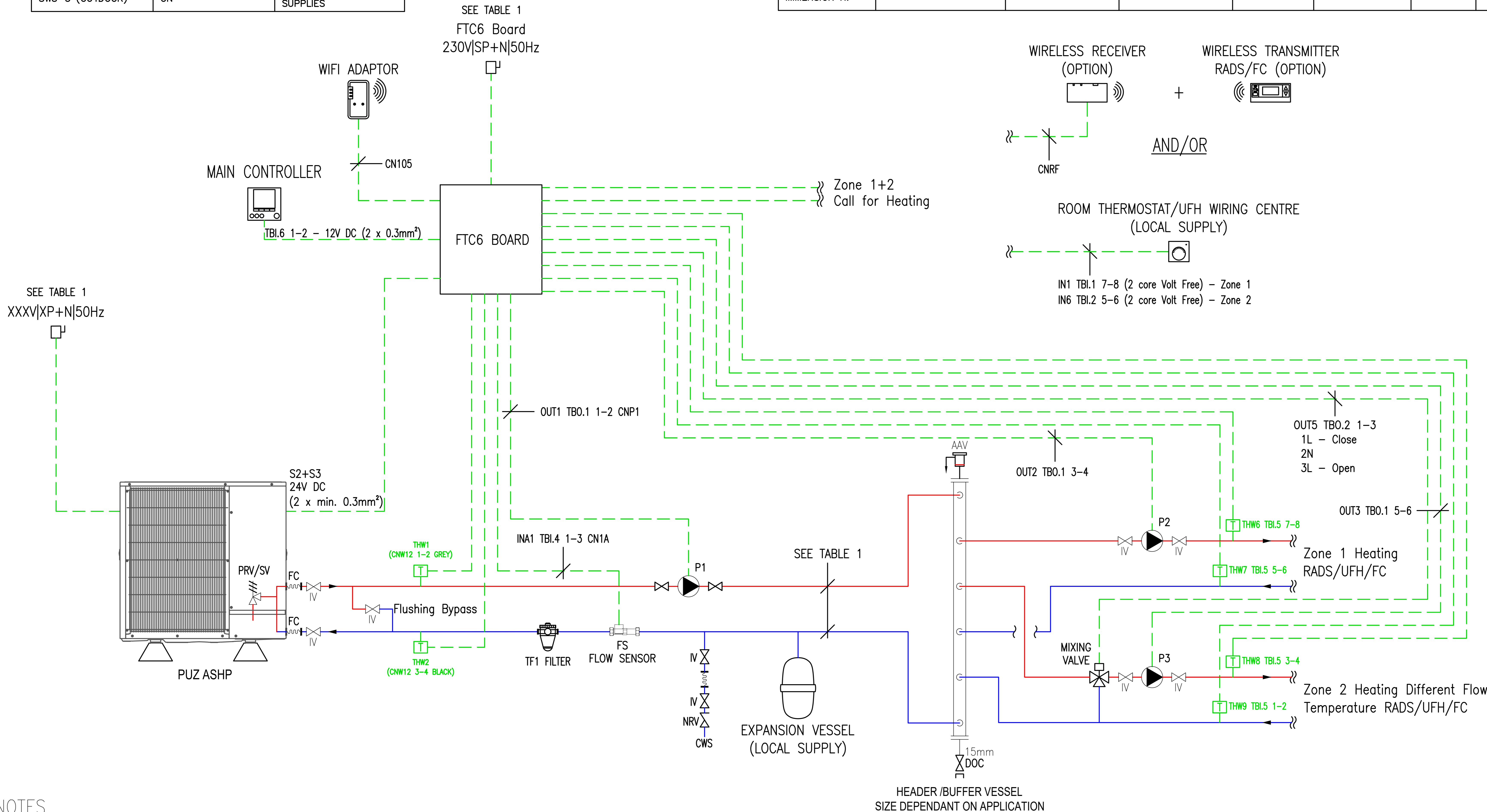

REV	DESCRIPTION	DESN	CHKD	DATE



CLIENT

PROJECT  
 FTC6 Standalone 2 x Heating Mixed

TITLE  
 MECHANICAL SERVICES  
 MITSUBISHI ECODAN FTC6  
 STANDALONE  
 2 HEATING ZONES  
 DIFFERENT FLOW TEMPERATURES

SCALE	ORIGINAL SIZE	DATE
NTS	A0	FEBRUARY 2022
DRAWN D. C.	DESIGNED D. C.	INIT R. T.
DRAWING NUMBER MEU-UK/FTC6/WMXXX/S/2ZM		REVISION 2

NOTES

- After removing the air, automatic air vent(s) must be closed.
- The Ecodan outdoor unit must be installed on anti-vibration mounts. Rubber mounting blocks are recommended.
- Adequate provision should be made to prevent condensate from collecting around the outdoor units. A soak away, drip tray or drain socket set can be used.
- Flexible connections shall be used to connect the Ecodan unit to the primary pipe work.
- It is the responsibility of the installing contractor to provide adequate protection against freezing of pipe work. MEUK recommend 25% glycol dosage of the primary circuit. If the water circuit freezes and damages the equipment the warranty will become void.
- All water systems should be designed, installed and commissioned in accordance with industry good practice guidelines; such as, but not limited to: BSRIA Guide BG2/2010 - Water System Commissioning, BSRIA Guide BG29/2011 - Pre-Commissioning of Pipework Systems, BSRIA Guide BG50/2013 - Water Treatment for Closed Heating & Cooling Systems, CIBSE Commissioning Code W - Water distribution systems.
- Isolation valves and flushing bypass circuit are recommended for the outdoor unit. This is best practice and not required for warranty purposes.
- The contractor should make the necessary arrangements to ensure the design of the system meets the requirement of the application and comply with all current building regulations.
- All electrical work must be carried out in accordance with the current version of BS7671.