

AIR CONDITIONING SYSTEMS

# CITY MULTI

## DATA BOOK

MODEL

**CMB-M-V-MA-SV(-TR)**

**CMB-M-V-MB-SV(-TR)**

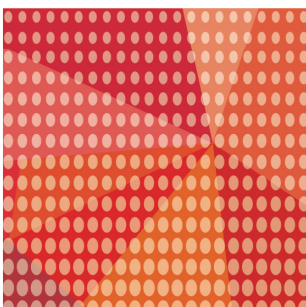

**CMB-M-V-MA-SV(-TR), CMB-M-V-MB-SV(-TR)**

1. SPECIFICATIONS .....	2
2. EXTERNAL DIMENSIONS .....	8
3. ELECTRICAL WIRING DIAGRAMS .....	14
4. SOUND LEVELS .....	20
4-1. Sound levels in cooling mode .....	20
4-2. Sound levels in heating mode.....	21
4-3. Sound levels in defrost mode .....	22
5. ELECTRICAL CHARACTERISTICS.....	23
6. OPTIONAL PARTS.....	24
6-1. JOINT and REDUCER.....	24
6-2. JOINT KIT "CMY-R170M-E" FOR BC CONTROLLER.....	28
7. INSTALLATION .....	29
7-1. Installing BC controllers .....	29

<b>Model</b>		<b>CMB-M104V-MA-SV(-TR)</b>				
Number of branch		4				
Power source		1-phase 220/230/240V 50Hz				
Power input	Cooling	kW	0.02/0.02/0.02			
	Heating	kW	0.01/0.01/0.01			
Current input	Cooling	A	0.08/0.09/0.09			
	Heating	A	0.05/0.05/0.05			
External finish		Galvanized steel plate				
Connectable outdoor/heat source unit capacity		*21 M200 to M1000				
Indoor unit capacity connectable to 1 branch		*15 Model M80 or smaller *19 (Use optional joint pipe combining 2 branches when the total unit capacity exceeds M81.)				
External dimension H x W x D		*16 mm	252 x 1040 x 880(970)			
		in.	9-15/16 x 41 x 34-11/16(38-1/4)			
Refrigerant piping diameter	To outdoor/heat source unit	Connectable unit capacity		High press. pipe	Low press. pipe	
		mm (in.) O.D.	M200	15.88 (5/8) Brazed	19.05 (3/4) Brazed	
		mm (in.) O.D.	M250 ~M300	19.05 (3/4) Brazed	22.2 (7/8) Brazed	
		*17	mm (in.) O.D.	M350	19.05 (3/4) Brazed or 22.2 (7/8) Brazed	28.58 (1-1/8) Brazed
			mm (in.) O.D.	M400 ~M500	22.2 (7/8) Brazed	28.58 (1-1/8) Brazed
		*17	mm (in.) O.D.	M550	22.2 (7/8) Brazed or 28.58 (1-1/8) Brazed	28.58 (1-1/8) Brazed
			*17	mm (in.) O.D.	M600	22.2 (7/8) Brazed or 28.58 (1-1/8) Brazed
		mm (in.) O.D.		M650	28.58 (1-1/8) Brazed	28.58 (1-1/8) Brazed
	mm (in.) O.D.	M700 ~M800	28.58 (1-1/8) Brazed	34.93 (1-3/8) Brazed		
	mm (in.) O.D.	M850 ~M1000	28.58 (1-1/8) Brazed	41.28 (1-5/8) Brazed		
	To indoor unit	*20	Liquid pipe		Gas pipe	
			mm (in.) O.D.	Indoor unit Model M80 or smaller 6.35 (1/4) Brazed bigger than M80 9.52 (3/8) Brazed	Indoor unit Model M50 or smaller 12.7 (1/2) Brazed bigger than M50 15.88 (5/8) Brazed (19.05 (3/4), 22.2 (7/8) with optional joint pipe used.)	
	To other BC controller	Total down-stream Indoor unit capacity		High press. pipe	Liquid pipe	Low press. pipe
		mm (in.) O.D.	to M200	15.88 (5/8) Brazed	9.52 (3/8) Brazed	19.05 (3/4) Brazed
		mm (in.) O.D.	M201 to M300	19.05 (3/4) Brazed	9.52 (3/8) Brazed	22.2 (7/8) Brazed
		mm (in.) O.D.	M301 to M350	19.05 (3/4) Brazed	12.7 (1/2) Brazed	28.58 (1-1/8) Brazed
		mm (in.) O.D.	M351 to M400	22.2 (7/8) Brazed	12.7 (1/2) Brazed	28.58 (1-1/8) Brazed
		mm (in.) O.D.	M401 to M600	22.2 (7/8) Brazed	15.88 (5/8) Brazed	28.58 (1-1/8) Brazed
		mm (in.) O.D.	M601 to M650	28.58 (1-1/8) Brazed	15.88 (5/8) Brazed	28.58 (1-1/8) Brazed
		mm (in.) O.D.	M651 to M800	28.58 (1-1/8) Brazed	19.05 (3/4) Brazed	34.93 (1-3/8) Brazed
mm (in.) O.D.		M801 to M1000	28.58 (1-1/8) Brazed	19.05 (3/4) Brazed	41.28 (1-5/8) Brazed	
mm (in.) O.D.	M1001 or above	34.93 (1-3/8) Brazed	19.05 (3/4) Brazed	41.28 (1-5/8) Brazed		
Field drain pipe size		mm (in.)	OD32 (1-1/4)			
Net weight		kg (lbs)	53 (117)			
Sound power level (measured in anechoic room)	Rated operation	dB <A>	68			
	Defrost	dB <A>	74			
Sound pressure level (measured in anechoic room)	*18 Rated operation	dB <A>	50			
	Defrost	dB <A>	56			
Accessories		Drain Connection pipe, Washer, Tie band, Reducer				
Remarks		-				

- Notes:
- 1.Installation/foundation work, electrical connection work, insulation work, power source switch, and other items shall be referred to the Installation Manual.
  - 2.The equipment is for R32 refrigerant.
  - 3.Install this product in a location where noise (refrigerant noise) emitted by the unit will not disturb the neighbors. (For use in quiet environments with low background noise, position the BC CONTROLLER at least 5m away from any indoor units.)
  - 4.Sound pressure /power level differs depending on the connected outdoor/heat source unit capacity or operation condition.  
The sound pressure level /power level at the rated operation is the value of the cooling mode.
  - 5.The sound pressure /power level values were obtained in an anechoic room. Actual sound pressure level is usually greater than that measured in anechoic room due to ambient noise and deflection sound.
  - 6.The solenoid valve switching sound is 56 dB (sound pressure level) regardless of the unit model.
  - 7.Refrigerant piping diameter for connection of plural indoor units with 1 branch shall be referred to the Installation Manual.
  - 8.This unit is not designed for outside installations.
  - 9.When brazing the pipes, be sure to braze, after covering a wet cloth to the insulation pipes of the units in order to prevent it from burning and shrinking by heat.
  - 10.The sound pressure level values were obtained at the location below 1.5m from the unit.
  - 11.The ambient relative humidity of the BC controller needs to be kept below 80%.
  - 12.R32 is flammable, and certain restrictions apply to the installation of units. When installing new units, moving the existing units, or changing the layout of the room, ensure that installation restrictions are observed. For detail, refer to the section in the DATA BOOK on installation restrictions.
  - 13.For the insulation work of the piping and the installation method of the unit, follow the installation manual.
  - 14.A minimum floor area requirement varies depending on the installation site
  - 15.Indoor unit capacity connectable to 1 branch is changed depending on the indoor unit type and connection method. Please refer to the Installation Manual for more information.
  - 16.The figure in parenthesis indicates the size including control box.
  - 17.For the refrigerant pipe size, refer to Installation Manual of outdoor units/heat source units.
  - 18.The sound pressure level measured by the conventional method in JIS for reference purpose.
  - 19.Indoor units M100, M125, M140 can be connected to 1 branch. (In this case, cooling capacity decrease a little.)
  - 20.If indoor units M63,M71,M80 are connected and the length of the liquid pipe exceeds the restriction, use the one size larger pipe. Please refer to the Installation Manual for more information.
  - 21.Only PURY-YXM series outdoor units can be connected.

<b>Model</b>			<b>CMB-M106V-MA-SV(-TR)</b>			
Number of branch			6			
Power source			1-phase 220/230/240V 50Hz			
Power input	Cooling	kW	0.02/0.02/0.02			
	Heating	kW	0.01/0.01/0.01			
Current input	Cooling	A	0.08/0.09/0.09			
	Heating	A	0.05/0.05/0.05			
External finish			Galvanized steel plate			
Connectable outdoor/heat source unit capacity			*21 M200 to M1000			
Indoor unit capacity connectable to 1 branch			*15 Model M80 or smaller *19 (Use optional joint pipe combining 2 branches when the total unit capacity exceeds M81.)			
External dimension H x W x D			*16 mm 252 x 1040 x 880(970) in. 9-15/16 x 41 x 34-11/16(38-1/4)			
Refrigerant piping diameter	To outdoor/heat source unit		Connectable unit capacity		High press. pipe	Low press. pipe
	mm (in.) O.D.		M200		15.88 (5/8) Brazed	19.05 (3/4) Brazed
			M250 ~M300		19.05 (3/4) Brazed	22.2 (7/8) Brazed
	*17	mm (in.) O.D.	M350		19.05 (3/4) Brazed or 22.2 (7/8) Brazed	28.58 (1-1/8) Brazed
			M400 ~M500		22.2 (7/8) Brazed	28.58 (1-1/8) Brazed
	*17	mm (in.) O.D.	M550		22.2 (7/8) Brazed or 28.58 (1-1/8) Brazed	28.58 (1-1/8) Brazed
			M600		22.2 (7/8) Brazed or 28.58 (1-1/8) Brazed	28.58 (1-1/8) Brazed or 34.93 (1-3/8) Brazed
	*17	mm (in.) O.D.	M650		28.58 (1-1/8) Brazed	28.58 (1-1/8) Brazed
			M700 ~M800		28.58 (1-1/8) Brazed	34.93 (1-3/8) Brazed
	*17	mm (in.) O.D.	M850 ~M1000		28.58 (1-1/8) Brazed	41.28 (1-5/8) Brazed
	To indoor unit		Liquid pipe		Gas pipe	
	*20	mm (in.) O.D.	Indoor unit Model M80 or smaller 6.35 (1/4) Brazed bigger than M80 9.52 (3/8) Brazed		Indoor unit Model M50 or smaller 12.7 (1/2) Brazed bigger than M50 15.88 (5/8) Brazed (19.05 (3/4), 22.2 (7/8) with optional joint pipe used.)	
	To other BC controller		Total down-stream Indoor unit capacity		Liquid pipe	Low press. pipe
	mm (in.) O.D.		to M200		9.52 (3/8) Brazed	19.05 (3/4) Brazed
			M201 to M300		9.52 (3/8) Brazed	22.2 (7/8) Brazed
	mm (in.) O.D.		M301 to M350		12.7 (1/2) Brazed	28.58 (1-1/8) Brazed
			M351 to M400		12.7 (1/2) Brazed	28.58 (1-1/8) Brazed
	mm (in.) O.D.		M401 to M600		15.88 (5/8) Brazed	28.58 (1-1/8) Brazed
M601 to M650			15.88 (5/8) Brazed	28.58 (1-1/8) Brazed		
mm (in.) O.D.		M651 to M800		19.05 (3/4) Brazed	34.93 (1-3/8) Brazed	
		M801 to M1000		19.05 (3/4) Brazed	41.28 (1-5/8) Brazed	
mm (in.) O.D.		M1001 or above		19.05 (3/4) Brazed	41.28 (1-5/8) Brazed	
Field drain pipe size			mm (in.) OD32 (1-1/4)			
Net weight			kg (lbs) 57 (126)			
Sound power level (measured in anechoic room)	Rated operation	dB <A>	68			
	Defrost	dB <A>	74			
Sound pressure level (measured in anechoic room)	Rated operation	dB <A>	*18 50			
	Defrost	dB <A>	56			
Accessories			Drain Connection pipe, Washer, Tie band, Reducer			
Remarks			-			

Notes:

- 1.Installation/foundation work, electrical connection work, insulation work, power source switch, and other items shall be referred to the Installation Manual.
- 2.The equipment is for R32 refrigerant.
- 3.Install this product in a location where noise (refrigerant noise) emitted by the unit will not disturb the neighbors. (For use in quiet environments with low background noise, position the BC CONTROLLER at least 5m away from any indoor units.)
- 4.Sound pressure /power level differs depending on the connected outdoor/heat source unit capacity or operation condition.  
The sound pressure level /power level at the rated operation is the value of the cooling mode.
- 5.The sound pressure /power level values were obtained in an anechoic room. Actual sound pressure level is usually greater than that measured in anechoic room due to ambient noise and deflection sound.
- 6.The solenoid valve switching sound is 56 dB (sound pressure level) regardless of the unit model.
- 7.Refrigerant piping diameter for connection of plural indoor units with 1 branch shall be referred to the Installation Manual.
- 8.This unit is not designed for outside installations.
- 9.When brazing the pipes, be sure to braze, after covering a wet cloth to the insulation pipes of the units in order to prevent it from burning and shrinking by heat.
- 10.The sound pressure level values were obtained at the location below 1.5m from the unit.
- 11.The ambient relative humidity of the BC controller needs to be kept below 80%.
- 12.R32 is flammable, and certain restrictions apply to the installation of units. When installing new units, moving the existing units, or changing the layout of the room, ensure that installation restrictions are observed. For detail, refer to the section in the DATA BOOK on installation restrictions.
- 13.For the insulation work of the piping and the installation method of the unit, follow the installation manual.
- 14.A minimum floor area requirement varies depending on the installation site
- 15.Indoor unit capacity connectable to 1 branch is changed depending on the indoor unit type and connection method. Please refer to the Installation Manual for more information.
- 16.The figure in parenthesis indicates the size including control box.
- 17.For the refrigerant pipe size, refer to Installation Manual of outdoor units/heat source units.
- 18.The sound pressure level measured by the conventional method in JIS for reference purpose.
- 19.Indoor units M100, M125, M140 can be connected to 1 branch. (In this case, cooling capacity decrease a little.)
- 20.If indoor units M63,M71,M80 are connected and the length of the liquid pipe exceeds the restriction, use the one size larger pipe. Please refer to the Installation Manual for more information.
- 21.Only PURY-YXM series outdoor units can be connected.

<b>Model</b>		<b>CMB-M108V-MA-SV(-TR)</b>				
Number of branch		8				
Power source		1-phase 220/230/240V 50Hz				
Power input	Cooling	kW	0.02/0.02/0.02			
	Heating	kW	0.01/0.01/0.01			
Current input	Cooling	A	0.08/0.10/0.10			
	Heating	A	0.06/0.06/0.06			
External finish		Galvanized steel plate				
Connectable outdoor/heat source unit capacity		*21 M200 to M1000				
Indoor unit capacity connectable to 1 branch		*15 Model M80 or smaller *19 (Use optional joint pipe combining 2 branches when the total unit capacity exceeds M81.)				
External dimension H x W x D		*16 mm	252 x 1040 x 880(970)			
		in.	9-15/16 x 41 x 34-11/16(38-1/4)			
Refrigerant piping diameter	To outdoor/heat source unit	Connectable unit capacity		High press. pipe	Low press. pipe	
		mm (in.) O.D.	M200	15.88 (5/8) Brazed	19.05 (3/4) Brazed	
		mm (in.) O.D.	M250 ~M300	19.05 (3/4) Brazed	22.2 (7/8) Brazed	
		*17	mm (in.) O.D.	M350	19.05 (3/4) Brazed or 22.2 (7/8) Brazed	28.58 (1-1/8) Brazed
			mm (in.) O.D.	M400 ~M500	22.2 (7/8) Brazed	28.58 (1-1/8) Brazed
		*17	mm (in.) O.D.	M550	22.2 (7/8) Brazed or 28.58 (1-1/8) Brazed	28.58 (1-1/8) Brazed
			mm (in.) O.D.	M600	22.2 (7/8) Brazed or 28.58 (1-1/8) Brazed	28.58 (1-1/8) Brazed or 34.93 (1-3/8) Brazed
		*17	mm (in.) O.D.	M650	28.58 (1-1/8) Brazed	28.58 (1-1/8) Brazed
			mm (in.) O.D.	M700 ~M800	28.58 (1-1/8) Brazed	34.93 (1-3/8) Brazed
		mm (in.) O.D.	M850 ~M1000	28.58 (1-1/8) Brazed	41.28 (1-5/8) Brazed	
	To indoor unit	*20	Liquid pipe		Gas pipe	
			mm (in.) O.D.	Indoor unit Model M80 or smaller 6.35 (1/4) Brazed bigger than M80 9.52 (3/8) Brazed	Indoor unit Model M50 or smaller 12.7 (1/2) Brazed bigger than M50 15.88 (5/8) Brazed (19.05 (3/4), 22.2 (7/8) with optional joint pipe used.)	
	To other BC controller	Total down-stream Indoor unit capacity		High press. pipe	Liquid pipe	Low press. pipe
		mm (in.) O.D.	to M200	15.88 (5/8) Brazed	9.52 (3/8) Brazed	19.05 (3/4) Brazed
		mm (in.) O.D.	M201 to M300	19.05 (3/4) Brazed	9.52 (3/8) Brazed	22.2 (7/8) Brazed
		mm (in.) O.D.	M301 to M350	19.05 (3/4) Brazed	12.7 (1/2) Brazed	28.58 (1-1/8) Brazed
		mm (in.) O.D.	M351 to M400	22.2 (7/8) Brazed	12.7 (1/2) Brazed	28.58 (1-1/8) Brazed
		mm (in.) O.D.	M401 to M600	22.2 (7/8) Brazed	15.88 (5/8) Brazed	28.58 (1-1/8) Brazed
		mm (in.) O.D.	M601 to M650	28.58 (1-1/8) Brazed	15.88 (5/8) Brazed	28.58 (1-1/8) Brazed
		mm (in.) O.D.	M651 to M800	28.58 (1-1/8) Brazed	19.05 (3/4) Brazed	34.93 (1-3/8) Brazed
		mm (in.) O.D.	M801 to M1000	28.58 (1-1/8) Brazed	19.05 (3/4) Brazed	41.28 (1-5/8) Brazed
		mm (in.) O.D.	M1001 or above	34.93 (1-3/8) Brazed	19.05 (3/4) Brazed	41.28 (1-5/8) Brazed
	Field drain pipe size		mm (in.)	OD32 (1-1/4)		
Net weight		kg (lbs)	63 (139)			
Sound power level (measured in anechoic room)	Rated operation	dB <A>	68			
	Defrost	dB <A>	74			
Sound pressure level (measured in anechoic room)	*18 Rated operation	dB <A>	50			
	Defrost	dB <A>	56			
Accessories		Drain Connection pipe, Washer, Tie band, Reducer				
Remarks		-				

- Notes:
- 1.Installation/foundation work, electrical connection work, insulation work, power source switch, and other items shall be referred to the Installation Manual.
  - 2.The equipment is for R32 refrigerant.
  - 3.Install this product in a location where noise (refrigerant noise) emitted by the unit will not disturb the neighbors. (For use in quiet environments with low background noise, position the BC CONTROLLER at least 5m away from any indoor units.)
  - 4.Sound pressure /power level differs depending on the connected outdoor/heat source unit capacity or operation condition.  
The sound pressure level /power level at the rated operation is the value of the cooling mode.
  - 5.The sound pressure /power level values were obtained in an anechoic room. Actual sound pressure level is usually greater than that measured in anechoic room due to ambient noise and deflection sound.
  - 6.The solenoid valve switching sound is 56 dB (sound pressure level) regardless of the unit model.
  - 7.Refrigerant piping diameter for connection of plural indoor units with 1 branch shall be referred to the Installation Manual.
  - 8.This unit is not designed for outside installations.
  - 9.When brazing the pipes, be sure to braze, after covering a wet cloth to the insulation pipes of the units in order to prevent it from burning and shrinking by heat.
  - 10.The sound pressure level values were obtained at the location below 1.5m from the unit.
  - 11.The ambient relative humidity of the BC controller needs to be kept below 80%.
  - 12.R32 is flammable, and certain restrictions apply to the installation of units. When installing new units, moving the existing units, or changing the layout of the room, ensure that installation restrictions are observed. For detail, refer to the section in the DATA BOOK on installation restrictions.
  - 13.For the insulation work of the piping and the installation method of the unit, follow the installation manual.
  - 14.A minimum floor area requirement varies depending on the installation site
  - 15.Indoor unit capacity connectable to 1 branch is changed depending on the indoor unit type and connection method. Please refer to the Installation Manual for more information.
  - 16.The figure in parenthesis indicates the size including control box.
  - 17.For the refrigerant pipe size, refer to Installation Manual of outdoor units/heat source units.
  - 18.The sound pressure level measured by the conventional method in JIS for reference purpose.
  - 19.Indoor units M100, M125, M140 can be connected to 1 branch. (In this case, cooling capacity decrease a little.)
  - 20.If indoor units M63,M71,M80 are connected and the length of the liquid pipe exceeds the restriction, use the one size larger pipe. Please refer to the Installation Manual for more information.
  - 21.Only PURY-YXM series outdoor units can be connected.

<b>Model</b>			<b>CMB-M1012V-MA-SV(-TR)</b>			
Number of branch			12			
Power source			1-phase 220/230/240V			
			50Hz			
Power input	Cooling	kW	0.02/0.02/0.02			
	Heating	kW	0.01/0.01/0.01			
Current input	Cooling	A	0.08/0.10/0.10			
	Heating	A	0.06/0.06/0.06			
External finish			Galvanized steel plate			
Connectable outdoor/heat source unit capacity			*21 M200 to M1000			
Indoor unit capacity connectable to 1 branch			*15 Model M80 or smaller *19 (Use optional joint pipe combining 2 branches when the total unit capacity exceeds M81.)			
External dimension H x W x D			*16 mm	252 x 1285 x 880(970)		
			in.	9-15/16 x 50-5/8 x 34-11/16(38-1/4)		
Refrigerant piping diameter	To outdoor/heat source unit	Connectable unit capacity		High press. pipe	Low press. pipe	
		mm (in.) O.D.	M200	15.88 (5/8) Brazed	19.05 (3/4) Brazed	
		mm (in.) O.D.	M250 ~M300	19.05 (3/4) Brazed	22.2 (7/8) Brazed	
		*17	mm (in.) O.D.	M350	19.05 (3/4) Brazed or 22.2 (7/8) Brazed	28.58 (1-1/8) Brazed
			mm (in.) O.D.	M400 ~M500	22.2 (7/8) Brazed	28.58 (1-1/8) Brazed
		*17	mm (in.) O.D.	M550	22.2 (7/8) Brazed or 28.58 (1-1/8) Brazed	28.58 (1-1/8) Brazed
			*17	mm (in.) O.D.	M600	22.2 (7/8) Brazed or 28.58 (1-1/8) Brazed
		mm (in.) O.D.		M650	28.58 (1-1/8) Brazed	28.58 (1-1/8) Brazed
		mm (in.) O.D.	M700 ~M800	28.58 (1-1/8) Brazed	34.93 (1-3/8) Brazed	
		mm (in.) O.D.	M850 ~M1000	28.58 (1-1/8) Brazed	41.28 (1-5/8) Brazed	
	To indoor unit	Liquid pipe			Gas pipe	
		*20 mm (in.) O.D.	Indoor unit Model M80 or smaller 6.35 (1/4) Brazed bigger than M80 9.52 (3/8) Brazed		Indoor unit Model M50 or smaller 12.7 (1/2) Brazed bigger than M50 15.88 (5/8) Brazed (19.05 (3/4), 22.2 (7/8) with optional joint pipe used.)	
	To other BC controller	Total down-stream Indoor unit capacity		High press. pipe	Liquid pipe	Low press. pipe
		mm (in.) O.D. to M200		15.88 (5/8) Brazed	9.52 (3/8) Brazed	19.05 (3/4) Brazed
		mm (in.) O.D. M201 to M300		19.05 (3/4) Brazed	9.52 (3/8) Brazed	22.2 (7/8) Brazed
		mm (in.) O.D. M301 to M350		19.05 (3/4) Brazed	12.7 (1/2) Brazed	28.58 (1-1/8) Brazed
		mm (in.) O.D. M351 to M400		22.2 (7/8) Brazed	12.7 (1/2) Brazed	28.58 (1-1/8) Brazed
		mm (in.) O.D. M401 to M600		22.2 (7/8) Brazed	15.88 (5/8) Brazed	28.58 (1-1/8) Brazed
		mm (in.) O.D. M601 to M650		28.58 (1-1/8) Brazed	15.88 (5/8) Brazed	28.58 (1-1/8) Brazed
		mm (in.) O.D. M651 to M800		28.58 (1-1/8) Brazed	19.05 (3/4) Brazed	34.93 (1-3/8) Brazed
mm (in.) O.D. M801 to M1000		28.58 (1-1/8) Brazed	19.05 (3/4) Brazed	41.28 (1-5/8) Brazed		
mm (in.) O.D. M1001 or above		34.93 (1-3/8) Brazed	19.05 (3/4) Brazed	41.28 (1-5/8) Brazed		
Field drain pipe size			mm (in.) OD32 (1-1/4)			
Net weight			kg (lbs) 77 (170)			
Sound power level (measured in anechoic room)	Rated operation	dB <A>	68			
	Defrost	dB <A>	74			
Sound pressure level (measured in anechoic room)	Rated operation	dB <A>	*18 50			
	Defrost	dB <A>	56			
Accessories			Drain Connection pipe, Washer, Tie band, Reducer			
Remarks			-			

- Notes:
- 1.Installation/foundation work, electrical connection work, insulation work, power source switch, and other items shall be referred to the Installation Manual.
  - 2.The equipment is for R32 refrigerant.
  - 3.Install this product in a location where noise (refrigerant noise) emitted by the unit will not disturb the neighbors. (For use in quiet environments with low background noise, position the BC CONTROLLER at least 5m away from any indoor units.)
  - 4.Sound pressure /power level differs depending on the connected outdoor/heat source unit capacity or operation condition.  
The sound pressure level /power level at the rated operation is the value of the cooling mode.
  - 5.The sound pressure /power level values were obtained in an anechoic room. Actual sound pressure level is usually greater than that measured in anechoic room due to ambient noise and deflection sound.
  - 6.The solenoid valve switching sound is 56 dB (sound pressure level) regardless of the unit model.
  - 7.Refrigerant piping diameter for connection of plural indoor units with 1 branch shall be referred to the Installation Manual.
  - 8.This unit is not designed for outside installations.
  - 9.When brazing the pipes, be sure to braze, after covering a wet cloth to the insulation pipes of the units in order to prevent it from burning and shrinking by heat.
  - 10.The sound pressure level values were obtained at the location below 1.5m from the unit.
  - 11.The ambient relative humidity of the BC controller needs to be kept below 80%.
  - 12.R32 is flammable, and certain restrictions apply to the installation of units. When installing new units, moving the existing units, or changing the layout of the room, ensure that installation restrictions are observed. For detail, refer to the section in the DATA BOOK on installation restrictions.
  - 13.For the insulation work of the piping and the installation method of the unit, follow the installation manual.
  - 14.A minimum floor area requirement varies depending on the installation site
  - 15.Indoor unit capacity connectable to 1 branch is changed depending on the indoor unit type and connection method. Please refer to the Installation Manual for more information.
  - 16.The figure in parenthesis indicates the size including control box.
  - 17.For the refrigerant pipe size, refer to Installation Manual of outdoor units/heat source units.
  - 18.The sound pressure level measured by the conventional method in JIS for reference purpose.
  - 19.Indoor units M100, M125, M140 can be connected to 1 branch. (In this case, cooling capacity decrease a little.)
  - 20.If indoor units M63,M71,M80 are connected and the length of the liquid pipe exceeds the restriction, use the one size larger pipe. Please refer to the Installation Manual for more information.
  - 21.Only PURY-YXM series outdoor units can be connected.

<b>Model</b>		<b>CMB-M104V-MB-SV(-TR)</b>				
Number of branch		4				
Power source		1-phase 220/230/240V 50Hz				
Power input	Cooling	kW	0.01/0.01/0.01			
	Heating	kW	0.01/0.01/0.01			
Current input	Cooling	A	0.05/0.05/0.05			
	Heating	A	0.05/0.05/0.05			
External finish		Galvanized steel plate				
Connectable Main BC controller		CMB-M104/106/108/1012V-MA-SV(-TR)				
The maximum number of connectable Sub BC controllers		11				
The maximum connectable capacity of indoor units		M350 for each				
Indoor unit capacity connectable to 1 branch		*16	Model M80 or smaller			
		*19	(Use optional joint pipe combining 2 branches when the total unit capacity exceeds M81.)			
External dimension H x W x D		*17 mm	252 x 1040 x 880(970)			
		in.	9-15/16 x 41 x 34-11/16(38-1/4)			
Refrigerant piping diameter	To outdoor/heat source unit	Connectable unit capacity		High press. pipe	Low press. pipe	
		mm (in.) O.D.	-	-	-	
	To indoor unit	Liquid pipe			Gas pipe	
		*20 mm (in.) O.D.	Indoor unit Model M80 or smaller 6.35 (1/4) Brazed bigger than M80 9.52 (3/8) Brazed		Indoor unit Model M50 or smaller 12.7 (1/2) Brazed bigger than M50 15.88 (5/8) Brazed (19.05 (3/4), 22.2 (7/8) with optional joint pipe used.)	
	To other BC controller	Total down-stream Indoor unit capacity		High press. pipe	Liquid pipe	Low press. pipe
		mm (in.) O.D.	to M200	15.88 (5/8) Brazed	9.52 (3/8) Brazed	19.05 (3/4) Brazed
		mm (in.) O.D.	M201 to M300	19.05 (3/4) Brazed	9.52 (3/8) Brazed	22.2 (7/8) Brazed
		mm (in.) O.D.	M301 to M350	19.05 (3/4) Brazed	12.7 (1/2) Brazed	28.58 (1-1/8) Brazed
		mm (in.) O.D.	M351 to M400	22.2 (7/8) Brazed	12.7 (1/2) Brazed	28.58 (1-1/8) Brazed
		mm (in.) O.D.	M401 to M600	22.2 (7/8) Brazed	15.88 (5/8) Brazed	28.58 (1-1/8) Brazed
mm (in.) O.D.		M601 to M650	28.58 (1-1/8) Brazed	15.88 (5/8) Brazed	28.58 (1-1/8) Brazed	
mm (in.) O.D.		M651 to M800	28.58 (1-1/8) Brazed	19.05 (3/4) Brazed	34.93 (1-3/8) Brazed	
mm (in.) O.D.	M801 to M1000	28.58 (1-1/8) Brazed	19.05 (3/4) Brazed	41.28 (1-5/8) Brazed		
mm (in.) O.D.	M1001 or above	34.93 (1-3/8) Brazed	19.05 (3/4) Brazed	41.28 (1-5/8) Brazed		
Field drain pipe size		mm (in.)	OD32 (1-1/4)			
Net weight		kg (lbs)	43 (95)			
Sound power level (measured in anechoic room)	Rated operation	dB <A>	59			
	Defrost	dB <A>	71			
Sound pressure level (measured in anechoic room)	Rated operation	dB <A>	41			
	Defrost	dB <A>	53			
Accessories		Drain Connection pipe, Washer, Tie band				
Remarks		-				

- Notes:
- 1.Installation/foundation work, electrical connection work, insulation work, power source switch, and other items shall be referred to the Installation Manual.
  - 2.The equipment is for R32 refrigerant.
  - 3.Install this product in a location where noise (refrigerant noise) emitted by the unit will not disturb the neighbors. (For use in quiet environments with low background noise, position the BC CONTROLLER at least 5m away from any indoor units.)
  - 4.Sound pressure /power level differs depending on the connected outdoor/heat source unit capacity or operation condition.  
The sound pressure level /power level at the rated operation is the value of the cooling mode.
  - 5.The sound pressure /power level values were obtained in an anechoic room. Actual sound pressure level is usually greater than that measured in anechoic room due to ambient noise and deflection sound.
  - 6.The solenoid valve switching sound is 56 dB (sound pressure level) regardless of the unit model.
  - 7.Refrigerant piping diameter for connection of plural indoor units with 1 branch shall be referred to the Installation Manual.
  - 8.This unit is not designed for outside installations.
  - 9.When brazing the pipes, be sure to braze, after covering a wet cloth to the insulation pipes of the units in order to prevent it from burning and shrinking by heat.
  - 10.The sound pressure level values were obtained at the location below 1.5m from the unit.
  - 11.The ambient relative humidity of the BC controller needs to be kept below 80%.
  - 12.R32 is flammable, and certain restrictions apply to the installation of units. When installing new units, moving the existing units, or changing the layout of the room, ensure that installation restrictions are observed. For detail, refer to the section in the DATA BOOK on installation restrictions.
  - 13.For the insulation work of the piping and the installation method of the unit, follow the installation manual.
  - 14.A minimum floor area requirement varies depending on the installation site
  - 15.Can't use singleness. (MAIN BC CONTROLLER is necessary)
  - 16.Indoor unit capacity connectable to 1 branch is changed depending on the indoor unit type and connection method. Please refer to the Installation Manual for more information.
  - 17.The figure in parenthesis indicates the size including control box.
  - 18.The sound pressure level measured by the conventional method in JIS for reference purpose.
  - 19.Indoor units M100, M125, M140 can be connected to 1 branch. (In this case, cooling capacity decrease a little.)
  - 20.If indoor units M63,M71,M80 are connected and the length of the liquid pipe exceeds the restriction, use the one size larger pipe. Please refer to the Installation Manual for more information.

Model			CMB-M108V-MB-SV(-TR)		
Number of branch			8		
Power source			1-phase 220/230/240V		
			50Hz		
Power input	Cooling	kW	0.01/0.01/0.01		
	Heating	kW	0.01/0.01/0.01		
Current input	Cooling	A	0.06/0.06/0.06		
	Heating	A	0.06/0.06/0.06		
External finish			Galvanized steel plate		
Connectable Main BC controller			CMB-M104/106/108/1012V-MA-SV(-TR)		
The maximum number of connectable Sub BC controllers			11		
The maximum connectable capacity of indoor units			M350 for each		
Indoor unit capacity connectable to 1 branch		*16	Model M80 or smaller		
		*19	(Use optional joint pipe combining 2 branches when the total unit capacity exceeds M81.)		
External dimension H x W x D		*17	252 x 1040 x 880(970)		
			9-15/16 x 41 x 34-11/16(38-1/4)		
Refrigerant piping diameter	To outdoor/heat source unit		Connectable unit capacity	High press. pipe	Low press. pipe
			mm (in.) O.D.	-	-
	To indoor unit		Liquid pipe		Gas pipe
			*20	Indoor unit Model M80 or smaller 6.35 (1/4) Brazed bigger than M80 9.52 (3/8) Brazed	Indoor unit Model M50 or smaller 12.7 (1/2) Brazed bigger than M50 15.88 (5/8) Brazed (19.05 (3/4), 22.2 (7/8) with optional joint pipe used.)
	To other BC controller		Total down-stream Indoor unit capacity	High press. pipe	Liquid pipe
			mm (in.) O.D.	to M200	15.88 (5/8) Brazed
			mm (in.) O.D.	M201 to M300	19.05 (3/4) Brazed
			mm (in.) O.D.	M301 to M350	19.05 (3/4) Brazed
			mm (in.) O.D.	M351 to M400	22.2 (7/8) Brazed
			mm (in.) O.D.	M401 to M600	22.2 (7/8) Brazed
		mm (in.) O.D.	M601 to M650	28.58 (1-1/8) Brazed	
		mm (in.) O.D.	M651 to M800	28.58 (1-1/8) Brazed	
		mm (in.) O.D.	M801 to M1000	28.58 (1-1/8) Brazed	
		mm (in.) O.D.	M1001 or above	34.93 (1-3/8) Brazed	
Field drain pipe size		mm (in.)	OD32 (1-1/4)		
Net weight		kg (lbs)	54 (120)		
Sound power level (measured in anechoic room)	Rated operation	dB <A>	59		
	Defrost	dB <A>	71		
Sound pressure level (measured in anechoic room)	Rated operation	dB <A>	41		
	Defrost	dB <A>	53		
Accessories			Drain Connection pipe, Washer, Tie band		
Remarks			-		

- Notes:
- 1.Installation/foundation work, electrical connection work, insulation work, power source switch, and other items shall be referred to the Installation Manual.
  - 2.The equipment is for R32 refrigerant.
  - 3.Install this product in a location where noise (refrigerant noise) emitted by the unit will not disturb the neighbors. (For use in quiet environments with low background noise, position the BC CONTROLLER at least 5m away from any indoor units.)
  - 4.Sound pressure /power level differs depending on the connected outdoor/heat source unit capacity or operation condition.  
The sound pressure level /power level at the rated operation is the value of the cooling mode.
  - 5.The sound pressure /power level values were obtained in an anechoic room. Actual sound pressure level is usually greater than that measured in anechoic room due to ambient noise and deflection sound.
  - 6.The solenoid valve switching sound is 56 dB (sound pressure level) regardless of the unit model.
  - 7.Refrigerant piping diameter for connection of plural indoor units with 1 branch shall be referred to the Installation Manual.
  - 8.This unit is not designed for outside installations.
  - 9.When brazing the pipes, be sure to braze, after covering a wet cloth to the insulation pipes of the units in order to prevent it from burning and shrinking by heat.
  - 10.The sound pressure level values were obtained at the location below 1.5m from the unit.
  - 11.The ambient relative humidity of the BC controller needs to be kept below 80%.
  - 12.R32 is flammable, and certain restrictions apply to the installation of units. When installing new units, moving the existing units, or changing the layout of the room, ensure that installation restrictions are observed. For detail, refer to the section in the DATA BOOK on installation restrictions.
  - 13.For the insulation work of the piping and the installation method of the unit, follow the installation manual.
  - 14.A minimum floor area requirement varies depending on the installation site
  - 15.Can't use singleness. (MAIN BC CONTROLLER is necessary)
  - 16.Indoor unit capacity connectable to 1 branch is changed depending on the indoor unit type and connection method. Please refer to the Installation Manual for more information.
  - 17.The figure in parenthesis indicates the size including control box.
  - 18.The sound pressure level measured by the conventional method in JIS for reference purpose.
  - 19.Indoor units M100, M125, M140 can be connected to 1 branch. (In this case, cooling capacity decrease a little.)
  - 20.If indoor units M63,M71,M80 are connected and the length of the liquid pipe exceeds the restriction, use the one size larger pipe. Please refer to the Installation Manual for more information.



**CMB-M104, 106, 108V-MA-SV(-TR)**

Unit: mm

BC controller

**Note 1.** Suspension bolt(ø10) and nut(M10) prepare in the field.

**2.** Take notice of service space as shown.  
(Please give attention not to occupy service space by letting ducts and pipes through.)

The access doors in the service space are required for maintenance. Provide separate openings to bring down the product.

**3.** If the piping is routed over the inspection port, it will not be possible to replace the service part.

**4.** Please take service space for connection pipe of SUB BC CONTROLLER.

**5.** Install this product in a location where noise (refrigerant noise) emitted by the unit will not disturb the neighbors.  
(For use in quiet environments with low background noise, position the BC CONTROLLER at least 5m away from any indoor units.)

**6.** Refer to the Installation Manual for refrigerant piping diameter size when connecting plural indoor units with 1 branch.

**7.** Refer to the Table-1,2 connection pipe of outdoor unit or SUB BC CONTROLLER diameter size.

**8.** Refer to the Installation Manual for insulation of connection pipe and drain piping.

**9.** Do not place the BC controller directly on the floor.

**10.** Installing pipes over the access doors will obstruct the replacement of service parts.

**11.** Seal the opened connection pipes of the indoor unit.  
(Recommended sealing parts are sold separately.)

**Table-1. To outdoor/heat source unit (Note.7)**

Connectable unit capacity	High press. Pipe	Low press. Pipe
M200	ø15.88	ø19.05
M250 to M300	ø19.05	ø22.2
M350	ø19.05	ø28.58
M400 to M600	ø22.2	ø28.58
M650	ø28.58	ø28.58
M700 to M800	ø28.58	ø34.93
M850 to M1000	ø28.58	ø41.28

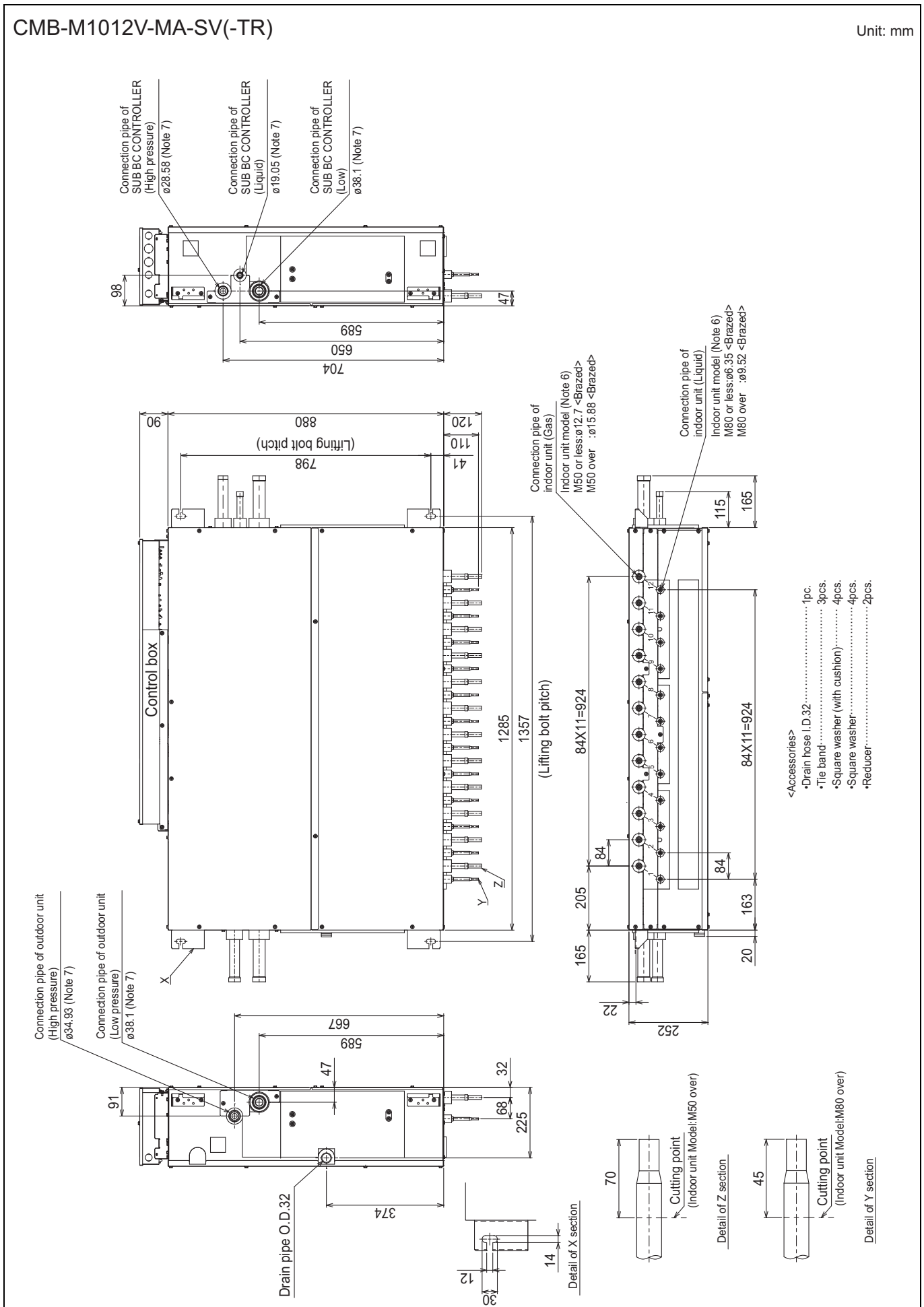

**Table-2. To other BC controller (Note.7)**

Total downstream Indoor unit capacity	High press. Pipe	Liquid Pipe	Low press. Pipe
M200 or below	ø15.88	ø9.52	ø19.05
M201 to 300	ø19.05	ø9.52	ø22.2
M301 to 350	ø19.05	ø12.7	ø28.58
M351 to 400	ø22.2	ø12.7	ø28.58
M401 to 600	ø22.2	ø15.88	ø28.58
M601 to 650	ø28.58	ø15.88	ø28.58
M651 to 800	ø28.58	ø19.05	ø34.93
M801 to 1000	ø28.58	ø19.05	ø41.28
M1001 or above	ø34.93	ø19.05	ø41.28

CMB-M1012V-MA-SV(-TR)

Unit: mm



Refrigerant (Low pressure) connection pipe is included in products manufactured in Oct. 2021 and later.

CMB-M1012V-MA-SV(-TR)

Unit: mm

**Note 1.** Suspension bolt(ø10) and nut(M10) prepare in the field.  
**2.** Take notice of service space as shown.  
 (Please give attention not to occupy service space by letting ducts and pipes through.)  
 The access doors in the service space are required for maintenance.  
 Provide separate openings to bring down the product.  
**3.** If the piping is routed over the inspection port, it will not be possible to replace the service part.  
**4.** Please take service space for connection pipe of SUB BC CONTROLLER.  
**5.** Install this product in a location where noise (refrigerant noise) emitted by the unit will not disturb the neighbors.  
 (For use in quiet environments with low background noise, position the BC CONTROLLER at least 5m away from any indoor units.)  
**6.** Refer to the Installation Manual for refrigerant piping diameter size when connecting plural indoor units with 1 branch.  
**7.** Refer to the Table-1,2 connection pipe of outdoor unit or SUB BC CONTROLLER diameter size.  
**8.** Refer to the Installation Manual for insulation of connection pipe and drain piping.  
**9.** Do not place the BC controller directly on the floor.  
**10.** Installing pipes over the access doors will obstruct the replacement of service parts.  
**11.** Seal the opened connection pipes of the indoor unit.  
 (Recommended sealing parts are sold separately.)

**Table-1. To outdoor/heat source unit (Note.7)**

Connectable unit capacity	High press. Pipe	Low press. Pipe
M200	ø15.88	ø19.05
M250 to M300	ø22.2	ø28.58
M350	ø19.05	ø28.58
M400 to M600	ø22.2	ø28.58
M650	ø28.58	ø34.93
M700 to M800	ø28.58	ø41.28
M850 to M1000	ø28.58	ø41.28

**Table-2. To other BC controller (Note.7)**

Total downstream Indoor unit capacity	High press. Pipe	Liquid Pipe	Low press. Pipe
M200 or below	ø15.88	ø9.52	ø19.05
M201 to 300	ø19.05	ø9.52	ø22.2
M301 to 350	ø19.05	ø12.7	ø28.58
M351 to 400	ø22.2	ø12.7	ø28.58
M401 to 600	ø22.2	ø15.88	ø28.58
M601 to 650	ø28.58	ø15.88	ø34.93
M651 to 800	ø28.58	ø19.05	ø41.28
M801 to 1000	ø28.58	ø19.05	ø41.28
M1001 or above	ø34.93	ø19.05	ø41.28

Refrigerant (Low pressure) connection pipe is included in products manufactured in Oct. 2021 and later.



CMB-M104, 108V-MB-SV(-TR)		Unit: mm	
<p>Note 1. Suspension bolt(ø10) and nut(M10) prepare in the field.                  2. Take notice of service space as shown.                  (Please give attention not to occupy service space by letting ducts and pipes through.)                  The access doors in the service space are required for maintenance. Provide separate openings to bring down the product.                  3. If the piping is routed over the inspection port, it will not be possible to replace the service part.                  4. Can't use singleness. (MAIN BC CONTROLLER is necessary.)                  5. Install this product in a location where noise (refrigerant noise) emitted by the unit will not disturb the neighbors.                  (For use in quiet environments with low background noise, position the BC CONTROLLER at least 5m away from any indoor units.)                  6. Refer to the Installation Manual for refrigerant piping diameter size when connecting plural indoor units with 1 branch.                  7. Refer to the Table-1 for connection pipe of MAIN BC CONTROLLER.                  8. Refer to the Installation Manual for insulation of connection pipe and drain piping.                  9. Do not place the BC controller directly on the floor.                  10. Installing pipes over the access doors will obstruct the replacement of service parts.                  11. Seal the opened connection pipes of the indoor unit.                  (Recommended sealing parts are sold separately.)</p>			
Table-1. To other BC controller (Note.7)			
Total downstream Indoor unit capacity	High press. Pipe	Liquid Pipe	Low press. Pipe
M200 or below	ø15.88	ø9.52	ø19.05
M201 to 300	ø19.05	ø9.52	ø22.2
M301 to 350	ø19.05	ø12.7	ø28.58
M351 to 400	ø22.2	ø12.7	ø28.58
M401 to 600	ø22.2	ø15.88	ø28.58
M601 to 650	ø28.58	ø15.88	ø28.58
M651 to 800	ø28.58	ø19.05	ø34.93
M801 to 1000	ø28.58	ø19.05	ø41.28
M1001 or above	ø34.93	ø19.05	ø41.28

CMB-M104V-MA-SV(-TR)

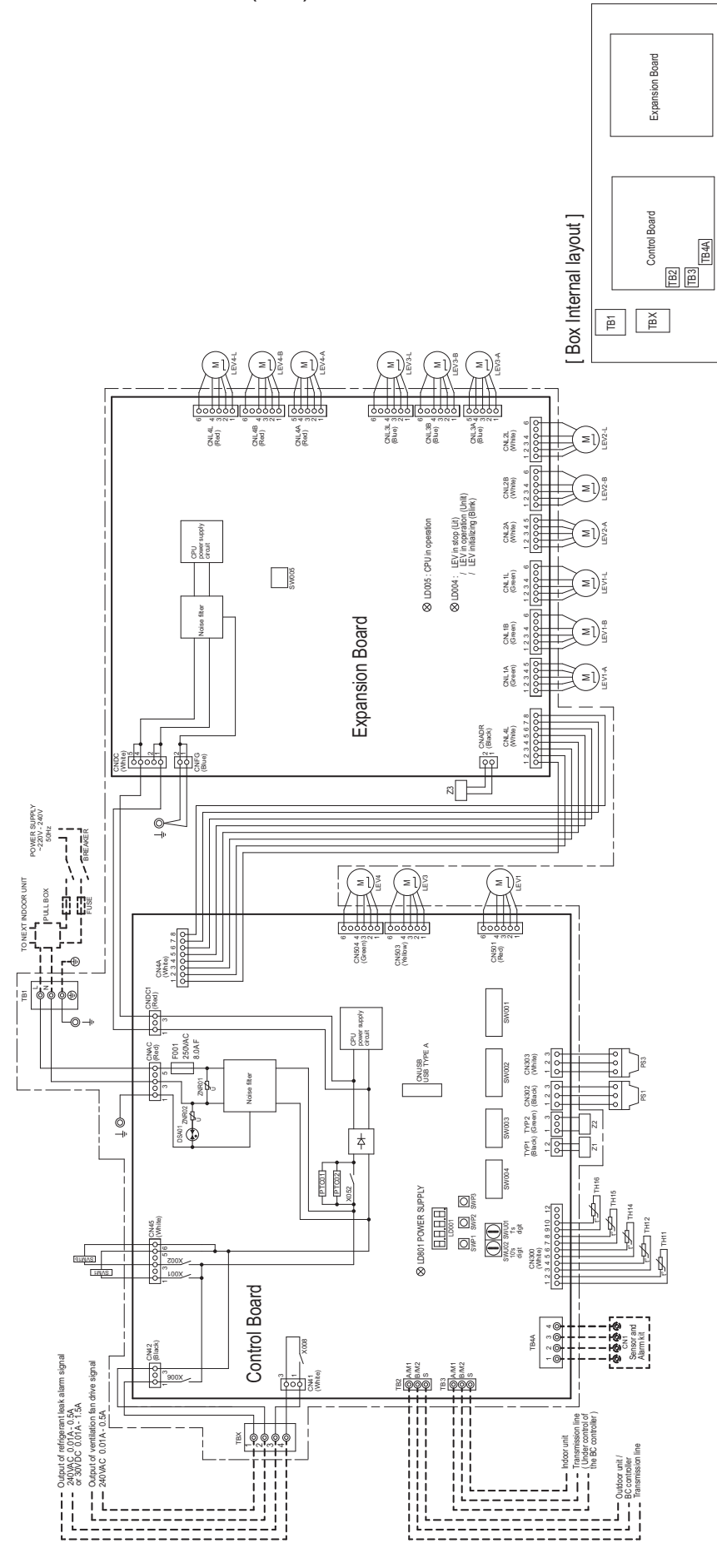

[ Symbol explanation ]

Symbol	Name	Symbol	Name
TH1,12,14,15,16	Thermistor sensor	TB1	Terminal block ( for power source )
LEV1,3,4	Expansion valve	TB2, 3	Terminal block ( for transmission )
PS1,3	Pressure sensor	TB4A	Terminal block ( Sensor and Alarm kit )
LEV-1 to 4-A, B, L	Expansion valve	TBx	Terminal block 1-2pin: Output of ventilation fan drive signal 3-4pin: Output of refrigerant leak alarm signal )
SVM1, SVM1b	Solenoid valve		
Z1 to Z3	Function setting connector		
F001	Fuse 250VAC 8.0A F		

- Note:
1. TB2, TB3, and TB4A are transmission terminal blocks. Never connect the power line to them.
  2. The initial set values of switch on Control Board are as follows.  
SWU01:0  
SWU02:0
  3. The wirings to TB1, TB2, TB3, TB4A, and TBx shown in dotted lines are carried out on site. Refer to the Installation Manual to carry out wirings to TB2, TB3, TB4A, and TBx on site properly.
  4. Dot-dash lines indicate the control box boundaries.
  5. If an airtightness test, vacuum drying, refrigerant recovery, or refrigerant charging is necessary with the power off, turn off the power to the outdoor unit or heat source unit first, and then turn off the power to the BC controller and the power to the indoor units.
  6. When turning on the power, start the BC controller and indoor units first, and then start the outdoor unit or heat source unit.

CMB-M106V-MA-SV(-TR)

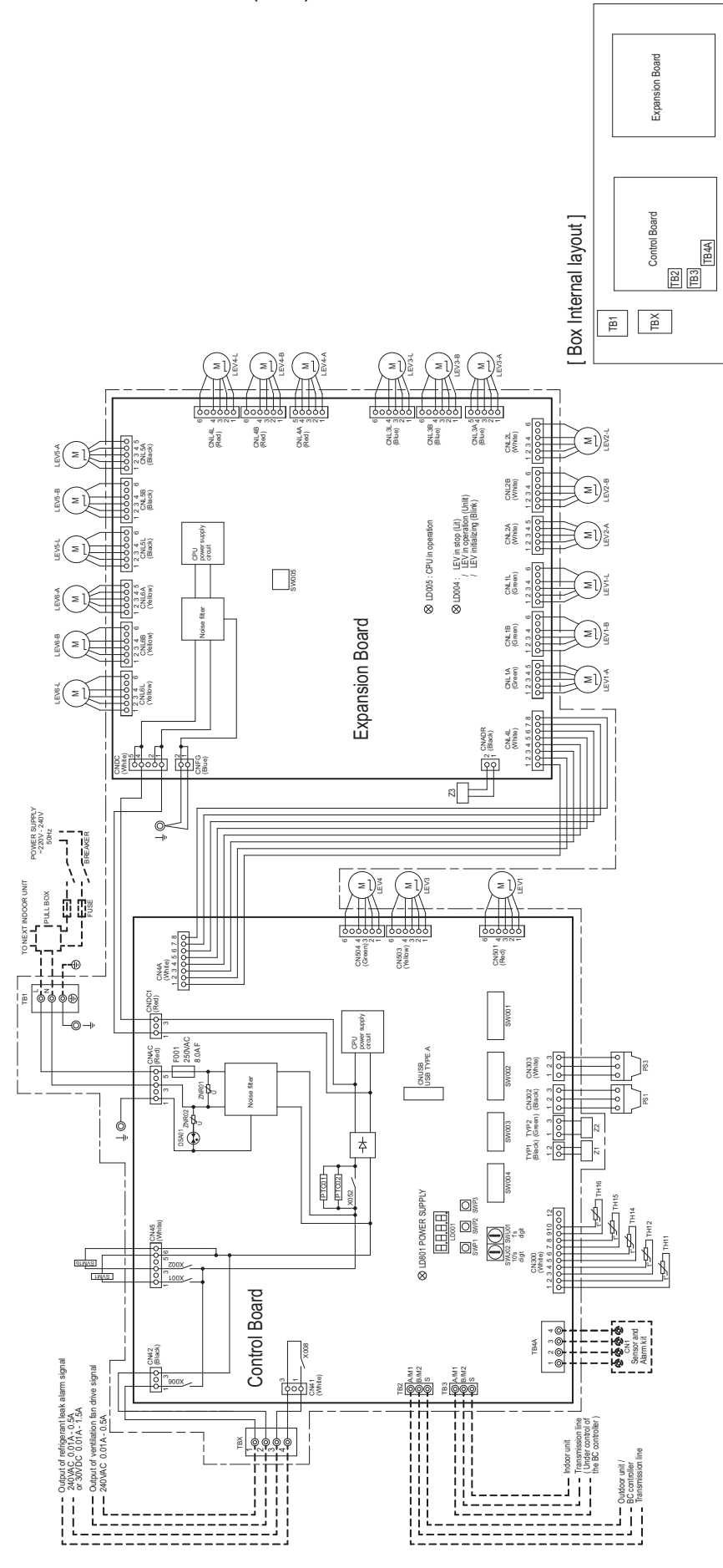

[ Symbol explanation ]

Symbol	Name	Symbol	Name
TH1,12,14,15,16	Thermistor sensor	TB1	Terminal block ( for power source )
EV1,3,4	Expansion valve	TB2, 3	Terminal block ( for transmission )
PS1,3	Pressure sensor	TB4A	Terminal block ( Sensor and Alarm kit )
LEV1 to 6 A, B, L	Expansion valve	TBX	Terminal block 1-2pin: Output of ventilation fan drive signal ) 3-4pin: Output of refrigerant leak alarm signal )
SVM1, SVM1b	Solenoid valve		
Z1 to Z3	Function setting connector		
F001	Fuse 250VAC 8.0A F		

- Note:**
1. TB2, TB3, and TB4A are transmission terminal blocks. Never connect the power line to them.
  2. The initial set values of switch on Control Board are as follows.  
SWU01:0  
SWU02:0
  3. The wirings to TB1, TB2, TB3, TB4A, and TBX shown in dotted lines are carried out on site.
  4. Refer to the Installation Manual to carry out wirings to TB2, TB3, TB4A, and TBX on site properly.
  5. Dot-dash lines indicate the control box boundaries.
  6. If an airtightness test, vacuum drying, refrigerant recovery, or refrigerant charging is necessary with the power off, turn off the power to the outdoor unit or heat source unit first, and then turn off the power to the BC controller and the power to the indoor units.  
When turning on the power, start the BC controller and indoor units first, and then start the outdoor unit or heat source unit.

CMB-M108V-MA-SV(-TR)

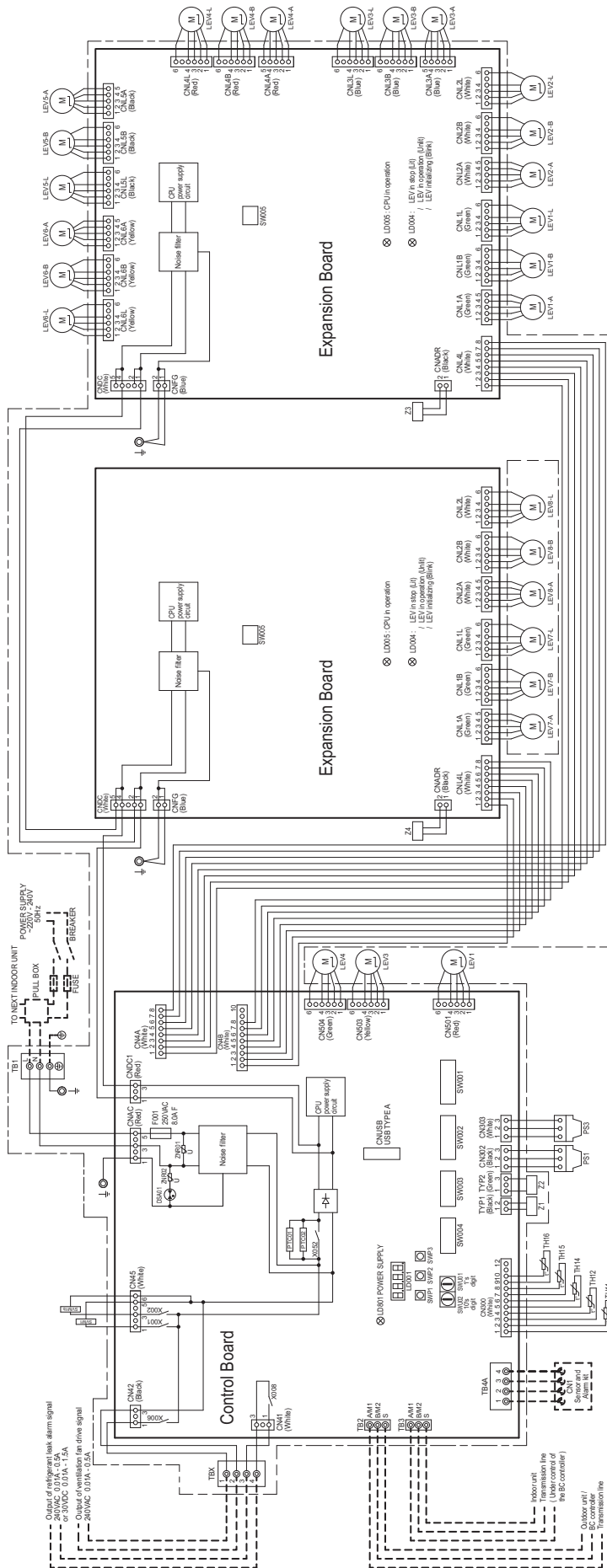

[ Symbol explanation ]

Symbol	Name
TB1, 12, 14, 15, 16	Thermistor sensor
LEV1, 3, 4	Expansion valve
PS1, 3	Pressure sensor
LEV-1 to 8, A, L	Expansion valve
SVM1, SVM1b	Solenoid valve
Z1 to Z4	Function setting connector
F001	Fuse 250VAC 8.0A F

[ Box internal layout ]

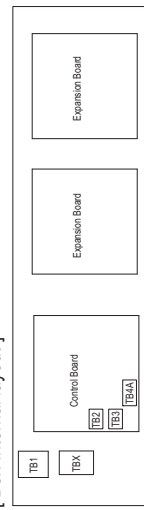

- Note:
1. TB2, TB3, and TB4A are transmission terminal blocks. Never connect the power line to them.
  2. The initial set values of switch on Control Board are as follows.  
SWU01:0  
SWU02:0
  3. The wirings to TB1, TB2, TB3, TB4A, and TBX shown in dotted lines are carried out on site. Refer to the Installation Manual to carry out wirings to TB2, TB3, TB4A, and TBX on site properly.
  4. Dot-dash lines indicate the control box boundaries.
  5. If an airtightness test, vacuum drying, refrigerant recovery, or refrigerant charging is necessary with the power off, turn off the power to the outdoor unit or heat source unit first, and then turn the power to the indoor units.
  6. When turning on the power, start the BC controller and indoor units first, and then start the outdoor unit or heat source unit.

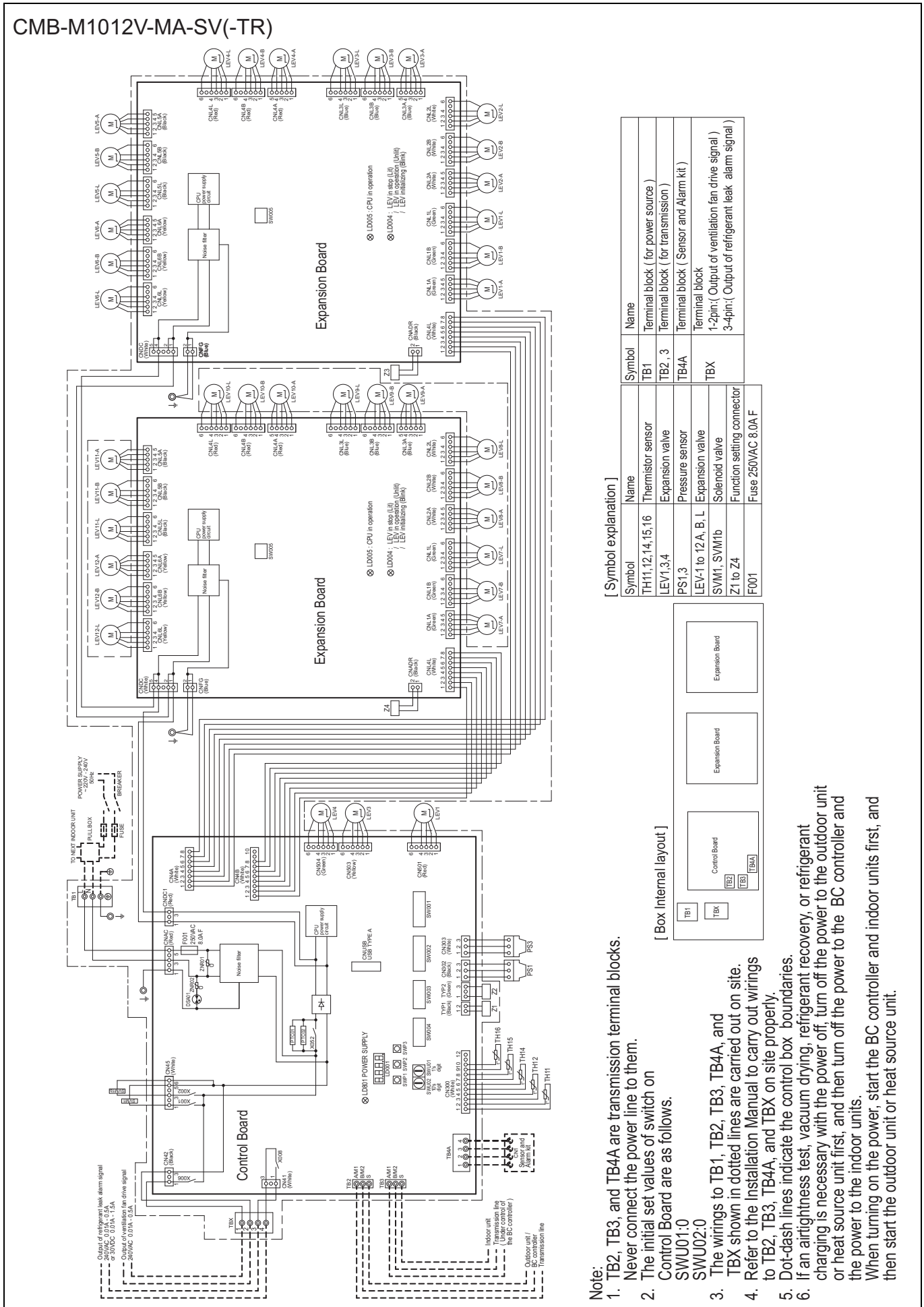

- Note:**
1. TB2, TB3, and TB4A are transmission terminal blocks.
  2. Never connect the power line to them.
  3. The initial set values of switch on Control Board are as follows.  
SWU01:0  
SWU02:0
  4. The wirings to TB1, TB2, TB3, TB4, and TBX shown in dotted lines are carried out on site.
  5. Refer to the Installation Manual to carry out wirings to TB2, TB3, TB4A, and TBX on site properly.
  6. Dot-dash lines indicate the control box boundaries.
- If an airtightness test, vacuum drying, refrigerant recovery, or refrigerant charging is necessary with the power off, turn off the power to the outdoor unit and heat source unit first, and then turn off the power to the BC controller and indoor units first, and then start the outdoor unit or heat source unit.

CMB-M104V-MB-SV(-TR)

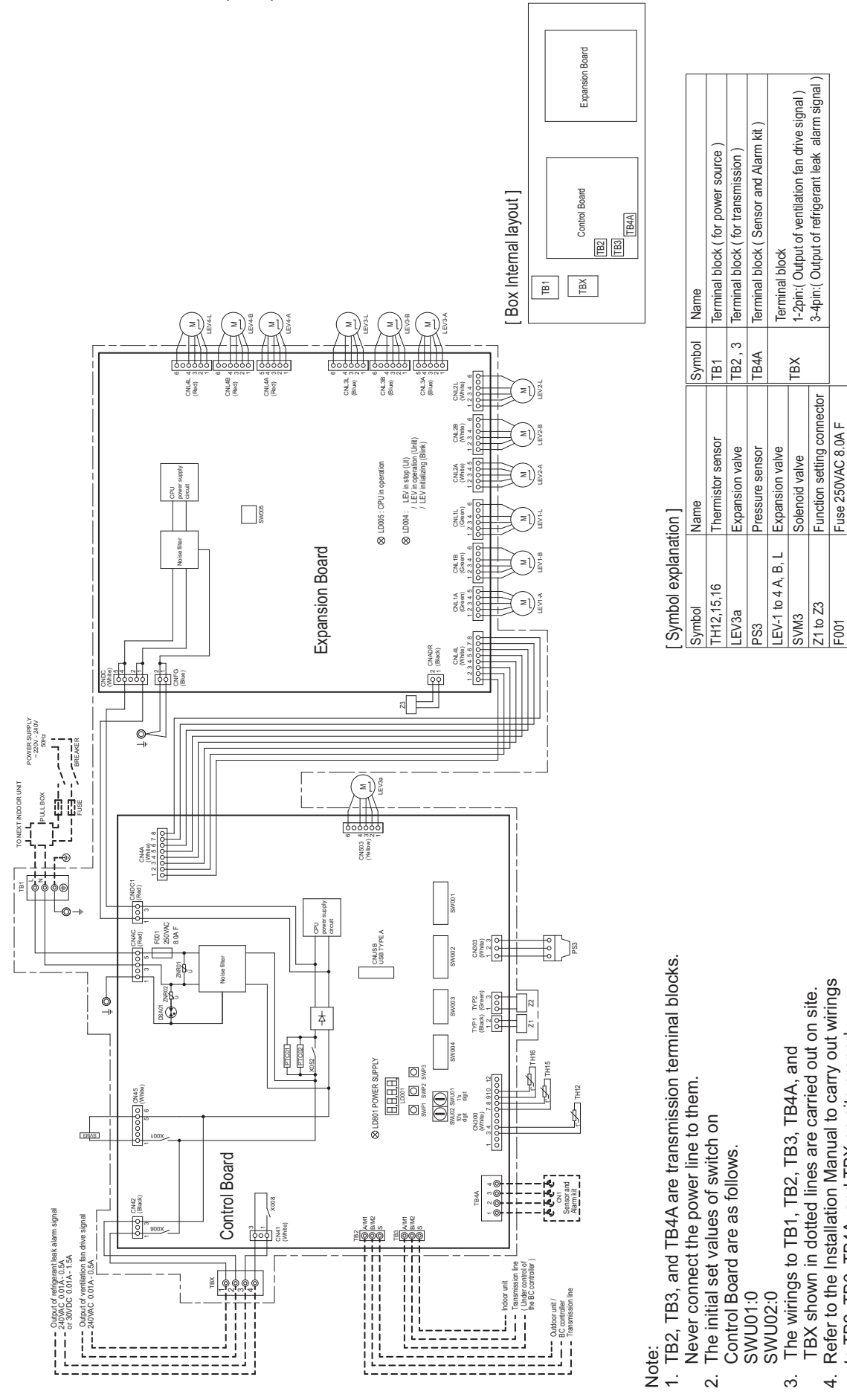

[ Symbol explanation ]

Symbol	Name	Symbol	Name
TH12,15,16	Thermistor sensor	TB1	Terminal block ( for power source )
LEV3a	Expansion valve	TB2 , 3	Terminal block ( for transmission )
PS3	Pressure sensor	TB4A	Terminal block ( Sensor and Alarm kit )
LEV-1 to 4 A, B, L	Expansion valve		Terminal block
SVM3	Solenoid valve		1-2pin:( Output of ventilation fan drive signal )
Z1 to Z3	Function setting connector		3-4pin:( Output of refrigerant leak alarm signal )
F001	Fuse 250VAC 8.0A F		

- Note:
1. TB2, TB3, and TB4A are transmission terminal blocks. Never connect the power line to them.
  2. The initial set values of switch on Control Board are as follows.  
SWJ01:0  
SWJ02:0
  3. The wirings to TB1, TB2, TB3, TB4A, and TBX shown in dotted lines are carried out on site.
  4. Refer to the Installation Manual to carry out wirings to TB2, TB3, TB4A, and TBX on site properly.
  5. Dot-dash lines indicate the control box boundaries.
  6. If an airtightness test, vacuum drying, refrigerant recovery, or refrigerant charging is necessary with the power off, turn off the power to the outdoor unit or heat source unit first, and then turn off the power to the BC controller and the power to the indoor units.  
When turning on the power, start the BC controller and indoor units first, and then start the outdoor unit or heat source unit.

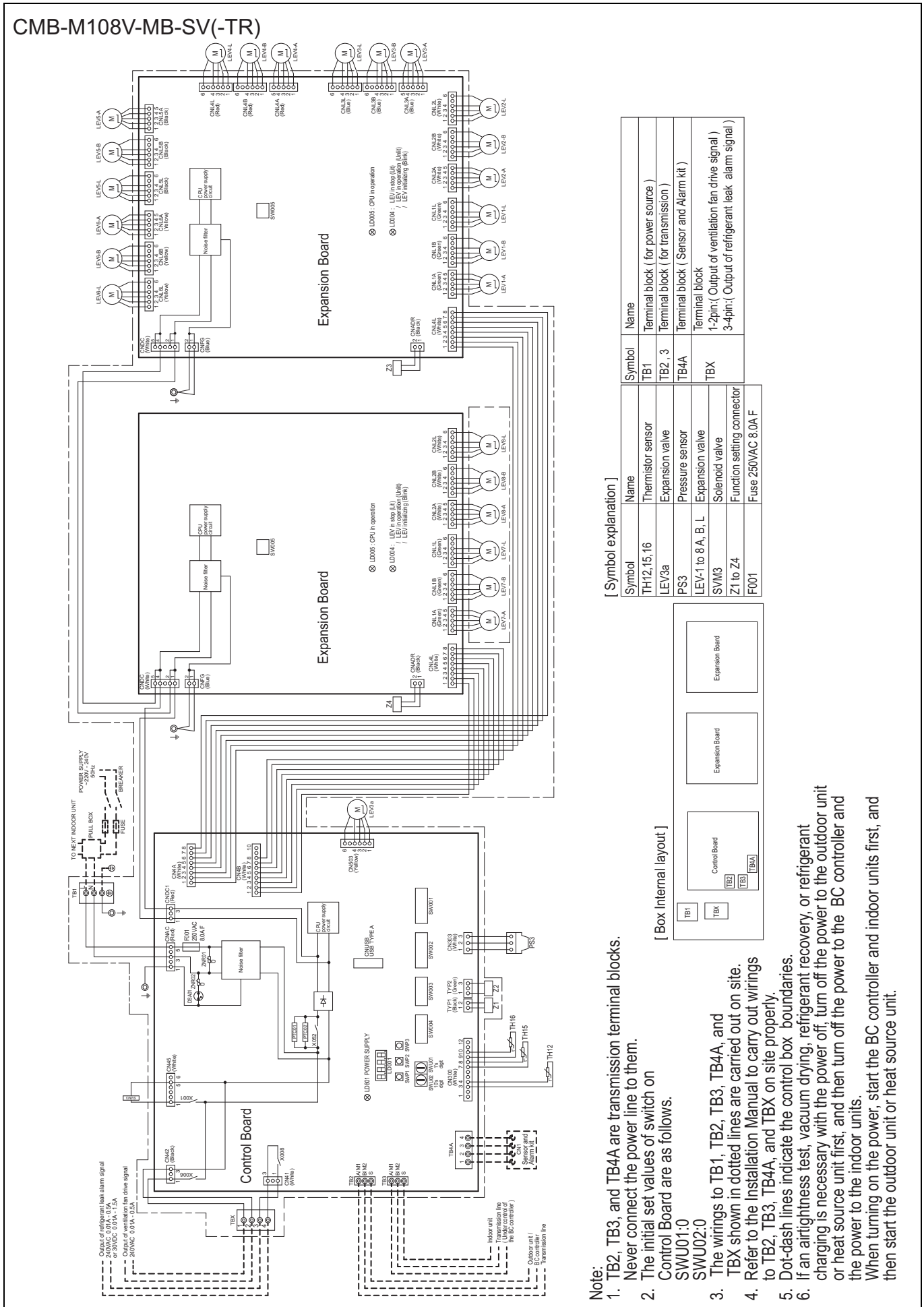

[ Symbol explanation ]

Symbol	Name
TH12, 15, 16	Thermistor sensor
LEV/3a	Expansion valve
PS3	Pressure sensor
LEV-1 to 8 A, B, L	Expansion valve
SWM3	Solenoid valve
Z1 to Z4	Function setting connector
F001	Fuse 250VAC 8.0A F

[ Box internal layout ]

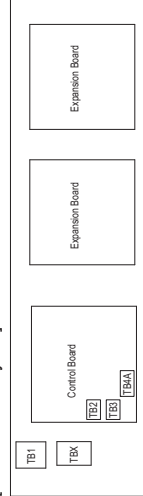

- Note:**
1. TB2, TB3, and TB4A are transmission terminal blocks.
  2. Never connect the power line to them.
  3. The initial set values of switch on Control Board are as follows.  
SWU01:0  
SWU02:0
  4. The wirings to TB1, TB2, TB3, TB4A, and TBX shown in dotted lines are carried out on site.
  5. Refer to the Installation Manual to carry out wirings to TB2, TB3, TB4A, and TBX on site properly.
  6. Dot-dash lines indicate the control box boundaries.
- If an airtightness test, vacuum drying, refrigerant recovery, or refrigerant charging is necessary with the power off, turn off the power to the outdoor unit or heat source unit first, and then turn off the power to the indoor units. When turning on the power, start the BC controller and indoor units first, and then start the outdoor unit or heat source unit.

4-1. Sound levels in cooling mode

BC controller

Measurement condition

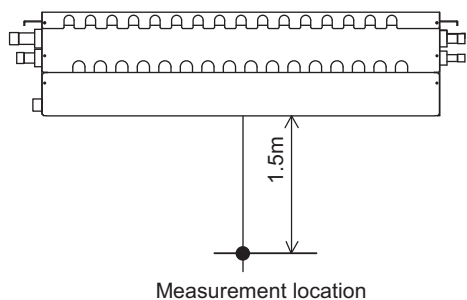

Sound level of CMB-M104-1012V-MA-SV(-TR)

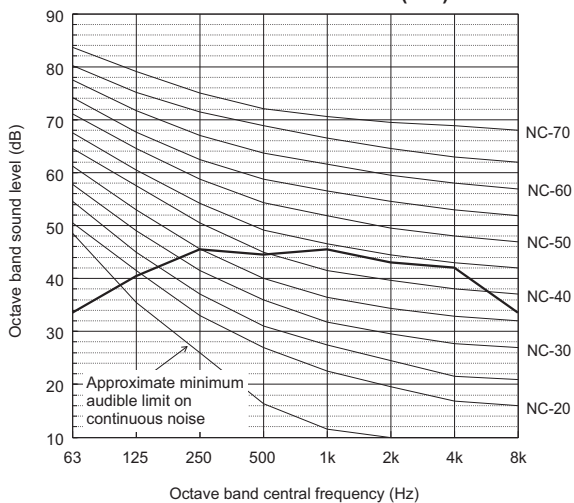

	63	125	250	500	1k	2k	4k	8k	dB(A)
Standard Cooling 50Hz	33.5	40.5	45.5	44.5	45.5	43.0	42.0	33.5	50.0

Sound level of CMB-M104-108V-MB-SV(-TR)

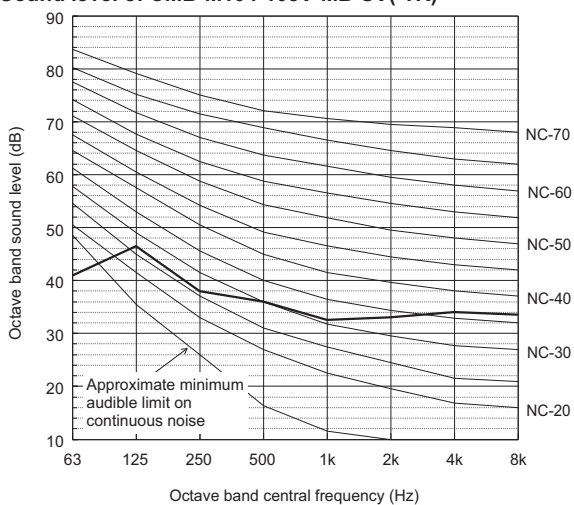

	63	125	250	500	1k	2k	4k	8k	dB(A)
Standard Cooling 50Hz	41.0	46.5	38.0	36.0	32.5	33.0	34.0	33.5	41.0

\*Depending on the operation conditions, the unit generates noise caused by valve actuation, refrigerant flow, and pressure changes when operating normally. Please consider to avoid location where quietness is required.  
The sound pressure level measured by the conventional method in JIS for reference purpose.

4-2. Sound levels in heating mode

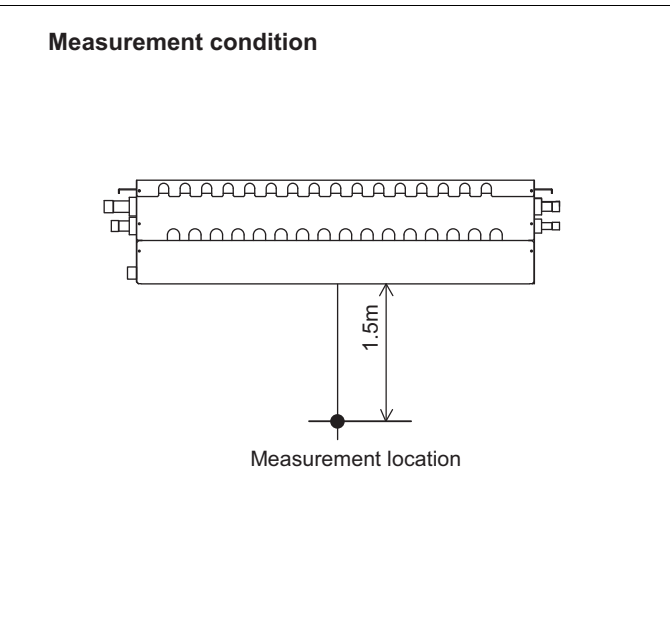

**Sound level of CMB-M104-1012V-MA-SV(-TR)**

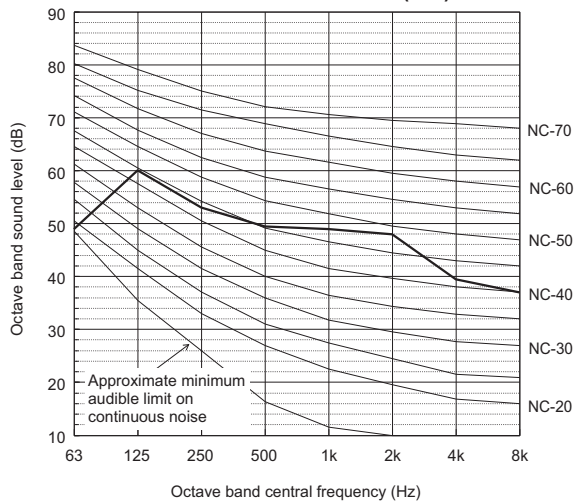

	63	125	250	500	1k	2k	4k	8k	dB(A)	
Standard Heating	50Hz	49.0	60.0	53.0	49.5	49.0	48.0	39.5	37.0	54.0

**Sound level of CMB-M104-108V-MB-SV(-TR)**

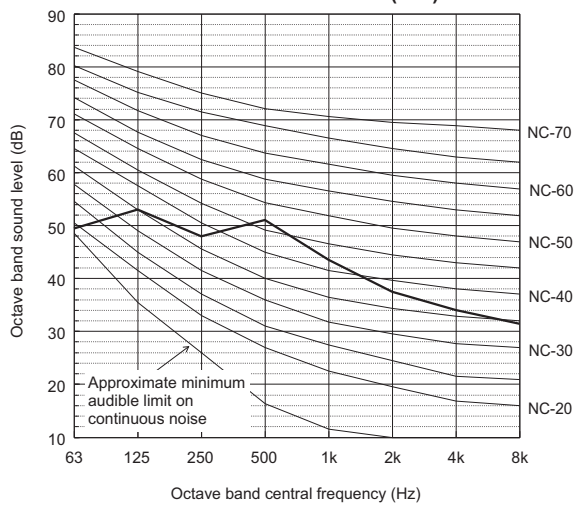

	63	125	250	500	1k	2k	4k	8k	dB(A)	
Standard Heating	50Hz	49.5	53.0	48.0	51.0	43.5	37.5	34.0	31.5	50.0

• Depending on the operation conditions, the unit generates noise caused by valve actuation, refrigerant flow, and pressure changes when operating normally. Please consider to avoid location where quietness is required.  
The sound pressure level measured by the conventional method in JIS for reference purpose.

4-3. Sound levels in defrost mode

BC controller

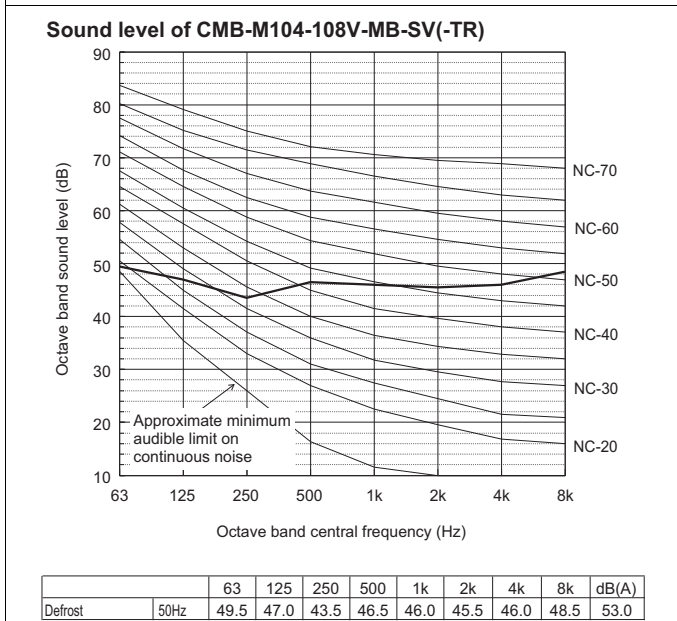
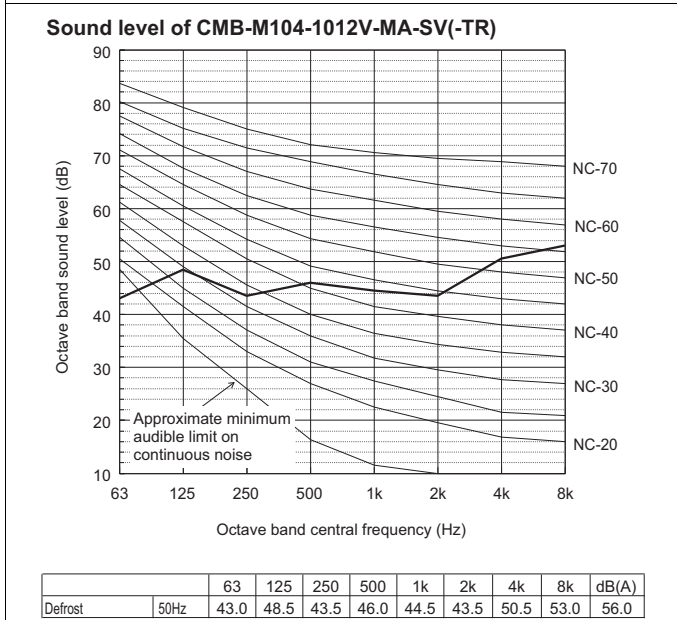
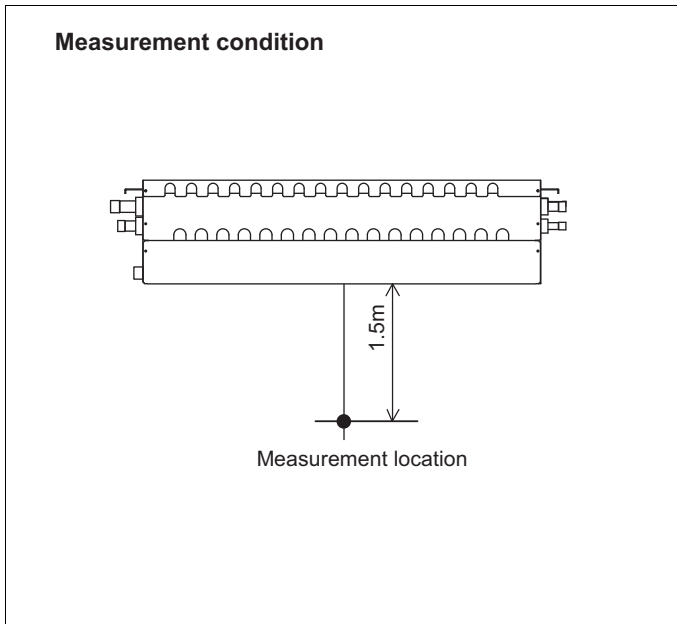

• Depending on the operation conditions, the unit generates noise caused by valve actuation, refrigerant flow, and pressure changes when operating normally. Please consider to avoid location where quietness is required.  
 The sound pressure level measured by the conventional method in JIS for reference purpose.

## 5. ELECTRICAL CHARACTERISTICS

BC controller

Symbols: MCA (Max. Circuit Amps), MFA (Max. Fuse Amps), RLA (Rated Load Amps)

BC controller	Power supply					RLA(A)
	Hz	Volts	Range+-10%	MCA(A)	MFA(A)	
CMB-M104V-MA-SV(-TR)	50	220	Max.: 264V Min.: 198V	0.12	15	0.08
		230				0.09
		240				0.09
CMB-M106V-MA-SV(-TR)		220		0.12		0.08
		230				0.09
		240				0.09
CMB-M108V-MA-SV(-TR)		220		0.13		0.08
		230				0.10
		240				0.10
CMB-M1012V-MA-SV(-TR)		220		0.13		0.08
		230				0.10
		240				0.10
CMB-M104V-MB-SV(-TR)		220		0.07		0.05
		230				0.05
		240				0.05
CMB-M108V-MB-SV(-TR)	220	0.08	0.06			
	230		0.06			
	240		0.06			

BC controller

6-1. JOINT and REDUCER

CITY MULTI units can be easily connected by using Joint sets and Reducer sets provided by Mitsubishi Electric. Refer to the "Piping Design" section in the DATA BOOK of outdoor units/heat source units or the Installation Manual that comes with the Joint set or Reducer set for how to install the Joint set or Reducer set.

BC controller

**CMY-Y102SS-G2** mm

For Gas pipe:

For Liquid pipe:

\*Pipe diameter is indicated by inside diameter.

**CMY-Y102LS-G2** mm

For Gas pipe:

For Liquid pipe:

\*Pipe diameter is indicated by inside diameter.

**CMY-R201S-G** mm

For High pressure

For Low pressure

For Liquid line

<Accessory>  
 • Cover .....3 Pcs.  
 Note. Pipe diameter is indicated by inside diameter.

**CMY-R202S-G** mm

For High pressure

For Low pressure

For Liquid line

<Accessory>  
 • Cover .....3 Pcs.  
 Note. Pipe diameter is indicated by inside diameter.

CMY-R203S-G

mm

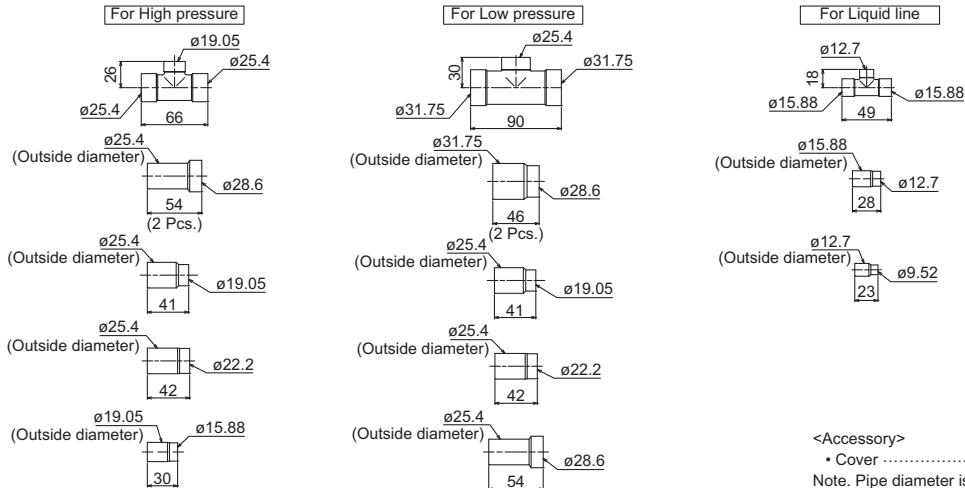

CMY-R204S-G

mm

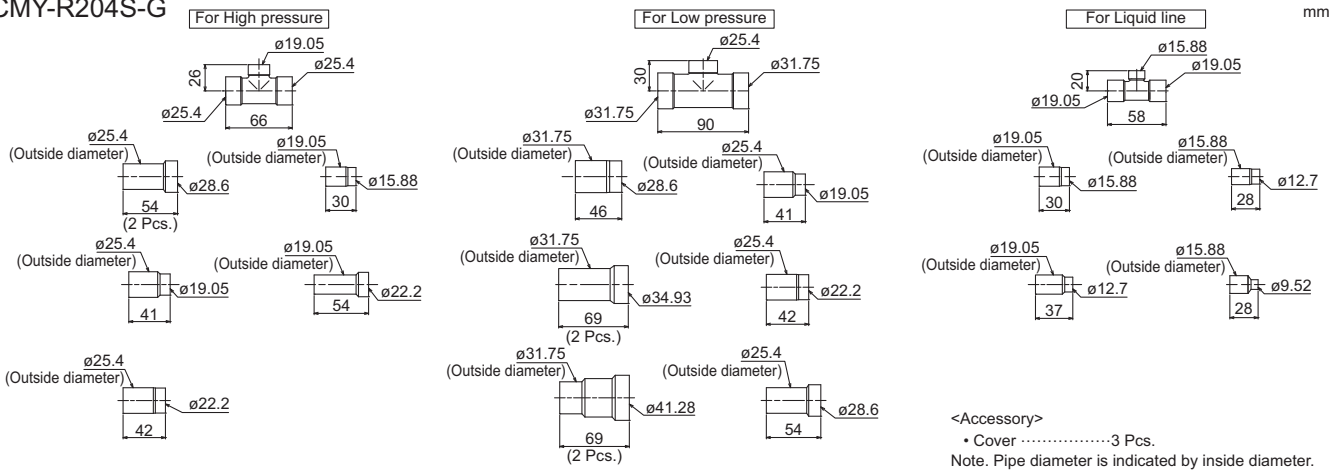

CMY-R205S-G

mm

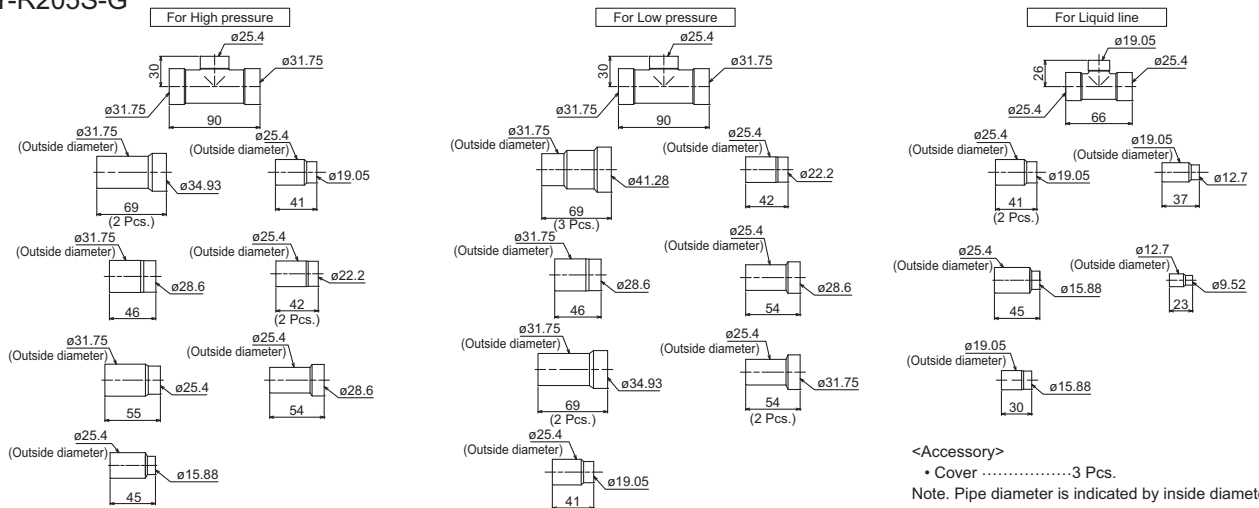

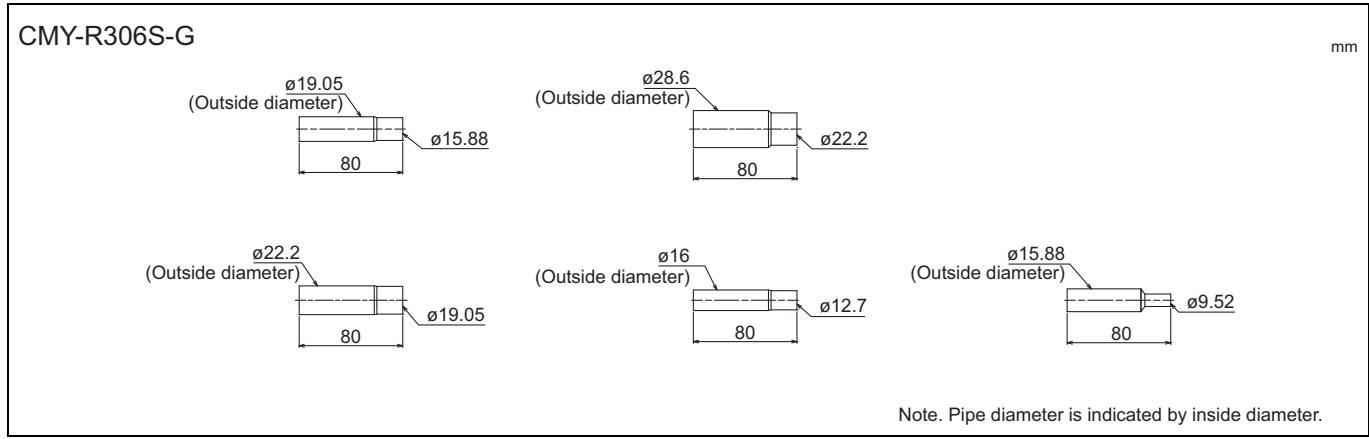
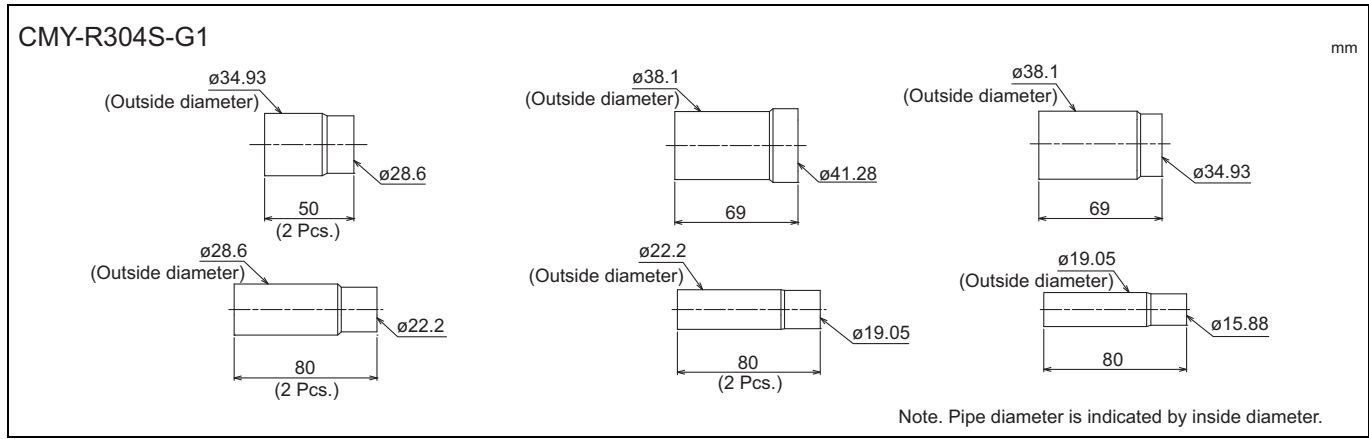
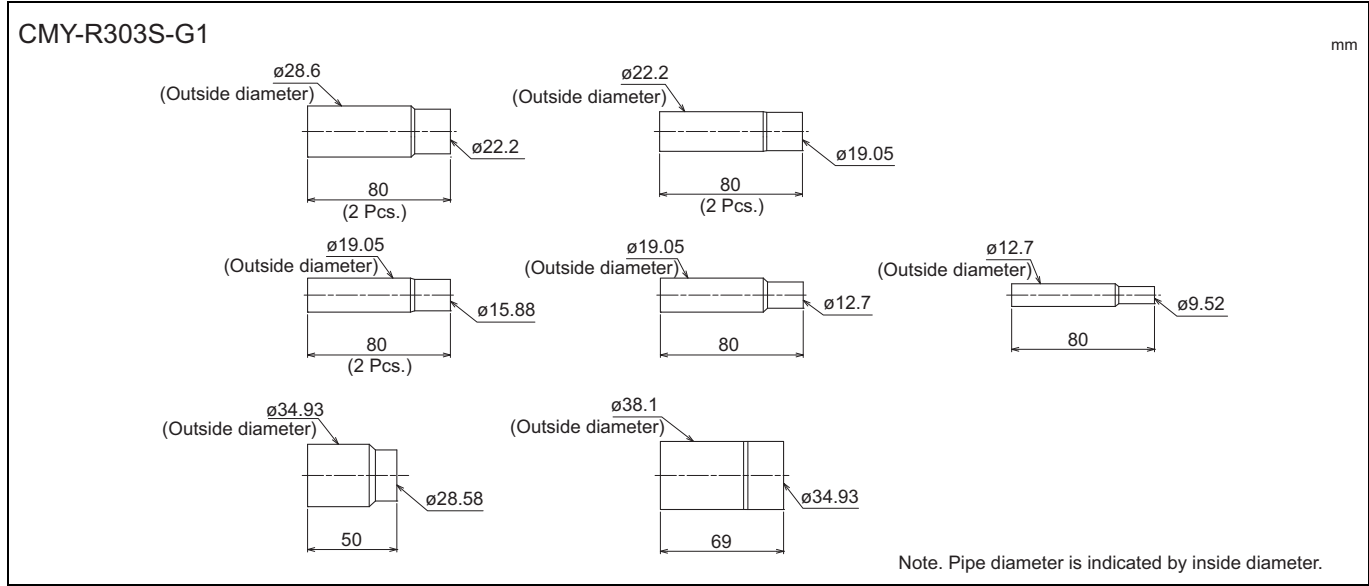

How to select Joint and Reducer

Outdoor/Heat source unit

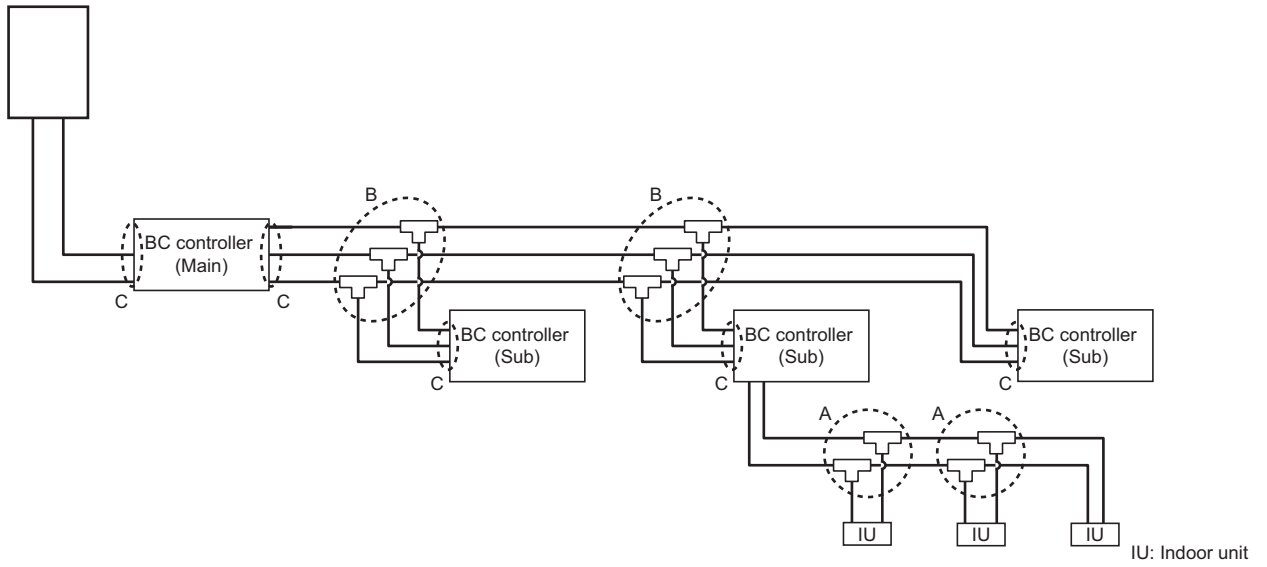

A	Branch joint	Between BC and indoor units	CMY-Y102SS-G2	Total down-stream indoor unit capacity: -200
			CMY-Y102LS-G2	Total down-stream indoor unit capacity: 201-250
B	Branch joint	Between Main BC and Sub BC	CMY-R201S-G	Total down-stream indoor unit capacity: -350
			CMY-R202S-G	Total down-stream indoor unit capacity: 351-600
			CMY-R203S-G	Total down-stream indoor unit capacity: 601-650
			CMY-R204S-G	Total down-stream indoor unit capacity: 651-1000
			CMY-R205S-G	Total down-stream indoor unit capacity: 1001-
C	Reducer	Between outdoor/heat source units and BC	CMY-R304S-G1	For MA type (Outdoor/Heat source unit capacity: (E)M200-1000)
		Between Main BC and Sub BC	CMY-R303S-G1	For MA type (When using the Sub BC controller)
			CMY-R306S-G	For MB type

6-2. JOINT KIT "CMY-R170M-E" FOR BC CONTROLLER

Joint kit "CMY-R170M-E" for BC controller is used to combine 2 ports of the BC controller at a PURY/PQRY system so as to enable down-stream Indoor capacity above 54 (80)\* as shown in Fig. 1.

The Joint kit include following items:

① Instruction	② Joint pipe (Small)	③ Joint pipe (Large)	④ Cover 1	⑤ Cover 2	⑥ Cover 3	⑦ Band	⑧ Reducer 1	⑨ Reducer 2
This sheet 1pc	1pc	1pc	2pcs	1pc for gas side	1pc for liquid side	8pcs	OD19.05-ID22.2 1pc	OD19.05-ID15.88 1pc

Please prepare the following items in the field. ① Tape for insulation material sealing ② Extension pipe for refrigerant circuit

② Joint pipe (for liquid side)

③ Joint pipe (for gas side)

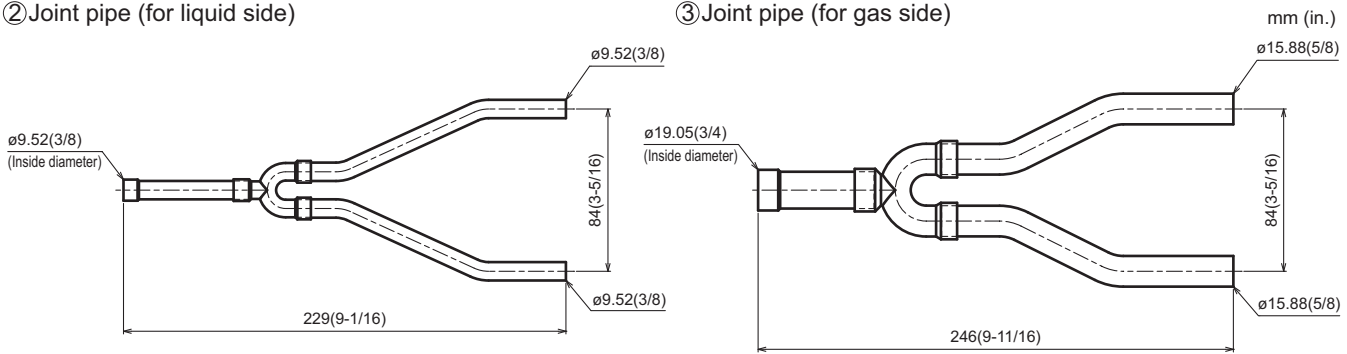

1. Designing CMY-R170M-E to a PURY/PQRY system

1-1. When connecting one indoor unit to the BC controller port

- The maximum capacity index of an indoor unit that can be connected to one port is 54 (80)\*.
- When connecting an indoor unit having the capacity index larger than 54 (80)\*, use the joint pipe kit to merge two ports.

1-2. When connecting multiple indoor units to the BC controller port

- Up to three indoor units can be connected to one port. Use the branch pipes (CMY-Y102SS-G2 or CMY-Y102LS-G2) to connect the indoor units to the BC controller.
- If the total downstream capacity index is 54 (80)\* or less, all the units can be connected to one port.
- If the total downstream capacity index is between 55 (81)\* and 96 (250)\*, use the joint pipe kit to merge two ports. However, the maximum capacity index per unit is 54 (80)\*.

\*All the indoor units connected to the same port must be operated in the same mode.

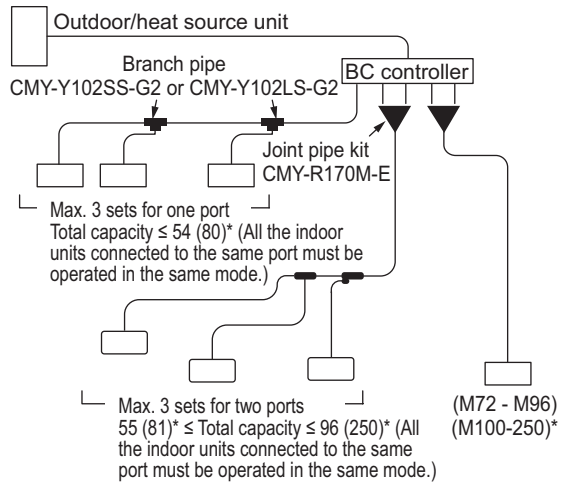

\* The capacity indices in parentheses apply to non-US models.

Fig.1. CMY-R170M-E applying scheme

2. Piping at the installation site

The connection of CMY-R170M-E to BC controller and pipe leading to Indoor units is referable to Fig. 2. Non-oxidized brazing is necessary. All piping must be careful to avoid foreign material getting inside.

After piping and air-tight testing, insulation work to the Joint and pipe should be done. Details is available at the Installation Manual.

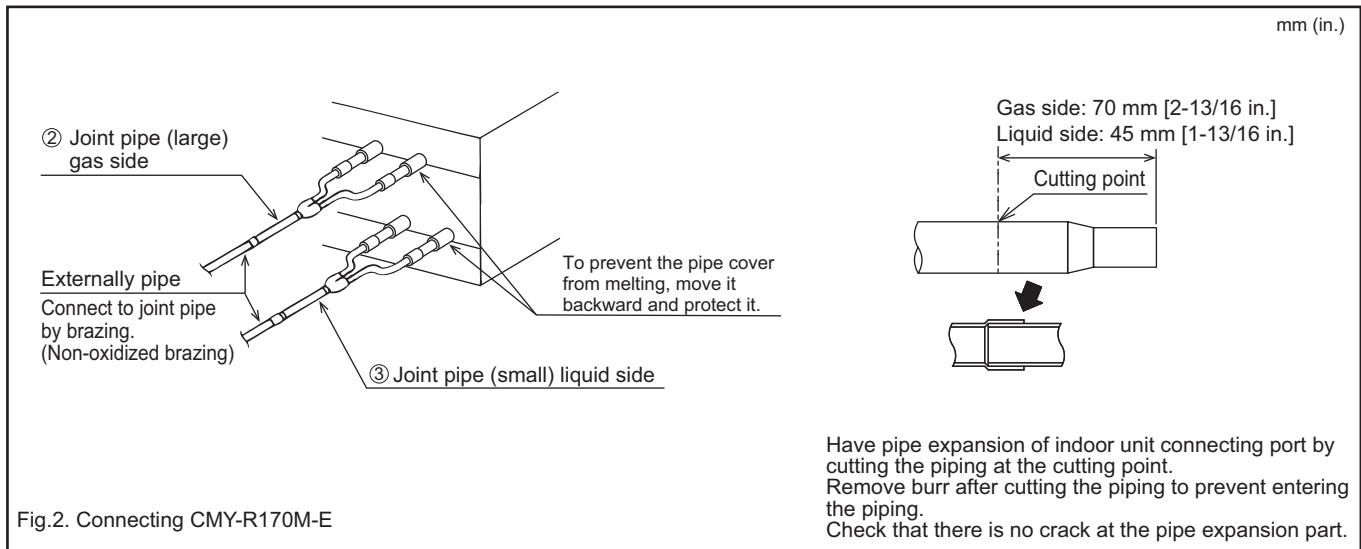

Fig.2. Connecting CMY-R170M-E

## 7-1. Installing BC controllers

### Installing hanging bolts

Install locally procured hanging bolts (threaded rod) following the procedure given in the figure.

The hanging bolt size is 10 mm (M10 screw).

To hang the unit, use a lifting machine to lift and pass it through the hanging bolts.

(Unit: mm)

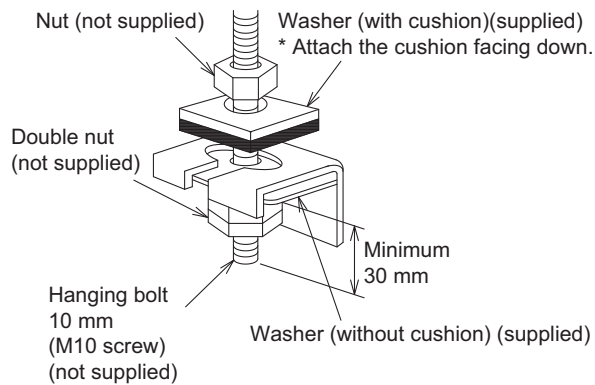

CMB-M104, 106, 108, 1012V-MA-SV(-TR)  
CMB-M104, 108V-MB-SV(-TR)

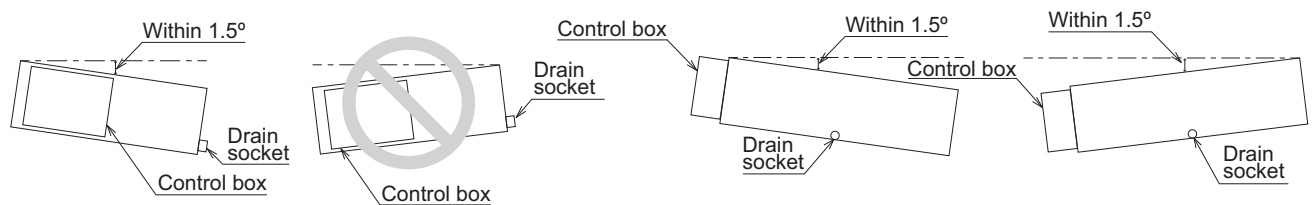
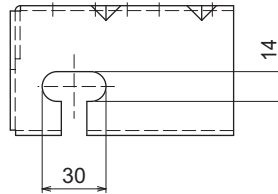

<Viewed from the front of the control box>

<Viewed from the drain socket side>

- ▶ Be sure to install the BC controller horizontally, using a level. If the controller is installed at an angle, drain water may leak out. If the controller is slanted, loosen the fixing nuts on the hanging brackets to adjust its position.
- ▶ Provide a downward pitch of 1.5° or below to the BC controller.
- ▶ Do not place the BC controller directly on the floor because the drain pan needs to be installed in a tilted position.
- ▶ Install the BC controllers with the hanging length within 200 mm or shorter.

### ⚠ CAUTION

Be sure to install the unit horizontally.



**⚠ Warning**

- Do not use refrigerant other than the type indicated in the manuals provided with the unit and on the nameplate.
  - Doing so may cause the unit or pipes to burst, or result in explosion or fire during use, repair, or at the time of disposal of the unit.
  - It may also be in violation of applicable laws.
  - MITSUBISHI ELECTRIC CORPORATION cannot be held responsible for malfunctions or accidents resulting from the use of the wrong type of refrigerant.
- Our air conditioning equipment and heat pumps contain a fluorinated greenhouse gas, R32.

**MITSUBISHI ELECTRIC CORPORATION**

[www.MitsubishiElectric.com](http://www.MitsubishiElectric.com)