

PRE-PLUMBED UNVENTED MAINS PRESSURE  
WATER HEATER WITH FTC7 CONTROL SYSTEM.  
FOR USE WITH ECODAN PUZ-WZ & PUZ-(H)WM  
AIR SOURCE HEAT PUMP RANGE.

April 2026

Doc. No. 758754

## SERVICE MANUAL

**EHPT15X-UKHLEW1S**  
**EHPT17X-UKHLEW1S**  
**EHPT15X-UKHEW1S**  
**EHPT17X-UKHEW1S**  
**EHPT21X-UKHEW1S**  
**EHPT21X-UKHEW1L**  
**EHPT25X-UKHEW1L**  
**EHPT30X-UKHEW1L**

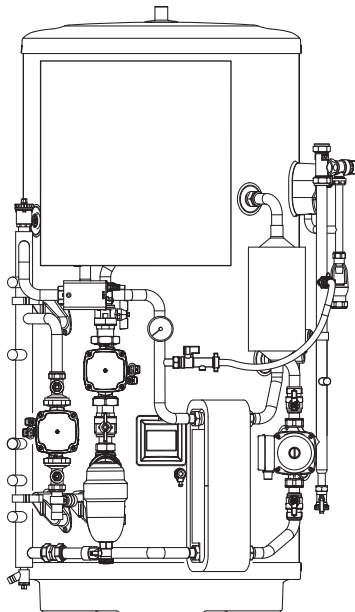

**IMPORTANT: PLEASE READ AND UNDERSTAND THESE INSTRUCTIONS  
BEFORE PERFORMING ANY MAINTENANCE.**

# CONTENTS

SAFETY PRECAUTION.....	3
SPECIFICATIONS.....	5
PART NAMES AND FUNCTIONS .....	7
OUTLINES AND DIMENSIONS.....	8
WIRING DIAGRAM.....	12
FIELD WIRING.....	14
WATER SYSTEM DIAGRAM .....	16
CONTROLS.....	19
TROUBLESHOOTING.....	42
DISASSEMBLY PROCEDURE.....	57
SUPPLEMENTARY INFORMATION .....	59
SERVICE AND MAINTENANCE.....	60
ENVIRONMENTAL INFORMATION.....	68
TECHNICAL SUPPORT .....	68

# SAFETY PRECAUTION





Please read the following safety precautions carefully.

**⚠ WARNING:**  
Precautions that must be observed to prevent injuries or death.

**⚠ CAUTION:**  
Precautions that must be observed to prevent damage to unit.

- Be sure to perform periodical maintenance.
- Be sure to follow your local regulations.
- Be sure to follow the instructions provided in this manual.

## MEANINGS OF SYMBOLS DISPLAYED ON THE UNIT

	<b>WARNING</b> (Risk of fire)	This mark is for R32 refrigerant only. Refrigerant type is written on nameplate of outdoor unit. In case that refrigerant type is R32, this unit uses a flammable refrigerant. If refrigerant leaks and comes in contact with fire or heating part, it will create harmful gas and there is risk of fire.
		Read the OPERATION MANUAL carefully before operation.
		Service personnel are required to carefully read the OPERATION MANUAL and INSTALLATION MANUAL before operation.
		Further information is available in the OPERATION MANUAL, INSTALLATION MANUAL, and the like.

<b>⚠ ⚠ WARNING</b>	
<b>Mechanical</b>	
The cylinder unit and outdoor unit must not be installed, disassembled, relocated, altered or repaired by the user. Ask an authorised installer or technician. If the unit is installed improperly or modified after installation by the user, water leakage, electric shock or fire may result.	
The outdoor unit should be securely fixed to a hard level surface capable of bearing its weight.	
The cylinder unit should be positioned on a hard level surface capable of supporting its filled weight to prevent excessive sound or vibration.	
Do not position furniture or electrical appliances below the outdoor unit or cylinder unit.	
The discharge pipework from the emergency devices of the cylinder unit should be installed according to local law.	
Only use accessories and replacement parts authorised by Mitsubishi Electric ask a qualified technician to fit the parts.	
<b>Electrical</b>	
All electrical work should be performed by a qualified technician according to local regulations and the instructions given in this manual.	
The units must be powered by a dedicated power supply and the correct voltage and circuit breakers must be used.	
Wiring should be in accordance with national wiring regulations. Connections must be made securely and without tension on the terminals.	
Earth unit correctly.	
Discharge the condenser before the work involving the electric parts.	
<b>General</b>	
Keep children and pets away from both the cylinder unit and outdoor units.	
Do not use the hot water produced by the heat pump directly for drinking or cooking. This could cause illness to the user.	
Do not stand on the units.	
Do not touch switches with wet hands.	
Annual maintenance checks on both the cylinder unit and the outdoor unit should be conducted by a qualified person.	
Do not place containers with liquids on top of the cylinder unit. If they leak or spill onto the cylinder unit, damage to the unit and/or fire could occur.	
Do not place any heavy items on top of the cylinder unit.	
When installing, relocating, or servicing the cylinder unit, use only the heat pump's specified refrigerant to charge the refrigerant lines. Do not mix it with any other refrigerant and do not allow air to remain in the lines. If air is mixed with the refrigerant, then it can be the cause of abnormal high pressure in the refrigerant line, and may result in an explosion and other hazards.	
The use of any refrigerant other than that specified for the system will cause mechanical failure or system malfunction or unit breakdown. In the worst case, this could lead to a serious impediment to securing product safety.	
In heating mode, to avoid the heat emitters being damaged by excessively hot water, set the target flow temperature to a minimum of 2 °C below the maximum allowable temperature of all the heat emitters. For Zone2, set the target flow temperature to a minimum of 5 °C below the maximum allowable flow temperature of all the heat emitters in Zone2 circuit.	
Do not install the unit where combustible gases may leak, be produced, flow, or accumulate. If combustible gas accumulates around the unit, fire or explosion may result.	
Do not use means to accelerate the defrosting process or to clean, other than those recommended by the manufacturer.	
The appliance shall be stored in a room without continuously operating ignition sources (for example: open flames, an operating gas appliance or an operating electric heater).	
Do not pierce or burn.	
Be aware that refrigerants may not contain an odour.	
Pipe-work shall be protected from physical damage.	
The installation of pipe-work shall be kept to a minimum.	
Compliance with national gas regulations shall be observed.	
Keep any required ventilation openings clear of obstruction.	
Do not use low temperature solder alloy in the case of brazing the refrigerant pipes.	

## ⚠ CAUTION

Use clean water that meets local quality standards on the primary circuit.
The outdoor unit should be installed in an area with sufficient airflow according to the diagrams in the outdoor unit installation manual.
The cylinder unit should be located inside to minimise heat loss.
Water pipe-runs on the primary circuit between outdoor and indoor unit should be kept to a minimum to reduce heat loss.
Ensure condensate from outdoor unit is piped away from the base to avoid puddles of water.
Remove as much air as possible from the primary and DHW circuits.
Refrigerant leakage may cause suffocation. Provide ventilation in accordance with EN378-1.
Be sure to wrap insulation around the piping. Direct contact with the bare piping may result in burns or frostbite.
Never put batteries in your mouth for any reason to avoid accidental ingestion.
Battery ingestion may cause choking and/or poisoning.
Install the unit on a rigid structure to prevent excessive sound or vibration during operation.
Do not transport the cylinder unit with water inside the DHW tank. This could cause damage to the unit.
If power to the cylinder unit is to be turned off (or system switched off) for a long time, the water should be drained.
If unused for a long period, before operation is resumed, DHW tank should be flushed through with potable water.
Preventative measures should be taken against water hammer, such as installing a Water Hammer Arrestor on the primary water circuit, as directed by the manufacturer.

As for the handling of refrigerant, refer to the outdoor unit installation manual.

### [1] Cautions for service

- (1) Perform service after recovering the refrigerant left in unit completely.
- (2) Do not release refrigerant in the air.
- (3) After completing service, charge the cycle with specified amount of refrigerant.
- (4) If moisture or foreign matter might have entered the refrigerant piping during service, ensure to remove them.

### [2] Additional refrigerant charge

**When charging directly from refrigerant cylinder**

- (1) Check that cylinder for R410A or R32 on the market is syphon type.
- (2) Charging should be performed with the cylinder of syphon stood vertically. (Refrigerant is charged from liquid phase.)

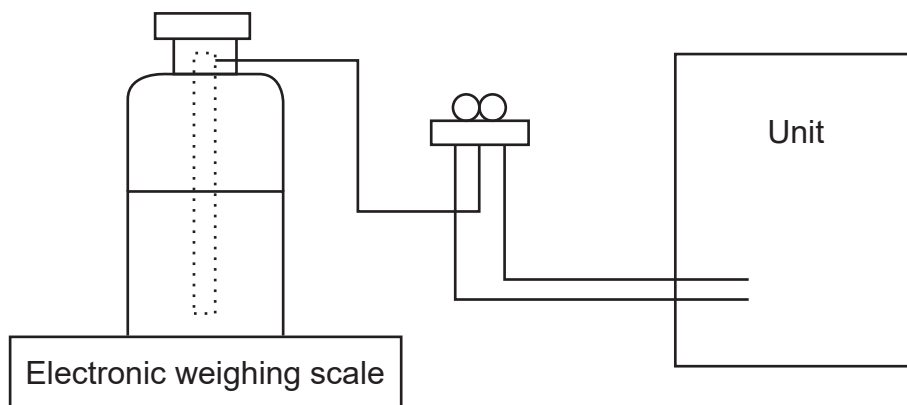

### [3] Service tools

Use the service tools below as exclusive tools for R410A or R32 refrigerant.

No.	Tool name	Specifications
1	Gauge manifold	· R410A or R32
		· Use the existing fitting specifications. (UNF1/2)
		· Use high-tension side pressure of 5.3 MPa·G or over.
2	Charge hose	· R410A or R32
		· Use pressure performance of 5.09 MPa·G or over.
3	Electronic weighing scale	—
4	Gas leak detector	· Use the detector for R134a, R407C, R410A or R32
5	Adaptor for reverse flow check	· Attach on vacuum pump.
6	Refrigerant charge base	—
7	Refrigerant cylinder	· R410A or R32      · Top of cylinder (Pink)
		· Cylinder with syphon
8	Refrigerant recovery equipment	—

# SPECIFICATIONS

UNIT		STANDARD					
		150	170	210 (Small)	210 (Large)	250	300
Nominal hot water capacity (litres)		Heat Pump - Grundfos UPM4L 25-75 130 AZA Heating - Grundfos UPM3 A L25-70 130 ZZZ W3 DHW - Grundfos UPSO 15-60 CIL2					
Water	Pump	22/22					
	Connection size Heating/DHW (mm)	28/22					
Safety devices	DHW Expansion vessel (litres)	12	18	18	18	24	24
	Charge pressure (MPa (bar))	0.35 (3.5)					
	Control thermistor (°C)	80					
	Pressure Relief Valve (MPa (bar))	0.3 (3.0) Contained within outdoor unit					
	Control thermistor (°C)	75					
Dimensions (mm)	Over-temperature cut-out (°C)	80 +/- 5					
	Temp/Pressure Relief Valve (°C/MPa (bar))	90 / 1.0 (10.0)					
	Expansion valve (MPa (bar))	0.8 (8.0)					
Weight empty/full (kg)	Width	730	730	730	748	748	748
	Depth	756	756	756	755	755	755
	Height	1131	1257	1509	1509	1761	2075
Materials	Vessel	55/205 58/228 64/274 68/278 74/324 82/382 Duplex stainless steel					
	Insulation	Expanded polyurethane (PU) 60					
Electrical data	Nominal thickness (mm)	60					
	Standing heat loss (kWh/24h)	1.15	1.23	1.53	1.53	1.80	2.09
	Ozone Depletion Potential	zero					
	Global Warming Potential	3.1					
	Electrical supply	220 - 240 V ~, 50Hz					
Mechanical zones	Phase	single					
	Fuse rating - MCB Size (A)	16					
	Electrical supply	220 - 240 V ~, 50Hz					
	Phase	single					
	Rating (kW at 240V)	3					
Optional wireless room thermostat and wireless receiver	Max current (A)	13					
	Fuse rating - MCB Size (A)	16					
Optional wireless room thermostat and wireless receiver		PAR-WT60R-E controller & PAR-WR61R-E receiver					

\* Optional 2-zone accessory pack available

UNIT		SLIMLINE	
Nominal hot water capacity (litres)		150	170
Water	Pump	Heat Pump - Grundfos UPM4L 25-75 130 AZA Heating - Grundfos UPM3 A L25-70 130 ZZZ W3 DHW - Grundfos UPSO 15-60 CIL2	
	Connection size Heating/DHW (mm)	22/22	
	DHW Expansion vessel (litres)	12	18
	Charge pressure (MPa (bar))	0.35 (3.5)	
Safety devices	Control thermistor (°C)	80	
	Pressure Relief Valve (MPa (bar))	0.3 (3.0) Contained within outdoor unit	
	Control thermistor (°C)	75	
	Over-temperature cut-out (°C)	80 +/- 5	
	Temp/Pressure Relief Valve (°C/MPa (bar))	90 / 1.0 (10.0)	
	Expansion valve (MPa (bar))	0.8 (8.0)	
Dimensions (mm)	Width	676	676
	Depth	654	654
	Height	1516	1690
Weight empty/full (kg)		59/209	63/233
Materials	Vessel	Duplex stainless steel	
	Insulation	Expanded polyurethane (PU)	
	Nominal thickness (mm)	50	
	Standing heat loss (kWh/24h)	1.40	1.59
	Ozone Depletion Potential	zero	
	Global Warming Potential	3.1	
Electrical data	Electrical supply	220 - 240 V ~, 50Hz	
	Phase	single	
	Fuse rating - MCB Size (A)	16	
	Electrical supply	220 - 240 V ~, 50Hz	
	Phase	single	
	Rating (kW at 240V)	3	
	Max current (A)	13	
	Fuse rating - MCB Size (A)	16	
Mechanical zones		DHW and 1 heating zone*	
Optional wireless room thermostat and wireless receiver		PAR-WT60R-E controller & PAR-WR61R-E receiver	

\*Optional 2-zone accessory pack available

# PART NAMES AND FUNCTIONS

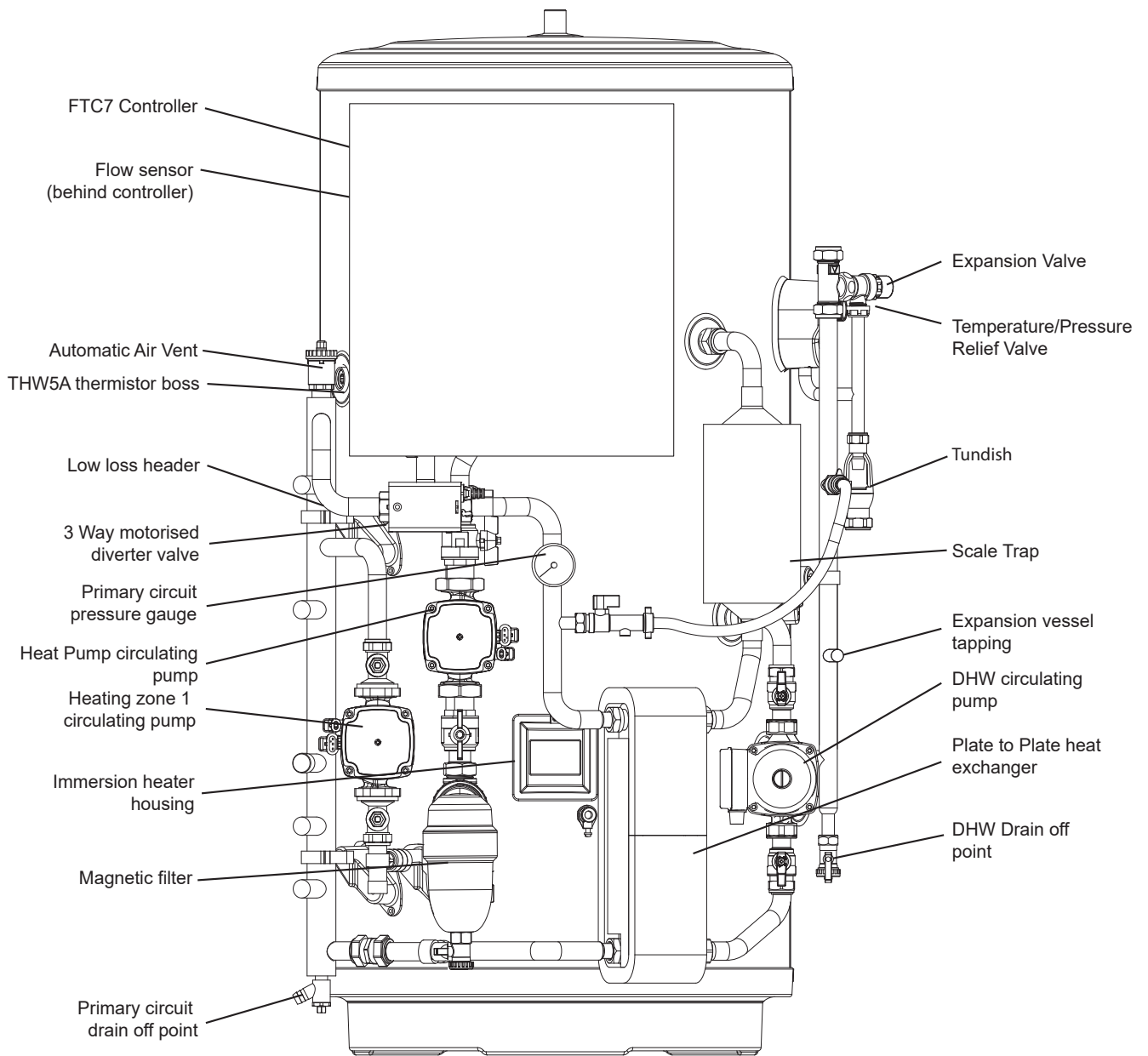

# OUTLINES AND DIMENSIONS

Dimensions - 28 mm Standard Models

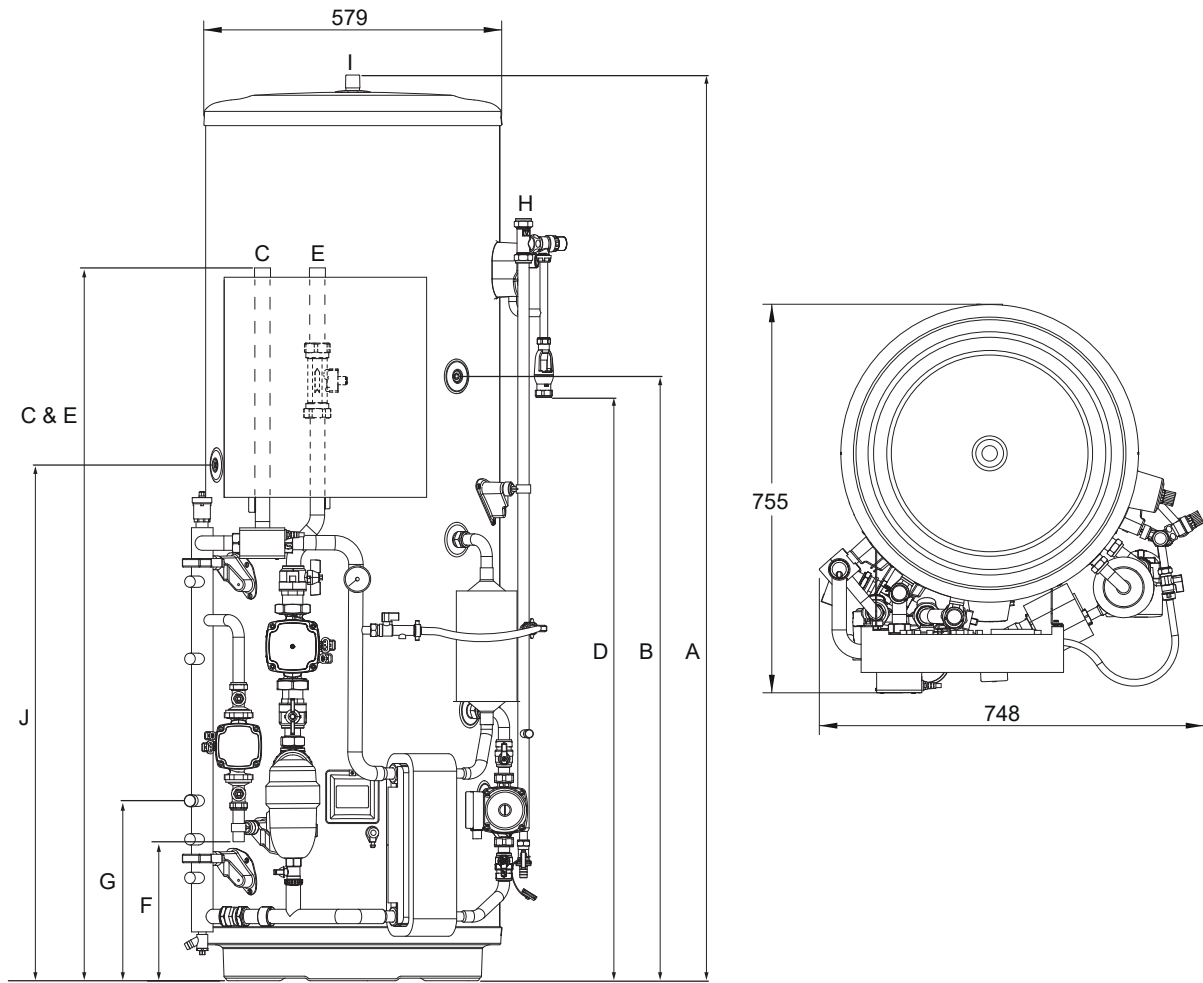

## KEY

- A OVERALL HEIGHT
- B SECONDARY RETURN TAPPING
- C HEAT PUMP FLOW CONNECTION (28 mm O/D COPPER)
- D TUNDISH OUTLET CONNECTION (22 mm COMPRESSION)
- E HEAT PUMP RETURN CONNECTION (28 mm O/D COPPER)
- F HEATING ZONE 1 CIRCUIT FLOW CONNECTION (22 mm O/D COPPER)
- G HEATING ZONE 1 CIRCUIT RETURN CONNECTION (22 mm O/D COPPER)
- H COLD WATER INLET CONNECTION (22 mm COMPRESSION)
- I HOT WATER OUTLET CONNECTION (22 mm COMPRESSION/3/4" BSP M)
- J THW5A SENSOR POCKET

CAPACITY	210	250	300
A	1509	1761	2075
B	1050	1175	1385
C	1370	1370	1370
D	880	1136	1450
E	1370	1370	1370
F	270	270	270
G	350	350	350
J	925	1005	1193

Dimensions - 22 mm Standard Models

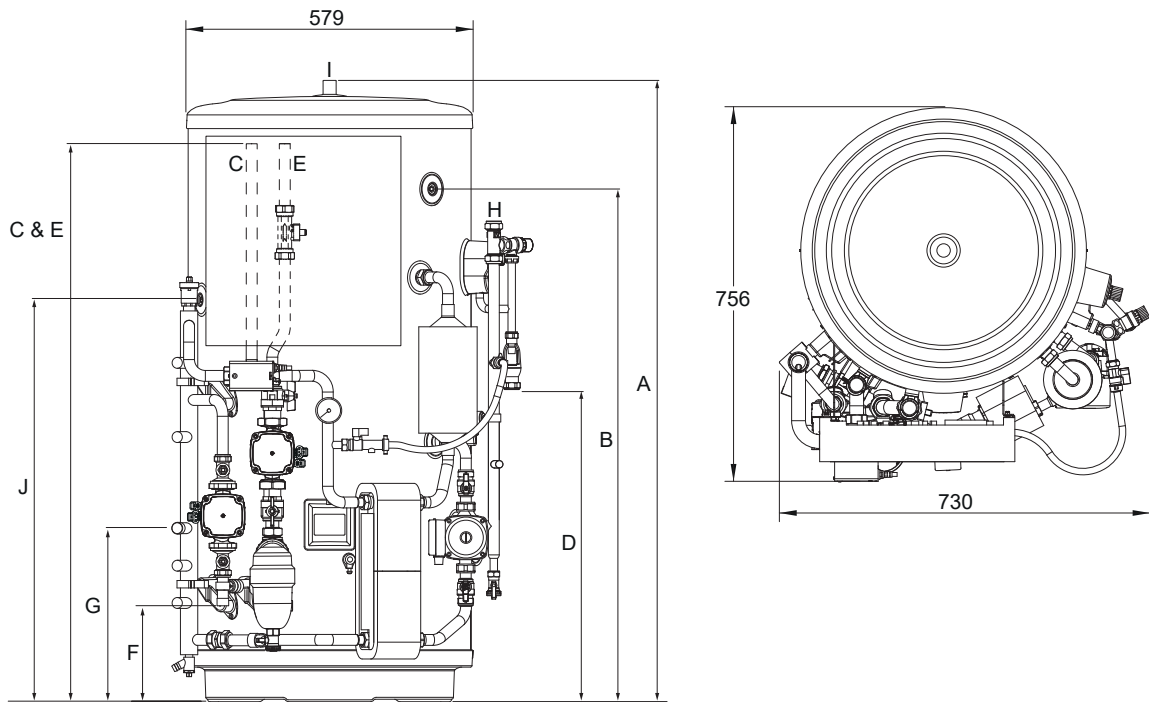

KEY

- A OVERALL HEIGHT
- B SECONDARY RETURN TAPPING (not fitted to EHPT15X-UKHEW1S / EHPT17X-UKHEW1S)
- C HEAT PUMP FLOW CONNECTION (22 mm O/D COPPER)
- D TUNDISH OUTLET CONNECTION (22 mm COMPRESSION)
- E HEAT PUMP RETURN CONNECTION (22 mm O/D COPPER)
- F HEATING ZONE 1 CIRCUIT FLOW CONNECTION (22 mm O/D COPPER)
- G HEATING ZONE 1 CIRCUIT RETURN CONNECTION (22 mm O/D COPPER)
- H COLD WATER INLET CONNECTION (22 mm COMPRESSION)
- I HOT WATER OUTLET CONNECTION (22 mm COMPRESSION/3/4" BSP M)
- J THW5A SENSOR POCKET

CAPACITY	150	170	210
A	1131	1257	1509
B	Not fitted	Not fitted	1050
C	1122	1122	1122
D	505	630	880
E	1122	1122	1122
F	194	194	194
G	350	350	350
J	675	815	925

Dimensions - 22 mm Slimline Models

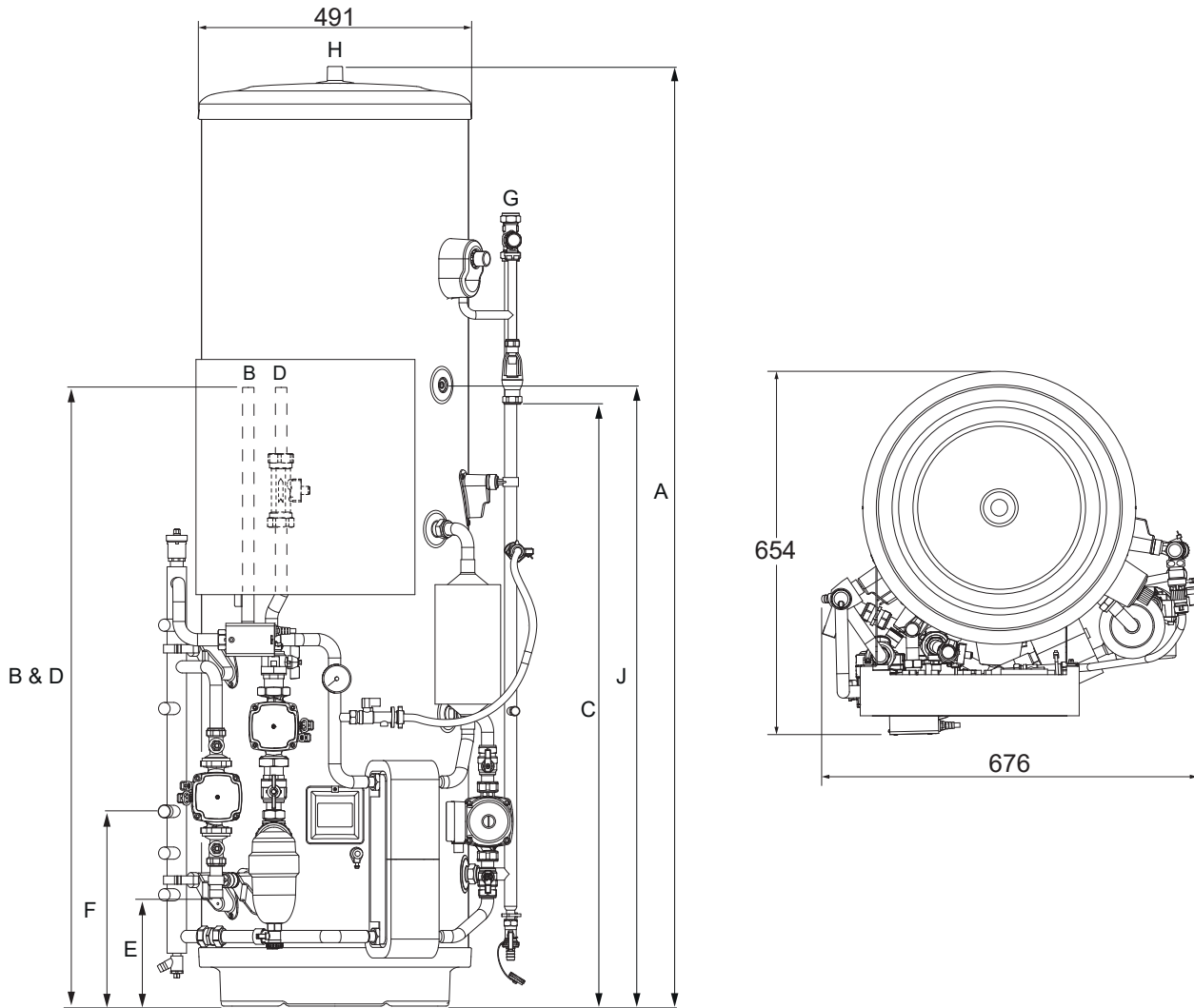

KEY

- A OVERALL HEIGHT
- B HEAT PUMP FLOW CONNECTION (22 mm O/D COPPER)
- C TUNDISH OUTLET CONNECTION (22 mm COMPRESSION)
- D HEAT PUMP RETURN CONNECTION (22 mm O/D COPPER)
- E HEATING ZONE 1 CIRCUIT FLOW CONNECTION (22 mm O/D COPPER)
- F HEATING ZONE 1 CIRCUIT RETURN CONNECTION (22 mm O/D COPPER)
- G COLD WATER INLET CONNECTION (22 mm COMPRESSION)
- H HOT WATER OUTLET CONNECTION (22 mm COMPRESSION/3/4" BSP M)
- J THW5A SENSOR POCKET

CAPACITY	150	170
A	1516	1690
B	1127	1127
C	909	1083
D	1127	1127
E	350	350
F	194	194
J	943	1117

Service Access Diagram

Clearances - Side, Front & Rear

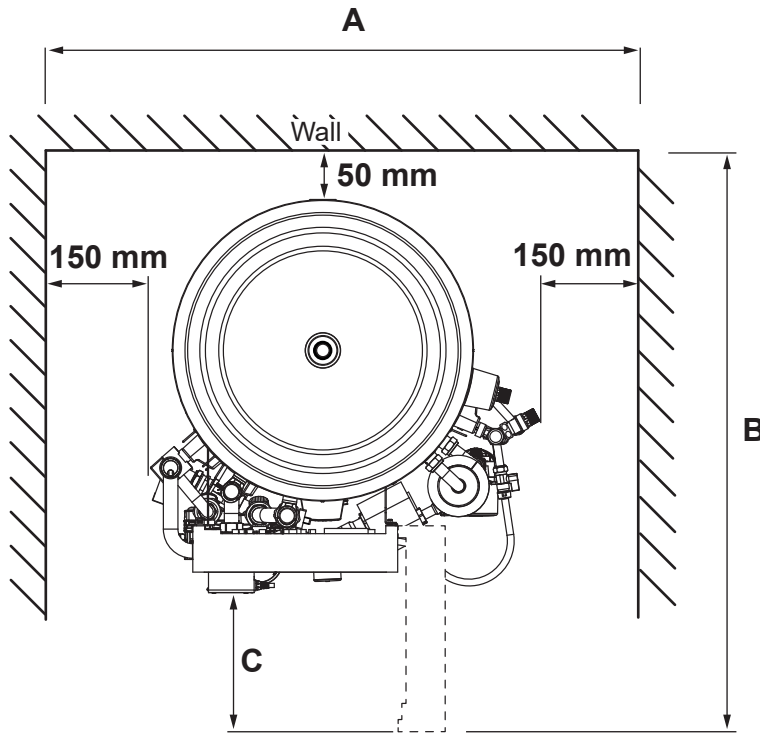

Clearances - Above

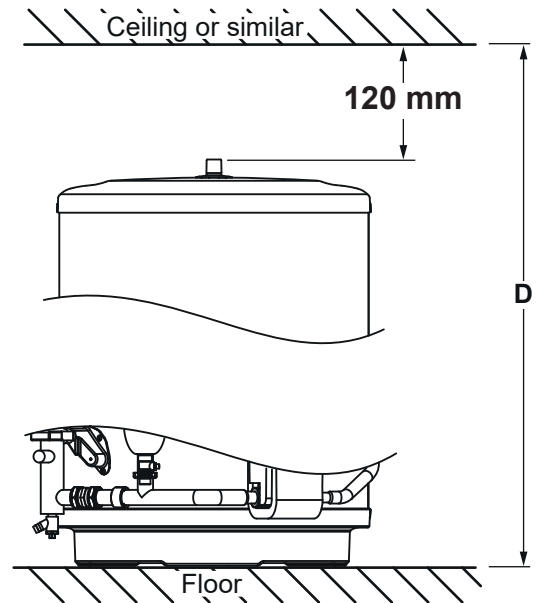

The cylinder must be located indoors and in a frost free environment, for example in a utility room, to minimise heat loss from the stored water. Please allow sufficient clearance at the front to close a door where fitted.

Sufficient space **MUST** be left for the provision of discharge pipework as detailed in National and Local Building Regulations.

Dimensions of A, B & C in above diagram

Model	Dimension		
	A	B	C
EHPT15X-UKHLEW1S EHPT17X-UKHLEW1S	976 mm	972 mm	268 mm
EHPT15X-UKHEW1S EHPT17X-UKHEW1S EHPT21X-UKHEW1S	1030 mm	1066 mm	260 mm
EHPT21X-UKHEW1L EHPT25X-UKHEW1L EHPT30X-UKHEW1L	1048 mm	1066 mm	260 mm

Dimension of D in above diagram

Model	Dimension D
EHPT15X-UKHLEW1S	1636 mm
EHPT17X-UKHLEW1S	1810 mm
EHPT15X-UKHEW1S	1251 mm
EHPT17X-UKHEW1S	1377 mm
EHPT21X-UKHEW1S	1629 mm
EHPT21X-UKHEW1L	1629 mm
EHPT25X-UKHEW1L	1881 mm
EHPT30X-UKHEW1L	2195 mm

# WIRING DIAGRAM

## FTC WIRING DIAGRAM <PAC-IF07\*B-E>

Table 1 Signal Inputs

Name	Terminal block/Connect	Item	OFF (Option)	ON (Standard)
IN1	TB1.1-7-8	Room thermostat	Refer to SW2-1 in Table 3 DIP Switch Functions	Refer to SW2-2 in Table 3 DIP Switch Functions
IN2	TB1.1-5-6	Flow switch 1	Refer to SW3-2 in Table 3 DIP Switch Functions	Refer to SW3-3 in Table 3 DIP Switch Functions
IN3	TB1.1-3-4	Flow switch 2	Refer to SW3-2 in Table 3 DIP Switch Functions	Refer to SW3-3 in Table 3 DIP Switch Functions
IN4	TB1.1-1-2	Standard operation and control	Normal	Boiler operation <sup>3</sup>
IN5	TB1.2-7-8	Outdoor thermostat	Standard operation	Heater operation <sup>3</sup>
IN6	TB1.2-5-6	Outdoor thermostat input-2	Standard operation	Boiler operation <sup>3</sup>
IN7	TB1.2-3-4	Flow switch 3	Refer to SW3-2 in Table 3 DIP Switch Functions	Refer to SW3-3 in Table 3 DIP Switch Functions
IN8	TB1.3-7-8	Electric energy meter 2	Electric energy meter 2	Electric energy meter 2
IN9	TB1.3-5-6	Heat meter	Heat meter	Heat meter
IN10	TB1.2-1-2	Flow sensor	Flow sensor	Flow sensor
IN11	TB1.3-1-2	Input	Input	Input
IN12	TB1.4-1-3	CNTA Flow sensor	Refer to installation manual.	Refer to installation manual.

1. Set the ON/OFF cycle time of the room thermostat for 10 minutes or more.  
 2. If using outdoor thermostat for controlling operation of heaters, the lifetime of the heaters and related parts may be reduced.  
 3. Remote controller to select "Boiler" in "External input setting" screen in the service menu.

Table 2 Outputs

Name	Terminal block/Connect	Item	ON	OFF
OUT1	TB0.1-1-2	Water circulation pump 1 output	ON	OFF
OUT2	TB0.1-3-4	Water circulation pump 2 output	ON	OFF
OUT3	TB0.1-5-6	Water circulation pump 3 output	ON	OFF
OUT4	TB0.2-4-8	3-way valve (2-way valve output)	Heating	DHW
OUT5	TB0.2-1-2	Mixing valve output <sup>1</sup>	Stop	Open
OUT6	TB0.2-2-3	Booster heater 1 output	OFF	ON
OUT7	TB0.3-2-3	Booster heater 2 output	OFF	ON
OUT8	TB0.4-7-8	Cooling signal output	OFF	ON
OUT9	TB0.4-5-6	Immersion heater output	ON	OFF
OUT10	TB0.3-1-2	Boiler output	ON	OFF
OUT11	TB0.3-3-4	Freeze output	Normal	Defrost
OUT12	TB0.4-3-4	2-way valve 2a output <sup>2</sup>	ON	OFF
OUT13	---	CNPA DHW ON signal	ON	OFF
OUT14	---	CNPA DHW ON signal	ON	OFF
OUT15	TB0.4-1-3	Thermo ON signal	ON	OFF
OUT16	TB0.3-3-4	Analog output	OFF	ON
BC1	TB0.5-3-4	Booster heater protection output	OFF (B1) Open	ON (B1) Short
BC2	TB0.5-1-2	CNBT Thermostat for booster heater	Thermostat (Open)	High temp. (Short)

1. For 2-zone temperature control.  
 2. For 2-zone valve ON/OFF control.

Table 3 DIP switch functions

DIP switch	Function	OFF	ON	Default settings
SW1	SM1-Boiler	WITHOUT	WITH Boiler	OFF
SW2	SM2-Boiler water temperature	WITHOUT	WITH 60°C	OFF
SW3	SM3-DHW tank	WITHOUT	WITH DHW tank	OFF
SW4	SM4-Immersion heater	WITHOUT	WITH Immersion heater	OFF
SW5	SM5-Booster heater	WITHOUT	WITH Booster heater	OFF
SW6	SM6-Booster heater for heating	WITHOUT	WITH Booster heater for heating	OFF
SW7	SM7-Booster unit	WITHOUT	WITH	OFF
SW8	SM8-Booster unit	WITHOUT	WITH	OFF
SW9	SM9-Booster unit	WITHOUT	WITH	OFF
SW10	SM10-Booster unit	WITHOUT	WITH	OFF
SW11	SM11-Booster unit	WITHOUT	WITH	OFF
SW12	SM12-Booster unit	WITHOUT	WITH	OFF
SW13	SM13-Booster unit	WITHOUT	WITH	OFF
SW14	SM14-Booster unit	WITHOUT	WITH	OFF
SW15	SM15-Booster unit	WITHOUT	WITH	OFF
SW16	SM16-Booster unit	WITHOUT	WITH	OFF
SW17	SM17-Booster unit	WITHOUT	WITH	OFF
SW18	SM18-Booster unit	WITHOUT	WITH	OFF
SW19	SM19-Booster unit	WITHOUT	WITH	OFF
SW20	SM20-Booster unit	WITHOUT	WITH	OFF
SW21	SM21-Booster unit	WITHOUT	WITH	OFF
SW22	SM22-Booster unit	WITHOUT	WITH	OFF
SW23	SM23-Booster unit	WITHOUT	WITH	OFF
SW24	SM24-Booster unit	WITHOUT	WITH	OFF
SW25	SM25-Booster unit	WITHOUT	WITH	OFF
SW26	SM26-Booster unit	WITHOUT	WITH	OFF
SW27	SM27-Booster unit	WITHOUT	WITH	OFF
SW28	SM28-Booster unit	WITHOUT	WITH	OFF
SW29	SM29-Booster unit	WITHOUT	WITH	OFF
SW30	SM30-Booster unit	WITHOUT	WITH	OFF
SW31	SM31-Booster unit	WITHOUT	WITH	OFF
SW32	SM32-Booster unit	WITHOUT	WITH	OFF
SW33	SM33-Booster unit	WITHOUT	WITH	OFF
SW34	SM34-Booster unit	WITHOUT	WITH	OFF
SW35	SM35-Booster unit	WITHOUT	WITH	OFF
SW36	SM36-Booster unit	WITHOUT	WITH	OFF
SW37	SM37-Booster unit	WITHOUT	WITH	OFF
SW38	SM38-Booster unit	WITHOUT	WITH	OFF
SW39	SM39-Booster unit	WITHOUT	WITH	OFF
SW40	SM40-Booster unit	WITHOUT	WITH	OFF
SW41	SM41-Booster unit	WITHOUT	WITH	OFF
SW42	SM42-Booster unit	WITHOUT	WITH	OFF
SW43	SM43-Booster unit	WITHOUT	WITH	OFF
SW44	SM44-Booster unit	WITHOUT	WITH	OFF
SW45	SM45-Booster unit	WITHOUT	WITH	OFF
SW46	SM46-Booster unit	WITHOUT	WITH	OFF
SW47	SM47-Booster unit	WITHOUT	WITH	OFF
SW48	SM48-Booster unit	WITHOUT	WITH	OFF
SW49	SM49-Booster unit	WITHOUT	WITH	OFF
SW50	SM50-Booster unit	WITHOUT	WITH	OFF

1. External output (OUT11) will be available. For safety reasons, this function is not available for certain errors. (In that case, system operation must be stopped and only the water circulation pump keeps running.)  
 2. Unit is connected with a PUHZ-FRP outdoor unit. When another type of outdoor unit is connected, the heating mode function is active regardless of the fact that this switch is ON or OFF.  
 3. Space heating and DHW can be operated only in indoor unit. In an electric heater.  
 4. Active only when SW3.6 is set to OFF.  
 5. Active only when SW3.6 is set to OFF.  
 6. Active only when SW4-1 is set to ON.

Symbol	Name
TB1	Terminal block -Power supply, Outdoor unit-
ECB2	Terminal block -Power supply for immersion heater (Except PAC-IF07*B-E)
MP1	Water circulation pump 1 (Space heating & DHW)
MP2	Water circulation pump 2 (Space heating & DHW)
MP3	Water circulation pump 3 (Local supply)
MP4	Water circulation pump 4 (DHW)(Local supply)
3WV	3-way valve (2-way valve 1)(Local supply)
2WV2a	2-way valve (For Zone 1)(Local supply)
2WV2b	2-way valve (For Zone 2)(Local supply)
IMV	Immersion heater (Local supply)
IHT	Heater (Except PAC-IF07*B-E)
IH	Immersion heater (Except PAC-IF07*B-E)
FTC	Controller for immersion heater (Except PAC-IF07*B-E)
TH4	Thermistor (Room temp.)(Option)
TH5	Thermistor (Flow water temp.)(Included in PAC-IF07*B-E)
THW1	Thermistor (Return water temp.)
THW2	Thermistor (Return water temp.)
THW5A	Thermistor (DHW tank upper water temp.)
THW5B	Thermistor (DHW tank lower water temp.) (Included in PAC-IF07*B-E)
THW5C	Thermistor (DHW tank lower water temp.) (Option for PAC-IF07*B-E)
THW6	Thermistor (Zone1 flow temp.)(Option)
THW7	Thermistor (Zone2 return temp.)(Option)
THW8	Thermistor (Zone2 return temp.)(Option)
THW9	Thermistor (Zone2 return temp.)(Option)
THW10	Thermistor (Mixing tank temp.)(Option)
THW11	Thermistor (Boiler flow temp.)(Option)
IN1	Room thermostat 1 (Local supply)
IN2	Room thermostat 1 (Local supply)
IN3	Flow switch 1 (Local supply)
IN4	Demand control (Local supply)
IN5	Outdoor thermostat (Local supply)
IN6	Room thermostat 2 (Local supply)
IN7	Flow switch 3 (Local supply)
IN8	Electric energy meter 1 (Local supply)
IN9	Electric energy meter 2 (Local supply)
IN10	Heat meter (Local supply)
IN11	Heat meter (Local supply)
IN12	Smart grid ready input (Local supply)
AN1	Flow sensor (Option)
FTC	Flow TEMP. CONTROLLER (FTC)
TB0.1-5	Terminal block -Outdoors-
TB1-1-4	Terminal block -Signal inputs, Thermistor-
F1	Fuse (IEC T10A,250V)
F2	Fuse (IEC T6,250V)
SW1-4	DIP switch "See Table 3"
XT-1-6	Relay
LED1	Power supply (FTC)
LED2	Power supply (Main remote controller)
LED3	Communication (FTC-Boiler unit)
LED4	Power supply (Main remote controller)
CN5W1	Communication control signal for MP1
CN5W2	Power supply control signal for MP1
CN100	SD card connector

1. Symbols used in wiring diagram are: **□**: connector, **○**: terminal block. Function with asterisk (\*) may not be available depending on model types.  
 2. Indoor unit and outdoor unit connecting wires have polarities, make sure to match terminal numbers (S1, S2, S3) for correct wiring.  
 3. Since the outdoor unit side electric wiring may change, be sure to check the outdoor unit electric wiring diagram for service.  
 4. When connecting a booster heater, the wiring method is different according to the type of built-in thermostat.  
 Please refer to the installation manual for details.

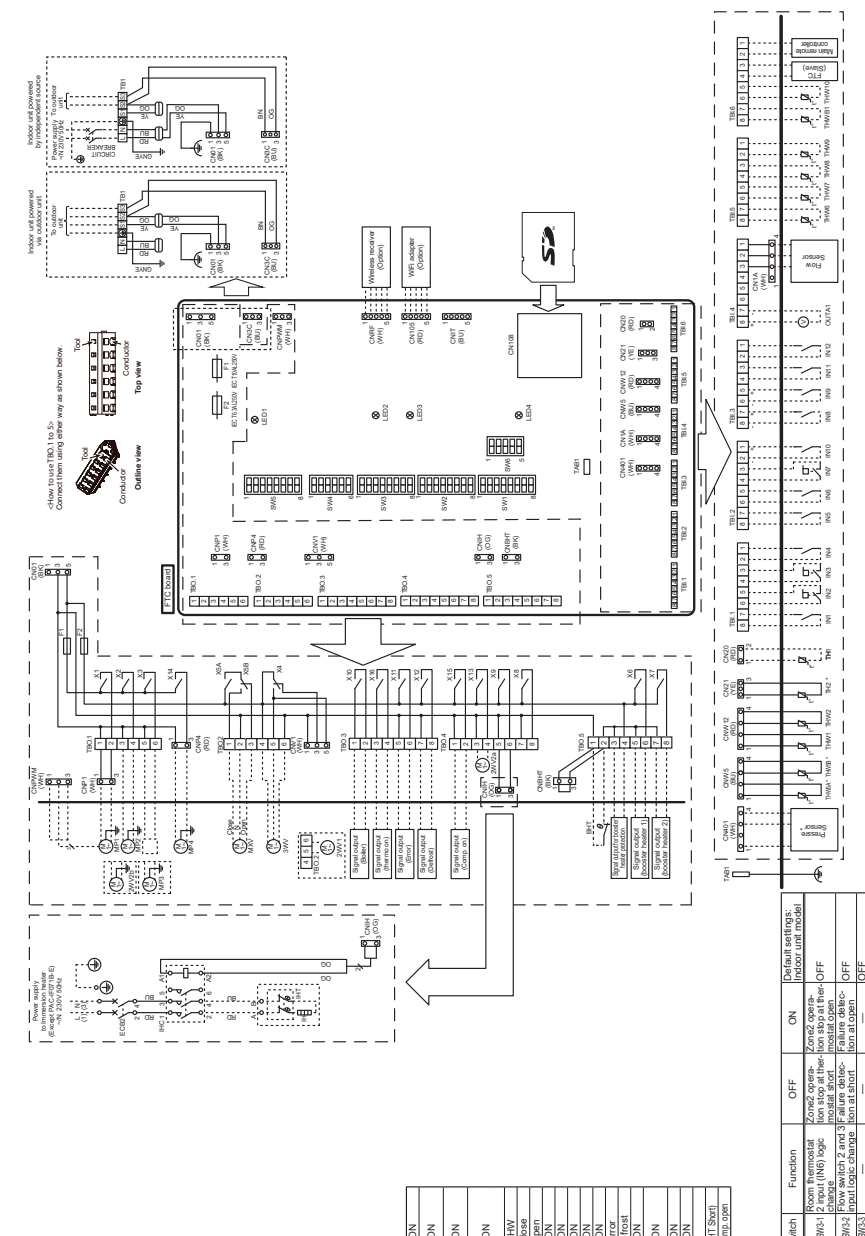

## DIP Switch Functions

Located on the FTC printed circuit board are 6 sets of small white switches known as DIP switches. The DIP switch number is printed on the circuit board next to the relevant switches. The word ON is printed on the circuit board and on the DIP switch block itself. To move the switch you will need to use a pin or the corner of a thin metal ruler or similar.

Only an authorised installer can change DIP switch setting under one's own responsibility according to the installation condition. Make sure to turn off both indoor unit and outdoor unit power supplies before changing the switch settings.

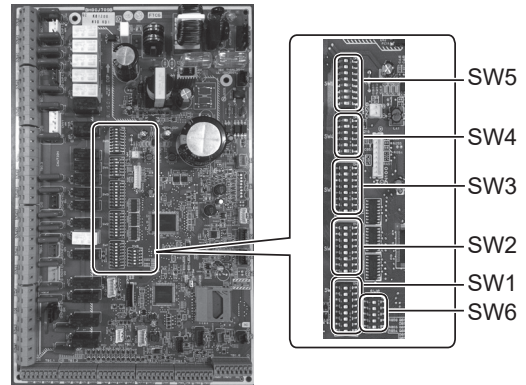

DIP switch	Function	OFF	ON	Default settings: Indoor unit model
SW1	SW1-1 Boiler	WITHOUT Boiler	WITH Boiler	OFF
	SW1-2 Heat pump maximum outlet water temperature	55 °C	60 °C	ON
	SW1-3 DHW tank	WITHOUT DHW tank	WITH DHW tank	ON
	SW1-4 Immersion heater	WITHOUT Immersion heater	WITH Immersion heater	ON
	SW1-5 Booster heater	WITHOUT Booster heater	WITH Booster heater	OFF
	SW1-6 Booster heater function	For heating only	For heating and DHW	OFF
	SW1-7 Outdoor unit type	Split type	Packaged type	ON
	SW1-8 Wireless remote controller	WITHOUT Wireless remote controller	WITH Wireless remote controller	OFF
SW2	SW2-1 Room thermostat1 input (IN1) logic change	Zone1 operation stop at thermostat short	Zone1 operation stop at thermostat open	ON
	SW2-2 Flow switch1 input (IN2) logic change	Failure detection at short	Failure detection at open	OFF
	SW2-3 Booster heater capacity restriction	Inactive	Active	OFF
	SW2-4 Cooling mode function	Inactive	Active	OFF
	SW2-5 Automatic switch to backup heat source operation (When outdoor unit stops by error)	Inactive	Active	OFF
	SW2-6 Mixing tank	WITHOUT Mixing tank	WITH Mixing tank	OFF
	SW2-7 2-zone temperature control	Inactive	Active	OFF
	SW2-8 Flow sensor	WITHOUT Flow sensor	WITH Flow sensor	ON
SW3	SW3-1 Room thermostat 2 input (IN6) logic change	Zone2 operation stop at thermostat short	Zone2 operation stop at thermostat open	ON
	SW3-2 Flow switch 2 and 3 input logic change	Failure detection at short	Failure detection at open	OFF
	SW3-3 —	—	—	OFF
	SW3-4 Electric energy meter	WITHOUT Electric energy meter	WITH Electric energy meter	OFF
	SW3-5 Heating mode function	Inactive	Active	ON
	SW3-6 2-zone valve ON/OFF control	Inactive	Active	OFF
	SW3-7 Heat exchanger for DHW	Coil in tank	External plate HEX	ON
	SW3-8 Heat meter	WITHOUT Heat meter	WITH Heat meter	OFF
SW4	SW4-1 Multiple outdoor unit control	Inactive	Active	OFF
	SW4-2 Position of multiple outdoor unit control	Sub	Main	OFF
	SW4-3 —	—	—	OFF
	SW4-4 Indoor unit only operation (during installation work)	Inactive	Active	OFF
	SW4-5 Emergency mode (Heater only operation)	Normal	Emergency mode (Heater only operation)	OFF
	SW4-6 Emergency mode (Boiler operation)	Normal	Emergency mode (Boiler operation)	OFF
SW5	SW5-1 —	—	—	OFF
	SW5-2 Advanced auto adaptation	Inactive	Active	ON
	SW5-3 —	—	—	OFF
	SW5-4 —	—	—	OFF
	SW5-5 —	—	—	OFF
	SW5-6 —	—	—	OFF
	SW5-7 —	—	—	OFF
	SW5-8 —	—	—	OFF
SW6	SW6-1 —	—	—	OFF
	SW6-2 —	—	—	OFF
	SW6-3 Pressure sensor	Inactive	Active	OFF
	SW6-4 Analog output signal (0-10 V)	Inactive	Active	OFF
	SW6-5 —	—	—	OFF

# FIELD WIRING

## FTC (Master) powered by independent source

If FTC (Master) and outdoor units have separate power supplies, the following requirements MUST be carried out:

- **FTC (Master) unit electrical box connector connections changed.**
  - **Outdoor unit DIP switch settings changed to SW8-3 ON.**
  - **Turn on the outdoor unit before the FTC (Master).**
  - **Power by independent source is not available for particular models of outdoor unit model.**
- For more detail, refer to the connecting outdoor unit installation manual.

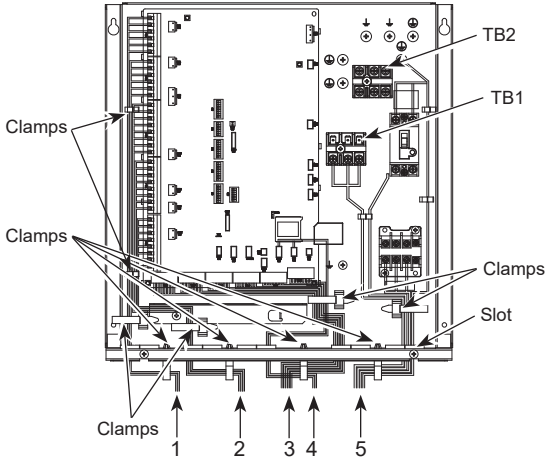
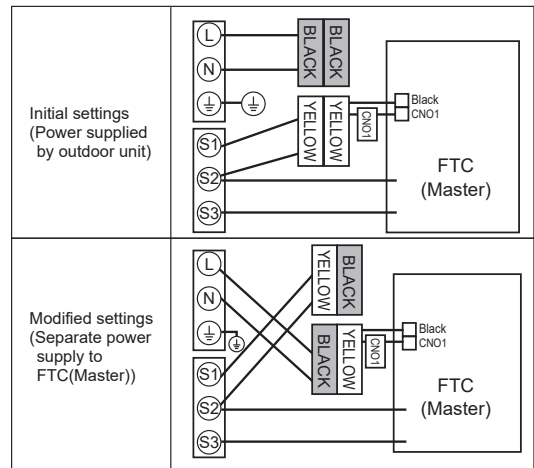

- 1 High voltage cables (OUTPUT)
- 2 High voltage cables (OUTPUT)
- 3 Low voltage cables (INPUT) and wireless receiver's cable
- 4 Thermistor cables
- 5 Power cables

For routing of mains, immersion heater & remote controller cables see page 15 of this manual.

### Wiring for PAC-IF07\*B-E

- Notes: 1. Do not run the low voltage cables through a slot that the high voltage cables go through.  
 2. Do not run other cables except low voltage cables through a slot that the wireless receiver's cable goes through.  
 3. Do not bundle power cables together with other cables.  
 4. Bundle cables as figure above by using clamps.

#### <1 phase>

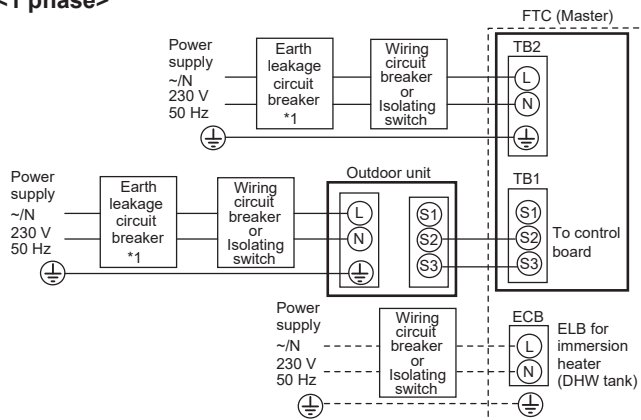

#### <3 phase>

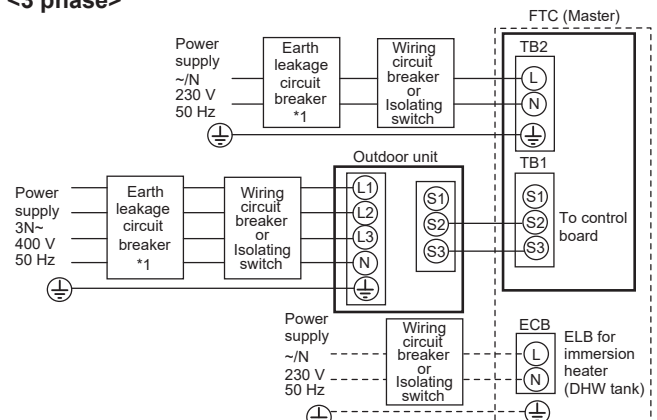

□ : PAC-IF071B-E  
 □ : PAC-IF072/073B-E

Description	Power supply	Capacity	Breaker	Wiring
Immersion heater (DHW tank)	~N 230 V 50 Hz	3 kW	16 A*1	2.5 mm <sup>2</sup>

### Electrical connections 1 phase/3 phase

\*1. If the installed earth leakage circuit breaker does not have an over-current protection function, install a breaker with that function along the same power line.

A breaker with at least 3.0 mm contact separation in each pole shall be provided. Use earth leakage breaker (NV).

The breaker shall be provided to ensure disconnection of all active phase conductors of the supply.

**Note:** In accordance with IEE regulations the circuit breaker/isolating switch located on the outdoor unit should be installed with lockable devices (health and safety).

FTC (Master) power supply		~N 230 V 50 Hz
FTC (Master) input capacity		*1 16 A
Main switch (Breaker)		
Wiring Wiring No. x size (mm <sup>2</sup> )	FTC (Master) power supply	2 x Min. 1.5
	FTC (Master) power supply earth	1 x Min. 1.5
Circuit rating	FTC (Master) - Outdoor unit	*2 2 x Min. 0.3
	FTC (Master) - Outdoor unit earth	—
	FTC (Master) L - N	*3 230 V AC
	FTC (Master) - Outdoor unit S1 - S2	*3 —
	FTC (Master) - Outdoor unit S2 - S3	*3 24 V DC

\*2. Max. 120 m

\*3. The values given in the table above are not always measured against the ground value.

- Notes: 1. Wiring size must comply with the applicable local and national codes.  
 2. FTC (Master) unit/outdoor unit connecting cords shall not be lighter than polychloroprene sheathed flexible cord. (Design 60245 IEC 57)  
 FTC (Master) unit power supply cords shall not be lighter than polychloroprene sheathed flexible cord. (Design 60227 IEC 53)  
 3. Install an earth longer than other cables.  
 4. Please keep enough output capacity of power supply for each individual heater. Insufficient power supply capacity might cause chattering.

Routing of mains, immersion heater & remote controller cables

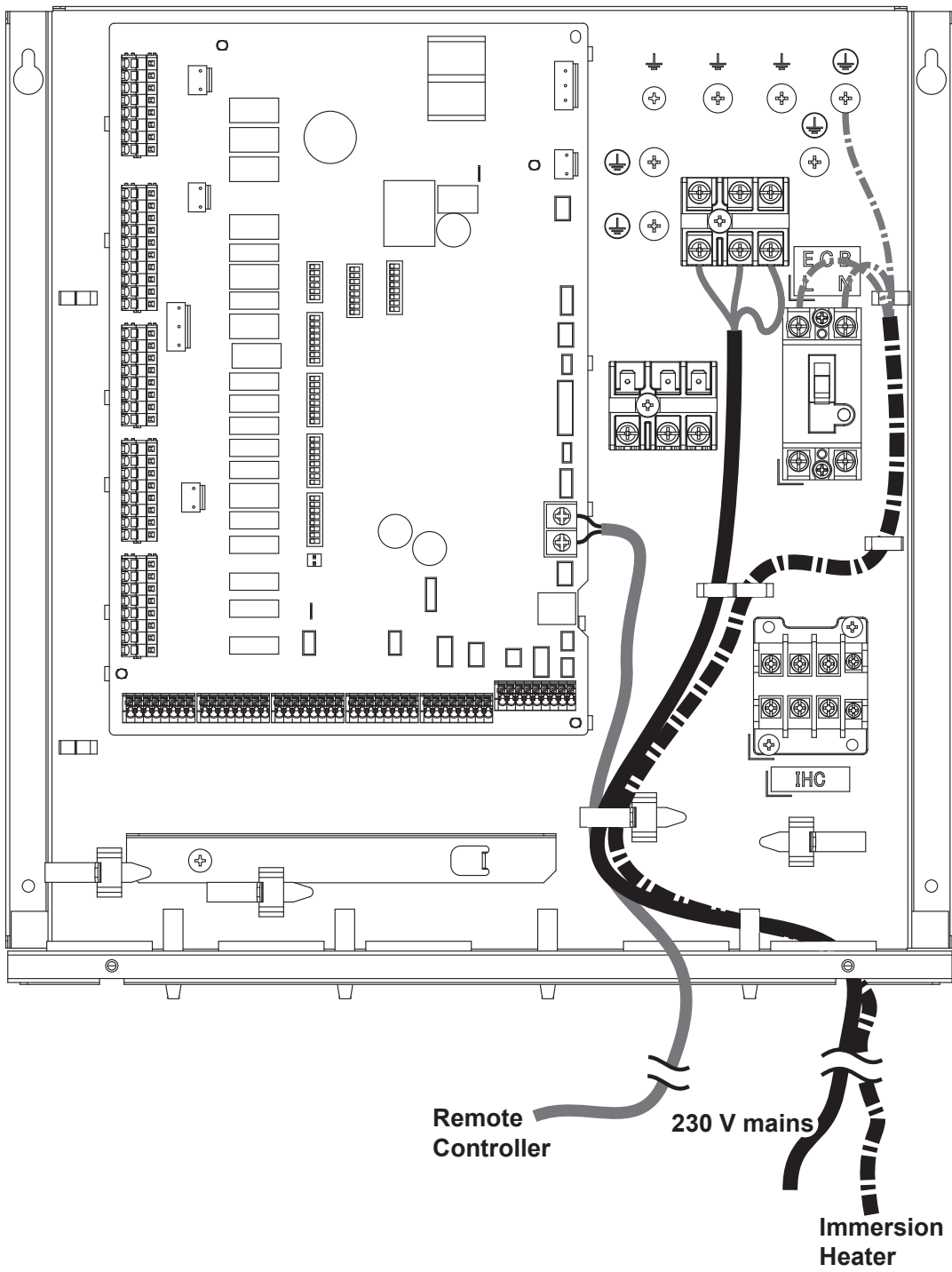

Remote  
Controller

230 V mains

Immersion  
Heater

# WATER SYSTEM DIAGRAM

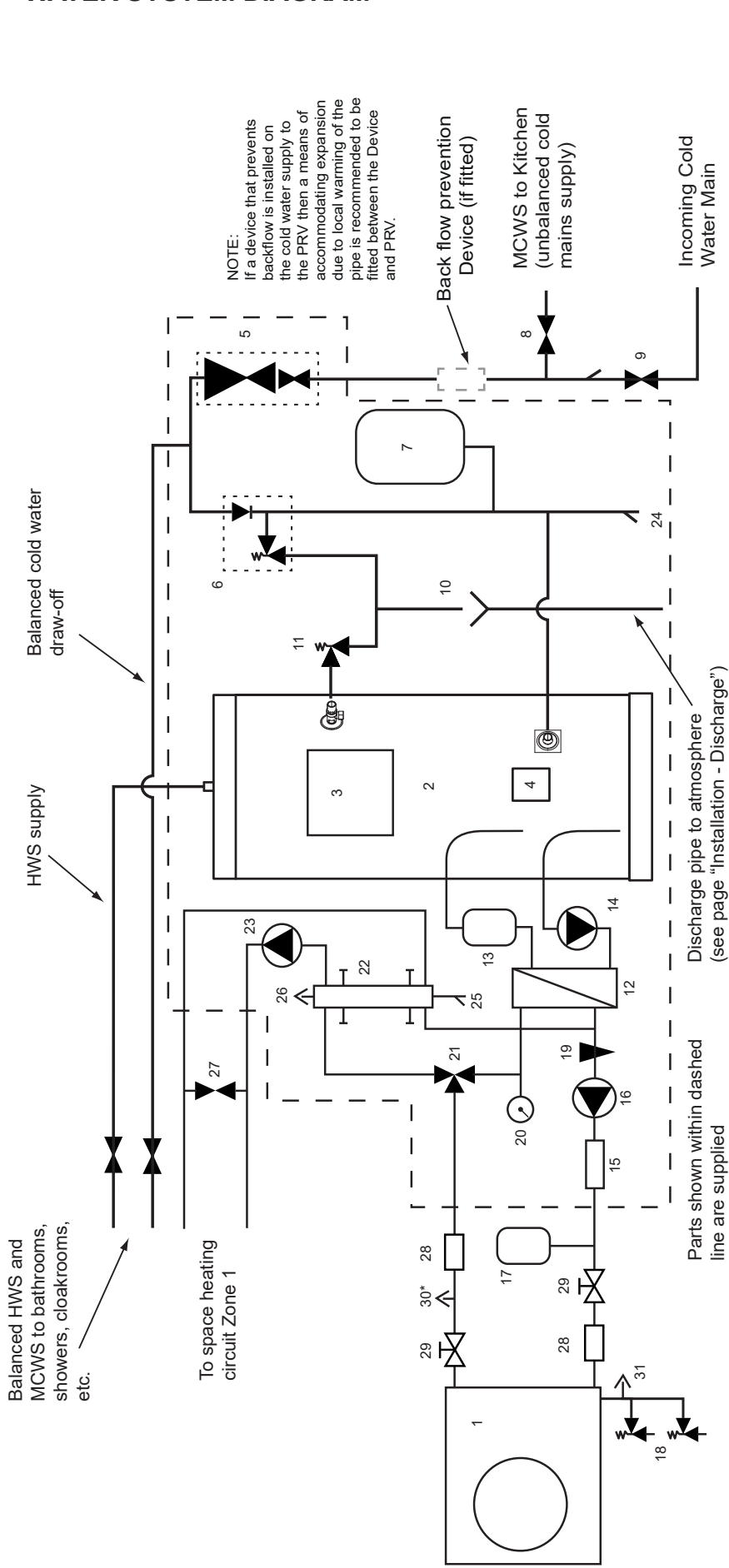

KEY	13	14	15	16	17	18	19	20	21	22	23	24	25	26	27	28	29	30	31	
1	Scale Trap	DHW Circulating Pump	Flow Sensor	Primary Pump	Primary Expansion Vessel	Primary Pressure Relief valve(s)	1 x valve PUZ-(H)WM models	2 x valve PUZ-WZ models	Filter	Primary System Pressure Gauge	Heating Pump	DHW Drainoff point	Primary circuit draw off point	Automatic Air Vent	Differential Pressure Bypass Valve	Strainer	Isolating Valve	Air Vent** - if the outdoor unit is higher than the indoor unit or if there is a location where air gets trapped in the upper part of the water pipe consider adding this part	Heat Pump Air Vent (PUZ-WZ models only)	
2																				
3																				
4																				
5																				
6																				
7																				
8																				
9																				
10																				
11																				
12																				

Local System

Optional 2 zone control pack - plumbing schematic

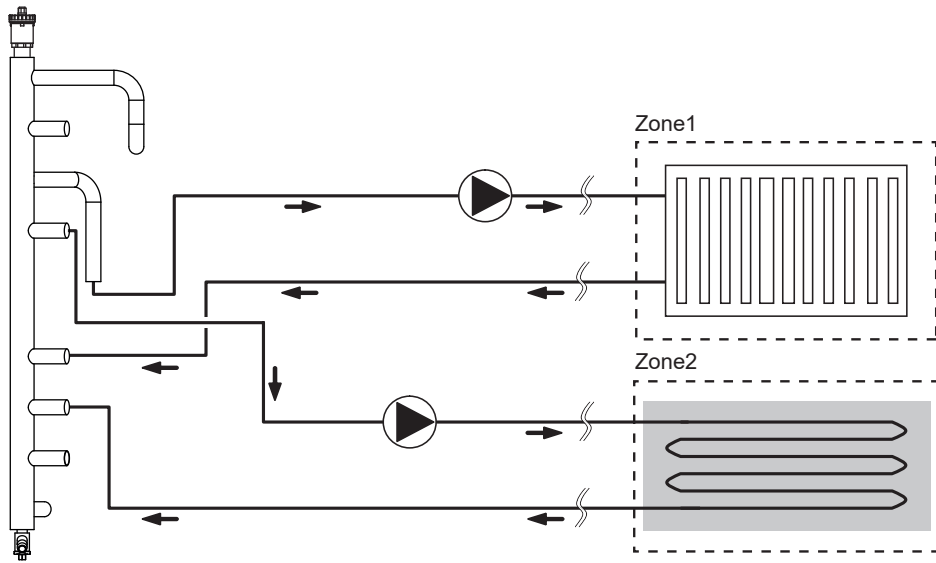

Optional 2 zone twin temperature control pack - plumbing schematic

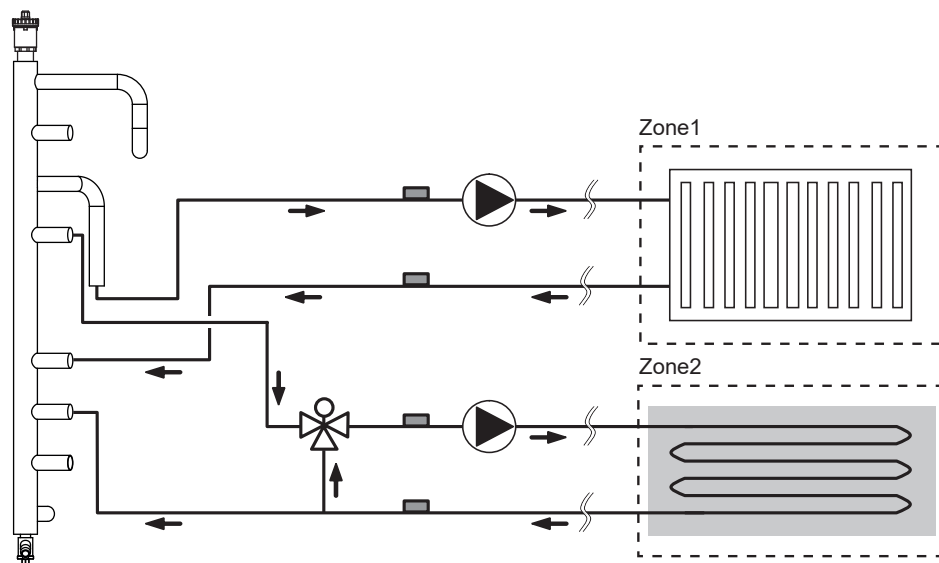

## Filling The Cylinder

### CYLINDER UNIT - INITIAL FILL PROCEDURE

- BEFORE FILLING CHECK AND TIGHTEN ALL MECHANICAL JOINTS AND CONNECTIONS IN CASE THESE HAVE LOOSENED DURING TRANSIT.
- Check expansion vessel pre-charge pressure. The vessel is supplied pre-charged to 3.5 bar to match the control pressure of the pressure reducing valve. The pre-charge pressure is checked using a car tyre gauge by unscrewing the plastic cap opposite the water connection.
- Check all connections for tightness including the immersion heater(s). An immersion heater key spanner is supplied for this purpose.
- Ensure the drain cock is CLOSED.
- Open a hot tap furthest from the cylinder.
- Open the cylinder isolating valve to fill the unit. When water flows from the tap, allow to run for a few minutes to thoroughly flush through any residue, dirt or swarf, then close the tap.
- Open successive hot taps to purge the system of air.
- Ensure all hot taps are closed to retain system charge.

### CYLINDER UNIT - SYSTEM CHECKS

- Check all water connections for leaks and rectify as necessary.
- Turn off water supply to the cylinder.
- Remove the Pressure Reducing Valve head work to access the strainer mesh, clean and re-fit.
- Manually open, for a few seconds, each relief valve in turn, checking that water is discharged and runs freely through the tundish and out at the discharge point.
- Ensure that the valve(s) re-seat satisfactorily and reinstate the cylinder water supply.

### CYLINDER UNIT - INITIAL FLUSH PROCEDURE

- Energise system to heat-up cylinder unit contents to a temperature of approx. 30 - 40 °C.
- Flush/drain the water contents to remove any residue/impurities resulting from the installation works.
- Use the cylinder unit drain cock to safely discharge the warmed water to drain via a suitable hose.
- On completion, close drain cock, re-fill system and resume system commissioning.

### PRIMARY CIRCUIT - FILLING THE SYSTEM

- Check and charge expansion vessel.
- Check all connections including factory fitted ones are tight.
- Insulate pipework between cylinder and outdoor unit.
- Thoroughly clean and flush, system of all debris.
- Fill cylinder unit with potable water. Fill primary heating circuit with water and suitable anti-freeze and inhibitor as necessary.  
**Always use a filling loop with double check valve when filling the primary circuit to avoid back flow contamination of water supply.**
- Check for leakages. If leakage is found, retighten the screws onto the connections.
- Pressurise system to 1 bar.
- Release all trapped air using air vents during and following heating period.
- Top up with water as necessary. (If pressure is below 1 bar)
- After removing the air, automatic air vent **MUST** be closed.

### Fernox HP5-c frost protection levels:

- 10% Concentration provides frost protection to -4 °C
- 20% Concentration provides frost protection to -9 °C
- 30% Concentration provides frost protection to -14 °C

### DRAINING THE CYLINDER UNIT - WARNING: DRAINED WATER MAY BE VERY HOT

- Before attempting to drain the cylinder unit, isolate from the electrical supply to prevent the immersion heater burning out.
- Isolate cold water feed to DHW tank.
- Attach a hose to the DHW tank drain off point. The hose should be able to withstand heat as the draining water could be very hot. The hose should drain to a place lower than the DHW tank bottom to encourage siphoning. Open a hot water tap to start draining without a vacuum.
- When the DHW tank is drained, close drain cock and hot tap.
- Attach hose to primary circuit drain off point. The hose should be able to withstand heat as the draining water could be very hot. The hose should drain to a place lower than the primary circuit drain off point to encourage siphoning. Open the pump valve.

# CONTROLS

## Main remote controller

To change the settings of your heating/cooling system, please use the main remote controller located on the wall or the front panel of the cylinder unit or hydrobox. The following is a guide to viewing the main settings. Should you require more information, please contact your installer or local Mitsubishi Electric dealer. Some functions are not available depending on the system configuration. These functions are grayed out or not shown.

Note: The terms displayed on the remote controller are enclosed in square brackets.

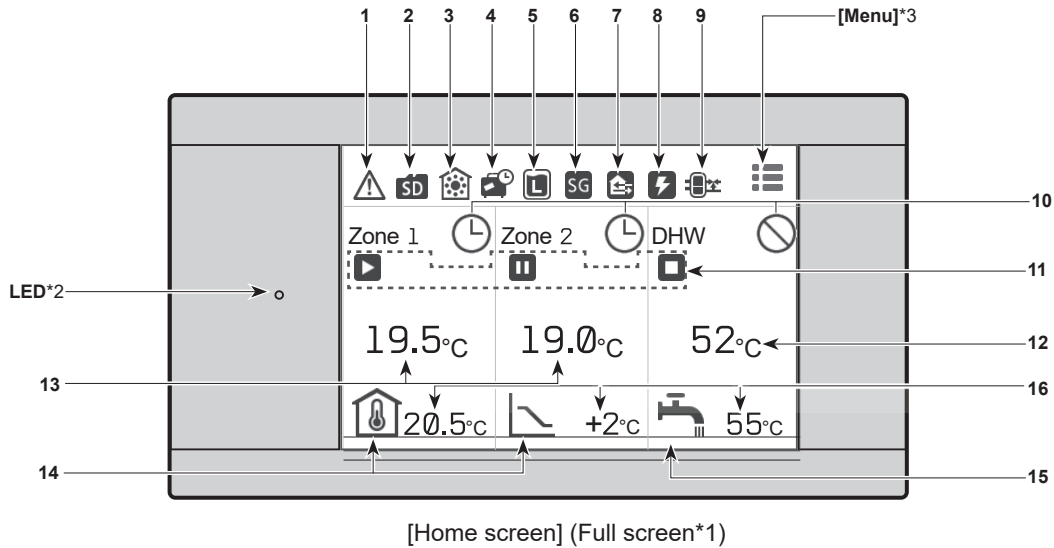

### Home screen icons

No.	Icons	Description
1		Alert (for multiple outdoor units control) Touching the menu icon displays error codes.
	J1	Alert Error codes are displayed.
2		SD card is inserted. Normal operation
		SD card is inserted. Abnormal operation
3		Heating mode
		Cooling mode
4		Holiday schedule is activated.
5		Legionella prevention mode is running.
6		Smart grid ready is running.
7		Compressor is running.
		Compressor is running and defrosting.
		Compressor is running and in quiet mode. The sound level is shown at left side of the icon.
		Emergency heating
8		Electric heater is running.

No.	Icons	Description
9		Boiler is running.
		Buffer tank control is running.
10		Schedule
		Prohibited
		Cloud control
11		Operation
		Standby
		This unit is in standby whilst other indoor unit(s) is in operation by priority.
		Stop
12		Actual DHW tank temperature values
13		Actual room temperature values [ -- °C] appears when the unit is not connected to the room RC (Remote Controller) and it is under control other than Auto Adaptation.

No.	Icons	Description
14		Weather compensation curve When the operation stops: Black During heating operation: Orange During cooling operation: Blue
		Auto Adaptation (Target room temperature) When the operation stops: Black During heating operation: Orange
		Flow temperature (Target flow temperature) When the operation stops: Black During heating operation: Orange During cooling operation: Blue
15		DHW icon is displayed when DHW is enabled. When the operation stops: Black During operation: Orange
		Target temperature values
16		The settable temperature differs depending on the control logic.

- The screen will turn off when the main remote controller is not operated for a while. Touching any part of the screen turns it on again.
- From [Touch screen] in [Setting], the brightness can be adjusted.
- By selecting [Always on] for [Backlight time] from [Touch screen] in [Setting], the backlight stays lit for 30 seconds and after it dims down.

\*1 From [Setting], the screen can be switched to the full screen or the base screen.

The base screen does not display the operation icons and the target temperature values.

\*2 From [Display] in [Setting], the LED lamp can be turned on/off.

\*3 Pressing and holding the menu icon for 3 seconds switches the lock menu to on/off.

Some functions cannot be edited when the lock menu is on.

(The icon changes to when the lock menu is on.)

\*4 Auto Adaptation cannot be selected during the cooling mode.

## Quick start

When the main remote controller is switched on for the first time, the screen automatically goes to the [Language], [Date/Time], [System configuration], and quick start setting screen in order. On the quick start setting screen, the following items can be set.

### Note:

[Electric booster heater use]

This setting restricts the booster heater capacity. It is NOT possible to change the setting after starting up.

If you do not have any special requirements (such as building regulations) in your country, skip this setting (select [Next]).

### Quick start

- [Zone sensor selection]\*1
- [Emitter selection]
- [Control logic]
- [Outdoor design temperature]
- [Zone sensor selection]\*2
- [DHW]
- [Flow rate & pump speed]
- [Electric booster heater use]\*3

\*1 Selection of zone to assign each wireless remote controller

\*2 Selection of room sensors for monitoring the room temperature

\*3 It cannot be reset, so be careful when you set it.

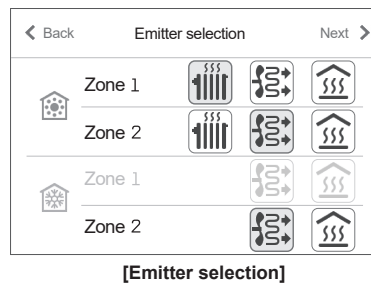
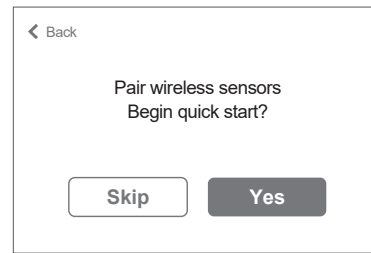

Next setting

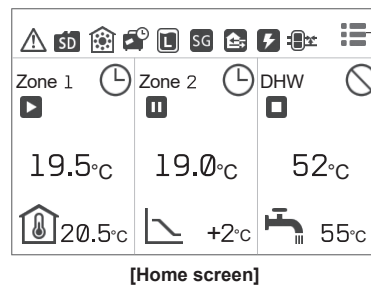

Press and hold the icon for 3 seconds.

Lock

## Lock menu

Pressing and holding the menu icon  for 3 seconds switches the lock menu to on.

(The icon changes to  when the lock menu is on.)

Some functions cannot be edited in this state.

**Note: You need a password to edit [Service] even when the lock menu is off.**

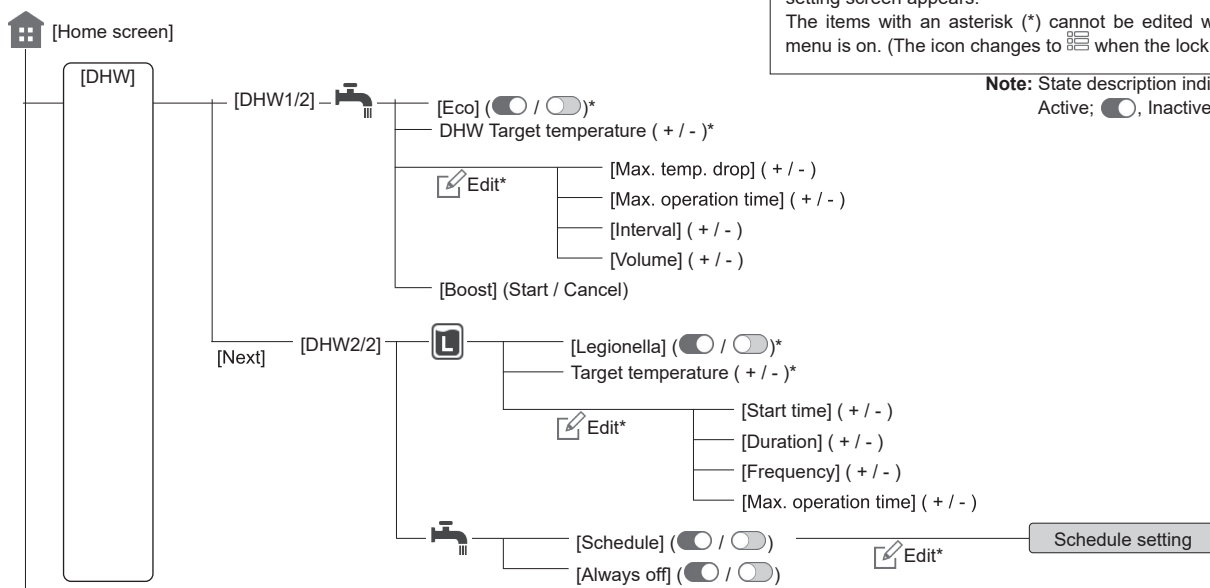

Refer to the main controller menu tree for details of the items which cannot be edited when the lock menu is on.

### <Main Controller Menu Tree>



When the system is started up for the first time, the quick start setting screen appears.

The items with an asterisk (\*) cannot be edited when the lock menu is on. (The icon changes to  when the lock menu is on.)

**Note:** State description indicated by toggle  
Active; , Inactive; 

<Main Controller Menu Tree>

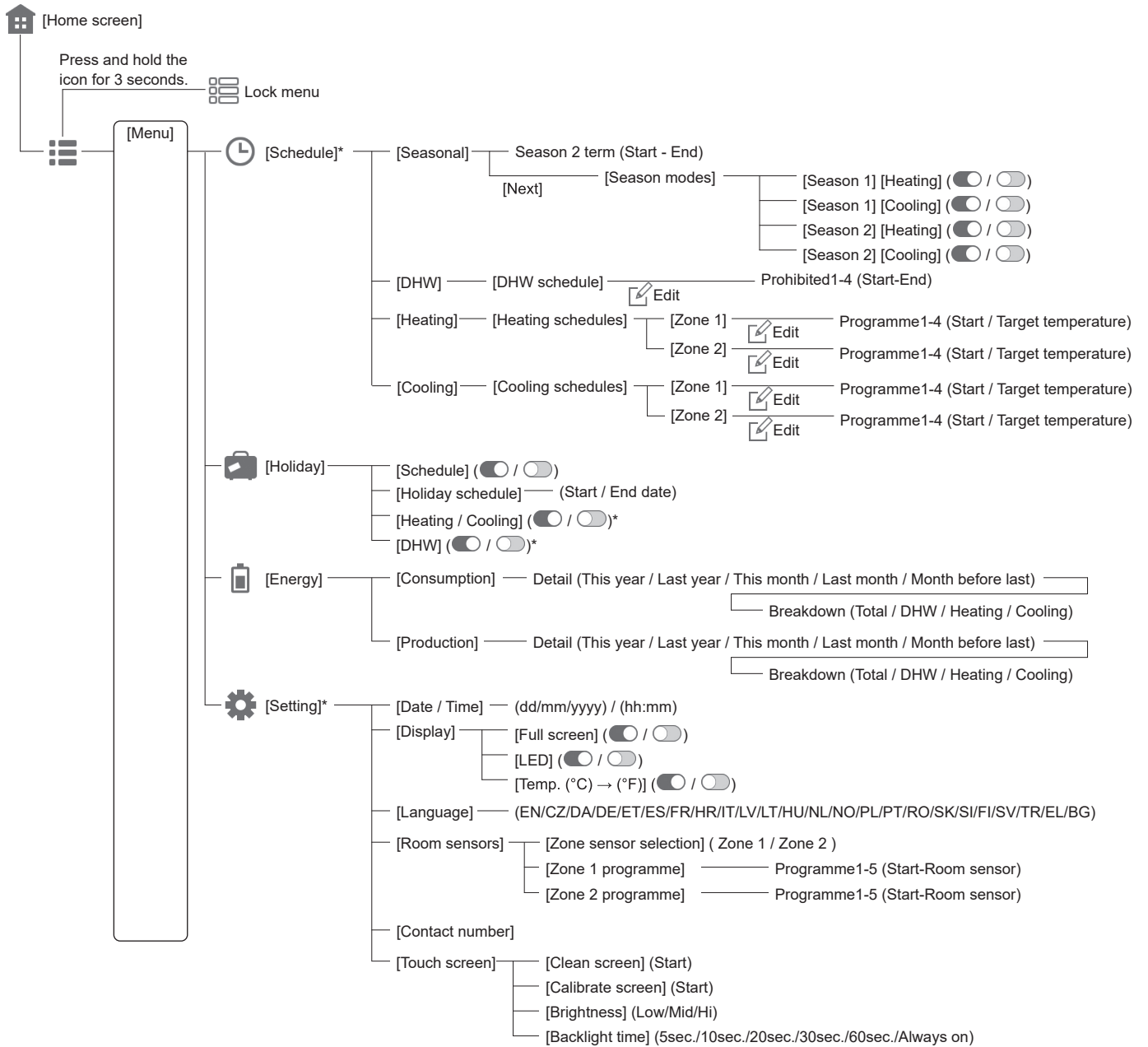
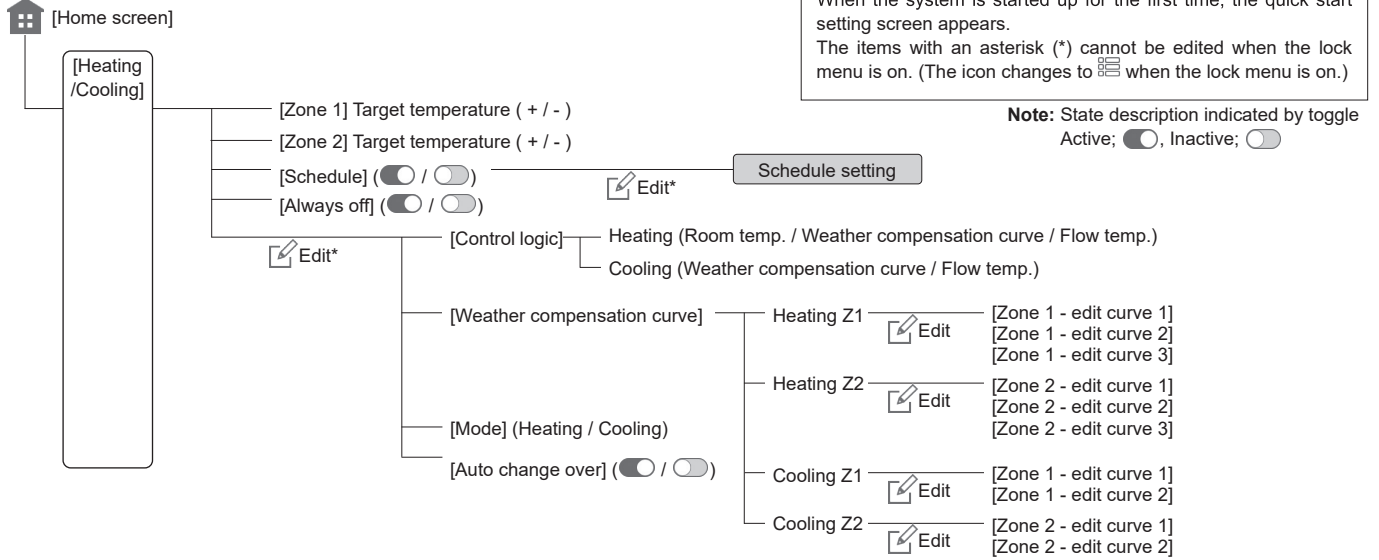

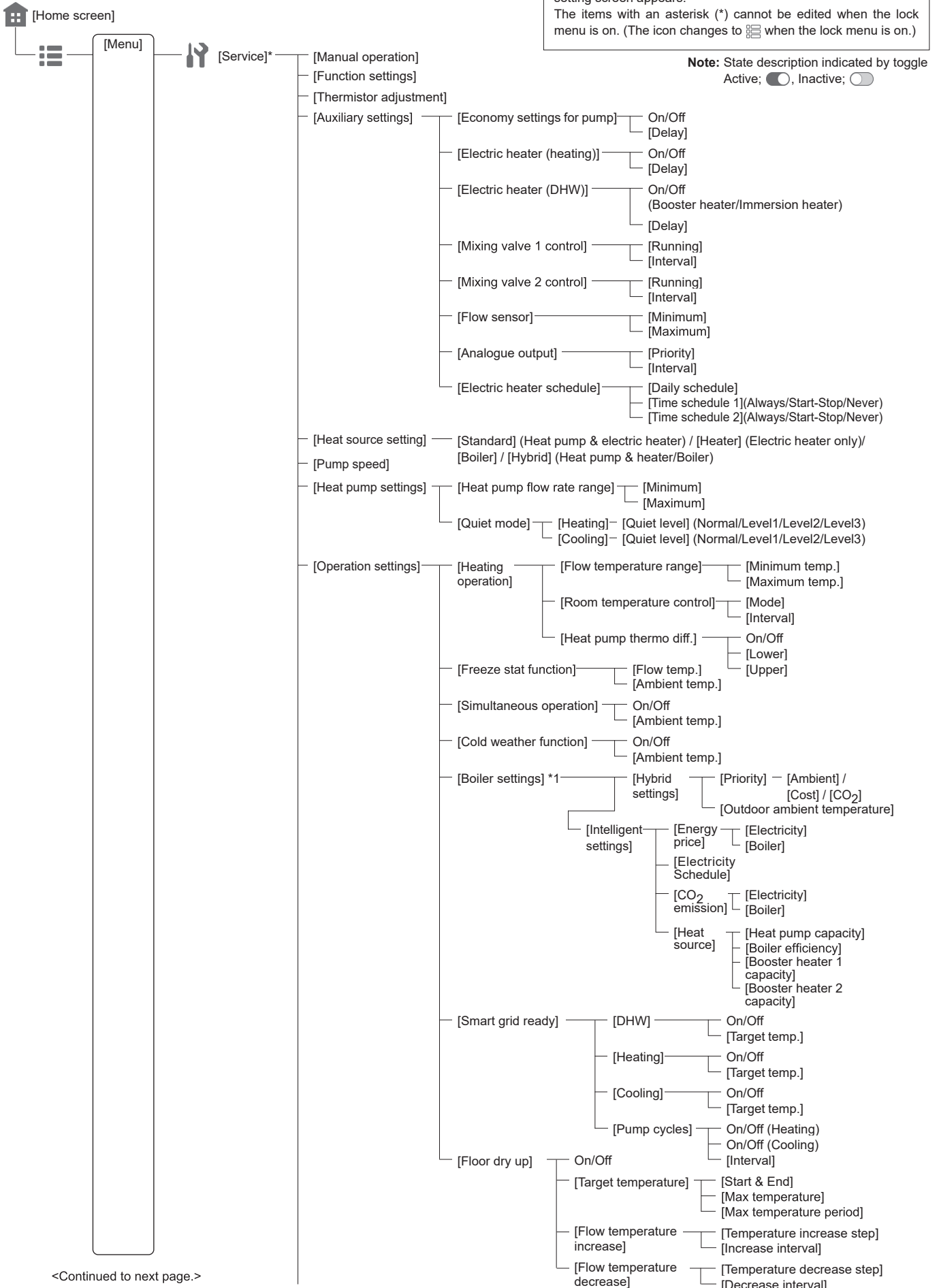

Continued from the previous page.

<Main Controller Menu Tree>



When the system is started up for the first time, the quick start setting screen appears.  
The items with an asterisk (\*) cannot be edited when the lock menu is on. (The icon changes to  when the lock menu is on.)

**Note:** State description indicated by toggle  
Active; , Inactive; 

<Continued to next page.>

\*1 For more details, refer to the installation manual of PAC-TH012HT(L)-E.

Continued from the previous page.

<Main Controller Menu Tree>

When the system is started up for the first time, the quick start setting screen appears. The items with an asterisk (\*) cannot be edited when the lock menu is on. (The icon changes to  when the lock menu is on.)

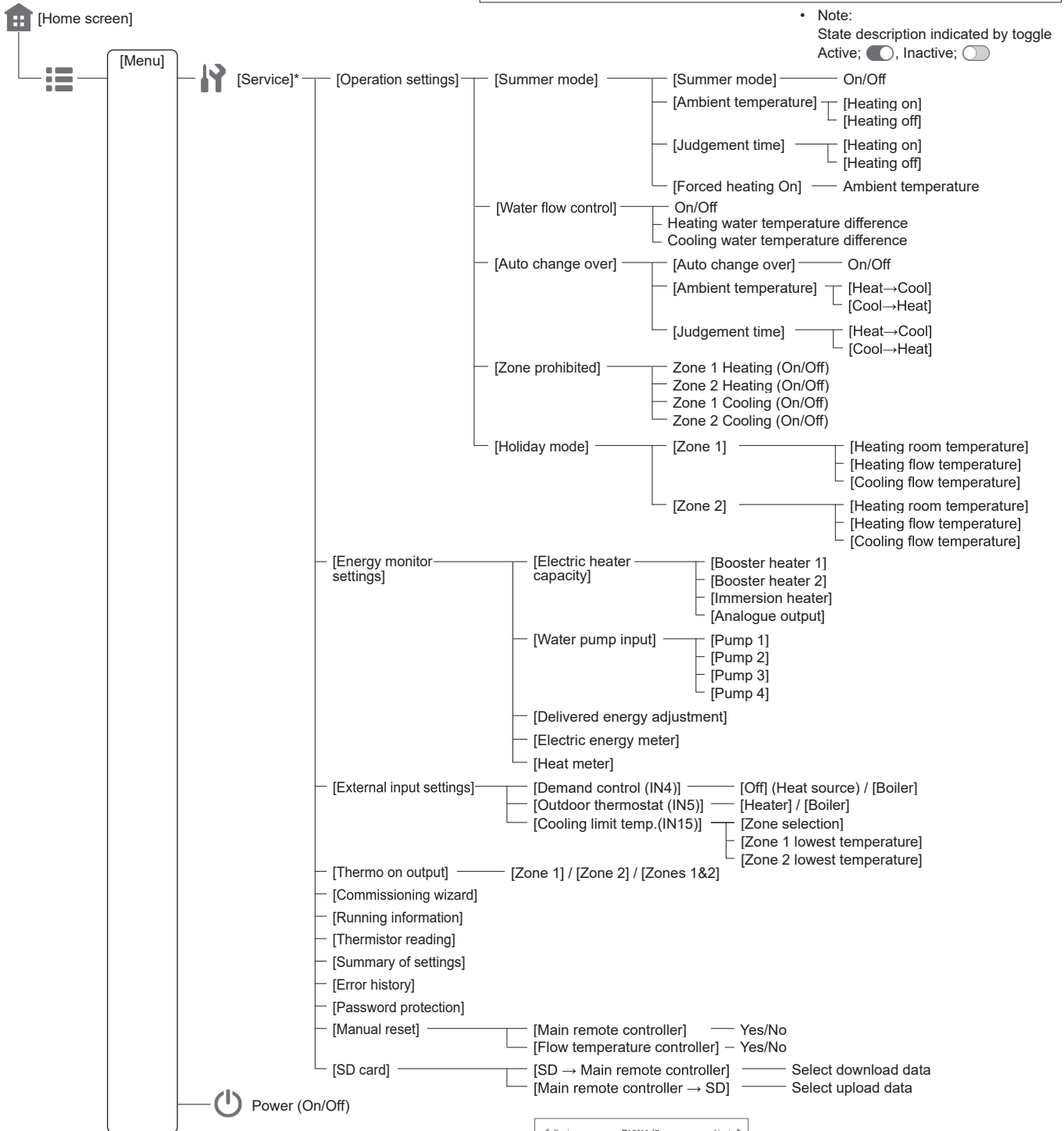

9-2. DHW (Domestic Hot Water) / Legionella Prevention

The DHW and legionella prevention menus control the operation of DHW tank heat ups.

DHW mode settings

- [DHW]: The Eco mode can be activated/deactivated by the toggle. The target temperature can be adjusted by +/-.
- From the edit icon , [Max. temp. drop], [Max. operation time], [Interval], and [Volume] can be set.

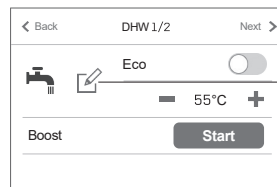

[DHW]

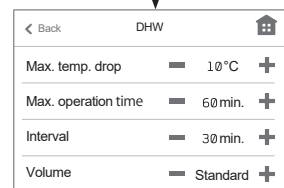

[DHW]

Menu subtitle	Function	Range	Unit	Default value
DHW target temp.	Desired temperature of stored hot water	40 - 70*1	°C	50
[Max. temp. drop]	Difference in temperature between the DHW maximum temperature and the temperature at which DHW mode restarts	5 - 40*2	°C	10
[Max. operation time]	Maximum time allowed for stored water heating DHW mode	30 - 120	min.	60
[Interval]	The time period after DHW mode when space heating has priority over DHW mode temporarily preventing further stored water heating (Only when DHW max. operation time has passed.)	30 - 120	min.	30

\*1 The maximum temperature differs depending on the connected outdoor unit. (60°C/65°C/70°C)

\*2 When the DHW maximum temperature is set over 55°C, the temperature at which DHW mode restarts must be less than 50°C to protect the device.

#### [Eco]

DHW mode can run in either normal or Eco mode. Normal mode will heat the water in the DHW tank fast using the full power of the heat pump. Eco mode takes a little longer to heat the water in the DHW tank, but the energy used is reduced. This is because heat pump operation is restricted using signals from the FTC based on measured DHW tank temperature.

**Note:** The actual energy saved in Eco mode will vary according to outdoor ambient temperature.

#### [Volume]

Select the amount of DHW tank. If you need much hot water, select [Large].

Return to the DHW/legionella prevention menu.

### Legionella prevention mode settings (LP mode)

- [Legionella]: It can be activated/deactivated by the toggle.  
The target temperature can be changed by +/-.  
From the edit icon , [Start time], [Duration], [Frequency], and [Max. operation time] can be set.
- [Schedule]: It can be activated/deactivated by the toggle.
- [Always off]: It can be activated/deactivated by the toggle.

During LP mode, the temperature of the stored water is increased above 60°C to inhibit legionella bacteria growth. It is strongly recommended that this is done at regular intervals. Please check local regulations for the recommended frequency of heat ups.

**Note 1:** When failures occur on the hydrobox, the LP mode may not function normally.

**Note 2:** Even when DHW operation is prohibited, LP mode will operate.

Menu subtitle	Function	Range	Unit	Default value
Hot water temp.	Desired temperature of stored hot water	60 - 70	°C	65
[Start time]	Time when LP mode will begin	0:00 - 23:00	-	03:00
[Duration]	The time period after LP mode desired water temperature has been reached	1 - 120	min.	30
[Frequency]	Time between LP mode DHW tank heat up	1 - 30	day	15
[Max. operation time]	Maximum time allowed for LP mode DHW tank heat	1 - 5	hour	3

Please note that LP mode uses the assistance of electric heaters to supplement the energy input of the heat pump. Heating water for long periods of time is not efficient and will increase running costs. The installer should give careful consideration to the necessity of legionella prevention treatment whilst not wasting energy by heating the stored water for excessive time periods. The end user should understand the importance of this feature.

**ALWAYS COMPLY WITH LOCAL AND NATIONAL GUIDANCE FOR YOUR COUNTRY REGARDING LEGIONELLA PREVENTION.**

## 9-3. Setting

From the menu icon , access [Setting].

The following items can be edited in [Setting].

- [Date / time]
- [Display] (From [Setting], the screen can be switched to the full screen or the base screen.)
- [Language]
- [Room sensors]
- [Contact number]
- [Touch screen] ([Calibrate screen]\*1, [Clean screen]\*2, [Brightness], and [Backlight time])

Follow the procedure described in General Operation for the set up operation.

\*1 Touching the 9 dots displayed on the screen starts calibration.

To properly calibrate the touch panel, use a pointy but not sharp object to touch the dots.

Note: A sharp object may damage or scratch the touch screen.

\*2 You can wipe the screen while touch operations are invalid for 30 seconds.

Wipe with a soft dry cloth, a cloth soaked in water with mild detergent, or a cloth dampened with ethanol.

Do not use acidic, alkaline, or organic solvents.

#### [Room sensors]

For [Room sensors], it is important to choose the correct room sensor depending on the heating and cooling mode the system will operate in.

Zone 1 programme		✓
Programme 1	00:00 - RC 1 >	
Programme 2	12:00 - RC 1 >	
Programme 3	15:00 - MainRC >	
Programme 4	19:00 - MainRC >	▼

[Zone 1 programme]

Menu subtitle	Description																	
[Zone sensor selection]	When 2-zone temperature control is active and wireless remote controllers are available, select [Zone sensor selection] in [Room sensors] from [Setting], and then select zone No. (Zone 1/Zone 2) to assign each remote controller.																	
[Zone 1 programme] [Zone 2 programme]	<p>From [Zone 1 programme] or [Zone 2 programme], select a wireless remote controller to be used for monitoring the room temperature from Zone 1 and Zone 2 separately.</p> <table border="1" data-bbox="347 259 1449 600"> <thead> <tr> <th data-bbox="347 259 911 309" rowspan="2">Control option *</th> <th colspan="2" data-bbox="911 259 1449 291">Corresponding initial settings room sensor</th> </tr> <tr> <th data-bbox="911 291 1270 313">[Zone 1]</th> <th data-bbox="1270 291 1449 313">[Zone 2]</th> </tr> </thead> <tbody> <tr> <td data-bbox="347 313 911 387">A Zone 1 ; Auto Adaptation (Target room temperature) Zone 2 ; Weather compensation curve or flow temperature control</td> <td data-bbox="911 313 1270 387">RC 1~8 (Wireless remote controller)</td> <td data-bbox="1270 313 1449 387">*1</td> </tr> <tr> <td data-bbox="347 387 911 461">B Zone 1 ; Auto Adaptation (Target room temperature) Zone 2 ; Weather compensation curve or flow temperature control</td> <td data-bbox="911 387 1270 461">TH1 (Room temperature thermistor (option))</td> <td data-bbox="1270 387 1449 461">*1</td> </tr> <tr> <td data-bbox="347 461 911 535">C Zone 1 ; Auto Adaptation (Target room temperature) Zone 2 ; Weather compensation curve or flow temperature control</td> <td data-bbox="911 461 1270 535">[MainRC] (Main remote controller)</td> <td data-bbox="1270 461 1449 535">*1</td> </tr> <tr> <td data-bbox="347 535 911 600">D Zone 1 ; Weather compensation curve or flow temperature control Zone 2 ; Weather compensation curve or flow temperature control</td> <td data-bbox="911 535 1270 600">*1</td> <td data-bbox="1270 535 1449 600">*1</td> </tr> </tbody> </table> <p data-bbox="1123 607 1461 629">* Refer to the website manual for details.</p> <p data-bbox="338 640 863 663">*1. Not specified (if a locally-supplied room thermostat is used)</p> <p data-bbox="363 663 943 685">RC 1-8 (if a wireless remote controller is used as a room thermostat)</p> <p data-bbox="338 685 1461 732">The wireless remote controller to be used can be changed up to 4 times within 24 hours according to the set time schedule. (Programme 1-5)</p>	Control option *	Corresponding initial settings room sensor		[Zone 1]	[Zone 2]	A Zone 1 ; Auto Adaptation (Target room temperature) Zone 2 ; Weather compensation curve or flow temperature control	RC 1~8 (Wireless remote controller)	*1	B Zone 1 ; Auto Adaptation (Target room temperature) Zone 2 ; Weather compensation curve or flow temperature control	TH1 (Room temperature thermistor (option))	*1	C Zone 1 ; Auto Adaptation (Target room temperature) Zone 2 ; Weather compensation curve or flow temperature control	[MainRC] (Main remote controller)	*1	D Zone 1 ; Weather compensation curve or flow temperature control Zone 2 ; Weather compensation curve or flow temperature control	*1	*1
Control option *	Corresponding initial settings room sensor																	
	[Zone 1]	[Zone 2]																
A Zone 1 ; Auto Adaptation (Target room temperature) Zone 2 ; Weather compensation curve or flow temperature control	RC 1~8 (Wireless remote controller)	*1																
B Zone 1 ; Auto Adaptation (Target room temperature) Zone 2 ; Weather compensation curve or flow temperature control	TH1 (Room temperature thermistor (option))	*1																
C Zone 1 ; Auto Adaptation (Target room temperature) Zone 2 ; Weather compensation curve or flow temperature control	[MainRC] (Main remote controller)	*1																
D Zone 1 ; Weather compensation curve or flow temperature control Zone 2 ; Weather compensation curve or flow temperature control	*1	*1																

## Service Menu

The service menu provides functions to be used by installer or service engineer. It is NOT intended for the home owner to alter settings within this menu. It is for this reason password protection is required to prevent unauthorised access to the service settings.

The factory default password is "0000".

Follow the procedure described in [Password protection] for the set up operation.

The service menu is navigated using the up and down icon to scroll through the functions. The menu is split across 4 screens and is comprised of the following functions;

1. Manual operation
2. Function settings
3. Thermistor adjustment
4. Auxiliary settings
5. Heat source setting
6. Pump speed
7. Heat pump settings
8. Operation settings
9. Energy monitor settings
10. External input settings
11. Thermo ON output
12. Commissioning wizard
13. Running information
14. Thermistor reading
15. Summary of settings
16. Error history
17. Password protection
18. Manual reset
19. SD card

Many functions cannot be set whilst the indoor unit is running. The installer should turn off the unit before trying to set these functions. If the installer attempts to change the settings whilst the unit is running the main remote controller will display a reminder message prompting the installer to stop operation before continuing. By selecting "Yes" the unit will cease operation.

### <Manual operation>

During the filling of the system the water circulation pump, 3-way valve and mixing valve 1 or 2 can be manually overridden using manual operation mode. When manual operation is selected a small timer icon appears in the screen. The function selected will only remain in manual operation for a maximum of 2 hours. This is to prevent accidental permanent override of the FTC.

#### ► Example

Touching the confirm icon ✓ will switch manual operation mode ON for the main 3-way valve. When filling of the DHW tank is complete the installer should access this menu again and touch the confirm icon ✓ to deactivate manual operation of the part. Alternatively after 2 hours manual operation mode will no longer be active and FTC will resume control of the part.

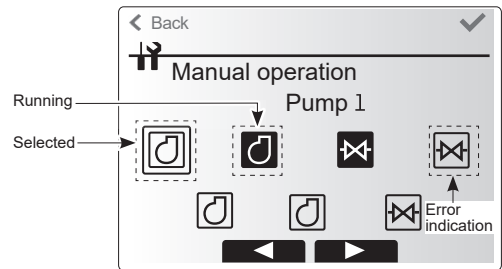

Manual operation menu screen

Manual operation and heat source setting cannot be selected if the system is running. A screen will be displayed asking the installer to stop the system before these modes can be activated. The system automatically stops 2 hours after the last operation.

### <Function settings>

1. Select function settings from the Service menu.
2. Touch the confirm icon ✓.
3. Ensure the Ref address and unit number are displayed to the right.
4. Touch the confirm icon ✓.
5. Touch the icon ▼▲ to select mode.
6. Touch the confirm icon ✓.
7. Touch the +/- icon to select number.
8. Touch the confirm icon ✓.

Setting	Unit	Mode	Number
Auto recovery after power failure	Grp	Mode1	1 - Inactive 2 - Active *1 3 - NO FUNCTION
Defrosting operation during DHW mode or Legionella prevention mode	1	Mode 10	1 - Heating circuit (default setting) 2 - DHW circuit *2 3 - NO FUNCTION

\*1 Approx. 4-minute delay after power is restored.

\*2 Defrosting operation can be performed in the heating circuit depending on conditions (operation time and temperature of the tank).

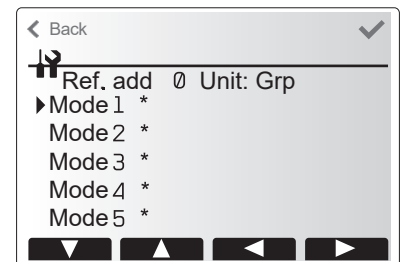
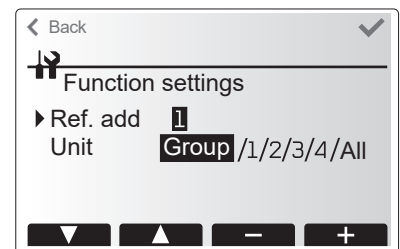

A number will be displayed on \* depending on the connected outdoor unit.

## <Thermistor adjustment>

This function allows adjustments to be made to the thermistor readings from -10 to 10°C in 0.5°C intervals.

- THW1: Thermistor (Flow water temp.)
- THW2: Thermistor (Return water temp.)
- THW5: Thermistor (DHW tank water temp.)
- THW6: Thermistor (Zone1 flow temp.)(Option)
- THW7: Thermistor (Zone1 return temp.)(Option)
- THW8: Thermistor (Zone2 flow temp.)(Option)
- THW9: Thermistor (Zone2 return temp.)(Option)
- THW10: Thermistor (Mixing tank temp.)(Option)
- THWB1: Thermistor (Boiler flow temp.)(Option)

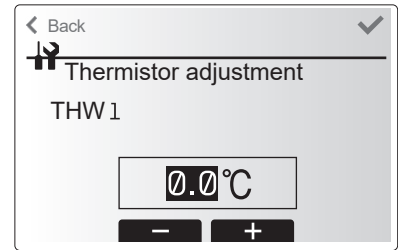

## <Auxiliary settings>

This function is used to set the parameters for any auxiliary parts used in the system

Menu subtitle	Function/ Description
Economy settings for pump	Water pump stops automatically in certain period of time from when operation is finished.
Delay	Time before pump switched off *1
Electric heater (Heating)	To select "WITH booster heater (ON)" or "WITHOUT booster heater (OFF)" in Heating mode.
Delay	The minimum time required for the booster heater to turn ON from after Heating mode has started.
Electric heater (DHW)	To select "WITH (ON)" or "WITHOUT (OFF)" booster heater or immersion heater individually in DHW mode.
Delay	The minimum time required for the booster heater or immersion heater to turn ON from after DHW mode has started. (This setting is applied for both booster and immersion heater.)
Mixing valve control 1/2	Period from valve fully open (at a hot water mixing ratio of 100%) to valve fully closed (at a cold water mixing ratio of 100%)
*2	Interval (min.) to control the Mixing valve.
Flow sensor *3	Minimum The minimum flow rate to be detected at Flow sensor.
	Maximum The maximum flow rate to be detected at Flow sensor.
Analogue output	Priority Normal; Prioritize the heater, High; Prioritize the analogue output.
Interval	Interval (min.) to control the analogue output.
Electric heater schedule	Determines the booster heater schedule in heating operation.

\*1 Decreasing "time before pump switched off" may increase the duration of stand-by in Heating/Cooling mode.

\*2 Set the Running time according to the specifications of the actuator of each mixing valve. It is recommended to set the interval to 2 minutes that is a default value. With the interval set longer, it could take longer to warm up a room.

\*3 Do not change the setting since it is set according to the specification of Flow sensor attached to the cylinder unit.

### Economy settings for pump

1. From the Auxiliary settings menu, select Economy Settings for water circulation pump.
2. Touch the confirm icon ✓.
3. The economy settings for water circulation pump screen is displayed.
4. Touch the check box to switch the economy settings ON/OFF.
5. Touch the +/- icon to adjust the time the water circulation pump will run. (3 to 60 minutes)

### Electric heater (Heating)

1. From the Auxiliary settings menu, select Electric heater (Heating).
2. Touch the confirm icon ✓.
3. The Electric heater (Heating) screen is displayed.
4. Touch the check box to switch the function ON/OFF.
5. Touch the +/- icon to adjust the time period of heat pump only operation before the booster heater will assist in space heating. (5 to 180 minutes)

### Electric heater (DHW)

1. From the Auxiliary settings menu, select Electric heater (DHW).
2. Touch the confirm icon ✓.
3. The Electric heater (DHW) screen is displayed.
4. Touch the check box to switch the function ON/OFF. (F1: booster heater, F2: immersion heater)
5. Touch the +/- icon to adjust the time period of heat pump only operation before the booster heater and the immersion heater (if present) will assist in DHW heating. (15 to 30 minutes)

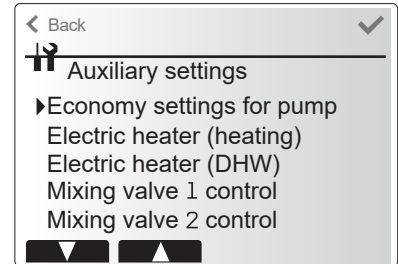

Auxiliary settings menu screen

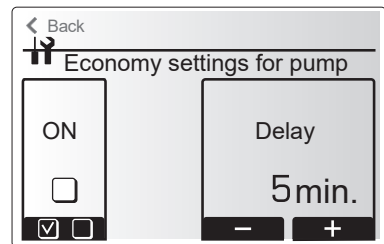

Economy settings for pump screen

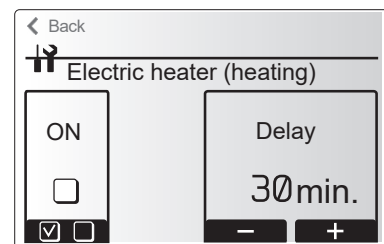

Electric heater (Heating) screen

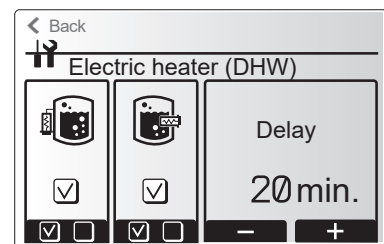

Electric heater (DHW) screen

### Mixing valve control 1/2

1. From the Auxiliary settings menu, select Mixing valve control 1/2.
2. Touch the confirm icon ✓.
3. The Mixing valve control screen is displayed.
4. Use the +/- icon to set Running time between 10 to 240 seconds. The Running time equals to a period from full open of the valve (at a hot water mixing ratio of 100%) to full close (at a cold water mixing ratio of 100%).

**Note: Set the Running time according to the specifications of the actuator of each mixing valve.**

1. From the Auxiliary settings menu, select Mixing valve control 1/2.
2. Touch the confirm icon ✓.
3. The Mixing valve control screen is displayed.
4. Touch the +/- icon to set the interval between 2-zone temperature controls of the mixing valve between 1 to 30 minutes.

**Note: It is recommended to set the interval to 2 minutes that is a default value. With the interval set longer, it could take longer to warm up a room.**

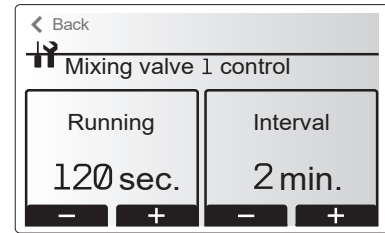

Mixing valve 1 control setting screen

### Flow sensor

1. From the Auxiliary settings menu, select Flow sensor.
2. Touch the confirm icon ✓.
3. Touch the +/- icon to select a refrigerant address of which you wish to configure or check the settings, and touch the confirm icon ✓. \*1
4. The Flow sensor screen is displayed.
5. Touch the +/- icon to set the minimum flow rate of flow sensor between 0 to maximum L/min.
6. Touch the +/- icon to set the maximum flow rate of flow sensor between minimum to 100L/min.

\*1 For multiple outdoor units control system only.

**Note: Do not change the setting since it is set according to the specification of Flow sensor attached to the cylinder unit.**

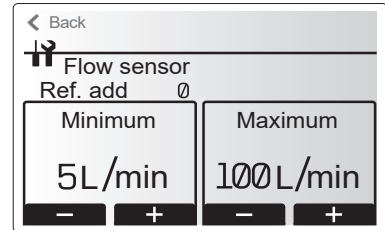

Flow sensor setting screen

### <Heat source setting>

The default heat source setting is heat pump and all electric heaters present in the system to be operational. This is referred to as Standard operation on the menu.



Heat source setting screen

### <Pump speed>

1. From the Service menu, select Pump speed.
2. Touch the confirm icon ✓.
3. Touch the +/- icon to select a refrigerant address of which you wish to configure or check the settings, and touch the confirm icon ✓. \*1
4. The Pump speed screen is displayed.
5. Touch the +/- icon to set the pump speed (1 to 5) of DHW operation.
6. Touch the +/- icon to set the pump speed (1 to 5) of space heating(cooling) operation.

\*1 For multiple outdoor units control system only.

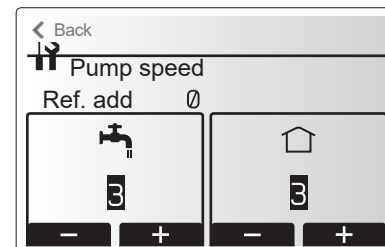

Pump speed setting screen

## <Operation settings>

### Heating operation

This function allows operational setting of flow temperature range from the Ecodan and also the time interval at which the FTC collects and processes data for the auto adaptation mode.

Menu subtitle		Function	Range	Unit	Default
Flow temp. range	Minimum temp.	To minimize the loss by frequent ON and OFF in mild outdoor ambient temperature seasons.	20 to 45	°C	30
	Maximum temp.	To set max. possible flow temperature according to the type of heat emitters.	35 to 60/70/75	°C	50
Room temp. control	Mode	Setting for Room temp. control At Quick mode, target outlet water temperature will set higher than the one set at Normal mode. This reduces the time to reach the target room temperature when the room temperature is relatively low.*	Auto/Quick/Normal/Slow	—	Auto
	Interval	Selectable according to the heat emitter type and the materials of floor (i.e. radiators, floor heating-thick, -thin concrete, wood, etc.)	10 to 60	min.	10
Heat pump thermo diff.adjust	ON/OFF	To minimize the loss by frequent ON and OFF in mild outdoor ambient temperature seasons.	ON/OFF	—	ON
	Lower limit	Prohibits heat pump operation until the flow temperature drops below the target flow temperature plus lower limit value.	-9 to -1	°C	-5
	Upper limit	Allows heat pump operation until the flow temperature rises above the target flow temperature plus upper limit value.	+3 to +5	°C	+5

< Heating operation (Room temp. control table) >

#### Notes:

1. The minimum flow temperature that prohibits heat pump operation is 20°C.
2. The maximum flow temperature that allows heat pump operation equals to the maximum temperature set in the Flow temp. range menu.

\* Quick mode may be not efficient and will increase running cost compared to normal mode.

### Freeze stat function

Menu subtitle	Function/ Description
Freeze stat function *1	An operational function to prevent the water circuit from freezing when outdoor ambient temperature drops.
Flow t.	The target outlet water temperature at water circuit when operating in Freeze stat function. *2
Outdoor ambient temp.	Minimum outdoor ambient temperature which freeze stat function will begin to operate, (3-20°C) or choose**. If asterisk (**) is chosen freeze stat function is deactivated. (i.e. primary water freeze risk)"

\*1. When the system is turned off, freeze stat function is not enabled.

\*2. Flow t. is fixed to 20°C and unchangeable.

### Simultaneous Operation

For periods of very low outdoor ambient temperature this mode can be used. Simultaneous operation allows both DHW and space heating to run together by using the heat pump and/or booster heater to provide space heating whilst only the immersion heater provides heating for DHW. This operation is only available if BOTH a DHW tank AND immersion heater are present on the system.

- Range of outdoor ambient temperature at which simultaneous operation starts is -30 to 10°C (default -15°C).
- System shall automatically return to routine operation. This will happen when the outdoor ambient temperature rises above the selected temperature for this specific mode of operation.

### Cold weather function

For extremely low outdoor ambient temperature conditions when the heat pump's capacity is restricted, the heating or DHW is provided only by the electric booster heater (and immersion if present). This function is intended for use during extreme cold periods only. Extensive use of direct electrical heaters ONLY will result in higher power consumption and may reduce working life of heaters and related parts.

Manual operation and heat source setting cannot be selected if the system is running. A screen will be displayed asking the installer to stop the system before these modes can be activated.  
The system automatically stops 2 hours after last operation

Target flow temp. (°C)

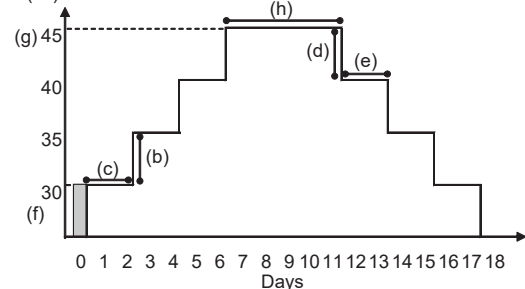

- This function is not available when a PUHZ-FRP outdoor unit is connected.
- Disconnect wiring to external inputs of room thermostat, demand control, and outdoor thermostat, or the target flow temperature may not be maintained.

### Floor dry up function

The Floor dry up function automatically changes the target hot water temperature in stages to gradually dry concrete when this particular type of underfloor heating system is installed.

Upon completion of the operation the system stops all the operations except the Freeze stat.

For Floor dry up function, the target flow temp. of Zone1 is the same as that of Zone2.

Functions	Symbol	Description	Option/Range	Unit	Default	
[Floor dry up function]	a	Set the function to on and power on the system using the main remote controller, and the dry up heating operation will start.	on/off	—	off	
[Flow temperature increase]	[Temperature increase step]	b	It sets the increase step of the target flow temperature.	+1 to +30	°C	+5
	[Increase interval]	c	It sets the period for which the same target flow temperature is maintained.	1 to 7	day	2
[Flow temperature decrease]	[Temperature decrease step]	d	It sets the decrease step of the target flow temperature.	-1 to -30	°C	-5
	[Decrease interval]	e	It sets the period for which the same target flow temperature is maintained.	1 to 7	day	2
[Target temperature]	[Start & End]	f	It sets the target flow temperature at the start and the finish of the operation.	20 to 60/70/75*	°C	30
	[Max temperature]	g	It sets the maximum target flow temperature.	20 to 60/70/75*	°C	45
	[Max temperature period]	h	It sets the period for which the maximum target flow temperature is maintained.	1 to 20	day	5

\* The maximum temperature differs depending on the connected outdoor unit.

## <Energy monitor setting>

### 1. General description

End user can monitor accumulated\*1 consumption and production energy in each operation mode\*2 on the main remote controller.

\*1 Monthly and Year to date

\*2 - DHW operation

- Space heating
- Space cooling

Refer to "9-1. Main remote controller" on the paper-based manual for how to check the energy, and "6-6. DIP switch functions" on the paper-based manual for the details on DIP-SW setting. Either one of the following two methods is used for monitoring.

**Note: Method 1 should be used as a guide. If a certain accuracy is required, the 2nd method should be used.**

	Booster heater 1	Booster heater 2	Immersion heater *3	Pump 1 *4
Default	2 kW	4 kW	0 kW	*** (factory fitted pump)
EHST17D-VM2E	2 kW	0 kW	0 kW	***
EHST17D-YM9E	3 kW	6 kW	0 kW	***
EHST20D-VM2E	2 kW	0 kW	0 kW	***
EHST20D-VM6E	2 kW	4 kW	0 kW	***
EHST20D-YM9E	3 kW	6 kW	0 kW	***
EHST20D-TM9E	3 kW	6 kW	0 kW	***
EHST30D-MEE	0 kW	0 kW	0 kW	***
EHST30D-VM6EE	2 kW	4 kW	0 kW	***
EHST30D-YM9EE	3 kW	6 kW	0 kW	***
EHST30D-TM9EE	3 kW	6 kW	0 kW	***
ERST17D-VM2E	2 kW	0 kW	0 kW	***
ERST17D-VM6E	2 kW	4 kW	0 kW	***
ERST20D-VM2E	2 kW	0 kW	0 kW	***
ERST20D-VM6E	2 kW	4 kW	0 kW	***
ERST20D-YM9E	3 kW	6 kW	0 kW	***
ERST30D-VM2EE	2 kW	0 kW	0 kW	***
ERST30D-VM6EE	2 kW	4 kW	0 kW	***
ERST30D-YM9EE	3 kW	6 kW	0 kW	***
ERST17D-VM2BE	2 kW	0 kW	0 kW	***
ERST17D-VM6BE	2 kW	4 kW	0 kW	***
ERST17D-YM9BE	3 kW	6 kW	0 kW	***
ERST20F-VM2E	2 kW	0 kW	0 kW	***

	Booster heater 1	Booster heater 2	Immersion heater *3	Pump 1 *4
ERST20F-VM6E	2 kW	4 kW	0 kW	***
ERST20F-YM9E	3 kW	6 kW	0 kW	***
ERST20F-TM9E	3 kW	6 kW	0 kW	***
ERST30F-VM2EE	2 kW	0 kW	0 kW	***
ERST30F-VM6EE	2 kW	4 kW	0 kW	***
ERST30F-YM9EE	3 kW	6 kW	0 kW	***
ERST30F-TM9EE	3 kW	6 kW	0 kW	***
ERST20C-VM2E	2 kW	0 kW	0 kW	***
ERST30C-VM2EE	2 kW	0 kW	0 kW	***
EHPT17X-VM2E	2 kW	0 kW	0 kW	***
EHPT17X-VM6E	2 kW	4 kW	0 kW	***
EHPT17X-YM9E	3 kW	6 kW	0 kW	***
EHPT20X-YM9E	3 kW	6 kW	0 kW	***
EHPT20X-TM9E	3 kW	6 kW	0 kW	***
EHPT20X-MEHEW	0 kW	0 kW	3 kW	***
EHPT30X-YM9EE	3 kW	6 kW	0 kW	***
ERPT17X-VM2E	2 kW	0 kW	0 kW	***
ERPT20X-VM2E	2 kW	0 kW	0 kW	***
ERPT20X-VM6E	2 kW	4 kW	0 kW	***
ERPT20X-YM9E	3 kW	6 kW	0 kW	***
ERPT30X-VM2EE	2 kW	0 kW	0 kW	***
ERPT30X-VM6EE	2 kW	4 kW	0 kW	***
ERPT30X-YM9EE	3 kW	6 kW	0 kW	***

#### (1) Calculation internally

Electricity consumption is calculated internally based on the energy consumption of outdoor unit, electric heater, water pump(s) and other auxiliaries.\*3

Delivered heat is calculated internally by multiplying delta T (Flow and Return temp.) and flow rate measured by the factory fitted sensors.

Set the electric heater capacity and water pump(s) input according to indoor model name and specs of additional pump(s) supplied locally. (Refer to the menu tree in "9-4. Main Settings Menu")

\*1 Change setting to 3kW when connecting optional immersion heater "PAC-IH03V2-E".

\*2 "\*\*\*\*" displayed in the energy monitor setting mode means the factory fitted pump is connected as Pump 1 so that the input is automatically calculated.

\*3 When the cylinder unit is connected with a PUHZ-FRP or PUMY models, electricity consumption is not calculated internally. To display the electricity consumption, conduct the 2nd method.

When additional pumps supplied locally are connected as Pump2/3, change setting according to specs of the pumps.

When anti-freeze solution (propylene glycol) is used for primary water circuit, set the delivered energy adjustment if necessary.

For further detail of above, refer to "5.7 Main remote controller".

#### (2) Actual measurement by external meter (locally supplied)

FTC has external input terminals for 2 'Electric energy meters' and a 'Heat meter'.

If two 'Electric energy meters' are connected, the 2 recorded values will be combined at the FTC and shown on the main remote controller.

(e.g. Meter 1 for H/P power line, Meter 2 for heater power line)

Refer to the [Signal inputs] in section "6. WIRING DIAGRAM" for more information on connectable electric energy meter and heat meter.

#### ● Connectable electric energy meter and heat meter

- Pulse meter type Voltage free contact for 12VDC detection by FTC (TBI.3 1, 3 and 5 pin have a positive voltage.)
- Pulse duration Minimum ON time: 40 ms  
Minimum OFF time: 100 ms
- Possible unit of pulse 0.1 pulse/kWh 1 pulse/kWh 10 pulse/kWh  
100 pulse/kWh 1000 pulse/kWh

Those values can be set by the main remote controller. (Refer to the menu tree in "9-4. Main Settings Menu".)

## 2. Settings using the main remote controller

In this menu, all parameters required to record the consumed electrical energy and the delivered heat energy which is displayed on the main remote controller can be set. The parameters are an electric heater capacity, supply power of water pump and heat meter pulse.

Follow the procedure described in General Operation for the set up operation.

For Pump 1, \*\*\* can be also set besides this setting.

In the case \*\*\* is selected, the system acknowledges "factory fitted pump" is selected.

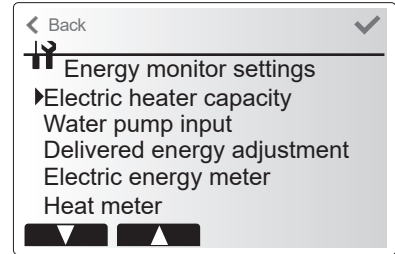

Energy monitor settings menu screen

## <External input settings>

### Demand control (IN4)

The selection of "OFF", whilst a signal is being sent to IN4, forcefully stops all the heat source operations and the selection of "Boiler" stops operations of heat pump and electric heater and performs boiler operation.

### Outdoor thermostat (IN5)

The selection of "Heater", whilst a signal is being sent to IN5, performs only electric heater operation and the selection of "Boiler" performs boiler operation.

### Cooling limit temp. (IN15)

Dew point thermostat can be connected to IN15. (To avoid condensation) When the input signal (IN15) is ON, the cooling target flow temperature is limited by remote controller.

Note : For outdoor unit protection, this target temp. is kept 60 minutes after changing IN15 input.

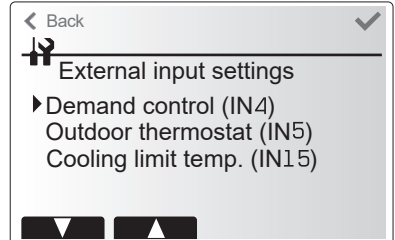

External input settings menu screen

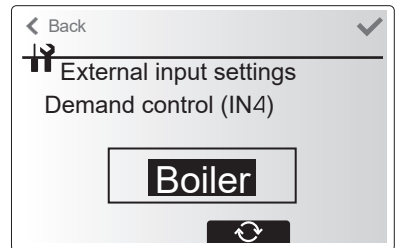

Demand control screen

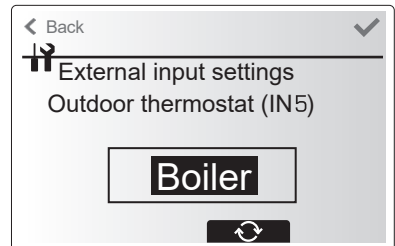

Outdoor thermostat setting screen

## <Running information>

This function shows current temperature and other data of main component parts of both the indoor and outdoor units.

1. From the Service menu, select Running information.
2. Touch the confirm icon ✓.
3. Touch the +/- icon to set the Ref. address. \*1
4. Enter index code for the component to be viewed.
5. Touch the confirm icon ✓.

\*1 For multiple outdoor units control system only.

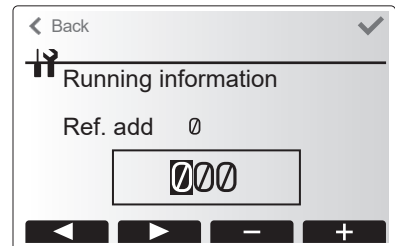

## <Thermistor reading>

This function shows the current readings of thermistors located on the water and refrigerant circuit

Thermistor	Description	Thermistor	Description
TH1A	Zone1 room temperature	TH7	Ambient (outdoor) temperature
TH1B	Zone2 room temperature	THW6	Zone1 flow temperature
TH2	Refrigerant return temperature	THW7	Zone1 return temperature
THW1	Flow water temperature	THW8	Zone2 flow temperature
THW2	Return water temperature	THW9	Zone2 return temperature
THW5A	DHW tank upper water temperature	THW10	Mixing tank temperature
THW5B	DHW tank lower water temperature	THWB1	Boiler flow temperature

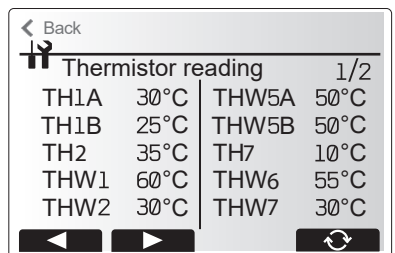

### <Summary of settings>

This function shows the current installer/user entered settings.

Abbreviation	Explanation	Abbreviation	Explanation
<b>HWtemp</b>	DHW max. temperature	<b>Z2 mode</b>	Operation mode
<b>HWdrop</b>	DHW temperature drop		- HER (Heating room temperature)
<b>HWtime</b>	DHW max. operation time		- HE (Heating flow temperature)
<b>NO HW</b>	DHW mode restriction		- HCC (Heating compensation curve)
<b>HWset</b>	DHW operation mode (Normal/Eco)		- COR (—)
<b>Ltemp</b>	Legionella hot water temperature		- CO (Cooling flow temperature /Cooling weather compensation curve)
<b>Lfreq</b>	Legionella operation Frequency	<b>Hroom 1</b>	Heating target room temperature
<b>Lstart</b>	Legionella mode start time	<b>Hroom 2</b>	Heating target room temperature
<b>Ltime</b>	Legionella max. operation time	<b>Hflow 1</b>	Heating target flow temperature
<b>Lkeep</b>	Duration of max. (Legionella) hot water temperature	<b>Hflow 2</b>	Heating target flow temperature
<b>Z1 mode</b>	Operation mode	<b>Croom 1</b>	Cooling target room temperature
	- HER (Heating room temperature)	<b>Croom 2</b>	Cooling target room temperature
	- HE (Heating flow temperature)	<b>Cflow 1</b>	Cooling target flow temperature
	- HCC (Heating compensation curve)	<b>Cflow 2</b>	Cooling target flow temperature
	- COR (—)	<b>FSflow</b>	Freeze stat function flow temperature
	- CO (Cooling flow temperature /Cooling weather compensation curve)	<b>FSout</b>	Freeze stat function ambient temperature

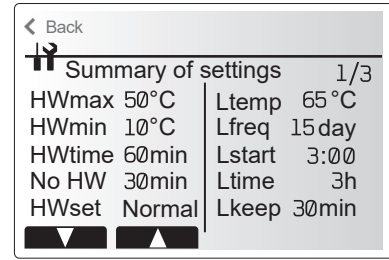

### <Error history>

Error history allows the service engineer to view previous check codes, the unit address and the date on which they occurred. Up to 16 check codes can be stored in the history the most recent Error event is displayed at the top of the list.

1. From the service menu select Error history
2. Touch the confirm icon ✓.

Please see "10-4. Self-diagnosis and action" for check code diagnosis and actions.

To delete an Error history item;

1. From Error history screen touch rubbish icon
2. Then touch Yes icon.

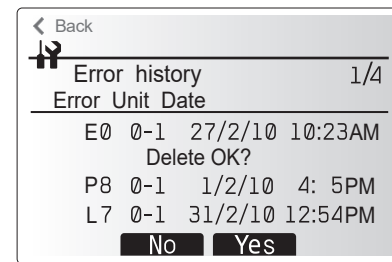
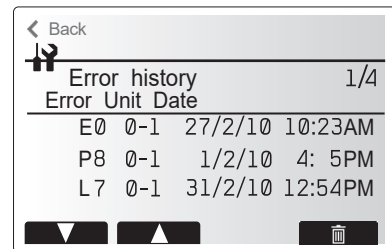

### <Password protection>

Password protection is available to prevent unauthorised access to the service menu by untrained persons.

#### Resetting the password

If you forget the password you entered, or have to service a unit somebody else installed, you can reset the password to the factory default of 0000.

1. From the main settings menu, select Password protection.
2. Touch the confirm icon ✓.
3. When password input screen is displayed, touch left and right icon ( / ) to move left and right between the 4 digits, set a password with the +/- icon.
4. When you have input your password, touch the confirm icon ✓.
5. The password verify screen is displayed.
6. To verify your new password, touch Yes icon.
7. Your password is now set and the completion screen is displayed.

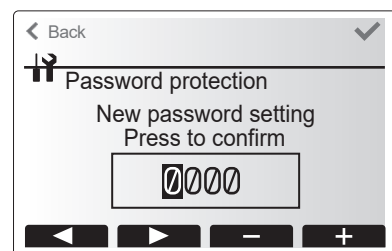

Password input screen

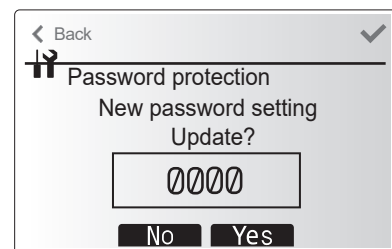

Password verify screen

### Password reset

If you forget the password you entered, or have to service a unit somebody else installed, you can reset and change the password.

1. From [Service] in [Menu], access the [Password protection] screen.
2. Press and hold the title section for 3 seconds to access the [Password reset] screen.
3. Enter a new password.
4. Touching [Back] or the confirm icon ✓ saves the password.

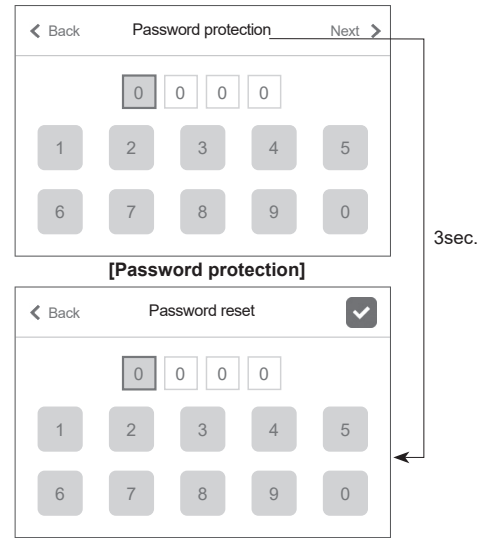

### <Manual reset>

Should you wish to restore the initial settings at any time, you should use the manual reset function. Please note this will reset ALL functions to the factory default settings.

1. From the service menu, select manual reset.
2. Touch the confirm icon ✓.
3. The Manual reset screen is displayed.
4. Choose either Manual Reset for Flow temperature controller or Main remote controller.
5. Touch confirm icon ✓ to confirm manual reset of chosen device.

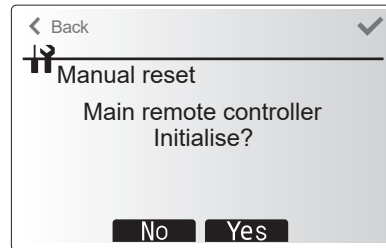
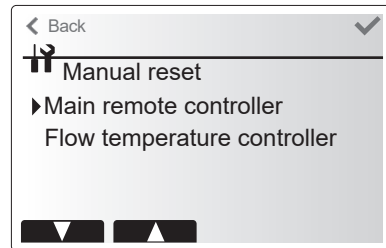

### <SD card>

The use of an SD memory card simplifies the main remote controller settings in the field.

\*Ecodan service tool (for use with PC tool) is necessary for the setting.

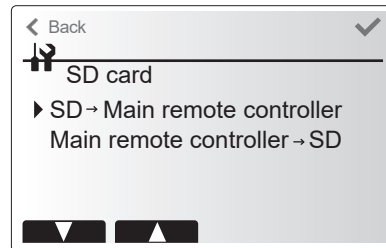

### SD → Main RC

1. From the SD card setting, select "SD → Main remote controller".
  2. Touch the confirm icon ✓.
  3. Touch the +/- icon to set the Ref. address. \*1
  4. Touch left/right icon (◀▶) and check icon (☑/☐) to select a menu to write to the main remote controller.
  5. Touch the confirm icon ✓ to start downloading.
  6. Wait for a few minutes until "Complete!" appears. \*2
- \*1 For multiple outdoor units control system only.  
\*2 Be sure to check that the setting values are suitable for the connected outdoor and indoor units.

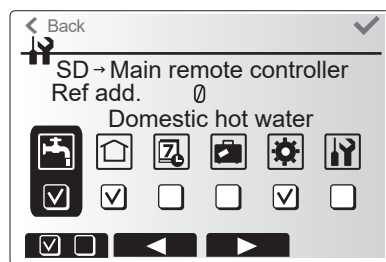

### Main RC → SD

1. From the SD card setting, select "Main remote controller → SD".
  2. Touch the confirm icon ✓.
  3. Touch the +/- icon to set the Ref. address. \*1
  4. Touch left/right icon (◀▶) and check icon (☑/☐) to select a menu to write to the SD memory card.
  5. Touch the confirm icon ✓ to start uploading.
  6. Wait for a few minutes until "Complete!" appears.
- \*1 For multiple outdoor units control system only.

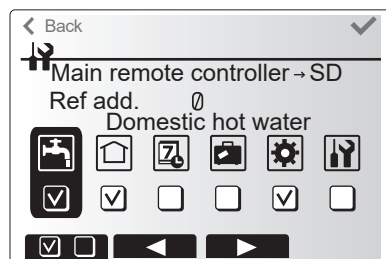

Request code	Request content	Range	Unit
103	Error history 1 (latest)	Displays error history. ("—" is displays if no history is present.)	Code
104	Error history 2 (second to last)	Displays error history. ("—" is displays if no history is present.)	—
105	Error history 3 (third to last)	Displays error history. ("—" is displays if no history is present.)	—
154	Water circulation pump 1 - Accumulated operating time (after reset)	0 to 9999	10 hours
156	Water circulation pump 2 - Accumulated operating time (after reset)	0 to 9999	10 hours
157	Water circulation pump 3 - Accumulated operating time (after reset)	0 to 9999	10 hours
158	Water circulation pump 4 - Accumulated operating time (after reset)	0 to 9999	10 hours
162	Indoor unit - DIP SW1 setting information	Refer to detail contents described hereinafter.	—
163	Indoor unit - DIP SW2 setting information	Refer to detail contents described hereinafter.	—
164	Indoor unit - DIP SW3 setting information	Refer to detail contents described hereinafter.	—
165	Indoor unit - DIP SW4 setting information	Refer to detail contents described hereinafter.	—
166	Indoor unit - DIP SW5 setting information	Refer to detail contents described hereinafter.	—
175	Indoor unit - Output signal information	Refer to detail contents described hereinafter.	—
176	Indoor unit - Input signal information	Refer to detail contents described hereinafter.	—
177	Mixing valve 2 opening step	0 to 10	Step
180	Mixing valve 1 opening step	0 to 10	Step
190	Indoor unit - Software version 1st 4 digits	Refer to Note below.	—
191	Indoor unit - Software version last 4 digits	Refer to Note below.	—
200	Initialisation of Function Setting	—	—
340	Water circulation pump 1 - Accumulated operating time reset	—	—
342	Water circulation pump 2 - Accumulated operating time reset	—	—
343	Water circulation pump 3 - Accumulated operating time reset	—	—
344	Water circulation pump 4 - Accumulated operating time reset	—	—
504	Indoor unit - Zone1 room temp. (TH1A)	-39 to 88	°C
505	Indoor unit - Ref. liquid temp. (TH2)	-39 to 88	°C
506	Indoor unit - Return water temp. (THW2)	-39 to 88	°C
507	Indoor unit - Zone2 room temp. (TH1B)	-39 to 88	°C
508	Indoor unit - DHW tank lower water temp. (THW5B)	-39 to 88	°C
509	Indoor unit - Zone1 flow water temp. (THW6)	-39 to 88	°C
510	Indoor unit - Outside air temp. (TH7)	-39 to 88	°C
511	Indoor unit - Flow water temp. (THW1)	-39 to 88	°C
512	Indoor unit - Zone1 return water temp. (THW7)	-39 to 88	°C
513	Indoor unit - Zone2 flow water temp. (THW8)	-39 to 88	°C
514	Indoor unit - Zone2 return water temp. (THW9)	-39 to 88	°C
515	Indoor unit - Boiler flow water temp. (THWB1)	-40 to 140	°C
534	Indoor unit - DHW tank upper water temp. (THW5A)	-39 to 88	°C
535	Indoor unit - Mixing tank water temp. (THW10)	-40 to 140	°C
540	Flow rate of the primary circuit	0 to 100	L/min
550	Indoor unit - Error postponement history 1 (latest)	Displays postponement code. ("—" is displays if no postponement code is present.)	—
551	Indoor unit - Operation control at time of error	0 Standard, 1 Heater, 2 Boiler	—
552	Indoor unit - Operation mode at time of error	0: OFF, 1: DHW, 2: Heating, 3: Cooling, 4: Legionella prevention, 5: Freeze protection, 6: Operation stop, 7: Defrost	—
553	Indoor unit - Output signal information at time of error	Refer to detail contents described hereinafter.	—
554	Indoor unit - Input signal information at time of error	Refer to detail contents described hereinafter.	—
555	Indoor unit - Zone1 room temp. (TH1A) at time of error	-39 to 88	°C
556	Indoor unit - Zone2 room temp. (TH1B) at time of error	-39 to 88	°C
557	Indoor unit - Ref. liquid temp. (TH2) at time of error	-39 to 88	°C
558	Indoor unit - Flow water temp. (THW1) at time of error	-39 to 88	°C
559	Indoor unit - Return water temp. (THW2) at time of error	-39 to 88	°C
560	Indoor unit - DHW tank water temp. (THW5) at time of error	-39 to 88	°C
561	Indoor unit - Zone1 flow water temp. (THW6) at time of error	-39 to 88	°C
562	Indoor unit - Zone1 return water temp. (THW7) at time of error	-39 to 88	°C
563	Indoor unit - Zone2 flow water temp. (THW8) at time of error	-39 to 88	°C
564	Indoor unit - Zone2 return water temp. (THW9) at time of error	-39 to 88	°C
565	Indoor unit - Boiler flow water temp. (THWB1) at time of error	-40 to 140	°C
567	Indoor unit - Failure (P1/P2/L5/L8/Ld) thermistor	0: Failure thermistor is none, 1: TH1A, 2: TH2, 3: THW1, 4: THW2, 5: THWB1, 6: THW5B, 8: TH1B, A: THW6, B: THW7, C: THW8, D: THW9	—
568	Mixing valve 2 opening step at time of error	0 to 10	Step
569	Operated Flow switch at time of failure (L9)	0: No operated flow switch, 1: Flow switch 1, 2: Flow switch 2, 3: Flow switch 3	—
571	Flow rate at time of error	0 to 100	L/min
575	Mixing valve 1 opening step at time of error	0 to 10	Step

**Note:**

Refer to outdoor unit service manual for request code 0 to 102, 106 to 149.

Request codes 103 to 105 indicate error histories of both indoor and outdoor units.

As only 4 digits can be displayed at one time, the software version number is displayed in two halves.

Enter code 190 to see the first 4 digits and code 191 to see the last 4 digits.

For example software version No. 5.01 A000, when code 190 is entered 0501 is displayed, when code 191 is entered A000 is displayed.

Request code 200 resets all Function Setting to the factory default settings.

**Indoor unit switch setting display (Request code: 162 to 166)**

0: OFF 1: ON

SW1, SW2, SW3, SW4, SW5								Display
1	2	3	4	5	6	7	8	
0	0	0	0	0	0	0	0	00 00
1	0	0	0	0	0	0	0	00 01
0	1	0	0	0	0	0	0	00 02
1	1	0	0	0	0	0	0	00 03
0	0	1	0	0	0	0	0	00 04
1	0	1	0	0	0	0	0	00 05
0	1	1	0	0	0	0	0	00 06
1	1	1	0	0	0	0	0	00 07
0	0	0	1	0	0	0	0	00 08
1	0	0	1	0	0	0	0	00 09
0	1	0	1	0	0	0	0	00 0A
1	1	0	1	0	0	0	0	00 0B
0	0	1	1	0	0	0	0	00 0C
1	0	1	1	0	0	0	0	00 0D
0	1	1	1	0	0	0	0	00 0E
1	1	1	1	0	0	0	0	00 0F
0	0	0	0	1	0	0	0	00 10
1	0	0	0	1	0	0	0	00 11
0	1	0	0	1	0	0	0	00 12
1	1	0	0	1	0	0	0	00 13
0	0	1	0	1	0	0	0	00 14
1	0	1	0	1	0	0	0	00 15
0	1	1	0	1	0	0	0	00 16
1	1	1	0	1	0	0	0	00 17
0	0	0	1	1	0	0	0	00 18
1	0	0	1	1	0	0	0	00 19
0	1	0	1	1	0	0	0	00 1A
1	1	0	1	1	0	0	0	00 1B
0	0	1	1	1	0	0	0	00 1C
1	0	1	1	1	0	0	0	00 1D
0	1	1	1	1	0	0	0	00 1E
1	1	1	1	1	0	0	0	00 1F
0	0	0	0	0	1	0	0	00 20
1	0	0	0	0	1	0	0	00 21
0	1	0	0	0	1	0	0	00 22
1	1	0	0	0	1	0	0	00 23
0	0	1	0	0	1	0	0	00 24
1	0	1	0	0	1	0	0	00 25
0	1	1	0	0	1	0	0	00 26
1	1	1	0	0	1	0	0	00 27
0	0	0	1	0	1	0	0	00 28
1	0	0	1	0	1	0	0	00 29
0	1	0	1	0	1	0	0	00 2A
1	1	0	1	0	1	0	0	00 2B
0	0	1	1	0	1	0	0	00 2C
1	0	1	1	0	1	0	0	00 2D
0	1	1	1	0	1	0	0	00 2E
1	1	1	1	0	1	0	0	00 2F
0	0	0	0	1	1	0	0	00 30
1	0	0	0	1	1	0	0	00 31
0	1	0	0	1	1	0	0	00 32
1	1	0	0	1	1	0	0	00 33
0	0	1	0	1	1	0	0	00 34
1	0	1	0	1	1	0	0	00 35
0	1	1	0	1	1	0	0	00 36
1	1	1	0	1	1	0	0	00 37
0	0	0	1	1	1	0	0	00 38
1	0	0	1	1	1	0	0	00 39
0	1	0	1	1	1	0	0	00 3A
1	1	0	1	1	1	0	0	00 3B
0	0	1	1	1	1	0	0	00 3C
1	0	1	1	1	1	0	0	00 3D
0	1	1	1	1	1	0	0	00 3E
1	1	1	1	1	1	0	0	00 3F

0: OFF 1: ON

SW1, SW2, SW3, SW4, SW5								Display
1	2	3	4	5	6	7	8	
0	0	0	0	0	0	1	0	00 40
1	0	0	0	0	0	1	0	00 41
0	1	0	0	0	0	1	0	00 42
1	1	0	0	0	0	1	0	00 43
0	0	1	0	0	0	1	0	00 44
1	0	1	0	0	0	1	0	00 45
0	1	1	0	0	0	1	0	00 46
1	1	1	0	0	0	1	0	00 47
0	0	0	1	0	0	1	0	00 48
1	0	0	1	0	0	1	0	00 49
0	1	0	1	0	0	1	0	00 4A
1	1	0	1	0	0	1	0	00 4B
0	0	1	1	0	0	1	0	00 4C
1	0	1	1	0	0	1	0	00 4D
0	1	1	1	0	0	1	0	00 4E
1	1	1	1	0	0	1	0	00 4F
0	0	0	0	1	0	1	0	00 50
1	0	0	0	1	0	1	0	00 51
0	1	0	0	1	0	1	0	00 52
1	1	0	0	1	0	1	0	00 53
0	0	1	0	1	0	1	0	00 54
1	0	1	0	1	0	1	0	00 55
0	1	1	0	1	0	1	0	00 56
1	1	1	0	1	0	1	0	00 57
0	0	0	1	1	0	1	0	00 58
1	0	0	1	1	0	1	0	00 59
0	1	0	1	1	0	1	0	00 5A
1	1	0	1	1	0	1	0	00 5B
0	0	1	1	1	0	1	0	00 5C
1	0	1	1	1	0	1	0	00 5D
0	1	1	1	1	0	1	0	00 5E
1	1	1	1	1	0	1	0	00 5F
0	0	0	0	0	1	1	0	00 60
1	0	0	0	0	1	1	0	00 61
0	1	0	0	0	1	1	0	00 62
1	1	0	0	0	1	1	0	00 63
0	0	1	0	0	1	1	0	00 64
1	0	1	0	0	1	1	0	00 65
0	1	1	0	0	1	1	0	00 66
1	1	1	0	0	1	1	0	00 67
0	0	0	1	0	1	1	0	00 68
1	0	0	1	0	1	1	0	00 69
0	1	0	1	0	1	1	0	00 6A
1	1	0	1	0	1	1	0	00 6B
0	0	1	1	0	1	1	0	00 6C
1	0	1	1	0	1	1	0	00 6D
0	1	1	1	0	1	1	0	00 6E
1	1	1	1	0	1	1	0	00 6F
0	0	0	0	1	1	1	0	00 70
1	0	0	0	1	1	1	0	00 71
0	1	0	0	1	1	1	0	00 72
1	1	0	0	1	1	1	0	00 73
0	0	1	0	1	1	1	0	00 74
1	0	1	0	1	1	1	0	00 75
0	1	1	0	1	1	1	0	00 76
1	1	1	0	1	1	1	0	00 77
0	0	0	1	1	1	1	0	00 78
1	0	0	1	1	1	1	0	00 79
0	1	0	1	1	1	1	0	00 7A
1	1	0	1	1	1	1	0	00 7B
0	0	1	1	1	1	1	0	00 7C
1	0	1	1	1	1	1	0	00 7D
0	1	1	1	1	1	1	0	00 7E
1	1	1	1	1	1	1	0	00 7F

**Indoor unit switch setting display (Request code: 162 to 166)**

0: OFF 1: ON

SW1, SW2, SW3, SW4, SW5								Display
1	2	3	4	5	6	7	8	
0	0	0	0	0	0	0	1	00 80
1	0	0	0	0	0	0	1	00 81
0	1	0	0	0	0	0	1	00 82
1	1	0	0	0	0	0	1	00 83
0	0	1	0	0	0	0	1	00 84
1	0	1	0	0	0	0	1	00 85
0	1	1	0	0	0	0	1	00 86
1	1	1	0	0	0	0	1	00 87
0	0	0	1	0	0	0	1	00 88
1	0	0	1	0	0	0	1	00 89
0	1	0	1	0	0	0	1	00 8A
1	1	0	1	0	0	0	1	00 8B
0	0	1	1	0	0	0	1	00 8C
1	0	1	1	0	0	0	1	00 8D
0	1	1	1	0	0	0	1	00 8E
1	1	1	1	0	0	0	1	00 8F
0	0	0	0	1	0	0	1	00 90
1	0	0	0	1	0	0	1	00 91
0	1	0	0	1	0	0	1	00 92
1	1	0	0	1	0	0	1	00 93
0	0	1	0	1	0	0	1	00 94
1	0	1	0	1	0	0	1	00 95
0	1	1	0	1	0	0	1	00 96
1	1	1	0	1	0	0	1	00 97
0	0	0	1	1	0	0	1	00 98
1	0	0	1	1	0	0	1	00 99
0	1	0	1	1	0	0	1	00 9A
1	1	0	1	1	0	0	1	00 9B
0	0	1	1	1	0	0	1	00 9C
1	0	1	1	1	0	0	1	00 9D
0	1	1	1	1	0	0	1	00 9E
1	1	1	1	1	0	0	1	00 9F
0	0	0	0	0	1	0	1	00 A0
1	0	0	0	0	1	0	1	00 A1
0	1	0	0	0	1	0	1	00 A2
1	1	0	0	0	1	0	1	00 A3
0	0	1	0	0	1	0	1	00 A4
1	0	1	0	0	1	0	1	00 A5
0	1	1	0	0	1	0	1	00 A6
1	1	1	0	0	1	0	1	00 A7
0	0	0	1	0	1	0	1	00 A8
1	0	0	1	0	1	0	1	00 A9
0	1	0	1	0	1	0	1	00 AA
1	1	0	1	0	1	0	1	00 AB
0	0	1	1	0	1	0	1	00 AC
1	0	1	1	0	1	0	1	00 AD
0	1	1	1	0	1	0	1	00 AE
1	1	1	1	0	1	0	1	00 AF
0	0	0	0	1	1	0	1	00 B0
1	0	0	0	1	1	0	1	00 B1
0	1	0	0	1	1	0	1	00 B2
1	1	0	0	1	1	0	1	00 B3
0	0	1	0	1	1	0	1	00 B4
1	0	1	0	1	1	0	1	00 B5
0	1	1	0	1	1	0	1	00 B6
1	1	1	0	1	1	0	1	00 B7
0	0	0	1	1	1	0	1	00 B8
1	0	0	1	1	1	0	1	00 B9
0	1	0	1	1	1	0	1	00 BA
1	1	0	1	1	1	0	1	00 BB
0	0	1	1	1	1	0	1	00 BC
1	0	1	1	1	1	0	1	00 BD
0	1	1	1	1	1	0	1	00 BE
1	1	1	1	1	1	0	1	00 BF

0: OFF 1: ON

SW1, SW2, SW3, SW4, SW5								Display
1	2	3	4	5	6	7	8	
0	0	0	0	0	0	1	1	00 C0
1	0	0	0	0	0	1	1	00 C1
0	1	0	0	0	0	1	1	00 C2
1	1	0	0	0	0	1	1	00 C3
0	0	1	0	0	0	1	1	00 C4
1	0	1	0	0	0	1	1	00 C5
0	1	1	0	0	0	1	1	00 C6
1	1	1	0	0	0	1	1	00 C7
0	0	0	1	0	0	1	1	00 C8
1	0	0	1	0	0	1	1	00 C9
0	1	0	1	0	0	1	1	00 CA
1	1	0	1	0	0	1	1	00 CB
0	0	1	1	0	0	1	1	00 CC
1	0	1	1	0	0	1	1	00 CD
0	1	1	1	0	0	1	1	00 CE
1	1	1	1	0	0	1	1	00 CF
0	0	0	0	1	0	1	1	00 D0
1	0	0	0	1	0	1	1	00 D1
0	1	0	0	1	0	1	1	00 D2
1	1	0	0	1	0	1	1	00 D3
0	0	1	0	1	0	1	1	00 D4
1	0	1	0	1	0	1	1	00 D5
0	1	1	0	1	0	1	1	00 D6
1	1	1	0	1	0	1	1	00 D7
0	0	0	1	1	0	1	1	00 D8
1	0	0	1	1	0	1	1	00 D9
0	1	0	1	1	0	1	1	00 DA
1	1	0	1	1	0	1	1	00 DB
0	0	1	1	1	0	1	1	00 DC
1	0	1	1	1	0	1	1	00 DD
0	1	1	1	1	0	1	1	00 DE
1	1	1	1	1	0	1	1	00 DF
0	0	0	0	0	1	1	1	00 E0
1	0	0	0	0	1	1	1	00 E1
0	1	0	0	0	1	1	1	00 E2
1	1	0	0	0	1	1	1	00 E3
0	0	1	0	0	1	1	1	00 E4
1	0	1	0	0	1	1	1	00 E5
0	1	1	0	0	1	1	1	00 E6
1	1	1	0	0	1	1	1	00 E7
0	0	0	1	0	1	1	1	00 E8
1	0	0	1	0	1	1	1	00 E9
0	1	0	1	0	1	1	1	00 EA
1	1	0	1	0	1	1	1	00 EB
0	0	1	1	0	1	1	1	00 EC
1	0	1	1	0	1	1	1	00 ED
0	1	1	1	0	1	1	1	00 EE
1	1	1	1	0	1	1	1	00 EF
0	0	0	0	1	1	1	1	00 F0
1	0	0	0	1	1	1	1	00 F1
0	1	0	0	1	1	1	1	00 F2
1	1	0	0	1	1	1	1	00 F3
0	0	1	0	1	1	1	1	00 F4
1	0	1	0	1	1	1	1	00 F5
0	1	1	0	1	1	1	1	00 F6
1	1	1	0	1	1	1	1	00 F7
0	0	0	1	1	1	1	1	00 F8
1	0	0	1	1	1	1	1	00 F9
0	1	0	1	1	1	1	1	00 FA
1	1	0	1	1	1	1	1	00 FB
0	0	1	1	1	1	1	1	00 FC
1	0	1	1	1	1	1	1	00 FD
0	1	1	1	1	1	1	1	00 FE
1	1	1	1	1	1	1	1	00 FF

**Output signal display (Request code: 175/553)**

Please refer to Table 2 on relevant wiring diagram whilst using the following.

0: OFF 1: ON

OUT								Display
1	2	3	4	5A	5B	6	7	
0	0	0	0	0	0	0	0	xx 00
1	0	0	0	0	0	0	0	xx 01
0	1	0	0	0	0	0	0	xx 02
1	1	0	0	0	0	0	0	xx 03
0	0	1	0	0	0	0	0	xx 04
1	0	1	0	0	0	0	0	xx 05
0	1	1	0	0	0	0	0	xx 06
1	1	1	0	0	0	0	0	xx 07
0	0	0	1	0	0	0	0	xx 08
1	0	0	1	0	0	0	0	xx 09
0	1	0	1	0	0	0	0	xx 0A
1	1	0	1	0	0	0	0	xx 0B
0	0	1	1	0	0	0	0	xx 0C
1	0	1	1	0	0	0	0	xx 0D
0	1	1	1	0	0	0	0	xx 0E
1	1	1	1	0	0	0	0	xx 0F
0	0	0	0	1	0	0	0	xx 10
1	0	0	0	1	0	0	0	xx 11
0	1	0	0	1	0	0	0	xx 12
1	1	0	0	1	0	0	0	xx 13
0	0	1	0	1	0	0	0	xx 14
1	0	1	0	1	0	0	0	xx 15
0	1	1	0	1	0	0	0	xx 16
1	1	1	0	1	0	0	0	xx 17
0	0	0	1	1	0	0	0	xx 18
1	0	0	1	1	0	0	0	xx 19
0	1	0	1	1	0	0	0	xx 1A
1	1	0	1	1	0	0	0	xx 1B
0	0	1	1	1	0	0	0	xx 1C
1	0	1	1	1	0	0	0	xx 1D
0	1	1	1	1	0	0	0	xx 1E
1	1	1	1	1	0	0	0	xx 1F
0	0	0	0	0	1	0	0	xx 20
1	0	0	0	0	1	0	0	xx 21
0	1	0	0	0	1	0	0	xx 22
1	1	0	0	0	1	0	0	xx 23
0	0	1	0	0	1	0	0	xx 24
1	0	1	0	0	1	0	0	xx 25
0	1	1	0	0	1	0	0	xx 26
1	1	1	0	0	1	0	0	xx 27
0	0	0	1	0	1	0	0	xx 28
1	0	0	1	0	1	0	0	xx 29
0	1	0	1	0	1	0	0	xx 2A
1	1	0	1	0	1	0	0	xx 2B
0	0	1	1	0	1	0	0	xx 2C
1	0	1	1	0	1	0	0	xx 2D
0	1	1	1	0	1	0	0	xx 2E
1	1	1	1	0	1	0	0	xx 2F
0	0	0	0	1	1	0	0	xx 30
1	0	0	0	1	1	0	0	xx 31
0	1	0	0	1	1	0	0	xx 32
1	1	0	0	1	1	0	0	xx 33
0	0	1	0	1	1	0	0	xx 34
1	0	1	0	1	1	0	0	xx 35
0	1	1	0	1	1	0	0	xx 36
1	1	1	0	1	1	0	0	xx 37
0	0	0	1	1	1	0	0	xx 38
1	0	0	1	1	1	0	0	xx 39
0	1	0	1	1	1	0	0	xx 3A
1	1	0	1	1	1	0	0	xx 3B
0	0	1	1	1	1	0	0	xx 3C
1	0	1	1	1	1	0	0	xx 3D
0	1	1	1	1	1	0	0	xx 3E
1	1	1	1	1	1	0	0	xx 3F

0: OFF 1: ON

OUT								Display
1	2	3	4	5A	5B	6	7	
0	0	0	0	0	0	1	0	xx 40
1	0	0	0	0	0	1	0	xx 41
0	1	0	0	0	0	1	0	xx 42
1	1	0	0	0	0	1	0	xx 43
0	0	1	0	0	0	1	0	xx 44
1	0	1	0	0	0	1	0	xx 45
0	1	1	0	0	0	1	0	xx 46
1	1	1	0	0	0	1	0	xx 47
0	0	0	1	0	0	1	0	xx 48
1	0	0	1	0	0	1	0	xx 49
0	1	0	1	0	0	1	0	xx 4A
1	1	0	1	0	0	1	0	xx 4B
0	0	1	1	0	0	1	0	xx 4C
1	0	1	1	0	0	1	0	xx 4D
0	1	1	1	0	0	1	0	xx 4E
1	1	1	1	0	0	1	0	xx 4F
0	0	0	0	1	0	1	0	xx 50
1	0	0	0	1	0	1	0	xx 51
0	1	0	0	1	0	1	0	xx 52
1	1	0	0	1	0	1	0	xx 53
0	0	1	0	1	0	1	0	xx 54
1	0	1	0	1	0	1	0	xx 55
0	1	1	0	1	0	1	0	xx 56
1	1	1	0	1	0	1	0	xx 57
0	0	0	1	1	0	1	0	xx 58
1	0	0	1	1	0	1	0	xx 59
0	1	0	1	1	0	1	0	xx 5A
1	1	0	1	1	0	1	0	xx 5B
0	0	1	1	1	0	1	0	xx 5C
1	0	1	1	1	0	1	0	xx 5D
0	1	1	1	1	0	1	0	xx 5E
1	1	1	1	1	0	1	0	xx 5F
0	0	0	0	0	1	1	0	xx 60
1	0	0	0	0	1	1	0	xx 61
0	1	0	0	0	1	1	0	xx 62
1	1	0	0	0	1	1	0	xx 63
0	0	1	0	0	1	1	0	xx 64
1	0	1	0	0	1	1	0	xx 65
0	1	1	0	0	1	1	0	xx 66
1	1	1	0	0	1	1	0	xx 67
0	0	0	1	0	1	1	0	xx 68
1	0	0	1	0	1	1	0	xx 69
0	1	0	1	0	1	1	0	xx 6A
1	1	0	1	0	1	1	0	xx 6B
0	0	1	1	0	1	1	0	xx 6C
1	0	1	1	0	1	1	0	xx 6D
0	1	1	1	0	1	1	0	xx 6E
1	1	1	1	0	1	1	0	xx 6F
0	0	0	0	1	1	1	0	xx 70
1	0	0	0	1	1	1	0	xx 71
0	1	0	0	1	1	1	0	xx 72
1	1	0	0	1	1	1	0	xx 73
0	0	1	0	1	1	1	0	xx 74
1	0	1	0	1	1	1	0	xx 75
0	1	1	0	1	1	1	0	xx 76
1	1	1	0	1	1	1	0	xx 77
0	0	0	1	1	1	1	0	xx 78
1	0	0	1	1	1	1	0	xx 79
0	1	0	1	1	1	1	0	xx 7A
1	1	0	1	1	1	1	0	xx 7B
0	0	1	1	1	1	1	0	xx 7C
1	0	1	1	1	1	1	0	xx 7D
0	1	1	1	1	1	1	0	xx 7E
1	1	1	1	1	1	1	0	xx 7F

**Output signal display (Request code: 175/553)**

Please refer to Table 2 on relevant wiring diagram whilst using the following.

0: OFF 1: ON

OUT								Display
1	2	3	4	5A	5B	6	7	
0	0	0	0	0	0	0	1	xx 80
1	0	0	0	0	0	0	1	xx 81
0	1	0	0	0	0	0	1	xx 82
1	1	0	0	0	0	0	1	xx 83
0	0	1	0	0	0	0	1	xx 84
1	0	1	0	0	0	0	1	xx 85
0	1	1	0	0	0	0	1	xx 86
1	1	1	0	0	0	0	1	xx 87
0	0	0	1	0	0	0	1	xx 88
1	0	0	1	0	0	0	1	xx 89
0	1	0	1	0	0	0	1	xx 8A
1	1	0	1	0	0	0	1	xx 8B
0	0	1	1	0	0	0	1	xx 8C
1	0	1	1	0	0	0	1	xx 8D
0	1	1	1	0	0	0	1	xx 8E
1	1	1	1	0	0	0	1	xx 8F
0	0	0	0	1	0	0	1	xx 90
1	0	0	0	1	0	0	1	xx 91
0	1	0	0	1	0	0	1	xx 92
1	1	0	0	1	0	0	1	xx 93
0	0	1	0	1	0	0	1	xx 94
1	0	1	0	1	0	0	1	xx 95
0	1	1	0	1	0	0	1	xx 96
1	1	1	0	1	0	0	1	xx 97
0	0	0	1	1	0	0	1	xx 98
1	0	0	1	1	0	0	1	xx 99
0	1	0	1	1	0	0	1	xx 9A
1	1	0	1	1	0	0	1	xx 9B
0	0	1	1	1	0	0	1	xx 9C
1	0	1	1	1	0	0	1	xx 9D
0	1	1	1	1	0	0	1	xx 9E
1	1	1	1	1	0	0	1	xx 9F
0	0	0	0	0	1	0	1	xx A0
1	0	0	0	0	1	0	1	xx A1
0	1	0	0	0	1	0	1	xx A2
1	1	0	0	0	1	0	1	xx A3
0	0	1	0	0	1	0	1	xx A4
1	0	1	0	0	1	0	1	xx A5
0	1	1	0	0	1	0	1	xx A6
1	1	1	0	0	1	0	1	xx A7
0	0	0	1	0	1	0	1	xx A8
1	0	0	1	0	1	0	1	xx A9
0	1	0	1	0	1	0	1	xx AA
1	1	0	1	0	1	0	1	xx AB
0	0	1	1	0	1	0	1	xx AC
1	0	1	1	0	1	0	1	xx AD
0	1	1	1	0	1	0	1	xx AE
1	1	1	1	0	1	0	1	xx AF
0	0	0	0	1	1	0	1	xx B0
1	0	0	0	1	1	0	1	xx B1
0	1	0	0	1	1	0	1	xx B2
1	1	0	0	1	1	0	1	xx B3
0	0	1	0	1	1	0	1	xx B4
1	0	1	0	1	1	0	1	xx B5
0	1	1	0	1	1	0	1	xx B6
1	1	1	0	1	1	0	1	xx B7
0	0	0	1	1	1	0	1	xx B8
1	0	0	1	1	1	0	1	xx B9
0	1	0	1	1	1	0	1	xx BA
1	1	0	1	1	1	0	1	xx BB
0	0	1	1	1	1	0	1	xx BC
1	0	1	1	1	1	0	1	xx BD
0	1	1	1	1	1	0	1	xx BE
1	1	1	1	1	1	0	1	xx BF

0: OFF 1: ON

OUT								Display
1	2	3	4	5A	5B	6	7	
0	0	0	0	0	0	1	1	xx C0
1	0	0	0	0	0	1	1	xx C1
0	1	0	0	0	0	1	1	xx C2
1	1	0	0	0	0	1	1	xx C3
0	0	1	0	0	0	1	1	xx C4
1	0	1	0	0	0	1	1	xx C5
0	1	1	0	0	0	1	1	xx C6
1	1	1	0	0	0	1	1	xx C7
0	0	0	1	0	0	1	1	xx C8
1	0	0	1	0	0	1	1	xx C9
0	1	0	1	0	0	1	1	xx CA
1	1	0	1	0	0	1	1	xx CB
0	0	1	1	0	0	1	1	xx CC
1	0	1	1	0	0	1	1	xx CD
0	1	1	1	0	0	1	1	xx CE
1	1	1	1	0	0	1	1	xx CF
0	0	0	0	1	0	1	1	xx D0
1	0	0	0	1	0	1	1	xx D1
0	1	0	0	1	0	1	1	xx D2
1	1	0	0	1	0	1	1	xx D3
0	0	1	0	1	0	1	1	xx D4
1	0	1	0	1	0	1	1	xx D5
0	1	1	0	1	0	1	1	xx D6
1	1	1	0	1	0	1	1	xx D7
0	0	0	1	1	0	1	1	xx D8
1	0	0	1	1	0	1	1	xx D9
0	1	0	1	1	0	1	1	xx DA
1	1	0	1	1	0	1	1	xx DB
0	0	1	1	1	0	1	1	xx DC
1	0	1	1	1	0	1	1	xx DD
0	1	1	1	1	0	1	1	xx DE
1	1	1	1	1	0	1	1	xx DF
0	0	0	0	0	1	1	1	xx E0
1	0	0	0	0	1	1	1	xx E1
0	1	0	0	0	1	1	1	xx E2
1	1	0	0	0	1	1	1	xx E3
0	0	1	0	0	1	1	1	xx E4
1	0	1	0	0	1	1	1	xx E5
0	1	1	0	0	1	1	1	xx E6
1	1	1	0	0	1	1	1	xx E7
0	0	0	1	0	1	1	1	xx E8
1	0	0	1	0	1	1	1	xx E9
0	1	0	1	0	1	1	1	xx EA
1	1	0	1	0	1	1	1	xx EB
0	0	1	1	0	1	1	1	xx EC
1	0	1	1	0	1	1	1	xx ED
0	1	1	1	0	1	1	1	xx EE
1	1	1	1	0	1	1	1	xx EF
0	0	0	0	1	1	1	1	xx F0
1	0	0	0	1	1	1	1	xx F1
0	1	0	0	1	1	1	1	xx F2
1	1	0	0	1	1	1	1	xx F3
0	0	1	0	1	1	1	1	xx F4
1	0	1	0	1	1	1	1	xx F5
0	1	1	0	1	1	1	1	xx F6
1	1	1	0	1	1	1	1	xx F7
0	0	0	1	1	1	1	1	xx F8
1	0	0	1	1	1	1	1	xx F9
0	1	0	1	1	1	1	1	xx FA
1	1	0	1	1	1	1	1	xx FB
0	0	1	1	1	1	1	1	xx FC
1	0	1	1	1	1	1	1	xx FD
0	1	1	1	1	1	1	1	xx FE
1	1	1	1	1	1	1	1	xx FF

**Output signal display (Request code: 175/553)**

Please refer to Table 2 on relevant wiring diagram whilst using the following.

0: OFF 1: ON

OUT								Display
8*	9	10	11	12	13	14	15	
0	0	0	0	0	0	0	0	00 xx
1	0	0	0	0	0	0	0	01 xx
0	1	0	0	0	0	0	0	02 xx
1	1	0	0	0	0	0	0	03 xx
0	0	1	0	0	0	0	0	04 xx
1	0	1	0	0	0	0	0	05 xx
0	1	1	0	0	0	0	0	06 xx
1	1	1	0	0	0	0	0	07 xx
0	0	0	1	0	0	0	0	08 xx
1	0	0	1	0	0	0	0	09 xx
0	1	0	1	0	0	0	0	0A xx
1	1	0	1	0	0	0	0	0B xx
0	0	1	1	0	0	0	0	0C xx
1	0	1	1	0	0	0	0	0D xx
0	1	1	1	0	0	0	0	0E xx
1	1	1	1	0	0	0	0	0F xx
0	0	0	0	1	0	0	0	10 xx
1	0	0	0	1	0	0	0	11 xx
0	1	0	0	1	0	0	0	12 xx
1	1	0	0	1	0	0	0	13 xx
0	0	1	0	1	0	0	0	14 xx
1	0	1	0	1	0	0	0	15 xx
0	1	1	0	1	0	0	0	16 xx
1	1	1	0	1	0	0	0	17 xx
0	0	0	1	1	0	0	0	18 xx
1	0	0	1	1	0	0	0	19 xx
0	1	0	1	1	0	0	0	1A xx
1	1	0	1	1	0	0	0	1B xx
0	0	1	1	1	0	0	0	1C xx
1	0	1	1	1	0	0	0	1D xx
0	1	1	1	1	0	0	0	1E xx
1	1	1	1	1	0	0	0	1F xx
0	0	0	0	0	1	0	0	20 xx
1	0	0	0	0	1	0	0	21 xx
0	1	0	0	0	1	0	0	22 xx
1	1	0	0	0	1	0	0	23 xx
0	0	1	0	0	1	0	0	24 xx
1	0	1	0	0	1	0	0	25 xx
0	1	1	0	0	1	0	0	26 xx
1	1	1	0	0	1	0	0	27 xx
0	0	0	1	0	1	0	0	28 xx
1	0	0	1	0	1	0	0	29 xx
0	1	0	1	0	1	0	0	2A xx
1	1	0	1	0	1	0	0	2B xx
0	0	1	1	0	1	0	0	2C xx
1	0	1	1	0	1	0	0	2D xx
0	1	1	1	0	1	0	0	2E xx
1	1	1	1	0	1	0	0	2F xx
0	0	0	0	1	1	0	0	30 xx
1	0	0	0	1	1	0	0	31 xx
0	1	0	0	1	1	0	0	32 xx
1	1	0	0	1	1	0	0	33 xx
0	0	1	0	1	1	0	0	34 xx
1	0	1	0	1	1	0	0	35 xx
0	1	1	0	1	1	0	0	36 xx
1	1	1	0	1	1	0	0	37 xx
0	0	0	1	1	1	0	0	38 xx
1	0	0	1	1	1	0	0	39 xx
0	1	0	1	1	1	0	0	3A xx
1	1	0	1	1	1	0	0	3B xx
0	0	1	1	1	1	0	0	3C xx
1	0	1	1	1	1	0	0	3D xx
0	1	1	1	1	1	0	0	3E xx
1	1	1	1	1	1	0	0	3F xx

\* Displayed only when the request code is 553.

0: OFF 1: ON

OUT								Display
8	9	10	11	12	13	14	15	
0	0	0	0	0	0	1	0	40 xx
1	0	0	0	0	0	1	0	41 xx
0	1	0	0	0	0	1	0	42 xx
1	1	0	0	0	0	1	0	43 xx
0	0	1	0	0	0	1	0	44 xx
1	0	1	0	0	0	1	0	45 xx
0	1	1	0	0	0	1	0	46 xx
1	1	1	0	0	0	1	0	47 xx
0	0	0	1	0	0	1	0	48 xx
1	0	0	1	0	0	1	0	49 xx
0	1	0	1	0	0	1	0	4A xx
1	1	0	1	0	0	1	0	4B xx
0	0	1	1	0	0	1	0	4C xx
1	0	1	1	0	0	1	0	4D xx
0	1	1	1	0	0	1	0	4E xx
1	1	1	1	0	0	1	0	4F xx
0	0	0	0	1	0	1	0	50 xx
1	0	0	0	1	0	1	0	51 xx
0	1	0	0	1	0	1	0	52 xx
1	1	0	0	1	0	1	0	53 xx
0	0	1	0	1	0	1	0	54 xx
1	0	1	0	1	0	1	0	55 xx
0	1	1	0	1	0	1	0	56 xx
1	1	1	0	1	0	1	0	57 xx
0	0	0	1	1	0	1	0	58 xx
1	0	0	1	1	0	1	0	59 xx
0	1	0	1	1	0	1	0	5A xx
1	1	0	1	1	0	1	0	5B xx
0	0	1	1	1	0	1	0	5C xx
1	0	1	1	1	0	1	0	5D xx
0	1	1	1	1	0	1	0	5E xx
1	1	1	1	1	0	1	0	5F xx
0	0	0	0	0	1	1	0	60 xx
1	0	0	0	0	1	1	0	61 xx
0	1	0	0	0	1	1	0	62 xx
1	1	0	0	0	1	1	0	63 xx
0	0	1	0	0	1	1	0	64 xx
1	0	1	0	0	1	1	0	65 xx
0	1	1	0	0	1	1	0	66 xx
1	1	1	0	0	1	1	0	67 xx
0	0	0	1	0	1	1	0	68 xx
1	0	0	1	0	1	1	0	69 xx
0	1	0	1	0	1	1	0	6A xx
1	1	0	1	0	1	1	0	6B xx
0	0	1	1	0	1	1	0	6C xx
1	0	1	1	0	1	1	0	6D xx
0	1	1	1	0	1	1	0	6E xx
1	1	1	1	0	1	1	0	6F xx
0	0	0	0	1	1	1	0	70 xx
1	0	0	0	1	1	1	0	71 xx
0	1	0	0	1	1	1	0	72 xx
1	1	0	0	1	1	1	0	73 xx
0	0	1	0	1	1	1	0	74 xx
1	0	1	0	1	1	1	0	75 xx
0	1	1	0	1	1	1	0	76 xx
1	1	1	0	1	1	1	0	77 xx
0	0	0	1	1	1	1	0	78 xx
1	0	0	1	1	1	1	0	79 xx
0	1	0	1	1	1	1	0	7A xx
1	1	0	1	1	1	1	0	7B xx
0	0	1	1	1	1	1	0	7C xx
1	0	1	1	1	1	1	0	7D xx
0	1	1	1	1	1	1	0	7E xx
1	1	1	1	1	1	1	0	7F xx

**Mixing valve 2 state**

OUT		Mixing valve 2 state
5A	5B	
0	0	Stop
0	1	Stop
1	0	Open
1	1	Close

**Input signal display (Request code: 176/554)**

Please refer to Table 1 on relevant wiring diagram whilst using the following.

0: OFF (open)      1: ON (short)

IN								Display
1	2	3	4	5	6	7	8	
0	0	0	0	0	0	0	0	00 00
1	0	0	0	0	0	0	0	00 01
0	1	0	0	0	0	0	0	00 02
1	1	0	0	0	0	0	0	00 03
0	0	1	0	0	0	0	0	00 04
1	0	1	0	0	0	0	0	00 05
0	1	1	0	0	0	0	0	00 06
1	1	1	0	0	0	0	0	00 07
0	0	0	1	0	0	0	0	00 08
1	0	0	1	0	0	0	0	00 09
0	1	0	1	0	0	0	0	00 0A
1	1	0	1	0	0	0	0	00 0B
0	0	1	1	0	0	0	0	00 0C
1	0	1	1	0	0	0	0	00 0D
0	1	1	1	0	0	0	0	00 0E
1	1	1	1	0	0	0	0	00 0F
0	0	0	0	1	0	0	0	00 10
1	0	0	0	1	0	0	0	00 11
0	1	0	0	1	0	0	0	00 12
1	1	0	0	1	0	0	0	00 13
0	0	1	0	1	0	0	0	00 14
1	0	1	0	1	0	0	0	00 15
0	1	1	0	1	0	0	0	00 16
1	1	1	0	1	0	0	0	00 17
0	0	0	1	1	0	0	0	00 18
1	0	0	1	1	0	0	0	00 19
0	1	0	1	1	0	0	0	00 1A
1	1	0	1	1	0	0	0	00 1B
0	0	1	1	1	0	0	0	00 1C
1	0	1	1	1	0	0	0	00 1D
0	1	1	1	1	0	0	0	00 1E
1	1	1	1	1	0	0	0	00 1F
0	0	0	0	0	1	0	0	00 20
1	0	0	0	0	1	0	0	00 21
0	1	0	0	0	1	0	0	00 22
1	1	0	0	0	1	0	0	00 23
0	0	1	0	0	1	0	0	00 24
1	0	1	0	0	1	0	0	00 25
0	1	1	0	0	1	0	0	00 26
1	1	1	0	0	1	0	0	00 27
0	0	0	1	0	1	0	0	00 28
1	0	0	1	0	1	0	0	00 29
0	1	0	1	0	1	0	0	00 2A
1	1	0	1	0	1	0	0	00 2B
0	0	1	1	0	1	0	0	00 2C
1	0	1	1	0	1	0	0	00 2D
0	1	1	1	0	1	0	0	00 2E
1	1	1	1	0	1	0	0	00 2F
0	0	0	0	1	1	0	0	00 30
1	0	0	0	1	1	0	0	00 31
0	1	0	0	1	1	0	0	00 32
1	1	0	0	1	1	0	0	00 33
0	0	1	0	1	1	0	0	00 34
1	0	1	0	1	1	0	0	00 35
0	1	1	0	1	1	0	0	00 36
1	1	1	0	1	1	0	0	00 37
0	0	0	1	1	1	0	0	00 38
1	0	0	1	1	1	0	0	00 39
0	1	0	1	1	1	0	0	00 3A
1	1	0	1	1	1	0	0	00 3B
0	0	1	1	1	1	0	0	00 3C
1	0	1	1	1	1	0	0	00 3D
0	1	1	1	1	1	0	0	00 3E
1	1	1	1	1	1	0	0	00 3F

0: OFF (open)      1: ON (short)

IN								Display
1	2	3	4	5	6	7	8	
0	0	0	0	0	0	1	0	00 40
1	0	0	0	0	0	1	0	00 41
0	1	0	0	0	0	1	0	00 42
1	1	0	0	0	0	1	0	00 43
0	0	1	0	0	0	1	0	00 44
1	0	1	0	0	0	1	0	00 45
0	1	1	0	0	0	1	0	00 46
1	1	1	0	0	0	1	0	00 47
0	0	0	1	0	0	1	0	00 48
1	0	0	1	0	0	1	0	00 49
0	1	0	1	0	0	1	0	00 4A
1	1	0	1	0	0	1	0	00 4B
0	0	1	1	0	0	1	0	00 4C
1	0	1	1	0	0	1	0	00 4D
0	1	1	1	0	0	1	0	00 4E
1	1	1	1	0	0	1	0	00 4F
0	0	0	0	1	0	1	0	00 50
1	0	0	0	1	0	1	0	00 51
0	1	0	0	1	0	1	0	00 52
1	1	0	0	1	0	1	0	00 53
0	0	1	0	1	0	1	0	00 54
1	0	1	0	1	0	1	0	00 55
0	1	1	0	1	0	1	0	00 56
1	1	1	0	1	0	1	0	00 57
0	0	0	1	1	0	1	0	00 58
1	0	0	1	1	0	1	0	00 59
0	1	0	1	1	0	1	0	00 5A
1	1	0	1	1	0	1	0	00 5B
0	0	1	1	1	0	1	0	00 5C
1	0	1	1	1	0	1	0	00 5D
0	1	1	1	1	0	1	0	00 5E
1	1	1	1	1	0	1	0	00 5F
0	0	0	0	0	1	1	0	00 60
1	0	0	0	0	1	1	0	00 61
0	1	0	0	0	1	1	0	00 62
1	1	0	0	0	1	1	0	00 63
0	0	1	0	0	1	1	0	00 64
1	0	1	0	0	1	1	0	00 65
0	1	1	0	0	1	1	0	00 66
1	1	1	0	0	1	1	0	00 67
0	0	0	1	0	1	1	0	00 68
1	0	0	1	0	1	1	0	00 69
0	1	0	1	0	1	1	0	00 6A
1	1	0	1	0	1	1	0	00 6B
0	0	1	1	0	1	1	0	00 6C
1	0	1	1	0	1	1	0	00 6D
0	1	1	1	0	1	1	0	00 6E
1	1	1	1	0	1	1	0	00 6F
0	0	0	0	1	1	1	0	00 70
1	0	0	0	1	1	1	0	00 71
0	1	0	0	1	1	1	0	00 72
1	1	0	0	1	1	1	0	00 73
0	0	1	0	1	1	1	0	00 74
1	0	1	0	1	1	1	0	00 75
0	1	1	0	1	1	1	0	00 76
1	1	1	0	1	1	1	0	00 77
0	0	0	1	1	1	1	0	00 78
1	0	0	1	1	1	1	0	00 79
0	1	0	1	1	1	1	0	00 7A
1	1	0	1	1	1	1	0	00 7B
0	0	1	1	1	1	1	0	00 7C
1	0	1	1	1	1	1	0	00 7D
0	1	1	1	1	1	1	0	00 7E
1	1	1	1	1	1	1	0	00 7F

## Indoor unit only operation

In indoor unit only operation, an operation without connecting outdoor unit is possible. When in Indoor unit only operation, the main control has control functions.

### <Heater>

Heating for DHW and space heating is provided by the heater.

#### • Activating indoor unit only operation mode

To activate indoor unit only operation, see the following:

1. Switch OFF the breaker for the outdoor unit (or both breakers if cylinder powered independently).
2. Change DIP switch SW4-4 and SW4-5 to ON.
3. Switch ON the breaker(s).
4. Indoor unit only operation is now activated.

#### • Deactivating indoor unit only operation mode

To deactivate indoor unit only operation, see the following:

1. Switch OFF the breaker for the outdoor unit (or both breakers if cylinder powered independently).
2. Change DIP switch SW4-4 and SW4-5 to OFF.
3. Switch ON the breaker(s).
4. Indoor unit only operation is now deactivated.

### <Boiler>

Heating for space heating is provided by the boiler.

#### • Activating indoor unit only operation mode

To activate indoor unit only operation, see the following:

1. Switch OFF the breaker for the outdoor unit (or both breakers if cylinder powered independently).
2. Change DIP switch SW4-4 and SW4-6 to ON.
3. Switch ON the breaker(s).
4. Indoor unit only operation is now activated.

#### • Deactivating indoor unit only operation mode

To deactivate indoor unit only operation, see the following:

1. Switch OFF the breaker for the outdoor unit (or both breakers if cylinder powered independently).
2. Change DIP switch SW4-4 and SW4-6 to OFF.
3. Switch ON the breaker(s).
4. Indoor unit only operation is now deactivated.

## ■ Emergency operation

In emergency operation, an operation without connecting outdoor unit and main remote controller is possible.

When in Emergency operation, the main control has NO control functions.

Space heating flow temp. is restarted 40°C and DHW tank temp. is restricted 50°C. \*1

### <Heater>

Heating for DHW and space heating is provided by the heater.

#### • Activating emergency operation mode

To activate emergency operation, see the following:

1. Switch OFF the breaker for the outdoor unit (or both breakers if cylinder powered independently).
2. Change DIP switch SW4-5 to ON.
3. Switch ON the breaker(s).
4. Emergency operation is now activated.

#### • Deactivating emergency operation mode

To deactivate emergency operation, see the following:

1. Switch OFF the breaker for the outdoor unit (or both breakers if cylinder powered independently).
2. Change DIP switch SW4-5 to OFF.
3. Switch ON the breaker(s).
4. Emergency operation is now deactivated.

### <Boiler>

Heating for space heating is provided by the boiler.

#### • Activating emergency operation mode

To activate emergency operation, see the following:

1. Switch OFF the breaker for the outdoor unit (or both breakers if cylinder powered independently).
2. Change DIP switch SW4-6 to ON.
3. Switch ON the breaker(s).
4. Emergency operation is now activated.

#### • Deactivating emergency operation mode

To deactivate emergency operation, see the following:

1. Switch OFF the breaker for the outdoor unit (or both breakers if cylinder powered independently).
2. Change DIP switch SW4-6 to OFF.
3. Switch ON the breaker(s).
4. Emergency operation is now deactivated.

### ⚠ WARNING

Do not attempt to change the DIP switches whilst the breaker(s) are ON as this could result in electric shock.

	Indoor unit only operation
Indoor unit	Necessary
Heat pump	Not necessary
Main remote controller	Necessary
DIP switch setting	Electric heater SW4-4 ON, SW4-5 ON
	Boiler SW4-4 ON, SW4-6 ON
Setting range for flow temp.	20 to 60°C Selectable
Setting range for tank temp.	40 to 60°C Selectable

	Emergency operation
Indoor unit	Necessary
Heat pump	Not necessary
Main remote controller	Not necessary
DIP switch setting	Electric heater SW4-5 ON
	Boiler SW4-6 ON
Setting range for flow temp.	Fixed at 40°C
Setting range for tank temp.	Fixed at 50°C *1

\*1 Default setting is 50°C. Once system has started running, emergency operation runs at the latest set temp.

# TROUBLESHOOTING

## <Summary of self-diagnosis based on Check codes and Service Procedures>

Present and past Check codes are logged, and they can be displayed on the main remote controller or control board of the outdoor unit. Please refer to the table below and subsequent explanations to diagnose and remedy typical problems that may occur in the field.

Unit Condition	Check code	Action
Reoccurring problem	Displayed	Use table "10-4. Self-diagnosis and action" to identify fault and correct.
	Not Displayed	Use table "10-5. Troubleshooting by inferior phenomena" to identify fault and correct.
Non reoccurring problem	Logged	1. Check temporary causes of defects such as the operation of safety devices on the refrigerant/water circuit including compressor, poor wiring, electrical noise, etc. Re-check the symptom and the installation environment, refrigerant amount (Split systems only), weather conditions at time of fault, etc. 2. Reset Check code logs, Service the unit and restart system.
	Not Logged	1. Recheck the abnormal symptom.
		2. Identify cause of problem and take corrective action according to Table "10-5. Troubleshooting by inferior phenomena".
		3. If no obvious problem can be found, continue to operate the unit.

### Note:

Electrical components should only be replaced as a final option. Please follow instructions in "10-4. Self-diagnosis and action" and "10-5. Troubleshooting by inferior phenomena" fully before resorting to replacing parts.

## Test Run

Before a test run

- After installation of outdoor unit, pipework and electrical wiring, recheck that there is no water leakage, loosened connections or miswiring.
- Measure impedance between the ground and the power supply terminal block (L,N) on the outdoor and indoor units with suitable (500V) ohmmeter. Resistance should be  $\geq 1.0M\Omega$ .
- Read the Installation and Operation Manuals fully especially the safety requirements before carrying out any test runs.

## Malfunction diagnosis method by main remote controller

If during start up or operation a malfunction occurs, the check code screen may be displayed on the main remote controller.

The check code screen shows the following; code, unit, ref. address, and telephone number of installer (only if previously entered by the installer)

Please note in the case of some malfunctions as check code is not generated please refer to table "10-5. Troubleshooting by inferior phenomena" for more details.

To reset

1. To reset the main remote controller press "RESET" button.
2. Then press "Yes" button to confirm.

Error

---

Code : L8  
 Unit : FTC Address : 0  
 Tel no. : 0123456789

**Reset**

Error

---

Code : L8  
 Unit : FTC Address : 0  
 Tel no. : 0123456789

Reset error?

## Self-diagnosis and action

Check if DIP SW is set correctly. (Refer to "6-6. DIP switch functions".)

Check code	Title and display conditions	Possible Cause	Diagnosis and action
L3	<p><b>Circulation water temperature overheat protection</b> &lt;DHW/Heating/Cooling/LP/FS/OS&gt; Check code displayed when THW1 detects a temp. <math>\geq 85^{\circ}\text{C}</math> for 10 consecutive seconds or THW2 detects a temp. <math>\geq 85^{\circ}\text{C}</math> for 10 consecutive seconds.</p> <p>DHW: Domestic hot water mode Heating: Heating mode Cooling: Cooling mode LP: Legionella prevention mode FS: Freeze stat OS: Operation stop TH1A/B: Room temp. thermistor TH2: Liquid refrigerant temp. thermistor THW1: Flow water temp. thermistor THW2: Return water temp. thermistor THW5B: DHW tank lower water temp. thermistor THW6: Zone1 flow water temperature thermistor THW7: Zone1 return water temperature thermistor THW8: Zone2 flow water temperature thermistor THW9: Zone2 return water temperature thermistor THWB1: Boiler flow water temperature thermistor</p>	<ol style="list-style-type: none"> <li>Insufficient system head</li> <li>Reduced flow in primary water circuit Due to 1 or more of the following; Faulty pump, insufficient air purge, blocked strainer, leak in water circuit.</li> <li>Valve operation fault</li> <li>2-way valve (local supply) actuator fault</li> <li>3-way valve actuator fault</li> <li>Booster heater relay (BHC1, BHC2, BHCP) operating fault</li> <li>Power supply voltage increase</li> <li>THW1 or THW5B has become detached from its holder.</li> <li>THW1 or THW2 fault</li> <li>FTC board failure</li> </ol>	<ol style="list-style-type: none"> <li>Refer to table in "10-6. Checking Component Parts' Function" to determine if system pump meets requirements. If more head required either add a pump of the same size or replace existing pump with capacity model. See "11. DISASSEMBLY PROCEDURE" for how to replace pump.</li> <li>Check circulation pump (See "10-6. Checking Component Parts' Function" for how to check). Open purge valve to remove trapped air. Check the strainer for blockages. Check the primary water circuit for leaks. Check that the flow amount is within the recommended range.</li> <li>Check valves on primary water circuit are installed level.</li> <li>Electrically test to determine fault</li> <li>1) Electrically test to determine fault. 2) Operate 3-way valve manually using the main remote controller. (Refer to &lt;Manual operation&gt; in "9-5. Service menu".) 3) Replace 3-way valve coil. 4) Replace 3-way valve. (Refer to Procedure 6 in "11. DISASSEMBLY PROCEDURE.")</li> <li>Electrically test the relays (BHC1, BHC2, BHCP) to determine fault. See "10-6. Checking Component Parts' Function" for how to check.</li> <li>Check the supply voltage.</li> <li>Visually inspect location and reattach as necessary.</li> <li>Check resistance of thermistor against table in "10-6. Checking Component Parts' Function". Compare FTC detected temperature to hand held detector.</li> <li>Replace board.</li> </ol>
L4	<p><b>Tank water temperature overheat protection</b> &lt;DHW/Heating/Cooling/LP/FS/OS&gt; Check code display when THW5B detects a temp. <math>\geq 75^{\circ}\text{C}</math> for 10 consecutive seconds.</p>	<ol style="list-style-type: none"> <li>3-way valve actuator fault</li> <li>Immersion heater relay (IHC) operating fault</li> <li>THW5B fault</li> <li>FTC board failure</li> </ol>	<ol style="list-style-type: none"> <li>1) Electrically test to determine fault. 2) Operate 3-way valve manually using the main remote controller. (Refer to &lt;Manual operation&gt; in "9-5. Service menu".) 3) Replace 3-way valve coil. 4) Replace 3-way valve. (Refer to Procedure 6 in "11. DISASSEMBLY PROCEDURE.")</li> <li>Check immersion heater relay (IHC).</li> <li>Check resistance of thermistor against table in "10-6. Checking Component Parts' Function". Compare FTC detected temperature to hand held detector.</li> <li>Replace board.</li> </ol>

Check code	Title and display conditions	Possible Cause	Diagnosis and action																																																			
P1/P2/L5/LD	<p><b>Indoor unit temperature thermistor failure</b>  Note: The thermistors subject to failure can be checked in "Request code: 567" in "Running information."</p> <p>&lt;DHW/Heating/Cooling/LP/FS/OS&gt;  Check code displayed when thermistor is at open or short (see table).</p> <p><u>Exceptions</u>  Check code will not be displayed for TH2; During defrost and for 10 minutes after defrost operation.</p>	<ol style="list-style-type: none"> <li>Connector/terminal wire has become detached or loose wiring.</li> <li>Thermistor fault</li> <li>FTC board failure</li> <li>The thermistor on the wireless remote controller or the main remote controller may be defective. (when Room temp. is chosen for the Heating operation and when Main remote controller or Room RC 1-8 is chosen for the Room Sensor setting in the Initial setting)</li> <li>Incorrect setting of the DIP switch(es)</li> </ol>	<ol style="list-style-type: none"> <li>Visually check the terminals and connections and reattaches appropriate.</li> <li>Check resistance of thermistor against table in "10-6. Checking Component Parts' Function". Compare FTC detected temperature to hand held detector.</li> <li>Replace board.</li> <li>Replace wireless remote controller or main remote controller.</li> <li>Check the DIP switch setting(s).</li> </ol>																																																			
	<table border="1"> <thead> <tr> <th rowspan="2">Check code</th> <th colspan="2">Thermistor</th> <th rowspan="2">Open detection</th> <th rowspan="2">Short detection</th> </tr> <tr> <th>Symbol</th> <th>Name</th> </tr> </thead> <tbody> <tr> <td>P1</td> <td>TH1A/TH1B</td> <td>Room temperature thermistor</td> <td>-39°C or below</td> <td>88.5°C or above</td> </tr> <tr> <td>P2</td> <td>TH2</td> <td>Liquid temperature thermistor</td> <td>-39°C or below</td> <td>88.5°C or above</td> </tr> <tr> <td rowspan="7">L5</td> <td>THW1</td> <td>Flow water temperature thermistor</td> <td>-39°C or below</td> <td>88.5°C or above</td> </tr> <tr> <td>THW2</td> <td>Return water temperature thermistor</td> <td>-39°C or below</td> <td>88.5°C or above</td> </tr> <tr> <td>THW5B</td> <td>DHW tank water temperature thermistor</td> <td>-39°C or below</td> <td>88.5°C or above</td> </tr> <tr> <td>THW6</td> <td>Zone1 flow water temperature thermistor</td> <td>-39°C or below</td> <td>88.5°C or above</td> </tr> <tr> <td>THW7</td> <td>Zone1 return water temperature thermistor</td> <td>-39°C or below</td> <td>88.5°C or above</td> </tr> <tr> <td>THW8</td> <td>Zone2 flow water temperature thermistor</td> <td>-39°C or below</td> <td>88.5°C or above</td> </tr> <tr> <td>THW9</td> <td>Zone2 return water temperature thermistor</td> <td>-39°C or below</td> <td>88.5°C or above</td> </tr> <tr> <td>LD</td> <td>THWB1</td> <td>Boiler flow water temperature thermistor</td> <td>-40°C or below</td> <td>140°C or above</td> </tr> </tbody> </table>	Check code	Thermistor		Open detection	Short detection	Symbol	Name	P1	TH1A/TH1B	Room temperature thermistor	-39°C or below	88.5°C or above	P2	TH2	Liquid temperature thermistor	-39°C or below	88.5°C or above	L5	THW1	Flow water temperature thermistor	-39°C or below	88.5°C or above	THW2	Return water temperature thermistor	-39°C or below	88.5°C or above	THW5B	DHW tank water temperature thermistor	-39°C or below	88.5°C or above	THW6	Zone1 flow water temperature thermistor	-39°C or below	88.5°C or above	THW7	Zone1 return water temperature thermistor	-39°C or below	88.5°C or above	THW8	Zone2 flow water temperature thermistor	-39°C or below	88.5°C or above	THW9	Zone2 return water temperature thermistor	-39°C or below	88.5°C or above	LD	THWB1	Boiler flow water temperature thermistor	-40°C or below	140°C or above		
Check code	Thermistor		Open detection	Short detection																																																		
	Symbol	Name																																																				
P1	TH1A/TH1B	Room temperature thermistor	-39°C or below	88.5°C or above																																																		
P2	TH2	Liquid temperature thermistor	-39°C or below	88.5°C or above																																																		
L5	THW1	Flow water temperature thermistor	-39°C or below	88.5°C or above																																																		
	THW2	Return water temperature thermistor	-39°C or below	88.5°C or above																																																		
	THW5B	DHW tank water temperature thermistor	-39°C or below	88.5°C or above																																																		
	THW6	Zone1 flow water temperature thermistor	-39°C or below	88.5°C or above																																																		
	THW7	Zone1 return water temperature thermistor	-39°C or below	88.5°C or above																																																		
	THW8	Zone2 flow water temperature thermistor	-39°C or below	88.5°C or above																																																		
	THW9	Zone2 return water temperature thermistor	-39°C or below	88.5°C or above																																																		
LD	THWB1	Boiler flow water temperature thermistor	-40°C or below	140°C or above																																																		
L6	<p><b>Circulation water freeze protection</b>  &lt;DHW/Heating/Cooling/LP/FS/OS&gt;  Check code displayed when THW1 detects a temp. ≤ 1°C for 10 consecutive seconds or THW2 detects a temp. ≤ 3°C for 10 consecutive seconds.</p> <p><u>Exception</u>  Check code will not be displayed if; FS function is disabled, For 10 minutes after water circulation pump1 is switched on.</p>	<ol style="list-style-type: none"> <li>Insufficient system head</li> <li>Reduced flow in primary water circuit  Due to 1 or more of the following;  Faulty pump, insufficient air purge, blocked strainer, leak in water circuit</li> <li>Valve operation fault</li> <li>2-way valve (local supply) actuator fault</li> <li>3-way valve actuator fault</li> <li>THW1 has become detached from its holder.</li> <li>THW1 or THW2 fault</li> <li>FTC board failure</li> </ol>	<ol style="list-style-type: none"> <li>Refer to table in "10-6. Checking Component Parts' Function" to determine if system pump meets requirements. If more head required either add a pump of the same size or replace existing pump with capacity model. See "11. DISASSEMBLY PROCEDURE" for how to replace pump.</li> <li>Check circulation pump (See "10-6. Checking Component Parts' Function" for how to check). Open purge valve to remove trapped air. Check the strainer for blockages. Check the primary water circuit for leaks. Check that the flow amount is within the recommended range.</li> <li>Check valves on primary water circuit are installed level.</li> <li>Electrically test to determine fault.</li> <li>1) Electrically test to determine fault.  2) Operate 3-way valve manually using the main remote controller. (Refer to &lt;Manual operation&gt; in "9-5. Service menu".)  3) Replace 3-way valve coil.  4) Replace 3-way valve. (Refer to Procedure 6 in "11. DISASSEMBLY PROCEDURE".)</li> <li>Visually inspect location and reattach as necessary.</li> <li>Check resistance of thermistor against table in "10-6. Checking Component Parts' Function". Compare FTC detected temperature to hand held detector.</li> <li>Replace board.</li> </ol>																																																			

Check code	Title and display conditions	Possible Cause	Diagnosis and action
L8	<b>Heating operation error</b> Note: "3" is displayed in "Request code: 567" in "Running information". <Heating/FS> If a), b) and c) occur, L8 is displayed; a) No change on THW1 and THW5B (under 1°C for 20 minutes from unit starts operation) b) No change on THW1 (under 1°C for 10 minutes from booster heater starts operation) c) THW1-THW2 < -5°C (for 10 minutes continuously)	1. THW1 has become detached from its holder. 2. Booster heater fault 3. THW1 or THW2 or THW5B fault 4. FTC board failure	1. Visually inspect location and reattach as necessary. 2. Electrically test to determine fault. See "10-6. Checking Component Parts' Function" for how to check. 3. Check resistance of thermistor against table in "10-6. Checking Component Parts' Function". Compare FTC detected temperature to hand held detector. 4. Replace board.
	<b>Heating operation error</b> Note: "A" is displayed in "Request code: 567" in "Running information".	1. THW6 has become detached from its holder. 2. THW6 or THW7 fault 3. FTC board failure	1. Visually inspect location and reattach as necessary. 2. Check resistance of thermistor against table in "10-6. Checking Component Parts' Function". Compare FTC detected temperature to hand held detector. 3. Replace board.
	<b>Heating operation error</b> Note: "C" is displayed in "Request code: 567" in "Running information".	1. THW8 has become detached from its holder. 2. THW8 or THW9 fault 3. FTC board failure	1. Visually inspect location and reattach as necessary. 2. Check resistance of thermistor against table in "10-6. Checking Component Parts' Function" Compare FTC detected temperature to hand held detector. 3. Replace board.
L9	<b>Low primary circuit (Heat source side) flow rate detected by flow sensor</b> Note: "1" is displayed in "Request code: 569" in "Running information". <DHW/Heating/LP/FS> Check code displayed when flow sensor detects low flow rate for 10 seconds.  <u>Exception</u> For 1 minute after water circulation pump1 is switched on.	1. Insufficient system head 2. Reduced flow in primary water circuit Due to 1 or more of the following; Faulty pump, insufficient air purge, blocked strainer, leak in water circuit. 3. Valve operation fault 4. 2-way valve (local supply) actuator fault 5. Connector/terminal wire has become detached or loose wiring. 6. Flow sensor fault 7. Incorrect setting of the SW2-2 8. FTC board failure	1. Refer to table in "10-6. Checking Component Parts' Function" to determine if system pump meets requirements. If more head required either add a pump of the same size or replace existing pump with capacity model. See "11. DISASSEMBLY PROCEDURE" for how to replace pump. 2. Check circulation pump (See "10-6. Checking Component Parts' Function" for how to check). Open purge valve to remove trapped air. Check the strainer for blockages. Check the primary water circuit for leaks. Check that the flow amount is within the recommended range. 3. Check valves on primary water circuit are installed level. 4. Electrically test to determine fault. 5. Visually check the CN1A connector and IN2 terminal and reattach if necessary. 6. Electrically test to determine fault. See "10-6. Checking Component Parts' Function" for how to check. 7. Check the SW2-2 setting. 8. Replace board.
	<b>Low primary circuit (Zone1 side) flow rate detected by flow switch</b> Note: "2" is displayed in "Request code: 569" in "Running information".	1. Insufficient system head 2. Reduced flow in primary water circuit Due to 1 or more of the following; Faulty pump, insufficient air purge, blocked strainer, leak in water circuit. 3. Terminal wire has become detached or loose wiring. 4. Flow switch fault 5. Incorrect setting of the SW3-2 6. FTC board failure	1. If more head required either add a pump of the same size or replace existing pump . 2. Check circulation pump (See "10-6. Checking Component Parts' Function" for how to check). Open purge valve to remove trapped air. Check the strainer for blockages. Check the primary water circuit for leaks. Check that the flow amount is within the recommended range. 3. Visually check the IN3 terminal and reattach if necessary. 4. Electrically test to determine fault 5. Check the SW3-2 setting. 6. Replace board.

Check code	Title and display conditions	Possible Cause	Diagnosis and action
L9	<b>Low primary circuit (Zone2 side) flow rate detected by flow switch</b> Note: "3" is displayed in "Request code: 569" in "Running information".	<ol style="list-style-type: none"> <li>Insufficient system head</li> <li>Reduced flow in primary water circuit Due to 1 or more of the following; Faulty pump, insufficient air purge, blocked strainer, leak in water circuit</li> <li>Terminal wire has become detached or loose wiring.</li> <li>Flow switch fault</li> <li>Incorrect setting of the SW3-3</li> <li>FTC board failure</li> </ol>	<ol style="list-style-type: none"> <li>If more head required either add a pump of the same size or replace existing pump.</li> <li>Check circulation pump (See "10-6. Checking Component Parts' Function" for how to check). Open purge valve to remove trapped air. Check the strainer for blockages. Check the primary water circuit for leaks. Check that the flow amount is within the recommended range.</li> <li>Visually check the IN7 terminal and reattach if necessary.</li> <li>Electrically test to determine fault.</li> <li>Check the SW3-3 setting.</li> <li>Replace board.</li> </ol>
LA	Pressure sensor failure	<ol style="list-style-type: none"> <li>Connector/terminal wire has become detached or loose wiring.</li> <li>Pressure sensor fault</li> <li>FTC board failure</li> </ol>	<ol style="list-style-type: none"> <li>Check pressure sensor cable for damage or loose connections.</li> <li>Electrically test to determine fault. See "10-6. Checking Component Parts' Function" for how to check.</li> <li>Replace board.</li> </ol>
LB	High pressure protection	<ol style="list-style-type: none"> <li>Flow rate of the heating circuit may be reduced.</li> <li>Plate heat exchanger may be clogged.</li> <li>Outdoor unit failure.</li> </ol>	<ol style="list-style-type: none"> <li>Check water circuit.</li> <li>Check the plate heat exchanger.</li> <li>Check refrigerant volume, valve, LEV coil and pipe crushing of outdoor unit.</li> </ol>
LC	Boiler circulation water temperature overheat protection <DHW/Heating/LP/FS/OS> Check code displayed when THWB1 detects a temp. ≥80°C for 10 consecutive seconds or THWB2 detects a temp. ≥80°C for 10 consecutive seconds	<ol style="list-style-type: none"> <li>The set temperature for Boiler is too high.</li> <li>Flow rate of the heating circuit from the boiler may be reduced.</li> </ol>	<ol style="list-style-type: none"> <li>Check if the set temperature for Boiler for heating exceeds the restriction. (See the manual for the thermistors "PAC-TH011HT-E")</li> <li>Check for <ul style="list-style-type: none"> <li>water leakage</li> <li>strainer blockage</li> <li>water circulation pump function.</li> </ul> </li> </ol>
LD	Boiler temperature thermistor (THWB1, THWB2) failure	Refer to check codes (P1/P2/L5/LD).	
LE	Boiler operation error <Heating> Boiler is running and THW6 detects a temperature <30°C for consecutive 60 minutes.	<ol style="list-style-type: none"> <li>THW6 has become detached from its holder.</li> <li>Incorrect wiring between FTC (OUT10) and the boiler.</li> <li>Boiler fuel has run out or the system is OFF.</li> <li>Boiler failure</li> <li>FTC board failure</li> </ol>	<ol style="list-style-type: none"> <li>Visually inspect location and reattach as necessary.</li> <li>See the manual of the thermistors "PAC-TH011HT-E".</li> <li>Check the status of the boiler.</li> <li>Check the status of the boiler.</li> <li>Replace board.</li> </ol>
LF	Flow sensor failure	Disconnection or loose connection of flow sensor	Check flow sensor cable for damage or loose connections.
LH	Boiler circulation water freeze protection	Flow rate of the heating circuit from the boiler may be reduced.	Check for <ul style="list-style-type: none"> <li>water leakage</li> <li>strainer blockage</li> <li>water circulation pump function.</li> </ul>
LJ	DHW operation error (type of external plate HEX)	<ol style="list-style-type: none"> <li>DHW tank water temp. thermistor (THW5B) has become detached from its holder.</li> <li>Flow rate may be reduced.</li> </ol>	<ol style="list-style-type: none"> <li>Check for disconnection of DHW tank water temp. thermistor (THW5B).</li> <li>Check for water circulation pump function.</li> </ol>
LL	Setting errors of DIP switches on FTC control board	Incorrect setting of DIP switches <ol style="list-style-type: none"> <li>Boiler operation</li> <li>2-zone temperature control</li> </ol>	<ol style="list-style-type: none"> <li>For boiler operation, check that DIP SW1-1 is set to ON (With Boiler) and DIP SW2-6 is set to ON (With Mixing Tank).</li> <li>For 2-zone temperature control, check DIP SW2-7 is set to ON (2-zone) and DIP SW2-6 is set to ON (With Mixing Tank).</li> </ol>
P1	Indoor unit temperature thermistor (TH1) failure	Refer to check codes (P1/P2/L5/LD).	
P2	Indoor unit temperature thermistor (TH2) failure	Refer to check codes (P1/P2/L5/LD).	

Check code	Title and display conditions	Possible Cause	Diagnosis and action
P6	<p>Anti-freeze protection of plate heat exchanger</p> <p>The error of P6 is detected when refrigerant temperature drops rapidly during cooling or defrosting operation. The thermistor of Ref. liquid temp. (TH2) or the pressure sensor attached on the refrigerant circuit of the indoor unit judges the refrigerant temperature. Judging condition differs depending on the type of the plate heat exchanger (capacity code).</p>	<ol style="list-style-type: none"> <li>Reduced water flow <ul style="list-style-type: none"> <li>Clogged filter</li> <li>Leakage of water</li> </ul> </li> <li>Low temperature <ul style="list-style-type: none"> <li>Low load</li> <li>Inlet water is too cold.</li> </ul> </li> <li>Defective water pump</li> <li>Defective outdoor fan control.</li> <li>Overcharge of refrigerant</li> <li>Defective refrigerant circuit (clogs)</li> <li>Malfunction of linear expansion valve</li> <li>Leakage or shortage of refrigerant</li> <li>Malfunction of pressure sensor</li> <li>Incorrect capacity code</li> </ol>	<ol style="list-style-type: none"> <li>1, 2. Check water piping.</li> <li>3. Check water pump.</li> <li>4. Check outdoor fan motor.</li> <li>5, 6. Check operating condition of refrigerant circuit.</li> <li>7. Check linear expansion valve.</li> <li>8. Correct to proper amount of refrigerant. Refer to outdoor unit manual.</li> <li>9. Check pressure sensor.</li> <li>10. Refer to the capacity code of DIP switch functions (SW5-3 to W5-7).</li> </ol>
E0/E4	<p><b>Main remote controller communication failure (Reception error)</b></p> <p>Check code E0 is displayed if main remote controller does not receive any signal from the indoor unit for ref. address "0" for 3 minutes. Check code E4 is displayed if indoor unit does not receive any data from the main remote controller for 3 minutes or indoor unit does not receive any signal from the main remote controller for 2 minutes.</p>	<ol style="list-style-type: none"> <li>Contact failure with transmission cable</li> <li>Wiring procedure not observed. (Cable length/cable diameter/number of indoor units/number of main remote controllers)</li> <li>Fault on the indoor unit FTC board section controlling Ref. address "0"</li> <li>Fault with the main remote controller circuit board</li> <li>Electrical noise causes interference with transmission/reception of data for main remote controller.</li> </ol>	<ol style="list-style-type: none"> <li>1. Check connection cable for damage or loose connections at the FTC and main remote controller terminals.</li> <li>2. Check main remote controller and FTC common wiring max cable length 150 m. Only use 2-core cable. Only connect 1 main remote controller to 1 FTC indoor unit board.</li> <li>3. to 5. If the problem is not solved by the above measures then: Turn the power to the indoor unit OFF and then ON. Power to both the indoor unit and outdoor units should be switched OFF then ON. (This may require switching 1 or 2 breakers depending if the unit is powered independently from the outdoor unit). If the E4 code is still displayed the FTC and/or the main remote controller circuit board should be replaced.</li> </ol>
E3/E5	<p><b>Main remote controller communication failure (Transmission error)</b></p> <p>Check code E3 is displayed if the main remote controller cannot find an empty transmission path and thus fails to transmit for 6 seconds or the data received by the main remote controller is different to what was sent (by the main remote controller) 30 consecutive times.</p> <p>Check code E5 is displayed if the FTC cannot find an empty transmission path for 3 minutes and thus cannot transmit or the data sent by the FTC is different to what was expected 30 consecutive times.</p>	<ol style="list-style-type: none"> <li>2 or more main remote controllers have been connected to the FTC.</li> <li>Fault with main remote controller transmission/receiving circuit board</li> <li>Fault with the main remote controller circuit board</li> <li>Electrical noise causes interference with transmission/reception of data for main remote controller.</li> </ol>	<ol style="list-style-type: none"> <li>1. Only connect 1 main remote controller to 1 FTC indoor unit board.</li> <li>2. to 4. Turn the power to the indoor unit OFF and then ON. Power to both the indoor unit and outdoor units should be switched OFF then ON. (This may require switching 1 or 2 breakers depending if the unit is powered independently from the outdoor unit). If the E3/E5 code is still displayed the FTC and/or the main remote controller circuit board should be replaced.</li> </ol>
E6	<p><b>Indoor/outdoor communication failure (Reception error)</b></p> <p>Check code E6 is displayed if after the power is switched ON to the indoor unit, the FTC board does not receive any signal or the signal received is not complete for 6 minutes, or after a period of operation the FTC board does not receive any signal or the signal received is not complete for 3 minutes.</p>	<ol style="list-style-type: none"> <li>Contact failure/short circuit/miswiring</li> <li>Fault with outdoor unit transmission/receiving circuit board</li> <li>Fault with FTC transmission/receiving circuit board</li> <li>Electrical noise causes interference with FTC-Outdoor unit transmission cable.</li> </ol>	<p>* Check the LED display on the outdoor unit circuit board. (Connect the A-control service tool, PAC-SK52ST to test.) Refer to the outdoor unit service manual for explanation of EA-EC codes.</p> <ol style="list-style-type: none"> <li>1. Check the connections on the indoor and outdoor units have not become loose and that the connecting cable is not damaged.</li> <li>2. to 4. Turn the power to the indoor unit OFF and then ON. Power to both the indoor unit and outdoor units should be switched OFF then ON. (This may require switching 1 or 2 breakers depending if the unit is powered independently from the outdoor unit). If the E6 code is still displayed the FTC and/or the outdoor unit circuit board should be replaced.</li> </ol>

Check code	Title and display conditions	Possible Cause	Diagnosis and action
E7	<b>Indoor/outdoor communication failure (Transmission error)</b> Check code E7 is displayed if despite the FTC board sending signal "0", signal "1" is received 30 consecutive times.	<ol style="list-style-type: none"> <li>1. Fault with FTC transmission/receiving circuit board</li> <li>2. Electrical noise causes interference with power supply.</li> <li>3. Electrical noise causes interference with FTC-outdoor unit transmission cable.</li> </ol>	<ol style="list-style-type: none"> <li>1. to 3. Turn the power to the indoor unit OFF and then ON. Power to both the indoor unit and outdoor units should be switched OFF then ON. (This may require switching 1 or 2 breakers depending if the unit is powered independently from the outdoor unit). If the E7 code is still displayed the FTC circuit board should be replaced.</li> </ol>
E1/E2	<b>Main remote controller control board failure</b> Check code E1 displayed if main remote controller cannot access it is non volatile (non power dependent) memory. Check code E2 is displayed when there is a fault with the main remote controller's internal clock.	<ol style="list-style-type: none"> <li>1. Fault with the main remote controller circuit board</li> </ol>	<ol style="list-style-type: none"> <li>1. Replace main remote controller circuit board.</li> </ol>
J0	<b>Indoor unit/wireless receiver communication failure</b> Check code J0 is displayed when the FTC cannot receive data from the wireless receiver for 1 minute.	<ol style="list-style-type: none"> <li>1. Connection fault with wireless receiver-FTC connection</li> <li>2. Fault with FTC receiving circuit board</li> <li>3. Fault with wireless receiver's transmission circuit board</li> <li>4. Electrical noise causes interference with wireless receiver communication cable.</li> </ol>	<ol style="list-style-type: none"> <li>1. Check the connections to the wireless receiver and FTC have not become loose and that the connecting cable is not damaged.</li> <li>2. to 4. Turn the power to the indoor unit OFF and then ON. Power to both the indoor unit and outdoor units should be switched OFF then ON. (This may require switching 1 or 2 breakers depending if the unit is powered independently from the outdoor unit). If the J0 code is still displayed the FTC and/or the wireless receiver circuit board should be replaced.</li> </ol>
J1 to J8	<b>Wireless remote controller/wireless receiver communication failure (Reception error)</b> Check code displayed if wireless receiver receives no/incomplete data from the wireless remote controller for 15 consecutive minutes.  The digit after the J refers to the address of the wireless remote controller that has the error. E.g. Check code "J3" refers to a communication fault between the wireless receiver and wireless remote control with address 3.	<ol style="list-style-type: none"> <li>1. Battery on wireless remote control may be flat.</li> <li>2. The wireless remote controller is out of range of the wireless receiver.</li> <li>3. Fault with wireless remote controller transmission circuit board</li> <li>4. Fault with wireless receiver's reception circuit board</li> </ol>	<ol style="list-style-type: none"> <li>1 Check and replace the battery if necessary the wireless remote controller battery.</li> <li>2. to 4. Reposition the wireless remote control closer to the receiver and perform a communication test. For procedure refer to wireless remote controller installation manual. If "OK" is displayed then the cause of the J1 to J8 error was the controller was out of range of the receiver. The wireless remote controller should be installed within range of the receiver. If "Err" is displayed replace wireless remote controller with a new controller and perform the pairing procedure. If after this procedure the "Err" code is still displayed the fault is with the receiver unit (attached to the indoor unit). The receiver unit should be replaced with a new part and the original remote control can be reconnected. If "OK" is displayed then the fault is with the remote control and this should be replaced.</li> </ol>
EE	Combination error between FTC and outdoor unit	R410A outdoor unit is combined incorrectly.	Check combination of FTC and outdoor unit.
U*, F*, A*	Outdoor unit failure	Outdoor unit failure	Refer to outdoor unit service manual.

Note: To cancel check codes, please switch system off (press button "RESET" on main remote controller).

## Troubleshooting by inferior phenomena

No.	Fault symptom	Possible cause	Explanation - Solution
1	Main remote controller display is blank.	<ol style="list-style-type: none"> <li>There is no power supply to main remote controller.</li> <li>Power is supplied to main remote controller, however, the display on the main remote controller does not appear.</li> </ol>	<ol style="list-style-type: none"> <li>Check LED2 on FTC. (See "6. WIRING DIAGRAM".)               <ol style="list-style-type: none"> <li>When LED2 is lit. Check for damage or contact failure of the main remote controller wiring.</li> <li>When LED2 is blinking. Refer to No. 5 below.</li> <li>When LED2 is not lit. Refer to No. 4 below.</li> </ol> </li> <li>Check the following:               <ul style="list-style-type: none"> <li>Disconnection between the main remote controller cable and the FTC control board</li> <li>Failure of the main remote controller if "Please Wait" is not displayed.</li> <li>Refer to No. 2 below if "Please Wait" is displayed.</li> </ul> </li> </ol>
2	"Please Wait" remains displayed on the main remote controller.	<ol style="list-style-type: none"> <li>"Please Wait" is displayed for up to 6 minutes.</li> <li>Communication failure between the main remote controller and FTC</li> <li>Communication failure between FTC and outdoor unit</li> </ol>	<ol style="list-style-type: none"> <li>Normal operation</li> <li>3. Main remote controller start up checks/procedure.               <ol style="list-style-type: none"> <li>If "0%" or "50 to 99%" is displayed below "Please Wait" there is a communication error between the main remote controller and the FTC control board.                   <ul style="list-style-type: none"> <li>Check wiring connections on the main remote controller.</li> <li>Replace the main remote controller or the FTC control board.</li> </ul> </li> <li>If "1 to 49%" is displayed there is a communication error between the outdoor unit's and FTC's control boards.                   <ul style="list-style-type: none"> <li>Check the wiring connections on the outdoor unit control board and the FTC control board.</li> <li>(Ensure S1 and S2 are not cross-wired and S3 is securely wired with no damage. (See "7. FIELD WIRING".))</li> <li>Replace the outdoor unit's and/or the FTC's control boards.</li> </ul> </li> </ol> </li> </ol>
3	The main screen appears with a press of the "ON" button, but disappears in a second.	The main remote controller operations do not work for a while after the settings are changed in the service menu. This is because the system takes time to apply the changes.	<p>Normal operation</p> <p>The indoor unit is applying updated settings made in the service menu. Normal operation will start shortly.</p>
4	LED2 on FTC is off. (See "6. WIRING DIAGRAM".)	<p>When LED1 on FTC is also off. (See "6. WIRING DIAGRAM".) &lt;FTC powered via outdoor unit.&gt;</p> <ol style="list-style-type: none"> <li>The outdoor unit is not supplied at the rated voltage.</li> <li>Defective outdoor controller circuit board</li> <li>FTC is not supplied with 220 to 240 VAC.</li> <li>FTC failure</li> <li>Faulty connector wiring</li> </ol>	<ol style="list-style-type: none"> <li>Check the voltage across the terminals L and N or L3 and N on the outdoor power board. (See "7. FIELD WIRING".)               <ul style="list-style-type: none"> <li>When the voltage is not 220 to 240 VAC, check wiring of the outdoor unit and of the breaker.</li> <li>When the voltage is at 220 to 240 VAC, go to "2." below.</li> </ul> </li> <li>Check the voltage across the outdoor unit terminals S1 and S2. (See "7. FIELD WIRING".)               <ul style="list-style-type: none"> <li>When the voltage is not 220 to 240 VAC, check the fuse on the outdoor control board and check for faulty wiring.</li> <li>When the voltage is 220 to 240 VAC, go to "3." below.</li> </ul> </li> <li>Check the voltage across the indoor unit terminals S1 and S2. (See "7. FIELD WIRING".)               <ul style="list-style-type: none"> <li>When the voltage is not 220 to 240 VAC, check FTC-outdoor unit wiring for faults.</li> <li>When the voltage is 220 to 240 VAC, go to "4." below.</li> </ul> </li> <li>Check the FTC control board.               <ul style="list-style-type: none"> <li>Check the fuse on FTC control board.</li> <li>Check for faulty wiring.</li> <li>If no problem found with the wiring, the FTC control board is faulty.</li> </ul> </li> <li>Check the connector wiring.               <ul style="list-style-type: none"> <li>When the connectors are wired incorrectly, re-wire the connectors referring to below. (See "7. FIELD WIRING".)</li> </ul> </li> </ol> <div data-bbox="821 1547 1121 1682" style="border: 1px solid black; padding: 5px; margin-top: 10px;"> <p>Initial settings (Power supplied by outdoor unit)</p> </div>

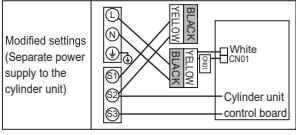
No.	Fault symptom	Possible cause	Explanation - Solution
4	LED2 on FTC is off. (See "6. WIRING DIAGRAM".)	<FTC powered on independent source> 1. FTC is not supplied with 220 to 240 VAC.  2. There are problems in the method of connecting the connectors.  3. FTC failure	1. Check the voltage across the L and N terminals on the indoor power supply terminal block. (See "7. FIELD WIRING".) • When the voltage is not 220 to 240 VAC, check for faulty wiring to power supply. • When the voltage is 220 to 240 VAC, go to 2. below. 2. Check for faulty wiring between the connectors. • When the connectors are wired incorrectly re-wire them correctly referring to below. (See "7. FIELD WIRING" and a wiring diagram on the control and electrical box cover.)  • If no problem found with the wiring, go to 3. below. 3. Check the FTC control board. • Check the fuse on FTC control board. • Check for faulty wiring. • If no problem found with the wiring, the FTC control board is faulty.
		When LED1 on FTC is lit. Incorrect setting of refrigerant address for outdoor unit (None of the refrigerant address is set to "0".)	Recheck the refrigerant address setting on the outdoor unit. Set the refrigerant address to "0". (Set refrigerant address using SW1(3-6) on outdoor controller circuit board.)
5	LED2 on FTC is blinking. (See "6. WIRING DIAGRAM".)	When LED1 is also blinking on FTC . Faulty wiring between FTC and outdoor unit	Check for faulty wiring between FTC and outdoor unit.
		When LED1 on FTC is lit. 1. Faulty wiring in main remote controller Multiple indoor units have been wired to a single outdoor unit. 2. Short-circuited wiring in main remote controller 3. Main remote controller failure	1. Check for faulty wiring in main remote controller. The number of indoor units that can be wired to a single outdoor unit is one. Additional indoor units must be wired individually to a single outdoor unit. 2,3. Remove main remote controller wires and check LED2 on FTC. (See "6. WIRING DIAGRAM".) • If LED2 is blinking check for short circuits in the main remote controller wiring. • If LED2 is lit, wire the main remote controller again and: - if LED2 is blinking, the main remote controller is faulty; - if LED2 is lit, faulty wiring of the main remote controller has been corrected.
6	LED4 on FTC is off. (See "6. WIRING DIAGRAM".)	1. SD memory card is NOT inserted into the memory card slot with correct orientation. 2. Not an SD standards compliant memory card.	1. Correctly insert SD memory card in place until a click is heard. 2. Use an SD standards compliant memory card. (Refer to installation manual, "5.8 Using SD memory card".)
	LED4 on FTC is blinking. (See "6. WIRING DIAGRAM".)	1. Full of data 2. Write-protected 3. NOT formatted 4. Formatted in NTFS file system	1. Move or delete data, or replace SD memory card with a new one. 2. Release the write-protect switch. 3. Refer to installation manual, "5.8 Using SD memory card". 4. FTC is Not compatible with NTFS file system. Use an SD memory card formatted in FAT12/FAT16/FAT32 file system.
7	No water at hot tap.	1. Cold main off 2. Strainer (local supply) blocked.	1. Check and open stop cock. 2. Isolate water supply and clean strainer.
8	Cold water at tap.	1. Hot water run out. 2. Prohibit, schedule timer or holiday mode selected or demand control input (IN4) or smart grid ready (switch-off command). 3. Heat pump not working. 4. Booster heater cut-out tripped.  5. The earth leakage circuit breaker for booster heater breaker (ECB1) tripped. 6. The booster heater thermal cut-out has tripped and cannot be reset using the manual reset button. 7. Immersion heater cut-out tripped.  8. Immersion heater breaker (ECB2) tripped. 9. 3-way valve fault	1. Ensure DHW mode is operating and wait for DHW tank to re-heat. 2. Check settings and change as appropriate.  3. Check heat pump – consult outdoor unit service manual. 4. Check booster heater thermostat and press reset button if safe. Reset button is located on the side of booster heater, covered with white rubber cap. See "4. PART NAMES AND FUNCTIONS" to find out its position. 5. Check the cause and reset if safe.  6. Check resistance across the thermal cut-out, if open then the connection is broken and the booster heater will have to be replaced. Contact your Mitsubishi Electric dealer. 7. Check immersion heater thermostat and press reset button, located on immersion heater boss, if safe. If the heater has been operated with no water inside it may have failed, so please replace it with a new one. 8. Check the cause and reset if safe. 9. Check plumbing/wiring to 3-way valve. (i) Manually override 3-way valve using the main remote controller. (Refer to <Manual operation> in "9-5. Service menu") If the valve does not still function, go to (ii) below. (ii) Replace 3-way valve coil. If the valve does not still function, go to (iii) below. (iii) Replace 3-way valve. (Refer to "11. DISASSEMBLY PROCEDURE".)

No.	Fault symptom	Possible cause	Explanation - Solution
9	Water heating takes longer.	<ol style="list-style-type: none"> <li>Heat pump not working.</li> <li>Booster heater cut-out tripped.</li> <li>Booster heater breaker (ECB1) tripped.</li> <li>The booster heater thermal cut-out has tripped and cannot be reset using the manual reset button.</li> <li>Immersion heater cut-out has been triggered.</li> <li>Immersion heater breaker (ECB2) tripped.</li> <li>Flow rate of the sanitary circuit may be reduced.</li> </ol>	<ol style="list-style-type: none"> <li>Check heat pump – consult outdoor unit service manual.</li> <li>Check booster heater thermostat and press reset button if safe. Reset button is located on the side of booster heater, covered with white rubber cap. See "4. PART NAMES AND FUNCTIONS" to find out its position.</li> <li>Check the cause and reset if safe.</li> <li>Check resistance across the thermal cut-out, if open then connection is broken and the booster heater will have to be replaced. Contact your Mitsubishi Electric dealer.</li> <li>Check immersion heater thermostat and press reset button located on immersion heater boss, if safe. If the heater kept running with no water inside, this may have resulted in failure, so replace it with a new one.</li> <li>Check the cause and reset if safe.</li> <li>Check the following items <ul style="list-style-type: none"> <li>Check for trapped air in water pump (sanitary circuit).</li> <li>Check if the speed of water pump (sanitary circuit) is set to 2.</li> <li>Check water pump (sanitary circuit) for malfunction. (Refer to "10-6. Checking Component Parts' Function".)</li> <li>Replace plate heat exchanger (water - water) or scale trap, if there are a blockage which blocks the sanitary circuit.</li> </ul> </li> </ol>
10	Temperature of DHW tank water dropped.	<p>When DHW operation is not running, the DHW tank emits heat and the water temperature decreases to a certain level. If water in the DHW tank is reheated frequently because of a significant drop in water temperature, check for the following.</p> <ol style="list-style-type: none"> <li>Water leakage in the pipes that connect to the DHW tank</li> <li>Insulation material coming loose or off.</li> <li>3-way valve failure</li> <li>Water pump (sanitary circuit) speed setting failure</li> </ol>	<ol style="list-style-type: none"> <li>Take the following measures. <ul style="list-style-type: none"> <li>Retighten the nuts holding the pipes onto the DHW tank.</li> <li>Replace seal materials.</li> <li>Replace the pipes.</li> </ul> </li> <li>Fix insulation.</li> <li>Check plumbing/wiring to 3-way valve. <ol style="list-style-type: none"> <li>Manually override 3-way valve using the main remote controller. (Refer to &lt;Manual operation&gt; in "9-5. Service menu".) If the valve does not still function, go to (ii) below.</li> <li>Replace 3-way valve motor. If the valve does not still function, go to (iii) below.</li> <li>Replace 3-way valve. (Refer to "11. DISASSEMBLY PROCEDURE".)</li> </ol> </li> <li>Water pump (sanitary circuit) MUST be set to speed 2. When it set to speed 1, hot water would be mixed with cold water due to circulation.</li> </ol>
11	Hot or warm water from cold tap.	Heat of hot water pipe is transferred to cold water pipe.	Insulate/re-route pipework.
12	Water leakage	<ol style="list-style-type: none"> <li>Poorly sealed connections of water circuit components</li> <li>Water circuit components reaching the end of life</li> </ol>	<ol style="list-style-type: none"> <li>Tighten connections as required.</li> <li>Refer to PARTS CATALOG for expected part lifetimes and replace them as necessary.</li> </ol>
13	Heating system does not reach the set temperature.	<ol style="list-style-type: none"> <li>Prohibit, schedule timer or holiday mode selected or demand control input (IN4) or smart grid ready (switch-off command).</li> <li>Check settings and change as appropriate.</li> <li>The temperature sensor is located in a room that has a different temperature relative to that of the rest of the house.</li> <li>Heat pump not working.</li> <li>Booster heater cut-out tripped.</li> <li>Booster heater breaker (ECB1) tripped.</li> <li>The booster heater thermal cut-out tripped and cannot be reset using the manual reset button.</li> <li>Incorrectly sized heat emitter</li> <li>3-way valve failure</li> <li>Battery problem (wireless control only)</li> <li>If a mixing tank is installed, the flow rate between the mixing tank and the cylinder unit is less than that between the mixing tank and the local system.</li> </ol>	<ol style="list-style-type: none"> <li>Check settings and change as appropriate.</li> <li>Check the battery power and replace if flat.</li> <li>Relocate the temperature sensor to a more suitable room.</li> <li>Check heat pump – consult outdoor unit service manual.</li> <li>Check booster heater thermostat and press reset button if safe. Reset button is located on the side of booster heater, covered with white rubber cap. (See "4. PART NAMES AND FUNCTIONS" for position.)</li> <li>Check the cause of the trip and reset if safe.</li> <li>Check resistance across the thermal cut-out, if open then the connection is broken and the booster heater will have to be replaced. Contact your Mitsubishi Electric dealer.</li> <li>Check the heat emitter surface area is adequate. Increase size if necessary.</li> <li>Check plumbing/wiring to 3-way valve. <ol style="list-style-type: none"> <li>Manually override 3-way valve using the main remote controller. (Refer to &lt;Manual operation&gt; in "9-5. Service menu".) If the 3-way valve does not function, go to (ii) below.</li> <li>Replace 3-way valve motor. If the 3-way valve coil is replaced but the 3-way valve does not function go to (iii) below.</li> <li>Replace 3-way valve. (Refer to "11. DISASSEMBLY PROCEDURE".)</li> </ol> </li> <li>Check the battery power and replace if flat.</li> <li>Increase the flow rate between the mixing tank and the cylinder unit decrease that between the mixing tank and the local system.</li> </ol>

No.	Fault symptom	Possible cause	Explanation - Solution
14	Heating system does not reach the set lower temperature.	Heating system operates depending on the heating load to prevent low-load heating system from the frequent switching (ON/OFF) of the compressor.	Normal operation, no action necessary.
15	In 2-zone temperature control, Zone1 or Zone2 does not reach the set temperature.	<ol style="list-style-type: none"> <li>When Zone1 and Zone2 are both in heating mode, the hot water temperature in Zone2 does not exceed that in Zone1.</li> <li>Faulty wiring of motorized mixing valve</li> <li>Faulty installation of motorized mixing valve</li> <li>Incorrect setting of Running time</li> <li>Motorized mixing valve failure</li> <li>Pump2(Zone1 pump) or Pump3(Zone2 pump) failure</li> <li>Valves on heating system are closed</li> </ol>	<ol style="list-style-type: none"> <li>Normal action no action necessary.</li> <li>Refer to installation manual, "5.3 Wiring for 2-zone temperature control".</li> <li>Check for correct installation. (Refer to the manual included with each motorized mixing valve.)</li> <li>Check for correct setting of Running time.</li> <li>Inspect the mixing valve. (Refer to the manual included with each motorized mixing valve.)</li> <li>Inspect the pumps</li> <li>Check the valves</li> </ol>
16	When a PUHZ-FRP outdoor unit is connected, DHW or Heating operation cannot run.	The outdoor unit is set to have operation of the indoor unit of air conditioner take precedence over that of the cylinder unit, and in the main remote controller settings "Electric heater (Heating)" or "Electric heater (DHW)" is turned off.	Turn ON Electric heater (Heating) or Electric heater (DHW) using the main remote controller.
17	When a PUHZ-FRP outdoor unit is connected and is in heat recovery operation, the set temperature is not reached.	When the outdoor unit is set to have cooling operation of the indoor unit of air conditioner take precedence over that of the cylinder unit, the outdoor unit controls the frequency of the compressor according to the load of air conditioner. The DHW and heating run according to that frequency.	Normal operation no action necessary. If Air-to-Water system is given priority in operation, comp Hz can be regulated depending on the load of DHW or Heating. For more details, refer to the PUHZ-FRP installation manual.
18	After DHW operation room temperature rises slightly.	At the end of the DHW mode operation the 3-way valve diverts hot water away from the DHW circuit into space heating circuit. This is done to prevent the cylinder unit components from overheating. The amount of hot water directed into the space heating circuit varies according to the type of the system and of the pipe run between the plate heat exchanger and the cylinder unit.	Normal operation no action necessary.
19	The room temperature rises during DHW operation.	3-way valve failure	<p>Check the 3-way valve.</p> <p>(i) Manually override 3-way valve using the main remote controller. (Refer to &lt;Manual operation&gt; in "9-5. Service menu".) If the 3-way valve does not function, go to (ii) below.</p> <p>(ii) Replace 3-way valve coil. If the 3-way valve coil is replaced but the 3-way valve does not function go to (iii) below.</p> <p>(iii) Replace 3-way valve. (Refer to "11. DISASSEMBLY PROCEDURE".)</p>
20	Water discharges from pressure relief valve. (Primary circuit)	<ol style="list-style-type: none"> <li>If continual – pressure relief valve could bite foreign objects and the valve seat may be damaged.</li> <li>If intermittent – expansion vessel charge may have reduced/bladder perished.</li> </ol>	<ol style="list-style-type: none"> <li>Turn the handle on the pressure relief valve several turns. If leakage persists, replace the pressure relief valve with a new one.</li> <li>Check pressure in expansion vessel. Recharge to 1 bar if necessary. If bladder perished replace expansion vessel with a new one.</li> </ol>
21	Water discharges from pressure relief valve. (Sanitary circuit)	<ol style="list-style-type: none"> <li>If continual – field supplied pressure reducing valve not working.</li> <li>If continual – pressure relief valve could bite foreign objects and the valve seat may be damaged.</li> <li>If intermittent – expansion vessel charge may have reduced/bladder perished.</li> <li>DHW tank may have subjected to backflow.</li> </ol>	<ol style="list-style-type: none"> <li>Check function of pressure reducing valve and replace if necessary.</li> <li>Turn the handle on the pressure relief valve several turns. If leakage persists, replace the pressure relief valve with a new one.</li> <li>Check gas-side pressure in expansion vessel. Recharge to correct precharge pressure if necessary. If bladder perished replace expansion vessel with a new one with appropriate pre-charge.</li> <li>Check the pressure in DHW tank. If pressure in DHW tank is similar to that in the incoming mains, cold water supply that merges with incoming mains water supply could flow back to DHW tank. Investigate source of back-feed and rectify error in pipework/fitting configuration. Adjust pressure in cold supply.</li> </ol>
22	Water discharges from temperature and pressure relief valve (EHPT20X-MEHEW only) (Sanitary circuit)	<ol style="list-style-type: none"> <li>If continual – field supplied pressure reducing valve not working.</li> <li>If continual – temperature and pressure relief valve could bite foreign objects and the valve seat may be damaged.</li> <li>If intermittent – expansion vessel charge may have reduced/bladder perished.</li> <li>DHW tank may have subjected to backflow.</li> <li>Unit has overheated – thermal controls have failed.</li> </ol>	<ol style="list-style-type: none"> <li>Check function of pressure reducing valve and replace if necessary.</li> <li>Turn the handle on the temperature and pressure relief valve several turns. If leakage persists, replace the temperature and pressure relief valve with a new one.</li> <li>Check gas-side pressure in expansion vessel. Recharge to correct precharge pressure if necessary. If bladder perished replace expansion vessel with a new one with appropriate pre-charge.</li> <li>Check pressure in DHW tank. If pressure in DHW tank is similar to that in the incoming mains, cold water supply that merges with incoming mains water supply could flow back to DHW tank. Investigate source of back-feed and rectify error in pipework/fitting configuration. Adjust pressure in cold supply.</li> <li>Switch off power to the heat pump and immersion heaters. Leave water running. Wait until discharge stops. Isolate water supply and replace if faulty.</li> </ol>

No.	Fault symptom	Possible cause	Explanation - Solution						
23	Water discharges from expansion relief valve - part of Inlet Control Group (EHPT20X-MEHEW only) (Sanitary circuit)	<ol style="list-style-type: none"> <li>1. If continual – field supplied pressure reducing valve not working.</li> <li>2. If continual – expansion relief valve may be damaged.</li> <li>3. If intermittent – expansion vessel charge may have reduced/bladder perished.</li> <li>4. DHW tank may have subjected to backflow.</li> <li>5. Unit has overheated – thermal controls have failed.</li> </ol>	<ol style="list-style-type: none"> <li>1. Check function of pressure reducing valve and replace if necessary.</li> <li>2. Turn the handle on the expansion relief valve to check for foreign objects inside. If the problem is not still solved, replace the expansion relief valve with a new one.</li> <li>3. Check gas-side pressure in expansion vessel. Recharge to correct precharge pressure if necessary. If bladder perished replace expansion vessel with a new one with appropriate precharge.</li> <li>4. Check pressure in DHW tank. If pressure in DHW tank is similar to that in the incoming mains, cold water supply that merges with incoming mains water supply could flow back to DHW tank. Investigate source of back-feed and rectify error in pipework/fitting configuration. Adjust pressure in cold supply.</li> <li>5. Switch off power to the heat pump and immersion heaters. Leave water running. Wait until discharge stops. Isolate water supply and replace if faulty.</li> </ol>						
24	Noisy water circulation pump	Air in water circulation pump	Use manual and automatic air vents to remove air from system. Top up water if necessary to achieve 1 bar on primary circuit.						
25	Noise during hot water draw off typically worse in the morning.	<ol style="list-style-type: none"> <li>1. Loose airing cupboard pipework</li> <li>2. Heaters switching on/off</li> </ol>	<ol style="list-style-type: none"> <li>1. Install extra pipe fastening clips.</li> <li>2. Normal operation no action necessary.</li> </ol>						
26	Mechanical noise heard coming from the cylinder unit.	<ol style="list-style-type: none"> <li>1. Heaters switching on/off</li> <li>2. 3-way valve changing position between DHW and heating mode</li> </ol>	Normal operation no action necessary.						
27	Water circulation pump runs for a short time unexpectedly.	Water circulation pump jam prevention mechanism (routine) to inhibit the build-up of scale	Normal operation no action necessary.						
28	Milky/Cloudy water (Sanitary circuit)	Oxygenated water	Water from any pressurised system will release oxygen bubbles when water is running. The bubbles will settle out.						
29	Heating mode has been on standby for a long time (does not start operation smoothly.)	The time of "Delay" set in "Economy settings for pump" is too short. (Go to "Service menu" → "Auxiliary settings" → "Economy settings for pump").	Increase the time of "Delay" in "Economy settings for pump" .						
30	The cylinder unit that was running in the heating mode before power failure is running in the DHW mode after power recovery.	The cylinder unit is designed to run in an operation mode with a higher priority (i.e. DHW mode in this case) at power recovery.	<ul style="list-style-type: none"> <li>• Normal operation</li> <li>• After the DHW max. operation time has elapsed or the DHW max. temperature has been reached, the DHW mode switches to the other mode (ex. Heating mode).</li> </ul>						
31	Cooling mode is NOT available.	DIP SW2-4 is OFF.	Turn DIP SW2-4 to ON. (Refer to "6-9. DIP switch functions".)						
32	The cooling system does not cool down to the set temperature.	<ol style="list-style-type: none"> <li>1. When the water in the circulation circuit is unduly hot, Cooling mode starts with a delay for the protection of the outdoor unit.</li> <li>2. When the outdoor ambient temperature is lower than the preset temperature that activates the freeze stat function, Cooling mode does not start running.</li> </ol>	<ol style="list-style-type: none"> <li>1. Normal operation</li> <li>2. To run Cooling mode overriding the freeze stat function, adjust the preset temperature that activates the freeze stat function. (Refer to "&lt;Freeze stat function&gt;" on Page 37.)</li> </ol>						
33	The electric heaters are activated shortly after DHW or LP mode starts running after Cooling mode.	The setting time period of Heat-pump-only operation is short.	Adjust the setting time period of Heat-pump only operation. (Refer to "<Electric heater (DHW)>" on Page 35.)						
34	During DHW or LP mode following the cooling mode, error L6 (circulation water freeze protection error) occurs and the system stops all the operations.	The unit runs in Cooling mode when the outdoor ambient temperature is lower than 10°C (outside of the guaranteed operating range). (When defrosting operation is running at such a low outdoor ambient temperature after Cooling mode is switched to DHW or LP mode, the water temperature in the cooling circuit drops too low, which could result in L6 error to stop all the operations.	<p>Do not run Cooling operation when the outdoor ambient temperature is lower than 10°C.</p> <p>To automatically stop or recover only Cooling operation and keep other operations running, the freeze stat function can be used. Set the preset temperature that activates the freeze stat function to adjust the outdoor ambient temperature as follows. (Refer to "&lt;Freeze stat function&gt;" on Page 41.)</p> <table border="1"> <thead> <tr> <th>Outdoor ambient temperature</th> <th>Cooling operation</th> </tr> </thead> <tbody> <tr> <td>3°C higher than the preset temperature</td> <td>Stop</td> </tr> <tr> <td>5°C higher than the preset temperature</td> <td>Recover</td> </tr> </tbody> </table>	Outdoor ambient temperature	Cooling operation	3°C higher than the preset temperature	Stop	5°C higher than the preset temperature	Recover
Outdoor ambient temperature	Cooling operation								
3°C higher than the preset temperature	Stop								
5°C higher than the preset temperature	Recover								

No.	Fault symptom	Possible cause	Explanation - Solution																
35	<p>The energy monitor value seems not correct.</p> <p>Note: There could be some discrepancies between the actual and the calculated values. If you seek for accuracy, please make sure to connect power meter(s) and heat meter to FTC board. Both should be locally supplied.</p>	<ol style="list-style-type: none"> <li>Incorrect setting of the energy monitor</li> <li>Non-connectable type of external meter (local supply) is connected.</li> <li>External meter (local supply) failure</li> <li>FTC board failure</li> </ol>	<ol style="list-style-type: none"> <li>Check the setting by following the procedure below. (1) Check if the DIP switch is set as the table below. <table border="1" style="margin-left: 20px;"> <thead> <tr> <th colspan="2">Consumed electric energy</th> <th colspan="2">Delivered heat energy</th> </tr> <tr> <th>SW3-4</th> <th>Electric energy meter (Local supply)</th> <th>SW3-8</th> <th>Heat meter (Local supply)</th> </tr> </thead> <tbody> <tr> <td>OFF</td> <td>Without</td> <td>OFF</td> <td>Without</td> </tr> <tr> <td>ON</td> <td>With</td> <td>ON</td> <td>With</td> </tr> </tbody> </table>   (2) In the case external electric energy meter and/or heat meter is not used, check if the setting for electric heater and water pump(s) input is correct by referring to &lt;Energy monitor setting&gt; in "9-5. Service menu".  (3) In the case external electric energy meter and/or heat meter is used, check if the unit of output pulse on external meter matches with the one set at the main remote controller by referring to &lt;Energy monitor setting&gt; in "9-5. Service menu". </li> <li>Check if the external meter (local supply) is connectable type by referring to &lt;Energy monitor setting&gt;" in "9-5. Service menu".</li> <li>Check if signal is sent to IN8 to IN10 properly. (Refer to section 6. WIRING DIAGRAM) Replace the external heat meter if defective.</li> <li>Check the FTC control board. <ul style="list-style-type: none"> <li>Check for faulty wiring.</li> <li>If no problem found with the wiring, the FTC control board is faulty. Replace the board.</li> </ul> </li> </ol>	Consumed electric energy		Delivered heat energy		SW3-4	Electric energy meter (Local supply)	SW3-8	Heat meter (Local supply)	OFF	Without	OFF	Without	ON	With	ON	With
Consumed electric energy		Delivered heat energy																	
SW3-4	Electric energy meter (Local supply)	SW3-8	Heat meter (Local supply)																
OFF	Without	OFF	Without																
ON	With	ON	With																
36	Heat pump is forced to turn ON and OFF.	Smart grid ready input (IN11 and IN12) is used, and switch-on and off commands are input.	Normal operation no action necessary.																

## Annual Maintenance

It is essential that the cylinder unit is serviced at least once a year by a qualified individual. Any spare parts required should be purchased from Mitsubishi Electric. NEVER bypass safety devices or operate the unit without them being fully operational.

### <Annual maintenance points>

Use the Annual Maintenance Log Book as a guide to carrying out the necessary checks on the cylinder unit and outdoor unit.

# Test point diagram

## FTC (Controller board)

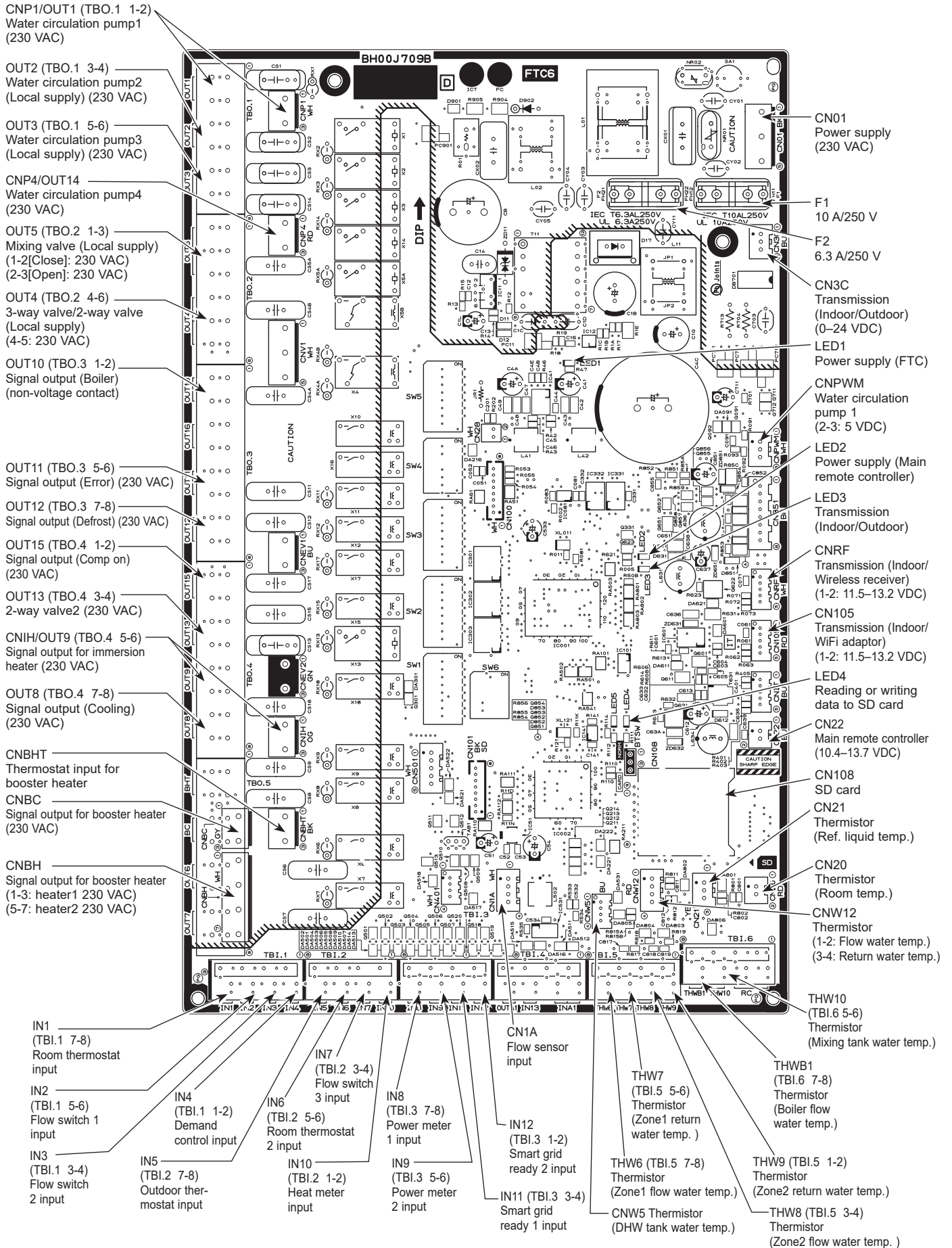

## FAULT FINDING

### IMPORTANT

- Any required parts should be purchased from Mitsubishi Electric parts.
- Disconnect the electrical supply before removing any electrical equipment covers.
- NEVER bypass any thermal controls or operate system without the necessary safety valves.
- Water contained in the Air Source Heat Pump pre-plumbed cylinder may be very hot, especially following a thermal control failure. Caution must be taken when drawing water from the unit.

Fault Finding Table

FAULT	POSSIBLE CAUSE	REMEDY
No hot water flow	1. Mains supply off.	1. Check and open stock cock.
	2. Strainer blocked.	2. Turn off water supply. Remove strainer and clean (see maintenance section).
	3. Cold water combination valve incorrectly fitted.	3. Check and refit as required.
Water from hot taps is cold	1. BACK UP immersion heater not switched on.	1. Check and switch on.
	2. BACK UP immersion heater thermal cut-out has operated.	2. Check. Reset by pushing button.
	3. Programmer set to Central Heating only.	3. Check. Set to Domestic Hot Water programme.
	4. Air Source Heat Pump not working.	4. Check heat pump operation. If fault is suspected, consult heat pump instructions.
	5. Thermal cut-out has operated.	5. Check. Reset by pushing button on cut-out. Check operation of DHW thermal sensor.
	6. DHW circulating pump not connected correctly.	6. Check wiring and/or plumbing connections to DHW circulating pump. Check isolating valves are open.
Water discharges from Expansion Valve	1. INTERMITTENTLY Expansion vessel charge pressure has reduced below 3.5 bar.	1. See Maintenance section for re-charging procedure.
	2. CONTINUALLY a. Cold water combination valve pressure reducer not working correctly. b. Expansion valve seat damaged.	2a. Check pressure from cold water combination valve. If greater than 3.6 bar, replace pressure reducer cartridge. 2b. Remove expansion valve cartridge. Check condition of seat. If necessary, fit new expansion valve cartridge.
Water discharges from T&P Relief Valve	1. Thermal control failure. NOTE: water will be very hot.	1. Switch off power to immersion heater(s) and / or shut down Heat Pump. DO NOT turn off water supply. When discharge stops check all thermal controls, replace if faulty.
Milky water	1. Oxygenated water.	1. Water from a pressurised system releases oxygen bubbles when flowing. The milky water will disappear after a short while.

The fault finding table (above) will enable operational faults to be identified and their possible causes rectified. Any work carried out on this unvented water heater and its associated controls MUST be carried out by a competent installer for unvented water heating systems. In case of doubt contact Technical Support (see contact details on back page).

### WARNING

**DO NOT TAMPER WITH ANY OF THE SAFETY VALVES OR CONTROLS SUPPLIED WITH THE PRE-PLUMBED CYLINDER AS THIS WILL INVALIDATE ANY GUARANTEE.**

# DISASSEMBLY PROCEDURE

## PREPARATION FOR DISASSEMBLY

- Prepare the proper tools.
- Prepare the proper protectors.
- Provide adequate ventilation.
- After stopping the operation of the cylinder and outdoor unit, turn off all the power-supply breakers.
- Allow parts to cool.
- Do not expose the electric parts to water.
- When replacing or servicing water circuit parts, drain system first.

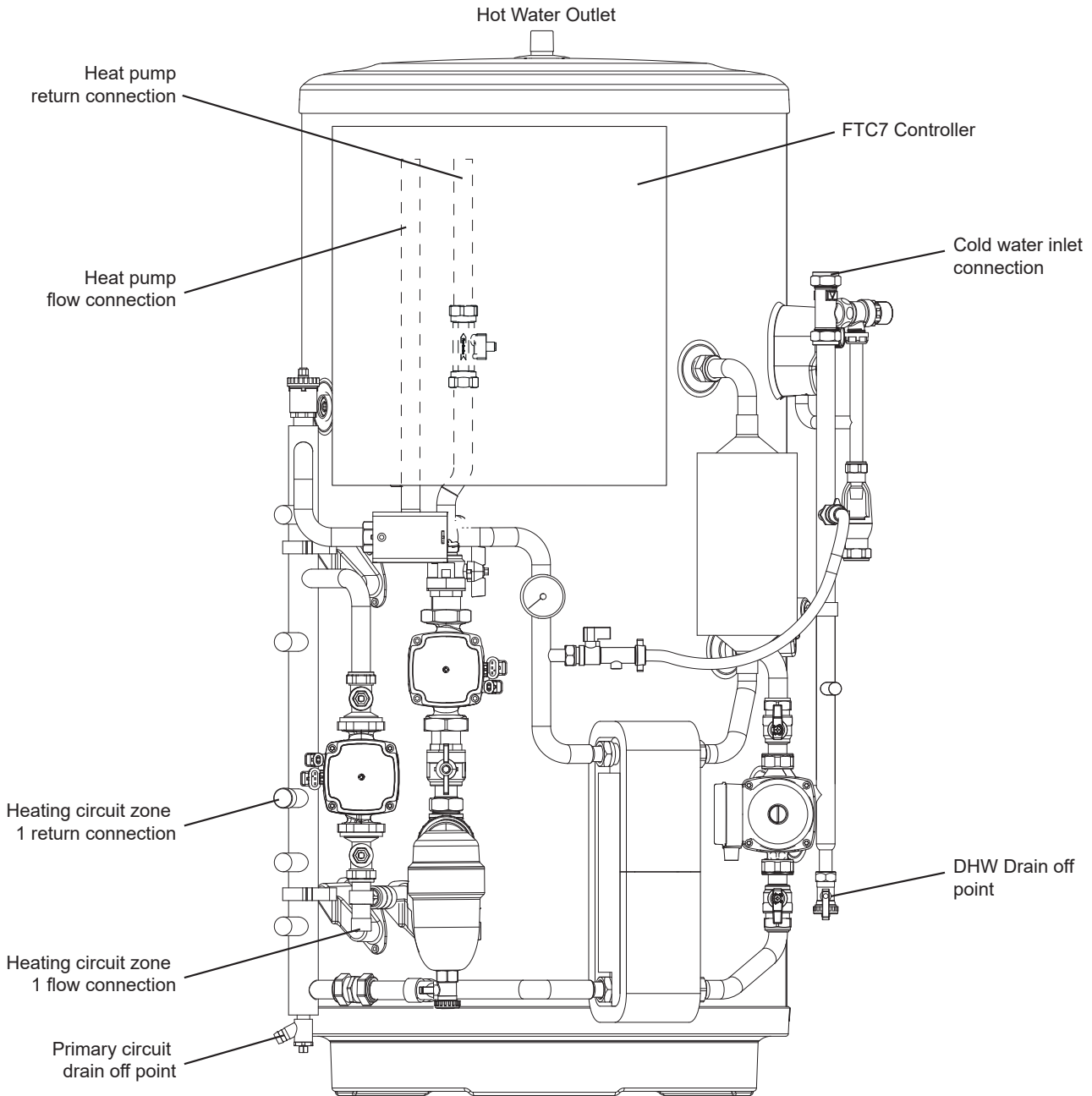

Isolate all electrical power connections to the installation and disconnect all wiring to the FTC7 controller. To remove the cylinder it is necessary to isolate the feed to the cold water inlet. The primary circuit & DHW can then be drained from the points shown in the diagram above. Disconnect the pipework from the hot water outlet, heat pump flow & return, heating circuit flow & return and expansion relief valve pipework. The cylinder can then be removed. See next page for step-by-step procedure and images.

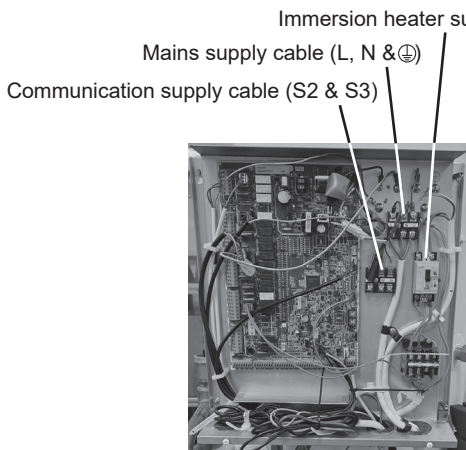

1. Turn off electrical supplies to both Cylinder and Heat Pump. Disconnect cables to main control panel.



2. Turn off cold water supply to Heat Pump Cylinder. Drain down cylinder making sure Hot water outlet is isolated, connect hose to tail and secure. Run hose to drain.



3. Drain down Heat Pump Primary fluid, ensuring it is disposed of in accordance with national environmental regulations.

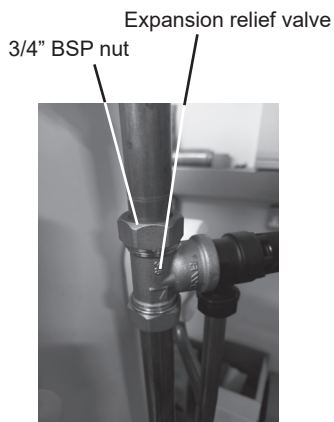

4. Disconnect cold water supply to cylinder. Disconnect expansion relief valve pipework.

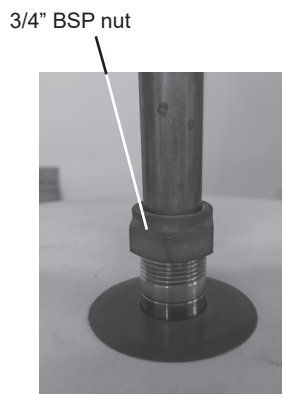

5. Disconnect hot water supply from cylinder.

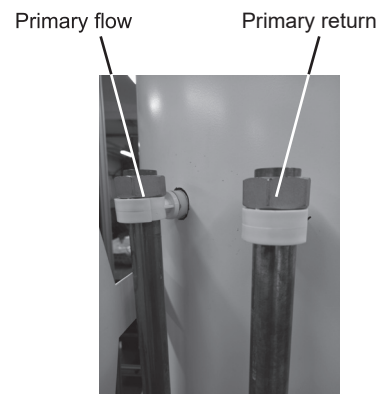

6. Disconnect primary flow & return from heat pump. Disconnect the heating circuit flow & return.

The cylinder can now be removed - care must be taken as the cylinder will be heavy.

## SUPPLEMENTARY INFORMATION

### ■ Back-up operation of boiler

Heating operation is backed up by boiler.

For more details, refer to the installation manual of PAC-TH012HT(L)-E.

#### <Installation & System set up>

1. Set DIP-SW1-1 to ON "With boiler" and SW2-6 to ON "With Mixing tank".
2. Install the thermistors THWB1 (Flow temp.) \*1 on the boiler circuit.
3. Connect the output wire (OUT10: Boiler operation) to the input (room thermostat input) on the boiler. \*2
4. Install one of the following room temperature thermostats. \*3

- Wireless remote controller (option)
- Room temp. thermostat (local supply)
- Main remote controller (remote position)

\*1 The boiler temperature thermistor is an optional part.

\*2 OUT10 has no voltage across it.

\*3 Boiler heating is controlled on/off by the Room temp. thermostat.

#### <Remote controller settings>

1. Go to Service menu > Heat source setting and choose "Boiler" or "Hybrid". \*4
2. Go to Service menu > Operation settings > Boiler settings to make detailed settings for "Hybrid" above.

\*4 The "Hybrid" automatically switches heat sources between Heat pump (and Electric heater) and boiler.

# SERVICE AND MAINTENANCE

## Engineers Forms

Should settings be changed from default, please enter and record new setting in 'Commissioning/Field settings record sheet' below. This will ease resetting in the future should the system use change or the circuit board need to be replaced.

### Commissioning/Field settings record sheet

Main remote controller screen			Parameters	Default setting	Field setting	Notes	
DHW	DHW *4	Eco	On/Off *5	Off			
		Boost	On/Off	—			
		DHW max. temp.	40°C to 55/60/65/70°C *6	50°C			
		Max. temp. drop	5°C to 40°C	10°C			
		Max. operation time	30 to 120 min.	60 min.			
		Interval	30 to 120 min.	30 min.			
		Volume	Large / Standard	Standard *7			
		Schedule	On/Off	Off			
		Always off	On/Off	Off			
	Legionella prevention *4	Legionella	On/Off	On			
		Hot water temp.	60°C to 70°C *6	65°C			
		Start time	00:00 to 23:00	03:00			
		Duration	1 to 120 min.	30 min.			
		Frequency	1 to 30 days	15 days			
		Max. operation time	1 to 5 h	3 h			
	Heating / Cooling *3	Heating / Cooling	Zone 1 heating room temp.	10°C to 30°C	20°C		
			Zone 2 heating room temp. *1	10°C to 30°C	20°C		
Zone 1 heating flow temp.			20°C to 60/70/75°C	45°C			
Zone 2 heating flow temp. *2			20°C to 60/70/75°C	35°C			
Zone 1 cooling flow temp. *3			5°C to 25°C	15°C			
Zone 2 cooling flow temp. *3			5°C to 25°C	20°C			
Zone 1 heating weather compensation curve			-9°C to +9°C	0°C			
Zone 2 heating weather compensation curve *2			-9°C to +9°C	0°C			
Zone 1 cooling weather compensation curve			-9°C to +9°C	0°C			
Zone 2 cooling weather compensation curve *2			-9°C to +9°C	0°C			
Schedule			On/Off	Off			
Always off			On/Off	Off			
Heating / Cooling			Heating / Cooling	Heating			
Zone 1 control logic			Heating room temp./ Heating flow temp./ Heating weather compensation curve / Cooling flow temp./ Cooling weather compensation curve	Heating weather compensation curve			
Zone 2 control logic *2			Heating room temp./ Heating flow temp./ Heating weather compensation curve / Cooling flow temp./ Cooling weather compensation curve	Heating weather compensation curve			
Auto change over		On/Off	Off				
Weather compensation curve (Heating)		Hi flow temp. set point	Zone 1 outdoor ambient temp.	-30°C to +33°C *8	-15°C		
			Zone 1 flow temp.	20°C to 60/70/75°C	50°C		
			Zone 2 outdoor ambient temp. *2	-30°C to +33°C *8	-15°C		
			Zone 2 flow temp. *2	20°C to 60/70/75°C	40°C		
		Lo flow temp. set point	Zone 1 outdoor ambient temp.	-28°C to +35°C *9	20°C		
			Zone 1 flow temp.	20°C to 60/70/75°C	25°C		
			Zone 2 outdoor ambient temp. *2	-28°C to +35°C *9	20°C		
			Zone 2 flow temp. *2	20°C to 60/70/75°C	25°C		
		Adjust	Zone 1 outdoor ambient temp.	-29°C to +34°C *10	—		
			Zone 1 flow temp.	20°C to 60/70/75°C	—		
			Zone 2 outdoor ambient temp. *2	-29°C to +34°C *10	—		
			Zone 2 flow temp. *2	20°C to 60/70/75°C	—		
Weather compensation curve (Cooling)		Hi flow temp. set point	Zone 1 outdoor ambient temp.	10°C to 46°C	35°C		
			Zone 1 flow temp.	5°C to 25°C	15°C		
	Zone 2 outdoor ambient temp. *2		10°C to 46°C	35°C			
	Zone 2 flow temp. *2		5°C to 25°C	20°C			
	Lo flow temp. set point	Zone 1 outdoor ambient temp.	10°C to 46°C	25°C			
		Zone 1 flow temp.	5°C to 25°C	25°C			
		Zone 2 outdoor ambient temp. *2	10°C to 46°C	25°C			
		Zone 2 flow temp. *2	5°C to 25°C	25°C			
Menu	Energy		Energy monitor	Consumed electrical energy/Delivered energy	—		
	Holiday		Schedule	On/Off/Set time	—		
			DHW *4	On/Off	Off		
			Heating / Cooling *3	On/Off	On		
	Setting	Language	EN/CZ/DA/DE/ET/ES/FR/HR/IT/LV/LT/HU/NL/NO/PL/PT/RO/SK/SI/FI/SV/TR/EL/BG		EN		
		Room sensors	Zone sensor selection *2	Zone 1/Zone 2	Zone 1		
			Zone 1 programme	TH1/Main RC/Room RC1-8/"Time/Zone"	TH1		
			Zone 2 programme *2	TH1/Main RC/Room RC1-8/"Time/Zone"	TH1		
		Display	Temp. (°C) → (°F)	On/Off	Off		
		Touch screen	Clean screen	On/Off	Off		
			Calibrate screen	On/Off	Off		
	Brightness		Low / Mid / Hi	Mid			
		Backlight time	5sec./10sec./20sec./30sec./60sec./Always on	30sec.			

# Engineers Forms

## Commissioning/Field settings record sheet

Main remote controller screen			Parameters		Default setting	Field setting	Notes		
Menu	Service	Thermistor adjustment	THW1	-10°C to +10°C	0°C				
			THW2	-10°C to +10°C	0°C				
			THW5B	-10°C to +10°C	0°C				
			THW6	-10°C to +10°C	0°C				
			THW7	-10°C to +10°C	0°C				
			THW8	-10°C to +10°C	0°C				
			THW9	-10°C to +10°C	0°C				
			THW10	-10°C to +10°C	0°C				
			THWB1	-10°C to +10°C	0°C				
			Auxiliary settings	Economy settings for pump.	On/Off *11	On			
		Delay (3 to 60 min.)			10 min.				
		Electric heater (heating)		Space heating: On (used)/Off (not used)	On				
				Electric heater delay timer (5 to 180 min.)	30 min.				
		Electric heater (DHW) *4		Booster heater	DHW: On (used)/Off (not used)	On			
				Immersion heater	DHW: On (used)/Off (not used)	On			
				Electric heater delay timer (15 to 30 min.)	15 min.				
		Mixing valve 1 control		Running (10 to 240 sec.)	120 sec.				
				Interval (1 to 30 min.)	2 min.				
		Mixing valve 2 control		Running (10 to 240 sec.)	120 sec.				
				Interval (1 to 30 min.)	2 min.				
		Flow sensor *12		Minimum (0 to 100 L/min)	5 L/min				
				Maximum (0 to 100 L/min)	100 L/min				
		Analogue output		Interval (1 to 30 min.)	5 min.				
				Priority (Normal / High)	Normal				
		Electric heater schedule *19	Daily schedule (Schedule 1/Schedule 2)	Schedule 1					
			Time schedule 1 (Always/Start-Stop/Never)	Always					
			Time schedule 2 (Always/Start-Stop/Never)	Always					
		Pump speed	DHW	Pump speed (1 to 5)	5				
			Heating / Cooling	Pump speed (1 to 5)	5				
		Heat source setting		Standard / Heater / Boiler / Hybrid *13	Standard				
		Heat pump settings	Heat pump flow rate range	Minimum (0 to 100 L/min)	5 L/min				
				Maximum (0 to 100 L/min)	100 L/min				
			Quiet mode	Heating	Day (Mon to Sun)	—			
					Time	0:00 to 23:45			
					Quiet level (Normal/ Level1/ Level2/ Level3)	Normal			
				Cooling	Day (Mon to Sun)	—			
					Time	0:00 to 23:45			
					Quiet level (Normal/ Level1/ Level2/ Level3)	Normal			
			Operation settings	Heating operation	Flow temperature range *14	Minimum temp. (20 to 45°C)	30°C		
						Maximum temp. (35 to 60/70/75°C)	50°C		
		Room temperature control *14			Mode (Auto/Quick/Normal/Slow)	Auto			
					Interval (10 to 60 min.)*15	10 min.			
		Heat pump thermo diff.			On/Off *11	On			
				Lower (-9 to -1°C)	-5°C				
				Upper (+3 to +5°C)	5°C				
		Freeze stat function *16		Ambient temp. (3 to 20°C) / **	5°C				
		Simultaneous operation (DHW/ Heating)		On/Off *11	Off				
		Cold weather function		Ambient temp. (-30 to +10°C) *8	-15°C				
				On/Off *11	Off				
		Boiler settings		Hybrid settings	Ambient temp. (-30 to -10°C) *8	-15°C			
					Outdoor ambient temp. (-30 to +10°C) *8	-15°C			
					Priority mode (Ambient/Cost/CO <sub>2</sub> ) *17	Ambient			
					Outdoor ambient temp. rise (+1 to +5°C)	+3°C			
			Intelligent settings		Electricity (0.001 to 999 */kWh)	0.5 */kWh			
			Energy price *18	Boiler (0.001 to 999 */kWh)	0.5 */kWh				
				CO <sub>2</sub> emission	Electricity (0.001 to 999 kg -CO <sub>2</sub> /kWh)	0.5 kg -CO <sub>2</sub> /kWh			
			Heat source	Boiler (0.001 to 999 kg -CO <sub>2</sub> /kWh)	0.5 kg -CO <sub>2</sub> /kWh				
				Heat pump capacity (1 to 40 kW)	11.2 kW				
				Boiler efficiency (25 to 150%)	80%				
		Booster heater 1 capacity (0 to 30 kW)	2 kW						
		Booster heater 2 capacity (0 to 30 kW)	4 kW						

# Engineers Forms

Commissioning/Field settings record sheet (continued from the previous page)

Main remote controller screen				Parameters		Default setting	Field setting	Notes
Menu	Service	Operation settings	Smart grid ready	DHW	On/Off		Off	
					Target temp. (+1 to +30°C) / -- (Non active)		--	
				Heating	On/Off		Off	
					Target temp.	Switch-on recommendation (20 to 60/70/75°C)	50°C	
						Switch-on command (20 to 60/70/75°C)	55°C	
				Cooling	On/Off		Off	
					Target temp.	Switch-on recommendation (5 to 25°C)	15°C	
						Switch-on command (5 to 25°C)	10°C	
				Pump cycles	Heating (On/Off)		On	
					Cooling (On/Off)		On	
			Interval (10 to 120 min.)		10 min.			
			Floor dry up	On/Off *11		Off		
				Target temperature	Start & End (20 to 60/70/75°C)	30°C		
					Max temperature (20 to 60/70/75°C)	45°C		
					Max temperature period (1 to 20 days)	5 days		
				Flow temperature increase	Temperature increase step (+1 to +30°C)		+5°C	
					Increase interval (1 to 7 days)		2 days	
				Flow temperature decrease	Temperature decrease step (-1 to -30°C)		-5°C	
					Decrease interval (1 to 7 days)		2 days	
			Summer mode	On/Off		Off		
				Ambient temperature	Heating on (4 to 19°C)	10°C		
					Heating off (5 to 20°C)	15°C		
				Judgement time	Heating on (1 to 48 h)	6 h		
					Heating off (1 to 48 h)	6 h		
			Forced heating On (-30 to 10°C)		5°C			
			Auto change over	On/Off		Off		
				Ambient temperature	Heat→Cool (10 to 40°C)	28°C		
					Cool→Heat (5 to 20°C)	15°C		
				Judgement time	Heat→Cool (1 to 48 h)	6 h		
			Cool→Heat (1 to 48 h)		6 h			
			Water flow control	On/Off		Off		
				Water temperature difference *20	Heating (+3 to +20°C)	+5°C		
					Cooling (+3 to +10°C)	+5°C		
			Holiday mode	Zone 1 heating room temp.	10°C to 30°C	15°C		
				Zone 2 heating room temp. *1	10°C to 30°C	15°C		
				Zone 1 heating flow temp.	20°C to 60/70/75°C	35°C		
				Zone 2 heating flow temp. *2	20°C to 60/70/75°C	25°C		
				Zone 1 cooling flow temp. *3	5°C to 25°C	25°C		
				Zone 2 cooling flow temp. *3	5°C to 25°C	25°C		
			Zone prohibited	Heating (Zone 1)	Permitted/Prohibited	Permitted		
				Heating (Zone 2)	Permitted/Prohibited	Permitted		
				Cooling (Zone 1)	Permitted/Prohibited	Permitted		
				Cooling (Zone 2)	Permitted/Prohibited	Permitted		

## Engineers Forms

### Commissioning/Field settings record sheet (continued from the previous page)

Main remote controller screen				Parameters	Default setting	Field setting	Notes
Menu	Service	Energy monitor settings	Electric heater capacity	Booster heater 1	0 to 30 kW	2 kW	
				Booster heater 2	0 to 30 kW	4 kW	
				Immersion heater	0 to 30 kW	0 kW	
				Analogue output	0 to 30 kW	0 kW	
			Delivered energy adjustment	-50 to +50%	0%		
			Water pump input	Pump 1	0 to 200 W or ***(factory fitted pump)	***	
				Pump 2	0 to 200 W	0 W	
				Pump 3	0 to 200 W	0 W	
				Pump 4 *7	0 to 200 W	72 W	
			Electric energy meter	0.1/1/10/100/1000 pulse/kWh	1000 pulse/kWh		
		Heat meter	0.1/1/10/100/1000 pulse/kWh	1000 pulse/kWh			
		External in- put settings	Demand control (IN4)		Heat source OFF/Boiler operation	Boiler operation	
			Outdoor thermostat (IN5)		Heater operation/Boiler operation	Boiler operation	
			Cooling limit temp. (IN15)	Zone selection	Zone 1/Zone 2/Zone 1&2	Zone 1	
				Zone 1 lowest temperature	5°C to 25°C	18°C	
				Zone 2 lowest temperature	5°C to 25°C	18°C	
			Thermo on output		Zone 1/Zone 2/Zone 1&2	Zone 1&2	

\*1 The settings related to Zone 2 can be switched only when 2-zone temperature control or 2-zone valve ON/OFF control is active.

\*2 The settings related to Zone 2 can be switched only when 2-zone temperature control is enabled (when DIP SW 2-6 and SW 2-7 are ON).

\*3 Cooling mode settings are available for ERS\* model only.

\*4 Only available if DHW tank is present in system.

\*5 When the indoor unit is connected with a PUMY-P outdoor unit, the mode is fixed to "Off".

\*6 For the model without both booster and immersion heater, it may not reach the set temperature depending on the outside ambient temperature.

\*7 This setting is valid for only cylinder units.

\*8 The lower limit is -15°C depending on the connected outdoor unit.

\*9 The lower limit is -13°C depending on the connected outdoor unit.

\*10 The lower limit is -14°C depending on the connected outdoor unit.

\*11 On: the function is active; Off: the function is inactive.

\*12 Do not change the setting since it is set according to the specification of flow sensor attached to the indoor unit.

\*13 When DIP SW1-1 is set to OFF "WITHOUT Boiler" or SW2-6 is set to OFF "WITHOUT Mixing tank", neither Boiler nor Hybrid can be selected.

\*14 Valid only when operating in Heating room temperature.

\*15 When DIP SW5-2 is set to OFF, the function is active.

\*16 If asterisk (\*\*) is chosen freeze stat function is deactivated. (i.e. primary water freeze risk)

\*17 When the indoor unit is connected with a PUMY-P and PXZ outdoor unit, the mode is fixed to "Ambient".

\*18 \*\*\* of "\*/kWh" represents currency unit (e.g. €, £, or the like)

\*19 Valid only during heating mode

\*20 To enable this function in the outdoor unit of PUZ-S(H)WM, switch the [Mode 7] in [Function settings] to "2".

([Menu] → [Service] → [Function settings], [Ref. add: 0], [Unit: 1] → [Mode 7], 1-High temperature control (default) / 2-Water temperature difference control)

## Annual Maintenance Log Book

Contractor name		Engineer name	
Site name		Site number	
Cylinder unit maintenance record sheet			
Warranty number		Model number	
		Serial number	
No.	Mechanical	Frequency	Notes
1	Turn OFF water supply, drain DHW tank, remove mesh from strainer clean and replace in strainer. *1		
2	Keep water supply OFF, open hot water taps and check the primary-side expansion vessel charge pressure. Top up if necessary (1 bar).		
3	Keep water supply OFF and check the potable vessel charge pressure. Top up if necessary (3.5 bar).		
4	Keep water supply OFF. In hard water areas de-scaling of the immersion heaters may be required.		
5	Drop the primary/heating system pressure to zero check and if necessary top up the expansion vessel (1 bar). Air valve of expansion vessel is TR-412.		
6	Turn water supply ON, open the pressure relief valve and then the expansion relief valve in turn. Check for unrestricted discharge to the tundish and that the valves reseal correctly. Check there are no blockages in the tundish and associated pipework.		
7	Check and if necessary top up the concentration of anti-freeze/inhibitor (if used in the system).		
8	Top up the primary/heating system using a temporary backflow prevention filling loop and repressurise to 1 bar.		
9	Heat system and check pressure does not rise above 3 bar and no water is released from the safety valves.		
10	Release any air from the system.		
11	To check the 3-way valve for inside leaks, confirm that the temperature of the heat emitter does not rise when running the DHW mode.		
Refrigerant models only [except EHPT20 series]		Frequency	Notes
1	Refer to outdoor unit manual.		
Electrical		Frequency	Notes
1	Check condition of cables.		
2	Check rating and fuse fitted on the electricity supply.		
Controller		Frequency	Notes
1	Check field settings against factory recommendations.		
2	Check operation of motorized valves ensure they reseal correctly.		
3	Check battery power of wireless thermostat and replace if necessary.		
Outdoor heat pump unit maintenance record sheet			
Model number		Serial number	
	Mechanical	Frequency	Notes
1	Inspect grill and air inlet for trapped debris/damage.		
2	Check condensate drain provision.		
3	Check integrity of water pipework and insulation.		
4	Check all electrical connections.		
5	Check and record the operation voltage.		

\* Checks should be carried out once a year.

\*1 Be sure to reattach the mesh after washing.

**Note: Within the first couple of months of installation, remove and clean the cylinder unit's filter plus any strainers that are fitted external to the cylinder unit. This is especially important when installing on an existing system.**

In addition to annual servicing, it is necessary to replace or inspect some parts after a certain period of system operation. Please see tables below for detailed instructions. Replacement and inspection of parts should always be done by a competent person with relevant training and qualifications.

### Parts which require regular replacement

Parts	Replace every	Possible failures
Air vent (Auto/Manual) Drain cock (Primary/Sanitary circuit) Manometer Inlet control group (ICG)*	6 years	Water leakage

### Parts which require regular inspection

Parts	Check every	Possible failures
Immersion heater	2 years	Earth leakage causing circuit breaker to activate (Heater is always OFF)
Water circulation pump	20,000 hrs (3 years)	Water circulation pump failure

### Parts which must NOT be reused when servicing

\* O-ring

\* Gasket

**Note: Always replace the gasket for pump with a new one at each regular maintenance (every 20,000 hours of use or every 3 years).**

## MAINTENANCE REQUIREMENTS

Unvented hot water systems have a continuing maintenance requirement in order to ensure safe working and optimum performance. It is essential that the relief valve(s) are periodically inspected and manually opened to ensure no blockage has occurred in the valves or discharge pipe work. Similarly cleaning of the strainer element and replacement of the air in the expansion vessel will help to prevent possible operational faults.

The maintenance checks described below should be performed by a competent person on a regular basis, e.g. Annually to coincide with Heat Pump maintenance.

After any maintenance, please complete the relevant service interval record documentation for the installation.

## INSPECTION

The immersion heater boss can be used as an access for inspecting the cylinder internally.

## SAFETY VALVE OPERATION

Manually operate the temperature/pressure relief valve for a few seconds. Check water is discharged and that it flows freely through the tundish and discharge pipe work. Check valve re-seats correctly when released. NOTE: Water discharged may be very hot!

Repeat the above procedure for the expansion relief valve.

## STRAINER

Turn off the cold water supply, Heat Pump and immersion heater. The lowest hot water tap should then be opened to depressurise the system. Remove the Pressure Reducing Cartridge to access the strainer mesh. Wash any particulate matter from the strainer under clean water. Re-assemble ensuring the seal is correctly fitted. DO NOT use any other type of sealant.

## DESCALING IMMERSION HEATER

Before removing the immersion heater, the cylinder unit must be drained. Ensure the water, electrical supply and Heat Pump are OFF before draining. Attach a hosepipe to the drain cock having sufficient length to take water to a suitable discharge point below the level of the unit. Open a hot tap close to the unit and open the drain cock to drain the unit.

## IMMERSION HEATER REMOVAL

Open the cover to the immersion heater housing and disconnect wiring from immersion heater over-temperature cut-out. Remove the over-temperature cut-out by pulling from the terminal connections on the immersion heater. Unscrew immersion heater backnut and remove immersion heater from the unit. A key spanner is supplied with the cylinder unit for easy removal/tightening of the backnut(s). Over time, the immersion heater gasket may become stuck to the mating surface. To break the seal, insert a round bladed screwdriver into one of the pockets on the immersion heater and gently lever up and down.

Carefully remove any scale from the surface of the element. DO NOT use a sharp implement as damage to the element surface could be caused. Ensure sealing surfaces are clean and seals are undamaged, if in doubt fit a new gasket.

Replace immersion heater ensuring the (right angled) element hangs vertically downwards towards the base of the unit. It may be helpful to support the immersion heater using a round bladed screwdriver inserted into one of the thermal control pockets whilst the backnut is tightened. Replace over-temperature cut-out rod into pocket. Replace the immersion heater over-temperature cut-out by carefully plugging the two male spade terminations on the underside of the thermostat head into the corresponding terminations on the element. Rewire, check, close and secure immersion heater housing cover.

## EXPANSION VESSEL CHARGE PRESSURE

Remove the dust cap on top of the vessel. Check the charge pressure using a tyre pressure gauge. The pressure (with system de-pressurised) should be 0.35 MPa (3.5 bar). If it is lower than the required setting it should be re-charged using a tyre pump (Schrader valve type). DO NOT OVER-CHARGE. Re-check the pressure and when correct replace the dust cap.

## RE-COMMISSIONING

Check all electrical and plumbing connections are secure. Close the drain cock. With a hot tap open, turn on the cold water supply and allow unit to refill. DO NOT switch on the immersion heater or Heat Pump until the unit is full. When water flows from the hot tap, allow to flow for a short while to purge air and flush through any disturbed particles. Close hot tap and then open successive hot taps in the system to purge any air. When completely full and purged, check system for leaks. The heating source (immersion heater and Heat Pump) can then be switched on.

## CLEANING THE FERNOX TF-1 HP FILTER

To clean the filter follow the procedure as described below. If necessary, once cleaning has been completed, re-pressurise the system using the filling loop fitted to the unit. Ensure the installation is not operating & the primary pump is OFF.

1. Turn both isolating valves to their OFF position.

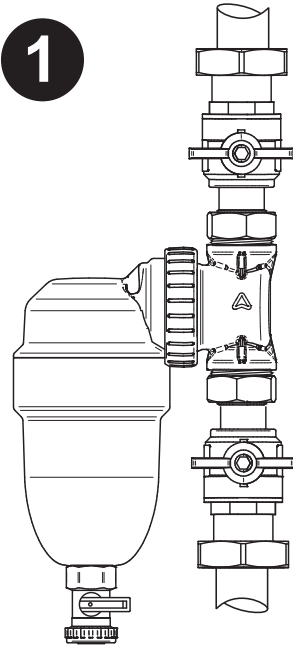

2. Remove the drain valve cap .

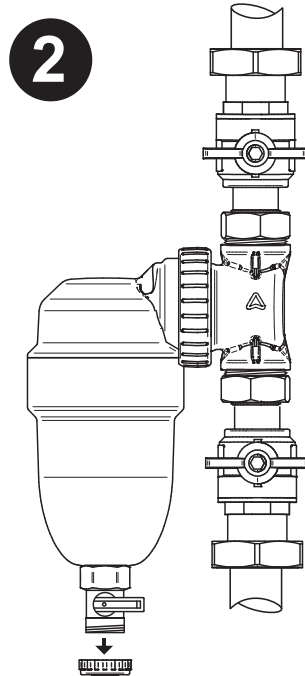

3. Place a suitable receptacle below the drain valve.

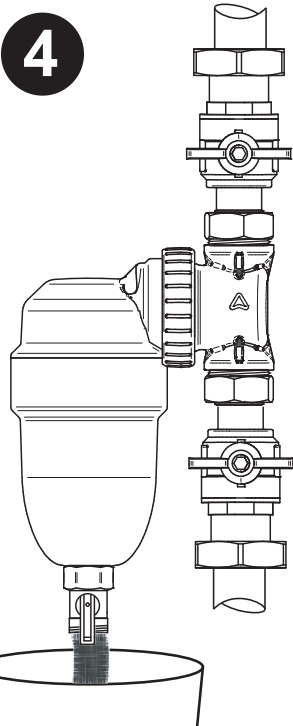
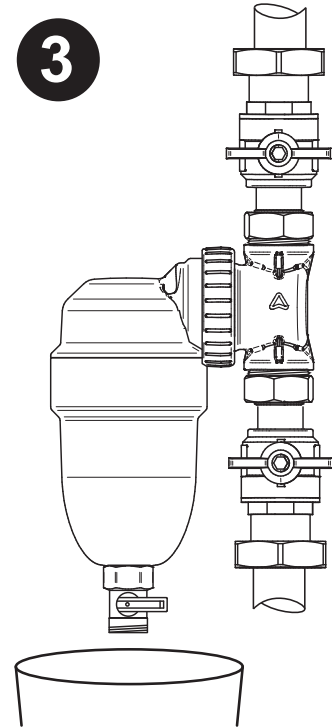

4. Open the drain valve.

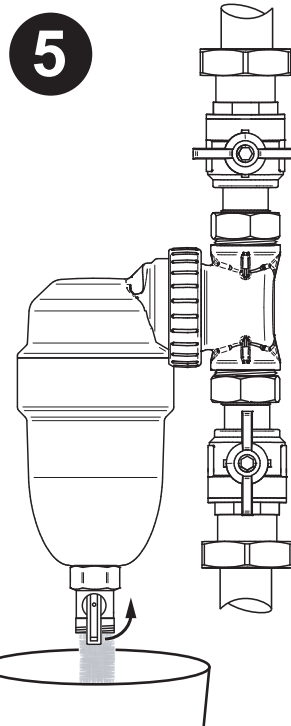

5. After approximately 10 seconds open the inlet isolating valve. When the water runs clear close the drain valve.

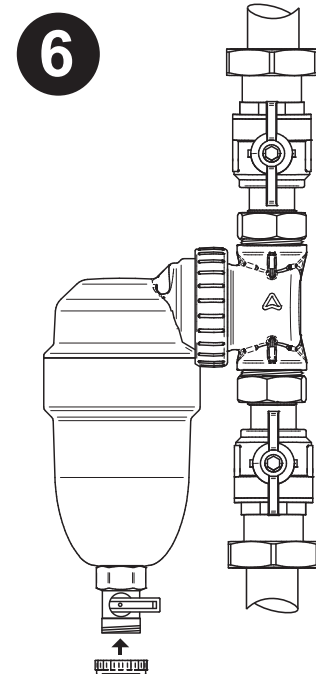

6. Open the outlet isolating valve and replace the drain valve cap.

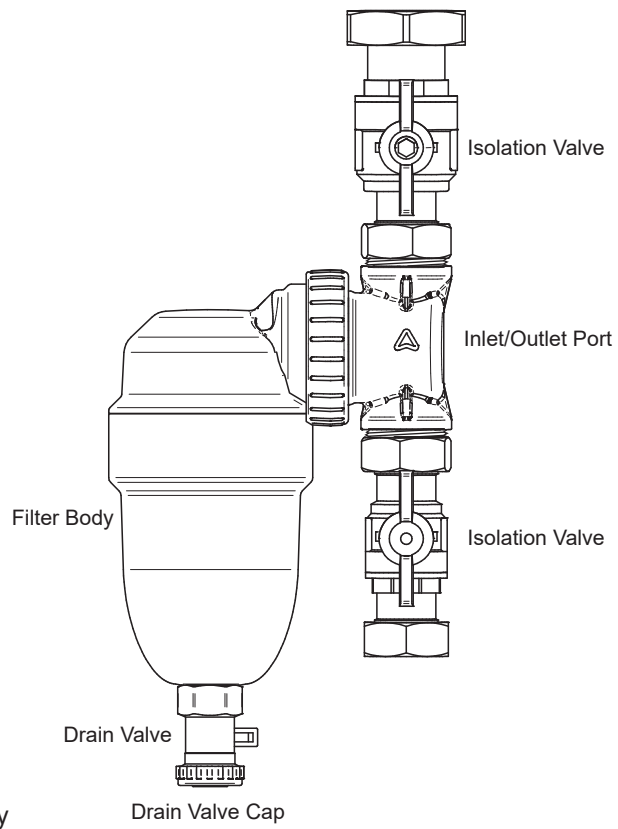

## ANNUAL MAINTENANCE LOG BOOK

On completion of any maintenance or service of the pre-plumbed cylinder, the Annual Maintenance Log Book should be filled in to record the actions taken and the date the work was undertaken.

## ENVIRONMENTAL INFORMATION

Products are manufactured from many recyclable materials. At the end of their useful life they should be disposed of at a Local Authority Recycling Centre in order to realise the full environmental benefits.

Insulation is by means of an approved CFC/HCFC free polyurethane foam with an ozone depletion factor of zero.

## WEEE Declaration

Disposal of Waste Equipment by Users in Private Household in the European Union.



This symbol on the product indicates that this product must not be disposed of with your other household waste. Instead, it is your responsibility to dispose of your waste equipment by handing it over to a designated collection point for the recycling of waste electrical equipment.

The separate collection and recycling of your waste equipment at the time of disposal will help to conserve natural resources and ensure that it is recycled in a manner that protects human health and the environment.

For more information about where you can drop off your waste equipment for recycling, please contact your local city office, your household waste disposal service or the company where this product was purchased.

## TECHNICAL SUPPORT

Residential Heating & Ventilation Telephone: 01707 278666

MELSmart Customer Services & Support: 0161 866 6089

Option 1 - Air Conditioning Technical

Option 4 - Heating Technical

Option 2 - Spares

Option 5 - Returns

Option 3 - Warranty

Option 6 - Product Training & Site Services

Email: [livingenvironmentalsystems@meuk.mee.com](mailto:livingenvironmentalsystems@meuk.mee.com)

Website: [les.mitsubishielectric.co.uk](http://les.mitsubishielectric.co.uk)

UNITED KINGDOM

Mitsubishi Electric Europe

Living Environmental Systems Division

Travellers Lane

Hatfield

Hertfordshire

AL10 8XB

General Enquiries

Telephone: 01707 282880

Fax: 01707 278881