

**Packaged Air Conditioner Optional Parts
POWER SUPPLY INTERFACE FOR ALARM KIT**

Model **PAC-SL73IFL-E**

INSTALLATION MANUAL

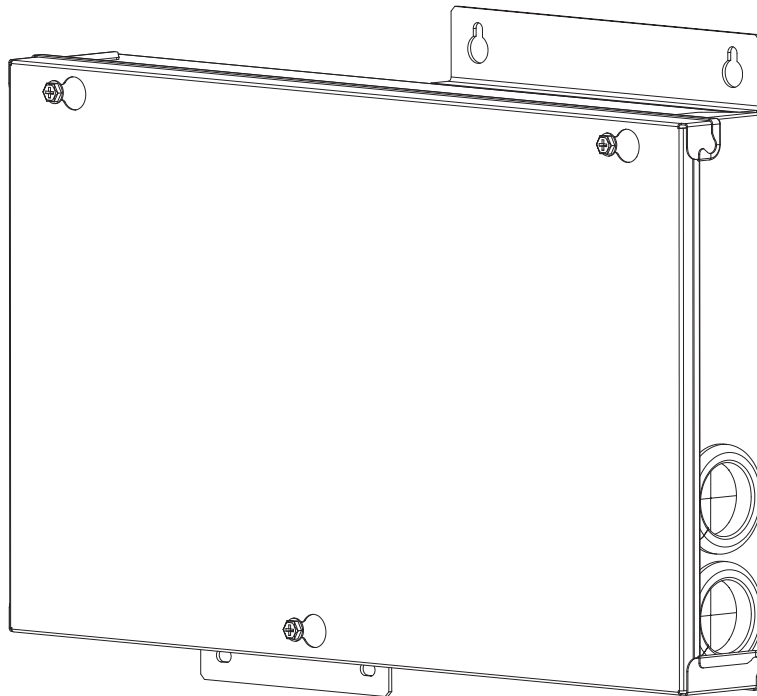

Contents

1. Safety precautions	1	4. Installing the Power Supply Interface for Alarm Kit	2
2. Selecting a location for installation	1	5. Electrical work	3
3. Confirming supplied accessories	2	6. Test run	9

This installation manual is only for the Power Supply Interface for Alarm Kit. In installing the indoor units and outdoor units, refer to the installation manual attached to each unit.

1. Safety precautions

▶ Before installing the unit, make sure you read all the “Safety precautions”.

▶ Please report to or take consent by the supply authority before connecting to the system.

- ⚠ **Warning:**
- Describes precautions that must be observed to prevent danger of injury or death to the user.
 - If the supply cord is damaged, it must be replaced by the manufacturer, its service agent or similarly qualified persons in order to avoid a hazard.
- ⚠ **Caution:**
- Describes precautions that must be observed to prevent damage to the unit.

- ⚠ **Warning:**
- Ask a dealer or an authorized technician to install the unit.
 - For installation work, follow the instructions in the installation manual.
 - This appliance is not intended for use by persons (including children) with reduced physical, sensory or mental capabilities, or lack of experience and knowledge, unless they have been given supervision or instruction concerning use of the appliance by a person responsible for their safety.
 - Children should be supervised to ensure that they do not play with the appliance.
 - The unit must be installed according to the instructions in order to minimize the risk of damage from earthquakes, typhoons, or strong winds. An incorrectly installed unit may fall down and cause damage or injuries.
 - The unit must be securely installed on a structure that can sustain its weight.
 - All electric work must be performed by a qualified technician according to local regulations and the instructions given in this manual.
 - Use only specified cables for wiring.
 - The terminal block cover panel of the unit must be firmly attached.
 - Use only authorized accessories and ask a dealer or an authorized technician to install them.
 - The user should never attempt to repair the unit or transfer it to another location.
 - Be sure to connect the power supply cords and the connecting wires for the indoor units, outdoor units, Branch boxes and Sensor and alarm kit directly to the units (no inter-mediate connections). If water enters the cords or wires, intermediate connections can lead to communication errors and causes insufficient insulation to ground or a poor electrical contact at the intermediate connection point. (If an intermediate connection is necessary, be sure to take measures to prevent water from entering the cords and wires.)
 - Do not alter the unit. It may cause fire, electric shock, injury or water leakage.
 - Do not install the unit to the location where water could come in contact with the unit, or high humidity could cause condensation. It may cause breakdown, short-circuit, electrical leakage, electric shock, smoke, ignition, or fire.
 - Perform the electrical construction with the circuit breaker turned off. It may cause electric shock, breakdown, or malfunction.

After installation work has been completed, explain “Safety precautions” and how to use and maintain the unit to customers according to the information in the operation manual and perform the test run to ensure normal operation. Both the installation manual and operation manual must be given to the user for keeping. These manuals must be passed on to subsequent users.

⚡ : Indicates a part which must be grounded.

⚠ **Warning:**

Carefully read the labels affixed to the main unit.

- ⚠ **Caution:**
- Do not use the unit in an unusual environment. If the air conditioner is installed in areas exposed to steam, volatile oil (including machine oil), or sulfuric gas, or areas exposed to high salt content such as the seaside, the performance can be significantly reduced and the internal parts can be damaged.
 - Do not install the unit where combustible gases may leak, be produced, flow, or accumulate. If combustible gas accumulates around the unit, fire or explosion may result.
 - When installing the unit in a hospital or communications office, be prepared for noise and electronic interference. Inverters, home appliances, high-frequency medical equipment, and radio communications equipment can cause the air conditioner to malfunction or breakdown. The air conditioner may also affect medical equipment, disturbing medical care, and communications equipment, harming the screen display quality.
 - Do not clean the Power Supply Interface for Alarm Kit with water. It may result in electric shock.
 - Be sure to install circuit breakers, if not installed, electric shock may result.
 - For the power lines, use standard cables of sufficient capacity. Otherwise, a short circuit, overheating, or fire may result.
 - When installing the power lines, do not apply tension to the cables. If the connections are loosened, the cables can snap or break and overheating or fire may result.
 - Do not connect the ground wire to gas or water pipes, lighting rods, or telephone grounding lines. If the unit is not properly grounded, electric shock may result.
 - Do not turn off the breaker of Power Supply Interface for Alarm Kit when installing the unit below -20°C, otherwise it may result in communication failure.
 - The unit must be powered except for service. Do not turn the breaker OFF except in the case of a burning smell, or when performing maintenance or inspection. If the breaker is off, the power cannot be supplied to the refrigerant sensor mounted in Sensor and alarm kit, and the sensor cannot detect the refrigerant leakage. This may cause fire.
 - Do not install the Power Supply Interface for Alarm Kit in places with direct sunlight or where the ambient temperature is 40°C or more or is 0°C or less.

2. Selecting a location for installation

• The Power Supply Interface for Alarm Kit is designed for indoor use.

• The Power Supply Interface for Alarm Kit shall only be installed to the location where maintenance space can be secured.

- Make sure that the Power Supply Interface for Alarm Kit is installed to the space where maintenance and servicing can be easily performed. (The required maintenance hole or servicing space shall be available.)
- The electrical wiring route shall be determined in advance.

• Do not install in location that is hot or humid for a long period of time.

• Power Supply Interface for Alarm Kit is only for indoor use.

• Never install Power Supply Interface for Alarm Kit in a room.

• Ensure that Power Supply Interface for Alarm Kit is installed above the ceiling of corridor, etc., where persons are not regularly there.

⚠ **Warning:**

Ensure that the unit is installed firmly in a location able to support its weight.

If the installation is of insufficient strength the unit may fall, resulting in injury.

There is a limitation in number that the Power Supply Interface for Alarm Kit can be connected to.

■ **Without Branch box**

Refer to the following table for the number of interfaces and indoor units that can be connected to the outdoor unit.

The number of indoor units that can be connected decreases as the number of interfaces increases.

Refer to the data book of the outdoor unit to be connected.

Table

Number of interfaces	Number of connectable indoor units
0	12
1	11
2	10
3	9

■ **With Branch box**

Two interfaces can be connected at the maximum.

The connection number of interfaces and Branch box shall always be equal.

■ **With BC controller**

Up to 50 interfaces and indoor units each can be connected to the BC controller.

4. Installing the Power Supply Interface for Alarm Kit

4.3. Wall mounting procedures

- (1) Secure the Power Supply Interface for Alarm Kit [1] with the 4 screws (procured locally) [K]. (Fig. 4-6)
- (2) Use a level to adjust the Power Supply Interface for Alarm Kit [1] to the horizontal.
 - [K] Screw (procured locally)
 - [L] Metal Fitting (procured locally)
 - [M] Screw (procured locally)

Note: To prevent the Power Supply Interface for Alarm Kit from falling off the installation location, select the appropriate screws (procured locally) and secure the base to the appropriate installation location with sufficient strength.

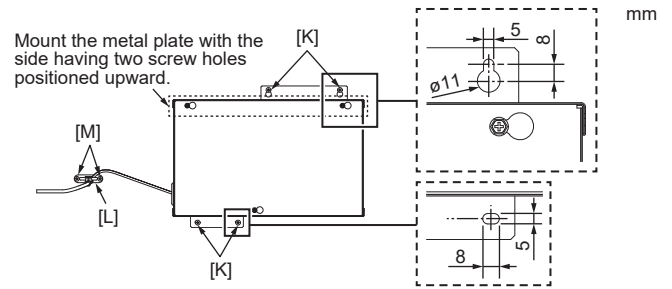

Fig. 4-6

<Important>

As a fall prevention measure, make sure to secure the power cable on the wall for installation in a place without a ceiling. (Fig. 4-7)

Make sure the wall and metal fitting can support a load of 15 kg or more. (Use the appropriate metal fitting and screws that are procured locally.)

*Secure the power cable on the wall with the band [2] included and the metal fitting at a position of 300 mm or less from the entry for power cable.

*Secure the metal fitting higher than the bottom of the unit.

*Make sure that the power cable doesn't move.

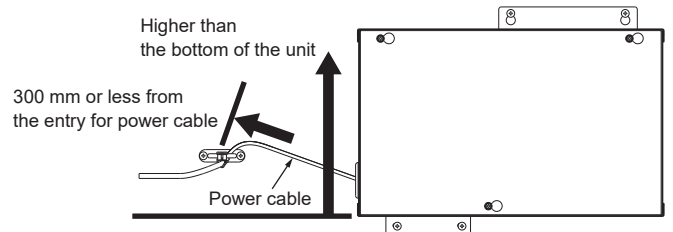

Fig. 4-7

<Securing the cable with bands>

- (1) Route the power supply cable through the metal fitting. (Fig. 4-8)
- (2) Make 2 bands [2] form loops <A> through the metal fitting.
- (3) Make 2 bands [2] form loops through the cable and loops <A>.
- (4) Tighten the loops <A>
- (5) Tighten the loops

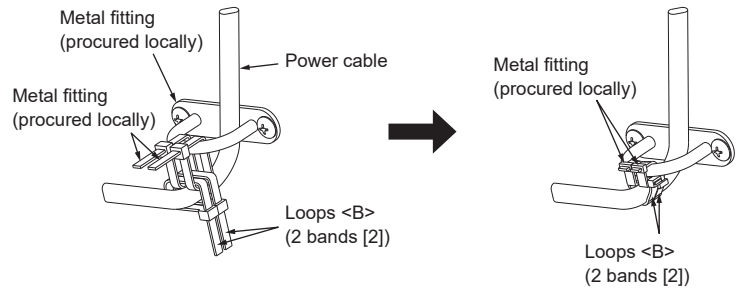

Fig. 4-8

5. Electrical work

5.1. Electrical work

⚠ Warning:

- Always use dedicated circuits with breakers, and at the rated voltage.
- Power supply circuits with insufficient capacity, and bad workmanship during installation, may result in electric shock or fire.
- Never splice the cable, otherwise it may result in smoke, fire, or communication failure.
- Refer to the installation manual of the Sensor and alarm kit for its installation restrictions.
- Be sure to install a refrigerant sensor and alarm in a room with the indoor unit.
- Disabling the refrigerant sensor of the indoor unit always requires the Sensor and alarm kit.

⚠ Caution:

- Be sure to connect the ground wire. Do not connect the ground wire to an utility pipe, arrester, or ground wire of telephone.
- Incomplete grounding may cause electric shock. A high surge current from lightning or other sources may cause damage to the air conditioner.
- Use the specified electrical wiring and ensure that it is connected properly, and that it is not under tension.
- Failure to follow these requirements may result in broken wiring, heating, or fire.
- Never connect the main power source to the terminal block of the transmission line. If connected, electrical parts will be burnt out.
- Wiring for control (hereinafter referred to as transmission line) shall be (5 cm or more) apart from power source wiring so that it is not influenced by electric noise from power source wiring. (Do not insert the transmission line and the power source wire in the same conduit.)

5.2. The system that uses the Power Supply Interface for Alarm Kit

The following are representative examples of the system that uses the Power Supply Interface for Alarm Kit.

<For City Multi system>

- Install the Power Supply Interface for Alarm Kit between the outdoor unit and the indoor unit in the room where you wish to install the Sensor and alarm kit.
- The Sensor and alarm kit which corresponds to the indoor unit shall be installed to the same room.

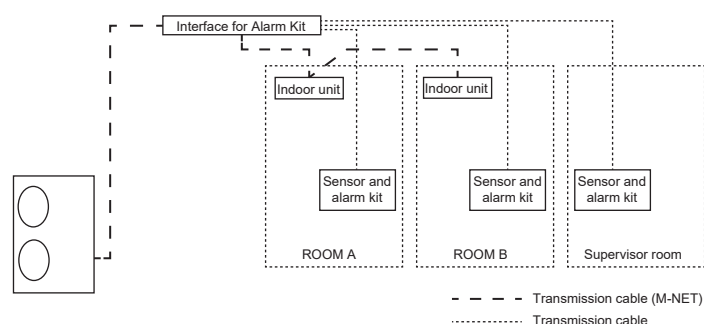

Fig. 5-1

5. Electrical work

<For Branch box system>

- Install the Power Supply Interface for Alarm Kit between the outdoor unit and the Branch box connected to the indoor unit in the room where you wish to install the Sensor and alarm kit.
- The Sensor and alarm kit which corresponds to the indoor unit shall be installed to the same room.
- When the indoor unit under the Branch box to which the Power Supply Interface for Alarm Kit is connected detects a refrigerant leak, all the Sensor and alarm kits connected to the Power Supply Interface for Alarm Kit activate the alarm.
- Only one Power Supply Interface for Alarm Kit can be connected per one Branch box.

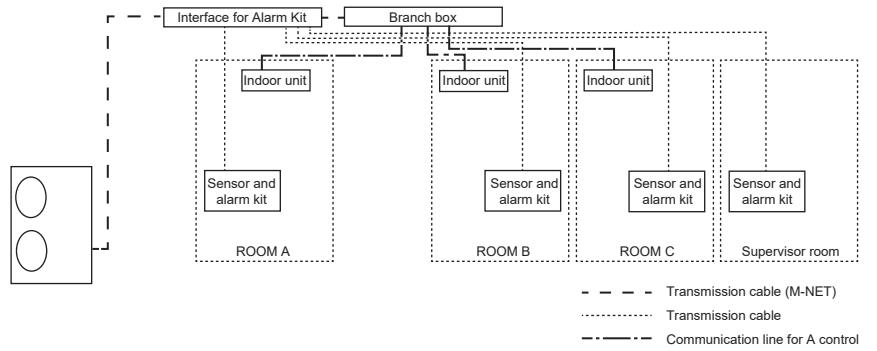

Fig. 5-2

<For BC controller system>

- Install the Power Supply Interface for Alarm Kit between the BC controller and the indoor unit for the room where you wish to install the Sensor and alarm kit.
- The Sensor and alarm kit which corresponds to the indoor unit shall be installed to the same room.
- Once the Sensor and alarm kit connected to the interface detects a refrigerant leak, all the indoor units connected to the interface will stop.
- When the pairing function is enabled while the system is connected to the BC controller, the notifications of abnormalities will be sent only to the Sensor and alarm kit that detected a refrigerant leak and the paired indoor units to stop operation.

For details of the pairing function, refer to the R32 City Multi Technical Manual.

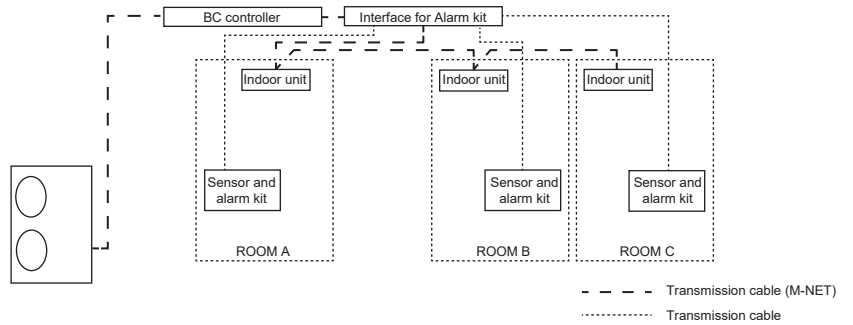

Fig. 5-3

⚠ Caution:

- Connect the Sensor and alarm kit to the Power Supply Interface for Alarm Kit.
 - The Power Supply Interface for Alarm Kit can connect up to 8 Sensor and alarm kits for the room and up to 1 for the supervisor room.
 - Refer to the installation manuals of the Power Supply Interface for Alarm Kit and the Sensor and alarm kit which are optional parts for the details.
 - When using multiple Power Supply Interfaces for Alarm Kit, the indoor unit and the Sensor and alarm kit installed in the same room shall be connected to the same Power Supply Interface for Alarm Kit. (See Fig. 5-4.)
- Never connect the indoor unit and the Sensor and alarm kit that are installed in the same room to different Power Supply Interfaces for Alarm Kit. (See Fig. 5-5.)

<Correct connection>

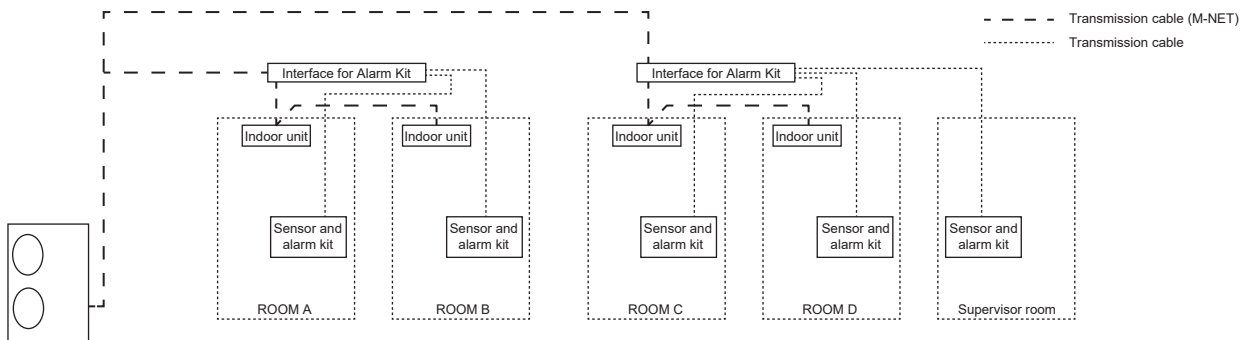

Fig. 5-4

<Wrong connection> With this connection, if the refrigerant leaks in ROOM C, the Sensor and alarm kit would not be activated in the room.

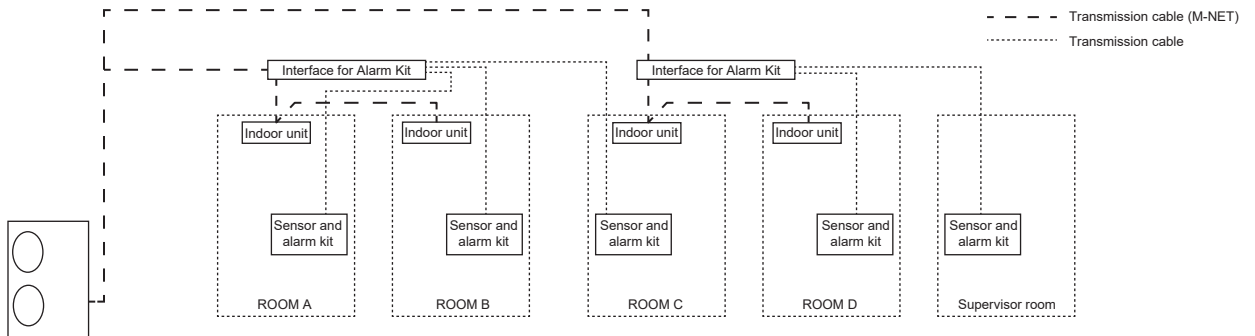

Fig. 5-5

5. Electrical work

5.3. Electrical work procedure

▶ Connect electrical wiring to the appropriate ports marked with matching alphabets (e.g., A, B, C, D, E) on this unit. Incorrect wiring will interfere with the correct operation of the unit.

- ▶ First, connect the power supply cable.
- ▶ Always fix each ground wire separately with a ground screw.

Wiring Specifications		
(A) Main power line/ Ground wire	(B) M-NET cable	(C) Power communication wire with Sensor and alarm kit
Shielding wire CVVS or CPEVS More than 1.25 mm ² Less than 200 m	Shielding wire MVVS 0.5 to 1.25 mm ² Add any portion in excess of 10 m to within the longest allowable transmission cable length 200 m	4-core cable (Tinned annealed copper wires) Cable outer diameter: Φ6.3 mm Conductor size: AWG24-AWG20 Less than 40 m.

- (1) Loosen the three screws securing the cover, then slide the cover. (Fig. 5-6)
- (2) Pass and wire the power cable and the ground wire through the wires entries given in the diagram. (Fig. 5-7)
- (3) Pass and wire the M-NET cable through the wiring entries given in the diagram. (Fig. 5-7)
 - Put the sheath portion of the power cable, ground wire, M-NET cable and Sensor and alarm kit cable into the box.
 - Refer to 5.5. and 5.6. for the connection.
 - Use round crimped terminals for the terminal block for M-NET cable and the power terminal block. (Fig. 5-8)
 - If you cannot use round crimped terminals, perform the procedure following in Fig. 5-9 to 5-10.
 - Do not allow slackening of the terminal screws.
 - Leave excess cable so that the box can be suspended below the unit during servicing (approx. 50 to 100 mm).

Screw tightening torque

	Tightening torque (N·m)
Terminal block for M-NET cable	1.2 ± 0.1
Power terminal block	1.6 ± 0.1

- [A] Cover
- [B] Slide direction of the cover
- [C] Box
- [D] Entry for power cable
- [E] Power cable
- [F] Secure with the cable strap
- [G] Secure with the band [2]
- [H] Ground wire connection point
- [J] Entry for M-NET cable
- [K] M-NET cable
- [L] Length of the cable not covered by power supply cable sheath
- [M] Length of the cable not covered by M-NET cable sheath
- [N] Terminal block for M-NET cable
- [O] Power terminal block
- [P] Terminal block for Sensor and alarm kit cable.
(TB4A-TB4H for the room, TB4K: for the supervisor room)
- [Q] Power communication wire with Sensor and alarm kit
- [R] Secure with the cable clip (the wires connected to TB4E, TB4F, TB4G, TB4H, TB4K)

⚠ Warning:

- Observe the following precautions for each terminal block.

<When wiring two M-NET connection cables>

- If the cables have the same diameter, insert them into the cutouts on both sides.
- If the cables have different diameters, insert them on one side into separate spaces with one cable positioned above the other.

Cutouts

WARNING

- Connecting two wires on one side is prohibited.
- Connecting three wires or more to the same terminal is prohibited.
- Connecting wires with different diameters is prohibited.

When using a single cable, a round crimped terminal or other terminal work is prohibited.

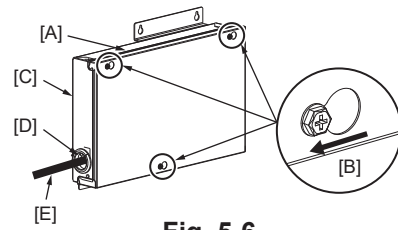

Fig. 5-6

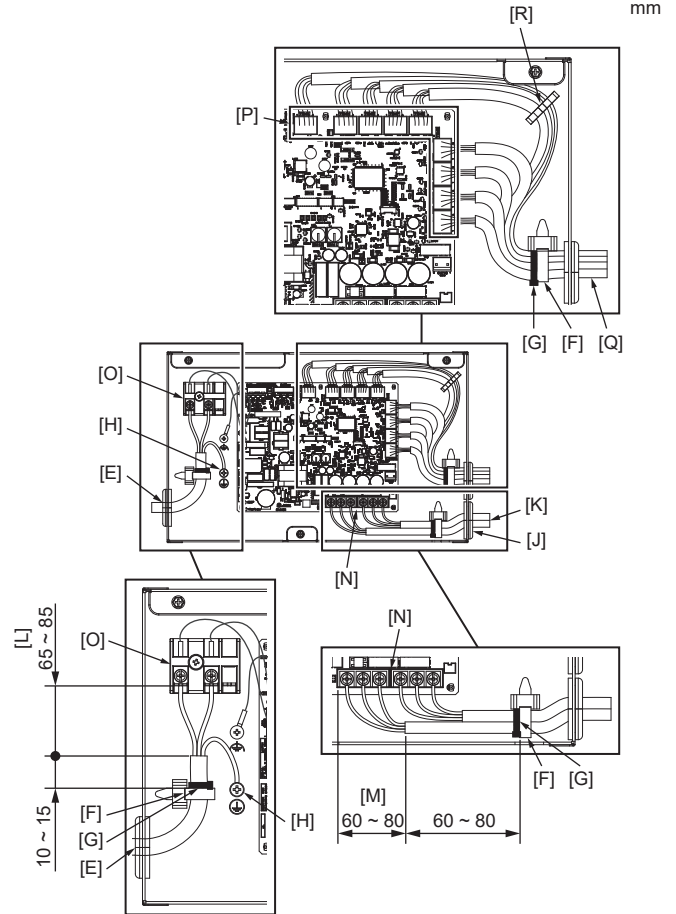

Fig. 5-7

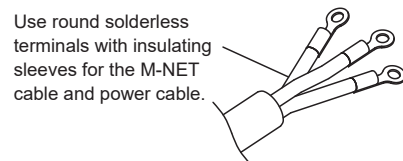
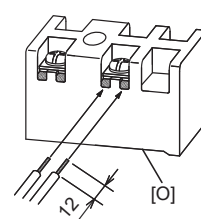
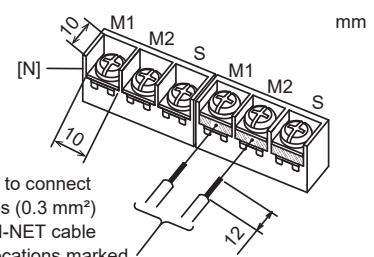

Fig. 5-8



- The U-shaped groove opens if you push the screw head after the screw is loosened.

Fig. 5-9



Be sure to connect the wires (0.3 mm²) of the M-NET cable at the locations marked on the diagram.

Fig. 5-10

5. Electrical work

5.3. Electrical work procedure (cont.)

Note:

- (1) Connect the wiring in accordance with the terminal block names to ensure correct polarity.
- (2) When using twisted wire for the wiring, the use of a round terminal is required. Take care when using stranded wires, because frayed wires may cause the wiring to short out.
- (3) Do not bundle the M-NET cable with the connection cable and power supply cable. It may cause erroneous operation.
- (4) How to connect the Power Supply Interface for Alarm Kit
 - Strip the core wire by about 9 mm and twist the conductors adequately before connection.
 - Press each button at the upper side on the terminal of the Power Supply Interface for Alarm Kit to open each wiring connection port and insert the lead wires until the core wire is hidden. (Fig. 5-12)
 - Make sure that there is no risk of short-circuit between terminals due to fraying wires after connection.
 - Pull the lead wires slightly after connection to make sure that they do not come off the port.
 - Do not solder the core wire.
 - Connect the Sensor and alarm kit for the room to TB4A-TB4H.
 - Connect the Sensor and alarm kit for the supervisor room to TB4K.

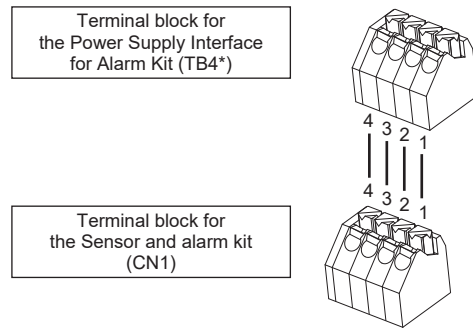

Fig. 5-11

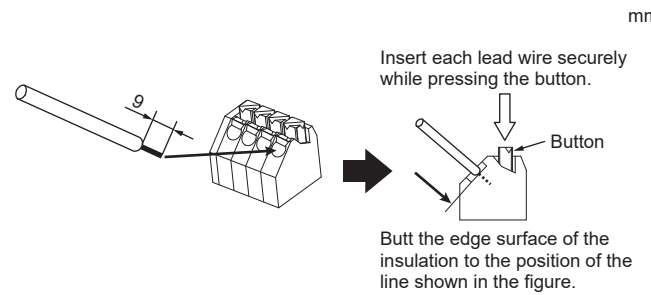

Fig. 5-12

5. Electrical work

5.4. External wiring procedure (Fig. 5-13, 5-14, 5-15)

- Supply power separately to Branch box and outdoor unit

<For City Multi system>

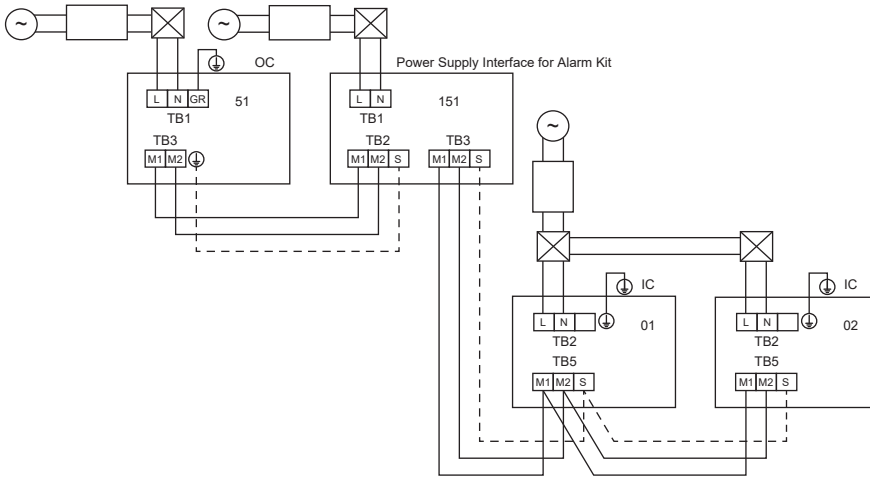

Fig. 5-13

<For Branch box system>

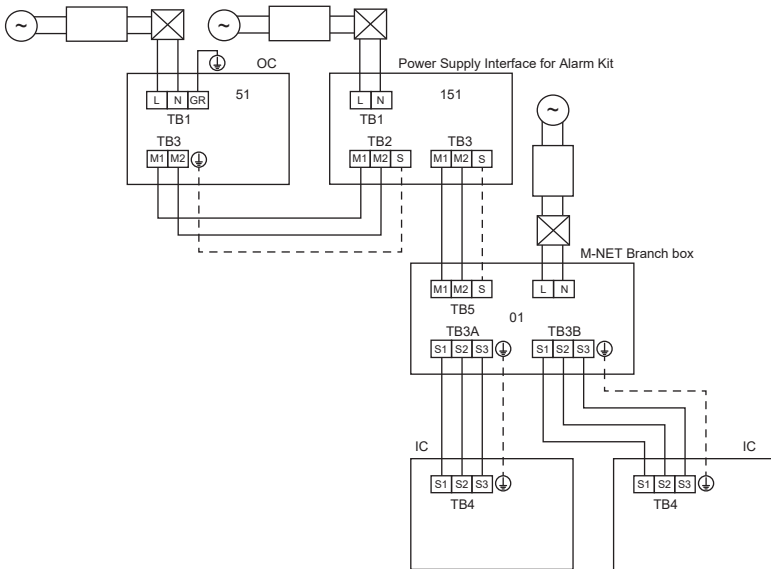

Fig. 5-14

<For BC controller system>

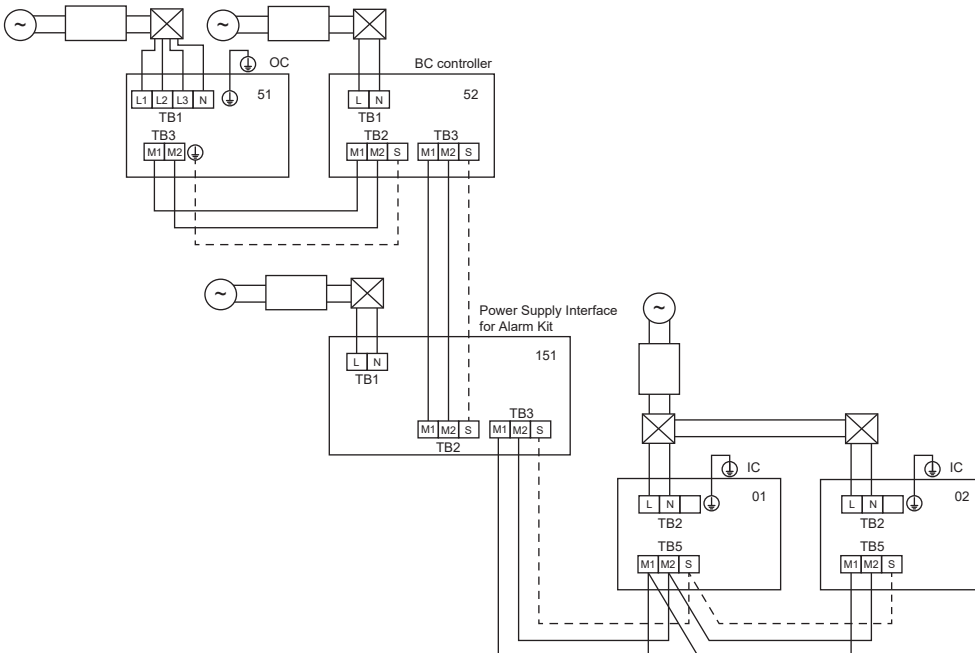

Fig. 5-15

5. Electrical work

5.5. Power supply wiring

- Wiring size must comply with the applicable local and national codes.
- Power supply cable of appliance shall not be lighter than design 60245 IEC 53 or 60227 IEC 53.
- Install a ground wire longer than other cables.
- A switch with at least 3 mm contact separation in each pole shall be provided by the air conditioner installation.

[Fig. 5-16]

- [A] Ground-fault interrupter
- [B] Local switch/Wiring breaker
- [C] Indoor unit
- [D] Pull box
- [E] Power Supply Interface for Alarm Kit (hereinafter referred to as I/F)

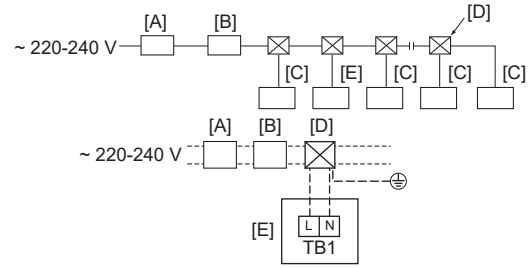

Fig. 5-16

⚠ Warning:

- Never splice the power cable or the indoor-outdoor connection cable, otherwise it may result in a smoke, a fire or communication failure.

Total operating current of the indoor unit	Minimum wire thickness (mm ² , AWG.No)			Ground-fault interrupter *1	Local switch (A)		Breaker for wiring (NFB)
	Main cable	Branch	Ground		Capacity	Fuse	
F0 = 16 A or less *2	1.5, AWG14	1.5, AWG14	1.5, AWG14	20 A current sensitivity *3	16	16	20
F0 = 25 A or less *2	2.5, AWG13	2.5, AWG13	2.5, AWG13	30 A current sensitivity *3	25	25	30
F0 = 32 A or less *2	4.0, AWG11	4.0, AWG11	4.0, AWG11	40 A current sensitivity *3	32	32	40

Apply to IEC61000-3-3 about max. permissible system impedance.

*1 The Ground-fault interrupter should support inverter circuit.

The Ground-fault interrupter should combine using of local switch or wiring breaker.

*2 Please take the larger of F1 or F2 as the value for F0.

F1 = Total operating maximum current of the indoor units × 1.2

F2 = {V1 × (Quantity of indoor unit 1)/C} + {V1 × (Quantity of I/F 2)/C} + {V1 × (Quantity of indoor unit 3)/C} + ...

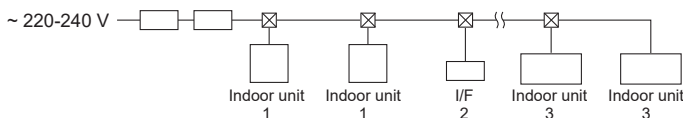

- V1 and V2

V1 and V2 are the breaker coefficient.

V1: Breaker coefficient of rated current

V2: Breaker coefficient of current sensitivity

The values of V1 and V2 differ from depending on the model. Therefore, please refer to the installation manual of each model.

- C: Multiple of tripping current at tripping time 0.01 s

Please pick up "C" from the tripping characteristic of the breaker.

	V1	V2
PAC-SL73IFL-E	7.4	2.4

<Example of "F2" calculation>

*Condition: PLFY-MS.VFM × 2 + PAC-SL73IFL-E × 1 + PLFY-MS.VEM × 2

V1 of PLFY-MS.VFM = 19.8, V1 of PAC-SL73IFL-E = 7.4, V1 of PLFY-MS.VEM = 19.8, C = 8 (refer to right sample chart)

F2 = 19.8 × 2/8 + 7.4 × 1/8 + 19.8 × 2/8

= 10.825

→ 15 A breaker (Tripping current = 8 × 15 A at 0.01 s)

*3 Current sensitivity is calculated using the following formula.

G1 = V2 × (Quantity of indoor unit 1) + V2 × (Quantity of I/F 2) + V2 × (Quantity of indoor unit 3)

+ ... + V3 × (Wire length [km])

<Example of "G1" calculation>

*Condition: PLFY-MS.VFM × 2 + PAC-SL73IFL-E × 1 + PLFY-MS.VEM × 2

V2 of PLFY-MS.VFM = 2.4, V2 of PAC-SL73IFL-E = 2.4, V2 of PLFY-MS.VEM = 2.4, Wire thickness and length: 1.5 mm² (AWG14) 0.2 km

G1 = 2.4 × 2 + 2.4 × 1 + 2.4 × 2 + 48 × 0.2

= 21.6

As a result, current sensitivity is 30 mA 0.1 sec or less.

G1	Current sensitivity
30 or less	30 mA 0.1 sec or less
100 or less	100 mA 0.1 sec or less

Wire thickness	V3
1.5 mm ² , AWG14	48
2.5 mm ² , AWG13	56
4.0 mm ² , AWG11	66

Sample chart

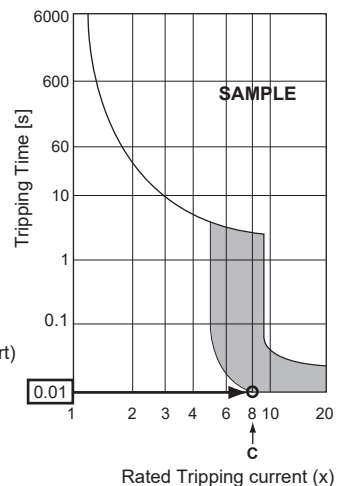

5. Electrical work

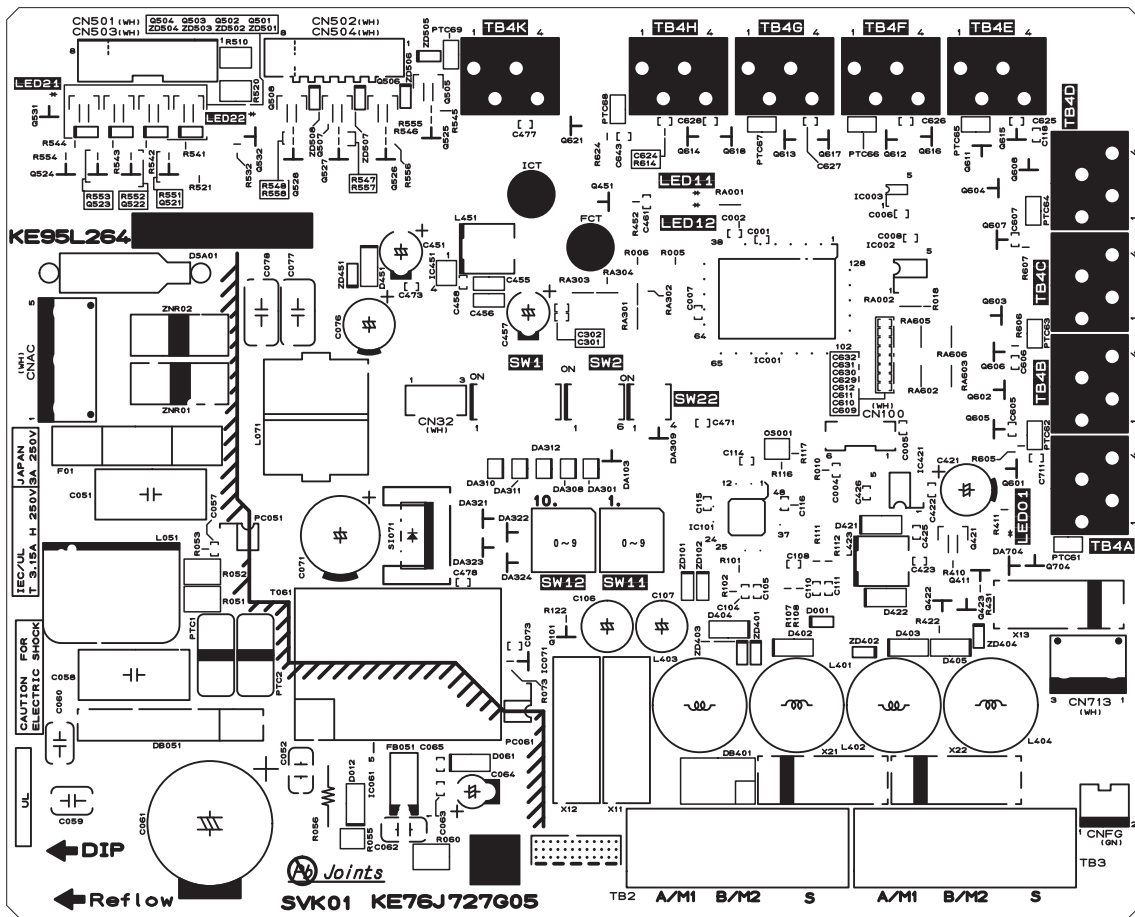

■ Address settings

(Make sure to perform the setting with the circuit breaker of the Power Supply Interface for Alarm Kit, indoor unit and outdoor unit turned OFF.)

Detail view of SW12 and 11

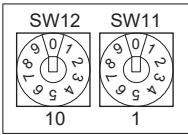

The above switches indicate "0".

The address can be set with the rotary switch on the control board of the Interface for Alarm Kit.

Address setting shall be performed with either (1) or (2) of the following.

(1) Automatic setting: SW11=0, SW12=0

(2) Manual setting: Set the address to the number from 151 to 200.

- Set ones and tens digits for the rotary switch. (All set to "0" as the initial setting)

- The rotary switch shall be set as follows: the target address - 100.

- If the address is set to "200", the rotary switch shall be "50".

- Refer to the installation manual of the outdoor unit for whether the automatic address setting is available.

How to set the address

(e.g.) If the address is "153", set SW12 (tens digit) to "5" and SW11 (ones digit) to "3."

■ When utilizing the external dry contact output

It can be output to an external source by using CN713 which is the output terminal for the external dry contact.

Refer to the following signal specifications.

Intended use	Signal specifications
Signals notifying a refrigerant leak or sensor failure can be extracted.	Relay: "a" contact output 30 VDC or 100/200 VAC Rate current at the contact: 1 A Minimum load at the contact: 10 mA When detecting a refrigerant leak/a refrigerant sensor is broken: short-circuit at the contact Normal status: open contact

6. Test run

- When the Power Supply Interface for Alarm Kit is not connected to the Branch box and the BC controller, turn on the power supply in the following order: the Power Supply Interface for Alarm Kit, the indoor unit and the outdoor unit.
- When the Power Supply Interface for Alarm Kit is connected to the Branch box and the BC controller, turn on the power supply in the following order: the Power Supply Interface for Alarm Kit, the the Branch box, the BC controller and the outdoor unit.
- Make sure there shall be no abnormality in the displays of the remote controller and Sensor and alarm kit. Refer to the service manual of the indoor unit for the alarm code.
- Always make sure that the display of the Sensor and alarm kit is normal. Refer to the installation manual of the Sensor and alarm kit for LED lighting patterns.
- Be sure to perform the test run in cooling mode for each indoor unit. Make sure each indoor unit operates properly following the installation manual attached to the unit.
- If you perform the test run for all indoor units at once, you cannot detect any erroneous connection, if any, indoor/outdoor unit connecting wires.
- To check for improper wiring, perform the test run for each indoor unit individually.

⚠ Caution:

- Use the remote controller to operate the indoor unit.

Manual Download



<http://www.mitsubishielectric.com/ldg/ibim/>

- en** Go to the above website and choose language to download INSTALLATION MANUAL.
- de** Besuchen Sie die oben stehende Website und wählen Sie die Sprache aus, um das INSTALLATIONSHANDBUCH herunterzuladen.
- fr** Rendez-vous sur le site Web ci-dessus et choisissez la langue pour télécharger le MANUEL D'INSTALLATION.
- nl** Ga naar de bovenstaande website en kies een taal om de INSTALLATIEHANDLEIDING te downloaden.
- es** Visite el anterior sitio web y elija el idioma para descargar el MANUAL DE INSTALACIÓN.
- it** Visitare il sito Web indicato sopra e selezionare la lingua per scaricare il MANUALE DI INSTALLAZIONE.
- el** Μεταβείτε στον παραπάνω ιστότοπο και επιλέξτε γλώσσα, για να κατεβάσετε το ΕΓΧΕΙΡΙΔΙΟ ΟΔΗΓΙΩΝ ΕΓΚΑΤΑΣΤΑΣΗΣ.
- pt** Aceda ao site Web acima indicado e seleccione o idioma para transferir o MANUAL DE INSTALAÇÃO.
- da** Gå til ovenstående hjemmeside, og vælg sprog for at hente INSTALLATIONSMANUALEN.
- sv** Gå till webbplatsen ovan och välj språk för att ladda ned INSTALLATIONSMANUALEN.
- bg** Посетете горепосочения уебсайт и изберете език, за да изтеглите РЪКОВОДСТВОТО ЗА МОНТАЖ.
- pl** Odwiedź powyższą stronę internetową i wybierz język, aby pobrać INSTRUKCJĘ MONTAŻU.
- no** Gå til nettstedet ovenfor og velg språk for å laste ned INSTALLERINGSHÅNDBOK.
- fi** Siirry yllä olevaan verkkosivustoon, valitse kieli ja lataa ASENNUSOPAS.
- uk** Переїдїть за вказаним вище посиланням на сайт і оберїть мову, щоб завантажити ПОСІБНИК ІЗ МОНТАЖУ.
- cs** Přejděte na výše zmíněnou webovou stránku a vyberte jazyk ke stáhnutí PŘÍRUČKY PRO INSTALACI.
- sk** Prejdite na vyššie uvedenú webovú stránku a zvoľte si jazyk na stiahnutie NÁVODU NA INŠTALÁCIU.
- hu** Látogasson el a fenti webhelyre, és a nyelv kiválasztása után tölts le a TELEPÍTÉSI KÉZIKÖNYVET.
- sl** Obiščite zgoraj navedeno spletno mesto in izberite jezik, da prenesete NAMESTITVENI PRIROČNIK.
- ro** Accesați site-ul web de mai sus și alegeți limba pentru a descărca MANUALUL DE INSTALARE.
- et** PAIGALDUSJUHENDI allalaadimiseks minge eelnimetatud veebisaidile ja valige keel.
- lv** Lai lejupielādētu MONTĀŽAS ROKASGRĀMATU, apmeklējiet iepriekš norādīto tīmekļa vietni un izvēlieties attiecīgo valodu.
- lt** Apsilankykite pirmiau minėtoje interneto svetainėje, pasirinkite kalbą ir parsisiųskite MONTAVIMO VADOVĄ.
- hr** Posjetite gore navedeno mrežno mjesto i izaberite jezik kako biste preuzeli PRIRUČNIK ZA POSTAVLJANJE.
- sr** Posetite gorenaveden veb-sajt i izaberite jezik da biste preuzeli UPUTSTVO ZA UGRADNJU.

This product is designed and intended for use in the residential, commercial and light-industrial environment.

Authorised Representative in EU

Mitsubishi Electric Europe B.V.
Living Environment Systems Sales and Marketing Headquarter
2, Rue de l'Union, 92565 Rueil-Malmaison Cedex, France

Importer in European and surrounding region.

Mitsubishi Electric Europe B.V.
Capronilaan 34, 1119 NS, Schiphol Rijk, The Netherlands
https://emea.mitsubishielectric.com/en/about/local/locations/emea_europeandcis001/

French Branch
2, Rue de l'Union, 92565 Rueil-Malmaison Cedex, France
<https://fr.mitsubishielectric.com/fr/>



German Branch
Mitsubishi-Electric-Platz 1 40882 Ratingen North Rhine-Westphalia, Germany
<https://de.mitsubishielectric.com/de/>

Irish Branch
Plunkett House, Grange Castle Business Park, Nangor Road Dublin 22 Ireland
<https://ie.mitsubishielectric.com/en/>

Italian Branch
Via Energy Park 14, 20871 Vimercate (MB), Italy
<https://it.mitsubishielectric.com/it/>

Norwegian Branch
Gneisveien 2D, 1914 Ytre Enebakk, Norway
<https://no.mitsubishielectric.com/no/>

Polish Branch
Krakowska 48, PL-32-083 Balice, Poland
<https://pl.mitsubishielectric.com/pl/>

Portuguese Branch
Avda. do Forte 10, 2794-019 Carnaxide, Lisbon, Portugal
<https://pt.mitsubishielectric.com/pt/>

Scandinavian Branch
Hammarbacken 14, P.O. Box 750, SE-19127, Sollentuna, Sweden
<https://se.mitsubishielectric.com/sv/>

Spanish Branch
Av. de Castilla 2, Edificio Europa, planta primera, 28830, Pq. Empresarial San Fernando, Madrid, Spain
<https://es.mitsubishielectric.com/es/>

UK Branch
Travellers Lane, Hatfield, Hertfordshire, AL10 8XB, United Kingdom
<https://gb.mitsubishielectric.com/en/>

This product is designed and intended for use in the residential,
commercial and light-industrial environment.

Please be sure to put the contact address/telephone number on
this manual before handing it to the customer.

MITSUBISHI ELECTRIC CORPORATION
HEAD OFFICE: TOKYO BUILDING, 2-7-3, MARUNOUCHI, CHIYODA-KU, TOKYO 100-8310, JAPAN