

TECHNICAL & SERVICE MANUAL

R32

[Model Name]
<Branch box>

PAC-MMK40BC

PAC-MMK60BC

PAC-MMK40BCB

[Service Reference]

PAC-MMK40BC

PAC-MMK60BC

PAC-MMK40BCB

<Sensor and Alarm Kit>

PAC-SK60SA-E

PAC-SL72SA-E

PAC-SK60SA-E

PAC-SL72SA-E

<POWER SUPPLY INTERFACE FOR ALARM KIT>

PAC-SL73IFL-E

PAC-SL73IFL-E

Note:

- This service manual describes technical data of branch box and Sensor and Alarm Kit. As for indoor units and outdoor unit, refer to its service manual.

Revision:

- Revised POWER SUPPLY INTERFACE FOR ALARM KIT in REVISED EDITION-B.

OCH799A is void.

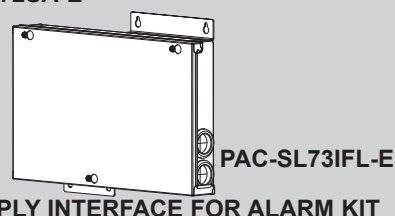
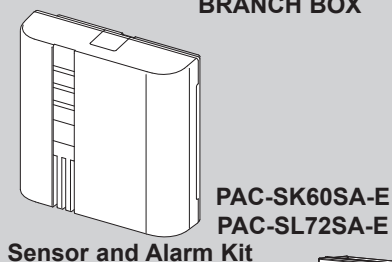
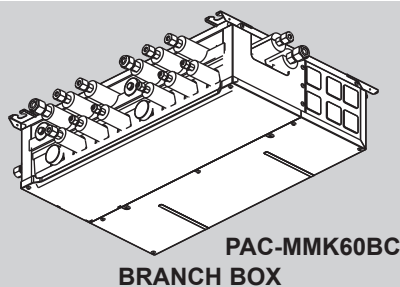

CONTENTS

1. SAFETY PRECAUTION.....	2
2. OVERVIEW OF UNIT	9
3. SPECIFICATIONS	15
4. OUTLINES AND DIMENSIONS.....	16
5. WIRING DIAGRAM.....	19
6. NECESSARY CONDITIONS FOR SYSTEM CONSTRUCTION	21
7. TROUBLESHOOTING.....	25
8. DISASSEMBLY PROCEDURE.....	43

PARTS CATALOG (OCB799)

1-1. ALWAYS OBSERVE FOR SAFETY

Before obtaining access to terminal, all supply circuits must be disconnected.

1-2. CAUTIONS RELATED TO NEW REFRIGERANT

Caution for units utilizing refrigerant R32

Preparation before the repair service

- Prepare the proper tools.
- Prepare the proper protectors.
- Provide adequate ventilation.
- After stopping the operation of the air conditioner, turn off the power-supply breaker.
- Discharge the condenser before the work involving the electric parts.

Use new refrigerant pipes.

In the case of using the existing pipes for R22, be careful with the following:

- Be sure to clean the pipes and make sure that the insides of the pipes are clean.
- Change flare nut to the one provided with this product. Use a newly flared pipe.
- Avoid using thin pipes.

Make sure that the inside and outside of refrigerant piping is clean and it has no contaminants such as sulfur, oxides, dirt, shaving particles, etc., which are hazard to refrigerant cycle. In addition, use pipes with specified thickness.

Contamination inside refrigerant piping can cause deterioration of refrigerant oil, etc.

Store the piping indoors, and both ends of the piping sealed until just before brazing. (Leave elbow joints, etc. in their packaging.)

If dirt, dust or moisture enters into refrigerant cycle, that can cause deterioration of refrigerant oil or malfunction of compressor.

The refrigerant oil applied to flare and flange connections must be ester oil, ether oil or alkylbenzene oil in a small amount.

If large amount of mineral oil enters, that can cause deterioration of refrigerant oil, etc.

Do not use refrigerant other than R32.

If other refrigerant (R22, etc.) is used, chlorine in refrigerant can cause deterioration of refrigerant oil, etc.

Precautions during the repair service

- Do not perform the work involving the electric parts with wet hands.
- Do not pour water into the electric parts.
- Do not touch the refrigerant.
- Do not touch the hot or cold areas in the refrigerating cycle.
- When the repair or the inspection of the circuit needs to be done without turning off the power, exercise great caution not to touch the live parts.
- When opening or closing the valve below freezing temperatures, refrigerant may spurt out from the gap between the valve stem and the valve body, resulting in injuries.

Use a vacuum pump with a reverse flow check valve.

Vacuum pump oil may flow back into refrigerant cycle and that can cause deterioration of refrigerant oil, etc.

Use the following tools specifically designed for use with R32 refrigerant.

The following tools are necessary to use R32 refrigerant.

Tools for R32	
Gauge manifold	Flaring tool
Charge hose	Size adjustment gauge
Gas leak detector	Vacuum pump adaptor
Torque wrench	Electronic refrigerant charging scale

Handle tools with care.

If dirt, dust or moisture enters into refrigerant cycle, that can cause deterioration of refrigerant oil or malfunction of compressor.

Use the specified refrigerant only.

Never use any refrigerant other than that specified.

Doing so may cause a burst, an explosion, or fire when the unit is being used, serviced, or disposed of.

Correct refrigerant is specified in the manuals and on the spec labels provided with our products.

We will not be held responsible for mechanical failure, system malfunction, unit breakdown or accidents caused by failure to follow the instructions.

Ventilate the room if refrigerant leaks during operation. If refrigerant comes into contact with a flame, poisonous gases will be released.

[1] Warning for service

- (1) Do not alter the unit.
- (2) For installation and relocation work, follow the instructions in the Installation Manual and use tools and pipe components specifically made for use with refrigerant specified in the outdoor unit installation manual.
- (3) Ask a dealer or an authorized technician to install, relocate and repair the unit.
For appliances not accessible to the general public.
- (4) Refrigerant pipes connection shall be accessible for maintenance purposes.
- (5) If the air conditioner is installed in a small room or closed room, measures must be taken to prevent the refrigerant concentration in the room from exceeding the safety limit in the event of refrigerant leakage. Should the refrigerant leak and cause the concentration limit to be exceeded, hazards due to lack of oxygen in the room may result.
- (6) Keep gas-burning appliances, electric heaters, and other fire sources (ignition sources) away from the location where installation, repair, and other air conditioner work will be performed.
If refrigerant comes into contact with a flame, poisonous gases will be released.
- (7) When installing or relocating, or servicing the air conditioner, use only the specified refrigerant (R32) to charge the refrigerant lines.
Do not mix it with any other refrigerant and do not allow air to remain in the lines.
If air is mixed with the refrigerant, then it can be the cause of abnormal high pressure in the refrigerant line, and may result in an explosion and other hazards.
- (8) After installation has been completed, check for refrigerant leaks. If refrigerant leaks into the room and comes into contact with the flame of a heater or portable cooking range, poisonous gases will be released.
- (9) Do not use low temperature solder alloy in the case of brazing the refrigerant pipes.
- (10) When performing brazing work, be sure to ventilate the room sufficiently. Make sure that there are no hazardous or flammable materials nearby.
When performing the work in a closed room, small room, or similar location, make sure that there are no refrigerant leaks before performing the work.
If refrigerant leaks and accumulates, it may ignite or poisonous gases may be released.
- (11) Do not install the unit in places where refrigerant may build-up or places with poor ventilation such as a semi-basement or a sunken place in outdoor: Refrigerant is heavier than air, and inclined to fall away from the leak source.
- (12) Do not use means to accelerate the defrosting process or to clean, other than those recommended by the manufacturer.
- (13) The appliance shall be stored in a room without continuously operating ignition sources (for example: open flames, an operating gas appliance or an operating electric heater).
- (14) Do not pierce or burn.
- (15) Be aware that refrigerants may not contain an odour.
- (16) Pipe-work shall be protected from physical damage.
- (17) The installation of pipe-work shall be kept to a minimum.
- (18) Compliance with national gas regulations shall be observed.
- (19) Keep any required ventilation openings clear of obstruction.
- (20) Servicing shall be performed only as recommended by the manufacturer.
- (21) The appliance shall be stored in a well-ventilated area where the room size corresponds to the room area as specified for operation.
- (22) Maintenance, service and repair operations shall be performed by authorized technician with required qualification.
- (23) Be sure to have appropriate ventilation in order to prevent ignition. Furthermore, be sure to carry out fire prevention measures that there are no dangerous or flammable objects in the surrounding area.
- (24) Do not turn off the power except for servicing as a safety device is installed.
- (25) If the Sensor and Alarm Kit is damaged, replace it. Otherwise it may not detect refrigerant leakage properly.

[2] Cautions for service

- (1) Perform service after recovering the refrigerant left in unit completely.
- (2) Do not release refrigerant in the air.
- (3) After completing service, charge the cycle with specified amount of refrigerant.
- (4) When performing service, install a filter drier simultaneously.
Be sure to use a filter drier for new refrigerant.

[3] Additional refrigerant charge

When charging directly from cylinder

R32 is a single refrigerant and its composition does not change. Therefore, both liquid charging and gas charging are possible. Liquid charging of refrigerant all at once from the low pressure side may cause the compressor malfunction. Accordingly, make sure that charging is gradual.

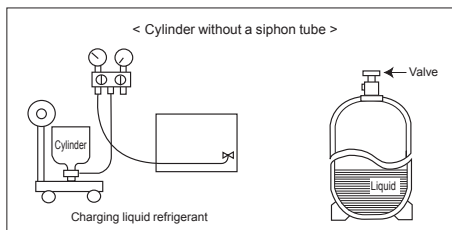
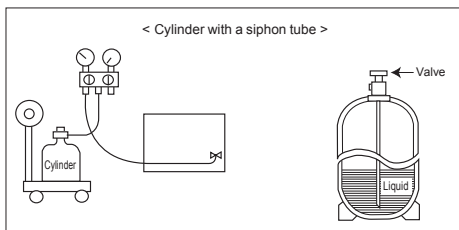

[4] Cautions for unit using R32 refrigerant

Basic work procedures are the same as those for conventional units using refrigerant R410A. However, pay careful attention to the following points.

(1) Information on servicing

(1-1) Checks on the Area

Prior to beginning work on systems containing flammable refrigerants, safety checks are necessary to ensure that the risk of ignition is minimized.

For repair to the refrigerating systems, (1-3) to (1-7) shall be completed prior to conducting work on the systems.

(1-2) Work Procedure

Work shall be undertaken under a controlled procedure so as to minimize the risk of a flammable gas or vapor being present while the work is being performed.

(1-3) General Work Area

All maintenance staff and others working in the local area shall be instructed on the nature of work being carried out. Work in confined spaces shall be avoided. The area around the workspace shall be sectioned off. Ensure that the conditions within the area have been made safe by control of flammable material.

(1-4) Checking for Presence of Refrigerant

The area shall be checked with an appropriate refrigerant detector prior to and during work, to ensure the technician is aware of potentially toxic or flammable atmospheres. Ensure that the leak detection equipment being used is suitable for use with all applicable refrigerants, i.e. non-sparking, adequately sealed or intrinsically safe.

(1-5) Presence of Fire Extinguisher

If any hot work is to be conducted on the refrigeration equipment or any associated parts, appropriate fire extinguishing equipment shall be available to hand.

Have a dry powder or CO2 fire extinguisher adjacent to the charging area.

(1-6) No Ignition Sources

No person carrying out work in relation to a refrigeration system which involves exposing any pipe work shall use any sources of ignition in such a manner that it may lead to the risk of fire or explosion. All possible ignition sources, including cigarette smoking, should be kept sufficiently far away from the site of installation, repairing, removing and disposal, during which refrigerant can possibly be released to the surrounding space. Prior to work taking place, the area around the equipment is to be surveyed to make sure that there are no flammable hazards or ignition risks. "No Smoking" signs shall be displayed.

(1-7) Ventilated Area

Ensure that the area is in the open or that it is adequately ventilated before breaking into the system or conducting any hot work. A degree of ventilation shall continue during the period that the work is carried out. The ventilation should safely disperse any released refrigerant and preferably expel it externally into the atmosphere.

(1-8) Checks on the Refrigeration Equipment

Where electrical components are being changed, they shall be fit for the purpose and to the correct specification. At all times the manufacturer's maintenance and service guidelines shall be followed. If in doubt, consult the manufacturer's technical department for assistance.

The following checks shall be applied to installations using flammable refrigerants:

- The charge size is in accordance with the room size within which the refrigerant containing parts are installed.
- The ventilation machinery and outlets are operating adequately and are not obstructed.
- Marking to the equipment continues to be visible and legible. Markings and signs that are illegible shall be corrected.
- Refrigeration pipe or components are installed in a position where they are unlikely to be exposed to any substance which may corrode refrigerant containing components, unless the components are constructed of materials which are inherently resistant to being corroded or are suitably protected against being corroded.

(1-9) Checks on Electrical Devices

Repair and maintenance to electrical components shall include initial safety checks and component inspection procedures. If a fault exists that could compromise safety, then no electrical supply shall be connected to the circuit until it is satisfactorily dealt with. If the fault cannot be corrected immediately but it is necessary to continue operation, an adequate temporary solution shall be used. This shall be reported to the owner of the equipment so all parties are advised.

Initial safety checks shall include that:

- capacitors are discharged: this shall be done in a safe manner to avoid possibility of sparking;
- no live electrical components and wiring are exposed while charging, recovering or purging the system;
- there is continuity of earth bonding

(2) Repairs to Sealed Components

(2-1) During repairs to sealed components, all electrical supplies shall be disconnected from the equipment being worked upon prior to any removal of sealed covers, etc. If it is absolutely necessary to have an electrical supply to equipment during servicing, then a permanently operating form of leak detection shall be located at the most critical point to warn of a potentially hazardous situation.

(2-2) Particular attention shall be paid to the following to ensure that by working on electrical components, the casing is not altered in such a way that the level of protection is affected. This shall include damage to cables, excessive number of connections, terminals not made to original specification, damage to seals, incorrect fitting of glands, etc.

Ensure that the apparatus is mounted securely.

Ensure that seals or sealing materials have not degraded to the point that they no longer serve the purpose of preventing the ingress of flammable atmospheres.

Replacement parts shall be in accordance with the manufacturer's specifications.

(3) Repair to Intrinsically Safe Components

Do not apply any permanent inductive or capacitance loads to the circuit without ensuring that this will not exceed the permissible voltage and current permitted for the equipment in use.

Intrinsically safe components are the only types that can be worked on while live in the presence of a flammable atmosphere. The test apparatus shall be at the correct rating.

Replace components only with parts specified by the manufacturer. Other parts may result in the ignition of refrigerant in the atmosphere from a leak.

(4) Cabling

Check that cabling will not be subject to wear, corrosion, excessive pressure, vibration, sharp edges or any other adverse environmental effects. The check shall also take into account the effects of aging or continual vibration from sources such as compressors or fans.

(5) Detection of Flammable Refrigerants

Under no circumstances shall potential sources of ignition be used in the searching for or detection of refrigerant leaks. A halide torch (or any other detector using a naked flame) shall not be used.

(6) Leak Detection Methods

Electronic leak detectors may be used to detect refrigerant leaks but, in the case of flammable refrigerants, the sensitivity may not be adequate, or may need re-calibration. (Detection equipment shall be calibrated in a refrigerant-free area.)

Ensure that the detector is not a potential source of ignition and is suitable for the refrigerant used. Leak detection equipment shall be set at a percentage of the LFL of the refrigerant and shall be calibrated to the refrigerant employed, and the appropriate percentage of gas (25% maximum) is confirmed.

Leak detection fluids are suitable for use with most refrigerants but the use of detergents containing chlorine shall be avoided as the chlorine may react with the refrigerant and corrode the copper pipe-work.

If a leak is suspected, all naked flames shall be removed/extinguished.

If a leakage of refrigerant is found which requires brazing, all of the refrigerant shall be recovered from the system, or isolated (by means of shut off valves) in a part of the system remote from the leak. For appliances containing flammable refrigerants, oxygen free nitrogen (OFN) shall then be purged through the system both before and during the brazing process.

(7) Removal and Evacuation

When breaking into the refrigerant circuit to make repairs – or for any other purpose conventional procedures shall be used. However, for flammable refrigerants it is important that best practice is followed since flammability is a consideration. The following procedure shall be adhered to:

- remove refrigerant
- purge the circuit with inert gas
- evacuate
- purge again with inert gas
- open the circuit by cutting or brazing.

The refrigerant charge shall be recovered into the correct recovery cylinders. For appliances containing flammable refrigerants, the system shall be “flushed” with OFN to render the unit safe. This process may need to be repeated several times.

Compressed air or oxygen shall not be used for purging refrigerant systems.

For appliances containing flammable refrigerants, flushing shall be achieved by breaking the vacuum in the system with OFN and continuing to fill until the working pressure is achieved, then venting to atmosphere, and finally pulling down to a vacuum. This process shall be repeated until no refrigerant is within the system. When the final OFN charge is used, the system shall be vented down to atmospheric pressure to enable work to take place. This operation is absolutely vital if brazing operations on the pipe-work are to take place.

Ensure that the outlet for the vacuum pump is not close to any ignition sources and that ventilation is available.

(8) Charging Procedures

In addition to conventional charging procedures, the following requirements shall be followed:

- Ensure that contamination of different refrigerants does not occur when using charging equipment. Hoses or lines shall be as short as possible to minimize the amount of refrigerant contained in them.
- Cylinders shall be kept upright.
- Ensure that the refrigeration system is earthed prior to charging the system with refrigerant.
- Label the system when charging is complete (if not already).
- Extreme care shall be taken not to overfill the refrigeration system.

Prior to recharging the system, it shall be pressure-tested with the appropriate purging gas. The system shall be leak-tested on completion of charging but prior to commissioning. A follow up leak test shall be carried out prior to leaving the site.

(9) Decommissioning

Before carrying out this procedure, it is essential that the technician is completely familiar with the equipment and all its detail. It is recommended good practice that all refrigerants are recovered safely. Prior to the task being carried out, an oil and refrigerant sample shall be taken in case analysis is required prior to re-use of reclaimed refrigerant. It is essential that electrical power is available before the task is commenced.

- a) Become familiar with the equipment and its operation.

Continued to the next page

- b) Isolate system electrically.
- c) Before attempting the procedure, ensure that:
 - mechanical handling equipment is available, if required, for handling refrigerant cylinders;
 - all personal protective equipment is available and being used correctly;
 - the recovery process is supervised at all times by a competent person;
 - recovery equipment and cylinders conform to the appropriate standards.
- d) Pump down refrigerant system, if possible.
- e) If a vacuum is not possible, make a manifold so that refrigerant can be removed from various parts of the system.
- f) Make sure that cylinder is situated on the scales before recovery takes place.
- g) Start the recovery machine and operate in accordance with manufacturer's instructions.
- h) Do not overfill cylinders. (No more than 80 % volume liquid charge).
- i) Do not exceed the maximum working pressure of the cylinder, even temporarily.
- j) When the cylinders have been filled correctly and the process completed, make sure that the cylinders and the equipment are removed from site promptly and all isolation valves on the equipment are closed off.
- k) Recovered refrigerant shall not be charged into another refrigeration system unless it has been cleaned and checked.

(10) Labelling

Equipment shall be labelled stating that it has been de-commissioned and emptied of refrigerant. The label shall be dated and signed. For appliances containing flammable refrigerants, ensure that there are labels on the equipment stating the equipment contains flammable refrigerant.

(11) Recovery

When removing refrigerant from a system, either for servicing or decommissioning, it is recommended good practice that all refrigerants are removed safely. When transferring refrigerant into cylinders, ensure that only appropriate refrigerant recovery cylinders are employed. Ensure that the correct number of cylinders for holding the total system charge are available. All cylinders to be used are designated for the recovered refrigerant and labelled for that refrigerant (i.e. special cylinders for the recovery of refrigerant). Cylinders shall be complete with pressure-relief valve and associated shut-off valves in good working order. Empty recovery cylinders are evacuated and, if possible, cooled before recovery occurs.

The recovery equipment shall be in good working order with a set of instructions concerning the equipment that is at hand and shall be suitable for the recovery of all appropriate refrigerants including, when applicable, flammable refrigerants. In addition, a set of calibrated weighing scales shall be available and in good working order. Hoses shall be complete with leak-free disconnect couplings and in good condition. Before using the recovery machine, check that it is in satisfactory working order, has been properly maintained and that any associated electrical components are sealed to prevent ignition in the event of a refrigerant release. Consult manufacturer if in doubt.

The recovered refrigerant shall be returned to the refrigerant supplier in the correct recovery cylinder, and the relevant waste transfer note arranged. Do not mix refrigerants in recovery units and especially not in cylinders. If compressors or compressor oils are to be removed, ensure that they have been evacuated to an acceptable level to make certain that flammable refrigerant does not remain within the lubricant. The evacuation process shall be carried out prior to returning the compressor to the suppliers. Only electric heating to the compressor body shall be employed to accelerate this process. When oil is drained from a system, it shall be carried out safely.

[5] Service tools

Use the below service tools as exclusive tools for R32 refrigerant.

No.	Tool name	Specifications
1	Gauge manifold	· Only for R32
		· Use the existing fitting specifications. (UNF1/2)
		· Use high-tension side pressure of 5.3MPa·G or over.
2	Charge hose	· Only for R32
		· Use pressure performance of 5.09MPa·G or over.
3	Electronic weighing scale	—
4	Gas leak detector	· Use the detector for R134A, R407C, R410A or R32.
5	Adaptor for reverse flow check	· Attach on vacuum pump.
6	Refrigerant charge base	—
7	Refrigerant cylinder	· Only for R32 · Top of cylinder (Pink)
		· Cylinder with syphon
8	Refrigerant recovery equipment	—

1-3. PRECAUTIONS WHEN REUSING EXISTING R22/R32/R410A REFRIGERANT PIPES

(1) Flowchart

- Refer to the flowchart below to determine if the existing pipes can be used and if it is necessary to use a filter drier.
- If the diameter of the existing pipes is different from the specified diameter, refer to technical data materials to confirm if the pipes can be used.

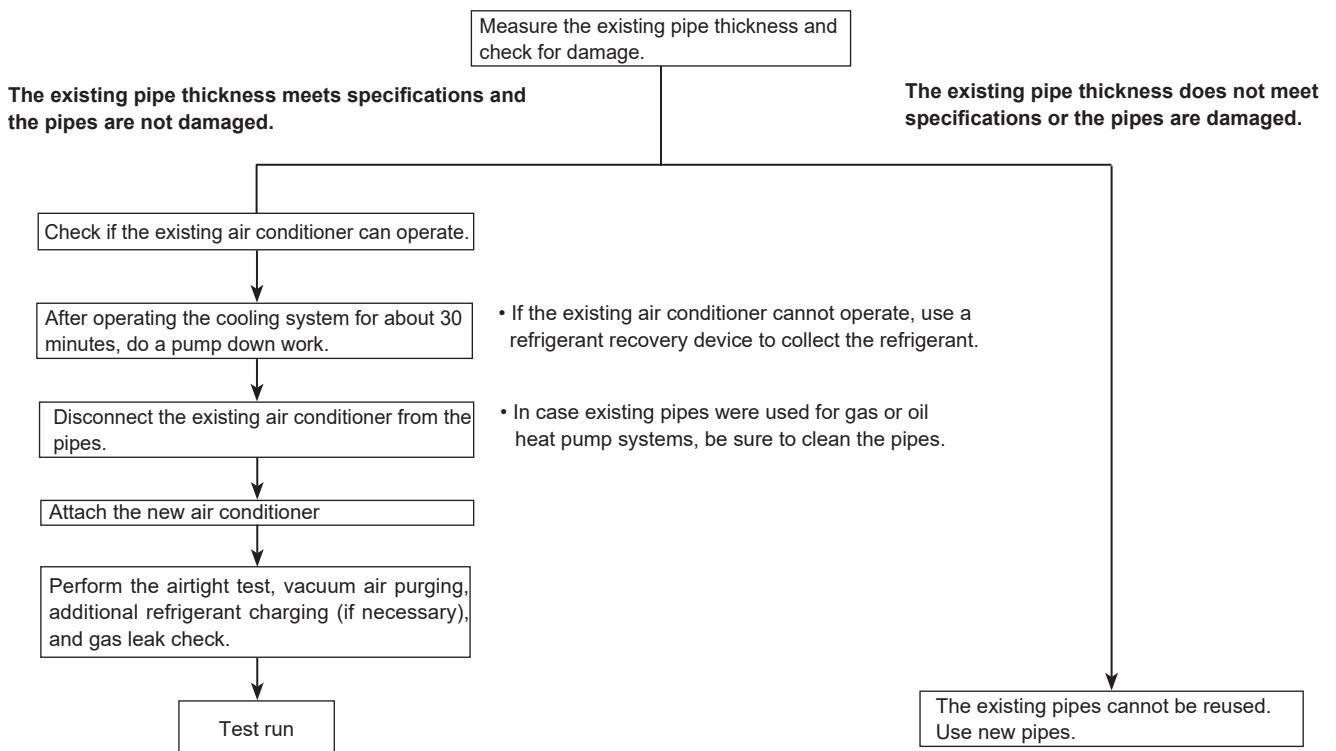

(2) Cautions for refrigerant piping work

New refrigerant R32 is adopted for replacement inverter series. Although the refrigerant piping work for R32 is same as for R22, exclusive tools are required to avoid mixing with different types of refrigerant. Furthermore as the working pressure of R32 is 1.6 times higher than that of R22, their sizes of flared sections and flare nuts are different.

① Thickness of pipes

Because the working pressure of R32 is higher compared to R22, be sure to use refrigerant piping with thickness shown below. (Never use pipes of 0.7 mm or below.)

Diagram below: Piping diameter and thickness

Nominal dimensions (in.)	Outside diameter (mm)	Thickness (mm)	
		R32/R410A	R22
1/4	ø 6.35	0.8	0.8
3/8	ø 9.52	0.8	0.8
1/2	ø12.70	0.8	0.8
5/8	ø15.88	1.0	1.0
3/4	ø19.05	—	1.0

② Dimensions of flare cutting and flare nut

The component molecules in HFC refrigerant are smaller compared to the conventional refrigerants. In addition, R32 is a refrigerant, which has higher risk of leakage because its working pressure is higher than that of other refrigerants. Therefore, to enhance airtightness and strength, flare cutting dimension of copper pipe for R32 has been specified separately from the dimensions for other refrigerants as shown below. The dimension B of the flare nut for R32 also has partly been changed to increase strength as shown below. Set copper pipe correctly referring to copper pipe flaring dimensions for R32 below. For 1/2 and 5/8 inch pipes, the dimension B changes. Use torque wrench corresponding to each dimension.

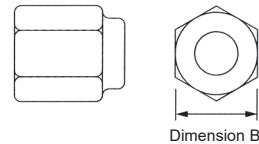
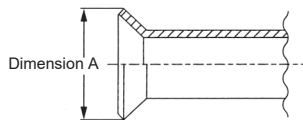

Flare cutting dimensions

Nominal dimensions (in.)	Outside diameter (mm)	Dimension A ($^{+0}_{-0.4}$)(mm)	
		R32/R410A	R22
1/4	ø 6.35	9.1	9.0
3/8	ø 9.52	13.2	13.0
1/2	ø12.70	16.6	16.2
5/8	ø15.88	19.7	19.4
3/4	ø19.05	—	23.3

Flare nut dimensions

Nominal dimensions (in.)	Outside diameter (mm)	Dimension B (mm)	
		R32/R410A	R22
1/4	ø 6.35	17.0	17.0
3/8	ø 9.52	22.0	22.0
1/2	ø12.70	26.0	24.0
5/8	ø15.88	29.0	27.0
3/4	ø19.05	—	36.0

③ Tools for R32 (The following table shows whether conventional tools can be used or not.)

Tools and materials	Use	R32 tools	Can R22 tools be used?	Can R407C tools be used?	Can R410A tools be used?
Gauge manifold	Air purge, refrigerant charge and operation check	Tool exclusive for R32	×	×	○
Charge hose		Tool exclusive for R32	×	×	○
Gas leak detector	Gas leak check	Tool for HFC refrigerant	×	○	○
Refrigerant recovery equipment	Refrigerant recovery	Tool exclusive for R32	×	×	○
Refrigerant cylinder	Refrigerant charge	Tool exclusive for R32	×	×	×
Safety charger	Prevent compressor malfunction when charging refrigerant by spraying liquid refrigerant	Tool exclusive for R32	×	×	○
Charge valve	Prevent gas from blowing out when detaching charge hose	Tool exclusive for R32	×	×	○
Vacuum pump	Vacuum drying and air purge	Tools for other refrigerants can be used if equipped with adapter for reverse flow check	△ (Usable if equipped with adapter for reverse flow)	△ (Usable if equipped with adapter for reverse flow)	△ (Usable if equipped with adapter for reverse flow)
Flaring tool	Flaring work of piping	Tools for other refrigerants can be used by adjusting flaring dimension	△ (Usable by adjusting flaring dimension)	△ (Usable by adjusting flaring dimension)	△ (Usable by adjusting flaring dimension)
Bender	Bend the pipes	Tools for other refrigerants can be used	○	○	○
Pipe cutter	Cut the pipes	Tools for other refrigerants can be used	○	○	○
Welder and nitrogen gas cylinder	Weld the pipes	Tools for other refrigerants can be used	○	○	○
Refrigerant charging scale	Refrigerant charge	Tools for other refrigerants can be used	○	○	○
Vacuum gauge or thermistor vacuum gauge and vacuum valve	Check the degree of vacuum. (Vacuum valve prevents back flow of oil and refrigerant to thermistor vacuum gauge)	Tools for other refrigerants can be used	○	○	○
Charging cylinder	Refrigerant charge	Tool exclusive for R32	×	—	×

× : Prepare a new tool. (Use the new tool as the tool exclusive for R32.)

△ : Tools for other refrigerants can be used under certain conditions.

○ : Tools for other refrigerants can be used.

2-1. SYSTEM OUTLINE

The additional connection of the branch box together with employment of the compact trunk-looking outdoor unit can successfully realize a long distance piping for big houses. Equipped with a microprocessor, the branch box can translate the transmission signal of indoor units to achieve the optimum control.

2-1-1. System example

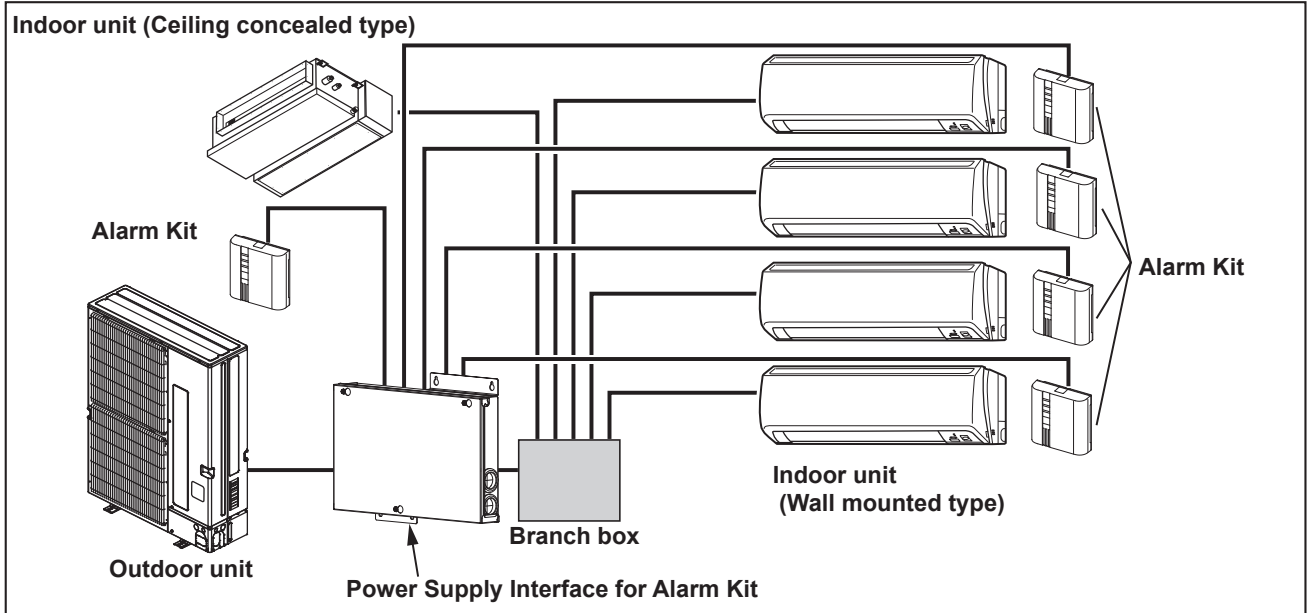

2-1-2. Method for identifying

■ Branch box

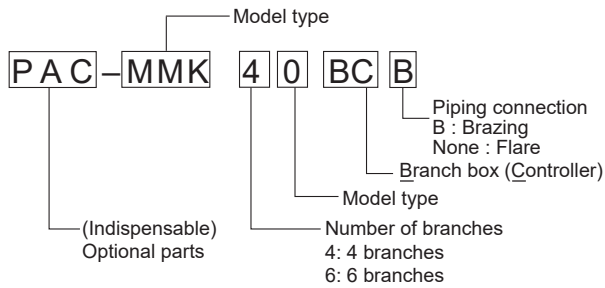

■ Sensor and Alarm Kit

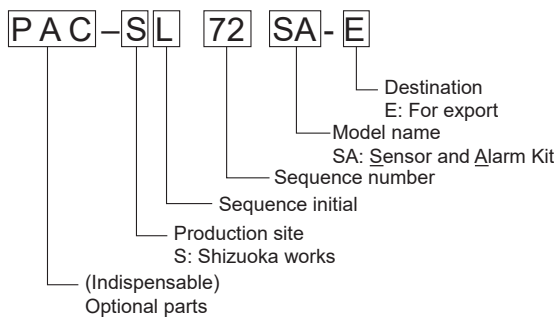
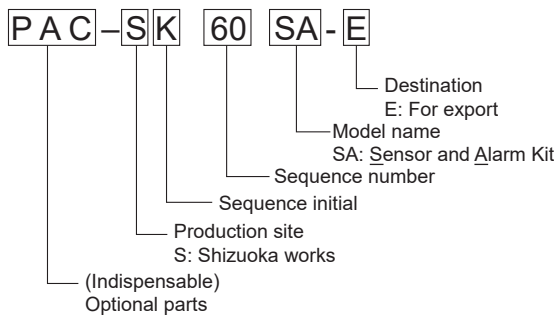

■ POWER SUPPLY INTERFACE FOR ALARM KIT

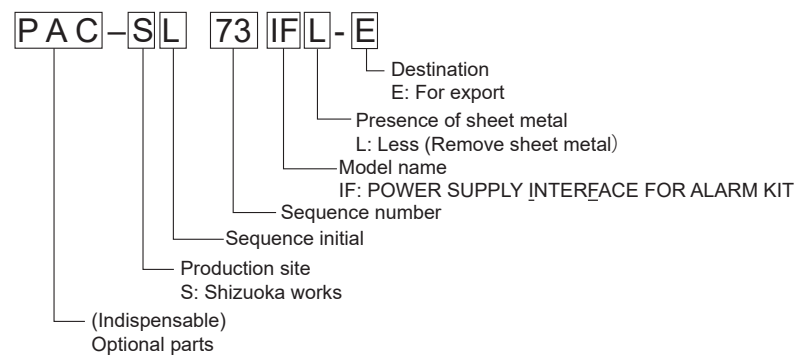

2-2. INSTALLATION

Space required for Installation and servicing for branch box for PAC-MMK40BC(B)/60BC and PAC-SL73IFL-E

For PAC-MMK40BC(B)/60BC

(1) The space when installing with the suspension bolts.

- A: Branch box
- B: On the side of piping
- C: Maintenance hole
- D: Ceiling board or Floor board or Wall board
- E: On the side of board assembly

1-1. Required space around the branch box at installation

Refer to Fig. 2-1. If the space shown in the figure is not ensured, it would be difficult to perform piping work or replace parts when servicing.

1-2. When providing a maintenance hole in a recommended size

When the main pipes are connected to one side of the branch box, refer to Fig. 2-2 and 2-3.

If the space shown in these figures is not ensured, it would be difficult to replace the circuit boards, LEV coil, sensor and branch box.

1-3. When a maintenance hole in a recommended size cannot be provided

Refer to Fig. 2-4 and Fig. 2-5. When providing a maintenance hole in a size of □ 450 mm, the LEV coil, sensor, and branch box cannot be replaced.

Additionally, it would be difficult to replace the circuit boards if the size of a maintenance hole is smaller than □ 450 mm.

*1 If enough space is not ensured around the branch box,, it would be difficult to replace circuit boards.

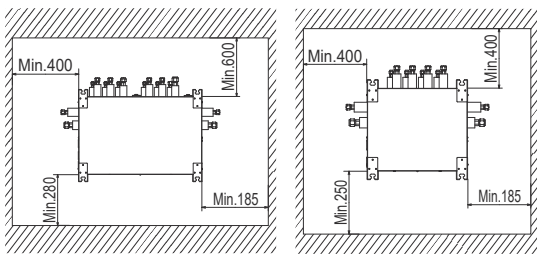

Fig. 2-1

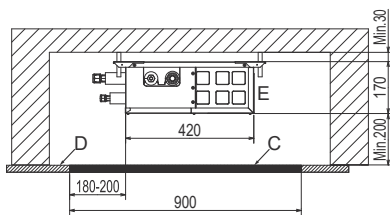

Fig. 2-3

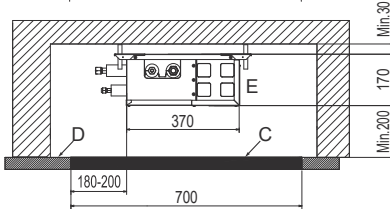

Fig. 2-3

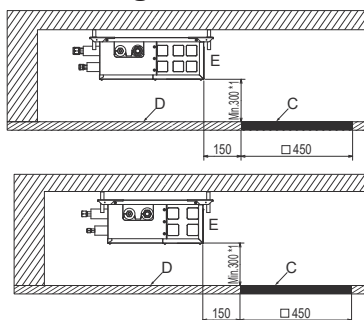

Fig. 2-5

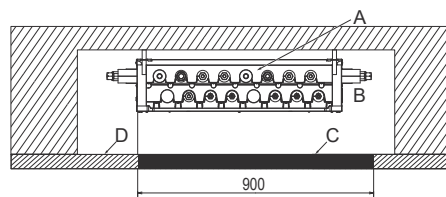

Fig. 2-2

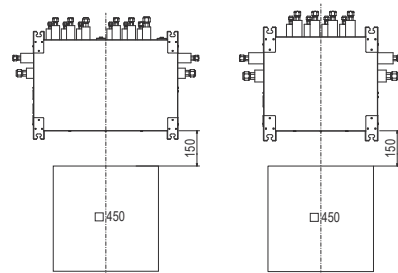
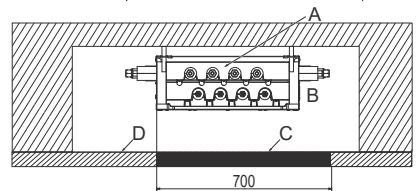

Fig. 2-4

Unit: mm

(2) The space when installing on the ceiling/floor/wall board directly.

- A: Branch box
- B: On the side of piping
- C: Maintenance hole
- D: Ceiling board or Floor board or Wall board
- E: On the side of board assembly

2-1. Required space around the branch box at installation

Refer to Fig. 2-6. If the space shown in the figure is not ensured, it would be difficult to perform piping work or replace parts when servicing.

2-2. When providing a maintenance hole in a recommended size

When the main pipes are connected to one side of the branch box, refer to Fig. 2-7 and 2-8 about the size and installation position of the inspection port in the horizontal direction.

If the space shown in these figures is not ensured, it would be difficult to replace the circuit boards, LEV coil, sensor and branch box.

2-3. When a maintenance hole in a recommended size cannot be provided.

Refer to Fig. 2-4 and Fig. 2-9. When providing a maintenance hole in a size of □ 450 mm, the LEV coil, sensor, and branch box cannot be replaced.

Additionally, it would be difficult to replace the circuit boards if the size of a maintenance hole is smaller than □ 450 mm.

*1 If enough space is not ensured around the branch box, it would be difficult to replace circuit boards.

Unit: mm

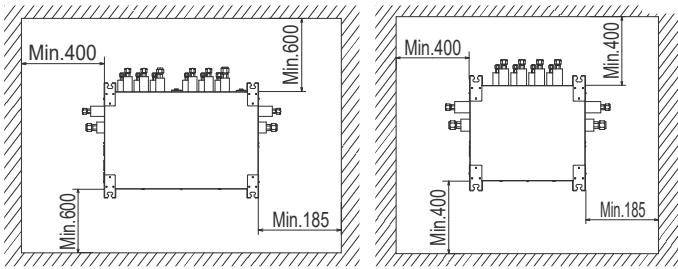

Fig. 2-6

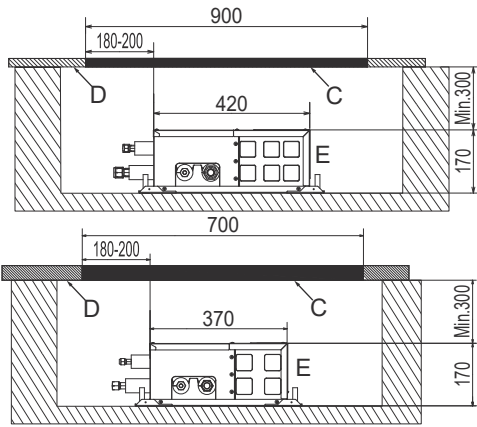

Fig. 2-8

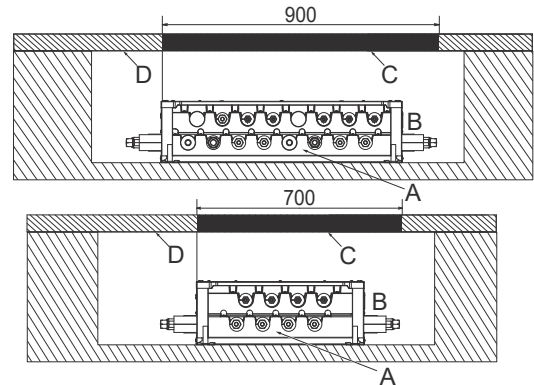

Fig. 2-7

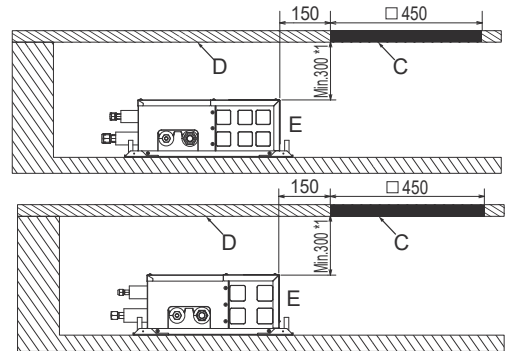

Fig. 2-9

For PAC-SL73IFL-E

(3) The space when installing with the suspension bolts.

- A: POWER SUPPLY INTERFACE FOR ALARM KIT
- B: Ceiling board

* Suspension bolt: W3/8 (M10)

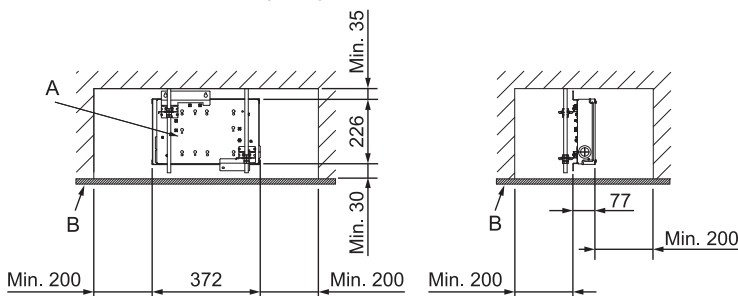

Fig. 2-10

(4) The space when installing on the wall directly
A: POWER SUPPLY INTERFACE FOR ALARM KIT

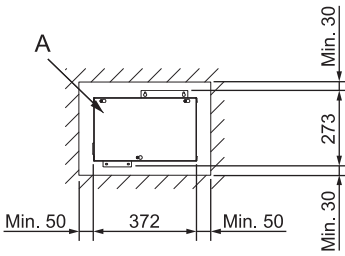

Fig. 2-11

2-3. SIMPLIFIED PIPING SYSTEM

The piping connection size differs according to the type and capacity of outdoor/indoor units.

Match the piping connection size of branch box with outdoor/indoor unit.

If the piping connection size of branch box does not match the piping connection size of outdoor/indoor unit, use optional different-diameter (deformed) joints to the branch box side.

(Connect deformed joint directly to the branch box side.)

■ In the case of using 1-branch box

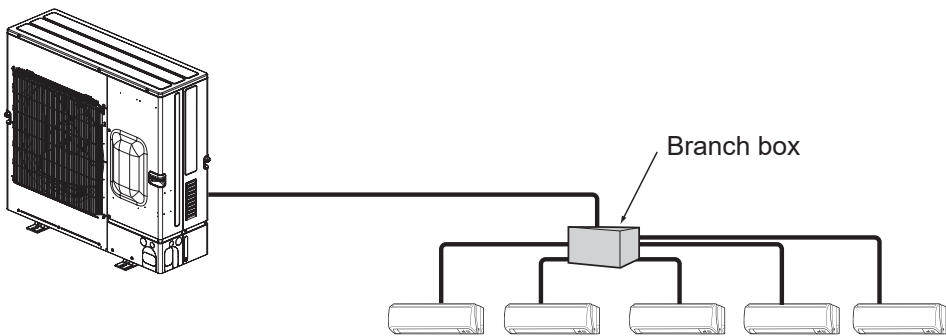

■ In the case of using 2-branch boxes

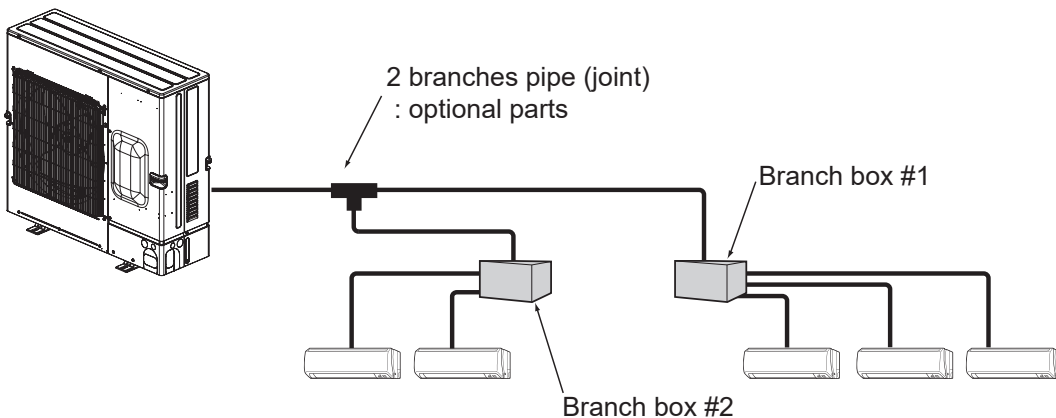

■ Installation procedure (2 branch pipe (joint))
 Refer to the installation manuals of MSDD-50AR2-E and MSDD-50BR-E.

Area where the Sensor and Alarm Kit can be installed (View from the top)

(1) When the connection part for refrigerant piping is exposed in the room.

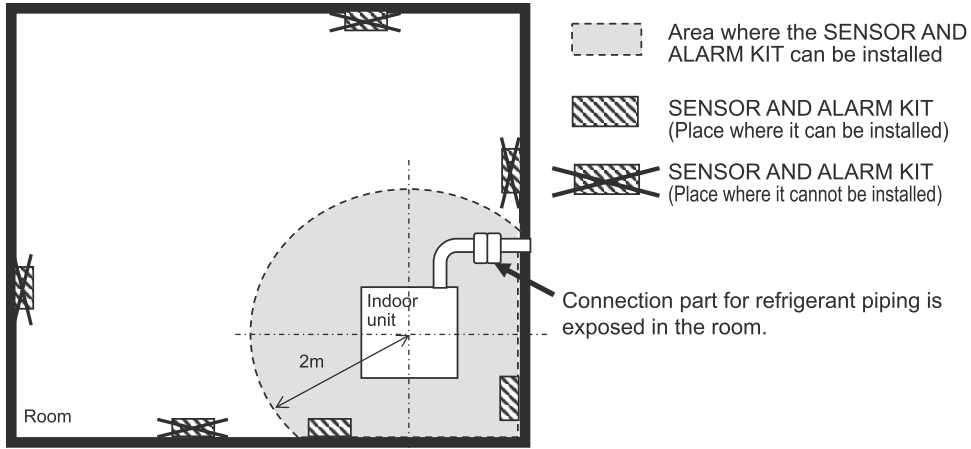

(2) When the connection part for refrigerant piping is NOT exposed in the room.

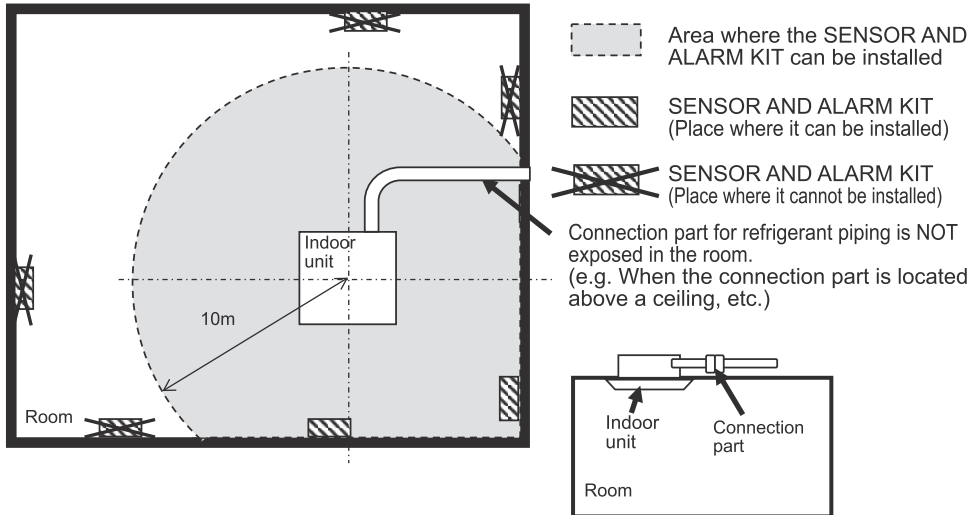

(3) When there are obstacles as shown in the figure below
The following requirement is added to (1) or (2).

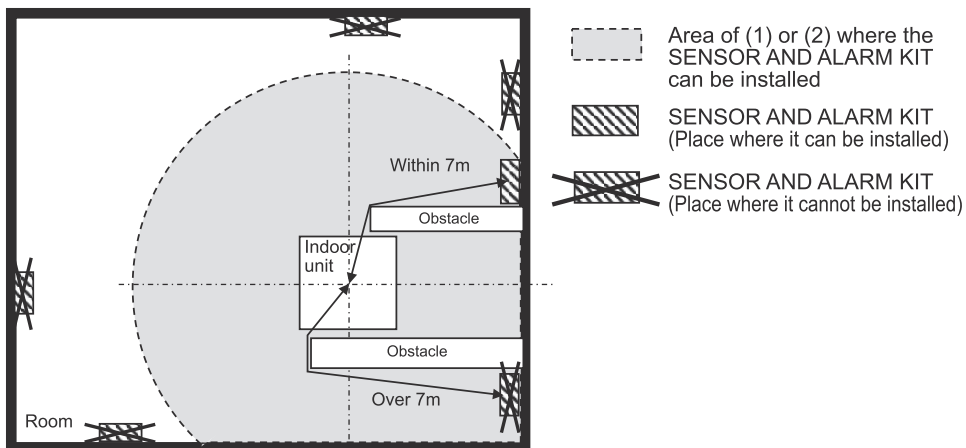

3

SPECIFICATIONS

3-1. BRANCH BOX

Model Name				PAC-MMK40BC	PAC-MMK60BC	PAC-MMK40BCB	
Connectable number of indoor units				Maximum 4	Maximum 6	Maximum 4	
Power supply (from outdoor unit)				~N, 220/230/240 V, 50 Hz, ~N, 220/230 V, 60 Hz			
Input		kW		0.003	0.006	0.003	
Running current		A		0.15	0.30	0.15	
External finish				Galvanized sheets			
Dimensions	Width	mm		450	665	450	
	Depth	mm		372	420	372	
	Height	mm		170			
Weight				kg	10.4	15.8	9.8
Piping connection	Branch (indoor side)*	Liquid	mm	ø 6.35 × 4 {A~D}		ø 6.35 × 4 {A~D}	
		Gas	mm	ø 9.52 × 4 {A~D}		ø 9.52 × 4 {A~D}	
	Main (outdoor side)	Liquid	mm	ø 9.52			
		Gas	mm	ø 15.88			
Connection method				Flare		Brazing	

* The piping connection size differs according to the type and capacity of outdoor/indoor units.

Match the piping connection size of branch box with outdoor/indoor unit. If the piping connection size of branch box does not match the piping connection size of outdoor/indoor unit, use optional different-diameter (deformed) joints to the branch box side. (Connect deformed joint directly to the branch box side.)

3-2. Sensor and Alarm Kit

Model Name	PAC-SK60SA-E, PAC-SL72SA-E
Input Voltage	10.5-13.5 VDC
Power consumption	2 W
Dimensions H × W × D	86 × 86 × 34 (mm)
Sounder	65 dB(A) (1m)

3-3. POWER SUPPLY INTERFACE FOR ALARM KIT

Model Name	PAC-SL73IFL-E
Input Voltage	220/230/240 V (50 Hz) 220/230 V (60 Hz)
Rated current	0.10 A
Power consumption	7 W
Dimensions H × W × D	274 × 372 × 80 (mm)

4

OUTLINES AND DIMENSIONS

PAC-MMK40BC

Unit: mm

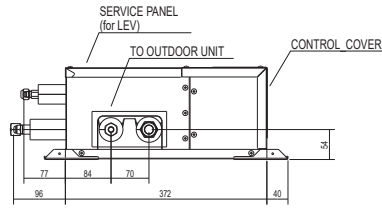

SUSPENSION BOLT -W3/8(M10)
REFRIGERANT PIPE FLARED CONNECTION

	A	B	C	D	TO OUTDOOR UNIT
LIQUID PIPE	ø 6.35	ø 6.35	ø 6.35	ø 6.35	ø 9.52
GAS PIPE	ø 9.52	ø 9.52	ø 9.52	ø 9.52	ø 15.88

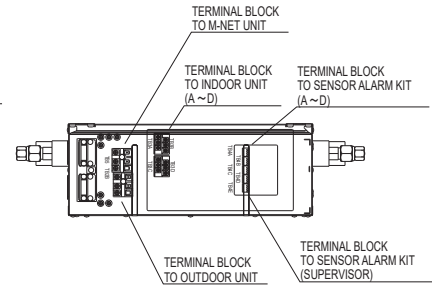
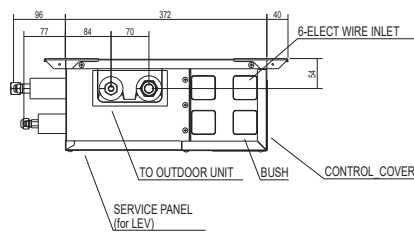
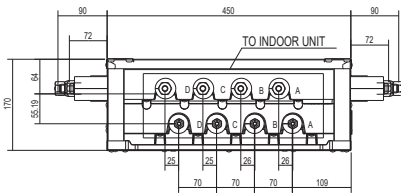
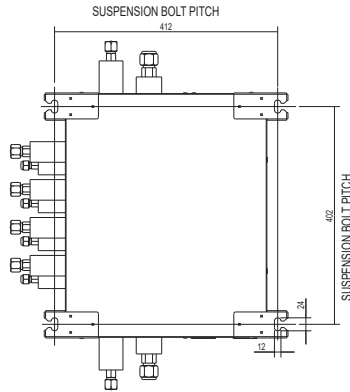

PAC-MMK60BC

SUSPENSION BOLT -W3/8(M10)
REFRIGERANT PIPE FLARED CONNECTION

	1A	1B	1C	2A	2B	2C	TO OUTDOOR UNIT
LIQUID PIPE	ø 6.35	ø 6.35	ø 6.35	ø 6.35	ø 6.35	ø 9.52	ø 9.52
GAS PIPE	ø 9.52	ø 9.52	ø 12.7	ø 9.52	ø 9.52	ø 15.88	ø 15.88

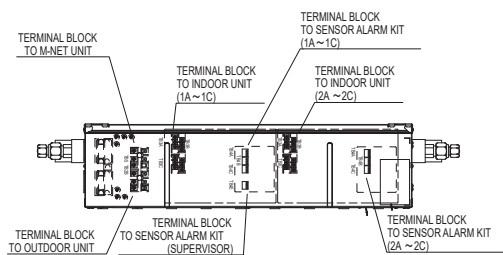
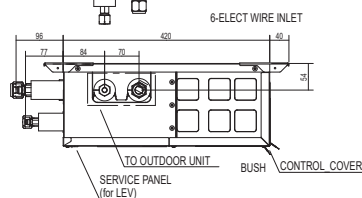
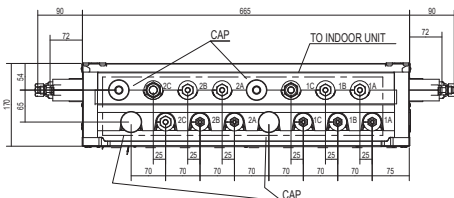
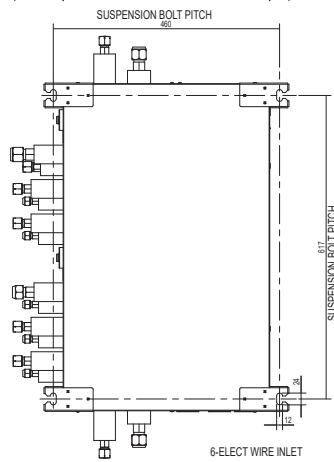
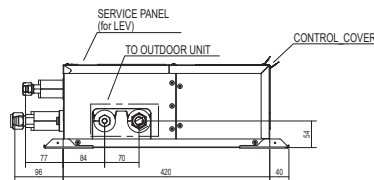

PAC-MMK40BCB

Unit: mm

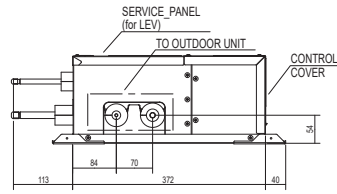

SUSPENSION BOLT: W3/8(M10)
REFRIGERANT PIPE BRAZED CONNECTION

	A	B	C	D	TO OUTDOOR UNIT
LIQUID PIPE	ø 6.35	ø 6.35	ø 6.35	ø 6.35	ø 9.52
GAS PIPE	ø 9.52	ø 9.52	ø 9.52	ø 9.52	ø 15.88

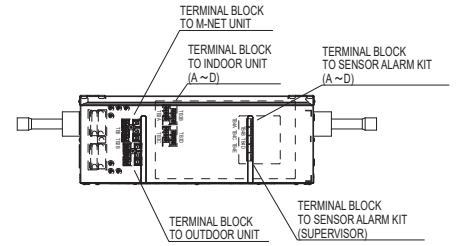
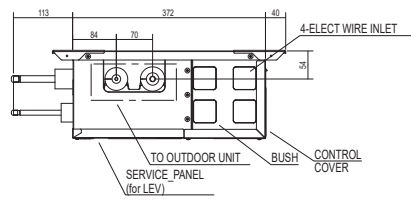
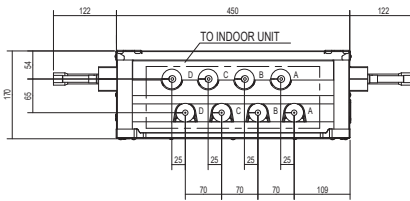
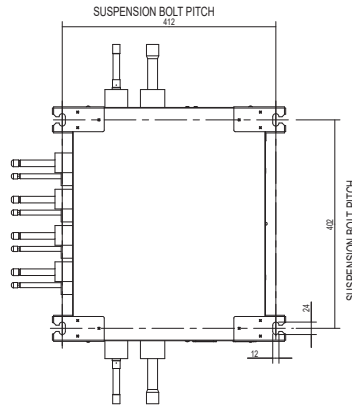

PAC-SL73IFL-E

Unit: mm

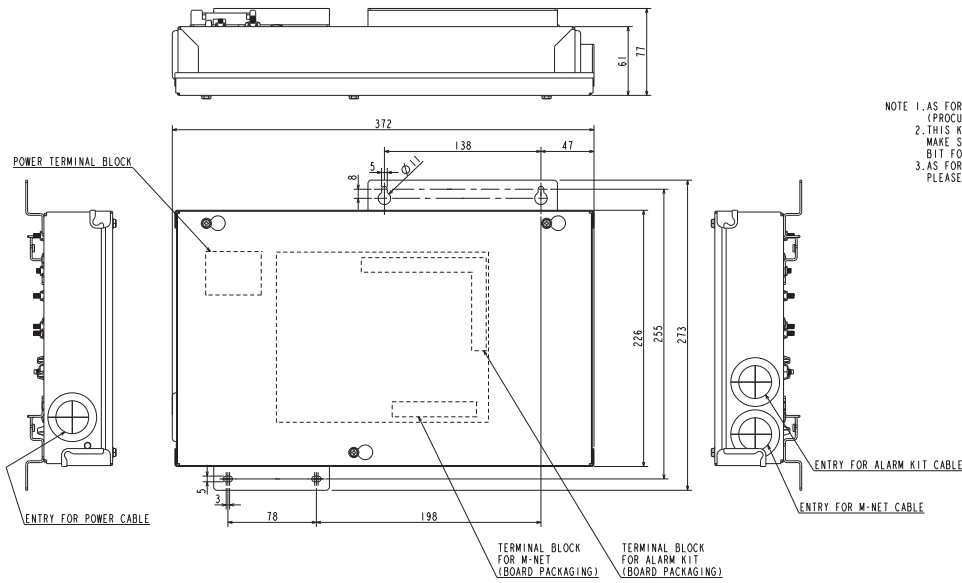

- NOTE 1. AS FOR WALL MOUNTING, PLEASE USE M4 SCREWS. (PROCURED AT LOCAL SITE)
 2. THIS KIT MAY BE REMOVED FOR THE SERVICE PURPOSE. MAKE SURE TO SLACK THE ELECTRICAL CABLE LITTLE BIT FOR POWER/M-NET/ALARM KIT CABLES CONNECTION.
 3. AS FOR NECESSARY INSTALLATION/SERVICE SPACE, PLEASE SEE THE FIGURE ABOVE.

Includes metal fitting

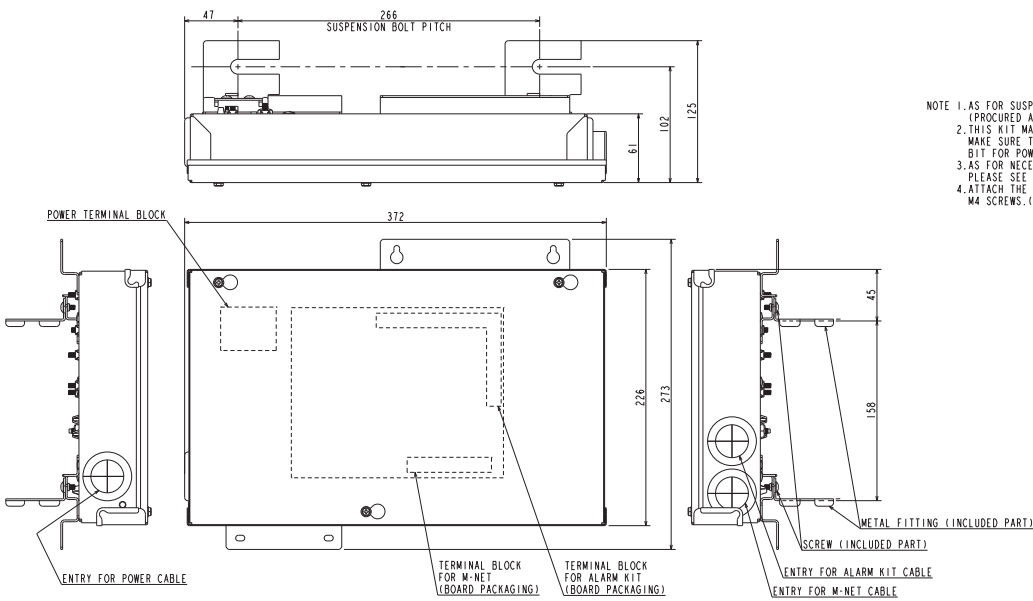

- NOTE 1. AS FOR SUSPENSION BOLT, PLEASE USE M10 OR M3/8. (PROCURED AT LOCAL SITE)
 2. THIS KIT MAY BE REMOVED FOR THE SERVICE PURPOSE. MAKE SURE TO SLACK THE ELECTRICAL CABLE LITTLE BIT FOR POWER/M-NET/ALARM KIT CABLES CONNECTION.
 3. AS FOR NECESSARY INSTALLATION/SERVICE SPACE, PLEASE SEE THE FIGURE ABOVE.
 4. ATTACH THE METAL FITTING TO THE MAIN UNIT USING M4 SCREWS. (INCLUDED PARTS)

PAC-MMK40BC PAC-MMK40BCB

[LEGEND]

SYMBOL	NAME
TB2B	Terminal block <To Power Supply>
TB5	Terminal block <Transmission line>
B.C.	Branch Box controller board
F1	Fuse <T6.3AL250V>
F2	Fuse <T10AL250V>
F3	Fuse <T10AL250V>
SW1	Switch for indoor unit connection *1
SW4	Switch for function selection *2
SW5	Switch for function selection *3
SW11	Address Setting 1s digit
SW12	Address Setting 10s digit
LED1,2	Light emitting diode *4
CND	Connector <Connection for TB2B>
CN3M	Connector <Connection for TB5>
CNM	Connector <Connection for service>
CNT	Connector <Connection for CNS>
TB1	Tab terminal <Connection for Earth>
TB3A-3D	Terminal block <To Indoor unit A~D>
LEV-A~D	Connector <Connection for LEV-A~D>
LEV-A~D	Linear expansion valve
INTC.B.	Interconnect board
CNS	Connector <Connection for CNT>
LED-A-E	Light emitting diode *6
TB4A-4E	Connector <Connection for CN1>
SENSOR AND ALARM KIT	
CN1	Connector <Connection for TB4A-E>
DIPSW	Switch for function selection *5
LED-O	Light emitting diode
LED-R	Light emitting diode
LED-W	Light emitting diode

*1 SW1 setting

B.C.		OFF	ON
SW1-1	INDOOR UNIT-A	NOT CONNECTION	CONNECTION
SW1-2	INDOOR UNIT-B	NOT CONNECTION	CONNECTION
SW1-3	INDOOR UNIT-C	NOT CONNECTION	CONNECTION
SW1-4	INDOOR UNIT-D	NOT CONNECTION	CONNECTION
SW1-5	NO USE		
SW1-6	SENSOR AND ALARM KIT for supervisor	NOT CONNECTION	CONNECTION

After each indoor unit is connected to the Branch Box, turn on the switch corresponding to each indoor unit. For example, when the indoor units are connected to INDOOR UNIT-A and D, turn SW1-1 and SW1-4 to on. When SENSOR AND ALARM KIT for supervisor is set, turn on SW1-6 to on.

*2 SW4 setting

B.C.		OFF	ON
SW4-5	Cooling & Heating system	Cooling only system	

When the outdoor unit is cooling only system, turn SW4-5 to on.

*3 SW5 setting

B.C.		OFF	ON
SW5-0	Normal		With Interface Kit connection

Refer to the service handbook of Branch box for details.

Address switch settings of SW11 and SW12 (Set them before turning on the power.)
The address of the Branch box is set with the combination of the 10s and 1s digits. The addresses of the indoor units A to D are assigned by the address switches of each controller board (SW11 and SW12) and the dip switches (SW1-1 to 1-4).
For setting methods, refer to both the Installation Manuals of the outdoor unit and the Branch box.

*4 LED on Branch box controller board for service

• start-up

Mark	Meaning	Function
LED 1	Main power supply	Main power supply (220-240V)
LED 2		Power on → Lamps are lit

• normal operating

Mark	Meaning	Function
LED 1	Main power supply	Lamp is lit
LED 2	Total number of indoor units	Blink depend on the total number <example> The total number is 2 ① Blink 2 times. ② Turn off for 3 sec. ③ Repeat ① to ②.

*5 DIPSW setting

SENSOR AND ALARM KIT	DIPSW-1	DIPSW-2
Room	ON	OFF
Supervisor room	OFF	ON

*6 Refer to the service handbook of Branch box for details.

<Notes>

- When servicing for outdoor unit, always follow the wiring diagram of outdoor unit.
- When work to supply power separately to Branch box and outdoor units are applied, refer to Fig. 1.
- For the connection method, please refer to the installation manual of Branch box, SENSOR AND ALARM KIT and Interface Kit for details.

<Symbols used in wiring diagram>

- Terminal block
- Connector
- Dip switch (■ (black square) indicates a switch position)

<Combination of indoor units>

Enter the location of combined indoor units with model name in each blank below because it is necessary for service and maintenance.

INDOOR UNIT-A	INDOOR UNIT-B	INDOOR UNIT-C	INDOOR UNIT-D

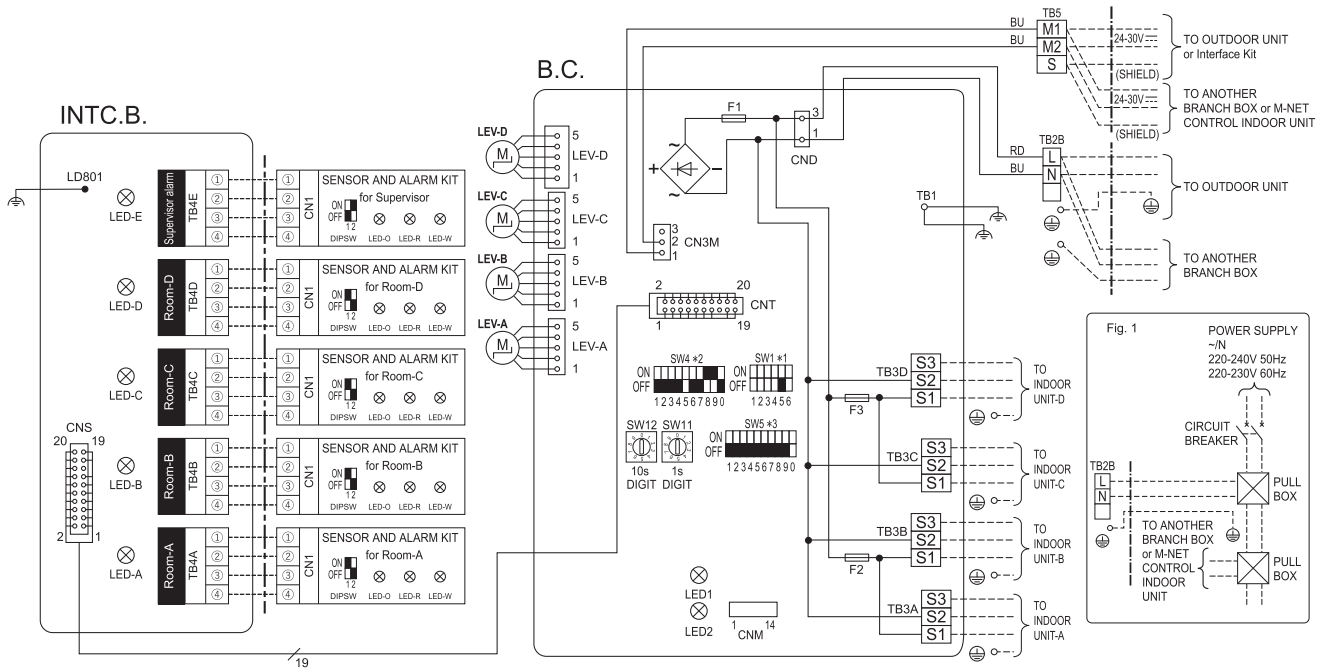

6-1. TRANSMISSION SYSTEM SETUP

Note: It is necessary to connect a sensor alarm kit that is compatible with the system. See 6-3 for connection details.

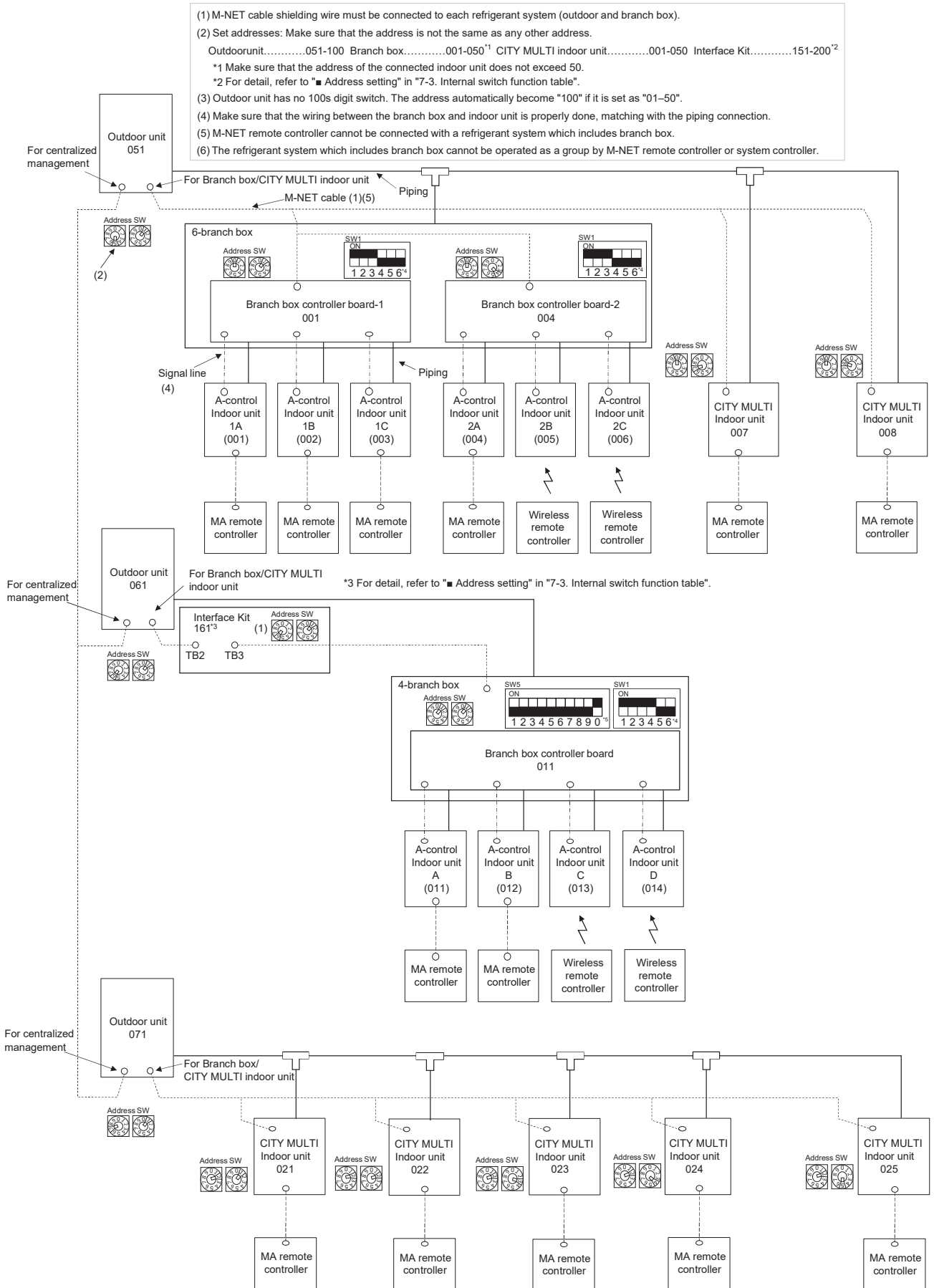

*4 When connect S/A kit for controller room, turn on the SW 1-6. (Refer to 7-3. INTERNAL SWITCH FUNCTION TABLE)
 *5 When the system connecting with Interface kit, turn on SW 5-0. (Refer to 7-3 INTERNAL SWITCH FUNCTION TABLE)

6-2. REFRIGERANT SYSTEM DIAGRAM

■ PAC-MMK40BC(B)

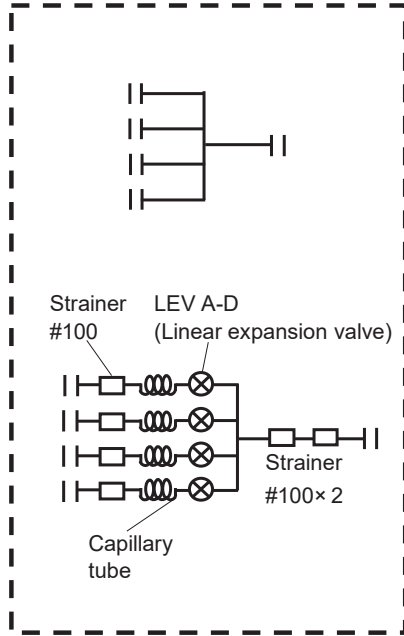

■ PAC-MMK60BC

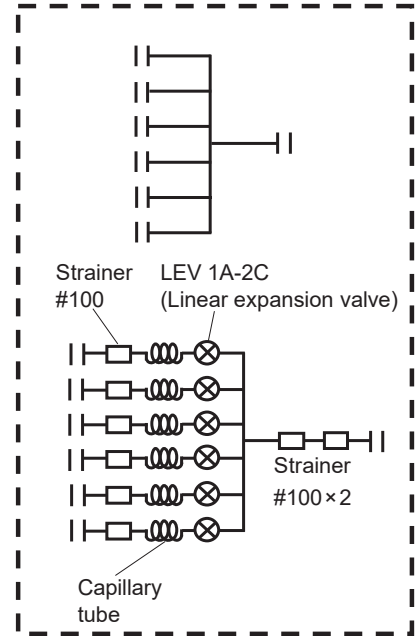

Unit: mm

		Capillary tube behind LEV (in cooling mode)
Branch box	PAC-MMK40BC(B)	($\varnothing 4 \times \varnothing 3.0 \times L130$) $\times 4$
	PAC-MMK60BC	($\varnothing 4 \times \varnothing 3.0 \times L130$) $\times 6$

6-3. TYPICAL CONTROL SYSTEM

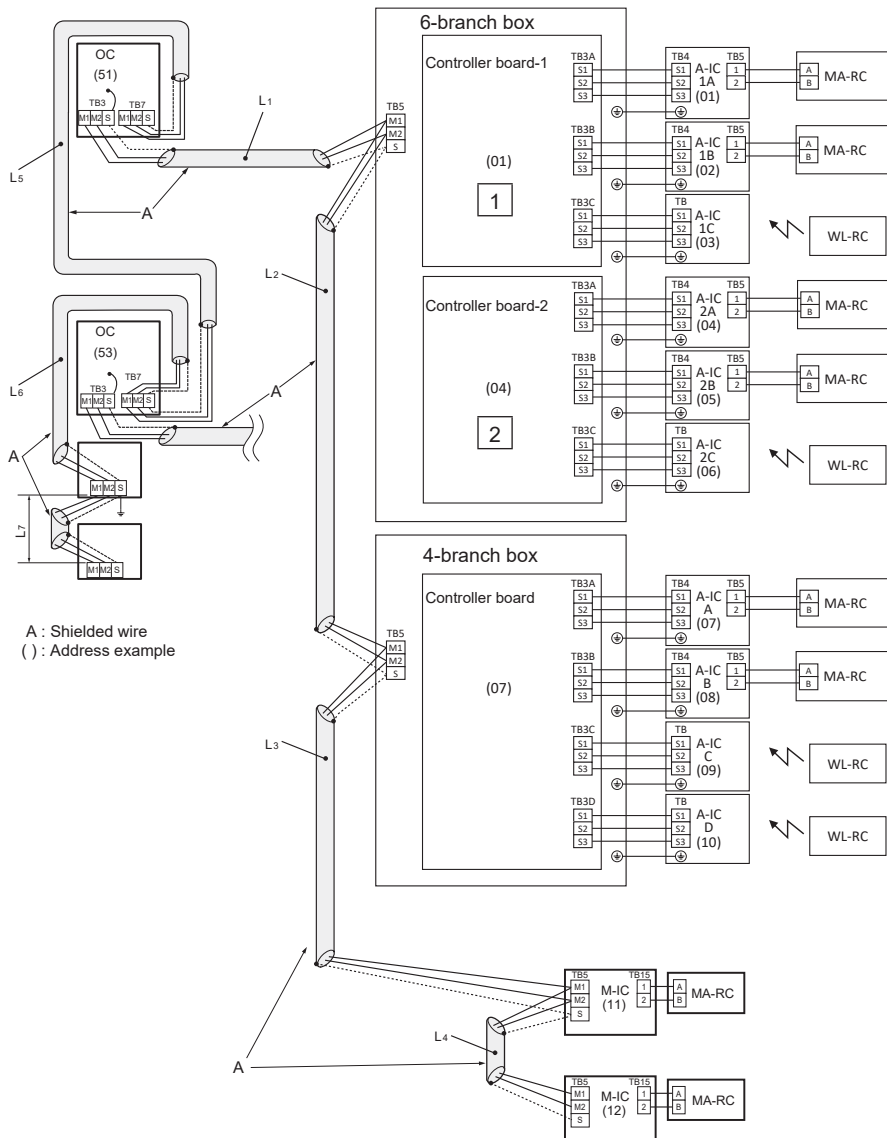

A : Shielded wire
() : Address example

OC: Outdoor unit
M-IC: M-NET Control indoor unit (CITY MULTI indoor unit)
A-IC: A-control indoor unit
MA-RC: MA Remote controller
WL-RC: Wireless Remote controller

* See the next page for connection wiring with the Sensor and Alarm Kit.

IMPORTANT:

Make sure that the current leakage breaker is one compatible with higher harmonics.

Always use a current leakage breaker that is compatible with higher harmonics as this unit is equipped with an inverter.

The use of an inadequate breaker can cause the incorrect operation of inverter.

Longest length via outdoor units:

$L1 + L2 + L3 + L4 + L5 + L6 + L7 \leq 500 \text{ m (1640 ft) (1.25 mm}^2 \text{ or more)}$

Longest transmission cable length

$L1 + L2 + L3 + L4, L5 + L6, L7 \leq 200 \text{ m (656 ft) (1.25 mm}^2 \text{ or more)}$

Note: M-NET remote controller cannot be connected with a refrigerant system which includes branch box.

(1) Difference between display and operation

- ① When operating the system using the system controller, details of those operations will not appear on the display of the wireless remote controller.
- ② The set temperature range is different in the wireless remote controller that comes with room air conditioner and the system controller. The room air conditioner has a wider range. If the target temperature is set to below 17°C or less, or 30°C or more by the wireless remote controller that comes with room air conditioner, the temperature displayed on the system controller may be converted to their maximum/minimum set temperature. For instance, when HEAT operation at 16°C is set at the room air conditioner, the system controller may display 17°C.
- ③ When DRY mode is set with the wireless remote controller, the room air conditioner automatically set the optimum target temperature. The system controller will display the target temperature as a set temperature.
- ④ When DRY mode is set with the system controller, the room air conditioner performs DRY mode control operation according to the temperature set with the system controller.

(2) Timer operation

- ① Timer operation should be set using only 1 controller from the remote controller that comes with the room air conditioner, the system controller or the MA remote controller. If more than 1 controller is used to set the timer at the same time, the timer will not function properly.
- ② When the timer is set with the wireless remote controller; the system controller will not show the timer display.
- ③ The timer set with the system controller will not be cancelled with the wireless remote controller.

(3) Manual operation prohibition

- ① When the manual operation (ON/OFF, set temperature, or operation mode) is prohibited with the system controller, the command to perform the prohibited operation will not be accepted from the wireless remote controller that comes with the room air conditioner. The operation partially enabled by the system controller can be operated with the wireless remote controller. Regardless of whether the operation is disabled or enabled, 3 short beeps will sound when the signal is sent from the wireless remote controller.

(4) Trouble

- ① If the MA remote controller or the system controller shows the abnormal indication, clear it by stopping the operation with one of the following: the MA remote controller, the system controller, or the wireless remote controller. (Abnormal indication of the air conditioner could be recovered automatically, but that of the MA remote controller or the system controller cannot be recovered unless the operation is stopped.)

(5) Group setting

- ① MA group or M-NET group setting cannot be set.

(6) Restricted functions

The following functions of system controller cannot be used.

- DIDO controller (Interlock with the air conditioner)
- Fan control of energy saving control or peak cut control function
- Air conditioning charge [TG-2000A]
- Set temperature range limiting function
- Operation mode changeover limit (season changing) [PAC-SF44SRA]
- Dual set point function

Example of Sensor and Alarm Kit Wiring

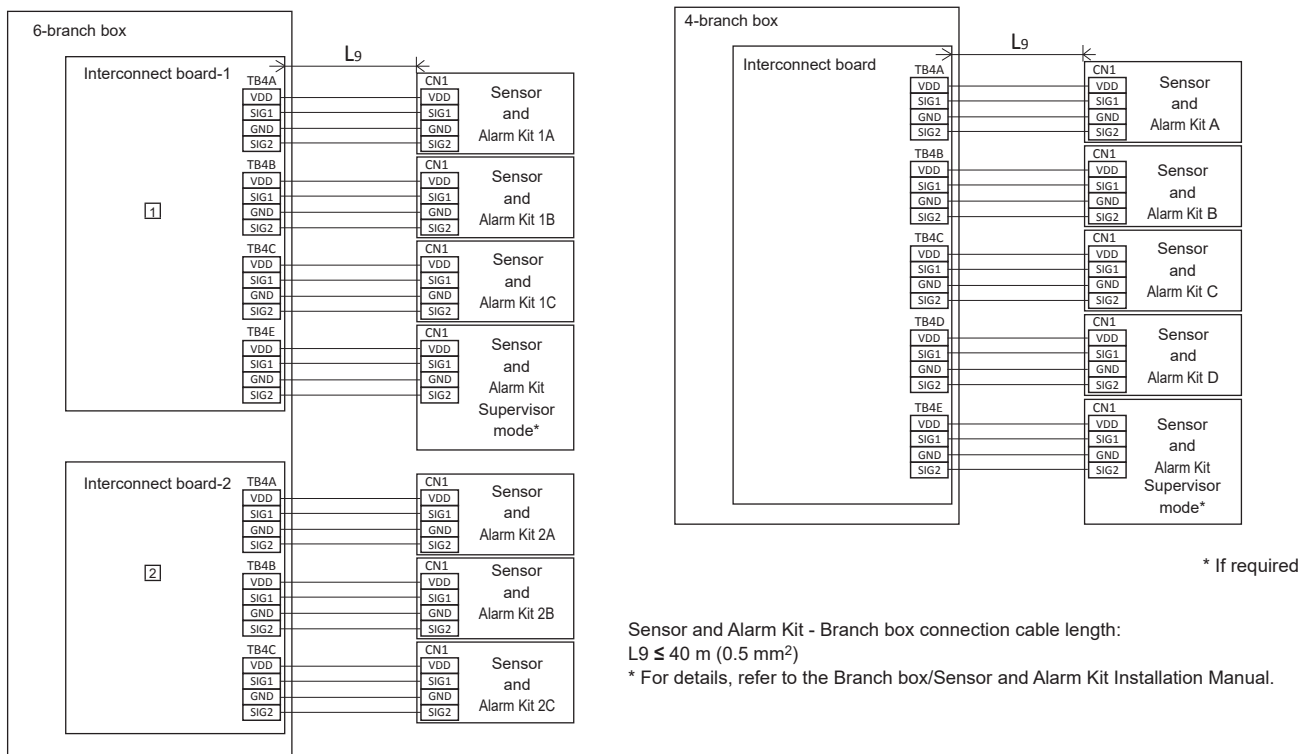

* If required

Sensor and Alarm Kit - Branch box connection cable length:
 $L9 \leq 40 \text{ m (0.5 mm}^2\text{)}$

* For details, refer to the Branch box/Sensor and Alarm Kit Installation Manual.

Example of a system using Branch box and A-Control indoor unit with Interface Kit

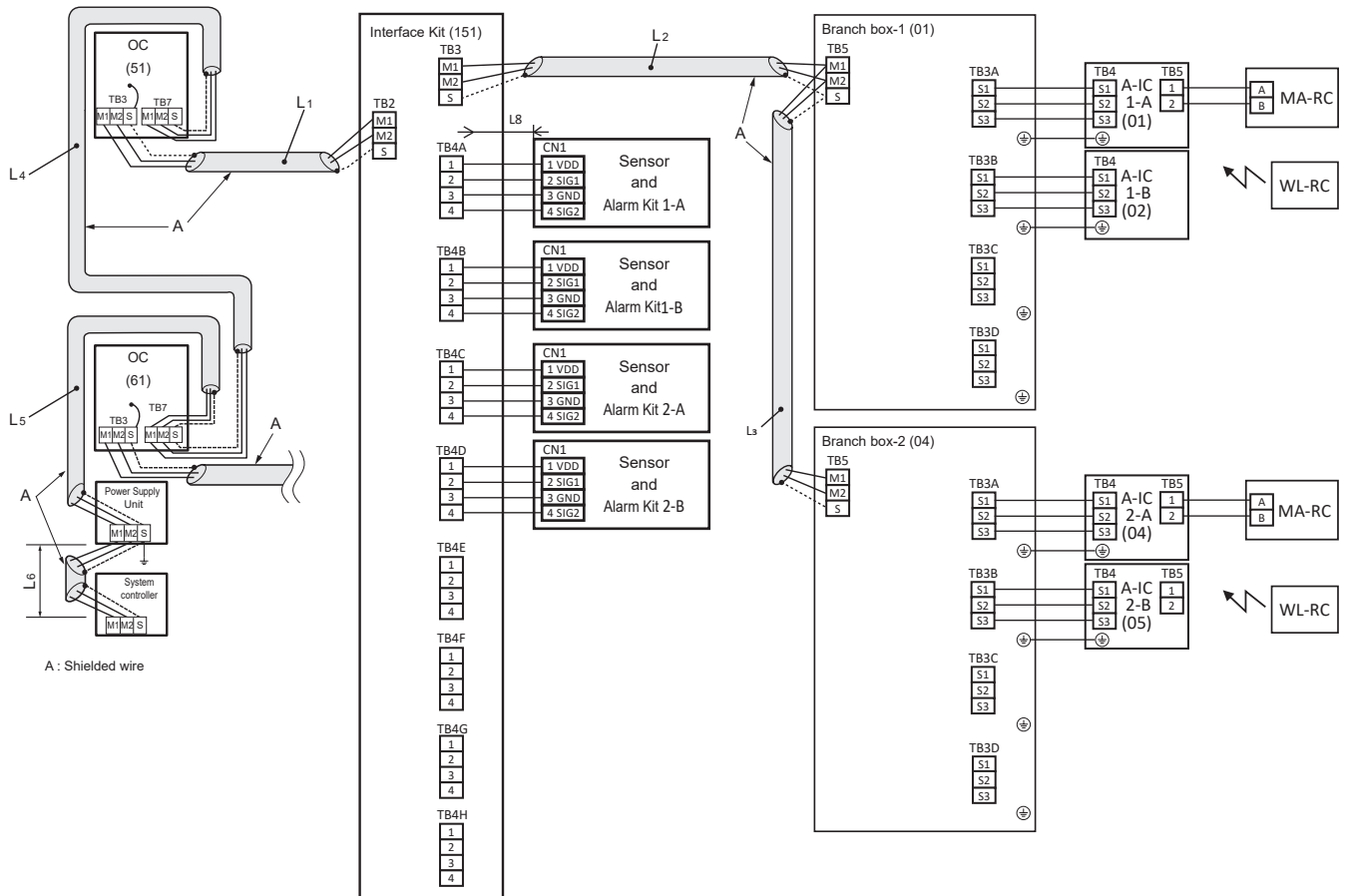

OC: Outdoor unit
 A-IC: A-control indoor unit
 MA-RC: MA Remote controller
 WL-RC: Wireless Remote controller

Sensor and Alarm Kit - Interface Kit connection cable length:
 $L8 \leq 40 \text{ m (0.5 mm}^2\text{)}$
 * For details, refer to the Interface Kit/Sensor and Alarm Kit Installation Manual.

IMPORTANT:
 When connecting Interface kit, mixed system is not possible (Cannot connect M-IC).
 Make sure that the current leakage breaker is one compatible with higher harmonics.
 Always use a current leakage breaker that is compatible with higher harmonics as this unit is equipped with an inverter.
 The use of an inadequate breaker can cause the incorrect operation of inverter.

Longest length via outdoor units:
 $L1 + L2 + L3 + L4 + L5 + L6 \leq 500 \text{ m (1640 ft) (1.25 mm}^2\text{ or more)}$
 Longest transmission cable length
 $L1 + L2 + L3, L4 + L5, L6 \leq 200 \text{ m (656 ft) (1.25 mm}^2\text{ or more)}$

7 TROUBLESHOOTING

7-1. HOW TO CHECK THE PARTS

Branch box: PAC-MMK40BC PAC-MMK60BC PAC-MMK40BCB

Parts name	Checkpoint														
Linear expansion valve (LEV) 	Disconnect the connector then measure the resistance with a multimeter. (Winding temperature 20°C) <table border="1" style="margin-top: 10px;"> <tr> <td colspan="4" style="text-align: center;">Normal</td> <td rowspan="2" style="text-align: center;">Abnormal</td> </tr> <tr> <td style="text-align: center;">Red - White</td> <td style="text-align: center;">Red - Orange</td> <td style="text-align: center;">Red - Yellow</td> <td style="text-align: center;">Red - Blue</td> </tr> <tr> <td colspan="4" style="text-align: center;">$46 \pm 4\Omega$</td> <td style="text-align: center;">Open or short</td> </tr> </table>	Normal				Abnormal	Red - White	Red - Orange	Red - Yellow	Red - Blue	$46 \pm 4\Omega$				Open or short
Normal				Abnormal											
Red - White	Red - Orange	Red - Yellow	Red - Blue												
$46 \pm 4\Omega$				Open or short											

Linear expansion valve (LEV) in branch box

(1) Operation summary of the linear expansion valve

- The linear expansion valve opens/closes through stepping motor after receiving the pulse signal from the branch box controller board.
 - The valve position can be changed in proportion to the number of the pulse signal.
- <Connection between the branch box controller board and the linear expansion valve>

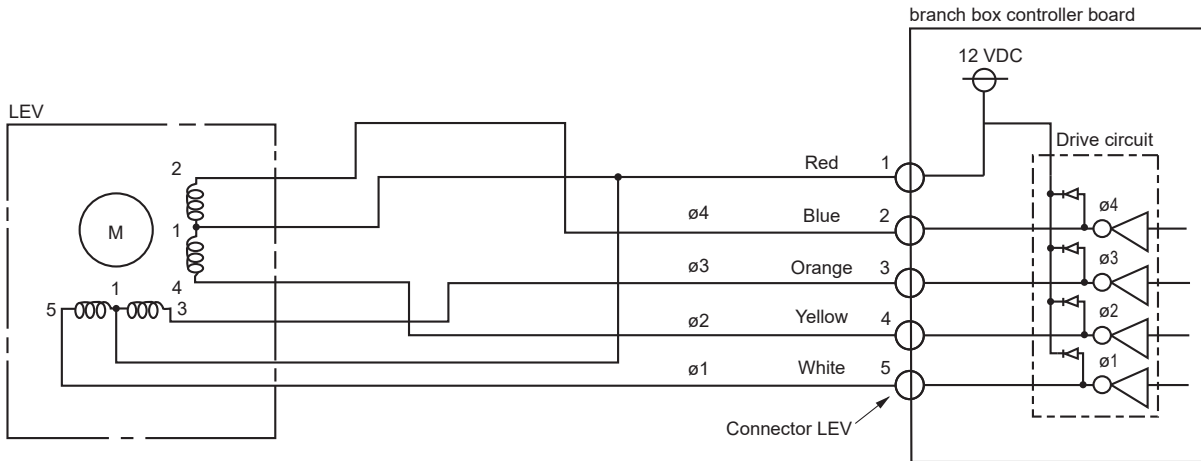

<Output pulse signal and the valve operation>

Output (Phase)	Output							
	1	2	3	4	5	6	7	8
ø1	ON	ON	OFF	OFF	OFF	OFF	OFF	ON
ø2	OFF	ON	ON	ON	OFF	OFF	OFF	OFF
ø3	OFF	OFF	OFF	ON	ON	ON	OFF	OFF
ø4	OFF	OFF	OFF	OFF	OFF	ON	ON	ON

The output pulse shifts in the following order.

Opening a valve: 8 → 7 → 6 → 5 → 4 → 3 → 2 → 1 → 8

Closing a valve: 1 → 2 → 3 → 4 → 5 → 6 → 7 → 8 → 1

- When the linear expansion valve operation stops, all output phases become OFF.

(2) Linear expansion valve operation

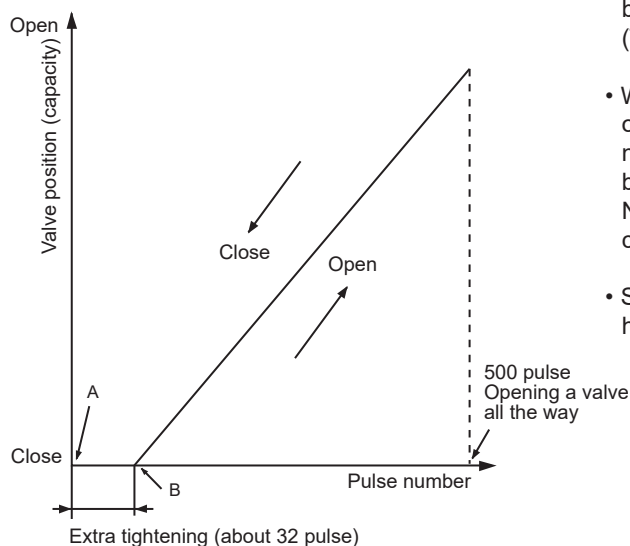

- When the power is turned on, 700 pulse closing the valve signal will be sent till it goes to A point in order to define the valve position. (The pulse signal is being sent for about 20 seconds.)
- When the valve moves smoothly, there is no sound or vibration occurring from the linear expansion valve: however, when the pulse number moves from B to A or when the valve is locked, sound can be heard. No sound is heard when the pulse number moves from B to A in case coil is burnt out or motor is locked by the open-phase.
- Sound can be detected by placing the ear against the screw driver handle while putting the screw driver to the linear expansion valve.

(3) How to attach and detach the coil of linear expansion valve

<Composition>

The linear expansion valve is separable into the main body and the coil as shown in the diagram below.

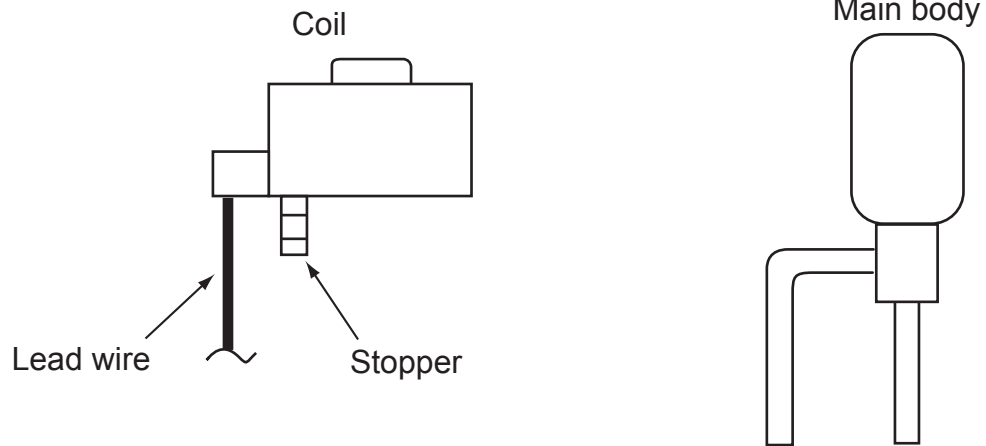

<How to detach the coil>

Hold the lower part of the main body (shown as A) firmly so that the main body does not move and detach the coil by pulling it upward.

Be sure to detach the coil holding main body firmly. Otherwise pipes can bend due to stress.

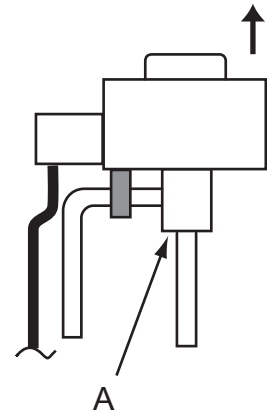

<How to attach the coil>

Hold the lower part of the main body (shown as A) firmly so that the main body does not move and attach the coil by inserting it downward into the main body. Then securely attach the coil stopper to pipe B. (At this time, be careful that stress is not added to lead wire and main body is not wound by lead wire.) If the stopper is not firmly attached to pipe B, coil may be detached from the main body and that can cause defective operation of linear expansion valve.

To prevent piping stress, be sure to attach the coil holding the main body of linear expansion valve firmly. Otherwise pipe may break.

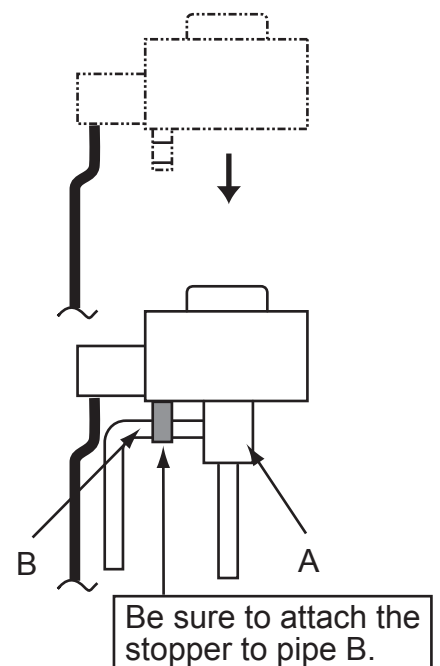

Troubleshooting

Problem	Checkpoint	Corrective measure
Locked expansion valve	If the linear expansion valve becomes locked and the motor is still operating, the motor will emit a clicking noise and will not function. This clicking noise indicates an abnormality.	Replace the linear expansion valve.
Short circuit or broken circuit in expansion valve motor coil	Use an all-purpose electrical meter to measure the resistance between the different coils (red-white, red-orange, red-yellow, red-blue). Normal resistance is within a range of $46\Omega \pm 4\Omega/\text{phase}$ (at 20°C).	Replace the linear expansion valve.
Valve does not close completely.	In order to check the linear expansion valve, operate 1 indoor unit in the fan mode and another in the cooling mode. Then, use the outdoor multi controller board to operate the monitor and check the pipe temperature of the indoor unit. The linear expansion valve should be fully closed when the fan is operating. The temperature measured by the temperature sensor will drop if there is any leakage. If the measured temperature is significantly lower than that on the remote controller, this indicates that the valve is not closed. It is not necessary to replace the linear expansion valve if the leak of refrigerant is small and does not cause a malfunction.	Replace the linear expansion valve if there is a major leak of refrigerant.
Incorrect connection or connection failure	(1) Check improperly connected connector terminals and the wire colors. (2) Remove the connector on the controller board side and check electrical conductance.	Continuity check of wrong part

7-2. TEST POINT DIAGRAM

Branch box controller board (B.C.)
PAC-MMK40BC PAC-MMK60BC

PAC-MMK40BCB

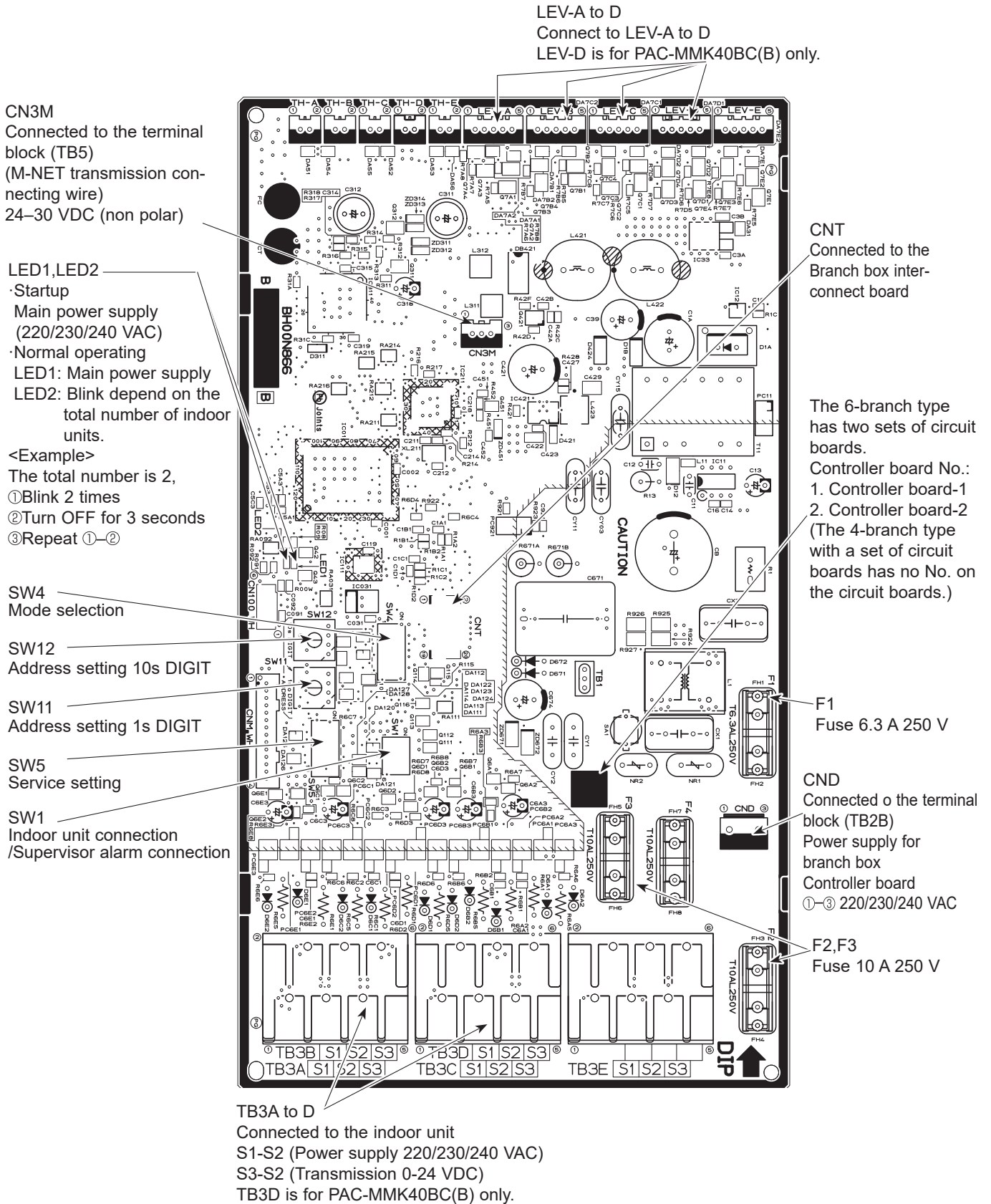

Branch box interconnect board (INTC.B.)
PAC-MMK40BC PAC-MMK60BC PAC-MMK40BCB

TB4E
 Terminal block for connecting
 the Sensor and Alarm Kit
 (Supervisor mode)
 * 6-branch interconnect board-2
 is not mounted.

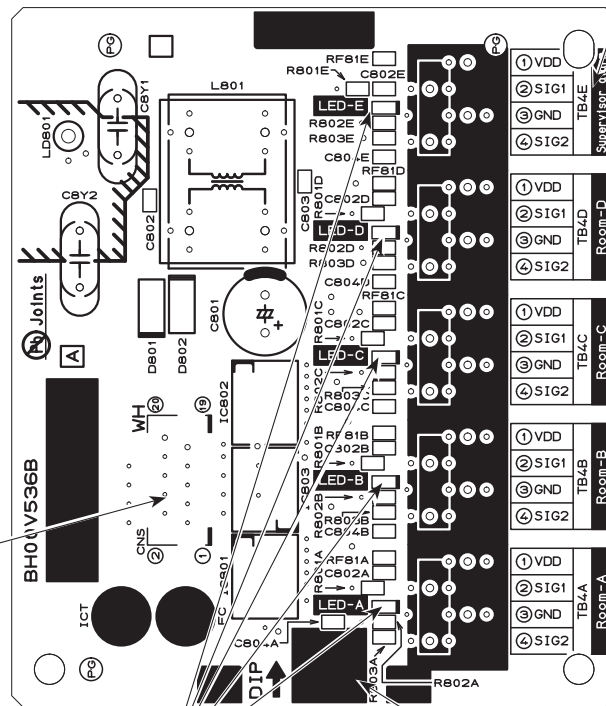

TB4A to D
 Connect to
 Sensor and Alarm Kit
 (Sensor and Alarm mode)
 * The 6-branch model does
 not have TB4D installed.
 * Match the terminal
 numbers on the
**SENSOR AND ALARM
 KIT.**

CNS
 Connect to controller board

LED-A to E
 Displays the connection status with the
 connected Sensor and Alarm Kit
 ex) LED-A indicates the status of the
 Sensor and Alarm Kit connected to the TB4A

The 6-branch type has two sets
 of circuit boards.
 Interconnect board No.:
 1. Interconnect board-1
 2. Interconnect board-2
 (The 4-branch type with a set
 of circuit boards has no No. on
 the circuit boards.)



Sensor and Alarm Kit alarm circuit board
PAC-SK60SA-E
PAC-SL72SA-E

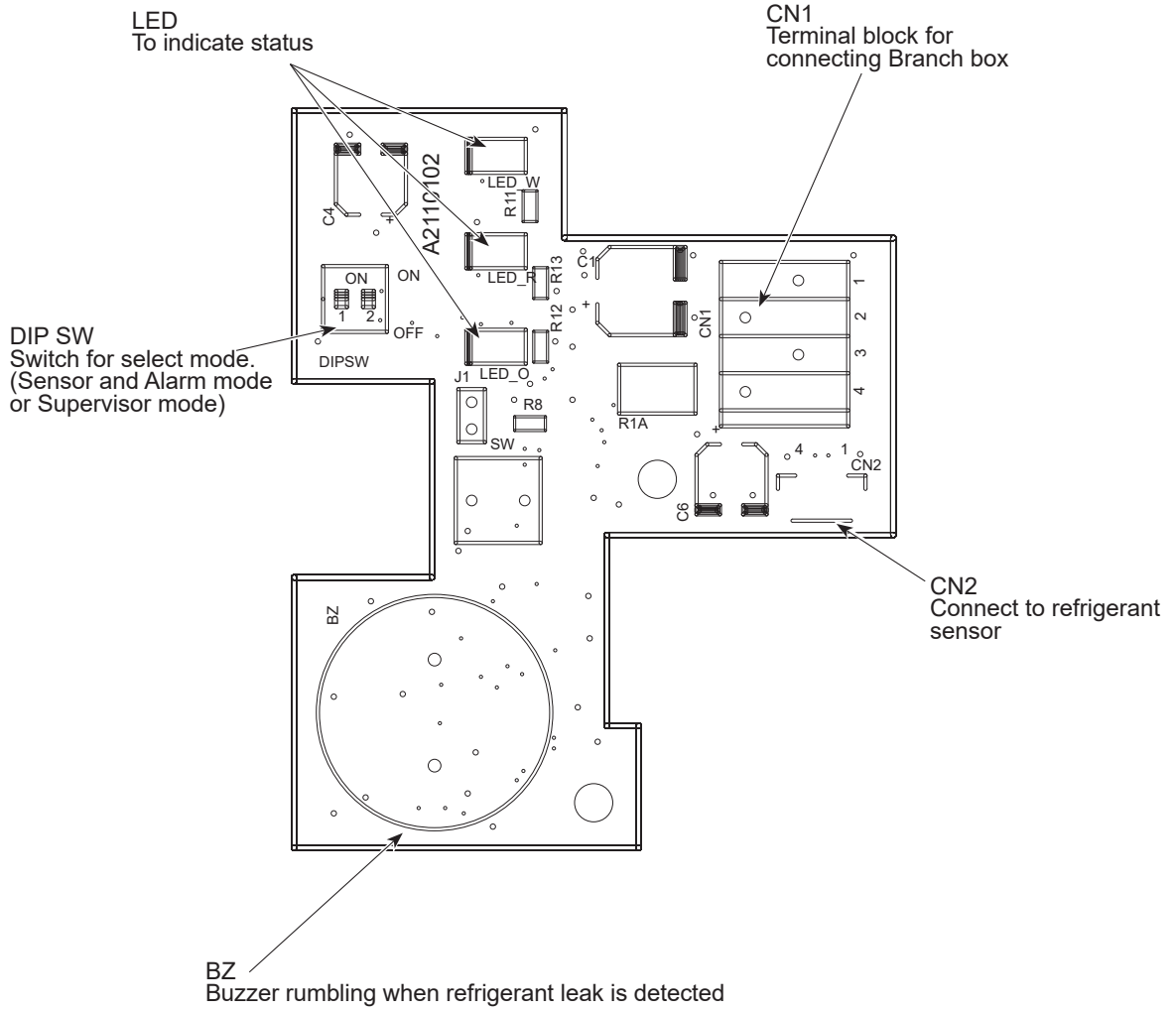

**POWER SUPPLY INTERFACE FOR ALARM KIT controller circuit board
PAC-SL73IFL-E**

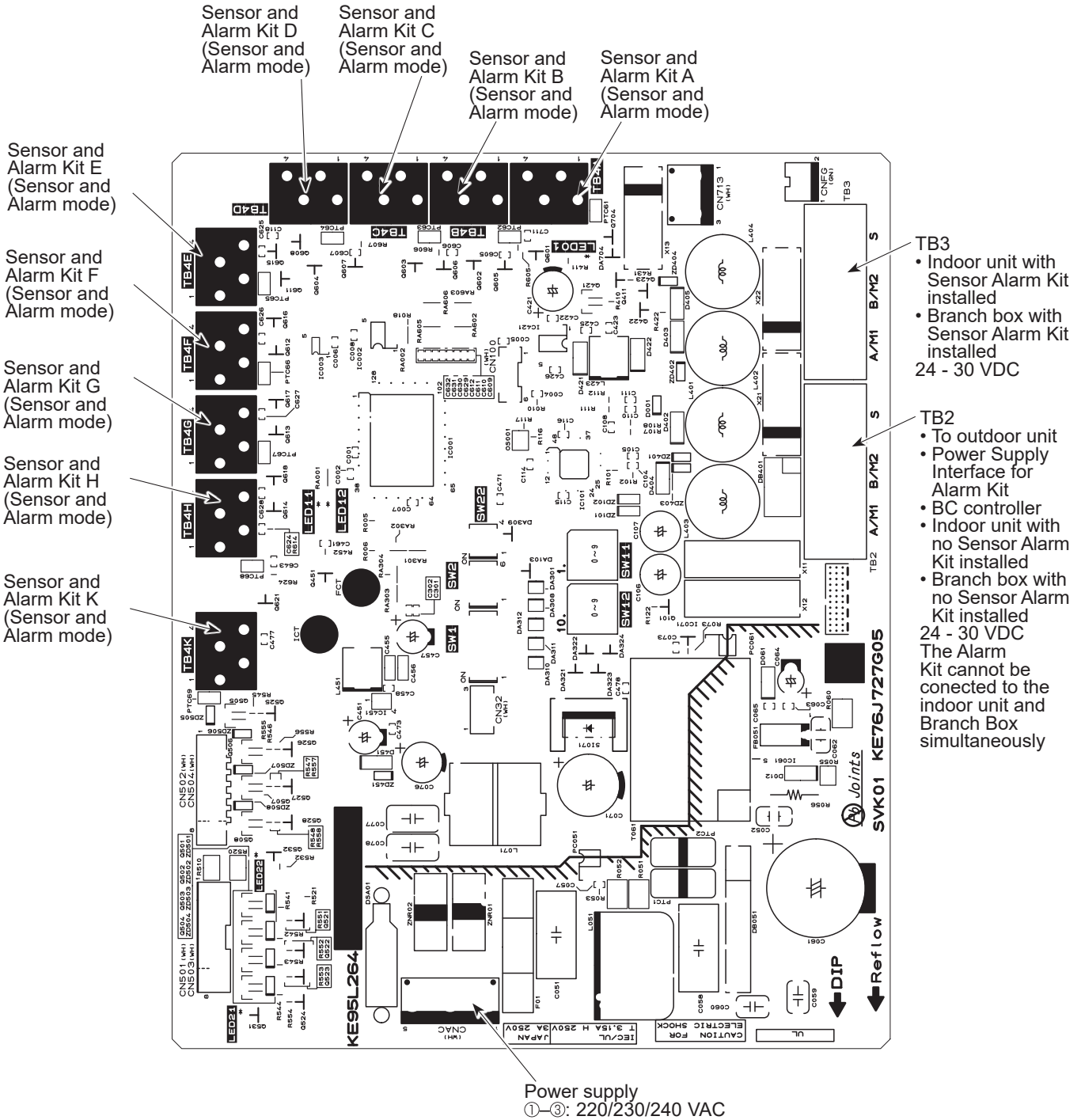

7-3. INTERNAL SWITCH FUNCTION TABLE Branch box (PAC-MMK40BC/PAC-MMK60BC/PAC-MMK40BCB)





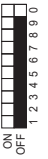

Switch	Step	Function	Operation in Each Switch Setting		Additional Information																																															
			ON	OFF																																																
SW11 1s digit address setting SW12 10s digit address setting	Rotary switch	<p>How to set addresses Example: if address is "1", remain SW12 (10s digit) at "0", and match SW11 (1s digit) with "1".</p>	<p>When to Set</p>	<p><Initial switch setting></p> <p>PAC-MMK40BC(B) SW12 10s digit SW11 1s digit</p> <p>PAC-MMK60BC Controller board: 1 SW12 10s digit SW11 1s digit</p> <p>Controller board: 2 SW12 10s digit SW11 1s digit</p>	<p>Switch setting example. Branch box: 001 (setting No. =x) indoor-A: 001 (=x) indoor-B: 002 (=x+1) indoor-C: 003 (=x+2) indoor-D: 004 (=x+3)</p>																																															
SW1 Indoor unit connection	1-6	<table border="1"> <thead> <tr> <th colspan="2">PAC-MMK40BC(B)</th> </tr> <tr> <th>Controller board</th> <th>Connection</th> </tr> </thead> <tbody> <tr> <td>1</td> <td>Indoor unit A</td> </tr> <tr> <td>2</td> <td>Indoor unit B</td> </tr> <tr> <td>3</td> <td>Indoor unit C</td> </tr> <tr> <td>4</td> <td>Indoor unit D</td> </tr> <tr> <td>5</td> <td>Not used</td> </tr> <tr> <td>6</td> <td>Supervisor alarm</td> </tr> </tbody> </table> <table border="1"> <thead> <tr> <th colspan="2">PAC-MMK60BC</th> </tr> <tr> <th>Controller board-1</th> <th>Connection</th> </tr> </thead> <tbody> <tr> <td>1</td> <td>Indoor unit 1A</td> </tr> <tr> <td>2</td> <td>Indoor unit 1B</td> </tr> <tr> <td>3</td> <td>Indoor unit 1C</td> </tr> <tr> <td>4</td> <td>Not used</td> </tr> <tr> <td>5</td> <td>Not used</td> </tr> <tr> <td>6</td> <td>Supervisor alarm</td> </tr> </tbody> </table> <table border="1"> <thead> <tr> <th colspan="2">Controller board-2</th> </tr> <tr> <th>Indoor unit 2A</th> <th>Connection</th> </tr> </thead> <tbody> <tr> <td>1</td> <td>Indoor unit 2A</td> </tr> <tr> <td>2</td> <td>Indoor unit 2B</td> </tr> <tr> <td>3</td> <td>Indoor unit 2C</td> </tr> <tr> <td>4</td> <td>Not used</td> </tr> <tr> <td>5</td> <td>Not used</td> </tr> <tr> <td>6</td> <td>Not used</td> </tr> </tbody> </table>	PAC-MMK40BC(B)		Controller board	Connection	1	Indoor unit A	2	Indoor unit B	3	Indoor unit C	4	Indoor unit D	5	Not used	6	Supervisor alarm	PAC-MMK60BC		Controller board-1	Connection	1	Indoor unit 1A	2	Indoor unit 1B	3	Indoor unit 1C	4	Not used	5	Not used	6	Supervisor alarm	Controller board-2		Indoor unit 2A	Connection	1	Indoor unit 2A	2	Indoor unit 2B	3	Indoor unit 2C	4	Not used	5	Not used	6	Not used	<p>OFF</p> <p>ON</p> <p>1 2 3 4 5 6</p>	<p>After each indoor unit is connected to the outdoor unit, turn ON the switch corresponding to each indoor unit. For example, when the indoor units are connected to INDOOR UNIT-A and C with PAC-MMK40BC(B), turn SW1-1 and SW1-3 to ON.</p>
PAC-MMK40BC(B)																																																				
Controller board	Connection																																																			
1	Indoor unit A																																																			
2	Indoor unit B																																																			
3	Indoor unit C																																																			
4	Indoor unit D																																																			
5	Not used																																																			
6	Supervisor alarm																																																			
PAC-MMK60BC																																																				
Controller board-1	Connection																																																			
1	Indoor unit 1A																																																			
2	Indoor unit 1B																																																			
3	Indoor unit 1C																																																			
4	Not used																																																			
5	Not used																																																			
6	Supervisor alarm																																																			
Controller board-2																																																				
Indoor unit 2A	Connection																																																			
1	Indoor unit 2A																																																			
2	Indoor unit 2B																																																			
3	Indoor unit 2C																																																			
4	Not used																																																			
5	Not used																																																			
6	Not used																																																			
SW4 Mode selection	1	Change temperature indication	Fahrenheit temperature	Celsius temperature	<p>Before turning the power ON</p> <p>Set at factory only</p>	<p>ON</p> <p>OFF</p> <p>1 2 3 4 5 6 7 8 9 0</p>																																														
	2	Power-supply voltage setting	220 or 230 V	240 V																																																
	3	Change operation if M-NET communication error occurs.	Stop operation	Continued operation	<p>Before turning the power ON</p>																																															
	4	Automatic restoration when the power comes back ON. *1	Inactive	Active																																																
	5	System type	Cooling only system	Cooling & heating system																																																
	6-0	Model setting	Refer to "Initial switch setting".																																																	

*1 Note that the automatic restoration starts after the unit has stopped once.









The black square (■) indicates a switch position.

Switch	Step	Function	Operation in Each Switch Setting		<Initial switch setting>	Additional Information
			ON	OFF		
SW5 Service setting	1-3	Change INDOOR UNIT No. for monitoring	Refer to "7-4: BRANCH BOX UNIT OPERATION MONITOR FUNCTION".			—
	0	Interface Kit connection	Yes	No		

Sensor and Alarm Kit (PAC-SK60SA-E)

Mode	DIP SW	Note
Sensor and Alarm mode	ON  OFF  1 2	Set when installed in the normal room
Supervisor mode	ON  OFF  1 2	Set when installed in the supervisor room
(factory default)	ON  OFF  1 2	All SW set to OFF at shipment. Please set to above settings.

Sensor and Alarm Kit (PAC-SL72SA-E)

Mode	DIP SW	Note
Sensor and Alarm mode	ON  OFF  1 2	Set when installed in the normal room.
Sensor and Alarm mode (EN378)	ON  OFF  1 2	Set when installed in the normal room. (When installed to the properties compliant with EN378)
Supervisor mode	ON  OFF  1 2	Set when installed in the supervisor room
(factory default)	ON  OFF  1 2	All SW set to OFF at shipment. Please set to above settings.

POWER SUPPLY INTERFACE FOR ALARM KIT (PAC-SL73IFL-E)

■ Address setting

(Make sure to perform the setting with the circuit breaker of the Power Supply Interface for Alarm Kit, indoor unit and outdoor unit turned OFF.)

Detail view of SW12 and 11

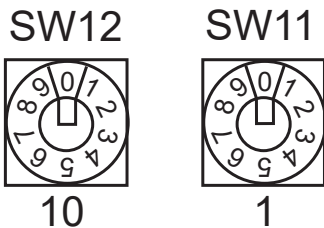

The above switches indicate "0".

The address can be set with the rotary switch on the control board of the Interface for Alarm Kit.

Address setting shall be performed with either (1) or (2) of the following.

(1) Automatic setting: SW11=0, SW12=0

(2) Manual setting: Set the address to the number from 151 to 200.

- Set ones and tens digits for the rotary switch. (All set to "0" as the initial setting)
- The rotary switch shall be set as follows: the target address - 100.
- If the address is set to "200", the rotary switch shall be "50".
- If it is connected with the outdoor unit of Fit Multi/PUMY series, it does not support the automatic address setting.
- Refer to the installation manual of the outdoor unit for whether the automatic address setting is available.

How to set the address

(e.g.) If the address is "153", set SW12 (ten digit) to "5" and SW11 (ones digit) to "3".

7-4. BRANCH BOX UNIT OPERATION MONITOR FUNCTION

[When optional part 'A-Control Service Tool (PAC-SK52ST)' is connected to branch box controller board (CNM)]

By controlling SW2 on the 'A-Control Service Tool', a 2-digit number or code is displayed on the digital indicator LED1 to indicate the operating status and the meaning of the error code.

'A-Control Service Tool (PAC-SK52ST)' is needed for each branch box controller board.

<Table1> SW5 setting The black square (■) indicates a switch position.

SW5 setting	Detail
	Common
	Indoor-A
	Indoor-B
	Indoor-C
	Indoor-D ^{*1}

Operation indicator:

- SW2 - Use to set the displayed item
- SW5 - Use to set the displayed unit

<Table2> Functions

The black square (■) indicates a switch position.

SW2 setting	SW5 setting ^{*2}	Display detail	Explanation for display	Unit
	Common	Status of branch box	<p>During startup</p> <p>During error detection Displays an error code, and M-NET address of the unit which the error code was detected. Example: If the error code 2520 is detected in the address3, 0.5 s 0.5 s 0.5 s 2.0 s 03 → 25 → 20 → □□</p> <p>During no power supply F8</p> <p>Other Displays the number of units in operation. 0 to 5</p>	—
	Individual unit	Status of branch box	<p>During startup</p> <p>During error detection Displays an error code, and M-NET address of the selected unit.</p> <p>During no power supply F8</p> <p>Other Displays an operation mode of the selected unit. 0: Stop C: Cool/ Dry H: Heat d: Defrost</p>	—

^{*1} Indoor D: PAC-MMK40BC(B) only

^{*2} Refer to the <Table 1> for the appropriate setting for the function.

The black square (■) indicates a switch position.

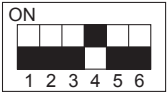
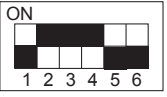
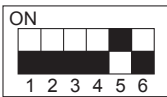
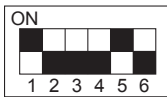
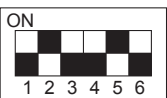
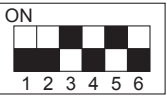



SW2 setting	SW5 setting*1	Display detail	Explanation for display	Unit
	Common	Not used	—	—
	Individual unit	Actual opening pulse of LEV (Direct-operated conversion value) 0 to 500	0 to 500 (When it is 100 pulse or more, it displays a hundredth, tens, and unit digit by turns.) Example: When 150 pulse, <div style="text-align: center;"> 0.5 s 0.5 s 2.0 s □ 1 → 50 → □ □ ↑—————┘ </div>	Pulse
	Common	Not used	—	—
	Individual unit	Error history	Displays an error code, and M-NET address of the unit which the error code was detected. Example: If the error code 2520 is detected in the address3, <div style="text-align: center;"> 0.5 s 0.5 s 0.5 s 2.0 s 03 → 25 → 20 → □ □ ↑—————┘ </div>	Code display
	Common	The number of unit(s) operating in Thermo-ON	0 to 5	Number
	Individual unit	Operating status of unit	83: Abnormal 00: Stop 06: Forced stop 0C: Defrost 29: Hot adjust mode 05: Standby mode 2A: Auxiliary heater is ON. 0A: Thermo-ON 01: In operation	Code display
	Common	The number of indoor unit(s) connected to this branch box	0 to 5	Number
	Individual unit	M-NET address	00 to FF M-NET address of the selected unit. M-NET address is displayed in hexadecimal. Display example: When the M-NET address is 23 (decimal number), 17 (hexadecimal) is displayed.	Code display
	Common	Not used	—	—
	Individual unit	Capacity setting in Qj	03 to 50	Code display
	Common	Not used	—	—
	Individual unit	Indoor thermistor <pipe temperature/ liquid> (TH2)	-39 to 88 (When the temperature is 0°C or less, "-" and temperature are displayed alternately.) Example: When -5°C, <div style="text-align: center;"> 0.5 s 0.5 s 2.0 s - □ → □ 5 → □ □ ↑—————┘ </div>	°C

*1 Refer to the <Table 1> for the appropriate setting for the function.

7-5. STATUS INDICATION OF SENSOR AND ALARM KIT

The connection status of the Sensor and Alarm Kit can be checked by the blinking status of the LED on the Sensor and Alarm Kit or the branch box interconnect board.

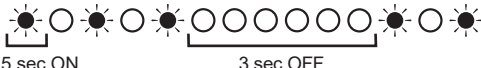
Branch Box interconnect board

LED A to E	Warming up	
	Monitoring	
	Leak detect	3 time blinks 
	Sensor failure	2 time blinks 
	Miswiring/ Switch setting error	1 time blinks 

Sensor and Alarm Kit (PAC-SK60SA-E)

No.	Status	LED (White)	LED (Red)	LED (Orange)	Buzzer	Note
1	Warming up	BLINK (Every 1 second)	OFF	OFF	OFF	Within 1-minute
2	Monitoring	ON	OFF	OFF	OFF	During normal operation
3	Leak detect-1 (Normal mode)	OFF	BLINK (Every 0.4 seconds)	OFF	ON	Refrigerant leak from the room with the Sensor and Alarm Kit
4	Leak detect-2 (Supervisor mode)	OFF	BLINK (Every 0.7 seconds)	OFF	ON	Refrigerant leak from the other room (Only for the supervisor room mode)
5	Miswiring	BLINK (Every 0.7 seconds)	BLINK (Every 0.7 seconds)	BLINK (Every 0.7 seconds)	OFF	The status is judged to be No.8 depending on miswiring states. So, connect the wiring correctly according to page 20.
6	Sensor failure	OFF	OFF	BLINK (Every 0.7 seconds)	OFF	
7	Switch setting error	OFF	BLINK (Every 0.7 seconds)	BLINK (Every 0.7 seconds)	OFF	Refer to page 34, and set the switches.
8	No power distribution	OFF	OFF	OFF	OFF	Miswiring/Controller board failure/Interconnect board failure of branch box/Sensor and Alarm Kit failure



Sensor and Alarm Kit (PAC-SL72SA-E)

No.	Status	LED (White)	LED (Red)	LED (Orange)	Buzzer	Note
1	Warming up	BLINK	OFF	OFF	OFF	Within 1-minute
2	Monitoring	ON	OFF	OFF	OFF	During normal operation
3	Leak detect-1	OFF	BLINK Faster blink (Every 0.4 seconds)	OFF	ON	Refrigerant leak from the room with the Sensor and Alarm Kit
4	Leak detect-2	OFF	BLINK Slower blink (Every 0.7 seconds)	OFF	ON	Refrigerant leak from the other room (only for the supervisor room mode)
5	Miswiring	BLINK	BLINK	BLINK	OFF	The status is judged to be No. 9 depending on miswiring states.
6	Sensor failure	OFF	OFF	BLINK	OFF	DipSW1=ON, DipSW2=OFF
		OFF	OFF	BLINK	ON	DipSW1=ON, DipSW2=ON
7	Switch setting error	OFF	BLINK	BLINK	OFF	Refer to page 34, and set the switches.
8	Test mode	LED(White)→LED(Red)→LED(Orange)→Buzzer→Monitoring				Check the unit about once a year to confirm that LED and alarm operates correctly.
9	No power distribution	OFF	OFF	OFF	OFF	Miswiring/Controller board failure/ Interconnect board failure of branch box/Sensor and Alarm Kit failure
10	Testing circuit	ON	ON	ON	ON	Performing circuit test. The buzzer will sound for up to 10 seconds, and the LEDs will light in sequence
11	Circuit test OK	ON	ON	ON	ON	System normal.
12	Circuit test Error	BLINK	OFF	BLINK	ON	System malfunction.

If the status is No.5, the wiring is wrong. So, connect the wiring correctly according to Fig. 7-5.

Pressing the button stops the alarm (buzzer). LED keeps blinking even when the button is pressed. Take the correct handling to cancel the abnormal state.

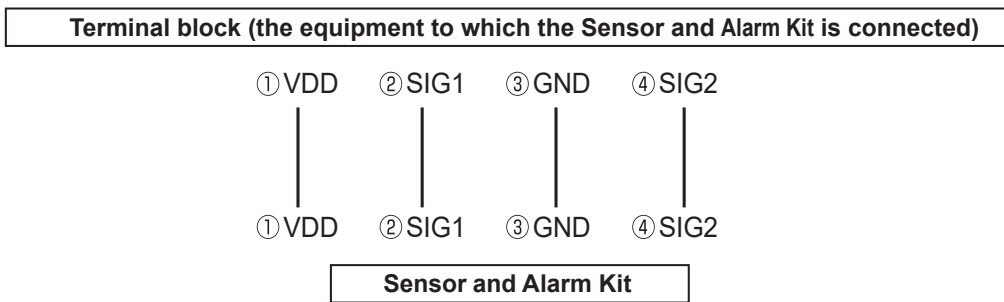
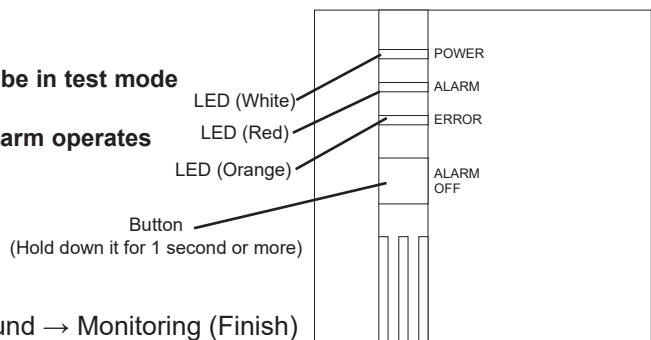

Fig. 7-5

7-6. SENSOR AND ALARM KIT TEST MODE

You can check the lighting of each LED and the buzzer. When holding down the button for 1 second or more, it will be in test mode and operate as follows. Check the unit about once a year to confirm that LED and alarm operates correctly.



<Test pattern>

LED (White) → LED (Red) → LED (Orange) → Buzzer sound → Monitoring (Finish)

How to check the abnormal operation of Sensor and Alarm Kit

If the Sensor and Alarm Kit does not operate properly, diagnose it by LED blinking patterns.

Check the following before diagnosing.

- Sensor and Alarm Kit DIP SW: Check that the mode setting of the Sensor and Alarm Kit (normal/supervisor) is proper. (Refer to "7-3. INTERNAL SWITCH FUNCTION TABLE")
 - Branch box controller board DIP SW: Check that the SW4-8 is ON.
 - Branch box controller board DIP SW: Check that the SW1 for the concerned indoor units is ON.
 - Check that the switch does not stop in the middle
- If there is a problem with the settings, turn off the power, correct them, and then turn the power on again.
If it still does not start normally, follow the flow below to diagnose it.

• Flow chart for failure diagnosis

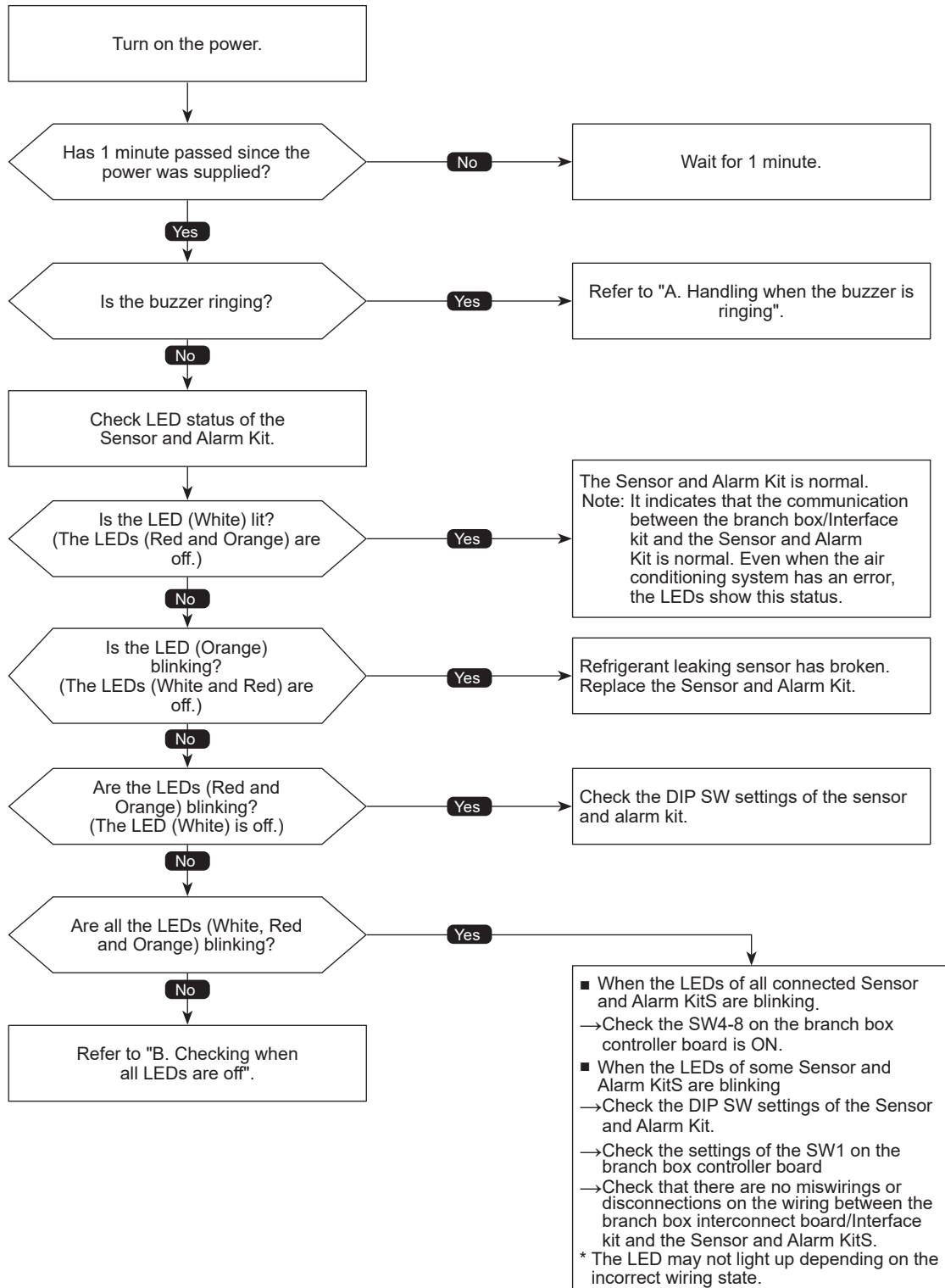

• A. Handling when the buzzer is ringing

When a refrigerant leak is detected, the buzzer rings and the LED blinks.
The LED blinking pattern differs in Sensor and Alarm mode/Supervisor mode.

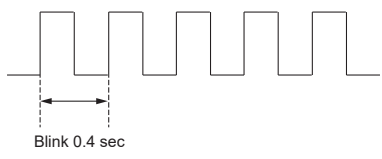
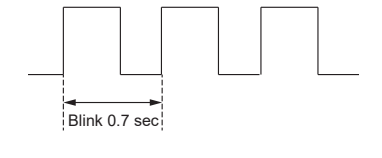
Setting mode	LED (White)	LED (Red)	LED (Orange)	Note
Sensor and Alarm mode	OFF		OFF	Refrigerant leakage in the indoor unit that is sounding the alarm.
Supervisor mode	OFF		OFF	Refrigerant leakage in an indoor unit of the same system. * If indoor unit of the same system is installed in the supervisor room, also check the Sensor and Alarm mode z AND ALARM KIT.

If a refrigerant leak is detected, the refrigerant recovery operation is performed and the system is shut down.
Note: When the sensor is sprayed, it will wrongly detect refrigerant leak. In this case, the Sensor and Alarm Kit needs to be replaced.

• B. Checking when all LEDs are off

When connecting branch box (Not connecting interface kit)

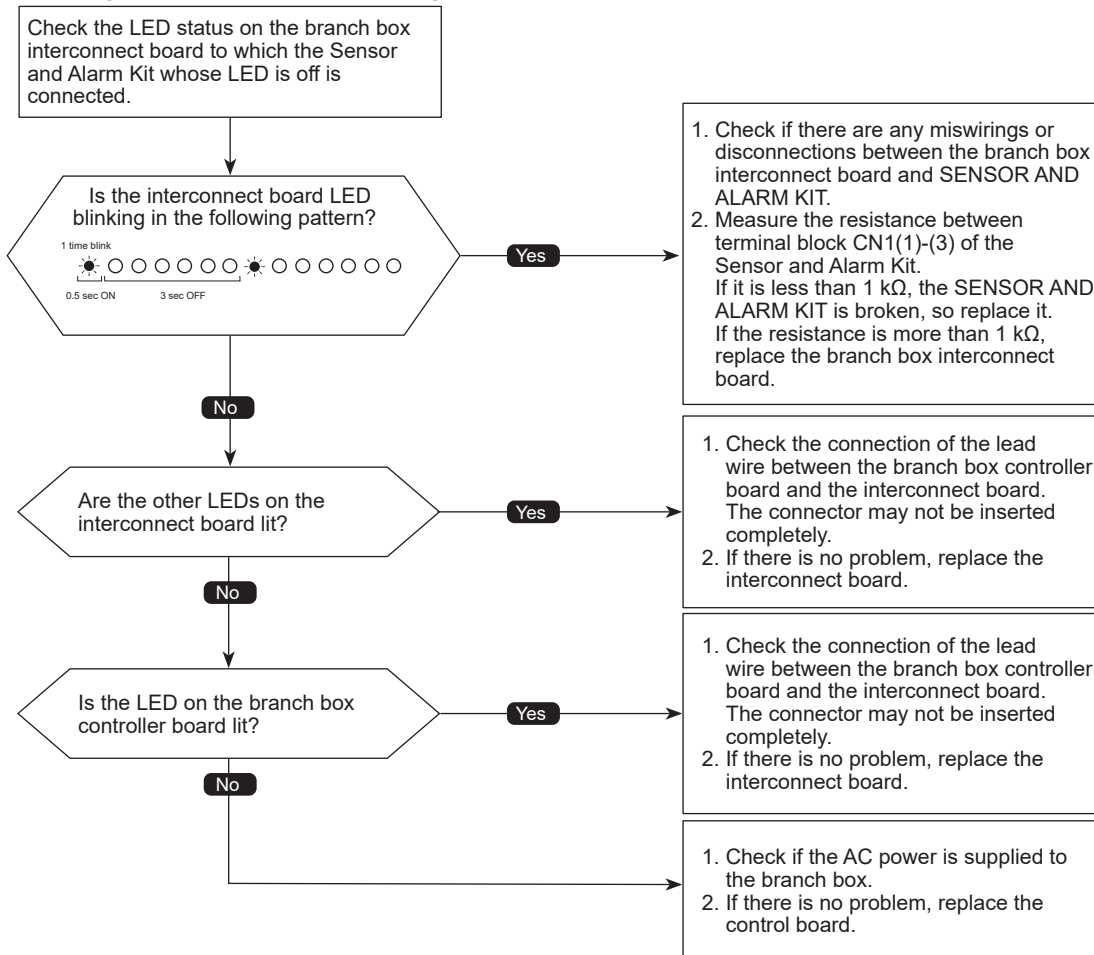

When connecting Interface kit

1. Check if the AC power is supplied to the branch box.
2. Check if there are any miswirings or disconnections between the Interface Kit and Sensor and Alarm Kit.
3. Measure the resistance between terminal block CN1(1)-(3) of the Sensor and Alarm Kit.
If it is less than 1 kΩ, the Sensor and Alarm Kit is broken, so replace it.
If the resistance is more than 1 kΩ, replace the Interface Kit.

Branch box: PAC-MMK40BC

PAC-MMK40BCB

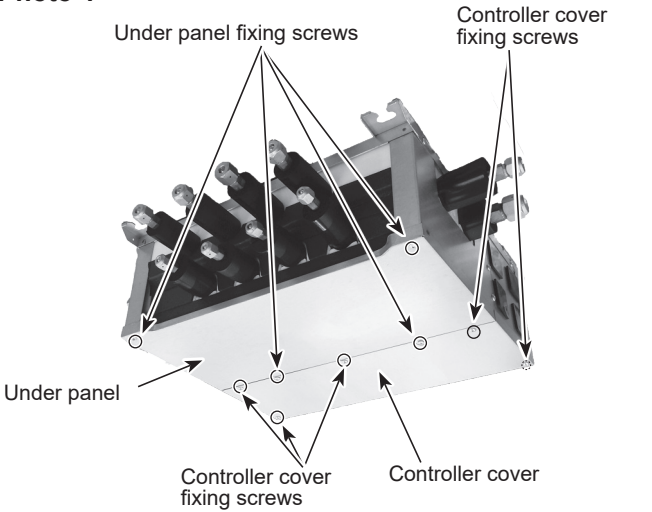
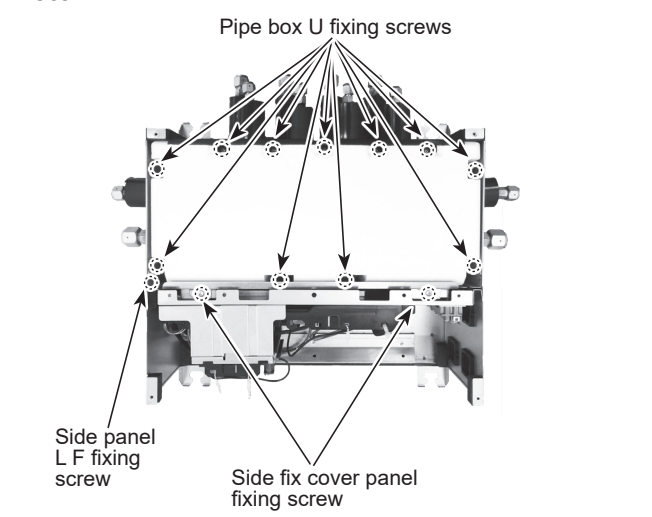
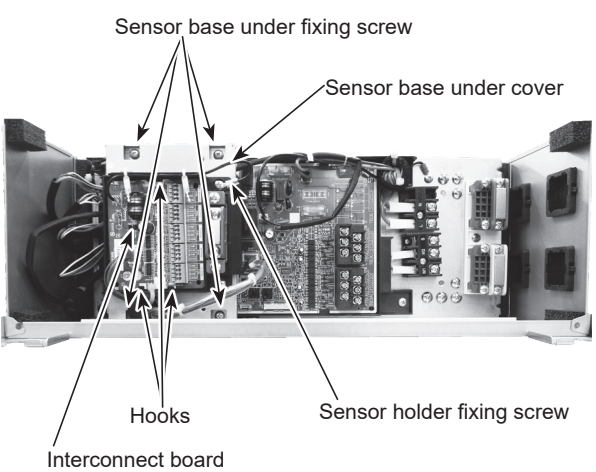
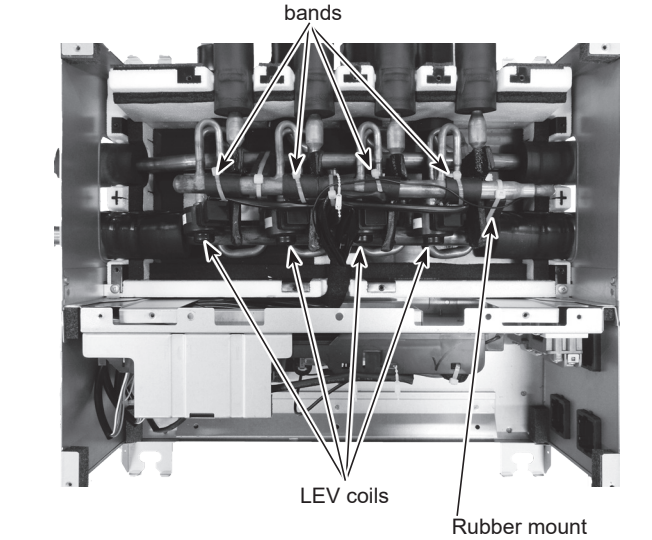
PROCEDURE	PHOTOS/FIGURES
<p>1. Removing the controller cover and under panel</p> <ol style="list-style-type: none"> (1) Remove 5 controller cover fixing screws (4 × 10) to detach the controller cover. (See Photo 1) (2) Remove 4 under panel fixing screws (4 × 10) to remove the under panel. (See Photo 1) 	<p>Photo 1</p> 
<p>2. Removing the LEV coil (LEV-A-D)</p> <ol style="list-style-type: none"> (1) Remove the controller cover. (See Photo 1) (2) Remove the under panel. (See Photo 1) (3) Remove 11 pipe box U fixing screws (4 × 10), then remove the pipe box U. (See Photo 2-1) (4) Remove 2 side fix cover panel fixing screws (4 × 10), then remove the side fix cover panel. (See Photo 2-1) (5) Remove 4 sensor base under cover fixing screws (4 × 10), then remove the sensor base under cover. (See Photo 2-2) (6) Remove the LEV connectors from the controller board. (See Photo 2-2) (7) Pull out the LEV coil from the separate bush, and pull out the LEV lead wires from the insulation sheet which bundles the LEV coil. (See Photo 2-3) (8) Cut the bands that fixes the lead wire, then remove the LEV coil. (See Photo 2-3) 	<p>Photo 2-1</p> 
<p>Photo 2-2</p> 	<p>Photo 2-3</p> 

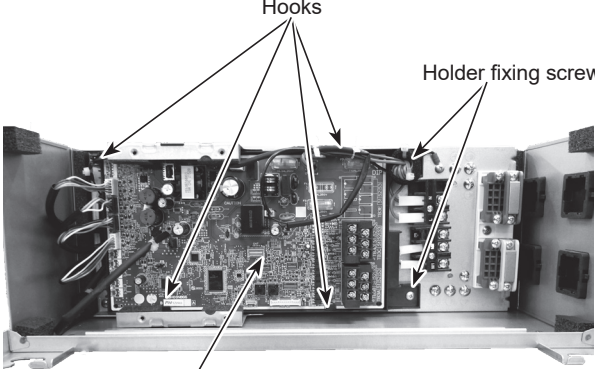
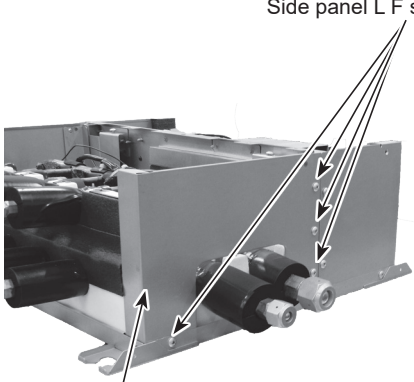

PROCEDURE	PHOTOS/FIGURES
<p>3. Removing the controller board</p> <ol style="list-style-type: none">(1) Remove the controller cover. (See Photo 1)(2) Remove 4 sensor base under cover fixing screws (4 × 10), then remove the sensor base under cover. (See Photo 2-2)(3) Remove the lead wire of the controller board. (See Photo 3)(4) Remove the 4 hooks, then remove the controller board from the controller board holder. (See Photo 3)	<p>Photo 3</p>  <p>Hooks</p> <p>Holder fixing screw</p> <p>Controller board</p>
<p>4. Removing the interconnect board</p> <ol style="list-style-type: none">(1) Remove the controller cover. (See Photo 1)(2) Remove the lead wire from the interconnect board. (See Photo 2-2)(3) Remove the black lead wire from the interconnect board fixing screw (4 × 10).(4) Remove the 3 hooks, then remove the interconnect board.	
<p>5. Removing the LEV assy</p> <ol style="list-style-type: none">(1) Remove the controller cover. (See Photo 1)(2) Remove the under panel. (See Photo 1)(3) Remove 11 pipe box U fixing screws (4 × 10), then remove the pipe box U. (See Photo 2-1)(4) Remove 2 side fix cover panel fixing screws (4×10), then remove the side fix cover panel. (See Photo 2-1).(5) Remove 4 sensor base under cover fixing screws (4 × 10), then remove the sensor base under cover. (See Photo 2-2)(6) Remove the lead wire from the controller board. (See Photo 2-2)(7) Remove the 5 side panel L F fixing screws (4×10) and remove the side panel L F. (See Photo 2-1, 4)(8) Remove the rubber mount fixing with the header assy, and pull out the LEV assy. (See Photo 2-3)	<p>Photo 4</p>  <p>Side panel L F screws</p> <p>Side panel L F</p>

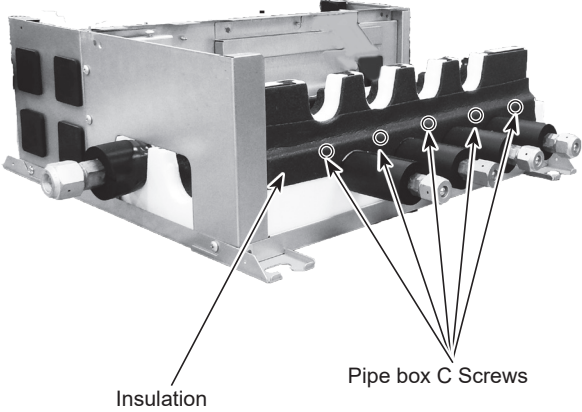

PROCEDURE
<p>6. Removing the header assy</p> <ul style="list-style-type: none">(1) Remove the controller cover. (See Photo 1)(2) Remove the under panel. (See Photo 1)(3) Remove 11 pipe box U fixing screws (4 × 10), then remove the pipe box U. (See Photo 2-1)(4) Remove 2 side fix cover panel fixing screws (4×10), then remove the side fix cover panel. (See Photo 2-1).(5) Remove 4 sensor base under cover fixing screws (4 × 10), then remove the sensor base under cover. (See Photo 2-2)(6) Remove the lead wire from the controller board. (See Photo 2-2)(7) Remove the 5 side panel L F fixing screws (4×10) and remove the side panel L F. (See Photo 2-1, 4)(8) Remove the rubber mount fixing with the header assy, and pull out the LEV assy. (See Photo 2-3)(9) Remove the insulation and 5 pipe box C fixing screws (4×10), then remove the pipe box C. (See Photo 5)(10) Remove the header assy like (8).

PHOTOS/FIGURES
<p>Photo 5</p>  <p>Insulation</p> <p>Pipe box C Screws</p>

BRANCH BOX : PAC-MMK60BC

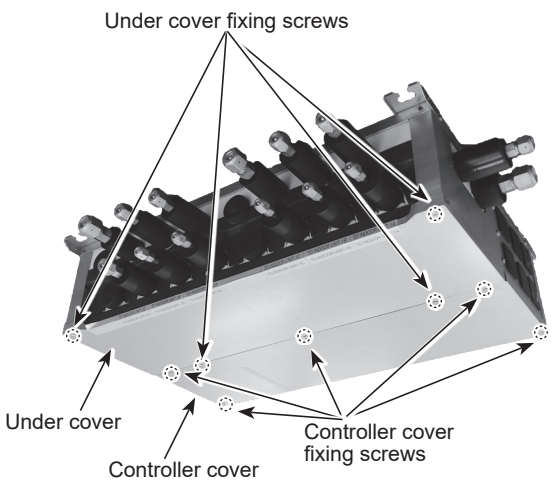
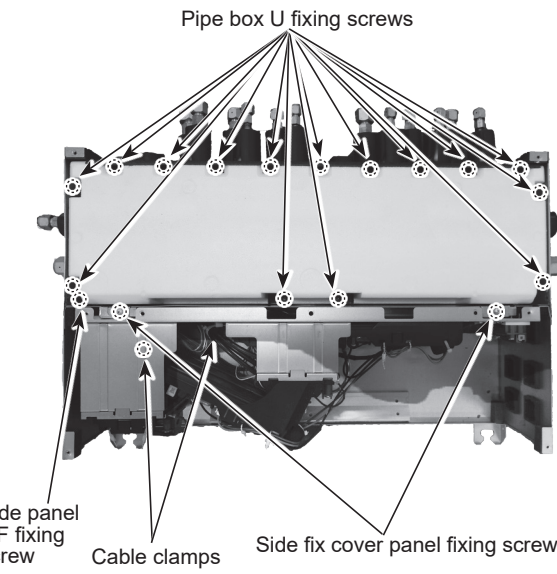
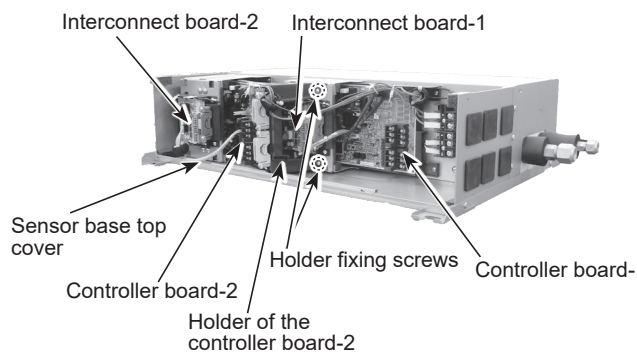
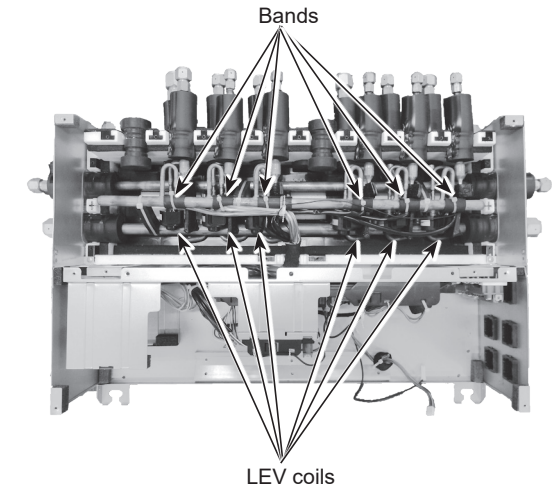
PROCEDURE	PHOTOS/FIGURES
<p>1. Removing the controller cover and under panel</p> <p>(1) Remove 5 controller cover fixing screws (4 × 10) to detach the controller cover. (See Photo 1)</p> <p>(2) Remove 4 under panel fixing screws (4 × 10) to remove the under panel. (See Photo 1)</p>	<p>Photo 1</p>  <p>Under cover fixing screws</p> <p>Under cover</p> <p>Controller cover</p> <p>Controller cover fixing screws</p>
<p>2. Removing the LEV coil (LEV-1A-2C)</p> <p>(1) Remove the controller cover. (See Photo 1)</p> <p>(2) Remove the under panel. (See Photo 1)</p> <p>(3) Remove 15 pipe box U fixing screws (4 × 10), then remove the pipe box U. (See Photo 2-1)</p> <p>(4) Remove 2 side fix cover panel fixing screws (4 × 10), then remove the side fix cover panel. (See Photo 2-1)</p> <p>(5) Remove 4 sensor base top cover fixing screws (4 × 10), then remove the sensor base top cover. (See Photo 2-2)</p> <p>(6) Remove 2 holder fixing screws (4 × 10) of the controller board-2, then remove the holder of the controller board-2. (See Photo 2-2)</p> <p>(7) Remove the lead wire from the controller board-1 and 2, then pull out the LEV lead wire from the cable clamps. (See Photo 2-2, 2-3, 3)</p> <p>(8) Pull out the LEV coil from the separate bush, and pull out the LEV lead wires from the insulation sheet which bundles the LEV coil. (See Photo 2-3, 3)</p> <p>(9) Cut the bands that fixes the lead wire, then remove the LEV coil. (See Photo 2-3)</p>	<p>Photo 2-1</p>  <p>Pipe box U fixing screws</p> <p>Side panel L F fixing screw</p> <p>Cable clamps</p> <p>Side fix cover panel fixing screws</p>
<p>Photo 2-2</p>  <p>Interconnect board-2</p> <p>Interconnect board-1</p> <p>Sensor base top cover</p> <p>Controller board-2</p> <p>Holder of the controller board-2</p> <p>Holder fixing screws</p> <p>Controller board-1</p>	<p>Photo 2-3</p>  <p>Bands</p> <p>LEV coils</p>

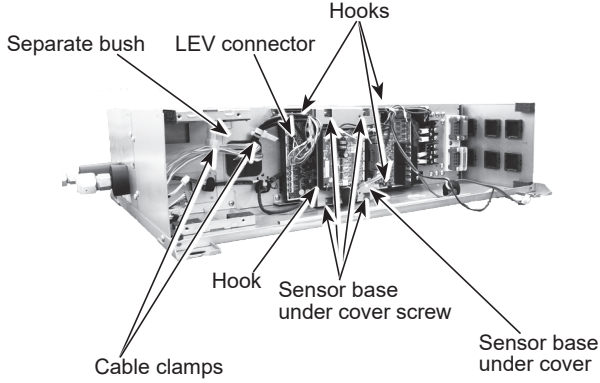
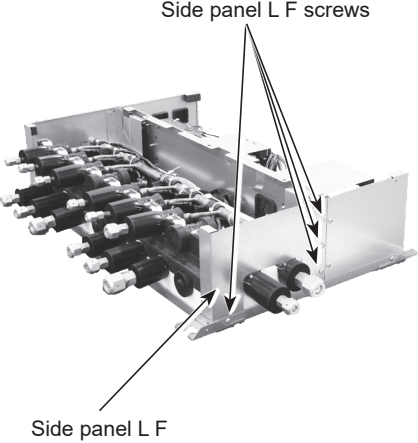

PROCEDURE	PHOTOS/FIGURES
<p>3. Removing the controller board</p> <ol style="list-style-type: none">(1) Remove the controller cover. (See Photo 1)(2) Remove 4 sensor base top cover fixing screws (4 × 10), then remove the sensor base top cover. (See Photo 2-2)(3) Remove 2 holder fixing screws of the controller board-2, then remove the holder of controller board-2.(4) Remove the lead wire from controller board-2, then pull out the LEV lead wire from the cable clamps. (See Photo 2-2, 2-3, 3)(5) Remove 4 fixing screws (4×10) of the sensor base under cover, then remove it. (See Photo 3)(6) Remove the lead wire of the controller board-1. (See Photo 3)(7) Remove the 4 hooks, then remove the controller board from the controller board holder. (See Photo 3)	<p>Photo 3</p>  <p>Separate bush LEV connector Hooks Cable clamps Hook Sensor base under cover screw Sensor base under cover</p>
<p>4. Removing the interconnect board</p> <ol style="list-style-type: none">(1) Remove the controller cover. (See Photo 1)(2) Remove the lead wire from the interconnect board-2. (See Photo 2)(3) Remove the black lead wire from the interconnect board-2 fixing screw (4 × 10). (See Photo 2)(4) Remove the 3 hooks, then remove the interconnect board-2.(5) Remove 4 sensor base top cover fixing screws (4× 10), then remove the sensor base top cover.(6) Remove 2 controller board-2 holder fixing screws, then remove the controller board-2 holder.(7) Remove the lead wire from controller board-2, then pull out the LEV lead wire from the cable clamp. (See Photo 2-2, 2-3, 3)(8) Remove the lead wire from the interconnect board-1. (See Photo 3)(9) Remove the black lead wire from the interconnect board-1 fixing screw (4 × 10). (See Photo 2)(10) Remove the 3 hooks, then remove the interconnect board-1.	<p>Photo 4</p>  <p>Side panel L F screws Side panel L F</p>
<p>5. Removing the LEV assy</p> <ol style="list-style-type: none">(1) Remove the controller cover. (See Photo 1)(2) Remove the under panel. (See Photo 1)(3) Remove 15 pipe box U fixing screws (4 × 10), then remove the pipe box U. (See Photo 2-1)(4) Remove 2 side fix cover panel fixing screws (4×10), then remove the side fix cover panel. (See Photo 2-1).(5) Remove 4 sensor base top cover fixing screws (4 × 10), then remove the sensor base top cover.(6) Remove 2 holder fixing screws (4 × 10) of the controller board-2, then remove the holder of the controller board-2. (See Photo 2-2)(7) Remove the lead wire from the controller board-1 and 2, then pull out the LEV lead wire from the cable clamps. (See Photo 2-2, 2-3, 3)(8) Remove the 5 side panel L F fixing screws (4×10) and remove the side panel L F. (See Photo 2-1, 4)(9) Remove the rubber mount fixing with the header assy, and pull out the LEV assy. (See Photo 4)	



PROCEDURE

6. Removing the header assy

- (1) Remove the controller cover. (See Photo 1)
- (2) Remove the under panel. (See Photo 1)
- (3) Remove 15 pipe box U fixing screws (4 × 10), then remove the pipe box U. (See Photo 2-1)
- (4) Remove 2 side fix cover panel fixing screws (4×10), then remove the side fix cover panel. (See Photo 2-1).
- (5) Remove 4 sensor base top cover fixing screws (4 × 10), then remove the sensor base top cover.
- (6) Remove 2 holder fixing screws (4 × 10) of the controller board-2, then remove the holder of the controller board-2. (See Photo 2-2)
- (7) Remove the lead wire from the controller board-1 and 2, then pull out the LEV lead wire from the cable clamps. (See Photo 2-2, 2-3, 3)
- (8) Remove the 5 side panel L F fixing screws (4×10) and remove the side panel L F. Then remove the rubber mount fixing with the header assy, and pull out the LEV assy.
- (9) Remove the insulation and 9 pipe box C fixing screws (4×10), then remove the pipe box C. (See Photo 5-1)
- (10) Remove the header assy like (8).

<Pipe box cap only for PAC-MMK60BC>
The pipe box caps are placed in 2 unused pipe holes between the pipe box top, center and under. (See Photo 5-2)

PHOTOS/FIGURES

Photo 5-1

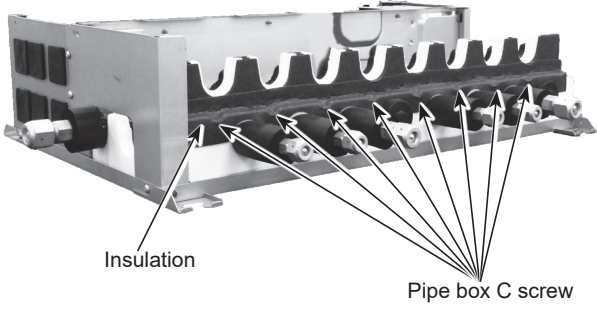
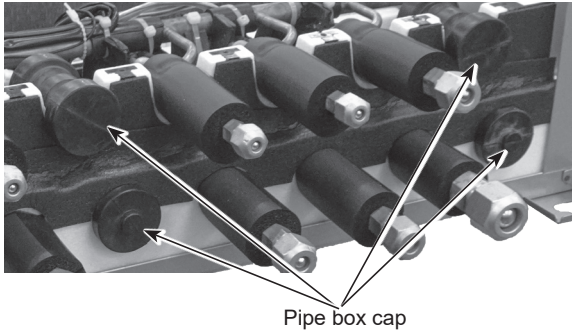

Photo 5-2



mitsubishi electric corporation

HEAD OFFICE: TOKYO BUILDING, 2-7-3, MARUNOUCHI, CHIYODA-KU, TOKYO100-8310, JAPAN

©Copyright 2023 MITSUBISHI ELECTRIC CORPORATION
Issued: Mar. 2026 No. OCH799B
Issued: May 2025 No. OCH799A
Published: Jun. 2023 No.OCH799
Made in Japan

Specifications are subject to change without notice.