

FRESH MASTER HANDBOOK

MODELS

GUF-50RD4

GUF-50RDH4

GUF-100RD4

GUF-100RDH4

GUF-100RDH4-60

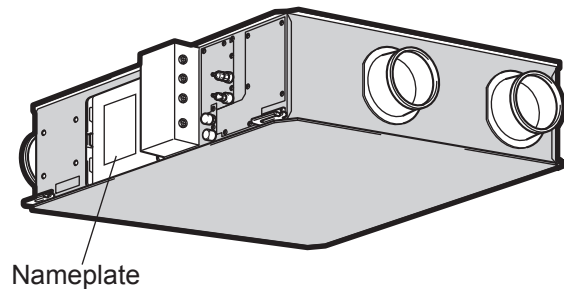

Warning:











Repair work must be performed by the manufacturer, its service agent or a similarly qualified person in order to avoid hazards.

Contents

1. Safety precautions	3-4
2. Names and functions of components	4
3. Specifications	5
4. Outside dimensions	6
5. Electrical wiring diagrams	7-8
6. Circuit board diagrams	9-10
7. Troubleshooting	11-17
8. Overhauling procedures	18-28
9. Parts catalog	29-63
GUF-50RD4	30-35
GUF-50RDH4	36-41
GUF-100RD4	42-47
GUF-100RDH4	48-55
GUF-100RDH4-60	56-63

1. Safety precautions

- Read the following precautions thoroughly before the maintenance, and then inspect and repair the product in a safe manner.
- The types and levels of danger that may arise if the product is handled incorrectly are described with the warning symbols shown below.

 Warning		Incorrect handling of the product may result in serious injury or death.
<p>◇ Electric shock If you must inspect the circuitry while the power is on, do not touch the live parts.</p> <p>(Failure to heed this warning may result in electric shock.)</p> <div style="text-align: right;">  <p>Caution against electric shock</p> </div>	<p>◇ Turn off the power supply Be sure to shut off the power supply isolator before disassembling the unit for repair.</p> <p>(Failure to heed this warning may result in electric shock.)</p> <div style="text-align: right;">  <p>Be sure to follow this instruction.</p> </div>	
<p>◇ Modification is prohibited Do not modify the unit.</p> <p>(Failure to heed this warning may result in electric shock, fire and/or injury.)</p> <div style="text-align: right;">  <p>Prohibited</p> </div>	<p>◇ Use proper parts and tools For repair, be sure to use the parts listed in the service parts list of the applicable model and use the proper tools.</p> <p>(Failure to heed this warning may result in electric shock, fire and/or injury.)</p> <div style="text-align: right;">  <p>Be sure to follow this instruction.</p> </div>	
<p>◇ Do not mix anything other than the specified coolant of the same type used in the outdoor unit. Do not charge any coolant different from the coolant used in the outdoor unit.</p> <p>(Failure to heed this warning may cause the pressure inside the freezing cycle to become abnormally high, leading to injury or other damage.)</p> <div style="text-align: right;">  <p>Prohibited</p> </div>	<p>◇ Proper electric work Use the electric wires designated for electric work, and conduct electric work in accordance with the "Electric Installation Engineering Standard", the "Indoor Wiring Regulations", and the Installation Instructions.</p> <p>(Improper connection or wiring installation may result in electric shock and/or fire.)</p> <div style="text-align: right;">  <p>Be sure to follow this instruction.</p> </div>	
<p>◇ Toxic gas generation</p> <ul style="list-style-type: none"> • Be careful that the coolant (R407C, R410A) does not leak in a flammable environment. • Conduct welding operation in an open room. • If the coolant gas leaks, open the windows while servicing. • Be sure to completely repair the leak. Close the service valve if the repair work is temporarily suspended. <p>(If the coolant gas comes into contact with flames such as open fire, sparks and a heater, it may generate toxic gas.)</p> <div style="text-align: right;">  <p>Be sure to follow this instruction.</p> </div>	<p>◇ Replace damaged and/or degraded parts Be sure to replace the power-supply cord and lead wires if they are damaged and/or degraded.</p> <p>(Failure to heed this warning may result in electric shock and/or fire.)</p> <div style="text-align: right;">  <p>Be sure to follow this instruction.</p> </div>	
	<p>◇ Check insulation Upon completing repair work, always measure the insulation resistance. Verify that it is at least 10 MΩ (with a 500 V DC insulation resistance tester), and then turn on the power.</p> <p>(Inadequate insulation may result in electric shock.)</p> <div style="text-align: right;">  <p>Be sure to follow this instruction.</p> </div>	



Caution

Incorrect handling of the product may result in injury or damage to properties including buildings and equipment.

◇ Caution for injury

Do not work at a location where you do not have a sure footing.

(Failure to heed this caution may result in a fall.)



Prohibited

◇ Wear gloves

Wear gloves when servicing.

(Failure to heed this caution may result in injury to your hands from sharp metal or other edges.)



Be sure to follow this instruction.

◇ Prevent water leakage

- Before removing any of the water-related parts, completely drain the residual water from the piping.
- Upon completing repair work, be sure to check the drainage of the indoor unit and that no water leaks from any of the piping connections.

(Water leakage may cause buildings to soil, leading to secondary failure of other parts.)



Be sure to follow this instruction.

Request for repair

- Inspect the earth condition, and repair it if it is incomplete. Make sure that an earth leakage breaker or an overload protection device is installed. If it is not installed, recommend the dealer to install one.
- Make sure that the product operates properly upon completing repair work. Clean the product and the surrounding area, and then notify the customer of the completion of repair.

2. Names and functions of components

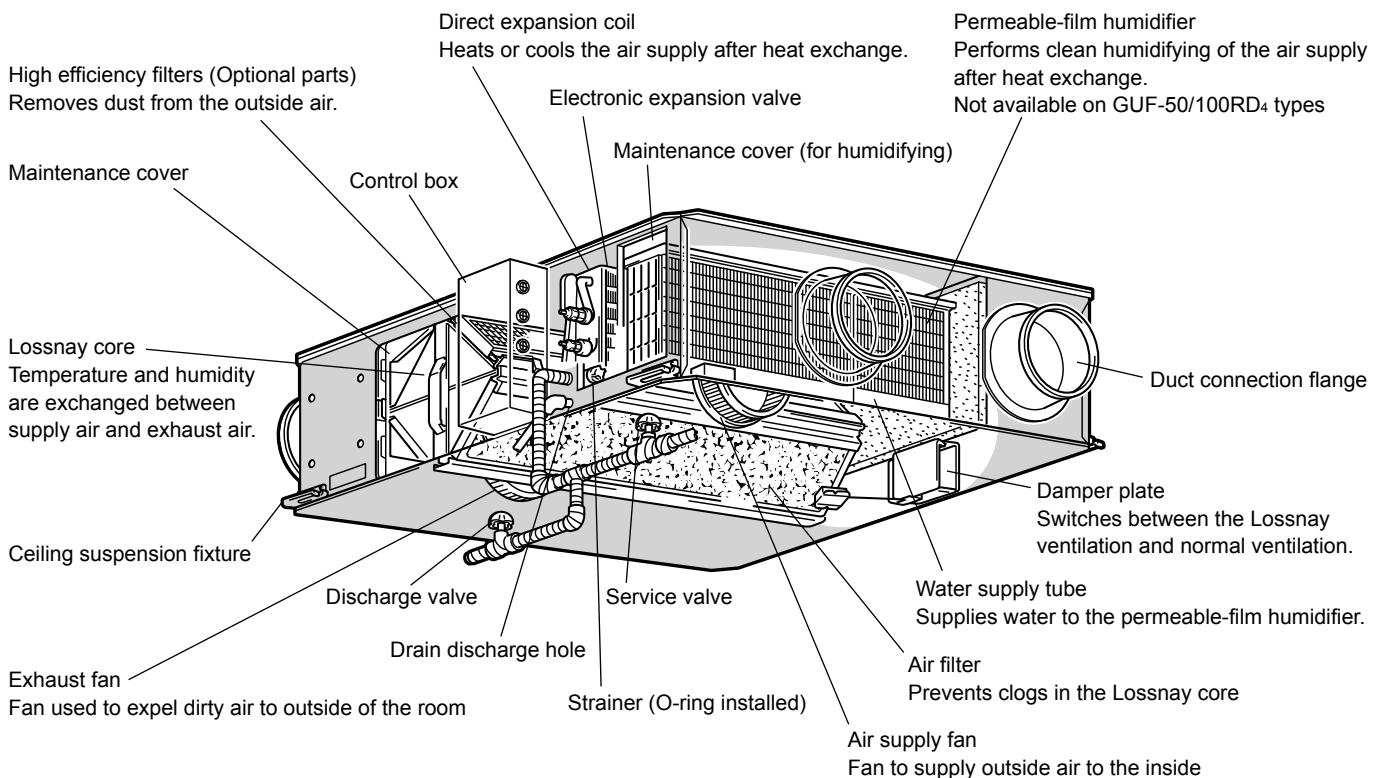

*The illustration shows GUF-50RDH4.

3. Specifications

Model name	Power supply (V)	Frequency (Hz)	Current (A)	Power consumption (W)	Air volume		External air load heat processing capability (kw)		Humidifying volume	Noise (dB)	Weight (kg)	Equivalent indoor unit capability
					m ³ /h	L/S	Cooling capability	Heating capability				
GUF-50RD ₄	Single-phase 220-240	50	1.15	235-265	500	139	5.57 (1.94)	6.21 (2.04)	-	33.5-34.5	54	P32
GUF-50RDH ₄			1.15	235-265	500	139	5.57 (1.94)	6.21 (2.04)	2.70	33.5-34.5	57	P32
GUF-100RD ₄			2.20	480-505	1,000	278	11.44 (4.12)	12.56 (4.26)	-	38-39	92	P63
GUF-100RDH ₄			2.20	480-505	1,000	278	11.44 (4.12)	12.56 (4.26)	5.40	38-39	98	P63
GUF-100RDH ₄ -60	Single-phase 220	60	3.20	685	1,000	278	11.44 (4.12)	12.56 (4.26)	5.40	40.5	98	P63

- The values given in the table for the noise level reflect the levels measured at a position 1.5 meters immediately below the unit in an anechoic chamber.
- The noise at the air outlets (at a 45° angle, 1.5 meters in front) is about 5-6 dB (A) higher than the values given in the table.
- The above values apply during Lossnay ventilation when the fan speed is set to high speed.
- * Capability in () is heat recovery capability by the Lossnay cores.
Cooling/Heating capability indicates the maximum value at operation under the following condition.
Cooling: Indoor: 27°C DB/19°C WB Outdoor: 35°C DB/24°C WB
Heating: Indoor: 20°C DB/13.8°C WB Outdoor: 7°C DB/6°C WB
- Mitsubishi Electric measures products according to Japan Industrial Standard (JIS B 8628).
- In the United Kingdom, on-site measurements by pitot tube method could be as much 20% different from JIS test room conditions. If the measuring point is close to sources of turbulence like bends, contractions and dampers, etc., it is difficult to measure the air volume correctly. A straight duct length more than 10D (D=duct diameter) from the source of turbulence is recommended for correct measurement. On-site measurement should therefore be carried out in accordance with BSRIA guideline (Commissioning Air Systems. Application procedures for buildings AG3/89.3 (2001)).

4. Outside dimensions

GUF-50RD4, GUF-50RDH4, GUF-100RD4, GUF-100RDH4, GUF-100RDH4-60

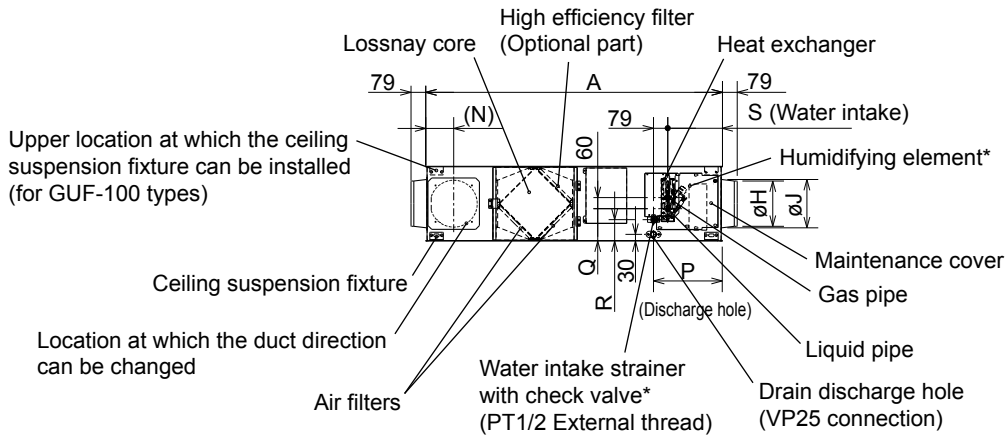
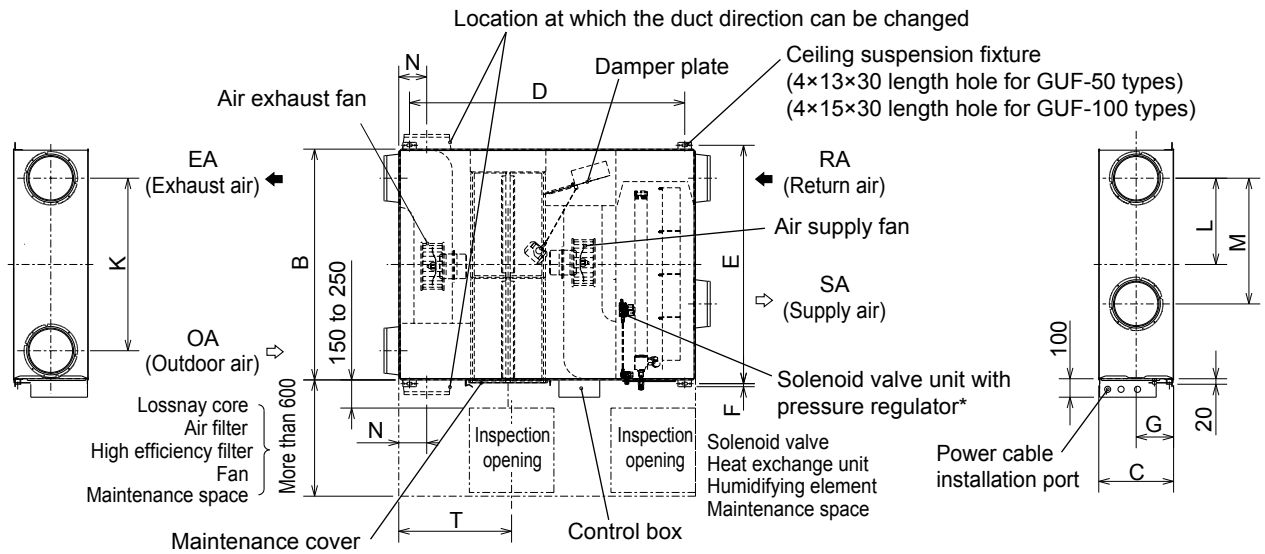

(The components marked with * are available for GUF-50/100RDH4 types only)

Model	External dimension			Ceiling suspension fixture pitch			Duct connection flange			Duct pitch				Humidification				Inspection opening	Weight (kg)	
	A	B	C	D	E	F	Nominal diameter	G	H	J	K	L	M	N	P	Q	R			S
GUF-50RD4	1288	1016	317	1185	1048	22	200	158.5	192	208	745	372.5	435	124	347	135	99	266	450	54
GUF-50RDH4																				57
GUF-100RD4	1580	1231	398	1465	1271	16	250	199	242	258	920	460	670	149	361	169	110	280	600	92
GUF-100RDH4																				98
GUF-100RDH4-60																				98

Unit (mm)

5. Electrical wiring diagrams

GUF-50RD4, GUF-100RD4

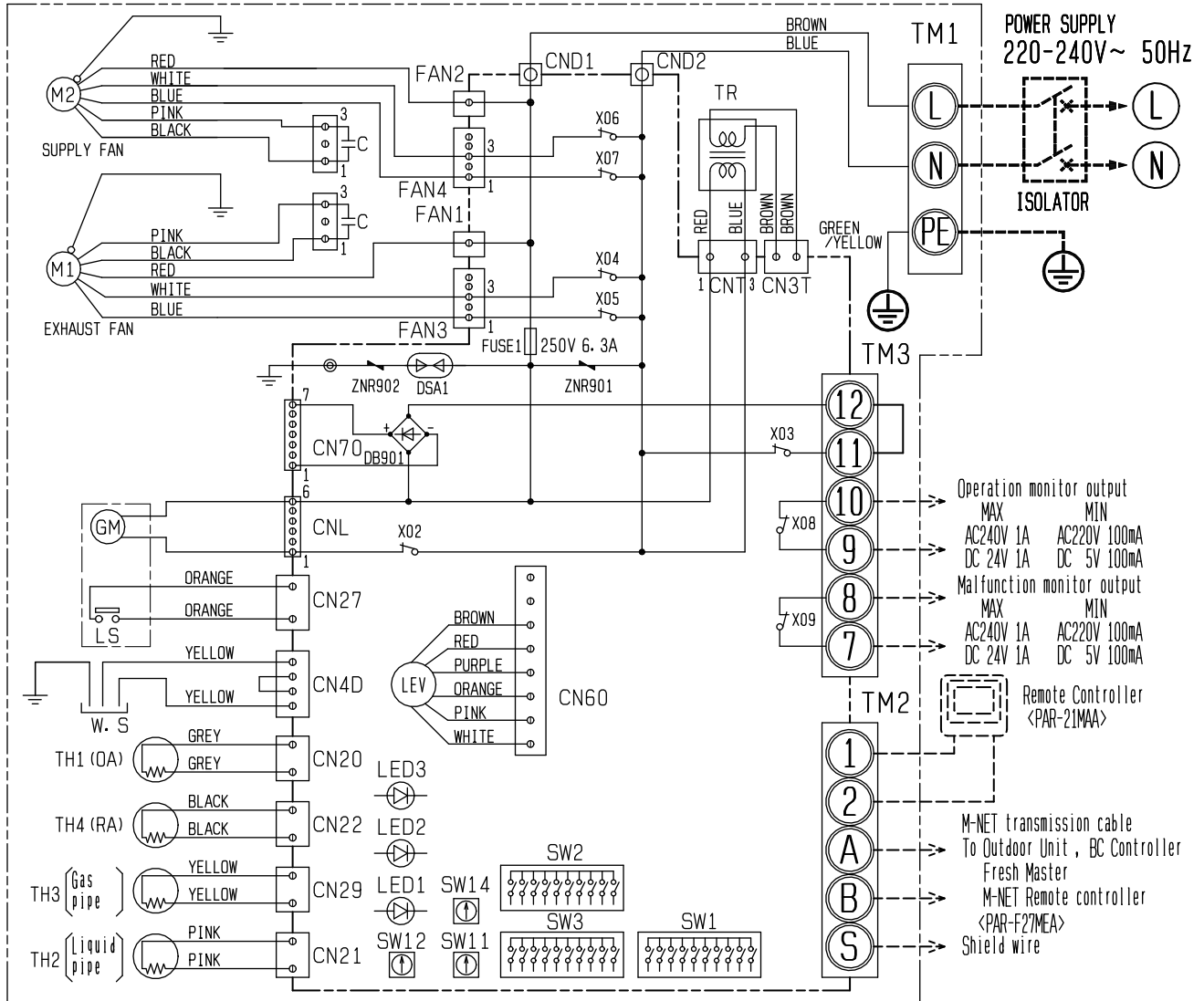

- NOTE 1. TM1, TM2, TM3 shown in dotted lines are field work.
- 2. Be sure to connect the grounding wire.
- 3. Isolator should be provided by the customer.
- 4. MARK \odot : indicates terminal block, \ominus : connector
- \oplus : board insertion connector or fastening connector of control board.

■ Warning
Before obtaining access to terminals, all supply circuits must be disconnected.

■ Symbol explanation

Symbol	Name	Symbol	Name	Symbol	Name
M1	Fan motor(exhaust)	TM1	Terminal block(power supply)	S	Shield
M2	Fan motor(supply)	TM2	Terminal block(transmission)	CND1, CND2	Connector (power supply)
C	Capacitor	TM3	Terminal block(humidistat, monitor)	X02-X09	Relay
W. S	Water sensor	SW1	Switch(function selection)	TR	Transformer
TH1	Thermistor(outdoor air temp. detection)	SW2	Switch(capacity code setting)	GM	Damper motor
TH2	Thermistor(pipe temp. detection/liquid)	SW3	Switch(function selection)	LS	Limit switch
TH3	Thermistor(pipe temp. detection/gas)	SW11	Switch(1st digit address set)	LED1	Power supply monitor
TH4	Thermistor(room air temp. detection)	SW12	Switch(2nd digit address set)	LED2	MA remote controller
LEV	Electronic linear expansion valve	SW14	Switch(branch NO. set)	LED3	Power supply monitor
		1, 2	Remote controller terminal		M-NET Power supply monitor
		A, B	M-NET transmission terminal		

GUF-50RDH4, GUF-100RDH4, GUF-100RDH4-60

	A	B
GUF-50RDH4, GUF-100RDH4	220-240 V	50
GUF-100RDH4-60	220 V	60

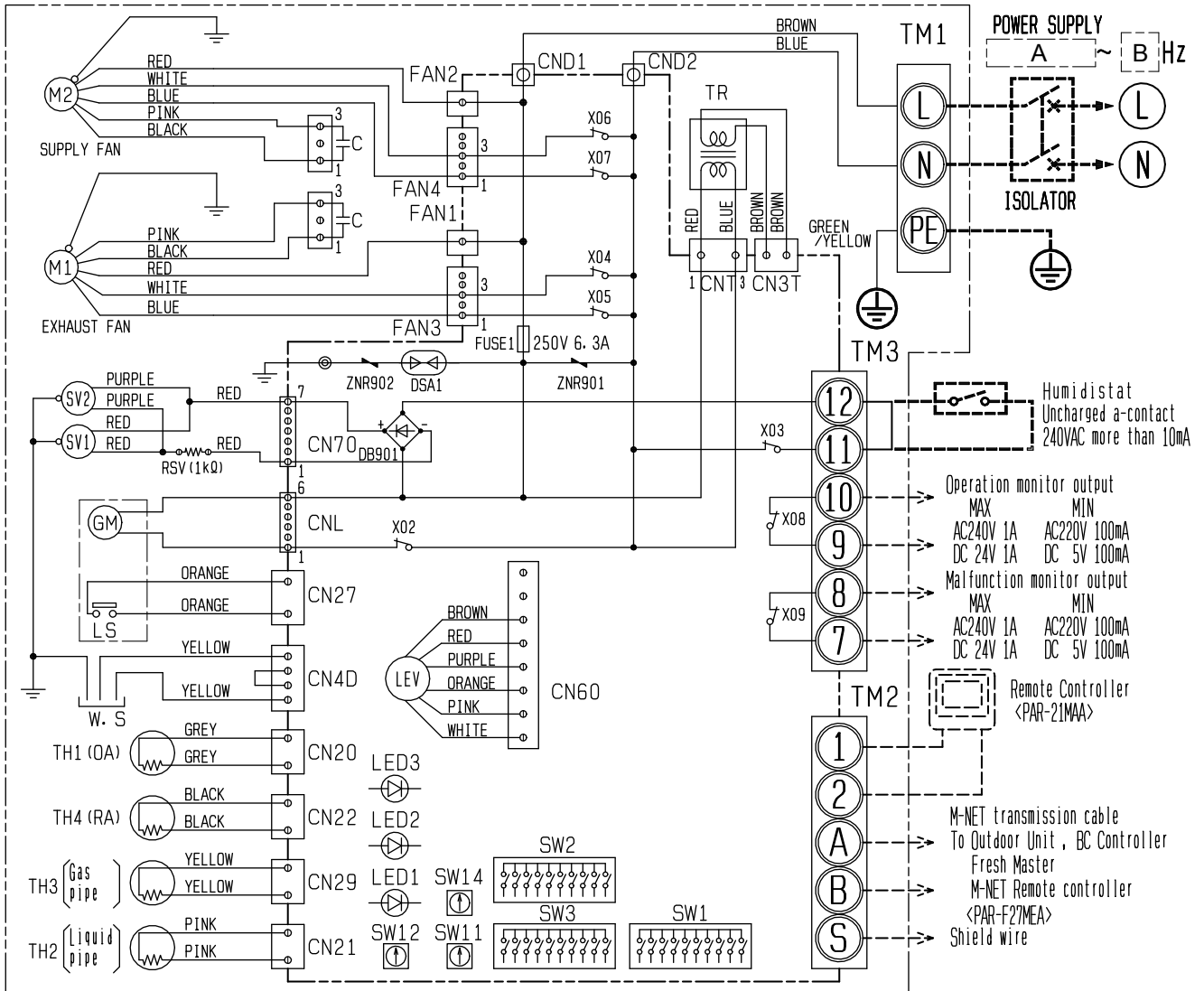

- NOTE 1. TM1, TM2, TM3 shown in dotted lines are field work.
- 2. Be sure to connect the grounding wire.
- 3. Isolator should be provided by the customer.
- 4. MARK \odot : indicates terminal block, \oplus : connector
 \otimes : board insertion connector or fastening connector of control board.

■ Warning
 Before obtaining access to terminals,
 all supply circuits must be disconnected.

■ Symbol explanation

Symbol	Name	Symbol	Name	Symbol	Name
M1	Fan motor(exhaust)	RSV	Resistance(solenoid valve)	A, B	M-NET transmission terminal
M2	Fan motor(supply)	TM1	Terminal block(power supply)	S	Shield
C	Capacitor	TM2	Terminal block(transmission)	CND1, CND2	Connector(power supply)
W. S	Water sensor	TM3	Terminal block(humidistat, monitor)	X02-X09	Relay
SV1	Solenoid valve(pressure regulator)	SW1	Switch(function selection)	TR	Transformer
SV2	Solenoid valve(exhaust)	SW2	Switch(capacity code setting)	GM	Damper motor
TH1	Thermistor(outdoor air temp. detection)	SW3	Switch(function selection)	LS	Limit switch
TH2	Thermistor(pipe temp. detection/liquid)	SW11	Switch(1st digit address set)	LED1	Power supply monitor
TH3	Thermistor(pipe temp. detection/gas)	SW12	Switch(2nd digit address set)	LED2	MA remote controller
TH4	Thermistor(room air temp. detection)	SW14	Switch(branch NO. set)	LED3	Power supply monitor
LEV	Electronic linear expansion valve	1, 2	Remote controller terminal		M-NET Power supply monitor

6. Circuit board diagrams

● Circuit board diagrams and check points <FU-M05-D4>

① GUF-50RD4, GUF-50RDH4, GUF-100RD4, GUF-100RDH4

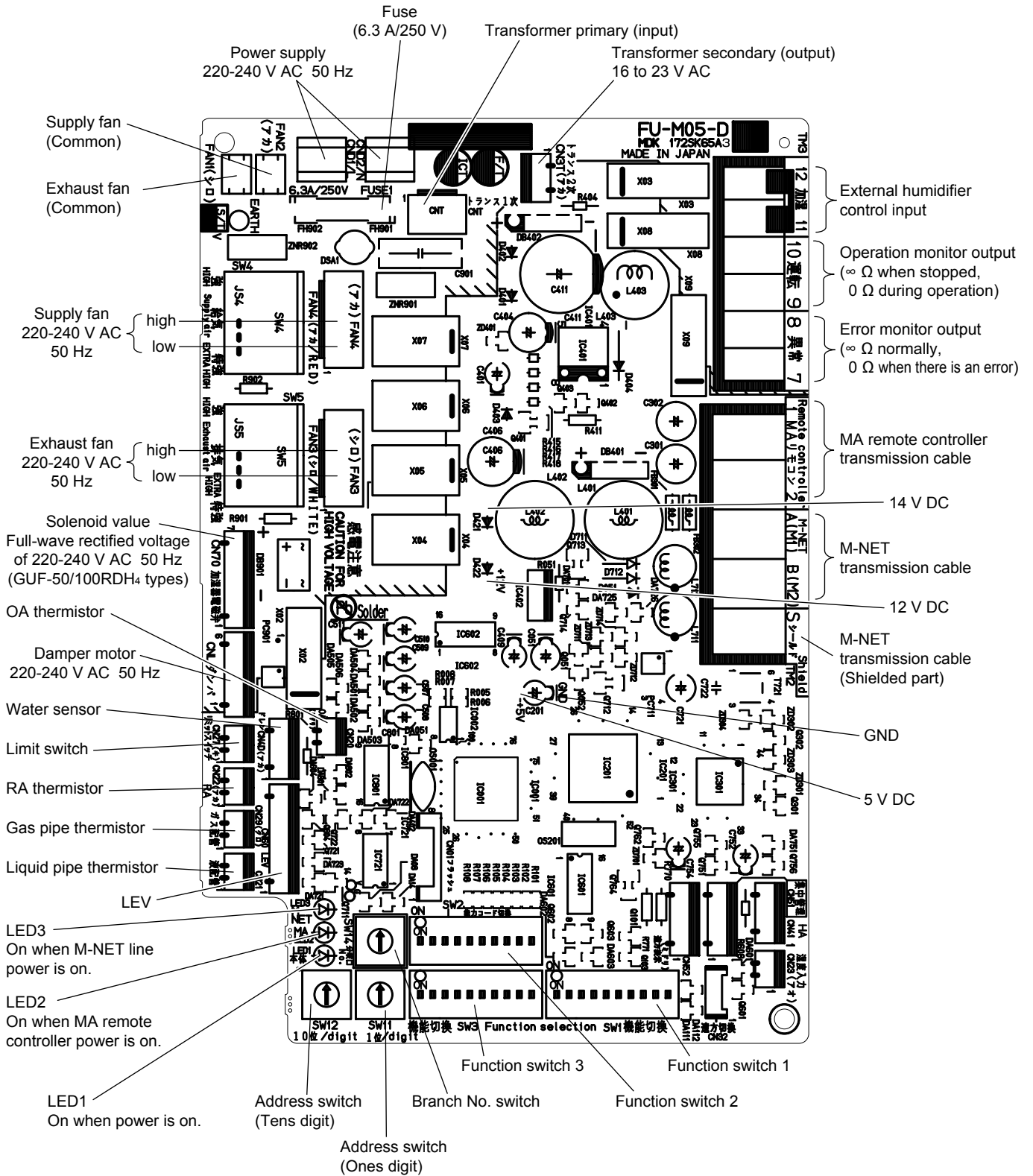

② GUF-100RDH4-60

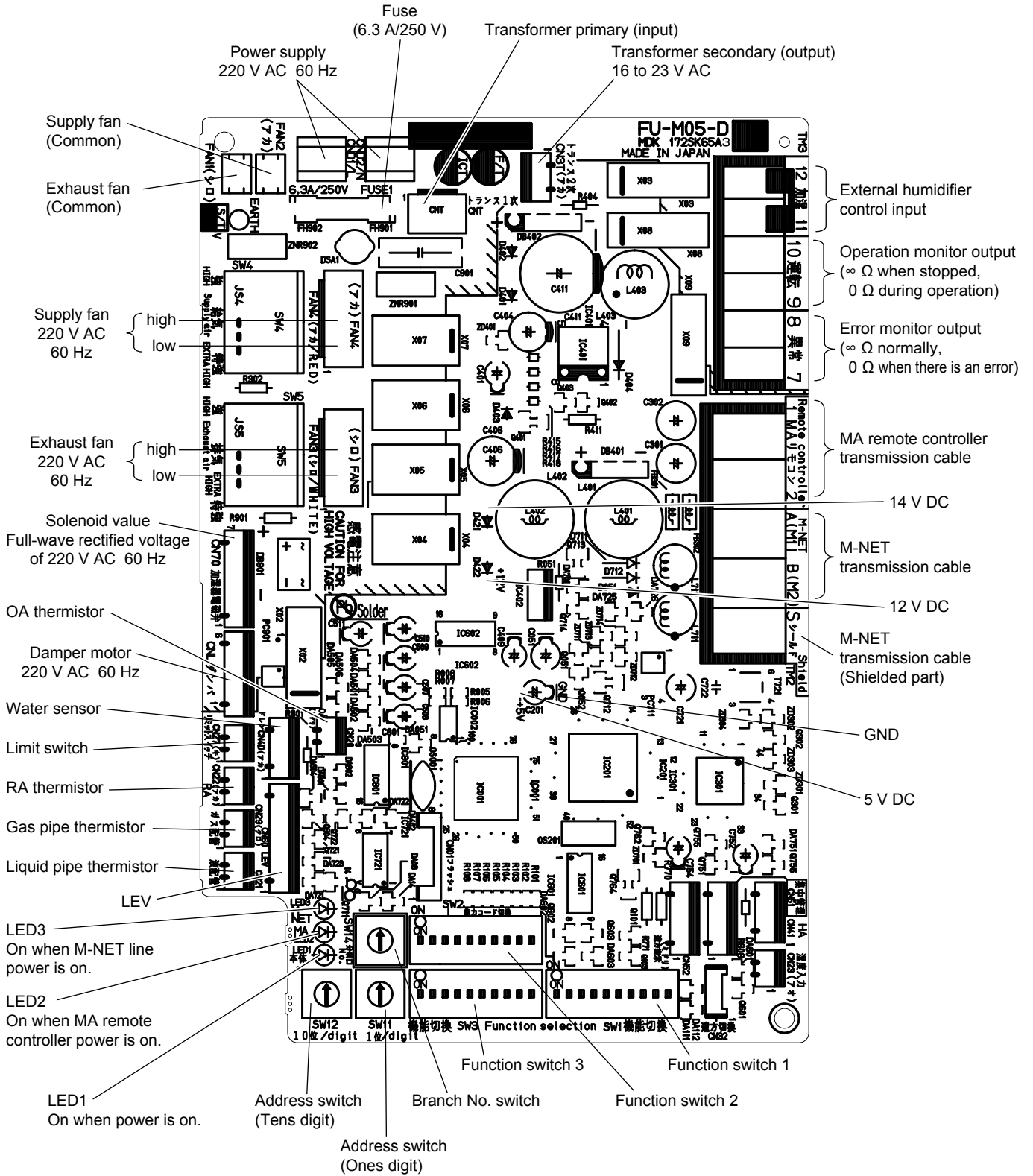

7. Troubleshooting

■ Work precautions

- When servicing, be sure to recreate the malfunction two or three times before starting repairs.
- When servicing, always keep proper footing.
- When servicing, make sure that the power supply isolator is off, so as no electrical shock or injury to occur. Pay sufficient attention when working on the product.
- Always connect the power wires properly.
- When removing the circuit board, always hold it at both ends and remove carefully so as not to apply force to the surface mounted parts.
- When removing the circuit board, be careful of the metal edges on the board.
- When removing or inserting the connectors for the circuit board, hold the entire housing section. Never pull on the lead wires.
- If it is thought that there is a printed circuit board malfunction, check for disconnected wires in the print pattern, burnt parts or discoloration.
- If the printed circuit board is replaced, make sure that the switch settings on the new board are the same as the old board.
- When servicing or checking around the humidifying unit, make sure to close the service valve.

(1) Troubleshooting 1: The system will not start properly.

Initialization checklist from installation to operation (Table 1)

After checking the system, check the checkpoints listed below.

Power supply (Table 1-1)

No.	Checkpoint	Action
1	Is the main power supply on?	Turn on the main power supply.
2	Do the main power supply switching capacity and wiring diameter meet specification?	Use specified items.
3	Is the specified power supply of 220 to 240 V AC (220 V AC for GUF-100RDH4-60) connected to the power supply terminal (TM1)?	Connect the specified power supply.
4	Has the fuse (FUUSE 1) on the circuit board blown?	Replace the circuit board.
5	Are connector CNT of the transformer primary (input) and connector CN3T of the transformer secondary (output) on the circuit board securely connected?	Connect them securely.
6	Is the power supply wiring incorrectly wired, or is there a faulty connection?	Make secure connections.
7	Is power display LED1 (red) on the circuit board unlit?	Check the above checkpoints.

Transmission cables (Table 1-2)

Check the following checkpoints when connecting with the remote controller or M-NET controller.

No.	Checkpoint	Action
1	Do the transmission cables meet regulations? (Type, diameter)	Use specified cables.
2	Is the transmission cable wired at least 5 cm away from the power supply cable?	Wire the transmission cable at least 5 cm away from the power supply cable.
3	Are multiple transmission or signal cables wired to the same power cable duct?	Wire the transmission cables away from the signal cables.
4	Are multiple transmission cables wired with multi-core cables?	Use suitable cables to wire the transmission cables so that they are separated from one another.
5	Are the transmission cables securely connected to the terminals?	Connect them securely.
6	Are the address switches on the circuit board (SW11 and SW12) set to the correct number?	Make the setting so that the address does not duplicate that of other devices within M-NET control.
7	Are the transmission cables connected to the specified terminal blocks? MA remote controller: TM2 ①, ② M-NET controller: TM2 ①A, ①B	Connect them to the specified terminal blocks.

Signal cables to external devices (Table 1-3)

Check the following checkpoints when outputting the operation monitor and malfunction monitor.

No.	Checkpoint	Action									
1	Do the signal cables meet regulations? (Type, diameter)	Use specified cables.									
2	Is the signal cable wired at least 5 cm away from the power supply cable?	Wire the signal cable at least 5 cm away from the power supply cable.									
3	Are multiple transmission or signal cables wired to the same power cable duct?	Wire the transmission cables away from the signal cables.									
4	Are multiple signal cables wired with multi-core cables?	Use suitable cables to wire the signal cables so that they are separated from one another.									
5	Are the signal cables securely connected to the terminals?	Connect them securely.									
6	Are the signal cables connected to the specified terminal blocks? Operation monitor: TM3 ⑨, ⑩ Malfunction monitor: TM3 ⑦, ⑧	Connect them to the specified terminal blocks.									
7	Are the output capacities of the operation monitor and malfunction monitor within the ratings?	Use them within the ratings.									
	<table border="1"> <thead> <tr> <th>Output</th> <th>Maximum rating</th> <th>Minimum rating</th> </tr> </thead> <tbody> <tr> <td>Operation monitor</td> <td>240 V AC, 1 A 24 V DC, 1 A</td> <td>220 V AC, 100 mA 5 V DC, 100 mA</td> </tr> <tr> <td>Malfunction monitor</td> <td>240 V AC, 1 A 24 V DC, 1 A</td> <td>220 V AC, 100 mA 5 V DC, 100 mA</td> </tr> </tbody> </table>	Output	Maximum rating	Minimum rating	Operation monitor	240 V AC, 1 A 24 V DC, 1 A	220 V AC, 100 mA 5 V DC, 100 mA	Malfunction monitor	240 V AC, 1 A 24 V DC, 1 A	220 V AC, 100 mA 5 V DC, 100 mA	
Output	Maximum rating	Minimum rating									
Operation monitor	240 V AC, 1 A 24 V DC, 1 A	220 V AC, 100 mA 5 V DC, 100 mA									
Malfunction monitor	240 V AC, 1 A 24 V DC, 1 A	220 V AC, 100 mA 5 V DC, 100 mA									

(Table 2)

State of machine	Remote controller	Cause	Remedy
Does not operate.	<ul style="list-style-type: none"> Remote controller display does not appear. The power display “●” does not appear on the remote controller. (When PAR-21MAA is used) 	Power is not supplied to Fresh Master, or power that does not follow specifications is used.	Check the power supply to Fresh Master. (Refer to Table 1-1)
		Is there a connection of 3 or more remote controllers, or 16 or more Fresh Master units?	Check the number of units connected.
		The remote controller is connected to TM2 ①, ② (terminal block for M-NET transmission cable).	Connect the transmission cable to TM2 ①, ②.
	The power display “●” does not appear on the remote controller when power is supplied to the system. (When PAR-F27MEA is used)	The power of the outdoor unit is not turned on.	ME remote controller is powered by the outdoor unit. Turn on the power of the outdoor unit.
		Power is not supplied to the transmission cable that connects indoor units and an outdoor unit.	Check the settings of the outdoor unit. See the City Multi databook for details.
		Faulty connection of the M-NET transmission cable	See Table 1-2.
	The number of Fresh Masters, indoor units, or remote controllers connected to the transmission cable exceeds the power supply capacity of the outdoor unit.	Connect Fresh Masters, indoor units, or remote controllers within the power supply capacity of the outdoor unit. See the City Multi databook for details.	

State of machine	Remote controller	Cause	Remedy
Does not operate.	The power display “●” does not appear on the remote controller when power is supplied to the system. (When PAR-F27MEA is used)	When a power supply unit is used: ①The power supply unit is not connected with the transmission cable. ②The power supply unit is not turned on. ③The length of the M-NET transmission cable wiring from the power supply unit is longer than specified (longer than 200 m).	①Connect the power supply unit with the transmission cable. ②Check the power of the power supply unit. ③Check the length of the transmission cable wiring. (See the technical manual for details about the regulations.)
		The transmission cable power supply restrictions have been exceeded.	Make connections within the transmission cable power supply restrictions of the outdoor units, or the power supply units. (See the technical manual for details about the restrictions.)
Cool air or warm air does not come out.	The LCD screen shows that it is in operation.	The restart protection delay circuit is in operation for 3 minutes.	Wait for a while. (To protect the compressor, a 3 minutes delay circuit is built into the OA processing unit. Therefore, sometimes the compressor will not start operating immediately. This delay may be up to 3 minutes.)
		OA processing unit operation has restarted following the heating and defrosting operation.	Wait for a while. (Heating operation starts after defrosting operation has ended.)
It runs briefly, but soon stops.	The (CHECK) and check code flashes on the LCD screen.	The air inlet or outlet of the OA processing unit and/or outdoor unit is obstructed.	Restart after removing the obstruction.
		The filters are clogged with dust and dirt.	Restart after cleaning the filters.
Does not humidify. (GUF-50/100RDH4 types only)	—	The OA processing unit is not set to the “☀ heating” mode.	Set to the heating mode.
		Water is not supplied.	Open the service valve.
Dry mode cannot be set from the remote controller.	—	There is no dry mode on the OA processing unit. Cannot set to dry mode from the remote controller.	Use a mode other than dry mode.
Dry mode can be set from the central controller, but does not operate.	Dry mode display is flashing in LCD.	When the unit is set to dry mode from the central controller, the dry mode display flashes on the LCD and the OA processing unit fan operates.	

(2) Troubleshooting 2: An error code is displayed on the remote controller.

See below for possible remedies when there is an error during test operation and **CHECK** followed by a 4-digit number is displayed on the remote controller.

Note: The components marked with * are available for GUF-50/100RDH4 types only.

Error code	Error content	Cause	Remedy
0900	Test run	Is the test operation switch of either the fan, bypass damper, or humidifier solenoid valve* turned ON?	Set the test operation switch (SW1-1, 7, 8*) to OFF.
2600	Drain error	Drain water is not properly discharged.	The body must be levelly installed. The drain pipe must be installed with a gradient of more than 1/100.
		Is there a leak from the permeable-film humidifier*?	<ul style="list-style-type: none"> • Fix the water leak. • Replace the humidifier element*.
		When no problem is found after checking the above items.	Replace the circuit board.
2601	Disconnected water sensor connector	Is the CN4D connector firmly connected?	Firmly connect the connector.
		Is the relay connector between the circuit board and water sensor firmly connected?	Firmly connect the connector.
		When no problem is found after checking the above item.	Replace the circuit board.
3602	Damper motor error	Is the CNL connector firmly connected?	Firmly connect the connector.
		Is the connector of the damper motor section firmly connected?	Firmly connect the connector.
		Does the damper operate when the damper motor is running?	Replace the damper motor if it is not working.
		When no problem is found after checking the above items.	Replace the circuit board.
4116	Fan motor error	The motor continues to run when the operation is stopped.	Replace the circuit board.
5101	Indoor temperature sensor error	<ul style="list-style-type: none"> • Are the connectors of each thermistor firmly connected? 	<ul style="list-style-type: none"> • Firmly connect each connector.
5102	Liquid pipe temperature sensor error	<ul style="list-style-type: none"> • Is each relay connector firmly connected? 	<ul style="list-style-type: none"> • Firmly connect each connector.
5103	Gas pipe temperature sensor error	<ul style="list-style-type: none"> • When no problem is found after checking the above item. 	<ul style="list-style-type: none"> • Replace the circuit board.
5104	Outdoor temperature sensor error		
6600	Indoor unit address setting error	There are duplicate address settings, meaning there are indoor units with the same address.	Check the addresses of devices in the system.
6602	Communication error (Transmission processor H/W error)	Any of the transmission cables of the indoor units, Fresh Master, or outdoor units was wired, or the polarity was changed with the power ON.	Simultaneously turn OFF the power of the indoor units, Fresh Master, and the outdoor units, and then, turn them ON again.
		Specified power supply is not used.	Check the power supply.
		Earth fault in the transmission cable	Check the transmission cable wiring and shielding.
		The setting of the outdoor unit is incorrect.	See the service manual of the outdoor unit.
		Transmission data was changed due to noise in the transmission cable line.	Inspect the transmission waveform and noise in the transmission cable line.
		Malfunction of a controller for the device in which the error occurs.	If the controller is normal, it is a malfunction of the circuit board.

Error code	Error content	Cause	Remedy
6603	Communication error (Bus busy error in the transmission line)	The transmission processor cannot transmit data because short-period voltages such as noise continuously occurs in the transmission cable line.	Inspect the transmission waveform and noise in the transmission cable line.
		Malfunction of a controller for the device in which the error occurs.	If the controller is normal, it is a malfunction of the circuit board in Fresh Master. Replace the circuit board.
6606	Communication error (Handshake error)	Data was not transmitted correctly due to an accidental misoperation of the controller for the device in which the error occurs.	Simultaneously turn OFF the power of the indoor units, Fresh Master, and the outdoor units, and then, turn them ON again.
		Malfunction of a controller for the device in which the error occurs.	If the same error occurs again, it is a malfunction of the circuit board in the device in which the error occurs.
6607	Communication error (No ACK error)	(Only when the error occurs in Fresh Master.)	
		<p>Single coolant system</p> <p>①The address has been changed in midstream.</p> <p>②Improper wiring or disconnection of the transmission cable</p> <p>③Malfunction of the controller</p> <p>④Malfunction of the remote controller (When the switch (SW3-1) is ON)</p>	<p>Simultaneously turn OFF the power of the outdoor units and Fresh Master, and then, turn them ON again.</p> <p>In the case of the accidental malfunction, the unit returns to normal.</p> <p>If the unit does not return to normal, check the causes ① to ④.</p>
		<p>Group operation system with multiple coolant lines</p> <p>①The above causes ① to ④ (When Fresh Master is interlocked with the indoor units in the different coolant line)</p> <p>②Short circuit or disconnection of the transmission cable to the terminal block for central control (TB7) in the outdoor unit</p> <p>③The outdoor unit in one of the coolant lines is shut down.</p> <p>④The setting of the outdoor unit is incorrect.</p> <p>If the error occurs after the unit operates normally, the following can be caused.</p> <ul style="list-style-type: none"> • Total capacity error (7100) • Capacity code setting error (7101) • The number of connected devices error (7102) • Address setting error (7105) 	<p>Simultaneously turn OFF the power of the outdoor units and Fresh Master, and then, turn them ON again.</p> <p>In the case of the accidental malfunction, the system returns to normal.</p> <p>If the system does not return to normal, check the causes ① to ④.</p> <p>If none of the above causes applies, check the error display LEDs of the other remote controllers or outdoor units.</p> <ul style="list-style-type: none"> • When there is an error See the error code, and repair troubled sections according to the instructions described in the troubleshooting. • When there is no error It is a malfunction of the circuit board in Fresh Master. <p>See the service manual of the outdoor unit.</p>

Error code	Error content	Cause	Remedy
6607	Communication error (No ACK error)	System connected with MELANS a) Malfunction only in some of the units • Refer to the causes for the single coolant system	Refer to the remedy for the single coolant system
		b) Malfunction in all the indoor units and Fresh Master units in one coolant line ① Causes of total capacity error (7100) ② Causes of capacity code setting error (7101) ③ Causes of the number of connected devices error (7102) ④ Causes of Address setting error (7105) ⑤ Short circuit or disconnection of the transmission cable to the terminal block for central control (TB7) in the outdoor unit ⑥ The outdoor unit is shut down. ⑦ Fault in the electrical system of the outdoor unit	Check the error display LEDs of the outdoor unit. • When there is an error See the error code, and follow the instructions described in the troubleshooting. • When there is no error Check the causes ⑤ to ⑦ written in the left. See the service manual of the outdoor unit.
		c) Malfunction in all the indoor units and Fresh Master units ① The above causes ① to ⑦ ② The setting of the outdoor unit is incorrect. ③ Wiring from the power supply unit to the transmission cables is disconnected, or the power supply unit is shut down. ④ Malfunction of the system controller (MELANS)	Check the voltage of the transmission cables for central control. • When the voltage is 20 V DC or more Check the causes ① and ② written in the left. • When the voltage is less than 20 V DC Check the cause ③ written in the left. See the service manual of the outdoor unit.
6608	Communication error (No answer error)	① The transmission cables were wired or the polarity was changed with the power ON. ② A transmission error repeatedly occurs due to noise or the like. ③ The voltage/signal in the transmission cable drops because the length of the transmission cable wiring is longer than specified. • Maximum extension: 500 m or less, Power supply line must be 200 m or less • ME remote controller wiring: 10 m or less ④ The voltage/signal in the transmission cable drops because the transmission cable does not meet specification. • Cable diameter: 1.25 to 2.0 mm ²	Simultaneously turn OFF the power of the indoor units, Fresh Master, and the outdoor units, and then, turn them ON again. • When the system returns to normal It means the error was detected because the transmission cables were wired with the power ON. • If the system does not return to normal Check the causes ③ and ④ written in the left, and repair the troubled sections. If none of the above causes applies, inspect the transmission waveform and noise in the transmission cable line. (If the error 6602 occurs, noise will probably be a cause.)

Error code	Error content	Cause	Remedy
6831 6832 6833 6834	MA remote controller communication error	Contact failure of the MA remote controller transmission cable	Check the transmission cable for disconnection or looseness.
		The voltage/signal in the MA remote controller transmission cable drops.	Check the transmission cable if the length is beyond the range of the wiring regulation
		A signal was changed due to noise in the MA remote controller transmission cable.	Inspect noise in the transmission signal.
		Failure in the transmit/receive circuit for the MA remote control of the MA remote controller or Fresh Master	If no problem is found after checking the above items, it is a malfunction of the MA remote controller or Fresh Master.
7101	Capacity code setting error	Capacity code setting of Fresh Master is wrong.	Check the capacity code setting switches (SW2-1 to SW2-6).
7106	Remote controller setting error	The MA Remote controller was connected with the switch (SW3-1) OFF.	When the MA remote controller is directly connected to Fresh Master, switch (SW3-1) must be ON.
HO	Booting system	Have 10 minutes passed since system boot-up?	After system boot-up, HO may flash for a maximum of 10 minutes. However, this is not a malfunction.
		Has group registration been made?	Conduct group registration. If there is a master system controller such as the central controller, use the controller to conduct group registration.
		Has the Fresh Master address been changed?	If the Fresh Master main unit address has been changed, conduct the group registration again.
		When no problem is found after checking the above items.	If HO continues to flash for more than 10 minutes after reregistering the group and rebooting, replace the circuit board.
-	Unable to register	Fresh Master which is linked with indoor units, cannot be group registered other than the interlock setting with the Remote controller.	Change the setting of the switch (SW3-1) and reset the registration or register it as interlocked.
-	Operation display comes up with the Remote controller, however it turns off immediately.	Main power is not supplied to Fresh Master.	Supply Main Power.

8. Overhauling procedures

■ Work precautions

- When touching the electric components such as circuit boards and fan motors, do not touch the components for more than 5 minutes after power-off, and then start working.
- Before replacing parts, follow the instructions described in the troubleshooting.
- When servicing, always keep proper footing.
- When servicing, make sure that the power supply isolator is off, so as no electrical shock or injury to occur. Pay sufficient attention when working on the product.
- Always connect the power wires properly.
- After completing repairs, verify that the product operates properly.
- Always wear gloves when servicing.

The following pictures show GUF-100RDH4.

(1) Turning power off

- ① Shut down the unit.
- ② Turn off the power supply isolator on the distribution board.

(2) Fan Section

- ① Unscrew the cover fixing screw (one special (spl.) screw 4×11 , indicated by ○).
- ② Pull back the hinge. Open the maintenance (maint.) cover and lift it off the fix piece.

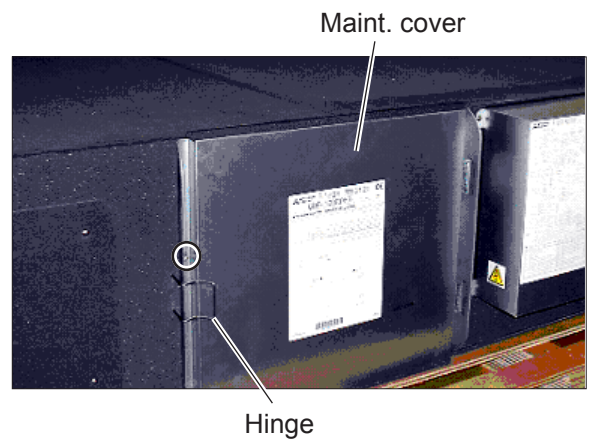

- ③ Remove the Lossnay cores from the unit.

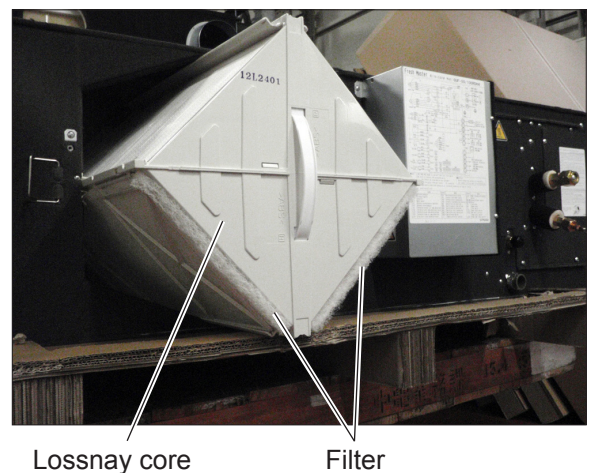

- ④ Unscrew the screws from the core guides (two PTT screws 4 × 12, indicated by ○), and remove the core guides.

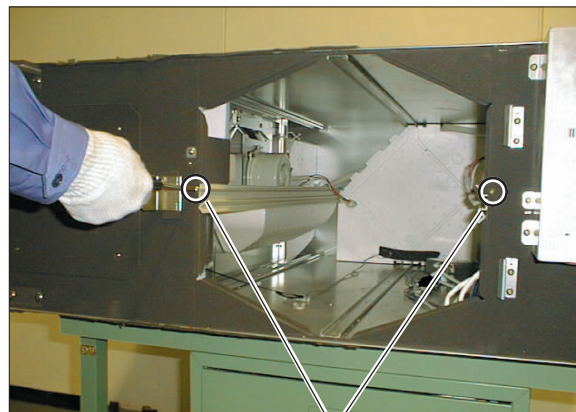

Core guide

- ⑤ Remove the separators from the fan parts.
⑥ Disconnect the connectors for the motor lead wire.

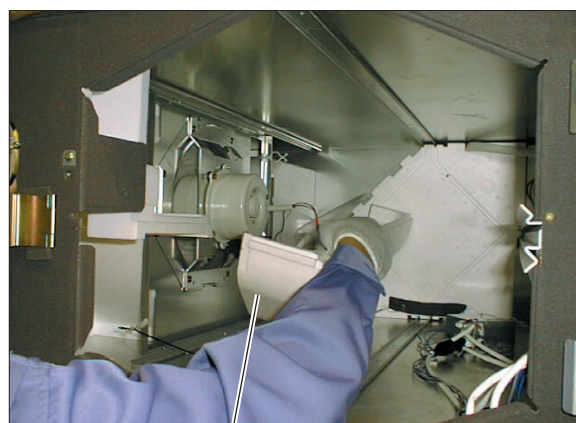

Separator

- ⑦ Unscrew the screws* (indicated by ○) from the motor fix plate.

*GUF-50 types: four PTT screws 5 × 10
GUF-100 types: six PTT screws 5 × 10

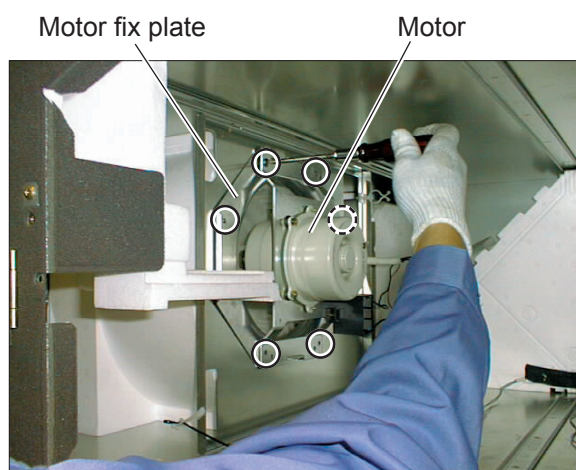

- ⑧ Remove the fan assembly.



Fan assembly

- ⑨ Unscrew the screws (two screws, indicated by ○) to remove the reinforcement.
- ⑩ Unfasten the cord clips (two clips, indicated by △) to release the motor lead wire.

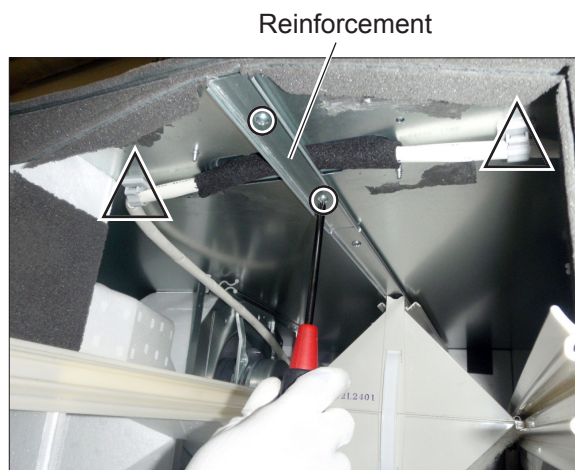

When the motor lead wire is sealed as shown in the picture below

- ⑨ Unscrew the screws (two screws, indicated by ○) to remove the reinforcement and sealing materials.
- ⑩ Unfasten the cord clips (two clips, indicated by △) to release the motor lead wire.

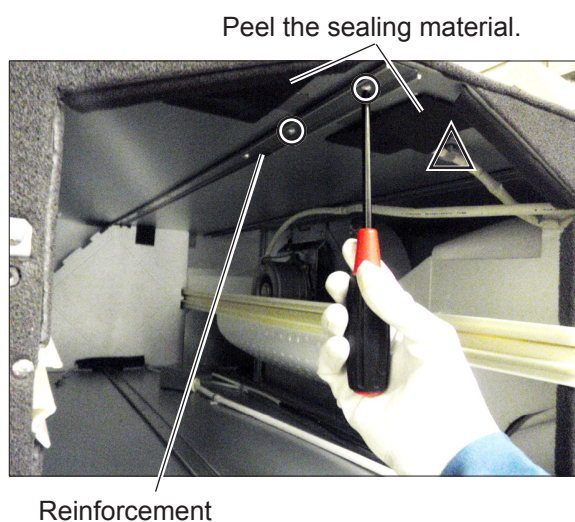

Assembly precaution

After replacing the motor, set the center of packing material of the motor lead wire under the reinforcement. It is not required to reinstall the metal part shown in the picture below.

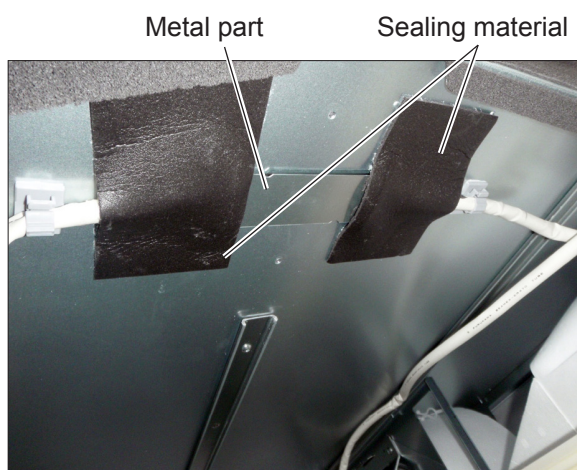

<Before replacing the motor>



<After replacing the motor>

(3) Damper Motor Section

- ① Unscrew the screws* (indicated by ○) from the motor cover.

*GUF-50 types: two PTT screws 4 × 6
GUF-100 types: two PTT screws 4 × 8

Motor cover



- ② Take the damper motor out of the cover.

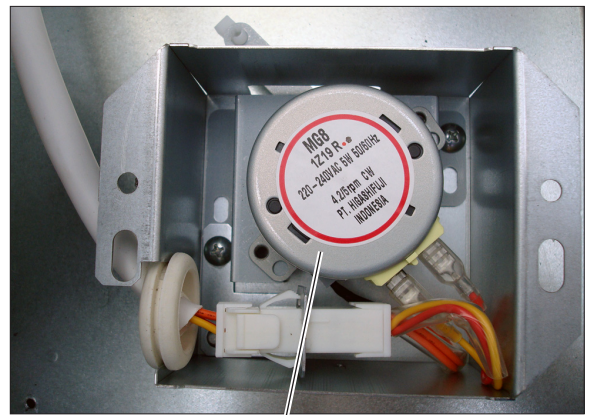

Damper motor

(4) Circuit Board Section

- ① Unscrew the screws (four PT screws 4 × 8, indicated by ○) from the control cover.

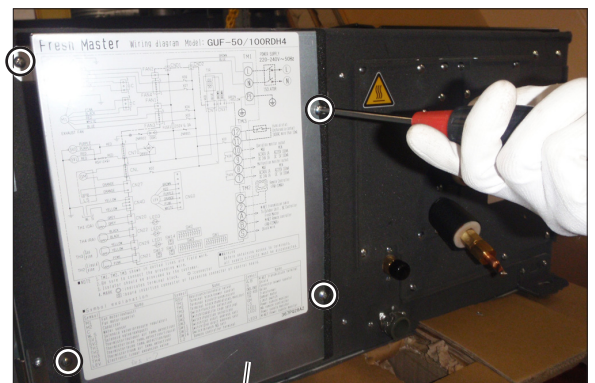

Control cover

- ② Unscrew the screws from the capacitors. (One PTT screw 4 × 8 for each capacitor, indicated by ○)

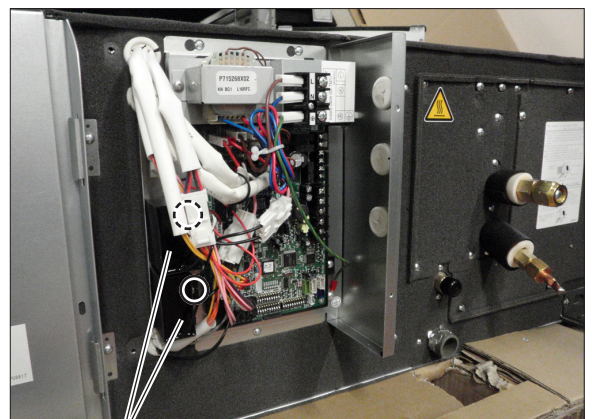

Capacitor

- ③ Remove all lead wires connected to the circuit board.
- ④ Take the circuit board out.

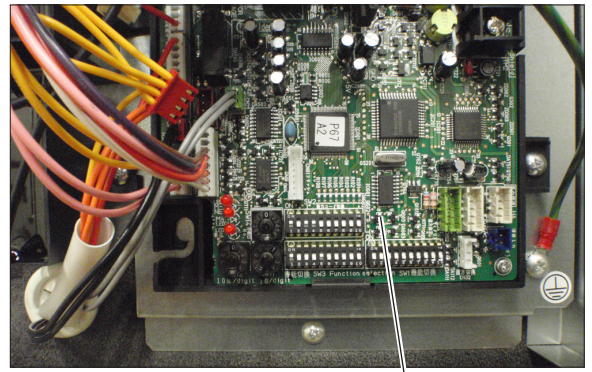

Circuit board

Note: The compatible circuit board, which is equipped with switches (SW4 and SW5), is used as a service part.

Assembly precaution
 After replacing the circuit board, switches (SW4 and SW5, indicated by ○) must be set to "HIGH".
 Otherwise, the unit will not work.

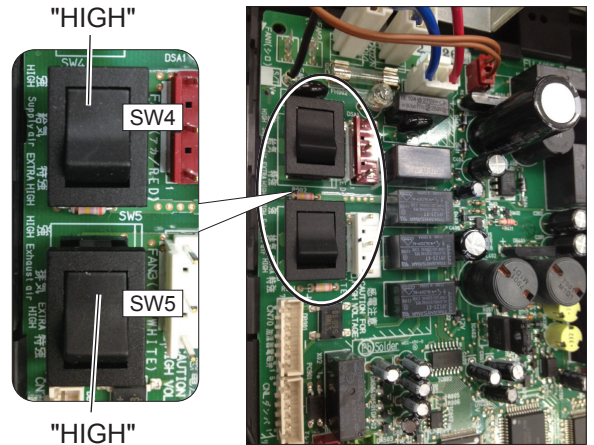

(5) Humidifier Section

Note: GUF-50/100RD4 types are not equipped with the humidifier elements, hose bands, and tubes.

- ① Unscrew the screws (seven PTT screws 5 × 10, indicated by ○) to remove the humidifier (H. elem.) cover.

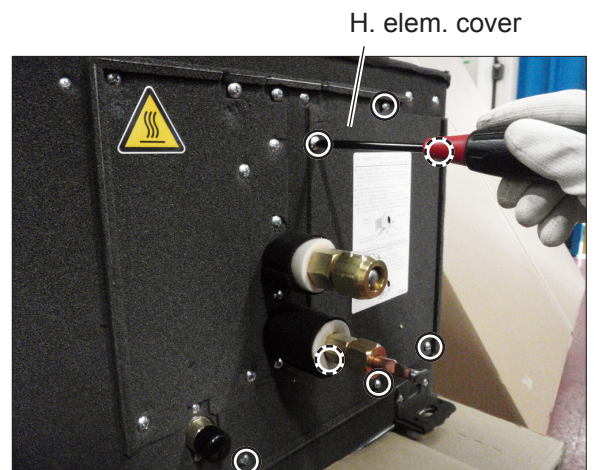

H. elem. cover

- ② Remove the H. elem. cover (inside).

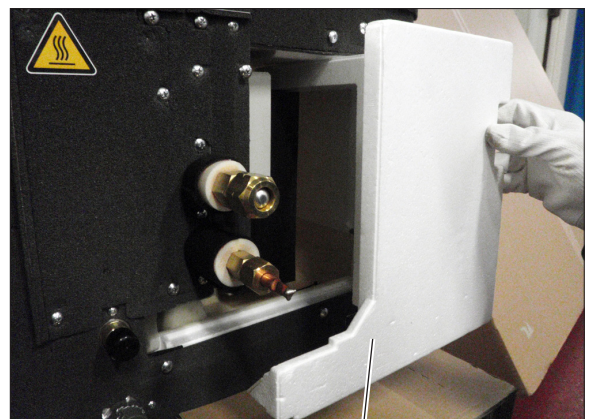

H. elem. cover (inside)

- ③ Remove the tubes from the humidifier elements (elem).



- ④ Holding the hose bands indicated by [1] to [6] with your fingers, remove the tubes. Referring to the procedure ⑤ below, remove the tube at the rear while taking out the front humidifier elem.

Precautions

- To remove the tubes, hold and slide the hose bands and remove the tubes.
- Do not remove the tube from the solenoid valve.
- When removing the tubes, be sure that water is collected on the drain pan inside the main unit.

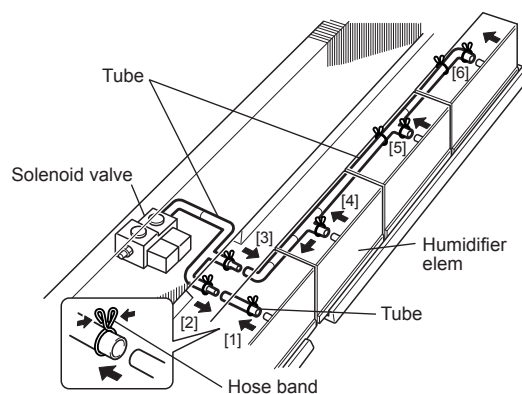

- ⑤ Remove the humidifier elems.

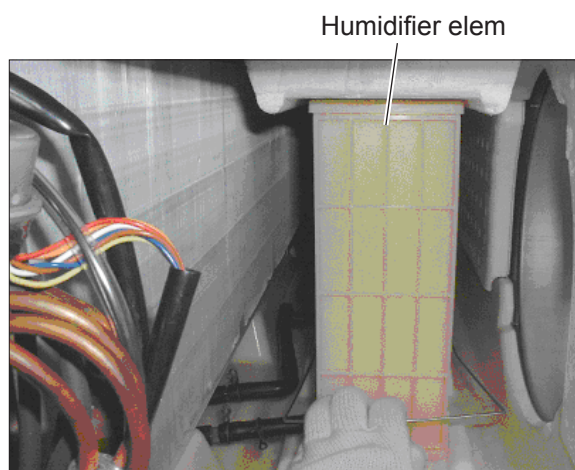

(6) Solenoid Valve and Water Sensor Section

Note: GUF-50/100RD4 types are not equipped with the solenoid valve and cover (SOLV).

- ① Remove the H. elem. covers. → See (5) ① to ②.
- ② Unscrew the screws (eleven PTT screws 5 × 10, indicated by ○) to remove the cover (left), cover (center), and cover (right).

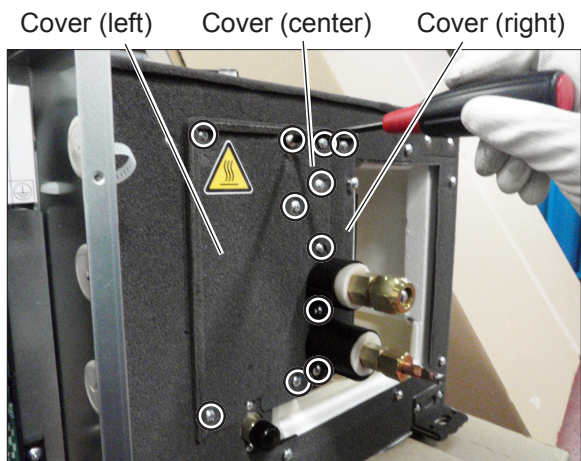

- ③ Disconnect the connectors for the thermistor lead wires and expansion valve lead wire. (Indicated by ○)
- ④ Unscrew the screws (two PTT screws 4 × 8, indicated by △) to remove the fix piece.

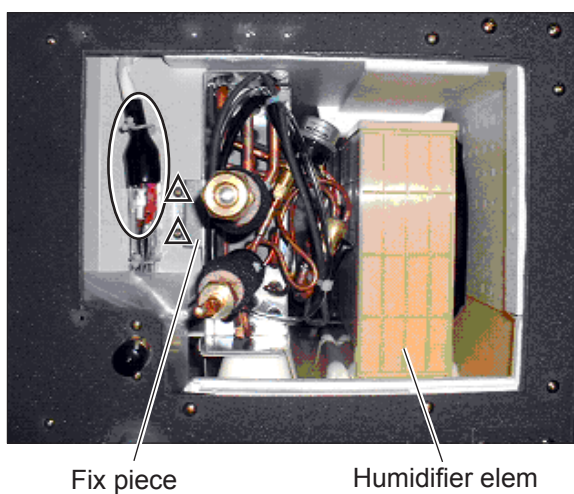

- ⑤ Unscrew the screws (two PTT screws 4 × 8, indicated by ○) to remove the fix plate.



Water sensor and solenoid valve installation positions



- ⑥ Disconnect the connectors for the solenoid valve lead wires and water sensor lead wires.
- ⑦ Remove the pipe connected to the solenoid valve.

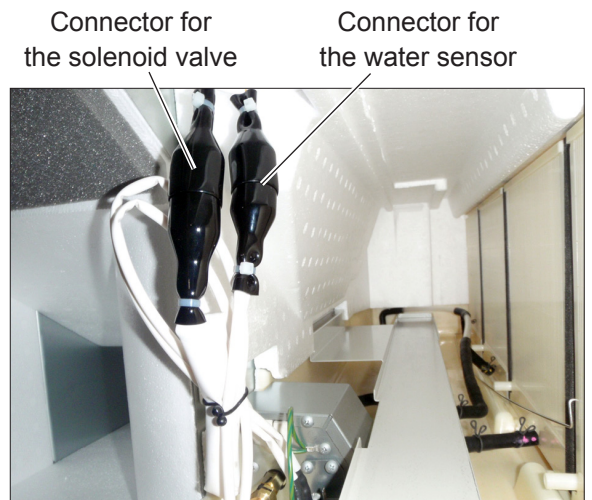

*The heat exchanger is exceptionally removed for easy understanding.

- ⑧ Loosen the screw (one PTT screw 4 × 8, indicated by ○) to remove the cover (SOLV).

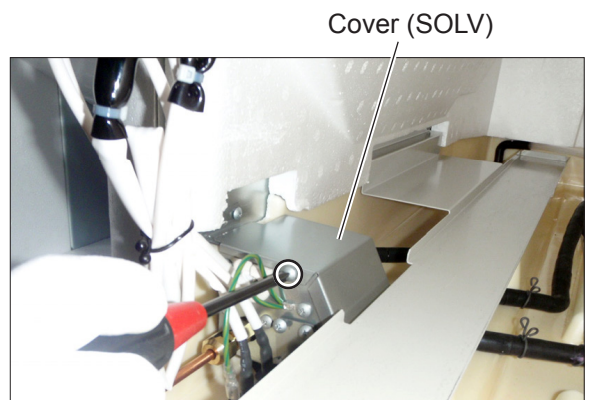

*The heat exchanger is exceptionally removed for easy understanding.

- ⑨ Unscrew the screws (two PTT screws 4 × 8, indicated by ○) to remove the cover B and solenoid valve from the unit.

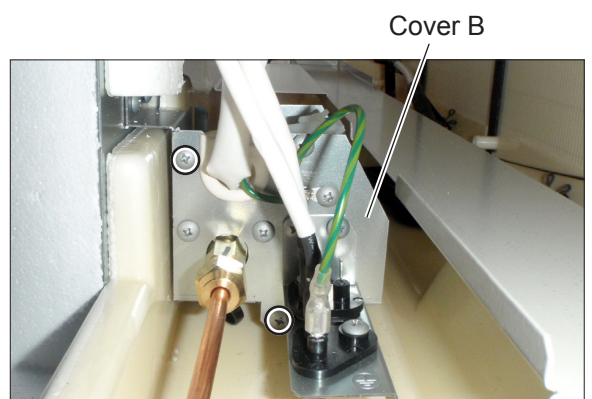

*The heat exchanger is exceptionally removed for easy understanding.

- ⑩ Unscrew the screws (two PTT screws 4 × 8, indicated by ○) to remove the water sensor.

*The heat exchanger is exceptionally removed for easy understanding.

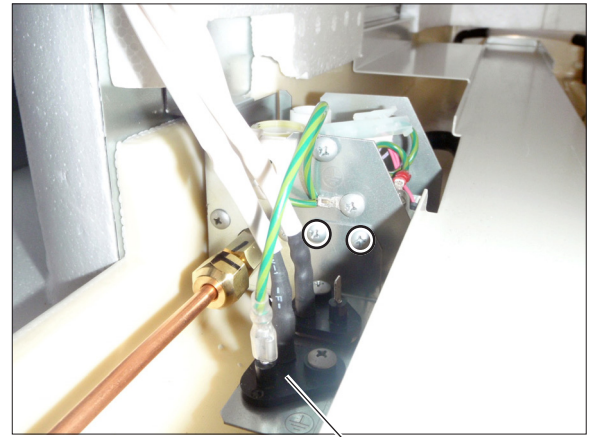

Water sensor

(7) Heat Exchanger Section

- ① Remove the covers (left, center, and right) and the H. elem. covers. → See (6) ① to ②.
- ② Disconnect the lead wire connectors (indicated by ○). (Lead wire for the expansion valve (LEV), and lead wires for the thermistors of the liquid and gas pipes)
- ③ Unscrew the screws (two PTT screws 4 × 8, indicated by △). Remove the fix piece, and then replace the heat exchanger.

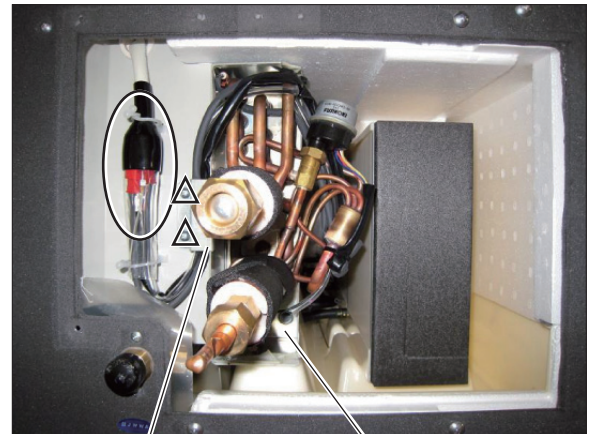

fix piece

Heat exchanger

Reassembly procedure

- ④ After inserting the new heat exchanger in the unit, connect the lead wire connectors for the expansion valve (LEV), and for the thermistors of the liquid and gas pipes (removed as shown in (7) ②). (Indicated by ○)



Water stop (resin)

- ⑤ Hold the water stop (resin) with your fingers, and hold the lead wires by the fix piece (removed as shown in (7) ③). Hook the fix piece on the slit of the heat exchanger. Tighten the screws (two PTT screws 4 x 8, indicated by Δ), and secure the heat exchanger to the unit. Set the lead wires u-shaped as shown in the following picture (indicated by \circ), and secure the lead wires with the cord bands so as not to move the lead wires toward the cover side.

Assembly precaution

If the lead wires are not secured, condensed water may run down the read wires, and result in water leak.

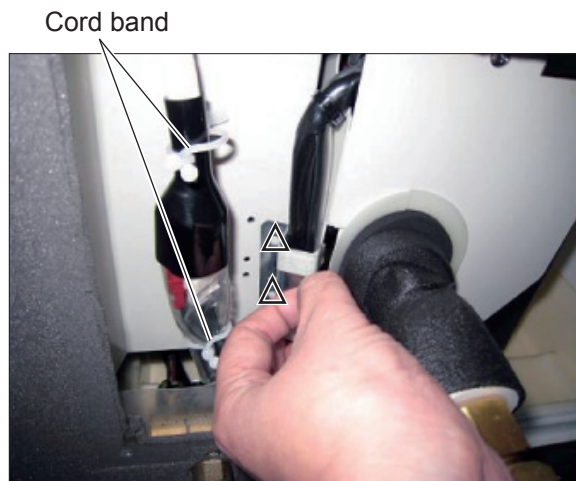

- ⑥ Tighten the screws (two PTT screws 5 x 10, indicated by \circ) to attach the cover (right).

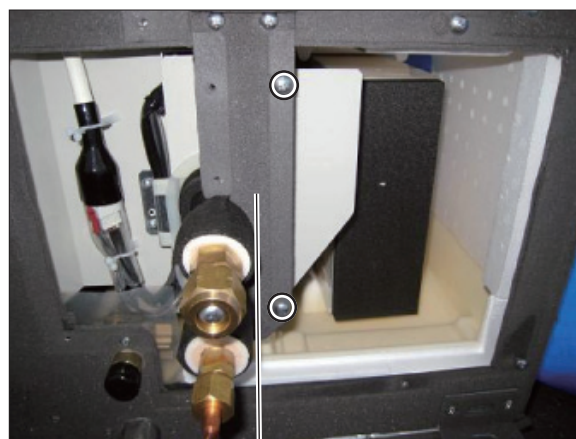

Cover (right)

- ⑦ Tighten the screws (five PTT screws 5 x 10, indicated by \circ) to attach the cover (center).

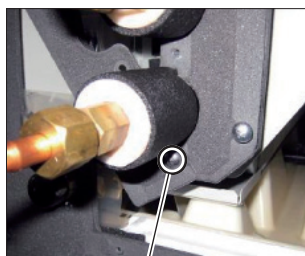

Tighten tentatively this screw first.

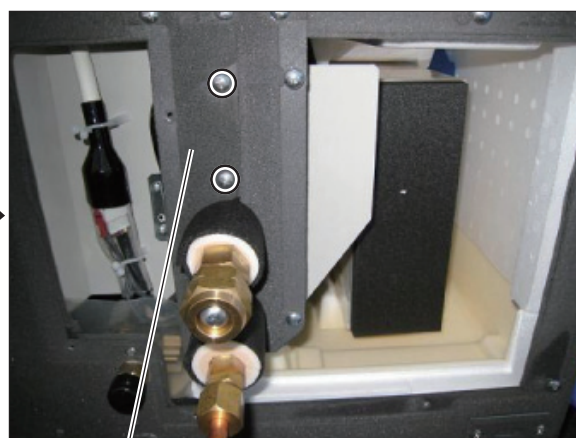

Cover (center)

- ⑧ Tighten the screws (four PTT screws 5 × 10, indicated by ○) to attach the cover (left).
- ⑨ Attach the H. elem. cover (inside).

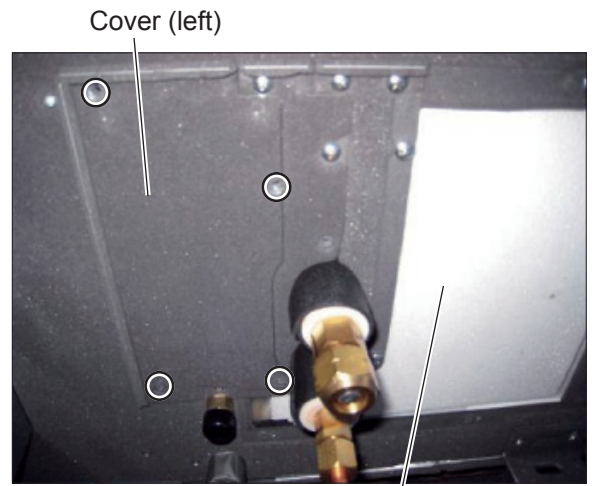

H. elem. cover (inside)

- ⑩ Tighten the screws (Seven PTT screws 5 x 10, indicated by ○) to attach the H. elem. cover.

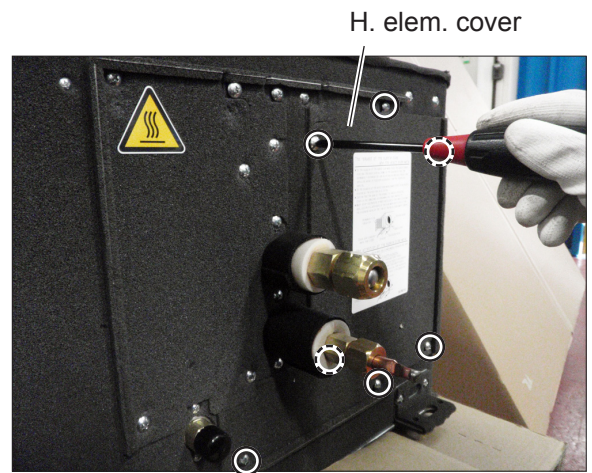

H. elem. cover

* When reassembling

- Reassemble the unit in the reverse order of disassembly.
- After reassembly, always make a test run to be sure that the unit operates properly.

9. Parts catalog

Please note the following when using the parts catalog.

1. When ordering parts, always indicate the part number, part name, and the number of parts required.
2. It may take time for you to receive the parts. Make an inquiry about a rush order.
3. Specifications may be subject to change without notice.
4. Parts marked with \triangle and \blacksquare are critical for safety.
5. To maintain safety and performance, always replace the parts with the parts prescribed.
6. When replacing the parts to which the nameplate is attached, remove the nameplate and attach it to the new parts.

Description of screw abbreviations

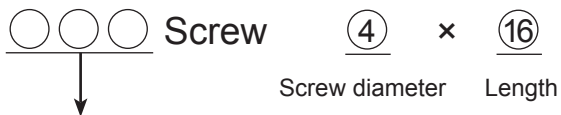

Abbreviation	Description
PC screw	Cross recess flat head machine screw
PRC screw	Cross recess oval head machine screw
PP screw	Cross recess pan head machine screw
SW · PP screw	Cross recess pan head screw with spring washer
PPT screw	Cross recess tapping screw
PCT screw	Cross recess flat head tapping screw
PTT screw	Cross recess truss head tapping screw
PT screw	Cross recess truss head machine screw
SET screw	Slotted head stop screw
SQ · SET screw	Square head stop screw
P · SET screw	Pan head stop screw
PMT screw	Primer truss head screw
HS · SET screw	Hexagon head stop screw
P · R · W screw	Cross recess round wood screw
P · C · W screw	Cross recess flat head wood screw
P · R · C · W screw	Cross recess round and flat wood screw
R · W screw	Slotted round wood screw
PW · PP screw	Cross recess pan head screw with small washer
SW-PW · PP screw	Cross recess pan head machine screw with spring washer and flat washer

GUF-50RD4

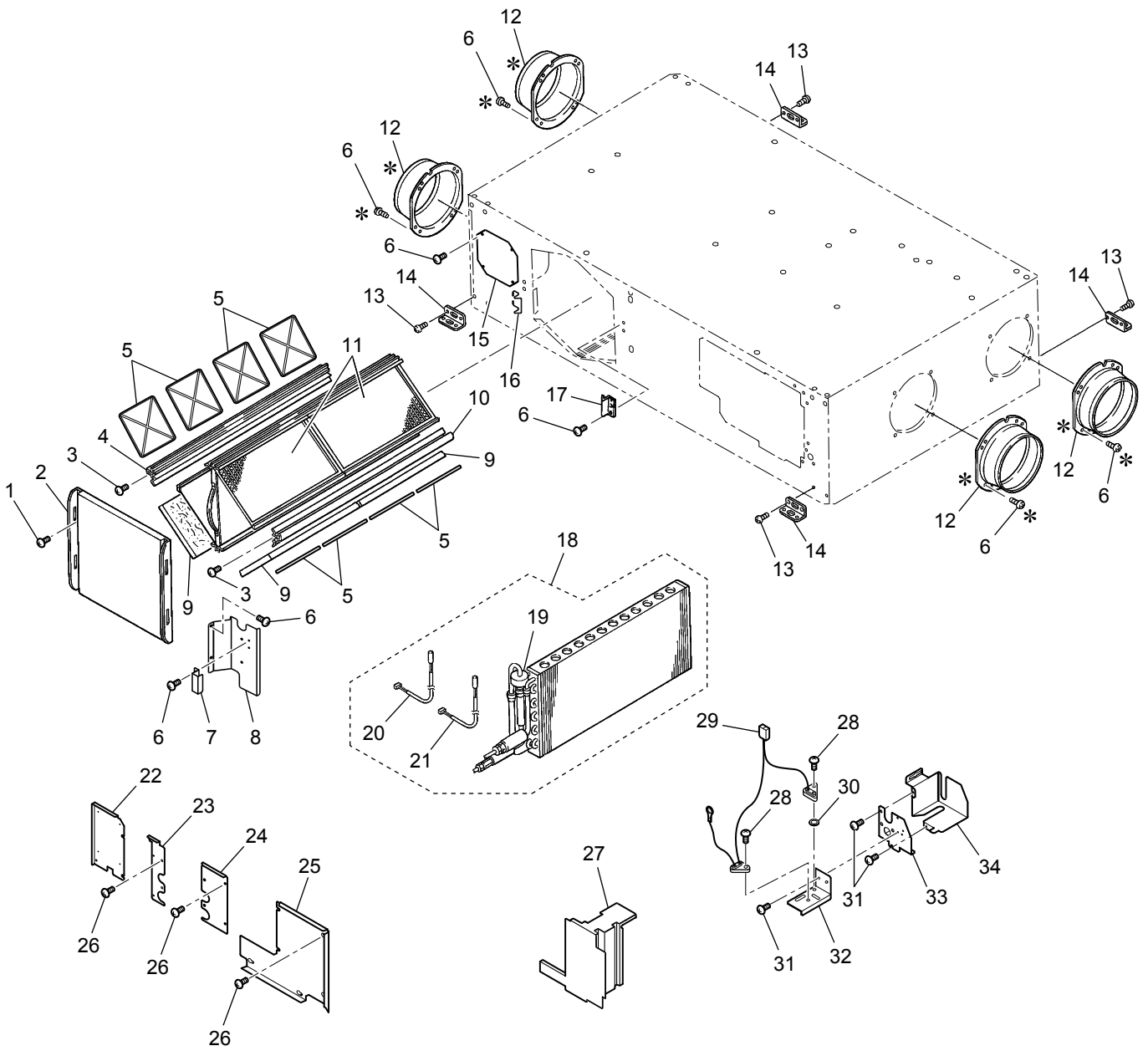

*		
6	35	36
16 pcs.	2 pcs.	2 pcs.

* shows accessory parts.

GUF-50RD4

No.	Name of part	Parts No.	Q'ty pcs/unit	Critical for safety	Remarks
1	Special screw 4x11	W00 000 066	1		
2	Maintenance cover	W50 022 486	1		
3	PTT screw 4x12	W00 000 007	2		
4	Core guide	W50 005 382	1		
5	Filter stopper	W50 004 718	8		
6	PTT screw 4x8	W00 000 009	45		
7	Fix piece	W50 010 704	1		
8	Fix plate	W50 010 701	1		
9	Filter	W50 004 723	4	⚠	
10	Core guide	W50 010 382	1		
11	Lossnay core	W50 003 726	2	⚠	With filter stoppers
12	Flange	W50 010 609	4		
13	PT screw 6x12	W00 000 060	15		
14	Hanger	W50 001 380	4		
15	Cover	W50 003 707	2		
16	Hinge	W50 004 344	1		
17	Fix piece	W50 004 722	1		
18	Heat exchanger	W50 010 722	1	⚠	For coolant
19	Expansion valve	W50 010 737	1		
20	Thermistor	W50 010 180	1	⚠	For the gas pipe
21	Thermistor	W50 010 179	1	⚠	For the liquid pipe
22	Cover (left)	W50 010 695	1		
23	Cover (center)	W50 010 696	1		
24	Cover (right)	W50 010 697	1		
25	Element cover	W50 010 691	1		
26	PTT screw 5x10	W00 000 044	31		
27	Element cover	W50 010 688	1		
28	Special screw 4x12	W00 000 045	2		
29	Water sensor	W50 010 213	1	⚠	With lead wires
30	Special washer (5)	W00 000 205	1		
31	PTT screw 4x8	W00 000 199	8		
32	Fix plate	W50 010 705	1		
33	Cover B	W50 010 700	1		
34	Cover A	W50 010 699	1		
35	Heat insulator	W50 012 705	2		For coolant
36	Heat insulator	W50 012 708	2		For the gas pipe

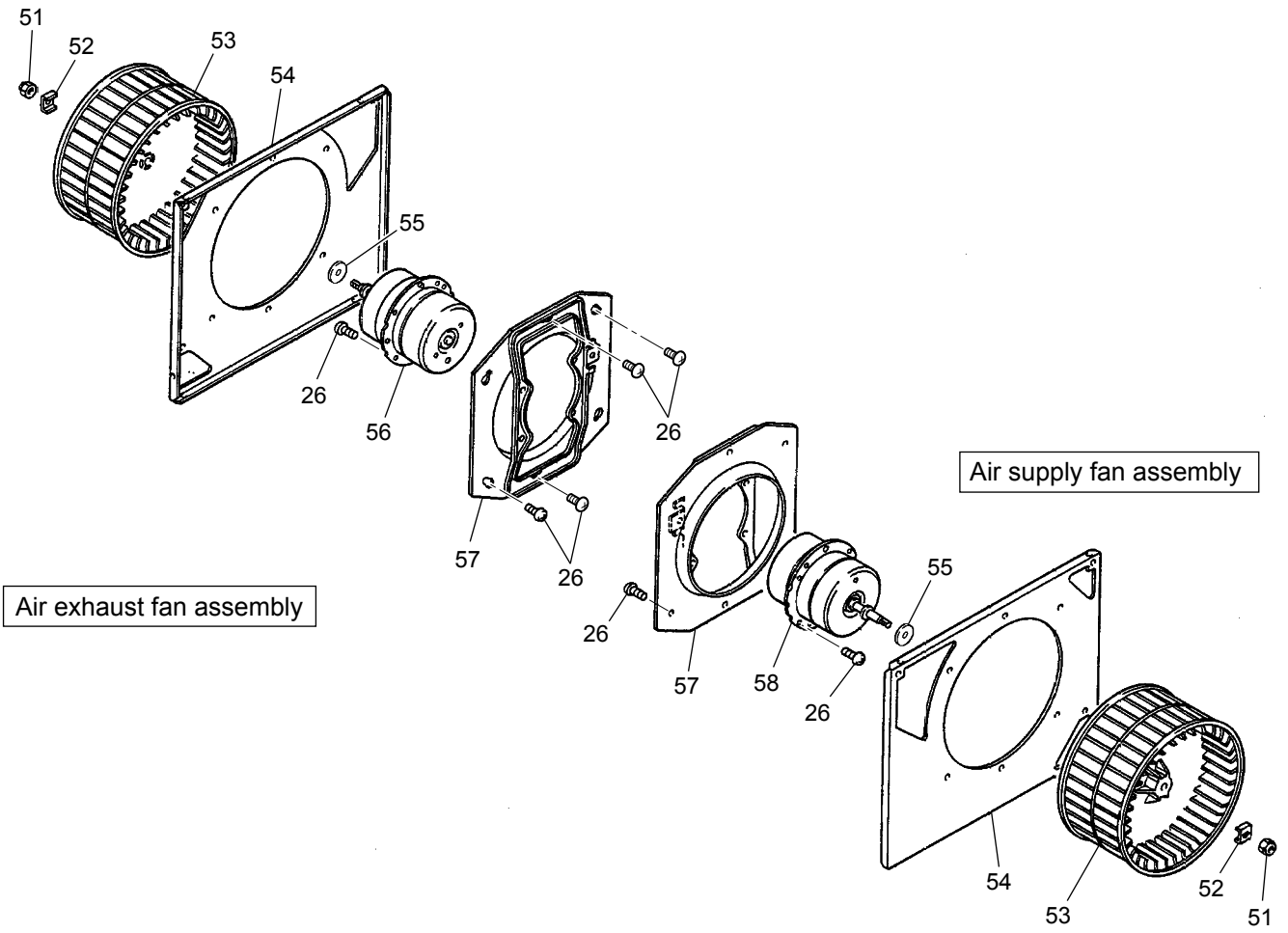

Air exhaust fan assembly

Air supply fan assembly

GUF-50RD4

No.	Name of part	Parts No.	Q'ty pcs/unit	Critical for safety	Remarks
51	Special nut (M8)	W00 000 121	2		Left-handed
52	Tab washer	W00 000 134	2		
53	Centrifugal fan	W50 010 480	2	⚠	φ 220
54	Fan base	W50 010 713	2		
55	Special washer (10)	W50 003 478	2		φ 40 (Outer dia.)
56	Motor	W50 010 453	1	⚠	
57	Motor fix plate	W50 010 717	2		
58	Motor	W50 010 454	1	⚠	

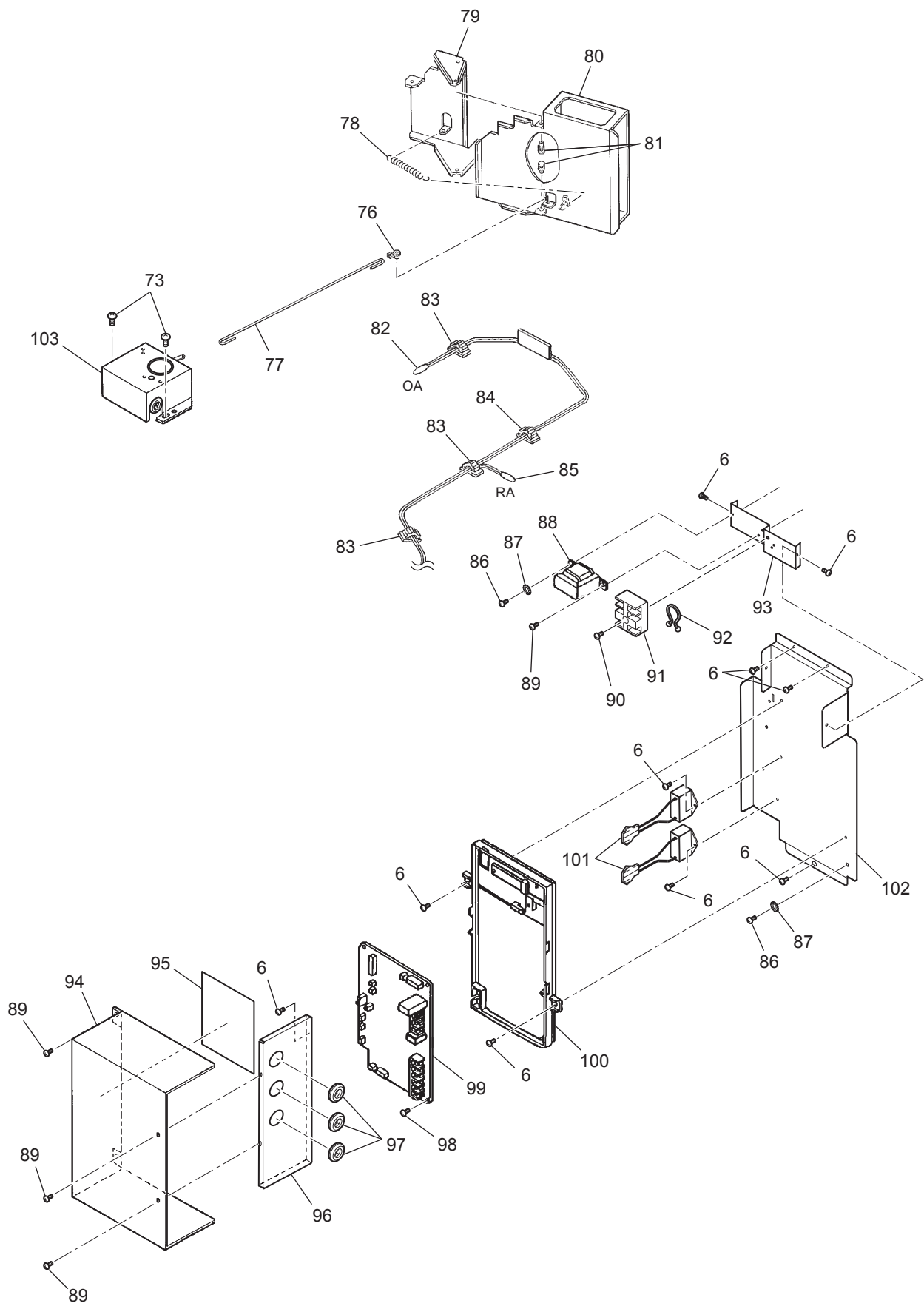

GUF-50RD4

No.	Name of part	Parts No.	Q'ty pcs/unit	Critical for safety	Remarks
73	PTT screw 4x6	W00 000 035	30		
76	Special bush	W50 001 228	1		
77	Rod	W50 006 150	1		
78	Pull spring	W50 010 156	1		
79	Damper support	W50 010 720	1		
80	Damper	W50 010 718	1		
81	Special bush	W00 000 268	2		
82	Thermistor	W50 010 216	1	⚠	
83	Cord clip	W00 000 262	3		
84	Cord clip	W00 000 263	4		
85	Thermistor	W50 010 217	1	⚠	
86	PT screw 4x8 BS	W00 000 011	2		
87	Lock washer (4)	W00 000 082	2		
88	Transformer	W50 010 222	1	⚠	
89	PT screw 4x8	W00 000 050	5		
90	PPT screw 4x20	W00 000 005	1		
91	Terminal block	W50 010 220	1	⚠	3P・With lead wires
92	Cord band	W00 000 231	1		White
93	TB fix plate	W50 010 708	1		
94	Control cover	W50 010 707	1		
95	Wiring diagram	W50 010 368	1		
96	Side plate	W50 010 709	1		
97	Bush	W00 000 289	3		
98	PPT screw 3x8	W00 000 012	1		
99	Circuit board	W50 006 171	1	⚠	FU-M05-D1
100	PCB fix plate	W50 010 715	1		
101	Capacitor	W50 010 287	2	⚠	4.0μF・440VAC
102	PCB fix plate	W50 010 710	1		
103	GM assembly	W50 010 260	1	⚠	AC220・240V

GUF-50RDH4

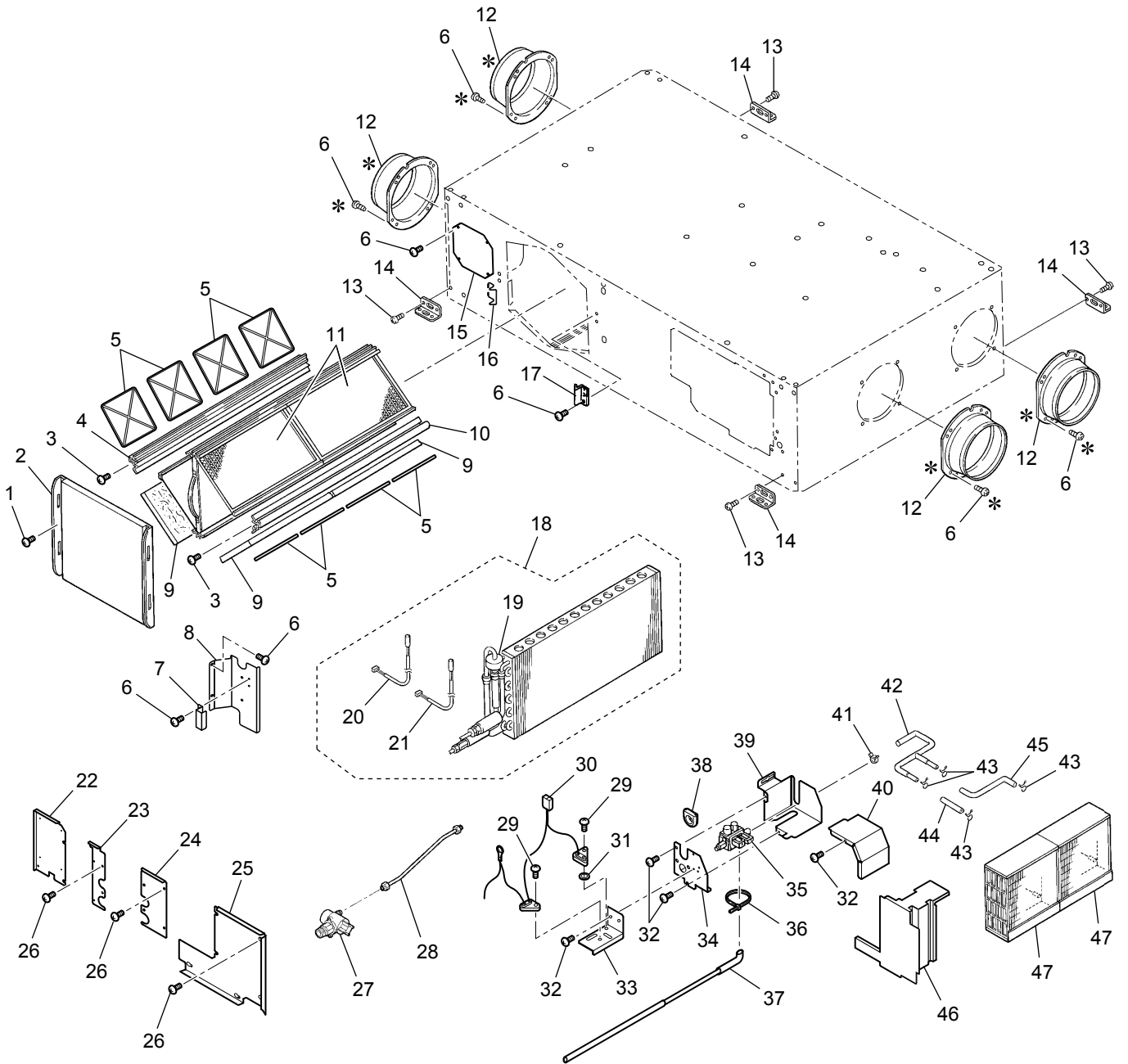

*		
6	48	49
16 pcs.	2 pcs.	2 pcs.

* shows accessory parts.

GUF-50RDH4

No.	Name of part	Parts No.	Q'ty pcs/unit	Critical for safety	Remarks
1	Special screw 4x11	W00 000 066	1		
2	Maintenance cover	W50 022 486	1		
3	PTT screw 4x12	W00 000 007	2		
4	Core guide	W50 005 382	1		
5	Filter stopper	W50 004 718	8		
6	PTT screw 4x8	W00 000 009	46		
7	Fix piece	W50 010 704	1		
8	Fix plate	W50 010 701	1		
9	Filter	W50 004 723	4	▲	
10	Core guide	W50 010 382	1		
11	Lossnay core	W50 003 726	2	▲	With filter stoppers
12	Flange	W50 010 609	4		
13	PT screw 6x12	W00 000 060	15		
14	Hanger	W50 001 380	4		
15	Cover	W50 003 707	2		
16	Hinge	W50 004 344	1		
17	Fix piece	W50 004 722	1		
18	Heat exchanger	W50 010 722	1	▲	For coolant
19	Expansion valve	W50 010 737	1		
20	Thermistor	W50 010 180	1	▲	For the gas pipe
21	Thermistor	W50 010 179	1	▲	For the liquid pipe
22	Cover (left)	W50 010 695	1		
23	Cover (center)	W50 010 696	1		
24	Cover (right)	W50 010 697	1		
25	H. elem. cover	W50 010 691	1		
26	PTT screw 5x10	W00 000 044	31		
27	Strainer	W50 010 319	1	▲	
28	Pipe	W50 010 303	1		
29	Special screw 4x12	W00 000 045	4		
30	Water sensor	W50 010 215	1	▲	With lead wires
31	Special washer (5)	W00 000 205	1		
32	PTT screw 4x8	W00 000 199	10		
33	Fix plate	W50 010 705	1		
34	Cover B	W50 010 700	1		
35	Solenoid valve	W50 010 214	1	▲	200V·With a drain valve
36	Cord band	W00 000 228	1		100mm
37	Drain tube	W50 010 392	1		
38	Cord bush	W00 000 225	1		
39	Cover A	W50 010 699	1		
40	Cover (SOLV)	W50 010 703	1		
41	Hose band	W50 010 223	1		D12.5
42	Tube	W50 010 391	1		
43	Hose band	W00 000 288	4		D12.5
44	Tube	W50 010 388	1		
45	Tube	W50 010 390	1		
46	Element cover	W50 010 688	1		
47	Humidifier element	W50 010 716	2	▲	With packing
48	Heat insulator	W50 012 705	2		For coolant
49	Heat insulator	W50 012 708	2		For the gas pipe

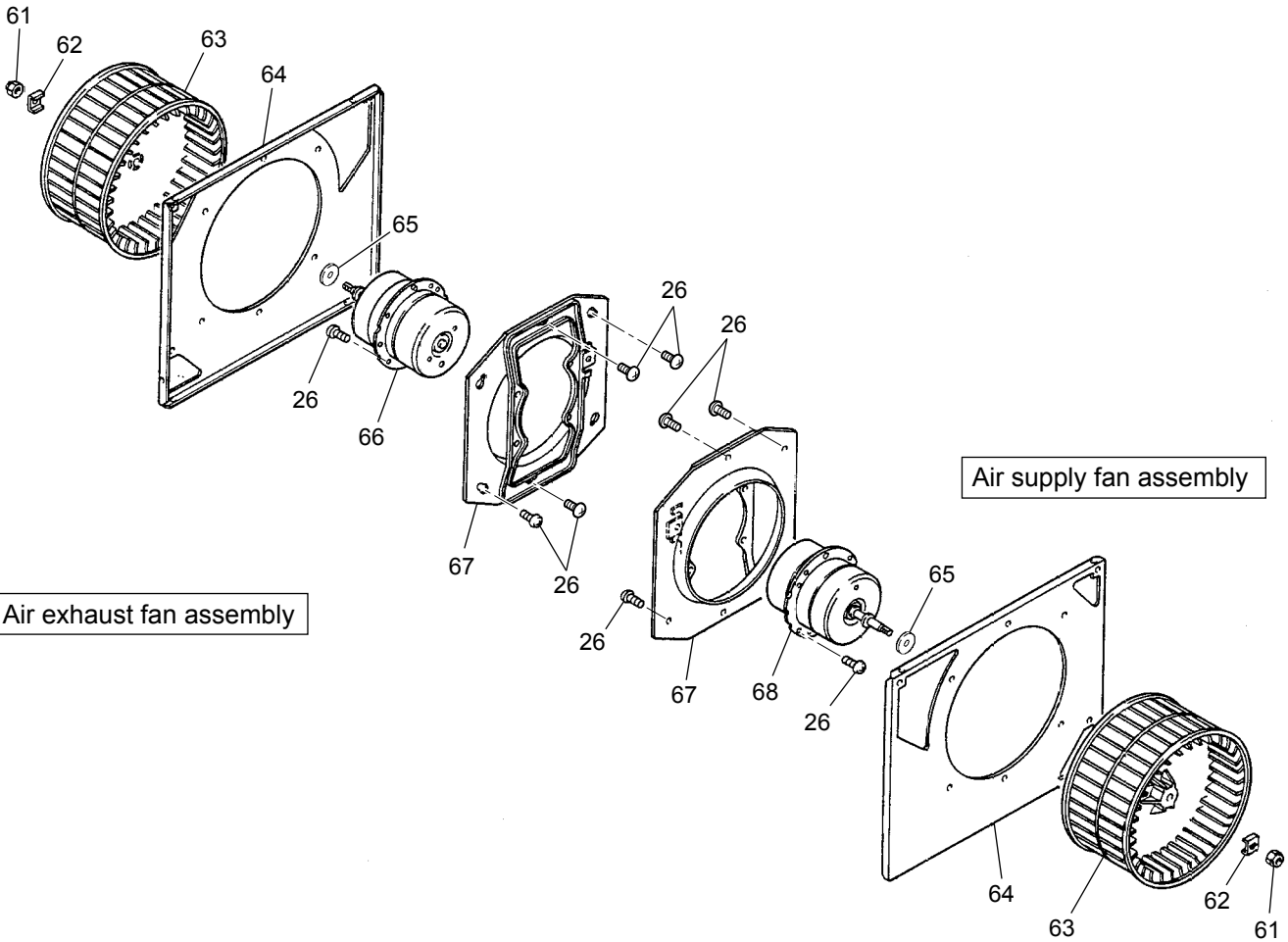

GUF-50RDH4

No.	Name of part	Parts No.	Q'ty pcs/unit	Critical for safety	Remarks
61	Special nut (M8)	W00 000 121	2		Left-handed
62	Tab washer	W00 000 134	2		
63	Centrifugal fan	W50 010 480	2	⚠	φ 220
64	Fan base	W50 010 713	2		
65	Special washer (10)	W50 003 478	2		φ 40 (Outer dia.)
66	Motor	W50 010 453	1	⚠	
67	Motor fix plate	W50 010 717	2		
68	Motor	W50 010 454	1	⚠	

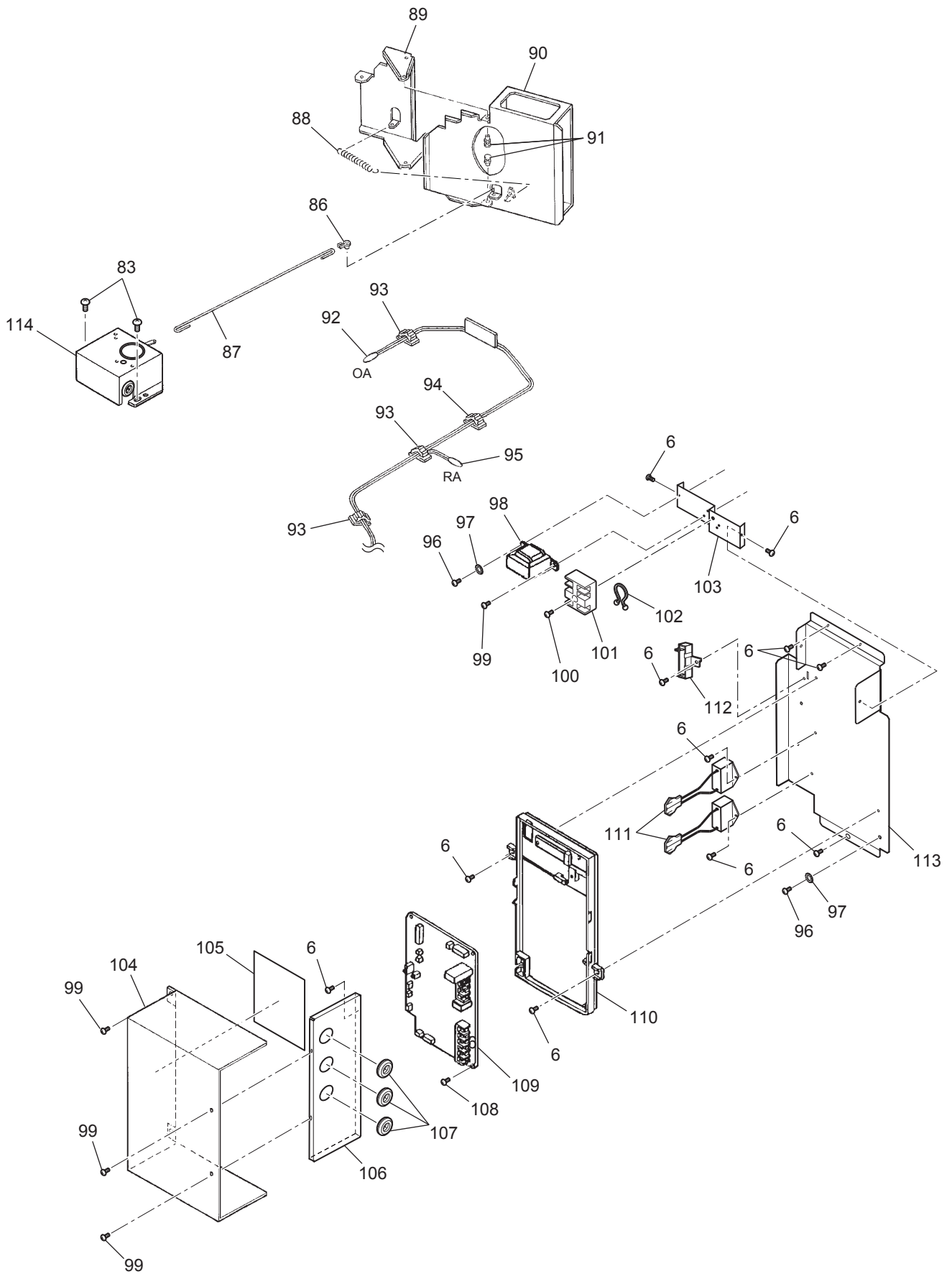



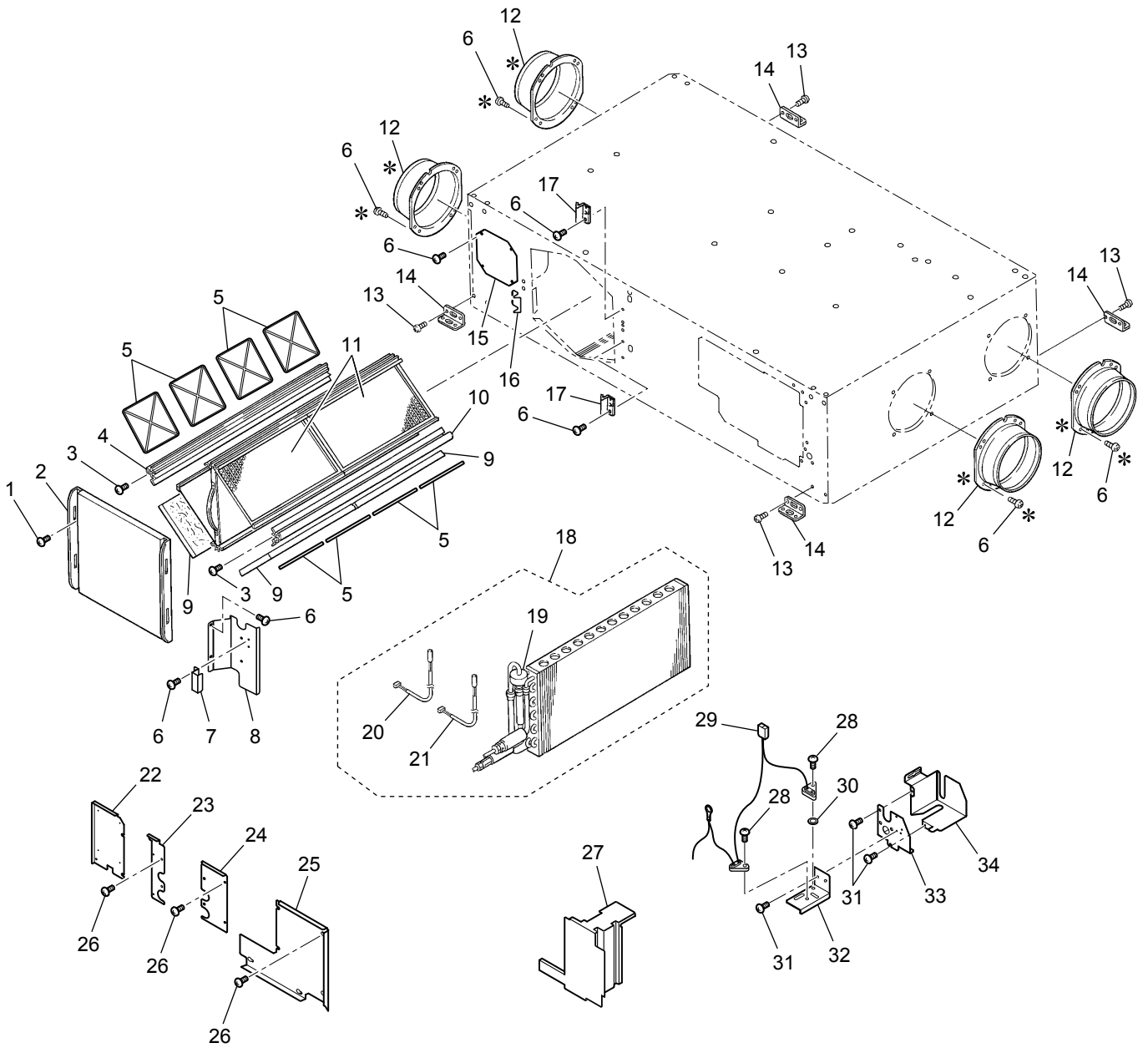

GUF-50RDH4

No.	Name of part	Parts No.	Q'ty pcs/unit	Critical for safety	Remarks
83	PTT screw 4x6	W00 000 035	30		
86	Special bush	W50 001 228	1		
87	Rod	W50 006 150	1		
88	Pull spring	W50 010 156	1		
89	Damper support	W50 010 720	1		
90	Damper	W50 010 718	1		
91	Special bush	W00 000 268	2		
92	Thermistor	W50 010 216	1	⚠	
93	Cord clip	W00 000 262	3		
94	Cord clip	W00 000 263	4		
95	Thermistor	W50 010 217	1	⚠	
96	PT screw 4x8 BS	W00 000 011	2		
97	Lock washer (4)	W00 000 082	2		
98	Transformer	W50 010 222	1	⚠	
99	PT screw 4x8	W00 000 050	7		
100	PPT screw 4x20	W00 000 005	1		
101	Terminal block	W50 010 220	1	⚠	3P・With lead wires
102	Cord band	W00 000 231	1		White
103	TB fix plate	W50 010 708	1		
104	Control cover	W50 010 707	1		
105	Wiring diagram	W50 010 367	1		
106	Side plate	W50 010 709	1		
107	Bush	W00 000 289	3		
108	PPT screw 3x8	W00 000 012	1		
109	Circuit board	W50 006 171	1	⚠	FU-M05-D1
110	PCB fix plate	W50 010 715	1		
111	Capacitor	W50 010 287	2	⚠	4.0μF・440VAC
112	Cement resistor	W50 010 221	1	⚠	
113	PCB fix plate	W50 010 710	1		
114	GM assembly	W50 010 260	1	⚠	AC220・240V

GUF-100RD4



*			
6	35	36	37
			
16 pcs.	4 pcs.	2 pcs.	2 pcs.

* shows accessory parts.

GUF-100RD4

No.	Name of part	Parts No.	Q'ty pcs/unit	Critical for safety	Remarks
1	Special screw 4x11	W00 000 066	1		
2	Maintenance cover	W50 022 487	1		
3	PTT screw 4x12	W00 000 007	2		
4	Core guide	W50 010 381	1		
5	Filter stopper	W50 004 716	8		
6	PTT screw 4x8	W00 000 009	81		
7	Fix piece	W50 010 704	1		
8	Fix plate	W50 010 702	1		
9	Filter	W50 004 724	4	⚠	
10	Core guide	W50 010 383	1		
11	Lossnay core	W50 003 729	2	⚠	With filter stoppers
12	Flange	W50 004 610	4		
13	PT screw 6x12	W00 000 060	16		
14	Hanger	W50 004 382	4		
15	Cover	W50 003 708	2		
16	Hinge	W50 004 344	1		
17	Fix piece	W50 004 722	2		
18	Heat exchanger	W50 010 711	1	⚠	For coolant
19	Expansion valve	W50 010 737	1		
20	Thermistor	W50 010 180	1	⚠	For the gas pipe
21	Thermistor	W50 010 179	1	⚠	For the liquid pipe
22	Cover (left)	W50 010 693	1		
23	Cover (center)	W50 010 694	1		
24	Cover (right)	W50 010 698	1		
25	Element cover	W50 010 692	1		
26	PTT screw 5x10	W00 000 044	34		
27	Element cover	W50 010 687	1		
28	Special screw 4x12	W00 000 045	2		
29	Water sensor	W50 010 213	1	⚠	With lead wires
30	Special washer (5)	W00 000 205	1		
31	PTT screw 4x8	W00 000 199	8		
32	Fix plate	W50 010 706	1		
33	Cover B	W50 010 700	1		
34	Cover A	W50 010 699	1		
35	Cord band	W00 000 292	4		301mm
36	Heat insulator	W50 012 705	2		For coolant
37	Heat insulator	W50 012 708	2		For the gas pipe

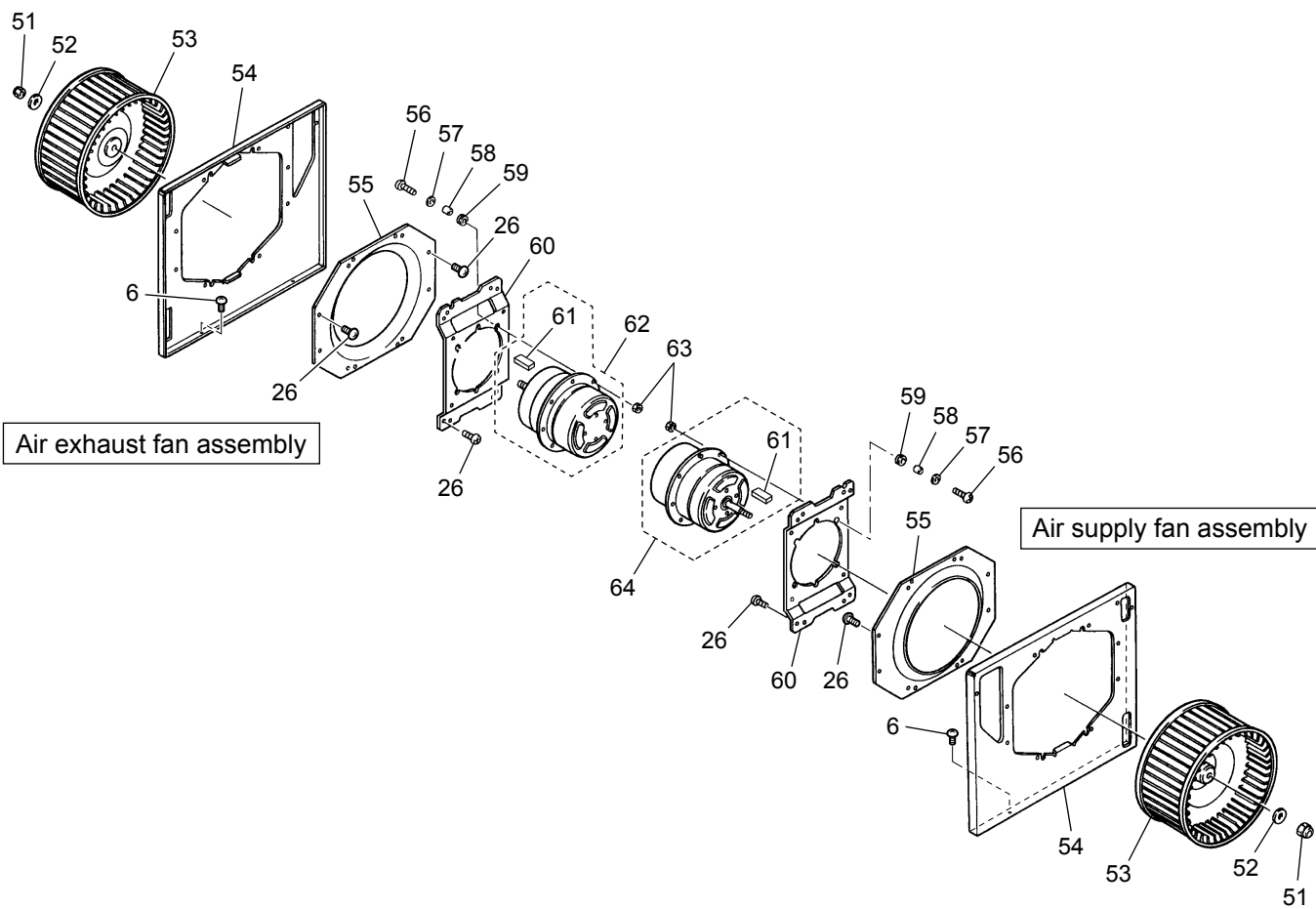

Air exhaust fan assembly

Air supply fan assembly

GUF-100RD4

No.	Name of part	Parts No.	Q'ty pcs/unit	Critical for safety	Remarks
51	Special nut (M12)	W00 000 117	2		Left-handed
52	Washer (12)	W00 000 123	2		
53	Centrifugal fan	W50 010 481	2	⚠	φ 245
54	Fan base	W50 010 714	2		
55	Inlet ring	W50 001 724	2		
56	PT screw 6x20	W00 000 063	8		
57	Special washer (6)	W00 000 162	8		
58	Spacer	W50 001 095	8		
59	Bush	W00 000 274	8		
60	Motor fix plate	W50 001 712	2		
61	Key	W50 001 104	2		5x5x11.5
62	Motor	W50 010 457	1	⚠	
63	Nut (M6)	W00 000 107	8		
64	Motor	W50 010 456	1	⚠	

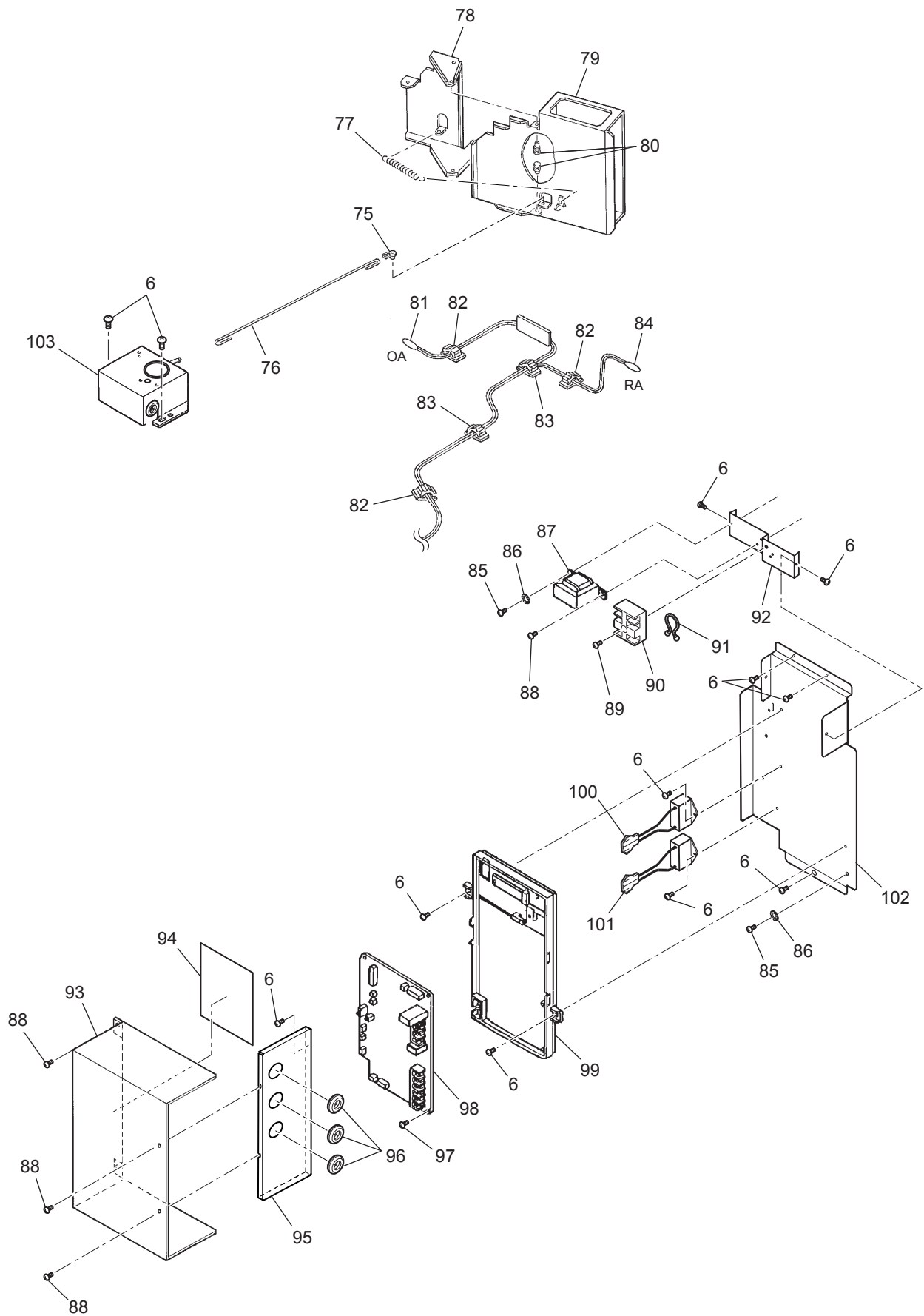



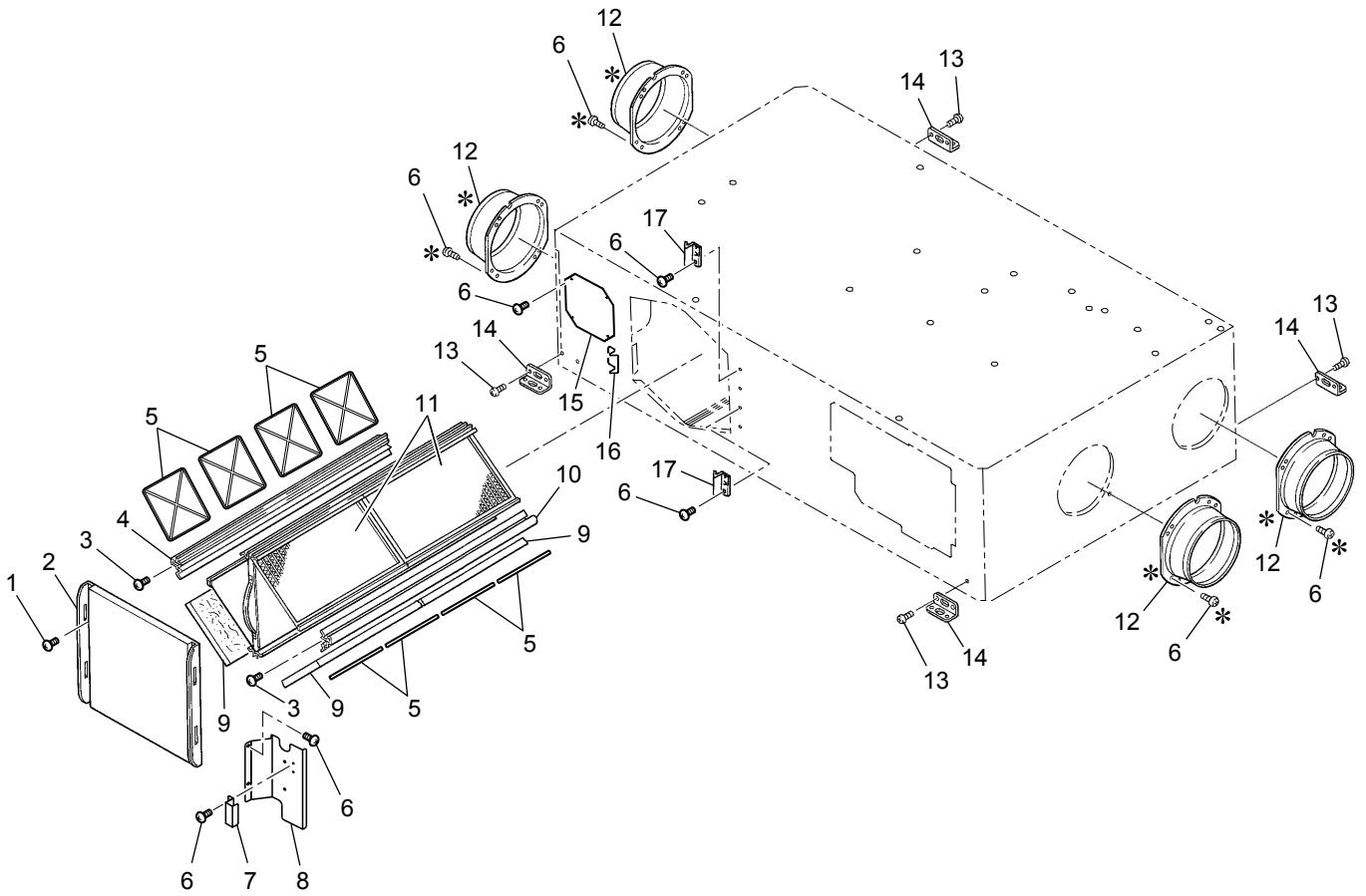

GUF-100RD4

No.	Name of part	Parts No.	Q'ty pcs/unit	Critical for safety	Remarks
75	Special bush	W50 001 228	1		
76	Rod	W50 010 150	1		
77	Pull spring	W50 010 157	1		
78	Damper support	W50 010 719	1		
79	Damper	W50 010 721	1		
80	Special bush	W00 000 268	2		
81	Thermistor	W50 010 219	1	⚠	
82	Cord clip	W00 000 262	3		
83	Cord clip	W00 000 263	6		
84	Thermistor	W50 010 218	1	⚠	
85	PT screw 4x8 BS	W00 000 011	2		
86	Lock washer (4)	W00 000 082	2		
87	Transformer	W50 010 222	1	⚠	
88	PT screw 4x8	W00 000 050	5		
89	PPT screw 4x20	W00 000 005	1		
90	Terminal block	W50 010 220	1	⚠	3P·With lead wires
91	Cord band	W00 000 231	1		White
92	TB fix plate	W50 010 708	1		
93	Control cover	W50 010 707	1		
94	Wiring diagram	W50 010 368	1		
95	Side plate	W50 010 709	1		
96	Bush	W00 000 289	3		
97	PPT screw 3x8	W00 000 012	1		
98	Circuit board	W50 006 171	1	⚠	FU-M05-D1
99	PCB fix plate	W50 010 715	1		
100	Capacitor	W50 003 298	1	⚠	9.0 μ F·440VAC
101	Capacitor	W50 010 288	1	⚠	7.0 μ F·440VAC
102	PCB fix plate	W50 010 710	1		
103	GM assembly	W50 010 261	1	⚠	AC220·240V

GUF-100RDH4



*			
6	18	19	20
			
16 pcs.	5 pcs.	2 pcs.	2 pcs.

* shows accessory parts.

GUF-100RDH4

No.	Name of part	Parts No.	Q'ty pcs/unit	Critical for safety	Remarks
1	Special screw 4x11	W00 000 066	1		
2	Maintenance cover	W50 022 487	1		
3	PTT screw 4x12	W00 000 007	2		
4	Core guide	W50 010 381	1		
5	Filter stopper	W50 004 716	8		
6	PTT screw 4x8	W00 000 009	82		
7	Fix piece	W50 010 704	1		
8	Fix plate	W50 010 702	1		
9	Filter	W50 004 724	4	⚠	
10	Core guide	W50 010 383	1		
11	Lossnay core	W50 003 729	2	⚠	With filter stoppers
12	Flange	W50 004 610	4		
13	PT screw 6x12	W00 000 060	16		
14	Hanger	W50 004 382	4		
15	Cover	W50 003 708	2		
16	Hinge	W50 004 344	1		
17	Fix piece	W50 004 722	2		
18	Cord band	W00 000 292	4		301mm
19	Heat insulator	W50 012 705	2		For coolant
20	Heat insulator	W50 012 708	2		For the gas pipe

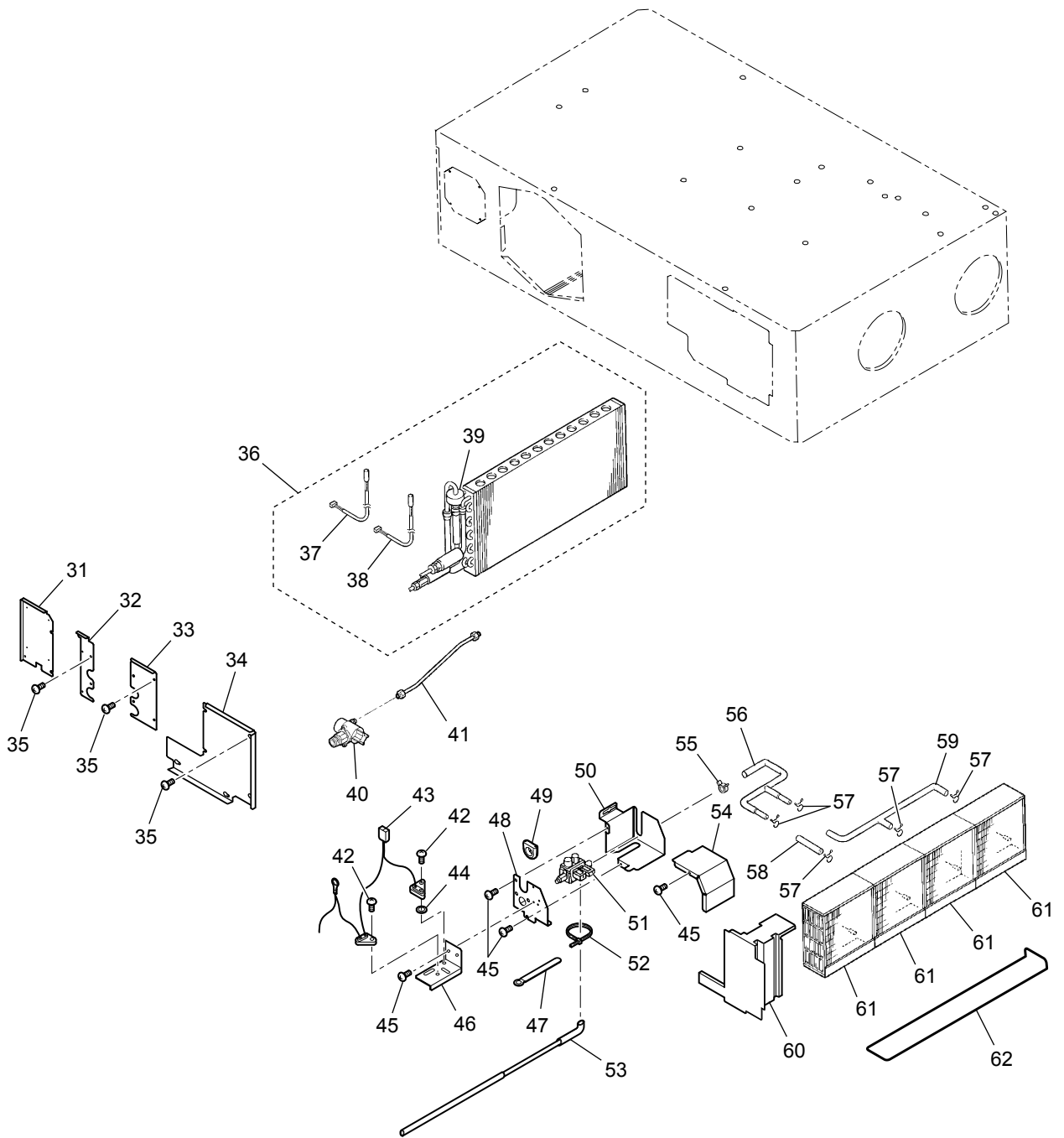

GUF-100RDH4

No.	Name of part	Parts No.	Q'ty pcs/unit	Critical for safety	Remarks
31	Cover (left)	W50 010 693	1		
32	Cover (center)	W50 010 694	1		
33	Cover (right)	W50 010 698	1		
34	Element cover	W50 010 692	1		
35	PTT screw 5x10	W00 000 044	34		
36	Heat exchanger	W50 010 711	1	⚠	For coolant
37	Thermistor	W50 010 180	1	⚠	For the gas pipe
38	Thermistor	W50 010 179	1	⚠	For the liquid pipe
39	Expansion valve	W50 010 737	1		
40	Strainer	W50 010 319	1	⚠	
41	Pipe	W50 010 303	1		
42	Special screw 4x12	W00 000 045	4		
43	Water sensor	W50 010 215	1	⚠	With lead wires
44	Special washer (5)	W00 000 205	1		
45	PTT screw 4x8	W00 000 199	10		
46	Fix plate	W50 010 706	1		
47	Lead wire clip	W00 000 238	1		
48	Cover B	W50 010 700	1		
49	Cord bush	W00 000 225	1		
50	Cover A	W50 010 699	1		
51	Solenoid valve	W50 010 214	1	⚠	200V·With a drain valve
52	Cord band	W00 000 228	1		100mm
53	Drain tube	W50 010 392	1		
54	Cover (SOLV)	W50 010 703	1		
55	Hose band	W50 010 223	1		D12.5
56	Tube	W50 010 391	1		
57	Hose band	W00 000 288	6		D12.5
58	Tube	W50 010 388	1		
59	Tube	W50 010 389	1		
60	Element cover	W50 010 687	1		
61	Humidifier element	W50 010 716	4	⚠	With packing
62	Rod	W50 010 712	1		

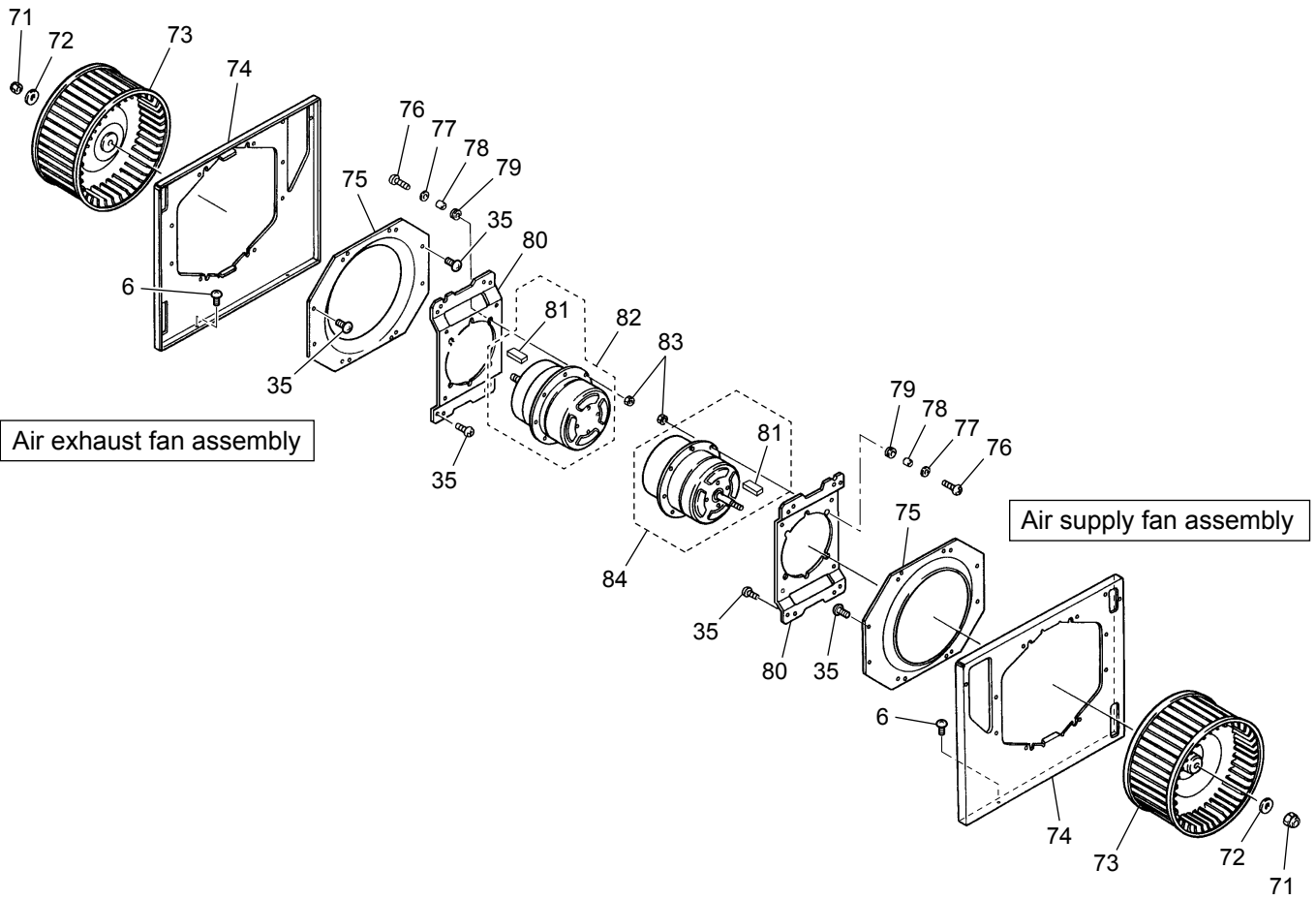

Air exhaust fan assembly

Air supply fan assembly

GUF-100RDH4

No.	Name of part	Parts No.	Q'ty pcs/unit	Critical for safety	Remarks
71	Special nut (M12)	W00 000 117	2		Left-handed
72	Washer (12)	W00 000 123	2		
73	Centrifugal fan	W50 010 481	2	⚠	φ 245
74	Fan base	W50 010 714	2		
75	Inlet ring	W50 001 724	2		
76	PT screw 6x20	W00 000 063	8		
77	Special washer (6)	W00 000 162	8		
78	Spacer	W50 001 095	8		
79	Bush	W00 000 274	8		
80	Motor fix plate	W50 001 712	2		
81	Key	W50 001 104	2		5x5x11.5
82	Motor	W50 010 457	1	⚠	
83	Nut (M6)	W00 000 107	8		
84	Motor	W50 010 456	1	⚠	

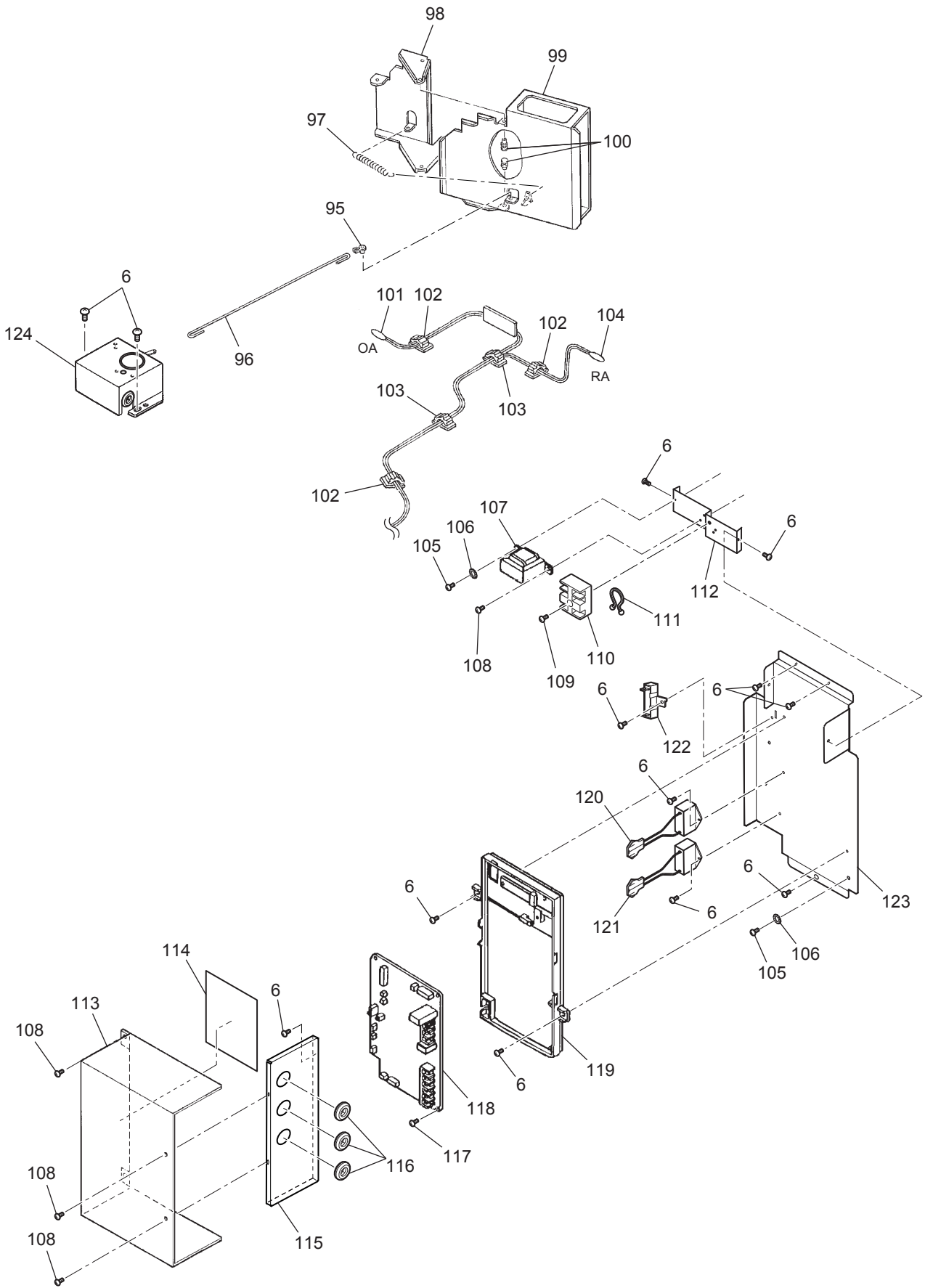



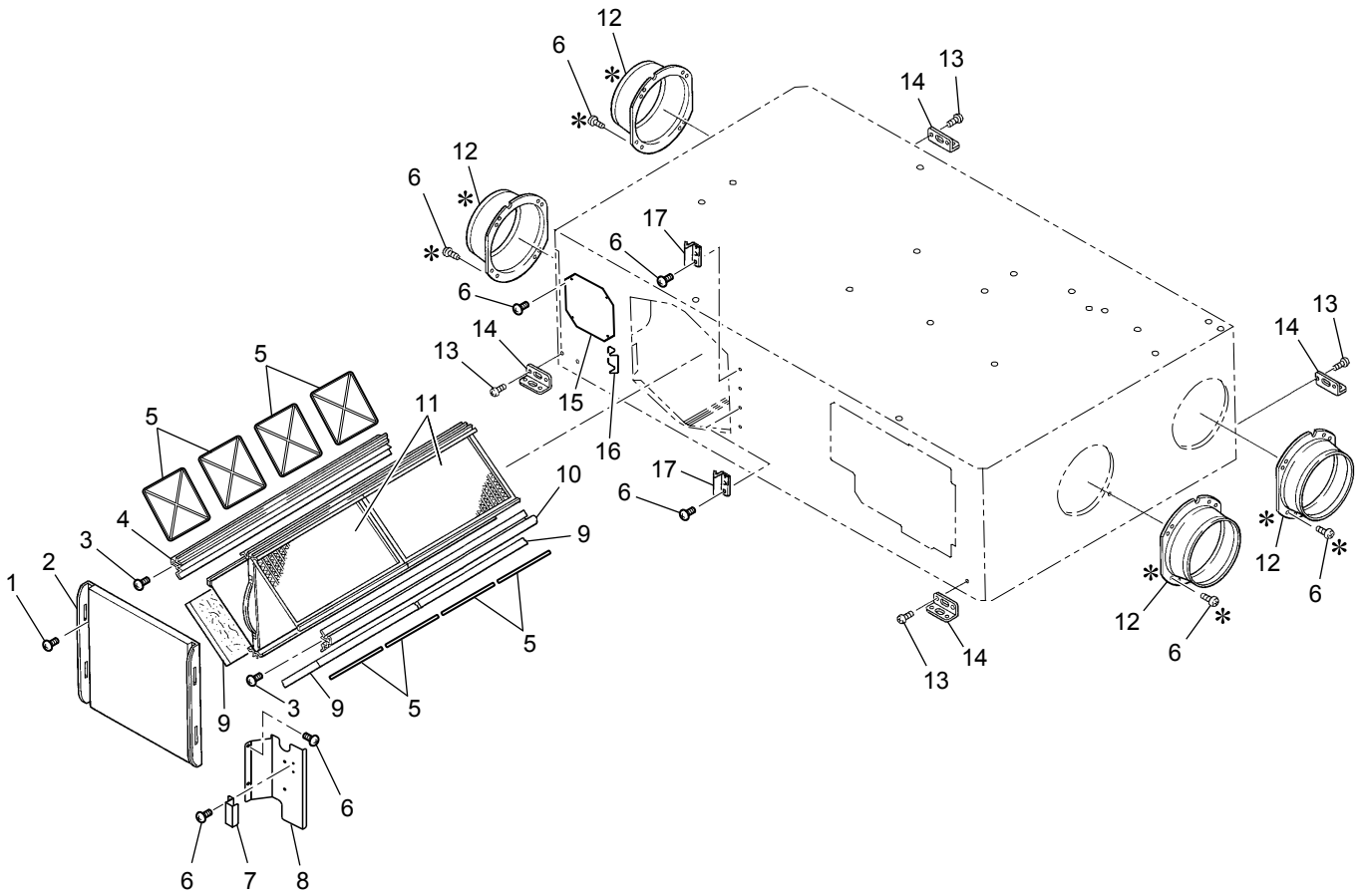

GUF-100RDH4

No.	Name of part	Parts No.	Q'ty pcs/unit	Critical for safety	Remarks
95	Special bush	W50 001 228	1		
96	Rod	W50 010 150	1		
97	Pull spring	W50 010 157	1		
98	Damper support	W50 010 719	1		
99	Damper	W50 010 721	1		
100	Special bush	W00 000 268	2		
101	Thermistor	W50 010 219	1	⚠	
102	Cord clip	W00 000 262	3		
103	Cord clip	W00 000 263	6		
104	Thermistor	W50 010 218	1	⚠	
105	PT screw 4x8 BS	W00 000 011	2		
106	Lock washer (4)	W00 000 082	2		
107	Transformer	W50 010 222	1	⚠	
108	PT screw 4x8	W00 000 050	7		
109	PPT screw 4x20	W00 000 005	1		
110	Terminal block	W50 010 220	1	⚠	3P·With lead wires
111	Cord band	W00 000 231	1		White
112	TB fix plate	W50 010 708	1		
113	Control cover	W50 010 707	1		
114	Wiring diagram	W50 010 367	1		
115	Side plate	W50 010 709	1		
116	Bush	W00 000 289	3		
117	PPT screw 3x8	W00 000 012	1		
118	Circuit board	W50 006 171	1	⚠	FU-M05-D1
119	PCB fix plate	W50 010 715	1		
120	Capacitor	W50 003 298	1	⚠	9.0μF·440VAC
121	Capacitor	W50 010 288	1	⚠	7.0μF·440VAC
122	Cement resistor	W50 010 221	1	⚠	
123	PCB fix plate	W50 010 710	1		
124	GM assembly	W50 010 261	1	⚠	AC220·240V

GUF-100RDH4-60



*			
6	18	19	20
			
16 pcs.	5 pcs.	2 pcs.	2 pcs.

* shows accessory parts.

GUF-100RDH4-60

No.	Name of part	Parts No.	Q'ty pcs/unit	Critical for safety	Remarks
1	Special screw 4x11	W00 000 066	1		
2	Maintenance cover	W50 022 487	1		
3	PTT screw 4x12	W00 000 007	2		
4	Core guide	W50 010 381	1		
5	Filter stopper	W50 004 716	8		
6	PTT screw 4x8	W00 000 009	82		
7	Fix piece	W50 010 704	1		
8	Fix plate	W50 010 702	1		
9	Filter	W50 004 724	4	⚠	
10	Core guide	W50 010 383	1		
11	Lossnay core	W50 003 729	2	⚠	With filter stoppers
12	Flange	W50 004 610	4		
13	PT screw 6x12	W00 000 060	16		
14	Hanger	W50 004 382	4		
15	Cover	W50 003 708	2		
16	Hinge	W50 004 344	1		
17	Fix piece	W50 004 722	2		
18	Cord band	W00 000 292	4		301mm
19	Heat insulator	W50 012 705	2		For coolant
20	Heat insulator	W50 012 708	2		For the gas pipe

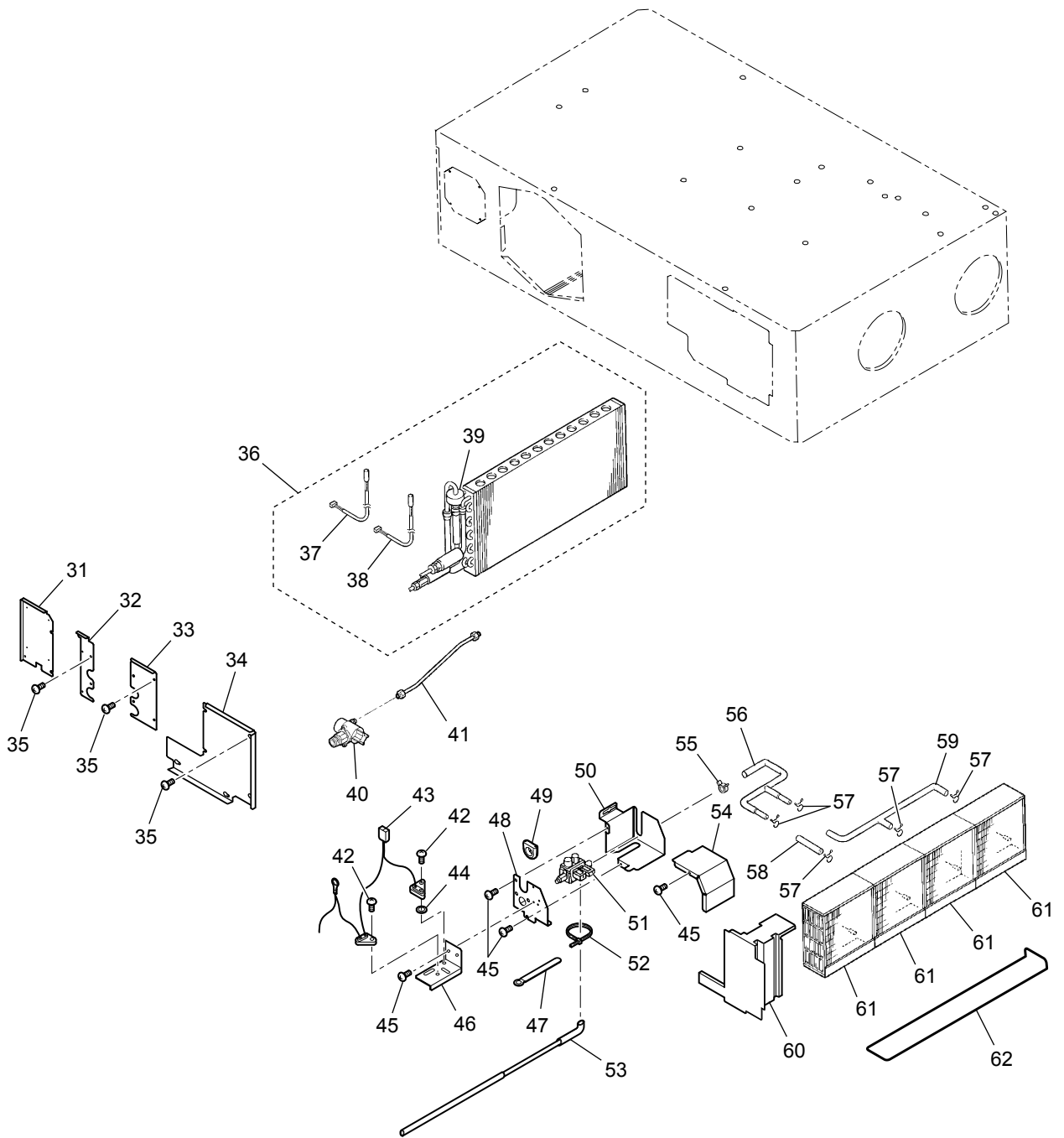

GUF-100RDH4-60

No.	Name of part	Parts No.	Q'ty pcs/unit	Critical for safety	Remarks
31	Cover (left)	W50 010 693	1		
32	Cover (center)	W50 010 694	1		
33	Cover (right)	W50 010 698	1		
34	Element cover	W50 010 692	1		
35	PTT screw 5x10	W00 000 044	34		
36	Heat exchanger	W50 010 711	1	⚠	For coolant
37	Thermistor	W50 010 180	1	⚠	For the gas pipe
38	Thermistor	W50 010 179	1	⚠	For the liquid pipe
39	Expansion valve	W50 010 737	1		
40	Strainer	W50 010 319	1	⚠	
41	Pipe	W50 010 303	1		
42	Special screw 4x12	W00 000 045	4		
43	Water sensor	W50 010 215	1	⚠	With lead wires
44	Special washer (5)	W00 000 205	1		
45	PTT screw 4x8	W00 000 199	10		
46	Fix plate	W50 010 706	1		
47	Lead wire clip	W00 000 238	1		
48	Cover B	W50 010 700	1		
49	Cord bush	W00 000 225	1		
50	Cover A	W50 010 699	1		
51	Solenoid valve	W50 010 214	1	⚠	200V·With a drain valve
52	Cord band	W00 000 228	1		100mm
53	Drain tube	W50 010 392	1		
54	Cover (SOLV)	W50 010 703	1		
55	Hose band	W50 010 223	1		D12.5
56	Tube	W50 010 391	1		
57	Hose band	W00 000 288	6		D12.5
58	Tube	W50 010 388	1		
59	Tube	W50 010 389	1		
60	Element cover	W50 010 687	1		
61	Humidifier element	W50 010 716	4	⚠	With packing
62	Rod	W50 010 712	1		

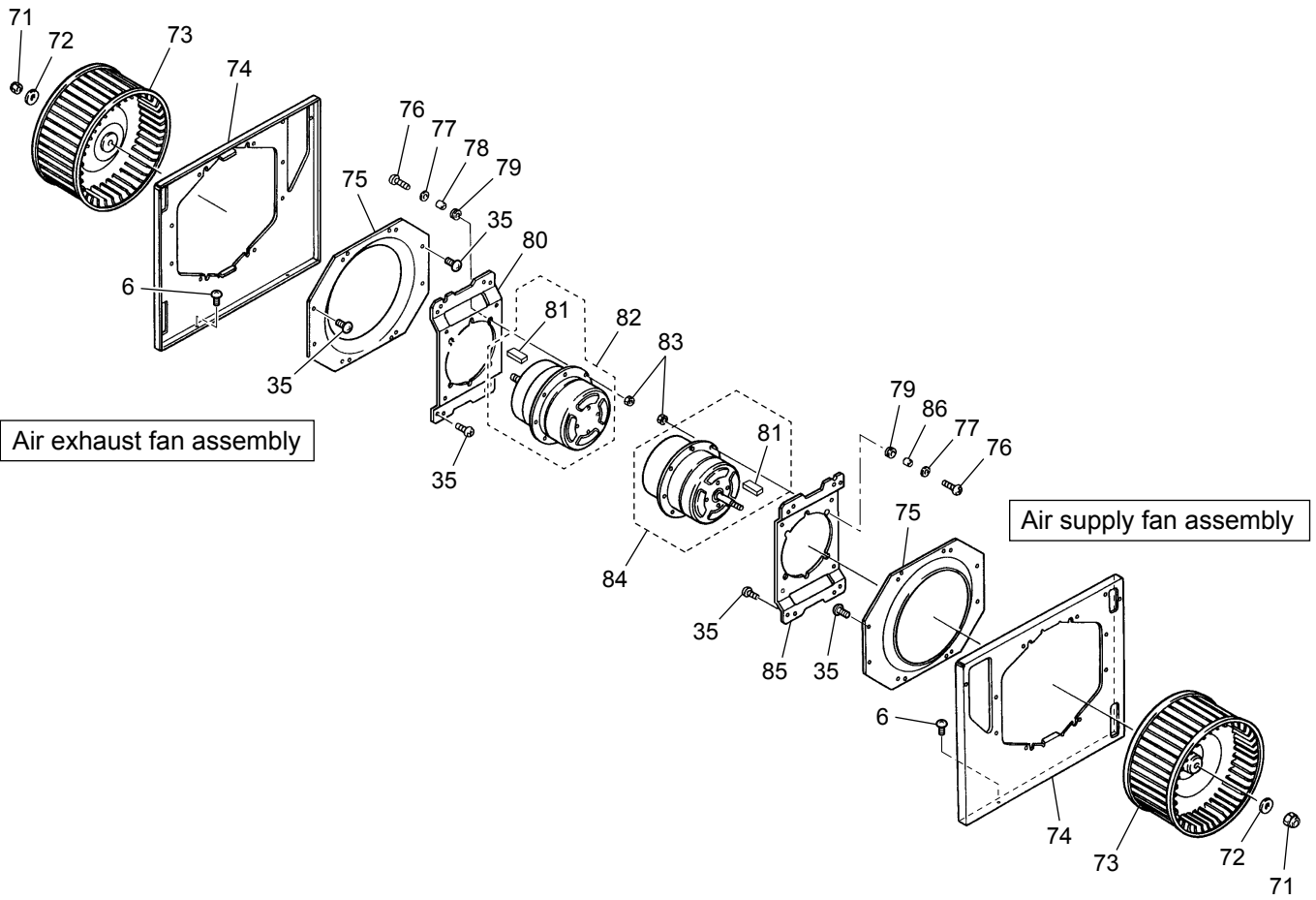

Air exhaust fan assembly

Air supply fan assembly

GUF-100RDH4-60

No.	Name of part	Parts No.	Q'ty pcs/unit	Critical for safety	Remarks
71	Special nut (M12)	W00 000 117	2		Left-handed
72	Washer (12)	W00 000 123	2		
73	Centrifugal fan	W50 010 481	2	⚠	φ 245
74	Fan base	W50 010 714	2		
75	Inlet ring	W50 001 724	2		
76	PT screw 6x20	W00 000 063	8		
77	Special washer (6)	W00 000 162	8		
78	Spacer	W50 001 098	4		
79	Bush	W00 000 274	8		
80	Motor fix plate	W50 001 725	1		
81	Key	W50 001 104	2		5x5x11.5
82	Motor	W50 010 455	1	⚠	
83	Nut (M6)	W00 000 107	8		
84	Motor	W50 010 456	1	⚠	
85	Motor fix plate	W50 001 712	1		
86	Spacer	W50 001 095	4		

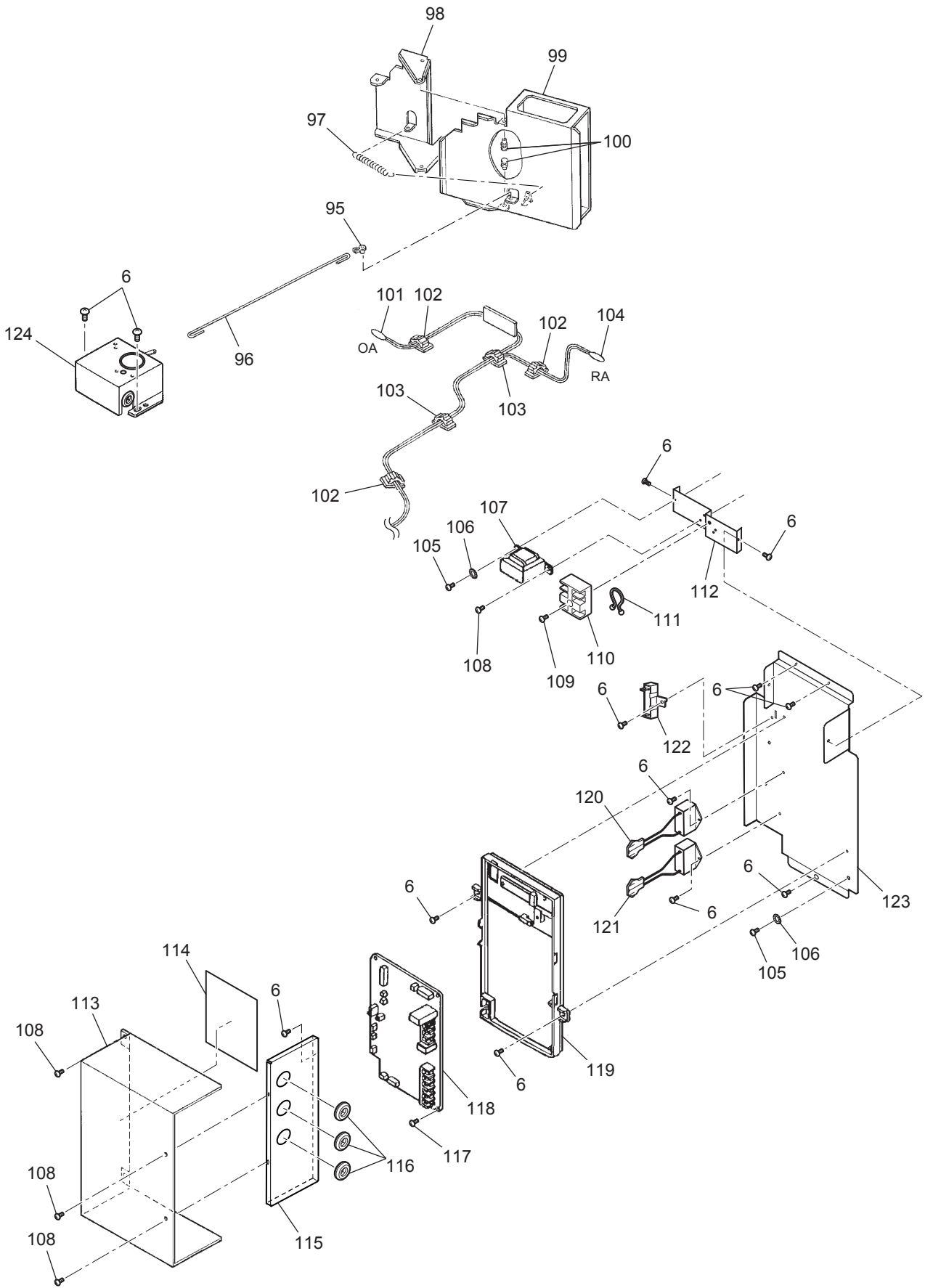

GUF-100RDH4-60

No.	Name of part	Parts No.	Q'ty pcs/unit	Critical for safety	Remarks
95	Special bush	W50 001 228	1		
96	Rod	W50 010 150	1		
97	Pull spring	W50 010 157	1		
98	Damper support	W50 010 719	1		
99	Damper	W50 010 721	1		
100	Special bush	W00 000 268	2		
101	Thermistor	W50 010 219	1	⚠	
102	Cord clip	W00 000 262	3		
103	Cord clip	W00 000 263	6		
104	Thermistor	W50 010 218	1	⚠	
105	PT screw 4x8 BS	W00 000 011	2		
106	Lock washer (4)	W00 000 082	2		
107	Transformer	W50 010 222	1	⚠	
108	PT screw 4x8	W00 000 050	7		
109	PPT screw 4x20	W00 000 005	1		
110	Terminal block	W50 010 220	1	⚠	3P·With lead wires
111	Cord band	W00 000 231	1		White
112	TB fix plate	W50 010 708	1		
113	Control cover	W50 010 707	1		
114	Wiring diagram	W50 010 369	1		
115	Side plate	W50 010 709	1		
116	Bush	W00 000 289	3		
117	PPT screw 3x8	W00 000 012	1		
118	Circuit board	W50 006 171	1	⚠	FU-M05-D1
119	PCB fix plate	W50 010 715	1		
120	Capacitor	W50 003 298	1	⚠	9.0μF·440VAC
121	Capacitor	W50 010 288	1	⚠	7.0μF·440VAC
122	Cement resistor	W50 010 221	1	⚠	
123	PCB fix plate	W50 010 710	1		
124	GM assembly	W50 010 261	1	⚠	AC220·240V